

Fall - 2013

Course: Sustainable Design of Technology Systems - ME589

Project Title: A Sustainable Solar Water Heater Design

Instructor

Steven Skerlos (skerlos@umich.edu)

Arthur F. Thurnau Professor: University of Michigan

Siddharth Kale (sidkale@umich.edu)

GSI: University of Michigan

Submitted by:

Project group 881-6

Pandurang Baliga (pbaliga@umich.edu)

Atul Singhal (atulymca@umich.edu)

Abhinav Singh (absingh@umich.edu)

Date:

December 16, 2013

EXECUTIVE SUMMARY

Government of India provides subsidies for solar water heaters which are now becoming compulsory in various localities. Solar water heaters though have low reliability, not just in the sense of a system failure, but also in the sense functional reliability, of not being able to provide water at required temperature, in required volume and at the time desired.

Addressing these shortcomings will have tremendous environmental and social impact as solar energy is renewable, the more we use it for our energy requirements, lesser is the burden on the non-renewable energy sources. Almost 95% of this saved power is generated using nonrenewable sources. Saved power can contribute to economic development.

Though there were many solutions to the problem we have identified, the key observation we had was that the solar water heaters still did not have widespread use. Basic solar heaters are pretty unreliable both from system and function perspectives. Most installations seem to be policy driven. Additionally we found that there were gaps in the value chain that was putting off customers. Essentially current designs don't seem to have been sustainable.

Our project goals are to Design a solar water heater that is reliable both on the systems and functional front and also to understand the gaps in the value chain that is impeding the rate of adoption and try to include these in our solution.

Concept of energy multiplication & increasing the energy per unit area led us to select Fresnel lens technology in our project. Our final design is better than the baseline as collector size is reduced by appx half and reducing the weight of the solar tank, thus decreasing the overall cost of the SWH. Also, the efficiency of the system has increased. All the above parameters could increase the overall acceptability of the Solar Water Heater & thus decreasing the overall environmental impacts due to less power consumption and decrease in wastage of water. We have generated concepts that fill the gaps present in the baseline design. We have been successful in ensuring the new design doesn't adversely affect the environment.

This concept could be improved more on sustainable aspects by doing some physical validation of few critical components.

CONTENTS

- 1. INTRODUCTION 6
- 2. PRODUCT/ PROCESS FUNCTIONAL STATUS 7
 - a. Solar water heating..... 7
 - b. Survey on Solar water heater users 8
 - c. General performance of a solar water heater 9
 - d. Basic Design & Principle of solar water heater..... 12
- 3. DESIGN ETHNOGRAPHY 16
 - a. Study on low penetration of solar water heater 16
 - b. Deficiencies causing barriers in better penetration of SWH 17
 - Details of ethnographic research on stakeholders..... 18
- 4. SUSTAINABILITY EVALUATION PROCESS AND STATUS 20
 - a. Description of the overall system..... 20
 - b. Overview of Environmental Impact & Finding Root Cause 21
 - c. Sketching the stakeholders 22
 - d. Connections between the stake holders..... 23
- 5. PERSONA 23
- 6. PROJECT REQUIEMENTS AND SPECIFICATIONS..... 24
- 7. SUSTAINABILITY EVALUATION OF THE BASELINE 26
 - b. Boundaries of our LCA..... 28
- 8. CONCEPT GENERATION FOR ENVIRONMENTAL/ SOCIAL IMPROVEMENT OF BASELINE 30
 - a. Concept generation & details..... 31
- 9. CONCEPT SELECTION PROCESS 40
- 10. CONCEPT DESCRIPTION & ALPHA DESIGN 43
 - a. Concept description 43
 - b. Alpha design concept details..... 44
- 11. FEEDBACK ON ALPHA DESIGN 46
- 12. FINAL CONCEPT 48
 - 1. Design changes from Alpha concept..... 48
 - 2. Design of SWH system & its components 51
 - 3. Technical specification of final solar water heater 52

4.	Validation of final design.....	53
5.	Technical advantages over baseline design	54
	BUSINESS PLAN	56
13.	COMPANY DESCRIPTION.....	56
a.	Market Need and the Increasing Energy Demand.....	56
b.	Customers	57
14.	Market Analysis	57
a.	Target Market and Expected Growth Size of the SWH market	57
b.	SWOT Analysis with respect to the competition	58
15.	Product Description:	59
a.	Technical and Cost advantages of our product over the competitors:	59
b.	Feedback from Future Customers	60
16.	Marketing and Sales Strategy.....	60
17.	Funds required for the Company and Sustainable Revenue analysis.....	61
a.	Investment	61
b.	Cost Analysis.....	62
	ADDITIONAL REFLECTIONS ON PROJECT OUTCOME.....	63
18.	PROJECT CONSISTENCY WITH AN ECO EFFICIENT OR SUSTAINABLE DESIGN	63
a.	Environmental aspects.....	63
b.	Social aspects.....	66
c.	Economic aspects.....	66
19.	DESIGN CRITIQUE.....	67
a.	Major Strengths of our design.....	68
b.	Major Weakness of our design.....	68
c.	Improvement points	69
20.	RECOMMENDATIONS.....	69
21.	PROJECT REFLECTIONS & FUTURE PROJECT RECOMMENDATIONS	70
22.	ACKNOWLEDGEMENTS	71
	APPENDIX I:.....	72
a.	Team introduction	72
	APPENDIX II.....	74

a. Team Member Preparation.....	74
APPENDIX III	77
a. Team Charter	77
APPENDIX IV.....	80
a. Observations from design ethnography	80
b. Interviews for design ethnography.....	80
APPENDIX V.....	88
a. Technical specification of existing domestic solar water heater (Sunrise solar water heater).....	88
APPENDIX VI.....	90
Electric Geyser available in Indian Market & the respective cost (Top 2 selling models	91
APPENDIX VII.....	94
REFERENCES	95

1. INTRODUCTION

Bangalore Mahanagara Palike (Municipal council) in 2007 made solar water heaters mandatory for new buildings¹. Government also gives subsidies varying between 30 to 60%², depending on the location (hills, islands, etc). Solar water heaters though have low reliability, not just in the sense of a system failure, but also in the sense functional reliability, of not being able to provide water at required temperature, in required volume and at the time desired. The functional reliability issue was also highlighted in Assignment #1 of one of our team member during his self-observation of switching over to electric geyser often, in spite of having a solar unit installed –

Based on my own solar water usage and from my past experiences, the solar unit was not used effectively. The below are the gaps with possible ideas to take forward...

Solar heated water is not available round the clock. We were switching to electric geyser (another bathroom) when water was not available.

- Can some heated water storage be devised?

It does not have auxiliary heating option. We were switching to electric geyser (another bathroom) when sufficiently warm water was not available.

- Providing auxiliary heating option will reduce % of electricity used to heat lukewarm water. During no water in the tank (there are water issues in the apartment), the solar energy goes unutilized.

- Can the solar energy be used elsewhere? Maybe generate electricity?

Once the water is available, it takes a while for water to be heated up.

- How can the heating be sped up? Can solar energy be multiplied using reflectors?

Almost all homes that have a solar water heater seem to have another contingency, usually in the form of LPG or Electric geysers. It was obvious that most of solar water heaters were not sustainable and mainly installed due to government policy/subsidy push. Hence we wanted to do research in this system and come up with a sustainable design, especially since the energy source was clean and renewable.

Environmental perspective: Solar energy is a renewable & clean energy source. The more we use it for our energy requirements, lesser is the burden on the non-renewable energy sources & reduces our carbon footprints. By investing in one we can avoid damage to our ecosystem by avoiding air, water & land pollution. When a solar water heater replaces an electric water heater, the electricity displaced over 20 years represents more than 50 tons of avoided carbon dioxide emissions alone. Carbon dioxide traps heat in the upper atmosphere, thus contributing to the Greenhouse effect. A family of four with a solar water heater can save up to 3 or 4 tons of greenhouse gas emissions compared to a conventional electric water heater. That's the same as taking a small car off the road³.

Social perspective: Access to electricity stands at 75%⁴ as of 2010. Even the population that has access doesn't get the power round the clock, sometimes just 1 hour per day⁵. Some of the outages during peak loads are due to use of electricity for heating water. The use of 1000 solar water heaters of 100 liters capacity each can contribute to a peak load saving of 1MW. Saved power can contribute to economic development. Almost 95% of this saved power is generated using nonrenewable sources. Households that opt for LPG based geysers instead of Electric/Solar geysers run the risk of health

hazards in the form of inhalation of carbon monoxide created due to improper burning in poorly ventilated spaces. LPG water heaters were blamed for a dozen Bangalore deaths in 2007⁶.

A lot of work has happened in the technological development of solar water heating systems. Different concepts and types of solar water heating systems are available in market. Many of the system⁷ and functional reliability issues are being put on priority. Now users have the choice to select based on their requirements, Geographic locations, etc.

The key observation we had that the solar water heaters still did not have widespread use. Most of installations seem to be policy driven. Essentially current designs don't seem to have been sustainable. The problem seems to be more to do with economics, specifically return on investment (ROI). Basic solar heaters are pretty unreliable both from system and function perspectives.

2. PRODUCT/ PROCESS FUNCTIONAL STATUS

As per the figures collected for renewable energy, more than 28905MW installed capacity of renewable energy sources as of now out of an estimated potential of about 189,000 MW, in the years to come. In India solar energy produced is 6% (1839MW) of the total renewable energy generated. In Chart 1 is break up of up of renewable energy in India.

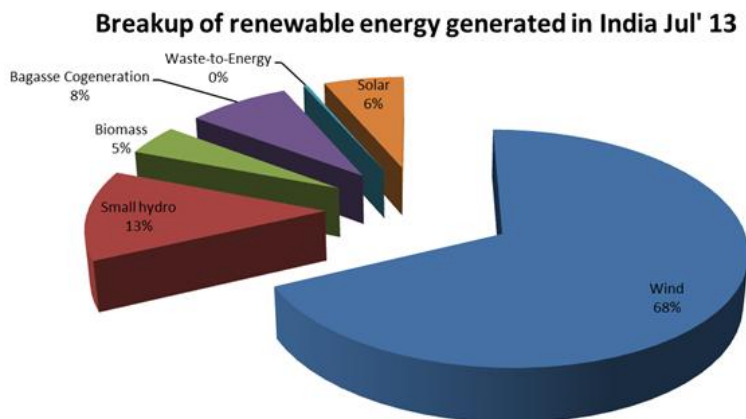

8

[Chart-1: Renewable energy generated in India Jul13](#)

a. Solar water heating

Solar water heating (SWH) is one of the simplest and oldest ways to harness renewable energy. It can contribute both to climate protection and sustainable development efforts. China's market, by far the world's largest, has increased dramatically over the past 20 years, with 40 million square meters (m²) of total installed capacity in 2002. Over one-third of homes in Barbados are equipped with SWH.⁹

A conservative estimate of solar water heating systems installed in India is estimated at over 475000 m² of the conventional flat plate collectors. Noticeable beneficiaries of the program of installation of solar water heaters so far have been cooperative dairies, guest houses, hotels, charitable institutions,

chemical and process units, hostels, hospitals, textile mills, process houses and individuals. In fact in India solar water heaters are the most popular of all renewable energy devices¹⁰.

In the residential sector, there are 0.7 million SWH user households; 65% of which are concentrated in Karnataka and Maharashtra. There is overall satisfaction with product - experience; some concern being voiced over after-sale support. The use of SWH-water is mainly for bathing. The average size of the domestic installations that were surveyed is around 150 lpd. Among non-users, in states other than Karnataka/Maharashtra, there is sketchy awareness of the bare concept of SWH. The customers perceive it as a product suited for independent houses and not so much for apartment buildings. Hot water demand expressed though months/year and supply chains are important demand drivers. The high demand regions report hot water demand for ≥ 9 months/year, while the lower end is 4 months/year¹¹. Below Table-1 shows the breakup of SWH installation in India till 2009.

Table 1. Estimated Breakup: Functional SWH Installations Till 2009

Sector	million m²
Residential (80%)	2.108
Hotels (6%)	0.158
Hospitals (3%)	0.079
Industry (6%)	0.158
Other (Railway + Defence + Hostel + Religious places, other) (5%)	0.132
Total	2.635

* It is assumed that 85% of the installed SWH are functional

[Table-1: Breakup & numbers of functional solar water installed in India till 2009¹²](#)

b. Survey on Solar water heater users

A survey conducted in a typical city of India amongst users of solar water heating system would give a breakup somewhat along the following line.

- 100% of the users are in the middle higher to higher income group.
- 70% and above prefer systems with electrical backup while less than 30% opted for standalone solar water heaters.
- More than 80% of the users bought the systems directly from the manufacturer without any third party financing or loan.
- More than 90% of the users found a solar water heating system to be satisfactory, especially in saving fuel costs.
- More than 90% of users would have liked "subsidy" to be available on solar water heating systems. In fact most have purchased the system under subsidy scheme¹³

- In India apartments most often government regulations & NOC policies are forcing apartment builders to install solar water heaters. Which don't count for the effectively & reliability of the system. Table-2 shows the cost of types of SWH with different capacities.

For ETC based Systems:

system capacity in LPD	No.of tubes	Upper cost limit
50	7	9500
75	11	14500
100	14	18000
200	28	35000
250	34	42500
300	40	50000
400	52	65000
500	64	80000
600 to 2000	12 tubes per 100 lpd	Rs.1207/- per tube
2100 & above	12 tubes per lpd	Rs.1000/- per tube

For FPC based systems,

System capacity in lpd	Collector area(in sq.m)	Upper cost limit
50	-	-
75	-	-
100	2	18000
200	4	35000
250	-	-
300	6	50000
400	8	65000
500	10	80000
600 to 2000	2 sq.m.per 100 lpd	14500 per collector
2100 & above	2 sq.m.per lpd	12000 per collector

Where ETC - Evacuated Tube Collector

FPC - Flat Plate Collector

Table-2: Cost of solar water heater in India¹⁴

c. General performance of a solar water heater

As we know that solar water heater is not an instant water heating solution. It uses the solar energy, heat the water & store it in a tank to the usage purpose.

There is always some stand by loss due to heat dissipation, in-efficiency loss, heat convection due to difference in ambient & tank temp etc. These losses are gradual loss in the system & keep bringing the tank temperature down over a period of time. Whenever we extract hot water from the tank the temp drops sharply. This makes substantial impact on the tank temp & water temp lowers sharply. Often it goes down below average usage temperature of hot water (especially in extracting more water than the tank capacity)

In a family of 5-6 members the usage of water is normally at the time between 7-8am & 9-10am & then 11:30-12:30am. At the start of the day around 6:30am temperature in the tank has already reduced due to losses & that time solar energy is not available to increase the temp or heat up the extra water. That time usage of hot water brings the temp down suddenly because during usage cold water from main tank starts mixing with hot water. Around 7:30am when sun rises, temp in the solar tank starts increasing as we start getting the solar energy. But the quantum of energy is not on its maximum also the direction of the panels installed affect the heat gain. Again usage of hot water at home does not provide the sufficient temperature in the water. So during these periods users are mostly affected for not getting the sufficient temperature & quantity of hot water. This creates the requirement to switch on the secondary heating source - electric or gas geysers.

Following graph-1 shows the behavior of a solar tank in account of temp & time.

Temperatures on Sunny Day with draws

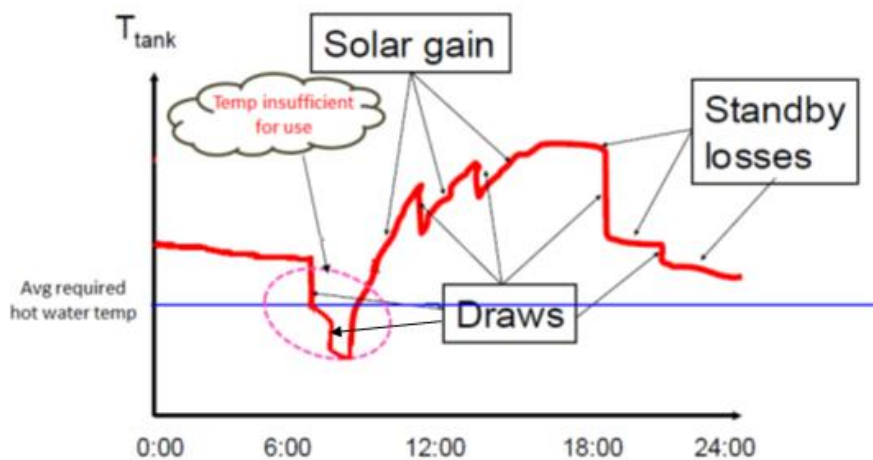

[Graph-1: Behavior of water temp in solar tank during usage](#)

Performance evaluation

Lot of studies & research has been done to conclude the performance of a SWH in different regions of India. In one of the studies a Thermosyphon flat plate SWH was tested in North Eastern region of India (This region face all season summer, cold & rain). This solar water heater has the capacity of 500 liter per day & total collector area of 10.8 m². The thermal performance of Thermosyphon flat plate solar water heater was investigated on both sunny day and cloudy day & by using ethylene glycol and water as a working fluid. The data was recorded from 07.00 to 19.00 hrs with the time interval of 30 minute in the month of November, 2011. It is found that on a sunny day using water as a working fluid, the maximum storage tank temperature and hot water output temperature were 69°C and 62°C respectively at 13:00-14:00 hrs. The storage tank temperature and hot water output temperature was 75°C and 71°C respectively at 13:00 to 14:00 hrs on a sunny day using ethylene glycol as a working fluid. The solar collector efficiency using water and ethylene glycol as a working fluid on a sunny day in the month of November, 2011, was 60% and 51.3% respectively.

This typical day analysis of the system shows that the collector efficiency is higher especially around mid-day when the solar collector receives the highest energy. Experiments were conducted for several days of November, 2011. To study the temperature and flow distribution in the system during its daily operation, experiments were conducted by filling the storage tank with cold water every morning. The period of testing for each run was from 7 a.m. to 19 p.m. and during the tests, no water was withdrawn from the storage.

Variation of Temperature

It was observed that the initial water temperature, storage tank temperature and hot water output temperature was 15°C, 52°C and 46°C respectively in the month of November, 2011 at 7:00 hrs using water as working fluid. It was found that the temperature gradually increased and at 13:00-14:00 hrs attained the maximum temperature of 23°C, 69°C and 62°C respectively and the temperature started gradually decreased towards the evening and at 19:00 hrs it was found to be 20°C, 61°C and 53°C respectively. The trend of results is shown in Graph-2

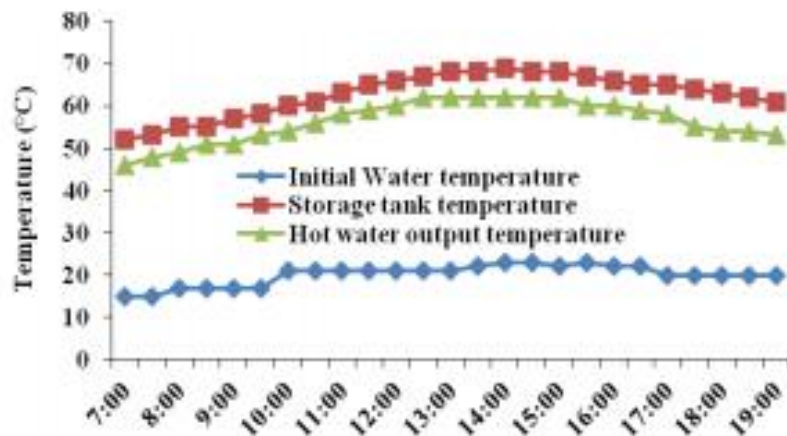

Graph-2: Time variation of initial water temperature, storage tank temperature and hot water output temperature using water as a working fluid on a sunny day

Variation of Solar Insolation

While studying the effectivity of a solar water heater, we found following experiments already conducted in rainy & cloudy regions of India.

The maximum temperature on the absorber plate occurs at 14:00 when it reaches 48°C. On this day the maximum incident energy on the plane of the absorber is 905 W/m² (Graph left) which only lasts for a short period of time. After 13:00, although incident radiation starts dropping, the absorber temperature continues rising for two more hours. The curve (Graph right) represents the measured solar insolation. The solar collector efficiency using water and ethylene glycol as a working fluid on a sunny day in the month of November, 2011, was 60% and 51.3% respectively

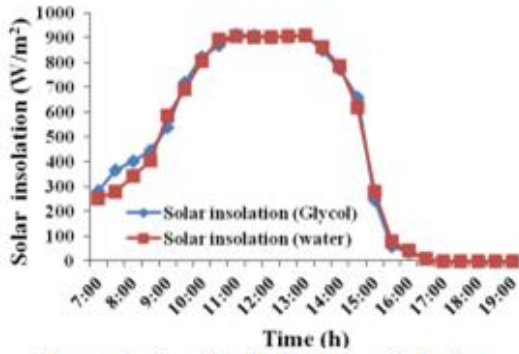

Time variation of solar insolation during the experiment using glycol and water as a working fluid on a sunny day

Graph-3

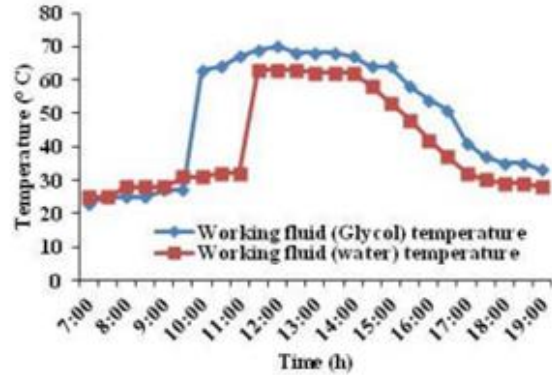

Variation of working fluid temperature

Graph-4

After these experiments it was concluded that solar water heater was performing effectively on cloudy days also¹⁵

d. Basic Design & Principle of solar water heater

In designing a solar water heater it includes following parts:

A solar collector: which heats water by solar radiation, an insulated storage tank: in it the heated water from the collector is stored. The storage tank must be put higher than the top of the collector, An insulated pipe connecting the lower part of the collector and the upper part of the storage tank, An insulated pipe connecting the lower part of the storage tank and the bottom of the collector, A cold water inlet connecting an existing water supply system to the storage tank. An insulated hot water outlet running from the storage tank to the tap, a vent (air escape pipe) to prevent overpressure, caused by air or steam. Arrangement shown in figure-1.

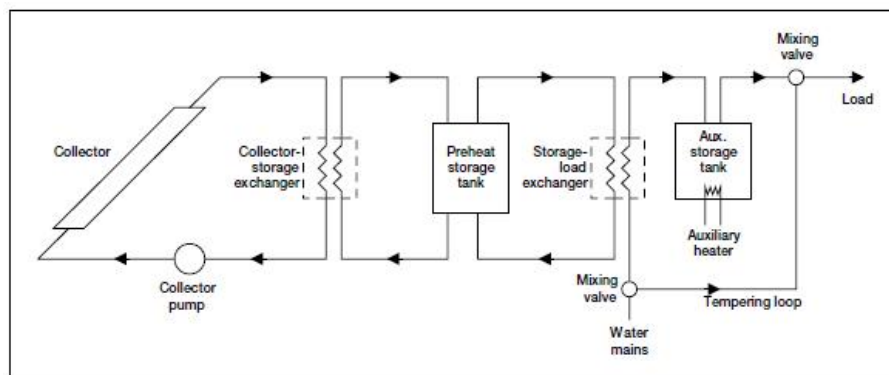

Figure-1: Basic design of solar water heater

For technical specification list of a baseline solar water heater (Refer to Appendix V)

Principle of solar water heater

A solar water heater works on the principle of "Thermosyphon" shown in figure-2. At point A, water from the cold-water tank enters the solar tank to fill it up. Then it flows in the bottom header pipe of the absorber at point B and into the copper tubes at point C. Due to Sun energy, it begins heating the water contained in absorber fins and tubes. The heated water being lighter than the cold water rises & flows into the top of the solar tank through point D & E. The more cold water from the solar flows into the absorber tubes gets heated and rises to the top, and so on. This process is called 'Thermosyphon Process' and this Thermosyphon Process continues until the temperature of the water in the solar tank and the absorber equalizes. Further the hot water is drawn from the solar tank outlet (point F) to the utilities point.¹⁶

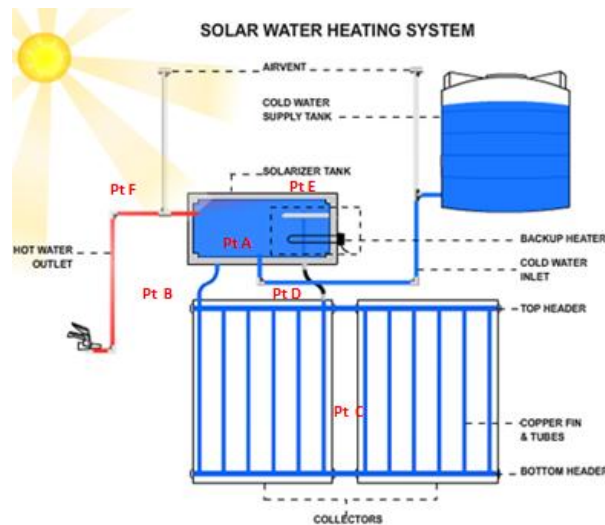

Figure-2: Principle of solar water heater

Types of solar water heating systems: There is a dazzling array of domestic hot water system designs. For the most part, however, they are broken into three groups depending on the following two characteristics.

Direct (Open Loop) vs Indirect (Closed Loop)

And

Passive vs Active

Direct or open loop systems circulate potable water through the collectors. They are relatively cheap but have some drawbacks – They have no over-heat protection, no freeze protection & collectors can accumulate scale in hard water. To overcome these problems we can use heat export pump, make collectors freeze tolerant & ion exchanger softeners in the system.

Indirect or closed loop systems use a heat exchanger that separates the potable water from the fluid, known as the "heat-transfer fluid" (HTF) that circulates through the collector. The two most common HTFs are water and an antifreeze/water mix that typically uses non-toxic propylene glycol.

Passive: The transfer of heat from the collector to the water is by natural convection, no outside energy is required.

Active: Pumps are used to move fluids around in the system.

Different combinations of these two characteristics result in the following three major classifications of solar domestic hot water systems. Examples and system diagrams are shown below.

1. Direct (Open Loop) Active

a. Differential controller operated pump systems: has one or more solar energy collectors installed on the roof and a storage tank somewhere below, usually in a garage or utility room. A pump circulates the water from the tank up to the collector and back again. This is called a direct (or open loop) system because the sun's heat is transferred directly to the potable water circulating through the collector tubing and storage tank; no anti-freeze solution or heat exchanger is involved (figure-3 left).

b. Photovoltaic operated systems: differs from other direct pumped systems in that the energy to power the pump is provided by a photovoltaic (PV) panel. The PV panel converts sunlight into electricity, which in turn drives the direct current (dc) pump. In this way, water flows through the collector only when the sun is shining. The dc pump and PV panel must be suitably matched to ensure proper performance. The pump starts when there is sufficient solar radiation available to heat the solar collector. It shuts off later in the day when the available solar energy diminishes. As in the previous systems, a thermally operated valve provides freeze protection. Common appliance timers also may control solar system operation. These timers must incorporate battery backup in the event of power failures (figure-3 right).

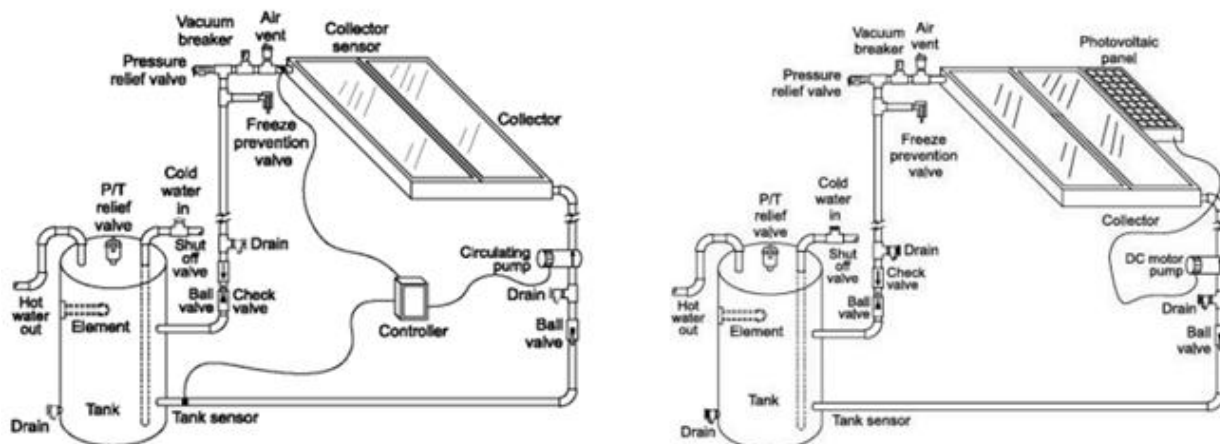

Figure-3: Differential controller operated (Left), Photovoltaic operated (Right)

2. Direct (Open Loop) Passive

a. Integrated Collector Systems: the hot water storage system is the collector. Cold water flows progressively through the collector where it is heated by the sun. Hot water is drawn from the top, which is the hottest, and replacement water flows into the bottom. This system is simple because pumps and controllers are not required (figure-4 left).

b. Thermosyphon Systems: As the sun shines on the collector, the water inside the collector flow-tubes is heated. As it heats, this water expands slightly and becomes lighter than the cold water in the solar storage tank mounted above the collector. Gravity then pulls heavier, cold water down from the tank and into the collector inlet. The cold water pushes the heated water through the collector outlet and into the top of the tank, thus heating the water in the tank. A Thermosyphon system requires neither pump nor controller. Cold water from the city water line flows directly to the tank on the roof. Solar heated water flows from the rooftop tank to the auxiliary tank installed at ground level whenever water is used within the residence (figure-4 right).

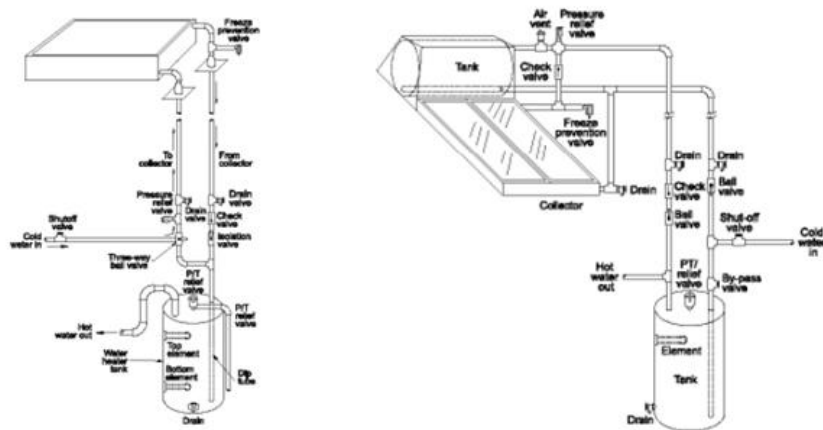

Figure-4: Integrated Collector Systems (Left), Thermosyphon Systems (Right)

3. Indirect (Closed Loop) Active

a. Indirect controller operated pump systems: This system design is common in northern climates, where freezing weather occurs more frequently. An antifreeze solution circulates through the collector, and a heat exchanger transfers the heat from the antifreeze solution to the tank water. When toxic heat exchange fluids are used, a double-walled exchanger is required. Generally, if the heat exchanger is installed in the storage tank, it should be in the lower half of the tank (figure-5 left).

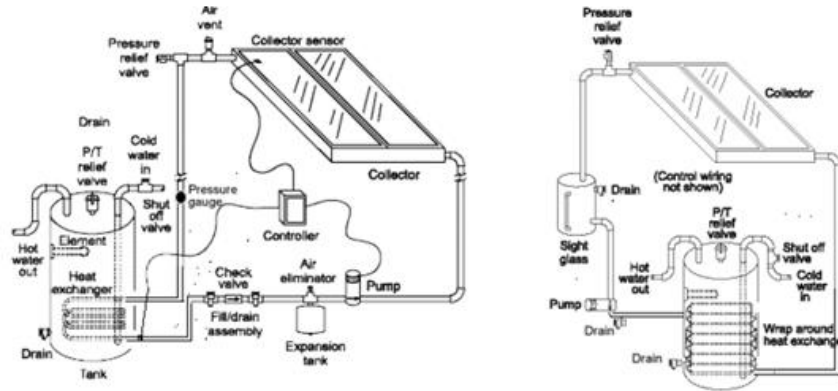

Figure-5: Indirect controller operated pump (Left), Drain back systems (Right)

b. Drain back Systems: A fail-safe method of ensuring that collectors and collector loop piping never freeze is to remove all water from the collectors and piping when the system is not collecting heat. This is a major feature of the drain back system illustrated in Figure 5 at right. Freeze protection is provided when the system is in the drain mode. Water in the collectors and exposed piping drains into the insulated drain-back reservoir tank each time the pump shuts off. A slight tilt of the collectors is required in order to allow complete drainage. A sight glass attached to the drain-back reservoir tank shows when the reservoir tank is full and the collector has been drained ¹⁷(figure-5 right).

3. DESIGN ETHNOGRAPHY

The below are the guiding questions to start our ethnography research on project.

- Why is the penetration of solar water heaters so low?
- How are solar water heaters being used?
- What are the deficiencies they are observing?
- What matters to prospective buyers?
- How is supply chain affecting the value?

a. Study on low penetration of solar water heater

Government of India released some studies on the popularity of SWH - The adoption of solar water heating has not been uniform across all market segments.

The commercial and institutional sector comprising of hotels and hostels have been more forthcoming in adopting this technology. There has been some success achieved in hotels in Himachal Pradesh (Manali, Shimla and Dharmshala), but in other large tourist destinations (Jammu, Leh, Srinagar, Mussoorie, Nainital, Haridwar, Rishikesh, Darjeeling, Shillong, Tawang, Gangtok etc.) the penetration of SWH remains very low.

The spread in the residential sector has been very limited. This is on account of the low level of awareness coupled with the low/ subsidized electricity tariffs being given by most of the state electricity boards to domestic consumers which acts as a disincentive. Though the requirement of hot water is a necessity in most of the rural areas particularly those located in the higher altitudes, in the absence of an appropriate product, the SWH use is almost non-existent.

In the industrial segment the market is yet to develop. A few installations are reported in industries in Haridwar but most of them are used to provide hot water for industrial canteens. The integration of SWH to provide hot water for process heat is not yet reported in any industrial clusters falling under the scope of this project. However this market (Jammu, Haridwar, Rudrapur, Dibrugarh, Tinsukia and Parwanoo) seems to be a major potential area for the SWH technology¹⁸.

b. Deficiencies causing barriers in better penetration of SWH

Technical

Lack of Appropriate Product to address issues such as:

- Low solar insolation in several parts (e.g. Kashmir valley, Sikkim, North-Eastern states)
- Small capacity requirements
- Low purchasing power of the people
- Technical problems associated with freezing in colder regions
- Difficulty in installing conventional SWH systems on sloping roofs made of metal sheets, stone tiles, etc.
- Lack of piped water supply, particularly in rural areas and quality of water, particularly presence of silt and hardness.

Financial

- High initial capital cost of the system, primarily due to high transportation, installation and marketing costs. Typically, capital cost of SWH system increases 2 fold than of the same system in plains due to the above factors.
- Low electricity tariff resulting in longer pay-back for SWH systems.
- Delays in disbursement of the subsidy and problems in accessing subsidy for the users living in remote areas.

SWH supply chain

- Lack of local manufacturing, with only one manufacturer located in the Himalayan region
- Weak SWH supply chain resulting in difficulty in procuring the systems as well as in poor after-sales service.
- Difficulty in transportation of the systems to remote areas
- Awareness related barriers
- Poor awareness across states and segments, except perhaps hotel segment

- Limited number of successfully operating SWH systems, thus the positive demonstration effect is low

After finding the suitable reasons to our questions, we started identifying our stakeholders for a solar water heater. We prepared our plan for collecting observations, doing interviews with them to define our project requirements & specification, which could satisfy the need of our persona. Below Table-3 summarize the modes chosen/available to gather data

		Observation	Interview	Surveys	Others
Apartment resident	User	Yes	Yes	Yes	
Independent house Resident	User	Yes	Yes	Yes	
Apartment Association	Stakeholder		Yes		
OEMs	Stakeholder		Yes		
Sellers	Stakeholder		Yes		
Importers	Stakeholder		Yes		
Experts in solar energy mgt	Expert		Yes		
Plumber	Expert		Yes		
Apartment Builder	Client		Yes		
Independent house owner	Client		Yes	Yes	
Govt officials	Client		Yes		RTI*

[Table-3: Ethnography strategy on Stakeholders](#)

*RTI: Right to Information (law in India)

We completed our interviews with at least one from each type of stake holders.

Details of ethnographic research on stakeholders

Self-observation on SWH

We had few observations from one of our team members who had a SWH in his society catering water to 9 flats from one 500LPD SWH. He was never able to use hot water from SWH on weekdays as the water wouldn't be hot enough in the early morning to use. His baby never got to use solar heated water as he was bathed early in the day. They could use it properly on weekends, for which the bathing schedule had to be moved to the afternoon. For regular days they were relying on an electric geyser. If when we did a bit of why-why analysis on why we are not getting hot water in the morning. We reached to a point that the system was installed to meet regulatory requirement only. The only thing he had to worry about was the LPD (liters per day) capacity of the overall installation which bears a direct relation to number of apartments. The builder hence had every reason to go for the cheapest solution in the market that met the above requirements.

Self-observation on hot water usage from SWH of an apartment owner

We couldn't observe the users directly during their use of the solar heated water, as it would intrude their privacy; hence we chose to do a few self-observations. A sample observation taken at a 2 minute

time interval is as shown in Appendix IV. One of the key learning was he was collecting and then wasting a lot of lukewarm for getting the sufficient temperature of water for bathing. This behavior can be attributed to tragedy of commons. The person is willing to waste water (which gets a common bill, borne by the apartment association) rather than use electricity for heating water (user has an electric geyser, he gets an individual electricity bill). Also to be noted is the time waste during this wait for hot water.

Interview with a house owner user

Another team member has a relative who installed a solar heater unit in his independent house and later had to get rid of it. He is using a LPG (liquefied petroleum gas) based geyser currently. The major finding from this interview was that he had repeated failures followed by poor service from dealer. We found that the vendor had monopoly in that region and hence he was passing on products without product knowledge & assessment of suitability and then was not ensuring good service. This brought the issue on reliability of SWH as a product. User was still ready to install a solar heater in future, but only after doing due diligence on the reliability aspect.

Interview with a builder

A SWH system is installed in the society primarily due to government regulations. Provision of SWH is shown in their designs for getting construction clearance. They have architect to make the design, position & decide the capacity of each SWH unit. They have tie-ups with different dealers to get the best price for them. Generally a SWH perform well in the society but sometimes users over use the system & it doesn't cater the needs of others. A SWH heater after installation does not need maintenance but if something damaged it will have to be replaced.

Interview with a SWH dealer

In India, government has put mandatory guidelines to install a SWH unit to get necessary certification for a house or society. Capacity of SWH heater is decided based on the daily requirements & number of family members. For domestic purpose (apartment of house owner) flat plate SWH are recommended. They are more durable for longer period of service than a heat exchanger or evacuated tube. These SWH are having longer warranty period with maintenance. For installation of any SWH, they survey for direct solar energy availability and water condition. If region is having hard water then they suggest using Mg anode rod inside tank to avoid scaling of tank shell. Users get subsidy from government in buying & running of a SWH. Dealer take care of all certifications required for the submission to government department. To resolve the customer issues & do the installation and commissioning, they have separate team of engineers. Life span of a Flat plate SWH is 15-20 years. After usage we don't have components to reuse.

Interview with a SWH Manufacturer as expert

In Bangalore region, flat plate collector is more successful as they have zero maintenance in the system. For SWH we need to follow guidelines from IS12933 which covers the manufacturing requirements &

validation requirements. A SWH need lots of validation during manufacturing as in-process and initial validation of design. They can't sale in India until it has been certified by the by government agencies after testing our component. Collector is the main part which is tested by these agencies. They send one collector box every year for testing & renew their certificate.

Details of all interviews are given in APPENDIX IV

4. SUSTAINABILITY EVALUATION PROCESS AND STATUS

Per the report published by Ministry of New and Renewable Energy (MNRE), India is one among the nations where the solar power is estimated to be 4.5-6.0 kWh/sq m with 256 days of clear days. Per the solar power mission (JNNSM)¹⁹, Government has initiated various policies to implement use of solar power in communities.

Also with respect to MNRE report, Bangalore is one of the cities where the penetration of SWH is the highest²⁰. Bangalore is also one of the cities where the impact of depleting groundwater is the highest. Only 1/3rd of the Bangalore city has the municipal water connection (water tax been paid) while the rest of the city relies on groundwater through bore well which at present is unregulated. At some areas in the city, bore well to the depth of 1500ft (450m) has gone dry.

a. Description of the overall system

For sustainability evaluation in our study, we started with our colleague's multi-story apartment in Bangalore as a system (where SWH is installed) which is also a representation of a typical high rise building with a large community size.

Below figure-6 shows a visual of the systems design of the Water Heating Unit in the apartment which caters to the hot water needs for the apartment. Usage of hot water is throughout the day with peaks during the morning 7-9am.

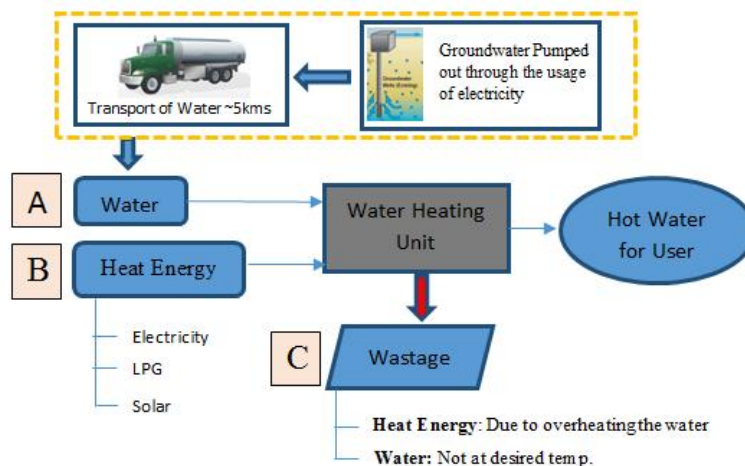

Figure-6: Study of overall system

b. Overview of Environmental Impact & Finding Root Cause

Observing each unit in the above chart team listed down the environmental impacts and tried to find the root cause which is described below:

Water: In most of the apartments in Bangalore, the bore wells have gone dry. Thus, the water is received from a dealer who pumps the groundwater at his premises and transports the water to apartments. As a fact, a large portion of the cost to the apartments is for water which is equally shared among all the individual occupants. As the cost of water is not distributed per the water usage by individual, this leads to unwanted water usage (an example of tragedy of commons which has been discussed earlier)

Heat Energy: Most of the hot water requirements in individual apartments are catered by electricity by the use of electric geyser. Per the present fact, only ~11% of the India's electricity is through renewable source of energy²¹, Refer chart-3. Thus, visualizing on the whole systems design, there is a considerable impact on environment.

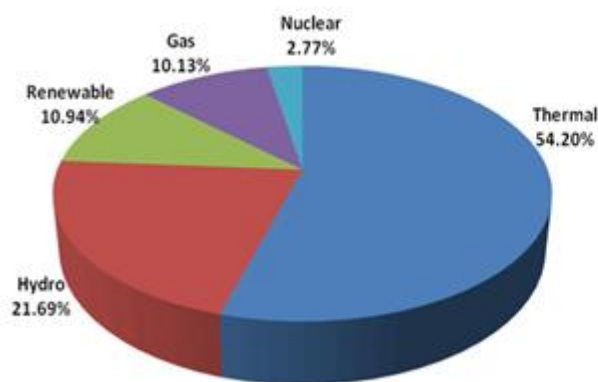

[Chart-2: Energy source % for Electricity generation](#)

Total Renewables in India till Aug 2012 = 25,445 MW (Approx.)

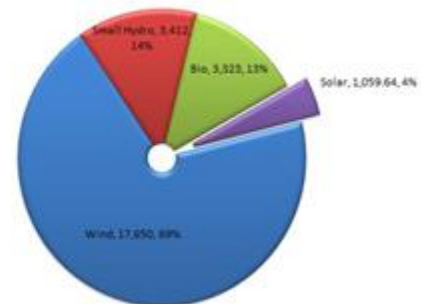

[Chart-3: Renewable energy data Aug 2012](#)

Some apartments utilize LPG for heating water. Dealers and marketing companies are promoting use of LPG as a clean energy thus reducing impact on environment. It makes economic sense to the user as LPG in India is subsidized by the government. In whole systems sustainable design thinking, this is a “trap” rather than a “trade-off”. While the burning of LPG is clean but extracting LPG is energy intensive and is a limited resource on earth. Conventional available LPG Heater for heating water is not energy efficient. Also, as the subsidy on LPG is getting reduced by the government, it will not make economic sense by the user for heating water.

The Building in study also has a common Solar Water Heater installed for catering hot water needs for individual apartments. Per the regulatory policy of the government, SWH needs to be installed on every high rise building. Also, there is subsidy on electricity bills if user has a SWH connection for their house. If the efficiency in the system is assumed to be 100%, this satisfies the triple bottom line. In sustainable thinking, this could be termed as “triumph” but observing the actual efficiency of the system, this is a

mere “trade-off” and if the installation of SWH is not properly done with respect to the building requirement of hot water this could become a “trap”

Wastage: In any of the conventional heating unit for providing hot water, there are two wastages: heat energy and water

Wastage of Heat energy: Most of the electrical unit available in the market does not have the user controlled temperature knob and thereof shut-down which tends to overheat the water more than the users requirement. This leads to wastage of heat energy and in turn the electricity. This needs to be studied further for available devices in the market and the economic dimension for the user.

Wastage of Water: The wastage of water is mostly ignored in all the design as it is a common asset for all. Any heating unit takes time to deliver hot water to the tap for the user’s requirement. The water below the user’s required temperature which comes initially while opening the tap goes as a waste. If the heating unit is nearby the tap, the waste water is less in comparison to a heating unit which is distant may be a terrace.

In the case of use of SWH, all the high rise building have SWH unit installed on terrace. With respect to the cost and government policy, all the building have only the basic type of installed SWH without any auxiliary tanks near individual apartment or auxiliary heating unit near to the tap. As a result, lot of water is being wasted just for waiting hot water from the SWH unit. The wasted water by utilizing SWH in a sunny day is ~15L per bathing cycle which accumulates to around 60L wastage of water per day (Ground level apartment in a 12 floor apartment). If there is cloud, the waiting times is more and hence increase in the wastage of water. Also, most of the hot water requirement by individual apartment is around 7-9am in the morning. As there is common SWH unit for a block of apartments and sun is not at its peak during the 7-9am the wastage of water by all the apartments is substantially high and subsequently users tend to use the electrical geyser for their need after waiting for hot water from SWH.

In whole systems thinking if the cost of water wastage is taken into consideration, the depleting ground water table and the payback period of SWH, the installation of SWH could be termed as mere “trap”

The proper installation of SWH in high rise building is mentioned per government but is not being strictly followed²². This has to be further studied.

c. Sketching the stakeholders

By observing the above cycle we can visualize the below stakeholders:

Apartment Association: For use of Water meters so that water cost is distributed per the usage of water (Utilizing the concept from Prof. Ronald Coase)

OEMs (Manufacturer of Electrical Geyser): Having a conventional product with user controlled temperature knob and enable the product such that it could be used as auxiliary heating device for heated water from SWH

Sellers in Solar Energy Management: Verifying SWH installation per the building requirement of hot water and per government standards

Importers

The above stakeholders have been already discussed in ethnographic survey.

d. Connections between the stake holders

More demand in quantity from apartment association: will lead to product up gradation, new manufacturers, better designs, better dealer & service network, reduced price, better quality, less installation costs, more servicing network, more employment & revenue generation

More Supplies from OEM's, Sellers and Importers: will lead to more choice for customers, more competition in market, more number of dealers & sellers.

Environmental impacts: Depletion of metal resources, fuel usage in transportation, waste generation at end of product life cycle, carbon foot prints, Green-house effect, chemical usage & land fill. Figure-7 shows the linkage among all stakeholders

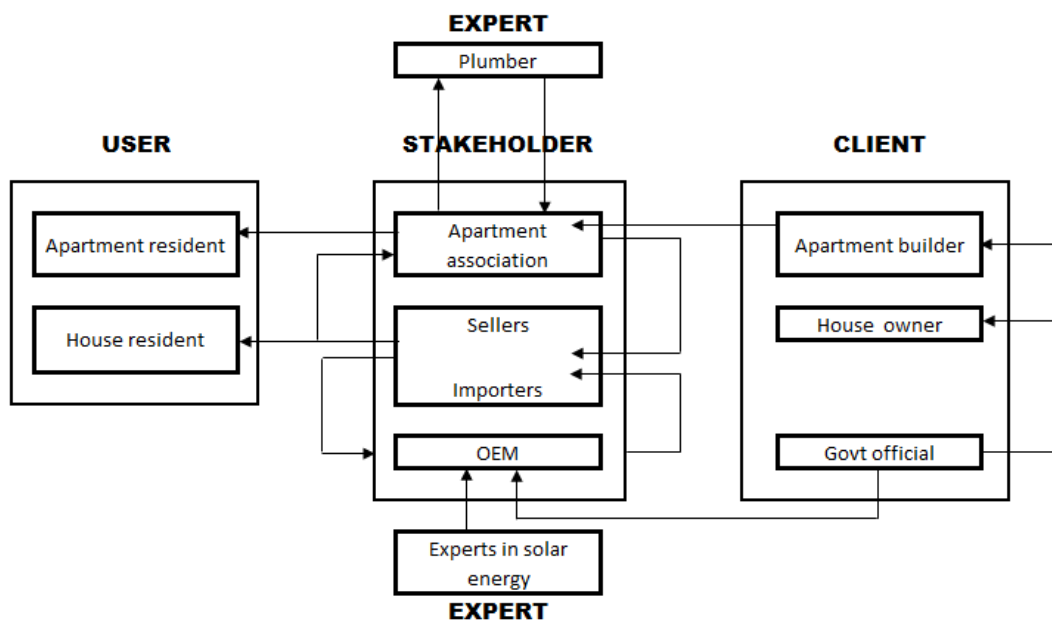

Figure-7: Graphical view of Interconnection of stakeholders

5. PERSONA

From design ethnography we saw that the apartment dweller is one persona which will be hugely interested in SWH. The benefits to him are multifold

- Shared cost of ownership
- Electricity savings
- Rebates on electricity bill
- Helps him avoid investing in a separate water heater (Electricity/LPG)
- Satisfaction/pride at using a renewable energy source and hence helping in reducing carbon footprint

As noted in the first bullet point, the cost of the SWH is borne by either the builder (during construction) or the apartment association (at a later date). This is a scenario similar to that of a toy in a playground. Though the toy is used by a child, the payment is done by somebody else; yet most of the design is developed keeping the child in mind while ensuring the payer is not too unhappy. We basically had to ensure we design including features that an end user seeks and yet it is attractive enough for the person paying for it. If we just consider the fact that SWH is a compulsory regulatory requirement in India for new apartments, the buyer will always be happy to have more features for the baseline amount, or, baseline features for lesser amount. The advantage the buyer gains are in the fact that the apartment has become that much more attractive for a prospective buyer/tenant. If we can educate the buyer he will invariably educate the buyer/tenant about SWH availability and the features it has.

In addition to the general benefits of SWH mentioned above, if we were to ask ourselves what motivates our persona of an apartment dweller (which includes buyer interests) towards our SWH, we can say...

- Will occupy less real estate on the roof
- Users will get 24 hours hot water
- The above will ensure that you don't have to plan your day around electricity availability
 - There is power shortage in many Indian cities, which will make the Electric heater, the most common heater, redundant
 - Electric heaters need high voltage power and will not run on the common backup generators
- Users will get instantaneous hot water
- The above feature additionally will help save water, which is scarce in many Indian cities

6. PROJECT REQUIREMENTS AND SPECIFICATIONS

During the interviews, observations and literature review, we came across multiple 'voice of the customers'. We had to properly understand them and convert them into meaningful Engineering requirements, to measure our final product against.

Customer's day to day requirements were to get hot water, in the volume he needed and at the time he needed. Keeping in mind the primary requirement of bathing we set the functional requirements to 45°C, 20 liters per bath and 24 hours per day availability.

The observation in AEIOU observation method was that the water was not turned off during soaping. This was because if the water is turned off, the water cools down due to forced convection over atmosphere-exposed pipes. And when the tap was turned back on, lots of water was wasted until hot

water was back in flow. We hence wanted to reduce this wastage which was possible only if we kept the time lag low between when tap was turned on and when hot water started flowing back. We hence set the time taken for the hot water (during which cold water is wasted) to flow at the tapping point to maximum of 15 seconds.

We are currently targeting to make the SWH to not cost more than the baseline. Our effort will be bring down the cost to as low as possible. We are currently not setting lower target as we didn't want that to become an hindrance of adding customer desired features and yet we didn't want to loosen the target either, as that will make the SWH unattractive in the eyes of the buyer.

We wanted to ensure that the safety is not compromised and hence set a maximum surface temperature of 35 °C, given the ambient temperature is well below that...

Since the customer wants low maintenance cost, we decided to target to have no breakdowns for 5 years which is the warranty we wanted to offer similar to existing baseline SWH.

We had to ensure we make ourselves eligible for getting government subsidies. These are in two forms. There is a huge subsidy of up to 33% on initial procurement cost and an additional benefit of Rs50 n the electricity bills. Passing the validation per government set standards was highly important to make available the product at a subsidized rate the customer. If we fail in this, the cost of the product will be so high compared to the baseline that not a single unit may sell!

Customer wanted the SWH to be functionally reliable so as he need not have to buy and alternate water heater (Electric/LPG) to fall back to.

Customers wanted the SWH to occupy as low as space as possible. At this moment we are targeting the space occupied to be not more than the baseline. The reasoning is similar to the costing logic discussed earlier.

Renewable energy proponents, who are our stakeholders, want the SWH to be adopted on a large scale. One important aspect is that the SWH should function in varied ambient conditions. We hence set the target that the SWH should function in the northernmost par of India as well as cover a huge percentage of cities in terms of altitude from the sea level.

All customer and Engineering requirements derived from them, as discussed in the preceding paragraphs, has been summarized in the table below.

Customer Specification	Engineering requirement	Value	Units
Hot water	Temperature	45	°C
Enough water	Volume	20	Liters per bath
Round the clock	Hours per day	24	Hours per day
Should not waste water waiting to get hot water at tapping point	Wait time to get hot water	15	Seconds
Cheap	Cost	30000	Indian Rupees
Safe	Surface temperature	35	°C
Low maintenance even in hard water conditions	# of breakdowns for 'n' warranty years	#=0; n=5	#=Unitless; n=Years
Should be eligible for Government subsidies	Should pass validation per Government standards	IS12933	Pass
No investment in individual Heater	# of other heaters inside the house	Zero	Unitless
Should occupy low space	% change in floor space occupied wrt equivalent LPD SWH	<0	%
Need widespread use	Latitudes and Altitudes at which it should function	Latitude=36; Altitude=1500	Latitude=°North; Altitude=m

[Table-4: Requirement & specifications](#)

7. SUSTAINABILITY EVALUATION OF THE BASELINE

Per the ethnographic study, we observed that user(persona) are not able to get heated water as soon as possible resulting in wastage of water for which one of the main cause is ineffective heating of water through SWH. We analyzed the complete life cycle inventory of the solar water heater shown in the chart-4

a. Life cycle inventory of a baseline SWH

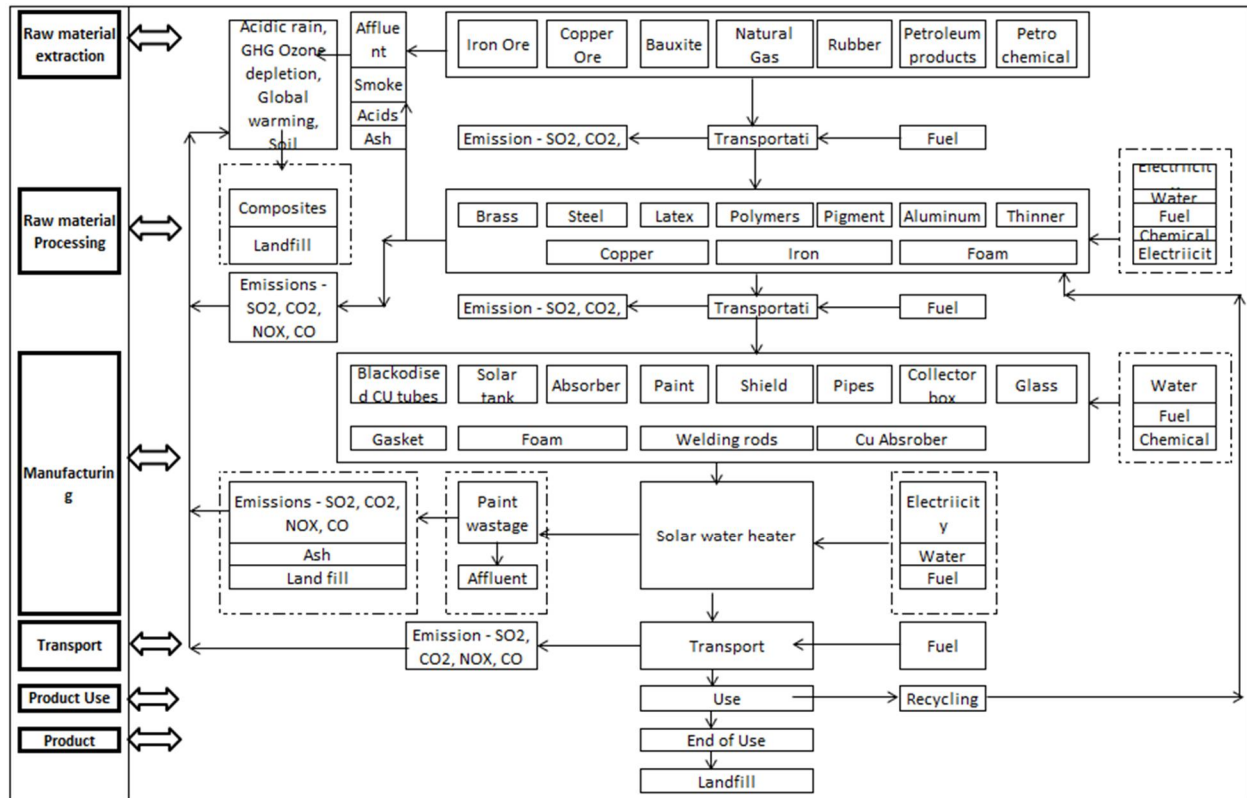

[Chart-4: Life cycle inventory of solar water heater](#)

For performing the LCA, in the present scenario we have utilized the solar water heater which is installed in our colleague's apartment.

Goal: To design a more efficient solar water heater utilizing environmentally conscious material

Scope: In our present scope, we have considered only the SWH as a unit. A comparative LCA will be performed between the baseline design and selected concept to ascertain the life cycle impact of each of them.

Function: To heat the water using solar energy

Functional unit: Heat the water from atmospheric temp to >60deg inside storage tank and deliver the water to user's at min 40deg during 24 hours of the day. Quick and more effective heating of water (less time taken to heat the water) and temperature in the hot water tank is sustained per the user's requirement.

Reference flow: Water Temperature at outlet valve of solar water heater to be 60 deg C

b. Boundaries of our LCA

In our project we have decided to concentrate on the flat plate type collector based solar instead of Vacuum glass tube type collector due to the following reasons.

- Tube get fuse very frequently so need frequent maintenance
- Life span is very less
- Running cost are higher due to tube replacements
- Need extra care/ protection to run the system

Also our major area of focus over here is the solar water heater unit. In the present study and as shown in the below list we have not considered the nut / bolts, insulating material, glass beading, gaskets, soldering / brazing material and absorber coating as we could not get more details on the same

Data: Below is the material list which we have gathered from installation manual of the respective solar water heater

We have utilized the below BOM (table-5) in SimaPro for analyzing the impact on the baseline SWH

Material quantity chart of baseline SWH						
Sr. No	Component	Sub component	Base line Water heater			
			Material	Qty	Dimensions (mm)	Weight (Kg)
1	Solar tank (100LPD)	Inner shell	Stainless steel	1	Dia 360, Length 950, Thk 20gauge (0.914mm)	7.91
		Outer shell	Galvanised steel	1	Dia 460, Length 1050, Thk 22gauge (0.711mm)	8.5
2	Collector	Bottom sheet	Aluminum	1	2050 x 1040 x 20 gauge (0.914mm)	5.3
		Box C channel	Aluminum	4	2050 X 100 X 25 (20 SWG # 2nos) 1040 X 100 X 25 (20 SWG # 2nos)	2.682
		Glass support angle	Aluminum	4	25 x 25, Len 2050, 20 SWG # 2nos 25 x 25 Len 1040, 20SWG # 2nos	0.736
3	Collector Glass		Toughened glass	1	2050x x 1040 x 4	22.17
4	Absorber material	Header	Copper	2	Length 1100, Dia 25, thk 0.71	1.07
		Riser	Copper	9	Length 1920, Dia 25, thk 0.71	4.14
		Absorber sheet	Copper	9	1920 X 110 X thk 0.27	4.44
5	Fresnel lens	-	-	-	-	-
6	Galvanised pipe	Routing pipe	Galvanised steel	1	1mtr length - 2inch OD, 2.9 wall thickness	4.22
7	Foam	Insulation foam in between tanks	PUF	1	Length 950, OD 360, thk 50	54.1477
8	PVC pipe	Routing pipe	PVC	1	1mtr length - 2inch OD,	0.804
9	Heater	Round Wire				
10	Foam	Insulation in Collector	Rock Wool		2050 x 1040 x 30	2.8782
11	Small Parts	(Connectors, Bolts)	Steel			0.5

Table-5: Bill of material of all major component of a FPC solar water heater

To access the environmental impacts, we have utilized SimaPro. Below network diagram (figure-8) gives a brief snapshot of the complete assembly and the subassembly which has major impacts (shown through wider line)

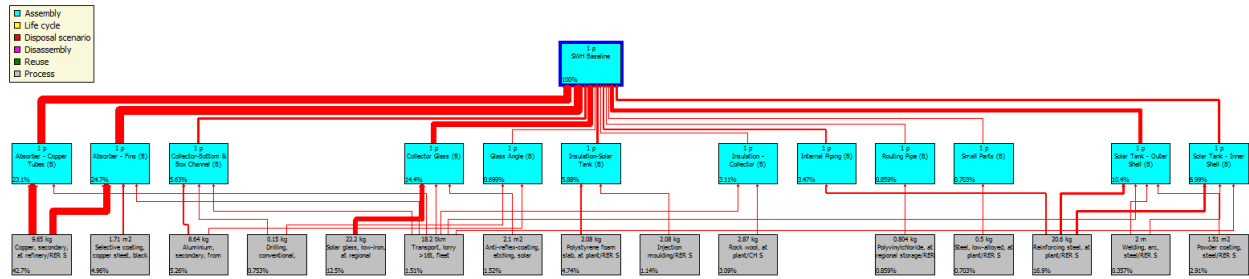

Figure-8: Complete network diagram of baseline design

Of the above, in the below network diagram, only the subassembly which has the highest single score is shown figure-9

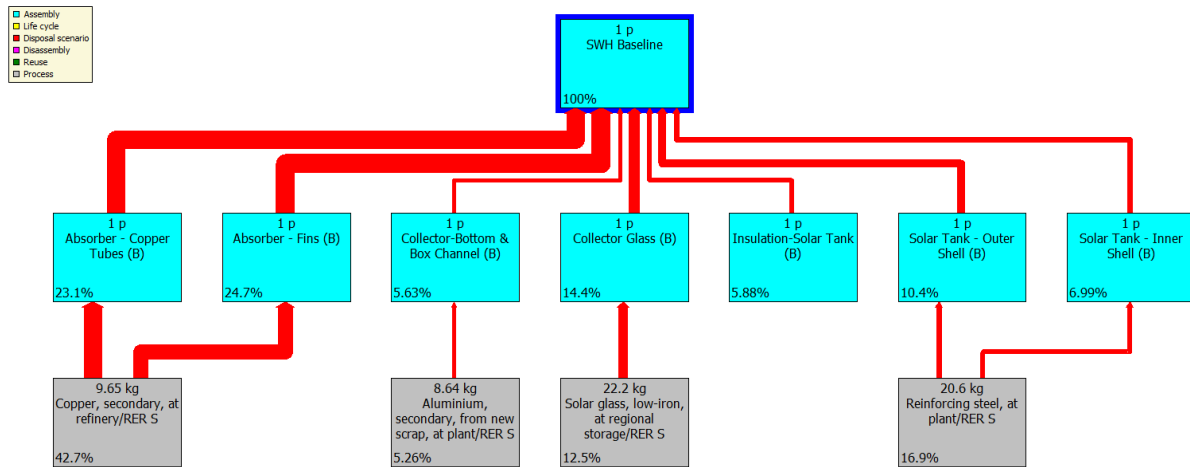

Figure-9: Sub-assemblies with major environmental impact

Of the above we observe that the major impacts are from the absorber components made of copper and the solar glass which shows the maximum impacts of 48% and 14% respectively

The respective damage assessment plots and single score plots per the EI99 indicator methodology were plotted which are shown in chart- 5, 6.

Damage Assessment

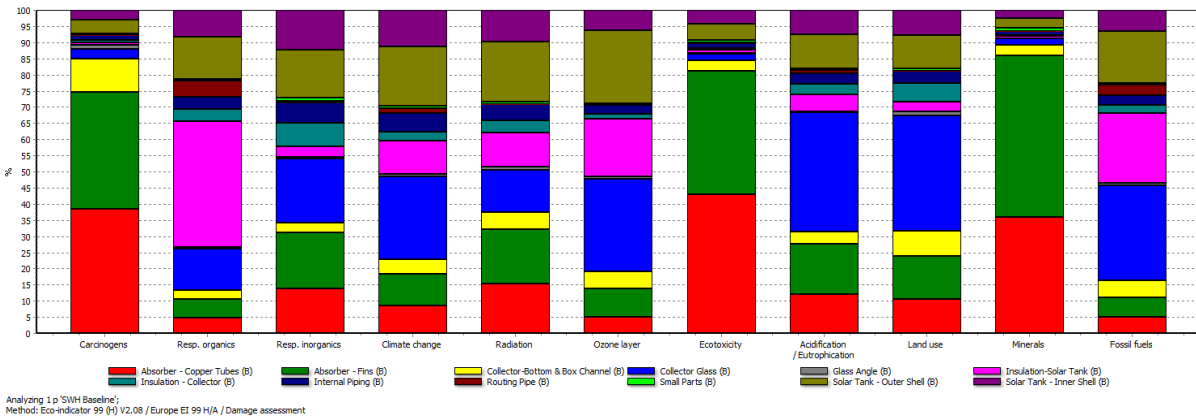

Chart-5: Damage assessment of baseline design

Single Score

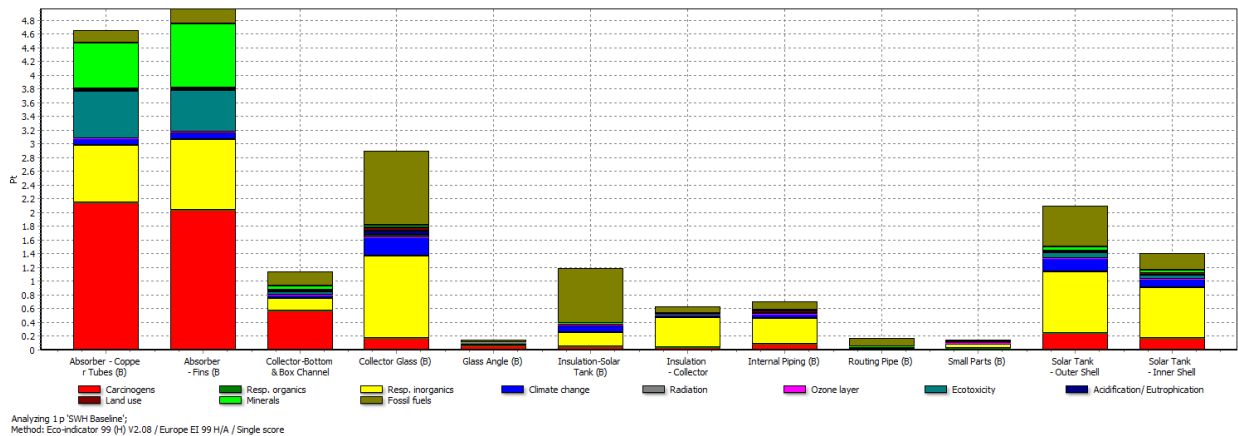

Chart-6: Single score point for baseline design

From the above, single score plot, we observe that Absorber components (copper fins and copper tubes) have the highest impact followed by the Collector Glass and then the components of the Solar Tank

The major impacts from the absorber components are towards carcinogens and the fossil fuels impacts are majorly from Collector glass, Solar Tank Insulation & Solar Tank – Outer Shell (powder coating done on outer layer to prevent rusting)

8. CONCEPT GENERATION FOR ENVIRONMENTAL/ SOCIAL IMPROVEMENT OF BASELINE

Though the government gave rebates in electricity bills and subsidies in buying SWH, the penetration was not huge as the cost of the unit was still high. During one of our interview with a dealer, he mentioned that usually this is the first question prospective customers ask him and only 4 out of 30

enquiries per month convert to orders. Hence to have a profound environmental and social impact, our major target was to ensure the price is reduced in spite of adding new features that were missing from the baseline. This meant that marginal efficiency improvements in existing system were not going to help.

Functional decomposition: If we functionally decompose the customer requirements then we see the below captures what the SWH is expected to do.

- Capture solar energy
- Heat water
- Store water
- Deliver water
- Maintain water temperature at the tapping point

Now the above has to be achieved with high efficiency and low cost without having and adverse safety or environmental impact.

a. Concept generation & details

We generated following few concepts in the initial phase

1. Solar water heater with Parabolic trough (2D) energy multiplier
2. Solar water heater with energy multiplier made of mirrors arranged in the form of a Linear Fresnel mirror
3. Solar water heater with Parabolic dish (3D) energy multiplier
4. Solar water heater 'solar tower' energy multiplier
5. Solar water heater with spot Fresnel lens energy multiplier
6. Hybrid Solar water heater with Linear Fresnel lens, auxiliary heater running on LPG/ BIOGAS
7. Solar water heater with spherical spot Fresnel lens energy multiplier
8. Solar water heater with extra auxiliary storage tank & external heater
9. Solar water heater with small auxiliary tank at users location
10. Hybrid Solar water heater with solar panels for auxiliary heating

1. Solar water heater with parabolic trough (2D) energy multiplier

Parabolic-trough collectors use curved mirrors to focus sunlight on a dark-surfaced tube running the length of the trough. A mixture of water and fluids that transfer heat is pumped through the tube. The fluids absorb solar heat and reach temperatures up to 299oC (570oF). The hot water is sent to a thermal storage tank, or the steam is directed through a turbine to generate electricity. Parabolic-trough collectors provide hot water and/or electricity for industrial and commercial buildings. Parabolic-trough collectors' use only direct radiation, and even though they use tracking systems to keep them facing the sun, they are most effective where there are good solar resources²³.

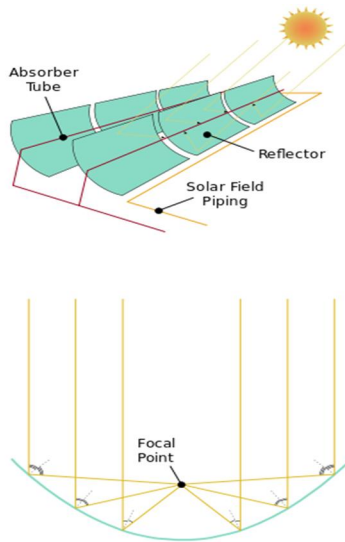

[Figure-10: SWH with parabolic trough](#)

Advantages:

- High heat generation in the tube
- Efficiency is good as compared to a baseline SWH, energy savings & environmental efficient

Disadvantages:

- High Initial cost
- Large area for mounting dishes & more efficient for large facilities
- Not much suitable for SWH
- Suitable only for high beam areas

[2. Solar water heater with energy multiplier made of mirrors arranged in the form of a Linear Fresnel mirror](#)

A compact linear Fresnel reflector (CLFR) – is a specific type of linear Fresnel reflector (LFR) technology. Linear Fresnel reflectors use long, thin segments of mirrors to focus sunlight onto a fixed absorber located at a common focal point of the reflectors. These mirrors are capable of concentrating the sun's energy to approximately 30 times its normal intensity. This concentrated energy is transferred through the absorber into some thermal fluid (this is typically oil capable of maintaining liquid state at very high temperatures). The fluid then goes through a heat exchanger to heat the water in a hot water storage tank²⁴.

Advantages:

- Cost of entire system is moderate
- High efficiency to heat water

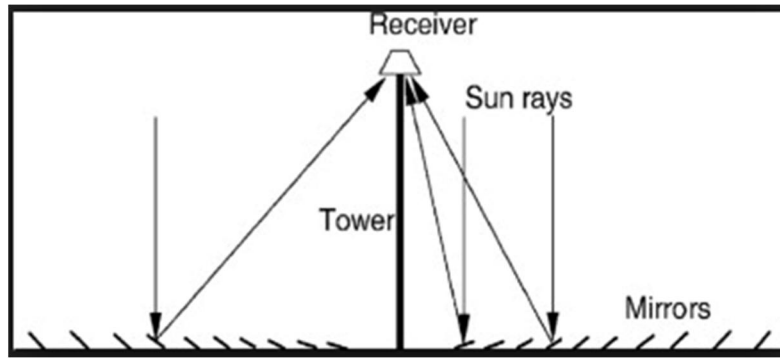

[Figure-11: SWH with linear Fresnel mirror](#)

Disadvantages:

- Need big area to implement
- Evacuated tubes which cause more maintenance
- Complex system - as the heating liquid will have to pass through the water tank & heat the water on principle of exchanger
- Cost is very high

[3. Solar water heater with parabolic dish \(3D\) energy multiplier](#)

In this system a parabolic dish is used which focuses the sunlight on to a point receiver where heat is concentrated. This heat is carried by the water flowing through the circular receiver. To increase the efficiency of concentration, special solar grade mirrors are used in the concentrator. The overall system assembly consists of the concentrator dish, receivers, two axis tracking system, and supporting structure. Capable of delivering temperatures up to 150 °C²⁵.



[Figure-12: SWH with parabolic dish](#)

Advantages:

- Installation of system is easy
- No chance of damage to components due to high heat
- Less maintenance

Disadvantages:

- Initial cost is high
- Low output/ unit. More numbers required to increase the output

4. Solar water heater 'solar tower' energy multiplier

A solar tower is a type of solar furnace using a tower to receive the focused sunlight. It uses an array of flat, movable mirrors (called heliostats) to focus the sun's rays upon a collector tower (the target). Concentrated solar thermal is seen as one viable solution for renewable, pollution-free energy. This systems using molten salts (40% potassium nitrate, 60% sodium nitrate) as the working fluids. These working fluids have high heat capacity, which can be used to store the energy before using it to heat water. These designs also allow power to be generated when the sun is not shining²⁶.

Advantages:

- Usage not limited to solar water heater, can be used for electricity generation
- Low carbon foot print

Disadvantages:

- Need big area to install, not feasible for apartments
- Initial cost is very high

5. Solar water heater with spot Fresnel lens energy multiplier

In a baseline solar water heater, Collector is fixed to a position such that solar energy is falling for maximum time in a day. Still this get the maximum energy in the mid of the day to next 2-3 hrs. Rest of the day energy does not fall properly on the solar panel.

To overcome this issue and increase the span of getting the solar energy, we have made our concept with a spherical spot fresnel lens. It will refract the light rays on form of spots on the collector box. The spherical is made in such a design that it will take care of any position of Sun & will refract the rays on the collector box. This concept will work effectively with evacuated tubes in the collector box. To overcome the stand by losses in the solar water storage tank we have used a auxiliary heater working on electricity.

Advantages:

- High power heat transfer (available in Crystal Clear Acrylic perfection cutting)
- Can be set at smaller focal length

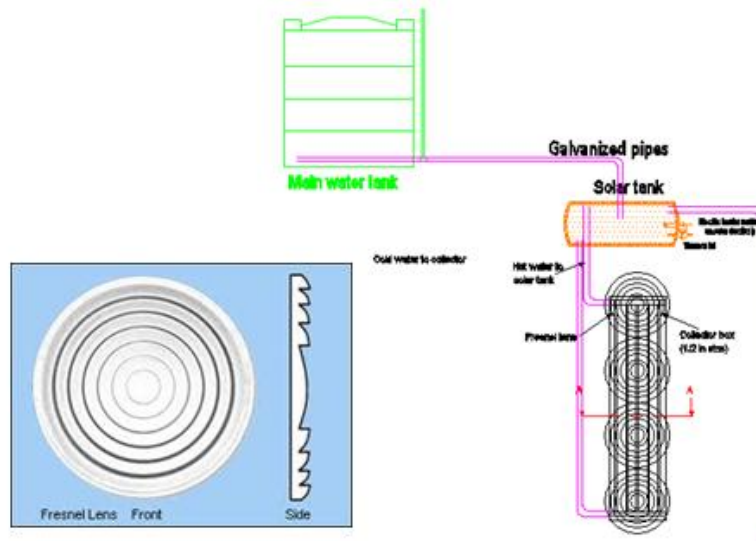

Figure-13: SWH with spot Fresnel mirror

Disadvantages:

- Instant flame and work hazard
- Equipment damage

Does not spread over a pipe surface evenly

6. Solar water heater with linear Fresnel lens and auxiliary heater

Normally a solar water heater performs best for very few hours in a sunny day. It starts from afternoon & till start of evening. Rest of the time in that day solar energy is less hence water don't get hot enough through a baseline system. As per our requirement of efficiency improvement, we had to increase the heating time period from early morning till late evening. We thought of multiplying the energy as well as increase the intensity per unit area on the collector box. During finding the solution for these factors, we came across the concept of Fresnel lens used for cohesion of the solar heat to the point or line. This heat was so much that it could burn wood or boil the water with in few minutes. We had an idea to use the similar technology for our solar water heater.

In this concept we have used a Fresnel lens over collector box to refract the solar rays. To reduce the manufacturing cost we have idea of not using separate solar water tank. We will connect the collector box directly with Main water tank. Hot water from the collector box will be stored in auxiliary hot water storage tank. To avoid the stand by loss in the night, we have given a provision for a heater which can run on biogas or LPG.

Advantages:

- Can work at the sunrise & late afternoon evening time
- This system is good in working in rainy or cloudy days

- No major changes in the base line SWH

Disadvantages:

- Additional cost for refracting material
- Risk of damage due to high heat concentration

7. Solar water heater with spherical spot Fresnel lens

In this concept assemblies of hexagonal lens are used in a spherical shape like a football. The solar rays falling on the each lens will project on the collector box to heat water. This concept does not need the tracking system as each lens works efficiently at the different time in a day. In this system collector box will be below the entire sphere. Water from storage tank will be transferred to the collector box & hot water will get back to storage tank as like a baseline SWH system.

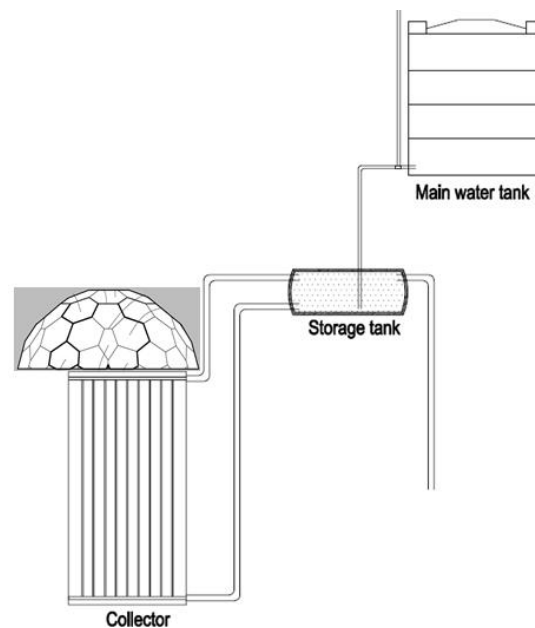

[Figure-14: SWH with spherical spot Fresnel mirror](#)

Advantages:

- High efficiency of system
- Works in rainy & cloudy days

Disadvantages:

- Huge space requirement
- Shape of collector need to be maintained as per the shape of sphere

8. Solar water heater with extra auxiliary storage tank & external heater

In this concept, a separate auxiliary storage tank is used after solar water heater tank to store the hot water. After heating, hot water will flow from collector box to solar water heater tank. It will have hot water on top side & bottom will have cold water flowing in from main water tank. Then the hot water from solar water heater storage tank will be pumped (Pump: low flow, low header) to an auxiliary insulated storage tank operating with an electric heater. This will initiate flow of cold water from main tank to the solar water heater tank then to the collector box. This will maintain the circulation of cold water & use the solar energy for maximum time in a day.

Whenever the temp in the auxiliary storage tank will go below a specified limit, heater inside the tank will start operating & will heat the water back to specified limits.

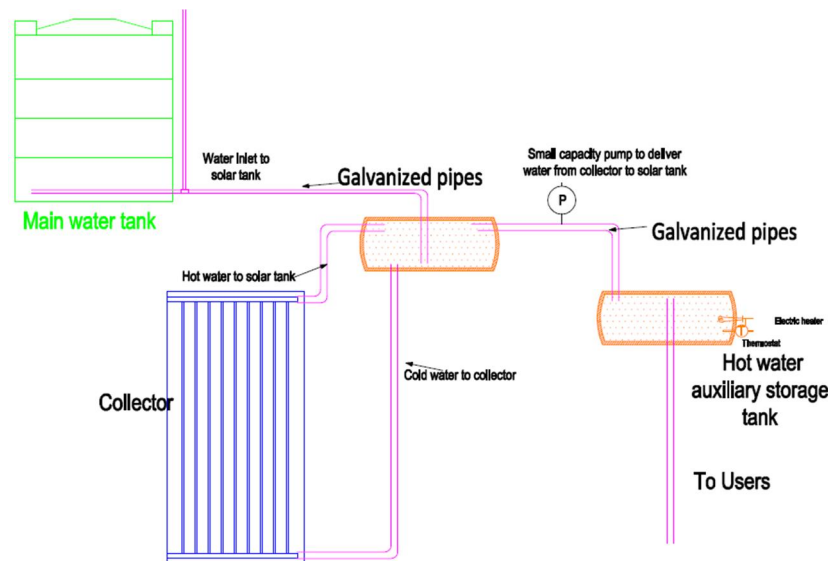

Figure-15: SWH with extra auxiliary tank

Advantages:

- Hot water availability at any point of time in the day
- Optimum usage of solar energy by recirculating the cold water

Disadvantages:

- High cost due to use of a second auxiliary insulated tank
- Running cost of a small pump & electric heater
- Large space requirement

9. Solar water heater with small storage tank at the user's location

In this concept, individual small capacity hot water storage tank will be installed at each user's apartment or home. Capacity of storage tank will be appx 20liters. This tank will be mounted very near to the point of use to avoid heat loss in pipe. The system on the top of the roof will be similar as a

baseline system. This small tank will remain always full with hot water. Whenever a user start using hot water it will start emptying & same time water from main storage tank on roof will start flowing in to this small tank. There will be no auxiliary heater required in the main storage tank on roof.

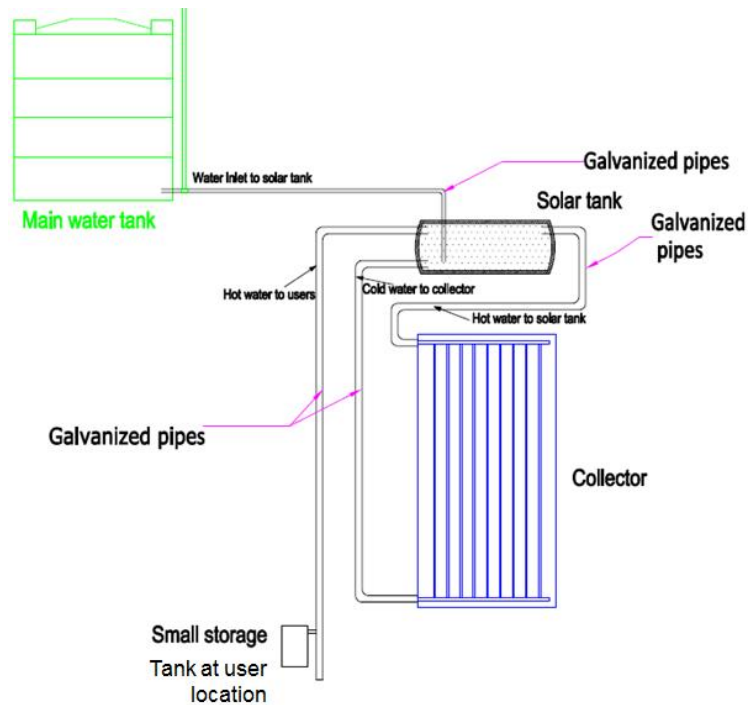

Figure-16: SWH with small tank at user's end

Advantages:

- Less capacity of Individual heater than a auxiliary heater in the tank
- Hot water will be available immediately and will take care of stand by loss in water pipeline
- Reduced capacity individual heater than a regular water heater
- No power loss due to intermittent heating in case of auxiliary heater as this will operate whenever the user needs water

Disadvantages:

- Not suitable for apartments or large building as individual users will have to buy heaters
- Overall cost of entire system would be high
- Total electrical energy consumption would be higher than other sustainable concepts
- Heater required at each point of use in a house or apartment

10. Hybrid Solar water heater with solar panels for auxiliary heating

In this concept, PV Solar panels are used in between the main tank & collector box shown in figure ?. These PV solar panels will generate electricity which will store in the batteries & converted to AC which will be further used for operating the electric heater. Water from the main tank will be circulated

through these panels for cooling the PV cells & then circulated to collector panel. It will help us in two ways one it will cool the panel second the water will get preheated hence less time for heating to suitable temperature.

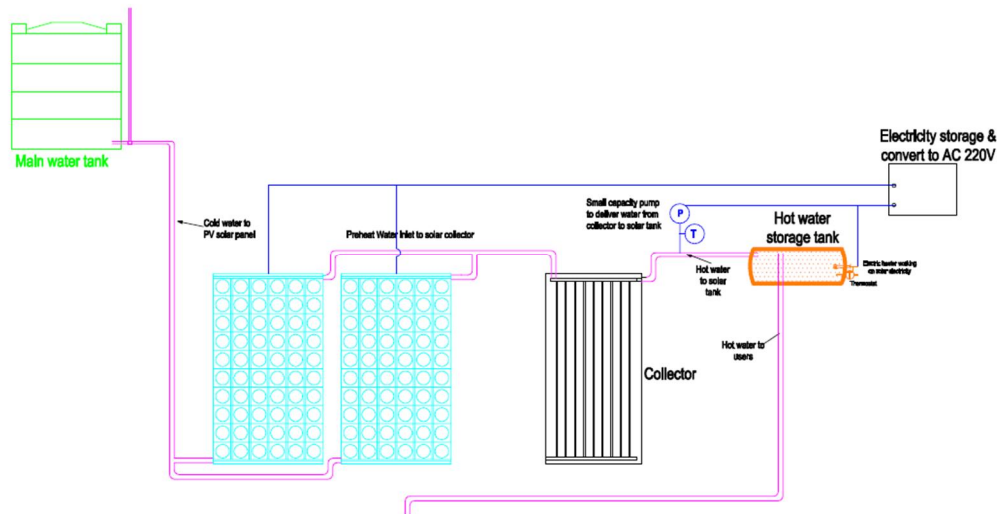

[Figure-17: SWH with solar panel](#)







Advantages:

- No impact on environment while running the system
- No running cost
- Satisfy the requirements of the user's

Disadvantages:

- Very high initial cost, SO house owners as well as builder will not accept this concept
- Large space requirement for putting PV solar panels for generating electricity to run a heater
- Very high maintenance cost of PV cells & battery

Following table shows the comparison of each concept w.r.t. major additional features.

		Concept #1	Concept #2	Concept #3	Concept #4	Concept #5	Concept #6	Concept #7	Concept #8	Concept	Concept #10
Concepts	Baseline	Solar water heater with Parabolic trough (2D) energy multiplier 	Solar water heater with energy multiplier made of mirrors arranged in the form of a Linear Fresnel 	Solar water heater with Parabolic dish (3D) energy multiplier 	Solar water heater 'solar tower' energy multiplier 	Solar water heater with spot Fresnel lens energy multiplier 	Solar water heater with Linear Fresnel lens energy multiplier 	Spherical spot Fresnel lens 	Solar water heater with extra auxiliary storage tank & external heater & no energy multiplier	Solar water heater with small auxiliary tank at the user's location	Hybrid Solar water heater with solar panels for electricity generation
Collector	Flat plate	Evacuated tube	Evacuated tube	Dish Stirling	Flat plate	Evacuated tube	Flat plate	Flat plate	Flat plate	Flat plate	Flat plate
Solar Tracking	None	Single Axis	Single Axis	Two Axes	Two Axes	None	None	None	None	None	None
Aux heating	None	Molten Salt storage + Heat Exchanger	Small Electric heater + Grid energy	Molten Salt storage + Heat Exchanger	Molten Salt storage + Heat Exchanger	Small Electric heater + Grid energy	LPG / Biogas burner	Small Electric heater + Grid energy	Small Electric heater + Grid energy	None	Large Electric heater + Photovoltaic energy
Aux heater location	N/A	At the solar unit	At the solar unit	At the solar unit	At the solar unit	At the solar unit	At the solar unit	At the solar unit	In the Auxiliary storage tank	None	At the solar unit
Recirculation	None	Electric Pump + Grid Energy	Electric Pump + Grid Energy	Stirling Engine driven pump	Electric Pump + Grid Energy	Electric Pump + Photovoltaic energy	Electric Pump + Grid Energy	Electric Pump + Grid Energy	None	None	None
Auxiliary Hot water Storage	None	No	No	No	No	No	No	No	Yes	Yes	No
Electricity generation	None	No	No	No	No	No	No	No	No	No	Yes

[Table-6: Comparison of SWH concepts](#)

9. CONCEPT SELECTION PROCESS

We decided to use the Pugh matrix to help us differentiate the different concepts we generated to meet the Customer requirements. We broke down the customer requirements into subsystem requirements. For example, cost and sizes. Maintenance requirement is specifically captured as durability of the collector as it is more stressed now in comparison with baseline with no energy multiplier. Additionally solar tracking, which helps in meeting multiple customer requirements, is captured as such. Costs of Auxiliary heater and recirculation pumps, which are required to meet instantaneous water demand, are captured separately as such. Since few concepts avoid the need of auxiliary heater by avoiding water mixing in the form of an auxiliary tank, are separately captured as such.

Cost of Collector	20
Cost of Energy Multiplier	15
Size of Collector	10
Size of Energy Multiplier	10
Solar Tracking cost	10
Aux heater cost	10
Durability of the collector	5
Hot water available instantaneously	5
Recirculation cost	5
Cold water does not mix with hot water	5
Auxiliary Tank cost	5

[Table-7: Weightage for different requirements used in PUGH matrix](#)

The above table-7 shows the weightage given. Since the collector is the most elaborate of design and as such costs more than the other subsystems, we wanted to give more weightage to this so as to encourage moving ahead with smaller designs which additionally helps in floor space reduction. Since we were adding a new subsystem altogether we gave the cost of the energy multiplier a high value too, so as to encourage us to choose a simple yet efficient design. Similarly other weights were chosen as shown above in table-7, after brainstorming.

Item	Requirement	Overall Importance	B A S E L I N E	Decision Criteria										
				Concept #1	Concept #2	Concept #3	Concept #4	Concept #5	Concept #6	Concept #7	Concept #8	Concept #9	Concept #10	Concept #11
				Solar water heater with Parabolic trough (2D) energy multiplier	Solar water heater with energy multiplier made of mirrors arranged in the form of a Linear Fresnel	Solar water heater with Parabolic dish (3D) energy multiplier	Solar water heater 'solar tower' energy multiplier	Solar water heater with spot Fresnel lens energy multiplier	Solar water heater with Linear Fresnel lens energy multiplier	Spherical spot Fresnel lens	Solar water heater with extra auxiliary storage tank & external heater & no energy multiplier	Solar water heater with small auxiliary tank at the user's location	Hybrid Solar water heater with solar panels for electricity generation	Hybrid Concept
1	Size of Energy Multiplier	10		0	0	-1	-2	0	0	-1	0	0	0	-1
2	Cost of Energy Multiplier	15		-2	-2	-2	-2	-1	-1	-1	0	0	0	-1
3	Size of Collector	10		1	1	2	0	1	1	-1	-2	-2	-2	1
4	Durability of the collector	5		-1	-1	-2	0	-2	-1	-1	0	0	0	-1
5	Cost of Collector	20		1	1	-2	-2	0	0	1	-1	-1	-1	1
6	Solar Tracking cost	10		-1	-1	-2	-2	0	0	1	0	0	0	1
7	Auxiliary heater cost	10		-2	-1	2	2	-2	-2	-1	-1	0	-1	-1
8	Hot water available instantaneously	5		1	1	1	1	1	1	1	0	0	0	1
9	Recirculation cost	5		-1	-1	-1	-1	-1	-1	-1	0	0	0	-1
10	Cold water does not mix with hot water	5		0	0	0	0	0	0	0	1	1	1	1
11	Auxiliary Tank cost	5		0	0	0	0	0	0	0	-2	-1	0	-1
		100												
Counts														
	Count of Pluses			3	3	3	2	2	2	3	1	1	1	5
	Count of Minuses			5	5	6	5	4	4	6	4	3	3	6
	Count of Same (0)			3	3	2	4	5	5	2	6	7	7	0
	Pluses - Minuses			-2	-2	-3	-3	-2	-2	-3	-3	-2	-2	-1
Sums														
	Sum of Pluses			3	3	5	3	2	2	3	1	1	1	4
	Sum of Minuses			-7	-6	-10	-9	-6	-5	-6	-6	-4	-4	-5
	Total			-4	-3	-5	-6	-4	-3	-3	-5	-3	-3	-1
Weighted Sums														
	Weighted Sum of Pluses			35	35	45	25	15	15	35	5	5	5	50
	Weighted Sum of Minuses			-70	-60	-115	-115	-50	-45	-55	-60	-45	-50	-50
	Total			-35	-25	-70	-90	-35	-30	-20	-55	-40	-45	0

Table-8: Pugh matrix for concept selection

Reasons for scores under each concept

Choosing for size of energy multiplier, solar tower in concept #4 would need to be very tall and would also lot of real estate in laid out mirrors. This concept hence was rejected on that basis.

Dish Stirling in concept #3 too gets low marks as the dish would have to be sufficiently large to ensure most of the space is not wasted due to the shadow of the Stirling engine and its mount.

Spherical spot lens in concept #7 gets low on size as it will have to be sufficiently large to be able to have the same exposed area in any direction as a flat collector may have with solar tracking. Otherwise the collector will not get sufficient energy.

Linear Fresnel lens size will be the same as the baseline collector which will allow it to capture the same amount of heat. Other concepts fare well on this front. Cost of making a flat lens in injection molding is not huge and hence all the four lens concepts fare well here.

Choosing for cost of energy multiplier, parabolic trough is formed into shape using a reflective material. Good quality of parabolic shape is very important otherwise the focus is easily missed from the collector. The cost of manufacturing is high.

Linear Fresnel mirrors setup is made up of small flat mirrors that are mounted on different axes to form the overall shape of a Fresnel. As this is assembly intensive which also affects ease of maintenance, this gets low score.

Cost of dish in dish Stirling will be high due to its bigger size as discussed in previous paragraph. Added cost of the Stirling engine itself makes it unattractive. Setup and running costs of the huge solar tower will be very prohibitive.

Size of the collector in Concept #1 and 2 will be small as the collector will be an evacuated tube. Similarly collector size, for capturing the same energy as baseline, will be smaller for the linear and spot Fresnel lenses. Collector on the spherical spot Fresnel lens will be larger as the lens itself is large, as discussed in an earlier paragraph.

Though smaller collectors mean lesser material cost, conversely they mean they will have to be able to sustain much higher temperatures for the same level of energy captured as the baseline. These are hence susceptible to thermal shocks which will affect durability.

Coming to cost of the collectors, Flat panel collectors are cheaper than vacuum tubes. Stirling engine is very expensive in this regard.

Solar tracking would require as many motors as the number of axes in which we are tracking. Spherical spot Fresnel concept wins here as it always is able to focus the light on the collector. Linear Fresnel concept fares moderately due to the mirrors at the end.

Auxiliary heating using molten salt storage and heat exchanger would be expensive and space consuming. Similarly setup costs would be huge to use photovoltaic energy to run electric heaters. Biogas burner would again lead to investments in biogas and related piping. Though LPG burner wouldn't need special piping, it's still expensive for commercial use. Since we get LPG in cylinders in India, that would need a person to regularly book, receive and install the cylinder.

'Hot water available instantaneously' was included so as to differentiate the performance of different concepts and rated as shown.

Recirculation concepts and related costs get rating based on availability of the system in the concept.

'Cold water does not mix with hot water' is included as this will encourage us to choose such a concept which does, which will help in reducing the time required to heat water using solar energy alone. This will help us reduce the size or totally eliminating the need for Auxiliary heater.

The above though will need an auxiliary tank as such, the cost of which has to be accounted for and hence the ratings, as shown in Table-8.

The ratings are then analyzed using the 'Counts', 'Sums' and 'Weighted Sums' methods. Each one has its inherent advantage and disadvantage and is influenced by the assumptions made, for example in weights chosen. We hence decided to look at all the three in analyzing the concepts.

Using the data available, we chose a hybrid design, which picks the best of other designs and is able to function well as a system (i.e. no conflicts between the different best choices across rows). More detail of this hybrid design is given in the final concept section.

It is important to note that the scores of the hybrid design are -1, -1 and 0 respectively under 'Counts', 'Sums' and 'Weighted Sums' methods, which is the best in comparison to other individual concepts. We can hence say that we have been able to effectively use Pugh matrix and come up with a Hybrid design.

10. CONCEPT DESCRIPTION & ALPHA DESIGN

In the baseline subsystem of SWH, there is a collector connected to solar water tank and tank is connected to the main water tank. The water gets heated in the collector box & transferred to storage tank on the top and Cold water flows in to the collector. This process keeps on happening until the entire water in the storage tank gets heated.

a. Concept description

In a SWH, collector box & storage tanks are the largest and most expensive component. We put our thought to reduce its cost without compromising their functional efficiency. This made us think in direction of changing material, reduction in size, energy multiplying & new concept of solar water heating. All these thoughts were applied in our finalized concept of "Hybrid solar water heater with Fresnel lens"

Now since the base line collector area is 2m^2 , using a conventional convex lens will become heavy. Research in this area revealed that Fresnel lens can be used which works on the same principle as the 'Flat Mirrors in Fresnel arrangement' system discussed above. The lens essentially was flat with grooves (linear/circular) on the surface. Each groove corresponding to an actual surface of a convex lens it is replacing. Flat Fresnel lens came in two kinds, linear focus or spot focus. Fresnel lens focuses best when the grooved side faces the sun. Since there is a possibility of dust gathering in the grooves due to exposure to atmosphere, we decided to invert the faces.

To make the system efficient, it will need tracking the sun. We also wanted to explore the option of the sun focusing always on the collector without having to track the sun. Geometry tells us that it will be possible if the shape of the concentrator is the shape of a sphere/hemisphere and the collector is at its center. When we researched for a lens system in the shape of a sphere we came across a patent for assembling conventional Fresnel lens in the shape hemisphere which looks similar to the method used to make soccer balls.

Movement of sun had additional challenges on the Linear Fresnel lens concept. If the line of focus on the linear Fresnel is perpendicular to the apparent movement of the sun, the focus will easily go beyond the

collector surface; hence the focus line has to be parallel to the movement of the sun. Moreover we added two mirrors at either end which will reflect back sunlight during sunrise and sunset. See figure18, 19 below.

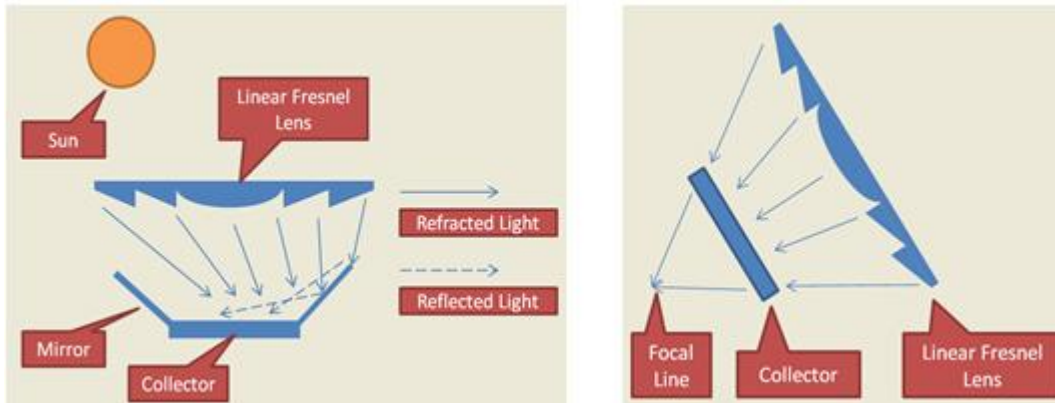

[Figure-18 \(left\), Figure-19 \(right\)](#)

We moreover decided to put the flat panel collector not at the focal point/line of the lens but somewhere in between. This would help reduce the thermal stress on the collector. See figure 10 below.

b. Alpha design concept details

In our design concept our area of main focus is to make the Design of a solar water heater more efficient w.r.t. heating time, stand by heat loss & maintaining the constant water temperature inside the tank. Considering these boundaries in our design we made our first concept design.

Breakup of concept in subsystems

1. Heating of water in collector Box

In our concept, we have used a Fresnel lens for refraction, plane mirrors for reflection. This will refract the solar heat on risers in any direction of sun. This cohesion of energy will improve the heating time as well as we can reduce the size of the collector box. Dimensions of Fresnel lens will be same as our base line collector box size - 2050mmx1040mmx 3mm thickness. Size of the collector box considered is half in to the width of the base line collector box -2050mm x 520mm x 100mm. To avoid the overheating/ burning of tubes & collector box, it will be placed between the lens & the focal point. Positional dimension of collector box can be decided at the later stage in project through validation.

In this arrangement collector box will not be connected to solar tank. It will be connected to main tank of cold water & output will go to a storage tank.

To increase heat gain by water inside riser we are proposing the new diameter of 15mm (We could not do any validation for it but continue our research during final project)

The material of the collector box is decided to Galvanized steel in place of Aluminum. The life expectancy of Galvanized steel in the collector box is also from 20-50 years. Rest the process & materials in the collector box are kept same.

2. Thermosyphon of water to the solar water storage tank

In a Thermosyphon SWH, as the water starts heating up it starts rising up through riser tubes to header & then finally get transferred to the solar tank. To maintain the efficiency of Thermosyphon process we have kept the same size 25mm of header tubes.

3. Storage of heated water in the tank

The heated water is transferred to the storage tank which varies as per the capacity of the system. We are keeping the tank volume same to the baseline as our system capacity is same. To reduce the stand by loss, we are changing the material from stainless to HDPE (High density polyethylene) with a thickness of 8mm inner tank, 4 mm outer tank (thickness can be optimized in later stage). We are removing the insulation between the walls of the tank & we will keep air inside as an insulating material²⁷. Heat Conductivity of Polyethylene is - 0.42-0.51 W m⁻¹ K⁻¹@23C whereas stainless steel - 43 W m⁻¹ K⁻¹²⁸. Storage tank will be having a provision for anode rod to protect from scaling

4. Auxiliary heating of solar tank

In SWH water will get heated to its maximum temperature in the day time. In the night time due to stand by loss temperature of water will start coming down. To maintain the temperature we are including an auxiliary heating source in our storage tank. We are putting a low watt electric water heater with thermostat in the storage tank to ON/OFF automatically in the specified limits. This intermittent heating will have less electricity consumption burden than a regular electric geyser for heating the cold water. This additional cost is compensated by reducing the initial cost of entire system.

5. Hot water output to the users

In this subsystem, we have decided to use the PEX material pipe in place of PVC or galvanized iron pipes. These pipes are cheaper, more heat resistant than PVC. In regular practice, pipe lines were having sharp bends & routed over the building walls. This can cause more heat loss due to forced convection.

PEX material piping can be bent easily with desired round bends. This pipeline should be routed inside the wall (as like electrical) as concrete is less heat conductor for benefit of less heat loss due to convection. Apart from this we have idea to use insulation over the delivery pipes to reduce the heat loss to minimum level. But this will increase the cost of the system, so right now we are keeping it as a backup plan for our concept study.

6. Recirculation of cold water to the storage tank

Hot water in the pipelines starts losing heat due to stand by losses/ forced convection. In morning, Users will not get hot water & waste water till hot water starts coming. We have decided a concept of recirculation of water in the pipeline back to the tank. This will operate through a small watt pump with an input from a thermostat.

Whole data shared in the concept is either in design or considered by experience. It needs to undergo the optimization & changes before the final specifications are released.

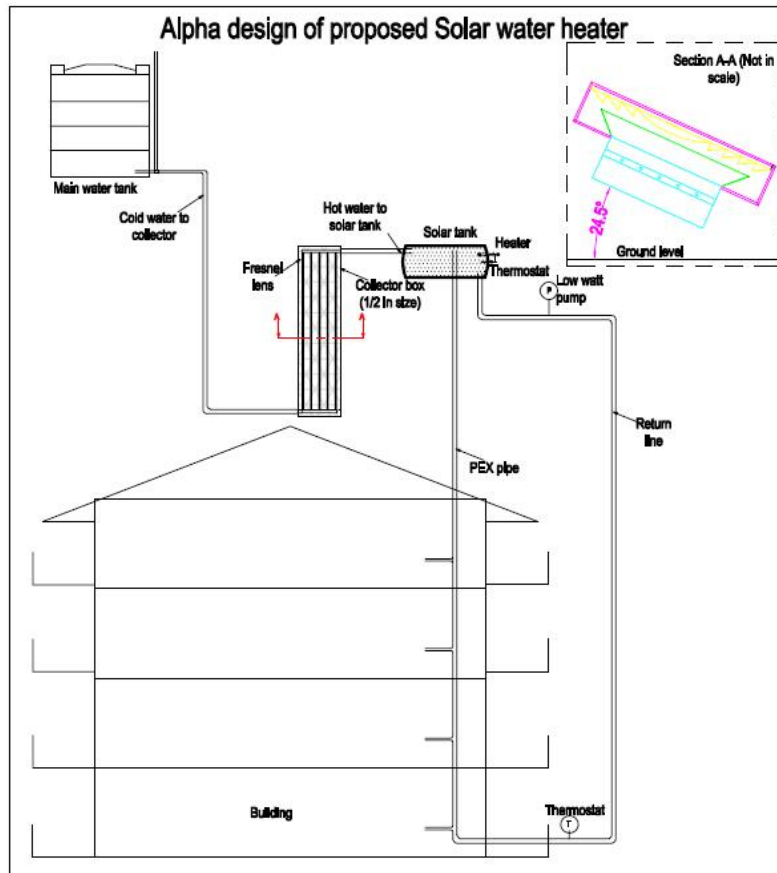

[Figure-20: Concept diagram of hybrid solar heater](#)

11. FEEDBACK ON ALPHA DESIGN

Steps taken for feedback on Alpha design:

During concepts preparation also, we had a discussion with few members in our office. We got few feedbacks from them on our concept designs of FPC type collectors e.g. tapping hot water from collector box to hot water storage tank without mixing it with cold water tank. Use pump to recirculate water in the pipe lines. These feedbacks were captured during our concept preparation & became a feature of our FPC type SWH systems. Our Alpha design was having both these two features which were little more refined by removing a tank between main tank & solar panel.

Discussion with office members: After Alpha design, we discussed our project again with a group of Engineers in our department. We had few more feedback from them for improvement as well as to decide the components final specifications.

1. Use thermic valve to work in the system for Auto close/ open the circuit.

2. Pump type – High header & low flow, place of pump should be on the ground as the maximum height of pump from suction point can be up to 1m.
3. Usage of thermocol material between the solar tank walls to avoid the heat loss through it. Heat dissipation through thermocol is very less.
4. Usage of stand by heater in every apartment for providing hot water any time
5. Usage of small SWH (evacuated tube type) in each apartment

As they were not aware of Fresnel lens technology so they didn't have any feedback on collector box.

Feedback from Professor after DR#2: Received feedback on DR#2 report from professor regarding our considerations in our alpha design. A few question points are written here.

1. Design considerations for deciding the half size of collector
2. Size of risers tube
3. Weightage used in concept selection process
4. Decision for Specification of components

Discussion with Technical team from SWH manufacturing unit: After alpha design & presentation, we visited a manufacturing unit "Sunrise solar water systems" & discussed the concept with their technical team. Team member was also not aware of the Fresnel lens technology hence he could not give any positive feedback on collector design. Apart from his view our design could have a concern while going through validation phase in the government test labs. As per him the design released in government papers was the only approved design. They had never tried any new technology in FPC type collector with different dimension. We got few observations during this visit

1. Usage of polyethylene insulation between the solar tank walls in place of rock wool
2. Usage of composite pipes in place of PVC pipes
3. Validation process of a solar water tank
4. Possibility of Using Galvanized steel in place of Aluminum frame

We used some of these feedbacks in our concepts during making the final design while few of them were used to improve our project report. Some of the feedbacks were not used directly as a change in our final design but it led us on a way to think more widely in selection of different material, component specifications. Some of the feedbacks used helped us in doing the following changes in final design

1. We did some extensive research on deciding the dimensions of Lens & collector. We could find the dimension of standard lens available in market. Used their dimensions in software to design the collector box size.
2. We could refer some manufacturers data for deciding the riser tube diameter
3. Thermic valve could be good option but need more clarification on its usage
4. Decision on in-process validation during the manufacturing build
5. Thermocol material is kept as an back plan to test if the prototype test fails for heat dissipation test at any stage and don't have another choice to change air with some other material
6. Type of pump to be used for recirculation

7. Composite material pipes are kept as a back-up plan & based on the choice of users too.
8. Galvanized steel for collector boxes in old designs (some boxes were lying in company for replacement) froze our concept of using the same

12.FINAL CONCEPT

After DR2, we started creating the designs of our concepts & considerations. This resulted in major changes in our design concepts of collector box & storage tank. After finalizing the design we released the final drawings of each component.

1. Design changes from Alpha concept

Following are the changes in final design of SWH

1. Design of Fresnel lens

In Alpha design the dimensions of the Fresnel lens were same as baseline collector box – 2050 x 1040 x 3mm, Qty 1no. In final design we are changing this dimension to a standard Fresnel lens available in market. The dimensions of final designed Fresnel lens are 457 x 457 x 2.8mm, focal length - 457²⁹ and quantity used is 8nos (figure-21)

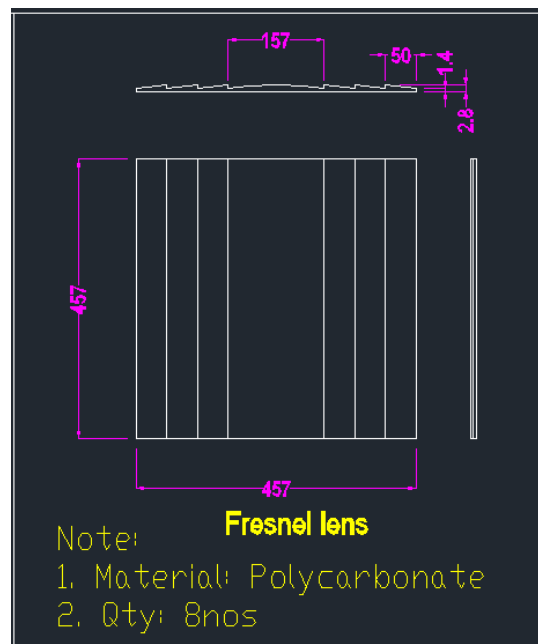

[Figure-21: design of a Fresnel lens](#)

2. Design of collector box

Initially we proposed a half size to baseline collector box but during final design release we validated the dimensions & realized need of major changes in same.

Our final design for collector box 1828 x 300 x 100mm & the quantity will be 2nos/ set up.

Design considerations: For maximum heat below lens, collector should be placed at its focal point but there are chances of high vacuum & heat inside collector box. This could damage the parts. We decided to put it at the half of the focal length. To avoid at user's end also we have error proofed the position of Fresnel lens by fixing it wrt to riser tube or collector box (Input from DFMEA) Angle of the collector box in relation to ground will change as per the distance from the equator. Rule of thumb is set the angle the same as latitude of location where it is being installed.

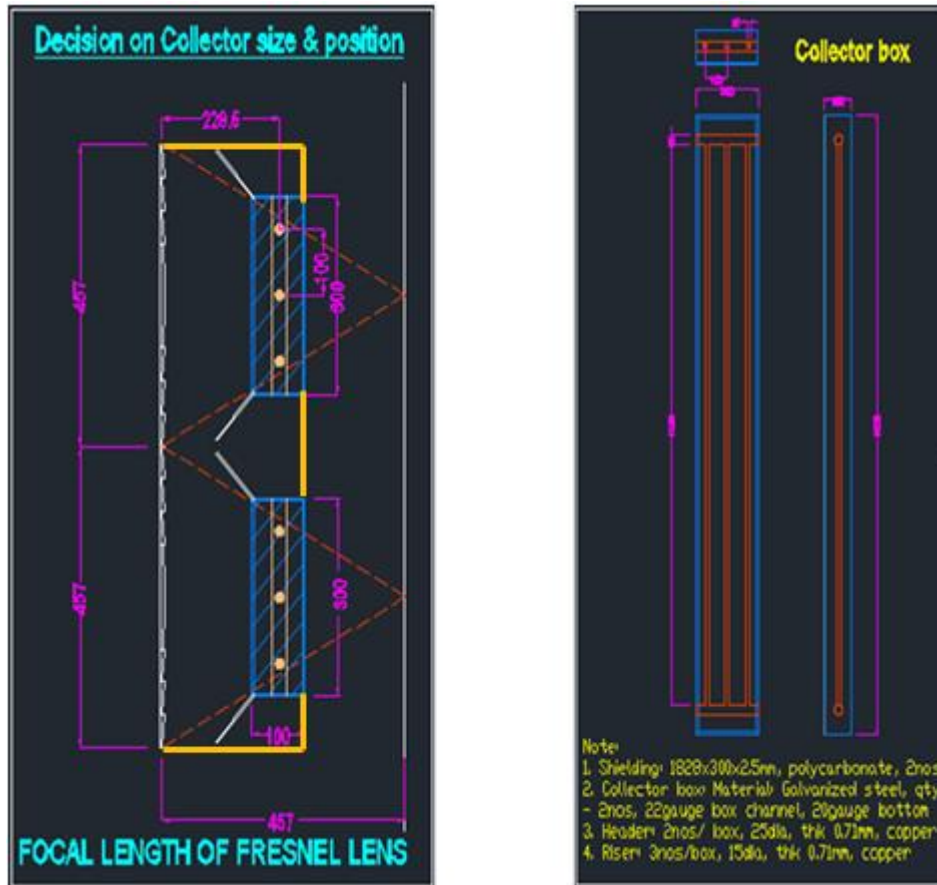

Figure-22: Design finalization of collector box by using Fresnel lens (Left), collector box design (right)

3. Design of riser/ header tubes

In alpha design size of riser tubes were: 1920mm, Dia 15, thk 0.71mm, header tube size – 1100mm, Dia 25, thk 0.71m. Final design dimensions are: riser tubes - 1650, Dia 15, thk 0.71mm, header tube size – 350mm, Dia 25, thk 0.71m.

Design consideration: We did research in finalizing the dia of each riser; we found that some manufacturers are using the risers with 15mm globally³⁰. As we needed to carry more water through each riser so we kept 15mm as our standard dimension. Length of riser & header tube achieved from the final design of collector box.

4. Design of Solar tank

Alpha design tank dimensions were – 1050 x 460 x 8mm thickness (Outer), 950 x 360 x 4mm (Inner).

In final design, we have reduced the thickness of outer & inner shell. To release final design, we did not any physical validation of the thickness but during our visit to a manufacturing industry, we understood more about the internal pressure & benchmarked it with thickness of plastic water/ chemical storage tanks.

Final design dimensions are: 1050 x 460 x 5mm thickness (Outer), 950 x 360 x 2.5mm (Inner)

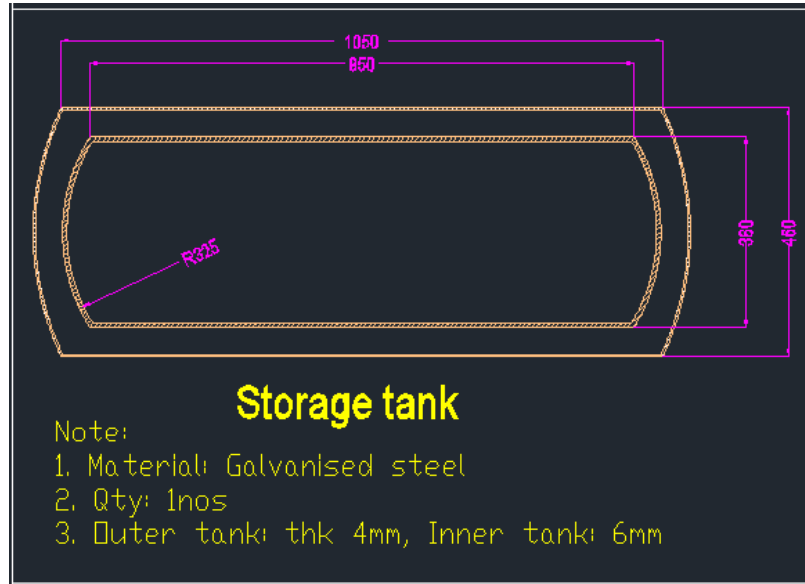

[Figure-23: Final design of solar tank](#)

5. Auxiliary heater

Final specification of heater is capacity – 2KW, Material element - Pyromax -c (High Al, High Cr)³¹

6. Water circulation pipes

There are no major changes in the pipes we are adding only one more option of using composite pipes along with previous design of PEX material. Heat loss from composite pipes is very less as they come with inner & outer coating on aluminum pipe. These composite pipes come in different grades & appx 3 times costlier than a PEX or PVC pipe. User can decide the type based on his economic conditions.



[Figure-24: End section of composite pipe](#)

7. Recirculation pump

We decided the position of recirculation pump in the system. In alpha design we were using this pump on the top of the roof but finally the pump will be used on the top of roof. Along with decided the working features of recirculation pump - Low flow high header.

2. Design of SWH system & its components

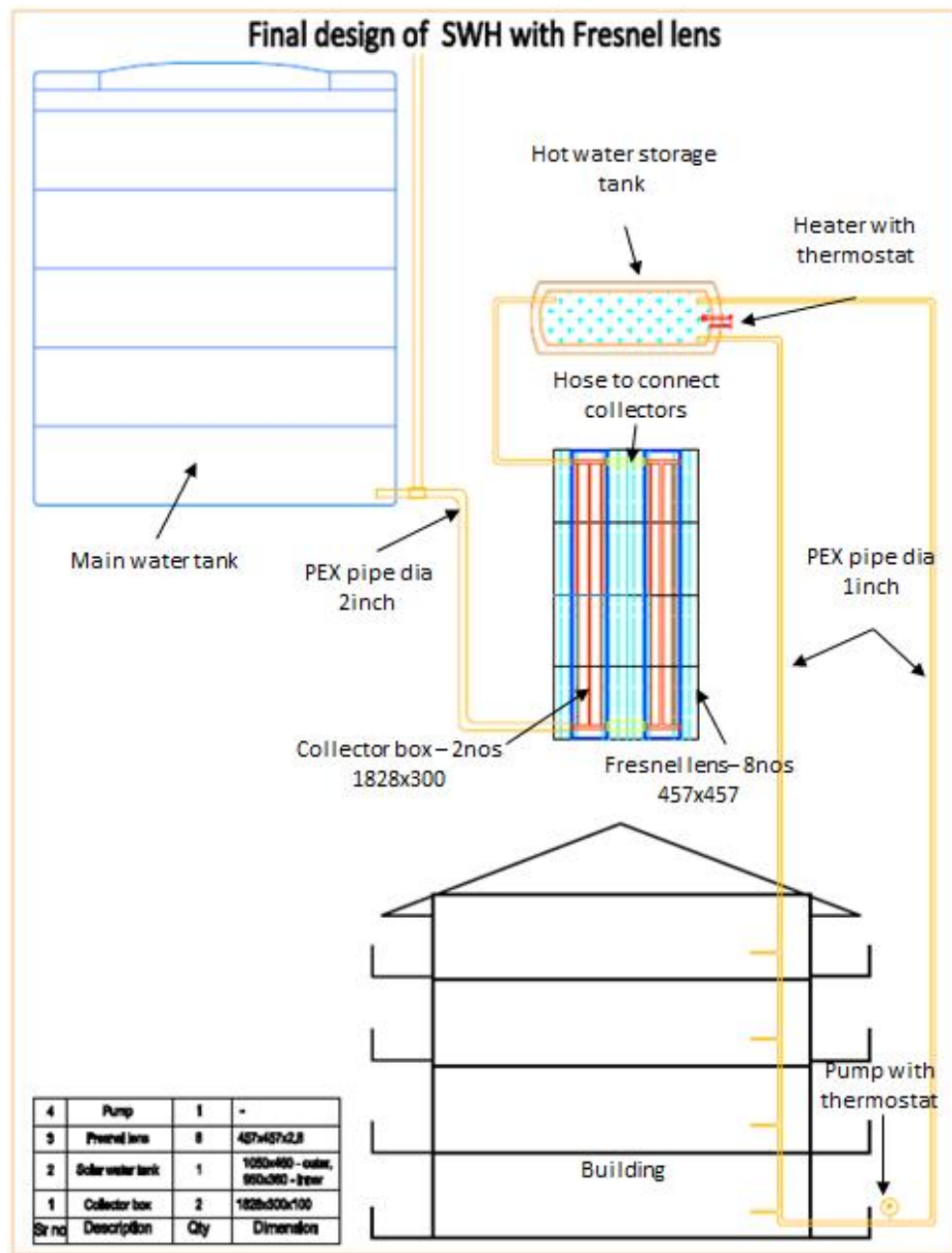

Figure-25: Final design of hybrid solar water heater

3. Technical specification of final solar water heater

Refraction medium

1. Fresnel lens - Glass , 2.8mm thickness (Injection molding), 457x457mm for one

Reflection medium

1. Flat mirror to be mounted along collector at an angle: Length – 1868mm, width 300mm – 2nos/lack

Collector

1. Absorber material: Electro Grade - Copper
2. Absorber Coating: Selectively coated black chrome on copper to withstand temperature up to 3000C.
3. Optical Property: Absorptivity = 0.96 + 0.02, Emissivity = 0.12 + 0.02
4. Riser: Copper tube, Length- 1648mm, dia 15mm + 0.5mm (standard from manufacturer's specification), 3nos/ box
5. Header: Copper tube, Length 350mm, dia 25mm + 0.5mm
6. Bonding between Riser & Header: Brazing
7. Bonding between Fin & Tube: Ultrasonic / TIG
8. Back Insulation: Resin bonded Rock wool, Density 48 kg/m³ - Thickness 50mm
9. Side Insulation: Polyurethane - Thickness 25mm
10. Collector Box: 100mm x 25mm Galvanized steel Channel (22 gauge)
11. Collector Bottom Sheet: Galvanized steel (24 gauge)
12. Collector Stand: Corrosion resistant Coated M S
13. Glazing: Polycarbonate, 2.5mm Thickness
14. Transmissivity >0.85% @ near normal incidence.
15. Retainer Angle for Glass: Galvanized steel angle, size 25 x 25 (22 gauge)
16. Beading for Glass: EPDM Rubber
17. Collector Tilt: 24.5 deg to HORIZON (non-variable) for places located between 12DegN and 15DegS
18. Heat Transfer Medium: Water
19. Collector Area: 0.55 Sq. meters/ unit
20. Number of fins: 3 per box
21. Dimensions: Length - 1828mm, width - 300mm, Height - 100mm (20 gauge sheet)

Hot Water Storage Tank (100LPD)

1. Material: High density Polyethylene (HDPE), Inner tank: 360dia, length 950mm, 5mm thk, Outer tank: 460dia, length 1050mm, 2.5 mm thk
2. Insulation: Not required (air is used as an insulating material)
3. Outer Cladding: High density Polyethylene (HDPE)
4. Inter connecting Pipe: Hydraulic Hose Pipe / EPDM Rubber
5. Auxiliary heater: Electrical Heater (Wattage not decided yet)
6. Working Pressure: Atmospheric

Inlet pipe

1. Material: PEX
2. Diameter : 3.2 cm

Outlet pipe

1. Material: PEX
2. Diameter: 2.16 cm
3. Insulation: Not required (optional)
4. Thickness of insulation: Not required

Recirculation arrangement

1. Material: PEX
2. Diameter: 2.16 cm
3. Insulation: Not required (optional)
4. Thickness of insulation: Not required
5. Recirculation pump: Electrical pump on top (specification not yet decided)

4. Validation of final design

Validation of our SWH will be done through design & process validation & in-process validation & quality inspection during production.

For Indian market it is mandatory to follow 'IS12933 standards - solar flat plate collector specification'³² released by government of India. These standards are made in-line with global standards to compete globally. There are certain dimensional guidelines released by the government to follow in collector design but different size & design may also be used provided other components are made in consonance. Following are few tests to be followed for validation of flat plate collector.

1. External thermal shock test (exposure to sudden rain storms)
2. Internal thermal shock test (sudden intake of cold heat-transfer fluids on hot sunny days)
3. Time constant test (reproduction of solar energy in zero and then measuring the time for specified quantity, This information would be useful for water heating system designers and for field installations)
4. Incident angle modifier test
5. Impact resistance test
6. Outdoor no flow exposure test
7. Thermal efficiency test
8. Rain penetration test
9. Transmittance test on cover plate

For details of each test procedure, refer: IS12933 standards: Part 5³³

For Fresnel lens we will recommend following tests. This feedback we got after doing the DFMEA of the collector box parts. Sample DFMEA is attached in the APPENDIX VII

1. Test of teeth cut on Fresnel lens
2. Validation of refraction of energy at fixed distance from collector box or riser tube

Along with initial tests we will incorporate some routine in-process tests in the manufacturing process

1. Differential or water dip air pressure leakage test of Riser & header tubes welded frame – 100% inspection with air pressure of $1.5 \sim 2\text{kgf/cm}^2$ for minimum 2-3 minutes. Pressurized frame can be dipped in water to observe the leakage
2. Hydraulic test of Riser & header tubes welded frame – 1 out of 100 samples at a pressure of minimum 8Kgf/cm^2 to observe swelling, distortion or ruptures. Time limit - minimum 10minutes.
3. Differential or water dip air pressure leakage test for inner tank - 100% inspection with air pressure of $1.5 \sim 2\text{kgf/cm}^2$ for minimum 2-3 minutes. Pressurized tank can be dipped in water to observe the leakage

For validation following parts are necessary to send to a government certified agency.

1. A fully assembled unit of solar collector (One piece of absorber with riser having total minimum area of 400 cm^2)
2. One piece of grommet
3. One piece of gasket/sealant of about 300 mm length
4. Two numbers of matching flanges/unions
5. Three numbers of flange blanks/plugs for closing the header ends
6. A manufacturer's certificate in respect of R value of insulation material

For Bangalore region SWH industries, this test lab is in Madurai. They conduct the performance & other tests on those components individually & release the necessary certificates if passed. After getting the certificates, our product will be good to sell in the market.

Initially we will prepare our prototypes samples with the support of a workshop. We will conduct our in-house testing on these prototypes. We will record the observations & will make necessary changes in the design if required. Design for regular productions will be released thereafter.

After this we will make a new sample of collector box in the same workshop for our product validation from lab. Other components which are new in our design will be developed on sample basis from suppliers; standard parts will be bought out from market.

This validation is going to be a challenge for us as our design is completely new from others available in the market & may face lots of resistance from the government. We will take care of all parameters while manufacturing the sample & will do all kind of routine in-process tests before sending.

5. Technical advantages over baseline design

Our concept has following technical advantages over the baseline design of a SWH.

- Energy per unit collector surface area is more

- Assembly weight is very less compared to baseline SWH due to reduced collector size & solar tank material
- System can work in rainy or cloudy days.
- System can work from morning till late in the evening as it can capture the solar rays at any time of the day
- Cost of system is cheaper than baseline SWH (reduced size of collector box, material of solar tank & collector box, piping material)
- All materials used are easily replaceable & maintainable
- Performance or process efficiency of collector box is better than a baseline SWH
- Less heat loss from the tank & other component of system
- Availability of hot water at any point of time
- Easy to do installation & commissioning
- System will pass any durability test as per IS12933
- Lesser packing & transportation cost

BUSINESS PLAN

13.COMPANY DESCRIPTION

With respect to the business, we want to cater the need of an efficient solar water heater for an urban environment through manufacturing and selling our products which would be cheaper, reliable and consumes less space for installation.

Per our interview at one of the manufacturing unit of SWH (Appendix IV), we found that only efficient solution available with them to cater to the urban high rise building is that to provide individual SWH and dedicated pipeline for individual apartment. This solution requires a large terrace space to handle all the SWH collectors which in many cases is not possible in urban environments. Hence, the less efficient SWH is installed which utilizes the community type sharing system.

a. Market Need and the Increasing Energy Demand

Below chart gives a snapshot of the rising demand for hot water in urban areas

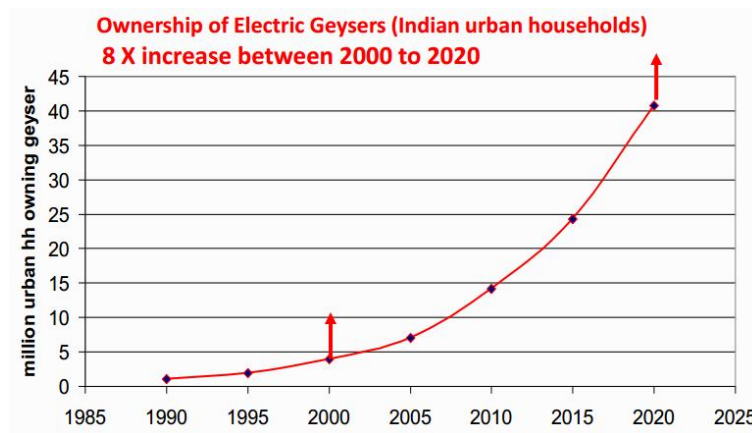

Graph-5: Source-Ministry of New and Renewable Energy³⁴

Per the above report, we observe that there will be exponential increase in the demand of electric geyser for hot water requirement in the coming years. With respect to the above chart, there is expected increase of 20M households in urban areas owning an electric geyser.

In a minimum requirement scenario and peak winter, if we assume that each household has an average of 3 people consuming 100lpd of heated water (equivalent to 5.7kWh/day) then total increase in requirement of energy is 114million kWh/day or 41.6 billion kWh/year.

If we assume a coal based thermal power plant, the above energy requirement is equivalent to increasing the power capacity by 6000MW or in a different perspective of burning of 16.9 million tons of coal per year.

The above summary drives for an alternative renewable energy solution to meet this exponential demand. Our project for an efficient solar water heater in urban areas utilizes renewable energy and is beneficial for

- Reduction in electricity consumption, peak electricity demand and hence electricity infrastructure.
- Reduction in pollution - Reduction in combustion of biomass, coal and petroleum products for heating water.
- Efficient use of roof space and money

b. Customers

In our business plan, we are targeting our initial buyers to be high rise apartment dwellers which are the persona in our business case. This will be beneficial for us as we would be able to sell more number of high capacity SWH units at one location itself (typical high rise urban building consists of 250-300 households and decision to install SWH is taken by society associations and communicated to all the people in their monthly meetings). This has been validated from our interview at one of the manufacturing unit with respect to their marketing strategy.

Apart from apartment dwellers, small buildings comprising of ~10 flats could utilize our product to take advantage of the cheaper price and lesser installation area on terrace.

14. Market Analysis

a. Target Market and Expected Growth Size of the SWH market

Key Parameters that affect SWH market in Residential Sector are mainly the requirement of heated water in months per year, shortage of electricity and the supply of SWH. A sample is shown below (Appendix VI) cites the report on major cities)

District	Hot water demand in middle & high income hh (Months/year)	State electricity shortage % (2008-09)	SWH Supply chain
Shimla	≥9	0.2	Poor
Gurgaon	4-5	8.5	Poor
Agra	4-5	20.9	Poor
Ludhiana	4-5	10.6	Fair
Delhi	4-5	0.6	Fair

From the study, we observe that the cities which requires heated water for high no. of months / year, has shortage of electricity and has poor supply network of SWH will have the market for SWH.

From the report on key urban cities, we can cite some of the cities like Agra, Pondicherry, Kochi, Indore, Guwahati, Shillong, etc which has highest potential for SWH growth

Per the below published report, there is SWH potential of ~7.06 million m² increase in the above cities by Y2022. Based on a cost estimate for a single unit of 500 lpd SWH (10 m² collector area) as Rs 85000 (~\$1400), the increase in market volume is expected to be \$1.0B for the above cities. Even if the cost per unit decreases due to competition, there is still a huge market to accommodate a large no of companies.

District/Region	SWH potential (excluding industry) million m ²
Bangalore	1.94
Pune	1.11
National Capital Region	0.77
Thane	0.68
Hyderabad	0.58
Nagpur	0.38
Kolkata	0.36
Chennai	0.35
Coimbatore	0.33
Ahmedabad	0.29
Jaipur	0.27

Table-7: Cumulative SWH potential in million m² for Y2022 under the realistic scenario³⁵

b. SWOT Analysis with respect to the competition

Ministry of New and Renewable energy lists all the manufacturers who are BIS certified to manufacture FPC type solar water heater (Appendix VI). Most of the manufacturers are small enterprises that mainly cater to a small region and their sales are minimal to outside states

Strengths: One of the key conceptual advantage of our product with respect to other competitor product is fulfilling the hot water need of the high rise apartment dweller during peak time with less investment and utilizing less installation space

Weakness: Competitive weakness is mainly in the market entry as other competitors are already well settled with respect to their customer base. Also, a typical customer wants to buy a known product which has already been validated by other consumers.

Opportunity: We want to have a product with a competitive price and yet be profitable for a sustainable business case. With respect to the market pricing of the competitor product, below shown is our tentative pricing of our product

Capacity (LPD)	Cost of Competitor SWH (INR)*	Tentative Cost of our Product (INR)
100	22,000	20,000
200	42,000	36,000
300	58,000	50,000
500	85,000	72,000

Per the current market scenario and with knowledge sharing with technical expert of a manufacturing unit, a lot of people are eager to install the SWH at their household. On the above pricing, central government gives a 30% subsidy. Over and above, state government is currently providing INR 0.5/kwh per month subsidy on the electricity bill.

Apart from the above, by utilizing SWH, each household will be saving at least Rs 328 /month (Calculation shown in Appendix VI). Assuming an installed SWH unit cost (100lpd) of Rs 14000 ($=0.3*20000$), the payback period for the capital cost would be 3.6 years and after that the user could benefit for rest of the SWH lifespan (assumed min. lifespan of 20 years). This payback reduces to 1.3 years if we install a 500lpd system for approx. 10 households which become more lucrative for a user to install the system.

Threats: We need to have a regulatory certification from government to avail 30% subsidy and need to be registered with Ministry of New and Renewable Energy [GOI]

We also require permission from Directorate of Industries & Commerce for setting up manufacturing unit, local authorities for safety certificate, power and water. The above process takes time and effort.

Apart from the above the initial market hindrance will be to change the perception of the consumer which many existing competitors have faced or are facing in existing & new market.

15. Product Description:

a. Technical and Cost advantages of our product over the competitors:

- Energy per unit collector surface area is more
- Assembly weight is very less compared to baseline SWH due to reduced collector size & solar tank material
- System can work in rainy or cloudy days.
- System can work from morning till late in the evening as it can capture the solar rays at any time of the day
- Cost of system is cheaper than baseline SWH (reduced size of collector box, material of solar tank & collector box, piping material)
- All materials used are easily replaceable & maintainable
- Performance or process efficiency of collector box is better than a baseline SWH
- Less heat loss from the tank & other component of system
- Availability of hot water at any point of time
- Easy to do installation & commissioning
- System will pass any durability test as per IS12933
- Lesser packing & transportation cost

As shown previously, we are also having a competitive cost with respect to our competitor's products. Our product is presently in an idea stage. We want to manufacture a prototype and validate / certify it with authorized government laboratory. We presently do not expect any maintenance during first year. Some repair work may be expected due to excessive hard water in this region and the position of Fresnel lens may require re-adjustment for effective heating.

b. Feedback from Future Customers

As an initial data gathering, I talked with few people in my present society associations with respect to our idea and if they would be interested to install if anybody approaches them. They are keen to get the SWH installed in the apartment but they have an apprehension of a new product being installed. Presently our apartment has only one SWH which cater to the demand of only top two floors. This was installed just to meet government regulatory norms. People wanted to have a solution for catering the need of all the apartment dwellers rather than top two floors and are waiting for the current supplier to come up with better cost and effectiveness.

16. Marketing and Sales Strategy

a. Market penetration strategy

In perspective of our persona of apartment dweller in high rise building, the SWH installation is given as an option by the builder of apartment or is decided by the society associations thereafter. Our initial approach for marketing our product would be to reach the various society associations and the builder of apartments with the technical advantages of our product and the competitive pricing for the same. To gain market, our approach would be delighting the customer and gain feedback for the same. As the Indian market is driven by word of mouth, gaining feedback would be the key for market penetration. Also, we thought of providing initial six months free maintenance to gain more market traction.

Per the cost analysis, if we are able to operate the manufacturing unit at 100% or reach a sales target of 375 units, our expected profit after tax would be INR 3,968,000.

b. Communication

We have thought of to promote our products mainly through newspaper clipping and interactive website. Personal marketing would be required to reach out to various society associations and reputed builders who would have upcoming housing projects in pipeline. Relationship would be required for gaining traction in personal marketing. We also thought of meeting the apartment dwellers in their monthly association meetings so as to market our self and distribute our brochure and flyers.

c. Channels of distribution

Our thought is to have internal strong sales and marketing team for sales and distribution of our products in a long term. During the initial market penetration period and for a short term, we may have to include retailers to sell our products and generate word of mouth. We may also require a local tie up

with technicians and installers for installation of our product and to provide maintenance / repair in a quick turnaround time.

d. Growth

To cater to the growth of the market of our product we may need to increase the production capacity of the marketing unit. To cater to this requirement, we may need to hire more skilled and unskilled labor. Also, we may need to have more branch offices in other regions for expansion of business and gaining market share. For proper inventory management, we may need to invest into companies who would be providing raw materials to us so as to strengthen the supply chain network. In this case, we may prefer to buy small enterprises so as to gain control on the supply chain network.

On a latter point in time, we would concentrate on the feasibility on very high capacity and efficient SWH so as to cater the need of hospitality sector like hotels and hostels which would increase the market share of our products.

17. Funds required for the Company and Sustainable Revenue analysis

We would be requiring funds for our initial capital investment for building the manufacturing unit and initial upfront operating cost to start of the business. Per the government policy on renewable energy, the funds could be materialized through bank loans at cheap interest rates. We also thought of involving venture capitalist to fund the project.

a. Investment

Below are the details of the Capital investment and the Operating Expense for our business case.

Initial Capital Investment

Description	Amount (INR)	Comments
Workshed including Floor Laying, workshop partitioning, lighting	3,000,000	~Rs300/sq ft which includes common utilities & electricity / water connection
Equipment	3,000,000	Welding machine, Brazing machine, Rolling machine, Buffing machine, Drilling machine, Compressor, Hydro Testing machine, Furnace, Grinders, Engineering tools, Bench Grinder, Lathe
Total	6,000,000	

Operating Expense (375 units of SWH)

Description	Amount (INR)	Comments
Land (Lease of 10000 sq ft.)	1,200,000	Benchmarking rate in Industrial Area : Rs 10/sq ft/month
Maintenance of Premises	250,000	Including cost of electricity/water, cleaning, repairs
Equipment Repairs	150,000	Repair for equipment
Raw Material	7,680,000	Raw materials required for the manufacturing are Copper tubes, Aluminum MS Sheet, PEX Pipe, Glass Fibre, GI Sheets, Fresnel Lens, insulation material and others
Labels & Packing Material	52,000	
Wages (Skilled & Unskilled)	2,100,000	15 Skilled & 5 Unskilled Employees
Management Salary	1,200,000	
Administrative Expenses incl stationary, legal fees, etc.	50,000	
Miscellaneous & Overheads	100,000	
Depreciation on Capital Assets	300,000	
Insurance on assets	60,000	
Interest on Capital Expenditure	600,000	The interest rate is considered at 10% which is SIDBI's rate of interest for energy efficient projects for a loan tenure of 5 years
Total	13,742,000	

b. Cost Analysis

Per our initial cost analysis and as shown below, the manufacturing unit needs to have minimum revenue of INR 15,360,000 and should run at least with 80% capacity for a breakeven in 3 years. We have assumed three years as break even time to have a successful business so as to get support from various lenders. Below are the details shown

Initial Capital Expenditure Outflow = INR 6,000,000

	Capacity Utilization (Value in INR 000's)			
	100%	80%	70%	60%
Fixed Cost	6084	6084	6084	6084
Variable Cost	7448	5958	5586	4469
Projected Sales (Revenue)	19200	15360	14400	11520
Earnings before Tax	5668	3318	2730	967
Profit after Tax	3968	2323	1911	677
NPV for 3 Years timeframe	4821	334	-788	-4153

For a financially sustained business, plan is to have a positive NPV within three years with the initial investment (assumed-10% discount rate), the manufacturing unit needs to have a minimum revenue of INR 15,360,000 and should run at least with 80% capacity

ADDITIONAL REFLECTIONS ON PROJECT OUTCOME

18. PROJECT CONSISTENCY WITH AN ECO EFFICIENT OR SUSTAINABLE DESIGN

A SWH itself is a Green solution and scores on all eco-efficiency indicator requirements during usage. To claim our concept as an Eco-efficient or a Sustainable design it should improve on all criteria's of triple bottom line. As per the SimaPro studies also, our new concept has less effect on eco indicators.

a. Environmental aspects

In our project, we spotted the inefficiencies of existing SWH, customer requirements & prepared our concept boundaries. This gave our concept a better edge on following environmental aspects.

- Suitable for cloudy & rainy season
- All the material can go under reprocessing after end of their life
- Working span in day of our concept is higher than baseline SWH
- High efficiency due to reduced losses
- Better functionality at the time of peak load in early span of morning
- Less effect on environmental indicators
- Less consumption of material (total weight of the system)
- Lesser period environmental payback due to less usage of electricity

We utilized SimaPro for evaluating the sustainability of the final design concept. Below network diagram shows the subassembly which has the major environmental impacts

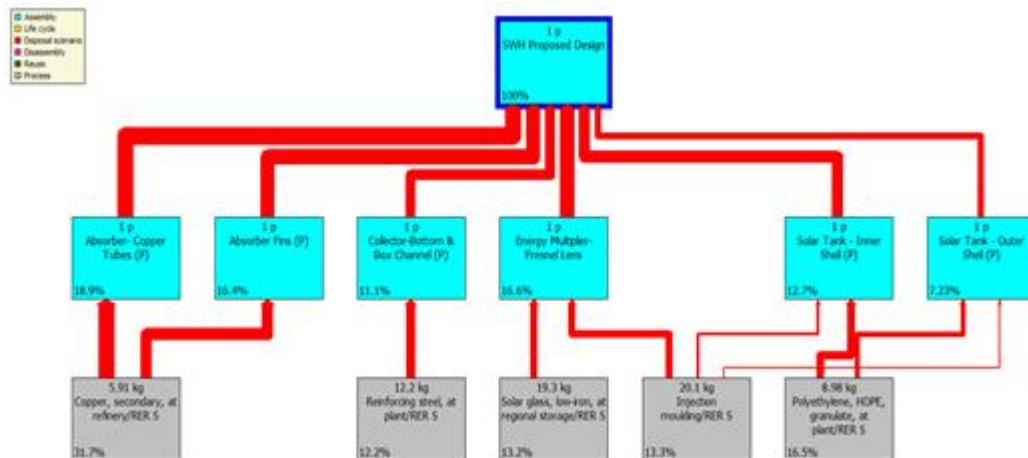

From the above diagram we observe that the major environmental impacts are coming from absorber components and the Fresnel lens

Component Assessment – Baseline vs Final Design

Below two plots shows the single score points of the baseline and Final Design respectively

Baseline Design

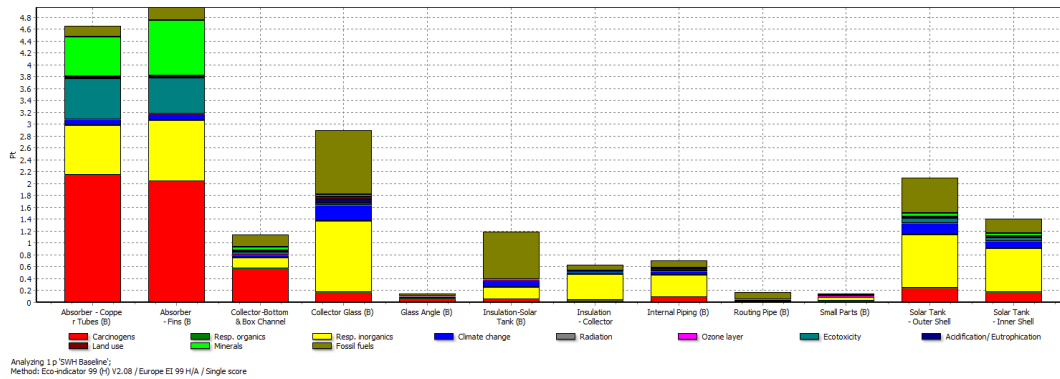

Final Design

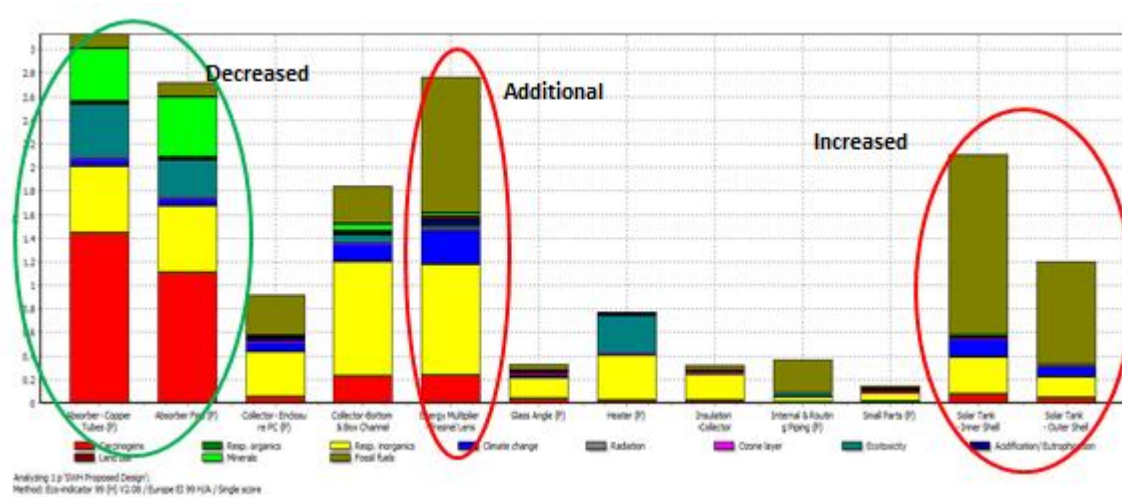

From the above plots, we observe that the impact from absorber components have decreased down (~1.4points) mainly due to small collector size. There has been additional increase in impact due to addition of Fresnel lens. Also, impact due to solar tanks has increased mainly due to conversion of Steel Tank to HDPE tank. This was done to reduce the overall assembly weight.

Comparison of the Impact Assessment – Baseline vs Final Design

Below plots shows the comparison of the single score values and the impact assessment of baseline versus the final design

Single Score

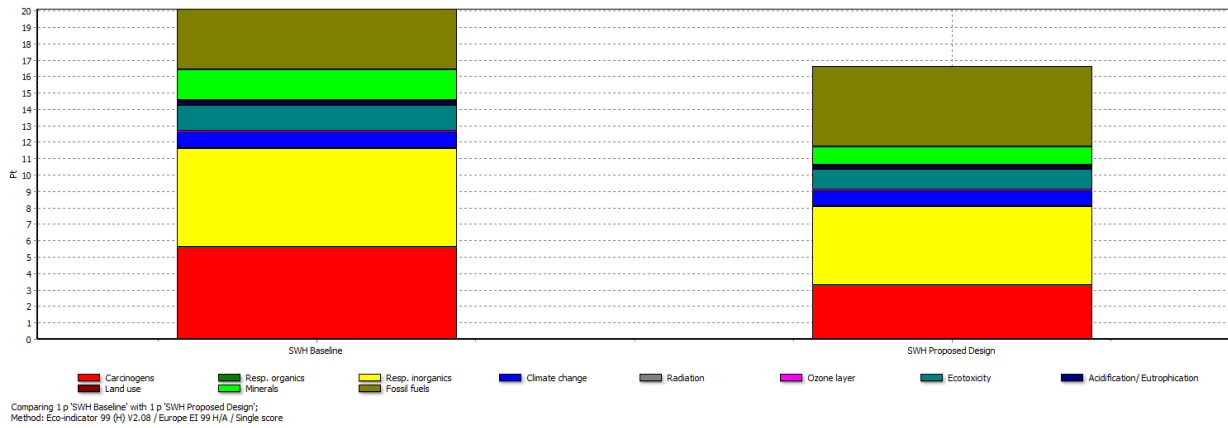

Damage Assessment

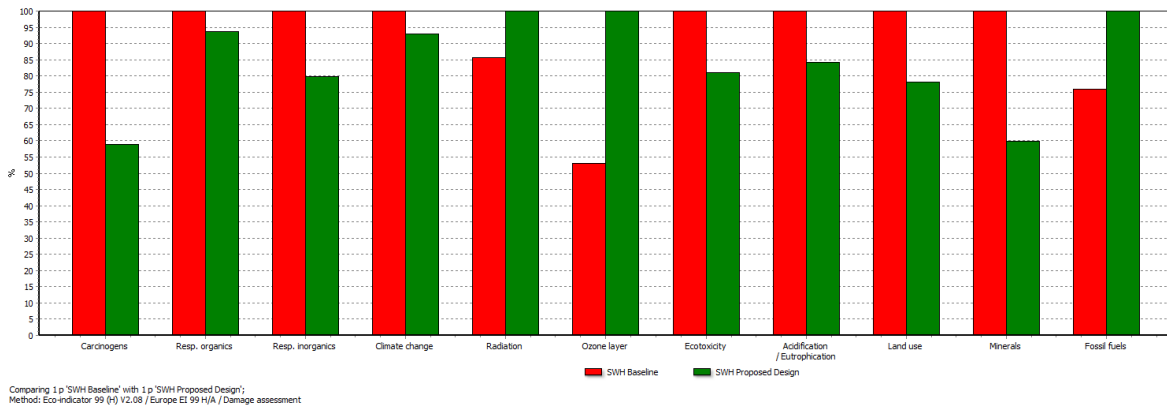

Impact Assessment (Normalized)

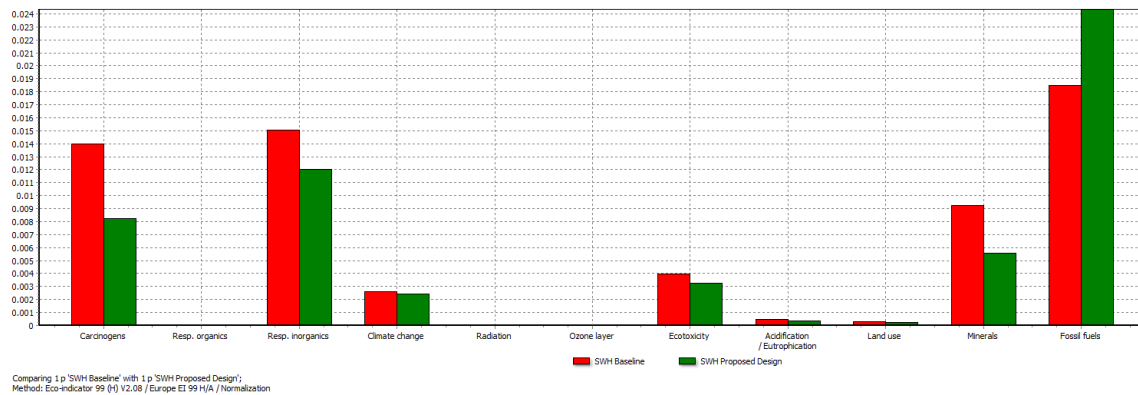

From the above plots we see that the overall single score point of the final design is lower than that of baseline (~3 points). From the normalized impact assessment graphs we observe that the final design has the lower values in all the impact components except the fossil fuels. Per a brief trial and error

methodology, this increase in fossil fuel consumption was found mainly due to HDPE usage in the Solar Tank.

From the above assessment, we believe that the final design is better than the baseline as we were also able to reduce the collector size by half and reducing the weight of the solar tank, thus decreasing the overall cost of the SWH. Also, the efficiency of the system has increased. All the above parameters could increase the overall acceptability of the Solar Water Heater & thus decreasing the overall environmental impacts due to less power consumption and decrease in wastage of water.

b. Social aspects

Our Persona of "Apartment dweller" is impacting the 70-80% population of a city. In an Apartment the decision on SWH is either driven by the builder or later by the society committee. Social impacts of this decision would be

- Energy concentration per unit area on collector box is high. Hence reduced area required for same amount of energy as baseline
- Lesser types of material chosen with reduced weight of overall system
- This concept will work efficiently in low solar energy time i.e. Morning & evening while a baseline SWH starts working from afternoon till early part of evening
- No extra facilities required for solar tracking. As flat reflective mirrors are taking care of sun position at any time in the day
- Lesser heat losses from the system will increase the efficiency of the entire system
- It will work in cloudy or rainy season efficiently. It make it useful for all major regions of India
- Easy manufacturability & installation

c. Economic aspects

Our concept design of SWH is cheaper than the baseline SWH available in the market and has following economic impacts

- Operating cost of this system will be very less as compared with a system with auxiliary heaters in each apartment
- As there is no wastage of water hence the cost of water procurement will be lowered.
- Initial cost of system is very less with better efficiency than a baseline SWH. Size & cost of collector is reduced by appx 30-35%
- Reduced weight of some components by changing the material resulting in lower cost
- Lesser payback time than a baseline SWH
- No effect on getting subsidies from government

Considering initial heating with SWH & auxiliary heating with electric heater at tank

Description	Scenario-1	Scenario-worst case	Scenario-best case	Unit
Thermostat Setting	60	60	60	degree C
Average hot water consumption/ household	50	50	50	Litres
Average daily losses	0.0115	0.0115	0.0115	kWh/l/day
Specific heat of water	0.00087	0.00087	0.00087	kWh/l/degree C
Average Water Temp	18	35	50	degree C
Energy required/day	2.4	1.7	1.0	kWh/day
Energy required/month	72	50	30	kWh/month
% savings		31%	58%	
Note: 95% efficiency of element assumed				

[Table9: Energy consumption comparison of electrical water heater vs. SWH](#)

From the table-9, if we consider the electric unit bill @5/- INR, average monthly savings in worst case is around 1109/-INR and in best case 2285/-. Average yearly saving will be 13311/-(worst case), 27419/-(Best case). Payback period of the system will be in 3-5 years.

19.DESIGN CRITIQUE

At the start of the project, we had a thought to work on changing the design of collector box risers & header from a frame type to completely different - a single pipe running all over the collector box & at the bottom there are reflective mirrors at angle to pipe all over in the box. We had a thought that will help us in increasing the efficiency of a SWH but due to lack of some statistical data in before & after conditions we had to keep it aside.

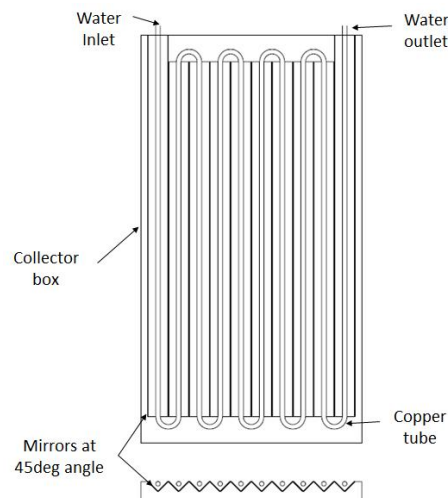

[Figure: Initial thought process design](#)

Also we were aspiring to create a solar water heater which can help in generate the electricity too but during working on project we found that it is having high initial cost, complexity in the system & huge space requirement. This led us to drop it as our idea to work upon in this project.

In our finalized project we could have taken more interviews of users, buyers & other stakeholders. We would have done the thermal/ CAE simulations but could not find agency & source to do & validate our design in real figures. We would have liked to do surveys & interviews for feedback on our concept as we didn't get much feedback from our visit to manufacturing industry. We have used 8nos of Fresnel lens in our concept as we used a standard size available on web we could have validate the size of lens 1850x1000with same as collector box design.

a. Major Strengths of our design

There is list of strengths & best features in our concept. I am highlighting only few major points of strength.

- In our design Fresnel lens is a unique concept for SWH.
- Dimensions of other component – collector box considering the standard & tested Fresnel lens in market. Hence there is very narrow chance for failure in collector performance.
- We have selected High density polyethylene material for solar tank. It is a unique idea in itself & reduces the environmental impact & give cost saving.
- We could achieve our target of cost reduction by reducing the size of collector box, changing the material of tank & others too.
- Our concept is on similar terms to existing SWH. It will not be much difficult to persuade customer for its benefits.
- High efficiency than a baseline SWH. Can be used in rainy season too.
- We have tried to use concept of environment mimicry & 10XE principle for design & material of major components collector box & tank

b. Major Weakness of our design

As we claimed strengths of our design above, there are few weakness also persisting in our design

- We have used a standard Fresnel lens in our concept; we don't know whether the companies are manufacturing a nonstandard design too.
- Prototypes are not prepared for design validation & further process validation.
- We still feel the risk of high heating/ vacuum inside a collector box due to refracted solar energy.
- No validation to understand the withstand pressure for solar tank.
- Major data collection is from the web research. We are not how the system will behave in different conditions, atmosphere etc.
- No advice from any expert regarding our concept design.
- Challenge from market to accept the new concept.
- Getting certification from government agencies to pass sample for start of production. In India every company only follow the design guidelines from IS 12933 standards. Agencies may show some friction in testing & accepting the new design.
- Risk of high heating inside the collector box

c. Improvement points

- Validation of component or its material through simulation software – In our design there certain components e.g. Fresnel lens, tank material which were standardized for other applications. We used these components directly in our design.
- Avoiding the circulation pump/ heaters in the system – To design the system such a way that we don't have need to recirculate water inside pipes as well as we don't heaters too. System should provide the hot water any time to the consumers without using these systems. A composite pipe can be looked as a solution to avoid standby heat losses but they are very costly & do not ensure resisting heat loss for longer duration.
- Reducing the thermal or heat dissipation more from the solar tank without loading with highly components inside. We have taken as HDPE as our solution but need to verify some more material which can be easily formed in shape, resist heat loss and withstand internal pressure.
- Comparison of Baseline SWH & new concept to calculate each eco indicator related to system & prepare improvement plan in process to make it more sustainable.
- Standardization of size of Fresnel lens used in our design. Need to validate for any working & manufacturability constraint with big size lens. We have used 8 nos of Fresnel lens in our design with a thought to make it compatible with length of collector box making it complex in system assembly.
- Physical prototypes for design & process validations of all major parts would have proven our design concept thoughts & would have given us another chance to improve the designs. After that we could have brought it in a stage of start of production.
- Minimal usage of electricity to approach for more sustainability – In our system we are still dependent on electricity to restore temperature & recirculate water. More thought process required to find alternate source of electricity to fulfill both requirements.
- We are claiming our design for persona "Apartment dwellers" which tags it not very much suitable for home users or industrial purpose. It needs some design improvements to make a standard solution for every type of customer. It should be flexible enough to accommodate some design changes based on some specific needs too.
- DFMEA of the all subsystem parts

20.RECOMMENDATIONS

We would like to follow the improvement points on the system level as our first recommendation to go on this project in future. More recommendations can be discussed here to go ahead.

- There should be some experts included as mentor in the project to guide from concept designing till validation.
- There are more local regulations included in the system due to subsidy factor from the government. Hence it is recommended to take nod of the local regulatory before going ahead.
- An expert in material is required to certify our choice in this concept as well as he can recommend us with different alternate.

- Consultation of design & manufacturing experts to validate the initial design & manufacturability of same.
- Need a test lab to conduct pressure & performance test after prototyping.
- As the solar tank is suggested in HDPE, it needs to search a supplier base to manufacture the solar tank components.
- Surveys on market analysts & technical experts over the design concept will give more clarity & connection with customer requirements.
- Usage of more Bio mimicry thinking will make it more environmentally & economic suitable.
- Testing the design through simulation & software will make the design concept more workable.
- Skills on SimaPro software will help to make better comparisons of baseline design vs. new concept design. This will give better thoughts to understand the impact of product on environment.

21.PROJECT REFLECTIONS & FUTURE PROJECT RECOMMENDATIONS

This subject gives a great insight to understand the impact on all 3 aspects by action of any individual. This course developed a thought that sustainability is not only limited to any design, manufacturing or transportation process but it is related to usage of the same too. After doing this course our group has fair knowledge on what is a sustainable design, how to make a sustainable design, what is the way to go for sustainable design. As we are related to a manufacturing industry, we will have more chances to expedite this thought process more.

We faced more challenges in developing understanding for the difference among CLCA, streamline LCA, sustainability principles as an off campus student. Most of the times we had the need to refer more paper to develop clear understanding of the same. At some points in course the topics the thoughts were getting mixed & didn't have clear understanding which model can be applied at that stage. More details & real examples with comparison of why that model was used in that case can develop more understanding. Solving quiz used to become difficult some times as it needed a full understanding & clarity of the studied concepts. We always had a priority to complete all questions in the fixed time first rather than putting thought process to reach the right answers.

We highly recommend using some links from ME499 course before the actual start of ME589. Taking the course ME499 will develop the basis for working on the details aspects of each model & method during ME589.

22.ACKNOWLEDGEMENTS

We would like to sincerely thank the following individuals who took time out of their busy schedules to share with us the insights and information in our project on Solar water heater.

1. Dr. Amit Sanghi
House Owner: Bhiwani, Haryana
User & Buyer: Single FPC solar water heater system
2. Mr. Pandurang Baliga
Apartment dweller: Bangalore
Building:
User: Common FPC solar water heater system
3. Mr. Narasappa
Executive – Pioneer enviro solution
Dealers of TATA power solar water heater systems
pioneerenvirosolution@gmail.com
4. Mr. Yogesh Reddy
Builder: Samhita Rainbow MTB, Bangalore
Buyer: FPC solar water heater system
5. Mr. Kiran Kumar Patel
Manager - Manufacturing & Engineering
Sunrise solar water heater system
6. Prof. Steven Skerlos
University of Michigan
7. Mr. Siddharth Kale
GSI – Course ME589
University of Michigan

APPENDIX I:

a. Team introduction

Our team 881-6 has 3 members:

1. Atul Singhal
2. Pandurang Baliga
3. Abhinav Singh

Biography of each team member:



Atul Singhal

Mechanical Engineering Graduate with 14yrs of experience in Automobile industries in production & manufacturing engineering. He is married & has 2 kids – 8 & 2 years. Associated with GMTCI, Bangalore in General assembly execution team as a Lead Engineer from last 2 years. This is his 1st course in the GAME. Hobbies & interests are cricket & exercise. More interested in water conservation & social dimensions of sustainability. Although it is not the main aim of design project but it is one of the target goals of our project. He is good in team work, sense of responsibilities, preparing the initial documents & conducting studies. More skills will be tested during the progress of the project.



Pandurang Baliga

Bachelor's degree in Mechanical engineering. This is his 7th course in GAME. Married with a 1.5 year old son. Has around 10 years of work experience, including leading others, in both manufacturing and product design settings. Around 6 of those years are at GM in varied roles. Currently Program Design Lead for Global Front Wheel Drive 6 speed Automatic Transmission. He has additionally volunteered to be a DFSS coach and have been supporting his team as such since last few months. Hobbies include Photography and Table tennis.



Abhinav Singh

B.Tech in Aerospace Engineering with 11 years of experience in Automotive Engg. with skills and interest in Occupant Safety Simulation using CAE tools. Presently on a special assignment in Business Planning team which caters to the budget and workload planning for ~1100 employees. Has interest in optimizing automotive design for future environmental friendly vehicles. Has also participated in some of the advanced vehicle development program.

Skills include keen eye on analysis results with ability to understand and make right directions. Skills also include cost analysis for various business cases (acquired from the current job role) and learning on the fly.

APPENDIX II

a. Team Member Preparation



CATME

Meeting Support

Team-Member Information for [Atul Singhal]

Class: ME589

Team Name: 881-6

Date: October 06, 2013

Contact information <i>(e-mail, cell, Facebook, etc.)</i> .	atulymca@umich.edu , +91-9945318376
Preferred contact method and limitations <i>(ex., no calls after...)</i> .	Email, Cell
Availability for meetings <i>(days, times)</i> .	Week days (12:30pm to 3:00pm eastern time), Weekends (9:30pm to 3:00pm eastern time)
Preferred meeting times and places.	During office hours in Office
Preferred work styles relating to teamwork.	Team meeting on every day (if possible), Work division based on capability, Discussion on individuals progress
Strengths related to teamwork.	Time management & deliveries, Keep vigil on the team work progress,
Strengths related to the team's task.	Active participation & inputs, Sharing of work & difficulties
Weaknesses related to teamwork.	Over consciousness, Anxious
Weaknesses related to the team's task.	Some times on travel due to job requirement
Personal Background <i>(whatever you want to share, such as major, interests, personality characteristics)</i> .	Mechanical graduate with 14years of Industrial experience, Interested in Reading books, playing. Health conscious, make friends, trust on friends, dynamic, energetic
List anything else that you want your teammates to know.	None



[Pandurang Baliga]

Class: ME589

Team Name: 881-6

Date: October 12, 2013

Contact information <i>(e-mail, cell, Facebook, etc.)</i> .	pbaliga@umich.edu , +91-9880204286, facebook.com/gnarudnap
Preferred contact method and limitations <i>(ex., no calls after...)</i> .	In person, Email, Cell
Availability for meetings <i>(days, times)</i> .	Tuesday thru Friday 2:00 PM to 4:30 PM Weekends 12:00 PM to 9:00 PM
Preferred meeting times and places.	Weekends work best for me.
Preferred work styles relating to teamwork.	I prefer discussing individual responsibilities and being allowed to work alone towards that. I prefer not to sit in groups to do the teamwork, unless absolutely necessary.
Strengths related to teamwork.	Can stretch myself for team requirements. Schedule adherence.
Strengths related to the team's task.	Good at writing, data analysis,
Weaknesses related to teamwork.	May not be able to devote equal amount of time each day of the week.
Weaknesses related to the team's task.	I may sometimes be stubborn about my viewpoint. Data rather than opinions convince me faster.
Personal Background <i>(whatever you want to share, such as major, interests, personality characteristics)</i> .	Bachelor's degree in Mechanical engineering. This is my 7 th course in GAME. Married with a 1.5 year old son. Photography is my hobby. Love to play table tennis.
List anything else that you want your teammates to know.	Trust matters most to me. I expect everyone to stick to promises made on team deliverables such that it doesn't affect teams work.

Team-Member Information for [Abhinav Singh]

Class: ME589

Team Name: 881-6

Date: 06-10-2013

Contact information (e-mail, cell, Facebook, etc.).	absingh@umich.edu , +91-9886752627
Preferred contact method and limitations (ex., no calls after...).	Email, Cell
Availability for meetings (days, times).	Week days (12:30pm to 3:00pm eastern time), Weekends (9:30pm to 3:00pm eastern time)
Preferred meeting times and places.	During office hours in Office
Preferred work styles relating to teamwork.	Team meeting per the requirement. Open Thinking and putting out of the box ideas.
Strengths related to teamwork.	Active participation with ample skills on learning on the fly
Strengths related to the team's task.	Sharing of work & difficulties
Weaknesses related to teamwork.	Getting to the solution of the problem as quickly as possible
Weaknesses related to the team's task.	Hectic present Job role and have 7 months old kid. Get ample time mostly from 12am – 6am
Personal Background (whatever you want to share, such as major, interests, personality characteristics).	B.Tech in Aerospace Engineering with interests in automotive designs. Keen on working difficult tasks
List anything else that you want your teammates to know.	None

APPENDIX III

a. Team Charter



Team Charter for 881-6

Team Member Names	Contact Information (e-mail, cell, Facebook, etc.)	Preferred Contact Method / Limitations (ex. no calls after...)
Atul Singhal]	atulymca@umich.edu , +91-9945318376	Email/ sometimes on business travel cell may not be reachable
Pandurang Baliga	pbaliga@umich.edu ,	Weekends work best for me
Abhinav Singh	absingh@umich.edu ,	During office hours in Office

Team Member Names	Strengths related to teamwork and the team's assigned task.	Weaknesses related to teamwork and the team's assigned task.
Atul Singhal]	Arrange meeting, Work input, monitoring, Reviews	Work anxious
Pandurang Baliga	Good at writing, data analysis, taking additional responsibilities	Stubborn
Abhinav Singh	Active participation with ample skills on learning on the fly	Hectic present Job role and have 7 months old kid. Get ample time mostly from 12am – 6am

1. What are your team's goals for the collaboration?

These should relate to the team's performance on the project as well as the processes that the team will follow to complete the project. What are your team's expectations regarding the quality and timeliness of the team's work?

To complete the project on time by dividing the work among ourselves. Open forum to share new idea, team meetings & review, Assessment & feedback from team on work from each individual, easily accessible to each other

2. Who is responsible for each activity? What roles will each member have?

Don't forget to include logistical tasks, such as arranging meetings, preparing agendas and meeting minutes, and team process roles, such as questioning (devil's advocate), ensuring that everyone's opinion is heard, etc.

Team decided to divide the work among each team member. Singhal will arrange for the meetings with Prof/ GSI, All 3 members will make ready the portions of design project, Baliga & Atul will conduct the interviews, Singh will prepare the notes, Baliga will organize the whole data to one file & upload on the site, Singh will assess the data for correction. Internal meetings will happen from 2pm to 4pm (IST) every day at Singh's place.

3. What is your timetable for activities?

(Due dates, meetings, milestones, deliverables from individuals, if appropriate)

Singhal – Preparation of Introduction, Product & process study, Interviews, Project Plan, Reference table – 12th Oct, GSI meeting – 7th & 9th Oct, Team meeting time 2:00pm to 4:00pm

Baliga - Preparation of Executive summary, Ethnography plan, Interviews, Project concern, Reference table – 12th Oct, Project upload – 13th Oct, GSI meeting – 7th & 9th Oct, Team meeting time 2:00pm to 4:00pm

Singh – Preparation of Sustainability evaluation & Project description – 13th Oct, GSI meeting – 7th & 9th Oct, Team meeting time 2:00pm to 4:00pm

4. What are your team's expectations regarding meeting attendance (being on time, leaving early, missing meetings, etc.)?

As per common availability time, team will meet every day for project review at 2pm India time. At any day, any member not attending the meeting will inform the team in advance, sometime other two continue the meeting & as per availability third member can join in between. Before leaving, for next day team checks the availability of each member & reconfirms the time.

5. What constitutes an acceptable excuse for missing a meeting or a deadline? What types of excuses will not be considered acceptable?

Acceptable: Unplanned office work load or meetings or any personal emergency.

Not acceptable: Some general personal works, chit-chat with colleagues etc.

6. What process will team members follow if they have an emergency and cannot attend a team meeting or complete their individual work promised to the team (deliverable)?

Team members are easily accessible over phone. In case of any problem in attending the meeting the other two members will continue the meeting & share with other member over the mail. In case of emergency & before coming to the stage of finding in complete work, other team members are doing some share of his work & help in completing the task.

7. What are your team's expectations regarding the quality of team members' preparation for team meetings and the quality of the deliverables that members bring to the team?

All team members are putting their best efforts during the project. Work is divided among members by considering their expertise in those areas. One member is good in preparation of final slide show, one member is very good in data collection and one is good in ethnography study.

8. What are your team's expectations regarding team members' ideas, interactions with the team, cooperation, attitudes, and anything else regarding team-member contributions?

Team members are really supportive & understand the work load on each. Considering office workload team member have divided the work among themselves. Team members encourage each other in idea generation & respect each other's ideas.

9. What methods will be used to keep the team on track?

How will your team ensure that members contribute as expected to the team and that the team performs as expected? How will your team reward members who do well and manage members whose performance is below expectations?

Individual's Work progress review in the team meeting

Flashing of individual's work on site everyday

Understanding the hurdles & suggest, if anyone is facing while completing his work share.

Sharing/ pat on back during meeting for the extra efforts put by any individual.

APPENDIX IV

a. Observations from design ethnography

Observation data collection structure:

We cannot observe the users directly during their use of the solar heated water, as it would intrude their privacy; hence we will do a few self-observations. A sample Observation taken at a 2 minute time interval is as shown in table below

Time	Activities	Environment	Interactions	Objects	Users
1:00 PM	Waiting for hot water	Bathroom	Turn on tap. Luke warm water collected in Bucket.	Water, Bucket, Tap.	One person
1:02 PM	Waiting for hot water	Bathroom	Bucket overflowing with excess water.	Water, Bucket, Tap.	One person
1:04 PM	Waiting for hot water. Take shower.	Bathroom	Tap turned off. Hot water redirected thru shower. Bucket of Luke warm water kept aside.	Water, Bucket, Tap, Shower.	One person
1:06 PM	Take shower	Bathroom	Shower not turned off during soaping.	Water, Shower, Soap.	One person
1:08 PM	Take shower. Towelng.	Bathroom	Shower turned off. Towelng.	Shower, Towel.	One person

b. Interviews for design ethnography

Interview questions for an independent house owner (client):

- If any of my questions is not clear, please do ask me clarify.
- I may ask some questions that you may want to think about, I will pause after I ask the questions and I will let the silence be there while you think about it.
- Could you give me a brief introduction about yourself?
- Could you tell me about your house, number of residents, etc.?
- Could you tell me about the solar water heater that you have installed?
- Could you tell me about the solar water heater installation experience?
- Please share with me your first user experience of the solar water heater?
- How is the usability at night?
- Have you observed any change in performance over the years?
- Tell me about any failures that you may have had.
- How was the service experience?
- <Some questions here will be built upon the answers received>
- Thinking back on all the experiences you described, what is the one thing you would have changed if you could?
- What else would you like changed?
- <Again, some questions here will be built upon the answers received>

- Are you aware of any experiences of your friends?
- <Some reflection questions here will be asked here based upon the answers received>
- I am done interviewing you. Thanks for your time and the valuable insight into your personal experience. Did you have any questions for me or any final thoughts?
- <Closing the interview, if no further info is forthcoming>Thanks again for your time!

Interview with a solar water heater dealer

Agenda of this interview was to understand considering the following situation as a user's prospective.

- Buying
- Installing
- Repairing
- Returning back the whole system (if not performing well)

At the time of buying a solar water heater system

Q1. When a buyer approaches, he wishes to buy a solar water heater for his home. How do you normally react to that query?

Reply: We tell them about the type & model of solar water heater available us.

Our company manufactures two types of solar water heater – flat plate collector (copper fins, toughened glass on top), tube technology (it has copper coating on ordinary glass tubes)

Both are OK to use but flat plate is safer, servicing is less & resale is good.

Q2. What question you generally ask him after that to understand more his queries.

Reply: How many persons in family, how many bathrooms are in house, how much their requirement is?

Q3. I asked him next question: what capacity you suggest after this information

Reply: 4 persons – 100L, 6-8 persons - 200L tank capacity

Q4. I asked him next question: Do people include the requirement of usage for utensils, floor cleaning.

Reply: No, they only look for bathing purpose.

Q5. I asked him next question: Is there any warranty come with this system

Reply: Yes, 5 year warranty where 1 year is free warranty.

Q6. Why buyers want to put a solar water heater?

Reply: due to government regulations to get the NOC from government, also there is subsidy involved after installing the system. They know

Q7. How much prior knowledge they have about the solar water heater? Is they have seen somewhere or they really know about the benefits of a solar water heater.

Reply: Yes generally they have knowledge about the solar water heaters through internet; rules from govt regulations & sometimes their architect also suggest them about the company & models.

Q8. What types of solar water heaters you have & how you suggest a model of any solar water heater to the buyer?

Reply: We have two types of SWH from our company, flat & tubular type, based on usage we suggest them to put SWH & we generally suggest flat collector type but if some customer want to put tubular type then we tell them the features of the same.

Q9. What kind of information you provide to a buyer?

Reply: We tell them how a SWH heater works, how much would be the servicing, normally what part they need to service frequently. We give them demo if they come in the shop & our technician show then through catalogues if they call at home.

Q10. How many people enquire & how many really buy a solar water heater.

Reply: I am attending 4-5 enquiries every day & generally I sell 10-15 numbers per month.

Q11. What other facility or services you provide along with it.

Reply: We can provide the servicing as we have technicians with us. Also we tell them that we have plumber who can fit their SWH at their home.

[At the time of Installation:](#)

Q1. For installation what points you ask to check about the site

Reply: We ask for the water – hard water or Kauvery water, apartment or house, what location they want to put, how far is the usage points, measurement of site, which direction they get more sunlight, Our technician inspect the site for sunlight. If the sunlight is not good then we suggest them the final location or we suggest them not to put solar as it will not work properly.

Q2. What points a buyer should take care for installation (regarding plumbing – when to do, how to do)

Reply: location of installation of SWH

I further asked: is there any point to check for the load carrying capacity of the roof or do its weight create any problem in the roof

Reply: Generally it is not required as it don't make any problem with the roof.

I further asked: how you do the installation

Reply: after putting the SWH we do the cementing of the panels & tank. We don't do any grouting now days.

I further asked: Do you do any grouting on roof?

Reply: Earlier it was being but later we used to have some complaints that bolts became loose etc. Now we have stopped it completely

Q3. How much time it takes for installation

Reply: if the system is 100L then the plumber can fit it within 2 hours of 200L he need to visit for two times appx 1.30hrs each time. Generally time is not taken very much for any model

Q4. How much skill level it need for installation

Reply: Technician knows how to do the servicing. They know in regular maintenance or after certain time person which part need to check first & replace if required.

Q5. How you develop the skill for installation

Reply: They get training from the company persons.

Q6. What points a customer ask you during installation?

Reply: In many days it will be ready to use, when we need to do the servicing. Whether they need dealer or they person will call them. How much costly is the maintenance. To whom to contact in case of any problem

At the time of any Repair:

Q1. What kind of parts come most for repair.

Reply: Generally no problem occurs to SWH but their Mg (Magnesium) anode rod get consume based on the water quality.

Q2. Why this rod is used in the SWH & do it really get consumed with in one year.

Reply: to save the rusting of the tank from hard water. Our technical check it during servicing if it is worn out then he suggest to change it immediately or if he finds that it can serve more then he tell them to change near to that time.

Q3. How much the usage is important to avoid quick faults?

Reply: Due to usage nothing occurs to SWH only need to take care is servicing should be on time. I have seen some SWH where we did not do any kind of servicing from last 15~20 years. Sometimes the glass tube gets fused.

Q4. Does it need any specific protection to avoid early damages?

Reply: Although nothing happen to SWH but if customer want to put some protection they may use some mesh on the top of the collector as flat has tough glass bu the tube type doesn't have anything on top of it to protect.

Q5. How much time it takes to fix the repair?

Reply: For changing rod it takes hardly 5-10mins

Q6. Whether it is charged to customer or free

Reply: Generally the free warranty period is over, so the customer needs to purchase a new Mg anode rod during servicing.

Q7. Do they need to keep some spares with them?

Reply: Normally they don't need as there is no replay generally. For the anode rod also they need not to put the spares as we have enough stock.

Q8. Do the spares are easily available?

Reply: We normally have sufficient stocks of rods with us. For other parts if damaged we order to the company & then they send it to us.

Q9. What the usual life of a heater?

Reply: Generally nothing happen to a solar water heater but you can assume around 20 years.

Q10. Is there a 2nd hand market? What happens after life over? are some parts reused?

Reply: I don't know about the second hand market as I never heard about that. Also they can get any part available with us so I think we don't have any big second hand market.

Returning:

Q1. What are the requirement which were not fulfilled & customer returned back the entire set?

Reply: It never happened with me till now as we have a proven product & good technicians for service.

Interview with builder office executive

This builder is constructing a project with 360 flats.

We could ask few questions to them as he told us to keep it a brief interview for max 5-10mins.

Questions & answers:

Q1. Why you decide to put a solar water heater

In Bangalore by government regulations, it is mandatory to put a SWH for getting clearance certificate. Now a day's buyers are also enquiring for SWH in the building plan.

Q2. What type of information you give to a buyer when he asks about the solar water?

We tell them whether the society will have the SWH or not, second we tell about the number of distribution points for water from SWH in a flat, number of SWH systems for the entire building & how many flats will be served by a single SWH & from when it will be started.

Q3. Does the buyer raise any query over the availability of water from SWH?

Yes, they generally ask how much hot the water would be from that point, will it be really sufficient for their usage. We give them details how much flats number a proposed SWH can serve.

Q4. How you decide the specification of a solar water heater?

We have used SWH so many times that we have idea how many numbers are required for a building & generally we use the same type of SWH in our projects. We have our architect or consultants who can also check about them. We have our fixed suppliers; sometimes they also give us information for the SWH.

Q5. How much preference is given to system cost over other specifications?

We have our fixed dealers & fixed type of models so the cost normally doesn't vary but systems are good enough to fulfill the requirements if used properly.

Q7. What kind of points you take care for the installation?

Our designer takes care of all requirements like pipe routing, location of SWH & its civil requirement during design of building.

Q8. What kind of problem you face while system is running?

If people are using it properly we don't have any complaint but some-times they have issues that they don't get the hot water.

Q9. Why it generally happens?

Some people over use the water that's why other don't get it.

Q10. Did you take any steps to overcome this problem?

Our persons tell them the same answer that users should use the water properly to avoid the over use. What we can do in it. We can't provide an individual SWH for each flat.

Q11. How you take care of repair of the system.

When the system is installed our office people attend the complaint & supplier's technician resolves any issue. During handing over the building to society we give them the details of the dealer then society itself can contact the dealer in case of any problem with the system.

Q12. Did you face any major challenge ever with any installed system?

No, we never heard of any major problem happened with our installed systems.

Interview with expert from SWH manufacturing industry

After our DR#3 we did a visit to the "Sunrise solar water heater systems" a SWH manufacturing company. We visited their production area & had discussion with their technical & business team. During this visit we could do following information sharing

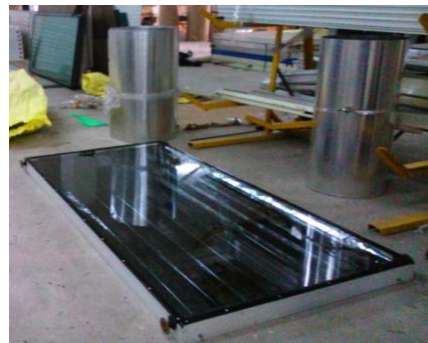

SWH functioning: Detailed description & visit of manufacturing process for each component, their facilities

Inspection of build components: They give details on inspection process for each component.

How their process is better than other manufacturers: Knowledge sharing on the material & process which is being used by them as a better option. Few other companies use rock wool inside tank shell while they are using liquid polyethylene. For shell making & its corner joining they use automatic machine for resistance welding while some competitors are using manual arc welding.

How they take care of repair & rework: Major repair come in only shell preparation, after including automatic welding machine repair has come down drastically.

Validation of components: In-process inspection for header & risers frame (100% water dip air leak test and 10% sampling by water pressure testing) & inner tank for solar water heater.

For validation they send one collector only to the test lab & get the certification. This need to be done every year & only collector is sent for validation.

Do they provide SWH high rise buildings: Their system is capable of working in apartments but for big apartments to cater the need of saving of cold water he suggested to put individual SWH in every apartment. Vacuum tube SWH can be customized. User can out these SWH in their apartment.

Market in India: They supply SWH for domestic as well as industrial purpose. Their major market is in Bangalore they are trying other regions now.

Marketing strategy: They have a marketing team which works only on how to increase the customer base. They do advertisement through newspaper, visit builders & society associations etc.

APPENDIX V

a. Technical specification of existing domestic solar water heater (Sunrise solar water heater)

Collector:

1. Absorber material: Electro Grade - Copper
2. Absorber Coating: Selectively coated black chrome on copper to withstand temperature up to 3000C.
3. 3. Optical Property: Absorptivity = 0.96 + 0.02 Emissivity = 0.12 + 0.02
4. Riser: Copper Tube of dia 12.5mm + 0.5mm
5. Header: Copper tube of dia 25mm + 0.5mm
6. Bonding between Riser & Header: Brazing
7. Bonding between Fin & Tube: Ultrasonic / TIG
8. Back Insulation: Resin bonded Rock wool, Density 48 kg/m³ - Thickness 50mm
9. Side Insulation: Polyurethane - Thickness 25mm
10. Collector Box: 100mm x 25mm Aluminum Channel
11. Collector Bottom Sheet: Aluminum
12. Collector Stand: Corrosion resistant Coated M S
13. Glazing: Toughened Glass, 4mm Thickness with low Iron
14. Transmissivity >0.85% @ near normal incidence.
15. Retainer Angle for Glass: Aluminum angle, size 25 x 25
16. Beading for Glass: EPDM Rubber
17. Absorber Area: 2 Sq. meter / Collector + 0.1 meter
18. Collector Tilt: 24.5 deg to HORIZON (non-variable) for places located between 12degN and 15degS
19. Heat Transfer Medium: Water
20. Collector Area: 2.132 Sq. meters
21. Number of fins: 9 (Nine)/ 8 (Eight)*
22. Dimensions: Length - 2050mm, Breadth - 1040mm, Height - 100mm (22 gauge sheet)

Hot Water Storage Tank (100LPD)

1. Material: Stainless Steel, AISI 304/ 316, Inner tank: 360Dia, 950mm length, thk 20SWG, Outer tank: 460Dia, 1050mm length, thk 22SWG
2. Insulation: PUF / density 40kg/ m³, 50 mm Thickness
3. Outer Cladding: Stainless Steel / CRCA / MS PP Coated*
4. Inter connecting Pipe: Hydraulic Hose Pipe / EPDM Rubber*
5. Electrical Back-up-Heater: 2kw up to 300 LPD*
6. Working Pressure: Atmospheric

Inlet pipe (Sunray solar water heater)

1. Material: Galvanized iron

2. Diameter : 3.2 cm

Outlet pipe (Sunray solar water heater)

1. Material: Galvanized iron
2. Diameter: 2.16 cm
3. Insulation: Glass wool
4. Thickness of insulation: 3.77 cm

Piping from storage tank to user's point – Galvanized iron pipes (currently used by the house owner's & builders)

APPENDIX VI

Growth Potential for SWH Market with respect to key parameters that affect SWH market in Residential Sector

District	Hot water demand in middle & high income hh (Months/year)	State electricity shortage % (2008-09)	SWH Supply chain
Shimla	≥9	0.2	Poor
Gurgaon	4-5	8.5	Poor
Agra	4-5	20.9	Poor
Ludhiana	4-5	10.6	Fair
Delhi	4-5	0.6	Fair
Haridwar	4-5	1.2	Poor
Coimbatore	8	7.9	Good
Bangalore	≥9	6	Good
Chennai	8	7.9	Fair
Pondicherry	9	12.3	Fair
Hyderabad	9	6.8	Good
Kochi	8	11.8	Fair
Thane	≥9	21.4	Good
Ahmedabad	4-5	9.8	Fair
Indore	5-6	17.2	Fair
Jaipur	4-5	1.1	Fair
Nagpur	5-6	21.4	Good
Pune	8	21.4	Good
Patna	4-5	17.6	Poor
Ranchi	5-6	4.7	Poor
Bhubaneswar	5-6	1.5	Poor
Sambalpur	5-6	1.5	Poor
Raipur	4-5	2.6	Fair
Guwahati	9	10.6	Poor
Darjeeling	7	3.2	Poor
Kolkata	6	3.2	Fair
Shillong	≥9	19.1	Poor
Agartala	4-5	9	Poor

Source: Primary survey and Central Electricity Commission.

Per observation, highlighted cities will have market growth potential for SWH.

Electric Geyser available in Indian Market & the respective cost (Top 2 selling models)

Capacity	Havell		Racold	
	Design	Cost	Design	Cost
25 L	 <p>Havells Geyser Monza 25 Ltr. (white)</p>	INR 10089	 <p>Racold 25 L Geyser Eterno 2 Vertical ER-2-25, multicolor</p>	INR 9941
15L	 <p>Havells Monza Sikkh 15 Ltr Water Heater. (white)</p>	INR 8727	 <p>Racold 15 L Geyser Eterno 2 Vertical ER-2-15, multicolor</p>	INR 8742
10L	 <p>Havells Geyser Opal 10 Ltr. (Multicolor)</p>	INR 8508	 <p>Racold 10 Ltr Geyser Eterno 2 Vertical ER-2-10, (Multicolor)</p>	INR 7477
6L	 <p>Havells Geyser Opal 6 Ltr. (Multicolor)</p>	INR 7363	 <p>Racold 6 L Geyser Pronto PR-6, multicolor</p>	INR 6337
3L	 <p>Havells Geyser Neo 3 Ltr. (white)</p>	INR 4629	 <p>Racold 3 Ltr Instant Water Heater Pronto PR-3, (Multicolor)</p>	INR 3780

Types of Solar Water Heater commonly available in Indian Market

Two types of solar water heater are commonly available in India market. One with Flat plate collectors (FPC) and other with Evacuated tube collectors (ETC)

FPC based systems are of metallic type and have longer life as compared to ETC based system where tubes are made of glass which are of fragile in nature. ETC based systems are, therefore, cheaper than FPC based system.



FPC based system



ETC based system

Selection of Solar Water Heater

Capacity of Solar Water heater is decided based upon the peak water requirements during the day (For eg: in the morning for bathing)

ETC based systems perform better in colder regions and avoid freezing problem during sub-zero temperature while FPC based systems can perform good in colder regions if they are used with anti-freeze solution and heat exchanger.

At places where water is hard and have larger chlorine content, heat exchanger must be installed with FPC based system as it will avoid scale deposition in copper tubes of solar collectors which can block the flow of water as well as reduce its thermal performance. ETC based systems do not face such problem but may reduce performance due to scale formation inside the tubes which can be easily cleaned by dismantling the tubes one in a year or so.

Other factors which need to be considered are

- Number of dwelling units or flats in the building
- Number of bathrooms needed solar heated water
- Number of persons occupying the flats
- Frequency of the requirement of hot water (whether on continuous basis or supply available at one time in the morning hours).
- Whether hot water is required for any other purpose also (like washing, cleaning etc).

Additional points which need to be kept in mind while installing solar water heater in high rise buildings and multistoried flats are provided at

Aerial View of Urban High Rise Building having SWH installed



Energy Required by an Average Household & Cost Associated with the Energy

Description	Scenario-1	Unit
Thermostat Setting	60	degree C
Average hot water consumption/household/day	50	Litres
Average daily losses	0.0115	kWh/l/day
Specific heat of water	0.00087	kWh/l/degree C
Average Water Temp (Ambient)	18	degree C
Energy required/day	2.4	kWh/day
Energy required/month	72	kWh/month
Ave monthly water heating cost (INR 4.55/kwh)	INR 328	/month
Note: 95% efficiency of element assumed		

List of Manufacturers of FPC type Solar Water Heaters in India

The list of all the BIS approved manufactures for FPC type Solar Water heaters could be found at³⁶

APPENDIX VII

DFMEA of components of concept solar water heater

Our validation plan includes doing DFMEA for individual subsystem & overall systems. A sample DFMEA for risers, Fresnel lens & Glass is included here.

DESIGN FAILURE MODE & EFFECT ANALYSIS													
Sl. No	Port / Interface	Function	Requirement / Specification (reference)	Potential Failure Mode (Loss of Function or value to customer)	Potential Effects of Failure	Severity (S)	Occurrence (O)	Potential Cause(s) / Mechanism(s) of Failure	Current Design Controls (Design actions planned or completed to prevent or reduce occurrence of failure, provide details and Particulars used) Prevention	Current Design Controls (Analysis of physical validation method planned/completed) Detection	Detection (D)	Recommended Action(s) (not already planned)	P/I/D Responsibility
1	Riser tubes	Heat absorption & transfer to water	R: XX KW/m ² R: Minimum heat loss from surface R: Minimum damage to pipe	Insufficient heat absorption	Less temp of water	7	7	Less heat absorption due to small diameter, Tube absorption coefficient is less, Scaling on outer / inner surface preventing heat	Copper material with high absorption coefficient, Diameter of 12.5mm, Black chrome coating outside & inside	Temperature test	2	14 1. Test the heat absorption with higher diameters 2. Material corrosion test	Quality
2	Riser tubes	Water circulation	R: Letre/ minute R: No leakage R: No obstruction in flow R: Thermosiphon of hot water	Insufficient water flow & water leak inside box	No water inside storage tank	7	7	Improper diameter of pipe, poor welding, physical blockage inside tubes, big diameter of tubes	Diameter 12.5mm	Water dip air leakage testing	1 14	1. Test the diameter range for best thermosiphon on a fix temp 2. Inspection for blockage inside ID of each riser tube	1. Quality 2. Manufacturer
3	Riser tubes	With stand internal pressure	R: No leakage R: No pressure bursting	Insufficient water inside tank	Poor heating of water / Less water in solar tank/ water loss	6	6	Over heat of water inside pipes, pipe blockage	High strength of material	Hydraulic testing	1 12	1. Inspection for blockage inside ID of each riser tube	Manufacturing
4	Glass	Solar rays transmissivity	R: XX % R: Min heat absorption R: Min refraction at angle	Less heat/ solar rays inside collector box	Temp of hot water low	6	6	Deposition of foreign particles over the glass Glass specifications	Proper grade & specifications of glass	Transmittance test	2	48 1. Repulsion to foreign particles/ poor sticking of particles over glass surface	Design
5	Glass	Withstand high pressure inside collector box	R: Max withstand pressure	Glass damage	Loss of heat from box	6	6	Glass toughness Glass thickness	Specifications for both parameters in drawings	Transmittance test	2 24	24 Test of transmittance property	Supplier SOC
6	Fresnel lens	Refraction at focal length	R: XX KW/m ² No damage to collector box & its parts due to overheating	No refraction of solar rays damage to collector box & entire collector due to overheating	Damage of collector	8	8	Angle on lens is not correct Distance between lens & riser/ collector box is reduced / reached to focal length	na	na	7 224	1. Angle of each refracting part in drawing 2. Testing of refraction angle 3. Error proofing to avoid movement of fresnel lens towards collector box/ fixed position of	1. Design 2. Quality
7	Fresnel lens	Solar rays transmissivity	R: XX % R: Min heat absorption R: Min refraction at angle	Less heat/ solar rays inside collector box	Temp of hot water low	6	6	Deposition of foreign particles over the glass Glass specifications	Proper grade & specifications of glass	Transmittance test	2	48 1. Repulsion to foreign particles/ poor sticking of particles over glass surface	Design

REFERENCES

- ¹ "Solar energy thermal", Karnataka renewable energy development Ltd, Available from URL ["http://kredl.kar.nic.in/SolarThermal.htm"](http://kredl.kar.nic.in/SolarThermal.htm)
- ² "Guidelines to Domestic Users of Solar Water Heaters on Cost, Selection & Availability of systems", Government of India, Ministry of new & renewable energy, Available from URL ["http://mnre.gov.in/file-manager/UserFiles/Guidelines_domestic_users_of_swh_cost_systems.pdf"](http://mnre.gov.in/file-manager/UserFiles/Guidelines_domestic_users_of_swh_cost_systems.pdf)
- ³ National renewable energy laboratory "Energy efficiency & renewable energy: Solar water heating system", U.S department of Energy. Available from URL ["http://www.nrel.gov/docs/legosti/fy96/17459.pdf"](http://www.nrel.gov/docs/legosti/fy96/17459.pdf)
- ⁴ World development indicators "Electricity production, sources & access" The World bank group, URL available from ["http://wdi.worldbank.org/table/3.7"](http://wdi.worldbank.org/table/3.7)
- ⁵ Electricity crisis in India, Available from URL ["http://www.electricityinindia.com/2011/06/darkness.html"](http://www.electricityinindia.com/2011/06/darkness.html)
- ⁶ Article from The Indian Express "LPG water heaters blamed for a dozen Bangalore death". Available from URL ["http://www.indianexpress.com/story-print/20172/"](http://www.indianexpress.com/story-print/20172/)
- ⁷ "Solar Water Heating System Reliability Information", Sustainable energy group, Available from URL ["http://www.theenergyguy.com/solar_reliability.html"](http://www.theenergyguy.com/solar_reliability.html)
- ⁸ Renewable energy sources in India "Total Renewable Energy Installed Capacity (July 2013)" Available from URL ["http://en.wikipedia.org/wiki/Renewable_energy_in_India"](http://en.wikipedia.org/wiki/Renewable_energy_in_India)
- ⁹ Samuel Milton & Steven Kaufman, "Solar Water Heating as a Climate Protection Strategy: The Role for Carbon Finance", Green Markets International, Inc, USA, Available from URL ["http://solarthermalworld.org/sites/gstec/files/SWH_carbon.pdf"](http://solarthermalworld.org/sites/gstec/files/SWH_carbon.pdf)
- ¹⁰ Renewable energy scenario in India, ["http://www.indiasolar.com/cal-value.htm"](http://www.indiasolar.com/cal-value.htm)
- ¹¹ Solar water heaters in India: Market assessment studies & surveys for different sectors & demand segments (Primary survey : Key findings, Page iv) http://mnre.gov.in/file-manager/UserFiles/greentech_SWH_MarketAssessment_report.pdf
- ¹² Solar water heaters in India: Market assessment studies & surveys for different sectors & demand segments (Primary survey : Key findings, Page iv) http://mnre.gov.in/file-manager/UserFiles/greentech_SWH_MarketAssessment_report.pdf
- ¹³ Government of India, "Renewable energy scenario in India" <http://www.indiasolar.com/cal-value.htm>
- ¹⁴ EAI catalyzing cleantech in India, ["http://www.eai.in/club/users/dheen/blogs/665"](http://www.eai.in/club/users/dheen/blogs/665)
- ¹⁵ Performance analysis of solar water heater in NEH region of India, "International Journal of Renewable and Sustainable Energy" <http://article.sciencepublishinggroup.com/pdf/10.11648.j.ijrse.20130203.13.pdf>
- ¹⁶ EMMVEE Solar Systems Private Limited, "Basic working principle of solar water heating system" Available from URL ["http://www.emmveesolar.com/products/working-principle-#"](http://www.emmveesolar.com/products/working-principle-#)
- ¹⁷ Wade Byrd Performance Building Consulting "Types of Solar Domestic Hot Water Systems" Available from URL http://www.lacleanetech.net/solar_hot_water_systems.pdf

-
- ¹⁸ Ministry of New and Renewable Energy Government of India " MARKET ASSESSMENT OF SOLAR WATER HEATING SYSTEMS IN THE HIMALAYAN REGION" Available from URL "http://mnre.gov.in/file-manager/UserFiles/undp_swhs_himalayan.pdf"
- ¹⁹ "Solar Water Heating Systems – Global Experiences", Available from URL "http://www.aeinet.org/reep/doc/DIREC_Background.pdf"
- ²⁰ "SWH Market Assessment", Available from URL "http://mnre.gov.in/file-manager/UserFiles/greentech_SWH_MarketAssessment_report.pdf"
- ²¹ "Percentage of Renewable Energy in India", Available from URL "<http://www.mnre.gov.in/mission-and-vision-2/achievements/>"
- ²² "Guidelines for Installation of Solar Water Heater", Available from URL "<http://www.solarwaterheater.gov.in/phpdurl5/speakers/userfiles/file/Guidelines%20for%20installation%20of%20Solar%20Water.pdf>"
- ²³ Building a parabolic trough collector "UNIT 5 – RENEWABLES, SECTION 3 - SOLAR ENERGY" Available from URL "<http://www.energyeducation.tx.gov/pdf/53cinv.pdf>"
- ²⁴ Compact linear Fresnel mirror, Available at URL "http://en.wikipedia.org/wiki/Compact_linear_Fresnel_reflector"
- ²⁵ Parabolic dish sol pac, Available at URL "<http://www.thermaxindia.com/Solar/Solar-Thermal/Parabolic-Dish.aspx>"
- ²⁶ Solar tower, Available at URL, "http://en.wikipedia.org/wiki/Solar_power_tower"
- ²⁷ "Thermal conductivity" http://en.wikipedia.org/wiki/Thermal_conductivity#Convection
- ²⁸ "The engineering tool box" http://www.engineeringtoolbox.com/thermal-conductivity-d_429.html
- ²⁹ Fresnel lens, Available at URL "<http://www.fresneltech.com/pdf/FresnelLenses.pdf>"
- ³⁰ Genersys South Africa, "Europe's Leading Solar Thermal Panel Manufacturer" <http://www.pow-a-mate.co.za/Genersys%20South%20Africa%20ECO2%20Brochure2.pdf>
- ³¹ Material of heating element "Riken environmental system co ltd" Available from URL "http://www.riken-kankyo.com/en/pdf/PYROMAX_Catalog_en.pdf"
- ³² Indian standard 12933 for solar plate collector specification (Part 1) by "Bureau of Indian standards" Available from URL "<https://law.resource.org/pub/in/bis/S08/is.12933.1.2003.pdf>"
- ³³ Indian standard 12933 for solar plate collector specification (Part 5) by "Bureau of Indian standards" Available from URL "<https://law.resource.org/pub/in/bis/S08/is.12933.5.2003.pdf>"
- ³⁴ Prospects & potential of SWHs in urban areas, Available from URL "http://mnre.gov.in/file-manager/UserFiles/presentations-23082012/sameer_urban_areas_shw.pdf"
- ³⁵ Prospects & potential of SWHs in urban areas, Available from URL "http://mnre.gov.in/file-manager/UserFiles/presentations-23082012/sameer_urban_areas_shw.pdf"

³⁶ List of BIS approved Manufacturers of FPC based Solar Water Heating Systems, Available at URL
“http://mnre.gov.in/file-manager/UserFiles/list_fpc_manufacturers.pdf”