

THE RELATIONSHIP BETWEEN LIGHT, DOPAMINE RELEASE AND HORIZONTAL CELL COUPLING IN THE MUDPUPPY RETINA

By CUN-JIAN DONG AND JOHN S. McREYNOLDS*

From the Department of Physiology, The University of Michigan, Ann Arbor, MI 48109-0622, USA

(Received 5 October 1990)

SUMMARY

1. The effect of different experimental conditions on electrical coupling between horizontal cells in the mudpuppy retina was studied by comparing the changes in responses to illumination of the central and peripheral portions of the receptive field, using centred spot and annulus stimuli. An increase in the amplitude of the response to a centred spot stimulus and a decrease in the amplitude of the response to a concentric annulus indicated a decrease in coupling, and vice versa.

2. Dopamine (10–250 μM) caused a decrease in coupling between horizontal cells. The uncoupling effect of dopamine was much greater in dark-adapted than in light-adapted retinas. The effect of the D_1 -receptor agonist SKF38393 was similar to that of dopamine. The effect of the D_2 -receptor agonist LY171555 on coupling was opposite to that of dopamine; this was attributed to a reduction in endogenous dopamine release.

3. The D_1 antagonist SCH23390 (15 μM) caused an increase in coupling between horizontal cells. This effect was much greater in light-adapted than in dark-adapted retinas.

4. The glutamate analogue 2-amino-4-phosphonobutyrate (APB), which hyperpolarizes on-centre bipolar cells and blocks their responses to light, caused an increase in coupling between horizontal cells. This effect of APB was greater in light-adapted retinas than in dark-adapted retinas. The effect of APB on coupling could be reversed by the addition of dopamine, but the effect of dopamine on coupling could not be reversed by the addition of APB. These results suggest that APB increases horizontal cell coupling by causing a decrease in dopamine release.

5. In dark-adapted retinas, 2.5 min exposure to an adapting light caused a decrease in coupling between horizontal cells; the uncoupling effect of the adapting light was blocked in the presence of either SCH23390 or APB.

6. The results suggest that coupling between horizontal cells in the mudpuppy retina is decreased by dopamine acting at D_1 receptors, that the release of dopamine affecting horizontal cells is greater under light-adapted conditions, and that the pathway by which exposure to light increases this dopamine release is mainly via on-centre bipolar cells.

* To whom correspondence should be sent.

INTRODUCTION

In vertebrate retinas horizontal cells of a given type are often electrically coupled by gap junctions (Kaneko, 1971). There is evidence that the coupling between horizontal cells is regulated by an endogenous neuromodulator substance; dopamine causes an increase in horizontal cell coupling resistance in fish (Teranishi, Negishi & Kato, 1983; Lasater & Dowling, 1985; Mangel & Dowling, 1985; DeVries & Schwartz, 1989) and turtle (Piccolino, Neyton & Gerschenfeld, 1984), but this has not yet been established in other classes of vertebrates.

The release of dopamine in the retina appears to be regulated by light. Direct measurements of dopamine release in fish, amphibian and mammalian retinas have shown that dopamine release is increased in the light-adapted state and decreased in the dark-adapted state (Godley & Wurtman, 1988; Boatright, Hoel & Iuvone, 1989; Kirsch & Wagner, 1989; Weiler, Kolbinger & Kohler, 1989), and both dopamine and exposure to light caused similar changes in horizontal cell gap-junction density in fish (Kurz-Isler & Wolburg, 1986; Baldrige, Ball & Miller, 1987) and in the balance of rod-cone input to horizontal cells in *Xenopus* (Witkovsky & Shi, 1990). However, electrophysiological evidence from the fish retina indicates that dopamine release and horizontal cell coupling resistance are increased after prolonged dark adaptation (Mangel & Dowling, 1985, 1987; Tornqvist, Yang & Dowling, 1988). Furthermore, although dopamine-containing cells are all located in the inner retina, either as interplexiform or amacrine cells (Dowling & Ehinger, 1978; Witkovsky, Eldred & Karten, 1984; Brunn, Ehinger & Tornqvist, 1985; Nguyen-Legros, Versaux-Botteri, Vigny & Raoux, 1985), the pathway by which light modulates dopamine release within the retina has not yet been determined in any species.

The functional organization of the mudpuppy retina has been extensively studied. Nevertheless, little is known about the regulation of horizontal cell coupling in this species, and whether dopamine is involved, although histochemical studies indicate that dopamine-containing cells are present in the inner retina (Brunn *et al.* 1985). The present study investigates the role of dopamine in the regulation of horizontal cell coupling in the mudpuppy retina and the pathway by which this is influenced by light. The results indicate that horizontal cell coupling in the mudpuppy is regulated by dopamine, as in fish and turtle retinas. The results also provide electrophysiological evidence that light causes an increase in dopamine release and horizontal cell coupling resistance, and that the major link between photoreceptors and the dopamine-releasing inner retinal neurons appears to be via on-centre bipolar cells.

METHODS

Mudpuppies (*Necturus maculosus*) were kept in a tank on a 12 h light-dark cycle; eyecup preparations were made under room illumination using animals that had been light-adapted for at least 6 h prior to killing. The animal was decapitated, the eye was removed and its anterior portion dissected away with fine scissors. As much vitreous humour as possible was removed with a wick of filter paper. In spring and summer months the vitreous humour was thicker and its removal was facilitated by 2 min exposure to a solution of 0.1% hyaluronidase and 0.025% collagenase dissolved in Ringer solution (see below). The eyecup was then mounted in the recording chamber which was superfused with a continuous flow (about 1 ml min⁻¹) of Ringer solution whose composition was (in mM): NaCl, 110; KCl, 2.5; CaCl₂, 1.8; glucose, 11; HEPES buffer 5.0. The

solution flowing over the retina could be rapidly switched to any one of several other Ringer solutions containing known concentrations of APB (2-amino-4-phosphonobutyrate), dopamine agonists and antagonists, or combinations of these substances. All solutions were adjusted to pH 7.8. The time required for the test solution to reach the retina after switching was about 10 s. APB, dopamine and forskolin were purchased from Sigma Chemical Co., 1,9-dideoxyforskolin from Cambridge Research Biochemicals and the D₁-receptor agonist SKF38393 from Research Biochemicals Inc. SCH23390 (a D₁ antagonist) and LY171555 (a D₂ agonist) were gifts of Schering Corp. and Lilly Laboratories, respectively.

Intracellular recordings were made using micropipettes of 200–400 M Ω resistance filled with 3 M-potassium acetate. Signals were amplified with a high-impedance DC amplifier (Colburn & Schwartz, 1972) and displayed on a penwriter (Brush 2200) or stored on magnetic tape for later analysis.

Light stimuli were from a dual-beam tungsten-halogen source; an interference filter in the combined beam provided monochromatic light of 560 nm. Stimulus intensities were controlled with neutral density filters and their irradiances, measured with a calibrated photodiode (UDT-555D) located at the plane of the retina, are given in the figure legends. Horizontal cells were identified by their large hyperpolarizing responses, large receptive fields and relative depth in the retina. After a horizontal cell was penetrated the light stimulus was centred in the cell's receptive field by moving a narrow slit of dim light in a direction perpendicular to its long axis until the response amplitude was maximal and then repeating this process with a second slit oriented perpendicular to the first one. The test stimuli were centred on this position. The maximal horizontal cell hyperpolarizations produced by diffuse illumination were between -40 and -50 mV.

All preparations were made under light-adapted conditions as described above. Retinas were divided into light-adapted and dark-adapted groups based on the subsequent treatment. Light-adapted retinas were those in which the experiment was begun within 10 min after the preparation was mounted in the recording chamber. During this time the retina was exposed to relatively bright (about 10 log quanta cm⁻² s⁻¹) flashes of diffuse 560 nm illumination every 3 s while searching for a horizontal cell. Dark-adapted retinas were dark adapted for more than 1 h before any light stimuli were presented; after this time searching for cells was begun, using light flashes about 1 log unit dimmer than in the light-adapted retinas. Although the state of adaptation may have varied somewhat in different experiments, the dark-adapted retinas were 0.8–1.0 log units more sensitive than those in the light-adapted group, as evidenced by the intensity of a 100 ms full-field stimulus required to produce a 10 mV response.

Changes in coupling were inferred from observing the changes in horizontal cell responses to spot and annulus test stimuli, as described in the Results. The test stimuli were a small, centred spot (240 μ m diameter) and a concentric annulus (inner diameter 800 μ m, outer diameter 1800 μ m), both 100 ms in duration. The intensities of the spot and annulus stimuli, which were always less than half-saturating, were adjusted to produced responses of approximately equal amplitudes in the control condition; exact matches of amplitude were not always possible because the light intensities could not be adjusted by amounts less than 0.2 log units.

RESULTS

Effect of dopamine on horizontal cell responses to spot and annulus stimuli

Figure 1 shows the effect of dopamine on responses of a horizontal cell in a dark-adapted retina to illumination of the central and peripheral portions of its receptive field. The downward deflections of the response trace are responses to 100 ms light flashes, which alternated between a small spot in the receptive field centre and an annulus that was concentric with the spot. The responses to the spot stimuli are indicated by dots. Prior to the addition of dopamine to the superfusate the intensities of the spot and annulus stimuli were adjusted to produce subsaturating responses of approximately equal amplitude. The addition of 20 μ M-dopamine caused an increase in the amplitude of the spot response and a decrease in the amplitude of the annulus response, as well as a slight depolarization in darkness. As described below, the increase in amplitude of the spot response and decrease in amplitude of the annulus

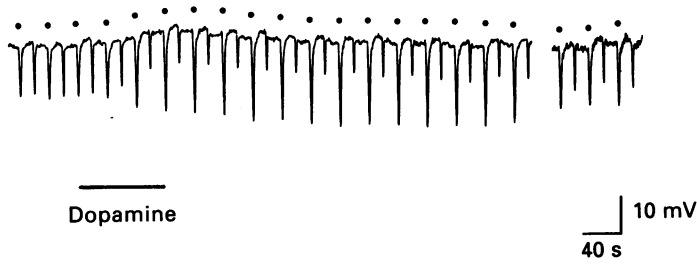

Fig. 1. Effect of $20 \mu\text{M}$ -dopamine on horizontal cell responses to spot and annulus stimuli. Dark-adapted retina. Downward deflections of response trace are responses of the horizontal cell to light flashes, which alternate between a small spot centred in the receptive field and a concentric annulus. The spot stimuli are indicated by dots above the responses. The intensities of the spot and annulus stimuli were adjusted to produce responses of approximately equal amplitude. During the time indicated by the horizontal line below the response trace the superfusate was switched to Ringer solution containing $20 \mu\text{M}$ -dopamine. Break in record is 18 min. The irradiances of the spot and annulus stimuli were both $9.7 \log \text{ quanta cm}^{-2} \text{ s}^{-1}$. In this and all subsequent figures the spot stimulus was $250 \mu\text{m}$ diameter, and the annulus was $800 \mu\text{m}$ inner diameter and $1800 \mu\text{m}$ outer diameter, and the durations of both stimuli were 100 ms. Resting potential was -24 mV .

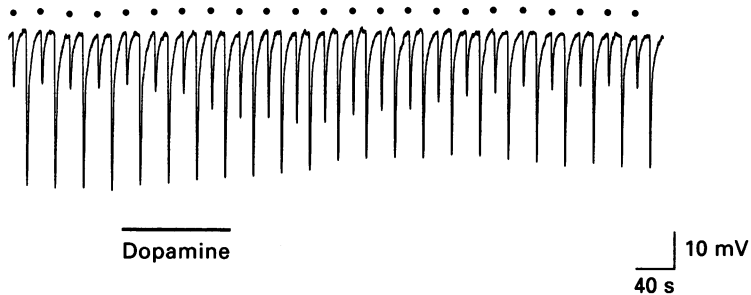

Fig. 2. Effect of $20 \mu\text{M}$ -dopamine on horizontal cell responses to spot and full-field illumination. Dark-adapted retina. Responses are to alternating, subsaturating spot and full-field illumination. Spot responses indicated by dots. The size of the spot was the same as in Fig. 1. Irradiances of both stimuli were $9.7 \log \text{ quanta cm}^{-2} \text{ s}^{-1}$. Resting potential was -22 mV .

response suggest that there was an increase in the coupling resistance (i.e. a decrease in coupling) between horizontal cells.

Several studies in fish and turtle retinas have shown that an increase in coupling resistance between horizontal cells (verified by a decrease in the spread of the dye Lucifer Yellow between horizontal cells) was accompanied by an increase in amplitude of responses to centred spot stimuli and a decrease in amplitude of responses to annuli or other distant stimuli (Teranishi *et al.* 1983; Piccolino *et al.* 1984; Miyachi & Murakami, 1989). The responses to the small spot stimulus is due mainly to direct synaptic input from photoreceptors, while the response to the annulus is generated mainly in distant horizontal cells and reaches the recorded cell through the horizontal-cell network via gap junctions. An increase in coupling resistance will increase the amplitude of the spot response by reducing its lateral

spread away from the recorded cell and decrease the amplitude of the annulus response by reducing its lateral spread from distant horizontal cells to the recording site. Although an increase in spot response and decrease in annulus response indicate a decrease in the length constant of the horizontal cell network, they would not necessarily indicate an increase in coupling resistance if similar response changes could also be produced by a decrease in membrane resistance, which would also cause a decrease in the length constant. Therefore it is necessary to control for the effect of dopamine on horizontal cell membrane resistance, which consists of synaptic and non-synaptic (leak) components in parallel. A decrease in either of these components would reduce the amplitude of the annulus response by causing a decrease in the length constant of the horizontal cell network. The shunting effect of a decrease in the non-synaptic component of horizontal cell membrane resistance would also cause a decrease in the amplitude of the response to the small spot. A decrease in synaptic resistance, however, might cause an increase in amplitude of the light response since there would be more glutamate-gated current to turn off, but the maximum amount of any such increase in amplitude of the light response should not be greater than the amount of depolarization in darkness produced by the decrease in synaptic resistance. In our experiments the increase in amplitude of the spot response was much larger than any depolarization in darkness caused by dopamine; in fact, in many cases the increase in spot response amplitude was accompanied by either no change in dark potential or a hyperpolarization. Thus it seems unlikely that a decrease in synaptic resistance could have caused the increase in spot response observed under these conditions. The experiment shown in Fig. 2 also provides additional evidence that the increase in amplitude of the spot response in the presence of dopamine was most likely due to an increase in coupling resistance.

Figure 2 shows responses of another horizontal cell to alternating stimulation with a small, centred spot (the same size as in Fig. 1) and to diffuse illumination of the entire retina. The two stimuli were of equal irradiance, so that the response to the diffuse illumination was much larger but still subsaturating. Dopamine caused an increase in the small spot response and a decrease in the response to diffuse illumination; similar results were seen in all of the four cells tested, each from a different retina. With diffuse illumination all of the coupled horizontal cells would be hyperpolarized to the same potential, so that there would be no lateral current flow through the gap junctions connecting them; therefore a change in coupling resistance should have no effect on the response to diffuse illumination. Therefore the reduction in the response to diffuse illumination caused by dopamine must have been due to the remaining actions of dopamine. Since the net effect of the remaining actions of dopamine, including any changes in the synaptic and/or non-synaptic membrane resistance of horizontal cells, causes a decrease in response amplitude, it is likely that the increase in spot response amplitude was due to a change in coupling resistance.

Results similar to those in Fig. 1 were seen in all of thirteen cells, each from a different dark-adapted retina, tested with dopamine (10–80 μM in twelve cells and 250 μM in one cell). In every case dopamine caused an increase in the amplitude of the spot response and a decrease in the amplitude of the annulus response. As a numerical measure of the relative effectiveness of dopamine and other agents in different retinas, the change in spot-annulus response ratio produced by a given

treatment was calculated. In each condition the ratio was obtained by dividing the average of two consecutive spot responses by the average of the two adjacent annulus responses. In the thirteen cells dopamine increased the spot-annulus response ratio to $272 \pm 66\%$ (mean \pm s.d.) of the control value. The slight depolarization in darkness caused by dopamine in Fig. 1 was not seen in all cells, and was probably due to an increase in responsiveness of horizontal cells to glutamate (Knapp & Dowling, 1987), rather than to a change in coupling. On return to normal Ringer solution there was a slow recovery of the responses. In light-adapted retinas the effect of dopamine was much weaker. In seven cells, each from a different light-adapted retina, dopamine (100–500 μM in six cells and 2 mM in one cell) increased the spot-annulus ratio to $120 \pm 20\%$ of the control value.

Effect of D₁- and D₂-receptor agonists on horizontal cell responses to spot and annulus stimuli

In fish and turtle retinas the uncoupling action of dopamine is mediated by D₁ receptors and an increase in intracellular cyclic AMP (Van Buskirk & Dowling, 1981; Teranishi *et al.* 1983; Piccolino *et al.* 1984). Although not shown, the D₁-receptor agonist SKF38393 (15–20 μM) had the same effect as dopamine on spot and annulus responses in the three dark-adapted retinas tested. Also, in seven dark-adapted retinas 10–50 μM forskolin, which activates adenylate cyclase, caused an increase in the spot response and a decrease in the annulus response (the spot-annulus response ratio was increased to $174 \pm 51\%$ of the control value). 1,9-Dideoxyforskolin, which has many of the side-effects of forskolin but does not activate adenylate cyclase, did not produce any change in the amplitudes of the spot or annulus responses ($n = 4$). Thus, the uncoupling effect of dopamine in the mudpuppy retina also appears to be mediated by D₁ receptors. The D₂-receptor agonist LY171555 had an effect opposite to that of dopamine; in all of the ten cells tested 15–50 μM LY171555 caused a decrease in the amplitude of the spot response and an increase in the amplitude of the annulus response, i.e. it caused an apparent increase in coupling between horizontal cells (the spot-annulus response ratio was decreased to $66 \pm 9\%$ of the control value). This result can be explained if activation of D₂ autoreceptors on dopamine-releasing cells leads to a reduction in dopamine release, as suggested by Dubocovich & Weiner (1985).

Effect of the D₁ antagonist SCH23390 on horizontal cell responses to spot and annulus stimuli

Since the effect of dopamine on horizontal cell coupling in the mudpuppy appears to be mediated by D₁ receptors, the effect of the D₁ antagonist SCH23390 on the spot-annulus response ratio was tested to determine whether coupling between horizontal cells in the mudpuppy is normally regulated by endogenous dopamine. Figure 3 shows the effect of this antagonist on horizontal cell responses in a light-adapted retina. The addition of 15 μM -SCH23390 had an effect opposite to that of dopamine; i.e. it caused a decrease in the response to the spot stimulus and an increase in the response to the annulus. The effect of SCH23390 often continued to increase for more than 10 min after application, even when the superfusate was switched back to control Ringer solution, and little recovery was seen in any cell,

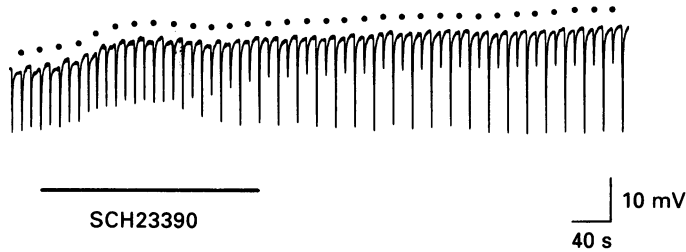

Fig. 3. Effect of $15 \mu\text{M}$ -SCH23390 on horizontal cell responses to spot and annulus stimuli. Light-adapted retina. Responses to alternating spot and annulus stimuli. Spot responses indicated by dots. Irradiances of spot and annulus stimuli were 10.1 and 10.7 log-quanta $\text{cm}^{-2} \text{s}^{-1}$, respectively. Resting potential was -19 mV.

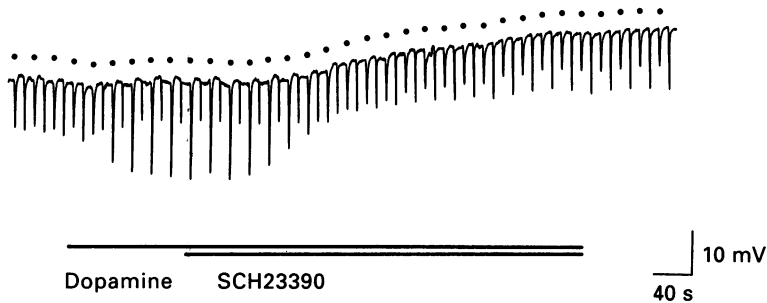

Fig. 4. SCH23390 ($15 \mu\text{M}$) blocks effect of exogenous dopamine ($80 \mu\text{M}$) on horizontal cell responses to centre and surround illumination. Dark-adapted retina. Responses to alternating spot and annulus stimuli. Spot responses indicated by dots. Irradiances of spot and annulus stimuli were 9.3 and 9.6 log quanta $\text{cm}^{-2} \text{s}^{-1}$, respectively. Resting potential was -26 mV.

even after washing for up to 30 min. SCH23390 caused a decrease in the spot response and an increase in the annulus response in all of seventeen cells tested, each from a different retina. The changes in amplitude of the spot and annulus responses were less pronounced in dark-adapted than in light-adapted retinas. The spot-annulus ratio was decreased to $40 \pm 5\%$ of the control value in light-adapted retinas ($n = 7$), and to $68 \pm 8\%$ of the control value in dark-adapted retinas ($n = 10$). SCH23390 also caused a slight depolarization of the membrane in darkness (5.1 ± 1.2 mV in light-adapted retinas ($n = 7$) and 5.9 ± 5.7 mV in dark-adapted retinas ($n = 10$)), but this is probably another effect not related to the change in coupling, since a change in coupling alone should not affect the membrane potential in darkness.

The specificity of SCH23390 was also verified. In dark-adapted retinas, where 10 – $20 \mu\text{M}$ -dopamine or SKF38393 normally caused a large increase in the spot-annulus response ratio, neither 80 – $100 \mu\text{M}$ -dopamine ($n = 3$) or $100 \mu\text{M}$ -SKF38393 ($n = 2$) had any effect in the presence of $15 \mu\text{M}$ -SCH23390. In fact, $15 \mu\text{M}$ -SCH23390 actually reversed the effect of these agonists on the spot-annulus response ratio. In the dark-adapted retina shown in Fig. 4, the addition of $80 \mu\text{M}$ -dopamine caused a large increase in the amplitude of the spot response and a decrease in the amplitude of the annulus response; while dopamine was still present, the subsequent addition of $15 \mu\text{M}$ -SCH23390 caused a reversal of the dopamine effect.

Comparison of effects of dopamine and SCH23390 in light- and dark-adapted retinas

Figure 5 summarizes the effects of dopamine and SCH23390 on the spot-annulus response ratio in light- and dark-adapted retinas. Dopamine caused an increase in the spot-annulus response ratio, with a much greater effect in dark-adapted than in

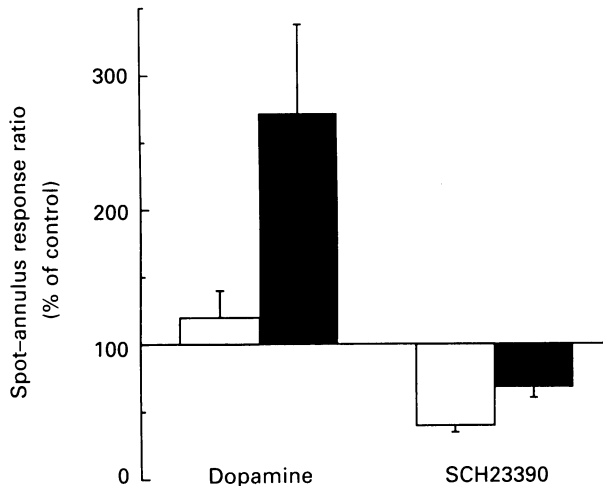

Fig. 5. Comparison of effects of dopamine and SCH23390 in light- and dark-adapted retinas. Ordinate indicates that spot-annulus response ratio relative to its control value; error bars indicate standard deviation. Open bars are from light-adapted retinas, filled bars from dark-adapted retinas. Dopamine increased the spot-annulus response ratio to $121 \pm 20\%$ of the control value in light-adapted retinas ($n = 7$) and to $272 \pm 66\%$ of the control value in dark-adapted retinas ($n = 13$). The difference between the effect of dopamine in dark- and light-adapted retinas was highly significant ($P < 0.001$, unpaired t test). SCH23390 ($15 \mu\text{M}$) decreased the spot-annulus response ratio to $68 \pm 8\%$ of the control values in light-adapted retinas ($n = 7$), and to $40 \pm 5\%$ of the control values in dark-adapted retinas ($n = 10$). The difference between the effect of SCH23390 in dark- and light-adapted retinas was highly significant ($P < 0.001$, unpaired t test).

light-adapted retinas, even though higher concentrations were used in the light-adapted retinas (see earlier text). This difference was highly significant ($P < 0.001$). On the other hand, SCH23390 caused a decrease in the spot-annulus response ratio, with a much greater effect in light-adapted than in dark-adapted retinas. This difference was also highly significant ($P < 0.001$). These results suggest that there is a tonic release of dopamine which is greater in light-adapted than in dark-adapted retinas. It is likely that the weak effect of exogenous dopamine in light-adapted retinas was due to a high endogenous release of dopamine under these conditions.

Effect of adapting illumination on horizontal cell responses to spot and annulus stimuli

The above indication that dopamine release is greater in light-adapted retinas was based on comparison of the effect of dopamine and SCH23390 in different retinas. Experiments were also carried out to determine if coupling resistance could be increased in a given retina by exposure to an adapting light, and if any such increase

in coupling resistance was mediated by dopamine. The recording in Fig. 6A was from a retina that had been dark adapted for more than one hour, after which the intensities of dim spot and annulus stimuli were adjusted to produce responses of approximately equal amplitude; in this case the spot response was slightly larger

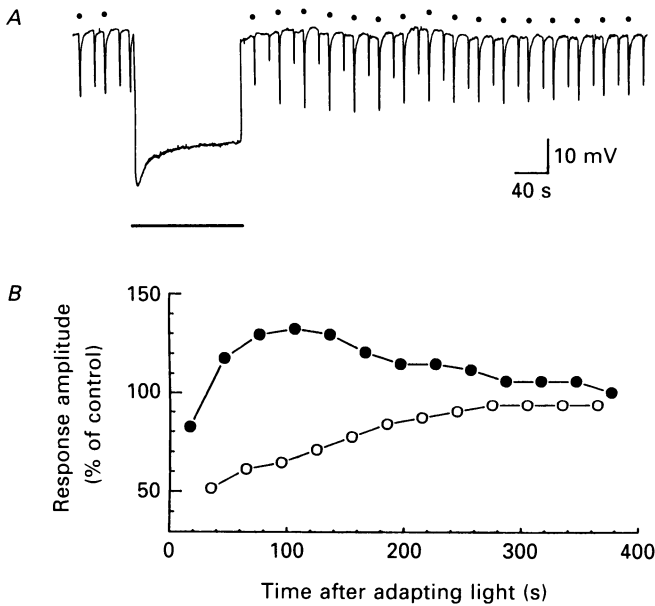

Fig. 6. Effect of adapting illumination on horizontal cell responses to centre and surround illumination. Dark-adapted retina. *A*, responses to alternating spot and annulus stimuli. Spot responses indicated by dots. Prior to exposure to the adapting illumination the response to the spot was slightly larger than the response to the annulus. Horizontal line below response trace indicates 2.5 min exposure of retina to diffuse adapting illumination ($9.9 \log \text{ quanta cm}^{-2} \text{ s}^{-1}$). Irradiances of spot and annulus test stimuli were also $9.9 \log \text{ quanta cm}^{-2} \text{ s}^{-1}$. Resting potential was -22 mV . *B*, amplitudes of spot (●) and annulus (○) responses at different times after termination of adapting light, relative to their respective values before onset of adapting light.

than the annulus response. The retina was then diffusely illuminated for 2.5 min (indicated by the horizontal line under the response trace); this adapting light, which was the same intensity as the small spot stimulus, produced a large, maintained hyperpolarization. After the end of the period of adapting illumination, the alternating spot and annulus test stimuli were resumed. Immediately after the termination of the adapting light both the spot and annulus responses were reduced in amplitude, probably due to desensitization of the photoreceptors by the adapting light. However, the response to the spot stimulus rapidly increased to an amplitude that was larger than before the exposure to the adapting light, while the response to the annulus remained smaller than it was before the adapting light, indicating that the adapting light caused a decrease in coupling between horizontal cells. The amplitudes of the spot and annulus responses gradually returned to their control values over the next few minutes. In Fig. 6B the amplitudes of the responses to the spot (●) and annulus (○) stimuli at different times after the termination of

the adapting light are plotted relative to their respective values before the onset of the adapting light. Results similar to those in Fig. 6 were seen in all of the fifteen dark-adapted retinas tested. In ten of these retinas the adapting light was presented again after the spot and annulus responses had recovered to their control values

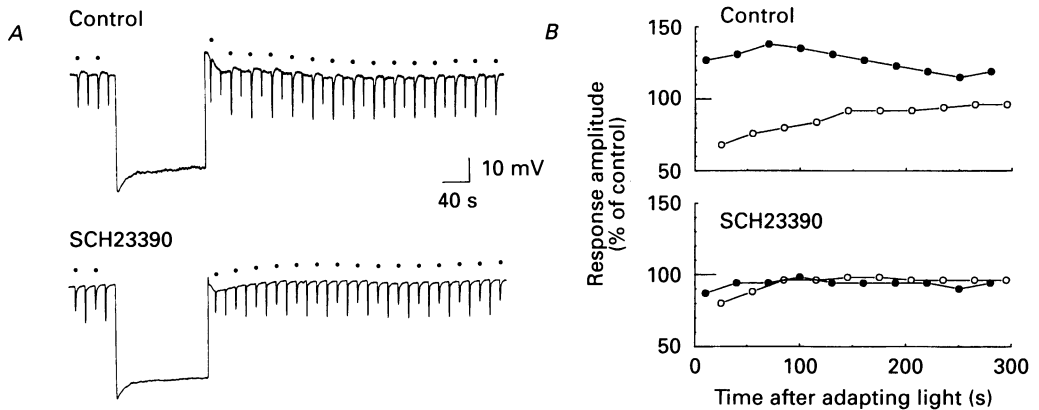

Fig. 7. SCH23390 prevents the uncoupling effect of adapting illumination. Dark-adapted retina. *A*, responses to alternating spot and annulus stimuli. Spot responses indicated by dots. Horizontal line below response trace indicates 2.5 min exposure of entire retina to adapting illumination ($10.1 \log \text{ quanta cm}^{-2} \text{ s}^{-1}$). Other details as in Fig. 6. The upper panel shows the effect of adapting illumination in normal Ringer solution; the lower panel shows the effect of the same adapting illumination in the presence of $15 \mu\text{M}$ -SCH23390. Lower trace begins 11 min after addition of drug. The interval between the two exposures to the adapting illumination was 19 min. Irradiances of spot and annulus test stimuli were 10.1 and $9.9 \log \text{ quanta cm}^{-2} \text{ s}^{-1}$, respectively. Resting potential was -27 mV . *B*, plot of spot (\bullet) and annulus (\circ) responses at different times after termination of adapting illumination, relative to their values before onset of the adapting illumination. Upper and lower panels show results in normal Ringer solution and in the presence of $15 \mu\text{M}$ -SCH23390, respectively.

(6–8 min after termination of first adapting exposure); in all of these cases, the subsequent exposures to the adapting light had the same effect on the spot and annulus responses as did the first exposure.

SCH23390 blocks the uncoupling effect of adapting light

The above results suggest that a relatively brief period of light adaptation can transiently decrease the amount of coupling between horizontal cells. If the uncoupling effect of the adapting light is mediated by an increase in dopamine release, then it should be blocked by D_1 -receptor antagonists. This was tested in the experiment illustrated in Fig. 7. In part *A* of this figure, the upper response trace is the control, showing the effect of the adapting light on the spot and annulus responses in this cell. Following the termination of the adapting light there was an increase in the spot response and a decrease in the annulus response, after which they gradually returned toward their pre-adaptation values. Shortly after the end of this trace $15 \mu\text{M}$ -SCH23390 was added to the superfusate; this caused a slight decrease

in the spot response and an increase in the annulus response (compare responses at the beginning of the lower trace, which begins 11 min after the addition of SCH23390, with those in the upper trace), suggesting that even in this dark-adapted retina there was still some tonic release of dopamine. In the presence of SCH23390

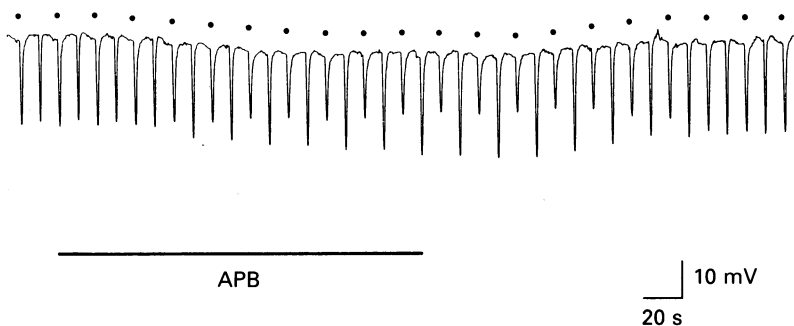

Fig. 8. Effect of $5 \mu\text{M}$ -APB on horizontal cell responses to centre and surround illumination. Light-adapted retina. Responses to alternating spot and annulus stimuli. Spot responses indicated by dots. Irradiances of spot and annulus stimuli were 10.5 and $11.3 \log \text{ quanta cm}^{-2} \text{ s}^{-1}$, respectively. Resting potential was -31 mV .

the same adapting illumination caused little change in the amplitudes of the spot and annulus responses. In control experiments it was established that in the absence of drug a second exposure to the adapting light always produced the same changes in spot and annulus responses as did the first exposure (see preceding section). Figure 7B plots the amplitudes of the spot (●) and annulus (○) responses at different times after the termination of the adapting illumination, relative to their values before the onset of the adapting light. The upper and lower graphs show these changes in normal Ringer solution and in the presence of SCH23390, respectively. This experiment was repeated in five other dark-adapted retinas, with similar results. The fact that SCH23390 prevented the uncoupling effect of the adapting light indicates that this effect was mediated by an increase in dopamine release.

Effect of APB on horizontal cell responses to spot and annulus stimuli

In order to test whether on-centre bipolar cells are involved in the uncoupling effect of light, we used the glutamate analogue 2-amino-4-phosphonobutyrate (APB), which causes a hyperpolarization of on-centre bipolar cells and blocks their responses to light (Slaughter & Miller, 1981). We previously reported that APB caused an apparent increase in coupling between horizontal cells in light-adapted mudpuppy retinas (Dong & McReynolds, 1989), and suggested that APB might cause a decrease in the release of a neuromodulator substance whose effect was to uncouple horizontal cells. An example is shown in Fig. 8, where it can be seen that $5 \mu\text{M}$ APB caused a decrease in the response to the small spot and an increase in the response to the annulus. Similar results were seen in twenty-nine of the thirty-one light-adapted retinas tested. In dark-adapted retinas APB caused much smaller changes in the spot and annulus responses. APB decreased the spot-annulus response ratio to $63 \pm 17\%$ of the control value in light-adapted retinas ($n = 31$) and to

$85 \pm 14\%$ of the control value in dark-adapted retinas ($n = 8$). The effect of APB on the spot–annulus ratios in light- and dark-adapted retinas was significantly different ($P < 0.01$, unpaired t test).

Since other postulated actions of APB, such as an increase in horizontal cell membrane resistance (Slaughter, 1986), or effects on synaptic transmission between

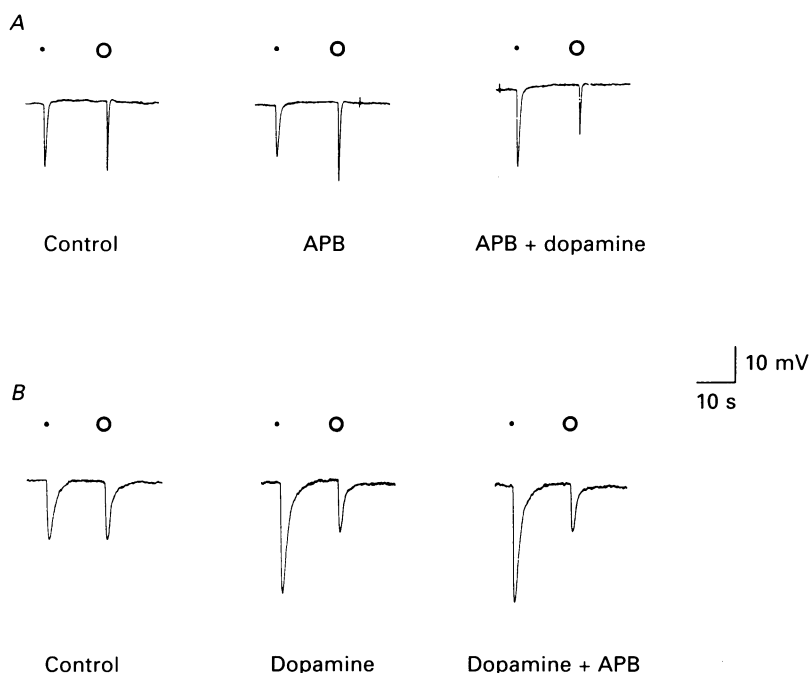

Fig. 9. Interacting effects of dopamine and APB on horizontal cell responses to spot and annulus stimuli. *A*, dopamine, reverses the effect of APB on horizontal cell spot–annulus response ratio. Light-adapted retina. Each trace shows a pair of responses, first to a small spot and then to an annulus, as indicated by symbols above responses. Responses on left were recorded before the addition of APB. Middle pair of responses begins 120 s after the addition of $5 \mu\text{M}$ -APB. Responses on right begin 30 s after addition of $20 \mu\text{M}$ -dopamine (APB still present). Irradiances of spot and annulus stimuli were both $10.5 \log \text{ quanta cm}^{-2} \text{ s}^{-1}$. Resting potential was -24 mV . *B*, APB does not reverse the effect of dopamine on horizontal cell spot–annulus response ratio. Dark-adapted retina. Each trace shows a pair of responses, first to a small spot and then to an annulus, as indicated by symbols above responses. Responses on left were recorded before the addition of dopamine. Middle pair of responses begins 5 min after the addition of $10 \mu\text{M}$ -dopamine. Responses on right begin 5 min after addition of $50 \mu\text{M}$ -APB (dopamine still present). Irradiances of spot and annulus stimuli were 9.7 and $9.3 \log \text{ quanta cm}^{-2} \text{ s}^{-1}$, respectively. Resting potential was -29 mV . *A* and *B* are from different retinas.

photoreceptors and horizontal cells (Nawy, Sie & Copenhagen, 1989), would not cause a decrease in spot responses and an increase in annulus responses, these changes most likely reflect an increase in coupling between horizontal cells. In most retinas APB also caused a slight hyperpolarization of horizontal cells in darkness ($3.7 \pm 2.8 \text{ mV}$, $n = 31$), but this was probably a separate effect since the dark potential should not be affected by a change in coupling resistance. Furthermore, the

opposite changes in spot and annulus responses were also seen in cells in which there was no change in the dark potential. The hyperpolarization in darkness might have been due to a postulated presynaptic effect of APB on cone terminals (Nawy *et al.* 1989). Since APB may act to decrease the endogenous release of dopamine (see below), the hyperpolarization of the membrane in darkness may also have been due to dopamine-modulated changes in responsiveness of glutamate receptors on horizontal cells (Knapp & Dowling, 1987).

Interacting effects of APB and dopamine

As noted above, exogenous dopamine had little effect on the spot and annulus responses in light-adapted retinas. However, it caused a rapid reversal of the increased coupling produced by APB in light-adapted retinas, as shown in Fig. 9A. In this figure, the left-hand pair of records shows the control responses after the intensities of the spot and annulus stimuli had been adjusted to produce responses of approximately equal amplitude. Within 120 s after the addition of 5 μM -APB the spot response became smaller and the annulus response larger (middle pair of records). Normally the effect of APB persisted as long as the drug was present. However, the addition of 20 μM -dopamine while APB was still present caused a rapid reversal of APB effect, as seen in the right-hand pair of records, which begin 30 s after the addition of dopamine. Similar results were seen in six of the seven retinas tested. Although not shown, the effect of APB on the spot and annulus responses was also reversed by the D₁ agonist SKF3893 (two of two cells), but not by the D₂ agonist LY171555 (three of three cells).

Although the above results are consistent with the hypothesis that APB acts by reducing the release of dopamine, they do not rule out the possibility that APB simply has a parallel action whose effect on horizontal cell coupling is opposite to that of dopamine. In such a case the addition of APB should counteract to some extent the effect of exogenous dopamine. However, APB had no effect when it was added in the presence of dopamine, as shown in Fig. 9B which is from a dark-adapted retina. The left-hand pair of records are control responses made after the intensities of the spot and annulus stimuli were adjusted to produce responses of approximately equal amplitude. The addition of 10 μM -dopamine caused an increase in amplitude of the spot response and a decrease in amplitude of the annulus response (middle pair of records). In the continued presence of dopamine, the addition of 50 μM -APB had no effect on the amplitudes of the spot and annulus responses, even after a 5 min exposure (right-hand pair of records). Similar results were seen in five of six cells tested. The findings that exogenous dopamine could reverse the effect of APB, whereas APB could not reverse the effect of exogenous dopamine, suggest that APB increases horizontal cell coupling by reducing the release of dopamine.

APB blocks the uncoupling effect of light adaptation

We also investigated whether APB could prevent the effect of an adapting light on coupling between horizontal cells. Figure 10 shows the results of such an experiment, in another dark-adapted retina. In part A the upper trace shows the normal effect of the adapting light on the spot and annulus responses in this cell. As usual, the adapting light caused an increase in the spot response and a decrease in the annulus

response, indicating a decrease in coupling. Then $50 \mu\text{M}$ -APB was added; the middle trace begins 5 min after the addition of APB. APB caused a slight decrease in the spot response and increase in the annulus response (compare the responses at the beginning of the middle trace with those in the upper trace), which suggests that there

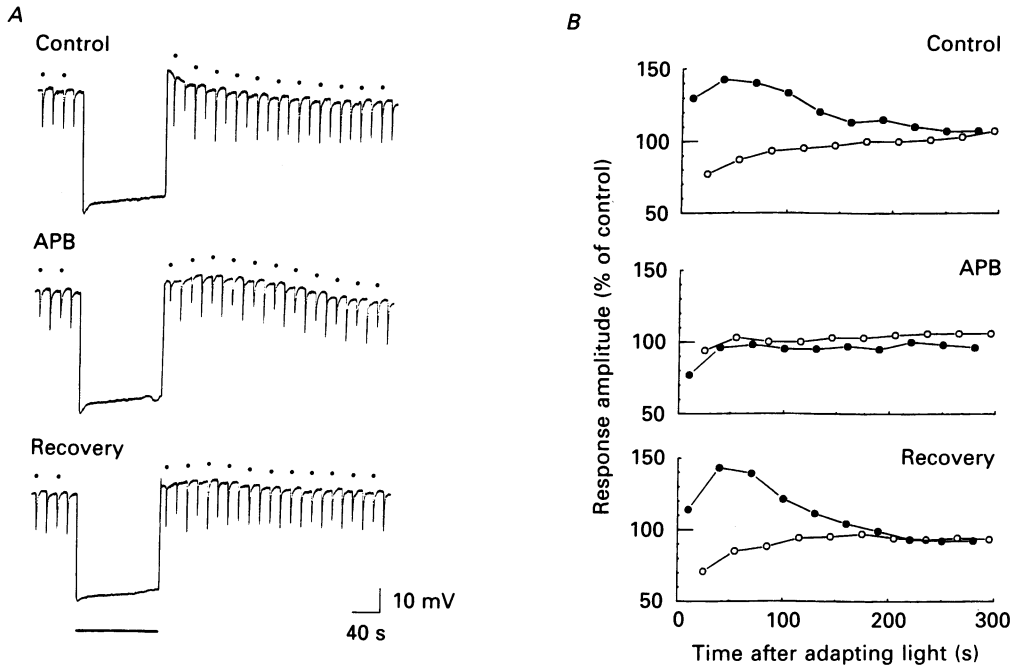

Fig. 10. APB prevents the uncoupling effect of adapting illumination. Dark-adapted retina. *A*, responses to alternating spot and annulus stimuli. Spot responses indicated by dots. Horizontal line below response trace indicates 2.5 min exposure of entire retina to adapting illumination ($9.7 \log \text{ quanta cm}^{-2} \text{ s}^{-1}$). Other details as in Fig. 7. The upper panel shows the effect of adapting illumination in normal Ringer solution and the middle panel shows the effect of the same adapting illumination in the presence of $50 \mu\text{M}$ -APB. Middle trace begins 5 min after addition of drug. The interval between the two exposures to the adapting illumination was 11 min. The lower panel shows recovery of the effect of the same adapting illumination, 13 min after returning to normal Ringer solution. Resting potential was -25 mV . Irradiances of spot and annulus test stimuli were both $9.7 \log \text{ quanta cm}^{-2} \text{ s}^{-1}$. *B*, plot of spot (●) and annulus (○) responses at different times after termination of adapting illumination, relative to their values before onset of the adapting illumination. Upper, middle and lower panels show results in normal Ringer solution, in the presence of $50 \mu\text{M}$ -APB, and 13 min after returning to normal Ringer solution, respectively.

was some tonic release of dopamine in this dark-adapted retina. However, in the presence of APB the adapting light did not cause an increase in the spot response or a decrease in the annulus response, indicating that APB prevented the decrease in coupling normally produced by the adapting light. The uncoupling effect of the adapting illumination was observed again when APB was washed out (lower trace). Figure 10*B* plots the amplitudes of the spot (●) and annulus (○) responses at different times after the termination of the adapting illumination, relative to their

values before onset of the adapting light. The upper, middle and lower graphs show the results in normal Ringer solution, in the presence of APB, and after return to normal Ringer solution, respectively. APB prevented the light-evoked increase in spot response and decrease in annulus response in all of the six dark-adapted retinas tested.

DISCUSSION

Dopamine modulates coupling between horizontal cells in mudpuppy retina

The finding that dopamine caused an increase in the amplitude of the responses to small, centred spot stimuli and a decrease in the responses to concentric annuli suggests that dopamine caused an increase in coupling resistance (i.e. a decrease in coupling) between horizontal cells. This conclusion seems reasonable, since the finding that dopamine caused a decrease in responses to diffuse illumination indicates that the net effect of dopamine on resistances other than coupling resistance was to decrease the amplitude of the light response. This does not imply that dopamine was without effect on synaptic resistance, merely that under our conditions its effects on membrane resistance, including any change in synaptic resistance, were unlikely to have caused the observed increase in spot response amplitude.

Although the results indicate that there was a change in coupling resistance, the actual amount of this change cannot be calculated because the amplitudes of the spot and annulus responses may also have been affected by unknown changes in membrane resistance. However, in the experiments like that shown in Fig. 2, in which small spot and full-field stimuli were used, it was possible to estimate the length constant, using the relationship shown in Fig. 2 of Lamb (1976). In these experiments 20 μM -dopamine caused a $42 \pm 5\%$ (mean \pm s.d.) decrease in the length constant. Since the length constant of the horizontal cell network is the square root of the ratio of the membrane resistance ($\Omega \text{ cm}^2$) to the coupling resistance (Ω) (Lamb, 1976), it could be calculated that the coupling resistance would have had to increase by about a factor of three to account for the decrease in length constant if there were no change in membrane resistance. Since it is likely that there was also a decrease in membrane resistance, the actual increase in coupling resistance was probably less than this. Although the actual amount of change in coupling resistance could not be calculated, the changes in spot-annulus response ratio do provide a numerical measure of the relative effectiveness of dopamine and other agents under different conditions (e.g. for dopamine in light- and dark-adapted retinas).

The fact that the effects of the D_1 antagonist SCH23390 on spot and annulus responses were opposite to those of dopamine further indicates that horizontal cell coupling is normally regulated by endogenous dopamine. Thus the modulatory action of dopamine on horizontal cell coupling in the mudpuppy is similar to that in fish and turtle retinas (Teranishi *et al.* 1983; Piccolino *et al.* 1984).

Dopamine release appears to be greater in light-adapted retinas

The present results provide electrophysiological evidence that dopamine release affecting horizontal cell coupling is greater in light-adapted than in dark-adapted retinas. This is of interest since previous electrophysiological results in fish indicated

that dopamine release affecting horizontal cell coupling was increased with prolonged dark adaptation (Mangel & Dowling, 1985, 1987; Tornqvist *et al.* 1988). The present results also indicate that a substantial, although transient, increase in dopamine release can be elicited by much briefer and dimmer light stimuli than previously shown. Although the results indicate that the release of dopamine was reduced in dark-adapted retinas, there seems to be a tonic, low-level release of dopamine even in dark-adapted retinas, since the effects of SCH23390 and APB in dark-adapted retinas were similar to, but weaker than, their effects in light-adapted retinas. This observation is consistent with biochemical studies in fish retinas indicating that a low, basal level release of dopamine is maintained during prolonged darkness (Kirsch & Wagner, 1989; Weiler *et al.* 1989).

Source of endogenous dopamine release in mudpuppy retina

The identity of the dopamine-releasing neurons in the mudpuppy retinas is not known. In fish it is thought that dopamine is released by interplexiform cells, which synapse onto horizontal cells (Dowling & Ehinger, 1978), but in the turtle, which lacks dopaminergic interplexiform cells, dopamine is probably released by a type of amacrine cell and reaches the horizontal cells by diffusion (Witkovsky *et al.* 1984; Nguyen-Legros *et al.* 1985). There is histochemical evidence for dopamine-containing neurons in the inner retina of mudpuppy (Brunn *et al.* 1985), but it is not known whether any of these cells are interplexiform cells.

Pathway by which light modulates horizontal cell coupling

The experiments with APB are of particular interest because they provide some clues about the pathway by which light regulates the release of dopamine and thereby horizontal cell coupling. First, the effect of APB on coupling was the same as that of D_1 -receptor antagonist SCH23390. Second, exogenous dopamine could reverse the effect of APB on coupling, but APB was ineffective in the presence of dopamine. Third, the effect of light adaptation on coupling could be blocked by either SCH23390 or APB. These findings suggest that light stimulates the release of dopamine by a pathway which involves an APB-sensitive synapse. Since the only pathway from photoreceptors to the inner retina which is blocked by APB is via on-centre bipolar cells (Slaughter & Miller, 1981), it is likely that the pathway by which light affects dopamine release is mainly via on-centre bipolar cells.

The postulated pathway by which light and APB affect horizontal cell coupling is shown in Fig. 11. A sign-preserving connection between on-centre bipolar cells (DB) and dopaminergic cells (DA) is shown as monosynaptic for simplicity, but it is possible that this connection is via one or more interneurons (see below). Adapting illumination would cause a depolarization of on-centre bipolar cells, an increase in dopamine release, and a decrease in coupling between horizontal cells. APB, which mimics the effect of photoreceptor transmitter on on-centre bipolar cells (Slaughter & Miller, 1981), would have the opposite effect, i.e. it would cause a hyperpolarization of on-centre bipolar cells, a decrease in dopamine release, and an increase in coupling between horizontal cells. Since APB prevents light-evoked depolarization of on-centre bipolar cells, it would also prevent the uncoupling effect of adapting illumination.

In both fish and turtle retinas there is evidence that the dopamine-releasing cells receive a tonic, inhibitory GABA input, presumably from amacrine cells (Piccolino, Neyton, Witkovsky & Gerschenfeld, 1982; Negishi, Teranishi & Kato, 1983). This input could be in parallel to the excitatory input shown in Fig. 11, or the GABA-

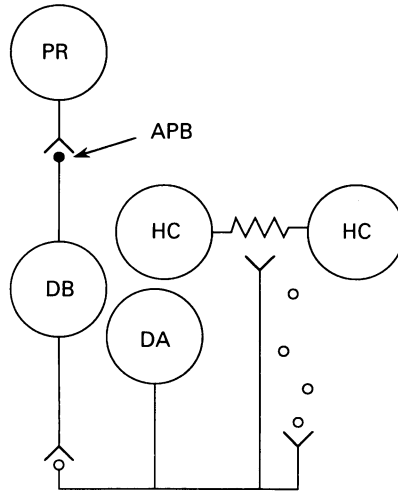

Fig. 11. Possible pathway by which light, APB and dopamine might affect coupling between horizontal cells. Large circles represent different cell types: PR, photoreceptor; DB, on-centre bipolar cell; HC, horizontal cell; DA, dopamine-releasing cell. At postsynaptic sites open symbols indicate excitatory (sign-preserving) synaptic action and filled symbols indicate inhibitory (sign-reversing) synaptic action. For the dopaminergic cell, two possible sites of transmitter release are indicated, depending on whether this cell is an amacrine or interplexiform cell. Arrow indicates site of APB action, which is the same as that of the photoreceptor transmitter on on-centre bipolar cells. A direct, sign-preserving connection from DB to DA cells is shown for convenience, but this connection may be via interneurons as described in the text.

releasing cells could be located between the on-centre bipolar cells and the dopamine-releasing cells. In the latter case, in order to maintain the overall sign-preserving character of the connection between the on-centre bipolar cells and dopamine-releasing cells, the effect of the bipolar-cell transmitter on the GABA-releasing amacrine cell would have to be hyperpolarizing, or there would have to be an additional sign-reversing synapse between the on-centre bipolar cell and the GABA-releasing amacrine cell.

The role of off-centre bipolar cells in the regulation of horizontal cell coupling can not be tested as directly, since all agents which block the responses of off-centre bipolar cells to light also block the responses of horizontal cells. However, since the responses of off-centre bipolar cells are not significantly suppressed by APB (Slaughter & Miller, 1981) the lack of effect of the adapting light on coupling in the presence of APB suggests that off-centre bipolar cells do not play a major role in the regulation of dopamine release by steady light.

In summary, the results of this study suggest that in the mudpuppy retina dopamine increases coupling resistance between horizontal cells via an action at D_1

receptors, that there is a tonic release of dopamine which is greater in light than in darkness, and that the retinal pathway by which steady light stimulates dopamine release is probably via on-centre bipolar cells.

We thank Drs Reto Weiler and Josef Ammermüller for reading the manuscript. This work was supported by NIH Grants EY-01653 and EY-07003.

REFERENCES

- BALDRIDGE, W. H., BALL, A. K. & MILLER, R. G. (1987). Dopaminergic regulation of horizontal cell gap junction particle density in goldfish retina. *Journal of Comparative Neurology* **265**, 428–436.
- BOATRIGHT, J. H., HOEL, M. J. & IUVONE, P. M. (1989). Stimulation of endogenous dopamine release and metabolism in amphibian retina by light- and K⁺-evoked depolarization. *Brain Research* **482**, 164–168.
- BRUNN, A., EHINGER, B. & TORNVIST, K. (1985). Neurotransmitters in the retina of the mudpuppy, *Necturus maculosus*. In *Neurocircuitry of the Retina: A Cajal Memorial*, ed. GALLEGO, A. & GOURAS, P., pp. 152–160. Elsevier, Amsterdam.
- COLBURN, T. R. & SCHWARTZ, E. A. (1972). Linear voltage control of current passed through a micropipette with variable resistance. *Medical and Biological Engineering* **10**, 504–509.
- DEVRIES, S. H. & SCHWARTZ, E. A. (1989). Modulation of an electrical synapse between solitary pairs of catfish horizontal cells by dopamine and second messengers. *Journal of Physiology* **414**, 351–375.
- DONG, C.-J. & McREYNOLDS, J. S. (1989). APB increases apparent coupling between horizontal cells in mudpuppy retina. *Vision Research* **29**, 541–544.
- DOWLING, J. E. & EHINGER, B. (1978). The interplexiform cell system. I. Synapses of the dopaminergic neurons in the goldfish retina. *Proceedings of the Royal Society B* **201**, 7–26.
- DUBOCOVICH, M. L. & WEINER, N. (1985). Pharmacological differences between the dopamine receptors of the D1 and D2 subtype in the rabbit retina. *Journal of Pharmacology and Experimental Therapeutics* **233**, 747–754.
- GODLEY, B. F. & WURTMAN, R. J. (1988). Release of endogenous dopamine from the superfused rabbit retina *in vitro*: effect of light stimulation. *Brain Research* **452**, 393–395.
- KANEKO, A. (1971). Electrical connexions between horizontal cells in the dogfish retina. *Journal of Physiology* **213**, 95–105.
- KIRSCH, M. & WAGNER, H. J. (1989). Release pattern of endogenous dopamine in teleost retinae during light adaptation and pharmacological stimulation. *Vision Research* **29**, 147–154.
- KNAPP, A. G. & DOWLING, J. E. (1987). Dopamine enhances excitatory amino acid-gated conductances in cultured retinal horizontal cells. *Nature* **325**, 437–439.
- KURZ-ISLER, G. & WOLBURG, H. (1986). Gap junctions between horizontal cells in the cyprinid fish alter rapidly their structure during light and dark adaptation. *Neuroscience Letters* **67**, 7–12.
- LAMB, T. D. (1976). Spatial properties of horizontal cell responses in the turtle retina. *Journal of Physiology* **263**, 239–255.
- LASATER, E. M. & DOWLING, J. E. (1985). Dopamine decreases conductance of the electrical junctions between cultured retinal horizontal cells. *Proceedings of the National Academy of Sciences of the USA* **82**, 3025–3029.
- MANGEL, S. C. & DOWLING, J. E. (1985). Responsiveness and receptive field size of carp horizontal cells are reduced by prolonged darkness and dopamine. *Science* **229**, 1107–1109.
- MANGEL, S. C. & DOWLING, J. E. (1987). The interplexiform–horizontal cell system of the fish retina: effects of dopamine, light stimulation and time in the dark. *Proceedings of the Royal Society B* **231**, 91–121.
- MIYACHI, E.-I. & MURAKAMI, M. (1989). Decoupling of horizontal cells in carp and turtle retinae by intracellular injection of cyclic AMP. *Journal of Physiology* **419**, 213–224.
- NAWY, S., SIE, A. & COPENHAGEN, D. R. (1989). The glutamate analog 2-amino-4-phosphonobutyrate antagonizes synaptic transmission from cones to horizontal cells in the goldfish retina. *Proceedings of the National Academy of Sciences of the USA* **86**, 1726–1730.

- NEGISHI, K., TERANISHI, T. & KATO, S. (1983). A GABA antagonist, bicuculline, exerts its uncoupling action on external horizontal cells through dopamine cells in carp retina. *Neuroscience Letters* **37**, 261–266.
- NGUYEN-LEGROS, J., VERSAUX-BOTTERI, C., VIGNY, A. & RAOUX, N. (1985). Tyrosine hydroxylase immunohistochemistry fails to demonstrate dopaminergic interplexiform cells in the turtle retina. *Brain Research* **339**, 323–328.
- PICCOLINO, M., NEYTON, J. & GERSCHENFELD, H. M. (1984). Decrease of gap junction permeability induced by dopamine and cyclic adenosine 3':5'-monophosphate in horizontal cells of turtle retina. *Journal of Neuroscience* **4**, 2477–2488.
- PICCOLINO, M., NEYTON, J., WITKOVSKY, P. & GERSCHENFELD, H. M. (1982). γ -Aminobutyric acid antagonists decrease junctional communication between horizontal cells of the retina. *Proceedings of the National Academy of Sciences of the USA* **79**, 3671–3675.
- SLAUGHTER, M. M. (1986). APB receptors on off bipolars and horizontal cells. *Investigative Ophthalmology and Visual Science* **27**, suppl., 130.
- SLAUGHTER, M. M. & MILLER, R. F. (1981). 2-amino-4-phosphonobutyric acid: a new pharmacological tool for retina research. *Science* **211**, 182–185.
- TERANISHI, T., NEGISHI, K. & KATO, S. (1983). Dopamine modulates S-potential amplitude and dye-coupling between external horizontal cells in carp retina. *Nature* **301**, 243–246.
- TORNQVIST, K., YANG, X.-L. & DOWLING, J. E. (1988). Modulation of cone horizontal cell activity in the teleost fish retina. III. Effects of prolonged darkness and dopamine on electrical coupling between horizontal cells. *Journal of Neuroscience* **8**, 2279–2288.
- VAN BUSKIRK, R. & DOWLING, J. E. (1981). Isolated horizontal cells from carp retina demonstrate dopamine-dependent accumulation of cyclic AMP. *Proceedings of the National Academy of Sciences of the USA* **78**, 7825–7829.
- WEILER, R., KOLBINGER, W. & KOHLER, K. (1989). Reduced light responsiveness of the cone pathway during prolonged darkness does not result from an increase of dopaminergic activity in the fish retina. *Neuroscience Letters* **99**, 214–218.
- WITKOVSKY, P., ELDRRED, W. & KARTEN, H. J. (1984). Catecholamine and indoleamine-containing neurons in the turtle retina. *Journal of Comparative Neurology* **228**, 217–225.
- WITKOVSKY, P. & SHI, X.-P. (1990). Slow light and dark adaptation of horizontal cells in the *Xenopus* retina: a role for endogenous dopamine. *Visual Neuroscience* **5**, 405–413.