

C57

Stuart B. Cohen

April 1981
346780

Correlation Allowances for Two Large, Full Form
Merchant Ships Determined From
Model Tests and Full Scale Trials

by

Stuart B. Cohen
Principal Investigator

for

Hydronautics, Inc.
Project Coordinator

Initiated by
U.S. Maritime Administration, Dept. of Commerce



April 1981
346780

Correlation Allowances for Two Large, Full Form
Merchant Ships Determined from Model Tests and Full Scale Trials

by

Stuart B. Cohen
Principal Investigator

for

Hydronautics, Inc.
Project Coordinator

Initiated by
U.S. Maritime Administration, Dept. of Commerce

CONTENTS

	Page
LIST OF TABLES AND FIGURES	i
INTRODUCTION	1
FULL SCALE SHIP DESCRIPTION	1
MODELS AND METHODOLOGY	2
RESULTS AND DISCUSSION	3
REFERENCES	4

INTRODUCTION

Several years ago, The Society of Naval Architects and Marine Engineers through its Panel H-2 (Resistance and Propulsion), conducted a survey of U.S. ship owners, designers and builders which indicated that increased knowledge of the correlation allowances for very large, full form merchant ships was needed. In response to this, the Maritime Administration agreed to fund the construction of four model hulls and propellers, to be tested by the David W. Taylor Naval Ship R&D Center (DTNSRDC), the University of Michigan, and Hydronautics, Inc. The full scale trial data were provided by private oil companies from the builder's trials. The tank tests were provided without charge by each of the model basins as their schedules permitted. Overall project administration and the actual model construction of hulls and propellers was done by Hydronautics, Inc. Model test results of DTNSRDC and Hydronautics can be found in reference [1]. The University of Michigan tested only models 7668-1 (Ship "A") and model 7668-2 (Ship "B") while all four models were tested by Hydronautics and DTNSRDC. In addition, the open water curves were produced by Hydronautics and provided to the other institutions.

FULL SCALE SHIPS

Three single screw merchant vessels of typical proportions that had well documented trials data were chosen for the four models. Table 1 and 2 list the principal hull and propeller characteristics and trial data of the two ships whose models were tested at the University of Michigan. Identification of the ships are limited to model numbers at the request of the private companies providing the trial data. Figures 1 to 4 reproduced from reference [5] show the lines and stern details of the two ships. The full scale data as used for this report were not corrected for still air drag, wind or currents.

MODELS AND METHODOLOGY

Three fiberglass models were built to different scale ratios such that the model propellers were about 8" in diameter and yet the hull size would be less than 26' to avoid large blockage effects in the smaller tanks. (The fourth model was a larger geosim of the smallest.) Table 3 contains the principal characteristics of the model hulls and propellers. Each model had a row of studs placed on the bulbous bow about midway between the bulb end and the forward perpendicular, and another row of studs at approximately $L/20$ aft of the F.P. In addition, a trip wire was placed in the area of the beginning of the parallel midbody to prevent separation at that point. Only model 7668-1 had bilge keels, and was repainted with grey rubber paint after leaks in the bilge keel due to damage in transport were sealed.

A standard EHP test (with rudder) was performed at full load draft and followed by an SHP test using the standard British overload-underload procedure as described in reference [3]. The propellers and open water curves used, Figures 5 and 6, were those provided by Hydronautics. A correlation allowance was chosen to match the model data to fullscale data (uncorrected for still air) at a ship speed of 15.5 knots, chosen as typical tanker service speed. Both models required a blockage correction and the subcritical blockage corrector of reference [2] was used with the skin friction determined from the ITTC friction line. No correction of RPM was made although in light of the discussion in reference [1] it appears the standard ITTC correction factor [4] could be applied with satisfactory results. The SHP directly comparable to the trial SHP was calculated from the tank measured DHP increased by 2.0%, to correct for stern tube friction in machinery aft single screw ships.

RESULTS AND DISCUSSION

The SHP and RPM predictions and full scale measurements are shown in Figures 7 and 8 based on correlation allowances below zero; C_A for model 7668-1 was $-.00032$ and for model 7668-2 was $-.00018$ (see Figure 9 from ref. [1]).

In comparing these values to results from other tanks we note the following:

- 1) A correction for air resistance (DTNSRDC's method in ref [1]) would make each C_A value more negative by 0.00009 .
- 2) The results are sensitive to the blockage correction applied and are less negative than if Scott's earlier [ref 6] corrector is used. The present semi-empirical corrector seems sound on theoretical grounds and is endorsed by the 13th ITTC Performance Committee [ref 4].
- 3) The subcritical blockage corrector that was applied is based on data from 2×1 rectangular tanks. The sectional area used for our non-rectangular cross section tank is based on the actual depth with the width defined as twice the depth. This has been found to be accurate in other full scale comparisons.
- 4) For a valid comparison with ship trials, a machinery transmission coefficient must be used if SHP rather than DHP is measured. We applied a 2% increase to DHP for comparison to the trials' SHP data. For these ships a 1% loss in transmission efficiency corresponds to about -0.00002 change in C_A .
- 5) The effects of wind, waves and current are sometimes compensated in C_A values or in an additional "allowance for trials" depending on individual institutions' practice. Since no environmental data was available from the trials data, the effect is unknown and neglected in this study. If trials were made on days that were not essentially calm, the C_A values probably will be more negative.

The above factors tend to make the correlation allowance more positive. Therefore, we conclude that calculated values are probably not as negative as they should be had perfect information been available.

REFERENCES

1. Day and Kirkman, "Correlation of Model Experiments with Ships Powering Data for Large, Full-Form Merchant Ships," Proceedings of the 19th American Towing Tank Conference, Ann Arbor Science Publishers, 1980.
2. Scott, J.R., "Blockage Correction at Sub-Critical Speeds," T.R.I.N.A., p. 169, 1976.
3. "Standard Procedure for Resistance and Propulsion Experiments with Ship Models," [N.P.L Report S.H.R. 10/59 revised], issued by the British Towing Tank Panel, 9th ITTC Proceedings, pp. 237-258, 1960.
4. Appendix 1 of the Report of the Performance Committee, 13th ITTC Proceedings, Vol. 1, p. 167, 1972.
5. "Towing Tank Correlation Studies for Large, Full Form Merchant Ships," published March 1979 by Hydronautics, Inc., for the Office of Commercial Development, Maritime Administration.
6. Scott, J.R., "A Comparison of Two Ships Resistance Correctors," T.R.I.N.A., p. 380, 1971.
7. Tamura, K., "Speed and Power Prediction Techniques for High Block Ships Applied in Nagasake Experimental Tank," Proceedings of the 1st STAR Symposium, SNAME, 1975.

TABLE 1

FULL-SCALE INFORMATION FOR SHIP "A" (Model 7668-1)

Length Overall	317.0 m	1040.0 ft
Length Between Perpendiculars	300.0 m	984.2 ft
Beam	50.0 m	164.0 ft
Draft Forward	20.70 m	67.9 ft
Draft Aft	20.72 m	68.0 ft
Displacement	267,763 tonne	263,550 LTSW
Wetted Surface	24,190 m ²	260,382 ft ²
Propeller Diameter	9.208 m	30.2 ft
Propeller Pitch	6.265 m	20.6 ft
Number of Blades		5
C _B		.841

TRIAL DATA

Ship Speed		Ship Speed Corrected for Still Air Drag (DTNSRDC)		Metric Horsepower	British Horsepower	kilowatts	Propeller Speed
knots	m/s	knots	m/s				RPM
12.70	6.53	12.87	6.62	16,400	16,180	12,060	64.9
15.00	7.72	15.20	7.82	24,875	24,530	18,300	74.9
16.40	8.44	16.60	8.54	33,100	32,650	24,340	82.5

TABLE 2

FULL-SCALE INFORMATION FOR SHIP "B" (Model 7668-2)

Length Overall	347.8 m	1141.1 ft
Length Between Perpendiculars	329.2 m	1080.0 ft
Beam	51.8 m	169.9 ft
Draft Forward	18.74 m	61.5 ft
Draft Aft	19.39 m	63.6 ft
Displacement	276,850 tonne	272,490 LTSW
Wetted Surface	26,216 m ²	282,180 ft ²
Propeller Diameter	9.392 m	30.8 ft
Propeller Pitch	6.668 m	21.9 ft
Number of Blades		4
C _B		.831

TRIAL DATA

Ship Speed		Ship Speed Corrected for Still Air Drag (DTNSRDC)		Metric Horsepower	British Horsepower	kilowatts	Propeller Speed
knots	m/s	knots	m/s				RPM
12.55	6.46	12.72	6.54	13,400	13,220	9,858	61.0
13.90	7.15	14.09	7.25	19,050	18,790	14,012	68.2
15.42	7.93	15.63	8.04	26,550	26,190	19,530	76.2
16.28	8.38	16.49	8.48	32,300	31,860	23,758	81.2

TABLE 3

PRINCIPAL DIMENSIONS OF MODELS AND PROPELLERS

U-M Model Number	7668-1	7668-2
Scale Ratio (λ)	42.793	46.958
Length Overall	24.30 ft (7.407 m)	24.30 ft (7.407 m)
Length Between Perpendiculars	23.00 ft (7.010 m)	23.00 ft (7.010 m)
Beam	3.83 ft (1.167 m)	3.62 ft (1.103 m)
Draft Forward	1.587 ft (0.484 m)	1.308 ft (0.399 m)
Draft Aft	1.589 ft (0.484 m)	1.354 ft (0.413 m)
Displacement	7326 lbs (32.59 kN)	5732 lbs (25.50 kN)
Wetted Surface	142.19 ft ² (13.210 m ²)	127.97 ft ² (11.889 m ²)
HSMB propeller number	7668-1P	7668-2P
U-M propeller number	39	38
Propeller Diameter	0.7059 ft (0.215 m)	0.6573 ft (0.200 m)
Propeller Pitch at 0.7 Radius	0.4803 ft (0.146 m)	0.4667 ft (0.142 m)
Number of Blades	5	4

TABLE 4

RPM AND SHP PREDICTIONS FOR SHIP "A"

from Model 7668-1

V_m	J_m	J_T	$1-W_T$	$1-W_Q$	$1-t$
3.00	.698	.317	.454	.506	.663
3.25	.703	.317	.451	.521	.677
3.50	.700	.315	.450	.504	.676
3.75	.700	.315	.450	.514	.686
4.00	.693	.313	.452	.522	.687
4.25	.689	.317	.460	.512	.696
4.50	.686	.307	.448	.510	.681

V_K	EHP	RPM	DHP	η_H	η_D	η_R	SHP
11.62	7071	55.8	12255	1.460	.628	1.029	11480
12.59	9045	60.1	13774	1.501	.657	1.047	14050
13.56	11430	65.0	17716	1.502	.645	1.032	18070
14.52	14280	69.6	21609	1.524	.661	1.043	22040
15.49	17780	75.0	26922	1.520	.660	1.054	27460
16.46	21650	80.1	33399	1.513	.648	1.025	34070
17.43	25960	85.2	40500	1.520	.641	1.036	41310

TABLE 5

RPM AND SHP PREDICTIONS FOR SHIP "B"

from Model 7668-2

V_m	J_m	J_T	$1-W_T$	$1-W_Q$	$1-t$
3.00	.714	.360	.504	.492	.780
3.25	.709	.360	.508	.504	.759
3.50	.714	.367	.514	.497	.780
3.75	.711	.362	.509	.502	.772
4.00	.709	.362	.511	.504	.767
4.25	.701	.352	.502	.509	.739
4.50	.697	.360	.516	.523	.754

V_K	EHP	RPM	DHP	η_H	η_D	η_R	SHP
12.17	8912	56.0	12870	1.548	.692	.959	13130
13.19	11190	61.1	16580	1.494	.675	.970	16910
14.20	13950	65.3	20370	1.518	.685	.948	20780
15.22	17290	70.1	25260	1.517	.684	.959	25770
16.23	20970	75.2	30910	1.501	.678	.961	31530
17.24	25430	80.8	38530	1.472	.660	.977	39300
18.26	30540	86.0	45770	1.461	.667	.980	46680

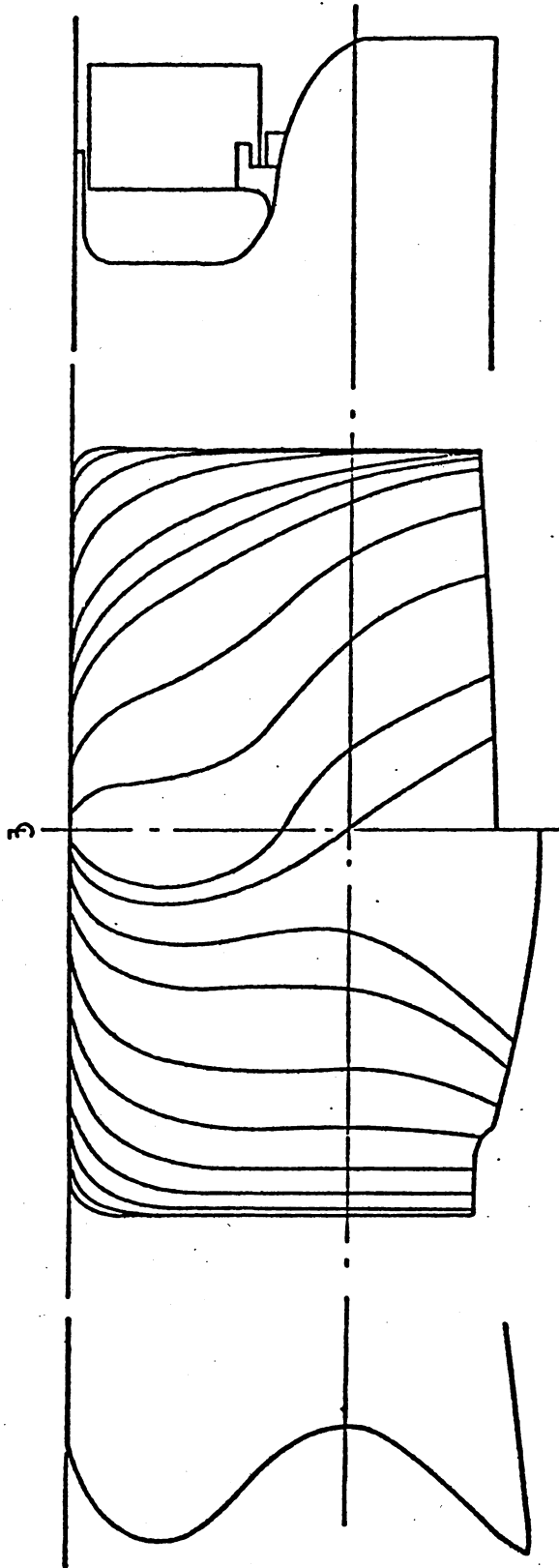

Fig 1 Lines of Ship "A"

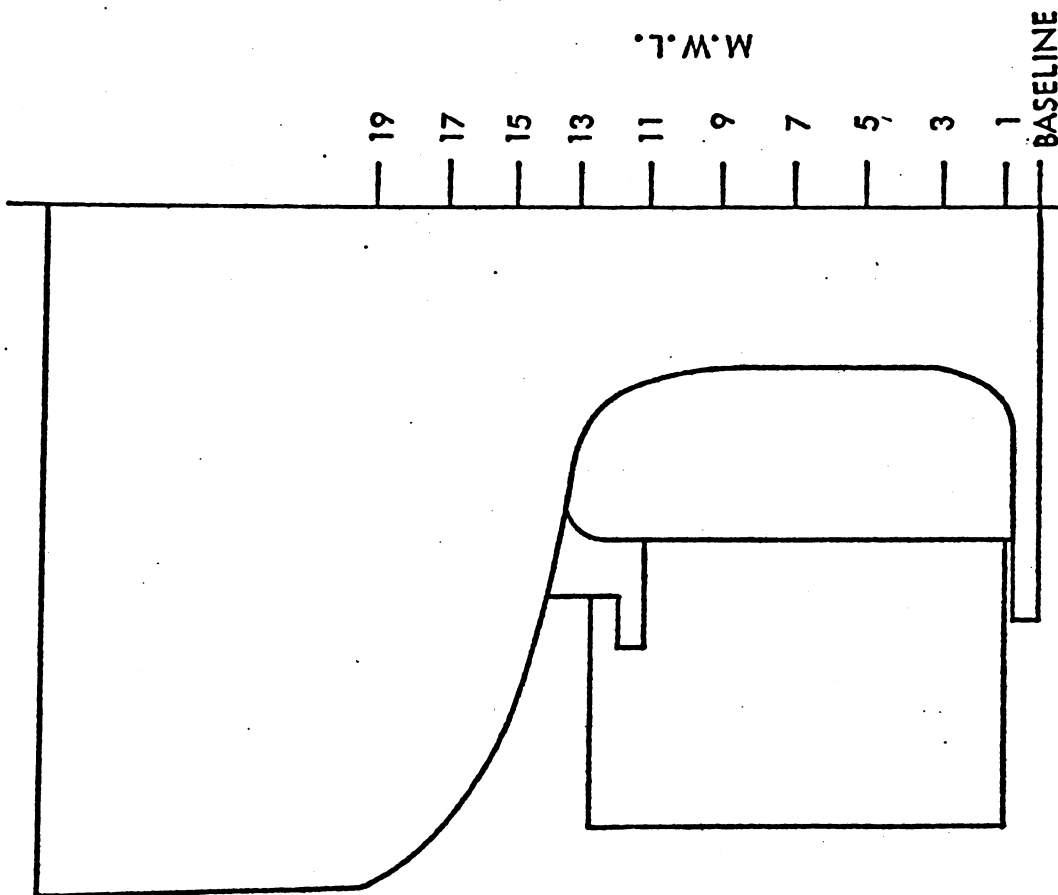
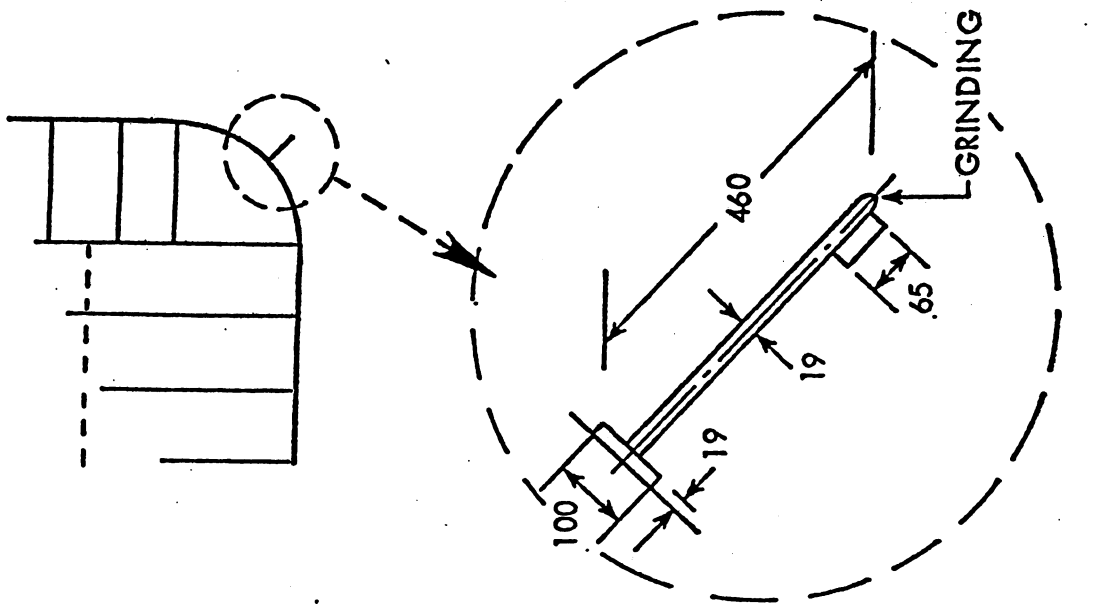

Fig 2 Details of Ship "A"

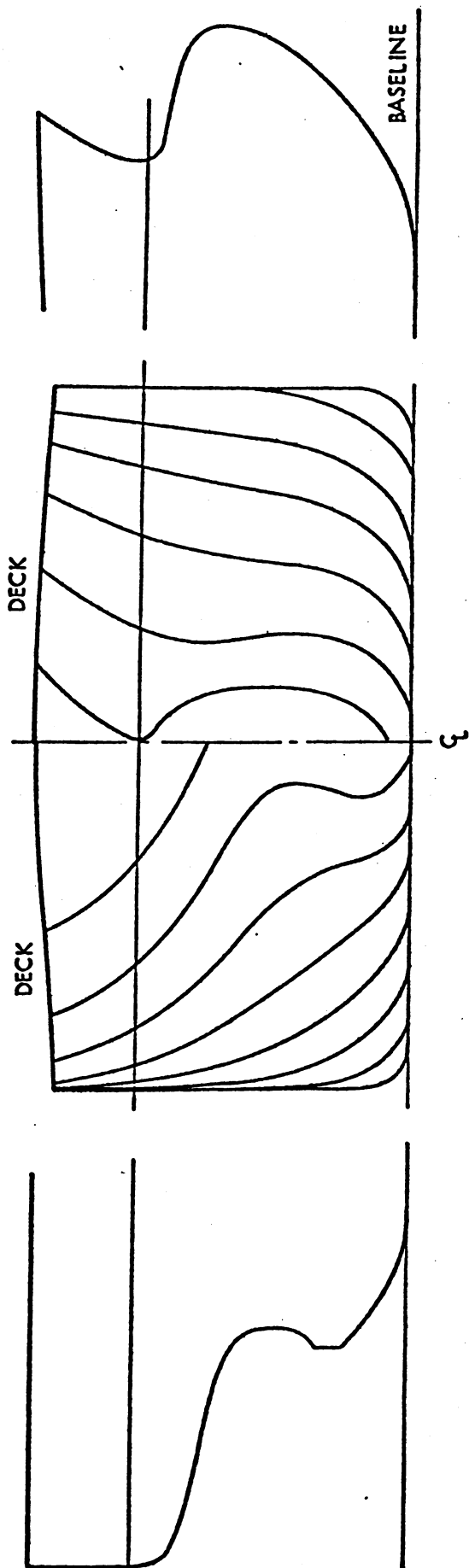

Fig 3 Lines of Ship "B"

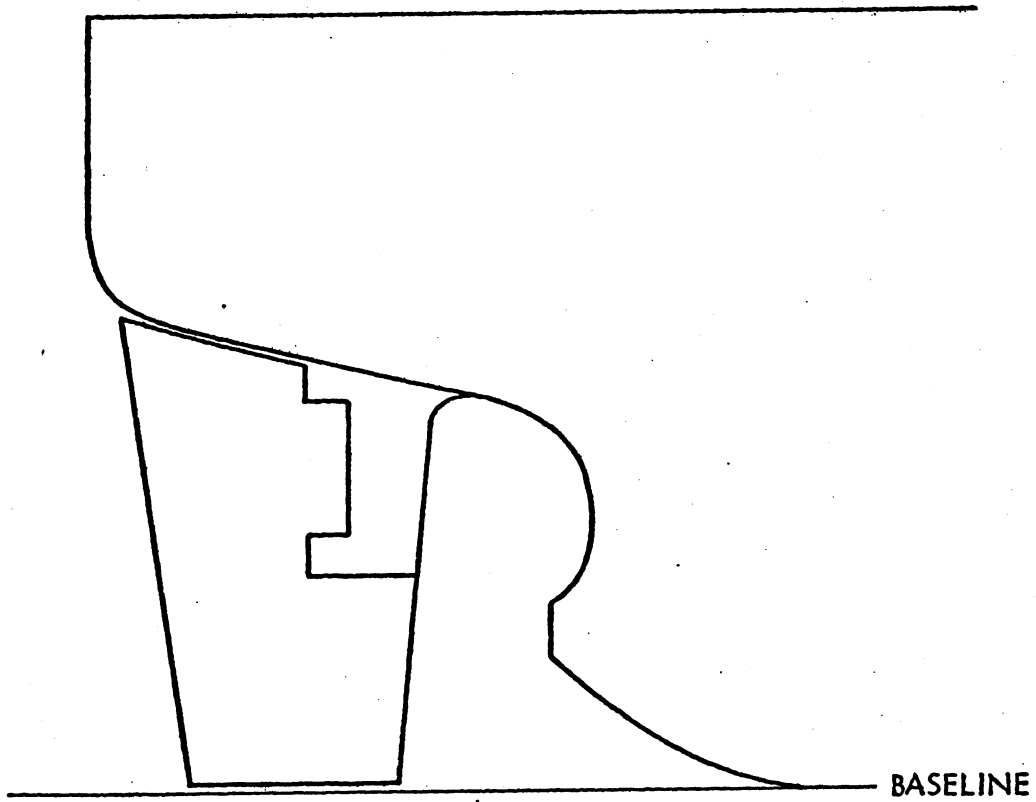

Fig 4 Details of Stern "B"

THRUST COEFFICIENT, K_T
 TORQUE COEFFICIENT, K_Q
 PROPELLER EFFICIENCY, e_p

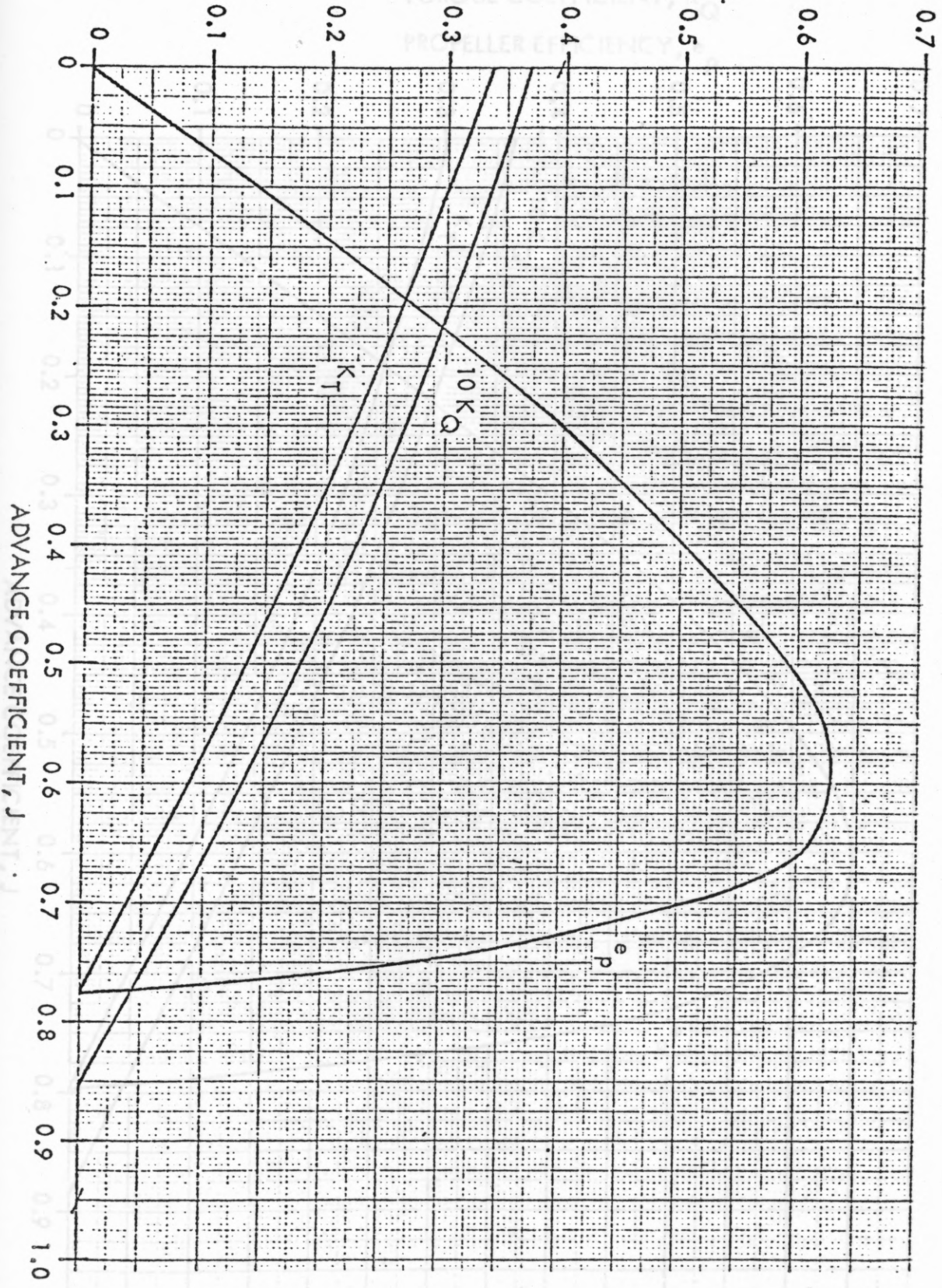

Fig 5 Open Water Curves for HSMB Propeller 7668-1P

THRUST COEFFICIENT, K_T
 TORQUE COEFFICIENT, K_Q
 PROPELLER EFFICIENCY, e_p

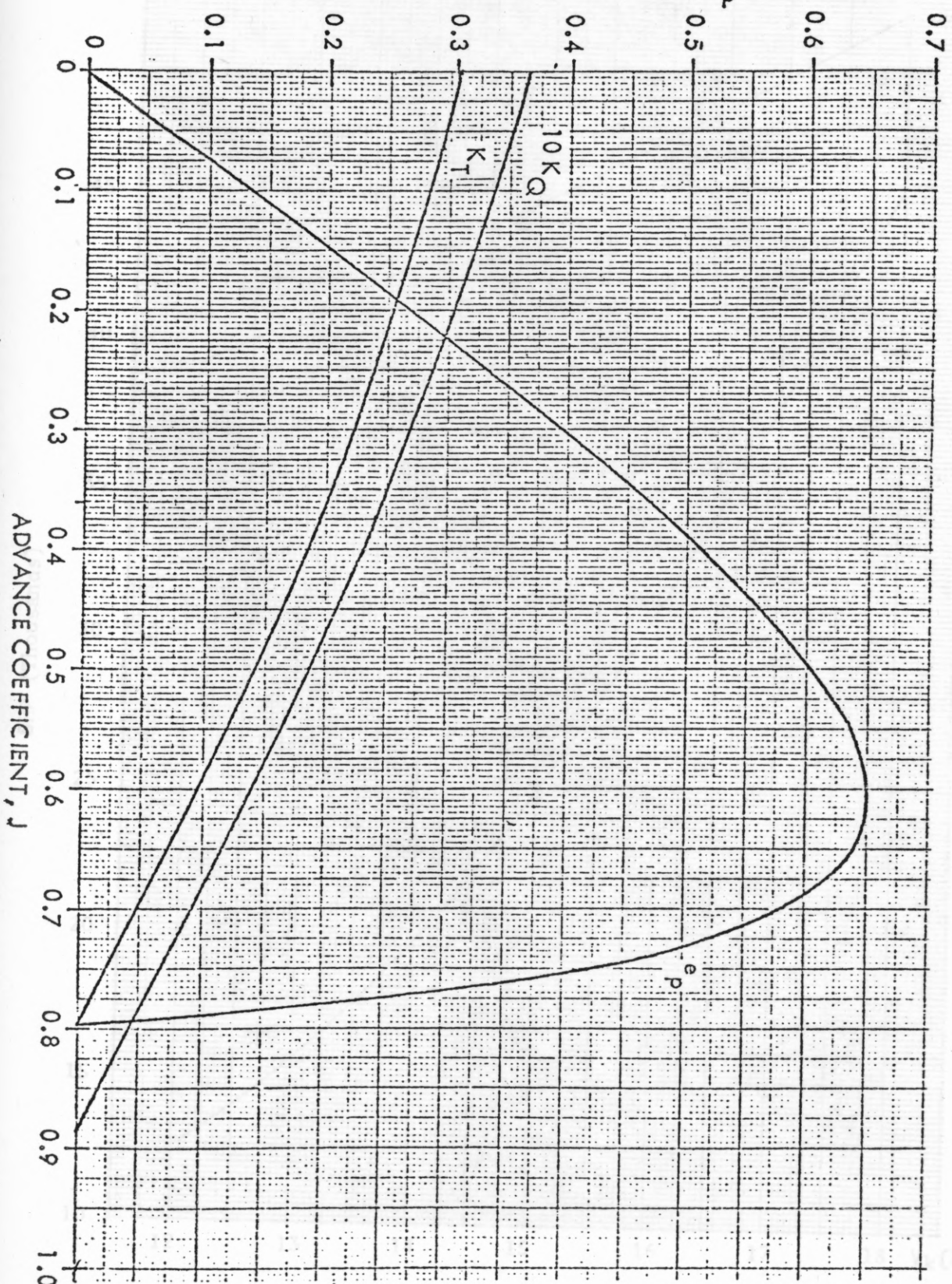

Fig 6 Open Water Curves for HSMB Propeller 7668-2P

+ = Full Scale Data

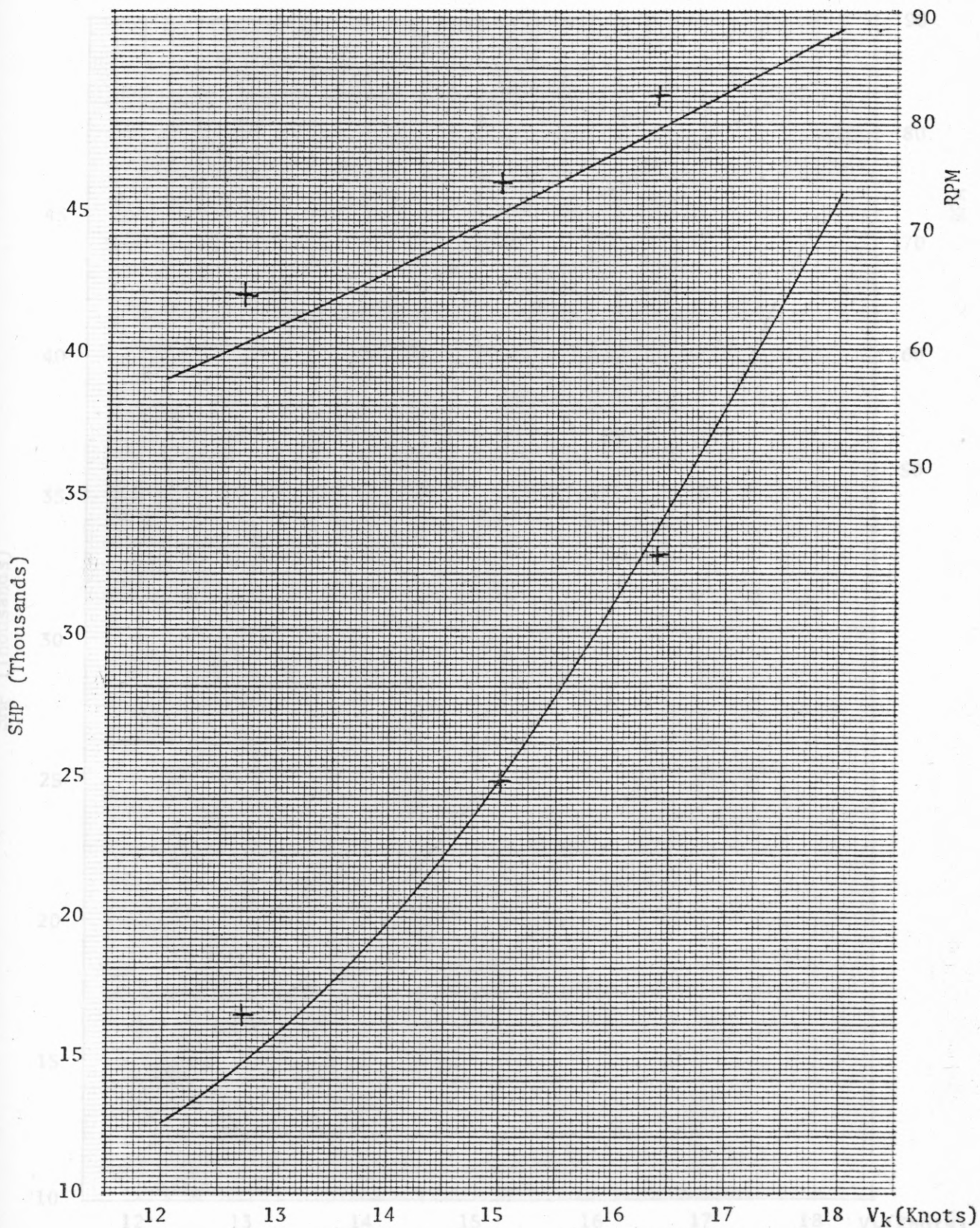

Figure 7 Curves of SHP and RPM for Ship "A"

+ = Full Scale Data

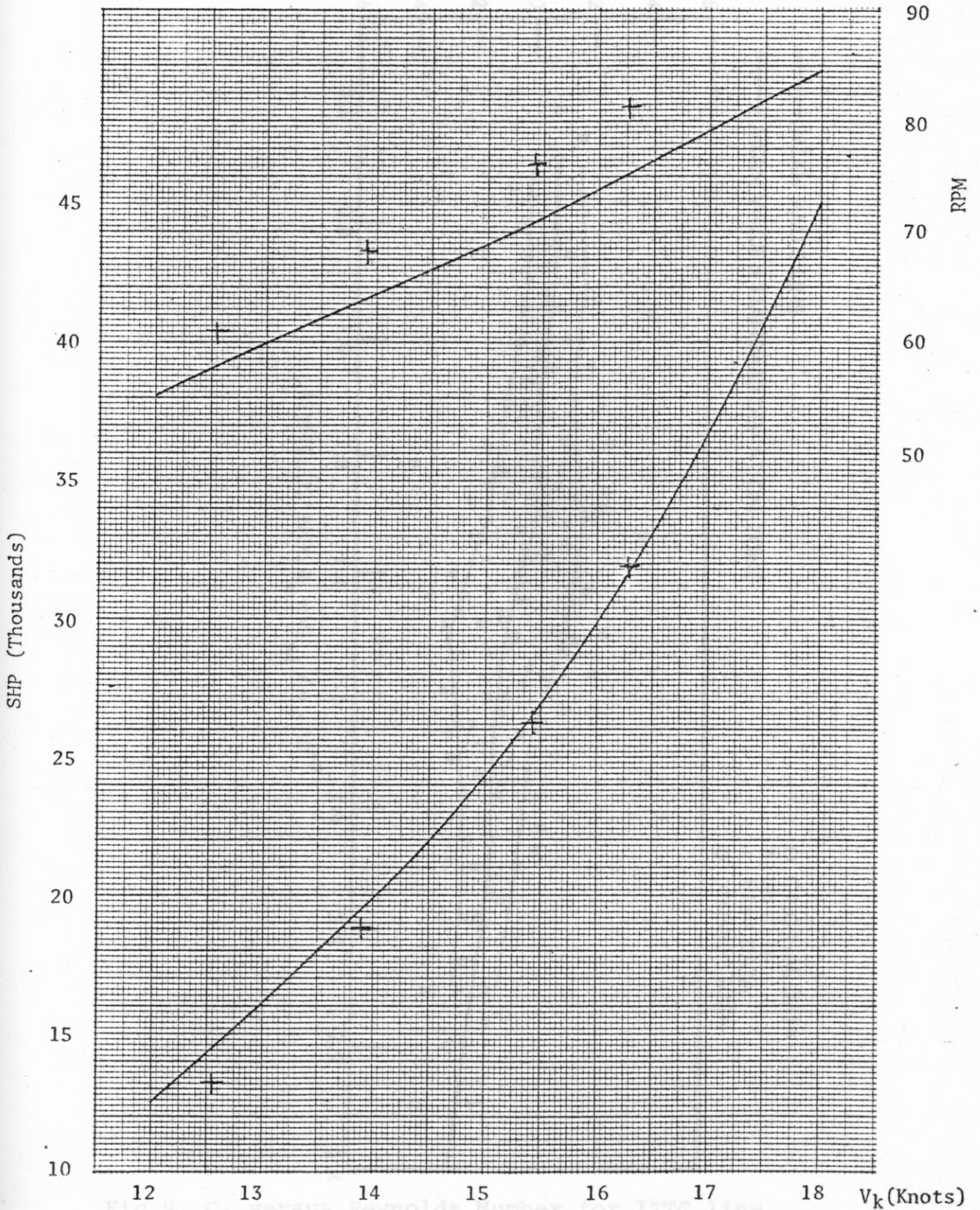

Figure 8 Curves of SHP and RPM for Ship "B"



UNIVERSITY OF MICHIGAN



3 9015 09579 6226