

Hollow Notched K-Wires for Bone Drilling With Through-Tool Cooling

Yuanqiang Luo,^{1,2} Lei Chen ,^{1,3} Albert J. Shih^{1,4}

¹Department of Mechanical Engineering, University of Michigan, Ann Arbor, Michigan, ²Department of Mechanical and Vehicle Engineering, Hunan University, Changsha, Hunan, China, ³Department of Psychiatry, University of Michigan, Ann Arbor, Michigan, ⁴Department of Biomedical Engineering, University of Michigan, Ann Arbor, Michigan

Received 25 April 2019; accepted 2 July 2019

Published online in 1 August 2019 Wiley Online Library (wileyonlinelibrary.com). DOI 10.1002/jor.24419

ABSTRACT: Kirschner wire (K-wire) is a common tool in clinical orthopedic surgery for bone fracture fixation. A significant amount of heat is generated in bone drilling using K-wires, causing bone thermal necrosis and osteonecrosis. To minimize the temperature rise, a hollow notched K-wire in a modified surgical hand drill with through-tool cooling was developed to study the bone temperature, debris evacuation, and material removal rate. The hollow notched K-wire was fabricated by grinding and micro-milling on a stainless steel tube. Bone drilling tests were conducted to evaluate its performance against the solid K-wires. Results showed that compared with solid K-wires, hollow notched K-wire drilling without cooling reduced the peak bone temperature rise, thrust force, and torque by 42%, 59%, and 62% correspondingly. The through-tool compressed air reduced the peak bone temperature rise by 48% with the forced air convection and better debris evacuation. The through-tool water cooling decreased the bone temperature by only 26% due to accumulation and blockage of bone debris in the groove and channel. This study demonstrated the benefit of using the hollow notched K-wire with through-tool compressed air to prevent the bone thermal necrosis. © 2019 Orthopaedic Research Society. Published by Wiley Periodicals, Inc. *J Orthop Res* 37:2297–2306, 2019

Keywords: hollow notched K-wire; through-tool cooling; bone drilling; bone temperature; air cooling

Kirschner wires (K-wires) are a common orthopedic surgical tool as fixation pins for bone fragments, anchors for skeletal traction, temporary joint immobilization, or precision guide wires for cannulated drills and screws.^{1–3} Insertion of K-wires is usually conducted using a power drill. Bone drilling with K-wires generates a large amount of heat between cutting edges of the rotating K-wire and the bone and bone debris.⁴ Due to low thermal conductivity of the bone material, heat accumulates around the drilling area and generates high temperature in bone. Such high bone temperature causes acute vascular insufficiency and reduction of osteocytes, leading to thermal osteonecrosis,^{5,6} which can result in complications like pin site infection and loss of fixation.⁷ To control the bone temperature under specific drilling speed (surgical time) and wire diameter, studies have been conducted on the K-wire design, drilling technique, and cooling method.

The K-wire design has a significant impact on debris removal and heat generation during bone drilling. The original K-wire introduced by Kirschner⁸ had a diamond shape tip with two opposing flat facets to form a pair of cutting edges (Fig. 1A). During bone drilling, the hole generated by this diamond tip had an elliptical shape and compromised its holding power to the bone.^{7,10} Another common K-wire tip design is the trocar tip (Fig. 1B) with three bevel planes and cutting edges forming a sharp point. Compared with the diamond tip K-wire, the trocar tip created smaller holes with better circumferential fit and holding to the bone.⁹ However, the trocar tip required larger thrust force for bone penetration and generated higher bone temperature than the diamond tip.^{7,9} Studies

have been conducted to modify the trocar tip K-wire with slots (Fig. 1C) and notches (Fig. 1D) to improve the debris evacuation and lower bone temperature rise was observed using these modified K-wires.^{11,12} Learning from surgical twist drills, Piska et al.¹³ developed a new point configuration called the Medin K-wire, as shown in Figure 1E. Two short segments of steep flutes were created at the drill tip to change the rake geometry and evacuate the bone debris during drilling. The Medin K-wire can reduce the thrust force, torque, and bone temperature rise compared with traditional diamond and trocar tip K-wires. Such Medin K-wires are available commercially as X-wire by Orthofix.

Studies of drilling technique showed that lower bone material removal rate and better debris evacuation reduced the bone temperature rise. Hutchinson et al.¹⁴ found that insertion of external fixation pins into pre-drilled holes generated lower temperature than insertions without predrilling. Luo et al.¹⁵ reported that, during the K-wire drilling by orthopedic surgeons, (i) the oscillatory drilling mode had lower bone temperature rise than the unidirectional mode due to lower material removal rate and (ii) the shaky and intermittent drilling techniques had lower bone temperature rise than continuous drilling because of improved debris evacuation and heat convection.

Studies have been conducted to control the temperature rise in bone cutting using through-tool cooling methods. Toksvig-Larsen et al.¹⁶ developed a saw blade with through-tool saline delivery and achieved 75% lower tibia temperature rise with 80 ml/min saline cooling compared with conventional osteotomy equipment. In porcine femur drilling tests by Augustin et al.,¹⁷ drill bits with through-tool water cooling of 10 ml/min generated statistically significantly lower bone temperature rise compared with tests without cooling. Brand et al.¹⁸ found that application

Correspondence to: Lei Chen (T: (734) 604-5897; F: (734) 647-9379; E-mail: leichan@umich.edu)

© 2019 Orthopaedic Research Society. Published by Wiley Periodicals, Inc.

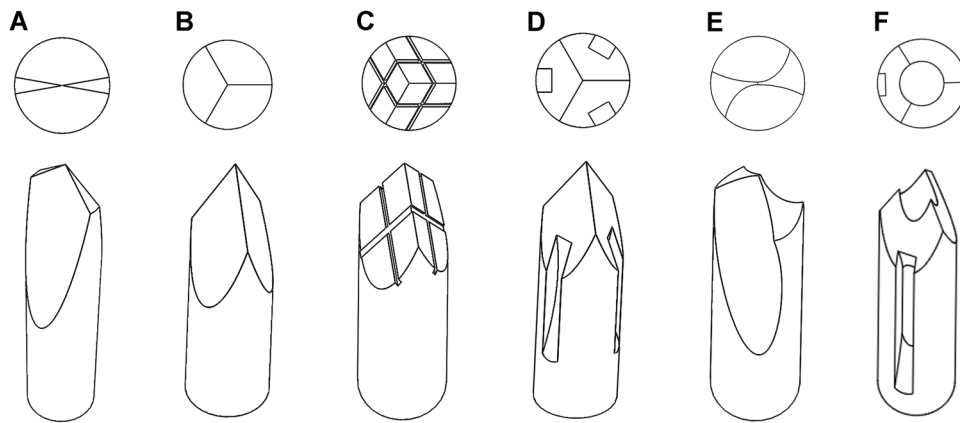

Figure 1. Different types of K-wire tips (A) diamond, (B) trocar, (C) slotted trocar, (D) notched trocar, (E) Medin, and (F) hollow notched trocar (this study).

of internal cooling (saline pressed by 600 kPa compressed air) through the drill bits led to a temperature below the tissue-preserving level. Shakouri et al.¹⁹ reported that bone drilling with through-tool gas cooling (room temperature carbon dioxide or nitrogen) resulted in 40% lower bone temperature rise and decreased the possibility of thermal necrosis. The through-tool delivery of air or water/saline cooling has not yet been utilized for bone drilling with K-wires. Effect of manually applied external cooling is minimal during percutaneous K-wire drilling because of the surrounding soft tissue.²⁰ Thus, in clinical practice, K-wires are usually inserted without proper cooling in a

current surgical operation.²⁰ A modified K-wire design and corresponding bone drilling device are needed for proper through-tool cooling to minimize the temperature rise and improve debris evacuation during bone drilling with K-wires.

Bone drilling trials using a hollow tube with three-plane bevel (without the notch in Fig. 1F) showed that the hollow tube would be clogged by bone debris. Therefore, a notch was fabricated on the hollow tube tip using a micro-saw cutting tool. In this study, a hollow notched K-wire (as shown in Fig. 1F) is designed and fabricated by grinding and micro-milling on a tube.

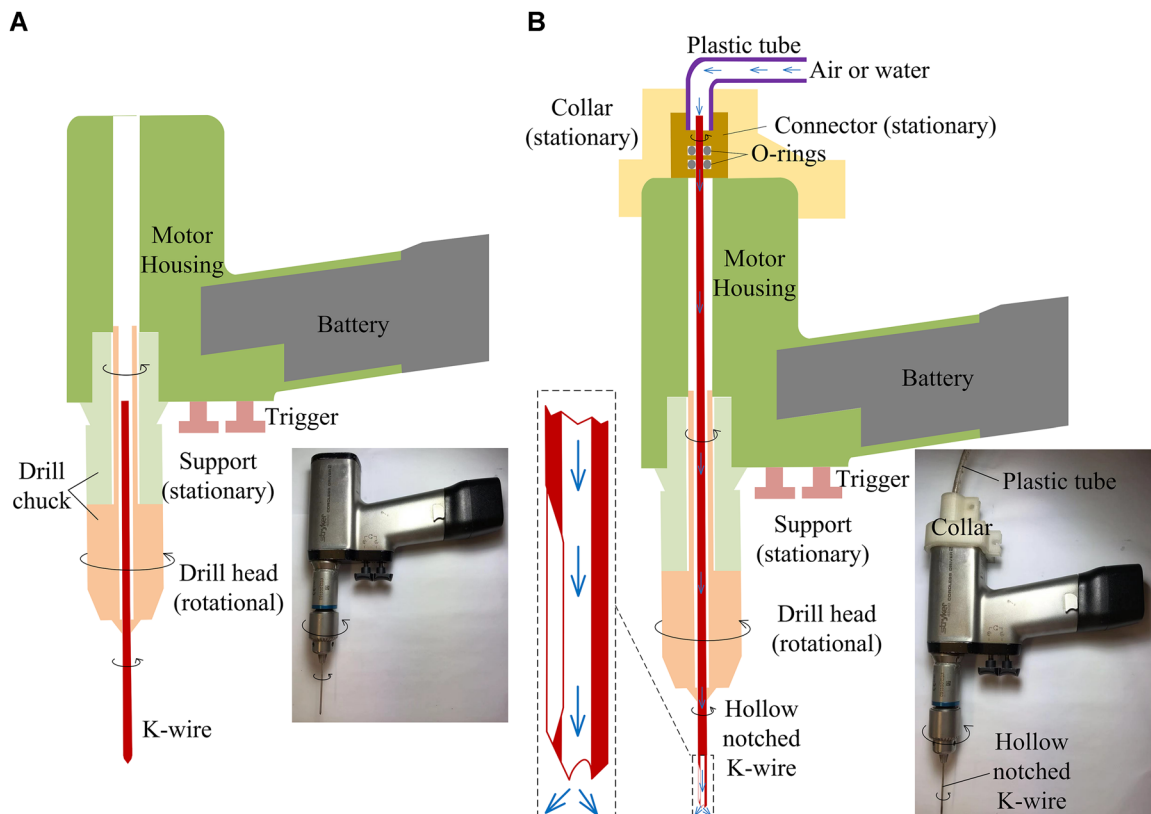

Figure 2. Surgical hand drill: (A) original configuration and (B) the collar adaptor and plastic tube for through-tool cooling. [Color figure can be viewed at wileyonlinelibrary.com]

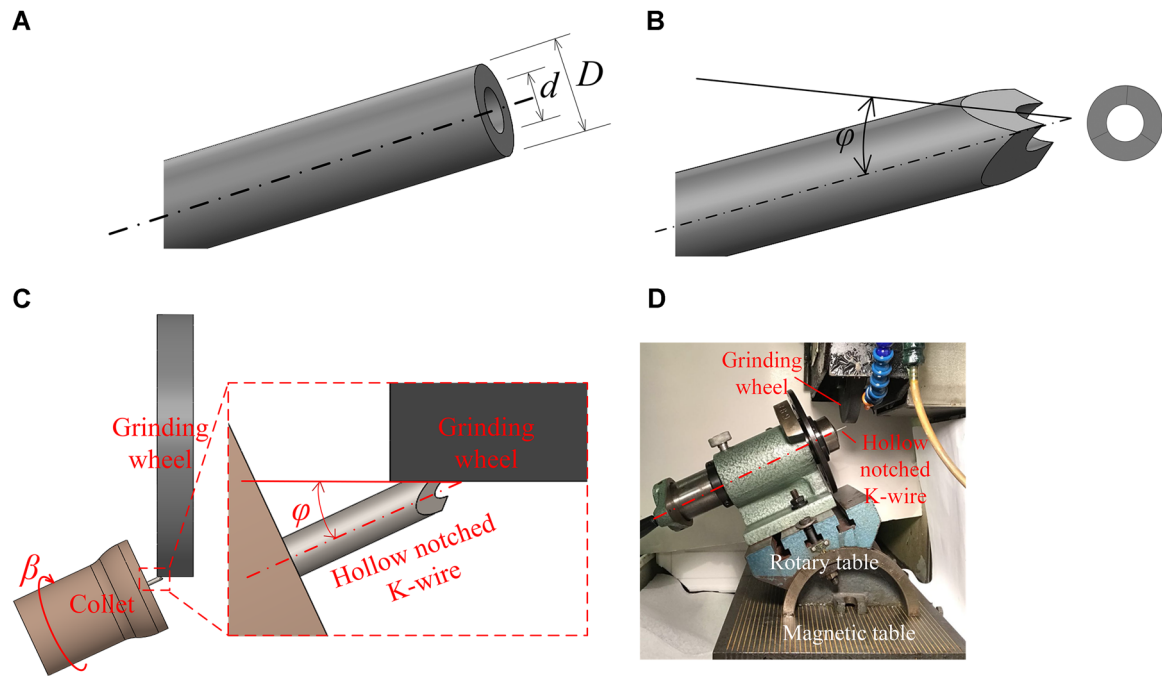

Figure 3. Bevel plane grinding of the hollow notched K-wire: (A) original hollow tube, (B) hollow tube with three bevel planes, (C) tip grinding configuration, and (D) experimental setup of the tip grinding. [Color figure can be viewed at wileyonlinelibrary.com]

A surgical hand drill is modified to enable the through-tool cooling using this hollow notched K-wire. Bone drilling using the solid and hollow notched K-wires is compared in the bovine bone drilling tests. Bone drilling without cooling and with through-tool compressed air and water cooling are studied and quantitatively evaluated in terms of thrust force, torque, and bone temperature rise.

METHODS AND MATERIALS

Modified Surgical Hand Drill for Through-Tool Cooling

A surgical hand drill (Model 4200 Cordless Driver 2; Stryker, Kalamazoo, MI) was used in this study to conduct bone drilling tests. This hand drill (Fig. 2A) had four major components: (i) a rechargeable battery as power supply (Model 4212-000-000; Stryker), (ii) a motor housing with electrical motor inside, (iii) triggers to control the spindle rotary direction and speed, and (iv) collet attachments for tools. In this study, a 6 mm keyed drill chuck (Model 4100-131-000; Stryker) was used. This chuck composed of two parts: stationary support connecting the collet to the motor housing and a drill head coupled with the spindle to rotate with the clamped K-wire during drilling. In this study, a common trocar tip solid K-wire (Model 292.160.10; DePuy Synthes, Raynham, MA) made of AISI 316 stainless steel with 1.6 mm diameter, 150 mm length, and 25° bevel angle was selected. Even though the trocar tip was not the optimal design for minimizing heat generation given its negative rake geometry, it was chosen due to its wide use and simple structure for through-tool cooling modification, making it a good

comparison baseline for this study to evaluate different cooling strategies during bone drilling with K-wires.

Most of the surgical hand drills have a hollow shaft, as shown in Figure 2B, and can be modified to adopt through-tool cooling capability. Instead of using a solid K-wire, a hollow notched K-wire (1.6 mm outer diameter and 250 mm in length) was clamped in the chuck with the other end protruding out of the top of the motor housing. A stationary collar with a connector and two O-rings (sealing between the rotating hollow K-wire and the connector) was installed at the top of the motor housing. A plastic tube (4 mm inner diameter) fit in the open end of the connector. This plastic tube delivered the pressured air or water through the hollow tube to the tip of the hollow K-wire (bone drilling site). During drilling, the plastic tube, collar, and connector were all stationary and the hollow K-wire was rotating.

Design and Fabrication of the Hollow Notched K-wire

The hollow notched K-wire was designed to have a hollow center, three bevel planes (same as the solid trocar tip K-wire), and a perforated notch on one of the bevel planes. Fabrication of the hollow notched K-wire was conducted in two steps: (i) grinding the bevel planes and (ii) micro-milling the notch.

The same bevel angle (25°), outer diameter (1.6 mm), and material (AISI 316 stainless steel) of the solid K-wire was selected for the hollow notched K-wire. A tube, as shown in Figure 3A, with an outer diameter (D) and inner diameter (d) of 1.6 and 0.8 mm, respectively, was used. This tube was ground to have three bevel planes with 25° bevel angle (ϕ), as shown in Figure 3B.

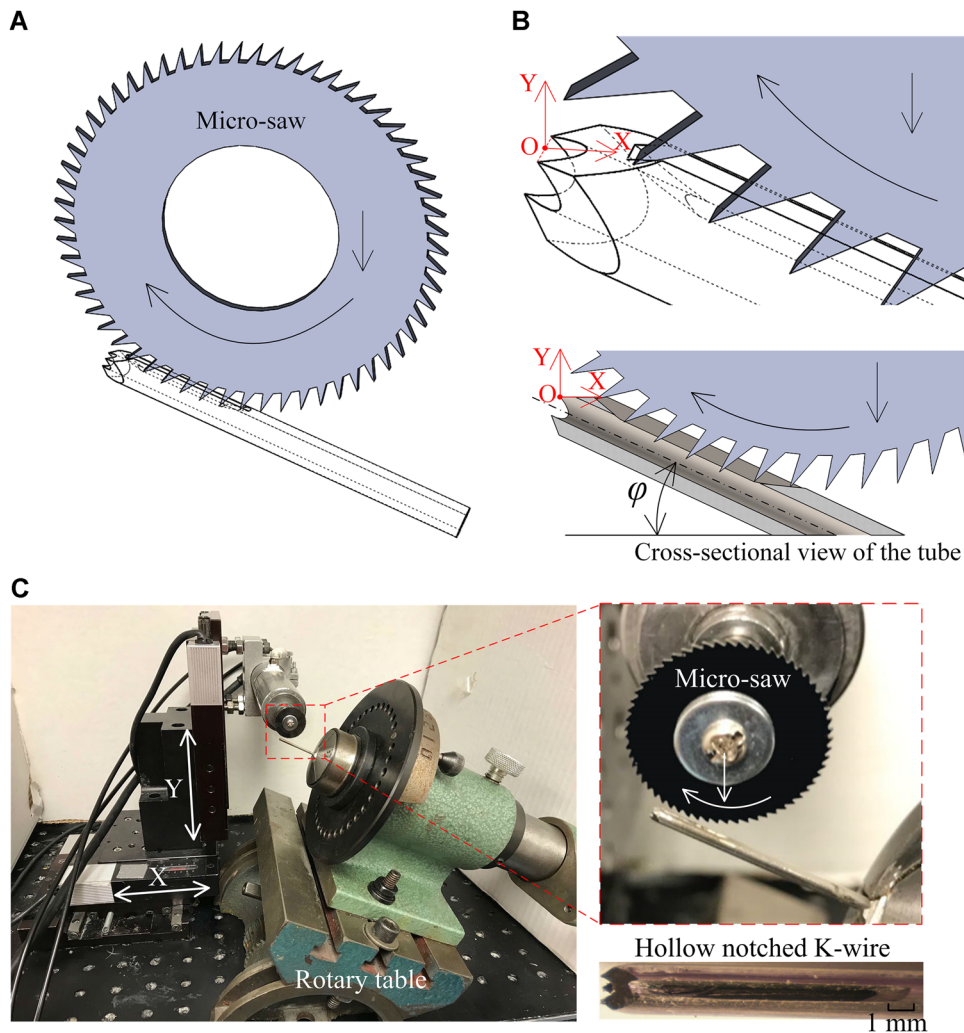

Figure 4. Notch micro-milling of the hollow notched Kirschner wire (K-wire): (A) overview and (B) close-up and cross-sectional views of the micro saw and hollow wire configuration and (C) the experimental setup. [Color figure can be viewed at wileyonlinelibrary.com]

The configuration for grinding is shown in Figure 3C. The tube was clamped by a collet. The center axis of the tube had a 25° bevel angle relative to grinding wheel axis. The experimental setup of the grinding process is shown in Figure 3D. A dual-axis rotary table, fixed on the magnetic table of the grinding machine (Model Smart 515; Chevalier, Santa Fe Springs, CA), was used to position the hollow K-wire tube for grinding. A vitreous bond silicon carbide grinding wheel (39C60-IVK; Milacron, Cincinnati, OH) was used to grind three bevel planes on the tube. After grinding each bevel plane, the tube and collet were spun by 120° (β in Fig. 3C) to re-orient the tube for grinding the next bevel plane.

A notch was micro-milled at the hollow K-wire tip by a micro-saw cutting tool (0.4 mm in thickness and 20 mm diameter) made of tungsten carbide in a cobalt matrix tool material, as shown in Figure 4A. A coordinate system was set up with middle point of two sharp tips associated with the bevel plane to be milled defined as the origin O. The X-axis was across the

middle of the bevel plane while Y-axis is perpendicular to the bevel plane, as shown in Figure 4B. The rotating micro-saw was fed along the negative Y direction, perpendicular to the bevel plane, to cut through the tube wall and form a perforated notch, as shown in the cross-sectional view in Figure 4B. Experimental setup of the micro-milling process, as shown in Figure 4C, was built with two linear stages (Model 200cri; Siskiyou, Grants Pass, OR) and a high-speed spindle (Model EM-801; NSK, Tokyo, Japan). The micro-saw rotated at 6,000 rpm and was driven by the Y-axis linear stage to cut at 20 mm/min feed rate. The dual-axis rotary table was used to orient the hollow tube with three-plane bevel so that the tube center axis was aligned with the center plane of the micro-saw cutting tool and had a 25° angle relative to the horizontal plane. A finished hollow notched K-wire is shown in Figure 4C.

Configuration of the finished notch was defined by two parameters: the feed depth of the micro-saw along the K-wire radial direction (h as in Figure 5A) and distance

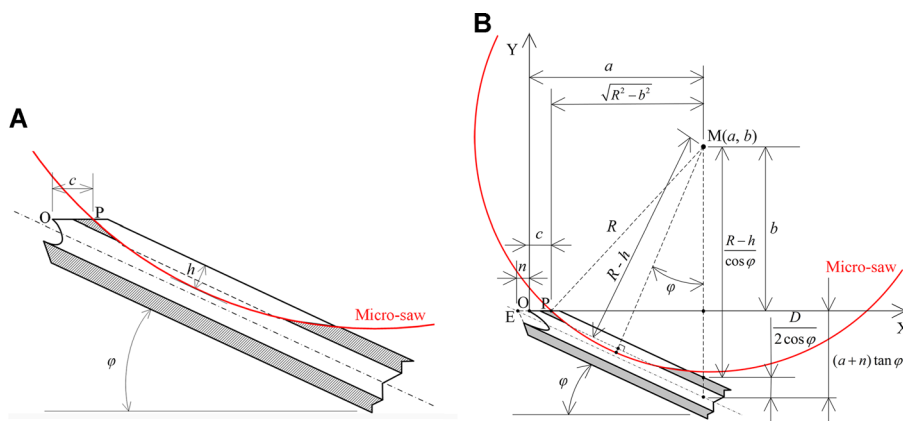

Figure 5. Notch micro-milling of the hollow notched K-wire: (A) notch configuration and (B) end position of the micro-saw. [Color figure can be viewed at wileyonlinelibrary.com]

between the origin O and the edge of the notch (point P) (denoted as *c* as in Figure 5A). In this study, the value of *h* was set as 0.65 mm so that the micro-saw cut through the tube wall (0.4-mm-thick) by 0.25 mm to form the perforated notch. The value of *c* was set as 1.0 mm.

To achieve the notch configuration, center of the micro-saw at end of the cut was defined as *M* with coordinate position (*a*, *b*) relative to the origin O in the XY plane, as shown in Figure 5B. On the basis of the geometric relationships in Figure 5B, *a* and *b* were calculated by solving the equation system in two variables:

$$a = c + \sqrt{R^2 - b^2} \text{ (in the X-direction)} \quad (1)$$

$$b = \frac{1}{\cos \phi} \left(R - h + \frac{D}{2} \right) - (a + n) \tan \phi \text{ (in the Y-direction)} \quad (2)$$

where *R* is the radius of the micro-saw and *n* is the distance between the origin O and the intersection point of three bevel planes *E*. In this study, the values of *R* and *n* were 10 and 0.5 mm, correspondingly. The calculated results of *a* and *b* were 7.8 and 7.3 mm, respectively.

Due to hollow structure of the hollow notched K-wire, its bending stiffness was different from the solid K-wire.

Bending stiffness was evaluated by flexural rigidity defined as Young’s modulus (*E*) multiplied with the moment of inertia for bending (*I*). The moment of inertia for bending of a tube is calculated as²¹:

$$I = \pi(D^4 - d^4)/64 \quad (3)$$

The hollow notched K-wire in this study was of the same stainless steel material as the solid K-wire (same Young’s modulus *E*) with same outer diameter (*D*) of 1.6 mm and inner diameter (*d*) of 0.8 mm. Thus, the flexural rigidity of the hollow notched K-wire was 94% of that of the solid K-wire. Sacrifice in the bending stiffness of the hollow notched K-wire was negligible.

Bone Sample Preparation

Bovine femur bone was used for cortical bone samples due to its similar properties to human cortical bones.²² All bone samples used in this study were prepared from the same piece of the bovine femur bone to minimize variations in material property. The bone was cut into blocks of 30 × 20 × 5 mm by a milling machine (Model PC MILL 125; EMCO Group, Hallein, Austria). To ensure accurate distances between drilling and temperature measurement locations and avoid K-wire skidding on the bone surface due to lack of self-centering ability in the trocar tip, eight

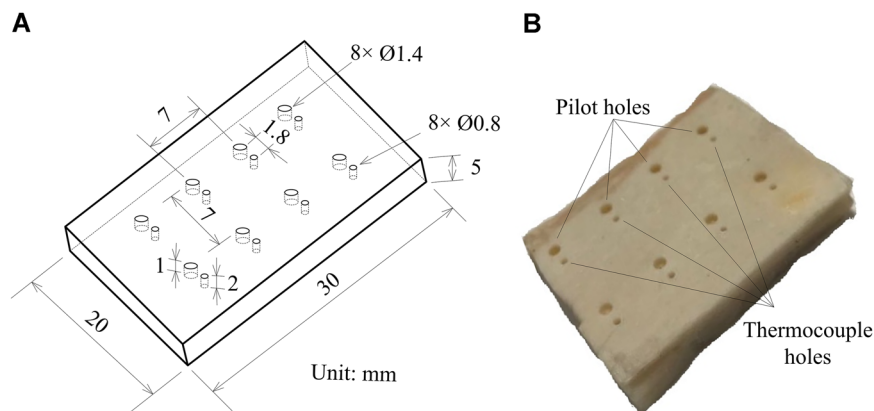

Figure 6. Bone sample preparation: (A) positions of pilot and thermocouple holes and (B) photo of a prepared bone sample. [Color figure can be viewed at wileyonlinelibrary.com]

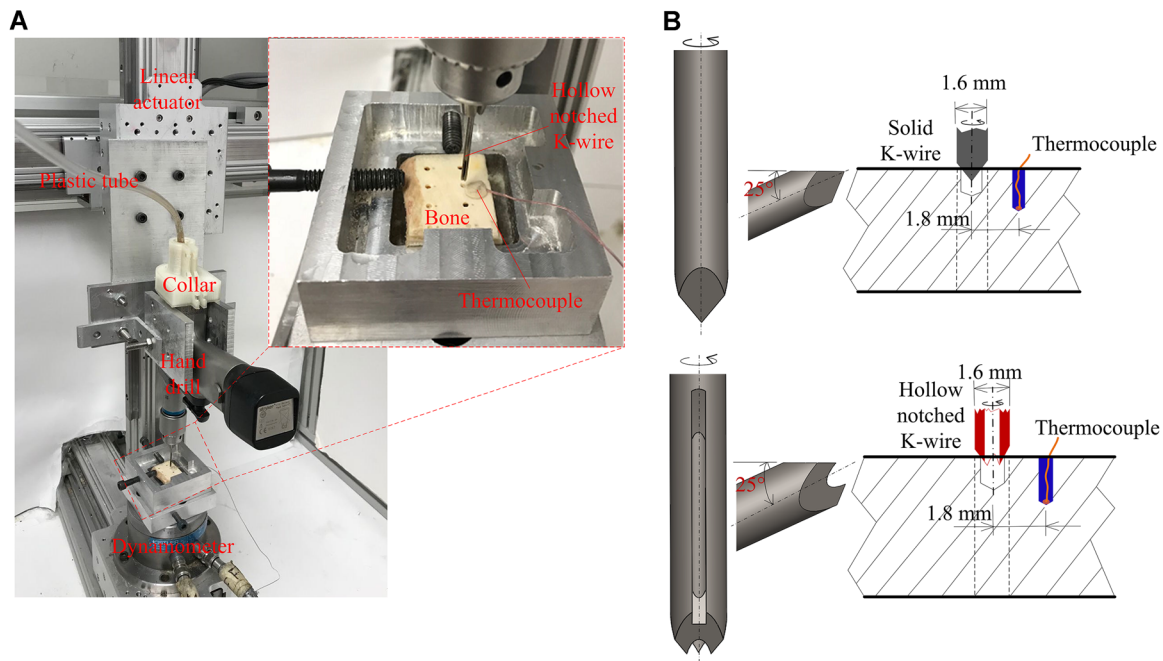

Figure 7. Bone drilling tests: (A) experimental setup and (B) drilling configurations for solid and hollow notched K-wires. [Color figure can be viewed at wileyonlinelibrary.com]

pilot holes with 1.4 mm diameter and 1 mm depth were pre-drilled in each bone sample, as shown in Figure 6A. A thermocouple hole (2.0 mm deep and 0.8 mm in diameter) was pre-drilled with 1.8 mm distance to each corresponding pilot hole center for embedded thermocouple fixation and remote temperature measurement. A distance of 7 mm was kept between adjunct pilot holes to minimize the structural influence on heat transfer, as shown in Figure 7B.

The bone samples were kept in the fridge at a temperature of -7°C . Before drilling tests, the bone sample was soaked in saline for 4 h to keep it hydrated and thaw to room temperature of 23°C .

Bone Drilling Experiment Design

Experimental setup of the bone drilling tests is shown in Figure 7A. The modified surgical hand drill with through-tool cooling capability was fixed onto the linear actuator. The bone sample was clamped by an aluminum fixture and mounted onto a piezoelectric dynamometer

(Mode type 9271A; Kistler, Winterthur, Switzerland) for thrust force and torque measurements. During each test, a solid or hollow notched K-wire (Fig. 7B) was driven by the surgical drill to rotate clockwise at 1,400 rpm. The linear actuator fed the surgical drill downward by 5 mm at 1 mm/s feed rate, similar speed to the surgical practice.²³ The rotating K-wire was retracted at the same feed rate out of the bone sample after the drilling. A T-type thermocouple (Model type 5TC-TT-T-36-36; Omega Engineering, Norwalk, CT) was embedded in the adjunct thermocouple hole (Fig. 7B) for remote temperature measurement. Proper contact between the thermocouple tip and the pre-drilled hole bottom was secured by high conductivity thermal paste (Model OT-201; Omega Engineering). A multi-channel digital oscilloscope (Model DL750; Yokogawa, Tokyo, Japan) was used to record the temperature, thrust force, and torque simultaneously at 2,000 Hz sampling rate.

Four different drilling conditions were investigated in this study: (i) solid K-wire drilling without cooling,

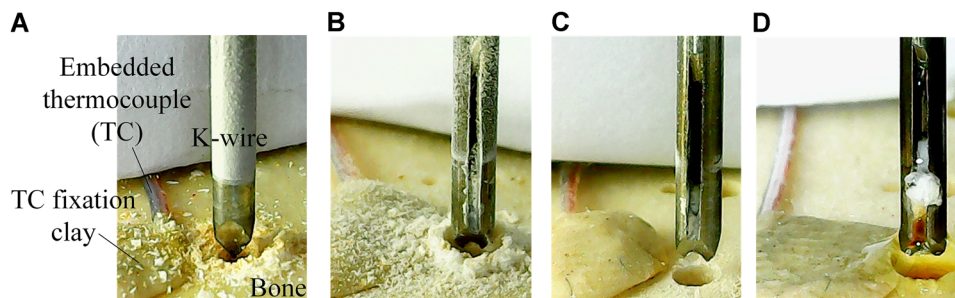

Figure 8. Bone debris after first bone drilling test under each condition: (A) solid Kirschner wire (K-wire) drilling without cooling, (B) hollow notched K-wire drilling without cooling, (C) hollow notched K-wire drilling with through-tool compressed air cooling, and (D) hollow notched K-wire drilling with through-tool water cooling. [Color figure can be viewed at wileyonlinelibrary.com]

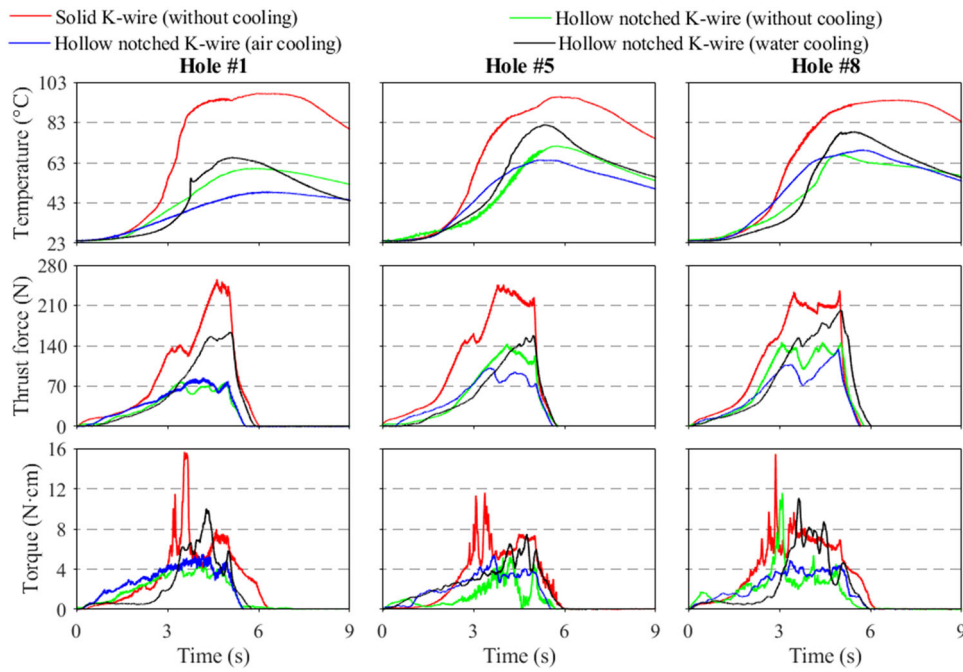

Figure 9. Comparison of temperature, thrust force, and torque in holes #1, #5, and #8. [Color figure can be viewed at wileyonlinelibrary.com]

(ii) hollow notched K-wire drilling without cooling, (iii) hollow notched K-wire drilling with through-tool compressed air (35 kPa) cooling, and (iv) hollow notched K-wire drilling with through-tool water cooling at 35 kPa pressure. Under each condition, a new and sharp K-wire and a fully charged battery were used to drill eight holes on a single bone sample. Drilling tests were separated 2 min apart to allow the bone to restore to room temperature. Drilling tests under each condition were repeated twice, yielding 64 bone drilling tests (=4 drilling

conditions × 8 holes under each condition × 2 repeated tests) in total.

RESULTS

Figure 8 shows the bone debris after the first hole drilled under each condition. For solid K-wire drilling without cooling, slightly burned debris of dark yellow was observed around the drilled hole. For hollow notched K-wire drilling without cooling, powdery white bone debris was evacuated through the hollow center and notch with some partially clogging the notch. For

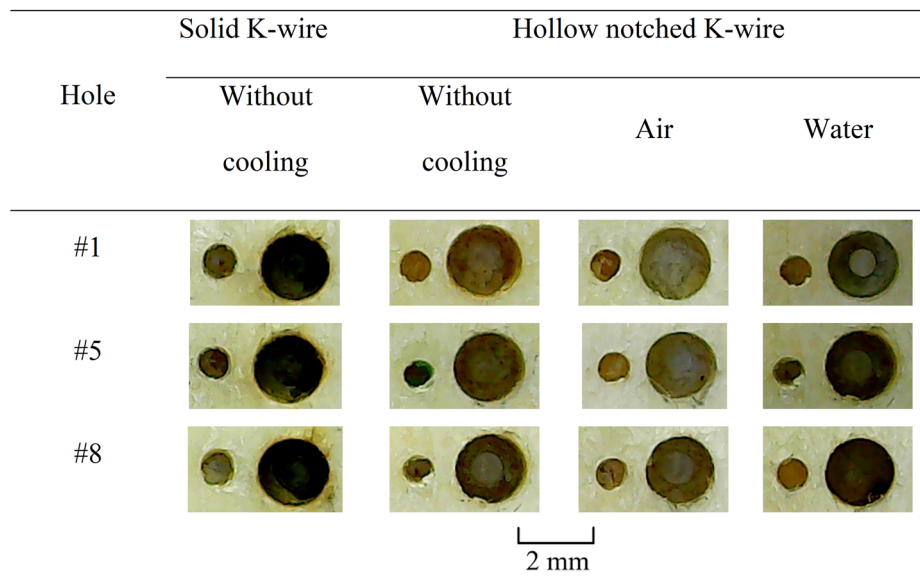

Figure 10. Comparison of drilled holes #1, #5, and #8 under four drilling conditions. [Color figure can be viewed at wileyonlinelibrary.com]

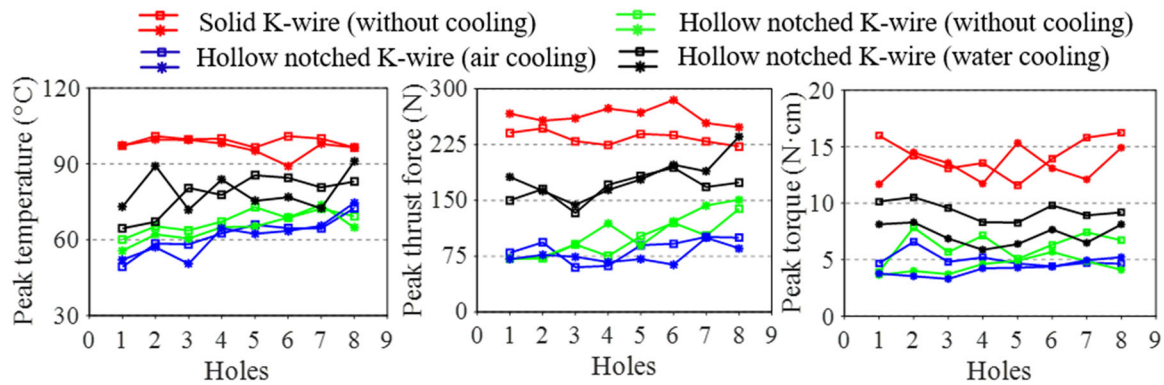

Figure 11. Change of peak bone temperature rise, thrust force, and torque along with number of holes drilled under four drilling conditions in two repeated trials. [Color figure can be viewed at wileyonlinelibrary.com]

hollow notched K-wire with through-tool air cooling, bone debris was evacuated and blown away with negligible blockage. For hollow notched K-wire with through-tool water cooling, white bone debris was mixed with water and formed a cement to clog the notch and hollow center.

Figure 9 compares the recorded temperature, thrust force and torque under four cutting conditions after holes #1, #5, and #8. Figure 10 shows pictures of the corresponding drilled holes. All the holes drilled were about 1.8 mm in diameter, larger than the K-wire diameter of 1.6 mm, likely due to vibration and bending of the K-wire during drilling. No significant difference in hole diameter was observed between the hollow notched and the solid K-wires. Solid K-wire drilling without cooling generated the highest bone temperature and mostly burned bone with the highest thrust force and torque. Hollow notched K-wire with water cooling yielded the second-highest temperature rise. Hollow notched K-wire with air cooling had the lowest bone temperature rise for holes #1 and #5 while at hole #8 the temperature rise was similar to hollow notched K-wire drilling without cooling.

Figure 11 shows the changes in peak bone temperature rise, thrust force, and torque along with number of holes drilled under four drilling conditions in two repeated trials. Average and standard deviation of the peak temperature rise, thrust force, and torque are summarized in Table 1. In general, bone temperature, thrust force, and torque stayed almost constant for solid K-wire drilling without cooling. For the hollow notched K-wires, after drilling three to four holes, both

peak bone temperature and thrust force tended to increase while the peak torque stayed at similar levels. Hollow notched K-wire reduced the average peak bone temperature rise, thrust force, and torque by 42%, 59%, and 62% correspondingly, compared to solid K-wire without cooling. The through-tool compressed air reduced the peak bone temperature rise by 48% while the through-tool water cooling decreased the bone temperature by only 26%.

DISCUSSION

Comparison Between the Hollow Notched K-Wire and Solid K-Wire

The hollow notched K-wire drilling without cooling generated lower bone temperature rise than solid K-wires because of lower heat generation and better heat dissipation.

The total energy during drilling is composed of translational energy (thrust force × feed rate × drilling time) and rotational energy (torque × spindle speed × K-wire radius × drilling time). Thrust force and torque were lower for the hollow notched K-wire comparing to solid ones, as in Figures 9 and 11. Under same feed rate, spindle speed, and K-wire outer diameter, the hollow notched K-wire drilling generated less energy than the solid one. Most of the energy generated was converted to heat and caused bone temperature rise.

Lower thrust force and torque with the hollow notched K-wire was likely due to lower material removal rate and frictional force. The hollow notched K-wire had a shorter cutting edge than the solid one. As

Table 1. Average and Standard Deviation of Peak Temperature Rise, Thrust Force, and Torque

| Type of K-wire | Solid | | Hollow Notched | |
|----------------------------|-----------------|-----------------|----------------|--------------|
| Cutting conditions | Without Cooling | Without Cooling | Air | Water |
| Peak temperature rise (°C) | 74.8 ± 2.9 | 43.6 ± 4.1 | 39.2 ± 6.6 | 55.6 ± 7.4 |
| Peak thrust force (N) | 248.9 ± 17.9 | 102.1 ± 26.3 | 80.5 ± 13.7 | 174.5 ± 23.2 |
| Peak torque (N·cm) | 13.8 ± 1.5 | 5.3 ± 1.3 | 4.5 ± 0.7 | 8.2 ± 1.3 |

seen in Figure 10, the hollow-notched K-wires did not cut through a rod of bone inside the blind hole due to the nature of cannulated drills, which reduced the material removal rate and the thrust force and torque needed to create the hole. Lower thrust force needed for bone penetration with the hollow notched K-wire could also reduce the risk of K-wire plunging into surrounding soft tissue after penetrating the bone.²⁴

Majority of the heat was generated by the cutting edges (rake geometry) of the K-wire during cutting of bone. In drilling tests without cooling, over 70% of the heat generated at the cutting edge partitioned into the bone debris while the rest went to the K-wire and the bone.^{25,26} Evacuation of the hot bone debris through the hollow notched K-wire dissipated the heat from the cutting area, leading to lower temperature rise in the bone. Also, by evacuating the bone debris through the hollow center and side notch, the hollow notched K-wire drilling mitigated the frictional force between the compressed debris and the K-wire, leading to lower torque and less frictional heat generation between the K-wire and compressed bone debris.

Application of Compressed Air or Water Cooling

Application of the through-tool compressed air cooling further decreased the bone temperature rise because of forced air convection at the cutting area, accelerated the evacuation of the bone debris by air pressure, and dredging of the partially blocked evacuation channel after extraction (Fig. 8C). Note that the 35 kPa air pressure used in this study was determined through preliminary tests with various pressure values. It was found that compressed air of too low pressure was not sufficient for debris evacuation while excessive pressure added resistance to drill penetration. The proper amount of air pressure for surgical uses need to be further investigated through clinical studies.

Through-tool water cooling with the hollow notched K-wire generated lower temperature than the solid K-wire due to lower material removal rate and lubrication effect of the water. However, through-tool water cooling had the highest bone temperature rise among conditions using the hollow-notched K-wire due to the worst debris evacuation and the highest heat generation. Compared to hollow notched K-wire drilling without cooling and with compressed air cooling, the hollow center and notch got clogged by the mix of water and bone debris (Fig. 8D), consistent to findings in Shakouri et al.¹⁹, preventing the debris evacuation and heat dissipation. Extra water pressure applied through the blockage debris led to higher thrust force needed. Friction between the bone debris inside the drilled hole and outer surface of the rotating K-wire resulted in higher torque, extra heat generation, and further bone temperature rise.

CONCLUSIONS

In this study, bone drilling with through-tool cooling was enabled using a hollow notched K-wire in a

modified surgical hand drill. The hollow notched K-wire was fabricated by bevel plane grinding on a tube and notch milling on one of the bevel planes. Results of drilling tests without cooling showed that compared with solid K-wires, usage of the hollow notched K-wire reduced the peak bone temperature rise, thrust force, and torque by 42%, 59%, and 62% correspondingly, with negligible reduction in bending stiffness. The through-tool compressed air reduced the peak bone temperature rise by 48% due to forced air convection and debris evacuation. The through-tool water cooling decreased the bone temperature by only 26% due to accumulation and blockage of bone debris on the groove and channel. Bone drilling with through-tool compressed air cooling using the developed hollow notched K-wire showed the potential for clinical use to control bone temperature rise and prevent thermal necrosis during K-wire insertion.

AUTHORS' CONTRIBUTION

Y.L.: experiments, data acquisition and processing, manuscript drafting and editing. L.C.: study design, data processing, manuscript drafting and editing. A.S.: manuscript editing, supervision. All authors have read and approved the final submitted manuscript.

REFERENCES

1. Strohm PC, Müller CA, Boll T, Pfister U. 2004. Two procedures for Kirschner wire osteosynthesis of distal radial fractures: a randomized trial. *J Bone Joint Surg Am* 86: 2621–2628.
2. Walton NP, Brammar TJ, Hutchinson J, et al. 2001. Treatment of unstable distal radial fractures by intrafocal, intramedullary K-wires. *Injury* 32:383–389.
3. Otsuka NY, Kasser JR. 1997. Supracondylar fractures of the humerus in children. *J Am Acad Orthop Surg* 5:19–26.
4. Tai BL, Palmisano AC, Belmont B, et al. 2015. Numerical evaluation of sequential bone drilling strategies based on thermal damage. *Med Eng Phys* 37:855–861.
5. Eriksson AR, Albrektsson T. 1983. Temperature threshold levels for heat-induced bone tissue injury: a vital-microscopic study in the rabbit. *J Prosthet Dent* 50:101–107.
6. Field JR, Sumner-Smith G. 2002. Bone blood flow response to surgical trauma. *Injury* 33:447–451.
7. Khanna A, Plessas SJ, Barrett P, et al. 1999. The thermal effects of Kirschner wire fixation on small bones. *J Hand Surg Am* 24:355–357.
8. Kirschner M. 1909. Ueber nagelextension. *Beitr Klin Chir* 64: 266–279.
9. Namba RS, Kabo JM, Meals RA, et al. 1987. Biomechanical effects of point configuration in Kirschner-wire fixation. *Clin Orthop Relat Res* 214:19–22.
10. Graebe A, Tsenter M, Kabo JM, et al. 1992. Biomechanical effects of a new point configuration and a modified cross-sectional configuration in Kirschner-wire fixation. *Clin Orthop Relat Res* 283:292–295.
11. Belmont B, Li W, Shih A, et al. 2014. Micromilling surface patterns for enhanced Kirschner wire bone drilling. *IWMF 2014, 9th International Work Microfactories 5*. p 75–79.
12. Liu Y, Belmont B, Wang Y, et al. 2017. Notched K-wire for low thermal damage bone drilling. *Med Eng Phys* 45:25–33.

13. Piska M, Yang L, Reed M, et al. 2002. Drilling efficiency and temperature elevation of three types of Kirschner-wire point. *J Bone Joint Surg Br* 84:137–140.
14. Hutchinson DT, Bachus KN, Higgenbotham T. 2000. External fixation of the distal radius: to predrill or not to predrill. *J Hand Surg Am* 25:1064–1068.
15. Luo Y, Chen L, Finney FT, et al. 2019. Evaluation of heat generation in unidirectional versus oscillatory modes during K-wire insertion in bone. *J Orthop Res* <https://doi.org/10.1002/jor.24345>
16. Toksvig-Larsen S, Ryd L, Lindstrand A. 1990. An internally cooled saw blade for bone cuts: lower temperatures in 30 knee arthroplasties. *Acta Orthop Scand* 61:321–323.
17. Augustin G, Davila S, Udiljak T, et al. 2012. Temperature changes during cortical bone drilling with a newly designed step drill and an internally cooled drill. *Int Orthop* 36:1449–1456.
18. Brand S, Klotz J, Petri M, et al. 2013. Temperature control with internally applied cooling in solid material drilling: an experimental, biomechanical study. *Int Orthop* 37:1355–1361.
19. Shakouri E, Haghghi Hassanalideh H, Gholampour S. 2018. Experimental investigation of temperature rise in bone drilling with cooling: a comparison between modes of without cooling, internal gas cooling, and external liquid cooling. *Proc Inst Mech Eng Part H J Eng Med* 232:45–53.
20. Franssen BBGM, Van diest PJ, Schuurman AH, et al. 2008. Drilling K-wires, what about the osteocytes? An experimental study in rabbits. *Arch Orthop Trauma Surg* 128:83–87.
21. Meriam JL, Kraige LG. 2012. *Engineering mechanics volume 2: dynamics*, 7th ed. New York, NY: John Wiley & Sons.
22. Karaca F, Aksakal B. 2013. Effects of various drilling parameters on bone during implantology: an in vitro experimental study. *Acta Bioengi Biomech* 15:25–32.
23. Palmisano AC, Tai BL, Belmont B, et al. 2015. Comparison of cortical bone drilling induced heat production among common drilling tools. *J Orthop Trauma* 29:e188–e193.
24. Esen H, Yano K, Buss M, et al. 2003. A control algorithm and preliminary user studies for a bone drilling medical training system. In: *12th IEEE Workshop Robot and Human Interactive Communication (ROMAN)*, San Francisco, USA. p 153–158.
25. Schmidt AO, Roubik JR. 1949. Distribution of heat generated in drilling. *Trans ASME* 71:242–245.
26. Komanduri R, Hou ZB. 2001. A review of the experimental techniques for the measurement of heat and temperatures generated in some manufacturing processes and tribology. *Tribol Int* 34:653–682.