

**WHITE LIGHT MEASUREMENT: A CATALYST FOR CHANGE IN AUTOMOTIVE  
BODY DIMENSIONAL VALIDATION**

**Measurement Strategies for Stamping and Body Assembly from Tryout through PPAP**

Patrick C. Hammett, Ph.D.

Luis Garcia-Guzman, Ph.D.

University of Michigan Transportation Research Institute (UMTRI)

Automotive Analysis Division (Formerly OSAT)

2901 Baxter Road

Ann Arbor, Michigan 48109-2150

U.S.A.

January 2006

**Technical Report Documentation Page**

1. Report No. UMTRI-2006-3	2. Government Accession No.	3. Recipient's Catalog No.	
4. Title and Subtitle White Light Measurement: A Catalyst for Change in Automotive Body Dimensional Validation		5. Report Date: January 2006	
		6. Performing Organization Code	
7. Author(s) Hammett, Patrick C. and Garcia-Guzman, L.		8. Performing Organization Report No.	
9. Performing Organization Name and Address The University of Michigan Transportation Research Institute 2901 Baxter Road Ann Arbor, Michigan 48109-2150 U.S.A.		10. Work Unit no. (TRAIS)	
		11. Contract or Grant No.	
12. Sponsoring Agency Name and Address General Motors Body Manufacturing Engineering, North America 2000 Centerpoint Parkway, Pontiac, MI 48341		13. Type of Report and Period Covered	
		14. Sponsoring Agency Code	
15. Supplementary Notes			
<p>16. Abstract</p> <p>This report examines the usage of 3D non-contact white light (WL) measurement technology and how its adoption could impact traditional North American automotive body dimensional evaluation strategies from die tryout through PPAP. The report includes several WL measuring studies involving a longitudinal analysis of door components and their resultant assembly throughout the preproduction process. It provides several recommendations for new part measurement strategies and business processes for automotive body stamped parts and subassemblies. The recommendations support a part quality evaluation process that places a greater emphasis on measuring <i>overall</i> part shape and feature conformance as well as intra-panel correlation patterns (e.g., twists and feature-to-feature relationships) versus process capability conformance of discrete points to individual specifications. These recommendations include adopting percent in specification metrics such as PIST, reducing measurement sample sizes for both tryout runs and PPAP, and utilizing new methods for analyzing and reporting part dimensional data. These new methods are aimed at providing more comprehensive part quality representation to increase the utility of dimensional measurement data for end-users.</p>			
17. Key Words 3D non-contact measurement system, sheet metal stamping, automotive body, PPAP, die tryout, white light measurement, photogrammetry, door assembly, measurement system capability, tolerance analysis		18. Distribution Statement Unlimited	
19. Security Classification (of this report) None	20. Security Classification (of this page) None	21. No. of Pages: 52	22. Price

**Table of Contents**

<b>List of Figures.....</b>	<b>iii</b>
<b>List of Tables .....</b>	<b>iv</b>
<b>Executive Summary .....</b>	<b>1</b>
<b>1. Introduction.....</b>	<b>3</b>
1.1 Report Organization.....	5
<b>2. Dimensional Evaluation Strategies Used in Stamping Tryout and PPAP.....</b>	<b>6</b>
<b>3. WL Measurement System Capability .....</b>	<b>11</b>
3.1 Check Fixtures versus WL Measurement .....	12
3.2 WL Measurement Reporting Using Color Maps and Profile Graphs.....	14
<b>4. Stamping-Assembly Analysis Using WL Measurement.....</b>	<b>19</b>
<b>5. PIST Metric and Reporting Using WL Measurement .....</b>	<b>30</b>
5.1 PIST Metric and Mean Deviation Distribution for a Single Part.....	31
5.2 Sample Size Considerations for Average PIST .....	35
5.3 PIST Metric by Feature Type: Surface, Hole/Slot, and Trim Edge.....	38
5.4 PIST Metric and Tolerance Considerations .....	41
<b>6. Part Submittal Criteria for Matching / Functional Build Events .....</b>	<b>44</b>
<b>7. PPAP Strategies for WL Measurement .....</b>	<b>46</b>
7.1 Part Sampling.....	46
7.2 Functional Master Part and Tolerance Adjustment Issues.....	47
<b>8. Production Monitoring and WL Part Measurement.....</b>	<b>49</b>
<b>9. WL Part Measurement – Future Direction .....</b>	<b>50</b>
<b>10. Conclusion .....</b>	<b>51</b>
<b>References.....</b>	<b>52</b>

## List of Figures

Figure 1. Typical Dimensional Evaluation Process for Stamped Body Parts.....	7
Figure 2. Range Measurements from a 30-Sample PPAP Run .....	9
Figure 3. Door Inner Panel Measured with 3D Non-Contact Measurement .....	12
Figure 4. Check Fixture Vs. WL (Optigo) Measurements – Door Assembly .....	13
Figure 5. Check Fixture Vs. WL (Optigo) Measurements – Door Outer .....	13
Figure 6. Surface Average Color Maps for Door Inner Stamped Panel .....	15
Figure 7. Door Outer Range Surface Color Map and Door Assembly .....	16
Figure 8. Trim Edge Hairline (Profile) Graph .....	17
Figure 9. Hole/ Rectangular Cutout Position and Size Deviations in Door Handle .....	18
Figure 10. Average Color Maps Door Inner Panel LH.....	21
Figure 11. Range Color Maps Door Inner Panel LH.....	21
Figure 12. Average Color Maps Door Outer Panel .....	21
Figure 13. Range Color Maps Door Outer Panel.....	22
Figure 14. Average Color Map for Door Assembly LH.....	23
Figure 15. Range Color Map for Door Assembly LH .....	23
Figure 16. Localized Deformation in Inner Door Panel and Door Assembly .....	24
Figure 17. Fore-Aft Analysis: Door Assembly Front Hem Edge at PPAP.....	24
Figure 18. Predicted Door Assembly Based on Inner and Outer Panels .....	25
Figure 19. In/Out (Flush) Analysis Door Assembly, PPAP Run.....	25
Figure 20. In/Out (Flush) Predictive Analysis Door Assembly.....	26
Figure 21. Fore/Aft (Gap) Analysis Rear Flange, PPAP Run .....	27
Figure 22. Fore/Aft (Gap) Prediction Rear Flange, PPAP Run .....	27
Figure 23. In/Out (Flush) Analysis Rear Flange, PPAP Run .....	28
Figure 24. In/Out Flush Prediction Rear Flange, PPAP Run.....	28
Figure 25. Range Color Maps for Door Inner Panel and Door Assembly.....	29
Figure 26. Histogram of Dimensional Deviations for a Single Part.....	32
Figure 27. Box Plots for PIST.....	33
Figure 28. Average Color Map for Body Side.....	33

Figure 29. Average Color Map for Front Door Inner .....	34
Figure 30. Average Color Map for Hood Inner .....	34
Figure 31. Range Color Map with Individual Panels .....	36
Figure 32. Range Color Map for Door Assembly based on small samples for 3 build events.....	37
Figure 33. Decomposition of PIST Metric .....	40
Figure 34. PIST Proportion Chart for RR Door Inner Panel .....	49

### **List of Tables**

Table 1. Longitudinal Door Study Parts and Build Events.....	4
Table 2. Parts Measured in Functional Build Tryout Events.....	5
Table 3. Comparison of Measurement Strategy by Manufacturers .....	8
Table 4. Study of Within-Run Standard Deviation over Five Vehicle Programs.....	10
Table 5. Historical Performance Vs. WL Measurement Results .....	14
Table 6. Standard Color Map Scale .....	15
Table 7. WL (Optigo) Sampling from Functional Build 1, Build 2, and PPAP .....	19
Table 8. Dimensional Summary, Rear Door Inner Panel LH.....	20
Table 9. Dimensional Summary, Rear Door Outer Panel LH .....	20
Table 10. Dimensional Summary, Rear Door Assembly LH .....	22
Table 11. Sample Size Effect on Observed Range Measurements.....	38
Table 12. Conformance by Feature Type .....	41
Table 13. Functional Build 1 Versus Build 2 .....	43
Table 14. Summary of Average PIST.....	45

## Executive Summary

This report provides recommendations for new part measurement strategies and business processes for automotive body stamped parts and subassemblies using 3D non-contact white light (WL) measurement technology. The recommendations support a part quality evaluation process that places a greater emphasis on measuring *overall* part shape and feature conformance as well as intra-panel correlation patterns (e.g., twists and feature-to-feature relationships) versus process capability conformance of discrete points to individual specifications. These recommendations impact typical dimensional evaluation processes used from die tryout through launch and into regular production.

The recommendations in this report are supported by various prior benchmark studies and two manufacturing validation studies of stamped part quality using WL part measurement. These WL studies include: (1) a longitudinal study of door stamped parts and their assembly from Die Source Tryout through Production Part Approval Process (PPAP)<sup>1</sup>, and (2) a study of 18 stamped parts evaluated using WL measurement for two-dimensional evaluation build events prior to vehicle launch.

Among the major findings in this report are:

- Most manufacturers outside North America measure significantly more dimensions per part on substantially fewer samples per run and use less statistically-rigorous evaluation metrics. This presents particular challenges among North American manufacturers striving toward common global processes.
- WL measurement has the capability to meet traditional measurement requirements for discrete points as well as to provide more comprehensive part quality assessment than traditional check fixtures for measuring individual parts and evaluating stamping-assembly relationships.
- WL measurement provides a catalyst to change existing dimensional evaluation processes to better align them with a functional-build-based part approval approach versus a historical PPAP approach that focuses on meeting statistical process capability criteria for every dimension.

---

<sup>1</sup> Part dimensional data for this study were obtained using CogniTens, Ltd. measurement systems and its Coreview Analysis Software, with project data collection and analysis support from Tesco Group Companies.

These findings support significant changes to traditional measurement approaches and dimensional validation business processes in moving from traditional check fixtures to a WL measurement approach. These changes include modifying part evaluation metrics, reducing measurement sample sizes for both tryout runs and PPAP, and utilizing new methods for analyzing and reporting part dimensional data. These new methods are aimed at providing more comprehensive part quality representation to increase the utility of the measurement data for end-users. The following list summarizes recommendations for these new methods:

- Provide full-surface, color map part quality representations for each measurement sampling event (Section 3.2)
- Incorporate more feature extractions per part to include more trim edge, hole/slot position, and size dimensions into normal measurement routines, eliminating the need for separate one-piece measurement layout studies (Section 3.2)
- Generate average and range color maps to show part conformance for multi-sample dimensional evaluations (Section 3.2)
- Adopt a percent in specification or PIST metric to measure overall part quality conformance for various build events (Section 5)
- Adopt PIST criteria by build event (Section 6)
- Change historical sample size requirements from five to three samples for key tryout build event part evaluations (Section 7)
- Change PPAP sampling requirements from a 30 to a nine sample study using three different stamping runs (setups) of three samples each (Section 7)
- Evaluate parts in regular production relative to a functional master part obtained during PPAP (Section 7)

While this report provides several recommendations for integrating WL measurement into part dimensional validation processes, readers should recognize that this technology is still relatively new. Thus, this report aims to provide only an initial foundation on how this technology may be utilized to produce higher part quality and make better rework decisions during manufacturing validation build event reviews.

## 1. Introduction

Historically, part measurement for automotive body applications has consisted of discrete point inspection and analysis. Here, a manufacturer measures stamped or assembled parts relative to a product design nominal at discrete point locations. These discrete measurements typically are measured using coordinate measuring machines (CMM) or checking fixtures (often with electronic data collection bushings and measurement probes).

Recently, certain 3D non-contact measurement systems using white light (WL) technology have been replacing or augmenting these traditional systems<sup>2</sup>. With the adoption of WL technology, manufacturers have new part quality measurement and analysis capabilities. Thus, manufacturers should reevaluate their existing dimensional evaluation processes and metrics to better align them with the added functionality of WL measurement.

For some companies, adopting WL measurement strategies can provide a catalyst to change other existing dimensional evaluation practices that historically have not yielded their desired intent. For example, several North American stamping manufacturers measure relatively large samples sizes (30 or more) from single die setups as part of the industry-standard Production Part Approval Process (PPAP) [2]. These sample size requirements have been shown to be excessive in stamping due to a predictable low within run stamping variability relative to tolerance widths [3]. Furthermore, the traditional PPAP approach often has led to an over-emphasis on trying to achieve Ppk criteria for discrete points versus focusing on how parts functionally affect downstream assembly operations regardless of whether they meet the Ppk criteria [3].

This report provides recommendations for changing several of these dimensional evaluation processes with the adoption of WL technology. In developing these recommendations, this report draws upon several broad stamping dimensional validation process comparison studies and two recent WL measurement studies.

The first WL measurement study involved a longitudinal analysis of door stamped parts and their respective assemblies from initial die tryout at the construction source through PPAP in the production facility. Table 1 provides a summary of the door parts, key quality build events, and build locations. An important aspect of this study is that the parts were evaluated using

---

<sup>2</sup> The WL measurement systems used in this report were from CogniTens, Ltd.



traditional check fixtures, evaluation processes, and part approval criteria. Thus, WL measurements were taken for comparison purposes only and did not play a significant role in rework decisions or achievement of desired quality goals.

Part	Build Event and Location		
	Sampling 1 (Functional Build 1)	Sampling 2 (Functional Build 2)	Sampling 3 (PPAP)
Door Inner Stamping	Die Source	Production Source	
Door Outer Stamping	Die Source	Production Source	
Door Assembly	Die Source	Production Source	

**Table 1. Longitudinal Door Study Parts and Build Events**

The second study examined 18 stamped parts evaluated at an initial functional build tryout event for a new vehicle program. These parts were measured only with WL systems. For a subset of them (seven parts), an additional set of quality evaluations was obtained for a second functional build event during home line tryout at the production source<sup>3</sup>. Table 2 provides a list of parts measured at each build event. In addition to full surface measurements, these evaluations also involved measuring parts at discrete checkpoint locations. For reference purposes, the typical number of discrete checkpoints when using traditional check fixtures is ~10 for moderately complex parts and ~30-40 for complex parts such as body sides. Thus, the number of discrete points measured here using WL systems is significantly higher.

---

<sup>3</sup> Unfortunately, at the time of the writing of this report, we were not able to obtain the complete set of measurement data for all parts at both matching build events.

Part Name	No. of Dimensions	Sampling 1 (Matching 1)	Sampling 2 (Matching 2)
BODY SIDE INR RH	165	X	X
BODY SIDE INR LH	185	X	
BODY SIDE OTR RH	196	X	
FRT DR OTR RH	61	X	
HOOD OUTER	46	X	
HOOD INNER	77	X	
FRT DR INR RH	139	X	
FRT DR INR LH	148	X	
REAR COMPT OTR	61	X	
REAR COMPT INR	97	X	X
ROOF	120	X	X
RR DOOR INR RH	134	X	X
RR DOOR INR LH	131	X	X
REINF-W/S INR	20	X	X
FRT DOOR REINF LH	88	X	X
FRT DOOR REINF RH	85	X	
REINF ROOF INR	24	X	
REINF-ROOF OTR	23	X	
	<b># Parts</b>	<b>18</b>	<b>7</b>

**Table 2. Parts Measured in Functional Build Tryout Events**

### 1.1 Report Organization

This report is organized as follows: Section 2 provides an overview of typical stamping measurement strategies used in North America and contrasts them with those used by European- and Asian-based manufacturers. This section also summarizes many of the dimensional evaluation processes which could be affected by adopting a WL measurement approach.

Sections 3 and 4 examine the capabilities of WL measurement and its functionalities. These capabilities are demonstrated using the longitudinal door study and the two functional build event studies. Together, these studies demonstrate the capabilities of WL measurement technology not only to replicate the dimensional evaluation processes of traditional check fixtures, but also to obtain significantly more information.

Sections 5 through 8 examine several dimensional evaluation metrics and processes, providing recommendations to align them with new WL measurement capabilities. Specifically, section 5 considers the use of a PIST (**P**ercent of **I**nspection Points that **S**atisfy **T**olerance) metric to evaluate overall panel quality. The PIST metric has been used in North America, but only sparingly for one-piece full dimensional layout studies. In contrast, this metric is used extensively by non-North American manufacturers. This section also proposes other evaluation methods to augment the PIST metric including average and range color maps and column charts by feature type to help in part diagnostics.

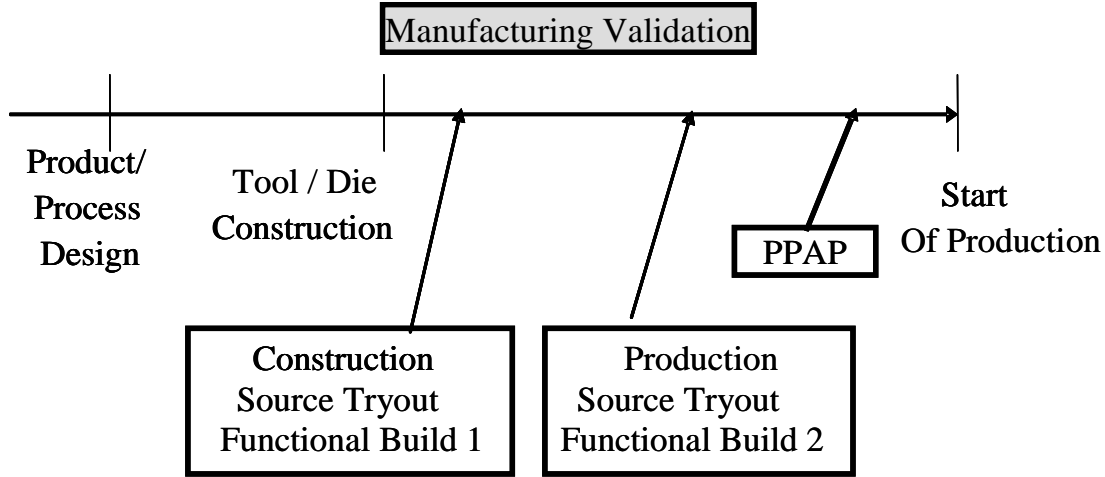
Section 6 expands on the PIST metric and discusses how it may be used as a part submittal criterion for functional build or assembly match build events. In section 7, new PPAP recommendations for WL measurement, including modifications to sample sizes and tolerance adjustment processes, are proposed.

Finally, Section 8 provides a recommended approach for monitoring general part quality during regular production using a PIST metric and a proportion conforming process control chart.

This report concludes with a discussion of future opportunities using WL measurement and potential implications for automotive body dimensional validation processes.

## **2. Dimensional Evaluation Strategies Used in Stamping Tryout and PPAP**

Manufacturing validation for sheet metal stamped parts in North America traditionally has been an iterative, inspect-and-rework process that begins with an initial tryout at a die construction facility and concludes with part approval at the production source through PPAP. Figure 1 summarizes the key dimensional evaluation events (boxes) in a typical manufacturing validation process. For each of these events, manufacturers take samples from tryout runs, assess their conformance to design, and make decisions about what to accept or rework.



**Figure 1. Typical Dimensional Evaluation Process for Stamped Body Parts**

A major challenge for stamping manufacturers throughout this validation process is the difficulty producing parts such that the mean for every dimension is centered at its design nominal. Even with extensive die rework, this objective rarely is achieved. Fortunately, centering every mean is not a hard requirement as some stamping deviations may be absorbed in downstream assembly processes without adversely affecting final vehicle quality. Thus, manufacturers often are faced with tough business decisions trying to determine how close they need to rework dimensions toward nominal before they begin adding *unnecessary rework costs*. They ultimately must decide which deviations to rework and which may be accepted as is.

These challenges have led to the use of methods such as functional build, panel matching, and assembly slow-build evaluations to make final determinations about the acceptance of single parts [3]. In most cases, stamped parts will require some tolerance adjustments for final part approval and long-term production monitoring. These adjustments often take the form of a mean offset to original design nominal, but may include a tolerance expansion (e.g., increase tolerance from  $\pm 0.5$  to, say,  $\pm 0.7$ ).

In evaluating part acceptance decisions, one difference among manufacturers is the emphasis on meeting process capability statistical criteria versus measurement comprehensiveness. North American manufacturers tend to rely more on statistical evaluations for relatively few dimensions per part using process capability indices such as Pp and Ppk. In

contrast, European- and Asian-based manufacturers tend to measure significantly more dimensions and evaluate part quality based on percent-in-specification metrics. Table 3 contrasts these differences in measurement sample sizes, number of dimensions measured per part (i.e., check point density), and evaluation criteria.

Sample size and checkpoint density differences are largely related to the evaluation criteria. For instance, the use of process capability indices tends to push manufacturers toward larger sample sizes (i.e., number of panels measured from an individual run) to insure reasonable confidence in the capability statistics calculated. For example, the North American part approval process (PPAP) for stamped parts typically involves measuring 30-100 samples from a single die setup. Given these large sample size requirements relative to the cost of checking per dimension, North American manufacturers tend to measure their panels less comprehensively (i.e., using fewer dimensions). In contrast, manufacturers measuring smaller samples per run tend to inspect more dimensions.

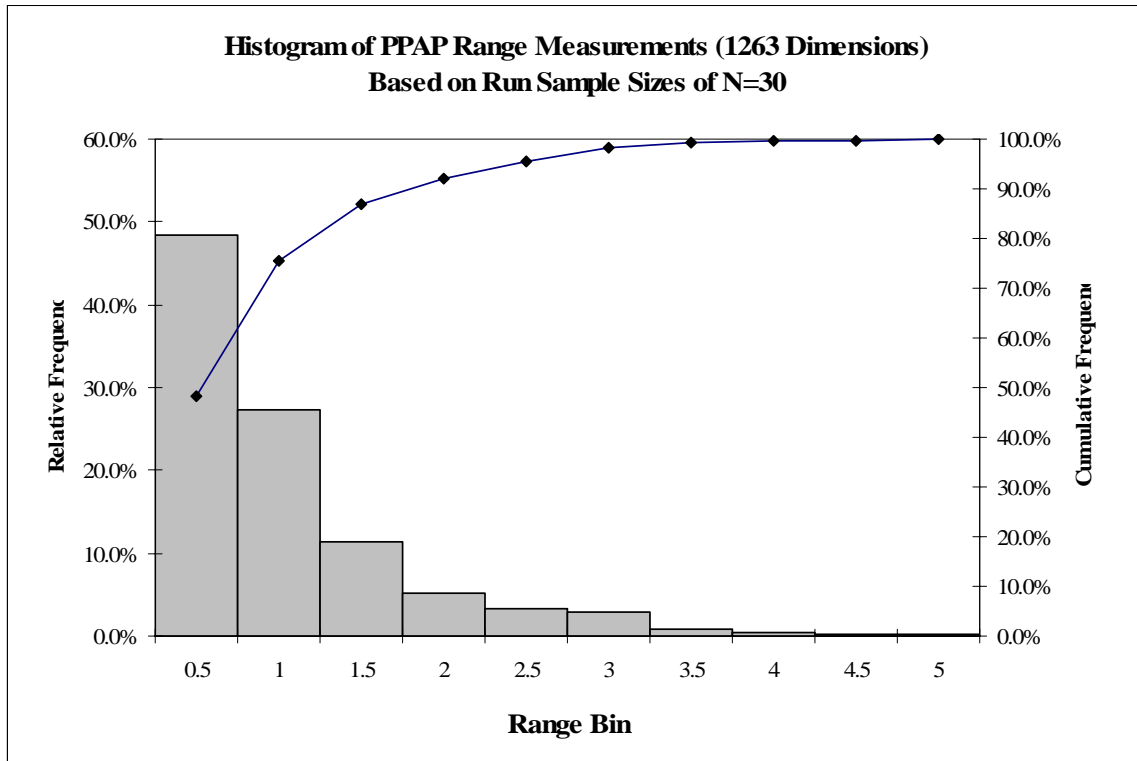
Category	Typical Japan	Typical Europe	Typical Korea	Typical North America
Measurement Sample Size Per Tryout Run	1-3	1-3	1-3	5 pc per tryout (30 pc for PPAP)
Number of Dimensions Measured	Large # Dimensions per part			Comparatively few dimensions per typical measurement sample
Part Approval Criteria	Percent in Specification (PIST)			Process Capability Indices (Pp/Ppk)

**Table 3. Comparison of Measurement Strategy by Manufacturers**

One important consideration in utilizing smaller sample sizes per run is the consistency of stamping variation. Although the North American PPAP approach requires a larger sample size (e.g., 30 or more), the within-run standard deviation for stamping dimensions is rarely a concern and is largely predictable from historical data of similar parts. Figure 2 summarizes range measurements across 1,263 dimensions on 160 parts taken from a PPAP study using traditional check fixtures. For nearly 50% of the dimensions, the range measurement *within a run* was less than 0.5 mm. This equates to an average within-run standard deviation of approximately 0.08, yielding a within-run tolerance capability of  $\pm 0.25$  mm. In other PPAP studies, the

percentage of dimensions with a range less than 0.5 mm has been as high as 70%. Furthermore, few dimensions exhibit ranges for a single run larger than 1.4 mm. This equates to a within-run standard deviation of 0.23 and a tolerance variation capability of  $\pm 0.7$  mm about the mean. Of note, the relatively few dimensions that exhibit larger within-run variation tend to occur on non-rigid areas of parts. These variations often may be compensated in downstream assembly weld operations.

Relatively low within-run standard deviation has been a consistent finding in studying stamping processes. Table 4 summarizes within-run stamping variation for five vehicle programs. These results show that the within-run stamping variation has been consistent for at least the last 10 years.



**Figure 2. Range Measurements from a 30-Sample PPAP Run**

<b>Program</b>	<b># Dimensions (Across Many Parts)</b>	<b>Median <math>\sigma_{\text{within-run}}</math></b>
Case1 (1995)	473	0.09
Case2 (1997)	580	0.07
Case3 (1999)	776	0.08
Case4 (2001)	1114	0.11
Case5 (2006)	1752	0.08

\* Note: Case 5 based on WL Measurement

**Table 4. Study of Within-Run Standard Deviation over Five Vehicle Programs**

Measuring smaller samples per run does not imply that manufacturers will be unable to detect quality problems. In fact, since within-run stamping variation is relatively small and predictable, manufacturers may still detect excessive mean deviations or large mean shifts between stamping runs caused by a lack of process control. In other words, small standard deviations allow manufacturers to detect more significant problems (large mean deviations or mean shifts between stamping runs). These findings support the use of smaller sample sizes per run.

While industry-wide PPAP requirements have been one roadblock in changing North American part measurement strategies, other obstacles have existed. These include the cost of checking a large number of dimensions for a single part and measurement system requirements for accuracy and repeatability [4]. In Europe and Asia, manufacturers often use manual feeler gages with undercut surface check fixtures (or check rails) to obtain a large number of measurement dimensions per part. This inspection approach is very labor intensive and not conducive to measuring the larger sample sizes needed to obtain reasonable statistical confidence in calculating process capability indices. In addition, manual feeler gage systems have limitations in terms of measurement accuracy and repeatability and are not widely regarded in North America [5]. Thus, North American sampling requirements and measurement system standards lead to more costly measurement equipment, which is then offset by measuring fewer dimensions per part.

Although North American manufacturers tend to measure fewer dimensions for part quality evaluations, they still may perform some comprehensive part measurements once or twice during preproduction. For example, most manufacturers perform a one-piece, full-panel

layout inspection (e.g., inspect in two directions every 25-50 mm around the periphery of a part) using either a check fixture with an undercut surface or a coordinate measuring machine. These part measurement studies are usually an additional requirement to the other process capability studies. Thus, North American manufacturers are saddled with trying to develop measurement systems that accommodate both large sample studies for PPAP and one-sample, full-panel layout studies. This historically has led to some redundancy in measurement system (e.g., usage of both check fixtures and CMM fixtures to measure the same parts).

Although WL measurement provides the flexibility to do either type of dimensional study, this dual usage is not a recommendation of this report. Rather, this report supports the adoption of the “high checkpoint density / low sample size” approach with one measurement routine that is commonly used outside North America. An important benefit of adopting such an approach is that North American manufacturers may better align their measurement processes with their global partners in their efforts to develop common processes.

### **3. WL Measurement System Capability**

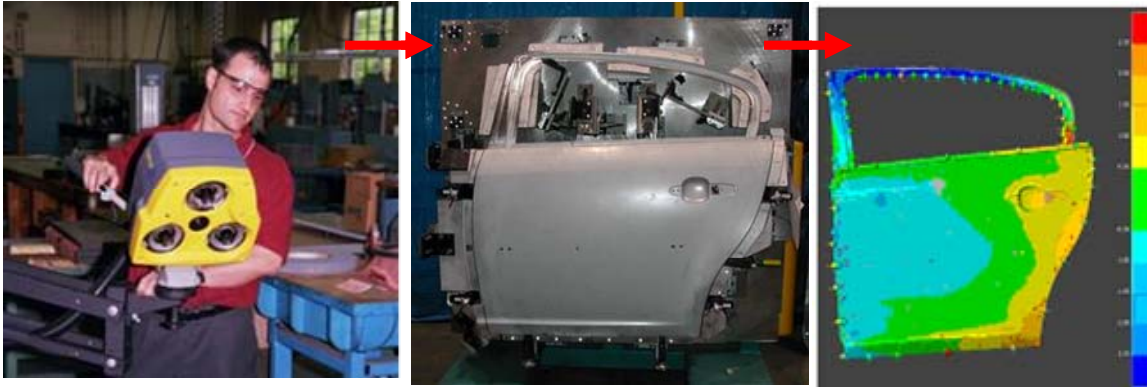
Various systems have been developed for 3D non-contact measurement, such as laser scanners/trackers and photogrammetry-based systems. The system used in this study is the Optigo 200 3D non-contact white light measurement system from CogniTens Ltd.<sup>4</sup> with the measurement results displayed using their Coreview software. This system was shown in a prior study to meet automotive body measurement requirements for accuracy and shop floor gage repeatability and reproducibility on automotive body parts. In addition, the study showed a strong correlation with CMM measurements using contact measurement sensors [1].

Figure 3 shows an operator using the Optigo 200 system, a door assembly from the study, and the resultant output. The colored balls in the output represent discrete point locations, whereas the remaining areas represent a cloud of points. The cloud of points illustrates the conformance of the part surface to design nominal values. Note: Dark blue and dark red represent areas with the largest deviations from nominal.

---

<sup>4</sup> Although this report examines the portable, manually-operated Optigo 200 system typically used for offline inspection, similar technology (the OptiCell from CogniTens) is available for automated measurement applications.





**Figure 3. Door Inner Panel Measured with 3D Non-Contact Measurement**

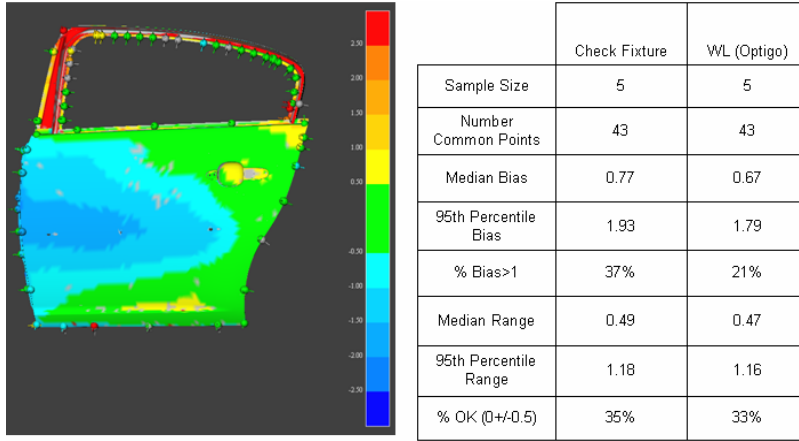
In the following subsections, we explore several issues related to WL measurement using the door and functional build tryout studies.

### 3.1 Check Fixtures versus WL Measurement

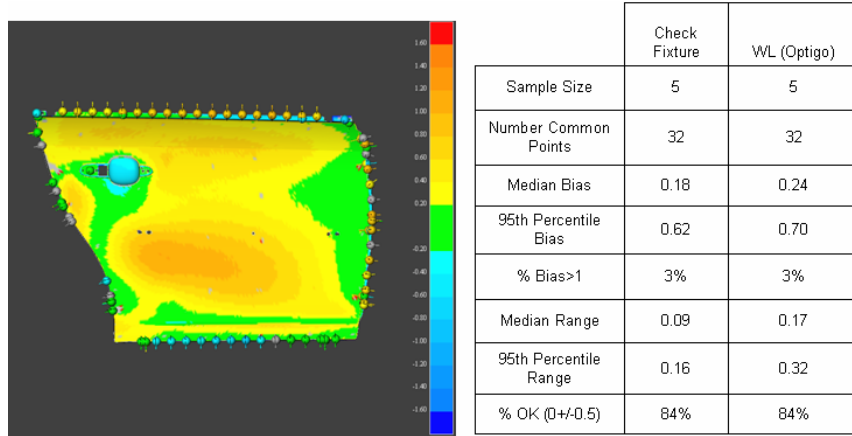
In the door study, we compared part measurements using traditional check fixtures with those based on WL measurements. Figures 4 and 5 compare these measurements for both a door assembly and its door outer component panel<sup>5</sup> at the first functional build tryout event. These comparisons are based on a common set of points based on the existing check fixture process monitoring point locations. The associated tables compare the mean bias (absolute deviation of the mean from nominal) and range values for a set of common points. As expected, these findings show similar dimensional results between measurement systems.

---

<sup>5</sup> The door outer panel measurements for this study were taken on the inside of the part, thus the color map pictures are flipped relative to assembly car position.



**Figure 4. Check Fixture Vs. WL (Optigo) Measurements – Door Assembly**



**Figure 5. Check Fixture Vs. WL (Optigo) Measurements – Door Outer**

In addition to the door study, we compared WL measurements for 18 parts relative to historical findings (based on five vehicle programs). These results, shown in Table 5, indicate that a WL measurement strategy will provide similar quality measurements as traditional check fixtures in terms of mean and range conformance – particularly for similar checkpoints at the start of tryout. These results are not surprising given that dimensional conformance at initial tryout events is primarily a measure of the capability of the die design and construction process. At this point of dimensional manufacturing validation, limited opportunities exist to rework parts closer to design nominal and thus we expect a similar distribution of conformance regardless of the measurement system and quality evaluation process used.

Build Event	Sample Size	~ Dimensions per Part	%  Mean  < 0.5	%  Mean  > 1	% Range < 0.5	% Range > 1
Historical ~FB 1*	~5 pcs	~10 PMPs	55-65%	10-15%	85-90%	~1%
FB1 (PIST)**	~ 3 pcs	~95 PIST	<b>62%</b>	<b>15%</b>	<b>91%</b>	<b>2%</b>

\* Compilation from 5 vehicle programs

\*\* Based on recent program using WL Part Measurement 18 parts, 1700 check pts

**Table 5. Historical Performance Vs. WL Measurement Results**

Given that the WL study involved significantly more dimensions (~95 per part versus ~10 per part), these findings also suggest that the historical subset of points was representative of the overall dimensional population. While this finding could be viewed as supporting evidence that inspecting and reporting more dimensions per part is unnecessary, we would argue that this is not the case. The point of more comprehensive measurement is not that it will identify a larger (or smaller) percentage of out-of-specification conditions, but rather that it will provide significantly better insight into patterns of variation (e.g., twists) and thus help identify modifications to improve part quality.

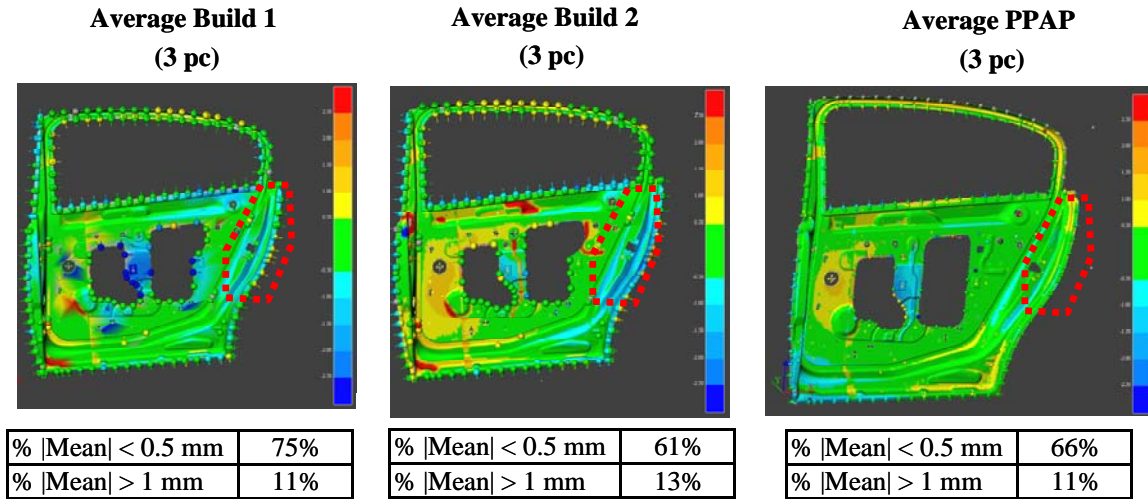
### 3.2 WL Measurement Reporting Using Color Maps and Profile Graphs

WL measurement systems provide dimensional reporting for full-part surfaces relative to design nominal as well as discrete dimensions for individual surface points, edge points, and holes/slots (position and size). This section provides examples of these reporting capabilities.

First, we provide examples of full-part surface color maps. Figure 6 shows surface color maps for the stamping door inner panels from the first tryout run through PPAP. These particular color maps are *average color maps*<sup>6</sup>, which means that the cloud of points is a compilation of multiple panels (in this example, three samples are used for each color map). The average color map provides an indication of the overall surface conformance and allows dimensional analysts to identify problem areas and changes between build events. In addition to full surfaces, color maps also may communicate discrete point deviations using colored balls or markers.

---

<sup>6</sup> Average, range, and standard deviation color maps were made using CogniTens Coreview software.



**Figure 6. Surface Average Color Maps for Door Inner Stamped Panel**

In displaying color maps, we support the use of a standard scale for all parts (see Table 6). As a general rule, we recommend using  $\pm 0.5$  for the green area,  $+2$  for the dark blue area, and  $-2$  for the red areas. For example, these color maps may be used to show improvement along the rear edge of the door from initial tryout to PPAP (e.g., from mostly blue to mostly green).

Colors*	Deviation
Dark Blue	$> 2$
Moderate Blue	$+ 1$ to $+ 2$
Light Blue	$+ 0.5$ to $+ 1$
Green	$+/-0.5$
Yellow	$- 0.5$ to $- 1$
Orange	$- 1$ to $- 2$
Red	$< 2$

\* Refer to actual output for exact colors and scale

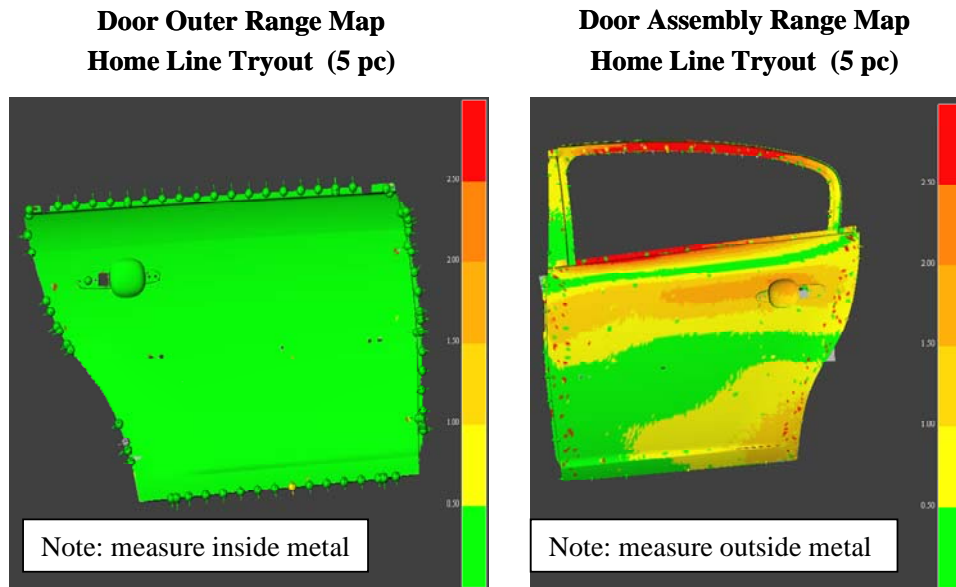
**Table 6. Standard Color Map Scale**

One important characteristic of an average surface color map is that it may be used to generate a functional master part. As discussed previously, manufacturers often incorporate dimensional mean offsets from nominal to approve parts for production. These mean offsets are necessary because of the difficulty in simultaneously producing all mean dimensions to nominal.

In accepting mean offsets, manufacturers often laterally shift specifications around new targets rather than expand tolerance widths. For example, suppose a dimension has a specification of nominal  $(0) \pm 0.5$  mm and the mean is 0.4 mm off with low variation relative to the tolerance width. Here, manufacturers often prefer to re-target the nominal to 0.4 and keep the same tolerance width (e.g., set lower specification limit = -0.1; target = 0.4; upper limit = 0.9).

Although this tolerance adjustment practice allows manufacturers to pass part buyoff criteria for PPAP, it results in a desired part that differs slightly from the original product design. By using an average color map to create a functional master, manufacturers can reference the as-built condition of individual parts in future measurements. This has several benefits including easier-to-maintain engineering documentation and a usable reference for future part monitoring.

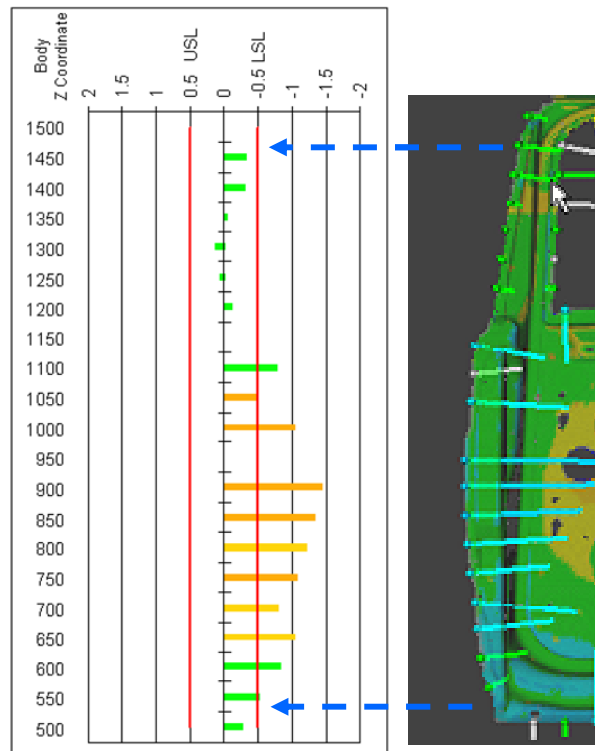
In addition to average color maps, WL measurement results may be configured to show sample variability by creating a range or standard deviation color map. Figure 7 shows a sample range color map from a five-piece study during home line tryout for a door outer and its associated door assembly. Here, one can see that the variation (as expressed using the range) in the door assembly significantly increases from the variation observed in the door outer stamping alone. For example, the range measurements in the door handle surface area double in the assembly compared to the door outer stamping.



**Figure 7. Door Outer Range Surface Color Map and Door Assembly**

(Note: Door Outer is measured on inside of part – thus picture is flipped from car position.)

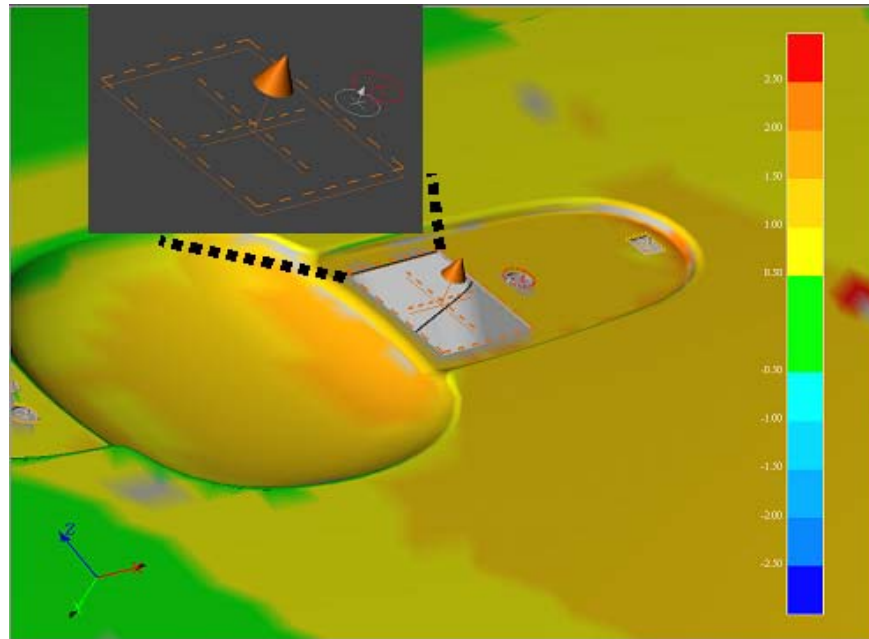
Color maps provide an effective visual representation of *surface* conformance to product design regardless of whether discrete point dimensions are defined. However, trim edge points, hem edges, holes, slots, and other like dimension types require predefining dimensional locations to measure. For instance, to show the profile of a trim surface, one needs to define a series of trim edge points. Then, one can use a trim edge profile graph or hairline graph to visually show the consistency of a trim line. Figure 8 provides a sample trim edge profile graph that shows a wavy, out-specification condition along the door trim line from top to bottom. Note: For reference purposes, the sample graph includes the approximate body position Z coordinate (height position relative to the ground) for the various discrete trim edge points measured.



**Figure 8. Trim Edge Hairline (Profile) Graph**

WL technology also may be used to measure hole and slot features using a variety of dimension types, though typically they are measured using size and position dimensions. For holes, users typically report the size dimension using diameter and the positional location using true position. For slots and rectangular cutouts, users may measure the minor and major axes for size measurements. Figure 9 provides a visual color map showing size and positional

measurements for a hole and a rectangular feature in the door handle area. Here, we can see that the hole and rectangular door handle cutout are forward and outboard (see orange arrow) relative to design nominal. The particular rectangular feature is off nominal by over 1.5 mm.



**Figure 9. Hole/ Rectangular Cutout Position and Size Deviations in Door Handle**

For North American manufacturers, variable data for size and position measurements of holes and slots historically have not been incorporated into detail stamping checking fixtures due to the costs and challenges involved in measuring them. These features have been measured primarily in one-piece full-layout studies (using CMM or manual gages), which tend to occur only once or twice throughout manufacturing validation. With WL technology, however, manufacturers can measure these characteristics on a more regular basis (e.g., at each build event and across multiple samples within a build event).

This increased measurement capability for these dimension types offers better problem solving capability in downstream general assembly operations where exterior parts get attached. For instance, final assemblers typically have not had ready access to hole and slot positional information at the detail part level through subassembly operations. In the next section, we

provide evidence that hole and slot positional conformance (e.g., true position conformance to design) represents a significant opportunity for improving stamping quality conformance.

#### 4. Stamping-Assembly Analysis Using WL Measurement

In this section, we provide examples of how WL measurement data may be used to compare part dimensional quality between build events and from stamping to assembly. We use the longitudinal door study to demonstrate this functionality. In this study, we collected and analyzed data at various build events as summarized in Table 7. The data collection efforts focused on the left rear door assembly and its major stamping components: the rear door inner and outer panels.

Part	Sample Size per Build Event		
	Sampling 1 (Functional Build 1)	Sampling 2 (Functional Build 2)	Sampling 3 (PPAP)
Door Inner Stamping	5 pcs	5 pcs	3 pcs
Door Outer Stamping	5 pcs	5 pcs	3 pcs
Door Assembly	5 pcs	5 pcs	3 pcs

**Table 7. WL (Optigo) Sampling from Functional Build 1, Build 2, and PPAP**

First, we provide discrete point summary tables to compare part quality from initial tryout through PPAP for the two stamped components, the door inner and door outer parts (see Tables 8 and 9). In this study, the door inner and outer stamping panels did not show significant changes in the discrete point dimensions measured in terms of either the mean or the range. The average mean bias<sup>7</sup> for the door inner panel varied only slightly from 0.49 mm during functional build 1 to 0.46 mm at PPAP; the average mean bias for the outer panel went from 0.3 mm to 0.45 mm, but the 95<sup>th</sup> percentile for mean bias was unchanged and remained at 0.83 mm. In terms of range, the consistency between events was similar. The average range for the inner panel at functional build 1 was 0.33 mm, while at PPAP the average range increased slightly to 0.37 mm. Similarly,

---

<sup>7</sup> Mean bias is the absolute deviation of the mean from nominal (Bias = |Mean|).



the outer panel did not exhibit any significant differences throughout the build events. The average range for functional build 1 was 0.37 mm and 0.36 mm at PPAP.

<b>Event</b>	<b>Average  Mean </b>	<b>95<sup>th</sup> Percentile  Mean </b>	<b>%  Mean  &lt; 0.5 mm</b>	<b>%  Mean  &gt; 1 mm</b>	<b>Average Range</b>	<b>95<sup>th</sup> Percentile Range</b>	<b>% Range &gt; 1 mm</b>
<b>Build 1</b>	0.49	1.85	75%	11%	0.33	0.64	3%
<b>Build 2</b>	0.50	1.43	61%	13%	0.23	0.40	1%
<b>PPAP</b>	0.46	1.44	66%	11%	0.37	1.01	5%

Average # of Dimensions per Part Measurement = 320

**Table 8. Dimensional Summary, Rear Door Inner Panel LH**

<b>Event</b>	<b>Average  Mean </b>	<b>95<sup>th</sup> Percentile  Mean </b>	<b>%  Mean  &lt; 0.5 mm</b>	<b>%  Mean  &gt; 1 mm</b>	<b>Average Range</b>	<b>95<sup>th</sup> Percentile Range</b>	<b>% Range &gt; 1 mm</b>
<b>Build 1</b>	0.30	0.83	86%	2%	0.18	0.37	0%
<b>Build 2</b>	0.36	0.78	73%	1%	0.18	0.35	0%
<b>PPAP</b>	0.45	0.83	70%	4%	0.16	0.36	0%

Average # of Dimensions per Part Measurement = 88

**Table 9. Dimensional Summary, Rear Door Outer Panel LH**

Using WL measurement, these summary results may be visualized using color maps with markers for discrete point dimensions. For example, Figures 10 through 13 show average and range color maps for the door inner and outer stamped parts during build 1, build 2, and PPAP. While certain areas and dimensions are changing (some getting closer to nominal, others moving away), the color maps also illustrate overall consistency in mean and range through the various build events particularly for dimensions toward the edges of the part.

This finding is consistent with other longitudinal studies of stamping part quality from initial tryout through PPAP [6]. Since these WL measurements were taken outside the normal quality evaluation process, we would expect similar patterns as historically found using traditional measurement processes. Although the overall mean and range conformance are consistent, the color maps and hairline graphs do provide a significantly more comprehensive

view of panel conformance to design, particularly in terms of profiles of trim edges and surface measurements along a flange (i.e., patterns of variation).

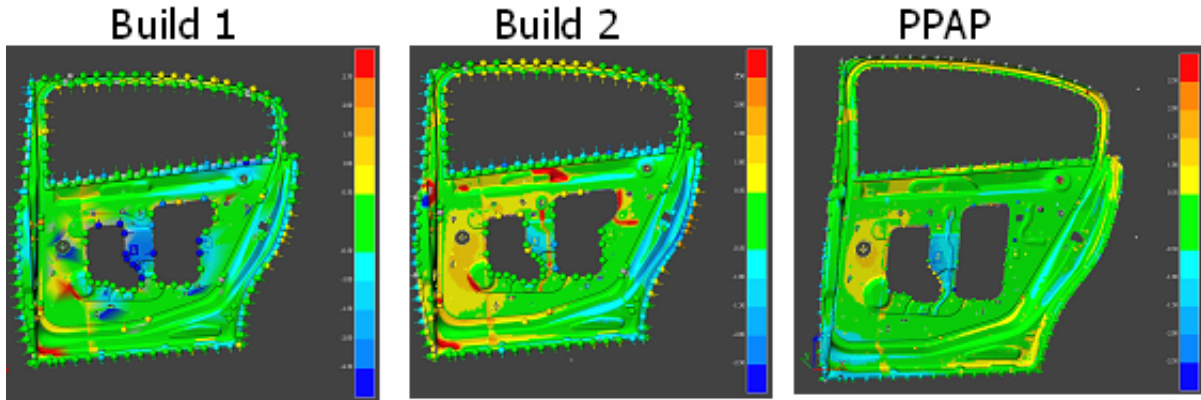


Figure 10. Average Color Maps Door Inner Panel LH

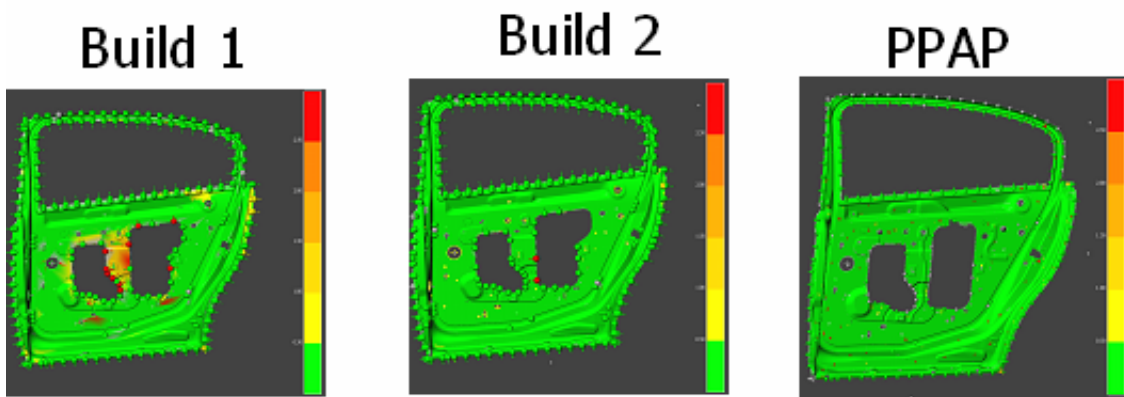


Figure 11. Range Color Maps Door Inner Panel LH

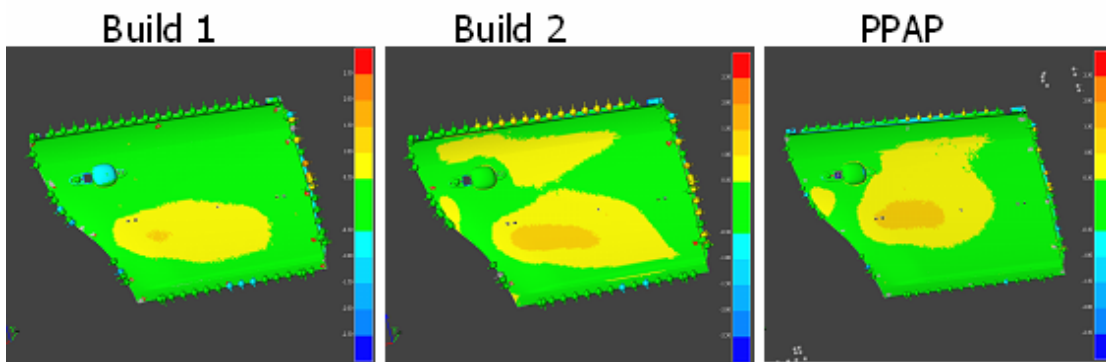
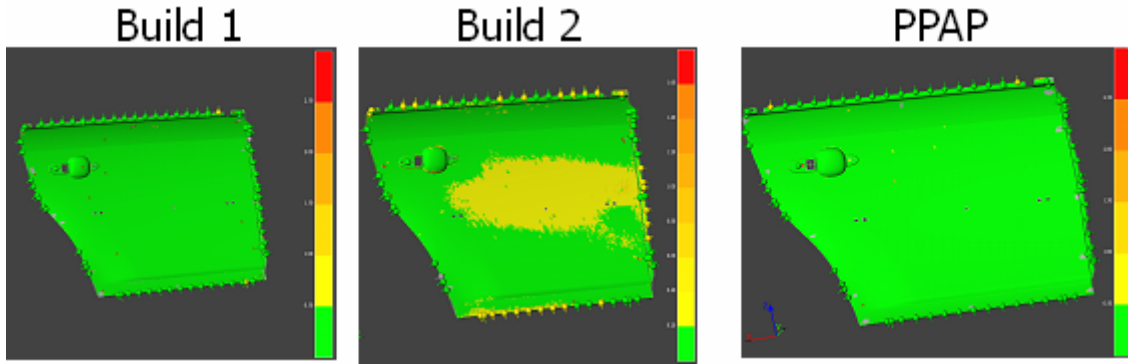


Figure 12. Average Color Maps Door Outer Panel



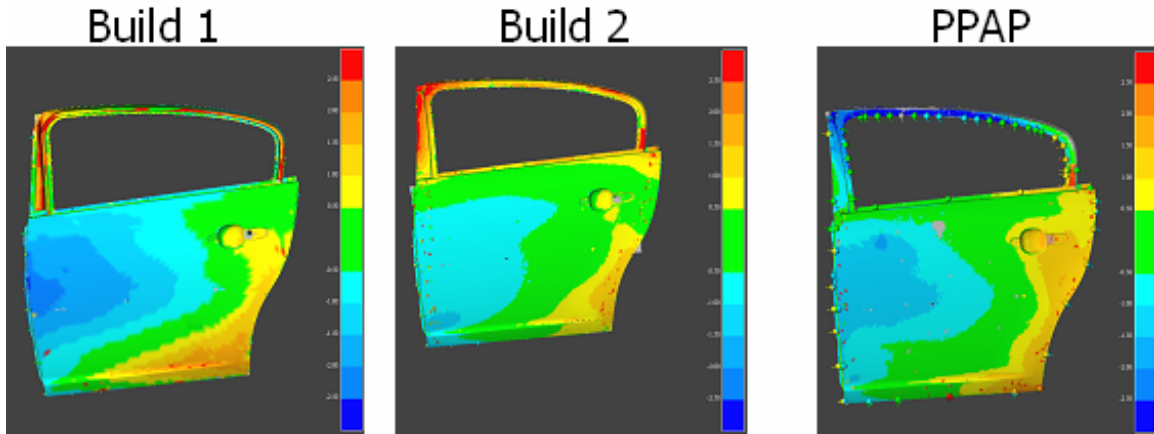
**Figure 13. Range Color Maps Door Outer Panel**

Despite the marginal changes in the stamping panels, the rear door *assembly* did show some improvements in terms of mean bias and range (see Table 10). The 95<sup>th</sup> percentile mean bias was 1.78 at functional build 1 and reduced to 1.49 mm by PPAP. The improvement in range variation in the rear door assembly was more significant. During build 1, the average range value across 112 inspection points was 0.74 mm with a 95<sup>th</sup> percentile of 2.17 mm. At PPAP, the average range decreased to 0.24 mm with a 95<sup>th</sup> percentile of 0.61 mm. From another perspective, about 23% of points exhibited ranges greater than 1 mm at build 1 but only 2% at PPAP. These changes are illustrated further in Figures 14 and 15.

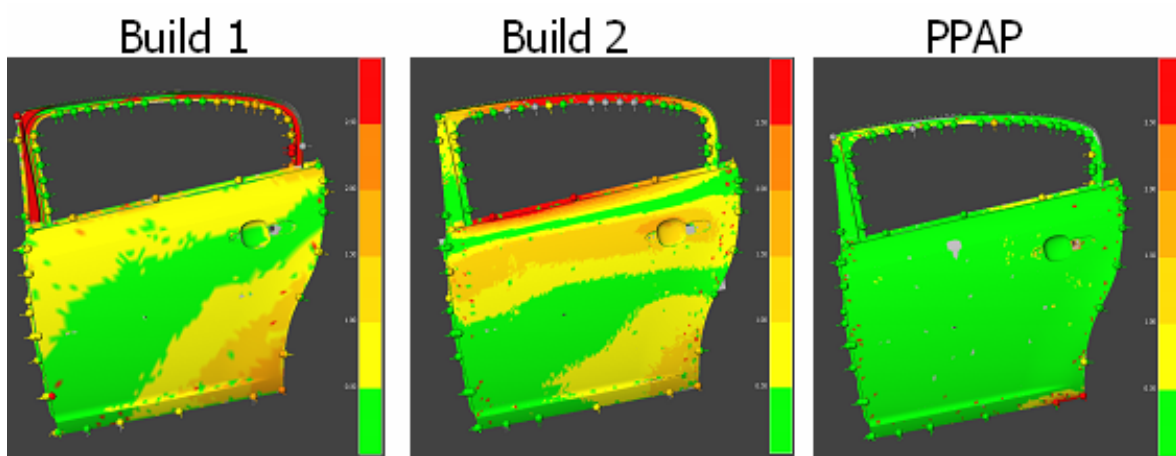
Event	Average  Mean	95 <sup>th</sup> Percentile  Mean	%  Mean  < 0.5 mm	%  Mean  > 1 mm	Average Range	95 <sup>th</sup> Percentile Range	% Range > 1 mm
<b>Build 1</b>	0.54	1.78	57%	15%	0.74	2.17	23%
<b>Build 2</b>	0.63	1.65	47%	19%	0.38	1.56	8%
<b>PPAP</b>	0.6	1.49	55%	20%	0.24	0.61	2%

Average # of Dimensions per Part Measurement = 112

**Table 10. Dimensional Summary, Rear Door Assembly LH**

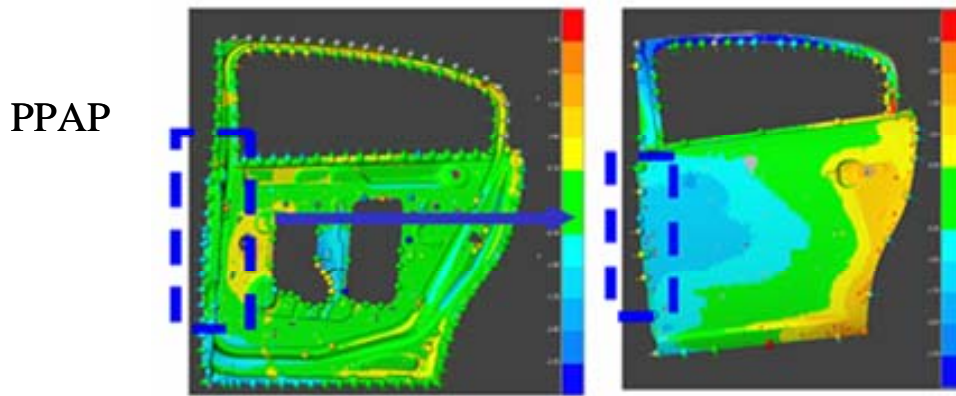


**Figure 14. Average Color Map for Door Assembly LH**



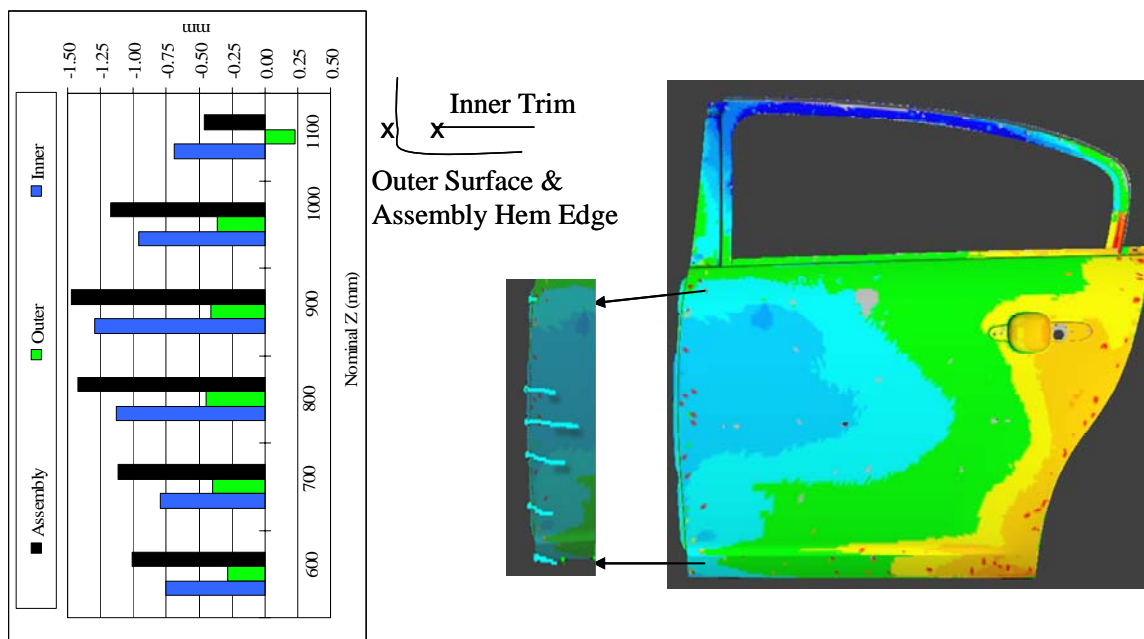
**Figure 15. Range Color Map for Door Assembly LH**

We also may use WL color maps and trim profile graphs to examine common areas from stamping to assembly for a given build event. For example, Figure 16 highlights the front trim region of the door assembly, which we will explore further for both fore/aft (gap) measurements and in/out (flush) measurements.



**Figure 16. Localized Deformation in Inner Door Panel and Door Assembly**

Figure 17 shows measurements for coordinated fore/aft (gap) dimensions along various Z body coordinates (up/down) for the door inner, outer, and assembly. The door assembly trim edge profile exhibits a similar pattern as the door inner. Furthermore, if one adds the door inner and outer profiles (the blue and green columns) at the coordinated body locations, these dimensions reasonably predict the trim edge profile of the door assembly, both in pattern from top to bottom and in magnitude of deviation from nominal (see Figure 18).



**Figure 17. Fore-Aft Analysis: Door Assembly Front Hem Edge at PPAP**

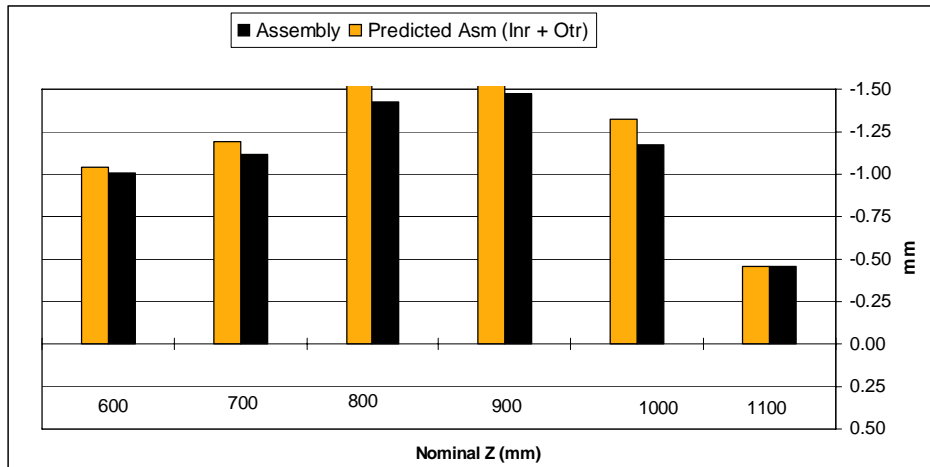


Figure 18. Predicted Door Assembly Based on Inner and Outer Panels

Figures 19 and 20 further examine this relationship for the same area using the in/out (flush) measurements from the PPAP run. These charts show a less predictive relationship between the inner and outer stamped panels and the door assembly. This less predictive relationship may be due to the effects of adding the crash impact beam.

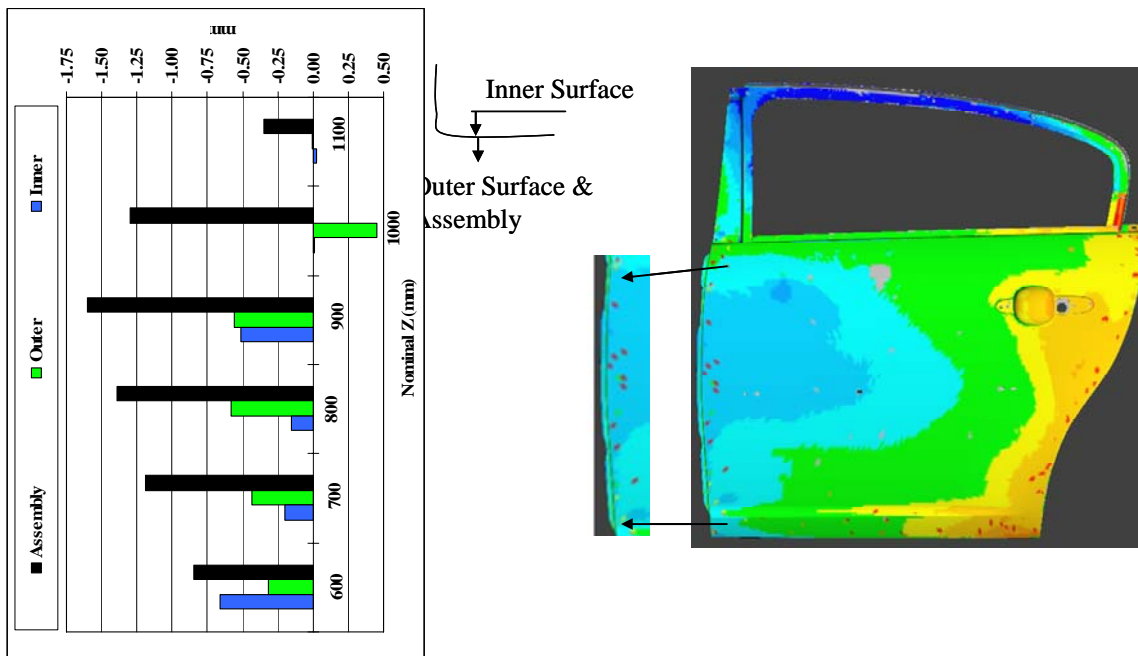
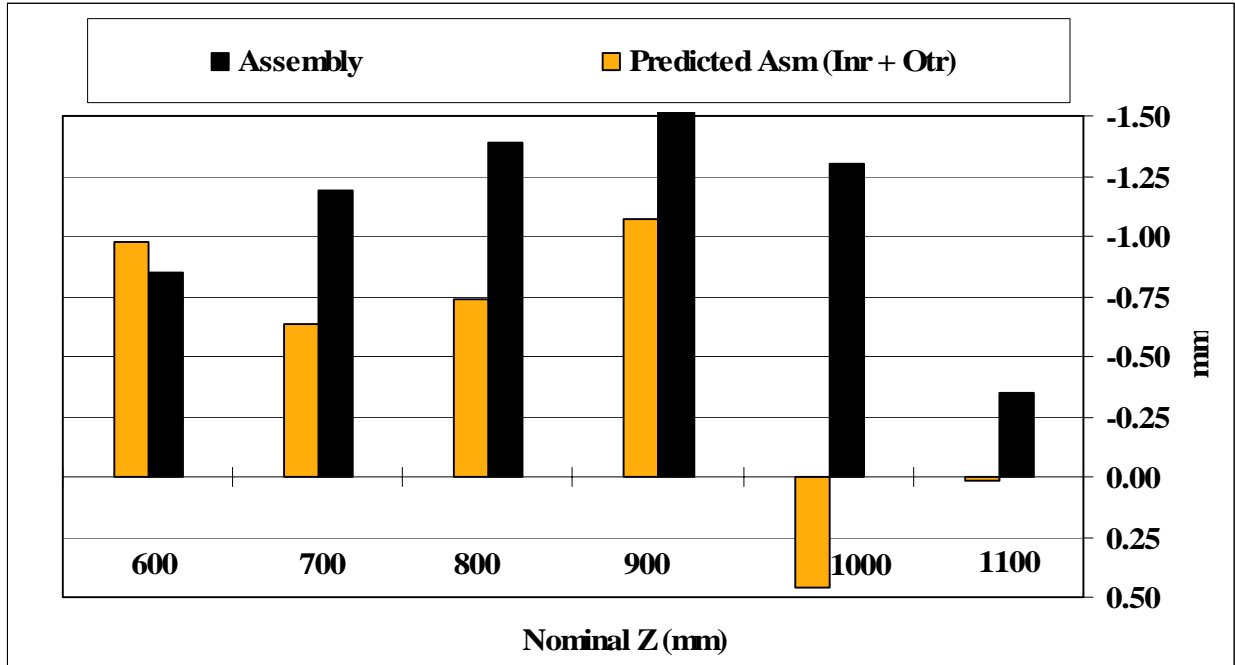


Figure 19. In/Out (Flush) Analysis Door Assembly, PPAP Run



**Figure 20. In/Out (Flush) Predictive Analysis Door Assembly**

In addition to the front flange of the door assembly, we also examined the gap and flush measurement along the rear flange edge. The results of the analyses are shown in Figures 21 through 24. Similar to the previous results, the fore/aft (gap) measurements had stronger predictability than the corresponding measurements in the in/out direction (flush). This particular stack-up also provides an example where the detail stamped components are within specification but their assembly is not.

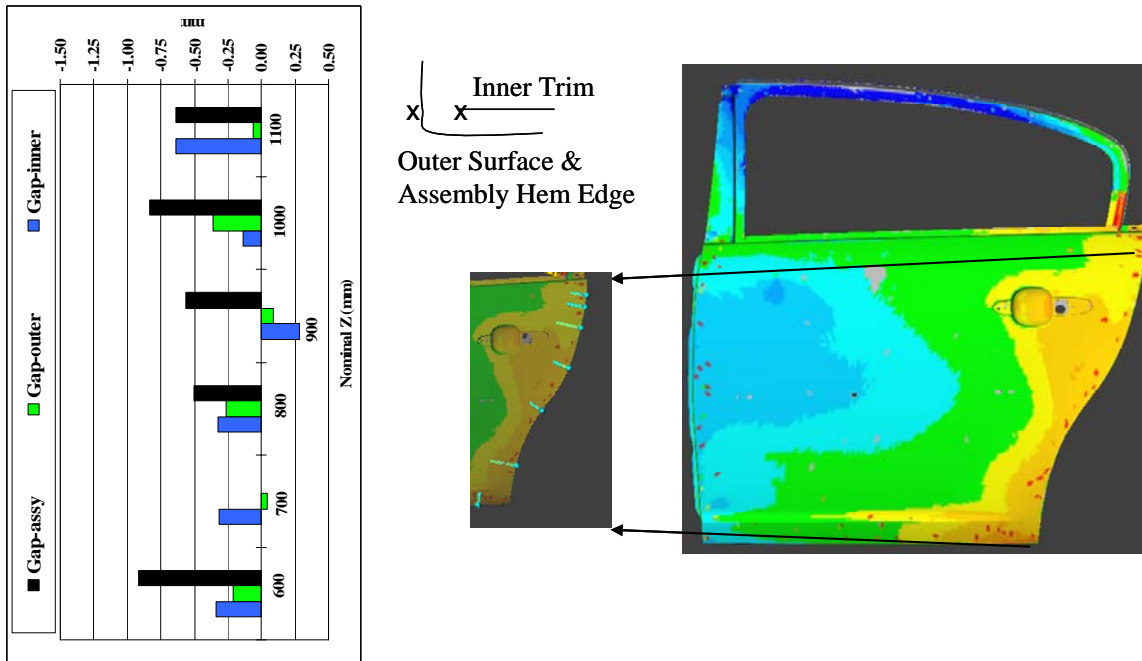


Figure 21. Fore/Aft (Gap) Analysis Rear Flange, PPAP Run

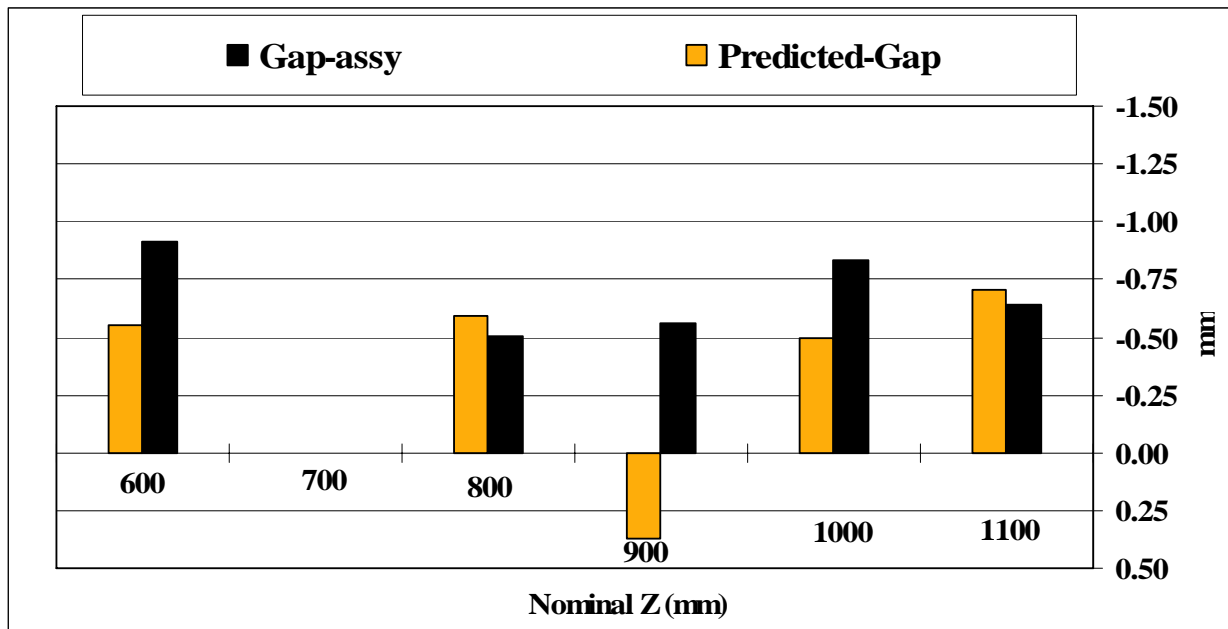


Figure 22. Fore/Aft (Gap) Prediction Rear Flange, PPAP Run



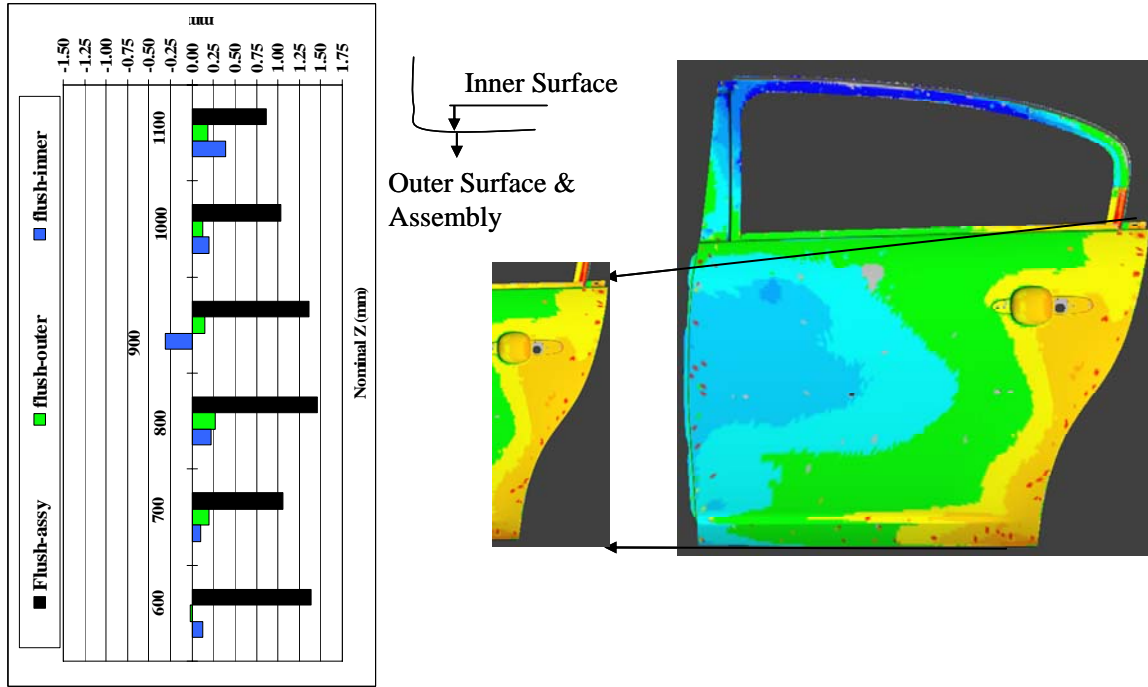


Figure 23. In/Out (Flush) Analysis Rear Flange, PPAP Run

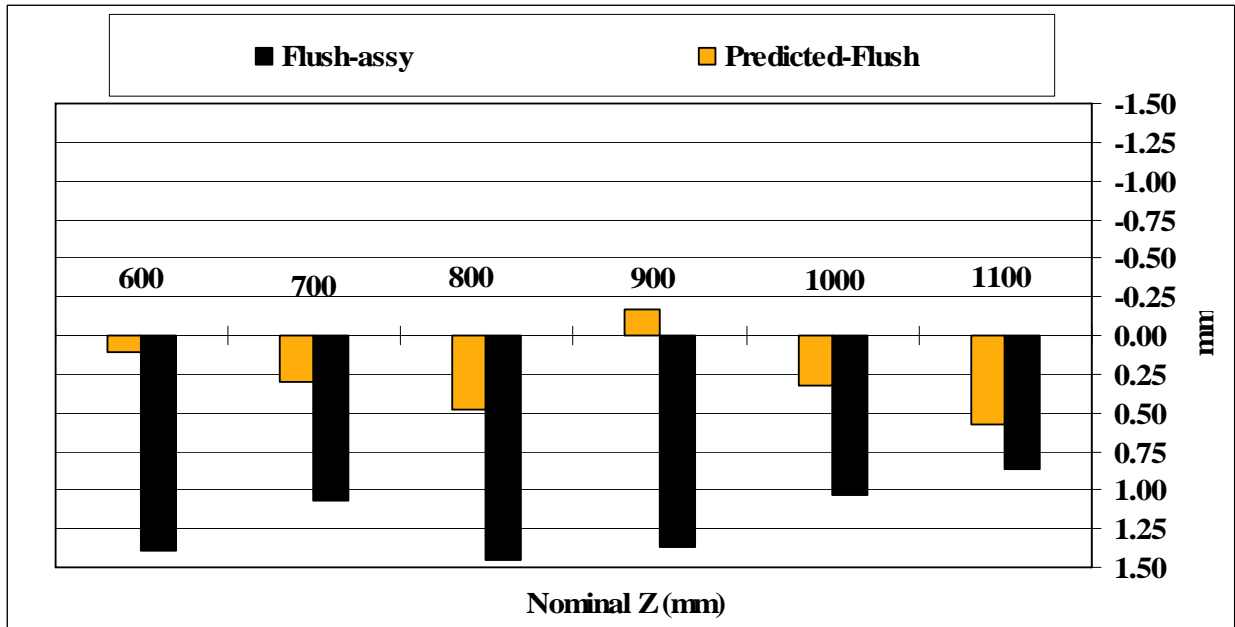
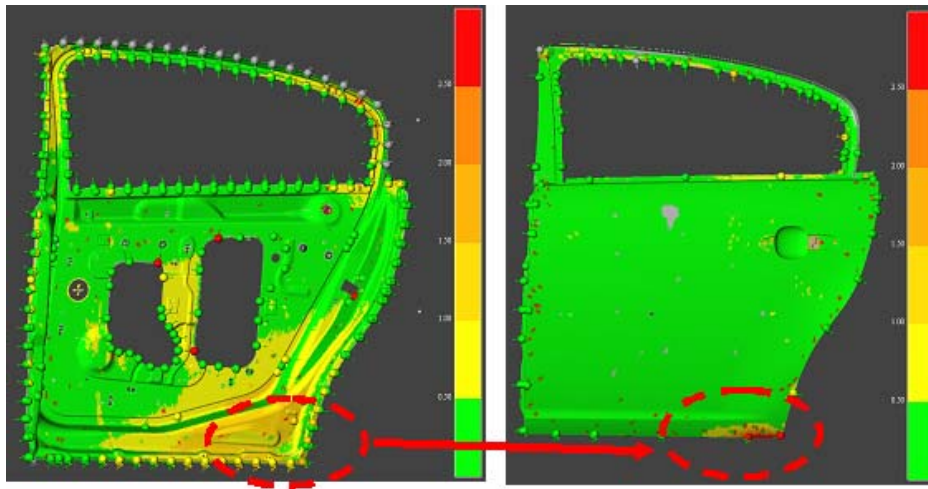


Figure 24. In/Out Flush Prediction Rear Flange, PPAP Run

Another stamping-assembly example using range color maps for the door inner and assembly is shown in Figure 25. Here, we observe a relationship between range measurements in the lower, rear in/out surface of the door inner panel and the resulting assembly. These graphs indicate some variance transmission from the door inner panel to the door assembly. (Note: Range measurements in the assembly are less than the door inner within the highlighted area.)



**Figure 25. Range Color Maps for Door Inner Panel and Door Assembly**

Although some dimensional patterns were similar from stamping to assembly, most were not. In other words, numerous cases existed where detail stamped panel deviations appeared to have minimal predictive effect on the assembly relative to the observed stamping deviations. This further confirms that one should exercise caution in trying to evaluate mating part stack-up conditions only by evaluating their stamping measurements. Thus, while comprehensive WL measurements provide a visual reference of variation patterns and profiles (trim edge points and flange surfaces) to help identify dimensional improvements, manufacturers should still review the as-built assembly conditions to make final determinations about which stamping areas to rework versus which to accept off nominal.

## 5. PIST Metric and Reporting Using WL Measurement

With the adoption of certain WL technology systems, defining and measuring additional checkpoint dimensions beyond historical levels is relatively easy and of minimal cost. This allows users to increase the number of discrete point dimensions. Although this functionality has less importance for surface dimensions, it does impact the number of trim edge, hole, and slot measurements. Even in the case of surface dimensions, manufacturers may easily add more predefined discrete point locations to insure a greater chance of measurement coordination when comparing mating parts to each other and their assemblies, and also when quantifying the consistency of a surface profile.

One effect of using a larger set of dimensions is that traditional reporting tools such as control charts, run charts, and process capability statistical summaries by individual dimension become more burdensome to create, report, and analyze. While these traditional methods certainly have diagnostic value, they are not necessarily required to summarize general panel conformance as evident by the majority of manufacturers outside North America that use a percent in specification metric instead. A common metric for measuring percentage of acceptable dimensions is PIST (an acronym for Percent of Inspection Points that Satisfy Tolerance). This metric has typically been used to summarize general part quality when a large number of dimensions are measured for a given part. Although the PIST metric is less common among North American manufacturers, some use it to summarize one-piece full panel dimensional layouts.

The PIST metric is calculated by dividing the number of points whose dimensions are within their specified tolerances by the total number of inspection points (Equation 1). If more than one panel is measured in a dimensional study, individual PIST values may be averaged resulting in an average PIST. Equation 2 provides a formula for average PIST. Thus, if one measures three panels in a sampling with PIST values of 85%, 80%, and 75%, the average PIST is 80%.

The average PIST does not require that the number of dimensions is the same for all panels measured. This is useful to note because average PIST values may be based on a slightly different set of dimensions at the start of tryout than during PPAP as manufacturers add or delete dimensions based on manufacturing validation build reviews. Although the dimensions measured

may change slightly, average PIST performance will unlikely be affected provided a representative number of dimensions (e.g., > 100 dimensions) are selected at the start of tryout.

$$PIST_i = \frac{\text{\# of Dimensions in Specification}}{\text{\# of dimensions inspected}}$$

#### Equation 1. PIST Calculation

$$\text{Average PIST \%} = \frac{\sum_i PIST\%_i}{N}$$

where

$i$  = sample panel number

$N$  = # of panels measured

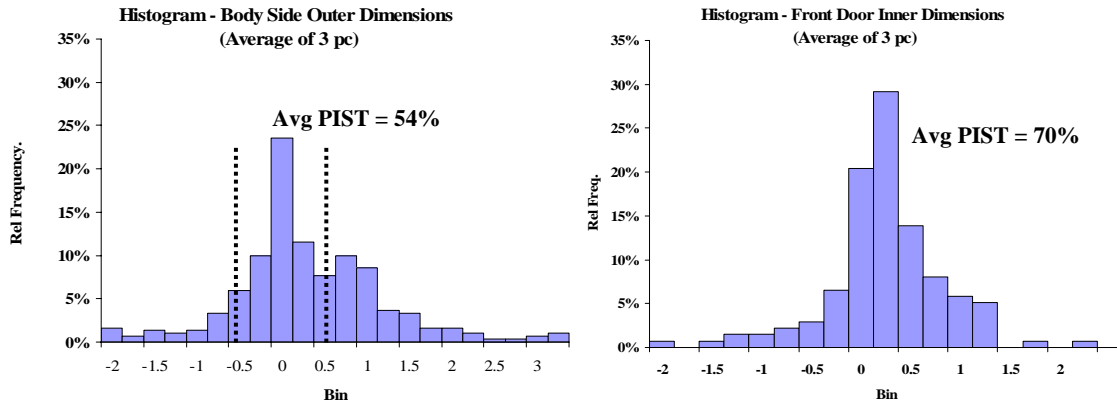
#### Equation 2. Average PIST Calculation

The PIST metric provides a high-level part quality summary and may be used to assess conformance to design and monitor part improvement throughout the preproduction build process. We should note that while the PIST metric provides a useful management summary, it still requires a more detailed review of individual features and part areas to determine rework decisions. This review of discrete points may be accomplished using average and range color maps or traditional diagnostic tools such as process capability analysis. In the remainder of this section, we provide a more detailed review of the PIST metric and how it may be utilized with WL measurement data.

### 5.1 PIST Metric and Mean Deviation Distribution for a Single Part

If one measures a large number of dimensions on a panel (e.g., greater than 50) to a common datum scheme, the distribution of these deviations will almost invariably be centered at nominal. In other words, the median *mean* dimension will almost invariably be near 0 (typically within  $\pm 0.1$  mm). This finding occurs if using a sample of one but particularly when using a multi-piece study and summarizing dimensional mean values. Figure 26 illustrates this concept

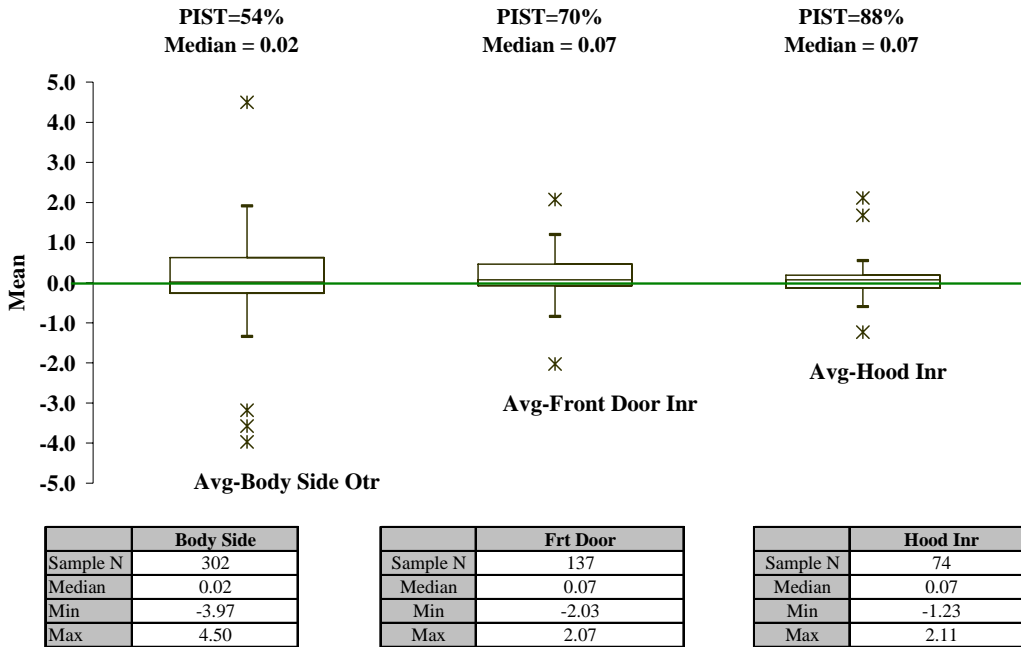
using histograms of individual dimensional means for two different parts. In both cases, the median (highest bar in the histogram) is near 0.



**Figure 26. Histogram of Dimensional Deviations for a Single Part**

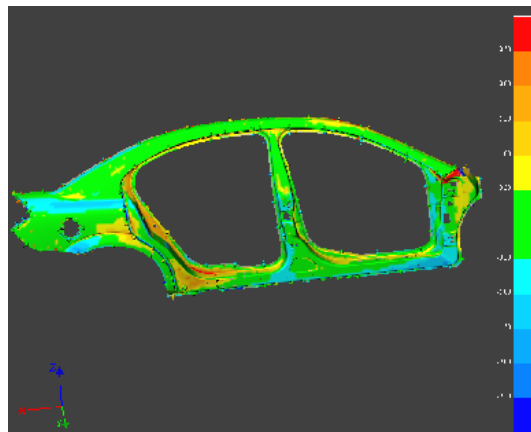
Although the center of the respective mean distributions is near 0, the spreads are not the same. The front door inner panel has a tighter spread than the body side outer resulting in an average PIST of 70% versus 54%. In other words, a tighter spread yields a higher average PIST as more part dimensions have means values closer to nominal.

The distribution of mean dimensions and their impact on the PIST is further illustrated in Figure 27 using box plots. This figure shows the above two parts and includes a hood inner with a PIST of 88%. As PIST scores increase, a greater number of mean dimensions will be closer to nominal and within  $\pm 0.5$  mm. We should note that even with high PIST values such as the hood inner, we may still have individual dimensions with potential mean deviation concerns as shown by the extreme values in the box plot. Thus, manufacturers may identify potential problem areas even if the PIST metric meets its target value.



**Figure 27. Box Plots for PIST**

Figures 28 through 30 show the average color maps for these parts. In the hood inner example shown in Figure 31, the area highlighted by the red circles may be a concern that needs to be investigated in the hood assembly process. Thus, even with a PIST metric, manufacturers should examine the average and range color maps for areas of concern.



**Figure 28. Average Color Map for Body Side**

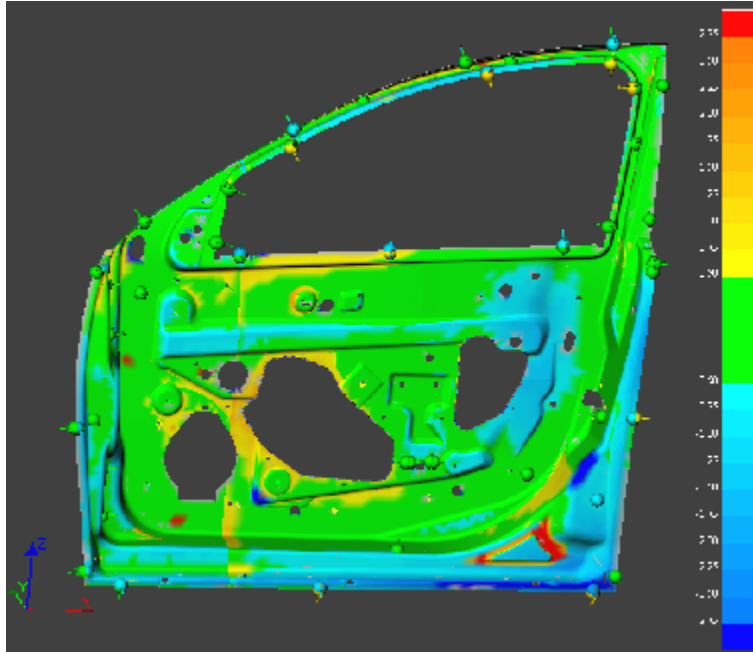


Figure 29. Average Color Map for Front Door Inner

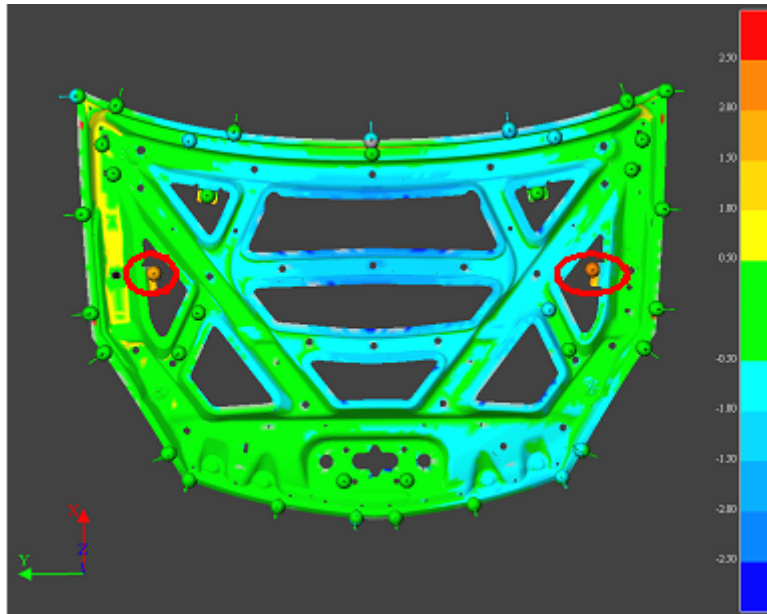


Figure 30. Average Color Map for Hood Inner

## 5.2 Sample Size Considerations for Average PIST

One issue in adopting an average PIST metric is the sample size. As mentioned previously, within run variation tends to be low and predictable in stamping operations. As such, many manufacturers measure fewer panels per run and place a greater emphasis on mean conformance for a larger number of dimensions. This is particularly true if the cost and time measure a single panel is extensive.

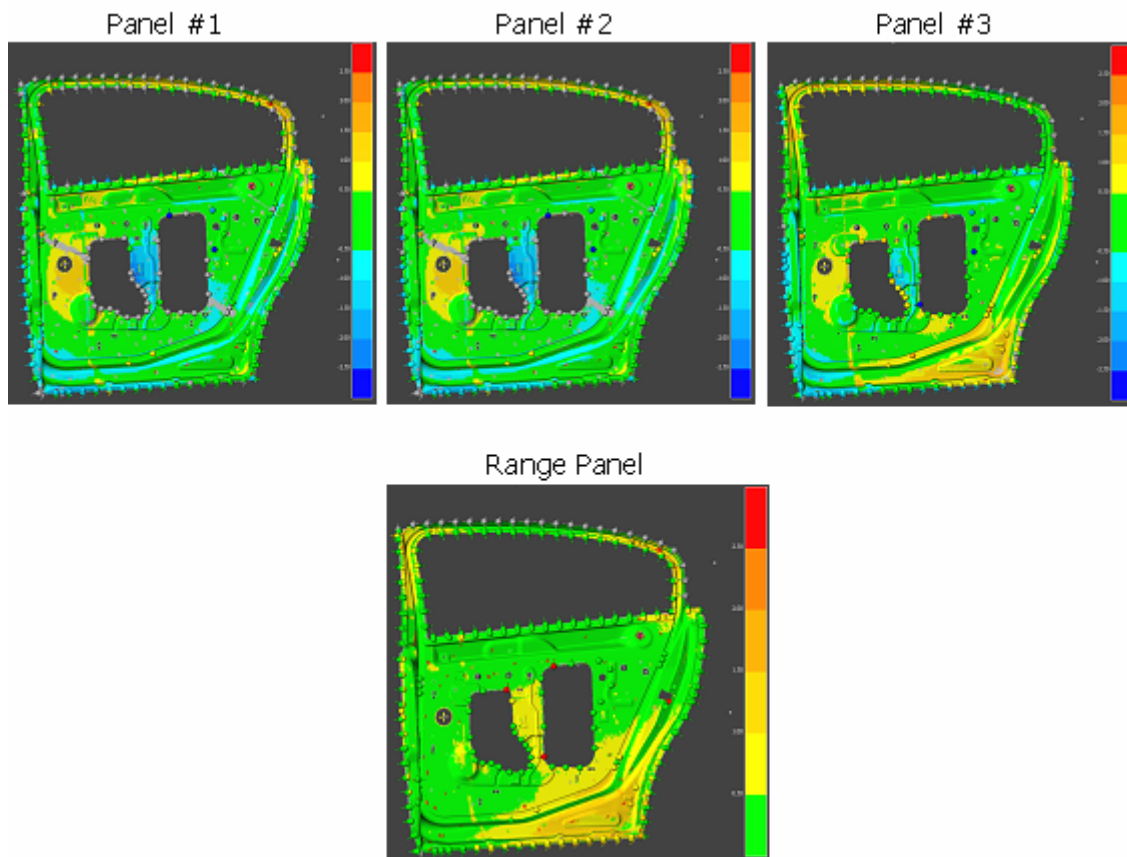
For the case of WL measurement, some systems may be mounted to robots to reduce the measurement time and cost per sample allowing larger samples. Still, users of this technology often prefer to minimize sample sizes per run. Most manufacturers have limited robotic WL measurement system resources and have a strong desire to minimize the capital expenditure necessary to procure more systems. This is particularly appealing given the historical evidence that within-run variation is sufficiently low and predictable and that measuring larger quantities (e.g., 10 or more) from die tryout runs or subsequent production runs is usually non-value added. Even in the case of production facilities that utilize robotic WL measurement systems, a push exists to right-size the technology implementation. In other words, manufacturers want to maximize part quality information without necessarily collecting more samples – particularly if the incremental value of larger sample sizes is low. Of course, robotic systems for WL measurement allow manufacturers to measure larger samples as needed for special diagnostic studies.

Given a process change toward smaller measurement samples per tryout run, an important question is how small is acceptable. In considering historical data and practical implications, we recommend that preproduction tryout runs utilize a sample of size 3 for key quality build events (e.g., matching or functional build events) and a sample of size 1 for other trial runs. Furthermore, we recommend that once a part has been approved for production and a manufacturer demonstrates an ability to repeatedly setup their process, then a sample of size 1 should be sufficient for regular production monitoring when using WL measurement. In some cases, manufacturers may even choose to reduce the inspection requirements during regular production even further if they demonstrate a highly stable process through effective process control of the die setup process.

We offer three reasons to support the recommendations for a sample of size 3. First, a sample of three is effective when part-to-part variation is low relative to the tolerance width.

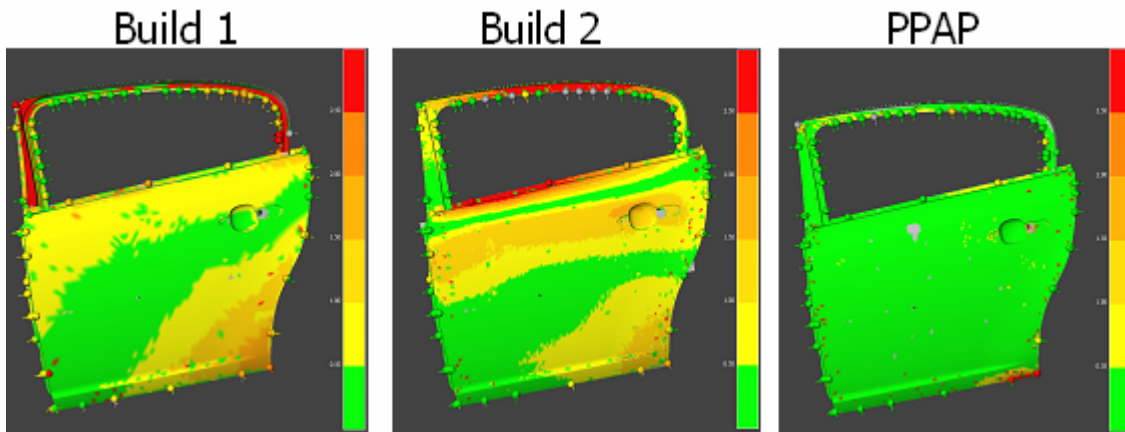


Second, a sample of three provides some outlier detection ability. For instance, if a large majority of dimensions have a small range of say 0.5 across a sample of three while a couple of dimensions have large ranges (say greater than 1 mm), a sample of size 3 allows users to check if the three panels were all different from each other or if one particular panel is different from the others. In some cases, such a difference between samples may be due to an outlier. Stamping outliers within a run typically trace back to a locating or part handling issue rather than to a special cause due a change in a material or stamping process settings. Figure 31 provides a range color map for a sample of size 3 and its individual panels. In this particular case, the higher range values (see Range Color Map) are observed due to differences in the third sample (relative to panel #1 and #2) in the lower rear area. The darker yellow area of panel #3 corresponds to the higher value in the assembly range color map.



**Figure 31. Range Color Map with Individual Panels**

A third supporting argument for using a sample of size 3 is that users still may identify potential part variation trends. Of note, with a sample of three, the observed range for each dimension in a given run is expected to be smaller than the actual range for a larger sample from the same run<sup>8</sup>. While the magnitude of the range for a sample of size 3 should be lower than a larger sample, the variation pattern should be similar. Figure 32 compares range color maps for three runs of three samples each for the door assembly. Here, we may observe similar variation patterns in build 1 and 2 with a reduction by PPAP.



**Figure 32. Range Color Map for Door Assembly based on small samples for 3 build events**

Even if using sample sizes of three, we may still estimate the variability for a larger sample from the same run using inherent relationships between observed ranges and sample sizes. The factor,  $d_2$ , which is used to create range charts for statistical process control applications provides a mechanism to adjust ranges for different sample sizes. For instance, if a dimension has values that are normally distributed and you take a sample of size 3 versus a sample of size 30, on average you would expect the sample of size 3 to exhibit ~40% of the 30-sample range. This relationship is based on the ratios of the  $d_2$  values for 3 versus 30 samples<sup>9</sup>.

<sup>8</sup> Based on statistical sampling theory, the range for a sample of size 3 will be proportionately lower than 30 or 100.

<sup>9</sup> Based on ratio of  $d_2$  values using the relative range distribution where  $d_2(n=3) = 1.693$  and  $d_2(n=30) = 3.931$ . Of note, the ratio of  $d_2$  values becomes proportionally smaller with larger sample sizes. Thus, it is unnecessary to adjust ranges for samples beyond 100.

In Table 11, we provide range measurements for 130 dimensions taken from a 30 sample PPAP study. If we take a subset of three panels for these same dimensions, we would observe significantly lower ranges. The number of dimensions with a range less than 0.5 would increase from 60% to 97%. Still, if we adjust these ranges by  $d_2$  ratios, we will notice that the 3-sample subset did provide a representative view of expected part variation across the larger sample. The adjusted 3-sample subset had essentially the same distribution as the 30 sample study.

	Range Values		
	< 0.5	0.5 - 1.4	> 1.4
30 sample study	60%	40%	0%
3 sample subset	97%	3%	0%
3 subset (with Range Adjusted by $d_2$ )	57%	42%	1%

Based on 130 Dimensions

**Table 11. Sample Size Effect on Observed Range Measurements**

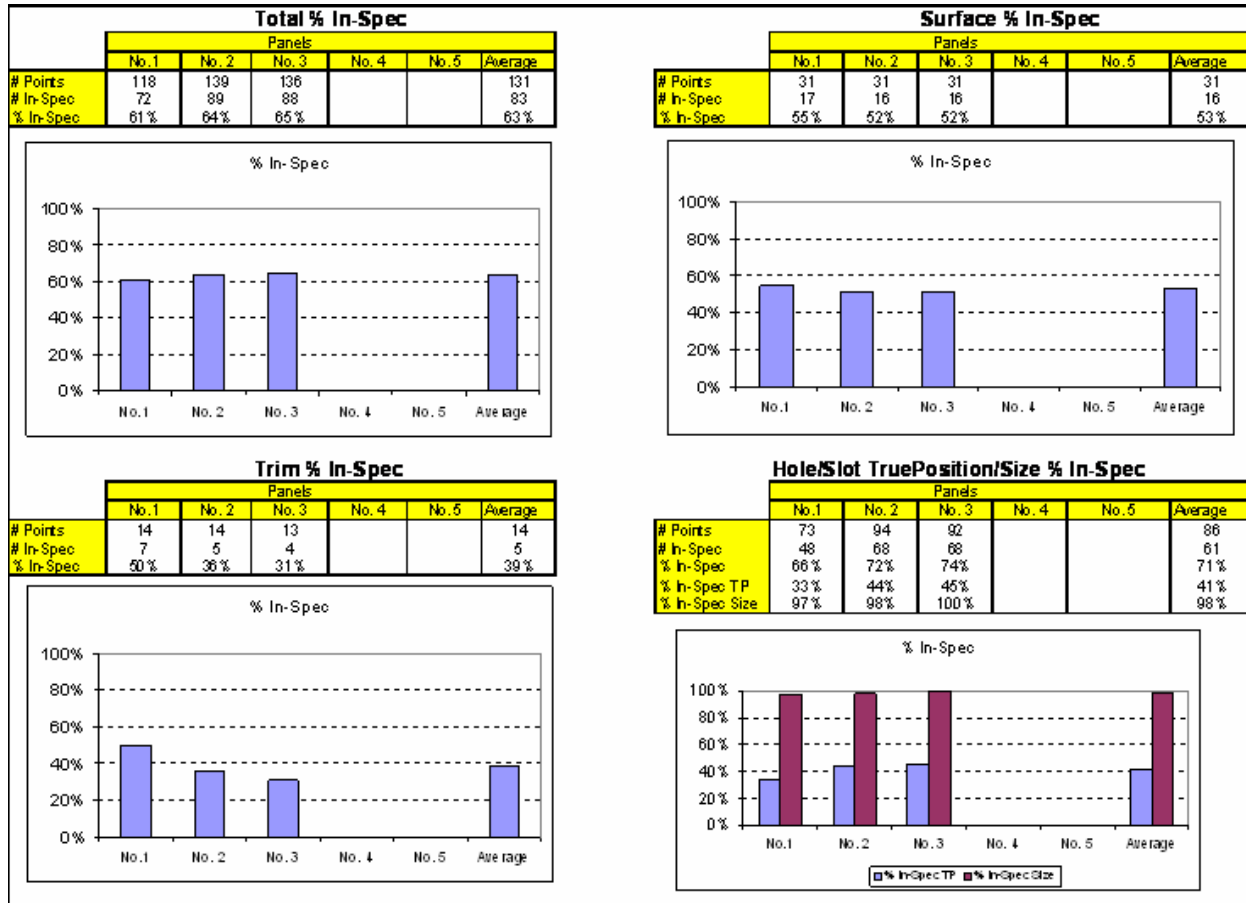
This adjustment works best if the process is stable and *within run variation is relatively low*, which is very common in stamping applications. Of note, measuring smaller samples always presents additional risk, particularly when trying to provide an estimate of variability. Even for the example above, the difference between the adjusted range for any individual dimension and the actual (i.e., if a larger sample is measured) may have been off significantly. Thus, if one wants high statistical confidence in a standard deviation estimate for a particular dimension, they should use a larger sample size (at least 10, and preferably 30 or more). Thus, the adjusted range shown here is not intended to suggest that standard deviation may be reasonably predicted using samples of size 3 for a particular dimension, but rather to show that variation patterns may be reasonably predicted, provided a stable process and a large number of dimensions are measured.

### 5.3 PIST Metric by Feature Type: Surface, Hole/Slot, and Trim Edge

Historically, manufacturers using hard checking fixtures have measured points largely on critical mating surfaces versus holes, slots, and trim edges. This has resulted in relatively few dimensions measured for a given part. A main driver for this approach has been the cost of

collecting variable data measurements. For example, data collection costs for variable data measurements of hole and slot features using traditional check fixtures are particularly high and thus manufacturers often use site checks or “go/no-go” gages. While mating flanges are certainly important, downstream operations also are concerned with hole and slot positions for assembly and other part attachments. Trim edges, while generally less critical than mating flange surface measurements, also may create problems such as part interferences or short trim lengths for welding. The use of WL part measurement allows manufacturers to more comprehensively measure holes, slots, and trim edges.

In measuring these additional dimensions, we recommend manufacturers stratify PIST conformance by dimension type. We suggest classifying dimensions into four basic categories: surface dimensions, trim edge dimensions, hole/slot size measurements, and hole/slot position measurements. Figure 33 provides an example of the PIST score stratified by these classifications. For this part, we observe an overall average PIST of 63% with trim edge and hole/slot positional dimensions as the larger concerns.



**Figure 33. Decomposition of PIST Metric**

We may use these classifications to further analyze the 18 parts measured at the first functional build event. The results are presented in Table 12. Here, we observe that the majority of PIST concerns are related to trim edge and hole/slot position measurements. As expected, size conformance for holes and slots tends to be quite high as manufacturers are able to meet tighter specifications for these dimensions than for other types. In those relatively few cases where size issues occur, they usually may be traced to either a design error (e.g., physical part not updated to latest design change) or a wrong punch used in the stamping operation. In both of these cases, identifying size errors is important early in the manufacturing validation process.

	Holes/Slots Position	Holes/Slots Size	Surface Points	Trim Points
# PIST Pts	334	319	780	319
% $ \text{Mean}  < 0.5$	43%	97%	61%	44%
% $ \text{Mean}  > 1$	17%	2%	18%	21%

**Table 12. Conformance by Feature Type**

#### 5.4 PIST Metric and Tolerance Considerations

One consideration in implementing a PIST metric is the tolerances used to assess conformance to specification. Two alternatives may be used. One approach is to evaluate the conformance for each dimension relative to its assigned tolerance. For instance, a manufacturer may use  $\pm 0.5$  tolerances for critical mating flanges,  $\pm 0.7$  tolerances for critical trim edge dimensions, and  $\pm 1$  or  $\pm 2.0$  for non-critical areas. Another approach to calculating PIST is to evaluate all dimensions versus a standard. For instance, a manufacturer may choose to measure all dimensions relative to a standard of, say,  $\pm 0.5$  mm or up to  $\pm 1.0$  mm. In this section, we examine advantages and concerns with these two approaches.

The advantage of using the first method (PIST relative to assigned tolerances) is that manufacturers often use tolerances to weigh the criticality of different features. For example, a manufacturer may wish to measure trim lengths to insure sufficient weld flange material for welding or to avoid interferences. For some trim lengths, they may need to meet a specification of  $\pm 1$  mm, while others may be allowed to deviate up  $\pm 2.0$  mm and still produce a good assembly. The assigned tolerances allow them to weigh the importance of the different areas. In contrast, if they use a single standard that is tighter than the assigned tolerances (e.g.,  $\pm 0.5$  when the tolerance is  $\pm 2.0$ ), they may perform unnecessary rework.

Another issue with this first method relates to the fact that tolerance specifications are intended to identify acceptable ranges of allowable variation for *long-term production* and that manufacturers should strive toward higher levels during preproduction. As discussed before, simultaneously getting all stamping means close to nominal is often very difficult and costly, particularly once dies are shipped to their production facilities. Still, most manufacturers believe that the closer they drive dimensional means toward their desired nominal values during

preproduction, the lower the likelihood of future downstream problems. During preproduction at the die construction source, manufacturers have the most opportunity to rework dies and adjust processes to get them more representative of design intent. Thus, rather than accept larger *mean* deviations from nominal at the beginning of tryout, it is reasonable to utilize this preproduction time to drive part features closer toward design intent (not necessarily to nominal), recognizing that some assembly compensation may be used later.

To drive toward nominal during production, manufacturers may set a single, tighter requirement. Here, the use of a single standard (e.g.,  $\pm 0.5$ ) essentially becomes a requirement for how close the stamping mean is desired to be relative to nominal, and not necessarily reflective of the allowable process variation expected in long term production (i.e., typical purpose of a manufacturing tolerance). Of course, the use of a single standard may be difficult to implement as manufacturers must be conscious of unnecessarily reworking dies to achieve a standard that is tighter than necessary to build a quality final vehicle body.

Another argument that supports the use of a standard to evaluate PIST during tryout is simplicity. In some cases, manufacturers cannot effectively assess the tolerance requirements prior to actually building assemblies. The fact that manufacturers routinely modify stamping tolerances for long-term production during PPAP indicates that design tolerances often do not reflect the true build quality needs. The use of a single standard removes some of the disputes between product designers and manufacturers regarding the appropriateness of different tolerance specifications.

Of course, using a standard also has its limitations if the standard is overly tight and unachievable. Historically, manufacturers have not been able to get all mean dimensions within 0.5 mm. Past studies indicate that manufacturers typically may achieve only ~60-70% of mean dimensions within 0.5 mm [6]. Of importance, even with 20-30% of dimensional means greater than 0.5 mm, manufacturers may still be able to meet their final body quality objectives through a combination of die rework in certain key areas and compensations in downstream assembly operations. Thus, the adoption of a single standard should not imply a requirement of 100% compliance to it. In fact, we support the requirement of 70-80% for preproduction build events (see next section).

Another concern with using a single, tighter standard is that it may not reflect improvements in the process. For instance, a manufacturer may actually make significant

improvements to a part by reducing the large deviations (say values > 1 mm) without affecting the PIST within a standard of  $\pm 0.5$ .

In our study of parts at build events' 1 and 2, we observe that the PIST metric relative to a global standard of  $\pm 0.5$  did not show the level of improvement as say the drop in the percentage of mean dimensions greater than 1 mm (see Table 13). In other words, a significant improvement (about half the dimensions exceeding 1 mm were reduced) was made even though the average PIST was fairly consistent between build events.

<b>Part Name</b>	<b>Avg PIST Build 1</b>	<b>Avg PIST Build 2</b>	<b>%  Mean  &gt; 1mm Build 1</b>	<b>%  Mean  &gt; 1mm Build 2</b>
BODY SIDE INR RH*	62%	67%	11%	9%
REAR COMPT INR	54%	65%	33%	15%
ROOF	61%	52%	16%	19%
RR DOOR INR RH	64%	65%	13%	7%
RR DOOR INR LH	63%	62%	22%	11%
REINF-W/S INR	50%	56%	35%	17%
FRT DOOR REINF LH*	89%	84%	3%	5%
Average	63%	64%	19%	12%

\* Based on one sample for Build 2

**Table 13. Functional Build 1 Versus Build 2**

In considering both the advantages and limitations, we support the use of a single standard during preproduction for simplicity and opportunity for improvement. We believe that a single tighter standard for tryout can help focus manufacturers toward designing and constructing dies to produce parts closer to nominal and it better utilizes the limited opportunities available during early tryout build events for rework. We issue this recommendation with the caveat that PIST compliance should not be 100% and that the use of this metric should not be the sole factor in making decisions to continue reworking dies or accepting them. As with any quality evaluation process, the experience of the stamping manufacturer, assembler, and quality engineer are critical to making good decisions regardless of the metric used.



## 6. Part Submittal Criteria for Matching / Functional Build Events

Most manufacturers recognize that stamped parts cannot be evaluated solely by measuring conformance to design at the component level. Studies have shown, empirically and theoretically, that manufacturers also must evaluate stamped parts relative to their mating components [7]. To evaluate parts relative to others, most manufacturers use part matching or functional build processes (either using physical or virtual builds) to determine rework issues. Still, prior to performing such evaluations, manufacturers recognize that parts need to be within a dimensional window. For instance, if over 50% of the dimensions are out-of-specification, a part will likely require rework before approving it for production. Historically, several manufacturers have set an objective of PIST greater than 80% compliance to ship dies from construction source to the production facility.

In this section, we analyze the potential to meet an 80% criterion based on the WL data collected. At the first matching or functional build event, stamped parts are typically in tryout at the die construction facilities. In some regards, conformance to this criterion is primarily a measure of the die design and construction process as limited time exists for rework.

Table 14 summarizes PIST conformance for 18 parts. The average PIST at the first matching event is ~63%. This is fairly predictable as historically manufacturers are able to achieve about 60%-70% of dimensions within  $\pm 0.5$  mm. This study also shows that the PIST is fairly consistent between samples for a given part. Of these parts, about 70% had a PIST range of less than 5% across the three samples measured.

Part Name	No of Dimensions	Sample 1 PIST(%)	Sample 2 PIST(%)	Sample 3 PIST(%)	Avg PIST (n=3)*	Range PIST (n=3)
BODY SIDE INR RH	165	59%	62%	66%	62.4%	7%
BODY SIDE INR LH	185	65%	60%	62%	62.6%	5%
BODY SIDE OTR RH	196	53%	55%	54%	54.2%	2%
FRT DR OTR RH	61	47%	50%	48%	48.1%	3%
HOOD OUTER	46	43%	43%	43%	43.5%	0%
HOOD INNER	77	85%	88%	91%	87.8%	6%
FRT DR INR RH	139	65%	67%	64%	65.4%	4%
FRT DR INR LH	148	68%	71%	70%	69.9%	3%
REAR COMPT OTR	61	63%	62%	65%	63.4%	2%
REAR COMPT INR	97	53%	55%	54%	53.8%	2%
ROOF	120	58%	63%		60.8%	5%
RR DOOR INR RH	134	66%	62%	63%	63.7%	4%
RR DOOR INR LH	131	61%	64%	65%	63.3%	4%
REINF-W/S INR	20	50%	50%	50%	50.0%	0%
FRT DOOR REINF LH	88	91%	85%	90%	88.6%	6%
FRT DOOR REINF RH	85	80%	76%	82%	79.6%	6%
REINF ROOF INR	24	65%	63%	71%	66.2%	8%
REINF-ROOF OTR	23	48%	43%	43%	44.9%	4%
<b>Overall PIST Avg</b>					<b>63%</b>	

\* based on tolerance +/- 0.5

**Table 14. Summary of Average PIST**

Given the difficulty in getting 80% of the dimensions within 0.5 mm, we recommend a 70% goal for the first functional build event and 80% for home line tryout. In addition, once stamped parts are in their home line at the regular production source, we do not believe that the PIST should be the sole indicator of part acceptability or the primary driver for rework decisions. At this point, we believe that manufacturers should rely on assembly build events to drive subsequent home line rework decisions. As shown in the door longitudinal study, assembly quality often may be improved without necessarily improving the PIST in stamping.

Finally, once all assembly issues are resolved, we support tolerance modifications to approve the detail stamping parts for production with a starting point of 100% PIST compliance. In other words, once a part is deemed acceptable, we support re-targeting nominal values and/or tolerance expansions to get all points within specification for the start of regular production monitoring (See next section on PPAP).

## 7. PPAP Strategies for WL Measurement

PPAP for stamped parts is currently a dimension-based evaluation process. The official North American PPAP methodology requires sampling 100 pieces and evaluating all dimensions relative to a Ppk value of 1.67<sup>10</sup>. Unfortunately, evaluating part quality on a *per dimension basis* in stamping often has led to an over-emphasis on trying to improve specific dimensions and a lack of focus on overall part conformance. Furthermore, improving a specific dimension within an area is often not feasible without affecting other related dimensions. In many cases, analysis by dimension has led to rework in stamping before assessing if the deviations actually affect the downstream assembly process.

Most stamping manufacturers have attempted to mitigate some of these challenges by incorporating functional build or assembly matching events to determine part acceptability, followed by the use of tolerance adjustments to meet stated Ppk objectives. With the adoption of WL technology, this approach may be further enhanced as average/range color maps and profile graphs help manufacturers perform a more comprehensive assessment of part quality and potential variation concern.

Even in moving from a dimension-based evaluation to a functional part-based evaluation, manufacturer likely will need to continue to use a PPAP-type process to provide a formal part approval event and establish final nominal and tolerance values for which production operations need to maintain. In other words, once parts are approved, stamping manufacturers need specifications to use for regular production monitoring. The purpose of this section is to provide a PPAP strategy that utilizes the capabilities of WL measurement technology and still aligns with a functional build-based part approval process. In developing a WL PPAP strategy, two important issues are examined: part sampling and tolerance adjustment for future production monitoring.

### 7.1 Part Sampling

North American automotive body stamping manufacturers have modified the official PPAP requirement by reducing the sample size to 30 [2]. Even with this reduction, most

---

<sup>10</sup> Per the PPAP guidelines, companies may change the sample size and requirements per agreements between suppliers and their customers. For instance, many stamping manufacturers use 30 samples for PPAP.

manufacturers still do not support measuring such a large sample size from a single run. As mentioned previously, given the relatively low within run variation in stamping, measuring a sample of 30 from a single die setup is often of minimal value.

Although we support the usage of smaller samples per run, we do not support a single run PPAP event. Manufacturers occasionally experience problems with consistency of their setup operations. While this inconsistency often does not affect within run variation, it can result in mean shifts between stamping runs. To insure that manufacturers evaluate mean consistency between runs, we support the use of a multi-run PPAP approach. As a practical recommendation for WL measurement, we support the use of 3 stamping runs with 3 samples measured per run.

By using this sampling structure, manufacturers may estimate both the mean relative to nominal and the consistency of the setup process between batches. Although smaller sample sizes affect the ability to detect *small* mean shifts between runs, the method of 3 runs of 3 does provide adequate sample size to detect *large* mean shifts. For example, the statistical power<sup>11</sup> to detect a shift of 0.6 mm using 3 runs of 3 samples is 0.9 (assuming an inherent standard deviation of 0.15 and alpha level of 0.05). In other words, even with relatively small sample sizes, a manufacturer may detect mean shifts of 0.6 mm or higher over 90% of the time. Of note, this statistical power drops to 0.3 for detecting shifts of 0.25. Thus, while using 3 runs with 3 samples each may detect major shifts (> 0.6 mm), it is not effective at detecting small shifts in the mean between batch runs. We maintain that this approach still offers an appropriate balance as small stamping mean shifts between runs in the order of 0.25 mm rarely have an effect on assembly operations because of the relatively weak correlation often observed from stamping-to-assembly.

## 7.2 Functional Master Part and Tolerance Adjustment Issues

Given a functional build-based part approval approach, we would argue that the objective for PPAP in stamped parts is different than other parts. For other automotive components, PPAP provides a process for evaluating conformance of supplier parts to design intent. This approach is particularly effective when a strong relationship exists between component quality and subsequent assembly operations. Unfortunately, with stamped parts this relationship is less clear.

---

<sup>11</sup> Statistical power is equal to 1 - Beta Error. Power represents the ability to detect a mean shift of some size, k.

In stamping, while very large deviation from design intent are likely to cause downstream problems, small to moderate deviations may not. Furthermore, some stamping mean deviations may be compensated in assembly processes. For example, it has been shown that non-rigid part dimensions will conform to more rigid mating parts or subassemblies. Thus, in stamping, once a part is stable and capable of building an assembly that meets its quality objectives, a key outcome of PPAP is provide specifications for production operations to maintain over time.

Tolerance or specification adjustment may take different forms. For certain dimensions, the variation requirements of a tolerance (e.g.,  $\pm 0.5$ ) may be met, but the mean is off target resulting in parts outside original design specifications. In this case, manufacturers usually prefer to make a lateral adjustment or a mean re-target. For example, if the mean of a process is 0.4 and the variation about this mean is capable of meeting a tolerance of  $\pm 0.5$ , then the specification would be changed to  $0.4 \pm 0.5$  (or -0.1 to 0.9) versus an expansion to  $\pm 0.9$  ( $0.4 + 0.5$ ).

For other dimensions, the process may exhibit larger inherent variation than allowed for in the original tolerances. For instance, a mating flange may have a tolerance of  $\pm 0.5$ , but the inherent variation may yield a process with an actual capability of  $\pm 0.7$ . Provided this additional variation does not affect the downstream assembly, a manufacturer may expand the tolerance width for regular production monitoring. This is particularly true if the large majority of dimensions are meeting their variation requirements for a particular part. One reason is that most stamping processes have limited adjustment capabilities to reduce variation in a local area.

While tolerance expansions may be more difficult to approve due to assembly uncertainty, they do not change the original design nominal intent like re-targeting mean dimensions does. Here, by accepting a mean at a new nominal location, the product design no longer resembles the desired part. This is particularly true when different dimensions along a flange have different mean re-targets, making it virtually impossible to adjust the product design in a CAD system. Even when modifying the CAD product design is possible, the time and cost to match the 'as-built' condition is often prohibitive. With the adoption of WL measurement technology, manufacturers have the ability to generate a master part of the 'as-built' condition.

In alignment with the prior sampling recommendations, we recommend creating an as-built or functional master part using the 9-sample PPAP run for all parts. Using WL measurement technology, one can then measure all future dimensions on a part relative to this approved master. This has tremendous advantages for simplifying future production monitoring.

In addition, the creation of a functional master part eliminates the need for mean re-targets at the end of the PPAP evaluation process. All dimensional means are effectively re-targeted to a functional master that reflects the goal to maintain in regular production. Thus, tolerance adjustment to approve parts for regular production becomes limited to tolerance expansion decisions.

## 8. Production Monitoring and WL Part Measurement

Once parts are approved with appropriate re-targets and tolerance adjustments, production processes need a method to assess general part consistency over time. Here, we recommend using a proportion chart which is commonly used for monitoring yield (or % defective) in statistical process control applications. Figure 34 illustrates the use of a PIST proportion chart using values for a Rear Door Inner panel.

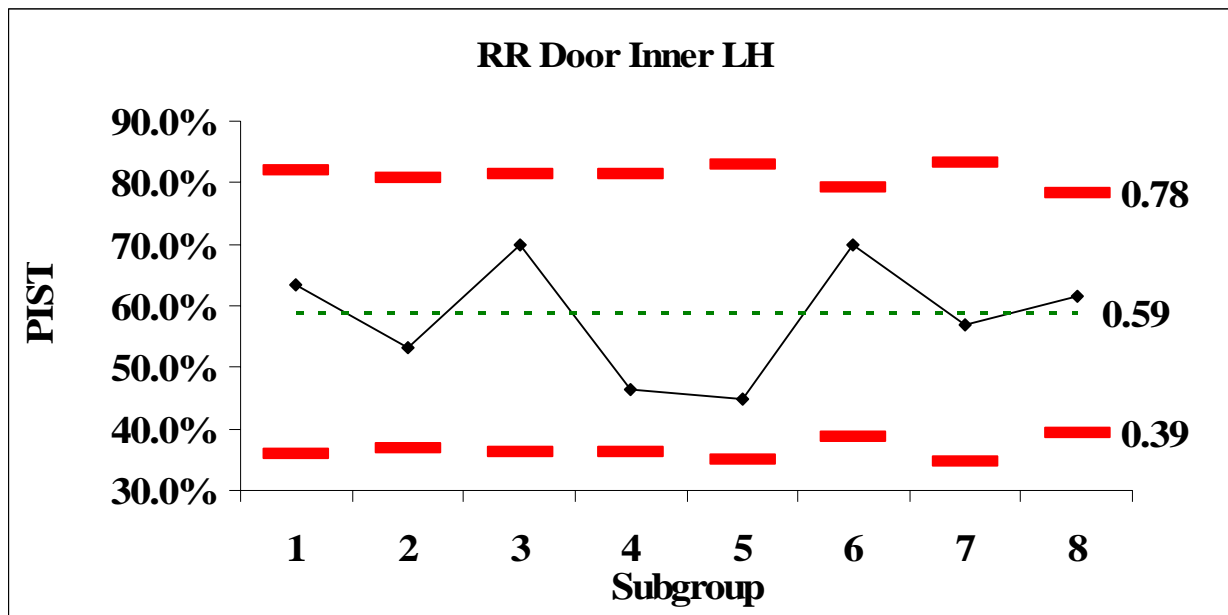


Figure 34. PIST Proportion Chart for RR Door Inner Panel

A PIST proportion chart monitors changes in percent in specification over time. Of note, if the number of points measured is not the same for every subgroup sample, the control limits get adjusted from subgroup to subgroup. Here, wider control limits indicate a smaller number of

points inspected than on average, while narrow control limits indicate a larger number of inspection points. For example, for subgroups 1 through 5, the number of points measured was around 40, while for subgroups 6 and 8, the number of points measured increased to about 50 points.

The value of a PIST proportion chart is that it provides an overall measure of part stability (consistency) over time on a single chart. Of course, if manufacturers need to react to an out-control average PIST, they may still require the use of traditional individual and moving range charts by specific dimensions to assess instability in local part areas.

## **9. WL Part Measurement – Future Direction**

The application of WL measurement technology described in this report should be viewed as only a starting point. WL measurement provides critical data that may potentially impact several longstanding industry challenges. These include better understanding of how to effectively rework dies closer to nominal and stamping-to-assembly relationships.

For example, die rework often is an inexact process. Manufacturers rarely make shifts in one local area without affecting other dimensions. In some cases, a part may be reworked to improve one area only to have other areas shift out of specification. The use of traditional measurement systems along with a small subset of discrete points per part limits the study of rework. In fact, one reason for evaluating stamped parts in assemblies using functional build events is the difficulty in reworking stamped parts to improve them. With WL measurement technology, die makers have more information to help them understand cause and effect relationships for different rework techniques.

WL measurement systems also provide capabilities to enhance virtual assembly or virtual panel matching of mating stamping components. Today, most virtual assembly tools cannot quickly and effectively account for the lack of rigidity of stamped components and the true effects of weld operations necessary to completely replace physical stamping-assembly build event evaluations. One reason is the lack of detailed component-quality representation to improve the modeling process. WL measurement technology provides needed as-built data to make significant improvements to the component-to-assembly virtual modeling process, allowing manufacturers to identify design concerns and build problems without physically

assembling parts. This has significant implications for streamlining manufacturing validation processes and reducing overall automotive body development time.

## 10. Conclusion

Historically, automotive body measurements have relied on discrete point checking systems for inspection data. The limitations of these systems are well known. Three-dimensional non-contact WL measurement systems have the technology to provide significantly more comprehensive measurement and better diagnostic capability. For successful adoption of WL measurement systems, however, we believe that many of the traditional quality evaluation business processes must be modified to take advantage of the new capabilities. This report identified several quality monitoring and evaluation strategies that can aid in the implementation of WL technology. These recommendations are summarized as follows:

- Provide full-surface, color map part quality representations for each measurement sampling event
- Incorporate more feature extractions per part to include more trim edge, hole/slot position, and size dimensions into normal measurement routines, eliminating the need for separate one-piece measurement layout studies
- Generate average and range color maps to show part conformance for multi-sample dimensional evaluations
- Adopt a percent in specification or PIST metric to measure overall panel quality for various build events, replacing the use of process capability indices such as Pp and Ppk to evaluate individual discrete dimensions
- Adopt PIST criteria by build event
- Change historical sample size requirements from five to three samples for key tryout build event part evaluations
- Change PPAP sampling requirements from a 30 to a nine sample study using three different stamping runs (setups) of three samples each
- Evaluate parts in regular production relative to a functional master part obtained during PPAP



## References

1. Hammett, P.C., Garcia Guzman, L., Frescoln, K., and Ellison, S., 2005, "Changing Automotive Body Measurement System Paradigms with 3D Non-Contact Measurement Systems", *Society of Automotive Engineers World Congress*, Paper No. 2005-01-0585.
2. Production Part Approval Process. Reference Manual. 3<sup>rd</sup> Edition. Automotive Industry Action Group, 2002.
3. Hammett P.C., Wahl, S.M., and Baron, J.S., 1999, "Using Flexible Criteria to Improve Manufacturing Validation During Product Development", *Concurrent Engineering: Research and Application (CERA)*.
4. Hammett, P. and Baron, J., Automotive Body Measurement System Capability. *Technical Report prepared for the Auto Steel Partnership Program*. 1999.
5. Measurement Systems Analysis. Reference Manual. 3<sup>rd</sup> Edition. Automotive Industry Action Group, 2002.
6. Baron, J. and Hammett, P., Stamping Process Variation: An Analysis of Stamping Process Capability and Implications for Design, Die Tryout and Process Control. *Technical Report prepared for the Auto Steel Partnership Program*. 1999.
7. Liu, S.C., S.J. Hu and T.C. Woo, 1996, "Tolerance Analysis for Sheet Metal Assemblies," *ASME Journal of Mechanical Design*, Vol. 118, March, pp. 62-67.