

DR. EDWARD H. IP (Orcid ID : 0000-0002-4811-4205)

DR. RUTH C. CARLOS (Orcid ID : 0000-0001-7055-7662)

DR. FENGMIN ZHAO (Orcid ID : 0000-0001-9826-3703)

DR. JOHN D. PEIPERT (Orcid ID : 0000-0001-5762-7881)

DR. LYNNE I. WAGNER (Orcid ID : 0000-0001-9685-4796)

Article type : Original Article

Tolerability of Bevacizumab and Chemotherapy in a Phase III Clinical Trial with HER-2  
Negative Breast Cancer: A Trajectory Analysis of Adverse Events

Running title: Tolerability Trajectory

Edward H. Ip, PhD<sup>1</sup>

Santiago Saldana, MS<sup>1</sup>

Kathy D. Miller, MD<sup>2</sup>

Ruth C. Carlos, MD<sup>3</sup>

Ilana F. Gareen, PhD<sup>4</sup>

Joseph A. Sparano, MD<sup>5</sup>

Noah Graham, MB<sup>6</sup>

Fengmin Zhao, PhD<sup>6,7</sup>

Ju-Whei Lee, PhD<sup>6</sup>

This is the author manuscript accepted for publication and has undergone full peer review but has not been through the copyediting, typesetting, pagination and proofreading process, which may lead to differences between this version and the [Version of Record](#). Please cite this article as [doi: 10.1002/CNCR.33992](https://doi.org/10.1002/CNCR.33992)

This article is protected by copyright. All rights reserved

Nathaniel S. O'Connell, PhD<sup>1</sup>

David Cella, PhD<sup>8</sup>

John D. Peipert, PhD<sup>8</sup>

Robert J. Gray, PhD<sup>6,7</sup>

Lynne I. Wagner, PhD<sup>9</sup>

**Co-Author Institutional Affiliations:**

<sup>1</sup>Department of Biostatistics and Data Science, Wake Forest School of Medicine,  
Winston-Salem, NC

<sup>2</sup>Department of Medicine Hematology/Oncology Division, Indiana University School of  
Medicine, Indianapolis, IN

<sup>3</sup>Department of Radiology, University of Michigan Comprehensive Cancer Center, Ann  
Arbor, MI

<sup>4</sup>Department of Epidemiology, Brown University, Providence, RI

<sup>5</sup>Department of Oncology, Montefiore Medical Center, Albert Einstein College of  
Medicine, Bronx, NY

<sup>6</sup>ECOG-ACRIN Biostatistics Center, Dana-Farber Cancer Institute, Boston, MA

<sup>7</sup>Department of Biostatics, Harvard T.H. Chan School of Public Health, Boston, MA

<sup>8</sup>Department of Medical Social Sciences, Northwestern University, Feinberg School of  
Medicine, Chicago, IL

<sup>9</sup>Department of Social Sciences and Health Policy, Wake Forest School of Medicine,  
Winston-Salem, NC

**Corresponding author:** Edward H. Ip; email: [eip@wakehealth.edu](mailto:eip@wakehealth.edu); address: Department of  
Biostatistics and Data Science, Wake Forest School of Medicine, Medical Center Blvd.,  
Winston-Salem, NC 27157; telephone: (336)716-9833

**Funding statement:** The work is funded by the National Cancer Institute (grant U01CA233169; PI: Lynne I. Wagner, Robert J. Gray). Edward H. Ip is also partly funded by the NCI grant U10CA081851 (PI: Glenn Lesser). The E5103 trial was supported by the National Cancer Institute of the National Institutes of Health under award numbers U01CA233169 and U10CA081851. The content is solely the responsibility of the authors and does not necessarily represent the official views of the National Institutes of Health. Additional support for E5103 was provided by Genentech.

**Registry Number:** NCT00433511

**Conflict of interest statement:** There is no conflict.

**Author contribution statement:** Edward H. Ip: Conceptualization, methodology, data analysis, and writing the first draft. Santiago Saldana: Methodology, data analysis. Kathy D. Miller: Writing-review and edit, resource. Ruth C. Carlos: Conceptualization, writing—review and edit. Ilana Gareen: Writing—review and edit. Joseph A. Sparano: Conceptualization, writing—review and edit. Noah Graham: Writing—review and edit. Fengmin Zhao: Data curation, writing—review and edit. Ju-Whei Lee: Data curation, resource, methodology, critical review, edit. Nathaniel Sean O'Connell: Conceptualization, critical review, edit. David Cella: Writing—review and edit, resource. John D. Peipert: Conceptualization, writing—review and edit, resource; Robert J. Gray: Data curation, supervision, funding acquisition. Lynne I. Wagner: Conceptualization, writing—review and edit, supervision, funding acquisition.

### Precis

In this secondary data analysis study of breast cancer patients treated with bevacizumab and chemotherapy, cumulative multiple toxicities, even of low grades, were found to be associated with early treatment discontinuation. Peripheral neuropathy was related to poor self-reported physical well-being, suggesting additional care for patients exhibiting such toxicity.

## Abstract

**BACKGROUND:** E5103 was a study to evaluate the efficacy and safety of bevacizumab. It was a negative trial for the endpoints of invasive-disease-free-survival and overall survival. The current work examines tolerability for bevacizumab and other medication exposure as related to clinical and patient-reported outcomes (PROs). **METHODS:** Adverse events (AEs) collected from the CTCAE were summarized to form an AE profile at each treatment cycle. All-grade and high-grade events were separately analyzed. The change in AE profile over treatment cycle was delineated as distinct clusters of AE trajectory. AE-related and any-reason early treatment discontinuation were treated as clinical outcome measures. PROs were measured by FACT-B + 4. The relationships between the AE trajectory and early treatment discontinuation, as well as PROs, were analyzed. **RESULTS:** More than half (57.5%) of all AEs were low grade. A cluster of patients with broad and mixed grades of AE (all-grade) trajectory was significantly associated with any-reason early treatment discontinuation (odds ratio, OR=2.87; p=0.01) as well as AE-related discontinuation (OR=4.14; p=0.001). This cluster had the highest count of all-grade AEs per cycle compared to other clusters. Another cluster of patients with primary neuropathic AEs in their trajectories had poorer physical well-being, compared to a trajectory of no or few AEs (p<0.01). High-grade AE trajectory did not predict discontinuations. **CONCLUSIONS:** Sustained and cumulative burden of across-the-board toxicities, although not necessarily all recognized as high-grade AEs, contributed to early treatment discontinuation. Patients with neuropathic all-grade AEs may require additional attention for preventing deterioration in physical well-being. (Word count: 250)

**Key words:** Breast cancer, adverse events, peripheral neuropathy, drug treatment, early treatment discontinuation, patient reported outcome

Tolerability of Bevacizumab and Chemotherapy in a Phase III Clinical Trial with HER-2  
Negative Breast Cancer: A Trajectory Analysis of Adverse Events

The ECOG-ACRIN Cancer Research Group E5103 was a randomized phase III, double-blind, clinical trial for patients with human epidermal growth factor receptor 2 (HER2)-negative breast cancer.<sup>1</sup> Previous research has suggested that the most successful clinical application of angiogenesis inhibitors is likely to be in patients with micrometastatic disease in the adjuvant setting.<sup>2-9</sup> E5103 was a study to test that hypothesis and evaluate the efficacy and safety of bevacizumab, the humanized monoclonal antibody, which targeted vascular endothelial growth factor (VEGF). Results from E5103 showed that incorporation of bevacizumab into sequential anthracycline- and taxane-containing adjuvant therapy did not improve invasive-disease-free-survival (IDFS) or overall survival in targeted patients.<sup>1</sup> The negative study result was partly attributed to early drug modification and discontinuation that resulted in severely limited bevacizumab exposure. As such, it is possible that even if bevacizumab was beneficial, the effect could be attenuated because many of the bevacizumab-specific toxicities had a constant, cumulative risk over time that led to drug intolerance, early adverse events (AEs), and eventual non-adherence.<sup>1,10</sup>

In this paper, rather than IDFS or overall survival, we turn our focus to tolerability of bevacizumab and other medication exposure. Operationally, we use discontinuation of treatment as a clinical outcome to indicate (in)tolerability. Critical to patients' adherence to protocol treatment, management of tolerability needs to address and prioritize the many dimensions of AE, including multiplicity, severity, and persistence. Consider the following two competing scenarios: Patient A has a high-grade but episodic, isolated case of diarrhea, and patient B has a grade 2 facial rash and a grade 2 joint pain that are both persistent. Current clinician practice would only regard Patient A's episodic diarrhea as severe, and not Patient B's constant rash and pain. However, Patient B may be more unwilling to continue treatment as the low-grade toxicity severely limits her daily activities and negatively impacts her health-related quality of life (HRQOL). In this paper we utilize a trajectory-based method that captures the full range of AE manifestation, including multiplicity, severity (grade), and pattern of occurrence over time. With a comprehensive representation of AE manifestation, our objective is to seek answers to the following questions (Objectives 1-3). First, what are the patterns of AE trajectories from bevacizumab and other medication exposure? Second, are AEs related to early discontinuation of treatment, and if so, what patterns in AE trajectories would likely lead to such an outcome?

Third, how are AE trajectories related to patient-reported outcomes (PROs), particularly the different aspects of well-being (e.g., physical, mental)?

## METHODS

### Study Design and Sample

This is a substudy of E5103, a phase III adjuvant breast cancer trial that randomly assigned 4,994 patients with node-positive or high-risk node-negative breast cancer to standard chemotherapy plus bevacizumab or placebo conducted by the ECOG-ACRIN Cancer Research Group (Figure. 1a). Detailed eligibility criteria have been reported.<sup>1,13</sup> The current tolerability study includes 515 patients who completed PROs<sup>1,13</sup> (Fig. 1b). PRO participants were representative of the original sample<sup>1</sup> with regard to demographic and clinical characteristics, and randomization assignment (Table 1). Institutional review boards for participating sites approved the protocol, and patients provided written informed consent before screening.

All patients received doxorubicin and cyclophosphamide (AC) followed by paclitaxel (T) weekly for 12 weeks. AC could be administered in a classic (every 3 weeks) or a dose-dense (every 2 weeks) schedule based on investigator discretion; the bevacizumab (B) dose was adjusted for the AC schedule choice (patients receiving classic AC received bevacizumab 15mg/kg; patients receiving dose-dense AC received bevacizumab 10 mg/kg). A placebo (arm A) or bevacizumab (arms B and C) were administered concurrently with chemotherapy. All patients were unblinded at week 10 of paclitaxel therapy—the first day of the last cycle in the first phase (8 cycles in total) of E5103. In the second (maintenance) phase, patients in arm C continued bevacizumab monotherapy (15 mg/kg every 3 weeks) for an additional 10 cycles unless the patient did not consent to continue. The current analyses focused on the first phase of the trial. We excluded participants that died or experienced disease progression in this phase from the analysis.

Insert Fig. 1 here

### Measures

Treatment-related variables for the purpose of this analysis are described below.

#### *Bevacizumab exposure*

Arm A participants were categorized as non-bevacizumab exposed, and both arm B and C participants were categorized as bevacizumab exposed.

#### *Clinical outcomes*

Early treatment discontinuation. Discontinuation was a dichotomous variable in which 1 = discontinued before completing the planned treatment and 0 otherwise. Discontinuation due to AE and discontinuation for any reason (including AE) were analyzed separately as distinct outcomes.

#### *Patient-reported outcomes*

FACT-B + 4. The Functional Assessment of Cancer Therapy – Breast + Lymphedema (FACT-B +4) questionnaire<sup>14</sup> was used to measure cancer-related well-being. The FACT-B+4 consists of the FACT-General (FACT-G) subscales (27 items) and the Additional Concerns subscale (AC, 14 items). The FACT-G consists of four subscales that assess physical, social/family, emotional, and functional well-being. The AC measures breast cancer-specific concerns. Items were based on a five-point scale and referred to the past seven days. After reverse coding items that were negatively-worded, responses were summed within a domain to derive a domain-level score, and higher scores reflected better well-being.

Demographic and other cancer-related variables. In addition to routine demographic (age, sex, race) and anthropometric (weight) variables, cancer-related variables included primary tumor size, histologic grade, estrogen receptors (ER) and progesterone receptors (PGR) status. Factors related to genetic ancestry were reported elsewhere and not included in this analysis.<sup>1,13</sup>

#### CTCAE and AE trajectory

Data on AEs were collected using the Common Terminology Criteria Adverse Event (CTCAE) version 3.0. The analysis included a total of 53 different AE events reported during the first phase of treatment in E5103. Because of the complexity and sparsity of the AE data, summary measures were derived to facilitate analysis. First, the AEs were grouped under 11 domains—cardiac, febrile, reaction-related, gastro-intestinal, hemorrhage, edema, metabolic, neuropathic, pain, breathing-related, and others. Because many AEs were sparse, instead of using individual event-level data, the presence of an AE within a domain in a specific cycle was treated as a domain-level indicator. We curated data both for (1) the presence of any grade AE (representing what a patient experienced), and (2) the presence of a severe AE (grade 3 and above,

representing what a clinician typically recorded). When discontinuation occurred, no AE data were collected afterward. For each type of AE data, two summary measures were further derived from the AE domain-level indicators. The first was derived from analyzing the 11 domain indicators such that individuals with similar profiles across domains were clustered into a specific AE “state” or latent class<sup>15,16</sup> at a given cycle. For example, “no or few AEs” formed a state. The second summary measure used the collection of AE states over cycles to identify distinct groups of trajectories, representing how patient AE profiles changed over time. An example of a trajectory group is patients belonging to the “no or few AE” state for all cycles. The AE trajectory group was used to represent the patient burden from AEs in the subsequent analysis. Specific details for the derivation of AE states and trajectories are provided in the following section. The any-grade AE trajectory forms the basis for primary analysis, and the same methodology was applied to high-grade (severe) AE for a sensitivity analysis.

### **Statistical analysis**

The statistical analysis plan used pertinent tools to achieve each objective. We operationalized the AE trajectory variable to capture the entire AE profile over all 8 cycles. Although AEs can be summarized by measures such as the total AE count over cycles, the approach has limitations like not differentiating AEs in different domains, which was important for understanding the patterns of toxicity. Instead, we used the multivariate hidden Markov model (MHMM) to capture the manifestation of AE patterns in the form of different states and trajectories.<sup>15-17</sup> Briefly, the MHMM uses multiple variables (in this case, the domain-level AE) to form an AE profile. Based on the pattern of the profile variables, the MHMM determines the appropriate number of states  $K$ , for capturing both intra-individual and inter-individual variation. A state represents a statistically distinguishable patient cluster within which the patients have similar profiles. Each individual was classified as exclusively belonging to one of the  $K$  states at a given time point, and state membership can change over time. The Bayesian Information Criterion (BIC), a goodness-of-fit statistical index, determines the value of  $K$ . In other words, a range of models with different number of states were fitted and the model with the lowest BIC was selected. The MHMM states thus represent the heterogeneity in multiple AE measures. Accordingly, an individual’s change in states over time constitute an AE trajectory. Based on inspection of the individual trajectories, we further identified a number of distinct AE trajectory groups, which were treated as categorical variables in subsequent analysis.



Missing values were treated as missing-at-random (MAR). For the MHMM analysis, if a patient missed an observation at a specific time point, the state was imputed using information from the previous states under the model assumptions.<sup>16</sup>

Depending on the objective, AE trajectory group was treated either as a dependent or an independent variable in the analysis. In Objective 1, AE trajectory group was the dependent variable in a multinomial logistic model, and the primary predictor was bevacizumab exposure (Model 1). For the selection of covariates, univariate logistic analysis was first used to determine significance of the individual variables age, race, weight, primary tumor size, ER status, and PGR status. Significant variables ( $p < 0.1$ ) were then entered into the final multivariable logistic model. A two-way interaction term between each included variable and bevacizumab exposure was also tested for significance.

In Objective 2, the dependent variables were early treatment discontinuations (for AE related and for any reason), and the primary predictor was the AE trajectory group. Independent logistic regression models were used to analyze the early treatment discontinuation outcomes (Model 2). The same set of covariates and interactions used in Model 1 were included in Model 2. For Objective 3, the multiple dependent variables were PROs, all measured at the end of Phase I of the study (cycle 8). PROs were treated as continuous, and linear regression models were fit with AE trajectory group as the primary predictor, adjusted for baseline PRO values (Model 3). A direct effect of bevacizumab on PROs was plausible, so a mediational model was used to explore the effect between bevacizumab and PRO, for which AE trajectory group was mediator. All analyses used two-sided testing with a significance level of 0.05, and 95% confidence intervals were reported for key predictor variables. MHMM and regression analyses were conducted using MATLAB and SAS v9.4, respectively.

Insert Table 1 here

## RESULTS

Table 1 shows descriptive statistics of the sample, and Table S1 (in Supplemental Materials) shows the corresponding statistics of the original full sample. Five distinct AE states were identified from the data such that each state represents a subgroup of patients with similar AE profiles (Fig. 2A). The profiles of the five states were respectively labeled Mixed Reactions (state 1), Cardiac (state 2), Neuropathic (state 3), First Low AE (state 4, labeled Low 1), and

Second Low AE (state 5, labeled Low 2). For example, a patient in the Cardiac state has a 78% chance on average of having a positive indicator of cardiac AE at a given cycle. The manifestation of cardiac AE includes hypertension as most prevalent. Others included left ventricular systolic dysfunction, cardiac ischemia/infarction, and ventricular diastolic dysfunction. The most prevalent neuropathic AE was neuropathy-sensory. Others included dizziness, mood alteration-depression, CNS cerebrovascular ischemia, and ataxia (incoordination). A patient in the Mixed Reactions state is likely to experience multiple AEs across domains, including fever, pain, and GI and breathing-related issues. Both the Low 1 AE and Low 2 AE states have low AE incidence. In our subsequent trajectory analysis, a decision was made to collapse these two statistical states into a single Low AE state. Figure 2B shows the prevalence of the states over time (in cycle). The two low AE states together constitute the most prevalent state. Both the Cardiac and Neuropathic states increase in prevalence over time whereas the Mixed Reactions state appears early and persists into the treatment cycles. Note that some states (e.g., Cardiac) only emerge after the initial cycle.

Insert Fig. 2 here

Individuals' trajectories were categorized into the following four groups—the *Low AE Traj* group within which only the Low 1 or Low 2 AE states were present throughout the cycles; the *Cardiac Traj* group within which the Cardiac state was present at some point in the cycles; the *Neuro Traj* group within which the Neuropathic state was present at some point in the cycles; and the *Mixed Reactions Traj* within which the Mixed Reactions state was present at some point in the cycles. Because there was very little movement from one state to another—with the exception of transition between the Low AE states and other states—all the trajectories could be readily classified into one of the aforementioned trajectory groups. Table 2 shows a sample of the most prevalent trajectories and how the trajectories were classified. The *Mixed Reactions Traj* shows a pattern distinct from the *Cardiac* and *Neuro Traj* groups. Table 2 also shows that for the *Mixed Reactions Traj*, the Mixed Reactions state tends to persist throughout the cycles, whereas for the *Cardiac* and *Neuro Traj* groups, the respective Cardiac and Neuropathic states tend to be episodic and only appear toward later cycles. Overall prevalence of the *Cardiac*,

*Neuro*, *Mixed Reactions*, and *Low AE Traj* groups were 7.7%, 25.1%, 8.7%, and 58.6%, respectively.

Insert Table 2 here

### **Objective 1 Result (Bevacizumab Exposure and AE Trajectory)**

The final model (Model 1) included bevacizumab exposure, age, and weight as independent variables. None of the interaction terms among the selected independent variables were significant, and therefore no interaction term was included in the model. Table 3 shows the multinomial logistic regression results for which AE trajectory group is the outcome. Compared to the *Low AE Traj* group, the *Cardiac Traj* group was significantly related to bevacizumab exposure (odds ratio OR=3.58; 95% confidence interval CI, 1.06-12.1; p=0.04). Descriptive statistics showed that 92.3% of participants in the *Cardiac Traj* group were exposed to bevacizumab versus 77.6% in the *Low AE Traj* group. Older participants had higher odds of belonging to the *Mixed Reactions Traj* group, participants with heavier body weights had significantly higher odds of belonging to the other trajectory groups compared to the *Low AE Traj* group (Table 3).

Insert Table 3 here

### **Objective 2 (AE Trajectory and Discontinuation) results**

Dependent variables for this objective included treatment discontinued due to any reason, and discontinued due to AE. Five participants – one that died, and four that experienced disease progression – were excluded from the analysis. In the sample, the percentages of discontinuation due to any reason and due to AE were 22.8% (116 out of 510), and 10.8% (55 out of 510), respectively. In other words, 47% (55 out of 116) of patients that discontinued treatment did so due to AE. Figure 3 shows, by trajectory group, the percentages of AE (incidence) per cycle, drug modification, treatment discontinuation due to any reason, and discontinuation due to AE.

The *Mixed Reactions Traj* group was highly significant in predicting early treatment discontinuation due to any reason (OR=2.87; 95% CI, 1.47 - 5.58, p=0.01), as well as due to AE (OR=4.14; 95% CI 1.90 - 9.06; p=0.001). None of the other trajectory groups were found to be

significantly associated with treatment discontinuation. Additionally, no other covariate was significant.

Insert Fig. 3 here

### **Objective 3 (AE Trajectory and PRO) Results**

For PRO analysis by domain of well-being, participants with missing PRO values were excluded, and the resulting range of sample size was between 445 and 447. *Neuro Traj* was significant in predicting physical well-being ( $p < 0.01$ ) whereas *Cardiac Traj* was marginally significant ( $p = 0.055$ ). The regression coefficients in Model 3 were such that being in the *Neuro Traj* group decreased the physical well-being score by 1.51 points (95% CI, -2.61 to -0.40), and being in the *Cardiac Traj* group decreased the score by 1.78 points (95% CI, -3.60 to 0.04), both implying worse physical well-being. There was no detectable direct effect from exposure to bevacizumab on physical well-being ( $p = 0.81$ ). Because no direct effect was found, no mediational model was further tested. In all the other domains of well-being (social, emotional, functional, and additional concerns), none of the AE trajectory group showed significant predictive effect, nor did exposure to bevacizumab.

Figure 4 visualizes the results for the relationships between bevacizumab exposure, AE trajectory, and clinical and PRO outcomes.

Insert Fig. 4 here

### **Sensitivity Analysis**

The analysis of the severe AE trajectory identified 3 states (Fig. S1 in supplemental materials). Besides a low AE state, the two other states were respectively labeled Cardiac/Neuropathic state and Other AE state. Three corresponding high-grade AE trajectories were derived from the data. The three trajectories were called, respectively, *Cardiac/Neuro High-Grade AE Traj* group (8.2%), *Other High-Grade AE Traj* group (14.7%), and *Low High-Grade AE Traj* group (77.1%). For Objective 1, bevacizumab exposure was not significantly related to any of the high-grade AE trajectory groups. For Objective 2, none of the high-grade trajectory groups were related to early discontinuation due to AE or any reason (all  $p > 0.1$ ). For Objective 3, the

*Cardiac/Neuro High-Grade AE Traj* group was only significantly associated with the patient's emotional well-being ( $p=0.03$ ).

## DISCUSSION

Although the efficacy of bevacizumab, in addition to chemotherapy, has been demonstrated in randomized clinical oncology trials, published studies have also revealed AEs implicated by the agent. The majority of such AEs are considered manageable, but others are severe and life-threatening.<sup>18</sup> The current retrospective study confirms previous findings that toxicity, specifically cardiac toxicity, is induced by bevacizumab in a study of patients with HER 2–negative breast cancer.<sup>1,19</sup> Our finding is also consistent with the literature on the presence of classic toxicities likely due to other drugs used in the study—for example, peripheral neuropathy as induced by paclitaxel, although we only distinguished bevacizumab from other medications (Objective 1)—and the analysis does not specifically tease out different toxicities due to these drugs.

It is important to understand the study findings regarding tolerability in the context of two unique features in our analysis. First, toxicities across multiple domains were *simultaneously* analyzed using a profile-based method. Unlike approaches based on counting the total number of AEs such that a low score in one domain may compensate for a high score in another, the profile-based approach allows a more comprehensive representation of the multiplicity of AE grouping and changes exhibited in longitudinal AE data.

The profile-based method identified four distinct and clinically-meaningful types of all-grade AE trajectory in the analyzed patients. More than half of the patients had a trajectory type that either did not show any AE, or had very low levels of AEs over the eight treatment cycles. For the neuropathy- and cardiac-dominated trajectory types, we found respective AEs that appeared later in the treatment cycles and tended to be episodic. In contrast, the group of patients labeled as the *Mixed Reactions Traj* experienced a broad range of toxicity burden that is persistent over treatment cycles, as well as AEs that began early in the cycle. One possible explanation is this group of patients had underlying health issues or being more sensitive to the treatment than other patients. The profile-based method captured salient features of AE patterns in the longitudinal data that were unlikely to be captured using traditional methods such as separate domain-level AE counts or overall AE counts.

A second important feature of the current study is the inclusion of low grade AEs in capturing overall patient burden. In addition to the standard high grade events (grade 3 or above), grades 1 and 2 AEs were also included. It has been shown that the high grade approach may miss important details of how patients experience the cumulative toxicity burden that contributes to overall treatment tolerability and HRQOL.<sup>11,20</sup> Our findings from the sensitivity analysis indeed suggest that the high-grade-only approach is not predictive of outcomes such as early treatment discontinuation. In the current data, a substantial proportion (57.5%) of the reported AEs are low grade. Importantly, patients belonging to the *Mixed Reactions Traj* group were significantly related to early discontinuation of treatment that was both AE-related and for any other reason. For example, rate of discontinuation for any reason for the *Mixed Reactions Traj* group was 42.3% compared to 23.1% and 25.6% respectively for the *Cardiac Traj* and *Neuro Traj* groups (Fig. 3). Inspection of AE counts confirmed that the *Mixed Reactions Traj* group had a higher AE incidence (any grade) per patient-cycle (0.638) compared to the *Cardiac traj* group (0.458), the *Neuro traj* group (0.366), and the *Low AE Traj* group (0.054). It is thus possible that simultaneous AEs -- regardless of type or grade -- that are sustained over time create a high toxicity burden, perhaps even more than a specific type of episodic, high-grade AE (e.g., cardiac AE). The cumulative burden of such across-the-board toxicities, although not necessarily all recognized as high-grade AEs, contributed to early treatment discontinuation. The sensitivity analysis lends further evidence to contrast the contribution to the predictive power (or lack thereof) of high-grade AEs only.

With the wide development and adoption of Molecularly Targeted Agents (MTAs) and immunotherapies for cancer treatment, accounting for sustained low and moderate grade AEs may be more important than ever before. Traditional cytotoxic agents are generally administered intermittently in 3 or 4 week cycles, and often result in immediate, acute AEs that resolve in a relatively short period of time. An acute grade 2 AE that resolves itself within a week may be of low concern. However, MTAs are often administered daily, and may be taken indefinitely. A grade 2 AE experienced chronically as a result of an MTA may present a significantly higher burden to a patient than the same AE if it were only experienced temporarily for a short period of time.

The *Cardiac Traj* group had the highest percentage of high-grade AEs (59.1%) among all patient-cycle AEs compared to the *Neuro Traj* group (31.1%), *Mixed Reactions Traj* group

(46.8%), and the *Low AE traj* group (50.0%). Further examination of data regarding dosage modification by trajectory groups confirmed that severe toxicities were more prevalent in the *Cardiac Traj* group. Per study protocol drug dosage was modified whenever specific severe AEs were reported; thus dosage modification was primarily driven by high-grade AEs. We found no one (0%) in the *Cardiac Traj* group that did not modify dosage, as compared to 6.2% of the *Neuro Traj* group that did not modify and 13.3% that did not modify in the *Mixed Reactions Traj* group (Fig. 3).

We noted that the *Low AE Traj* group had a non-trivial dosage modification and discontinuation percentage, although the rates were substantially lower than the other trajectory groups. Only 25.5% of this group did not experience any dosage modification, and 19.9% discontinued early for any reason. This suggests that other factors, such as personal reasons or individual differences in tolerability, also contributed to early discontinuation.

This report also examines treatment tolerability via patient-reported outcomes (PROs).<sup>12,21</sup> While clinician-centered assessment information such as that captured by CTCAE is useful, it indicates proximal effects due to treatment and provides a specific, and likely limited perspective on tolerability.<sup>22</sup> Studies have shown that the CTCAE approach has an under-detected symptom burden by as much as one-half of AEs compared with patient self-reports.<sup>23,24</sup> Thus, incorporating PROs and perspectives on treatment burden can provide unique information and higher precision on how patients experience treatment both at the initial and later stages, as well as which symptoms and AEs might impact treatment decisions. This information could lead to better management of chemotherapy to enhance treatment tolerability, optimize treatment outcomes, and enhance patient HRQOL.<sup>25,26</sup>

The findings from this study indicate that the physical well-being domain of PROs, measured at the end of the first trial phase, is significantly associated with the *Neuro Traj* group and marginally associated with the *Cardiac Traj* group. This suggests that neuropathic and cardiac toxicity may have a longer and lasting negative effect on a patient's physical well-being. At the end of cycle 8, treatment toxicity did not appear to have negative effects on other patient well-being domains such as social, emotional, functional, and breast cancer-related concerns. Compared to the *Low AE Traj* group, differences in physical well-being scores for the *Neuro Traj* and *Cardiac Traj* groups were respectively 1.51 and 1.78 points lower. While minimal importance difference (MID) has not been established for physical well-being, the MID for Trial

Outcome Score (TOI), which combines physical, functional, and breast cancer scores, was 5–6 points.<sup>27</sup> By using 5 points as a benchmark, the proportionally-derived MID for physical well-being is approximately 1.46. Therefore, the above-reported differences appear to be clinically meaningful. The finding points to the need for additional care for patients that experience neuropathic and/or cardiac toxicity during treatment even if the experience might only be episodic.

Our sensitivity analysis revealed that while high-grade AEs were not predictive of early discontinuation, AE-related or otherwise, they may exact a higher toll on some HRQOL domains than do all-grade AEs. Specifically, high-grade cardiac and neuropathic toxicities tend to contemporaneously occur within a small proportion of patients (8.2% in the current sample) and affect their emotional and functional well-being.

There are limitations to the study. We only retrospectively examined bevacizumab and chemo exposure and did not disentangle toxicities due to other specific medications, as E5103 was not designed to study other medications. The CTCAE form for this study only required clinicians to report all-grade AEs for toxicities related to the treatment. Low grade AEs were likely underreported in this study.

Finally, the results regarding the prediction of early treatment discontinuation by AE trajectory may not be readily generalizable to other populations. The reported methodology for summarizing the multidimensional, multi-cycle AE data, however, should remain applicable to other applications.

## REFERENCES

1. Miller KD, O'Neill A, Gradishar W, et al. Double-Blind Phase III Trial of Adjuvant Chemotherapy With and Without Bevacizumab in Patients With Lymph Node-Positive and High-Risk Lymph Node-Negative Breast Cancer (E5103). *J Clin Oncol*. 2018 Sep 1;36(25):2621-2629.



2. Miles DW, Chan A, Dirix LY, et al. Phase III study of bevacizumab plus docetaxel compared with placebo plus docetaxel for the first-line treatment of human epidermal growth factor receptor 2-negative metastatic breast cancer. *J Clin Oncol* 2010; 28:3239-3247.
3. Robert NJ, Di´eras V, Glaspy J, et al. RIBBON1: Randomized, double-blind, placebo-controlled, phase III trial of chemotherapy with or without bevacizumab for first-line treatment of human epidermal growth factor receptor2-negative, locally recurrent or metastatic breast cancer. *J Clin Oncol* 2011; 29:1252-1260.
4. Miles D, Cameron D, Bondarenko I, et al. Bevacizumab plus paclitaxel versus placebo plus paclitaxel as first-line therapy for HER2-negative metastatic breast cancer (MERiDiAN): A double blind placebo-controlled randomised phase III trial with prospective biomarker evaluation. *Eur J Cancer* 2017; 70:146-155.
5. von Minckwitz G, Puglisi F, Cortes J, et al. Bevacizumab plus chemotherapy versus chemotherapy alone as second-line treatment for patients with HER2-negative locally recurrent or metastatic breast cancer after firstline treatment with bevacizumab plus chemotherapy (TANIA): an open-label, randomised. *Lancet Oncol* 2014;15:1269-78.
6. Brufsky AM, Hurvitz S, Perez E, et al. RIBBON-2: A Randomized, Double-Blind, Placebo-Controlled, Phase III Trial Evaluating the Efficacy and Safety of Bevacizumab in Combination With Chemotherapy for SecondLine Treatment of Human Epidermal Growth Factor Receptor 2-Negative Metastatic Breast C. *J Clin Oncol* 2011; 29: 4286-93.
7. Robert NJ, Di´eras V, Glaspy J, et al. RIBBON-1: Randomized, Double-Blind, Placebo-Controlled, Phase III Trial of Chemotherapy With or Without Bevacizumab for First-Line Treatment of Human Epidermal Growth Factor Receptor 2-Negative, Locally Recurrent or Metastatic Breast Cancer. *J Clin Oncol* 2011; 29:1252-60.
8. Miller K, Wang M, Gralow J, et al. Paclitaxel plus Bevacizumab versus Paclitaxel Alone for Metastatic Breast Cancer. *N Engl J Med* 2007; 357:2666-76.
9. Jubb AM, Miller KD, Rugo HS, et al. Impact of exploratory biomarkers on the treatment effect of bevacizumab in metastatic breast cancer. *Clin Cancer Res* 2011 ;17:372-381.
10. Roviello G, Generali D, Sobhani N. The combination of bevacizumab with chemotherapy is more beneficial in the metastatic setting rather than in the adjuvant setting for the

treatment of HER2-negative breast cancer—a commentary on the E5103 randomized phase III clinical study. *Transl Cancer Res* 2019; 8(Suppl 2): S94-S96.

11. Wong ML, Gao J, Thanarajasingam G, et al. Expanding Beyond Maximum Grade: Chemotherapy Toxicity over Time by Age and Performance Status in Advanced Non-Small Cell Lung Cancer in CALGB 9730 (Alliance A151729). *Oncologist*. 2020 Sep 20. doi: 10.1002/onco.13527. Epub ahead of print. PMID: 32951293.
12. Basch E, Jia X, Heller G, et al. Adverse symptom event reporting by patients vs clinicians: relationships with clinical outcomes. *J Natl Cancer Inst* 2009; 101 (23):1624-1632.
13. Schneider BP, Shen F, Jiang G, et al. Impact of Genetic Ancestry on Outcomes in ECOG-ACRIN-E5103. *JCO Precis Oncol*. 2017; PO.17.00059. doi: 10.1200/PO.17.00059. Epub 2017 Aug 21. PMID: 29333527; PMCID: PMC5765553.
14. Coster S, Poole K, Fallowfield, LJ. The validation of a quality of life scale to assess the impact of arm morbidity in breast cancer patients post-operatively. *Breast Cancer Res Treat* 2001; 68: 273–282.
15. Ip EH, Zhang Q, Rejeski WJ, Harris TB, Kritchevsky S. Partially ordered mixed hidden Markov model for the disablement process of older adults. *J Am Stat Assoc* 2013; 108: 370-380.
16. Ip EH, Zhang Q, Schwartz R, et al. Multi-profile hidden Markov model for mood, dietary intake, and physical activity in an intervention study of childhood obesity. *Stat Med* 2013; 32: 3314-3331.
17. Rejeski WJ, Ip EH, Bertoni A, et al. Lifestyle Change and Mobility in Aging Obese Adults with Type 2 Diabetes. *N Engl J Med* 2012; 366: 1209-1217.
18. Gressett SM, Shah SR. Intricacies of Bevacizumab-Induced Toxicities and Their Management. *Ann Pharmacother* 2009; 43(3): 490-501.
19. Gullo G, J Eustace A, Canonici A, et al. Pilot study of bevacizumab in combination with docetaxel and cyclophosphamide as adjuvant treatment for patients with early stage HER-2 negative breast cancer, including analysis of candidate circulating markers of cardiac toxicity: ICORG 08-10 trial. *Ther Adv Med Oncol*. 2019; 11, 1-9. doi:10.1177/1758835919864236

20. Thanarajasingam G, Leonard JP, Witzig TE, et al. Longitudinal Toxicity over Time (ToxT) analysis to evaluate tolerability: a case study of lenalidomide in the CALGB 50401 (Alliance) trial. *Lancet Haematol* 2020 Jun; 7(6): e490-e497.
21. Basch E, Abernethy AP, Mullins D, et al. Recommendations for incorporating patient-reported outcomes into clinical comparative effectiveness research in adult oncology. *J Clin Oncol* 2012 30; 34: 4249-4255.
22. Basch E, Rogak LJ, Dueck AC. Methods for implementing and reporting patient-reported outcome (PRO) measures of symptomatic adverse events in cancer clinical trials. *Clin Therap* 2016; 38: 821-830.
23. Di Maio, M, Gallo, C, Leighl NB, et al. Symptomatic toxicities experienced during anticancer treatment: agreement between patient and physician reporting in three randomized trials. *J Clin Oncol* 2015; 33: 910-915.
24. Basch E, Iasonos A, McDonough T, et al. Patient versus clinician symptom reporting using the National Cancer Institute Common Terminology Criteria for Adverse Events: results of a questionnaire-based study. *Lancet Oncol* 2006; 7: 903-909.
25. Basch E, Wilfong L, Schrag D. Adding Patient-Reported Outcomes to Medicare's Oncology Value-Based Payment Model. *JAMA* 2020; 323(3): 213–214.
26. Kluetz PG, Kanapuru BK, Lemery S, et al. Informing the tolerability of cancer treatments using patient-reported outcome measures: Summary of an FDA and Critical Path Institute Workshop. *Value in Health* 2018; 21(6): 742-747.
27. Eton DT, Cella D, Yost KJ, et al. A combination of distribution- and anchor-based approaches determined minimally important differences (MIDs) for four endpoints in a breast cancer scale. *J Clin Epidemiol.* 2004; 57(9): 898-910.

Table 1. Descriptive Sample Statistics

Characteristic	Mean (SD) or N (Percentage) ARM A, N=108	Mean (SD) or N (Percentage) ARM B, N= 204	Mean (SD) or N (Percentage) ARM C, N= 203	Mean (SD) or N (Percentage) Total, N=515
Age	51.19 (10.65)	51.69 (10.07)	52.00 (10.07)	51.71 (10.28)
Patient Weight, kg	79.72 (21.99)	78.57 (19.58)	80.21 (19.58)	79.48 (19.11)
Sex				
Female	106 (98.2%)	204 (100%)	202 (99.5%)	512 (99.4%)
Male	2 (1.9%)		1 (0.5%)	3 (0.6%)
Race				
Non-White	14 (13.0%)	26 (12.8%)	34 (16.8%)	74 (14.4%)
White	94 (87.0%)	178 (87.2%)	169 (83.3%)	441 (85.6%)
Primary tumor size, cm				
<= 2	43 (39.8%)	63 (30.9%)	77 (37.9%)	183 (35.5%)
>2 to <=5	53 (49.1%)	114 (55.9%)	101 (49.8%)	268 (52.1%)
>5	12 (11.1%)	27 (13.2%)	25 (12.3%)	64 (12.4%)
Histologic grade				
1	12 (11.1%)	16 (7.8%)	14 (6.9%)	42 (8.2%)
2	34 (31.5%)	70 (34.3%)	71 (35.0%)	175 (34.0%)
3	61 (56.5%)	114 (55.9%)	111 (54.7%)	286 (55.5%)
Missing	1 (0.9%)	4 (2.0%)	7 (3.5%)	12 (2.3%)

Characteristic	Mean (SD) or N	Mean (SD) or N	Mean (SD) or N	Mean (SD) or N
	(Percentage) ARM A, N=108	(Percentage) ARM B, N= 204	(Percentage) ARM C, N= 203	(Percentage) Total, N=515
ER status				
Negative	43 (39.8%)	74 (36.1%)	78 (38.4%)	195 (37.9%)
Positive	64 (59.3%)	131 (63.9%)	124 (61.1%)	318 (61.8%)
Missing	1 (0.9%)		1 (0.5%)	2 (0.4%)
PGR status				
Negative	49 (45.4%)	82 (40.2%)	93 (45.8%)	224 (43.5%)
Positive	58 (53.7%)	122 (59.8%)	109 (53.7%)	289 (56.1%)
Missing	1 (0.9%)		1 (0.5%)	2 (0.4%)
HER2/neu chromosome				
0	37 (34.3%)	62 (30.4%)	85 (41.9%)	184 (35.7%)
1+	36 (33.3%)	71 (34.8%)	56 (27.6%)	163 (31.7%)
2+	16 (14.8%)	35 (17.2%)	27 (13.3%)	78 (15.2%)
Missing	19 (17.6%)	36 (17.7%)	35 (17.2%)	90 (17.5%)

Table 2. A Sample of Top 10 Trajectories (Ordered by Prevalence) with Corresponding Group Labels

Rank	Count	%	Cycle								Traj Group <sup>a</sup>	
			1	2	3	4	5	6	7	8		
1	302	58.6	Low	Low	Low	Low	Low	Low	Low	Low	Low	Low AE
2	41	8.0	Low	Low	Low	Low	Low	Low	Low	Neuro	Neuro	Neuro
3	24	4.7	Low	Low	Low	Low	Low	Low	Low	Low	Neuro	Neuro
4	13	2,5	Low	Low	Low	Low	Low	Low	Neuro	Neuro	Neuro	Neuro
5	6	1.2	Low	Low	Low	Low	Low	Neuro	Neuro	Neuro	Neuro	Neuro
6	5	1.0	Mixed	Mixed	Mixed	Mixed	Mixed	Mixed	Mixed	Mixed	Mixed	Mixed
7	3	0.6	Low	Mixed	Mixed	Mixed	Mixed	Mixed	Mixed	Mixed	Mixed	Mixed
8	3	0.6	Low	Low	Low	Low	Low	Cardiac	Cardiac	Low	Low	Cardiac
9	3	0.6	Low	Low	Low	Low	Low	Low	Low	Cardiac	Cardiac	Cardiac
10	3	0.6	Low	Low	Low	Low	Low	Low	Low	Low	Cardiac	Cardiac

Abbreviation: Mixed, Mixed Reactions AE state; Low, Low (1) or Low (2) AE states (collapsed); Neuro, Neuropathic AE state; Cardiac, Cardiac AE state

<sup>a</sup>Trajectory Group: Low AE, Low AE Traj group; Neuro, Neuro Traj group; Mixed, Mixed Reactions Traj group, Cardiac, Cardiac Traj group.

Table 3. Parameter estimates in Model 1 for the analysis of relationship between bevacizumab exposure and adverse event trajectory (n=510)

Parameter	AE Trajectory group <sup>a</sup>	Odds ratio	95% CI	p-value <sup>b</sup>
BV exposed	Cardiac Traj	3.58	(1.06, 12.1)	<b>&lt;0.05</b>
	Neuro Traj	1.08	(0.65, 1.80)	0.77
	Mixed Traj	1.11	(0.50, 2.46)	0.79
Age (10 yr)	Cardiac Traj	1.29	(0.92, 1.82)	0.14
	Neuro Traj	1.17	(0.95, 1.44)	0.13
	Mixed Traj	1.60	(1.15, 2.22)	<b>&lt;0.01</b>
Weight (10 kg)	Cardiac Traj	1.26	(1.07, 1.49)	<b>&lt;0.01</b>
	Neuro Traj	1.14	(1.02, 1.27)	<b>&lt;0.05</b>
	Mixed Traj	1.17	(1.00, 1.38)	0.05

Abbreviation: BV, bevacizumab; CI, confidence interval.

<sup>a</sup>Low AE trajectory group is the reference group for odds ratio.

<sup>b</sup>Bold type indicates statistical significant result.

### Figure legend

**Figure 1.** Randomization for original sample (A) and selection for subsample (B) for ECOG-ACRIN-5103. AC indicates intravenous doxorubicin and cyclophosphamide; B, bevacizumab; BAC, bevacizumab concurrent with intravenous doxorubicin and cyclophosphamide; BT, bevacizumab concurrent with paclitaxel; PROs, patient reported outcomes.

**Figure 2A.** Profiles of the AE states. Each bar indicates probability of having the specific AE and grade (1-2=low, 3-4=high). For AE indicators, reaction indicates reaction-related; GI, gastrointestinal; hemor, hemorrhage; metabol, metabolic; neuro, neuropathic; breath, breathing-related.

**Figure 2B.** Prevalence of AE states over eight cycles. The order for the states follow (from top to bottom) Low 2, Low 1, Neuropathic, Cardiac, and Mixed Reactions.

**Figure 3.** Percentages of treatment intolerability outcomes by AE trajectory groups. The four clusters of bar graph from left to right indicate incidence rate of AE per cycle, drug modification at any cycle, early treatment discontinued (Discont) due to any reason, and discontinued (Dicont) due to AE.

\* $p < 0.05$ , \*\* $p < 0.01$ , \*\*\* $p < 0.001$ ; for all pairwise comparisons with the Low AE Traj group

**Figure 4.** A schematic diagram summarizing significant relationships between bevacizumab exposure, the AE trajectory group, clinical outcomes, and PROs. Cardiac indicates the Cardiac Traj group; Neuro, Neuro Traj group; Mixed Reactions, Mixed Reactions Traj group, Low AE, Low AE Traj group. The thickest arrow indicates  $p < 0.001$ , medium arrow  $p < 0.01$ , and thin arrow  $p < 0.05$ . Cardiac Traj group  $\rightarrow$  Physical well-being domain has  $p = 0.054$ .

**A**

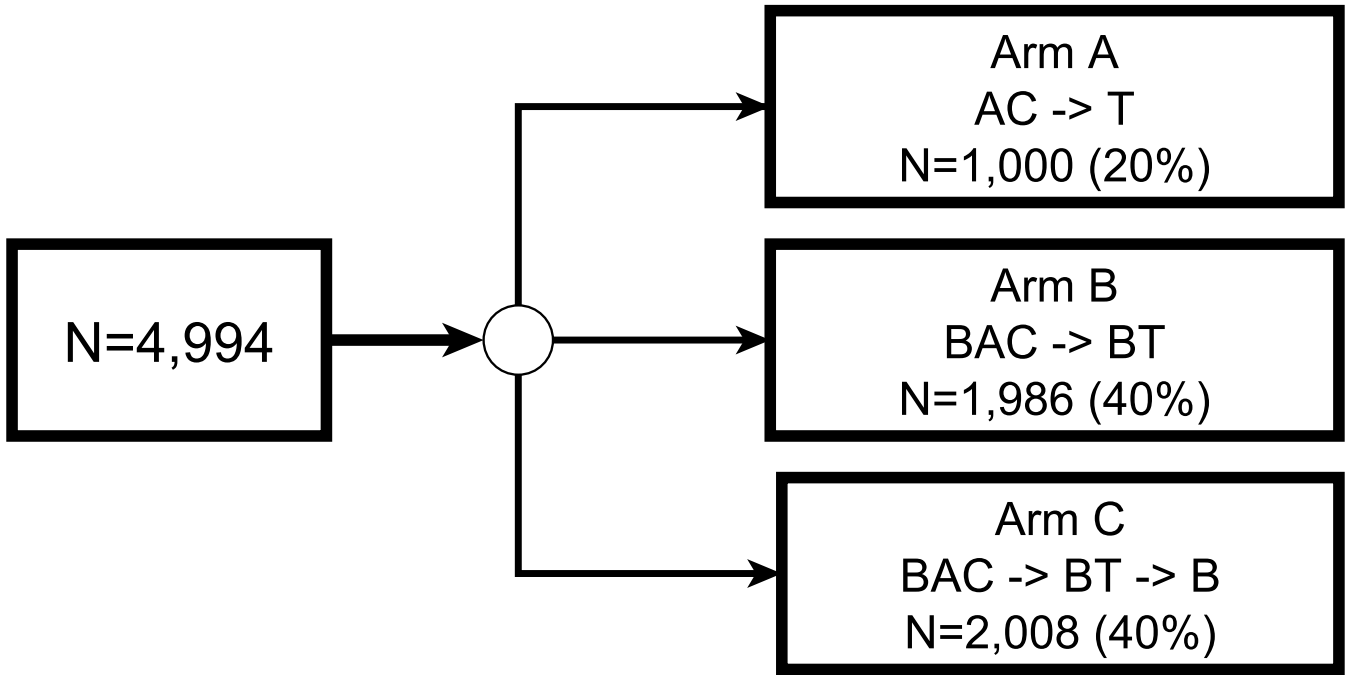

**B**

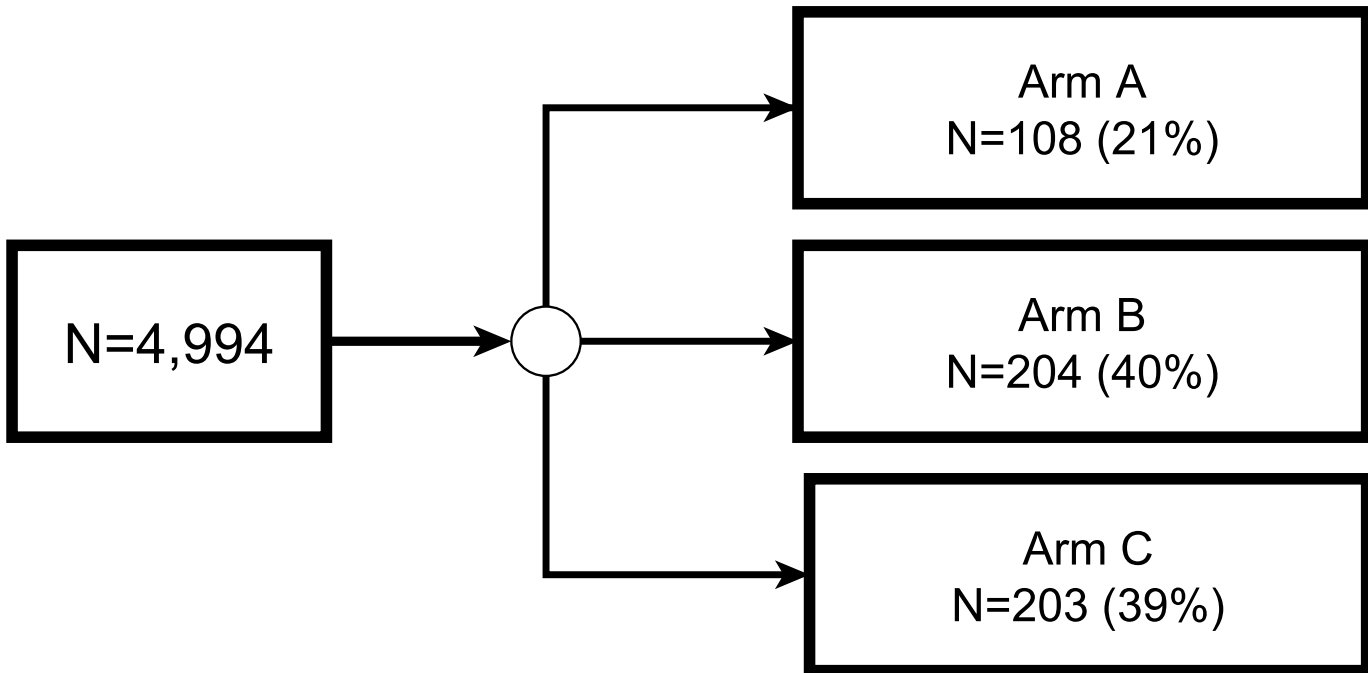

cncr\_33992\_f1.eps



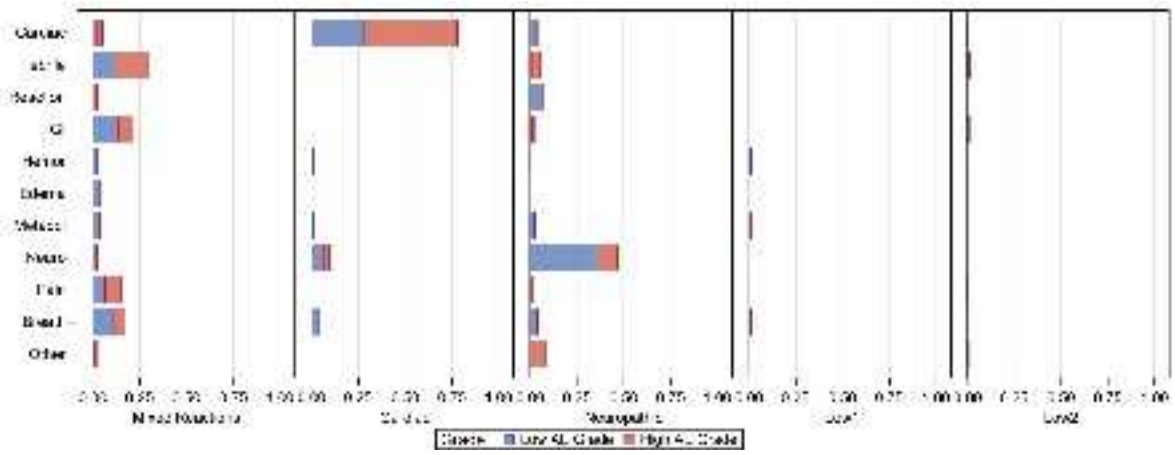

cncr\_33992\_f2a.tiff

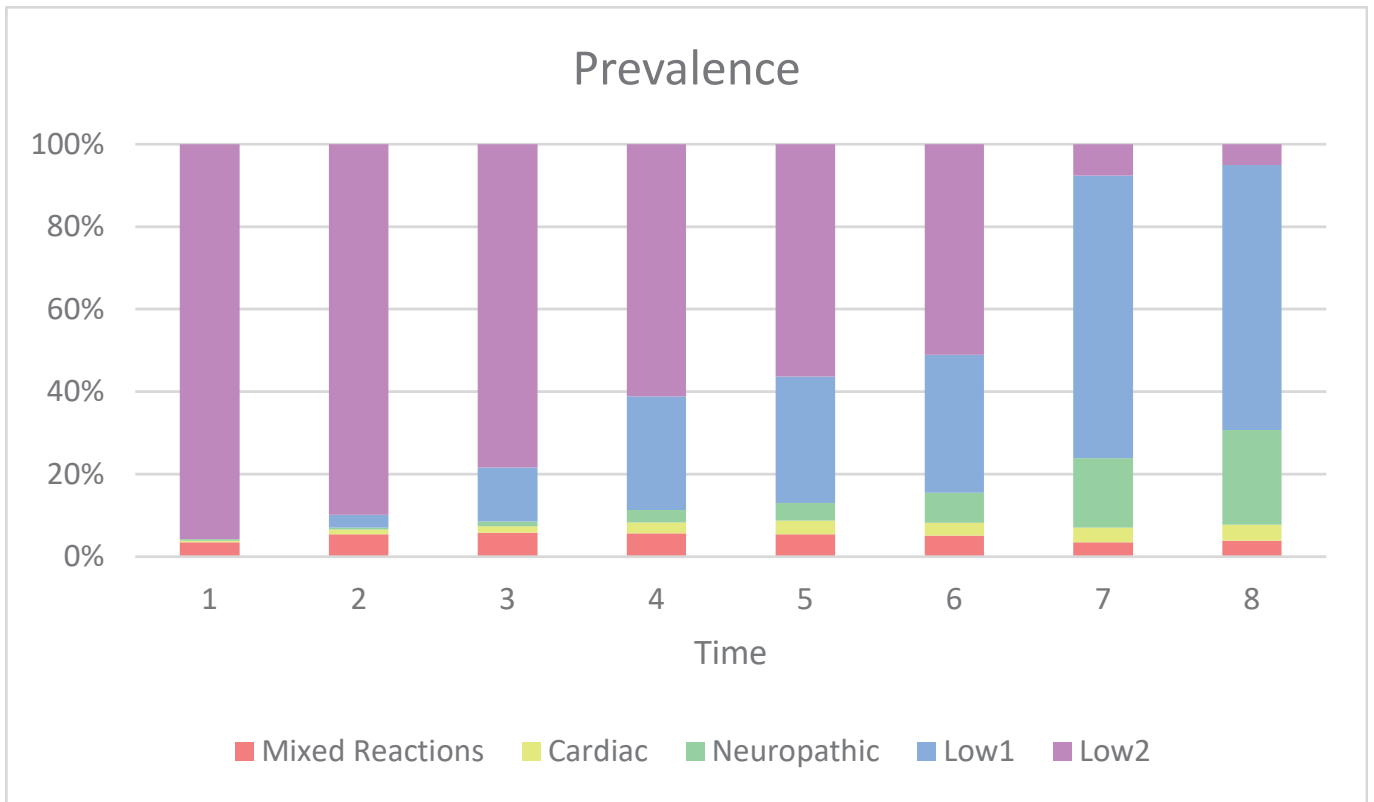

cncr\_33992\_f2b.eps

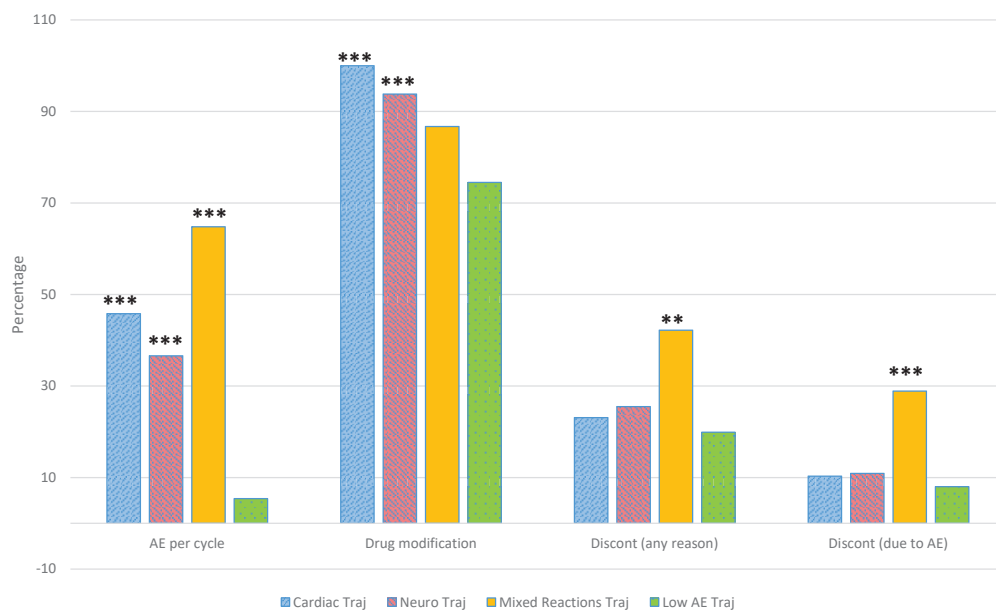

cncr\_33992\_f3.eps

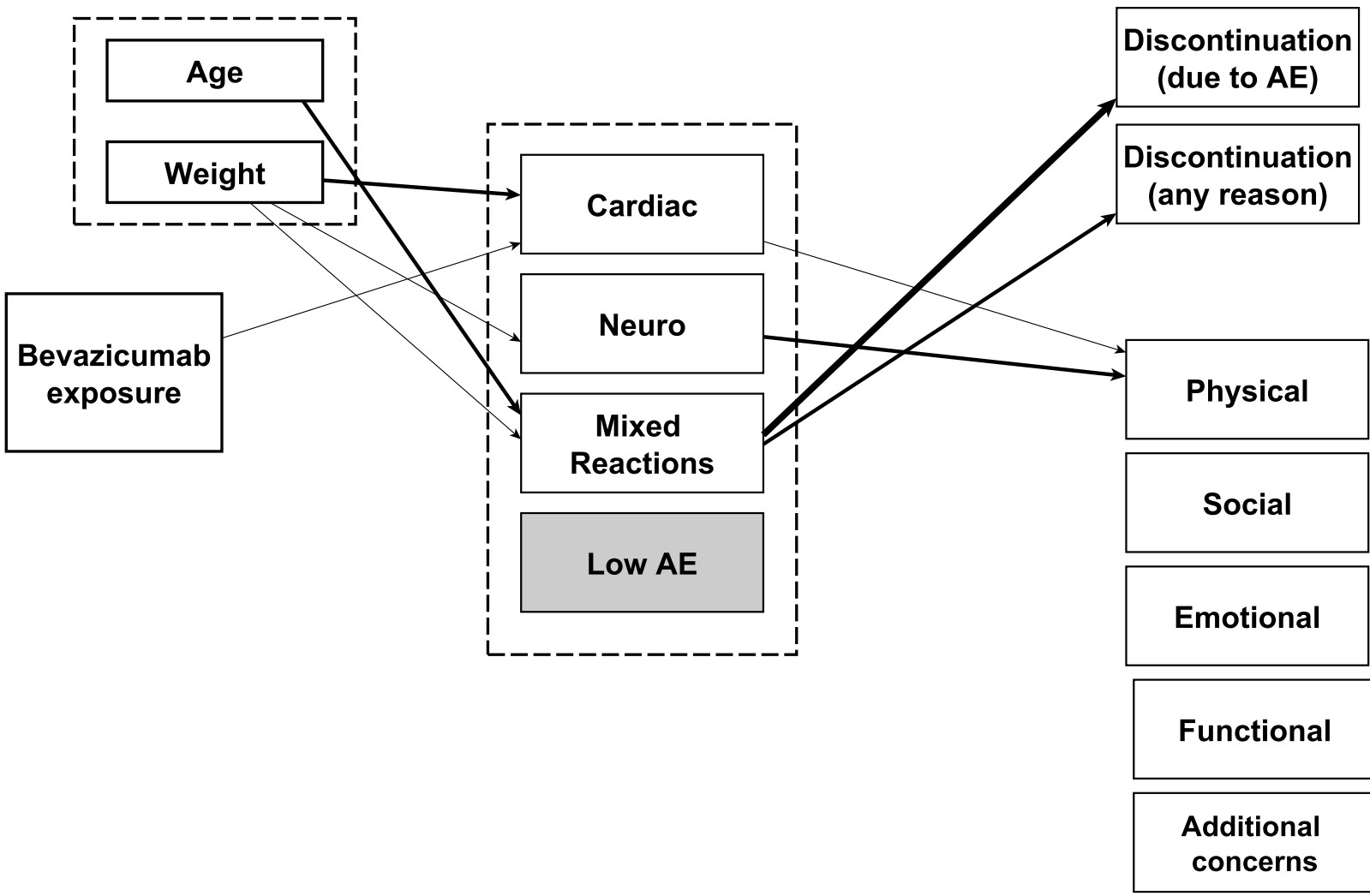

cncr\_33992\_f4.eps