

GAS-LIQUID MASS TRANSFER IN A MULTI-STAGE
PERFORATED-DISK TYPE STIRRING CASCADE

Wen-Jei Yang
Department of Mechanical Engineering
The University of Michigan, Ann Arbor, Michigan 48109

(Communicated by J.P. Hartnett and W.J. Minkowycz)

ABSTRACT

Experimental study is conducted to determine interphase mass transfer of a solute (carbon dioxide) in gas-liquid systems (air and water) in counter-current flow through a three-stage perforated-disk type stirring cascade. Test results over the entire cascade can be correlated as

$$\frac{NTU_f}{NTU_{f\infty}} = \frac{j_{Df}}{j_{Df\infty}} = 1 - \exp(-\dot{V}_g / \dot{V}_{g\infty})$$

wherein NTU , j_D and \dot{V}_g are the number of transfer unit, modified mass transfer factor and gas flow rate, respectively, based on the liquid phase (f). The subscript ∞ denotes an asymptotic value. The criterion corresponding to the state of overflow limit is determined by a certain value of the separation factor A (using the subscript $f1$ for overflow limit) beyond which the stirrer is flooded with the gas resulting in undesirable dispersion and high power requirement. Within the range of $A = A_{f1}$, the overall mass-transfer performance may be predicted by

$$NTU_f = j_{Df} Sc_f^{-2/3} = 1.03 \times 10^{-4} A^{0.6} Re_r^{0.449}$$

in which Sc_f is the liquid-phase Schmidt number and Re_r expresses the impeller (disk) Reynolds number.

Introduction

Mass transfer processes and chemical reaction in gas-liquid systems are usually conducted in stirred vessels. This apparatus is designed to achieve a certain optimal process condition when the gaseous phase is dispersed in the liquid. Three functions are performed in stirred vessels: 1. To change a continuous flow of the gas into a discontinuous one exhibiting in the form

of bubbles at prescribed size; 2. To homogeneously distribute the bubbles in the liquid; and 3. To set the liquid in motion all over the entire vessel space. The first two functions constitute the dispersion, while the third function is the stirring.

The technique for the gassing of liquids can be classified into the suction gassing using suction stirrers and the pressure (or forced) gassing by means of pressure stirrers.

The action of a suction stirrer is initiated by the low pressure which is developed in the liquid beyond the tip of rotating agitators. The gas is automatically transferred through a hollow drive shaft via hollow canals in the agitator into the liquid. This type stirrer is thus not suitable for high rate of gassing without elaborate construction. In pressure stirrers, the gas is injected into the liquid by pressure, most commonly through the stirrer bottom and most effectively along the stirrer axle. Turbines and propellers have been known to be the stirrers suitable for pressure gassing.

Recently, the perforated-disk stirrer has been found to be somewhat better than propellers and turbines as gas dispersion equipment [3]. While both the propeller and perforated-disk devices have the same order of magnitude of the gas holdups as well as the power requirements, the latter is advantageous in having a greater range of operating gas Reynolds number and a high amount of gas holdup, up to 20% which is considerably higher than that in other stirrers.

The power performance and gas holdup in a three-stage perforated-disk type stirring cascade in the absence of liquid flow and interphase mass transfer have been investigated by Brauer et al [4]. Experimental results have indicated a substantial power reduction that is associated with the presence of the gaseous phase. Yang [5] has offered exact explanation for the physical causes of the large power reduction.

This paper deals with interphase mass transfer between the gas and liquid phases in countercurrent flow in the mixing cascade (the same unit as reference 4). Carbon dioxide is selected as the solute. Experiments were conducted by Mosch [6, a diploma thesis supervised by Professors W.J. Yang and H. Brauer]. Test data are correlated in terms of dimensionless parameters which control the mixing and mass transfer phenomena. Experimental correlation equations are derived to predict the interphase mass transfer performance. A criterion indicating the flooding of the stirrer is found to be the operating limit of the equipment.

Experimental Apparatus and Measurements

The physical system is schematically illustrated in Fig. 1. It is a countercurrent-flow, perforated-disk stirrer system with three identical stages arranged in cascade. The vessel walls of each stage consist of one cylindrical and two cone-shaped elements. A drive shaft centered in the cylindrical vertical axis. In each stage, a perforated disk of 120 mm diameter is attached on the drive shaft at the center of the cylindrical vessel element. Eight circular holes of 18 mm diameter are drilled near the outer edge of the disk at a distance 91 mm from the center of the disk. The freely suspended shaft was held by a coupling and centered in the lower (third) stage by a waterproof ball bearing. The shaft was driven by a motor whose rotational speed may be varied in the range from 300 RPM to 1200 RPM using a tachogenerator and a resistance regulator. The rotational speed of the shaft was detected by a photo cell with the aid of a digital indicator.

The gas flow was regulated by a valve with the flow rate measured by a flowmeter. The gas pressure and temperature were measured by a pressure gage and a thermometer before it was introduced into a double shell. The gas was dispersed into the lower stage in a ring form with the aid of the double shell.

Carbon dioxide was used as the mass transfer medium in the study. Supplied from a carbon-dioxide tank, it was dissolved in the circulating water coming out from a heat exchanger which was used to regulate the water temperature in the system at a constant value, say 20 °C. The water saturated with dissolved carbon dioxide was forced by a pump to an overhead tank where the water head was maintained constant. The water then flowed down into the head tank through a flowmeter where the flow rate was measured. The water temperature was measured in the head tank by a thermometer. Four flow breakers were built in the connecting part between the head tank and the upper stage. Mass transfer of carbon dioxide from the water to the air in counter flow took place in the cascade. The air was dispersed in the water in the form of small bubbles in each stage through the action of the rotating perforated disk. The water returned to the pump through the heat exchanger after it left the cascade from the double shell. A valve regulated its flow rate. The concentrations of the dissolved carbon dioxide at the inlet and exit of the cascade were measured by a pH electrode with the aid of a pH meter and a recorder. Thus, the amount and consequently the rate of mass

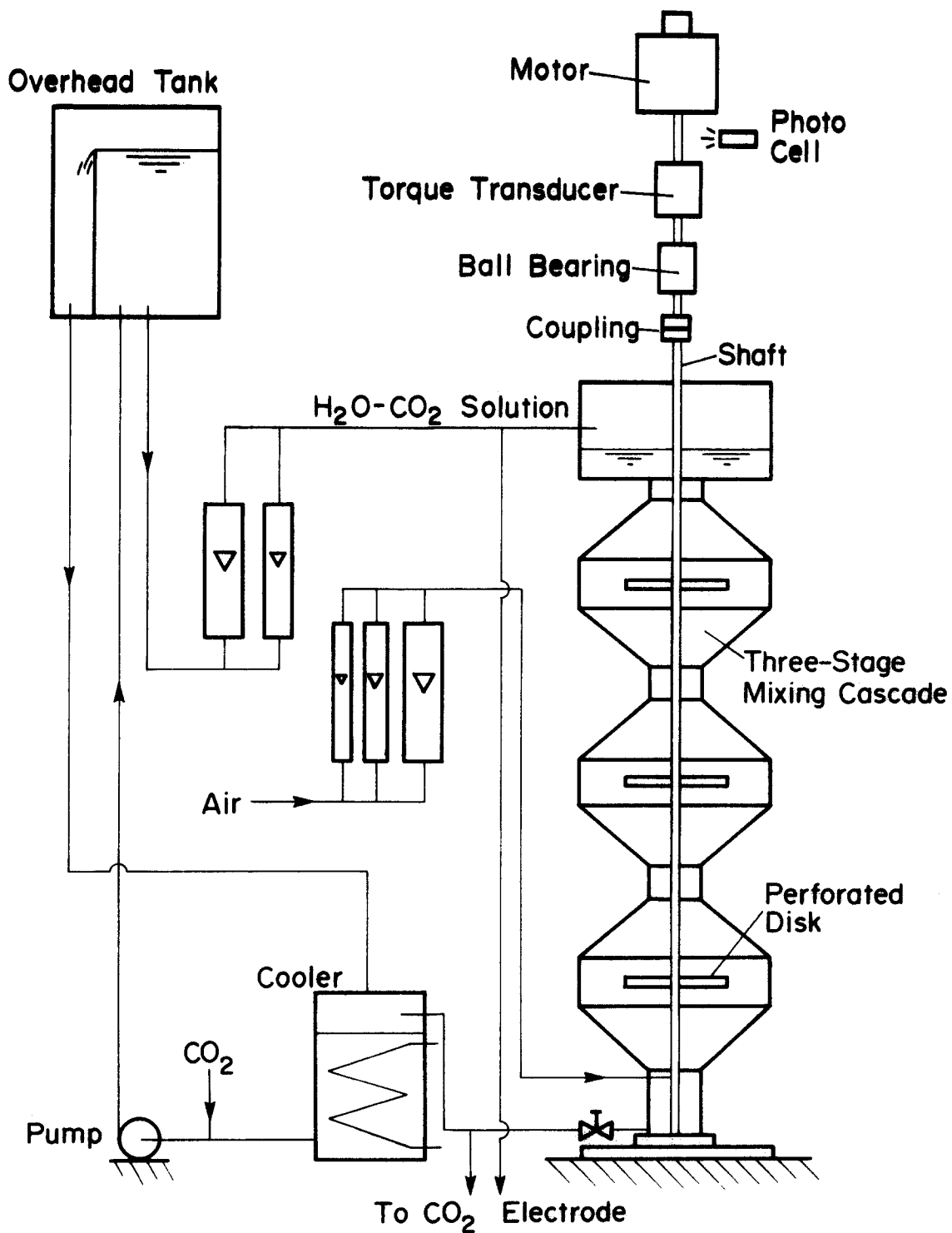

Fig. 1 Three-stage perforated-disk type stirring cascade for interphase mass transfer of carbon dioxide in air-water system

transfer of carbon dioxide from the water to air bubbles in the cascade were calculated, from which the mass transfer coefficient and its dimensionless form, the Sherwood number, were determined.

Data Correlations

Consider a stirrer wherein the gas and liquid phases to be contacted are brought together, resulting in mass transfer of a substance (solute) from one phase to the other. Such an operation is carried out with the fluids in continuous and countercurrent flow. The mixing involves dispersing the gas in the form of small bubbles (the dispersed phase) throughout the liquid (the continuous phase).

Let x and y be the mole fractions of solute in the continuous and dispersed phases, respectively. x^* and y^* indicate the values of x and y in equilibrium with y and x , respectively. Under the assumption of linear x - y , x^* - y and x - y^* relationships, the applications of the two-film theory (for the rate equations), the material balance, the equilibrium relationship (Henry's and distribution laws), and the boundary conditions for counter-flow operation yield the expression for the number of transfer unit based on the liquid side as

$$NTU_f = \frac{1}{1 - (1/A)} \ln \left[\frac{1 - (E_x/A)}{1 - A} \right] \quad (1)$$

wherein

$$NTU_f = K_f \frac{aV}{\dot{V}_f} = \int_2^1 \frac{dx}{x - x^*} \quad (2a)$$

$$A = \text{separation factor} = \frac{H\dot{V}_g}{P\dot{V}_f} \quad (2b)$$

$$E_x = \text{mass transfer efficiency} = \frac{x_1 - x_2}{x_1 - x_2^*} \quad (2c)$$

Here, K_f denotes the overall mass transfer coefficient in the unit of velocity; a , interfacial area per unit volume of mixed phases; V , total volume of the device occupied by phases x and y ; H , the Henry's constant; P , total pressure in gas mixture; \dot{V} , volumetric flow rate; subscripts 1 and 2, respectively at the inlet and exit locations of the continuous phase; and the subscripts f and g ; the continuous and dispersed phases, respectively. Derivation of equation (1) is available in all standard textbooks on interphase mass transfer. Since both \dot{V}_g and \dot{V}_f cannot be zero for interphase mass transfer to take place steadily in a gas-liquid system, A must be non-zero and finite.

For high solubility of solute such as carbon dioxide in water or very low molar flow rate of the continuous phase, the separation factor A will take a large value and equation (1) may be approximated as

$$NTU_f \cong -\ln(1 - E_x) = \ln(x_1/x_2) \quad (3)$$

Under these conditions, the driving force in the y phase is large compared with that in the x phase which therefore imposes the major resistance to mass transfer. That is, the interphase mass transfer process is controlled by the liquid side. The overall mass transfer coefficient K_f is approximately equal to the liquid-film mass transfer coefficient k_f :

$$K_f \cong k_f \quad (4)$$

In batch operation, the mass transfer factor is defined as

$$j_{Df} = (k_f/v_f)Sc_f^{2/3} \quad (5)$$

in which v_f and Sc_f are the flow velocity and Schmidt number of the liquid phase, respectively. However, for application to continuous operation in a stirrer cascade, it is proposed that the definition of j_{Df} be modified to read

$$j_{Df} = (K_f a V / \dot{V}_f) Sc_f^{2/3} \quad (6a)$$

Then, according to the definition of NTU_f , one gets

$$j_{Df} = NTU_f Sc_f^{2/3} \quad (6b)$$

Test data for mass transfer of carbon dioxide from the liquid to gas phases are first correlated in terms of dimensionless mass transfer conductance C_f and gas flow rate \dot{V}_g in Fig. 2, where C_f is defined as $K_f a V$ in m^3/s . Both $C_{f\infty}$ and $\dot{V}_{g\infty}$ are determined from a plot of C_f versus \dot{V}_g in which C_f approaches asymptotically a finite value $C_{f\infty}$ as the value of \dot{V}_g increases. $\dot{V}_{g\infty}$ is determined as the value of \dot{V}_g at which C_f reaches 63.2 percent of $C_{f\infty}$. By the definition of NTU_f , the ratios of $C_f/C_{f\infty}$, $NTU_f/NTU_{f\infty}$ and $j_{Df}/j_{Df\infty}$ are equal:

$$\frac{C_f}{C_{f\infty}} = \frac{NTU_f}{NTU_{f\infty}} = \frac{j_{Df}}{j_{Df\infty}} \quad (7)$$

in which $NTU_{f\infty}$ is defined as $C_{f\infty}/V_f$. It is shown in Fig. 2 that all test data fall within $\pm 15\%$ of the negative exponential line

$$\frac{C_f}{C_{f\infty}} = 1 - \exp\left(-\frac{\dot{V}_g}{\dot{V}_{g\infty}}\right) \quad (8)$$

irrespective of nature of the two-phase boundary-layer flow over the rotating perforated disks and the liquid flow rate. This means that interphase mass transfer in gas-liquid systems may be enhanced by increasing the rate of the gas phase to be dispersed in the liquid phase but only to a certain extent:

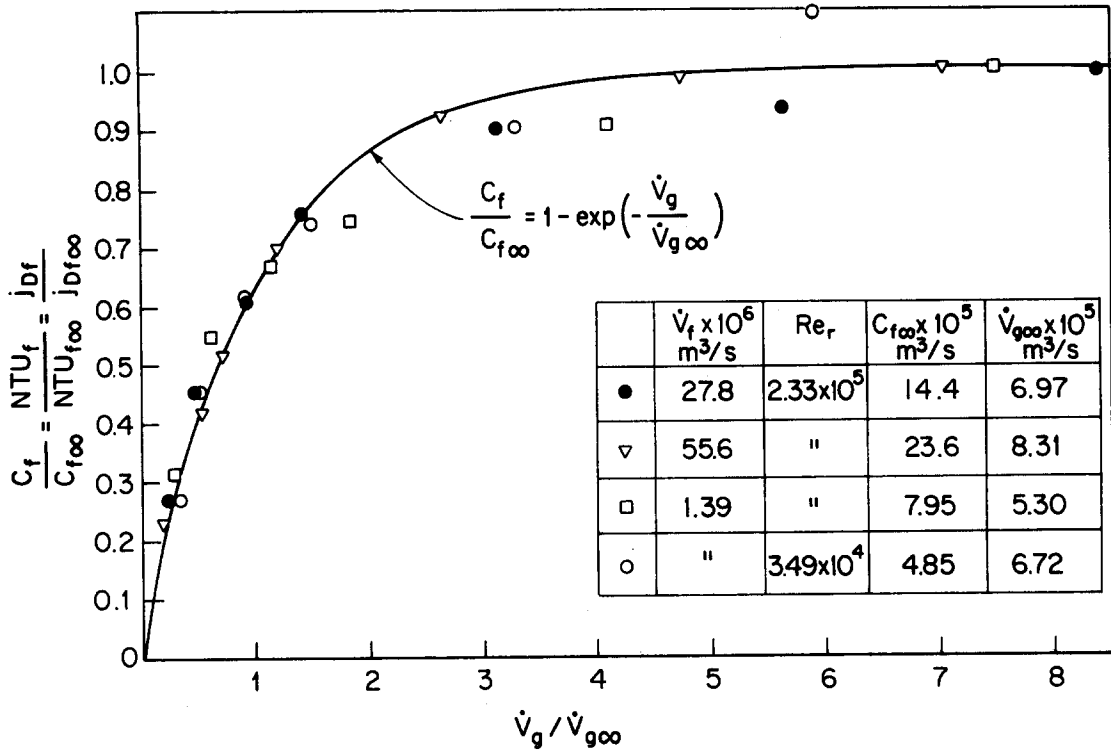

Fig. 2 Data correlation in terms of NTU and gas flow rate

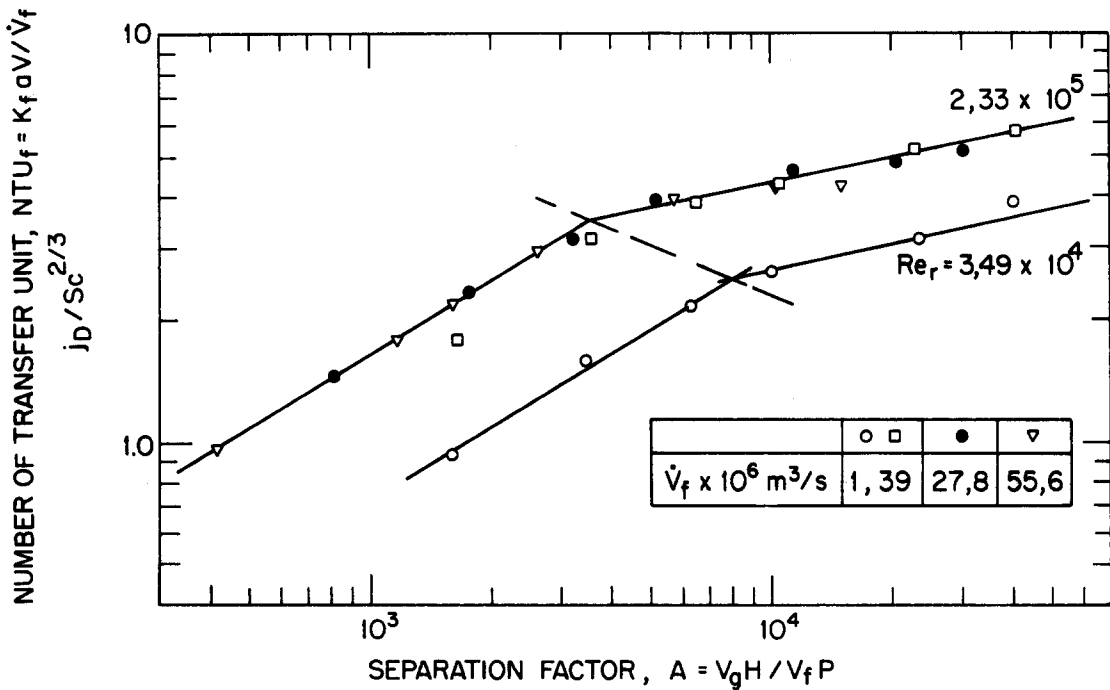

Fig. 3 Mass transfer performance of carbon dioxide in air-water system in countercurrent flow through three-stage perforated-disk type stirring cascade

There is a critical value of \dot{V}_g beyond which a further increase in \dot{V}_g becomes less effective in mass transfer enhancement. The critical value may be taken as \dot{V}_g based on the concept of a first-order system which can be described by equation (8).

The test data are correlated in Fig. 3 as NTU_f versus the separation factor A with the stirrer Reynolds number Re_r as parameter. It is observed that there is a change in the slope of the line correlating the experimental data at certain values of the separation factor, denoted as A_{f1} . The reason for the change in slope is that there exists a maximum gas flow rate, called the overflow limit (corresponding to A_{f1} in dimensionless form), beyond which the disk is flooded by the gas resulting in undesirable gas dispersion. The occurrence of disk flooding marks the end of power reduction or the beginning of power increase with a further increase in the gas flow rate, i.e. Re_g . In the absence of interphase mass transfer and liquid flow, the overflow limit is found to occur at the gas Reynolds number Re_g from 70 to 150 and the gas hold-up V_g/V of about 20% when the stirrer Reynolds number Re_r is between 1.34×10^5 and 3.42×10^5 [4]. V_g denotes the volume occupied by the gas phase in the cascade, while Re_g and Re_r are defined as $V_g/(\pi d_r \nu_g)$ and nd_r^2/ν_f , respectively, where ν_g and ν_f are respectively the gas and liquid kinematic viscosities, d_r indicates the disk diameter and n is the number of disk revolution per unit time. The empirical correlation equations are found for all the test data represented by the straight lines in Fig. 3 as

$$NTU_f = 1.03 \times 10^{-4} A^{0.6} Re_r^{0.449} \quad \text{for } A \leq A_{f1} \quad (9a)$$

$$NTU_f = 1.68 \times 10^{-2} A^{0.2} Re_r^{0.303} \quad \text{for } A \geq A_{f1} \quad (9b)$$

The operation of the equipment in the $A = A_{f1}$ range is undesirable as it would be plagued by an increase in power requirements [5]. The criterion $A = A_{f1}$ for equation (9a) can be rewritten as

$$\dot{V}_g / \dot{V}_f \leq A_{f1}^{P/H} \quad (10)$$

which specifies the limitation on \dot{V}_g / \dot{V}_f for effective operation. It is deduced from the figure that A_{f1} may be increased by either reducing Re_r or increasing \dot{V}_f .

Conclusions

Overall mass transfer performance of carbon dioxide in the counter-current air-water system in a three-stage perforated-disk type stirring cascade can be predicted by equations (8) and (9). The criterion for effective

mass transfer performance is found to be in the range of $A \leq A_{f1}$ beyond which the stirrer would be flooded with the gas resulting in undesirable dispersion and power requirement increase. If the equilibrium and operating relationships are linear mass transfer performance in each mixing stage may be determined using its relationship with the overall performance of the cascade available in analytical form [7].

Acknowledgment

The study was conducted at Institut für Chemieingenieurtechnik of Technische Universität Berlin while the author was associated with it as an exchange professor from the University of Michigan. The author wishes to express his gratitude toward the institute director, Professor-Dr. H. Brauer for his hospitality and valuable suggestions on the subject.

References

1. V.W. Uhl and J.B. Fray (Eds.), Mixing, Theory and Practice, Volumes I and II, Academic Press, New York (1966).
2. F.A. Holland and F.S. Chapman, Liquid Mixing and Processing in Stirred Tanks, Reinhold Publishing Co., New York (1966).
3. H. Glaeser, B. Biesecker and H. Brauer, Verfahrenstechnik, 7, 31 (1973).
4. H. Brauer, H. Schmidt-Traub and H. Thiele, Chemie Ingenieur Technik, 18, 699 (1974).
5. Wen-Jei Yang, "Mechanism of Power Dissipation in Liquid-Gas Mixing in a Perforated-Disk Type Stirring Cascade," Manuscript in preparation (1976).
6. J. Mosch, "Experimentelle Untersuchung des flüssigkeitsseitig kontrollierten Stoffübergangs in einer mehrstufigen Ruhrkaskade," Studienarbeit Matr.-Nr. 41449, Institut für Chemieingenieurtechnik, Technische Universität Berlin (1976).
7. T.K. Sherwood and R.L. Pigford, Absorption and Extraction, McGraw-Hill Book Co., New York (1952).