

An adiabatic calorimeter for use at superambient temperatures. The heat capacity of synthetic sapphire (α -Al₂O₃) from 300 to 550 K^a

JOHN T. S. ANDREWS, PAUL A. NORTON,

Liquid Crystal Institute, Kent State University, Kent, Ohio 44242, U.S.A.

and

EDGAR F. WESTRUM, JR.

Department of Chemistry, University of Michigan, Ann Arbor, Michigan 48109, U.S.A.

(Received 25 July 1977; in revised form 9 January 1978)

We report the construction of a superambient temperature adiabatic heat-capacity calorimeter which has been successfully operated from 300 to 550 K. We detail results on the heat capacity of a portion of the Calorimetry Conference sample for α -Al₂O₃. These results are compared with those of other investigators.

1. Introduction

Although adiabatic calorimetry has been practiced from below 1 K to temperatures approaching the limits imposed by materials themselves, the temperature range immediately above ambient temperatures has been relatively neglected. In part, this is due to the difficulty of ensuring good thermal contact between heater, thermometer, and calorimeter in an apparatus where a thermally conductive grease cannot be used, and in part to the increased precision required to maintain adequate adiabatic-shield control in a region where radiative energy transfer becomes more important. Hence, most of the measurements in this temperature range have been obtained by drop calorimetry, a procedure which can lead to relatively large errors when phase transformations intervene (because of the probability of quenching a metastable state). Moreover, differentiation of the resulting enthalpy increments does not yield accurate heat-capacity values.

Chemical thermodynamicists with interests in measuring transition or fusion processes above 300 K have developed adiabatic apparatuses capable of operating in this region.⁽¹⁻⁵⁾ The apparatus described here was designed to have an experimental

^a This research was supported in part at the University of Michigan by the Chemical Thermodynamics Program of the Chemistry Section of the National Science Foundation under Contract No. GP-42525X, and at Kent State University by the Air Force Office of Scientific Research Project No. F 44620-69-C-0021 and by the National Science Foundation Contract No. GH-34164X.

precision of better than 0.1 per cent over the range 300 to 550 K and to be operated by one person with ease, either in manual or in automatic modes. Upper limits on the temperature range are occasioned by the electrical conductivity of the glass seal on the thermometer and the enamel used to bond the windings to the shields. In this paper we describe the features of the calorimeter and vacuum thermostat, the measurement and control circuitry, and the data-acquisition system. High thermal diffusivity was sought for all calorimetric components to facilitate as strict maintenance of adiabatic conditions as possible. Where necessary, refractory sample containers (e.g. pyrex, vitreous silica) may be utilized.⁽³⁾ We sought to provide ready interchange of samples and convenience in operation. We also discuss the performance of the system as revealed by measurements made on the Calorimetry Conference sample of synthetic sapphire.

2. Apparatus

SILVER CALORIMETER

The silver calorimeter is illustrated in figure 1. It is similar to one presented previously,⁽⁴⁾ tersely described elsewhere,⁽¹⁾ and uses similar devices for sealing the calorimeter and for contacting the thermometer and heater with the calorimeter. With the exception of the closure, the calorimeter is machined entirely from two billets of fine silver rod. The first was bored out and machined to make the top and the cylindrical portion of the outer can (wall thickness 0.5 mm), while the second billet was machined to form the bottom, the entrant well, and the six vertical vanes integral with the well. These vanes taper from 0.50 to 0.25 mm in thickness radially and promote thermal equilibration.

The external taper of the (thermometer + heater) assembly illustrated in figure 2 is firmly contacted to the matching taper of the entrant calorimeter well. A special socket wrench facilitates assembly and disassembly. (There is no need for disconnection of any lead wires). The platinum-enclosed platinum resistance thermometer (Leeds and Northrup Co., no. 8164, 25-ohm, capsule-type) is held by a beryllium-copper collet which screws into the internal taper of the silver heater sleeve, D, to provide good thermal contact. An electrical heater (270 Ω , 0.1 mm diameter, double-fiberglass-insulated Karma wire) is wound in a bifilar groove machined on the outer tapered surface of the heater sleeve. Advancing the thermometer collet F into the tapered heater sleeve causes the thermometer G to be firmly clamped into place. The copper heater leads, silver-alloy brazed to the Karma resistance wire, are brought into thermal contact with the heater sleeve and both sets of leads were brought to the calorimeter surface temperature by enameling them around a silver spool C. Both GE 7031 varnish and Formvar enamel have been employed.

The spool is attached to the calorimeter proper with six screws. The calorimeter is suspended from the top of the adiabatic shield by means of a length of 0.2 mm diameter Constantan wire fastened by a screw bushing.

The calorimeter is sealed by a gold-gasketed knife-edged screw-closure device.⁽¹⁾ A threaded Monel-metal fitting is attached to the top of the calorimeter, and is equipped with a hexagon-shaped base and a finely polished knife edge.⁽⁴⁾ A stainless-

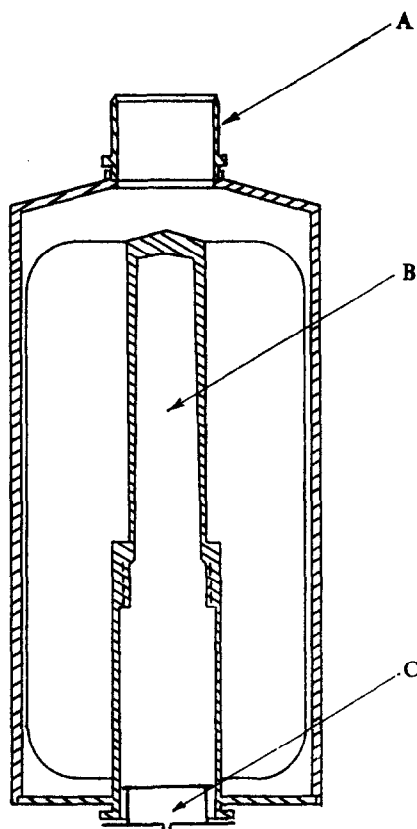

FIGURE 1. Cross-sectional view of silver calorimeter and spool. A, the knife-edged screw closure for sealing the sample space; B, the (thermometer heater) well; C, the spool for tempering the lead wires.

steel cap, also provided with a hexagonal section, screws down over the fitting forcing an annealed gold gasket on to the circular edge. The seal is made by mounting the assembled calorimeter in a jig which securely grips the hexagonal Monel fitting within a small portable vacuum enclosure. Another wrench-like fitting engages the cap, and may be turned by means of a shaft emerging from the enclosure through an O-ring shaft seal. After evacuation of the loading chamber and addition of the desired pressure of helium gas to improve thermal diffusivity, the seal is closed and may be tested with a helium-leak detector.

ANEROID THERMOSTAT

The adiabatic thermostat is illustrated in figure 3 and is an improvement on the Mark IV intermediate-temperature apparatus constructed at the University of Michigan.^(4,5) The special features of the apparatus include three unheated shields and the means of their suspension. These "floating" shields J are of chromium-plated copper and serve to establish uniform temperature zones between the calorimeter

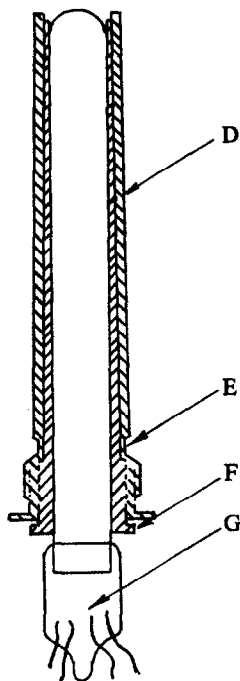

FIGURE 2. (Heater thermometer) assembly. D, the silver heater sleeve with lead tie-down E; F, the beryllium-copper thermometer collet; G, the platinum-encased platinum resistance thermometer.

and the laboratory. These shields significantly limit the energy loss to the environment; even at 550 K, less than 20 W will maintain the temperature of the apparatus, without a surrounding furnace. The apparatus is remarkably rigid, because stainless-steel tubes with conduction minimized by staggered radial holes serve to suspend the top plates of the shields one from the other. The tops of the three floating shields and guard shield are also equipped with spools around which the leads *I* are tempered.

Inside the three floating shields lie the guard shield, K, the adiabatic shield, L, and the calorimeter assembly, M. The guard shield is also rigidly mounted beneath the top of the innermost floating shield by three stainless-steel tubes. It is equipped with two heaters, the more important of which ($500\ \Omega$) is apportioned between the top, bottom, and middle of the guard shield in proportion to the masses of these parts. A second auxiliary heater ($80\ \Omega$) is wound around the middle portion of the shield, and is used only above 500 K. Both heaters are connected to the leads by small demountable pins attached to but insulated from the top of the guard shield, so that removal of the lower part of the guard shield is simplified.

The adiabatic shield is also of chromium-plated copper, and is suspended from the top of the guard shield by three steel wires. The electrical leads pass down the adiabatic shield in a spiral groove, and are thereby tempered. The three parts of the adiabatic shield are equipped with separate heaters and thermocouple anchors, and the top and side are designed to remain undisturbed; the bottom is removed to install the calorimeter.

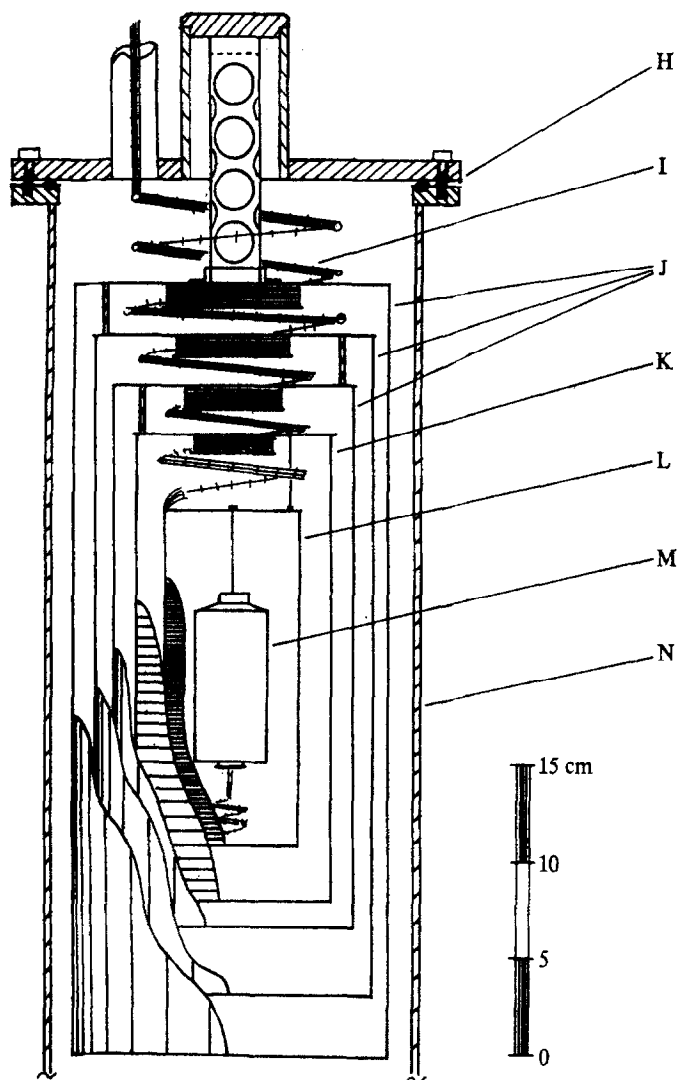

FIGURE 3. Cross-sectional diagram of intermediate-temperature adiabatic calorimetric thermostat. H, the evacuated tank; I, the lead bundle; J, (three) floating guard shields (with tie-down spools for the leads); K, the guard shield; L, the adiabatic shield; M, the calorimeter assembly; N, the vacuum can.

TEMPERATURE MEASUREMENT

The resistance of the platinum thermometer is compared with that of a standard resistor by means of an automatic a.c. resistance bridge (Automatic Systems Laboratories model A7). We use an ESI, Inc. $10\ \Omega$ card resistor as a standard, mounted in a Guildline (model 8000) air thermostat. Since the bridge operates at 390 Hz, thermal e.m.f.'s developed in the thermometer circuit may be ignored; however, the question of the validity of d.c. calibrations under a.c. conditions occurs. We determined the ratio of the thermometer resistance at the triple point of water to that of the standard resistor (in the thermostat) for both d.c. (using a Leeds and Northrup K-5 potentiometer) and a.c. (using the A7 bridge) and found no difference within the precision of our measurements. We conclude, then, that the transfer ratios of the thermometer and the ESI standard resistor are unity to within a few parts in 10^5 , leading to an uncertainty of about $10^{-4}\ \Omega$ or $10^{-3}\ \text{K}$. (We found that the transfer ratio of a Leeds and Northrup standard resistor is unity only to within a few parts in 10^4 , with corresponding temperature uncertainty of $10^{-2}\ \text{K}$.)

For measurements of the highest precision the effect of the (relatively) low input impedance of the bridge must be considered. The bridge indicates the ratio:

$$R_t/R_s = \{n/(1-n)\}[1 + (z_1/nZ) - \{z_2/(1-n)Z\}], \quad (1)$$

where Z is the bridge input impedance, z_1 the resistance of one of the thermometer leads, z_2 the resistance of one of the standard resistor leads, n the measured indicated ratio, R_t the thermometer resistance, and R_s the standard resistance. These values are needed for measurements of the highest precision: Z may be determined from measurements in which known lead resistances are used; z_1 is determined routinely by deliberately halving the bridge input resistance; z_2 is determined separately.

Although the seven-decade bridge output is available as binary-coded decimal digits, the instrument has been found to be so stable that an eighth decade may be interpolated from the reading of the residual meter on the instrument. With a $25\ \Omega$ thermometer and a $10\ \Omega$ standard, the experimental resolution of the measurement system is $10^{-6}\ \Omega$ or $10^{-5}\ \text{K}$. The stability of the system is such as to make this resolution significant for time periods comparable to the length of the temperature drifts. The circuit is illustrated in figure 4.

ENERGY MEASUREMENT

The power supplied to the calorimeter heater is determined by observation of the potential drop across the heater and the $10\ \Omega$ standard resistor connected in series with the heater (compare figure 4). A d.p.d.t. knife switch H is used to connect a Hewlett Packard differential voltmeter, Model no. HP 3420B, G, alternatively from one to the other. The current is supplied by a Guildline constant-current power supply, Model no. 9770B, D, and is so stable that the standard resistance potential need be determined only infrequently.

The current is switched from the calorimeter heater 3 to a dummy heater 4 (which is still advantageous even when batteries are replaced by modern constant-current supplies especially one in which mechanical optical feedback is employed) by means of a second d.p.d.t. switch E, the second pole of which controls an electric stop

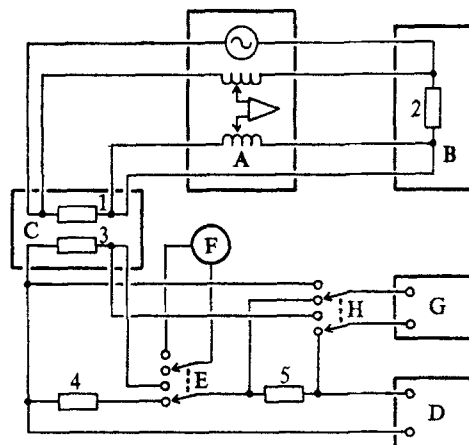

FIGURE 4. Temperature- and energy-measurement circuits. A, the ASL A7 a.c. bridge; B, the Guildline constant-temperature air bath; C, the (thermometer heater) assembly; D, the Guildline constant-current power supply; E, the drift/energy switch; F, the electric stop clock; G, the Hewlett Packard differential voltmeter; H, the heater current/potential selector switch. 1, the platinum resistance thermometer; 2, the standard $10\ \Omega$ thermometer-comparison resistor; 3, the heater; 4, the substitute heater; 5, the standard resistor for measuring heater current.

clock F, so as to determine the duration of energy additions. The potential leads are attached to the calorimeter heater in the manner indicated in figure 4, one being connected to a current lead at the calorimeter, and the other being connected at the adiabatic shield.

SHIELD CONTROL CIRCUITS

Four similar feedback circuits (one of which is illustrated in figure 5) are used to control the temperature of the guard shield and of the three sections of the adiabatic shield. For each "channel" a copper-to-Constantan thermocouple is mounted so as to measure the difference in temperature between the controlled surface and a reference surface. For the middle (cylindrical portion) of the adiabatic shield the reference surface is the calorimeter itself, but for the three other channels the reference

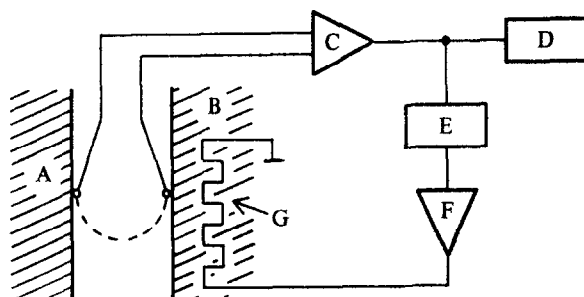

FIGURE 5. Adiabatic-shield-control circuitry. A, the calorimeter; B, the adiabatic shield; C, a Keithley microvolt amplifier; D, a recorder; E, a Leeds and Northrup CAT-80 three-action controller; F, a power amplifier; G, the shield heater.

surface is the middle of the adiabatic shield. The signals developed by the thermocouples, being minute analogs of the temperature differences, are greatly amplified using Keithley 150B microvolt-ammeters the high-level outputs of which are directly connected to Leeds and Northrup CAT Model 80 controllers. The Keithley amplifier also includes a zero-offset capability which is used for "bucking" adventitious e.m.f.'s in the thermocouples and facilitating the attainment of zero-drift conditions. The controllers compute the desired power needed by the controlled surface from proportional, rate, and reset terms, and control programmable power supplies (Kepco, model PCX-MAT) which heat the surfaces. A fifth Kepco power supply is manually programmed to supply the auxiliary heater of the guard shield. A three-channel potentiometric recorder (Leeds and Northrup, Speedomax M) is used to record simultaneously any three of the four channels. D.c. control of shield heaters is essential for this apparatus so as to prevent the introduction of spurious a.c. signals into the thermometric circuits and (possibly) saturate the bridge input.

DATA ACQUISITION SYSTEM

We use a Hewlett-Packard coupler-controller to record the readings of the A7 bridge as a function of time. A quartz-crystal clock initiates the readings, and a record of time and reading are obtained on a teletype.

The differential voltmeter is being replaced by a digital voltmeter under the control of a PDP-11V03 micro-computer which will enable automatic acquisition of data and calculation of the experimental heat capacities.

3. Experimental procedures

Exploitation of this apparatus is very similar to the details in reference 6 for cryogenic adiabatic calorimetry. We are especially careful to allow the calorimeter and contents to reach thermal equilibrium after each energy increment. This occurs within 30 to 45 min after the input, but may take as long as several days if the sample in the calorimeter is undergoing a transition process. Under these conditions, the data-acquisition system is of especial utility in the monitoring of the equilibration process.

The equipment, moreover, provides a convenient way of ascertaining on cooling, the temperature at which the kinetics of conversion to phases stable at lower temperatures are most favorable. Moreover, the drift itself can be used as an indication as to whether the conversion is complete. Obviously, the drift provides a diagnostic tool for the occurrence of chemical reactions such as the decomposition of the sample or reaction between the calorimeter and the sample itself.

4. Results and Discussion

THE HEAT CAPACITY OF SYNTHETIC SAPPHIRE

We have tested the calorimetric apparatus by measuring the heat capacity of a portion of the Calorimetry Conference sample of $\alpha\text{-Al}_2\text{O}_3$.⁽⁷⁾ The sample had a mass of 66.270 g and the calorimeter also contained 1.42 mg of helium to enhance thermal equilibration. The results were corrected for curvature, and also for the (small)

differences in the masses of helium and gold in the calorimeter when the measurements with $\alpha\text{-Al}_2\text{O}_3$ were made, and when the heat-capacity measurements of the empty calorimeter were made. The experimental points given in table 1 are given in chrono-

TABLE 1. Experimental heat capacity of $\alpha\text{-Al}_2\text{O}_3$
 [$M(\text{Al}_2\text{O}_3) = 101.96 \text{ g mol}^{-1}$]

$\frac{T}{\text{K}}$	$\frac{C_p}{\text{J K}^{-1} \text{ mol}^{-1}}$	$\frac{T}{\text{K}}$	$\frac{C_p}{\text{J K}^{-1} \text{ mol}^{-1}}$	$\frac{T}{\text{K}}$	$\frac{C_p}{\text{J K}^{-1} \text{ mol}^{-1}}$	$\frac{T}{\text{K}}$	$\frac{C_p}{\text{J K}^{-1} \text{ mol}^{-1}}$
Series I		340.11	87.27	514.35	107.23	398.82	96.07
306.34	80.80	347.88	88.61	521.89	107.69	406.51	97.05
311.70	81.84	355.54	89.82	529.41	108.18	414.16	97.92
318.51	83.29	363.13	91.07	536.90	108.64	421.75	98.81
326.13	84.73	370.67	92.12	542.95	109.03	429.30	99.63
334.01	86.17	378.35	93.26	547.60	109.38	436.80	100.42
341.80	87.48	386.20	94.35			443.56	101.20
349.36	88.83	393.99	95.42	Series III		450.98	101.84
357.01	90.01	401.65	96.42	300.27	79.53	458.59	102.56
364.59	91.20	409.33	97.35	307.75	81.08	466.37	103.33
372.10	92.35	416.96	98.25	315.14	82.65	474.11	104.03
379.78	93.42	424.55	99.07	322.46	84.05	481.81	104.71
387.62	94.49	432.09	99.93	329.70	85.40	489.48	105.33
395.40	95.58	439.58	100.73	337.20	86.75	497.11	105.96
403.12	96.54	447.02	101.50	344.96	88.12	504.71	106.44
410.79	97.50	454.44	102.19	352.65	89.36	512.28	107.01
		460.91	102.84	360.27	90.56	519.82	107.68
Series II		483.89	104.89	367.82	91.71	527.44	108.19
312.80	82.14	491.56	105.50	375.53	92.87	535.13	108.73
319.06	83.45	499.19	106.10	383.39	94.00	542.79	109.19
325.25	84.64	506.78	106.70	391.07	95.03	548.29	109.62
332.27	85.93						

logical sequence; the temperature increments used in the measurements may usually be inferred from adjacent mean temperatures. All measurements are made at essentially the same heating rate (0.8 K min^{-1}). The results are illustrated as a difference plot in figure 6. The overall precision may be gauged from the deviations of the points from a fourth-degree polynomial:

$$C_p/\text{J K}^{-1} \text{ mol}^{-1} = 99.155455 + 14.504616X - 4.7789644X^2 + 1.2469744X^3 - 0.2381150X^4, \quad (2)$$

in which $X = \{(T/\text{K}) - 425.0\}/130.0$. This equation was least-squares fitted and is valid from 300 to 550 K. Of the 82 points, only three have deviations exceeding 0.1 per cent, and these all lie at the high end of the experimental range.

We have assessed the accuracy of this apparatus by comparing our results with those of other investigators;^(2,7-9) deviations from the least-squares polynomial of this research are shown in figure 6. The results of Furukawa *et al.* as well as of Martin and Snowdon and of Grønvdol should be directly comparable to the present results since we have all used portions of the Calorimetry Conference sample of $\alpha\text{-Al}_2\text{O}_3$, and all report results with reference to IPTS-48, whilst Ditmars and Douglas

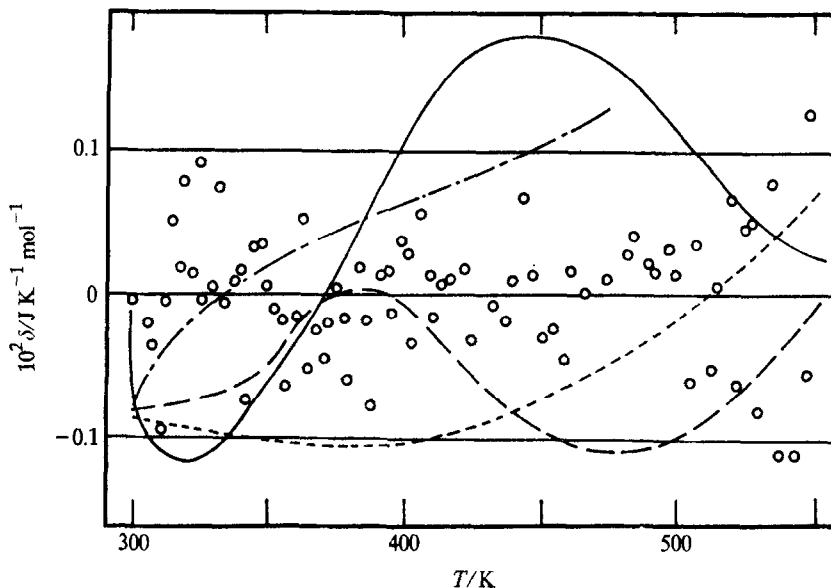

FIGURE 6. Deviations δ of experimental heat capacity of synthetic sapphire from least-squares curve. \circ , results from this research; - - -, Ditmars and Douglas;⁽⁹⁾ — — —, Furukawa *et al.*;⁽⁷⁾ — · — · —, Martin and Snowdon;⁽⁸⁾ — — —, Grønvold.⁽²⁾

report their results in terms of IPTS-68, and made their measurements on the new standard sample NBS SRM-720. This deviation plot shows that over the common range of temperature, our measurements are indeed within 0.1 per cent of the commonly accepted values.

REFERENCES

1. West, E. D.; Westrum, E. F., Jr. In *Experimental Thermodynamics* Vol. 1. McCullough, J. P.; Scott, D. W.; editors. Butterworths: London. 1968. p. 333.
2. Grønvold, F. *Acta Chem. Scand.* 1967, 21, 1695.
3. Trowbridge, J. C.; Westrum, E. F., Jr. *J. Phys. Chem.* 1964, 68, 42.
4. Trowbridge, J. C. Ph.D. Thesis, The University of Michigan, Ann Arbor, Michigan. 1963. Compare *Diss. Abst.* 64-00897.
5. Trowbridge, J. C.; Westrum, E. F., Jr. *J. Phys. Chem.* 1963, 67, 2381.
6. Westrum, E. F., Jr.; Furukawa, G. T.; McCullough, J. P. In *Experimental Thermodynamics* Vol. 1. McCullough, J. P.; Scott, D. W.; editors. Butterworths: London. 1968. p. 133.
7. Furukawa, G. T.; Douglas, T. B.; McCoskey, R. E.; Ginnings, D. C. *J. Res. Nat. Bur. Stand. U.S.* 1956, 57, 67.
8. Martin, D. L.; Snowdon, R. L. *Rev. Sci. Inst.* 1970, 41, 1869.
9. Ditmars, D. A.; Douglas, T. B. *J. Res. Nat. Bur. Stand. U.S.* 1971, 75A, 401.