

FIBRINOGEN PETOSKEY: IDENTIFICATION OF A NEW DYSFIBRINOGENEMIA
CHARACTERIZED BY ALTERED RELEASE OF FIBRINOPEPTIDE A¹

Deborah L. Higgins^a, John A. Penner^{b,2} and Jules A. Shafer^{a,3}
From the Departments of Biological Chemistry^a and
Internal Medicine^b,
The University of Michigan, Ann Arbor, Michigan 48109

(Received 9.4.1981; in revised form 10.8.1981.
Accepted by Editor J.S. Finlayson)

ABSTRACT

A new congenital dysfibrinogenemia, designated fibrinogen Petoskey, which was traced through four generations of a Michigan family, was found to exhibit an abnormally slow rate of release of fibrinopeptide A upon treatment with thrombin and batroxobin. Batroxobin only partially hydrolyzed and polymerized the fibrinogen from affected individuals, suggesting that these patients had both normal and abnormal fibrinogen in their circulation and that batroxobin was not capable of releasing fibrinopeptide A from the abnormal fibrinogen. Polymerization of fibrin monomers from fibrinogen Petoskey and plasmin mediated digestion of fibrinogen Petoskey were normal. The Factor XIIIa-catalyzed cross-linking of fibrinogen Petoskey was slightly delayed at low (but not at high) concentrations of thrombin. This delayed cross-linking appeared to be a secondary effect of the lower rate of release of fibrinopeptide A.

INTRODUCTION

The first report of a functional abnormality in fibrinogen appeared in 1958 (1). Since then over 50 congenital dysfibrinogenemias have been reported. (See 2,3,4 for reviews discussing most of the known dysfibrinogenemias). Although in most affected individuals the concentration of fibrinogen and

¹A preliminary report of this work appeared at the 71st annual meeting of the American Society of Biological Chemists, June, 1980.

²Present address: Department of Medicine, Michigan State University, East Lansing, Michigan 48824.

³To whom inquiries should be sent.

Key Words: Dysfibrinogenemia, Batroxobin, Fibrinogen, Fibrinopeptide Release

other clotting factors is normal, fibrinogen from affected individuals usually exhibits a prolonged thrombin clotting time or a prolonged prothrombin time (or both). The affected step in the clotting process has been determined in many of these dysfibrinogenemias. In some cases, the rate of proteolysis and release of fibrinopeptide A or B is decreased due to an alteration in interactions between the thrombin and fibrinogen. In other cases, altered rates of spontaneous polymerization of fibrin monomers or altered rates of Factor XIIIa-mediated cross-linking of fibrin are observed. In addition to showing one or more of these functional defects, fibrinogen from individuals with certain dysfibrinogenemias exhibits altered degradation rates and products upon digestion with plasmin.

Only two dysfibrinogenemias (fibrinogens Paris I and Detroit) have been characterized on a molecular level. In fibrinogen Paris I (5), a fraction of the γ -chains is elongated, and in fibrinogen Detroit (6), Arg-19 of the α -chains is replaced by Ser. Detailed functional and structural studies of inherited abnormal fibrinogens provide a powerful method for characterizing interactions of fibrinogen which are important in the formation of a functionally competent blood clot. In the case of fibrinogen Detroit such a study (6) has revealed that interactions involving aminoacyl residues at the amino termini of the α -chains are necessary for polymerization of fibrin and thrombin mediated cleavage of fibrinopeptide B from the $B\beta$ -chains.

The present report describes a new congenital abnormality in a Michigan family (7), characterized by fibrinogen which shows abnormally slow release of fibrinopeptide A with thrombin and resistance to proteolysis by batroxobin (reptilase). It is anticipated that further study of this fibrinogen will increase our understanding of the structural determinants of the interaction between thrombin and fibrinogen.

METHODS

Normal human plasma was obtained from the American Red Cross. It had been prepared from 450 ml of whole blood collected into 63 ml of citrate phosphate dextrose anticoagulant. Plasma from affected individuals was prepared from whole blood collected in a similar manner. All plasma was stored frozen.

Fibrinogen was purified from plasma by glycine precipitations to obtain fraction I-2 as described previously (8), and was further purified to fraction I-4 by the method of Blombäck and Blombäck (9). Contaminating plasminogen was removed by passing fraction I-4 through a lysine-Sepharose column (10). The resulting fibrinogen preparations were at least 95% clottable.

The clottability of fibrinogen was determined by a modification of the method of Mosesson and Sherry (8) and Laki (11), in which the absorbance at 280 nm was measured before and after clotting. In this procedure, 0.94 ml of fibrinogen in 0.3 M NaCl was mixed with 50 μ l of a 0.64 M potassium phosphate buffer which brought the pH of the resulting solution to 6.4. The solution was clotted by the addition of 1 U of human thrombin (labeled greater than 3000 U/mg as obtained from Sigma Chemical Company, St. Louis, Missouri) in 10 μ l. After 3 hours at room temperature the clot was removed and the absorbance (280 nm) of the clot supernatant was determined and compared to the absorbance of a diluted sample of the original fibrinogen solution. The clottability of fibrinogen from affected individuals was determined in a

similar manner, except that 5 U of human thrombin in 10 μ l was used to clot the fibrinogen.

Clinical coagulation assays, including thrombin clotting time (12), prothrombin time (13) and partial thromboplastin time (14), were performed by standard procedures, and the results obtained with patients' plasma were compared to those obtained with pooled normal plasma. Factor V and Factor VIII levels were measured by modifications of the methods used to determine prothrombin time (13) and partial thromboplastin time (14), respectively. Factor XIII levels were measured as described by Duckert *et al.* (15). Fibrinogen concentrations were determined by the thrombin clotting time assay of Clauss (16) or by assay of the fibrin tyrosine content (17).

Thrombin- and batroxobin-mediated polymerizations were studied by the following modification of the method of Gralnick *et al.* (18). A fibrinogen solution (0.15 ml) in 0.3 M NaCl was equilibrated at 25°C in a cuvette with 1.35 ml of 0.06 M sodium phosphate buffer, pH 6.8. Either 10 μ l thrombin or 50 μ l batroxobin (reconstituted Reptilase-R obtained from Abbott Laboratories, North Chicago, Illinois) was added and the absorbance at 350 nm was continuously monitored in a thermostated cell compartment of a GCA/McPherson spectrophotometer.

Radioimmunoassays of FPA were done with a kit from IMCO Corp., Ltd. AB Stockholm, Sweden. Samples were prepared using hirudin to inhibit the thrombin (19).

The total amount of fibrinopeptides released upon treating fibrinogen with thrombin was measured as described previously (18) using the method of Lowry (20) to determine trichloroacetic acid (TCA)⁴ soluble peptides in the clot supernatant.

Fibrin monomers were prepared and subsequently aggregated by a modification of the method of Gralnick *et al.* (18 and references cited therein). Fibrinogen in 0.15 M Tris-HCl buffer, 0.15 M NaCl, pH 7.4 was clotted with human thrombin. After approximately 90% of the fibrinogen had clotted, the clot was wound around a glass rod and then dissolved in 0.02 M acetic acid. Polymerization of the fibrin monomers was initiated by adding a portion of the monomer solution to a 31-fold excess of 0.06 M potassium phosphate buffer at pH 6.8 which either contained no NaCl (for runs at an ionic strength of 0.12) or 0.3 M NaCl (for runs at an ionic strength of 0.42) at 25°C.

The cross-linking of fibrin was monitored as described previously (21).

Digestion of fibrinogen with plasmin was carried out by a method similar to that described by Sherman *et al.* (22). Plasminogen (profibrinolysin, labeled 2.5 U/mg as obtained from Sigma Chemical Co., St. Louis, Missouri) at 5 mg/ml in 0.046 M Tris-HCl, 0.115 M CaCl₂ pH 8.1 was activated with 100 Plough U/ml of urokinase (obtained from Calbiochem-Behring Corp., La Jolla, California) for one hour, prior to the start of digestion.

⁴Abbreviations used in this paper: TCA, Trichloroacetic acid; PAGE, polyacrylamide gel electrophoresis; SDS, sodium dodecyl sulfate.

Polyacrylamide gel electrophoresis (PAGE) in the presence of sodium dodecyl sulfate (SDS) was done on slab gels as described by Laemmli (23).

Circular dichroism spectra were obtained with a Jasco, J-40C automatic recording spectropolarimeter.

RESULTS

Case History. The propositus, an 80 year old Caucasian male, was first studied in 1977 prior to total hip replacement surgery. He was in excellent health, except for severe degenerative arthritis in the left hip. When studies of his clotting system indicated an abnormality, he was referred to The University of Michigan Hospital. He had no history of unusual bleeding, except in 1973 when he required two units of blood after a cholecystectomy.

Coagulation studies (Table I) demonstrated that the patient's prothrombin time and thrombin clotting times were abnormally long. The partial thromboplastin time, and Factor V and XIII levels of the propositus were normal, whereas his Factor VIII level was elevated. The fibrinogen concentration in the plasma of the propositus was abnormally low when measured using the indirect thrombin clotting time assay, and normal when measured from the tyrosine content of the fibrin. These studies suggested a diagnosis of dysfibrinogenemia, wherein the actual level of fibrinogen in the plasma was normal, but some of the fibrinogen was functionally deficient so as to give an abnormally long thrombin clotting time.

Family studies. The dysfibrinogenemia was traced through four generations (Fig. 1). Twenty-seven of the descendants of the propositus were tested and eleven had prolonged thrombin clotting times. The apparent fibrinogen concentration based on the thrombin clotting times of affected individuals ranged from 59 mg/dl to 101 mg/dl. The Reptilase time determined for plasma from the propositus' daughter (III-4 in Fig. 1) was also found to be prolonged (31.5 s vs. 14.8 s for normal plasma). All affected individuals were asymptomatic; several had undergone surgery, including hysterectomy, appendectomy, cholecystectomy, and tonsillectomy with no unusual bleeding or requirements for blood products. There was no known consanguinity in the

TABLE I

Coagulation Assays on Plasma from the Propositus

<u>Assay</u>	<u>Patient</u>	<u>Normal</u>
Thrombin Clotting Time	13.6 s	8-9 s
Prothrombin Time	13.0 s	11 s
Partial Thromboplastin Time	30.1 s	35 s
Factor V	111%	80-120%
Factor VIII	208%	80-120%
Factor XIII	Insoluble Clots	
Fibrinogen Concentration		
Based on the Thrombin Clotting Time	96 mg/dl	200-300 mg/dl
Based on the Fibrin Tyrosine Content	298 mg/dl	200-300 mg/dl

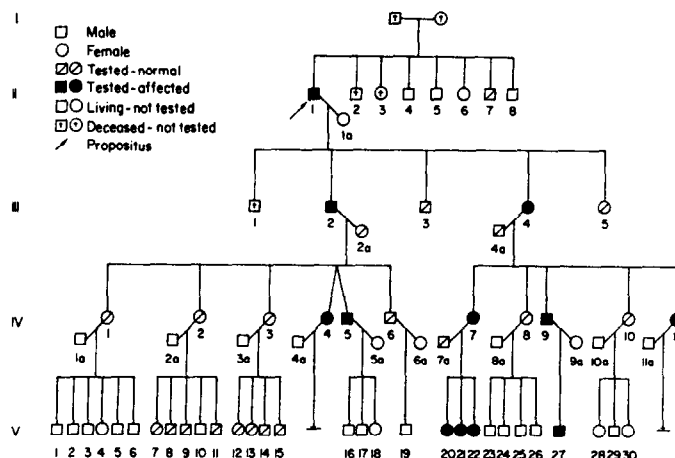

FIG. 1.
Pedigree of fibrinogen Petoskey

family and the family pedigree (Fig. 1) indicated that the defect was inherited as an autosomal dominant trait.

Localization of the Defect to Fibrinogen. Fibrinogen purified from patients' plasma was only 46% clottable after three hours with one unit of thrombin per ml of fibrinogen solution, whereas normal fibrinogen was greater than 95% clottable. When the thrombin concentration was increased to five U/ml, however, both the patient's fibrinogen and normal fibrinogen were greater than 95% clottable. Polyacrylamide gel electrophoresis in SDS of fibrinogen, as well as reduced $\text{A}\alpha$ -, $\text{B}\beta$ -, and γ -chains obtained from normal and affected individuals indicated that the molecular weights of the polypeptide chains of fibrinogen from normal and affected individuals were similar. Circular dichroism spectra of both fibrinogens were also identical, suggesting that there was no major conformational alteration in the abnormal fibrinogen. Immunodiffusion of fibrinogen from normal individuals and affected family members against goat antibodies to human fibrinogen revealed complete lines of identity. These results suggested a close structural resemblance between the normal and abnormal fibrinogens.

Mixing a patient's plasma with normal plasma in various ratios revealed no inhibitory effect in thrombin clotting time when compared with normal plasma mixed with barbital buffered saline. A similar result was obtained when thrombin-mediated clotting of purified fibrinogen was studied at several ratios of normal fibrinogen, abnormal fibrinogen and buffer. These results suggest that the slower clotting of the fibrinogen from affected individuals was not due to an inhibitor to clotting in their plasma and that the fibrinogen from affected individuals had no inhibitory effect on the clotting of normal fibrinogen.

Thrombin-Mediated Polymerization of the Abnormal Fibrinogen. The thrombin-catalyzed cleavage of normal and abnormal fibrinogen near the amino termini of the A α - and B β -chains, to release fibrinopeptides A and B, and the subsequent spontaneous polymerization of the fibrin monomers (24) was monitored by following the increase in turbidity of the solution caused by the polymerization reaction. Although the increase in turbidity of the solution reflects polymerization of fibrin monomers, subsequent to the thrombin-mediated proteolysis of the fibrinogen, the rate at which the turbidity of a solution of fibrinogen increases upon addition of thrombin may be determined either by the rate of proteolysis or polymerization, whichever is slower. As shown in Fig. 2A, a fifteen-fold increase in the concentration of thrombin (from 2.9 U/ml to 43.7 U/ml) had no effect on the rate of thrombin-mediated polymerization of normal fibrinogen as measured from the time dependent increase in turbidity. Since the increased thrombin concentration should have increased the rate of proteolysis, this result suggests that polymerization and not proteolysis was rate limiting under the conditions used with normal fibrinogen. The fibrinogen from an affected family member displayed markedly different behavior (Fig. 2B). At a low thrombin concentration (2.9 U/ml), thrombin-mediated polymerization of the patient's fibrinogen was much

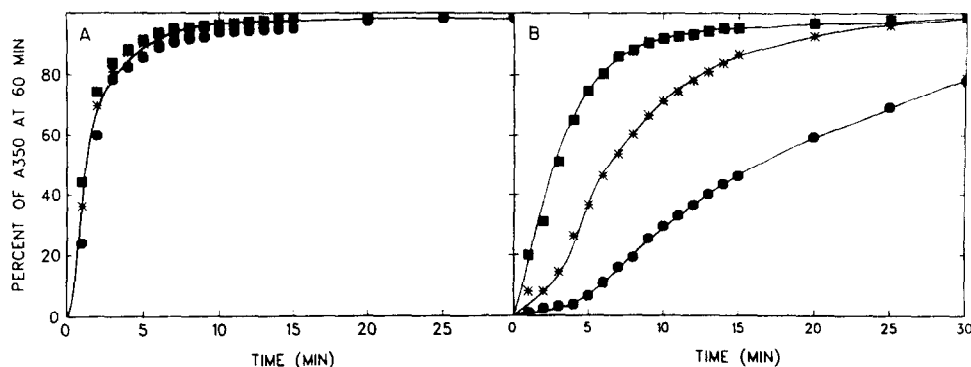

FIG. 2.

Thrombin-mediated polymerization of normal fibrinogen (A), and fibrinogen from an affected individual (B). The fibrinogen (0.052 mg/ml) in 0.054 M potassium phosphate buffer, 0.027 M NaCl, pH 6.8 was treated with ■, 43.7 U/ml; *, 11.3 U/ml; and ●, 2.9 U/ml thrombin.

slower than thrombin-mediated polymerization of normal fibrinogen. Moreover, increasing the concentration of thrombin, which presumably increased the rate of release of fibrinopeptide A and B, markedly increased the rate of polymerization (Fig. 2B). These observations suggested that proteolysis of abnormal fibrinogen was rate limiting under the same conditions where polymerization of fibrin monomers was rate limiting with normal fibrinogen. Differences in the rate of thrombin-mediated polymerization of abnormal and normal fibrinogen similar to those depicted in Fig. 2 were observed at all fibrinogen concentrations studied (0.05 mg/ml to 5.7 mg/ml).

Although thrombin-mediated polymerization of the patient's fibrinogen was slower (at low thrombin concentrations) than that of normal fibrinogen,

the amounts of fibrinopeptides ultimately released were within experimental error ($\pm 5\%$) of each other as judged by Lowry (20) determinations of TCA soluble peptide material in the clot supernatants (18). The low sensitivity of this procedure, however, made it impractical to use it to compare rates of release of fibrinopeptides.⁵

Radioimmunoassay of Fibrinopeptide A. The release of fibrinopeptides from fibrinogen was monitored using a radioimmunoassay to obtain additional evidence in support of the conclusion that the abnormal fibrinogen exhibits a decreased rate of proteolysis. Normal fibrinogen and fibrinogen from an affected family member at 2.82 mg/ml (8.3 μ M) were each incubated with equal aliquots of a dilute solution of thrombin, so as to achieve a slow rate of release of fibrinopeptide A which could be measured conveniently. Radioimmunoassay of the fibrinopeptide A released after 6 hours indicated that the normal fibrinogen had released 50% of fibrinopeptide A, whereas the abnormal fibrinogen had released only 33% of fibrinopeptide A. This result provided direct evidence that the rate of release of fibrinopeptide A from the abnormal fibrinogen is decreased.

Batroxobin-Mediated Hydrolysis and Polymerization of Fibrinogen. The protease batroxobin, like thrombin, catalyzes hydrolytic cleavage of fibrinopeptide A from fibrinogen (25). Batroxobin, however, does not cleave the B β - chains to release fibrinopeptide B. Thus, it was used to compare the release of fibrinopeptide A from the fibrinogen of an affected individual with that of normal fibrinogen. When batroxobin was added to a solution of normal fibrinogen, the fibrinogen clotted completely, as measured by an increase in turbidity (Fig. 3). Subsequent addition of thrombin had no further effect. This result indicated that removal of fibrinopeptide A from normal fibrinogen resulted in a degree of polymerization which was sufficient to produce the maximal change in turbidity. The addition of batroxobin to the fibrinogen from an affected family member, clotted only about one quarter of the fibrinogen as estimated from the turbidity of the solution (Fig. 3). After 2.5 hours when the maximum batroxobin induced polymerization was complete (as reflected by a constant absorbance at 350 nm), the fibrin product was wound around a glass rod and removed. Subsequent addition of thrombin caused an additional rapid increase in the turbidity of the solution. This result suggested that a portion of the affected family's fibrinogen was totally resistant to proteolysis by batroxobin, but was susceptible to thrombin mediated proteolysis. This view is supported by the data in Table II which show a decreased velocity of batroxobin mediated release of fibrinopeptide A from a patient's fibrinogen. As might be expected if the abnormal fibrinogen molecules in the sample were totally resistant to batroxobin, the yield of fibrinopeptide A from the fibrinogen of a patient was about one half of that obtained from normal fibrinogen even when the patient's fibrinogen was incubated with a large excess of batroxobin for prolonged times. These results, together with the slower thrombin-mediated release of fibrinopeptide A from a patient's fibrinogen seen with the radioimmunoassay, indicated that removal of fibrinopeptide A was the functionally defective step in the clotting of the abnormal fibrinogen.

⁵A comparative study (using HPLC) of the kinetics of the thrombin catalyzed release of fibrinopeptides A and B from normal fibrinogen and the fibrinogen of an affected family member will be the subject of another study.

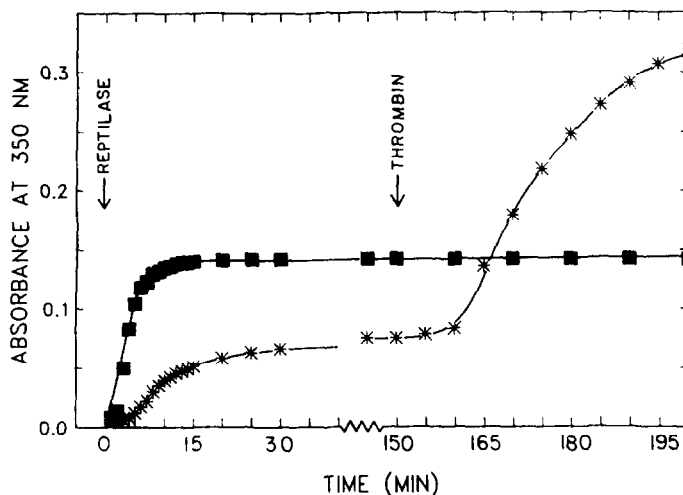

FIG. 3.

Batroxobin- and thrombin-mediated polymerization of normal fibrinogen and fibrinogen from an affected individual. Samples were in 0.05 M potassium phosphate buffer, 0.05 M NaCl, pH 6.8. ■, 0.135 mg/ml normal fibrinogen; *, 0.27 mg/ml fibrinogen from an affected individual. The concentration of the patient's fibrinogen was twice that of the normal fibrinogen in order to obtain a fair comparison of the polymerization of the two proteins, since batroxobin mediated the release of fibrinopeptide A from only one half of the patient's fibrinogen. At zero time, 50 μ l of reconstituted Reptilase-R was added to each 1.35-ml sample of fibrinogen. After the maximum amount of polymerization had occurred (150 min) the clots were removed from the solution, causing the optical density at 350 nm to return to zero. Thrombin (5 U) was then added to each sample. Any increase in the absorbance of the sample is shown here as an additional rise in the absorbance at 350 nm.

Polymerization of Preformed Fibrin Monomers. Fibrin monomers were prepared from normal fibrinogen and the patient's fibrinogen under conditions where about 90% of the fibrinogen had formed fibrin. When these monomers were dissociated at low pH, and then returned to a neutral pH, the monomers polymerized. No significant differences could be detected between the polymerization (as monitored at 350 nm) of monomers from normal and the patient's fibrinogen at an ionic strength of 0.12 or 0.42. This result provided additional support for the view that the proteolysis step and not the polymerization of fibrin monomers was the altered step in the clotting of abnormal fibrinogen.

Covalent Cross-linking of Fibrin with Factor XIII. Fibrinogen preparations which had been subjected to treatment with urea to inactivate endogenous Factor XIII (21) contaminants were clotted in the presence of CaCl_2 , 4.4 U/ml thrombin and 1 μ l/ml normal plasma so as to provide the same amount of Factor XIII to both samples. The progression of cross-linking was

TABLE II

Batroxobin Mediated Release of Fibrinopeptide A
From Fibrinogen of Normal Individuals and a Patient^a

Time (hr)	Fibrinopeptide A Released ^b (nmol/ml)	
	Normal	Patient
0.25	1.4 (18)	1.0 (13)
0.50	2.7 (34)	1.7 (22)
1	4.3 (55)	2.9 (37)
2	6.3 (80)	3.8 (48)
6	7.3 (93)	4.3 (55)
6 ^c	7.8 (99)	4.4 (56)

^aFibrinogen (1.34 mg/ml, 3.94 nmol/ml) in 0.25 M NaCl, 30 mM sodium phosphate pH 6.6 was incubated with 1 μ l reconstituted Reptilase-R per ml fibrinogen solution at 37°C. At the indicated times 1 volume of 3 N perchloric acid was added to 10 volumes of the reaction mixture to stop the reaction. Following centrifugation, the amount of fibrinopeptide A in each sample was determined using high performance liquid chromatography as described in reference 26.

^bThe numbers in parentheses indicate the % yield of fibrinopeptide A based on two α -chains per molecule and a molecular weight of 340,000 for fibrinogen.

^cThis sample contained 100 μ l reconstituted Reptilase-R per ml fibrinogen.

evaluated by reducing the fibrin and using PAGE in SDS to determine the extent of cross-linking of α - and β -chains. Both normal fibrinogen and the fibrinogen from an affected family member formed α -polymers and γ -dimers with the concomitant disappearance of the α -monomers and γ -monomers; however, the rate of cross-linking differed in the two samples. After 15 min, the γ -monomers could not be detected in the normal fibrinogen, but were still detectable in the sample of abnormal fibrinogen at one hour. After two hours, γ -monomers also were no longer seen in the sample of abnormal fibrinogen. The disappearance of α -monomers also was delayed in the sample of abnormal fibrinogen during the first hour of incubation.

The difference in the rates of cross-linking of abnormal and normal fibrinogen was abolished, however, when higher concentrations of thrombin (44 U/ml) were present. This result suggested that the delayed cross-linking is a secondary effect due to the slower proteolysis of the fibrinogen from an affected family member. The rate of formation of cross-linked fibrin from fibrinogen will reflect primarily the rate of the slowest step in this multistep process. At high thrombin concentrations where release of fibrinopeptide A is probably not determining the rate of conversion of soluble fibrinogen to cross-linked fibrin, no difference in the rates of formation of normal and abnormal cross-linked fibrins should be observed.

Plasmin-Mediated Degradation of Fibrinogen. Normal fibrinogen and fibrinogen from an affected family member were incubated with plasmin to

determine whether the abnormal fibrinogen exhibited altered degradation products. At appropriate times 2 mM α -toluenesulfonyl fluoride was added to samples of the incubation mixture to inhibit the plasmin. PAGE in SDS of the samples before and after reduction with β -mercaptoethanol indicated that the two fibrinogens were equally susceptible to proteolysis by plasmin. The degradation products formed at identical rates in the two fibrinogen samples and had similar molecular weights. Thus, the structural alteration in the abnormal fibrinogen did not lead to a detectable alteration in the normal pattern (27) of degradation of fibrinogen by plasmin.

DISCUSSION

The propositus described here and several of his descendants have dysfibrinogenemia, a qualitative alteration in their fibrinogen. The congenital disorder was traced through four generations. It appeared to be inherited in an autosomal dominant manner, as described for other dysfibrinogenemias (2-4). The observation that prolonged batroxobin treatment of fibrinogen Petoskey mediated only partial release of fibrinopeptide A (56%) and the observation that batroxobin mediated only partial polymerization of fibrinogen indicated that there are two species of fibrinogen in the plasma of affected individuals. These observations provide biochemical proof that affected family members are heterozygotes as suggested by the mode of inheritance of the dysfibrinogenemia. The normal component of the fibrinogen Petoskey was presumed to aggregate when it was treated with batroxobin, because the removal of fibrinopeptide A alone is sufficient to support end to end polymerization of normal fibrinogen (25).

The absorbance measurements depicted in Fig. 3 suggest that only about 25% of the patient's fibrinogen polymerized normally upon treatment with batroxobin. This result taken together with the data in Table II suggests that batroxobin-mediated hydrolysis of half of an affected individual's fibrinogen causes polymerization of only one quarter of the fibrinogen. This apparent discrepancy might be due to the absorbance not being a linear function of the degree of polymerization. An alternative explanation also should be considered, however. Assuming that a single structural alteration in one polypeptide chain is responsible for this abnormality, equal rates of synthesis of the normal and abnormal polypeptide chains would result in 50% of either the $A\alpha$ -, $B\beta$ -, or γ -chains containing the structural abnormality. For purposes of illustration let us assume the abnormality is in the $A\alpha$ -chain.⁶ Given that each fibrinogen molecule contains two of each of the $A\alpha$ -, $B\beta$ -, and γ -chains, random assembly would result in a mixture in which 25% of the molecules contained two normal $A\alpha$ -chains, 25% of the molecules contained two abnormal $A\alpha$ -chains, and 50% of the molecules contained one normal and one abnormal $A\alpha$ -chain. If polymerization (under the experimental conditions used) required that both $A\alpha$ -chains in a molecule be converted to α -chains, batroxobin treatment would be expected to polymerize only 25% of the fibrinogen upon release of 50% of the fibrinopeptide A. Further work is underway to verify this hypothesis about the assembly of fibrinogen and the structural requirements for polymerization.

⁶The amino acid replacement in fibrinogen Petoskey is established in another communication (26).

The dysfibrinogenemia reported in this work is one of a class of dysfibrinogenemias which exhibit an abnormality in the release of fibrinopeptide A. Of the 14 dysfibrinogenemias (18, 28-40) in this class only fibrinogen Bethesda I and fibrinogen New Orleans exhibit normal polymerization of fibrin monomers as does the abnormal fibrinogen reported here. Unlike this fibrinogen, however, fibrinogen Bethesda I (18) and fibrinogen New Orleans (37) inhibit the thrombin clotting time of normal plasma. It is interesting to note that fibrinogen Metz (36), like the abnormal fibrinogen reported here, is resistant to proteolysis by batroxobin. Fibrin monomers from fibrinogen Metz, however, exhibit altered rates of polymerization. Therefore, the fibrinogen reported in this work appears to be unique. Following accepted nomenclature, we designate this new dysfibrinogenemia, fibrinogen Petoskey.

Ultimately, the dysfibrinogenemias must be distinguished on the basis of the amino acid replacement responsible for the functional alteration. As exemplified by the characterization of fibrinogen Detroit (6), knowledge of dysfibrinogenemias should greatly enhance our understanding of the complex set of interactions necessary for the conversion of circulating fibrinogen to a covalently cross-linked fibrin clot. Fibrinogen Petoskey offers a unique opportunity to determine an important structural feature of fibrinogen which is essential for its susceptibility to batroxobin and which is important for its interaction with thrombin.

Acknowledgements: The authors are happy to acknowledge the cooperation of the propositus and his family, and the help in collecting plasma samples given us by Dr. Hilal and the staff at the Northern Michigan Hospital in Petoskey, Michigan. This study was made possible by research grants from the National Institutes of Health (AM-09276), and from the Skillman Foundation, Detroit, Michigan, as well as a grant from the National Science Foundation (PCM76-82844) to the Faculty of the Biological Chemistry Department, along with Medical School funds for purchase of the Jasco 40C spectropolarimeter.

REFERENCES

1. IMPERATO DI, C. and DETTORI, A. G. Ipfibrinogenemia congenita con fibrinoastenia. Helv. Paediatr. Acta **13**, 380-399, 1958.
2. MAMMEN, E. F. Congenital abnormalities of the fibrinogen molecule. Semin. Thromb. Haemost. **1**, 184-201, 1974.
3. CRUM, E. D. Abnormal Fibrinogens. In: Hemostasis: Biochemistry, Physiology and Pathology. D. Ogston and B Bennett, (Eds.) New York: John Wiley & Sons, Ltd., 1977, pp. 424-445.
4. MORSE, E. E. The fibrinogenopathies. Ann. Clin. Lab. Sci. **8**, 234-238, 1978.
5. MOESSON, M. W., AMRANI, D. L., and MENACHE, D. Studies on the structural abnormality of fibrinogen Paris I. J. Clin. Invest. **57**,

782-790, 1976.

6. BLOMBÄCK, B. and BLOMBÄCK, M. Molecular defects and variants of fibrinogen. Nouv. Rev. Fr. Hemotol. **10**, 671-678, 1970.
7. HIGGINS, D. L., PENNER, J. A., and SHAFER, J. A. Characterization of a new dysfibrinogenemia: fibrinogen Petoskey. Fed. Proc. **39**, Abst. 1502, 1980.
8. MOSESSON, M. W. and SHERRY, S. The preparation and properties of human fibrinogen of relatively high solubility. Biochemistry **5**, 2829-2835, 1966.
9. BLOMBÄCK, B. and BLOMBÄCK, M. Purification of human and bovine fibrinogen Ark. Kemi **10**, 415-443, 1956.
10. MATSUDA, M., IWANAGA, S., and NAKAMURA, S. A simple, large scale method for preparation of plasminogen-free fibrinogen. Thromb. Res. **1**, 619-630, 1972.
11. LAKI, K. The polymerization of proteins: the action of thrombin on fibrinogen. Arch. Biochem. Biophys. **32**, 317-324, 1951.
12. PENNER, J. A. Experience with a thrombin clotting assay for measuring heparin activity. Am. J. Clin. Path. **61**, 645-655, 1974.
13. QUICK, A. J. The determination of prothrombin by the method of Quick. In: Transactions of the 1st Conference on Blood Clotting and Allied Problems of the Josiah Macy Jr. Foundation, J. E. Flynn (Ed.), New York: Josiah Macy Jr. Foundation, 1948, pp. 170-172.
14. NYE, S. W., GRAHAM, J. B., and BRINKHOUS, K. M. The partial thromboplastin time as a screening test for the detection of latent bleeders. Am. J. Med. Sci. **243**, 279-284, 1962.
15. DUCKERT, F., JUNG, E., and SHMERLING, D. H. A hitherto undescribed congenital haemorrhagic diathesis probably due to fibrin stabilizing factor deficiency. Thromb. Diath. Haemorrh. **5**, 179-186, 1961.
16. CLAUSS, VON A. Gerinnungsphysiologische schnellmethode zur bestimmung des fibrinogens. Act. Haematol. **17**, 237-246, 1957.
17. REINER, M. and CHEUNG, H. L. A practical method for the determination of fibrinogen. Clin. Chem. Winston-Salem, N.C. **5**, 414-420, 1959.
18. GRALNICK, H. R., GIVELBER, H. M., SHAINOFF, J. R., and FINLAYSON, J. S. Fibrinogen Bethesda: a congenital dysfibrinogenemia with delayed fibrinopeptide release. J. Clin. Invest. **50**, 1819-1830, 1971.
19. NOSSEL, H. L., TI, M., KAPLAN, K. L., SPANONDIS, K., SOLAND, T., and BUTLER, JR., V. P. The generation of fibrinopeptide A in clinical blood samples. J. Clin. Invest. **58**, 1136-1144, 1976.
20. LOWRY, O. H., ROSEBROUGH, N. J., FARR, A. L., and RANDALL, R. J. Protein measurement with the folin phenol reagent. J. Biol. Chem. **193**,

265-275, 1951.

21. MCKEE, P. A., SCHWARTZ, M. L., PIZZO, S. V., and HILL, R. L. Cross-linking of fibrin by fibrin-stabilizing factor. Ann N.Y. Acad. Sci. **202**, 127-148, 1972.
22. SHERMAN, L. A., MOESSON, M. W., and SHERRY, S. Isolation and characterization of the clottable low molecular weight fibrinogen derived by limited plasmin hydrolysis of human fraction I-4. Biochemistry **8**, 1515-1528, 1969.
23. LAEMMLI, U. K. Cleavage of structural proteins during the assembly of the head of bacteriophage T4. Nature (London) **227**, 680-685, 1970.
24. DOOLITTLE, R. F. Structural aspects of the fibrinogen to fibrin conversion. Adv. Protein Chem. **27**, 1-109, 1973.
25. BLOMBÄCK, B., BLOMBÄCK, M., and NILSSON, I. M. Coagulation studies on "Reptilase," an extract of the venom from Bothrops jararaca. Thromb. Diath. Haemorrh. **1**, 76-86, 1957.
26. HIGGINS, D. L. and SHAFER, J. A. Fibrinogen Petoskey, a dysfibrinogenemia characterized by replacement of Arg-A α 16 by a His: Evidence for thrombin-catalyzed hydrolysis at a histidyl residue. J. Biol. Chem., (In press).
27. MOESSON, M. W., FINLAYSON, J. S., and GALANKIS, D. K. The essential covalent structure of human fibrinogen evinced by analysis of derivatives formed during plasmin hydrolysis. J. Biol. Chem. **218**, 7913-7929, 1973.
28. BECK, E. A., SHAINOFF, J. R., VOGEL, A., and JACKSON, D. P. Functional evaluation of an inherited abnormal fibrinogen: Fibrinogen "Baltimore." J. Clin. Invest. **50**, 1874-1884, 1971.
29. GRALNICK, H. R., GIVELBER, H. M., and FINLAYSON, J. S. A new congenital abnormality of human fibrinogen. Thromb. Diath. Haemorrh. **29**, 562-571, 1973.
30. CRUM, E. D., SHAINOFF, J. R., GRAHAM, R. C., and RATNOFF, O. D. Fibrinogen Cleveland II: an abnormal fibrinogen with defective release of fibrinopeptide A. J. Clin. Invest. **53**, 1308-1319, 1974.
31. SANDBJERG HANSEN, M., CLEMMENSEN, I., and WINTHER, D. Fibrinogen Copenhagen; an abnormal fibrinogen with defective polymerization and release of fibrinopeptide A, but normal absorption of plasminogen. Scand. J. Clin. Lab. Invest. **40**, 221-226, 1980.
32. BÖTTCHER, D., HASLER, K., KÖTTGEN, E., and MAURATH, T. Hereditary hypodysfibrinogenemia with defective release of fibrinopeptide A (fibrinogen Freiburg). Thromb. Haemost. **42**, 78, 1979.
33. KRAUSE, W. H., HEENE, D. L., and LASCH, H. G. Congenital dysfibrinogenemia (fibrinogen Giessen). Thromb. Diath. Haemorrh. **29**, 547-561, 1973.

34. DENNINGER, M. H., FINLAYSON, J. S., REAMER, L. A., PARQUET-GERNEZ, A., GOUEMEND, M., and MENACHE, D. Congenital dysfibrinogenemia: fibrinogen Lille. Thromb. Res. **13**, 453-456, 1978.
35. LANE, D. A., VANROSS, M., KAKKAR, V. V., DHIR, K., HOLT, L. P. J., and MACIVER, J. E. An abnormal fibrinogen with delayed fibrinopeptide A release. Thromb. Haemost. **42**, 77, 1979.
36. SORIA, J., SORIA, C., SAMAMA, M., POIROT, E., and KLING, C. Fibrinogen Troyes-Fibrinogen Metz. Two new cases of congenital dysfibrinogenemia. Thromb Diath. Haemorrh. **27**, 619-631, 1972.
37. CHAVIN, S. I., ANDES, W. A., BELTRAN, W. G., and STUCKEY, W. J. Fibrinogen New Orleans: an inherited variant with abnormal peptide release. Thromb. Haemost. **42**, 77, 1979.
38. AL-MONDHIRY, H. A. B., BILEZIKIAN, S. B., and NOSSEL, H. L. Fibrinogen "New York" - an abnormal fibrinogen associated with thromboembolism: functional evaluation. Blood **45**, 607-619, 1975.
39. SHERMAN, L. A., GASTON, L. W., KAPLAN, M. E., and SPIVACK, A. R. Fibrinogen St Louis: a new inherited fibrinogen variant coincidentally associated with hemophilia A. J. Clin. Invest. **51**, 590-597, 1972.
40. HOFMANN, V., GATI, W. P., and STRAUB, P. W. Fibrinogen Zurich I: impaired release of fibrinopeptide A. Thromb. Haemost. **41**, 709-713, 1979.