

**Ostracods of the
Middle Devonian Silica Formation**

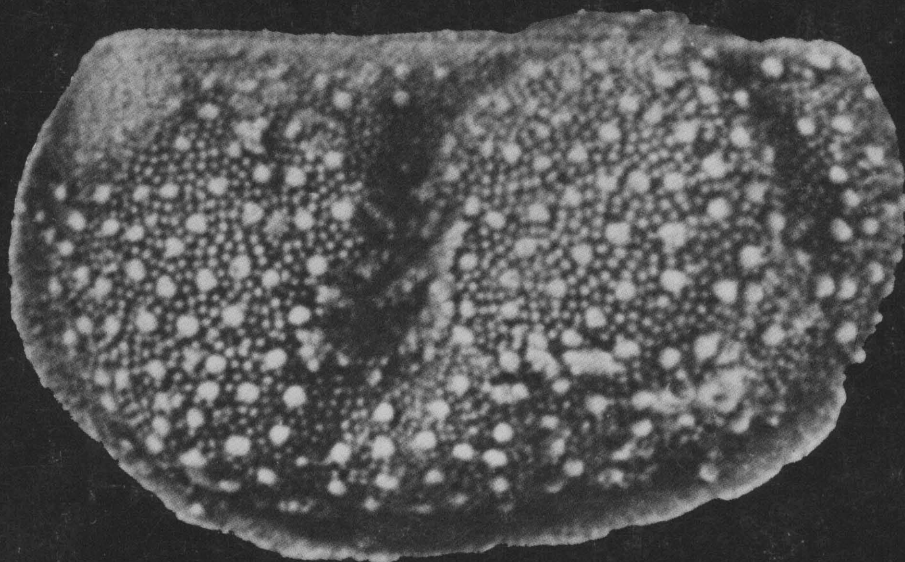

Volume 1:-

Text

Robert V. Kesling and Ruth B. Chilman

It is clear in the first place that the world in its present state is the outcome of movement. Whether we consider the rocky layers enveloping the Earth [or] the arrangement of the forms of life that inhabit it, ... we are forced to the same conclusion: that everything is the sum of the past and that nothing is comprehensible except through its history.

-- Pierre Teilhard de Chardin,
The Future of Man

Front cover: *Adelphobolbina trilobata*,
UMMP 58805. x 80

Back cover: *Falsipollex lativelatus*,
UMMP 60081. x 125

Ostracods of the Middle Devonian Silica Formation

Robert V. Kesling and Ruth B. Chilman

Volume 1:- Text



1978

Papers on Paleontology

No. 18

CONTENTS

Introduction	1
Previous work	3
Methods	8
Geology	11
Localities	12
Section	14
Fauna of the Silica Formation	23
Subclass OSTRACODA Latreille 1806	37
Order PALAEOCOPIIDA Henningsmoen 1953	37
Suborder BEYRICHIOCOPINA Scott 1961	37
Superfamily Beyrichiacea Matthew 1886	37
Family Beyrichiidae Matthew 1886	37
Subfamily Treposellinae Henningsmoen 1954	37
Genus PHLYCTISCAPHA Kesling 1953	37
PHLYCTISCAPHA APLETA Kesling 1954	40
Superfamily Drepanellacea Ulrich & Bassler 1923	44
Family Aechminellidae Sohn 1961	44
Genus BALANTOIDES Morey 1935	44
BALANTOIDES TRILOBATA (Turner 1939)	45
BALANTOIDES sp.	46
Family Aechminidae Swartz 1936	46
Genus AECHMINA Jones & Holl 1869	46
AECHMINA CHOANOBASOTA Kesling 1952	46
AECHMINA CRENULATA Stewart 1936	46
AECHMINA spp.	46
Genus AECHMINARIA Coryell & Williamson 1936	47
AECHMINARIA HORMATHOTA Kesling 1953	47
AECHMINARIA sp.	47
Genus SIGYNUS Kesling 1953	47
SIGYNUS DICTYOTUS Kesling 1953	47
SIGYNUS cf. DICTYOTUS Kesling 1953	47
Family Bolliidae Boucek 1936	47
Genus CORNIGELLA Warthin 1930	47
CORNIGELLA IMMOTIPEDA Kesling 1953	47
Genus STICTOBOLLIA n. gen.	49
STICTOBOLLIA ALETHAE (Coley 1954)	50
Genus TETRASTORTHYNX Kesling 1953	50
TETRASTORTHYNX DIABOLICUS Kesling 1953	50
Genus ULRICHIA Jones 1890	50
ULRICHIA CONRADI Jones 1890	50
ULRICHIA FASTIDIOSA n. sp.	51
ULRICHIA FRAGILIS Warthin 1934	52
ULRICHIA ILLINEARIS Kesling 1953	52
ULRICHIA SPINIFERA Coryell & Malkin 1936	52
ULRICHIA sp.	53
Genus XYSTINOTUS Kesling 1953	53
XYSTINOTUS SUBNODATUS (Turner 1939)	53
XYSTINOTUS WRIGHTORUM Kesling 1953	53

Family Kirkbyellidae Sohn 1961	53
Genus KIRKBYELLA Coryell & Booth 1933	53
Subgenus KIRKBYELLA Coryell & Booth 1933	53
KIRKBYELLA (KIRKBYELLA) BELLIPUNCTA (Van Pelt 1933)	53
Subgenus BERDANELLA Sohn 1961	55
KIRKBYELLA (BERDANELLA) STEWARTAE Sohn 1961	55
KIRKBYELLA (BERDANELLA) UNICORNIS Coryell & Malkin 1936	55
Family Richinidae Scott 1961	55
Genus RICHINA Coryell & Malkin 1936	55
RICHINA SUBCIRCULARIS Coryell & Malkin 1936	55
RICHINA TRINODOSA n. sp.	55
RICHINA TRUNCATA Coryell & Malkin	56
Superfamily Hollinacea Swartz 1936	56
Family Ctenoloculinidae Jaanusson & Martinsson 1956	56
Subfamily Ctenoloculininae Jaanusson & Martinsson 1956	57
Genus CTENOLOCULINA Bassler 1941	57
CTENOLOCULINA CICATRICOSA (Warthin 1934)	58
CTENOLOCULINA ACANTHINA Kesling 1953	58
CTENOLOCULINA EURYBATHROTA Kesling 1952	59
Subfamily Parabolbininae Bless & Jordan 1971	59
Genus SUBLIGACULUM Kesling & McMillan 1951	59
SUBLIGACULUM BIFIDUM (Stewart 1936)	59
SUBLIGACULUM SCROBICULATUM Kesling & McMillan 1951	59
Genus TETRASACCULUS Stewart 1936	60
TETRASACCULUS BILOBUS Stewart 1936	60
Family Hollinidae Swartz 1936	60
Subfamily Falsipollicinae Bless & Jordan 1971	60
Genus FALSIPOLLEX Kesling & McMillan 1951	60
FALSIPOLLEX LATIVELATUS (Kesling & McMillan 1951)	60
FALSIPOLLEX LAXIVELATUS Kesling 1952	62
FALSIPOLLEX sp.	62
Genus HANAITES Pokorny 1950	62
HANAITES PLATUS (Kesling & McMillan 1951)	62
Family Hollinellidae Bless & Jordan 1971	63
Genus HOLLINELLA Coryell 1928	63
Subgenus KESLINGELLA Bless & Jordan 1970	63
HOLLINELLA (KESLINGELLA) PUMILA Kesling 1952	64
HOLLINELLA (KESLINGELLA) ANTESPINOSA (Ulrich 1891)	64
HOLLINELLA (KESLINGELLA) LABROSA Kesling & Weiss 1953	65
HOLLINELLA (KESLINGELLA) cf. LABROSA Kesling & Weiss 1953 ...	65
Genus ADELPHOBOLBINA Stover 1956	65
ADELPHOBOLBINA SPICATA (Kesling & McMillan 1951)	66
ADELPHOBOLBINA TRILOBATA (Stewart 1936)	66
ADELPHOBOLBINA sp.	66
Superfamily Kirkbyacea Ulrich & Bassler 1906	66
Family Amphisellidae n. fam.	66
Genus DORACLATUM Stover 1956	68
DORACLATUM CONATUM (Coryell & Malkin 1936)	68
Genus DIRHABDUS n. gen.	68
DIRHABDUS MULTICOSTATUS (Pauken 1966)	68
Genus TETRARHABDUS n. gen.	68
TETRARHABDUS PYGMAEUS n. sp.	69
Family Arcyzonidae Kesling 1961	69
Genus ARCYZONA Kesling 1952	70
ARCYZONA BYTHICLIMACOTA Kesling 1952	70
ARCYZONA CAMPYLACTINOTA Kesling 1952	71

ARCYZONA DIADEMATA (Van Pelt 1933)	71
ARCYZONA HOMALOSAGENOTA Kesling 1952	71
ARCYZONA RHABDOTA Kesling 1952	71
ARCYZONA spp.	72
Family Scrobiculidae Posner 1951	72
Genus SCROBICULA Posner 1951	72
SCROBICULA XYSTA n. sp.	72
SCROBICULA MICROSPINOSA n. sp.	73
Superfamily Aparchitacea Swartz 1936	73
Family Aparchitidae Jones 1901	73
Genus EHLERSIA Kesling, Crafts, Darby Shuback, & Smith 1960	73
EHLERSIA HYPERCALA (Kesling & Kilgore 1952)	73
Genus KAVARYELLA n. gen.	73
KAVARYELLA CRACENS (Kesling & Kilgore 1952)	74
Family Coelonellidae Sohn 1971	74
Genus COELOENELLINA Polenova 1952	75
COELOENELLINA RARA n. sp.	75
Genus COELONELLA Stewart 1936	76
COELONELLA PLANA Stewart 1936	76
COELONELLA SCAPHA (Stewart 1930)	76
Suborder KLOEDENELLOCOPINA Scott 1961	76
Superfamily Kloedenellacea Ulrich & Bassler 1908	76
Family Kloedenellidae Ulrich & Bassler 1908	76
Subfamily Dizygopleurinae Egorov 1950	76
Genus DIZYGOPLEURA Ulrich & Bassler 1923	76
DIZYGOPLEURA EUGLYPHEA Warthin 1934	77
DIZYGOPLEURA TRISINUATA Van Pelt 1933	77
Genus POLONIELLA Gürich 1896	79
POLONIELLA CINGULATA Warthin 1934	79
Subfamily Kloedenellinae Egorov 1950	79
Genus EUKLOEDENELLA Ulrich & Bassler 1923	79
EUKLOEDENELLA DOVERENSIS Turner 1939	79
Genus PUNCTOPRIMITIA Stewart & Hendrix 1945	80
PUNCTOPRIMITIA SIMPLEX (Stewart 1936)	80
Subfamily Knoxitinae Egorov 1950	80
Genus KNOXIELLA Egorov 1950	80
KNOXIELLA RUTKOWSKIAE n. sp.	80
KNOXIELLA TRUNCATA n. sp.	81
KNOXIELLA sp.	81
Family Geisinidae Sohn 1961	81
Genus HYPOTETRAGONA Morey 1935	81
HYPOTETRAGONA AEQUITALIS Peterson 1964	81
HYPOTETRAGONA FRACTODORSALIS n. sp.	82
HYPOTETRAGONA HARRIETENSIS (Coryell & Malkin 1936)	83
Order ERIDOSTRACA Adamczak 1961	83
Family Eridoconchidae Henningsmoen 1953	83
Genus CRYPTOPHYLLUS Levinson 1951	83
CRYPTOPHYLLUS ARSINIUS Stover 1956	83
CRYPTOPHYLLUS MINUSCULUS n. sp.	83
Order PODOCOPIDA Müller 1894	84
Suborder PODOCOPINA Sars 1866	84
Superfamily Bairdiacea Sars 1887	84
Family Bairdiidae McCoy 1884	84
Genus RECTOBAIRDIA Sohn 1960	84
RECTOBAIRDIA EMACIATA (Kesling & Kilgore 1952)	84

Genus ACRATIA Delo 1930	85
ACRATIA SIMPLEX n. sp.	85
Family Beecherellidae Ulrich 1894	85
Genus ACANTHOSCAPHA Ulrich & Bassler 1923	85
ACANTHOSCAPHA DEVONICA (Kesling & Sohn 1958)	85
Genus PRONIPANTEX n. gen.	86
PRONIPANTEX PLANUS n. sp.	87
Genus WIDENERIA n. gen.	87
WIDENERIA LISPA n. sp.	87
Superfamily Cytheracea Baird 1850	88
Family Bythocytheridae Roth 1928	88
Genus MONOCERATINA Roth 1928	88
MONOCERATINA CASEI Warthin 1934	88
Suborder METACOPINA Sylvester-Bradley 1961	88
Superfamily Healdiacea Harlton 1933	88
Family Healdiidae Harlton 1933	88
Subfamily Healdiinae Harlton 1933	88
Genus HEALDIA Roundy 1926	89
HEALDIA ARKONENSIS Coryell & Malkin 1936	89
HEALDIA GIBBA Kesling & Weiss 1953	90
HEALDIA MEDUSAENSIS n. sp.	90
HEALDIA cf. MEDUSAENSIS n. sp.	90
HEALDIA spp.	90
Subfamily Healdiopsidinae Gründel 1962	90
Genus MICROCHEILINELLA Geis 1933	90
MICROCHEILINELLA MARIETTENSIS n. sp.	90
Genus NANNOHEALDIA n. gen.	91
NANNOHEALDIA ARCUATA n. sp.	91
Genus PONDERODICTYA Coryell & Malkin 1936	91
PONDERODICTYA PUNCTULIFERA (Hall 1860)	92
PONDERODICTYA OHIOENSIS (Stewart 1936)	92
PONDERODICTYA RHODESI n. sp.	92
Family Bairdiocyprididae Shaver 1961	93
Genus BAIRDIOCYPRIS Kegel 1932	93
BAIRDIOCYPRIS GONGYLUS n. sp.	93
BAIRDIOCYPRIS TRANSPITYXIS (Stover 1956)	94
Genus PRAEPILATINA Polenova 1970	94
PRAEPILATINA SILICENSIS n. sp.	94
Genus CYTHERELLINA Jones & Holl 1869	95
CYTHERELLINA KUTASII n. sp.	96
CYTHERELLINA LECHRIA n. sp.	96
CYTHERELLINA SUBQUADRATA (Stewart 1936)	97
CYTHERELLINA TANYMEKA n. sp.	97
CYTHERELLINA sp.	97
Genus RUGOCYTHERELLINA n. gen.	97
RUGOCYTHERELLINA EHLERSI n. sp.	97
Family Cavellinidae Egorov 1950	98
Genus BIRDSALLELLA Coryell & Booth 1933	98
BIRDSALLELLA DEVONICA Coryell & Malkin 1936	98
BIRDSALLELLA TUMIDA Stewart 1936	98
Genus MENOEIDINA Stewart 1936	98
MENOEIDINA SUBRENIFORMIS Stewart 1936	98
MENOEIDINA ARCUATA Turner 1939	99
MENOEIDINA PAUCIPUNCTATA n. sp.	100
Superfamily Quasillitacea Coryell & Malkin 1936	100
Family Quasillitidae Coryell & Malkin 1936	100

Genus QUASILLITES Coryell & Malkin 1936	100
QUASILLITES CONCENTRICUS (Turner 1939)	100
QUASILLITES FORDEI Coryell & Malkin 1936	102
QUASILLITES OBLIQUUS Coryell & Malkin 1936	102
QUASILLITES SUBLUNATUS (Stewart 1936)	103
QUASILLITES spp.	103
Genus GLYPHELLA n. gen.	104
GLYPHELLA RETICULATA n. sp.	104
Genus JENNINGSINA Coryell & Malkin 1936	104
JENNINGSINA CATENULATA (Van Pelt 1933)	104
Family Bufinidae Sohn & Stover 1961	105
Genus BUFINA Coryell & Malkin 1936	105
BUFINA ABBREVIATA Peterson 1966	106
BUFINA CURTI Coley 1954	106
BUFINA SPINULIFERA (Stewart 1936)	106
Genus BYTHOCYPROIDEA Stewart & Hendrix 1945	106
BYTHOCYPROIDEA ERIENSIS Stewart & Hendrix 1945	106
Family Ropolonellidae Coryell & Malkin 1936	107
Genus ROPOLONELLUS Van Pelt 1933	107
ROPOLONELLUS PAPILLATUS Van Pelt 1933	107
Genus RUDDERINA Coryell & Malkin 1936	107
RUDDERINA EXTENSA Coryell & Malkin 1936	107
Genus EUGLYPHELLA Warthin 1934	107
EUGLYPHELLA COMPRESSA Coryell & Malkin 1936	107
EUGLYPHELLA LISPA Peterson 1966	108
EUGLYPHELLA MODESTA Peterson 1966	108
EUGLYPHELLA PROJECTA Coryell & Malkin 1936	109
EUGLYPHELLA SIGMOIDALIS (Jones 1890)	112
Superfamily Thlipsuracea Ulrich 1894	113
Family Thlipsuridae Ulrich 1894	113
Genus HYPHASMAPHORA Van Pelt 1933	113
HYPHASMAPHORA TEXTILIGERA Van Pelt 1933	113
Genus OCTONARIA Jones 1887	114
OCTONARIA CRESCENTIFORMIS Van Pelt 1933	114
OCTONARIA LAEVILITATA Kesling & Kilgore 1952	114
OCTONARIA QUADRICOSTATA Van Pelt 1933	114
? Subclass Ostracoda Latreille 1806	114
Suprageneric taxa uncertain	114
? Order PALAEOCOPIDA Henningsmoen 1953	114
Genus BURSULELLA Jones 1887	114
BURSULELLA sp.	114
Interpreting the record	117
Paleoecology and pyritization	127
Notes on lithotopes and biotopes (by Ruth B. Chilman)	136
Distribution of species by Silica units	141
Distribution of species in other formations	143
Correlations	147
European ostracod faunas	155
References	158
Index	165

Ostracods of the Middle Devonian Silica Formation

By

Robert V. Kesling and Ruth B. Chilman

ABSTRACT

The Middle Devonian Silica Formation of northwestern Ohio and southeastern Michigan yields excellently preserved ostracods in abundance. The diverse fauna includes 27 families, 61 genera, and 112 species. Of these, one family, nine genera, and 25 species are new to science. Many of these ostracods occur in outcrops of equivalent formations elsewhere: in western New York, Ontario, and northern Michigan. Stratigraphic distribution appears to be controlled more by lithology than by age. In certain units of the formation, crystals of authigenic pyrite pass through valves and carapaces without distorting fine details of the ornamentation. We present keys to families, genera, and species for convenience.

INTRODUCTION

OSTRACODS -- those marvelously intricate little crustaceans which today inhabit waters of many salinities, temperatures, depths, and energies -- were highly successful members of the community in the Middle Devonian Silica sea and left an extraordinarily abundant record of their presence.

Study of fossil ostracods contains both encouraging and discouraging aspects. It is only fair to point out some of the latter to the reader who may not be familiar with these creatures. Alas, fossil ostracods are not as popular with all paleontologists as they are with us. Only a few specialists investigate them intensively. The field-oriented stratigrapher generally ignores them completely. Several reasons could be cited.

First, ostracods are so tiny (most under 2 mm long) that they must be studied under the

microscope. Without constant access to a good microscope, one cannot hope to get together a collection of them. A rich fauna could be present in a shale formation and not a single specimen sighted in a full day of field collecting.

Second, fossil ostracods require special techniques to free them from the matrix, to separate them from other small particles in the processed sediment, and to clean individual specimens for final study. Proper orientation for photography is tedious. Handling is a risky business and great care must be taken to avoid damage to delicate structures. Compared to a brachiopod that is twenty times as large, the ostracod is at least twenty times as fragile.

Third, the smooth-shelled forms are hard to classify. Unlike their living descendants, which can readily be differentiated by the nature of their appendages, the fossil ostracods have only their two-valved carapace preserved. If the particular species occurs only as complete

carapaces, with no isolated valves, even the hingement and adductor muscle scars may be difficult to examine.

Fourth, even among the highly ornamented and distinctive forms, classification has become formidably complex. The last half century has witnessed a multitude of new species, genera, families, and suprafamilial categories and a proliferation of changes in the old taxa. Ostracoda are beset with the taxonomic malaise that has for years affected Foraminifera. The necessary divisions for properly expressing their phylogenetic relationships increase so rapidly and attain such overwhelming proportions that the beginning student cannot assimilate the big picture immediately. Only by persistence bordering on devotion can he become an expert. Even now, some micropaleontologists confine their research to Paleozoic ostracods and others to Mesozoic or Cenozoic forms. The day can be forseen when there will be no ostracodologist -- one familiar with the whole field; instead, there may be specialists on one or two families -- beyrichiidologists, hollinidologists, and bairdiidologists.

Fifth, literature on ostracods is disseminated in many journals and books, published in several languages. The Russians are active, the French continue, and the Germans add their contributions, not to mention the outpouring in English. The revision of a genus may be critical to your work, but it could easily be overlooked in the volume of ostracod literature. To all the other drawbacks and deterrents, we must add that of the incomplete library (and no library can hope to keep current with all publications, past and present, on Ostracoda). And while we are on the subject, the older literature (and even some of the recent) contains poor illustrations. Some questions can only be answered by examination of the type specimens themselves.

Enough about the problems. Encouraging aspects are present, too. Enough ornamented and highly distinctive ostracods can be found in sedimentary strata to make them significant index fossils. In the Paleozoic formations, the Ostracoda are by far the most useful microfossils for dating rock units. Their minute size and abundance tend to insure that a significant

sample can be intercepted in a well core. Species are often widespread, aiding in correlation. Evolution was sufficiently rapid (geologically) to provide accurate dating. Techniques can be mastered with a little determination. The American Treatise on Invertebrate Paleontology (Volume Q) and the Russian Osnovy volume provide a guide to the genera described up to the 1960's. Better illustrations are being issued. All in all, ostracodology is not an impossible subject.

In this frame of mind, we began our investigation of the ostracod fauna of the Silica Formation several years ago. Progress was slow and interrupted by our work on the "Strata and Megafossils of the Middle Devonian Silica Formation," which came out in July 1975. This effort was not entirely aside from our ostracod study, for it gives the reader our views on the stratigraphic and paleoecologic setting in which the Silica ostracods thrived and competed with other invertebrates.

To our surprise, the fauna of ostracods increased well beyond our anticipations as we processed more and more shale. Rare species in the formation were discovered, and even now we feel rather certain that still other species will be found in the future. Notwithstanding the possibility of increasing the faunal list, we decided that the "common" and most of the not-so-common species have been found. Hence we progressed to the writing and illustrating of this work. For both numbers of species and exquisite preservation, the Silica Formation yields one of the world's outstanding ostracod faunas.

In this publication we offer the reader the necessary information to classify ostracods of the Silica Formation. For the previously described species, we present significant entries in the synonymy so that detailed descriptions can be located if desired. For the new species, we give a description. For all species, we illustrate good specimens in several orientations. For easy comparison, all figures are made at one magnification -- x 40. Even though certain details might show more clearly at higher magnifications, we believe that our choice permits the reader to check his specimen against our pictures with minimum inconvenience. Greater

depth of field could have been achieved with an electron microscope (SEM), but the cost was prohibitive. (Offered the choice of SEM photographs OR publication, we would elect the latter every time.)

Ostracod investigations in general have not yet reached the state where accurate and intricate conclusions can be formulated on the paleoecology of these fascinating little animals. For one reason, the faunal lists are all biased in favor of the species preserved in soft shales. We confess to being contributors to this state of affairs, but we have been as unsuccessful as our colleagues in finding a convenient method to get ostracods free from limestone or highly calcareous sediment. Another reason for the lack of paleoecologic information is the piecemeal description of faunas. Literature is replete with little studies of the ostracods from one family or another from a formation. Yet each family was just as important as the next in its contribution to the community structure. That is why we delayed publishing on the Silica Formation ostracods until the whole fauna was investigated. The day may come when ostracods are reported as faunas instead of selected genera and families. And some time the faunas may be extracted from limestones and other sediments besides soft shales. Then the exciting work of paleoecology can be firmly established.

Our deepest gratitude goes to Mr. Karl Kutasi in this, as in many other endeavors. He contributed his high skills and talents to the very difficult job of processing the film and printing the many photographs in this book. Such excellence and devotion deserves more praise than we could ever express.

PREVIOUS WORK

As is usually the case for a fauna from a well-known locality that has been visited by collectors for many years, the Silica ostracod fauna has been gradually increased and revised over a number of years. Many micropaleontologists have contributed to the present status of our knowledge concerning these little crustaceans. Some workers have described and listed

species from the outcrops of the Silica Formation. Others, too numerous to mention here, have meanwhile extended our understanding of the ostracod faunas of the same age in nearby regions. Below, therefore, we present only the significant publications which concerned the Silica fauna directly.

The fossils of the Silica Formation were first described by Dr. Grace Ann Stewart (1927) from the quarry of the Sandusky Cement Company in Lucas County, Ohio, not far south of the Michigan-Ohio line. From the 23 feet of exposed strata, she described a fauna of 63 species, only one of which was an ostracod -- a conspicuous punctate form known today as Ponderodictya punctulifera (Hall). This species is widespread in Middle Devonian beds in the Great Lakes region, and has been recorded under 9 different names.

Also in 1927, a similar fauna was noted by Dr. G. M. Ehlers and Mary E. Cooley from a shaft at Waterworks Park in Detroit along the Detroit River, across from the head of Belle Isle. Described as a Hamilton fauna with affinities to the faunas of New York State and the Traverse beds of Michigan, their list included some 23 species of ostracods from the strata penetrated by the water intake shaft.

In 1930 Dr. Stewart described three more ostracods from what she called the Silica shale: Isochilina ? scapha (now Coelonella scapha), Leperditia ? subrotunda ? (now Coelonella plana), and Bythocypris indianensis Ulrich. In her paper on "Ostracodes of the Silica Shale, Middle Devonian of Ohio" (1936), she listed 39 species of Ostracoda. All of her specimens were collected from the part of the quarries south of Brint Road, and now referred to as the South Quarry. Long abandoned, this quarry has partly filled with water and many of the upper units are obscured by slump and by dumped ash from the cement plant.

When the present owners, the Medusa Portland Cement Company, took over the quarry and expanded operations, they opened a new area north of Brint Road which became the North Quarry and extended back over $\frac{1}{2}$ mile. Until the past few years, this was the site of all operations and collecting, with people coming from all

over the United States, Canada, and even from abroad as the multitude of excellently preserved megafossils became known. In our previous paper on the Silica Formation megafossils, we list and illustrate the gamut of taxa known from uniquely preserved specimens. The formation provides one of the truly fine records of Middle Devonian life.

In 1939 Mary C. Turner described ostracods obtained from cores of wells drilled in the Dover, Dawn, D'Clute, and East Tilbury oil and gas fields of southwestern Ontario. She compared this fauna with that of the Silica Shale, listing 13 species common to both places (see chart). We have found an additional 8 species of her Ontario occurrences to be present in the Silica.

A. S. Warthin listed ostracods from the Silica Formation on three sets of large cards describing Invertebrate Fossils of North America (Devonian) published by the Wagner Free Institute of Science. In 1937 the Beyrichiacea were described on 106 cards. In 1942 the Leperditacea were described on 14 cards, including two species from the Silica:

- Card 13 - Coelonella plana Stewart
- Card 14 - Coelonella scapha Stewart.

In 1945 the Thlipsuracea were printed on 82 cards and included five Silica species:

- Card 35 - Strepulites crescentiformis = Octonaria crescentiformis (Van Pelt)
- Card 41 - Strepulites quadricostata = Octonaria quadricostata (Van Pelt)
- Card 71 - Moorea bicornuta = Bufina bicornuta (Ulrich)
- Card 76 - Euglyphella primitiva = Euglyphella sigmoidalis (Jones)
- Card 78 - Euglyphella sigmoidalis (Jones)

Shimer & Shrock (1944) in their book on "Index Fossils" listed six ostracod species from Silica Shale.

Stewart & Hendrix (1945a) compared the ostracods of the Plumbrook Shale of Erie Co., Ohio, with those of the Silica, and noted six species in common.

In 1951 G. M. Ehlers, R. V. Kesling, & Erwin C. Stumm, three professors at the Univ-

ersity of Michigan, prepared a guidebook for a field excursion by members of the Geological Society of America to study Devonian strata of southeastern Michigan and northwestern Ohio. By this time a nearly complete section of the Silica Formation had been exposed in the Medusa South Quarry, a total of 45 feet of shales and argillaceous limestones underlain by 8 feet of bluish-gray limestone that is somewhat argillaceous in the upper part. This bluish-gray section, directly overlying the Dundee Limestone, was given the name "Blue" limestone by J. E. Carman in Bassett (1935, p. 437). After a field conference with Doctors Carman and Stewart, Ehlers, Kesling, & Stumm (1951) dropped the name "Blue" limestone and extended the Silica Formation to include strata between the Dundee Limestone and the Ten Mile Creek Dolomite -- about 53 feet of beds, which they divided into 26 units. In their division, the principal ostracod-bearing beds of Stewart (1936; beds 1, 3, 5, and 6) became units 7, 9, 11, and 12. The greatest numbers of ostracods come from these beds, although some species are found elsewhere.

Tyrol B. Coley (1954) studied the ostracods of the Arkona Shale, Hungry Hollow Formation, and Widder beds of southwestern Ontario, the Centerfield, Ledyard, and Wanakah formations of western New York State, and the Silica Formation of northwestern Ohio. His chart listed 29 species from the Silica. The tiny ostracod Dizygopleura alethae was described by Coley (1954, p. 462, 463) from the Silica Formation. Later, Pauken (1966) identified it as Nodella tetralobata. Herein, we erect a new genus, Stictobollia, for it, inasmuch as its lobation and pitted surface are not like those of Dizygopleura or Nodella, nor is its hinge like that of Dizygopleura.

In describing species of his new genus Arcyzona from the Bell Shale (1952), Kesling compared specimens of Arcyzona campylactinota (p. 34-36) with Stewart's (1936, p. 752) Amphissites subquadratus Ulrich, and decided that Stewart's identification was incorrect and that her ostracods actually belonged in his new Arcyzona campylactinota. This was confirmed by Sohn (1961, p. 138), who also placed Boursella

TABLE 1 -- Previously Listed Occurrences (cont'd)

SPECIES	Author										
	Stewart 1927, 1930, 1936, 1937	Ehlers & Cooley 1927	Warthin 1937, 1942, 1945	Turner 1939	Shimer & Shrock 1944	Stewart & Hendrix 1945	Coley 1954	Sohn 1961, 1971	Peterson 1964, 1966	Pauken 1966	Abdul-Razzaq 1973
<i>Strepulites quadricostata</i> = <i>Octonaria</i>							X				
<i>Tetradella cicatricosa</i> = <i>Ctenoloculina</i>	X			X			X				
<i>Tetrasacculus bifidus</i> = <i>Subligaculum</i>	X										
<i>Tetrasacculus bilobus</i>	X						X				
<i>Ulrichia conradi</i>	X	X		X	X	X	X			X	
<i>Ulrichia fragilis</i>	X						X			X	

METHODS

Even one who is unfamiliar with paleontology can understand that megafossils, which can be measured in centimeters or in meters, differ from microfossils, which may be less than a millimeter long. But to the micropaleontologist, these differences become exasperatingly critical in his work -- the problems are inversely proportional to the size of the fossils. To put it simply, one can scale down neither the micropaleontologist nor his tools to be suited for minute fossils. Therefore, new techniques must be devised for collecting, cleaning, and photographing specimens which can scarcely be discerned with the unaided eye.

Collecting. -- The first difference between megapaleontology and micropaleontology begins with collecting the specimens. The collector of large fossils can see what he picks up in the field, he may even search for only the better preserved specimens at the exposure, and at the end of the day he can say how many he has selected. Not so with the micropaleontologist. His initial field work is exploratory, trial-and-error, and only after hours in the laboratory does he know whether he has any microfossils for his efforts. Even in a "rich" fauna, the chances of his observing a single specimen in the field are very small.

In this study, samples were taken from all the non-limestone units at the Medusa quarries (northwestern Ohio), the Martin-Mari-

etta Quarry (southeastern Michigan), and the material collected years ago from the shaft dug in Waterworks Park (Detroit, Michigan). About 10 pounds of shale were taken from each unit and prepared in the laboratory. Then from each unit found to be productive, additional material was collected at a future time. Ultimately, as much as 50 pounds of shale was processed from some of the units.

Processing shale. -- Because contamination by slumping was probable, the weathered faces of quarry exposures were avoided and only fresh shale from each unit was collected. For nearly all such collections, a long processing procedure was necessary.

When the sediment had been broken into fairly small fragments by soaking and (when necessary) by alternate freezing and thawing, they were washed through a strainer which was large enough to permit all ostracods to pass through the mesh. The larger pieces, caught on the strainer, were soaked and handled again to yield as much material to pass through the mesh as possible. The residue was then rinsed and decanted many times to eliminate particles of mud (clay and finely disseminated pyrite). The remainder, containing the microfossils, was then spread in thin layers on plastic trays to dry.

When thoroughly dried, the material was soaked in mineral spirits or kerosene for several days. This solvent was then carefully decanted (avoiding the removal of any clay or fossils in the process) and stored to be used

again.

Warm water was added to the spirit-soaked residues and the containers set aside for several days. During this interval, water gradually soaked into the pore spaces of any shale matrix present, replacing the spirits or kerosene and disseminating the clay particles of the matrix. When successful, this procedure frees the specimens of all adhering matrix.

Again the residues are washed, this time with detergent added to clear away the spirits from the particles of clay and from the specimens. After repeated washing and decanting, carefully leaving the smallest specimens behind, the residue is spread in thin layers on plastic trays and allowed to slowly air-dry. When the drying is complete, the material is ready for scanning under the microscope. It consists of ostracods, small broken fragments of larger invertebrates, and larger particles of pyrite or sand (if such is present). Ostracods and/or other microfossils can thereupon be removed individually to a slide with a moistened sable brush (size 0 or 00 is suitable).

Shales of units 9 and 11 respond best to this method of processing. Fortunately, the greatest number of ostracods occur in these units. Units 7, 12, and 15, for example, are more calcareous, and specimens from these units often require some additional cleaning by needles or by ultrasonic vibration.

Just a warning word for anyone starting to study faunas from several units or localities. Throughout the processing of matrix, the exact data with each batch must be kept with the material being washed, dried, and treated. For material or residues in dishes, the data can be entered on the container with wax pencil, and for material spread to dry in trays it can be written in waterproof ink on a small card. No matter how methodical or meticulous one may be in such matters, sooner or later some interruption will occur that breaks the chain of memory and you will return to the processing with doubts about which residues are from which collection. The whole interpretation of faunas depends upon the precise identity of the processed washings.

Cleaning individual specimens. -- Whenever small quantities of matrix persist in sulci or depressions of the ostracod valves, individual cleaning may succeed in removal of such shale and reveal the ostracod surface below. Yet if not carefully controlled and applied, such treatment can break the ostracod in two, damage delicate structures, or even shatter the valves into minute fragments.

We have achieved some excellent results with a small Branson ultrasonic vibrator using glass or plastic dishes that fit across the top of the well. From one to 20 ostracods were placed in one of these, covered with $\frac{1}{4}$ to $\frac{1}{2}$ inch of water to which a small quantity of detergent had been added, and then submerged in the detergent mixture in the well below a depth of $\frac{1}{2}$ inch. This has proved quite satisfactory for cleaning single valves with fine ornamentation. It is well to start with only 15 seconds of vibration, then decant and rinse to check the state of the specimens. If done a few at a time, whole carapaces can be vibrated up to two minutes without breakage.

The nature of the matrix requires some experimentation for maximum benefit and a reasonable balance between cleaning and abrasion. Other specimens from the unit should be used as a test before rare or choice specimens are subjected to ultrasonic treatment.

Photography. -- Until one actually tries to photograph an ostracod, the operation seems simple. If a macrofossil can be photographed natural size using a lens with a focal length of 200 mm, then one might assume that a microfossil could be photographed at ten diameters magnification using a lens of 16 mm focal length and all other factors kept the same. However, problems are introduced by both the camera and the coating of the specimen.

With the camera, the chief difficulty is sufficient depth of field. And once again, the root of the problem is the inescapable fact that tools cannot be scaled down. The part of the photographic system that becomes critical is the diaphragm (the element which controls the depth of field). For suitable depth of field with macrofossils, most photographs are made with

an opening of $f/32$ or $f/45$; to produce such an opening in a lens of long focal length, the diaphragm is "closed down" to a circle of a few millimeters diameter. To produce a comparable $f/45$ opening in a 16-mm lens would require a pinhole; but now we must deal with the metal of which the diaphragm is made. Whereas the blades comprising the diaphragm are thin enough to function well around an opening a few millimeters in diameter, they form a relatively thick faceted tube when brought around a pinhole. Light does not just pass through the opening of the pinhole; a great deal is reflected from the edges of the diaphragm blades. In fact, manufacturers of short focal length lenses do not ordinarily install diaphragm elements closing to smaller than $f/16$.

This is only one of the problems concerning the camera and its operation in optical photomicrography. Because ready-made or "packaged" instruments which can produce good pictures at magnifications of 10x and up are available only to the very affluent institutions, most micropaleontologists adapt available and less expensive pieces of equipment to do the job. Even the high-priced outfits may not produce the desired quality of pictures without adjustment or modification.

The ideal optical photomicrographic camera is one which will yield (1) good depth of field at 10x and higher magnifications in the negative, (2) consistent clarity of detail, and (3) quick operation. Some helpful suggestions are offered in the succeeding article, "Planning Photography of Microfossils."

The best solution we have found lies in using (1) 35-mm film, (2) coordinated lenses, and (3) uniform lighting. The film is selected not so much for its small size as for (1) the ease of handling, developing, and processing of film in small rolls, and (2) the variety of finegrained emulsions readily available in such films. Coordinated lenses are a matter of experimentation with available makes. One way to achieve a balance between depth of field and resolution of detail is to photograph through the tube of a microscope in which the objective (low-power with diaphragm) gives the desired depth of field and the eyepieces (high-power and

corrected to match the objective) enlarge the image so produced to focus on the film of the camera. Uniform lighting is advisable so that the pictures of various specimens on a plate can be compared in detail; this becomes impossible if one is photographed with strong low-level highlight and the next is photographed with nearly uniform high-level illumination.

The camera which was used here is a "home-made" affair contrived from an ancient Leitz monocular microscope body, an American Optical base and 4 x 5" adapter, a Kodak 35-mm camera, and a 48-mm Microtessar lens -- all joined and held together by suitable wood, brass, and felt couplings. Lighting was provided by three microscope illuminators.

The coating is another major problem in photomicrography. The sublimate of ammonium chloride for macrofossils being photographed natural size can vary considerably without concealing detail or showing its grain. For microfossils, however, it must be applied sparingly and evenly. If built up to the thickness commonly used for macrofossils, the sublimate takes on aspects of a snowdrift when magnified to 30 diameters in the print. We find that a "thin smoke" of heated ammonium chloride allowed to drift upward onto the specimen can be controlled much more satisfactorily than smoke blown onto the specimen by any means.

If several photographs are to be taken of a specimen in various orientations, all traces of the first coating must be removed before the second is applied. If the removal is incomplete, the chloride traces will dry and crystallize and give a pattern like frost on a cold window pane. It is advisable to remove the specimen to clear water and agitate it for several seconds after each photograph has been taken.

To assist the reader of a paper, the pictures on the plates should supply clear-cut, unquestionable illustrations of the characters mentioned in the text -- or as many of them as can be shown. If a species is typically punctate, the photographs should show punctae; if it has L/R overlap, photographs should demonstrate that the left valve is larger than the right. Pictures of several specimens in various orientations

may be required to illustrate the morphology of a variable species.

The selection of prints is highly important in obtaining a fairly even balance of contrast and intensity of figures on a plate. On a black background, the shadowed margins should not blend into the black, and in any photograph the highlighted areas should still show detail. This requires careful adjustment of the lighting before any photographs are taken, selection of the proper film to register as much contrast as is necessary, and careful control of the printing process.

GEOLOGY

Age. -- As shown by its fauna, the Silica Formation is Middle Devonian. This places it at about 350 million years old (the figure varies somewhat according to the method used to determine age).

Correlation. -- The formation is underlain by the Dundee Limestone and overlain by the Ten Mile Creek Dolomite. If, as generally believed, the Ten Mile Creek is correlated with the Four Mile Dam Limestone of northeastern Michigan and with the Hungry Hollow Formation of southwestern Ontario, then the Silica may be the time equivalent of the Bell Shale, Rockport Quarry Limestone, Ferron Point Formation, Genshaw Formation, Newton Creek Formation, and the Alpena Limestone of Alpena and Presque Isle Counties, Michigan, and the Arkona Shale of the Thedford-Arkona region, Ontario. However, since the fauna shows no affinities with the Rockport Quarry (probably deposited on shallow flats) or with the Newton Creek (probably deposited in a lagoon), the Silica Formation appears to be lithologically and paleoecologically related to the Bell, Ferron Point, Genshaw, and the middle thin shale bed of the Alpena Limestone. It thus occupies a position in the lower part of the Traverse Group of Michigan.

Lithology. -- The Silica Formation is a series of soft clay shales interbedded with slightly more resistant calcareous shales and with a few distinctly more resistant argillaceous

limestones. The succession of units is shown in text-figure 2. In most sections of the well-known quarries at Silica, the formation is around 55 feet thick.

As the formation is traced northeastward from the quarries in northwestern Ohio to the strata encountered in the shaft at Waterworks Park (text-fig. 1), it becomes more uniform and shaly. The limestones at the base in the Ohio exposures are replaced by the Tropidoleptus-bearing shale in Michigan. The strata at Waterworks Park differ only slightly in fauna and lithology from the soft Arkona shales exposed along the Ausable River at Hungry Hollow and in the Tileyard at Thedford, Ontario.

For a detailed description of the units exposed in the Medusa quarries of Ohio, please see our section in "Strata and Megafossils of the Middle Devonian Silica Formation" (Kesling & Chilman, 1975, p. 39-43), and for photographs of exposures, please refer to our text-figures in the same publication (1975, text-figs. 7-74).

Structure. -- The Silica Formation is part of a zone of Middle Devonian rocks exposed around the Michigan Basin and extending under the central part of the basin. The Localities from which our ostracods were obtained (text-fig. 1) lie on the west-northwest flank of the Findlay Arch, a northeastern extension of the Cincinnati Arch, on the southeast margin of the Michigan Basin. In northwestern Ohio, the strata trend almost north-south and dip rather sharply (nearly 4°) to the west in the Lucas County Monocline. In Michigan, however, the dip decreases drastically to a few feet per mile.

Exposures. -- As noted under "Localities" Silica strata are exposed extensively in only two small areas, both the result of quarrying. Elsewhere in northwestern Ohio and southeastern Michigan, the beds are concealed beneath a relatively shallow cover of glacial drift. Over extensive areas, this cover of sand and gravel is only a few feet thick.

LOCALITIES

Material for ostracods was processed from only three main localities -- one in northwestern Ohio, one in southeastern Washtenaw County, Michigan, and one in Detroit, Michigan.

Unfortunately, the exposures are becoming inaccessible as the quarries are abandoned. At present, the lower units of the formation are available only in the South-south Quarry of the Medusa Portland Cement Company. Within the foreseeable future, this quarry will also be exhausted as a source of cement rock and abandoned; soon thereafter it will also fill with water, as have the other abandoned quarries of the company. Our faunal lists, therefore, may be the best available for some time. Hopefully, as the demand for cement in the region increases, new quarries will be opened in the Silica Formation and additional collections will be possible.

The units from which faunas were obtained are listed in the charts and in text-figure 2.

1. Medusa quarries.

a. Medusa North-north Quarry. Small quarry opened and operated by the Medusa Portland Cement Company in the 1960's and soon abandoned. It is an extension from the Medusa North Quarry, and situated in the S $\frac{1}{2}$ NE $\frac{1}{4}$ sec. 7, from 1/8 to $\frac{1}{4}$ mile west of Centennial Road and from $\frac{1}{4}$ to $\frac{1}{2}$ mile south of Sylvania-Metamora Road (which is one mile south of the Ohio-Michigan state line).

b. Medusa North Quarry. Quarry developed by the company in the late 1940's and abandoned around 1970. It began near the base of the steeply dipping formation and continued down dip to utilize the full thickness of the formation. Its west wall is capped by several feet of the Ten Mile Creek Dolomite. Now it is filled with water to about the base of unit 18. Located in SE $\frac{1}{4}$ sec. 7, from 1/8 to 3/8 mile west of Centennial Road and from Brint Road to $\frac{1}{2}$ mile north.

c. Medusa South Quarry. Started by the Sandusky Cement Company in the 1920's, this quarry was the source of fossils described

by Dr. Grace Ann Stewart. Later, it was operated by the Medusa Company and gradually abandoned as the Medusa North Quarry was developed. Presently, it is nearly filled with water and the walls are being obscured by dumped waste from the cement company; the only exposures, in the southeast wall, are slowly slumping and stratigraphic units may not be identifiable for much longer. Located in NE $\frac{1}{4}$ sec. 18, from 1/8 to slightly over $\frac{1}{4}$ mile west of Centennial Road and from Brint Road to $\frac{1}{2}$ mile south.

d. Medusa South-south Quarry. The only presently active quarry for cement rock, this quarry is still being developed. In the southwest corner, however, the wall already exposes the contact with the overlying Ten Mile Creek Dolomite, and the reserves will probably last for a decade at most. Unless land can be purchased reasonably to the south, this will be the last quarry operated for Silica Formation rock in the area. Located in SE $\frac{1}{4}$ sec. 18, from 1/8 to 3/8 mile west of Centennial Road and from Sylvania Avenue to about $\frac{1}{2}$ mile north.

2. Martin-Marietta Quarry. Ill-fated quarry opened around 1960 by the Martin-Marietta Corporation to obtain rock from the Dundee Limestone. Because the Silica Formation and the glacial cover were overburden to the operation, they were stripped and piled helter-skelter around the margins of the proposed quarry center. No clean face of the Silica was ever developed. Shortly after quarrying began, a well drilled in the bottom of the quarry penetrated a stratum bearing hydrogen-sulphide-charged water. The quarry flooded rapidly and, since no disposal was available for pumping out the continuously renewed water, the company decided to abandon the project. Silica units can be identified in some of the dumped slabs and piles by their fauna (as compared with the units at the Medusa quarries). Located in NE $\frac{1}{4}$ sec. 31, T 4 S, R 7 E, just south of Arkona Road and about $\frac{1}{4}$ miles east of US 23, between Sanford and Godkins Roads and southeast of the Wabash Railroad right-of-way, Augusta Township, Washtenaw County, Michigan.

3. Waterworks Park. During the summer of 1925, the Board of Commissioners of the City of Detroit made a series of borings in the

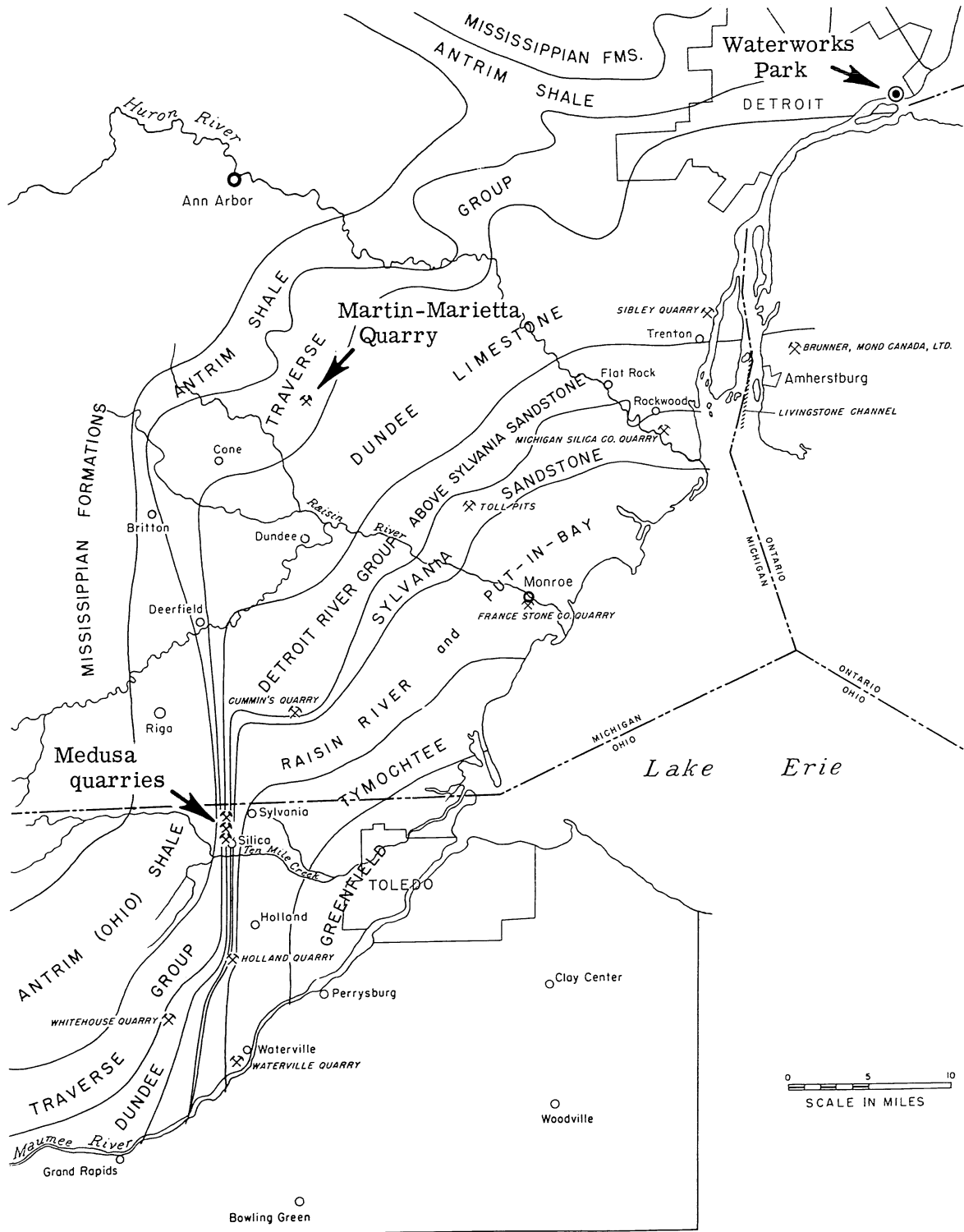

TEXT-FIG. 1 -- Geologic map of southeastern Michigan and northwestern Ohio. The band labeled "Traverse Group" includes the Silica Formation and the Ten Mile Creek Dolomite. The three localities from which ostracods were obtained are indicated by bold arrows.

vicinity of the north end of Belle Isle to plan for a water intake tunnel extending under the Detroit River. The following year, a shaft was sunk at Waterworks Park, between Jefferson Avenue and the Detroit River at a point opposite the head of Belle Isle. The hole was 16 feet in diameter. Before the excavation was sealed off with concrete, Professor George M. Ehlers of the University of Michigan Museum of Paleontology persuaded the commissioners to allow him to be let down in a basket to measure the

strata and collect samples. The descent took place on November 10, 1928, at which time the upper layers were exposed; additional trips down the shaft, finally reaching a depth of 185 feet 4 inches, took place at intervals shortly afterward. The shaft penetrated into the Dundee Limestone. Ehlers' important notes were first published in Bassett (1935, p. 434-436) and later copied in our paper on megafossils (Kesling & Chilman, 1975, p. 24-27). Enough material was still available to us to study the stratigraphic distribution of the ostracod fauna.

SECTION

Silica Formation Exposed in Quarries of Medusa Portland Cement Company near Silica, Sylvania Township, Lucas County, Ohio

Adapted from sections by Ehlers, Stumm, & Kesling (1951, p. 18-20), Nussmann (1961), and Mitchell (1967, p. 186-190).

	North Quarry (1967) Ft. In.	South Quarry (1951) Ft. In.
Ten Mile Creek Dolomite (basal unit)		
Limestone, dolomitic, grainy to crystalline, brownish-gray to drab, somewhat laminated, in layers 2 to 4 inches thick		1 4

SILICA FORMATION

Berkey Member (of Mitchell)

29. Limestone, very argillaceous, blue-gray, much dolomitized. As much as 3 inches of uppermost part belonging probably to Ten Mile Creek Dolomite, containing mixture of Silica species (<u>Pholidostrophia</u> and others) and Ten Mile Creek species (<u>Atrypa</u> and rugose corals) as well as marcasite concretions	0 7-11	} 6+ 0
28. Limestone, very argillaceous in lower part, less so near top, blue-gray, some small marcasite concretions. Massive bryozoa and <u>Strophodonta</u>	0 6 $\frac{1}{2}$ -8	
27. Limestone, argillaceous, massive, dark blue-gray, some small marcasite concretions. Massive bryozoa and <u>Strophodonta</u>	0 14-16	
26. Limestone, very argillaceous, dark blue-gray, some small marcasite concretions. Abundant <u>Pholidostrophia</u> and <u>Strophodonta</u>	0 3	
25. Limestone, massive, argillaceous, dark blue-gray. Massive bryozoa and <u>Strophodonta</u> ; basal 6 inches with abundant <u>Streblotrypa</u>	0 10-11	
24B. Limestone, extremely argillaceous, weathering into angular fragments, gray. Fossils rare except for abundant <u>Mucrospirifer</u> at base	0 6	} 0 6
24A. Limestone, very argillaceous, gray, containing scattered marca-		

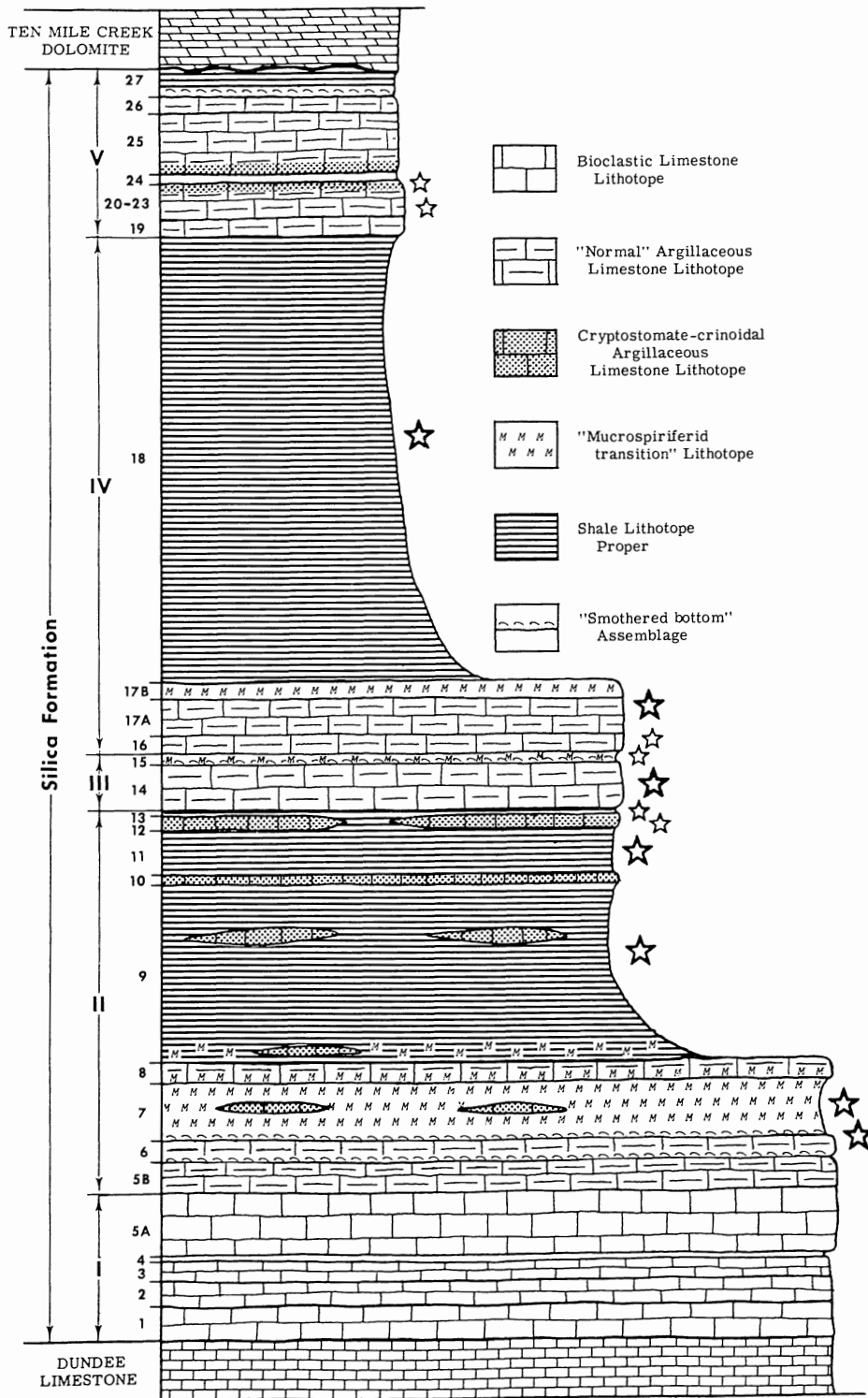

TEXT-FIG. 2 -- Stratigraphic column through the Silica Formation in the Medusa quarries. Stars mark the units from which ostracods were collected: upper part of unit 6, 7, 9, 11, 12, 13, 14, 15, 16, 17, 18, 21, and 23. After Nussmann in Kesling & Chilman, 1975, p. 210.

	North Quarry		South Quarry	
	Ft.	In.	Ft.	In.
site. Abundant massive bryozoa and <u>Mucrospirifer</u> ; pyritized concentrations of <u>Streblotrypa</u> at top and base	0	4		
23. Limestone, massive, argillaceous, dark-gray but lighter than underlying unit, many marcasite concretions, grading into units below and above but harder than either. <u>Leiorhynchus kelloggi</u> abundant, <u>Mucrospirifer</u> common	0	8	0	8
22. Limestone, massive, argillaceous, dark-gray, some marcasite concretions. <u>Devonochonetes</u> , <u>Leiorhynchus kelloggi</u> , <u>Mucrospirifer</u> , and massive bryozoa characteristic	0	4	0	4
21. Limestone, massive, slightly argillaceous, dark-gray, many marcasite concretions, harder than units below and above. Numerous <u>Aulocystis</u> ; <u>Mucrospirifer</u> , <u>Strophodonta</u> , and massive bryozoa present	0	5	0	5
20. Limestone, argillaceous, dark-gray. <u>Strophodonta</u> and massive bryozoa; few auloporoids (South Quarry only)	0	3	0	3
19. Limestone, massive, slightly argillaceous, hard. Base containing phosphate nodules and comminuted fish bones; basal surface preserving casts of trails from uppermost surface of underlying unit. Abundant <u>Leiorhynchus kelloggi</u> , <u>Mucrospirifer</u> , and <u>Strophodonta</u> ; some massive bryozoa	0	7	0	7

Disconformity

18B. Shale, calcareous, dark-gray, carbonaceous, strong petroliferous odor on fresh surface; weathering into light-gray angular fragments; some pyrite noted on weathered surfaces. Fossils scarce except where <u>Aulocystis</u> bioherm is developed in North Quarry in unit 18A	21	0	} 20	0
18A. Shale, calcareous, gray to dark-gray, similar to unit 18B. One or more argillaceous limestone lenses may be present near base. Abundant <u>Aulocystis</u> , <u>Mucrospirifer</u> , and " <u>Sphenophragmus</u> "; an <u>Aulocystis</u> thicket or bioherm well developed in north end of North Quarry, where <u>Camarotoechia</u> and numerous pelecypods also occur in both 18A and 18B	0'9"	-10'3"		
17. Limestone, massive and argillaceous at base, becoming very argillaceous at top, dark-gray. Very abundant " <u>Ambocoelia umbonata</u> "; <u>Leiorhynchus</u> , <u>Mucrospirifer</u> , and <u>Rhipidomella</u> fairly common	0	10-11	1	0
16. Limestone, massive, slightly argillaceous, gray, weathering olive-gray, grading into overlying unit but sharply separated from underlying shale; concentrically banded marcasite concretions. Abundant <u>Devonochonetes</u> , <u>Mucrospirifer</u> , and massive bryozoa; fauna concentrated near base	0	6-12	1	0

Disconformity (?)

15. Shale, calcareous, gray. Abundant <u>Devonochonetes</u> and <u>Mucrospirifer</u>	0	5-7	0	3
--	---	-----	---	---

	North Quarry Ft. In.	South Quarry Ft. In.
14B. Limestone, very argillaceous, dark-gray. Very abundant <u>Rhipidomella</u> and <u>Strophodonta</u>	0 3	} 1 10
14A. Limestone, massive, argillaceous, light- to dark-gray. Massive bryozoa, <u>Protoleptostrophia</u> , and <u>Strophodonta</u> common. Base of unit preserving casts of trails and burrows from uppermost surface of underlying unit	1 9-14	

Disconformity

Brint Road Member (of Mitchell)

13. Shale, calcareous, dark-gray. Where unit 12 is developed as a limestone lens (as in part of South Quarry), shale contains many crinoids and blastoids, including <u>Arthroacantha carpenteri</u> , <u>Gilbertsocrinus ohioensis</u> , and <u>Euryocrinus laddii</u> ; <u>Streblotrypa anomala</u> , <u>Sulcoretepora deissi</u> , and other cryptostomatous bryozoa very abundant. At other places, where unit 12 is represented by shale, top of unit contains comminuted echinoderm columnals and concentrations of bryozoa	0 ¼-1	0 ¼-1¼
12. Limestone, argillaceous, light-gray, usually consisting of several lenses (North Quarry); in many parts of South Quarry absent or represented by shale. <u>Streblotrypa anomala</u> , <u>Sulcoretepora deissi</u> , and other cryptostomatous bryozoa very abundant (North Quarry and limestone lens in South Quarry)	0 6-12	0 3-4
11. Shale, calcareous, gray, many marcasite concretions, weathering into angular fragments. <u>Devonochonetes</u> and <u>Styliolina fissurella</u> abundant; some ostracods; few <u>Paraspirifer</u> valves and fragments of <u>Rhinocaris</u>	1 7-12	2 2
10. Limestone, argillaceous, gray, in North Quarry consisting of 1 to 3 lenses. Abundant bryozoa, including <u>Acanthoclema ohioense</u> , <u>Streblotrypa anomala</u> , <u>Helopora inexpectata</u> , and <u>Sulcoretepora deissi</u>	0 5-6	0 4
9B. Shale, calcareous, blue-gray, abundant marcasite concretions. <u>Devonochonetes</u> , <u>Mediospirifer audaculus</u> , <u>Phacops rana milleri</u> , and <u>Rhinocaris ehlersi</u> characteristic	6 10	} 7 6
9A. Limestone, argillaceous at base to very argillaceous at top, blue-gray, abundant marcasite concretions, weathering to sticky clay when wet. Very fossiliferous, producing most of the common Silica species; <u>Mucrospirifer prolificus</u> , <u>Phacops rana milleri</u> , and <u>Paraspirifer bownockeri</u> common	0 8	
8. Limestone, massive, argillaceous, blue-gray, abundant marcasite concretions, relatively hard. All fossils strongly pyritized. <u>Mucrospirifer prolificus</u> and <u>Strophodonta</u> abundant	0 8-12	0 8
7C. Shale, calcareous, blue-gray. Many fossils worn by wave action before burial. Best developed in north end of North Quarry. <u>Megastrophia</u> and <u>Strophodonta</u> abundant	0 2-3	
7B. Shale, calcareous, blue-gray. <u>Devonochonetes</u> and <u>Mucrospirifer prolificus</u> abundant	0 10	

	North Quarry Ft. In.	South Quarry Ft. In.
7A. Shale, calcareous, blue-gray, with occasional argillaceous limestone lens. Contains much water-worn fossil debris. Large <u>Atrypa</u> abundant in lower 1 foot; <u>Devonochonetes</u> , <u>Fistulipora vesiculata</u> , <u>Megastrophia</u> , <u>Mucrospirifer prolificus</u> , <u>Pholidostrophia</u> , <u>Protoleptostrophia</u> , <u>Strophodonta</u> , and many other species abundant; <u>Cystiphyllodes americanum</u> , <u>Heliophyllum halli</u> , and <u>Heterophrentis simplex</u> found at base. <u>Hercostrophia robusta</u> and <u>Pleurodictyum (Procteria) cornu</u> restricted to this unit	0 18	2 6

Disconformity

"Blue limestone" of older reports

6. Limestone, argillaceous, blue-gray, very argillaceous at top and base. <u>Atrypa</u> and <u>Strophodonta</u> abundant; " <u>Spinocyrtia euryteines</u> " abundant at top of unit; <u>Athyris</u> , <u>Lophonychia cordata</u> , <u>Mucrospirifer</u> , <u>Schizophoria ferronensis</u> , and tetracorals less common; <u>Platyceras</u> and trepostomatous bryozoa present	1 0	1 0
5B. Limestone, massive, argillaceous, blue-gray, crystalline. " <u>Spinocyrtia euryteines</u> ," <u>Strophodonta</u> , and massive bryozoa common	1 3	4 0
5A. Limestone, massive, slightly argillaceous, blue-gray; composed of bands of brachiopod debris. <u>Cyrtina</u> , <u>Heterophrentis</u> , and other tetracorals abundant	2 9	
4. Limestone, very argillaceous, blue-gray, weathering to clay. Fossils rare	0 2-4	0 3
3. Limestone, massive, bioclastic, blue-gray weathering to brown. <u>Atrypa</u> , <u>Cyrtina</u> , <u>Hexagonaria anna</u> , <u>Hexagonaria tabulata</u> , and <u>Strophodonta</u> abundant; numerous simple rugose corals, tabulate corals, and spiriferid brachiopods	0 12-14	1 0
2. Limestone, massive, bioclastic, blue-gray weathering to brownish-gray. Abundant <u>Devonochonetes coronatus</u> near base; <u>Favosites</u> and <u>Hexagonaria</u> common	1 2	0 10
1. Limestone, massive, bioclastic, blue-gray. Abundant <u>Atrypa</u> , <u>Devonochonetes coronatus</u> , <u>Megastrophia</u> , <u>Protoleptostrophia</u> , <u>Strophodonta</u> , and <u>Tropidoleptus carinatus</u> ; <u>Paracyclas</u> and <u>Gosselettia triquetra</u> present	1 4	1 4
Total	53'9''-57'0''	54'8''-54'10''

Disconformity

Dundee Limestone (top unit)

Limestone, light bluish-gray, in beds 4 to 12 inches thick, highly fossiliferous. Most characteristic fossil of unit <u>Productella spinulicosta</u> ; <u>Cyrtina</u> abundant in lower and upper parts; <u>Brevi-spirifer lucasensis</u> , an excellent guide fossil, present; <u>Atrypa costata</u> , other brachiopods, <u>Hexagonaria</u> , <u>Favosites</u> , and bryozoa present	5 0
--	-----

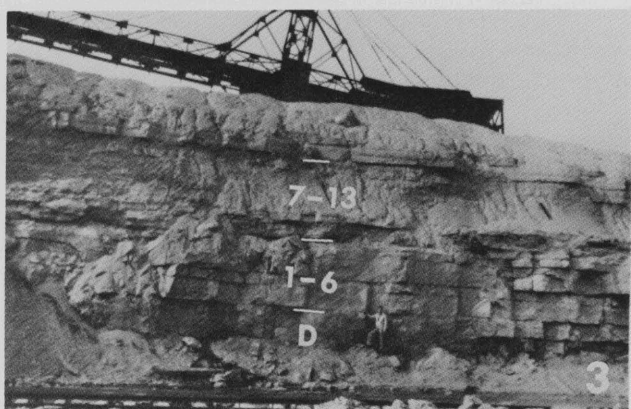

TEXT-FIG. 3 -- Six views of Silica Formation exposures. 1, Medusa South-south Quarry, looking south, 1974. 2, Medusa South-south Quarry, southwest corner, 1974. 3, Medusa South Quarry, west wall, 1950. 4, Medusa North Quarry, west wall, 1960, exposing full extent of the formation. 5, Medusa South-south Quarry, south wall, 1974. 6, Medusa North Quarry, top of west wall, 1974. In the photographs, units of the formation are indicated by small numbers, the Dundee Limestone by D, and the Ten Mile Creek Dolomite by T or TMC. For additional views, see Kesling & Chilman, 1975, text-figures 7 through 75.

Silica Formation Exposed in Martin-Marietta Quarry
near southeast corner of Washtenaw County, Michigan

Thicknesses unknown; section reconstructed by faunal correlations with section exposed in Medusa quarries.

PLEISTOCENE

Glacial gravel and sand.

MIDDLE DEVONIAN

Silica Formation

- 17-18. Shale, gray, calcareous but weathering slowly. Upper part less resistant and relatively unfossiliferous except locally where a thicket was formed by the coral Aulocystis and the tiny brachiopod Sphenophragmus (the same as the thicket in Medusa North Quarry); a few cryptostomatous bryozoa and poorly preserved ostracods. Lower part containing some "Ambocoelia" and Mucrospirifer mucronatus and a few fish plates (probably Protitanichthys); only about 12 genera of ostracods present, with Octonaria laevilitata abundant and characteristic.
- 14-15. Shale, calcareous, containing Mucrospirifer grabau and Devonochonetes scitulus in appreciable numbers, but also yielding Cyrtina, Sphenophragmus, Rhipidomella, Aulocystis, Tentaculites, Phacops, and cryptostomatous bryozoa (mostly Acanthoclema, Streblotrypa, Helopora, and fenestellids). Lower part with few fossils. Ostracods few and many pyritized to some degree, but several genera represented. Upper part with Ponderodictya, ornamented Quasillites, Punctoprimitia, and Menoeidina most common; lower part with Octonaria laevilitata most common but over a dozen other genera present. Base of unit marked by strap-like furrow and channel fillings, as at the Medusa quarries.
12. Shale, slightly calcareous, highly fossiliferous. Fossils pyritized, many apparently water-worn before burial. Matrix almost completely free of crystalline pyrite. Cryptostomatous bryozoa abundant, especially Streblotrypa anomala and Sulcoretepora deissi. Conodonts fairly common, mostly Icriodus and Polygnathus types. Few large scolecodonts. Tentaculites numerous, Styliolina rare. Where matrix contains many broken pieces of crinoids, trilobites, brachiopods, and other invertebrates, ostracods are scarce. Where matrix is mostly clay shale, ostracods are abundant, including Adelphobolbina, Aechmina, Arcyzona, Bufina, Eridoconcha, Coelonella, Ctenoloculina, Dizygopleura, Eukloedenella, Healdia, Hollinella, Monoceratina, Poloniella, Ponderodictya, Punctoprimitia, Quasillites, Ropollonellus, Stictobollia, Subligaculum, Tetrasacculus, and Ulrichia species. Most ostracods pyritized in some part, but many displaying fine details.
- 9-11. Shale, gray, very soft and disintegrating in water. With treatment first in mineral spirits, matrix yields exceedingly well preserved ostracods of about 100 species. Only unit at this locality containing Paraspirifer bownockeri. Matrix containing some iridescent crystals, thought to be marcasite, some of which appear "embedded" in fossils. Devonochonetes fragilis and Styliolina distinctive and plentiful. Nowakia and Sulcoretepora present in considerable numbers. Pleurodictyum (Procteria) cornu especially well preserved. Mucrospirifer, cryptostomatous bryozoa, Tentaculites, scolecodonts, Phacops, conodonts, and crinoid plates. Different beds within the unit produce megafossils and ostracods in different percentages, associations, and abundances.
7. Shale, gray, calcareous and harder than above but weathering rather rapidly, apparently somewhat thinner than at the Medusa quarries. Matrix with disseminated pyrite weathering to limonite and staining weathered dump piles of material. Upper part is fine-grained shale

with Mucrospirifer prolificus. Lower part contains some tabulate corals: Trachypora minutissima, T. labyrinthica, T. silicensis, Aulocystis jacksoni, A. auloporoidea, and Pleurodictyum (Procteria) cornu. Localized thicket of Aulocystis jacksoni. Abundant articulate brachiopods, many with inarticulates (Philhedra and Petrocrania) attached: Strophodonta, Protoleptostrophia, Pholidostrophia, Schizophoria, Mucrospirifer, Schuchertella, Sphenophragmus, and a few small Hercostrophia and Cyrtina. Bryozoa plentiful. Phacops rana crassituberculata fairly common. Ostracods fairly numerous, including the only occurrence at this locality of Octonaria quadricostata. Other invertebrates present but rare.

1-6. Shale, gray, calcareous. Upper part (probably equivalent to units 5 and 6) similar to unit 7, breaking down in Quaternary-O and mineral spirits; fine specimens of brachiopods: Devonochonetes scitulus (common), Atrypa, Protoleptostrophia, Sphenophragmus, Schizophoria, Cyrtina, and others. Ostracods from this upper part few but clean and well preserved. Lower part very fine grained, containing some fine grains and a few crystals of pyrite; Tropidoleptus carinatus numerous and typical, but other brachiopods and bryozoa common. Phacops rana milleri present; Tentaculites and Styliolina rare. Pleurodictyum (Procteria) cornu the only coral present. Ostracods few; Quasillites most abundant, but not more than a dozen other genera found.

Dundee Limestone

Essentially the same lithology and fauna as at the Medusa quarries.

Silica Formation Formerly Exposed in Shore Shaft of
Water Intake Tunnel, Waterworks Park, Detroit, Michigan

Revised from description by G. M. Ehlers (1928) with addition of
unit numbers thought to correspond with units at Medusa quarries.

PLEISTOCENE

Soil and glacial drift	Ft.	In.
	20	0

PLEISTOCENE AND MIDDLE DEVONIAN

Mostly Silica Formation from nearby moved by glacier, mixed with a little gravel and boulders, and re-deposited. Part of the shale may be in place.

Clay, yellow	2	0
Clay, blue with small pebbles and patches of sand	82	0
Clay ("hard pan" of engineers), stiff, bluish-gray, arenaceous, with numerous small pebbles and a few boulders. <u>Spirifer bownockeri</u> and a few other fossils, characteristic of Silica shale of Ohio found in clay	4	0

MIDDLE DEVONIAN

Silica Formation

12. Clay, blue, with many blocks of limestone and a few boulders of igneous and metamorphic rocks. Numerous blocks of bluish-gray, argillaceous limestone (or calcareous shale, to judge from samples) with Silica shale fossils are present, especially near the base of the interval. These blocks were derived from thin layers of limestone within a bluish-gray shale. This shale was

	<u>Ft.</u>	<u>In.</u>
reduced to a clay by weathering prior to the advent of the Wisconsin glacier; shearing planes in the clay indicate that the glacier squeezed this soft material. The calcareous matrix contains the same megafossil and microfossil fauna as the unit 12 material from Martin-Marietta Quarry and the Medusa quarries. The blue clay may represent other units that were churned and redeposited by the glacier	19	0
9-11. These units are not clearly equivalent to each of the units at Medusa quarries. In the notes accompanying the material collected by Ehlers, the following three beds were called the "pyrite band."		
Shale, bluish-gray with scattered crystals of pyrite and a few remains of <u>Chonetes</u> and ostracods	2	6
Shale, bluish-gray with numerous disseminated crystals of pyrite. Numerous specimens of <u>Spirifer mucronatus</u> var., <u>Chonetes</u> , and <u>Phacops</u> sp. -- very similar or identical with <u>Phacops rana</u> var. <u>milleri</u> Stewart.....	0	6
Shale, bluish-gray with scattered crystals of pyrite and a few small lenses (1 to 2 inches in thickness) of this mineral. Shale has a few oblique joints and a splintery fracture, tending to be parallel with the bedding	14	10
7. Two beds have the fauna of typical unit 7 at Martin-Marietta Quarry.		
Shale, bluish-gray with numerous disseminated crystals of pyrite. Remains of <u>Spirifer mucronatus</u> , <u>Leptostrophia perplana</u> , and ostracods in abundance. Cranidia and pygidia of <u>Phacops</u>	8	
Shale, bluish-gray with scattered crystals of pyrite. Nodules of finely crystalline pyrite 1 to 4 inches in length and $\frac{1}{2}$ to 1 inch in thickness are present in a band about 4 feet below top of interval. The lower part of this interval contains numerous remains of <u>Tropidoleptus carinatus typicalis</u> and many other fossils of Hamilton relationship noted by G. M. Ehlers and Mary E. Cooley (1927, p. 231-236)	15	6
1-6. Two beds called "Delaware limestone (? Sellersburg)" by Ehlers are the equivalent of units 1-6, the "Blue limestone" of the Medusa quarries. Here, as at Martin-Marietta Quarry, <u>Tropidoleptus carinatus</u> is common, and in the material collected by Ehlers are labels stating " <u>Tropidoleptus zone</u> ."		
Limestone, massive, crystalline, bluish-gray, containing simple corals, <u>Atrypa</u> sp., and <u>Tropidoleptus carinatus</u> . From the remnants of matrix still available in the Museum of Paleontology, we would suggest that at least part of this unit could be called a calcareous shale	5	4
Limestone, crystalline, dark bluish-gray, crumbly, with some argillaceous bands and hydrogen sulphide-bearing water	2	6
Dundee Limestone		
Limestone, massive, crystalline, buff and fossiliferous, especially in lower part ...	4	2
Limestone, massive, crystalline, bluish-gray to buff-gray and fossiliferous	7	0
Limestone, massive, crystalline, gray to buff-gray and fossiliferous	5	4

FAUNA OF THE SILICA FORMATION

Among the descriptions and systematic listings that follow, we have interspersed KEYS to the families and species of Silica ostracods. These KEYS are tailored to apply particularly to the ostracods found in the formation, although they may in part find broader application.

In resorting to KEYS, we may be guilty of contributing to the paleontologist's dilemma, which was explored in some depth by Professor E. C. Case in 1951, at which time he was Emeritus Curator in our Museum of Paleontology. His warnings and admonitions came near the close of a long lifetime of studying evolution; they were incited by the appearance of "emergent evolution" and the beginnings of the "new paleontology." A few quotations from his paper on "The Dilemma of the Paleontologist" are still timely and can hardly be considered out of place in this or any other work treating with taxonomy of an extensive fauna. Case remarked (1951, extracts from p. 173-185):

... The troubled paleontologist is commonly unacquainted with recently proposed theories of evolution and is confused by the fact that much of the paleontologic evidence originally arrayed to prove evolution is now rejected as invalid. Things long accepted as basic evidence are now known to have been supported by untenable assumptions and abstractions. Unless these be made the paleontological record is incoherent, and if they are made the results are questionable.... The dilemma of the paleontologist is that he is attempting with static and inadequate material to realize the life processes (physiology) of extinct organisms. His material is inadequate because each fossil specimen was a static end result of evolution at the time the organism died.... The fossil offers no explanation of the machinery of evolution, but the material accumulated through geological time constitutes an enormous amount of evidence which may be arranged, rightly or wrongly, in evolutionary series.

The hints of history or futurity in a delimited fossil specimen are necessarily based on the similarity of structural characters, but this does not necessarily mean identity of origin; ... series in a museum is by no means proof of series in nature. Many series that

have been acclaimed as evidence have later been proved false by the recognition of convergence, divergence, polyphylety, or parallelism.

The evidence furnished by fossils of the activities of the organism when alive is exclusively, or nearly so, circumstantial evidence. A series of specimens in a supposed phylogenetic line may be such as they appear, or they may be unrelated items in a fortuitous juxtaposition....

To the paleontologist the fossil "smells of mortality" and is subject to all the methods of biological investigation insofar as they are applicable to the preserved hard parts. This latter field is so large and so seductive that the enthusiastic and unwary paleobiologist may be, and has been, led to conclusions far beyond those warranted by the material at hand. There is constant temptation to apply genetic principles to the explanation of phylogeny, but such explanations can only be specious and suggestive; only the result can be shown by the fossil, never the machinery.

... the paleontological record is fore-shortened by omissions, losses, misinterpretations... breaks in the record have been patched with assumptions....

Enthusiasm for new revelations has caused fragmentary evidence to be arranged and rearranged to fit the idea of continuous, step-by-step evolution. This resulted in ubiquitous phylogenetic trees...

Our KEYS also leave us in the undefended position of trying to show relationships (based on similarities) by means of taxonomy (based on differences). Nevertheless, the clear separation of taxa is a step toward more precise considerations of classification. If further work discloses inconsistencies or inaccuracies, then we can pinpoint the exact place for revision.

The Treatise volume on Ostracoda (1961) was supposed, at the time, to stabilize the higher taxonomic categories for an appreciable interval of time. Perhaps fortunately, this did not transpire. Many revisions and innovations have appeared in recent publications, some well conceived and documented and others not so well. Because we treat many suprageneric categories in this fauna, we have not found any one source to include a classification with which we would entirely agree. Therefore, the following systematic treatment is based on various sources. The need for further exploration is

[continued on page 37]

KEY TO OSTRACOD FAMILIES IN THE SILICA FORMATION

(See *Treatise on Invertebrate Paleontology*, Volume Q, p.Q47-Q56, for terminology)

1. Valves retaining earlier molts Order ERIDOSTRACA, Family Eridoconchidae
Valves never retaining earlier molts 2
2. Dorsal edge straight, free border usually convex; no duplicature; structures commonly developed along or parallel to ventral margin as a frill (velum), histium, or carina; the so-called "straight-backed" ostracods Order PALAEOCOPIDA .. 3
Dorsal edge convex or, if nearly straight, much shorter than rest of valve; ventral part of free border gently concave to gently convex; duplicature; no true frill, histium, or carina; the so-called "round-backed" ostracods Order PODOCOPIDA .. 16
3. Larger valve without strong overlap of smaller valve; dimorphism (if present) in the relative development of the velar structure or histium OR in the presence of a crumina (brood pouch) or loculi in the female; corners clearly angular..Suborder BEYRICHICOPINA .. 4
Larger valve strongly overlapping the smaller along most or all of free edge, often thick; dimorphism (if present) expressed as posterior inflation in female; corners in many genera somewhat rounded Suborder KLOEDENELLOCOPINA .. 15
4. Dimorphism well marked by crumina (brood pouch) in female.....
..... Superfamily Beyrichiacea, Family Beyrichiidae
No crumina 5
5. Dimorphism in form of well-developed velar structure; many genera lobed, with vertical sulci Superfamily Hollinacea.. 6
No well-developed dimorphic velar structure; genera unlobed or with short sulci 8
6. Female with loculi or incipient loculi between velum and marginal ridge.....
..... Family Ctenoloculinidae
No loculi developed 7
7. Frill confined (for the most part) to anterior part of valve Family Hollinidae
Frill extending well back past mid-length, to posteroventral position Family Hollinellidae
8. Surface reticulate; many genera with well-developed frill (and, in some, a well-developed carina)..... Superfamily Kirkbyacea .. 14
Surface smooth or pitted, not reticulate 9
9. Valve convex, with no nodes or other projections; no sulcus or, at most, a very shallow pit in dorsocentral area Superfamily Aparchitacea .. 25
Valve with lobation of major spine or nodes; may be sulcate ... Superfamily Drepanellacea .. 10
10. Lobation consisting of one large tapering hollow spine in each valve, rising from near center of dorsal region and extending far above hinge line; any other lobe (if any) small Family Aechminidae
Lobation consisting of more than one element, none long or nearly central 11
11. Lobes unequal, tending to extend down on valve, some or all terminating dorsally in rather blunt spines Family Aechminellidae
Lobes (if present) nearly equal 12
12. Dorsal part of valve with distinct sulcus (S_2) but without bordering lobes; subventral horizontal lobe terminating in posterior projection Family Kirkbyellidae
Dorsal part of valve with two distinct lobes; no subventral horizontal lobe 13
13. Hinge nearly as long as valve; subquadrate to subovate; marginal rim in most genera; two dorsal lobes may be isolated as nodes or joined below S_2 to form a U-shaped ridge
..... Family Bolliidae
Hinge conspicuously shorter than valve; subovate to ovate; no marginal rim; dorsal nodes never joined below S_2 Family Richinidae

14. Surface bearing nodes, humps, or costae in addition to reticulation; S_2 expressed as a smooth spot; no adventral structures (velum or carina) Family Amphissellidae
 Surface reticulate but without nodes, humps, or costae; S_2 expressed as a smooth spot OR a central to subcentral pit 26
15. Larger valve overlapping smaller along free margin and with anterodorsal tooth-like process fitting over exterior of smaller, which is usually beveled or notched at that place Family Kloedenellidae
 Overlap slight, no anterodorsal tooth-like process projecting Family Geisinidae
16. Muscle-scar pattern of discrete scars; duplicature usually wide, may have vestibule, especially the anterior Suborder PODOCOPINA .. 17
 Muscle-scar pattern a circular aggregate of many small scars; duplicature narrow and poorly developed Suborder METACOPINA .. 19
17. Dorsal border gently convex; adductor-muscle scars usually in nearly vertical row of four elements Superfamily Cytheracea, Family Bythocytheridae
 Dorsal border very gently convex to strongly convex, often a conspicuous hump; adductor-muscle scars discrete, more or less radially arranged Superfamily Bairdiacea .. 18
18. High-arched dorsum; not markedly elongate, typically "lemon-seed" shaped; anterior duplicature notably large, with spacious vestibule Family Bairdiidae
 Very gently convex dorsal border; carapace markedly elongate; anterior duplicature not particularly large Family Beecherellidae
19. Dorsal borders strongly arched; hinge short; surface never sculptured Superfamily Healdiacea .. 20
 Dorsal borders gently arched; hinge relatively long; surface may be sculptured 22
20. R/L overlap and overreach, the right valve conspicuously overreaching completely around the margin Family Cavellinidae
 L/R overlap and overreach 21
21. Posterior sculpturing in form of ridge and/or spines; many forms tending to be subtriangular, with a dorsal or anterodorsal angularity Family Healdiidae
 No posterior sculpturing; no dorsal angularity Family Bairdiocyprididae
22. Posteriorly compressed in lunate zone at posterior margin (name from the Greek *thlips* = "pinched" and *ura* = "behind") Superfamily Thlipsuracea, Family Thlipsuridae
 No posterior compressed zone Superfamily Quasillitacea .. 23
23. Lateral outline subtriangular to subpyriform, conspicuously higher at the anterior end, posterior end strongly tapered or pointed Family Ropolonellidae
 Lateral outline subquadrangular to subovate, anterior end not much higher than the posterior, posterior end not pointed 24
24. Lateral surface bearing ridges and grooves or coarse reticulation of irregular elements; ornamented area usually terminating well in front of posterior edge as a ridge and/or spines Family Quasillitidae
 Lateral surface smooth, striate, or finely reticulate, never ornamented with ridges or coarse reticulation; with rounded structural ridges subconcentric to both ends, with the posterior ridge reduced to two rounded spines, or with the anterior ridge reduced or even absent Family Bufinidae
25. Hinge line straight but concealed in lateral view by convex dorsal border Family Coelonellidae
 Hinge line straight and clearly seen in lateral view Family Aparchitidae
26. S_2 developed as a pit; frill, carina, or adventral ridge in most genera; hinge not impressed Family Arcyzonidae
 S_2 expressed as central smooth spot; no frill, carina, or adventral ridge; hinge impressed below dorsal border Family Scrobiculidae

NOTES ON THE NUMBERED ITEMS IN THE KEY TO OSTRACOD FAMILIES

1. The ERIDOSTRACA, if indeed they are ostracods, are very different from all others. As shown in the thin section through the middle of a carapace of *Cryptophyllus*, ecdysis was incomplete. Instead of shedding the carapace at the time of molting, as nearly all crustacean animals do, the eridostracan retained it. The new shell was secreted as a thin lamina lining the inside of the old carapace and extending beyond it as a thicker section; hence, the adult, which had gone through the process of incomplete ecdysis and new secretion several times, had each valve formed as a series of fused shingles of which the most recent shingle was the largest and innermost, the ventral addition as seen in lateral view. In the eridostracan valve, subconcentric grooves mark the edges of each retained instar valve.

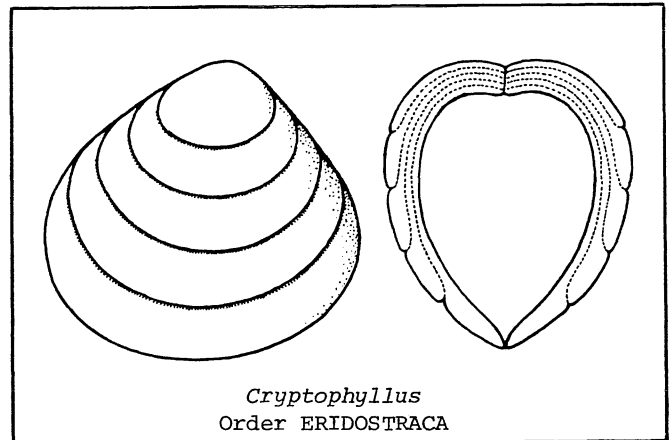

Cryptophyllus
Order ERIDOSTRACA

The shell strongly resembles that of the Sphaeriidae (the freshwater "finger-nail shells"), living bivalves, which have subconcentric growth lines; a thin section, however, quickly reveals the lack of laminations in the small, thin, non-nacreous sphaeriids.

A thin section through any other ostracod would show only the last-formed carapace, the others having been successively discarded in ecdysis. The unique retention of the old shells has raised some question on the classification and relationships of the eridostracans, but most micropaleontologists now accept them as ostracods -- the only ones with laminations in the valves.

2. All other ostracods of the Silica Formation, like those in other Devonian beds, can be divided into two orders, the PALAEOCOPIDA and the PODOCOPIDA, briefly characterized as the "straight-backed" and the "round-backed" ostracods. More significant than the shape of the dorsal border is the presence of a duplicature (an inner calcified rim around the free edge) in the podocopes and the absence of any such structure in the palaeocopes. However, the duplicature is hidden in complete carapaces and is often obscured by matrix in isolated valves, so the conspicuous shape of the back is more often cited and used as a criterion of separation. The terms "straight-backed" and "round-backed" must be applied with some care and caution: the hinge line in some palaeocopes is relatively short (although straight) and in others it is partly concealed in lateral view by a dorsal hump or by protruding lobes; and the dorsal border in some podocopes may be very gently convex, not conspicuously arched. Only the palaeocopes have a true velar structure (such as a frill). Some typical representatives of the two orders are shown on the following page.

3. The two suborders of the PALAEOCOPIDA are not identifiable on any one character. If dimorphism is present in the carapace, it is associated with anteroventral to ventral structures in the BEYRICHICOPINA and with posterior proportions and inflation in the KLOEDENELLOCOPINA. If no dimorphism is present or detectable, the overlap is more conspicuous and stronger in the kloedenellocopines, in some involving the dorsal border as well as the free border; the corners tend to be thick and rounded, especially the anterior one; and the valves may be very thick. In the typical beyrichicopines, by contrast, the overlap is a thin edge of the larger valve extended over a narrow margin of the free edge of the smaller valve; the corners are more sharply defined, so that the cardinal angles can be measured; and the valves are never a

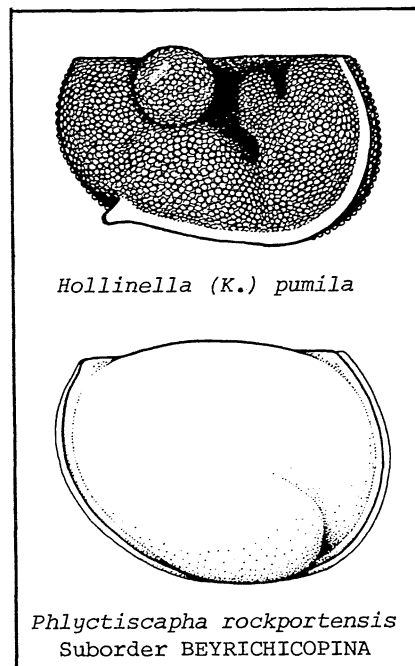
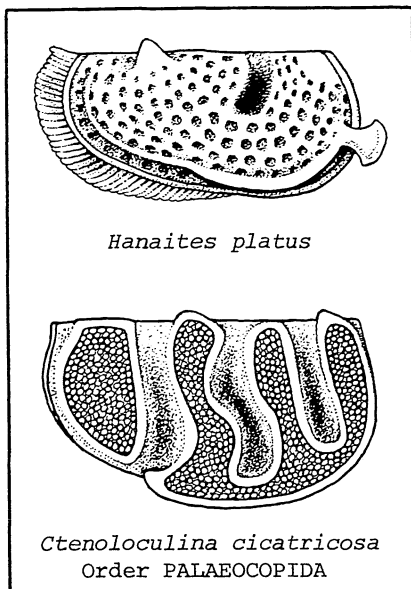
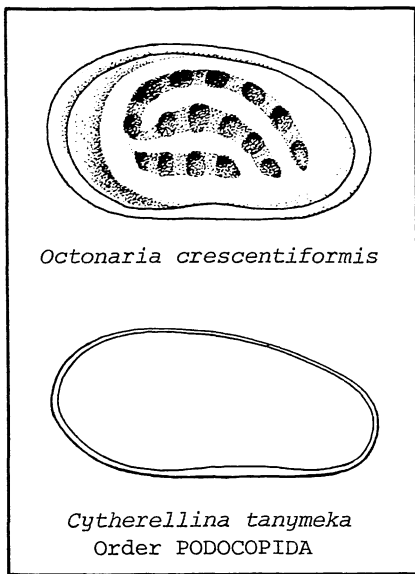

continuously thick sheet of carbonate, normally thin but in some species extended outward into papillae, reticulation, or other ornamentation.

4. Only beyrichiid ostracods have strong dimorphism in the form of a ventral to anteroventral crumina or brood pouch in the valve of the female. Although the brood pouches in *Phlyctiscapha* are not as protuberant and conspicuous as those in many genera of the Beyrichiidae, they are clearly evident in ventral or anterior view (see the following page). Some other beyrichiids which have been thin-sectioned revealed young instars within the pouches, confirming that the structures were indeed adapted for protection of the young brood. The species illustrated in the sketches is *Phlyctiscapha rockportensis* Kesling, the type species of the genus. The Silica species, *P. apleta*, is not as wide but agrees in all other characteristics.

5. The Hollinacea are separated from the other superfamilies of the suborder Beyrichicopina by their velar dimorphism and by their strong lobes and sulci. The velar dimorphism is not as strong in some families as in others; in the Ctenoloculinidae, having loculi between the frill and the free edge in the females, the dimorphism is obvious and unmistakable, but in some of the Hollinellidae the dimorphism is more or less expressed in the anteroventral convergence and the degree of curvature of the frill, and must be examined by comparison of specimens.

6. Loculi or little pockets along the anteroventral and ventral margins of the female identify the Ctenoloculinidae -- which means "family with hidden little pockets," so-named because the loculi are not visible in lateral view of the valve. Loculi are shaped more or less like a bullet-mold, opening as a short cylinder and

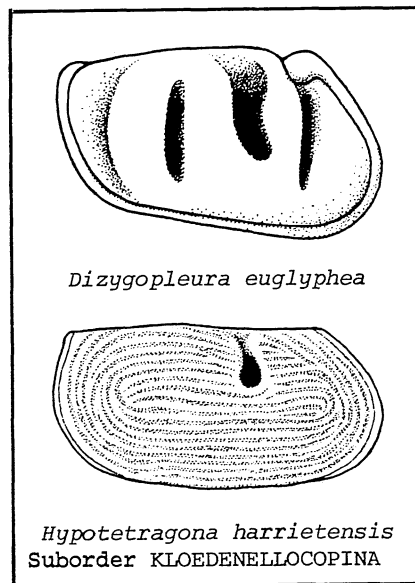

terminating as a smoothly rounded concavity. They do not connect with the interior of the valve; they are formed by short transverse partitions between the frill and the sub-marginal ridge.

There are seven sharply defined and rimmed loculi in *Ctenoloculina*, the male of which has the long lobes of L_1 , L_2 , and L_3 extended ventrally into spurs.

Tetrasacculus and *Subligaculum* have about four less sharply defined and unrimmed loculi; in the male, *Tetrasacculus* has a narrow velar ridge and an anteroventral "spur" (scarcely more than an acuminate lower tip on L_1) and *Subligaculum* has a posteroventral spur and a short anteroventral "frill" (more or less a large flattened and attenuated spur).

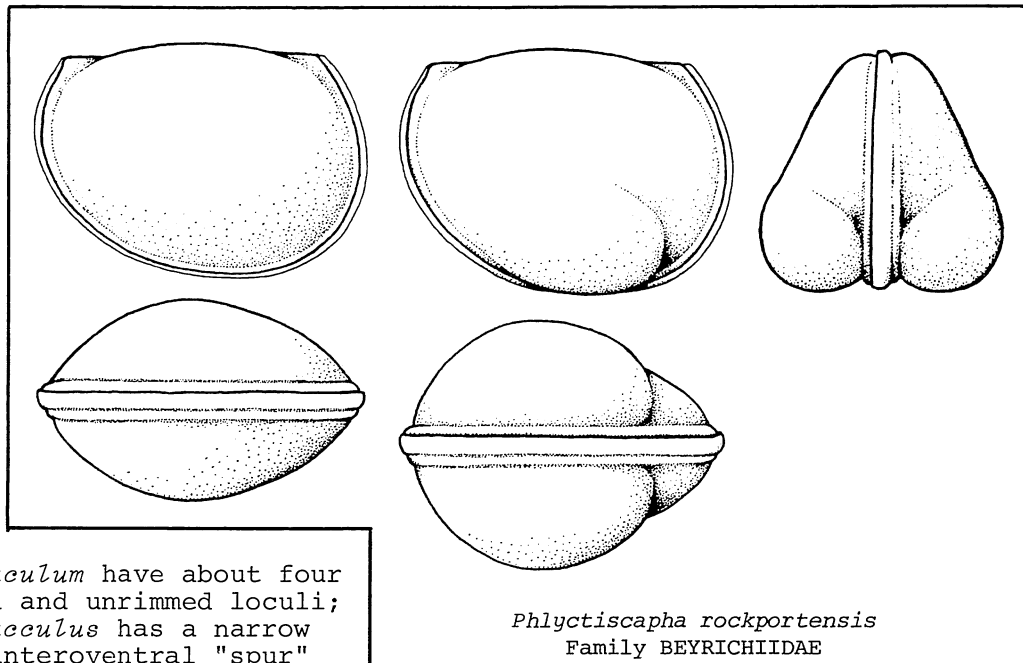

Phlyctiscapha rockportensis
Family BEYRICHIIDAE

7. Although the hollinids have generally shorter velar structures than the hollinellids, the difference is one of degree. In most species of *Hollinella* and *Adelphobolina*, the two genera of hollinellids present in the Silica Formation, the rear end of the frill is behind L_3 (actually, in most species nearly half-way between L_3 and the posterior border) and the posterior section of the frill is curved upward very little if at all. In *Falsipollex*, which resembles *Hollinella* in lobation, the rear end of the frill is below L_3 or only slightly behind it; and in those species of *Falsipollex* with the frill ending behind L_3 , the posterior section of the frill is curving upward definitely. In this part of the classification we are following Bless & Jordan (1971), who created the family Hollinellidae and placed *Falsipollex* in the subfamily Falsipollicinae of the family Hollinidae. The familial boundaries are not clearly discernible to the beginner, and might be argued by the professional.

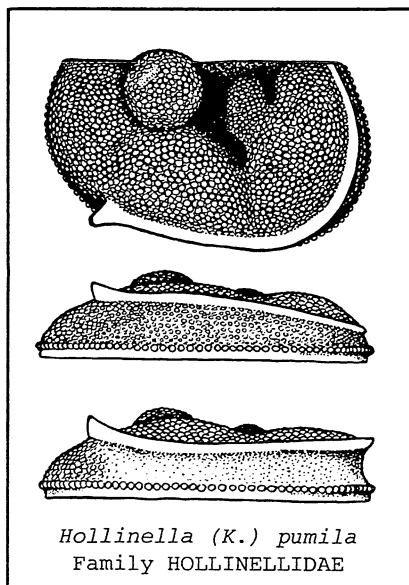

Hollinella (K.) pumila
Family HOLLINELLIDAE

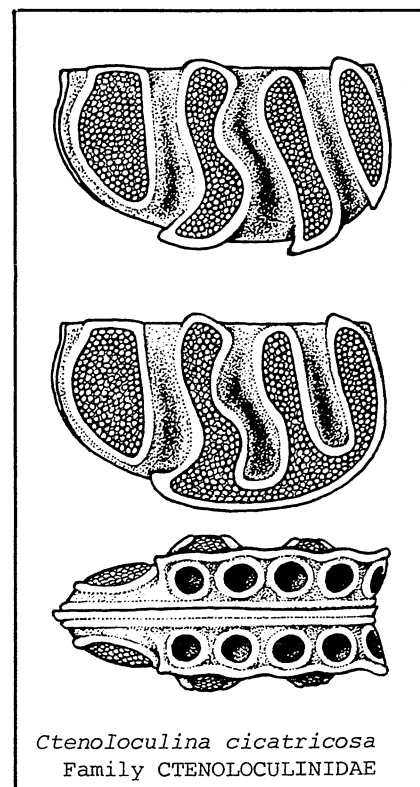

Ctenoloculina cicatricosa
Family CTENOLOCULINIDAE

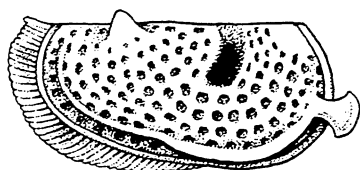
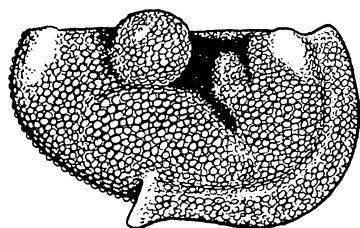
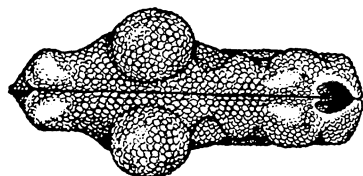
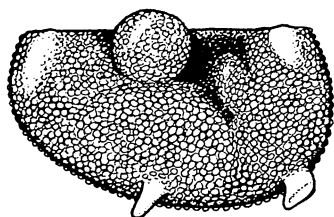
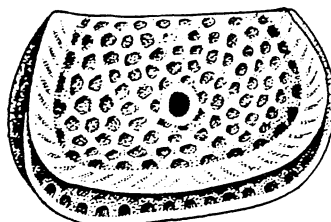
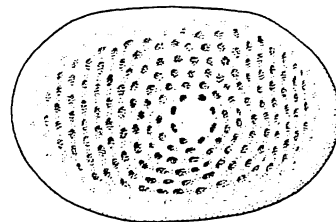
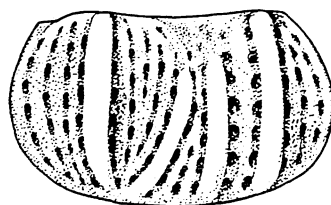
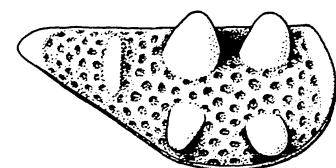
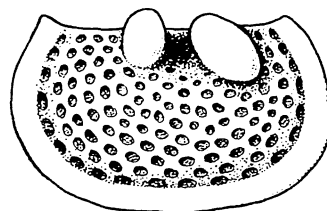
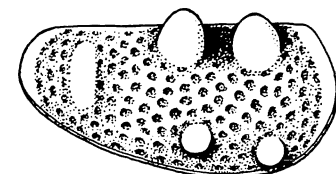
*Hanaites platus**Falsipollex lativelatus*
Family HOLLINIDAE*Arcyzona diademata**Scrobicula concentrica**Dirhabdus multicostatus*
Superfamily KIRKBYACEA*Cornigella immotipedata**Ulrichia conradi**Kirkbyella bellipuncta*
Superfamily DREPANELLACEA

The peculiar ostracod *Hanaites* was recognized as a distinct genus independently by Pokorný at Caroline University in Prague and by Kesling & McMillan at The University of Michigan. Pokorný published first (1950) and the Czech name *Hanaites* has priority over the American name *Proplectrum* published the following July by Kesling & McMillan. *Hanaites* has been assigned to the Hollinidae, even though its modified frill continues posteriorly as a narrow ridge on the lateral surface nearly to the posterior corner. If it is to fit the family definition and the key, the wider part of the structure must be interpreted as the frill and the narrow section rising onto the valve in the posterior region must be regarded as an ornamental ridge confluent with the frill; only by thus "stretching" the interpretation of the velar structure can *Hanaites* be accommodated in the family Hollinidae. *Hanaites* has some features that differ appreciably from those in other genera of either the Hollinidae or Hollinellidae; its S_2 has a decided backward slant, its conical L_3 is separated from S_2 by a rather extensive reticulate area, the narrow frill (scarcely more than a velar ridge) terminates anteriorly in a palmate spur (unique among all Palaeocopida), and the posterior

half of its free edge bears a delicate keel constructed of fused tubercles like a frill. The genus is also more elongate than any of its relatives.

8. The kirkbyacean ostracods, here represented by *Arcyzona*, *Dirhabdus*, and *Scrobicula* in the sketches, is separated from the Hollinacea by their lack of velar dimorphism and shorter sulci (which may be reduced to a central pit or simply a central bare spot). They are separated from the Aparchitacea and Drepanellacea by their typically reticulate surface and, in the majority of species, by some kind of well-developed frill (with or without parallel carina). Some qualification and exception must be made to the reticulation criterion; the drepanellacean families Bolliidae and Kirkbyellidae include ostracods that could be described as "reticulate" instead of "pitted." Such drepanellacean genera as *Cornigella*, *Ulrichia*, and *Kirkbyella* are not ornamented very differently from the kirkbyacean genera *Arcyzona*, *Dirhabdus*, and *Scrobicula*. A further character that can be used when in doubt is the lobation, especially in the dorsal half of the valve: the kirkbyaceans have no development of lobation except for the central or subcentral pit or (rarely) a very shallow dorsal depression for S_2 , whereas the pitted (seemingly "reticulate") drepanellaceans have a distinct and deep S_2 reaching the dorsal border and/or bordering nodes representing L_2 and L_3 .

9. The Aparchitacea, represented by *Ehlersia*, *Kavaryella*, and *Coelonella*, have no sulcus except for a very shallow pit in some species and no projecting lobes or nodes. The genus *Kavaryella* is most typical of these convex and nearly equivalved ostracods. The Drepanellacea, by contrast, have most definitely some kind of

lobation in the dorsal half of the valve, varying from the single large spine in *Aechmina* to the distinct nodes for L_2 and L_3 in *Ulrichia* and *Richina* to the sharply defined sulcus (S_2) in *Kirkbyella*. Neither superfamily has any kind of frill or carina.

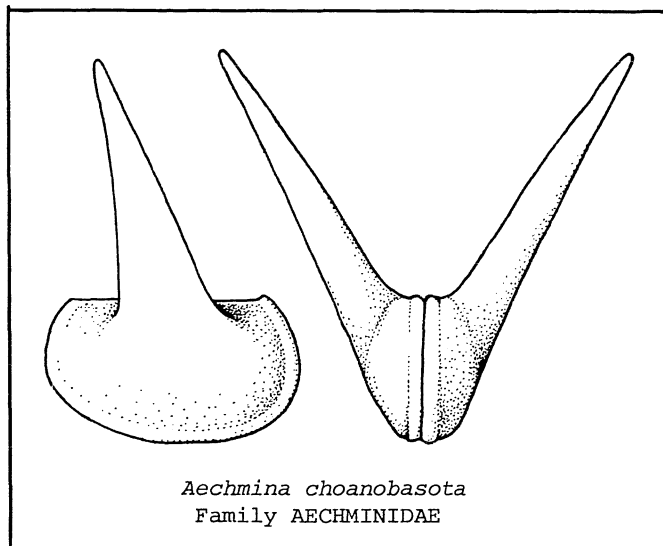

Aechmina choanobasota
Family AECHMINIDAE

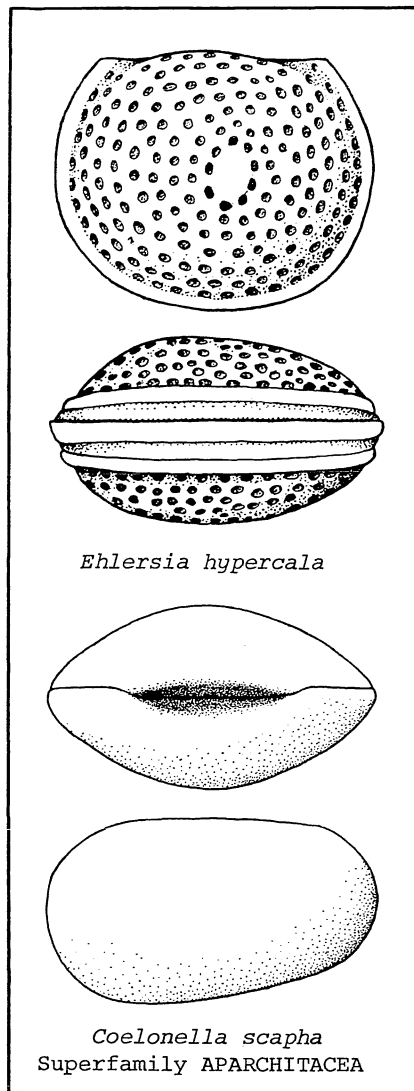

Ehlersia hypercala

Coelonella scapha
Superfamily APARCHITACEA

10. The Aechminidae have one major spine near the center of the dorsal area. This structure is hollow, and provides an extension of the interior of the valve; in fact, the spine seems to have nearly as great a volume as the remainder of the valve in such species as *Aechmina choanobasota*. In the type genus *Aechmina*, this is the only lobe present. In the genus *Aechminaria*, addit-

tional smaller elements of lobation are found in front of the major spine.

11. The Aechminelliidae differ from the Aechminidae in having more than one element of lobation, no one of which is dominant and central. These ostracods differ from the Kirkbyellidae in having distinctly developed lobes in addition to the major sulcus; they differ from the Bolliidae in having unequal lobes and/or a long S_3 ; and they differ from the Richinidae in having long sulci reaching well down the sides from the hinge line. The genus present in the Silica Formation, *Balantoides*, appears nearly smooth in some specimens, but well-preserved and weathered specimens show a pattern of small punctae to be present over much of the surface.

12. The Kirkbyellidae have no lobes bordering the distinct median sulcus (S_2), which sets them apart from the Bolliidae and Richinidae. The kirkbyellids are noted most for their subventral horizontal lobe, which truncates the sulcus and may end posteriorly in a projection or tip. The lobe, better developed in some species than others, is so distinctive that these ostracods are easily spotted among all Silica forms.

13. If all bolliids were like *Ulrichia* and *Cornigella*, they would be easily distinguished from the richinids, for they have subequal nodes for L_2 and L_3 and a reticulation of pits on the lateral surface. More difficult to classify is the smooth to granular *Tetrastorothyx*, which like *Richina* has strongly unequal L_2 and L_3 (see illustrations on the next page); however, the hinge line of *Tetrastorothyx* is nearly as long as the valve, as compared to the hinge line of *Richina*, which is conspicuously shorter and may be only half as long in some species of the genus. A marginal rim is developed along the border in many bolliids, nearly the same width throughout its length from corner to corner; no true marginal rim is developed in the richinids, although some show an anterior sausage-like inflation parallel to the free border in the anteroventral region (from this maximum prominence, fading out rapidly at about midlength). Such a structure is not found in any of the Silica species of *Richina*, and the valves are essentially smooth except for the dorsal lobes.

14. In the superfamily Kirkbyacea, which includes many reticulate palaeocopes, the Amphissellidae is herein created as a new family for those few genera which lack any sort of adventral structure (frill or carina) or a central pit, and which have typically more ornamentation than reticulation. This excess ornamentation may take the form of ridges or costae (*Dirhabdus* and *Tetrarhabdus*) or scattered papillae at some of the intersections of ridges composing the reticulation (*Doraclatum*). The conical central dorsal projection on *Doraclatum* seems to be part of the lobation, a feature foreign to other genera of the superfamily. In contrast, the Arcyzonidae have simple reticulation and a central pit, and most genera have a frill (or a frill and carina); and the Scrobiculidae have a reticulation on the surface and an impressed hinge that has not been observed in any of the Amphissellidae.

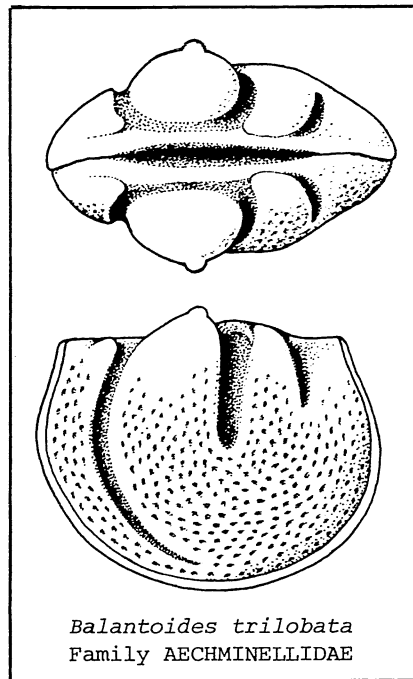

Balantoides trilobata
Family AECHMINELLIDAE

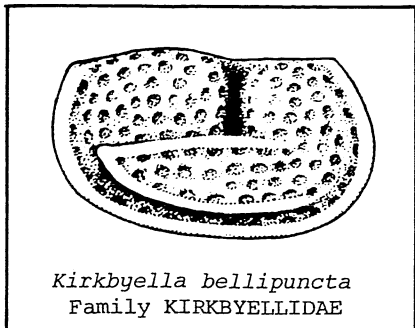

Kirkbyella bellipuncta
Family KIRKBYELLIDAE

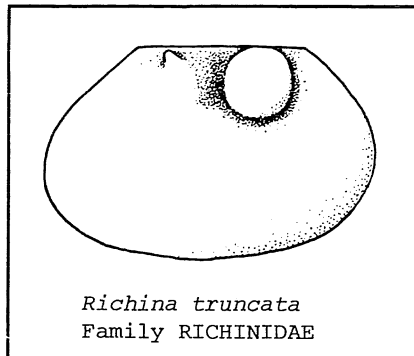

Richina truncata
Family RICHINIDAE

15. The difference between the kloedenellids and the geisinids, as defined, is the development of an anterodorsal process in the former. Nevertheless, the difference is in reality one of degree and interpretation, inasmuch as the geisinid *Hypotetragona* has some anterodorsal development of the larger valve, comparable to that present in the kloedenellid *Eukloedenella*. If we select *Dizygopleura* to represent the kloedenellids, the

difference is more striking.

The family Kloedenellidae is itself diverse, so much so that the Silica Formation representatives can be assigned to three subfamilies. In one, the Dizygopleurinae, the anterodorsal process reaches maximum expression, forming a toothlike projection called the stragulum in the overlapping valve and an accommodating deep notch in the overlapped valve. No stragulum is developed in the other subfamilies. They are divided according to the relative development of S_2 -- weak in the Kloedenellinae and strong in the Knoxitinae.

The so-called "kloedenellid" dimorphism involves posterior enlargement in one dimorph, assumed to be the female. Only from several specimens can the limits of the "male" and "female" members of the population be determined; and the dimorphism in some species is so weak that one might doubt that it is present. Certainly, the dimorphism in some species of kloedenellids is not as clearly expressed in carapace morphology as it is in the pouched beyrichiids or in the loculi-bearing ctenoloculinids. The best example of kloedenellid dimorphism to be found in the Silica fauna is *Dizygopleura*, as can be seen in dorsal views of the two dimorphs (see next page).

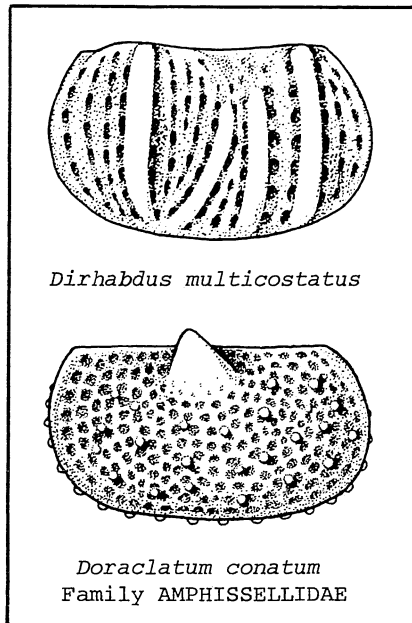

Dirhabdus multicostatus

Doraclatum conatum
Family AMPHISSELLIDAE

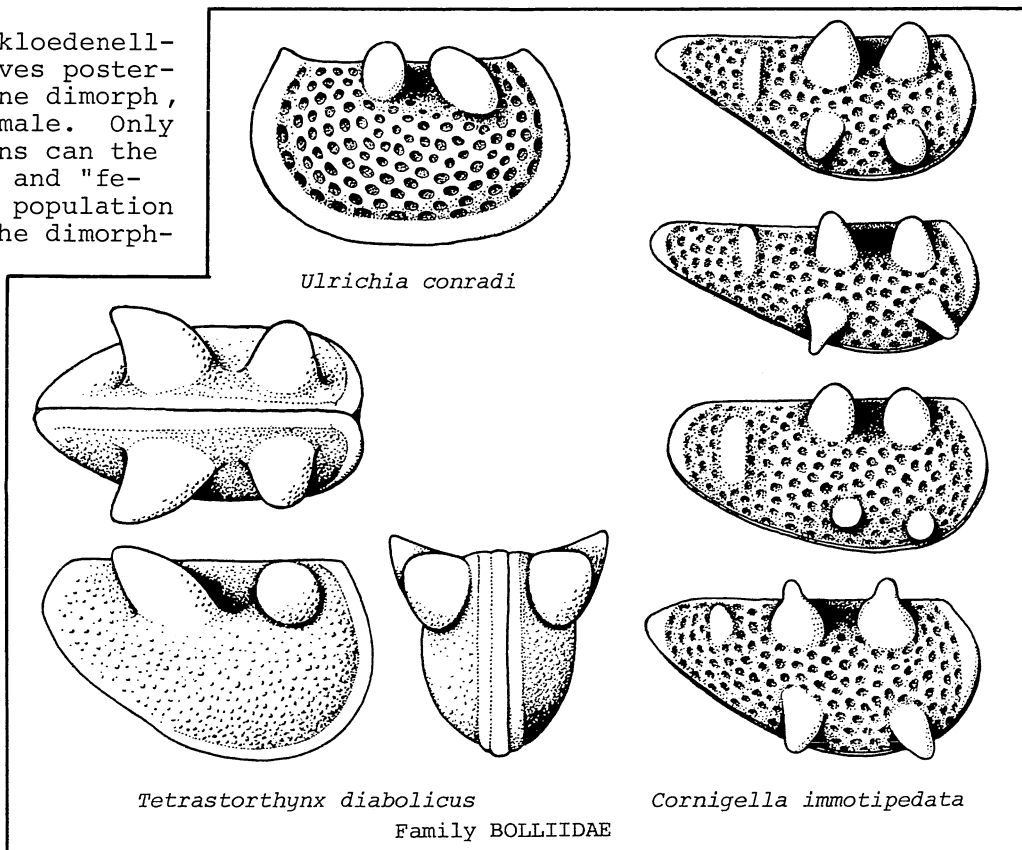

Ulrichia conradi

Tetrastorthynx diabolicus

Family BOLLIIDAE

Cornigella immotipedata

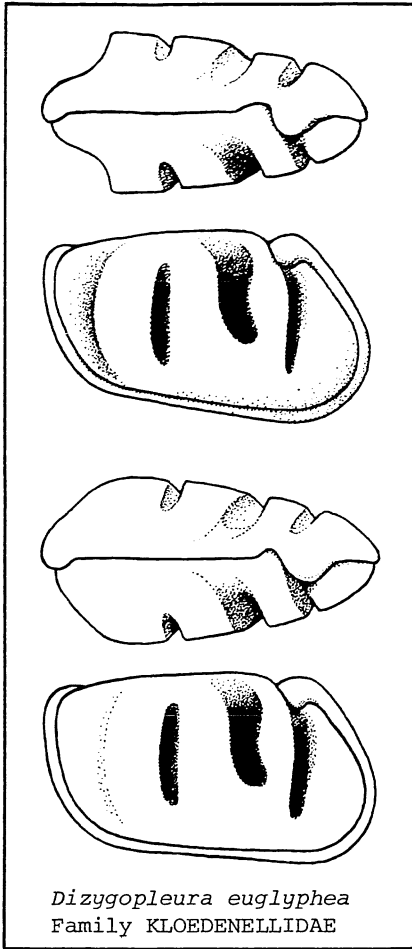

16. The basic difference between the valves assigned to the Podocopina and those assigned to the Metacopina lies in the muscle-scar pattern. The scars in the podocopines are discrete, but those in the metacopines are an aggregate of tiny scars filling up the one circular to oval adductor-scar area. Unfortunately, preservation and adhering matrix may obliterate or obscure the scars in single valves; and, of course, complete carapaces conceal the muscle scars on the interior of their valves.

Similarly, well-preserved and clean isolated valves are necessary to observe the nature of the duplicature, a calcified rim around the inner edge of the valve. In all Metacopina in which it has been noted, the duplicature is narrow; in some Podocopina it is wide and clearly defined from the rest of the valve by a space or cavity (called the vestibule), but some Podocopina are also known to have a poorly developed duplicature not very different from that in the Metacopina.

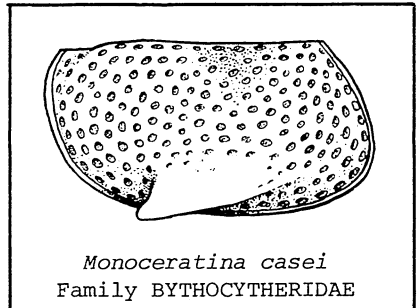
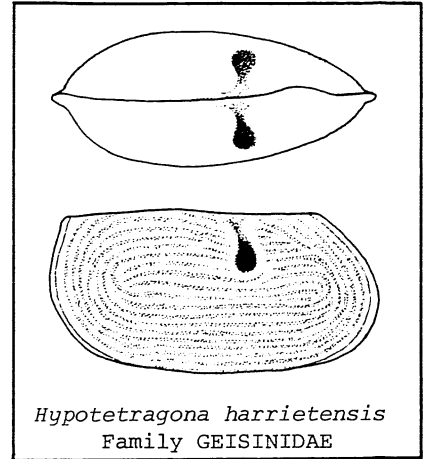

divide the Podocopina. If the scars are nearly aligned in a vertical row, the ostracod is placed in the Cytheracea; if they are radially arranged, the ostracod is put in the Bairdiacea. Both superfamilies became more diverse and successful after the Paleozoic.

The Middle Devonian species of *Monoceratina* was examined a few years ago by Dr. I. G. Sohn of the Smithsonian Institution, who found no essential differences from the Mesozoic species of the genus. *Monoceratina* was evidently a successful model and persevered for a long geologic interval with no generic change. The shape is distinctive among Middle Devonian ostracods, and the genus can be reliably identified even though the muscle scars are concealed.

The Bairdiacea include some ostracods which, like the Cytheracea, have a gently arched hinge line. Nevertheless, the hinge in these bairdiaceans is invariably much shorter, with an appreciable portion of the valve extending fore and aft beyond the hinge ends. The Bairdiacea also include ostracods with a high dorsal arch quite unlike any observed in the Cytheracea.

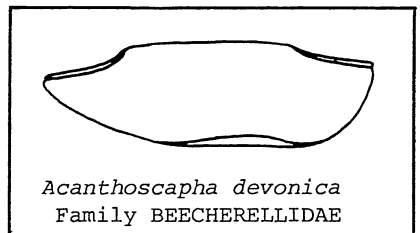
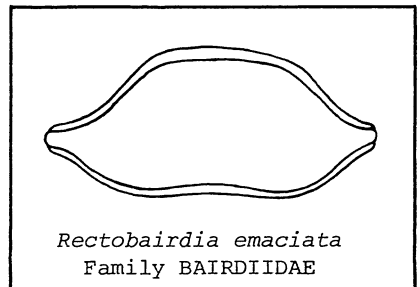

18. Although there are only five species of the superfamily Bairdiacea found in the Silica Formation, they belong to two different families and two are classified as new genera. The ostracods in the family Bairdiidae are typically high-arched and acuminate at the ends; some have been described as "lemon seed shaped" and some elongate forms suggest a spindle. *Rectobairdia*, shown on the previous page, exemplifies the "lemon seed" group.

The Beecherellidae have a gently curved dorsal border, nearly straight in *Acanthoscapha*, sketched on the previous page. The new genus *Pronipantex* is assigned to the Beecherellidae, although it is not as gently curved along the dorsum as is *Acanthoscapha*.

19. The Metacopina in the Silica fauna belong to three superfamilies: Healdiacea, Quasillitacea, and Thlipsuracea. Of these, the Healdiacea are distinguished by their lack of surface sculpturing, such as lineations and fine grooves that are present in many Quasillitacea or deep pits and furrows that are present in the Thlipsuracea. The hinge in healdiaceans is typically short, but its exact extent may be difficult to determine in a complete carapace. Depression of the hinge line is no criterion, for it is found also in many of the quasillitaceans as well.

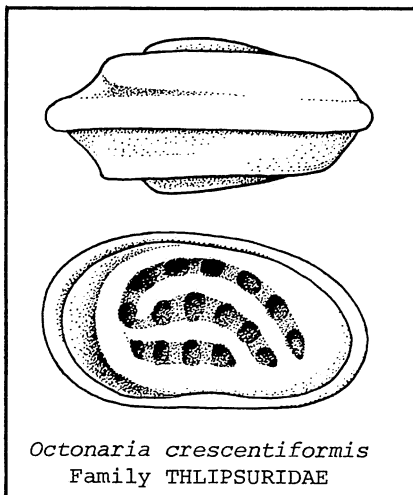
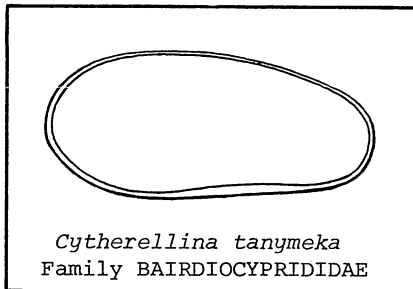

20. Of the three families assigned to the Healdiacea, the Cavellinidae only have the right valve overlapping the left. One might logically question how such a significant change as reversal of overlap could have evolved in the same superfamily. Nevertheless, the classification agreed upon by leading ostracodologists in the *Treatise on Invertebrate Paleontology* has the Healdiidae and Bairdiocyprididae assigned to the superfamily without question, and the Cavellinidae assigned to the superfamily with question. *Birdsallella* is a cavellinid, although the overlap is not as pronounced dorsally as it is in other genera.

21. The ostracods of the family Healdiidae have a characteristic angulation or bend at the front of the short hinge, so that many appear to be somewhat triangular; this feature is not so apparent in the Bairdiocyprididae. The easiest feature to note in separating the healdiids from the bairdiocypridids is the posterior development in the former of a ridge and/or spines. Behind this development of spines in *Healdia gibba*, shown here, the valves have an angulation or bend leading to the posterior border, nearly concave in some specimens and strongly resembling the posterior end in the Thlipsuracea.

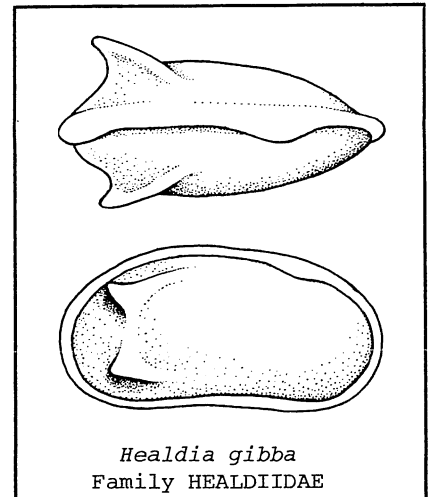
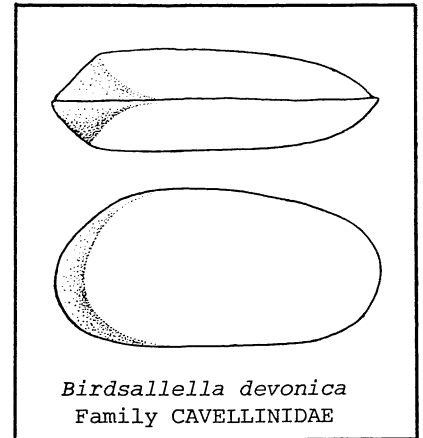

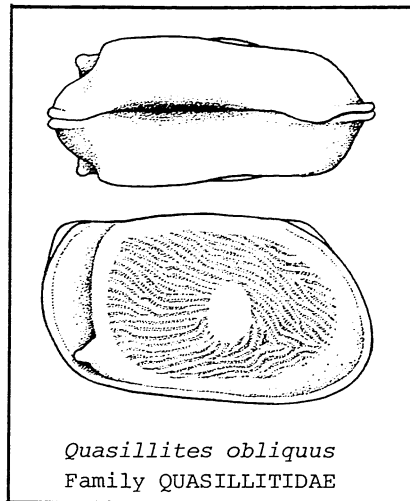
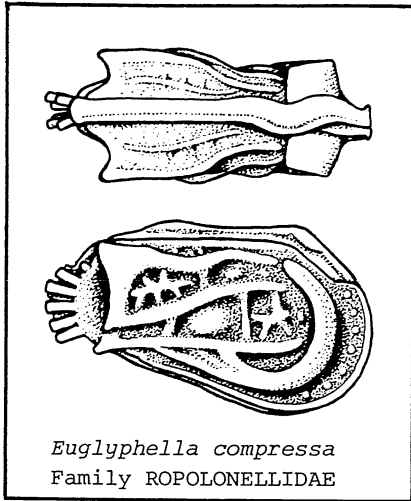

The ostracods of the family Bairdiocyprididae, on the other hand, lack any posterior ridge or spines and are smooth bean-like carapaces. Because they lack particular points of reference, they are exceedingly difficult to classify into genera and species. *Cytherellina tanymeka*, shown on the previous page, is the most elongate species of the genus found in the Silica Formation to date. Here the "splitter" could make numerous additional species on minute changes in proportions.

22. Aside from the smooth, dorsally arched, short-hinged Healdiacea, the suborder Metacopina contains two other superfamilies in the Silica fauna: the Quasillitacea and the Thlipsuracea. Both by definition and by its derivation from the Greek, the Thlipsuracea is characterized by a "pinched rear end" or compressed posterior area of the carapace. This definition does not adequately split off the thlipsuraceans from the quasillitaceans, however, for some of the latter, such as *Quasillites* and *Euglyphella*, also have a compressed (even concave) area along the posterior margin. There are other characters which can be added to the definition. The thlipsuraceans tend to have a strong overlap dorsally as well as around the free edge, and their lateral sculpturing (ornament) is of a different kind from that of the quasillitaceans. In the thlipsuraceans, the pits and/or troughs on the lateral surface are incised *below* the general level of the surface; similar sculpturing might be made in a board by a router equipped with a box-core bit. The non-sculptured areas of these ostracods is very thick, since the deep sculpturing is incised into the valve. On the other hand, the sculpturing in such quasillitaceans as *Euglyphella* is formed by ridge elements or tubercles extending *above* the general level of the valve, and the "fingerprint" pattern in *Quasillites* is very shallow and readily distinguished from the coarser and deeper sculpturing of the lateral surface in the thlipsurids.

23. Ostracods of the family Ropolonellidae, in contrast to other families of the Quasillitacea, are high anteriorly and taper backward conspicuously, giving them a subtriangular or pyriform shape in lateral view. The ropolonellids are not all as highly ornamented as *Euglyphella*, and the Silica fauna includes two other genera with simpler surface features and overlap.

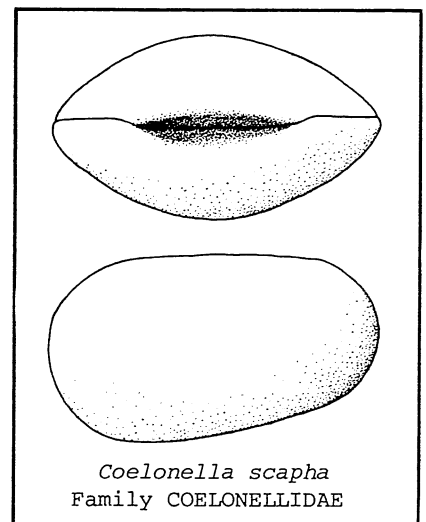
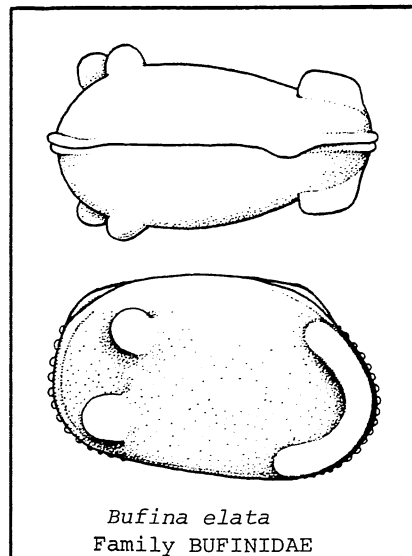

24. The Quasillitidae have coarser ornamentation in general than that of the Bufinidae, many of the latter being smooth or slightly granular. Behind the ornamented area, the quasillitids also have a characteristic ridge or flexure which may bear a posteroventral spine. This flexure of the lateral surface may not be elevated as a ridge, but it is clearly expressed as an arc subparallel to the posterior border along which the surface abruptly slopes down to the posterior edge. Although the Bufinidae may have posterior spines, they are not associated with such a well-defined flexure or bend in the surface. Some Bufinidae also have an anterior ridge, not found in the Quasillitidae, but not all have it and its absence is not diagnostic.

25. The ostracods of our fauna include two families of the superfamily Aparchitacea. The content, limits, and relationships of the Aparchitacea have been questioned for many years, and altered several times by revision. Here we adopt a simple separation into two families, the Aparchitidae with the hinge line clearly visible as a straight line in lateral view, and the Coelonellidae with a dorsal hump on each valve that rises above the hinge line and hides much of it in lateral view.

26. In the superfamily Kirkbyacea, the family Amphissellidae was identified in item 14 above as the one having extra ornamentation of nodes and costae in addition to the reticulation. The Silica Formation contains ostracods of two other families of Kirkbyacea: the Arcyzonidae and the Scrobiculidae. The Arcyzonidae are characterized by a pit for S_2 and most genera have a frill (some also with a carina). The Scrobiculidae are characterized by an impressed hinge, set below the dorsal border as seen in lateral view and resembling that of the Coelonellidae in the superfamily Aparchitacea.

In the classification presented in the key and in these notes, we wish again to emphasize that the system is designed specifically for the Silica ostracods and does not include families and subfamilies that are represented in other Middle Devonian formations.

On the following pages we have a flow chart showing the divisions of the Ostracoda down to the level of subfamily for the fauna of the Silica Formation. It summarizes the information in the key and the notes and presents all the classification in one overview.

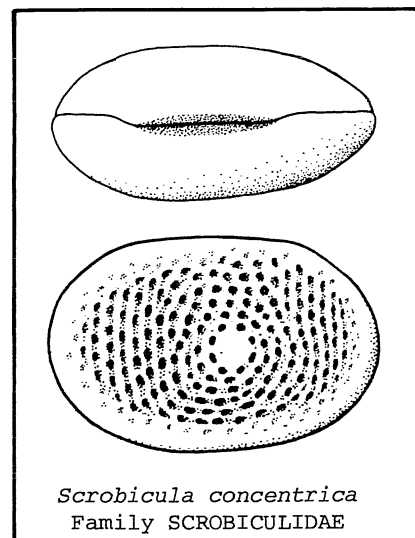
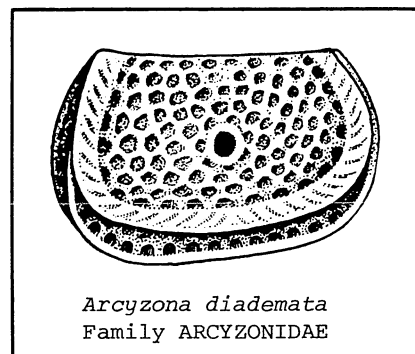
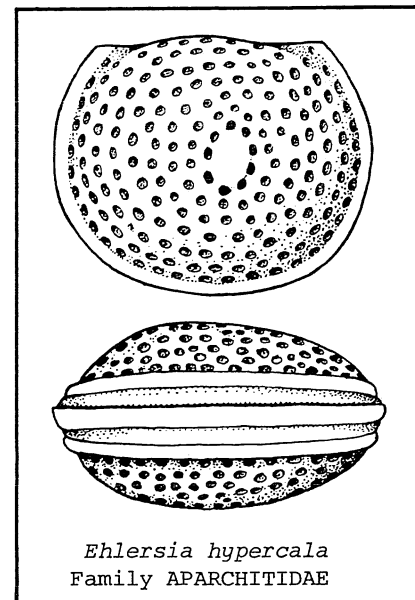

clear and obvious to us, for we cannot bring ourselves to full satisfaction with the placement of some of our species, genera, and families. Doubts persist. We tend to be conservative in changing established taxa in content or assignment.

Subclass OSTRACODA Latreille 1806

Small laterally compressed crustaceans with a bivalved carapace, more or less calcified, hinged along the dorsal margin. Living forms have a body with only slight segmentation, if any, and bearing 4 pairs of cephalic appendages (antennules, antennae, mandibles, and maxillae), 1 to 3 pairs of thoracic appendages, and a pair of furcae, but no abdominal appendages; all or nearly all appendages can be retracted within the carapace when it is closed.

Carapaces of the ostracods in this fauna (Middle Devonian) are all strongly calcified and were hermetically sealed when shut, completely enclosing the appendages. The closure was effected by adductor muscles passing through the body and attaching to the inner surfaces of the two valves, producing scars which can be seen in well-preserved and well-cleaned single valves. Opening was accomplished by the relaxation of the adductor muscles and contraction of the dorsal ligament of chitin. The hinge varied from a simple tongue-and-groove (often shallow and inconspicuous) to more complex teeth and sockets, in many genera a combination of the two.

Order PALAEOCOPIDA Henningsmoen 1953

Straight and usually long hinge line; dorsal border may rise above hinge line as a dorsal hump or extension of the lobes, obscuring

part (rarely all) of hinge line as seen in lateral view of the carapace. Hinge line can be seen as a straight border of the valve in an inside view of an isolated valve.

Over half of the species in the Silica fauna belong to this extinct (Lower Ordovician to Middle Permian) order.

Suborder BEYRICHICOPINA Scott 1961

Overlap not strong, scarcely discernible in lateral view; corners angular; dimorphism (if present) of cruminal, velar, or histial type (never kloedenellid).

Superfamily Beyrichiacea Matthew 1886

Cruminal-type dimorphism always present (brood pouch in the female).

Family Beyrichiidae Matthew 1886

Long-hinged beyrichiaceans.

Subfamily Treposellinae Henningsmoen 1954

Genus PHLYCTISCAPHA Kesling 1953

Type species.-- By original designation, *Phlyctiscapha rockportensis* Kesling, 1953, p. 222-225, pls.1,2.

Remarks.-- Apart from their uniformly long hinge lines and pouch-bearing females, the beyrichiids include an assortment of lobations and sizes. In most genera, lobation is strongly developed, with protuberant lobes and nodes and deeply emplaced pits and sulci, distinctive for each genus. *Phlyctiscapha* is one of the few genera without lobes, and the only non-lobate beyrichiid to lack any vestige of a frill and to have the crumina blend posteriorly into the rest of the valve.

SPECIES	Medusa quarries				Martin-Marietta Quarry						Waterworks Park						
	Unit 6	7	8	11	12	13	14	15	16	17	18	21	23	1-6	7	9-11	12
Family BEYRICHIIDAE																	
<i>Phlyctiscapha apleta</i>	x	x	x	x				x	x	x		x	x	x	x		x
Family AECHMINELLIDAE																	
<i>Balantoides trilobata</i>	x	x	x	x	x	x	x	x	x					x	x	x	

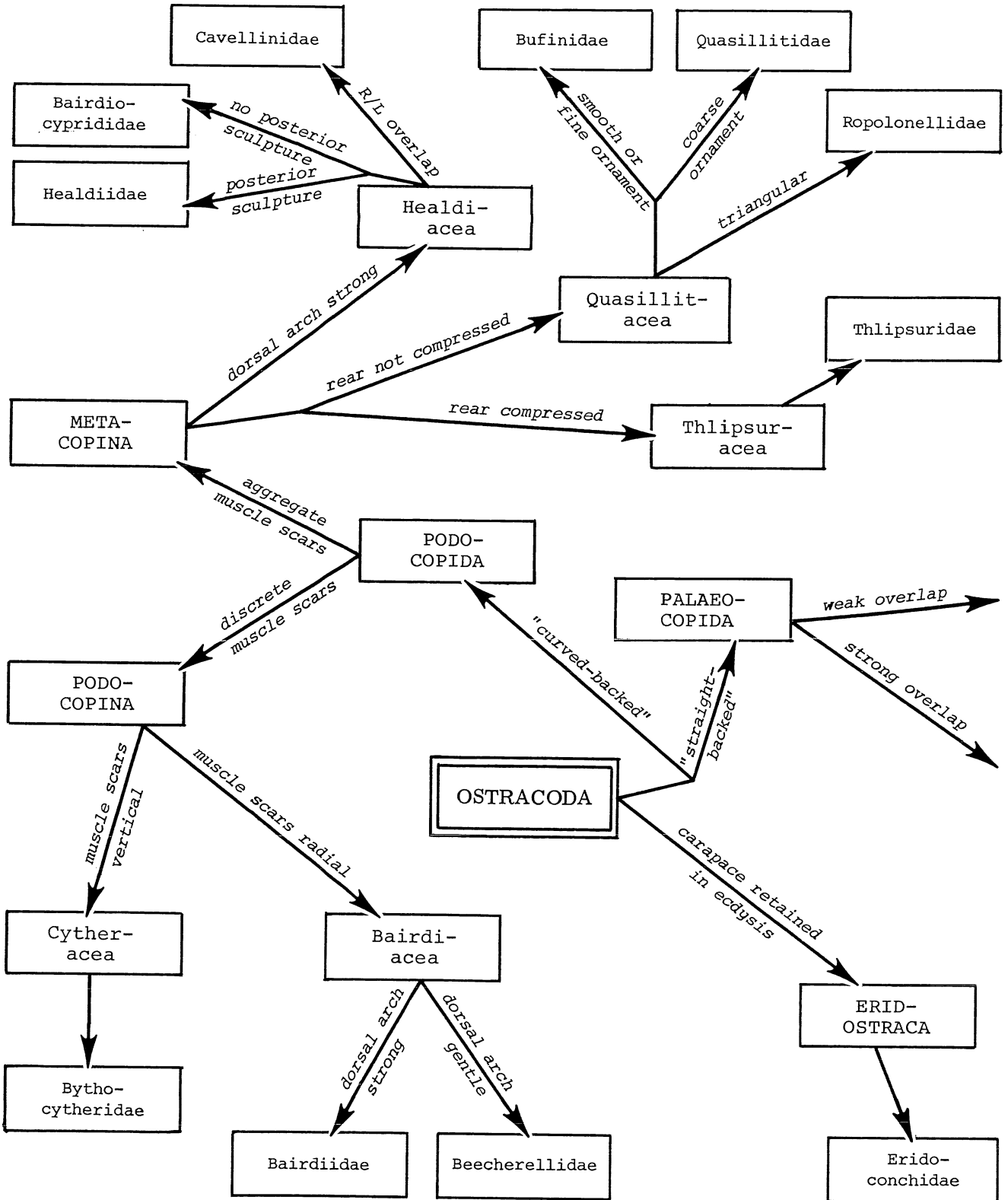

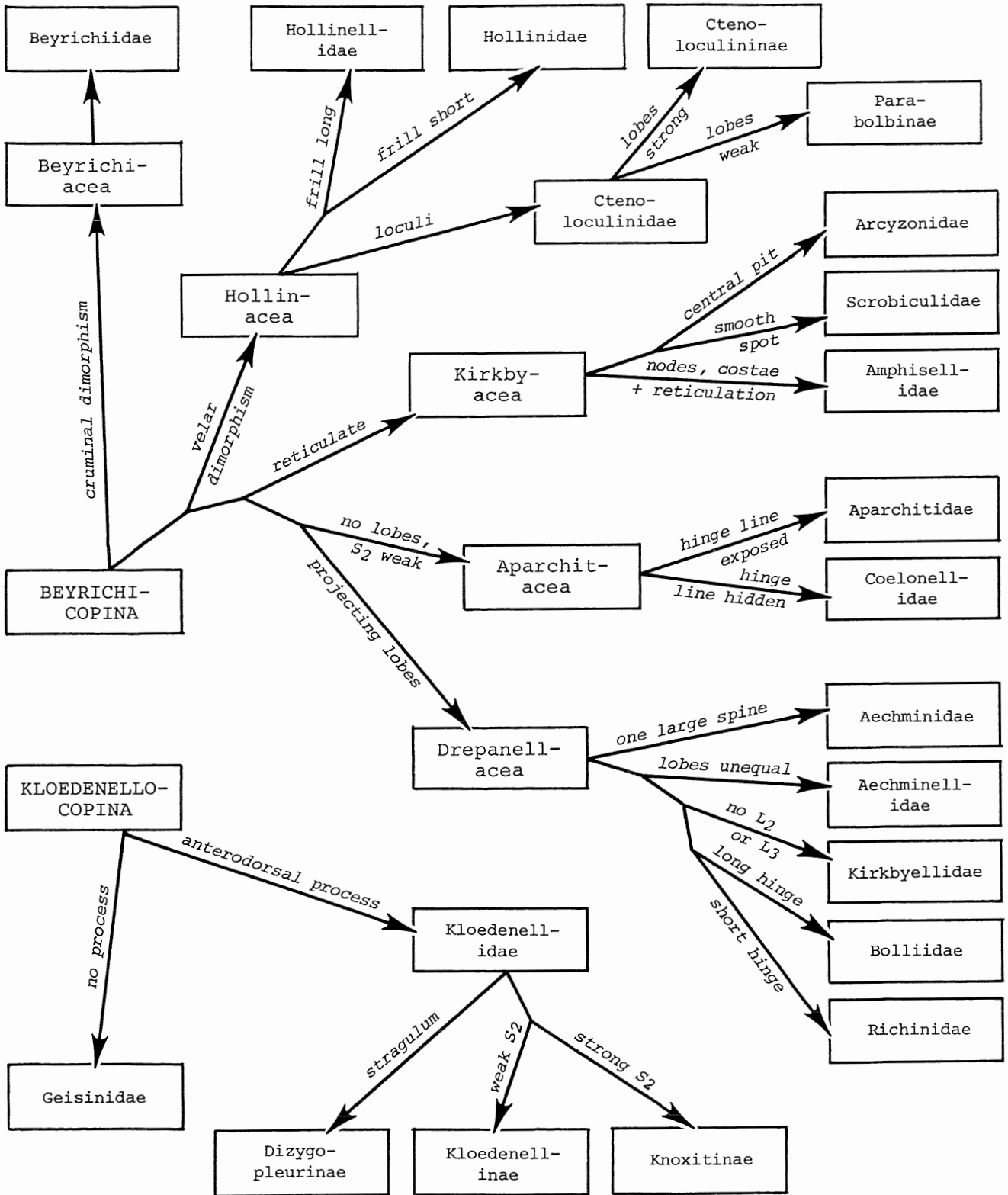

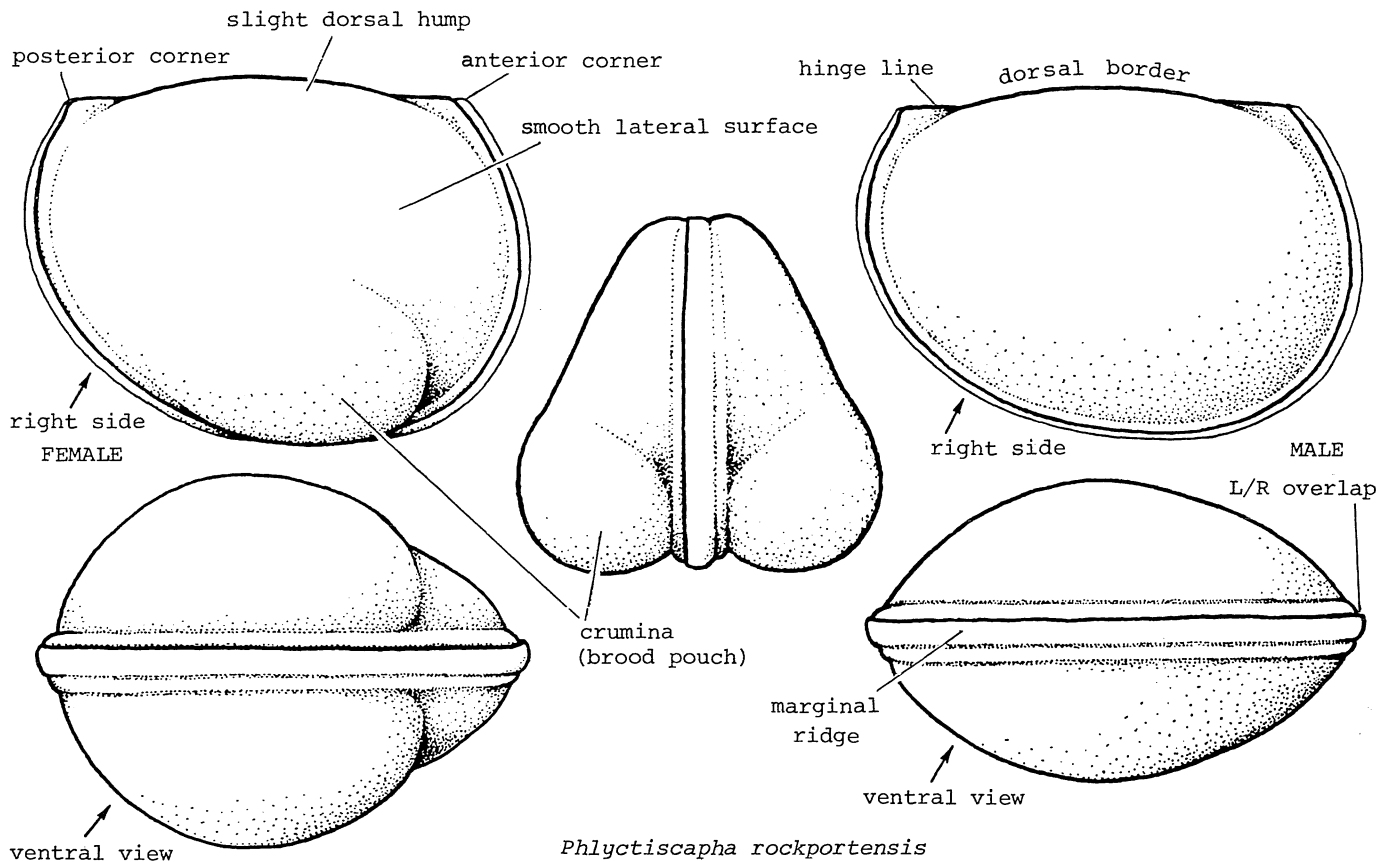

Phlyctiscapha rockportensis

PHLYCTISCAPHA APLETA Kesling

34/1-10; 35/1-11; 36/5-20; 37/1-20

Phlyctiscapha apleta Kesling, 1954, p.188-190, pl.1, figs.1-15 [Ferron Point Fm].

Phlyctiscapha apleta Kesling, 1957e, p.59, pl.7, figs.4-6.

Phlyctiscapha apleta Kesling, 1969, p.298, text-fig.13g,r.

Remarks.-- The type specimens for this species are from the Ferron Point Formation in Alpena County, Michigan. No doubt can exist that the ostracods described and listed here belong to the same species. The adults have the same shape in all views; the adults are remarkably close to the dimensions of the types; and the ratios of height/length and height/width are nearly the same. Although the species is rather rare at any one locality, it occurs over a large area wherever the lower strata of the Traverse Group crop out.

Occurrence.-- Even though specimens are relatively rare, they are distributed stratigraphically through the formation at all three

major localities. At the Medusa quarries in northwestern Ohio, they are present in units 7-12, 15-17, and 21-23; they are conspicuously absent in units 1-6 (the "blue limestone"), 13 and 14, and the thick unit 18. At Martin-Marietta Quarry, specimens are found in units 1-6 (*Tropidoleptus carinatus* zone), 9-11 ("Chonetes" zone), 12, and 14 and 15. At Waterworks Park in Detroit, they occur in the *Tropidoleptus* zone and in unit 12. In all occurrences, immature instars are found associated with the adults.

Instars

Inasmuch as *Phlyctiscapha apleta* is represented by specimens of several sizes, this is an appropriate place to discuss ostracod ontogeny in general and the application of Przhibram's Law to this species in particular.

The ostracod, like other crustaceans, grows by molting its old hard parts and secreting new and larger ones. The animal is enclosed in a bivalved carapace, composed mostly of calcite. The body, suspended like a pouch from the

dorsal part of the carapace, and the attached appendages are encased in chitin, with thin flexible chitin at the joints to allow movement. Thus all soft tissues are covered by some kind of armor, so that the ostracod cannot grow continuously by small additions and is able to reach a larger size only by breaking open its hard covering and shedding it completely -- a process termed ecdysis. Only during the brief interval before new hard parts are secreted can the animal increase; as a result, the pattern of its ontogeny, or growth, is said to be discontinuous (in contrast, for example, to the continuous growth of mammals). Most of each animal's life is spent in fixed stages, called instars, and its ontogeny consists of a number of these in sequence. During each brief but critical period of ecdysis, the individual not only increases in volume but also adds new appendages and organs, changes the form and function of the previous structures, and alters the shape of its carapace somewhat to accommodate the new form it has assumed. Consequently, carapaces of successive instars may show slight but discernible alterations in proportions and/or ornamentation.

We have no reason to doubt that Middle Devonian ostracods were essentially the same kind of animals as living ostracods and that their ontogeny consisted of the same stair-step alternation of prolonged fixed instars, each terminated by ecdysis, and sudden brief intervals of size increase to the next fixed instar. In fact, we have appreciable evidence that fossil species grew in the very same manner as their present-day descendants. Recognition of immature instars and their correct assignment to species present serious problems for the micro-paleontologist, so that dependable methods of solution need be known for proper taxonomy. We must know which of the smaller specimens constitute a different species and which are simply immature instars of species already established from the adults.

In 1931, H. Prziabram wrote an article on "Connecting Laws in Animal Morphology," incorporating information previously presented as lectures at the University of London, in which he proposed that crustaceans increase their weight, or volume, to twice its former value during each molting. From this it followed that

each of the three primary dimensions would increase by the cube root of 2, or 1.25992, from one instar to the next. From the work of Needham (1950) and others, we know now that Prziabram's Law (as it has come to be known) does not apply at all to certain crustaceans; yet it does appear to be a good approximation for ostracod species.

This was an extension of an idea originating with W. K. Brooks in 1886, who found that stomatopods increased from one instar to the next by a fixed percentage, and that the percentage remained constant for all instars in the ontogeny of a species. G. H. Fowler (1909) applied "Brook's Law" to ostracods for the first time. The only change introduced by H. Prziabram was the fixing of the percentage increase in each dimension to produce a doubling in total size.

From time to time, succeeding authors commented on Prziabram's Law in connection with their ostracod investigations. The law itself was studied by Kesling in a series of papers and its application tested. Three articles provide the essentials of his conclusions: "Doubling in size of ostracod carapaces in each molt stage" (1952), "A slide rule for the determination of instars in ostracod species" (1953), and "A chart useful for study of ostracod carapaces" (1957). In the latter two studies, he reduced the use of Prziabram's Law to mechanical mathematics by a special slide rule and chart. He (1952, p. 773) pointed out that the factor of growth of a single dimension could be exactly 1.2599 only if the shape of the ostracod did not change from one instar to the next, but that it would perforce differ from this value for one dimension or another if the shape did change. The data he presented in numerous papers on Devonian ostracods indicated that Prziabram's proposal that crustaceans double their size from one instar to the next holds generally true for ostracods of a species. Slight departures from the doubling factor are sometimes encountered from the ultimate immature instar to the adult stage, particularly in species having dimorphic adult carapaces; nevertheless, with rare exceptions, each individual can be assigned to a particular instar of its species by mathematical considerations. By the use of double-logarithm

paper, plots of length vs. height, length vs. product of height x length, or length vs. product of length x height x width for specimens of a given species will fall into clusters with clearly defined limits. In other words, despite individual variations in size and shape, each instar keeps its identity, distinct from older and younger instars.

The slide rule devised by Kesling (1953) is based on an increase factor of 1.25992 (cube root of 2) for a single dimension, 1.5874 (square of the cube root of 2) for the product of two dimensions, and 2 for the product of all three dimensions. It provides a convenient and quick method of comparing the relative sizes of a number of individuals and selecting the best-fit means for the instars represented. This set of idealized means can then be used to compare other specimens against the dimensions of the specimens already measured and studied.

As applied to this dimorphic species, the measurements of length, height, and width for the immature instars cluster with the following average dimensions:

Length	Height	Width	L x H x W
1.49	1.07	.77	.123
1.14	.82	.59	.055
.91	.66	.45	.027
.75	.54	.38	.015
.50	.35	.26	.0045

These approximate an ideal series of products (each doubling from the previous value): .0094 - .0188 - .0375 - .075 - .150 - .30 - .60 - .120. By use of the special slide rule mentioned above, it can be seen further that the measurements approximate ideal series of length (.465 - .585 - .738 - .930 - 1.170 - 1.475), height (.340 - .430 - .540 - .680 - .859 - 1.080), and width (.238 - .300 - .378 - .476 - .600 - .755). Using

these figures and adding 10% range for individual variation in each instar, we have the following:

This table is then used as a guide or indicator for the assignment of each specimen to an instar. Compare how very closely each fits the idealized dimensions of length, height, width, and product.

REFERENCES

- BROOKS, W. K., 1886, Report on the Stomatopoda dredged by H. M. S. "Challenger" during the years 1873-1876: Report on the Sci. Results of the Voyage of H. M. S. *Challenger*, Zoology, v. 9, p. 1-116, 16 pls.
- FOWLER, G. H., 1909, The Ostracoda; Biscayan plankton collected during a cruise of H. M. S. *Research*, 1900, Pt. XII: Trans. Linnean Soc., Zoology, 2d ser., v. 10, pt. 9, p. 219-336, pls. 16-27.
- KESLING, R. V., 1952, Doubling in size of ostracod carapaces in each molt stage: Jour. Paleontology, v. 26, no. 5, p. 772-780, 1 fig.
- , 1953, A slide rule for the determination of instars in ostracod species: Contrib. Mus. Paleontology, Univ. Mich., v. 11, no. 5, p. 97-109, 2 figs.
- , 1957, A chart useful for study of ostracod carapaces: Ibid., v. 14, no. 2, p. 17-20, 2 figs.
- NEEDHAM, A. E., 1950, Growth and regeneration in relation to age in Crustacea, with special reference to the isopod, *Asellus aquaticus* (Linn.): Jour. Gerontology, v. 5, no. 1, p. 5-16.
- PRZIBRAM, H., 1931, Connecting laws in animal morphology. Four lectures held at the University of London, March, 1929: London, Univ. London Press, 62 p.

Illustrated specimens.— UMMP 59078 (37/17-20), 59220 (37/9-12), 59222 (35/4-7), 59223 (34/1-6), 59224 (34/7-10), 59225 (35/1-3), 59226 (37/13-16), 59227 (36/13-16), 61818 (36/9-12), 61819 (35/8-11), 61820 (36/17-20), 61821 (37/5-8), 61822 (36/5-8), and 61823 (37/1-4).

Idealized Dimensions of *Phlyctiscapha apleta* Based on a Growth Pattern in Accord with Przibram's Law, showing lower, mean, and upper limits for a 10 per cent range in each instar (mm)

Stage	Length	Height	Width	L x H x W
Adult	1.77-1.86-1.95	1.30-1.36-1.43	0.90-.95-1.00	2.07-2.40-2.79
A-1	1.41-1.48-1.55	1.03-1.08-1.13	.72-.75-.79	1.04-1.20-1.40
A-2	1.12-1.18-1.23	.81-.86-.90	.57-.60-.63	.52-.60-.70
A-3	.89-.93-.98	.65-.68-.71	.45-.48-.50	.26-.30-.35
A-4	.71-.74-.78	.51-.54-.57	.36-.38-.40	.13-.15-.17
A-5	.56-.59-.62	.41-.43-.45	.29-.30-.32	.065-.075-.087
A-6	.45-.47-.49	.32-.34-.36	.23-.24-.25	.032-.038-.044
A-7	.35-.37-.39	.26-.27-.28	.18-.19-.20	.016-.019-.022
A-8	.28-.29-.31	.20-.21-.23	.14-.15-.16	.008-.009-.011

Actual Dimensions of Specimens of *Phlyctiscapha apleta*
from the Silica Formation (in mm)

Stage	No.	Pl./Figs.	Length	Height	Width	L x H x W
Female	59223	34/1-6	1.70	1.21	1.09	2.242
Male	59221*	37/17-20	1.67	1.25	.82	1.710
A-1	59222	35/4-7	1.51	1.09	.79	1.300
A-1	59224	34/7-10	1.50	1.05	.77	1.213
A-1	61820	36/17-20	1.45	1.03	.76	1.135
A-1	61822	36/5-8	1.49	1.05	.75	1.172
A-2	59220	37/9-12	1.13	.79	.60	.536
A-2	61823	37/1-4	1.15	.84	.58	.560
A-3	61818	36/9-12	.90	.64	.43	.247
A-3	61819	35/8-11	.92	.68	.47	.294
A-4	59225	35/1-3	.74	.54	.38	.152
A-4	59226	37/13-16	.76	.53	.40	.161
A-4	59227	36/13-16	.75	.54	.37	.150
A-6	61821	37/5-8	.50	.35	.26	.045

* Slightly crushed anteriorly.

regard *Balantoides* as a genus which can include the non-dimorphic *Balantoides trilobata* of the Silica.

BALANTOIDES TRILOBATA (Turner)

89/21-55; 118/3

Boursella trilobata Turner, 1939, p.14, pl.1, fig.4 [Well cuttings, SW Ontario. Holotype GSC (Ottawa) 9397].

Boursella trilobata Kesling, 1953, p.197, pl.1, figs.11-16 [Arkona Shale].

Boursella trilobata Coley, 1954, p.455, fig.2 [Wanakah Shale].

Boursella trilobata Smith, 1956, p.2, table 1 [Ledyard and Wanakah Shales].

Boursella trilobata Sohn, 1961, p.113.

Aechminella trilobata Sohn, 1961, p.113; Sohn in Moore, 1961, p.125.

Nodella digitalis Pauken, 1966, p.540, pl.2, figs.9,10,12,13 [Silica Formation].

Balantoides trilobata Sohn, 1975, p.G5.

Remarks.— Pauken (1966) described this species as *Nodella digitalis*, but it does not have the three lobes joined ventrally to a fourth lobe as in that genus.

This lobate little ostracod is common in the Silica Formation, occurring in most of the beds. Some excellent complete carapaces and single valves were recovered, but the majority of specimens are poorly preserved single

KEY TO SPECIES OF AECHMINIDAE

1. Surface reticulate; small depression or pit below spine ... *Sigynus dictyotus*
Surface smooth or papillose; no depression or pit below spine 2
2. Surface papillose; sulcus in front of major spine; submarginal row of tubercles along entire free margin ...
..... *Aechminaria hormathota*
Surface smooth; no sulcus; no submarginal tubercles *Aechmina* .. 3
3. Base of major spine flaring; free margin smooth or bearing at most a few granules *Aechmina choanobasota*
Base of major spine rather well delineated; free margin bearing very fine spinules *Aechmina crenulata*

valves. In the best preserved, the lateral surfaces of the valves are faintly pitted or punctate. Some smaller specimens were found in the Waterworks Park sediments, which differ in size only.

Illustrated specimens.— UMMP 58824 (89/46, 47), 58825 (89/50; 118/3), 58826 (89/36, 37), 58827 (89/48, 49), 58828 (89/42-45), 58829 (89/38-41), 58830 (89/33-35), 58833

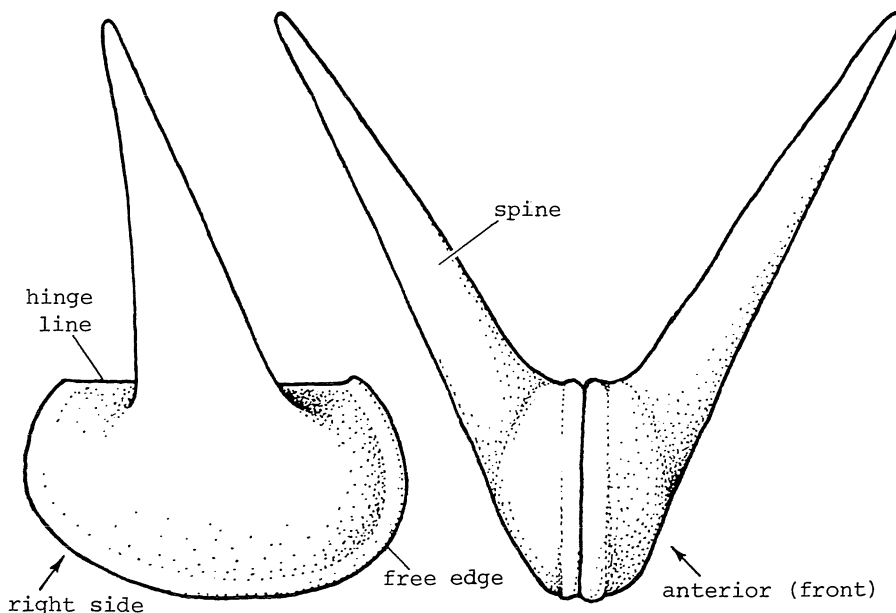

Aechmina choanobasota

(89/30-32), 59676a (89/53), 59676b (89/22), 59676c (89/51), 59676d (89/27), 59676e (89/29), 59676f (89/52), 59676g (89/24), 59676h (89/25), 59676i (89/55), 59676k (89/23), 59676l (89/54), 59676m (89/26), 59676n (89/21), and 59676o (89/28).

BALANTOIDES sp.

89/1-20

Very little doubt exists that these specimens belong to Balantoides trilobata, although their surface does not preserve the fine ornamentation.

Illustrated specimens.-- UMMP 58831 (89/15-17), 58832 (89/1-4), 59582 (89/9-11), 59583 (89/5-8), 59584 (89/18-20), and 59585 (89/12-14).

Family Aechminidae Swartz 1936

Major lobation consisting of a prominent hollow spine in the centrodorsal area of the valve, with or without an additional lobe or node.

Genus AECHMINA Jones & Holl 1869

Type species.-- By original designation, Aechmina cuspidata Jones & Holl, 1869, p.218, fig.2, pl.14, fig.8.

AECHMINA CHOANOBASOTA Kesling

11/13,14

- Aechmina choanobasota Kesling, 1953d, p.29,30, pl.2, figs.15-25; pl.3, figs.1-20 [Bell Shale. Holotype, a right valve, UMMP 27609].
Aechmina choanobasota Kesling & Weiss, 1953, p.50,51, pl.3, figs.15,16 [Norway Point Fm].
Aechmina sp. cf. A. choanobasota Kesling, 1953b, p.3,4, pl.1, figs.8,9 [Arkona Shale].
Aechmina choanobasota Tillman, 1969, p.206, fig.4 [Lower Olentangy Shale].

Remarks.-- Rare in the Silica Formation, Aechmina choanobasota bears a strong resemblance to the more common species, Aechmina crenulata, differing from it in the greater length/width ratio, the more tilted dorsal spine, and the lack of fine marginal denticles or crenulations.

Illustrated specimens.-- UMMP 59408 (11/13) and 59658 (11/14).

AECHMINA CRENULATA Stewart

10/1,2; 11/1-6; 13/1-4; 108/6

Aechmina serrata Stewart, 1936, p.748, pl.100, figs.21,22 [Silica Formation. Syntypes OSU 18179].

Aechmina crenulata Stewart, 1937, p.368.

Aechmina crenulata Stewart & Hendrix, 1945a, p.89 [Plum Brook Shale].

Aechmina serrata Coley, 1954, chart p.455 [Silica Formation].

Remarks.-- Complete carapaces as well as single valves were recovered in good condition, along with many specimens with broken spines. The very long and slender spines, sometimes attaining twice the height of the rest of the valve, are fragile because they are hollow. Many carapaces display the minute denticles (crenulations or serrations) along the margins of the free edges. The major spines appear to be somewhat more slender than those of A. choanobasota. These delicate ostracods are found in most of the Silica beds.

Illustrated specimens.-- UMMP 58813 (13/1,2), 58814 (10/1,2), 58815 (11/3,4; 108/6), 58816 (13/3,4), 58817 (11/5,6), and 59407 (11/1,2).

AECHMINA spp.

11/7-12; 13/5-10

More than one species is included under this heading. One small specimen with a short extremely sharp spine, UMMP 58818 (11/11, 12), is probably a new species. Another small specimen with blunt or worn short spines, UMMP 58820 (11/9,10), may also be new, but the variation in the outline and the form of the spines has not been established with adequate specimens.

In UMMP 59659 (11/7,8), the presence or absence of marginal denticles or spinules cannot be definitely discerned and the large spines are broken off, so that it could be either A. crenulata or A. choanobasota. Three specimens, UMMP 58819 (13/9,10), 59660 (13/7,8), and 59661 (13/5,6) are all probably A. crenulata, although the bases of the broken spines are somewhat atypical for the species.

Genus AECHMINARIA Coryell & Williamson

Type species.-- By original designation, *Aechminaria nodosa* Coryell & Williamson, 1936, p.5, fig.8.

AECHMINARIA HORMATHOTA Kesling

11/17-22; 49/1-4

Aechminaria hormathota Kesling, 1953d, p.5-7, pl.1, figs.21,22,24-29 [Arkona Shale. Holotype, complete carapace, UMMP 29588].

Aechminaria hormathota Melik, 1966, p.208,209, pl.1, figs.6-8; pl.5, figs.22-30; pl.6, figs.1-7 [Arkona Shale, Widder Formation].

Remarks.-- Rare in the Silica Formation. Preservation of specimens rather poor, but identification certain.

Illustrated specimens.-- UMMP 58821 (11/17, 18), 58822 (11/21, 22), 59338 (49/1-4), and 59431 (11/19, 20).

AECHMINARIA sp.

11/15,16

UMMP 58823, although the same size as adults of *Aechminaria hormathota* and bearing the same ornamentation on its sides, lacks the submarginal row of large denticles or tubercles typical of that species. It also has an unusual anteroventral bevel. The lack of denticles on the ventral area may be attributed to abrasion and the bevel to slight wear or deformation. We would accept this specimen as an *Aechminaria hormathota*.

Genus SIGYNUS Kesling

Type species.-- By original designation, *Sigynus dictyotus* Kesling, 1953d, p.4,5, pl.1, figs.10-12.

SIGYNUS DICTYOTUS Kesling

81/22-27

Sigynus dictyotus Kesling, 1953d, p.5, pl.1, figs.10-12 [Arkona Shale. Holotype, a crushed carapace, UMMP 29596].

Remarks.-- This rare ostracod occurs in the *Styliolina* beds (MM-Chon) at the Martin-Marietta Quarry. Only two specimens were found, one definitely and one probably belonging to the species. The one listed here shows the characteristic ornamentation very well.

The pit below the major spine described in the holotype (and only previously known specimen) cannot be discerned in the Silica ostracods, and may be a fortuitous enlargement of part of the reticulation.

Illustrated specimen.-- UMMP 59046 (81/22-27).

SIGYNUS cf. DICTYOTUS Kesling

103/29-34

We feel rather confident that this specimen is indeed one of the rare *Sigynus dictyotus*, even though the preservation has damaged and masked much of the typical reticulation for which the species is named.

Illustrated specimen.-- UMMP 60052.

Family Bolliidae Bouček 1936

Lobation of more than one element, none long or nearly central. Two dorsal lobes nearly equal (L_2 and L_3); no subventral lobe distinct from dorsal lobes. Hinge long.

Genus CORNIGELLA Warthin 1930

Type species.-- By original designation, *Cornigella minuta* Warthin, 1930, p.59, pl.4, fig.7.

Remarks.-- Sohn (1968, p. 12-14) took this genus out of the Drepanellidae because of a "dimorphic outline." Although there is a great variation in the outline of carapaces, we find no evidence of either beyrichiid or kloedenellid dimorphism in our specimens. If dimorphism exists, it must lie in the posterodorsal angulation and constitute an undescribed type of sexual dimorphism. In light of variation in other characters, we doubt that this is a case of dimorphism.

Inasmuch as the reticulate surface, nodes, and spines fit the description of the Bolliidae, we place *Cornigella* in that family of the superfamily Drepanellacea.

CORNIGELLA IMMOTIPEDATA Kesling

38/10-33; 39/1-22; 109/4,5

Cornigella immotipedata Kesling, 1953a, p.200, 201, pl.1, figs.35-45 [Arkona Shale. Holotype, carapace, UMMP 28917].

Cornigella immotipedata Sohn, 1968, p.13,14.

Family BOLLIIDAE	Medusa quarries													Martin-Marietta Quarry			Waterworks Park				
	SPECIES													Quarry			Park				
	Unit	6	7	9	11	12	13	14	15	16	17	18	21	23	1-6	9-11	14-15	17-18	1-6	9-11	12
<i>Cornigella immotipedata</i>		X																			
<i>Stictobollia alethae</i>		X	X	X	X	X	X	X						X	X	X	X		X		X
<i>Tetrastorhynch diabolicus</i>					X																
<i>Ulrichia conradi</i>		X	X		X		X				X	X								X	X
<i>Ulrichia fastidiosa</i>						X									X						X
<i>Ulrichia fragilis</i>		X	X	X	X	X	X	X				X		X	X	X	X		X	X	X
<i>Ulrichia illinearis</i>			X	X	X	X	X							X	X	X	X		X	X	X
<i>Ulrichia spinifera</i>		X	X	X	X	X	X	X	X	X	X	X	X	X	X	X	X		X	X	X
<i>Xystinotus subnodatus</i>							X							X	X	X	X		X	X	X
<i>Xystinotus wrightorum</i>														X	X	X	X		X	X	X

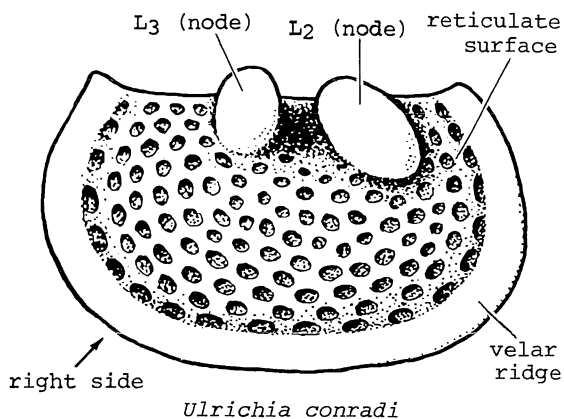

Cornigella immotipedata Tillman, 1970, p.210, fig.4, no.5,6 [Lower Olenyok Shale].

Remarks.-- Although specimens of *C. immotipedata* are relatively rare in the Silica Formation, carapaces are well preserved and numerous enough to show the great variation in the outline of the posterior end, which ranges from rather gently round to acutely pointed with a definite swing. These and the excellent specimens from the Arkona Shale form a broad series with no clear evidence of dimorphism.

Illustrated specimens.-- UMMP 58909 (38/14-17), 58910 (38/10-13), 58911 (39/7-

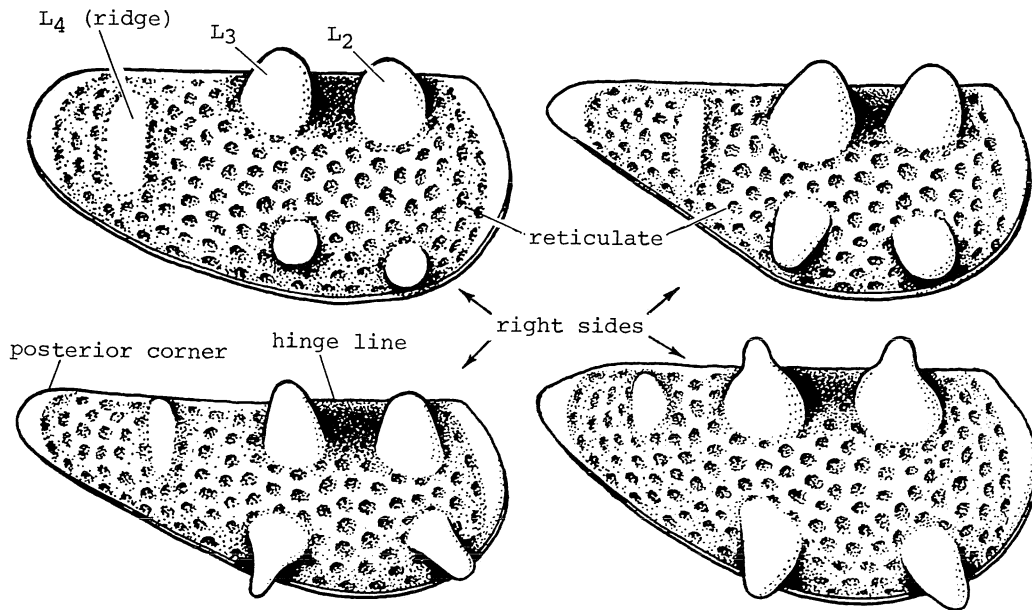

Cornigella immotipedata

KEY TO SPECIES OF BOLLIIDAE

1. Surface granulose to smooth; L₃ developed as a large dorsolaterally projecting spine *Tetrastorthynx diabolicus*
Surface reticulate or pitted; L₃ developed as a spine, node, or ridge (if not effaced), projecting (if at all) more dorsally than laterally 2
2. Surface coarsely pitted; L₂ and L₃ ridges, joined below S₂; S₁ and S₃ vertical, nearly reaching ventral border
..... *Stictobollia alethae*
Surface reticulate; L₂ and L₃ (if present) nodes or spines, isolated from each other; S₁ and S₃ faint or absent 3
3. Velar ridge present, distinct throughout its length with its ends at or near dorsal border; no ventral projections; posterior end rounded 4
No velar ridge, at least not in ventral part of valve; two conspicuous projecting nodes or blunt spines, one below L₂ and one below L₃ (possibly ventral expressions of lobation); valves distinctly acuminate towards posterodorsal corner
..... *Cornigella immotipedata*
4. Dorsum "scraped" (? abraded), strongly affecting or effacing L₂, L₃, and reticulation in upper third of valve (may be an ecological variant of the genus *Ulrichia*) *Xystinotus* .. 5
Dorsum well preserved, with lobes and reticulation clearly unaffected by any abrasion *Ulrichia* .. 6
5. Elongate, length more than twice the height *Xystinotus subnodatus*
Subovate, length less than twice the height *Xystinotus wrightorum*
6. Nodes clearly set off from lateral surface and small; L₃ set appreciably higher than L₂ *Ulrichia illinearis*
Nodes large and clearly defined OR medium and not sharply set off from rest of lateral surface ventrally; L₂ and L₃ set at about same level on valve 7

7. Valve elongate, posteriorly tapering and subpyriform; velar ridge nearly semi-circular, with appreciable part of posterior area of valve exposed behind it; L₂ and L₃ not sharply defined ventrally, tending there to be confluent with the lateral surface *Ulrichia fragilis*
Valve subovate to subrectangular; velar ridge forming free border; L₂ and L₃ distinctly set off from lateral surface . 8
8. L₂ larger than L₃, ovate and slanting; marginal ridge smooth; corners tending to extend above hinge line, especially in well-preserved specimens
..... *Ulrichia conradi*
L₂ equal or smaller than L₃, not slanting; marginal ridge in each valve bearing small spines (in closed carapace, alternating between left and right valves); corners nearly aligned with hinge line 9
9. L₂ and L₃ about equal, both vertical; reticulation fairly coarse
..... *Ulrichia spinifera*
L₃ appreciably larger than L₂, hornlike, curved, sloping backward and flaring outward; reticulation fine
..... *Ulrichia fastidiosa*

Genus STICTOBOLLIA n. gen.

Type species.-- Here designated, *Dizygopleura alethae* Coley, 1954, p.462, pl.53, fig.6.

Derivatio nominis.-- The name *Stictobollia* is derived from the Greek word *στικτος* ("pricked, punctured, spotted") and the generic name *Bollia*, referring to the ornamentation of this ostracod with lobation like that of *Bollia*.

Description.-- Carapace small, nearly equivalved, subelliptical in lateral view. Dorsal border straight, anterior border rounded, ventral border gently curved with a slight swing to the rounded posterior border. S₁ and S₃ terminate near ventral border, whereas S₂ terminates about at midheight. Surface coarsely pitted. Hinge tongue-and-groove. Interior of each valve with a low vertical ridge marking the external position of S₂, and a broader, lower ridge marking the position of S₃.

10), 58912 (38/22-25), 59065 (39/5, 6), 59505 (38/30-33), 59612 (39/15-18), 59613 (39/19-22; 109/5), 59614 (39/11-14), 59615 (38/26-29; 109/4), 59616 (39/1-3), 59617 (38/18-21), and 59652 (39/4).

Remarks.-- Originally placed in the genus *Dizygopleura* by Coley (1954), this little ostracod lacks both the stragulum and the posterior overlap (left/right) along the hinge line as is present in that genus. The coarse pitting is also foreign to known species of *Dizygopleura*. Pauken (1966) placed it in the genus *Nodella*, but its lobes are neither spinose nor do they project from the valves dorsally. In addition, they are not confined to the dorsal half of the valve, as they are in *Nodella*. The U-shaped lobe characteristic of the Bolliidae is seen in the ventral confluence of L₂ and L₃. The surface ornamentation is also common to that family.

STICTOBOLLIA ALETHAE (Coley)

81/67-86; 82/23-29; 83/44-46

Dizygopleura alethae Coley, 1954, p.462,463, pl.53, fig.6 [Silica Formation. Holotype, Wayne Univ. T50004].

Nodella tetralobata Pauken, 1966, p.542, pl.2, figs.6-8 [Silica Formation].

Description.-- Same as for the genus, as given above, in which it is the only species known at present. Very small, length from 0.40 to 0.48 mm, height from 0.20 to 0.25 mm. The lobation is particularly distinctive.

Occurrence.-- Common in the Silica and Martin-Marietta quarries, abundant in the Styliolina beds at the latter. A few specimens have been found in the Arkona, Widder, and Ipperwash formations of western Ontario, and in the Wanakah, Kashong, and Windom formations of western New York. One specimen was discovered in the Ferron Point Formation of northeastern Michigan.

Illustrated specimens.-- UMMP 58935 (81/67,68), 58936 (81/69,70; 82/23), 58937 (81/75,76; 82/24), 58939 (81/77,78; 82/29), 58940 (81/73,74), 58941 (81/79-82; 82/25), and 58942 (81/83-86; 82/26-28; 83/44-46). These include three right valves, three left valves, and two complete carapaces.

Genus TETRASTORTHYNX Kesling

Type species.-- By original designation, *Tetrastorthynx diabolicus* Kesling, 1953a, p.196, 197, pl.1, figs.7-10.

TETRASTORTHYNX DIABOLICUS Kesling

83/21-39; 84/18-23; 113/5

Tetrastorthynx diabolicus Kesling, 1953, p.196, 197, pl.1, figs.7-10 [Arkona Shale. Holotype, complete carapace, UMMP 28900].

Remarks.-- This very small ostracod resembles *Ulrichia* in general shape and location of the two hornlike spines in the dorsal part of each valve. The spines are spaced farther apart than in *Ulrichia*, however, and are proportionately longer. *Tetrastorthynx* also lacks the reticulation of *Ulrichia*.

Genus ULRICHIA Jones

Type species.-- By original designation, *Ulrichia conradi* Jones, 1890, p.544, fig.2.

ULRICHIA CONRADI Jones

41/21-27

Ulrichia conradi Jones, 1890, p.544, fig.2

[Holotype, Brit. Mus. 19431; plesiotype, USNM 62129].

Ulrichia conradi Jones, 1891, p.95, pl.11, fig.13.

Ulrichia conradi Whiteaves, 1898, p.409.

Ulrichia conradi Bassler in Cleland, 1911, p.145, pl.44, fig.6.

Ulrichia conradi Kindle, 1912, p.115, pl.9, fig.12.

Ulrichia conradi Ulrich & Bassler, 1923, p.299-301.

Ulrichia conradi Ehlers & Cooley, 1927, p.233 [Silica Formation].

Ulrichia conradi Knight, 1928, p.252.

Ulrichia conradi Warthin, 1934, p.213, pl.1, fig.10 [Norway Point Formation].

Ulrichia conradi Bassler & Kellett, 1934, p.489, fig.6, no.10 [Theford, Ontario].

Ulrichia conradi Warthin, 1937, card 94, fig.10.

Ulrichia conradi Turner, 1939, p.8, table 1; p.9, table 2.

Ulrichia conradi Shimer & Shrock, 1944, p.667, pl.281, fig.38.

Ulrichia conradi Kesling, 1952b, p.26,27, pl.4, figs.13-21 [Bell Shale].

Ulrichia conradi Smith, 1956, pl.2, table 1 [Ledyard and Wanakah Shales].

non *Ulrichia conradi* Stewart, 1936, p.747, pl.100, figs.17,18 [Silica Formation].

non *Ulrichia conradi* Warthin (part), 1937, card 94, figs.1,1a,2.

non *Ulrichia conradi* Stewart & Hendrix, 1945a, p.89, pl.10, fig.2 [Plum Brook Shale].

Remarks.-- Ulrichia conradi is rare in the Silica Formation as compared to the extensive population of Ulrichia spinifera, which it closely resembles. The pronounced dorsal spines of the latter differ from the lower and blunter nodes of U. conradi, especially the anterior node, which is elongate and inclined to the dorsal border. The shorter hinge of U. conradi results in a more rounded pair of dorsal extremities than the definite corners of U. spinifera. Marginal spines are absent or greatly reduced in U. conradi.

Illustrated specimens.-- UMMP 59354 (41/23), 59389 (41/21, 22), 59390 (41/24, 25), and 59391 (41/26, 27).

ULRICHIA FASTIDIOSA n. sp.

41/7-20; 42/9-24; 106/20-23; 114/7

Derivatio nominis.-- The name *fastidiosa* is derived from the Latin *fastidiosus* ("proud, delicately attired, showing great care, discrimination, and taste in choice of personal adornment"), referring to the fine reticulation with much smaller meshes than those in related species.

Description.-- Carapace small, subelliptical in lateral view with straight hinge line extending the length of the valve. Valves almost equal, with overlap inconspicuous. General shape typical for the genus with the exception of the marginal ridge; ridge greatly reduced.

Dorsal spines of each valve large, the posterior one inclined backward noticeably.

Surface of each valve finely pitted, appearing almost smooth and giving it a neat appearance. Free edge bearing fine spinules. Hinge not observed.

Remarks.-- This species appears to be an intermediate form between the larger, thicker Ulrichia spinifera and the smaller, smoother Tetrastorhynchus diabolicus. It resembles U. spinifera in the marginal spinules or papillae, but differs in the much finer reticulation and in the stronger inclination of the posterior spine. It resembles Tetrastorhynchus diabolicus in general lobation, but has greater size, different ornamentation (fine reticulation of tiny pitting instead of granulation), and proportionally smaller L₃ spine.

Occurrence.-- This new species is rare, found only in the soft shales of the Styliolina beds at the Martin-Marietta Quarry. A few specimens were found in the Widder Formation of Ontario and in the Centerfield Limestone and Wanakah Shale beds of western New York state.

Types.-- Holotype, UMMP 59392 (42/21-24). Paratypes: UMMP 59375 (42/17-20), 59376 (41/9-12; 114/7), 59377 (41/13-16),

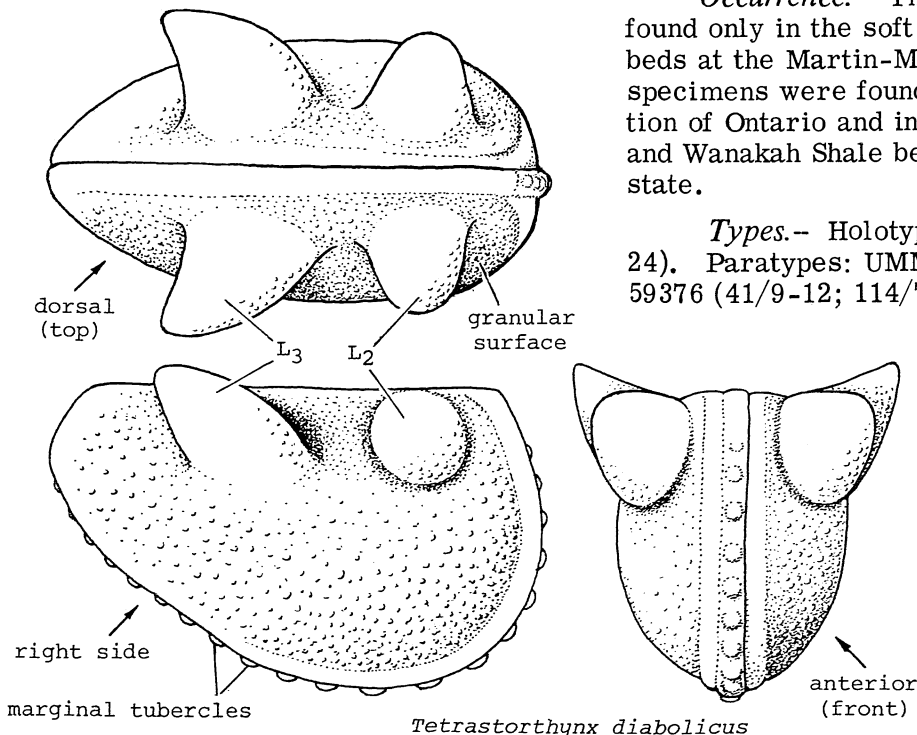

59378 (41/7, 8), 59380 (42/13-16), 59381 (41/17-20), 59393 (42/9-12), and 60080 (106/20-23).

ULRICHIA FRAGILIS Warthin

42/39-54; 43/23-30; 110/3; 114/6

- Ulrichia fragilis* Warthin, 1934, p.213, 214, pl. 1, fig.11 [Widder Formation. Holotype, UMMP 14540].
- Ulrichia fragilis* Stewart, 1936, p.747, pl.100, figs.19,20 [Silica Formation].
- Ulrichia fragilis* Warthin, 1937, card 95, fig.11.
- Ulrichia fragilis* Kesling, 1952b, p.27, pl.4, figs.9-12 [Bell Shale].
- Ulrichia fragilis* Kesling & Weiss, 1953, p.49, pl.3, figs.23-26 [Norway Point Formation].
- Ulrichia fragilis* Smith, 1956, p.2, table 1 [Ledyard Shale, Wanakah Formation].
- Ulrichia fragilis* Stover, 1956, p.1110, pl.113, fig.12 [Windom Shale].
- Ulrichia fragilis* Melik, 1966, p.210, 211, pl.1, figs.4,5; pl.6, figs.8-11,48; pl.16, figs.1-6 [Widder Formation, Bell Shale].

Remarks.-- Smaller than *Ulrichia conradi* or *U. spinifera*, this little ostracod has a pronounced swing and much sharper posterior end. A smooth velar ridge curves upward into the posterior region, differentiating it from other species of the genus. The dorsal nodes are smaller than in other species, and merge ventrally into the lateral surface. Only a few badly preserved specimens were found at all localities; it is more common and better preserved at other Middle Devonian outcrops in the Michigan Basin.

Illustrated specimens.-- UMMP 59356 (42/43-46), 59357 (42/51-54), 59358 (42/39-42), 59359 (43/23-26; 110/3), 59360 (42/47-50), and 59361 (43/27-30; 114/6).

ULRICHIA ILLINEARIS Kesling

43/31-36; 114/5

- Ulrichia illinear* Kesling, 1953a, p.199, 200, pl.1, figs.28-32 [Arkona Shale. Holotype, carapace, UMMP 28914].
- Ulrichia illinear* Stover, 1956, p.1110, pl.113, fig.13 [Windom Shale].
- Ulrichia illinear* Melik, 1966, p.211, pl.1, figs.1-3; pl.4, figs.38-47 [Widder Formation, Arkona Shale, Bell Shale, Centerfield Limestone].
- Ulrichia illinear* Tillman, 1970, p.210, pl.5, figs.3,4 [Plum Brook Shale, Olentangy Shale].

Remarks.-- Resembling *Ulrichia spinifera* in outline, *U. illinear* is much smaller and its dorsal nodes are at different distances from the hinge line. It also resembles *Xystinotus wrightorum*, which has smaller, effaced nodes, perhaps from abrasion during life. Rare and poorly preserved specimens occur in the Silica Formation.

Illustrated specimens.-- UMMP 59363 (43/35, 36) and 59365 (43/31-34; 114/5).

ULRICHIA SPINIFERA Coryell & Malkin

41/1-6; 42/25-38; 43/1-22; 114/4; 115/3

- Ulrichia spinifera* Coryell & Malkin, 1936, p.1, 2, figs. 1,2 [Hungry Hollow Formation. Holotype, AMNH 21628].
- Ulrichia conradi* Stewart, 1936, p.747, pl.100, figs.17,18 [Silica Formation].
- Ulrichia acricula* Kesling 1952b, p.28,29, pl.4, figs.1-8 [Bell Shale].
- Ulrichia spinifera* Kesling 1952b, p.27, pl.4, figs.9-12 [Bell Shale].
- Ulrichia spinifera* Kesling & Weiss, 1953, p.40, pl.3, figs.32-35 [Norway Point Formation].
- Ulrichia spinifera* Stover, 1956, p.1109, pl.113, figs.14-17 [Windom Shale].
- Ulrichia acricula* Stover, 1956, p.1109, pl.113, figs.18-22 [Windom Shale].
- Ulrichia spinifera* Melik, 1966, p.209, 210, pl.2, figs.7-9; pl.6, figs.12-38; pl.16, figs.20-23; pl.17, figs.14,15 [Widder Formation].
- Ulrichia acricula* Tillman, 1970, p.210, fig.5, no.1,2 [Plum Brook Shale, Olentangy Shale].

Remarks.-- *Ulrichia spinifera* is common and very well preserved in the Silica Formation. Excellent single valves show hinge structure, hollow spines, and apparently pore openings on the inside, as well as fine denticles or spinules along the free margin. Inasmuch as size, shape, and inclination of dorsal spines vary considerably, evidently at random, we have placed *U. acricula* in synonymy with *U. spinifera*. *Ulrichia conradi* has the same size and shape but more obtuse dorsal angles, with tips of the cardinal areas directed upward; it also lacks marginal denticles which are so prominent in *U. spinifera*. L_2 in *U. conradi* is developed as a blunt elongate node set at an angle to the hinge line, whereas in *U. spinifera* it is an upward-pointing spine.

Illustrated specimens.-- UMMP 59348 (42/29-32), 59349 (41/1,2), 59350 (41/5,6), 59351 (41/3,4), 59352 (42/25-28), 59368 (42/33,34; 43/5,6; 114/4), 59369 (42/35-38), 59370 (43/7,8; 115/3), 59371 (43/9,10), 59372 (43/1-4), 59373 (43/11-14), 59374 (43/19-22), and 59694 (43/15-18).

ULRICHIA sp.

42/1-8; 116/7

Description.-- Carapace medium in size, with length about twice the height; otherwise similar to U. conradi in lateral outline. Valves gently convex, sloping to a thin velar ridge. Prominent rounded nodes instead of spines for L₂ and L₃, projecting above the hinge line, the elongate posterior spine inclined backward.

Lateral surface very finely reticulate, including the nodes. No denticles observed on the free margins.

Remarks.-- This ostracod is very rare in the formation. It may be a variant of U. conradi, although it is distinctly longer and has a much lower velar ridge, and its surface ornamentation is much finer. These features also distinguish it from U. spinifera, and in addition it lacks marginal spinules or denticles. It is much larger than U. fastidiosa, with greater length/height ratio. Because the few specimens found are poorly preserved, no attempt has been made to formally name them.

Illustrated specimens.-- UMMP 59681 (42/1-4; 116/7) and 59682 (42/5-8).

Genus XYSTINOTUS Kesling

Type species.-- By original designation, Xystinotus wrightorum Kesling, 1953c, p.197, 198, pl.1, figs.17-21

Some question persists as to the separation of Xystinotus and Ulrichia. The effacement of dorsal reticulation and degrading of the nodes have been found to vary in degree, suggesting that this may have been ecological, due to some difference in life habits. If so, the genus may be found to be synonymous with Ulrichia, although the effacement in some specimens and not in others needs to be explained.

XYSTINOTUS SUBNODATUS (Turner)

43/52-64; 44/1-12; 115/5; 116/3

Ulrichia fragilis var. subnodata Turner, 1939, p.11,12, pl.1, fig.2 [Dover Field, Ontario. Holotype, GSC 9396].

Ulrichia fragilis subnodata Smith, 1956, table 1 [Ledyard Shale, Wanakah Shale].

Xystinotus subnodatus Kesling, 1953c, p.199, pl.1, fig.2 [Arkona Shale].

Remarks.-- Xystinotus resembles Ulrichia illinearis in general appearance. X. subnodatus is smaller, more elongate than U. illinearis, with a lower velar ridge and smaller and smoother nodes.

Illustrated specimens.-- UMMP 59362 (44/1-4), 59364 (43/52,53; 116/3), 59394 (43/61-64; 115/5), 59395 (44/9-12), 59396 (43/54-56), 59688 (43/57-60), and 59695 (44/5-8).

XYSTINOTUS WRIGHTORUM Kesling

43/37-51; 116/2

Xystinotus wrightorum Kesling, 1953c, p.198, pl.1, figs.17-21 [Arkona Shale. Holotype, complete carapace, UMMP 28904].

Remarks.-- Xystinotus wrightorum also resembles Ulrichia illinearis in shape and placement of the nodes. It is consistently somewhat smaller and narrower than that species, with a much less prominent velar ridge and smooth nodes.

Illustrated specimens.-- UMMP 59366 (43/37-40), 59399 (43/48-51; 116/2), 59400 (43/41,42,46,47), and 59401 (43/43-45).

Family Kirkbyellidae Coryell & Booth

Lobation consisting of a short but distinct dorsal sulcus (S₂).

Genus KIRKBYELLA Coryell & Booth 1933

Type species.-- By original designation, Kirkbyella typa Coryell & Booth, 1933, p.262, pl.3, fig.7.

Subgenus KIRKBYELLA Coryell & Booth

KIRKBYELLA (KIRKBYELLA) BELLIPUNCTA
(Van Pelt)

39/23-36; 40/1-12; 112/1

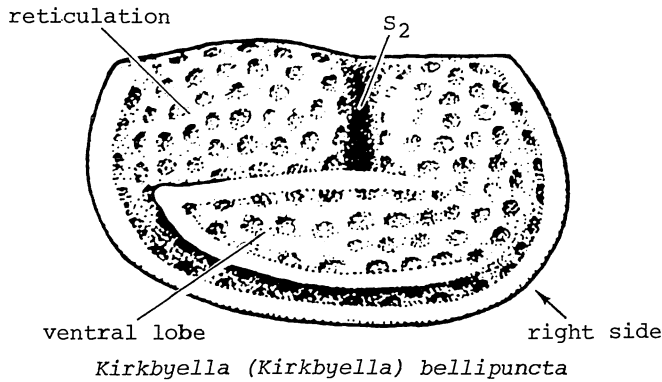

KEY TO SPECIES OF KIRKBYELLIDAE

1. Ventral (subventral) lobe distinct throughout its length except at anterior end, raised above rest of lateral surface and emphasized by bordering rim
 *Kirkbyella (Kirkbyella) bellipuncta*
 Ventral (subventral) lobe indistinct except for posterior-directed spine in posteroventral quadrant of lateral surface
 *Kirkbyella*, subgenus *Berdanella* .. 2
2. Reticulation elements horizontally aligned; posterior corner tending to be acute; posterior end of ventral lobe somewhat swollen in front of spine *Kirkbyella (Berdanella) stewartae*
 Reticulation elements fine, not aligned; posterior corner tending to be slightly obtuse and rounded; posterior end of ventral lobe scarcely discernible ahead of terminal spine
 *Kirkbyella (Berdanella) unicornis*

Amphissites bellipunctus Van Pelt, 1933, p.332, pl.39, figs.37-40 ["Bell Shale." Lectotype, fig.38].

Halliella bellipuncta Warthin, 1934, p.208, pl. 1, fig.2 [Norway Point Formation].

Halliella bellipuncta Stewart, 1936, p.746, pl. 100, figs.15,16 [Silica Formation].

Kirkbyella bellipuncta Warthin, 1937, card 80, figs.37-40.

Halliella bellipuncta Turner, 1939, p.12, pl.1, fig.3 [Well cuttings, SW Ontario].

Kirkbyella bellipuncta Shimer & Shrock, 1944, p.671, pl.282, figs.43,44.

Kirkbyella bellipuncta transversa Stewart & Hendrix, 1945a, p.90, pl.10, figs.12-14 [Plum Brook Shale].

Halliella bellipuncta Kesling, 1952b, p.26, pl.1, figs.16-25 [Bell Shale].

Halliella bellipuncta Kesling & Weiss, 1953, p. 35, pl.3, figs.21,22 [Norway Point Formation].

Kirkbyella bellipuncta Coley, 1954, p.455, fig. 2 [Silica Formation, Arkona Shale, Widder Formation, Centerfield Limestone, Wanakah Shale].

Halliella bellipuncta Loranger, 1954, p.109, pl. 2, figs.21,22 [Alberta, Canada].

Kirkbyella bellipuncta transversa Smith, 1956, p.2, table 1 [Ledyard Shale, Wanakah Shale].

Kirkbyella tora Stover, 1956, p.1133, pl.119, figs.17-21 [Windom Shale].

Kirkbyella (Kirkbyella) bellipuncta Sohn, 1961,

pl.143,144, pl.12, figs.1-12,24.

Kirkbyella (Kirkbyella) bellipuncta Melik, 1966, p.212, pl.16, figs.7-10; pl.17, figs.12,13 [Bell Shale, Arkona Shale, Widder Formation].

Remarks.-- The smallest of the three *Kirkbyella* species found in the Silica Formation, this is also distinguished by the fewer pits and the distinct ventral groove below the horizontal ventral ridge. It is common in unit 7 and the *Styliolina* beds (MM-Chon), where it is usually found as single valves.

Illustrated specimens.-- UMMP 59150 (39/29, 30), 59151 (39/25, 26), 59152 (39/27, 28), 59153 (39/23, 24; 112/1), 59154 (39/31, 32), 59155 (40/5-8), 59156 (40/1-4), 59157 (40/9-12), and 59171 (39/33-36).

Family KIRKBYELLIDAE	SPECIES	Unit	Medusa quarries		Martin-Marietta	Waterworks						
					Quarry	Park						
			6	7	1-6	9-11	12					
	<i>Kirkbyella (K.) bellipuncta</i>		x	x	x	x	x	x	x	x	x	x
	<i>Kirkbyella (Berdanella) stewartae</i>											x
	<i>Kirkbyella (Berdanella) unicornis</i>			x	x	x	x	x				

Subgenus BERDANELLA Sohn

KIRKBYELLA (BERDANELLA) STEWARTAE
Sohn

39/37-42; 112/2

Kirkbyella unicornis Coryell & Malkin, Stewart, 1950, p.662, pl.86, figs.13,14 [3rd Bone Bed, Delaware Formation. Holotype, right valve, OSU 19594].

Kirkbyella (Berdanella) stewartae Sohn, 1961, p.146, pl.10, figs.34-36.

non *Kirkbyella unicornis* Coryell & Malkin, 1936.

Remarks.-- This species has a horizontal pattern of reticulation and a more acute dorso-posterior angle than *K. (B.) unicornis*. The ventral lobe rises abruptly from the free edge. It is rare at all Silica localities, and preservation is generally poor.

Illustrated specimens.-- UMMP 59158 (39/42), 59159 (39/39), 59160 (39/41; 112/2), 59161 (39/40), and 59419 (39/37, 38).

KIRKBYELLA (BERDANELLA) UNICORNIS
Coryell & Malkin

39/43-56; 40/13-25; 112/3

Kirkbyella unicornis Coryell & Malkin, 1936, p.5, pl.1, fig.13 [Hungry Hollow Formation. Holotype, AMNH 24619].

Kirkbyella unicornis Warthin, 1937, card 83, fig.13.

Kirkbyella unicornis Stover, 1956, p.1133, pl.119, fig.26 [Windom Shale].

Kirkbyella (Berdanella) unicornis Sohn, 1961, p.146, pl.10, fig.43.

non *Kirkbyella unicornis* Stewart, 1951.

Remarks.-- This species is longer and larger than *K. (K.) bellipuncta*, with much finer reticulation and lacking the distinctly bordered horizontal ventral lobe. It is rare in the Silica Formation.

Illustrated specimens.-- UMMP 59162 (39/49-52), 59163 (39/45-48), 59164 (40/19, 20; 112/3), 59165 (39/53), 59166 (40/22-25), 59167 (40/17, 18), 59168 (39/54-56), 59169 (40/15, 16), 59170 (40/13, 14), 59420 (39/43, 44), and 59515 (40/21).

Family Richinidae Coryell & Malkin

Dorsal part of valve with two distinct lobes (L_2 and L_3); no elongate subventral lobe. Hinge much shorter than rest of valve, producing subovate to ovate shape in lateral view.

Genus RICHINA Coryell & Malkin

Type species.-- By original designation, *Richina truncata* Coryell & Malkin, 1936, p.3, figs.5,5a,6.

RICHINA SUBCIRCULARIS Coryell & Malkin

46/1-4; 107/1-4

Richina subcircularis Coryell & Malkin, 1936, p.4, fig.7 [Hungry Hollow Formation. Holotype, AMNH 24613].

Richina subcircularis Warthin, 1937, card 52, fig.7.

Remarks.-- The more circular lateral outline distinguishes *R. subcircularis* from *R. truncata*. A few poorly preserved single valves were found in the Silica Formation.

Illustrated specimens.-- UMMP 59336 (46/1), 59587 (46/4), 59588 (46/3), 59589 (46/2), and 60068 (107/1-4).

RICHINA TRINODOSA n. sp.

46/5-19

Derivatio nominis.-- The name *trinodosa* is derived from the Latin *tri-* ("three") and *nodosus* ("knotty, node-bearing"), referring to the three prominent sharp nodes on each valve.

Description.-- Medium size, subcircular outline in lateral view. Hinge straight, about two-thirds the length of the valve. Greatest length midway between hinge and ventral border, greatest height about midway between the equal ends of the valve.

Surface smooth. Three nodes on each valve instead of usual two in the genus: rounded dorsal node located in anterodorsal area; postero-dorsal node smaller and pointed; the third node also pointed, with tip directed outward, located near center of valve and below the others.

KEY TO SPECIES OF RICHINIDAE

1. Third node in dorsal half of valve, situated between and below other two nodes *Richina trinodosa*
Only two nodes in dorsal half of valve 2
2. Outline subcircular, length/height less than 3/2; ends about evenly rounded with nearly the same radius of curvature; L₂ set distinctly below hinge line; posterodorsal border rounded; sulcus nearly median *Richina subcircularis*
Outline elongate oval, length/height more than 3/2; ends somewhat tapered into rounded part, the anterior with larger radius of curvature; L₂ set nearly tangent to hinge line; posterodorsal border obliquely truncate; sulcus anterior *Richina truncata*

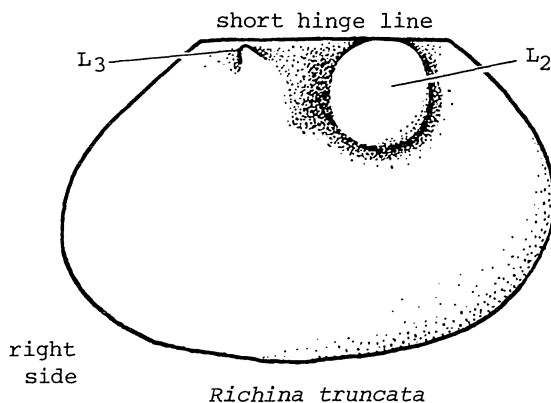

Richina truncata

RICHINA TRUNCATA Coryell & Malkin

103/21,22; 107/5-14

Richina truncata Coryell & Malkin, 1936, p.3, figs.5,5a,6 [Hungry Hollow Formation. Types, AMNH 24611 (figs.5,5a) and AMNH 24612 (fig. 6)].

Richina truncata Warthin, 1937, card 53, figs. 5,5a,6.

Richina truncata Coley, 1954, p.455, fig.2 [Hungry Hollow Formation, Widder Shale, and Wanakah Formation].

Remarks.-- The lateral outline is less rounded than that of *R. subcircularis* or *R. trinodosa*, with the posterior third of the margin truncated. Rare in the Silica beds.

Illustrated specimens.-- UMMP 60065 (107/13,14), 60067 (103/21,22), 60069 (107/9-12), and 60070 (107/5-8).

Superfamily Hollinacea Swartz 1936

Dimorphism in the form of well-developed velar structure.

Family Ctenoloculinidae Jaanusson & Martinsson 1956

Female with loculi or incipient loculi between velum and marginal ridge.

Sulcus shallow, extending from the third node to the hinge. Nodes surrounded by a narrow semicircular groove or fissure, extending from anterior to posterior areas of the hinge.

Remarks.-- Two poorly preserved specimens from the Silica still show the characteristic features. One very well preserved carapace was found in the Centerfield Limestone.

The centrally situated spined lobe and the narrow circular groove distinguish this new species from both *R. subcircularis* and *R. truncata*.

Types.-- Holotype, carapace, UMMP 59656 (46/9-13). Paratypes: UMMP 59337 (46/5-8), 59590 (46/16-19), and 59591 (46/14,15).

Family RICHINIDAE	Unit	Medusa quarries		Martin-Marietta	Waterworks					
				Quarry	Park					
SPECIES	6	7	9	11	12	17-18	1-6	7	11	12
<i>Richina subcircularis</i>			X							
<i>Richina trinodosa</i>				X				X		
<i>Richina truncata</i>			X				X	X		

KEY TO SPECIES OF CTENOLOCULINIDAE

1. Loculi more than five, each complete and surrounded by rim; L₁, L₂, and L₃ developed as prominent vertical lobes *Ctenoloculinae*, *Ctenoloculina* .. 2
- Loculi four or less, each developed as a scallop of the frill or complete and rimmed; L₁, L₂, and L₃ extending down very little on valve, never elongate; lobation mostly defined by a prominent S₂ *Parabolbininae* .. 4
2. Large; ornamented areas of L₁, L₂, and L₃ extending down onto the frill *Ctenoloculina cicatricosa*
- Small to medium; ornamented areas of lobes separated from area of frill by surrounding rim 3
3. Ornamented areas and surrounding rims of lobes bearing scattered small spines, conspicuously larger than reticulation elements *Ctenoloculina acanthina*
- Ornamented areas of lobes with uniform reticulation, the surrounding rims smooth *Ctenoloculina eurybathrota*
4. S₂ a prominent and slanting sulcus reaching nearly to ventral border, its ventral half bordered by inflated areas which in female lie outside the loculi; ornamentation a reticulation formed by a network around little punctae; prominent loculi with rims; male with short inconspicuous velar ridge between ventral inflations *Tetrasacculus bilobus*
- S₂ a short vertical sulcus reaching only to center of valve, ventral part of valve not conspicuously inflated; ornamentation of closely spaced papillae; "loculi" formed as scallops of the frill, more or less distended pouches, without well-developed transverse processes linking the frill to the marginal ridge; no rims around "loculi"; male with two spurs, both developed as spines or the anterior one as a short projecting ridge *Subligaculum* ... 5
5. Posterocentral pit between deepest part of S₂ and posterior border, linked to S₂ by a horizontal groove *Subligaculum scrobiculatum*
- No posterior pit behind S₂ *Subligaculum bifidum*

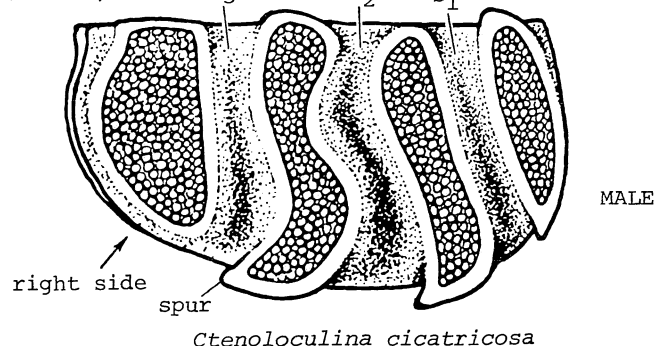
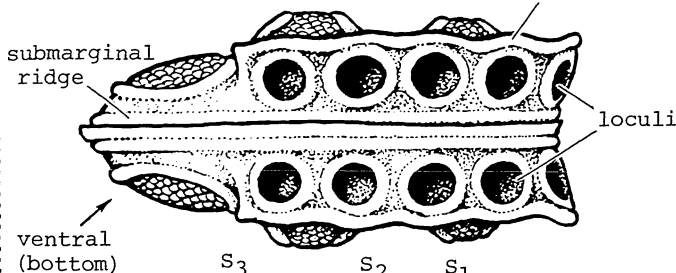
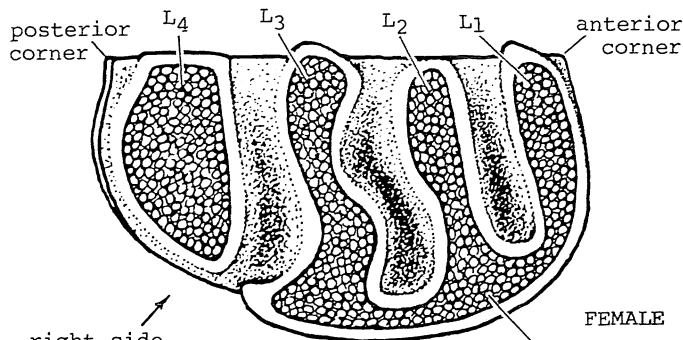

Ctenoloculina cicatricosa

Subfamily Ctenoloculinae
Jaanusson & Martinsson 1956

Loculi fully developed as pocket-like structures, typically rimmed.

Genus CTENOLOCULINA Bassler 1941

Ctenoloculina Bassler, 1941.
Paractenoloculina Polenova, 1968.

Type species.-- *Tetradella cicatricosa* Warthin, 1934, p.209, pl.1, figs.4-6, by subsequent designation of Bassler, 1941, p.22,23.

Remarks.-- Recently, William Collier (1971) completed a cladistic investigation of the species in the genus *Ctenoloculina*, including the European representatives. His results, published in our Contributions from the Mus-

eum of Paleontology, provide a necessary and important basis for further research on the genus.

CTENOLOCULINA CICATRICOSA (Warthin)

5/1-22; 6/10-19; 16/3-6; 17/7-9; 18/1-20;
19/1-18; 20/1-18; 21/11-13; 109/6,7;
110/5; 118/5,8; 119/1-4; 120/3;
121/1; 122/3

Tetradella cicatricosa Warthin, 1934, p.209,
pl.1, figs.4-6 [Norway Point Formation.
Holotype, UMMP 14535].

Tetradella cicatricosa Stewart, 1936, p.748, pl.
100, figs.23,24 [Silica Formation].

Tetradella cicatricosa Warthin, 1937, card 54,
figs.4-6.

Tetradella cicatricosa Triebel, 1941, p.358,
pl.13, fig.148.

Ctenoloculina cicatricosa Bassler, 1941, p.22,
23.

Ctenoloculina cicatricosa Shimer & Shrock, 1944,
p.557, pl.281, figs.36,37 [Norway Point
Formation].

Ctenoloculina cicatricosa Stewart & Hendrix,
1945b, p.102, pl.11, fig.11 [Olentangy
Shale].

Ctenoloculina acanthophora Swartz & Oriol, 1948,
p.553, pl.79, figs.8-14 [Windom Shale].

Ctenoloculina cicatricosa Kesling 1951b, p.166,
pl.13, figs.1a,lb,2,3 [Norway Point Forma-
tion].

Ctenoloculina cicatricosa Kesling & McMillan,
1951, p.49,50, pl.4, figs.9,10 [Bell Shale].

Tetradella cicatricosa Moore, Lalicker, & Fush-
er, 1952, p.531, figs.12a,12b.

Ctenoloculina cicatricosa Kesling, 1952a, p.247-
290, pls.1-3, 5 text-figs., 2 charts [Nor-
way Point Formation].

Ctenoloculina cicatricosa Kesling & Weiss, 1953,
p.43,44, pl.2, figs.9-14; pl.3, fig.1 [Nor-
way Point Formation].

Ctenoloculina cicatricosa Weiss, 1954, p.24,25,
pl.7, figs.1-10.

Tetradella cicatricosa Coley, 1954, p.455, fig.
2 [Silica Formation, Arkona Shale, Widder
Formation, Wanakah Shale].

Ctenoloculina acanthophora Smith, 1956, p.2.

Ctenoloculina cicatricosa Melik, 1966, p.215-
217, pl.1, figs.9-11; pl.7, figs.15-24; pl.
17, figs.8-11; pl.19, figs.8,9.

Ctenoloculina cicatricosa Bless & Jordan, 1971,
P.873,874, table 2.

Ctenoloculina cicatricosa Collier, 1971, p.357-
376, 3 pls., 6 text-figs.

Tetradella cicatricosa Coryell & Malkin,
1936, p.3, fig.9.

Remarks.-- Common in the Silica Forma-
tion, *Ctenoloculina cicatricosa* is present in
most of the Middle Devonian beds of the Great
Lakes region, particularly the shales. Preser-
vation is excellent, with many fine single val-
ves showing hingement as well as complete
carapaces showing closure.

In size it is equalled only by *C. thliberi-
lobota* from the Arkona Shale, which has nar-
rower lobes and broader sulci. On the other
hand, *C. acanthina*, *C. eurybathrota*, and *C.
platyzanclota* are all smaller, with lobes and
sulci terminating above a flat, uninterrupted
ventral frill. *C. myurilobota* is smaller than
C. cicatricosa, with lobes only half as wide as
the sulci and with L₃ terminating above the
frill.

Illustrated specimens.-- UMMP 58113 (17/
8,9), 58115 (5/21,22), 58117 (6/14,15), 58123
(5/19,20), 58124 (6/10,11), 58125 (6/18,19),
58127 (5/17,18), 59129 (6/16,17), 58137 (5/16),
58139 (17/7), 58141 (16/5,6; 118/5; 119/1;
120/3), 58143 (6/12,13), 58146 (21/11,12; 109/
7; 118/6; 119/3), 58150 (5/5,6), 58152 (5/9),
58153 (5/10,11), 58154 (19/7), 58155 (5/14,15),
58158 (5/1,2), 58161 (5/12,13), 58163 (5/7,8),
58164 (5/3,4), 58168 (18/13,14), 58921 (18/11,
12,15-18), 58922 (19/1-6), 58923 (20/9-12;
119/4), 58924 (19/8-12), 58925 (20/1-5; 110/5),
58926 (20/13-16), 58927 (18/5-10), 58928 (19/
13-18; 121/1; 122/3), 58929 (20/6-8; 21/13),
58930 (18/1-4), 58932 (20/17,18), 59461 (18/
19,20), and 59462 (16/3,4; 109/6; 119/2).

CTENOLOCULINA ACANTHINA Kesling

16/1,2; 17/10-20; 21/1-10; 111/3,4

Ctenoloculina acanthina Kesling, 1953b, p.206,
207, pl.2, figs.1-13 [Arkona Shale. Holo-
type, complete female carapace, UMMP 28940].

Ctenoloculina acanthina Kesling 1954c, p.16,
18, pl.1, figs.39-41.

Ctenoloculina acanthina Tillman, 1970, p.210,
talbe 1, pl.4, figs.9,10 [Plum Brook Shale,
Olentangy Shale].

Ctenoloculina acanthina Bless & Jordan, 1971,
p.874.

Ctenoloculina acanthina Collier, 1970, p.370,
pl.1, figs.1-4 [Arkona Shale, Widder Forma-
tion, Ferron Point Formation].

Remarks.-- Smaller than *C. cicatricosa*, with continuous frill as in *C. eurybathrota*, this little species is distinguished by the large, widely spaced papillae on lobes and frill. It is rare but well preserved in the Silica beds.

Illustrated specimens.-- UMMP 58399 (17/20), 58913 (17/10-13; 111/4), 58914 (17/18, 19; 111/3), 58915 (17/14-17), 58916 (21/1-4), 58917 (21/5-8), 58919 (16/1,2), and 59680 (21/9,10).

CTENOLOCULINA EURYBATHROTA Kesling
17/1-6

- Ctenoloculina eurybathrota* Kesling, 1952c, p. 46-48, pl.1, figs.1-9 [Ferron Point Formation. Holotype, female right valve, UMMP 28025].
- Tetradella cicatricosa* Coryell & Malkin, 1936, p.3 (part), fig.9 [Hungry Hollow Formation].
- Ctenoloculina eurybathrota* Kesling, 1953b, p. 207,208, pl.2, figs.17-19 [Arkona Shale].
- Ctenoloculina eurybathrota* Weiss, 1954, p.26, 27, pl.8, figs.1-6 [Bell Shale, Ferron Point Formation, Genshaw Formation, Arkona Shale, Hungry Hollow Formation].
- Ctenoloculina eurybathrota* Kesling & Tabor, 1953, p.94, pl.1, figs.1,2 [Genshaw Formation].
- Ctenoloculina eurybathrota* Bless & Jordan, 1971, p.874.
- Ctenoloculina eurybathrota* Collier, 1970, p.373, pl.1, figs.14-16 [Kashong Shale, Wanakah Formation].

Remarks.-- Smaller than *C. cicatricosa*, *C. eurybathrota* has a flat, uninterrupted frill from the anterodorsal corner to just below L₃ on the venter, which is separated from L₂ and L₃. The species is rare in the Silica beds.

Illustrated specimens.-- UMMP 58443 (17/4), 58452 (17/5), 58471 (17/6), 58920 (17/1), and 59646 (17/2,3).

Subfamily Parabolbininae Bless & Jordan
1971

Incipient loculi (not fully developed between velum and marginal ridge) or deeply scalloped frill forming "false pouches" in a closed carapace.

Genus SUBLIGACULUM Kesling & McMillan
1951

Type species.-- By original designation, *Subligaculum scrobiculatum* Kesling & McMillan, 1951, p.65,66, pl.2, figs.1-4; pl.7, figs.1-8.

SUBLIGACULUM BIFIDUM (Stewart)
31/27-34; 33/17-32

- Tetrasacculus bifidus* Stewart, 1936, p.745, pl.100, figs.12-14 [Silica Formation. Holotype, OSU 18175].
- Parabolbina bifida* Warthin, 1937, card 64, figs. 12-14.
- Subligaculum bifidum* Weiss, 1954, p.73, pl.22, figs.16-27 [Silica Formation].
- Subligaculum bifidum* Bless & Jordan, 1971, p. 876, table 2.

Remarks.-- *Subligaculum bifidum* is common in the Silica Formation, where it is excellently preserved. Female specimens with clear scalloped frills are found as closed carapaces, gaped carapaces, and single valves. It differs from *S. scrobiculatum* in the absence of the posterior pit, although the distinction is not clearly defined in all specimens.

Illustrated specimens.-- UMMP 59002 (33/29-32), 59003 (33/25-28), 59004 (33/17-20), 59005 (33/21-24), 59006 (31/31-34), and 59007 (31/27-30).

SUBLIGACULUM SCROBICULATUM
Kesling & McMillan

31/15-26; 32/10-24; 33/1-16; 36/1-4;
104/17-20; 116/4

- Subligaculum scrobiculatum* Kesling & McMillan, 1951, p.65,66, pl.2, figs.1-4; pl.7, figs. 1-8 [Bell Shale. Holotype, male right valve, UMMP 26639].
- Subligaculum scrobiculatum* Weiss, 1954, p.72, pl.19, figs.14-17 [Silica Formation].
- Subligaculum scrobiculatum* Melik, 1966, p.277, pl.19, fig.10; pl.21, figs.7,8 [Bell Shale].
- Subligaculum scrobiculatum* Bless & Jordan, 1971, p.876.

Remarks.-- A few specimens were found in the Silica Formation. They are distinguished from the above species by the small pit in the mid-posterior area of each valve. The pit usually connects ventrally with the margin by a shallow slanting sulcus.

Illustrated specimens.-- UMP 59008 (33/1-4), 59009 (33/5-8), 59010 (32/10-13), 59011 (31/19-22), 59012 (31/23, 24), 59013 (31/25, 26), 59014 (32/19, 20), 59015 (33/9-12; 116/4), 59016 (32/21-24), 59017 (33/13-16), 59018 (36/1, 2), 59019 (32/14-18), 59264 (36/3, 4), 59422 (31/15-18), and 60077 (104/17-20).

Genus TETRASACCULUS Stewart

Type species.-- By original designation, *Tetrasacculus bilobus* Stewart, 1936, p.744, 745, pl.100, figs.8-11.

TETRASACCULUS BILOBUS Stewart

30/1-53; 31/1-10; 117/1,2

Tetrasacculus bilobus Stewart, 1936, p.744, 745, pl.100, figs.8-11 [Silica Formation. Holotype, OSU 18174].

Tetrasacculus minimus Warthin, 1937, card 65, figs.8-11.

Tetrasacculus bilobus Kesling & McMillan, 1951, p.50, pl.1, figs.3-5 [Bell Shale].

Tetrasacculus bilobus Weiss, 1954, p.76, pl.21, figs.17-23 [Silica Formation, Bell Shale, Norway Point Formation, Gravel Point Formation].

Tetrasacculus bilobus Bless & Jordan, 1971, p.876, 877, table 2.

Remarks.-- Stewart's orientation of anterior and posterior was reversed, and consequently so was her identification of left and right valves. The broader, higher end is the anterior, with a pronounced swing in the valves and a posterodorsal taper. In the male, the velar ridge extends along the anterior end and onto a subtriangular spur; there it is interrupted, starting on the ventral margin below the spur and continuing to the posteroventral area. In the female, four loculi are spaced in each valve from the anterior end along the free margin to the posteroventral area (about 2/3 the distance to the posterior end), with the rear loculum lacking full development of a posterior wall. Reticulation of lateral surfaces varies, perhaps from post-mortem, pre-burial abrasion.

Tetrasacculus bilobus is common in the Silica units, with the greatest numbers of carapaces and single valves in units 9-11. *T. magnivelatus* differs in the tumidity of part of the ventral lobe.

Illustrated specimens.-- UMP 59020 (30/1-5), 59021 (31/9, 10), 59022 (30/26, 27), 59023 (30/12-15), 59024 (30/50-53), 59025 (30/35-40), 59026 (30/16-21), 59027 (30/6-11), 59028 (30/41-45), 59029 (30/28-34), 59030 (30/46-49), 59031 (30/22-25; 117/2), 59032 (31/1-4), and 59620 (31/5-8; 117/1).

Family Hollinidae Swartz 1936

No loculi. Frill confined (for most part) to anterior part of valve.

Subfamily Falsipollicinae Bless & Jordan 1971

Genus FALSIPOLLEX Kesling & McMillan

Type species.-- By original designation, *Falsipollex altituberculatus* Kesling & McMillan, 1951, p.68, 69, pl.3, figs.1-3.

FALSIPOLLEX LATIVELATUS (Kesling & McMillan)

21/14-22; 22/8-19; 23/1-10; 25/10-16; 28/11,12; 32/1-9; 38/5-7; 104/1-6; 110/4; 117/4,5; 121/2,3; 123/2

Hollinella lativelata Kesling & McMillan, 1951, p.58-60, pl.5, figs.1-5 [Bell Shale. Holotype, female right valve, UMP 26725].

Falsipollex lativelatus Weiss, 1954, p.31-34, pl.1, figs.1-44; pl.2, figs.1-8; pl.5, figs.18,19 [Bell Shale, Ferron Point Formation, Arkona Shale].

Hollinella (Keslingella) lativelata Bless & Jordan, 1971, p.883.

Hollinella (Keslingella) lativelata Bless & Jordan, 1972, p.53.

Remarks.-- We have accepted Weiss' (1954) designation of this large, ornate species as a *Falsipollex* because of the spurs found in the velar region of the adult male valves. The prominent smooth frill of the female lacks papillae, distinguishing it from the ornamented frill of *Falsipollex laxivelatus*, which is more common in the Silica beds.

Illustrated specimens.-- UMP 58931 (28/11, 12), 58983 (23/1-4), 58984 (22/11), 58985 (32/8, 9), 58986 (21/18, 19), 58999 (26/9), 59000 (25/11-14), 59001 (23/7-11), 58988 (22/15-19; 110/4), 59036 (21/20, 21), 59038 (26/4-8; 117/4), 59039 (21/22), 59040 (23/12, 13), 59218 (21/14-17), 59219 (25/15-19), 59221

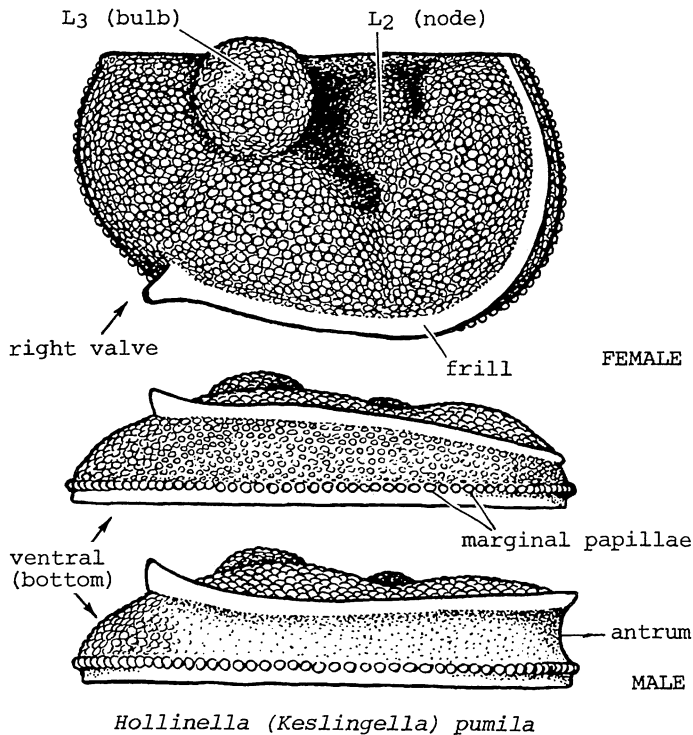

Hollinella (Keslingella) pumila

FALSIPOLLEX LAXIVELATUS Kesling

22/1-7; 24/5-18; 25/1-10; 26/10-16; 27/1-17;
28/1-10; 29/1-18; 31/11-14; 38/1-4; 110/4

- Falsipollex laxivelatus* Kesling, 1952c, p.51, pl.2, figs.1-9 [Ferron Point Formation. Holotype, female carapace, UMMP 28040].
Hollinella senticosta Kesling, 1953d, p.211, 212, pl.3, figs.22,23 [Arkona Shale].
Falsipollex laxivelatus Weiss, 1954, p.37, pl.3, figs.1-40; pl.4, figs.1,2 [Silica Formation, Ferron Point Formation, Hungry Hollow Formation, Arkona Shale].
Falsipollex laxivelatus Melik, 1966, p.218, pl.1, figs.24-26; pl.8, figs.25-30; pl.9, figs.1-4 [Arkona Shale].
Falsipollex laxivelatus Bless & Jordan, 1971, p.879.

Remarks.-- The ornamentation of *Falsipollex laxivelatus* is more spinose than that of *F. lativelatus*, especially in the immature specimens. Other differences are the more prominent, bulbous L₃, wider spurs in the male, and the papillose incurved frill of the female. *Hollinella attenuata* Pauken (1966) is probably an instar of *Falsipollex laxivelatus*.

Illustrated specimens.-- UMMP 58754 (28/9,10), 58755 (27/1,2), 58756 (28/4-6), 58796 (31/11-14), 58797 (28/7,8), 58798 (27/3), 58799 (25/1-4), 58800 (27/6-9), 58968 (24/13-16; 108/5), 58969 (26/10-13), 58970 (29/1,2), 58971 (26/14-16), 58972 (29/14-18), 58973 (27/10-13), 58974 (24/17,18), 58975 (27/14-17), 58976 (22/7), 58977 (24/9-12), 58978 (22/3-6), 58979 (27/4,5), 59041 (24/5-8), 59471 (28/1-3), 59472 (25/9,10), 59473 (22/1,2), 59474 (25/5-8), 59475 (29/3-8), 59476 (29/9-13), 59672 (38/2-4), and 59673 (38/1).

FALSIPOLLEX sp.

24/1-4

Males of the genus are always difficult to identify. UMMP 59477 (24/1-4) is probably an exceptionally wide immature *F. lativelatus*.

Genus HANAITES Pokorný

Type species.-- By original designation, *Hallietta (Hanaites) givetiana* Pokorný, 1950, p.599-601, pl.2, fig.5; pl.5, figs.12,13. Weiss (1954 Ph.D. thesis) proposed raising *Hanaites* from subgenus to genus within the family Hollinellidae, but did not publish. Stover (1956, p.1105) formally removed it from the genus *Hallietta* and elevated *Hanaites* to generic rank.

HANAITES PLATUS (Kesling & McMillan)

35/12-20; 119/6

- Proplectrum platum* Kesling & McMillan, 1951, p.64,65, pl.1, figs.1,2; pl.7, fig.2 [Bell Shale. Holotype, incomplete adult left valve, UMMP 26687. Kesling & McMillan had not seen Pokorný's publication of the previous year and independently created a genus for this ostracod; their *Proplectrum* thus became a junior synonym of *Hanaites*].
Hanaites platum Weiss, 1954, p.84, pl.22, figs.4-15 [Bell Shale, Ferron Point Formation, Petoskey Formation].
Hanaites platus Stover, 1956, p.1105,1106, pl.112, figs.10-14 [Windom Shale].
Hanaites platus Bless & Jordan, 1971, p.879,880, table 3.

Remarks.-- Only two specimens of this rare ostracod were found in the Silica Formation.

Illustrated specimens.-- UMMP 59412 (35/16-20) and 59413 (35/12-15; 119/6).

KEY TO SPECIES OF HOLLINELLIDAE

- 1. L₃ inflated but not bulbous, extending little if any above hinge line, confluent with ventral lobe; frill invariably narrow *Adelphobolbina* .. 2
 - L₃ developed as a bulb, extending above hinge line, ventrally sharply set off from rest of valve; frill relatively wide in many species *Hollinella*, subgenus *Keslingella* .. 3
- 2. Ornamentation consisting of papillae of two sizes; the larger scattered over surface, distally bluntly rounded, about three times the diameter of the smaller, and about twice as high; anterodorsal "shoulder" area slightly protuberant and nearly smooth ... *Adelphobolbina trilobata*
Ornamentation consisting of spinelets and small papillae; spinelets scattered over surface, acuminate but not sharply pointed, and much higher than papillae; no "shoulder" area developed *Adelphobolbina spicata*
- 3. Lobation coarsely developed, somewhat irregular from specimen to specimen; L₂ large and very long and slanting, reaching anteroventrally to frill; L₄ a sausage-shaped ridge parallel to posterior border; ventral lobe strongly protuberant, subtriangular; frill especially thick; ornamentation of irregular papillae, inconspicuous, surface appearing rough and granular *Hollinella (Keslingella) labrosa*
Lobation more uniform in the species; L₂ small, separated by ventral lobe from frill; L₄ low, poorly developed; ventral lobe long, parallel to all of frill and linking L₁ to L₄, not interrupted by S₂; frill thin and fragile; ornamentation uniformly developed 4
- 4. Small (adults less than 1.2 mm long); frill narrow (not over .055 mm in widest part); valves anteriorly plicate, with greatest height distinctly in front of S₂; posterior end of frill thickened *Hollinella (Keslingella) pumila*
Large (adults more than 1.4 mm long); frill moderately wide (reaching at least .12 mm in width); valves almost symmetrically curved along free border, with greatest height about through S₂; posterior end of frill only slightly thickened *Hollinella (Keslingella) antespinosa*

Family Hollinellidae Bless & Jordan 1971

No loculi. Frill extended far back of center of valve into posteroventral area.

Genus HOLLINELLA Coryell 1928

Type species.-- By original designation, *Hollinella dentata* Corvell, 1928, p.377,378, pl. 51, fig.1; emended by Kellett, 1929.

Subgenus KESLINGELLA Bless & Jordan 1970

Type species.-- *Hollinella pumila* Kesling, 1952, p.48,49, pl.1, figs.16-23, by subsequent designation of Bless & Jordan, 1970, p.84.

Remarks.-- "A subgenus of *Hollinella* with adventral structures of juveniles consisting of a pair of spurs. Adventral structures of adults with well developed tubulous layer" (Bless & Jordan, 1970, p. 84).

Family HOLLINELLIDAE	Medusa quarries																							Martin-Marietta Quarry				Waterworks Park		
	Unit																							Quarry				Park		
SPECIES	6	7	9	11	12	13	14	15	16	17	18	21	23	1-6	7	9-11	12	14-15	17-18	1-6	7	9-11	12							
<i>Adelphobolbina spicata</i>	x	x			x									x						x			x							
<i>Adelphobolbina trilobata</i>	x	x	x	x	x		x	x		x		x	x	x	x	x	x		x			x								
<i>Hollinella (Keslingella) antespinosa</i>	x	x	x	x		x					x				x	x			x		x	x								
<i>Hollinella (Keslingella) labrosa</i>					x	x									x	x						x								
<i>Hollinella (Keslingella) pumila</i>	x	x	x	x	x	x						x			x	x	x					x								

HOLLINELLA (KESLINGELLA) PUMILA
Kesling

13/11-24; 14/1-3; 15/1-7; 16/7-19; 109/1,2

Hollinella pumila Kesling, 1952c, p.48,49, pl. 1, figs.16-23 [Ferron Point Formation. Holotype, male carapace, UMMP 28032].

Hollinella pumila Kesling 1953b, p.211, pl.3, figs.1-21 [Arkona Shale].

Hollinella (Keslingella) pumila Bless & Jordan, 1970, p.84.

Hollinella (Keslingella) pumila Bless & Jordan, 1972, p.46, table 28.

Remarks.-- This beautifully preserved species of *Hollinella* is common in the Silica Formation, with the population represented by juveniles as well as adults. Dimorphism is not readily apparent because of the narrow frills or velar ridges, and is nearly impossible to detect in lateral view; ventral views of carapaces, however, show clearly the parallel vela of the males, flaring outward at the anterior end, as compared with the converging vela of the females. Carapaces of females are also consistently slightly narrower than those of the presumed males. Juveniles have velar spines like those of young *Falsipollex*.

Hollinella (K.) pumila is much smaller than *H. (K.) antespinoza* or *H. (K.) labrosa*, and its frill is much narrower.

Illustrated specimens.-- UMMP 58990 (16/12, 13), 58991 (14/1-3), 58992 (13/19-21), 58993 (16/7-9; 109/1), 58994 (16/14-16), 58995 (13/11, 12), 58996 (13/13-15), 58997 (13/16-18; 109/2), 58998 (13/22-24), 59496 (16/17-19), 59497 (16/10, 11), 59498 (15/7), 59499 (15/1, 2),

59500 (15/3, 4), and 59501 (15/5, 6).

HOLLINELLA (KESLINGELLA) ANTESPINOSA
(Ulrich)

15/8-21; 16/20,21; 105/1-9

Ctenobolbina (? *Bollia*) *antespinosa* Ulrich, 1891, p.187, pl.15, figs.9a-c [Holotype, USNM 41319].

Hollina antespinosa Ulrich & Bassler, 1908, p.315.

Hollina antispinosa (sic) Grabau & Shimer, 1910, p.367, figs.1660y,y'.

Hollinella antispinosa (sic) Kellett, 1929, p.200.

Hollinella antespinosa Bassler & Kellett, 1934, p.331.

Hollinella subcircularis Turner, 1939, p.17, pl.1, fig.20 [Well cuttings, Ontario, Canada].

Hollinella amplilobata Kesling & Tabor, 1953, p.84, pl.1, figs.9-17 [Genshaw Formation].

Hollinella cuspilobata Kesling & Tabor, 1953, p.85,86, pl.2, figs.1-4 [Genshaw Formation].

Hollinella plauta Kesling & Tabor, 1953, p.86, 87, pl.1, figs.18-22 [Genshaw Formation].

Parabolbina hypercala Kesling & Tabor, 1953, p.88,89, pl.3, figs.1-7 [Genshaw Formation].

Parabolbina oxypages Kesling & Tabor, 1953, p.89, pl.3, figs.8-15 [Genshaw Formation].

Hollinella inclinisulcata Kesling & Weiss, 1953, p.40,41, pl.2, figs.5-8 [Norway Point Formation].

Hollinella plauta Stover, 1956, p.1102, pl.111, fig.14 [Windom Shale].

Hollinella antespinosa Kesling & Peterson, 1958, pl.141,142, pl.2, figs.39-42 [Falls of the Ohio].

Hollinella antri Adamczak, 1968, p.58,59, figs.16,39A,40; pl.17, figs.4,5; pl.18, figs.4, 5 [Skaly beds, Sniadka, Poland].

Family CTENOLOCULINIDAE	Medusa quarries																							Martin-Marietta Quarry					Waterworks Park		
	Unit																							1-6					1-6		
SPECIES	6	7	9	11	12	13	14	15	16	17	18	21	23	1-6	7	9-11	12	14-15	17-18	1-6	7	12									
Subfamily CTENOLOCULININAE																															
<i>Ctenoloculina acanthina</i>	x			x			x									x															
<i>Ctenoloculina cicatricosa</i>	x	x	x	x	x	x	x	x				x		x	x	x	x	x	x			x									
<i>Ctenoloculina eurybathrota</i>	x	x	x	x						x						x		x				x									
Subfamily PARABOLBININAE																															
<i>Subligaculum bifidum</i>	x	x	x	x			x	x				x	x	x	x	x	x					x									
<i>Subligaculum scrobiculatum</i>			x		x											x	x	x													
<i>Tetrasacculus bilobus</i>		x	x	x	x	x	x	x	x	x	x	x	x	x	x	x	x	x		x	x	x									

Hollinella (*Keslingella*) *antespinosa* Bless & Jordan, 1972, p.47-49, table 29, pl.18, fig.2.

Remarks.-- This species shows much more variation than *H. (K.) pumila*, which is smaller, or *H. (K.) labrosa*, which is larger. Bless & Jordan place many of the Michigan species and an Ontario and New York species in synonymy under this species, as well as a Polish species, *H. (K.) antri* Adamczak -- making it the most widespread *Hollinella* in Middle Devonian strata. Specimens are rare or few at all localities. Surface ornamentation seems to vary genetically as well as according to preservation.

Illustrated specimens.-- UMMP 58918 (15/8-11), 58987 (15/16, 17), 58989 (15/18), 59087 (15/20, 21), 59414 (15/14), 59415 (15/15), 59492 (15/12, 13), 59493 (16/20, 21), 59494 (15/19), 60058 (105/9), 60078 (105/5-8), and 60079 (105/1-4).

HOLLINELLA (KESLINGELLA) LABROSA
Kesling & Weiss

10/18,19; 14/10-13

Hollinella labrosa Kesling & Weiss, 1953, p.35, 38, pl.2, figs.1-4 [Norway Point Formation. Holotype, right valve, UMMP 27371].

Hollinella labrosa Weiss, 1954, p.54,55, pl.14, figs.1-12; pl.15, figs.1-6 [Genshaw Formation, Norway Point Formation, Potter Farm Formation, Ipperwash Limestone].

Hollinella labrosa Melik, 1966, p.223,224, pl.21, figs.1-6 [Arkona Shale, Centerfield Limestone].

Hollinella (Keslingella) labrosa Bless & Jordan, 1972, p.52,53, pl.21.

Remarks.-- This large distinctive *Hollinella* is very similar to *H. (K.) retusilobata* Stover, from which it is differentiated by the short ventral lobe. The thick, heavy shells are usually found as single valves. The largest of the three *Hollinella* species found in the Silica Formation, it is further distinguished from *H. (K.) antespinosa* and *H. (K.) pumila* by the high relief of its lobes and deep sulci.

Occurrence.-- *Hollinella (Keslingella) labrosa* is found in the three Middle Devonian formations of Ontario, the Centerfield Limestone of New York, and four of the Traverse Group formations of northern Michigan. It is rare in

all except, possibly, the Potter Farm Formation, where many beautifully preserved valves and a few carapaces were found. These Potter Farm specimens differ somewhat from the typical form of the species, as indicated below, and may constitute an undescribed species that is closely related.

Illustrated specimens.-- UMMP 58980 (14/12), 58981 (14/10, 11), 58982 (14/13), 60049 (10/19), and 60050 (10/18).

HOLLINELLA (KESLINGELLA) cf. LABROSA
Kesling & Weiss
12/1-10; 14/4-9

Specimens of *Hollinella (Keslingella) labrosa* or a very closely related species from the Potter Farm Formation of Alpena County, Michigan, are illustrated for comparison with the Silica forms. The latter are much closer to the types of *H. (K.) labrosa* from the Norway Point Formation so that their identification is not doubted. The Potter Farm forms, although coming from the formation immediately above the Norway Point and evidently much closer in age to the types than are the Silica ostracods, may well be separated as a new species, distinguished by their rather pyriform rather than subspherical L_3 , slightly larger size, and exceptional development of an anteroventral flange along the margin. The unusually fine preservation of the Potter Farm specimens shows elaborate structures involved in closure, which may be present also in some manner in the Silica specimens but which cannot be discerned because of poorer preservation.

Illustrated specimens.-- UMMP 59663 (14/8, 9), 59664 (14/4, 5), 59665 (14/6, 7), 59666 (12/8-10), 59667 (12/5-7), and 59668 (12/1-4).

Genus ADELPHOBOLBINA Stover

Type species.-- *Ctenobolbina papillosa* (part) Ulrich, 1890, p.186, pl.15, figs.8a-8e, by subsequent designation of Stover, 1956, p.1103. Weiss (1954 Ph.D. thesis) proposed the genus *Zeuctobolba* to include *Ctenobolbina trilobata* and *C. spicata*, but did not publish. Stover (1956, p.1103) formally erected the genus *Adelphobolbina*, including the two species.

ADELPHOBOLBINA SPICATA (Kesling & McMillan)

11/1; 2/1; 111/1

- Ctenobolbina spicata* Kesling & McMillan, 1954, p.52, pl.4, figs.1-6 [Bell Shale, Holotype, adult male left valve, UMMP 26640].
Adelphobolbina spicata Stover, 1956, p.1104.
Zeuctobolba spicata Weiss, 1954, p.50,51, pl.6, figs.7-13 [Bell Shale, Gravel Point Formation, Silica Formation].
Adelphobolbina spicata Bless & Jordan, 1972, p.69.

Remarks.-- Only two incomplete and worn valves and a few fragments of this species were found in the Silica Formation, but they definitely show the essential characters. The larger papillae or blunt spines scattered in the field of closely spaced smaller and regular papillae are much more numerous than those in Adelphobolbina trilobata.

Illustrated specimens.-- UMMP 59638 (2/1; 111/1) and 59657 (1/1).

ADELPHOBOLBINA TRILOBATA (Stewart)

1/2-12; 2/2-12; 3/2-12; 4/1-4; 38/8,9;
 111/2; 118/1,2; 120/1; 122/1,2; 123/1

- Ctenobolbina trilobata* Stewart, 1936, p.749, pl.100, figs.25-27 [Silica Formation. Syntypes, OSU 18181].
Ctenobolbina trilobata Warthin, 1937, card 70, figs.25-27.
Ctenobolbina pinguis Kesling & McMillan, 1951, p.53,54, pl.4, figs.7,8 [Bell Shale].
Zeuctobolba trilobata Weiss, 1954, p.48,49, pl.10, figs.7-12; pl.11, figs.1-32; pl.12, figs.1-10; pl.13, figs.1-8 [Silica Formation, Bell Shale, Ferron Point Formation].
Adelphobolbina trilobata Stover, 1956, p.1104.
Adelphobolbina trilobata Bless & Jordan, 1972, p.70.

Remarks.-- Bless & Jordan (1972, p. 70) correctly place Adelphobolbina pinguis in synonymy with A. trilobata. The species has a distinctive smooth L₁ or "eye spot" at the anterodorsal corner and ornamentation over the rest of the lateral surface consisting of regular small discrete papillae with a scattering of irregular larger papillae. Some specimens retain the thin epidermal covering over the papillae to give the valve a roughened pebbly texture instead of discrete papillae.

Dimorphism is shown by the adventral frills. Those of the presumed male (and the sexual distinction is uncertain) are slightly broader and almost parallel in the anteroventral area, each bordering a smooth trough-like antrum; those of the presumed female converge anteriorly in a carapace, and the narrow shallow, flat-bottomed antrum bears papillae. Both sexes have a beaded line of submarginal papillae near and parallel to the free edge.

Juveniles show small spines on the posteroventral and anteroventral areas of each valve. Even in young specimens, the smooth L₁ area can be discerned.

Occurrence.-- Adelphobolbina trilobata has been found in most of the Silica units, especially good specimens derived from units 7-11. The species is present in the Bell Shale and Ferron Point Formation of the Traverse Group in northern Michigan. Preservation is usually good.

Illustrated specimens.-- UMMP 58803 (4/1-6), 58804 (2/2; 4/10-14; 118/2), 58805 (1/2-8; 3/2; 111/2), 58806 (1/9-12), 58807 (2/3-8; 118/1), 58808 (3/6-8), 58809 (3/9-12), 58810 (3/3-5), 58811 (2/9-12; 120/1), 58812 (4/7-9), and 59674 (38/8,9).

ADELPHOBOLBINA sp.

3/1

UMMP 59639 (3/1) cannot be cleaned sufficiently to permit accurate identification. The spacing of the papillae suggests that it may be Adelphobolbina spicata.

Superfamily Kirkbyacea Ulrich & Bassler 1906

Surface reticulate, many genera with well-developed frill, some with distinctive carina.

Family Amphissellidae n. fam.

Type genus.-- Here designated, *Amphisella* Stover, 1956, p.1136.

Surface bearing nodes, humps, or costae in addition to reticulation. No adventral structures (velum or carina).

Description.-- Carapace small to medium, subelliptical to subquadrate, nearly equivalved.

KEY TO SPECIES OF AMPHISSELLIDAE

1. Ornamentation in addition to reticulation consisting of scattered small tubercles or sharp papillae developed at intersections of certain ridges of the reticulation; conical node near center of dorsum in each valve; some adults exceeding 0.5 mm in length *Doraclatum conatum*

Ornamentation in addition to reticulation consisting of more or less vertical ridges raised above the general level of the cross (horizontal) elements of the reticulation; no dorsal node; adults 0.5 mm or less in length 2

2. Of vertical ridges, four somewhat more prominent than others; no ridge slanting in posteroventrocentral area; greatest height posterior, valves slightly but distinctly postplete; no suggestion of sulcate dorsal depression *Tetrarhabdus pygmaeus*

Of vertical ridges, two more prominent, the posterior one leading upward to protrude slightly above hinge line; prominent short ridge in posteroventrocentral area, sloping backward and down from central area; greatest height nearly median, valves amplete; variable development of sulcate dorsal depression for S_2 *Dirhabdus multicostatus*

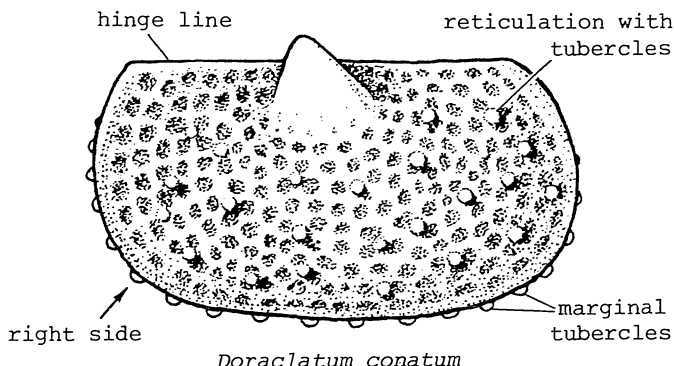

Doraclatum conatum

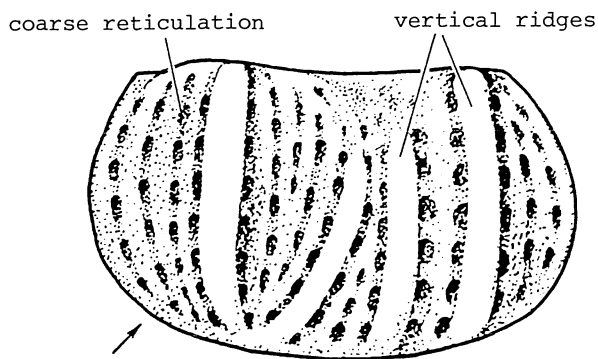

Dirhabdus multicostatus

Remarks.-- This family has been erected to include several small reticulate ostracods assigned doubtfully to other families, as well as new genera. Included are three genera erected by Stover in 1956: *Amphissella* and *Doraclatum*, which were questionably included in the Placideidae by Sohn in Moore (1961, p. Q168) and *Bideirella*, which was questionably assigned to the Scrobiculidae by Sohn in Moore (1961, p. Q169) but which resembles the Amphissellidae in shape, reticulation, and the small dorsocentral spot. *Amphicostella* Adamczak 1961, with family unknown, probably belongs in our new family. *Dirhabdus* and *Tetra-*

Lateral surface moderately convex, reticulate, bearing nodes, humps, papillae, ridges, or costae. Central spot, if present, small and without rim. Adventral structures incomplete or absent.

Family AMPHISSELLIDAE	SPECIES	Unit	Medusa quarries		Martin-Marietta	Waterworks
			6	7	Quarry	Park
	<i>Dirhabdus multicostatus</i>	6			1-6	1-6
	<i>Doraclatum conatum</i>	7			7	7
	<i>Tetrarhabdus pygmaeus</i>	9	X	X	9-11	9-11
		11	X	X	11	11
		12	X	X	12	12
		13	X	X	13	13
		14	X	X	14	14
		15	X	X	15	15
		16	X	X	16	16
		17	X	X	17	17
		18	X	X	18	18
		21	X	X	21	21
		23	X	X	23	23
					17-18	17-18
					14-15	14-15
					12	12
					12	12

rhabdus, two new genera from the Silica Formation, have also been assigned to this family.

Genus DORACLATUM Stover 1956

Type species.-- *Amphissites conatus* Coryell & Malkin, 1936, p.5, figs.12,12a, by subsequent designation as *Doraclatum compandium* by Stover, 1956, p.1136, pl.119, figs.1-5. Sohn (1961, p.149) established the conspecificity and the priority of *conatus* over *compandium*.

DORACLATUM CONATUM (Coryell & Malkin)

82/1-19; 90/24,25; 93/11-18; 120/2

Amphissites conatus Coryell & Malkin, 1936, p.5, figs.12,12a [Hungry Hollow Formation. Holotype, AMNH 24618].

Amphissites conatus Warthin, 1937, card 97, figs.12,12a.

Doraclatum compandium Stover, 1956, p.1136, pl.119, figs.1-5 [Windom Shale].

Arcyzona conata Smith, 1956, table 1.

Doraclatum compandium Moore, 1961, p.Q168, fig.103, no.2.

Doraclatum conatum Sohn, 1961, p.149.

Remarks.-- The Silica specimens are rare and smaller than those from New York and Ontario.

Illustrated specimens.-- UMMP 58953 (82/1-4; 93/11), 58954 (82/13-15), 58955 (82/9-12; 90/24, 25; 93/12, 13; 120/2), 58956 (82/5-8; 93/14-16), and 58957 (82/16-19; 93/17, 18).

Genus DIRHABDUS n. gen.

Type species.-- Here designated, *Primitiella multicostata* Pauken, 1966, p.544, pl.2, figs.11, 14-16.

Derivatio nominis.-- The name *Dirhabdus* is derived from the Greek $\delta\iota$ - ("two") and $\rho\alpha\beta\delta\omicron\varsigma$, f. ("rod"), referring to the two prominent vertical ridges on each valve.

Description.-- Small, semielliptical, equivalved; with straight tongue and groove hinge, slightly shorter than length of carapace. Ends equally rounded, hinge line straight, ventral border gently convex. Lateral surface ridged and pitted. Two vertical ridges or costae from the dorsal to ventral borders at one-fourth the length from each end, projecting very slightly dorsally but enough to give the dorsal border

between them a distinct concavity. Between the costae and ends, faint vertical ridges or ridgelets subparallel to the border. Central area between the costae reticulated by pits and small ridges. Pit located slightly anterior to center of valve, with slight sulcus extending dorsally; interior of valve showing a small node to mark the position of the exterior pit.

Remarks.-- Pauken (1966, p. 544) placed this small ostracod in the Ordovician genus *Primitiella*, which is smooth and lacks any costae or ridges.

DIRHABDUS MULTICOSTATUS (Pauken)

98/21-41; 99/1-10; 103/10-17; 106/18,19; 108/4

Primitiella multicostata Pauken, 1966, p.544, pl.2, figs.11,14-16 [Silica Formation. Holotype, BG-SU 660].

Description.-- As for the genus, of which it is the only known species.

Remarks.-- A few of these beautifully preserved little ostracods have been found at all three Silica Formation localities, as well as in formations in northern Michigan, southern Ontario, and western New York. It occurs as complete carapaces and many single valves.

Illustrated specimens.-- UMMP 59276 (98/38, 39; 99/5), 59277 (98/40, 41; 99/10), 59278 (98/30, 31), 59279 (98/21-24; 103/12), 59280 (99/8, 9; 103/10, 11), 59281 (98/29; 99/1-4; 103/15-17), 59282 (98/36, 37; 106/18, 19), 59283 (98/32, 33), 59463 (98/34, 35; 103/13, 14), and 59464 (98/25-28; 99/6, 7; 108/4).

Genus TETRARHABDUS n. gen.

Type species.-- Here designated, *Tetrarhabdus pygmaeus*, n. sp.

Derivatio nominis.-- The name *Tetrarhabdus* is derived from the Greek $\tau\epsilon\tau\rho\alpha$ - ("four") and $\rho\alpha\beta\delta\omicron\varsigma$, f. ("rod"), referring to the four prominent vertical ridges on typical valves.

Description.-- Carapace very small, subrectangular, with a straight hinge line slightly shorter than length of carapace. Valves almost equal, the right overlapping the left a little along the free edge. Fine vertical ridges (normally four) extending from dorsal to ventral

borders, with fainter lines and very small punctae interspersed between them. In some specimens, a very small smooth spot visible in central area.

Remarks.-- Tetrarhabdus is similar to Dirhabdus in shape, but is smaller in the known species, bears less prominent reticulation, and has a narrower carapace as seen in dorsal view.

TETRARHABDUS PYGMAEUS n. sp.

46/42-57; 47/23-29; 113/4

Derivatio nominis.-- The name *pygmaeus* is derived from the Greek *πυγμαλιος* ("dwarfish"), referring to the size of the carapace.

Description.-- Carapace very small, sub-rectangular, with a straight hinge line and almost equal valves; right valve overlapping the left very slightly along free edge, mostly along the venter. Posterior end perceptibly higher than anterior end. Ventral border gently convex. Ornamentation faint, consisting of about four (some more) major vertical ridges running from dorsal to ventral border with tiny pits scattered between them to produce a re-

ticulation. Some specimens appearing to have a very shallow pit (= S₂) a little above the center of the valve.

Remarks.-- This ostracod is similar to Dirhabdus multicostatus in outline, but it is slightly smaller and lacks the prominent vertical ridges and distinct pattern of pitting; Tetrarhabdus also lacks the oblique ridges in the middle of the valve that distinguish Dirhabdus. All specimens are small.

Occurrence.-- Tetrarhabdus pygmaeus has been found only in the Silica Formation, where it is rare, most specimens occurring in the soft shales of the Waterworks Park locality.

Types.-- Holotype, carapace, UMMP 59233 (47/36-39); paratypes: UMMP 59231 (47/28-31), 59232 (46/42-45), 61812 (46/46-49), 61813 (46/54-57; 113/4), 61814 (47/32-35), 61815 (47/23), 61916 (46/50-53), and 61817 (47/24-27).

Family Arcyzonidae Kesling 1961

No nodes, humps, or costae on reticulate surface. S₂ developed as a definite deep pit

Characteristics of *Arcyzona* Species in the Silica Formation*

Species	Velar ridge	Carina	Reticulation	
<i>diademata</i>	Not reaching corners	Complete, reaching corners	Even throughout	
<i>homalosagenota</i>	Even reticulation	None		
<i>rhabdota</i>	Reticular elements along direction of velar ridge forming ridgelets	Only even ridges present	Some ridges higher than others	
<i>bythyclimacota</i>		Two main ridges linked by cross ridgelets into "chain"		One level
<i>campylactinota</i>				Two levels

* Heavy lines represent clear and invariable separations. Stippled bars represent separations not universally clear-cut, where a few "intermediate" specimens are known; the majority of specimens in these taxa, however, are distinctive.

KEY TO SPECIES OF ARCYZONIDAE

1. Velar structure (ridge) not reaching corners; carina complete from corner to corner; adults 0.75 mm or less in length *Arcyzona diademata*
 Velar structure (ridge of some kind) complete, reaching corners; carina terminating far short of corners, usually a horizontal structure; adults more than 0.75 mm long 2
2. Carina not developed, the reticulation in the ventrocentral area indistinguishable from that on rest of valve *Arcyzona homalosagenota*
 Carina developed from specialized reticulation 3
3. About four ridges of reticulation pattern below pit raised and aligned parallel to velar ridge to form carina *Arcyzona rhabdota*
 Only two ridges of reticulation pattern, midway between pit and velar ridge, raised and aligned parallel to the latter to form the carina 4
4. Reticulation fairly regular; its elements raised to a common level *Arcyzona bythyclimacota*
 Reticulation irregular; some elements raised above level of others, particularly the crooked raised ridges in the dorsal area more or less converging to the pit at the center ...
 *Arcyzona campylactinota*

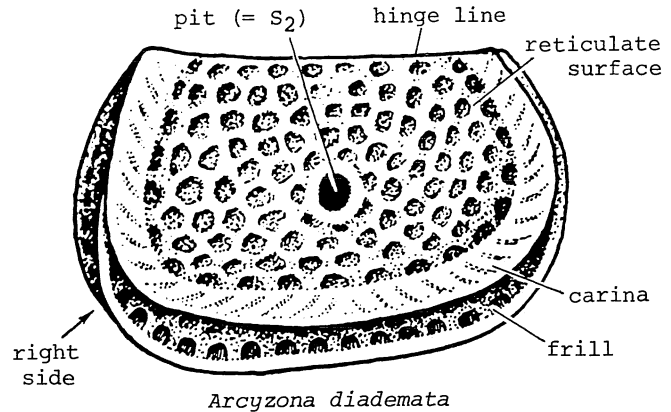

Genus ARCYZONA Kesling

Type species.-- *Amphissites diadematus* Van Pelt, 1933, p.329, pl.39, figs.11,14,15, by subsequent designation of Kesling, 1952b, p.30,31.

Remarks.-- This genus contains many closely related and variable species. The chart shows some of the inferred relationships.

ARCYZONA BYTHICLIMACOTA Kesling

7/9-13; 8/5-8; 9/18-25; 10/12-17; 118/4

- Amphissites diadematus* Van Pelt, 1933 (part), p.329-331, pl.39, fig.8 ["Bell Shale" -- exact stratigraphic formation unknown].
Arcyzona bythyclimacota Kesling, 1952b, p.32,33, pl.2, fig.10; pl.5, figs.12-16 [Bell Shale. Holotype, left valve, UMMP 27652].
Arcyzona bythyclimacota Sohn, 1961, p.138.
Arcyzona bythyclimacota Melik, 1966, p.229,230, pl.3, figs.7-9; pl.12, figs.19-31; pl.13, figs.1-4; pl.23, figs.7-12 [Bell Shale].
Arcyzona bythyclimacota Tillman, 1970, p.210, pl.1, fig.3 [Lower Olentangy Shale].

Remarks.-- Abundant and well preserved in the Silica Formation, both as carapaces and as single valves; particularly good specimens in units 9-11 at the Medusa and Martin-

in the middle area, without an overlying node. Frill and carina in most genera. Hinge not impressed.

Family ARCYZONIDAE	Medusa quarries													Martin-Marietta Quarry			Waterworks Park					
	Unit													1-6			7-12					
	6	7	9	11	12	13	14	15	16	17	18	21	23	1-6	7	9-11	12	14-15	17-18	1-6	7	9-11
<i>Arcyzona bythyclimacota</i>	x	x	x	x	x	x	x				x	x	x	x	x	x						
<i>Arcyzona campylactinota</i>	x	x	x	x		x	x					x			x	x	x					x
<i>Arcyzona diademata</i>		x	x	x		x	x					x			x	x						
<i>Arcyzona homalosagenota</i>		x	x	x											x							
<i>Arcyzona rhabdota</i>	x	x	x	x		x	x								x			x				

Marietta localities. It can be distinguished from other species of *Arcyzona* by the ventral carina made of two intertwined ridges with a row of large reticulation between them and the velar ridge, giving the appearance of a chain strung horizontally across spaced vertical supports. Reticulation of valve is on one level.

Illustrated specimens.— UMMP 58834 (9/20, 21), 58835 (8/5-8), 58836 (7/9-13), 58837 (9/18, 19; 118/4), 58838 (10/16, 17), 58839 (10/12-15), and 58840 (9/22-25).

ARCYZONA CAMPYLACTINOTA Kesling

8/17-22; 9/12-17; 10/10, 11; 54/5-8

Amphissites subquadratus Stewart, 1936, p.752, pl.101, figs.5, 6 [Silica Formation].

Arcyzona campylactinota Kesling, 1952b, p.34-36, pl.2, figs.11-13; pl.5, figs.7-11 [Bell Shale. Holotype, complete carapace, UMMP 27599].

Arcyzona apobathrota Kesling, 1952b, p.33, 34, pl.5, fig.19 [Bell Shale].

Arcyzona campylactinota Sohn, 1961, p.138.

Arcyzona campylactinota Melik, 1966, p.230, pl.24, figs.10-12 [Bell Shale].

Remarks.— This common species differs from other species of *Arcyzona* in having a carina made of two ridges connected by short cross ridges and ridges of two heights in the dorsal reticulation, which are irregular (particularly so in most specimens) and retain large quantities of shale matrix between them.

Illustrated specimens.— UMMP 58841 (9/12-14), 58842 (8/19-22), 58843 (8/17, 18), 58844 (9/15-17), 58845 (10/10, 11), and 61829 (54/5-8).

ARCYZONA DIADEMATA (Van Pelt)

7/1-8; 9/4-11

Amphissites diadematus Van Pelt, 1933, p.329, pl.39, figs.11, 14, 15 ["Bell Shale" -- exact stratigraphic formation unknown. Lectotype, fig.11].

Amphissites diadematus Coryell & Malkin 1936, p.4, fig.10 [Hungry Hollow Formation].

Amphissites subquadratus Warthin, 1937 (part), card 102, figs.11, 14, 15.

Arcyzona diademata Kesling, 1952b, p.31, pl.2, fig.14; pl.4, figs.34-38; pl.5, fig.1 [Bell Shale].

Arcyzona diademata Kesling & Weiss, 1953, p.51,

pl.3, figs.39-41 [Norway Point Formation].
Arcyzona diademata Sohn, 1961, p.138, pl.7, figs.11, 12.

Arcyzona diademata Melik, 1966, p.230, 231, pl.23, figs.13-18 [Widder Formation, Arkona Shale].

Arcyzona diademata Tillman, 1970, p.210, pl.4, fig.2 [Lower Olenangy Shale].

Remarks.— This is the most widely distributed *Arcyzona* species in the Middle Devonian beds of the Great Lakes region. It is also the smallest. Many instars were found associated with adults; the characteristic complete prominent carina from corner to corner make identification easy and sure, even in very young specimens.

Illustrated specimens.— UMMP 58846 (9/8-11), 58847 (7/1, 2), 58848 (7/6-8), 58849 (7/3-5), and 58850 (9/4-7).

ARCYZONA HOMALOSAGENOTA Kesling

8/9-16; 41/28-34

Arcyzona homalosagenota Kesling, 1952b, p.34, pl.5, figs.17, 18 [Bell Shale. Holotype, right valve, UMMP 27656].

Reticestus ? homalosagenota Sohn, 1961, p.139.

Remarks.— This rarest of the *Arcyzona* species in the Silica Formation is clearly distinguished from other species by its even reticulation, lack of a definite carina or ridges in the carinal area, and its low velar ridge. It is well preserved, appearing neat and clean in prepared washings.

Illustrated specimens.— UMMP 58851 (8/13-16), 58852 (8/9-12), 59524 (41/28-31), and 59525 (41/32-34).

ARCYZONA RHABDOTA Kesling

8/1-4; 10/6-9

Arcyzona rhabdota Kesling, 1952b, p.31, 32, pl.2, figs.8, 9; pl.5, figs.2-6 [Bell Shale. Holotype, right valve, UMMP 27596].

Arcyzona rhabdota Sohn, 1961, p.138.

Arcyzona rhabdota Melik, 1966, p.231, pl.2, figs.18, 19; pl.13, figs.5-13; pl.23, figs.19-21 [Bell Shale, Arkona Shale, Centerfield Limestone].

Remarks.— This species has four raised horizontal ridges across the ventral half of the valve, but no distinct carina. In some

specimens, however, the meshes of the reticulation between the two adjacent longest ridges may be slightly stronger than between others, giving a suggestion of a "chain-like" carina such as is present in *Arcyzona bythyclimacota*. Raised ridges running vertically and diagonally in the upper half of the valve are all at one level. This species is fairly common, with many well-preserved carapaces and single valves found. The interior node opposite the exterior pit, serving for adductor muscle attachment, is distinct in cleaned valves.

Illustrated specimens.— UMMP58853 (10/6, 7), 58854 (8/1-4), and 58855 (10/8, 9).

ARCYZONA spp.

51/1-4; 52/5-12; 54/9-12; 56/1-4

Some of the *Arcyzona* specimens which are victims of pyritization cannot be identified with certainty. UMMP 61834 (51/1-4) shows so little of the critical ventral area that its species cannot be even suggested. UMMP 61827 (52/5-8) appears to be *A. homalosagena*, and UMMP 61825 (52/9-12) appears to be either *A. bythyclimacota* or *A. campylactinota*. UMMP 61831 (54/9-12) may be *A. campylactinota*, to judge from the coarse and irregular reticulation in the dorsal half of the carapace. UMMP 61835 (56/1-4) suffered also from abrasion prior to pyritization; it could possibly be *A. bythyclimacota*.

Family Scrobiculidae Posner 1951

Surface without nodes or costae on reticulation. S_2 expressed as a smooth spot, never a sulcus or pit. No frill or carina. Hinge impressed below dorsal border.

Genus SCROBICULA Posner 1951

Type species.— By original designation, *Cytherella ? scrobiculata* Jones, Kirkby, & Brady, 1884, p.76, pl.6, fig.10.

SCROBICULA XYSTA n. sp.

81/28-66; 82/20-22

Derivatio nominis.— The name *xysta* is derived from the Greek $\xi\upsilon\sigma\tau\omicron\varsigma$ ("scraped"), referring to the appearance of the ornamentation.

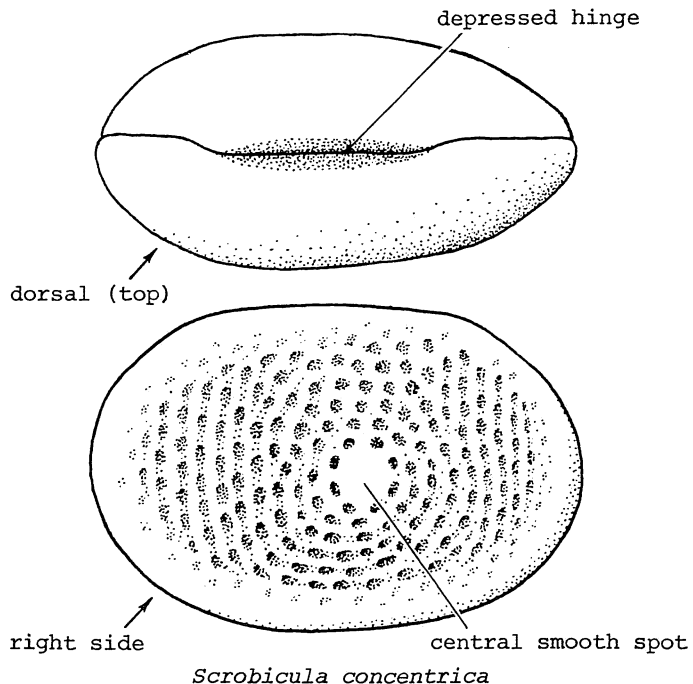

Description.— Carapace very small, sub-round to subelliptical in lateral view. Dorsal border gently curved around straight hinge line, about two-thirds as long as the valve. Right valve slightly larger, overlapping the left around free edge.

Reticulation consisting of very fine punctae concentrically arranged, somewhat decreasing in size towards the margins. Very small, usually inconspicuous bald spot at center of each valve. Very slightly raised ridges emphasizing the concentric pattern in the reticulation.

Remarks.— This small ostracod resembles *Roundyella ? concentrica* Stover (1956), which was included in the genus *Scrobicula* by Sohn in Moore (1961, p. Q169). However, *S. concentrica* is larger, and it has larger pits scattered over the surface, a prominent anterodorsal bald spot at the corner, and a small anterior swelling dorsad of the smooth spot.

Types.— Holotype, carapace, UMMP 59604 (81/37-40; 82/22); paratypes: UMMP 59595 (81/33-36), 59596 (81/61-64), 59597 (81/57-60; 82/21), 59598 (81/41-44; 82/20), 59599 (81/45-48), 59600 (81/53-56), 59601

(81/65, 66), 59603 (81/28-31), and 59605 (81/49-52).

SCROBICULA MICROSPINOSA n. sp.

81/1-21; 82/30-41

Derivatio nominis.-- The name *micro-spinosa* is derived from the Greek *μικρος* ("small") and the Latin *spinatus* ("provided with thorns, spiny"), referring to the small spine on each valve.

Description.-- As for *Scrobicula xysta* n. sp., but with a very small spine or sharp node on the posterodorsal shoulder of each valve. All ridges of the reticulation at one level. Central smooth spot clear.

Occurrence.-- All specimens of *Scrobicula microspinosa* came from the Waterworks Park locality, units 9-11, in which no specimens of *Scrobicula xysta* were found.

Types.-- Holotype, complete carapace, UMMP 59703 (81/1-6); paratypes: UMMP 59701 (81/12-16), 59702 (81/7-11), 59704 (81/30-33), 59705 (81/17-21), 59706 (82/34-37), and 59707 (82/38-41).

Superfamily Aparchitacea Swartz 1945

Valve convex, no nodes or other projections. No sulcus or, at most, a very shallow dorsocentral pit.

Family Aparchitidae Jones 1901

Hinge line straight and clearly visible in lateral view.

Genus EHLERSIA Kesling, Crafts, Darby, Shuback, & Smith 1960

Type species.-- *Macronotella hypercala* Kesling & Kilgore, 1952, pl.1, figs.25-36, by designation of Kesling, Crafts, Darby, Shuback, & Smith, 1960, p.307,308.

EHLERSIA HYPERCALA (Kesling & Kilgore)

40/26-29; 105/24-29

Macronotella hypercala Kesling & Kilgore, 1952, pl.2, pl.1, figs.25-36 [Genshaw Formation. Holotype, complete carapace, UMMP 27955].

Ehlersia hypercala Kesling, Crafts, Darby, Shuback, & Smith, 1960, p.307,308.

Occurrence.-- Two complete carapaces of this rare ostracod were found in the *Styliolina* beds at the Martin-Marietta locality. The species was also found in the Genshaw, Gravel Point, and Petoskey formations of northern Michigan.

Illustrated specimens.-- UMMP 58958 (40/26-29) and 60053 (105/24-29).

Genus KAVARYELLA n. gen.

Type species.-- Here designated, *Glyptopleura cracens* Kesling & Kilgore, 1952, pl.1, pl.2, fig.21.

Derivatio nominis.-- The name *Kavaryella* is a patronymic honoring Emadeddin Kavary, who received his Master of Science degree from The University of Michigan in 1959 and wrote his dissertation on species of this ostracod. He is now Senior Stratigrapher and Paleontologist, Exploration & Production Division, National Iranian Oil Company, Tehran, Iran.

Description.-- Carapace medium, suboval to subrectangular in lateral view. Greatest length through center, greatest height slightly posterior. Valves centrally convex, gently sloping to free edge and hinge line. Hinge straight, dorsal borders very slightly curved near center but scarcely obscuring the hinge line.

Valves ornamented with numerous small, mostly longitudinal ridges, curving to become parallel or subparallel to free edges of valve; ridges more strongly developed centrally, and there separated by rows of fine pitting to form a reticulation; marginal ridges becoming faint and closer spaced. Small vertical pit or sulcus located a little anterior to center of valve.

Remarks.-- This genus is removed from the Glyptopleuridae because the carapace is ridged rather than coarsely costate, valves are nearly or quite equal with apparently a flat contact area rather than the larger valve overlapping strongly, and no cardinal teeth are present.

Occurrence.-- Although rare in the Silica Formation, specimens of this genus have been found in the Arkona Shale as well as the Genshaw and other Traverse Group formations.

KEY TO SPECIES OF COELONELLIDAE

1. Distinct bulge in posterodorsal area, extending well above hinge line; valve nearly subcircular; very shallow depression in anterocentral area, presumably marking external position of closing muscles *Coeloenellina rara*
- Dorsal border gently and evenly convex throughout, extending only slightly above hinge line; valve definitely ovate to subelliptical; sides convex without any depression *Coelonella* .. 2
2. In dorsal view, carapace with distinct median bulge, from which sides slope straight or even slightly concave to each narrow end; length not more than twice the height; anterior end with much smaller radius of curvature than posterior end *Coelonella plana*
- In dorsal view, carapace evenly rotund, with ends well rounded; length distinctly more than twice the height; anterior end with only slightly smaller radius of curvature than posterior end *Coelonella scapha*

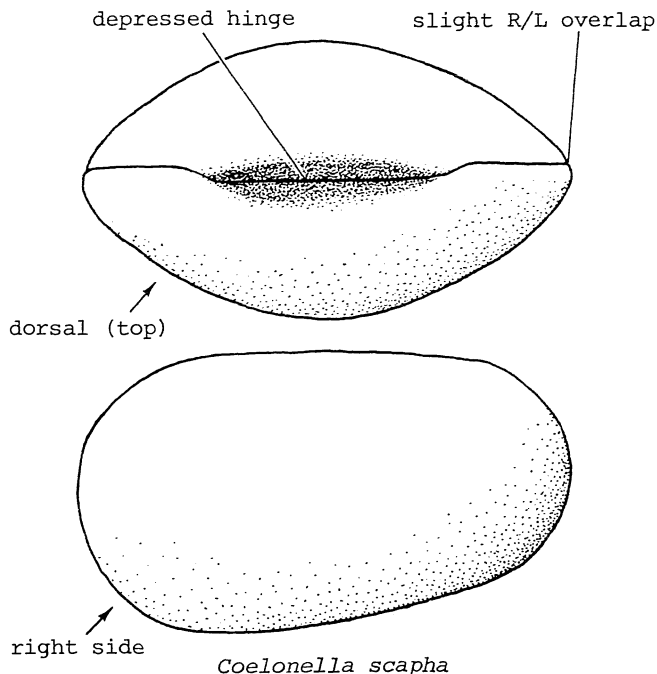

Derivatio nominis.-- The name *rara* is derived from the Latin *rarus* ("infrequent, rare") referring to the few specimens found in the type formation.

Description.-- Carapace small, ovoid to subround, with greatest width central and greatest height posterior. From apex, dorsal border gently convex and sloping forward and down to anterior cardinal corner. Dorsum strongly arched with apex decidedly posterior, sloping inward and down to straight, strongly depressed hinge line. Corners not apparent in lateral view because of arched dorsum. Posterior border rising rather abruptly to rounded apex. Surface smooth with no lobes, sulci, or protuberances, but bearing a few (apparently morphologic and normal) large but very shallow pits like pox scars.

genus *Coeloenellina*, suggesting that all might be conspecific.

Sohn (1971, p. A18) compares the Devonian genus *Coeloenellina* Polenova with the genus *Coelonella* Stewart, mentioning that *Coeloenellina* was smaller and "having a groove along the hinge of the right valve for the reception of the dorsal margin of the left valve." The *Treatise* (1961, p. Q409) placed *Coeloenellina* in "Ostracoda, Order, Suborder, and Family Uncertain."

COELOENELLINA RARA n. sp.
100/17-20; 107/17-20

Family COELONELLIDAE	Medusa quarries																							Martin-Marietta Quarry			Waterworks Park							
	Unit																							1-6			9-11			14-15			17-18	
SPECIES	6	7	9	11	12	13	14	15	16	17	18	21	23	1-6	7	9-11	12	14-15	17-18	1-6	9-11	12												
<i>Coelonella plana</i>	x	x	x	x	x	x	x	x	x	x	x	x	x	x	x	x	x	x	x	x	x	x	x											
<i>Coelonella scapha</i>	x	x	x	x	x	x	x	x	x	x	x	x	x	x	x	x	x	x	x	x	x	x	x											
<i>Coeloenellina rara</i>	x																																	

Occurrence.-- Rare in the Silica Formation and unknown elsewhere.

Types.-- Holotype, best specimen, UMMP 59458 (100/19, 20); paratypes: 59457 (100/17, 18) and 60076 (107/17-20).

Genus COELONELLA Stewart 1936

Coelonella Stewart, 1936.

Sansabella (*Coelonella*) Pribyl, 1955, p.280.
Paraparchites Scott, 1959 [*fide* Sohn, 1971, p.A18].

Type species.-- *Isochilina* ? *scapha* Stewart, 1930, p.57, pl.1, figs.11,12, by designation of Stewart, 1936, p.742,743, pl.100, figs.3,4.

Sohn (1961, p. A6, A7, A17, A18) discusses *Coelonella* thoroughly and illustrates *C. plana* and *C. scapha* in his plate 1, figs.1-8, 9-23, and plate 2, figs.3-6.

COELONELLA PLANA Stewart

102/15-25; 103/1-9

Leperditia ? *subrotunda* ? Stewart, 1930, p.57, pl.1, fig.10 [Silica Formation].

Coelonella plana Stewart, 1936, p.743, pl.100, figs.3,4 [Silica Formation. Holotype, OSU 18171].

Coelonella plana Smith, 1956, p.2, table 1 [Ledyard Shale, Wanakah Shale].

Coelonella plana Sohn, 1971, p.A18, pl.1, figs.1-8.

Remarks.-- The carapace of *Coelonella plana* is slightly smaller and flatter than that of *C. scapha* and has a distinct flattening of the margins of the valves. It is conceivable that this is an undescribed type of dimorphism in which this is the male valve (although we think it unlikely). Both species occur in the same beds, with *C. scapha* the more numerous.

Illustrated specimens.-- UMMP 58905 (103/1-3), 58906 (102/22-25; 103/4), 58907 (103/5-9), 58908 (102/15-19), and 59459 (102/20, 21).

COELONELLA SCAPHA (Stewart)

102/26-38; 103/18-20; 107/30

Isochilina ? *scapha* Stewart, 1930, p.57, pl.1, figs.11,12 [Silica Formation. Holotype, OSU 16538].

Coelonella scapha Stewart, 1936, p.742, pl.100, figs.1,2 [Silica Formation].

Coelonella scapha Wright, 1948, p.22, pl.2, figs.7,8.

Coelonella scapha Kesling & Weiss, 1953, p.67, pl.5, figs.13-16 [Norway Point Formation].

Coelonella scapha Sohn, 1971, p.A18, pl.1, figs.9-23; pl.2, figs.3-6 [Silica Formation].

Remarks.-- The distinct sheen of the smooth surface of this ostracod makes it easily distinguishable, and shows the prominent, almost ribbed ventral overlap. *Coelonella scapha* is much thicker and more rotund than *C. plana*. The invagination of the dorsum to form the hinge gives it a liplike appearance. If dimorphism is ever established for this genus, *C. scapha* would be the female. It is abundant and present in almost all of the Silica units, represented by adults and many immature instars. Disarticulated valves are rare and poorly preserved because of the thinness of the valves.

Illustrated specimens.-- UMMP 58901 (102/34-38), 58902 (103/18-20), 58903 (102/28-31), 58904 (102/32, 33), 59460 (102/26, 27), and 60074 (107/30).

Suborder KLOEDENELLOCOPINA Scott 1961

Larger valve strongly overlapping the smaller. Valves often thick. Dimorphism (if present) expressed as posterior inflation in the female.

Superfamily Kloedenellacea Ulrich & Bassler 1908

Family Kloedenellidae Ulrich & Bassler 1908

Larger valve overlapping along free margin and with anterodorsal tooth-like projection or stragulum. Smaller valve with accommodating anterodorsal bevel or notch.

Subfamily Dizygopleurinae Egorov 1950

Genus DIZYGOPLEURA Ulrich & Bassler 1923

Type species.-- By original designation, *Dizygopleura swartzi* Ulrich & Bassler, 1923, p.682,693, pl.62, figs.1-8.

DIZYGOPLEURA EUGLYPHEA Warthin

44/17-28; 45/1-4; 47/40-42

Dizygopleura euglyphea Warthin, 1934, p.210, pl.1, fig.7 [Gravel Point Formation. Holotype, UMMP 14536].

Dizygopleura euglyphea Warthin, 1937, card 57, fig.7.

Dizygopleura euglyphea Stewart & Hendrix, 1945a, p.90, pl.10, figs.6-8 [Plum Brook Shale].

Dizygopleura euglyphea Kesling & Weiss, 1953, p.54, pl.3, figs.30,31 [Norway Point Formation].

Dizygopleura euglyphea Melik, 1966, p.235,236, pl.3, figs.10-14; pl.14, figs.15-23; pl.15, figs.1-11,23-29; pl.24, figs.13-20 [Gravel Point Formation, Genshaw Formation].

Remarks.-- This large, robust ostracod is found in most of the Middle Devonian beds studied, common in many, but rare in the Silica Formation. The few specimens found there were well preserved, showing the triangular stragulum fitting into the right valve notch, which, with its greater size and straighter sulci, distinguish it from the abundant *D. trisinuata* Van Pelt.

Illustrated specimens.-- UMMP 58933 (44/17-20), 58934 (44/21-24), 59465 (44/25-28), 59466 (45/1-4), and 59467 (47/40-42).

DIZYGOPLEURA TRISINUATA Van Pelt

44/13-16; 45/5-24; 47/43-54; 103/25-28

Dizygopleura trisinuata Van Pelt, 1933, p.328, pl.39, figs.61,62 ["Bell Shale" - exact stratigraphic formation unknown. Holotype Walker Mus. Univ. Chicago 38606].

Dizygopleura oblonga Warthin, 1934, p.211, pl.1, fig.8 ["Long Lake series, Traverse fm."].

Dizygopleura oblonga Stewart, 1936, p.750,751, pl.101, figs.1-4 [Silica Formation].

Dizygopleura trisinuata Warthin, 1937, card 6, figs.61,8.

Dizygopleura trisinuata Stewart & Hendrix, 1945a, p.90, pl.10, figs.9-11 [Plum Brook Shale].

Dizygopleura trisinuata Stewart, 1950, p.660, 661, pl.86, figs.1-3 [3rd Bone Bed, Delaware Limestone].

Dizygopleura trisinuata Tillman, 1970, p.210, fig.4, no.11 [Lower Olentangy Shale].

Remarks.-- Abundant and well preserved in the Silica Formation, *Dizygopleura trisinuata* shows excellently the kloedenellid type of dimorphism in the tumid posterior of the female carapaces. Many males and juveniles were found, as well as a few single valves displaying the elongate stragulum in the anterodorsal part of the left valve. This structure differs from the large triangular tooth in *Dizygopleura euglyphea* by its greater

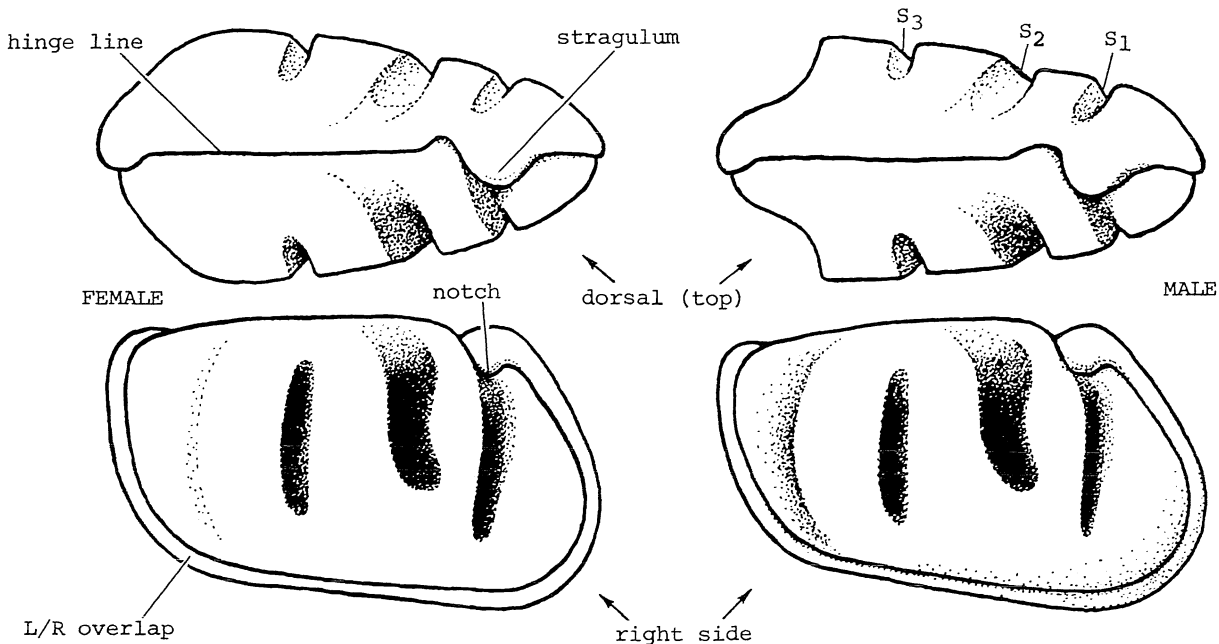
*Dizygopleura euglyphea*

length and less overlap and inset of the right valve.

Illustrated specimens.-- UMMP 58943 (45/21-24), 58944 (45/9-11), 58945 (47/47-50), 58946 (47/45, 46), 58947 (44/13-16), 58948 (45/17-20), 58949 (45/12-16), 58950 (47/43, 44), 58951 (45/5-8), 58952 (47/51-54), 60055 (103/25, 26), and 60056 (103/27, 28).

Genus POLONIELLA Gürich 1896

Type species.-- By original designation, *Poloniella devonica* Gürich, 1896, p.388.

POLONIELLA CINGULATA Warthin

61/1-16; 62/1-21; 63/27-34

Poloniella cingulata Warthin, 1934, p.212, pl.1, fig.9 [Upper Gravel Point Formation. Holotype, UMMP 14538].

Poloniella cingulata Warthin, 1937, card 161, fig.9.

Poloniella cingulata Stewart & Hendrix, 1945a, p.91, pl.10, fig.18 [Plum Brook Shale].

Poloniella cingulata Coley, 1954, p.455 [Silica Formation, Arkona Shale].

Poloniella cingulata Adamczak, 1961, p.308-310, fig.14; pl.6, figs.1,2 [Holy Cross Mountains, Poland].

Remarks.-- This large kloedenellid is common in the Silica Formation, particularly in units 9 and 11, where many males and immature instars are found, as well as tumid females. The latter are often crushed or distorted, especially in the large dimorphic posterior ends. A triangular toothlike stragulum, resembling that of *Dizygopleura euglyphea*, is present in the larger left valve. *Poloniella cingulata* has curved S_1 and S_3 sulci like those of *Dizygopleura trisinuata*, but they are joined ventrally below S_2 and are bordered by a sharp ventral ridge. The stragulum of *P. cingulata* is short and triangular, whereas that of *Dizygopleura trisinuata* is long and slender.

Illustrated specimens.-- UMMP 59235 (61/13-16), 59236 (63/31-34), 59237 (62/19-21), 59238 (61/5-8), 59239 (62/9-12), 59240 (62/5-8), 59241 (61/1-4), 59242 (62/1-4), 59243 (63/27, 28), 59244 (61/9-12), 59245 (62/15-18), and 59246 (62/13, 14; 63/29, 30).

POLONIELLA sp.

56/5-8

A *Poloniella* specimen bearing great quantities of pyrite is probably *P. cingulata*, the only species identified in the Silica Formation, but identification carries some doubt.

Illustrated specimen.-- UMMP 61830.

Subfamily Kloedenellinae Egorov 1950

Genus EUKLOEDENELLA Ulrich & Bassler 1923

Type species.-- By original designation, *Eukloedenella umbilicata* Ulrich & Bassler, 1923, p.313,669, pl.57, figs.8-12.

EUKLOEDENELLA DOVERENSIS Turner

82/42-53; 83/1-20; 88/1-8

Eukloedenella sp. Stewart, 1936, p.750, pl.100, fig.28 [Silica Formation].

Eukloedenella doverensis Turner, 1939, p.20, pl.1, figs.5-8 [Dover field well, Ontario. Holotype, GSC 9400].

Eukloedenella doverensis Kesling & Weiss, 1953, p.54, pl.3, figs.17-20 [Norway Point Formation].

Remarks.-- This large ostracod is quite common in the Silica Formation, with many specimens of males, females, and juveniles found. Females exhibit kloedenellid dimorphism in the tumid posterior part of the carapace. This species has a distinctive sheen on its smooth valves. The short, narrow dorsal sulcus, which reaches from the hinge for about one-third the height of the valve, is very characteristic.

Illustrated specimens.-- UMMP 59079 (82/50-53), 59080 (82/42-45; 88/1), 59081 (82/46-49), 59082 (83/1-4; 88/2-5), 59083 (83/17-20), 59084 (83/13-16), 59085 (83/5-8; 88/6-8), and 59086 (83/9-12).

Genus PUNCTOPRIMITIA Stewart & Hendrix

Type species.-- *Haploprimitia simplex* Stewart, 1936, p.743, pl.100, fig.5, by designation of Stewart & Hendrix, 1945a, p.90, pl.10, figs.4,5.

PUNCTOPRIMITIA SIMPLEX (Stewart)

46/20-39; 48/1-12

Haploprimitia simplex Stewart, 1936, p.743, pl. 100, fig.5 [Silica Formation. Holotype, OSU 18172].

Haploprimitia simplex Warthin, 1937, card 1.1, fig.5.

Haploprimitia punctata Turner, 1939, p.10, pl.1, fig.1 [Oil well, Ontario].

Punctoprimitia simplex Stewart & Hendrix, 1945a, p.90, pl.10, figs.4,5 [Plum Brook Shale].

Punctoprimitia simplex Tillman, 1971, p.206, fig.4, no.13 [Lower Olentangy Shale].

Remarks.-- Stewart & Hendrix (1945a) erected the genus *Punctoprimitia*, including in it *Haploprimitia simplex* Stewart and *Haploprimitia punctata* Turner. Scott in Moore (1961, p. Q182) listed *Punctoprimitia* as a junior synonym of *Eukloedenella*. It differs from that genus, however, in size, shape, ornamentation, and hingement. Although most of the Silica specimens appear smooth, many have been found with well defined punctae. The valves are much more convex than those of *Eukloedenella*, with an abrupt rise a short distance from the posterior border. *Punctoprimitia subaequalis* Swartz & Oriel is very similar to *Punctoprimitia simplex*, differing mainly in its larger valves and larger punctae.

Most specimens found in the Silica are single valves, perhaps because the overlap is not pronounced and the hinge seems to be rather weak.

Illustrated specimens.-- UMMP 59284 (48/5, 6), 59285 (48/7, 8), 59286 (46/38, 39), 59287 (48/1, 2), 59288 (48/3, 4), 59289 (46/36, 37), 59290 (46/20-23), 59291 (46/26, 27), 59292 (48/10), 59293 (48/9), 59429 (46/28-31), 59430 (46/32-35), 59553 (48/11, 12), and 59554 (46/24, 25).

Subfamily Knoxitinae

[corrected name for Knoxinae Egorov 1950]

Genus KNOXIELLA Egorov 1950

Type species.-- By original designation, *Knoxella semilukiana* Egorov, 1950, p.90, 93, pl.15, figs.25-34.

KNOXIELLA RUTKOWSKIAE n. sp.

63/1-26; 64/1,2

Derivatio nominis.-- The name *rutkowskiae* is a patronymic honoring Patricia Rutkowski for her generous gifts of specimens to our Museum of Paleontology.

Description.-- Carapace medium to large, unisulcate, subquadrate to subelliptical in lateral view and wedge-shaped in dorsal view. Valves nearly equal, with right valve slightly larger; overlap slight, partly obscured by low submarginal ridges. Ventral border almost straight, indented slightly near middle. Hinge kloedenellid, divisible into anterior, postero-central, and posterior elements: anterior element long and narrow process of right valve extending above and over left valve, postero-central elements meeting at mid-width in a shallow elongate lanceolate groove, and posterior element a small but distinct lobe from the right valve extending over and onto left valve. Ends rounded.

Crescent-shaped sulcus from a little above mid-height to just below hinge line. Prominent tumid posterior of female expressing the dimorphism as in other kloedenellids.

Convex valve surfaces rather smooth or very finely granular, some with glossy sheen.

Remarks.-- *Knoxella rutkowskiae* resembles *Eukloedenella doverensis* in the smooth appearance of the lateral surface, but that genus is larger and flatter, with a smaller, narrower sulcus and without the posterocentral groove along the hinge line as seen dorsally. *Knoxella truncata* is smaller, and its flattened posterior end is sharply truncated, making it so distinctive that no possible confusion exists with *K. rutkowskiae*.

Types.-- Holotype, carapace, UMMP 59147 (63/9-12); paratypes: UMMP 59066 (63/13-16), 59067 (64/1, 2), 59516 (63/1-4), 59517 (63/21-24), 59518 (63/5-8), 59519 (63/17-20), and 59520 (63/25, 26).

KNOXIELLA TRUNCATA n. sp.

64/25-53; 116/1

Derivatio nominis.-- The name *truncata* is derived from the Latin *truncatus* ("shortened by being cut off"), referring to the blunt posterior end of the carapace.

Description.-- Carapace small to medium, unisulcate, rhomboidal in lateral view, subtriangular in posterior view (widest dorsally), and strongly wedge-shaped in dorsal view. Right valve slightly larger than left. Greatest length at about one-third the height below the hinge line; very little variation in height; greatest width between the posterodorsal corners, with valves tapering forward to narrow anterior end.

Kloedenellid hinge extending full length of carapace; as seen dorsally, a deep groove in the posterocentral part of valve along hinge line, bordered by extensions of the right valve at the rear (small rounded lobe) and in front (long narrow process extending over onto the left valve).

Deep pit located in dorsocentral area, with a pronounced sulcus extending upward almost to the hinge line. Some specimens with a small elevation alongside the pit anteriorly.

Posterior end most distinctive, broad, flattened, sharply truncated in lateral view and sloping forward from the rear of the hinge to the venter. Males with sharp posterior marginal ridge on side of valve. Females with this area very tumid, showing typical kloedenellid type of dimorphism.

Very faint horizontal lineation on better preserved specimens, appearing almost as wrinkles.

Remarks.-- The sharply truncated flat posterior end distinguishes *Knoxiella truncata* from all other Middle Devonian kloedenellids.

Occurrence.-- Rare in the Silica Formation, this ostracod has also been found in some of the Traverse beds of northern Michigan, the Widder Formation of Ontario, and in several of the New York formations. It is rare in all localities.

Types.-- Holotype, complete carapace, UMMP 59068 (64/32-36); paratypes: UMMP 59069 (64/50), 59070 (64/37-41), 59071 (64/51), 59072 (64/44, 45), 59073 (64/42, 43; 116/1), 59426 (64/25-28), 59427 (64/29-31), 59428 (64/46-49), and 59450 (64/52, 53).

KNOXIELLA sp.

63/35-38

An exceptionally large specimen of *Knoxiella* has the general form of *K. rutkowskiae*, but it is smoother and differs in details of configuration. It is also half again as large as supposed adults of *K. rutkowskiae*. It probably belongs in a new species, but because it is the only specimen of its kind discovered, we decline to name it.

Family Geisinidae Sohn 1961

Overlap slight. No anterodorsal projection or stragulum in larger valve, nor accommodation or notch in smaller valve.

Genus HYPOTETRAGONA Morey

Hypotetragona Morey

Janetina Coryell & Malkin, 1936.

Kloedenellina Coryell & Johnson, 1939.

Gillina Coryell & Johnson, 1939.

? *Kuleschovkia* Egorov, 1950.

Type species.-- By original designation, *Hypotetragona impolita* Morey, 1935, p.326.

HYPOTETRAGONA AEQUITALIS Peterson

58/22-25; 59/1-8; 107/23-28; 108/1

Hypotetragona aequitalis Peterson, 1964, p.136, fig.15 [Bell Shale. Holotype, carapace, UMMP 42871].

Remarks.-- The fine reticulate ornamentation of this species and its smaller size distinguish it from *H. harrietensis* Coryell & Malkin. It is thinner, with more moderately sloping valves and shorter, shallower sulcus than *H. fractodorsalis*, our new species. It is very rare in the Silica Formation.

Illustrated specimens.-- UMMP 59106 (59/1-4; 108/1), 59137 (59/5-8), 59654 (58/22-25), 60054 (107/23-25), 60072 (107/28), and 60073 (107/26, 27).

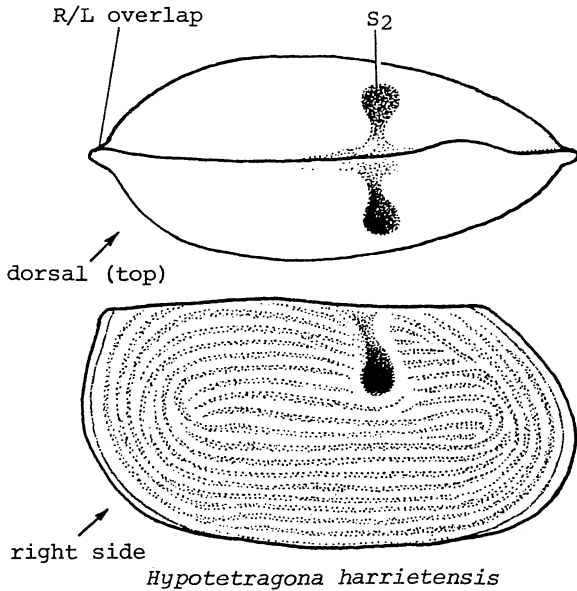

HYPOTETRAGONA FRACTODORSALIS n. sp.

59/9-12, 25-46; 108/3

Derivatio nominis.— The name *fractodorsalis* is derived from the Latin *fractus* ("broken, feeble") and *dorsum* ("the back"), referring to the large numbers of specimens having the dorsal border caved in.

Description.— Carapace small to medium, subrectangular in lateral view, with a pronounced tumidity in the ventral half of the postero-central region. Sulcus deep, extending from a large pit in anterocentral area to the hinge, probably responsible for the crushing of the carapace in the median dorsal region of nearly all specimens. Hinge originally straight, running the length of the valve, rarely preserved in its original shape. Ends rounded.

Strong chain-like reticulation over the entire surface of valves. Kloedenellid dimor-

KEY TO SPECIES OF GEISINIDAE

- Carapace posteriorly and ventrally strongly inflated; very deep S₂, resulting in most specimens buckling at the dorsal border
..... *Hypotetragona fractodorsalis*
Carapace posteriorly and ventrally convex but not strongly inflated; S₂ only moderately deep; dorsal border preserved as straight line ... 2
- Reticulation elements distinctly aligned horizontally; length more than 0.8 mm. *Hypotetragona harrietensis*
Reticulation elements even except for weak alignment parallel to free border in ventral and posteroventral areas; length less than 0.8 mm *Hypotetragona aequitalis*

phism pronounced in the females, with the tumidity occurring more posteroventral and making the ventral part of carapace broader and more rounded than in other kloedenellids.

Remarks.— This species differs from other species of *Hypotetragona* in its broad, tumid posteroventral region and its concentric chain-like reticulation. Because of the shape of the carapace and the evident weakness in the deep sulci, nearly all specimens are buckled down at the middle of the hinge line.

Occurrence.— *Hypotetragona fractodorsalis* is rare in the Silica Formation, where most specimens are crushed and distorted. Far better specimens were recovered from the Centerfield and Wanakah formations of New York and from the Genshaw Formation of the Traverse Group in northern Michigan, wherein they are common.

Types.— Holotype, UMMP 59057 (59/39-

Family GEISINIDAE	Medusa quarries																							Martin-Marietta Quarry			Waterworks Park				
	Unit																							1-6			9-11			17-18	
SPECIES	6	7	9	11	12	13	14	15	16	17	18	21	23	1-6	7	9-11	12	14-15	17-18	1-6	7	9-11	12								
<i>Hypotetragona aequitalis</i>	x	x	x	x	x	x	x									x	x	x													
<i>Hypotetragona fractodorsalis</i>			x					x								x															
<i>Hypotetragona harrietensis</i>	x	x	x	x			x			x		x				x				x	x		x								

42; 108/3); paratypes: UMMP 59055 (59/27, 28), 59136 (59/9-12), 59504 (59/31-34), 59506 (59/29, 30), 59507 (59/25, 26), 59508 (59/45, 46), 59509 (59/43, 44), and 59510 (59/35-38).

HYPOTETRAGONA HARRIETENSIS
(Coryell & Malkin)

59/13-19; 60/1-9; 108/2

Janetina harrietensis Coryell & Malkin, 1936, p.19, fig.34 [Hungry Hollow Formation. Holotype, AMNH 24643].

Janetina harrietensis Wright, 1948, p.125, pl.16, fig.19.

Hypotetragona harrietensis Peterson, 1964, p.863, pl.134, figs.27,37; pl.135, figs.22, 28; pl.136, fig.14 [Hungry Hollow Formation, Ipperwash Limestone, Centerfield Limestone, Wanakah Shale].

Remarks.-- The largest *Hypotetragona* species in the Silica Formation, its entire carapace is concentrically circled by faint ridges around the margins, which merge into even fainter horizontal lineation in the center of the valves. It is also rare in the Silica Formation. It is larger than *Hypotetragona aequitalis*, which has a mesh-like reticulation, and flatter than *H. fractodorsalis*, which has chain-like reticulation.

Illustrated specimens.-- UMMP 59050 (59/17-19), 59138 (60/1-4; 108/2), 59139 (59/13-16), 59140 (60/5-8), and 59511 (60/9).

Order ERIDOSTRACA Adamczak 1961

Valves retaining unmolted earlier valves, the incomplete ecdysis producing concentric markings at distal edges of incorporated younger valves.

Family Eridoconchidae Henningsmoen 1953

Genus CRYPTOPHYLLUS Levinson 1951

Type species.-- *Eridoconcha oboloides* Ulrich & Bassler, 1923, p.296,297, fig.14, no.6-8, by designation of Levinson, 1951, p.558.

Remarks.-- *Cryptophyllus* is distinguished from *Eridoconcha* Ulrich & Bassler by its lower, gently rounded growth lamellae separated by less conspicuous grooves. Adamczak (1961) redefined the genera *Cryptophyllus* and *Erido-*

concha on the basis of the number of lamellae they possessed (presumably in adult stage, so that the lamellae recorded more ecdyses in one than the other genus). Jones (1962b) felt this was an unstable character on which to define a genus, and we concur. A new small species of *Cryptophyllus* has been described below with fewer lamellae.

CRYPTOPHYLLUS ARSINIUS Stover

101/9-17; 102/1-8; 103/23,24; 120/4

Cryptophyllus arsinus Stover, 1956, p.1139, pl.119, figs.37-40 [Windom Shale. Holotype, NYSM 11031].

Eridoconcha arsinata Adamczak, 1961, p.85,86. *Cryptophyllus arsinus* Jones, 1962b, p.67.

Remarks.-- *Cryptophyllus arsinus* is rare but well preserved, particularly in unit 12. It has an almost centrally placed umbo with no spines. The surface tends to be lustrous. The concentric lamellae vary from 9 to 12.

Illustrated specimens.-- UMMP 58959 (101/17; 102/1-4; 103/23,24; 120/4), 58960 (101/11-16; 102/7,8), 58961 (101/9,10), and 58962 (102/5,6).

CRYPTOPHYLLUS MINUSCULUS n. sp.

100/39-54; 102/9-12; 104/9-16; 105/10-18;
109/3

Derivatio nominis.-- The name *minusculus* is derived from the Latin *minusculus* ("very small"), referring to the diminutive size of the species.

Description.-- Carapace equivalved, very small, subtriangular in lateral view, cardioid in end view. Hinge straight, depressed between the umbos.

Umbos anterior, each with a short slender spine projecting from its top, commonly pointing a little toward the anterior. Concentric growth lamellae forming distinct but narrow grooves, dividing the smooth sides into 5 or 6 flattened ridges.

Remarks.-- The small, fragile shells of this ostracod are rare, with very few undamaged specimens found. They differ from *C. arsinus* in their much smaller size, small umbonal spines, and more anterior umbos.

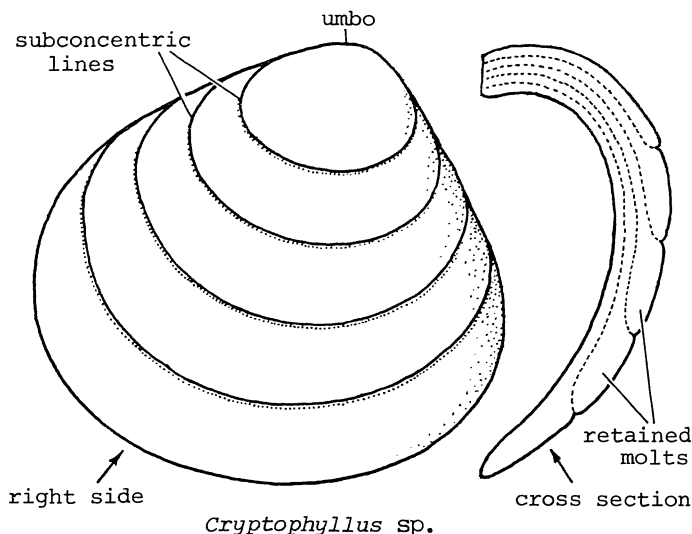

Occurrence.-- The Silica specimens were found mostly in the Waterworks Park sediments. A few specimens were also found in the Petoskey and Gravel Point formations of northern Michigan.

Types.-- Holotype, UMMP 58966 (100/50-54; 102/9, 10; 109/3); paratypes: UMMP 58963 (100/39, 40), 58964 (100/41, 42), 58965 (100/45, 46), 58967 (100/47), 59627 (100/43, 44), 59628 (100/48), 59629 (100/49; 102/11), 60061 (105/10-13), 60062 (104/13-16), 60063 (104/9-12), and 60064 (105/14-17).

Order PODOCOPIDA Sars 1866

Dorsal border convex or (if nearly straight but slightly convex) much shorter than the rest of valve. Duplicature present. No true frill or adventral structures.

Suborder PODOCOPINA Sars 1866

Muscle-scar pattern of discrete scars. Duplicature usually wide and may form vestibule, especially at anterior end.

KEY TO SPECIES OF ERIDOCONCHIDAE

Umbo rounded, without spine; more than 6 subconcentric lines marking boundaries between retained molts; length greater than 0.5 mm *Cryptophyllus arsinus*

Umbo with sharp spine projecting dorsally; less than 6 subconcentric lines marking boundaries between molts; length less than 0.5 mm. *Cryptophyllus minusculus*

Superfamily Bairdiacea Sars 1887

Adductor-muscle scars more or less radially arranged.

Family Bairdiidae McCoy 1884

Dorsum highly arched. Valves typically "lemon-seed"-shaped. Anterior duplicature large with spacious vestibule.

Genus RECTOBAIRDIA Sohn 1960

Type species.-- *Bairdia depressa* Geis, 1932 (non Kafka, 1885), p.178, pl.25, figs.12a,12b, by designation of Sohn, 1960, p.52.

RECTOBAIRDIA EMACIATA (Kesling & Kilgore)

7/14-17; 78/8-11; 106/24-27; 107/31-34

Bairdia emaciata Kesling & Kilgore, 1952, p.13, pl.4, figs.4-8 [Genshaw Formation. Holotype, complete carapace, UMMP 28016].

Rectobairdia ? emaciata Sohn, 1960, p.54, pl.2, figs.14,15 [Genshaw Formation].

Remarks.-- *Rectobairdia emaciata* is rare in the Silica Formation, with specimens often crushed and broken. The long, slender carapace is light in color, never pyritized. No single valves were found.

Illustrated specimens.-- UMMP 58801 (7/14-17), 59421 (78/8-11), 60051 (106/24-27),

Family ERIDOCONCHIDAE	Medusa quarries													Martin-Marietta Quarry			Waterworks Park					
	Unit													1-6			9-11			12		
	6	7	9	11	12	13	14	15	16	17	18	21	23	1-6	7	9-11	1-6	7	12			
<i>Cryptophyllus arsinus</i>		x	x	x												x	x	x	x		x	
<i>Cryptophyllus minusculus</i>														x	x				x	x	x	

KEY TO SPECIES OF BEECHERELLIDAE

1. Carapace subtriangular in end view; large flat area forming ventral surface *Pronipantex planus*
Carapace subelliptical in end view; no ventral flat area set off from lateral area by sharp angulation ... 2
2. Ends pointed; much more than 1 mm long; sides evenly and gently convex, subparallel; posterodorsal and anterodorsal borders truncate to concave
..... *Acanthoscapha devonica*
Ends rounded; only about 1 mm long; in dorsal view, sides with median bulge; posterodorsal and anterodorsal borders rounded from dorsal border *Wideneria lispa*

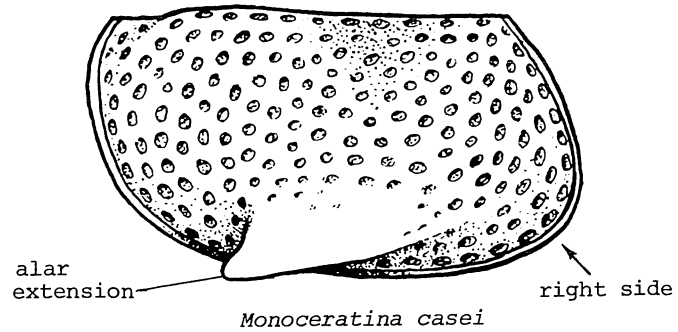

Illustrated specimen. -- From the Hungry Hollow Formation, UMMP 59669 (7/18-20).

Genus PRONIPANTEX n. gen.

Type species. -- Here designated, *Pronipantex planus* n. sp.

Derivatio nominis. -- The name *Pronipantex* is derived from the Latin *pronus* ("bent down, prone, stooped") and *pantex*, m. ("the paunch"), referring to the lateral spread of the venter and to the inferred position of the soft parts of the animal.

Description. -- Carapace small with slightly convex dorsum and very broad flattened ventral surface. Trapezoidal in lateral view, distinctly subtriangular in posterior and anterior views. Each side bent inward at a ventral fold to form a large, lanceolate, flattened ventral surface. Valves with sinuous ventral closure, the left overlapping the right with a lip in the middle of the free edge. Venter normally flat to indented. Posterior ends of ventral fold extended into spine-like points. Surface smooth and shiny, without grooves, protuberances, or ornamentation.

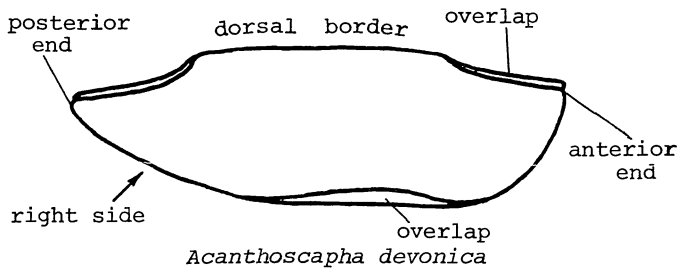

field Limestone. Holotype, UMMP 30521].
Alanella devonica Kesling, Kavary, Takagi, Tillman, & Wulf, 1959, p.23, fig.3 [Centerfield Limestone, Hungry Hollow Formation].
Acanthoscapha devonica Berdan, 1960, p.471.

Remarks. -- The single complete specimen found in the Silica Formation has been lost. A few fragments were also found in unit 12.

SPECIES	Medusa quarries													Martin-Marietta Quarry			Waterworks Park					
	Unit 6	7	9	11	12	13	14	15	16	17	18	21	23	1-6	9-11	12	17-18	14-15	1-6	9-11	12	
Family BEECHERELLIDAE																						
<i>Acanthoscapha devonica</i>					x																	
<i>Pronipantex planus</i>																		x				
<i>Wideneria lispa</i>	x				x		x							x	x					x		
Family BYTHOCYATHERIDAE																						
<i>Monoceratina casei</i>		x	x	x				x	x					x	x	x		x		x	x	x

Remarks.-- This very unusual ostracod with its flattened, sometimes indented ventral surface is similar to "Beecherella ? angularis" Ulrich 1891, which was subsequently put in Acanthoscapha by Bassler & Kellett (1934, p. 45). Berdan (1960, p. 474, 475) placed it under Genus Uncertain, calling it "Beecherella" angularis. This ostracod was said by Ulrich (1891, p. 197) to be from material sent to him by C. E. Beecher and Charles Schuchert and the types are labeled "Lower Helderberg group, Indian Ladder, N. Y."; according to the investigations of Berdan (1960), however, it appears that they are actually from the Kalkberg Limestone. Although the flat base in Ulrich's species is not as developed as in the type species described here, we are convinced that it belongs in the new genus Pronipantex; possibly, it was the ancestor of P. planus.

The type species is also similar to the Silurian genus Pseudocyproides Morris & Hill (1952, p. 15, 16), which differs in the alate expansion along the ventral border, resembling a frame around the ventral surface. In the Treatise (1961, p. Q207), Shaver placed Pseudocyproides in the family Bairdiidae.

The peculiar low profile and wide flat venter suggest that this ostracod was adapted to a unique ecological niche, but we have no evidence as to its nature.

PRONIPANTEX PLANUS n. sp.

75/1-18; 78/3-7

Derivatio nominis.-- The name *planus* is derived from the Latin planus ("even, flat, level, plane"), referring to the very flat venter.

Description.-- As for the genus. Greatest height slightly anterior; greatest length nearly ventral; and greatest width median.

Occurrence.-- Very rare in the Silica Formation, but excellent specimens have been found in the Widder Formation of southwestern Ontario and in the Wanakah Shale of western New York.

Types.-- Holotype, complete carapace, UMMP 61811 (75/1-5); paratypes: UMMP 59033 (75/9-12), 59382 (78/3-7), 59526 (75/6-8), and 61810 (75/13-18).

Genus **WIDENERIA** n. gen.

Type species.-- Here designated, Wideneria lispa, n. sp.

Derivatio nominis.-- The name *Wideneria* is a patronymic honoring Millard Widener, a Charter Member of the Friends, who has provided our Museum with numerous fine specimens from the Silica Formation.

Description.-- Carapace medium-sized, elongate subrectangular, with compressed, gently rounded ends. Greatest length through midheight with little decrease in height between anterior and posterior ends. Valves almost equal, smooth, with a very slight left/right overlap ventrally. No pit, sulcus, or protuberances. Valves with typical becherellid sheen. Carapace widest centrally and tapering to somewhat flattened ends.

Remarks.-- This elongate, flattened ostracod resembles the genus Scaphina Polenova (1968, p. 53, 54), but it is much smaller and lacks the ventral tumidity and pronounced overlap of that genus. The smooth surface is similar to Acanthoscapha, but it lacks the pointed processes at the ends, and it is much smaller.

WIDENERIA LISPA n. sp.

83/40-43; 84/24-45; 89/56-60

Derivatio nominis.-- The name *lispa* is derived from the Greek λίσπος ("smooth, polished"), referring to the surface texture.

Description.-- As for the genus, in which it is the only known species. Hingement unknown, inasmuch as no single valves have ever been found.

Remarks.-- No pyritized carapaces were discovered, all shell material having the light coloration and sheen of other becherellids. Several carapaces were crushed, indicating very thin shell material. A few good specimens have been obtained from the Silica Formation, and the species is also present in the Widder and Wanakah formations.

Types.-- Holotype, complete carapace, UMMP 59054 (84/24-27); paratypes: UMMP 59051 (84/30-33; 89/58-60), 59052 (84/34-37),

59053 (84/38-41), 59685 (83/40-43), 59686 (84/42-45; 89/56, 57), and 59693 (84/28, 29).

Superfamily Cytheracea Baird 1850

Dorsal border gently convex. Adductor-muscle scars usually set in vertical row of four elements.

Family Bythocytheridae Roth 1928

Genus MONOCERATINA Roth

Monoceratina Roth, 1928.

Bythocytheromorpha Mandelstam, 1958.

Type species.-- By original designation, *Monoceratina ventrale* Roth, 1928, p.16, text-figs.1a-1c.

Remarks.-- The Bythocytheridae, to which *Monoceratina* belongs, comprises the longest ranging family of the Cytheracea (Treatise, 1961, p. Q267). *Monoceratina* is recorded from Devonian to Recent, and attempts to differentiate the Paleozoic, Mesozoic, and Cenozoic forms into different genera have failed.

MONOCERATINA CASEI Warthin

70/16-21; 71/9-30; 74/19-21

Monoceratina casei Warthin, 1934, p.207,208, pl. 1, fig.1 [Norway Point Formation. Holotype, UMMP 14531].

Monoceratina casei Kesling & Weiss, 1953, p.48, pl.3, figs.8-11 [Norway Point Formation].

Monoceratina casei Coley, 1954, p.455, chart [Widder Formation, Norway Point Formation].

Monoceratina casei Smith, 1956, p.2, chart [Wanakah Shale, Ledyard Formation].

Monoceratina casei Stover, 1956, p.1113, pl.116, fig.15 [Windom Shale].

Occurrence.-- *Monoceratina casei* was found at each of the Silica localities, where it is slightly smaller than specimens from northern Michigan, Ontario, and New York.

Illustrated specimens.-- UMMP 59191 (71/9-12), 59192 (71/29, 30; 74/19-21), 59193 (71/25-28), 59194 (70/21), 59195 (71/21-24), 59196 (71/17-20), 59197 (71/13-16), and 59198 (70/16-20).

Suborder METACOPINA Sylvester-Bradley 1961

Muscle-scar pattern circular, an aggregate of small scars. Duplicature narrow, poorly developed.

Superfamily Healdiacea Harlton 1933

Dorsal border strongly arched. Hinge short. Surface never deeply sculptured.

Family Healdiidae Harlton 1933

Left/right overlap. Posterior sculpturing in form of backward-directed spines and/or ridges.

Subfamily Healdiinae Harlton 1933

SPECIES	Medusa quarries													Martin-Marietta Quarry			Waterworks Park								
	Unit													1-6			9-11			12					
	6	7	9	11	12	13	14	15	16	17	18	21	23	1-6	9-11	12	14-15	17-18	1-6	9-11	12				
Subfamily HEALDIINAE																									
<i>Healdia arkonensis</i>			x												x					x	x				
<i>Healdia gibba</i>		x	x	x	x	x						x			x	x	x					x			
<i>Healdia medusaensis</i>			x	x	x			x						x	x		x				x	x	x		
<i>Healdia cf. medusaensis</i>								x							x						x		x		
Subfamily HEALDIOPSIDINAE																									
<i>Microcheilinella mariettensis</i>					x	x									x						x	x	x	x	
<i>Nannohealdia arcuata</i>						x									x	x					x		x	x	
<i>Ponderodictya ohioensis</i>		x	x	x	x	x	x	x	x	x	x	x	x	x	x	x	x				x	x	x	x	
<i>Ponderodictya punctulifera</i>	x	x	x	x	x	x	x	x	x	x	x	x	x	x	x	x	x	x				x	x	x	x
<i>Ponderodictya rhodesi</i>			x	x	x										x	x	x				x		x		

KEY TO SPECIES OF HEALDIIDAE

1. Posterior region of each valve protuberant and marked by a ridge (with or without spines) *Healdiinae* .. 2
 - Posterior region not protuberant and not bearing a ridge (although discrete spines may be present)
..... *Healdiopsidinae* .. 4
2. Posterior ridge with only slight protuberances at upper and lower ends, these directed backward
..... *Healdia arkonensis*
Posterior ridge with strong protuberances (referred to as spines) at upper and lower ends, directed somewhat outward, the intervening ridge low 3
3. Posterior spines set in nearly vertical alignment; dorsal border of left valve gently convex; carapace elongate elliptical *Healdia medusaensis*
Posterior spines not aligned vertically, the ventral spine strongly developed and set well behind the dorsal spine, directed strongly outward; dorsal border of left valve strongly arched slightly anterior to midlength; carapace subovate *Healdia gibba*

4. Small (less than 0.5 mm long); valves rotund, ovate, the length not much more than height; each valve with small sharp spine set posteroventrally very close to free border
..... *Nannohealdia arcuata*
Medium to large (over 0.5 mm long); valves elliptical, appreciably longer than high; any posterior spine or spines fairly broad at the base or blunt, set well away from free border .. 5
5. No posterior spines or protuberances on either valve; dorsally, overreach remains L/R but overlap is reversed
..... *Microcheilinella mariettensis*
One or two posterior spines or protuberances on at least one valve; overreach and overlap both L/R throughout
..... *Ponderodictya* .. 6
6. Adult carapace less than 1.5 mm long; shell not especially thick; sides gently rounded ... *Ponderodictya ohioensis*
Adult carapace more than 1.5 mm long; shell very thick; sides strongly rounded, robust 7
7. Surface reticulate
..... *Ponderodictya punctulifera*
Surface smooth *Ponderodictya rhodesi*

Genus HEALDIA Roundy 1926

Type species.-- By original designation, *Healdia simplex* Roundy, 1926, p.8, pl.1, figs. 11a-11c.

HEALDIA ARKONENSIS Coryell & Malkin

85/44-51,56,57

Healdia arkonensis Coryell & Malkin, 1936, p.14, fig.25 [Hungry Hollow Formation. Types, AMNH 24633].

Healdia cf. *arkonensis* Stover, 1956, p.1121, pl.116, figs.1-3 [Windom Shale].

Remarks.-- *Healdia arkonensis* is rare in the Silica Formation. It is somewhat smaller than specimens from the Hungry Hollow Formation. It differs from *Healdia gibba* in its smaller size, more tapered outline, and the sharp ventrally curved crescentic ridge on the posterior end of each valve. Larger than *Healdia medusaensis*, it lacks the sharp, backward-pointing spines of that species but has a much stronger posterior ridge.

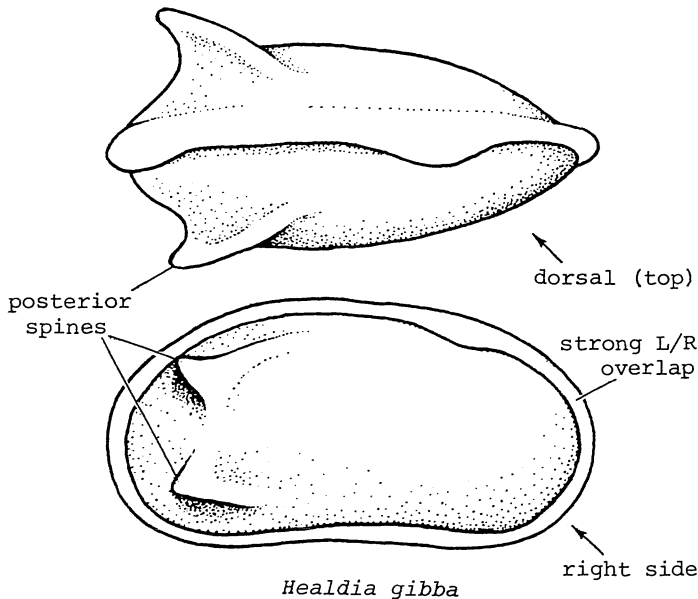

Illustrated specimens.-- UMMP 59416 (85/44-47), 59417 (85/48-51), and 59424 (85/56, 57).

HEALDIA GIBBA Kesling & Weiss 1953

84/13-15; 85/1-16; 86/7-10

Healdia gibba Kesling & Weiss, 1953, p.56,57, pl.5, figs.9,10,12 [Norway Point Formation. Holotype, carapace, UMMP 29841].

Remarks.-- Larger and broader than *H. arkonensis* with two stout backward-curving spines near the posterior end of each valve, it lacks the ridges of that species. Good carapaces and single valves were found at the Medusa and Martin-Marietta localities. It also occurs in most of the Traverse beds of northern Michigan.

Illustrated specimens.-- UMMP 59118 (85/5-8), 59119 (84/13,14), 59120 (85/13-16), 59121 (85/3,4), 59122 (85/9-12), 59425 (85/1,2), 59482 (84/15; 86/9,10), and 59684 (86/7,8).

HEALDIA MEDUSAENSIS n. sp.

85/17-32

Derivatio nominis.-- The name *medusaensis* is derived from the occurrence of the species at the Medusa quarries in Lucas County, Ohio.

Description.-- Carapace small, subelliptical, with a typical healdiid outline. Dorsal border curved, posterior end rounded, ventral border straight to slightly convex, anterior end more acutely rounded and tapered. Four small sharp spines, two on each valve, directed back and outward from the posterior end. Carapace smooth, usually pyritized.

Remarks.-- *Healdia medusaensis* resembles *H. arkonensis* in general outline, but is much smaller and lacks the distinct crescentic ridge of that species. It is very much smaller than *H. gibba*, with its finer, sharper spines more posteriorly placed than those of that species.

Some smaller specimens with more rounded lateral outlines and proportionally longer spines may be instars, but these have here been relegated to *Healdia* cf. *medusaensis* un-

til additional and better specimens can be acquired for examination.

Types.-- Holotype, UMMP 59126 (85/17-20); paratypes: UMMP 59127 (85/21-24), 59128 (85/25-28), 59129 (85/30), 59131 (85/31), 59491 (85/29), and 59522 (85/32).

HEALDIA cf. MEDUSAENSIS n. sp.

85/33-39

Immature specimens of *Healdia* may or may not belong in *H. medusaensis*, but they appear to resemble adults of that species more closely than any other.

Illustrated specimens.-- UMMP 59483 (85/35), 59484 (85/39), 59485 (85/33), 59486 (85/36-38), and 59487 (85/34).

HEALDIA spp.

84/5-12,16,17; 85/40-43,52-55; 86/1-6

Some specimens of *Healdia* are immature and/or deformed by pressure. UMMP 59124 (84/16,17) may be a juvenile of *H. arkonensis*. UMMP 59125 (85/52-55), 59123 (86/1-3), 59124 (86/4), and 59480 (86/5,6) appear to be appreciably higher than typical *H. medusaensis*. UMMP 59132 (84/5-8), 59488 (84/9-12), and 59130 (85/40-43) are probably young instars of one or another of the named species.

Subfamily Healdiopsidinae Gründel 1962

Genus MICROCHEILINELLA Geis 1933

Microcheilus Geis, 1932 (non Kittl, 1894).
Microcheilinella Geis, 1933.

Type species.-- *Microcheilus distortus* Geis, 1932, p.181, by designation of Geis, 1933, p.181.

Classified in the Treatise (1961, p. Q387) under Podocopida, Suborder and Family Uncertain. Placed in the family Healdiidae by Rozdhesventskaya (1962, p. 215; 1972, p. 70) and by Polenova (1968, p. 69; 1970, p. 34). We agree with our Russian colleagues.

MICROCHEILINELLA MARIETTENSIS n. sp.

101/18-48; 102/13,14; 104/21-24

Derivatio nominis.-- The name *mariettensis* is derived from the occurrence of particularly good specimens in the abandoned Martin-Marietta Quarry in southeastern Michigan.

Description.-- Carapace very small, sub-elliptical in lateral view. Valves equal or nearly so, with dorsum and venter somewhat flattened, ends rounded. Posterior end broadly convex, tapering to the flattened anterior end. Hinge slightly depressed posteriorly with dorsum curved gently above it. Surface smooth and lacking any sculpturing or ornamentation. Posterior end notably thicker than anterior.

Remarks.-- Specimens are few in the Silica Formation. Most are from unit 12; none of them are pyritized. The broad posterior end, depressed hinge, and broad venter are readily distinguished from contemporary ostracods. No single valves were found.

Microcheilinella mariettensis is similar to *M. larinova* Polenova (1955, p. 227, pl. 9, fig. 2), but is appreciably smaller than that species and has slightly different proportions.

Types.-- Holotype, UMMP 59533 (101/34-37); paratypes: UMMP 59047 (101/26-29), 59048 (101/22-25), 59049 (101/30-33), 59432 (101/18-21; 102/13, 14), 59534 (101/42-44), 59535 (101/45-48), and 59536 (101/38-41; 104/21-24).

Genus NANNOHEALDIA n. gen.

Type species.-- Here designated, *Nannohealdia arcuata*, n. sp.

Derivatio nominis.-- The name *Nannohealdia* is derived from the Greek *ναυνος*, m. ("a dwarf") and the generic name *Healdia*, referring to the diminutive size of a genus related to *Healdia*.

Description.-- Carapace very small, sub-elliptical, with strongly arched dorsum. Greatest height just posterior of median; greatest length about one-third height above ventral border; and greatest width posterior. Dorsal border sloping gently from apex to posterior end, there descending almost vertically to the flattened venter; anterior part of dorsal border sloping more steeply to the narrower, rounded

end. Height/length ratio approximately 3/4.

Left valve slightly larger than right, overlapping strongest along ventral part of free edge. Posterior end of venter extending into a small horizontal spine on each valve; the two spines of a carapace subparallel, separated by not more than two-thirds the width of the carapace. Surface smooth.

Remarks.-- The type species is the only member of the genus at present. It lacks the ridges and prominent spines of *Healdia*, the single small spines at each posteroventral end set well within the extension of maximum width. The arcuate dorsum distinguishes it from the immature *Quasillites*.

NANNOHEALDIA ARCUATA n. sp.

98/11-20; 100/21-38; 115/2

Derivatio nominis.-- The name *arcuata* is derived from the Latin *arcuatus* ("bent like a bow, curved"), referring to the arched dorsal border.

Description.-- As for the genus.

Remarks.-- This very small ostracod is rare in the Silica Formation and has not been noted in any of the other Middle Devonian beds of the Michigan Basin or western New York. Because of its small size, it could easily be overlooked in usual picking of washings.

Types.-- Holotype, UMMP 59044 (98/17-20); paratypes: UMMP 59043 (100/37, 38), 59045 (100/33-36), 59537 (100/23-26; 115/2), 59539 (98/13-16), 59540 (100/29-32), 59541 (98/11, 12; 100/27, 28), and 59542 (100/21, 22).

Genus PONDERODICTYA Coryell & Malkin

Ponderodictya Coryell & Malkin, 1936.

Hamiltonella Stewart, 1936, type *Leperditia punctulifera* Hall.

Type species.-- *Cytherella* ? *bispinulatus* Stewart, 1927, p.60, pl.5, figs.18,19, by designation of Coryell & Malkin, 1936, p.15, figs. 28,28a,29,30. In 1936 (issued shortly after the publication of Coryell & Malkin but in press at the same time), p.756,757, the original author, Stewart, considered the species *bispinulatus* to be a junior synonym of *Leperditia punctulifera* Hall, and proposed it as the type species of her

new genus *Hamiltonella*, which genus became a junior synonym of *Ponderodictya* Coryell & Malkin.

PONDERODICTYA PUNCTULIFERA (Hall)

52/1-4; 53/5-8; 65/43,44; 67/1-12; 68/13-17;
69/1-8; 70/1-10; 71/1-8; 114/2,3; 117/3

- Leperditia punctulifera* Hall, 1860, p.92.
Primitiopsis punctulifera Jones, 1890a, p.9,
pl.2, figs.7,12,13.
Primitiopsis punctulifera Grabau & Shimer, 1910,
p.345, figs.1660e-1660g.
Cytherella ? bispinulatus Stewart, 1927, p.60,
pl.5, figs.18,19 [Silica Shale. Cotypes,
OSU 16265].
Primitiopsis unicornis Van Pelt, 1933, p.326,
pl.39, figs.23-28 [Bell Shale].
Cytherellina punctulifera Warthin, 1934, p.222,
pl.1, figs.24,25 [Norway Point Formation].
Ponderodictya bispinulata Coryell & Malkin, 1936,
p.16, figs.28,28a,29,30 [Hungry Hollow For-
mation].
Ponderodictya unicornis Coryell & Malkin, 1936,
p.16, figs.31,31a [Hungry Hollow Formation].
Hamiltonella punctulifera Stewart, 1936, p.756,
757, pl.102, figs.1-5 [Silica Formation,
Hungry Hollow Formation].
Ponderodictya punctulifera Turner, 1939, p.23,
pl.1, fig.7 [Ontario oil wells].
Ponderodictya bispinulata Shimer & Shrock, 1944,
p.687, pl.288, figs.55-58.
Ponderodictya unicornis Stewart & Hendrix, 1945a,
p.94, pl.10, figs.30,31 [Plum Brook Shale].
Ponderodictya bispinulata Wright, 1948, p.120,
pl.15, figs.35-38.
Ponderodictya unicornis Wright, 1948, pl.15,
figs.39,40.
Cytherellina punctulifera Moore, Lalicker, &
Fischer, 1952, p.530, fig.14.
Ponderodictya punctulifera Kesling & Weiss, 1953,
p.66, pl.5, figs.21-29 [Norway Point Forma-
tion].
Ponderodictya bispinulata Smith, 1956, p.2,
chart [Ledyard SShale, Wanakah Shale].
Ponderodictya punctulifera Stover, 1956, p.1117,
pl.114, fig.20 [Windom Shale].
Ponderodictya unicornis Tillman, 1970, p.210,
fig.4, no.14 [Lower Olentangy Shale].

Remarks.-- This large punctate ostracod has been recognized under a variety of names since first described by James Hall in 1860. It is one of the most abundant ostracods in the Silica Formation as well as in almost all other Middle Devonian formations of the Great Lakes region. It shows great variation in size and ornamentation, whereas the outline remains

rather constant. Reticulation, numbers of punctae, size, and numbers and development of spines vary from one unit to another as well as within units. The Silica specimens have excellently preserved carapaces, and single valves display clearly the hinge and muscle-scars. Many specimens are pyritized differentially, with the muscle scars discernible on exteriors as well as interiors of valves.

Illustrated specimens.-- UMMP 59247 (65/43, 44; 114/3), 59250 (67/5-8; 117/3), 59252 (68/13, 14), 59253 (69/1, 2), 59254 (70/5-8), 59255 (69/3, 4; 114/2), 59256 (68/15-17), 59257 (71/5-8), 59258 (70/9, 10), 59259 (71/1-4), 59260 (67/1-4), 59261 (67/9-12), 59262 (69/5-8), 59263 (70/1-4), 61826 (53/5-8), and 61828 (52/1-4).

PONDERODICTYA OHIOENSIS (Stewart)

65/35-42; 66/1-12; 68/18-22

- Hamiltonella ohioensis* Stewart, 1936, p.757,
758, pl.101, figs.22,23 [Silica Formation.
Syntypes, OSU 18185].
Hamiltonella ohioensis var. *subcompressa* Stewart,
1936, p.758, pl.101, fig.24 [Silica Forma-
tion].
Ponderodictya ohioensis Stewart & Hendrix, 1945a,
p.93,94, pl.10, fig.29 [Plum Brook Shale].

Remarks.-- *Ponderodictya ohioensis* is smaller than *P. punctulifera* and appears to consistently lack the anterior ridges characteristic of that species.

Illustrated specimens.-- UMMP 59251 (68/18-22), 59647 (65/35-38), 59648 (66/1-4), 59649 (66/9-12), 59650 (66/5-8), and 59651 (65/39-42).

PONDERODICTYA RHODESI n. sp.

51/5-8; 53/1-4; 72/1-12; 73/1-12;
74/1-12; 114/1

Derivatio nominis.-- The name *rhodesi* is a patronymic honoring Frank H. T. Rhodes, our friend of long standing, successful paleontologist, and now President of Colgate University.

Description.-- Carapace large, robust, ovoid, distinctly inequivalved, the larger left valve overlapping the right on all sides except the posterior half of the dorsal border. Dorsal border curved in posterior half, slightly trun-

cate anteriorly; ends evenly rounded; ventral border straight or slightly concave in middle. Size and shape like those of Ponderodictya punctulifera but surface smooth, without any punctae.

Left valve evenly and gently convex, sloping alightly anteriorly, with greatest height and width just behind center. Margins thickened to overlap the smooth, flattened edges of right valve. Hinge straight along truncated anterior half of dorsal border, with a strong groove to receive the edge of the right valve; slight short groove at posterior corner.

Surface of valves smooth, usually provided with one to three strong spines, of which two located at posterior end; spines vary from scarcely discernible to robust, sharply pointed spines. A few specimens apparently lacking spines, perhaps having them effaced by abrasion. In the absence of reticulation, the round centrally situated area outside the muscle-scar area not easily discerned except (rarely) by differences in coloration. Prominent lip on ventral margin of overlapping valve.

Right valve slightly smaller than left, more elongate with straighter sides, flattened along margins to fit into left valve. Right valve also more convex than left, with sides rising more abruptly. Ornamentation extremely variable, consisting of rounded node on central part of anterior shoulder and two sharp robust spines pointing backward (sometimes also directed somewhat outward) equally spaced on posterior shoulder. Posterior spines often broken, showing them to be solid where attached to the carapace. In general, spines larger and more pointed than those of P. punctulifera.

Remarks.-- The preservation of carapaces and valves is excellent, as is that of the associated P. punctulifera, in the Styliolina beds (MM-Chon). The difference between the smooth, almost luminous carapace with robust spines and a central blunt node on the anterior of the right valve in Ponderodictya rhodesi with the punctate carapace and lesser spines in P. punctulifera is striking.

Occurrence.-- This handsome species is abundant in the Styliolina beds at Martin-Marietta Quarry, but is rare or absent at the other

two localities of Silica Formation. A few specimens were found in the Genshaw and Gravel Point formations of northern Michigan.

Types.-- Holotype, UMMP 59266 (72/1-4); paratypes: UMMP 59248 (72/5-8), 59249 (73/1-4), 59265 (72/9-12), 59267 (73/7, 8), 59268 (74/9, 10), 59269 (74/11, 12), 59270 (73/9, 10; 114/1), 59271 (73/11, 12), 59273 (73/5, 6), 59274 (74/5-8), 59275 (74/1-4), 61824 (53/1-4), and 61836 (51/5-8).

Family Bairdiocyprididae Shaver 1961

Left/right overlap. No posterior sculpturing.

Genus BAIRDIOCYPRIS Kegel 1932

Type species.-- By original designation, *Bythocypris (Bairdiocypris) gerolsteinensis* Kegel, 1932, p.249, pl.13, figs.5a-5d.

BAIRDIOCYPRIS GONGYLUS n. sp.

91/13-30; 92/21-24

Derivatio nominis.-- The name *gongylus* is derived from the Greek γογγυλος ("round") referring to the shape of the carapace.

Description.-- Carapace small, subovate to subtriangular in lateral outline. Left valve larger than right with conspicuous overlap along the dorsal border ending in a straight edge across the right valve; slight overlap along ventral border. Sides curved or slightly truncate, ventral border straight. Surface smooth with no protuberances.

Remarks.-- *Bairdiocypris gongylus* is much smaller than *B. transptyxis*, with a more uniform dorsal overlap and less overlap on the sides and venter; it is also less tumid and not as subject to crushing or distortion. The most distinguishing feature is the smooth, straight edge of the left valve overlapping the right.

Occurrence.-- This species is rare in the Silica Formation, but has been found in other strata of northern Michigan, Ontario, and New York.

Types.-- Holotype, UMMP 59623 (91/13-16); paratypes: UMMP 59621 (91/21-24), 59624 (91/25, 26), 59622 (92/21-24), 59625 (91/17-20),

KEY TO SPECIES OF BAIRDIOCYPRIDIDAE

1. Lateral surface with shallow but distinct irregular rugosity, more or less aligned horizontally
..... *Rugocytherellina ehlersi*
Lateral surface smooth 2
2. Overlap of left valve incomplete, interrupted posteroventrally and anteroventrally by thin projecting flanges of right valve; anteroventral flange narrowly rounded, confluent with rest of anterior border and directed downward and slightly forward, extending only a little beyond left valve; posteroventral flange more acuminate, extending posteriorly definitely beyond the left valve *Praepilatina silicensis*
Overlap of left valve complete, at least around free border; right valve without posteroventral or anteroventral flanges 3
3. Short straight dorsal border on the right valve; overlap by left valve very strong dorsally. *Bairdiocypris* .. 4
Dorsal border of right valve evenly curved, without any conspicuous straight section; overlap by left valve no stronger dorsally than elsewhere, commonly very weak there *Cytherellina* .. 5
4. Posterior border sloping, less convex than posteroventral corner and forming a weak angulation with the ventral border; length over 1.3 mm in adults *Bairdiocypris transptyxis*
Posterior border rounded nearly evenly, no angulation with ventral border; length not over 1.1 mm ...
..... *Bairdiocypris gongylus*

5. Adults over 1.2 mm long
..... *Cytherellina kutasii*
Adults less than 1.2 mm long 6
6. Valves very elongate, tapering from rounded posterior end to narrowly rounded anterior end, the long dorsal border gently and evenly convex *Cytherellina tanymeka*
Valves either not elongate (length less than twice the height) OR posteriorly or posterodorsally truncate (posterior end not evenly rounded) 7
7. Posterior end rather rounded, not truncate; dorsal border bent downward slightly a little in front of midlength; ventral border of right valve distinctly concave
..... *Cytherellina lucasensis*
Posterior end distinctly truncate, not evenly rounded; dorsal border evenly and gently convex, not deflected near midlength; ventral border of right valve straight or only slightly concave 8
8. Posterior border set at about 120° to the dorsal border; length twice the height; height decreasing distinctly to round anterior end *Cytherellina lechria*
Posterior border set less than 120° to dorsal border; length less than twice the height; height decreasing very little to anterior end; anterior end tending to be somewhat blunt and not rounded fully and evenly ... *Cytherellina subquadrata*

Types.— Holotype, UMMP 59060 (77/1-4; 116/5); paratypes: UMMP 59059 (78/1, 2), 59061 (77/5-8), 59386 (74/13, 14), 59387 (74/15-18), 59544 (75/23-26), and 59545 (75/19-22; 116/6).

Genus CYTHERELLINA Jones & Holl 1869

Cytherellina Jones & Holl, 1869.
Bythocypris Bassler & Kellett, 1934, p.224-235
(*non Bythocypris* Brady, 1880).
Orthocypris Kummerow, 1953.

Type species.— *Beyrichia siliqua* Jones, 1885, p.90, pl.5, fig.22, by designation of Jones & Holl, 1869, p.216, pl.14, figs.1-6.

Remarks.— Shaver in Moore (1961, p. Q365) stated that "possibly *Bythocypris* does not exist in the Paleozoic strata." Here we have reassigned *Bythocypris indianensis*, *B. lucasensis*, and *B. subquadrata* of Stewart (1936) to *Cytherellina*, since the specimens show no duplicature or vestibule characteristic of *Bythocypris*. *Cytherellina* is abundant

in the Silica strata.

CYTHERELLINA KUTASII n. sp.

94/21-25; 95/1-16

Derivatio nominis.-- The name *kutasii* is a patronymic honoring Karoly Kutasi, retired famous photographer of our Museum of Paleontology.

Description.-- Carapace medium to large, flattened, semiovoid in outline. Greatest length below middle; greatest height in posterior half of valve. Valves moderately convex, with the larger left valve overlapping the right on all sides; greatest overlap in centroventral area. Dorsal border gently arched, posterior end broadly rounded, ventral border straight to slightly concave with medial sinuosity; anterior end less broadly rounded than posterior. Surface of valves smooth.

Remarks.-- *Cytherellina kutasii* is the *Bythocypris indianensis* of Stewart (1930, p. 58; 1936, p. 755). The Silica species is not reniform and shows no evidence of duplicature or vestibule. *C. kutasii* is the largest of the five species of *Cytherellina* in the Silica Formation and the most elliptical.

Types.-- Holotype, UMMP 58883 (94/21, 22; 95/16); paratypes: UMMP 58884 (95/15), 59559 (95/9, 10), 59560 (95/11, 12), 59561 (95/5, 6), 59562 (95/1, 2), 59563 (94/25; 95/3, 4), 59564 (94/23, 24), 59565 (95/7, 8), and 59692 (95/13, 14).

CYTHERELLINA LECHRIA n. sp.

94/1-13; 95/17-27; 96/1-6

Derivatio nominis.-- The name *lechia* is derived from the Greek *λεχρῖος* ("slanting or oblique"), referring to the beveled outline.

Description.-- Carapace medium-sized, elongate, with a subrhomboidal outline in lateral view. Dorsal border straight, sloping gently from posterior to anterior end. Posterior end truncate from dorsal border three-fourths the distance to the ventral border. Ventral border straight or very slightly concave in lateral view; as seen ventrally, juncture of valves with distinct sinuosity due to overlapping lip.

Anterior border evenly rounded. Greatest length one-third height above ventral border; greatest height one-fourth the length from the posterior end. Valves smooth.

Remarks.-- This thin-shelled species is usually somewhat crushed or distorted. The distinct truncation of the posterior end is the most distinguishing feature. It is not as large as *C. kutasii*, proportionally longer and slender than *C. lucasensis*, smaller and flatter than *C. tanymeka*, and lacks the straight posterior border of *C. subquadrata*.

Occurrence.-- This species is rare in the Silica Formation. A few specimens were found in sediments from Ontario and New York localities.

Types.-- Holotype, UMMP 59566 (94/10-13); paratypes: UMMP 59062 (94/8,9; 95/17-20), 59063 (96/4-6), 59064 (95/24-27), 59567 (94/6, 7), 59568 (95/21-23), 59569 (96/1-3), and 59570 (94/1-4).

CYTHERELLINA LUCASENSIS (Stewart)

94/14-20; 95/28-37; 97/8-15

- Bythocypris lucasensis* Stewart, 1936, p.755, pl.101, fig.17 [Silica Formation. Holotype, OSU 18191].
Bythocypris lucasensis Stewart & Hendrix, 1945b, p.111, pl.12, figs.15,16 [Olentangy Shale].
Bythocypris lucasensis Stover, 1956, p.1119, pl.115, figs.13,14 [Windom Shale].
Bythocypris cf. *lucasensis* Smith, 1956, p.2, chart [Wanakah Shale, Ledyard Shale].

Remarks.-- *Cytherellina lucasensis* is the smallest and most abundant of the cytherellinids in the Silica Formation. It differs in its reniform lateral outline, its greatest height almost medial, and the strong overlap of the left valve along the ventral border. Well-preserved single valves show no trace of a vestibule, justifying its removal from *Bythocypris* to *Cytherellina*.

Illustrated specimens.-- UMMP 58885 (95/28-31), 58886 (95/36, 37), 58887 (97/12, 13), 58888 (95/32-35; 97/8-11), 58889 (94/14-17; 97/14), and 58890 (94/18-20; 97/15).

CYTHERELLINA SUBQUADRATA (Stewart)

94/26-36; 96/7-16

Bythocypris subquadrata Stewart, 1936, p.755, 756, pl.101, figs.18,19 [Silica Formation. Syntypes, OSU 18192].

Bythocypris subquadrata Kesling & Weiss, 1953, p.56, pl.5, figs.1-3 [Norway Point Formation].

Bythocypris subquadrata Stover, 1956, p.1119, 1120, pl.115, fig.12 [Windom Shale].

Bythocypris subquadrata Smith, 1956, p.2, table 1 [Wanakah Formation].

Remarks.-- Carapace medium, subrectangular in lateral view, and the straight posterior border serve to distinguish this species from the other *Cytherellina* species in the Silica. It is rare in the formation.

Illustrated specimens.-- UMMP 58891 (94/33-36), 58892 (94/28-30), 58893 (96/10-12), 58894 (96/13-16), 59571 (94/31, 32), 59572 (94/26, 27), and 59573 (96/7-9).

CYTHERELLINA TANYMEKA n. sp.

96/17-23, 32-35; 97/1-7

Derivatio nominis.-- The name *tanymeke* is derived from the Greek *τανυω* ("to stretch or to elongate") and *μηκος*, n. ("length"), referring to the elongation of the carapace.

Description.-- Carapace subelliptical, notably elongate, medium to large with a height/length ratio of 2/3 or less. Left valve larger and more convex than right valve, with greatest overlap along middle of ventral border. Anterior end much more narrowly rounded than the posterior, almost acuminate in some specimens. Great thickness producing a cylindrical midsection as seen in end view. Junction of valves sinuous at mid-venter as viewed ventrally due to gentle lip in left valve. Otherwise, overlap slight. Valves smooth.

Remarks.-- *Cytherellina tanymeke* is common in the Silica Formation, wherein it varies considerably in size. Its cylindrical tapered shape distinguishes it from the higher and flatter *C. kutasii*, the smaller and more reniform *C. lucasensis*, the slender truncated *C. lechria* and the subrectangular and shorter *C. subquadrata*. The genus has a good representation in

several units of the formation.

Types.-- Holotype, UMMP 59580 (96/32-35); paratypes: UMMP 59574 (96/19-22), 59575 (97/1-3), 59577 (96/23), 59579 (97/4-7), and 59618 (96/17, 18).

CYTHERELLINA sp.

55/5-8; 96/24-31

One specimen, UMMP 61833 (55/5-8), is badly pyritized, making specific identification dubious. Two others, UMMP 59576 (96/28-31) and 59578 (96/24-27), have been deformed by compression, but may belong to *C. kutasii*.

Genus RUGOCYTHERELLINA n. gen.

Type species.-- Here designated, *Rugocytherellina ehlersi*, n. sp.

Derivatio nominis.-- The name *Rugocytherellina* is derived from the Latin *rugosus* ("to crease, wrinkle") and the generic name *Cytherellina*, referring to the unusual ornamentation of an ostracod related to *Cytherellina*.

Description.-- Medium to small cytherellinid, elongate-elliptical in lateral outline. Dorsal border gently convex, ends rounded with the posterior end higher and more broadly curved. Ventral border straight. In ventral view, left valve with median slight sinuosity due to overlapping lip.

Surface of valves rugose or roughly wrinkled from hinge to venter; pattern variable in each specimen, with a general horizontal trend to the rugae and intervening irregular furrows.

Remarks.-- The genus is similar to *Cytherellina* in general outline but is distinguished by its rugose surface, which is definitely foreign to that genus.

RUGOCYTHERELLINA EHLERSI n. sp.

80/14-38

Derivatio nominis.-- The name *ehlersi* is a patronymic honoring the late George Marion Ehlers, the noted paleontologist and stratigrapher at our Museum of Paleontology.

Description.-- As for the genus, in which

it is the only species at present.

Remarks.-- Resembling Cytherellina lucasi most nearly in size and outline, Rugocytherellina ehlersi differs in the consistently rugose or wrinkled surface and the slightly higher anterior end. Careful scrutiny is necessary to distinguish these rare ostracods because the sculpturing is not conspicuous in uncoated specimens, being somewhat obscured by the sheen of the surface. In our opinion, the rugosity is original structure, not the result of abrasion or corrosion; it is consistent in all individuals assigned to the species.

Types.-- Holotype, complete carapace, UMMP 59696 (80/14-18); paratypes: UMMP 59355 (80/19-22), 59592 (80/35-38), 59593 (80/23-26), 59594 (80/27-30), and 59675 (80/14-18).

Family Cavellinidae Egorov 1950

R/L overlap typical, may be reversed. Overreach around all of overlapped valve.

Genus BIRDSALLELLA Coryell & Booth

Type species.-- By original designation, Birdsallella simplex Coryell & Booth, 1933, p. 271, pl.5, fig.6.

BIRDSALLELLA DEVONICA Coryell & Malkin

92/25-40

Birdsallella devonica Coryell & Malkin, 1936, p.17, fig.33 [Hungry Hollow Formation. Holotype, AMNH 24639].

Birdsallella devonica Smith, 1956, p.2, table 1 [Wanakah Shale, Ledyard Shale].

Birdsallella devonica Stover, 1956, p.1113, pl. 114, figs.4-6 [Windom Shale].

Remarks.-- The few carapaces and single valves found in the Silica Formation were all shorter and higher posteriorly than those of Birdsallella tumida, with a well-defined posterior crescentic ridge.

Illustrated specimens.-- UMMP 58859 (92/25, 26), 58863 (92/27-30), 58864 (92/35, 36), 58865 (92/37, 38), 58866 (92/39, 40), and 58867 (92/31-34).

BIRDSALLELLA TUMIDA Stewart

92/1-20; 93/21-43; 104/7,8

Birdsallella tumida Stewart, 1936, p.763, pl. 102, figs.27,28 [Silica Formation. Syntypes, OSU 18206].

Birdsallella tumida Kesling & Weiss, 1953, p. 65, pl.5, figs.5,6 [Norway Point Formation].

Remarks.-- Birdsallella tumida is very common and well preserved at all Silica localities. With abundant specimens for study, we detected definite dimorphism in the posterior region of carapaces. In some rather flat-sided specimens, presumably males, the main lateral area terminates at a lunate ridge where the valve abruptly descends in a concavity to the posterior and posterodorsal border. In other specimens, much greater posterior tumidity tends to obscure the lunate ridge and the descent to the posterior border is more nearly rounded off than declivitous. Some carapaces, unfortunately, are not clearly of one type or the other, and the sex of their former occupants is uncertain. Females are much more abundant than males.

Illustrated specimens.-- UMMP 58860 (92/1-4), 58861 (93/31-33), 58862 (93/40-43), 59439 (92/5-7), 59440 (92/17-20), 59441 (93/34-36), 59442 (92/8-10), 59443 (93/37-39), 59444 (92/14-16), 59445 (92/11-13), 59446 (93/25-28), 59677 (93/29, 30), 59690 (93/21-24), and 60057 (104/7, 8).

Genus MENOEIDINA Stewart 1936

Type species.-- By original designation, Menoeidina subreniformis Stewart, 1936, p.762, 763, pl.101, figs.22-24.

MENOEIDINA SUBRENIFORMIS Stewart

64/3-24; 65/1-8; 69/9-13; 113/1,2

Menoeidina subreniformis Stewart, 1936, p.762, 763, pl.101, figs.22-24 [Silica Formation. Syntypes, OSU 18204].

Menoeidina subreniformis Coley, 1954, p.455.

Menoeidina subreniformis Benson in Moore, 1961, p.Q370, pl.290, figs.2a,2b.

Remarks.-- This abundant species in the Silica Formation is the largest of the Menoeidina. The valves vary in length, but otherwise have identical characteristics. Stewart called

found in Middle Devonian formations of northern Michigan, Ontario, and western New York.

Illustrated specimens.-- UMMP 59182 (68/7, 8; 70/11, 12), 59183 (68/9-12), 59184 (69/18-21; 112/5), 59185 (70/13-15), 59186 (69/22-25), 59527 (69/14-17), and 60085 (107/15, 16).

MENOEIDINA PAUCIPUNCTATA n. sp.

65/9-34; 68/1-6; 112/6

Derivatio nominis.-- The name *paucipunctata* is derived from the Latin *paucus* ("few, little") and *punctum*, n. ("puncture, small indentation, little spot"), referring to the paucity of punctae in the posterior area of each valve.

Description.-- Carapace very small, subreniform in lateral view. Larger left valve overlapping right slightly on all borders, with overreach apparent in lateral view. Dorsal border gently arcuate, sloping from median to the broadly rounded posterior end and narrowly rounded anterior end. Ventral border straight. Greatest length and height median; greatest width posterior.

Very low ridge parallel to posterior border of each valve, with a few coarse punctae just in front of it; rest of surface smooth.

Remarks.-- *Menoeidina subreniformis*, very common in the formation, is much larger and more rectangular, with more pronounced dorsal ridges. It lacks the punctae or other surface markings. *Menoeidina arcuata* has a more triangular, elongate outline with sharper posterior ridges ending in a small ventral spine and more numerous punctae. *Menoeidina scopeli* Stover, from the Windom Shale of New York, is also more triangular, with a regular row of pits just inside the ridges and a similar row inside a faint anterior ridge. *Menoeidina multicostata* Stover, from the same formation, approximates *Menoeidina paucipunctata* in size and outline, but has 16 to 25 pits posteriorly and some irregularly placed anterior pits. *M. versicula* Stover has a row of 4 to 6 small, horizontally elongate grooves on the inner side of the posterior ridge and 3 to 4 in the ventral area.

Occurrence.-- Rare in the Silica Formation and unknown elsewhere.

Types.-- Holotype, UMMP 59531 (65/9-12); paratypes: UMMP 59187 (68/1-4), 59188 (65/13, 14), 59189 (65/15-18; 112/6), 59190 (68/5, 6), 59528 (65/27-30), 59529 (65/23-26), 59530 (65/19-22), and 59532 (65/32-34).

Superfamily Quasillitacea Coryell & Malkin

Dorsal border gently arched. Hinge relatively long. No posterior compressed zone.

Family Quasillitidae Coryell & Malkin 1936

Lateral outline subquadrangular to subovate. Posterior end not pointed. Lateral surface with ridges, grooves, or coarse irregular reticulation.

Genus QUASILLITES Coryell & Malkin 1936

Quasillites Coryell & Malkin, 1936.

Bullella Coryell & Booth, 1933, p.268, type

B. pecanata [Penn. Wayland Shale].

Spinovina Coryell & Malkin, 1936.

Lucasella Stewart, 1936.

Allostracites Přibyl, 1953 [*pro Paracythere*

Ulrich & Bassler, 1932, p.236, type *P. cornuta* (*non Paracythere* Müller, 1894)].

Type species.-- By original designation, *Quasillites obliquus* Coryell & Malkin, 1936, p.18, figs.36,36a.

Remarks.-- This is the most abundant and widely distributed genus in the Middle Devonian strata of the Great Lakes region. The size and ornamentation varies greatly from locality to locality, some species showing heavy ridges and prominent lines in one bed, but almost smooth surfaces in another. Because of the variation in surface ornament and markings, size of spines, and other features, we have reduced the number of species and subspecies listed by Peterson, placing many of them in synonymy with the commoner species.

QUASILLITES CONCENTRICUS (Turner)

48/13-24; 49/5-8; 50/23-30; 57/27-34;

60/26-28; 115/6

Jenningsina concentrica Turner, 1939, p.28,29, pl.1, fig.16 [D'Clute oil field, SW Ontario, Holotype, GSC 9405].

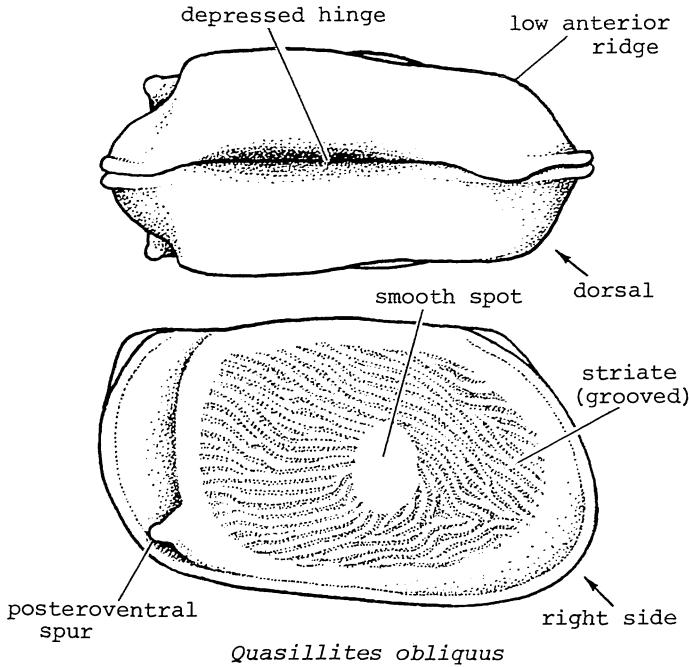

- Quasillites jubatus* Kesling & Weiss, 1953, p.61, pl.4, figs.17-21 [Norway Point Formation].
- Quasillites binodosus* Swartz & Oriel, 1948, p.559,560, pl.79, figs.18-21 [Windom Shale].
- Quasillites concentricus* Peterson, 1964, p.858, pl.134, figs.9-11,36 [Silica Formation, Arkona Shale, Ipperwash Limestone, Gravel Point Formation].
- Quasillites binodosus* Peterson, 1964, p.857,858, pl.134, figs.33-35 [Ipperwash Limestone, Wanakah Shale].
- Quasillites jubatus* Peterson, 1964, p.858,859, pl.135, fig.20, pl.136, figs.3,4 [Widder Formation, Kashong Shale, Wanakah Shale].

Remarks.-- In the more than fifty specimens studied from the units of the Silica as well as those from other formations, we note that this beautiful small ostracod exhibits considerable variation in shape, marginal extensions, spines, and ornamentation. The anterior platform ranges from large and denticulate to almost nothing at all. The posterior platform, though smaller, has the same variation. Posteroventral projections range from well developed, sharply pointed spines to blunt nodes, nubbins, or nothing at all. Posterodorsal nodes are always blunt when present. The fine concentric ridges and whorls also vary. Because these variations form a broad series, we have included *Quasillites jubatus* and *Q. bi-*

KEY TO SPECIES OF QUASILLITIDAE

1. No central pit, only a central to anteroventral spot with subdued ornamentation or smooth *Quasillites* .. 2
Central pit 5
2. Small (adults less than 0.8 mm long); ornamentation reticulate, equispaced discrete ridges nearly concentric and joined by short elements; anteroventral denticles conspicuous on wide platform-like structure *Quasillites concentricus*
Medium to large (adults over 0.8 mm long); ornamentation dominated by ridges not arranged concentrically; anteroventral denticles (if any) inconspicuous 3
3. Medium size (adults about 0.85 mm long); wide and cylindrical; no conspicuous central spot *Quasillites fordei*
Large (adults over 1.0 mm long); subquadrate, sides not round; conspicuous, slightly protuberant, unornamented central spot, may be large 4
4. Anterior ridge wide and bulbous; posteroventral spur massive, its base flaring; posterodorsal corner forming bulge or rounded spur confluent with main lateral surface and protuberant posteriorly *Quasillites sublunatus*
Anterior ridge low, most prominent anterodorsally; posteroventral spur small, conical; posterodorsal corner without protuberance *Quasillites obliquus*
5. Small subcircular central pit; ornamented area of valve bearing fine ridges (intervening grooves may be pitted) subparallel to anterior and ventral borders; ridges tend to diverge posteriorly from central pit *Jenningsina catenulata*
Vertically elongate central pit (S_2), a horizontally elongate pit between central pit and dorsal border; ornamentation consisting of coarse reticulation *Glyphella reticulata*

nodosus as junior synonyms.

Illustrated specimens.— UMMP 59294 (48/15-18; 115/6), 59295 (48/23, 24), 59296 (48/13, 14; 60/27), 59297 (48/19-22; 60/26), 59298 (57/27-30), 59299 (50/23-26; 60/28), 59300 (57/31-34), 59301 (50/27-30), 59555 (49/7, 8), and 59556 (49/5, 6).

QUASILLITES FORDEI Coryell & Malkin

57/1-26

- Quasillites fordei* Coryell & Malkin, 1936, p.18, 19, fig.38 [Hungry Hollow Formation. Holotype, AMNH 24642].
Burllella brevispinata Stewart, 1936, p.759,760, pl.102, figs.11,12 [Silica Formation].
Lucasella mundula Stewart, 1936, p.761, pl.102, figs.18,19 [Silica Formation].
Quasillites fordei var. *minus* Turner, 1939, p.27,28, pl.1, fig.13 [Oil wells, Ontario].
Quasillites reticulata Turner, 1939, p.26,27, pl.1, fig.10 [Oil wells, Ontario].
Quasillites ? *brevispinata* Stewart & Hendrix, 1945a, p.94, pl. 10, figs.35-37 [Plum Brook Shale].
Quasillites fordei Wright, 1948, p.125, pl.16, fig.18.
Quasillites ornatus Swartz & Oriol, 1948, p.558, 559, pl.80, figs.11-17 [Windom Shale].
Quasillites ornatus Kesling & Weiss, 1953, p.60, pl.4, figs.22-24,31 [Norway Point Formation].
Lucasella mundula Coley, 1954, p.455 [Centerfield Limestone].
Quasillites fordei Smith, 1956, table 1 [Ledyard Shale].
Quasillites fordei fordei Peterson, 1964, p.852-854, pl.134, figs.6-8,19,38,39; pl.135, fig.19 [All formations of Traverse Group. Ledyard Shale, Windom Shale, Arkona Shale, Hungry Hollow Formation, Widder Formation, Ipperwash Limestone, Silica Formation, Plum Brook Shale of Ohio].
Quasillites fordei brevispinatus Peterson, 1964, p.854,855, pl. 135, figs.16-18 [Silica Formation].

- Quasillites fordei mundulus* Peterson, 1964, p. 855, pl.135, fig.7.
Quasillites puteculatus Peterson, 1964, p.855, 856, pl.135, figs.5-7,23,24,29; pl.136, fig. 5, [Windom Shale, Kashong Shale].
Quasillites fordei fordei Tillman, 1970, p.210, fig.4, no.17 [Lower Olentangy Shale].

Remarks.— This variable species is perhaps the most abundant in the Silica Formation as well as in certain other Middle Devonian beds; it occurs in all Silica units from which ostracods were extracted and in numerous formations at other localities. Usually longer and more slender than the other three common species of *Quasillites*, it is almost cylindrical in end view. Immature instars were also found associated with adults.

The posteroventral spines or nodes range from a trace to long posterior-pointing spines; they are more ventrally situated than those of *Quasillites obliquus* or *Q. sublunatus*.

Specimens from the Silica are usually smooth and cylindrical carapaces, sometimes compressed slightly, and either black (pyritized) or beige (calcareous only). Good single valves show hinging.

Illustrated specimens.— UMMP 59302 (57/1-4), 59303 (57/5, 6), 59304 (57/21-24), 59305 (57/15, 16), 59306 (57/25, 26), 59307 (57/7-10), 59308 (57/11-14), and 59309 (57/17-20).

QUASILLITES OBLIQUUS Coryell & Malkin

58/6-21

- Quasillites obliquus* Coryell & Malkin, 1936, p. 18, figs.36,36a [Hungry Hollow Formation. Holotype, AMNH 24641].

Family QUASILLITIDAE	Medusa quarries													Martin-Marietta Quarry			Waterworks Park		
	Unit													1-6			9-11		
	6	7	9	11	12	13	14	15	16	17	18	21	23	1-6	7	9-11	1-6	9-11	12
<i>Glyphella reticulata</i>																			
<i>Jenningsina catenulata</i>		x		x		x								x	x				
<i>Quasillites concentricus</i>			x	x	x		x	x			x					x	x	x	
<i>Quasillites fordei</i>	x	x	x	x	x	x	x	x	x	x	x	x	x	x	x	x	x	x	x
<i>Quasillites obliquus</i>	x	x	x	x			x					x		x	x	x	x	x	x
<i>Quasillites sublunatus</i>	x	x	x	x			x	x			x	x		x	x	x	x	x	x

- Burlella* ? *bisulcata* Stewart, 1936, p.760, pl. 102, figs.14,15 [Silica Formation].
- Burlella sublunata* Stewart (part), 1936, p.759, pl.102, figs.1-10 only [Silica Formation].
- Spinovina distributa* Coryell & Malkin, 1936, p. 17, fig.37 [Hungry Hollow Formation].
- Quasillites obliquus* Turner, 1939, p.25,26, pl. 1, figs.15-18 [Oil wells, Ontario].
- Quasillites obliquus* Stewart & Hendrix, 1945a, p.94, pl.10, figs.32-34 [Plum Brook Shale].
- Quasillites obliquus* Wright, 1948, p.125, pl.16, figs.16,17.
- Spinovina distributa* Wright, 1948, p.123, pl.17, fig.7 (non fig.6).
- Quasillites lobatus* Swartz & Oriol, 1948, p.556, 557, pl.80, figs.1-8 [Windom Shale].
- ? *Quasillites* cf. *lobatus* Swartz & Oriol, 1948, p.557, pl.80, fig.18 [Windom Shale].
- Quasillites obliquus* Kesling & Weiss, 1953, p. 61, pl.4, figs.50,51 [Norway Point Formation].
- Quasillites lobatus* Kesling & Weiss, 1953, p.61, pl.4, fig.28 [Norway Point Formation].
- Burlella cuppsi* Coley, 1954, p.460, pl.53, fig. 13 [Wanakah Shale].
- Burlella obliquus* Coley, 1954, p.459,460, pl.53, fig.12 [Wanakah Shale].
- Quasillites subobliquus* Stover, 1956, p.1125, 1126, pl.117, figs.1-12 [Windom Shale].
- Quasillites lobatus* Smith, 1956, table 1 [Wanakah Shale, Ledyard Shale].
- Quasillites obliquus* Kesling, Kavary, Takagi, Tillman, & Wulf, 1959, p.22, pl.2, figs.1-24; pl.4, figs.28-34 [Centerfield Limestone].
- Quasillites obliquus* Sohn & Stover, 1961, p.Q374, fig.297, la-1d.
- Quasillites obliquus obliquus* Peterson, 1964, p. 846-848, pl.133, figs.1-10; pl.134, figs.1-3, 12,31; pl.135, fig.15.
- Quasillites distributus* Peterson, 1964, p.848, 849, pl.133, figs.17-20; pl.134, fig.32.

Remarks.-- The much-described *Quasillites obliquus* is characterized by a prominent finger-print ridge pattern in most Middle Devonian beds which is subdued or missing entirely in the Silica specimens. The greater height/length ratio and the truncated anterodorsal border distinguish it from *Quasillites fordei*. It lacks the nodes and swellings, the crescentic posterior depression, and the robust, outward-pointing spines of *Quasillites sublunatus*. It is not common in the Silica Formation.

Illustrated specimens.-- UMMP 59327 (58/18,19), 59328 (58/14-17), 59329 (58/20,21), 59557 (58/6-9), and 59558 (58/10-13).

QUASILLITES SUBLUNATUS (Stewart)

48/25-36; 49/11-32; 50/1-22; 58/1-4; 113/3

- Burlella sublunata* Stewart (part), 1936, p.759, pl.102, figs.6-8 (non figs.9,10) [Silica Formation. Syntypes, OSU 18198].
- Burlella rhomboidalis* Stewart, 1936, p.760,761, pl.102, figs.16,17 [Silica Formation].
- Burlella sublunata* Coley, 1954, p.455, fig.14 [Silica Formation].
- Quasillites sublunatus* Peterson, 1964, p.851, pl. 134, figs.1-4; pl.135, figs.24,25 [Bell Shale Arkona Shale, Silica Formation].
- Quasillites obliquus rhomboidalis* Peterson, 1964, p.849, pl.133, fig.21 [Silica Formation].

Remarks.-- One of the most abundant species in the formation, especially in units 9-11, the *Styliolina* beds. Robust, beautifully preserved, it is variable in size, shape, and ornamentation. About the same height as *Q. obliquus*, it is longer, wider, and has many swellings or bulges and humps on the anterior and posterior ends of the valves. The ridge pattern, when present, is very faint. Many excellent single valves were found showing the hinge structure. Massive posteroventral spines project backward and outward from each valve.

Illustrated specimens.-- UMMP 59312 (58/1-4), 59313 (50/19,20), 59314 (50/15-18), 59315 (48/29-32; 113/3), 59316 (50/21,22), 59317 (50/5,6), 59318 (50/7,8), 59319 (49/23-26), 59320 (48/33-36), 59321 (49/19-22), 59322 (50/9,10), 59323 (49/27,28), 59324 (49/29-32), 59325 (49/11-14), 59326 (49/15-18), 59330 (50/1-4), 59331 (48/25-28), and 59332 (50/11-14).

QUASILLITES spp.

48/37-40; 49/9,10; 54/1-4; 55/1-4; 58/5

UMMP 59355 (48/37-40) is smaller than presumed adults of the named species; it may be a juvenile of one of them, or it may be an adult of a rare and unnamed species. UMMP 59334 (49/9,10) is also probably an immature specimen. UMMP 59333 (58/5) is exceptionally elongate, but may be a young *Q. sublunatus*. Two pyritized adults (?) contain so much pyrite, that insidious mineral, that we do not commit ourselves to an identification; they are UMMP 61837 (54/1-4) and 61832 (55/1-4).

Genus GLYPHELLA n. gen.

Type species.-- Here designated, *Glyphella reticulata*, n. sp.

Derivatio nominis.-- The name *Glyphella* is derived from the Greek $\gamma\lambda\upsilon\phi\eta$, f. ("carving, carved work") and the Latin diminutive suffix *-ellus* ("small, little"), referring to the surface ornamentation of the species.

Description.-- Carapace medium-sized, subelliptical, inequivalved. Larger left valve wrapping around right valve on all margins. Dorsal border gently curved, ends rounded, ventral border flattened.

Surface coarsely reticulate with an elongate, rimmed, vertical pit centrally situated; another elongate horizontal pit between the vertical pit and the dorsal border. Short spines projecting from the anterior shoulder of each valve, as well as the posterodorsal and ventral corners.

Remarks.-- This unusual ostracod differs from any other found in the Middle Devonian beds of the Great Lakes region, occurring only in one bed of shale from the Waterworks Park locality.

GLYPHELLA RETICULATA n. sp.

40/30-46; 41/35-42; 115/4

Derivatio nominis.-- The name *reticulata* is derived from the Latin *reticulatus* ("like a net, reticulate"), referring to the ornamentation of the species.

Description.-- Carapace medium-sized, subelliptical, inequivalved, with left valve overlapping smaller right valve on all margins. Dorsal border gently curved, anterior border subround, ventral border flattened, and posterior border rounded. Greatest length at mid-height, greatest height just anterior to pits, and greatest width in posterior half.

Surface of each valve coarsely reticulate, with a vertically elongate, rimmed pit from middle of valve extending dorsally toward the hinge line. Another elongate pit stretched horizontally above it, a little below the dorsal border. Short spines projecting from the anterodorsal shoulder of each valve and from the pos-

terodorsal and posteroventral corners. Short small spines or denticles along the posterior margin. Dorsal and ventral margins smooth.

Occurrence.-- Found only in the *Tropido-leptus* beds at the Waterworks Park locality, where fifteen specimens of complete carapaces and right valves were found. It is the only species of the genus known.

Types.-- Holotype, UMMP 59056 (41/35-38; 115/4); paratypes: UMMP 59034 (41/41, 42), 59035 (40/43-46), 59058 (40/32-35), 59410 (40/30, 31), 59411 (40/36, 37), 59423 (40/38), 59478 (40/39-42), and 59479 (41/39, 40).

Genus JENNINGSINA Coryell & Malkin

Type species.-- *Graphiodactylus catenulatus* Van Pelt, 1933, p.333,334, pl.39, figs.31,32, by designation of Coryell & Malkin, 1936, p.19,20, figs.31,32.

JENNINGSINA CATENULATA (Van Pelt)

59/20-24; 60/10-25; 110/1,2

- Graphiodactylus catenulatus* Van Pelt, 1933, p. 333,334, pl.39, figs.31,32 ["Bell Shale" -- exact formation unknown. Lectotype, fig.32].
Jenningsina catenulata Coryell & Malkin, 1936, p.19,20, fig.35 [Hungry Hollow Formation].
Jenningsina catenulata Wright, 1948, p.126, pl. 16, fig.20.
Jenningsina divaricata Swartz & Oriol, 1948, p. 561, pl.79, fig.24 [Windom Shale].
Jenningsina catenulata Kesling & Weiss, 1953, p.62, pl.4, figs.40,41,44-49 [Norway Point Formation].
Jenningsina catenulata Stover, 1956, p.1122, pl. 116, figs.16-26 [Windom Shale].
Jenningsina catenulata Kesling, Kavary, Takagi, Tillman, & Wulf, 1959, p.21, pl.2, figs.25-36 [Centerfield Limestone].
Jenningsina catenulata Sohn & Stover, 1961, p. Q375, fig.300,2a-2e.
Jenningsina cf. *catenulata* Becker, 1965, p.410, 411, pl.34, fig. 7 [Germany].

Remarks.-- A few specimens of this very distinctive species were found in the Silica Formation, most from unit 7. In some strata, as in the Widder Formation and Wanakah Shale, it is abundant and well preserved. The ridge pattern is not as prominent in the Silica specimens as it is in other Middle Devonian formations in the Great Lakes region.

KEY TO SPECIES OF BUFINIDAE

1. Anterior end lower than posterior (less plenate); posterior ridge parallel to posterior border on right valve only; no anterior ridge on either valve; no tuberculation on margins *Bythocyproidea eriensis*
 Anterior end of larger (left) valve as high or higher than posterior (plenate); ridges may be developed at both ends of each valve, OR posterior ridge may be reduced to two thick blunt and/or rounded spines, and anterior ridge may be reduced to an anterodorsal spine on right valve and even absent on left valve; row of small marginal tubercles at both ends of each valve ... *Bufina* .. 2
2. Complete crescent-shaped ridge on right valve; crescent-shaped anterior ridge extending fairly far down the valve in left valve *Bufina curti*
 Anterior ridge short on right valve, restricted to dorsal half of valve, may be reduced to anterodorsal spine; anterior ridge on left valve very short, reduced to anterodorsal spine, or absent 3
3. Right valve with short anterior ridge, restricted to dorsal half of valve; left valve usually with very short anterior ridge or spine, rarely with no spine *Bufina abbreviata*
 Right valve with anterodorsal spine, no ridge; left valve usually bare anterodorsally, rarely with a small spine *Bufina spinulifera*

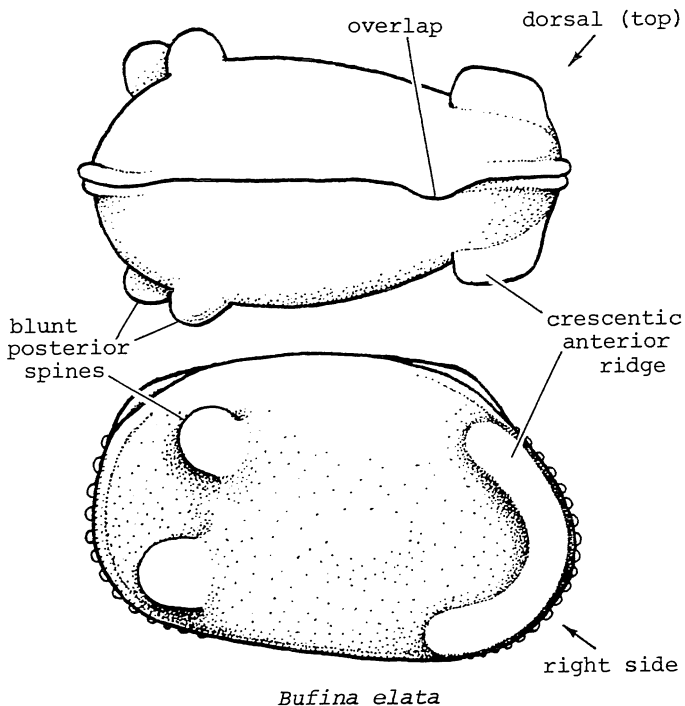

Bufina elata

Family Bufinidae Sohn & Stover 1961

Lateral surface never ornamented with coarse ridges or coarse reticulation. Each valve bearing posteriorly a structural ridge or two spines (usually rounded); may also have a ridge subparallel to the anterior end.

Genus BUFINA Coryell & Malkin 1936

Bufina Coryell & Malkin, 1936.
Parabufina Smith, 1956.

Type species.-- By original designation, *Bufina elata* Coryell & Malkin, 1936, p.8, fig.22 [= *Moorea bicornuta* Ulrich, 1891, p.191,192, pl. 16, figs.4a-4c (*fide* Peterson, 1966, p.15)].

Illustrated specimens.-- UMMP 59141 (60/10-12), 59142 (60/22, 23; 110/1), 59143 (60/20, 21), 59144 (60/24, 25), 59145 (60/13-15; 110/2), 59146 (59/20-24), and 59512 (60/16-19).

Family BUFINIDAE	Medusa quarries													Martin-Marietta Quarry				Waterworks Park						
	Unit																							
SPECIES	6	7	9	11	12	13	14	15	16	17	18	21	23	1-6	7	9-11	12	14-15	17-18	1-6	7	9-11	12	
<i>Bufina abbreviata</i>	x	x	x	x	x		x	x		x	x	x			x	x	x	x			x	x	x	x
<i>Bufina curti</i>	x	x		x	x					x	x			x	x	x						x	x	x
<i>Bufina spinulifera</i>		x	x	x	x		x	x		x	x	x	x	x	x	x			x			x	x	x
<i>Bythocyproidea eriensis</i>		x	x	x						x	x	x		x	x	x	x	x				x	x	x

BUFINA ABBREVIATA Peterson

93/1-10; 97/16-26; 107/29; 119/5

- Ponderodictya* sp. Kesling & Weiss, 1953, p.67, pl.5, fig.11 [Norway Point Formation].
- Bufina abbreviata* Peterson, 1966, p.17,18, pl.3, fig.3; pl.4, figs.18-22 [Gravel Point Formation. Holotype, carapace, UMMP 42879. Also Silica Formation, Plum Brook Shale, Ipperwash Limestone, Hungry Hollow Formation, Bell Shale].

Remarks.-- *Bufina abbreviata* is midway between *B. bicornuta* and *B. spinulifera* in form. The anterior ridges are shorter and less well developed than in the former, and more prominent than in the latter. Spines are much stronger and better developed than in *B. spinulifera*. The general size and shape is closest to *B. bicornuta*, with a finely pitted surface resembling that species; in fact, *Bufina abbreviata* appears to be the Michigan counterpart of *B. bicornuta* elsewhere.

Illustrated specimens.-- UMMP 58868 (93/5-7), 58869 (97/23-26), 58870 (97/19-22; 107/29), 58871 (93/8-10; 97/16-18; 119/5), 58872 (93/1, 2), and 58873 (93/3, 4).

BUFINA CURTI Coley

93/19,20; 97/27-37; 98/1-10; 105/19-23

- Moorea bicornuta* Stewart (non Ulrich), 1936 p. 752, pl.100, fig.29 [Silica Formation].
- Bufina curti* Coley, 1954, p.463, pl.53, fig.2 [Silica Formation. Holotype, Wayne State U. T-50003].
- Bufina curti* Peterson, 1964, p.14,15, pl.3, fig. 6 [Silica Formation, Widder Formation].

Remarks.-- *Bufina curti* has more prominent ridges than *B. abbreviata*, resembling *B. bicornuta* in the concavity and pitting of the lateral surface. The distinctive flattened, posteriorly pointing spines with coalescing bases make identification easy. A few fine specimens are present in units 7-11.

Illustrated specimens.-- UMMP 58874 (97/32-37), 58875 (97/28-31; 98/6), 58876 (93/19, 20), 58877 (97/27), 58878 (98/7-10), 59689 (98/1-5), and 60059 (105/19-23).

BUFINA SPINULIFERA (Stewart)

98/42-61

- Lucasella spinulifera* Stewart, 1936, p.761,762, pl.102, figs.20,21 [Silica Formation. Syntypes, OSU 18203].
- Bufina serrata* Stewart, 1950, p.663, pl.86, fig. 15 [3rd Bone Bed, Delaware Limestone].
- Quasillites pentagonus* Stewart (part), 1950, pl. 86, fig.20 only [3rd Bone Bed, Delaware Limestone].
- ? *Lucasella spinulifera* Stover, 1956, p.1126, pl.118, figs.15,16 [Windom Shale].
- Bufina spinulifera* Peterson, 1966, p.18,19, pl.3, figs.1,2,13-15; pl.4, figs.16,17,27-30.

Remarks.-- This small species is very common in all Silica beds as well as in most of the Middle Devonian formations in northern Michigan, Ontario, and western New York. The typical *Bufina* outline, with fine spinules on anteroventral ends of both valves are the most distinguishing feature. The posteroventral margin of the left valve (in well-preserved specimens) has a small spine; an equally small spine is situated posterodorsally, and a small node is present in the anterodorsal area. The spines in a carapace are so small that they are inconspicuous unless the specimen is tipped to bring the ventral or dorsal side uppermost. The surface is smooth. Identification can be made from the larger, slightly flattened posterior end.

Illustrated specimens.-- UMMP 58879 (98/52-55), 58880 (98/44, 45), 58881 (98/42, 43), 58882 (98/56-59), 59447 (98/60, 61), 59448 (98/48-51), and 59449 (98/46, 47).

Genus BYTHOCYPROIDEA Stewart & Hendrix

Type species.-- By original designation, *Bythocyproidea sanduskyensis* Stewart & Hendrix, 1945a, p.91, pl.10, figs.26-28.

BYTHOCYPROIDEA ERIENSIS Stewart & Hendrix

99/11-40; 100/1-16; 101/1-8; 107/21,22

- Bythocyproidea eriensis* Stewart & Hendrix, 1945a, p.92,93, pl.10, figs.23-25 [Plum Brook Shale. Syntypes, OSU 18873].
- ? *Bythocyproidea eriensis* Sohn & Stover in Moore, 1961, p.Q376, fig.301,3a,3b.
- Bythocyproidea eriensis* Tillman, 1970, p.210, table 1, pl.4, fig.4 [Plum Brook Shale, Olen-tangy Shale].

Remarks.-- Outline is important in determining this species, inasmuch as the very fine punctae on the posterior ends are not always preserved in the Silica specimens. The low crescentic ridge and flattened area anterior to it bearing the fine punctae are at the posterior end of the smaller right valve. The anterior end is definitely smaller than the posterior. This species may have been the Macrocypris acutula of Stewart (1936, p. 758, pl. 101, figs. 25, 26).

Illustrated specimens.-- UMMP 58895 (99/19-22), 58896 (99/39, 40), 58897 (99/27-30; 100/10; 101/7), 58898 (98/31-33; 100/7, 8), 58899 (99/11-14), 58900 (100/1-4; 101/6), 59133 (99/15-18; 100/11; 101/8), 59433 (101/4, 5), 59434 (100/13-16), 59451 (99/34), 59452 (101/1, 2), 59453 (101/3), 59454 (99/35-38), 59455 (100/5, 6, 9; 107/21, 22), and 59456 (99/23-26; 100/12).

Family Ropolonellidae Coryell & Malkin

Subtriangular to subpyriform in lateral view. Anterior end conspicuously high; posterior end may be acuminate to posterodorsal corner.

Genus ROPOLONELLUS Van Pelt 1933

Type species.-- By original designation, *Ropolonellus papillatus* Van Pelt, 1933, p. 339, pl. 39, figs. 29, 30.

ROPOLONELLUS PAPILLATUS Van Pelt

47/1-22; 115/1

- Ropolonellus papillatus* Van Pelt, 1933, p. 339, pl. 39, figs. 29, 30 ["Bell Shale" - exact formation unknown. Holotype, fig. 29].
- Ropolonellus papillatus* Coryell & Malkin, 1936, p. 6, fig. 15 [Hungry Hollow Formation].
- Ropolonellus papillatus* Warthin, 1945, card 82.
- Ropolonellus papillatus* Wright, 1948, p. 100, pl. 12, figs. 33, 34.
- Ropolonellus papillatus* Kesling & Weiss, 1953, p. 63, pl. 4, figs. 37, 38 [Norway Point Formation].
- Ropolonellus papillatus* Kesling, Kavary, Takagi, Tillman, & Wulf, 1959, p. 22, pl. 3, figs. 19-34 [Centerfield Limestone].
- Ropolonellus papillatus* Sohn in Moore, 1961, p. Q376, fig. 303, 3a-3d.
- Ropolonellus papillatus* Peterson, 1964, p. 861, 862, pl. 135, fig. 21; pl. 136, figs. 20, 21.

Remarks.-- This small, distinctive ostracod is not common in the Silica Formation, but some good carapaces and valves were found. The species is widely distributed in the Great Lakes region.

Illustrated specimens.-- UMMP 59339 (47/1-4), 59340 (47/21, 22), 59341 (47/7-10), 59342 (47/20), 59343 (47/5, 6; 115/1), 59344 (47/16-19), and 59345 (47/11-15).

Genus RUDDERINA Coryell & Malkin 1936

Type species.-- By original designation, *Rudderina extensa* Coryell & Malkin, 1936, p. 6, fig. 15.

RUDDERINA EXTENSA Coryell & Malkin

46/40, 41

Rudderina extensa Coryell & Malkin, 1936, p. 6, fig. 15 [Hungry Hollow Formation. Holotype, AMNH 24625].

Rudderina extensa Kesling, Kavary, Takagi, Tillman & Wulf, 1959, p. 22, pl. 3, figs. 1-18 [Centerfield Limestone].

Only one specimen found.

Illustrated specimen.-- UMMP 59347 (46/40, 41).

Genus EUGLYPHELLA Warthin 1934

Type species.-- *Strepula sigmoidalis* Jones, 1890a, p. 11, pl. 2, fig. 4, by designation of Warthin, 1934, p. 220.

Remarks.-- An excellent discussion of the evolution in the genus and cladistic analysis of the species was done by Sabeekah Abdul-Razzaq (1973, p. 47-64, 12 text-figs.). Becker (1965, p. 412) placed the genus in the family Ropolonellidae. The accompanying figures show the terminology used for tracing structures through the various species, the cladistic tree of the species found in the Silica Formation, and the evolutionary development of each species.

EUGLYPHELLA COMPRESSA Coryell & Malkin

76/5-13; 80/1-4

Euglyphella compressa Coryell & Malkin, 1936, p. 7, fig. 19 [Hungry Hollow Formation. Holotype, AMNH 24624]

Euglyphella jenningsi Coryell & Malkin, 1936, p.

8, fig.20 [Hungry Hollow Formation].

Euglyphella compressa Warthin, 1945, card 74, fig.19.

Euglyphella jenningsi Warthin, 1945, card 75, fig.20.

Euglyphella compressa Wright, 1948, p.101, pl. 13, fig.2.

Euglyphella compressa Kesling & Weiss, 1953, p. 58, pl.4, fig.16 [Norway Point Formation].

Euglyphella cf. *E. compressa* Smith, 1956, table 1 [Ledyard Shale, Wanakah Shale].

Euglyphella compressa Kesling, Kavary, Takagi, Tillman, & Wulf, 1959, p.19, text-fig.2, pl. 1, figs.25-42; pl.4, figs.20-27 [Centerfield Limestone].

Euglyphella compressa compressa Peterson, 1966, p.3,4, pl.1, figs.6,24,26,27; pl.2, figs.4, 25 [Centerfield Limestone, Ledyard Shale, Wanakah Shale, Potter Farm Formation, Gravel Point Formation].

Euglyphella compressa Abdul-Razzaq, 1973, p.48, 52, text-figs.9,10,12.

Remarks.-- Rare in the Silica Formation, *Euglyphella compressa* specimens are poorly preserved, with subdued ridges. These specimens appear to grade into *E. lispa*, which is also rare in these strata.

Illustrated specimens.-- UMMP 59097 (76/12, 13), 59148 (80/1-4), 59468 (76/5-8), and 59678 (76/9-11).

EUGLYPHELLA LISPA Peterson

76/1-4; 79/15-21

Euglyphella compressa lispa Peterson, 1966, p.4, pl.1, figs.7,28,29; pl.2, figs.13-15,18,22, text-fig.1 [Widder Formation. Lectotype, UMMP 43073. Also Ledyard Shale].

Euglyphella lispa Abdul-Razzaq, 1973, p.49,54, text-figs.3,9,10,12 [Widder Formation, Ledyard Shale, Wanakah Shale].

Remarks.-- *Euglyphella lispa* is very similar to *E. compressa*, differing mainly in the fading out and obliteration of the ridges along the anterior and ventral margins. It is rare and poorly preserved in the Silica Formation.

Illustrated specimens.-- UMMP 59088 (79/18, 19), 59090 (79/15), 59091 (79/20, 21), 59094 (76/1-4), and 59095 (79/16, 17).

EUGLYPHELLA MODESTA Peterson

76/24-27; 79/1-14; 80/5-13

Euglyphella compressa modesta Peterson, 1966, p.

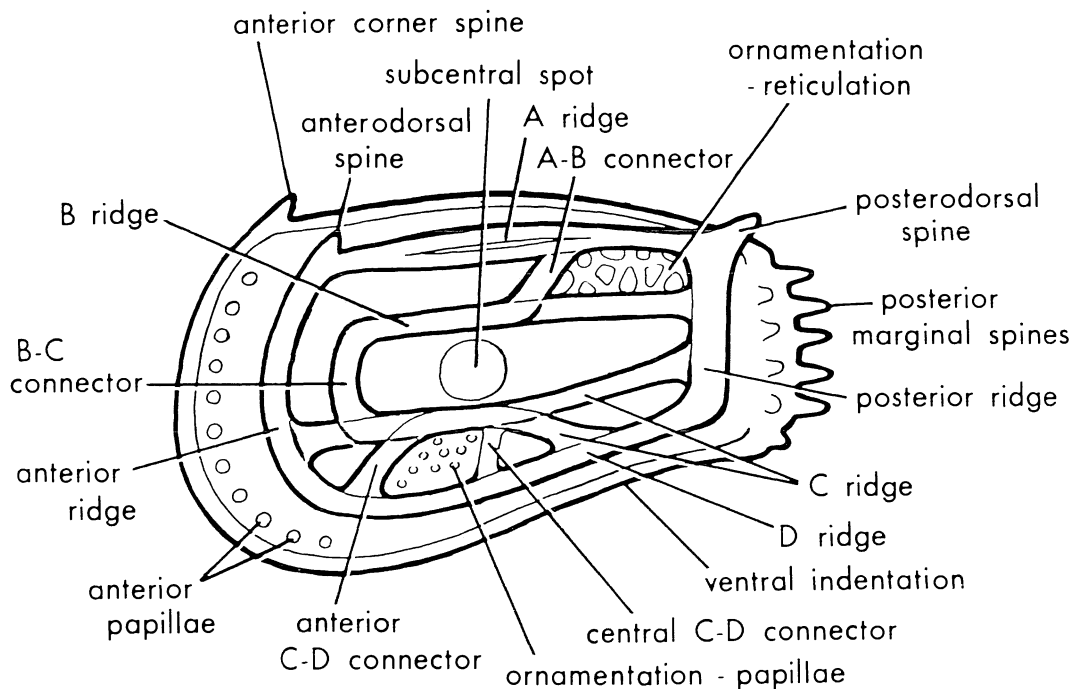

Terminology of *Euglyphella* left valve.

KEY TO SPECIES OF ROPOLONELLIDAE

1. Surface smooth or granular, never ridged; anterior end much higher than posterior 2
 Surface ornamented with ridges or (in some species) papillae; anterior end only slightly higher than posterior *Euglyphella* .. 3
2. Subtriangular, only moderately elongate; row of small denticles at each end; surface smooth
 *Ropolonellus papillatus*
 Very elongate; prominent spine anteroventral and exceptionally large spine posterior, the latter curving outward and backward well beyond posterior edge of valve; surface granular *Rudderina extensa*
3. Left valve (see Abdul-Razzaq, 1973, p.57-59, text-figs.1,2, for terminology) ornamented area without reticulation; no A-B connector ridge .
 *Euglyphella sigmoidalis*
 Left valve ornamented area with some reticulation in posterodorsal region between A and B ridges; A-B connector ridge in centrodorsal region 4

4. Left valve posterior ridge joined to D ridge but not to B ridge; posterior marginal spines (if discernible) very weakly developed; no subcentral spot .. *Euglyphella projecta*
 Left valve posterior ridge joined to B ridge, there terminating and separated from posterior end of D ridge; posterior marginal spines well developed; conspicuous subcentral spot 5
5. Left valve with B ridge joined to posterior ridge.. *Euglyphella compressa*
 Left valve with B ridge scarcely reaching posterior ridge or terminating in front of it 6
6. Reticulation between major ridges; posterodorsal spine weakly developed; anterior corner spine of left valve small; C and D ridges weak, nearly effaced *Euglyphella lispa*
 Papillae between major ridges, replacing reticulation; posterodorsal spine prominent; anterior corner spine distinct, sharp; C and D ridges present, decreasing posteriorly *Euglyphella modesta*

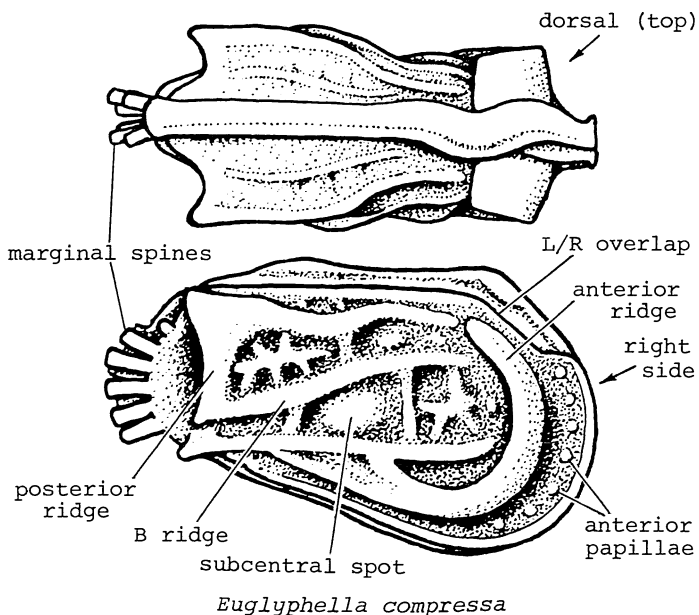

4, pl.1, figs.14,15; pl.2, figs.24-27, text-fig.1 [Wanakah Shale, Lectotype, UMMP 43067].
Euglyphella modesta Abdul-Razzaq, 1973, p.49,54, 59, text-figs.9,10,12 [Silica Formation, Wanakah Shale].

Remarks.— *Euglyphella modesta* is similar to *E. compressa*, differing in the prominent anterodorsal corner spine and the increase of papillae between major ridges and along the anterior border. The posterodorsal spine is also more prominent. Both *Euglyphella lispa* and *E. modesta* are in the *E. compressa* group. This species is rare in the formation.

Illustrated specimens.— UMMP 59089 (76/24-27), 59092 (79/9, 10), 59093 (79/11-14; 80/12, 13), 59096 (79/1-4; 80/5-7), 59098 (80/9-11), and 59149 (79/5-8; 80/8).

EUGLYPHELLA PROJECTA Coryell & Malkin

76/14-23; 77/9-15

Euglyphella projecta Coryell & Malkin, 1936, p.7,

pl.1, fig.18 [Hungry Hollow Formation. Holotype, AMNH 24622].

Euglyphella projecta Warthin, 1945, card 77.

Euglyphella spinosa Stewart, 1950, p.663,664, pl.86, figs.16,17 [3rd Bone Bed, Delaware Limestone].

Euglyphella projecta Coley, 1954, chart p.455 [Silica Formation, Hungry Hollow Formation Centerfield Limestone, Wanakah Shale].

Euglyphella projecta Smith, 1956, table 1 [Ledyard Shale, Wanakah Shale].

Euglyphella projecta Stover, 1956, p.1131, text-fig.6 [Windom Shale].

Euglyphella deltella Stover, 1956, p.1130,1131, pl.118, figs.19-23, text-figs.3-5 [Windom Shale].

Euglyphella projecta Kesling, Kavary, Takagi, Tillman, & Wulf, 1959, p.17, text-fig.1, pl. 1, figs.5-24; pl.4, figs.8-19 [Centerfield Limestone].

Euglyphella projecta Peterson, 1966, p.10,11, pl.1, figs.17-20,37,38; pl.2, figs.8-12

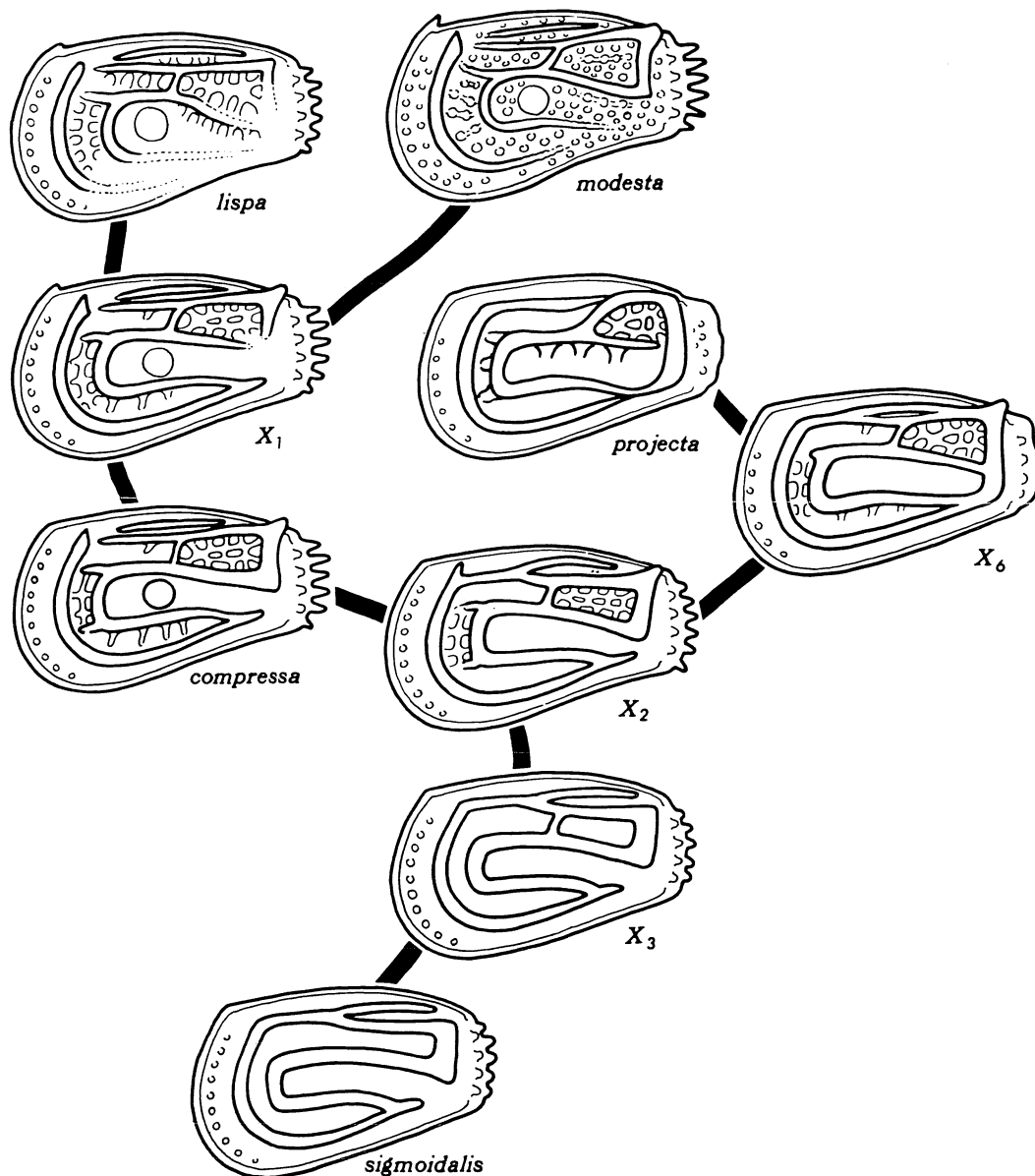

Evolution of species of *Euglyphella* in the Silica Formation (after Abdul-Razzaq, 1973).

[New York Middle Devonian formations, Hungry Hollow Formation, Ipperwash Limestone, Silica Formation].

Euglyphella projecta Abdul-Razzaq, 1973, p.49, 54,61, text-figs.3,9,10,12.

Remarks.-- *Euglyphella projecta* differs from other species of the genus by having a triangular reticulated posterior area enclosed

by enlarged and flaring posterior ridge and connectors. It is rare in the Silica Formation.

Illustrated specimens.-- UMMP 59099 (77/13), 59100 (77/9,10), 59101 (77/11,12), 59102 (77/14,15), 59103 (76/14,15), 59104 (76/16-19), and 59700 (76/20-23).

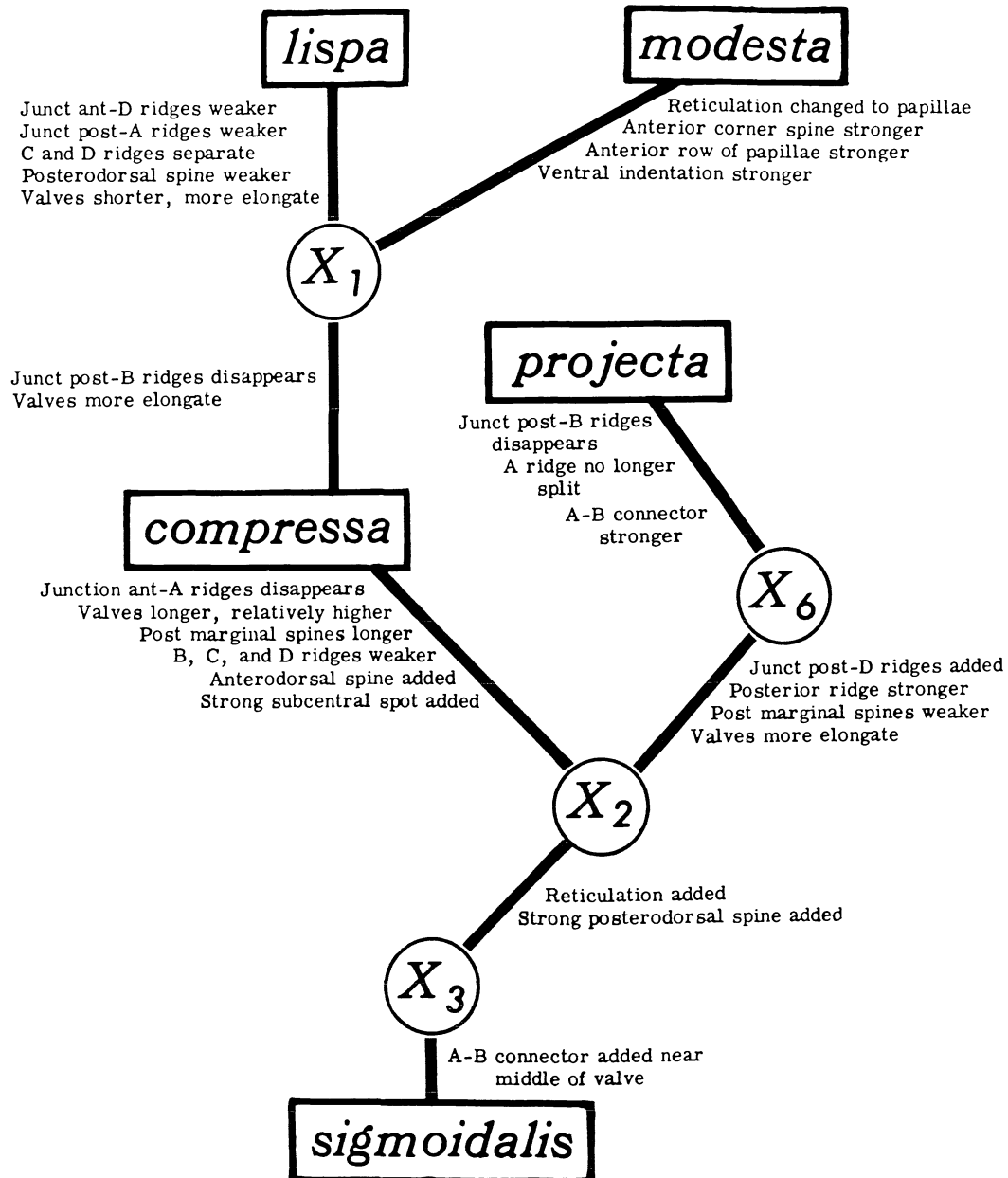

Relationships of Silica Formation species of *Euglyphella* as indicated by cladistic analysis (after Abdul-Razzaq, 1973).

Family ROPOLONELLIDAE	SPECIES	Unit	Medusa quarries																			Martin-Marietta Quarry			Waterworks Park							
			Quarry																													
			6	7	9	11	12	13	14	15	16	17	18	21	23	1-6	9-11	12	14-15	17-18	1-6	9-11	12									
<i>Euglyphella compressa</i>	X	X	X	X	X	X	X	X													X	X	X	X	X	X	X	X	X			
<i>Euglyphella lispa</i>		X					X																	X	X		X			X	X	
<i>Euglyphella modesta</i>		X	X																					X		X				X		X
<i>Euglyphella projecta</i>		X					X	X																X	X		X			X	X	
<i>Euglyphella sigmoidalis</i>	X	X	X	X	X	X	X	X	X	X	X	X	X	X	X	X	X	X	X	X	X	X	X	X	X	X	X	X	X	X	X	X
<i>Ropolonellus papillatus</i>			X	X	X																				X				X	X	X	
<i>Rudderina extensa</i>					X																											

EUGLYPHELLA SIGMOIDALIS (Jones)

76/28-35; 77/16-24; 78/12-28; 79/22-26

- Strepula sigmoidalis* Jones, 1890a, p.11, pl.2, fig.4 [Formation unknown].
- Strepula plantaris* Jones, 1890a, p.540, pl.20, figs.8a,8b.
- Strepula sigmoidalis* Grabau, 1899, p.305, text-fig.245 [Eighteen Mile Creek, Erie Co., N.Y.].
- Strepula plantaris* Grabau, 1899, p.305, text-fig.246 [Eighteen Mile Creek, Erie Co., N.Y.].
- Strepula sigmoidalis* Raymond, 1904, p.173.
- Strepula sigmoides* [sic] Grabau & Shimer, 1910, p.350, text-fig.1660.
- Strepula plantaris* Grabau & Shimer, 1910, p.350, text-fig.1660n,1660n'.
- Otonaria percarinata* Van Pelt, 1933, p.335, pl.39, figs.52-54 ["Bell Shale" - exact formation unknown].
- Euglyphella sigmoidalis* Warthin, 1934, p.220, pl.1, fig.21 [Gravel Point Formation].
- Euglyphella sigmoidalis* var. *primitiva* Warthin, 1934, p.221, pl.1, fig.22.
- Euglyphella sigmoidalis* Bassler & Kellett, 1934, p.37,311, fig.14.
- Euglyphella sigmoidalis* Coryell & Malkin, 1936, p.7, fig.17 [Hungry Hollow Formation].
- Euglyphella sigmoidalis* var. *primitiva* Stewart, 1936, p.754, pl.101, figs.13,14 [Silica Formation].
- Euglyphella sigmoidalis* Warthin, 1945, card 78, fig.B.
- Euglyphella sigmoidalis* var. *primitiva* Warthin, 1945, card 76.
- Euglyphella sigmoidalis* Wright, 1948, p.101, pl.12, figs.36,37.
- Euglyphella sigmoidalis* Kesling & Kilgore, 1952, p.10,11, pl.3, figs.30-36 [Genshaw Formation].
- Euglyphella sigmoidalis* Coley, 1954, p.455 [Silica Formation, Arkona Shale].
- Euglyphella sigmoidalis* Smith, 1956, table 1 [Ledyard Shale, Wanakah Shale].

Euglyphella sigmoidalis primitiva Smith, 1956, table 1.

Euglyphella sigmoidalis Jones, 1956, p.165, figs.8-11.

Euglyphella sigmoidalis Kesling, Kavary, Takagi, Tillman, & Wulf, 1959, p.17, pl.1, figs.1-4 [Centerfield Limestone].

Euglyphella sigmoidalis Sohn & Stover in Moore, 1961, p.Q375, fig.298,la,lb.

Euglyphella sigmoidalis Peterson, 1966, p.7-9, pl.1, figs.13,21-23; pl.2, figs.7,17,19,23,26.

Euglyphella sigmoidalis Abdul-Razzaq, 1973, p.49, 54,61, text-figs.3,9,10,12.

Remarks.- One of the commonest, most widely distributed ostracods of the Middle Devonian strata of the Great Lakes region, *Euglyphella sigmoidalis* has been found in all Silica units and in nearly all other beds of other formations. It shows some variation in height of the ridges from one stratum to another, but all specimens are readily recognized by the prominent C-shaped ridge in the center of the valve. Preservation is usually good because of the thick walls. Posterior spines are retained more often than not. Single valves are common and well preserved, showing the marked difference in size of left and right valves and the distinctive anterodorsal fit.

Illustrated specimens.- UMMP 59105 (78/21-24), 59107 (76/28-31), 59108 (78/17-20), 59109 (77/17-20), 59110 (78/13-16), 59111 (76/32,33), 59112 (77/21-24; 79/22), 59113 (76/34,35), 59114 (77/16; 78/25-28), and 59115 (78/12; 79/23-26).

KEY TO SPECIES OF THLIPSURIDAE

1. Ornamented area of each valve dominated by conspicuous central circular pit; four ridges radiating from rim around central pit toward dorsal, ventral, anterior, and posterior margins; areas between ridges coarsely reticulate
Hyphasmophora textiligera
 Ornamented area of each valve without central pit and radiating ridges ..
 *Octonaria* .. 2
2. Left valve smooth or, at most, with two (very rarely three) shallow furrows or rows of shallow pits in posterior and dorsal areas
 *Octonaria laevilitata*
 Left valve with conspicuous furrows (with pits) extending over much of lateral surface 3
3. Right valve with notch at anterodorsal border (but no process of overlapping left valve to fit into this notch); right valve with two longitudinal furrows in rear half, and C-shaped furrow parallel to anterior border in front half (ventrally confluent or nearly so with lower

furrow of rear half); left valve with three furrows, the upper and lower confluent or nearly confluent to form a continuous subelliptical furrow subparallel to the entire border, the middle furrow reaching to the posterior junction of the other two; pits in furrows clearly defined by relatively high short cross bars..... *Octonaria quadricostata*
 Right valve lacking any notch anterodorsally; each valve with three distinct longitudinal furrows, of which the dorsal is longest and curves from posterodorsal to anteroventral region subparallel to border of valve, the middle furrow extends from posteroventral to anteroventrocentral region parallel to part of dorsal furrow, and the ventral furrow is shortest, extending from posteroventrocentral to near centroventral region, seldom extending beyond midlength; no furrows confluent; pits in furrows poorly delineated except in very clean specimens, the cross bars separating them notably lower than rest of valve surface. *Octonaria crescentiformis*

Superfamily Thlipsuracea Ulrich 1894

Carapace distinctly compressed at posterior margin.

Family Thlipsuridae Ulrich 1894

Genus HYPHASMAPHORA Van Pelt

Type species.-- By original designation, *Hyphasmaphora textiligera* Van Pelt, 1933, p.340, pl.39, figs.3-7.

HYPHASMAPHORA TEXTILIGERA
 Van Pelt

58/26-28; 60/29-32; 112/4

Hyphasmaphora textiligera Van Pelt, 1933, p.340, pl.39, figs.3-7 ["Bell Shale" - exact formation unknown. Holotype, fig.5].

Hyphasmaphora textiligera Warthin, 1934, p.219, pl.1, fig.20.

Hyphasmaphora textiligera Warthin, 1945, card 80, figs.3-7.

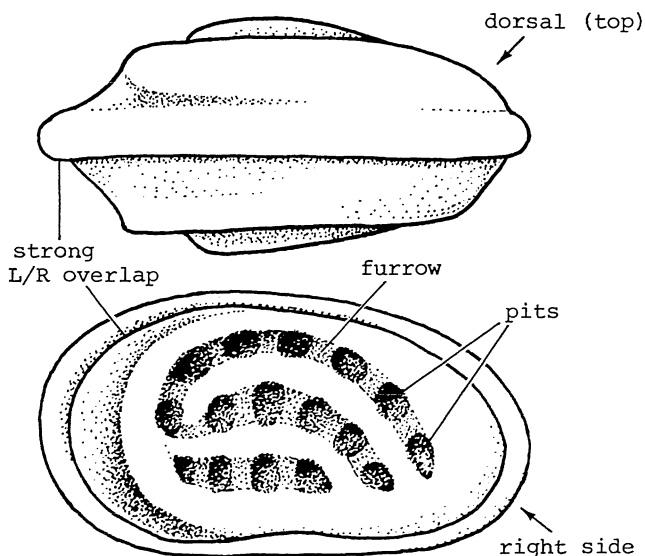

Octonaria crescentiformis

- Hyphasmaphora textiliger*a Wright, 1948, p.96, pl.11, fig.46.
*Hyphasmaphora textiliger*a Moore, Lalicker, & Fischer, 1952, p.531, fig.5.
*Hyphasmaphora textiliger*a Kesling & Weiss, 1953, p.60, pl.4, figs.34-36 [Norway Point Formation].
*Hyphasmaphora textiliger*a Kesling in Moore, 1961, p.Q378, fig.304,4.

Remarks.-- A pit with a raised rim in the middle of a coarsely reticulated area distinguishes this species with smooth sloping margins. It is rare in the Silica Formation.

Illustrated specimens.-- UMMP 59134 (58/26-28), 59135 (60/32), 59418 (60/31), and 59502 (60/29, 30; 112/4).

Genus OCTONARIA Jones

- Octonaria* Jones, 1887.
Streplulites Coryell & Malkin, 1936, type *S. mooki* Coryell & Malkin, 1936, p.5.
Octonariella Bassler, 1941.

Type species.-- By original designation, *Octonaria octoformis* Jones, 1887, p.404, pl.12, figs.2a,2b.

Remarks.-- Coryell & Malkin (1936, p. 5) created the genus *Streplulites* to include ostracods which differ from *Octonaria* in having more strongly developed narrow ridges, somewhat parallel to the borders. In it, they included *Octonaria crescentiformis* and *Octonaria quadricostata*, two species of Van Pelt (1933) from the Traverse Group of Michigan. Kesling & Kilgore (1952) and Kesling & Weiss (1953) preferred a broader interpretation of the genus *Octonaria*, and replaced *O. crescentiformis* and *O. quadricostata* in their originally assigned genus.

OCTONARIA CRESCENTIFORMIS Van Pelt

87/1-6; 88/13-16

- Octonaria crescentiformis* Van Pelt, 1933, p.334, 335, pl.39, figs.55-60 ["Bell Shale" - exact formation unknown. Type, fig.48].
Octonaria crescentiformis Warthin, 1934, p.218, pl.1, fig.18.
Streplulites crescentiformis Coryell & Malkin, 1936, p.5.
Streplulites crescentiformis Warthin, 1945, card 35, figs.55-60.

- Octonaria crescentiformis* Stewart & Hendrix, 1945a, p.91, pl.10, figs.15-17.
Octonaria crescentiformis Kesling & Kilgore, 1952, p.9, pl.3, figs.27,28 [Genshaw Formation].

Remarks.-- The crescent-shaped ridges of this species are similar to those of *Octonaria laevilitata*, especially the right valve ridges. Although left valves of *O. laevilitata* show great variation, most of them smooth but some with furrows and pits, a few approach the sculpturing of *O. crescentiformis*. *Octonaria crescentiformis* is somewhat smaller than *O. laevilitata*.

Illustrated specimens.-- UMMP 59206 (87/1-4, 59228 (87/5, 6), and 59229 (88/13-16).

OCTONARIA LAEVILITATA Kesling & Kilgore

86/22-35; 87/7-18; 88/17-30; 89/68-71

- Octonaria laevilitata* Kesling & Kilgore, 1952, p.9,10, pl.3, figs.1-26,29 [Genshaw Formation. Holotype, complete carapace, UMMP 27992].
Octonaria laevilitata Kesling in Moore, 1961, p.Q378, fig.304,1d.

Remarks.-- This rather large and variable species of *Octonaria* occurs only in the Traverse Group of northern Michigan and in the Silica Formation; none were found in Ontario and New York sediments. The species is very abundant in the Genshaw Formation and in unit 17 at the Medusa quarries. The larger left valve is extremely variable; many specimens are completely smooth and lacking any sculpturing, whereas some have three furrows bearing a few pits each. The surface appears to have greater sheen than either of the other two species in the Silica Formation.

Illustrated specimens.-- UMMP 59199 (86/26-29), 59200 (88/23-26), 59201 (86/32-35; 87/17, 18), 59202 (86/22-25; 89/68-71), 59203 (88/27-30), 59204 (87/13-16), 59205 (88/19-22), 59230 (87/11, 12), 59234 (87/7-10), 59543 (86/30, 31), and 59683 (88/17, 18).

OCTONARIA QUADRICOSTATA Van Pelt

86/11-21; 87/19-32; 88/9-12; 89/61-67

- Octonaria quadricostata* Van Pelt, 1933, p.336, pl.39, figs.41-51 ["Bell Shale" - exact for-

Family THLIPSURIDAE	Medusa quarries													Martin-Marietta Quarry			Waterworks Park					
	Unit													1-6			9-11			12		
SPECIES	6	7	9	11	12	13	14	15	16	17	18	21	23	1-6	7	9-11	12	14-15	17-18	1-6	9-11	12
<i>Hyphasmophora textiligera</i>	x				x		x	x	x	x												
<i>Octonaria crescentiformis</i>			x		x		x	x				x	x		x		x					
<i>Octonaria laevilatata</i>							x	x	x	x	x						x	x	x			
<i>Octonaria quadricostata</i>	x	x			x		x	x	x	x			x	x	x		x	x	x	x	x	

mation unknown. Type, fig.45].
Octonaria quadricostata Warthin, 1934, p.217, pl.1, figs.16,17 [Gravel Point Formation].
Octonaria quadricostata Stewart, 1936, p.751, pl.101, figs.5,6 [Silica Formation].
Strepulites quadricostata Coryell & Malkin, 1936, p.5.
Strepulites quadricostata Warthin, 1945, card 41, figs.41-51.
Octonaria quadricostata Kesling & Weiss, 1953, pl.4, figs.1-4 [Norway Point Formation].
Strepulites quadricostata Kesling in Moore, 1961, p.Q379, fig.305,4b.

Remarks.— A very heavy-shelled robust ostracod, it is found in the lower units of the Silica Formation at all localities. The abundant carapaces and valves are usually pyritized and well preserved, and seem to occur in wave-washed or current-accumulated argillaceous limestones more frequently than in shales. The best specimens are found in the Bell Shale, wherein it is the most abundant ostracod by far. The strongly sculptured valves readily identify this *Octonaria* in Middle Devonian beds.

Illustrated specimens.— UMMP 59207 (86/14,15), 59208 (86/20,21), 59209 (87/19,20), 59210 (86/13), 59211 (86/11,12), 59212 (86/16,17), 59213 (86/18,19), 59214 (87/21-24; 89/64-67), 59215 (87/25-28; 89/61-63), 59216 (88/9-12), and 59217 (87/29-32).

? Subclass OSTRACODA Latreille 1806

Suprageneric taxa uncertain

? Order PALAEOCOPIDA Henningsmoen 1953

Genus BURSULELLA Jones

Type species.-- *Bursulella triangularis* Jones, 1887, by subsequent designation of Shaver in Moore, 1961, p.Q412.

In a rare little publication (8 pages), "Notes on some Silurian Ostracoda," published by "Kongl. Boktryckeriet, P. A. Norstedt & Söner" in Stockholm in 1887, Prof. T. Rupert Jones described this genus as follows (p. 7):

This is a small, bivalved, probably Ostracodal form, with more or less triangular valves, which have one or two horn-like projections on the ventral edge of each valve.

The first of his three species, and presumably the type, is the one which most closely fits the characters of the Silica specimens. Jones illustrated it with two small lithographs, and offered the following description (p. 7):

Bursulella triangularis, spec. nov.

The upper and lower edges of the valves are straight, but the ventral edge is much shorter than the other, and a delicate spike projects from each of its angles. The corners of the lower half of each valve are much rounded, and are marked inside with a series of shallow pits, making a slightly-crenate contact-line. In outline this curious bivalve, which is probably an Ostracod, looks like a little subtriangular *purse* (hence the generic name), widest at the top, and ornamented below with two neat little projections.

It occurs in the cephalopodan limestone of Samsugn in Othem, and the uppermost beds of Slite, some twenty specimens having been found.

No size was given, but except for changing the nature of the crenulations along the contact edges from "shallow pits" to prominent tooth-like denticles, his description presented 91 years ago for Silurian microfossils agrees remarkably well with the Silica forms.

For many years the ostracodal nature of

the genus was unquestioned. In their oft-cited "Bibliographic index" Bassler & Kellett (1934, p. 223) placed it in the Primitiidae. Frank McKim Swartz (1936, p. 550) stated, "Bursulella (sic!) is best classed as a provisional member of the Leperditellidae."

E. A. Schmidt (1941, p. 18) placed the genus in the Aparchitidae with reservation. As late as 1955, Henry V. Howe in his "Handbook" included "Bursullela" (sic!) in the Ostracoda.

While working on his doctorate at Washington University, St. Louis, Robert W. Morris wrote me on 15 February 1951 and referred to "a paper I am writing jointly with Dr. Shideler of Miami University. This paper deals with a new family, the Bursulellidae..." He had reference to Dr. William Henry Shideler (1886-1958), long famous for his researches on the Ostracoda of the Midwest. Morris wrote again on 15 August 1952, at which time he was at the Standard 11-C Club, Taft, California. He said in this letter:

I wonder if, in your work on the Devonian of Michigan, you have ever found any representatives of the genus *Bursulella*? I am at present working on this genus and 2 undescribed genera, and would be very much obliged for any information on the group. I have one new species of *Bursulella* from the Silica shale of Ohio and it seems likely that this species should be present in Michigan.

The genus, so far as I have determined, ranges from M. Silurian to U. Devonian: M. Silurian of Europe & Missouri, M. Devonian of Ohio, & U. Devonian of Iowa & Missouri.

I do not find that Morris or Shideler ever published the results of their investigations.

Later, doubts were expressed as to nature of *Bursulella*. In the Russian treatise (Osnovy paleontologii, Arthropoda Volume) I. E. Zanina & E. N. Polenova (1960, p. 411) relegated it to "incertae sedis."

In our own Treatise of the following year, Robert H. Shaver (1961, p. Q412) placed the genus under *Nomina Dubia* and stated:

Probably not an ostracode; species assigned to the genus by later authors

not considered to be congeneric.

It is our opinion that *Bursulella* is definitely a crustacean and most likely an ostracod. Although no interlocking hinge elements are present, the dorsal contact area is long and straight and with little doubt functioned as a hinge for the two valves. The thick shell apparently eliminated the animal from the plankton. Some of the *Myodocopa* have similar siphon structures, but the straight hinge line of *Bursulella* does not fit well into any of the divisions of that taxon.

As stated above, these enigmatic fossils have not been accepted as ostracods by all workers, particularly in recent years. Like ostracods, they have a bivalved carapace and increase their size by molting. Unlike most ostracods, however, they have an exceptionally thick shell and show no evidence of overlap. The long straight hinge line is like that of the Paleocopida, and the nearly or completely equal valves resemble those in the family Aparchitidae (even though the rough surface and spines are foreign to that family).

BURSULELLA sp.

From the domiciliar space, a groove extends along the length of the inner face of each ventral spine; these grooves have the potential to act as siphons when the carapace is closed, allowing a meager intake and exhaust of water. Lining the sides of these grooves and extending along the sides of the valves are large toothlike processes (giant denticles?) which seem to interfinger with those of the opposite valve as the carapace closes; these could serve as a straining structure. Each valve is so nearly bilaterally symmetrical that orientation remains tentative. Muscle scars were not seen. Short shallow grooves divide the dorsal half of each valve into three lobes.

The fauna includes some adults, such as UMMP 59384 (106/16, 17), and some immature carapaces, such as UMMP 59385 (106/9-15).

Illustrated specimens.— UMMP 59383 (6/3, 4; 106/5, 6), 59384 (6/1, 2; 106/16, 17), 59385 (6/5-9; 106/9-15), 60060 (106/5, 6), and 60075 (106/7, 8).

INTERPRETING THE RECORD

We are like a judge confronted by a defendant who declines to answer and we must determine the truth from circumstantial evidence. All the proof we can muster has the deceptive character of this type of evidence. How would we assess a judge who based his decision on only part of the evidence?

-- Alfred Wegener

Few micropaleontologists are so devoid of scientific curiosity that they are satisfied merely to identify and list the fossils found in a particular formation. We are presented with the remains of a once-living creature, and, like Sherlock Holmes, we are spurred to investigate further. Many questions immediately present themselves. Who was the deceased? Did he die here? What was his position in the community? Does he have surviving heirs in younger formations? Can we trace his ancestry into older formations? What was his main occupation? Are there siblings residing in distant lands? As soon as one question is settled, others are generated. And none of them are elementary, my dear Watson.

Before proceeding to our analysis and application of the faunal data just concluded, we might pause to consider the current uses of such data and to look at the factors involved in these uses.

First, the fossil record and the strata are both end products of many factors (text-fig. 4). In neither the organic nor the inorganic world is there such a thing as a fresh start. Every animal is the product of its ancestry, inheriting some characteristics which are essential and some which are not. Similarly, each sedimentary unit is the product of previously formed rock units which are being recycled by physical processes.

Second, certain chains of control and feedback can be identified. Factors are highlighted in our flow chart (text-fig. 4), expanded and modified from that presented by Imbrie & Newell (1964, figs. 5, 6). As we see it, the

story of the fossils and the matrix which encloses them actually begins with global tectonics, those deep and powerful forces by which

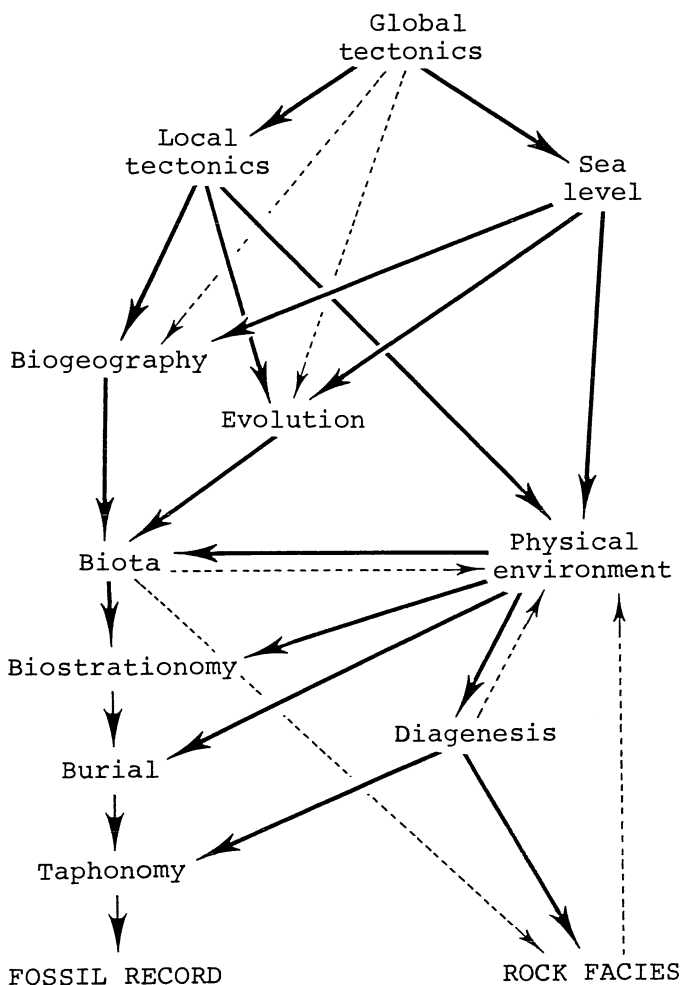

TEXT-FIG. 4 -- Flow chart of factors affecting the fossil record and the rock facies. Modified from Imbrie & Newell, 1964, figs. 5, 6.

continents are rifted and drifted, oceanic basins created and closed up, mountain systems upwarped, and volcanic chains activated. Global tectonics control sea level and the local tectonic setting and, to a lesser degree, influence biogeography and evolution. These are the prime forces that determine distribution of continents and seas, vital considerations for all forms of life. Major evolutionary change-overs and expansions are now being linked to surges of global tectonic activity, and major extinctions to intervals of quiescence.

In turn, local tectonics and sea level bear directly on temperature, water-land separation, pressure, and aeration (physical environment), on distribution of living organisms (biogeography), and on the survival, extinction, and succession of new forms (evolution). All are agreed, we believe, that biogeography, evolution, and physical environment determine the biota. Reciprocally, the creatures composing the biota may modify the physical environment by their activities.

Physical processes continue to act upon the organisms after death in biostratigraphy, control the manner of their burial, and, through diagenesis, may decide the manner of their preservation in taphonomy. The fossil record that results from the biota is universally acknowledged as drastically incomplete, the individuals having suffered from physical factors in the interval from death until final fossilization. All are affected, most are eliminated. The diagenetic factors of heat, pressure, and chemical changes that affect the fossil through time also play the star role in formation of the rock facies from sediments and, at least in initial stages, may influence the physical environment for surviving life forms. In rare instances, such as hard bottom, the rock facies may become part of the physical environment.

The list of problems in paleontology is long and seems to expand; to mention a few: (1) not all biota are preserved in the fossil record, (2) fossils that do persist through time are never complete, most of them represented only by hard parts, (3) even the hard parts of fossils have most likely suffered alteration through time, (4) spatial coincidence of bio-

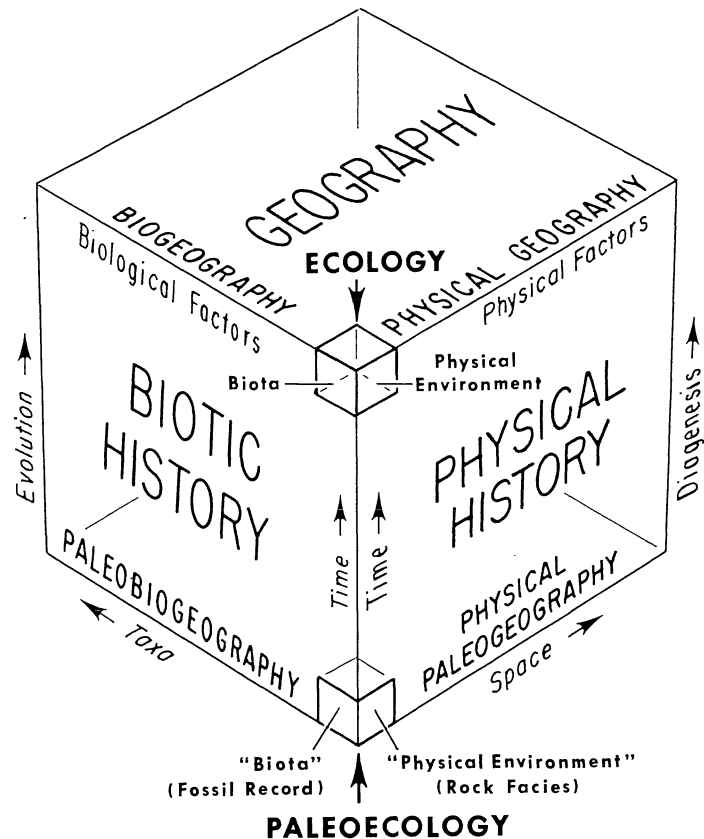

TEXT-FIG. 5 -- Isometric diagram of interrelations of biological factors, physical factors, and time in ECOLOGY and PALEOECOLOGY. Modified from Fischer in Imbrie & Newell, 1964, fig.1.

coenosis and thanatocoenosis must always be questioned, for many animals come to rest far from their homeland, (5) extinct species may not have been ecologically similar to their (presumed) descendants, (6) certain physical factors of environment may not have left their incontrovertible mark in the lithology -- the list could continue on and on. To solve these problems, or to enlighten the nature of the difficulties and dilemmas, modern workers have devised several approaches to utilize the data on fossils and their occurrence.

Applied Paleontology

Three factors enter into each application, or method of wringing useful information from fossil data. These are biological factors, physical factors, and time. By isometric dia-

grams, we can present a simplified version of the relative usage of each of these factors for each of the applications.

Paleoecology. -- As shown in text-figure 5, paleoecology represents the synthesis of the biota and rock facies through a selected time interval. It is the combination of paleobiogeography and physical paleogeography, in which time is represented both by evolution in the biotic history and by diagenesis in the physical history. The dimensions of either the biota or the extent of physical factors are left to the nature of the problem and the discretion of the investigator.

The idea is excellent, but its application is fraught with shortcomings. The only way to arrive at the way in which extinct organisms lived is to study their supposed descendants and to look for environmental clues in the rock

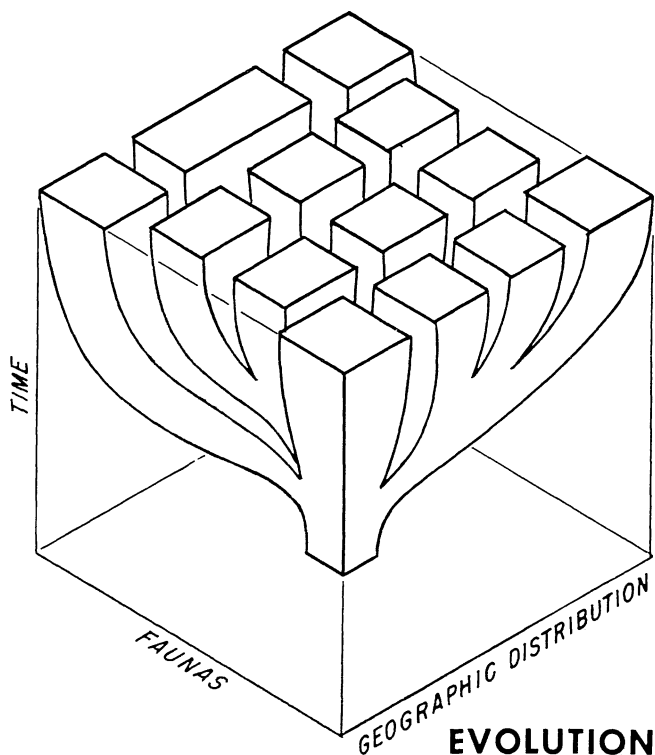

TEXT-FIG. 6 -- Isometric diagram of interrelations of biological factors, physical factors, and time in EVOLUTION, showing expansion and diversification of life forms through time and space.

facies. Today, in the various ecological settings of our earth -- quiet deep-sea floors, tropical highlands, arctic lowlands, temperate streams, warm lakes, etc. -- different physical factors are associated with the different communities of animals and plants. As we look at the past, the spatial distribution of physical and biological factors has seldom remained constant for very long: at any geographic locality the physical factors change as continents emerge, seas transgress and regress, and climates warm and cool, and the biota composing the community changes through evolution, with new immigrants, competition, and extinctions at that place. Through time, the physical factors alter sediments through diagenesis and fossils through selective preservation processes. The upward path of a community not only responds to evolutionary change in its composition but likewise to the geographic position of its habitat. Relationships of living creatures and their environments are intricate; and those between fossils and their rock facies are fully as intricate, having developed in the same manner. In reconstructing conditions under which the Middle Devonian animals lived, we are trying to work backward from effect to cause -- always an equivocal procedure.

The "biota" dimension in "paleoecology" more often than not is seriously eroded by physical factors, both figuratively and literally, not only at the time of burial but afterwards by solution, compression, and diagenetic alteration of mineral hard parts. This erosion of the "biota" dimension poses a major problem in restoration of the original faunal composition. It creates an even greater problem in interpretation -- the present "ecology" of particular kinds of animals in a particular environmental setting cannot be simply "lowered down" (in text-fig. 5) through time and accepted as the true and incontrovertible interpretation of "paleoecology" for long-extinct animals of presumed direct ancestry entombed in presumed identically formed sediments. We suspect that the record of physical factors in the rock facies may be every bit as faulty as the record of the biota preserved in the fossils.

Evolution. -- Basically, evolution is here meant to include the study of the expansion and

diversification of life forms through time and space. From an ancestor, various modifications led through time to a set of clearly differentiated descendants. Here, one can choose the three dimensions to fit his investigation. He may consider the evolution of all brachiopods of the world from Cambrian to Recent, or he may more modestly undertake to unravel the evolution of ostracods of the family Hollinidae in North America during the Devonian. Actually, evolution requires careful work on both taxonomy (correct identification of the fossils) and phylogeny (the tracing of particular lines of descent through time and space). As the term "evolution" is usually applied, it refers to a "big picture" of life expansion to fill all available ecological niches.

Faunal studies. -- Faunal studies are needed as the essential blocks for building the struc-

ture of paleontology. Most investigations of this kind are not limited taxonomically, but they cover only a brief period of time within a restricted area. For example, our faunal study of the megafossils in the Silica Formation, published in 1975, dealt with corals, brachiopods, bryozoa, crinoids, starfish, blastoids, bivalves, gastropods, other invertebrates, and the fishes of this part of the Middle Devonian in southeastern Michigan and northwestern Ohio. It did not trace the same fossils into other areas; it did not follow the faunal changes through extensive geologic intervals. Nevertheless, it is one more contribution about particular fossils of a particular time in a particular area, to be added to the carefully documented faunal studies of other formations in other areas and in other times -- finally building up the full scope of paleontological information for future workers.

Phylogeny. -- In phylogeny, attention is focussed on a very narrow segment of the biota, following the inferred relationships through time and space. The old method of establishing relationships was by intuition, guesswork, and "experience" in working with the group. Today, we have cladistics, by which all characteristics can be included in a numerical procedure to determine the most logical set of relationships. Nevertheless, this fascinating field is not sure ground, for the paleontologist cannot be certain that he has included the essential characteristics that were affected by evolution or that all characteristics were affected equally in descent.

The results of phylogenetic studies are reflected in the taxonomy. By our choice of higher taxonomic units, we attempt to demonstrate our convictions on phylogeny. Thus, all the Ostracoda included in the Palaeocopida are believed to have descent from a common ancestor and to have closer relationship to one another than to any ostracod in the Podocopida.

Phylogeny (text-fig. 8) usually encompasses a broad expanse of physical space and an extensive segment of geological time, but it has a very narrow biological dimension. Despite its geographical coverage, however, not all physical factors are considered, as they

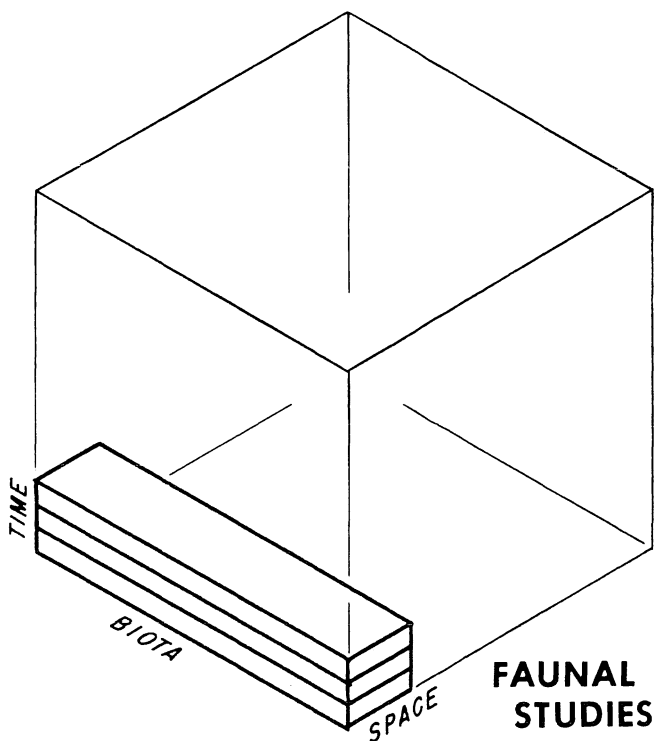

TEXT-FIG. 7 -- Isometric diagram of interrelations of biological factors, physical factors, and time in FAUNAL STUDIES, involving all the biota in a restricted area through a brief time span.

are in paleoecology.

"Classical" paleontology. -- The classroom version of paleontology too often contains little or no paleoecology. Such teaching seems to have advanced only slightly from the old Cabinet of Curiosities of medieval times. The fossils are presented as objects and have no "smell of mortality." The Cambrian is a drawer of so many differing objects, the Ordovician another drawer, and so on. Environments receive scant lip service. (See text-fig. 9).

The concept of life is essential in portraying the nature of fossils. True paleontology should embody practically all of the various applications discussed here.

Physical geology. -- To the paleontologist, physical geology, as it is taught in most intro-

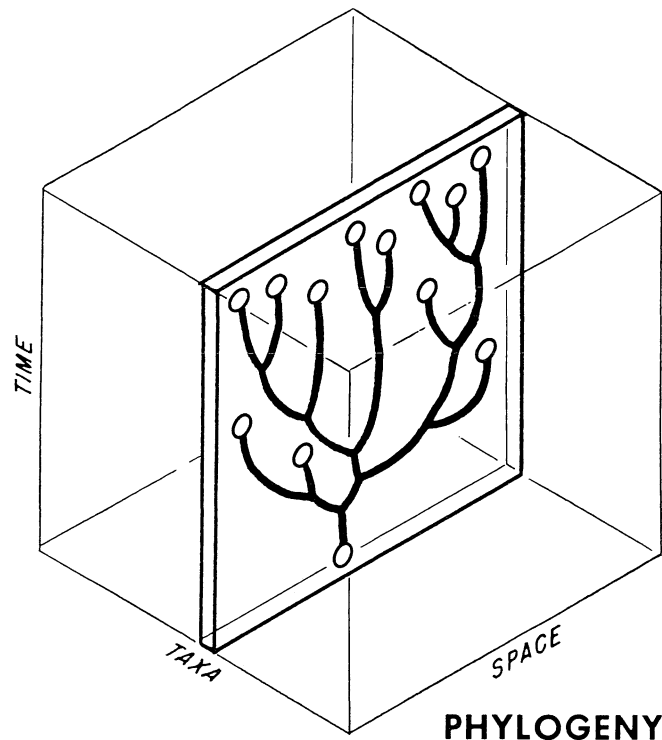

TEXT-FIG. 8 -- Isometric diagram of interrelations of biological factors, physical factors, and time in PHYLOGENY, showing the inferred relationships by descent of a small taxon through time and space.

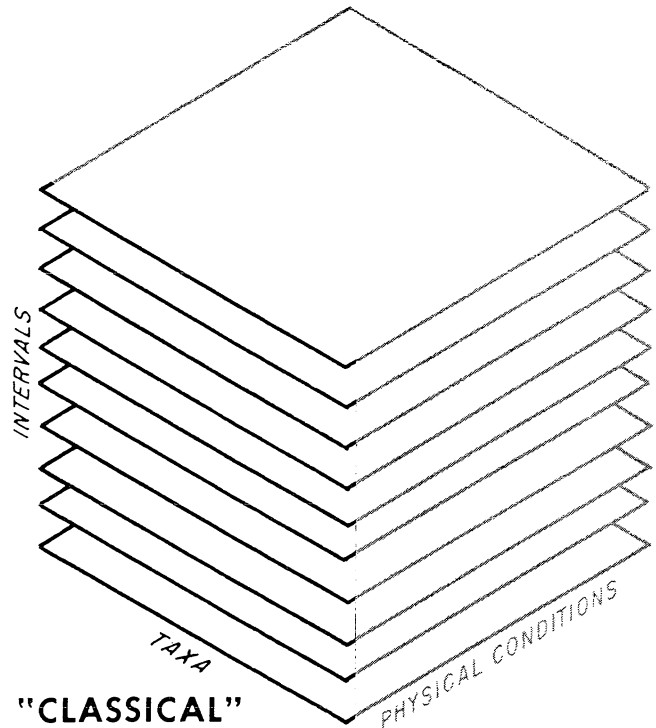

"CLASSICAL" PALEONTOLOGY

TEXT-FIG. 9 -- Isometric diagram of interrelations of biological factors, physical factors, and time in "CLASSICAL" PALEONTOLOGY, distribution of various fossils by taxa and time intervals with little regard for environments.

ductory courses, can be unbearably sterile, the dullest of lifeless worlds. It is a creation of seas without corals, lakes without fish, mountains lacking any alpine flowers, plains devoid of grazing antelope, hills with no trees, ponds in which no turtle swims, caves that shelter no bats, and mesas from which no coyote ever howls. It is totally inorganic. Barren.

Geography interests us only insofar as it provides habitats, and rock strata only insofar as they record past geographies, the conditions under which animals once existed. Physical parameters of climate, currents, and sediment strongly influence the biological parameters of toleration, adjustment, competition, survival, and extinction. Because physical geology can yield information on living conditions in the past, it deserves all the study we can devote

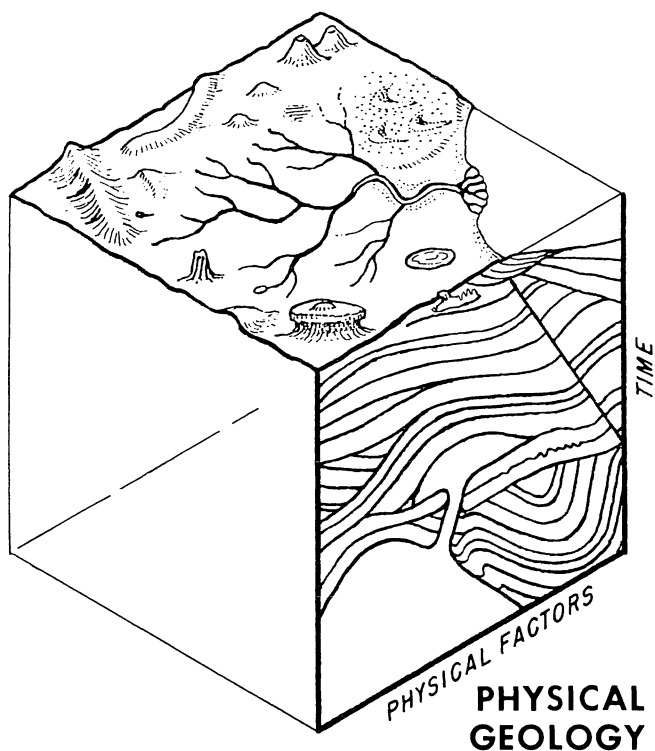

TEXT-FIG. 10 -- Isometric diagram of interrelations of biological factors, physical factors, and time in **PHYSICAL GEOLOGY**, stressing physical factors operating through geologic time and disregarding biological factors.

to it. Tectonics, continental drift, sedimentation, and glaciation have meaning to paleontology because they affected environments for creatures living and long dead.

The significance of physical geology in our science is that it bears directly upon the questions of how animals passed their day-to-day existence, where they found suitable conditions in their migrations, what they encountered in temperature, oxygen, substrate footing, and buffeting turbulence, and why some were ultimately eliminated. Briefly, the physical dimension must not be ignored, but it becomes fertile only when thoroughly integrated with the biological dimension through time.

Taxonomy. -- Taxonomy -- the naming, grouping, and differentiating of fossil organisms -- is a fine art. It is taxonomy. It in-

volves familiarity with a multitude of morphological structures as well as the legalistic rules and regulations which govern the use and application of scientific names. Taxonomy is a very necessary step in every application of paleontology, for only by accurate identifications can we communicate with other paleontologists.

Yet taxonomy is not an end in itself. It is completely isolated and insulated from considerations of the environment, the geographic distribution, the community association, or even functional morphology. As shown in text-figure 11, taxonomy has only two dimensions.

Devising and revising groupings and separations of the biota of many ages calls for much expertise. In the previous section, we have grouped the ostracod genera into families

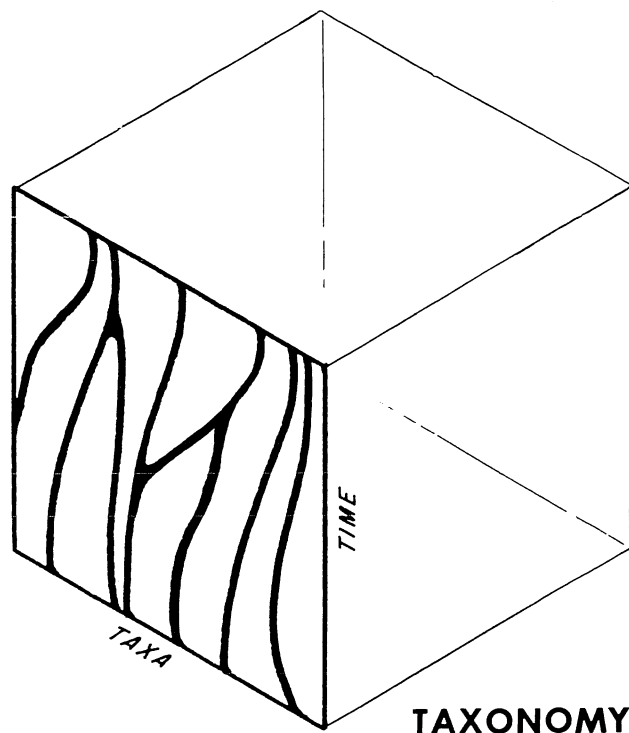

TEXT-FIG. 11 -- Isometric diagram of interrelations of biological factors, physical factors, and time in **TAXONOMY**, the naming, grouping, and differentiating of organisms through the ages without consideration of spatial distribution or physical environments.

to show our understanding of the closeness of their relationship and have presented keys to show our evaluation of their essential differences. Such decisions demand close concentration on all available observations.

Paleosynecology. -- The study of how contemporaneous animals once lived in communities, the relationships between and among the species in each community, and the interactions between communities comes close to being multiple paleoecologies within a very brief geological interval. This application can concern food chains, order of dominance, measures of success, and other fascinating lines of investigation.

Paleoautecology. -- Examining one very narrow taxon through its distribution in time and space, or even one individual through its

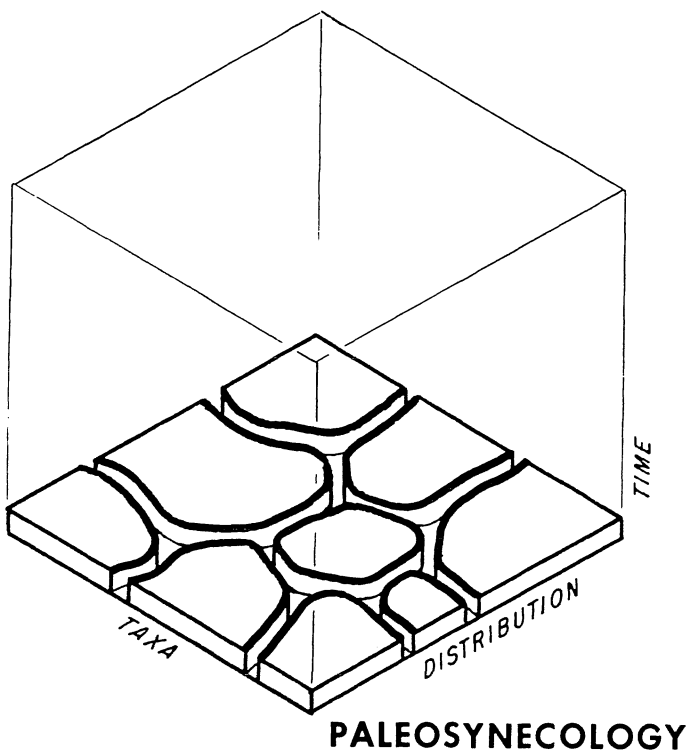

TEXT-FIG. 12 -- Isometric diagram of interrelations of biological factors, physical factors, and time in PALEOSYNECOLOGY, the study of fossil organisms associated in communities, their interrelations, and ecological distribution.

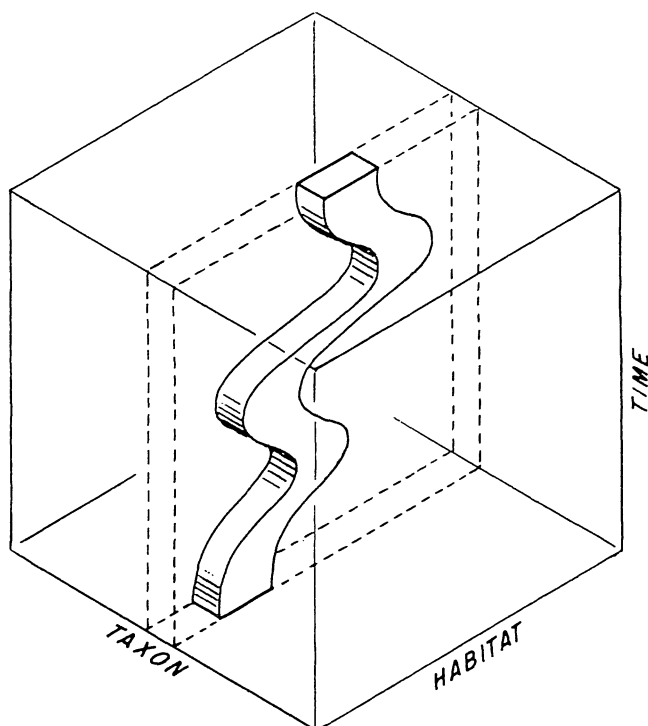

TEXT-FIG. 13 -- Isometric diagram of interrelations of biological factors, physical factors, and time in PALEOAUTECOLOGY, showing the adaptations through space and time of one small taxon or individual.

lifetime calls for astute observations and for logical inferences from a background of biology. From its interactions with other animals and with physical factors of environment, the individual may bear mute testimony. Some of the epifaunas on specimens of *Paraspirifer bownockeri*, which we illustrated in our book on the megafossils of the Silica Formation in 1975, are so remarkably complex in their sequence of infestation, their effects on the host, and marks of competition, that each of the brachiopods could serve as a research project.

Community succession. -- Within one small geographic area, the inhabitants change from time to time. Part of the change is due to evolution, but most is due to emigration-immigration responses to altered physical conditions. Deeper water, increased current vel-

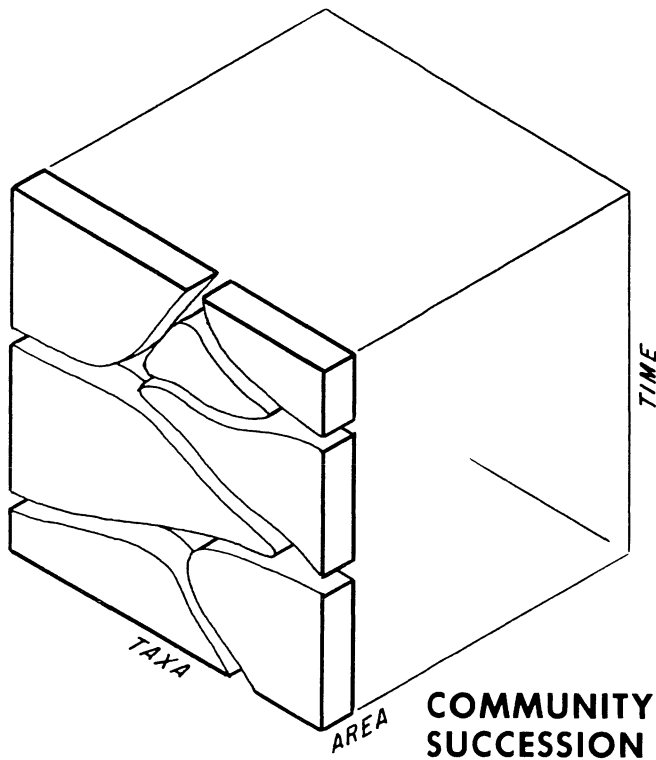

TEXT-FIG. 14 -- Isometric diagram of interrelations of biological factors, physical factors, and time in **COMMUNITY SUCCESSION**, the study of successive biota compositions through time in a restricted geographic area.

ocity, different sediment, or colder temperature may make the environment impossible for some of the present inhabitants and ideal for animals in other areas. Drastic changes in environment can empty the ecological niche and make it available for entrepreneurs and new settlers. As recorded in the rocks, one community was replaced by another.

From faunal studies of successive rock units in a small area, the paleontologist can detect the nature and magnitude of changes in the biota. In the material and structures of the rock units, he searches for clues to the nature of physical change which contributed to the biotic changeover. Community succession is an approach synthesizing paleoecology, faunal studies, paleosynecology, paleoautecology, and phylogeny in the attempt to sort out the

often subtle changes brought on by evolution of the older inhabitants from those brought on by emigration and ecological replacement resulting from a new set of physical parameters in the environment. It is a complicated exercise in detection.

Correlation. -- Correlation is chiefly responsible for the development of paleontology as a science. It was discovered long ago that each kind of animal survives for a limited geological time, then becomes extinct. The span of its existence is relatively brief compared to the time which is to be established. A few million years is insignificant if we are trying to determine if the formation is Silurian or Devonian.

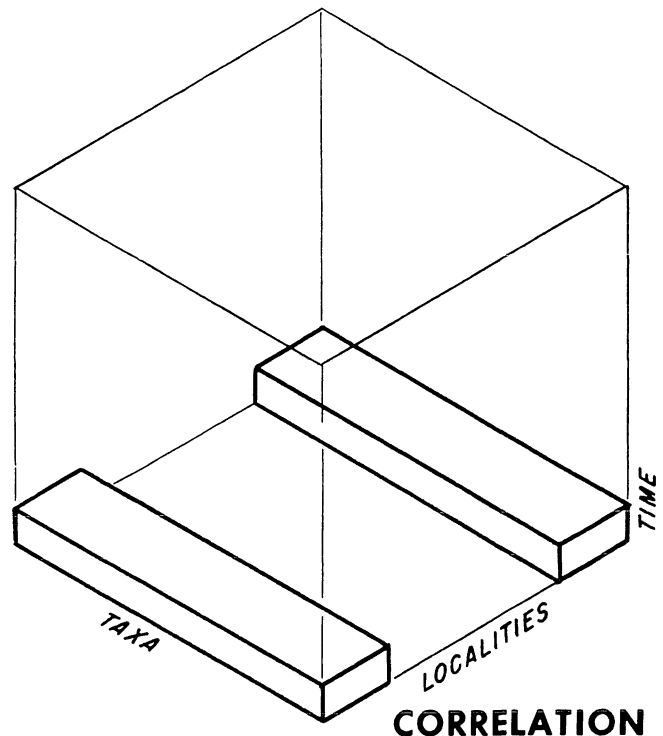

TEXT-FIG. 15 -- Isometric diagram of interrelations of biological factors, physical factors, and time in **CORRELATION**, whereby the biota and lithology of a thin zone at one locality are matched with those at another geographically separated locality to establish their time equivalence. The biota are much more important and useful than the lithology.

Simple correlation is based on comparison of species from one area with those of nearby areas. It may happen that the species is tolerant of variations in physical conditions if it is a bottom-dweller, or it may be independent of the sediment if it is a swimmer or floater. At any rate, fossils are much better indices of age than are sediment types for correlating rock units and determining their geological position.

The more species that two localities have in common, the more likely they are of the same age. We can even apply a formula to test the degree of certainty. If we select the locality with the fewer species (F) and count the number of species shared with the other locality (s), we can arrive at an index, called the faunal index (C):

$$C = 100 \times s/F.$$

Thus, if we have 150 species at one locality and 60 at the other, and 45 species occur in both, the faunal index is:

$$C = 100 \times 45/60 = 75.$$

If we are concerned with distantly separated localities, such as on different continents, we could compare the number of genera in common, or even the number of families in common, to arrive at some measure of correlation.

It is true that fossils do not measure time exactly. With transgressions and regressions of the sea, physical conditions move from one place to another. The fauna tends to migrate along with its favorite environment. Such a migration takes time. Therefore, the two outcrops with a high faunal index may not be exactly the same age; the one to which immigration took place would be slightly younger. Nevertheless, the time for survival of the species composing the fauna is so brief that the rocks may be regarded as very nearly equivalent in age.

If a certain species is found at one locality to occupy only a very thin zone, and occurs at the other locality in a similarly thin zone, one is led to believe that correlation is reliable.

Briefly, correlation is matching the re-

sults of two or more faunal studies.

Whenever a geologist uses a time-rock term, such as Devonian, he is utilizing the efforts of numerous paleontologists who have identified the fossils, compared them with those at Devon, England, and concluded that they are sufficiently similar to be correlated.

The specialist. -- Some micropaleontologists focus their life's efforts upon one small taxon as it is present in a particular area in strata formed during a brief geologic span. For an example, they might become authorities on the ostracods of Middle Devonian age in the Michigan Basin. This does not imply that they ignore any part of the physical setting in reconstructing the environment of that time. In specializing, however, such paleontologists

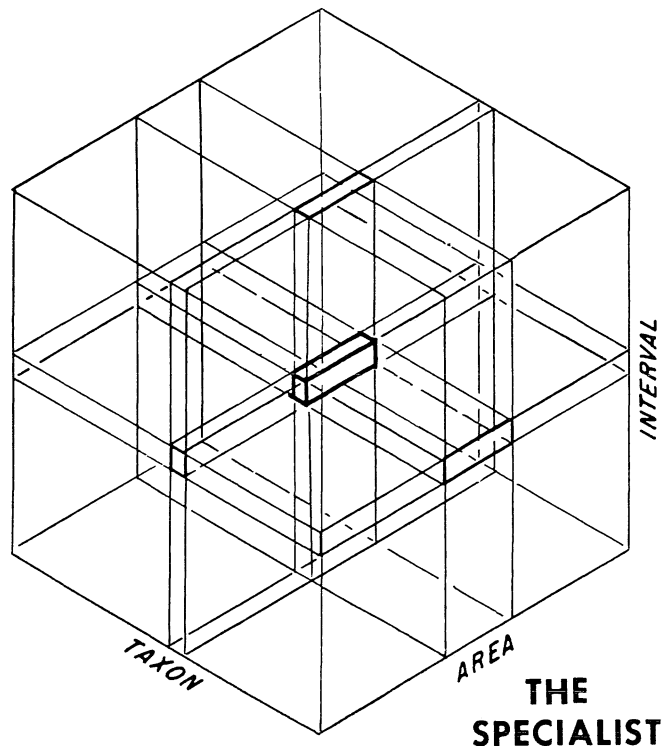

TEXT-FIG. 16 -- Isometric diagram of interrelations of biological factors, physical factors, and time in investigations by THE SPECIALIST, who intensively studies a small taxon of a particular age at a particular small geographic area.

may sacrifice the broader aspects of faunal associations, the diversity of the total community, and the correlations with other areas in order to concentrate and refine their clearly limited investigations.

The facets of paleontology grow increasingly complex, taxonomic categories proliferate exponentially, and a multitude of new names are published each year. No longer is it possible in one lifetime to become the "complete" paleontologist. It is not surprising, therefore, to find the professional paleontologist curtailing his research to become an expert on one small fossil group. After all, no one wishes to be a Jack-of-all-taxa and master of none.

Summary

Although biological factors, physical factors, and time are involved in the applications

discussed above, they differ in scope, degree, and nature for each particular application.

There are many ways to do paleontology, and the selection of one particular application can be made to suit the answers desired. Some fossil occurrences are much better suited to one application than are others, and the approach to the research can be tailored accordingly. In addition, some applications, such as evolution, may need a lifetime for adequate results, whereas others, such as a faunal study of one formation, may be a short-term project.

We have discussed these applications of paleontology not only to explain some of the work which follows but also to suggest to you, the reader, some lines of investigation that remain.

PALEOECOLOGY AND PYRITIZATION

Sediments

As outlined by Nussmann (in Kesling & Chilman, 1975, p. 173-223), the Silica Formation contains five major lithotopes: bioclastic limestone, argillaceous limestone, mucrospiriferid transition, shale, and crinoidal-bryozoan transition. As we interpret the sequences (text-figs. 17-20), the transgressive cycle involved a pattern of bioclastic limestone, argillaceous limestone, smothered bottom (shale upon limestone), mucrospiriferid transition, and clay shale, whereas the regressive cycle involved a pattern of clay shale, channeled bottom, crinoidal-bryozoan transition of fossil hash lenses in calcareous shale, argillaceous limestone, and bioclastic limestone. In general, the transgressive cycle was characterized at a particular site by decreasing energy (turbulence and currents), continued winnowing of clay particles, decreasing calcareous content, and concentration of clay in the deeper parts of the basin. On the other hand, the regressive cycle was characterized at a particular site by channeling in the soft shale at certain horizons, production of fossil hash by abrasion and breakage of shells from the relatively unconsolidated deposits and transport of such material to somewhat deeper water, and finally emergence into the shallow-water turbulent zone of the limestones.

The differences between the two cycles appear to be related to the condition of available sediment. As the sea flooded inland in transgression, the waves along the shoreline encountered subaerial indurated rocks, and as the water deepened far from shore the currents buried more resistant calcareous beds under successively softer and more argillaceous sediment. But as the sea ebbed away in regression, the waves along the shoreline attacked relatively unconsolidated sediments, with appreciable breakage of the released fossils; as the water shallowed offshore, waves and currents took on a more prominent role as shale deposition gave way to more calcareous beds with occasional

lenses of ground-up fossil hash and finally to bioclastic limestones of shallow water.

Megafossils

Among megafossils, the biotopes closely agreed with the lithotopes. However, certain brachiopods (Devonochonetes, Protoleptostrophia, and Mucrospirifer) and the trilobite Phacops occur in all rock types. The corals Hexagonaria, Cladopora, Favosites, Bethanyphyllum, Cystiphyllodes, Heliophyllum, and Heterophrentis, the brachiopods Longispina, Elytha, Strophodonta, Tropidoleptus, Megastrophia, and Spinocyrtia, and the molluscs Conocardium, Gosseletia, Loxonema, Lophonychia, Platyostoma, Paracyclas, and Modiomorpha all occur in bioclastic limestone, and many persisted into deeper water during transgression although very few tolerated the shale environment. Argillaceous limestone is the exclusive rock type in which Ambocoelia, Athyris, and Limoptera are found; in addition, this litho-biotope shared several genera of corals and brachiopods with the bioclastic limestone, as well as many genera with the mucrospiriferid transition, including: the bryozoans Botryllopora, Lioclema, and Anomalotoechus, the brachiopods Schizophoria, Camarotoechia, and Brachyspirifer, and the bivalve Grammysia. A number of large invertebrates tolerated all depths of water and all sediments except the bioclastic limestones, evidently excluded by the near-shore turbulence; these were the brachiopods Petrocrania, Pholidostrophia, and Paraspirifer, the bryozoans Fistulipora, Hederella, Streblotrypa, and Sulcoretepora, the coral Aulocystis, and the molluscs Cornellites and Tentaculites. Another group characterized the intermediate and deep water of the transgressive cycle (absent in bioclastic limestone and crinoidal-bryozoan transition beds); these included the brachiopods Leiorhynchus and Philhedra, the coral Aulopora, the worm Spirorbis, and the bryozoans Reptaria and Leptotrypella.

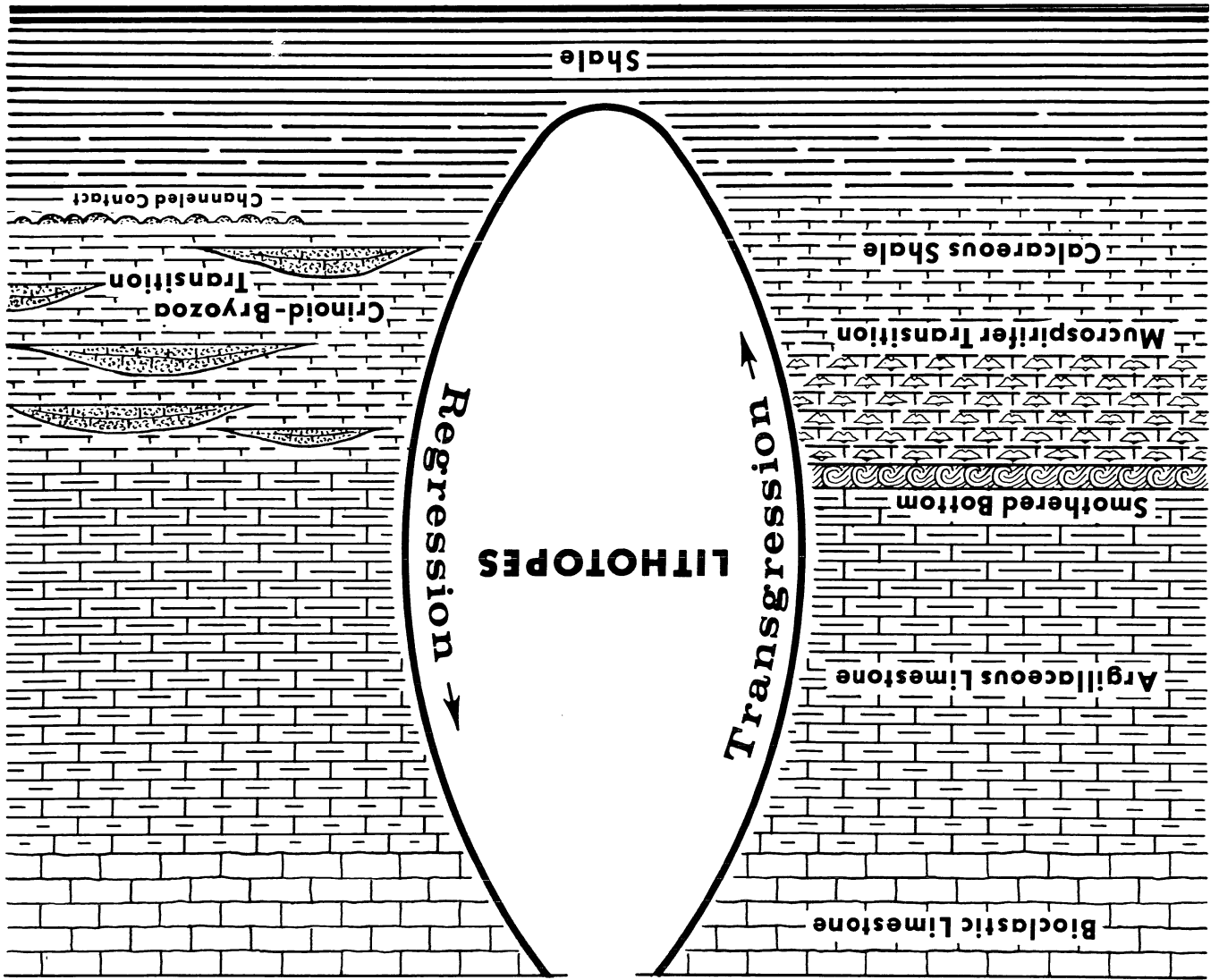

TEXT-FIG. 17 -- Cycles of transgression and regression as expressed in lithology of the rocks deposited at a particular site. Transgression (left side of figure) involves beds of shallow water (top) succeeded by beds of progressively deeper water. Regression (right side of figure) involves beds of deep water (bottom) overlain by progressively shallower water. A smothered bottom occurs during a phase of rapid transgression. Channelled contacts probably form during a pause in regression.

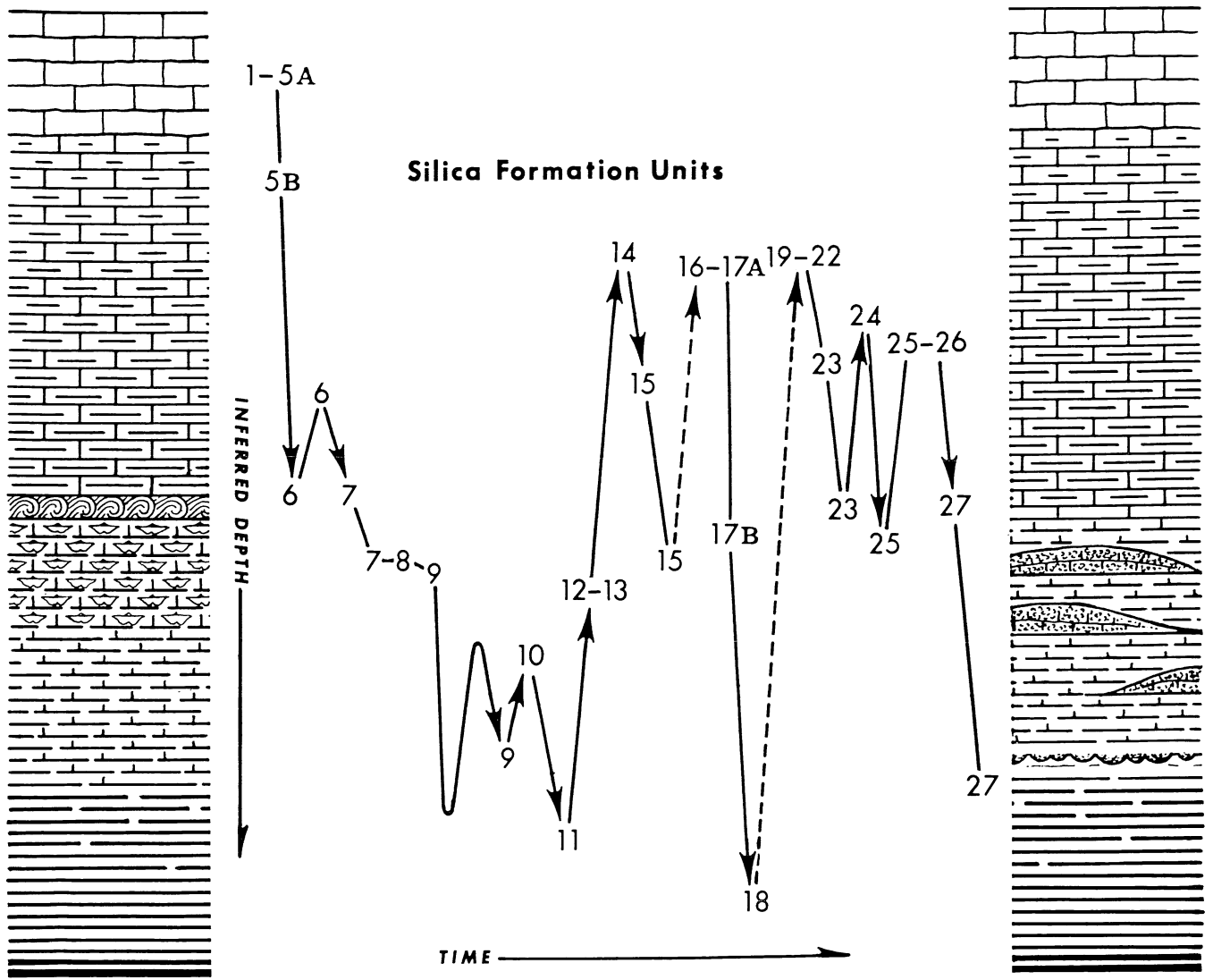

TEXT-FIG. 18 -- Lithotope types of Silica Formation units, based on lithology and inferred depth and genesis. Only units 1 through 5A represent bioclastic limestone; all others are deeper water. Units 11 and 18 are significant examples of clay shale, the latter perhaps deeper and less stirred by currents (inferred from its sparse fauna). Units 12 and 13 provide the best illustration of a crinoidal-bryozoan transition formed during a regression, whereas units 7 through 9 are excellent for a mucrospiriferid transition formed during a transgression.

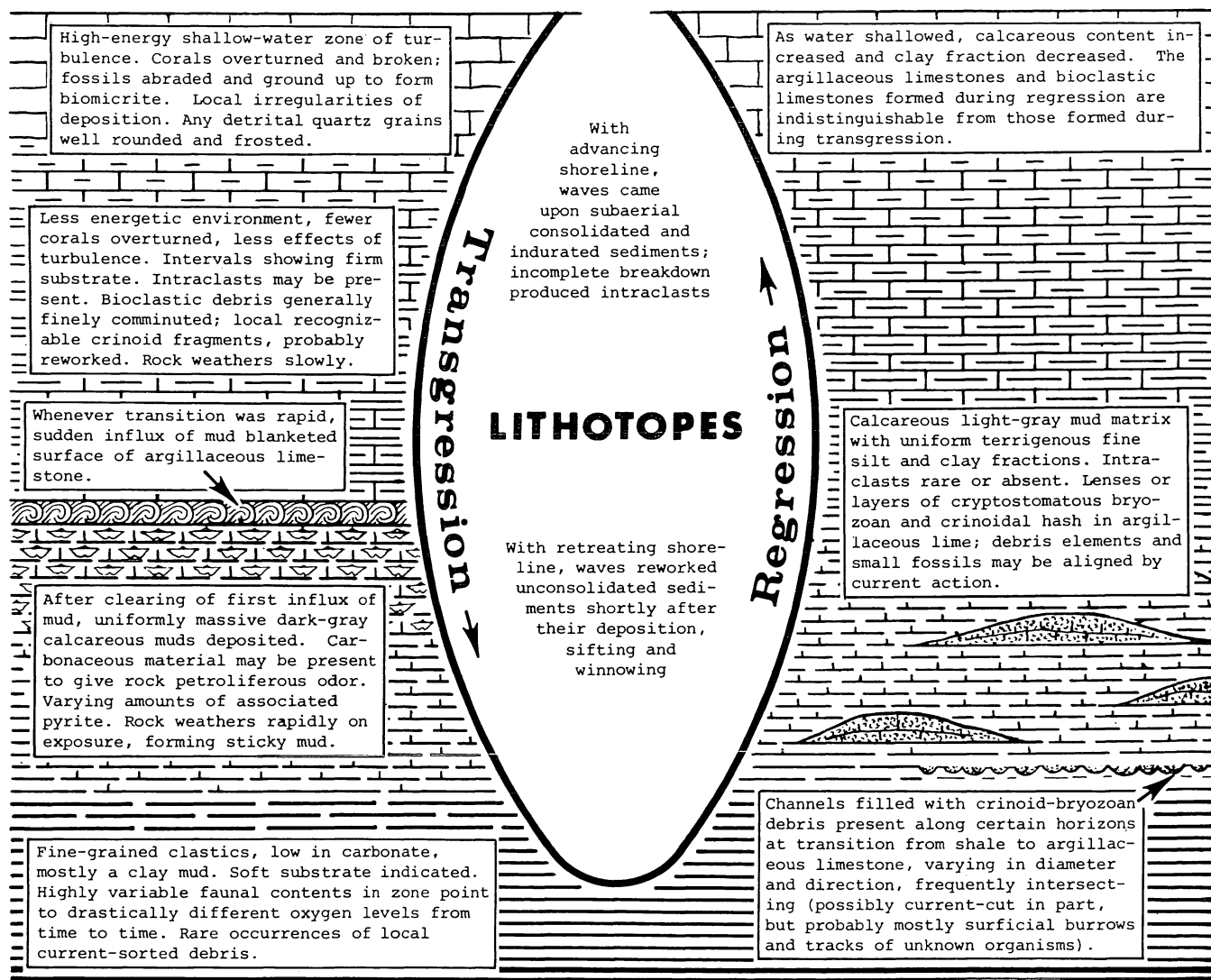

TEXT-FIG. 19 -- Environmental conditions assumed for lithotopes represented in the Silica Formation, stressing the physical factors of depth, turbulence, substrate firmness, aeration, carbonate content, clay fraction, current action, and biologic activity. Much of the difference between lithologies formed during transgression and those formed during regression can be attributed to the consolidated nature of sediment sources in the former and the soft unconsolidated sediment readily available in the latter.

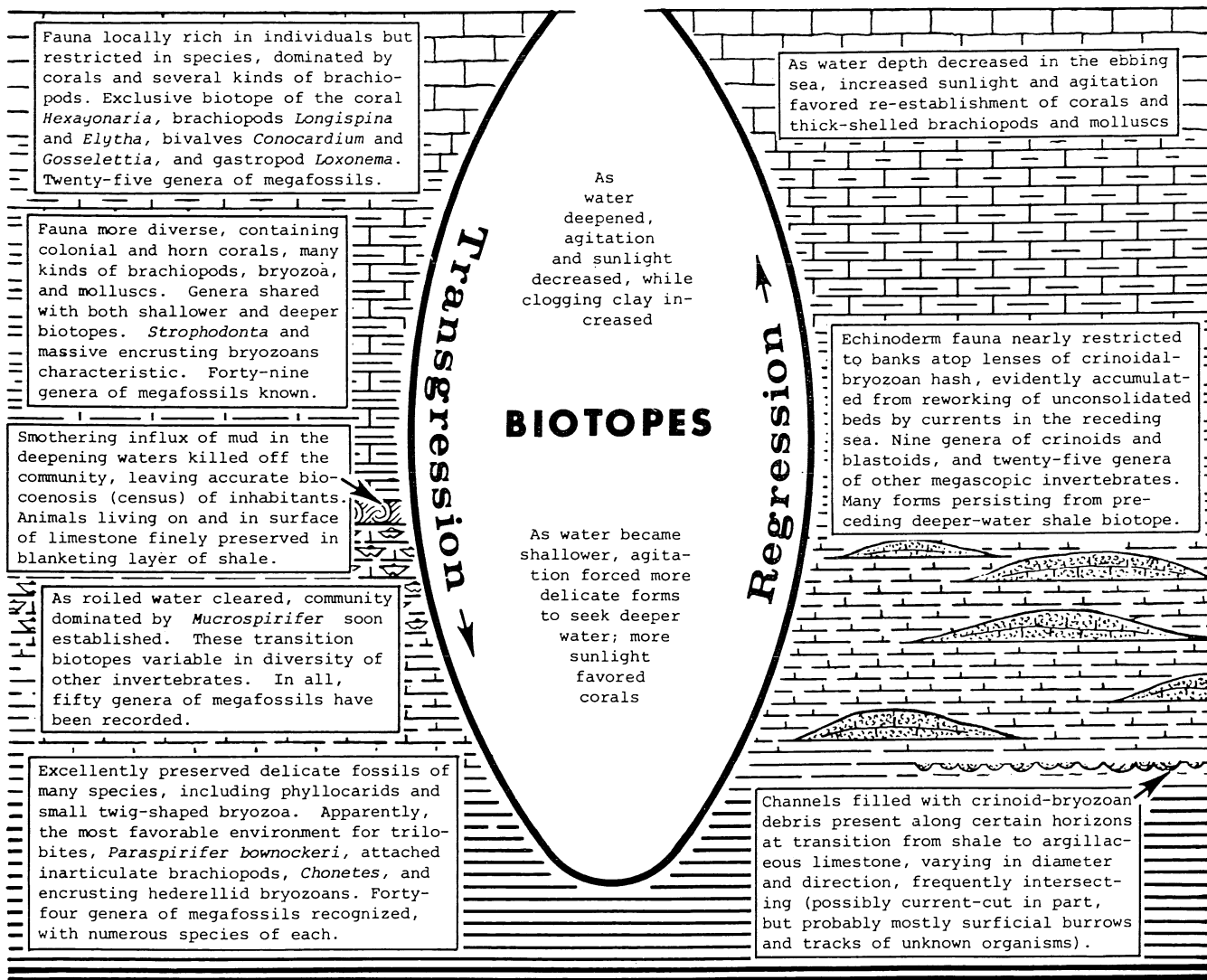

TEXT-FIG. 20 -- Environmental conditions assumed for biotopes represented in the Silica Formation, stressing the biologic factors of light intensity and penetration, turbulence of wave action, associated fauna in community interactions, interspecific competition, smothering effects of sediment, firmness of substrate for anchorage, food-supplying currents for filter-feeders, organic content of sediment for molluscs, and faunal assemblages. Light and turbulence were probably the most critical factors limiting species distribution.

With the first major influx of mud into the deepening water during transgression, the community on the argillaceous limestone was snuffed out. Clay clogged respiratory organs, and roiled water irritated soft tissues; vagrant benthos hastened to escape from the area, sessile animals were gradually and inexorably buried alive, and the sea floor scene changed dramatically. Where yesterday the area teemed with life, now only the soft sterile surface of newly settled mud was to be seen. The result was the preservation of an accurate census of the anchored and slow-moving animals -- a biocoenosis; the only members of the community not represented in the entombment were those swift enough to flee to unaffected areas, those quick enough to swim upward from the clouded bottom, and those strong enough to continuously clamber upward to stay above the accumulating mud. On the nearly deserted mud floor, currents continued to bring in finely comminuted food supply with scarcely an interruption. The area was ripe for exploitation and habitation again.

The mucrospiriferid transition biotope was dominated by species of Mucrospirifer, evidently because of the quick dispersal and settling success of this entrepreneur. Nevertheless, the beds also contain numerous other megafossils shared with genetically adjacent biotopes. The only faunal elements restricted to this biotope were the pincushion coral Pleurodictyum, the tabulate coral Trachypora, the encrusting bryozoan Ascodictyon, the brachiopods Hercostrophia and Cranaena, and the cephalopod Tornoceras.

The matrix succeeding the first influx of mud was usually a calcareous shale. It was exceptionally suited for preservation of fine details of the invertebrates buried in it. As the water became still deeper, even the finely ground-up silt-size particles of carbonate failed to reach so far from shore, and the only sediment was clay particles. Just how deep the sea was when this shale was deposited can only be inferred from the nature of the fauna. The surface community was one of filter-feeding brachiopods and bryozoans; near and below the sediment-water interface, bivalves plowed and burrowed; and the scaven-

ging arthropods fed upon the dead. We suspect that the bottom was well within the photic zone, where sunlight filtered down on clear days and dim light penetrated on most cloudy days; yet the soft bottom sediment was rarely if ever affected by storm-generated turbulence. Perhaps 120 to 150 feet (20 to 25 fathoms; 37 to 46 meters) was not far from the actual depth at that time. This is the only lithology where the delicate carapaces of Hebertocaris, Echinocaris, and Rhinocaris -- the latter still retaining iridescent coloration -- are found. Whether this means that these phyllocarids lived only at these depths, or that the shale was the only sediment capable of preserving such fragile remains, can only be a guess.

As regression began, the soft mud of the shale lithotope came into a zone where current action was effective. Probably certain soft-bodied organisms (such as holothurians?) which left no fossil record plowed through the surficial layers to utilize the organic content of the mud. Whatever produced the channels, varying in diameter, direction, and straightness and frequently intersecting, they soon filled with current-carried crinoidal-bryozoan debris like that found in lenses and thin layers in the overlying strata. As the rocks are quarried, these channel fillings invariably form prominent surface features of the overlying layer, expressed as an irregular network of various ridges upon the bottom of the layer.

As the shoreline receded during regression, the high-energy near-shore zone of turbulence acted upon recently deposited bottom sediments which were still soft and unconsolidated. Fragile shells of animals which lived far from shore were quickly exposed, as the waves and currents winnowed out the particles of matrix and left the shells behind as lag deposits. Shells thus concentrated were dashed together by waves, fractured, broken, and ground up to make a hash of fragments. From time to time, exceptional currents carried quantities of such hash into deeper water, spreading it as thin layers or distributing it as lenses. If transgression and regression were rapid enough, such deposits could be recycled several times before being either

Occurrences of Silica Ostracod Species by Litho-Biotopes

SPECIES	LITHO-BIOTOPE			
	Bioclastic limestone	Argillaceous limestone	Mucrospirifer Transit.	Shale Crinoid-Bryozoan Tran.
<i>Adelphobolbina trilobata</i>	█	█	█	█
<i>Aechmina crenulata</i>	█	█	█	█
<i>Birdsallella tumida</i>	█	█	█	█
<i>Bufina abbreviata</i>	█	█	█	█
<i>Bufina curti</i>	█	█	█	█
<i>Coelonella scapha</i>	█	█	█	█
<i>Dizygopleura euglyphea</i>	█	█	█	█
<i>Dizygopleura trisinuata</i>	█	█	█	█
<i>Euglyphella sigmoidalis</i>	█	█	█	█
<i>Kirkbyella (K.) bellipuncta</i>	█	█	█	█
<i>Ponderodictya punctulifera</i>	█	█	█	█
<i>Punctoprimitia simplex</i>	█	█	█	█
<i>Quasillites fordei</i>	█	█	█	█
<i>Quasillites obliquus</i>	█	█	█	█
<i>Quasillites sublunatus</i>	█	█	█	█
<i>Ulrichia conradi</i>	█	█	█	█
<i>Adelphobolbina spicata</i>	█	█	█	█
<i>Hyphasmophora textiliger</i>	█	█	█	█
<i>Octonaria quadricostata</i>	█	█	█	█
<i>Aechminaria hormathota</i>	█	█	█	█
<i>Bairdiocypris transptyxis</i>	█	█	█	█
<i>Balantoides trilobata</i>	█	█	█	█
<i>Bufina spinulifera</i>	█	█	█	█
<i>Bythocyproidea eriensis</i>	█	█	█	█
<i>Coelonella plana</i>	█	█	█	█
<i>Ctenoloculina cicatricosa</i>	█	█	█	█
<i>Cytherellina kutasii</i>	█	█	█	█
<i>Cytherellina lucasensis</i>	█	█	█	█
<i>Cytherellina subquadrata</i>	█	█	█	█
<i>Cytherellina tanymeke</i>	█	█	█	█
<i>Dirhabdus multicostatus</i>	█	█	█	█
<i>Eukloedenella doverensis</i>	█	█	█	█
<i>Falsipollex lativelatus</i>	█	█	█	█
<i>Healdia gibba</i>	█	█	█	█
<i>Hollinella (Keslingella) antespinosa</i>	█	█	█	█
<i>Hollinella (Keslingella) labrosa</i>	█	█	█	█
<i>Hollinella (Keslingella) pumila</i>	█	█	█	█
<i>Hypotetragona aequitalis</i>	█	█	█	█
<i>Hypotetragona harrietensis</i>	█	█	█	█
<i>Jenningsina catenulata</i>	█	█	█	█
<i>Menoeidina arcuata</i>	█	█	█	█
<i>Menoeidina subreniformis</i>	█	█	█	█
<i>Monoceratina casei</i>	█	█	█	█
<i>Octonaria laevilitata</i>	█	█	█	█
<i>Phlyctiscapha apleta</i>	█	█	█	█

SPECIES	LITHO-BIOTOPE			
	Bioclastic limestone	Argillaceous limestone	Mucrospirifer Transit.	Shale Crinoid-Bryozoan Tran.
<i>Poloniella cingulata</i>	█	█	█	█
<i>Ponderodictya ohioensis</i>	█	█	█	█
<i>Quasillites concentricus</i>	█	█	█	█
<i>Stictobollia alethae</i>	█	█	█	█
<i>Subligaculum bifidum</i>	█	█	█	█
<i>Tetrasacculus bilobus</i>	█	█	█	█
<i>Ulrichia fragilis</i>	█	█	█	█
<i>Ulrichia illinearis</i>	█	█	█	█
<i>Ulrichia spinifera</i>	█	█	█	█
<i>Wideneria lispa</i>	█	█	█	█
<i>Xystinotus subnodatus</i>	█	█	█	█
<i>Xystinotus wrightorum</i>	█	█	█	█
<i>Arcyzona diademata</i>	█	█	█	█
<i>Knoxiiella truncata</i>	█	█	█	█
<i>Octonaria crescentiformis</i>	█	█	█	█
<i>Aechmina choanobasota</i>	█	█	█	█
<i>Euglyphella modesta</i>	█	█	█	█
<i>Euglyphella projecta</i>	█	█	█	█
<i>Kirkbyella (Berdanella) stewartae</i>	█	█	█	█
<i>Menoeidina paucipunctata</i>	█	█	█	█
<i>Kavaryella cracens</i>	█	█	█	█
<i>Arcyzona bythyclimacota</i>	█	█	█	█
<i>Arcyzona campylactinota</i>	█	█	█	█
<i>Arcyzona rhabdota</i>	█	█	█	█
<i>Cornigella immotipedata</i>	█	█	█	█
<i>Cryptophyllus arsinus</i>	█	█	█	█
<i>Cryptophyllus minisculus</i>	█	█	█	█
<i>Ctenoloculina acanthina</i>	█	█	█	█
<i>Ctenoloculina eurybathrota</i>	█	█	█	█
<i>Cytherellina lechria</i>	█	█	█	█
<i>Doraclatum conatum</i>	█	█	█	█
<i>Kirkbyella (Berdanella) unicornis</i>	█	█	█	█
<i>Praepilitina silicensis</i>	█	█	█	█
<i>Scrobicula xysta</i>	█	█	█	█
<i>Subligaculum scrobiculatum</i>	█	█	█	█
<i>Euglyphella lispa</i>	█	█	█	█
<i>Glyphella reticulata</i>	█	█	█	█
<i>Healdia arkonensis</i>	█	█	█	█
<i>Healdia medusaensis</i>	█	█	█	█
<i>Hypotetragona fractodorsalis</i>	█	█	█	█
<i>Tetrahabdus pygmaeus</i>	█	█	█	█
<i>Coelonellina rara</i>	█	█	█	█
<i>Arcyzona homalosagenota</i>	█	█	█	█
<i>Falsipollex laxivelatus</i>	█	█	█	█
<i>Hanaites platus</i>	█	█	█	█

Occurrences of Silica Ostracod Species by Litho-Biotopes (cont'd)

SPECIES	LITHO-BIOTOPE				SPECIES	LITHO-BIOTOPE				
	Bioclastic limestone	Argillaceous limestone	Mucrospirifer Transit.	Shale		Crinoid-Bryozoan Tran.	Bioclastic limestone	Argillaceous limestone	Mucrospirifer Transit.	Shale
<i>Microcheilinella mariettensis</i>				■	<i>Birdsallella devonica</i>				■	
<i>Nannohealdia arcuata</i>				■	<i>Ehlersia hypercala</i>				■	
<i>Ponderodictya rhodesi</i>				■	<i>Knoxella rutkowskiae</i>				■	
<i>Richina subcircularis</i>				■	<i>Pronipantex planus</i>				■	
<i>Richina truncata</i>				■	<i>Rectobairdia emaciata</i>				■	
<i>Ropolonellus papillatus</i>				■	<i>Richina trinodosa</i>				■	
<i>Rugocytherellina ehlersi</i>				■	<i>Sigynus dictyotus</i>				■	
<i>Ulrichia fastidiosa</i>				■	<i>Acanthoscapha devonica</i>				■	
<i>Acratia simplex</i>				■	<i>Rudderina extensa</i>				■	
<i>Bairdiocypris gongylus</i>				■						

consolidated or ground into fine unrecognizable particles.

Whenever regression was relatively slow, such sporadic outbreaks of hash deposition settled and were held in place by a mixture of finely ground carbonate and clay, which gradually drifted in on the currents. On this rather firm base, numerous stemmed echinoderms made their anchorage, so that crinoid gardens flourished atop the low mounds of hash. The remarkable crinoid collecting in Unit 13 came from such a situation.

The shallower water deposits of argillaceous limestone and bioclastic limestone contained the same faunal assemblages, apparently whether formed during transgression or regression.

Ostracods

As can be learned from the tables of ostracod occurrences by formational units and by lithotopes, these fossils do not show nearly as much influence of sediment on their distribution as do the megafossils. Does this mean that the majority of ostracods were so tolerant that they could live equally well in all environments? Or does it mean that the shells of dead ostracods, being no heavier than a small

sand grain and shaped to settle slowly in the water, were distributed throughout the area like fine sediment particles? Or were they particularly subject to being carried to deeper water by currents as they clambered along the bottom to feed? Certainly, ostracods did not have the resistance to currents as did other invertebrates, which were heavier and many of which possessed some kind of anchorage.

As the tables clearly demonstrate, the abundant ostracod species were distributed into all lithotopes and were present in all units. To what degree they were reworked after initial deposition is hard to say, but most show little sign of wear. It is within the realm of probability that occasional strong currents could carry numbers of them into deeper water environments than the one where they were hatched, and that great numbers of dead shells could be reworked after deposition by the waves and nearshore turbulence during regression. It might also be borne in mind that ostracods, like other small crustaceans, are notably adaptable to a wide range of conditions; perhaps many of the Silica species could thrive at all depths.

If we take a census of the species present (the fauna) from each of the litho-biotopes

from the table just given, we find the following sums:

Silica Ostracod Species	
Bioclastic limestone	19
Argillaceous limestone	66
Mucrospiriferid Trans	81
Shale	102
Crinoidal-Bryozoan	88

From this, alone, one might be led to presume that shale was the favored environment for the vast majority of ostracod species. There is a numerical gradient of total species from shallow water to deep, just as has been established for living Foraminifera in the Gulf of Mexico. Yet this may be in large part an illusion.

If we compare the litho-biotopes/species for megafossils and for ostracods on a percentage basis, we find the following:

Litho-Biotopes/Species (percent of species sharing a given number of litho-biotopes)			
Litho-biotopes	Megafossils	Ostracods	
Five (all)	2.7)	14.6)	52.2
Four	12.4) 15.1	37.6)	
Three	21.2	18.4	
Two	20.4)	18.4)	29.4
One only	43.3) 63.7	11.0)	
Total	100.0	100.0	

Note that among megafossils nearly 64% are found in only one or two litho-biotopes and around 15% are present in four or five litho-biotopes, whereas among ostracods the situation is nearly the reverse, with around 29% present in one or two litho-biotopes and over half the species are found in four or five litho-biotopes. In the case of megafossils we can assume that, because of their size and weight, the majority were deposited at or near their favored environment. In the case of ostracods, however, such an assumption cannot be de-

fended. It would appear from this data, that (1) the majority of ostracod species in the Silica Formation were adapted to a wide range of environments (depths, light conditions, sediments, pressures, carbonate contents, etc.), or that (2) the majority of ostracod species were moved after or during life to a foreign biotope, being carried outward into deeper water by adverse currents. The latter is certainly possible, and the truth may have involved both factors -- adaptability and movement by currents.

Pyrite

The iron sulfide mineral associated with fossils in certain units is pyrite, as stressed by Nussmann (in Kesling & Chilman, 1975, p. 211). Confirmation of authigenic pyrite as the mineral penetrating through ostracod carapaces was made by Prof. E. William Heinrich of our Department of Geology & Mineralogy at The University of Michigan.

Pyrite affects the preservation of a considerable number of ostracod specimens in certain units (see plates 51 to 56), in which the crystals grew within and through carapaces and valves. Most of the occurrences are families of crystal forms rather than single pure crystals, but some show distinct cubes and pyritohedrons of the isometric system. Crystals vary from very small and barely discernible to larger than any of the ostracod carapaces, even to nodules several centimeters in longest diameter.

Replacement is so precise that fine details of ornamentation in parts of the carapace immediately adjacent to the pyrite crystals are undistorted and undisturbed. In the pyritiferous units, crystals of comparable size are present which reveal no projecting parts of an ostracod carapace, but which nevertheless may have completely replaced the entire ostracod specimen. Washings from these units contain quantities of pyrite "sand" of small crystals, indicating that a mere speck of organic matter may have sufficed as the nucleus around which pyrite could form and grow.

NOTES ON LITHOTOPES AND BIOTOPES

Ruth B. Chilman

The following remarks summarize my observations of faunal distribution and lithologies of the Silica Formation, and supplement the information presented above.

Units 1 through 16

At the Medusa quarries, the continuous sequence of beds exposed in the North Quarry in the 1960's was divided into 27 units, from the massive bioclastic limestones resting on the Dundee Limestone at the base, through alternating layers of argillaceous limestones and calcareous shales and siltstones. The bioclastic limestones, formerly known as the "Blue beds" of Stewart (1927) and Carmen (in Bassett, 1935) occur only at these exposures, and are apparently replaced by shales at the Martin-Marietta and Waterworks Park localities. The corals and stromatoporoids of the limestones are not present in the shales, but both lithotopes have an extensive brachiopod fauna. Two species which are very common in these lower beds (units 1-5), Cyrtina alpenensis (Hall & Clarke) and Tropidoleptus carinatus (Conrad), are very rare or absent in the beds above unit 5. Ostracods are abundant in the shales of units 1-6 at the Waterworks Park and Martin-Marietta localities.

Medium- to fine-grained beds of limestone, variably argillaceous and containing abundant pyrite, comprise units 6, 8, 10, 12, 14, 16, 17A, and 19-27. They produce a rich and varied benthonic fauna. The water of the Middle Devonian sea was apparently well aerated at those times and not too deep for some wave and current action to churn up and grind quantities of comminuted material from many taxa. Some lenses and beds of an argillaceous limestone composed almost entirely of cryptostomatous bryozoa and crinoid debris occur interspersed through the shales and normal argillaceous limestones from units 6 through 13. Rugose corals are present in units 6-8, where several genera, such as Heterophrentis, Bethanyphyllum, and Cystiphyllodes, are abundant. Tabulate corals are more numerous, with Aulocystis, Trachypora, and Aulopora common.

Many large brachiopods, including Megastrophia and Orthospirifer (formerly Spinocyrtia), occur up to unit 8, where Paraspirifer first makes its appearance. The best preserved specimens of Phacops rana milleri Stewart, the prized trilobite of the Silica fossils, are found in unit 8 and adjacent lower beds of unit 9. Bryozoa are present in most of the units, with the greatest concentrations in the argillaceous limestones and calcareous shales.

The shale lithotopes show considerable variation in composition and faunas. Units 7, 9, 11, 13, 15, 17A, and 18 consist of shales varying from very calcareous (as in lower 7, 9, 15, and 17A) to the mud or siltstones in upper 7, 11, and all 22 feet of unit 18. The greatest concentration of megafossils is found in the layers adjacent to the underlying argillaceous limestones. Pyrite is abundant, especially in units 7 and 9.

Unit 7 has the most taxa represented, including rugose and tabulate corals, 5 orders of bryozoa (in great abundance), and a profusion of brachiopods with many families well represented. The spiriferids include the large Orthospirifer (previously called Spinocyrtia), Mediospirifer (formerly called Brachyspirifer), and the very abundant Mucrospirifer prolificus (Stewart). Strophomenids include Megastrophia, Pholidostrophia, Protopleptostrophia, Hercostrophia (found only in unit 7), and several species of Strophodonta. Pseudatrypa (formerly Atrypa), Rhipidomella, and several species of Devonochonetes are common. Annelids are represented by Spirorbis and the black mandibles of scolecodonts.

Molluscs are less common and, except for some gastropods, are poorly preserved. Platyceras is most common, with three or four species represented. Good bivalves are rare, as are cephalopods. The cricoconarid Tentaculites is found in most of the shale units. Many molted carapaces of Phacops rana crassituberculata Stumm are found in this unit, but entire specimens are rare. Most crinoids belong to the genus Arthroacantha, many of them reaching large size here.

Ostracods are few in numbers and species, perhaps due to wave action, as there is a great

deal of comminuted material in the sediments. The ostracod species found in units 7 and 12 have thicker tests than those of the finer shales where less comminuted material is present. Ponderodictya, Euglyphella, and Octonaria are good examples of these ostracods.

Because of the shale lithology, hard substrate for attachment was at a premium, and the larger shells, corals, bryozoan zoaria, and even fish plates are often covered with a wealth of epifauna. The beautifully preserved little ctenostomes Eliasopora, Ascodictyon, and Hederella form delicate tracery on corals, brachiopods, and other bryozoans.

Unit 9 has an extensive fauna in the lower part, but registers a change in taxa. Brachiopods, so numerous in the lower units, are pretty much limited to spiriferids and chonetids. Paraspirifer bownockeri (Stewart) is characteristic of units 9 and 11, and Devonochonetes coronatus, D. fragilis, and D. scitulus are found in great numbers, often massed in beds. Phacops species are beautifully preserved here, especially in the more calcareous shales near the bottom of the unit. All four species of phyllocarid crustaceans occur in this unit -- the small brown Echinocaris, the larger iridescent Rhinocaris, the large distinctively ornamented Dithyrocaris, and the gigantic Hebertocaris, which undoubtedly exceeded 18 inches (half a meter) in length. Many fine crinoids have also been obtained here and there, sometimes in clusters, especially Arthroacantha carpenteri (Hinde) and Gilbertsocrinus ohioensis Stewart. Ostracods reach their greatest abundance and diversity in the shales of units 9 and 11. Of the 112 species named from the Silica Formation, all but ten were present in these two units. The strata have been called the Styliolina-Chonetes beds from the abundance of these fossils. To judge from the excellent preservation, the carapaces of the extensive pelagic fauna must have been buried rapidly in fine mud and silts. The matrix breaks down readily in water to release these very fine specimens. Microfossils are especially abundant around clusters or beds of chonetids, which range from 0.1 mm to adults of 25 to 30 mm diameter. Styliolina fissurella

(Hall) is found by thousands in these beds. Conodonts, mostly of the genus Icriodus, are common in the fine shales of units 7, 9, and 11.

The ostracod assemblages in the argillaceous limestones and shale units 6-15 show little variation between biotopes. The hard argillaceous limestone of unit 16 is practically barren. A distinct change in the biota shows up in units 17 and 18.

Ostracods of units 17 and 18

The massive granular limestone of unit 16 becomes increasingly argillaceous in the lower part of unit 17 (17A), grading into some very calcareous shale at the top (17B). This shale is very tenacious and does not readily release the enclosed fossils, so that most specimens recovered are somewhat broken and exfoliated.

A limited brachiopod fauna in this unit differs from those of lower units, with a genus of the family Ambocoeliidae very abundant. Identified by Stewart (1927) as "Ambocoelia umbonata" but differing from that genus in several respects, it is more probably an Echinocoelia; it occurs only in this unit in the Silica Formation. In some places, specimens are jumbled and cemented together, from tiny juveniles to mature adults; fossils from these pockets are well preserved wherever the shale is less calcareous and weathering has been slow. Although absent from other strata of Michigan, "Ambocoelia" or Echinocoelia is common in the Ludlowville and Moscow formations of western New York. Mucrospirifer mucronatus (Conrad) is common in unit 17, where it appears for the first time in the Silica succession. A small dalmanellid, Sphenophragmus nanus Imbrie, is common in unit 17 but rare in lower units. Some small unidentified chonetids have also been found.

These brachiopods, with a few trepostomatous bryozoans and the cricoconarid Tentaculites, are closely packed in a "smothered bottom" assemblage at the top of the unit. This biocoenosis was fixed in place when the fine mud of unit 18 suddenly deluged the top surface of unit 17 and extinguished all living creatures.

A limited number of ostracod species is found in unit 17, most of them poorly preserved but identifiable. One is unique in abundance and preservation. It is Octonaria laevilatata Kesling & Kilgore, described (1952) from the Genshaw Formation, where its abundance and appearance closely resemble the Silica occurrence. This species is very rare in the beds immediately below, but common in unit 17; it is absent in higher units. The ostracod has a brownish color (unusual in Silica species) and a distinct sheen on the carapace. A few specimens were found in some of the other Traverse beds in northern Michigan and in the coral bioherm of unit 18A at Medusa North Quarry, but it has not been found in any of the Ontario and New York localities. About 31 other species were found, but only Ponderodictya, Euglyphella sigmoidalis, and Bufina are at all common.

In the 22 feet of almost barren shales comprising unit 18, one feature is particularly significant. In the late 1960's, quarrying along the west wall of the Medusa North Quarry exposed a coral thicket or bioherm growing on the hard substrate of unit 17. It was a roughly circular mound about 100 feet in diameter and rising to a height of almost 15 feet in the center, composed almost entirely of the auloporoid coral Aulocystis auloporoidea (Davis). This deposit, designated as unit 18A by Prof. G. M. Ehlers, appears to have been formed by the surviving fauna from unit 17 which continued to grow and build above the great quantities of mud forming unit 18; as a deposit of densely packed auloporoids, it was unique not only in the Silica Formation but perhaps among Middle Devonian reefs, as reported by the late Prof. E. C. Stumm (1969e, p. 244).

This dense thicket of small coral tubes harbored a most interesting fauna. It provided a breeding place for a multitude of small brachiopods, particularly Sphenophragmus nanus, which is present by thousands, from juveniles less than 0.1 mm to adults 4 or 5 mm in diameter. Other small species of Cupulorostrum, Rhipidothyris, unidentified small chonetids, and other brachiopods were there in fewer num-

bers. As a reef, unit 18A was miniaturized in its overall magnitude and in the size of its inhabitants.

The thinly bedded fine shales in and around the bioherm contain specimens of small linguloid brachiopods, small bivalves, and fragments of the carapaces of Rhinocaris ehlersi. Gardens of the flexible crinoid Eutaxocrinus widen-eri Kesling & Strimple (1971) apparently grew on the coral thicket, and brittle-stars swarmed around it. Strataster ohioensis has been described from fine clay strata of Mississippian age in northern Ohio by Kesling & LeVasseur (1970), in which bedding planes expose a profusion of writhing, often intertwined little brittle-stars. Strataster devonicus, a similar filter-feeding little brittle-star from the Silica Formation described by Kesling (1972), may have been as prolific as the later S. ohioensis; microwashings are rich with the flat scapula-shaped oral spines of the species, and some of the fine shales near the 18A bioherm display surfaces impregnated with these spines. A larger echinoderm, the starfish Silicaster esseri Kesling (1969), was found in dissolved blocks of the bioherm.

A modest ostracod fauna of some 38 species was identified. Preservation, especially of the smooth species, was poor because of distortion and formation of calcite crystals. Ponderodictya species and Euglyphella sigmoidalis were most abundant; Octonaria laevilatata and Bufina spinulifera occur in moderate numbers.

The bioherm was completely removed during quarrying operations at North Quarry, but fossils from the deposit are still weathering from dumped blocks. Enough are present to show the nature of the bioherm to quarry visitors for several years to come.

Occurrences of Silica Ostracod Species by Stratigraphic Units

SPECIES	Medusa quarries													Martin-Marietta Quarry					Waterworks Park		
	Unit													1-6	9-11	12	14-15	17-18	1-6	9-11	12
	6	7	9	11	12	13	14	15	16	17	18	21	23								
<i>Acanthoscapha devonica</i>				x																	
<i>Acratia simplex</i>																					
<i>Adelphobolbina spicata</i>	x	x			x										x						
<i>Adelphobolbina trilobata</i>	x	x	x	x	x	x	x	x	x	x	x	x	x		x	x	x	x	x		
<i>Aechmina choanobasota</i>		x	x									x				x	x	x			
<i>Aechmina crenulata</i>		x	x	x	x	x	x	x	x	x	x	x	x		x	x	x	x	x		
<i>Aechminaria hormathota</i>		x	x		x	x										x	x	x			
<i>Arcyzona bythyclimacota</i>		x	x	x	x	x	x	x	x	x		x	x		x		x	x			
<i>Arcyzona campylactinota</i>		x	x	x	x	x	x	x	x						x		x	x			
<i>Arcyzona diademata</i>			x	x	x	x	x	x	x							x	x	x			
<i>Arcyzona homalosagenota</i>			x	x	x			x	x							x					
<i>Arcyzona rhabdota</i>		x	x	x	x	x	x	x								x			x		
<i>Bairdiocypris gongylus</i>			x	x													x				
<i>Bairdiocypris transptyxis</i>		x	x	x	x	x	x										x	x			
<i>Balantoides trilobata</i>		x	x	x	x	x	x	x	x	x					x		x	x			
<i>Birdsallella devonica</i>					x												x				
<i>Birdsallella tumida</i>	x	x	x	x	x	x	x	x	x	x	x				x		x	x	x		
<i>Bufina abbreviata</i>	x	x	x	x	x	x	x	x	x	x	x	x	x			x	x	x	x		
<i>Bufina curti</i>	x	x			x	x						x	x			x	x	x			
<i>Bufina spinulifera</i>		x	x	x	x	x	x	x	x	x	x	x	x			x	x	x	x		
<i>Bythocyproidea eriensis</i>			x	x	x						x	x	x			x	x	x	x		
<i>Coelonellina rara</i>			x																		
<i>Coelonella plana</i>		x	x	x	x	x	x	x	x	x	x	x	x			x	x	x	x		
<i>Coelonella scapha</i>	x	x	x	x	x	x	x	x	x	x	x	x	x			x	x	x	x		
<i>Cornigella immotipedata</i>		x															x				
<i>Cryptophyllus arsinus</i>			x	x	x													x	x		
<i>Cryptophyllus minisculus</i>																	x	x			
<i>Ctenoloculina acanthina</i>		x			x			x									x				
<i>Ctenoloculina cicatricosa</i>		x	x	x	x	x	x	x	x	x	x	x	x			x	x	x	x		
<i>Ctenoloculina eurybathrota</i>		x	x	x	x												x				
<i>Cytherellina kutasii</i>		x	x	x	x			x	x	x	x	x	x			x	x	x	x		
<i>Cytherellina lechria</i>			x	x												x	x	x	x		
<i>Cytherellina lucasensis</i>		x	x	x	x	x	x	x	x	x	x	x	x			x	x	x	x		
<i>Cytherellina subquadrata</i>		x	x	x	x	x	x	x	x	x	x		x			x	x				
<i>Cytherellina tanymeke</i>		x	x	x	x	x	x									x	x	x			
<i>Dirhabdus multicostatus</i>			x	x	x	x	x										x	x	x		
<i>Dizygopleura euglyphea</i>	x	x			x	x	x										x	x			
<i>Dizygopleura trisinuata</i>	x	x	x	x	x	x	x	x	x	x	x	x	x			x	x	x	x		
<i>Doraclatum conatum</i>																	x				
<i>Ehlersia hypercala</i>					x												x				
<i>Euglyphella compressa</i>	x	x	x	x	x	x	x	x									x	x			
<i>Euglyphella lispa</i>		x					x										x	x	x		
<i>Euglyphella modesta</i>		x	x														x				
<i>Euglyphella projecta</i>		x					x	x									x	x			
<i>Euglyphella sigmoidalis</i>	x	x	x	x	x	x	x	x	x	x	x	x	x			x	x	x	x		
<i>Eukloedenella doverensis</i>			x	x	x	x	x	x								x	x	x			
<i>Falsipollex lativelatus</i>		x	x	x	x	x	x	x								x	x	x			
<i>Falsipollex laxivelatus</i>				x	x	x										x	x	x			
<i>Glyphella reticulata</i>																					
<i>Hanaites platus</i>																	x			x	

Occurrences of Silica Ostracod Species by Stratigraphic Units (cont'd)

SPECIES	Medusa quarries													Martin-Marietta Quarry				Waterworks Park					
	6	7	9	11	12	13	14	15	16	17	18	21	23	1-6	7	9-11	12	14-15	17-18	1-6	7	9-11	12
<i>Subligaculum bifidum</i>		x	x	x	x		x	x					x	x		x	x	x					x
<i>Subligaculum scrobiculatum</i>			x		x											x	x	x					
<i>Tetrarhabdus pygmaeus</i>																x				x	x		
<i>Tetrasacculus bilobus</i>			x	x	x	x	x	x	x	x	x	x	x	x	x	x	x	x		x	x	x	x
<i>Tetrastorhynchus diabolicus</i>					x											x							
<i>Ulrichia conradi</i>	x	x			x			x			x	x				x						x	x
<i>Ulrichia fastidiosa</i>						x										x							x
<i>Ulrichia fragilis</i>		x	x	x	x	x	x	x				x		x	x	x	x	x		x	x		
<i>Ulrichia illinearis</i>			x	x	x	x	x							x		x		x		x	x	x	x
<i>Ulrichia spinifera</i>		x	x	x	x	x	x	x	x	x	x	x		x	x	x	x	x		x	x	x	x
<i>Wideneria lispa</i>			x		x		x							x		x				x			
<i>Xystinotus subnodatus</i>							x							x		x	x	x		x	x	x	
<i>Xystinotus wrightorum</i>														x		x	x	x		x	x	x	

DISTRIBUTION OF SPECIES BY SILICA UNITS

... there will be no difficulty in explaining why the habitations of so many species are now restrained within exceedingly narrow limits. Every local revolution ... tends to circumscribe the range of some species, while it enlarges that of others; and if we are led to infer that new species originate in one spot only, each must require time to diffuse itself over a wide area. It will follow, therefore, ... that the recent origin of some species, and the high antiquity of others, are equally consistent with the general fact of their limited distribution; some being local, because they have not existed long enough to admit of their wide dissemination; others, because circumstances in the animate or inanimate world have restricted the range which they may once have obtained.

-- Charles Lyell, Principles of Geology

These words written by Sir Charles Lyell in 1830, long before Darwin published his books on evolution, are startlingly clear and ecologically sound. They concern species distribution of the present and past equally well.

As the above table shows, the distribution of ostracod species is irregular throughout the formation. A few species have been found only

in one unit; certain others are restricted to a few units; and many continue without interruption through nearly all units.

It so happens that some species are present in the lowermost and uppermost units, from which we may conclude that the Silica Formation did not last longer than the time span of an ostracod species (or at least the time span of certain species). Based on the antiquity of living species, we may presume that the whole of the Silica was concluded in a few million years at most.

A few species are stratigraphically limited for one reason or another. *Acanthoscapha devonica* is so rare that no complete carapace has been discovered; it is represented only in unit 12, where diagnostic fragments occur. *Acratia simplex* is another rare species, being present only in units 9-11 at Martin-Marietta Quarry. *Birdsallella devonica* has the same occurrence, quite unlike the stratigraphically widely disseminated *Birdsallella tumida*. The same beds at Martin-Marietta are the only matrix for *Ehlersia hypercala*, the new *Richina trinodosa*, and the new distinctive *Pronipantex planus*. On the other hand, the same strata contain numerous ostracods which are found in other units. It seems to us that some physical parameter in the environment allowed an influx of species from other localities; the

habitat soon changed and the new settlers were eliminated. The case of Octonaria laevilatata is slightly different. A few entrepreneurs of that species arrived at the time of unit 14 and managed to survive until unit 17, at which time they experienced highly favorable conditions and flourished during that interval; they became more successful than the older residents of the area. Then, due to some unknown cause, they were forced out of the area; in fact, some of the few specimens found in unit 18 may be reworked from older deposits.

In notable contrast, every sample which contained any ostracods at all was rife with the ubiquitous Ponderodictya punctulifera and Quasillites fordei. Most units were rich in other species, including Adelphobolbina trilobata, Aechmina crenulata, Balantoides trilobata, Bufina abbreviata, B. spinulifera, Coelonella scapha, Ctenoloculina cicatricosa, Cytherellina lucasensis, C. subquadrata, Dizygopleura trisinuata, Euglyphella sigmoidalis, Kirkbyella bellipuncta, Menoeidina subreniformis, Ponderodictya ohioensis, Punctoprimitia simplex, Quasillites sublunatus, and Ulrichia spinifera.

Nearly all of the long-ranging ostracod species are represented at many levels by abundant individuals. At least part of the prolonged success of these species may be attributed to their large standing populations.

Some ostracods have no immediate ancestors in the older units of the Silica, and represent late immigrants into the area. By and large, however, the formation is not faunally zoned, and units of the lower half contain many of the species which persisted into the upper half. Hence, little evidence of evolution or of phylogenetic lines can be identified in the Silica Formation.

The faunules of the units are distinctive according to lithology, as indicated by the charts on pages 133 and 134. From the occurrences, one might believe that the bioclastic limestones and argillaceous limestones formed during transgression did not support distinctive ostracod faunas, for the species found in them are, without exception, found also in deeper water deposits. However, as pointed out, the minute size and light weight of ostracods may

have made them subject to currents, which distributed them farther from shore. This is highly likely. Most of the species (excepting the thin-shelled and oddly-shaped Aechmina crenulata) which are present in the bioclastic limestone of unit 6 are heavy, thick-shelled forms. These include Adelphobolbina trilobata, Birdsallella tumida, Bufina abbreviata, B. curti, Coelonella scapha, Dizygopleura euglyphea, D. trisinuata, Euglyphella sigmoidalis, Kirkbyella bellipuncta, Ponderodictya punctulifera, Punctoprimitia simplex, Quasillites species, Ulrichia conradi, and Octonaria quadricostata. Thus, the bioclastic limestone environment supported a Ponderodictya-Birdsallella-Dizygopleura-Quasillites fauna.

Similarly, the transgressive argillaceous limestones are characterized by species that also occur in deeper water. They are also robust forms, not perhaps as strongly constructed as those in the typical bioclastic limestone. Such units as 14, 15, 17A, 19-23, and 26 are typical of the "normal" argillaceous limestones formed during transgression; they contain a Cytherellina-Hollinella-Menoeidina-Poloniella-Ulrichia fauna.

The mucrospiriferid transition units, such as 7-9, 15B, 17B, and 25, share a few more species with the shallower water deposits than with the deeper water muds. As the water became quieter and farther from shore during transgression, the area experienced the first invasion of an Arcyzona-Cryptophyllus-Subligaculum fauna, along with a few species of other genera.

The deep-water mud flats are the exclusive homeland for several species, some of them rare. The distinctive fauna included the thin-shelled Acratia simplex, Bairdiocypris gongylus, Birdsallella devonica, Ehlersia hypercala, Knoxiella rutkowskiae, Pronipantex planus (with its extreme flat base, particularly suited for skimming on ultra-soft bottom sediment), Rectobairdia emaciata (relatively fragile despite its size), and the ornate Sigynus dictyotus.

Most of the species found in the regressive crinoidal-cryptostomate transition beds are holdovers from the previous shale environment.

To what degree these species actually inhabited the rougher waters may be questioned. Perhaps most of the specimens were reworked from the unconsolidated deep-water muds. Only *Acanthoscapha devonica* and *Rudderina extensa* are recorded exclusively from this biotope; both are so rare that their occurrence does not assume much significance.

After sorting out and identifying thousands of ostracods from the Silica sediments, we are led to believe that the benthonic ostracods followed the migration of their preferred bottom sediment through the region for long spans of time, leaving their valves and carapaces to mark the lithology. In the time span of the Silica Formation, physical factors outweighed

biological factors in shaping the faunal content. We see little evidence of evolutionary replacement and a great deal of faunule-lithology association.

The following chart lists the ostracod genera of the whole formation according to abundance based on our identification of approximately 15000 specimens. It appears highly unlikely that the rare species were swept in by currents from far distant localities or that they were reworked from much older deposits. Instead, we conclude, the populations of some ostracod species were small during the Silica interval -- the "endangered species" of their time.

RELATIVE ABUNDANCE OF GENERA IN THE SILICA FORMATION

(in over 15000 specimens seen)

VERY ABUNDANT (1000+)	COMMON (100-499)	FEW (25-100)	RARE (5-24)	VERY RARE (1-5)
<i>Quasillites</i>	<i>Kirkbyella</i>	<i>Bairdiocypris</i>	<i>Aechminaria</i>	<i>Acanthoscapha</i>
<i>Ponderodictya</i>	<i>Birdsallella</i>	<i>Bythocyproidea</i>	<i>Cornigella</i>	<i>Acratia</i>
<i>Cytherellina</i>	<i>Punctoprimitia</i>	<i>Dirhabdus</i>	<i>Cryptophyllus</i>	<i>Coelonellina</i>
	<i>Poloniella</i>	<i>Healdia</i>	<i>Doraclatum</i>	<i>Ehlersia</i>
ABUNDANT (500-999)	<i>Ctenoloculina</i>	<i>Jenningsina</i>	<i>Glyphella</i>	<i>Hanaites</i>
	<i>Tetrasacculus</i>	<i>Hypotetrгона</i>	<i>Hyphasmophora</i>	<i>Kavaryella</i>
<i>Dizygopleura</i>	<i>Adelphobolbina</i>	<i>Monoceratina</i>	<i>Knoxella</i>	<i>Pronipantex</i>
<i>Euglyphella</i>	<i>Eukloedenella</i>	<i>Phlyctiscapha</i>	<i>Microcheilinella</i>	<i>Rectobairdia</i>
<i>Coelonella</i>	<i>Ulrichia</i>	<i>Praepilatina</i>	<i>Nannohealdia</i>	<i>Rudderina</i>
<i>Arcyzona</i>	<i>Hollinella</i>	<i>Scrobicula</i>	<i>Richina</i>	<i>Sigynus</i>
<i>Menooidina</i>	<i>Falsipollex</i>	<i>Stictobollia</i>	<i>Rugocytherellina</i>	<i>Bursullella</i>
<i>Subligaculum</i>	<i>Octonaria</i>	<i>Xystinotus</i>	<i>Tetrarhabdus</i>	
<i>Bufina</i>	<i>Balantoides</i>	<i>Ropolonellus</i>	<i>Tetrastorthynx</i>	
			<i>Wideneria</i>	

DISTRIBUTION OF SPECIES IN OTHER FORMATIONS

The following chart shows the distribution of Silica ostracod species in other areas of the Great Lakes region. Some of the species may range into Middle Devonian formations of southern Indiana, but we have not studied the faunas of that region in detail.

In general, the Silica-Arkona-lower Traverse sea was shallower in northern Michigan,

where the lower Traverse Group contains several units formed of near-shore carbonates; the Genshaw Formation contains thick units of impure limestone, the Alpena Limestone is made up of consolidated carbonate muds punctuated by numerous reefs and bordering flank beds, and the Rockport Quarry Limestone represents extremely shallow water or even supratidal deposition of carbonate. Even the Ferron Point Formation has alternating limestone and shale strata in its lower half in Alpena County.

The deepest part of the sea lay in Ontario, where the fine clays of the Arkona Shale pro-

Distribution of Silica Species in Formations of the Great Lakes Region

- x = species present
- ⊙ = holotype from Silica Formation
- = holotype from other formation

SPECIES

- Richina truncata*
- Ropolonellus papillatus*
- Rudderina extensa*
- ⊙ *Rugocytherellina ehlersi*
- ⊙ *Scrobicula xysta*
- Sigynus cf. dictyotus*
- ⊙ *Stictobollia alethaeae*
- Subligaculum scrobiculatum*
- ⊙ *Tetrasacculus bilobus*
- Tetrastorhynchus diabolicus*
- Ulrichia conradi*
- ⊙ *Ulrichia fastidiosa*
- Ulrichia fragilis*
- Ulrichia illinearis*
- Ulrichia spinifera*
- ⊙ *Wideneria lispa*
- Xystinotus subnodatus*
- Xystinotus wrightorum*

	OHIO	ONTARIO	TRAVERSE GROUP OF MICHIGAN	NEW YORK
	Delaware Bone Beds Plumbrook Shale Olentangy Shale	Arkona Shale Hungry Hollow Fm. Widder Formation Ipperwash Ls.	Bell Shale Ferron Point Fm. Genshaw Formation Four Mile Dam Fm. Norway Point Fm. Potter Farm Fm. Gravel Point Fm. Petoskey Formation	Centerfield Ls. Ledyard Shale Wanakah Shale Kashong Shale Windom Shale
<i>Richina truncata</i>		⊙		x
<i>Ropolonellus papillatus</i>		x	⊙	x
<i>Rudderina extensa</i>		●		x
⊙ <i>Rugocytherellina ehlersi</i>			x	
⊙ <i>Scrobicula xysta</i>		x		
<i>Sigynus cf. dictyotus</i>		●		
⊙ <i>Stictobollia alethaeae</i>		x	x	x
<i>Subligaculum scrobiculatum</i>				
⊙ <i>Tetrasacculus bilobus</i>			x	x
<i>Tetrastorhynchus diabolicus</i>		●		
<i>Ulrichia conradi</i>	x	x	x	x
⊙ <i>Ulrichia fastidiosa</i>		x		x
<i>Ulrichia fragilis</i>		x	x	x
<i>Ulrichia illinearis</i>	x	●	x	x
<i>Ulrichia spinifera</i>		x	x	x
⊙ <i>Wideneria lispa</i>		x		x
<i>Xystinotus subnodatus</i>		x	x	x
<i>Xystinotus wrightorum</i>		●	x	x

vide the raw material for a brick and tile industry. There exists a gradient toward clay concentration at the Thedford-Arkona region: from the Medusa quarries in northwestern Ohio the Silica Formation becomes progressively more shaly at Martin-Marietta and still more at Waterworks Park; and the limestone units in the lower Traverse Group in northern Michigan disappear from the geologic section towards the east and south, as shown conclusively by well records.

That the sea of Silica time extended into western New York can not be doubted. A host of marine species ranges through this vast area. The Silica Formation shares species with the Arkona Shale, the Traverse Group, and with numerous formations of the Hamilton Group of western New York.

In the following chart, we did not attempt to indicate all the ostracod species which are present in other areas, and we omitted those that are not represented in the Silica Forma-

tion. Our purpose in preparing these abbreviated faunal lists for northern Michigan, Ontario, and western New York is to show the geographic distribution and stratigraphic spread of Silica ostracods. This provides basic data for correlation.

The chart graphically establishes that many of the Silica ostracods survived elsewhere long after the close of Silica time. Again, we are confronted with evidence that the Silica was a geologically brief episode in earth history.

It does not particularly surprise us that the same ostracod genera which are prevalent in the Silica Formation itself are likewise well represented elsewhere. As the following chart of common to very abundant genera shows by comparison with the distribution charts (pages 144-146), the species of these genera are widespread. The chart also shows that some families were more successful than others: thus, the Kloedenellidae produced four of the genera

with large populations and the Ctenoloculinidae three, whereas the Beyrichiidae, Aechminellidae, Aechminidae, Richinidae, Amphissellidae, Scrobiculidae, Aparchitidae, Geisinidae, Eridonconchidae, Bairdiidae, Beecherellidae, and

Bythocytheridae together failed to produce any! Hence, abundance is very inequitably spread through the superfamilies of Silica ostracods, both in the Silica Formation itself and in other Middle Devonian formations.

VERY ABUNDANT, ABUNDANT, AND COMMON OSTRACODS OF THE SILICA FORMATION
BY SUPERFAMILIES, FAMILIES, AND GENERA

Superfamily	Family	Genera
Quasillitacea	Quasillitidae	<i>Quasillites</i> , <i>Bufina</i>
	Ropolonellidae	<i>Euglyphella</i>
Healdiacea	Healdiidae	<i>Ponderodictya</i>
	Bairdiocyprididae	<i>Cytherellina</i>
	Cavellinidae	<i>Menoeidina</i> , <i>Birdsallella</i>
Kloedenellacea	Kloedenellidae	<i>Dizygopleura</i> , <i>Poloniella</i> <i>Punctoprimitia</i> , <i>Eukloedenella</i>
Aparchitacea	Coelonellidae	<i>Coelonella</i>
Drepanellacea	Kirkbyellidae	<i>Kirkbyella</i>
	Bolliidae	<i>Ulrichia</i>
Kirkbyacea	Arcyzonidae	<i>Arcyzona</i>
Hollinacea	Ctenoloculinidae	<i>Ctenoloculina</i> , <i>Subligaculum</i> , <i>Tetrasacculus</i>
	Hollinidae	<i>Falsipollex</i>
	Hollinellidae	<i>Hollinella</i> , <i>Adelphobolbina</i>
Thlipsuracea	Thlipsuridae	<i>Octonaria</i>

CORRELATIONS

Ideally, the fossils used for correlation are abundant, easily identified, geographically widespread, present in all lithologies, and short-lived as species. Only a few satisfy all these criteria. It follows that planktonic creatures, quite independent of bottom sediments, are better qualified than benthonic forms. Yet the Silica ostracods are heavy-shelled bottom-dwelling animals. What can we learn from their distributions in other formations?

If the ostracod species are tested over a time span sufficiently long, they will be diagnostic of that geologic interval; but if the time for deposition of all the formations is brief, the

ostracods may be expected to show only their lithotopic preferences in their occurrences. So we are anticipating one or another situation: the ostracods persist through all of the Middle Devonian formations and demonstrate only their lithologic frequencies, or they became gradually extinct during Middle Devonian time with decreasing numbers of survivors in successively younger strata.

To evaluate the distribution charts and faunal indices based on Silica ostracod species, let us review the correlations based on megafossils and accepted by stratigraphers as essentially correct. The key stratum is the Cen-

MIDDLE DEVONIAN FORMATIONS OF THE GREAT LAKES REGION
AND THEIR SUGGESTED CORRELATION

Formations in parentheses are subsurface

Ohio-S Mich	NE Michigan	NW Michigan	W Ontario	W New York
	Thunder Bay	Whiskey Creek		Windom Shale
	Potter Farm	Petoskey Fm		Kashong Shale
	Norway Pt Fm		Ipperwash Ls	Tichenor Ls
			Widder Fm	Wanakah Sh
				Ledyard Sh
Ten Mile Cr	Four Mile Dam	Charlevoix Ls	Hungry Hollow	Centerfield Ls
	Alpena Ls	Gravel Pt Fm		
	Newton Creek	(Koehler Ls)		
	Genshaw Fm	(Genshaw Fm)		
Silica Fm	Ferron Pt Fm		Arkona Shale	Levanna Shale
	Rockport Qy	(Rockport Qy)		
	Bell Shale	(Bell Shale)		

terfield Limestone of western New York, which contains a distinctive suite of fossils that is also found in the Hungry Hollow Formation of Ontario, the Four Mile Dam Formation of northeastern Michigan, the Charlevoix Limestone of northwestern Lower Peninsula of Michigan, and the Logansport Limestone of northern Indiana. Other formations can be stratigraphically placed with reference to this stratum. The following is our interpretation of correlations of selected Middle Devonian formations in the Great Lakes region. The Silica Formation is equivalent to the pre-Four Mile Dam portion of the Traverse Group in Alpena and Presque Isle counties in northeastern Michigan; the Bell Shale and Ferron Point Formation (containing mostly shales) appear to continue in subsurface to the Silica outcrop area, whereas the Rockport Quarry Limestone pinches out within a short distance to the south of its type locality, and the Genshaw Formation cannot be traced directly into beds in southern Michigan. Possibly, the Alpena Limestone is a shallow-water facies of the upper part of the Silica Formation, but this can only be suggested on faunal comparison. In the northwestern part of the Lower Peninsula of Michigan, the only outcropping strata that may be correlated with the Silica are in the upper part of the Gravel Point For-

mation; nevertheless, well cores in that area reveal that in subsurface the Bell Shale is represented by around 100 feet of soft shales, the Rockport Quarry by around 65 feet of limestone, the Genshaw by over 200 feet of various limestones and argillaceous limestones, the Koehler (? = part of Alpena Limestone) by 45 feet of fine-grained limestone, and the total Gravel Point by nearly 200 feet of argillaceous limestones and shales.

In western Ontario exposures near Theford and along the Ausable River, the Arkona Shale is definitely the equivalent of the Silica Formation. The ostracod-bearing shales and argillaceous limestones of western New York are all younger than the Silica, including the Centerfield Limestone, Ledyard Shale, Wanakah Shale, Tichenor Limestone, Kashong Shale, and Windom Shale.

To obtain an indication of the origin of the Silica ostracod fauna, we can compare the number of species shared with each of the other areas, confining our counts to strata which are of the same age as the Silica Formation. This is essential, for obviously the Silica ostracod species cannot have originated in strata any younger than those in which they are found in the Ohio-southern Michigan area. Hence, we

counted Silica species in the combined Bell, Ferron Point, and Genshaw formations for northeastern Michigan, in the Gravel Point Formation for northwestern Michigan, and in the Arkona Shale for Ontario. Thus, we derive the following chart.

DISTRIBUTION OF SILICA OSTRACOD SPECIES
IN STRATA OF THE SAME AGE IN OTHER AREAS
OF THE GREAT LAKES REGION

Numbers in parentheses indicate approximate
separation in miles

	NW Ohio - SE Michigan	Western Ontario	Northeastern Michigan	Northwestern Michigan
NW Ohio -	--	65	77	54
SE Michigan	--	(130)	(230)	(250)
Western Ontario	65 (130)	--	49 (160)	32 (220)
Northeastern Michigan	77 (230)	49 (160)	--	60 (80)
Northwestern Michigan	54 (250)	32 (220)	60 (80)	--

If we attempt to find the origin of the Silica fauna, however, the geographic separation of localities must be strongly considered. As a species extends its range from the spot of origin, its abundance might be expected to be inversely proportional to the square of the distance its members have migrated (other factors being equal). Therefore, it would be unfair and unwarranted to compare directly the number of Silica species in northwestern Michigan (some 250 miles distant) with the number in Ontario (only some 130 miles away). The origin of the majority of Silica species cannot be proved without complete search of all formations and precise dating of each formation -- much more precise than is presently possible; but the odds of the ostracod species having originated in one or another of the areas can be calculated by multiplying the number of shared species by the square of the geographic separation. This is done in the next table.

PRODUCT OF NUMBER OF SHARED SPECIES x
SQUARE OF GEOGRAPHIC SEPARATION (MILES)
FOR OTHER AREAS OF GREAT LAKES REGION

Based on Silica species only.
Figures are Species (Miles²)/10⁴

	Ohio	Ont	NE Mich	NW Mich
Ohio-Mich	--	110	407	338
Ontario	110	--	125	155
NE Mich	407	125	--	38
NW Mich	338	155	38	--

From these figures we have an indication that nearby Ontario is the least likely evolving ground for the majority of Silica ostracod species and that odds of 407 to 110 favor northeastern Michigan. In fact, the chart seems to point to the Silica fauna as having been derived or exchanged with northeastern Michigan and with northwestern Michigan independently (for these areas show little faunal affinity with each other).

Insofar as our investigations have progressed, we are led to believe that certain ostracods are endemic to the Silica Formation in the Ohio-southern Michigan area, including *Glyphella reticulata*, *Scrobicula microspinosus*, and *Tetrarhabdus pygmaeus*, three new species described herein which we have failed to find elsewhere.

It is entirely possible that all ostracods in the Silica fauna evolved in the Ohio area and migrated north and east. All we can show for sure is that during Silica time there existed a much stronger faunal tie (faunal interchange ?) with the Traverse Group in northern Michigan than with the Arkona Shale in Ontario. At any rate, some cause is provided for considering that the majority of ostracod species in the Silica Formation may have originated in northern Michigan. Only an absolute date on the oldest occurrence of each species can settle the matter of the area or areas of faunal evolution. Based on Silica species only, the Arkona Shale ostracod fauna shows clearer relationships to the northern Michigan areas than to the Ohio area; if the total ostracod faunas were consid-

ered, we suspect that the affinities with northern Michigan areas would be expressed even more strongly.

Just as we derived an inkling as to whence the ostracod fauna came to the Silica Formation area in southeastern Michigan and northwestern Ohio, so we can find some stronger clues as to whence the species dispersed from the area when the final curtain rang down on the Silica interval. We do this by comparing the distribution of Silica species in formations geologically younger than the Silica Formation. These include the Four Mile Dam, Norway Point, Potter Farm, and Thunder Bay formations in northeastern Michigan, the Petoskey Formation in northwestern Michigan, the Hungry Hollow, Widder, and Ipperwash formations in western Ontario, and the Centerfield, Ledyard, Wanakah, Tichenor, Kashong, and Windom formations in western New York state. Combining the species by areas, we have the following

DISTRIBUTION OF SILICA OSTRACOD SPECIES
IN YOUNGER STRATA IN OTHER AREAS
OF THE GREAT LAKES REGION

Numbers in parentheses indicate
approximate separation in miles

	Ohio	Ont	NE Mich	NW Mich	N York
Ohio-	--	79	66	49	86
S Mich	--	(130)	(230)	(250)	(250)
Western	79	--	56	38	73
Ontario	(130)	--	(160)	(220)	(150)
Northeast	66	56	--	38	59
Michigan	(230)	(160)	--	(80)	(270)
Northwest	49	38	38	--	45
Michigan	(250)	(220)	(80)	--	(350)
Western	86	73	59	45	--
New York	(250)	(150)	(270)	(350)	--

We now take into account the geographic separations of these areas (as we did above) and arrive at the following figures indicating faunal relationships.

From this chart we learn that the ostracod fauna of the Silica Formation migrated to (and/or survived in) the area of western New York, more or less bypassing the nearby Ontario area, and that the secondarily strong

PRODUCT OF NUMBER OF SHARED SPECIES x
SQUARE OF GEOGRAPHIC SEPARATION (MILES)
FOR OTHER AREAS OF GREAT LAKES REGION

Based on Silica species only.
Figures are Species (Miles²)/10⁴

	Ohio	Ont	NE Mich	NW Mich	N York
Ohio-Mich	--	133	349	306	538
Ontario	133	--	143	184	164
NE Mich	349	143	--	24	430
NW Mich	306	184	24	--	551
New York	538	164	430	551	--

direction of dispersal was to northeastern and northwestern Michigan. Again, as during Silica time, northeastern and northwestern Michigan areas had little faunal interchange even though they were only about 80 miles apart. The generally low values (based only on Silica species) for the Ontario area and the high values between New York and the northern Michigan areas would imply that the post-Silica migration route by which species reached New York may have lain somewhere north of the Ontario localities.

In summary, the majority of the Silica ostracods most likely evolved in the area of northern Michigan, whence they spread southward into the northern Ohio area during Silica time, with only a few extending into Ontario. When the Silica interval came to a close and the ostracods were forced from the Ohio area, they enlarged their range into New York (where they were highly successful), either migrating through northern Michigan or going directly out from that area into western New York and, for the most part, bypassing the Ontario area around Thedford and Arkona.

Next we turn to the occurrences of Silica species in other Middle Devonian formations individually in the Michigan Basin. This affords an opportunity to test the significance of time against that of bottom sediments for these benthonic ostracods. If it happens that the species persisted long after the close of the Silica interval, occurring wherever their preferred physical environment was still to be found, then the whole time of Middle Devonian sedimenta-

NUMBER OF SILICA OSTRACOD SPECIES SHARED BY MIDDLE DEVONIAN
FORMATIONS IN THE MICHIGAN BASIN

		ONTARIO				NORTHEASTERN MICHIGAN					NW MICH			
		Arkona Shale	Hungry Hollow	Widder Fm	Ipperwash Ls	Bell Shale	Ferron Point	Genshaw Fm	Four Mile Dam	Norway Point	Potter Farm	Gravel Point	Petoskey Fm	
<i>Number of Silica species present</i>		65	42	57	32	55	65	36	45	49	33	54	49	
	19+	37	29	12	22	14	24	30	14	23	24	15	22	21
Silica units	16-18	49	34	13	27	19	30	35	20	35	31	20	30	24
	14-15	77	46	26	48	28	47	52	26	37	43	27	44	40
	1-13	112	65	42	57	32	55	65	36	45	49	33	54	49
	Petoskey Fm	49	31	25	27	18	33	35	26	29	29	26	33	--
	Gravel Point Fm	54	32	21	28	18	33	40	26	30	32	28	--	33
	Potter Farm Fm	33	19	18	22	12	23	24	16	21	27	--	28	26
	Norway Point Fm	49	34	23	31	22	37	39	21	32	--	27	32	29
	Four Mile Dam	45	36	20	26	25	36	35	20	--	32	21	30	29
	Genshaw Fm	36	20	15	17	14	24	31	--	20	21	16	26	26
	Ferron Point Fm	65	47	25	38	26	47	--	31	35	39	24	40	35
	Bell Shale	55	37	21	32	25	--	47	24	36	37	23	33	33
	Ipperwash Ls	33	29	15	26	--	25	26	14	25	22	12	18	18
	Widder Fm	58	44	22	--	26	32	38	17	26	31	22	28	27
	Hungry Hollow	42	19	--	22	15	21	25	15	20	23	18	21	25
	Arkona Shale	65	--	19	44	29	37	47	20	36	34	19	32	31

tion in the Michigan Basin was of short duration. Modern ostracod faunas with several long-lived species last only a few million years, and we might expect that a fauna with numerous Silica species in it would endure about the same length of time. On the other hand, if the Middle Devonian was of long duration, we might expect that fauna after fauna would disappear as its species became extinct.

In the following chart, certain interesting points are immediately highlighted. First, within the Silica Formation, less than half of the species present in units 1-13 are to be found above unit 15. Second, bearing in mind that the Widder Formation in Ontario, the Norway Point

Formation in northeastern Michigan, and the Petoskey Formation in northwestern Michigan were all deposited long after Silica time, nevertheless it happens that the Widder contains 58 Silica species, the Norway Point 49, and the Petoskey also 49; each of these formations contains more Silica ostracod species than any of the units above 18 at the type locality of the Silica Formation itself. As we interpret this situation, the Widder, Norway Point, and Petoskey formations were laid down in environments much like those during deposition of the lower part of the Silica Formation, and many of the same ostracod species took refuge there and prospered.

FAUNAL INDICES BASED ON SILICA SPECIES ONLY

	ONTARIO				NORTHEASTERN MICHIGAN					NW MICH			
	Arkona Sh	Hungry Hollow	Widder Fm	Ipperwash Ls	Bell Shale	Ferron Point	Genshaw Fm	Four Mile Dam	Norway Point	Potter Farm	Gravel Point	Petoskey Fm	
<i>Number of Silica species present</i>	65	42	57	32	55	65	36	45	49	33	54	49	
19+	37	78	32	59	44	65	81	39	62	65	45	59	57
Silica units	49	69	31	55	59	61	71	56	78	63	61	61	49
14-15	77	71	62	83	88	85	80	72	82	88	82	81	82
1-13	112	100	100	98	100	100	100	100	100	100	100	100	100
Petoskey Fm	49	63	60	55	56	67	71	72	64	59	79	67	--
Gravel Point Fm	54	59	50	52	56	61	74	72	67	65	85	--	67
Potter Farm Fm	33	58	55	67	38	70	73	48	64	82	--	85	79
Norway Point Fm	49	69	55	63	69	76	80	58	71	--	82	65	59
Four Mile Dam	45	80	48	58	78	80	78	56	--	71	64	67	64
Genshaw Fm	36	56	42	47	44	67	86	--	56	58	48	72	72
Ferron Point Fm	65	73	60	66	81	85	--	86	78	80	73	74	71
Bell Shale	55	67	50	58	78	--	85	67	80	76	70	61	67
Ipperwash Ls	33	88	45	79	--	78	81	44	78	69	38	56	56
Widder Fm	58	76	52	--	79	58	66	47	58	63	67	52	55
Hungry Hollow	42	45	--	52	45	50	60	42	48	55	55	50	60
Arkona Shale	65	--	45	76	88	67	73	56	80	69	58	59	63

Third, of the other formations deposited at the same time as the Silica, the Arkona Shale (Ontario) and the Ferron Point (northeastern Michigan), each with 65 Silica species, are the closest related faunally to the Silica. Both of these formations are composed largely of soft shale and some argillaceous limestone layers, much the same lithology as that in the lower part of the Silica. We see clearly that the majority of Silica species lived elsewhere, both during and after Silica time, were clay and clay-lime muds were being carried into fairly deep water. A fourth observation also indicates that time was less a factor than environment in shaping Middle Devonian ostracod faunas: in northeastern Michigan, the Genshaw Formation, deposited simultaneously with at least part of

the Silica, contains only 36 Silica species, whereas the much younger Norway Point Formation contains 49 species and the intermediate (but still younger than Silica) Four Mile Dam Formation contains 45.

Using only the ostracod species present in the Silica Formation will not reveal which of the other formations has actually the closest faunal resemblance to the Silica, because some of them may have even more species in their total fauna than the Silica (in which case the shared species are only a fraction of their fauna), whereas some formations may contain only the species shared with the Silica (in which case the faunal relationship is at its highest possible value). At this time, we have not identified all of the non-Silica ostracods in

all of the other formations. Hence, our yield of information is necessarily curtailed. Yet the 112 species in the Silica Formation provide a very good sampling of Middle Devonian ostracod faunas generally, and within limits can provide useful comparisons between other formations.

As explained elsewhere, faunal indices are useful for quantitative faunal comparisons. If we count the species in two formations, one will be found to have n species and the other to have N species, with N equal to or more than n , and s will be the number of shared species. The faunal index is

$$I = s/n \times 100.$$

A perfect index of 100 would mean that one formation contains no species which are not present in the other (even though the actual number of shared species might be as few as one or as many as several hundreds).

"Faunal indices" based on Silica species only are not, therefore, true faunal indices, for they fail to take into account any non-Silica species which might be present. Nevertheless, some useful information can be gained from the following "faunal indices."

Without exception, all other formations (whether contemporaneous or later than the Silica) have highest indices with the lower units of the Silica Formation (units 1-13). Units 14 and 15 together show strongest faunal relationship to the younger Ipperwash and Norway Point formations; we do not know what physical factors contributed to these high indices. Units 16-18 have greatest faunal similarity to the Four Mile Dam (younger) and Ferron Point (same age) formations in northeastern Michigan. Units 19 and above in the Silica Formation contain a fauna most closely resembling the Ferron Point and Arkona formations.

The Hungry Hollow Formation of Ontario shows low indices for nearly all other formations. Here we think the source of faunal dissimilarity can be pinpointed: the Hungry Hollow is a high-energy shallow-water deposit, containing many overturned corals and other evidence of turbulence. Apparently, this environment was unfavorable for most of the benthonic

ostracod species, and very atypical of the Silica environment.

The Genshaw Formation of Alpena County, Michigan, also contains characteristic signs of powerful wave action. Ehlers & Kesling (1970, p. 69) noted:

... alternating calcareous shales and argillaceous limestones of varying composition and hardness ... were deposited under several depths of water. While inspecting an outcrop freshly exposed by ditching along M 65, Professor Lecompte pointed out one bed in which the large corals were overturned in place and specimens were broken and worn; he pronounced it an excellent example of his zone of turbulence.

Even though most units in the Genshaw seem to have been deposited in somewhat quieter water, the formation yields rather low indices when compared with the upper units (19+) of the Silica in Ohio and with the Widder and Ipperwash formations in Ontario.

The two formations with the greatest number of Silica species are the Arkona Shale of Ontario and the Ferron Point Formation of northeastern Michigan, each with 65. Both have high indices with all divisions of the Silica. Both formations are fairly deep-water deposits, containing mostly soft shales. The Ferron Point has high indices with the Bell Shale below and the Genshaw Formation immediately above. The Arkona, on the other hand, shows strongest faunal similarity to the much younger Ipperwash Limestone in its area and the younger Four Mile Dam Formation in northeastern Michigan; the latter high index is unexplained. It may be pointed out here that the Arkona is faunally more like any one of the formations in northern Michigan, including those much younger, than the Hungry Hollow Formation which immediately overlies it. It also seems significant that the Arkona has slightly stronger faunal linkage with the younger Petoskey Formation than with the contemporary Gravel Point Formation in northwestern Michigan.

Of the 112 species of ostracods in the pre-Centerfield Silica Formation, an unusual number persist into some of the post-Centerfield

formations; thus, we note that the Widder Formation with 58 (52%), the Norway Point with 49 (44%), and the Petoskey also with 49 (44%). Note that the same ostracod species did not endure in both northeastern and northwestern Michigan in post-Centerfield time: of the 49 Silica species in each formation, only 29 (59%) were common to the Norway Point and Petoskey. Here is another hint that these two areas, only some 80 miles apart, were not directly connected faunally and/or physically by seaway, but that each was part of a common sea reaching to Ontario; the suggestion is strong that north-central Michigan during this time was occupied by an island or shallow-water shoal area which impeded the direct migration of ostracods from one place to the other.

Other relationships are apparent in the table of indices, but call for no special attention. We can summarize the results of tables of occurrences, shared species, and faunal indices simply: (1) more Silica species are found in most of the younger formations of Middle Devonian age (Hungry Hollow, Widder, Four Mile Dam, Norway Point, and Petoskey) than in one of the contemporary formations (Genshaw), (2) the two formations with lowest indices and weakest faunal relationships to the other Middle Devonian formations (the Hungry Hollow and Genshaw) are both high-energy coral-rich products of the zone of turbulence, (3) the two formations bearing most Silica species and having high indices with most

other formations (Arkona and Ferron Point) are both soft shales produced in deep-water mud flats, and (4) the upper units in the Silica Formation itself (units 19+) contain fewer Silica species of ostracods (37) than many of the younger formations in distant places, such as the Widder in Ontario (58), the Four Mile Dam (45) and Norway Point (49) in northeastern Michigan, and the Petoskey in northwestern Michigan (49).

Four conclusions have ample justification. First, the Middle Devonian formations in the Great Lakes region were laid down in geologically quick succession, before many of the ostracod species became extinct. Second, more of the Silica ostracod species preferred deep quiet waters than the shallow turbulent environment. Third, the ostracod species responded to the frequent changes in depth during the Middle Devonian by migrating to maintain their preferred habitat. And lastly, the vast majority of Middle Devonian ostracod species were not index fossils for formations. For the most part, these ostracods, being long-lived and closely attuned to sea-bottom environments, became better indicators of lithology (which are not needed) than of time intervals (which are always needed). Identifying the few which did extend their geographic range suddenly, flourished, and abruptly became extinct is a tedious and long-term task, for all formations in the region must be sampled and searched thoroughly.

For the plain and inescapable truth is that no one was there to see, and in the absence of eyewitness accounts there is bound to be a certain amount of disagreement.

-- Rachel Carson, *The Sea Around Us*

EUROPEAN OSTRACOD FAUNAS

General remarks. -- The Middle Devonian (Givetian) formations of north-central Europe have yielded ostracod faunas that are strikingly similar to those of the same age in the Great Lakes region of North America. This similarity appears to be restricted to the generic level, with the possible exception of the robust Ponderodictya punctulifera, ubiquitous in North American formations and reported (nearly always with question) in certain European strata.

Middle Devonian paleogeography, very different from present continental separation in the Northern Hemisphere, is a factor to be weighed in connection with faunal similarities. At that time, the extended Caledonian Orogeny, which had compressed and metamorphosed old sedimentary rocks in the Greenland-Scandinavian area, had lost most of its mobility. The orogenic activity terminated in regional uplift and the complementary thick accumulation of the Old Red Sandstone over large areas of East Greenland, Scandinavia, Britain, and Spitzbergen. The Old Red Sandstone continent thus created blocked off the North Atlantic, its southern shore extending from the Maritimes of Canada, through the southern part of Britain, south of Denmark, and up the Baltic Sea. From the maps of mid-Paleozoic paleogeography presented by Reed & Watson (1975, figs. 2.1, 2.12), we calculate that the Silica localities and the Bergisches Land region of Germany were in Middle Devonian time separated by only about 2700 miles, less than the air distance from Miami to Seattle.

How did it come about that a considerable number of ostracod genera are common to sediments of both continents but their species are restricted to one continent or the other? One explanation might be that each genus evolved in one continent and gradually spread to the other, consuming so much time en route that speciation took place. Our dating of strata on the two continents is not precise enough at this stage to decide where each genus made its first appearance.

A second, and thoroughly logical, explanation is that most Middle Devonian ostracod

genera evolved in the marginal regions of the remnant ocean and spread thence over the cratonic interiors of North America and Europe, the spread being so slow that the species were different by the time they reached the two extremes of the expanded generic range. It is even possible that the eastbound and westbound emigrants from the pioneer homeland became adapted to somewhat differing ecological conditions during their treks, made ready to exploit new habitats whenever fortunate transgressions opened the way into cratonic interiors. If we suppose that the origin of the genera was midway between Ohio and Germany localities, then each migration occupied only 1350 miles, less than the distance from Miami (Florida) to Portland (Maine). Such a distance might well have been covered even by benthonic ostracods in a few hundred thousand years with favorable currents and in only a few million against weak currents.

Progress in solving the generic distribution problem is hampered at this time by the dual taxonomies employed by European and North American micropaleontologists. As we read descriptions and view illustrations of some ostracods by our European colleagues, we recognize our own genera under unfamiliar names; and certainly this situation must be just as vexing for them. Add to this the different criteria for generic distinction used by various workers, and the taxonomy becomes highly unsettled. The serious investigator has an ever-lurking suspicion that he may not have recognized all the generic identities because of the taxonomic camouflage.

Despite these uncertainties, however, it is definite that many of the Middle Devonian ostracod genera ranged into both continents. We call attention to three faunas that have generic affinities with the Silica ostracods and that have been recently reliably reviewed.

Bergisches Land, Germany. -- Recently, Groos (1969) described the ostracods from Middle Devonian strata exposed in various outcrops east of the Rhine and between two of its tributaries, the Ruhr and the Sieg rivers. This old Westphalian region is known as Bergisches Land. From Groos' publication, the list pre-

Ostracod Genera from the Givetian of
Bergisches Land, Germany
(East of the Rhine, between the Ruhr
and Sieg Rivers)
(from Groos, 1969)

* <i>Acanthoscapha</i>	<i>Kielciella</i>
* <i>Acratia</i>	* <i>Kirkbyella</i>
* <i>Aechminella</i> ¹	<i>Kozlowskiella</i>
<i>Amphisella</i>	<i>Leptoprimitia</i>
<i>Amphissites</i>	<i>Marginia</i>
<i>Aparchites</i>	<i>Mauryella</i>
* <i>Bairdia</i> ²	<i>Nezamyslia</i>
* <i>Bairdiocypris</i>	<i>Ochescapha</i>
<i>Berounella</i>	<i>Ovornina</i>
<i>Beyrichia</i>	<i>Parabolbina</i>
* <i>Birdsallella</i>	<i>Parakozlowskiella</i>
<i>Bohemina</i>	<i>Polenovula</i>
* <i>Bufina</i>	* <i>Poloniella</i>
<i>Buregia</i>	<i>Polyzygia</i>
<i>Cavellina</i>	* <i>Ponderodictya</i>
<i>Cleithranchiste</i>	<i>Pribylites</i>
* <i>Coelonellina</i>	* <i>Quasillites</i>
<i>Cribroconcha</i>	<i>Samarella</i>
* <i>Ctenoloculina</i>	<i>Selebratina</i>
* <i>Cytherellina</i>	<i>Subtella</i>
<i>Evlanella</i>	* <i>Sulcella</i> ³
<i>Fabalitypris</i>	* <i>Svantovites</i> ⁴
* <i>Falsipollex</i>	<i>Tricornina</i>
<i>Healdianella</i>	* <i>Tubulibairdia</i> ⁵
* <i>Hollinella</i>	* <i>Varicobairdia</i> ⁶

* Genera which are also present in the Silica Formation.

1 Species probably equivalent to our *Balan-toides*.

2 Species = our *Rectobairdia*.

3 Some species congeneric with our *Eukloeden-ella*.

4 Some species closely related or congeneric with our *Jenningsina*.

5 Species = our *Microcheilinella*.

6 Species = our *Ropolonellus*.

sented here shows the genera she identified in Givetian rocks of the region with asterisks to mark those genera also present in the Silica, including those under different names which we feel are synonymous with Silica genera we described above. Some which are not synonymous are very closely related to some of ours, split off on minor differences.

The German fauna has 20 of its 50 genera in common with that of the Silica Formation. Thus, the two have a faunal index of 40 at the generic level. As might be expected, some of the German unshared (endemic ?) genera are very different from any of the Silica ostracods, and conversely some of the genera confined to the Silica are not at all related to the German ostracods.

Grzegorzowice Formation, Poland. -- The ostracod fauna of this Givetian formation was recently investigated by Adamczak (1976, text-figs. 9, 10). As the list shows, 15 of the 40 Grzegorzowice genera are also found in the Silica Formation. This gives a faunal index of 38 at the generic level. With less splitting by workers on both faunas, the shared genera would be even more.

Skały Formation, Poland. -- In an excellent work on Givetian ostracods of Poland, Adamczak (1976, text-figs. 11, 12) recorded the genera listed here from the Skały Formation. As can be seen, 14 of the 30 genera are shared with the Silica Formation. The faunal index is 47 at the generic level, an unexpectedly high value.

One shale unit is the Skały has even closer faunal similarity to the Silica. The list shown here was compiled from the occurrences given by Adamczak with his descriptions. Unit 3 of the Skały Formation has 7 of its 11 genera in common with the Silica Formation. The faunal index of 64 shows the extent to which ostracods of Middle Devonian time were able to spread through the two-continent region without losing their generic identity.

Summary. -- Even taking into account the latest assessments of continental locations during Middle Devonian time, the ties between the ostracod faunas of Europe and North America are exceptionally strong. Over such a distance,

Ostracod Genera from the
Grzegorzowice Formation of Poland

(from Adamczak, 1976, text-figs. 9, 10)

* <i>Acanthoscapha</i>	<i>Kummerowia</i>
* <i>Acratia</i>	<i>Lysogorella</i>
<i>Amphicostella</i>	* <i>Microcheilinella</i>
<i>Arikloedenia</i>	<i>Obotrita</i>
<i>Bairdia</i>	<i>Ochescapha</i>
<i>Bairdiocypris</i>	<i>Parabolbina</i>
* <i>Bairdiocypris</i>	<i>Perunus</i>
* <i>Birdsallella</i>	* <i>Poloniella</i>
<i>Bodzentia</i>	<i>Polyzygia</i>
* <i>Bufina</i>	* <i>Ponderodictya</i>
* <i>Bythocyproidea</i>	<i>Poniklacella</i>
<i>Clavoflabella</i>	* <i>Praepilatina</i>
<i>Cleithranchiste</i>	<i>Pseudorayella</i>
* <i>Ctenoloculina</i>	<i>Rishona</i>
<i>Evlanella</i>	* <i>Ropolonellus</i>
<i>Guerichiella</i>	* <i>Sohnia</i> = <i>Rectobairdia</i>
<i>Jefina</i>	<i>Sulcella</i>
* <i>Jenningsina</i>	* <i>Tetrasacculus</i>
<i>Kielciella</i>	<i>Triglavus</i>
<i>Kozlowskiella</i>	<i>Zeuschneria</i>

* Genera which are also in the Silica Formation and described in this paper.

a faunal index above 50 at the generic level would be unusual for large nektonic animals; for tiny benthonic ostracods it is startling.

Ostracod Genera from the
Skały Formation of Poland

(from Adamczak, 1976; text-figs. 11,12)

<i>Amphissites</i>	<i>Parabolbinella</i>
<i>Bairdia</i>	<i>Piastia</i>
* <i>Bairdiocypris</i>	* <i>Poloniella</i>
* <i>Birdsallella</i>	<i>Polyzygia</i>
<i>Bodzentia</i>	* <i>Ponderodictya</i>
* <i>Bufina</i>	<i>Poniklacella</i>
* <i>Bythocyproidea</i>	<i>Parakozlowskiella</i>
* <i>Ctenoloculina</i>	* <i>Praepilatina</i>
* <i>Cytherellina</i>	* <i>Quasillites</i>
<i>Evlanella</i>	* <i>Ropolonellus</i>
* <i>Hollinella</i>	<i>Roundyella</i>
<i>Kozlowskiella</i>	<i>Skalyella</i>
<i>Leptoprimitia</i>	<i>Sulcella</i>
* <i>Microcheilinella</i>	* <i>Tetrasacculus</i>
<i>Pachydomella</i>	<i>Zeuschneria</i>

* Genera which are also in the Silica Formation and described in this paper.

Ostracod Genera Present in Unit 3
of the Skały Formation in northern Sniadka,
Poland

(from Adamczak, 1976)

* <i>Bairdiocypris</i>	<i>Piastia</i>
* <i>Bufina</i>	<i>Polyzygia</i>
* <i>Ctenoloculina</i>	* <i>Praepilatina</i>
* <i>Hollinella</i>	* <i>Tetrasacculus</i>
* <i>Microcheilinella</i>	<i>Zeuschneria</i>
<i>Parabolbinella</i>	

* Genera which are also present in the Silica Formation.

REFERENCES

- ABDUL-RAZZAQ, Sabeekah, 1973, Evolution of Middle Devonian species of *Euglyphella* as indicated by cladistic analysis: *Contributions Mus. Paleontology, Univ. Mich.*, v.24, no.6, p.47-64, 12 text-figs.
- ADAMCZAK, F., 1961, Eridostraca -- a new suborder of ostracods and its phylogenetic significance: *Acta palaeontol. Polonica*, v.6, no.1, p.29-104, pls.1-4, 23 figs.
- , 1968, Palaeocopa and Platycopa (Ostracoda) from Middle Devonian rocks in the Holy Cross Mountains, Poland: *Stockholm, Contrib. in Geology*, v.17, p.1-109, 46 pls.
- , 1971, On some ostracod assemblages of Middle Devonian rocks, in H. J. Oertli (ed.), *Colloque sur la Paléoécologie des Ostracodes - Colloquium on the Paleoeecology of Ostracodes*, Pau, 20-27, VII, 1970: *Centre Recherches Pau Bull.*, v.5 suppl., p.787-800, 8 figs.
- ADAMCZAK, Franciszek, 1976, Middle Devonian Podocopida (Ostracoda) from Poland; their morphology, systematics, and occurrence: *Senckenbergiana Lethaea*, v.57, no.4/6, p.265-467, 30 pls., 53 text-figs.
- , & M. WEYANT, 1973, *Rishona Sohn* (Ostracoda, Devonian) morphology and intercontinental distribution: *Senckenbergiana Lethaea*, Bd.53, no.6, p.523-541, pls.1-3, 9 text-figs.
- AGNEW, A. F., 1942, Bibliographic index of new genera and families of Paleozoic Ostracoda since 1934: *Jour. Paleontology*, v.16, p.756-763.
- BASSLER, R. S., 1941, Ostracoda from the Devonian (Onondaga) chert of western Tennessee: *Jour. Washington Acad. Sci.*, v.31, no.1, p.21-27, 1 pl.
- , & B. KELLETT, 1934, Bibliographic index of Paleozoic Ostracoda: *Geol. Soc. Amer., Spec. Papers*, no.1, 500 p., 24 figs.
- BECKER, Gerhard, 1964, Palaeocopida (Ostracoda) aus dem Mitteldevon der Söteniches Mulde (N.-Eifel): *Senckenbergiana Lethaea*, Bd.45, nos.1-4, p.43-113, pls.6-15.
- , 1965a, Podocopida (Ostracoda) aus dem Mitteldevon der Söteniches Mulde (N.-Eifel) *Ibid.*, Bd.46, p.367-441, pls.28-35, 1 fig.
- , 1965b, Revision Kummerow'sher Ostracodenarten aus dem deutschen Mitteldevon: *Fortschr. Geol. Rheinl. Westf.*, v.9, p.151-188, pls.1-9, 1 tab.
- , 1968, Zur Morphologie und Systematik der Palaeocopida-Gattungen *Nodella Zaspelova* und *Aechminella Harlfon*: *Senck. Leth.*, Bd.49, no.5/6, p.547-563, 1 pl.
- , 1969, Ostracoda aus dem Mitteldevon der Söteniches Mulde (N.-Eifel), *Biostratigraphie, Palaökologie, und taxonomische Bemerkungen: Senckenbergiana Lethaea*, v.50, p.239-271, 1 pl.
- , 1970, Primitiopsacea (Paleocopida) aus dem Rheinischen Devon: *Ibid.*, Bd.51, p.49-65, 2 pls., 8 figs.
- , 1971, Ostracoda aus dem Mittel-Frasium (Oberdevon) der Mulde von Dinant: *Bull. K. Belge. Inst. Nat. Wet.*, v.47, p.1-82, 12 pls., 1 table.
- , & M. J. M. BLESS, 1971, Zur Verbreitung der Ostracoden-Familie *Hollinellidae* Bless und Jordan, mit Beschreibung neuer Funde aus dem Mittel und Oberdevon Westeuropas: *Senckenbergiana Lethaea*, Bd.52, p.537-567, pls.1-4, 5 figs.
- BERDAN, J. M., 1960, Revision of the ostracode family *Beecherellidae* and redescription of Ulrich's types of *Beecherella*: *Jour. Paleontology*, v.34, no.3, p.467-478, 1 pl.
- , & M. J. COPELAND, 1973, Ostracodes from Lower Devonian formations in Alaska and Yukon Territory: *U. S. Geol. Survey, Prof. Paper* 825, 43 p., 14 pls., 7 figs.
- BLESS, M. J. M., & H. JORDAN, 1970, Stratigraphical and taxonomical remarks on the ostracode genus *Hollinella* Coryell: *Mededelingen Rijks Geol. Dienst, n. ser.*, no.21, p.81-91, 3 pls.
- & -----, 1971, Classification of paleocopid ostracodes belonging to the families *Ctenoloculinidae*, *Hollinidae*, and *Hollinellidae*, in H. J. Oertli (ed.), *Colloque sur la paléoécologie des Ostracodes - Colloquium on the Paleoeecology of Ostracodes*, Pau, 20-27, VII, 1970: *Centre Recherches Pau Bull.*, v.5 suppl., p.869-890, 4 tables.

- & -----, 1972, Ostracodes of the family Hollinellidae: Mededelingen Rijks Geol. Dienst, ser. C-V-3, no. 1, p. 8-83, 35 pls.
- BOUČEK, Bedřich, 1936, Die Ostracoden des böhmischen Ludlows (Stufe e β): Neues Jahrb. Mineralogie, Geologie u. Paläontologie, Beil.-Bd. 76, Abt. B, no. 1, p. 31-98, 5 pls.
- BRAUN, W. K., 1967, Upper Devonian Ostracod Faunas of Great Slave Lake and north-eastern Alberta, Canada, in D. H. Oswald (ed.), International Symposium on the Devonian System, Calgary, 1967: Alberta Soc. Petrol. Geologists, v. 2, p. 617-652.
- COLEY, T. B., 1954, Stratigraphic distribution and correlation of some Middle Devonian ostracodes: Jour. Paleontology, v. 28, no. 4, p. 452-464, 1 pl.
- COLLIER, W. W., 1971, Phylogeny of the Devonian ostracod genus *Ctenoloculina* Bassler: Contrib. Mus. Paleontology, Univ. Mich., v. 23, no. 23, p. 357-376, 3 pls., 6 text-figs.
- COOPER, C. L., 1941, Chester ostracodes of Illinois: Ill. State Geol. Survey, Rept. Investigations, no. 77, p. 5-101, 14 pls.
- , 1942, Occurrence and stratigraphic distribution of Paleozoic ostracodes: Jour. Paleontology, v. 16, no. 6, p. 764-776, 9 text-figs.
- CORYELL, H. N., 1928, Some new Pennsylvanian Ostracoda: Jour. Paleontology, v. 2, p. 377-381, pl. 51.
- , & D. S. MALKIN, 1936, Some Hamilton ostracodes from Arkona, Ontario: Amer. Mus. Novitates, no. 891, p. 1-20, 2 pls.
- , & M. WILLIAMSON, 1936, A study of the ostracoda fauna of the Waldron Shale, Flat Rock Creek, St. Paul, Indiana: Amer. Mus. Novitates, no. 870, p. 1-7, figs. 1-15.
- EGOROV, V. G., 1950, Ostrakody franskogo iarusia Russkoi platformy (Ostracods of the Frasnian Stage of the Russian platform), I. Kloedenellidae: Moscow-Leningrad Vses. Neft. Nauchno-Issled. Geol.-Razved. Inst. Moscow, Filial, 140 p., 18 pls.
- EHLERS, G. M., & M. E. COOLEY, 1927, Discovery of a Hamilton fauna in south-eastern Michigan: Contrib. Mus. Paleontology, Univ. Mich., v. 2, no. 13, p. 231-236.
- , E. C. STUMM, & R. V. KESLING, 1951, Devonian rocks of southeastern Michigan and northwestern Ohio: Edwards Bros., Ann Arbor, 40 p., 5 pls., 3 figs. (prepared for field trip of Geol. Soc. Amer. Detroit Meeting, Nov. 1951).
- GEIS, H. L., 1932, Some ostracodes from the Salem Limestone, Mississippi of Indiana: Jour. Paleontology, v. 6, p. 149-188, pls. 22-26.
- GRABAU, A. W., 1898-1899, Geology and Palaeontology of Eighteen Mile Creek and the lake shore sections of Erie County, New York: Buffalo Soc. Nat. Sciences, pt. 1, Geology, p. i-xxiii, 1-91 (1898); pt. 2, Palaeontology, p. 93-403 (1899); 27 pls., viii + 263 figs.
- , & H. W. SHIMER, 1910, North American index fossils, Invertebrates, v. 2: A. G. Seiler & Co., New York, 909 p., figs. 1211-1937.
- GROOS, Helga, 1969, Mitteldevonische Ostracoden zwischen Ruhr und Sieg (Rechts-rheinisches Schiefergebirge): Göttinger Arbeiten zur Geologie und Paläontologie, no. 1, 110 p., 20 pls., 48 figs.
- GRÜNDEL, J., 1962, Zur Taxionomie der Ostracoden der *Gattendorfia*-Stufe Thüringens: Freiburger Forschungshefte, no. C 151, p. 51-105, 4 pls.
- GÜRICH, G., 1896, Das Palaeozoicum im Polnischen Mittelgebirges: Russ. Kais. Min. Ges. St. Petersburg, Verh., ser. 2, v. 32, p. 374-391, pls. 10, 14, 15.
- HARLTON, H. B., 1933, Micropaleontology of the Pennsylvanian Johns Valley Shale of the Ouachita Mountains of Oklahoma, and its relationship to the Mississippian Caney Shale: Jour. Paleontology, v. 7, p. 3-29, pls. 1-7.
- HENNINGSMOEN, Gunnar, 1953, Classification of Paleozoic straight-hinged ostracods: Norsk Geol. Tidsskr., v. 31, p. 185-288, 2 pls.
- , 1965, On certain features of palaeocene ostracods: Geologiska Fören. Stockholm Förhandlingar, v. 86, p. 329-394, 16 text-figs.
- HOWE, H. V., 1955, Handbook of ostracod taxonomy: Louisiana State Univ. Studies,

- no. 1, 389 p.
- JONES, D. J., 1956, Introduction to microfossils: Harper & Bros., N. Y., 406 p.
- JONES, P. J., 1962, The ostracod genus Cryptophyllus in the Upper Devonian and Carboniferous of Western Australia: Bur. Mineral. Resources Australia, Bull. 62, no. 3, p. 1-37, 3 pls.
- , 1968, Upper Devonian Ostracoda and Eridostraca from the Bonaparte Gulf Basin, N. W. Australia: Dept. Nat. Development, Bur. Resources, Geology & Geophysics, Bull. 99, p. 1-93, pls. 1-7, 21 text-figs.
- JONES, T. Rupert, 1887, Notes on some Silurian Ostracoda from Gothland: P. A. Norstedt & Söner, Stockholm, 8 p., 2 figs.
- , 1889, Notes on Paleozoic bivalved Entomostraca, no. 27: Ann. & Mag. Nat. History, ser. 6, v. 3, p. 373-387, pls. 16-17.
- , 1890a, On some Paleozoic Ostracoda from North America, Wales, and Ireland: Quart. Jour. Geol. Soc. London, v. 46, p. 1-31, pls. 1-4.
- , 1890b, On some Devonian and Silurian Ostracods from North America, France, and the Bosphorus: Ibid., p. 534-556, pl. 20.
- , 1891, On some Ostracoda from the Cambro-Silurian and Devonian rocks: Geol. Survey Canada, Contrib. Micro-Palaeontology, pt. 3, p. 59-99, pls. 10-113, wood-cut figs. 4-8.
- , & H. B. HOLL, 1869, Notes on the Paleozoic bivalved Entomostraca, No. IX. Some Silurian species: Ann. & Mag. Nat. History, ser. 4, v. 3, no. 15, p. 211-228, figs. 2-7, pls. 14, 15.
- JORDAN, H., 1965, Ostracoden aus dem tieferen Mitteldevon des Vogtlandes: Freiburger Forschungsh., Bd. C 182, p. 37-48 (Leipzig).
- KEGEL, Wilhelm, 1932, Zur Kenntnis paläozoischen Ostrakoden, 2. Bairdiidae aus dem Mitteldevon des Rheinischen Schiefergebirges: Press. Geol. Landesanst., Jahrb. 1931, v. 52, p. 245-250, 1 pl.
- KELLETT, Betty, 1929, The ostracode genus Hollinella, expansion of the genus and description of some Carboniferous species: Jour. Paleontology, v. 3, no. 2, p. 196-217.
- KESLING, R. V., 1951, Mechanical solution of formulas for growth rates: Contrib. Mus. Paleontology, Univ. Mich., v. 8, no. 10, p. 231-237.
- , 1951b, Terminology of ostracod carapaces: Ibid., v. 9, no. 4, p. 93-171, 5 charts, 7 figs., 18 pls.
- , 1952a, A study of Ctenoloculina cicatricosa (Warthin): Ibid., v. 9, no. 8, p. 247-290, 2 charts, 5 figs., 3 pls.
- , 1952b, Ostracods of the families Leperditellidae, Primitiidae, Drepanellidae, Aechminidae, and Kirkbyidae from the Middle Devonian Bell Shale of Michigan: Ibid., v. 10, no. 2, p. 21-44, 5 pls.
- , 1952c, Ostracods of the family Hollinidae from the Ferron Point Formation of Michigan: Ibid., v. 10, no. 3, p. 45-57, 2 pls.
- , 1952d, Dimorphism in Devonian hollinid ostracods of North America: Jour. Paleontology, v. 26, no. 5, p. 764-771, text-fig. 1.
- , 1953a, Ostracods of the family Drepanellidae from the Arkona Shale of Ontario: Contrib. Mus. Paleontology, Univ. Mich., v. 10, no. 8, p. 193-202, 1 pl.
- , 1953b, Ostracods of the family Hollinidae from the Arkona Shale of Ontario: Ibid., v. 10, no. 9, p. 203-219, 4 pls.
- , 1953c, A new beyrichiid ostracod from the Middle Devonian Rockport Quarry Limestone of Michigan: Ibid., v. 10, no. 10, p. 221-229, 2 pls., 1 fig.
- , 1953d, Ostracods of the family Aechminidae from the Arkona Shale of Ontario: Ibid., v. 11, no. 1, p. 1-10, 1 pl.
- , 1953e, A slide rule for the determination of instars in ostracod species: Ibid., v. 11, no. 5, p. 97-109, 2 figs.
- , 1954a, A new species of Phlyctiscapha from the Middle Devonian Ferron Point Formation of Michigan: Ibid., v. 11, no. 9, p. 187-192, 1 pl.
- , 1954b, An instrument for cleaning small fossils: Ibid., v. 11, no. 10, p. 193-199, 2 pls.
- , 1954c, Ornamentation as a character in specific differentiation of ostracods: Ibid., v. 12, no. 2, p. 13-21, 2 pls.
- , 1957a, A chart useful for study of ostracod carapaces: Ibid., v. 14, no. 2, p. 17-20, 2 figs.
- , 1957b, A peel technique for ostracod carapaces and structures revealed there-

- with in *Hibbardia lacrimosa* (Swartz & Oriel) *Ibid.*, v. 14, no. 4, p. 27-40, 5 pls.
- , 1957c, Origin of beyrichiid ostracods: *Ibid.*, v. 14, no. 6, p. 57-80, 7 pls., 5 figs.
- , 1969, Copulatory adaptations in ostracods, Part III. Adaptations in some extinct ostracods: *Ibid.*, v. 22, no. 21, p. 273-312, 23 text-figs.
- KESLING, R. V., 1969b, *Silicaster*, a new genus of Devonian starfish: *Contrib. Mus. Paleontology, Univ. Mich.*, v. 22, no. 19, p. 249-261, 4 pls., 2 text-figs.
- , 1972, *Strataster devonicus*, a new brittle star with unusual preservation from the Middle Devonian Silica Formation of Ohio: *Ibid.*, v. 24, no. 2, p. 9-15, 2 pls., 3 text-figs.
- , 1976, Planning photography of microfossils: *Papers on Paleontology*, no. 16, 52 p., illus.
- , & R. B. CHILMAN, 1975, Strata and megafossils of the Middle Devonian Silica Formation: *Papers on Paleontology*, no. 8, 408 p., 141 pls., 75 text-figs.
- , F. S. CRAFTS, D. G. DARBY, K. E. SHUBAK, & R. N. SMITH, 1960, Middle Ordovician Black River ostracods from Michigan, Introduction and Part 1, The nature of *Macronotella*: *Contrib. Mus. Paleontology, Univ. Mich.*, v. 15, no. 13, p. 293-314, 3 pls.
- , Emadeddin KAVARY, R. S. TAKAGI, J. R. TILLMAN, & G. R. WULF, 1959, Quasillitid and alanellid ostracods from the Centerfield Limestone of western New York: *Ibid.*, v. 15, no. 2, p. 15-31, 4 pls., 4 figs.
- , & J. E. KILGORE, 1952, Ostracods of the families Leperditellidae, Drepanellidae, Glyptopleuridae, Kloedenellidae, Bairdiidae, Barychilinidae, and Thlipsuridae from the Genshaw Formation of Michigan: *Ibid.*, v. 10, no. 1, p. 1-19, 4 pls.
- , & D. LEVASSEUR, 1971, *Strataster ohioensis*, a new early Mississippian brittle-star, and the paleoecology of its community: *Ibid.*, v. 23, no. 20, p. 305-341, 13 pls., 9 text-figs.
- , & G. W. McMILLAN, 1951, Ostracods of the family Hollinidae from the Bell Shale of Michigan: *Contrib. Mus. Paleontology, Univ. Mich.*, v. 9, no. 2, p. 45-81, 7 pls., 2 figs., map.
- , & R. M. PETERSON, 1958, Middle Devonian hollinid ostracods from the Falls of the Ohio: *Micropaleontology*, v. 4, no. 2, p. 129-148, 2 pls., 2 tables.
- , & K. J. ROGERS, 1957, Size, lobation, velate structures, and ornamentation in some beyrichiid ostracods: *Jour. Paleontology*, v. 31, no. 5, p. 997-1009, pls. 127-130.
- , & I. G. SOHN, 1958, The Paleozoic ostracode genus *Alanella* Bouček 1936: *Jour. Paleontology*, v. 32, no. 3, p. 517-524, pl. 78, text-figs.
- , & H. L. STRIMPLE, 1971, *Eutaxocrinus wideneri*, a new flexible crinoid from the Middle Devonian Silica Formation of northwestern Ohio: *Ibid.*, v. 23, no. 19, p. 291-303, 6 pls., 2 text-figs.
- , & E. C. STUMM, 1957, Citations and references in the Journal of Paleontology: *Jour. Paleontology*, v. 31, no. 3, p. 666-672.
- , & N. R. TABOR, 1952, Two new species of ostracods from the Genshaw Formation (Middle Devonian) of Michigan: *Jour. Paleontology*, v. 26, no. 5, p. 761-763, pl. 111.
- , & Martin WEISS, 1953, Ostracods from the Norway Point Formation of Michigan: *Contrib. Mus. Paleontology, Univ. Mich.*, v. 11, no. 3, p. 33-76, 5 pls.
- KILENYI, T. I., 1971, Some basic questions in the paleoecology of ostracodes, in H. J. Oertli (ed.), *Colloque sur la Paleocologie des Ostracodes - Colloquium on the Paleocology of Ostracodes*, Pau, 20-27, VII, 1970: *Centre Recherches Pau Bull.*, v. 5 suppl., p. 31-44, 3 figs.
- KRÖMMELBEIN, K., 1953, Ostracoden-Studien in Devon der Eifel, 3. Nachweis der polnischen Gattungen *Polyzygia* und *Poloniella* im Mittel-Devon der Eifel: *Senckenbergiana Lethaea*, Bd. 34, no. 1/3, p. 53-59.
- , 1954, Devonische Ostracoden aus der Gegend von Buchan und von der Küste der Waratah Bay, Victoria, Australien: *Ibid.*, Bd. 35, no. 3/4, p. 193-229, 5 pls.
- KUMMEROW, E., 1953, Über oberkarbonische

- und devonische Ostracoden im Deutschland und der Volksrepublik Polen: Beih. Z. Geologie, v. 7, 75 p., 7 pls. (Berlin).
- LETHIERS, Francis, 1970, Quelques ostracodes frasnien du Bas-Boulonnais (France): Ann. Soc. Géol. Nord, v. 90, no. 2, p. 69-75, pls. 6, 7.
- LEVINSON, S. A., 1950, The hingement of Paleozoic Ostracoda and its bearing on orientation: Jour. Paleontology, v. 24, no. 1, p. 63-75, 16 text-figs.
- , 1951, Thin sections of Paleozoic Ostracoda and their bearing on taxonomy and morphology: Ibid., v. 25, no. 5, p. 553-560, pl. 77, 1 text-fig.
- , 1957, Bibliography and index to new genera and species of Ostracoda for 1956: Micropaleontology, v. 3, p. 367-392.
- LORANGER, D. M., 1954, Ireton microfossil zones of central and northeastern Alberta, in L. M. Clark (ed.), Western Canada Sedimentary Basin: Amer. Assoc. Petroleum Geologists (Tulsa), p. 182-203, 2 pls.
- , 1963, Devonian microfauna from northeastern Alberta: Part I, Ostracoda, orders Leperditicopa and Palaeocopida, 55 p. (published by author, available from Evelyn De Mille Books, Ltd., Calgary), 4 pls.
- LUNDIN, R. F., 1968, Ostracodes of the Hargan Formation (Devonian) in Oklahoma: Okla. Geol. Survey, Bull. 116, 121 p., 21 pls.
- MARTINSSON, Anders, 1955, Studies on the ostracode family Primitiopsidae: Bull. Geol. Inst. Uppsala, v. 36, p. 1-33, 2 pls.
- ; 1962, Ostracodes of the family Beyrichiidae from the Silurian of Gotland: Publ. Palaeont. Inst. Univ. Uppsala, v. 41, p. 1-369, 1 pl., 203 figs.
- MELIK, J. C., 1966, Hingement and contact margin structure of palaeocopid ostracodes from some Middle Devonian formations of Michigan, southwestern Ontario, and western New York: Contrib. Mus. Paleontology, Univ. Mich., v. 20, no. 8, p. 195-269, 24 pls., 4 figs.
- MITCHELL, S. W., 1967, Stratigraphy of the Silica Formation of Ohio and the Hungry Hollow Formation of Ontario, with paleogeographic interpretations: Papers Mich. Acad. Sci., Arts, & Letters, v. 52 (for 1966), p. 175-196, figs.
- MOORE, R. C. (ed.), 1961, Part Q - Arthropoda 3 (Ostracoda): Treatise on Invertebrate Paleontology, Geol. Soc. Amer. & Univ. Kansas Press, New York & Lawrence, Kansas, 442 p., illus.
- , C. G. LALICKER, & A. G. FISHER, 1952, Invertebrate fossils: McGraw-Hill Book Co., New York, 766 p., illus.
- MOREY, P. S., 1935a, Ostracoda from the basal Mississippian sandstone in central Missouri: Jour. Paleontology, v. 9, no. 4, p. 316-326, pl. 28.
- , 1935b, Ostracoda from the Amsden Formation of Wyoming: Ibid., v. 9, no. 6, p. 474-482, pl. 54.
- MORRIS, R. W., & B. L. HILL, Jr., 1952, New Ostracoda from the Middle Silurian Newsome Shale of Tennessee: Bull. Amer. Paleontology, v. 34, no. 142, 22 p., 2 pls.
- PAUKEN, R. J., 1966, New species of ostracodes from the Silica Formation (Middle Devonian) in northwestern Ohio: Ohio Jour. Sci., v. 66, p. 536-547, 2 pls., 2 text-figs.
- PAYNE, R. A., 1937, Pennsylvanian Ostracoda from Sullivan County, Indiana: Jour. Paleontology, v. 11, p. 276-288, pls. 38-40, 2 text-figs.
- PETERSON, R. M., 1964, Ostracodes of the superfamilies Quasillitacea and Kloedenellacea from the Middle Devonian strata of Michigan, Ohio, New York, and Ontario: Jour. Paleontology, v. 38, no. 5, p. 836-865, pls. 133-136, 6 text-figs.
- , 1966, Ostracodes of the genera *Bufina* and *Euglyphella* from the Middle Devonian of New York, Ohio, Michigan, and Ontario: Ibid. v. 40, p. 1-20, pls. 1-4.
- POKORNÝ, Vladimír, 1950, The ostracods of the Middle Devonian Red Coral Limestones of Čelechovice: Czechoslovakia, Státní Geol. Ústav, Sborník, v. 17, p. 580-632, 5 pls. (Czech).
- , 1971, The diversity of fossil ostracode communities as an indicator of paleogeographic conditions, in H. J. Oertli (ed.), Colloque sur la Paleoecologie des Ostracodes - Colloquium on the Paleoecology of Ostracodes, Pau, 20-27, VII, 1970: Centre Recherches

- Pau Bull., v. 5 suppl., p. 45-61, 4 figs.
- POLENOVA, E. N., 1952, Ostrakody verknei chasti Zhivetskogo Yarusy Russkoi platformy, in Mikrofauna SSSR, Sbornik 5: Vses. Neft. Nauchni-Issled. Geol.-Razved. Inst. VNIGRI, Trudy, n. ser., no. 60, p. 65-156, 15 pls.
- , 1953, Ostrakody devonskikh otlozhenii tsentralenogo Devonskogo polya i srednego Povolzhya (Ostracods of the Devonian in the central Devonian field and the middle Volga region): VNIGRI, Trudy, n. ser., no. 68, 156 p., 14 pls.
- , 1955, Ostrakody devona Volgo-Uralskoi oblasti: Mikrofauna SSSR, v. 5, VNIGRI, Trudy, n. ser., no. 87, p. 191-317, 15 pls.
- , 1960, Devonskie ostrakody Kuznetskogo basseina i Minusinskoi kotloviny: VNIGRI, Trudy, no. 152, p. 1-166, 13 pls.
- , 1968, Ostrakody nizhnego Devona Salaira: Akad. Nauk SSSR Sibirsk, Otdeleniye Inst. Geologii i Geofiziki Trudy, 154 p., 26 pls.
- , 1970, Ostrakody pozdnego Silura i ranego Devona Altaye-Sayanskoi oblasti: Akad. Nauk SSSR Sibirsk, Otdeleniye Inst. Geologii i Geofiziki Trudy, v. 127, 104 p., 34 pls.
- , 1974, Early Devonian ostracods of the USSR Arctic Regions: Akad. Nauk SSSR Sibirsk, Otdeleniye Inst. Geologii i Geofiziki Trudy, v. 234, 117 p., 34 pls.
- POSNER, V. M., 1951, Lower Carboniferous Ostracoda of the western part of the Moscow Kettle Valley: VNIGRI, Trudy, n. ser., no. 56, p. 5-108, 21 pls.
- READ, H. H., & Janet WATSON, 1975, Introduction to Geology, Volume 2, Earth History, Part II, Later stages of earth history: John Wiley & Sons, xii + 371 p.
- ROTH, R., 1928, *Monoceratina*, a new genus of Ostracoda from the Pennsylvanian of Oklahoma: Jour. Paleontology, v. 2, no. 1, p. 15-19.
- ROUNDY, P. V., 1926, Mississippian formations of San Saba County, Texas, Pt. 2, The microfauna: U. S. Geol. Survey, Prof. Paper 146, p. 5-23, 4 pls.
- ROZHDESTVENSKAYA, A. A., 1962, Srednidevonskie ostrakody zapadnogo sklona Yuzhnogo Urala, Predural'skogo progiba i plattformennoi chasti Bashkiri, in Tyazheva, A. P., Rozhdestvenskaya, A. A., & Chibrikova, E. V., Brakhipody, ostrakody i spory srednego i verkhnego Devona Bashkiri: Akad. Nauk SSSR, Bashkiri Filial, Gorno-Geologicheskii Inst., p. 169-349, 35 pls.
- , 1972, Ostrakody verkhnego Devona Bashkiri: Akad. Nauk SSSR, Bashkiri Filial, Inst. Geol., 194 p., 40 pls., 4 text-figs.
- ROZKOWSKA, M., 1956, Pachyphyllinae from the Middle Devonian of the Holy Cross Mountains, Part I: Acta Palaeont. Polonica, v. 1, no. 4, p. 271-330.
- SCHMIDT, E. A., 1941, Studien im böhmischen Caradoc (Zahořan-Stufe). 1. Ostrakoden aus den Bohdalec-Schichten und über die Taxonomie der Beyrichiacea: Abh. Senck. Naturf. Gesell., Abh. 454, 96 p., 5 pls., 2 text-figs.
- SHIMER, H. W., & R. R. SHROCK, 1944, Index fossils of North America: John Wiley, New York, 837 p., 303 pls.
- SMITH, M. L., 1956, Some ostracods from the Middle Devonian Ledyard and Wanakah members of the Ludlowville Formation in western New York: Jour. Paleontology, v. 30, no. 1, p. 1-8, 1 pl., 1 text-fig.
- SOHN, I. G., 1954, Ostracoda from the Permian of the Glass Mountains, Texas: U. S. Geol. Survey, Prof. Paper 264-A, 24 p., 5 pls.
- , 1960, Paleozoic species of *Bairdia* and related genera: U. S. Geol. Survey, Prof. Paper 330-A, 105 p., 6 pls.
- , 1961 (1962), *Aechminella*, *Amphissites*, *Kirkbyella*, and related genera: Ibid., Prof. Paper 330-A, p. 105-160, pls. 7-12.
- , 1968, Triassic ostracodes from Makhtesh Ramon, Israel: Ministry Develop., State of Israel, Bull. 44, p. 1-67, 4 pls., 3 text-figs. (USGS, Washington, D. C.).
- , 1971, New Late Mississippian ostracode genera and species from Alaska, a revision of the Paraparchitacea: U. S. Geol. Survey, Prof. Paper 711-A, 24 p., 9 pls., 3 figs.
- , 1975, Mississippian Ostracoda of the Amsden Formation (Mississippian and Pennsylvanian) of Wyoming: Ibid., Prof. Paper 848-G, p. 1-22, 3 pls.
- , & L. E. STOVER, 1961, (Systematic

- descriptions of Bufinidae and Geisinidae) in R. C. Moore (ed.), *Treatise on Invertebrate Paleontology, Part Q* (q.v.)
- STEWART, G. A., 1927, *Fauna of the Silica Shale of Lucas County, Ohio: Ohio Jour. Sci.*, ser. 4, bull. 32, 76 p., 5 pls.
- , 1930, Additional species from the Silica Shale of Lucas County, Ohio: *Bull. Geol. Survey Ohio*, v. 30, no. 1, p. 52-58, 1 pl.
- , 1936, Ostracodes of the Silica Shale, Middle Devonian of Ohio: *Jour. Paleontology*, v. 10, p. 739-763, 3 pls.
- , 1937, *Aechmina crenulata*, new name for *Aechmina serrata* Stewart, not Coryell & Cuskey (*Paleontological Notes: Jour. Paleontology*, v. 11, p. 368).
- , 1950, Ostracoda from the Middle Devonian Bone Beds in central Ohio: *Jour. Paleontology*, v. 24, p. 652-666, pls. 85, 86.
- , & W. E. HENDRIX, 1945a, Ostracoda of the Plum Brook Shale, Erie County, Ohio: *Ibid.*, v. 19, no. 2, p. 87-95, pl. 10.
- , & -----, 1945b, Ostracoda of the Olen tangy Shale, Franklin and Delaware Counties, Ohio: *Ibid.*, v. 19, no. 2, p. 96-115, pls. 11, 12.
- STUMM, E. C., 1969, Devonian bioherms of the Michigan Basin: *Contrib. Mus. Paleontology, Univ. Mich.*, v. 22, no. 18, p. 241-247, 2 pls., 4 text-figs.
- STUMM, E. C., & R. B. CHILMAN, 1967, Check list of fossil invertebrates described from the Middle Devonian Silica Formation of northwestern Ohio and southeastern Michigan: *Contrib. Mus. Paleontology, Univ. Mich.*, v. 21, no. 7, p. 123-137.
- SWARTZ, F. M., 1936, Revision of the Primitiidae and Beyrichiidae, with new Ostracoda from the Lower Devonian of Pennsylvania: *Jour. Paleontology*, v. 10, p. 541-586, pls. 78-89.
- , 1945, Orientation, morphology, and classification of Paleozoic straight-backed Ostracoda: *Geol. Soc. Amer. Bull.*, v. 56, p. 1205.
- , & S. S. ORIEL, 1948, Ostracoda from Middle Devonian Windom Beds in western New York: *Jour. Paleontology*, v. 22, no. 5, p. 541-566, pls. 79-81.
- , & F. M. SWAIN, 1941, Ostracodes of the Middle Devonian Onondaga Beds of central Pennsylvania: *Geol. Soc. Amer. Bull.*, v. 52, no. 3, p. 381-458, 8 pls, 2 text-figs.
- SYLVESTER-BRADLEY, P. C., & R. H. BENSON, 1971, Terminology for surface features in ornate ostracodes: *Lethaia*, v. 4, no. 3, p. 249-286, 48 figs.
- TILLMAN, J. R., 1970, The age, stratigraphic relationships, and correlation of the lower part of the Olen tangy Shale of central Ohio: *Ohio Jour. Sci.*, v. 70, no. 4, p. 202-217, 6 figs.
- TRIEBEL, Erich, 1941, Zur Morphologie und Ökologie der fossilen Ostracoden. Mit Beschreibung einiger neuer Gattungen und Arten: *Senckenbergiana*, v. 23, no. 4/5, p. 294-400, 15 pls., 2 text-figs.
- TURNER, M. C., 1939, Middle Devonian ostracodes from oil wells in southwestern Ontario: *Bull. Amer. Paleontology*, v. 25, p. 5-32, 1 pl.
- ULRICH, E. O., 1891, New and little known American Paleozoic Ostracoda: *Jour. Cincinnati Soc. Nat. History*, v. 13, p. 104-137, 173-211, pls. 11-18.
- , 1900, New American Paleozoic Ostracoda; No. 1 -- *Ctenobolbina* and *Kirkbya*: *Ibid.*, v. 19, p. 179-186, pl. 8.
- , & R. S. BASSLER, 1908, New American Paleozoic Ostracoda, Preliminary revision of the Beyrichiidae with descriptions of new genera: *Proc. U. S. Nat. Mus.*, v. 35, p. 277-340, pls. 37-44.
- , & -----, 1913, On the Ostracoda, Middle and Upper Devonian: *Maryland Geol. Survey, Devonian Vol.*, p. 335-338, pl. 44, figs. 6-9.
- , & -----, 1923, Paleozoic Ostracoda: their morphology, classification, and occurrence: *Ibid.*, p. 271-391, 500-704, pls. 36-65, figs. 11-27.
- VAN PELT, H. L., 1933, Some ostracodes from the Bell Shale, Middle Devonian of Michigan: *Jour. Paleontology*, v. 7, p. 325-342, pl. 39.
- WARTHIN, A. S., Jr., 1930, Micropaleontology of the Wetumka, Wewoka, and Holdenville Formations: *Okla. Geol. Survey, Bull.* 53, 94 p., 9 pls.
- , 1934, Common Ostracoda of the Traverse Group: *Contrib. Mus. Paleontology, Univ. Mich.*, v. 4, p. 205-226, 1 pl.

- , 1937, Beyrichiacea, in Type invertebrate fossils of North America (Devonian): Wagner Free Inst. Sci., unit 9-A, 106 cards.
- , 1942, Leperditiacea, in Type invertebrate fossils of North America (Devonian): Wagner Free Inst. Sci., 14 cards.
- , 1945, Thlipsuridae, in Type invertebrate fossils of North America (Devonian): Wagner Free Inst. Sci., 82 cards.
- WEISS, Martin, 1954, Ostracods of the family Hollinidae from the Middle Devonian formations of Michigan and adjacent areas: Unpublished doctoral dissertation, Univ. Mich., 132 p., 22 pls.
- WHITEAVES, J. F., 1898, On some additional or imperfectly understood fossils from the Hamilton Formation of Ontario: Geol. Survey Canada, Contrib. Can. Palaeontology, v.1, pt.2, p.361-418.
- WRIGHT, L. M., 1949, A handbook of Paleozoic Ostracoda: privately published, 138 p., 16 pls.

Index

FAMILIES

Aechminellidae	44
Aechminidae	46
Amphissellidae	66
Aparchitidae	73
Arcyzonidae	69
Bairdiidae	84
Bairdiocyprididae	93
Beecherellidae	85
Beyrichiidae	37
Bolliidae	47
Bufinidae	105
Bythocytheridae	88
Cavellinidae	98
Coelonellidae	74
Ctenoloculnidae	56
Eridoconchidae	83
Geisinidae	81
Healdiidae	88
Hollinellidae	63
Hollinidae	60
Kirkbyellidae	53
Kloedenellidae	76
Quasillitidae	100
Richinidae	55
Ropolonellidae	107
Scrobiculidae	72
Thlipsuridae	113

SPECIES BY GENERA

<i>Acanthoscapha devonica</i>	85
<i>Acratia simplex</i>	85
<i>Adelphobolbina trilobata</i>	66
<i>Adelphobolbina spicata</i>	66
<i>Aechmina choanobasota</i>	46
<i>Aechmina crenulata</i>	46
<i>Aechminaria hormathota</i>	47
<i>Arcyzona bythiiclimacota</i>	70
<i>Arcyzona campylactinota</i>	71
<i>Arcyzona diademata</i>	71
<i>Arcyzona homalosagenota</i>	71
<i>Arcyzona rhabdota</i>	71
<i>Bairdiocypris gongylus</i>	93
<i>Bairdiocypris transptyxis</i>	94
<i>Balantoides trilobata</i>	45
<i>Birdsallella devonica</i>	98
<i>Birdsallella tumida</i>	98
<i>Bufina abbreviata</i>	106
<i>Bufina curti</i>	106
<i>Bufina spinulifera</i>	106
<i>Bythocyproidea eriensis</i>	106
<i>Coelonella plana</i>	75
<i>Coelonella scapha</i>	76
<i>Coeloenellina rara</i>	76
<i>Cornigella immotipedata</i>	47
<i>Cryptophyllus arsinus</i>	83
<i>Cryptophyllus minusculus</i>	83
<i>Ctenoloculina acanthina</i>	58
<i>Ctenoloculina eurybathrota</i>	58
<i>Ctenoloculina cicatricosa</i>	59
<i>Cytherellina kutasii</i>	96
<i>Cytherellina lechria</i>	96
<i>Cytherellina lucasensis</i>	96
<i>Cytherellina subquadrata</i>	97
<i>Cytherellina tanymeka</i>	97

<i>devonica</i> , <i>Acanthoscapha</i>	85	<i>reticulata</i> , <i>Glyphella</i>	104
<i>devonica</i> , <i>Birdsallella</i>	98	<i>rhabdota</i> , <i>Arcyzona</i>	71
<i>diabolicus</i> , <i>Tetrastorothyx</i>	50	<i>rhodesi</i> , <i>Ponderodictya</i>	92
<i>diademata</i> , <i>Arcyzona</i>	71	<i>rutkowskiae</i> , <i>Knoxiella</i>	80
<i>dictyotus</i> , <i>Sigynus</i>	47	<i>scapha</i> , <i>Coelonella</i>	76
<i>doverensis</i> , <i>Eukloedenella</i>	79	<i>scrobiculatum</i> , <i>Subligaculum</i>	59
<i>ehlersi</i> , <i>Rugocytherellina</i>	97	<i>sigmoidalis</i> , <i>Euglyphella</i>	112
<i>emaciata</i> , <i>Rectobairdia</i>	84	<i>silicensis</i> , <i>Praepilitina</i>	94
<i>eriensis</i> , <i>Bythocyproidea</i>	106	<i>simplex</i> , <i>Acratia</i>	85
<i>euglyphea</i> , <i>Dizygopleura</i>	77	<i>simplex</i> , <i>Punctoprimitia</i>	80
<i>eurybathrota</i> , <i>Ctenoloculina</i>	59	<i>spicata</i> , <i>Adelphobolbina</i>	66
<i>extensa</i> , <i>Rudderina</i>	107	<i>spinifera</i> , <i>Ulrichia</i>	52
<i>fastidiosa</i> , <i>Ulrichia</i>	51	<i>spinulifera</i> , <i>Bufina</i>	106
<i>fordei</i> , <i>Quasillites</i>	102	<i>stewartae</i> , <i>Kirkbyella</i> (<i>Berdanella</i>)	55
<i>fractodorsalis</i> , <i>Hypotetragona</i>	82	<i>subcircularis</i> , <i>Richina</i>	55
<i>fragilis</i> , <i>Ulrichia</i>	52	<i>sublunatus</i> , <i>Quasillites</i>	103
<i>gibba</i> , <i>Healdia</i>	90	<i>subnodatus</i> , <i>Xystinotus</i>	53
<i>gongylus</i> , <i>Bairdiocypris</i>	93	<i>subquadrata</i> , <i>Cytherellina</i>	97
<i>harrietensis</i> , <i>Hypotetragona</i>	83	<i>subreniformis</i> , <i>Menoeidina</i>	98
<i>homalosagenota</i> , <i>Arcyzona</i>	71	<i>tanymeke</i> , <i>Cytherellina</i>	97
<i>hormathota</i> , <i>Aechminaria</i>	47	<i>textiliger</i> , <i>Hyphasmophora</i>	113
<i>hypercala</i> , <i>Ehlersia</i>	73	<i>transptyxis</i> , <i>Bairdiocypris</i>	94
<i>illinear</i> , <i>Ulrichia</i>	52	<i>trilobata</i> , <i>Adelphobolbina</i>	66
<i>immotipedata</i> , <i>Cornigella</i>	47	<i>trilobata</i> , <i>Balantoides</i>	45
<i>kutasii</i> , <i>Cytherellina</i>	96	<i>trinodosa</i> , <i>Richina</i>	55
<i>labrosa</i> , <i>Hollinella</i> (<i>Keslingella</i>)	65	<i>trisinuata</i> , <i>Dizygopleura</i>	77
<i>laevilitata</i> , <i>Octonaria</i>	114	<i>truncata</i> , <i>Knoxiella</i>	81
<i>lativeatus</i> , <i>Falsipollex</i>	60	<i>truncata</i> , <i>Richina</i>	56
<i>laxiveatus</i> , <i>Falsipollex</i>	62	<i>tumida</i> , <i>Birdsallella</i>	98
<i>lechria</i> , <i>Cytherellina</i>	96	<i>unicornis</i> , <i>Kirkbyella</i> (<i>Berdanella</i>)	55
<i>lispa</i> , <i>Euglyphella</i>	108	<i>wrightorum</i> , <i>Xystinotus</i>	53
<i>lispa</i> , <i>Wideneria</i>	87	<i>xysta</i> , <i>Scrobicula</i>	72
<i>lucasensis</i> , <i>Cytherellina</i>	96		
<i>mariettensis</i> , <i>Microcheilinella</i>	90		
<i>medusaensis</i> , <i>Healdia</i>	90		
<i>minusculus</i> , <i>Cryptophyllus</i>	83		
<i>microspinosa</i> , <i>Scrobicula</i>	73		
<i>modesta</i> , <i>Euglyphella</i>	108		
<i>multicostatus</i> , <i>Dirhabdus</i>	68		
<i>obliquus</i> , <i>Quasillites</i>	102		
<i>ohioensis</i> , <i>Ponderodictya</i>	92		
<i>papillatus</i> , <i>Ropolonellus</i>	107		
<i>paucipunctata</i> , <i>Menoeidina</i>	100		
<i>plana</i> , <i>Coelonella</i>	76		
<i>planus</i> , <i>Pronipantex</i>	87		
<i>platus</i> , <i>Hanaites</i>	62		
<i>projecta</i> , <i>Euglyphella</i>	109		
<i>pumila</i> , <i>Hollinella</i> (<i>Keslingella</i>)	64		
<i>punctulifera</i> , <i>Ponderodictya</i>	92		
<i>pygmaeus</i> , <i>Tetrarhabdus</i>	69		
<i>quadricostata</i> , <i>Octonaria</i>	114		
<i>rara</i> , <i>Coeloenellina</i>	75		

SPECIES BY AUTHOR

COLEY

<i>Bufina curti</i>	106
<i>Stictobollia alethae</i>	50

CORYELL & MALKIN

<i>Birdsallella devonica</i>	98
<i>Doraclatum conatum</i>	68
<i>Euglyphella compressa</i>	107
<i>Euglyphella projecta</i>	109
<i>Healdia arkonensis</i>	89
<i>Hypotetragona harrietensis</i>	83
<i>Kirkbyella</i> (<i>Berdanella</i>) <i>unicornis</i>	55
<i>Quasillites fordei</i>	102
<i>Quasillites obliquus</i>	102
<i>Richina subcircularis</i>	55
<i>Richina truncata</i>	56
<i>Rudderina extensa</i>	107
<i>Ulrichia spinifera</i>	52

HALL

Ponderodictya punctulifera 92

JONES

Euglyphella sigmoidalis 112
Ulrichia conradi 50

KESLING

Aechmina choanobasota 46
Aechminaria hormathota 47
Arcyzona bythiclimacota 70
Arcyzona campylactinota 71
Arcyzona homalosagenota 71
Arcyzona rhabdota 71
Cornigella immotipedata 47
Ctenoloculina acanthina 58
Ctenoloculina eurybathrota 59
Falsipollex laxivelatus 62
Hollinella (Keslingella) pumila 64
Octonaria laevilitata 114
Phlyctiscapha apleta 40
Sigynus dictyotus 47
Tetrastorthynx diabolicus 50
Ulrichia illinearis 52
Xystinotus wrightorum 53

KESLING & CHILMAN, new

Acratia simplex 85
Bairdiocypris gongylus 93
Coeloenellina rara 75
Cryptophyllus minusculus 83
Cytherellina kutasii 96
Cytherellina lechria 96
Cytherellina tanymeke 97
Glyphella reticulata 104
Healdia medusaensis 90
Hypotetragona fractodorsalis 82
Knoxiella rutkowskiae 80
Knoxiella truncata 81
Menoetidina paucipunctata 100
Microcheilinella mariettensis 90
Nannohealdia arcuata 91
Ponderodictya rhodesi 92
Praepilitina silicensis 94
Pronipantex planus 87
Richina trinodosa 55
Rugocytherellina ehlersi 97
Scrobicula microspinosa 73
Scrobicula xysta 72
Tetrarhabdus pygmaeus 69
Ulrichia fastidiosa 51
Wideneria lispa 87

KESLING & KILGORE

Ehlersia hypercala 73
Kavaryella cracens 74
Rectobairdia emaciata 84

KESLING & McMILLAN

Adelphobolbina spicata 66
Falsipollex lativelatus 60
Hanaites platus 62
Subligaculum scrobiculatum 59

KESLING & SOHN

Acanthoscapha devonica 85

KESLING & WEISS

Healdia gibba 90
Hollinella (Keslingella) labrosa 65

PAUKEN

Dirhabdus multicostatus 68

PETERSON

Bufina abbreviata 106
Euglyphella lispa 108
Euglyphella modesta 108
Hypotetragona aequitalis 81

SOHN

Kirkbyella (Berdanella) stewartae 55

STEWART

Adelphobolbina trilobata 66
Aechmina crenulata 46
Birdsallella tumida 98
Bufina spinulifera 106
Bythocyproidea eriensis 106
Coelonella plana 76
Coelonella scapha 76
Cytherellina lucasensis 96
Cytherellina subquadrata 97
Menoetidina subreniformis 98
Ponderodictya ohioensis 92
Punctoprimitia simplex 80
Quasillites sublunatus 103
Subligaculum bifidum 59
Tetrasacculus bilobus 60

STOVER

Bairdiocypris transptyxis 94
Cryptophyllus arsinus 83

TURNER

Balantoides trilobata 45
Eukloedenella doverensis 79
Menoetidina arcuata 99
Quasillites concentricus 100
Xystinotus subnodatus 53

ULRICH

Hollinella (Keslingella) antespinosa 64

VAN PELT

<i>Arcyzona diademata</i>	71
<i>Dizygopleura trisinuata</i>	77
<i>Hyphasmophora textiliger</i>	113
<i>Jenningsina catenulata</i>	104
<i>Kirkbyella (Kirkbyella) bellipuncta</i>	53
<i>Octonaria crescentiformis</i>	114
<i>Octonaria quadricostata</i>	114
<i>Ropolonellus papillatus</i>	107

WARTHIN

<i>Ctenoloculina cicatricosa</i>	58
<i>Dizygopleura euglyphea</i>	77
<i>Monoceratina casei</i>	88
<i>Poloniella cingulata</i>	79
<i>Ulrichia fragilis</i>	52

Families of Ostracoda in the Silica Formation

Order PALAEOCOPIDA Henningsmoen	37	Order ERIDOSTRACA Adamczak	83
Suborder BEYRICHIOPINA Scott	37	Family Eridoconchidae	83
Superfamily Beyrichiacea	37	Order PODOCOPIDA Müller	84
Family Beyrichiidae	37	Suborder PODOCOPINA Sars	84
Superfamily Drepanellacea	44	Superfamily Bairdiacea	84
Family Aechminellidae	44	Family Bairdiidae	84
Family Aechminidae	46	Family Beecherellidae	85
Family Bolliidae	47	Superfamily Cytheracea	88
Family Kirkbyellidae	53	Family Bythocytheridae	88
Family Richinidae	55	Suborder METACOPINA Sylvester-Bradley ...	88
Superfamily Hollinacea	56	Superfamily Healdiacea	88
Family Ctenoloculinidae	56	Family Healdiidae	88
Family Hollinidae	60	Family Bairdiocyprididae	93
Family Hollinellidae	63	Family Cavellinidae	98
Superfamily Kirkbyacea	66	Superfamily Quasillitacea	100
Family Amphissellidae	66	Family Quasillitidae	100
Family Arcyzonidae	69	Family Bufinidae	105
Family Scrobiculidae	72	Family Ropolonellidae	107
Superfamily Aparchitacea	73	Superfamily Thlipsuracea	113
Family Aparchitidae	73	Family Thlipsuridae	113
Family Coelonellidae	74	? Ostracod - ? Order PALAEOCOPIDA	114
Suborder KLOEDENELLOCOPIINA Scott	76	Suprageneric taxa uncertain	114
Superfamily Kloedenellacea	76		
Family Kloedenellidae	76		
Family Geisinidae	81		



By these researches into the state of the earth and its inhabitants at former periods, we acquire a more perfect knowledge of its present condition, and more comprehensive views concerning the laws now governing its animate and inanimate productions.

-- Charles Lyell,
Principles of Geology

The interest in a science such as geology must consist in the ability of making dead deposits represent living scenes.

-- Hugh Miller

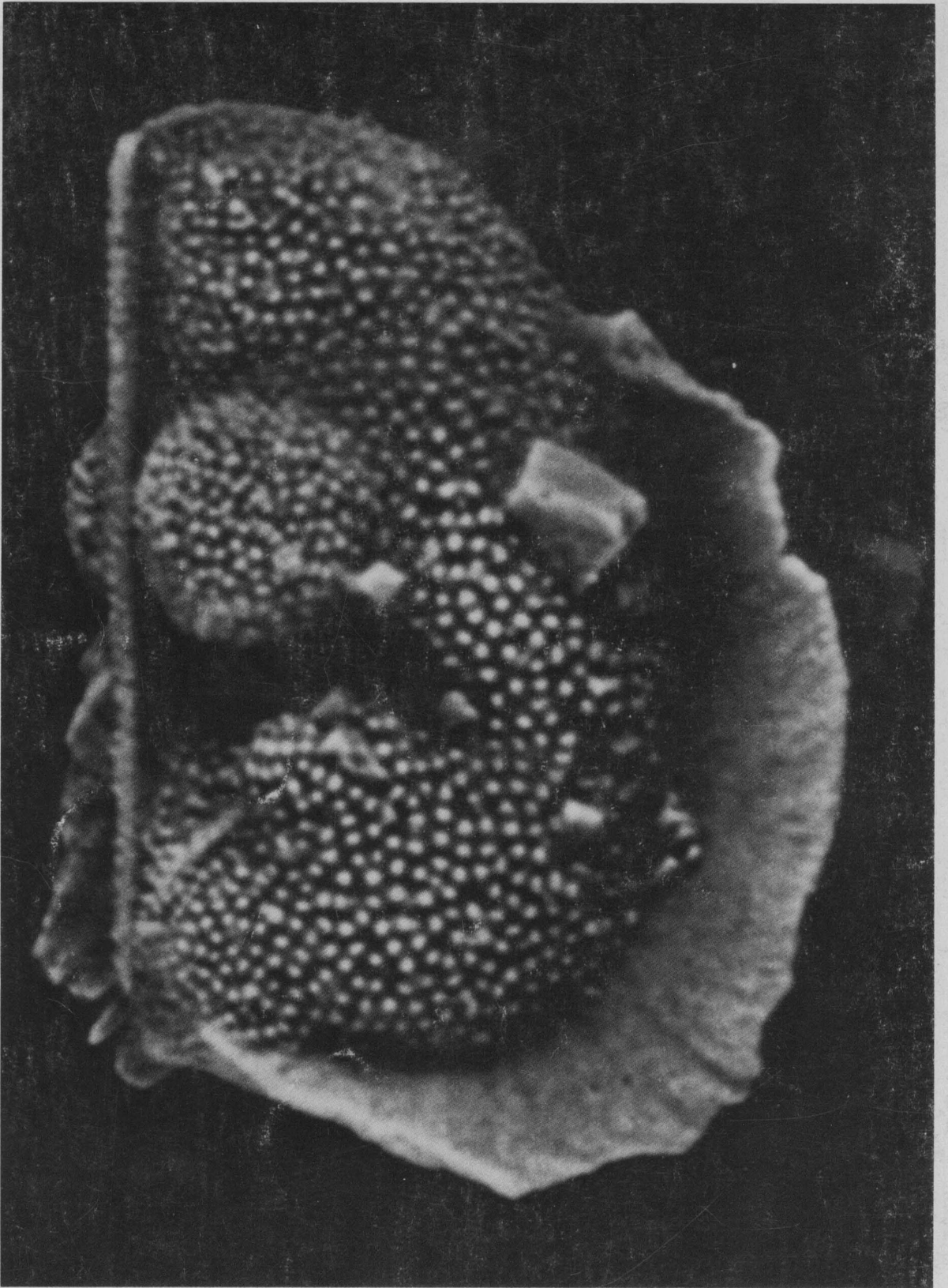

**Ostracods of the
Middle Devonian Silica Formation**

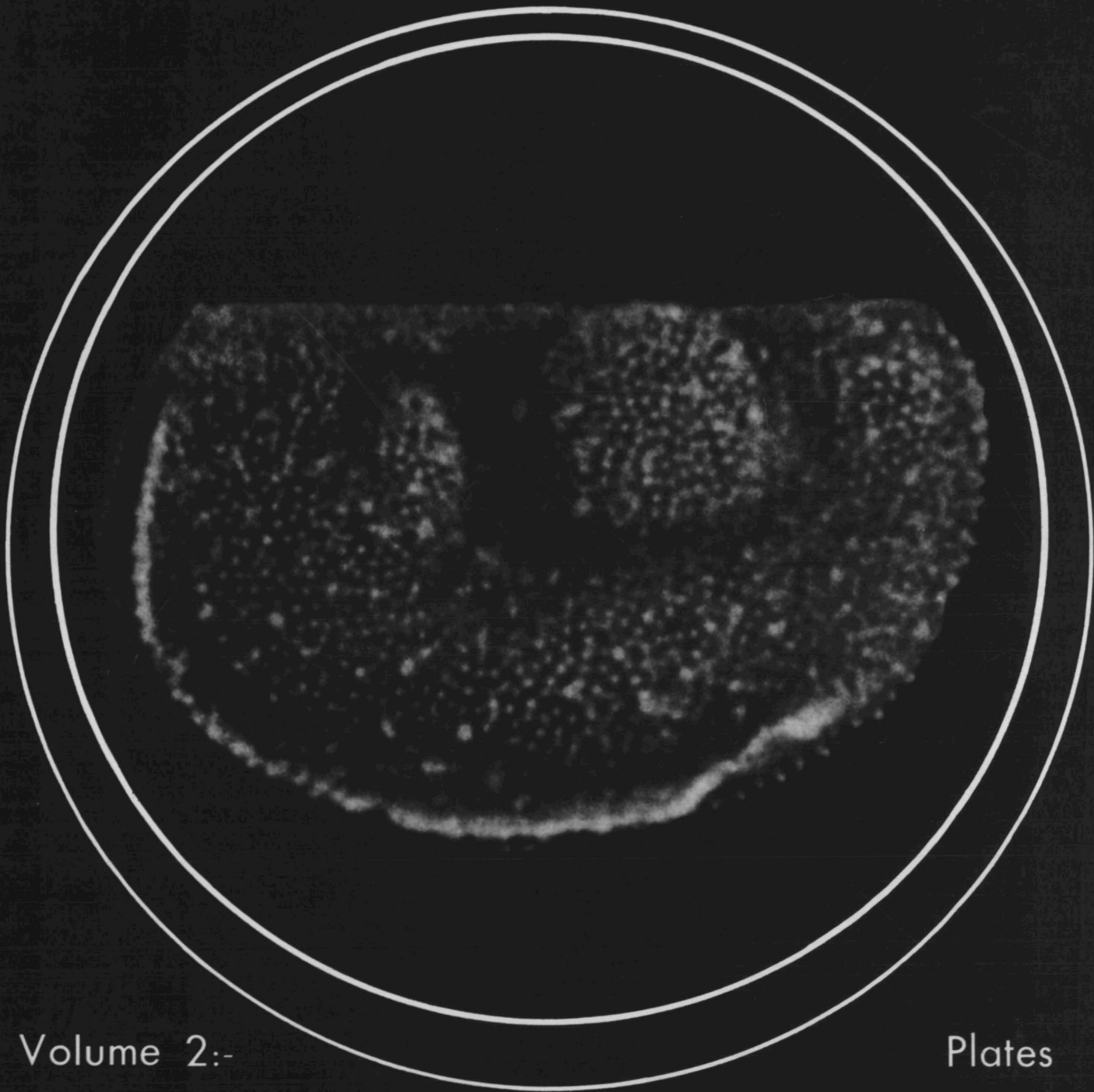

Volume 2:-

Plates

Robert V. Kesling and Ruth B. Chilman

Front cover: *Hollinella (Keslingella) pumila*,
UMMP 58991, x 150.

Back cover: *Falsipollex lativelatus*,
UMMP 60081, x 125.

Ostracods of the Middle Devonian Silica Formation

Robert V. Kesling and Ruth B. Chilman

Volume 2:- Plates



Published with generous support of
**Friends of the Museum of Paleontology
at The University of Michigan, Inc.**

1978

Papers on Paleontology

No. 18

Abbreviations

In the plate explanations, locality data are abbreviated as follows:

MQ = Medusa quarries undifferentiated
 NN = Medusa North-north Quarry
 N = Medusa North Quarry
 S = Medusa South Quarry
 SS = Medusa South-south Quarry
 MM = Martin-Marietta Quarry
 WP = Waterworks Park

If the stratigraphic unit is known, the number follows the geographic location; if the precise unit cannot be determined (as in Martin-Marietta Quarry and Waterworks Park), a zone designation is substituted as follows:

Trop = Tropidoleptus zone (approximately
 Units 1-4)
 Scit = Devonochonetes scitulus zone (ap-
 proximately Units 5 and 6)
 Chon = Devonochonetes fragilis and Sty-
 liolina zone (approximately
 Units 9-11)

Thus, "MM-Scit" translates as "Martin-Marietta Quarry, Devonochonetes scitulus zone" "N-15" as "Medusa North Quarry, unit 15"; and "WP-Trop" as "Waterworks Park, Tropidoleptus zone." For listing and illustration of the guide fossils for which zones are named, see Kesling & Chilman, 1975.

All specimens illustrated are deposited in the Museum of Paleontology of The University of Michigan, and bear the designation "UMMP."

Photography

The camera was constructed as a single-lens type (see Kesling, 1976). At the top of a long bellows, lined with black felt, a 35-mm camera back was mounted with a reflex mirror for focusing on ground glass. To produce an enlargement of $\times 10$ on the film, a 48-mm Microtessar lens was mounted 528 mm from the film; this allowed a working distance (lens-to-ostracod) of 52.8 mm. To produce an enlargement of $\times 31\frac{1}{4}$ on film (for detailed enlargements of specimens), a 16-mm Microtessar lens was mounted 516 mm from the film; this allowed a working distance of 16.5 mm. Only these two lenses and magnifications on film were used. Orientation of specimens for photography was done with a simplified universal stage. All exposures were made with the diaphragm closed down to $f/16$.

The film used was Kodak Panatomic-X, developed $4\frac{1}{2}$ minutes in HC-110 diluted with 200 cc of base chemical per gallon of solution.

Lighting was done by three microscope "spot" illuminators, set for all exposures at angles of about 120 degrees around the specimen but at varying inclinations and intensities to emphasize particular features. All illuminators were connected through a Dreml rheostat to a Kodak timer. The rheostat was adjusted to yield a satisfactory density of negative when the exposure time was 8 seconds. All specimens were coated, as evenly and uniformly as possible, with sublimated ammonium chloride.

Printing was done mostly on Kodak Kodabromide RC-N Extra Hard resin-coated paper, but a few frames were printed on Kodabromide

RC-N Ultra Hard or Polycontrast N (with 4 and $4\frac{1}{2}$ filters) papers for special effects. All enlargements were $\times 4$ from negatives (giving final prints $\times 40$ or $\times 125$ from negatives $\times 10$ or $\times 31\frac{1}{4}$ respectively).

After figures were mounted on plates, the background was blacked with a solution of Prang Tempera Color 834 Black.

Once production procedures were established, it was possible to orient specimens on slides with gum tragacanth, clean away all excess tragacanth with sable brush and water, coat specimens lightly with sublimated ammonium chloride, orient specimen on universal stage, focus camera, close diaphragm to $f/16$, expose 8 seconds, advance film in camera, develop finished 36-exposure rolls in HC-110, fix in hypo, wash, and dry film at the rate of 72 frames per 8-hour day. Printing was slower, at best averaging only about 30 satisfactory prints per 8-hour day. Mounting figures on the plates and applying "black-ground" consumed an additional 2 hours per plate. Thus, preparation of a 20-figure plate involved about $9\frac{1}{2}$ person-hours -- even when all systems were "go." The process of photography proves to be necessarily slow, but it is still the most important phase of conveying one's taxonomic ideas to the reader. As has been said, "One picture is worth a thousand words," -- and the corollary, "One bad picture is worth a thousand bad words." We hope that the good words in our production will outweigh the bad.

EXPLANATION OF PLATE 1

All figures x 40

- 1 -- *Adelphobolbina spicata*. UMMP 59657, left lateral view of slightly damaged valve, showing size and distribution of large papillae; Loc. WP-12.
- 2-12 -- *Adelphobolbina trilobata*. Loc. MM-Chon. 2-8, UMMP 58805, two dorsal, right, ventral, left, anterior, and inclined views of excellently preserved female carapace; fig. 2 lighted at very low angle and focused on hinge line to emphasize fine papillae on dorsum and granular shoulder areas. 9-12, UMMP 58806, right, left, slightly inclined, and inclined views of male carapace; fig. 10 lighted at very low angle to emphasize papillae.

PLATE 1

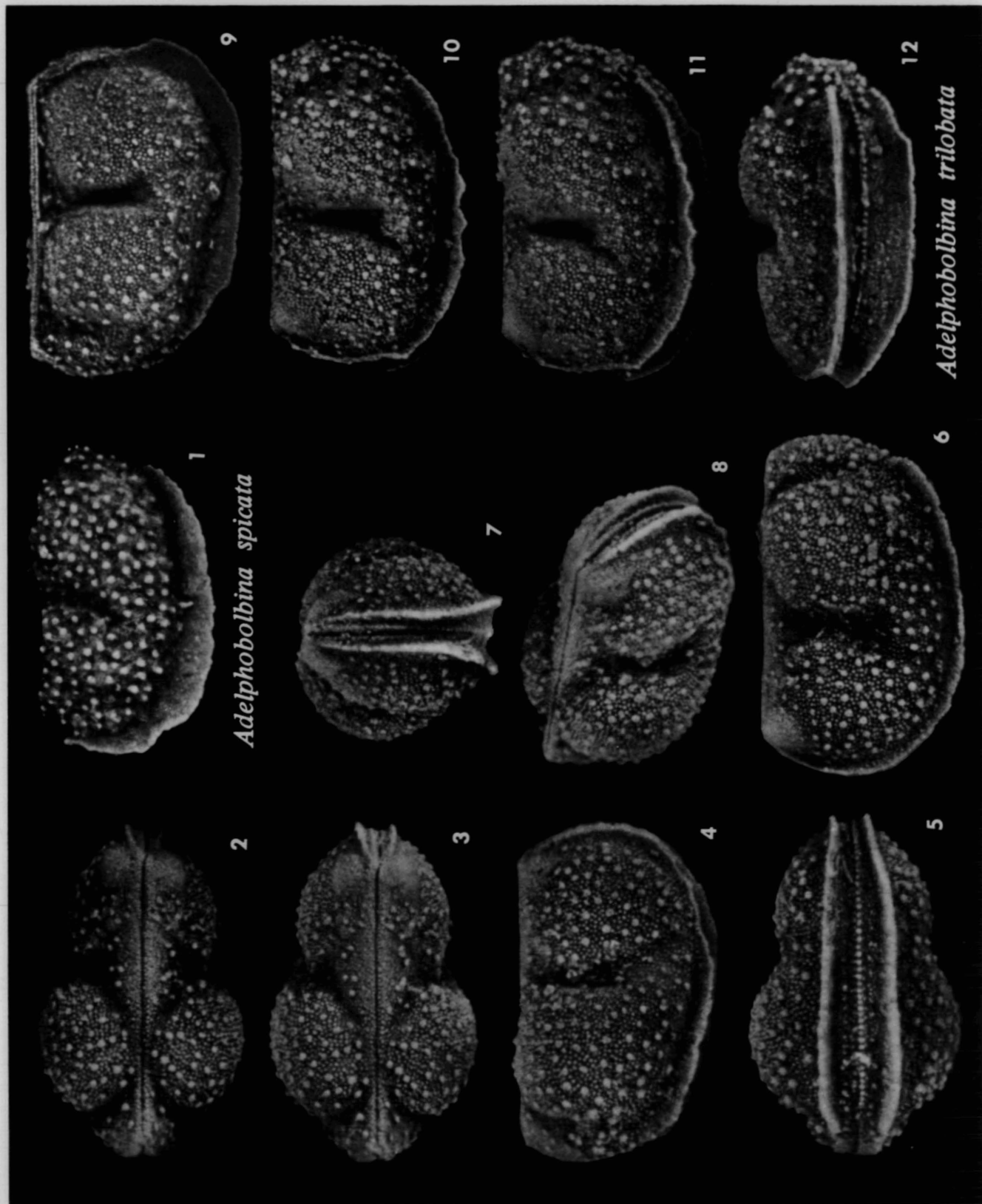
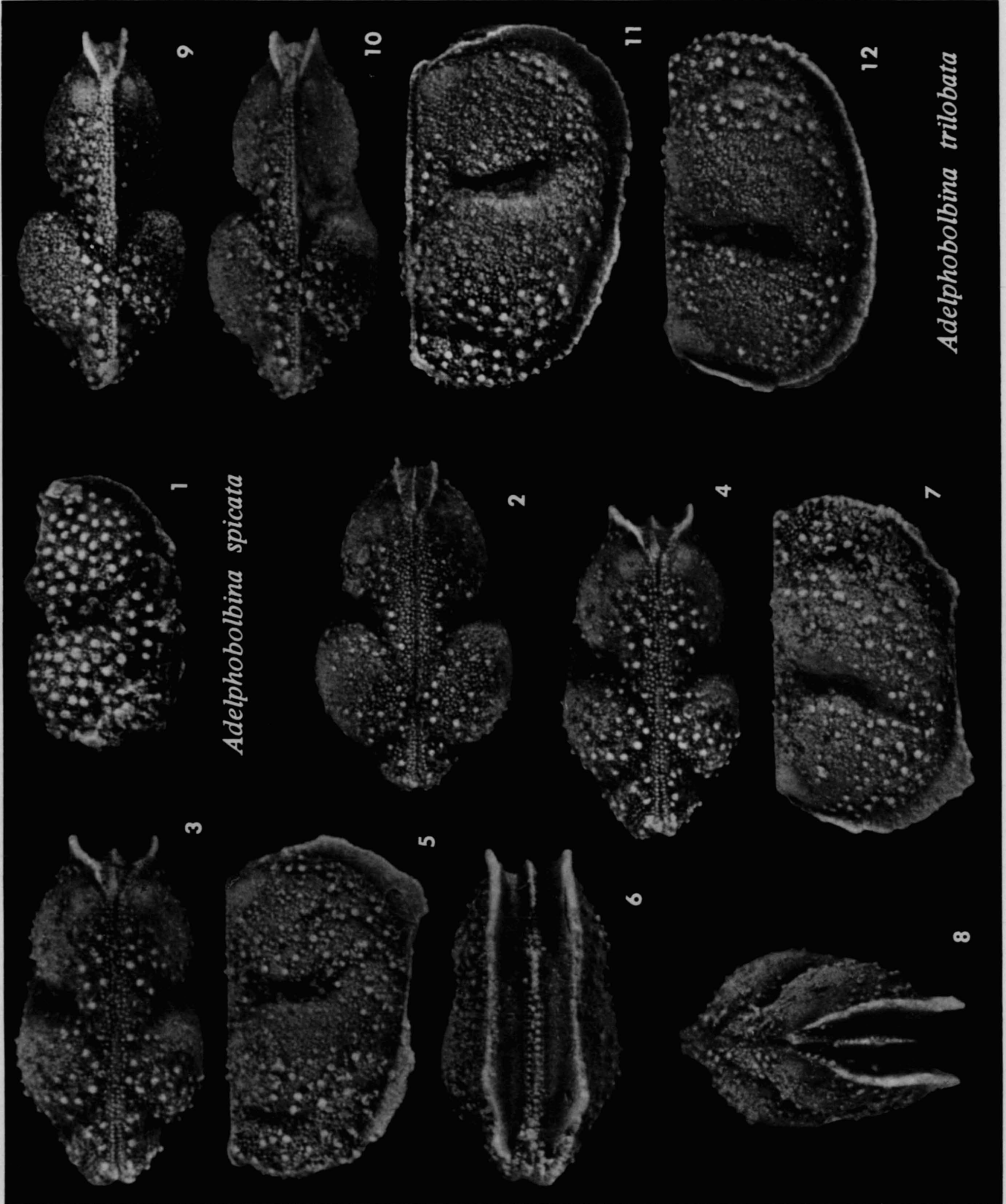

PLATE 2



Adelphobolbina spicata

Adelphobolbina trilobata

EXPLANATION OF PLATE 2

All figures x 40

- 1 --*Adelphobolbina spicata*. UMMP 59638, incomplete left valve preserving characteristic ornamentation; Loc. N-7.
- 2-12 --*Adelphobolbina trilobata*. Loc. MM-Chon. 2, UMMP 58804, dorsal view of female carapace shown for comparison of shape with male carapace (fig. 4). 3-8, UMMP 58807, two dorsal, right, ventral, left, and inclined views of male carapace; note wide antrum (fig. 6); fig. 4 lighted at low angle to emphasize the granulose shoulder areas, the part of lobation which suggested the name. 9-12, UMMP 58811, two dorsal, right, and left views of somewhat crushed male carapace; fig. 9 lighted to emphasize protuberant shoulder areas.

EXPLANATION OF PLATE 3

All figures x 40

- 1 -- *Adelphobolbina* sp. UMMP 59639, right lateral view; specimen not sufficiently clean for specific determination; Loc. N-7.
- 2-12 -- *Adelphobolbina trilobata*. Loc. MM-Chon. 2, UMMP 58805, dorsal view of female carapace shown for comparison with ventral view of typical male carapace (fig. 4). 3-5, UMMP 58810, right, ventral, and left views of male carapace; note relatively smooth wide antra (fig. 4). 6-8, UMMP 58808, right, left, and inclined ventral views of male carapace with valves somewhat agape. 9-12, UMMP 58809, dorsal, left, right, and ventral views of carapace, probably a female.

PLATE 3

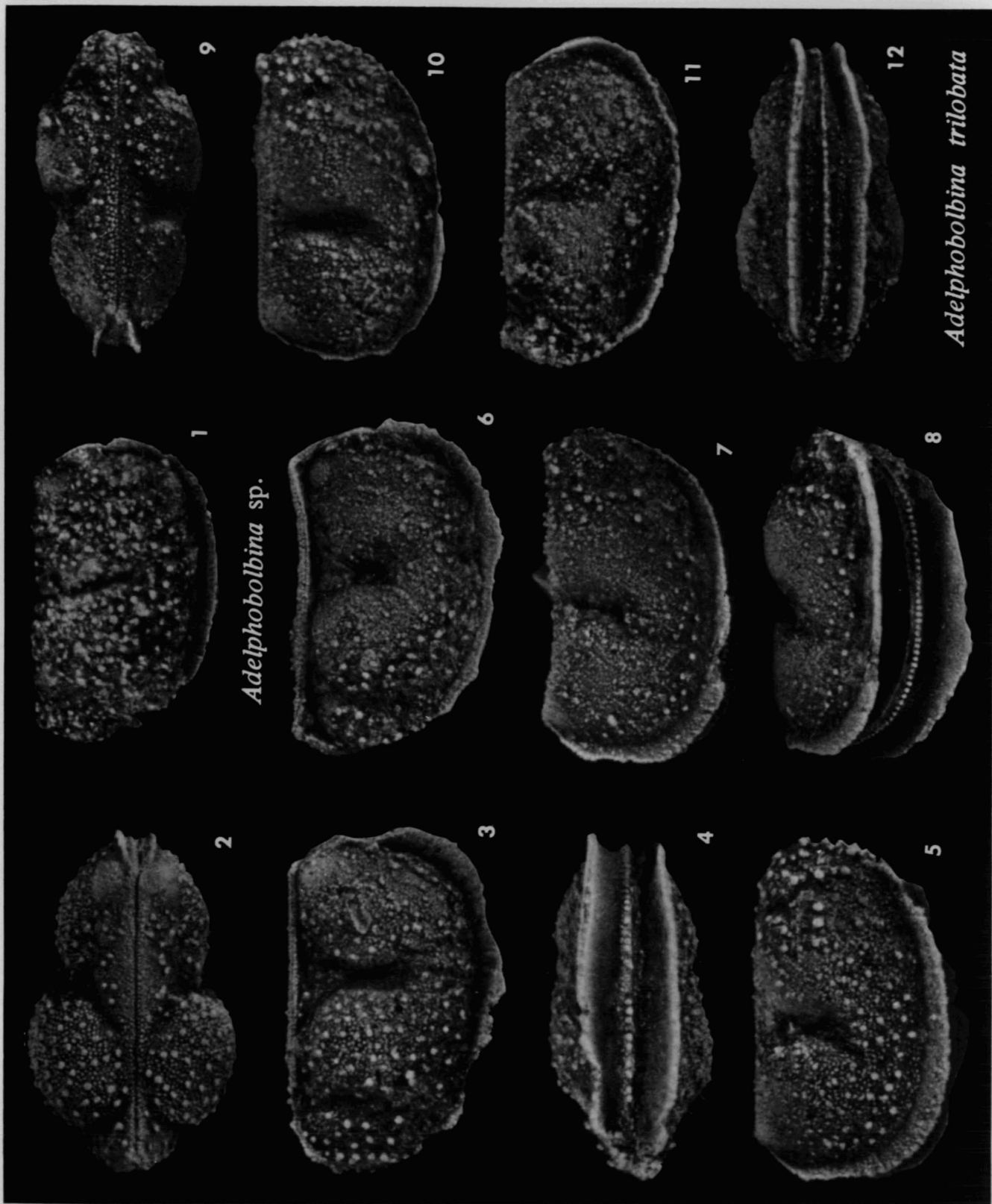
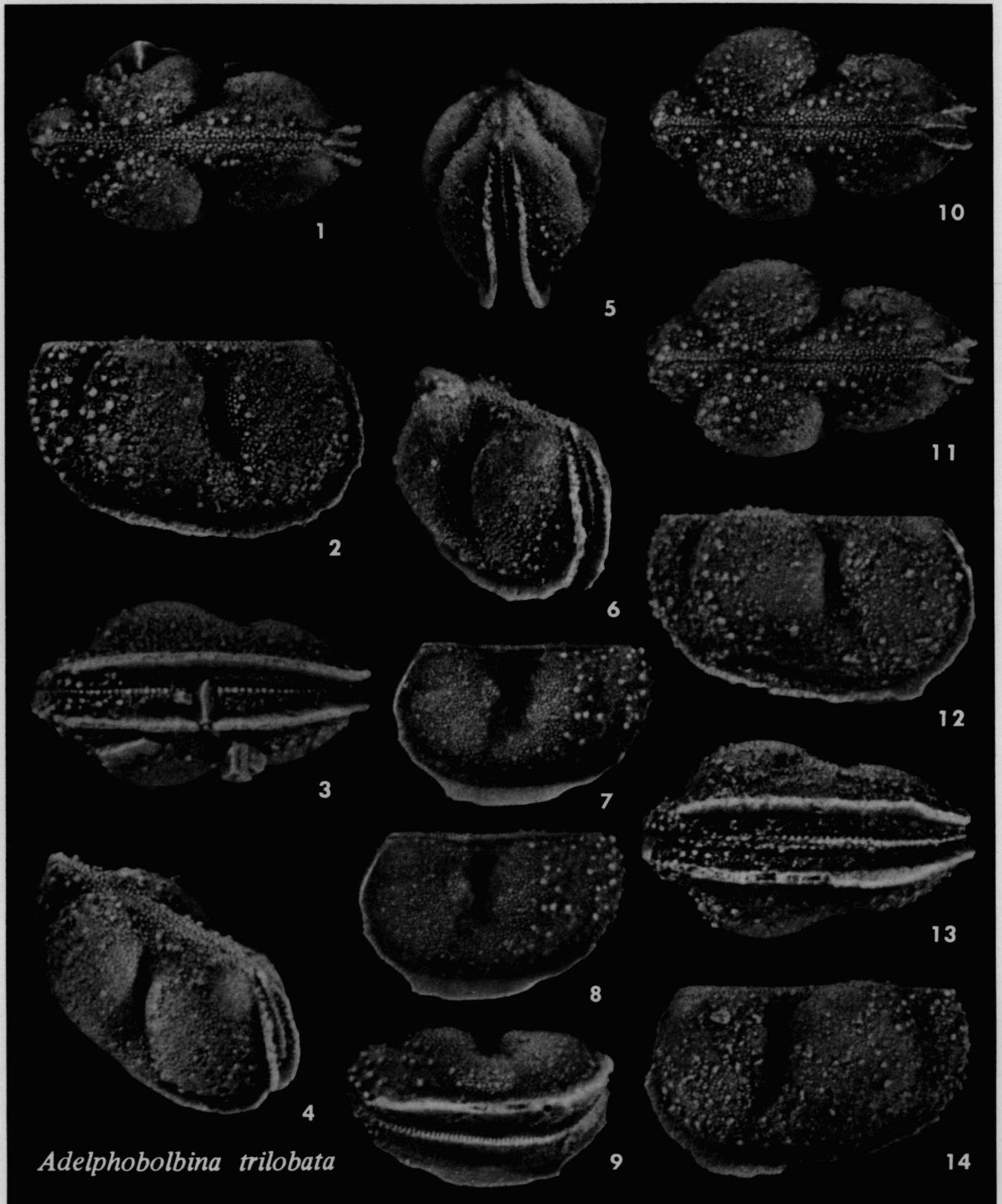

PLATE 4



EXPLANATION OF PLATE 4

All figures x 40

1-14 --*Adelphobolbina trilobata*. Loc. MM-Chon. 1-6, UMMP 58803, dorsal, right, ventral, and three inclined views of female carapace; some pyrite crystals marring ventral and left side. 7-9, UMMP 58812, two left and inclined (right-ventral) views of immature carapace; fig. 7 lighted at low angle to emphasize papillae; inclined view shows papillae along ventral margin. 10-14, UMMP 58804, two dorsal, right, ventral, and left views of female carapace; one dorsal view (fig. 10) lighted at very low angle to emphasize papillae along dorsum; note left/right overlap.

EXPLANATION OF PLATE 5

All figures x 40

- 1-22 -- *Ctenoloculina cicatricosa*. Loc. N. Twelve single female valves to show some variations in size, lobation, and preserved ornamentation. 1-8, 10-15, lateral and ventral views of seven right valves, UMMP 58158, 58164, 58150, 58163, 58153, 58161, and 58155. 9, lateral view of right valve, UMMP 58152. 16, lateral view of left valve, UMMP 58137. 17-22, lateral and ventral views of three left valves, UMMP 58127, 58123, and 58115.

PLATE 5

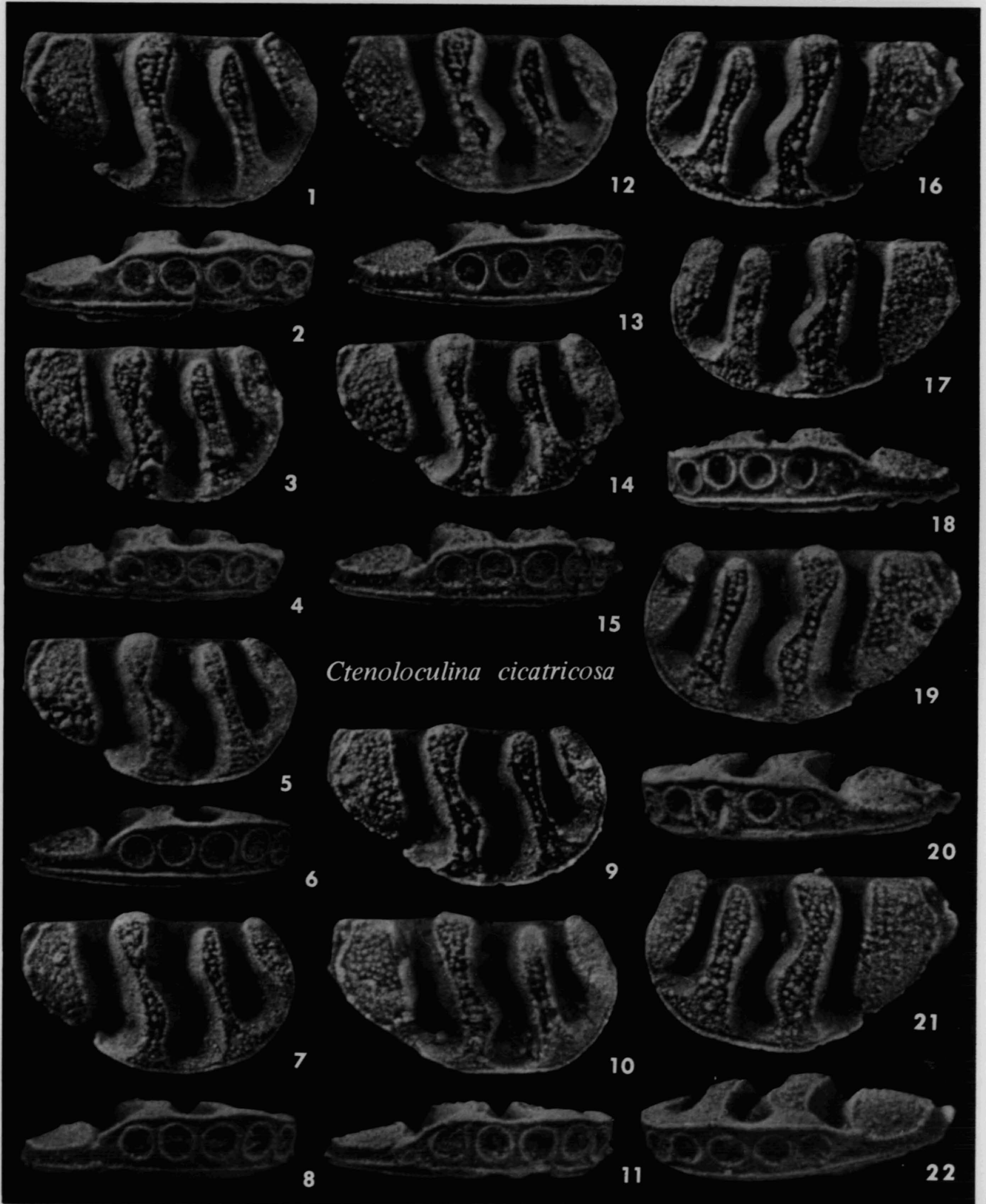
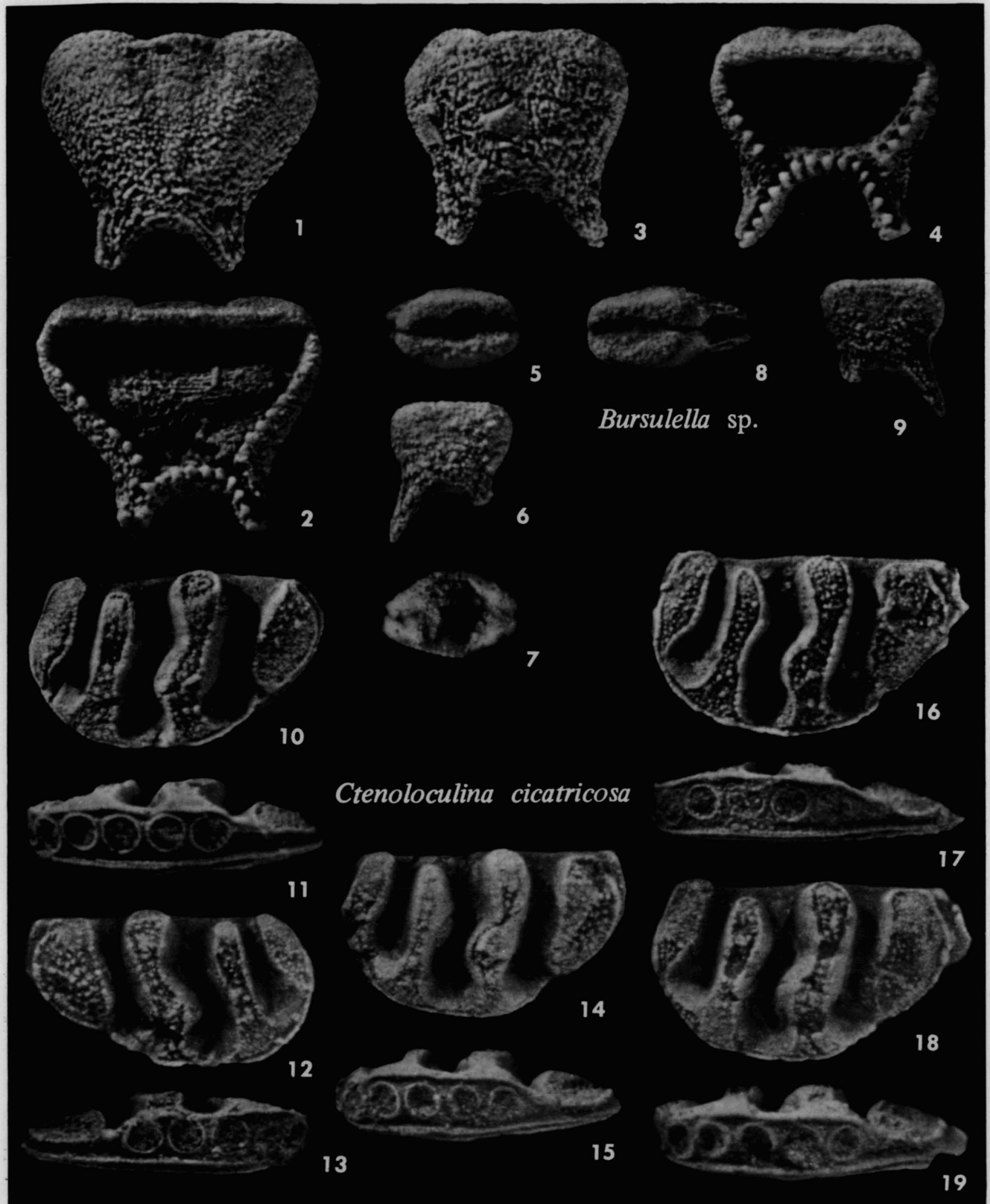

PLATE 6



EXPLANATION OF PLATE 6

All figures x 40

- 1-9 -- *Bursulella* sp. 1-4, lateral and interior views of two valves, UMMP 59384 and 59383; note the large tooth-like denticles along end borders and along ventral border and proximal margins of prominent spines; Loc. MM-Chon. 5-9, UMMP 59385, dorsal, lateral, ventral, inclined dorsal, and lateral views of small carapace; Loc. MQ-14.
- 10-19 -- *Ctenoloculina cicatricosa*. Loc. N. 10, 11, 14-19, lateral and ventral views of four female left valves, UMMP 58124, 58117, 58129, and 58125. 12, 13, lateral and ventral views of right female valve, UMMP 58143. Note deformed L4 in fig. 10 and L3 in fig. 14, and striated posterodorsal flange of left valve in fig. 18.

EXPLANATION OF PLATE 7

All figures x 40

- 1-8 -- *Arcyzona diademata*. Loc. MM-Chon. 1, 2, UMMP 58847, dorsal and right views of immature carapace. 3-5, UMMP 58849, right, left, and ventral views of fine adult specimen showing carina reaching to corners. 6-8, UMMP 58848, right, ventral, and left views of carapace with good preservation of carinae.
- 9-13 -- *Arcyzona bythyclimacota*. Loc. MM-Chon. UMMP 58836, left, posterior, dorsal, right, and ventral views of typical adult.
- 14-17 -- *Rectobairdia emaciata*. Loc. MQ-12. UMMP 58801, dorsal, right, left, and ventral views of exceptionally large carapace (1.93 mm long).
- 18-20 -- *Acanthoscapha devonica*. UMMP 59669, dorsal, left, and ventral views of good adult carapace. Illustrated specimen from Hungry Hollow Formation at Hungry Hollow in Ontario, selected to show a complete carapace; specimens from Silica Formation have one or both ends damaged but are identical in all other respects.

PLATE 7

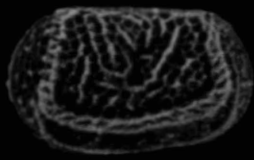

3

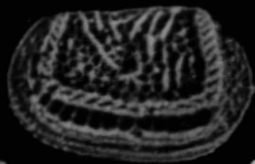

4



1

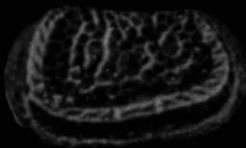

6

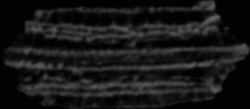

5

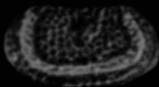

2

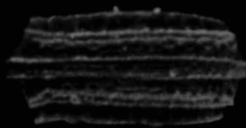

7

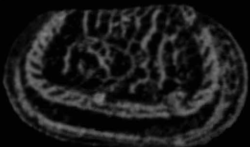

8

Arcyzona diademata

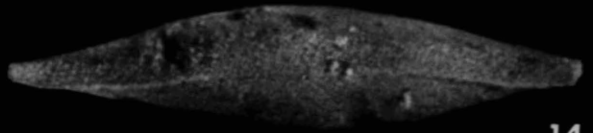

14

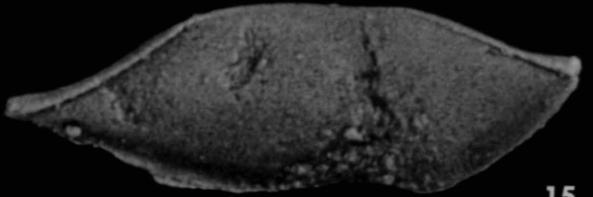

15

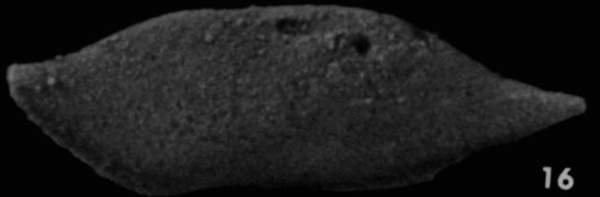

16

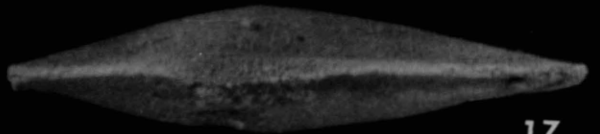

17

Rectobairdia emaciata

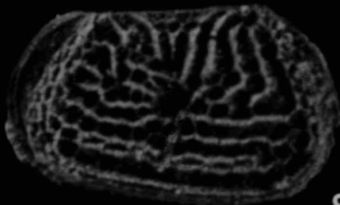

9

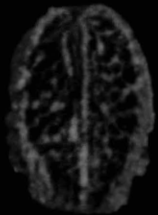

10

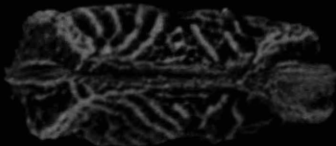

11

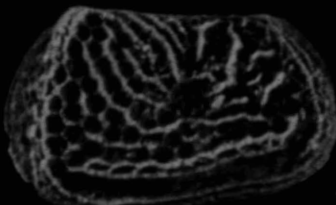

12

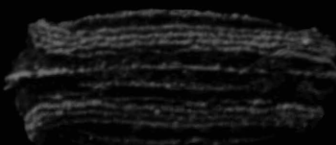

13

Arcyzona bythyclimacota



18

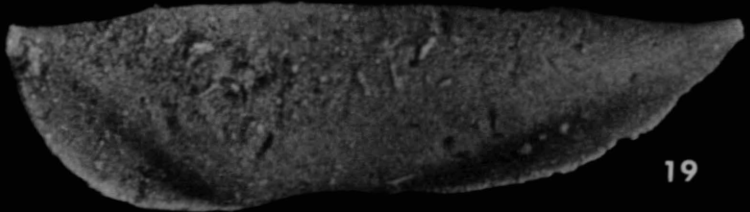

19

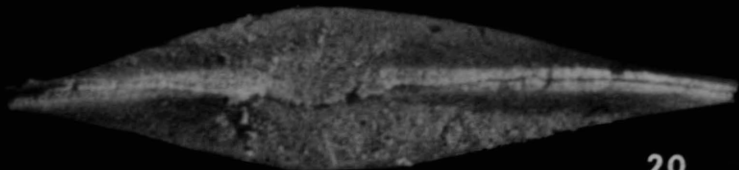

20

Acanthoscapha devonica

PLATE 8

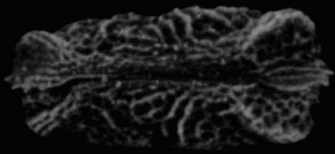

1

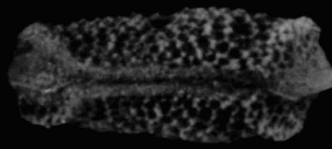

9

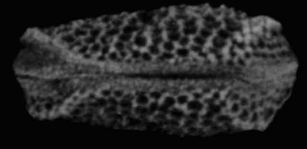

13

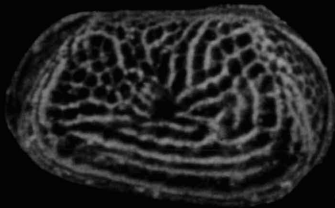

2

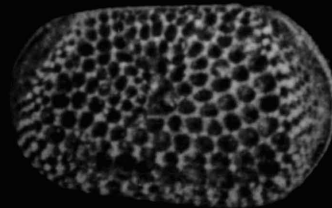

10

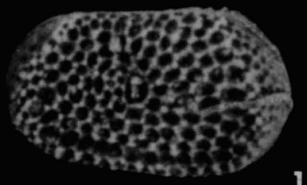

14

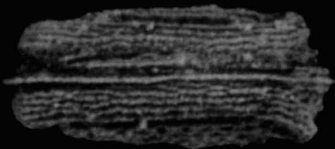

3

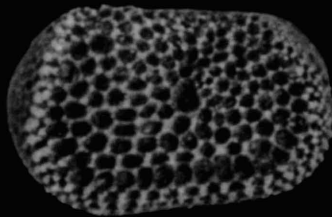

11

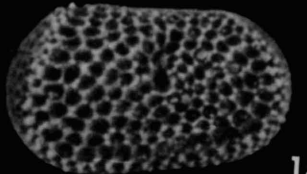

15

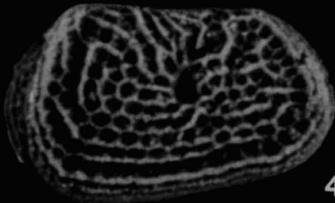

4

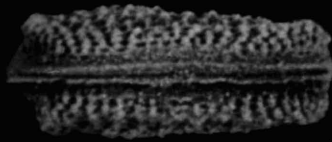

12

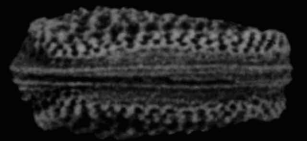

16

Arcyzona rhabdota

Arcyzona homalosagenota

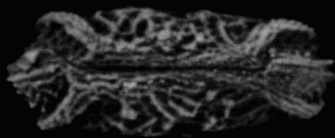

5



17

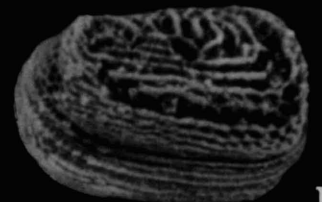

19

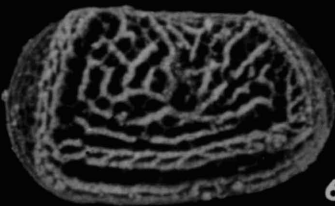

6

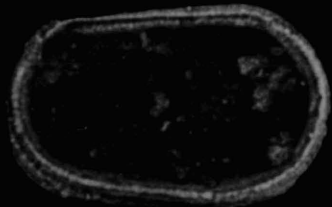

18

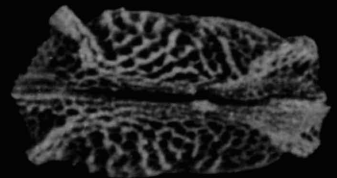

20

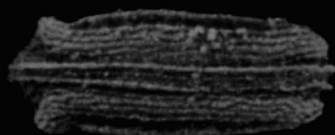

7



8

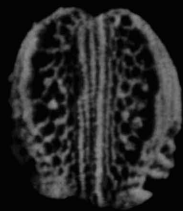

22

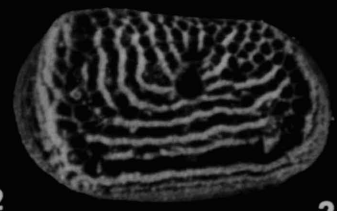

21

Arcyzona bythyclimacota

Arcyzona campylactinota

EXPLANATION OF PLATE 8

All figures x 40

- 1-4 -- *Arcyzona rhabdota*. Loc. MM-Chon. UMMP 58854, dorsal, left, ventral, and right views of carapace, showing even ridges forming or representing the carinal structure; note also the differences in details of ornamentation on the opposite valves, the factor which makes specific separation difficult in this genus.
- 5-8 -- *Arcyzona bythyclimacota*. Loc. MM-Chon. UMMP 58835, dorsal, right, ventral, and anterior views; carina typically developed as a "chain" formed by two ridges linked together by short cross ridgelets at an angle.
- 9-16 -- *Arcyzona homalosagenota*. 9-12, UMMP 58852, Loc. MQ-9, dorsal, left, right, and ventral views of carapace. 13-16, UMMP 58851, Loc. MM-Chon, dorsal, left, right, and ventral views of small carapace, probably immature. Both specimens show the even reticulation in the position of the carina; note that reticulation extends onto velar ridge.
- 17-22 -- *Arcyzona campylactinota*. 17, 18, UMMP 58843, Loc. MQ-9, lateral and interior views of right valve, the latter showing hinge structure; this valve has the typical coarse pattern of reticulation and ridges. 19-22, UMMP 58842, Loc. MM-Chon, inclined (left-antero-ventral), dorsal, right, and posterior views of carapace with typical coarse ornamentation on left valve and atypical reticulation and ridges on right valve (compare with figure 6 on this plate).

EXPLANATION OF PLATE 9

All figures x 40

- 1-3 -- *Acratia simplex*. Loc. MM-Chon. UMMP 59481, dorsal, right, and ventral views. This specimen less deformed by skewing of valves than most.
- 4-11 -- *Arcyzona diademata*. Loc. MM-Chon. 4-7, UMMP 58850, dorsal, right, left, and ventral views. 8-11, UMMP 58846, dorsal, left, right, and ventral views.
- 12-17 -- *Arcyzona campylactinota*. Loc. MM-Chon. 12-14, UMMP 58841, dorsal, right, and ventral views. 15-17, UMMP 58844, dorsal, left, and ventral views.
- 18-25 -- *Arcyzona bythyclimacota*. 18, 19, UMMP 58837, Loc. MQ-9, lateral and interior views of left valve. 20, 21, UMMP 58834, Loc. MM-Chon, lateral and interior views of right valve; note that the hinge is formed by a bar in the left valve fitting into a long groove in the right valve. 22-25, UMMP 58840, Loc. MQ-9, dorsal, right, ventral, and left views of carapace.

PLATE 9

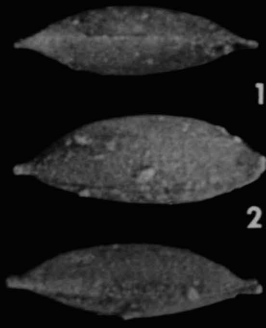

1

2

3

Acratia simplex

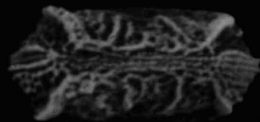

4

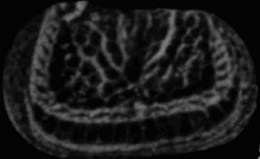

5

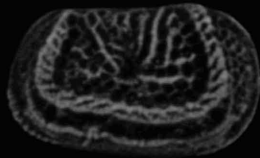

6

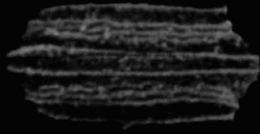

7

Arcyzona diademata

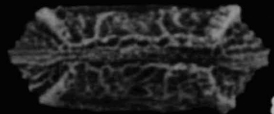

8

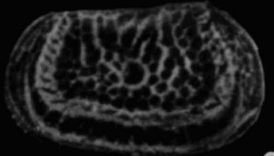

9

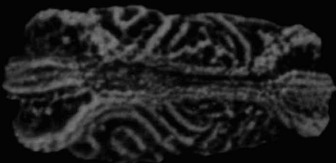

12

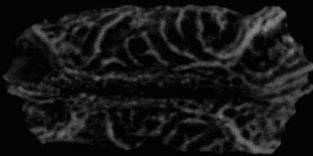

15

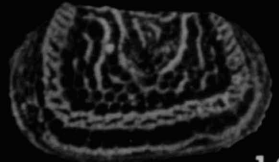

10

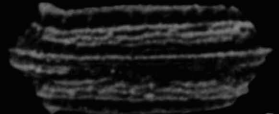

11



13



16

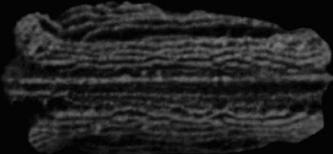

14

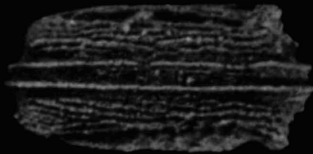

17

Arcyzona campylactinota

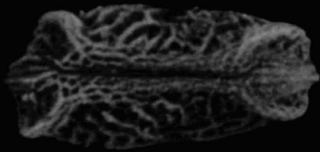

22

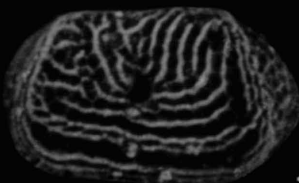

18

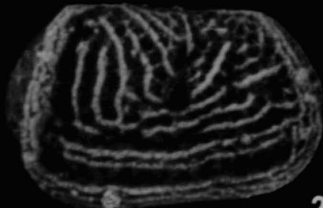

20

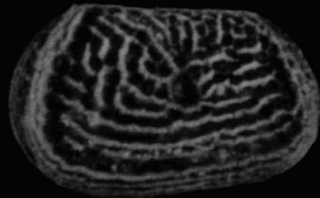

23

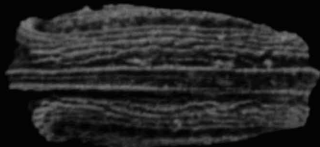

24

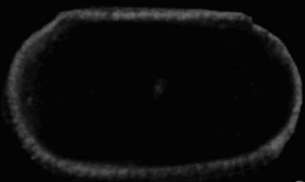

19

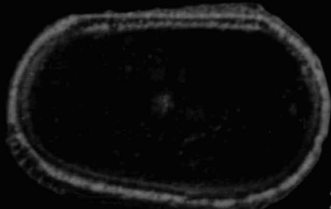

21

Arcyzona bythyclimacota

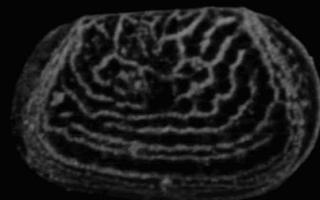

25

PLATE 10

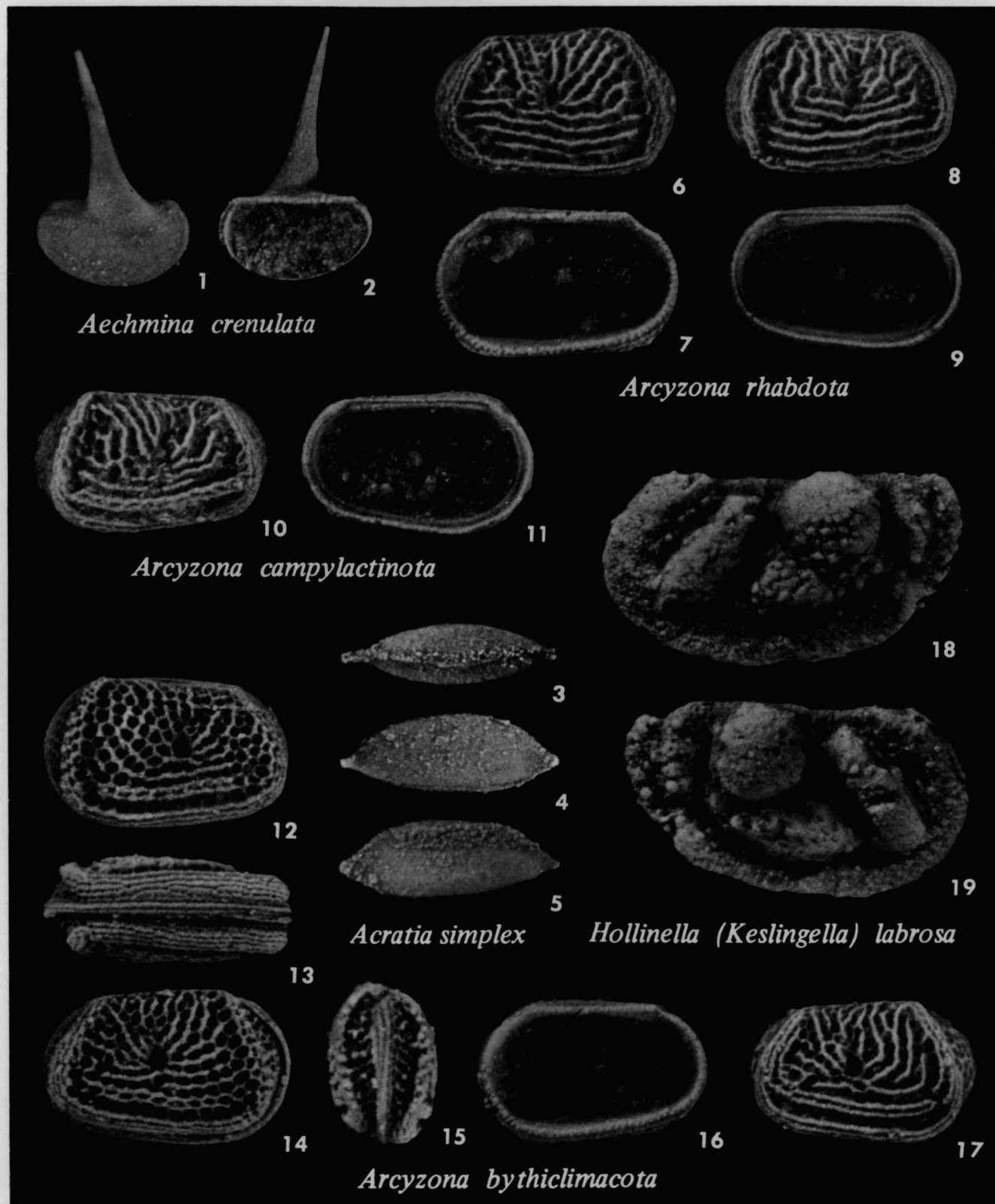

EXPLANATION OF PLATE 10

All figures x 40

- 1,2 -- *Aechmina crenulata*. Loc. MM-Chon. UMMP 58814, lateral and interior (slightly inclined to rest on L2) views of right valve.
- 3-5 -- *Acratia simplex*. Loc. MM-Chon. UMMP 59523, dorsal, right, and left views of carapace slightly crushed so that left valve overlaps right abnormally at the hinge line.
- 6-9 -- *Arcyzona rhabdota*. Loc. MM-Chon. 6,7, UMMP 58853, lateral and interior views of left valve. 8,9, UMMP 58855, lateral and interior views of right valve. The hinge and marginal fine denticles are clearly shown; the even ridges between the pit (S2) and the velar ridge occupy the position of the carina.
- 10,11 -- *Arcyzona campylactinota*. Loc. MQ-9. UMMP 58845, lateral and interior views of right valve, showing interior hinge and outer surface ornamented with coarse ridges of varying elevations and featuring a carina composed of a "chain" of two ridges connected by short angled cross ridgelets.
- 12-17 -- *Arcyzona bythyclimacota*. Loc. MM-Chon. 12-15, UMMP 58839, right, ventral, left, and posterior views of typical carapace. 16,17, UMMP 58838, interior and lateral views of left valve.
- 18,19 -- *Hollinella (Kestlingella) labrosa*. Loc. MM-12. 18, UMMP 60050, lateral view of left valve. 19, UMMP 60049, lateral view of right valve. In addition to the strong lobation, this species is characterized by papillae and various coarse tubercles.

EXPLANATION OF PLATE 11

All figures x 40

- 1-6 -- *Aechmina crenulata*. Loc. MM-Chon. 1, 2, UMMP 59407, anterior and inclined left views of nearly complete carapace. 3, 4, UMMP 58815, lateral and inclined views of left valve, the latter exposing several of the fringe of denticles along the free edge. 5, 6, UMMP 58817, anterior and inclined right views of carapace.
- 7-12 -- *Aechmina* spp. Loc. MM-Chon. 7, 8, UMMP 59659, anterior and left views of carapace with ends of spines (L2) broken off; presence or absence of marginal denticles not clear. 9, 10, UMMP 58820, dorsal and left views of small carapace with unusually thick spines; it is not known whether spines in *Aechmina crenulata* and *Aechmina choanobasota* can be thus abnormally developed. 11, 12, UMMP 58818, left and ventral views of small carapace with exceptionally tapering laterally directed spines.
- 13, 14 -- *Aechmina choanobasota*. 13, UMMP 59408, Loc. MQ-17, lateral view of fractured right valve. 14, UMMP 59658, Loc. MM-Chon, lateral view of left valve. This species has a flaring base (especially anteriorly) and appears to have only low faint discrete marginal denticles or papillae.
- 15, 16 -- *Aechminaria* sp. Loc. MM-Chon. UMMP 58823, dorsal and left views. Except for the rather blunt posteroventral border, this specimen is like those illustrated below.
- 17-22 -- *Aechminaria hormathota*. 17, 18, UMMP 58821, Loc. MM-Chon, right and ventral views of carapace apparently dorsoventrally compressed. 19, 20, UMMP 59431, Loc. MQ-7, right and ventral views, the latter showing pyrite crystals projecting from the left valve. 21, 22, UMMP 58822, Loc. MQ-14, left and ventral views of carapace.

PLATE 11



1 2

Aechmina crenulata

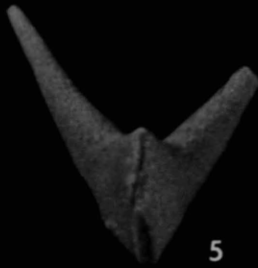

5

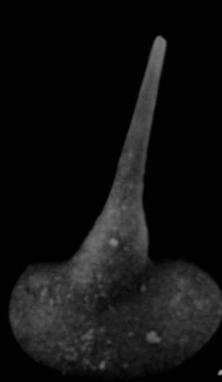

3

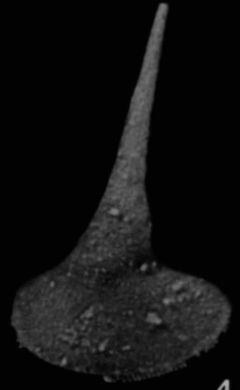

4

Aechmina crenulata

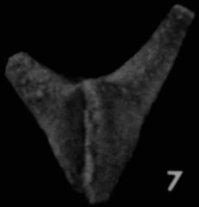

7

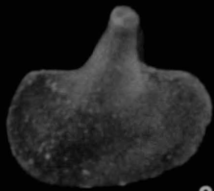

8

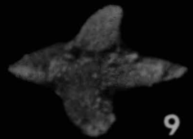

9

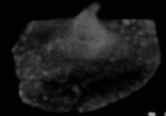

11

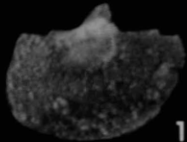

10

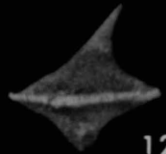

12

Aechmina spp.



13



14

Aechmina choanobasota

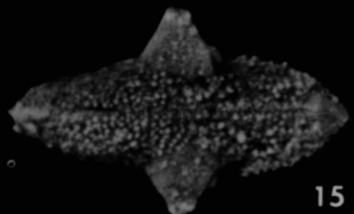

15

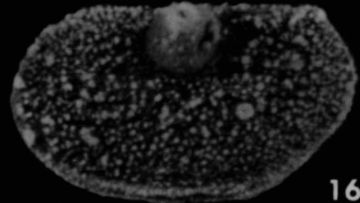

16

Aechminaria sp.

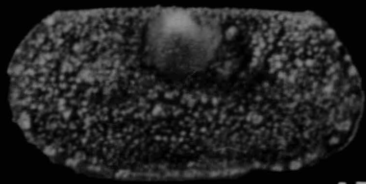

17

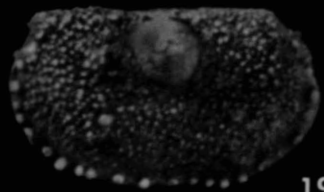

19

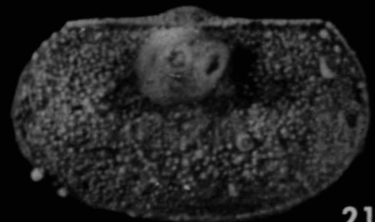

21

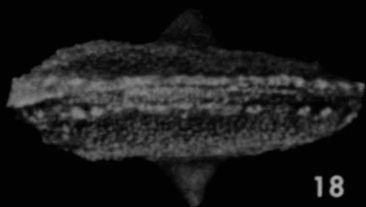

18

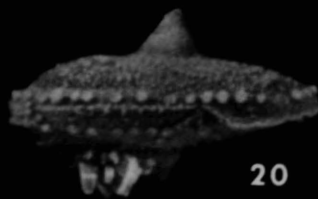

20

Aechminaria hormathota

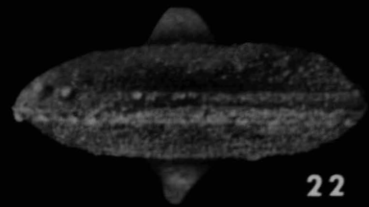

22

PLATE 12

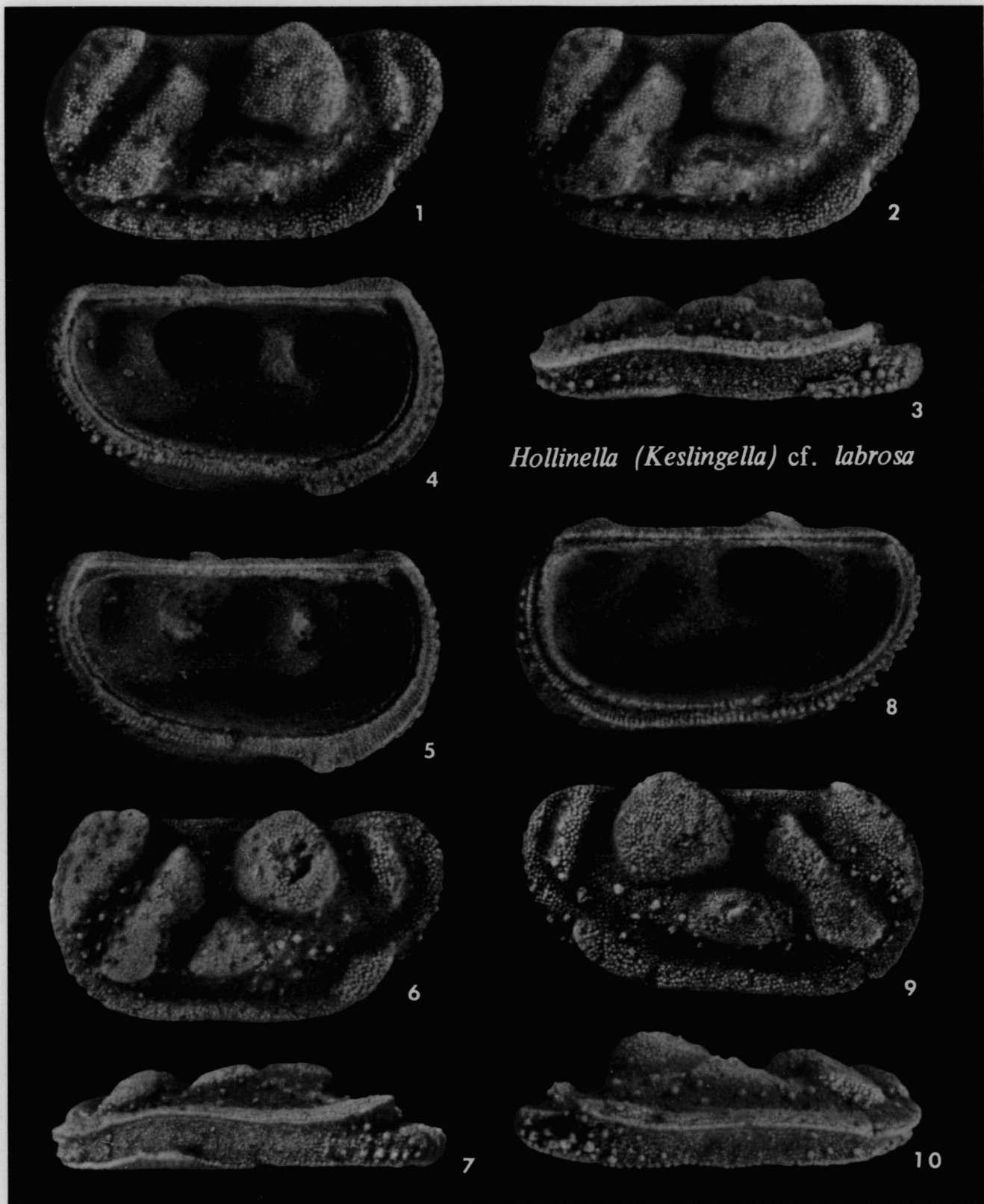

EXPLANATION OF PLATE 12

All figures x 40

1-10 -- *Hollinella (Keslingella) cf. labrosa*. 1-4, UMMP 59668, two lateral, ventral, and interior views of left valve; first lateral view printed to emphasize the fine papillation on the surface. 5-7, UMMP 59667, interior, lateral, and ventral views of left valve. 8-10, UMMP 59666, interior, lateral, and ventral views of right valve. All valves illustrated on this plate are from the Potter Farm Formation exposed in the shale pit of Evergreen Cemetery in Alpena, Michigan. They are shown here for comparison with specimens from the Silica Formation; after washing and treatment with ultrasonic vibration, the Potter Farm specimens are much cleaner than those from the Silica Formation. These ostracods focus attention on the acceptable limits of a species. The types of H. (K.) labrosa are from the Norway Point Formation, slightly older than the Potter Farm Formation and much younger than the Silica Formation specimens. The latter are, however, morphologically closer to the types than to the Potter Farm specimens in lobation and size. Whereas the Potter Farm forms have a dorsally produced L3, rather pyriform, the Silica examples (and the Norway Point type specimens) have a bulbous subspherical L3; the Potter Farm forms are also slightly larger; and the Potter Farm forms have an anteroventral marginal flange much more prominent than any known in the Silica and Norway Point forms. From the specimens illustrated in this paper, one could readily separate the Potter Farm forms and erect a new species. Note here the rather ornate and elaborate structures involved in closure. Interior views show that the coarse exterior lobation is reflected internally, indicating that the shell has nearly the same thickness throughout the valve. Scars on the lateral surface of lobes appear to mark spots where the bead-like ends of tubercles were broken off. Compare with Silica Formation specimens in plates 10 and 14.

EXPLANATION OF PLATE 13

All figures x 40

- 1-4 -- *Aechmina crenulata*. Loc. MM-Chon. 1, 2, UMMP 58813, inclined interior and lateral views of left valve, with well-preserved denticles along the anterior margin. 3, 4, UMMP 58816, lateral and inclined lateral views of right valve, showing preserved marginal denticles.
- 5-10 -- *Aechmina* spp. Loc. MM-Chon. 5, 6, UMMP 59661, dorsal and left views of carapace with broken spines. 7, 8, UMMP 59660, lateral and inclined lateral views of right valve. 9, 10, UMMP 58819, inclined lateral and lateral views of right valve. All specimens probably belong to *Aechmina crenulata*, although spine bases are somewhat atypical.
- 11-24 -- *Hollinella (Keslingella) pumila*. Loc. MM-Chon. 11, 12, UMMP 58995, lateral and interior views of right valve, showing marginal denticles and hinge (valve partly filled with matrix and other ostracod valve). 13-15, UMMP 58996, dorsal, right, and ventral views of male carapace. 16-18, UMMP 58997, anterior, left, and ventral views of female carapace. 19-21, UMMP 58992, inclined (left-anterior), anterior, and left views of male carapace, showing wide antra. 22-24, UMMP 58998, dorsal, right, and ventral views of female carapace, showing papillose antra narrowed anteriorly.

PLATE 13



1

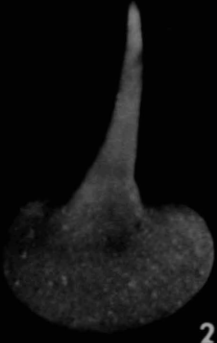

2

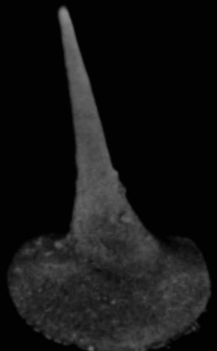

3



4

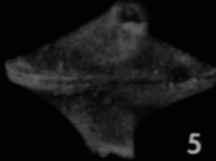

5

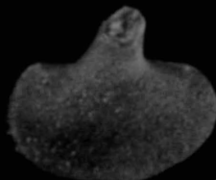

6

Aechmina crenulata

Aechmina sp.

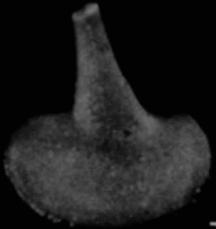

7

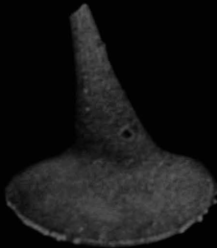

8

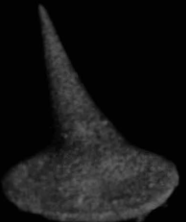

9

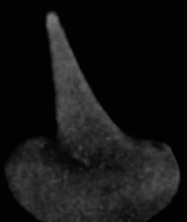

10

Aechmina sp.

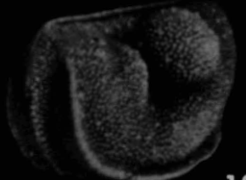

19

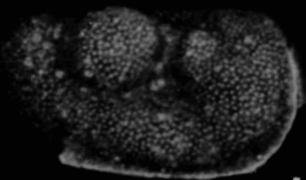

11

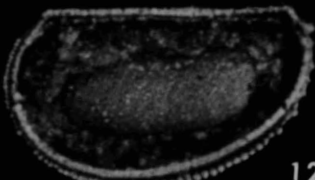

12

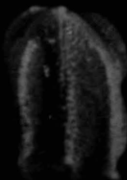

20

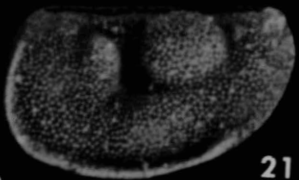

21

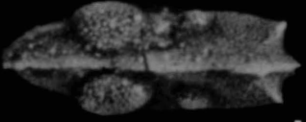

13



16

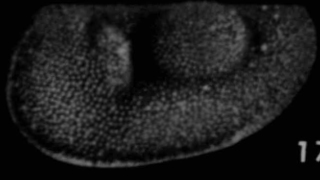

17

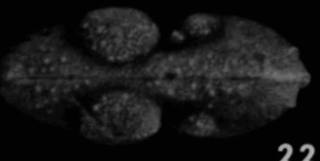

22

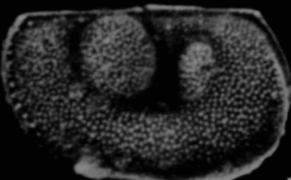

14

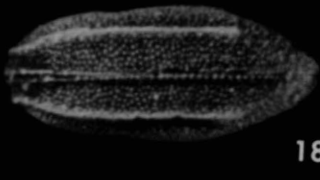

18

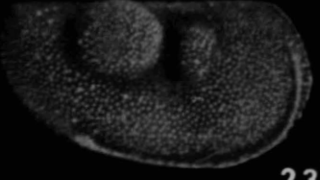

23

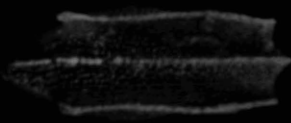

15

Hollinella (Keslingella) pumila

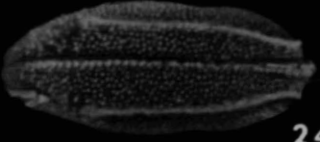

24

PLATE 14

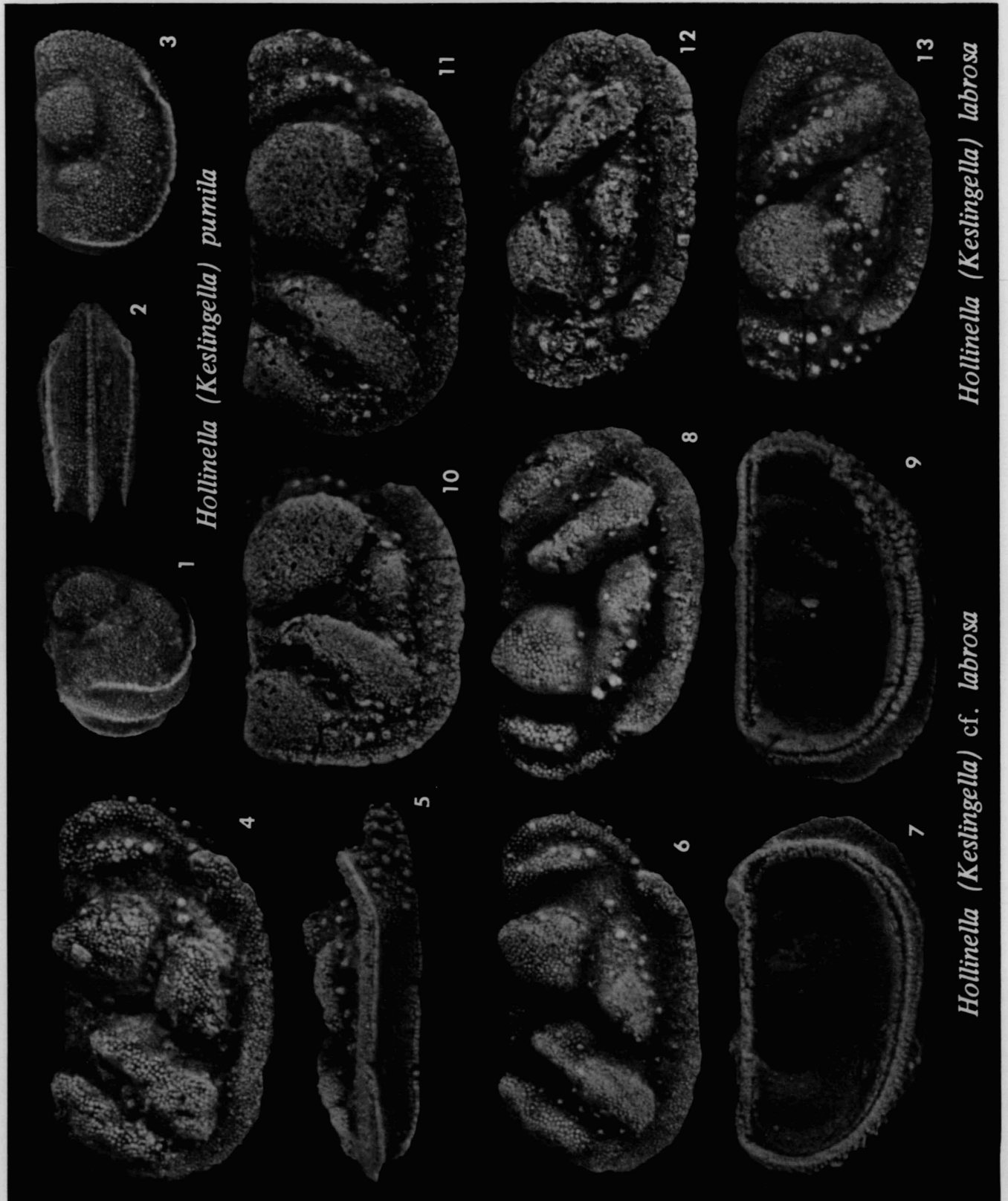

Hollinella (Kestlingella) pumila

Hollinella (Kestlingella) labrosa

Hollinella (Kestlingella) cf. labrosa

EXPLANATION OF PLATE 14

All figures x 40

- 1-3 -- *Hollinella (Kestlingella) pumila*. Loc. MM-Chon. UMMP 58991, inclined, ventral, and left views of male carapace.
- 4-9 -- *Hollinella (Kestlingella) cf. labrosa*. Specimens from Potter Farm Formation, Evergreen Cemetery, Alpena, Michigan, illustrated for comparison with specimens from Silica Formation (see also plate 12). 4,5, UMMP 59664, lateral and ventral views of left valve. 6,7, UMMP 59665, lateral and interior views of left valve; note that the anteroventral marginal flange is less developed than in larger specimens from the same locality (see pl. 12, figs. 4, 5), indicating that this valve may be in the ultimate immature instar. 8, 9, UMMP 59663, lateral and interior views of right valve, possibly immature (compare with pl. 12, figs. 8-10).
- 10-13 -- *Hollinella (Kestlingella) labrosa*. Loc. MM-12. 10, 11, UMMP 58981, inclined and lateral views of left valve, exceptionally large and with unusual development of L3. 12, 13, UMMP 58980 and 58982, lateral views of two right valves; in comparison with figure 11, above, both these valves may be immature.

EXPLANATION OF PLATE 15

All figures x 40

- 1-7 -- *Hollinella (Kestlingella) pumila*. Loc. MM-Chon. 1-6, UMMP 59499-59501, left and ventral views of three carapaces. 7, UMMP 59498, left view of carapace. All four specimens immature, showing the characteristic pre-adult development of velar structure as a pair of small blunt spines in each valve, one anteroventral and the other posteroventral; compare with adults of the species in plates 13 and 14.
- 8-21 -- *Hollinella (Kestlingella) antespinoza*. 8-11, UMMP 58918, Loc. MM-Chon, dorsal, left, inclined posterior, and ventral views of excellently preserved carapace. 12, 13, UMMP 59492, Loc. MQ-9, right and ventral views of fine carapace. 14, UMMP 59414, Loc. MQ-9, right view. 15, UMMP 59415, Loc. MQ-9, left view. 16, 17, UMMP 58987, Loc. MQ-9, dorsal and left views of carapace. 18, UMMP 58989, Loc. MM-Chon, right view of dorsally crushed carapace. 19, UMMP 59494, Loc. MQ-9, left view. 20, 21, UMMP 59087, Loc. MQ-7, left and ventral views of weathered specimen.

PLATE 15

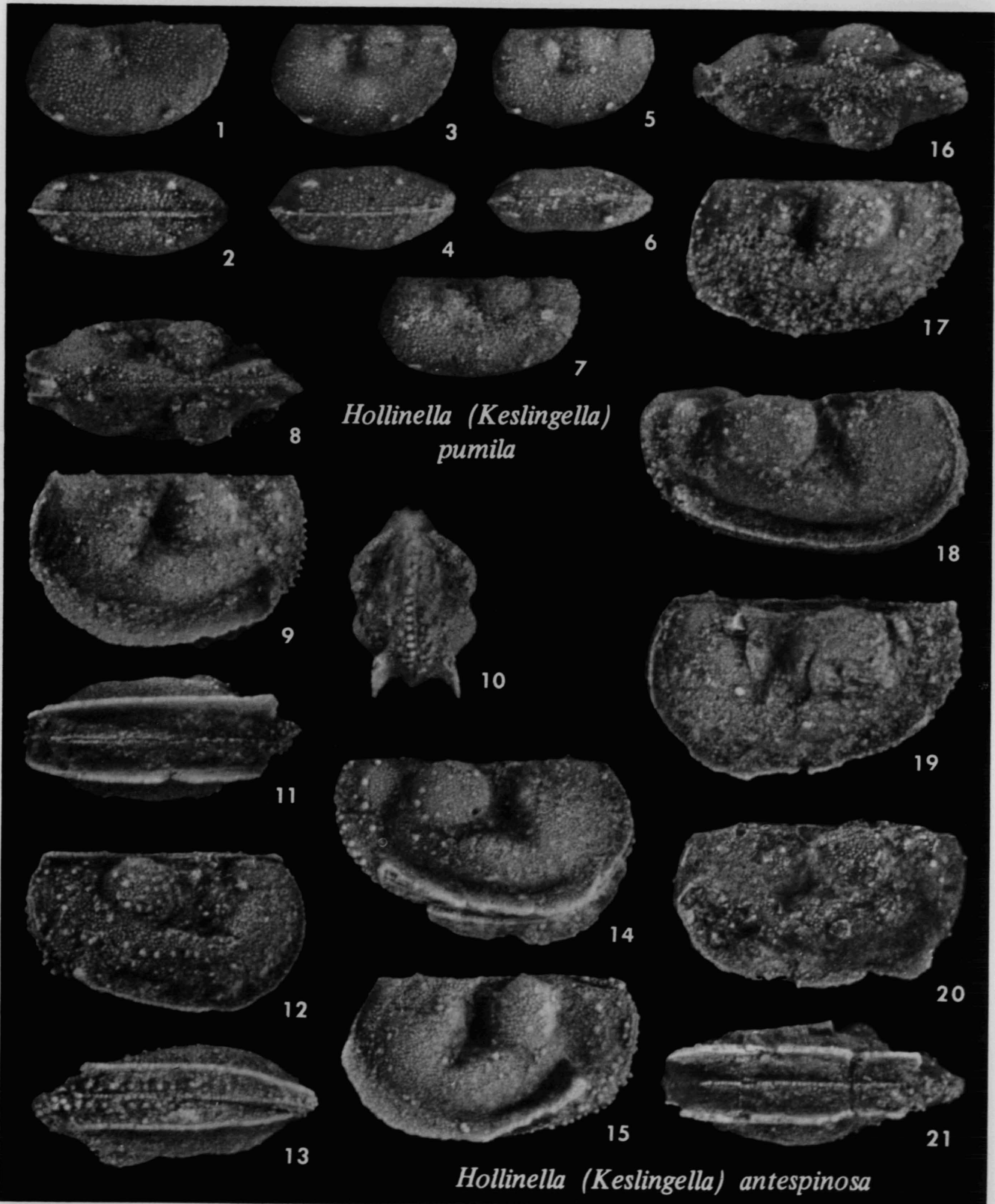
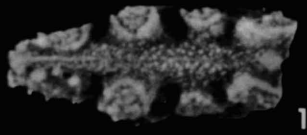
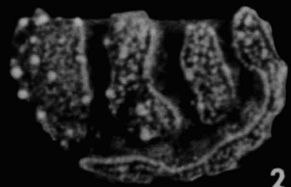

PLATE 16



1

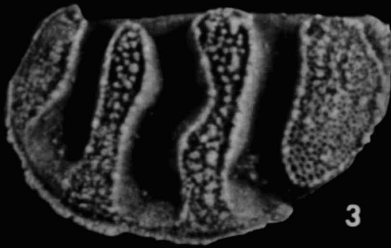

2

Ctenoloculina acanthina

3

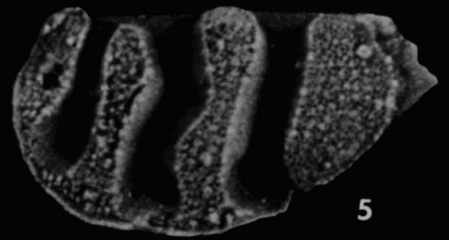

5

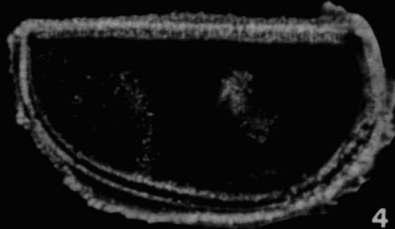

4

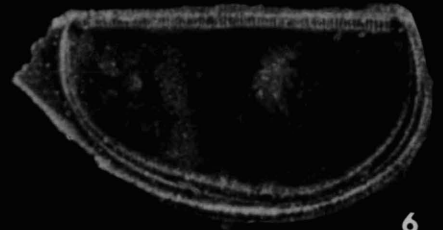

6

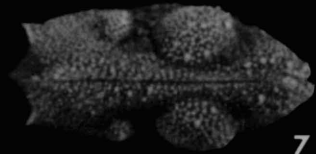
Ctenoloculina cicatricosa

7

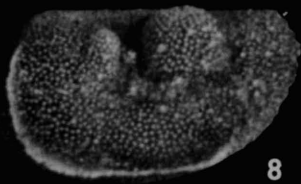

8

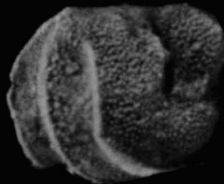

9

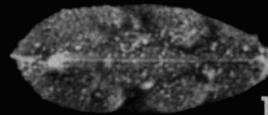

10

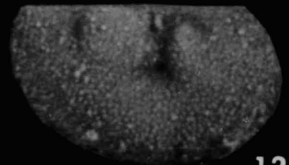

12

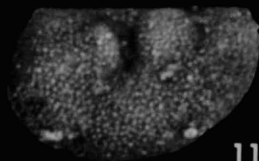

11

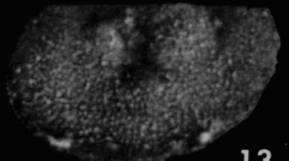

13

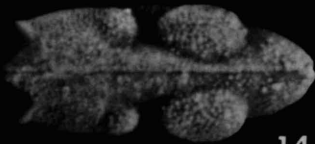

14

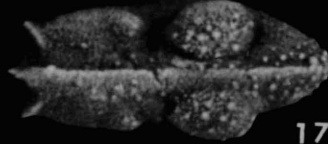

17

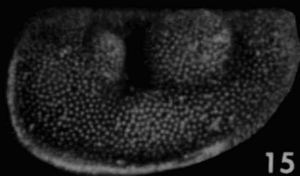

15

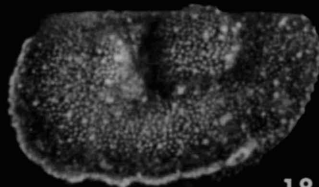

18

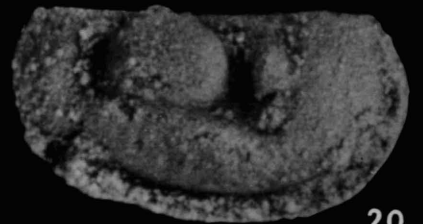

20

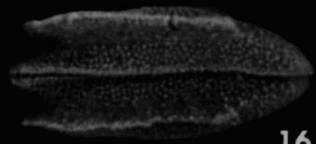

16

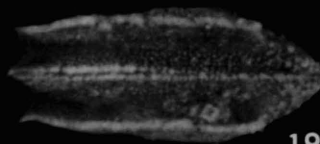

19

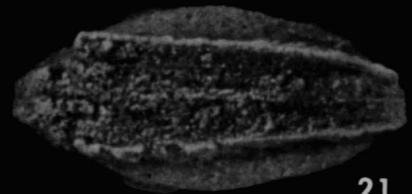

21

*Hollinella (Keslingella) pumila**Hollinella (Keslingella) antespinoza*

EXPLANATION OF PLATE 16

All figures x 40

- 1, 2 -- *Ctenoloculina acanthina*. Loc. MQ-9. UMMP 58919, dorsal and right views of female carapace; note distinct narrowing of the frill below S2 and the distribution of spines bordering and within the ornate areas of the lobes.
- 3-6 -- *Ctenoloculina cicatricosa*. Loc. MM-Chon. UMMP 59462 and 58141, lateral and interior views of two left valves; note the ornamentation differences between the lobes where the outermost veneer of shell material is preserved (fine reticulation, nearly finely punctate) and where it is absent (revealing the papillose supports below).
- 7-19 -- *Hollinella (Kestlingella) pumila*. Loc. MM-Chon. 7-9, UMMP 58993, dorsal, left, and inclined (anterior-left) views of adult male carapace. 10, 11, UMMP 59497, dorsal and left views of immature carapace; note development of velar structure as two small ventral spines on each valve. 12, 13, UMMP 58990, right and left views of immature carapace. 14-19, UMMP 58994 and 59496, dorsal, left, and ventral views of two male carapaces, showing wide antra and the frills running parallel almost to the anterodorsal corner.
- 20, 21 -- *Hollinella (Kestlingella) antespinoza*. Loc. MQ-9. UMMP 59493, right and ventral views of female carapace; note anterior convergence of frills and consequent narrowing of the antra.

EXPLANATION OF PLATE 17

All figures x 40

- 1-6 -- *Ctenoloculina eurybathrota*. 1, UMMP 58920, Loc. MM-Chon, lateral view of left valve; the frill has the general form of that in *C. acanthina*, but the spines associated with the lobes are not nearly as well developed; this suggests that during Silica time, the two species had not diverged sufficiently to assume their distinctive characters. 2, 3, UMMP 59646, Loc. MM-Chon, lateral and interior views of right valve; the frill differs from that of *C. acanthina*, although the spines associated with the lobes are fairly distinct. The following three specimens are from the Tile Yard north of Thedford, Ontario, where they occurred in the Arkona Shale of the same age as the Silica Formation; they are illustrated to offer comparison of the specimens in two geographic areas. 4, 5, UMMP 58443 and 58452, lateral views of two left valves. 6, UMMP 58471, lateral view of right valve.
- 7-9 -- *Ctenoloculina cicatricosa*. 7, UMMP 58139, Loc. MM-Chon, lateral view of left valve; outermost layer preserved on L4 but mostly destroyed on L1. 8, 9, UMMP 58113, Loc. MQ-9, lateral and ventral views of left valve; outermost layer partly destroyed on L4 but still present on L1.
- 10-20 -- *Ctenoloculina acanthina*. All specimens from Loc. MM-Chon except as noted. 10-13, UMMP 58913, dorsal, right, ventral, and left views of small female carapace. 14-17, UMMP 58915, dorsal, right, left, and ventral views of large female carapace partly damaged at the posterior end by pyrite crystals; nearly all of the outermost layer preserved on the lobes, showing the projection of the spines through this thin lamina. 18, 19, UMMP 58914, lateral and interior views of left female valve. 20, UMMP 58399, lateral view of left female valve from the Widder Formation exposed near the former site of the village of Widder, near Thedford, Ontario, shown for comparison with the Silica specimens; all of the thin outer layer missing from the lobes, revealing the supporting papillae beneath. Note the consistent arrangement of spines on the lobes in this species, and the consistent shape of the frill.

PLATE 17

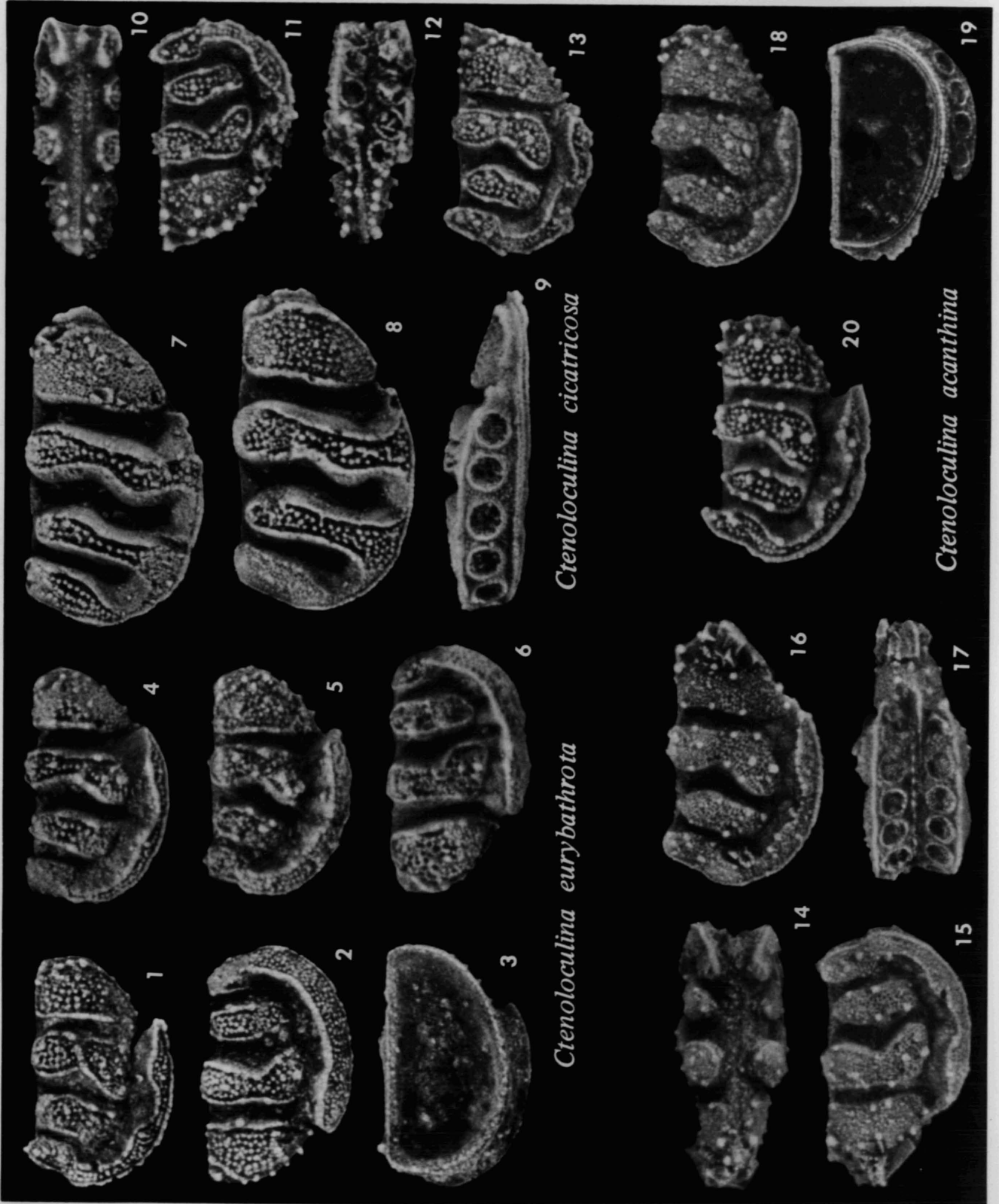
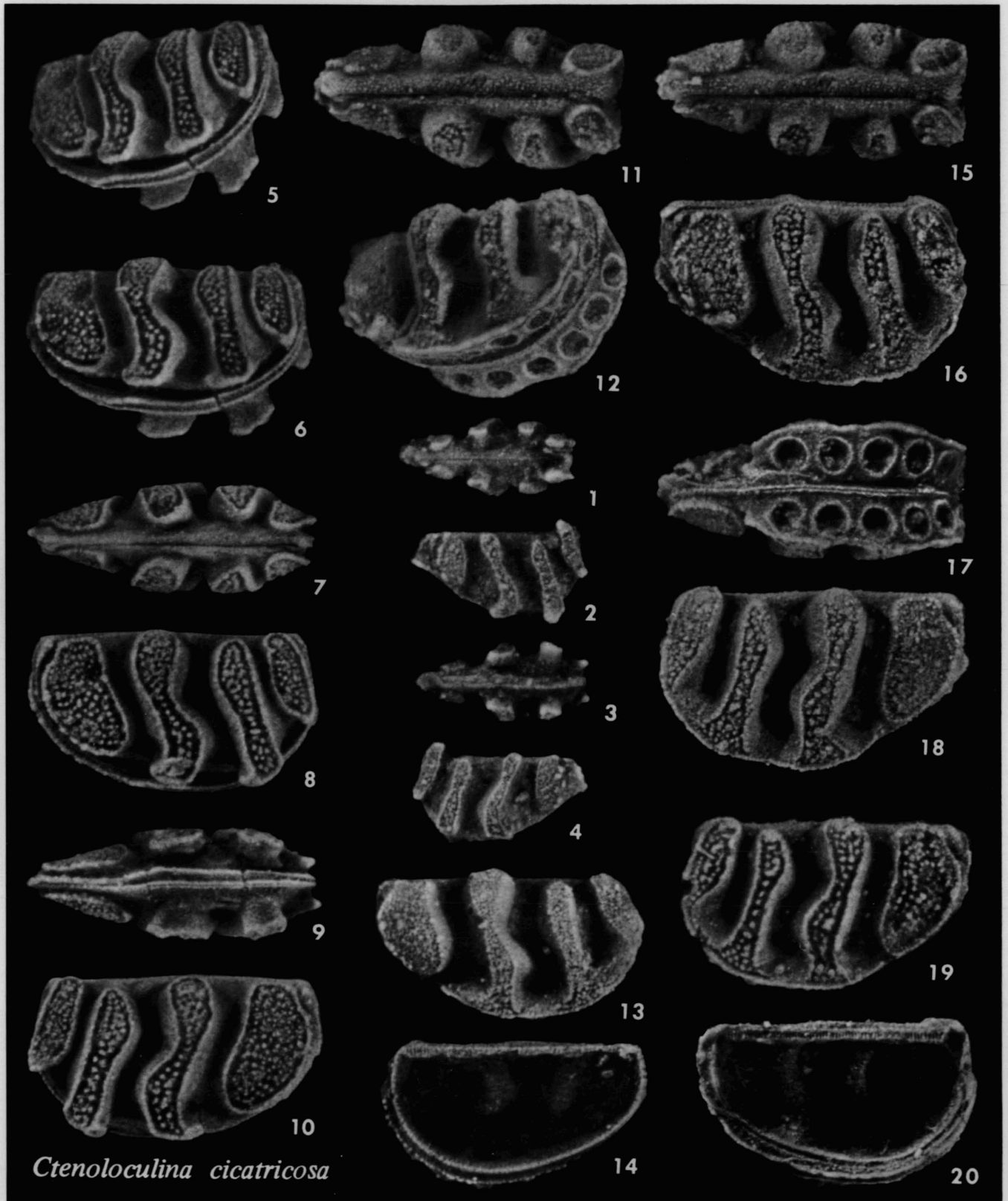

PLATE 18



EXPLANATION OF PLATE 18

All figures x 40

1-20 -- *Ctenoloculina cicatricosa*. 1-4, UMMP 58930, Loc. MM-Chon, dorsal, right, ventral, and left views of immature carapace; note the general form of the male but exceptionally high L1 and very narrow lobes. 5-10, UMMP 58927, Loc. MQ-9, two inclined (right-anteroventral and right-ventral), dorsal, right, ventral, and left views of male carapace; outer lamella missing from lobate areas, but otherwise carapace well preserved. 11, 12, 15-18, UMMP 58921, Loc. MM-Chon, dorsal (slightly inclined), inclined (right-anteroventral), dorsal, right, ventral, and left views of female carapace; note blunt anterior end of female in dorsal view, as compared with acuminate anterior end of male (fig. 7). 13, 14, 19, 20, UMMP 58168 and 59461, Loc. MM-Chon, lateral and interior views of a right and a left female valve; the right valve retains the outer lamella of ornamentation on the lobes, whereas the left valve shows only the supporting papillae.

EXPLANATION OF PLATE 19

All figures x 40

1-18 -- *Ctenoloculina cicatricosa*. 1-6, UMMP 58922, Loc. MM-Chon, two inclined (right-posteroventral and right-anteroventral), dorsal, right, ventral, and left views of female carapace; note pyrite crystals projecting from anterior loculi. 7, UMMP 58154, Loc. MQ-9, lateral view of right female valve. 8-12, UMMP 58924, Loc. MM-Chon, dorsal, right, ventral, left, and inclined (right-anteroventral) views of female carapace. 13-18, UMMP 58928, Loc. MM-Chon, two inclined (right-ventral and right-anteroventral), dorsal, left, ventral, and right views of male carapace (spur broken from left L3).

PLATE 19

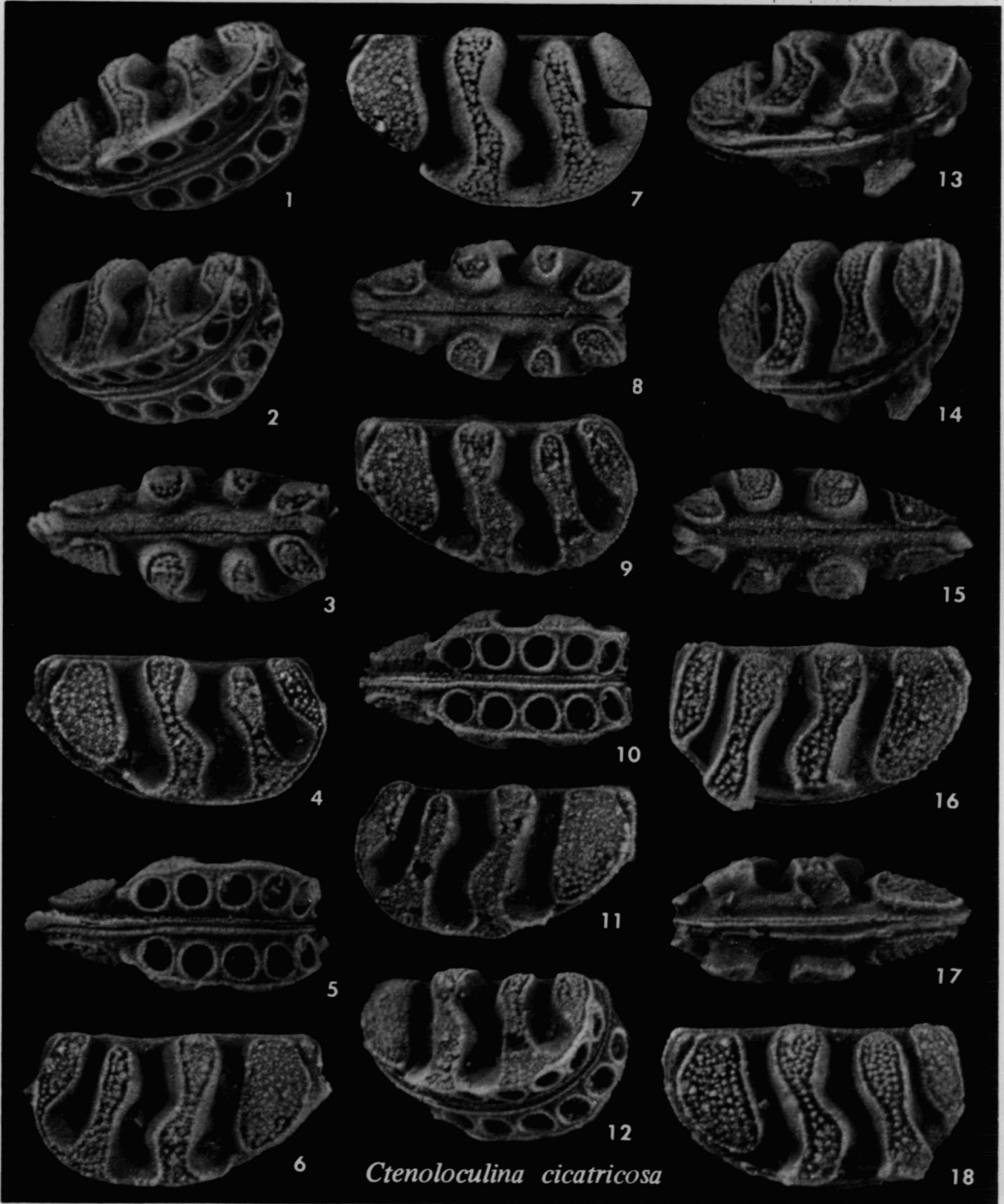

Ctenoloculina cicatricosa

PLATE 20

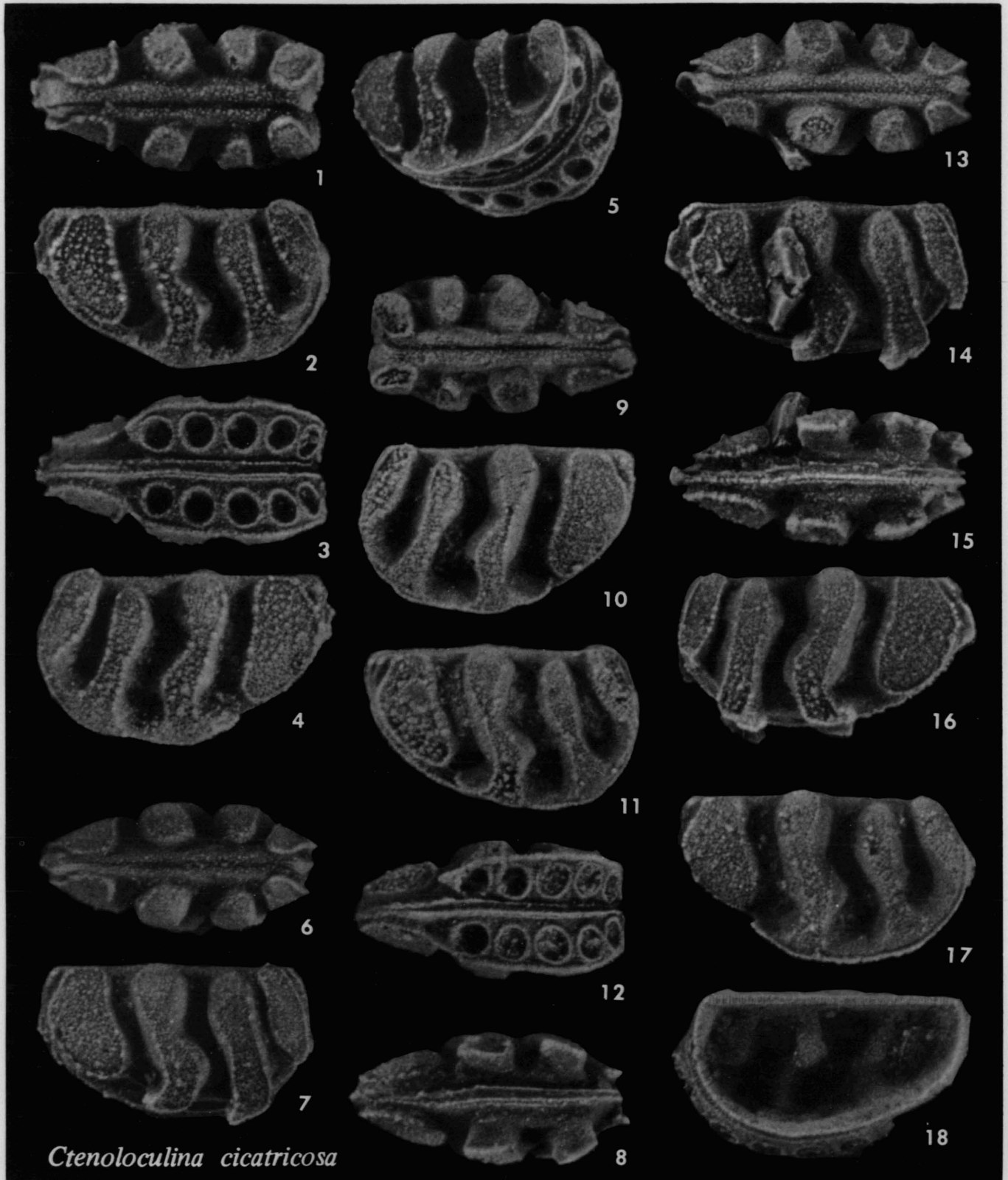

EXPLANATION OF PLATE 20

All figures x 40

1-18 -- *Ctenoloculina cicatricosa*. Loc. MM-Chon. 1-5, UMMP 58925, dorsal, right, ventral, left, and inclined (right-anteroventral) views of female carapace. 6-8, UMMP 58929, dorsal, right, and ventral views of female carapace. 13-16, UMMP 58926, dorsal, right, ventral, and left views of male carapace; pyrite crystals projecting through S3 and L4 of right valve. 17, 18, UMMP 58932, lateral and interior views of right female valve. 9-12, UMMP 58923, dorsal, left, right, and ventral views of female carapace.

EXPLANATION OF PLATE 21

All figures x 40

- 1-10 -- *Ctenoloculina acanthina*. Loc. MM-Chon. 1-4, UMMP 58916, dorsal, right, ventral, and left views of male carapace. 5-8, UMMP 58917, dorsal, right, left, and ventral views of carapace, probably immature. 9, 10, UMMP 59680, lateral and ventral views of female right valve, one of the largest specimens known of the species.
- 11-13 -- *Ctenoloculina cicatricosa*. 11, 12, UMMP 58146, Loc. MQ-9, lateral and interior views of female right valve, the latter showing the hinge and a suggestion of closing muscle scars on inner surface of S2. 13, UMMP 58929, Loc. MM-Chon, lateral view of male left valve.
- 14-22 -- *Falsipollex lativelatus*. 14-17, UMMP 59218, Loc. MQ-9, dorsal, right, ventral, and left views of immature carapace. 18, 19, UMMP 58986, Loc. MQ-9, left and right views of slightly crushed female carapace. 20, 21, UMMP 59036, Loc. MM-Chon, left and ventral views of immature carapace. 22, UMMP 59039, Loc. MM-Chon, right view of immature carapace preserving posterodorsal corner spine and showing marginal denticles. Note the similarity in lobation and ornamentation between immature and adult specimens.

PLATE 21

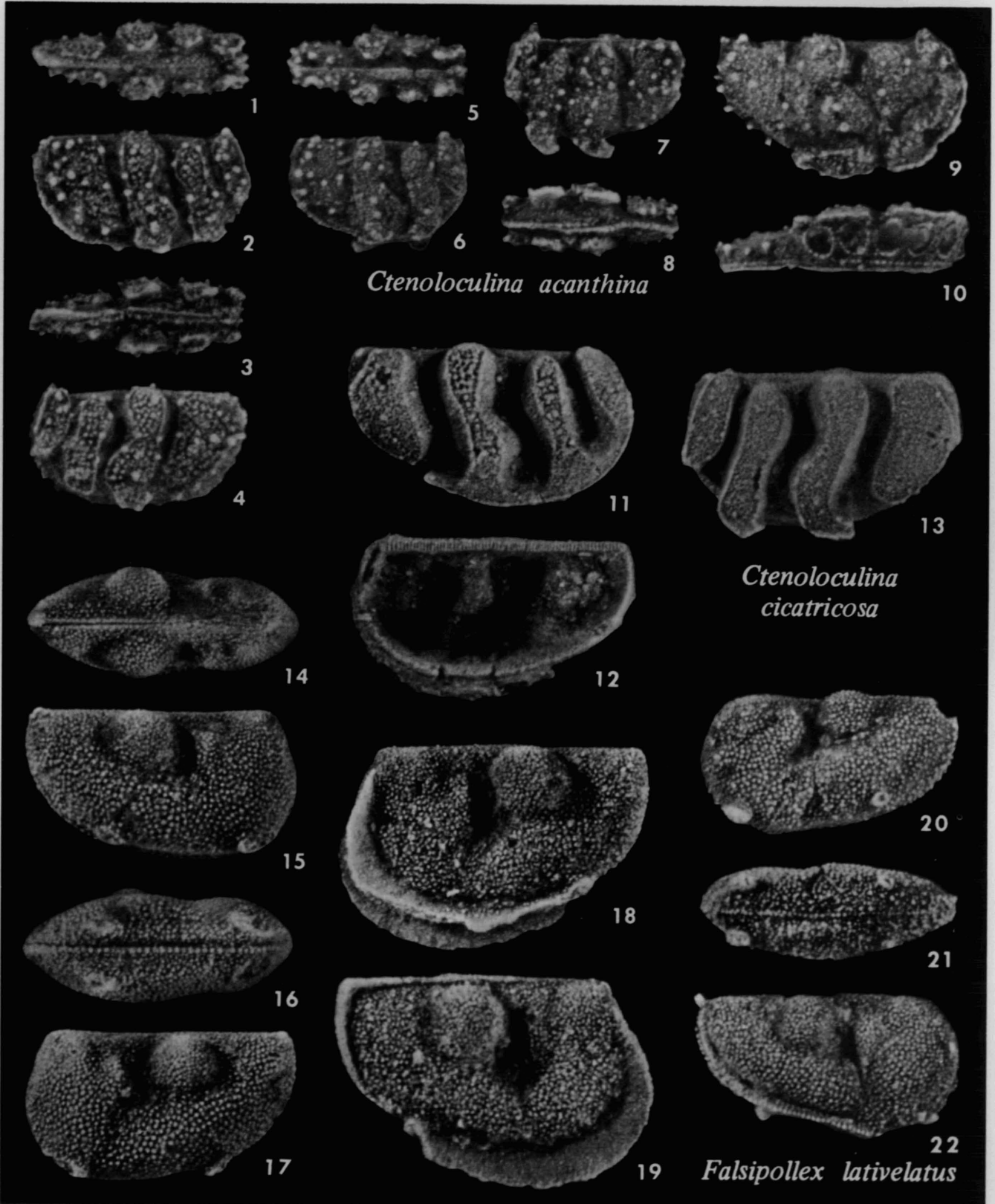
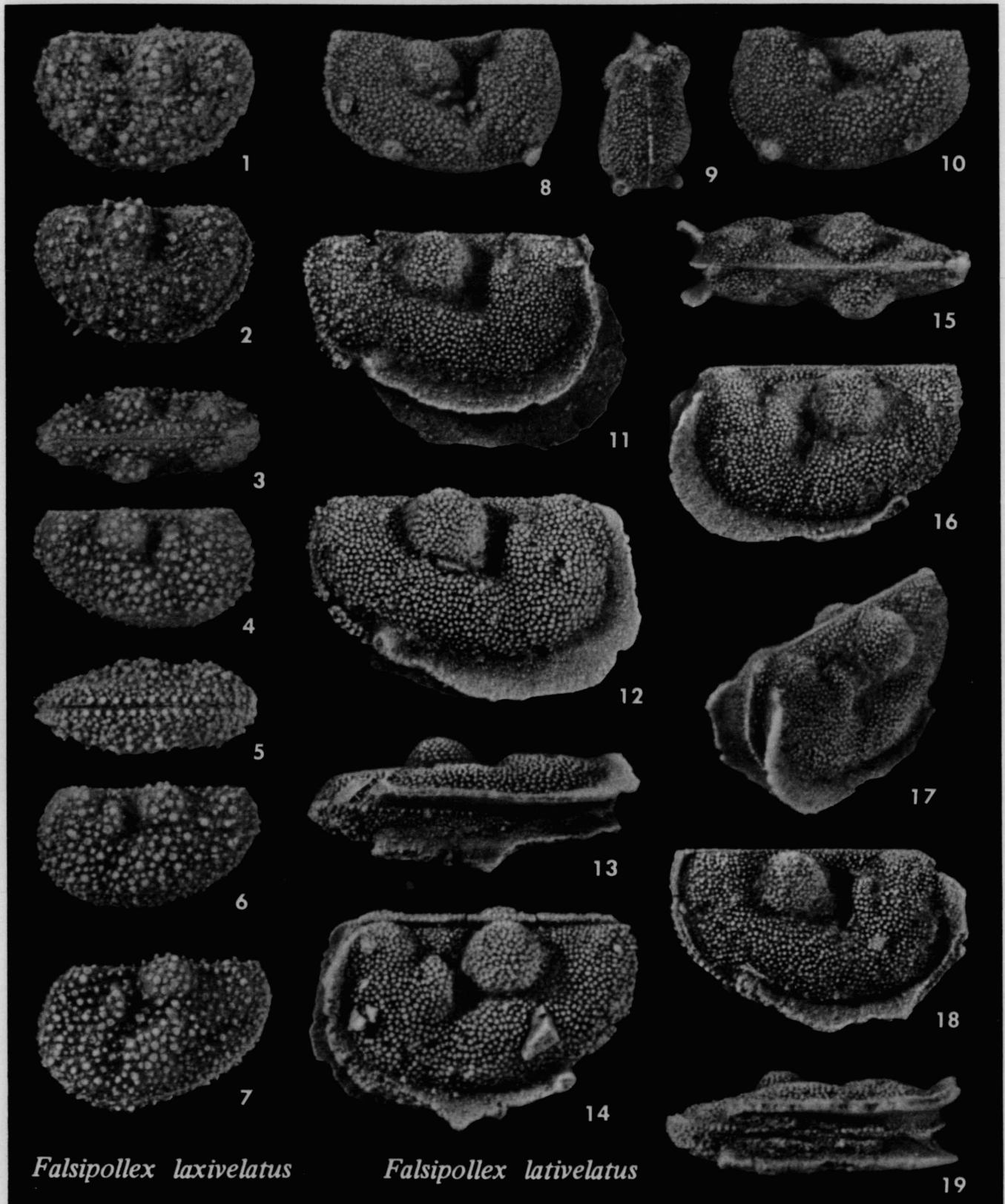

PLATE 22

*Falsipollex laxivelatus**Falsipollex lativelatus*

EXPLANATION OF PLATE 22

All figures x 40

- 1-7 -- *Falsipollex laxivelatus*. 1, 2, UMMP 59473, Loc. MM-Chon, left and right views of immature carapace. 3-6, UMMP 58978, Loc. MM-Chon, dorsal, right, ventral, and left views of immature carapace. 7, UMMP 58976, Loc. MQ-9, left view of immature carapace. On these immature carapaces, note the coarse and irregular ornamentation and the lack of discernible velar structure.
- 8-19 -- *Falsipollex lativelatus*. 8-10, UMMP 59691, Loc. MQ-9, right, anterior, and left views of immature carapace; as compared with adult male specimen (pl. 23, figs. 7-11), note the absence of the anterior velar structures in the immature forms. 11, UMMP 58984, Loc. MM-Chon, right view of female carapace with most of the frill preserved on the left valve and visible below the broken frill of the right valve. 12-14, UMMP 58697, Loc. MM-Chon, right, ventral, and left views of female carapace with small cubes of pyrite projecting from left valve. 15-19, UMMP 58988, Loc. MQ-12, dorsal, left, inclined (left-anterodorsal), right, and ventral views of very small female carapace; although appreciably smaller than other females from lower units of the Silica Formation, this specimen has all the essential characters of the species.

EXPLANATION OF PLATE 23

All figures x 40

- 1-13 -- *Falsipollex lativelatus*. 1-4, UMMP 58983, Loc. MM-Chon, dorsal, left, ventral, and right views of female carapace. 5, 6, UMMP 59409, Loc. MM-Chon, right and left views of female carapace. 7-11, UMMP 59001, Loc. MM-Chon, dorsal, right, anterior, left, and ventral views of male carapace; note that the velar structures on each valve include three flattened spurs -- posteroventral, anteroventral, and anterior, the last not known in other males of the genus. 12, 13, UMMP 59040, Loc. MQ-9, right and left views of female carapace, somewhat crushed in dorsally but showing exceptional preservation of the rather delicate broad smooth frills.

PLATE 23

Falsipollex lativelatus

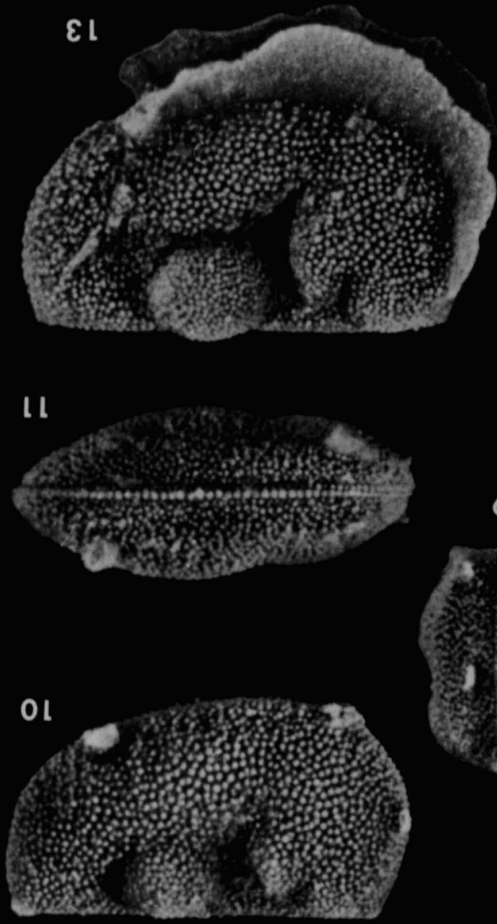
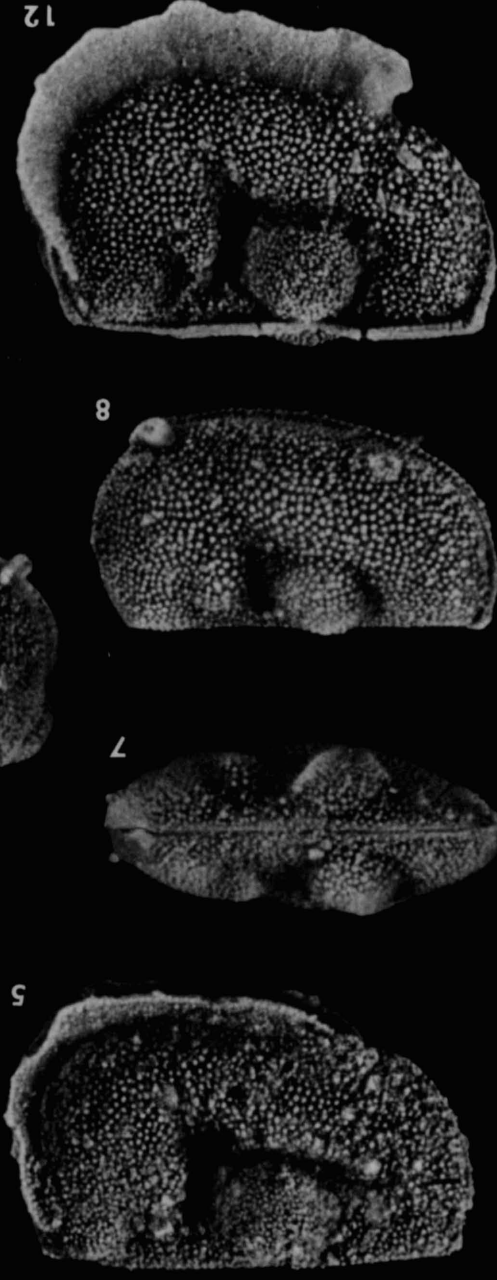
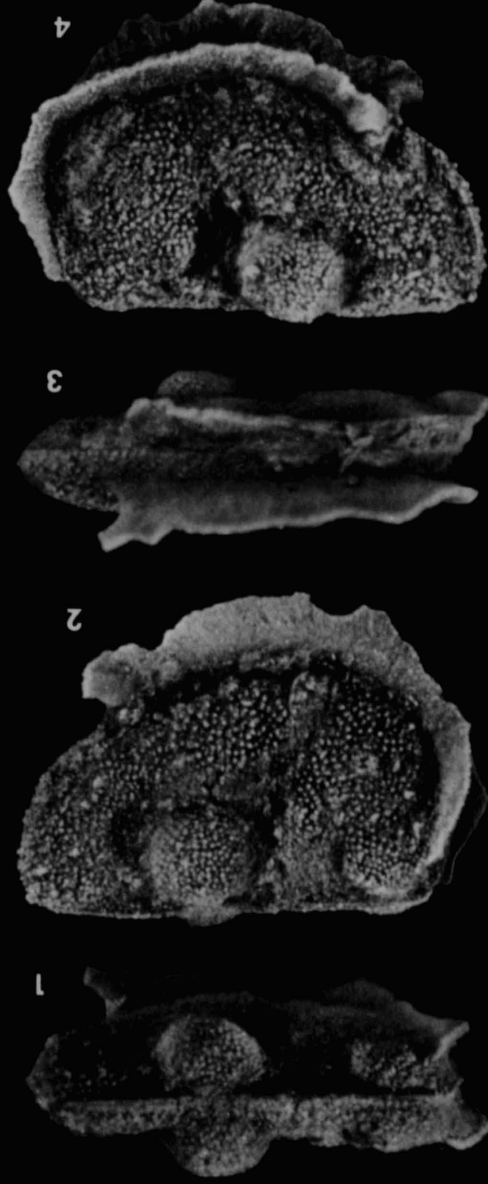
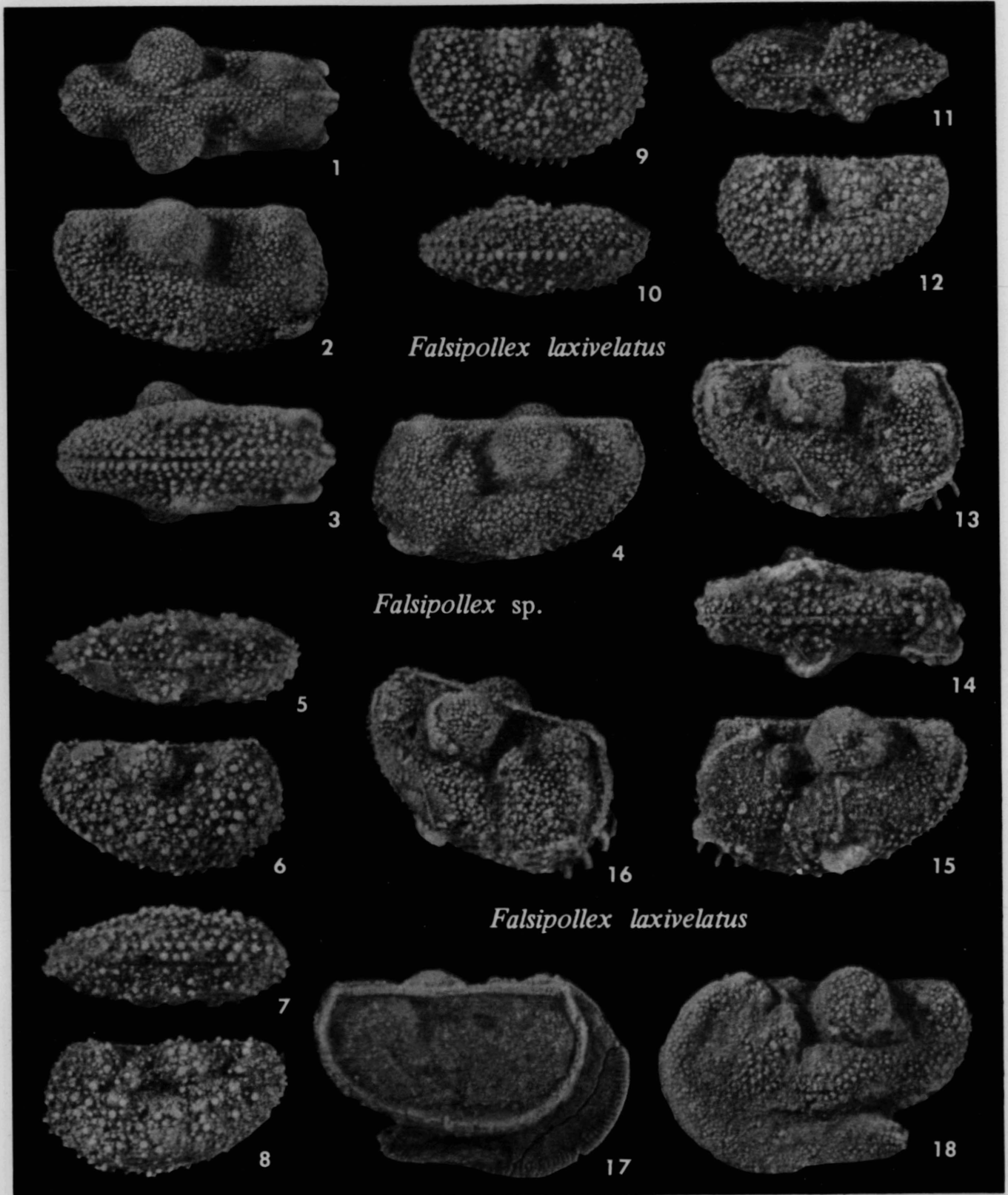

PLATE 24



EXPLANATION OF PLATE 24

All figures x 40

- 1-4 -- *Falsipollex* sp. Loc. S-9. UMMP 59477, dorsal, right, ventral, and left views of male type carapace; although very wide, this specimen may be an immature *F. lativelatus*.
- 5-18 -- *Falsipollex laxivelatus*. Loc. MM-Chon. 5-8, UMMP 59041, dorsal, right, ventral, and left views of immature carapace. 9-12, UMMP 58977, right, ventral, dorsal, and left views of immature carapace. 13-16, UMMP 58968, right, ventral, left, and inclined views of male carapace; note the preservation of exceptionally long marginal spines projected between the anteroventral flat spurs. 17, 18, UMMP 58974, interior and lateral views of female left valve; note the "crimping" on the inner margin of the frill.

EXPLANATION OF PLATE 25

All figures x 40

- 1-10 -- *Falsipollex laxivelatus*. Loc. MM-Chon. 1-4, UMMP 58799, right, ventral, dorsal, and left views of male carapace; note extension of papillae onto the spurs. 5-8, UMMP 59474, dorsal, right, ventral, and left views of immature carapace. 9, 10, UMMP 59472, right and left views of immature carapace with crystal of pyrite protruding from the posteroventral part.
- 11-19 -- *Falsipollex lativelatus*. 11-14, UMMP 59000, Loc. MM-Chon, dorsal, right, ventral, and left views of male carapace; note exceptional size of preserved anteroventral spur on left valve (most spurs broken off from males). 15-19, UMMP 59219, Loc. MQ-9, dorsal, right, anterior, ventral, and left views of male carapace; note anterior velar structures (short ridges).

PLATE 25

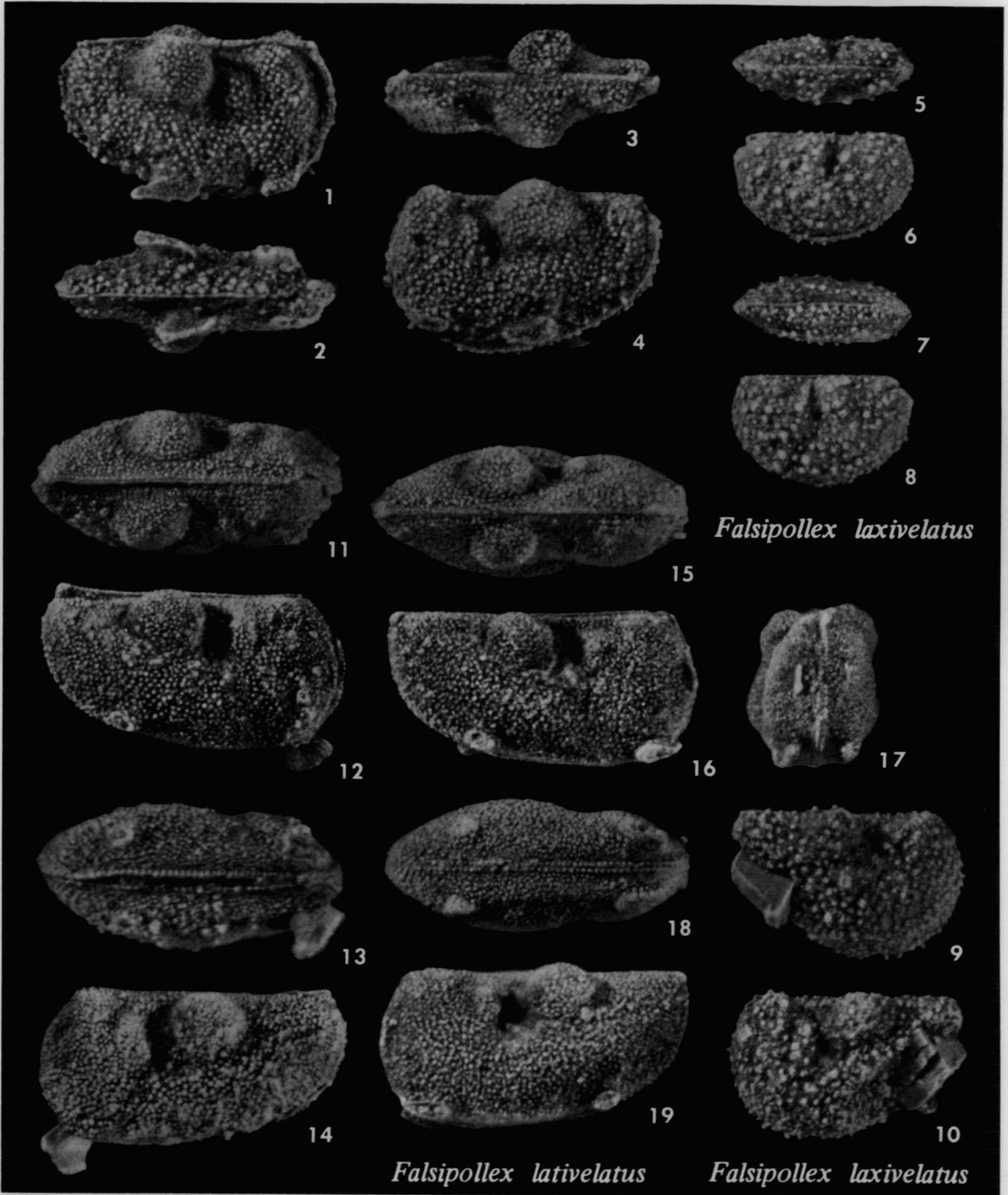

Falsipollex laxivelatus

Falsipollex lativelatus

Falsipollex laxivelatus

PLATE 26

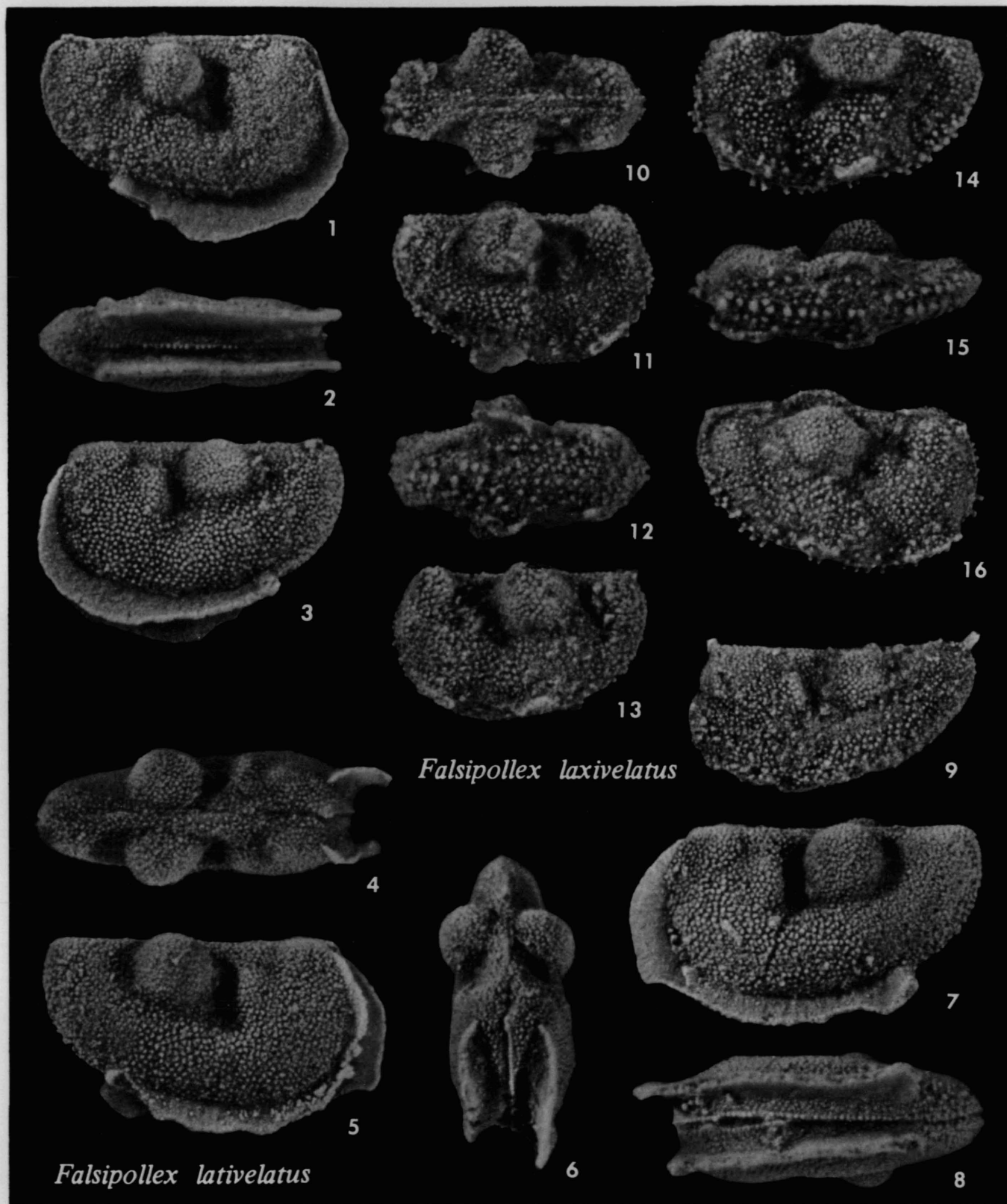

EXPLANATION OF PLATE 26

All figures x 40

- 1-9 -- *Falsipollex lativelatus*. 1-3, UMMP 59470, Loc. MM-Chon, right, ventral, and left views of female carapace. 4-8, UMMP 59038, Loc. S-9, dorsal, right, inclined anterior, left, and ventral views of female carapace. 9, UMMP 58999, Loc. MM-Chon, left view of immature carapace, somewhat crushed but still retaining the corner spines typical of juveniles of the species.
- 10-16 -- *Falsipollex laxivelatus*. Loc. MM-Chon. 10-13, UMMP 58969, dorsal, right, ventral, and left views of male carapace. 14-16, UMMP 58971, left, ventral, and right views of male carapace with the valves slightly skewed.

EXPLANATION OF PLATE 27

All figures x 40

- 1-17 -- *Falsipollex laxivelatus*. Loc. MM-Chon. 1, 2, UMMP 58755, lateral and interior views of female right valve. 3, UMMP 58798, lateral view of female left valve with frill intact. 4, 5, UMMP 58979, lateral and interior views of immature left valve. 6-9, UMMP 58800, dorsal, right, ventral, and left views of male carapace; note that where papillae are scraped off, the surface shows tiny punctae (pores ?) marking their former positions. 10-13, UMMP 58973, dorsal, right, ventral, and left views of female carapace with frills retained and showing the formation of a "false pouch" when the valves are closed. 14-17, UMMP 58975, dorsal, right, ventral, and left views of female carapace with badly damaged frills.

PLATE 27

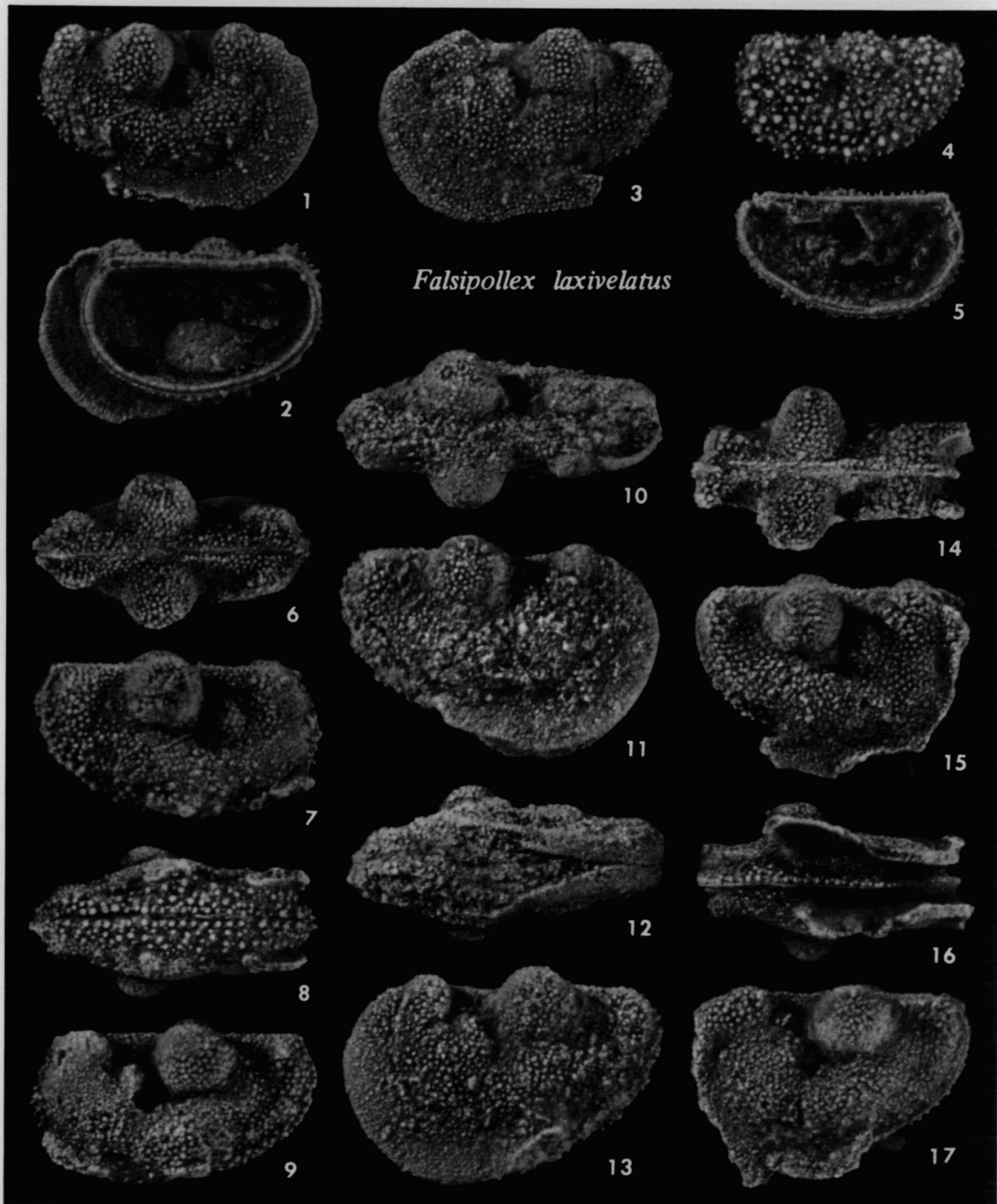
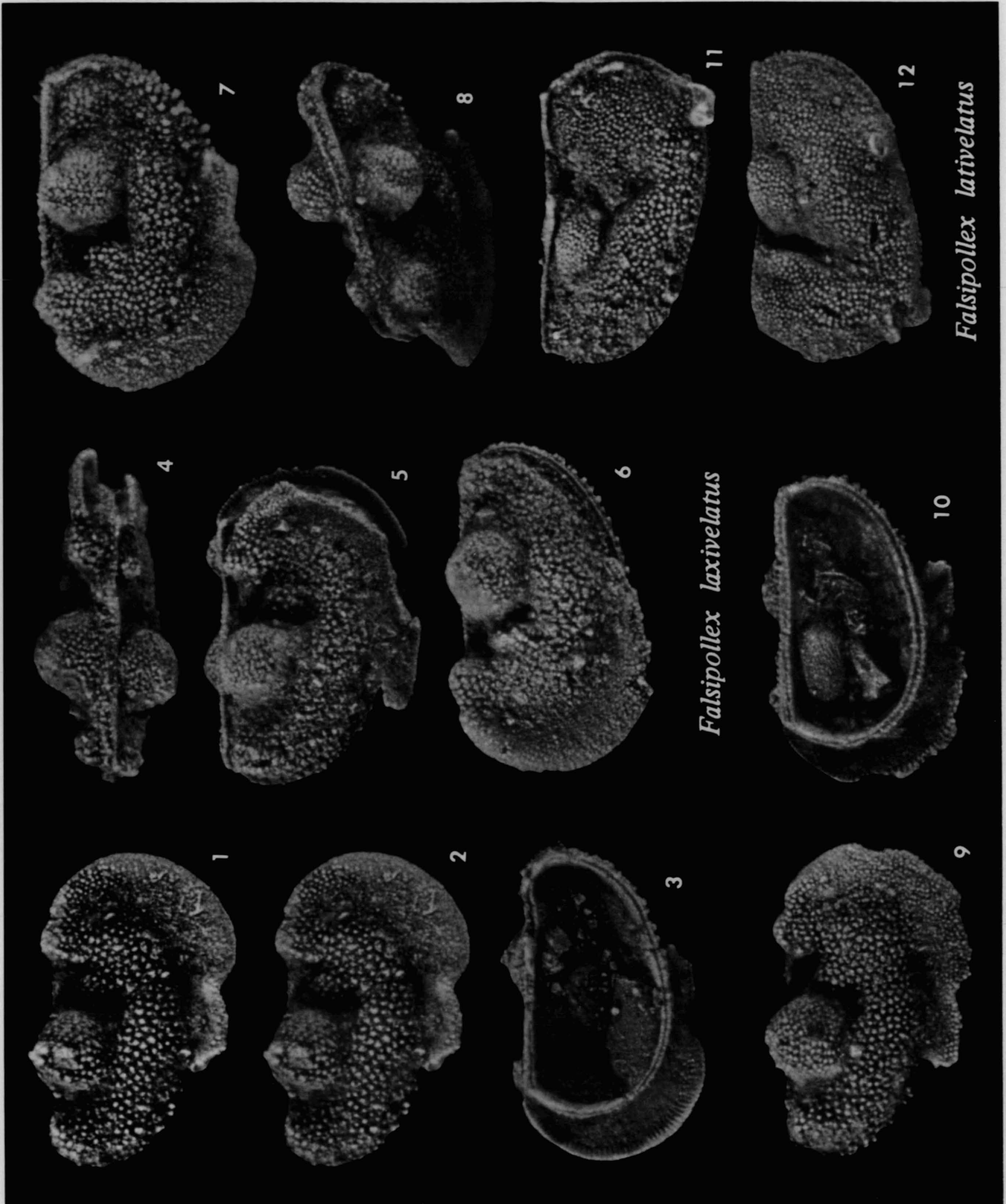

PLATE 28



Falsipollex lativelatus

Falsipollex laxivelatus

EXPLANATION OF PLATE 28

All figures x 40

- 1-10 -- *Falsipollex laxivelatus*. Loc. MM-Chon. 1-3, UMMP 59471, two lateral and an interior view of female right valve; the first lateral view printed in high contrast to show the somewhat irregular papillae of the lateral surface extending onto the frill and there grading into granulation; interior view showing the "crimping" ornamentation on the inside margin of the frill. 4-6, UMMP 58756, dorsal, right, and left views of female carapace. 7, 8, UMMP 58797, left and inclined (left-anterodorsal) views of female carapace with left valve crushed in to fit below the hinge line. 9, 10, UMMP 58754, lateral and interior views of female right valve.
- 11, 12, -- *Falsipollex lativelatus*. Loc. MM-Chon. UMMP 58931, right and left views of male carapace, crushed dorsally.

EXPLANATION OF PLATE 29

All figures x 40

- 1-18 -- *Falsipollex laxivelatus*. 1, 2, UMMP 58970, Loc. MM-Chon, right and left views of male carapace, showing particularly well the nature of the velar spurs. 3-8, UMMP 59475, Loc. S-9, inclined, anterior, dorsal, right, ventral, and left views of immature male-type carapace, rather atypical in the form of the spurs. 9-13, UMMP 59476, Loc. S-9, anterior, inclined (right anterodorsal), dorsal, right, and ventral views of immature carapace; note the coarse and irregular ornamentation persisting on the ventral surface of this specimen, probably the ultimate immature instar; it differs from still younger instars in the development of spurs and in the more regular papillae on the lateral surface. 14-18, UMMP 58972, Loc. MM-Chon, anterior, dorsal, right, ventral, and left views of female carapace.

PLATE 29

Falsipollex laxivelatus

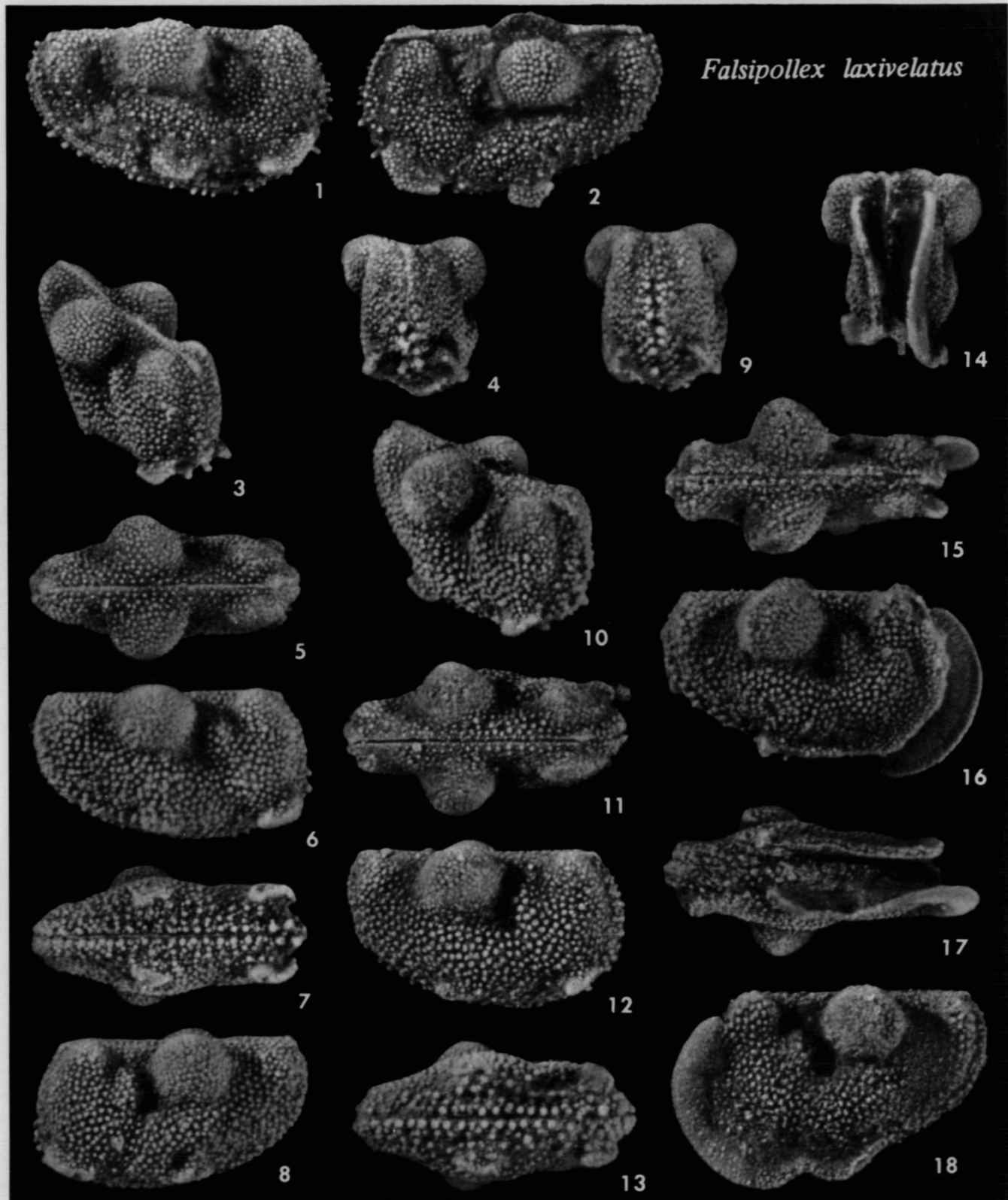
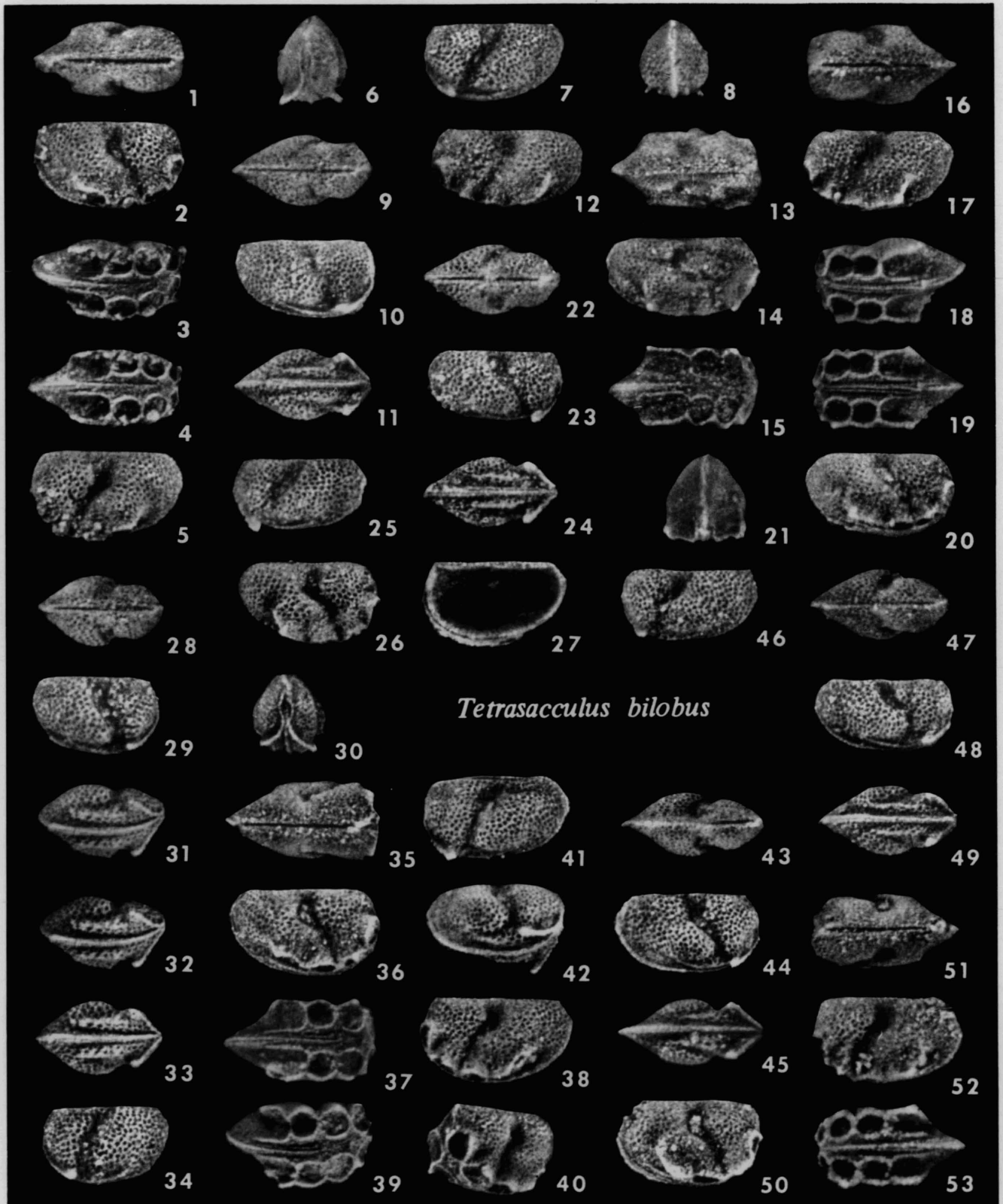

PLATE 30



EXPLANATION OF PLATE 30

All figures x 40

- 1-53 -- *Tetrasacculus bilobus*. Specimens from Loc. MM-Chon except as noted. 1-5, UMMP 59020, dorsal, right, inclined (right-ventral), ventral, and left views of female carapace. 6-11, UMMP 59027, anterior, left, posterior, dorsal, right, and ventral views of male carapace. 12-15, UMMP 59023, Loc. MQ-9, left, dorsal, right, and ventral views of female carapace. 16-21, UMMP 59026, dorsal, left, inclined (left-ventral), ventral, right, and posterior views of female carapace. 22-25, UMMP 59031, dorsal, right, ventral, and left views of male carapace. 26, 27, UMMP 59022, lateral and interior views of female right valve. 28-34, UMMP 59029, dorsal, right, anterior, two inclined (right-ventral), ventral, and left views of immature carapace (probably ultimate instar); the second inclined view printed to emphasize the bi-partite velar structure in each valve. 35-40, UMMP 59025, dorsal, right, ventral, left, and two inclined (right-ventral and left-anteroventral) views of excellent female carapace. 41-45, UMMP 59028, left, inclined (right-ventral), dorsal, right, and ventral views of excellent male carapace, showing the short velar ridge (ventral) and the disjunct spur at the anteroventral termination of the anterior ridge, comprising the male velar structure. 46-49, UMMP 59030, left, dorsal, right, and ventral views of male carapace. 50-53, UMMP 59024, right, dorsal, left, and ventral views of female carapace.

EXPLANATION OF PLATE 31

All figures x 40

- 1-10 -- *Tetrasacculus bilobus*. 1-4, UMMP 59032, Loc. MQ-9, dorsal, right, ventral, and left views of male carapace. 5-8, UMMP 59620, Loc. MM-Chon, dorsal, right, ventral, and left views of male carapace. 9, 10, UMMP 59021, Loc. MM-Chon, interior and lateral views of female left valve.
- 11-14 -- *Falsipollex laxivelatus*. Loc. MM-Chon. UMMP 58796, dorsal, right, ventral, and left views of female carapace, somewhat laterally compressed and with frill margins broken off, but preserving the distinctive ornamentation.
- 15-26 -- *Subligaculum scrobiculatum*. 15-18, UMMP 59422, Loc. MM-Chon, dorsal, right, ventral, and left views of male carapace. 19-22, UMMP 59011, Loc. MM-Chon, dorsal, left, right, and ventral views of male carapace. 23, 24, UMMP 59012, Loc. MM-Chon, lateral and interior views of male right valve. 25, 26, UMMP 59013, Loc. MQ-9, lateral and interior views of female right valve.
- 27-34 -- *Subligaculum bifidum*. Loc. MM-Chon. 27-30, UMMP 59007, dorsal, right, ventral, and left views of immature carapace; as with related hollinids, the immature forms resemble the adult male in velar structure. 31-34, UMMP 59006, dorsal, right, ventral, and left views of female carapace.

PLATE 31

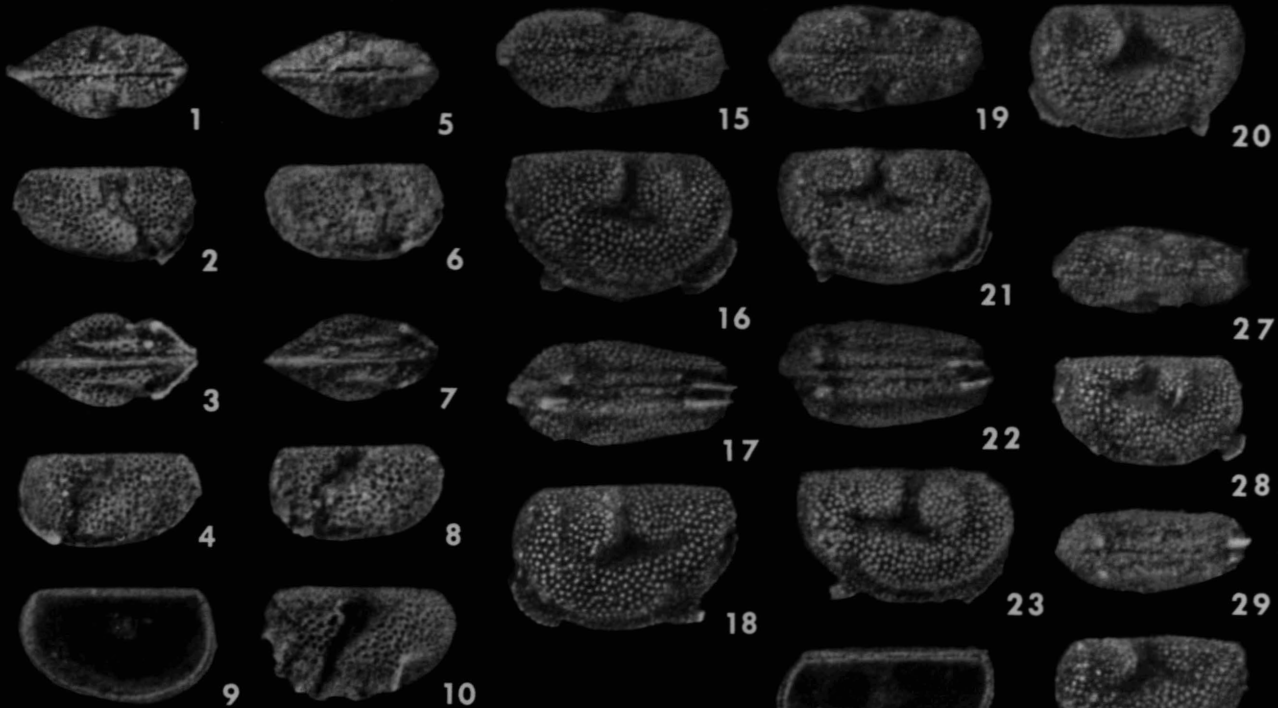

Tetrasacculus bilobus

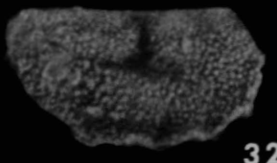
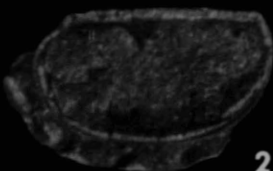
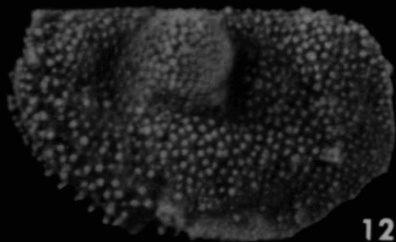
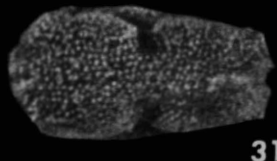
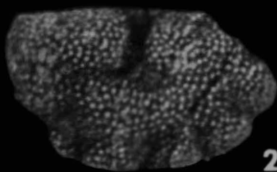
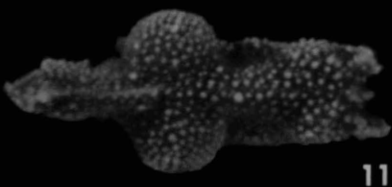

Subligaculum scrobiculatum

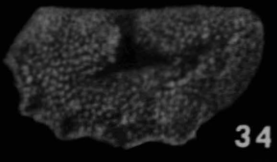
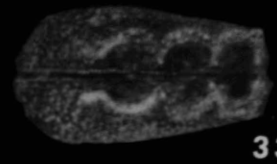
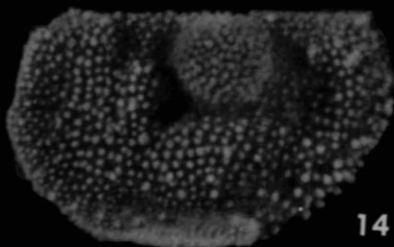
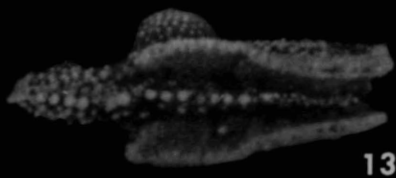

Falsipollex laxivelatus

Subligaculum bifidum

PLATE 32

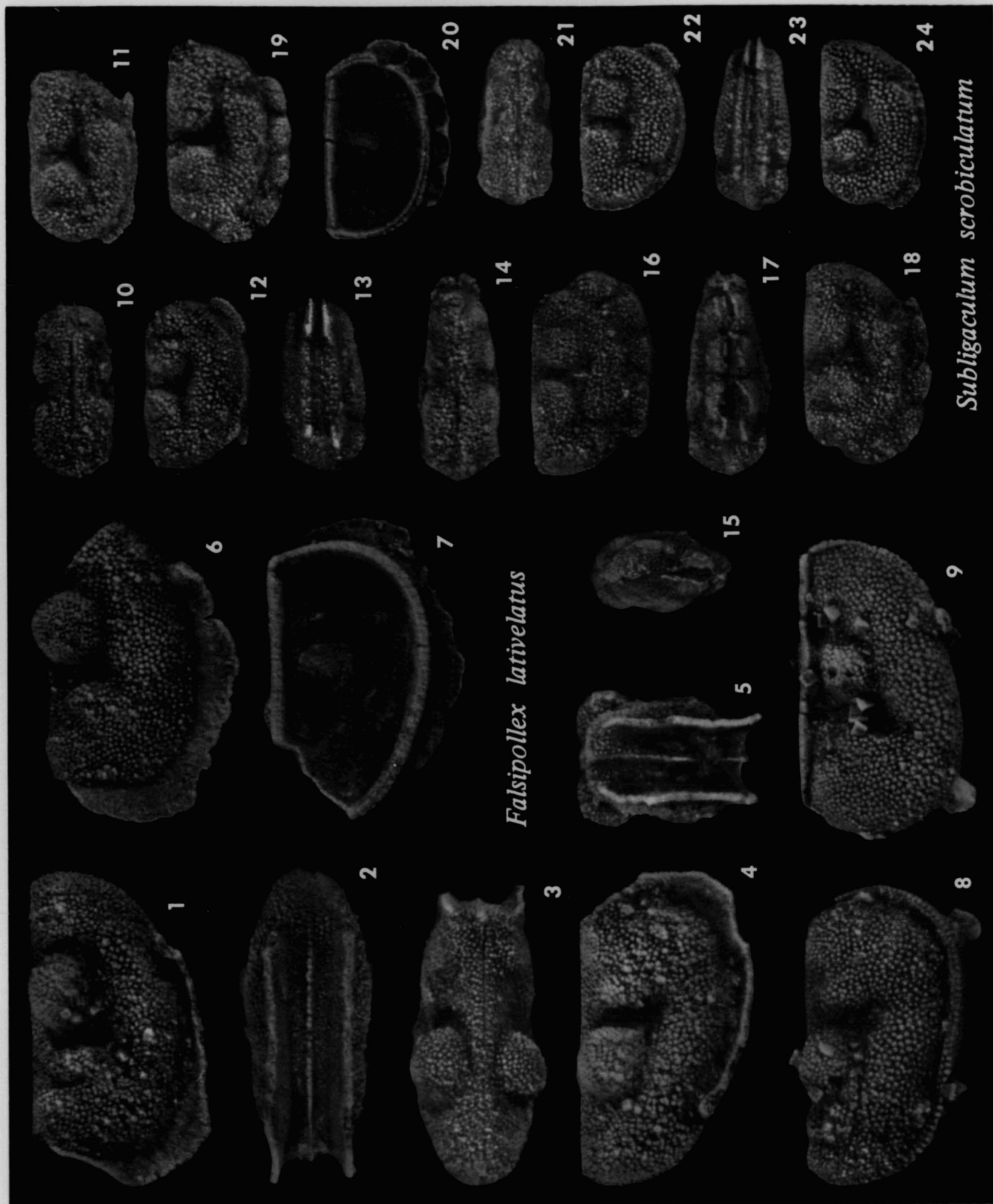

Falsipollex lativelatus

Subligaculum scrobiculatum

EXPLANATION OF PLATE 32

All figures x 40

- 1-9 -- *Falsipollex lativelatus*. 1-5, UMMP 59490, Loc. MM-Chon, left, ventral, dorsal, right, and anterior views of female carapace. 6, 7, UMMP 59221, Loc. N-9, lateral and interior views of female left valve with posterodorsal corner broken off; note that papillae stop abruptly at the frill. 8, 9, UMMP 58985, Loc. N-9, right and left views of crushed male carapace; note small cubes of pyrite projecting from the shell; on right side, marginal denticles of both valves are skewed by the crushing and anteroventrally lie with those of the left valve outside those of the right; the anterior velar spurs are discernible.
- 10-24 -- *Subligaculum scrobiculatum*. 10-13, UMMP 59010, Loc. MM-Chon, dorsal, left, right, and ventral views of male carapace. 14-18, UMMP 59019, Loc. N-9, dorsal, anterior, right, ventral, and left views of female carapace. 19, 20, UMMP 59014, Loc. MM-Chon, lateral and interior views of female left valve. 21-24, UMMP 59016, Loc. MM-Chon, dorsal, right, ventral, and left views of male carapace.

EXPLANATION OF PLATE 33

All figures x 40

- 1-16 -- *Subligaculum scrobiculatum*. 1-4, UMMP 59008, Loc. N-9, dorsal, right, ventral, and left views of female carapace. 5-8, UMMP 59009, Loc. MM-Chon, dorsal, left, ventral, and right views of fine male carapace, showing clearly the postero-central pit and the furrow leading therefrom to the ventral border. 9-12, UMMP 59015, Loc. MM-Chon, dorsal, left, ventral, and right views of female carapace. 13-16, UMMP 59017, Loc. MM-Chon, dorsal, right, ventral, and left views of male carapace; a small crystal of pyrite protrudes from the left valve in the sulcus connecting S2 to the postero-central pit.
- 17-32 -- *Subligaculum bifidum*. 17-20, UMMP 59004, Loc. N-9, dorsal, right, left, and ventral views of female carapace. 21-24, UMMP 59005, Loc. MM-Chon, dorsal, right, ventral, and left views of male carapace; the postero-central area is slightly indented at the position of the postero-central pit in *S. scrobiculatum*, but the specimen appears to belong to *S. bifidum*. 25-28, UMMP 59003, Loc. N-9, dorsal, right, ventral, and left views of female carapace. 29-32, UMMP 59002, Loc. MM-Chon, dorsal, right, ventral, and left views of female carapace with excellently preserved frills.

PLATE 33

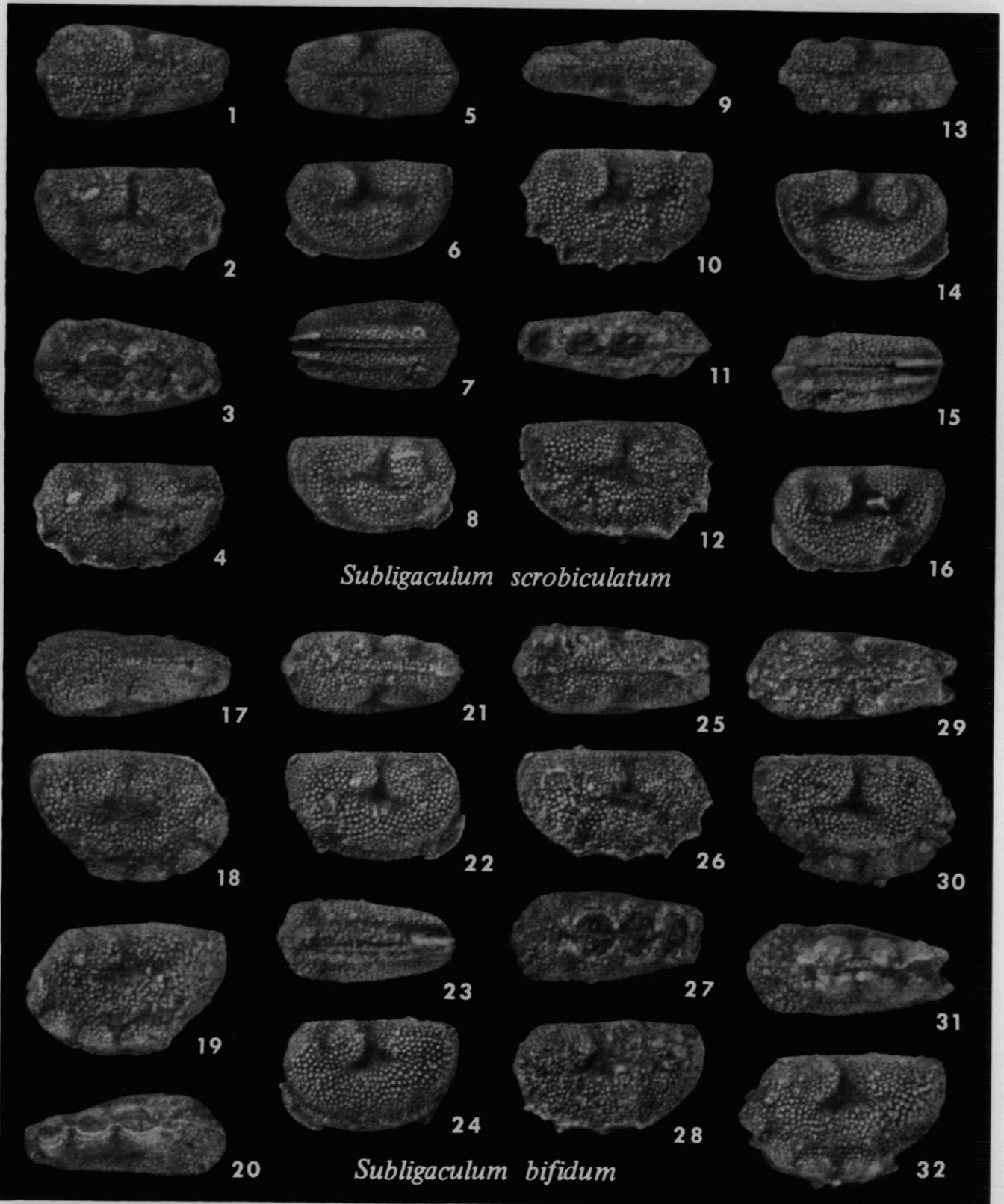

PLATE 34



Phlyctiscapha apleta

EXPLANATION OF PLATE 34

All figures x 40

- 1-10 -- *Phlyctiscapha apleta*. Loc. MM-Chon. 1-6, UMMP 59223, right, anterior, ventral, inclined (right-anteroventral), dorsal, and left views of excellent female carapace; the anterior boundaries of the brood pouches (cruminae) are clearly defined. (The name of the genus means "blister-cradle," referring to the form and function of each brood pouch.) 7-10, UMMP 59224, dorsal, right, left, and ventral views of immature carapace; the specimen is undoubtedly an ultimate immature instar.

EXPLANATION OF PLATE 35

All figures x 40

- 1-11 -- *Phlyctiscapha apleta*. Loc. MM-Chon. 1-3, UMMP 59225, dorsal, right, and ventral views of immature carapace, four instars younger than the adult. 4-7, UMMP 59222, right, ventral, dorsal, and left views of carapace in the ultimate immature instar. 8-11, UMMP 61819, dorsal, right, ventral, and left views of immature carapace, three instars younger than the adult.
- 12-20 -- *Hanaites platus*. 12-15, UMMP 59413, Loc. MM-Chon, right, ventral, and two inclined (left-ventral) views of female carapace; inclined views clearly show the striated keel. 16-20, UMMP 59412, Loc. WP-12, dorsal, right, ventral, inclined (right-ventral), and left views of compressed adult carapace, probably a male.

PLATE 35

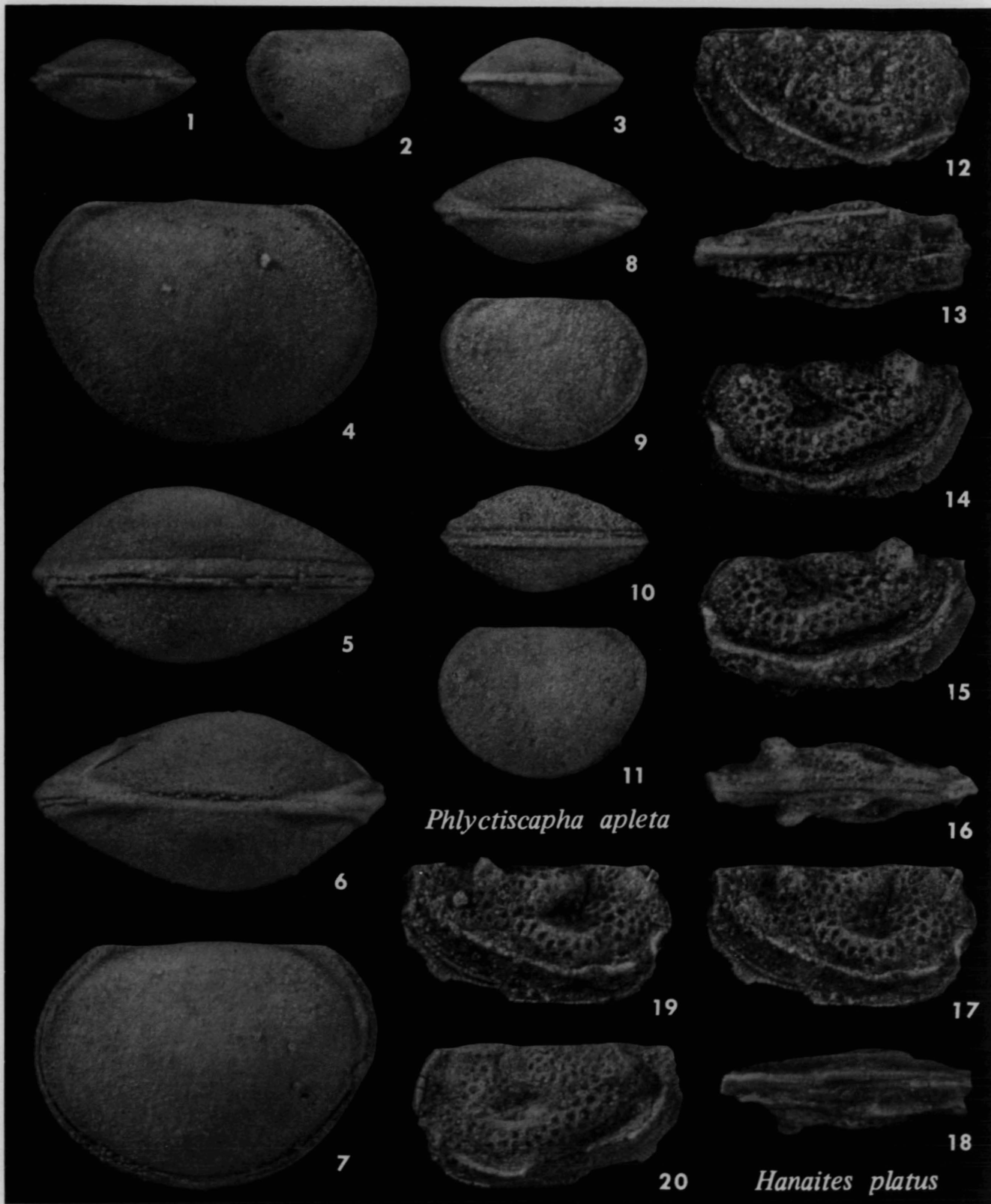
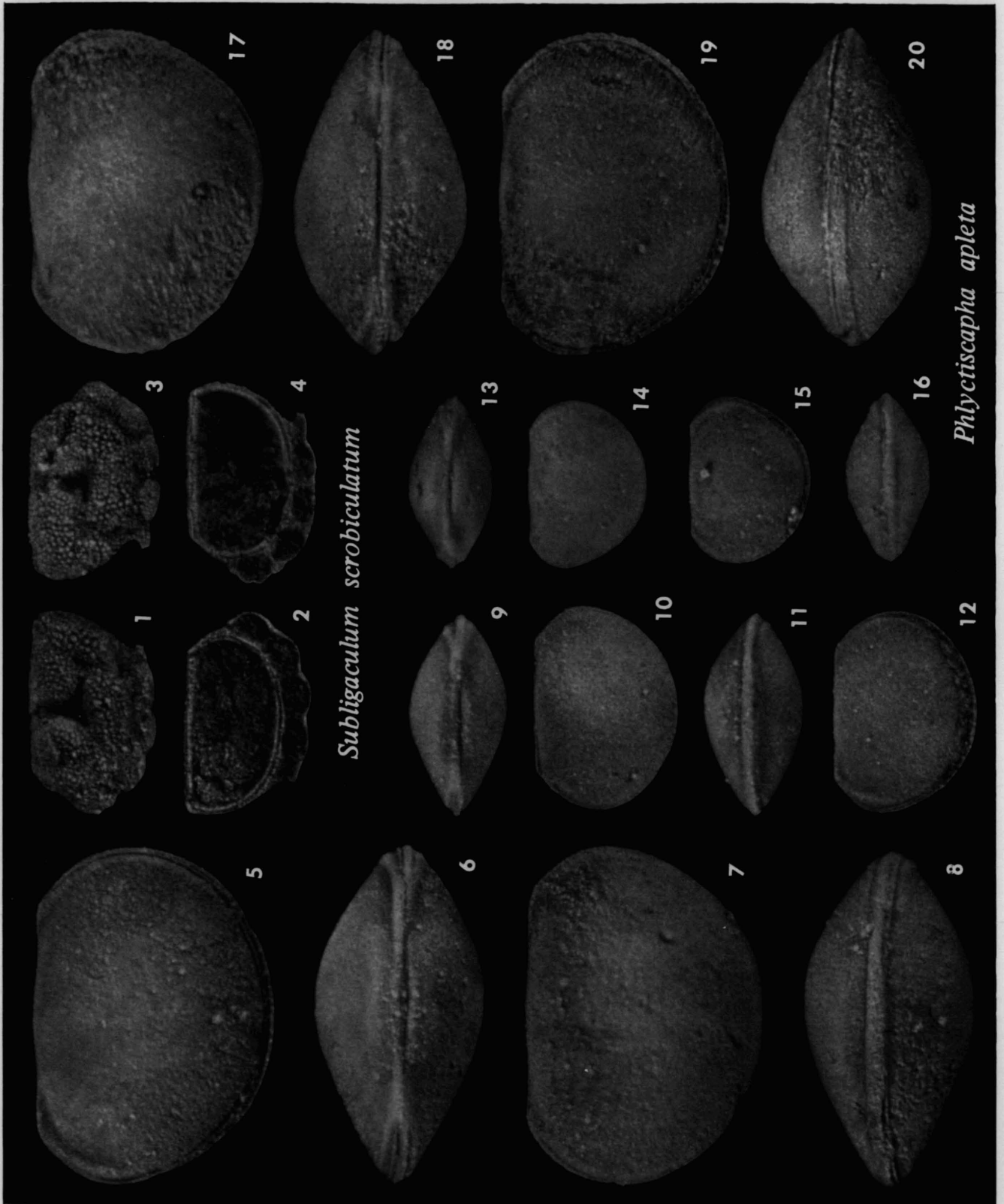

PLATE 36



EXPLANATION OF PLATE 36

All figures x 40

- 1-4 -- *Subligaculum scrobiculatum*. 1, 2, UMMP 59018, Loc. N-9, lateral and interior views of female left valve. 3, 4, UMMP 59264, Loc. MM-Chon, lateral and interior views of female right valve. The hinge consists in this species mainly of a bar in the left valve fitting into a groove in the right.
- 5-20 -- *Phlyctiscapha apleta*. Loc. MM-Chon. 5-8, UMMP 61822, right, dorsal, left, and ventral views of carapace of ultimate immature instar. 9-12, UMMP 61818, dorsal, left, ventral, and right views of immature carapace, three instars younger than the adult. 13-16, UMMP 59227, dorsal, right, ventral, and left views of immature carapace, four instars younger than the adult. 17-20, UMMP 61820, left, dorsal, right, and ventral views of carapace of ultimate immature instar.

EXPLANATION OF PLATE 37

All figures x 40

1-20 -- *Phlyctiscapha apleta*. Loc. MM-Chon. 1-4, UMMP 61823, dorsal, right, left, and ventral views of immature carapace, two instars younger than the adult. 5-8, UMMP 61821, right, ventral, dorsal, and left views of immature carapace, six instars younger than the adult. 13-16, UMMP 59226, dorsal, right, ventral, and left views of immature carapace, four instars younger than the adult. 17-20, UMMP 59078, dorsal, right, ventral, and left views of male carapace, slightly crushed in the anterior region. 9-12, UMMP 59220, dorsal, right, left, and ventral views of immature carapace, two instars younger than the adult.

PLATE 37

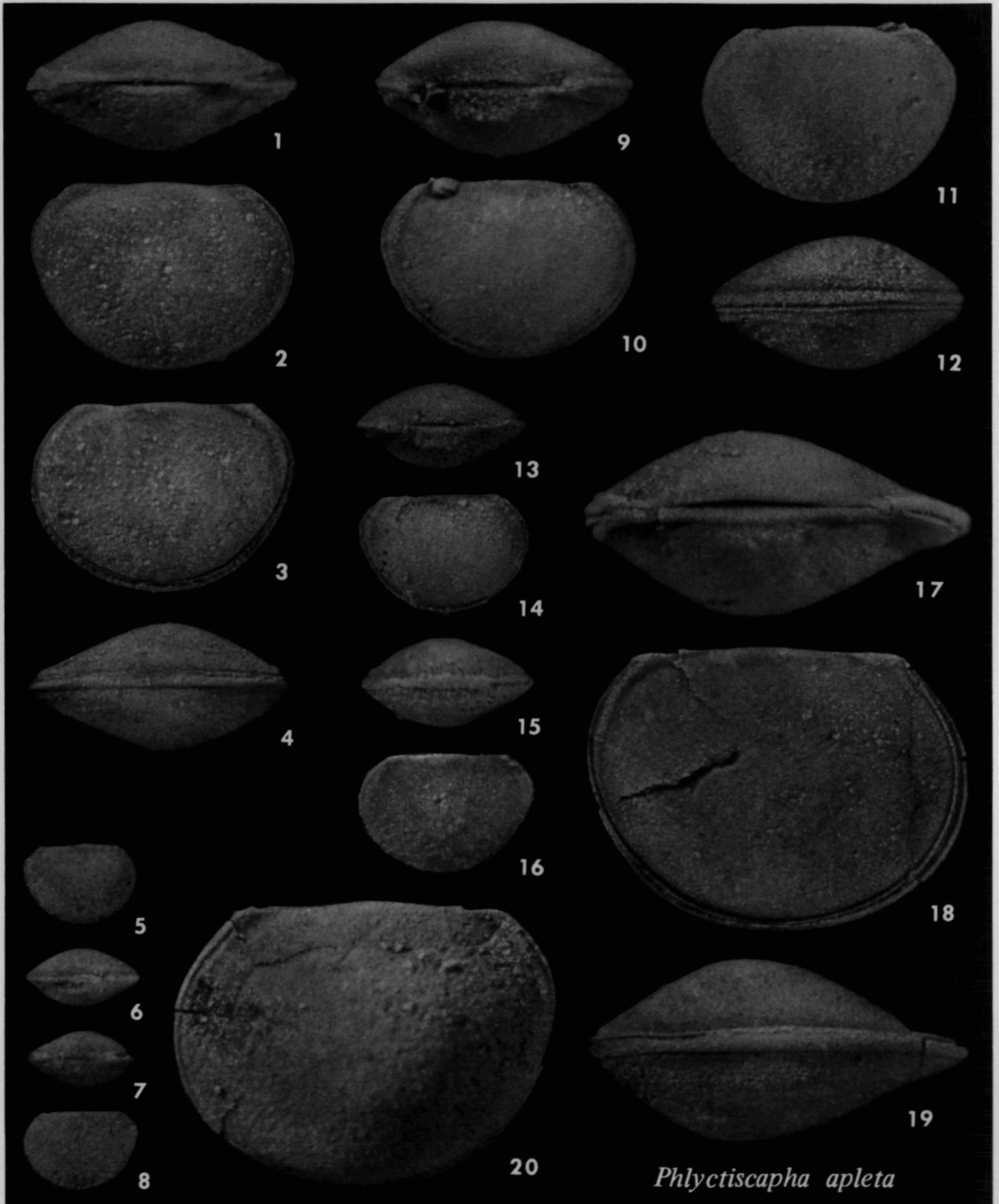

Phlyctiscapha apleta

PLATE 38

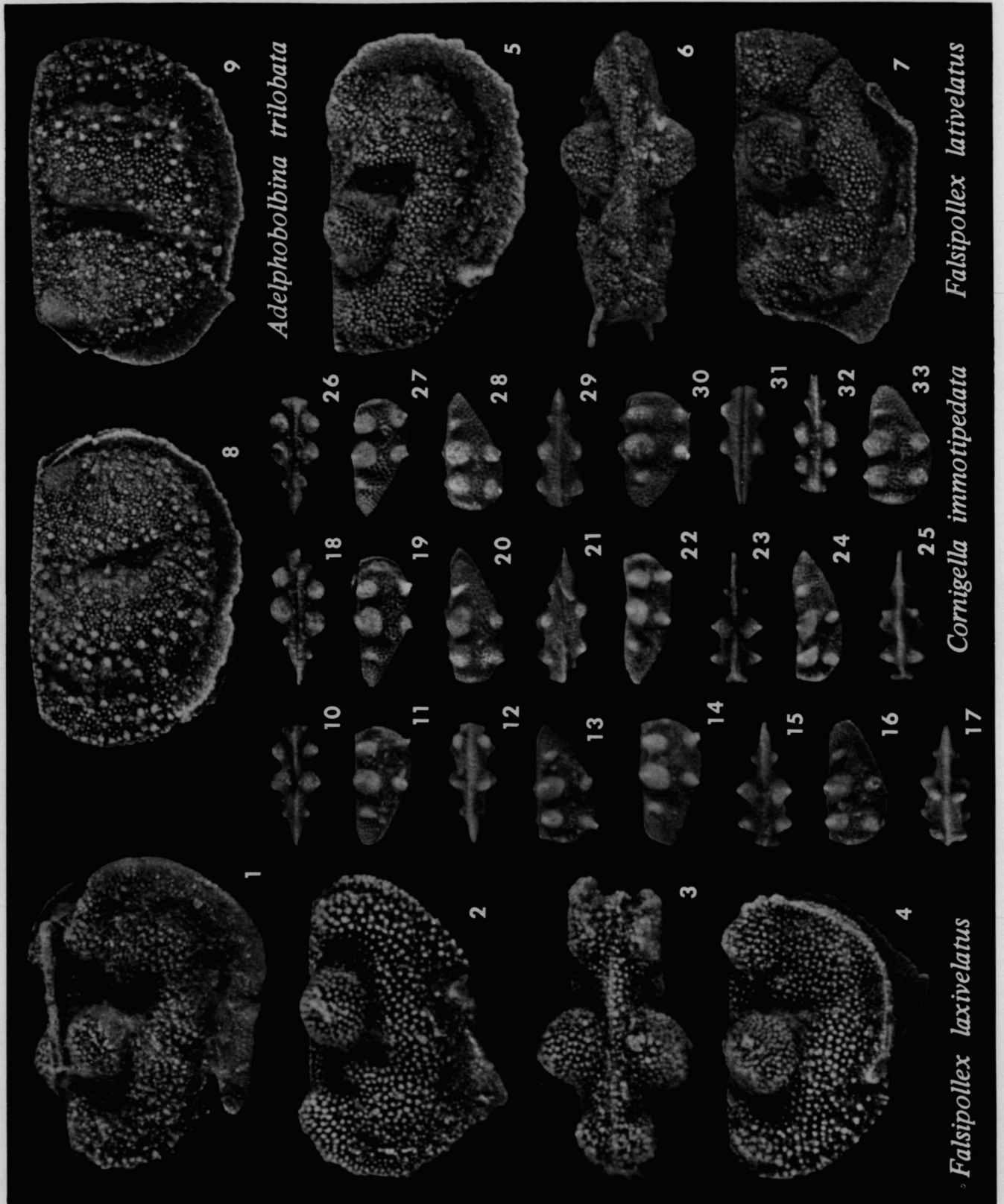

EXPLANATION OF PLATE 38

All figures x 40

- 1-4 -- *Falsipollex laxivelatus*. Loc. MM-Chon. 1, UMMP 59673, right view of female carapace with the two valves askew but preserving the entire frill of the right valve; note the extension of papillae onto the frill, especially at the anterodorsal corner. 2-4, UMMP 59672, left, dorsal, and right views of female carapace with much of the frills broken off.
- 5-7 -- *Falsipollex lativelatus*. Loc. MM-Chon. UMMP 59671, right, dorsal, and left views of female carapace with a particularly good right valve. Compare with the female carapace of *Falsipollex laxivelatus* shown opposite in figures 2-4; the papillae on the posterocentral area (behind L3) average about 335 per square millimeter in this species, but only about 170 per square millimeter in *F. laxivelatus*.
- 8, 9 -- *Adelphobolbina trilobata*. Loc. MM-Chon. UMMP 59674, right and left views of carapace.
- 10-33 -- *Cornigella immotipedata*. Three specimens from Loc. MM-Chon and three from the type locality of the species in the Arkona Shale of Ontario for comparison. From the Silica Formation: 10-13, UMMP 58910, dorsal, right, ventral, and left views; 14-17, UMMP 58909, right, dorsal, left, and ventral views; 30-33, UMMP 59505, right, ventral, dorsal, and left views. From the Arkona Shale: 18-21, UMMP 59617, dorsal, right, left, and ventral views of carapace with valves slightly offset; 22-25, UMMP 58912, right, dorsal, left, and ventral views of much compressed carapace; 26-29, UMMP 59615, dorsal, right, left, and ventral views of carapace.

EXPLANATION OF PLATE 39

All figures x 40

- 1-22 -- *Cornigella immotipedata*. Three specimens from Loc. MM-Chon and four from the type locality of the species in the Arkona Shale shown for comparison. From the Silica Formation: 4, UMMP 59652, left view of carapace; 5, 6, UMMP 59065, left and ventral views of badly deformed specimen, with lobes compressed and contorted from their normal shape; 7-10, UMMP 58911, dorsal, right, ventral, and left views of laterally compressed carapace. From the Arkona Shale: 1-3, UMMP 59616, right, left, and ventral views of carapace; 11-14, UMMP 59614, dorsal, left, right, and ventral views of immature carapace; 15-18, UMMP 59612, dorsal, right, ventral, and inclined right views of carapace, the last showing the ventral overlap of left valve over right; 19-22, UMMP 59613, left, dorsal, right, and ventral views of carapace. Specimens with acute posterior ends and those with rounded posterior ends may be sexual dimorphs of the species.
- 23-36 -- *Kirkbyella (Kirkbyella) bellipuncta*. Specimens from Loc. MM-7 except as noted. 23, 24, UMMP 59153, lateral and interior views of typical right valve. 25, 26, UMMP 59151, lateral and interior views of typical left valve. 27, 28, UMMP 59152, lateral and interior views of typical right valve. 29, 30, UMMP 59150, lateral and interior views of typical left valve. 31, 32, UMMP 59154, Loc. MM-Chon, lateral and interior views of typical right valve. 33-36, UMMP 59171, right, dorsal, left, and ventral views of carapace with more punctae than most specimens. Note that the hingement, consisting of a bar in one valve and a groove in the other, reverses from specimen to specimen: in some the groove is in the right valve (figs. 28, 32) whereas in others it is in the left valve (fig. 30); similarly, the bar may be in the right (fig. 24) or in the left valve (fig. 26).
- 37-42 -- *Kirkbyella (Berdanella) stewartae*. Loc. MM-Chon. 37, 38, UMMP 59419, lateral and interior views of right valve. 39, UMMP 59159, lateral view of right valve. 40, UMMP 59161, lateral view of left valve. 41, UMMP 59160, lateral view of right valve. 42, UMMP 59158, lateral view of right valve.
- 43-56 -- *Kirkbyella (Berdanella) unicornis*. 43, 44, UMMP 59420, Loc. N-9, interior and lateral views of left valve with punctae more sharply defined than is typical of the species. 45-48, UMMP 59163, Loc. MM-Chon, dorsal, left, ventral, and right views of typical carapace. 49-52, UMMP 59162, Loc. MM-Chon, dorsal, right, ventral, and left views of carapace. 53, UMMP 59165, Loc. MM-Chon, left view of exceptionally large carapace. 54-56, UMMP 59168, Loc. N-11, dorsal, left, and right views of carapace.

PLATE 39

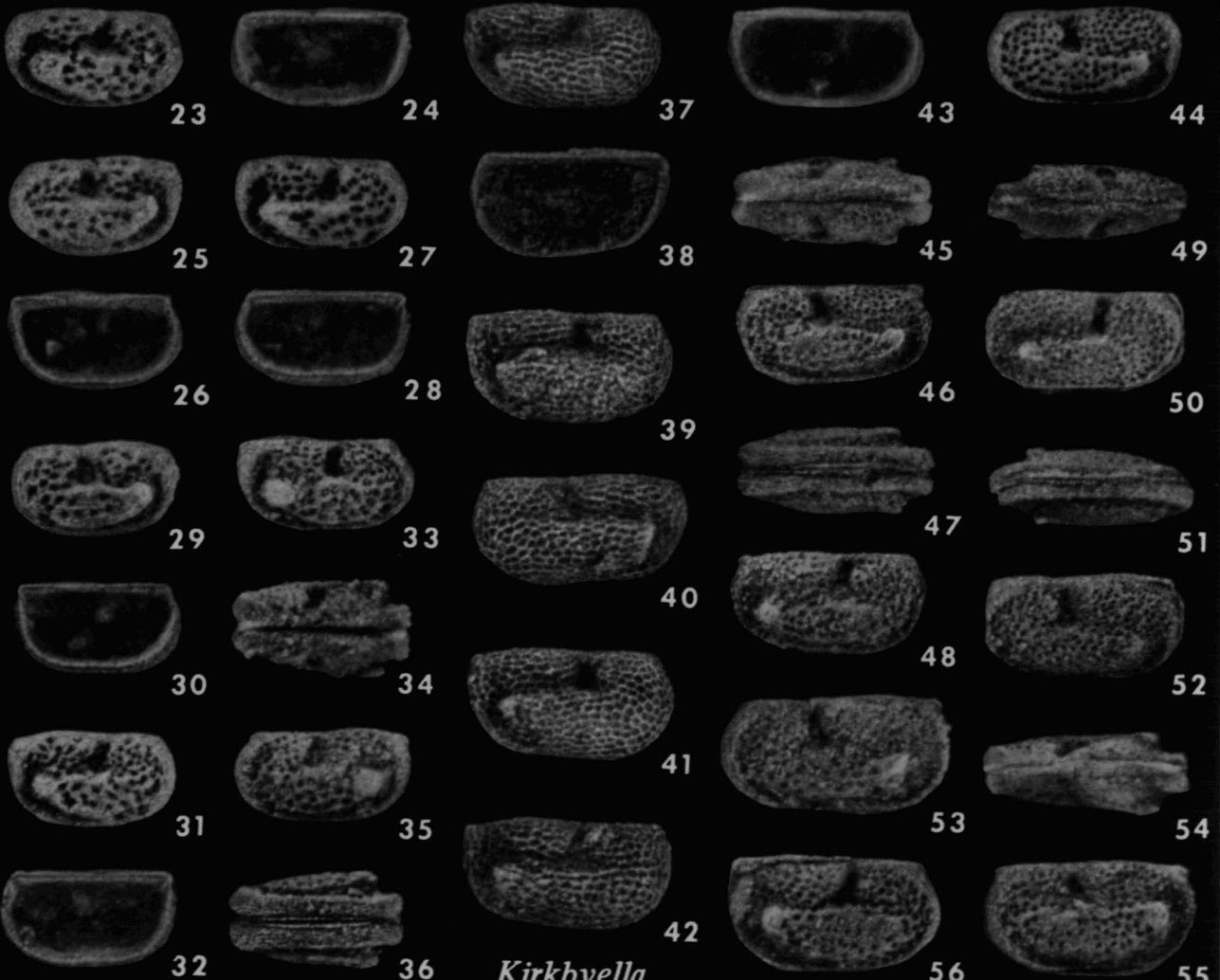
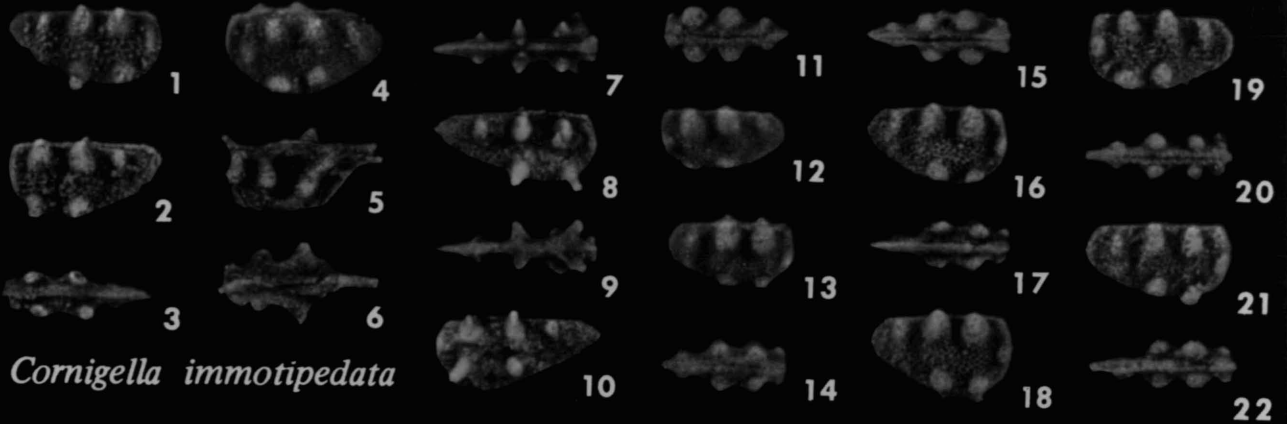

Kirkbyella (Kirkbyella) bellipuncta

Kirkbyella (Berdanella) stewartae

Kirkbyella (Berdanella) unicornis

PLATE 40

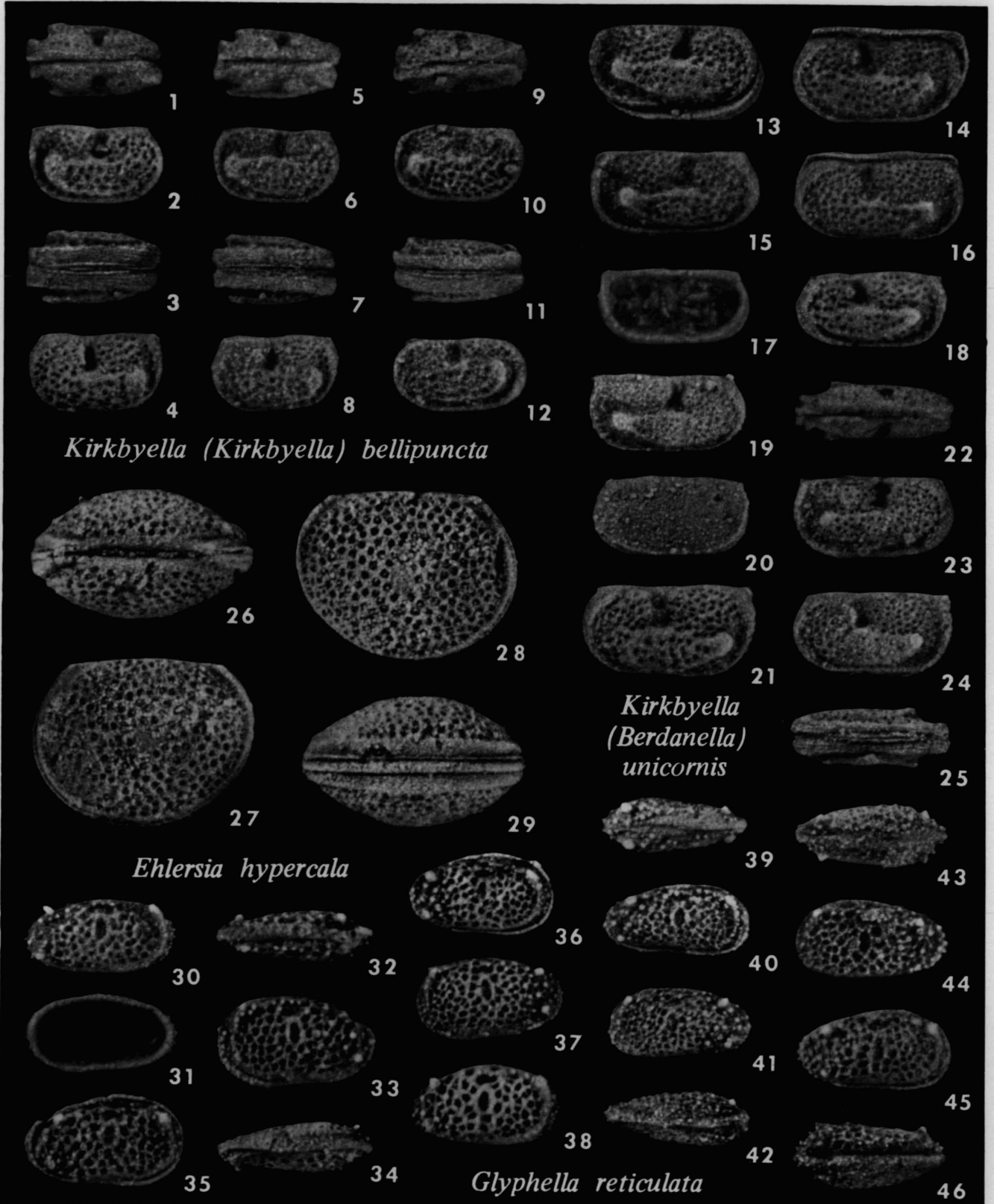

Kirkbyella (Kirkbyella) bellipuncta

Kirkbyella (Berdanella) unicornis

Ehlersia hypercala

Glyphella reticulata

EXPLANATION OF PLATE 40

All figures x 40

- 1-12 -- *Kirkbyella (Kirkbyella) bellipuncta*. Loc. MM-7. 1-4, UMMP 59156, dorsal, right, ventral, and left views of carapace with typical posterior cardinal angle. 5-8, UMMP 59155, dorsal, right, ventral, and left views of carapace. 9-12, UMMP 59157, dorsal, right, ventral, and left views of carapace with exceptionally rounded posterior corner.
- 13-25 -- *Kirkbyella (Berdanella) unicornis*. 13, 14, UMMP 59170, Loc. N-9, right and left views of carapace with valves askew. 15, 16, UMMP 59169, Loc. N-9, right and left views of carapace with valves offset. 17, 18, UMMP 59167, Loc. MM-Chon, interior and lateral views of left valve. 19, 20, UMMP 59164, Loc. MM-Chon, right and left views of one of the most bizarre carapaces we have ever seen; the left valve has all of the characteristic lobation and ornamentation completely effaced; this mysterious deformity may have been acquired early in ontogeny. 21, UMMP 59515, Loc. MM-12, lateral view of left valve. 22-25, UMMP 59166, Loc. MM-Chon, dorsal, right, left, and ventral views of carapace.
- 26-29 -- *Ehlersia hypercala*. Loc. MM-Chon. UMMP 58958, dorsal, right, left, and ventral views of well-preserved carapace.
- 30-46 -- *Glyphella reticulata*. Loc. WP-Trop. 30, 31, UMMP 59410, lateral and interior views of right valve. 32-35, UMMP 59058, dorsal, left, ventral, and right views of carapace; note left/right overlap. 36, 37, UMMP 59411, right and left views of carapace. 38, UMMP 59423, lateral view of right valve. 39-42, UMMP 59478, dorsal, right, left, and ventral views of carapace. 43-46, UMMP 59035, dorsal, left, right, and ventral views of carapace.

EXPLANATION OF PLATE 41

All figures x 40

- 1-6 -- *Ulrichia spinifera*. 1, 2, UMMP 59349, Loc. MM-Chon, lateral and interior views of excellent right valve. 3, 4, UMMP 59351, Loc. MM-Chon, lateral and interior views of left valve. 5, 6, UMMP 59350, Loc. N-11, lateral and interior views of left valve. Note the prominent marginal spines and the acuminate L3.
- 7-20 -- *Ulrichia fastidiosa*. Loc. MM-Chon. 7, 8, UMMP 59378, dorsal and left views of deformed carapace. 9-12, UMMP 59376, dorsal, right, ventral, and left views of carapace. 13-16, UMMP 59377, dorsal, right, ventral, and left views of carapace. 17-20, UMMP 59381, dorsal, right, left, and ventral views of diagonally compressed carapace. Note presence of marginal spines in this species.
- 21-27 -- *Ulrichia conradi*. 21, 22, UMMP 59389, Loc. MM-Chon, interior and lateral views of left valve. 23, UMMP 59354, lateral view of right valve. 24-27, UMMP 59390 and 59391, Loc. N-12, lateral and interior views of two left valves. Note inclined ovate L2, rounded L3, absence of marginal spines, and dorsally protuberant posterior end of velar ridge.
- 28-34 -- *Arcyzona homalosagenota*. Loc. MM-Chon. 28-31, UMMP 59524, dorsal, right, ventral, and left views of adult carapace. 32-34, UMMP 59525, right, left, and ventral views of carapace of ultimate immature instar.
- 35-42 -- *Glyphella reticulata*. Loc. WP-Trop. 35-38, UMMP 59056, right, ventral, dorsal, and left views of well-preserved carapace, showing L/R overlap. 39-42, UMMP 59479 and 59034, lateral and interior views of two right valves.

PLATE 41

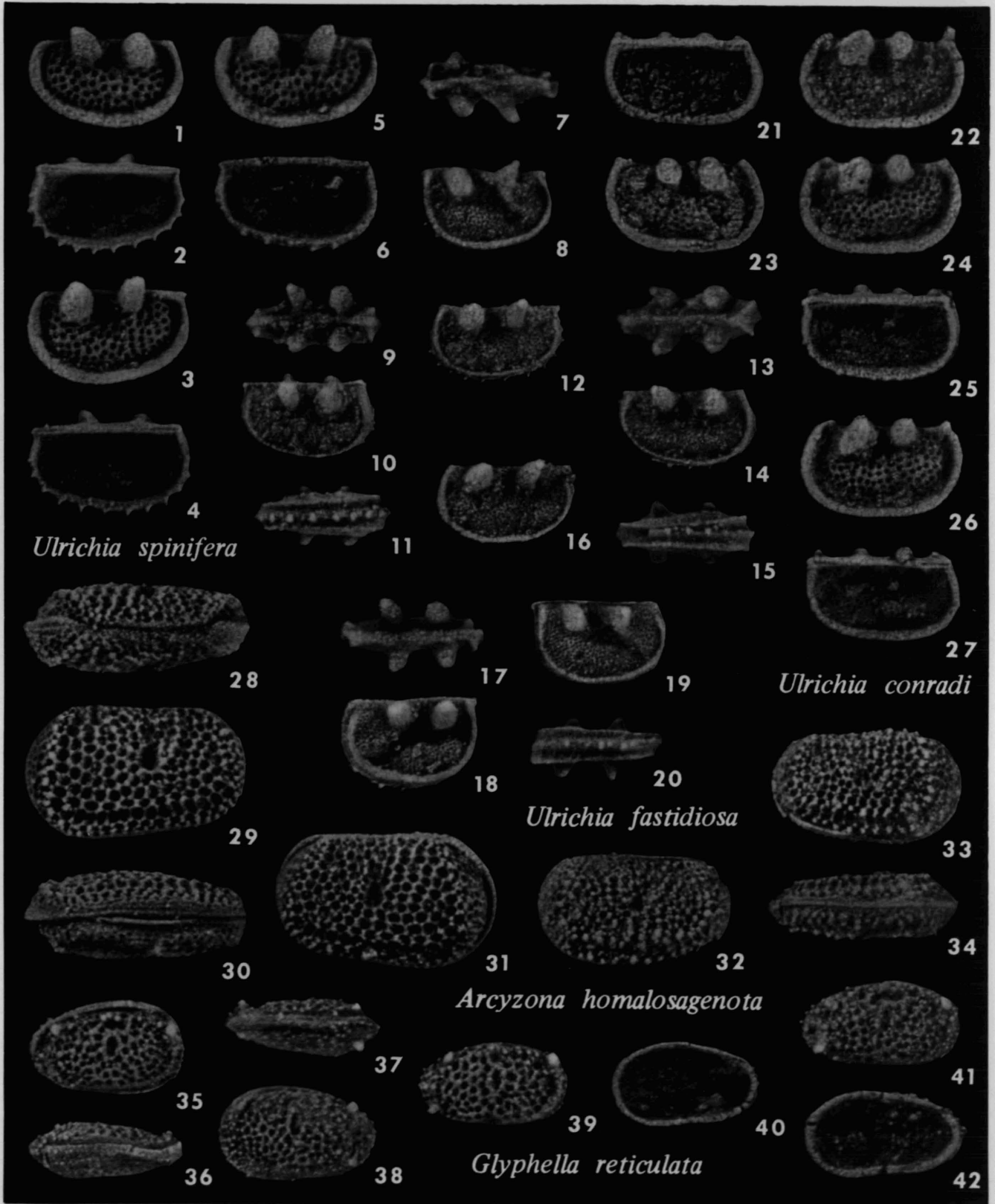
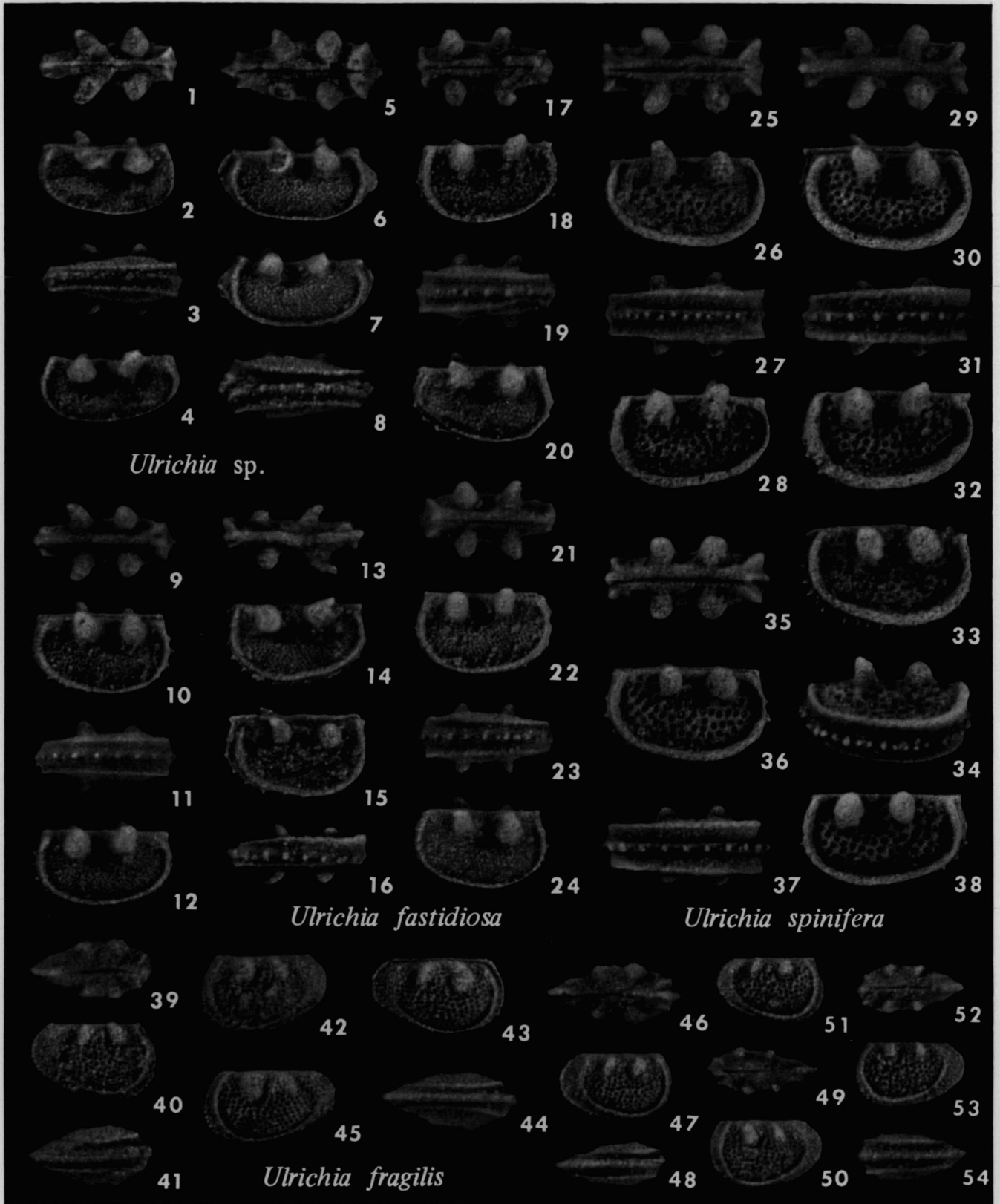

PLATE 42



EXPLANATION OF PLATE 42

All figures x 40

- 1-8 -- *Ulrichia* sp. Loc. MM-Chon. 1-4, UMMP 59681, dorsal, right, ventral, and left views of carapace; except for height (which may have been shortened by dorsoventral compression), this specimen resembles *Ulrichia fastidiosa*. 5-8, UMMP 59682, dorsal, right, left, and ventral views of carapace; this unusual shape, with protruding ends, may be the result of severe dorsoventral compression which buckled the valves strongly outward in the middle; otherwise, it resembles *Ulrichia fastidiosa*.
- 9-24 -- *Ulrichia fastidiosa*. Loc. MM-Chon. 9-12, UMMP 59393, dorsal, right, ventral, and left views of carapace showing little distortion. 13-16, UMMP 59380, dorsal, left, right, and ventral views of laterally compressed carapace. 17-20, UMMP 59375, dorsal, left, ventral, and right views of carapace. 21-24, UMMP 59392, dorsal, left, ventral, and right views of good carapace.
- 25-38 -- *Ulrichia spinifera*. Loc. MM-Chon. 25-28, UMMP 59352, dorsal, right, ventral, and left views of carapace; ventral view shows alternate disposition of marginal spines to interlock. 29-32, UMMP 59348, dorsal, right, ventral, and left views of carapace with valves slightly offset. 33, 34, UMMP 59368, right and inclined (right-ventral) views of carapace, showing marginal spines. 35-38, UMMP 59369, dorsal, right, ventral, and left views of carapace.
- 39-54 -- *Ulrichia fragilis*. Loc. MM-Chon. 39-42, UMMP 59358, dorsal, right, ventral, and left views of adult carapace. 43-46, UMMP 59356, right, ventral, left, and dorsal views of adult carapace. 47-50, UMMP 59360, right, ventral, dorsal, and left views of immature carapace. 51-54, UMMP 59357, right, dorsal, left, and ventral views of immature carapace. Note separation of posterior border and posterior part of the velar ridge. Position of greatest width lies in anterior half of carapace in this species.

EXPLANATION OF PLATE 43

All figures x 40

- 1-22 -- *Ulrichia spinifera*. Loc. MM-Chon. 1-4, UMMP 59372, dorsal, right, ventral, and left views of well-preserved carapace. 5, 6, UMMP 59368, right and inclined views of carapace. 7, 8, UMMP 59370, lateral and interior views of left valve. 9, 10, UMMP 59371, lateral and interior views of right valve. 11-14, UMMP 59373, left, dorsal, right, and ventral views of carapace. 15-18, UMMP 59694, right, dorsal, left, and ventral views of carapace. 19-22, UMMP 59374, dorsal, right, left, and ventral views of carapace. Note the alternate ("zipper-like") disposition of marginal spines on closed valves.
- 23-30 -- *Ulrichia fragilis*. Loc. MM-Chon. 23-26, UMMP 59359, dorsal, right, ventral, and left views of adult carapace. 27-30, UMMP 59361, dorsal, left, ventral, and right views of immature carapace.
- 31-36 -- *Ulrichia illinearis*. 31-34, UMMP 59365, Loc. MM-Chon, dorsal, right, left, and ventral views of carapace. 35, 36, UMMP 59363, Loc. MM-Trop, right and left views of carapace.
- 37-51 -- *Xystinotus wrightorum*. Loc. MM-Chon. 37-40, UMMP 59366, dorsal, left, right, and ventral views of carapace. 43-45, UMMP 59401, dorsal, right, and left views of carapace. 41, 42, 46, 47, UMMP 59400, right, ventral, dorsal, and left views of immature carapace. 48-51, UMMP 59399, dorsal, right, ventral, and left views of adult carapace. This "species" has a consistently higher H/L ratio than X. subnodatus and its dorsum has more effacement of reticulation than Ulrichia illinearis; perhaps, both species of Xystinotus are dimorphic ecological variants of Ulrichia illinearis.
- 52-64 -- *Xystinotus subnodatus*. Loc. MM-Chon. 52, 53, UMMP 59364, left and right views of carapace. 54-56, UMMP 59396, dorsal, right, and left views of carapace. 57-60, UMMP 59688, dorsal, right, ventral, and left views of well-preserved carapace. 61-64, UMMP 59394, dorsal, left, ventral, and right views of carapace. See comments on X. wrightorum above.

PLATE 43

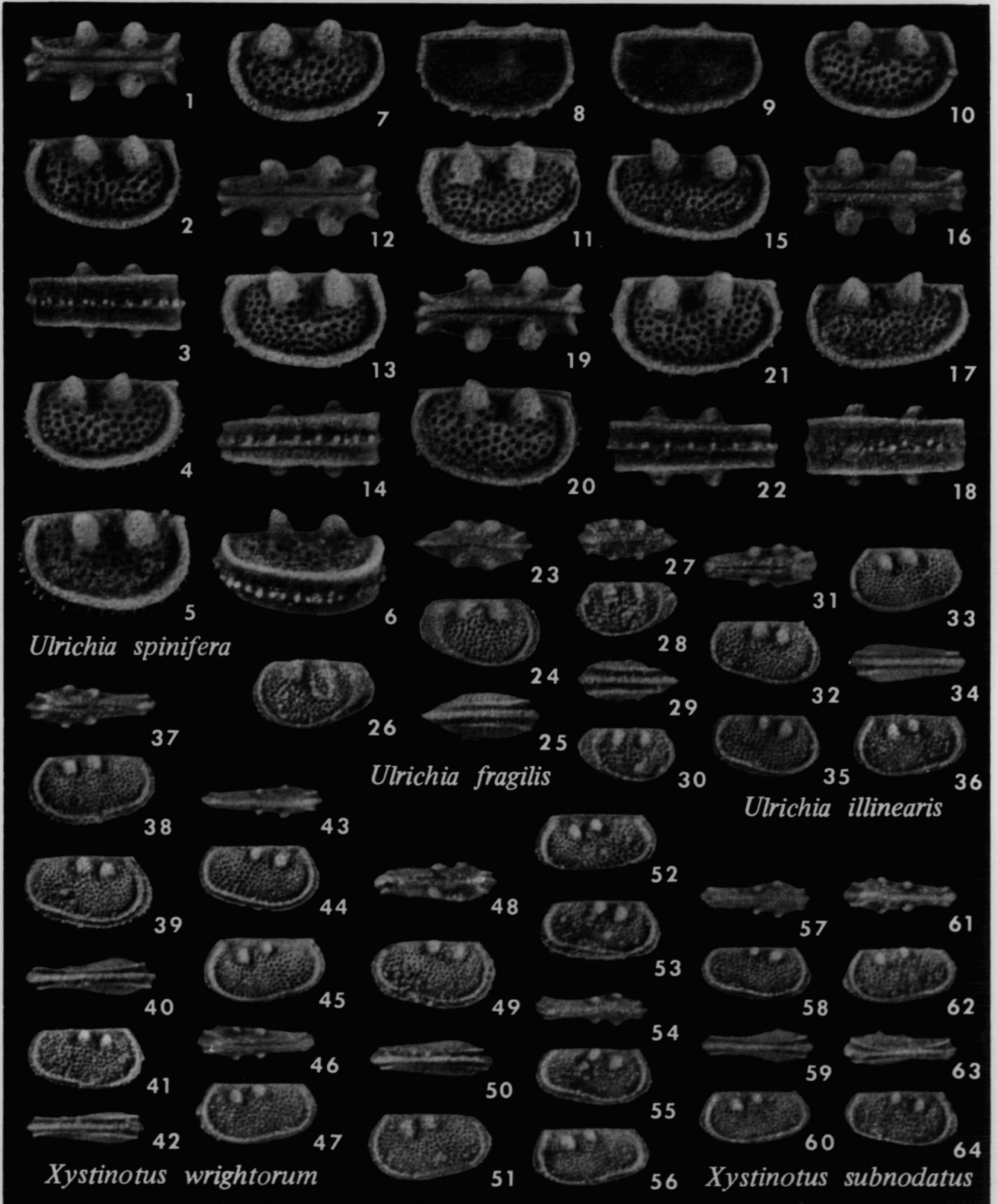
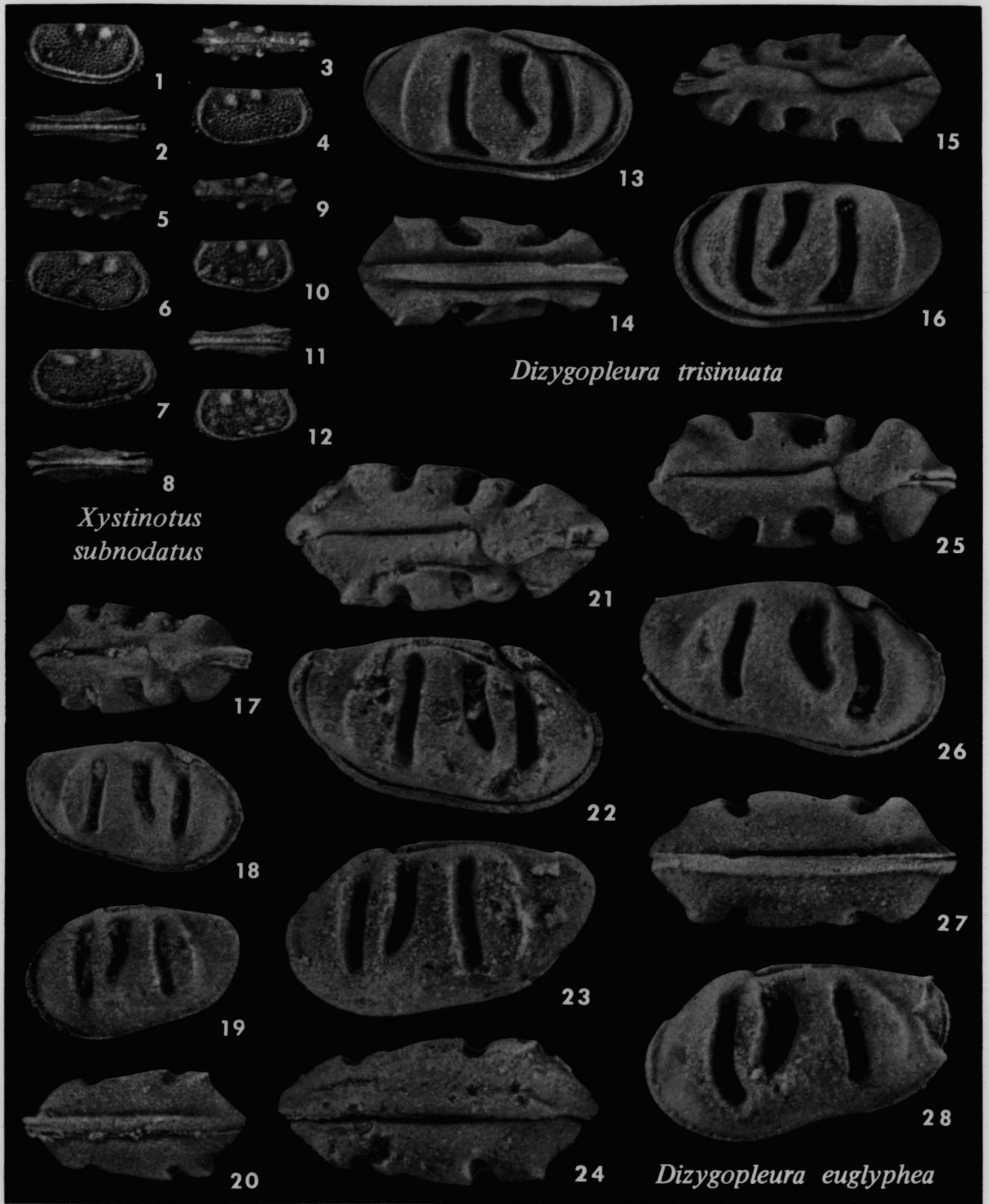

PLATE 44



EXPLANATION OF PLATE 44

All figures x 40

- 1-12 -- *Xystinotus subnodatus*. 1-4, UMMP 59362, Loc. MM-Chon, right, ventral, dorsal, and left views of carapace. 5-8, UMMP 59695, Loc. MM-Chon, dorsal, right, left, and ventral views of carapace. 9-12, UMMP 59395, Loc. WP-Chon, dorsal, right, ventral, and left views of carapace.
- 13-16 -- *Dizygopleura trisinuata*. Loc. MM-Chon. UMMP 58947, right, ventral, dorsal, and left views of female carapace; compared with *Dizygopleura euglyphea* (see below), this species has a longer, narrower, less acuminate stragulum in the left valve, and S1 and S3 curve strongly toward each other below S2.
- 17-28 -- *Dizygopleura euglyphea*. 17-20, UMMP 58933, Loc. MM-Chon, dorsal, right, left, and ventral views of immature carapace. 21-24, UMMP 58934, Loc. N-14, dorsal, right, left, and ventral views of adult carapace. 25-28, UMMP 59465, Loc. S-12, dorsal, right, ventral, and left views of adult carapace.

EXPLANATION OF PLATE 45

All figures x 40

- 1-4 -- *Dizygopleura euglyphea*. Loc. S-12. UMMP 59466, dorsal, left, ventral, and right views of adult carapace.
- 5-24 -- *Dizygopleura trisinuata*. Loc. MM-Chon. 5-8, UMMP 58951, dorsal, left, ventral, and right views of immature carapace. 9-11, UMMP 58944, lateral and two interior views of immature left valve; one interior view printed with normal contrast to show the hinge and the other printed light to show the inner ribs marking positions of the sulci. 12-16, UMMP 58949, right, inclined (right-ventral), dorsal, left, and ventral views of male carapace. 17-20, UMMP 58948, dorsal, right, ventral, and left views of female carapace. 21-24, UMMP 58943, dorsal, right, ventral, and left views of female carapace. The two species illustrated in this plate differ in adult size, extent and shape of S1 and S3, and development of the stragulum.

PLATE 45

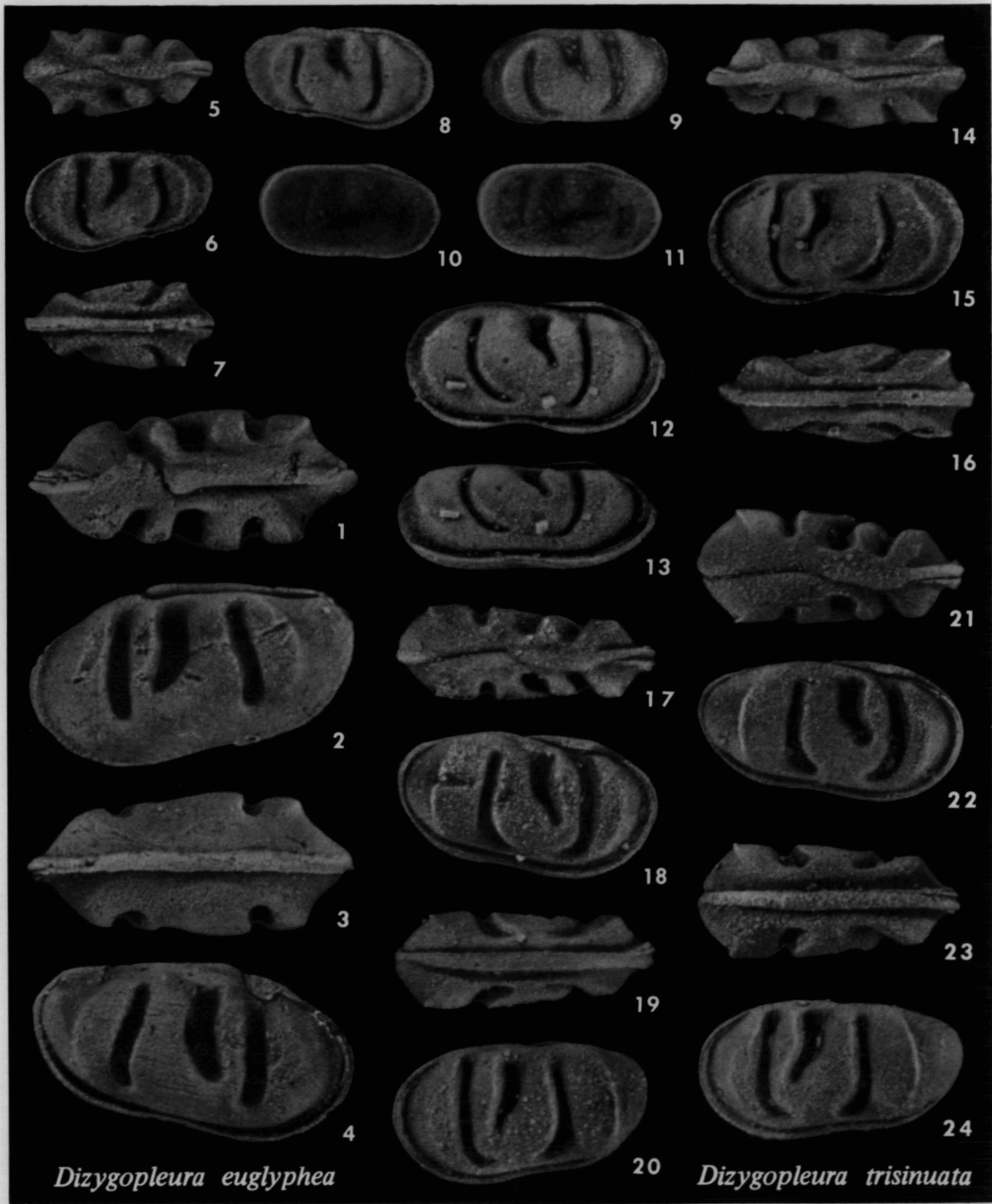

Dizygopleura euglyphea

Dizygopleura trisinuata

PLATE 46

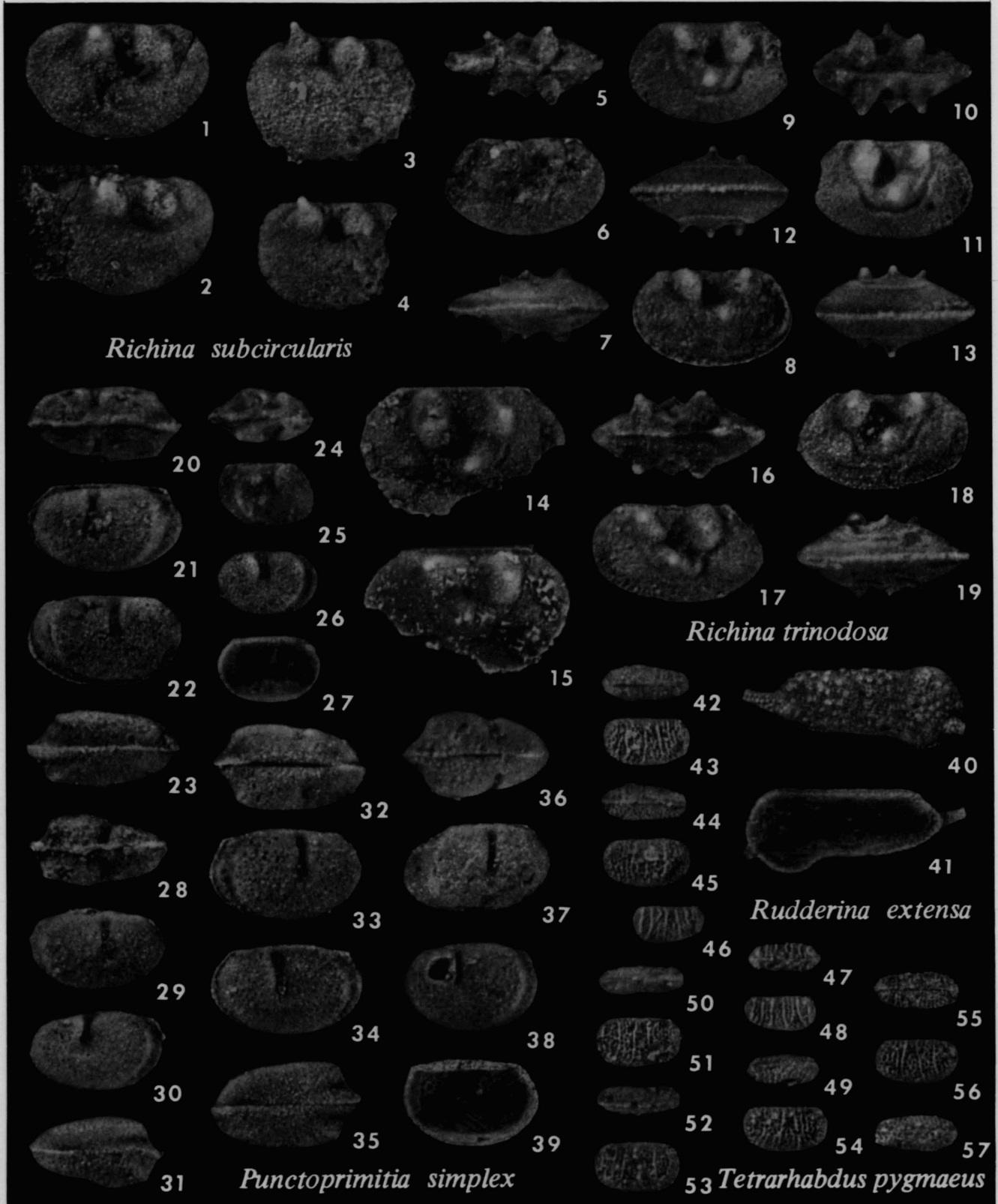

EXPLANATION OF PLATE 46

All figures x 40

- 1-4 -- *Richina subcircularis*. 1, UMMP 59336, Loc. MM-Chon, lateral view of right valve. 2, UMMP 59589, Loc. N-9, lateral view of right valve partly embedded in matrix. 3, UMMP 59588, Loc. MM-Chon, slightly inclined lateral view of right valve. 4, UMMP 59587, Loc. MM-Chon, lateral view of broken right valve.
- 5-19 -- *Richina trinodosa*. Loc. MM-Chon. 5-8, UMMP 59337, dorsal, right, ventral, and left views of carapace. 9-13, UMMP 59656, right, dorsal, left, and two ventral views of carapace; from the Widder Formation at Jim Bell's Quarry, Ontario. 14, 15, UMMP 59591, left and right views of incomplete and compressed carapace; note pyrite crystals on right valve. 16-19, UMMP 59590, dorsal, right, left, and ventral views of carapace; note the shallow but distinct groove around the lobate area.
- 20-39 -- *Punctoprimitia simplex*. 20-23, UMMP 59290, Loc. MM-15, dorsal, left, right, and ventral views of adult carapace. 24, 25, UMMP 59554, Loc. MM-Chon, dorsal and right views of immature carapace. 26, 27, UMMP 59291, lateral and interior views of immature left valve. 28-31, UMMP 59429, Loc. MM-Chon, dorsal, right, left, and ventral views of carapace. 32-35, UMMP 59430, Loc. MM-Chon, dorsal, right, left, and ventral views of adult carapace. 36, 37, UMMP 59289, Loc. MM-15, dorsal and right views of carapace. 38, 39, UMMP 59286, Loc. MM-7, lateral and interior views of left valve.
- 40, 41 -- *Rudderina extensa*. UMMP 59347, Loc. N-12, lateral and interior views of right valve preserving fine details of ornamentation. Only specimen found.
- 42-57 -- *Tetrarhabdus pygmaeus*. Loc. WP-Trop. 42-45, UMMP 59232, dorsal, right, ventral, and left views of good adult carapace. 46-49, UMMP 61812, right, dorsal, left, and ventral views of immature carapace. 50-53, UMMP 61816, dorsal, right, ventral, and left views of compressed carapace. 54-57, UMMP 61813, right, dorsal, left, and ventral views of carapace.

EXPLANATION OF PLATE 47

All figures x 40

- 1-22 -- *Ropolonellus papillatus*. 1-4, UMMP 59339, Loc. N-12, dorsal, right, ventral, and left views of carapace. 5, 6, UMMP 59343, Loc. MM-Chon, lateral and interior views of right valve. 7-10, UMMP 59341, Loc. N-12, dorsal, right, ventral, and left views of carapace. 11-15, UMMP 59345, Loc. MM-Chon, dorsal, right, ventral, right, and left views of carapace; one ventral view printed dark to emphasize the end tubercles. 16-19, UMMP 59344, Loc. MM-Chon, dorsal, right, left, and ventral views of carapace. 20, UMMP 59342, Loc. N-12, lateral view of right valve. 21, 22, UMMP 59340, Loc. MM-Chon, interior and lateral views of left valve.
- 23-39 -- *Tetrarhabdus pygmaeus*. Loc. WP-Trop. 23, UMMP 61815, right view of immature carapace. 24-27, UMMP 61817, right, ventral, dorsal, and left views of carapace. 28-31, UMMP 59231, dorsal, right, ventral, and left views of carapace with subdued vertical ridges. 32-35, UMMP 61814, left, dorsal, right, and ventral views of carapace with typical vertical ridges. 36-39, UMMP 59233, dorsal, right, left, and ventral views of carapace.
- 40-42 -- *Dizygopleura euglyphea*. Loc. MM-Chon. UMMP 59467, dorsal, right, and ventral views of poorly preserved specimen.
- 43-54 -- *Dizygopleura trisinuata*. Loc. MM-Chon. 43, 44, UMMP 58950, interior and lateral views of adult left valve. 45, 46, UMMP 58946, lateral and interior views of left valve of immature specimen. 47-50, UMMP 58945, dorsal, right, ventral, and left views of female carapace. 51-54, UMMP 58952, left, dorsal, right, and ventral views of immature carapace; note concavity behind L4 in each valve.

PLATE 47

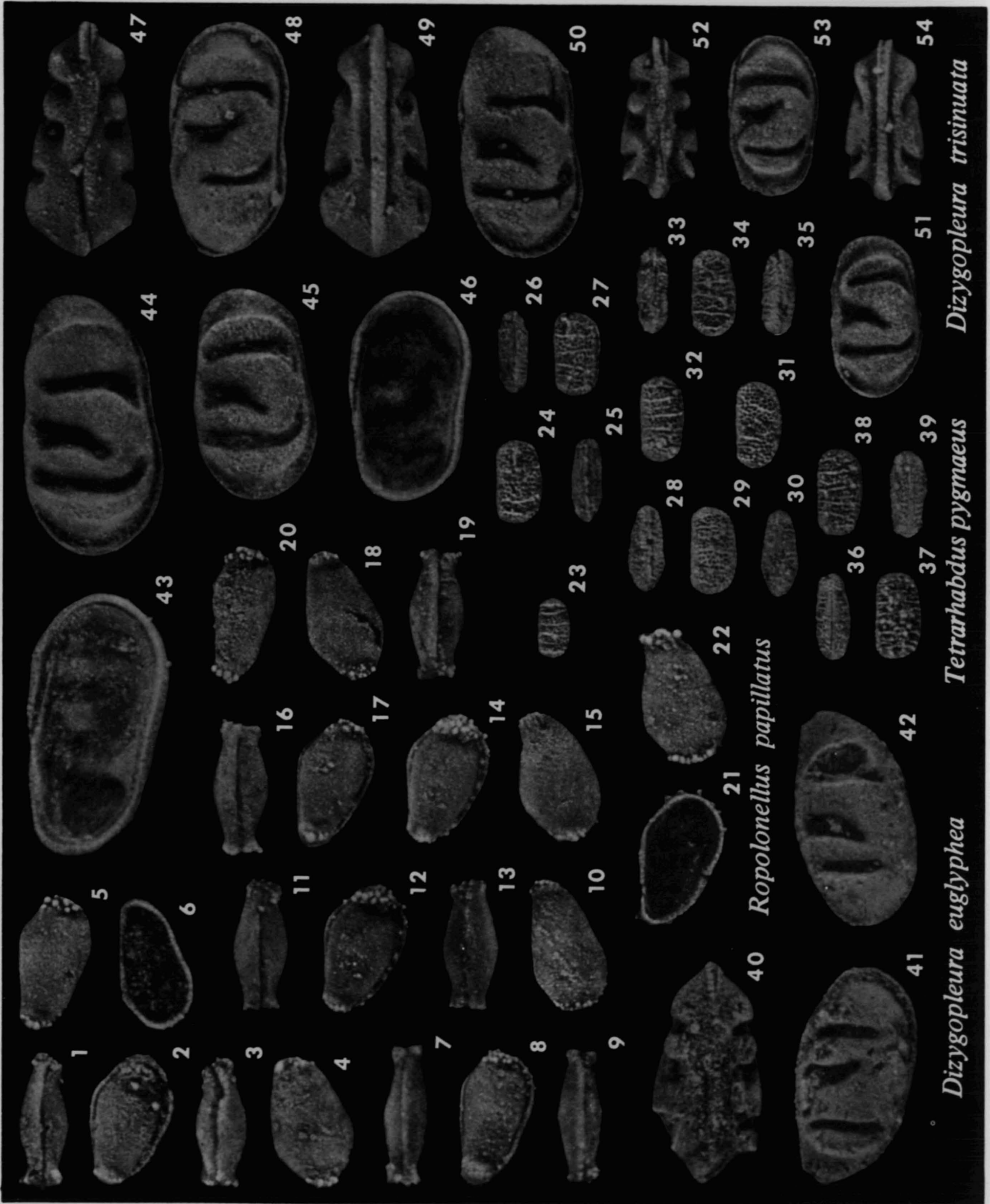

Dizygopleura trisinuata

Tetrarhabdus pygmaeus

Ropolonellus papillatus

Dizygopleura euglyphea

PLATE 48

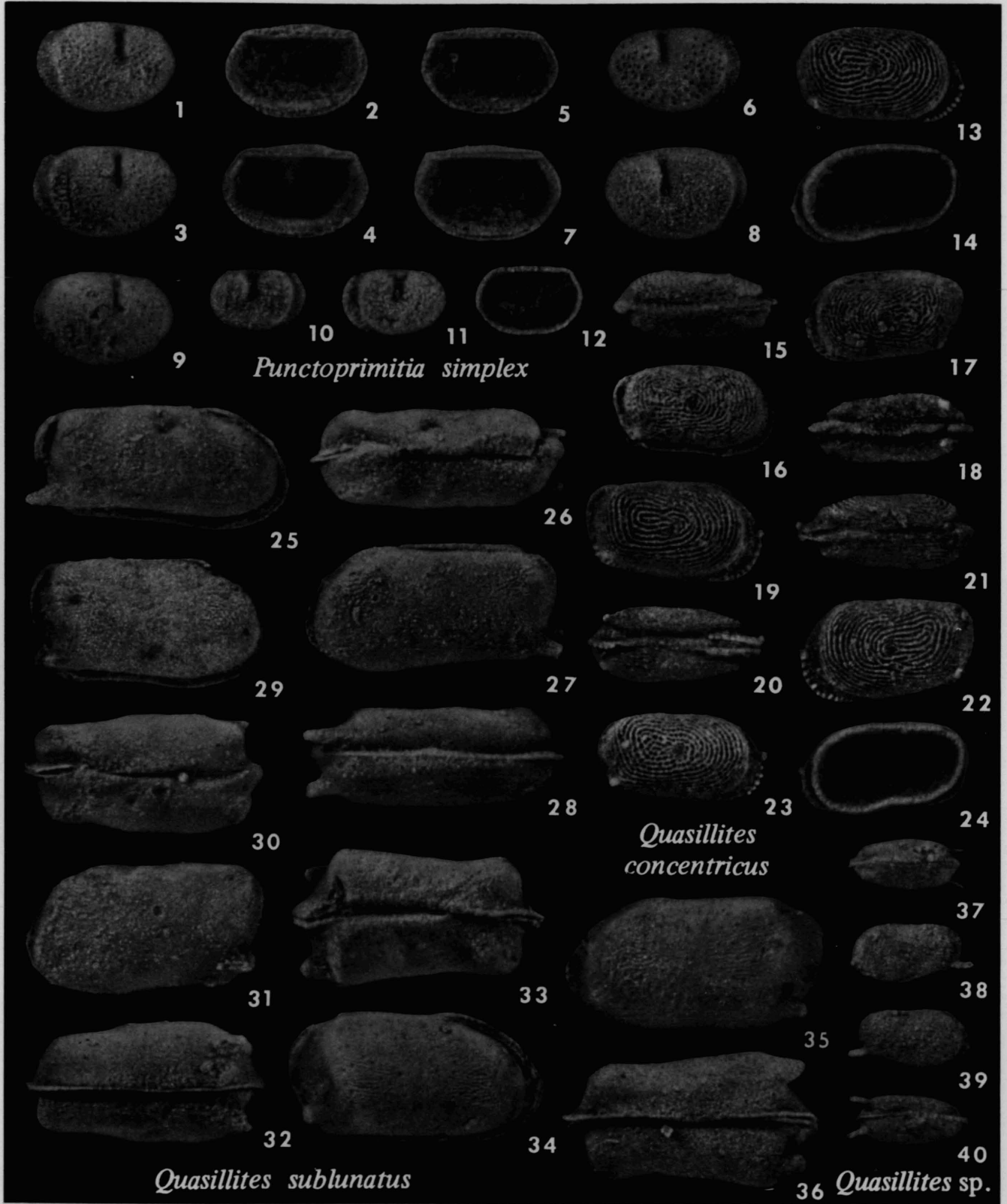

EXPLANATION OF PLATE 48

All figures x 40

- 1-12 -- *Punctoprimitia simplex*. 1, 2, UMMP 59287, Loc. MM-15, lateral and interior views of right valve. 3, 4, UMMP 59288, Loc. MM-15, lateral and interior views of right valve. 5, 6, UMMP 59284, Loc. MM-Chon, interior and lateral views of left valve. 7, 8, UMMP 59285, Loc. MM-15, interior and lateral views of left valve. 9, UMMP 59293, Loc. MM-7, lateral view of right valve. 10, UMMP 59292, Loc. MM-15, lateral view of immature left valve. 11, 12, UMMP 59553, Loc. MM-Chon, lateral and interior views of immature right valve. Most specimens of this species occur as isolated valves.
- 13-24 -- *Quasillites concentricus*. 13, 14, UMMP 59296, lateral and interior views of right valve. 15-18, UMMP 59294, dorsal, right, left, and ventral views of carapace. 19-22, UMMP 59297, right, ventral, dorsal, and ventral views of carapace. 23, 24, UMMP 59295, lateral and interior views of right valve. All specimens from Loc. MM-Chon, showing some of the minor variations in surface ornamentation within the same unit.
- 25-36 -- *Quasillites sublunatus*. Loc. MM-Chon. 25-28, UMMP 59331, right, dorsal, left, and ventral views of carapace. 29-32, UMMP 59315, right, dorsal, left, and ventral views of carapace. 33-36, UMMP 59320, dorsal, right, left, and ventral views of carapace. Variations in length and width may be related to sexual dimorphism.
- 37-40 -- *Quasillites* sp. Loc. MM-Chon. UMMP 59335, dorsal, left, right, and ventral views of carapace. This may be an immature specimen of one of the named species, or it may be an adult of a very small rare species.

EXPLANATION OF PLATE 49

All figures x 40

- 1-4 -- *Aechminaria hormathota*. Loc. N-12. UMMP 59338, right, ventral, dorsal, and left views of immature carapace. This specimen has a more pronounced swing and lacks the typical border of tubercles found in the adult.
- 5-8 -- *Quasillites concentricus*. Loc. MM-Chon. 5, 6, UMMP 59556, left and right views of carapace. 7, 8, UMMP 59555, lateral and interior views of left valve.
- 9, 10 -- *Quasillites* sp. Loc. MM-Chon. UMMP 59334, lateral and interior views of right valve. Specimen probably an immature individual of one of the named species.
- 11-32 -- *Quasillites sublunatus*. 11-14, UMMP 59325, Loc. MM-Chon, right, dorsal, left, and ventral views of immature carapace. 15-18, UMMP 59326, Loc. N-9, right, dorsal, left, and ventral views of immature carapace. 19-22, UMMP 59321, Loc. MM-Chon, dorsal, right, ventral, and left views of carapace. 23-26, UMMP 59319, Loc. N-11, dorsal, right, left, and ventral views of carapace. 27, 28, UMMP 59323, Loc. MM-Chon, lateral and interior views of left valve. 29-32, UMMP 59324, Loc. MM-Chon, left, dorsal, right, and ventral views of carapace. Note strong differences in elongation and width in adults.

PLATE 49

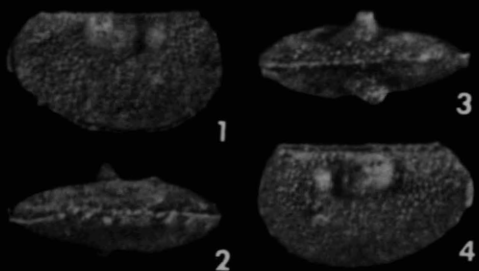

Aechminaria hormathota

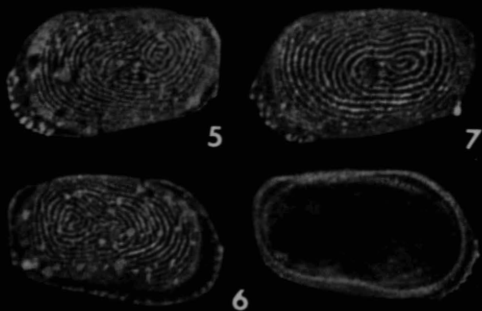

Quasillites concentricus

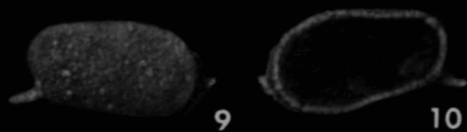

Quasillites sp.

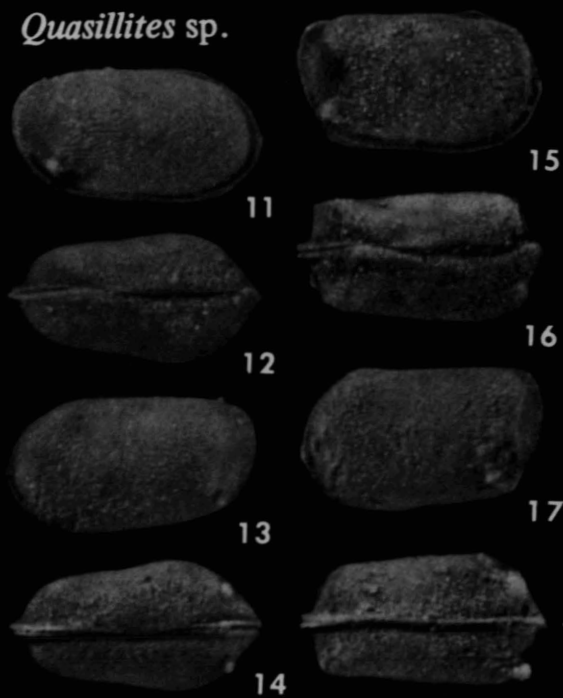

Quasillites sublnatus

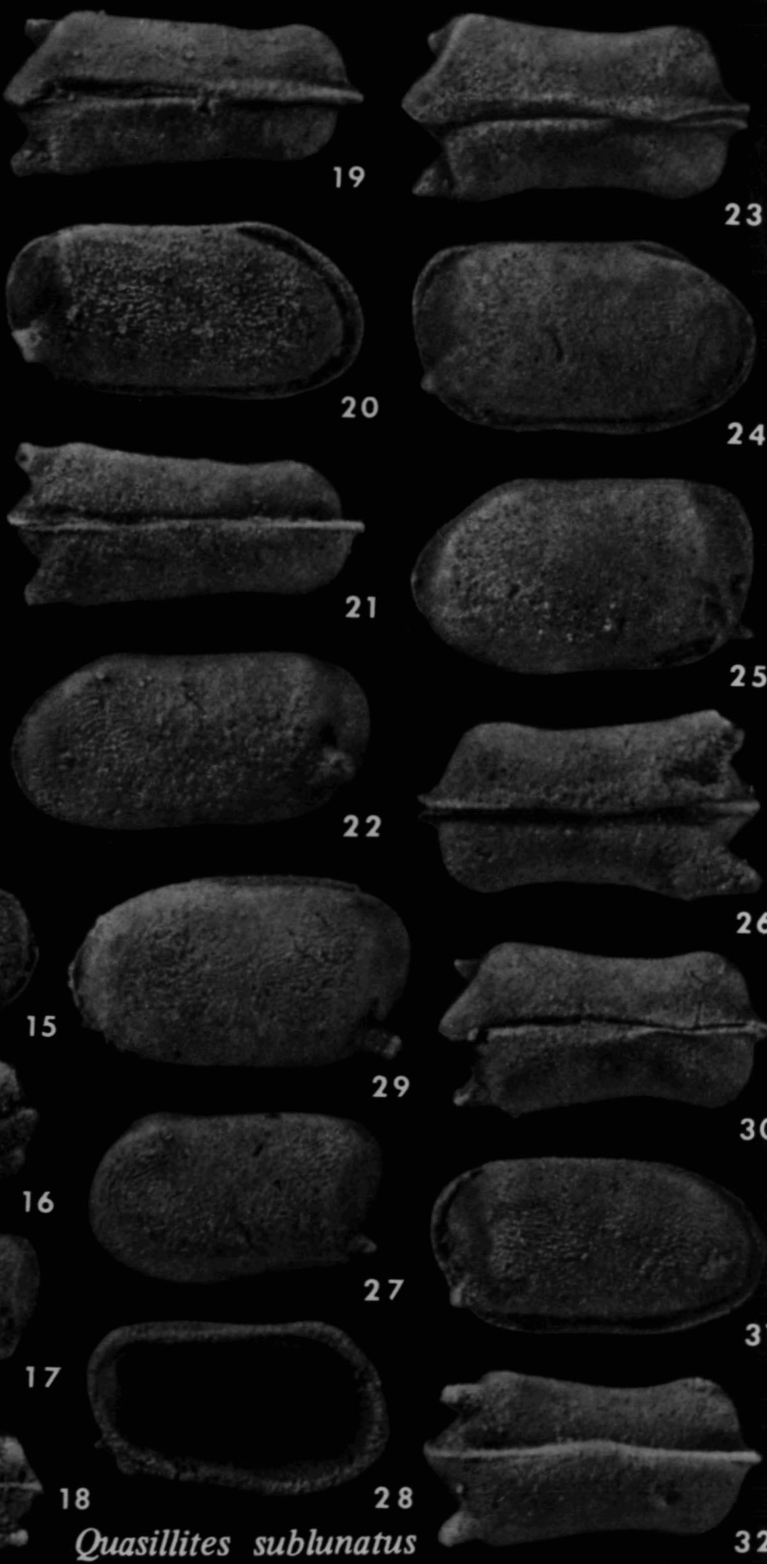

EXPLANATION OF PLATE 50

All figures x 40

- 1-22 -- *Quasillites sublunatus*. 1-4, UMMP 59330, Loc. N-9, dorsal, right, ventral, and left views of carapace. 5, 6, UMMP 59317, Loc. MM-Chon, dorsal and interior views of right valve, showing hingement. 7, 8, UMMP 59318, Loc. MM-Chon, lateral and interior views of right valve. 9, 10, UMMP 59322, Loc. N-11, interior and lateral views of left valve. 11-14, UMMP 59332, Loc. MM-Chon, dorsal, left, ventral, and right views of carapace. 15-18, UMMP 59314, Loc. MM-Chon, dorsal, left, ventral, and right views of carapace. 19, 20, UMMP 59313, Loc. MM-Chon, lateral and interior views of right valve. 21, 22, UMMP 59316, Loc. MM-Chon, lateral and interior views of right valve. Note the variations in elongation of carapaces and valves.
- 23-30 -- *Quasillites concentricus*. 23-26, UMMP 59299, Loc. MM-Chon, dorsal, right, ventral, and left views of carapace. 27-30, UMMP 59301, Loc. N-9, right, dorsal, left, and ventral views of carapace. Note the variations in the "thumbprint" pattern of ornamental ridgelets. The marginal ridges bear papillae in the anteroventral section in each valve.

EXPLANATION OF PLATE 51

All figures x 40

Specimens with pyrite crystals; Loc. MM-Chon

1-4 -- *Arcyzona* sp. UMMP 61834, left, dorsal, right, and ventral views.

5-8 -- *Ponderodictya rhodesi*. UMMP 61836, dorsal, right, ventral, and left views; note that
cobe of pyrite cuts off section of carapace without dislodging or moving it.

PLATE 51

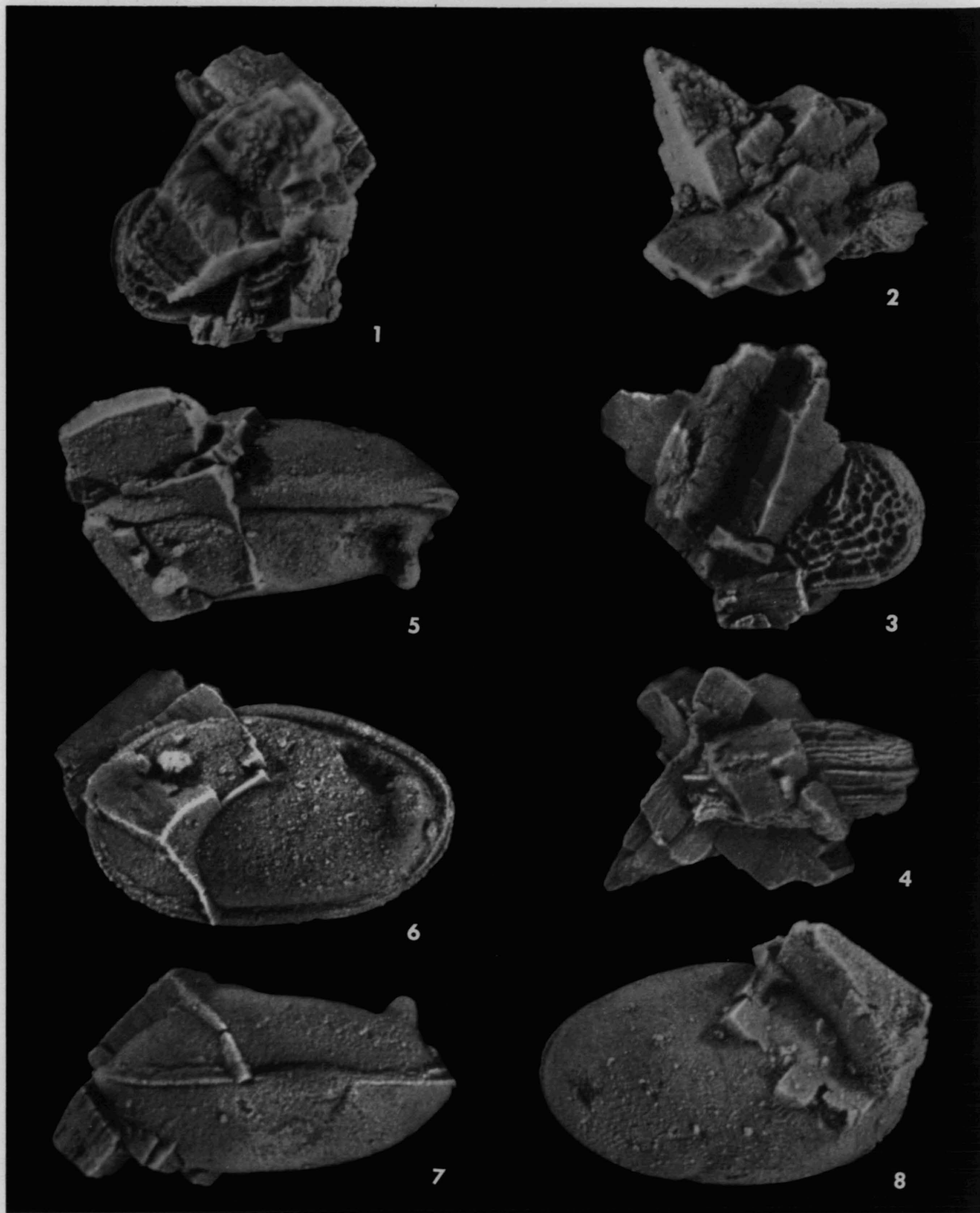
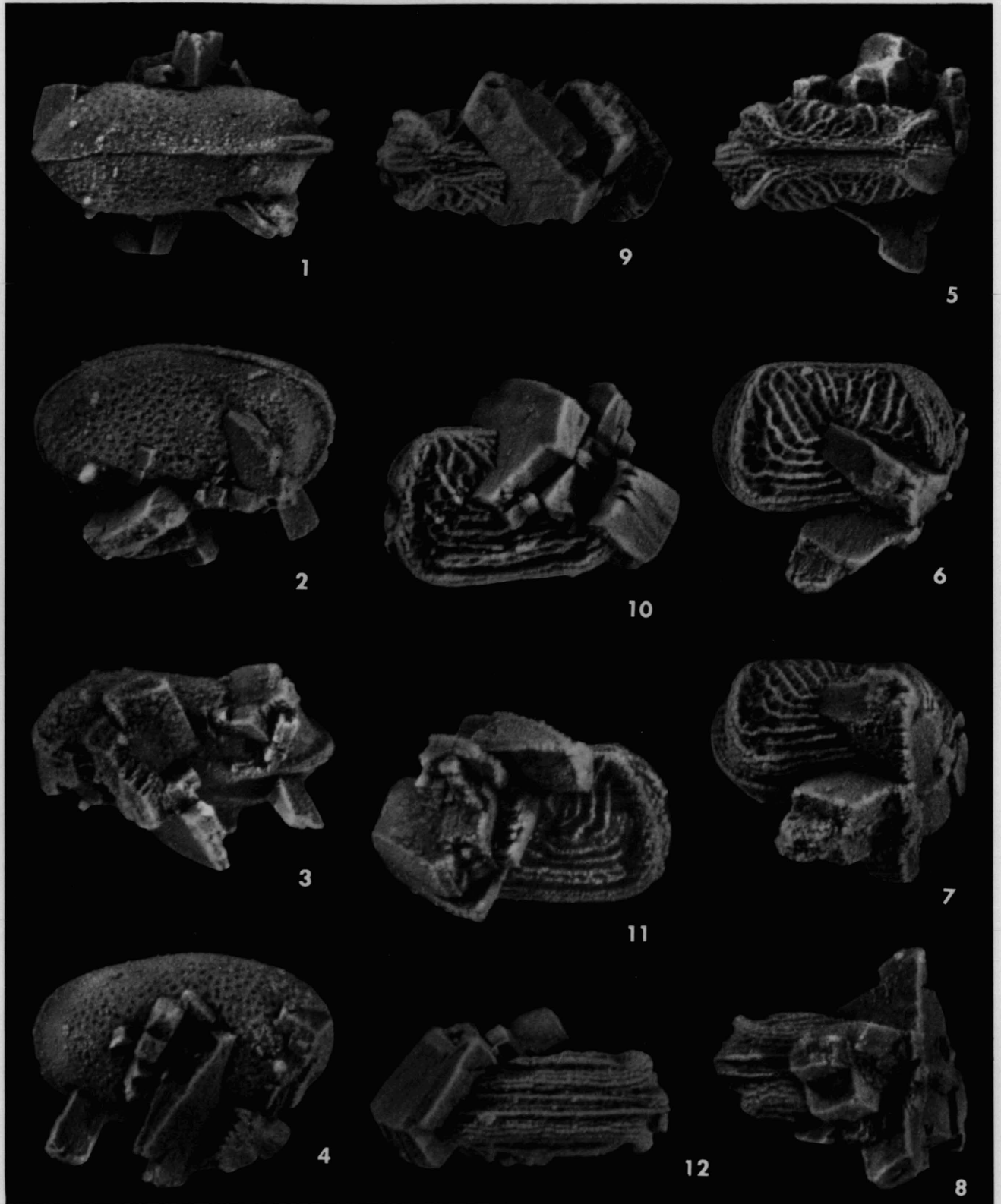

PLATE 52



EXPLANATION OF PLATE 52

All figures x 40

Specimens with pyrite crystals; Loc. MM-Chon

1-4 -- *Ponderodictya punctulifera*. UMMP 61828, dorsal, right, inclined ventral, and left views.

5-8 -- *Arcyzona* sp. UMMP 61827, dorsal, right, inclined ventral, and ventral views.

9-12 -- *Arcyzona* sp. UMMP 61825, dorsal, right, left, and ventral views.

EXPLANATION OF PLATE 53

All figures x 40

Specimens with pyrite crystals; Loc. MM-Chon

- 1-4 -- *Ponderodictya rhodesi*. UMMP 61824, dorsal, right, ventral, and left views.
- 5-8 -- *Ponderodictya punctulifera*. UMMP 61826, dorsal, right, ventral, and left views; several crystals radiate from antero-central region of carapace.

PLATE 53

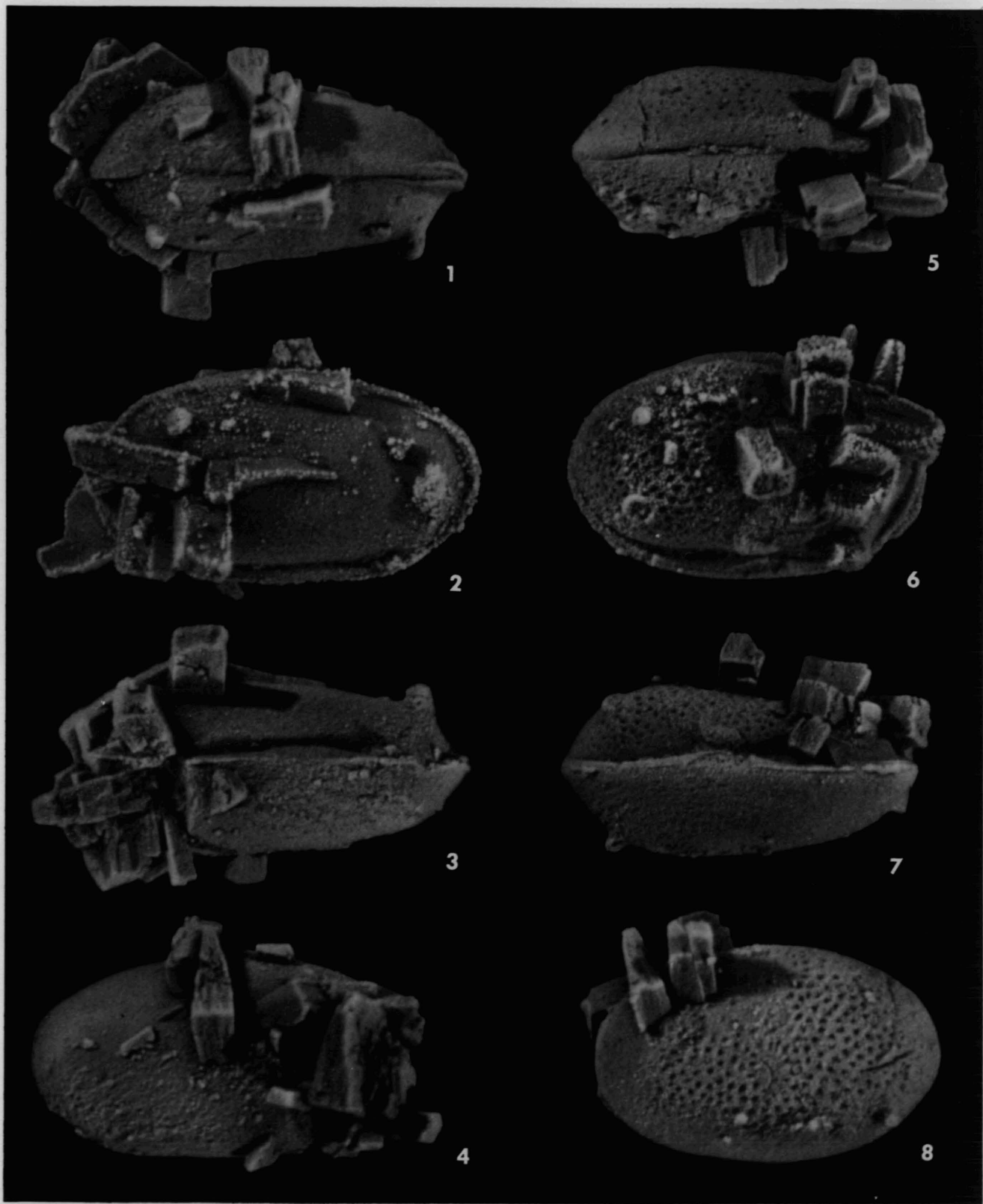
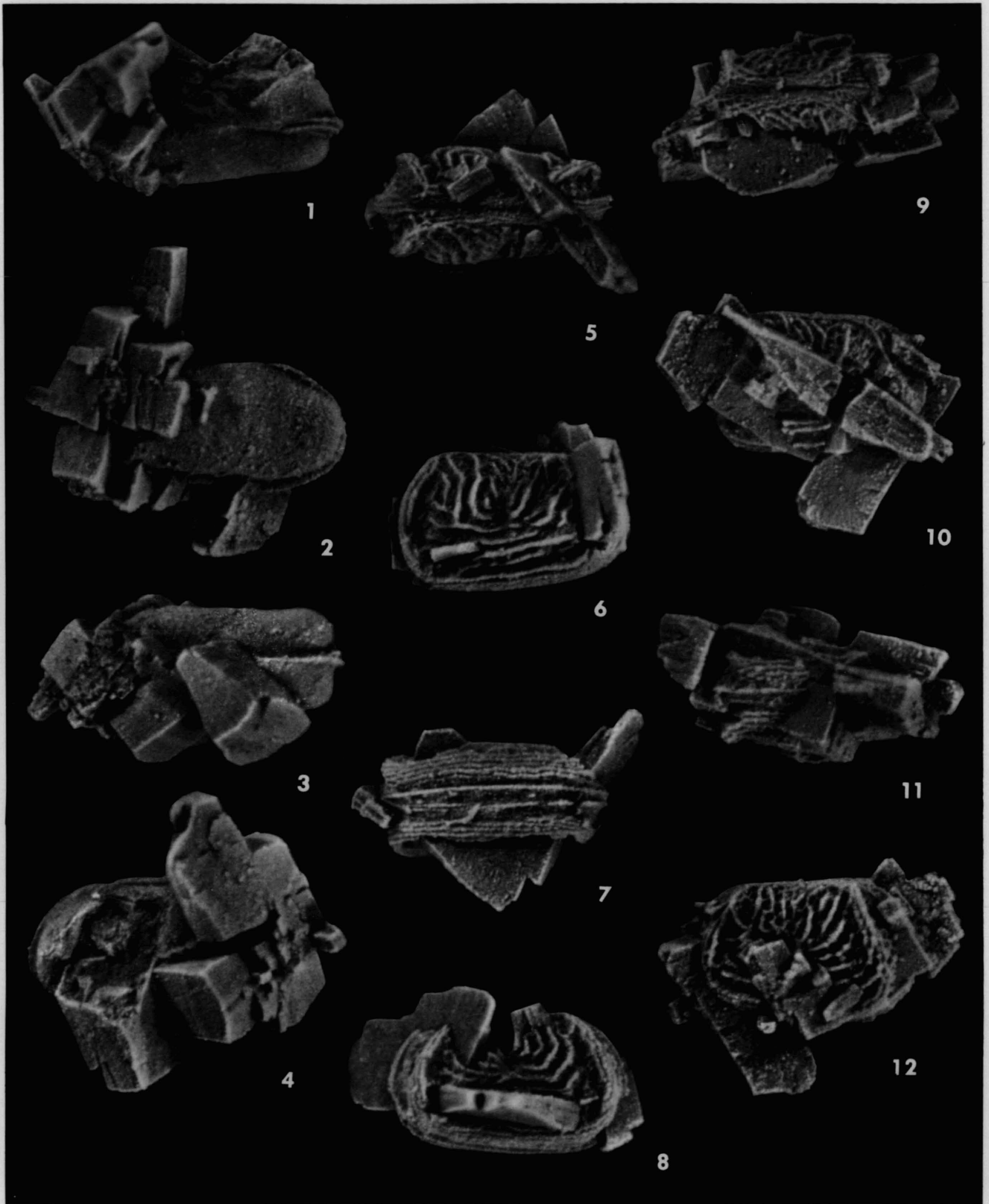

PLATE 54



EXPLANATION OF PLATE 54

All figures x 40

Specimens with pyrite crystals; Loc. MM-Chon

- 1-4 -- *Quasillites* sp. UMMP 61837, dorsal, right, ventral, and left views.
- 5-8 -- *Arcyzona campylactinota*. UMMP 61829, dorsal, right, ventral, and left views.
- 9-12 -- *Arcyzona* sp. UMMP 61831, dorsal, right, ventral, and left views; note that delicate ornamentation immediately adjacent to pyrite replacement is unaffected.

EXPLANATION OF PLATE 55

All figures x 40

Specimens with pyrite crystals; Loc. MM-Chon

- 1-4 -- *Quasillites* sp. UMMP 61832, dorsal, right, left, and ventral views; posteroventral spine on right valve is perfectly preserved (fig. 2) and that on the left valve is nearly concealed between pyrite crystals (fig. 4).
- 5-8 -- *Cytherellina* sp. UMMP 61833, dorsal, right, ventral, and left views; damage to dorsal overlap probably not related to pyritization.
- 9, 10 -- Two pyrite crystals (actually families of crystals), the first essentially a flat hexagonal slab and the second an aggregate of cubes and wedges.

PLATE 55

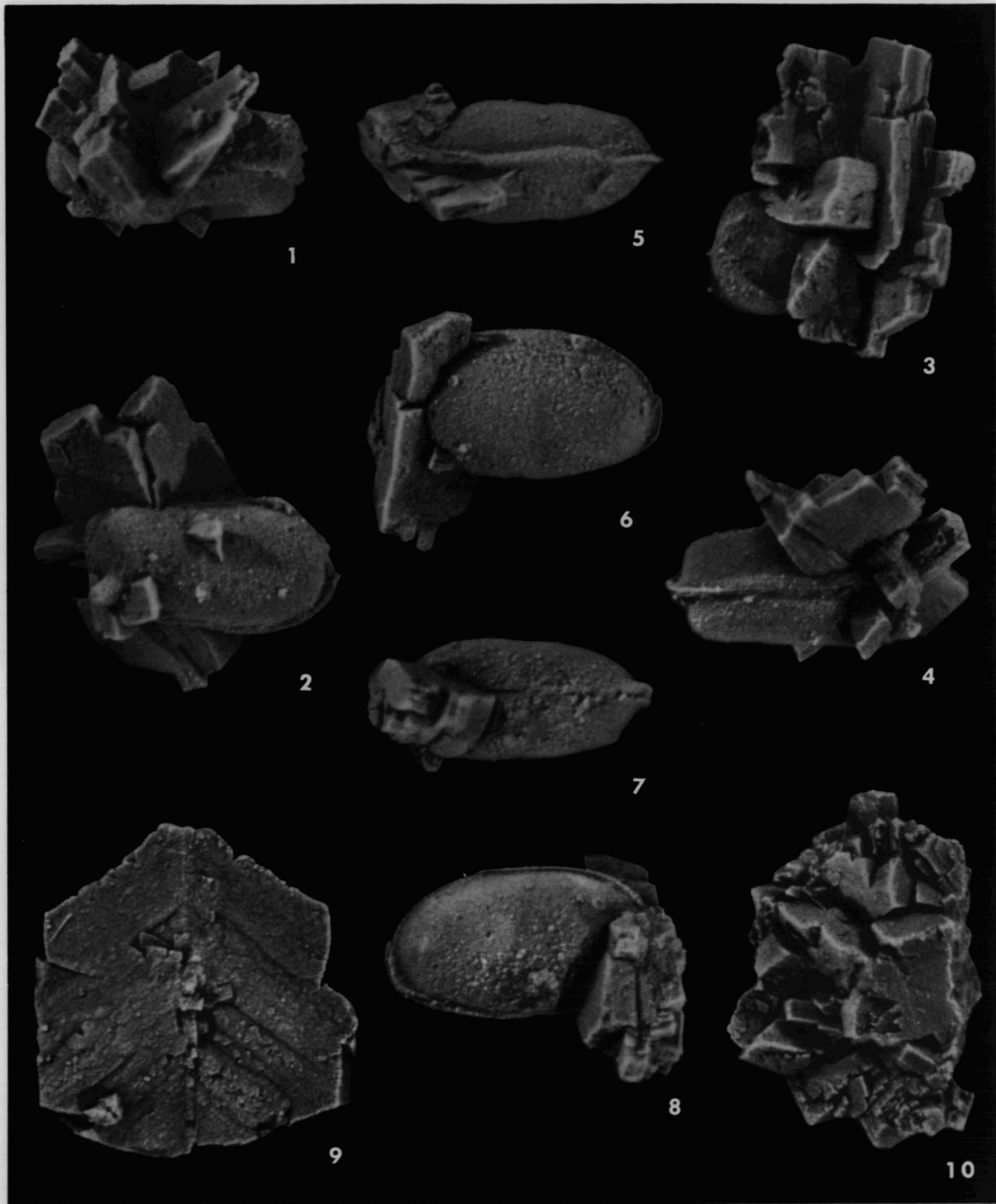
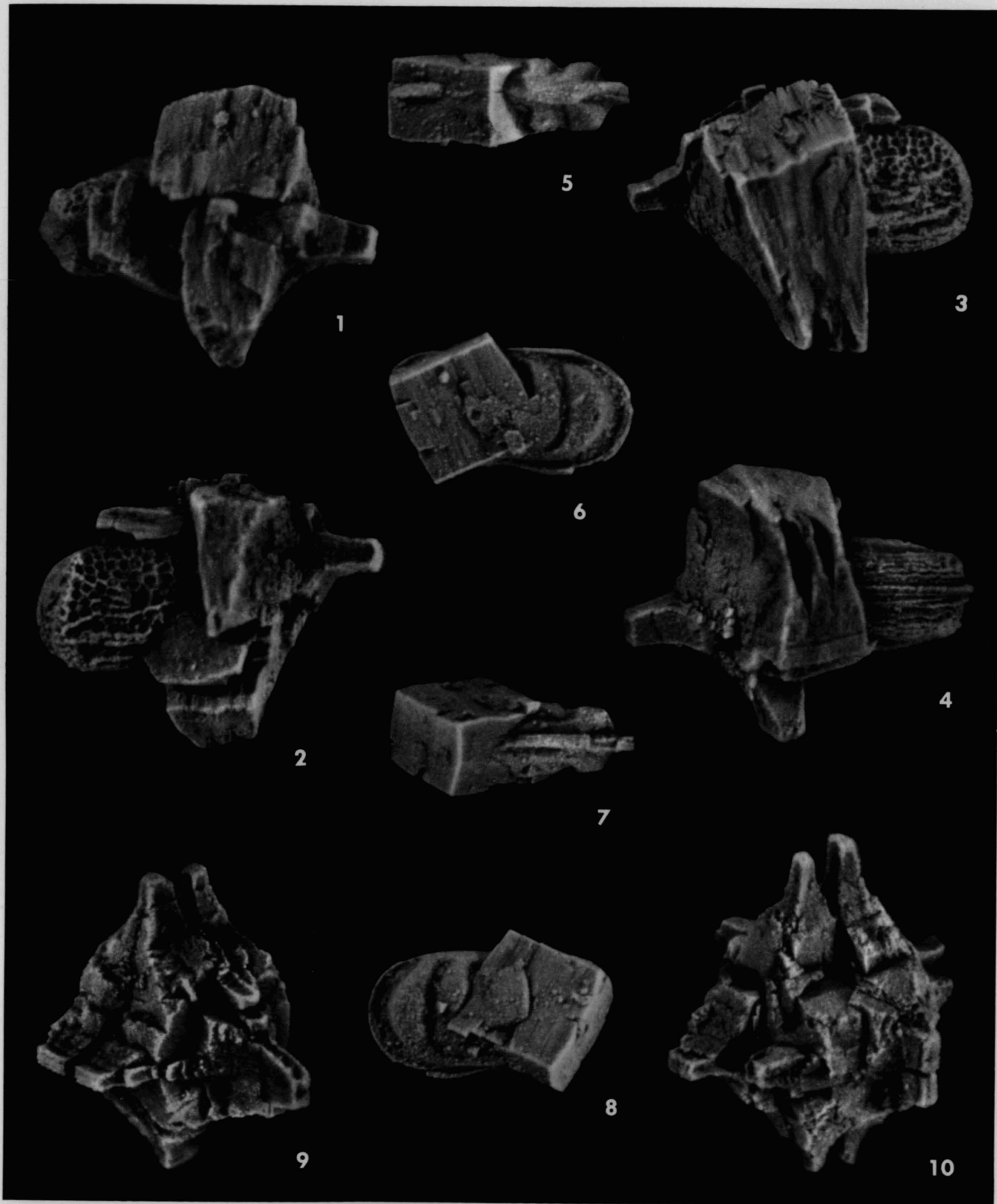

PLATE 56



EXPLANATION OF PLATE 56

All figures x 40

Specimens with pyrite crystals; Loc. MM-Chon

- 1-4 -- *Arcyzona* sp. UMMP 61835, dorsal, right, left, and ventral views.
- 5-8 -- *Poloniella* sp. UMMP 61830, dorsal, right, ventral, and left views of specimen with posterior end replaced by large cube of pyrite.
- 9, 10 -- Two crystals of pyrite; in both, the three major axes are obvious. Such crystals may enclose an ostracod completely, or may be formed around a bit of other organic matter.

EXPLANATION OF PLATE 57

All figures x 40

- 1-26 -- *Quasillites fordei*. 1-4, UMMP 59302, Loc. MM-Chon, dorsal, right, ventral, and left views of carapace. 5, 6, UMMP 59303, Loc. MM-Chon, lateral and interior views of left valve, showing typical hinge. 7-10, UMMP 59307, Loc. MM-Chon, dorsal, right, left, and ventral views of carapace; note the subangular descent of the lateral surface aligned with the posteroventral spine. 11-14, UMMP 59308, Loc. MM-Chon, dorsal, right, ventral, and left views of carapace. 15, 16, UMMP 59305, Loc. MM-Chon, lateral and interior views of left valve. 17-20, UMMP 59309, Loc. N-9, dorsal, left, ventral, and right views of immature carapace. 21-24, UMMP 59304, Loc. MM-Chon, dorsal, right, left, and ventral views of immature carapace; note appearance of hinge in dorsal view, with offset structures at each end. 25, 26, UMMP 59306, Loc. MM-Chon, lateral and interior views of right valve, showing hinge.
- 27-34 -- *Quasillites concentricus*. Loc. MM-Chon. 27-30, UMMP 59298, dorsal, right, left, and ventral views of carapace. 31-34, UMMP 59300, dorsal, right, ventral, and left views of carapace. Lateral views printed with strong contrast (figs. 28, 34) to emphasize the strong "thumbprint" pattern of ornamentation. Note sharp similarity of hinge in dorsal view to that of the above species.

PLATE 57

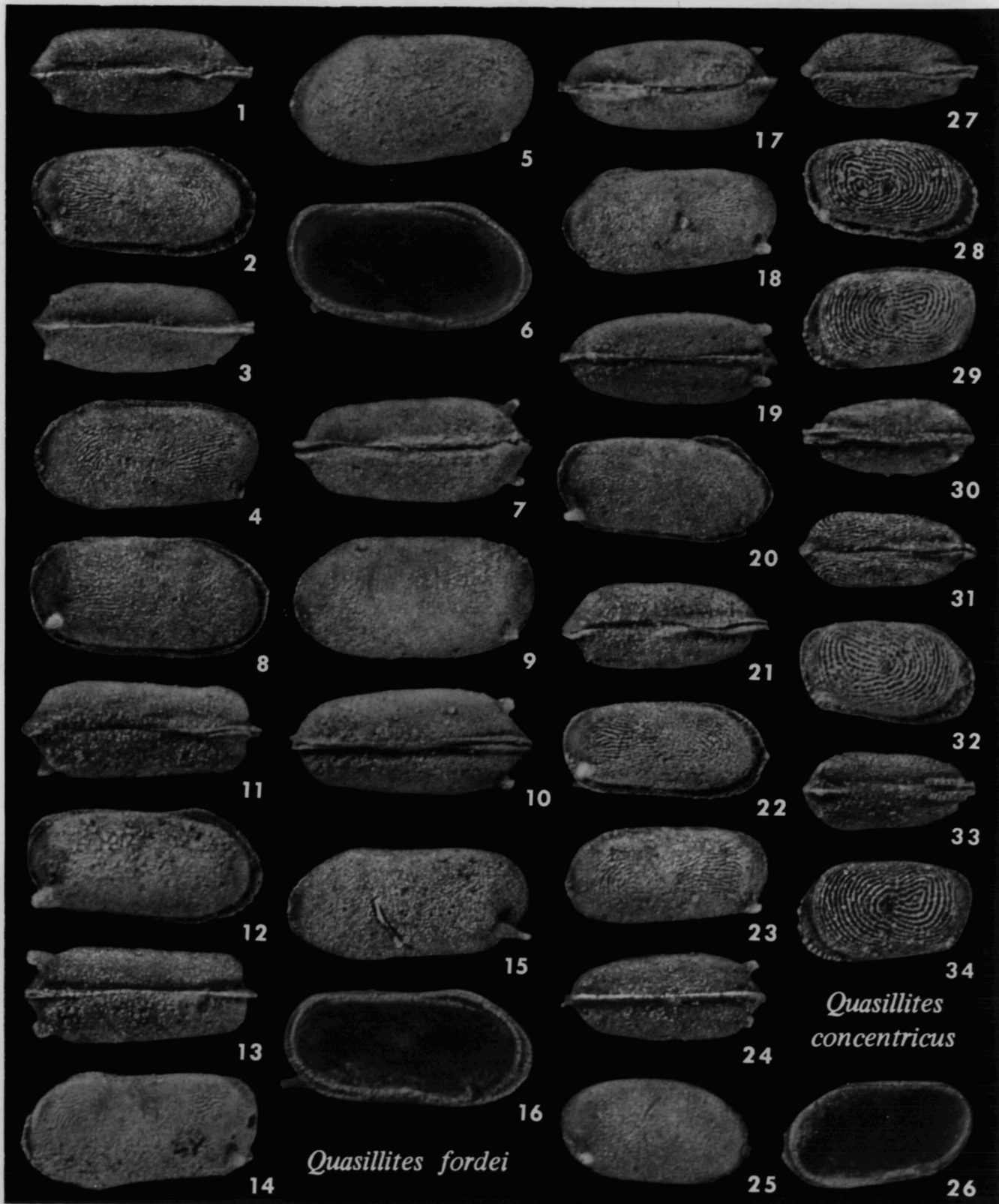

PLATE 58



EXPLANATION OF PLATE 58

All figures x 40

- 1-4 -- *Quasillites sublunatus*. Loc. MM-Chon. UMMP 59312, dorsal, right, ventral, and left views of carapace. Even when printed with maximum contrast, the species shows very little ornamentation.
- 5 -- *Quasillites* sp. Loc. N-9. UMMP 59333, right view of small and very elongate carapace, possibly the same species as above.
- 6-21 -- *Quasillites obliquus*. 6-9, UMMP 59557, Loc. MM-14/15, dorsal, left, ventral, and right views of carapace; note typical "inflated tapering" shape in dorsal view. 10-13, UMMP 59558, Loc. MM-Trop, dorsal, left, ventral, and right views of carapace. 14-17, UMMP 59328, Loc. MM-14/15, dorsal, right, ventral, and left views of carapace. 18, 19, UMMP 59327, Loc. MM-Chon, lateral and interior views of immature right valve. 20, 21, UMMP 59329, Loc. MM-Chon, interior and lateral views of immature left valve; with the above specimen, the hingement is clearly shown. Ornamentation is faint in this species, but discernible.
- 22-25 -- *Hypotetragona aequitalis*. Loc. N-14. UMMP 59654, dorsal, left, ventral, and right views of the largest specimen found, showing the characteristic ornamentation of ridgelets and punctae.
- 26-28 -- *Hyphasmophora textiligera*. Loc. N-12. UMMP 59134, inclined (left-ventral), left, and inclined (left-dorsal) views of left valve, showing the typical pattern of ridges and reticulation around a central spot.

EXPLANATION OF PLATE 59

All figures x 40

- 1-8 -- *Hypotetragona aequitalis*. Loc. MM-Chon. 1-4, UMMP 59106, dorsal, right, ventral, and left views of immature carapace with good preservation. 5-8, UMMP 59137, dorsal, right, ventral, and left views of carapace.
- 9-12, 25-46 -- *Hypotetragona fractodorsalis*. 9-12, UMMP 59136, Loc. N-11, dorsal, left, ventral, and right views of immature carapace with good preservation. 25, 26, UMMP 59507, Loc. N-9, left and right views of large compressed carapace. 27, 28, UMMP 59055, Loc. MM-Chon, right and left views of carapace with rather good preservation. 29, 30, UMMP 59506, Loc. MM-Chon, dorsal and right views of carapace typically buckled dorsally, and affected by pyritization. 31-34, UMMP 59504, Loc. MM-Chon, dorsal, right, ventral, and left views of immature carapace. 35-38, UMMP 59510, Loc. MM-Chon, dorsal, right, ventral, and left views of immature carapace. 39-42, UMMP 59057, Loc. MM-Chon, dorsal, left, ventral, and right views of well-preserved carapace. 43, 44, UMMP 59509, Loc. MM-Chon, dorsal and right views of carapace. 45, 46, UMMP 59508, Loc. N-15, left and ventral views of carapace.
- 13-19 -- *Hypotetragona harrietensis*. 13-16, UMMP 59139, Loc. WP-2, dorsal, right, ventral, and left views of well-preserved carapace. 17-19, UMMP 59050, Loc. N-17, left, right, and ventral views of carapace damaged anterodorsally.
- 20-24 -- *Jenningsina catenulata*. Loc. WP-Trop. UMMP 59146, dorsal, two right, and two left views of carapace; two side views printed with strong contrast to emphasize ornamentation.

PLATE 59

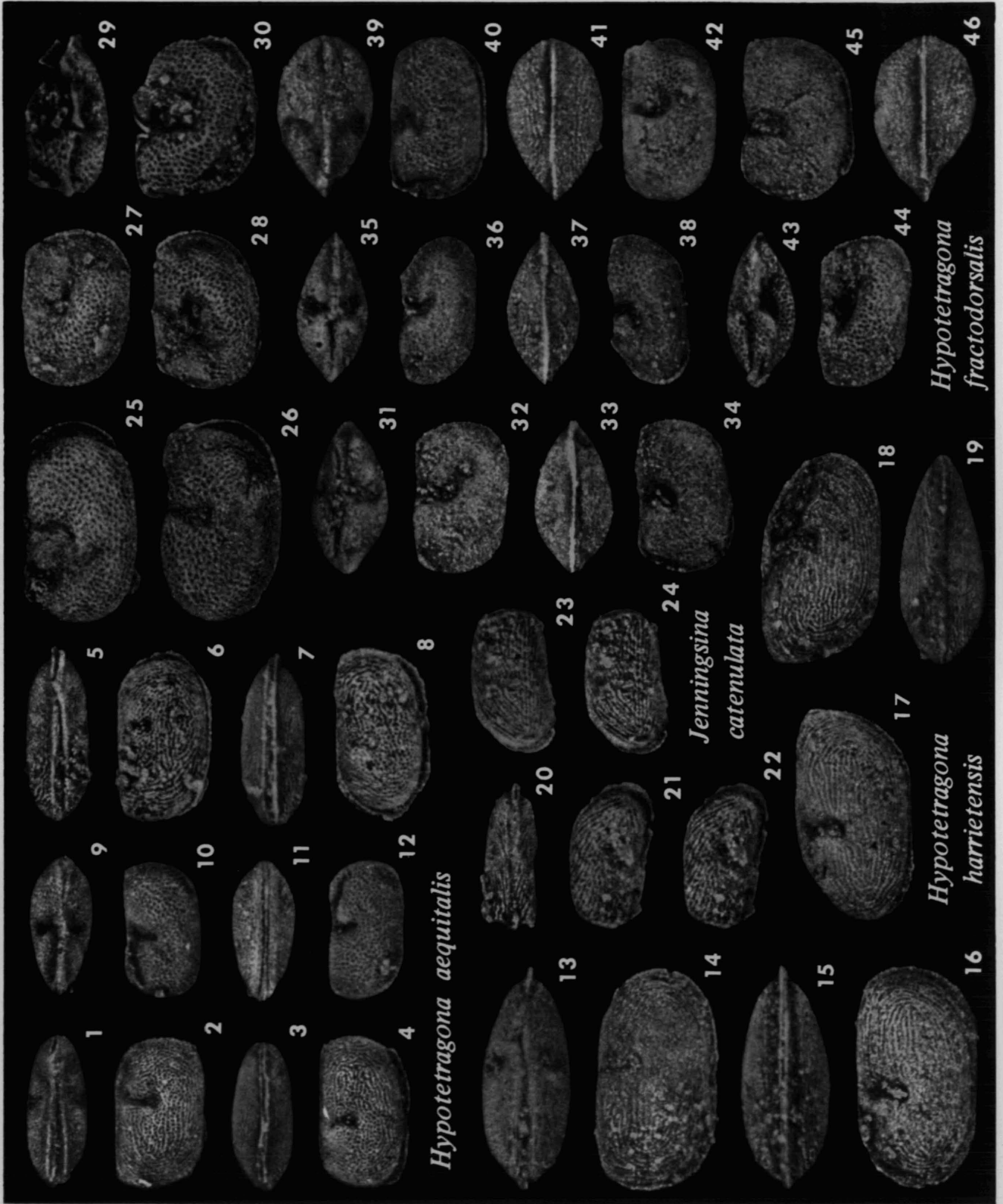
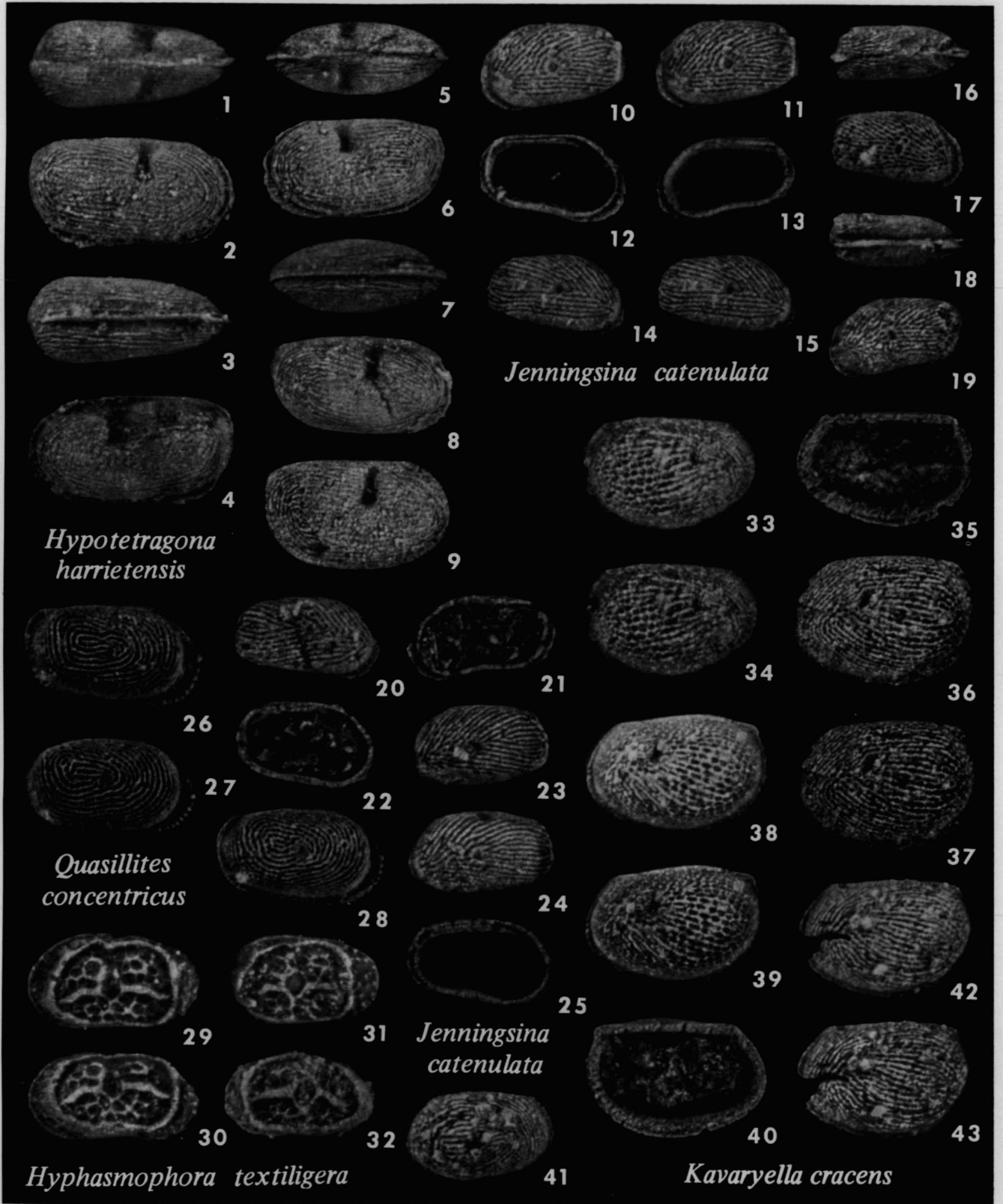

PLATE 60



EXPLANATION OF PLATE 60

All figures x 40

- 1-9 -- *Hypotetragona harrietensis*. Loc. N-12. 1-4, UMMP 59138, dorsal, right, ventral, and left views of good carapace. 5-8, UMMP 59140, dorsal, left, ventral, and right views of carapace, probably the ultimate immature instar. 9, UMMP 59511, lateral view of right valve.
- 10-25 -- *Jenningsina catenulata*. 10-12, UMMP 59141, Loc. WP-Trop, two lateral and interior views of left valve. 13-15, UMMP 59145, Loc. MM-7, interior and two lateral views of right valve; with the previous specimen, the hingement is well shown; lateral views of the two are presented to show the ornamentation, which is faint in uncoated specimens. 16-19, UMMP 59512, Loc. WP-7, dorsal, right, ventral, and left views of carapace. 20, 21, UMMP 59143, Loc. N-7, lateral and interior views of right valve. 22, 23, UMMP 59142, Loc. N-7, interior and lateral views of left valve. 24, 25, UMMP 59144, Loc. MM-7, lateral and interior views of left valve with abnormal hinge.
- 26-28 -- *Quasillites concentricus*. Loc. MM-Chon. UMMP 59297, 59296, and 59299, right views of three carapaces printed with strong contrast to show the individual patterns of ornamentation.
- 29-32 -- *Hyphasmophora textiliger*. 29, 30, UMMP 59502, Loc. N-14, left and inclined (left-ventral) views of left valve. 31, UMMP 59418, Loc. N-17, lateral view of left valve damaged anteriorly. 32, UMMP 59135, Loc. N-17, lateral view of right valve.
- 33-43 -- *Kavaryella cracens*. 33-35, UMMP 59514, Loc. N-14, two lateral and interior views of right valve. 36, 37, UMMP 59117, Loc. N-12, two lateral views of left valve. 38-40, UMMP 59513, Loc. N-14, two lateral and interior views of left valve. 41, UMMP 59116, Loc. MM-12, lateral view of immature right valve. 42, 43, UMMP 59042, Loc. MM-12, two lateral views of left valve. Lateral views shown in two contrasts, the lighter having the appearance of the uncoated specimens and the darker showing details of ornamentation.

EXPLANATION OF PLATE 61

All figures x 40

1-16 -- *Poloniella cingulata*. Loc. MM-Chon. 1-4, UMMP 59241, dorsal, right, ventral, and left views of ultimate immature (A-1) carapace; compare posterior ends of this specimen and the following in dorsal views, showing the nature of the dimorphism. 5-8, UMMP 59238, dorsal, right, left, and ventral views of adult female carapace; note the tubercle on the anterior (L1) ridge in each valve. 9-12, UMMP 59244, right, ventral, dorsal, and left views of penultimate immature (A-2) carapace; note the configuration of the hinge line in dorsal view. 13-16, UMMP 59235, left, dorsal, right, and ventral views of adult female carapace, showing the characteristic stragulum at the anterior cardinal position.

PLATE 61



PLATE 62

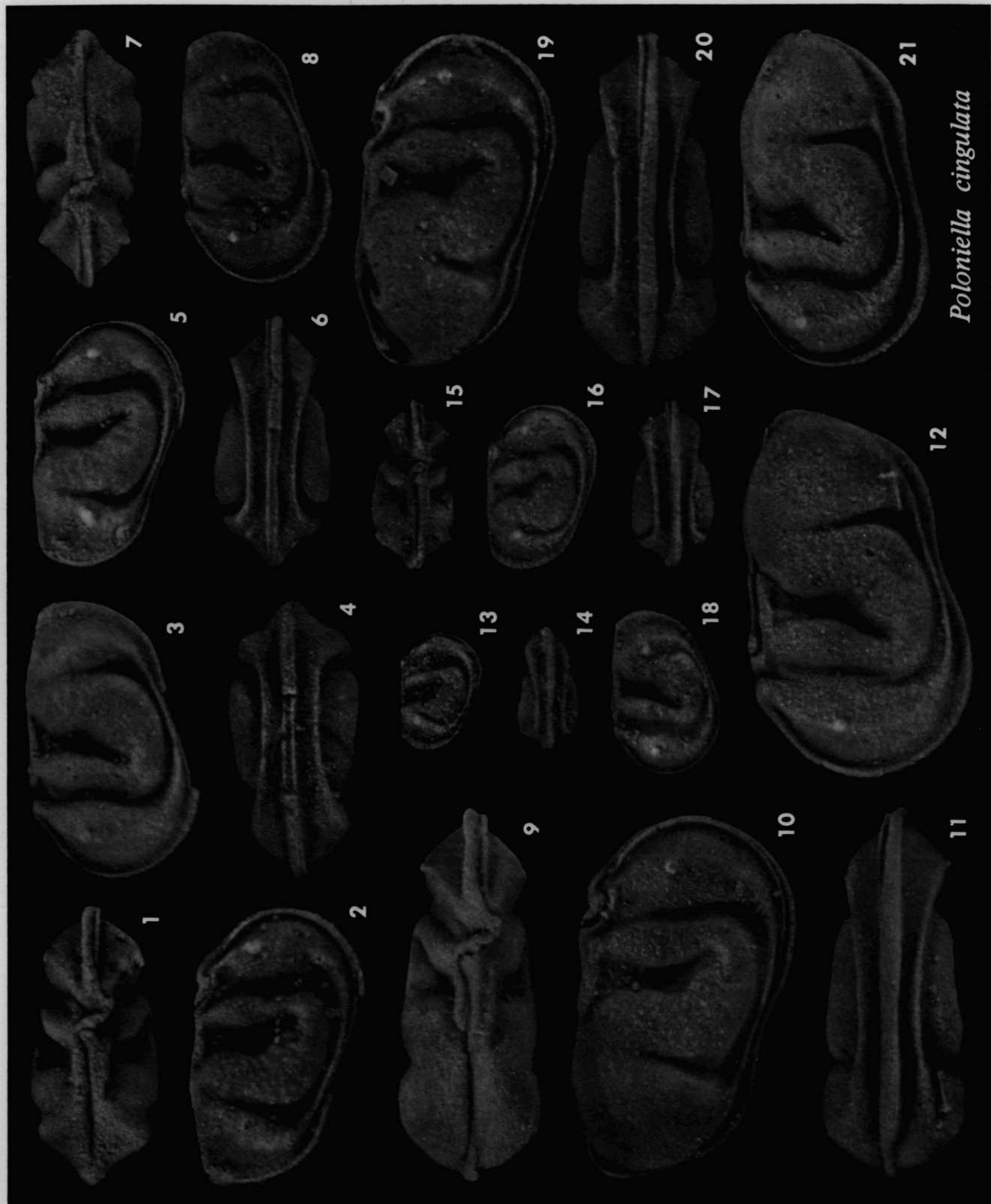

EXPLANATION OF PLATE 62

All figures x 40

1-21 -- *Poloniella cingulata*. Loc. MM-Chon. 1-4, UMMP 59242, dorsal, right, left, and ventral views of ultimate immature (A-1) carapace; note the clear-cut stragulum fitting into a notch of the right valve. 5-8, UMMP 59240, right, ventral, dorsal, and left views of ultimate immature (A-1) carapace; in this and the preceding specimen, the overlapping marginal ridge of the left valve is broken in the ventral part, probably indicating structural weakness. 9-12, UMMP 59239, dorsal, right, ventral, and left adult female carapace, showing the inflated dimorphic posterior region. 13, 14, UMMP 59246, right and ventral views of immature (A-5) carapace; the L3 does not project dorsally nearly as conspicuously in this as in the older instars. 15-18, UMMP 59245, dorsal, right, ventral, and left views of immature (A-3) carapace; there appears to be a tubercle developed on the L4 ridge in each valve, as well as on L1; no function can be envisaged for these structures. 19-21, UMMP 59237, right, ventral, and left views of adult female carapace, somewhat buckled along the dorsal margin.

EXPLANATION OF PLATE 63

All figures x 40

- 1-26 -- *Knoxiella rutkowskiae*. 1-4, UMMP 59516, Loc. MM-Chon, dorsal, right, left, and ventral views of carapace. 5-8, UMMP 59518, Loc. MM-Chon, dorsal, left, ventral, and right views of carapace. 9-12, UMMP 59147, Loc. MM-Chon, dorsal, right, ventral, and left views of carapace. 13-16, UMMP 59066, Loc. MM-Chon, dorsal, left, right, and ventral views of carapace; small crystal of pyrite protrudes from anteroventral region of right valve. 17-20, UMMP 59519, Loc. MM-Chon, dorsal, left, ventral, and right views of carapace with break in the dorsum. 21-24, UMMP 59517, Loc. N-9, dorsal, right, left, and ventral views of carapace. 25, 26, UMMP 59520, Loc. N-9, lateral and ventral views of right valve. These views printed with strong contrast to show the faint ornamentation.
- 27-34 -- *Poloniella cingulata*. Loc. MM-Chon. 27, 28, UMMP 59243, lateral and interior views of right immature (A-2) valve; note the distinct notch to accommodate the stragulum. 29, 30, UMMP 59246, dorsal and left views of immature (A-5) carapace. the smallest found. 31-34, UMMP 59236, dorsal, right, ventral, and left views of ultimate immature (A-1) carapace.
- 35-38 -- *Knoxiella* sp. UMMP 59521, Loc. MM-Chon, right, dorsal, left, and ventral views of carapace. This specimen has some of the configuration of *Knoxiella rutkowskiae*, but it is half again as large as the presumed adults of that species and has a smoother surface. Since it is the only one of its kind discovered, we have decided to leave it unnamed.

PLATE 63

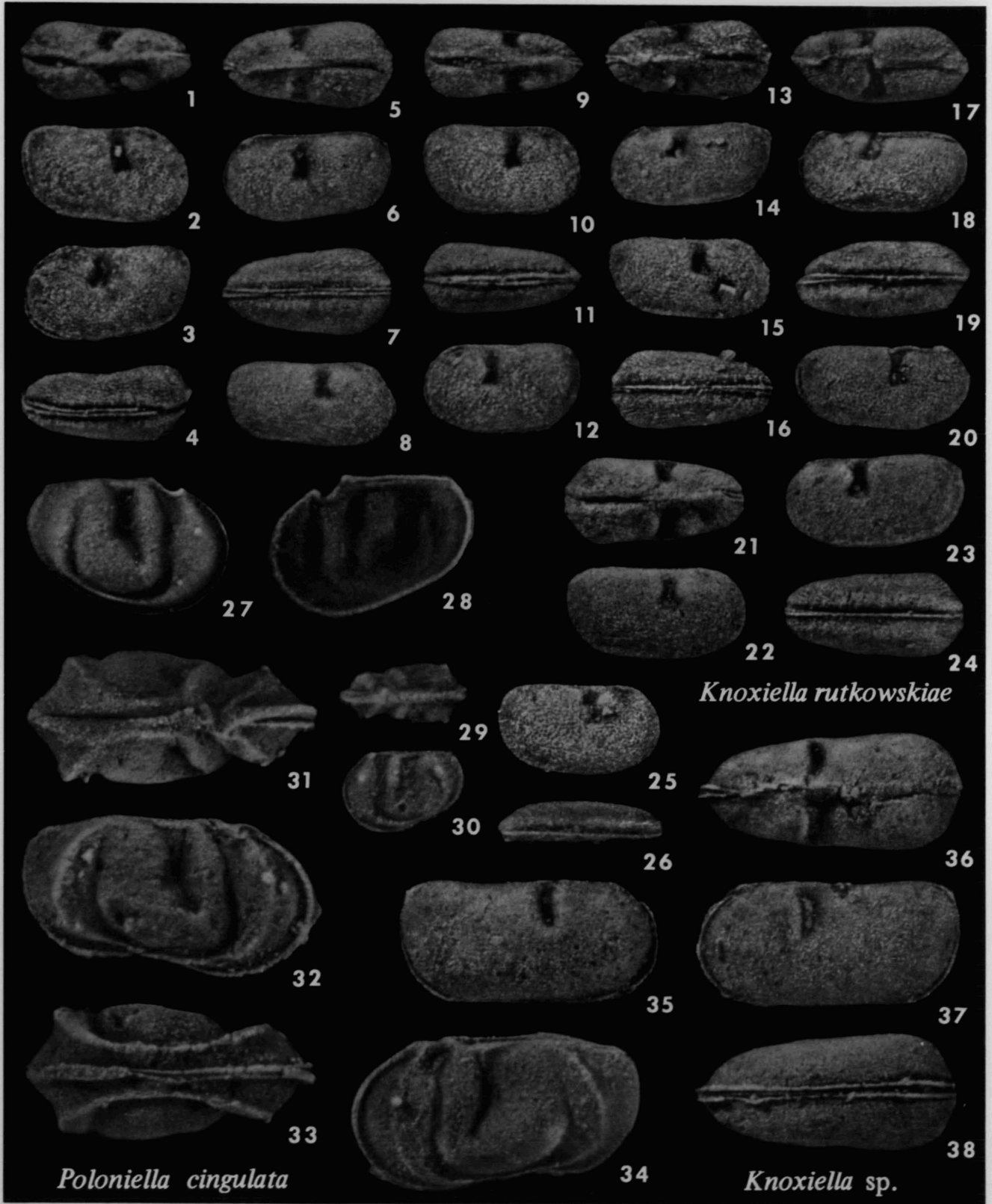

Poloniella cingulata

Knoxiella rutkowskiae

Knoxiella sp.

PLATE 64

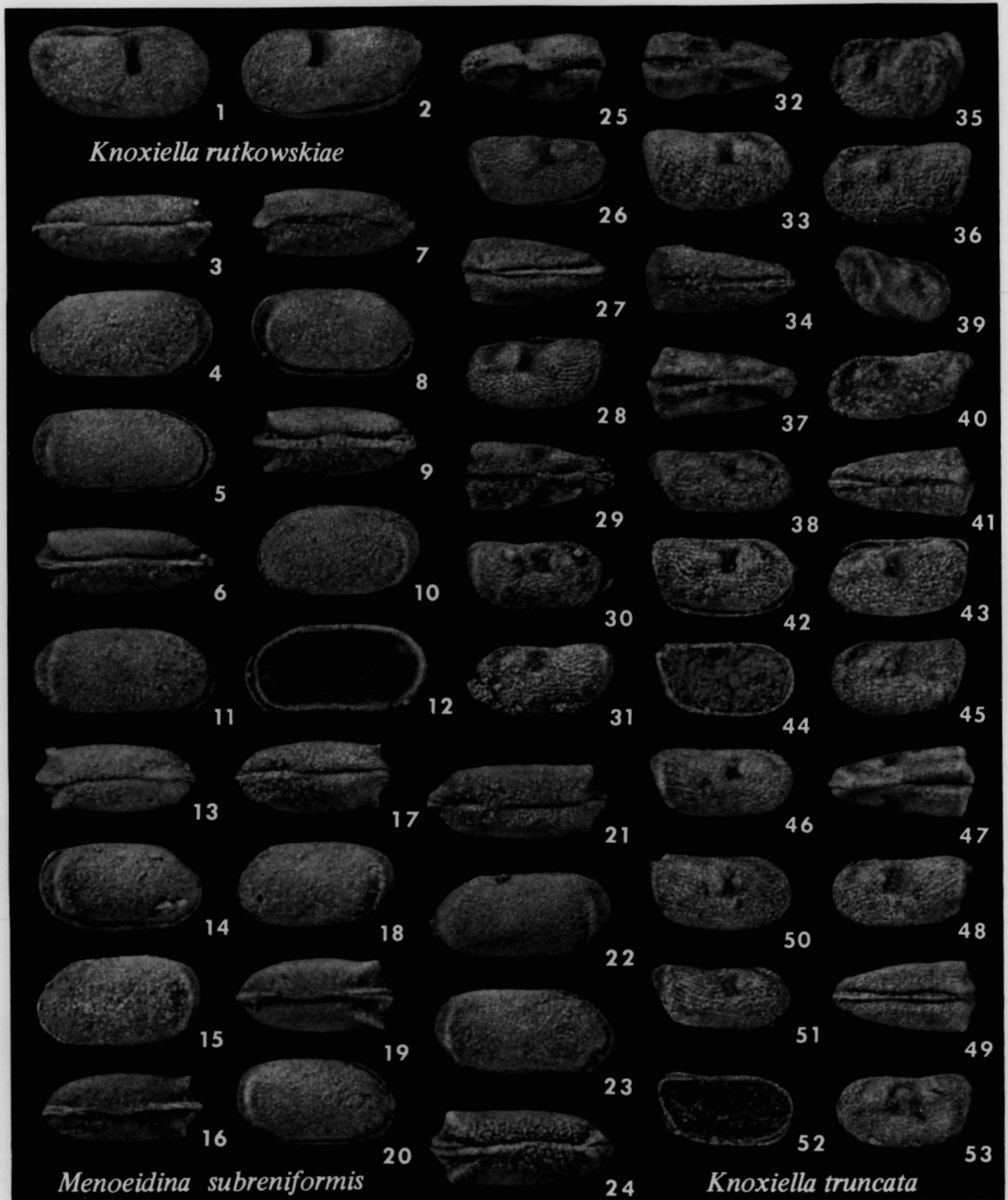

EXPLANATION OF PLATE 64

All figures x 40

- 1, 2 -- *Knoxiella rutkowskiae*. Loc. MM-Chon. UMMP 59067, right and left views of carapace with valves slightly askew.
- 3-24 -- *Menoetidina subreniformis*. 3-6, UMMP 59174, Loc. N-9, dorsal, left, right, and ventral views of carapace with well-preserved hinge and closure. 7-10, UMMP 59176, Loc. MM-Chon, dorsal, right, ventral, and left views of carapace; note the overlapping lip of the left valve on the venter. 11, 12, UMMP 59181, Loc. MM-Chon, lateral and interior views of a right valve. 13-16, UMMP 59172, Loc. MM-Chon, dorsal, right, left, and ventral views of carapace. 17-20, UMMP 59175, Loc. MM-Chon, dorsal, left, ventral, and right views of carapace. 21-24, UMMP 59179, Loc. MM-Chon, dorsal, left, right, and ventral views of carapace.
- 25-53 -- *Knoxiella truncata*. 25-28, UMMP 59426, Loc. N-9, dorsal, right, ventral, and left views of carapace; note the blunt posterior end, truncated in dorsal view and beveled in side view. 29-31, UMMP 59427, Loc. MM-Chon, dorsal, right, and left views of carapace. 32-36, UMMP 59068, Loc. MM-Chon, dorsal, right, ventral, inclined (left-posterior, slightly dorsal), and left views of carapace; the inclined view shows the rounded bends at the junctions of the lateral and posterolateral surfaces of the valves, which rise above the hinge line. 37-41, UMMP 59070, Loc. MM-Chon, dorsal, right, inclined (right-posteroventral), left, and ventral views of carapace; the inclined view shows the large posterior area of the carapace. 42, 43, UMMP 59073, Loc. N-9, right and left views of carapace with valves slightly offset. 44, 45, UMMP 59072, Loc. MM-Chon, interior and lateral views of left valve. 46-49, UMMP 59428, Loc. MM-Chon, right, dorsal, left, and ventral views of well-preserved carapace; note the dorsal and ventral views in particular. 50, UMMP 59069, Loc. N-12, lateral view of right valve. 51, UMMP 59071, Loc. MM-Chon, lateral view of right valve. 52, 53, UMMP 59450, Loc. WP-Chon, interior and lateral views of left valve.

EXPLANATION OF PLATE 65

All figures x 40

- 1-8 -- *Menoeidina subreniformis*. Loc. MM-Chon. 1-4, UMMP 59177, dorsal, right, left, and ventral views of carapace; note the development of a ventral overlapping lip. 5-8, UMMP 59180, dorsal, right, ventral, and left views of carapace; note the hinge line in dorsal view.
- 9-34 -- *Menoeidina paucipunctata*. 9-12, UMMP 59531, Loc. MM-Trop, dorsal, left, right, and ventral views of carapace. 13, 14, UMMP 59188, Loc. MM-Chon, lateral and interior views of right valve. 15-18, UMMP 59189, Loc. MM-Chon, dorsal, left, right, and ventral views of carapace. 19-22, UMMP 59530, Loc. MM-Trop, dorsal, right, ventral, and left views of carapace. 23-26, UMMP 59529, Loc. MM-Trop, dorsal, right, ventral, and left views of carapace. 27-30, UMMP 59528, Loc. MM-Trop, right, ventral, dorsal, and left views of carapace. 32-34, UMMP 59532, Loc. MM-Chon, dorsal, right, and ventral views of carapace. Note the almost straight overlapping edge ventrally, and the narrowly rounded high point on the dorsal border. Number and depth of the posterocentral punctae varies.
- 35-42 -- *Ponderodictya ohioensis*. 35-38, UMMP 59647, Loc. MM-Chon, dorsal, right, left, and ventral views of immature carapace. 39-42, UMMP 59651, Loc. MM-Trop, dorsal, right, left, and ventral views of carapace. Compare these immature carapaces with those of adults in the following plate. Ornamentation is fairly subdued.
- 43, 44 -- *Ponderodictya punctulifera*. Loc. MM-Chon. UMMP 59247, lateral and interior views of right valve. The subanterior ridge is exceptionally well developed in this valve.

PLATE 65

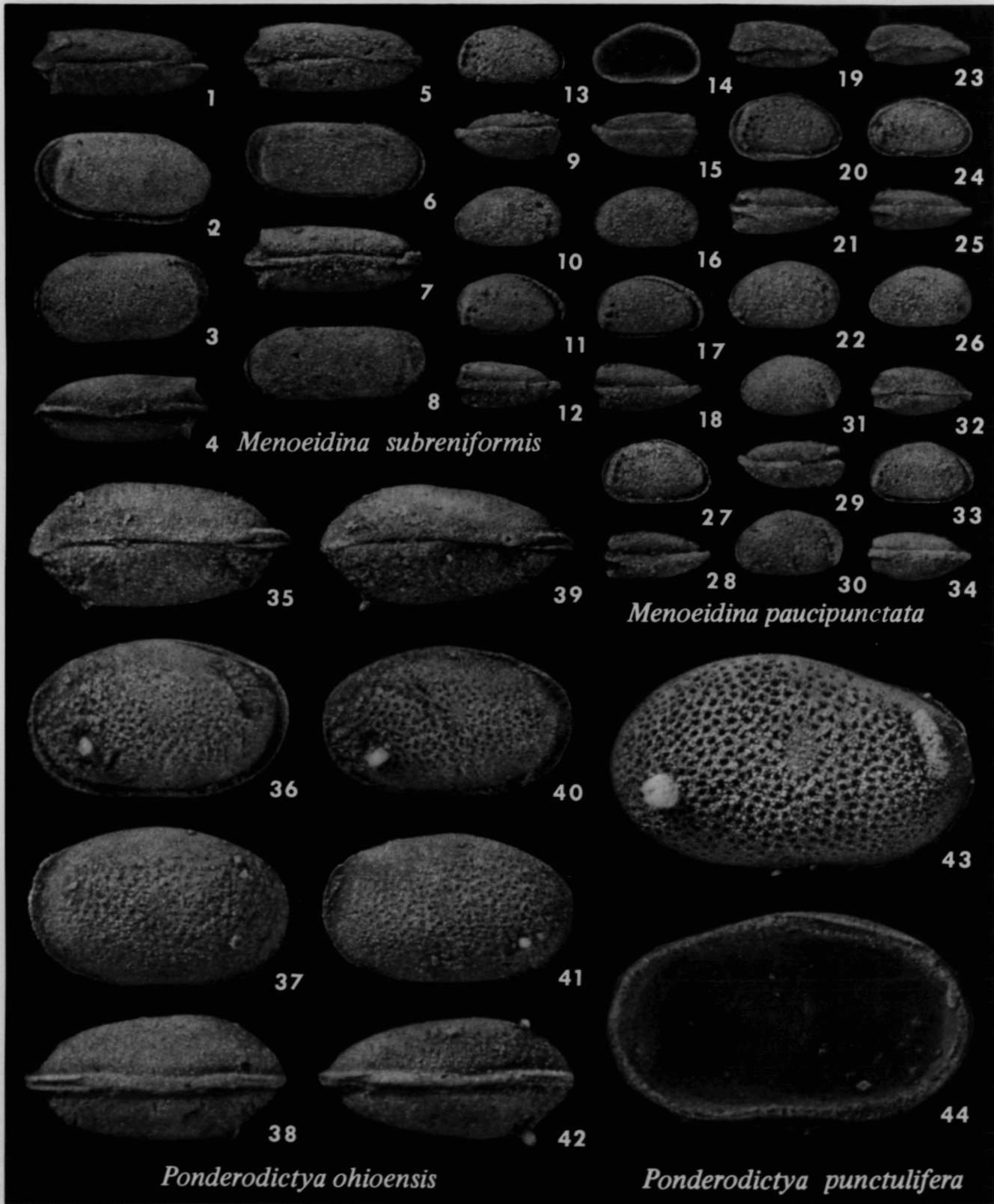

4 *Menoeidina subreniformis*

Menoeidina paucipunctata

Ponderodictya ohioensis

Ponderodictya punctulifera

PLATE 66

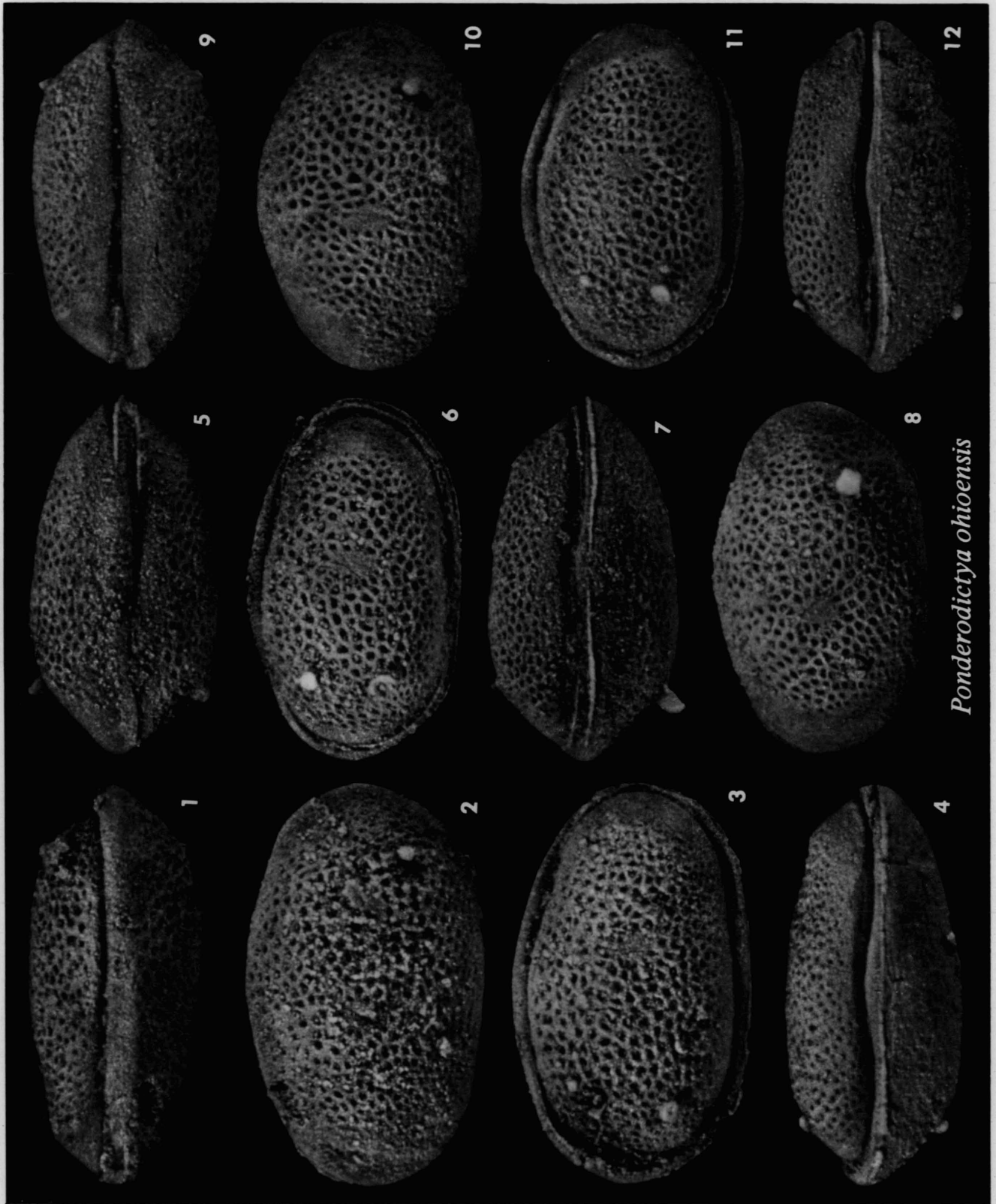

EXPLANATION OF PLATE 66

All figures x 40

1-12 -- *Ponderodictya ohioensis*. 1-4, UMMP 59648, Loc. MM-Trop, dorsal, left, right, and ventral views of carapace. 5-8, UMMP 59650, Loc. MM-7, dorsal, right, ventral, and left views of carapace; narrow anterior flanges are well preserved in this specimen. 9-12, UMMP 59649, Loc. MM-Chon, dorsal, left, right, and ventral views of carapace; the overlapping ventral lip of the left valve is well illustrated.

EXPLANATION OF PLATE 67

All figures x 40

1-12 -- *Ponderodictya punctulifera*. 1-4, UMMP 59260, Loc. N-7, dorsal, right, ventral, and left views of carapace. 5-8, UMMP 59250, Loc. MM-Chon, dorsal, left, right, and ventral views of carapace. 9-12, UMMP 59261, Loc. N-7, dorsal, left, ventral, and right views of carapace. These three specimens illustrate the variations in what we consider to be one species, including variations in height/length ratio, shape in dorsal view, and the number and size of meshes in the reticulation. Note that UMMP 59260 has two posterior spines on the left valve, whereas the other two specimens have only the posteroventral spine present.

PLATE 67

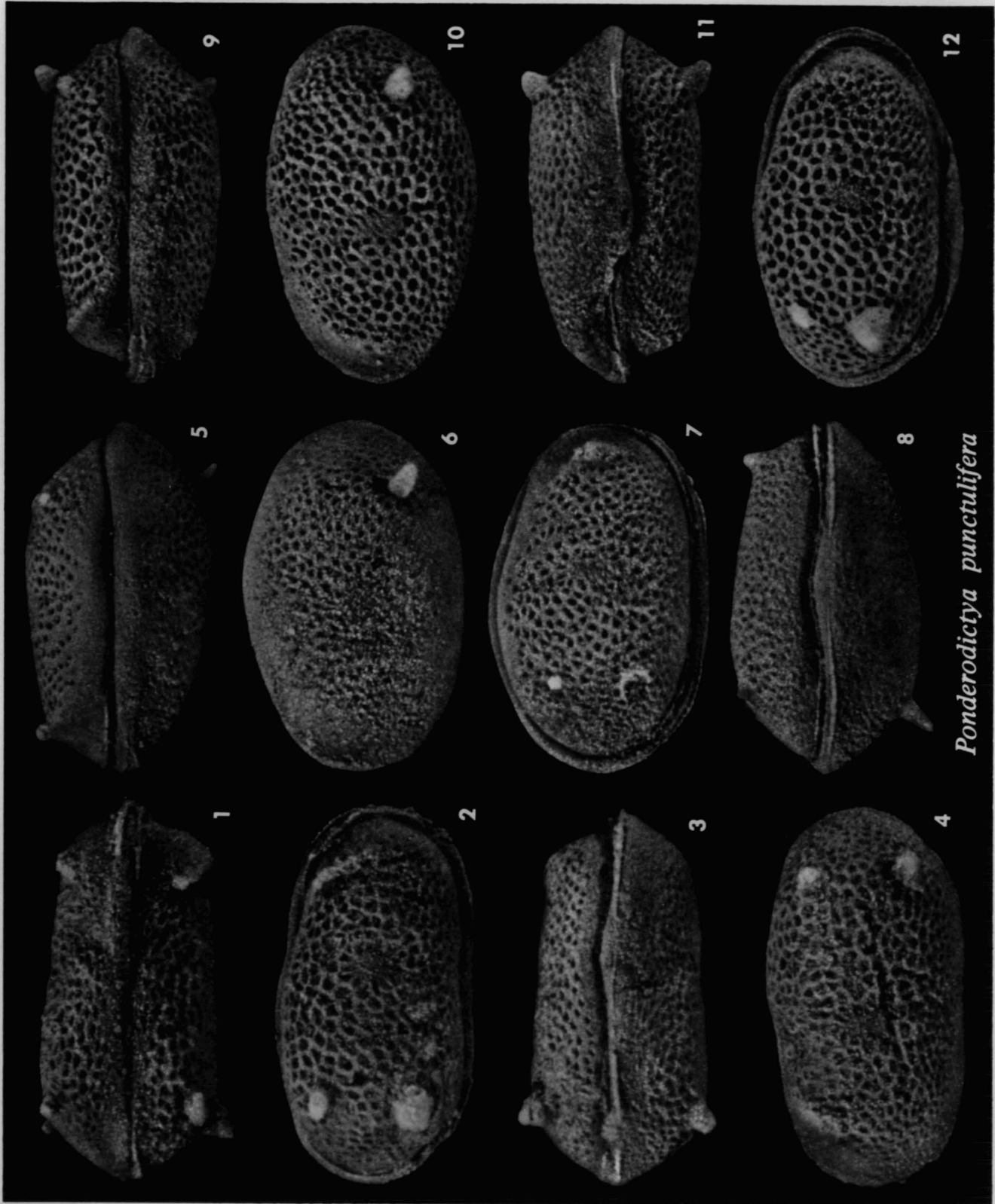

Ponderodictya punctulifera

PLATE 68

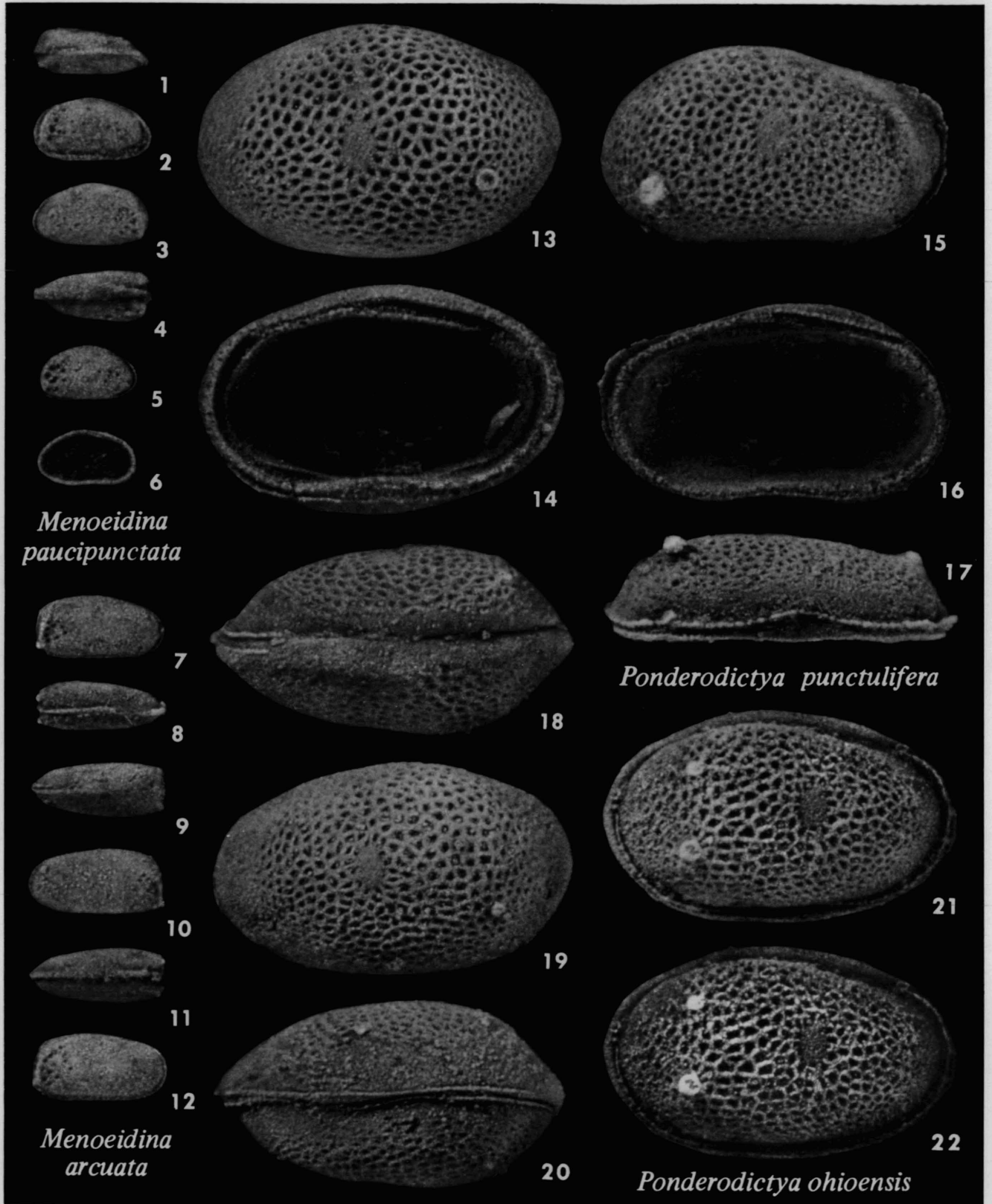

EXPLANATION OF PLATE 68

All figures x 40

- 1-6 -- *Menoetidina paucipunctata*. Loc. MM-Chon. 1-4, UMMP 59187, dorsal, right, left, and ventral views of carapace. 5, 6, UMMP 59190, lateral and interior views of right valve.
- 7-12 -- *Menoetidina arcuata*. Loc. MM-Chon. 7, 8, UMMP 59182, right and ventral views of carapace. 9-12, UMMP 59183, dorsal, left, ventral, and right views of carapace. Compare dorsal border and elongation with those of the above species.
- 13-17 -- *Ponderodictya punctulifera*. Loc. MM-Chon. 13, 14, UMMP 59252, lateral and interior views of left valve. 15-17, UMMP 59256, lateral, interior, and ventral views of right valve; note the accommodation ventrally on this right valve for the overlapping lip of the opposite valve.
- 18-22 -- *Ponderodictya ohioensis*. Loc. MM-Chon. UMMP 59251, dorsal, left, ventral, and two right views of carapace, the last two views printed in different contrasts to emphasize the reticulation around the central bare spot, which marks the position of the internal adductor muscle scars.

EXPLANATION OF PLATE 69

All figures x 40

- 1-8 -- *Ponderodictya punctulifera*. 1, 2, UMMP 59253, Loc. MM-Chon, lateral and interior views of left valve. 3, 4, UMMP 59255, Loc. MM-Chon, lateral and interior views of right valve; interior views of this and the previous specimen show the manner in which the hinge elements fit together; note that the actual hinge is less than half the length of the valves. 5-8, UMMP 59262, Loc. N-7, dorsal, right, left, and ventral views of carapace without strong development of anterior ridge, in this respect resembling the very closely similar *Ponderodictya ohioensis*.
- 9-13 -- *Menoeidina subreniformis*. Loc. MM-Chon. 9, 10, UMMP 59178, lateral and interior views of left valve. 11-13, UMMP 59173, interior and two lateral views of right valve; even printed with strong contrast scarcely shows the very faint punctation in front of the posterior ridge. This species differs in this respect from others of the genus, which show large and clearly defined punctae in this region of the valves.
- 14-25 -- *Menoeidina arcuata*. Loc. MM-Chon. 14-17, UMMP 59527, dorsal, left, right, and ventral views of carapace with good preservation. 18-21, UMMP 59184, dorsal, right, ventral, and left views of carapace. 22-25, UMMP 59186, dorsal, left, ventral, and right views of carapace.

PLATE 69

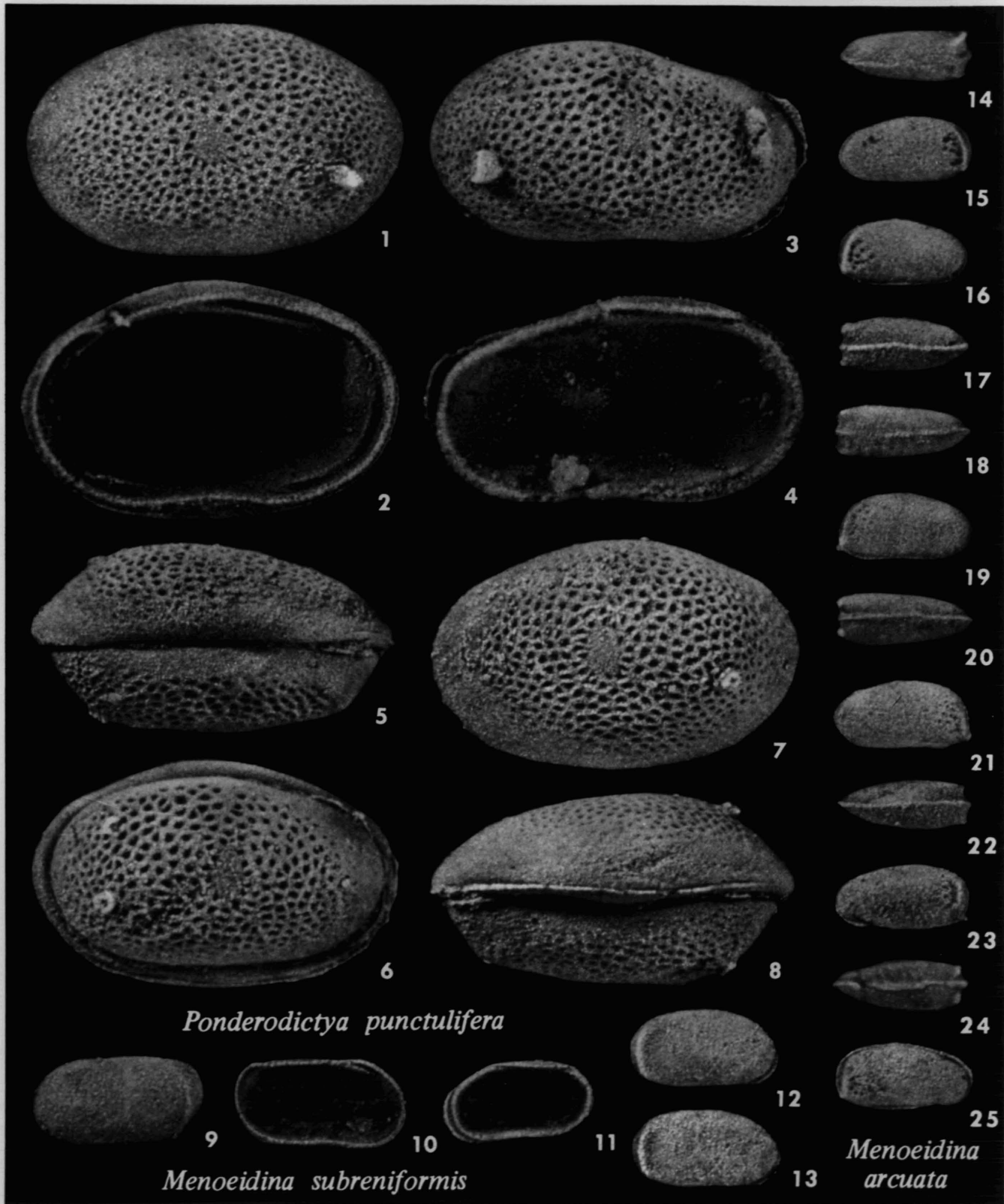

Ponderodictya punctulifera

Menoeidina subreniformis

Menoeidina arcuata

PLATE 70



Menoeidina arcuata

Monoceratina casei

Ponderodictya punctulifera

EXPLANATION OF PLATE 70

All figures x 40

- 1-10 -- *Ponderodictya punctulifera*. 1-4, UMMP 59263, Loc. N-7, dorsal, ventral, dorsal, and right views of elongate, coarsely reticulate carapace. 5-8, UMMP 59254, Loc. MM-Chon, right, ventral, dorsal, and left views of high, finely reticulate carapace. 9, 10, UMMP 59258, Loc. N-7, lateral and interior views of immature right valve, with the interior edge worn by abrasion.
- 11-15 -- *Menoeidina arcuata*. Loc. MM-Chon. 11, 12, UMMP 59182, dorsal and left views of carapace. 13-15, UMMP 59185, dorsal, left, and right views of carapace.
- 16-21 -- *Monoceratina casei*. Loc. MM-Chon. 16-20, UMMP 59198, dorsal, right, ventral, inclined (left-ventral), and left views of carapace. 21, UMMP 59194, right view of carapace, slightly inclined to show the spine.

EXPLANATION OF PLATE 71

All figures x 40

- 1-8 -- *Ponderodictya punctulifera*. 1-4, UMMP 59259, Loc. N-7, right, ventral, dorsal, and left views of carapace. 5-8, UMMP 59257, Loc. MM-Chon, right, dorsal, left, and ventral views of carapace. These two specimens are typical of the end members of series in elongation and coarseness of reticulation.
- 9-30 -- *Monoceratina casei*. 9-12, UMMP 59191, Loc. MM-Chon, dorsal, right, left, and ventral views of carapace. 13-16, UMMP 59197, Loc. MM-Chon, dorsal, right, ventral, and left views of carapace. 17-20, UMMP 59196, Loc. MM-Chon, dorsal, left, ventral, and right views of carapace. 21-24, UMMP 59195, Loc. N-9, dorsal, right, left, and ventral views of carapace. 25-28, UMMP 59193, Loc. MM-Chon, dorsal, right, left, and ventral views of carapace. 29, 30, UMMP 59192, Loc. MM-Chon, right and ventral views of carapace. Some of the variation in shape is the result of compression and skewing of the valves.

PLATE 71

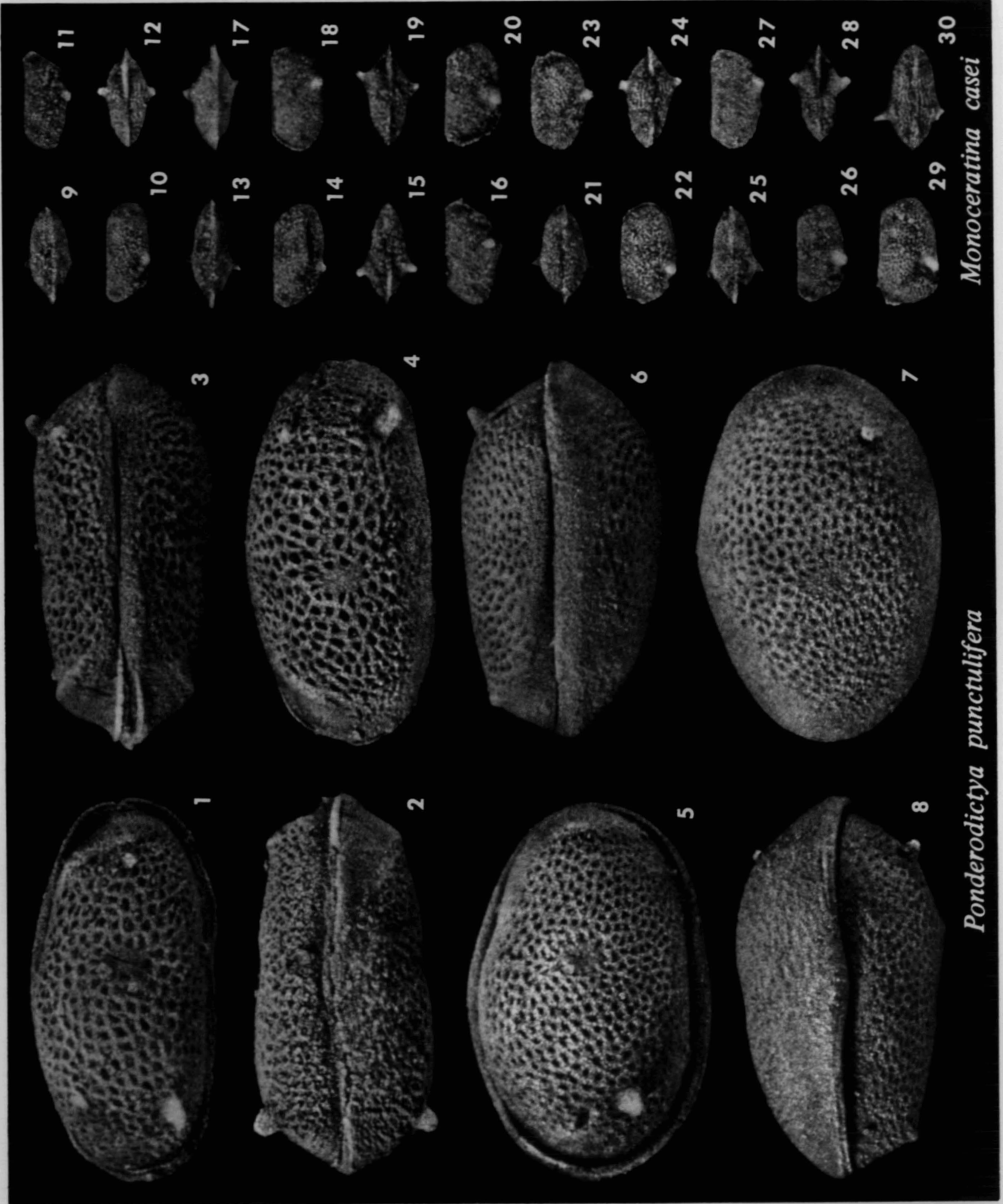

Ponderodictya punctulifera

Monoceratina casei

PLATE 72

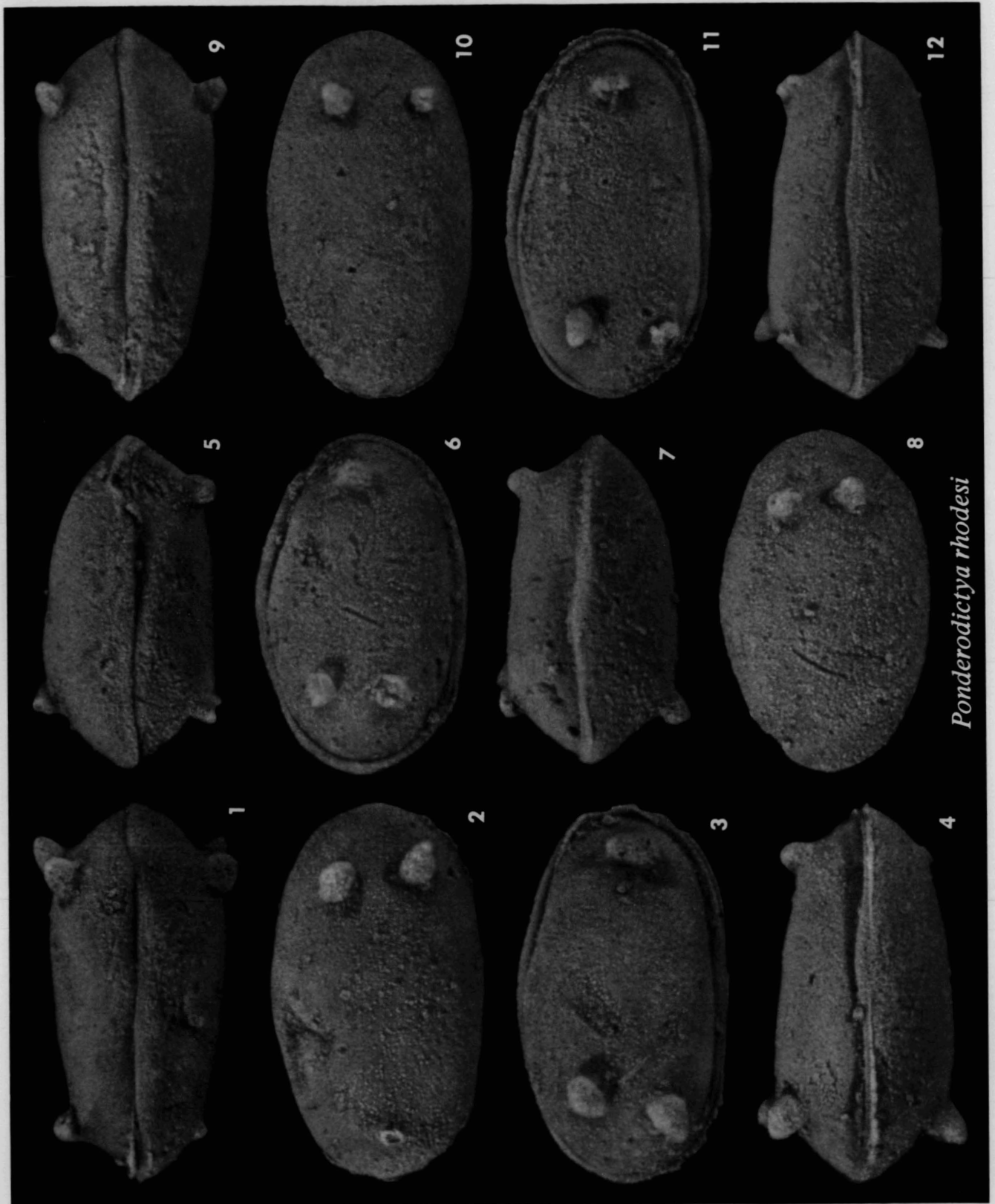

Ponderodictya rhodesi

EXPLANATION OF PLATE 72

All figures x 40

1-12 -- *Ponderodictya rhodesi*. Loc. MM-Chon. 1-4, UMMP 59266, dorsal, left, right, and ventral views of well-preserved carapace. 5-8, UMMP 59248, dorsal, right, ventral, and left views of carapace. 9-12, UMMP 59265, dorsal, left, right, and ventral views of carapace. Even when slightly over-exposed and fully developed (as here), the valves show no indication of reticulation like that of *Ponderodictya punctulifera* or *Ponderodictya ohioensis*.

EXPLANATION OF PLATE 73

All figures x 40

1-12 -- *Ponderodictya rhodesi*. Loc. MM-Chon. 1-4, UMMP 59249, dorsal, right, ventral, and left views of well-preserved carapace; note the difference in dorsal view of the anterior ridges on the two valves. 5, 6, UMMP 59273, lateral and interior views of left valve. 7, 8, UMMP 59267, lateral and interior views of large left valve. 9, 10, UMMP 59270, lateral and interior views of right valve. 11, 12, UMMP 59271, lateral and interior views of right valve. Interior views of the valves are nearly identical with those of *Ponderodictya punctulifera* shown in plate 69, figures 2 and 4.

PLATE 73



PLATE 74

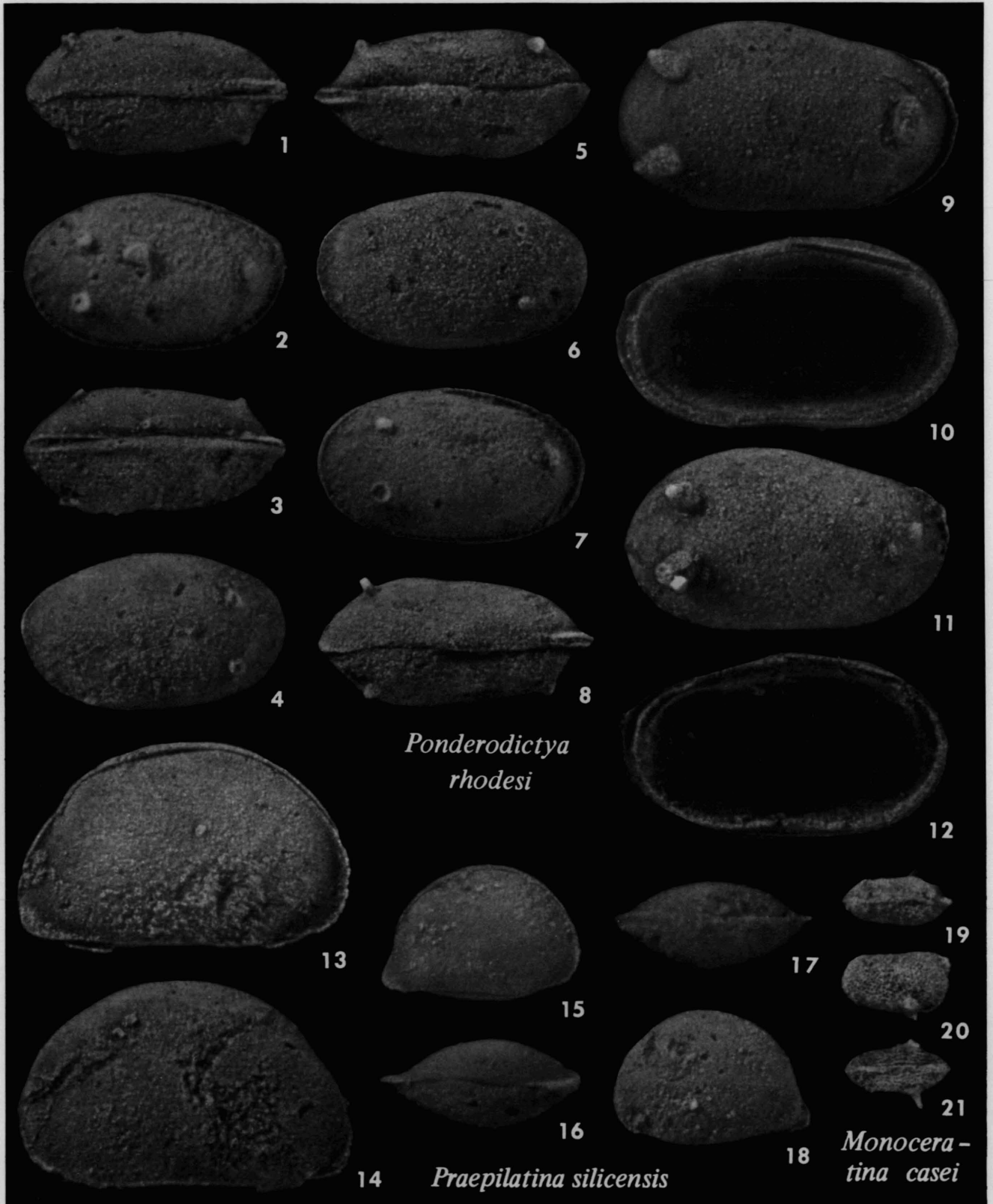

EXPLANATION OF PLATE 74

All figures x 40

- 1-12 -- *Ponderodictya rhodesi*. Loc. MM-Chon. 1-4, UMMP 59275, dorsal, right, ventral, and left views of immature carapace. 5-8, UMMP 59274, dorsal, left, right, and ventral views of immature carapace. 9, 10, UMMP 59268, lateral and interior views of adult right valve, showing the short hinge in the posterior part of the valve. 11, 12, UMMP 59269, lateral and interior views of adult right valve; the lower posterior spine has a crystal of pyrite near its tip. Note that even with slight overexposure and full development, the surface of this species shows no indication of reticulation.
- 13-18 -- *Praepilatina silicensis*. 13, 14, UMMP 59386, Loc. N-18a, right and left views of adult carapace. 15-18, UMMP 59387, Loc. MM-Chon, right, ventral, dorsal, and left views of immature carapace. The left valve overlaps the right except at the ventral corners, where the right projects beyond the left valve.
- 19-21 -- *Monoceratina casei*. Loc. MM-Chon. UMMP 59192, dorsal, left, and ventral views of carapace with the left spine broken.

EXPLANATION OF PLATE 75

All figures x 40

- 1-18 -- *Pronipantex planus*. Loc. MM-Chon. 1-5, UMMP 61811, right, dorsal, left, ventral, and anterior views of excellent carapace. 6-8, UMMP 59526, dorsal, inclined (right-dorsal, perpendicular to surface of side), and left views of carapace. 9-12, UMMP 59033, dorsal, left, right, and ventral views of carapace. 13-18, UMMP 61810, inclined (anterior-ventral), anterior, dorsal, left, right, and ventral views of carapace. Note that the venter has a rim projecting slightly beyond the lateral surfaces, so that it fits like the sole on a shoe.
- 19-26 -- *Praepilatina silicensis*. 19-22, UMMP 59545, Loc. N-15, dorsal, right, ventral, and left views of adult carapace; the side and ventral views show the manner in which the ventral corners of the right valve project beyond the edges of the overlapping left valve. 23-26, UMMP 59544, Loc. MM-Chon, dorsal, right, left, and ventral views of immature carapace.

PLATE 75



PLATE 76

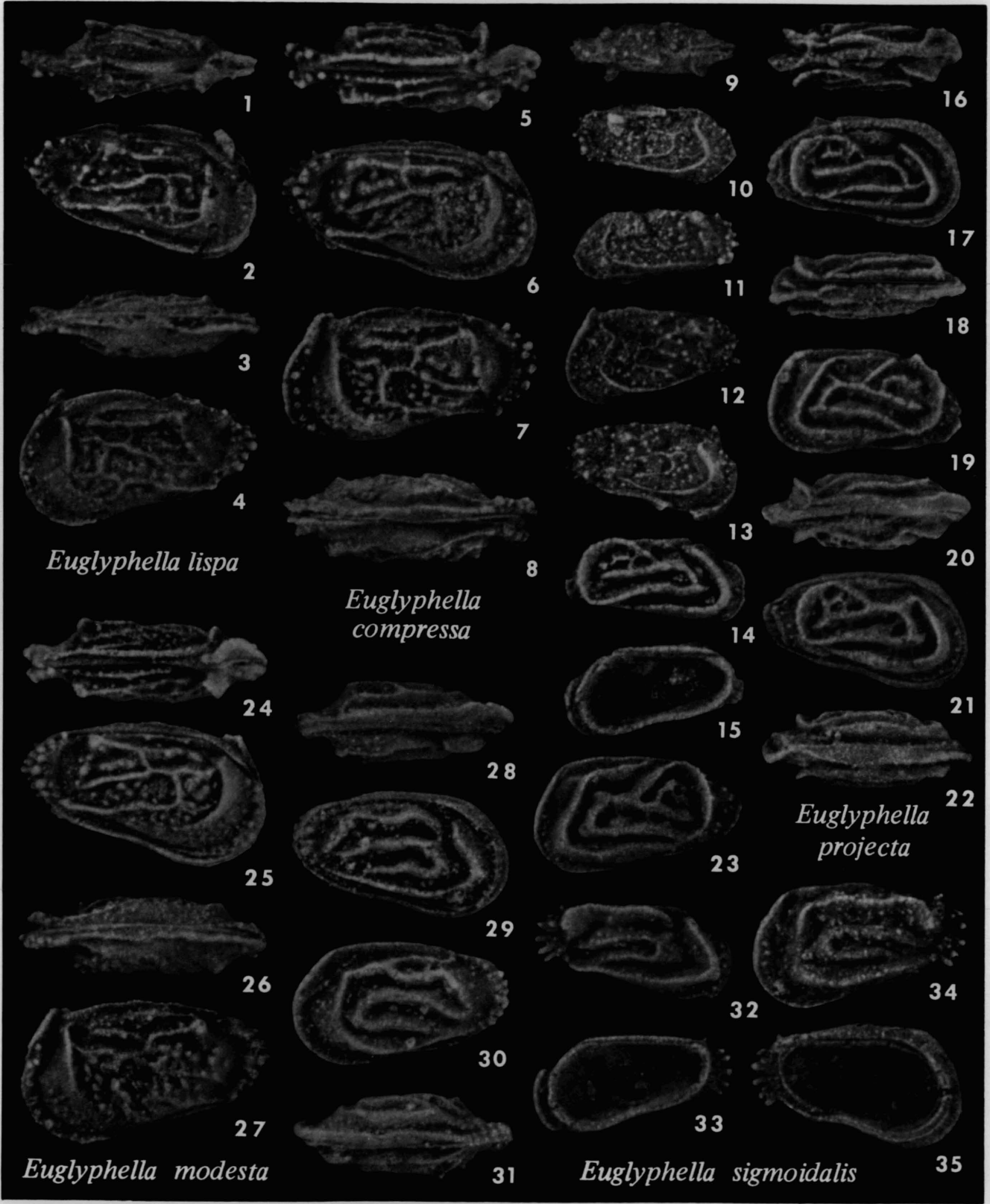

Euglyphella lispa

Euglyphella compressa

Euglyphella projecta

Euglyphella modesta

Euglyphella sigmoidalis

EXPLANATION OF PLATE 76

All figures x 40

This plate illustrates specimens of each of the five species of *Euglyphella* which occur in the Silica Formation. It emphasizes the strong similarities of some species.

1-4 -- *Euglyphella lispa*. Loc. N-7. UMMP 59094, dorsal, right, ventral, and left views of an adult carapace.

5-13 -- *Euglyphella compressa*. 5-8, UMMP 59468, Loc. MM-7, dorsal, right, left, and ventral views of fine adult specimen. 9-11, UMMP 59678, Loc. MM-7, dorsal, right, and left views of immature carapace presumed to belong to this species. 12, 13, UMMP 59097, Loc. MM-Chon, left and right views of immature carapace presumed to belong to this species.

14-23 -- *Euglyphella projecta*. 14, 15, UMMP 59103, Loc. MM-7, lateral and interior views of right valve. 16-19, UMMP 59104, Loc. MM-7, dorsal, right, ventral, and left views of carapace. 20-23, UMMP 59700, Loc. MM-Chon, dorsal, right, ventral, and left views of carapace with excellent preservation.

24-27 -- *Euglyphella modesta*. Loc. MM-7. UMMP 59089, dorsal, right, ventral, and left views of excellent adult carapace.

28-35 -- *Euglyphella sigmoidalis*. 28-31, UMMP 59107, Loc. N-18a, dorsal, right, left, and ventral views of carapace. 32, 33, UMMP 59111, Loc. MM-Chon, lateral and interior views of right valve. 34, 35, UMMP 59113, Loc. MM-Chon, lateral and interior views of left valve. The two interiors show the drastic difference in size of the two valves, as well as the restricted anterior flange of the right valve which extends forward from the overlapped anterodorsal corner.

EXPLANATION OF PLATE 77

All figures x 40

- 1-8 -- *Praepilatina silicensis*. 1-4, UMMP 59060, Loc. MM-Chon, right, ventral, dorsal, and left views of excellent specimen, its perfection marred only by a pyrite crystal in the antero-ventral region of the right valve and a slight gouge in the ventral region of the left valve; the right view shows clearly the left/right overlap interrupted at the ventral corners, and the ventral view shows the overlapping lip (bow-shaped projection) of the left valve. 5-8, UMMP 59061, Loc. N-12, right, ventral, dorsal, and left views of adult carapace.
- 9-15 -- *Euglyphella projecta*. 9, 10, UMMP 59100, Loc. MM-7, lateral and interior views of left valve. 11, 12, UMMP 59101, Loc. MM, lateral and interior views of right valve. The two interiors show how the two valves fit together. 13, UMMP 59099, Loc. MM-7, lateral view of left valve. 14, 15, UMMP 59102, Loc. MM-7, lateral and interior views of right valve. Because the valves are relatively fragile, the interiors could not be completely cleaned of adhering matrix.
- 16-24 -- *Euglyphella sigmoidalis*. Loc. MM-Chon. 16, UMMP 59114, left view of carapace. 17-20, UMMP 59109, dorsal, right, left, and ventral views of carapace. 21-24, UMMP 59112, dorsal, right, left, and ventral views of excellently preserved carapace.

PLATE 77

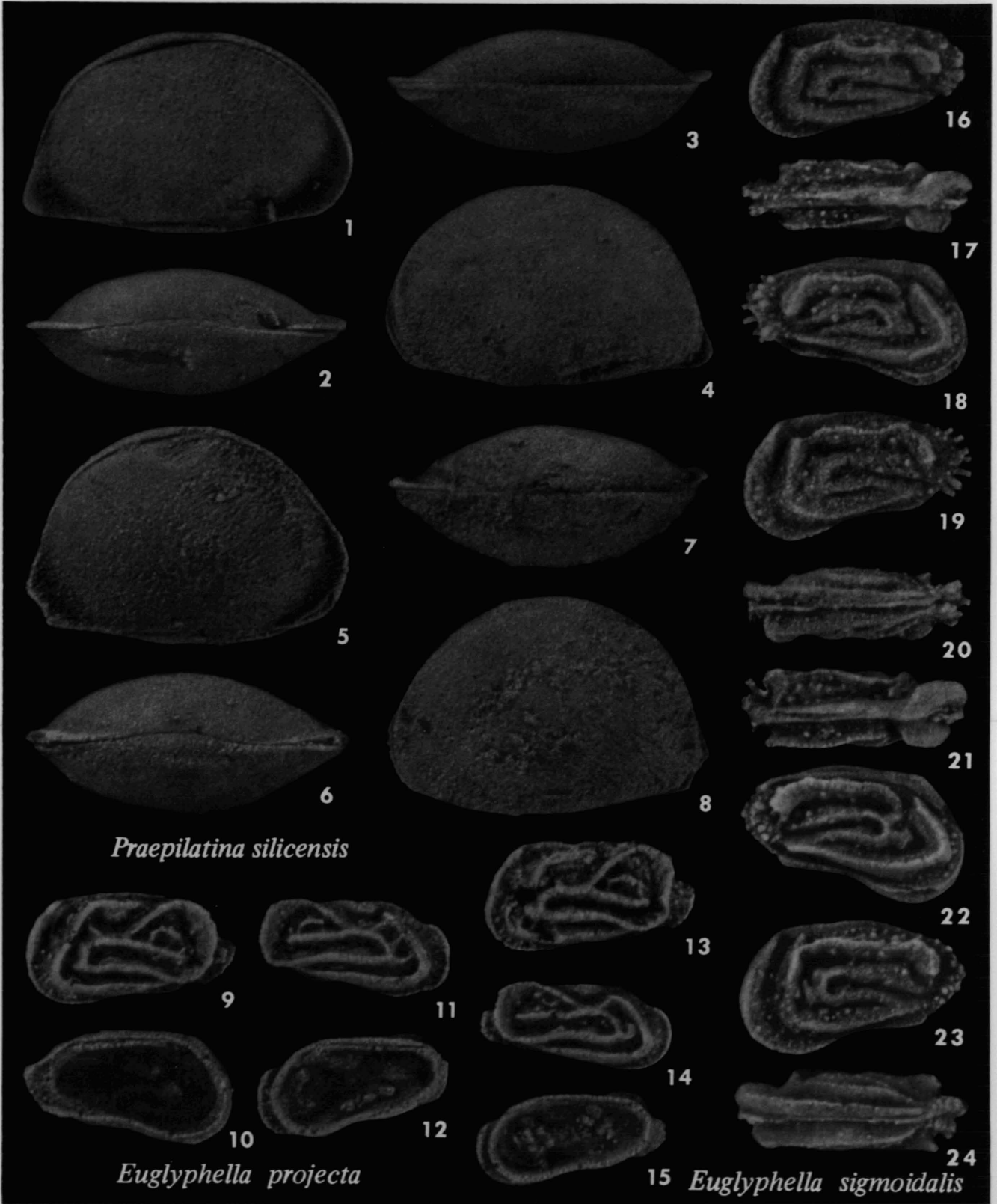

Praepilatina silicensis

Euglyphella projecta

15 *Euglyphella sigmoidalis*

PLATE 78

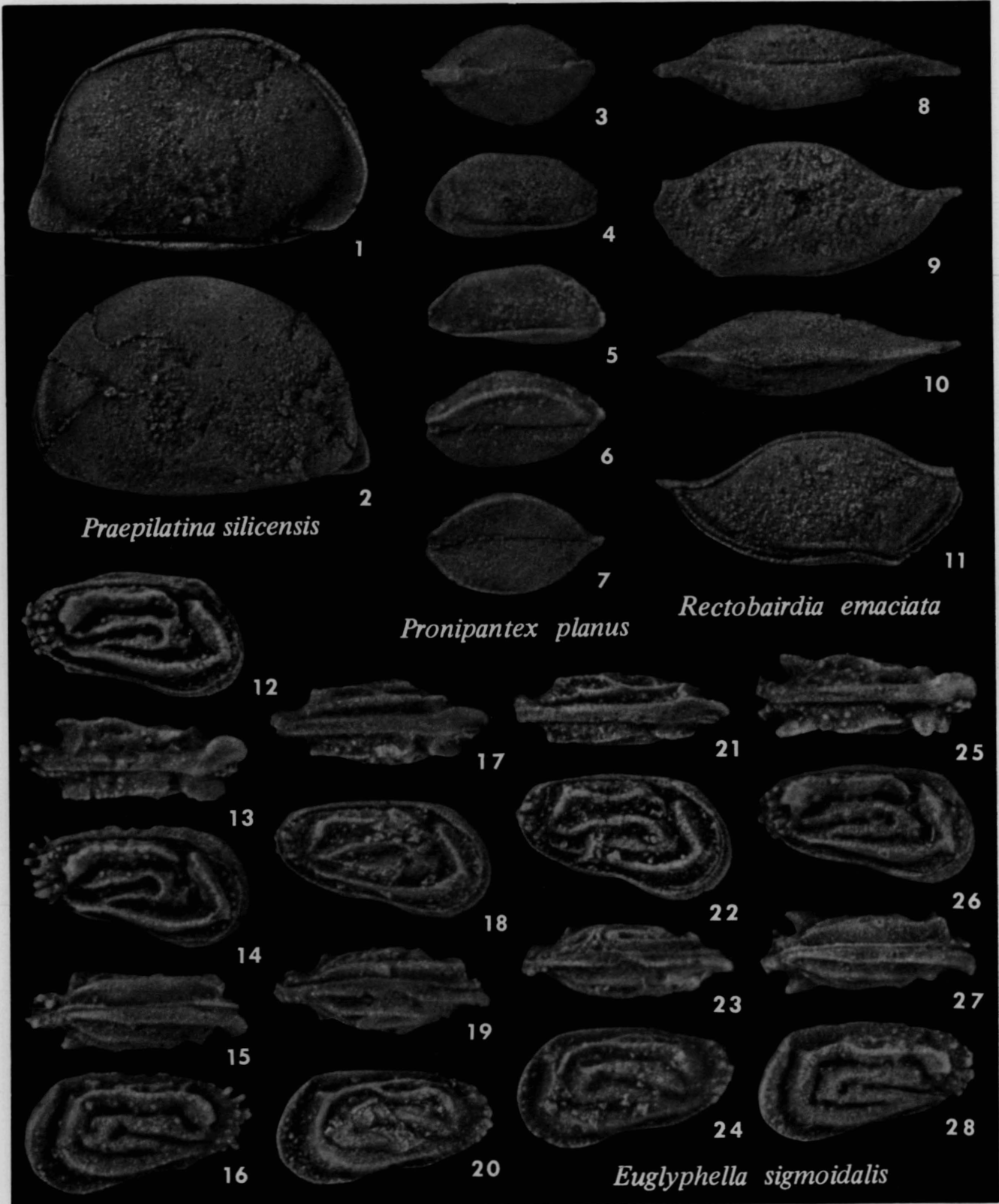

Praepilatina silicensis

Pronipantex planus

Rectobairdia emaciata

Euglyphella sigmoidalis

EXPLANATION OF PLATE 78

All figures x 40

- 1, 2 -- *Praepilatina silicensis*. Loc. MM-Chon. UMMP 59059, right and left views of slightly crushed carapace, preserving the posterior projection and the anteroventral flange projecting beyond the overlapping left valve.
- 3-7 -- *Pronipantex planus*. Loc. MM-Chon. UMMP 59382, dorsal, left, right, inclined (left-ventral), and ventral views of carapace.
- 8-11 -- *Rectobairdia emaciata*. Loc. MM-Chon. UMMP 59421, dorsal, left, ventral, and right views of carapace with anterior point broken.
- 12-28 -- *Euglyphella sigmoidalis*. 12, UMMP 59115, right view of carapace. 13-16, UMMP 59110, Loc. MM-Chon, dorsal, right, ventral, and left views of carapace. 17-20, UMMP 59108, Loc. N-18a, dorsal, right, ventral, and left views of carapace. 21-24, UMMP 59105, Loc. N-18a, dorsal, right, ventral, and left views of carapace. 25-28, UMMP 59114, Loc. MM-Chon, dorsal, right, ventral, and left views of excellent carapace, preserving the delicate posterior projections.

EXPLANATION OF PLATE 79

All figures x 40

- 1-14 -- *Euglyphella modesta*. 1-4, UMMP 59096, Loc. MM-Chon, dorsal, right, left, and ventral views of carapace. 5-8, UMMP 59149, Loc. N-7, dorsal, right, ventral, and left views of carapace. 9, 10, UMMP 59092, Loc. MM-Chon, right and left views of carapace preserving the large flat spine on the dorsum of the left valve. 11-14, UMMP 59093, Loc. MM-14/15, right, ventral, dorsal, and left views of carapace.
- 15-21 -- *Euglyphella lispa*. 15, UMMP 59090, Loc. MM-15, lateral view of left valve. 16, 17, UMMP 59095, Loc. MM-Chon, lateral and interior views of right valve. 18, 19, UMMP 59088, Loc. MM-7, interior and lateral views of left valve, with fine details of hingement. 20, 21, UMMP 59091, Loc. MM-Chon, lateral and interior views of left valve; the adductor muscle scar can be seen in the interior view.
- 22-26 -- *Euglyphella sigmoidalis*. Loc. MM-Chon. 22, UMMP 59112, lateral view of left valve. 23-26, UMMP 59115, dorsal, right, ventral, and left views of good carapace.

PLATE 79



Euglyphella modesta

Euglyphella lispa

Euglyphella sigmoidalis

10

13

14

23

24

25

26

9

11

12

22

20

21

3

4

8

15

17

19

1

2

5

6

7

16

18

PLATE 80

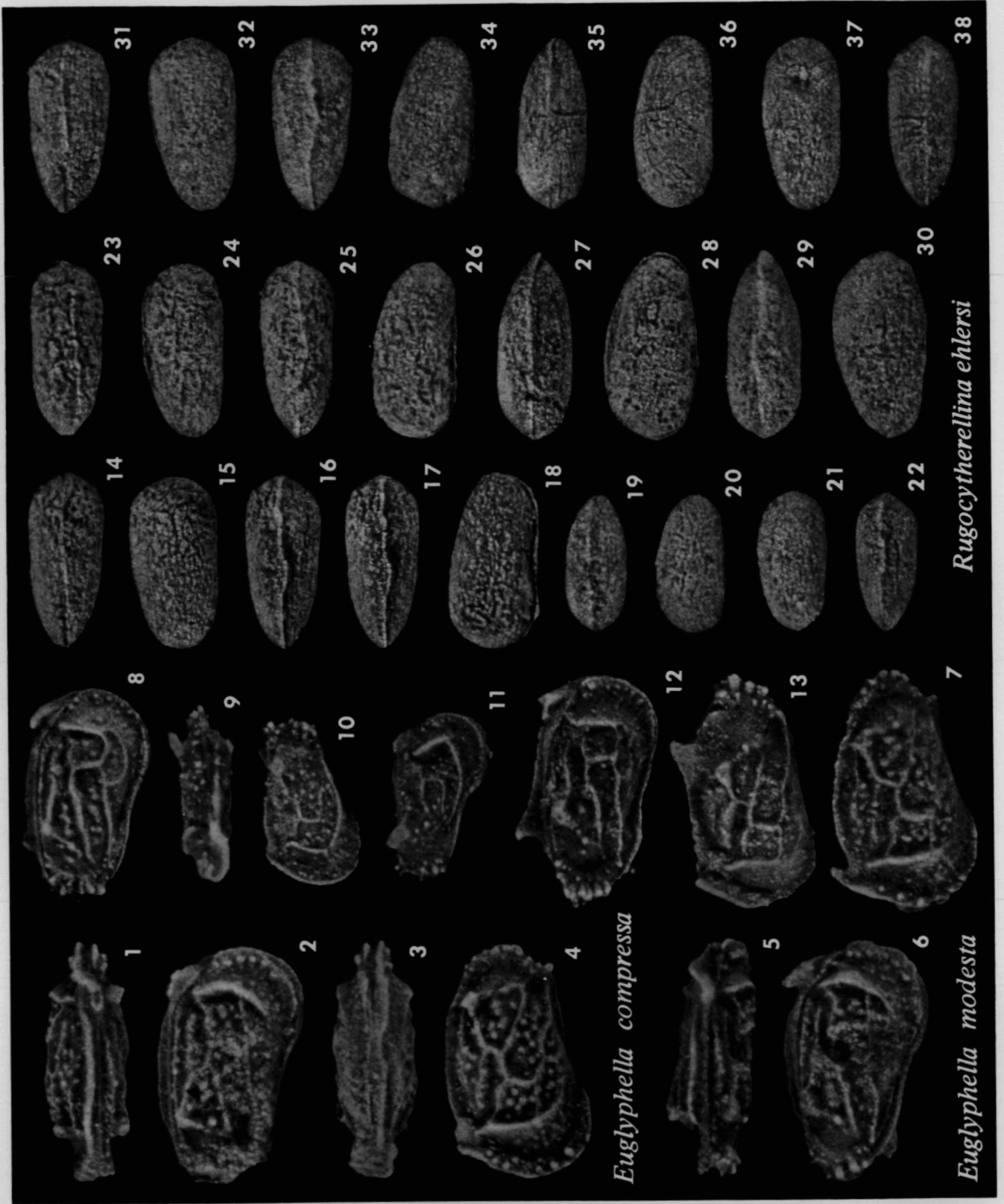

Eglyphella compressa

Eglyphella modesta

Rugocytherellina ehlersi

EXPLANATION OF PLATE 80

All figures x 40

- 1-4 -- *Euglyphella compressa*. Loc. MM-7. UMMP 59148, dorsal, right, ventral, and left views of adult carapace. The left valve shows no indication of the triangular dorsal flange which is present in specimens of the following species.
- 5-13 -- *Euglyphella modesta*. 5-7, UMMP 59096, Loc. MM-Chon, dorsal, right, and left views of adult carapace. 8, UMMP 59149, Loc. N-7, right view of carapace. 9-11, UMMP 59098, Loc. MM, dorsal, left, and right views of immature carapace presumed to belong to this species. 12, 13, UMMP 59093, Loc. MM-14/15, right and left views of adult carapace, showing the preserved triangular flange on the dorsum of the left valve.
- 14-38 -- *Rugocytherellina ehlersi*. 14-18, UMMP 59696, Loc. MM-Chon, dorsal, left, two ventral, and right views of carapace showing the typical coarse ornamentation. 19-22, UMMP 59355, Loc. N-12, dorsal, right, left, and ventral views of immature carapace. 23-26, UMMP 59593, Loc. MM-Chon, dorsal, left, ventral, and right views of carapace. 27-30, UMMP 59594, Loc. MM-Chon, dorsal, right, ventral, and left views of carapace, somewhat more plicate in the posterior half than other specimens. 31-34, UMMP 59675, Loc. N-9, dorsal, left, ventral, and right views of carapace. 35-38, UMMP 59592, Loc. MM-Chon, dorsal, right, left, and ventral views of carapace.

EXPLANATION OF PLATE 81

All figures x 40

- 1-21 -- *Scrobicula microspinosa*. Loc. WP-Chon. 1-6, UMMP 59703, dorsal, two left, two right, and ventral views of fine carapace, preserving the posterodorsal spine on each valve and showing the subconcentric arrangement of punctae around the central "bare spot." 7-11, UMMP 59702, dorsal, right, ventral, and two left views of carapace. 12-16, UMMP 59701, dorsal, two right, ventral, and left views of carapace. 17-21, UMMP 59705, dorsal, two right, ventral, and left views of carapace.
- 22-27 -- *Sigynus dictyotus*. Loc. MM-Chon. UMMP 59046, two inclined (right-dorsal), right, ventral, dorsal, and left views of carapace. The pit below the major spine in each valve, described in the holotype (and only previously known specimen), is not discernible in this one and probably is anomalous.
- 28-66 -- *Scrobicula xysta*. 28-31, UMMP 59603, Loc. N-12, dorsal, right, left, and ventral views of carapace. 32, UMMP 59601, Loc. N-12, right view of carapace. 33-34, UMMP 59595, Loc. N-12, dorsal, left, right, and ventral views of carapace bearing small pyrite crystals on the dorsum of the right valve. 37-40, UMMP 59604, Loc. WP-12, dorsal, left, right, and ventral views of carapace. 41-44, UMMP 59598, Loc. N-12, dorsal, right, left, and ventral views of carapace. 45-48, UMMP 59599, Loc. N-12, dorsal, left, ventral, and right views of carapace. 49-52, UMMP 59605, Loc. MM-Chon, dorsal, right, left, and ventral views of carapace. 53-56, UMMP 59600, Loc. N-12, right, ventral, dorsal, and left views of carapace. 57-60, UMMP 59597, Loc. N-12, dorsal, right, left, and ventral views of carapace. 61-64, UMMP 59596, Loc. N-12, dorsal, left, ventral, and right views of carapace. 65, 66, UMMP 59602, Loc. N-12, right and left views of carapace. In contrast to the other species of the genus, shown above on this plate, this one is ornamented with irregular subconcentric low ridges in addition to the punctae. It is also less consistent in its lateral shape, perhaps because it possessed less resistance to deformation by compression. In this species, the greatest width of the carapace seems to be slightly posterior in the dorsal half and slightly anterior in the ventral half, as suggested by differences in dorsal and ventral views; in other words, it has a slight swelling extending posterodorsally-anteroventrally. The illustrated specimens are the best of the collection, and many others are seriously crushed and deformed.
- 67-86 -- *Stictobollia alethae*. Loc. MM-Chon. 67, 68, UMMP 58935, lateral and interior views of right valve. 69, 70, UMMP 58936, lateral and interior views of right valve. 71, 72, UMMP 58937, interior and lateral views of left valve. 73, 74, UMMP 58940, lateral and interior views of right valve. 75, 76, UMMP 58938, lateral and interior views of left valve. 77, 78, UMMP 58939, lateral and interior views of left valve. 79-82, UMMP 58941, dorsal, left, right, and ventral views of carapace. 83-86, UMMP 58942, dorsal, left, right, and ventral views of carapace. The weak hingement seems to have been responsible for the scarcity of complete carapaces. Note the fairly consistent pattern of punctae in the illustrated sample.

PLATE 81

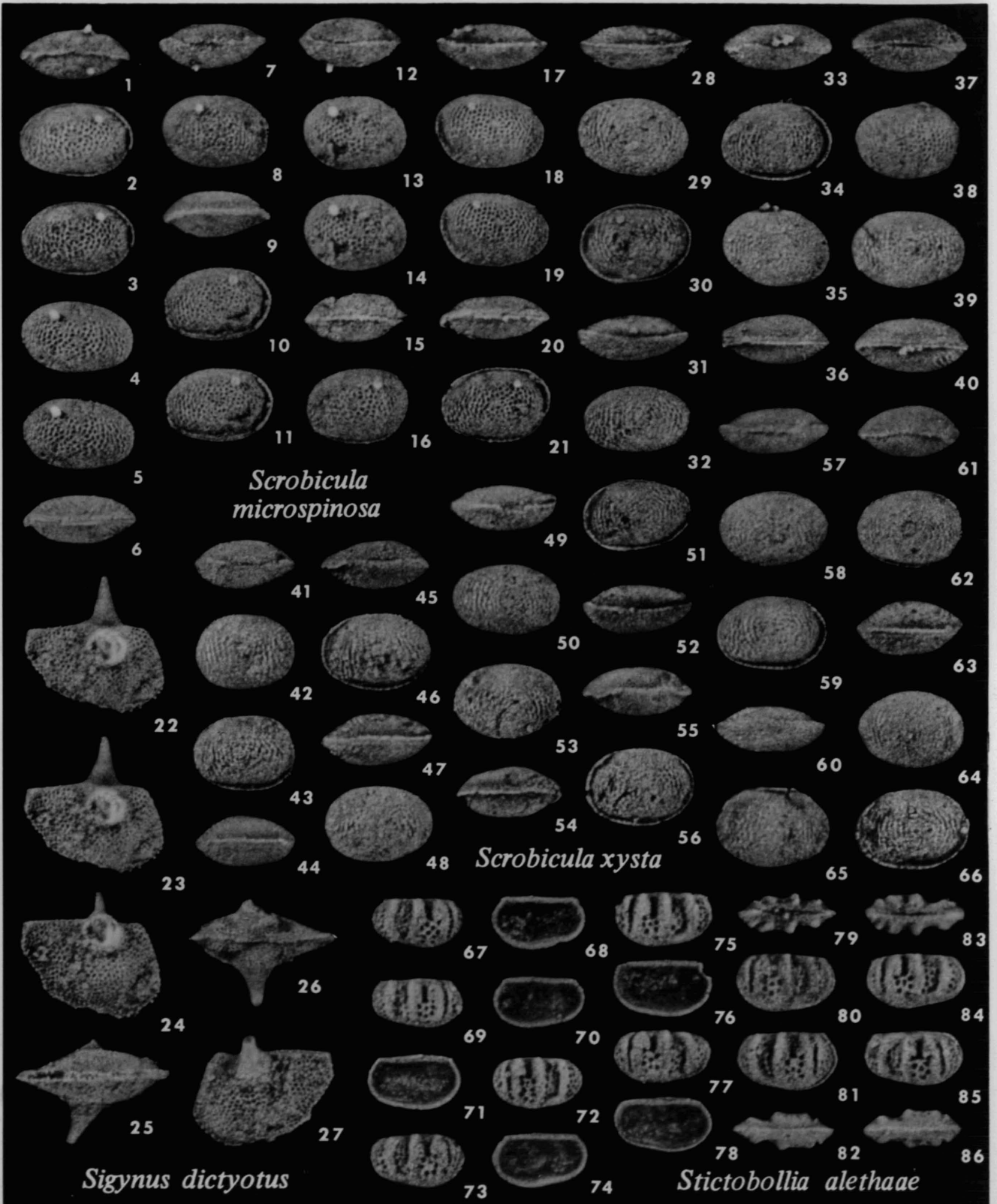
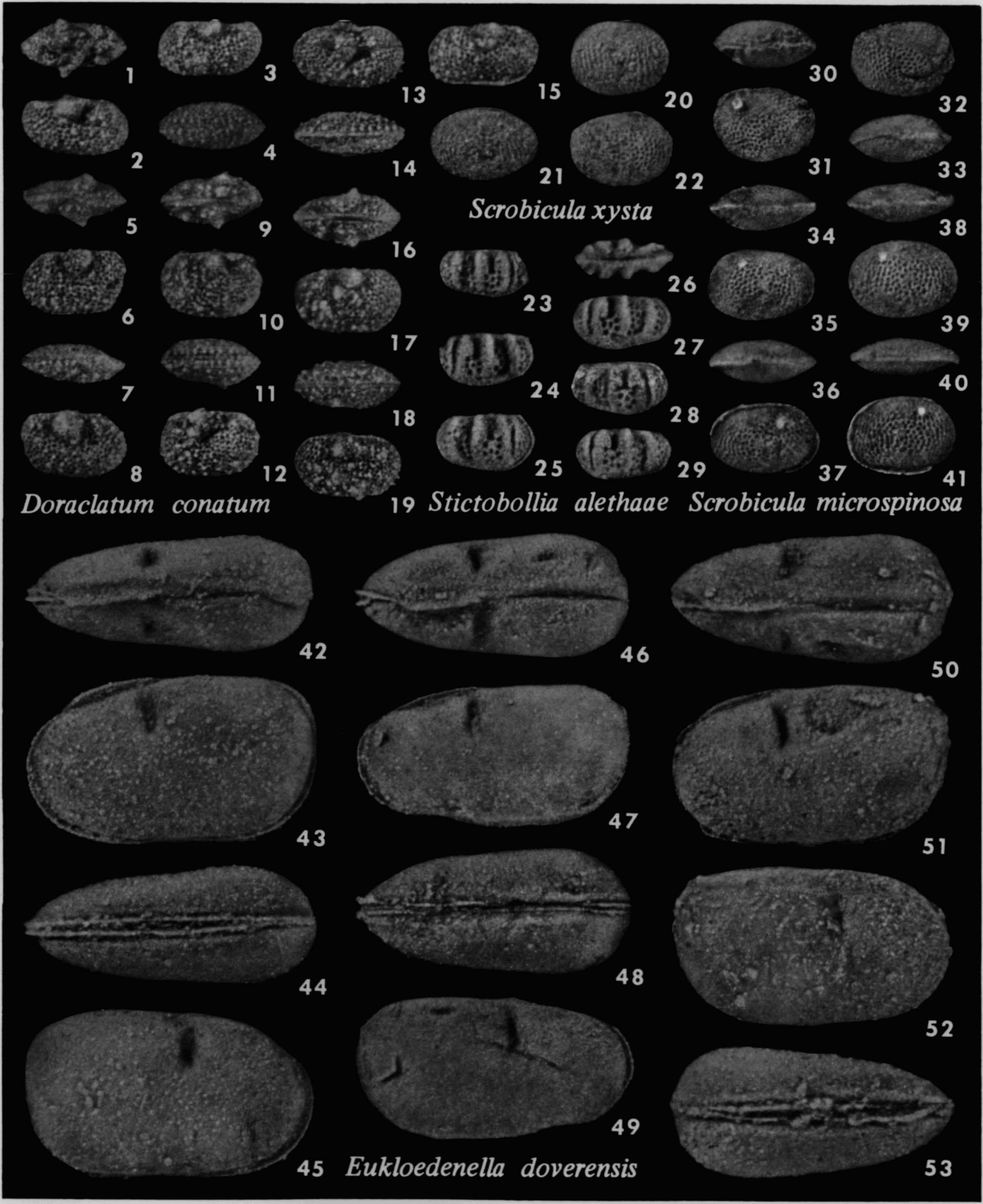

PLATE 82



EXPLANATION OF PLATE 82

All figures x 40

- 1-19 -- *Doraclatum conatum*. 1-4, UMMP 58953, Loc. MM-Chon, dorsal, right, left, and ventral views of carapace. 5-8, UMMP 58956, Loc. WP-Trop, dorsal, left, ventral, and right views of carapace. 9-12, UMMP 58955, Loc. MM-Chon, dorsal, left, ventral, and right views of carapace. 13-15, UMMP 58954, Loc. WP-Trop, left, ventral, and right views of carapace. 16-19, UMMP 58957, Loc. WP-7, dorsal, left, ventral, and right views of carapace. Note the superposition of papillae on the punctate reticulation.
- 20-22 -- *Scrobicula xysta*. 20, UMMP 59598, Loc. N-12, right view of carapace. 21, UMMP 59597, Loc. N-12, right view of carapace. 22, UMMP 59604, Loc. WP-12, left view of carapace. Note absence of posterodorsal spine on each valve.
- 23-29 -- *Stictobollia alethae*. Loc. MM-Chon. 23, UMMP 58936, lateral view of right valve. 24, UMMP 58938, lateral view of left valve. 25, UMMP 58941, lateral view of right valve. 26-28, UMMP 58942, dorsal, left, and right views of carapace. 29, UMMP 58939, lateral view of left valve.
- 30-41 -- *Scrobicula microspinosa*. Loc. WP-Chon. 30-33, UMMP 59704, dorsal, right, left, and ventral views of carapace. 34-37, UMMP 59706, dorsal, right, ventral, and left views of carapace. 38-41, UMMP 59707, dorsal, right, ventral, and left views of carapace. Note wear on posterodorsal spines as indicated by their aspect in dorsal view.
- 42-53 -- *Eukloedenella doverensis*. 42-45, UMMP 59080, Loc. MM-Chon, dorsal, left, ventral, and right views of adult carapace. 46-49, UMMP 59081, Loc. N-9, dorsal, left, ventral, and right views of carapaceslightly crushed in anteroventrally. 50-53, UMMP 59079, Loc. MM-Chon, dorsal, left, right, and ventral views of carapace. Note strong overlap anterodorsally and at posterior corner.

EXPLANATION OF PLATE 83

All figures x 40

- 1-20 -- *Eukloedenella doverensis*. Loc. MM-Chon. 1-4, UMMP 59082, dorsal, left, right, and ventral views of adult carapace. 5-8, UMMP 59085, dorsal, left, ventral, and right views of immature carapace. 9-12, UMMP 59086, dorsal, right, ventral, and left views of immature carapace. 13-16, UMMP 59084, dorsal, right, ventral, and left views of immature carapace. 17-20, UMMP 59083, dorsal, right, left, and ventral views of immature carapace. Note the difference in dorsal and ventral outlines of adult and immature carapaces: the latter are about equally plicate at both ends, whereas the adults are inflated posteriorly to have a fully rounded posterior end and taper distinctly to an acuminate anterior end.
- 21-39 -- *Tetrastorthynx diabolicus*. Loc. MM-Chon. 21-23, UMMP 59405, right, ventral, and left views of carapace. 24-27, UMMP 59403, dorsal, right, ventral, and left views of carapace. 28-31, UMMP 59402, dorsal, left, ventral, and right views of carapace. 32-35, UMMP 59404, dorsal, right, left, and ventral views of carapace. 36-39, UMMP 59406, dorsal, left, right, and ventral views of carapace. In having no development of a velar ridge posteroventrally and posteriorly, this genus differs from *Ulrichia*.
- 40-43 -- *Wideneria lispa*. Loc. MM-Chon. UMMP 59685, dorsal, right, left, and ventral views of carapace. The carapace is round in end views, and tapers nearly equally to the ends as seen in dorsal or ventral views.
- 44-46 -- *Stictobollia alethae*. Loc. MM-Chon. UMMP 58942, dorsal, left, and ventral views of carapace. Only the lobes are free of punctae.

PLATE 83

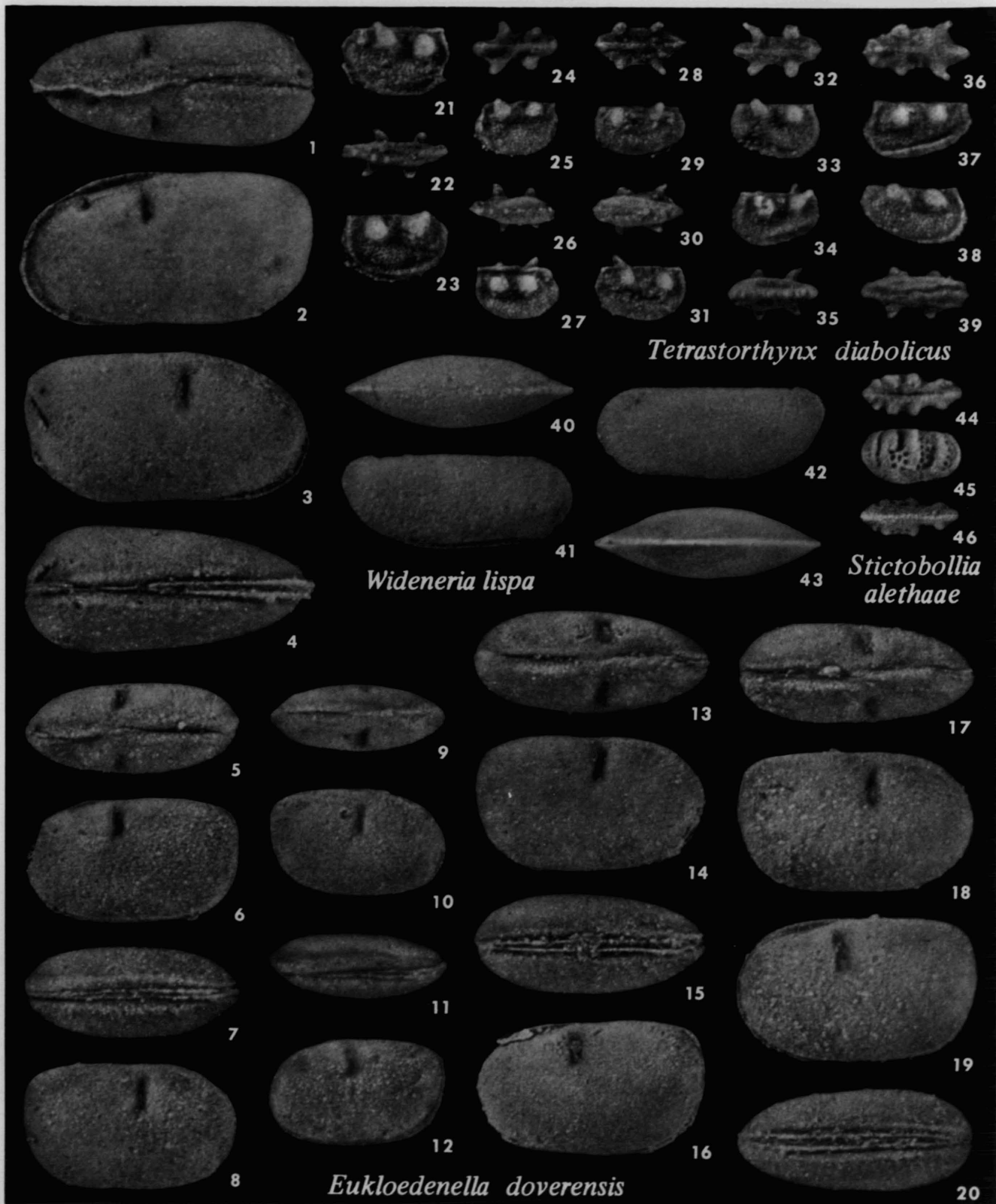

Tetrastorthynx diabolicus

Wideneria lispa

Stictobollia alethae

Eukloedenella doverensis

PLATE 84

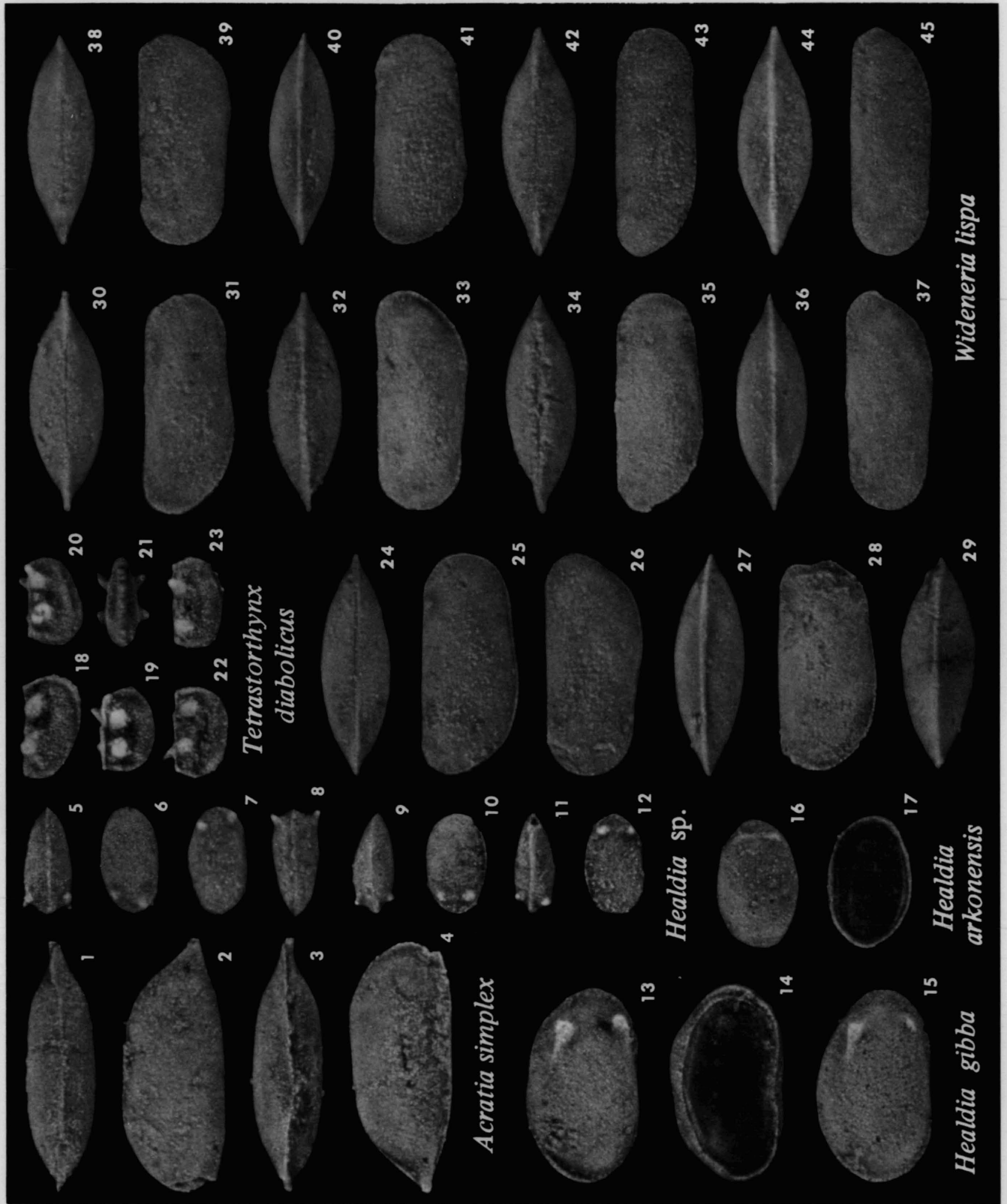

EXPLANATION OF PLATE 84

All figures x 40

- 1-4 -- *Acratia simplex*. UMMP 59670, Hungry Hollow Formation, type locality on the Ausable River, Ontario, illustrated for comparison with specimens from the Silica Formation shown in plate 9, figs. 1-3, and plate 10, figs. 3-5; dorsal, left, ventral, and right views.
- 5-12 -- *Healdia* sp. 5-8, UMMP 59132, Loc. MM-12, dorsal, right, left, and ventral views. 9-12, UMMP 59488, Loc. MM-Chon, dorsal, right, ventral, and left views. These specimens may be juveniles of one of the named species.
- 13-15 -- *Healdia gibba*. 13, 14, UMMP 59119, Loc. MM, lateral and interior views of left valve. 15, UMMP 59482, Loc. MM-12, left view of carapace.
- 16, 17 -- *Healdia* sp. UMMP 59124, Loc. MM-Chon, lateral and interior views of left valve. This may be a juvenile of *Healdia arkonensis*.
- 18-23 -- *Tetrastorthynx diabolicus*. Loc. MM-Chon. 18, UMMP 59406, right view of carapace. 19, UMMP 59403, left view of carapace. 20, 21, UMMP 59404, left and ventral views of carapace. 22, 23, UMMP 59402, right and left views of carapace.
- 24-45 -- *Wideneria lispa*. 24-27, UMMP 59054, Loc. MM-Chon, dorsal, right, left, and ventral views of carapace. 28, 29, UMMP 59693, Loc. N-9, left and ventral views of carapace damaged posteriorly. 30-33, UMMP 59051, Loc. MM-Chon, dorsal, right, ventral, and left views of fine carapace. 34-37, UMMP 59052, Loc. MM-Chon, dorsal, right, ventral, and left views of carapace. 38-41, UMMP 59053, Loc. MM-Chon, dorsal, left, ventral, and right views of carapace. 42-45, UMMP 59686, Loc. MM-Chon, dorsal, right, ventral, and left views of carapace.

EXPLANATION OF PLATE 85

All figures x 40

- 1-16 -- *Healdia gibba*. 1, 2, UMMP 59425, Loc. MM-Chon, lateral and interior views of left valve. 3, 4, UMMP 59121, Loc. S-12, lateral and interior views of right valve: note the anterior flange and the relatively short hinge, inclined when carapace rests on venter. 5-8, UMMP 59118, Loc. MM-12, dorsal, left, ventral, and right views of carapace. 9-12, UMMP 59122, Loc. MM-12, dorsal, right, ventral, and left views of excellent carapace. 13-16, UMMP 59120, Loc. MM-12, dorsal, left, right, and ventral views of carapace.
- 17-32 -- *Healdia medusaensis*. 17-20, UMMP 59126, Loc. N-11, dorsal, left, ventral, and right views of adult carapace. 21-24, UMMP 59127, Loc. N-11, dorsal, left, ventral, and right views of adult carapace. 25-28, UMMP 59128, Loc. MM-Chon, dorsal, right, left, and ventral views of immature carapace with small projecting pyrite crystals on venter. 29, UMMP 59491, Loc. MM-Chon, lateral view of immature right valve somewhat crushed and expanded dorsally. 30, UMMP 59129, Loc. MM-Chon, right view of immature carapace with anterior split. 31, UMMP 59131, Loc. MM-Chon, lateral view of immature right valve. 32, UMMP 59522, Loc. MM-Chon, lateral view of immature right valve.
- 33-39 -- *Healdia cf. medusaensis*. Loc. MM-Chon. Immature specimens that may or may not belong to the above species. 33, UMMP 59485, lateral view of right valve. 34, UMMP 59487, lateral view of left valve. 35, UMMP 59483, lateral view of right valve. 36-38, UMMP 59486, dorsal, right, and ventral views of carapace. 39, UMMP 59484, lateral view of right valve.
- 40-43, 52-55 -- *Healdia* sp. Loc. MM-Chon. 40-43, UMMP 59130, dorsal, left, right, and ventral views of carapace bearing faint reticulate pattern and lacking ridge connecting the posterior spines. 52-55, UMMP 59125, dorsal, left, ventral, and right views of carapace appreciably higher than typical *Healdia medusaensis*.
- 44-51, 56, 57 -- *Healdia arkonensis*. 44-47, UMMP 59416, Loc. WP-Trop, dorsal, left, right, and ventral views of adult carapace. 48-51, UMMP 59417, Loc. WP-Trop, dorsal, left, right, and ventral views of carapace. 56, 57, UMMP 59424, Loc. MM-Chon, lateral and interior views of left valve.

PLATE 85

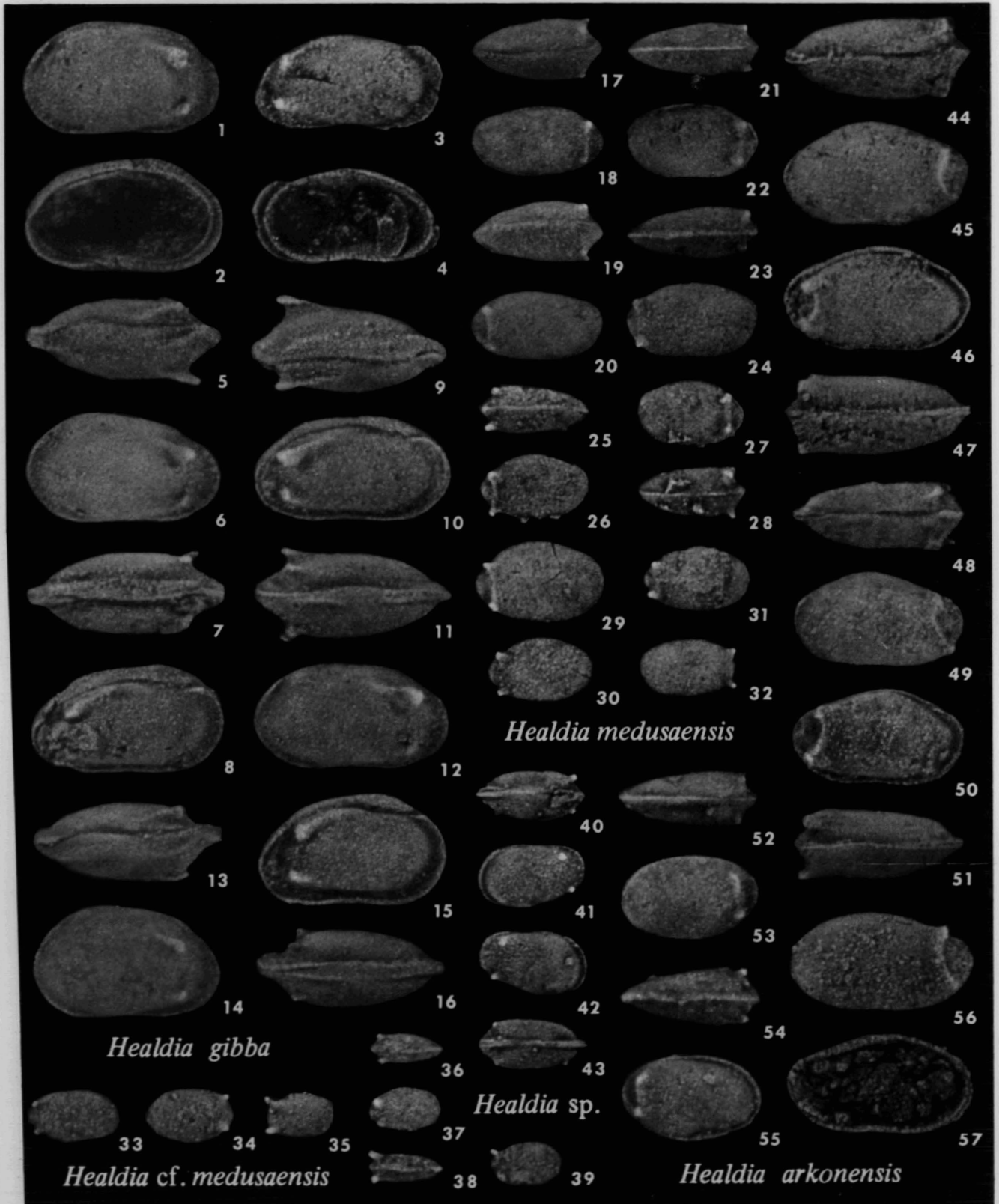
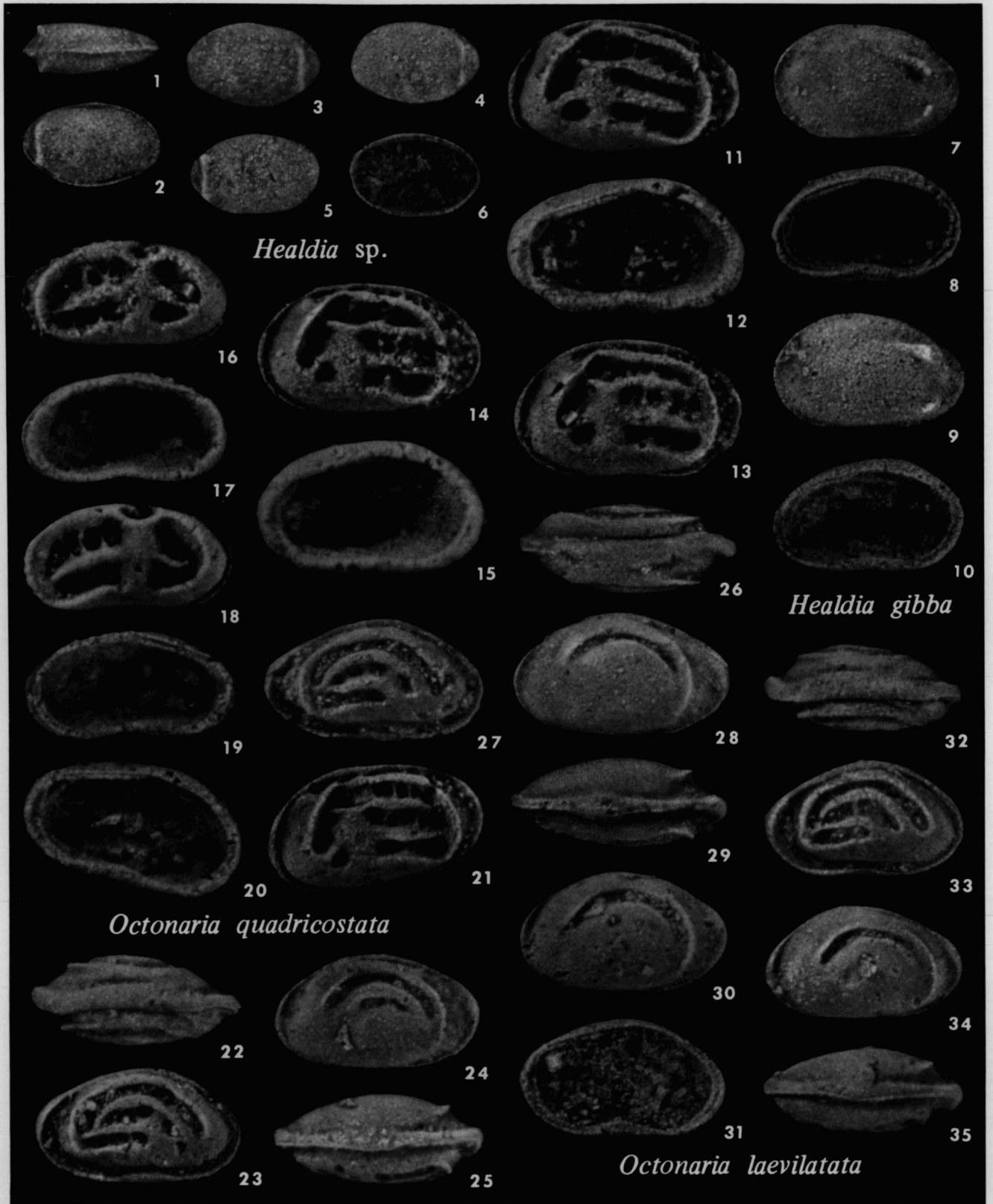

PLATE 86



EXPLANATION OF PLATE 86

All figures x 40

- 1-6 -- *Healdia* sp. Loc. MM-Chon. 1-3, UMMP 59123, dorsal, right, and left views of carapace. 4, UMMP 59124, lateral view of left valve. 5, 6, UMMP 59480, lateral and interior views of right valve. These specimens resemble the one shown in plate 85, figs. 52-55.
- 7-10 -- *Healdia gibba*. Loc. MM-12. 7, 8, UMMP 59684, lateral and interior views of left valve. 9, 10, UMMP 59482, lateral and interior views of left valve.
- 11-21 -- *Octonaria quadricostata*. 11, 12, UMMP 59211, Loc. MM-7, lateral and interior views of left valve; note that hinge slants when valve rests on venter. 13, UMMP 59210, Loc. MM-7, lateral view of left valve. 14, 15, UMMP 59207, Loc. N-7, lateral and interior views of left valve. 16, 17, UMMP 59212, Loc. N-7, lateral and interior views of right valve. 18, 19, UMMP 59213, Loc. MM-7, lateral and interior views of right valve, oriented with venter horizontal. 20, 21, UMMP 59208, Loc. N-7, interior and lateral views of left valve, oriented with hinge horizontal.
- 22-35 -- *Octonaria laevilatata*. Loc. N-17. 22-25, UMMP 59202, dorsal, right, left, and ventral views of carapace with two grooves on left valve. 26-29, UMMP 59199, dorsal, right, left, and ventral views of carapace with single groove on left valve. 30, 31, UMMP 59543, lateral and interior views of left valve. 32-35, UMMP 59201, dorsal, right, left, and ventral views of carapace.

EXPLANATION OF PLATE 87

All figures x 40

- 1-6 -- *Octonaria crescentiformis*. 1-4, UMMP 59206, Loc. MM-7, dorsal, left, right, and ventral views of carapace. 5, 6, UMMP 59228, Loc. N-12, right and left views of carapace; note three distinct grooves on left valve.
- 7-18 -- *Octonaria laevilatata*. 7-10, UMMP 59234, Loc. MM-?12, dorsal, left, ventral, and right views of carapace. 11, 12, UMMP 59230, Loc. MM, right and left views of damaged carapace. 13-16, UMMP 59204, Loc. N-17, dorsal, right, ventral, and left views of carapace. 17, 18, UMMP 59201, Loc. N-17, dorsal and right views of carapace.
- 19-32 -- *Octonaria quadricostata*. 19, 20, UMMP 59209, lateral and interior views of left valve. 21-24, UMMP 59214, Loc. MM-7, dorsal, right, left, and ventral views of carapace. 25-28, UMMP 59215, Loc. MM-7, dorsal, right, left, and ventral views of carapace. 29-32, UMMP 59217, Loc. N-7, dorsal, left, right, and ventral views of carapace.

PLATE 87

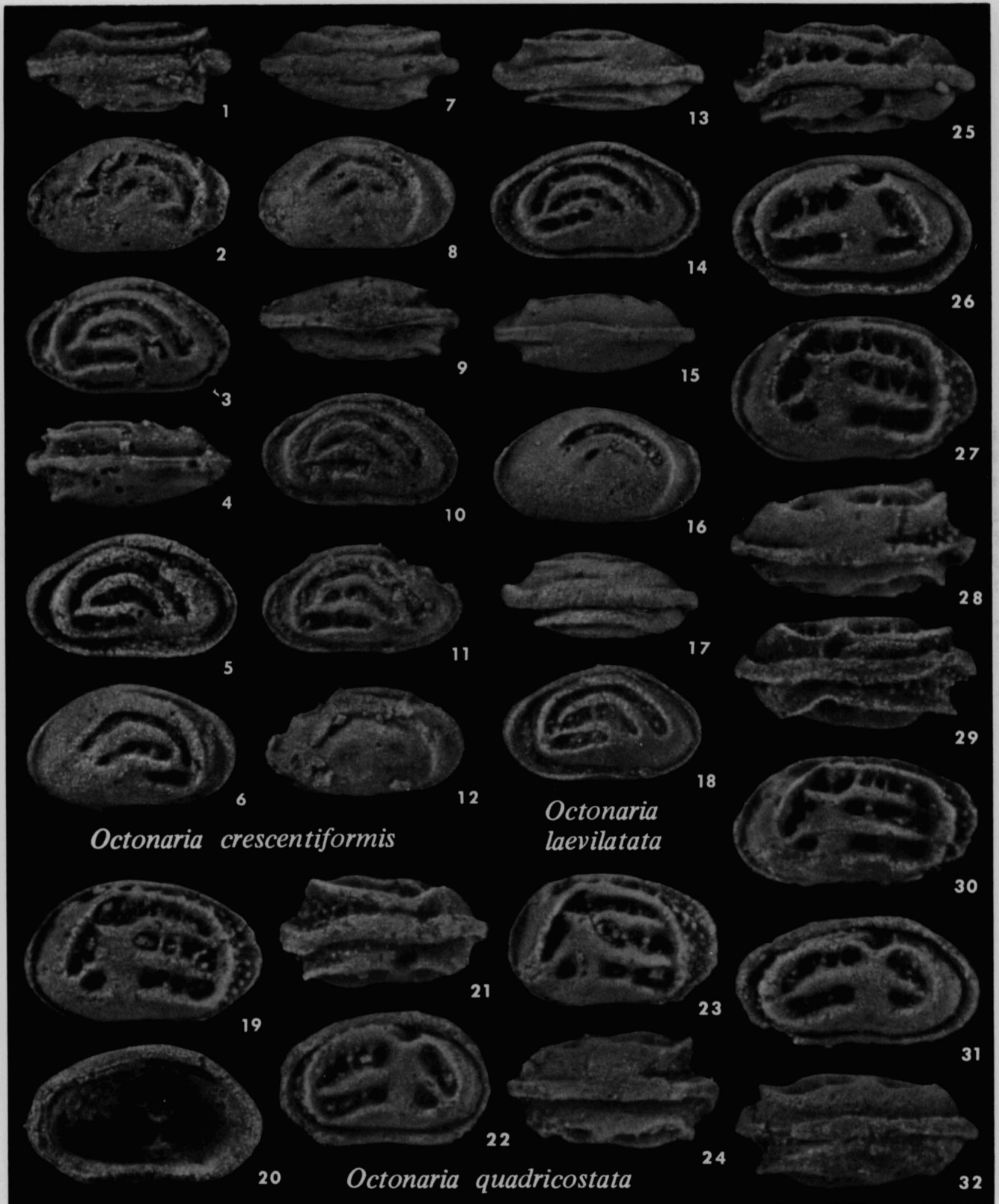
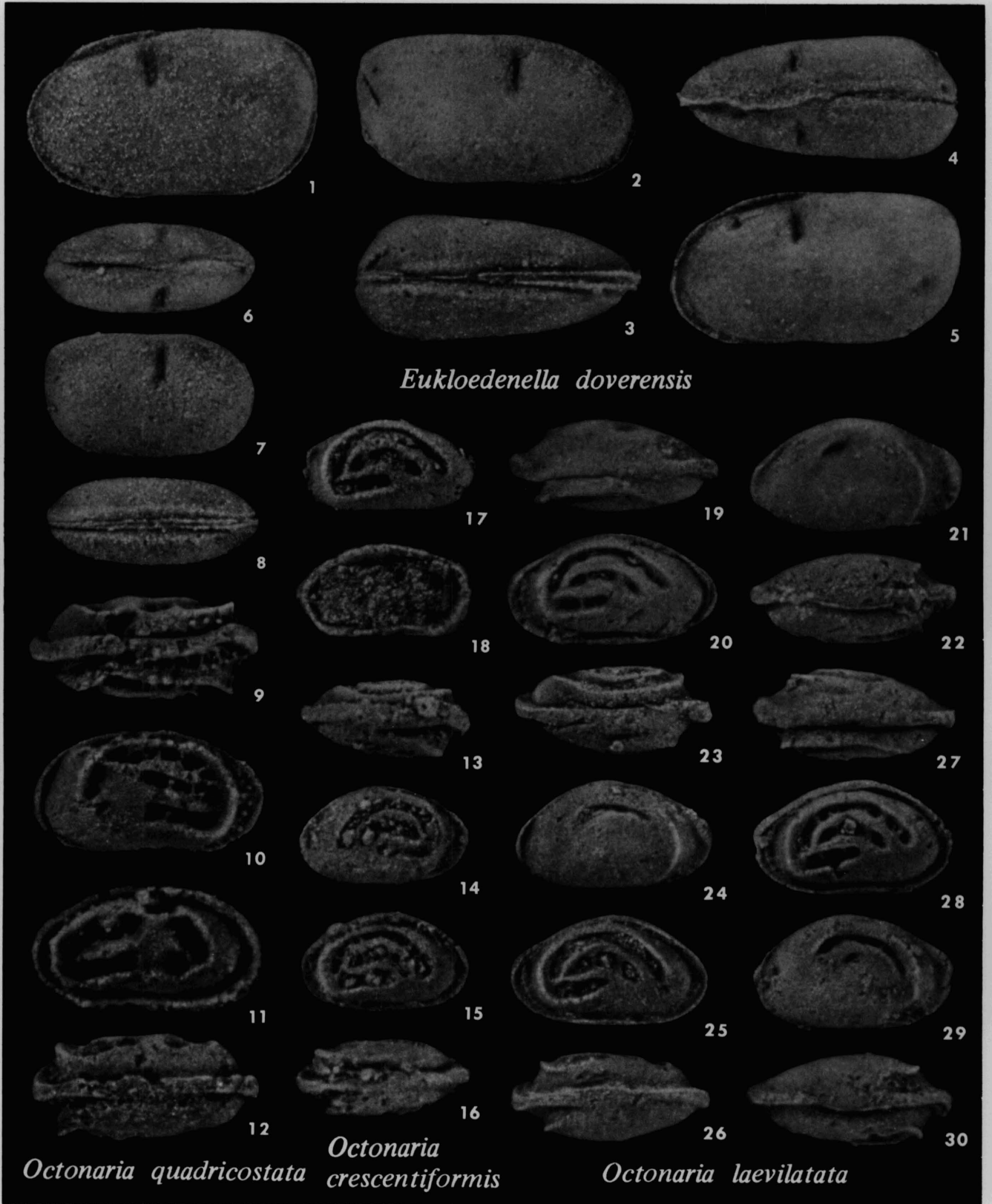

PLATE 88



Eukloedenella doverensis

Octonaria quadricostata

Octonaria crescentiformis

Octonaria laevilatata

EXPLANATION OF PLATE 88

All figures x 40

- 1-8 -- *Eukloedenella doverensis*. Loc. MM-Chon. 1, UMMP 59080, left view of carapace. 2-5, UMMP 59082, right, ventral, dorsal, and left views of adult carapace. 6-8, UMMP 59085, dorsal, right, and ventral views of immature carapace.
- 9-12 -- *Octonaria quadricostata*. Loc. N-7. UMMP 59216, dorsal, left, right, and ventral views of carapace.
- 13-16 -- *Octonaria crescentiformis*. Loc. N-12. UMMP 59229, dorsal, left, right, and ventral views of carapace.
- 17-30 -- *Octonaria laevilatata*. Loc. N-17. 17, 18, UMMP 59683, lateral and interior views of right valve. 19-22, UMMP 59205, dorsal, right, left, and ventral views of carapace. 23-26, UMMP 59200, dorsal, left, right, and ventral views of carapace. 27-30, UMMP 59203, dorsal, right, left, and ventral views of carapace. Note the variation in grooves on left valve in the carapaces.

EXPLANATION OF PLATE 89

All figures x 40

- 1-20 -- *Balantoides* sp. Loc. WP. 1-4, UMMP 58832, dorsal, right, ventral, and left views of carapace. 5-8, UMMP 59583, inclined (right-posterior), ventral, inclined (right-dorsal), and left views of carapace. 9-11, UMMP 59582, left, right, and inclined (right-dorsal) views of carapace. 12-14, UMMP 59585, left, right, and inclined (right-dorsal) views of carapace. 15-17, UMMP 58831, dorsal, right, and left views of carapace. 18-20, UMMP 59584, left, ventral, and right views of carapace. These specimens probably all belong in the species below.
- 21-55 -- *Balantoides trilobata*. 21, UMMP 59676n, Loc. WP, right view of carapace. 22, 23, UMMP 59676b and 59676k, inclined (left-anterodorsal) views of two carapaces. 27, UMMP 59676d, inclined (right-dorsal) view of carapace. 28, UMMP 59676o, Loc. WP, right view of carapace. 29, UMMP 59676e, Loc. WP, inclined (right-dorsal) view of carapace. 30-32, UMMP 58833, Loc. WP, dorsal, right, and left views of carapace. 33-35, UMMP 58830, Loc. S-12, dorsal, left, and right views of carapace. 36, 37, UMMP 58826, Loc. MM-Chon, interior and lateral views of left valve. 38-41, UMMP 58829, Loc. MM-Chon, dorsal, left, ventral, and right views of carapace. 42-45, UMMP 58828, Loc. S-12, dorsal, left, ventral, and right views of carapace. 46, 47, UMMP 58824, Loc. S-12, lateral and interior views of left valve. 48, 49, UMMP 58827, Loc. S-12, interior and lateral views of right valve. 51, UMMP 59676c, Loc. WP, inclined (left-dorsal) view of carapace. 52, UMMP 59676f, Loc. WP, inclined (left-posterodorsal) view of carapace. 53, UMMP 59676a, Loc. WP, inclined (left-dorsal) view of carapace. 54, UMMP 59676l, Loc. WP, inclined (right-dorsal) view of carapace. 55, UMMP 59676i, Loc. WP, inclined (right-anterodorsal) view of carapace. 50, UMMP 58825, Loc. S-12, right view of carapace.
- 56-60 -- *Wideneria lispa*. Loc. MM-Chon. 56, 57, UMMP 59686, right and left views of carapace. 58-60, UMMP 59051, dorsal, right, and left views of carapace.
- 61-67 -- *Octonaria quadricostata*. Loc. MM-7. 61-63, UMMP 59215, dorsal, right, and left views of carapace. 64-67, UMMP 59214, dorsal, right, ventral, and left views of carapace. Compare proportions of the two specimens.
- 68-71 -- *Octonaria laevilatata*. Loc. N-17. UMMP 59202, dorsal, right, left, and ventral views of carapace.

PLATE 89

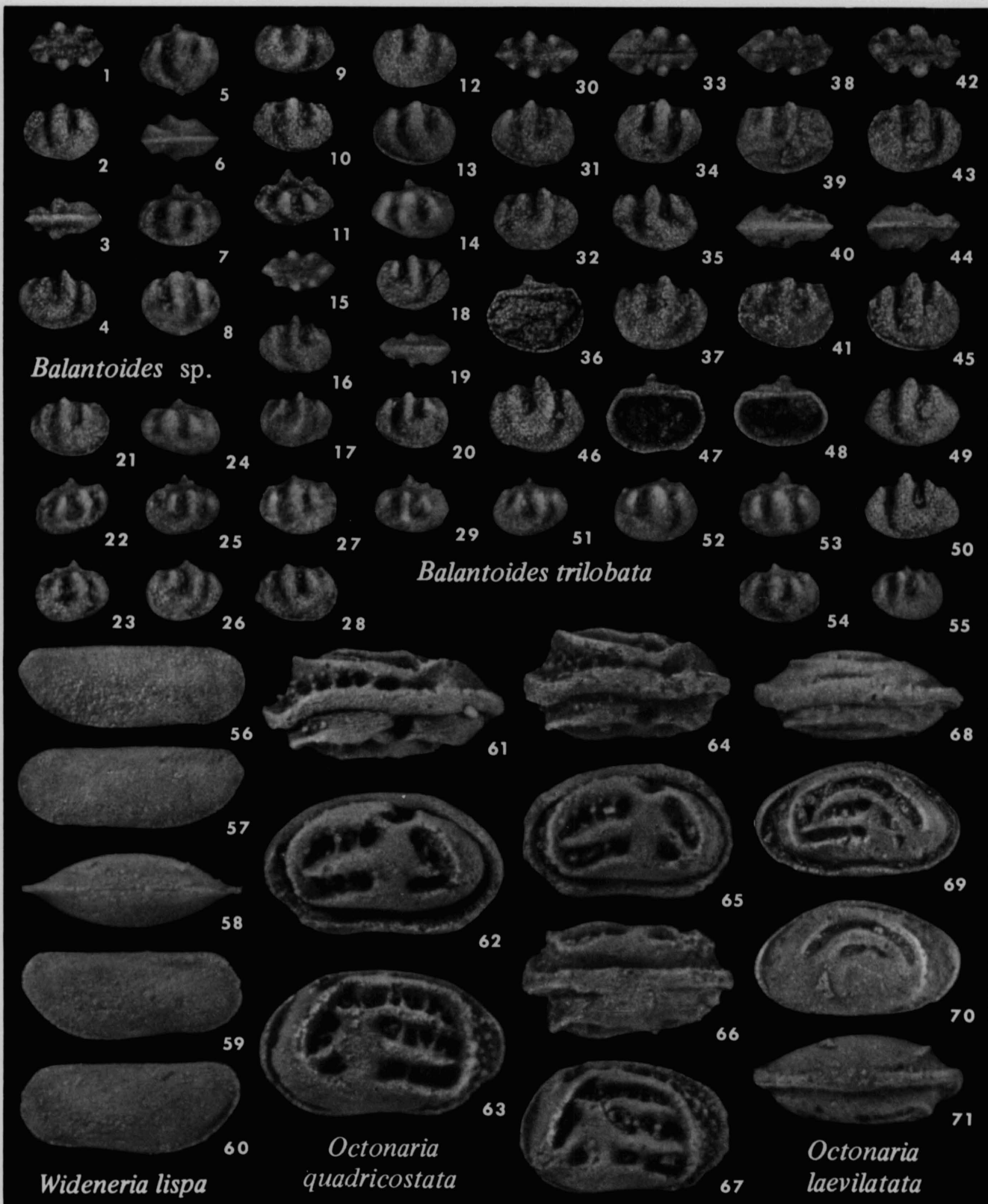

PLATE 90



EXPLANATION OF PLATE 90

All figures x 40

- 1-23 -- *Bairdiocypris transptyxis*. 1-4, UMMP 58856, Loc. MM-Chon, dorsal, left, right, and ventral views of adult carapace. 5-7, UMMP 58857, Loc. MM-Chon, dorsal, left, and right views of carapace. 8-11, UMMP 59076, Loc. S-12, dorsal, left, right, and ventral views of carapace. 12-15, UMMP 59075, Loc. S-12, dorsal, left, right, and ventral views of well-preserved carapace; only a slight "bow-shaped projection" developed in the ventral part of the overlapping left valve. 16-19, UMMP 59437, Loc. MQ, right, ventral, dorsal, and left views of immature carapace. 20-23, UMMP 59077, right, ventral, dorsal, and left views of adult carapace.
- 24, 25 -- *Doraclatum conatum*. Loc. MM-Chon. UMMP 58955, right and left views of carapace.

EXPLANATION OF PLATE 91

All figures x 40

- 1-12 -- *Bairdiocypris transptyxis*. 1-4, UMMP 59435, Loc. MM-Chon, dorsal, left, right, and ventral views of adult carapace. 5-8, UMMP 59436, Loc. S-12, right, ventral, dorsal, and left views of adult carapace. 9-12, UMMP 58858, Loc. MM-Chon, right, ventral, dorsal, and left views of immature carapace; note that even the immature carapace differs in proportions and shape from the species below.
- 13-30 -- *Bairdiocypris gongylus*. Loc. MM-Chon. 13-16, UMMP 59623, dorsal, left, right, and ventral views of fine adult carapace. 17-20, UMMP 59625, dorsal, left, ventral, and right views of carapace. 21-24, UMMP 59621, dorsal, right, ventral, and left views of carapace. 25, 26, UMMP 59624, lateral and interior views of left valve. 27-30, UMMP 59626, dorsal, left, right, and ventral views of carapace.

PLATE 91

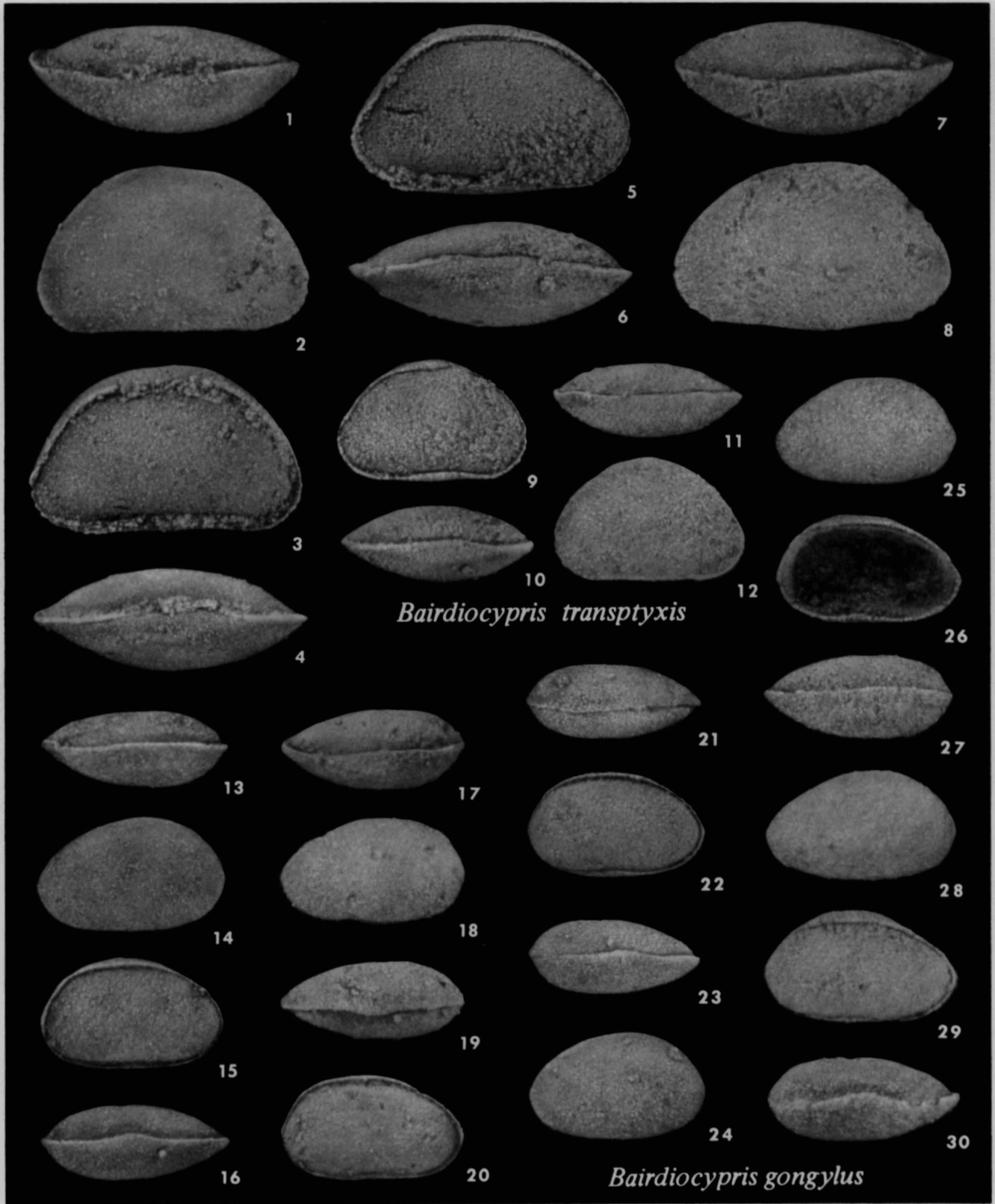
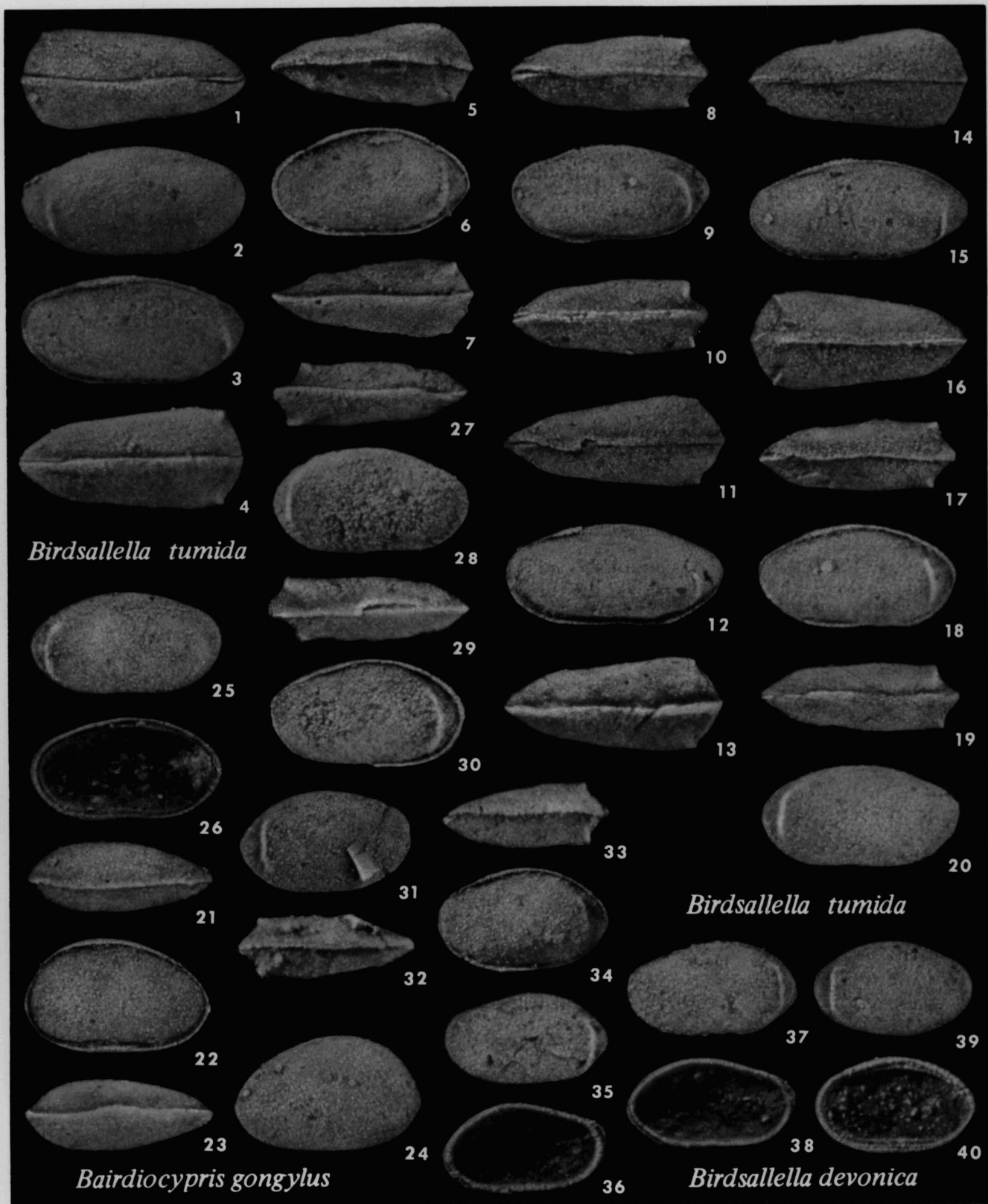

PLATE 92



EXPLANATION OF PLATE 92

All figures x 40

- 1-20 -- *Birdsallella tumida*. Loc. MM-Chon. 1-4, UMMP 58860, dorsal, right, left, and ventral views of adult (probably female) carapace. 5-7, UMMP 59439, dorsal, left, and ventral views of carapace (male type). 8-10, UMMP 59442, dorsal, left, and ventral views of male carapace. 11-13, UMMP 59445, dorsal, left, and ventral views of adult carapace. 14-16, UMMP 59444, dorsal, left, and ventral views of female carapace. 17-20, UMMP 59440, dorsal, left, ventral, and right views of male carapace.
- 21-24 -- *Bairdiocypris gongylus*. Loc. MM-Chon. UMMP 59622, dorsal, right, ventral, and left views of adult carapace. Note on this plate that the genus *Bairdiocypris* has L/R overlap, whereas the genus *Birdsallella* has the opposite overlap -- R/L.
- 25-40 -- *Birdsallella devonica*. Loc. MM-Chon. 25, 26, UMMP 58859, lateral and interior views of right valve. 27-30, UMMP 58863, dorsal, right, ventral, and left views of carapace. 31-34, UMMP 58867, right, ventral, dorsal, and left views of carapace with pyrite crystal protruding from anteroventral region of right valve. 35, 36, UMMP 58864, lateral and interior views of left valve. 37, 38, UMMP 58865, lateral and interior views of left valve. 39, 40, UMMP 58866, lateral and interior views of right valve; note that the right valve overlaps the left in this genus.

EXPLANATION OF PLATE 93

All figures x 40

- 1-10 -- *Bufina abbreviata*. Loc. MM-Chon. 1, 2, UMMP 58872, lateral and interior views of left valve, oriented with the hinge line horizontal. 3, 4, UMMP 58873, lateral and interior views of right valve, oriented with the hinge line horizontal. 5-7, UMMP 58868, right, ventral, and left views of carapace, oriented in lateral views with venter horizontal (in the position at rest on the flat bottom sediment). 8-10, UMMP 58871, right, ventral, and left views of carapace; note the strong overlap of the left valve around the free edge.
- 11-18 -- *Doraclatum conatum*. 11, UMMP 58953, Loc. MM-Chon, left view of carapace. 12, 13, UMMP 58955, right and ventral views of carapace. 14-16, UMMP 58956, Loc. WP-Trop, dorsal, left, and ventral views of carapace. 17, 18, UMMP 58957, Loc. WP-7, dorsal and right views of carapace.
- 19, 20 -- *Bufina curti*. Loc. MM-Chon. UMMP 58876, lateral and interior views of right valve, oriented with the venter horizontal (the normal position of the animal at rest); note that in this orientation the hinge line slopes backward and downward from the dorsal apex and that the gape of the opened carapace is greatest anteroventrally.
- 21-43 -- *Birdsallella tumida*. Loc. MM-Chon. 21-24, UMMP 59690, dorsal, right, ventral, and left views of carapace; note the R/L overlap around all of left valve; comparison of the posterior width with that of other adult specimens suggests that the species is dimorphic and that this is a male. 25-28, UMMP 59446, dorsal, right, ventral, and left views of carapace presumed to be in the ultimate immature instar. 29, 30, UMMP 59677, lateral and interior views of left valve. 31-33, UMMP 58861, dorsal, left, and ventral views of adult presumed female carapace; note the tumid posterior region and the short posterior ridge (developed only in the posteroventral area). 34-36, UMMP 59441, dorsal, left, and ventral views of immature carapace. 37-39, UMMP 59443, dorsal, left, and ventral views of adult presumed female carapace. 40-43, UMMP 58862, dorsal, right, left, and ventral views of adult presumed female carapace. The surface of the valves in this species is basically smooth, but nearly all specimens show effects of corrosion or irregular replacement.

PLATE 93

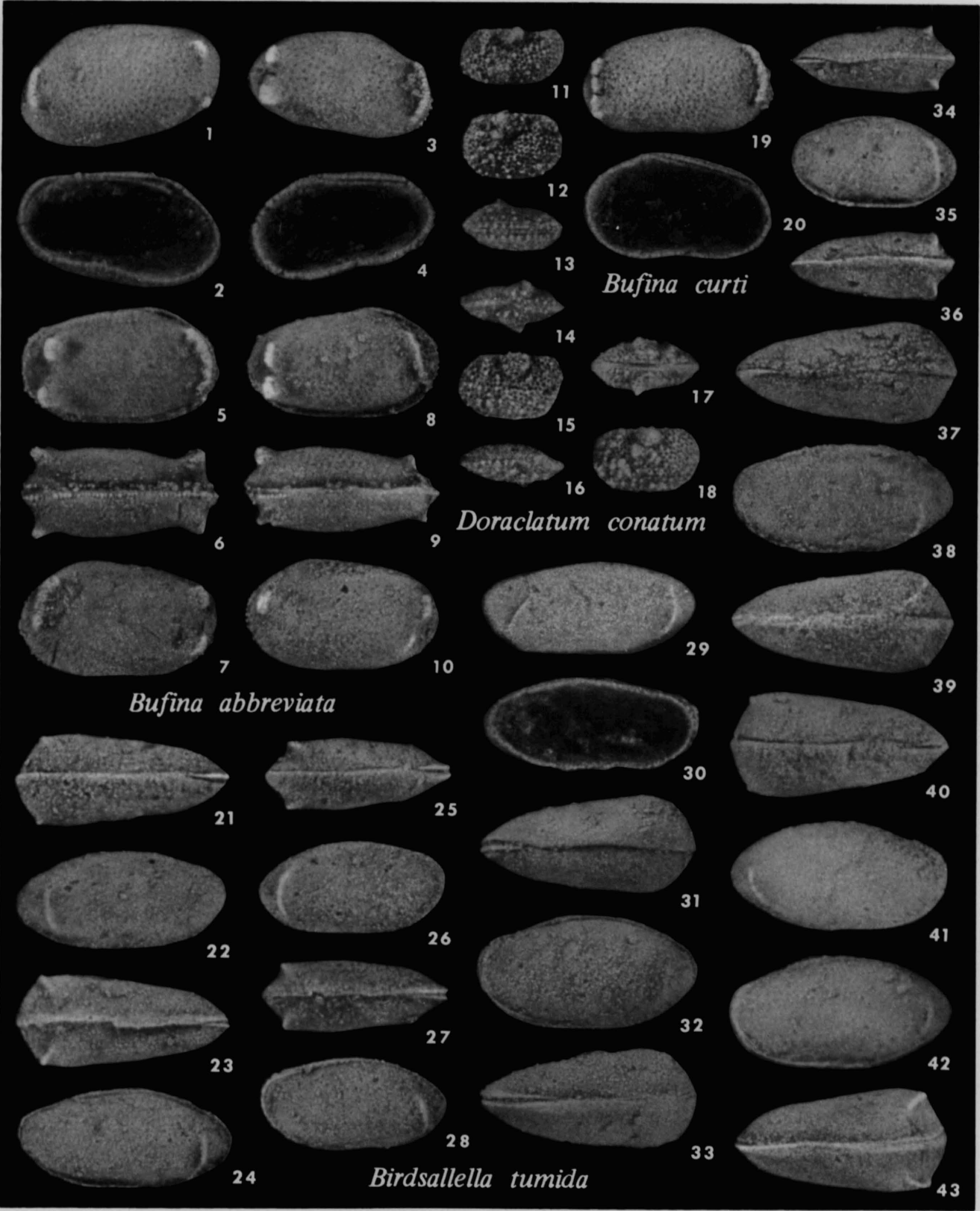
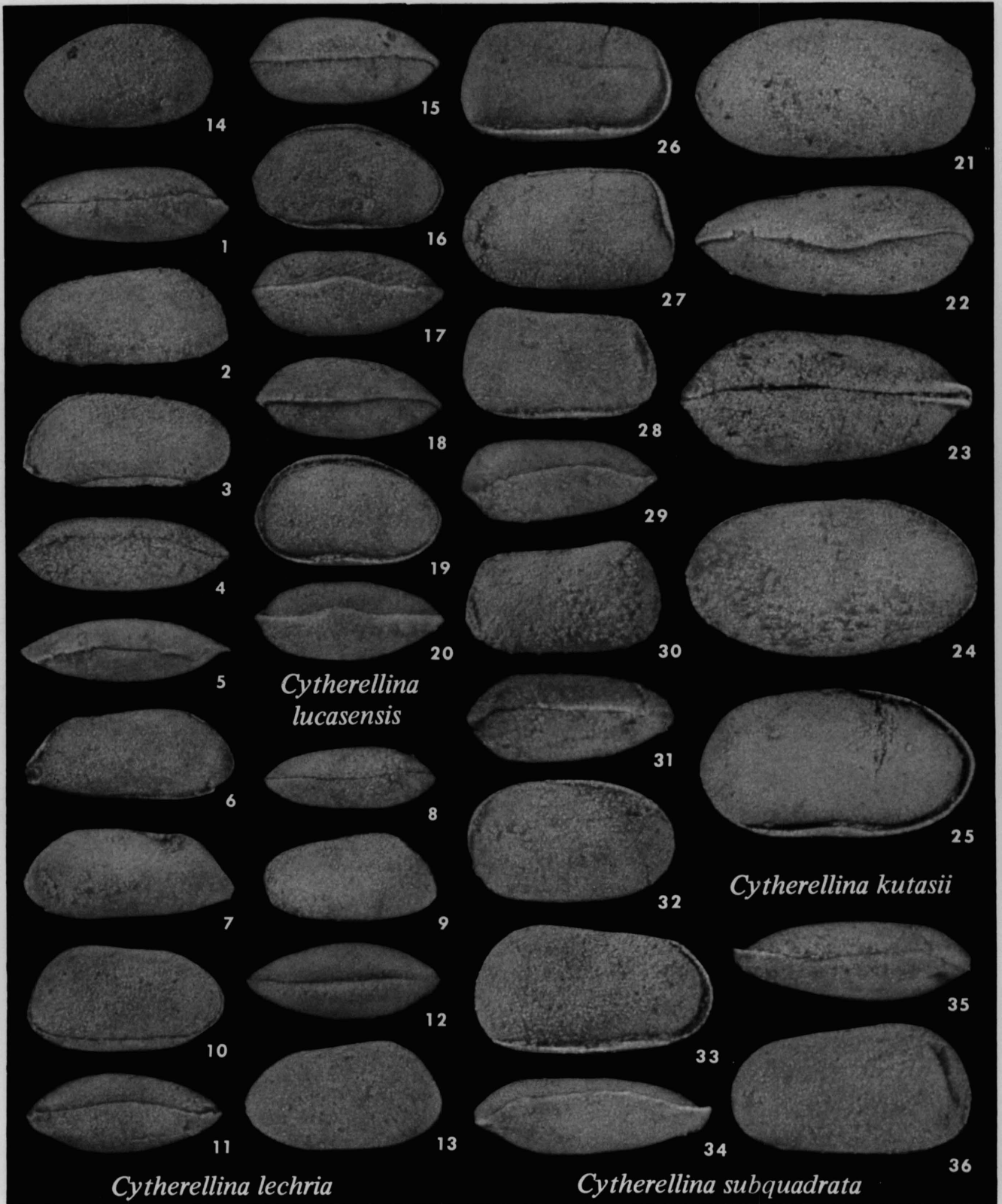

PLATE 94



EXPLANATION OF PLATE 94

All figures x 40

- 1-13 -- *Cytherellina lechria*. 1-4, UMMP 59570, Loc. WP-Chon, dorsal, left, right, and ventral views of carapace. 6,7, UMMP 59567, Loc. N-18, right and left views of damaged carapace. 8,9, UMMP 59062, Loc. MM-Chon, dorsal and left views of carapace. 10-13, UMMP 59566, Loc. N-18, right, ventral, dorsal, and left views of carapace. Specimens are oriented in the position the carapace would assume at rest on a horizontal surface, not with reference to the hinge line.
- 14-20 -- *Cytherellina lucasensis*. Loc. MM-Chon. 14-17, UMMP 58889, left, dorsal, right, and ventral views of carapace. 18-20, UMMP 58890, dorsal, right, and ventral views of carapace. The overlapping left valve has a distinct ventral lip.
- 21-25 -- *Cytherellina kutasii*. 21,22, UMMP 58883, Loc. MM-Trop, left and ventral views of carapace. 23,24, UMMP 59564, Loc. MM-Chon, dorsal and right views of carapace. 25, UMMP 59563, Loc. N-9, right view of carapace.
- 26-36 -- *Cytherellina subquadrata*. Loc. MM-Chon. 26,27, UMMP 59572, right and left views of carapace. 28-30, UMMP 58892, right, ventral, and left views of carapace. 31,32, UMMP 59571, dorsal and right views of carapace. 33-36, UMMP 58891, right, ventral, dorsal, and left views of carapace. The ventral lip of the overlapping left valve is very broad in this species. Valves are commonly askew, probably because of the weak overlap.

EXPLANATION OF PLATE 95

All figures x 40

- 1-16 -- *Cytherellina kutasii*. 1, 2, UMMP 59562, Loc. MM-Chon, left and ventral views of carapace. 3, 4, UMMP 59563, Loc. N-9, dorsal and right views of carapace. 5, 6, UMMP 59561, Loc. MM-Chon, dorsal and right views of fine carapace, showing undeformed hinge line. 7, 8, UMMP 59565, Loc. MM-Chon, dorsal and right views of carapace. 9, 10, UMMP 59559, Loc. MM-Chon, dorsal and left views of good carapace. 11, 12, UMMP 59560, Loc. MM-Chon, dorsal and right views of carapace. 13, 14, UMMP 59692, Loc. MM-Chon, dorsal and right views of carapace. 15, UMMP 58884, Loc. MM-Trop, right view of carapace. 16, UMMP 58883, Loc. MM-Trop, left view of carapace. Note that the anterior radius of curvature of the border is only slightly less than that of the posterior.
- 17-27 -- *Cytherellina lechria*. 17-20, UMMP 59062, dorsal, left, right, and ventral views of fine carapace; note the very broad lip on the venter of the overlapping left valve. 21-23, UMMP 59568, Loc. N-18, dorsal, right, and ventral views of carapace. 24-27, UMMP 59064, Loc. MM-Chon, dorsal, left, right, and ventral views of carapace. Note the posteroventral acuminate corner of the valves.
- 28-37 -- *Cytherellina lucasensis*. Loc. MM-Chon. 28-31, UMMP 58885, dorsal, right, ventral, and left views of typical carapace. 32-35, UMMP 58888, dorsal, left, right, and ventral views of carapace. 36, 37, UMMP 58886, lateral and interior views of right valve; note the narrow anterior flange projecting slightly beyond the free edge of the valve.

PLATE 95

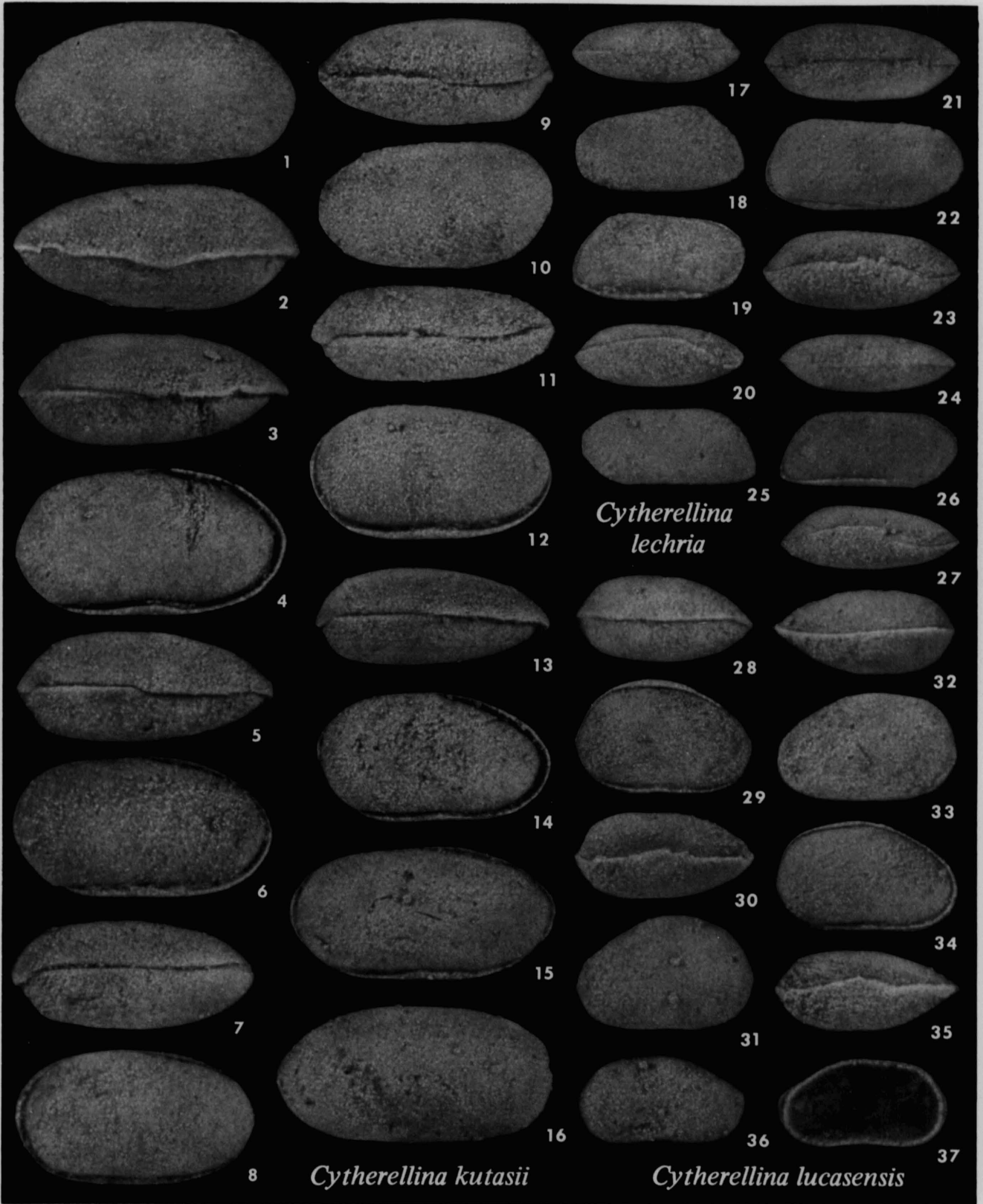

PLATE 96



EXPLANATION OF PLATE 96

All figures x 40

- 1-6 -- *Cytherellina lechria*. 1-3, UMMP 59569, Loc. N-15, dorsal, right, and ventral views of carapace. 4-6, UMMP 59063, Loc. MM-Chon, dorsal, right, and left views of carapace.
- 7-16 -- *Cytherellina subquadrata*. 7-9, UMMP 59573, Loc. MM-Chon, dorsal, right, and ventral views of carapace. 10-12, UMMP 58893, Loc. MM-Chon, dorsal, right, and left views of carapace with valves slightly offset laterally. 13-16, UMMP 58894, Loc. N-12, dorsal, right, ventral, and left views of immature carapace.
- 17-23, 32-35 -- *Cytherellina tanymeka*. 17, 18, UMMP 59618, Loc. MM-Chon, lateral and interior views of right valve. 19-22, UMMP 59574, Loc. N-Chon, dorsal, right, ventral, and left views of carapace. 23, UMMP 59577, Loc. N-Chon, dorsal view of carapace. 32-35, UMMP 59580, Loc. MM-Chon, dorsal, right, ventral, and left views of fine carapace.
- 24-31 -- *Cytherellina* sp. 24-27, UMMP 59578, Loc. MM-Chon, dorsal, right, ventral, and left views of carapace. 28-31, UMMP 59576, Loc. N-Chon, dorsal, right, ventral, and left views of carapace. In both specimens, compression in the anterior region of the carapace has probably increased the height somewhat. The carapaces may belong in *kutasii*, a species characterized by an anterior end only slightly smaller than the posterior, rather than in *tanymeka*, a species characterized by a forward taper and an anterior end conspicuously smaller than the posterior.

EXPLANATION OF PLATE 97

All figures x 40

- 1-7 -- *Cytherellina tanymeka*. 1-3, UMMP 59575, Loc. MQ-Chon, dorsal, left, and ventral views of adult carapace. 4-7, UMMP 59579, Loc. MM-Chon, dorsal, right, ventral, and left views of carapace. Note the distinctive shape in lateral views.
- 8-15 -- *Cytherellina lucasensis*. Loc. MM-Chon. 8-11, UMMP 58888, right, ventral, dorsal, and left views of carapace. 12, 13, UMMP 58887, interior and lateral views of left valve. 14, UMMP 58889, right view of carapace. 15, UMMP 58890, right view of carapace.
- 16-26 -- *Bufina abbreviata*. Loc. MM-Chon. 16-18, UMMP 58871, right, ventral, and left views of carapace, oriented with the ventral border horizontal, in the position of resting on a flat surface. 19-22, UMMP 58870, dorsal, right, left, and ventral views of carapace, oriented with the hinge line horizontal. 23-26, UMMP 58869, dorsal, right, ventral, and left views of carapace; fine denticles fringe the anterior and posterior borders.
- 27-37 -- *Bufina curti*. 27, UMMP 58877, Loc. MM-Chon, lateral view of right valve. 28-31, UMMP 58875, Loc. N-7, dorsal, right, ventral, and left views of carapace. 32-37, UMMP 58874, Loc. MM-Chon, anterior, inclined (left-anterior), dorsal, left, right, and ventral views of carapace; the flat posterior spines in this species nearly form a ridge.

PLATE 97

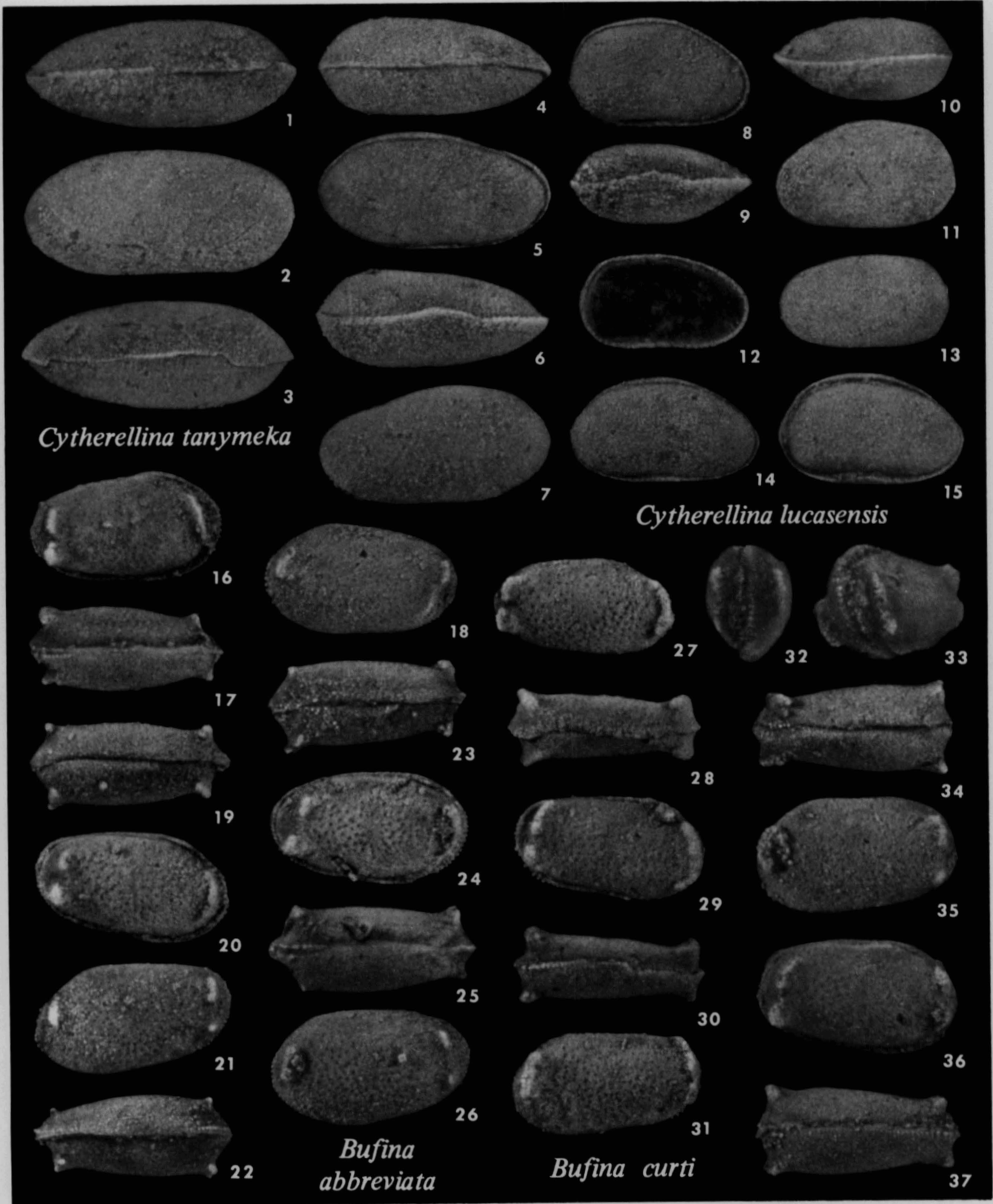

Cytherellina tanymeke

Cytherellina lucasensis

Bufina abbreviata

Bufina curti

PLATE 98

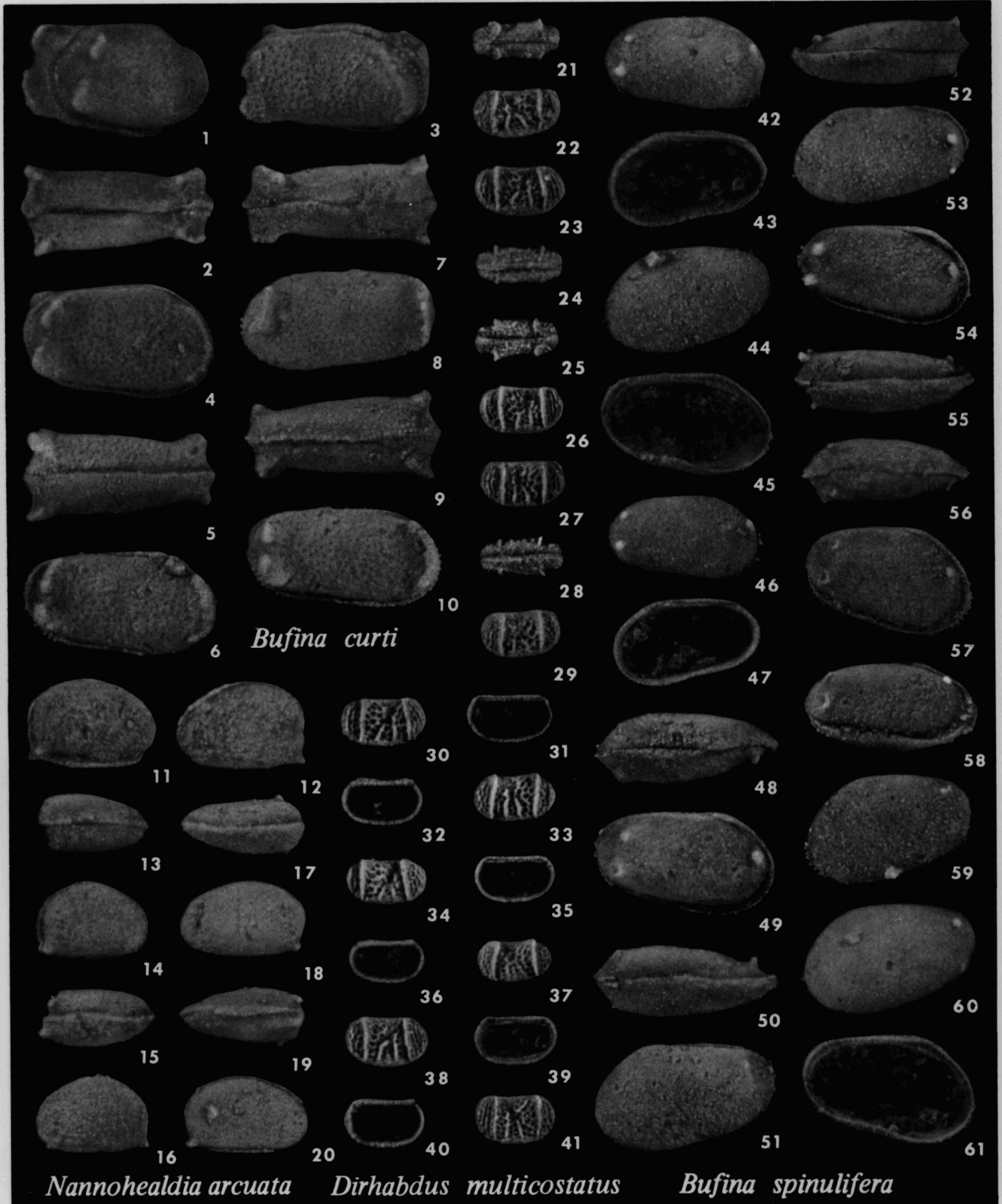

EXPLANATION OF PLATE 98

All figures x 40

- 1-10 -- *Bufina curti*. 1-5, UMMP 59689, Loc. N-18a, inclined (right-posterior), dorsal, inclined (right-anterodorsal), right, and ventral views of carapace. 6, UMMP 58875, Loc. N-7, right view of carapace. 7-10, UMMP 58878, Loc. N-7, dorsal, left, ventral, and right views of carapace.
- 11-20 -- *Nannohealdia arcuata*. 11, 12, UMMP 59541, Loc. MM-Chon, right and left views of carapace with valves slightly askew. 13-16, UMMP 59539, Loc. S-12, dorsal, right, ventral, and left views of carapace. 17-20, UMMP 59044, Loc. MM-Chon, dorsal, left, ventral, and right views of carapace with projecting pyrite crystal in posterior area of right valve.
- 21-41 -- *Dirhabdus multicostatus*. Loc. MM-Chon. 21-24, UMMP 59279, dorsal, left, right, and ventral views of carapace. 25-28, UMMP 59464, dorsal, right, left, and ventral views of carapace. 29, UMMP 59281, left view of carapace. 30, 31, UMMP 59278, lateral and interior views of right valve. 32, 33, UMMP 59283, interior and lateral views of left valve. 34, 35, UMMP 59463, lateral and interior views of right valve. 36, 37, UMMP 59282, interior and lateral views of left valve. 38, 39, UMMP 59276, lateral and interior views of right valve. 40, 41, UMMP 59277, interior and lateral views of left valve.
- 42-61 -- *Bufina spinulifera*. Loc. MQ-9/11. 42, 43, UMMP 58881, lateral and interior views of right valve. 44, 45, UMMP 58880, lateral and interior views of left valve. 46, 47, UMMP 59449, lateral and interior views of right valve. 48-51, UMMP 59448, dorsal, right, ventral, and left views of carapace. 52-55, UMMP 58879, dorsal, left, right, and ventral views of carapace. 56-59, UMMP 58882, dorsal, right, inclined (right-ventral), and left views of carapace with pyrite crystal on ventral edge of left valve. 60, 61, UMMP 59447, lateral and interior views of left valve.

EXPLANATION OF PLATE 99

All figures x 40

- 1-10 -- *Dirhabdus multicostatus*. Loc. MM-Chon. 1-4, UMMP 59281, dorsal, right, left, and ventral views of carapace. 5, UMMP 59276, lateral view of right valve. 6,7, UMMP 59464, dorsal and right views of carapace. 8,9, UMMP 59280, lateral and interior views of right valve. 10, UMMP 59277, lateral view of left valve.
- 11-40 -- *Bythocyproidea eriensis*. 11-14, UMMP 58899, Loc. MM-Chon, dorsal, left, ventral, and right views of carapace. 15-18, UMMP 59133, Loc. MM-Trop, dorsal, right, ventral, and left views of carapace. 19-22, UMMP 58895, Loc. MM-Chon, dorsal, right, ventral, and left views of carapace. 23-26, UMMP 59456, Loc. MM-Chon, dorsal, right, ventral and left views of carapace. 27-30, UMMP 58897, Loc. MM-Chon, dorsal, right, inclined (right-dorsal), and left views of carapace. 31-33, UMMP 58898, Loc. MM-Chon, dorsal, right, and left views of carapace. 34, UMMP 59451, Loc. WP-Chon, lateral view of immature right valve. 35-38, UMMP 59454, Loc. MM-Chon, dorsal, right, ventral, and left views of immature carapace. 39,40, UMMP 58896, Loc. MM-Trop, lateral and interior views of right valve.

PLATE 99



PLATE 100

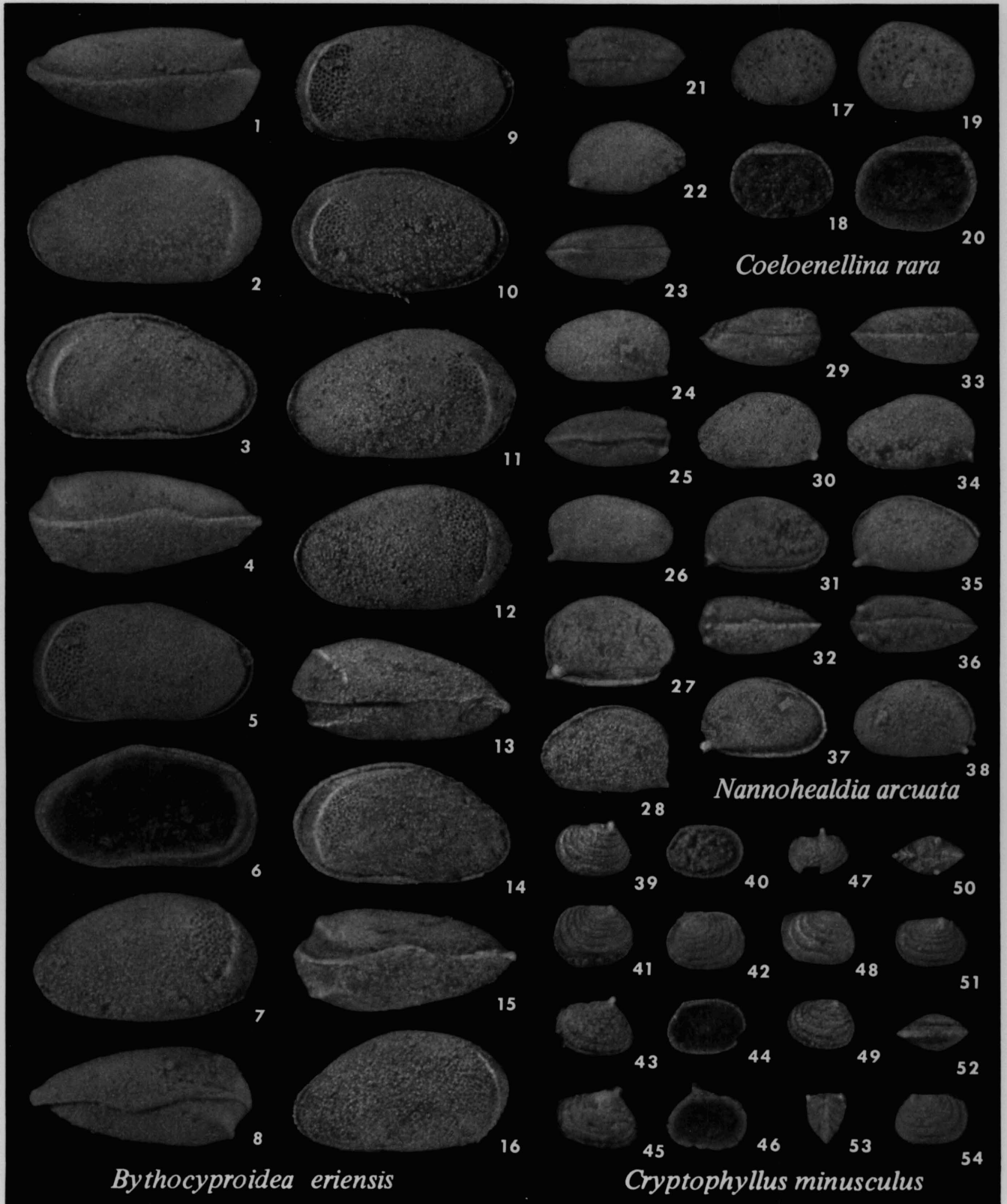

EXPLANATION OF PLATE 100

All figures x 40

- 1-16 -- *Bythocyproidea eriensis*. 1-4, UMMP 58900, Loc. MM-Chon, dorsal, left, right, and ventral views of carapace. 5, 6, UMMP 59455, Loc. MM-Trop, lateral and interior views of right valve. 7, 8, UMMP 58898, Loc. MM-Chon, left and ventral views of carapace. 9-12, lateral views printed on ultra-hard paper to emphasize the punctae in the posterior region: 9, UMMP 59455, Loc. MM-Trop, lateral view of right valve; 10, UMMP 58897, Loc. MM-Chon, right view of carapace; 11, UMMP 59133, Loc. MM-Trop, left view of carapace; 12, UMMP 59456, Loc. MM-Chon, left view of carapace. 13-16, UMMP 59434, Loc. MM-Trop, dorsal, right, ventral, and left views of carapace.
- 17-20 -- *Coeloenellina rara*. Loc. N-7. 17, 18, UMMP 59457, lateral and interior views of immature left valve. 19, 20, UMMP 59458, lateral and interior views of right valve.
- 21-38 -- *Nannohealdia arcuata*. 21, 22, UMMP 59542, Loc. MM-Chon, dorsal and right views of carapace with anteroventral section broken off. 23-26, UMMP 59537, Loc. S-13, dorsal, left, ventral, and right views of carapace. 27, 28, UMMP 59541, Loc. MM-Chon, right and left views of carapace somewhat flattened and with skewed valves. 29-32, UMMP 59540, Loc. S-12, dorsal, left, right, and ventral views of carapace. 33-34, UMMP 59045, Loc. MM-Chon, dorsal, left, right, and ventral views of carapace. 37, 38, UMMP 59043, Loc. MM-Chon, right and left views of carapace.
- 39-54 -- *Cryptophyllus minusculus*. 39, 40, UMMP 58963, Loc. MM-Chon, lateral and interior views of presumed right valve. 41, 42, UMMP 58964, Loc. MM-Chon, right and left views of carapace. 43, 44, UMMP 59627, Loc. WP-Trop, lateral and interior views of right valve. 45, 46, UMMP 58965, Loc. MM-Chon, right and interior views of right valve. 47, UMMP 58967, Loc. WP-Chon, lateral view of immature right valve. 48, UMMP 59628, Loc. WP-Trop, lateral view of right valve. 49, UMMP 59629, Loc. WP-Trop, lateral view of right valve. 50-54, UMMP 58966, Loc. WP-Trop, dorsal, right, ventral, anterior, and left views of carapace.

EXPLANATION OF PLATE 101

All figures x 40

- 1-8 -- *Bythocyproidea eriensis*. 1, 2, UMMP 59452, Loc. MM-Chon, dorsal and left views of carapace. 3, UMMP 59453, Loc. MM-15, lateral view of right valve. 4, 5, UMMP 59433, Loc. MM-Trop, lateral and interior views of right valve. 6, UMMP 58900, right view of carapace. 7, UMMP 58897, Loc. MM-Chon, inclined (right-dorsal) view of carapace. 8, UMMP 59133, Loc. MM-Trop, left view of carapace.
- 9-17 -- *Cryptophyllus arsinius*. 9, 10, UMMP 58961, lateral and interior views of presumed right valve. 11-16, UMMP 58960, dorsal, left, inclined, ventral, anterior, and right views of carapace. 17, UMMP 58959, left view of carapace. All from Loc. N-9.
- 18-48 -- *Microcheilinella mariettensis*. Loc. MM-Chon. 18-21, UMMP 59432, dorsal, right, left, and ventral views of carapace. 22-25, UMMP 59048, dorsal, left, right, and ventral views of carapace. 26-29, UMMP 59047, dorsal, left, ventral, and right views of carapace. 30-33, UMMP 59049, dorsal, left, right, and ventral views of carapace. 34-37, UMMP 59533, dorsal, right, left, and ventral views of carapace. 38-41, UMMP 59536, dorsal, left, right, and ventral views of carapace. 42-44, UMMP 59534, dorsal, right, and ventral views of carapace. 45-48, UMMP 59535, right, ventral, dorsal, and left views of carapace.

PLATE 101

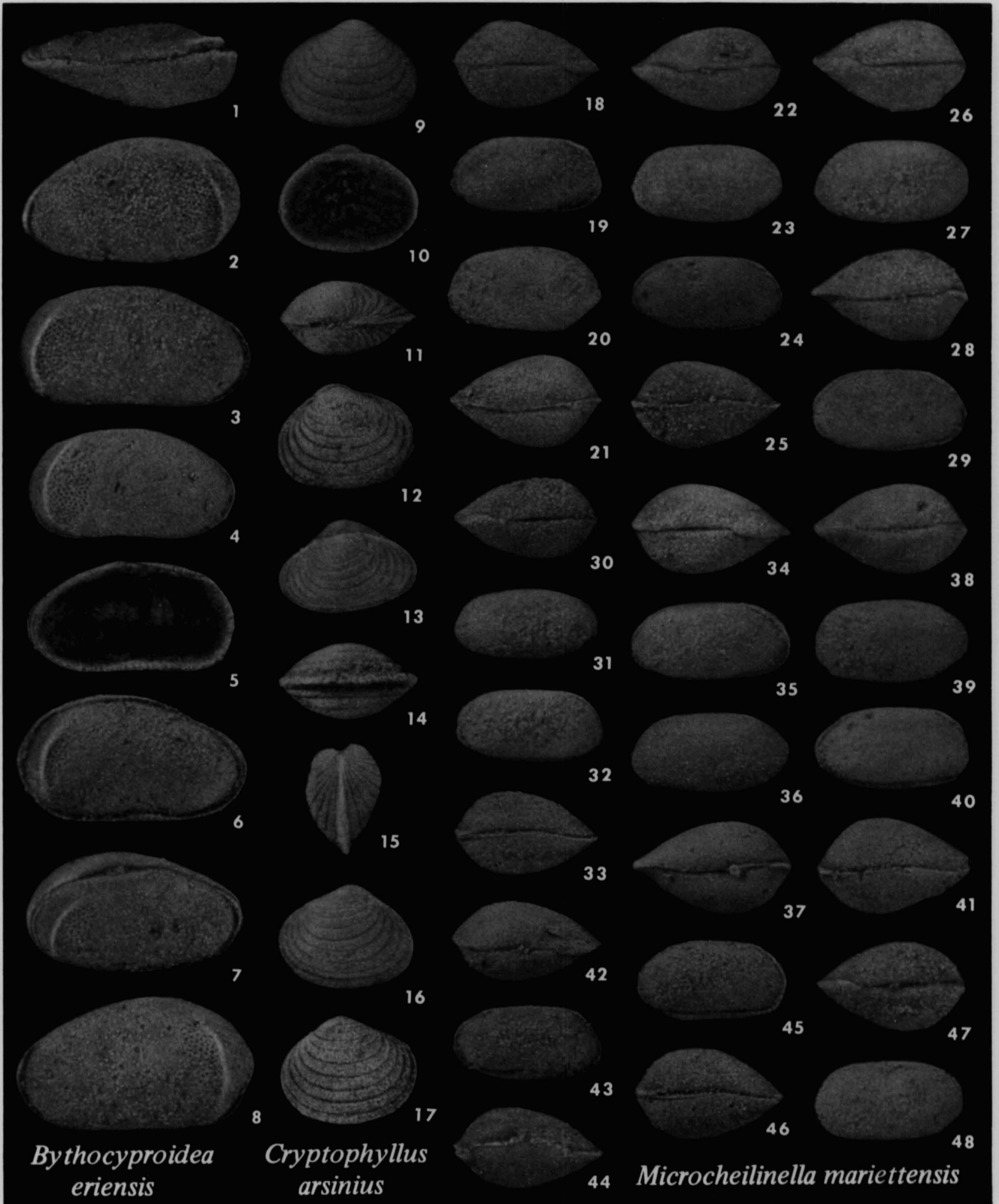

Bythocyproidea eriensis

Cryptophyllus arsinius

Microcheilinella mariettensis

PLATE 102

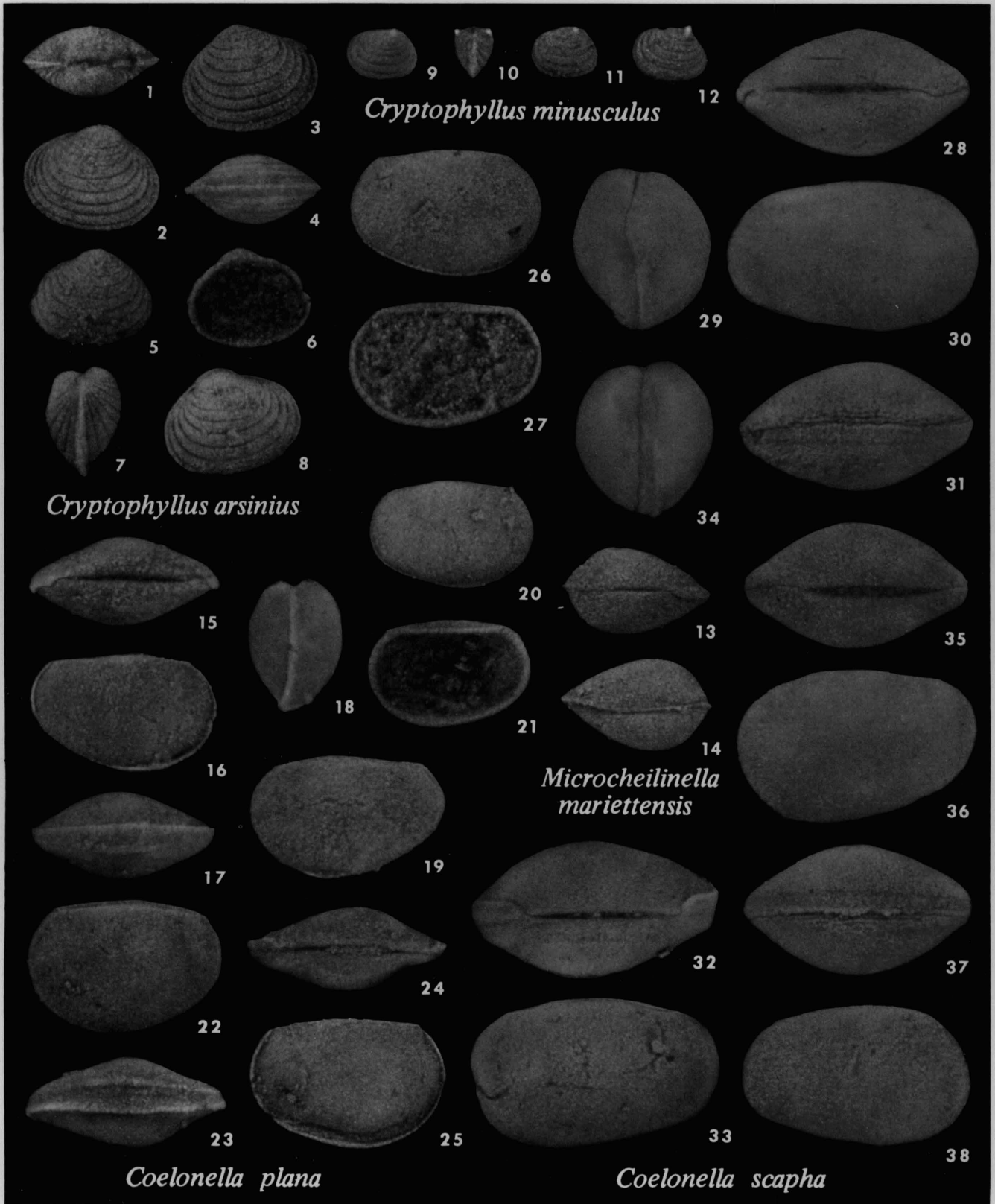

EXPLANATION OF PLATE 102

All figures x 40

- 1-8 -- *Cryptophyllus arsinius*. 1-4, UMMP 58959, Loc. N-9, dorsal, right, left, and ventral views of well-preserved carapace. 5, 6, UMMP 58962, Loc. MM-Chon, lateral and interior views of right valve. 7, 8, UMMP 58960, Loc. N-9, anterior and left views of carapace.
- 9-12 -- *Cryptophyllus minusculus*. 9, 10, UMMP 58906, Loc. WP-Trop, right and anterior views of carapace. 11, UMMP 59629, Loc. WP-Trop, lateral view of right valve. 12, UMMP 58963, Loc. MM-Chon, lateral view of right valve. Compare size and "umbonal" region with the above species.
- 13, 14 -- *Microcheilinella mariettensis*. Loc. MM-Chon. UMMP 59432, dorsal and ventral views of carapace; these are the diagnostic views to identify the species in the Silica fauna.
- 15-25 -- *Coelonella plana*. 15-19, UMMP 58908, Loc. N-9, dorsal, left, ventral, posterior, and right views of carapace. 20, 21, UMMP 59459, Loc. N-9, lateral and interior views of left valve. 22-25, UMMP 58906, Loc. MM-Chon, right, ventral, dorsal, and left views of carapace.
- 26-38 -- *Coelonella scapha*. 26, 27, UMMP 59460, Loc. S-12, lateral and interior views of left valve. 28-31, UMMP 58903, Loc. N-9, dorsal, posterior, left, and ventral views of carapace. 32, 33, UMMP 58904, Loc. N-9, dorsal and right views of carapace. 34-38, UMMP 58901, Loc. N-14, posterior, dorsal, right, ventral, and left views of carapace.

EXPLANATION OF PLATE 103

All figures x 40

- 1-9 -- *Coelonella plana*. 1-3, UMMP 58905, Loc. N-9, dorsal, right, and left views of carapace. 4, UMMP 58906, Loc. MM-Chon, left view of carapace. 5-9, UMMP 58907, Loc. MM-Chon, dorsal, right, left, ventral, and anterior views of carapace.
- 10-17 -- *Dirhabdus multicostatus*. Loc. MM-Chon. 10, 11, UMMP 59280, lateral and interior views of right valve. 12, UMMP 59279, lateral view of left valve. 13, 14, UMMP 59463, lateral and interior views of right valve. 15-17, UMMP 59281, dorsal, right, and left views of carapace.
- 18-20 -- *Coelonella scapha*. Loc. N-9. UMMP 58902, left, ventral, and right views of carapace.
- 21, 22 -- *Richina truncata*. Wanakah Formation, East Bethany, N. Y. UMMP 60067, lateral and interior views of right valve, shown for comparison with Silica Formation specimens.
- 23, 24 -- *Cryptophyllus arsinius*. Loc. N-9. UMMP 58959, dorsal and right views of carapace.
- 25-28 -- *Dizygopleura trisinuata*. Loc. N-12. 25, 26, UMMP 60055, lateral and interior views of left valve. 27, 28, UMMP 60056, lateral and interior views of right valve.
- 29-34 -- *Sigynus cf. dictyotus*. Loc. MM-Chon. UMMP 60052, inclined (right-dorsal), left, inclined (left-dorsal), dorsal, right, and ventral views of carapace; preservation does not show the reticulation to advantage.

PLATE 103

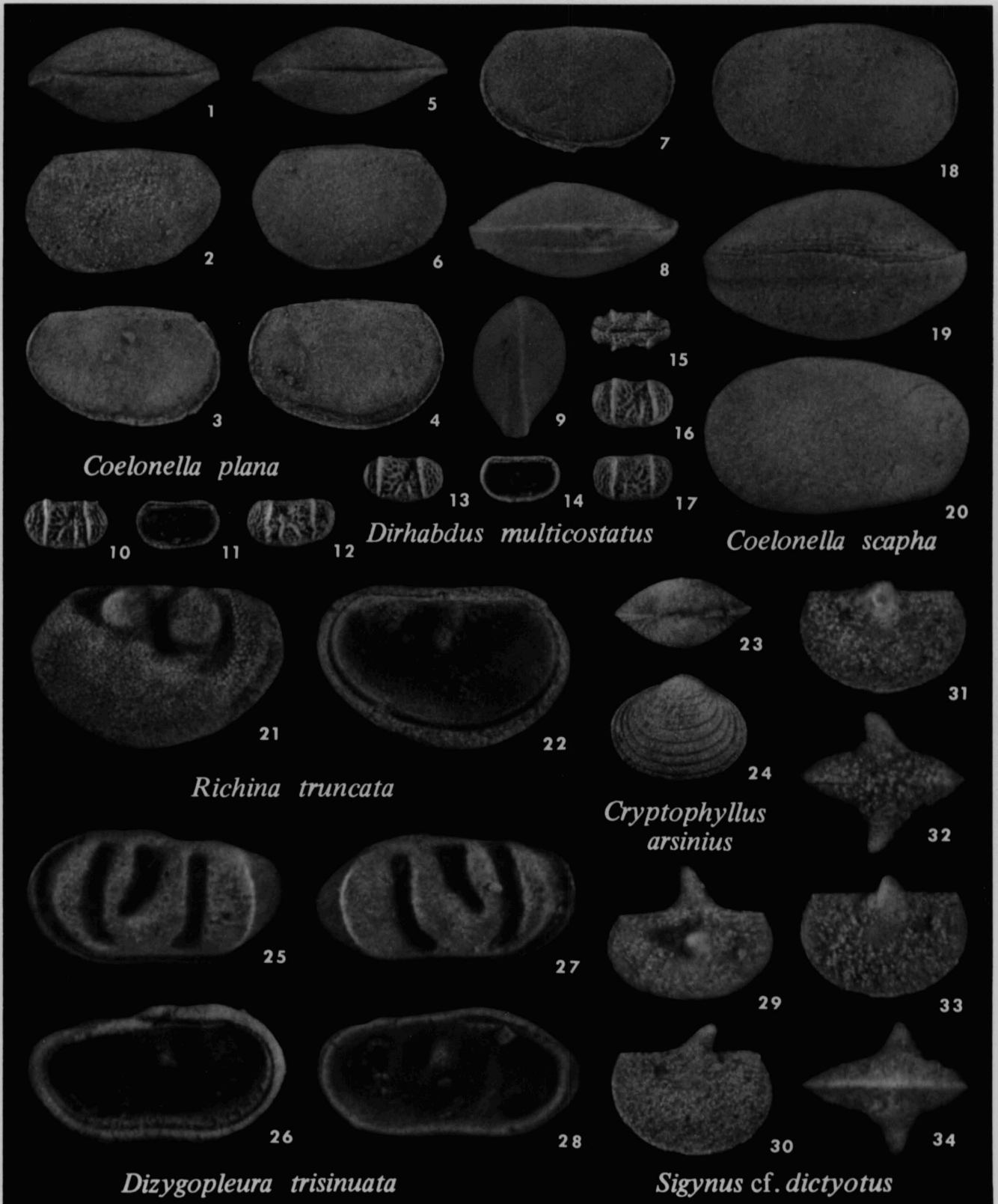
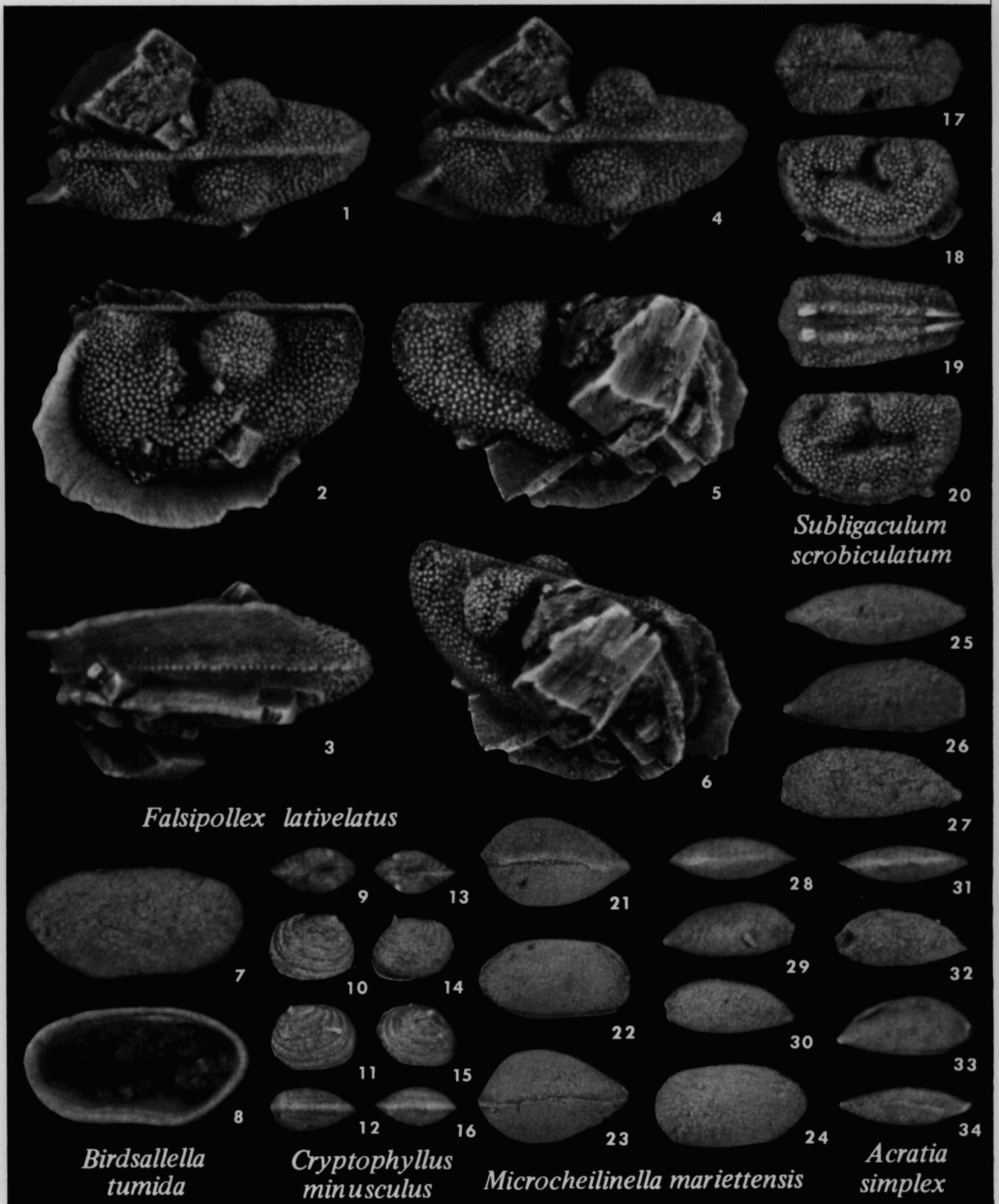

PLATE 104



Falsipollex lativelatus

Birdsallella tumida

Cryptophyllus minusculus

Microcheilinella mariettensis

Subligaculum scrobiculatum

Acratia simplex

EXPLANATION OF PLATE 104

All figures x 40

- 1-6 -- *Falsipollex lativelatus*. Loc. MM-Chon. Specimen lost; dorsal, left, ventral, inclined (left-dorsal), right, and inclined (right-anterodorsal) views of carapace with pyrite crystals protruding.
- 7, 8 -- *Birdsallella tumida*. Loc. N-9. UMMP 60057, lateral and interior views of right valve.
- 9-16 -- *Cryptophyllus minusculus*. Loc. WP-Trop. 9-12, UMMP 60063, dorsal, right, left, and ventral views of carapace. 13-16, UMMP 60062, dorsal, left, right, and ventral views of carapace.
- 17-20 -- *Subligaculum scrobiculatum*. Loc. MM-Chon. UMMP 60077, dorsal, right, ventral, and left views of carapace.
- 21-24 -- *Microcheilinella mariettensis*. Loc. MM-Chon. UMMP 59536, dorsal, right, ventral, and left views of carapace.
- 25-34 -- *Acratia simplex*. 25-27, UMMP 60071, Loc. MM-Scit, dorsal, right, and left views of carapace. 28-30, UMMP 60084, Loc. MM-Chon, dorsal, right, and left views of immature carapace. 31-34, UMMP 60083, Loc. MM-Chon, dorsal, left, right, and ventral views of immature carapace.

EXPLANATION OF PLATE 105

All figures x 40

- 1-9 -- *Hollinella (Keslingella) antespinoza*. 1-4, UMMP 60079, Loc. MM-Chon, dorsal, left, ventral, and right views of carapace. 5-8, UMMP 60078, Loc. N-9, dorsal, left, ventral, and right views of slightly crushed carapace. 9, UMMP 60058, Loc. N-14, right view of immature carapace.
- 10-18 -- *Cryptophyllus minusculus*. Loc. WP-Trop. 10-13, UMMP 60061, dorsal, right, ventral, and left views of carapace. 14-17, UMMP 60064, dorsal, left, right, and ventral views of carapace. 18, UMMP 60061, right view of carapace.
- 19-23 -- *Bufina curti*. Loc. N-12. UMMP 60059, dorsal, right, ventral, left, and inclined (left-anterior) views of carapace.
- 24-29 -- *Ehlersia hypercala*. Loc. N-12. UMMP 60053, inclined (left-anterodorsal), anterior, right, dorsal, left, and ventral views of carapace.

PLATE 105

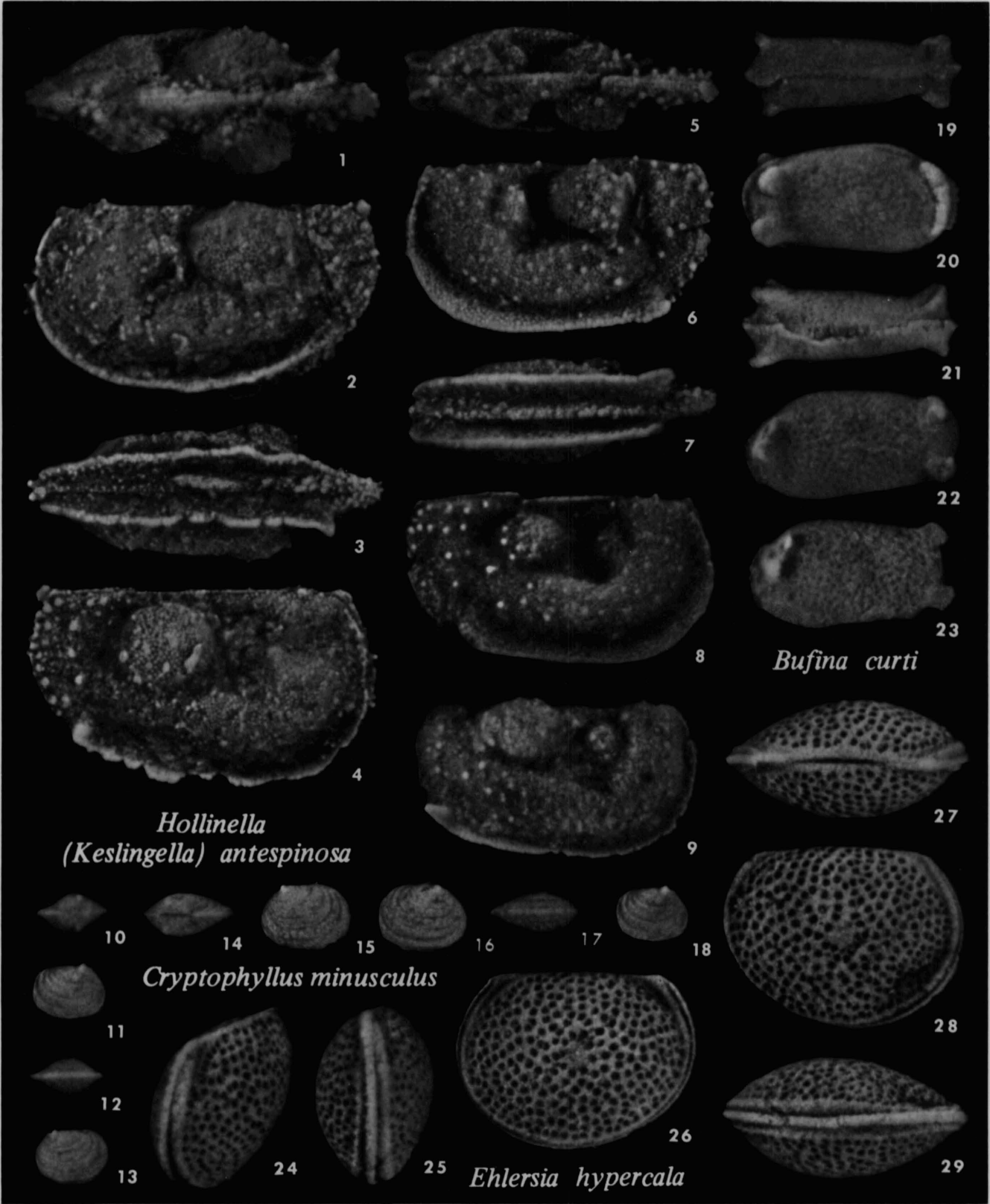

Hollinella (Keslingella) antespinsa

Bufina curti

Cryptophyllus minusculus

Ehlersia hypercala

PLATE 106

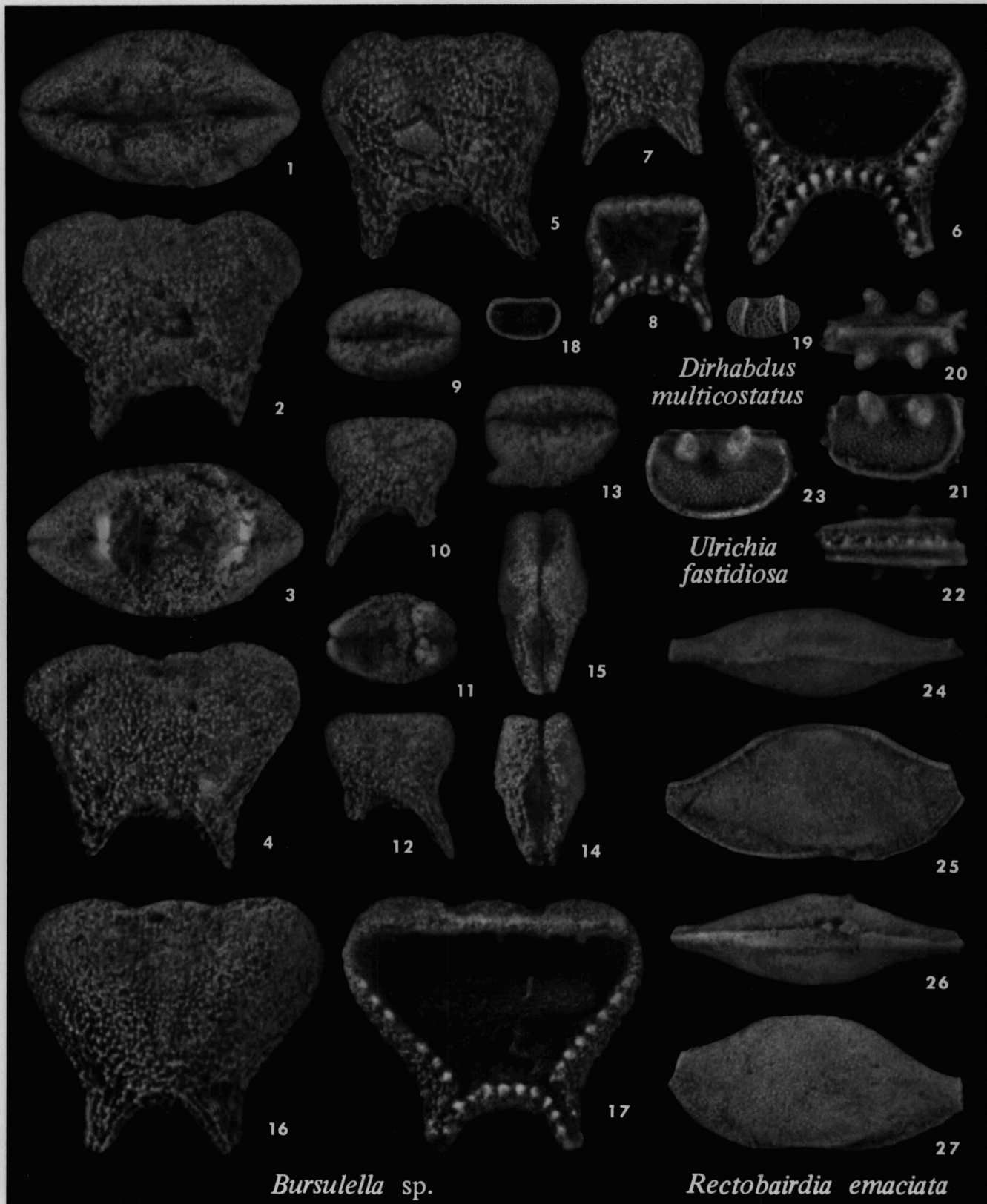

Bursulella sp.

Rectobairdia emaciata

EXPLANATION OF PLATE 106

All figures x 40

- 1-17 -- *Bursulella* sp. 1-4, UMMP 60060, Loc. MM-Chon, dorsal, lateral (right ?), ventral, and lateral (left ?) views of carapace. 5, 6, UMMP 59383, Loc. MM-Chon, lateral and interior views of valve. 7, 8, UMMP 60075, Loc. N-12, lateral and interior views of immature valve. 9-15, UMMP 59385, Loc. N-14, dorsal, lateral, ventral, lateral, inclined (dorsal-lateral), end, and inclined (dorsal-end) views of immature carapace. 16, 17, UMMP 59384, Loc. MM-Chon, lateral and interior views of valve.
- 18, 19 -- *Dirhabdus multicostatus*. Loc. MM-Chon. UMMP 59282, interior and lateral views of left valve.
- 20-23 -- *Ulrichia fastidiosa*. Loc. MM-12. UMMP 60080, dorsal, right, ventral, and left views of carapace.
- 24-27 -- *Rectobairdia emaciata*. Loc. WP-Chon. UMMP 60051, dorsal, right, ventral, and left views of carapace.

EXPLANATION OF PLATE 107

All figures x 40

- 1-4 -- *Richina subcircularis*. Hungry Hollow Formation at type locality on Ausable River, Ontario. UMMP 60068, dorsal, right, ventral, and left views of carapace, shown for comparison with Silica Formation specimens.
- 5-14 -- *Richina truncata*. Specimens from other formations, shown for comparison. 5-8, UMMP 60070, Widder Formation at type locality, near Thedford, Ontario, dorsal, right, ventral, and left views of carapace. 9-12, UMMP 60069, Widder Formation at type locality, dorsal, left, ventral, and right views of carapace. 13, 14, UMMP 60065, Wanakah Formation, near East Bethany, N. Y., lateral and interior views of left valve.
- 15, 16 -- *Menoetidina arcuata*. Loc. MM-Chon. UMMP 60085, lateral and interior views of right valve.
- 17-20 -- *Coeloenellina rara*. Loc. MM-Chon. UMMP 60076, left, dorsal, right, and anterior views of carapace; preservation poor.
- 21, 22 -- *Bythocyproidea eriensis*. Loc. MM-Trop. UMMP 59455, lateral and interior views of right valve.
- 23-28 -- *Hypotetragona aequitalis*. 23-25, UMMP 60054, Loc. N-12, dorsal, right, and ventral views of carapace. 26, 27, UMMP 60073, Loc. N-7, left and right views of carapace. 28, UMMP 60072, Loc. N-7, left view of carapace.
- 29 -- *Bufina abbreviata*. Loc. MM-Chon. UMMP 58870, right view of carapace.
- 30 -- *Coelonella scapha*. Loc. NN-6. UMMP 60074, left view of carapace.
- 31-34 -- *Rectobairdia emaciata*. Loc. MM-Chon. UMMP 60082, dorsal, right, ventral, and left views of carapace.

PLATE 107

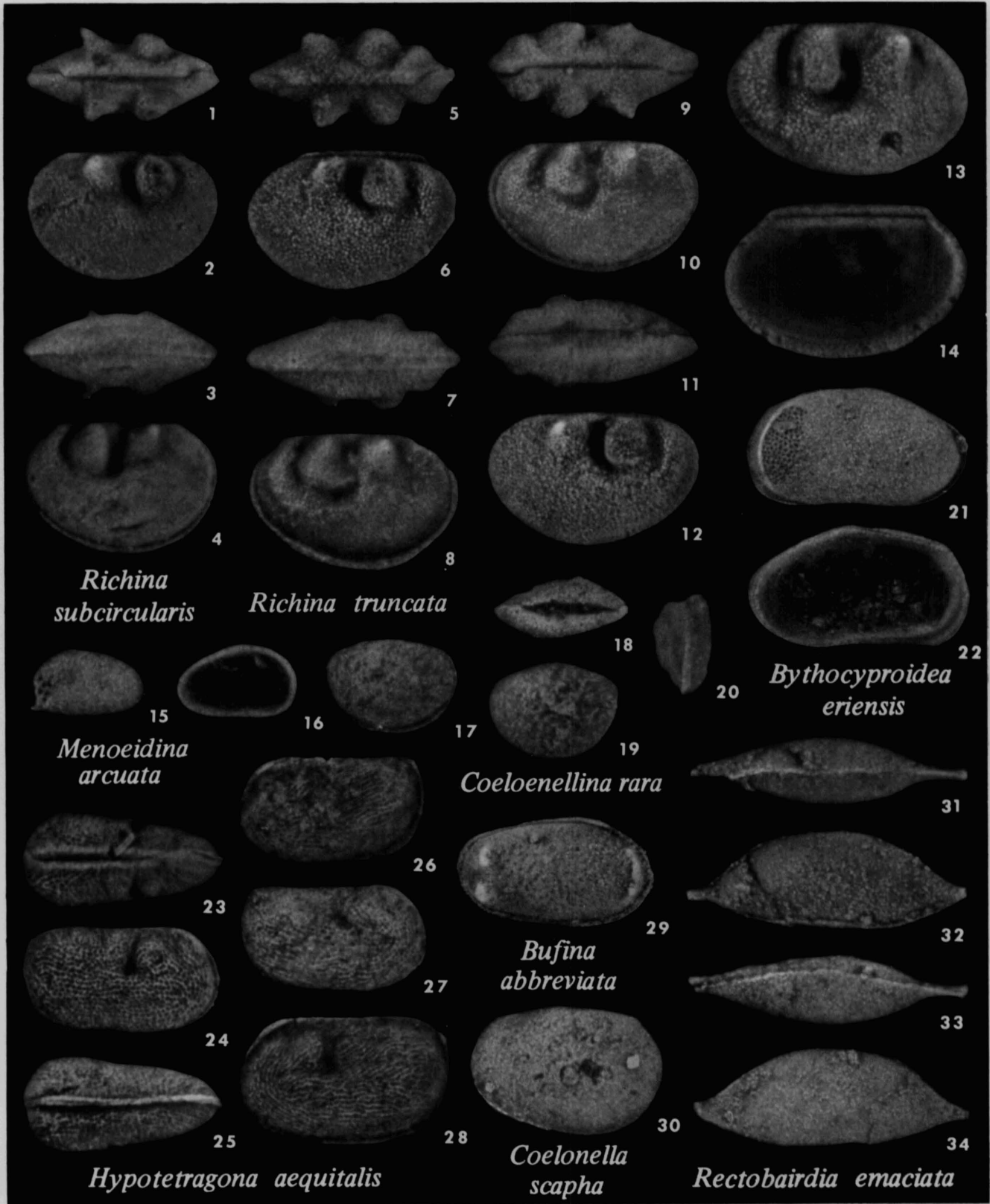

Richina subcircularis

Richina truncata

Bythocyproidea eriensis

Menoeidina arcuata

Coeloenellina rara

Bufina abbreviata

Coelonella scapha

Hypotetragona aequitalis

Rectobairdia emaciata

PLATE 108

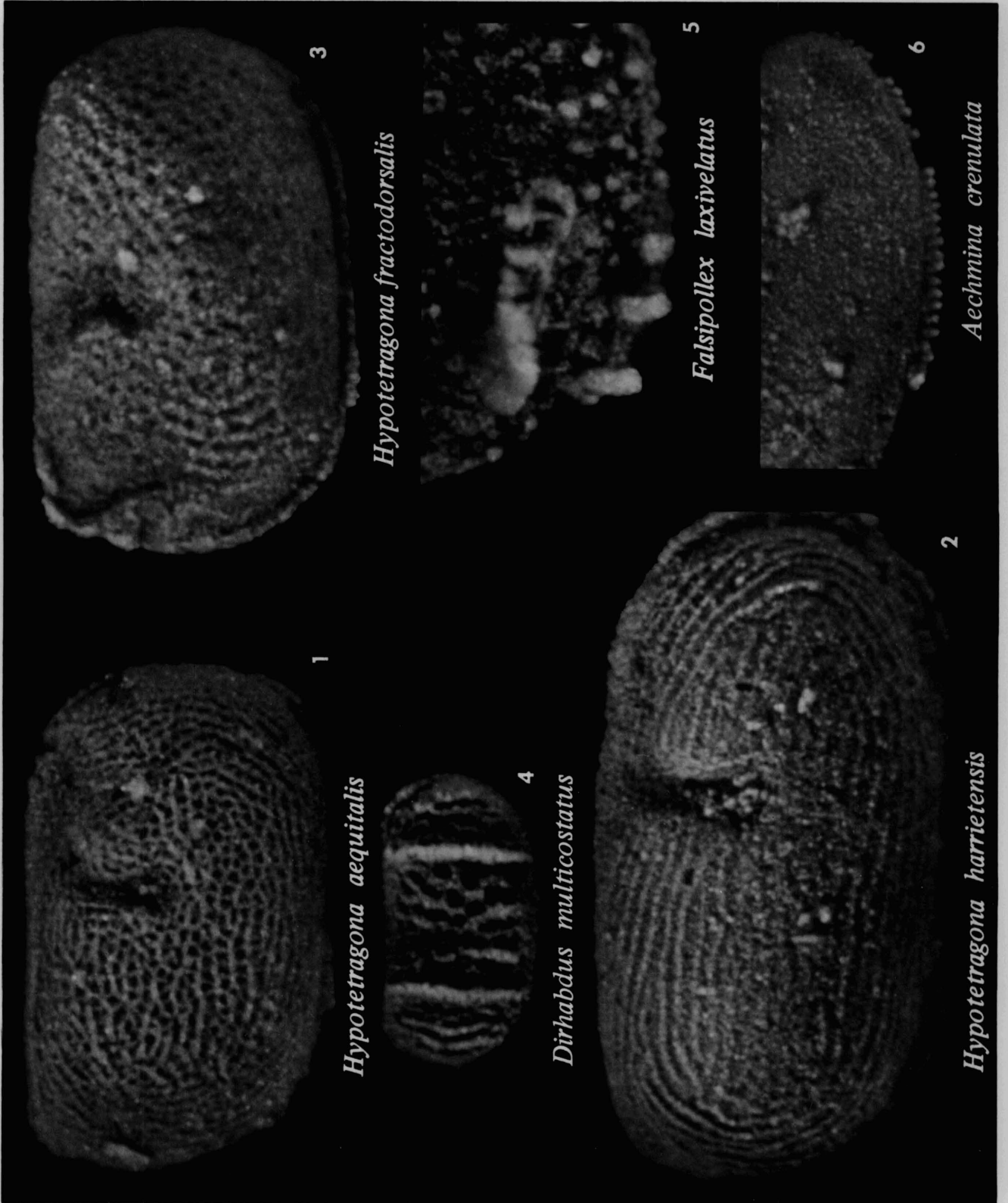

EXPLANATION OF PLATE 108

All figures x 125

- 1 -- *Hypotetragona aequitalis*. UMMP 59106, right lateral view showing ornamentation of fine reticulation.
- 2 -- *Hypotetragona harrietensis*. UMMP 59138, right lateral view showing ornamentation of subconcentric fine ridges.
- 3 -- *Hypotetragona fractodorsalis*. UMMP 59057, left lateral view of rare uncrushed specimen showing ornamentation of low ridges and punctae.
- 4 -- *Dirhabdus multicostatus*. UMMP 59464, left lateral view.
- 5 -- *Falsipollex laxivelatus*. UMMP 58968, inclined left lateral view of anteroventral region of male, showing elongate marginal spines set between anterior spurs (left spur damaged).
- 6 -- *Aechmina crenulata*. UMMP 58815, anteroventral part of right valve, showing remnants of row of delicate marginal spines.

EXPLANATION OF PLATE 109

All figures x 125

- 1,2 -- *Hollinella (Kestlingella) pumila*. Ventral views, showing dimorphism in convergence of the frills. 1, UMMP 58993, male carapace (anterior toward right). 2, UMMP 58997, female carapace (anterior toward left).
- 3 -- *Cryptophyllus minisculus*. UMMP 58966, slightly inclined lateral view of presumed right valve, showing "growth lines" (junctures of retained immature shells).
- 4, 5 -- *Cornigella immotipedata*. Two extremes of shape, suggesting dimorphism. 4, UMMP 59615, possibly a male. 5, UMMP 59613, possibly a female.
- 6,7 -- *Ctenoloculina cicatricosa*. Interiors of opposing valves showing anterior hingement. 6, UMMP 59462, left valve. 7, UMMP 58146, right valve.

PLATE 109

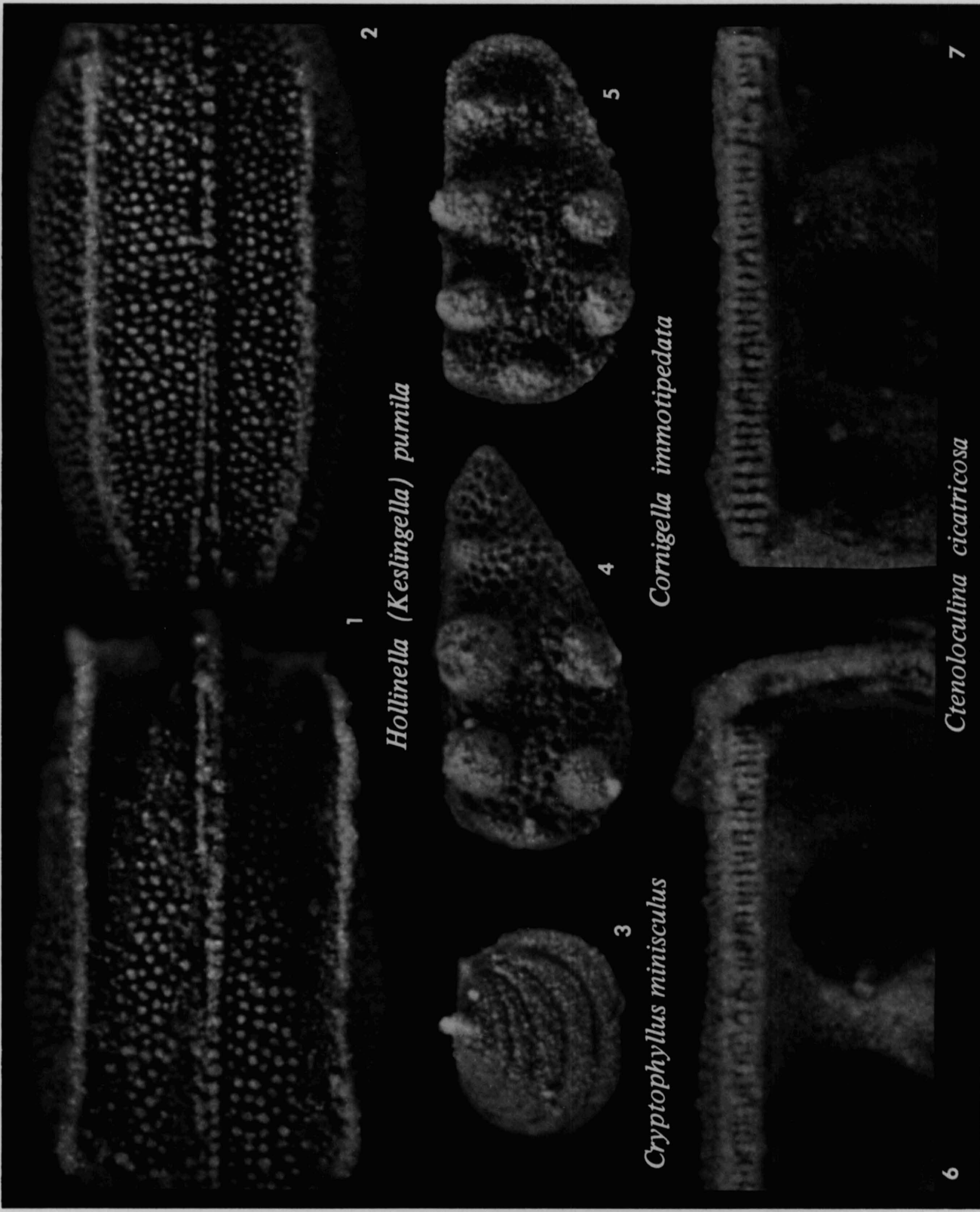

1
Hollinella (Kestingella) pumila

2

4

5

3

Cornigella immotipedata

Cryptophyllus minisculus

Ctenoloculina cicatricosa

7

6

PLATE 110

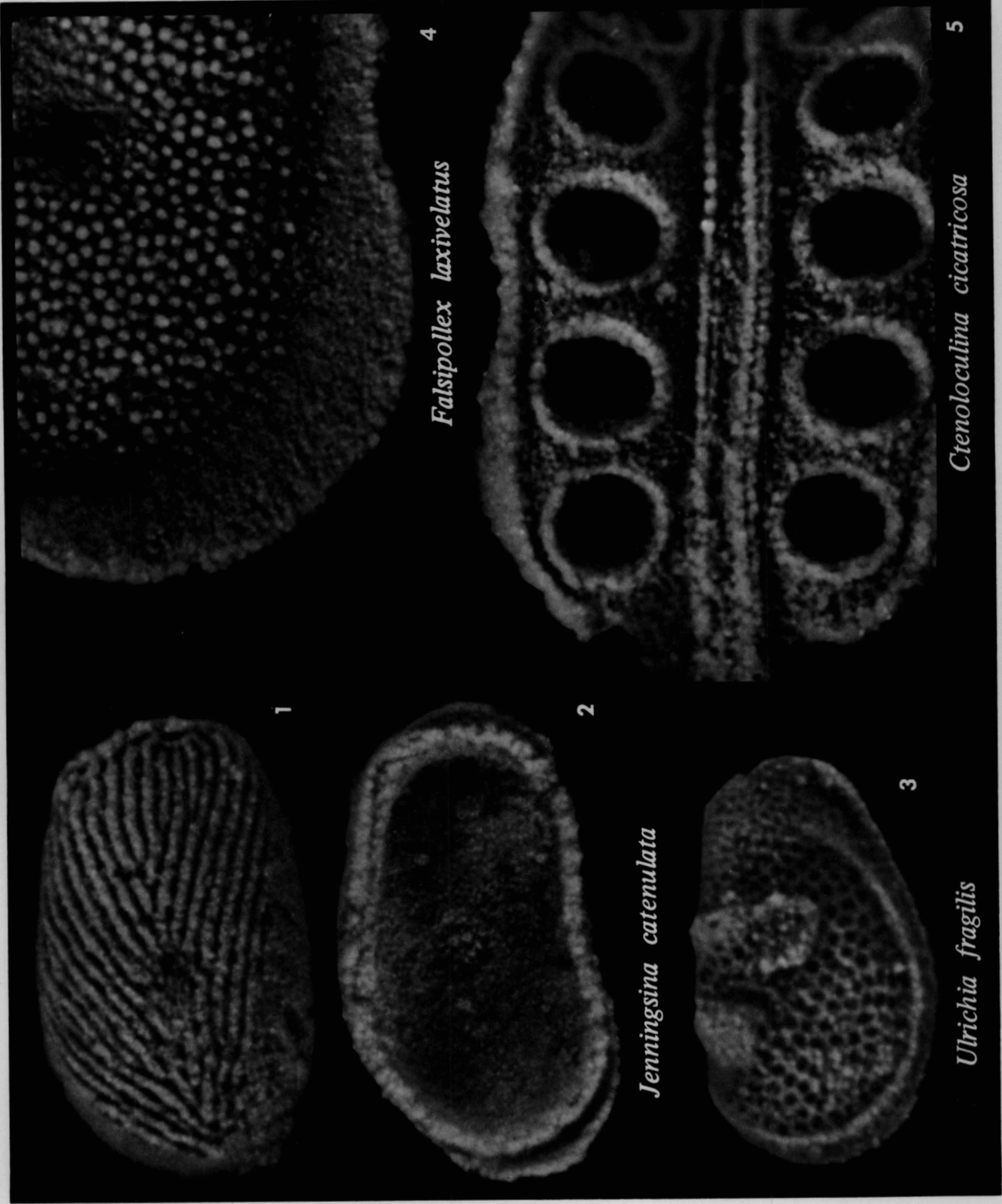

1

2

3

4

5

Falsipollex laxivelatus

Ctenoloculina cicatricosa

Jenningsina catenulata

Ulrichia fragilis

EXPLANATION OF PLATE 110

All figures x 125

- 1, 2 -- *Jenningsina catenulata*. 1, UMMP 59142, left lateral view, showing ornamentation and pit marking position of internal muscle scar. 2, UMMP 59145, interior of right valve, showing hinge and adductor muscle scar.
- 3 -- *Ulrichia fragilis*. UMMP 59359, left lateral view, showing reticulation and extent of velar ridge.
- 4 -- *Falsipollex laxivelatus*. UMMP 58988, anteroventral part of left valve of female, showing papillae of lateral surface and frill.
- 5 -- *Ctenoloculina cicatricosa*. UMMP 58925, ventral view of female carapace (anterior toward right), showing rimmed loculi and marginal structures along junction of valves.

EXPLANATION OF PLATE 111

All figures x 125

- 1 -- *Adelphobolbina spicata*. UMMP 59638, part of lateral surface, showing the great size difference and relative spacing of short spines and papillae.
- 2 -- *Adelphobolbina trilobata*. UMMP 58805, dorsal view near posterior end, showing the two distinct sizes of papillae ornamenting the surface of L3's; hinge line bordered by fine papillae; anterior toward left.
- 3, 4 -- *Ctenoloculina acanthina*. Posterior parts of two left valves showing differences in ornamentation of lobes produced by weathering and abrasion. 3, UMMP 58914, retaining the delicate surface layer, finely punctate, and the posterior striate flange. 4, UMMP 58913, with surface layer retained in only a few spots, and showing the "papillae" serving as support pillars for the delicate surface layer. Note the pattern of spines is the same in both, demonstrating that these structures extend through the surface layer.

PLATE 111

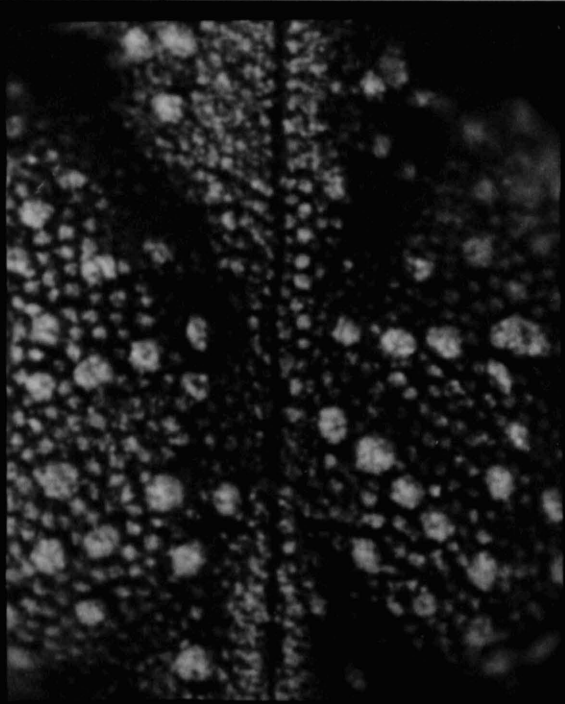

2

Adolphobolina trilobata

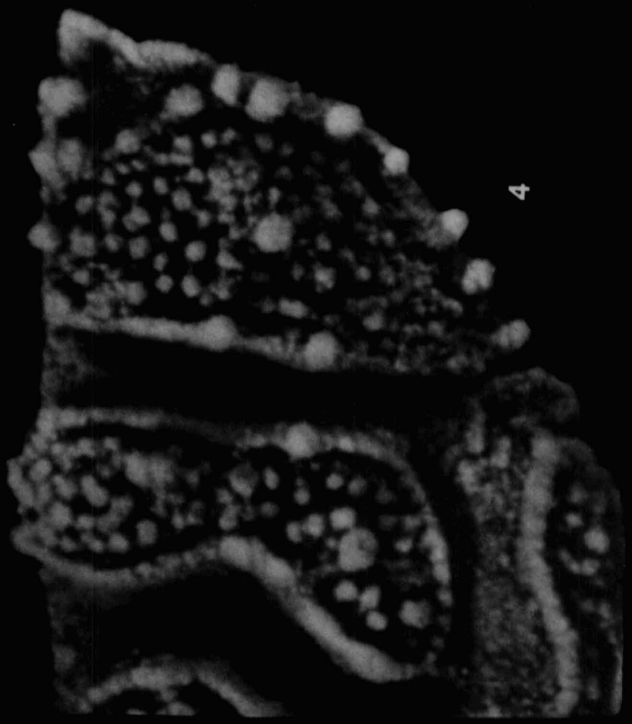

4

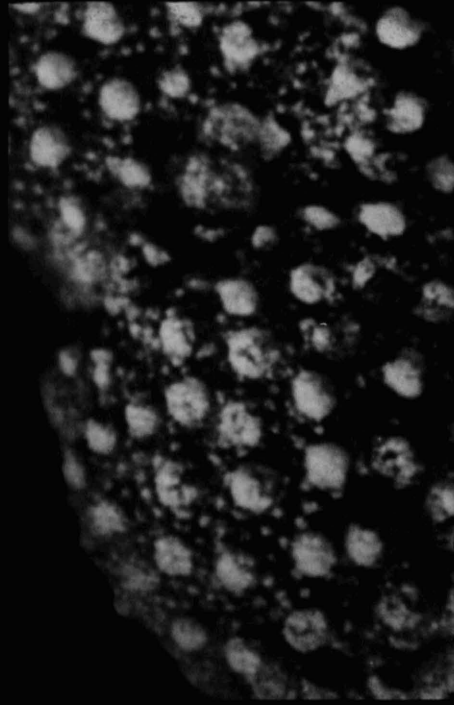

1

Adolphobolina spicata

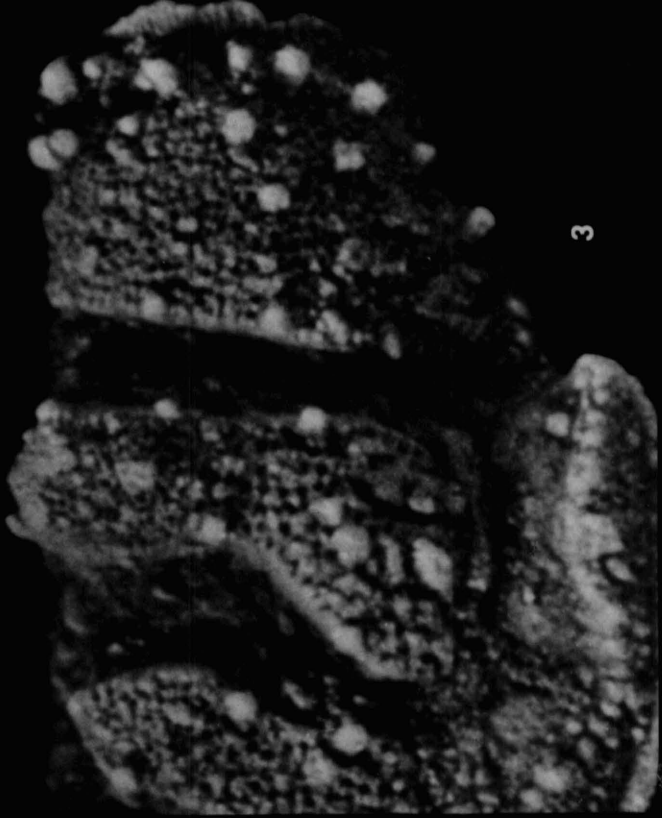

3

Ctenoloculina acanthina

PLATE 112

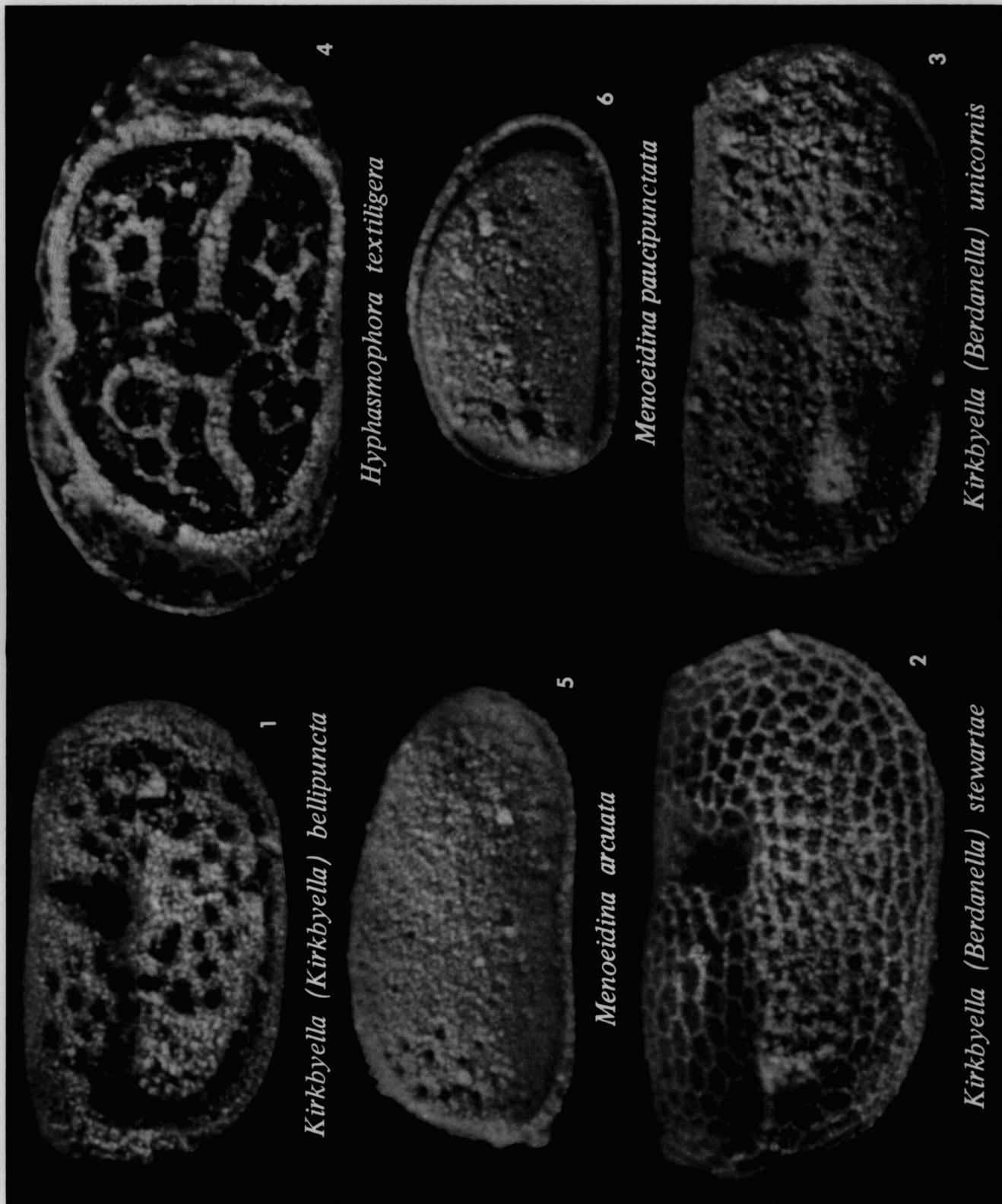

EXPLANATION OF PLATE 112

All figures x 125

- 1 -- *Kirkbyella (Kirkbyella) bellipuncta*. UMMP 59153, right lateral view.
- 2 -- *Kirkbyella (Berdanella) stewartae*. UMMP 59160, right lateral view.
- 3 -- *Kirkbyella (Berdanella) unicornis*. UMMP 59164, right lateral view.
- 4 -- *Hyphasmophora textiliger*a. UMMP 59502, left lateral view.
- 5 -- *Menoeidina arcuata*. UMMP 59184, right lateral view.
- 6 -- *Menoeidina paucipunctata*. UMMP 59189, right lateral view.

EXPLANATION OF PLATE 113

All figures x 125

- 1, 2 -- *Menoeidina subreniformis*. UMMP 59175 and 59179, right lateral views of two carapaces, showing faint lineament of ornamentation; the second specimen fits the description of "*Menoeidina subreniformis* var. *elongata*," but the differences in relative length in the species are probably due to dimorphism, in which case the left specimen is a male and the right specimen a female.
- 3 -- *Quasillites sublunatus*. UMMP 59315, right lateral view of specimen with typical posterior compression and anterior ridge.
- 4 -- *Tetrarhabdus pygmaeus*. UMMP 61813, right lateral view of this new genus and species of the new family Amphissellidae.
- 5 -- *Tetrastorthynx diabolicus*. UMMP 59404, left lateral view; L2 damaged but L3 fully preserved.

PLATE 113

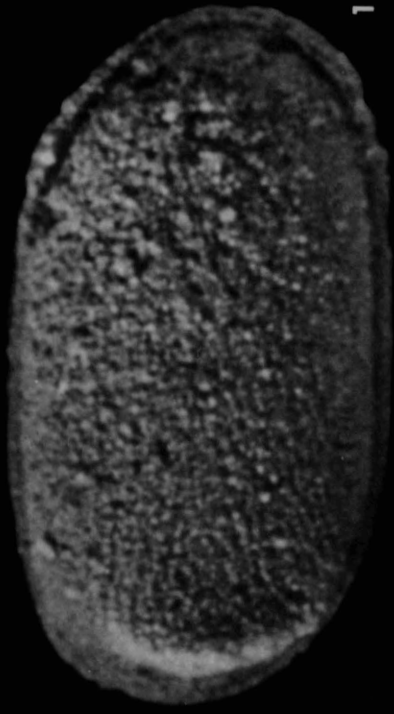
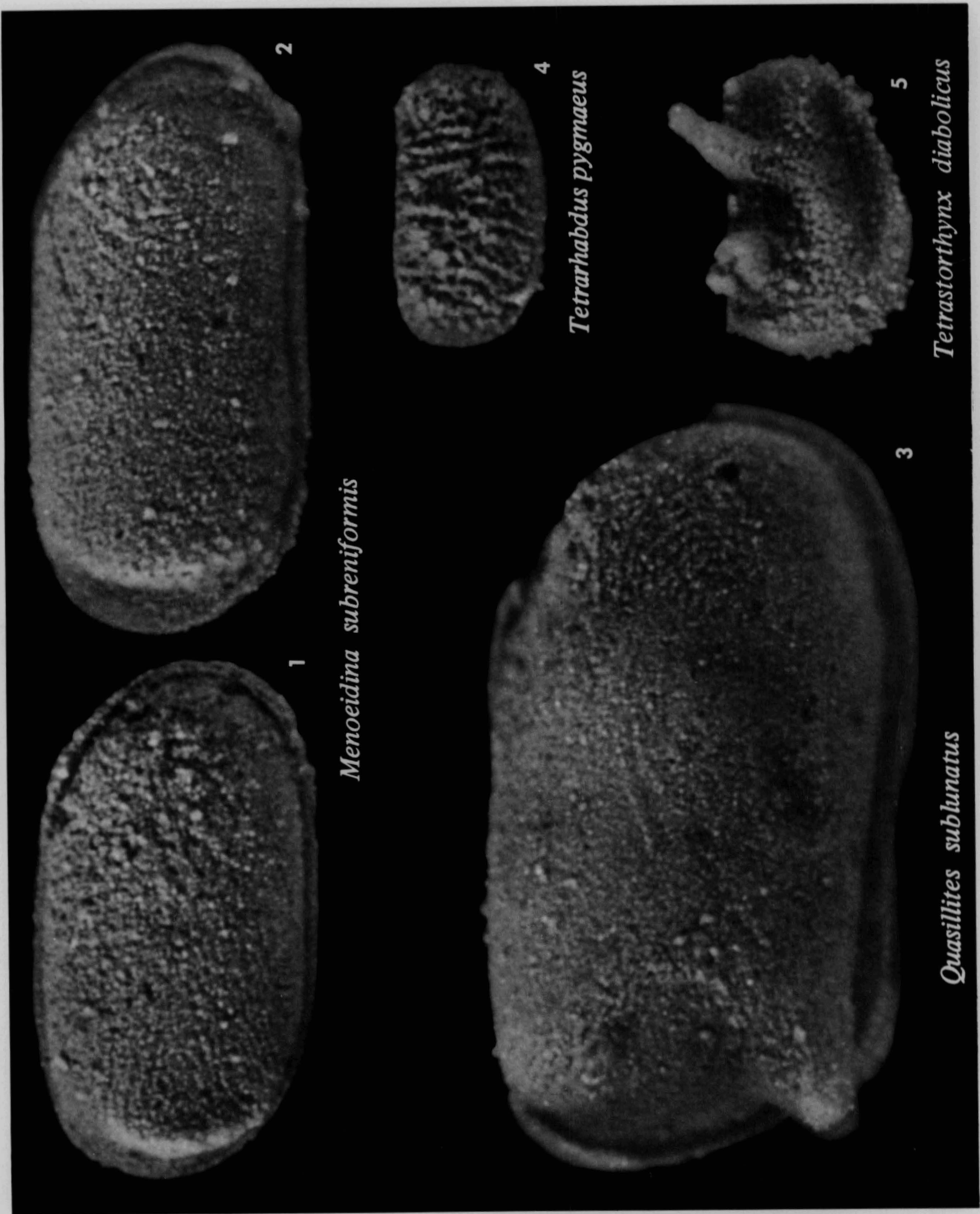

1

Menooidina subreniformis

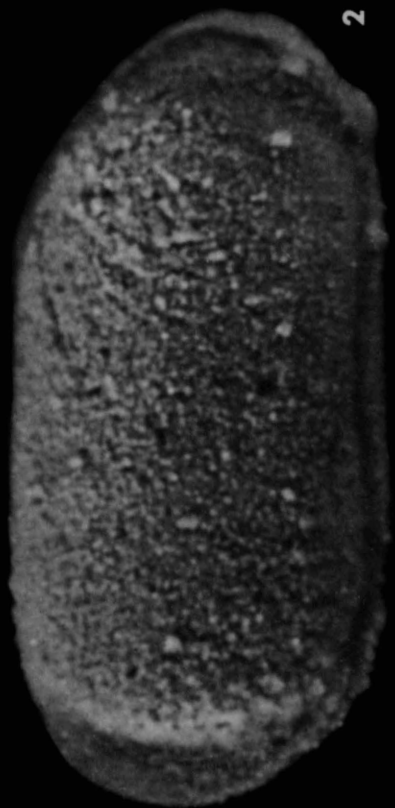

2

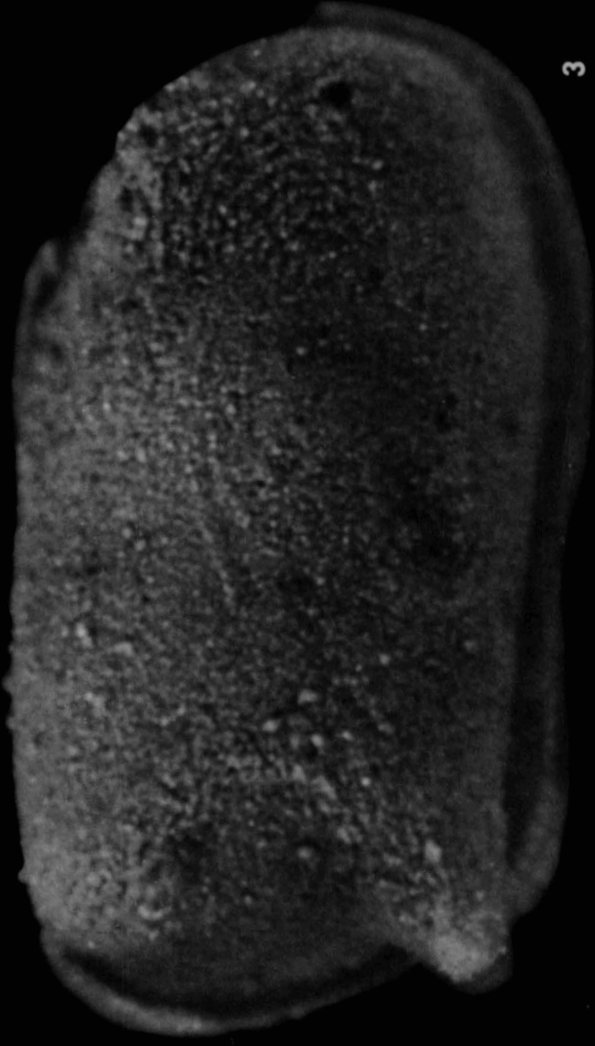

3

Quasillites sublunatus

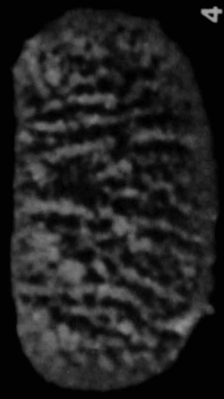

4

Tetrarhabdus pygmaeus

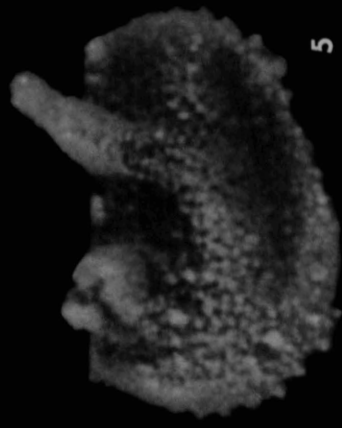

5

Tetrastorthynx diabolicus

PLATE 114

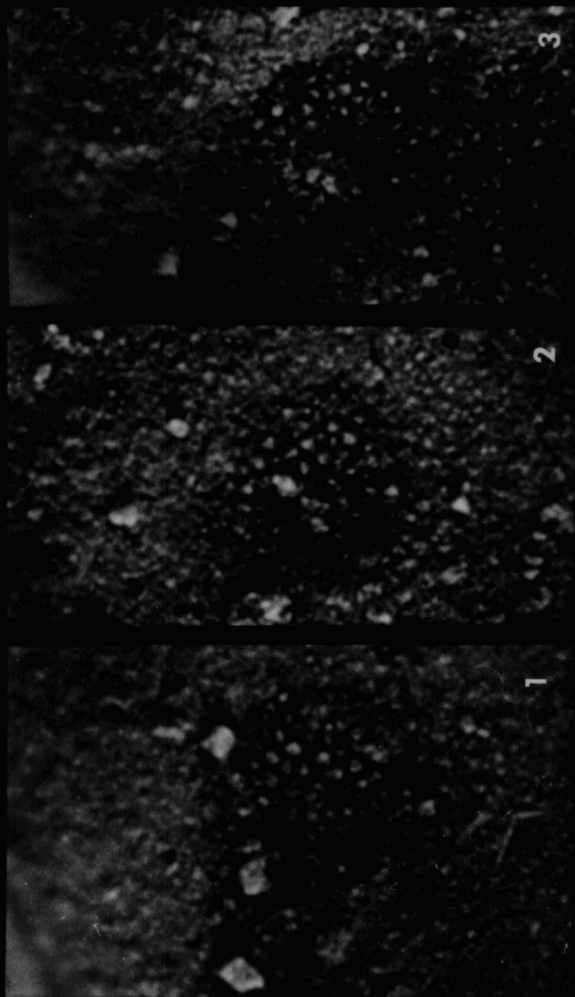

Ponderodictya rhodesi

Ponderodictya punctulifera

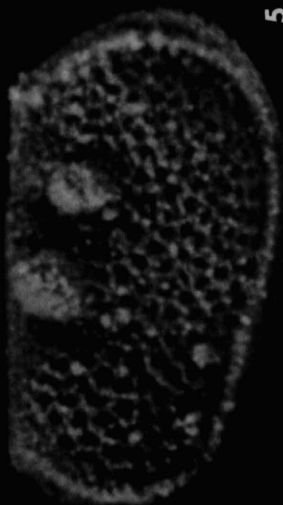

5

Utrichia illinearis

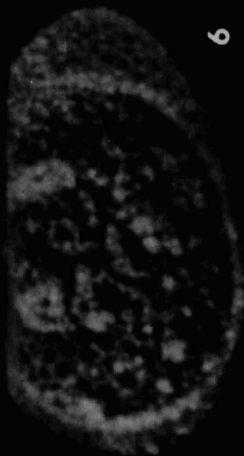

6

Utrichia fragilis

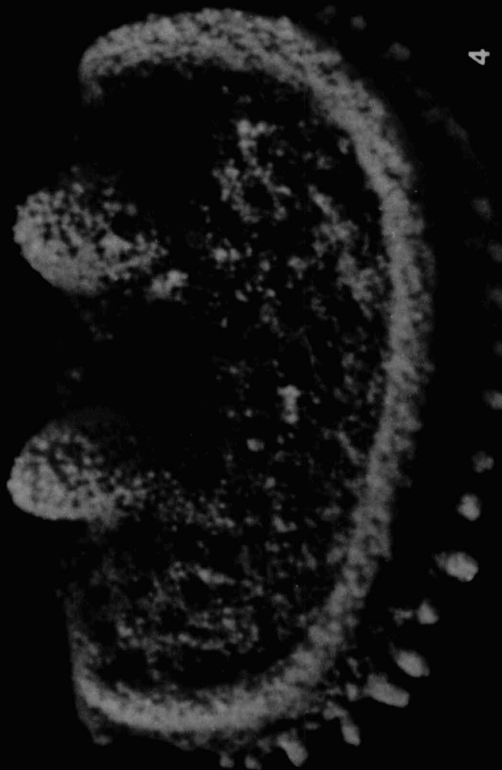

4

Utrichia spinifera

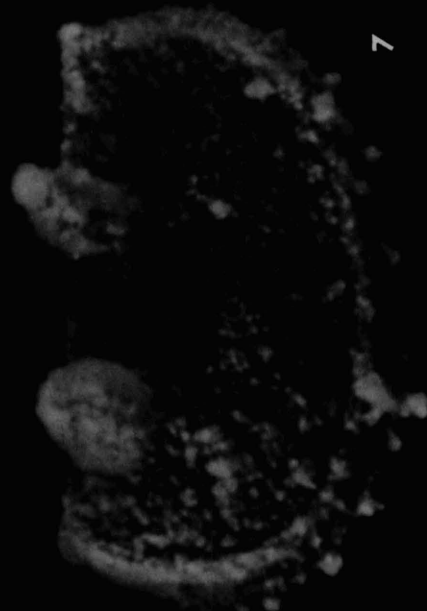

7

Utrichia fastidiosa

EXPLANATION OF PLATE 114

All figures x 125

- 1 -- *Ponderodictya rhodesi*. UMMP 59270, interior of right valve, showing adductor muscle scars typical of the genus.
- 2, 3 -- *Ponderodictya punctulifera*. UMMP 59255 and 59247, interiors of two right valves, showing adductor muscle scars.
- 4 -- *Ulrichia spinifera*. UMMP 59368, slightly inclined right lateral view, showing exceptional preservation of marginal spines.
- 5 -- *Ulrichia illinearis*. UMMP 59365, right lateral view.
- 6 -- *Ulrichia fragilis*. UMMP 59361, left lateral view, showing course of the velar ridge.
- 7 -- *Ulrichia fastidiosa*. UMMP 59376, left lateral view; compare size of reticulation elements with those of *Ulrichia spinifera* (fig. 4).

EXPLANATION OF PLATE 115

All figures x 125

- 1 -- *Ropolonellus papillatus*. UMMP 59343, lateral view of right valve.
- 2 -- *Nannohealdia arcuata*. UMMP 59537, ventral view, showing overlap and the location and direction of the small posteroventral spines.
- 3 -- *Ulrichia spinifera*. UMMP 59370, interior of left valve, focused on adductor muscle scar on inner surface of S2.
- 4 -- *Glyphella reticulata*. UMMP 59056, right lateral view of carapace, showing overlap and ornamentation.
- 5 -- *Xystinotus subnodatus*. UMMP 59394, left lateral view; this species is here distinguished from the very similar *Ulrichia illinearis* by the absence of reticulation in the dorsal area, but it may be only an ecological variant.
- 6 -- *Quasillites concentricus*. UMMP 58294, right lateral view showing distinctive ornamentation.

PLATE 115

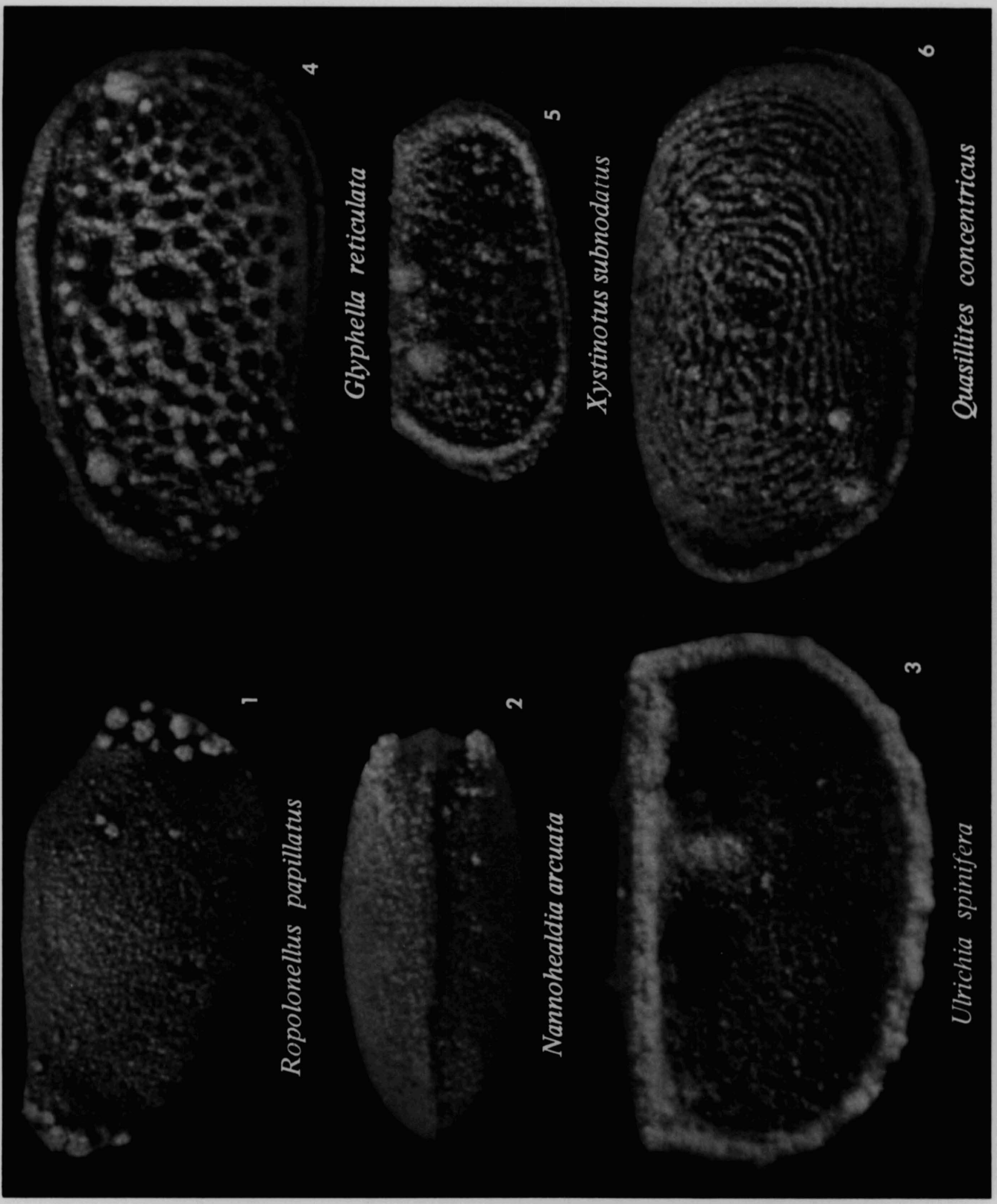

1

Ropolonellus papillatus

2

Nannohealdia arcuata

3

Ulrichia spinifera

4

Glyphella reticulata

5

Xystinotus subnodatus

6

Quasillites concentricus

PLATE 116

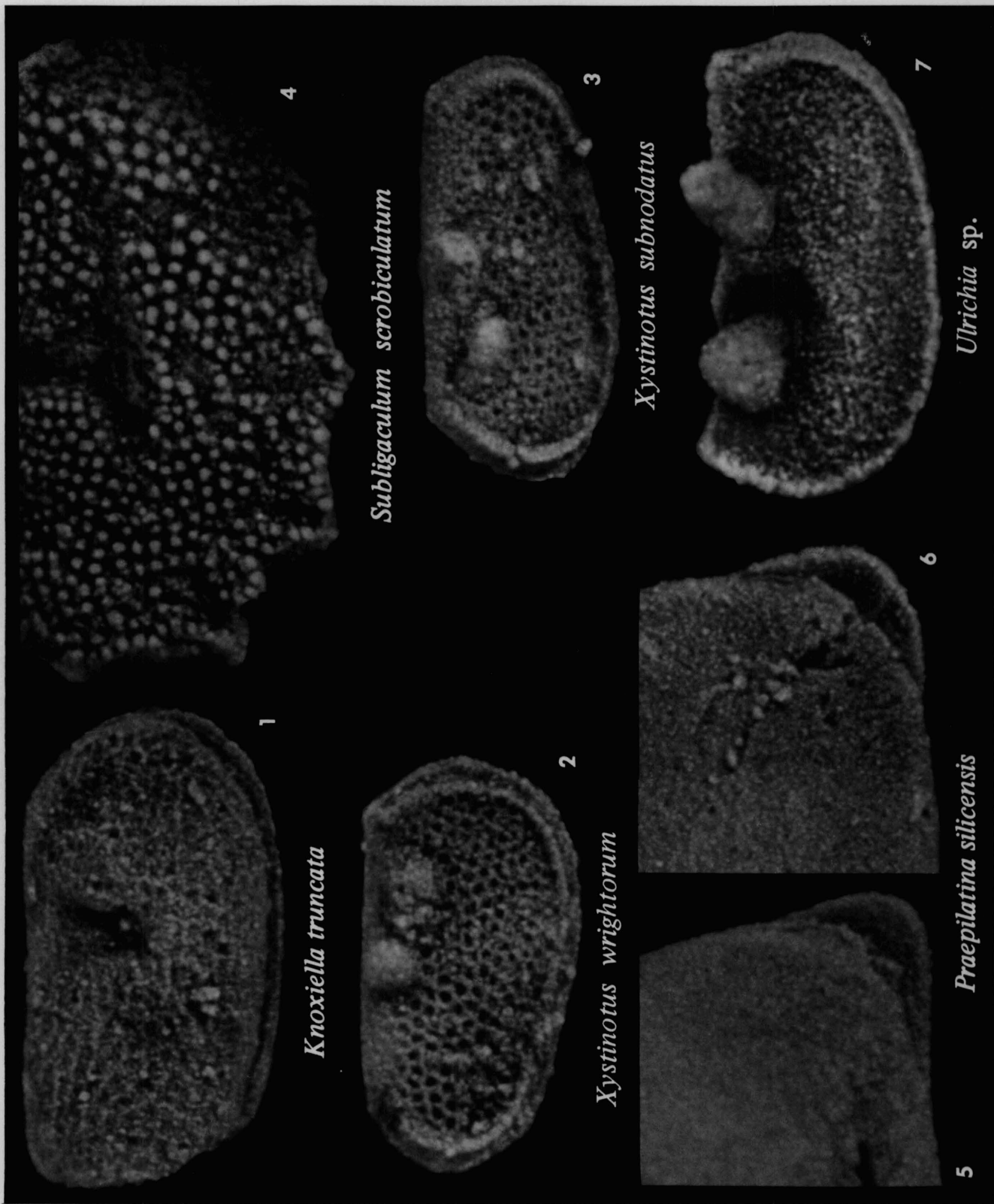

EXPLANATION OF PLATE 116

All figures x 125

- 1 -- *Knoxiella truncata*. UMMP 59073, right lateral view.
- 2 -- *Xystinotus wrightorum*. UMMP 59399, right lateral view.
- 3 -- *Xystinotus subnodatus*. UMMP 59364, left lateral view.
- 4 -- *Subligaculum scrobiculatum*. UMMP 59015, left lateral view, anteroventral region of female carapace, showing ornamentation, frill, and sulci.
- 5, 6 -- *Praepilatina silicensis*. UMMP 59060 and 59545, left lateral views of posteroventral corners, showing acuminate end of right valve projecting beyond rounded end of left valve.
- 7 -- *Ulrichia* sp. UMMP 59681, left lateral view.

EXPLANATION OF PLATE 117

All figures x 125

- 1, 2 -- *Tetrasacculus bilobus*. UMMP 59620 and 59031, ventral views of two male carapaces, showing the interrupted velar structure.
- 3 -- *Ponderodictya punctulifera*. UMMP 59250, right lateral surface, showing central "bare" spot in the reticulation.
- 4, 5 -- *Falsipollex lativelatus*. 4, UMMP 59038, dorsal view of female, showing junction of valves at the anterior cardinal corner. 5, UMMP 59221, lateral view of left valve of female, showing lateral ornamentation and frill.

PLATE 117



3
Ponderodictya punctulifera

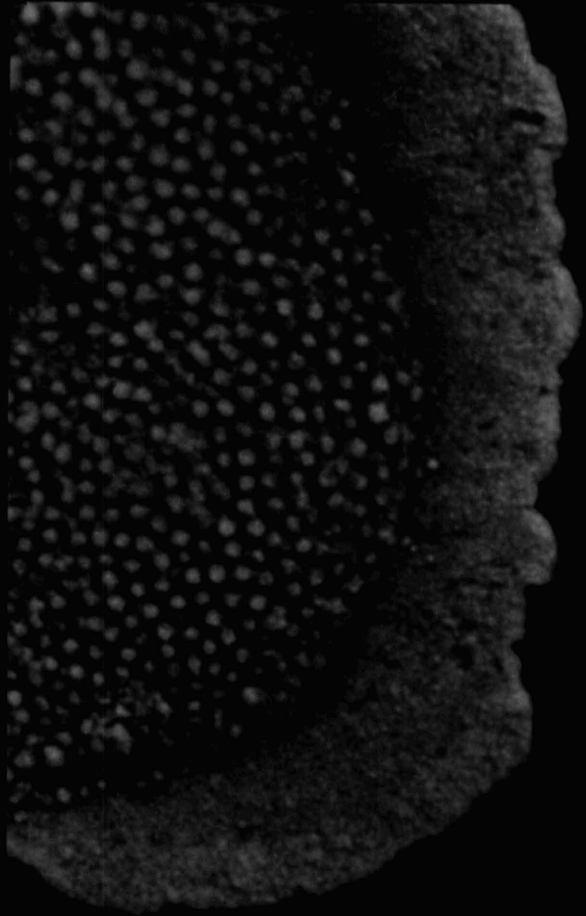

5
Falsipollex lativelatus

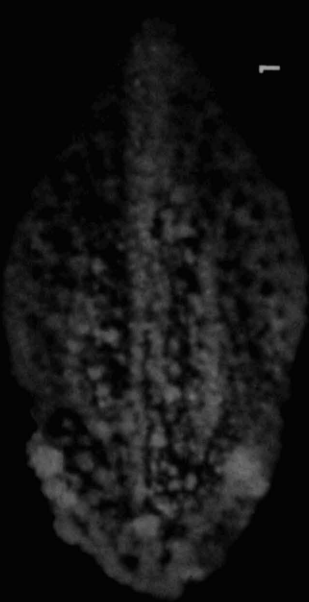

1

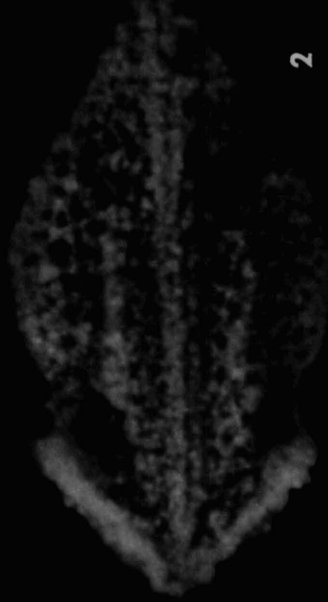

2

Tetrasaccus bilobus

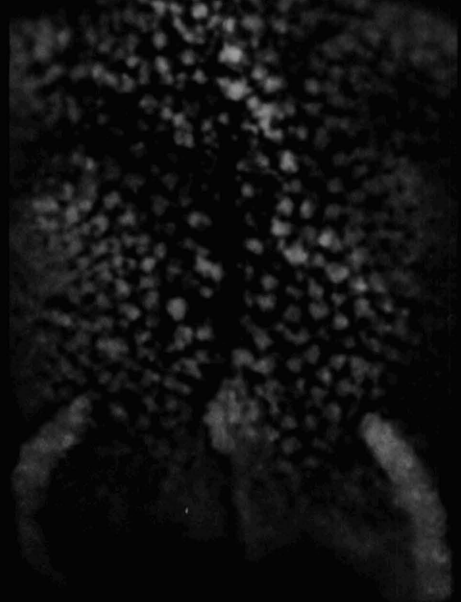

4

PLATE 118



1

Adelphobolbina trilobata

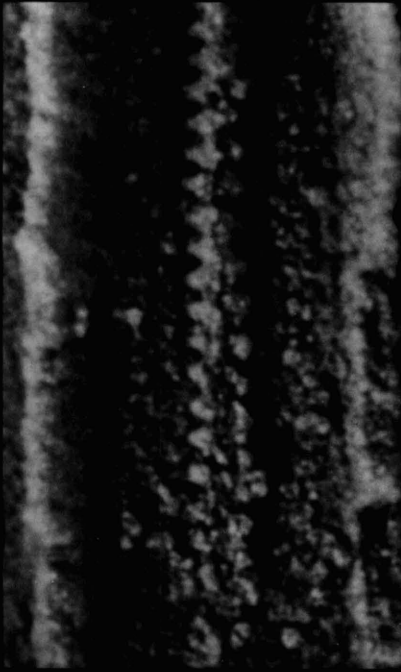

2

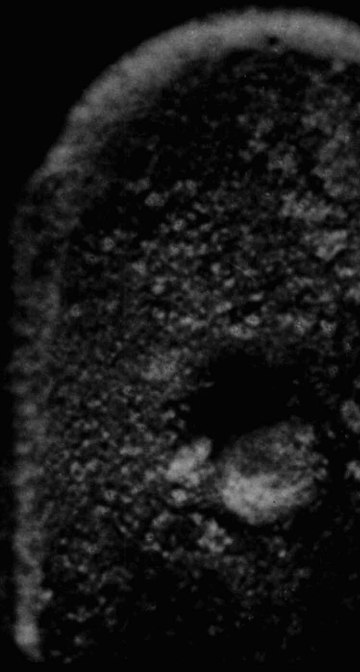

3

Balantoides trilobata



4

Arcyzona bythictimacota

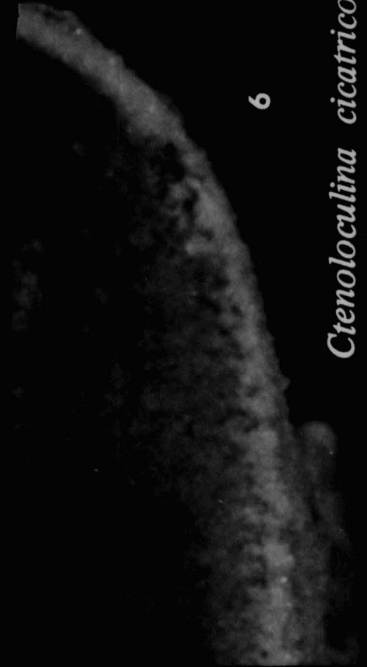

5

Ctenoloculina cicatricosa

EXPLANATION OF PLATE 118

All figures x 125

- 1, 2 -- *Adelphobolbina trilobata*. UMMP 58807 and 58804, ventral views of two carapaces, showing frill, antrum, and marginal papillae.
- 3 -- *Balantoides trilobata*. UMMP 58825, right lateral view.
- 4 -- *Arcyzona bythyclimacota*. UMMP 58837, interior view of left valve, focused on attachment area (knob) of adductor muscles, opposite to external pit (= S2).
- 5, 6 -- *Ctenoloculina cicatricosa*. UMMP 58141 and 58146, interiors of left valve and right valve showing groove and bar closures along posteroventral part of the free edge.

EXPLANATION OF PLATE 119

All figures x 125

- 1-4 -- *Ctenoloculina cicatricosa*. 1-3, UMMP 58141, 59462, and 58146, interior views of two left and one right valve, focused on the adductor muscle scar areas (inside of S2); in the latter two, the attachment areas appear in each to be two elongate ovals; in the first, the attachment area appears to be obscured by a finely punctate veneer. 4, UMMP 58923, ventral view of female carapace, showing marginal closure structures and rimmed loculi.
- 5 -- *Bufina abbreviata*. UMMP 58871, right lateral view of anterior end of carapace, showing anterior ridge and development of marginal tubercles.
- 6 -- *Hanaites platus*. UMMP 59413, inclined left lateral view of specimen retaining delicate keel in posterior part of carapace.

PLATE 119

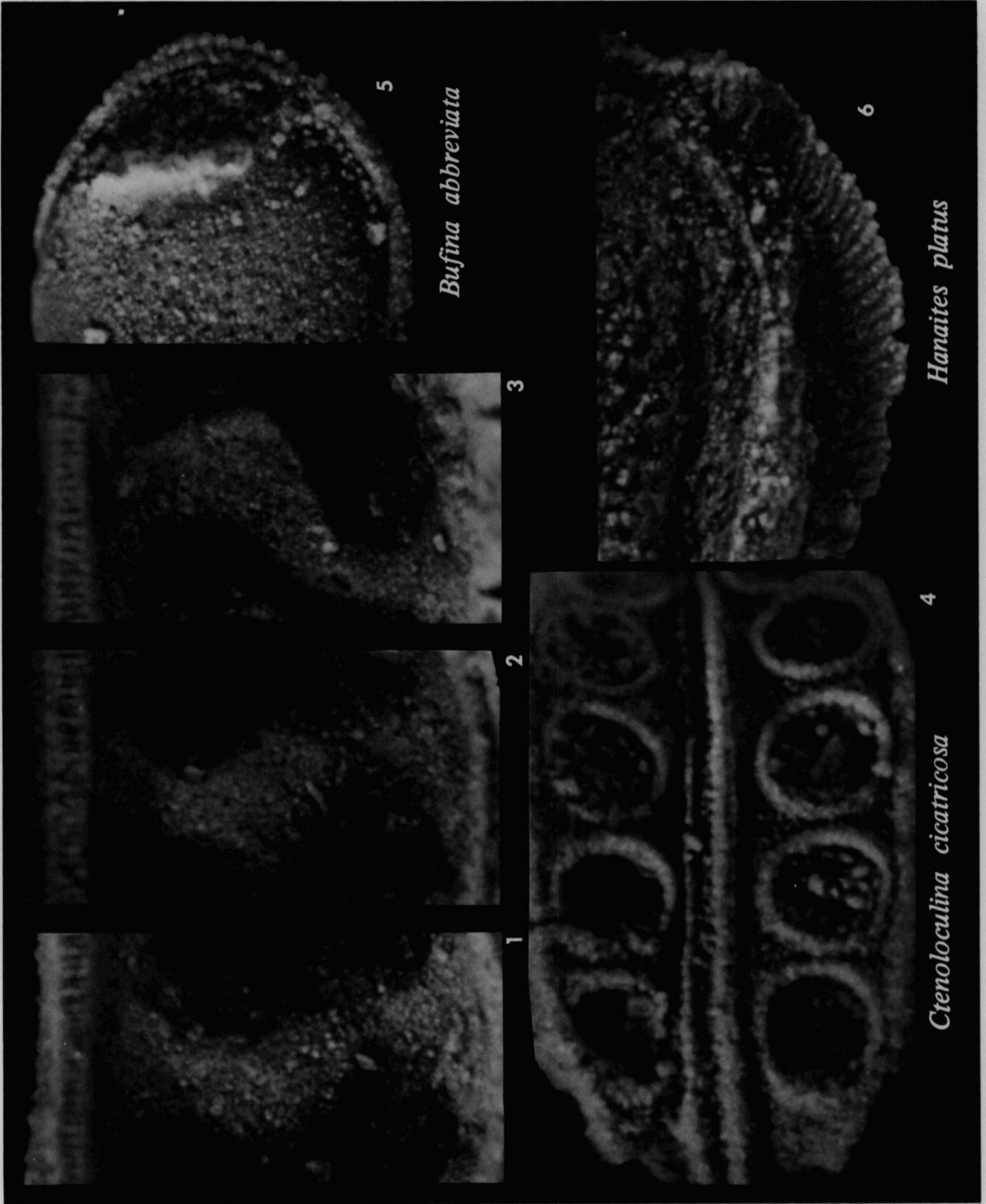

Bufo abbreviata

Hanaites platus

Ctenoloculina cicatricosa

PLATE 120

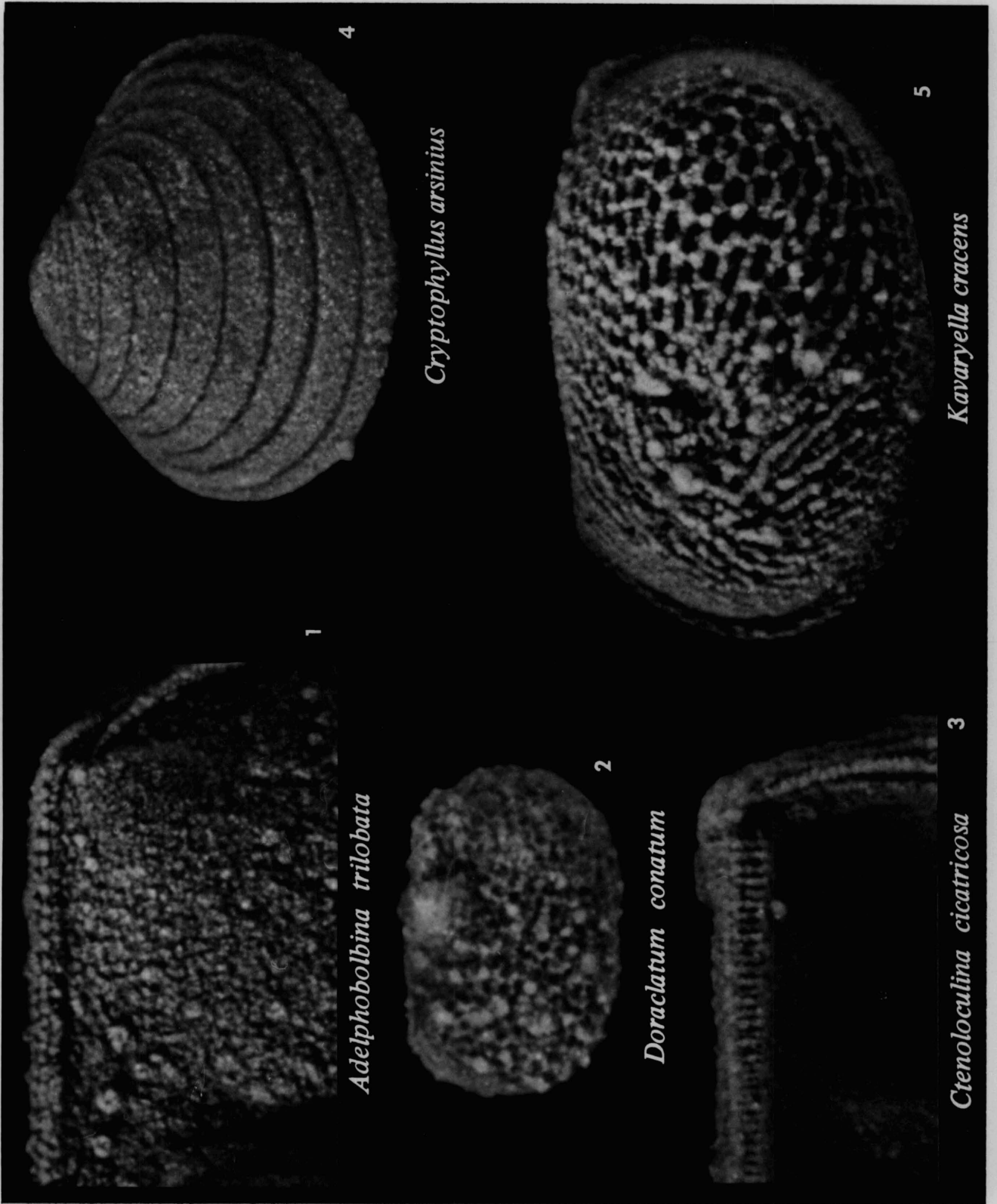

1

Adelphobolbina trilobata

2

Doraclatum conatum

3

Ctenoloculina cicatricosa

4

Cryptophyllus arsinus

5

Kavaryella cracens

EXPLANATION OF PLATE 120

All figures x 125

- 1 -- *Adelphobolbina trilobata*. UMMP 58811, right lateral view of anterodorsal area (slightly inclined), showing that the "smooth" corner area is finely granular.
- 2 -- *Doraclatum conatum*. UMMP 58955, left lateral view, showing ornamentation of basic reticulation and small scattered tubercles situated at junctions of reticular elements.
- 3 -- *Ctenoloculina cicatricosa*. UMMP 58141, interior of left valve, anterodorsal area, showing hingement of toothed (vertically serrate) bar and anterior socket.
- 4 -- *Cryptophyllus arsinius*. UMMP 58959, lateral view of presumed left valve, showing the "growth" lines (actually junctures between retained shells of younger instar stages).
- 5 -- *Kavaryella cracens*. UMMP 59513, lateral view of left valve, showing exceptionally strong development of ornamentation.

EXPLANATION OF PLATE 121

Figures on this and the following two plates show photographs of Silica Formation ostracods made by Scanning Electron Microscope, presented for comparison with those made by the single-lens optical camera. Clearly, (1) the SEM photographs have unlimited depth of field, (2) The gold plating for SEM photography extends into deep sulci and pits, (3) the gold plating is extremely thin as compared to ammonium chloride coating, yielding a more accurate rendition of small structures, (4) highlighting in the conventional manner is possible only in the optical photographs, (5) the ammonium chloride coating for optical photography produces more evenly distributed light over the specimens, and (6) extremely high magnifications can only be achieved by SEM photography.

SEM photographic negatives require more dodging and burning in printing because of the uneven density and marginal "flares" inherent in their production. With gold plating, location of the specimen in the field, and adjustment of magnification, SEM photography proves to be fully ten times as lengthy as optical photography; and even then, magnifications are never quite the same from one exposure to the next. Magnification on the negative must be checked against the specimen for each exposure, and correction made to the desired magnification in enlarging. Furthermore, SEM photography is ten times as expensive as optical photography. Briefly then, SEM offers the advantages of extreme depth of field and minimal distortion of fine detail; it has the disadvantages of lacking traditional highlighting, yielding negatives with strong imbalances (particularly in the case of marginal flares), and costing appreciably more in time and money. Optical photography offers even illumination, traditional highlighting, speed in shooting and printing, and economy; it is deficient in depth of field, and the necessary chloride coating produces a "snowdrift" effect to obscure fine details and to modify others.

A quick and cheap process is preferred if its results fall in the range of acceptability. That is why we chose the optical camera for making more than 3000 photographs reproduced in this volume. At the magnification selected as standard for this study (x 40), the superiority of the SEM may be overestimated. As can be seen, the depth of field in the optical photographs can be made adequate, especially where several views are given for each specimen. In fact, the restriction of sharp focus to a narrow depth more closely duplicates the view of the specimen seen through the binocular microscope than does the SEM view with unlimited depth of field. In addition, by using a thin smoke of sublimated ammonium chloride to coat the specimens, the "snowdrift" effect can be greatly reduced. Traditional highlighting and even illumination are significant factors in ostracod illustrations, in our estimation.

- 1 -- *Ctenoloculina cicatricosa*. UMMP 58928, right stereogram of male carapace, x 40. Compare with plate 19, fig. 18, a photograph of the same specimen taken with optical camera. See also the enlargement of one view in plate 122.
- 2, 3 -- *Falsipollex lativelatus*. 2, UMMP 59409, left stereogram of female carapace, x 40; compare with plate 23, fig. 6, a photograph of the same specimen taken with optical camera; see also enlargement of one view in plate 123. 3, specimen destroyed during photography, left view of adult female, x 100.

PLATE 121

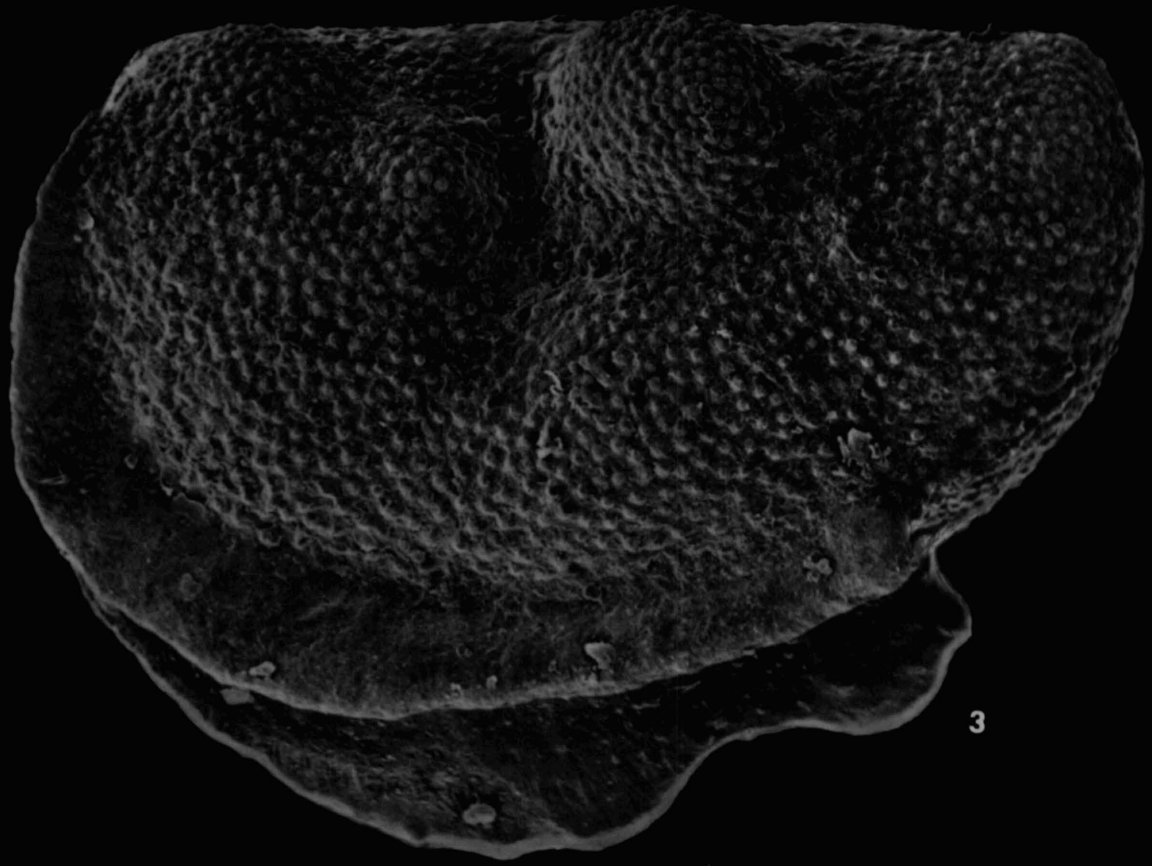
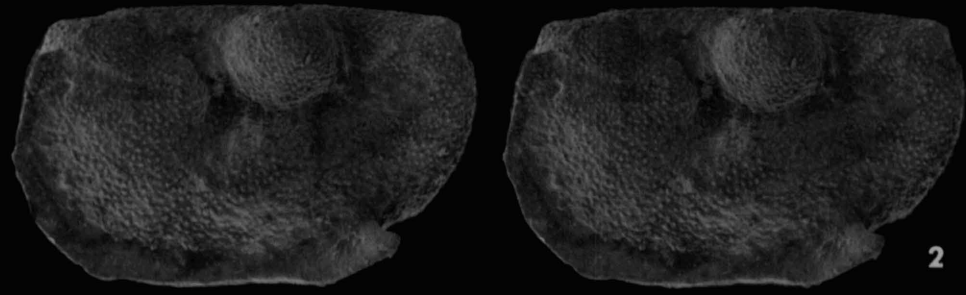
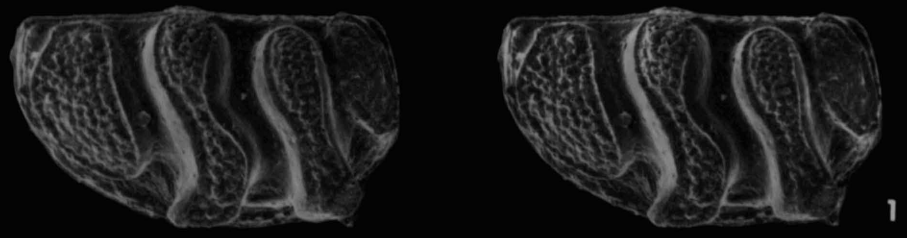
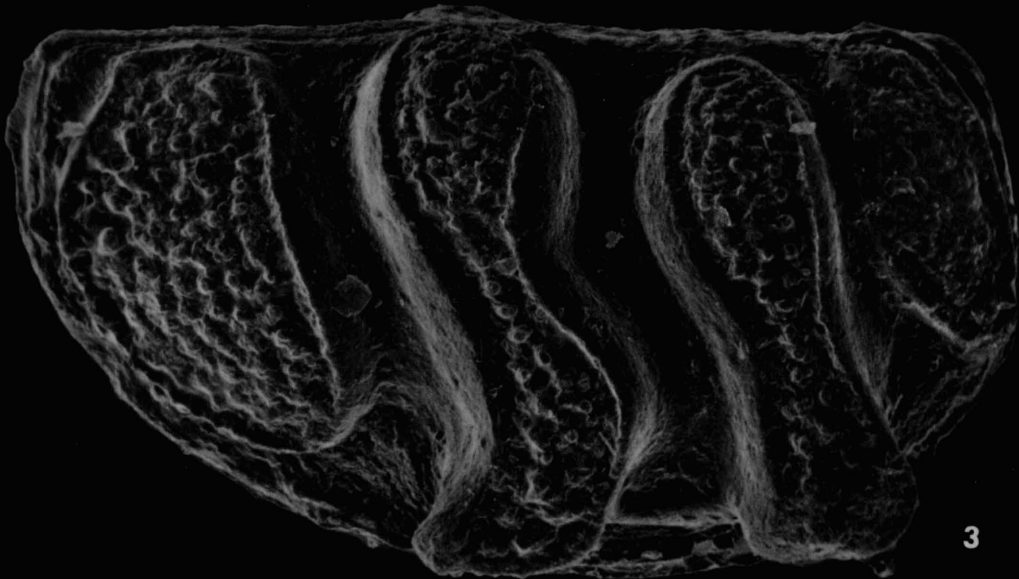
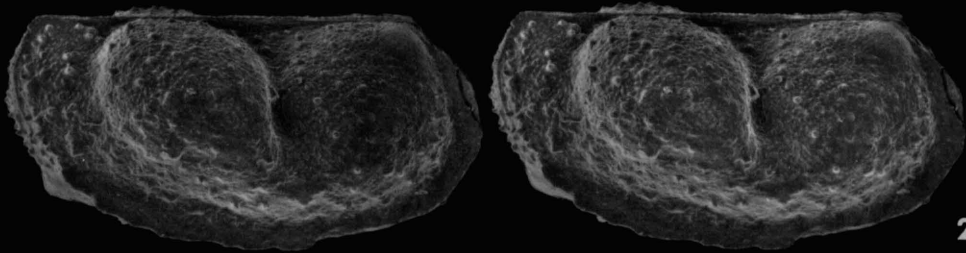
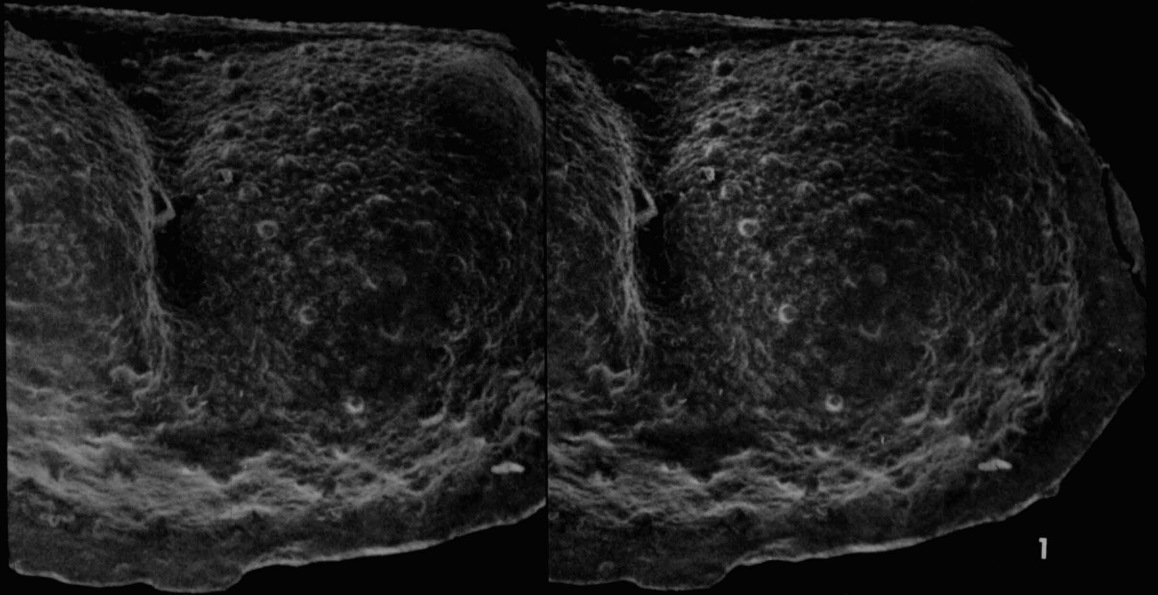

PLATE 122



EXPLANATION OF PLATE 122

- 1,2 --*Adelphobolbina trilobata*. Specimen destroyed during photography. 1, right stereogram of part of carapace, x100, showing ornamentation. 2, right stereogram of entire carapace, x40.
- 3 -- *Ctenoloculina cicatricosa*. UMMP 58928, right view of male carapace, x100. See also stereogram in plate 121.

EXPLANATION OF PLATE 123

- 1 -- *Adelphobolbina trilobata*. Specimen destroyed during photography, right view of carapace, x100. See also stereogram in plate 122, fig. 2.
- 2 -- *Falsipollex lativelatus*. UMMP 59409, left view of female carapace, x100. Compare with plate 19, fig. 18, a photograph of the same specimen taken with optical camera. See also stereogram in plate 121, fig. 2.

PLATE 123

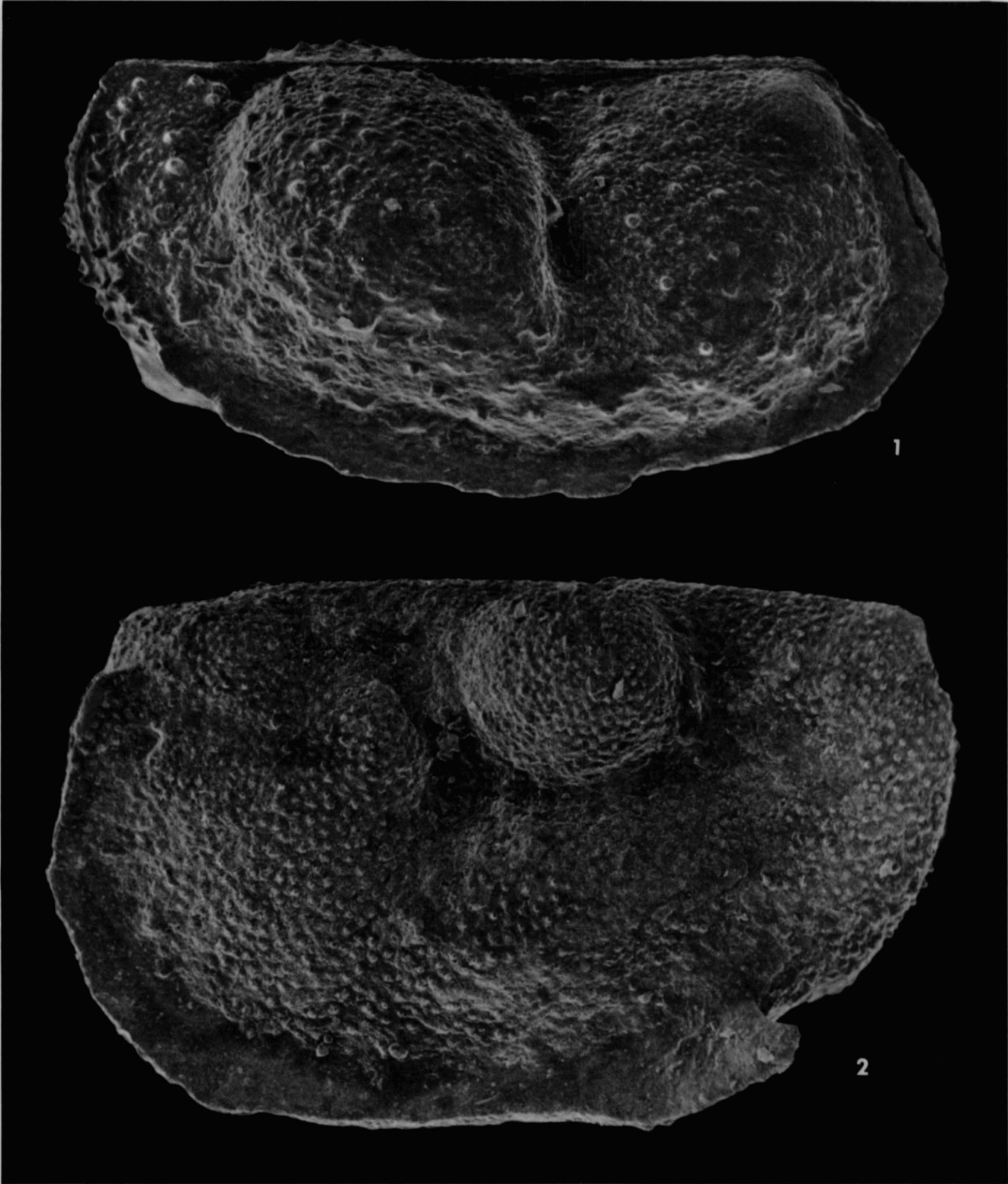

In the index which follows, the first number represents the plate and the following numbers the figures on the plate. Thus, an entry of 98/5-10 means plate 98, figures 5 through 10.

INDEX

- Acanthoscapha devonica* 7/18-20
Acratia simplex 9/1-3; 10/3-5; 84/1-4;
 104/25-34
Adelphobolbina trilobata 1/2-12; 2/2-12;
 3/2-12; 4/1-4; 38/8,9; 111/2; 118/1,2;
 120/1; 122/1,2; 123/1
Adelphobolbina spicata 1/1; 2/1; 111/1
Adelphobolbina sp. 3/1
Aechmina choanobasota 11/13,14
Aechmina crenulata 10/1,2; 11/1-6; 13/1-4;
 108/6
Aechmina spp. 11/7-12; 13/5-10
Aechminaria hormathota 11/17-22; 49/1-4
Aechminaria sp. 11/15,16
Arcyzona bythioliclimacota 7/9-13; 8/5-8;
 9/18-25; 10/12-17; 118/4
Arcyzona campylactinota 8/17-22; 9/12-17;
 10/10,11; 54/5-8
Arcyzona diademata 7/1-8; 9/4-11
Arcyzona homalosagenota 8/9-16; 41/28-34
Arcyzona rhabdota 8/1-4; 10/6-9
Arcyzona spp. 51/1-4; 52/5-12; 54/9-12; 56/1-4
Bairdiocypris gongylus 91/13-30; 92/21-24
Bairdiocypris transptyxis 90/1-23; 91/1-12
Balantoides trilobata 89/21-55; 118/3
Balantoides sp. 89/1-20
Birdsallella devonica 92/25-40
Birdsallella tumida 92/1-20; 93/21-43; 104/7,8
Bufina abbreviata .. 93/1-10; 97/16-26; 107/29;
 119/5
Bufina curti 93/19,20; 97/27-37; 98/1-10;
 105/19-23
Bufina spinulifera 98/42-61
Bursulella sp. 6/1-9; 106/1-17
Bythocyproidea eriensis ... 99/11-40; 100/1-16;
 101/1-8; 107/21,22
Coelonella plana 102/15-25; 103/1-9
Coelonella scapha 102/26-38; 103/18-20; 107/30
Coelonellina rara 100/17-20; 107/17-20
Cornigella immotipedata 38/10-33; 39/1-22;
 109/4,5
Cryptophyllus arsinus 101/9-17; 102/1-8;
 103/23,24; 120/4
Cryptophyllus minusculus . 100/39-54; 102/9-12;
 104/9-16; 105/10-18; 109/3
Ctenolocolina acanthina 16/1,2; 17/10-20;
 21/1-10; 111/3,4
Ctenolocolina eurybathrota 17/1-6
Ctenolocolina cicatricosa 5/1-22; 6/10-19;
 16/3-6; 17/7-9; 18/1-20; 19/1-18; 20/1-18;
 21/11-13; 109/6,7; 110/5; 118/5,8; 119/1-4;
 120/3; 121/1; 122/3
Cytherellina kutasii 94/21-25; 95/1-16
Cytherellina lechria 94/1-13; 95/17-27; 96/1-6
Cytherellina lucasensis ... 94/14-20; 95/28-37;
 97/8-15
Cytherellina subquadrata 94/26-36; 96/7-16
Cytherellina tanymeke .. 96/17-23,32-35; 97/1-7
Cytherellina sp. 55/5-8; 96/24-31
Dirhabdus multicostatus 98/21-41; 99/1-10;
 103/10-17; 106/18,19; 108/4
Dizygopleura euglyphea 44/17-28; 45/1-4;
 47/40-42
Dizygopleura trisinuata 44/13-16; 45/5-24;
 47/43-54; 103/25-28
Doraclatum conatum 82/1-19; 90/24,25;
 93/11-18; 120/2
Ehlersia hypercala 40/26-29; 105/24-29
Euglyphella compressa 76/5-13; 80/1-4
Euglyphella lispa 76/1-4; 79/15-21
Euglyphella modesta 76/24-27; 79/1-14; 80/5-13
Euglyphella projecta 76/14-23; 77/9-15
Euglyphella sigmoidalis ... 76/28-35; 77/16-24;
 78/12-28; 79/22-26
Eukloedenella doverensis ... 82/42-53; 83/1-20;
 88/1-8
Falsipollex lativelatus 21/14-22; 22/8-19;
 23/1-13; 25/11-19; 26/1-9; 28/11,12;
 32/1-9; 38/5-7; 104/1-6; 110/4; 117/4,5;
 121/2,3; 123/2
Falsipollex laxivelatus 22/1-7; 24/5-18;
 25/1-10; 26/10-16; 27/1-17; 28/1-10;
 29/1-18; 31/11-14; 38/1-4; 108/5
Falsipollex sp. 24/1-4
Glyphella reticulata 40/30-46; 41/35-42; 115/4
Hanaites platus 35/12-20; 119/6
Healdia arkonensis 85/44-51,56,57
Healdia gibba 84/13-15; 85/1-16; 86/7-10
Healdia medusaensis 85/17-32
Healdia cf. *medusaensis* 85/33-39
Healdia sp. 84/5-12,16,17;
 85/40-43,52-55; 86/1-6
Hollinella (Keslingella) antespinoza . 15/8-21;
 16/20,21; 105/1-9
Hollinella (Keslingella) labrosa 10/18,19;
 14/10-13
Hollinella (Keslingella) cf. labrosa . 12/1-10;
 14/4-9
Hollinella (Keslingella) pumila 13/11-24;
 14/1-3; 15/1-7; 16/7-19; 109/1,2
Hyphasmophora textiliger . 58/26-28; 60/29-32;
 112/4

- Hypotetragona aequitalis* 58/22-25; 59/1-8; 107/23-28; 108/1
- Hypotetragona fractodorsalis* ... 59/9-12,25-46; 108/3
- Hypotetragona harrietensis* .. 59/13-19; 60/1-9; 108/2
- Jenningsina catenulata* 59/20-24; 60/10-25; 110/1,2
- Kavaryella cracens* 60/33-43; 120/5
- Kirkbyella (Kirkbyella) bellipuncta* . 39/23-36; 40/1-12; 112/1
- Kirkbyella (Berdanella) stewartae* ... 39/37-42; 112/2
- Kirkbyella (Berdanella) unicornis* ... 39/43-56; 40/13-25; 112/3
- Knoxiiella rutkowskiae* 63/1-26; 64/1,2
- Knoxiiella truncata* 64/25-53; 116/1
- Knoxiiella* sp. 63/35-38
- Menoeidina arcuata* 68/7-12; 69/14-25; 70/11-15; 107/15,16; 112/5
- Menoeidina paucipunctata* 65/9-34; 68/1-6; 112/6
- Menoeidina subreniformis* 64/3-24; 65/1-8; 69/9-13; 113/1,2
- Microcheilinella mariettensis* 101/18-48; 102/13,14; 104/21-24
- Monoceratina casei* 70/16-21; 71/9-30; 74/19-21
- Nannohealdia arcuata* 98/11-20; 100/21-38; 115/2
- Octonaria crescentiformis* 87/1-6; 88/13-16
- Octonaria laevilitata* 86/22-35; 87/7-18; 88/17-30; 89/68-71
- Octonaria quadricostata* ... 86/11-21; 87/19-32; 88/9-12; 89/61-67
- Phlyctiscapha apleta* 34/1-10; 35/1-11; 36/5-20; 37/1-20
- Poloniella cingulata* 61/1-16; 62/1-21; 63/27-34
- Poloniella* sp. 56/5-8
- Ponderodictya ohioensis* 65/35-42; 66/1-12; 68/18-22
- Ponderodictya punctulifera* 52/1-4; 53/5-8; 65/43,44; 67/1-12; 68/13-17; 69/1-8; 70/1-10; 71/1-8; 114/2,3; 117/3
- Ponderodictya rhodesi* 51/5-8; 53/1-4; 72/1-12; 73/1-2; 74/1-12; 114/1
- Praepilitina silicensis* ... 74/13-18; 75/19-26; 77/1-8; 78/1,2; 116/5,6
- Pronipantex planus* 75/1-18; 78/3-7
- Punctoprimitia simplex* 46/20-39; 48/1-12
- Quasillites concentricus* 48/13-24; 49/5-8; 50/23-30; 57/27-34; 60/26-28; 115/6
- Quasillites fordei* 57/1-26
- Quasillites obliquus* 58/6-21
- Quasillites sublunatus* 48/25-36; 49/11-32; 50/1-22; 58/1-4; 113/3
- Quasillites* spp. ... 48/37-40; 49/9,10; 54/1-4; 55/1-4; 58/5
- Rectobairdia emaciata* 7/14-17; 78/8-11; 106/24-27; 107/31-34
- Richina subcircularis* 46/1-4; 107/1-4
- Richina trinodosa* 46/5-19
- Richina truncata* 103/21,22; 107/5-14
- Ropolonellus papillatus* 47/1-22; 115/1
- Rudderina extensa* 46/40,41
- Rugocytherellina ehlersi* 80/14-38
- Scrobicula microspinosa* 81/1-21; 82/30-41
- Scrobicula xysta* 81/28-66; 82/20-22
- Sigynus dictyotus* 81/22-27
- Sigynus* cf. *dictyotus* 103/29-34
- Stictobollia alethae* 81/67-86; 82/23-29; 83/44-46
- Subligaculum scrobiculatum* 31/15-26; 32/10-24; 33/1-16; 36/1-4; 104/17-20; 116/4
- Tetrarhabdus pygmaeus* 46/42-57; 47/23-39; 113/4
- Tetrasacculus bilobus* 30/1-53; 31/1-10; 117/1,2
- Tetrastorthynx diabolicus* . 83/21-39; 84/18-23; 113/5
- Ulrichia conradi* 41/21-27
- Ulrichia fastidiosa* 41/7-20; 42/9-24; 106/20-23; 114/7
- Ulrichia fragilis* 42/39-54; 43/23-30; 110/3; 114/6
- Ulrichia illinearis* 43/31-36; 114/5
- Ulrichia spinifera* 41/1-6; 42/25-38; 43/1-22; 114/4; 115/3
- Ulrichia* sp. 42/1-8; 116/7
- Wideneria lispa* .. 83/40-43; 84/24-45; 89/56-60
- Xystinotus subnodatus* 43/52-64; 44/1-12; 115/5; 116/3
- Xystinotus wrightorum* 43/37-51; 116/2

OSTRACOD OR OSTRACODE

Robert V. Kesling

INTRODUCTION

If you are unacquainted with the word "ostracode," be assured you will soon hear it spoken or see it in print. The fact is this: micropaleontologists are divided on whether the common name applied to the Ostracoda should be "ostracod" (as we use it in this volume) or "ostracode" (as many of our friends use it). Good reasons can be found for either word. To me, it is a matter of little concern, for the choice of "ostracod" or "ostracode" does not affect classification, it does not prevent using these microfossils for dating the strata, and it certainly has no influence on their evolutionary history. Chilman and I will not be offended if you refer to our work on "ostracodes."

Certain micropaleontologists, however, get very perturbed whenever they encounter the word "ostracod." They have suggested that any idiot who persists in using it should have his body quartered, his head impaled, and his soul consigned to everlasting fire. Further, his mouth should be scrubbed with soap and he should not be invited to conventions. It is time to say a few words in self-defense. Let us start with a brief look at the history of both the scientific and the vernacular names for these tiny bivalved crustaceans.

HISTORY

Ostracods have been known for a long time. Back in 1761, Martin Frobenius Ledermüller published a volume of 204 pages entitled "Mikroskopische Gemüths- und Augen-Ergötzung" in Brandenburg, Germany. It was illustrated with 100 woodcuts, each painstakingly hand-colored, showing the wonders to be seen through that exciting new instrument, the microscope. Plate 73 was listed as "Eine besondere Art von Schaalenthierchens in Wasser; oder die nierenförmige Pücerons" (a special kind of little shelled animals in water, or the kidney-shaped lice). Actually, the ensuing description was rather good of a living ostracod, probably a Candona.

A formal attempt at classification was made by P. A. Latreille in 1802, in volume 3 of his "Histoire naturelle, générale, et particulière des Crustacés et des Insects," published in Paris. On page 17 of this work, Latreille listed "Ostrachoda," a taxon in which he placed not only ostracods but also cladocerans. By strictest priority, this was the first appearance in print of a taxon for the ostracods (even though it included other crustaceans), and whereas its content was subsequently revised, Latreille's 1802 "Ostrachoda" might rightly be claimed for the correct spelling of the scientific name for our little friends. Of course, other authors have asserted that his intent was to name them "Ostracoda" since such a word has an appropriate antecedent in Greek. In fact, Latreille himself four years later, in a revised version of his work on crustaceans and insects, spelled it as the now accepted "Ostracoda." In the ostracod volume of the Treatise on Invertebrate Paleontology (volume Q) on page Q100 the taxon is credited to Latreille with the date 1806.

The first clear separation of ostracods from all other crustaceans, to my knowledge, was made by H. E. Straus in 1821 in his "Mémoire sur les Cypris, de la classe des Crustacés." On page 58 of his work, Straus separated off the ostracods as the "Ostrapodes," a name which, because it does not end in the familiar "a" of suprafamilial names, could be

considered as informal. The Rules of the International Commission on Zoological Nomenclature (ICZN), however, contain no stipulation concerning the form of order/class-group names, and such can be emended freely by arbitrary changes of the ending. Hence, in the Treatise (p. Q100), Straus is credited with the "Ostrapoda" of 1821. Should we retain the classification as it evolved, Latreille would be the author of the Ostrachoda, a taxon including the Ostrapoda of Straus; the animals described herein would then be known commonly as "ostrapods." Usage did not follow such a path.

An attempt to introduce a vernacular name for the Ostracoda was made by Fritz Johansen in 1921 in an article published in The Canadian Field-Naturalist. On page 88, he suggested that the common German name "Muschelkrebse" could be translated as "mussel-shrimps" and used in English for the Ostracoda. His attempt fell flat. Insofar as I know, Johansen was the first, last, and only one to use the term "mussel-shrimps."

A few naturalists, including William H. Amos (1977, p. 567), have called them the "seed shrimp." The term is descriptive, but many ostracodologists are still unfamiliar with it.

Many British micropaleontologists and several American came to use "ostracod" as the vernacular name. Writers in French, of course, called them "ostracodes," just as they referred to "pelecypodes," "cephalopodes," and "gasteropodes" in their publications. Authors writing in English at the turn of the century, however, either called them "ostracods" or, as did the noted contributor E. O. Ulrich, carefully avoided any vernacular name and always called them "Ostracoda."

In their monographic "Paleozoic Ostracoda" (1923), Ulrich & Bassler made one spelling serve two purposes; they used "ostracoda" (uncapitalized) as the vernacular term and "Ostracoda" (capitalized) as the scientific taxon. They opened their discussion of anatomy (1923, p. 271) with the statement:

The ostracoda are small, generally minute crustacea with the entire body enclosed in a horny or calcareous carapace, the right and left sides of which are separate and articulated along the dorsal edge so as to form a bivalved shell ...

These eminent authors did, nevertheless, discuss the "Ostracod Zones" (1923, p. 349, 368) and referred to the "ostracod beds" (1923, p. 547). On page 279 they abandoned their usual vernacular name, and stated:

Many of us in our field work have no doubt come across small pools, sometimes a foot or less in diameter, swarming with fresh-water ostracods. In such instances, as evaporation proceeds, the pool will become a fairly solid mass of ostracods ...

Hence, wherever Ulrich & Bassler used a vernacular name, they chose either "ostracoda" or "ostracods."

The Second Edition of Webster's New International Dictionary of the English Language (1948, p. 1728) gave the spelling "ostracod" preference over "ostracode."

Most of the dissension stems from the spelling used in the Treatise on Invertebrate Paleontology (1961, p. Q2). In a footnote it was said:

Although the spelling "ostracod" is employed by most British and some American writers, the *Treatise* adopts "ostracōde" because this word is derived from the Greek *ὀστρακώδης* (ostracodes); Webster's New International Dictionary recognizes both spellings. -- Editor.

This preference was taken as gospel by many workers. Strangely, some of these authors

offered more credence to this item than to the taxonomy proposed in the Treatise.

It may be pointed out in passing that *ὄστρακώδης* is not a common word itself; I have a Greek-English dictionary of 835 pages which does not list it.

COMMENTS ON THE GREEK

Many persons are convinced that the classical languages are absolute in grammar, perfect in spelling, and the ultimate in precision. A word in Latin or Greek, they sincerely believe, has a single, exact, undeniable meaning, and its translation into English follows rigid rules; as a result, in their view, only one interpretation is possible, and that one is correct and immutable.

Apparently such persons forget that our own language has evolved from Chaucer to King James to the Oxford dictionary to the Webster's dictionary to current addenda and revisions. Language grows, for better or worse. "Plough" changes to "plow," some words become archaic and are abandoned, and new words arise from various sources. Almost any language that is used for more than one generation will experience completely new words introduced for new inventions and ideas, nuances in meaning for old words, and local patois and regional cant to perpetuate the concepts of specific situations of impact or impression. Such changes led Latin grammarians to group writings into "Classical" (75 B.C. to 200 A.D.), "Late" (200 to 600), "Low" or "Middle" (600-1500), and "New" (after 1500). Similarly, Greek contributions have been grouped and identified as "Classical" (to 200 A.D.), "Late" (200-600), "Middle" (600-1500), and "New" (after 1500); in addition, certain Greek words are provincial, as Doric or Attic. Sources from which scientific names are compounded are most often selected from the Classical period of Latin or Greek.

The saying that "The Greeks had a word for it" has contributed to the unqualified trust placed in such sources. It is obvious, of course, that the Greeks could have had no word for "submarine," "radio," or "television," for such inventions were unknown and unsuspected in the Classical period. On the other hand, for many objects and concepts the Greeks had not only one word for "it" but several, and for a number of "its" one word was made to suffice. And even serious scholars of the language may have doubts about just what a Greek word meant to the Athenian man-in-the-street in 50 B.C. We certainly do not have a complete dictionary of all Greek words from the period.

Let us look at the way in which "ostracode" can be derived, going back first to the Greek roots. In his introduction to The Naturalist's Lexicon (1944, p.xiv), Robert S. Woods explains:

The copulative vowel *ο* is also retained before the Greek suffix *-ides* (*-ειδης*: resembling); in many original Greek adjectives thus formed, however, the separate vowels *οι* (*οει*) are contracted to *ο* (*ω*).

Thus, the adjective meaning "testaceous" was derived from the noun *οστρακον*, n. ("tile; earthen vessel; shell of a mollusk, tortoise, or egg") by taking the stem *οστρακ-* and adding the copulative vowel and a suffix to mean "resembling" or "like":

$$-ο- + -ειδης = ωδης$$

Hence, *ostrac-* + *-odes* = *ostracodes*.

In many Greek words, however, the vowels involved in forming an adjective "-like" from a noun were not so contracted. From them we derive numerous English words ending in "-oid" and meaning "like the noun to which the suffix is added." In this way we get such words as *blastoid*: from the noun *βλαστος*, m. ("bud, sprout") we use the stem *βλαστ-*, add the copulative vowel *-ο-* and *-ειδης*, and create *βλαστοειδης*;

hence, the English "blastoid" (but not "blastoide"), meaning "bud-like" or "having the characteristics of a bud." Similarly, we derive the common word rhomboid: from the noun *ῥομβος*, m. ("a rhomb"), we use the stem *ῥομβ-*, add the copulative vowel -ο- and -ειδης, and create *ῥομβοειδης*; hence, the English "rhomboid" (but not "rhomb-oid"), meaning "rhomb-like." Therefore, it is only by the choice of the Greeks that we have *οστρακωδης* instead of *οστρακοειδης*, or else the word might have come into English as "ostracoid."

At times, the Greeks themselves left the matter of vowel contraction optional, as for example in their word meaning "raven-like": from the noun *κοραξ*, m., they used the stem *κορακ-* and added the suffixes to form both *κορακωδης* and *κορακοειδης*; hence, in English one might find some justification for "coracode" even though "coracoid" is the only form recognized by the Webster's and Oxford dictionaries.

It could also be mentioned that despite numerous and complex "rules" for transliteration from Greek to English, which have evolved among language scholars, many exceptions are found in the vernacular names. As examples:

<u>Greek</u>	<u>English</u>
<i>αραχνη</i> , f. ("spider")	arachnid (not "arachne")
<i>ναυσια</i> , n. ("sea-sickness")	nausea (not "nausia")
<i>κοχλιας</i> , m. ("something spiral")	cochlea (not "cochlia")
<i>κλων</i> , m. ("twig, shoot")	clone (not "clon")

The point I stress is that transliteration itself is not an iron-clad, rigid, absolute, inflexible, strict procedure, and vernacular names do not always reflect the original Greek spelling. Numerous "violations" of the rules are to be found in scientific names, wherein the Greek aspirate at the beginning of the word is ignored in transliteration, as for instance in the use of the stem "ist-" instead of "hist-" from the Greek *ἴστος*, m. ("mast, pole, web of cloth") or "raph-" instead of "rraph-" from the Greek *ῥαφίς*, f. ("needle, pin").

The Greeks often used various suffixes (endings) to a stem for the same meaning, as for example in their words for "thief":

κλωψ, *κλοπευς*, and *κλοπος*, m.

On the other hand, they frequently added different suffixes to the same stem to form words of drastically different meanings, as for example in the stems "acanth-", "aul-", and "mel-":

{	<i>ακανθ-</i>	-α, f., thorn, thorny plant	-ιου, n., cotton-thistle
		-ηεις, thorny, prickly	-ιων, m., hedgehog, porcupine
		-εων, m., thicket	-ις, f., goldfinch, linnet
		-ιας, m., kind of shark; kind of grasshopper; prickly asparagus	-ος, m., bear's breech plant; Egyptian evergreen
{	<i>αυλ-</i>	-η, f., court, hall	-ος, m., flute, tube; cow-bane
		-ις, f., stall, tent	-ιος, rustic
		-ων, m., channel, defile, aqueduct	-ιας, m., cattle fold

μελ-	{	-αυ, n., black ink or dye	-λα, f., manna ash tree
		-εος, fruitless, vain	-λυη, f., Italian millet
		-ας, black	-ος, n., song, tune; limb
		-ης, f., teasel	-ι, n., honey
μηλ-	{	-η, f., a probe	-ωυ, m., orchard
		-εα, f., apple tree	-ου, n., apple or other tree fruit; sheep or goat
		-ειος, belonging to sheep; apple-like	

In addition, the Greek language, like the English, contained not a few homonyms. For a few examples:

αγκος, n.	angle; valley; crag
ακτη, f.	sea shore; rocky promontory; corn, meal
ανθος, m.	flower; excellence; a bunting-like bird
αρμα, m.	food; chariot
ασπις, f.	round shield; viper, asp
βρομος, m.	oats; rank smell; poison
βροτος, m.	a man; a mortal; blood, gore
καιρος, m.	opportune moment; convenient time; fitness, due measure; right proportion; webbing in a loom
κιρκος, m.	racecourse; kind of hawk
ιστος, m.	ship's mast; loom
λος, m.	arrow; rust, verdigris; snake poison

Obviously, the stem as it appears in a scientific name does not in itself invariably convey a certain meaning; the suffix may be just as important a part of the word from which derivation is intended. In addition, nuances and connotations varied from one Greek dialect to another, and from one period to another. Since the Greeks did not describe Ostracoda, and presumably did not recognize them, any thoughts on what they might have called them must remain pure conjecture. (As you see, it becomes very important for authors of new names to explain the precise derivation.)

SCIENTIFIC NAMES

Names for different taxonomic groups are judged differently. The Law of Priority and the Rules laid down by the International Commission on Zoological Nomenclature (ICZN) apply to specific and subspecific names, generic and subgeneric names, and to family-group names. For such names, the rules and regulations are rigorous and elaborately detailed. Names for suborders, orders, subclasses, classes, and still higher taxonomic categories, however, have no stipulations concerning form under the Rules, and such names can be emended by arbitrarily devised changes. For such categories, there is no regulation against substituting an entirely new name for an old one, but paleontologists and zoologists show commendable restraint and good judgment in maintaining the stability and consistency of the taxa with which they work. As classified in the *Treatise* (Moore, 1961, p. Q100), Ostracoda is a subclass and as such falls into one of the unregulated categories.

At all taxonomic levels, confusion and uncertainty are compounded by the manner in which scientific names are formed. By convention, names for suprageneric taxa end in -a, as in Scaphopoda, Ostracoda, Arthropoda, or Decapoda. It is generally agreed among

scientists that each name should be different from every other name of a suprageneric taxon in the animal kingdom, although no ICZN Rules are enacted for the situation. Otherwise, acceptance or rejection of a particular name is a matter of peer pressure; if most agree that the taxon is a useful, logical entity, they will accept the name applied to it on priority or long usage. They may or may not accept emendations of the ending. Not that they are forced either way, mind you. Any micropaleontologist could decide on his own to rename the Ostracoda as the Yunowotta or any other nonsense name terminating in -a; odds are extremely high that his work would be ignored by all peers and that any subsequent publication would be at his own expense.

In the absence of specific rules, however, some adjustments and revisions are made. If not, taxonomy would be static. Such changes may arise from the need for additional categories to express new concepts of relationships, or they may come from a re-evaluation of priority versus usage. It is impossible to foretell how ostracodologists would react to the resurrection and re-definition of Latreille's original "Ostrachoda" as a substitute for his later "Ostracoda"; my feeling is that the majority would favor long usage of the latter over priority of the former. The same might apply in attempting to revive Straus' term "Ostrapodes" or its revised form "Ostrapoda."

Whatever the status of a suprageneric name, its Greek or Latin derivation has no bearing on its "legality" or usage. Of those names which trace back to the Greek, a Latin ending (such as -a) is added to the Greek stem or combination of stems. Sometimes, a Greek stem is combined with a Latin stem and ending, thereby creating a hybrid word that might not have been understood by either the classical Greeks or Romans. The meaning of such a combination of letters may not have been too clear to the original author, and may have remained a complete enigma to subsequent readers, but it could be nevertheless an accepted and rightful name for the taxon.

In reviewing the problems raised by incorrectly formed and inappropriate names, G. Winston Sinclair (1951, p. 252-254) was moved to say:

It is the uniqueness of the combination of letters that is important, and that alone makes the name an acceptable one in nomenclature. The "meaning," if any, is entirely secondary. So secondary that even though the "meaning" be completely incongruous ... the name still stands as a valid one.... A problem arises when, in the opinion of some worker, a describing author has planned that his name should have a certain meaning but has not, in fact, framed the name in such a way that this meaning is inherent. From this situation arises the suggestion that some names should be emended, to give them a form more consonant with the intention of their author...

Nothing can expunge the original name from the literature: no agency can collect all copies of the original work and alter them. No certainty can exist that all later workers referring to the original work will also have at hand the emending paper. In short, the original name exists, and it cannot be legislated into non-existence.

...an error which can only be detected by one having special knowledge of Greek, of biography, of Siwash, should not be emendable, since those with the special knowledge would emend it, while those lacking this information would use the original name, and we would have a dual nomenclature.

I think it is obvious that permissive emendation is unthinkable. If any change is to be made, it must be made by everyone, so that the original name passes completely out of current usage. To have some using an original name, some an emended one, would be chaotic. It follows that the necessity for emendation must be obvious to all who might use the name, and the correct form must also be so obvious that none can miss it.

Let us hold up standards of brevity, euphony, and classical appropriateness as desirable. Let us lay down for the unlettered suggestions as to how names may be formed. But if through ignorance, or inadvertence, or perversity, an

author publishes an uncouth name, then let it stand as a monument to his barbarity. He will not be offended, since he is oblivious to his fault, and his name will serve as a dreadful warning to the young, and a source of self-complacency to the smug.

Whereas Sinclair aimed his remarks at generic and specific names, his suggestion that names be generally accepted as a unique combination of letters is worth consideration for suprageneric taxa.

The relation of the scientific name to the vernacular differs according to taxonomic rank. For generic and specific names, no problem arises because no vernacular names are used: an ostracod of the genus *Arcyzoa* is referred to by its scientific name, never in the vernacular as an "arcyzone" or "arcyzon." Family names are based on type generic names according to definite rules. Such well-regulated and well-monitored names always end in -idae and the vernacular in -id; thus, an ostracod of the family Beyrichiidae is called a "beyrichiid." Names for subfamilies are formed by adding -inae to the stem of the name for the type genus, so that the genus *Ctenoloculina* serves as the type genus for the subfamily Ctenoloculininae, and an ostracod in this subfamily is called a "ctenoloculinin." Names for superfamilies are similarly based on a type genus, so that the superfamily based on the genus *Hollina* is the Hollinacea, and an ostracod belonging in the superfamily is a "hollinacean." But the vernacular for names of suprageneric taxa, which have arbitrary terminations, follows no such conventions -- as we shall see below.

VERNACULAR NAMES

The ICZN offers no rules or even suggestions for vernacular names. Insofar as the "legality" is concerned, the form of a vernacular name can be just as arbitrary as is the form of the name of the suprageneric taxon on which it is based. One can say that one vernacular name is more widely used and therefore preferred, but not that one is right and "legal" and another is wrong and "illegal."

THE CASE FOR "OSTRACOD"

Four considerations support continued use of the term "ostracod" for an animal of the subclass Ostracoda. First, the original spelling of the name for the taxon was not the one currently in use, and even though the change was made by the original author it is still a subsequent emendation, a kind of second thought. Second, evidence can be cited to show that the vernacular names for some suprageneric taxa are derived from the general form of the scientific name, independently, and not from the original Greek or Latin word or words from which the scientific name was itself derived. Third, since for any suprageneric taxon the scientific name is not absolute and stabilized by regulation, any vernacular name based upon it can logically be subjected to rather arbitrary interpretation or revision. Fourth, usage of "ostracod" continues in scientific literature and the term has enjoyed as much popularity as has "ostracode." Let us look closer at each of these considerations.

Original spelling. -- The name for the subclass traces back to Latreille's 1802 "Ostrachoda." It was not until four years later that Latreille himself "corrected" it to the now-used "Ostracoda." We know what the printed form of the name was from the paper itself; we can only guess at what Latreille had in mind when he wrote it first. From the original spelling one might readily conclude that it was derived from different Greek words. The Greeks had a demonstrative pronoun *ὅδε* (hode), formed by adding the enclitic particle *-δε* to the old demonstrative pronoun *ὅ* for additional emphasis. Hence, Ostrachoda could be derived:

οστρακ- + *ὅδε* → Ostrachoda,
("shell") ("this one here")

meaning "this particular shelled one." Note that the short *o* (omicron) was used instead of the long ω (omega), so that there would be good reason for using a vernacular name "ostrachod," rhyming with "rod," "pod," and "God." If later, for any reason, the "h" should be dropped from Ostrachoda (as indeed it was), what better course than to change the vernacular name from "ostrachod" to "ostracod"? Therefore, even if one clings to the fantasy that all vernacular names come directly from classical sources, support can be found for "ostracod."

Origin of vernacular names. -- Precedents can be cited to show that the vernacular name may be contrived from the scientific name and not derived by tracing back to the original Latin or Greek roots. Let us compare the common names for the Rhombifera (cystoids) and Foraminifera (protozoans), both scientific names being derived from the Latin:

<u>Latin roots</u>		<u>Scientific</u>	<u>Vernacular</u>
rhombus, m.	+ fero + -a		
("rhomb")	("to bear")		
rhomb-	-i- -fer- -a	Rhombifera	rhombiferan
foramen, n.	+ fero + -a		
("perforation")	("to bear")		
foramin-	-i- -fer- -a	Foraminifera	foraminifer

It is obvious that the vernacular names evolved separately from the scientific names "Rhombifera" and "Foraminifera," for if both vernacular names followed a standard transliterative process, both would have the same ending. No one questions that "rhombifer" would be an unusual form of the vernacular name.

Another example can be supplied from the Greek concerning the common terms for Coelenterata and Echinodermata:

<u>Greek roots</u>		<u>Scientific</u>	<u>Vernacular</u>
<i>κοιλος</i>	+ <i>εντερα</i> + -ata		
("hollow")	("intestines") ("provided with")		
coel-	-enter- -ata	Coelenterata	coelenterate
<i>εχινωδης</i>	+ <i>δερμα</i> + -ata		
("prickly")	("skin") ("provided with")		
echin-	-o- -derm- -ata	Echinodermata	echinoderm

Here, one would hardly be understood by coral specialists if he referred to a "coelenter," or by crinoid specialists if he referred to an "echinodermate."

These examples are sufficient to emphasize that the root and termination of the scientific name do not control the form of the vernacular name. No regulations apply. Vernacular names come into being independently by common consent and preference.

Instability of suprageneric names. -- We have already noted that the form of suprageneric names is arbitrary, even for the scientific name. The ICZN has no set of rules covering the naming of such taxa. No regulation prevents substitution of an entirely new name at any time by anyone. This happens infrequently because of the innate desire for stability by nearly all who deal with classification. Sometimes, however, arbitrary changes in the form of an existing name are introduced, all quite legally if unnecessarily.

As an appropriate example, let us look at the name of the order for the straight-backed ostracods. In 1953, Henningsmoen proposed the name "Paleocopa"; eight years later, in the influential Treatise (Moore, 1961, p. Q110), H. W. Scott "corrected" the

name to "Palaeocopida," changing both the spelling of the stem and the form of the suffix. Henningsmoen's name was not wrong in any way, and Scott retained essentially the same taxonomic content for the taxon. Hence, according to which form of the name one chooses to follow, one could call an ostracod of this order a "paleocopan," "paleocope," "palaeocopidan," or perhaps a "palaeocopide."

For another pertinent example, the Treatise (Moore, 1961, p. Q197) recognizes an order Podocopida and a suborder Podocopina. Both names come from "Podocopa" proposed by G. O. Sars in 1865 and expanded in taxonomic content by G. W. Müller in 1894. The name was "corrected" (even though it was not previously "incorrect") to "Podocopida" by Pokorný in 1953. The name "Podocopina" for a suborder was proposed by Fred Swain in the Treatise. Now a complex and intricate situation presents itself. One could refer to a "podocopan" or a "podocope" and still not reveal whether he regarded the ostracod as a member of the narrowly restricted taxon of Sars or the broader and more inclusive taxon of Müller. The name "Podocopa" did not disappear or lose legality with the publication of the Treatise volume; it is still in existence for any author wishing to use it, as do the Russian micropaleontologists as well as a number of micropaleontologists and microzoologists in western Europe and America. For those selecting the Treatise classification, the ostracod of the order could be a "podocopidan" or a "podocopide" but not a "podocopid" (since the termination -id would imply that the ostracod was in a family "Podocopidae," and there is no such family). An ostracod of the suborder could be called a "podocopinan" or a "podocopine" with perhaps equal justification.

"Ostracoda" is just another suprageneric scientific name and should be equally vulnerable to "correction" if enough authors and editors could agree. Similarly, its vernacular name (whichever is used) is neither fixed nor inviolate.

Priority and usage. -- Although I have reading ostracodal literature for over four decades, I am still not certain as to whether "ostracode" or "ostracod" was first used in English. The most influential man on classification and taxonomy who ever lived was G. O. Sars: his 1865 publication outlined the suprageneric taxa still in use by most workers (sometimes with changed spelling, sometimes without), and sixty-three years later the last section of his monograph on the "Crustacea of Norway" was published posthumously. In his last publication, in English, Sars called the animals "Ostracods."

Before 1951, workers on Paleozoic Ostracoda were divided on the choice of the common name. In 1951, the first draft of parts of the Treatise volume on Ostracoda was completed, and the editor demanded that the numerous contributors achieve conformity with "ostracode." Thereafter, many workers switched to that spelling in the belief that the Treatise would set the style and standard of all future contributions.

Around mid-century, many micropaleontologists concerned with Paleozoic Ostracoda were using "ostracod" as the common name. In 1949, Ivar Hessland brought out his thorough treatment of "Lower Ordovician ostracods of the Siljan district, Sweden." In 1951, I published my long-standard "Terminology of ostracod carapaces." In 1953, Gunnar Henningsmoen produced his very significant "Classification of Paleozoic straight-hinged ostracods," and in 1954, his work on "Silurian ostracods from the Oslo region."

Influenced by the zoological literature, in which "ostracode" is seldom if ever seen, I continued to publish on "ostracods" (often with my students) with a few papers on "ostracodes" in journals whose editors insisted on that spelling. During the 1950's we produced over 40 papers with "ostracod" or "ostracods" in the title.

Anyone studying post-Paleozoic genera soon becomes familiar with Peter Sylves-

-----, 1969, Comparative and functional sex in ostracods and cephalopods, in G. E. G. WESTERMANN, edit., Sexual Dimorphism in Fossil Metazoa and Taxonomic Implications: Internatl. Union Geol. Sciences, ser. A, no. 1, p. 242-250.

ULRICH, E. O., & R. S. BASSLER, 1923, Paleozoic Ostracoda: their morphology, classification,

and occurrence: Maryland Geol. Surv., Silurian Volume, p. 271-391, figs. 11-25; Arthropoda, Class Crustacea, Superorder Ostracoda, p. 500-704, pls. 36-65.

WOODS, R. S., 1944, The Naturalist's Lexicon: Abbey Garden Press, Pasadena, xviii + 282 p.

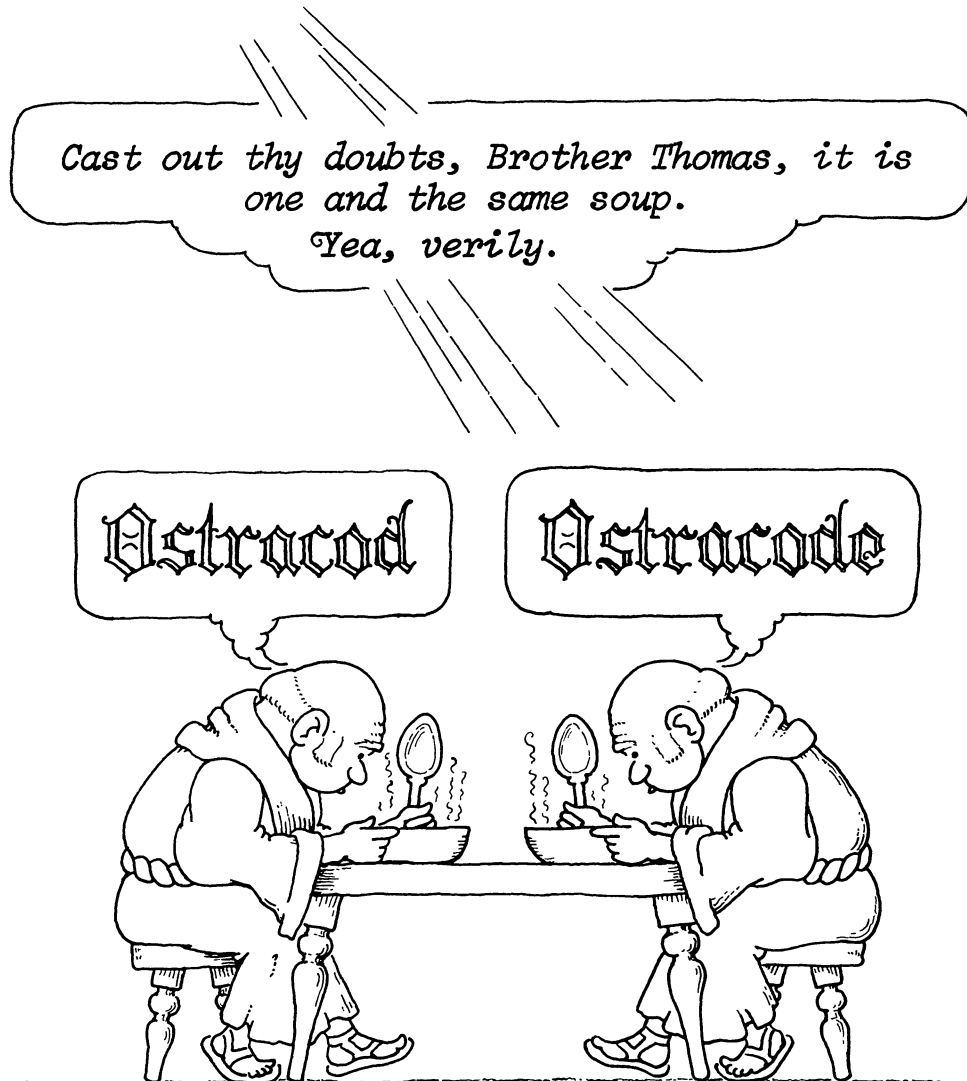

OSTRACOD, OSTRACODE, OR ELSE

The ostracod was made by God
 When Earth was very youthful,
 Now "ostracode" is a *la mode*
 And some claim it is truthful.

Poor old Latreille is o'er the hill
 And can't say how he meant it,
 Nor from the bench, in fluent French,
 Convincingly present it.

Some purists speak that scholars Greek
 The scales of justice totter,
 But some with crust would never trust
 Grammarians with their daughter.

While most agree on what they see
 (The creatures are spectacular!),
 They start a storm, and tempers warm,
 In choosing the vernacular.

Now "kidney-shaped lice" is not very nice
 For fossils so appealing,
 And "mussel-shrimp" is rather limp
 Though somewhat more revealing.

So all insist that one enlist
 With "-code"-ers or with "-cod"-ers;
 And so demand: "Go take your stand
 "With Nouveaux or with Plodders."

Send out the call for vitriol,
 May none escape our wrath!
 Make every moron henceforth go on
 The Holy path (*which we hath*).

Up with defiance! Abandon science!
 Let microscopes be dusty!
 While we disagree on the letter "e"
 Taxonomy grows rusty.

For goodness' sake, let's take a break
 Ere all of us are loony.
 Why get so frantic and pedantic
 On a matter picayune-y?

We'll someday meet when Peace is sweet
 In the Happiness Pagoda --
 As you surmise, we'll compromise
 And all say "Ostracoda"
 (Or "Ostrapodes" or maybe "Ostrachoda").

-- Robert V. Kesling

We acknowledge with gracious thanks the assistance of Karna Steelquist, photographer at our Museum of Paleontology, who remained pleasant and sane while helping develop yards of film and thousands of prints. Without her efficient contributions, these plates would have been delayed longer than we like to contemplate.

ENVOY

So we come to the end of our investigation of the Silica Formation ostracods.

Statistics do not convey all the involvement, but we identified 27 families, 61 genera, and 112 named species. Of over 15000 specimens studied, we selected 942 as representative and illustrated them. Our publication contains 123 plates with 3236 photographs of the ostracods. This work took nearly three years, including nearly 4000 microscope hours and over 800 darkroom hours. Although it was difficult, extended, arduous -- exasperating at times -- it was also exciting and rewarding.

The Silica ostracods have proved to be the most extensive Middle Devonian fauna ever discovered, and they provide a wealth of morphological information by their excellent preservation. The community inhabiting the sea in this area some 370 million years ago is now sufficiently well known to serve as the base for some detailed paleoecology.

We can now view the Silica Formation as a brief episode in earth history. It was an interval of numerous but not drastic changes of the environment. Each creature of the time continuously sought its favorite setting of currents and sediments. The short span of time was insufficient for major evolutionary changes, and faunules followed the lithology upward through geological succession.

Throughout our study we caught glimpses of the excitement of the times: struggle for survival, competition within the community, colonization and exploitation of preferred habitats, the successes and the tragedies, life and death. Now it is over. We strive for the dynamic with only the static. From what Providence has preserved for us, we see something of the long ago -- as through a glass darkly.

