

# Haptic Device for Research in Brain Computer Interface

Carlos Groth, Abbe Karp, Kyle Miller,  
Justin Philips and Matt VanNortwick

ME450, Winter 2007

Instructor: Professor Brent Gillespie  
Department of Mechanical Engineering  
University of Michigan  
Ann Arbor, MI 48109-2125

## PROJECT 10

April 17, 2007



### ABSTRACT

Brain Computer Interfaces (BCIs), or controlling a computer without touching it, may seem like science fiction but the reality is that these devices are a remarkable leap in technology. They have the potential to provide a method of communication to people with paralysis or other physical disabilities; however, the learning process for control of a BCI is very difficult and various learning techniques are being considered. The University of Michigan Direct Brain Interface project along with Jane Huggins, PhD is interested in studying the effect of back-driving a subject's passive limb to see whether it aids in the learning process. Moving or back-driving a limb will provide proprioceptive/sensory feedback in addition to the visual feedback typically used for a BCI. The proposed design receives signals from the BCI software, and moves the subject's hand in response along with hand position and muscle activity monitors. The hope is that back-driving a limb will provide the necessary visual cues that will increase the effectiveness of the learning procedure.

# TABLE OF CONTENTS

<b>ABSTRACT</b>	<b>1</b>
<b>I. INTRODUCTION</b>	<b>3</b>
<b>II. INFORMATION SEARCH</b>	<b>3</b>
<b>II.1. BACKGROUND INFORMATION</b>	<b>3</b>
<b>II.2. CURRENT RESEARCH</b>	<b>3</b>
<b>II.3. MEETING WITH OUR SPONSOR</b>	<b>3</b>
<b>II.4. RESEARCHING A NEW PROJECT</b>	<b>4</b>
<b>III. CUSTOMER REQUIREMENTS AND ENGINEERING SPECIFICATIONS</b>	<b>4</b>
<b>IV. QUALITY FUNCTION DIAGRAM DESIGN</b>	<b>5</b>
<b>V. CONCEPT GENERATION</b>	<b>6</b>
<b>V.1. X-Y TABLE AND ROBOTIC ARM SYSTEM CONCEPTS</b>	<b>7</b>
<b>V.2. PULLEY-SYSTEM CONCEPTS</b>	<b>7</b>
<b>V.2.I. GROUND-BASED PULLEY SYSTEMS</b>	<b>8</b>
<b>V.2.II. CEILING- OR TOP-BASED PULLEY SYSTEMS</b>	<b>9</b>
<b>V.2.III. “JOYSTICK” TYPE PULLEY SYSTEMS</b>	<b>10</b>
<b>VI. CONCEPT EVALUATION AND SELECTION</b>	<b>11</b>
<b>VI.1. COMPARING, COMBINING, AND REFINING CONCEPTS</b>	<b>12</b>
<b>VI.2. CONCEPT MERITS AND LIMITATIONS</b>	<b>13</b>
<b>VII. SELECTED CONCEPT</b>	<b>14</b>
<b>VIII. ENGINEERING ANALYSIS</b>	<b>14</b>
<b>VIII.1. KEY VARIABLES</b>	<b>15</b>
<b>VIII.2. MATERIAL CHOICES</b>	<b>16</b>
<b>VIII.3. FINITE ELEMENT ANALYSIS</b>	<b>17</b>
<b>VIII.4. MOTOR SPECIFICATIONS</b>	<b>18</b>
<b>VIII.5. CHOICE OF SUPPLIERS</b>	<b>19</b>
<b>VIII.6. QUANTITATIVE ANALYSIS</b>	<b>19</b>
<b>VIII.6.I. FBD OF THE PIVOT ARM</b>	<b>20</b>
<b>VIII.6.II. FBD OF THE CABLE</b>	<b>21</b>
<b>VIII.6.III. FBD OF THE PULLEY</b>	<b>21</b>
<b>VIII.7. QUALITITATIVE ANALYSIS</b>	<b>21</b>
<b>VIII.7.I. DESIGN FOR MANUFACTURABILITY &amp; ASSEMBLY</b>	<b>21</b>
<b>VIII.7.II. DESIGN FOR ENVIRONMENT</b>	<b>22</b>

<b>VIII.7.III. FAILURE MODE AND EFFECTS ANALYSIS</b>	<b>22</b>
<b>IX. FINAL DESIGN</b>	<b>22</b>
<b>X. MANUFACTURING</b>	<b>24</b>
<b>XI. TESTING</b>	<b>28</b>
<b>XII. DISCUSSION FOR FUTURE IMPROVEMENTS</b>	<b>28</b>
<b>XII.1. STRENGTHENING THE STRUCTURE OF THE HAPTIC DEVICE</b>	<b>28</b>
<b>XII.2. IMPROVING ALIGNMENT</b>	<b>29</b>
<b>XII.3. REPLACING FISHING LINE WITH STEEL CABLE</b>	<b>30</b>
<b>XII.4. REDESIGN OF OUR PULLEYS</b>	<b>31</b>
<b>XIII. PROJECT PLAN</b>	<b>31</b>
<b>XIV. CONCLUSIONS</b>	<b>33</b>
<b>XV. ACKNOWLEDGEMENTS</b>	<b>34</b>
<b>XVI. REFERENCES</b>	<b>34</b>
<b>XVII. BIOGRAPHIES</b>	<b>36</b>
<b>APPENDIX A - BENCHMARKING</b>	<b>38</b>
<b>APPENDIX B – MOCK-UPS</b>	<b>39</b>
<b>APPENDIX C – QUANTITATIVE ANALYSIS</b>	<b>42</b>
<b>APPENDIX D – MOTOR DATA SHEET</b>	<b>43</b>
<b>APPENDIX E – DIMENSIONED DRAWINGS AND PROCESS PLANS</b>	<b>46</b>
<b>APPENDIX F – PICTORIAL SUMMARY OF PROJECT MANUFACTURING AND DESIGN EXPO</b>	<b>61</b>

## **I. INTRODUCTION**

A non-invasive Brain Computer Interface (BCI) uses electrodes that are placed on the scalp of a user to control a computer device, specifically a cursor on a computer screen. The primary purpose of BCI is to allow people with paralysis or other physical disabilities to have a renewed method of communication with the outside world. Training a subject to control a BCI can be difficult if there is no sensory feedback to aid the subject in the learning process. The University of Michigan Direct Brain Interface project along with Jane Huggins, Ph.D. is running experiments to determine the effect of back-driving an arm in the learning process of BCI.

In order to perform this research, it is necessary to create a mechanical device that has the capability of moving a subjects arm after receiving an input signal from the BCI software. The range of motion should at least include movement in one direction on a flat surface (forward and backward). The hope is that by introducing this physical motion to the learning process, a subject may increase their familiarity with controlling BCI. Many concept designs have been generated by our team to control the motion of a subject's arm in two directions. Creating a device like this required us to take into account a variety of design specifications, which included safety, ease of use, durability, and cost. In the end, our final design will be used in experimental procedure to increase the learning efficiency of a BCI.

## **II. INFORMATION SEARCH**

### ***II.1. Background Information***

Before meeting with our sponsor, Jane Huggins, we needed to perform some background research on a brain computer interface. After our meeting, we were provided a list of internet links for various haptic devices and BCIs. We found that the websites not only clarified what a BCI was, but also how it has been used in research for humans and animals. Several of these informational sources are summarized in Appendix A. In addition we were able to access great videos of BCI. For instance, one of our recommended sites included a video that showed a patient using a BCI to control a cursor on a computer screen to perform specific tasks.

### ***II.2. Current Research***

Currently, there are only a few universities that either have a department or program that focuses on BCIs. For instance, at the Technical University of Graz in Austria, there is a team currently working together with the University of Michigan Direct Brain Interface Project [6]. Compared to other research fields, research into BCI is relatively small. Also, there are a limited number of companies that sell products for or related to BCIs. However, one company that we were able to locate was Cortech Solutions. They currently provide a variety of products that range from complete systems to small modular components for research in electrophysiology and behavior [1].

### ***II.3. Meeting with our Sponsor***

During our meeting with Jane Huggins, we shared our ideas and thoughts on what we thought her project was all about. Although we were on the right path, the conversation eventually turned into an entirely new brainstorming session. Originally, our task was to create a hand-clenching device operated using a BCI. Prior to our sponsor meeting, we had even created a mock-up clenching device. This mockup can be found in Appendix B. However, as Jane

Huggins studied our mock-up, a simpler, and perhaps more research-rewarding concept was brainstormed. The concept involved an interface where a patient would imagine moving a cursor to a target a location on the screen (similar to current research), while a mechanical device would move the patient’s hand or arm providing sensory feedback. This new idea changed the scope of our project. Therefore, we started focusing our information searches on devices that could operate in two plains to create planar movement similar to that of a computer mouse.

**II.4. Researching a New Project**

We began our new information search by researching current motorized x-y tables. We originally thought that it would be simpler to purchase a motorized table and focus more on the BCI aspect of the project. However, the costs of the tables quickly overshot our budget by several hundred dollars [13]. As we studied the available x-y tables, we realized that the mechanics were simple, and we thought that we could fabricate a table ourselves for a fairly low price. Therefore, we began brainstorming ways of creating a motorized x-y table and created a simple mock-up as shown in Appendix B.

**III. CUSTOMER REQUIREMENTS AND ENGINEERING SPECIFICATIONS**

Our sponsor, Jane Huggins, PhD would like us to create a mechanical device that has the capability of moving a subject’s arm after receiving an input signal from BCI software. Specifically, she would like a device that moves in one direction on a flat surface, can be computer controlled, is visible to the user, and is safe and reliable. A complete list of the customer requirements can be found in Table 1. Also listed in Table 1 are the engineering specifications. These specifications will aid our group in designing a device that meets her needs.

<b>Customer Requirements</b>	<b>Engineering Specifications</b>
Aesthetically Pleasing	Computer Interface
Computer Controlled	Feedback Sensors
Ease of Use	Length, Width & Height
Easy Setup	Motor Control
External Joystick Controller	Range of Motion
Low Cost	Response Time
Safe	Weight
Reliable	
Transportable	
Visible Motions	
X-Axis Motion	
Y-Axis Motion	

**Table 1: Customer requirements and engineering specifications that will be used in the design of our mechanical device.**

#### IV. QUALITY FUNCTION DIAGRAM DESIGN

In order to systematically translate customer requirements into engineering specifications, a quality function diagram (QFD) was created. The diagram, as shown in Figure 1, displays each customer requirement, their importance as specified by our customer, and their relation to each engineering specification. A key to the diagram is provided in Table 2. Each relation value was determined by evaluating how each engineering specification could be used to meet each customer requirement.

Importance to Customer	Engineering Specifications								
	Weight	Length x Width x Height	Motor Control	Computer Interface	Physical Interface	Feedback Sensors	Range of Motion	Response Time	
<b>Customer Requirements</b>									
Y-Axis Motion	3		9	3		3	9		
X-Axis Motion	1		9	3		3	9		
External Joystick Controller	2			3				3	
Visible Motions	3	1			1		3	1	
Computer Controlled	3		9	9		3		9	
Safe	3	1	1	3		9	9	3	
Ease of Use	2			3	9	1			
Easy Setup	2	1	1		3	3			
Aesthetically Pleasing	1	1	3	1		3			
Reliable	3			3	3	3		1	
Transportable	2	9	9		3				
Low Cost	2	1	1	3	9	9	3	1	
<b>Importance Weighting</b>		26	31	88	84	84	65	54	44
<b>Target Values</b>		< 30 lbs.	< 24 x 24 x 6 in.				≈ 8 x 6 in. <sup>2</sup>	< 3 sec.	

Figure 1: The QFD used to translate customer requirements to engineering specifications.

Value	Relationship	Symbol	Relationship
9	Strong	++	Strong Positive
3	Medium	+	Medium Positive
1	Small	-	Medium Negative
(blank)	Not Rated	--	Strong Negative

Table 2: A key to the QFD diagram shown in Figure 1.

For example, a “3” for “Y-Axis Motion” corresponds to an important customer requirement, which significantly relates (9 = Strong Relationship) to the motor control and the range of motion. Motor control, for instance, allows the device operator to control any direction of movement that the device’s range of motion will allow, which, if the operator chooses, can be along the y-axis. “Y-Axis Motion” also slightly relates to the computer interface and the feedback sensors, which is described by the number “3.” Both of these specifications affect “Y-Axis Motion,” but they do not directly control the device’s movement like motor control and/or range of motion.

Another feature that is shown in the QFD diagram is the importance weighting, which identifies the most important technical requirements. By multiplying the “importance to the customer” rating with the relationship value and then summing the column, the importance of each engineering specification was determined. As shown in the diagram, motor control, computer interface and human interface were determined to be the most important engineering specifications.

The correlation matrix, which is located on the top of the diagram, indicates any relationship between technical requirements. For example, the “+” symbol between “weight” and “length x width x height” indicates that there is a medium positive relation between the two engineering specifications. As in most cases involving volume and weight, we predict that as the length, width and height of the device increase, so will the total weight.

Finally, rough quantifiable goals for each technical requirement are listed in the target values. It was only possible to quantify the weight, dimensions, range of motion and response time. The other specifications can only be listed as either existent or non-existent. As for the goals that can be determined, their values were estimated from the information that we gathered from our customer, literature searches, and initial concept designs.

## **V. CONCEPT GENERATION**

Originally, our plan was to create an x-y table to be used with the BCI software. While the benefits of such a design were clearly understood by the group early on, such as achieving the multi-planar motion relatively easily, the design proved to have substantial drawbacks. For example, during one of our meeting with our advisor, Professor Gillespie, we realized that such a design required 2 motors with very high torque ratings. These motors were possibly outside of our budget range. To test the required torque, we performed some basic measurements using a scale. We found that a patient’s arm weighed about 5 lbs. The second issue that we found with the x-y table involved the originality of the design. We decided that we had not sufficiently explored other opportunities that may be more original and effective.

For this reason, our group held several design meetings to determine other possible designs that would fulfill the customer requirements. We thought of new concepts such as using a robotic arm, a pulley-system, or even a joystick type of device that would fulfill the same motion requirements as an x-y table. These three concept areas are described in detail below. In all the sketches of the concepts, we have shown the ‘codename’ for the design. These correspond to the family of concepts that the design belongs to and the order of conception. For example, the x-y

table is designated A1, because it belongs to the x-y table and robotic arm family and was the first design created within that family.

### V.1. X-Y Table and Robotic Arm System Concepts

Our original concept was a simple x-y table. Design 3 shows a pair of sliders that would be driven using motor operated screws to move the user's hand in each direction (Figure 2). Next, we derived several designs based upon the x-y table concept. Instead of using a track for the x-axis and another for the y-axis we generated design 7 that would use a rotating robotic arm that would have a slider or a pulley system built on top of it (Figure 3). The rotation and extension of the arm would therefore work with cylindrical coordinates to determine angle and radius from the pivot point. The "glove" would be mounted on the slider and while one motor would cause the rotation of the arm, another motor would pull the slider by using a chain or pulley mechanism. Design 8 is essentially the same as design 7, but this design uses a crane instead of a slider which the "glove" would hang from (Figure 4).

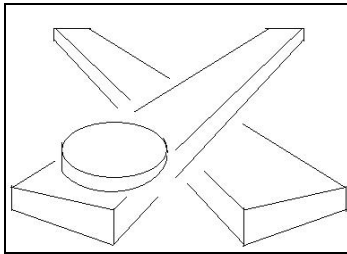


Figure 2: Design 3 (A1)

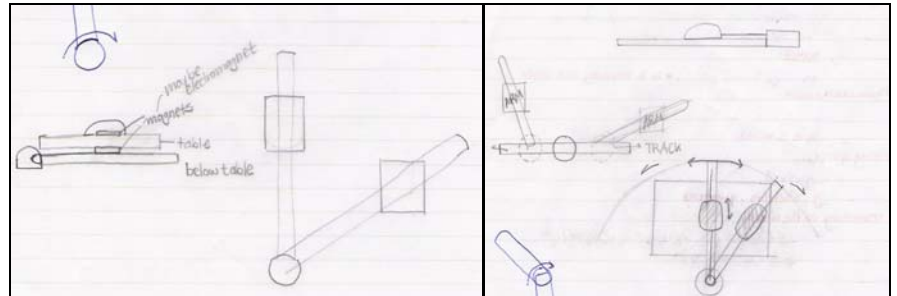


Figure 3: Design 7 (A2)

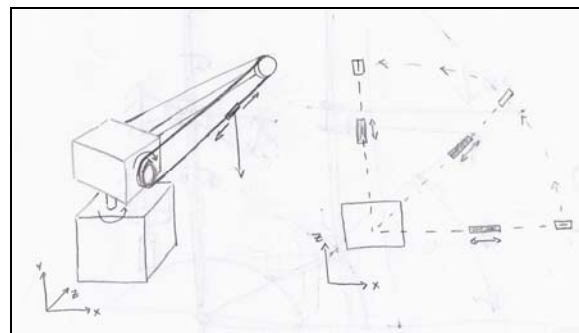


Figure 4: Design 8 (A3)

### V.2. Pulley-System Concepts

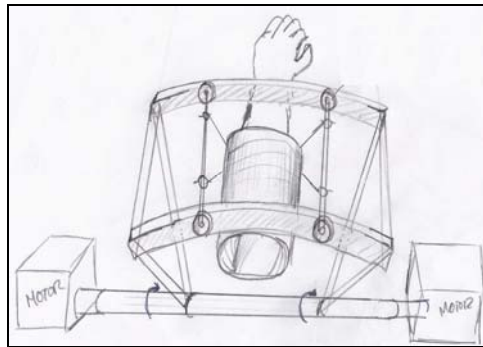
The basic idea behind a pulley-system was to use a set of pulleys that are driven by at least two motors, one each for the x- and y- directions, to pull instead of push the haptic device to a desired location. For this concept scheme, three design families were developed. This first was to have ground-based pulley systems (Designs 4, 9, 10, and 11). The next was to have top or ceiling based pulley-system (Designs 5 and 6). And the last was to have a "joystick" type pulley system (Designs 1, 2, and 12).



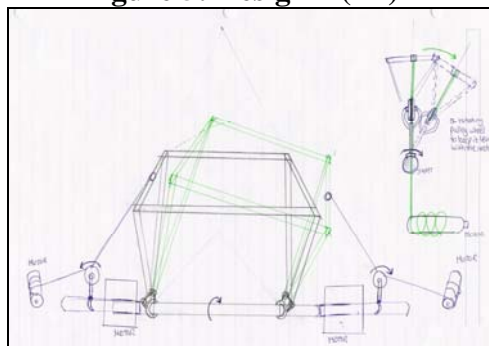
### V.2.i. Ground-Based Pulley Systems

Designs 4 and 9 explored the possibility of designing a frame from which to hang an arm supporting “glove” and using both a motor shaft system and pulleys to create the desired x-y motion. Design 4 was a precursor to design 9 that basically shows a frame from which the “glove” would be hung using 4 flexible strings attached to two rotating shafts that are set into 4 wheels with ball bearings (Figure 5). What this does is to basically roll the “glove” to the left and right using gravity. We thought it was best for the shaft to stay fixed, while the rollers rotate. This would let the “glove” slide on the tracks without having the shafts rotating thus avoiding any entanglement with the 4 strings that hold the “glove.” The 4 stings are themselves attached to the two shafts in a way that let them slide forward or backward when the setup is moving in those directions. The frame is mounted on a rotating shaft that is operated by a motor. This would ensure the forward and backward motion.

To explore the left and right movement, design 9 was developed to explore the possibility of installing two grounded pulley-motor systems that would pull the frame in those directions (Figure 6). While one pulley pulls, the other would release the string. The other possibility achieving the same result was to install a hydraulic or pneumatic system below the motor and the driver to lift the setup and let the device roll to the desired left or right direction. Both designs 4 and 9 would require at least two motors.



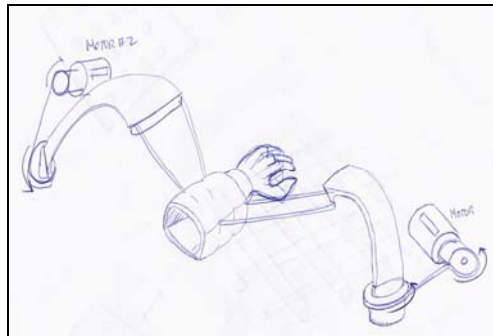
**Figure 5: Design 4 (B1)**



**Figure 6: Design 9 (B2)**

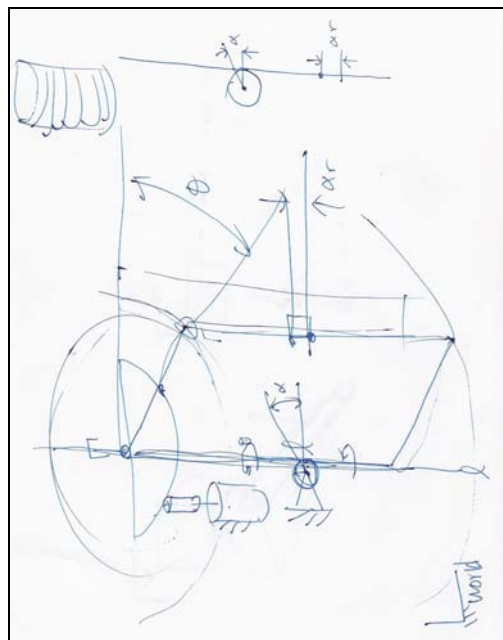
Design 10 explored the possibility of using two flexible “cranes,” to not only hold the “glove,” but also drag it to the desire position (Figure 7). Again as in the previously mentioned designs, this design would require two motors that would make sure the cranes would rotate clockwise or counter-clockwise giving the glove its forward and backward movement. The two cranes were to be mounted on bearing to allow for their rotations when being pulled by the pulley-system.

To create the other axis motion, another two pulley-systems would have to be installed that would pull on the two cranes to move the device left or right.



**Figure 7: Design 10 (B3)**

Design 11 is the combination of a pulley system and pivoting frame, similar to a swinging door (Figure 8). As the frame swings forward and backward, the pulley system moves the user's hand which is attached to a cable. Because the pulley system would be driven by a motor which is on axis with the pivot point for the frame, the cable will not stretch or move out of plane.



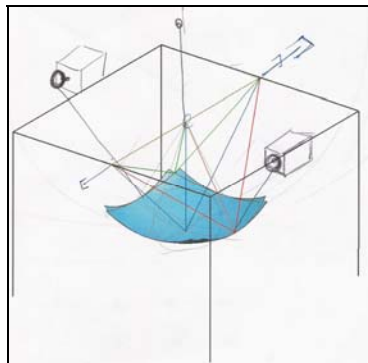
**Figure 8: Design 11 (B4)**

### ***V.2.ii. Ceiling- or Top-Based Pulley Systems***

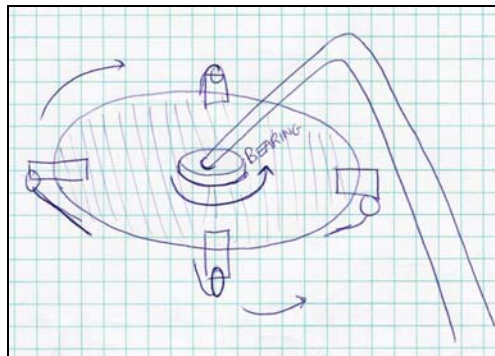
These types of designs explored the possibility of using the ceiling or a tall frame from which the “glove” could be hung. The idea originated during the discussion with Professor Gillespie to define the plane on which the haptic device would move. While originally the x-y table constrained a purely two dimensional space, a device that was hung from the ceiling using a pulley-system attached to it would move in an ellipsoidal space, making the movement perhaps more natural to a human being.

Design 5 is a two motor, two pulley loop system that is mounted on a rectangular frame (Figure 10). The two motors drive cables that are attached to a cradle which holds the user's hand. These cables are looped around a pair of pulleys opposite the motors which will allow the cable to support the cradle from opposite sides. We have also considered using four motors with this concept and feeding the cables in and out using precise motor control.

Design 6 was the sequel that explored the possibility of creating a rotating disk on which the pulley system was attached to, while the disk was attached with ball bearings to a metal hinge (Figure 10). This would eliminate the frame design of Design 5 and make this design more flexible. The movement principle, however, would be similar to that of Design 5.



**Figure 9: Design 5 (C1)**

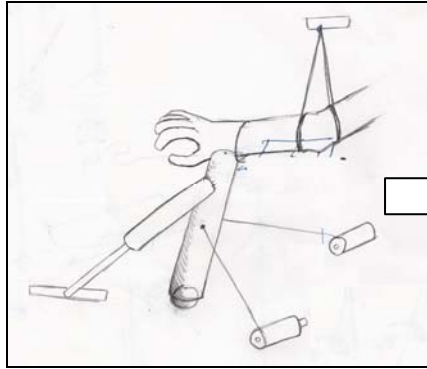


**Figure 10: Design 6 (C2)**

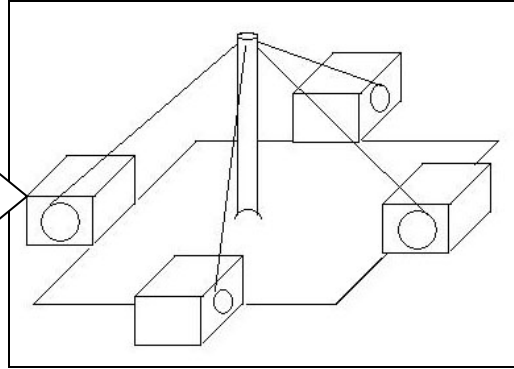
### **V.2.iii. “Joystick” Type Pulley Systems**

Design 12 is the original “joystick” concept (Figure 11). It features the ceiling supported arm sling and a table mounted mechanism. The generation of the concept came from the idea of having a motion based on a motorized joystick. It has a minimal amount of framing and very few moving parts. It makes for easy manufacturability and costs mainly depend on the pricing of four motors. Design 12 was also originally sketched to have an optional pneumatic or hydraulic movement system.

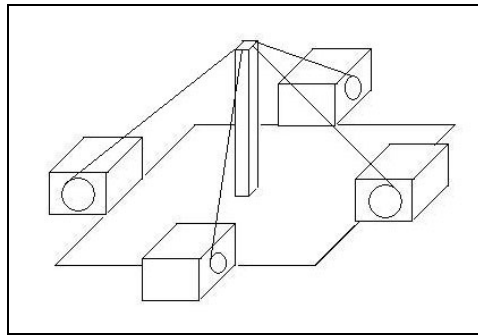
Design 2 is the updated and realistic concept taken from design 12 (Figure 12). It uses a ball joint for 360° rotation as well as a four pulley/four motor movement system. Design 1 is a more complex version of design 2 that uses a spring steel bar in order to assist the motors (Figure 13). This design would require less powerful motors, in theory, however the side effects of the spring steel are still unknown.



**Figure 11: Design 12 (D1)**



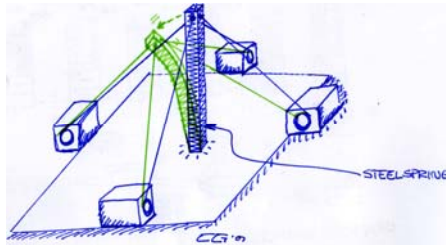
**Figure 12: Design 2 (D2)**



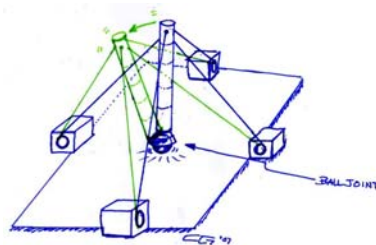
**Figure 13: Design 1 (D3)**

## **VI. CONCEPT EVALUATION AND SELECTION**

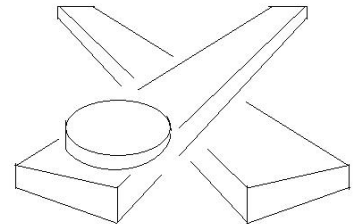
Immediately following our first sponsor meeting, we selected a design concept similar to an x-y table. However, we began considering the possibility of other design concepts following the first design review. Using the important design aspects listed in Table 3, we examined the merits and limitations of not only a XY table, but any imaginable concept. By the end of our design process, we had approximately 12 design concepts, which were described previously in the concept generation section. The final 5 concepts, which have been selected based upon multiple design reviews, are shown below in Figure 14.



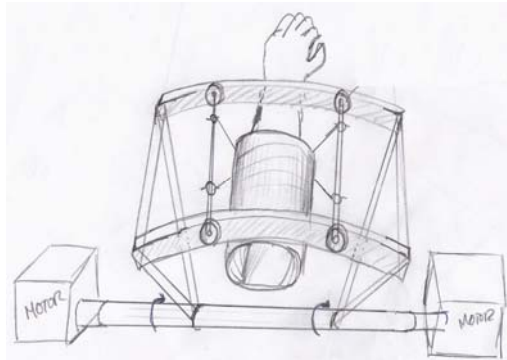
Design 1



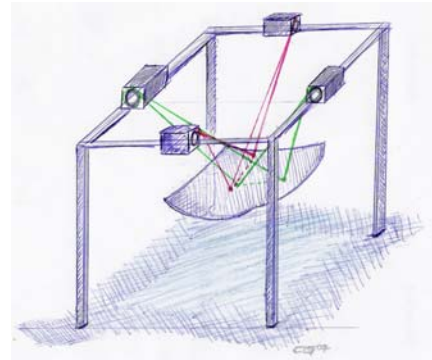
Design 2



Design 3



Design 4



Design 5

Figure 14: Most promising concept designs.

### VI.1. Comparing, Combining, and Refining Concepts

In order to rate and compare all of our design concepts, we created a list of important design aspects, which can be found in Table 3. We felt that each design should have a low cost, be feasible, effective at solving the design problem, not require excessive machining, be original and be comfortable for the user. For example, our original concept, the x-y table, was only effective and comfortable. It was too expensive, complicated, difficult to manufacture and unoriginal.

#### Important Design Aspects

- Cost
- Feasibility
- Effectiveness
- Manufacturability
- Originality
- Comfort

Table 3: Important design considerations used for each of the initial design concepts.

Following multiple brainstorming sessions and the first design review, we selected five design concepts that met most of the criteria in Table 3. The designs, which are shown above, are compared in the Pugh chart shown below (Table 4). We listed each of the design aspects, and then, we determined the corresponding relationships. As the chart shows, design 5 and 2 had the highest scores.

Design Aspects	Design 1	Design 2	Design 3	Design 4	Design 5
Cost	-	-	-	0	+
Feasibility	+	+	-	0	-
Effectiveness	+	+	+	0	+
Manufacturability	+	+	-	-	+
Originality	0	+	-	+	+
Comfortable	-	+	+	+	+
$\Sigma$ Positive	3	5	2	2	5
$\Sigma$ Negative	2	1	4	1	1
Score	1	4	-2	1	4

Using '+' or '-' and tallying the total

**Table 4: Pugh chart for ranking design concepts shows that design 5 ranked the highest.**

## VI.2. Concept Merits and Limitations

**COST** Although our budget is \$400, a cost-effective design (approximately <\$300) is desirable. By minimizing our total costs, we hope to account for any unseen future expenses. Concepts such as design 1, 2, 3, 4 are much more expensive than design 5. Design 5, for example, requires only 2 motors instead of 4. Also, because of design 5's support structure, it requires less material than design 3 or 4. Finally, because of its additional supporting rod, the weight of a subject's hand will be dispersed, and design 5 will require less powerful motors to achieve motion.

**FEASIBILITY** The least complicated and most feasible designs are design 1 and 2. They both require 4 motors for motion, a pivoting pillar (spring steel or ball joint) and cable. Neither design involves a complicated pulley motion or any kind extensive analysis to determine the range of motion like design 5.

**EFFECTIVENESS** With the exception of design 4, all of the designs can easily meet the desired range of motion. Design 1, 2 and 5 require vertical motion to access all possible points in the x- and y- axes, but we believe that, with thorough design, we can minimize this z- axis motion. Because they are our final 5 designs, most of the concepts that were not effective have already been eliminated, and any of the remaining 5 can solve our design problem.

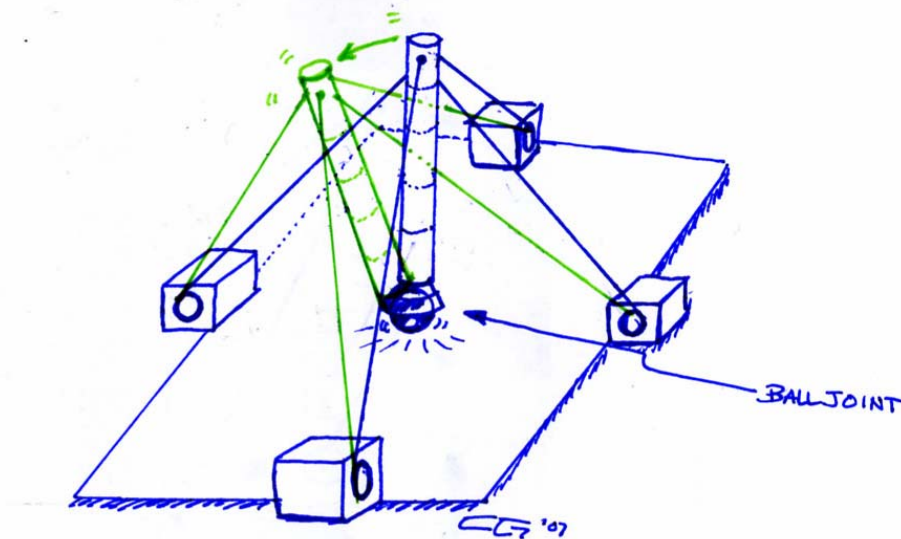
**MANUFACTURABILITY** Design 1,2 and 5 are the easiest to manufacture. As previously stated, design 1 and 2 require very few parts to be manufactured (a supporting base & 4 devices to coil wire).

**ORIGINALITY** The first issue that arose with the x-y table concept, design 3, was that it was not original. From web searches, we found multiple design projects involving the use of XY tables in BCI. Our group wanted to create a whole new device that was original, cost effective and able to provide a full range of motion.

**COMFORT** Design 3,4 and 5 are theoretically the most comfortable design concepts. For example, the motion involved in design 3 is only two-dimensional. The subject's hand simply rests on the device and is pulled in either direction. However, in design 3 and 4, there is a slight upwards motion in the z- direction. We have tested similar motions on our own arms and do not believe that this motion will cause any discomfort to a subject. In design 1 and 2, however, the hand is actually pulled forward and over the supporting middle rod. This motion may actually cause some discomfort in an individual's wrist, elbow, or shoulder.

## VII. SELECTED CONCEPT

**DESIGN OVERVIEW** We selected design 2. This design is better defined in figure 15. The proposed design is a rod supported by a ball bearing that is controlled by motors at each side. These motors control the x- and y- motions of the rod. The motion of the rod is that of an arc, which is precisely calculated so that the user does not notice the arc motion. The rod will tentatively be 6 to 10 inches in height and be controlled by four DC motors. The user's arm will be placed in a glove that is attached to the top of the rod. The approximate plane of motion for this design is 5" x 7" in the x- and y- directions respectively.



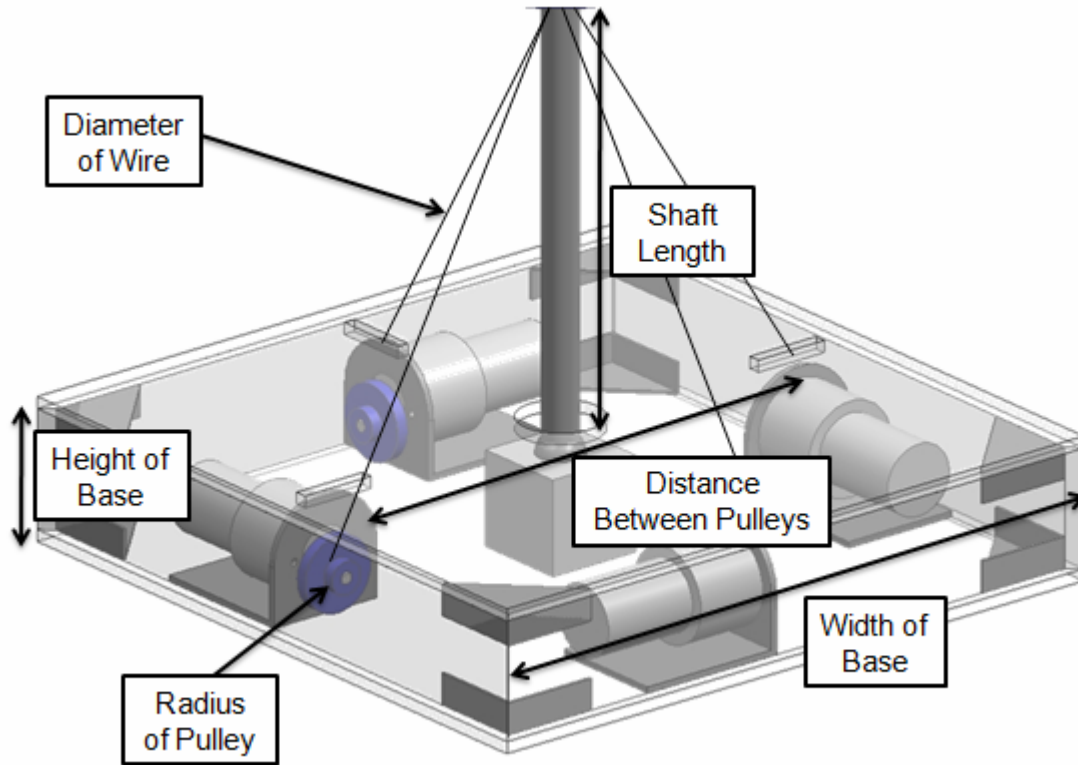
**Figure 15: Design 2, which received the second highest design rating during evaluation and eventually became our final design.**

## VIII. ENGINEERING ANALYSIS

In order to determine what the dimensions of our final design will be, we were required to run an engineering analysis on each individual part. In order to do this we first identified our key variables, then selected material for each, and finally conducted a finite element analysis on each part. Once the dimensions for everything were determined, we could adequately select the motors that would run our design.

### VIII.1. KEY VARIABLES

Figure 16 shows a mock-up 3D model of our selected concept. This was used for dimensioning purposes only and the final model will be different. The dimensioning of this model required both educated approximations as well as an engineering analysis.



**Figure 16: 3D model of the proposed system.**

The design of the product has key variables which can be manipulated in order to meet the requirements of the design. These key variables can be seen in Figure 16 above. In order to determine the values of these dimensions, we took both an engineering analysis method as well as a “guess and check” method. Table 5 outlines the final dimensions for this design.

<i>Key Variables</i>	<i>Values</i>
Shaft Length	<b>8.5 inches</b>
Pulley Radius	<b>0.5 inches</b>
Base and Top Width	<b>15 inches</b>
Distance Between Pulleys	<b>12 inches</b>
Distance Between Top and Bottom Plates	<b>2.5 inches</b>
Wire Diameter	<b>1/16 inch</b>

**Table 5: The final values of the key variables**

The primary objective of determining each variable is to lead to our final decision of determining a motor, which will be outlined in a later section. Every variable plays a key role in either reducing or increasing the force imparted on the motor that is needed to drive the rod.



**SHAFT LENGTH** In order to determine an adequate shaft length we first determined what a person would feel comfortable with while sitting down. We decided that between 8 and 9 inches would allow the product to be used on an average height table.

**PULLEY RADIUS** The pulley radius is very influential in the design. A radius that is too big could yield a very small tensions force, and a radius that is too small could yield a very large tension force. In determining the pulley radius, we need to be aware that the radius is directly related to the torque of the motor. Once the equation for the force of the string was determined, the pulley radius could be calculated.

**BASE & TOP WIDTH** The total width of the base allows the user to have a wide range of motion as well as a stable bottom. The base is designed to be 15 inches so that the user has a wide clearance between the range of motion of their arm and the edge of the platform.

**DISTANCE BETWEEN PULLEYS** The distance from the center of one pulley to the center of its opposite is important because this defines the actual range of motion of the hand. While the arm may move more, the hand itself will travel only in this plane. In determining this dimension, we needed to determine first, what a reasonable range of motion for a human hand would be. There were a few important factors in this which, include safety and sensory feedback usefulness. The hand must move in a plane which is comfortable to the user. This in turn allows the sensory feedback of the arm to mimic the motion of the computer cursor. In determining this specification we mimicked the dimensions of a computer mouse pad.

**DISTANCE BETWEEN THE TOP AND BASE PLATE** The structure of the unit is comprised of a top and bottom acrylic board. The distance between the top and bottom is calculated based on the size of the motors and pulley. There needs to be enough clearance so that the moving parts are free of any obstructions. We determined this size to be no less than 2.5 inches.

**WIRE THICKNESS** The wire that is going to be used has to be thin enough to wind around a pulley while still being able to support the required loads. We originally intended to purchase steel cable from Savacable.com, but they required a minimum order of 250 feet. To solve this issue, we decided to use fishing line provided to us by our professor. The fishing line was rated to 125 pounds, which was very similar to the 100 pound rating for the recommended 1/32” stainless steel cable.

## **VIII.2. MATERIAL CHOICES**

**SHAFT MATERIAL** The shaft material is chosen to be made from aluminum. The reason for this selection is that the design calls for a lightweight material yet with a strength that could withhold the weight of an arm. Aluminum proved to fit these requirements.

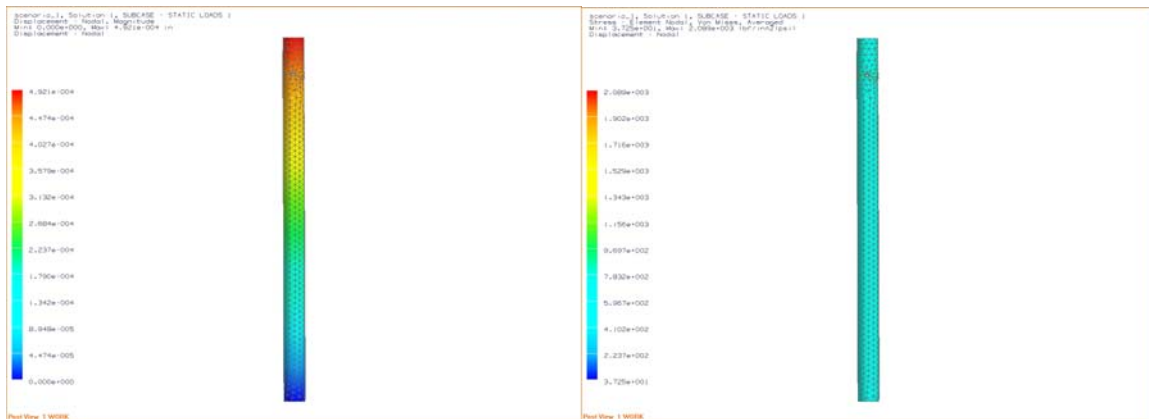
**BASE AND TOP MATERIAL** The bottom and top of the base needs to be made of a material that is strong yet lightweight. Metal was disregarded as it is much too heavy and would add unneeded weight. The material also needs to be something that is easy to manufacture, therefore we chose acrylic plastic. Using the CO<sub>2</sub> laser cutter, the intricate design of the base can easily be manufactured while providing a sturdy platform for motion.

**PULLEY MATERIAL** The pulleys will also be made from aluminum to ensure a strong yet lightweight design. A groove can easily be machined using the lathe to allow the wire to maintain a direct path.

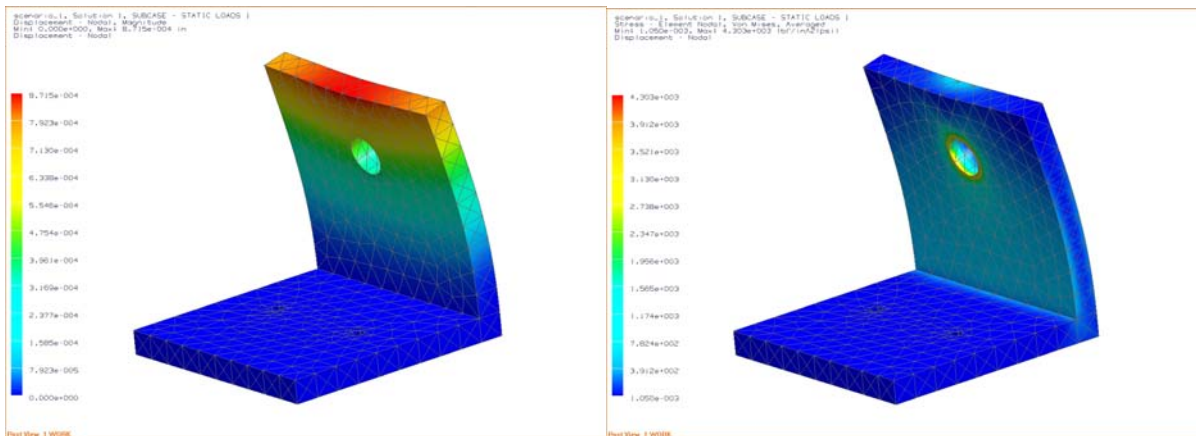
**CABLE MATERIAL** We have decided to use fishing line that is rated to 125 lbs for our driving cables. In order to prevent wear and tear on the cable, we purchased a coaxial cable from a local retailer and removed its inner wires. Next, we strung the fishing line through a 0.75 inch piece of casing that is secured at the top of the pivot arm. The casing is simply the insulation stripped off a length of copper wire and will protect the fishing line from being torn by the set screws.

### VIII.3. FINITE ELEMENT ANALYSIS

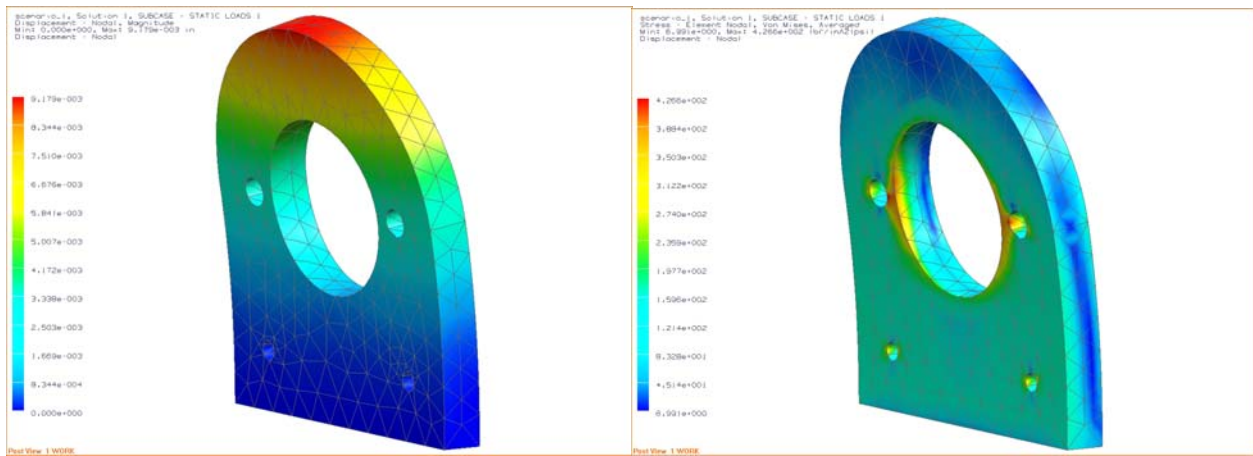
Once the dimensions and key variables were determined, a finite element analysis (or FEA) was conducted on certain elements to determine if they would withstand the forces that it would be put under. We chose the hand support rod, ball joint support bracket, and motor mount for further analysis. For each, we focused on the maximum displacement and stress given specific loads and constraints. Figures 17-19 show the resulting FEA models for displacement and stress for each of the key components.



**Figure 17: FEA for hand support rod shows maximum displacement of 0.0004 in. and maximum stress of 2000 psi given a maximum load of 100 lbs.**



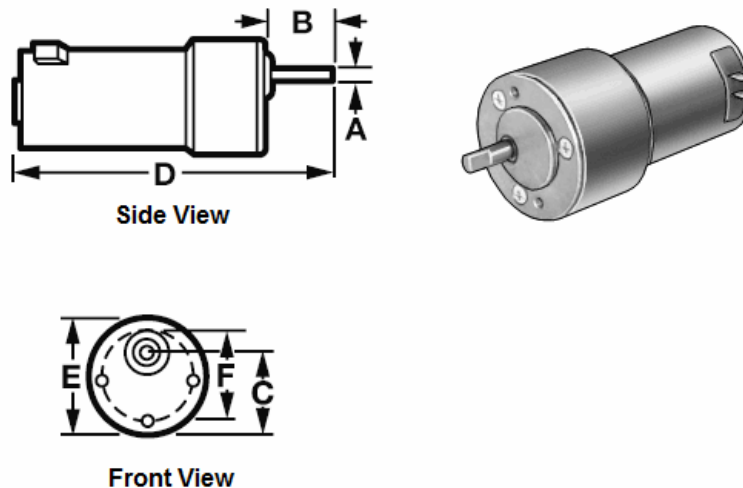
**Figure 18: FEA for ball joint support bracket shows maximum displacement of 0.0009 in. and maximum stress of 4300 psi given a maximum load of 100 lbs.**



**Figure 19: FEA for motor mount shows maximum displacement of 0.009 in. and maximum stress of 420 psi given a maximum load of 50 lbs.**

### VIII.4. MOTOR SPECIFICATIONS

From the results of our engineering analysis, we chose the motor displayed in Figure 20. As outlined in Table 6, this motor has enough torque to drive our device. It is a DC mini-gear motor with a torque rating of 175 in.-oz. Our calculations required that we have at least 90 in.-oz. of torque so this motor is more than sufficient. The rpm of 7.4 is also adequate for our design since we will be operating at very low speeds. This motor was found on the McMaster-Carr Supply Company website [17]. The motor’s manufacture data sheet, which includes the gear ratio, can be found in Appendix D.



**Figure 20: Views of the DC Mini-Gearmotor.**

<i>rpm</i>	<i>Torque</i> (in.-oz.)	(A)	(B)	(C)	(D)	(E)	(F)	<i>Mounting</i> <i>Holes</i> ( <i>qty.</i> )	<i>Full</i> <i>Load</i> <i>Amps</i>
24	175	0.25"	0.75"	1.329"	4.29"	2"	1.5"	10-32(2)	0.18

**Table 6: Specific values of motor**

## VIII.5. CHOICE OF SUPPLIERS

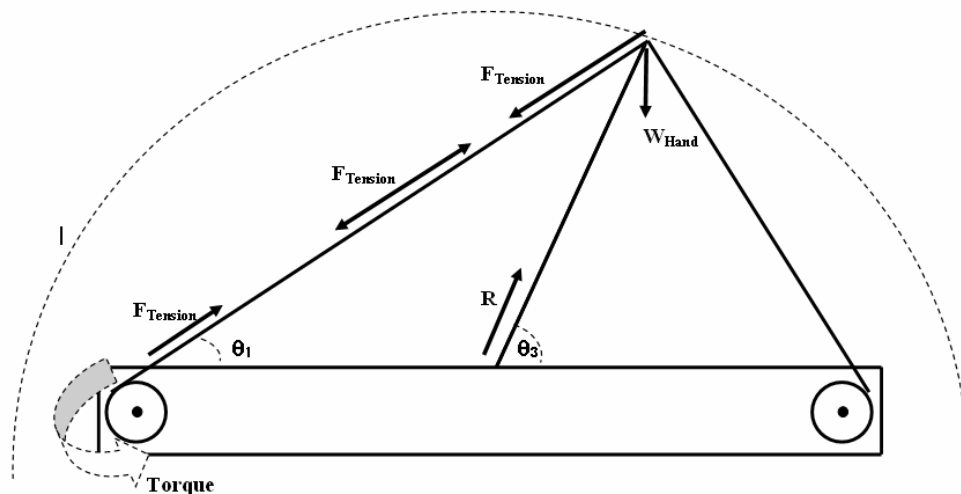
**McMaster-Carr Supply Company** To purchase our ball joint and motors we have decided to use McMaster-Carr Supply Company ([www.mcmaster.com](http://www.mcmaster.com)). This company allowed us to simply purchase motors and parts without requiring estimates or dealing with a sales representative. Bulk orders are not required, and the pricing is well within our range.

**US Digital** To control our motors, we need to purchase four encoder kits. US digital was recommended to us by our professor. Like McMaster-Carr, they allow us to purchase encoders without requiring estimates or dealing with a sales representative. Furthermore, bulk orders are not required, and the pricing is well within our range.

**Local Hardware Stores** Local hardware stores will be used to purchase all of the required fastening devices. In addition, any last minute parts will be purchased at these retailers. Like previous the previous suppliers, the local hardware stores allow us to purchase parts without having to buy in bulk.

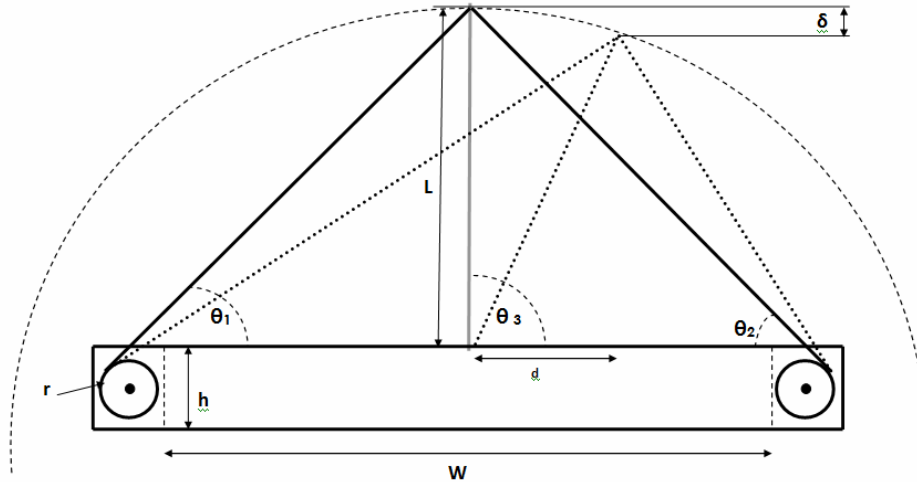
## VIII.6. QUANTITATIVE ANALYSIS

Our prototype's primary concern is to move a subject's hand in two directions. To simplify our analysis of these motions, we analyzed each direction independently. Figure 21 shows one of these 2-Dimensional cross sections of the prototype at its maximum horizontal position. The figure also displays the forces involved in the movement. It is further broken down into free body diagrams in the following sections. Each diagram was used to calculate the motor torque necessary for motion. All of the final calculations were performed in Microsoft Excel and two example spreadsheets can be found in Appendix C.



**Figure 21: A 2-Dimensional cross section of the prototype, which displays the forces involved, the path traveled and the maximum horizontal position.**

In the quantitative analysis, it was necessary to determine the angles and lengths involved in the prototype's motion. Figure 22 defines each of these geometric variables, which are also used in the free body diagrams. The detailed calculations of these angles and lengths can be found in Appendix C.



**Figure 22: A 2-Dimensional cross section of the prototype, which displays the geometric variables used in the free body diagrams.**

### VIII.6.1. FBD OF THE PIVOT ARM

In order to determine the motor torque, the force required to move a subject's hand had to be calculated. From figure 21, the free body diagram shown in figure 23 was created. It displays the reaction forces involved at the base of the pivot arm, the hand weight and the force being exerted by the cable. The weight of the pivot arm was neglected since it was much less than our estimated hand weight (10 lbs.).

From the FBD, the summations of the forces in the vertical and horizontal directions were calculated.

$$\Sigma F_{vertical} = R \sin \theta_3 - F_T \sin \theta_1 - W_{Hand} = 0 \quad [1]$$

$$\Sigma F_{Horizontal} = R \cos \theta_3 - F_T \cos \theta_1 = 0 \quad [2]$$

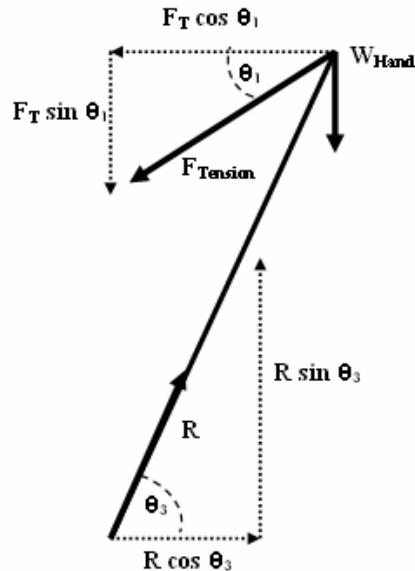
Solving equation 2 for R, and substituting the result (Eqn. 3) into equation 1 produced equation 4.

$$R = \frac{F_T \cos \theta_1}{\cos \theta_3} \quad [3]$$

$$\frac{F_T \cos \theta_1}{\cos \theta_3} \sin \theta_3 - F_T \sin \theta_1 = W_{Hand} \quad [4]$$

Simplifying equation 4 and then solving for the cable tension produced equation 5.

$$F_T = \frac{W_{Hand}}{(\tan \theta_3 \cos \theta_1 - \sin \theta_1)} \quad [5]$$



**Figure 23: The FBD of the pivot arm.**

Equation 5 describes the force being exerted by the cable when the pivot arm is at its maximum horizontal position. The next step is to calculate the tension force in the cable.

### VIII.6.II. FBD OF THE CABLE

Because we neglected the weight of the cable, it is essentially a two-force member. The two forces, which act on the body, are therefore equal in magnitude, co-linear and opposite in sense. This result is shown in the forces due to tension displayed in figure 24.

At the prototypes position displayed in figure 24, there is no force in the shorter cable located to the right of the pivot arm. It is neither in tension nor in compression. Therefore, it is not included in any of our free body diagrams.

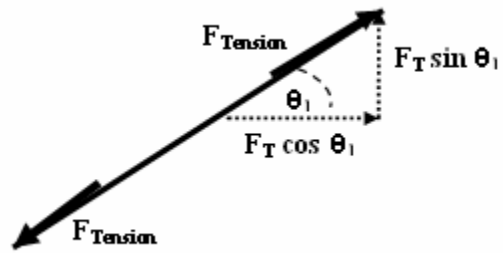


Figure 24: The FBD of the cable.

### VIII.6.III. FBD OF THE PULLEY

The motor torque was calculated from equation 6. It was derived using the FBD shown in Fig. 25.

$$Torque = F_T r \quad [6]$$

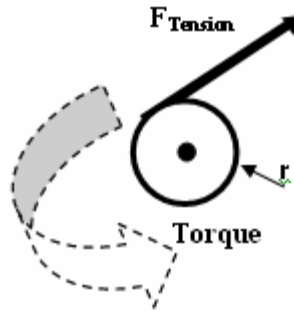


Figure 25: The FBD of the pulley.

From the results of equation 6, we were able to determine the effects of varying our drive pulley's radius. This result enabled us to specify the motor torque required for motion.

### VIII.7. QUALITATIVE ANALYSIS

The following section outlines our qualitative analysis for specific design goals and other analyses.

#### VIII.7.I. DESIGN FOR MANUFACTURABILITY & ASSEMBLY

In order to design for manufacturability and assembly, the following 5 guidelines were applied. Each component satisfies all or most of these manufacturing goals.

- Simplify the design and reduce the number of components

- Design for ease of fabrication
- Standardize similar components and materials
- Design for ease of assembly
- Design so that components can easily be replaced and altered

### **VIII.7.II. DESIGN FOR ENVIRONMENT**

In order to design for the environment, the following 5 guidelines were created. The purpose of each guideline is essentially to prevent waste and improve our manufacturing processes.

- Reduce scrap associated with fabrication by maximizing and recycling material
- Thoroughly analyze each component design to prevent manufacturing wasting material
- Create models to verify the prototypes effectiveness
- Design components so that each may be reused and recycled
- Thoroughly plan each component’s fabrication to prevent any mistakes

### **VIII.7.III. FAILURE MODE AND EFFECTS ANALYSIS**

Table 7 displays a failure mode and effects analysis. It lists possible part failures and the recommended solution for problems that may arise during the prototype’s use. The probability and severity of each of the possible failures are also ranked and compared using the risk priority number. As the table shows, a reliable motor is critical to the prototype’s success.

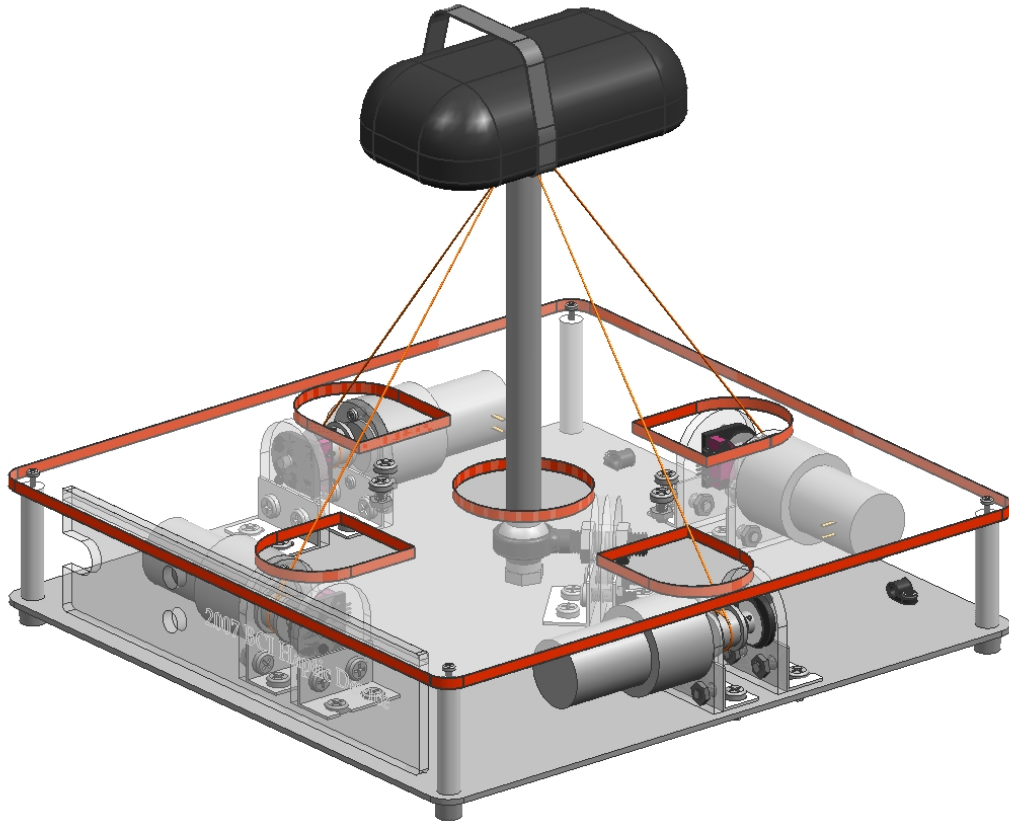
<b>Part</b>	<b>Function</b>	<b>Cause of Failure</b>	<b>Effect of Failure</b>	<b>Probability</b>	<b>Severity</b>	<b>RPN</b>	<b>Recommended Action</b>
Motor	Moves cables	Motor stalled	No motion	2	5	10	Purchase motors with higher torque
Motor	Moves cables	Motor died	No Motion	2	5	10	Purchase new motor
Cable	Moves hand	Cable broke	No Motion	1	5	5	Purchase new cables

1: None  
 2: Minor  
 3: Moderate  
 4: High  
 5: Catastrophic  
 RPN = Probability x Severity

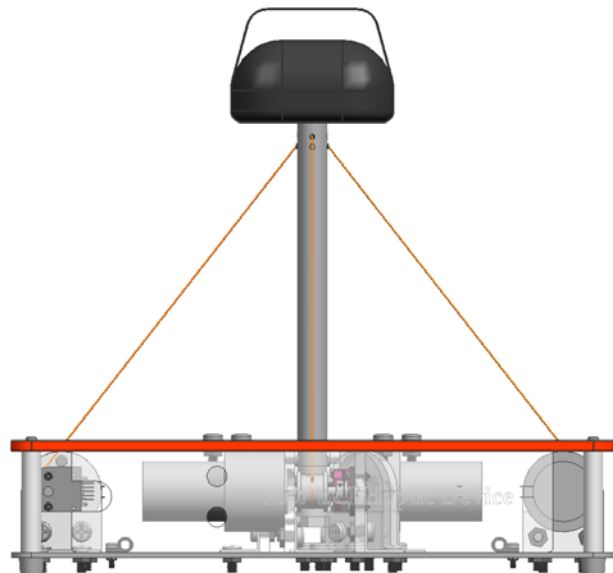
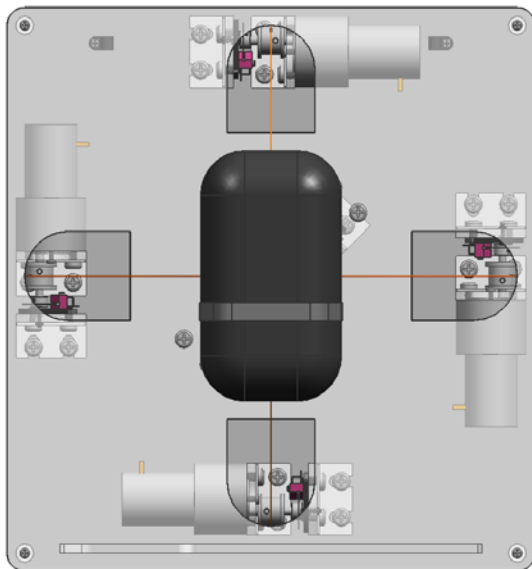
**Table 7: FMEA of failures that may occur during prototype use.**

## **IX. FINAL DESIGN**

Our final design was created from a combination of several previous designs. We decided to use cable driven motors attached to an inverted pendulum. Figures 26 through 29 show our final CAD model of the haptic feedback device.

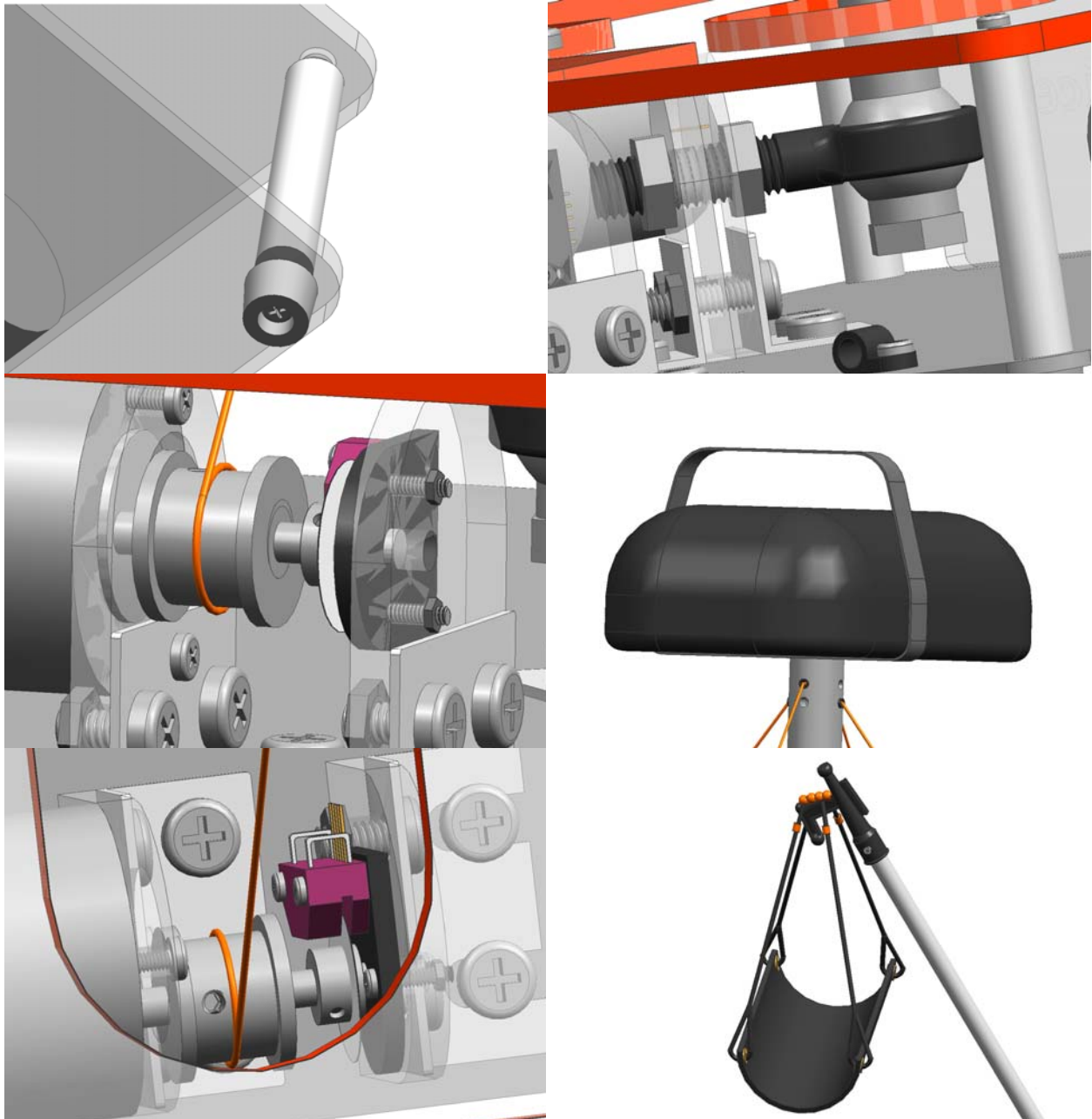


**Figure 26: Trimetric view of haptic feedback device.**



**Figures 27 and 28: Top view and front view of haptic feedback device.**





**Figure 29: Detailed views of haptic feedback device. Clockwise from upper left, base support, ball joint connection, hand support, arm support sling, and two images of the motor assembly with pulley and encoder.**

## X. MANUFACTURING

The following section discusses the manufacturing of our device. It is broken up into multiple sections which include: the support structure, pulleys, mounts, pivot arm and the hand support and arm harness. For each major part that we manufactured in-house, there is a detailed dimensioned drawing and process plan located in Appendix E.

The only parts that were ordered online were the motors, encoders and ball joint; all of them were purchased at the beginning of March. The remaining parts, which included an aluminum plate, pieces of acrylic, bolts, nuts, set screws, fishing line, weights, aluminum pole, aluminum rod and “L” brackets were purchased at local retailers.

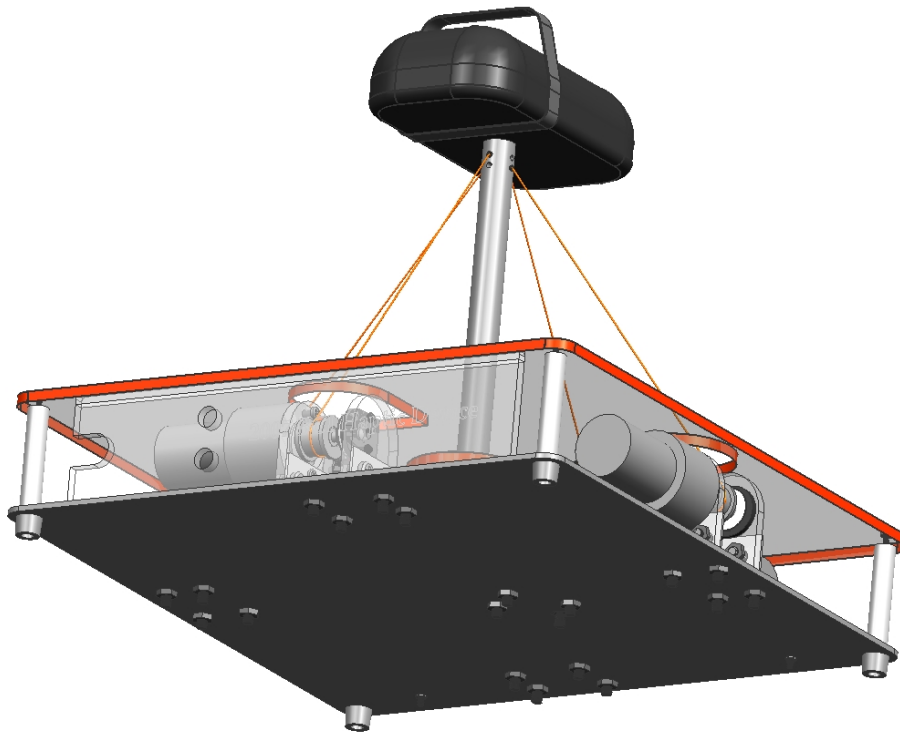
If our device were to be made available for public use, we would have no ethical issues. It is very safe, and even comes with a safety plate to prevent user injury. As far as we know, the device is also completely original and does not copy/imitate/violate any device or patents in existence.

**THE SUPPORT STRUCTURE** The support structure of our device consists of two plates (acrylic & aluminum) fastened together by 4 aluminum rods, 4 (3/4”) bolts on the top, 4 (1”) bolts on the bottom and 4 purchased rubber base supports.

The base was originally manufactured out of acrylic, but due to structural concerns, it was changed to aluminum. We purchased a 1/8 inch thick piece of aluminum since it was light weight and within our budget. Additional thickness would have dramatically increased the base’s price. The original acrylic base was used as a template and the aluminum piece was created using a band saw and drill press

The top plate was created using a laser cutter. It was cut from a piece of acrylic 0.25 in. thick. The scraps from this top plate were used to manufacture an acrylic centering device that double as a safety shield.

The 4 supporting rods located in-between the base and top plates were cut using a band saw. Next, screw holes were added using a lathe.

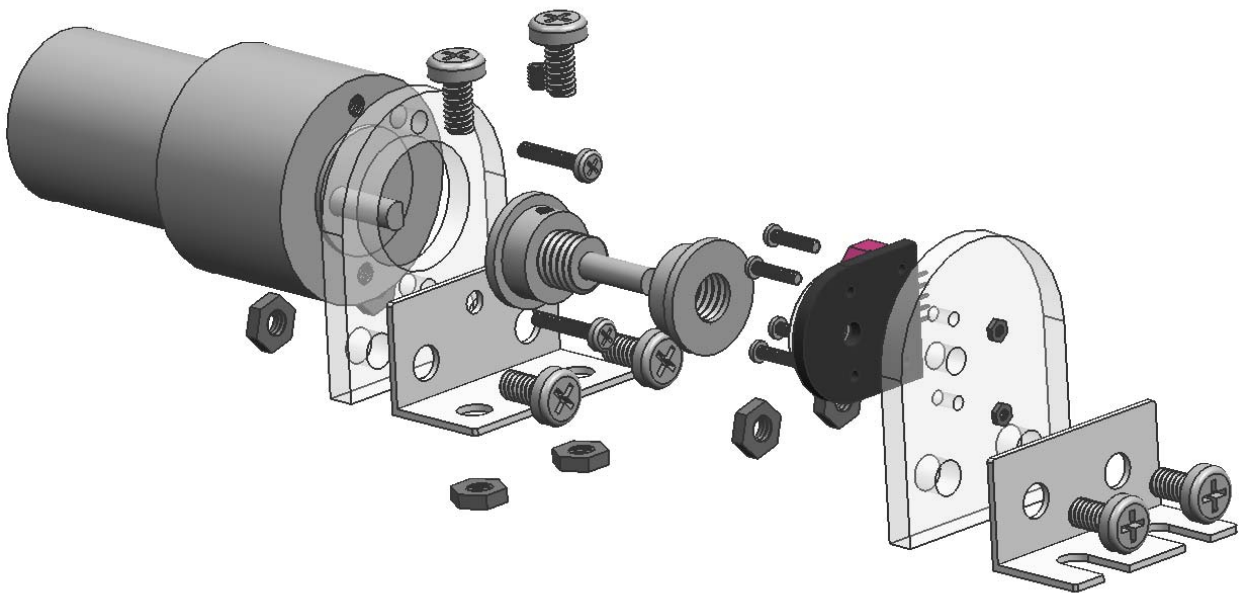


**Figure 30: Bottom view of the aluminum base plate.**

**PULLEYS** Four aluminum pulleys were manufactured to drive our device. As can be seen in Appendix E and Figure 31 below, each pulley consisted of two parts.

The larger section of the pulley was used as a means of motor attachment and encoder mounting. The first step in manufacturing the pulley was to cut a 3 inch piece of aluminum stock (1 in. diameter). Next, each piece was lathed to the correct dimensions and threaded. The shaft holes were then drilled, and the pieces were cut to the actual lengths. Finally, set screw holes were added using a mill and a tap.

The smaller section of the pulley was manufactured using a similar technique. First, aluminum stock was cut to approximately 2 inches. Next, the pieces were lathed to the correct dimensions. A hole was then drilled through the pieces and they were threaded. Finally, the pieces were cut their final length.



**Figure 31: Exploded view of the motor/encoder assembly with two-part pulley.**

**MOUNTS** Our device consisted of three different types of mounts. These mounts included motor mounts (x4), encoder mounts (x4) and a ball joint mount (x2). All of the mounts were cut out of 0.25 in. acrylic on the laser cutter using the dimensions in Appendix E.

In order to support of the mounts, “L” brackets were manufactured. Each of the brackets were created from 1/8 in. thick “L” brackets. They were cut using a band saw and drilled using a drill press. Two brackets were made for the ball joint mount. Only one bracket was made for each of the motor and encoder mounts. Each type of bracket is different; they each had to be designed to accommodate motor and encoder dimensions.

**PIVOT ARM** The pivot arm was manufactured using an aluminum rod (1 in. diameter). The rod was first lathed down to the correct dimensions and then cut to its final length. Next, the top portion of the rod was threaded to accommodate a hand rest. Four pairs of holes were then drilled in the top of the rod using a mill. Two of the holes were then threaded for a set screw. Next, the bottom of the rod was drilled and threaded to fit the ball joint.



**Figure 32: Exploded view of the pivot support mount and hand rest.**

**HAND SUPPORT & ARM HARNESS** The hand support was created using a pair of scissors to shape a sponge. It was designed to resemble an oversize mouse. The casing for the hand harness was then sewed using fabric purchased a local retailer. Velcro straps were also sewn in place to assist in holding a user's hand. The final step for manufacturing was to cut, drill and tap an acrylic block and then set into the bottom of the sponge using epoxy.

The arm harness was created by altering an extendable aluminum pole purchased from Meijer. First, it was welded to a base plate so that weights (at least 50 lbs) could be used to support the structure. Four bungee cords were then attached between a padded pillow and the end of the pole to form an arm sling. This can be seen in Figure 33 below.



**Figure 33: Model of the final arm harness support system.**

## **XI. TESTING**

**SIMPLE MOTION** In order to test our device, we performed simple motion tests after we finished manufacturing our prototype. Although we had no controls, we powered each of the motors separately using power supplies available in the GGB X50 lab. These power supplies allowed us to drive the pivot arm in multiple directions, and test the strength of the driving cable and motors. From our tests, we found that the fishing line was strong enough to move the pivot arm without breaking. Also, we were able to verify our engineering analysis and free body diagrams, and prove that our motors had enough torque to drive our device.

**ARM HARNESS** By testing the arm harness, we were able to design a sufficient support structure for the arm harness. These tests consisted of setting up previous harness models and making appropriate adjustments for the height of a seated individual.

**CONTROLS TESTING** The controls for our device were tested at our design expo. During the expo, multiple people came up to our table and used the device. It worked successfully for approximately 3 hours. The controls failed when users dragged the mouse, which controlled the device. According to our controls group, the dragging of the mouse input too many commands to the device which caused it to error out.

**DESIGN TESTING** The testing of the prototype will require using forces that far exceed what the product will eventually be used for. We will begin by applying an arm force of 20 pounds to see how the motors react to this force. This is our biggest concern as subject's arm weight can vary significantly. Ensuring that the product can be used for a weight that exceeds the estimated weight is important in ensuring the quality of our design. The next step in our testing phase is to control the rod into moving to all the corners of the plane. Doing this will ensure that our design can travel in a wide range of motion without stalling the motors. This will eventually be controlled by the computer control, so this testing phase will also ensure that any errors in the computer control will not cause the motors to stall.

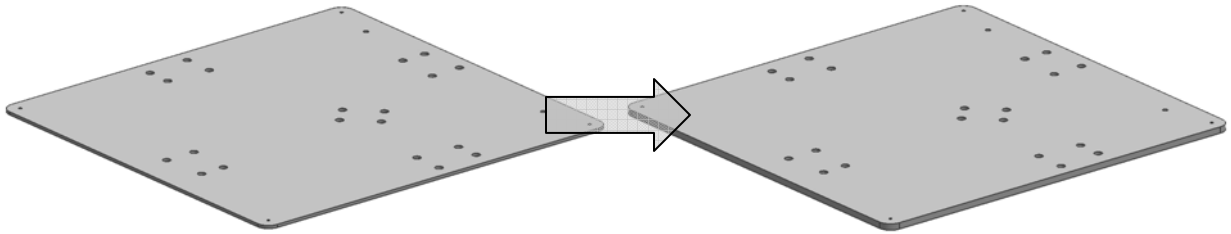
## **XII. DISCUSSION FOR FUTURE IMPROVEMENTS**

There are several steps to improve the haptic device for future use which are to strengthen the overall structure of the device, to improve the alignment between the motor and encoder mounts, and to replace our existing fishing line with (1/16") steel cables from Sava Industries. In addition a redesign of our pulleys would encompass either higher outer walls to prevent the cable from slipping to the shaft, or perhaps redesigning the pulley altogether to make it more efficient in taking and giving cable.

### ***XII.1. Strengthening the Structure of the Haptic Device***

The first step of strengthening the structure is to strengthen the base. This can be done by adding either a thicker sheet of aluminum metal (at least 1/4") that can support the load of the 4 motors' weights as well as the loads caused by the pulling of the wires. The base support will be enhanced by adding more rubber stoppers in the middle of the base plate, preferably below the

motors. Also, all the motor and encoder mounts should be made out of a stronger material such as aluminum.



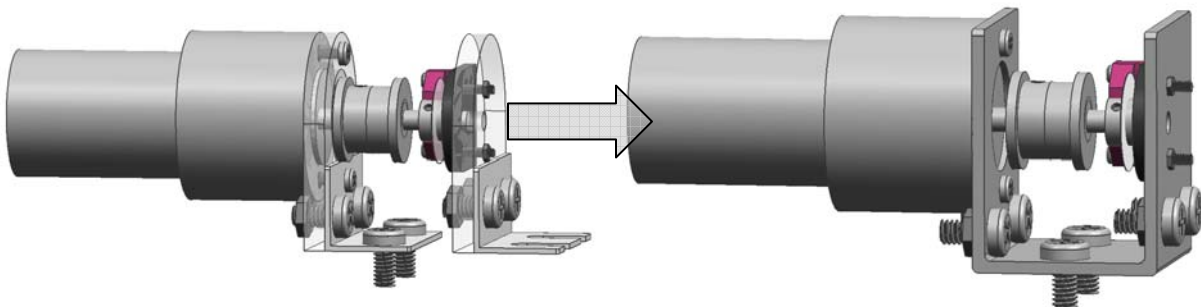
**Figure 34: Thicker base plate increases overall rigidity.**

## ***XII.2. Improving Alignment***

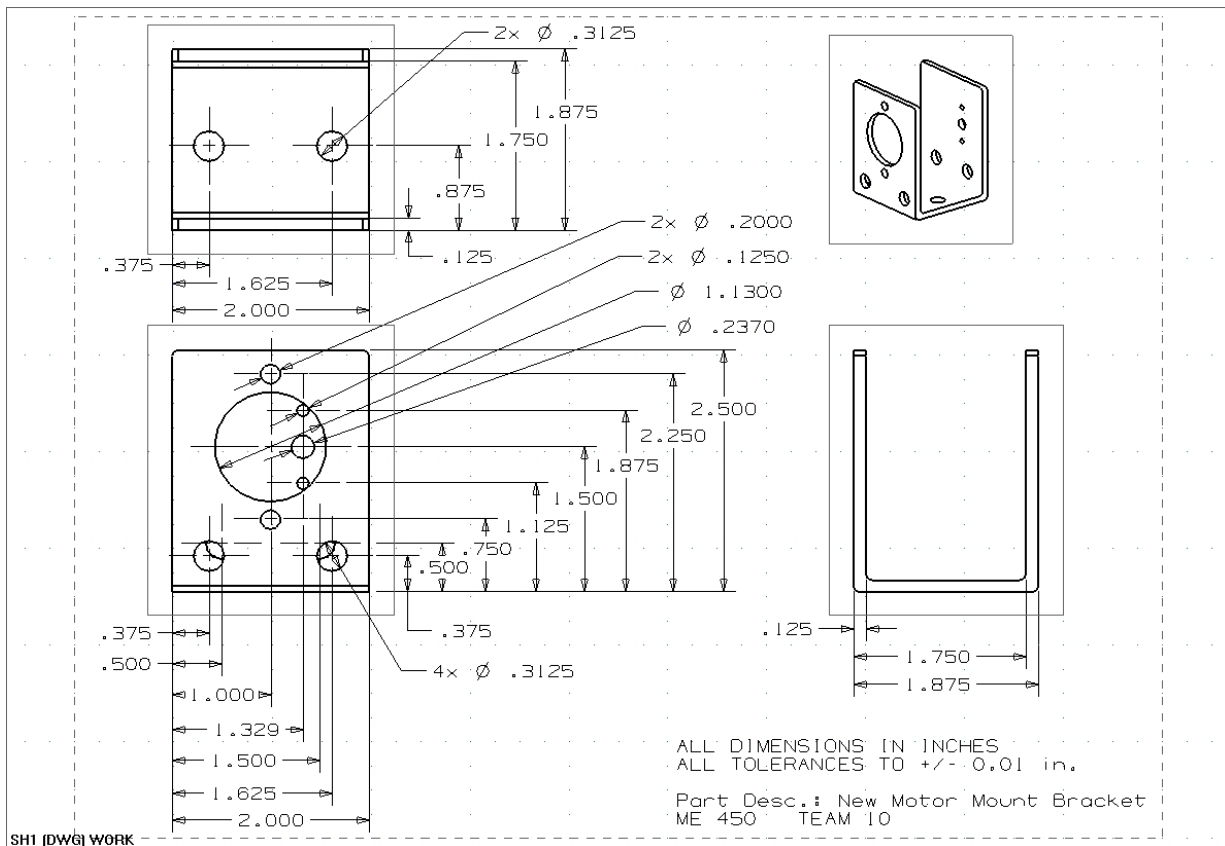
We decided it be best to reduce the mounts for each motor-encoder system to one mount. That way, the motor and the encoder would be fixed on that single mount in order to improve the following problem:

***Problem:*** Currently there are a lot of fluctuations in the rotary motion of the encoder wheel. This is caused by the two different mounts, one for the motor and one for the encoder, which flex and bend differently to each other. The problem lies that the motor shaft is what holds the encoder wheel, while the encoder itself is supported by a different mount. This causes a discrepancy in the motion of the encoder wheel during operation.

***Solution:*** By making one mount for the motor-encoder system, the fluctuations would be based on that mount only and the encoder software would be able to account for that error more easily.



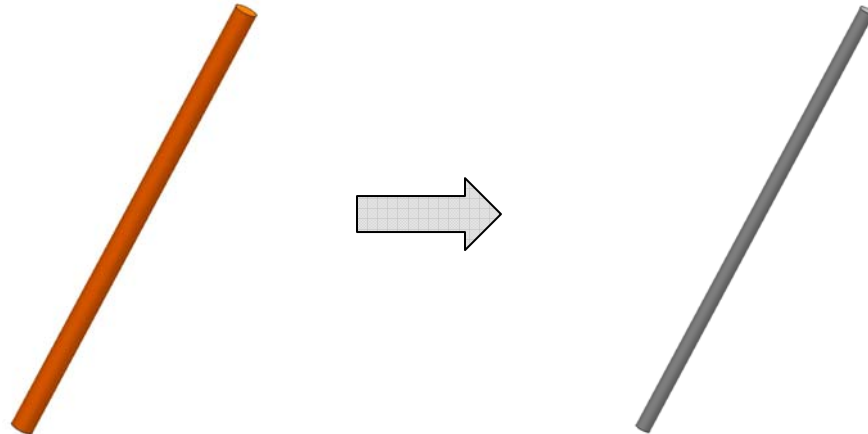
**Figure 35: Solid aluminum motor/encoder mount reduces errors in shaft alignment.**



**Figure 36: Detailed dimensioned drawings for the new motor/encoder mount bracket.**

### ***XII.3. Replacing Fishing Line with Steel Cable***

Due to the failure of Sava Industries in sending us their free 10 feet sample of steel cable we found a quick fix for our problem by using high strength fishing line. The reason for using Sava's steel cable is due to the reason that is strong, flexible, and tearless.



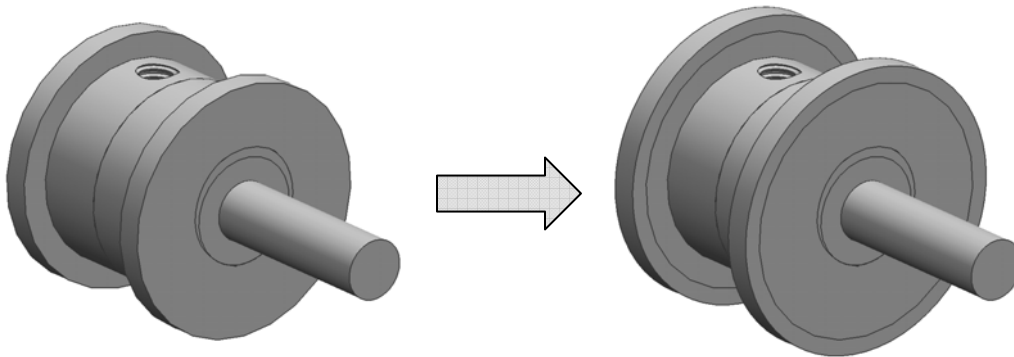
**Figure 37: Braided stainless steel cable improves durability by reducing stretch and fray.**

## **XII.4. Redesign of our Pulleys**

The current design of the Pulleys is acceptable for doing a decent job of giving and taking the driving cable. However, during the testing phase a few issues arose.

**Problem:** *The cable doesn't wind and unwind orderly causing the cable to overlap and cause it to slip off the pulley to the shaft. This is not supposed to happen, since the cable is only supposed to be on the pulley itself.*

**Solution:** *By putting perhaps little dimples onto the pulley, the cable will orderly align. To account for the slipping issue, we could make the pulley walls higher to prevent the cable from ending up in the shaft system.*



**Figure 38: Higher pulley walls reduce chance of cable escaping onto drive shaft.**

## **XIII. PROJECT PLAN**

The major tasks of project included brainstorming and selecting a final concept, translating this concept into a CAD model, fabricating the prototype, developing a working controller interface, and refining our finished prototype. For each stage, we chose someone from within our group to lead that phase of the project (Table 8).

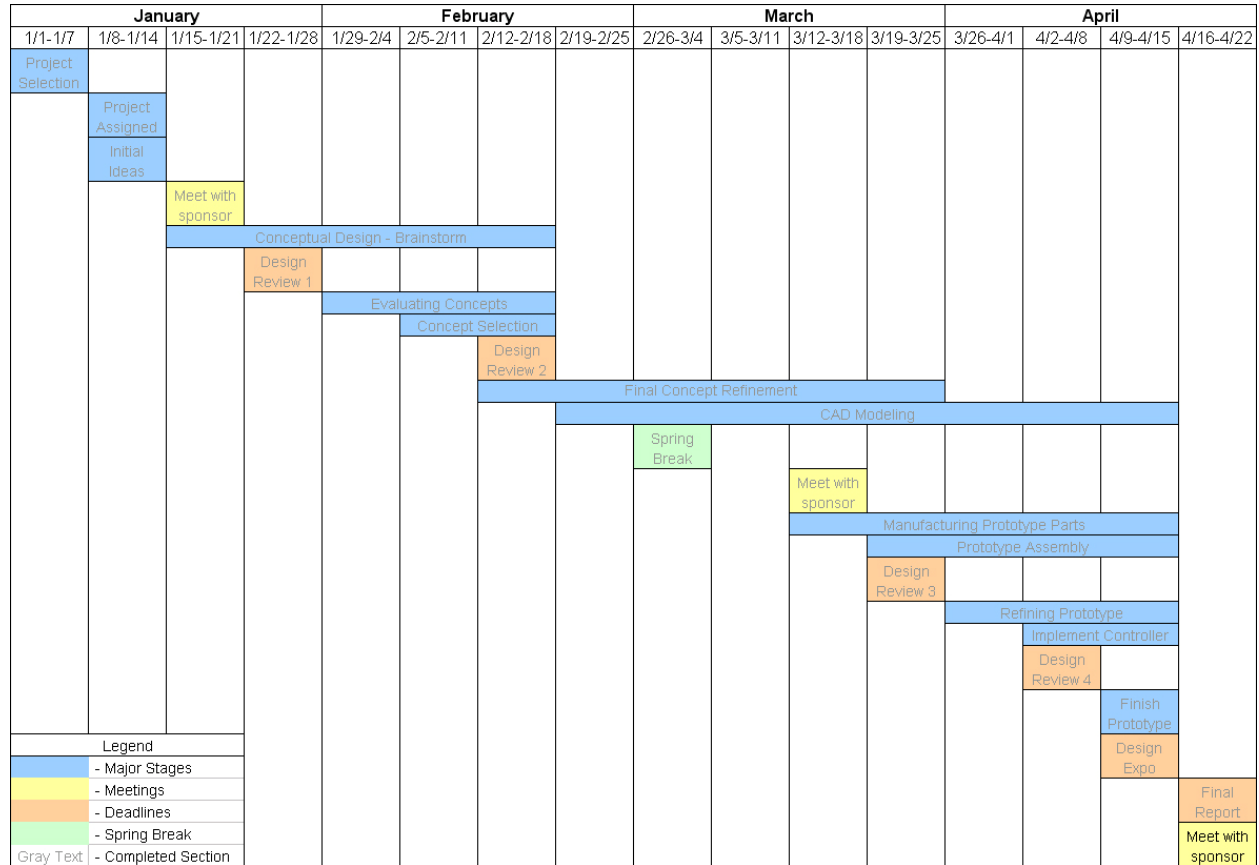
<b>Project Stage</b>	<b>Stage Leader</b>
Concept Design	Carlos Groth
CAD Modeling	Kyle Miller
Prototype Fabrication	Abbe Karp
Controller Design	Justin Philips
Prototype Refinement	Matt VanNortwick

**Table 8: Project stage and stage leaders.**

We met our sponsor, Jane Huggins, during the design process to gain background information on the project and to attain prototype approval. The project deadlines are shown in Figure 30 which included the design reviews, the design expo, and the final report deadline. We estimated the time needed for each major stage of our project, which included all meetings and deadlines, and we developed a Gantt chart to keep us on schedule throughout the semester (Figure 30).



Throughout the semester, we continued to adjust our Gantt chart based upon our progress. Our initial project plan was very optimistic, which we found to be difficult to follow due to the large number of concepts we were able to generate. However, we were successfully able to begin machining parts before most teams to avoid the rush, partly because of our optimistic original goals.



**Figure 35: Gantt chart shows major project stages, meetings, and deadlines.**

In addition, we have attached the bill of materials for our project below. This itemized list shows our purchasing timeline as well as the costs and vendors associated with each component of the project. There are one or two missing items due to missing receipts, but no major or big budget item has been overlooked. As you can see, we overshot our budget of \$400 by roughly \$170. We were given permission throughout the project to purchase the two large orders for our motors (\$240) and for our encoders (\$201) so that our end prototype would be as complete as possible.

Quantity	Part Description	Purchased From	Part Number	Date of Purchase	Price (each)	Total Price
1	Rubber Feet - 4 pack	Carpenter Bros. Hardware	222887	3/13/2007	\$1.49	\$1.49
2	Solid Aluminum Rod - 1/2" x 12"	Carpenter Bros. Hardware	KS3048	3/13/2007	\$3.59	\$7.18
2	Plexiglass - 16" x 16" x 1/4"	Carpenter Bros. Hardware	N/A	3/13/2007	\$10.00	\$20.00
5	Cable Ferrules - 1/16"	Carpenter Bros. Hardware	104210	3/13/2007	\$1.19	\$5.95
10	Stainless Steel Cable - 1/16"	Carpenter Bros. Hardware	N/A	3/13/2007	\$0.13	\$1.30
12	Bolts - #10-32 x 3/4"	Carpenter Bros. Hardware	N/A	3/13/2007	\$0.06	\$0.72
4	Miniature DC Gearmotor - 175 in-oz	www.mcmaster.com	6331K34	3/13/2007	59.85	\$239.40
1	Solid Aluminum Rod - 1" x 24"	UofM Machine Shop	N/A	3/15/2007	\$0.00	\$0.00
4	Optical Encoder Kit	www.usdigital.com	E2-1000-237	3/22/2007	50.37	\$201.48
6	Set Screw - #8-32	UofM Machine Shop	N/A	3/27/2007	\$0.00	\$0.00
1	Cellufoam Sponge	Carpenter Bros. Hardware	578226	4/2/2007	\$1.99	\$1.99
1	Vinyl Electrical Tape - Black	Carpenter Bros. Hardware	265349	4/2/2007	\$2.99	\$2.99
1	Velcro Adhesive Strips - Black	Carpenter Bros. Hardware	644471	4/2/2007	\$2.89	\$2.89
1	Velcro Tie Straps - Black - 12"	Carpenter Bros. Hardware	515736	4/2/2007	\$7.49	\$7.49
1	Plexiglass - 16" x 16" x 1/4"	Carpenter Bros. Hardware	N/A	4/2/2007	\$9.50	\$9.50
1	Spray Paint - Gloss Black	Carpenter Bros. Hardware	789800	4/2/2007	\$2.99	\$2.99
2	Bolts - 1/4" x 1"	Carpenter Bros. Hardware	N/A	4/2/2007	\$0.11	\$0.22
8	Bolts - 1/4" x 1/2"	Carpenter Bros. Hardware	N/A	4/2/2007	\$0.09	\$0.72
10	Nuts - 1/4"	Carpenter Bros. Hardware	N/A	4/2/2007	\$0.05	\$0.50
1	Aluminum Plate - 24" x 24" x 1/8"	Alro Metals Plus	26902260	4/4/2007	\$44.79	\$44.79
1	PVC Block - 3" x 3" x 1/2"	UofM Machine Shop	N/A	4/5/2007	\$0.00	\$0.00
1	Olympic Weight Plate - 25 lb	Dunhams Sporting Goods	3685518	4/6/2007	\$14.75	\$14.75
1	Steel Plate - 1/4"	UofM Machine Shop	N/A	4/6/2007	\$0.00	\$0.00
1	Solid Steel Rod - 1" x 3"	UofM Machine Shop	N/A	4/6/2007	\$0.00	\$0.00
1	Electrical Wire	Carpenter Bros. Hardware	N/A	4/11/2007	\$0.19	\$0.19
1	Vinyl Electrical Tape - Black	Carpenter Bros. Hardware	505705	4/11/2007	\$0.99	\$0.99
4	Miscellaneous	Carpenter Bros. Hardware	N/A	4/11/2007	\$0.05	\$0.20
4	Bolts - 1/4" x 1/2"	Carpenter Bros. Hardware	N/A	4/11/2007	\$0.09	\$0.36
6	Electrical Clamps	Carpenter Bros. Hardware	N/A	4/11/2007	\$0.15	\$0.90
6	Bolts - #4-40 x 3/8"	Carpenter Bros. Hardware	N/A	4/11/2007	\$0.07	\$0.42
6	Nuts - #4-40	Carpenter Bros. Hardware	N/A	4/11/2007	\$0.05	\$0.30
					Total =	\$569.71

**Figure 36: Bill of materials shows the major components we purchased and from what vendors. Other than the two online purchases, all materials were found in local stores.**

#### **XIV. CONCLUSIONS**

We spent a lot of time as a group researching and brainstorming before we even met with our sponsor. It was important to begin learning about what a brain-computer interface (BCI) is in order to properly understand the requirements of the project. We used several modes of literature and media search to familiarize ourselves with a BCI. Our initial design concept was a mechanical device that would open and close a user's hand according to their usage of the BCI. We then brainstormed methods to create this mechanical device for production in hopes that it could be tested and proven to aid in the BCI learning process.

After meeting with Jane Huggins, we had a clear idea of what she desired, and the concept changed from a clenching motion of the user's hand to a movement in the x- and y- directions.

Our first step was to use Jane's requirements to create a QFD diagram. This diagram allows us to prioritize which characteristics were most important to the final product. The QFD aided us during the brainstorming process to determine the functionality of our manufactured prototype. Once we determined the direction that the project was going to take we were able to set up a project plan. Our brainstorming sessions proved to be very successful and gave us several very promising concept designs to choose from. Using a Pugh chart, we were able to narrow the design down to a ball-joint "joystick" device. Next, we analyzed the mechanics behind the device and ordered the appropriate parts. Using the machine shop, we then constructed the prototype and had a ME 552 team provide its controls.

As requested, our manufactured prototype can move a subject's hand in two directions. Our next step is to implement our future changes and further improve our device. Over the next few days, we plan on transporting the prototype to Jane's office and helping her set it up. Hopefully over the next few months, the university will attain the appropriate software and BCI equipment to put our device to use.

## **XV. ACKNOWLEDGEMENTS**

We would like to thank Jan Huggins, PhD for providing us the opportunity to work on such an exciting project. Also, we would like to thank Brent Gillespie, PhD for assisting us throughout the semester and encouraging us to think of new and exciting ways to solve our problem. Finally, we would like to thank Bob Coury for assisting us in the shop with the manufacturing of our device. Without these individuals, it would have been impossible to design and fabricate our project.

## **XVI. REFERENCES**

### **Brain Computer Interfaces / Haptic Devices Bibliography**

[1] Cortech Solutions. "Products." [Online] 18 January 2007. <<http://www.cortechsolutions.com/Products.htm>>.

[2] Nature.com. "Streaming video: Brain machine interfaces." [Online] 18 January 2007. <<http://www.nature.com/nature/focus/brain/video/index.html>>.

[3] Neurophilosophy.wordpress.com. "Brain-machine interface controls movement of prosthetic limb." [Online] 18 January 2007. <<http://neurophilosophy.wordpress.com/2006/07/13/brain-machine-interface-controls-movement-of-prosthetic-limb/>>.

[4] Bciresearch.com. "BCI Research and Development Program." [Online] 18 January 2007. <[http://www.bciresearch.org/html/BCI\\_Video.html](http://www.bciresearch.org/html/BCI_Video.html)>.

[5] Bci200.org. "BCI 2000 Software." [Online] 18 January 2007. <<http://bci2000.org/BCI2000/Features.html>>.

[6] [BCI-info.org](http://www.bci-info.org). “Portal for Brain Computer Interfaces.” [Online] 18 January 2007. <[http://www.bci-info.tugraz.at/general\\_info](http://www.bci-info.tugraz.at/general_info)>.

[7] [Cyber Kinetics Neurotechnology Systems, Inc.](http://www.cyberkinetics.com) [Online] 19 January 2007. <<http://www.cyberkinetics.com/content/aboutus/index.jsp>>.

[8] [Institute for Knowledge Discovery](http://bci.tugraz.at). [Online] “Laboratory of Brain Computer Interfaces.” 19 January 2007. <<http://bci.tugraz.at/>>.

[9] GSU Brain Lab. “Projects.” [Online] 19 January 2007. <<http://cis.gsu.edu/brainlab/ProjectsTechAccomplishments.htm>>.

[10] “Teenager moves video icons by just imagination” Tony Fitzpatrick, [Washington University in St. Louis](http://news-info.wustl.edu). 21 January 2007. <<http://news-info.wustl.edu/news/page/normal/7800.html>>.

### **Animatronics**

[11] [Animatronics.org](http://www.animatronics.org). “Behind the Scenes (How To).” [Online] 10 January 2007. <<http://www.animatronics.org/howto.htm>>.

[12] [MakingThings.com](http://www.makingthings.com). “Animatronic Hand.” [Online] 10 January 2007. <[http://www.makingthings.com/teleo/teleo/hand\\_mechanism/hand\\_mechanism.htm](http://www.makingthings.com/teleo/teleo/hand_mechanism/hand_mechanism.htm)>.

### **XY Tables**

[13] [Velmex Inc.](http://www.velmex.com). “Motor driven assembled XY Tables with work plate.” [Online] 17 January 2007. <[http://www.velmex.com/motor\\_maxy\\_tables.html](http://www.velmex.com/motor_maxy_tables.html)>.

[14] [LittleMachineShop.com](http://www.littlemachineshop.com). “LittleMachineShop.com – X-Y Tables.” [Online] 17 January 2007. <[http://www.littlemachineshop.com/products/product\\_focus.php?Focus=X-Y%20Tables](http://www.littlemachineshop.com/products/product_focus.php?Focus=X-Y%20Tables)>.

[15] [Free and Easy Project](http://freeandeasy.sourceforge.net). “Free and Easy: XY Table Prototype.” [Online] 17 January 2007. <<http://freeandeasy.sourceforge.net/xytable.php>>.

[16] Crear, Donnell. 2006. “Design of an X-Y Table for Investigating And Rehabilitating Human Motor Control.” Undergraduate Honors Thesis – Ohio State University – Department of Mechanical Engineering. <<https://ctools.umich.edu/access/content/group/66df6d7d-fa27-4eca-80a5-7874397e42bb/XY%20Table%20Thesis.pdf>>.

### **Online Vendors**

[17] McMaster-Carr Supply Company. “Miniature DC Gear Motor.” March 19, 2007. <<http://www.mcmaster.com>>.

[17] US Digital. “Optical Encoders.” March 19, 2007. <<http://www.usdigital.com>>.

## XVII. BIOGRAPHIES



**Carlos Groth, 5<sup>th</sup> year, Mechanical Engineering.** I was born in Puebla, Mexico and lived there my first 4 years. In 1987 my family moved to Niedersachsen (The State of Lower Saxony), Germany and I pretty much grew up and went to elementary and middle school there. In 1997 we moved to Rochester Hills, Michigan where I went to high school. I chose Mechanical Engineering because of the many future possibilities it offers in the workplace. I've always been very creative and inventive as a kid and those traits accompany me to this day. I'm also an avid photographer who is trying to find an employment in the product design engineering field or some other related field. I love traveling and seeing different people and places and my hope is to continue doing so in the near future. I will be graduating in 3 months and I'm currently looking for jobs in California.



**Abbe Karp, 4<sup>th</sup> Year, Mechanical Engineer.** Born in Buffalo, NY; I spent my early childhood years in Danbury, CT. I then returned to Buffalo where I completed middle school and high school. I have always shown interest and aptitude in the fields of science and math. As a child I would constantly take things apart just to see how they worked and try to put them together again. After graduation I plan to start a full time job, at a company that is yet to be determined. I am considering returning to graduate school once I have had real-world industry experience. I enjoy traveling to various locations all over the world, and am hoping to make it to Europe this summer before I become a "slave to the man". I am an avid viewer of the television show "The Office" and I also enjoy skiing, watching movies, and playing trivia games.



**Kyle Miller, 5<sup>th</sup> year, Mechanical Engineering.** I was born in Lake Orion, Michigan and lived there my entire life before coming to the University of Michigan. I chose to be an engineer at an early age, growing up with Legos and Erector sets. I began my academic career at the university as an electrical engineer, but switched to mechanical after my first two years. I enjoy the hands-on nature of mechanical engineering where you can think of an idea, then go design and fabricate it. I plan on continuing after graduating this year and getting my Master's degree in mechanical engineering from Michigan.



**Justin Philips, 4<sup>th</sup> Year, Mechanical Engineer.** I was born in South Brunswick, New Jersey but moved to Ann Arbor, MI when I was 12 and consider it my home. I chose to be a mechanical engineer because I had the “engineering knack,” as Dilbert puts it. Everything I touched as a child would break, but I would fix it gaining knowledge of how it worked. I couldn’t see myself anywhere else. I plan to work for General Electric in the Operations Management Leadership Program once I graduate school. I am excited to be part of such a big company and even more excited about getting to travel. I’m not sure what the long term goal is, but I do see myself in management in the future. I love to play guitar, listen to good music, and watch *Scrubs* in my free time. Go Blue!



**Matt VanNortwick, 4<sup>th</sup> Year, Mechanical Engineer.** I was born in Novi, Michigan. In approximately 3 months, I will be the fourth engineer in my family to graduate from the University of Michigan. I went into engineering at UM because it seemed like the next natural step after high school. After I graduate, I plan on working at Precision Castparts Corporation (PCC) where I’ll have the opportunity to explore 4 different engineering roles in the Management Development Program. In my free time, I enjoy staying active by participating in a variety of sports.

## APPENDIX A - BENCHMARKING

### Brain Computer/Machine Interface or Robotic/Movable Arm



#### Honda Research Institute Japan and Advanced Telecommunications Research Institute International

New Brain-Machine Interface Creating Technology for Manipulating Robots Using Human Brain Activity

[http://www.atr.jp/html/topics/press\\_060526\\_e.html](http://www.atr.jp/html/topics/press_060526_e.html)



#### Cortech Solutions

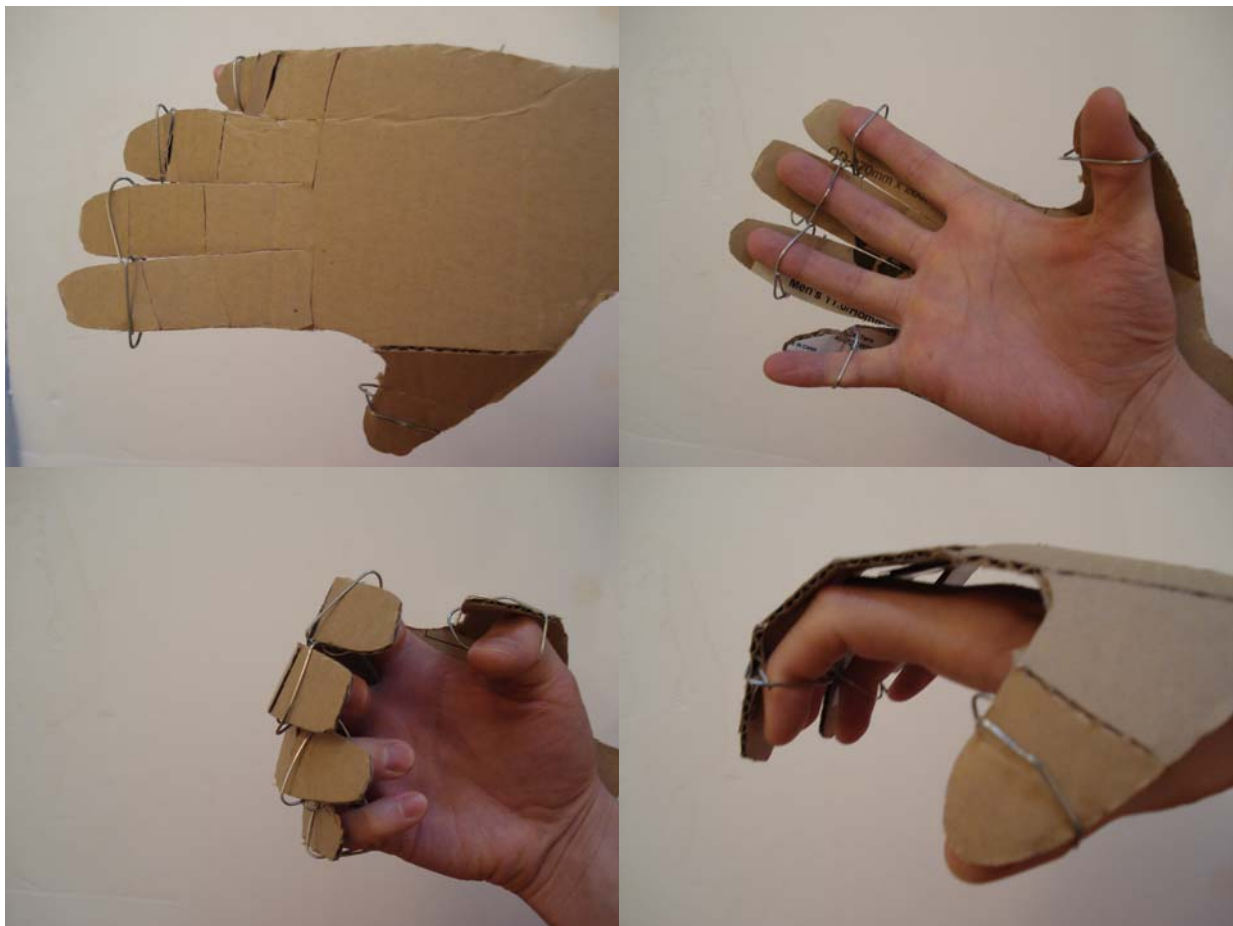
Brain-computer and Brain-machine Interface

[http://www.cortechsolutions.com/Application\\_Brain-Computer\\_Interface.htm](http://www.cortechsolutions.com/Application_Brain-Computer_Interface.htm)

## APPENDIX B – MOCK-UPS

### Original Mock-up – “The Hand”

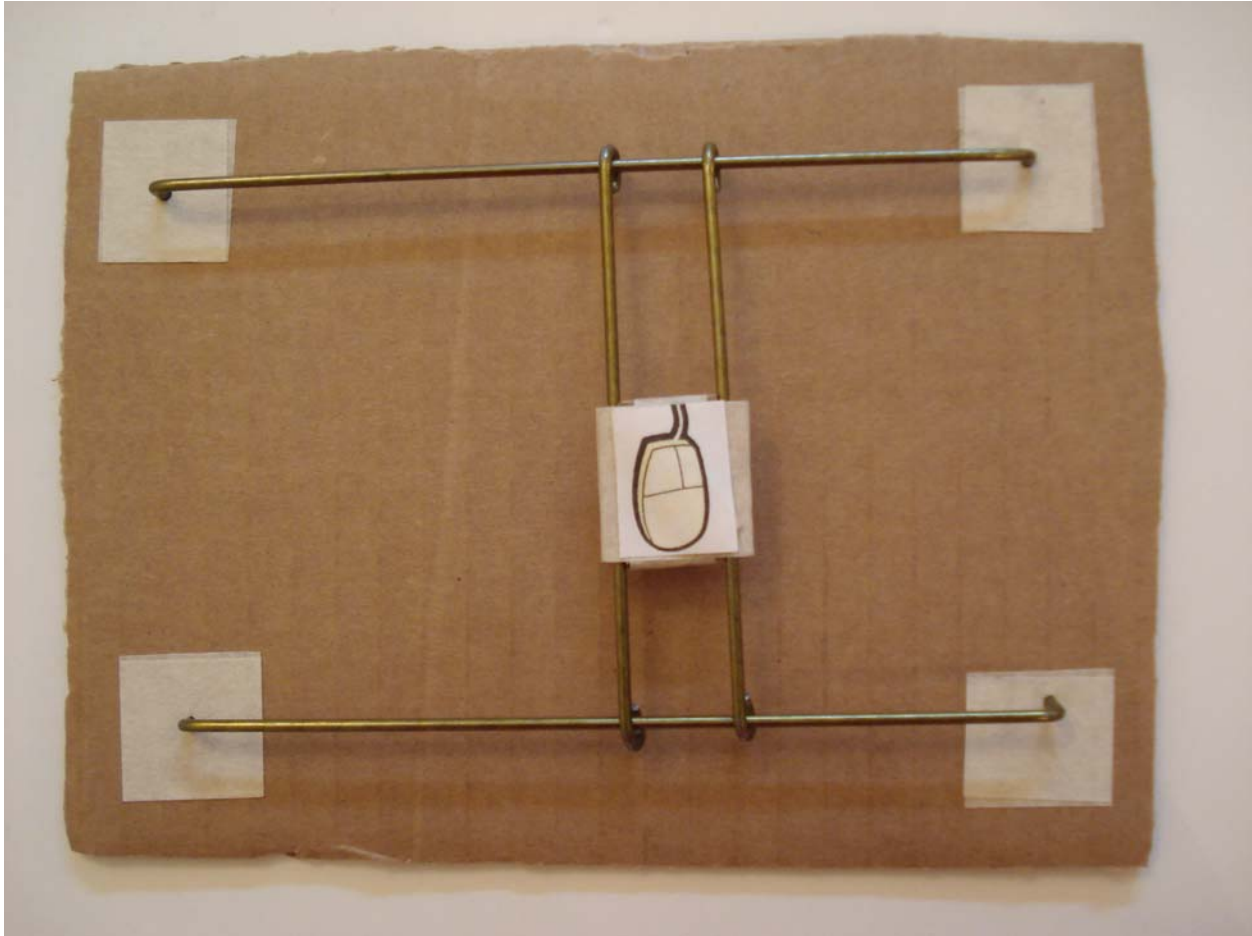
Our original mock-up was constructed out of cardboard and paper clips in about 15 minutes. We used it to generate ideas about how to back-drive a person’s hand from behind. It was also very useful in determining whether a one-size-fits-all design would be adequate. The mock-up was also useful during our meeting with Jane Huggins. After wearing the mock-up for a while, Jane realized that a more useful experiment would be mimicking the computer cursor motion with the patient’s hand, similar to a computer mouse.





### Modified Mock-up – “XY-Table”

Our second mock-up was constructed out of cardboard, a coat hanger, and masking tape. It is a simple xy-table that slides in both the vertical and horizontal. Using this, we hope to be able to develop many creative concepts during our design phase before the next design review.



### **Modified Mock-up – “Cup and String”**

Our third mock-up was constructed out of cardboard, a coat hanger, masking tape, foam, paper plates, string, a cup, and acrylic paint. It is an inverted version of our final design where motors mounted to the pulleys would pull the user’s hand, which would rest inside the central tube, in the x- and y- directions. Using this, we were able to examine the feasibility of such a design. We were able to determine that the strings or cables cannot be a constant length because of the geometry of the motion along a spherical motion like a bowl. Therefore, we decided that we either had to have the pulleys adjust the length of string such as using capstans or to go with a simpler geometry.



### Modified Mock-up – “Inverted Pendulum”

Our final mock-up was constructed out of a pizza box, cardboard, masking tape, string, and fasteners. It is basically an inverted pendulum which is connected to the base with a pivot and four strings for support. This model allowed us to explore the geometry of our final design before we created our prototype. We were able to make more accurate estimations for how large we should make the prototype beforehand. We were also able to feel how the user’s hand would move with a centralized pivot point.



## APPENDIX C – QUANTITATIVE ANALYSIS

The following are excerpts from our force analysis. The tables show how the forces and dimensions change as the prototype moves from its starting position to its maximum position in one dimension.

Parameter	Variable	Value	
<i>Displacement (Inches)</i>	$\delta$	0.00	
<i>theta 1 (radians, degrees)</i>	$\theta 1$	0.96	55
<i>theta 2 (radians, degrees)</i>	$\theta 2$	0.96	55
<i>theta 3 (radians, degrees)</i>	$\theta 3$	1.57	90
<i>Rod Length (Inches)</i>	L	8.50	
<i>Distance Travelled (Inches)</i>	d	0.00	
<i>Tension Force (lbs)</i>		0.00	
<i>Pivot Arm Force (lbs)</i>		10.00	
<i>Arm Weight (lbs)</i>	M	10.00	
<i>Base Width (inches)</i>	W	12.00	
<i>Torque (in-lbs, in-oz)</i>	T	0.00	0.00
<i>Radius (inches)</i>	r	0.50	
<i>Height of Base (inches)</i>	h	2.00	
<i>Left String Length (inches)</i>		10.40	
<i>Right String Length (inches)</i>		10.40	

**Table 9: The table shows a summary of our calculations when the distance traveled is set to 0 inches. At this position, the tension force is equal to zero and all of the weight is supported by the pivot arm.**

Parameter	Variable	Value	
<i>Displacement (Inches)</i>	$\delta$	1.00	
<i>theta 1 (radians, degrees)</i>	$\theta 1$	0.64	37
<i>theta 2 (radians, degrees)</i>	$\theta 2$	1.31	75
<i>theta 3 (radians, degrees)</i>	$\theta 3$	1.08	62
<i>Rod Length (Inches)</i>	L	8.50	
<i>Distance Traveled (Inches)</i>	d	4.00	
<i>Tension Force (lbs)</i>		11.11	
<i>Pivot Arm Force (lbs)</i>		18.89	

<i>Arm Weight (lbs)</i>	M	10.00	
<i>Base Width (inches)</i>	W	12.00	
<i>Torque (in-lbs, in-oz)</i>	T	5.56	88.89
<i>Radius (inches)</i>	r	0.50	
<i>Height of Base (inches)</i>	h	2.00	
<i>Left String Length (inches)</i>		12.50	
<i>Right String Length (inches)</i>		7.76	

**Table 10: The table shows a summary of our calculations when the distance traveled is set to 4 inches. At this position, the tension force is longer equal to zero.**

# APPENDIX D – MOTOR DATA SHEET



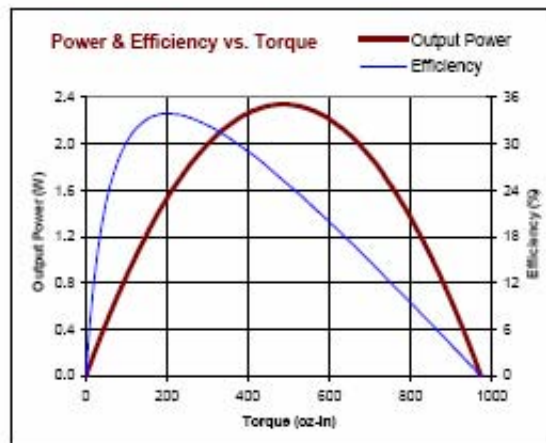
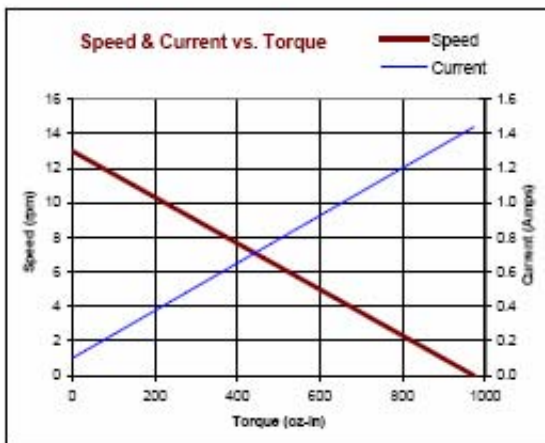
## GM9413-4

Lo-Cog® DC Gearmotor

Assembly Data	Symbol	Units	Value	
Reference Voltage	E	V	12	
No-Load Speed	$S_{NL}$	rpm (rad/s)	13	(1.4)
Continuous Torque (Max.) <sup>1</sup>	$T_C$	oz-in (N-m)	175	(1.2E+00)
Peak Torque (Stall) <sup>2</sup>	$T_{PK}$	oz-in (N-m)	873	(6.9E+00)
Weight	$W_M$	oz (g)	16.0	(452)
Motor Data				
Torque Constant	$K_T$	oz-in/A (N-m/A)	5.60	(3.9E-02)
Back-EMF Constant	$K_E$	V/krpm (V/rad/s)	4.14	(3.9E-02)
Resistance	$R_T$	$\Omega$	8.33	
Inductance	L	mH	6.17	
No-Load Current	$I_{NL}$	A	0.10	
Peak Current (Stall) <sup>2</sup>	$I_P$	A	1.44	
Motor Constant	$K_M$	oz-in/√W (N-m/√W)	1.94	(1.37E-02)
Friction Torque	$T_F$	oz-in (N-m)	0.50	(3.5E-03)
Rotor Inertia	$J_M$	oz-in-s <sup>2</sup> (kg-m <sup>2</sup> )	3.9E-04	(2.8E-06)
Electrical Time Constant	$\tau_E$	ms	0.74	
Mechanical Time Constant	$\tau_M$	ms	14.7	
Viscous Damping	D	oz-in/krpm (N-m-s)	0.011	(7.6E-07)
Damping Constant	$K_D$	oz-in/krpm (N-m-s)	2.8	(1.9E-04)
Maximum Winding Temperature	$\theta_{MAX}$	°F (°C)	311	(155)
Thermal Impedance	$R_{TH}$	°F/watt (°C/watt)	66.4	(19.1)
Thermal Time Constant	$\tau_{TH}$	min	11.1	
Gearbox Data				
Reduction Ratio			216.4	
Efficiency			0.59	
Maximum Allowable Torque		oz-in (N-m)	175	(1.24)
Encoder Data				

- Included Features**
- 2-Pole Stator
  - Ceramic Magnets
  - Heavy-Gauge Steel Housing
  - 7-Slot Armature
  - Silicon Steel Laminations
  - Stainless Steel Shaft
  - Copper-Graphite Brushes
  - Diamond Tumed Commutator
  - Motor Sleeve Bearings
  - Output Sleeve Bearing
  - Standard Gears
- Customization Options**
- Alternate Winding
  - Sleeve or Ball Bearings
  - Modified Output Shaft
  - Custom Cable Assembly
  - Special Brushes
  - EMI/RFI Suppression
  - Alternate Gear Material
  - Special Lubricant
  - Optional Encoder
  - Fail-Safe Brake

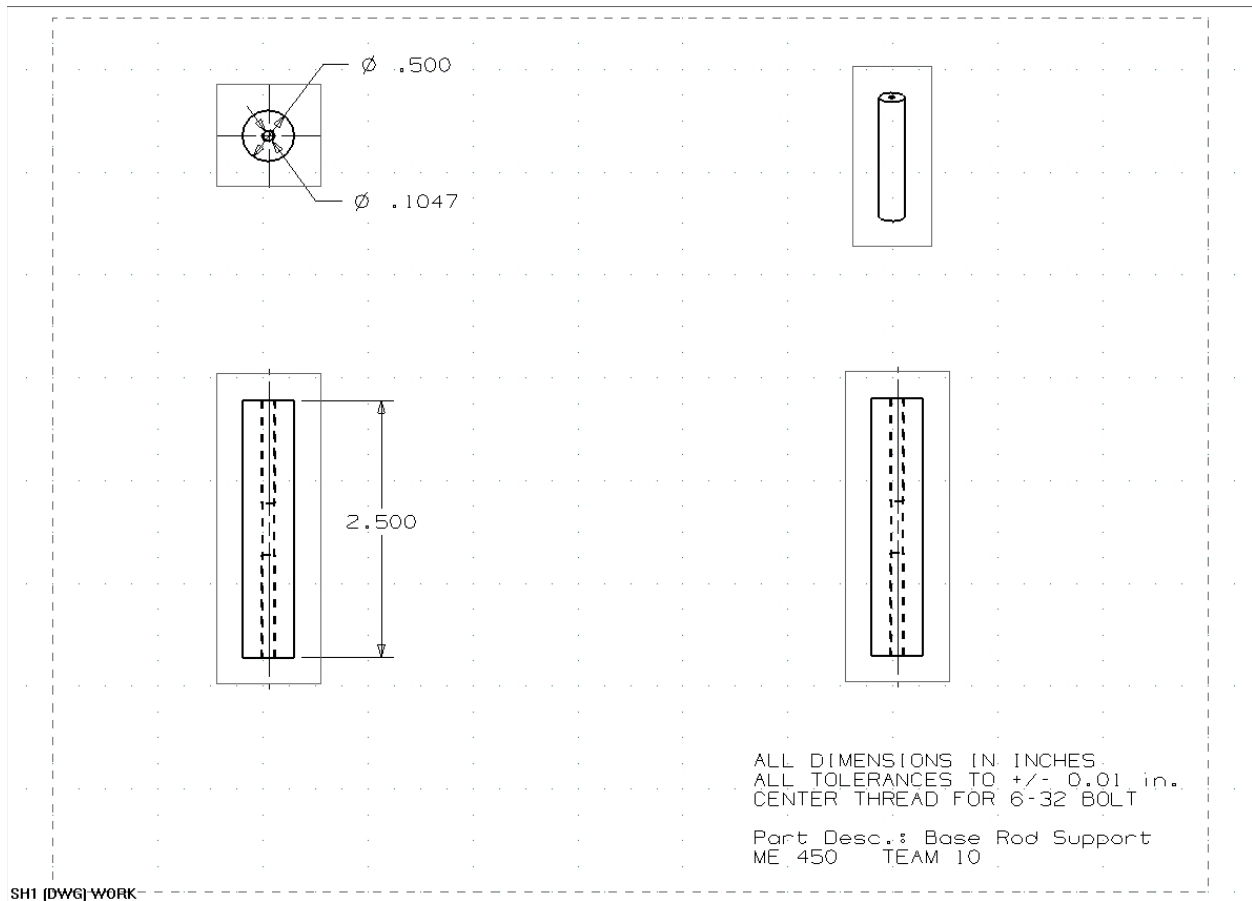
1 - Specified at max. winding temperature at 25°C ambient without heat sink. 2 - Theoretical values supplied for reference only.



All values are nominal. Specifications subject to change without notice. Graphs are shown for reference only.

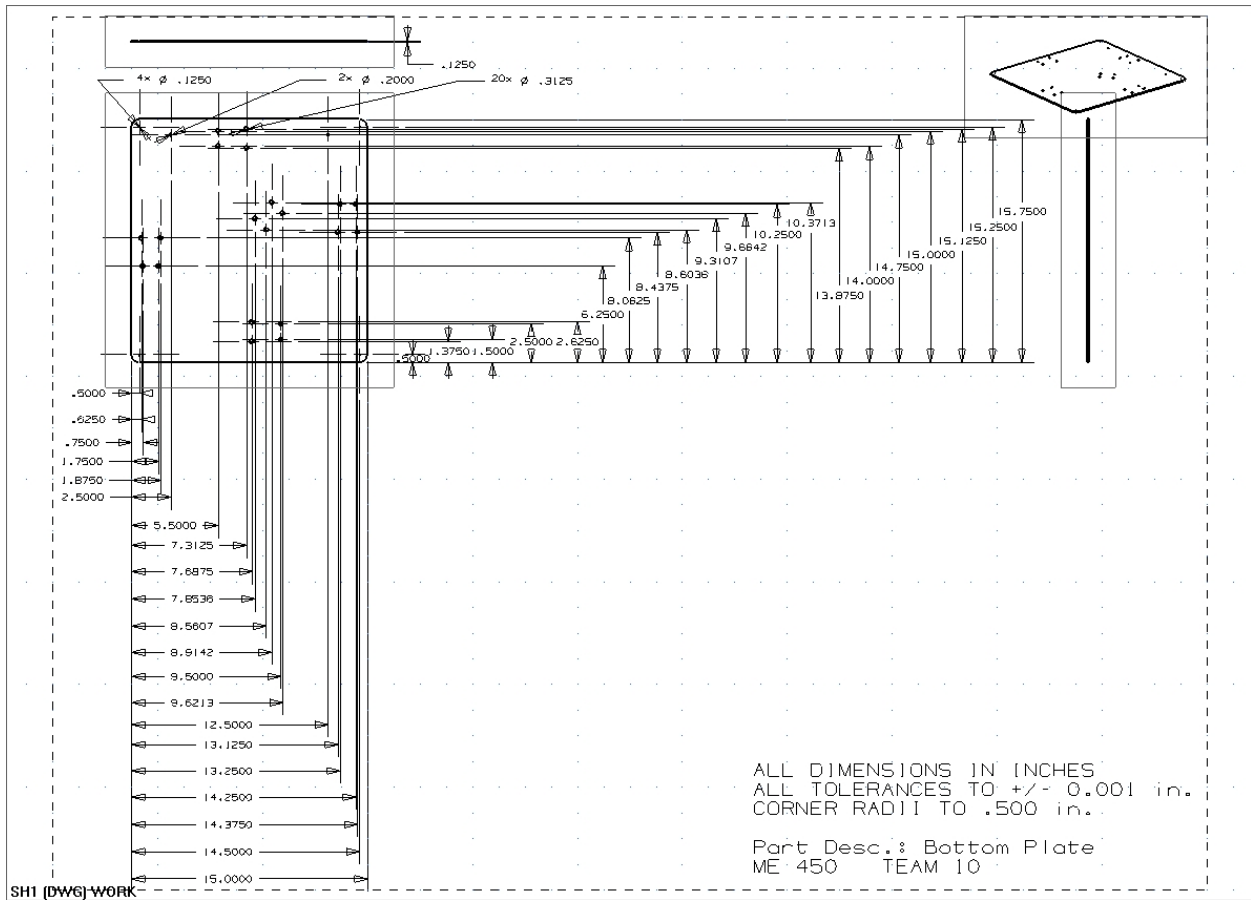
© 2001 Pittman.

## APPENDIX E – DIMENSIONED DRAWINGS AND PROCESS PLANS



<b>Part Name:</b>	<b>Base Rod Support</b>
<b>Raw Material:</b>	<b>Aluminum Rod - 0.5" x 3"</b>

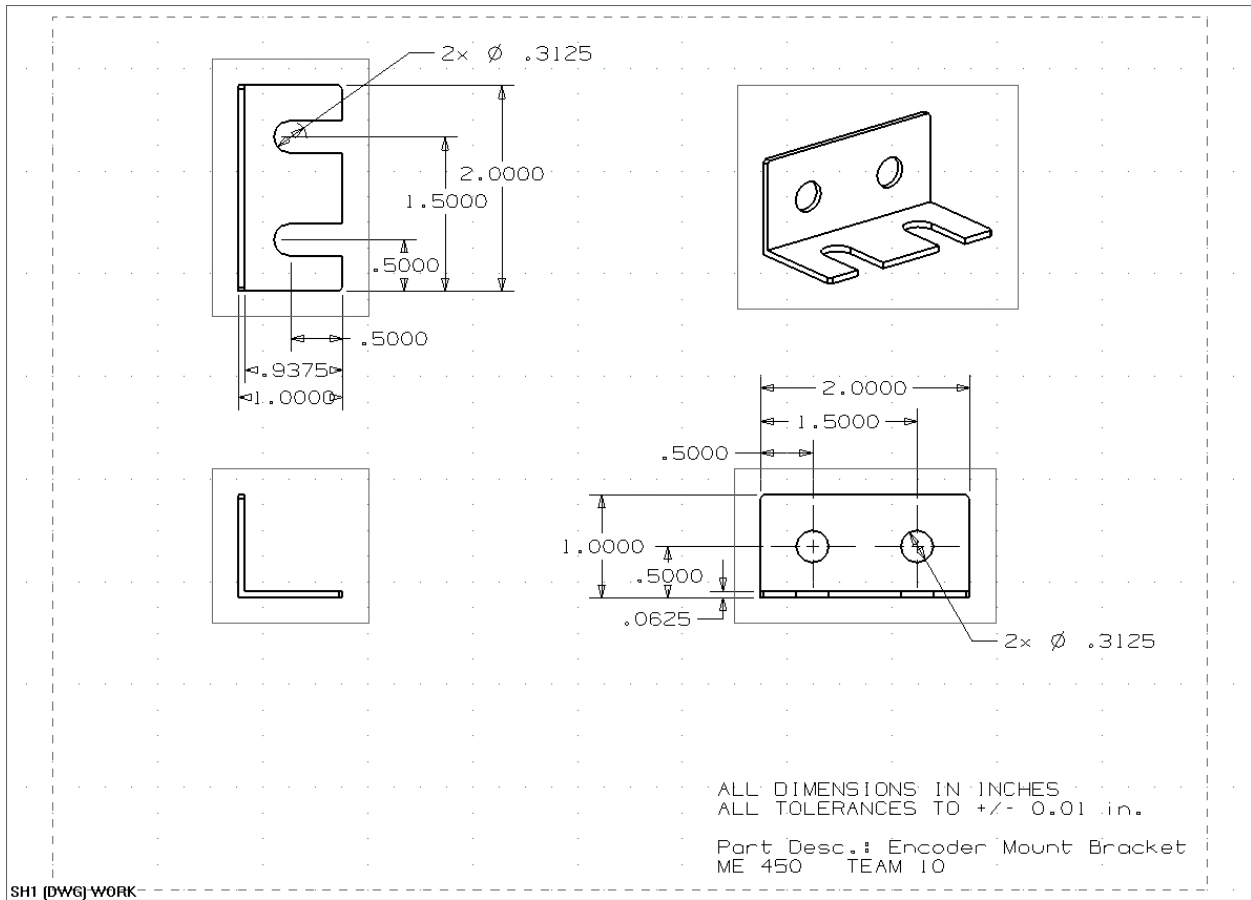
#	Process Description	Machine	Speed	Tool	Fixtures	Est. Time
1	Cut to rough length >2.5"	Band Saw	300 FPM	Band Saw	Vice	1 min
2	Face one end	Lathe	1200 RPM	Facing Tool	3 Jaw Chuck	5 min
3	Make 0.1" diameter hole	Lathe	800 RPM	0.1" Drill Bit	3 Jaw Chuck	5 min
4	Tap hole for 6-32 bolt	Lathe	0 RPM	6-32 Tap	3 Jaw Chuck	5 min
5	Face other end to 2.5"	Lathe	1200 RPM	Facing Tool	3 Jaw Chuck	5 min
6	Make 0.1" diameter hole	Lathe	800 RPM	0.1" Drill Bit	3 Jaw Chuck	5 min
7	Tap hole for 6-32 bolt	Lathe	0 RPM	6-32 Tap	3 Jaw Chuck	5 min



<b>Part Name:</b>	<b>Bottom Plate</b>
<b>Raw Material:</b>	<b>Aluminum Plate - 16" x 16" x 0.125"</b>

#	Process Description	Machine	Speed	Tool	Fixtures	Est. Time
1	Cut to size - 15" x 15.75"	Band Saw	300 FPM	Band Saw	None	10 min
2	Drill support holes	Drill Press	1000 RPM	0.125" Drill Bit	Clamp	5 min
3	Drill wire holder holes	Drill Press	1000 RPM	0.2" Drill Bit	Clamp	5 min
4	Drill placement holes	Drill Press	1000 RPM	0.3125" Drill Bit	Clamp	20 min
5	Round corner edges	None	None	Metal File	None	20 min

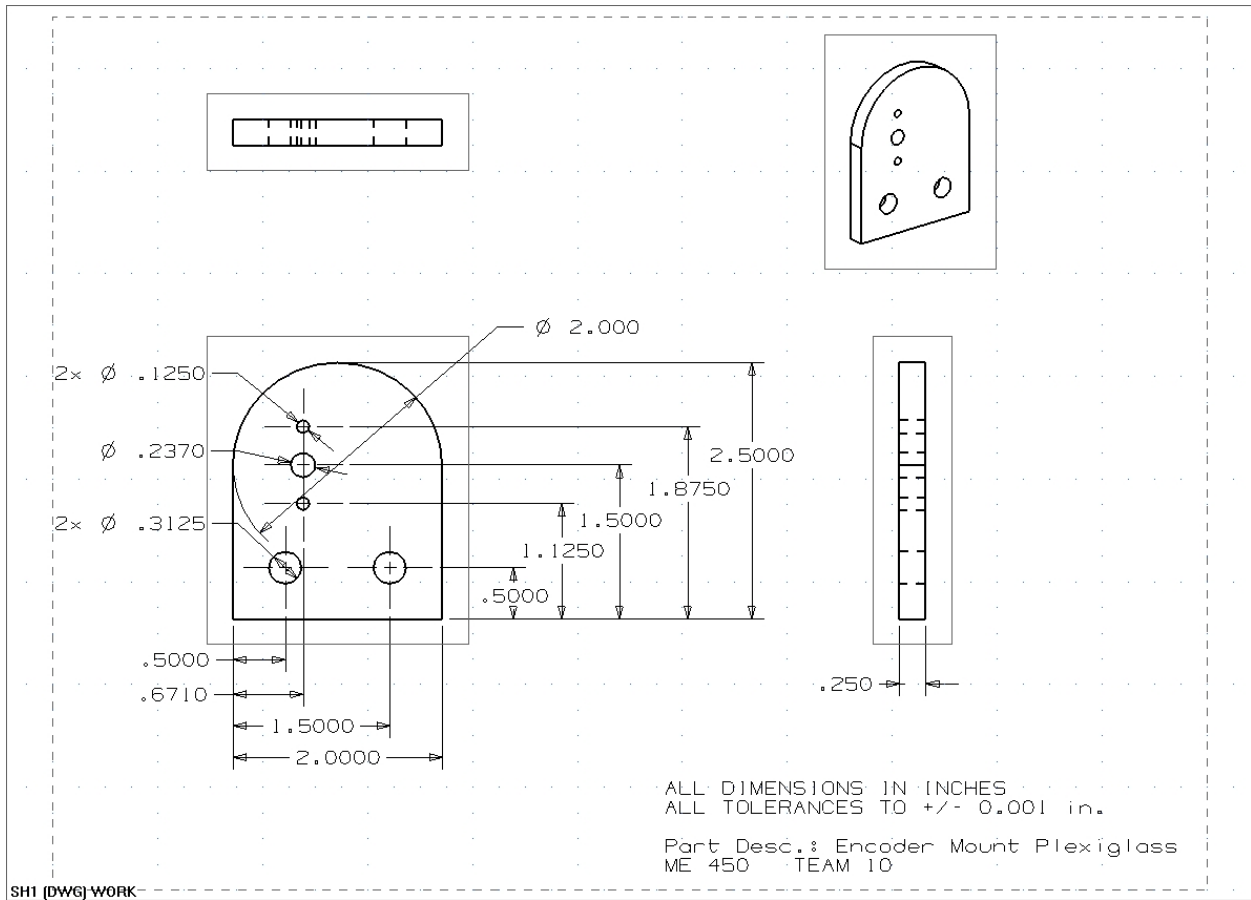




SH1 (DWG) WORK

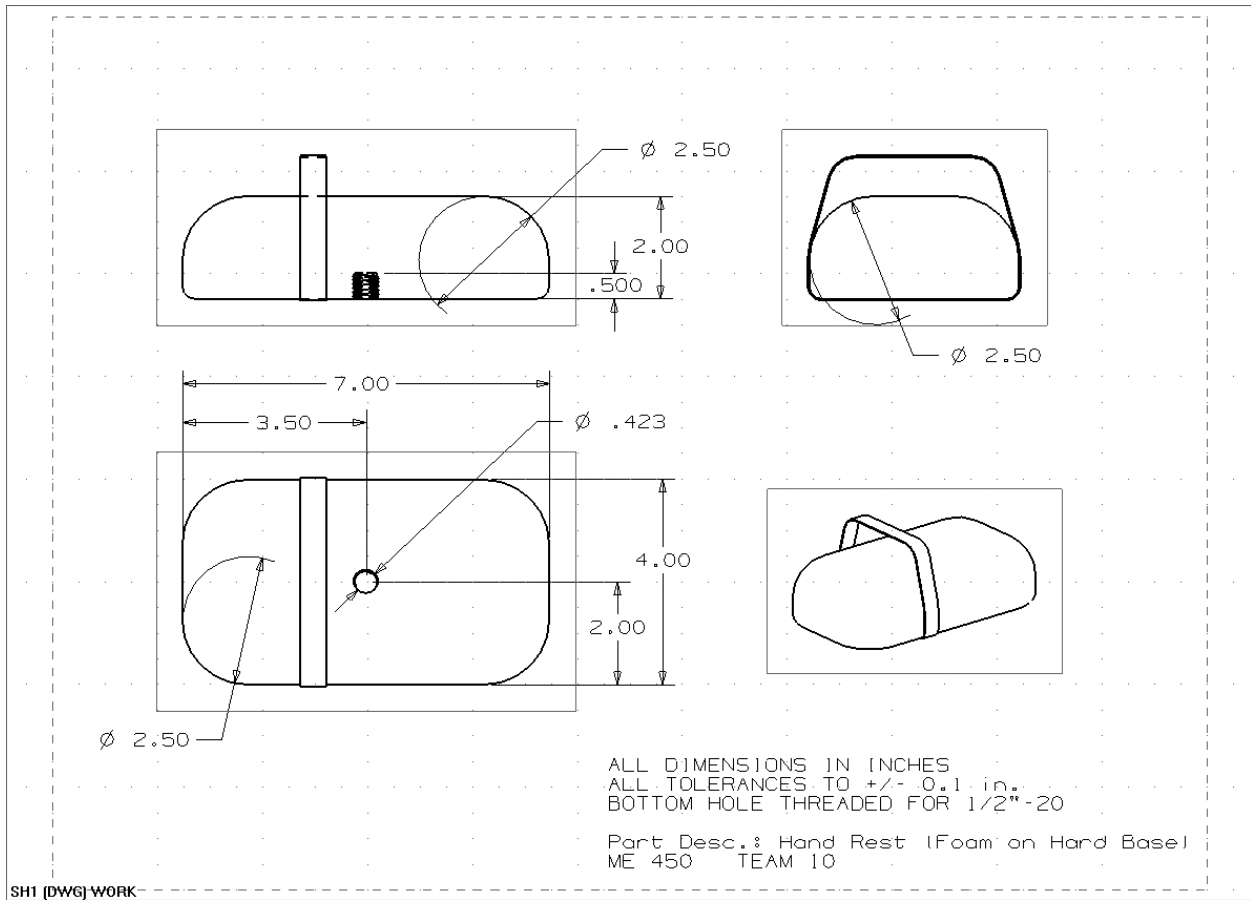
<b>Part Name:</b>	<b>Encoder Mount Bracket</b>
<b>Raw Material:</b>	<b>Aluminum L Bar - 1" x 1"</b>

#	Process Description	Machine	Speed	Tool	Fixtures	Est. Time
1	Cut to length - 2"	Band Saw	300 FPM	Band Saw	Vice	2 min
2	Drill 0.3125" holes	Drill Press	1000 RPM	0.3125" Drill Bit	Vice	5 min
3	Mill 0.3125" slot	Mill	1000 RPM	0.3125" End Mill	Vice	5 min
5	Round corner edges	None	None	Metal File	None	3 min



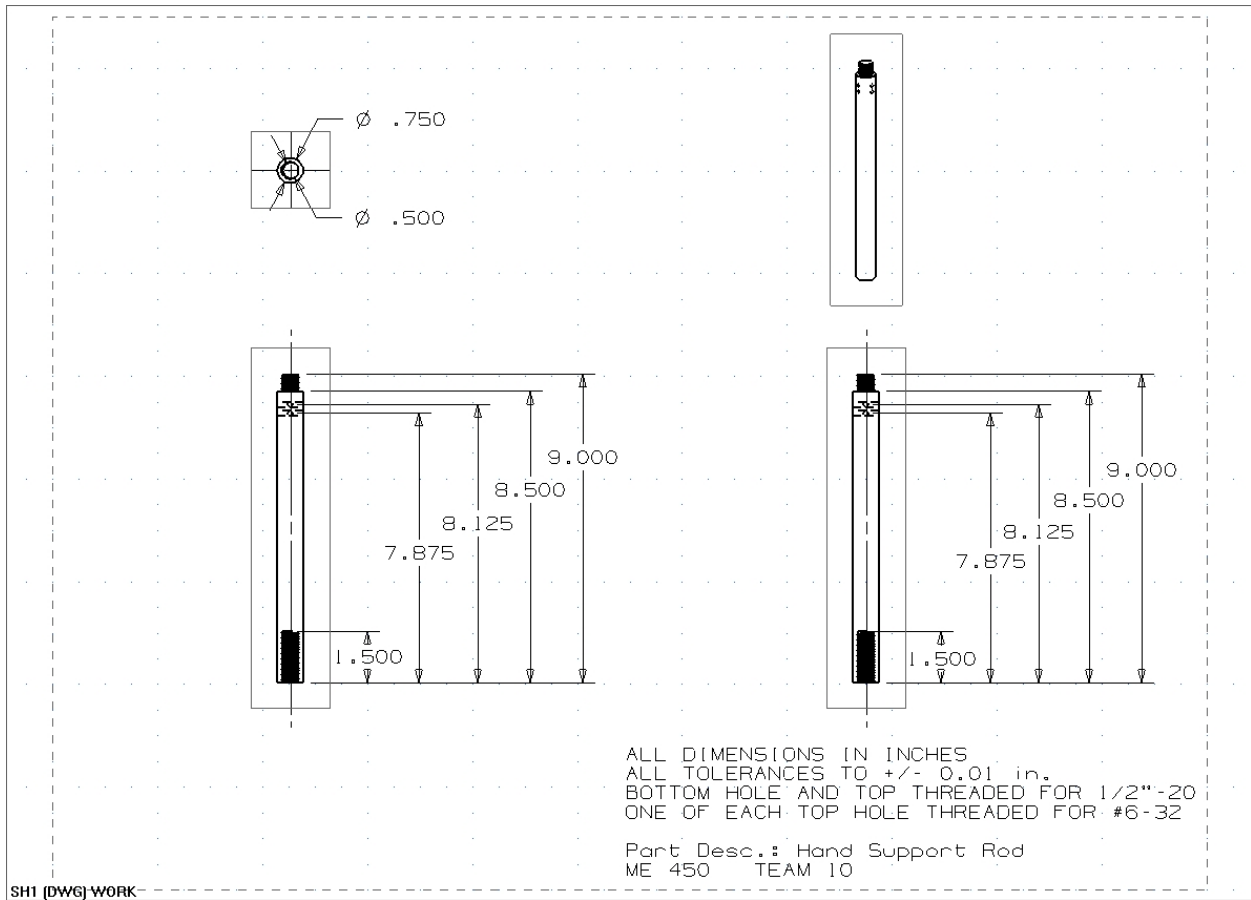
<b>Part Name:</b>	<b>Encoder Mount Plexiglass</b>
<b>Raw Material:</b>	<b>Plexiglass - 2.5" x 3" x 0.25"</b>

#	Process Description	Machine	Speed	Tool	Fixtures	Est. Time
1	Laser cut using BobCAD	Laser Cutter	50%	CO2 Laser	None	3 min



<b>Part Name:</b>	<b>Hand Rest</b>
<b>Raw Material:</b>	<b>PVC Block - 3" x 3" x 0.5" + Foam Block</b>

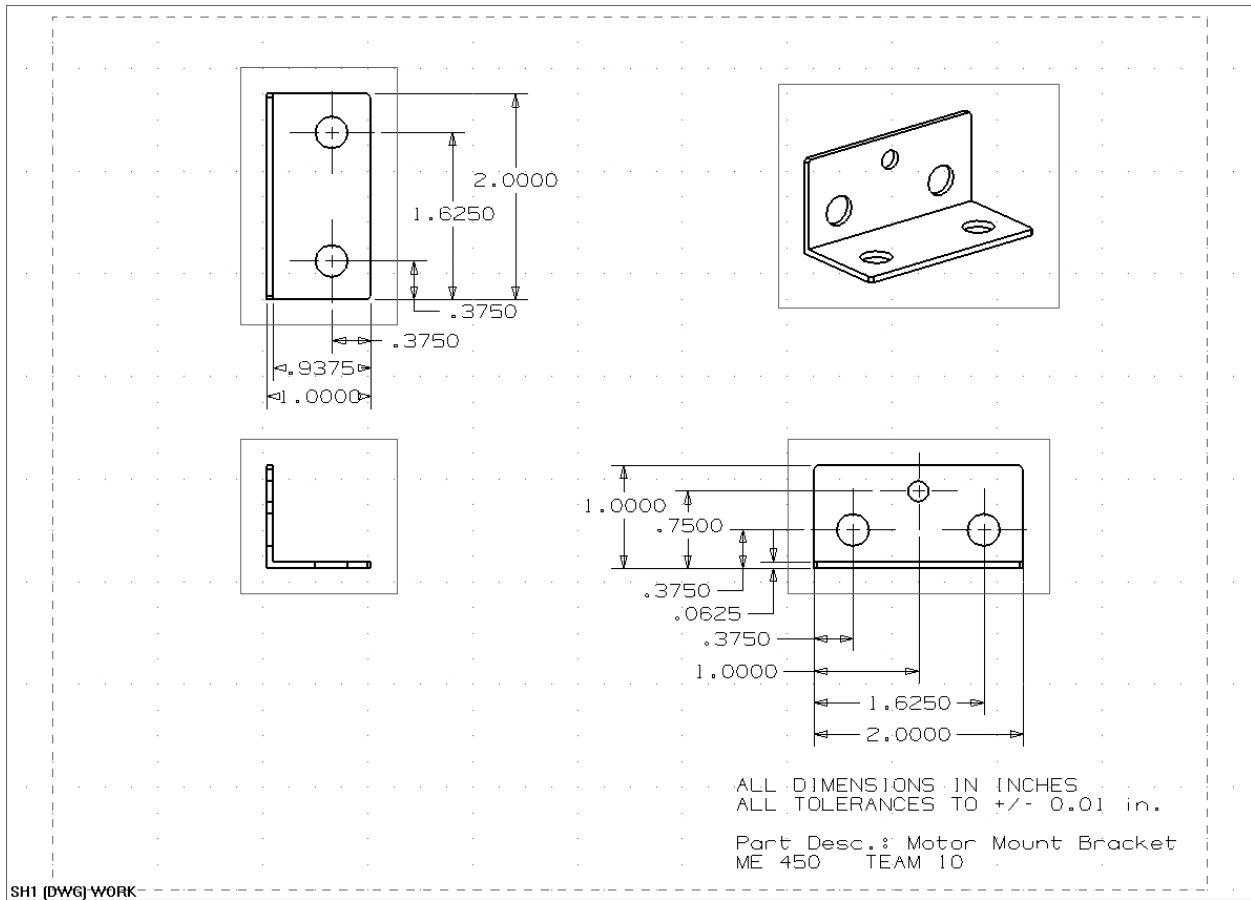
#	Process Description	Machine	Speed	Tool	Fixtures	Est. Time
1	Drill 29/64" hole in PVC	Drill Press	1000 RPM	29/64" Drill Bit	Vice	2 min
2	Tap hole for 1/2"-20 bolt	None	None	1/2"-20 Tap	Vice	5 min
3	Shape foam to hand	None	None	Scissors	None	10 min
4	Mount foam on PVC block	None	None	Epoxy	None	5 min
5	Cover foam with padding	None	None	Fabric Glue	None	20 min
6	Cover padding with cloth	None	None	Sewing needle	None	30 min
7	Adhere velcro straps to cloth	None	None	Adhesive	None	10 min



SH1 (DWG) WORK

<b>Part Name:</b>	<b>Hand Support Rod</b>
<b>Raw Material:</b>	<b>Aluminum Rod - 1" x 12"</b>

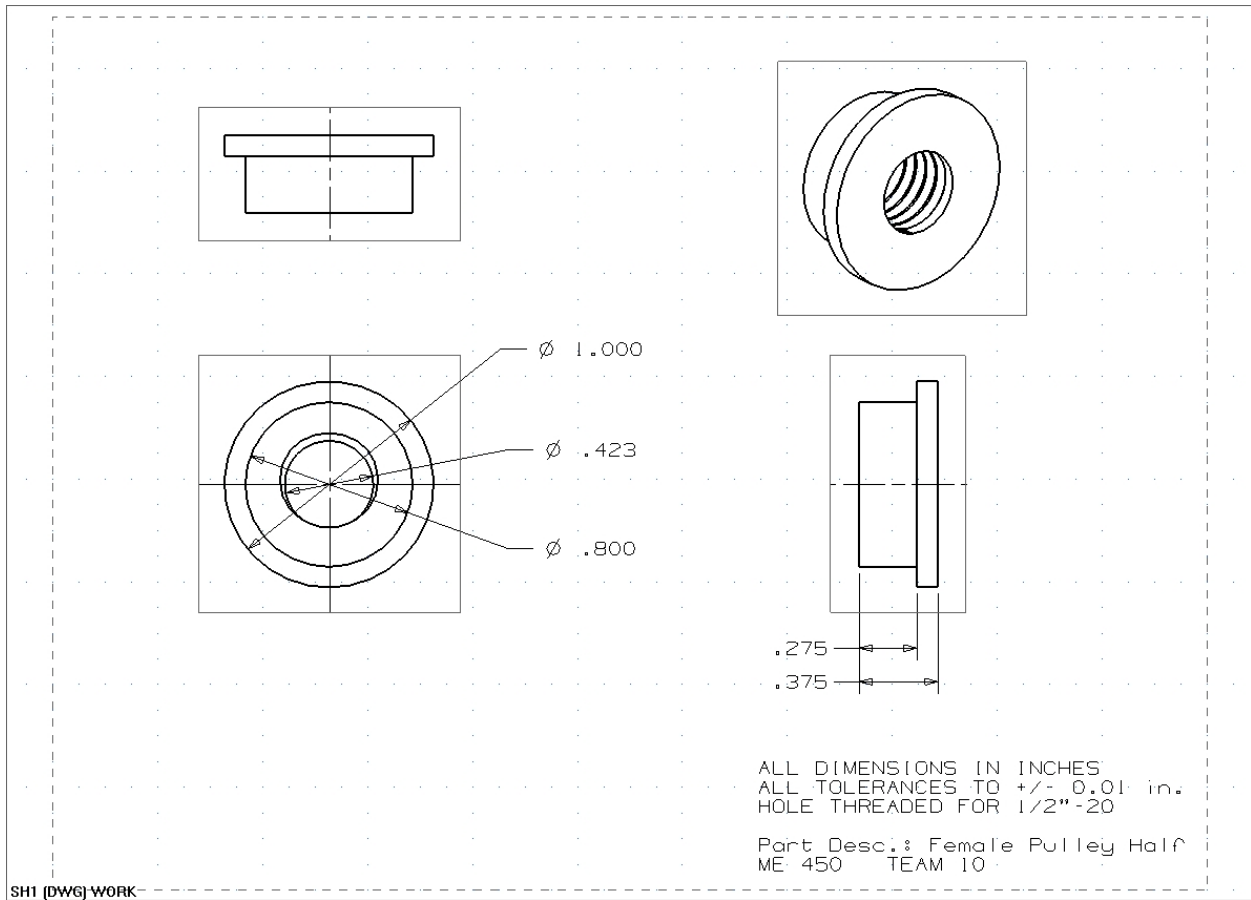
#	Process Description	Machine	Speed	Tool	Fixtures	Est. Time
1	Cut to rough length >9"	Band Saw	300 FPM	Band Saw	Vice	2 min
2	Face one end	Lathe	1200 RPM	Facing Tool	3 Jaw Chuck	5 min
3	Turn down to 3/4" diameter	Lathe	1200 RPM	Turning Tool	3 Jaw Chuck	30 min
4	Make 29/64" diameter hole	Lathe	800 RPM	29/64" Drill Bit	3 Jaw Chuck	5 min
5	Tap hole for 1/2"-20 bolt	Lathe	0 RPM	1/2"-20 Tap	3 Jaw Chuck	10 min
6	Face other end to length of 9"	Lathe	1200 RPM	Facing Tool	3 Jaw Chuck	10 min
7	Turn down end to 1/2"	Lathe	1200 RPM	Turning Tool	3 Jaw Chuck	10 min
8	Thread end for 1/2"-10 nut	Lathe	0 RPM	1/2"-20 Threader	3 Jaw Chuck	10 min
9	Drill set screw and open holes	Mill	1000 RPM	#29 Drill Bit	Vice	10 min
10	Tap set screw holes for #8-32	None	None	#8-32 Tap	Vice	10 min



<b>Part Name:</b>	<b>Motor Mount Bracket</b>
<b>Raw Material:</b>	<b>Aluminum L Bar - 1" x 1"</b>

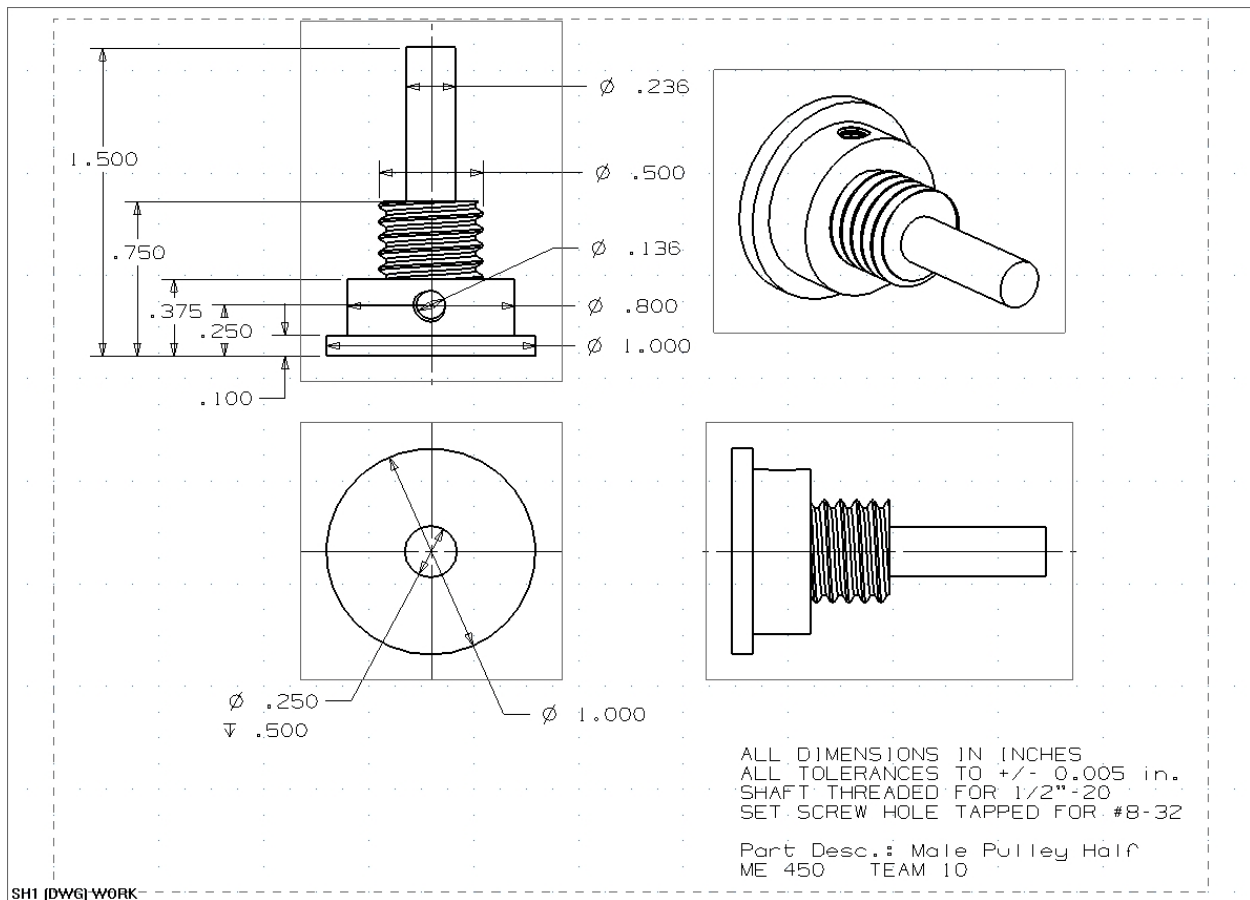
#	Process Description	Machine	Speed	Tool	Fixtures	Est. Time
1	Cut to length - 2"	Band Saw	300 FPM	Band Saw	Vice	2 min
2	Drill 0.3125" holes	Drill Press	1000 RPM	0.3125" Drill Bit	Vice	5 min
2	Drill 0.2" holes	Drill Press	1000 RPM	0.2" Drill Bit	Vice	2 min
5	Round corner edges	None	None	Metal File	None	3 min





<b>Part Name:</b>	<b>Female Pulley Half</b>
<b>Raw Material:</b>	<b>Aluminum Rod - 1" x 12"</b>

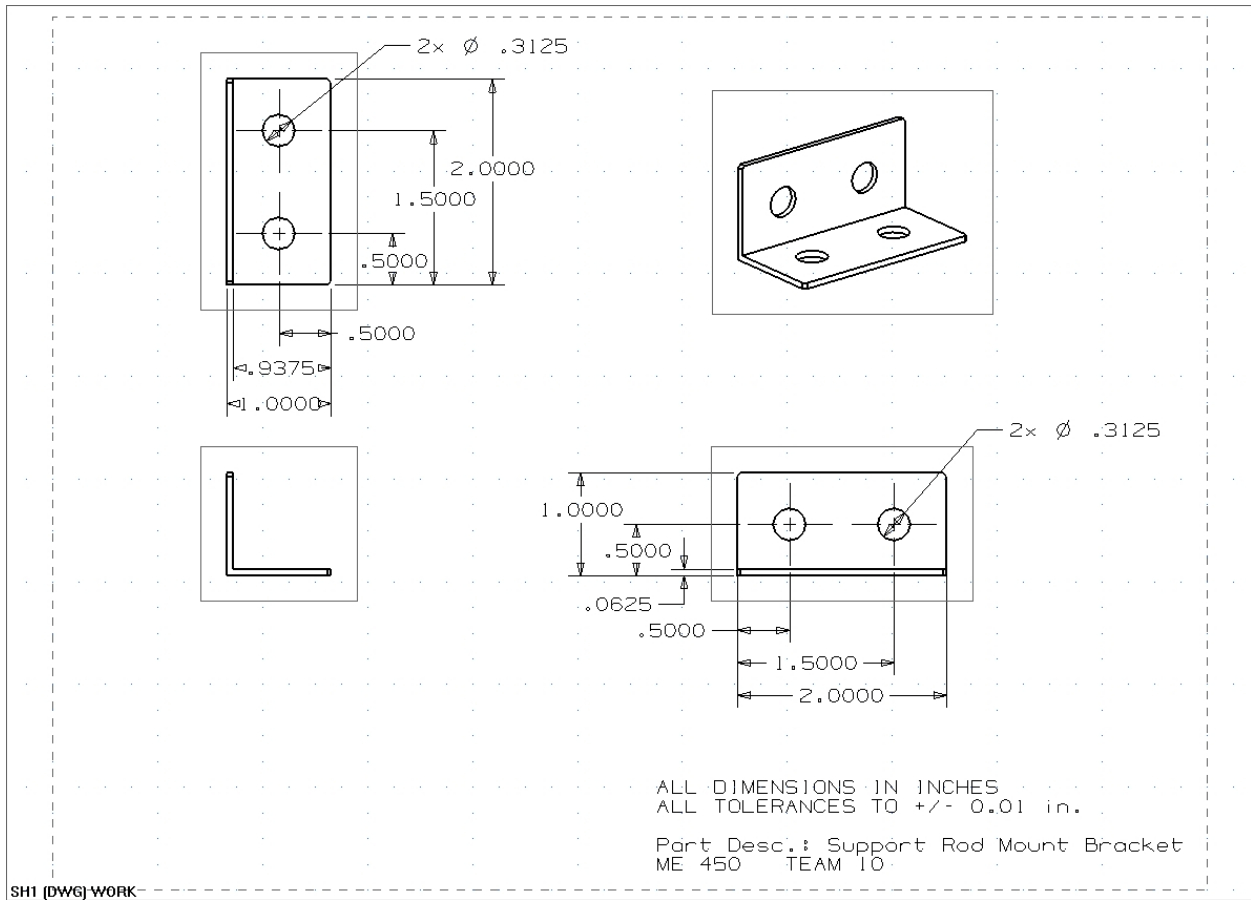
#	Process Description	Machine	Speed	Tool	Fixtures	Est. Time
1	Face one end	Lathe	1200 RPM	Facing Tool	3 Jaw Chuck	5 min
2	Turn down to 0.8" diameter	Lathe	1200 RPM	Turning Tool	3 Jaw Chuck	10 min
3	Make 29/64" diameter hole	Lathe	800 RPM	29/64" Drill Bit	3 Jaw Chuck	5 min
4	Tap hole for 1/2"-20 bolt	Lathe	0 RPM	1/2"-20 Tap	3 Jaw Chuck	10 min
5	Cut to rough length >0.375"	Band Saw	300 FPM	Band Saw	Vice	2 min
6	Face other end to length of 0.375"	Lathe	1200 RPM	Facing Tool	3 Jaw Chuck	10 min



<b>Part Name:</b>	<b>Male Pulley Half</b>
<b>Raw Material:</b>	<b>Aluminum Rod - 1" x 12"</b>

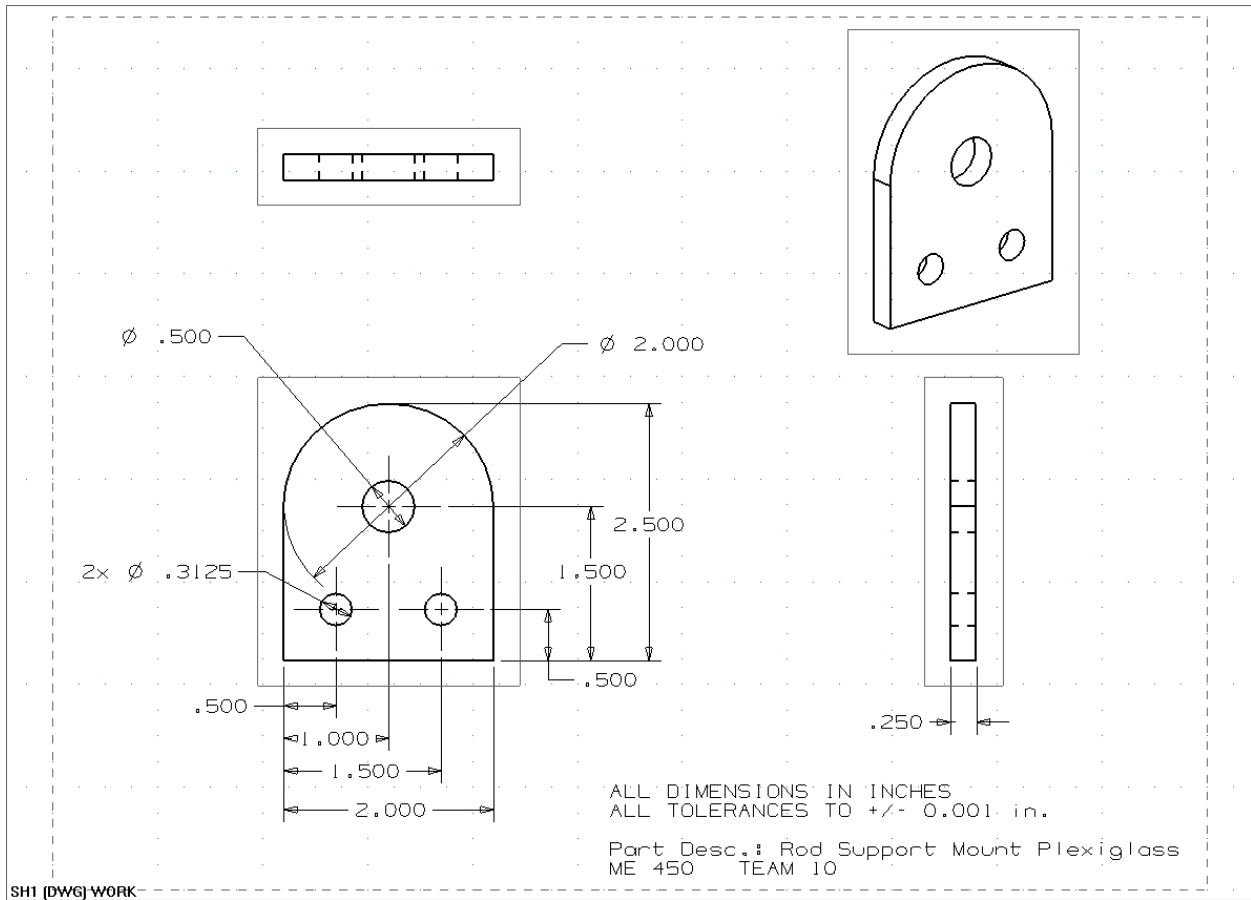
#	Process Description	Machine	Speed	Tool	Fixtures	Est. Time
1	Face one end	Lathe	1200 RPM	Facing Tool	3 Jaw Chuck	5 min
2	Turn down to 0.8" diameter	Lathe	1200 RPM	Turning Tool	3 Jaw Chuck	10 min
3	Turn down to 0.5" diameter	Lathe	1200 RPM	Turning Tool	3 Jaw Chuck	10 min
4	Turn down to 0.236" diameter	Lathe	1200 RPM	Turning Tool	3 Jaw Chuck	10 min
5	Make threads for 1/2"-20 nut	Lathe	0 RPM	1/2"-20 Threader	3 Jaw Chuck	10 min
6	Cut to rough length >0.75"	Band Saw	300 FPM	Band Saw	Vice	2 min
7	Face other end to length of 0.75"	Lathe	1200 RPM	Facing Tool	3 Jaw Chuck	10 min
8	Drill 0.25" hole	Lathe	800 RPM	0.25" Drill Bit	3 Jaw Chuck	10 min
9	Drill set screw hole	Mill	1000 RPM	#29 Drill Bit	Vice	5 min
10	Tap hole for #8-32 set screw	None	None	#8-32 Tap	Vice	5 min





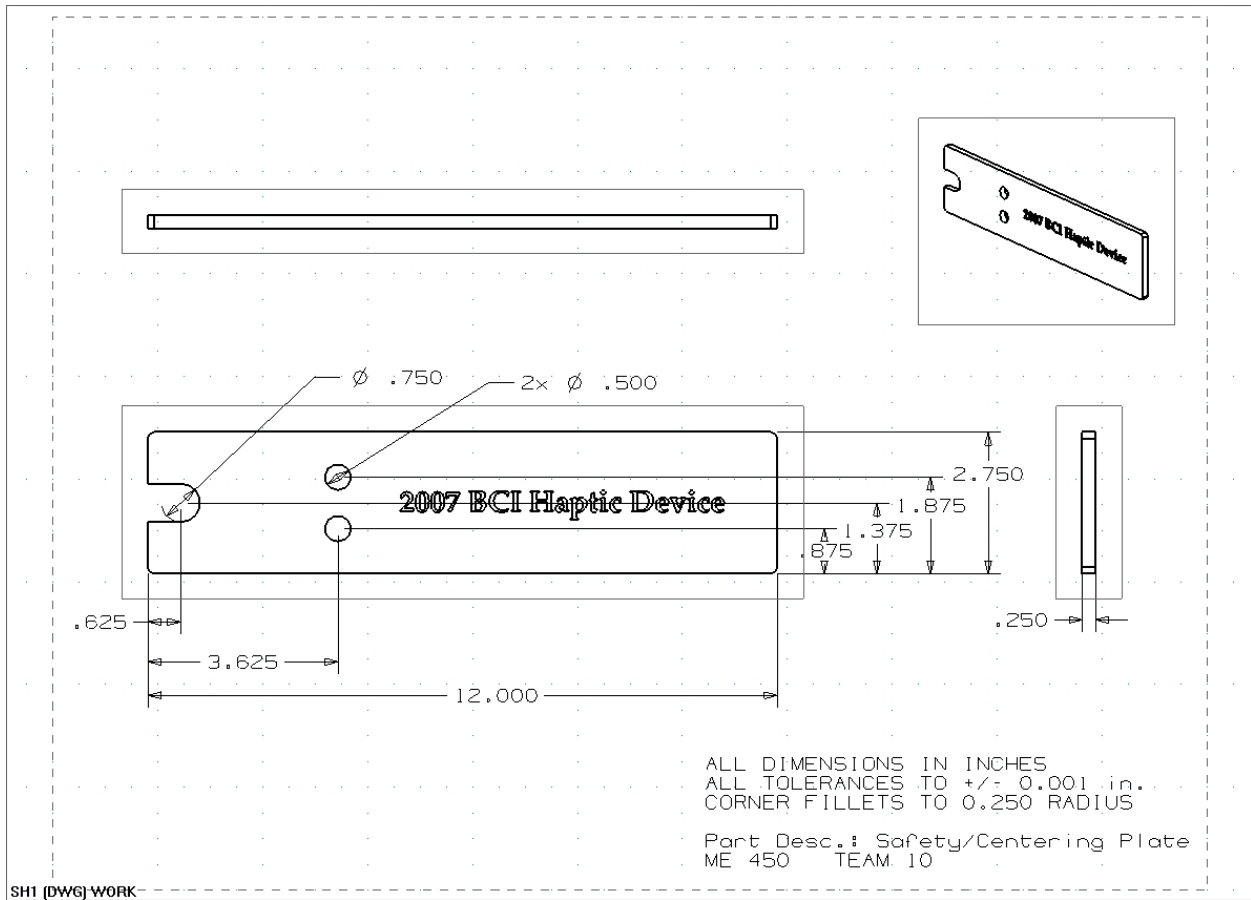
<b>Part Name:</b>	<b>Support Rod Mount Bracket</b>
<b>Raw Material:</b>	<b>Aluminum L Bar - 1" x 1"</b>

#	Process Description	Machine	Speed	Tool	Fixtures	Est. Time
1	Cut to length - 2"	Band Saw	300 FPM	Band Saw	Vice	2 min
2	Drill 0.3125" holes	Drill Press	1000 RPM	0.3125" Drill Bit	Vice	5 min
5	Round corner edges	None	None	Metal File	None	3 min



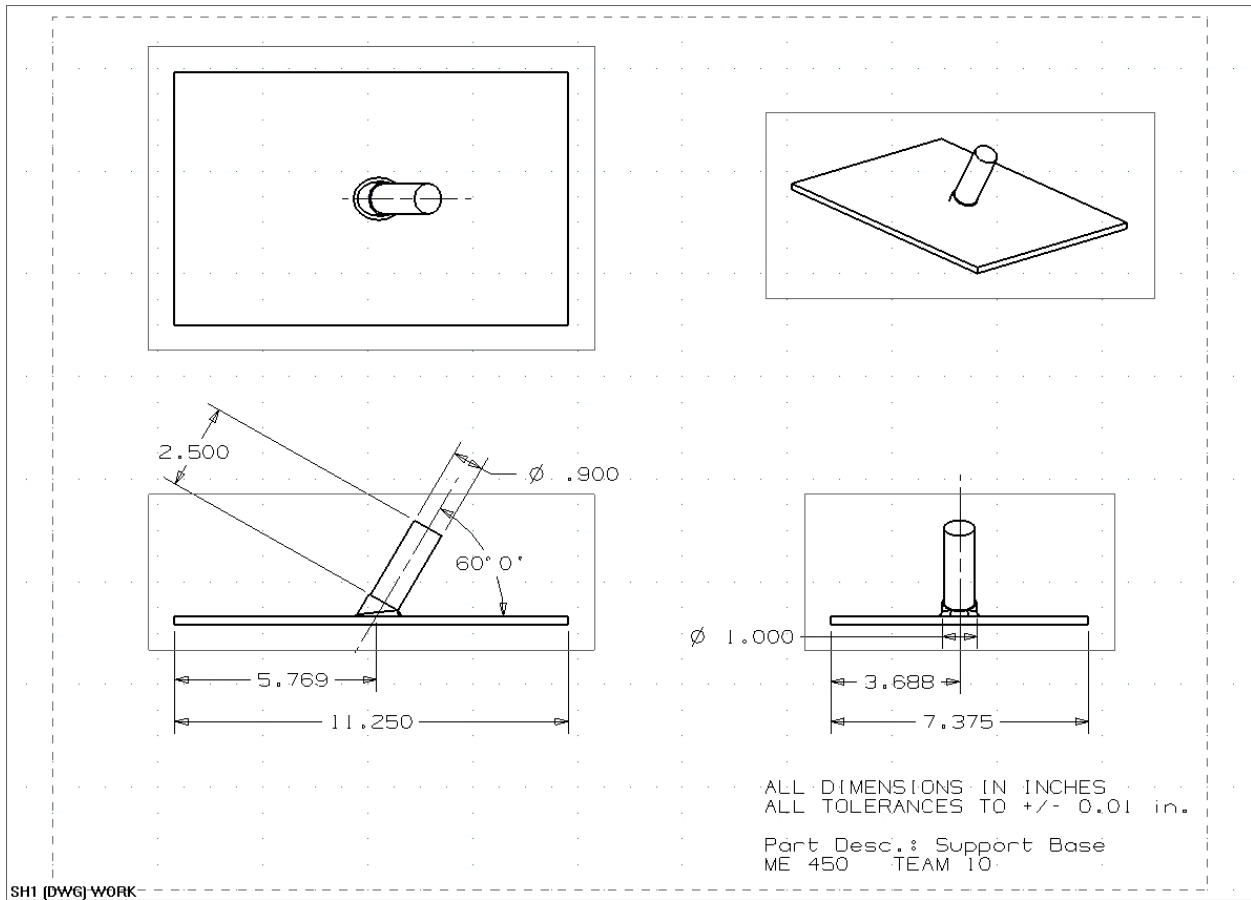
<b>Part Name:</b>	<b>Rod Support Mount Plexiglass</b>
<b>Raw Material:</b>	<b>Plexiglass - 2.5" x 3" x 0.25"</b>

#	Process Description	Machine	Speed	Tool	Fixtures	Est. Time
1	Laser cut using BobCAD	Laser Cutter	50%	CO2 Laser	None	3 min



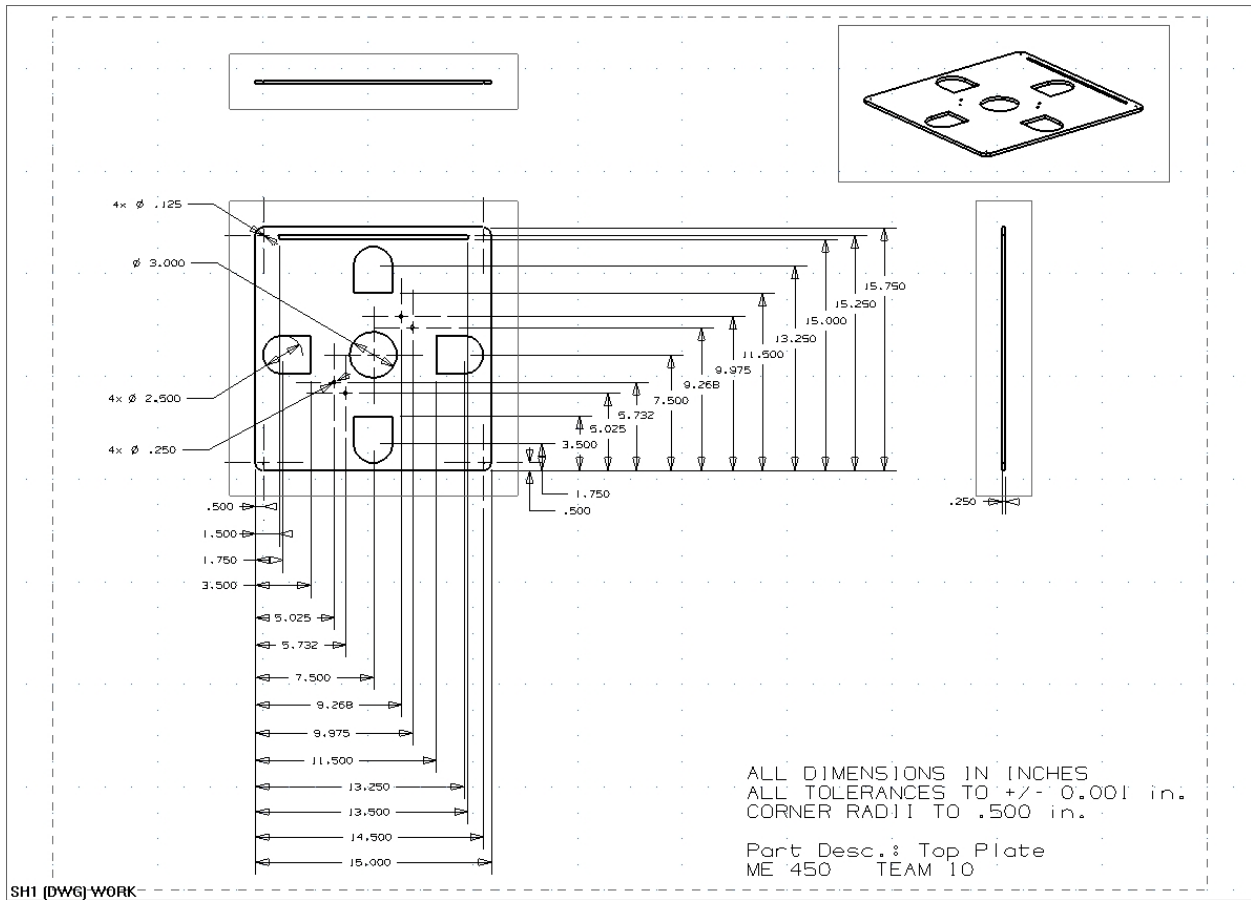
<b>Part Name:</b>	<b>Safety / Centering Plate</b>
<b>Raw Material:</b>	<b>Plexiglass - 12.5" x 3" x 0.25"</b>

#	Process Description	Machine	Speed	Tool	Fixtures	Est. Time
1	Laser cut using BobCAD	Laser Cutter	50%	CO2 Laser	None	6 min
2	Laser etch using BobCAD	Laser Cutter	90%	CO2 Laser	None	6 min



<b>Part Name:</b>	<b>Support Base</b>
<b>Raw Material:</b>	<b>Steel Plate - 0.25" + Steel Rod - 1"</b>

#	Process Description	Machine	Speed	Tool	Fixtures	Est. Time
1	Cut plate to 11.25" x 7.375"	Band Saw	200 FPM	Band Saw	None	10 min
2	Cut rod to length of 3"	Band Saw	200 FPM	Band Saw	Vice	5 min
3	Turn down rod to 0.9"	Lathe	800 RPM	Turning Tool	3 Jaw Chuck	15 min
4	Mill rod to 60°	Mill	600 RPM	1/2" End Mill	Vice	10 min
5	Weld rod to plate	Welder	None	Welder	Clamp	10 min
6	Round sharp edges	None	None	Metal File	None	20 min



<b>Part Name:</b>	<b>Top Plate</b>
<b>Raw Material:</b>	<b>Plexiglass - 16" x 16" x 0.25"</b>

#	Process Description	Machine	Speed	Tool	Fixtures	Est. Time
1	Laser cut using BobCAD	Laser Cutter	50%	CO2 Laser	None	10 min

## APPENDIX F – PICTORIAL SUMMARY OF PROJECT MANUFACTURING AND DESIGN EXPO

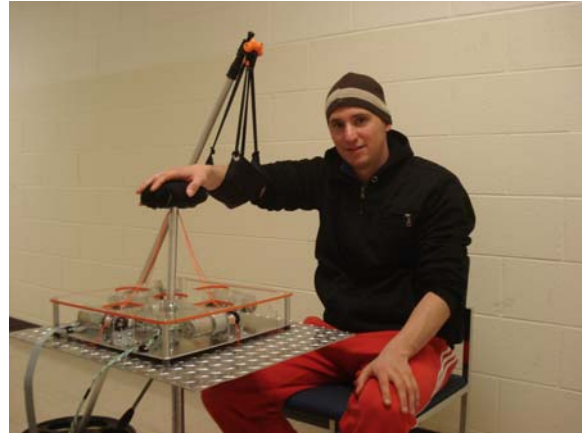
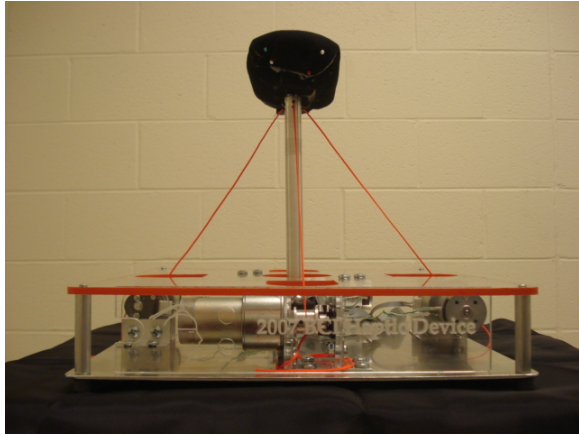
### Manufacturing the prototype



Machining the pulleys on the lathe and finished pulley.

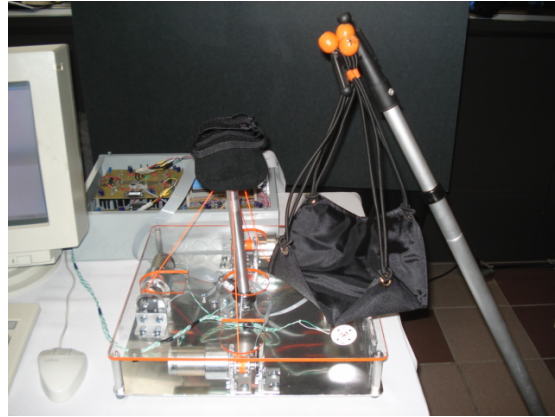
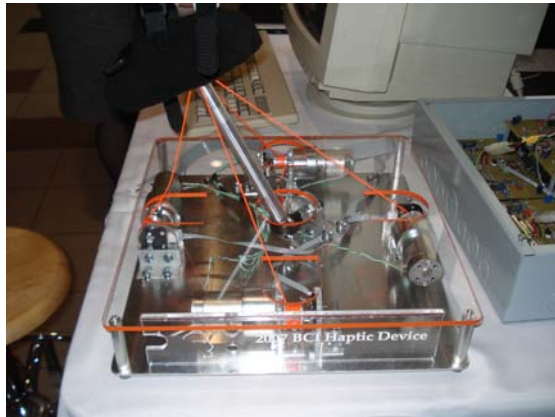


Laser-cut top and base plated and mounting brackets (left). Painting the top plate (right).



Finished prototype and first trial.

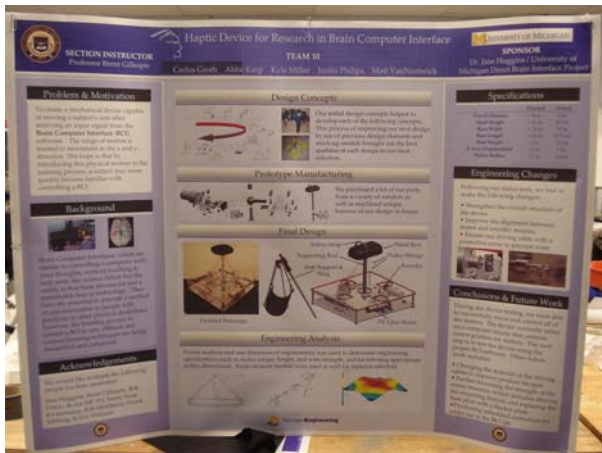
**At the Design Expo (April 12<sup>th</sup>, 2007)**



Our finalized prototype at the design expo (top). Engineering students enthusiastically trying out our haptic device.



Professors Brent Gillespie (left) and Suman Das (right) trying out our haptic device during the design expo presentation.



Project poster and table set up for the design expo.