

TEAM 19



Making Mobility

A Folding Tricycle Attachment for Standard Wheelchairs in Tanzania

Brian Holcomb, Alex Klonick, Michael Swift, and Michael Tran
Mentor: Mr. Amos Winter, Massachusetts Institute of Technology
Sponsor: Professor Kathleen Sienko , ME 450
University of Michigan
4/21/2009

Thousands of Tanzanians are unable to attend school, work, or participate in the community due to an immobilizing disability. Those lucky enough to have a wheelchair are frustrated by long trips across rough terrain. Hand-powered tricycles are easier for long trips but are too big to use inside or on a bus. The goal of this project is to produce a low-cost, foldable and stowable tricycle attachment for standard wheelchairs in collaboration with an MIT course. This hybrid design will allow users to travel freely between regions and more effectively function within their community.

EXECUTIVE SUMMARY

Current wheelchairs and hand-tricycles do not provide the affordable range of mobility required to participate fully in Tanzanian life. Wheelchairs are difficult to use to travel long distances on the rough terrain found in Tanzania and standalone hand-tricycles are too bulky for transit in cars, buses, and inside buildings. We have worked with Mr. Amos Winter at MIT to develop an easily foldable and stowable tricycle attachment for the Whirlwind Roughrider wheelchair. This attachment provides the long range and stability of a tricycle with the compact comfort of a folding wheelchair. The current MIT attachment design works but is not foldable and stowable. This is an issue when the user wants to travel long distances and does not have a place to put the attachment away after using it.

The key specifications include a folded width of 6 inches, 60 second attachment and detachment time, a gain ratio between the wheel and the hand cranks of about 1.6, and a weight of less than 25 pounds. These specifications were decided based upon literature research and engineering judgment based on comfort and practicality.

The concept chosen in our final design is a two-chain fold over drive system that stows beneath the wheelchair. The two chain system allows the steering column to fold in half while keeping tension in the chain system. Ideally in a two chain system, no chain tensioners are needed. An attachment arm folding system was also used in order to reduce the width down to 6 inches. This allows the user to more easily place the device past the legs and underneath the wheelchair while folded. The attachment arms simply slide and rest on top of the wheelchair cross brace.

In order to simulate the manufacturing environment in Tanzania, the prototype was created using only materials and processes available in Tanzania. The materials used were scrap bicycle parts, fasteners, and standard mild steel pieces. The processes used included grinding, cutting, drilling, and welding. Since precision machining is widely available in Tanzania, no use of a lathe or mill was used on the prototype.

While the prototype is in working condition, there are still a number of outstanding issues related. The coupling system could be made more robustly to ensure a more secure attachment. The chain alignment is currently off and can cause the chain all off. A last minute addition in adding adjustability to the prototype has a tendency to cause bending in the bar. While all of these issues affect the performance of the attachment, they can all be rectified with further work. Due to time constraints, we were not able to fully address these issues on our prototype.



Figure 1(a): The prototype in its in-use state



Figure 1(b): The prototype in its stowed away state

Table of Contents

IJSLE Article	4
Appendix A: Updated DR3 Document.....	5
Appendix B: Bill of Materials	80
Appendix C: Description of Changes since DR3	81
Appendix D: Design Analysis Assignment from lecture	93

Development of a Folding Tricycle Attachment for Wheelchairs in Tanzania

Brian Holcomb

Senior, Department of Mechanical Engineering
University of Michigan
Ann Arbor, MI 48109
bholcomb@umich.edu

Alexander Klonick

Senior, Department of Mechanical Engineering
University of Michigan
Ann Arbor, MI 48109
aklonick@umich.edu

Michael Swift

Senior, Department of Mechanical Engineering
University of Michigan
Ann Arbor, MI 48109
mrswift@umich.edu

Michael Tran

Senior, Department of Mechanical Engineering
University of Michigan
Ann Arbor, MI 48109
miketran@umich.edu

Abstract – Thousands of Tanzanians are unable to attend school, work, or participate in the community due to an immobilizing disability. Those lucky enough to have a wheelchair are frustrated by long trips across rough terrain. Hand-powered tricycles are easier for long trips but are too big to use inside or on a bus. The goal of this project is to produce a low-cost, foldable and storable tricycle attachment for the Whirlwind RoughRider Wheelchair. This hybrid design will allow users to travel freely between regions and more effectively function within their community. Throughout the course of this project, there were efforts to simulate the materials and manufacturing capability available in Tanzania. The project made no use of precision machining and limited its materials to bicycle parts and mild steel. This document describes the development process and makes recommendations for future development of a folding mobility aid.

Index Terms - developing countries, handcycle, mobility aid, tricycle, wheelchair, manufacture

INTRODUCTION

Wheelchairs are excellent devices for providing mobility to handicapped persons worldwide. The typical wheelchair can navigate the paved streets and halls of any American town with relative ease. However, without the intricate system of lifts, ramps, and roads even the most basic travel can be almost impossible.

This is the challenge faced by thousands of wheelchair users in developing countries such as Tanzania, where only 8.3% of roads are paved. Most of the wheelchairs are old, damaged US-style four-wheeled devices, designed to navigate the typical American town (United States. Central Intelligence Agency 2006). As a result, these wheelchairs do not solve the problem of mobility aid in Tanzania.

More robust hand powered tricycles are the preferred solution for long distance travel on rough terrain. These tricycles are more commonly seen on the streets and villages of developing nations. The problem with tricycles is that they often are too bulky for use indoors, and present great problems with space and fees when using mass transit (Winters 2006).

The best option for improving mobility for the 30,000 people in need of a mobility aid in Tanzania is a foldable combination of a tricycle and standard wheelchair, in order to allow for excellent mobility indoors, on streets, as well as on different means of transportation (Winters 2005). The goal of this project was to explore the option of having a foldable attachment that allows a standard wheelchair to turn into a hand powered tricycle while traveling long distances.

Literature Supporting a Combination of a Wheelchair and a Tricycle:

In Mr. Amos Winter's journal article, *Assessment of Wheelchair Technology in Tanzania*, it is noted that disabled Tanzanians prefer tricycles over standard wheelchairs during outside travel. In fact, Mr. Winter mentions that he did not see a single wheelchair being used outside at all. He attributes this preference for tricycles to requiring much less energy when traveling long distances and a tricycle's ability to better traverse the rough Tanzanian terrain. During his visit, he got the chance to interview many of the disabled Tanzanians and summarizes his evaluation of the hand powered tricycle by saying "tricycles are much more common and popular than wheelchairs" and "a tricycle is a more sensible choice for long-distance travel" (Winters 2006).

In Uganda, there is a similar need for mobility aids. In an article by Mr. Tone Øderud, *Feasibility Study on Production and Provision of Wheelchairs and Tricycles in Uganda*, a team reports its findings after visiting and surveying wheelchair users in Uganda. After spending time interviewing the Ugandans, the team found that while standard wheelchairs that were donated from hospitals are foldable and more easily storable, they were not very durable in the rural terrain and broke down easily. This problem is compounded by the fact that spare parts are not readily available to the community. Tricycles are noted to be the preferred method of mobility aid for traveling intermediate distances, but users were often denied access to public transportation because the tricycles are not foldable and easily transportable (Øderud and Hotchkiss 2004).

Research performed by Joe Mellin at Freedom Technology in the Philippines showed that there are many limitations that tricycle users encounter. First, the tricycle could not be used inside a building or home. Many of the tricycle users choose to keep their wheelchair for these situations, because they favored its small turning radius and better maneuverability. Additionally, while many users liked the comfort provided by the tricycle over longer distances, tricycle users could not use public transportation because the tricycle was too large to fit on the bus. In contrast, wheelchair users could fold their wheelchairs and use public transportation (Mellin 2007).

In an article written by Mr. R. Lee Kirby and Mr. Rory A. Cooper, *Applicability of the Wheelchair Skills Program to the Indian context*, the authors write about their observations on mobility aids used in India. During their two-week visit, they noticed that hand powered tricycles were the preferred type of mobility aid used to travel. Similarly Tanzania, obstacles were more prevalent and extreme than those seen in North America. While the tricycles were preferred, they noted that they were difficult to maneuver in tight spaces due to a larger turning radius compared to a standard wheelchair (Kirby and Cooper 2007).

Other Literature Useful in Design Process:

The project team used various sources to research the use of wheelchairs and tricycles as mobility aids in Tanzania. The most valuable resources were those taken from the MIT class 784 website. The purpose of this class is to analyze wheelchair design in developing countries. In order to fully understand the demographics and needs of people that will be using our device, the team relied heavily on Mr. Amos

Winter's paper and the materials from the MIT website. These resources are very detailed and include user complaints about wheelchairs and tricycles. These resources were valued highly because the team could not directly interact with the users they were designing for. Other resources that were linked from the MIT website included two videos that documented the manufacturing process that a wheelchair and tricycle manufacturer used in Nairobi, Kenya. Even though this is outside of the target country of Tanzania, manufacturing capabilities are very similar in both countries.

The research was not limited to sources on the MIT website. Details about the ergonomics of the wheelchairs and their users were found in *Positioning in a Wheelchair* by Mayall and Desharnais. Additionally, limited data was found on the size of people in the Hadza tribe of Tanzania from *Annals of Human Biology*. These two sources allowed the team to design a wheelchair attachment that will provide proper ergonomic support to the user while being able to be used by a large variation of user sizes in Tanzania. Additionally, research into current patents of wheelchairs, tricycles and wheelchair attachments was conducted in order to become familiarized with the types of devices similar to this project. These patents aided in understanding the design problem by demonstrating past solutions to similar problems.

Because the team was not able to directly interact with the Tanzanian people, all of the research is secondhand. This created some holes in the research that the team was forced to accept. For example, the team could not find any reliable anthropometric data that describes the height, weight, leg length, and arm reach of the users that we were targeted. Additionally, the demographics concerning the types of users needing mobility aid in Tanzania are taken directly from Mr. Amos Winter's thesis, *Assessment of Wheelchair Technology in Tanzania*. He describes how he was only able to see those wheelchair users that were mobile enough to use the streets during the day. Those users who were immobilized to the point where they had to stay indoors could not be counted. For this reason, Mr. Amos Winter believes that there are more users who suffer from spinal injuries than reported (Winter 2006).

CONCEPT GENERATION AND SELECTION

The engineering specifications for this project were dynamic throughout the design process. The team began by identifying and ranking the importance of our initial specifications using a quality function deployment (QFD). After discussions with the team's mentor, Mr. Amos Winter from the Massachusetts Institute of Technology (MIT), the team was able further refine the existing specifications as well as identify new specifications that were not examined previously.

In order to keep the team focused on the key functions of the device throughout the process, they created a functional decomposition of the project. The functional decomposition broke the system down into the most important functions and then listed what sub-functions would contribute to each key function in order to map out the process. The six most important functions were determined from our QFD and were found to be attaching to the wheelchair, propelling the wheelchair, compacting into a smaller size, stowing on the wheelchair, traversing long terrain, and adjusting to different people.

Once all the necessary engineering specifications and functions had been clearly defined the team used them as a solid base from which to generate concepts.

Scoring Matrix:

In order to reach a single design from all of the concepts we generated in brainstorming, the team used a methodical ranking system in order to determine the best concepts for each main component of the attachment. The main components that were used were how the drive system would be folded and the stowing location, and the attachment method.

Inside the scoring matrix for each component, the columns going across were different design concepts and the rows going vertically were different design criteria and customer requirements. The team ranked

each concept from best to worst against each design criterion. For example, if there were 4 different concepts considered, each option was ranked from 1 to 4, 1 being best and 4 being worst. After evaluating each ranking each option against each criterion, the total ranks were summed for each option. The option with the lowest total score was considered the best choice using our ranking matrix.

For each of the 5 main components, the team considered 3 to 6 different design concepts that were gathered from brainstorming. Next, they chose 5 to 10 different criteria to evaluate against. For each of the main components, they compiled a list of criteria that we determined to be the most important and crucial to the success of the project.

Folding Drive System:

The team deemed the folding drive system to be the most important aspect of the design. Because of this, the choice that arrived from this selection partly governed choices from other aspects of the design. They were willing to make sacrifices in other aspects in order to be able to use the best design that arose for folding the drive system. The concepts we considered after brainstorming were the accordion system, the single-chain fold over, and the two-chain fold over. Figure 1 illustrates these concepts.

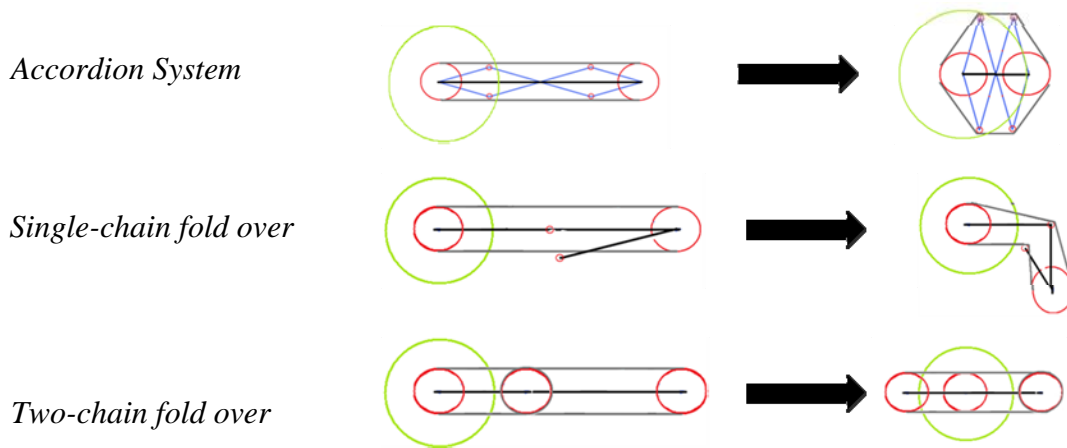

FIGURE 1
FOLDING DRIVE SYSTEM CONCEPTS

After applying the matrix scoring system, the two-belt fold over design ranked the best. This will be the folding drive system concept that we strive towards and will help govern other aspects of the overall attachment.

Attachment Method:

One of the most important features of the wheelchair attachment is the ability for the user to remove the device when it is not in use. Therefore, the mechanism that we use to attach the third wheel to the wheelchair will greatly affect the way that the consumer uses our attachment.

The team created a variety of specific methods that would all achieve the task of keeping the attachment fastened to the wheelchair during use. These ideas are sliding, the triangle clamp, vice grips, simple hooks, and the tri-clamp.

After applying the scoring matrix to the wide variety of attachment methods evaluated, the scores were very close. While no single method excelled above the rest, no single method performed much poorly than the rest either. Therefore, the team had some freedom to select which attachment method to be used. The

team decided to pursue a system of simple hooks because they would be the easiest to manufacture and repair.

Stowing Location:

In considering where the attachment should be stored on the wheelchair while it is not in use, the most feasible locations are behind, on the side, and underneath the wheelchair. Another possibility was an attachment that could be disassembled, allowing the parts to be spread across different locations on the wheelchair.

Each option scored very similarly in the matrix, so they were all viable options. We decided to design to an underneath location, because it works the best with the two-chain fold over drive system. The attachment arms can be very conveniently placed underneath the chair and above the cross brace.

DESIGN DESCRIPTION

Technical Specifications

This design emphasized performance against the design criteria and manufacturability in developing countries. The finished prototype is shown in Figure 2 attached to a Whirlwind RoughRider wheelchair. It features a folded with of 6 inches so that the user can stow it beneath the wheelchair seat easily. A wheel diameter of 12 inches was chosen to balance the need for compactness and robustness. Figure 3 shows the two sprocket hub that is integral to the two chain fold over system's folding axis.



FIGURE 2
PROPOSED TRICYCLE ATTACHMENT DESIGN



FIGURE 3
TWO SPROCKET HUB ALLOWS THE CHAINS TO STAY IN TENSION WHEN FOLDED

Manufacturability:

A major goal of the design was to make a production ready device that could be manufactured with little to no modification in the local bike shops of Tanzania. We validated this through our production process itself. The entire prototype was made from mild steel and recycled bike parts without the use of any precision machinery. This caused the process to take much longer but provided vital feedback as to what parts were likely to cause issues. Often a part that would take five minutes on a mill would take an hour or more of cutting, drilling, and grinding. Table I illustrates the top candidates for precision machining and an estimation of how much time would be saved. These times take into account total time to get the proper fit, but do not account for the raw material wasted by improperly machined parts.

TABLE I
THREE PARTS THAT WOULD BENEFIT FROM PRECISION MACHINING

Part	Current Method	Time (Hrs)	Ideal Method	Time (Hrs)
Two Sprocket Hub	Cut, drilled, ground to fit, welded together	3	Cast or Milled then welded	1
Bar Inserts	Cut, drilled, threaded, ground to fit	1	Milled, threaded	0.25
Attachment arms	Cut, ground, welded (no-jigs), drilled, ground to fit	10	precision cut, ground, jigged, and welded	1

The importance of proper tolerances became very apparent. With so many moving parts and linkages, a few 16ths of an inch off on a hole would ruin an entire part. There were multiple instances where parts were remade three to five times before they had the proper fit. In the future an interesting study to run would be whether it is cheaper for a skilled machinist to make these parts with simple tools, or to order them precision-made from a local city.

ENGINEERING ANALYSIS

Gear Ratio:

There exists existing gear ratio analysis for handcycles. One study published in the Journal of Medical Engineering and Technology shows that when compared to each other, lower gear ratios are more mechanically efficient than the higher gear ratios tested. Additionally, these lower gear ratios provided a less stressful experience with the hand crank wheelchair device than that provided by the higher gear ratios (Ashby 2004). We will need to choose a gear ratio that is just large enough to provide the amount of mechanical advantage to the user that is required. If the gear ratio is too much larger than this minimal amount, it could make the device too difficult for the user to operate. If this becomes the case, the device will not be used.

Aaron Wieler describes in his End of Year Five Project Report released by the Center for International Rehabilitation (CIR) in October 2008 that users in the developing world need to climb slopes of gradient 1:14. Via in house testing at Whirlwind Wheelchair International and the Center for International Rehabilitation, Wieler determined the appropriate gain ratio in order to climb this gradient is [1:1.6] (Wieler). The gain ratio takes into account the crank diameter, wheel diameter and gear ratio. For our folding device, the gear ratio becomes the combination of the two ratios of rotation created by our two chained gear systems. The hand crank is rotating the same rate as the top gear, the wheel is rotating the same rate as the bottom gear and the two middle gears are rotating at the same rate all because these sets share a common fixed axis of rotation – they are not free to rotate different speeds. For this reason, these ratios are removed from the gear ratio formula. Because bike teeth and bike chain dimensions are standardized, the gear ratio formula simply becomes the ratios of the number of teeth, N, on the gears. The formula for the gear ratio of the device is shown in Equation 1.

$$\text{Gear Ratio} = \frac{N_{T2} * N_M}{N_{M1,2} * N_{B2}} \quad \text{EQUATION 1}$$

The gain ratio incorporates the gear ratio of the device as well as the physical dimensions of the wheel and the crank. The gain ratio becomes the combination of the gear ratio and the ratio of the radius of the wheel to the radius of the crank. Therefore, with the desired gain ratio shown above of [1:1.6], for every meter the user's hands travel along the crank path, the wheelchair will move 1.6 meters forward. The equation for the gain ratio of our device is shown in Equation 2.

$$\text{Gain Ratio} = \{\text{Gear Ratio}\} * \frac{R_W}{R_C} \quad \text{EQUATION 2}$$

Using dimensions for the radius of the wheel (6.0 inches) and the crank (6.5 inches) for the device and the desired gain ratio, the formula for the necessary gear ratio becomes 1.7333 as shown in Equation 3.

$$\begin{aligned} \text{Gain Ratio} &= 1.6 = \{\text{Gear Ratio}\} * \frac{6.0}{6.5} \\ \text{Gear Ratio} &= 1.6 * \frac{6.5}{6} = 1.7333 \end{aligned} \quad \text{EQUATION 3}$$

Failure Analysis:

In order to validate the final design, critical methods of failure in the device were examined. Using some preliminary hand calculations, the team was able to show that the design will not fail under the anticipated loading conditions.

Reaction Forces and Moments:

The team began by identifying the static loads on the wheelchair and attachment when the attachment is in use. A conservative estimate was made and it was assumed that the center of gravity of the user will be at the center of the seat. Using equations from summing moments about the rear wheel axle, and summing the vertical forces in the device, the reaction forces at both wheels could be obtained for a predetermined human load. In order to make a simple calculation of the moment on the device at the place the attachment connects to the wheelchair, we made the assumption that the full moment acts on a single supporting arm. This assumption will cause the forces and stresses calculated to be larger than those which are actually experienced by the device.

Impulses and Safety Factors:

After a discussion with Mr. Amos Winter, the team realized that the impulses experienced in the device from going over rough terrain would be difficult to calculate using the typical failure equations. Amos Winter recommended that the team simplify these calculations by multiplying all static forces in the device by a factor of 5.0 as a guideline for handling all impulses on the system. This factor has been applied to all applicable calculations in order to validate that the design does not fail.

Crumple Mechanics and Local Buckling:

The team looked at local buckling (crumple mechanics) on the hollow square cross section tubing used in the attachment arms. The calculations showed that after applying the safety factor of 5.0, the shape of the tube can support stresses that are larger than the max stress of 500 MPa before crumpling. Therefore crumpling mechanics will not be a limiting factor on the design.

Yield Failure by Bending:

Using previously calculated values for the moments on the attachment arms, the team used the linear bending equation to determine the stress caused by this moment. The horizontal attachment arm is being made from a solid circular cross section rod. We determined that stress on the rod using the safety factor of 5 to be less than the elastic yield stress for mild steel (500 MPa). The vertical attachment arm is being made from a hollow square cross section. The stress on the beam with the included safety factor is less than the elastic yield stress for mild steel. Therefore, the attachment arms will not fail by yield due to bending.

Buckling in Horizontal Bar:

Using the buckling equation, a critical force was calculated in order to cause buckling on the horizontal attachment arm. The actual force was calculated to be less than the critical force. Therefore, the attachment arm will not buckle. It is important to note that for these calculations, the safety factor of 5 was not used. This was ignored because under the types of impulsive loadings which the safety factor was being used to estimate, the buckling equation is not accurate. Beams can handle large impulsive forces without buckling. The local buckling equations govern these types of impulses. This was examined with crumple mechanics.

Bolt Moments:

One of the major components that the team needed to test for failure is the bolt that interacts with all four attachment arms. This bolt experiences shear forces from the moments. These moments and perpendicular distances were used to determine the force on the pin. This force was divided by the area projected by the side of the pin being acted upon by the moments in order to get a stress on the pin. The final stress on the pin was shown to be less than the 500 MPa max stress for mild steel. Therefore, the bolt will not fail from the combined loading of the attachment arms.

Assumptions:

The main wheelchair wheels and the backrest are aligned vertically from the ground. The load from the user causes a moment about the main wheel contact points. The load from the user was assumed to be effectively applied halfway up the seat of the wheelchair, 7.5 inches. We deemed this to be a conservative assumption since a person's weight is most likely shifted toward the back end of the seat by the backrest resulting in a shorter moment arm.

We assumed that the weight of the attachment itself was negligible compared to the external loads placed on it. Therefore the masses of the bars are left out of the stress calculations.

The mechanical properties of the old bicycle parts and mild steel were assumed to be constant and without depreciation in the strength of the material. The tensile strength was assumed to be 500 MPa and the Young's modulus was assumed to be 210 GPa.

PROTOTYPE VALIDATION AND RESULTS

In order to verify that the achievement of building a low-cost, foldable and storable tricycle attachment for the Whirlwind RoughRider wheelchair, the team planned a vigorous validation schedule. However, due to the complexity of the manufacturing required for the project and short time frame for the course, the team was not able to properly conduct many validation experiments. This section describes the results of current validation tests as well as laying out a plan for future, more thorough, testing.

Deployable in Less Than One Minute:

The main requirement for the device was that it can be folded and stowed easily. The team specified that the device could be attached or detached in less than one minute by a somewhat familiar user. This was the shortcoming of the current MIT design and was the first validation test we ran. The team's expert user, Mike Tran, has been able to fully unstow, unfold, and attach the device in under 29 seconds, and can detach, fold, and stow in less than 17s; more than satisfying the requirement. It is important to note that Mike is an able bodied man, who helped design the device and has demonstrated it at least twenty times. In order to more fully evaluate this specification, the team ran additional tests.

In order to properly evaluate this test, the team decided to run a random-user usability survey with a time trial element. This test gathered qualitative information about the overall operation and ease of use of the device, as well as quantitative data for the time required to perform the two operations.

We designed a simple form, shown in Figure 4 to instruct users and record data. The form showed the basic steps of operation in a flowchart style using CAD renderings. The team asked multiple users to rate the device using simple word examples rather than numbers, and correlated those numbers with values of one, three and five, five being the best. The topics rated were ease of use, force required, and comfort level. The team took into account that the average user was an able bodied college student and not a 12 year old

polio survivor and so the target value was ‘barely tried’. Three open ended questions were asked regarding the placement of the stowed device, biggest issue with device, and best feature. It was hoped to gain a basic understanding of whether the placement was acceptable, what features were a problem, and which ones may be worth an additional cost.





Name:	Time to Attach:				
Date:	Time to Detach:				
Observer:					
How to Use					
					
Ease of use? Confusing OK Very Intuitive	Biggest issue with device?				
Force required? Too much OK Barely tried	Best feature?				
Comfort Level? It hurt OK Could do it 20x	Comments.				
What did you think about the placement when stowed?					

FIGURE 4
USABILITY SURVEY FORM

The team selected a random user in the lobby of the Duderstadt center for our usability trial. The team explained the operation of the device, demonstrated a sample attach/detach sequence, and then had the user attempt the attach process. Time was taken for the attach process, then reset for the detach process.

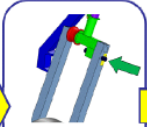

FIGURE 5
INSTRUCTION, DEMONSTRATION, AND TESTING FOR THE RANDOM USER TRIAL

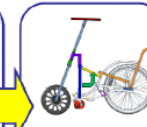
The results of the random user's first attempt were 1:40.1 to attach, and 47.3s to detach. A second test was attempted but the nut for the handle bar assembly was missing; causing the upper assembly to rotate around and preventing further trials. This seemingly small incident exposed a serious design flaw. If one lost the nut on either the handlebar lock or the folding lock the device would be unusable. To solve this problem we will attach the pin using a wire and consider a one piece slotted pin.

Observations from the limited random testing were still helpful. Handing to device to a total novice and watching the process helped highlight other possible design issues to be improved before implementation. One key observation was that the user struggled to manipulate the device with one hand in order unstow from under the chair and insert the folding lock pin. The device wanted to rotate about various axes and it was difficult to steady. The user put his feet on the ground to support the weight; something not easily done for the typical polio survivor. There was some difficulty in guiding the attachment arms into place. The detach, fold and stow process went much smoother with the only difficulty being in aligning the device properly to fit in the space between the cross brace and seat fabric.



FIGURE 6

THE RANDOM USER NEEDED HIS LEGS TO SUPPORT THE DEVICE AND HAD ISSUES WITH THE ATTACHMENT ARMS

Throughout the test we spoke with user about any issues they had, as well as having them fill out the survey once the tasks were complete. The user's biggest issue was "the bottom piece (tension arms) doesn't secure until side pieces (compression arms) in place". He suggested adding some sort of lock or mount to guide the process. Based on the team's own trials with the device, they found that backing up until the front casters are in front of the chair to be the best solution. The user found that the stowing location between the legs did impede ingress/egress but still rated comfort OK. Ease of use and force required were also rated OK. Overall he was pleased with the device but could tell it was an early prototype. Videos of the process were recorded.

Weight of Device:

Our target weight was specified to be 22 lbs. The weight of the prototype was 20.7 lbs. Even with a hurried prototype and some last minute additions like the chain tensioners, the engineering specification was able to be met. Given more time, this weight would be able to reduced even further.

CONCLUSION

Current wheelchairs and tricycles do not provide sufficient mobility aid in Tanzania. They cost too much, have a limited range and are not suited to the harsh terrain. We have designed a solution to this problem by

combining the comfort and maneuverability of a wheelchair with the rugged capability and efficiency of a tricycle in a cheap, stowable package that provides full mobility to those in need.

Due to time constraints, full validation tests and geometry refinement on the prototype were not able to be completed. In the report, we have laid out a structure for test that we could not complete. Upon the current analysis that we have, we recommend the use of a clamping system for the tension arms. We found that when the caster wheels get lifted up due to not being able to clear an obstacle, the tension arms can potentially lose contact with the wheelchair and become uncoupled.

Because tolerances become an issue when precision machining is not used, we found that some of the geometries were not completely accurate in our prototype model. We were unable to perfect these due to the limited time. If time or accuracy is an issue in implementing the design, we recommend removing the adjustable angle feature of the attachment. This removes unnecessary complexities and welds to the design.

We recommend that this project be continued with future teams as a way to expand upon our solution provided in this paper. Possible topics for future work have been identified in this paper and include fixing some key areas of the design which need to be examined. Overall, our device is one solution to the problem of mobility in Tanzania and future work will enable this device to be improved.

ACKNOWLEDGMENT

The authors would like to acknowledge assistance with this project from Dr. Kathleen Sienko, University of Michigan; Robert Coury, University of Michigan; Marv Cressey, University of Michigan; Corey Wiermont, University of Michigan; Amos Winter, Massachusetts Institute of Technology; Aaron Wieler, Whirlwind International.

REFERENCES

- APDK (2006). APDK Handcycle Production. August, 2006.
<http://web.mit.edu/sp.784/www/IMAGES/VIDEOS/APDK%20-%20Tricycle%20Production.wmv>
- Ashby, M. F. (2005) Materials selection in mechanical design. Amsterdam: Elsevier Butterworth-Heinemann.
- Chandler, D. (2008) On a roll: Students help bring mobility to developing countries. On a roll: Students help bring mobility to developing countries. MIT News Office. <http://web.mit.edu/newsoffice/2008/itw-wheelchairs-tt0521.html>
- Diffrient, N., Tilley, A., & Harman, D. (1981). *Humanscale 7, 8, 9*. Cambridge: MIT Press.
- Fionik, D. (2008). *DUBIKE - foldable bicycle concept*. NASA Tech Briefs "Create the Future Design Contest": <http://www.createthefuturecontest.com/pages/view/entriesdetail.html?entryID=1844> Date accessed: 2/11/09.
- Hiernaux, J. and Hartono, D. Boedhi(1980)'Physical measurements of the adult Hadza of Tanzania',*Annals of Human Biology*,7:4,339 — 346
- Kirby, R. L. and R. A. Cooper (2007). "Applicability of the Wheelchair Skills Program to the Indian context." *Disability & Rehabilitation* **29**(11): 969-972.

- Mayall, Jan K., and Guylaine Desharnais. Positioning in a Wheelchair : A Guide for Professional Caregivers of the Disabled Adult. Danbury: SLACK, Incorporated, 1995.
- Mellin, J. (2007). tricycle research, YouTube.com. <http://www.youtube.com/watch?v=UC1MgP2fXAQ>.
Date accessed: 1/15/09.
- Øderud, T. and R. Hotchkiss (2004). Feasibility Study on Production and Provision of Wheelchairs and Tricycles in Uganda. Trondheim, SINTEF Health Research: 36.
- Ramon, Alex. "How To Calculate Chain Length - Bicycle Tutor." Bicycle Tutor - Bike Repair Video Tutorials. 27 Mar. 2009 <<http://bicycletutor.com/calculate-chain-length/>>.
- Statistics, T. N. B. o. (2000/01). Tanzanian Household Budget Survey. Minister of State. H. D. A. O. Kigoda.
- Technology, F. (2006). "Freedom Technology." Retrieved 01/19/2009, 2009, from <http://www.freedomtechnology.com.ph/products.htm>.
- United States. Central Intelligence Agency. "The world factbook." from <http://www.odci.gov/cia/publications/factbook/index.html>.
- Van der Woude, Luc H. V., I. Bosmans, B. Bervoets, and H. E. J. Veeger. "Handcycling: different modes and gear ratios." Journal of Medical Engineering & Technology 24 (2000): 242-49.
- Winters, A. G. (2005). Conversations with The Tanzania Association of the Disabled (CHAWATA)
- Winters, A. G. (2006). "Assessment of Wheelchair Technology in Tanzania." International Journal for Service Learning in Engineering 2(1): 60-77.

Appendix A: Updated DR3 Report

PROBLEM DESCRIPTION

Wheelchairs are excellent devices for providing mobility to handicapped persons worldwide. The typical wheelchair can navigate the paved streets and halls of any American town with relative ease. However, without the intricate system of lifts, ramps, and roads even the most basic travel can be almost impossible.

This is the challenge faced by thousands of wheelchair users in developing countries such as Tanzania, where only 8.3% of roads are paved. Most of the wheelchairs are old damaged US-style four-wheeled devices, designed to navigate the typical American town (United States. Central Intelligence Agency 2006). Wheelchairs are often being used by people they never were designed for and being used in environments they were never meant to go. As a result these chairs do not solve the problem.

More robust hand powered tricycles are the preferred solution for long distance and more rugged handicapped travel and are commonly seen on the streets and villages of developing nations. The problem with tricycles is that they often are too bulky for use indoors, and present great problems with space and fees when using mass transit (Winters 2006).

The best option for improving mobility for the 30,000 people in need of a mobility aid in Tanzania is a foldable combination of a tricycle and standard wheelchair, in order to allow for excellent mobility indoors, on streets, as well as on different means of transportation (Winters 2005). A visualization of the range limits of current devices in relation to key services can be seen in Figure A.1.

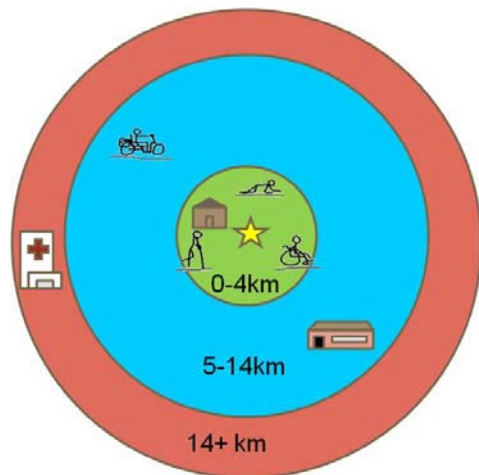

- Distance to services
 - 1.9 km to primary school
 - 2.8 km to shop
 - 6.4 km to secondary school
 - 26 km to hospital
- Gaps in current mobility-aid range
 - 36% travel 5+ km daily
 - Tricycles not allowed on buses, indoors

Figure A.1: Range limits of current mobility aids, along with distances to services (Tanzanian National Bureau of Statistics 2000/01).

We will design and produce a low-cost foldable and stowable tricycle attachment for Whirlwind Roughrider wheelchairs. We will work with Mr. Amos Winter's 'Wheelchairs for Developing Nations' class at MIT. Mr. Winter and his students have worked for years both in Africa and Cambridge to improve the lives of mobility impaired people by not only designing new devices, but by also setting up the infrastructure to support these projects and provide long term sustainable solutions. While Amos Winter is our mentor, our interaction with the MIT student teams will help us throughout our project. The biggest way that this

interaction has benefitted us is in our research into the environment of Tanzania and the manufacturing capabilities there. They have already implemented a basic tricycle attachment and the focus of this project will be to design the folding system that is vital for use on mass transportation and indoors. By working together with Mr. Winter as well as contacts at the University Hospital, in Tanzania, and at Whirlwind Wheelchairs we will be able to develop a more complete solution to the needs of the mobility impaired. Upon successful completion of the project, it will be tested this summer in rural Tanzania and possibly incorporated into future Whirlwind developments directed toward providing the world with sustainable mobility solutions.

BACKGROUND

The purpose of this section is to outline some of the background information necessary to fully understand the design problem that we are solving in our project.

Why Tricycles?

In Mr. Amos Winter's journal article, *Assessment of Wheelchair Technology in Tanzania*, the author notes that in his observations, disabled Tanzanians prefer tricycles over standard wheelchairs when traveling outside. In fact, Mr. Winter mentions that he did not see a single wheelchair being used outside at all. He attributes this preference for tricycles to requiring much less energy when traveling long distances and a tricycle's ability to better traverse the rough Tanzanian terrain. During his visit, he got the chance to interview many of the Tanzanian disabled and summarizes his evaluation of the tricycle by saying "tricycles are much more common and popular than wheelchairs" and "a tricycle is a more sensible choice for long-distance travel" (Winters 2006).

In Uganda there is a similar need for mobility aids. In an article by Mr. Tone Øderud, *Feasibility Study on Production and Provision of Wheelchairs and Tricycles in Uganda*, a team reports its findings after visiting and surveying wheelchair users in Uganda. According to the interviewees, the team found that while standard wheelchairs that were donated from hospitals are foldable and more easily stowable, they were not very durable in the rural terrain and broke down easily. This problem is compounded by the fact that spare parts are not readily available to the community. Tricycles are noted to be the preferred method of mobility aid for traveling intermediate distances, but users were often denied access to public transportation because the tricycles are not foldable and easily transportable (Øderud and Hotchkiss 2004).

Research performed by Joe Mellin at Freedom Technology in the Philippines showed that there are many limitations that tricycle users encounter. First, the tricycle could not be used inside a building or home. Many of the tricycle users choose to keep their wheelchair for these situations because they favored its small turning radius and better maneuverability. Additionally, while many users liked the comfort provided by the tricycle over longer distances, tricycle users could not use public transportation because the tricycle was too large to fit on the bus. Previously, users could fold their wheelchairs and use public transportation (Mellin 2007).

In an article written by Mr. R. Lee Kirby and Mr. Rory A. Cooper, *Applicability of the Wheelchair Skills Program to the Indian context*, the authors write about their observations on mobility aids used in India. During their two-week visit, they noticed that arm-crank-propelled tricycles were the preferred type of mobility aid used to travel. Like in Tanzania, obstacles were more prevalent and extreme than those seen in North America. While the tricycles were preferred, they noted that they seemed to be difficult to maneuver in tight spaces due to a larger turning radius compared to a standard wheelchair (Kirby and Cooper 2007).

Prototypes and Current Devices

Currently, there are a wide variety of wheelchairs that improve user mobility. The most common type of wheelchair has four wheels: two large wheels are in the back and two smaller wheels in the front. The back wheels are situated directly under the user's seat and as the user sits in the chair, the front wheels are behind the user's feet rest so that they line up with their knees or ankles. The caster wheels are the two smaller wheels that are in the front of the wheelchair and provide support as well as a resting place for the feet and legs of the user. The typical wheelchair is shown in Figure A.2. This design is well suited for paved surfaces and movement inside cramped areas because of its tight turning radius and short wheelbase. Unfortunately, these same characteristics make this type of wheelchair unsuitable for rural environments where traditional wheelchairs get stuck or tip over in the rough terrain. The solution to this problem has been to create a wheelchair that balances on three wheels similar to a tricycle. Prototypes and current tricycle devices can be broken down into two categories: a tricycle made from the ground up and a third wheel attachment made to the wheelchair.

The majority of tricycle wheelchairs are made as a new device. One example of this type of device is the Commuter model made by Freedom Technology in the Philippines. This model is a device that lies close to the ground and resembles a child's big wheel toy; the user is not sitting in the device, but is laying in it. In place of the pedals, however, a hand crank system is used to propel the user. The Commuter is named for its ability to propel a user at high speeds enabling him to get from one area to another much quicker than an ordinary wheelchair (Technology 2006). Another example of a tricycle is that made by APDK in Nairobi, Kenya and is pictured in Figure A.3. The APDK tricycle is built on the same principles as the tricycle created by Freedom Technology but is set up so that the user is sitting upright, similar to a traditional wheelchair. The tricycle is powered by a hand crank that rotates on a bearing used in bicycles in order to turn the device (APDK 2006).

The other approach to creating a three wheeled device for users was to design a front wheel attachment for a standard wheelchair. A design team from MIT has designed a device shown in Figure A.4 that attaches to a wheelchair and lifts the front wheels off the ground making the wheelchair become a tricycle. The device makes use of bicycle parts that are readily available to many manufacturers in Africa. The device attaches to a wheelchair using a series of clamps. A hand-crank powers the wheelchair (Chandler 2008).



Figure A.2: The typical medical wheelchair indicative of the models that are donated from charity organizations and manufactured by local Tanzanian companies. (http://majorsmedicalokc.com/LTWT_WHEELCHAIR_LRG.jpg)



Figure A.3: An example of a tricycle manufactured by APDK in Nairobi, Kenya.
(<http://mit.tricycle.googlepages.com/morefinalwheelchair006.JPG/morefinalwheelchair006-full;init:.JPG>)



Figure A.4: The wheelchair attachment designed by MIT is shown in use on a working wheelchair. Note the attachment lifts the front wheels off the ground. (MIT SP.784 2008).

Ergonomics

There are many ergonomic issues to be considered in the design of the product. These issues encompass the users comfort and health as well as the overall ease of use of the product.

There are multiple comfort and health issues that arise from being disabled and sitting for long periods of times without repositioning. A few of these are contractions, deformities, tissue breakdown, reduced performance, reduced tolerance, urinary and respiratory infection, fatigue, and discomfort. “Ideally, the wheelchair seat should be inclined toward the back by 10 degrees, the legs should be 20 degrees from the vertical, and the back 10 to 15 degrees from the vertical”. A figure displaying this positioning can be seen in Figure A.5 (Mayall and Desharnais 1995).

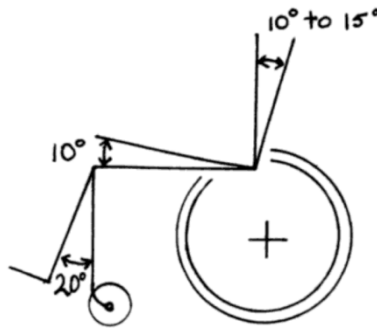

Figure A.5: The seat is inclined 10 degrees, the legs are inclined 20 degrees, and the back is inclined 10 to 15 degrees in the ideal seated position.

It was shown “that submaximal physiological responses are lower, and gross efficiency is higher, in handcycling compared to handrim wheelchair propulsion” (Dallmeijer et al. 2004). When comparing different ways to handcycle, “greater power, longer test times, and higher post test blood lactates were achieved with asynchronous cranking versus synchronous cranking” (Mossberg et al. 1999).

LITERATURE REVIEW

We used various sources to research the use of wheelchairs and tricycles as mobility aids in Tanzania. The most valuable resources were those taken from the MIT class 784 website. The purpose of this class is to analyze wheelchair design in developing countries. In order to fully understand the demographics and needs of people that will be using our device, we relied heavily on Mr. Amos Winter’s paper and the materials from the MIT website. These resources are very detailed and include user complaints about wheelchairs and tricycles. We valued these resources highly because we could not directly interact with the users we are designing for. Other resources that were linked from the MIT website included two videos that documented the manufacturing process that a wheelchair and tricycle manufacturer used in Nairobi, Kenya. Even though this is outside our target country of Tanzania, manufacturing capabilities are very similar in both countries. Therefore these videos will enable us to assess whether our design is appropriate.

Our research was not limited to sources on the MIT website. We were able to find details about the ergonomics of the wheelchairs and their users from *Positioning in a Wheelchair* by Mayall and Desharnais. Additionally, we were able to find limited data on the size of people in the Hadza tribe of Tanzania from *Annals of Human Biology*. These two sources will allow us to design a wheelchair attachment that will provide proper ergonomic support to the user while being able to be used by a large variation of user sizes in Tanzania. Additionally, research into current patents of wheelchairs, tricycles and wheelchair attachments was conducted in order to get a feel for the types of devices that we would be designing. These patents helped us understand the design problem by demonstrating past solutions to similar problems.

Because we are not able to directly interact with the Tanzanian people, all of our research is secondhand. This creates some holes in our research that we are forced to accept. For example, we cannot find any reliable anthropometric data that describes the height, weight, leg length, and arm reach of the users that we are targeting. Additionally, our demographics concerning the types of users needing mobility aid in Tanzania are taken directly from Mr. Amos Winter’s thesis, *Assessment of Wheelchair Technology in Tanzania*. He describes how he was only able to see those wheelchair users that were mobile enough to use the streets during the day. Those users who were immobilized to the point where they had to stay indoors could not be counted. For this reason, Mr. Amos Winter believes that there are more users who suffer from

spinal injuries than reported (Winter 2006). This is a major gap in our information that we are trying to address.

Coaster Brake

From collaboration with our mentor, we were able to determine that the user wanted to be able to propel themselves forward, stop, and propel themselves backwards. Current tricycle designs incorporate all of this but in order for the user to go in reverse, they must awkwardly turn the hand cranks around the steering column since they use a coaster brake and cannot hand crank in the opposite direction. We wanted to use a coaster brake but did not want to have to turn the hand crank around the steering column. After looking into much research into coaster brakes, we were able to determine that the braking force is not contained within the hub of the braking system.

Using a patent for a typical coaster brake, we were able to gain a much better understanding of the way it worked to stop the wheels from turning. The first page of this patent (#2982384) is reproduced in Figure A.6. The full patent can be seen in Appendix U.

When the user peddles clockwise, they drive a gear that is attached to a screw. As this screw is driven clockwise, it engages and pulls the clutch towards the gear. The clutch has a beveled edge and as it is pulled toward the gear, it butts up against the inside beveled edge of the wheel hub. This drives the bicycle forward.

When the user does not peddle, the gear is not being driven. Therefore the screw is not engaging the clutch, which does not engage the wheel. The wheel is free to rotate about its bearings.

When the user peddles counterclockwise, they drive the screw attached to the gear counterclockwise. This engages the clutch, but instead of pulling it towards the gear, it pushes it away. The clutch pushes brake pads away from the gear and towards an inclined surface that has grooves that are parallel to the axis of rotation. The brake pads are always stationary in these grooves and cannot rotate at all. This incline with grooves is always stationary and attached out of the hub to a torque arm which is secured to the frame of the bike. As the brake pads are pushed up the incline, they rub against the inside of the wheel hub. This force causes the wheel to stop spinning. The braking force is transferred through the torque arm/grooved inclined plane, to the brake pads, and finally to the wheel.

This gave us an idea to find a safe and secure way to have a torque arm that could be disengaged easily. This is tricky design concept and not crucial to the success of our project but it is something that we are considering implementing in our final design.

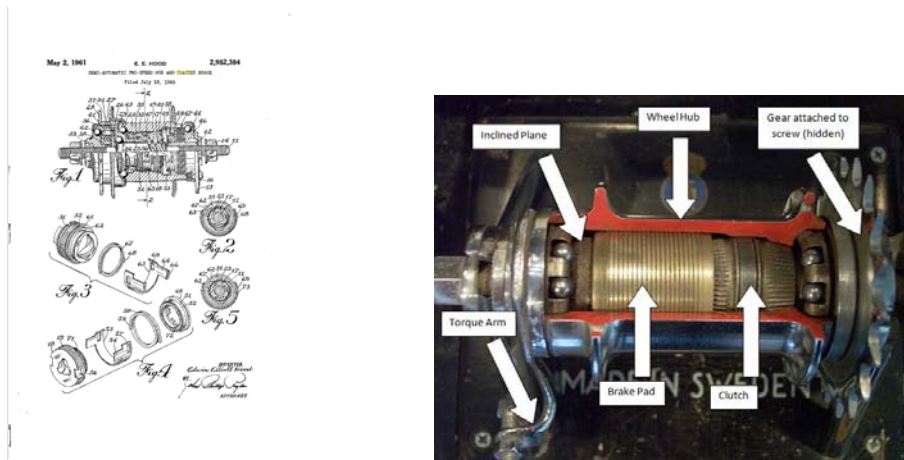

Figure A.6: Patent of the typical coaster brake (left). Cross section of a coaster brake (right).
 (http://upload.wikimedia.org/wikipedia/commons/3/35/R%C3%BCcktrittbremse_geschnitten.jpg)

INITIAL ENGINEERING SPECIFICATIONS

This section will describe the engineering specifications that we used for our wheelchair attachment as well as the process that we used to arrive at these specifications. Our engineering specifications for our project were dynamic throughout the design process. We began by identifying and ranking the importance of our initial specifications using a quality function deployment (QFD). After discussions with our mentor, Amos Winter from MIT, we were able further refine our existing specifications as well as identify new specifications that we had not examined previously. Furthermore, during the concept generation process it became apparent that we needed to create additional design specifications to quantify a few parameters of the attachment device.

Quality Function Deployment

The quality function deployment (QFD) exercise was invaluable to defining the ranking of our engineering specifications. This ranking allowed us to focus on the most important engineering specifications during the design process in order to create a product that would fully satisfy the user's needs. A copy of our QFD can be seen in Appendix E.

QFD development process

We began by identifying customer needs via brainstorming, our research and discussions with our project mentor Amos Winter. Our discussions with Mr. Winter were especially helpful because of his experiences in Tanzania and observations of tricycle and wheelchair users. The most important customer needs were identified to be making the attachment foldable and compact in the folded state. These needs held the most weight because making the attachment foldable is the focus of our project. Creating a foldable attachment that is compact and can fit on the wheelchair will encourage wheelchair bound people to use the attachment and become more mobile.

Initially, foldable and compact made up a single customer need, but we decided to split foldable and compact into two separate components for the QFD so that more detailed information about our technical requirements could be taken.

The next most important customer need was low cost. Knowing that the average able bodied worker in Tanzania makes only \$24 a month, we set the user need of low cost to a high priority. One thing we do not want to do in this project is to make a device that is prohibitively expensive for the user. The attachment we design could be ideal, but if it costs too much, it will never be used.

Many of the remaining customer needs reflect areas that we will not be focusing on in our design, but are still very relevant to the project. Safety is a large concern in every project. Every design that we create will be evaluated with respect to the safety of the user. One major concern when designing any vehicle is tipping. We will need to examine the angle that the wheelchair is tipped in order to see if there is any concern about the user falling backwards during the installation process or during normal use. Durability is a concern because our device will be used in the rough terrain of Tanzania. The design must be able to withstand the elements and the repeated loading that occurs when it is used in the rocky terrain. Light weight is a concern because we need the attachment to be light enough for the handicapped user to be able to manipulate the device during the folding, stowing and installing processes. However, in order for the attachment to be strong enough to ensure durability and functionality, it needs to have some minimum weight which we will examine later. Ease of repair, user comfort and visual appeal all held below average weighing in the customer needs because they are not the primary focus of this project. They are all important, but we decided that it is more important to create a functional design first. After we arrive at a functional design that satisfies the focus of our project we can return and look into ways to make it easier to repair, more comfortable and more visually appealing.

Results of QFD exercise

The results of the QFD exercise can be seen in the ranking of our technical requirements. We assigned target values for each technical specification in the same order of importance that the QFD exercise produced. A sample of our initial design specifications from our QFD analysis can be seen in Table A.1. The full table can be seen in Appendix E.

Table A.1: Sample of our table of initial design specifications from our QFD analysis.

Ranking	Specification	Value	Unit
1	Material used	-	-
2	Amount of material used	610	in ³
3	Young's modulus of material	7250	kpsi
4	Weight	22	pounds
4	Force it takes to clamp	3.37	pounds force
4	Force it takes to unclamp	3.37	pounds force

Material properties The most important technical requirements were shown to be the material used, the amount of material used, and the Young’s modulus of the material used. In order to examine a variety of design options, we left the specific material as a free variable. We set an upper limit of 610 in³ of material used and a lower limit of 7250 kpsi for the Young’s modulus for the material used. These parameters were chosen in order to provide a small limit to our material choices while at the same time giving us a wide range of materials to examine.

Total weight The next property examined was the total weight of the attachment. We created an upper limit of 22 lbs on the weight of the attachment because it is a suitable mass for the disabled user to manipulate during use.

Force required The force required to install and uninstall were set at an upper bound of 3.37 pounds force. We wanted to make this force roughly 15% of the maximum finger force that can be exerted by men. This percentage was chosen in order to account for the fact that women and handicapped individuals will be using this attachment. Women and handicapped individuals will not be able to exert as much force as healthy men. Because this max finger force is approximately 22.5 pounds force, our upper bound of 3.37 pounds force is suitable (Diffrient, 1981).

Working load We assigned the maximum working load to be 450 pounds force in order to accommodate a large individual with some cargo. This assumes that the load will be centered in the seat of the chair. This was chosen as a broad lower bound to the working load because of our lack of anthropometric data on the Tanzanian people. This working load values was determined after assuming that these people will be similar to those that use wheelchairs in the United States. This is obviously a large assumption to make and will need to be re-examined later in the project.

Dimensions The folded and unfolded dimensions were created as a guideline for our future brainstorming and design development phases. These values will be re-examined when we get a better idea of where we are able to store the attachment on the wheelchair and the size available to us at those places.

Cost The price of labor constraint was created in order to make us realize that the total cost of the attachment is more important than the material cost and the labor cost alone. Often, designers neglect labor cost and create a product that does not minimize total cost. This constraint will help us minimize total cost of our attachment.

Mechanical advantage The mechanical advantage constraint describes the mechanical advantage of the drive system from the handles to the wheel. An adequate mechanical advantage is required in order to optimize the work input to the system by the user on the hand cranks and the work done by the wheel of the attachment in order to propel the wheelchair. The value of 5 arrived at during our QFD exercise was just an initial guideline that we will tweak after initial concept selection. This value likely will change during the course of the project.

User accommodation A large number of our design specifications were focused on making the attachment so that it could accommodate a wide variety of possible users. The parameters of 'range of user arm length', 'range of user height', 'hand crank height range', 'hand crank angle range', and 'hand crank length range' refer to ways that the attachment can be adjusted so that it can comfortably accommodate a large number of different users. Values for these ranges were taken from preliminary ergonomic analysis so that the user would not have to overly exert himself to drive the device. Our detailed ergonomic analysis is prepared later in the report. These values can be seen on the sketch of the wheelchair attachment in Figure A.7. The values were chosen as guidelines for concept generation.

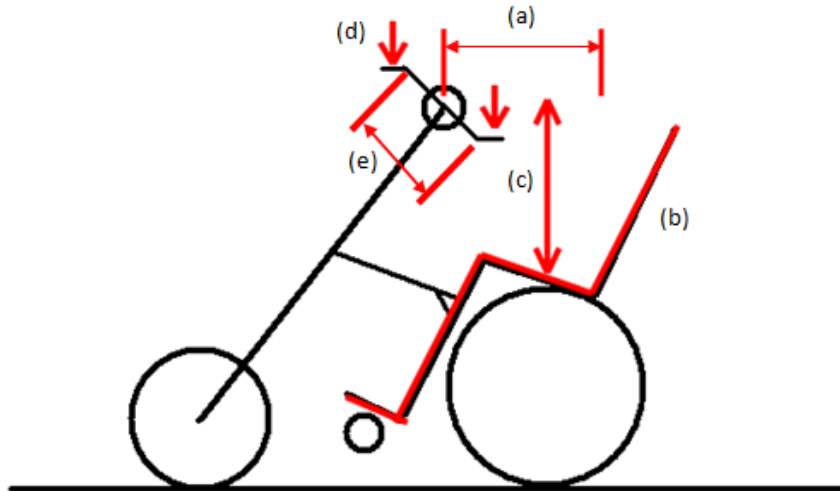

Figure A.7: Sketch of the wheelchair attachment with user accommodation specifications labeled: (a) range of user arm length, (b) range of user height, (c) hand crank height range, (d) hand crank angle range, and (e) hand crank length range.

Attachment Wheel diameter The specification of attachment wheel diameter was applied as a guideline for the future concept generation and will be reexamined after getting more detailed information about the availability of parts in Tanzania.

Braking One of the design improvements that we would like to make for the new device is to incorporate a braking system on the attachment. Two design specifications that we have specified here include braking force and braking distance from 6.21 mph to 0 mph. Values for these specifications were taken from our personal experiences with bicycles. Using these specifications, we can identify and evaluate possible braking systems for the attachment.

Fillet radii We set a design specification on the fillet radii of our parts to be 0.05 in. This fillet size specification was created to improve the safety of the attachment. It will remove any sharp corners on the attachment that could cut the consumer during use, installation or storage.

Flexion and time required The final four specifications that we defined from our QFD analysis were degree of flexion the attachment takes to install/uninstall and the time it takes to install/uninstall. These specifications were created with the handicapped user in mind. We know that the user will have limited mobility so we wanted to limit the degree of flexion required to install and uninstall the attachment to 90 degrees. This value of flexion was found after sitting in the wheelchair and attempting to manipulate a part that was placed behind the wheelchair. Any device that requires more flexion than this will be too difficult to maneuver and use. Additionally, we wanted to limit the time it takes to install and uninstall the attachment to less than 60 seconds. These specifications are subject to change as we get more detailed knowledge about how we want to store the attachment on the wheelchair while not in use and more information from our mentor Amos Winter about the physical ability of our user.

Additional Specifications

The specifications taken from our QFD analysis did not completely reflect the engineering specifications that were required of the wheelchair attachment. After completing our initial concept generation and after

conversations with our mentor Amos Winter at MIT, we were able to create additional specifications that will guide the rest of the project.

Specifications from concept generation

After some preliminary design conceptualization it became apparent that we needed to create additional design specifications that described the physical limitations of the attachment more fully. Giving these parameters a limiting value allowed us to better evaluate the different designs that we arrived at during the concept generation phase.

Front wheel and feet The first is the clearance between the front drive wheel and the user's feet. In order for the attachment to steer unhindered it must be free to rotate. Therefore, we set 3 inches for the clearance between the front wheel and the user's feet. This value of clearance was chosen by our mentor Amos Winter as a guideline for our design. This clearance can be seen in Figure A.7.

Turning angle range Along the same lines, we examined the total angle that the attachment can turn in the drive column. This specification is set at 180 degrees which allows for the entire attachment to be turned from facing forward to facing backwards. This is not limited by the drive bearing properties, but is limited by the physical size of our attachment. In order to turn 180 degrees, we need to examine what will be in the way of the parts of the attachment. This 180 degree specification was determined because it is really easy for the user to go in reverse by just turning the attachment 180 degrees. This rotational specification can be seen in Figure A.8.

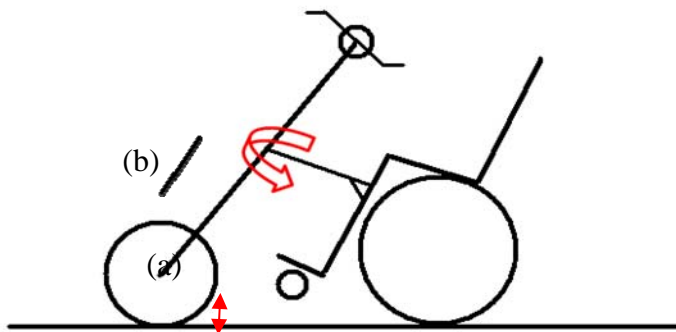

Figure A.8: Sketch of the wheelchair attachment showing (a) 3 inch clearance between front casters and ground and (b) the 180 degrees of rotation specification.

Attachment angle The next specification is the angle of the attachment when it is attached to the wheelchair. Our target right now is 80 degrees because that provides a good trade-off between the size of the attachment and the total length it adds to the wheelchair. This specification can be seen graphically in Figure 10 on page 15.

Total length Using this angle range, we determined that in order to make the handles reach the user's torso we will need to have a total freestanding vertical attachment length of 40 to 45 inches. This length was chosen using the attachment angle specified above along with anthropometric data of our user so that the hand cranks would be in the optimal height. This length dimension can be seen in Figure A.9.

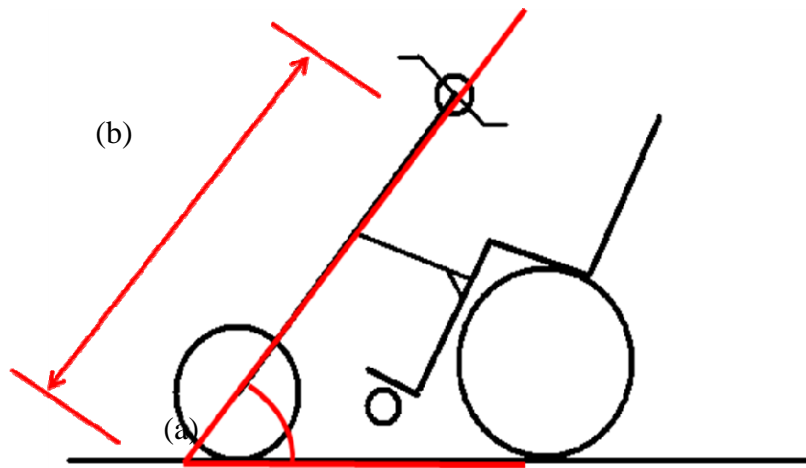

Figure A.9: Sketch of the wheelchair attachment labeling (a) the wheelchair attachment angle and (b) the total vertical length of the attachment.

Attachment arms length We also examined the length of the attachment frame arms that connect to the wheelchair during use. These needed to be long enough so that the user would have enough room for their legs and short enough so the overall length of the wheelchair with attachment would be reasonable. After sitting in a full sized wheelchair and measuring the area around the leg rests and combining this data with our information about the user gained from anthropometric data and our ergonomic analysis, we determined that the length of the attachment arms should be 16 inches.

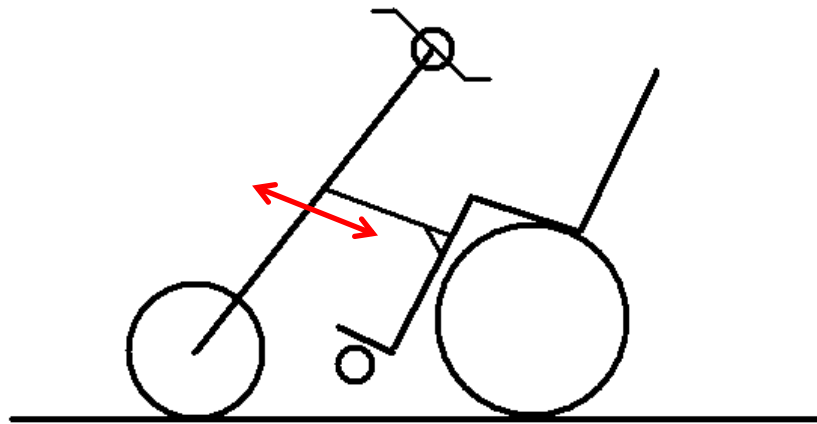

Figure A.10: Sketch of the wheelchair attachment with the attachment arms outlined in red.

Specifications from conversations with Amos Winter

Amos Winter from MIT has been an exceptional resource for this project. His first hand knowledge of tricycles and their users in Tanzania is particularly helpful because we cannot physically talk to or examine the people for which we are designing this attachment. From multiple conversations we were able to identify additional design specifications for the attachment.

Specific wheelchair The first is the specific wheelchair that we are designing this attachment for. Mr. Winter described that the Whirlwind wheelchair is the most popular wheelchair being manufactured in developing countries. He recommended that we focus on the Whirlwind Roughrider because it was popular

in the developing countries but also because that is the chair that is being used in our project's sister team at MIT. For the remainder of the project, we will focus on using this wheelchair as our model.

Available manufacturing processes An additional specification that arose from talks with Mr. Winter was the limitation of processes available in workshops in Tanzania. Tools that are commonplace in workshops include saws, grinders, welders (typically MIG, but sometimes arch) as well as hand tools for metal working. It is common for workshops to outsource machined parts to shops in cities where lathes and mills are available. Therefore, we want to limit our design to that which can be made from manufacturing techniques that are typical of the Tanzanian workshop. If necessary, we will use machined parts, but we will make the effort to avoid them in favor of a more simple part.

Material availability Along the same lines, Amos told us that the only metal available is mild steel. This contrasts with our initial design specifications where we would examine materials with a Young's modulus above 50 GPa. The main material that this excludes is aluminum. This is not a severe limitation in our design, but it is very important. Finally, Amos Winter has provided us with a list of materials that are commonly available to workshops in Tanzania. This spreadsheet can be seen in Appendix F and includes prices of these materials. This will be a valuable resource to helping us determine the total cost of our attachment design and if our design is feasible to manufacture in Tanzania.

Wheel size Through further discussions about the size of the front wheel and problems it will have with storage on the wheelchair when the attachment is not in use, we were able to get a more comprehensive list of varying sizes of wheels that are available to workshops in Tanzania. In addition to those listed in the parts list, a 16 inch wheel and a 12 inch wheel are available. We have decided to use a 16 inch wheel because it provides a balance of size and work output from the handlebars to propel the wheelchair. Additionally, this is the size that is used on the prototype design previously created by the team from MIT.

Trade Offs

In order to optimize certain aspects of a design, it is necessary to incorporate other less desirable features into the design. The main trade off that we identified during the course of our design conceptualization was balancing the ability to be folded with the extra weight and cost it adds to the attachment. Making the attachment foldable is our primary customer requirement as identified by our QFD analysis, so this tradeoff is necessary. During the design process we will further examine this tradeoff in order to see what the penalties are for each different folding mechanism we investigate. Our goal is to choose a folding mechanism that minimizes these penalties in the design while maximizing the desirable feature of folding.

Another major tradeoff that we encountered was balancing the attachment's ability to accommodate a variety of users with the weight and cost of the attachment. Initially, we wanted the various parts of the wheelchair attachment to be highly adjustable in order to accommodate a variety of user sizes. All of these adjustable parts will add a considerable amount of weight to the attachment. This will make the attachment much more difficult for the manufacturer to create and more difficult for the user to operate. Additionally, the extra material required to make the attachment parts adjustable will cause the price of the attachment to increase. This price increase is caused by the greater amount of manufacturing steps and greater amount of raw material used. We will need to examine if all the wheelchair attachment parts will need to be fully adjustable and if we can replace fully adjustable parts with a piece that will be suitable for most users. We have changed our initial focus toward creating a working prototype. After we have created a working prototype we will re-examine making the parts more adjustable. Initial design creation will be completed by designing a product that will be comfortable for most users while balancing cost and weight of the attachment.

The third major tradeoff that we examined during this project is that between the wheel size and the ability of the attachment to be folded and stored on the wheelchair. Wheel size was one of our most important design features for us to choose because it affected so many other aspects of the design and the method of manufacture. After getting the list of available wheel sizes from Amos Winter, we were able to take each size and see which was most viable for our wheelchair attachment. In order to evaluate the best size we examined how easy the attachment would be to fold and be stored on the wheelchair when not in use. If we used a wheel size that was too small then we would be maximizing the ability to be folded and stowed away, but the mechanical advantage of the attachment would suffer and the attachment might not be able to clear the rough terrain. Choosing a wheel size that is too large would maximize the ability for the attachment to handle the rough terrain and provide a mechanical advantage to the user, but would greatly hinder the folding mechanism and would be too large to be stowed on the wheelchair. The wheel diameter of 16 inches was chosen as a good balance to this tradeoff.

These tradeoffs will continue to be examined throughout the design and prototyping process in order to further optimize our attachment design.

CONCEPT GENERATION

Once all the necessary engineering specifications had been clearly defined we used them as a solid base from which to generate concepts. As a team of right brained kinesthetic people, our concept generation was exciting but sometimes difficult to properly organize. To help the team understand issues as well as communicate we heavily used our two wheelchairs, a small bicycle and later purchased a box of K'Nex to demonstrate our thinking.

Functional Decomposition

In order to keep the team focused on the key functions of the device throughout the process we gathered to come up with a functional decomposition. Our functional decomposition broke the system down into the most important functions and then listed what sub-functions would contribute to each key function in order to map out the process. The six most important functions were determined from our QFD to be, attaching to the wheelchair, propelling the wheelchair, compacting into a smaller size, stowing on the wheelchair, traversing long terrain, and adjusting to different people. We then broke each of those down into what sub-functions were required to achieve a top function. For example in order to compact into a smaller size the attachment must compress into a more manageable shape, the handles must compact, the attachment arms must compact, the drive system must also compact, and it is vital that it stays secure while folding. It is important to note that we said only that certain components, e.g. handles, must compact but not how. The decomposition is concerned with functions instead of forms. Our brainstorming would address how to achieve each function. Our functional decomposition for attaching is listed below along with the five other functions evaluated, the full document can be found in Appendix I .

Table A.2: Sample of the Functional Decomposition

1. Attaches to wheelchair
 - 1.1 Maintains safe and secure lock onto wheelchair
 - 1.2 Does not impede user while in use
 - 1.3 Does not require a large amount of force, flexion, or time to attach
 - 1.4 Does not require any tools to attach if detaching is necessary for storage
2. Propels wheelchair
3. Compact into smaller size
4. Stows away on wheelchair
5. Traverses rough terrain
6. Adjusts to different people

Brainstorming Process

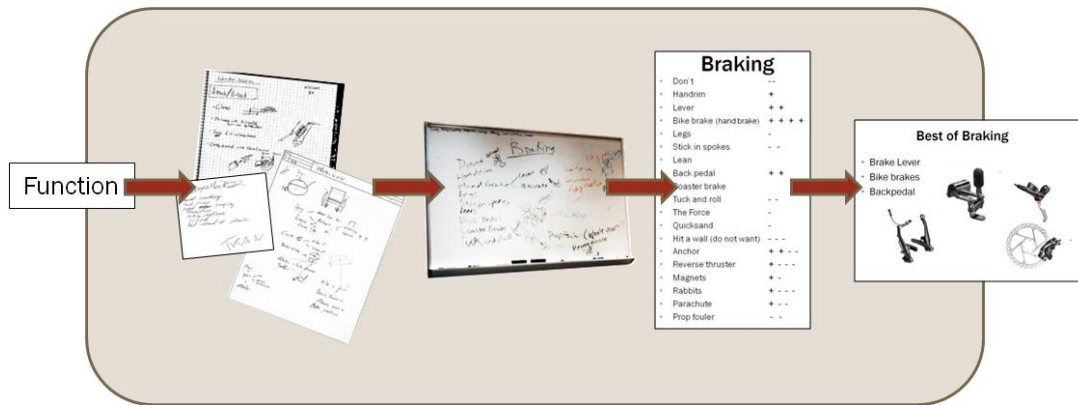

Figure A.11: The process of defining the function, individual and group brainstorming, and initial screening

In order to determine how to perform each function we began with a very loose and informal brainstorm. We all met in a large conference room with two whiteboards, large tables, and a projector. A pediatric wheel chair was placed on a table where team members could inspect it and demonstrate ideas to one another on a real world device. The environment was kept very relaxed, with sugary snacks and music to help break out of the standard routine and encourage creative energy. We started by using our QFD and functional decomposition to set seven key components of the design to focus on. The seven key functions of folding, stowing, attachment, wheels, propulsion, braking, and steering can be seen in Table A.3.

Table A.3: The functions and sample questions asked in brainstorming

Function	Question
Folding	How will the device compact?
Stowing	How and where will the device stow?
Attach	How will the device attach to the chair? What kind/size wheel will the device use?
Wheels	
Propulsion	What powers the device?
Braking	How does one stop the device?
Steering	How does one steer the device?

Although our team planned on using many of the MIT components in our design, it was important to start from scratch and consider even what seemed like the most outlandish solutions. For each system we would spend roughly ten minutes individually thinking on paper about any possible solution, and then each person would sequentially write their ideas on the board as they explained them. Initially we tried to write all of our ideas simultaneously, but found it to be inefficient with many repeats and the need to still explain each one. Once all ideas were explained and on the board we all took markers and added a plus or minus to our five favorite and least favorite designs, this system adapted slightly when a number of more outlandish examples, like the force or rabbits, were present. From there we actively discussed why an idea was good or bad and compiled the top three to five ideas for each area to continue with.

For example when looking at various braking systems the team came up with things like the standard handbrake, a bicycle brake, coaster brake, parachute, anchor, magnets, back-pedaling and a prop-fouler, to name a few. A full list of all brainstormed ideas can be found in Appendix K. As each member wrote their ideas on the board were able to discuss and clarify them, then we all graded five we liked and five we did not, with discussions as to which were the favorites. Using this quick rating system we were able quickly eliminate less feasible options like the prop fouler in order to focus our more rigorous evaluations on realistic solutions like the bicycle options.

The main goal of this project is to make an attachment that goes on quickly and can be stowed on the wheelchair. In order to quickly stow it we determined that it must fold, and choose to design the system around the drive-system folding mechanism. Because of the collaboration with MIT and the implementation of their current device, we choose a modular approach to our design. A modular approach would allow us to be more flexible in the details of our design, like the cranks and mounts, as more information about parts availability and other factors became available throughout the process. We defined the drive-system folding mechanism as the system that transfers power from the user to the road; the wheel, chain or chains, gears, supports and steering column.

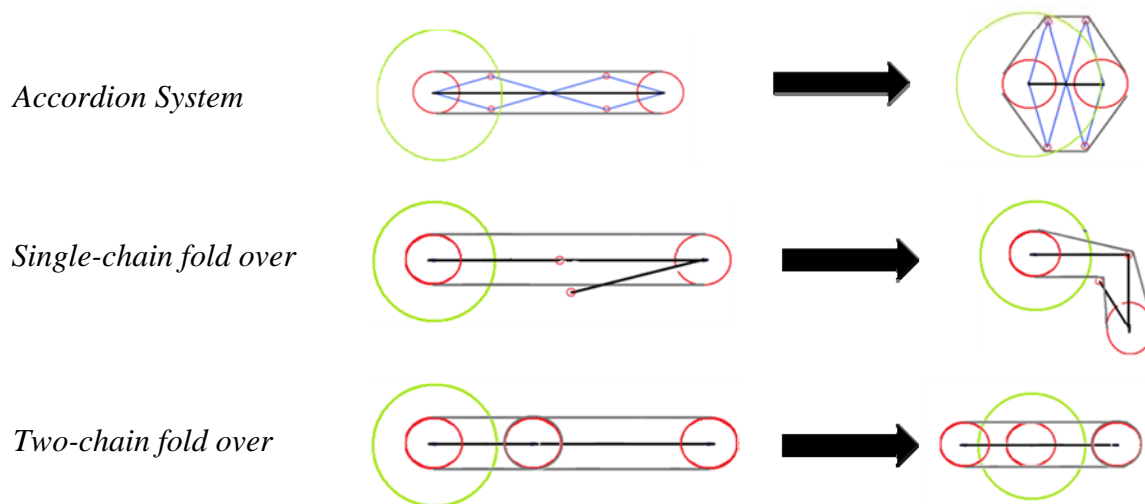

Figure A.12: Shows three possible folding mechanisms

After our initial brainstorming and screening we came up with three possible ways to fold the drive-system: a two-chain fold over, one-chain fold over, or accordion style, shown in Figure A.12.

Accordion System

The accordion system was inspired by the scissoring motion of an accordion or wine rack. It used a complex linkage of bars joined by channel guides to compact. The idea was that the angle between the bars would decrease, with the guides pushing the chain outward, until the system was a more circular package, with an overall footprint similar to that of the wheel. It was the most complex system, using numerous moving parts.

Single-chain fold over

The single-chain system was similar to the two-chain, but used a small guiding channel and chain-tensioner when folded. When in use, the system would operate similar to a standard mountain bike with the chain connected only to the crank, wheel and tensioner. To fold it, one would unlock the system and run the chain through the channel guide, with the tensioner keeping it intact while they folded it into the 'L' shape shown in Figure A.12. This system was simple but there were concerns over the added cost and availability of a chain tensioner.

Two-chain fold over

The two-chain fold consists of two chains connected in series by a gear, which also serves as the folding point. The two chains would remain attached even when folded, but add additional parts and complexity to the system. The goal here was to have the upper mechanism fold entirely over the wheel as shown in Figure A.13. The mechanism was inspired by a future cycle designed by David Fionik, a Polish design student for a NASA "Create the Future" contest.

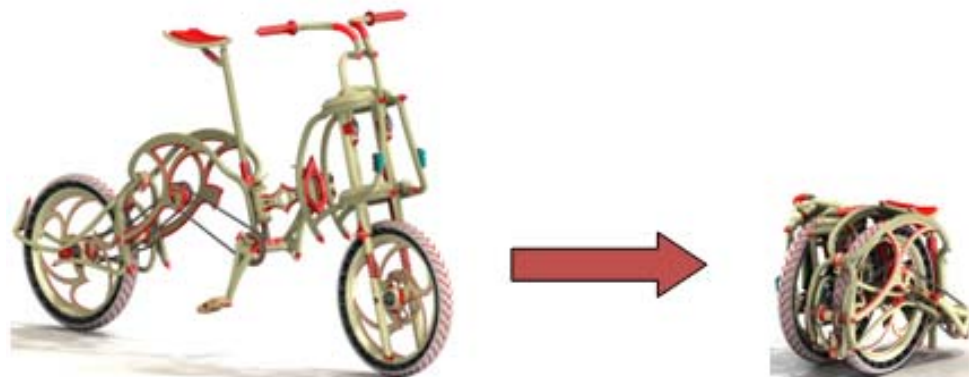

Figure A.13: David Fionik's Bicycle Design

The next step was to evaluate these folding mechanisms with our engineering tools in order to form the core of our design. We would then analyze the best options for each subsystem of the mounting bars, brakes, hand crank, and method for stowing in order to provide the best solution for the mobility needs of Tanzanians.

In this section, we highlighted a few methods that we examined to fold our attachment device. The rest of our ideas and rough sketches from our concept generation for the other subsystems are shown in Appendix V. In order to better visualize the different subsystems, Figures A.12 provide a breakdown of where the subsystems fit together.

CONCEPT SELECTION

The purpose of this section is to outline the method we used to evaluate the concepts we generated and single out an alpha design for pursuit.

Design and Concept Evaluation

In order to reach a single design from all of the concepts we generated in brainstorming, we used a methodical ranking system in order to determine the best concepts for each main component of the attachment. The main components that we used were how the drive system would be folded, the attachment method, the stowing location, the stowing method, and the type of wheel to be used.

Since our project is unprecedented, we were not able to use a traditional Pugh chart with a datum to compare to, so we modified the system to suit our project in particular. Similar to a Pugh chart, the columns going across were different options or design concepts and rows going vertically were different design criteria and customer requirements.

However, inside the matrix, instead of scoring each option against a datum as -1, 0, or +1, we ranked each option from best to worst against each criterion. For example, if there were 4 different options considered, each option was ranked from 1 to 4, 1 being best and 4 being worst. After evaluating each ranking each option against each criterion, the total ranks were summed for each option. The option with the lowest total score was considered the best choice using our ranking matrix.

For each of the 5 main components, we considered 3 to 6 different design concepts that were gathered from brainstorming. Next, we chose 5 to 10 different criteria to evaluate against. For each of the main components, we compiled a list of criteria that we determined to be the most important and crucial to the success of our project.

The actual ranking matrices we used in our decision making process can be seen in Appendix L.

The ranking system was used to help us decide on concepts generated for the folding system, the stowing location, the stowing method, and the attachment mechanism.

Folding Drive System

We deemed the folding drive system to be the most important aspect of our design. Because of this, the choice that arrived from this selection partly governed choices from other aspects of the design. We were willing to make sacrifices in other aspects in order to be able to use the best design that arose for folding the drive system. The concepts we considered after brainstorming were the accordion system, the single-chain fold over, and the two-chain fold over. Descriptions of them can be found in the concept generation section on pages 19 and 20.

Folding drive system selection

To evaluate the folding drive systems, we used the modified Pugh chart shown in Appendix L(a). The customer requirements of size, light weight, durability, easy to use, easy to repair, and low cost were selected as evaluation criteria. Additional criteria we chose were number of parts and visually appealing since they were directly related to the performance of the folding drive system.

A low of number of parts is desirable since it leads to a simpler and easier design. Visually appealing measures how aesthetic the device is and can be important to get users to accept the design initially.

After applying the matrix and scoring, the two-belt fold over design ranked the best. This will be the folding drive system concept that we strive towards and will help govern other aspects of the overall attachment.

Stowing Location

In considering where the attachment should be stored on the wheelchair while it is not in use, the most feasible locations are behind, on the side, and underneath the wheelchair. Another possibility was an attachment that could be disassembled, allowing the parts to be spread across different locations on the wheelchair.

Behind The back of the wheelchair would provide ample space for the attachment to be stowed away. The big problems with this location would be issues with the high center of mass and how the user would need to twist around and reach behind their chair to stow the attachment.

On the side The side of the wheelchair would be extremely easy for the user to reach and also provides a great amount of space for the attachment. However, stowing it on the side would limit the user's mobility in its stowed state, because of the added size on the side of the wheelchair.

Underneath Underneath the wheelchair would be an easy place for the user to reach, very minimally impede the user while stowed away, and be very stable since the added mass would be very low on the chair. The main issue with this location would be the very limited space that is available because of the supports and the cross-brace located beneath the chair.

Spreading it out Spreading the parts out would be excellent for space issues, since large parts, like the wheel, could be stowed on the back, while the rest of the attachment could be easily placed underneath the chair. The primary issue with this is its complexity and how it requires the user to assemble and disassemble the attachment.

Stowing location selection

To evaluate the different stowing locations, we used the modified Pugh chart shown in Appendix L(b). The customer requirement of easy to use was chosen as an evaluation criterion. Stability, impedance, adaptability, and space were also chosen as evaluation criteria, because they were directly related to the strength of the stowing location.

Stability referred to center of mass and how stable the wheelchair will be while the attachment is stowed away at the location. Impedance ranked how intrusive the attachment would be to the user in the particular location. Adaptability was a measure of how easily the location could be applied on different wheelchairs. Finally, space was a measure of the space available for the attachment to be stowed away.

Each option scored very similarly, they were all viable options. We decided to design to an underneath location, because it works the best with the two-chain fold over system. The attachment arms can be very conveniently placed underneath the chair and above the cross-brace.

Stowing Method

One of the critical components to the design is how the attachment will be stowed when it is not in use. A faulty stowing design will lead to the user not wanting to have it on their wheelchair and ready to use whenever he or she needs it. The goal is to have an effective mechanism that encourages the user to have the attachment ready at all times. We reduced our initial brainstorming concepts to a bag, a shelf, a sliding rail, straps, fasteners, and a mechanical arm.

Bag For the bag, the attachment would simply fold up and be put inside the bag. For storage below the chair, some sort of hooks or mounts would be placed for the bag to hang from. If the bag were stored behind

the chair, it could be hung from the rear push handles. The advantages of using a bag would be its very low cost, its ability to be adapted to many different wheelchairs, and its ease of repair. A bag's disadvantages would include issues with durability and ripping and problems with keeping the bag secure on the wheelchair. While the bag is hanging, it can swing and cause problems with momentum, hitting parts of the wheelchair, and noise.

Shelf The shelf would be mounted the wheelchair and create a compartment for the attachment to rest on. The main advantage of using a shelf would be its ease of use. The user could just easily set the attachment on the shelf and not worry a lot about making sure it is placed in a certain way or using a certain method. The shelf is disadvantageous in its size, weight, and ability to keep the attachment secure. While traveling with the attachment on a shelf, extra precautions such as shelf walls or straps would be needed to ensure that the attachment does not slide or move much or even completely off the shelf while it is stowed away.

Sliding rail A pair of sliding rails was a concept generated that would allow the attachment to easily slide and secure into place onto the wheelchair. The rails would work similarly to drawers on a dresser or desk. Advantages of the rails would be its ease of use and its ability to keep the attachment secure in place like a drawer. However, the main disadvantages of these rails would be difficulty in repairing them and adaptability to a wide range of wheelchairs since distance between the rails becomes a large issue in designing them.

Straps Straps could be used to very simply tie the attachment to the wheelchair while it is not in use. The straps could come in the form of Velcro, snapping buttons, buckles, etc. They could be used virtually anywhere on the wheelchair, are extremely lightweight, and are minimal in cost. However, straps would be difficult to use, since the user would have to hold the attachment in place with one hand and strap it in with the other. This would also cause issues with making sure the attachment is securely locked onto the wheelchair. An unsecure strapping would allow the attachment to easily fall off the wheelchair.

Fasteners Fasteners, such as nuts and bolts, could be used to secure the attachment directly to the wheelchair itself. Similarly to straps, they could be used all over the wheelchair and are very lightweight. They would also be able to very securely lock the attachment in place on the wheelchair. The problems with using fasteners would be its difficulty in use, since the user would have to fasten the attachment on while holding it steady.

Mechanical arm A more outlandish concept we considered was the use of a mechanical arm. The idea behind this was to design the attachment so that it would never have to be detached. The mechanical arm could swing do different parts of the wheelchair and allow it to be stowed away in many different areas, and it would take away any hassles of the attaching and detaching processes. While it would be very easy to use an idea like this, it would be quite expensive, be very heavy and bulky, and be very difficult to repair.

Stowing method selection

To evaluate the different methods of stowing, we used the modified Pugh chart shown in Appendix L(c). Customer requirements of size, lightweight, durability, easy to use, low cost, and easy to repair were selected as evaluation criteria. Additional criteria directly related to the stowing mechanism in particular of number of parts, adaptability, and security were selected.

The number of parts is a ranking based on how many parts are used in the mechanism. A lower number of parts is desired since it drives simplicity. Adaptability ranked the ability for the mechanism to be possibly

used on different wheelchairs. Security ranked how well the mechanism locks the attachment in place while it is not in use.

While the bag ending up scoring the best, the straps and the fasteners were very close behind and were treated as viable options as well. We chose to go with the straps because it was the best fit in considering our two-chain fold over system. The straps would easily allow the attachment to sit underneath the chair and strap it in place while it is stowed.

Attachment Device

One of the most important features of our wheelchair attachment is the ability for the user to remove the device when it is not in use. Therefore, the mechanism that we use to attach the third wheel to the wheelchair will greatly affect the way that the consumer uses our attachment.

After refining our initial ideas from brainstorming, we created a variety of specific methods that would all achieve the task of keeping the attachment fastened to the wheelchair during use. These ideas are sliding, the triangle clamp, vice grips, the master lock, and the tri-clamp. Visual representations of these devices can be seen in Appendix N.

Sliding The sliding mechanism takes advantage of its unique shape to help the user install the device. The outer shaft of the sliding mechanism would be permanently fastened to the structure of the wheelchair. The inner shaft connected to the attachment would slide into the outer shaft when the unique shape of the shafts line up. Once they slide into place, a pin could be used to secure the bars in place during use of the attachment.

Triangle The triangle device describes a mechanism that has three static bars perpendicular to the attachment arm. These three bars slide over a joint in the wheelchair frame. The shape of this joint and the three bars lock the wheelchair attachment in place. The static nature of this attachment mechanism means that it will be very easy to manufacture and will require a small number of parts. On the other hand, since the bars are not free to move around the wheelchair, a hinged frame must be developed for this mechanism.

Vice Grip The vice grip attachment mechanism was taken from the attachment that the team from MIT created. The team used three commercial vice grips welded to their attachment's frame that would clamp onto the wheelchair frame bars. This method is very simple to implement and is very easy for the user to understand. Vice grips can apply a large gripping force on the wheelchair frame with a minimal force requirement from the user. Additionally, removal is just as easy with the spring loaded latch on the tool. The size of the vice grip's jaws can be adjusted to accommodate a variety of wheelchairs. The major drawback to using vice grips as an attachment method is that they are costly. Three vice grips would make up the majority of our \$24 price target of our attachment.

Master Lock The Master Lock concept was inspired by the small master lock brand locks. The locking arm of these locks is free to rotate in the device. The end of the attachment arm to the wheelchair would be placed next to the frame of the wheelchair. The curved locking bar slides out, rotates around the bar and then is brought back through a hole on the attachment bar before being clamped down with fasteners. A problem with this method is the need for fasteners that are being repeatedly used is that they can be lost and can be very difficult for a person to manipulate. On the other hand, this will be very easy to manufacture and will not add much cost to the device because of the low number of complex parts that are required in the design.

Tri-clamp The tri-clamp attachment describes a mechanism which has three fingers that grip the front bar in the frame of the wheelchair. Two of the fingers act as an anchor for the bar while the third finger is used on a ratchet below the bar. As the ratchet is engaged by the user, the bar pushes up on the wheelchair bar. This will cause the attachment to lift the wheelchair's front wheels off the ground while at the same time being tightened onto the wheelchair. Therefore, this attachment method will allow the user to install the attachment in far fewer steps than the current design.

Attachment device selection

In order to evaluate our ideas in terms of our design requirements we used the modified Pugh chart shown in Appendix L(d). The majority of evaluation criteria used was based upon our customer requirements identified in our QFD diagram. These include the criteria of light weight, durability, easy to use, low cost, and easy to repair. In addition to these, we added evaluation criteria that were directly related to the performance and use of an attachment system. These include grip force, size of attachment method, easy to machine, steps required by attachment method to install/uninstall, number of parts, and adaptability.

Grip force describes the relative ability of the attachment method to hold the attachment in place during use; large force is better. The size of the attachment method describes the physical size of the attachment method; smaller size is better. The criteria easy to machine indicates the relative ease which this attachment method can be manufactured; higher ranking indicates a device that can be more easily manufactured. Steps required by attachment method to install/uninstall indicated the number of steps that the user will need to execute to use this method to install and uninstall the extra wheel to the wheelchair; lower number of steps is best. The number of parts criteria describes the number of parts that would be used on the attachment method; lower number of parts is best. Finally, adaptability describes how easy the attachment method is to use with a variety of wheelchairs; a high ranking here indicates that the attachment method is able to be used on a variety of wheelchairs with little to no modification.

The modified Pugh chart shows that even with the wide variety of attachment methods evaluated, the scores were still very close. While no single method excelled above the rest, no single method performed much poorly than the rest. Therefore, we have some freedom to select which attachment device we will be using as a part of our Alpha Design. From the Pugh chart analysis we chose to further examine the master lock and the tri-clamp methods of attachment. While the tri-clamp did not do extremely well in the Pugh chart, we believe that it remains a worthy attachment method that we will pursue.

For the alpha design, we have chosen to focus on the tri-clamp method because we believe the difficulty to manufacture and slightly higher cost will be properly balanced with the benefit it provides to the consumer. The tri-clamp idea will make the attachment easy to install and uninstall on the wheelchair because it will aid the user in these processes. Additionally, the mechanism will be adaptable to a variety of wheelchairs making it a better option than something like the triangle mechanism which can only be used with a specific wheelchair frame size. The ratcheted tri-clamp allows the mechanism to grip the wheelchair frame with a large force so that the clamp will not slip and makes the attachment sturdy. One disadvantage of the tri-clamp device is its moderate production cost. Because it is a complex device it will be more expensive to make. Additionally, because of the device's complexity, it will be difficult to manufacture.

FINAL DESIGN DESCRIPTION (BETA DESIGN)

This section will describe the functions of our beta design. The naming conventions will provide a standard for explaining the rest of the section. The major dimensions will give a basic size reference. The attachment implementation will establish a procedure for use as well as give basic ideas of how the components of our device

work. The system breakdown section will address the considerations that went into the attachment arm and folding drive systems. NOTE: The chain or gears have not been modeled because of their complexity. The length of chain and gear size that is being used has been accounted for in the beta design and is documented in the gear ratio section.

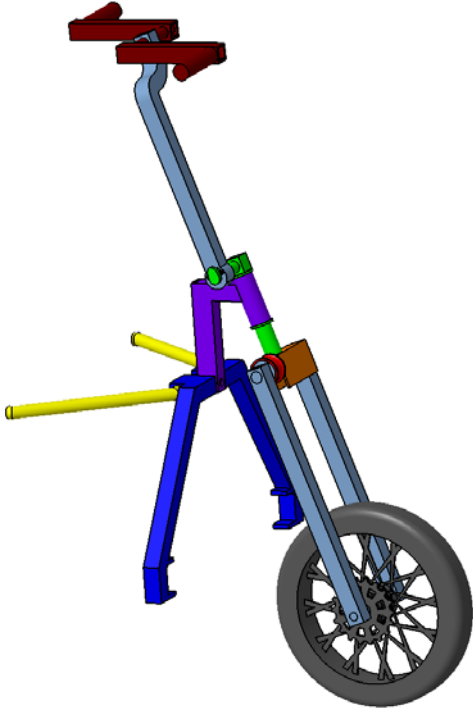

Figure A.14(a): Unfolded attachment

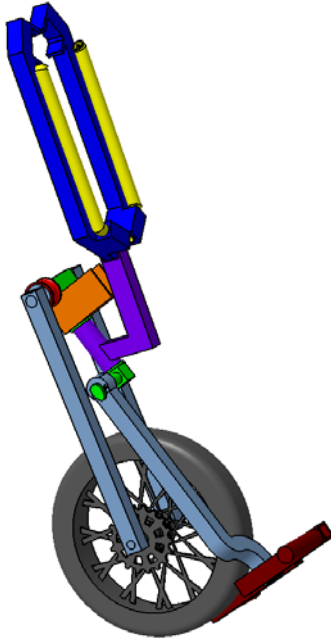

Figure A.14(b): Folded attachment

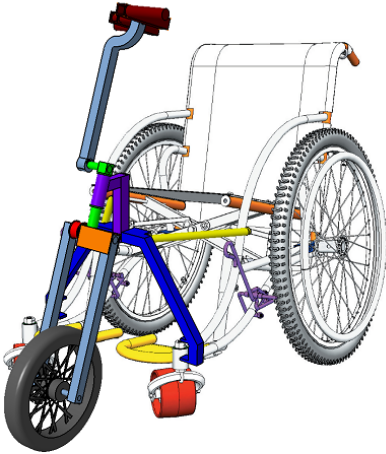

Figure A.14(c): Attached attachment

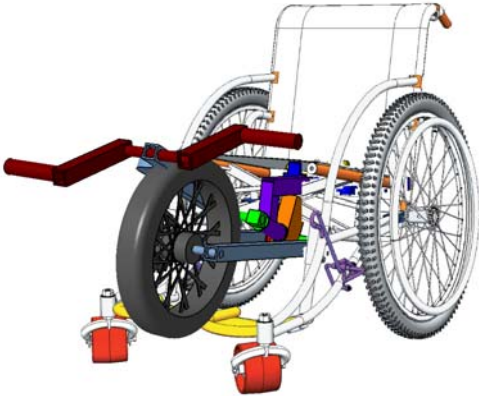

Figure A.14(d): Stowed attachment

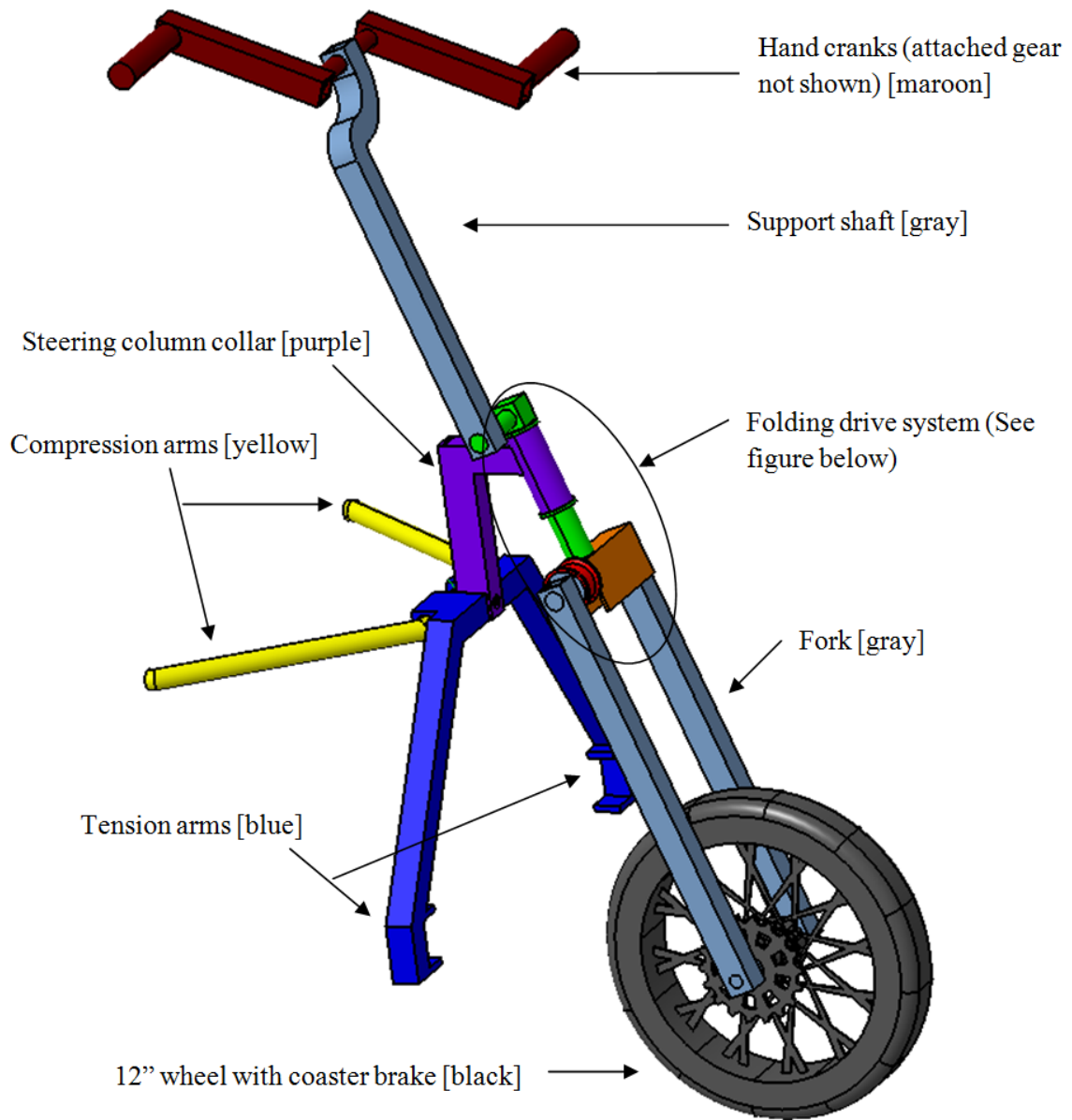

Figure A.15: Naming convention for beta design

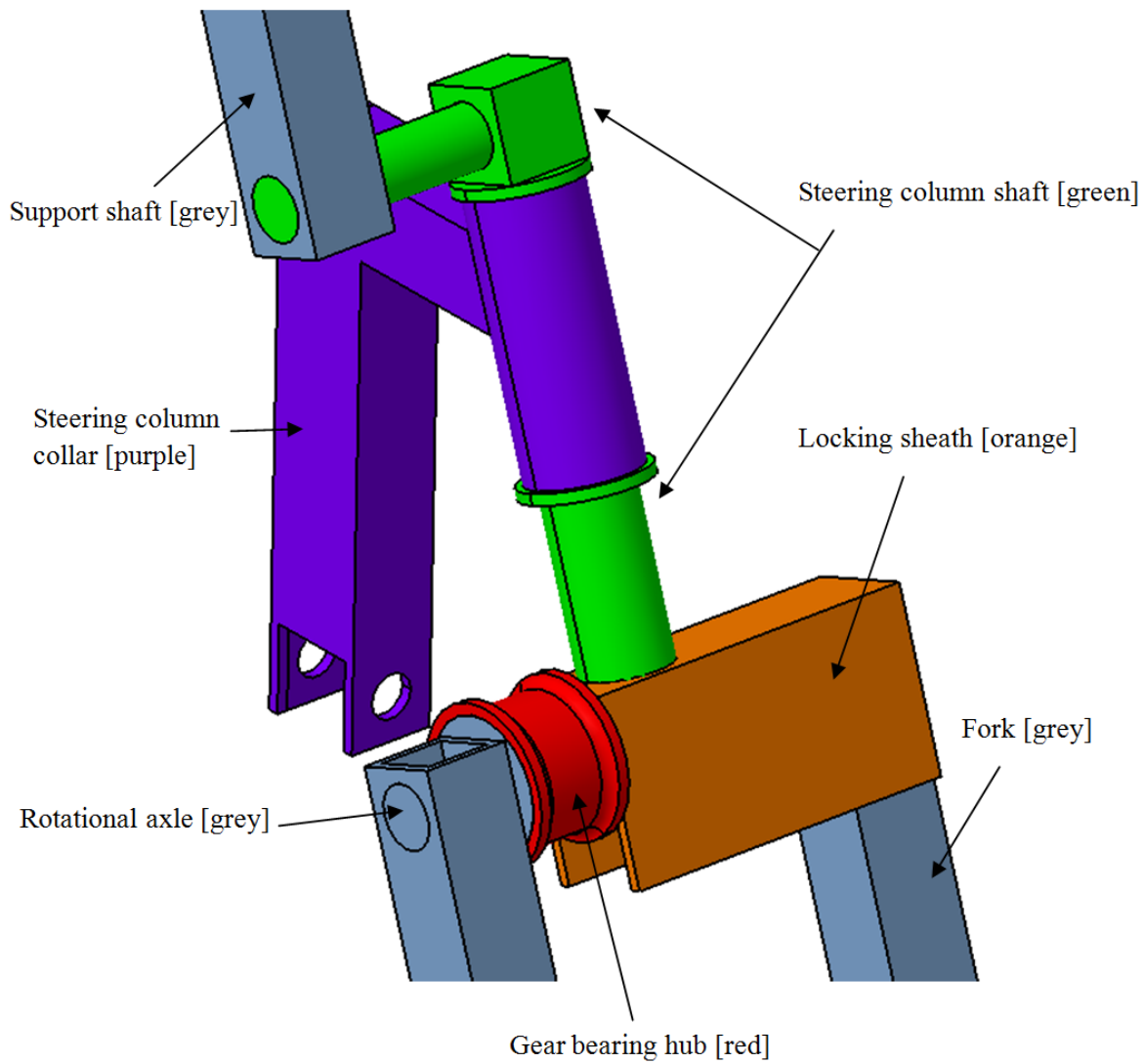

Figure A.16: Naming convention for folding drive system (locked)

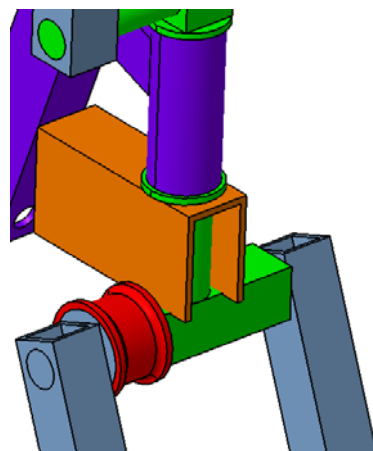

Figure A.17: Folding drive system (unlocked)

Major dimensions

The following figures show the major overall dimensions of the attachment in its folded and unfolded states.

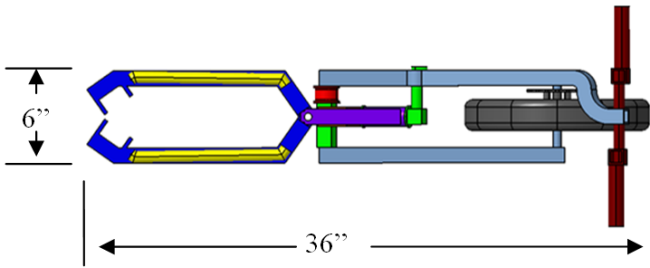

Figure A.18(a): Folded length and attachment arm width

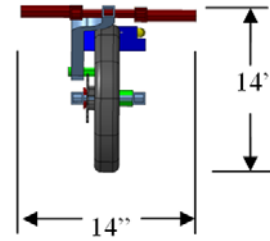

Figure A.19(b): Folded height and hand crank width

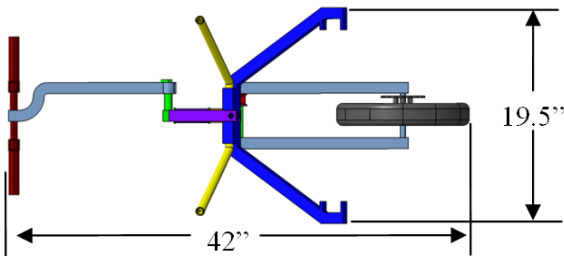

Figure A.20(c): Unfolded length and tension arm width

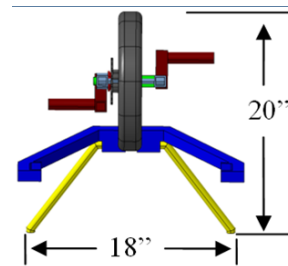

Figure A.21(d): Unfolded height and compression arm width

Using the attachment

This section describes each step that is necessary to properly utilize the device.

Step 1 - Attach the compression insert bracket onto the frame of the Whirlwind Roughrider in the location shown in Figure 48.

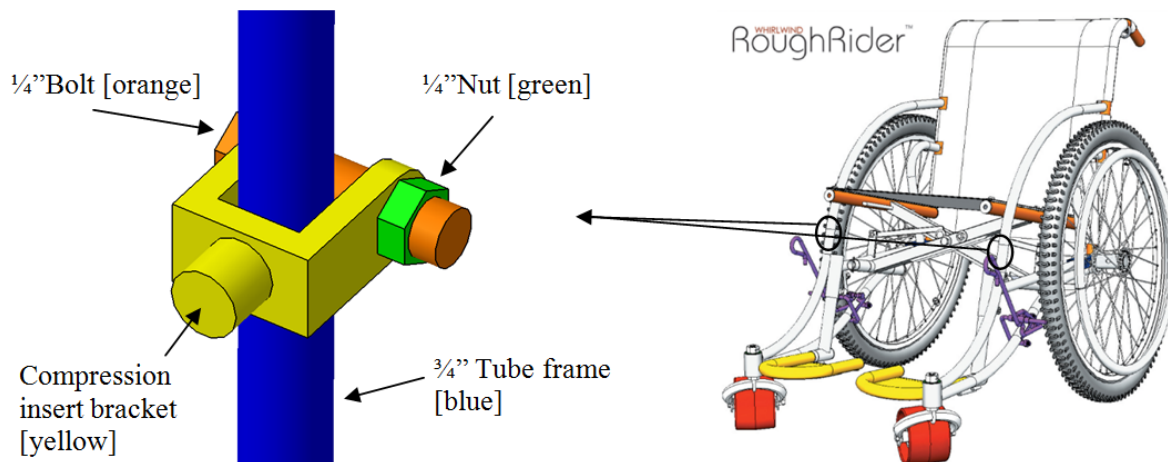

Figure A.22: Compression insert bracket arrangement around tubing and positioning on Roughrider frame

Step 2 - Unfold drive system about rotational axle so that the locking pin can be inserted into the side fork arm (Figure A.23).

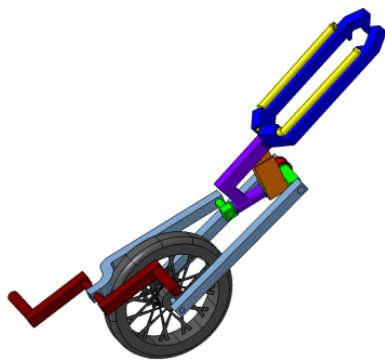

Figure A.23(a): Fully folded device

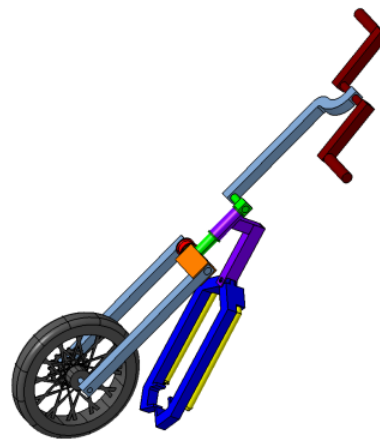

Figure A.23(c): Drive system locked with sheath slid down around fork and steering column shaft

Step 3 - Unfold tension arms and attach around frame at the location shown in Figure A.24. Ensure that the attachment arms are squeezed together so that the attachment hands are fully around the frame. Make sure that the hands are pushed forward all the way against the caster wheel bearing assembly.

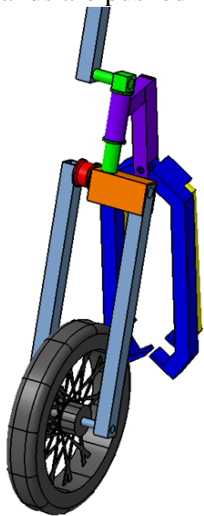

Figure A.24(a): Folded tension arms

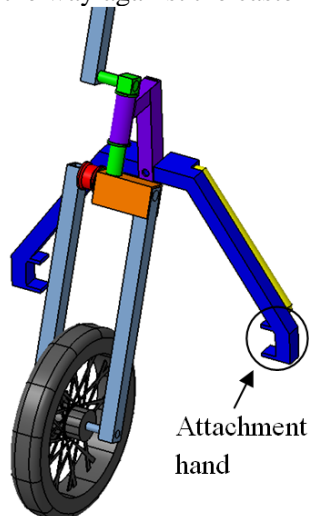

Figure A.24(b): Unfolded tension arms

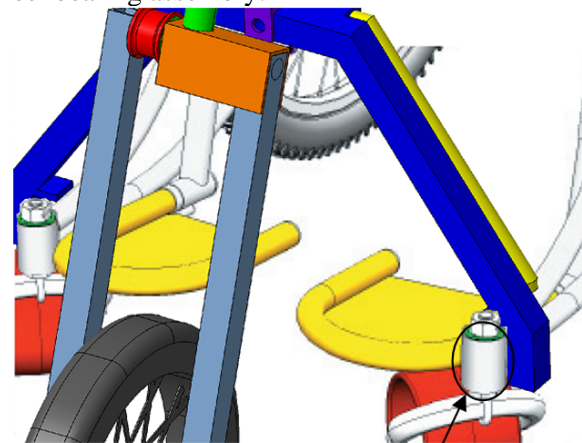

Figure A.24(c): Tension arms attached to wheelchair

Step 4 - The attachment is now ready to be fully attached and is in the position shown in Figure A.25. Push the top of the steering column shaft forward far enough so that with your free hand you are able to rotate the compression arms upwards so that they align with the compression insert bracket.

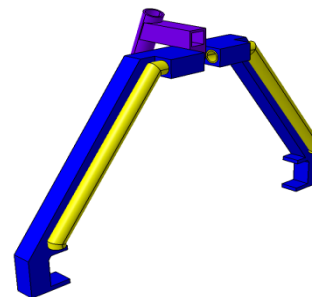
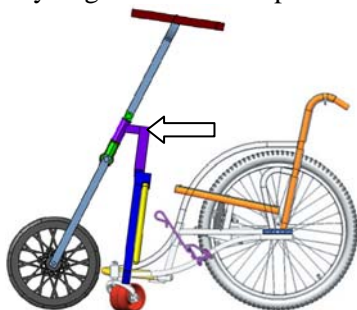

Figure A.25(a): Push forward to rotate casters upward

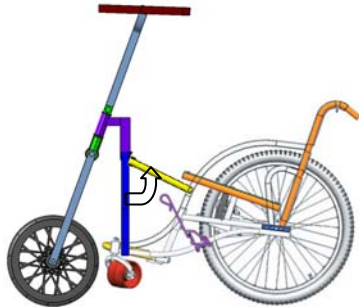

Figure A.25(c): Rotate compression arms upward and align with compression insert bracket

Figure A.25(b): Compression arms rotated down

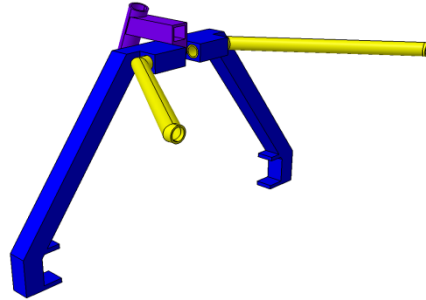

Figure A.25(d): compression arms rotate upward

Step 5 - Rotate support shaft about its attachment with the steering column shaft to achieve a desirable hand crank position. Once the desired position is found, slide the support shaft outward from the steering column shaft onto the desired pin setting. Use a cotter pin or bolt on the opposite side of the support shaft to prevent the shaft from sliding off of the pin.*NOTE: This step is only done when initially adjusting the angle to the user.

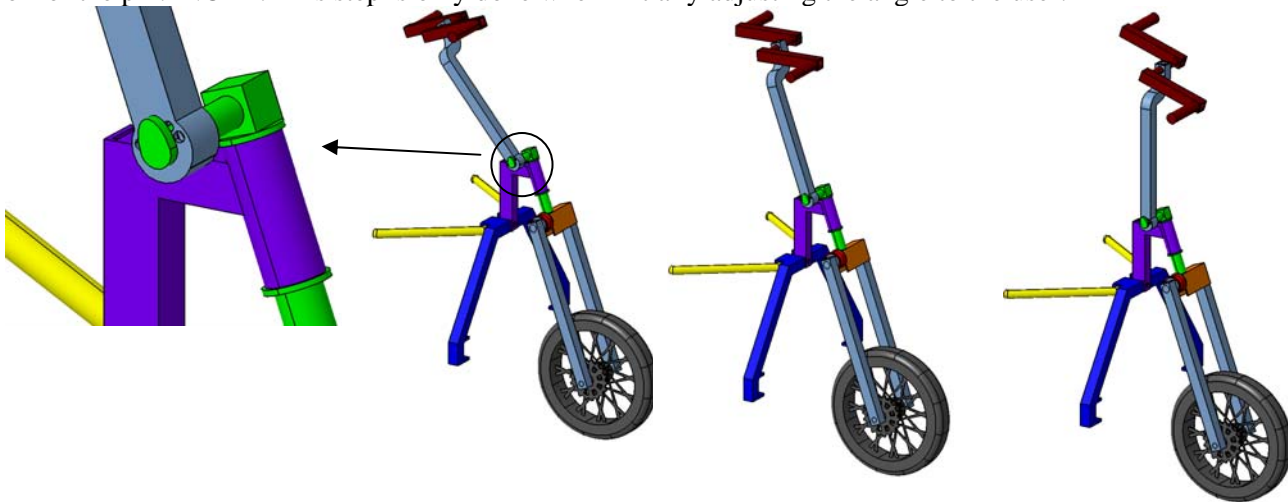

Figure A.26(a): Angle lock

Figure A.26(b): Short user

Figure A.26(c): Average user

Figure A.26(d): Tall user

System Breakdown

This section will address the problems and considerations we faced while developing the attachment arm and folding drive systems of our beta design.

Attachment arms

While trying to develop an attachment system we ran into problems that involved the user interaction and geometrical orientation.

User Interaction The three main user interaction issues we faced were the clamping force required to attach the device to the wheelchair, the attachment bars interfering with the users' legs while the device is in use and also when the device is stored.

Our alpha design had a complex clamping device that would have required a user input force that far exceeded the force of 5kgf established by Whirlwind International in a five year study. The force that the user had to input was determined by mocking up the attachment and attempting to fix it to the wheelchair. It was difficult to physically measure this force so we applied a force to a bathroom scale to establish what a 5kgf felt like. We then tried to apply

the same force to the mocked up prototype. The force that was finally required to engage the clamp was gauged to be nearly 10 times that of the force that we had measured on the bathroom scale. Another issue with the clamping movement was that there was no simple and easy-to-manufacture way to secure the clamp in place once the force had been applied.

When the attachment arms are in use we had to ensure that they did not injure the user or interfere with their natural posture. With the existing non-foldable third wheel wheelchair attachments, this is normally not an issue. However our problem differs from those devices because we have to try and compact our attachment arms much more than the current products. While trying to develop a safe and robust attaching system we had to also consider this compactness. We ran through a number of possible designs. We still felt the best storing option was beneath the wheelchair so we tried to design an attachment system that could be folded up and stored either around or on the cross brace that is under the wheelchair. We found that the best configuration for ease of storing the attachment arms was on top of the cross brace. We established this by taking a number of PVC tubes of a number of different diameters and trying to put them underneath the wheelchair while we sat in the chair. Once we determined this was the best arrangement we tried to establish what dimensional constraints we were dealing with. We determined that a 6 inch was the largest width possible before the attachment arms would begin to interfere with the user's seat or legs.

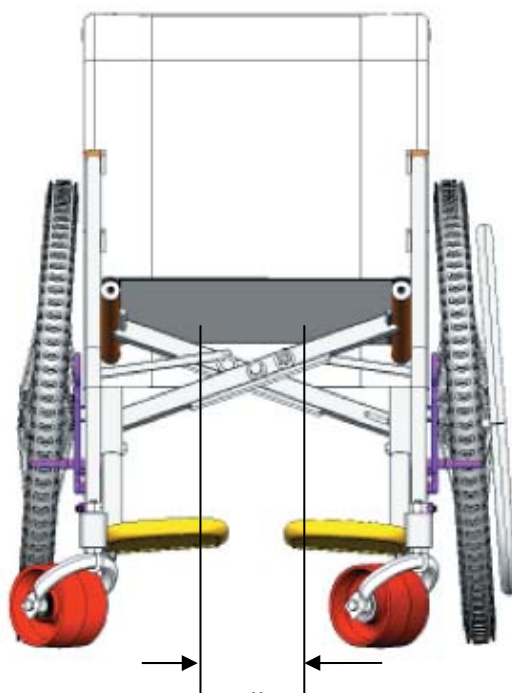

Figure A.27: Storing configuration under chair which drove attachment arm specifications

Once we had the folded attachment arm dimensions we began brainstorming for how to best fold the attachment arms to match these dimensions. We mocked up a number of possible designs in PVC and tested them under the chair. A problem with mocking up the designs in PVC was that PVC could not easily be bent and therefore we could not simulate an angle tube. We wanted to simulate an angled tube because one of our folding designs had the attachment arms fold in on each other and the different widths can be seen in Figure A.28. A tradeoff with the rounded tube is that it does not provide as much space for the users legs when the attachment is in use.



Figure A.28: Squared and rounded tubes that pivot about the same axis and have the same end points will have different widths when folded

We came up with a number of designs that utilized the curved tube. We settled on a final design after eliminating a number of other concepts because of their complexity to manufacture, attach, and store (Figure A.29). This design had a folded width of the desired 6” and our preliminary CAD model testing and crude PVC model indicates that neither the tension arms nor compression arms interfere with the users’ legs.

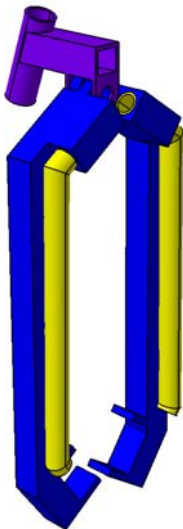

Figure A.29(a): Folded attachment arms

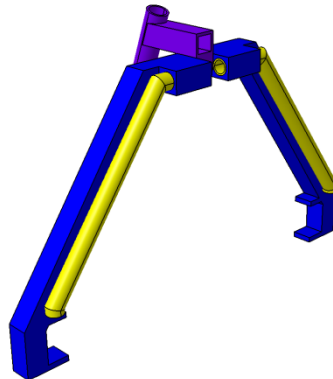

Figure A.29(b): Unfold the tension arms

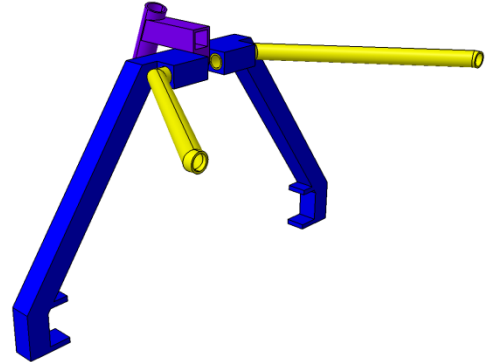

Figure A.29(c): Unfold the compression arms

Geometrical orientation The main geometric issues we faced while designing the attachment arms were where on the wheelchair the arms would attach and how the attachment arms would be in relation to the drive system of the device.

It took us a while to determine where exactly we wanted the attachment points to be on the wheelchair. We took a lot of inspiration from the MIT attachment design. We determined that our alpha design would put too much force on the wheelchair frame and possibly cause the tube to be crushed (Figure A.30).

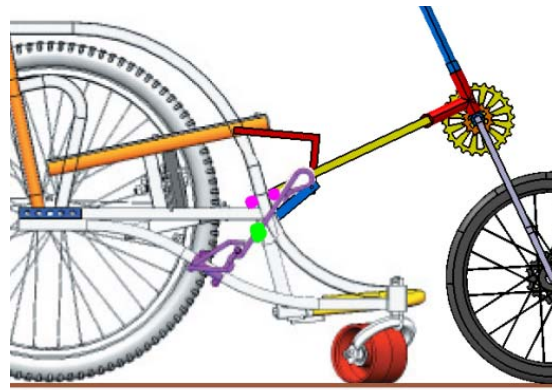

Figure A.30: The alpha design attachment points close proximity to each other causes a concentrated stress and bending moment on the wheelchair frame

After we used the MIT design and took it on and off we were more aware of the forces that were required to rotate the chair upwards and put the device into use. As can be seen in Figure A.31, the MIT design uses compressive and tensile forces on the wheelchair that are roughly offset by 30 degrees.

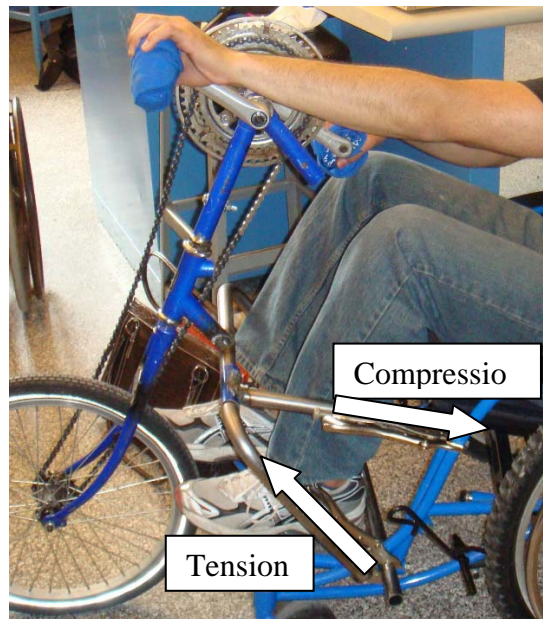

Figure A.31: MIT wheelchair attachment design

We took the MIT design one step further and moved the tensile bar even further out on the wheelchair so that the compression and tension are roughly 60 degrees offset (Figure A.32).

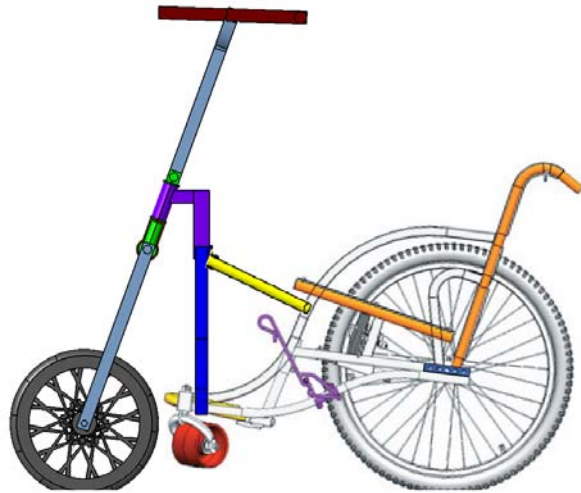

Figure A.32: Attachment arm configuration for the beta design

We found that by moving the tensile bar further out on the footrest of the wheelchair, the force required to rotate the wheelchair into position for locking is significantly smaller than the MIT design.

Once we determined where the attachment arms would attach to the wheelchair we needed to figure out how they would then be attached to the drive system. We have devised the simple solution of having a 90 degree tube come out from the steering column collar at an 80degree angle. We have yet to determine the ideal height and width of this component but given the simplicity of the design it should be relatively easy to determine the configuration once we begin prototyping.

Prototype description:

The folding two chain drive system that we have design works because the gear bearing hub and steering column shaft can both rotate independently of each other. Furthermore the steering column shaft can be locked in place and the gear bearing hub can continue to rotate freely.

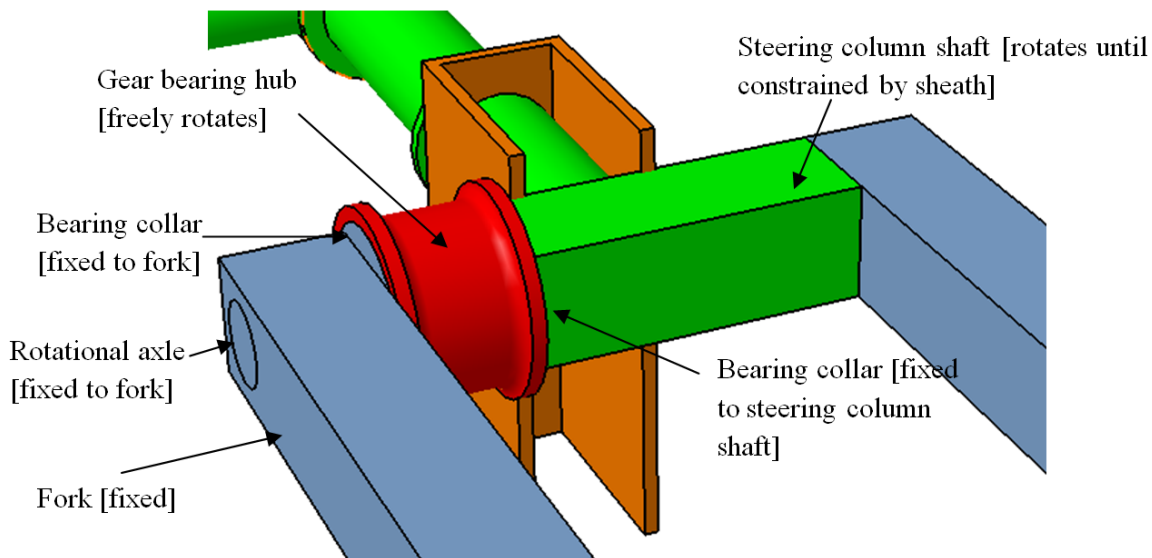

Figure A.33: folding two chain drive system

The placement of the attachment arms on the wheelchair will work because it is a basic improvement on the proven MIT design.

The coaster brake arrangement on our design is going to work because it is an off the shelf product and is not being modified in any way. Coaster brakes are widely used in similar devices already and they have been proven to work. We will however test the effects that the torque arm from the coaster brake has on the fork and frame once it has been implemented on the prototype.

The trail of 6 cm giving a rake angle of 80 degrees is going to work because we used information from a five year study done by Whirlwind International. We are not allowed to share this information publicly because we have a non-disclosure agreement with our contact at Whirlwind International.

Problems

Folding drive system The issues that we need to further explore with regard to the folding drive system are the chain and gear placement, hand crank location, and possibly folding the hand cranks.

Chain placement We need to consider the chain going from the hand crank to the folding hub and make sure that it does not hit the support shaft, steering column collar, or the attachment arms when the user is steering. We need to consider the chain going from the folding hub to the coaster brake and make sure that it is properly aligned with the coaster brake gear, that it does not hit the fork or wheel, and that it does not rub against the other chain. Another key issue is determining which side we should have the coaster brake gear on so that the proper pedaling motion drives the attachment forward and not in reverse.

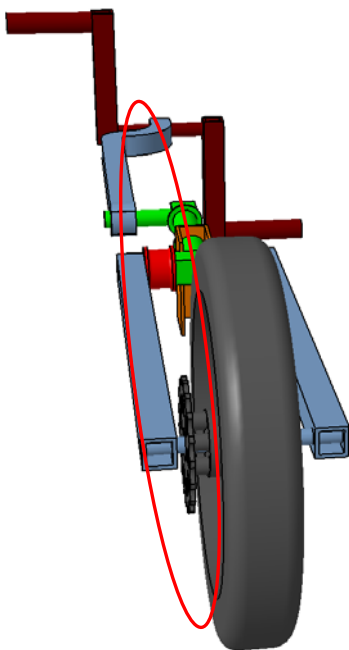

Figure A.34: Alignment of chain needs to be explored further

Hand crank location We need to consider where the hand crank will actually be located and how it will be fixed to the support shaft. We know that we want it to be approximately 3 feet away from the wheel hub. Aside from that we do not know that it has to be in line with the steering axis. We need to do a considerable amount of research into this and testing as well. The hand crank location is going to affect the gear location and chain going to the gear bearing hub.

Folding hand cranks As of right now the widest part of the design when folded is from the hand cranks. We do not have them compact in anyway whatsoever. Neither we nor our mentor have identified the compacting hand cranks as

a serious user concern. Once we complete the rest of the design, if the hand cranks are a serious impediment, we will attempt to design a way to fold the handles down.

Attachment arm system The issue that we need to further explore with regard to the attachment arm system is the securing of the tension arms to the frame. The rest of the issues such as the geometric orientation and the user interaction have already been addressed in the system breakdown.

Securing of the tension arms - Our beta design does not have anything preventing them from sliding off the attachment sideways. We believe that the upper force on the pin will cause the arms to be pulled inwards at the attachment point by using the same principle that is used for ice tongs. (Figure A.35) We can use our beta design, but we need to consider the possibility that this may not work and design for a type of clamping mechanism at the tension arm attachment hands.

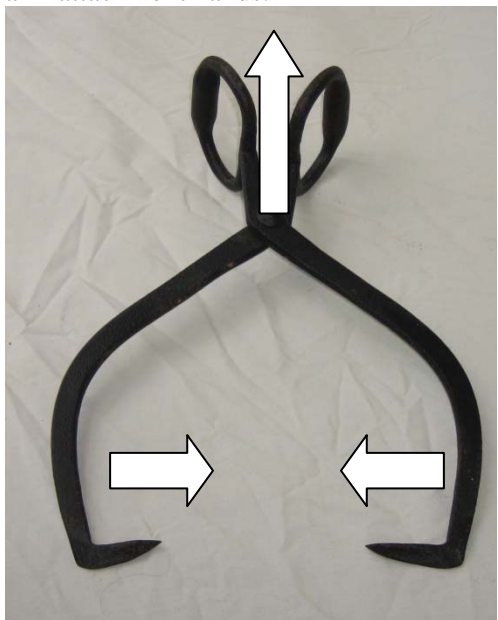

Figure A.35(a): Ice tongs
(<http://jamescolabella.com/icepick.jpg>)

Figure A.35(b): Man carrying block of ice with one hand
(http://tbn0.google.com/hosted/images/c?q=aa1750137269393f_landing)

ENGINEERING DESIGN PARAMETER ANALYSIS

The purpose of this section is to show the approaches used to arrive at the various design parameters in the project.

Material Selection

In order to properly design our wheelchair attachment device, we must first decide what material we will use for the bars and linkages in the device. For this project, our material selection has been very limited to mild steel because that is the main material that is available to workshops in Tanzania and the developing world where our device will be produced. However, this section will show the complete material selection process using the CES EduPack software as if there were no limitations on what material we could use in our device. Full details of the analysis can be seen in Appendix D.

Gear Ratio

Choosing an appropriate gear ratio for our wheelchair attachment device is very important because it will greatly affect the user's perception of the device. An appropriate gear ratio is one that balances the need of

the user to propel himself long distances in a short amount of time and the ability of the user to climb slopes efficiently. The gear ratio indicates the number of times the bottom wheel rotates divided by the number of times the user rotates the hand cranks.

The appropriate gear ratio

For the purpose of this project, we do not have enough time to empirically find the best gear ratio for our device. However, there exists existing gear ratio analysis for handcycles. One study published in the Journal of Medical Engineering and Technology shows that when compared to each other, lower gear ratios are more mechanically efficient than the higher gear ratios tested. Additionally, these lower gear ratios provided a less stressful experience with the hand crank wheelchair device than that provided by the higher gear ratios (Ashby). We will need to choose a gear ratio that is just large enough to provide the amount of mechanical advantage to the user that is required. If the gear ratio is too much larger than this minimal amount, it could make the device too difficult for the user to operate. If this becomes the case, the device will not be used.

Aaron Wieler describes in his End of Year Five Project Report released by the Center for International Rehabilitation (CIR) in October 2008 that users in the developing world need to climb slopes of gradient 1:14. Via in house testing at Whirlwind Wheelchair International and the Center for International Rehabilitation, Wieler determined the appropriate gain ratio in order to climb this gradient is [1:1.6] (Wieler). The gain ratio takes into account the crank diameter, wheel diameter and gear ratio. For our folding device, the gear ratio becomes the combination of the two ratios of rotation created by our two chained gear systems. The hand crank is rotating the same rate as the top gear, the wheel is rotating the same rate as the bottom gear and the two middle gears are rotating at the same rate all because these sets share a common fixed axis of rotation – they are not free to rotate different speeds. For this reason, these ratios are removed from the gear ratio formula. Because bike teeth and bike chain dimensions are standardized, the gear ratio formula simply becomes the ratios of the number of teeth, N, on the gears. The formula for the gear ratio of our device is shown in equation 1.

$$Gear\ Ratio = \frac{N_{Top} * N_{Mid_2}}{N_{Mid_1} * N_{Bottom}} \tag{1}$$

The gain ratio incorporates the gear ratio of the device as well as the physical dimensions of the wheel and the crank. The gain ratio becomes the combination of the gear ratio and the ratio of the radius of the wheel to the radius of the crank. Therefore, with the desired gain ratio shown above of [1:1.6], for every meter the user’s hands travel along the crank path, the wheelchair will move 1.6 meters forward. The equation for the gain ratio of our device is shown in equation 2.

$$Gain\ Ratio = \{Gear\ Ratio\} * \frac{R_{Wheel}}{R_{Crank}} \tag{2}$$

Using dimensions for the radius of the wheel (6.0 inches) and the crank (6.5 inches) for our device and the desired gain ratio, the formula for the necessary gear ratio becomes 1.7333 as shown in equation 3.

$$Gain\ Ratio = 1.6 = \{Gear\ Ratio\} * \frac{6.0}{6.5}$$

$$Gear\ Ratio = 1.6 * \frac{6.5}{6} = 1.7333 \tag{3}$$

Achieving optimal gear ratio

For this project, using scrap bicycle parts in manufacturing is key because it shows that the device can be manufactured in developing countries with materials that are readily available there. In order to examine the various gear ratios that we could attain in our device, we took apart two bikes and inventoried the gears that were used in them. Using these gear sizes and a short piece of Maple code (Appendix S), we were able to identify all of the possible combinations of gears to identify all of the possible gear ratios that were possible to create with our available materials. This code dumped these combinations to a excel file (part of which is shown in Appendix T). Using this spreadsheet, we were able to identify all combinations of gears that achieved a gear ratio as close as possible to our optimal gear ratio calculated above. The best gear ratio identified that we can achieve using the gears available to us is 1.7284. We determined this to be acceptable. The gear combination that achieves this gear ratio is shown in Table A.4 below.

Table A.4: Chosen gears that achieve the near optimal gear ratio.

	Gear:	Teeth:
Top (chain 1)	28 C	28
Mid (chain 1)	3 (AFW)	18
Mid (chain 2)	4 (AFW)	21
Bottom (chain 2)	8 (CB)	18

Chain Length

After determining the gears we would use to obtain our optimal gear ratio, we were able to calculate the total length of bicycle chain required to drive our device. The proper length of chain to use is defined as the length required to encircle the two gears being connected plus one inch and then rounded to the next highest integer (in inches) (Ramon). The extra inch is added so that there is adequate slack in the chain when it is being used. The length is rounded to the next highest integer length in inches because of the way the bicycle chain is manufactured. The chain is made up of 1 inch links. Since it is impossible to have a partial link in the bicycle chain, the length must be rounded up to the next highest number of links. The complete analysis for the total length of the bicycle chain needed to drive our attachment device can be seen in Appendix U. The length required for chain 1 is 53 inches and the length required for chain 2 is 42 inches.

Improvements and Updated Engineering Specifications since DR2

The main improvement to our design between Design Review #2 and today is the redesign of the attachment method to the wheelchair. Our design presented in Design Review #2 called for only two attachment bars clamping to the wheelchair. The initial thinking was to make the attachment mechanism simpler by only using two bars to attach our device to the wheelchair instead of the four bars that are required by the MIT design. However, this proved to cause more problems than it solved. In order to only use two attachment bars, the clamp that secures the attachment to the wheelchair needs to also be used to lift the front wheels of the wheelchair off the ground 3 inches. To accomplish this, the clamp was designed so that with a ratcheting mechanism, the user could use a single lever to rotate the wheelchair into the appropriate position and secure and lock the attachment to the wheelchair. The ratcheting mechanism proved to be too complex to manufacture easily and with the tools available to the typical Tanzanian workshop. Additionally, the force required to perform the attachment actions with the ratcheted clamp would have been larger than that recommended to us by Whirlwind International. Therefore, the complex two attachment arm clamping mechanism was replaced by a four bar attachment arm setup similar to that used on the MIT attachment.

The in depth analysis performed also helped redefine our design specifications. The wheel diameter, the gain ratio, the attachment angle, and the folded attachment width were reexamined.

Wheel diameter The primary factor that narrowed our wheel diameter choices was spare wheel availability in Tanzania. The wheels that are most readily available there are 12, 16, 26, and 27 inches in diameter. The 26 and 27 inch wheels were eliminated immediately since they were far too large to stow away on the wheelchair while not in use.

We originally planned to use the 16 inch wheel, because we thought it would be a good balance between size and robustness on rough terrain. Unfortunately as we started dimensioning our design and mocking up ideas on places to place the wheel while stowed away, we found that the 16 inch wheel was also too difficult to stow away. This led us to our decision of using the readily available 12 inch diameter wheel. This should still be an effective wheel size since it is still much larger than the wheelchair caster wheels.

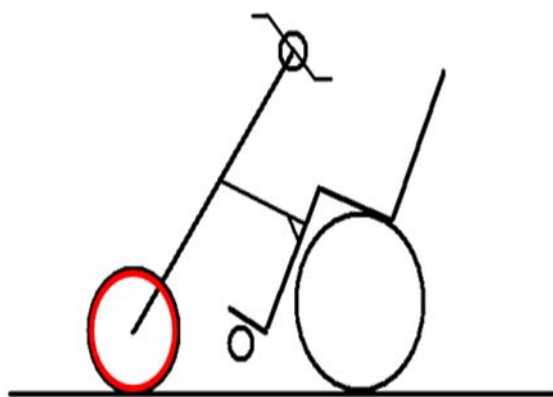

Figure A.36: The front wheel has been scaled back from 16 inches to 12 inches.

Gain ratio In our original engineering specifications, we chose a gain ratio of 5.0. Since then, we have scaled back our desired gain ratio to 1.7333. We made this change based upon outside sources. The first source was our mentor, Amos Winter. We contacted him about a suggested gear ratio to use, and he said that the usual consensus was lower is better. Upon hearing this advice from him, we made an additional effort to find literature that supported this notion. We were able to find a report from Whirlwind International that supported this claim, as explained in the “The appropriate gear ratio” section found on page 34, and this aided us in determining the new specification for our gain ratio.

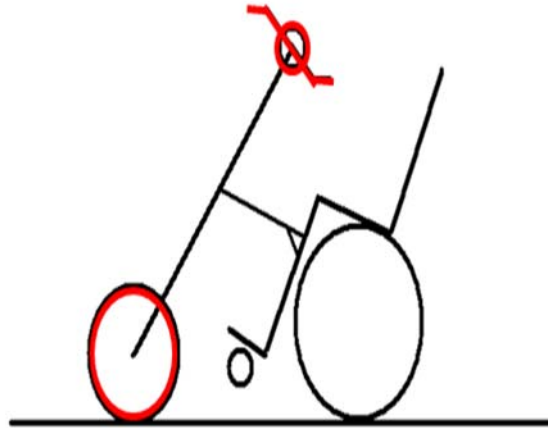

Figure A.37: The ratio between the wheel and the hand crank was reduced from about 5.0 to 1.7

Attachment angle The attachment angle, also known as the rake angle, has been adjusted from 60° to 80° . This change forces the front wheel into the ground more solidly while still providing a sufficient steering column trail on the wheel. This higher angle also optimizes the maneuverability more and will make steering of the device easier while it is in use. When examining the attachment angle, we also examined the angle the wheelchair will rotate during the installation process. This angle is only 7 degrees and because it is so small, we do not predict any problems with the user tipping backwards during use.

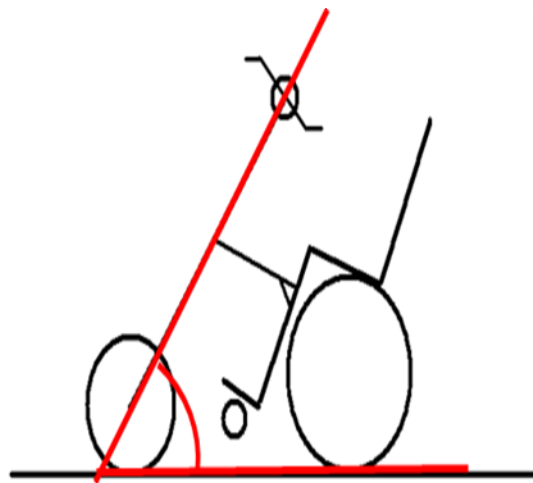

Figure A.38: The rake angle has been increased from 60° to 80°

Folded attachment width We originally set the folded attachment width of our device at 10 inches, because we thought this was going to be easy enough for the user to be able to fit between his or her legs and beneath the wheelchair seat. However, when we received the Whirlwind wheelchair and actually sat in it to test our ideas, we found that 10 inches wide would be too difficult to stow away and impeded on the user too much. We adjusted this specification and our new dimension is 6 inches wide. We found that this width would be satisfactory in being able to stow away beneath the wheelchair seat.

Failure Analysis

In order to validate our final design, we examined the methods of failure in the device. Using some preliminary hand calculations, we were able to show that the current design will not fail under the anticipated loading conditions. All hand calculations can be seen in detail in Appendix O.

Reaction forces and moments We began by identifying the static loads on the wheelchair and attachment when the attachment is in use. We made the conservative estimate that the center of gravity of the user will be at the center of the seat. Using equations from summing moments about the rear wheel axle, and summing the vertical forces in the device, the reaction forces at both wheels could be obtained for a predetermined human load. In order to make a simple calculation of the moment on the device at the place the attachment connects to the wheelchair, we made the assumption that the full moment acts on a single supporting arm. This assumption will cause the forces and stresses calculated to be larger than those which are actually experienced by the device. Balancing moments at points B (horizontal attachment point) and C (vertical attachment point) allowed us to calculate these moments.

Impulses and safety factors After a discussion with our mentor, Amos Winter, we realized that the impulses experienced in the device from going over rough terrain would be difficult to calculate using the typical failure equations. Amos Winter recommended that we simplify these calculations by multiplying all static forces in the device by a factor of 5.0 as a guideline for handling all the impulses on the system. This factor has been applied to all applicable calculations in order to validate that the design does not fail.

Crumple mechanics /local buckling We began by looking at local buckling (crumple mechanics) on the hollow square cross section tubing used in the attachment arms. Our calculations showed that after applying the safety factor of 5.0, the shape of the tube can support stresses that are larger than the max stress of 500 MPa before crumpling. Therefore, crumpling mechanics will not be a limiting factor on our design.

Yield failure by bending Using our previously calculated values for the moments on the attachment arms at points B and C, we use the linear bending equation to determine the stress caused by this moment. The horizontal attachment arm is being made from a solid circular cross section rod. We determined that stress on the rod using the safety factor of 5 to be less than the elastic yield stress for mild steel. The vertical attachment arm is being made from a hollow square cross section. The stress on the beam with the included safety factor is less than the elastic yield stress for mild steel. Therefore, the attachment arms will not fail by yield due to bending.

Buckling in horizontal bar Using the buckling equation, a critical force was calculated in order to cause buckling on the horizontal attachment arm. The actual force was calculated to be less than the critical force. Therefore, the attachment arm will not buckle. It is important to note that for these calculations, the safety factor of 5 was not used. This was ignored because under the types of impulsive loadings which the safety factor was being used to estimate, the buckling equation is not accurate. Beams can handle large impulsive forces without buckling. The local buckling equations govern these types of impulses. This was examined with crumple mechanics.

Bolt moments One of the major components that we needed to test for failure is the bolt that interacts with all four attachment arms. This bolt experiences shear forces from the moments at B and C. These moments and perpendicular distances were used to determine the force on the pin. This force was divided by the area projected by the side of the pin being acted upon by the moments in order to get a stress on the pin. The final stress on the pin was shown to be less than the 500 MPa max stress for mild steel. Therefore, the bolt will not fail from the combined loading of the attachment arms.

Assumptions The main wheelchair wheels and the backrest are aligned vertically from the ground. The load from the user causes a moment about the main wheel contact points. The load from the user was assumed to be effectively applied halfway up the seat of the wheelchair, 7.5 inches. We deemed this to be a conservative assumption since a person's weight is most likely shifted toward the back end of the seat by the backrest resulting in a shorter moment arm. This assumption is illustrated in Appendix N.

We assumed that the weight of the attachment itself was negligible compared to the external loads placed on it. Therefore the masses of the bars are left out of the stress calculations.

The mechanical properties of the old bicycle parts and mild steel were assumed to be constant and without depreciation in the strength of the material. The tensile strength was assumed to be 500 MPa and the Young's modulus was assumed to be 210 GPa.

Additional Notes and Concerns about Engineering Analysis

One concern about the safety of our device is the ability of the user to tip himself backwards when installing the attachment. This was dismissed however because the user never places his center of mass past the wheels of the wheelchair or attachment. Because the user's mass is between these two wheels, the user will not be able to tip themselves backwards under normal use. A simple test was done in the laboratory using just the wheelchair to find the tip angle before the user would fall backwards. This angle was found to be so large that it is not necessary to analyze the tipping criteria of the wheelchair; the user will have to be intentionally tipping the wheelchair in order to achieve this angle. This angle will not be experienced during normal use. Therefore, we are not worrying about tipping of our device.

As a final check to our design specification of weight, the attachment device was weighed in the laboratory. The final weight of our device is approximately 20.7 lbs. Therefore, we have accomplished this design specification.

For the purposes of failure mechanism calculations, our design is modeled as a 3D beam structure connected with pins. This model is accurate because the vast majority of pieces in the design are beams and the majority of connections between members are pin joints. Failure mechanisms examined for analysis include yield by bending in the beams, buckling from compressive loading and local buckling also known as crumpling in the hollow beams and tubes. One joint that was examined more closely was the pin that holds the attachment arms together. This pin had combined loading from the tension arms, compression arms and the weight of the wheelchair and user. Making sure this pin did not fail is one of the keys to our design. A more complex look into finite element analysis was not examined because of the large safety factor used in the design of our device. The relatively large safety factor of 5.0 was chosen after discussions with our mentor Amos Winter at MIT. He recommended this factor of safety as a general guideline to design for the impact loadings of the rough terrain that the user will be driving over. These failure criteria and factor of safety guided our design.

The main difference between our prototype and the device being produced in Tanzanian bike shops is the fact that these shops will be using metric measurements of mild steel tubes instead of English units. Therefore, the analysis completed using cross sections measured in inches will not be entirely accurate to the cross sections available in Tanzania. However, the calculations provided for this project can be used as a guideline for sizes of bars that will be safe to use. Final calculations and optimization will need to be completed in order to find the lightest cross section that will fulfill the failure criteria laid out in this report.

After examining the bending of the hand crank support arm caused by normal use, it is apparent that further analysis will need to be completed on the minimum cross section required to not fail. This part will need to be redesigned before production begins. Further analysis into the failure of this part will be integral into the redesign process. The easiest fix to this problem would be not making the support arm larger, but making the support arm into two forks

with one on each side of the chain. Then the part will not bend from the loading of the chain because it will be loaded between two supports as compared to the old case where it was essentially a cantilever.

One final area that will require more analysis is the strength of the welds. Welding was used extensively in our project because it is easily reproducible and is readily available in Tanzania. Because welding is such an integral part of our design, further analysis into the strength of these welds will need to be completed to be sure the design does not fail unexpectedly. We do not predict the welds to fail under the loading conditions examined in this device.

Design for Safety

Over the course of designing our wheelchair attachment, it became apparent that safety of the user and the producer needed to be considered. In order to minimize the hazard to the user, we needed to examine the worst possible case scenario. We needed to design our device with the mindset that the user would try to use it unsafely. This mindset helped us think about how make our attachment safer during the design process. For example, the folding mechanism can be hazardous in the form of pinched fingers if not used properly. The rotating component was designed so that as little area as possible slid against each other. This reduced the region where pinches to fingers could occur. The pin was situated so that the user could keep their hands on the outside of the device; their hands were not in the center of the device where they could be injured if a slip occurred. The logical hand placement to tip the wheelchair backwards in order to attach the device to the chair is located away from the folding axis. Therefore, if the pin is incorrectly installed and the attachment collapses together, the user's hands are not near any parts that could crush their hands. This line of thinking was implemented throughout our design and improved the design of the device.

The safety of the producer is just as important as that of the consumer. The majority of this section was covered by our own shop experience and personal knowledge of what would constitute unsafe manufacturing processes. Personal experience manufacturing our device greatly aided the created of our validation plan as well as fostered a better understanding and respect of the tools in the machine shop. Our final validation plan will take the producers through a safe method of producing our device.

FABRICATION PLAN

The purpose of this section is to explain how the design will be fabricated and what materials, tools, operations, and assembly processes will be used.

Fabrication Processes

This section details the parts and materials that we will be fabricating and manufacturing. ALL MATERIALS ARE MILD STEEL!

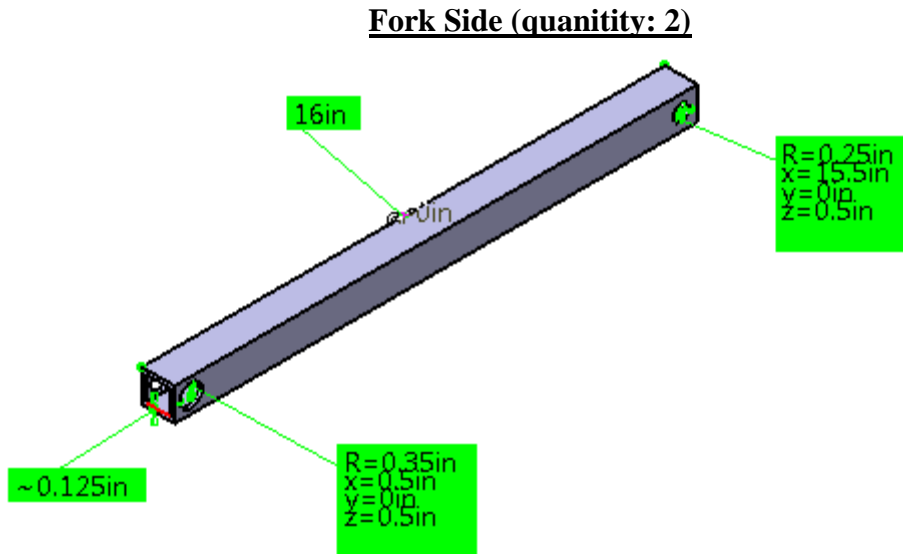

Figure A.39: Fork

Material: 1/8" thick 1"x1" square tubing

Step 1: Cut tube 16" long using a band saw or hack saw.

Step 2: Drill a 1/4" radius hole all the way through the middle of the tube 1/2" from one end using a drill press. Use a vice to keep the drill bit squared with the surface of the tube.

Step 3: Drill a .35" radius hole all the way through the middle of the tube 1/2" from the other end on the same face using a drill press. Use a vice to keep the drill bit squared with the surface of the tube.

Tension arm (quantity: 2 (different step 11))

Material: 1/8" thick 1"x1" square tubing
 Solid 1"x1" square rod
 1/4" thick sheet

Step 1: Cut tube into 11.165", 2.125", and 2.8" sections using hack saw or band saw.

Step 2: Measure 62.5 degree angle from one corner of the 11.165" and 2.8" pieces as shown in Figure A.40.

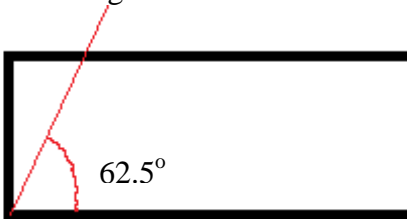

Figure A.40: Step 2 cut

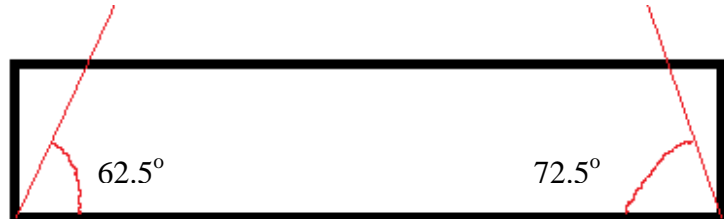

Figure A.41: Orientation of angle for 11.165" piece for step 3

Step 3: Measure 72.5 degree angle from one corner of the 2.125" piece similar to step 2. Also cut a 72.5 degree angle from the 11.165" piece from the orientation shown in Figure A.41.

Step 4: Weld the three pieces together at their similar angles as show in Figure 70. Weld entire way around the tube connections.

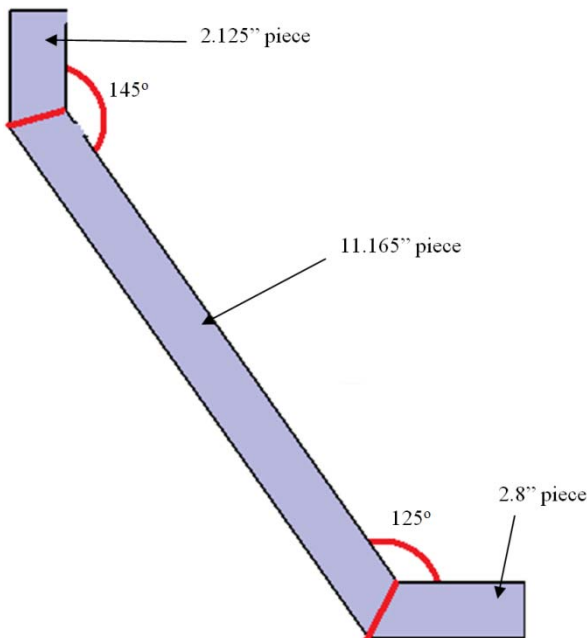

Figure A.42: Weld tubes

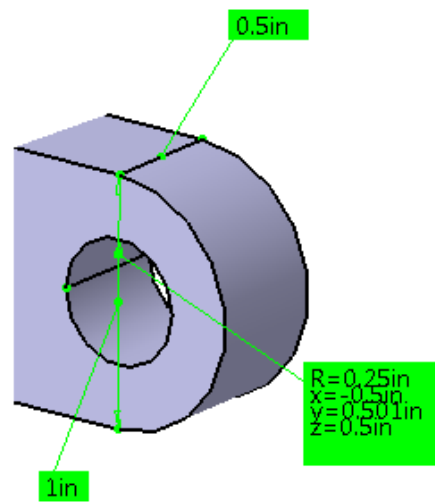

Figure A.43: Rotational joint

Step 5: Cut 2 inch long piece of solid square rod.

Step 6: Drill a 3.75" radius hole through the middle of the piece along the long axis. This piece will be called the tension arm collar.

Step 7: Cut a 1/2" long section of the square rod.

Step 8: Drill a 1/4" radius hole in the middle of this piece.

- Step 9:** Grind down two of the edges on this piece. This should be done by clamping it in a vice and first hack sawing the majority of the material away and then using a file to finish the rest. The end result will be called the rotational joint (Figure A.43).
- Step 10:** Weld the rotational joint onto the end of 2.8" section of the weld tubes in the orientation shown in Figure A.44.
- Step 11:** Weld the tension arm collar on the side of the 2.8" weld tubes in the orientation shown in Figure A.45. *NOTE* This orientation is for the right tension arm. To make the left tension arm, weld the tension arm collar on the opposite side of the tube.

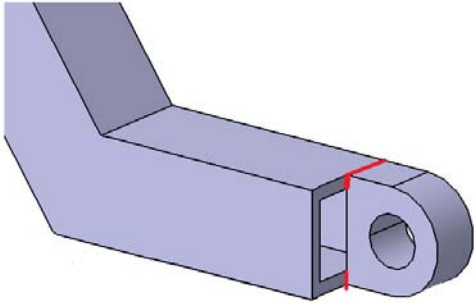

Figure A.44: Rotational joint weld configuration

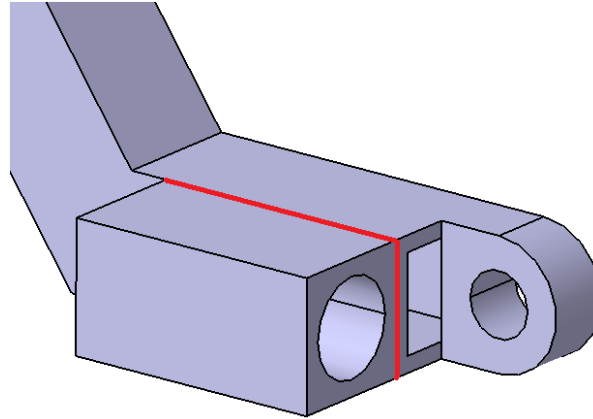

Figure A.45: Tension arm collar weld for right arm

- Step 12:** Cut a 2" x 1" rectangle and 1" x 3/4" rectangle from the 1/4" thick sheet.
- Step 13:** Weld the 2" x 1" rectangle onto the end of the 2.125" tube section according to Figure A.46

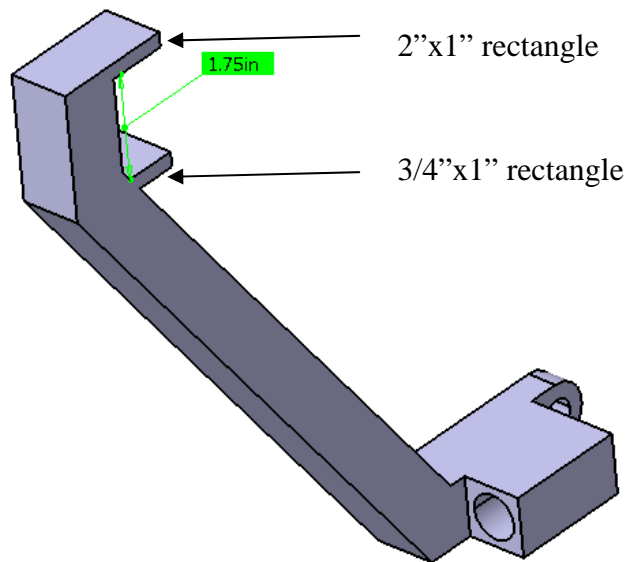

Figure A.46: Hand weld orientations

- Step 14:** Measure 1.75" from the 2"x1" rectangle and weld the 1"X3/4" rectangle to the tension arm.

Compression arm (create two identical pieces)

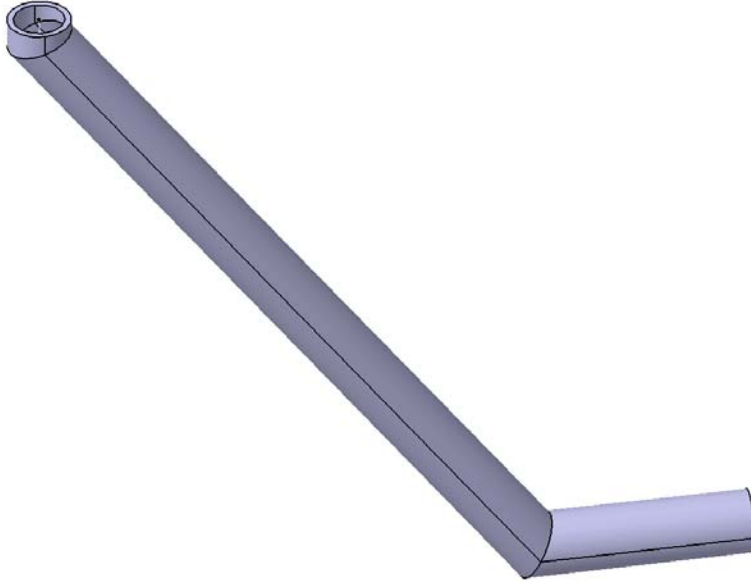

Figure A.47: Compression Arm

- Material:** 1/8" thick 1" circular hollow tube.
- Step 1:** Cut tube into 2.5", 9.25", and .5" sections.
- Step 2:** Make the same angular cuts as on step 2 for the tension arm on the 2.5" and 9.25" pieces.
- Step 3:** Make the same angular cuts as on step 3 for the tension arm on the 9.25" and .5" pieces.
- Step 4:** Follow the same weld orientation as on step 4 for the tension arm except replace the 2.125" piece with the .5" piece, the 11.165" piece for the 9.25" piece, and the 2.8" piece with the 2.5" piece.

Steering column collar

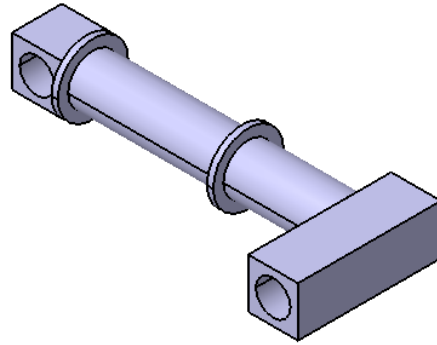

Figure A.48: Steering column collar

Material: 1/8" thick .5" radius circular tubing
Solid 1"x1" square rod
2 Bearing collars

- Step 1:** Cut the square rod into a 2.875", and 1" long section.
Step 2: Drill a .35" radius hole through the middle of both of these pieces along the long axis.
Step 3: Cut the circular tubing into a 5.275" long section.
Step 4: Weld the circular tubing so that one end is flat against the surface of the 2.875" long section so that it is 2" from one end to the center point of the tube. See Figure A.49.

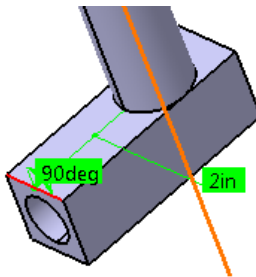

Figure A.49: Weld orientation for step 4

- Step 5:** DO NOT GO FURTHER UNTIL CREATING THE LOCKING SHEATH!!!
Step 6: With the locking sheath down in the locked position, weld a bearing collar to the steering column shaft so that there is a 2" gap between the flat surface of the square rod and the bottom of the bearing collar.
Step 7: DO NOT GO FURTHER UNTIL CREATING THE STEERING COLUMN COLLAR!!!
Step 8: Place a bearing assembly on top of the bearing collar. Place the steering column collar over the circular tubing down onto the bearing assembly.
Step 9: Place another bearing assembly on top of the steering column collar. Weld the bearing collar to the steering column shaft so that it constrains the steering column collar.
Step 10: Weld the 1" long section from step 1 and 2 onto the top of the bearing collar and tube and positioned so that the axis of the drilled hole is parallel to that from the 2.875" section.

Steering column shaft

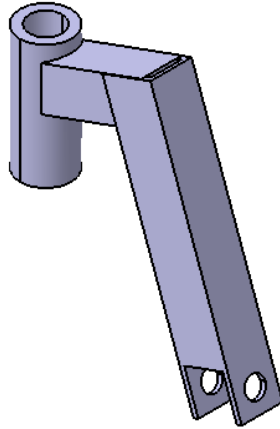

Figure A.50: Steering column shaft

Material: 1/8" Thick 1.25" square tubing
1/8" Thick 1" radius circular tubing
2 Inner bearing collars

Step 1: Cut a 3" long section of the circular tubing.

Step 2: Cut a 4" and 6" long section of square tubing.

Step 3: Drill a 1/4" radius hole all the way through 1/2" from one end of the 6" square tube.

Step 4: Cut away 1" x 1" square sections from the same end that has the hole through it on the 6" square tube (Figure A.51).

Step 5: Cut an 80° angle from the end the 4" section.

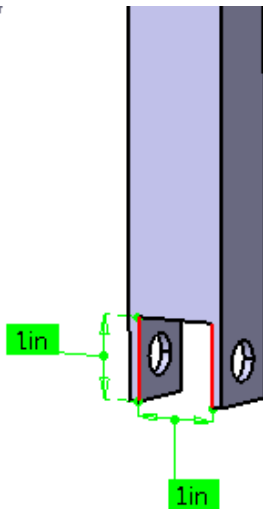

Figure A.51: Square section to cut from 6" long section

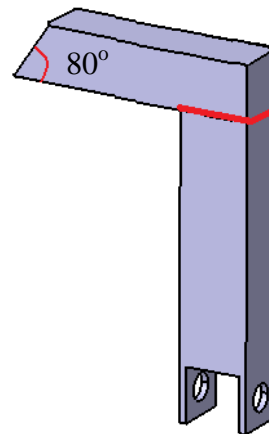

Figure A.52: Square tube weld orientation

Step 6: Weld the other end of the 6" Square tube to the bottom of the squared end of the 4" long section in the orientation shown in figure x. Ensure that the angle orientation is proper for the 4" piece.

Step 7: Weld the circular tubing to the angled side of the 4" tube so that the tube is equidistant from the top and bottom.

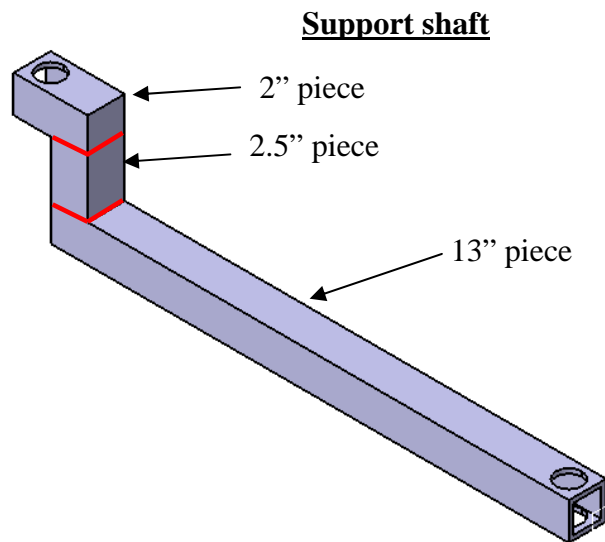

Figure A.53: Welding orientation for step 4

Material: 1/8" thick 1"x1" square tubing

Step 1: Cut the tube into 13", 2.5" and 2" long sections.

Step 2: Drill a .35" radius hole all the way through the middle of the 13" tube exactly .5" away from one of the ends.

Step 3: Drill a .35" radius hole all the way through the middle of the 2" tube exactly .5" away from one of the ends.

Step 4: Weld the pieces together according to Figure A.53.

Gear bearing hub

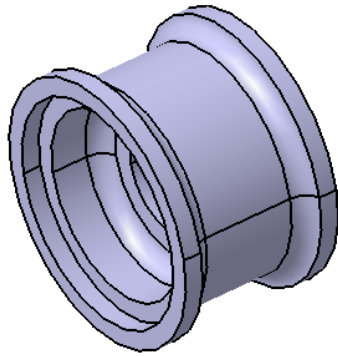

Figure A.54: Gear bearing hub

- Material:** Two inner bearing collars
Desired gears for the middle hub
- Step 1:** Weld the first gear to the outside of the thinner diameter portion of the bearing collar.
- Step 2:** Weld the second gear to the outside of the thinner diameter portion of the other bearing collar.
- Step 3:** Weld the Bearing collars together.

Assembly Processes

Components list required for assembly:

Quantity	Part
1	12" Wheel with coaster brake assembly
1	Bike hand crank
2	Bearing assemblies compatible for a .5" outer radius and .35" inner radius
2	Bearing assemblies compatible for a 1" outer radius and a .5" inner radius
4	Gears
1	6" long .35" radius axle with screw ends
1	6" long .25" radius axle with screw ends
1	4" long .35" radius axle with screw ends
2	Fork sides
1	Locking sheath/ steering column shaft/ steering column collar assembly
1	Support shaft
2	Tension arms
2	Compression arms
1	1/4" bolt and nut

Step 1: Put the 6" long 1/4" radius axle through the 1/4" hole on one fork side

Step 2: Put the 6" long .35" radius axle through the .35" radius hole on the same fork side (Figure A.55)

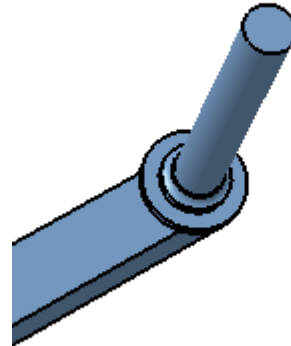
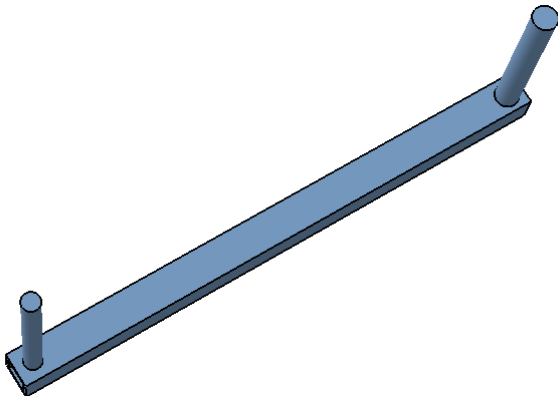

Figure A.55: Axles inserted in fork side

Figure A.56: Bearing collar weld

Step 3: Weld a bearing collar onto the fork side (Figure A.56)

Step 4: Place bearings on bearing collar and place gear bearing hub on top of the bearings. Make sure that you have the larger gear nearest to the fork side because this gear will be connected to the wheel. (Figure A.57)

Step 5: Place the wheel and coaster brake assembly onto the 1/4" axle with the gear facing downwards (Figure A.58)

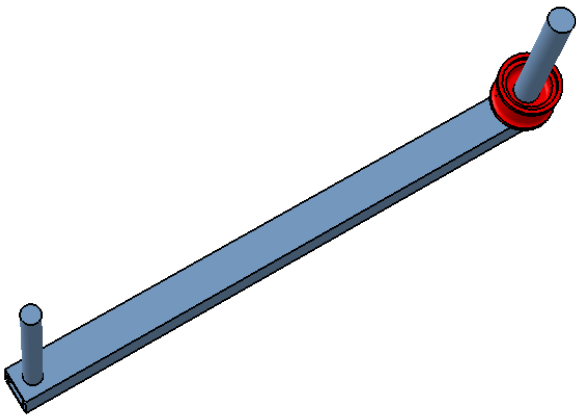

Figure A.57: Gear bearing hub attached

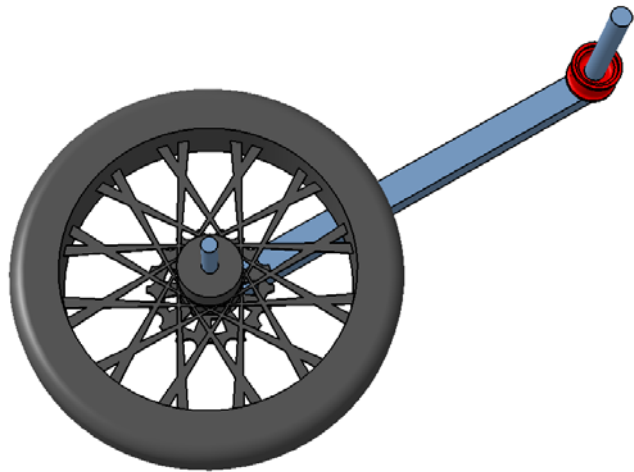

Figure A.58: Wheel attached

Step 6: Place the steering column shaft and the attached sheath and steering column collar onto the .35" axle (Figure A.59)

Step 7: Place the other fork side onto the assembly and secure it using nuts (Figure A.60)

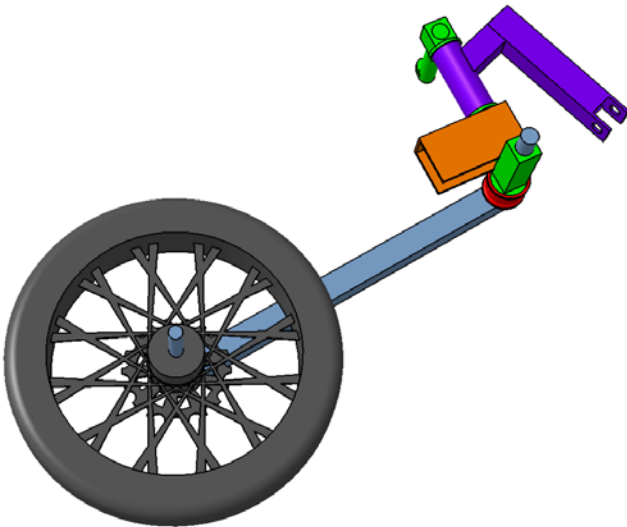

Figure A.59: Steering and locking assembly attached

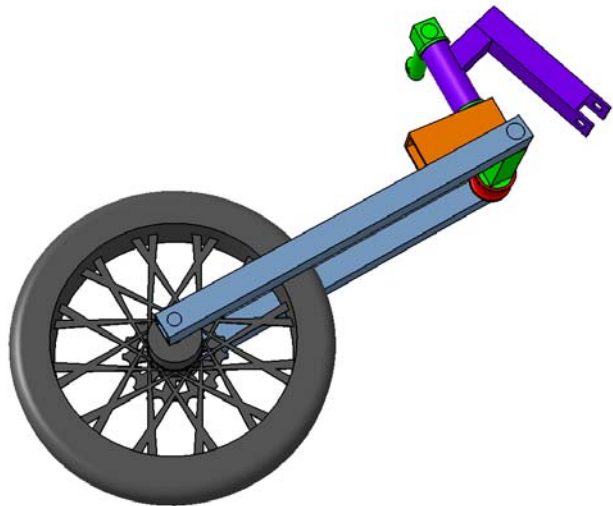

Figure A.60: Fork side locks drive system together

Step 8: Slide the tension arms into the steering column collar as shown in Figure A.61 so that the holes align. Use the nut and bolt to fast the tension arms to the steering column collar

Step 9: Slide the compression arms into their respective inserts on the tension arms (Figure A.62)

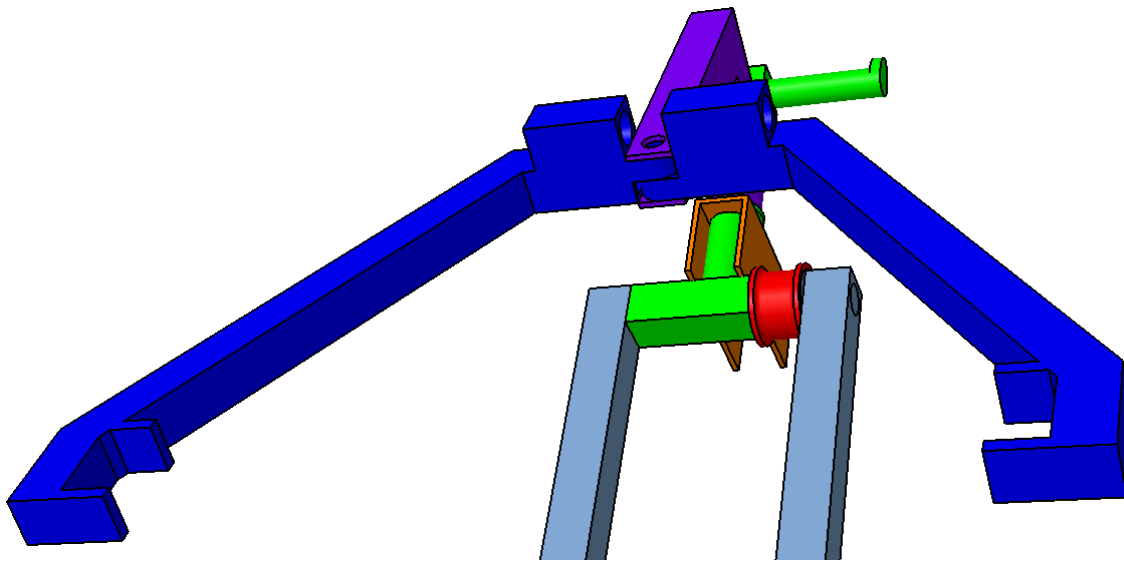

Figure A.61: Tension arms attached

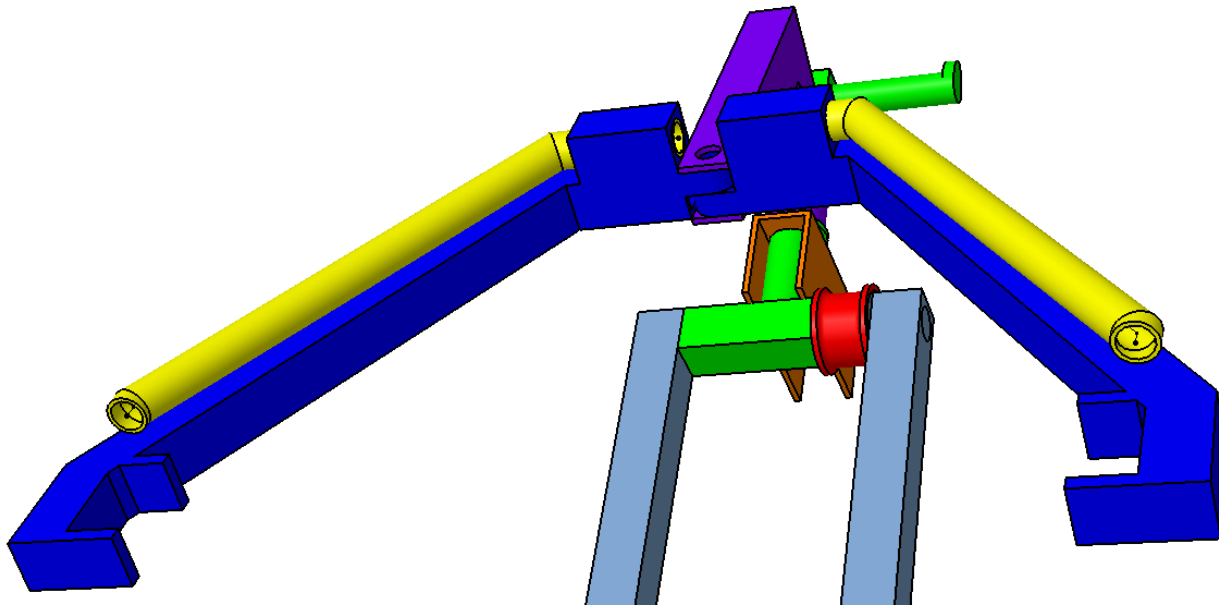

Figure A.62: Compression arms inserted

Step 10: Attach the support shaft to the steering column using the 4" long .35" radius axle (Figure A.63)

Step 11: Attach the hand crank to the top of the support shaft (Figure A.64)

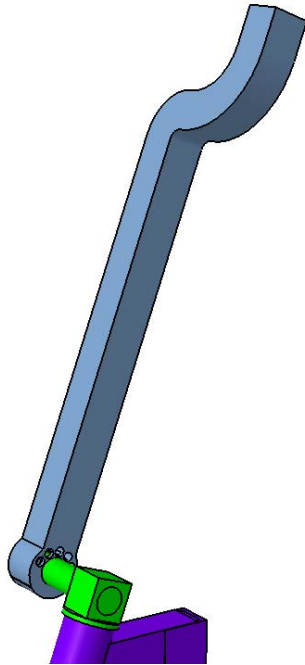

Figure A.63: Support shaft attached

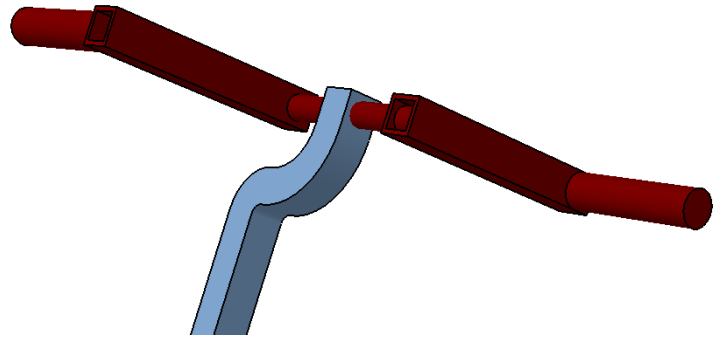

Figure A.64: Hand crank attached

VALIDATION RESULTS AND PLANS

In order to verify that we met our objective of building a low-cost, foldable and storable tricycle attachment for the Whirlwind RoughRider wheelchair, we planned a vigorous validation schedule. However, due to the complexity of the manufacturing required for our project and short time frame for the course, we were not able to properly conduct many validation experiments. This section describes the results of current validation tests as well as laying out a plan for future, more thorough, testing.

Current Validation Results

USABILITY

Deployable in Less than One Minute

The main requirement for our device was that it can be folded and stowed easily. We specified that the device could be attached or detached in less than one minute by a somewhat familiar user. This was the shortcoming of the current MIT design was the first validation test we ran. Our expert user, Mike Tran, has been able to fully unstow, unfold, and attach the device in less than 29 seconds, and can detach, fold, and stow in less than 17s; more than satisfying the requirement. A video of this performance can be seen at: http://www.youtube.com/watch?v=Ks0_s0yJh7k. It is important to note that Mike is an able bodied man, who helped design the device and has demonstrated it at least twenty times. In order to more fully evaluate this specification, we ran additional tests.

In order to properly evaluate this test we decided to run a random-user usability survey with a time trial element. This test gathered qualitative information about the overall operation and ease of use of the device, as well as quantitative data for the time required to perform the two operations.





Name:	Time to Attach:				
Date:	Time to Detach:				
Observer:					
How to Use					
					
Ease of use? Confusing OK Very Intuitive	Biggest issue with device?				
Force required? Too much OK Barely tried	Best feature?				
Comfort Level? It hurt OK Could do it 20x	Comments.				
What did you think about the placement when stowed?					

Figure A.65: Shows the usability survey form

We designed a simple form, shown in Figure A.65 to instruct users and record data. The form showed the basic steps of operation in a flowchart style using CAD renderings from DR3. We asked multiple users to rate the device using simple word examples rather than numbers, and correlated those numbers with values of one, three and five, five being the best. The topics rated were ease of use, force required, and comfort level. We took into account that our average user was an able bodied college student and not a 12 year old polio survivor and so the target value was ‘barely tried’. Three open ended questions were asked regarding the placement of the stowed device, biggest issue with device, and best feature. We hoped to gain a basic understanding of whether the placement was acceptable, what features were a problem, and which ones may be worth an additional cost.

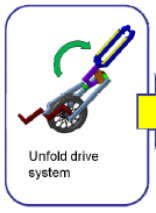
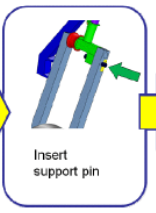

Figure A.66: Shows the instruction (a), demonstration (b) and testing (c) for the random user trial

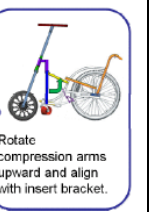
We selected a random user in the lobby of the Duderstadt center for our usability trial. We explained the operation of the device, (Fig A.66a) demonstrated a sample attach/detach sequence, (Fig A.66b) and then

had the user attempt the attach process. (Fig A.66c) Time was taken for the attach process, then reset for the detach process.

The results of the random user's first attempt were 1:40.1 to attach, and 47.3s to detach. A second test was attempted but the nut for the handle bar assembly was missing; causing the upper assembly to rotate around and preventing further trials. This seemingly small incident exposed a serious design flaw. If one lost the nut on either the handlebar lock or the folding lock the device would be unusable. To solve this problem we will attach the pin using a wire and consider a one piece slotted pin.

Observations from the limited random testing were still helpful. Handing to device to a total novice and watching the process helped highlight other possible design issues to be improved before implementation. One key observation was that the user struggled to manipulate the device with one hand in order unstow from under the chair and insert the folding lock pin. The device wanted to rotate about various axes and it was difficult to steady. The user put his feet on the ground to support the weight; something not easily done for the typical polio survivor. There was some difficulty in guiding the attachment arms into place. The detach, fold and stow process went much smoother with the only difficulty being in aligning the device properly to fit in the space between the cross brace and seat fabric.



Figure A.67: The random user needed their legs to support the device (a) and had issues with the attachment arms (b & c)

Throughout the test we spoke with user about any issues they had, as well as having them fill out the survey once the tasks were complete. The user's biggest issue was "the bottom piece (tension arms) doesn't secure until side pieces (compression arms) in place". He suggested adding some sort of lock or mount to guide the process. Based on our own trials with the device we found backing up until the front casters are in front of the chair to be the best solution. The user found that the stowing location between the legs did impede ingress/egress, but still rated comfort OK. Ease of use and force required were also rated OK. Overall he was pleased with the device but could tell it was an early prototype. Videos of the process were recorded.

Dimensions Folded

Our specification's purpose was to ensure proper storage under the chair. The working prototype meets this specification with overall maximum folded dimensions of 38x15x18".

Weight of Device

Our target weight was specified to be 22lbs. The weight of the prototype was 20.7 lbs, more than a pound lighter than specified. Most of the weight comes from the dense steel used in the device and the additional parts needed for adjustability.

MANUFACTURABILITY

Production Ready for Tanzanian Bike Shops

A major goal of our design was to make a production ready device that could be manufactured with little to no modification in the local bike shops of Tanzania. We validated this through our production process itself. Our entire prototype was made from mild steel and recycled bike parts without the use of any precision machinery. This caused the process to take much longer but provided vital feedback as to what parts were likely to cause issues. Often a part that would take five minutes on a mill would take an hour or more of cutting, drilling, and grinding. Table A.5 illustrates the top candidates for precision machining and an estimation of how much time would be saved. These times take into account total time to get the proper fit, but do not account for the raw material wasted by improperly machined parts.

Table A.5: Three parts that would benefit from precision machining

Part	Current Method	Time (Hrs)	Ideal Method	Time (Hrs)
Two Sprocket Hub	Cut, drilled, ground to fit, welded together	3	Cast or Milled then welded	1
Bar Inserts	Cut, drilled, threaded, ground to fit	1	Milled, threaded	0.25
Attachment arms	Cut, ground, welded (no-jigs), drilled, ground to fit	10	precision cut, ground, jugged, and welded	1

The importance of proper tolerances became very apparent. With so many moving parts and linkages, a few 16th's of an inch off on a hole would ruin an entire part. There were multiple instances where parts were remade three to five times before they had the proper fit. In the future an interesting study to run would be whether it is cheaper for a skilled machinist to make these parts with simple tools, or to order them precision-made from a local city.

ERGONOMICS

Studying the interaction between the user and the device is vital to smooth and efficient operations. We used a combination of real-world mock-ups in conjunction with CATIA's human builder in order to fully integrate our design with the intended user at all stages of development.

Intended user

Ideally the device would be able to be used by all people, but due to budgets and timing that is not feasible. In the United States there are extensive databases of anthropometric data with details on anything from weight to index finger width. These details are available for a range of users from the 1st to 99th percentile. The same quality of data does not exist readily in Tanzania and other parts of Africa. We were able to find an anthropometric study done on the Hadza tribe in Tanzania (Hiernaux). We recorded the stature [12 below], sitting height, upper arm length [103], forearm length [79], and bi-iliocrystal diameter [71] from the study, as they were the most relevant to our device.

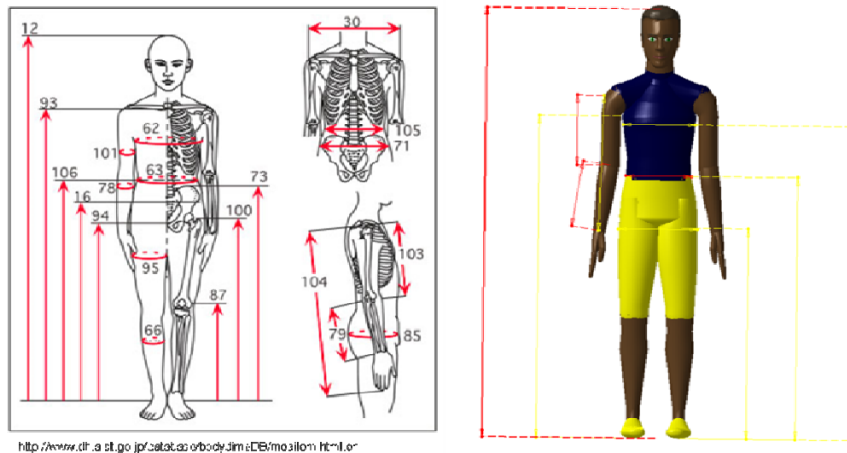

Figure A.68: Definitions of anthropometric variables and our adapted manikin, “Manny”

CATIA Mannequin

We used the key measurements from the study to refine the CATIA model of the 50th percentile US male. This was done by editing the parameters of a manikin, nicknamed Manny, in CATIA’s human builder. Having a representative mannequin present in our virtual modeling allowed us to check each design change’s effects on the user before making any cuts in a real world prototype. An example of this would be verifying that our design would stow between the user’s legs,. As shown in Figure A.69.



Figure A.69: A mannequin was used to analyze the stowing location

We manipulated both Manny and the device in order to simulate the stowing process. CATIA’s posture analysis has a number of useful features for evaluating ergonomic performance that we will continue to use in the future.

Mock-Ups

While CATIA does have some helpful features for ergonomic analysis, it still cannot replace a physical mockup. Comfort and feel are very hard to understand in a virtual model and so physical mockups were used to analyze and understand any issues. Two key mock ups that were made were the ‘spider’ attachment and a bicycle wheel. By simply putting a bicycle wheel between the footrests of the wheelchair and wheeling around various classrooms, hallways, and lavatories we were able to determine that a 16 inch wheel would impair mobility, especially ingress and egress, from the chair when the attachment was stowed. Based on this trial we reevaluated our wheel size and switched to a smaller 12 inch wheel. This issue would not have been as clear on the on our computer screen, but was very noticeable when in the tight confines of a bathroom stall. We will continue to run similar analysis throughout the coming weeks.

Future Validation Plans

In order to fully validate our design for implementation more rigorous testing is required. Issues with chain alignment and timescale of the course prevented us from completing all validation. Before the device is sent to Tanzania we plan on running the following tests.

Field trials

The main reason for using a tricycle attachment is to handle rugged terrain and long distance travel. In order to evaluate the effectiveness of our device in its intended environment we will operate the device in rough surfaces as well as a long distance 'commute' test.

Rough surface test We will test the device over a wide variety of terrain. We have chosen to test at the Nichols Arboretum here in Ann Arbor because it offers multiple surfaces in a small area. We will be able to pedal on gravel, grass, dirt and some sand. There are many hills to evaluate the stability of the device as well. During the course of the tests we will take notes and evaluate the effort required to navigate the terrain.



Figures A.70: Tests will be run on rough terrain and indoors

Indoor test A tight obstacle course will be set up in the lab to simulate a tight indoor environment. We will have different users run this course with the attachment stowed and observe the biggest difficulties. This will help us evaluate whether the wheel protruding from the front of the chair will impair mobility in any noticeable manner as well as other factors. We will perform similar tests in classrooms and houses to further validate the design.

Commute test Our device is intended to provide users with a full range of mobility by combining the compactness and comfort of a wheelchair with the robustness and efficiency of a hand-tricycle in a small storable package. To verify that it does this effectively we will run it through the commute test.

The commute test will start at the UM Nursing School, where we will place the device in the trunk of a car and drive to the Michigan Union. From the Union we will unfold the wheelchair, unfold and attach the tricycle attachment, and then pedal from the Union to the G.G. Brown labs, a distance of 2.5 miles. In G.G. Brown we will run a small obstacle course with the device folded and stowed. We will then exit G.G. Brown and take a bus back to the Nursing School. While one person will be performing the test, riding in the chair, the other three team members will record video, take photos, and take notes. This test will simulate a rigorous commute in an urban environment, with big elevation changes and varied terrain.

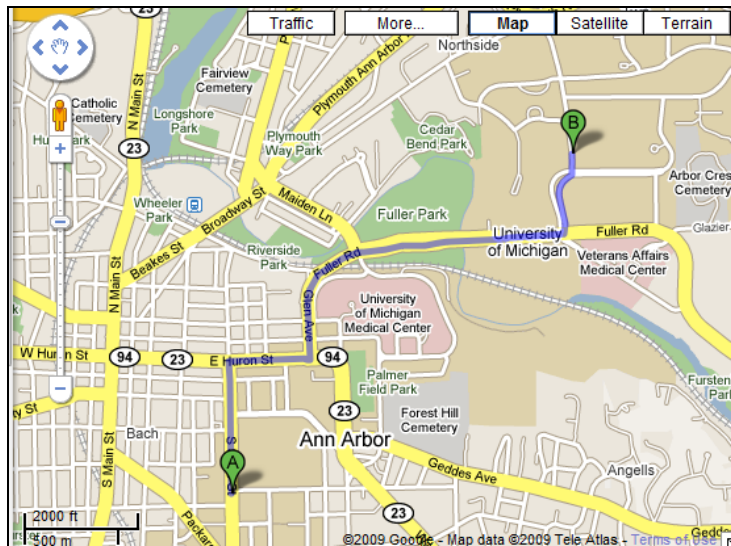

Figure A.71: The route of the Commute Test pedal portion will be 2.5 miles long

Motion capture If given more time and resources we would run rigorous ergonomic tests in Professor Sienko’s motion capture lab. Using her equipment we would model key procedures like the pedaling motion or installation and refine our device for maximum efficiency. It would be very beneficial to gather data as to the specific mobility limitations most common in sub-Saharan polio survivors and alter our design to accommodate those needs. However the equipment produces large quantities of data and is not practical on our timescale and budget, our more basic measurements and CATIA analysis provide more readily usable results.

Other trials

Maximum working load Typically destructive testing is required to verify the maximum working load of a part. It is unlikely that we will have the time or budget to load a prototype device until failure. In order to make up for this we will look into specific components and possibly physically-test the weakest link. We will load the device to a more likely working load and make sure there is no failure. FEA analysis with either the Roughrider or a mockup will help support our predictions. We will look into failure mode and determine whether we want our attachment to fail before the wheelchair or vice versa.

Price of labor With the production process and design finalized, we will verify with our contact Peter Mbuguah in Tanzania if our device could be built for less than \$10.00 of local labor.

Mechanical advantage The actual mechanical advantage offered by our system may be less than the calculated gain ratio of 1.6 due to improper gear size. We will measure this on our physical prototype by comparing the number of teeth on each gear. We will also compare the angular velocity out to the angular velocity in. We will test the effectiveness of our gear selection by operating the device on a variety of surfaces and terrain as well as over long distances.

Range of user’s arm length and height In order to verify that the device will be usable for a variety of users we will have different size people test our device. We will also use mock-ups of both the maximum and minimum specified arm lengths and heights (16-19” and 39-90” respectively) to check usability over a more specific range.

Wheel diameter The choice of a 12” wheel will be justified through mobility tests. We will have a range of users enter and exit the device as well as travel for extended periods of time in order to evaluate the obstruction caused by placing a small wheel between their legs. The tests for mechanical advantage will also play a role in proving this specification

Braking We will run series of braking tests to verify that the device will produce at least 11.24 lbs and be able to stop from 10 km/h in less than 10 ft. A test will be run on an inclined plane to measure the maximum brake force. An additional test will be run by measuring the stopping distance from 10 km/h. The speed will be measured using either time and distance or a simple tachometer.

Degree of flexion to install/uninstall We will measure the degree of flexion it takes to install and uninstall through user tests. We will mark users with reference points (like a dot on a headband or belt), and then take images at specified angles during the installation of the device. These images provide us with basic information on how much flexion is required. If given more time and resources we would make use of Professor Sienko’s motion capture lab.



Figures A.72: Physical Tests will be run for flexion and installation time respectively

Young’s modulus We rely on the manufacturers specifications for the young’s modulus of the steel (7250 kpsi) we are using in our design. International standards lend credibility to these claims and so it is not necessary to perform our own physical testing. If given more time and money we would like to test material properties of the old bike parts like the cranks, and gears. These parts are sourced from a wide variety of places and are not uniform, and so understanding the level of quality to expect would help ensure the integrity of the device.

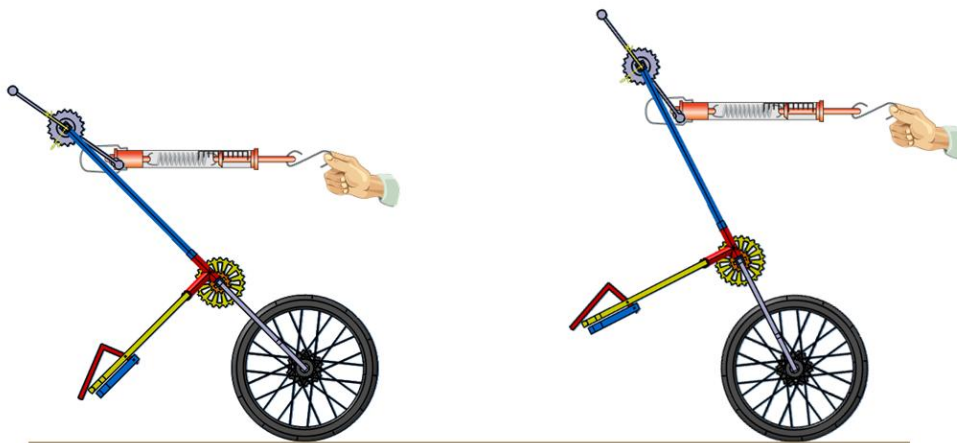

Figure A.73: Force Springs will be used to measure force inputs

Force to attach/unattach It is important that the user be able to install the attachment with less than 3.37 pounds of force. We will verify this specification by using simple force springs to measure the force required to physically secure the device to the wheelchair. Further testing will be performed to insure that the specification is appropriate. If our specification does not correspond to real users it is of little use. We will have non-trained, and possibly handicapped, users attach and detach the device, while timing them and observing any issues.

Discussion and Critique of Design

After completing this design project, there are a variety of things that we would change in order to more efficiently produce our device. The main change is that we should have just focused on the folding mechanism in our project. At the start of the project, we attempted to do too much at once instead of just focusing on the purpose of the project.

Two weeks were spent examining how to redesign the attachment mechanism from our device to the wheelchair when ultimately, our final mechanism was not very different than that which the current MIT device uses. While this time was not necessarily wasted, it represents time that was not spent focusing directly on our chartered topic of folding. Additionally, we approached this topic by creating a new design around the folding mechanism. This worked very well because our new design was radically different than the contemporary device. If we were to redo this project, we would start by taking the MIT design and building a folding mechanism around it. If this analysis showed that the current MIT design could not be easily manipulated so that a folding mechanism could be incorporated into it, then it would be appropriate to create a new design with our folding mechanism at its core. Because of our short time frame, our design process incorporated large changes to our design. In future work, a longer time frame would allow incremental changes to be made so that a more optimal design can be created. However, our timeframe is something that we had very little control over during the course of our project; proper time management allowed us to get as much done as possible.

The design of our device has its strengths and weaknesses. The biggest strength of our device is the folding mechanism and the key is the use of two chains to facilitate folding. This mechanism solved the biggest problem that arises when attempting to fold other attachments: the chain will lose tension and fall off when folded. Two additional strengths of our device are the ability to be stored on the wheelchair when not in use and the ability to be manipulated by the user with no outside help. Understanding that the user would normally be alone when using the device, it was important that the device be light and not awkward to manipulate. Additionally, making sure the attachment folded up into a shape that could be stored on the wheelchair was very important. While the majority of the attachment fits underneath the wheelchair, a small part protrudes from the front of the foot rest. While this is a minor problem, it is a weakness of our design. Future work can examine a method to make the design shorter in order to make it fit completely under the wheelchair. One strength of our design is that we implemented a coaster brake in the front wheel of the device. Because coaster brakes are typically found on kids bikes which are the same bikes where the small front wheels are harvested, it is a simple addition that adds safety and value to the design. The last main strength of our design is that it is designed to be manufactured using only scrap bicycle parts as well as materials and manufacturing processes readily available in Tanzanian bike shops. This ensures that our design can be implemented immediately in the developing world and will have a low enough cost to make it appealing to the disabled in these areas.

Our device also has a few key weaknesses that could be seen during the manufacturing process or during initial testing procedures. The main weakness is that our design is very complex and requires a lengthy production procedure. We believe that this is a good tradeoff for our foldable design and future work can examine methods to reduce the complexity of our device while maintaining functionality. Another major weakness of our device is the gear ratio of the device. Though we used the ideal gain ratio between hand cranks and the wheel of 1.6 as presented by Whirlwind International (Wieler), initial testing showed that the user had some trouble traveling up inclines and was tired after traveling a long distance over flat ground. Further testing will need to determine if the gain ratio needs to be adjusted and what the optimal gain ratio will be. This brings up another limitation in our design: gear ratio of the device is impossible to adjust on the fly. The user is stuck with the gears the manufacturer installed on the device. One obvious area of improvement is including multiple gears like on typical bicycles. One further weakness of our design is that the hand crank support arm bends during normal device use. This bending causes the chain to loosen, come out of alignment and eventually slip off the gears. Before this device can be commercially produced, this problem must be fixed. The easiest fix will be to make the support bar into two forks on either side of the chain. Therefore, the force from the chain will be between the two supports instead of at the end of a cantilever. The support arm will not bend in this new configuration. Future work will need to be done to examine other methods to counter this problem and how these solutions affect the ability of the device to be stowed underneath the wheelchair and how the device folds together. Because our device is produced using no precision machining, the tolerances between parts are difficult to control. One time that this became a problem was when we needed to drill a hole through two pieces of the frame for the safety pin. After drilling the hole, the pin would slide freely, but when the device was folded up and unfolded again, the two holes did not line up and the pin was not able to slide through. This was solved by trial and error using a hand drill and ream to widen the holes enough so they would line up with enough wiggle room in frame. This is just a limitation on the design that is caused by the available machining processes in our target country. Future work can examine these limitations and methods to reduce them.

RECOMMENDATIONS

Our primary recommendation to our sponsor Dr. Sienko is to continue expanding on the work that we have started in this project. The current device and supporting documentation is a good starting point for future work. The future work cycle for this project will involve validation of the device, consumer testing in the field and finally prototype rework based on these results. We have been able to identify a few key areas that require more analysis and rework.

The most glaring problem is that of the chain alignment and the hand crank support shaft. During normal use, the hand crank support arm bends under the load from the chain enough to cause the chain to loosen around the gears. The chain then slips off the gear causing the attachment to become useless. We recommend using a two forked piece so that the two forks would support the hand cranks on both sides of the chain. The load would then be placed between the supports greatly reducing the cantilever action that causes the support arm to bend. Once this problem is countered, the chain alignment will not be an issue; the bending of the support arm on the current device is what causes the chain to come out of alignment.

Another area that needs to be examined is the use of metric cross sections of mild steel in place of the English sizes used in the prototype. English unit cross sections are not available in Tanzanian bike shops, so further analysis will need to be done in order to examine what cross sections need to be used in the final design. The analysis presented in this report will be fine to use, but will need to be replaced with different cross sections available in Tanzania.

Further research needs to be completed in the area of testing the optimal gain ratio for the device. The gain ratio used in the prototype was provided by Whirlwind International as the optimal for use in wheelchair attachments. However, initial testing showed that the prototype was difficult to travel up an inclined surface. Further testing with different gain ratios can be done to empirically determine the optimal value. Additionally, while it will increase cost and complexity of the device, a multiple gear ratios can be incorporated in the device to allow the user to select the best one to use for different conditions. This was not examined for the prototype, but will be a valuable addition to future devices.

We recommend that future work examine the ergonomics of the design. Understanding the physical capabilities of the user will be very helpful in designing the way that the user is able to manipulate the attachment during attaching/detaching as well as how the device will be moved around during stowing and unstowing. During the course of the design process these considerations greatly affected the final prototype and will need to be considered during future iterations of the design. However, specific anthropometric data for our users in Tanzania is difficult to obtain. We were able to attain some data in this area, but more data will be needed to get a full picture of the user limitations. Amos Winter at MIT is an invaluable resource because he can provide firsthand knowledge of the people using these devices and we recommend that future teams continue to work with him.

Overall, we recommend that future teams be tasked with a specific part of the design that needs to be improved. Because manufacturing our complex device can be quite lengthy, focusing the team on a specific goal will allow them to spend more time producing a quality prototype. Our team was tasked with the specific goal of making the MIT design foldable. Initially, we attempted to redesign many parts of the device such as the hand cranks, the attachment device, and the attachment bars and quickly saw that we would not have time to examine all of the areas we wanted. After focusing on specifically the task of folding, we were more able to manage our available time and produce a quality prototype. This allowed us to then go back and introduce a variety of improvements to the design including a coaster brake and chain tensioners that were initially discussed. A few design goals that we recommend for future teams include: weight reduction, reduction in number of parts, manufacturing time reduction, hand cranks examination, and the use of multiple gears to adjust the gain ratio of the attachment. Additionally, giving a new team the task of folding would be a good way to get a new perspective in the area.

CONCLUSIONS

Current wheelchairs and tricycles do not provide sufficient mobility aid in Tanzania. They cost too much, have a limited range and are not suited to the harsh terrain. We have worked with Dr. Sienko and Mr. Winter to solve this problem by combining the comfort and maneuverability of a wheelchair with the rugged capability and efficiency of a tricycle in a cheap, stowable package that provides full mobility to those in need. All of the work was done with the manufacturing capability and materials available in Tanzania in mind to ensure that the design could be properly implemented.

First, we researched the problem using a variety of sources, defined key requirements and specifications, set a plan for the future, as well as identifying specific challenges. After a concept generation and selection phase, we developed an Alpha Design for intense engineering evaluation in the coming weeks. Then we used our engineering tools and knowledge to analyze the feasibility of the design and how well it met our specifications to come up with a Beta Design. During manufacturing and fabrication of the prototype, continuing design changes were made. This ultimately led to the Final Design and fabrication plan discussed in this report.

Now that we have created a working prototype, there are several conclusions and recommendations we can make. We conclude that the two-chain fold over system is a viable option in compacting the tricycle attachment and that it is a worthwhile option to further refine. While adjustability would be a nice feature to have on the design, it presented problems when we implemented. Several smaller subsystems need to be reworked, such as the chain alignment, the gain ratio, and the steering column locking mechanism. However, we can still say with confidence that while fine tuning and refinement need to be made, the overall concept works.

We hope that these conclusions and recommendations create an impact on the Tanzanian people and help provide these people with their own piece of the Michigan difference.

ACKNOWLEDGEMENTS

The authors would like to acknowledge assistance with this project from Dr. Kathleen Sienko, University of Michigan; Robert Coury, University of Michigan; Marv Cressey, University of Michigan; Corey Wiermont, University of Michigan; Amos Winter, Massachusetts Institute of Technology; Aaron Wieler, Whirlwind International.

REFERENCES

- APDK (2006). APDK Handcycle Production. August, 2006.
<http://web.mit.edu/sp.784/www/IMAGES/VIDEOS/APDK%20-%20Tricycle%20Production.wmv>
- Ashby, M. F. (2005) Materials selection in mechanical design. Amsterdam: Elsevier Butterworth-Heinemann.
- Chandler, D. (2008) On a roll: Students help bring mobility to developing countries. On a roll: Students help bring mobility to developing countries. MIT News Office. <http://web.mit.edu/newsoffice/2008/itw-wheelchairs-tt0521.html>
- Diffrient, N., Tilley, A., & Harman, D. (1981). *Humanscale 7, 8, 9*. Cambridge: MIT Press.
- Fionik, D. (2008). *DUBIKE - foldable bicycle concept*. NASA Tech Briefs "Create the Future Design Contest": <http://www.createthefuturecontest.com/pages/view/entriesdetail.html?entryID=1844> Date accessed: 2/11/09.
- Hiernaux, J. and Hartono, D. Boedhi(1980)'Physical measurements of the adult Hadza of Tanzania',*Annals of Human Biology*,7:4,339 — 346
- Kirby, R. L. and R. A. Cooper (2007). "Applicability of the Wheelchair Skills Program to the Indian context." Disability & Rehabilitation **29**(11): 969-972.
- Mayall, Jan K., and Guylaine Desharnais. Positioning in a Wheelchair : A Guide for Professional Caregivers of the Disabled Adult. Danbury: SLACK, Incorporated, 1995.
- Mellin, J. (2007). tricycle research, YouTube.com. <http://www.youtube.com/watch?v=UC1MgP2fXAQ>. Date accessed: 1/15/09.
- Øderud, T. and R. Hotchkiss (2004). Feasibility Study on Production and Provision of Wheelchairs and Tricycles in Uganda. Trondheim, SINTEF Health Research: 36.
- Ramon, Alex. "How To Calculate Chain Length - Bicycle Tutor." Bicycle Tutor - Bike Repair Video Tutorials. 27 Mar. 2009 <<http://bicycletutor.com/calculate-chain-length/>>.
- Statistics, T. N. B. o. (2000/01). Tanzanian Household Budget Survey. Minister of State. H. D. A. O. Kigoda.
- Technology, F. (2006). "Freedom Technology." Retrieved 01/19/2009, 2009, from <http://www.freedomtechnology.com.ph/products.htm>.
- United States. Central Intelligence Agency. "The world factbook." from <http://www.odci.gov/cia/publications/factbook/index.html>.
- Van der Woude, Luc H. V., I. Bosmans, B. Bervoets, and H. E. J. Veeger. "Handcycling: different modes and gear ratios." Journal of Medical Engineering & Technology 24 (2000): 242-49.
- Winters, A. G. (2005). Conversations with The Tanzania Association of the Disabled (CHAWATA)
- Winters, A. G. (2006). "Assessment of Wheelchair Technology in Tanzania." International Journal for Service Learning in Engineering **2**(1): 60-77.

Appendix B: Bill of Materials

Item	Quantity	Source	Cost	Notes
Used bike	3	Ann Arbor Reuse	\$13.78	Used for scrap parts
Pedal bearing hub assembly	1	Used bike	N/A	
Pedal	2	Used bike	N/A	
12" wheel assembly	1	Used bike	N/A	Includes bolt and nuts
Wheel bracket	2	Used bike	N/A	
Coaster brake assembly	1	Used bike	N/A	
Chain tensioner	1	Used bike	N/A	
Bike chain	2	Used bike	N/A	
Bike chain gear – 18 teeth	2	Used bike	N/A	
Bike chain gear – 21 teeth	1	Used bike	N/A	
Bike chain gear – 28 teeth	1	Used bike	N/A	
1" square steel tubing 1/16" thick	86"	Alro Steel	\$16.01	Fork sides, tension arms
1" circular steel tubing 1/16" thick	12"	Alro Steel	\$7.10	Compression arm collars, Pedal hub extension
¾" circular steel tubing 1/16" thick	36"	Alro Steel	\$8.39	Compression arms, support shaft
¼" thick steel plate	8"x1.5"	Alro Steel	\$2.40	Hand cranks

Appendix C: Description of Engineering Changes since Design Review #3.

Wheel brackets on fork sides

WAS:



IS:

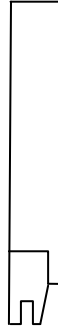

Replaced 0.35 inch wheel axle hole with a wheel bracket cut from a standard bicycle to facilitate easier assembly. The bracket was welded directly onto the fork side.

Folding lock mechanism

WAS:

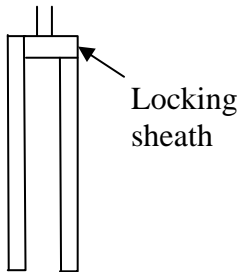

IS:

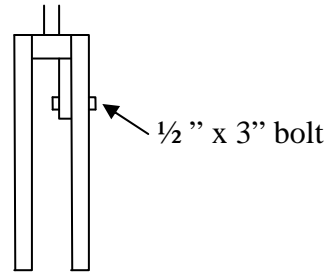

Replaced the locking sheath with a locking pin. An extension to the folding axis was created and a simple bolt locks it into place. This change facilitated easier manufacturability.

Support shaft

WAS:

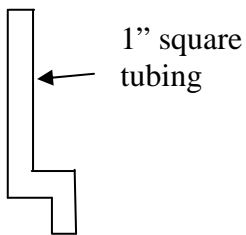

IS:

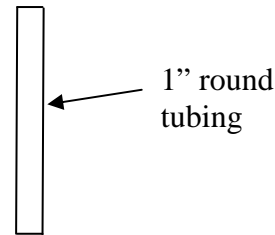

Changed the geometry of the support shaft. Used to jog to the side in order to clear the wheel when folded. This is no longer necessary to achieve the desired level of compacting. Also changed from square to round tubing to facilitate easier assembly to the pedal hub extension.

Additional Fabrication Plans since Design Review #3

This section outlines additional fabrication and manufacturing plans

HAND CRANKS

To make the hand cranks we began by cutting the main pedal hub out of a standard bicycle. This hub included a bearing system for the cranks already. In order to connect this hub to the support shaft and the steering column, it was welded onto an extension to be placed on top of the support shaft. The extension was approximately 8 inches long as is seen in figure C.1 below.



Figure C.1. Bike with pedal hub cut out

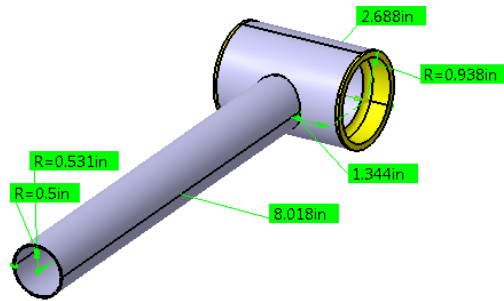

Figure C.2. CAD rendering of pedal hub

Next the two crank bars were made by cutting two sheets of steel into dimensions of 0.25 x 0.75 x 8 inches. A tap of 0.5 inch 18 count thread was used to thread a 0.5 inch hold located 0.5 inches from an end of each bar. This hole size and tap will change depending on the peddles that are used for the attachment.

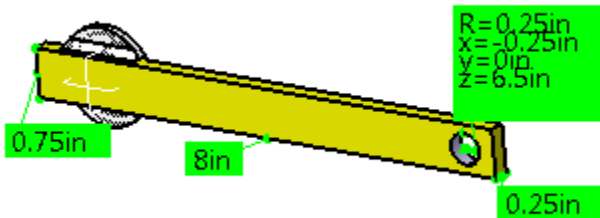

Figure C.3. CAD rendering of individual crank

Peddles

This will allow for the use of pedals from a standard bicycle. The pedals from an existing bicycle were taken off and inserted into the newly tapped holes. The majority of the pedal was cut away enough so that the remaining plastic could be used to press fit on handles from a used bicycle. The handles were simply cut away from the rest of the handlebars.

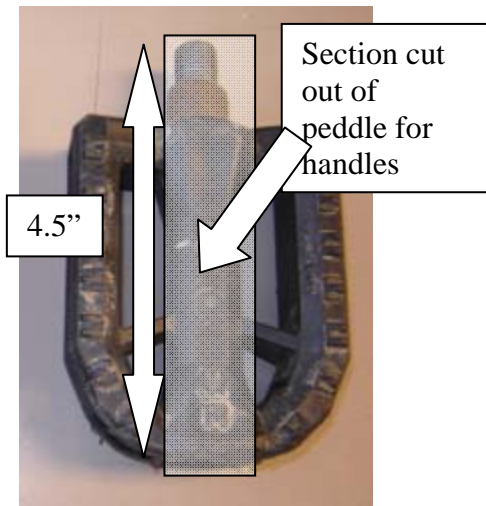

Figure C.4. Standard peddle from a mid sized bike

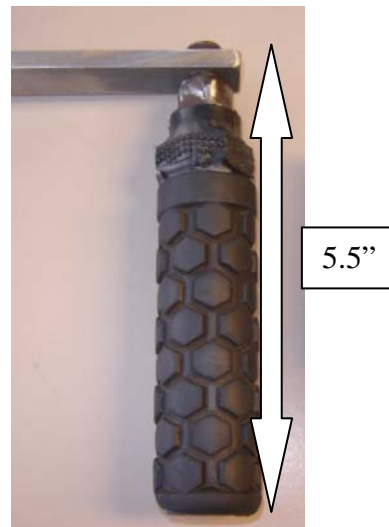

Figure C.5. Handles cut off and pressed onto trimmed down peddle

Welded hand crank

To begin the assembly of the hand crank hub, if there are cranks attached through one piece to the axle, cut them off so that there is only the straight portion of the crank that has the threads on it. Then weld this portion of the shaft to one of the hand cranks as shown below. Ensure that the side of the axle that the gear is attaching to goes closest to the hand crank

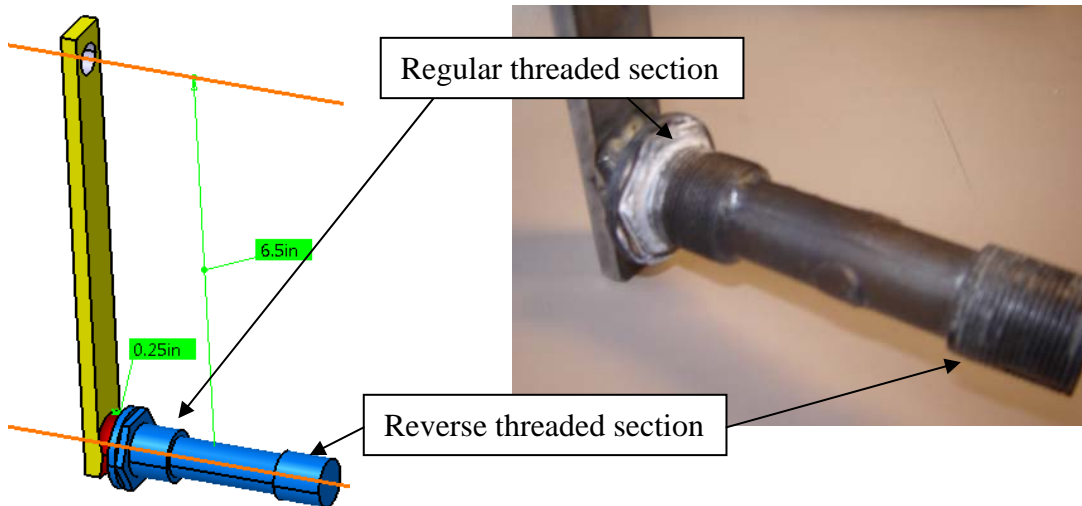

Figure C.6. CAD Rendering of gear side hand crank and axle

Figure C.7. Actual gear side hand crank and axle

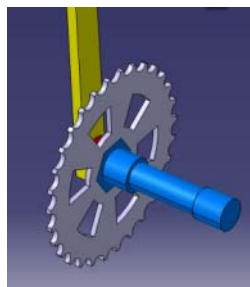

Figure C.8. Relation of gear to hand crank axle

The red filleted area indicates welding. Ensure that the center axis of the axle aligns so that it is exactly 6.5” from the axis of the previously drilled hole on the hand crank where the handles will screw in.

Screw on hand crank

To make the other hand crank, you will need to obtain another bearing collar that has the same reverse threading that aligns with other side of the axle. Weld this collar on as shown below in the same fashion as the welding was done for the previous crank.

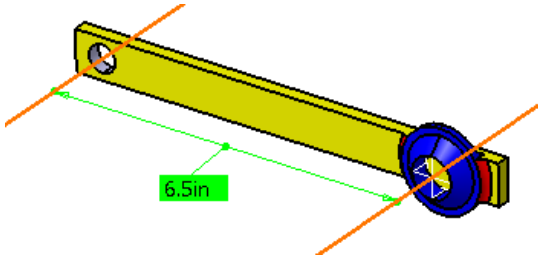

Figure C.9. Orientation of bearing collar on screw on hand crank



Figure C.10. Close up of reverse threaded bearing collar welded onto hand crank

The entire assembly is ready to be put back together. Put the hub, gear, axle, and bearings together just as they were before. However in addition to this, reverse thread the other hand crank onto the end of the axle.

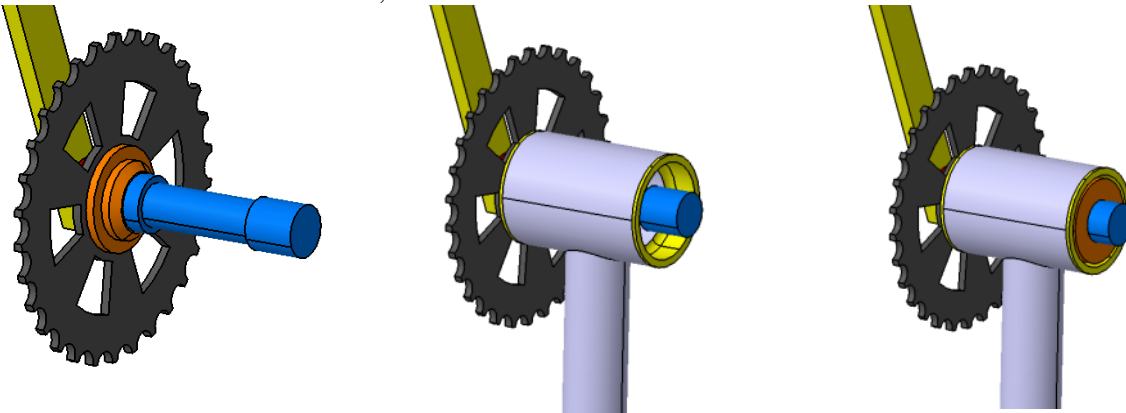

Figure C.11. Regular hub, gear, axle, and bearings assembly

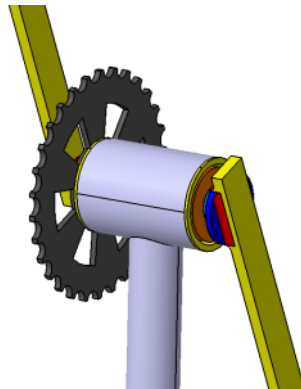

Figure C.12. Extra hand crank reverse threaded on to hub assembly

There will need to be some adjusting to ensure that the hand cranks either align in a perfectly synchronous or asynchronous fashion. A possible solution is to add washers in the hand crank between the end of the axle and the crank. This will stop the hand crank from threading on earlier and with some tweaking can be fit to the user.

Additional notes:

The right-hand crank was welded straight onto bearing axis while the left hand-crank was screwed onto the bearing axis. We did not want to weld both of the cranks onto the axis, because that would prevent the cranks from being able to be removed from the hub. This would not facilitate easy repair within the hub. Due to the nature of this crank, left-handed threading needed to be used so that the hand crank would stay threaded in during normal use. Left-handed taps were not readily available to us in the machine shop, so we worked around this idea by using a left-hand threaded bearing collar (again found from a scrap bicycle) and welding it onto the hand crank itself. Since this collar was already sized to fit on the bearing axis, this solution worked perfectly without having to find a properly sized left-handed tap. The weld made can be seen in red on Figure C.12

Height Adjustment

To ensure that this device can be used for any size user we wanted to have a section that allowed for the user to adjust the height and angle of the hand crank position. The current design simply uses a number of pin holes and a bolt that can be inserted in these holes to adjust the height.



Figure C.13. Simple height adjustment using bolts through a series of holes on the hub drop down bar

Angular adjustment and steering column shaft interior

The angular adjustment was another issue. To adjust the angle we would utilize yet another feature from the scrap bikes. The piece shown below is the steering column shaft interior which has a bracket to which the handlebars are attached. By loosening the 4 bolts, we were able to remove the handlebars. Also by tightening the hex nut on top, it would screw the angled metal brake pad towards the nut. As this happened it would slide up and out on the angled shaft causing enough force to secure the angled shaft and bracket inside the steering column shaft.



Figure C.14. Steering column shaft interior showing the handlebar bracket and angled shaft

This gave us an idea. We cut a 2 inch piece of circular tubing that was roughly the same size as the handlebar tubing and an additional piece the same length of hollow square tubing. We then cut two 1/4" x 1" x 3" pieces of sheet and welded the 4 pieces together in the configuration below. Then weld a piece of tubing that fits inside the support part of the hub in the middle on top of this piece as seen below.

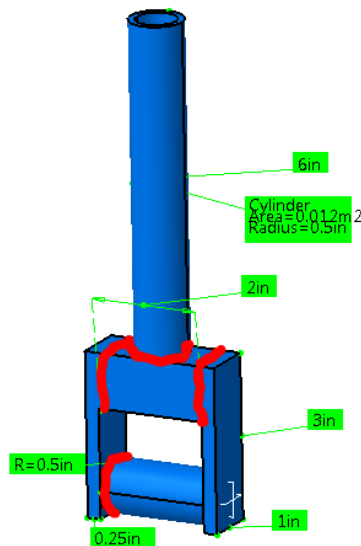

Figure C.15. Angular adjustment. The red squiggly lines represent the spots to weld.

The hub to angular adjustment can now be put together.

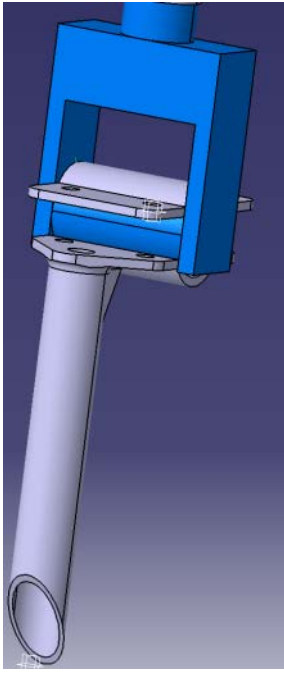

Figure C.16. Handlebar bracket with angular adjustment

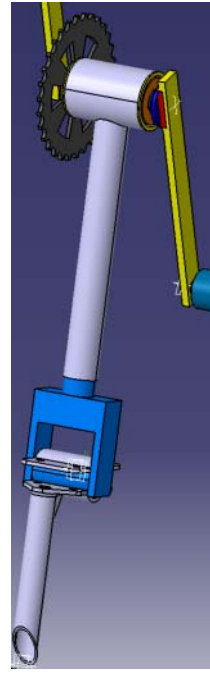

Figure C.17. Assembly thus far.

Steering column shaft exterior

Cut a 3" and 3.5" long piece of 1" square hollow tubing with a wall thickness of approximately 1/16th of an inch. Cut the rest of the threaded section of the steering column off so you over all have a circular piece of tubing with threads at one end that is 4.25" long. Weld the circular piece of tubing on one face of the 3" piece so that the center of the tube is 7/8th of an inch from one end. Then weld the 3.5" piece to the side of the 3" piece on the opposite face of the 3" piece and so it is flush with the end.



Figure C.18. Steering column shaft exterior

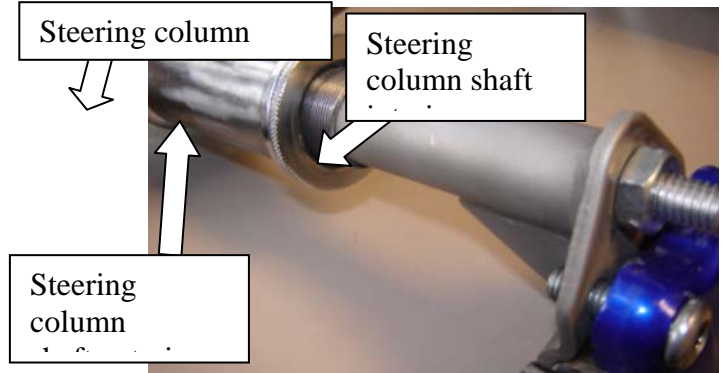

Figure C.19. Steering column assembly

The only thing left to do is cut square sections out of sheet to fit into the ends of the 3" piece. Ensure a snug fit. Tack welds can be used to ensure they stay in place. Once that is done, drill a hole the diameter of the bolt axle (1/2") through the axis of these squares. Once the entire assembly is put together a hole should be drilled through the end of the 3.5" piece and the fork side for the locking pin to insert into. The steering column bottom bearing should fit snugly down around the circular shaft, bearings go on top of this, followed by the attachment arm assembly and steering column collar and finally that is all secured in place by some more bearings and the thread down restraining bearing collar. The handlebar bracket can be inserted into the top of the steering column shaft exterior and the hex nut on top can be tightened to lock the assembly together thus far. Make sure that the gear at the top is perfectly perpendicular to the axis going through the steering column shaft exterior.

Gear bearing middle hub

for the 2 gear middle hub, we began by cutting a .75" long piece of circular tubing that had an outer diameter of 1.25" and wall thickness of 1/8". Figure C.20.

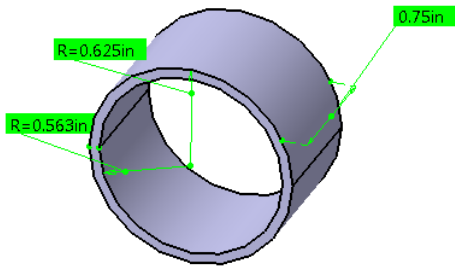

Figure C.20. Bearing collar tube for hub

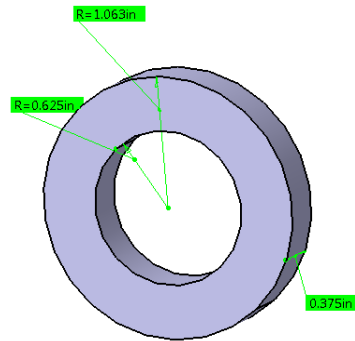

Figure C.21. Gear donut for hub

We then made the gear donut by drilling a 5/8" hole through 3/8" inch thick sheet. Using a series of cuts with a band saw, we shaped the piece into a semi donut that was just wide enough so that both gears had plenty of surface contact on either side so the gears can be securely welded to the surface and so that the chain could still fit on the teeth without hitting the chain.

The gears should be aligned with the center hole on the donut, fixed in place, and welded to the donut. Once the gears are welded to the donut, insert the circular tubing so that there is equal spacing on each side. Tack weld in place if necessary.

Press fit inner bearing collars on both sides of the tubing.



Figure C.22. Fully assembled gear bearing middle hub

Bearing axle

Now that the gear bearing hub has been made, we needed to make a sturdy axle for the gears to rotate about. We began by cutting off a 1.625" long section of the threaded portion of a front fork steering column assembly. We use this portion of the bike so that we can also utilize the restraining bearing collars.

We press fit a slightly smaller piece of circular solid metal stock into the threaded portion of the front fork. After securely clamping down this piece, we drilled a 1/2" hole through the axle of the piece and tapped the hole so that the entire assembly could be threaded onto the 1/2" bolt axle we were using for our folding axle.

Once the axle is threaded on, thread a restraining bearing collar onto the assembly until it reaches the end.



Figure C.23. Threaded axle with threaded assembly on as well as a restraining bearing collar on

Place a bearing ring on the collar and place the gear bearing hub on the axle, place another bearing ring into the other side of the gear bearing hub and using another restraining bearing collar, constrain the entire assembly together.



Figure C.24. Fully assembled gear bearing rotating hub

Critique

The most important critique is that there are issues with the chain alignment. This arises mainly from the problem with the bending in the piece that connects the steering column insert and the hand crank hub. The current design was not tested for the high stresses that would be placed on it and thus the idea has been scrapped.



Figure C.25. Bent connection piece between steering column insert and hand crank hub

The feature has been redesigned and now equally distributes the force over two pieces of sheet thus preventing the bending that was occurring before.

Another issue with chain alignment was ensuring that the chain was the proper length so that it meshed perfectly with the gears at the hand crank, folding hub, and wheel. We designed and produced two quick fix chain tensioners. The first tensioner was for the lower half and uses a tension spring to keep the gears meshing.

The upper chain tensioner was more of an issue due not only to the longer chain but also once again the failure in bending of the before mentioned support structure but also to the lack of time to design and fabricate a proper solution.

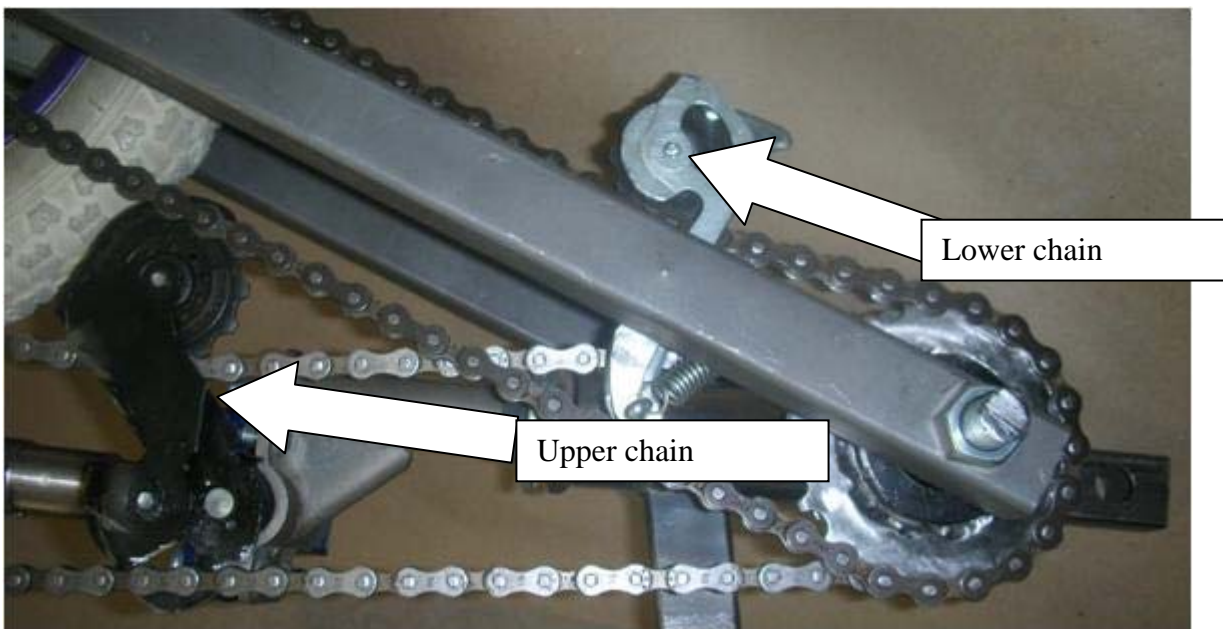

Figure C.26. Upper and lower chain tensioners when in the folded state.

There is also an issue that arose with storage. The original plan to fit the device under the user and on top of the wheelchairs cross brace works but it is difficult to maneuver the attachment underneath and can cause slight discomfort on the user's seat.



Figure C.27. Stowed attachment

When we did get the attachment working, we found that when we went up slight inclines, we found it difficult to pedal and the wheel would often slip on the ground. The slipping wheel could possibly be because the tread was so bare or because there is still not enough force being applied downward on the front wheel. We can look at our gain ratio, using newer tires, or possibly moving the main axle of the wheelchair backwards or forward to change the amount of downward force on the front wheel.

Another issue is the attachment disengaging when going over bumps. When going over a slight bump and the caster wheels are hit upwards, there is no longer any pressure on the compression arms and the attachment detaches from the wheelchair. This is not good. A simple way to alleviate this problem would be to do what MIT did with their design and put small clasps on the connection points for the compression arms. This would ensure that if turbulence was encountered, the compression arms would not be allowed to move.

A smaller issue is the locking pin. It is difficult to get the pin to insert between the two locking pieces. It can be done but often requires lots of jiggling and smacking of the attachment. It is also a concern that this is a loose piece and is not permanently attached to the device and therefore can be easily lost.

Appendix D: Design Analysis Assignment from Lecture

Material Selection

Constraints on the material we use for the bars and linkages in our device are shown below in Table D.1. In order for a material to pass one of the limit stages, it must satisfy at least one of the conditions in the phase. In order for the material to be considered, it must pass through all of the stages.

Table D.1: Limit stages used in CES EduPack Software

Material	[MaterialUniverse:\Metals and alloys] [MaterialUniverse:\Hybrids: composites, foams, natural materials] [MaterialUniverse:\Polymers and elastomers]
Shape	[Shape:\Prismatic] [Shape:\3-D]
Process 1	[ProcessUniverse:\Shaping\Machining\Machining\Band saw] [ProcessUniverse:\Shaping\Machining\Machining\Circular saw] [ProcessUniverse:\Shaping\Machining\Machining\Drilling]
Process 2	[ProcessUniverse:\Joining\Thermal welding]
Operating Temperature	Minimum Melting Point: 750 °F Range of device operating temperatures: 0 °F – 150 °F
Durability	Non-flammable Fresh water resistance: Average, Good, Very Good Salt water resistance: Average, Good, Very Good Organic solvent resistance: Good, Very Good Sunlight (UV Radiation) resistance: Very Good

Material types For this project, we limited the materials examined three main categories: metals and alloys, hybrids (composites, foams and natural materials) and polymers and elastomers. We eliminated ceramics and glasses due to safety. If our device were to fail, we would prefer it to do so in a method that will not harm the user. Ceramics and glasses are typically very brittle and during failure, these materials will fracture in many sharp pieces that can harm the user. This is not desirable.

Shape limitation This constraint was used as a way to make sure that the material we choose can be shaped into those used by our design. We only allowed materials that could be shaped into simple 3-D or prismatic shapes to pass through this filter. There are no sheets of material in our design, so this filter was ignored.

Process universe This is one of the most important filters for material selection. This filter allows us to only examine materials that are compatible with the manufacturing processes that are readily available in the typical Tanzanian workshop. Only materials that were compatible with sawing and drilling passed through this filter. Additionally, the most common method these workshops have for joining material is welding. Therefore only those materials that could be joined with welding were examined.

Environment In order to make sure the material could be used in the environment of Tanzania, we filtered the materials based on service temperature, melting point and various durability characteristics. We defined the service temperature range of our device to be between 0 and 150 degrees Fahrenheit as these temperatures cover the range of temperatures typically seen in the world and will allow our device to be used in regions besides Tanzania. Additionally, we defined the minimum melting point of the material to be 750 degrees Fahrenheit because at five times the max service temperature, the material properties will not be greatly affected by the environmental temperature approaching the melting point.

We realize that our device is not going to be used in a sterile environment and must anticipate some of the problems the material could experience in Tanzania. These include fire, water damage, and contact with organic solvents such as gasoline and oils. To combat fire, the material needs to be non-flammable. To combat water damage, the material

needs to have a resilience to water and salt water that is average, good or very good. The material must also have a good to very good resilience to organic solvents. Since the device will be used outdoors, the material must be extremely resilient to UV radiation.

Material analysis

In order to determine the best materials which pass all of our filters and constraints, these materials were compared to each other in terms of mass and cost. In our device, there are two loading conditions that we need to consider – compressive buckling and yield by bending.

Yield by bending The material performance indices for yield by bending are shown in equation D.1 for mass and in equation D.2 for cost (Ashby). In order to minimize mass and cost, these indices need to be maximized.

$$M = \frac{\sigma_y^3}{\rho} \tag{D.1}$$

$$M = \frac{\sigma_y^3}{\rho c_m} \tag{D.2}$$

The above performance indices are graphed together in Appendix L. We want to use a material that minimizes mass and cost. Therefore, we want to maximize the performance indices above.

Compressive buckling The material performance indices for compressive buckling are shown in equation D.3 for mass and in equation D.4 for cost (Ashby). In order to minimize mass and cost, these indices need to be maximized.

$$M = \frac{E^3}{\rho} \tag{D.3}$$

$$M = \frac{E^3}{\rho c_m} \tag{D.4}$$

The above performance indices are graphed together in Appendix P. We want to use a material that minimizes mass and cost. Therefore, we want to maximize the performance indices above.

Material selection conclusions

Using the graphs as guides, two groups of materials that excel in both the yield by bending and compressive yielding failure mechanisms are steels and aluminums. These two groups of materials are displayed in the top right corner of the graphs showing that they maximize both performance indices. Further material analysis into the single best material for this device is not necessary because we know from discussions with our mentor Amos Winter, that we will be limited to using only mild steel. The current material selection process shows that mild steel is an appropriate material for this project.

Ethical and Environmental Issues

Product development

Our device is designed to improve mobility for handicapped people in developing nations. It utilizes basic construction techniques such as cutting, drilling, grinding and welding and relies on spare bicycle parts and mild steel for materials. There are risks involved with these processes but the construction would be handled by local bicycle shops that are already very skilled in these methods, so there is little additional risk in construction.

Our device’s reliance on used bike parts could lead to some possible ethical issues. An increase in bike theft in order to supply parts is possible; especially if the device is sold for more than an average bike. If the device is wildly

successful than many bike shops could be overwhelmed with orders and would not be able to repair bicycles as efficiently. What will be done to dispose of the unused bike parts, in our assembly lab we currently have a pile of gutted bikes, and these frames lose their functionality after key components are removed. It would be beneficial to use as much of the bike as possible in our design.

The group and future teams need to be careful of the “savior” mentality. Our mentor Amos Winter mentioned that often in these ‘developing nation’ projects the teams approach the problem like by

“thinking that they are helping these helpless people. In reality, people in developing countries are super smart and have tons of knowledge about their clients, how to make stuff, local terrain, cultural norms, etc, that you don’t. A collaboration between...engineers like you and the people that have tons of local knowledge can yield great new technology that is appropriate and that effectively meets user needs.”

Our team did not take advantage of talking to the local people and may have missed some valuable insight. Teams need to be careful that the locals will reject foreign involvement without much dialogue.

Societal benefits and harms

Our device is intended to provide complete mobility to those who currently rely on a traditional wheelchair or handcycle. The device is capable of short range indoor travel as well as long range over rugged outdoor terrain; it can also be folded to fit on a bus or in a taxi. The benefit is that these previously range-limited people are now able to fully function in society. They can travel the 6.4 km to high school using the handcycle attachment or fold it up to take a bus 20km to a hospital for treatment. Once at their location they are able to use the device like a regular wheelchair, rather than crawling around. The user has more options for comfortable travel and the intent is that they will be more likely to travel to these previously inaccessible places to continue their education or maintain their health. The increased mobility of these people will benefit society through the increased dialog and work done for society.

There are some possible harmful effects to society. Some buses and schools may be overcrowded already, and an influx of wheelchair users may do more to crowd these places. Another possible issue is the method of design and manufacture. The device was designed in the United States by four students who had never been to Tanzania, never been regular wheelchair users, and were relying on literature and conversations with partners to design the device. Once implemented it may not be suitable for the environment. There is a chance that the manufacturing assumptions were wrong and that the device will not be made properly in Tanzania.

Quantification of environmental considerations

One basic way that the environmental considerations associated with our design can be quantified is by examining the impact of our chosen material on the environment. During our project the team was limited to only using mild steel due to the limited availability of other materials in Tanzania. Aluminum alloys are another group of materials that are appealing to use in our device because they are light weight and strong. In order to compare the environmental impact of these two sets of materials, 10 kg of St13 I steel was compared to 7 kg of AlMgSi0.5 (6060) I aluminum alloy using SimaPro 7. This steel material was chosen because it is representative of the mild steel used in our project. The aluminum alloy was chosen because it is cited in SimaPro as being used in bicycle frames. Scrap steel bicycle parts make up a large portion of our device and this aluminum alloy is a candidate for the material for our project. The environmental impact simulation showed that the aluminum alloy had a larger impact on the environment when compared to mild steel. First, we examined the mass of all emissions involved in the production of these two materials. Figure D.1 shows that aluminum has a larger effect on the environment. The largest contributor to aluminum emissions is in its manufacture: a large amount of energy is required in order to extract and process bauxite ore into aluminum. Figure D.2 shows that with respect to various aspects of the environment, the aluminum alloy is much more detrimental than the steel alloy.

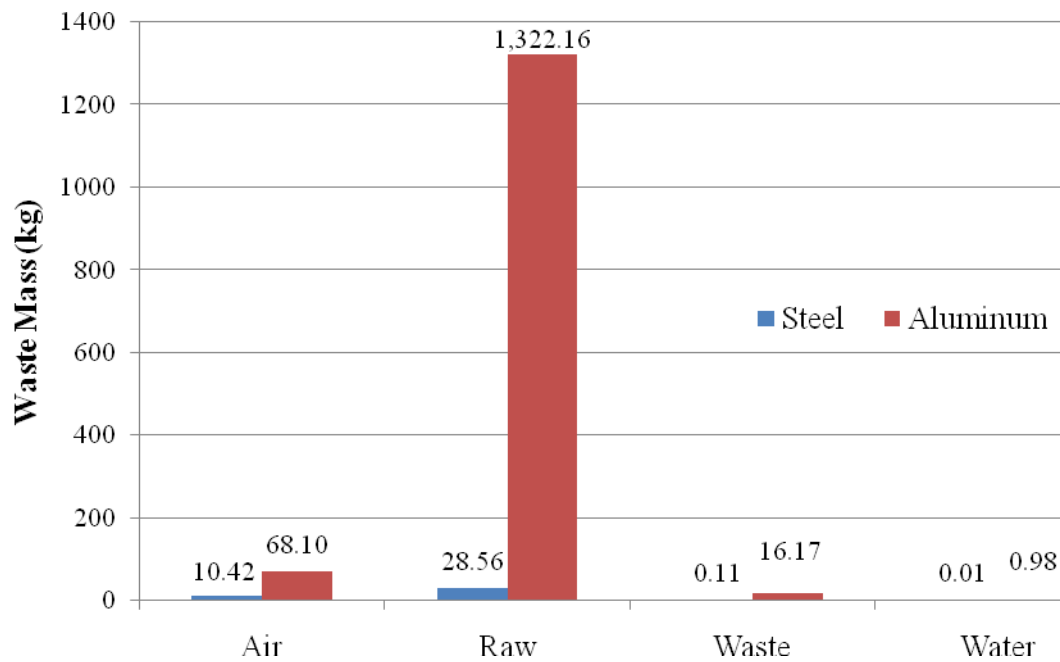

Figure D.1: Mass of emission products with respect to provided mild steel and aluminum alloy.

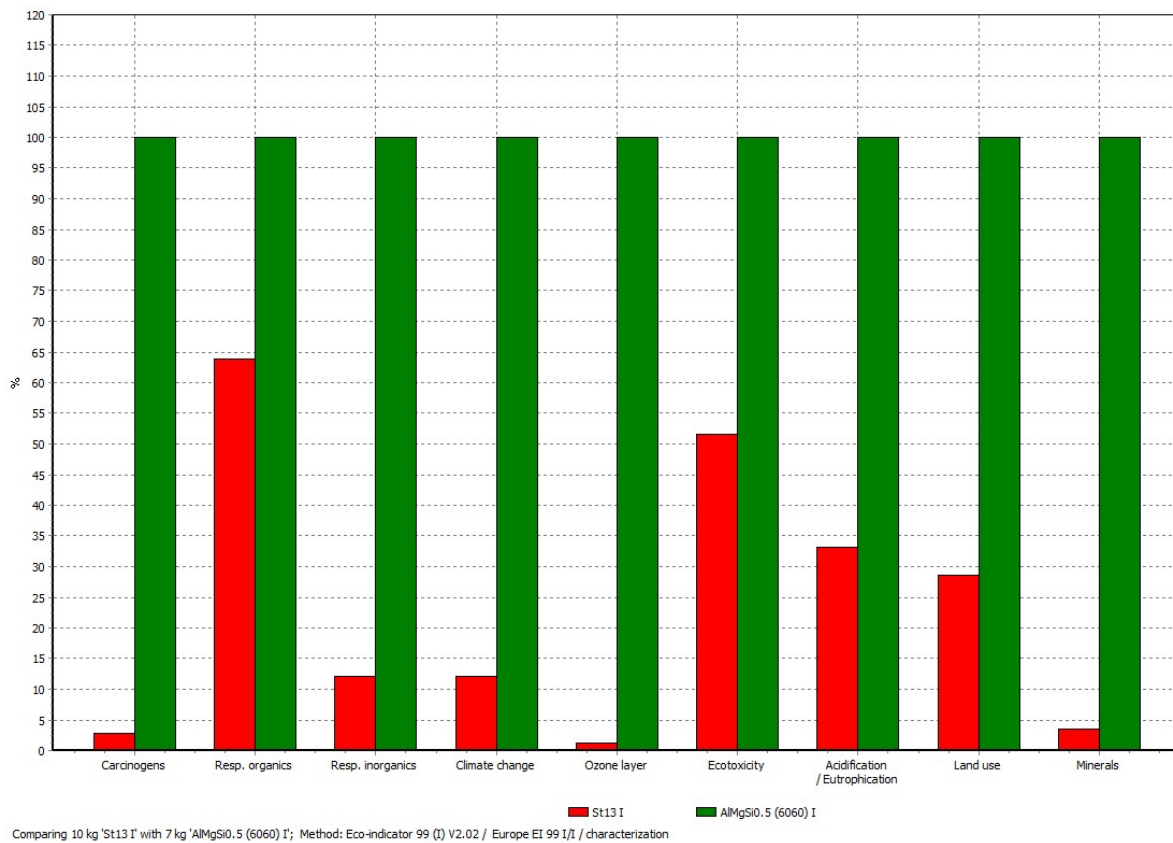

Figure D.2: Effect of mild steel and sample aluminum alloy on various aspects of the environment with respect to aluminum alloy.

Figure D.3 compares the two materials with respect to the categories of Human Health, Ecosystem Quality and Resources. Mild steel and the aluminum alloy have an approximately equal affect in terms of ecosystem quality. However, when compared to mild steel, the aluminum alloy has an order of magnitude larger impact on the environment with respect to the resources required to extract and process the raw material. Additionally, these processes have a much larger impact on human health when compared to mild steel.

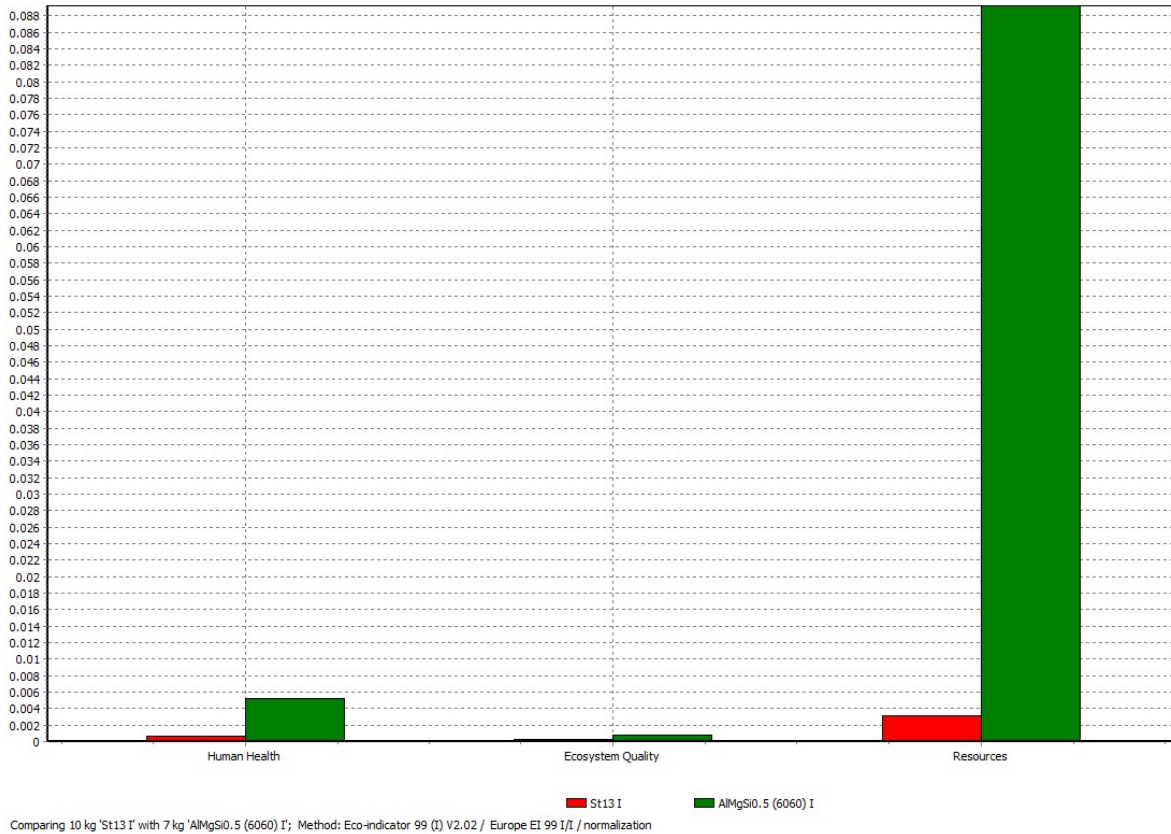

Figure D.3: The environmental impact of mild steel and aluminum alloy with respect to human health, ecosystem quality and resources.

Figure D.4 shows that the aluminum alloy has a much larger effect on the environment than the mild steel material. Additionally, the largest group contributors to the environmental impact for the aluminum alloy are the resources required to extract and process the material. The total impact of the aluminum alloy is approximately 20 times the size of the impact of the mild steel material.

To conclude, mild steel is a more logical choice for the final material because not only is it cheap and readily available in our target country, it has a much smaller impact on the environment than aluminum alloys.

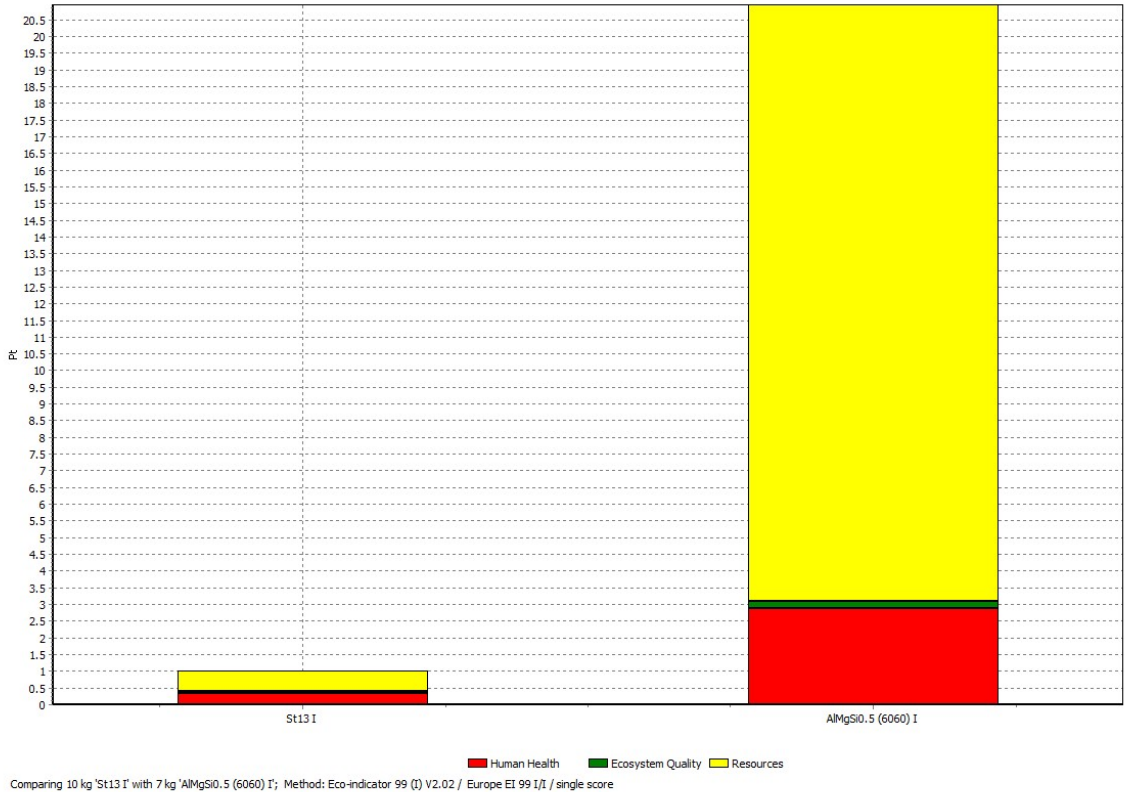

Figure D.4: The total impact on the environment from the aluminum alloy is about 20 times larger than that of the mild steel material.

Appendix F: Component Price List from MIT course page

<http://web.mit.edu/sp.784/www/DOCUMENTS/Tanzania%20Components%20Price%20List.xls>

Tanzania Component Listing

Exchange rate (US\$/KE Shilling)	0.000779727
---	-------------

Bicycle Components			
Description	Quantity	Unit Price (TZ Shilling)	Unit Price (US\$)
Bullet Front Fork	1	3000	2.339181287
Mountain Bike Front Fork	1	3500	2.729044834
Avon Front Fork	1	3500	2.729044834
Phoenix Front Fork	1	3500	2.729044834
Bullet Pedal Set	1	1500	1.169590643
V Brand Spoke Set	1	3000	2.339181287
FIT Brand Spoke Set	1	2700	2.105263158
Sawan Rear Hub	2	1000	0.779727096
Front Hub No Name	1	800	0.623781676
Pheonix Front Hub	2	800	0.623781676
Yong Ling Rear Hub	2	1500	1.169590643
Phoenix 48 Tooth Chainring/Crank w/ Long Arms	1	3000	2.339181287
Phoenix 48 Tooth Chainring/Crank w/ Long Arms	1	3000	2.339181287
Bullet Bottom Bracket Axle	2	1000	0.779727096
Plain Bottom Bracket Axle	2	1000	0.779727096
Bottom Bracket Shell	2	1000	0.779727096
Rear Derailleur	1	3000	2.339181287
Red Star Chain	1	1000	0.779727096
Tipson Bottom Bracket Cup Set	2	1000	0.779727096
Flying Pigeon Bottom Bracket Cup Set	2	1000	0.779727096
Flying Pigeon 20 Tooth Free Wheel	4	1000	0.779727096
Diamond 20 Tooth Free Wheel	2	1000	0.779727096
Front Fork Cup Bearings, for Mountain Bike	2	1500	1.169590643
Simhwa Front Fork Cup Bearings	2	1000	0.779727096
Tipson Front Fork Cup Bearings	2	1000	0.779727096
Front Fork Caged Bearings	6	500	0.389863548
Bottom Bracket Caged Bearings	6	500	0.389863548
Pack of loose 1/4" Bottom Bracket Bearing Balls	1	500	0.389863548
Cotter Pins for Securing Crank Arms	6	500	0.389863548
Alfa Cycle Calliper Brake Set	1	3500	2.729044834
Old-Style Brake Set	1	1500	1.169590643
Pair of Multi-Color Hand Grips	1	1000	0.779727096
Multi-Speed Mountain Bike Freewheel	1	2500	1.949317739
28" Wheel	1	3500	2.729044834
26" Wheel	1	4000	3.118908382

Appendix G: Project Planning for the Tricycle Attachment

Task Name	Team Member Responsible	Start	Finish	Duration	Gantt Chart (Jan 2009 - Aug 2009)																											
Final Design Review	Smith	1/13/2009	1/13/2009	1d	[Gantt bar from 1/13/2009 to 1/13/2009]																											
research - Patents	Team	1/13/2009	1/20/2009	8d	[Gantt bar from 1/13/2009 to 1/20/2009]																											
research - Current Devices and Users	Holcomb	1/13/2009	1/20/2009	8d	[Gantt bar from 1/13/2009 to 1/20/2009]																											
research - Wheelbar Ergonomics	Kovick	1/13/2009	1/20/2009	8d	[Gantt bar from 1/13/2009 to 1/20/2009]																											
design Requirements & Specifications	Team	1/21/2009	1/28/2009	8d	[Gantt bar from 1/21/2009 to 1/28/2009]																											
select Draft of Design Review # 1	Team	1/23/2009	1/23/2009	1d	[Gantt bar from 1/23/2009 to 1/23/2009]																											
complete Quality Function Diagram	Team	1/24/2009	1/24/2009	1d	[Gantt bar from 1/24/2009 to 1/24/2009]																											
initial Design Review # 1	Team	1/24/2009	1/28/2009	5d	[Gantt bar from 1/24/2009 to 1/28/2009]																											
select Design Review # 1	Team	1/29/2009	1/29/2009	1d	[Gantt bar from 1/29/2009 to 1/29/2009]																											
research Physical Ability of Users	Kovick	1/30/2009	2/1/2009	3d	[Gantt bar from 1/30/2009 to 2/1/2009]																											
select Wheelbar for a Day	Team	2/1/2009	2/1/2009	1d	[Gantt bar from 2/1/2009 to 2/1/2009]																											
multiple Possible Design Options	Team	1/30/2009	2/8/2009	10d	[Gantt bar from 1/30/2009 to 2/8/2009]																											
refine Possible Designs	Team	2/7/2009	2/10/2009	4d	[Gantt bar from 2/7/2009 to 2/10/2009]																											
select Features of Possible Designs	Team	2/10/2009	2/12/2009	3d	[Gantt bar from 2/10/2009 to 2/12/2009]																											
select Alpha Design	Team	2/13/2009	2/19/2009	7d	[Gantt bar from 2/13/2009 to 2/19/2009]																											
refine Alpha Design	Team	2/19/2009	2/19/2009	1d	[Gantt bar from 2/19/2009 to 2/19/2009]																											
define the Alpha Design	Team	2/19/2009	3/18/2009	28d	[Gantt bar from 2/19/2009 to 3/18/2009]																											
bring Back (no work)	Team	2/19/2009	2/27/2009	9d	[Gantt bar from 2/19/2009 to 2/27/2009]																											
submit Paper Design to Access Wheelbar	Smith	2/27/2009	3/1/2009	5d	[Gantt bar from 2/27/2009 to 3/1/2009]																											
refine and Submit Design	Team	3/1/2009	3/1/2009	1d	[Gantt bar from 3/1/2009 to 3/1/2009]																											
select Report Delivery	Team	3/26/2009	3/26/2009	1d	[Gantt bar from 3/26/2009 to 3/26/2009]																											
initial Design Review # 3	Team	3/19/2009	3/25/2009	7d	[Gantt bar from 3/19/2009 to 3/25/2009]																											
select Design Review # 3	Team	3/26/2009	3/26/2009	1d	[Gantt bar from 3/26/2009 to 3/26/2009]																											
plan Prototypes Manufacturing	Team	3/27/2009	4/8/2009	10d	[Gantt bar from 3/27/2009 to 4/8/2009]																											
initial Design Review # 4	Team	4/2/2009	4/8/2009	4d	[Gantt bar from 4/2/2009 to 4/8/2009]																											
select Design Review # 4	Team	4/7/2009	4/7/2009	1d	[Gantt bar from 4/7/2009 to 4/7/2009]																											
10 Prototypes Manufacturing	Team	4/7/2009	4/13/2009	7d	[Gantt bar from 4/7/2009 to 4/13/2009]																											
design Expo Poster Creation	Team	4/11/2009	4/15/2009	5d	[Gantt bar from 4/11/2009 to 4/15/2009]																											
design Expo	Team	4/16/2009	4/16/2009	1d	[Gantt bar from 4/16/2009 to 4/16/2009]																											
complete Final Journal Piece	Team	4/14/2009	4/20/2009	7d	[Gantt bar from 4/14/2009 to 4/20/2009]																											
deliver Final Report	Team	4/21/2009	4/21/2009	1d	[Gantt bar from 4/21/2009 to 4/21/2009]																											
initial Prototypes	Team	4/22/2009	4/29/2009	8d	[Gantt bar from 4/22/2009 to 4/29/2009]																											
deliver Final Prototype	Team	4/20/2009	4/20/2009	1d	[Gantt bar from 4/20/2009 to 4/20/2009]																											

Appendix H: A visualization of the range limits of current devices in relation to key services.

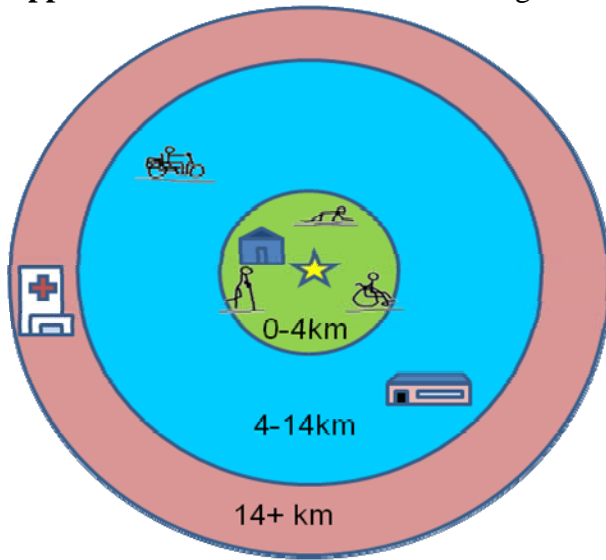

- **Distance to services**
 - 1.9 km to primary school
 - 2.8 km to shop
 - 6.4 km to secondary school
 - 26 km to hospital
- **Gaps in current mobility-aid range**
 - 36% travel 5+ km daily
 - Tricycles not allowed on buses, indoors

2000/01 Tanzanian Household Budget Survey (HBS)
Winter, V, Amos G. 2005. *Assessment of Wheelchair Technology in Tanzania.*

Appendix I: Full functional decomposition for a wheelchair tricycle attachment.

1. *Attaches to wheelchair*
 - 1.1 Maintains safe and secure lock onto wheelchair
 - 1.2 Does not impede user while in use
 - 1.3 Does not require a large amount of force, flexion, or time to attach
 - 1.4 Does not require any tools to attach if detaching is necessary for storage

2. *Propels wheelchair*
 - 2.1 Provides mechanical advantage to user
 - 2.2 Users can power attachment with upper body
 - 2.3 Allows user to brake safely and without removing hands from hand crank
 - 2.4 Powering hand crank does not affect the steering of the wheelchair

3. *Compact into smaller size*
 - 3.1 Attachment compresses into a more manageable shape
 - 3.2 Handles compact
 - 3.3 Attachment arms compact
 - 3.4 Drive system compacts
 - 3.5 Stays attached while folding

4. *Stows away on wheelchair*
 - 4.1 Fits into a space on wheelchair
 - 4.2 Does not impede user while stowed
 - 4.3 Stays securely stowed
 - 4.4 Does not require a large amount of force, flexion, or time to stow/unstow
 - 4.5 Does not limit wheelchair maneuverability/ mobility
 - 4.6 Stays attached while stowed

5. *Traverses rough terrain*
 - 5.1 Stabilizes wheelchair during travel
 - 5.2 Can clear typical rough Tanzanian terrain
 - 5.3 Maintains traction while going up hill

6. *Adjusts to different people*
 - 6.1 Adjusts to different heights
 - 6.2 Adjusts to different arm lengths
 - 6.3 Creates an ergonomic seating position

Folding

- Crutches notches w spring++++
- Hinge
- Ball joint
- Swivel hinge
- Extension twister+
- Accordion++
- Hand crank fold over+++
- Disassembly -
- Removable wheel+
- Chain Tensioner++-
- Thumb release
- Slider+++
- Tent-style cord
- Rollup flexible- - -
- Inflatable- - - -
- Foldable with chair
- Universal joint w lock
++

rankings

Stowing

Where?

- Trailer --
- Back++-
- Under+++
- Sidecar -
- Spreading it out++++

How?

- Bag +
- Shelf
- Rope 'straps +
- Mechanical arm ++
- Friend - -
- Disposable - - - -
- Rental vending machines - - - +
- Basket ++
- Mesh pouch ++-
- Slide clip
- Glue - - -
- Zip up pouch

Steering

- Steer w/ crank +++++
- Torso +
- Weight shift +
- Lean back
- Wedges
- Alternate wheel size
- HU steering +
- Mental
- Segway-style
- GPS

Propulsion

- | | | | |
|-----------------------|---------|--|-------|
| • Standard hand crank | + + + + | • Wind | + - |
| • Pumping motion | + | • Rap dj | + - |
| • Friend | - - | • Fuel cell | - - - |
| • Head nodding | - | • Steam | + - - |
| • Momentum shifting | - | • Breast stroke | |
| • Rowing/levering | + + + | • Lapbar | + |
| • Hand rimming | + - | • Gravity | - - - |
| • Stick/gondola | - | • Alternating wheels (tricycle system) | |
| • Rubber bands | | • Matter ejection | |
| • Solar | - - | | |

Braking

- | | | | |
|---------------------------|---------|--------------------|---------|
| • Don't | -- | • Anchor | + + - - |
| • Handrim | + | • Reverse thruster | + - - - |
| • Lever | + + | • Magnets | + - |
| • Bike brake (hand brake) | + + + + | • Parachute | + - - |
| • Lean | | • Prop fouler | - - |
| • Back pedal | + + | | |
| • Coaster brake | | | |

Attach/Detach

- | | | | |
|---------------------|---------|------------------------|---------|
| • Vice grip | ++ | • Velcro TM | - |
| • C-clamp | + | • Slider | ++ |
| • Triangle | ++++ | • Glue | - - - - |
| • Zeus fastener | + | • Zip ties | - |
| • Magnets | + - | • Hooks | - |
| • Rope | - - - - | • Thumb screws | + |
| • Bolts/nuts/screws | | • Ratchet | |

Wheels

• Rubber wheel	++++	• Mechanical feet	+ - -
• Foldable	++++	• Paddle wheel	- -
• Ski	+ - -	• Rocket wheel	- -
• Tank treads - -		• Inflatable wheel	+++
• Metal	- - -	• Plastic wheel	- -
• Hover device	- -	• Two wheels	
• Tricycles 2	-+	side by side	++

Appendix K: Pugh Charts for Specific Component

(a) Folding drive system:

Evaluation Criteria	2-belt fold over	Single belt fold over w/ tensioner	Accordian
Folded dimensions	2	1	3
Unfolded dimensions	1	2	3
Light weight	2	1	3
Durability	1	2	3
Easy to use	1	1	3
Low cost	2	1	3
Number of parts	2	1	3
Easy to repair	1	3	2
Visually appealing (Sexy)	1	3	2
Steps required	1	2	3
SUM (golf scoring)	14	17	28

(b) Stowing Location:

Evaluation Criteria	Back	Under	On side	Spread it out
Stability	4	1	3	2
Easy to use	2	2	1	4
Impedence	2	1	4	3
Adaptability	1	3	2	4
Space	2	4	1	3
SUM (golf scoring)	11	11	11	16

(c) Stowing Method:

Evaluation Criteria	Bag	Shelf	Sliding rail	Straps	Fasteners	Arm
Size	3	5	4	2	1	6
Light weight	2	5	4	1	3	6
Durability	5	1	3	4	2	6
Easy to use	4	2	3	5	6	1
Low cost	1	4	5	2	3	6
Easy to repair	1	4	5	3	2	6
Number of parts	1	3	4	2	5	6
Adaptability	1	4	5	3	2	6
Security	5	6	3	4	2	1
SUM (golf scoring)	23	34	36	26	26	44

(d) Attachment Method:

Evaluation Criteria	Sliding	Triangle	Vice grip	Master lock	tri-clamp
Grip force	4	5	1	3	2
Size	5	2	4	1	3
Light weight	4	1	5	2	3
Durability	3	1	5	2	4
Easy to use	2	5	1	4	3
Low cost	3	1	5	2	4
Easy to repair	3	3	5	1	3
Easy to machine	3	4	1	2	5
Steps required	3	1	4	5	2
Number of parts	3	1	5	4	2
Adaptability	4	5	1	2	3
SUM (golf scoring)	37	29	37	28	34

Appendix L: Initial Specs

Ranking	Specification	Value	Unit
1	Material used		
2	Amount of material used	610	in ³
3	Young's modulus of material	7250	kpsi
4	Weight	22	pounds
4	Force it takes to clamp	3.37	pounds force
4	Force it takes to unclamp	3.37	pounds force
7	Maximum working load	450	pounds force
8	Dimensions folded	1.64x 1.64 x 0.82	ft
9	Dimensions unfolded	3.3 x 1.97 x 1.64	ft
10	Price of labor	10	USD
11	Mechanical advantage	5	
12	Range of user arm length	20-40	in

Ranking	Specification	Value	Unit
13	Wheel diameter	19.68	in
14	Range of user height	39-90	in
15	Hand crank height range	16-39	in
15	Hand crank angle range	45-90	degrees
15	Hand crank length range	3.9-5.9	in
18	Braking force	11.24	pounds force
18	Braking distance from 10-0 kmh	10	ft
20	Fillet radii	0.05	in
21	Degree of flexion it takes to install	90	degrees
21	Degree of flexion it takes to uninstall	90	degrees
23	Time it takes to install (unstow, unfold, and attach)	60	s
23	Time it takes to uninstall (detach, fold, and stow)	60	s

Appendix M: Visual diagrams of the attachment mechanisms

(a) Slider:

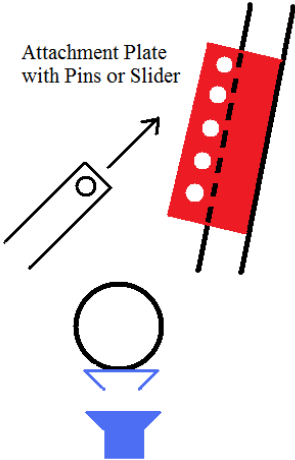

(b) Triangle attachment mechanism:

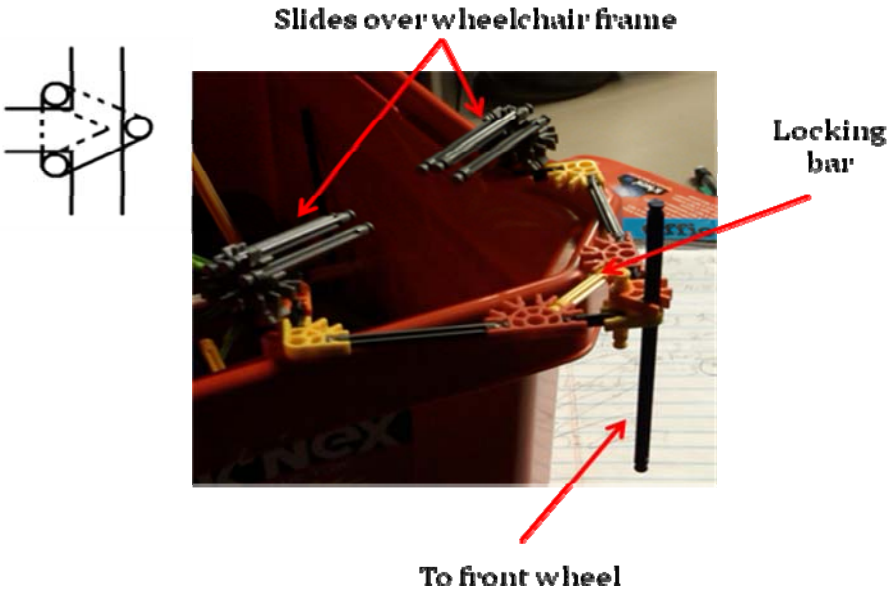

(c) Vice Grip Clamp:



<http://mit.tricycle.googlepages.com/morefinalwheelchair006.JPG/morefinalwheelchair006-full;init:.JPG>

(d) Master Lock Clamp Method:

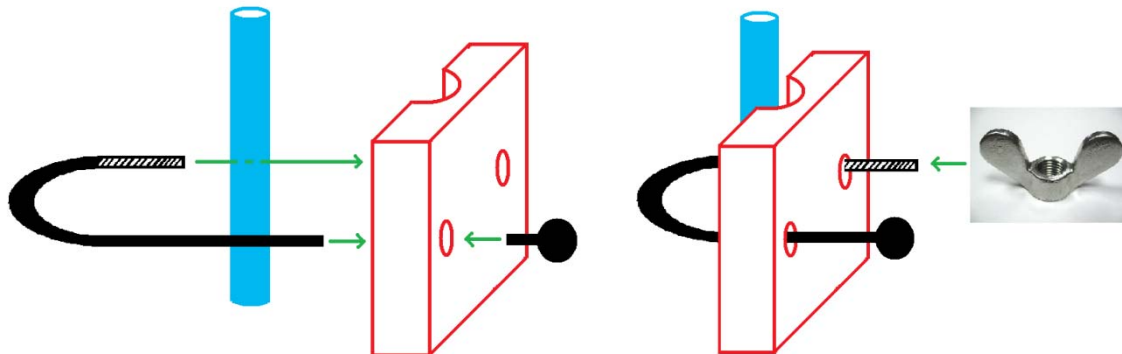

Appendix N: Failure Analysis Hand Calculations

Local Buckling (Square cross-section) (crumpling)

$$\sigma_{fb, max} = \frac{\pi^2}{3} \cdot \frac{E}{1-\nu^2} \left(\frac{t}{b}\right)^2$$

$t = 1.5 \text{ mm}$, $b = 25 \text{ mm}$, mild steel



$$\sigma_{fb, max} = \frac{\pi^2}{3} \cdot \frac{210 \times 10^9}{1-(0.3)^2} \left(\frac{1.5}{25}\right)^2 = \frac{\pi^2}{3} (2.3077 \times 10^{11}) (0.0036)$$

$$\sigma_{fb, max} = 2.733 \text{ GPa} \quad \sigma_{fb, safe} = \frac{\sigma_{fb, max}}{\text{Safety factor}} = \frac{2.733 \times 10^9}{5} = \underline{546.63 \text{ MPa}}$$

This shape can handle stresses up to 546.63 MPa without crumpling. For steel, this is longer than the yield stress of 500 MPa . Therefore, crumpling mechanics do not limit this bar.

Force & moments in System:

$$F_w = (80 \text{ kg})(9.98 \text{ m/s}^2) = \underline{798.4 \text{ N}}$$

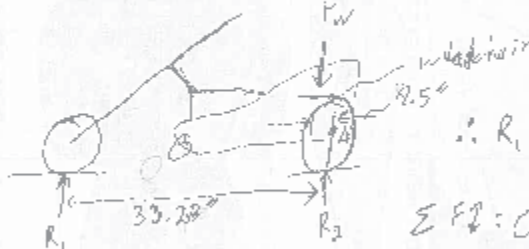

$$\sum M_A \uparrow 0 = F_w(7.5)(0.0254) - R_1(33.23)(0.0254)$$

$$\therefore R_1 = \frac{(798.4)(7.5)(0.0254)}{(33.23)(0.0254)} = \underline{180.20 \text{ N}}$$

$$\sum F \uparrow = 0 = R_1 + R_2 - F_w$$

$$\therefore R_2 = F_w - R_1 = \underline{618.20 \text{ N}}$$

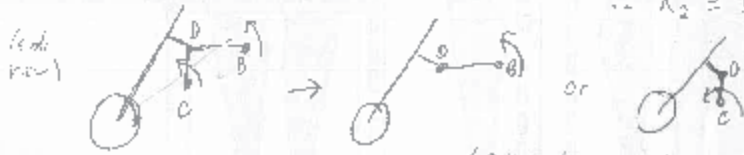

worst case (full loading moment on single support)



$$\sum M_B \uparrow 0 = -M_B - F_w(15-7.5)(0.0254) + R_2(15)(0.0254)$$

$$\therefore M_B = (15R_2 - 7.5F_w)(0.0254) = \underline{83.44 \text{ Nm}}$$

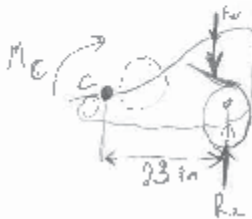

$$\sum M_C \uparrow 0 = -M_C - F_w(0.0254)(23-7.5) + R_2(0.0254)(23)$$

$$M_C = (0.0254)(23R_2 - 15.5F_w) = \underline{116.82 \text{ Nm}}$$

Yield Failure by Bending

worst case horiz bar:



$$\sigma = \frac{My}{I} = \frac{(M_B) \left(\frac{22.23}{2} \right)}{\frac{\pi}{64} \left(\frac{22.23}{1000} \right)^4} = 77.65 \text{ MPa} \quad \sigma_{\text{safe}} = 378.23 \text{ MPa} = 5\sigma$$

$\sigma_{\text{safe}} < \sigma_{\text{el}} = 500 \text{ MPa}$ ✓

worst case vertical bar

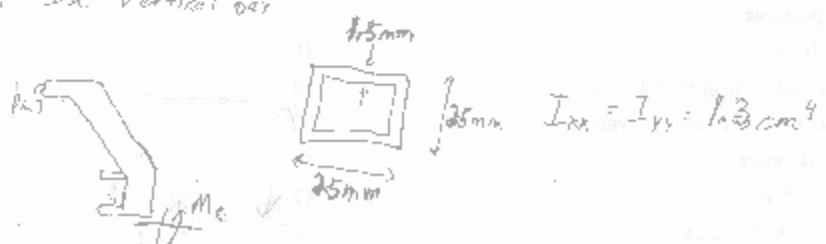

$$\sigma = \frac{My}{I} = \frac{(M_e) \left(\frac{25}{1000} \right)}{\left(\frac{1.3}{100^4} \right)} = 45.02 \text{ MPa} \quad \sigma_{\text{safe}} = 5(\sigma) = 225.10 \text{ MPa}$$

$\sigma_{\text{safe}} < \sigma_{\text{el}} = 500 \text{ MPa}$ ✓

Static Buckling in Horizontal Bar



$$\sigma_{\text{static}} = \frac{F}{A} = 0.15$$

$$77.65 = \frac{F}{\frac{\pi}{4} \left(\frac{22.23}{1000} \right)^2}$$

$F = 120.6 \text{ kN}$

$$F = \frac{\pi^2 EI}{(L_0)^2}$$

$$F_{\text{crit}} = \frac{\pi^2 (210 \text{ GPa}) \left(\frac{\pi}{64} \right) \left(\frac{22.23}{1000} \right)^4}{\left(\sqrt{5^2 + 6.125^2} \right) \left(\frac{2154}{1000} \right)^2}$$

$F_{\text{crit}} = 379 \text{ kN}$

$F_{\text{crit}} > F$ ✓
no buckling

Factor only
 5. apply to static
 buckling, dynamic
 from impacts
 with crumpling
 20 mm

Bolt Moment Mechanism

$$\sigma_{bolt} = 2 \times \sigma_{shear} + 2 \times \sigma_{tension}$$

Shear on side

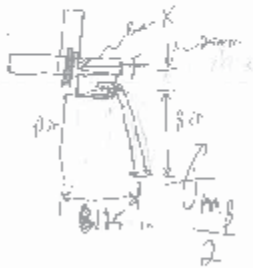

$$F = \frac{M_B \cdot 0.5}{0.2292m} = 182.8 N$$

$$\sigma_H = \frac{F}{A_{shear}} = \frac{F}{(D/2)(L)} = \frac{182.8 N}{(0.003175)(0.011252)}$$

$$\sigma_H = 5.175 MPa$$

Shear on pin:



$$L = (0.0254) \left(\frac{9.786 \cos(25.12) \cdot 0.5721}{1} \right)$$

$$L = 0.2697 m$$

$$F_v = \frac{M_C(s)}{L} = 86.8 N$$

$$\sigma_v = \frac{F}{A_{pin}} = \frac{F}{(D)(L)} = \frac{86.8}{(0.003175)(0.011252)}$$

$$\sigma_v = 2.4574 MPa$$

$$\sigma_{bolt} = 15.265 MPa < \sigma_{el} = 550 MPa \text{ for mid steel}$$

PASS ✓

Appendix O: Anthropometric of a Hadza, a Tanzanian tribe

Anthropometry of Hadza

341

Table 1. Means and standard deviations of the measurements of adult Hadza.

Variable	Males			Females		
	N	Mean	SD	N	Mean	SD
Weight (kg)	126	54.26	5.79	110	48.26	6.24
Stature (cm)	125	160.95	5.93	109	150.37	5.72
Suprasternal height (cm)	125	132.51	5.04	108	123.71	4.77
Height of anterior superior iliac spine (cm)	125	92.11	4.26	—	—	—
Sitting height (cm)	113	82.09	2.94	103	77.18	2.77
Total arm length (cm)	124	71.93	3.51	109	67.08	3.49
Upper arm length (cm)	123	30.04	1.63	108	28.03	1.75
Forearm length (cm)	124	24.86	1.59	109	22.89	1.36
Bicondylar humerus (cm)	125	6.45	0.36	109	5.76	0.35
Wrist breadth (cm)	125	5.26	0.30	109	4.71	0.23
Hand breadth (cm)	124	7.52	0.43	109	6.73	0.35
Bicondylar femur (cm)	123	8.73	0.43	109	7.76	0.39
Ankle breadth (cm)	125	6.97	0.37	108	6.22	0.29
Biacromial diameter (cm)	125	34.65	1.59	109	31.52	1.61
Transverse chest (cm)	125	24.58	0.99	—	—	—
Bi-iliocristal diameter (cm)	124	24.42	1.35	—	—	—
Neck circumference (cm)	125	32.87	1.44	109	28.44	1.09
Upper arm circumference (cm)	125	26.12	2.09	108	24.47	2.13
Calf circumference (cm)	125	32.36	2.11	108	31.17	2.35
Tricipital skinfold (mm)	125	4.89	1.38	109	10.04	4.08
Subscapular skinfold (mm)	125	6.34	1.53	108	8.62	3.66
Supra-iliac skinfold (mm)	125	4.56	1.53	—	—	—
Calf skinfold (mm)	125	4.24	1.27	99	9.31	3.80
Head length (cm)	126	18.99	0.55	109	18.30	0.55
Head breadth (cm)	123	13.69	0.39	107	13.16	0.39
Bizygomatic diameter (cm)	125	13.09	0.50	108	12.38	0.40
Bigonial diameter (cm)	125	10.46	0.62	109	9.54	0.44
Face height (nasion-gnathion) (cm)	124	11.50	0.61	109	10.69	0.58
Nose height (cm)	126	4.96	0.37	109	4.65	0.36
Nose breadth (cm)	126	4.23	0.29	108	3.83	0.25
Lip thickness (cm)	126	2.58	0.37	108	2.38	0.31

Table 2. Means of skinfolds in samples of adults of rural African populations and female/male mean ratio.

Population	N		Tricipital			Subscapular			Supra-iliac		
	♂	♀	♂	♀	♀:♂	♂	♀	♀:♂	♂	♀	♀:♂
Hadza ¹ (Tanzania)	125	109	4.89	10.04	2.05	6.34	8.62	1.36	4.56	—	—
Sara ² (Chad)	292	322	6.42	11.37	1.77	8.19	9.55	1.17	5.12	5.38	1.05
Fali ³ (Cameroon)	164	60	5.69	9.37	1.65	8.98	10.73	1.19	4.16	4.27	1.03
Fur ⁴ (Sudan)	359	202	7.0	12.3	1.76	10.1	12.2	1.21	—	—	—
Konda Oto ⁵ (Zaire)	66	33	6.26	8.98	1.43	10.39	11.27	1.08	6.58	—	—

¹ Present study.

² Crognier 1969.

³ Huizinga and Reijnders 1974.

⁴ Sukkar 1976.

⁵ Hiernaux *et al.* 1976 (males); Pagezy 1973 (females).

the highest sexual difference, the Sara, Fali and Fur, with a similar and intermediate sexual difference, and the Konda Oto with the lowest.

Table 3 gives the sum of the means of tricipital and subscapular skinfolds and, when data on the supra-iliac skinfold are available, the sum of the means of the three skinfolds, in a number of rural populations of sub-Saharan Africa (male samples only).

Appendix P: Graph of performance indices for mass and cost for yield by bending.

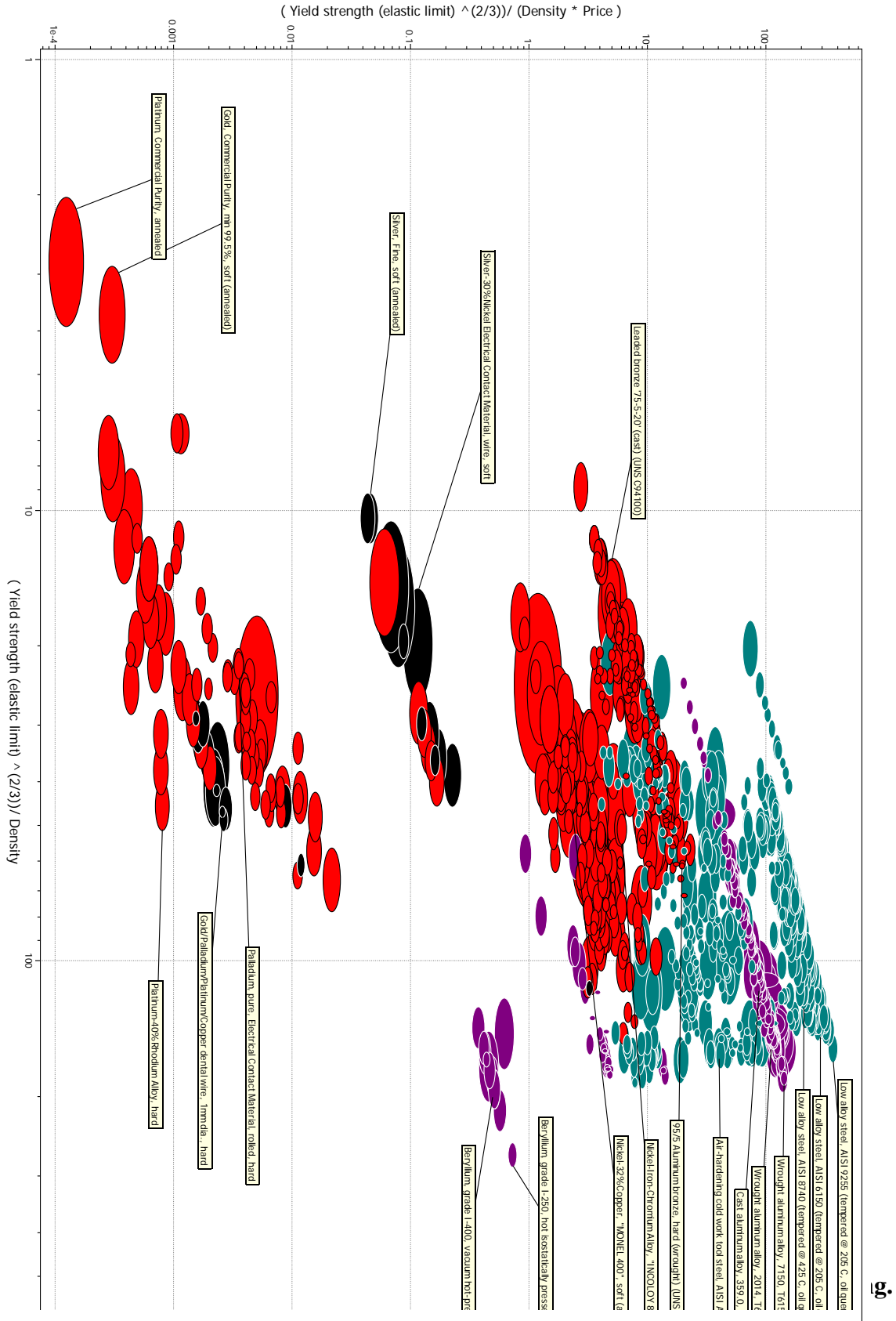

Appe

Appendix Q: Maple code (gears.mw) used to analyze possible gear ratios.

```

> restart;
> Gears := [14, 16, 18, 20, 22, 24, 28, 28, 24, 21, 18, 16, 14, 18]; CBreak
    := [18];

                                Gears := [14, 16, 18, 20, 22, 24, 28, 28, 24, 21, 18, 16, 14, 18]
                                CBreak := [18]

> ratio := Array(1..(nops(Gears)4), 1..5);

                                ratio :=  $\left[ \begin{array}{l} 1..38416 \times 1..5 \text{ Array} \\ \text{Data Type: anything} \\ \text{Storage: rectangular} \\ \text{Order: Fortran\_order} \end{array} \right]$ 

>

sup := 1 :
for n from 1 to nops(Gears) do
for m from 1 to nops(Gears) do
for o from 1 to nops(Gears) do
for p from 1 to nops(Gears) do
ratio[sup, 1] := Gears[n];
ratio[sup, 2] := Gears[m];
ratio[sup, 3] := Gears[o];
ratio[sup, 4] := Gears[p];
ratio[sup, 5] := evalf(1 * (Gears[n] / Gears[m]) * (Gears[o] / Gears[p]));
sup := sup + 1;
end do;
end do;
end do;
end do;

> ratio[3, 5]; ratio[342, 5]; ratio[294, 5];

                                0.7777777777;
                                0.6562500000;
                                1.361111111;

> with(ExcelTools) :
> Export(ratio);
>

```

Appendix R: First page of excel file ratio.xls used to sort the output from the Maple file.

	A	B	C	D	E
1	top	mid1	mid2	bottom	ratio
2	14	28	14	28	0.25
3	14	28	14	28	0.25
4	14	28	14	28	0.25
5	14	28	14	28	0.25
6	14	28	14	28	0.25
7	14	28	14	28	0.25
8	14	28	14	28	0.25
9	14	28	14	28	0.25
10	14	28	14	28	0.25
11	14	28	14	28	0.25
12	14	28	14	28	0.25
13	14	28	14	28	0.25
14	14	28	14	28	0.25
15	14	28	14	28	0.25
16	14	28	14	28	0.25
17	14	28	14	28	0.25
18	14	28	16	28	0.285714
19	14	28	16	28	0.285714
20	14	28	16	28	0.285714
21	14	28	16	28	0.285714
22	14	28	16	28	0.285714
23	14	28	16	28	0.285714
24	14	28	16	28	0.285714
25	14	28	16	28	0.285714
26	16	28	14	28	0.285714
27	16	28	14	28	0.285714
28	16	28	14	28	0.285714
29	16	28	14	28	0.285714
30	16	28	14	28	0.285714
31	16	28	14	28	0.285714
32	16	28	14	28	0.285714
33	16	28	14	28	0.285714
34	16	28	14	28	0.285714
35	16	28	14	28	0.285714
36	16	28	14	28	0.285714
37	16	28	14	28	0.285714
38	16	28	14	28	0.285714
39	16	28	14	28	0.285714
40	16	28	14	28	0.285714
41	16	28	14	28	0.285714
42	14	28	16	28	0.285714
43	14	28	16	28	0.285714
44	14	28	16	28	0.285714
45	14	28	16	28	0.285714
46	14	28	16	28	0.285714

Appendix S: This shows the complete analysis for length of bicycle chain required to drive the attachment device.

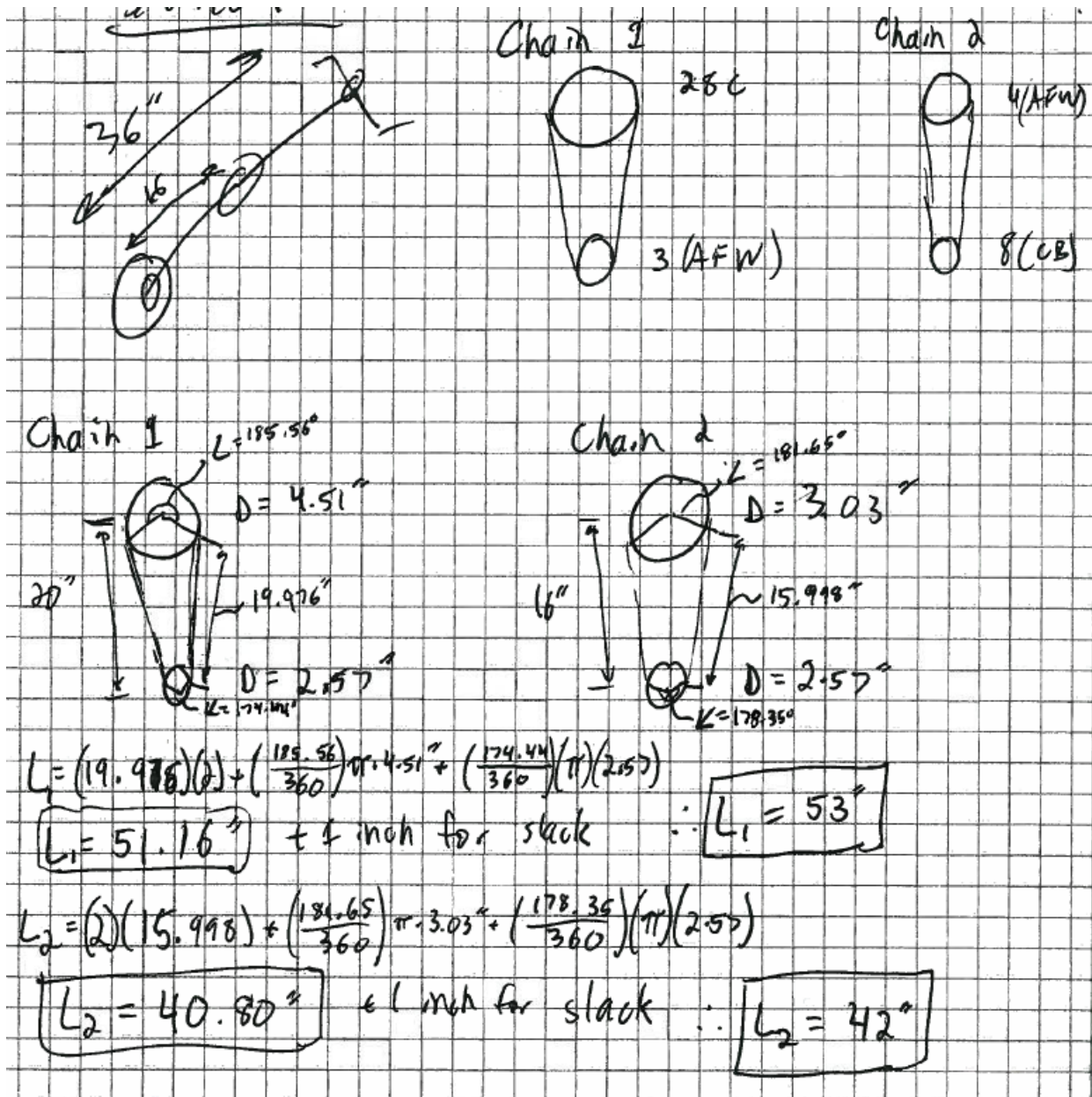

Appendix T: Brainstorming Drawings
 Attach/Detach



MODEL		TITLE	BY	SWIFT
FILE		Attach / Detach	DATE	2/3/08
JOB	10/04		PAGE	OF

o Clamping  slider

o  resistive cup
 "memory-type clamp"

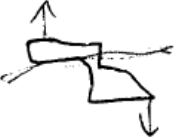
o  triangle
 between bars

o  counter weight

o Screws 
 Bolts & Nuts 

Zeus fasteners 

Magnets? 

Velcro? 

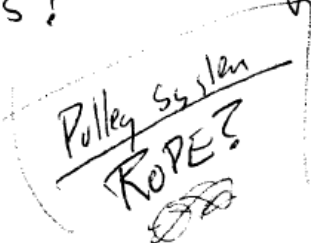
Pulley system
 ROPE? 

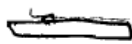
SLIDER 
 notch
 o Spring
 o Gas
 o Air

Brainstorming

Attach/Detach

• Clamps



• Pin system with pre-installed part on wheel chair

• Snap fit w/attachment

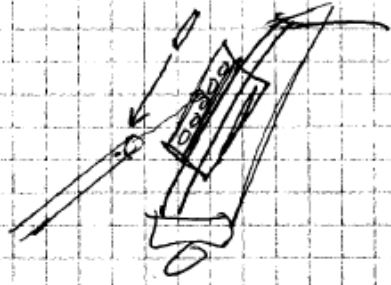

• Clamp around with thumb screws



2/19/09

BH
Triangle

Attach / Detach



Top

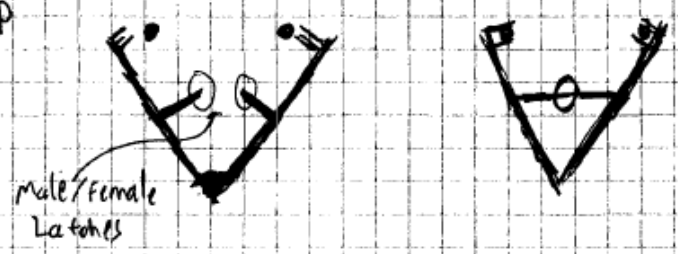

male/female
Latches

Clamp

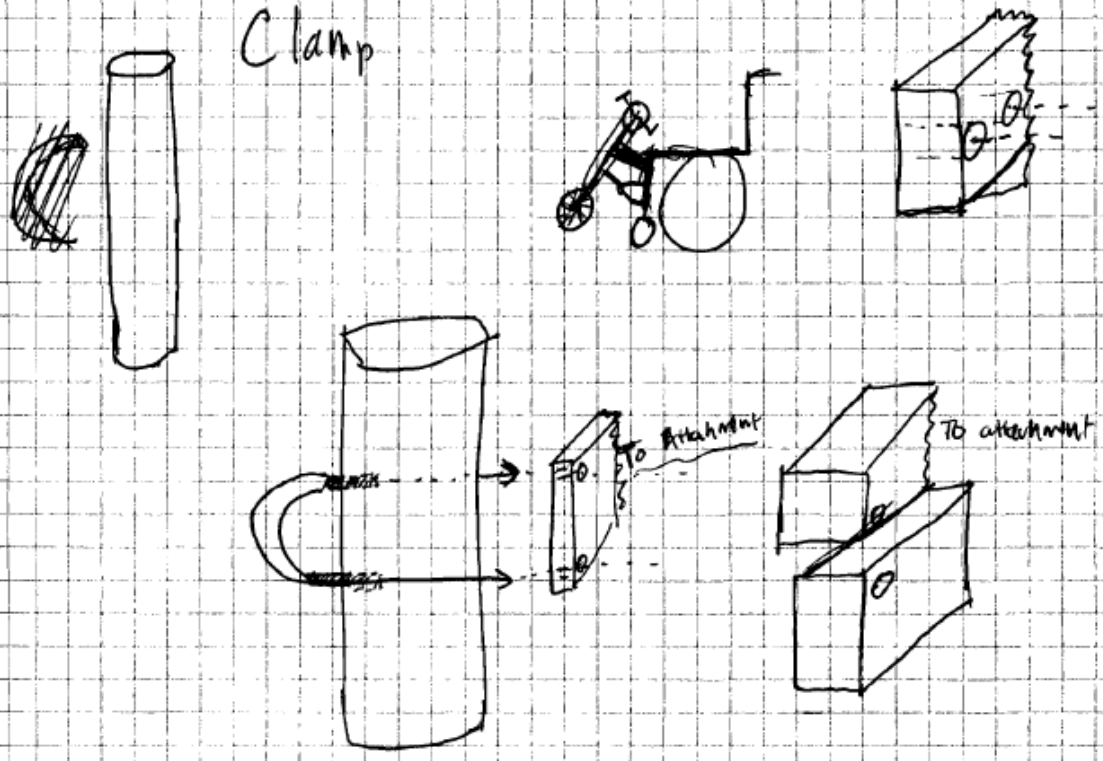

Propulsion
Brainstorming

MODEL		TITLE	PROPULSION	BY	M. SWIFT
FILE				DATE	
JOB	33			PAGE	OF

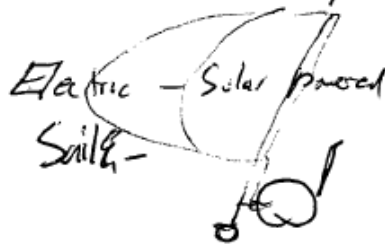
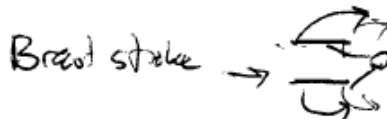
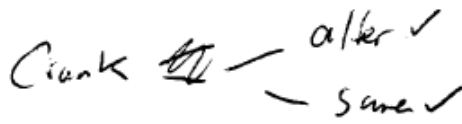
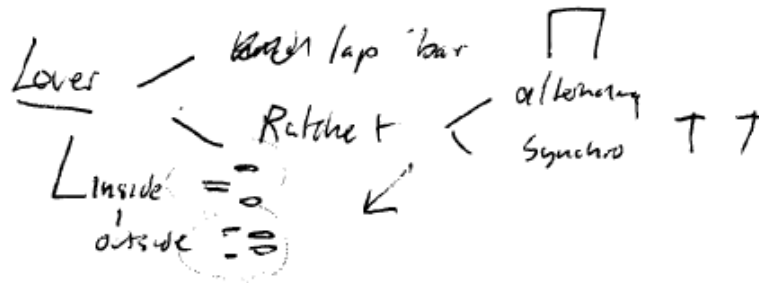
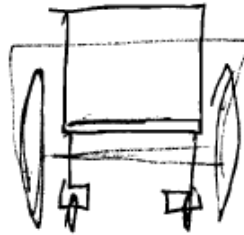
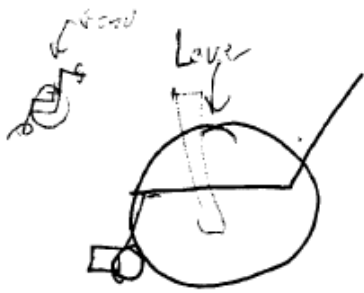

Kite —

Gravity Powered —

Alternating wheels =
Matter propels on



Stowing
Brainstorming

Stowing:

2/3/2009
BH

- Behind Wheelchair
- In a carrying caddy



- Under chair
- Side Car



Folding Brainstorm

2/3/2009
BH

Folding

• Hinge w/ spring holder

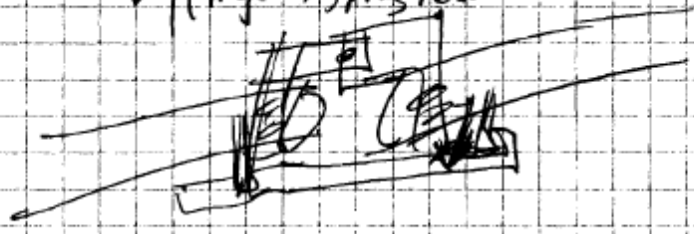

• Add internal Gear in middle

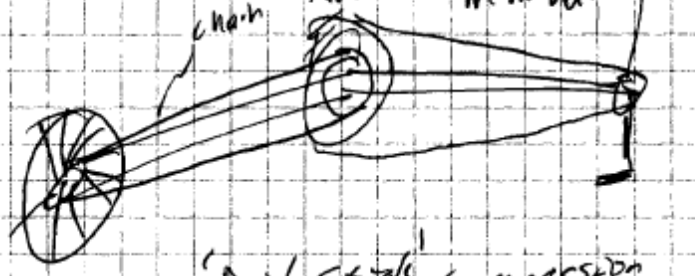

• 'Pool Stroke' compression

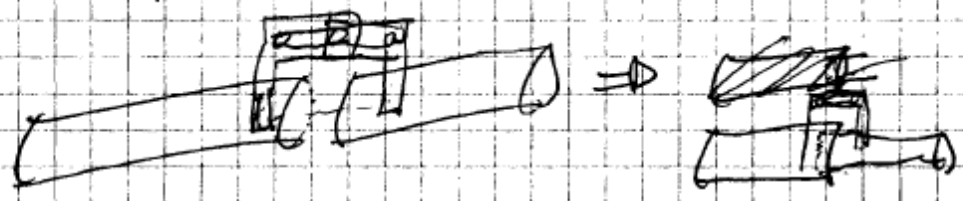

Handles telescope

• Button snaps release to telescope

BH

1/11/09
1/11/09
1/12/09

Bar Clamp

Simple Hand Clamp

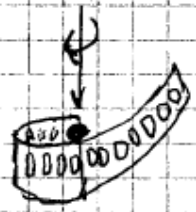
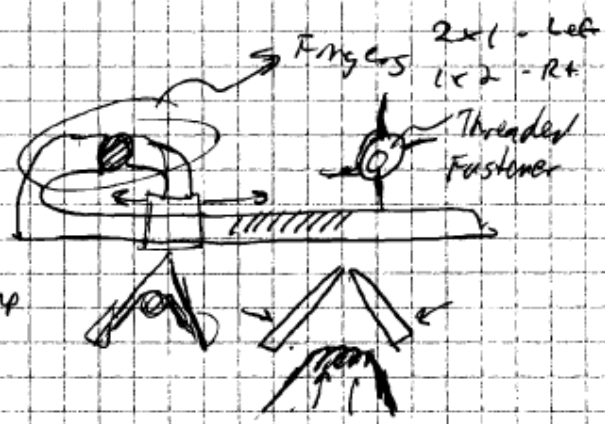

Toggle Clamp w/ Screw & Belt

Can it Turn Around? or Reverse?

- (A) - Can 180° freedom
- Bearing @ Front of handle?
- (B) Yes.

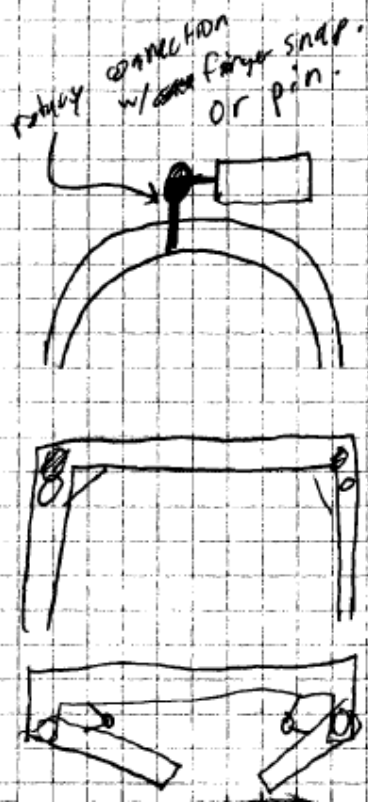
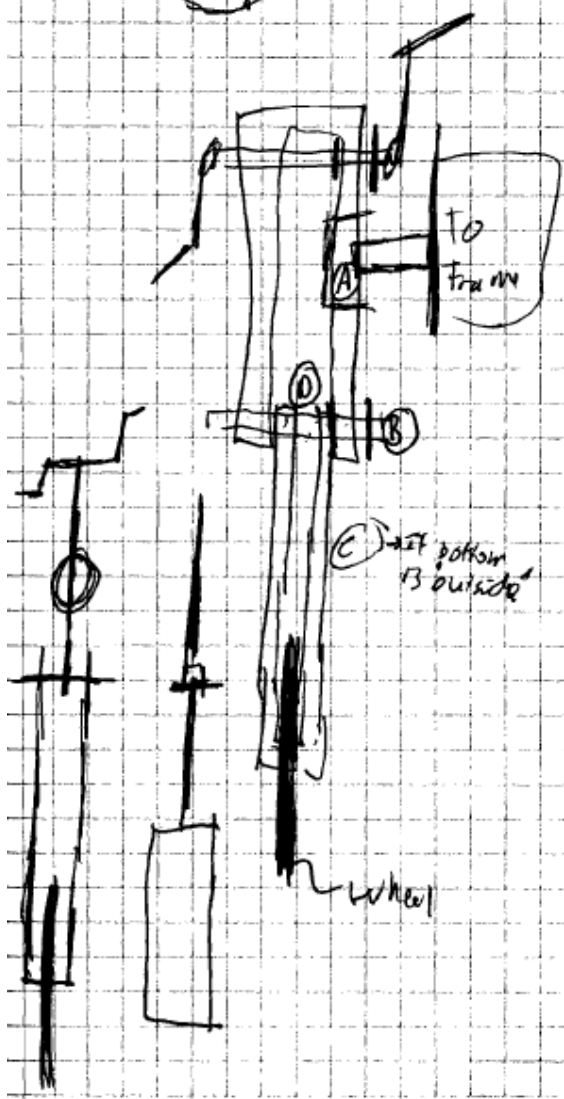

May 2, 1961

E. E. HOOD

2,982,384

SEMI-AUTOMATIC TWO-SPEED HUB AND COASTER BRAKE

Filed July 18, 1960

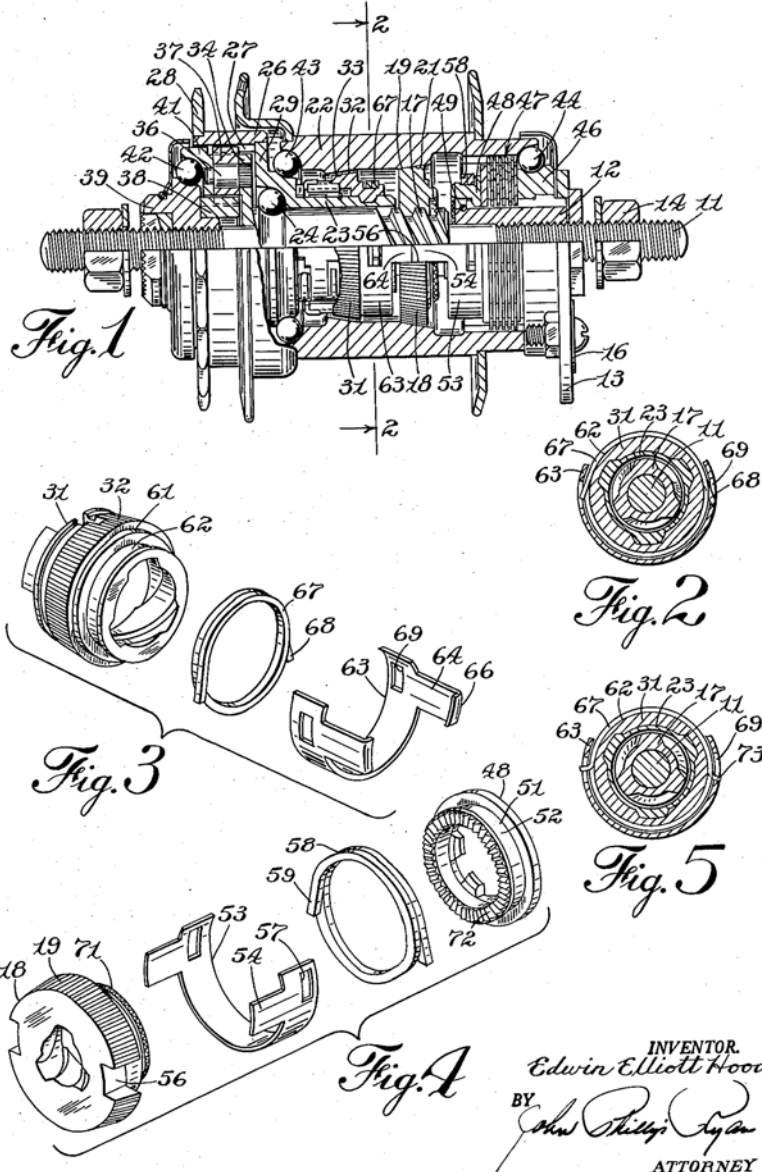

INVENTOR
Edwin Elliott Hood
BY
John Phillip Taylor
ATTORNEY

1

2,982,384

SEMI-AUTOMATIC TWO-SPEED HUB AND COASTER BRAKE

Edwin Elliott Hood, Elmira, N.Y., assignor to The Bendix Corporation, Elmira Heights, N.Y., a corporation of Delaware

Filed July 18, 1960, Ser. No. 43,368

15 Claims. (Cl. 192-6)

The present invention relates to a semi-automatic two-speed hub and coaster brake for velocipedes and the like, and more particularly relates to that type in which the shift from one gear or speed to the other is brought about by a slight backward rotation of the driving member.

In devices of this type the retardation of the various cooperating elements has been obtained in the past by the use of a chain of frictional retarder means having radially biased wiping spring arms. Each of these retarder means necessarily differs in its torque transferring capabilities. In the Gleasman Patent 2,882,754, issued April 21, 1959, there is illustrated the common retarder means presently used in devices of this type. As a general rule there is a first frictional retarder element which is fixed to either the low speed clutch nut and/or the braking elements. This first retarder is required to have the highest torque transmitting capabilities and either directly or indirectly, this first retarder means is secured to a fixed element such as the axle. Rotation of the low speed screw shaft will cause the low speed clutch nut to be retarded and, consequently, threaded upon forward rotation of the screw shaft into engagement with the clutching surface of the hub and upon retrograde rotation of the shaft into engagement with braking means. A second frictional retarder is connected either to the high speed clutch nut or the low speed clutch nut and engages the other of these clutch nuts. The torque carrying capacities of the second retarder must be sufficient to cause the high speed clutch nut to be threaded upon the high speed screw shaft upon rotation of that shaft, but the retardation forces of this second retarder must not equal or exceed those exerted between the first retarder and its fixed element. In some present day devices, as illustrated in the Hood Patent 2,865,478, issued December 23, 1958, still other retarder elements are used to control selector and indexing mechanisms. These other retarders are generally coupled to the high speed clutch nut and exert retarding forces upon the selector and indexing mechanisms. Again the torque transferring capabilities of these other retarders must not equal or exceed the force exerted by any preceding retarders. Additionally, the functions served by these chain frictional retarders must be accomplished in either direction of rotation since the screw shafts and their clutch nuts are subject to rotation in either direction.

The prior art retarders, as illustrated in the mentioned patents, have been provided by biased spring fingers frictionally wiping on some portion of the cooperating elements. Each of these retarders is physically different due to the fact that each must possess varying torque transferring capabilities or meet varying torque requirements. The spring biased finger type of retarders have the added drawback in that there is considerable variation in their break-away and running torque capacities. Tests have shown that it is desirable to have the retarders exert a break-away and a running or sliding torque capacity which are substantially identical. Another drawback to the finger type of frictional retarder is the fact that the finger generally is established with a point contact against

2

the cooperating element. This point contact provides an initial high unit resistance for the degree of bias, however, wear reduces the point of contact thus enlarging the area of contact on the spring finger and this results in a lower unit resistance pressure. In order to compensate for this wear, it has been necessary to provide excess resistance initially with the hope that as wear occurs the resistance will diminish to the ideal value.

While the spring biased type of retarder is a unitary element and does not require the use of an additional element or coupling member, it is nonetheless extremely expensive to manufacture. In addition to its manufacturing cost, it is also difficult to manufacture it with any degree of quality control.

It has been found that wrap-down spring retarders provide substantially identical break-away and running torque values and that they are subject to little or negligible changes due to wear thereby providing a substantially constant frictional or retardation force during the entire life of the device. Because wrap-down spring retarders are not subject to appreciable wear changes, these retarders can be initially set for the minimum required torque value and this value will be maintained during the active life of the device. The wrap-down spring type of retarders have the added beneficial feature in that they provide identical torque values in either direction of rotation. While wrap-down spring retarders do require an additional element such as a coupler, the overall cost is considerably less than that of the spring biased finger type of frictional retarder and the manufacturing quality control aspects are much more easily attained and maintained.

It is an object of the present invention to provide a semi-automatic two-speed hub and coaster brake which is efficient and reliable in operation, compact and durable as well as simple and economical in construction.

It is another object to provide a semi-automatic hub and coaster brake utilizing wrap-down spring frictional retarders.

It is still another object to provide a velocipede hub and coaster brake utilizing and incorporating wrap-down spring type frictional retarders which are subject to little or no wear over the normal life expectancy of the hub thus allowing the use of the retarder means which can be initially set to meet the minimum torque value requirements.

A further object is to provide wrap-down spring type frictional retarders that are bi-directional in operation.

It is still a further object to provide a bicycle hub and coaster brake incorporating wrap-down spring type of frictional retarders which provide break-away and running or sliding torque values which are of substantially equal value and with the torque value maintainable in either direction of operation.

It is still a further object to provide wrap-down spring type of frictional retarders for bicycle hubs and coaster brakes in which the frictional value or torque carrying capacities of the retarders are reduced by an unwinding action of a coupling means.

A related object is to provide coupler means to actuate the wrap-down spring type of retarder regardless of the direction of rotation.

It is still another related object to provide a coupler which has a lost motion connection with the wrap-down spring frictional retarder to prevent a wind-down of the spring retarder upon actuation by the coupler.

An ancillary object is to provide a retarder and coupler means that will provide anti-brake locking features which prevent brake lockup during driving engagement of one of the driving clutch nut members with the hub.

The foregoing and other objects and advantages of the invention will appear more fully from consideration of

the detailed description which follows in conjunction with the accompanying drawing wherein one embodiment of the invention and a modification thereof are illustrated. It is to be expressly understood, however, that the drawing is for the purpose of illustration and description and is not to be construed as defining the limits of the invention.

The following description is taken in connection and conjunction with the accompanying drawing in which:

Figure 1 is a front elevation, partly broken away and in section, of a preferred embodiment of the invention;

Figure 2 is a fragmentary sectional view taken substantially on the plane of line 2—2 of Figure 1;

Figure 3 is an exploded perspective of the high speed clutch nut, the second or high speed coupling member and the high speed wrap-down spring retarder;

Figure 4 is an exploded perspective of the brake pressure ring, the low speed clutch nut, the low speed retarder and the low speed wrap-down spring retarder member; and

Figure 5 is a fragmentary sectional detail view similar to Figure 2 of a second embodiment of the invention.

In Figure 1 of the drawing there is illustrated a stationary axle 11 adapted to be mounted in the rear fork of a bicycle or the like. A brake anchor sleeve 12 is threaded on the axle and held from rotation by an anchor arm 13 non-rotatably mounted and retained thereon by a clamping nut 14. The anchor arm is prevented from rotation by a clip 16 adapted to be attached to the frame of the vehicle in any conventional and convenient manner.

A low speed screw shaft 17 is rotatably mounted on the axle 11 and has a low speed clutch nut 18 threaded thereon having a conical clutch surface 19 adapted to be moved into and out of clutching engagement with a conforming clutch surface 21 formed on the interior of the hub 22.

A high speed screw shaft 23 is rotatably mounted on the low speed screw shaft 17 by means of a bearing 24. A driving member 26 incorporating an orbit gear 27 has a sprocket 28 fixedly mounted thereon in any suitable manner and is united with the high speed screw shaft 23 by a ring member 29 rigidly connected thereto and mounted on the adjacent end of the high speed screw shaft by suitable means such as brazing. A high speed clutch nut 31 is threaded on the high speed screw shaft 23 and has a conical clutch surface 32 adapted to be moved into and out of clutching engagement with a conforming clutch surface 33 in the interior of the hub 22.

A planet carrier ring 34 is fixedly mounted on the end of the low speed screw shaft 17 and has a plurality of pintles 36 fixedly mounted therein serving as bearings for planet pinions 37 which engage in the orbit gear 27. The pinions also mesh with a sun gear 38 rigidly mounted on the stationary bearing cone member 39 which is threaded on the axle 11. A bearing cup member 41 receives and supports the ends of the pintles 36 and is rotatably mounted on the cone member 39 by means of a bearing 42.

The hub 22 is rotatably supported by means of bearings 43, 44 journalled in races formed on the high speed screw shaft 23 and in a bearing cone 46, respectively. The bearing cone member 46 is fixedly mounted on the anchor sleeve 12.

Brake discs, generally indicated at 47, are splined alternately to the hub 22 and the anchor sleeve 12 and are arranged to be pressed together against the bearing cone 46 by means of a brake pressure ring 48 also splined on the anchor sleeve 12 and loosely retained thereon by a lock ring 49.

The brake pressure ring 48 is provided with an axially extending pilot portion 51 in which there is provided a circumferential groove or track 52. A low speed coupling member 53 is rotatably journalled on the pilot portion 51 and has axially extending arms 54 engaging

in slots 56 in the periphery of the low speed clutch nut 18 so as to form a splined connection therewith. The low speed coupling member is formed with a pair of circumferentially spaced apertures 57. A low speed helically coiled wrap-down spring frictional retarder 58 is contractively and frictionally journalled in the track 52 and has its tangentially oppositely extending extremities 59 engageable with the apertures 57 in the low speed coupling member 53.

The high speed clutch nut 31 is provided with an axially extending pilot portion 61 in which is formed a track or circumferential groove 62. A high speed coupling member 63 is rotatably journalled on the pilot portion 61 and has axially extending arms 64 which engage in the slot 56 of the low speed clutch member intermediate the axial extending arms 54 of the low speed retarder 53 and the bottom of the low speed clutch nut slot 56. The arms 64 are provided with radially inturned lug members 66 to prevent or limit a hereinafter described axial separation between the high and low speed clutch nuts. A high speed helically coiled wrap-down spring frictional retarder 67 is contractively and frictionally journalled in the track 62 of the pilot portion 61. The extremities 68 of the spring 67 extend tangentially and oppositely from the circumferential body portion thereof to engage in circumferentially spaced apertures 69 of the high speed coupling member (Figure 2) and thereby provide a lost motion connection between the high speed retarder spring and the coupling member 63.

Secured to the high speed clutch nut opposite the pilot portion 61 is a selector and indexing mechanism which is alternatively operable to prevent the high speed clutch nut from drivingly engaging the hub 22. The structure of the selector and indexing mechanism constitutes no part of this invention and, consequently, will not be described in further detail. Reference is made to my co-pending application 50,770 filed August 19, 1960 which fully describes and claims the structure and operation of the selector and indexing mechanism.

In operation, starting with the parts in the position illustrated in Figure 1, forward rotation (which is clockwise when viewing the left-hand end of Figure 1) of the driving member 26 by the sprocket 28 is transmitted to the high speed screw shaft 23. Since the selector and abutment indexing mechanism are illustrated in abutting relation, the high speed clutch nut will be effectively prevented from drivingly engaging the hub. The low speed screw shaft 17 is concomitantly rotated by means of the planetary gearing 27, 37, 38 whereby the low speed clutch nut 18 is threadedly traversed into driving engagement with the hub clutch surface 21 and rotates the hub at the lower gear or speed. Traversal of the low speed clutch nut 18 on the low speed screw shaft 17 is caused by the low speed retarder 58. The low speed retarder 58 is frictionally journalled on the pilot portion 51 in the track 52 with the frictional engagement being of sufficient torque transmitting capacity to cause the low speed clutch nut to be restrained from rotating with its screw shaft. The low speed coupling member transfers the frictional torque values of the retarder 58 to the low speed clutch nut via the splined connection of arms 54 and slots 56. The high speed clutch nut 31 through its retarder 67 will be simultaneously caused to traverse the high speed screw shaft 23 but because of the abutting engagement between the selector mechanism and the abutment member, the clutch will be prevented from engaging the hub. The high speed retarder spring 67 which is frictionally journalled in the track 62 of the pilot portion 61 of the high speed clutch nut 31 will be caused to slip due to its being coupled to the low speed clutch nut. The reason for slippage results from an unwinding operation caused by the ends of the retarder extremities 68 abutting an end portion of the lost motion aperture 69 in the high speed coupling member 63 which is being driven at a slower

rate by the low speed clutch nut. The abutting engagement between the extremity 68 and aperture 69 will cause an unwinding effect to take place in the helically coiled body of the high speed retarder 67 thereby diminishing the frictional engagement between the retarder and the track 62 allowing the high speed clutch nut to rotate relative to the low speed clutch nut member. The apertures 69 are of sufficient circumferential extent that there is no tendency for the aperture opposite the extremity-aperture engagement to wrap-down on its cooperating retarder extremity. In this manner undesirable friction creating wrap-down is effectively prevented. Once an engagement between the low speed clutch nut and hub clutch surface has been established the low speed coupler will be driven by the clutch nut in a manner to cause an aperture 57 to abut a low speed retarder extremity 59. This abutting engagement between the extremity 59 and coupler aperture 57 will cause an unwinding action to occur thereby diminishing the frictional engagement between the retarder 58 and the groove 52 allowing relative rotation between the low speed clutch nut and the brake pressure ring.

When it is desired to operate in high gear, the operator back pedals slightly thus rotating the high speed screw shaft 23 backwardly and through the driving member and planetary gearing and also concomitantly rotating the low speed screw shaft 17 backwardly. The high and low speed clutch nuts are prevented from rotating backwardly by their frictional connection through the retarders 58 and 67 thus they are threaded on their respective screw shafts away from the hub clutch surfaces. The backward rotation also indexes the indexing and selector mechanisms in such a way as to cause an aligning of the members to allow on future forward rotation the threading of the high speed clutch nut into driving engagement with the hub clutch surface 33. Upon subsequent forward rotation of the driving member the high speed clutch nut is permitted by the indexing and selector mechanisms to engage and drive the hub at the same speed as the driving member. Since the high speed clutch nut is traversed at a higher rate of speed, it will engage the hub prior to any engagement of the hub by the low speed clutch nut. Once the high speed clutch nut has drivingly engaged the hub clutch surface 33 the hub will overrun the low speed clutch nut and intermittently cause the clutch surfaces 19 and 21 to engage. This intermittent engagement will propel the low speed clutch nut towards the braking position counteracting its axial movement resulting from its being threadedly traversed towards driving engagement along the rotating low speed screw shaft. This hub overrunning thus causes a spacial separation to exist between the low speed clutch nut conical driving surface 19 and the clutch surface 21 which prevents it from effectively drivingly engaging the hub.

When the clutch nuts are rotated by their respective screw shafts, their rotational rates will, of course, be different resulting in a rotational difference. Since the clutch nuts are coupled together, this rotational difference must be effectively dissipated. Dissipation of the differential is accomplished through the high speed coupling member 63 and the high speed retarder 67. The coupler aperture 69 will engage the retarder extremity 68 and tend towards unwinding the retarder 67. This unwinding releases the frictional engagement between the retarder and groove 62 thereby allowing for temporary rotation equalization. This equalization or dissipation can occur whenever necessary and is an inherent automatic operation. It will be noted that rotational differences will always be dissipated by the high speed retarder regardless of direction of rotation.

In the event the operator desires to operate the brakes, he merely pedals backwardly an amount sufficient to cause the low speed clutch nut to traverse the low speed screw shaft in a backwardly direction and cause the dentil

surface 71 of the low speed clutch nut to engage the dentil surface 72 of the brake pressure ring 48 pilot portion 51. The backward rotation of the low speed screw shaft causes the clutch nut 18 to engage and operate the brake pressure ring 48 and compress the brake discs 47. The dentils 71 and 72 provided therebetween effectively prevent relative rotation when the engagement between the clutch nut and brake pressure ring occurs.

The high speed screw shaft also rotates backwardly during brake operation and, consequently, the high speed clutch nut will also be traversed along its screw shaft. This traversal will be at a faster rate than that of the low speed clutch nut due to the greater rotational rate of the high speed screw shaft and because of its faster thread lead. When the high speed clutch nut has been previously blocked from drivingly engaging the hub, it will be at its axially closest point to the low speed clutch nut. This closeness and the high rate of traversal can cause two possible conditions to occur during braking operation. The high speed coupling member can become wedged or jammed between the opposing faces of the clutch nuts or the axially extending arms 64 can project beyond the low speed clutch nut into abutting engagement with the pilot portion 51 of the brake pressure ring 48 to initiate braking operation before the low speed clutch nut is properly positioned with the dentils 71 engaging the dentils 72. In both instances the coupling member 63 and retarder 67 will function to prevent any binding or lockup. The coupling member aperture 69 will abut the retarder extremity 68 and because the retarder is bi-directionally actuatable, it will be unwound a slight degree to release the frictional engagement. The releasing of frictional engagement again will dissipate or allow any rotational differences necessary for proper brake operation. In the case of the abutting arms the retarder will slip off any differential allowing the low speed clutch nut to axially move into braking position after which it will exert the desired and necessary braking forces.

Should the hub be rolled backwards while the high speed clutch nut and hub are drivingly engaged, the low speed clutch nut will be resultingly threaded on its screw shaft towards braking engagement. This low speed clutch nut braking movement is, however, effectively limited by the engagement between the nut 18 and the lugs 66 and braking cannot be accomplished until the high speed clutch nut relinquishes its driving engagement.

In Figure 4 of the drawing there is illustrated an embodiment of the invention wherein the retarder spring members are provided with substantially radially extending extremities 73 in place of the tangential extremities 59 or 68. The remaining parts are the same as the embodiment first described and are similarly numbered. The operation of this embodiment is the same as above described.

Although certain structures have been shown and described in detail, it will be understood that changes may be made in the design and arrangement of parts without departing from the spirit of the invention.

I claim:

1. In a two-speed hub and brake for velocipedes and the like: a stationary axle; a hub mounted on the axle having a plurality of clutch surfaces; brake means interengaging the hub and the axle for braking hub rotation; a first screw shaft journaled on the axle; a first clutch nut threaded on the first screw shaft for alternative movement into driving engagement with one of the hub clutch surfaces and into braking engagement with the brake means; a second screw shaft rotatably mounted on the first screw shaft; a second clutch nut threaded on the second screw shaft for movement into engagement with other of the hub clutch surfaces; driving means for rotating both screw shafts at different speeds; a first coupling member rotatably journaled on the brake means having a splined connection with the first clutch nut; a

first retarder member journalled on the brake means and cooperating with the first coupling member to frictionally resist rotation of the first coupling member; a second coupling member rotatably journalled on second clutch nut having a splined connection with the first clutch nut; a second retarder member journalled on second clutch nut and cooperating with the second coupling member to frictionally resist rotation of the second clutch nut; and, alternatively controllable means for preventing the second clutch nut from engaging said other hub clutch nut surfaces.

2. A device as set forth in claim 1 in which the brake means includes a brake pressure ring slidably but non-rotatably mounted on the axle, said brake pressure ring including an axially extending pilot portion for rotatably journaling said first coupling member; cylindrical track means formed on the pilot portion for limiting the axial movement of the first retarder member; said first retarder member engaging the track means and having the extremities thereof freely cooperating with said first coupling member whereby said first retarder member frictionally resists rotation of said first coupling member relative to said brake means.

3. A device as set forth in claim 2 in which the second clutch nut includes an axially extending pilot portion for rotatably journaling the second coupling member; cylindrical track means formed on the pilot portion of the second clutch nut for limiting the axial movement of the second retarder means; said second retarder means engaging the track means and having the extremities thereof freely cooperating with said second coupling member whereby said second retarder member frictionally resists rotation of said second clutch nut relative to said second coupling member.

4. A device as set forth in claim 3 in which the retarder members comprise wrap-down helical spring members having at least one coil thereof contractively encompassing said pilot portions to provide normal frictional engagement therewith, the extremities of the spring member extending tangentially in opposite directions to provide the connection with said coupling members, said tangential connection being subject to bi-directional actuation in an unwinding direction by said coupling members to diminish the extent of the frictional engagement thereby allowing relative rotation between the coupled elements.

5. A device as set forth in claim 4 in which the coupling members include lost motion connections to said tangential retarder extremities, said lost motion connections comprising circumferentially spaced apertures of sufficient circumferential extent to prevent wind-down of a coupling member on one of the extremities of a coacting retarder member during actuation of the other retarder extremity.

6. A device as set forth in claim 3 in which the retarder member comprises wrap-down helical spring members having at least one coil thereof contractively encompassing said pilot portions to provide normal frictional engagement therewith; the extremities of the spring member extending substantially radially outward to provide the connection with said coupling members, said radial connections being subject to bi-directional actuation in an unwinding direction by said coupling members to diminish the extent of the frictional engagement thereby allowing relative rotation between the coupling elements.

7. A device as set forth in claim 6 in which the coupling members include lost motion connections to said radial extremities, said lost motion connections comprising circumferentially spaced apertures of sufficient circumferential extent to prevent wind-down of a coupling member on one of the extremities of a coacting retarder member during actuation of the other retarder extremity.

8. A device as set forth in claim 1 including further means on said second coupling member for preventing braking movement by said first clutch nut when said sec-

ond clutch nut is in engagement with the hub, in which said means comprising means for limiting the axial separation between said clutch nuts.

9. A device as set forth in claim 1 in which the retarder members comprise torque transmitting helical coil spring members, said spring members having the extremities thereof extending freely therefrom to provide the cooperative engagement with said coupling members.

10. The torque transmitting helical coil spring member set forth in claim 9 characterized by the fact that the coils thereof contractively encircle the journaling means to provide a normal frictional engagement therewith; and, further characterized by the fact that the extremities thereof are subject to bi-directional actuation in an expanding direction by said coupling members whereby the frictional engagement is diminished to allow for relative rotation between coupled elements.

11. In a two-speed hub and brake for velocipedes and the like: a fixed axle; a hub rotatably mounted relative to the axle having a first clutch surface and a second clutch surface; brake means including a brake pressure ring interengaging the hub and axle; a first screw shaft journalled on the axle; a first clutch nut threaded on said first screw shaft for movement by forward rotation of said first screw shaft into engagement with the said first clutch surface and by backward rotation of said first screw shaft into engagement with said brake pressure ring; a second screw shaft rotatably mounted on said first screw shaft; a second clutch nut threaded on said second screw shaft for movement by forward rotation of said second screw shaft into engagement with said second clutch surface; a driving member; means for rotating both screw shafts at different speeds from the driving member; a first coupling member rotatably supported on said brake pressure ring having a splined connection with said first clutch nut; a first retarder member journalled on said brake pressure ring and engaging said first coupling member for frictionally resisting rotation of said first coupling member; a second coupling member rotatably supported on said second clutch nut having a splined connection with said first clutch nut; a second retarder member journalled on said second clutch nut and engaging said second coupling member for frictionally resisting rotation of said second clutch nut; and, manually controllable means for preventing said second clutch nut from engaging said second clutch surface.

12. A device as set forth in claim 11 in which the retarder members comprise torque transmitting helical spring members, said spring members having at least one coil thereof encircling portions of the journaling means of the supporting elements, the extremities of said spring members extending freely therefrom to provide the engagement with said coupling members.

13. The torque transmitting helical coil spring member set forth in claim 12 characterized by the fact that the coils thereof contractively encircle the journaling means to provide normal frictional engagement therewith; and further characterized by the fact that the extremities thereof are subject to bi-directional actuation in an expanding direction by said coupling members whereby the frictional engagement is diminished to allow relative rotation between coupling elements.

14. In a two-speed hub and brake for velocipedes and the like: a fixed axle; a hub rotatably mounted relative to the axle and having on its interior a low speed clutch surface and a high speed clutch surface; brake means including a brake pressure ring interengaging the hub and axle; a low speed screw shaft journalled on the axle; a low speed clutch nut threaded on the low speed screw shaft for movement by forward rotation of the low speed shaft towards driving engagement with the hub low speed clutch surface and by backward rotation of the low speed screw shaft into engagement with the brake pressure ring for brake actuation; a high speed screw shaft rotatably mounted on the low speed screw shaft; a high speed

clutch nut threaded on the high speed screw shaft for movement by forward rotation of the high speed screw shaft towards driving engagement with the hub high speed clutch surface; driving means; reduction gearing for rotating both screw shafts from the driving means at different speeds; said brake pressure ring having an axially extending pilot portion; cylindrical track means on said pilot portion; a first coupling member rotatably supported on said pilot portion having a splined driving connection with the low speed clutch nut; a first bi-directional actuated wrap-down helical spring retarder member journaled in said track means and having the extremities thereof engageable with the first coupling member for frictionally resisting rotation of said clutch nuts; said high speed clutch nut having an axially extending pilot portion; cylindrical track means on said high speed clutch nut pilot portion; a second coupling member rotatably supported on said high speed clutch nut pilot portion having a splined connection with the low speed clutch nut; a second bi-directional actuated wrap-down helical spring retarder member journaled in said high speed clutch nut track and having the extremities thereof engageable with the second coupling member for frictionally resisting rotation of said high speed clutch nut; means on the second coupling member preventing braking engagement of the low speed clutch nut when the high speed clutch nut is in engagement with the hub; and, manually alternately controllable means for preventing the high speed clutch nut from engaging said hub high speed clutch surface.

15. In a two-speed hub and brake for bicycles: an axle; a hub journaled on the axle having interior clutch surfaces; brake means interengaging the hub and axle;

a low speed screw shaft journaled on the axle; low speed clutch means including a low speed clutch nut threaded on the low speed screw shaft for alternatively drivingly engaging a hub clutch surface and actuating the brake means; a high speed screw shaft journaled on the low speed screw shaft; high speed clutch means including a high speed clutch nut threaded on the high speed screw shaft for drivingly engaging other of said hub clutch surfaces; means for rotating said shafts at different speeds; a first helical coil spring retarder journaled on the axle and cooperating with the low speed clutch means to frictionally but yieldably oppose rotation of said low speed screw shaft causes driving engagement between the low speed clutch nut and a hub clutch surface and backward rotation causes braking engagement between the low speed clutch nut and brake means; a second helical coil spring retarder journaled on the high speed clutch nut and cooperating with the high speed clutch means to frictionally but yieldably oppose rotation of said high speed clutch nut whereby forward rotation of the high speed screw shaft causes high speed clutch nut movement towards driving engagement with other hub clutch surfaces; and, manually controllable means for preventing the high speed clutch nut from drivingly engaging the hub.

References Cited in the file of this patent

UNITED STATES PATENTS

30	2,742,124	Hood	Apr. 17, 1956
	2,865,478	Hood	Dec. 23, 1958
	2,940,339	Hood	June 14, 1960
	2,944,443	Spencer	July 12, 1960