

MRoller: Final Report

Layer-by-Layer Assembly of Nano-Composites

Team 25

Javier Canavati
University of Michigan
Mechanical Engineer

Justin Lefevre
University of Michigan
Mechanical Engineer

Neil Patel
University of Michigan
Mechanical Engineer

Brett Perry
University of Michigan
Mechanical Engineer

Sponsor

Professor Nicholas Kotov
University of Michigan

Section Instructor

Professor John Hart
University of Michigan
Professor of Mechanical Engineering

December 11, 2008

Table of Contents

Executive Summary	4
1 Introduction.....	5
1.1 Problem Background	5
1.2 Customer Requirements.....	7
1.3 Engineering Specifications	7
1.4 Information Sources.....	8
1.4.1 Patent Search.....	8
1.4.2 References Consulted.....	9
2 Function Decomposition	10
3 Concept Generation Process	11
4 Concepts.....	11
4.1 Concept 1: Rotating Cylinder	11
4.2 Concept 2: Rollers.....	13
4.3 Concept 3: Waterfall.....	13
4.4 Concept 4: Sponsor Concept.....	14
4.5 Concept 5: Magnetic Field.....	15
5 Concept Screening	16
6 Bench Level Testing	17
7 Final Design.....	19
7.1 Modules.....	20
7.1.1 Solution Application Module.....	21
7.1.2 Rinse Water Delivery Module	22
7.1.3 Air Supply Module	23
7.1.4 Substrate mounting/moving modules	23
7.2 Bill of Materials	25
7.3 Design Parameter Analysis	26
7.3.1 Motor.....	26
7.3.2 Inner Tube Pressure	27
7.3.3 Gear Box	28
7.4 Material Selection	29
7.4.1 Aluminum	29
7.4.2 Polyethylene.....	30

7.5 Safety/Failure Mode.....	31
7.6 Environmental Analysis.....	33
8 Prototype Manufacturing Plan	34
9 Usability Analysis	35
9.1 Making a Film.....	36
9.2 Machine Maintenance.....	36
10 Validation Plan.....	37
10.1 Basic Operation.....	37
10.2 Cycle Time.....	37
10.3 Assembly Time	38
10.4 Film Size	38
10.5 Film Uniformity	38
10.6 Versatility.....	38
11 Risks and Counter Risks	39
Appendix A: QFD Diagram.....	40
Appendix B: Engineering Drawings.....	41
Appendix C: Bill of Materials.....	50
Appendix D: Component Specifications	52
Appendix E: 80/20 Frame Information.....	58
Appendix F: Changes Since DR3	61
Appendix G: Additional Images	62

Executive Summary

Professor Nicholas Kotov, from the University of Michigan, specializes in creating nanostructured films using a Layer-by-Layer (LBL) assembly process. The traditional method of producing these films is by routinely dipping a negatively charged substrate into charged polyelectrolyte solutions. First, the substrate is dipped into a positively charged polyelectrolyte. After rinsing with water, the substrate is dipped into a negatively charged nanocolloid creating a new layer of polyelectrolyte. The whole cycle is repeated from 200-300 times to create a film. The current process in the lab is a dipping method exemplified by the NanoStrata, which is slow, finicky and produces a small film size. Another method, also demonstrated in the lab, is the Spin Grower, which was created by a previous ME 450 team. This process reduces the assembly time because it applies the solution to a rapidly spinning substrate.

From our discussions with our sponsors, Professor Kotov and Professor John Hart, and with PhD student Ming Qin, we have established the requirements that our design needs. The most important issues are that the design needs to be a novel approach to LBL, and it needs to reduce the assembly time significantly. Enlarging the surface area of the substrate will allow us to increase the film size created. The film irregularity should be minimized to improve lab testing accuracy. The sponsors also requested that we make the parts within the device easily changed and manipulated, creating a more versatile machine.

Reducing the film assembly time is our greatest challenge. The majority of the process time is contingent on solution adsorption time and film drying time. Laboratory experiments have been conducted to test our concept designs. We then chose a concept after several experiments and focused on the specifications of that design. The design is based on the roller application concept that was tested in the lab. The solutions will be applied to soft, rubber rollers that will apply it to a motor-driven substrate. The rollers will rotate due to the friction between the substrate and itself. The film will be rinsed by a stream of water that will follow the rollers and will be dried using an air knife that will blow the remaining water off of the substrate. The device will be versatile in that the position and number of rollers, water streams, and air knives can be changed. The flow rate of the solutions and water, and the substrate rotation speed can all be controlled through LabView. The air velocity of the air knives will be controlled by an outside regulator.

Some of the parts will be ordered because the level of precision needed will be outside of our manufacturing capabilities. Also, motors and pumps will be ordered from vendors. Because the parts will be ordered from different suppliers, it will create issues in compatibility between the parts. The custom designed parts are being machined in the mechanical engineering lab by our team except for one piece that will be machined by an outside shop. Once the device is assembled, we will calibrate it through experimentation.

Abstract

Layer-by-layer (LBL) assembly is a proven method of producing multilayered nanocomposite films. At the University of Michigan, Professor Nicholas A. Kotov has used two processes to create these films for his research. The traditional method is a dip-coating process that creates layers by dipping a substrate into solutions to build bi-layers. The disadvantages of this process include its lengthiness and the production of only small films. The second method was introduced by a former ME 450 design team and is based on a spin-coating process. The solutions are dripped onto a spinning substrate, constructing layers at a faster rate than the previous device but not eliminating the size dilemma entirely. The purpose of this project is to design an innovative process that will produce an LBL assembly prototype while simultaneously reducing the cycle time and creating larger films.

1 Introduction

1.1 Problem Background

Layer-by-Layer (LBL) assembly is a common technique used to produce multilayered nanocomposite films. The most common method of producing these films is by routinely dipping a negatively charged substrate into a positively charged polyelectrolyte solution. After rinsing with water, the substrate is dipped into a negatively charged nanocolloid creating a new layer. The whole cycle is repeated from 200-300 times to create a thin film. The sequential process is depicted in the figure below.

Figure 1.1: Illustration of Dip LBL Method

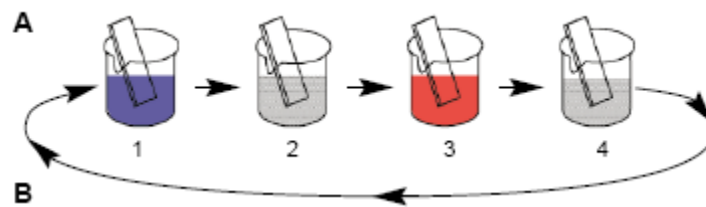

This process can be depicted in the Nanostrata, which is shown Figure 1 below. This is a sound, simple method, but it also has several problems including size limitations and long assembly times. The resulting films are of good quality, but the size of the films is limited by the small substrates. This method also takes up to several days to produce a single film.

Figure 1.2: Picture of Nanostrata Machine Currently Used in Lab



A previous ME 450 team improved the process by using a spin-coating process that dramatically reduces the cycle time. Here, a substrate spins horizontally while the solution is dripped over it. This process can be seen in the SpinGrower which is depicted in Figure 2 below. The device reduces the assembly time to approximately 8 hours. Similar to the Nanostrata, the film output is small due to the substrate size.

Figure 1.3: Picture of SpinGrower Currently Used in Lab



The sponsors of this project are Professor Nicholas A. Kotov from the Chemical Engineering department and Professor John Hart in the Mechanical Engineering department at the University of Michigan. The current devices are used in Prof. Kotov's lab to produce films for research. The sponsors are excited about creating a novel process for LBL. They want to address the problems of the previous devices by creating a novel approach that will reduce cycle time, improve machine reliability and create larger, more uniform films. This project could significantly accelerate the deposition process, leading to faster development of new materials, which could develop into new commercial applications.

1.2 Customer Requirements

From our meetings with our sponsors, we were able to determine a list of customer requirements:

- The sponsors require that the assembly process be a novel approach to layer-by-layer film assembly.
- The assembly time is the highest priority and will be reduced dramatically from the current processes.
- The surface area of the substrate will be larger to increase film output.
- The film irregularity will be minimized to increase the accuracy of the film testing, where the irregularity is seen as bubbles in the film. Complete film coverage is more important than film uniformity in our prototype.
- Versatility in the configuration and mode of application will be built-in.
- The reliability of the device will be improved by reducing the number of moving parts.
- The design will improve computer interface so the machine is more user friendly.
- The design will also minimize wasted solutions and polymers.

Reducing film assembly time is our greatest challenge. The majority of the process time is contingent on solution adsorption time and film drying time. We have focused on these two functions in our design.

1.3 Engineering Specifications

To measure the importance of each customer requirement, we calculated the percentage importance of each based on the sponsor responses to our questions during the meeting. We took these percentages and divided them in half to scale them from 1 to 10; 10 being the most important. We subsequently produced a list of engineering specifications which will dictate the design of our final product, and correlated the specifications to requirements in a Quality-Function Design Diagram (QFD) (Appendix A).

Three of the customer requirements do not translate directly into engineering specifications and need clarification: versatility, good quality film, and novel design.

The versatility of the design refers to a range of configurations that can be assembled using the different application modules. Our design accommodates for roller assembly as well as spray assembly, or a combination of the two. It also accommodates for different assembly surfaces.

The user can either construct a film directly on the glass substrate or opt to use cellulose acetate tape.

The quality film refers to the formation of uniform layers on the substrate (i.e. no bubbles or gaps in the film).

The most important of these three requirements, a novel design, denotes a radical redesign of the current mechanisms to produce a LBL thin film.

After normalizing the results of the QFD we now have quantitative values for the importance of the design specifications. From the normalized results we know the time scale for our device is the key to meeting customer requirements. Producing films in much less time than the SpinGrower is our first priority.

The relevant engineering specifications which were valid to all of our design concepts were a film size of greater than 50 cm² and a 300 bi-layer cycle time of less than 8 hours.

1.4 Information Sources

1.4.1 Patent Search

The following patents are relevant techniques used in the production of thin films and are or may be applied on the nanoscale.

US Patent #5,472,502

This relates to thin film coatings of semiconductor wafers and flat panel displays. It is a method for controlling the rate at which a high viscosity liquid chemical dries, when it is applied to flat spinning article. The driving force is the centrifugal force that spreads the chemical and makes evaporation of a solvent from the chemical easier. However, the rate of drying can be controlled by controlling the saturation level of the solvent. To do this, solvent vapor must be added to the surrounding atmosphere of the spinning surface. This slows the evaporation of the solvent, slowing the drying time of the chemical.

US Patent #5,238,713

This relates to applying even coatings onto a substrate. The method requires that a coating material be applied to a spinning substrate. Then a stream of air is guided over the substrate in the direction of rotation. The airflow is created by fans and guided by guide-vanes to eliminate undesirable deposition or contamination.

US Patent #7,045,087

This relates to a method of LBL assembly. The basic steps for the assembly of a thin film having a plurality of layers on the substrate are outlined in the patent, as well as a method for removing said film from the substrate without compromising the film.

US Patent #5,861,061

This relates to coating a substrate. In this process, a substrate is spun by a motor while a dispense system sprays liquid onto the wafer. The air ring is also a part of the assembly; this helps with the drying process.

US Patent #6,460,424

Patent held for the mechanism used to move the slide in Nanostrata LBL machine. It is an attempt to create movement in both a fixed arc and purely linear motion in a simple way. This is used to move the slide around to each beaker, and then dip the slide directly into the beakers.

US Patent #6,585,936

This is a flow control method for slide strainers. If too much or too little water is used to rinse a stained slide, the specimen on the microscope may be damaged, hence the need for a flow control.

1.4.2 References Consulted

Chiarelli, Peter A., Malkiat S. Johal, Joanna L. Casson, Jerrad B. Roberts, Jeanne M. Robinson, and Hsing-Lin Wang. "Controlled Fabrication of Polyelectrolyte Multilayer Thin Films Using Spin-Assembly." Advanced Materials 13 (2001): 1167-170.

Cho, Jinhan, Kookheon Char, Jong-Dal Hong, and Ki-Bong Lee. "Fabrication of Highly Ordered Multilayer Films Using a Spin Self-Assembly Method." Advanced Materials 13 (2001): 1076-078.

Coury, Bob. Mechanical Engineering Shop Director. Interviews. (October – November, 2008).

Crow, Kenneth. "Failure Modes and Effects Analysis." <http://www.npd-solutions.com/fmea.html>. 2002. Retrieved November 7th, 2008.

Decher, Gero, et. al. "Fuzzy Nanoassemblies: Toward Layered Polymeric Multicomposites." Science 277 (1997): 1232-236.

Hart, John. Professor at University of Michigan. Interviews. (September – November, 2008).

Kotov, Nicholas. Professor at University of Michigan. Interviews. (September – November, 2008).

Krogman, K. C., N. S. Zacharia, S. Schroeder, and P. T. Hammond. "Automated Process for Improved Uniformity and Versatility of Layer-by-Layer Deposition." Langmuir 23 (2007): 3137-141.

Porcel, C. H., A. Izquierdo, V. Ball, G. Decher, J. C. Voegel, and P. Schaaf. "Ultrathin Coatings and (Poly(glutamic acid)/ Polyallylamine) Films Deposited by Continuous and Simultaneous Spraying." Langmuir 21 (2005): 800-02.

Qin, Ming. University of Michigan PhD Candidate. Interviews. (September – November, 2008).

Tomita, Shigeru, Katsuhiko Sato, and Jun-ichi Anzai. "Layer-by-layer assembled thin films composed of carboxyl-terminated poly(amidoamine) dendrimer as a pH-sensitive nano-device." Journal of Colloid and Interface Science 326 (2008): 35-40.

2 Function Decomposition

In order to meet the customer requirements in our design we decomposed our problem in order to better understand the key difficulties in our design process. By analyzing the system for producing nanostructured thin films we were able to focus our brainstorming and module designing. Our functional decomposition comprised three parts:

- Breaking the process into key functions
- Brainstorming strategies to address those functions
- Translating the strategies into design modules

From analyzing the process, we were able to break the function down according to the problems of the previous devices. We decomposed the process by discussing the system inputs and seeing how they interacted to produce a film. We developed a block diagram, Figure 3, to exemplify the interactions.

Figure 2.1: This block diagram shows the basic inputs and functions required for the automated growth of nanostructured thin films.

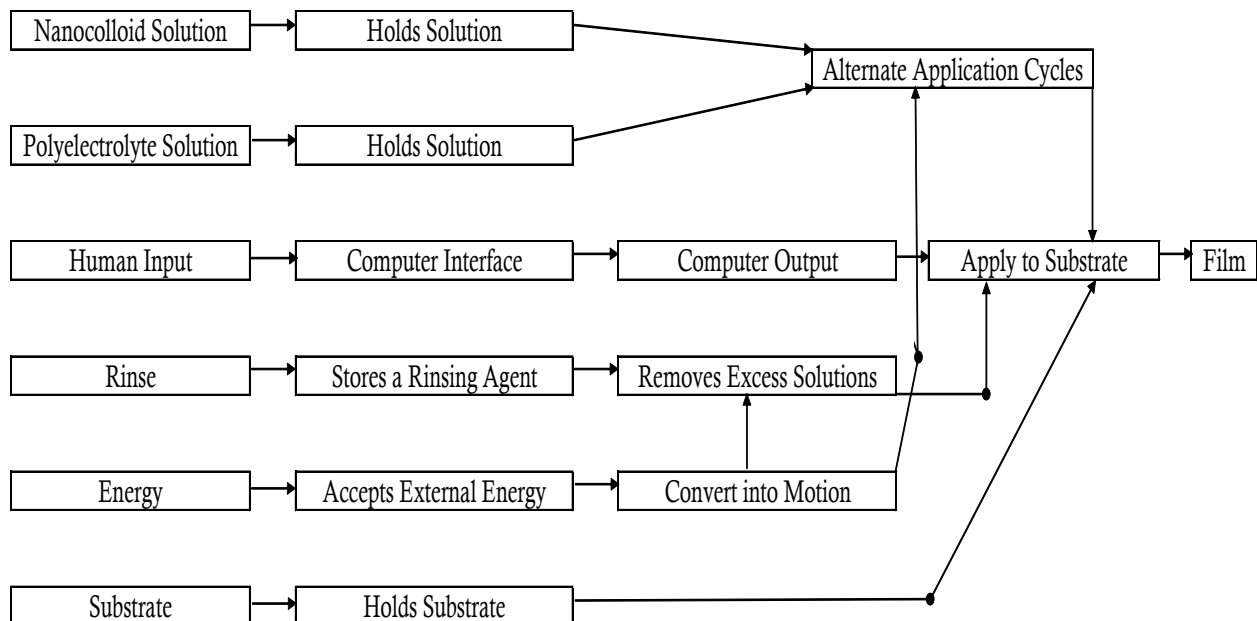

But the interactions were complex and so we decided to break the process into four key functions:

- Applying the solutions to the film
- Adsorbing the solutions onto the film
- Removing the excess solution/wash from the film
- Drying the film

3 Concept Generation Process

With the system broken down into these four processes, we then brainstormed numerous ways to address them. These lists of solutions translated into modules for our designs and greatly aided in our concept generation process.

From researching existing manufacturing techniques on both the nano and macro scale, we began to notice common themes for certain functions. Using concepts seen on a larger scale, we tried to develop ways to apply them to our project. Initially, our group separated and individually sketched out specific functions that ranged from conservative to eccentric. Then we started to combine each function to create a concept. A few days later we came together to compare our concepts, even mixing a few of the similar ones. This gave us the initial concepts for which we began to discuss with our sponsors and test.

4 Concepts

4.1 Concept 1: Rotating Cylinder

A cylindrical substrate spins while continuously being sprayed by both solutions. As seen in the figures below, the solution is sprayed and then immediately followed by a rinse and hot air. The concept utilizes spraying, which has been commonly used due to its decrease in absorption time¹. Water is applied as a rinsing agent and is applied in a stream that runs vertically down the substrate, similar to water coming out of a faucet.

¹ Porcel, C. H., A. Izquierdo, V. Ball, G. Decher, J. C. Voegel, and P. Schaaf. "Ultrathin Coatings and (Poly(glutamic acid)/ Polyallylamine) Films Deposited by Continuous and Simultaneous Spraying." *Langmuir* 21 (2005): 800-02.

Figure 4.1: Rotating Cylinder - Top View

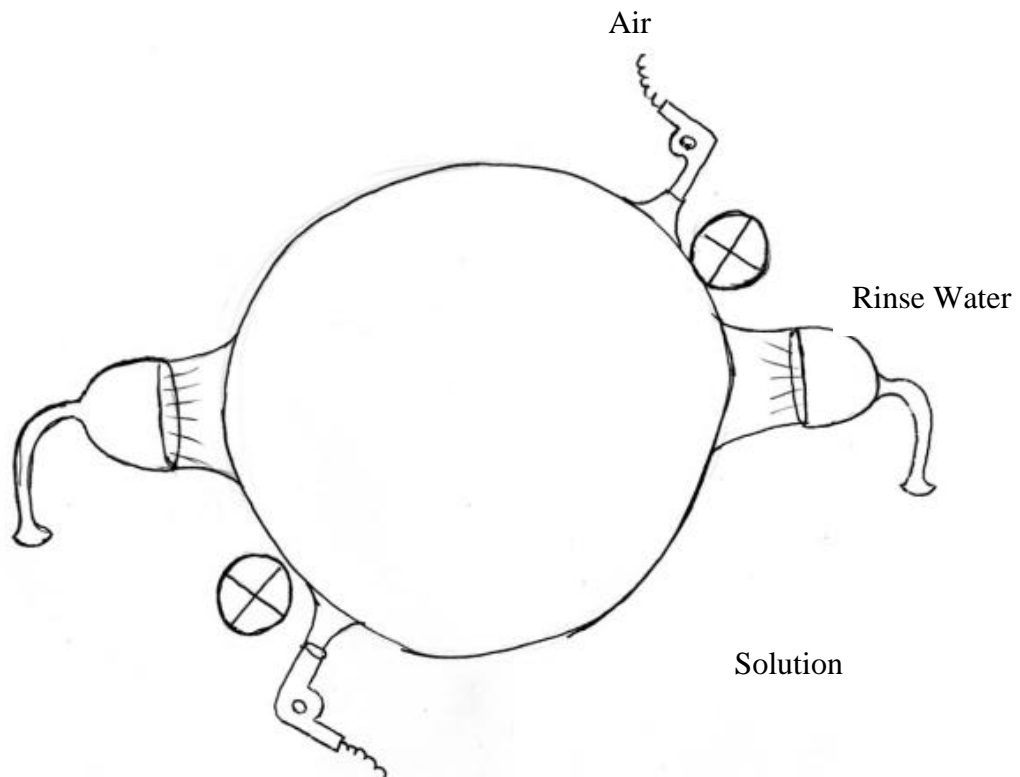
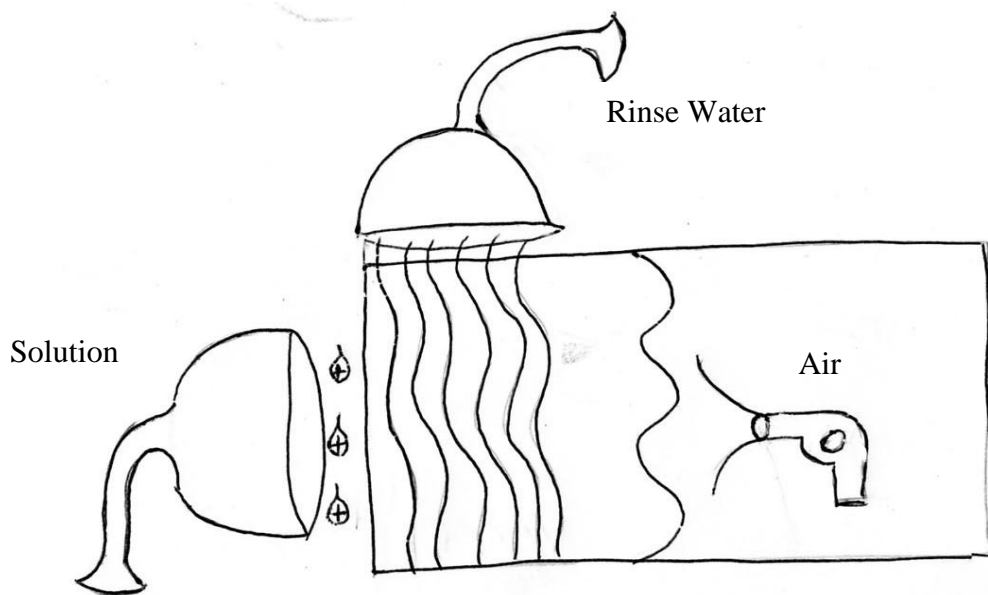

Figure 4.2: Rotating cylinder – Side View



4.2 Concept 2: Rollers

The substrate spins while rollers apply the solutions simultaneously. The solutions are sprayed onto the roller and the excess is removed with wipers.

Figure 4.3: Rollers – Top View

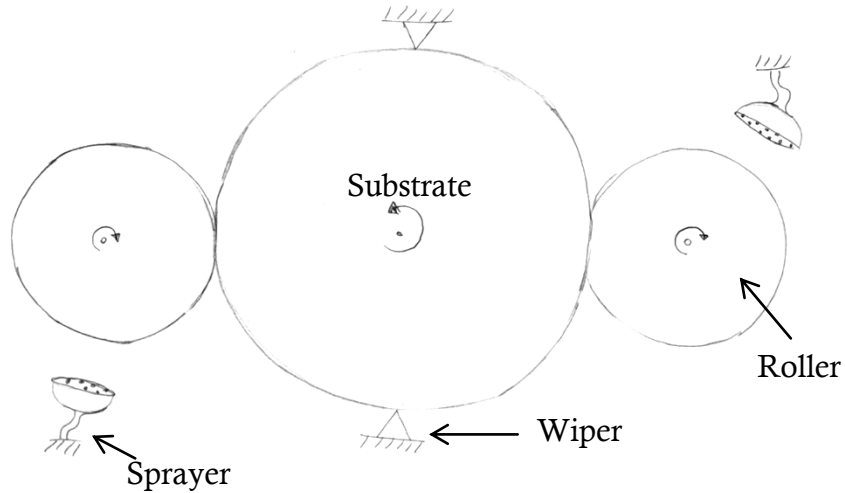

4.3 Concept 3: Waterfall

Substrates spin around on a mesh surface under a waterfall of each of the solutions. The force from the falling solution is thought to create enough agitation to decrease absorption time but more laboratory tests are needed to determine its effects. The substrates will rotate slowly enough so that they dry before they reach the other solution.

Figure 4.4 (Left): Top View of Substrate Motion
Figure 4.5 (Right): Waterfall Concept

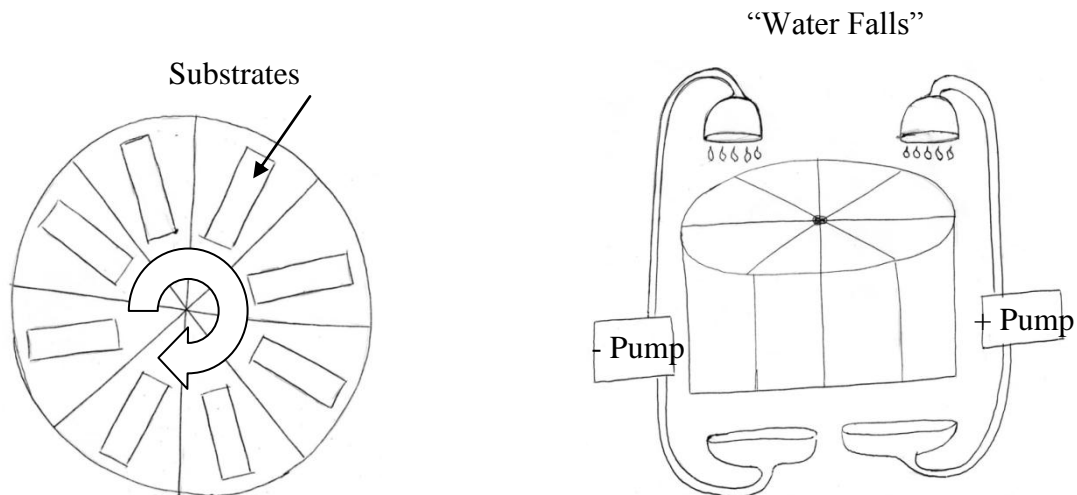
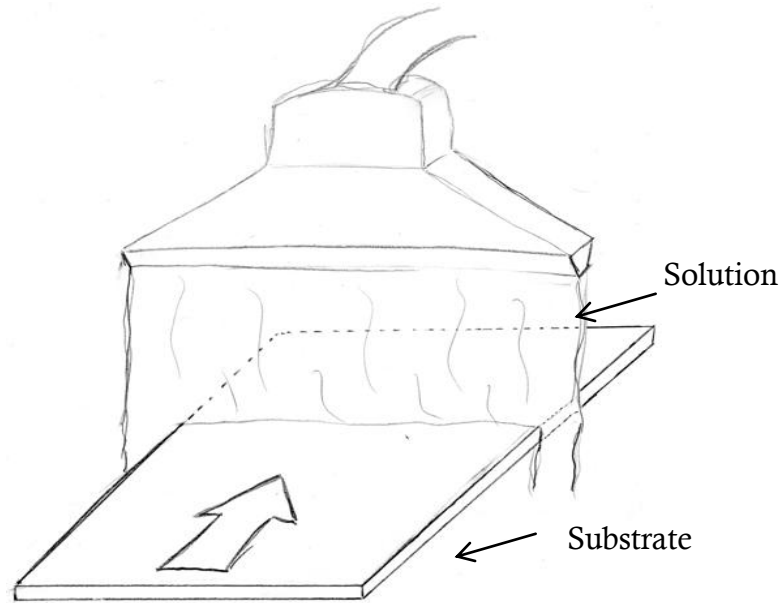

Figure 4.6: Individual Waterfall Image



4.4 Concept 4: Sponsor Concept

A cylindrical substrate is revolving within a larger cylinder that holds the solutions and water. The idea behind this is that the solutions are separated by a wiper which will also remove excess solution from the substrate leaving a thin layer. From our initial bench-level experiments, we have determined that the wiping method removes all of the solution resulting in no film growth, and therefore, some modifications will need to be made to the concept.

Figure 4.7: Sponsor Concept

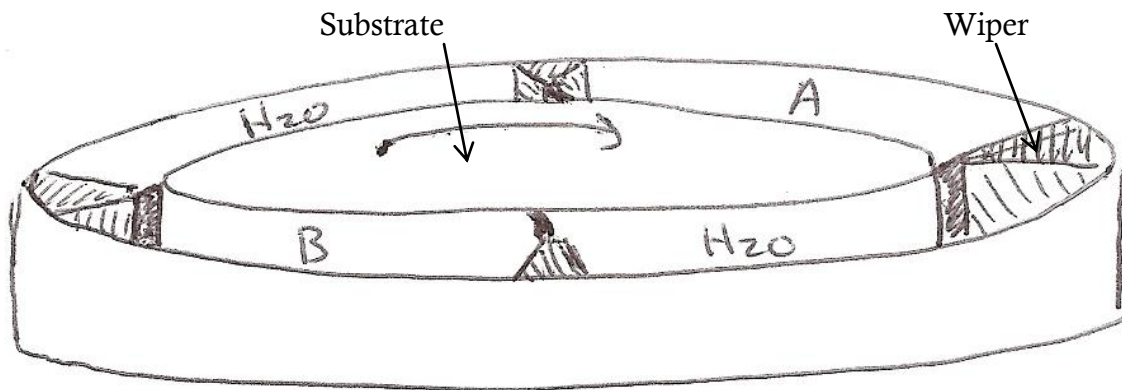
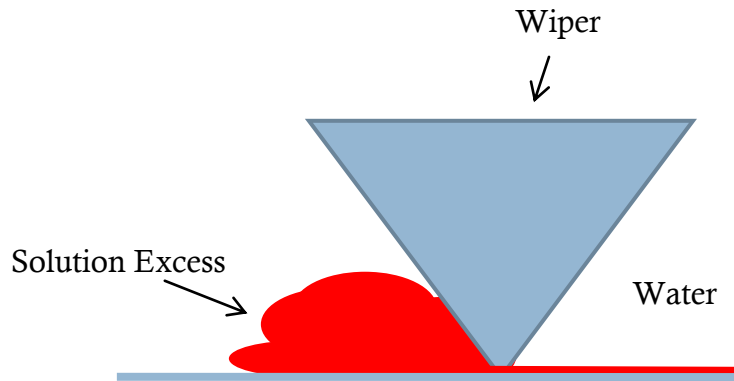

Figure 4.8: Wiping Action



4.5 Concept 5: Magnetic Field

This radical idea is based on creating a magnetic or electrical field around the substrate. The field helps the charged solutions align faster to decrease absorption time. The solutions are applied using a sprayer, and the excess solution is removed by a roller.

Figure 4.9: Magnetic Field Concept

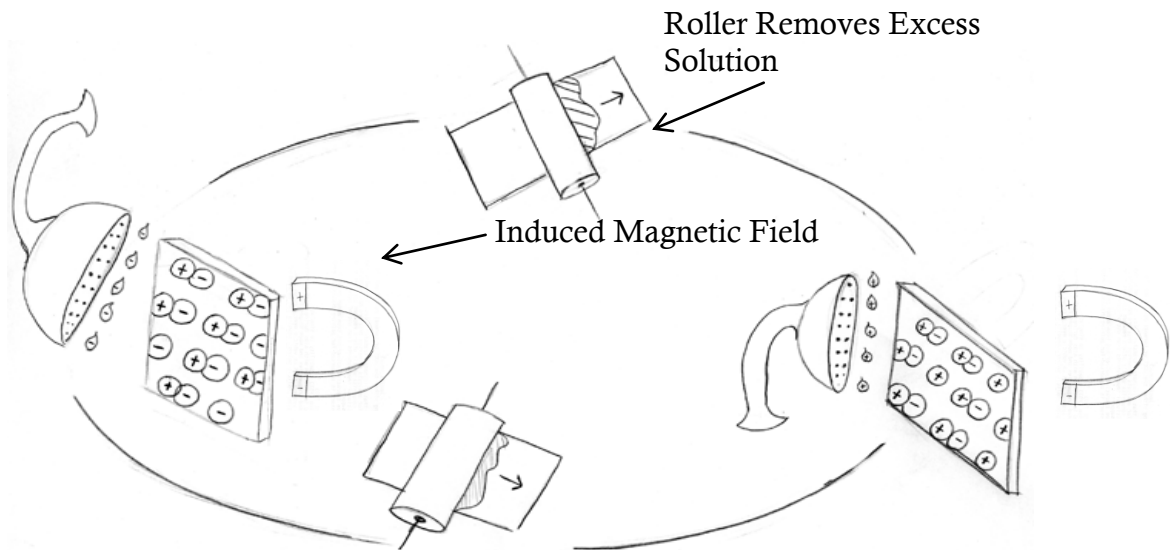
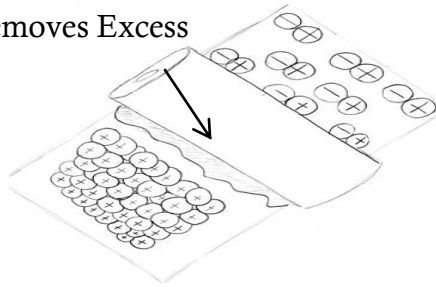

Figure 4.10: Roller Close-Up

Roller Removes Excess Solution



5 Concept Screening

In order to help select the best concept to move forward with, a concept selection matrix was used. This matrix consisting of the most promising concepts is shown in Table 1 below. The methods were each compared to a baseline for each different customer requirement for the project; in this case, the baseline used was the Nanostrata machine. Cycle time, versatility, ease of use, reliability, film size, film quality, cost, and large scale potential were the criteria used in the matrix. If the concept was believed to be superior to the Nanostrata for a particular criterion, a one would be placed in the matrix. Zero indicates a predicted performance equal to that of the Nanostrata, and a negative one would be worse. The total sum for each concept was then used to rank the concepts in order of potential.

Table 5.1: Concept Screening

Selection Criteria	Concepts							
	1 Rotating Sprayer	2 Rollers	3 Waterfalls	4 Kotov's idea	5 Magnetic Field			
Cycle Time	1	1	0		1	1	Better than datum	
Versatile	0	0	0		0	0	Same as datum	
Ease of use	0	0	1		-1	-1	Worse than datum	
Reliability	0	1	1		-1		Does Not Work	
Film size	1	1	0		0		Requires Testing	
Film quality	1	0	0		0			
Cost	0	0	0		-1			
Large scale possibility	0	1	0		-1			
Net Score	3	4	2	0	-3			

As Table 5.1 shows, the roller system and the rotating sprayer both scored well in the matrix. The roller system could drastically decrease the cycle time of the process because the substrate does not need a long exposure time to allow for proper adsorption. It would also improve the reliability of the machine because there would be fewer moving parts, and no complicated mechanisms like the arm on the Nanostrata. Film size would be greater as well because the substrate could be as large as desired depending on the size of the rollers used. Rolling would also provide a simple and proven large scale production method, similar to a printing press. The remaining criteria would have similar results to the datum.

The rotating sprayer would also improve the cycle time of the assembly because research has shown that spraying is the fastest proven method of solution deposition available¹. Film size would also be improved because the machine would be designed to use a large cylindrical substrate. The film quality could also be improved by the spraying method because there are many variables to tweak in order to get the best quality such as solution spray rate, water flow rate, and substrate spin speed. The rotating sprayer machine would be comparable to the Nanostrata in the rest of the criteria.

The other concepts in the matrix were eliminated for several different reasons. The waterfall application design showed positive results, but is ultimately too similar to the current methods to be considered. The electric/magnetic field concept could be used for LBL assemblies, but it would be extremely complex and expensive. It is also unknown if it would actually work for the purposes of this project. The concentric cylinders concept was also quite promising, but initial bench level experiments showed that the wiper would remove all the material and not allow any layers to be formed.

6 Bench Level Testing

The experiments conducted since Design Review 2 were based on the concepts in the previous section. We tested the effects of a roller application versus a sprayer application. We compared the results to previous control tests that were performed in the lab for Design Review 2. In addition, we took uniformity tests of the control samples as well as the application tests. We did this by using an ellipsometry machine to measure the thickness of 5 bi-layers at several different locations on the substrate.

In testing the roller, a four inch soft rubber roller (shown below) was dipped and rolled in the polyelectrolyte solution and then rolled across the substrate. The substrate was then rinsed and dried in a similar matter to the control tests from earlier. Another roller was then dipped and rolled in the negative clay particle colloid and the steps were repeated. Two tests were taken for the roller: 2 rolls and 4 rolls, where the 2 roll was a back and forth motion and 4 rolls were 2 back and forth motions.

Figure 6.1: Roller used for bench level roller deposition testing

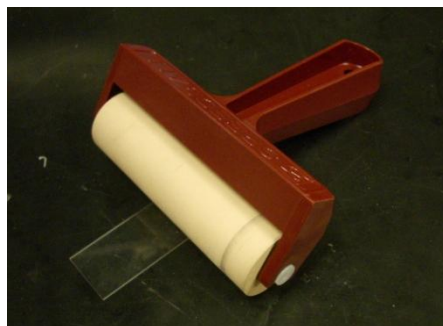

The sprayer was tested using air-brushes. The polyelectrolyte solution was sprayed and then the substrate was rinsed and dried in a similar matter to the control tests. And the colloid was then sprayed and the steps were repeated. The sprayer was tests for two different applications: 1 spray

and 2 sprays, where the 1 spray was just 1 sweeping motion and the 2 sprays consisted of a back and forth sweeping motion.

The results of the tests were rather consistent and can be seen in Graphs 6.1 and 6.2 below. However, the single roll test created less consistent layers compared to the other tests, while 2 sprays created the most consistent. This could be a result because spraying allows the solution to spread out more evenly before it is rinsed and dried. Specifically, for comparing the rollers though, the extra rolls may force the particles to distribute more evenly for the 4 roll test. Each of the tests created layers at similar rates.

Figure 6.1: Graph Showing Consistent Film Uniformity After 4 Bi-Layers for All Methods

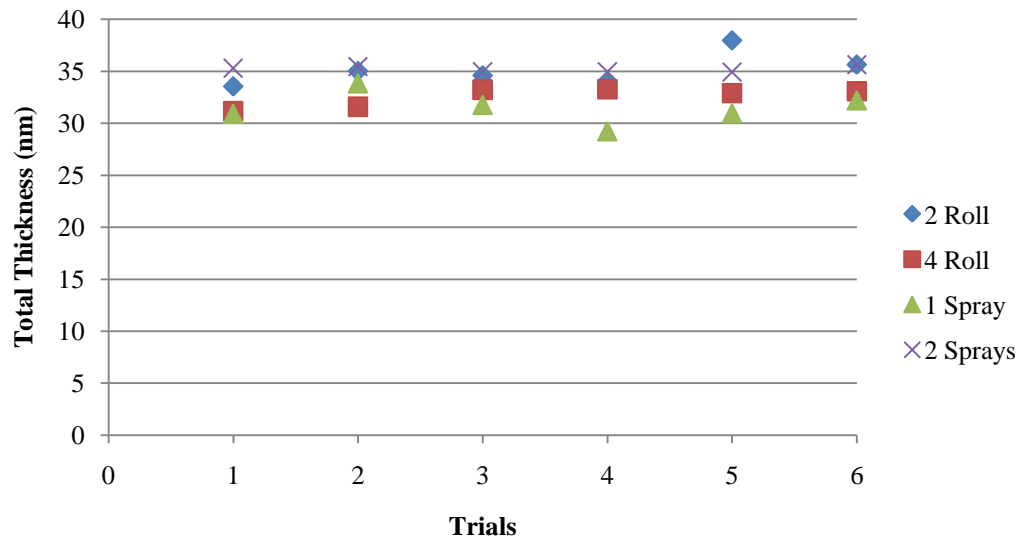
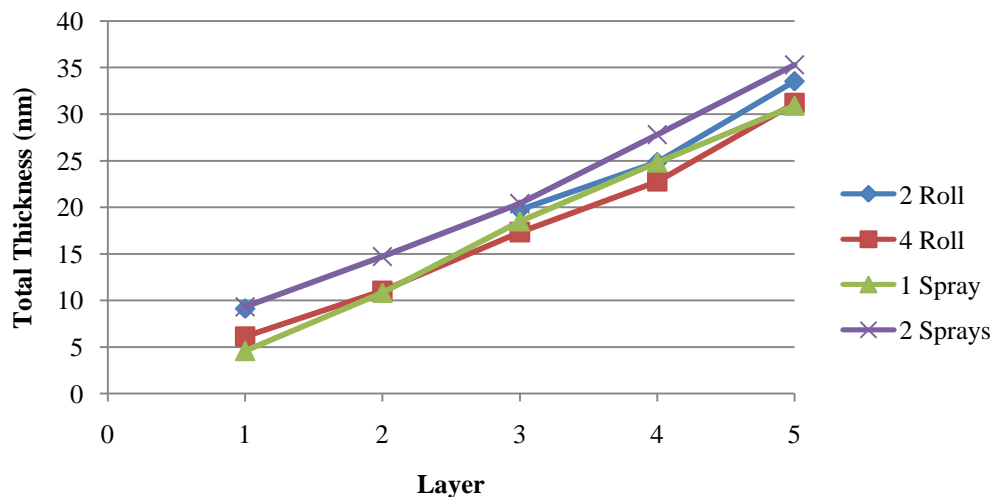

Figure 6.2: Graph Showing Consistent Film Growth with Roll and Spray Deposition



From our bench-level experiments, either rolling or spraying will be acceptable. But because developing a novel approach is a main customer requirement, we have chosen the roller application for our design because it is not as common as the spraying technique.

The air knife concept was chosen because it was a more efficient use of a concept that was already tested. We used compressed air to dry the substrates in all of our experiments, but the air knife is concentrated air flow, which will decrease the drying time compared to our controlled tests. The same approach was given to choosing the rinsing concept. Since we used the distilled water tap to rinse the substrate, we will use a more focused stream in our design because we already know that it will effectively rinse the film.

7 Final Design

Figure 7.1: CAD Model of Final Design (frame, tubing not shown)

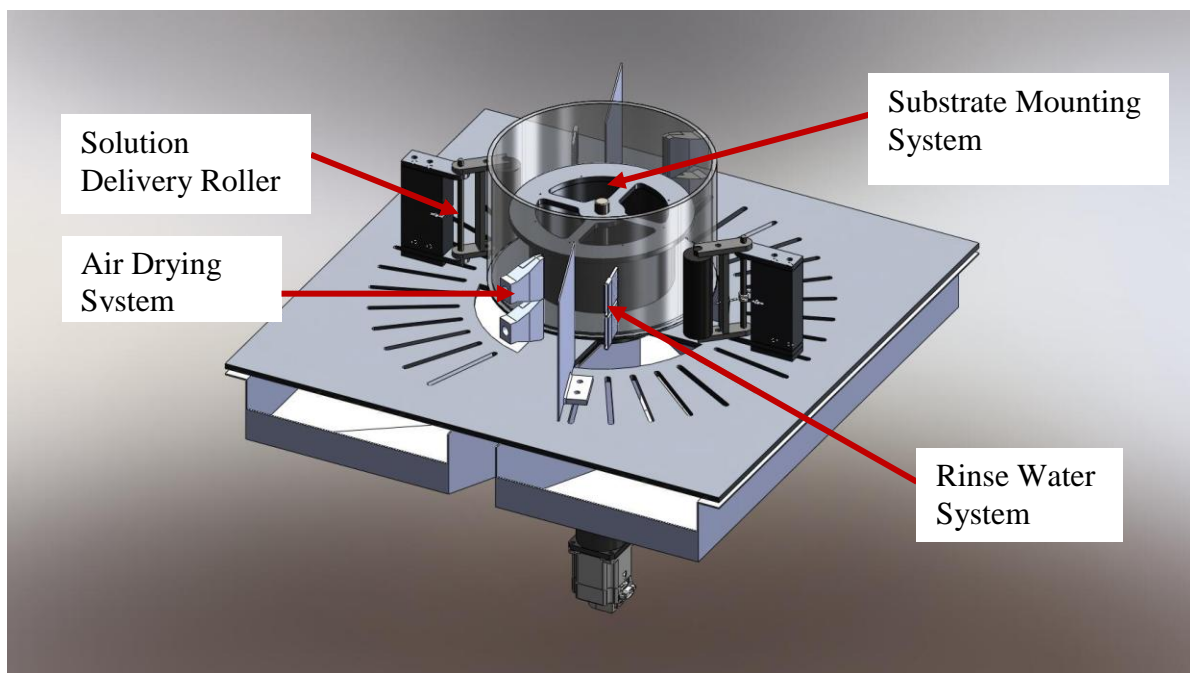

Our design utilizes roller assemblies to deliver the polymer and colloid solutions to a cylindrical substrate. As the cylinder rotates the excess solution is rinsed off with de-ionized water, which is delivered through wide nozzles on flexible arms, and, after the rinse, air-knives blow the rinse solution off of the cylinder. The process described above is supported by the following four systems:

- Solution delivery system
- Rinse water delivery system
- Air supply system
- Substrate mounting/moving system

These four systems are controlled mainly by direct user input. The following sections describe the design systems and the modules within it.

Figure 7.2: Top View of Assembly

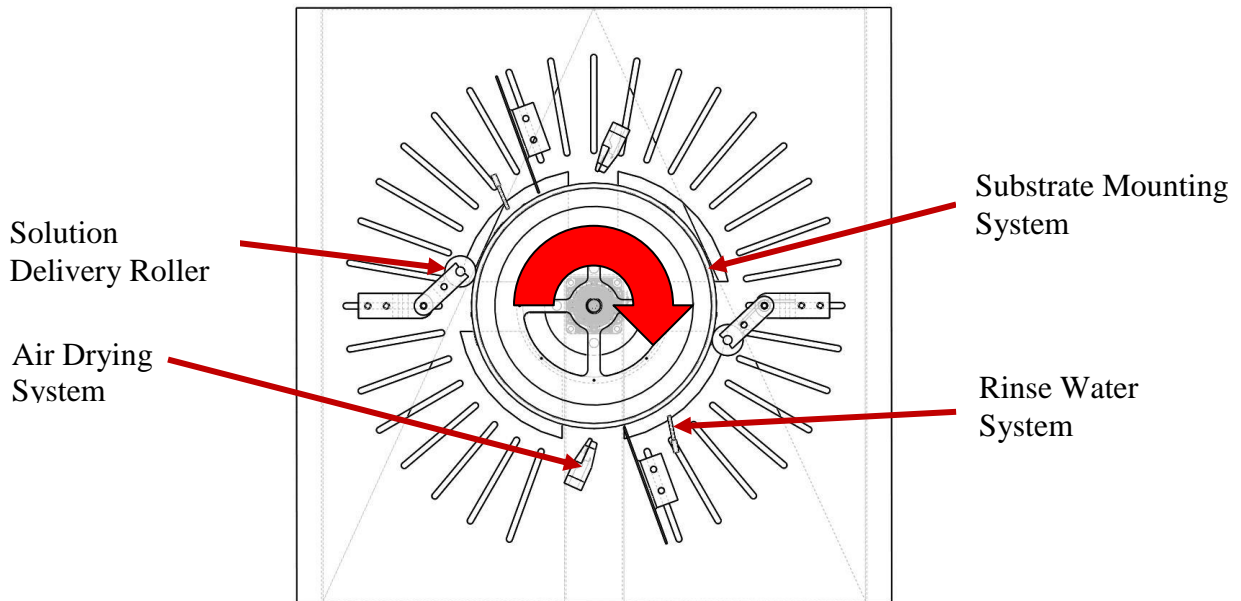
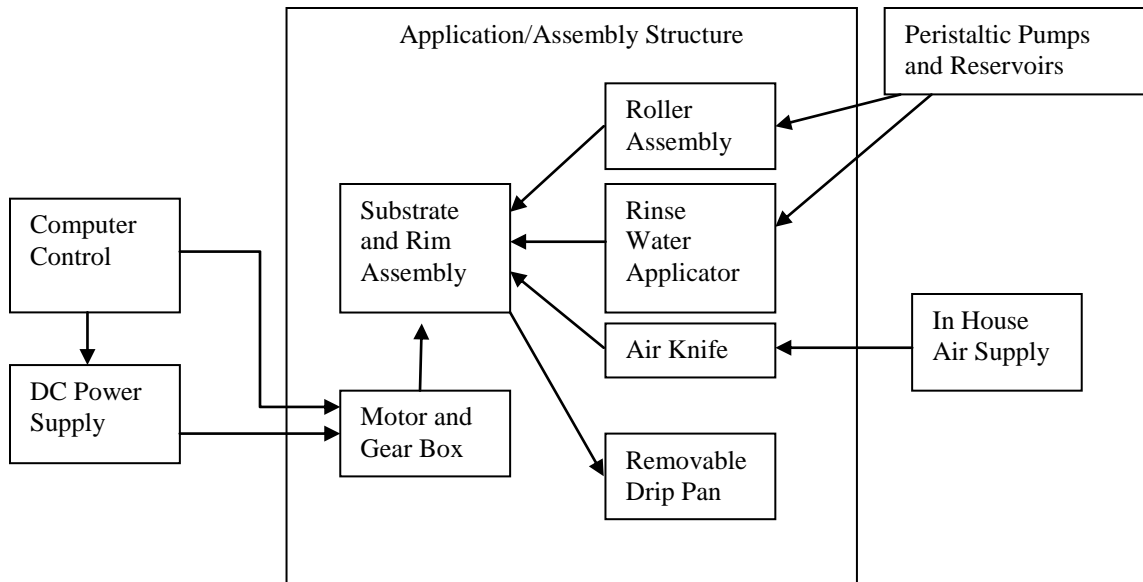

Figure 7.3: System diagram



We developed our final design concept to arrive at our system design by investigating the components of our concept to determine the feasibility of procuring or fabricating each and developing them accordingly. The components shown in the CAD models above are fed and powered by a series of pumps and controls as shown in Figure 7.3 above.

7.1 Modules

7.1.1 Solution Application Module

The key component of this module is the roller assembly pictured below.

Figure 7.4: Roller Assembly

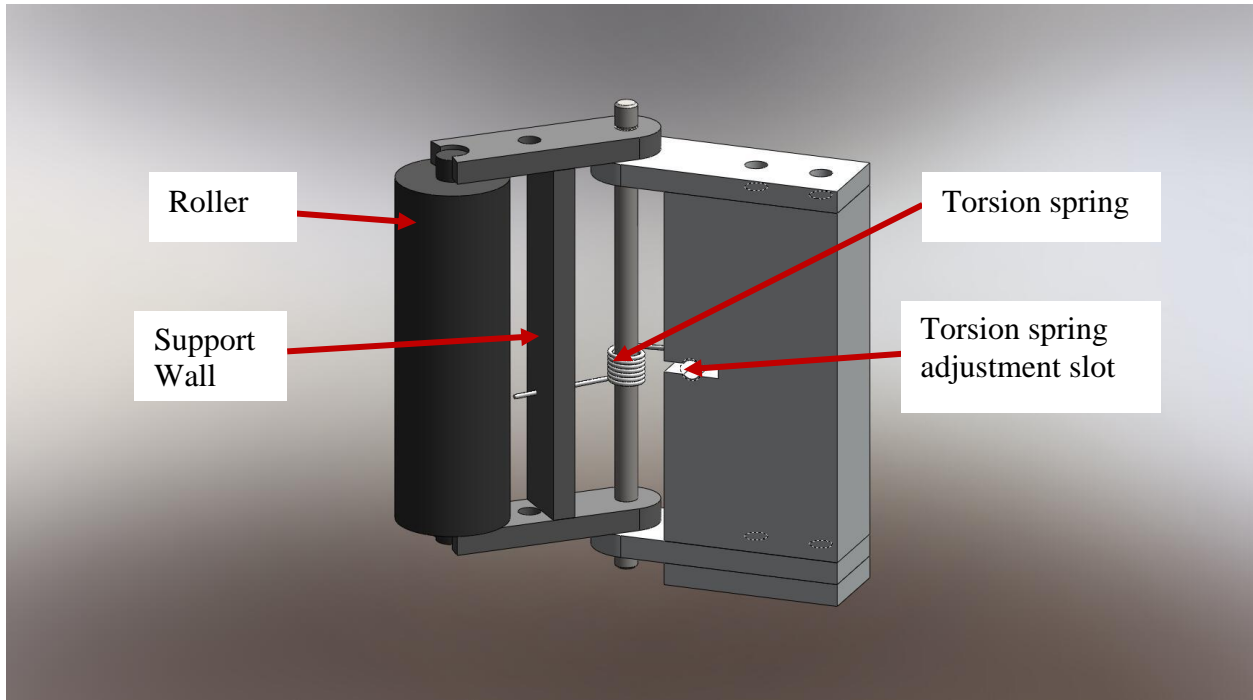

The roller is held in contact with the substrate by a torsion spring. The normal force applied to the cylinder by the roller can be adjusted in two ways. The spring can have the preload adjusted on the roller assembly, and the assembly can be adjusted radially on the mounting plate.

Figure 7.5: Block Diagram showing the solution delivery system

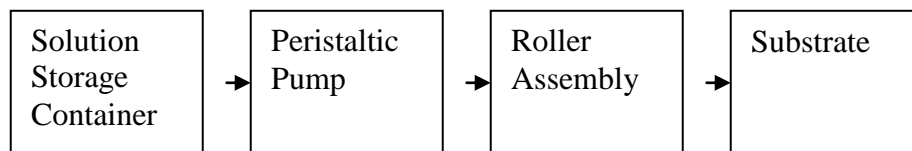

Fluid is applied directly to substrate and the rollers at the same time. Loc-Line (flexible, yet rigid hose) is used to drip the solutions very close to the rollers. The contact between the rollers and substrate then pull the solution down the full height of the roller in order to apply a coating along the full film area. This method of applying the solutions was verified to be effective with experimentation.

Fluid is delivered to the roller assembly through plastic tubing using Stenner 85MPH40 variable speed peristaltic pumps. These pumps are AC powered with direct flow control. The flow rate of the pumps will be determined manually for enough flow to maintain full saturation of the foam.

7.1.2 Rinse Water Delivery Module

The key components of this system are the Loc-Line tubes and nozzles. They allow many degrees of freedom for the positioning of the streams of de-ionized water onto the substrate.

Figure 7.6: Photo of Loc-Line Rinse Water System from Alpha Prototype

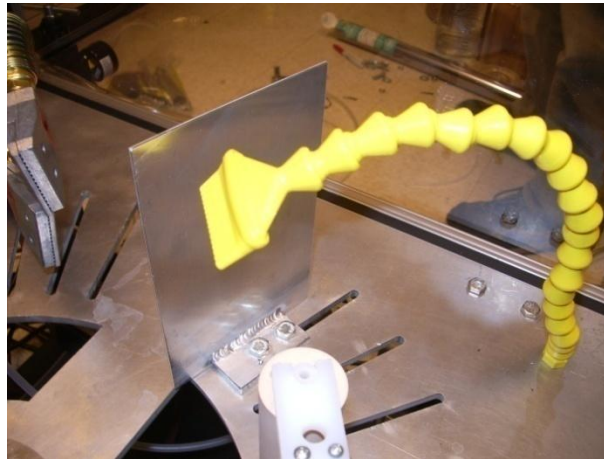

By using Loc-Line Acid Resistant parts all the components of the rinse water delivery system will be tolerant to the working conditions in our assembly. Quarter inch Loc-Line tubing will be used. The Loc-Line 1/4" Swivel Nozzle 40 pictured in the figure above should apply water evenly onto the substrate and maximize rinse efficiency.

De-ionized water will be supplied to the Loc-Line components through 5/16" ID flexible tubing and pumped using Anko Series 4000 variable speed peristaltic pumps. These pumps are also AC powered and manually controlled. An in house de-ionized water supply will continually refill the 2 liter bottle which the pump uses as a reservoir. The block diagram below shows the rinse water delivery system as a whole.

Figure 7.7: Rinse Water Delivery System

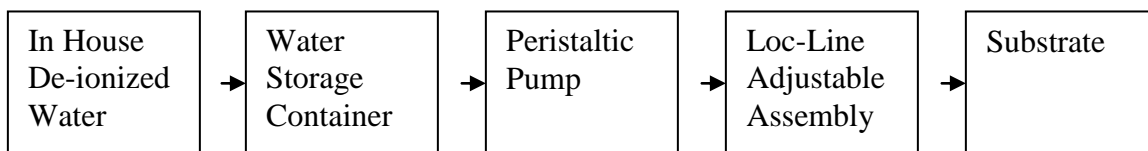

The rinse water and excess solution drains down through the mounting plate which has many openings in it. Underneath the mounting plate is a drip pan which is on an angle to collect the waste solution and drains through a hose in the front to a waste container. The drip pan is easily removable for cleaning because it is on a sliding track on the frame and fits around the structural tube. The drip pan is easily removable because it will likely need to be washed between uses to prevent buildup and so the roller assemblies can be adjusted or removed easily. The hoses which

will protrude through the bottom of the mounting plate pass out the slot in the back of the drip pan.

Figure 7.8: Drip Pan

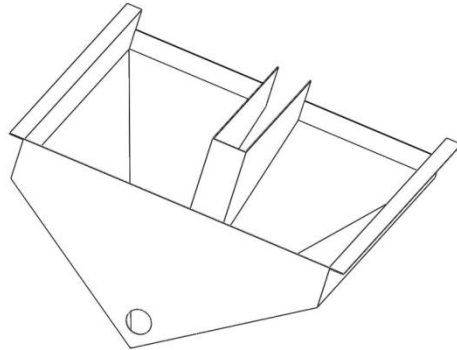

7.1.3 Air Supply Module

The drying of the film will be done using miniature air knife nozzles on stay set hose attached to the mounting plate. This will allow for the nozzles to be adjusted so that the optimum drying time is achieved. This system does not have computer control, since it only requires a constant pressure once the machine is turned on. Therefore, the input air will be controlled with an inline pressure regulator for each side of the device. Since the lab in which this device will be used has in house airlines we will utilize these rather than purchasing a compressor. The stay-set hose which comes with the air nozzles we have procured has 1/4" NPT threading on the end, so it will be threaded into our mounting plate and supplied by a connection from underneath.

Figure 7.9: Photo of Air Drying Nozzle System from Alpha Prototype

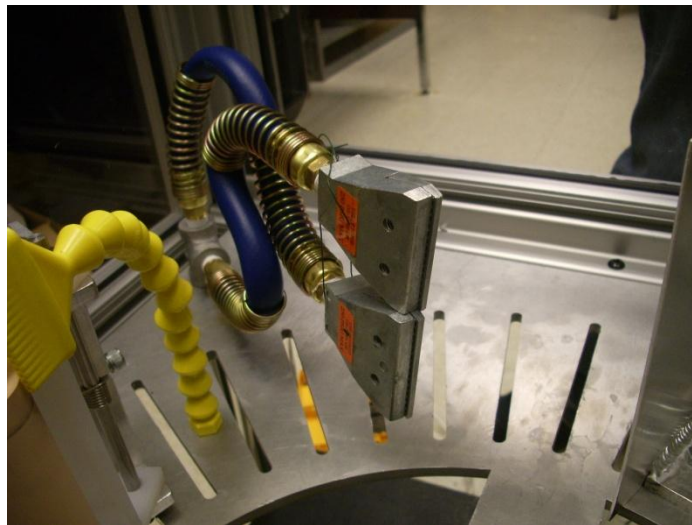

7.1.4 Substrate mounting/moving modules

The aluminum rim assembly, shown below, supports the quartz tube substrate. The assembly

consists of a top and bottom plate welded to a center cylinder. Vertically, the tube is supported by a 1/8" lip on the lower rim. The rim assembly slides onto the drive shaft from above and rests on a shaft collar. Since the shaft has a D profile the rim will have similarly shaped holes on its top and bottom plates to transmit the torque from the motor generating the rotation of the substrate. A rubber inner tube will be inflated in between the glass cylinder the rim assembly. The inner tube utilizes friction to rotate the glass cylinder with the driveshaft.

Figure 7.10: An Exploded view of the rim assembly without inner tube.

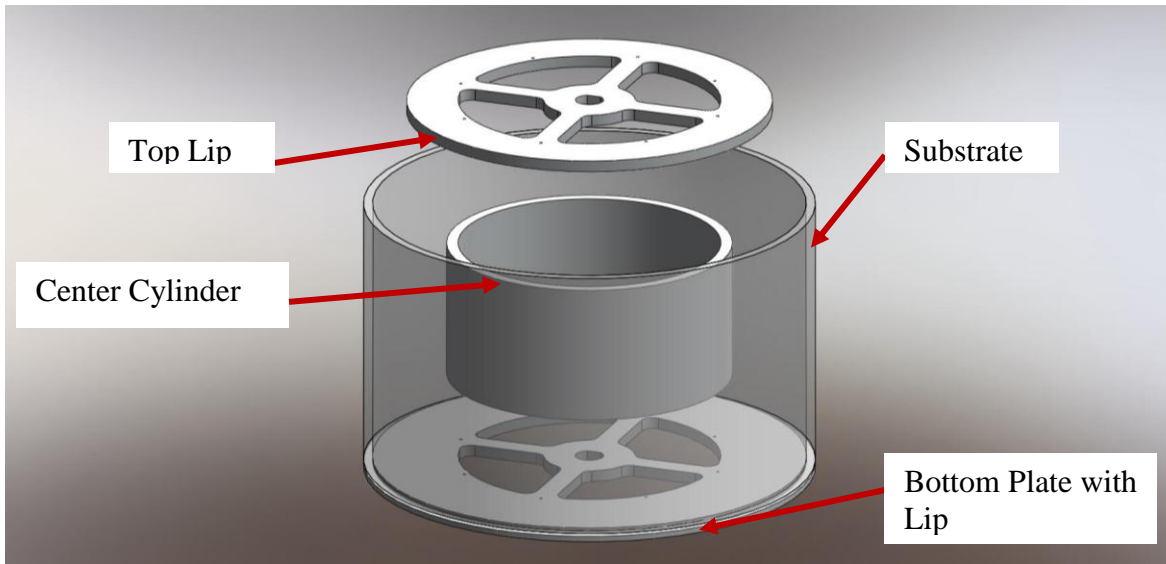

Power is transmitted to the substrate through a Lin Engineering NEMA 23 step motor, which is geared down to increase torque and decrease irregularities caused by the steps in a CGI gearbox with a 70:1 gear ratio. The gearbox shaft will be coupled to the 5/8" D-profile driveshaft.

Figure 7.11: Cross Section of Final Design Assembly

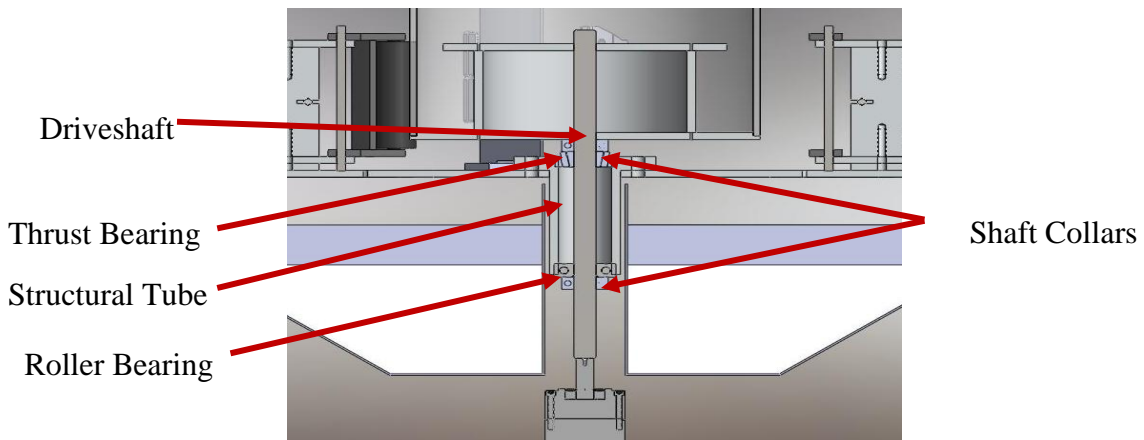
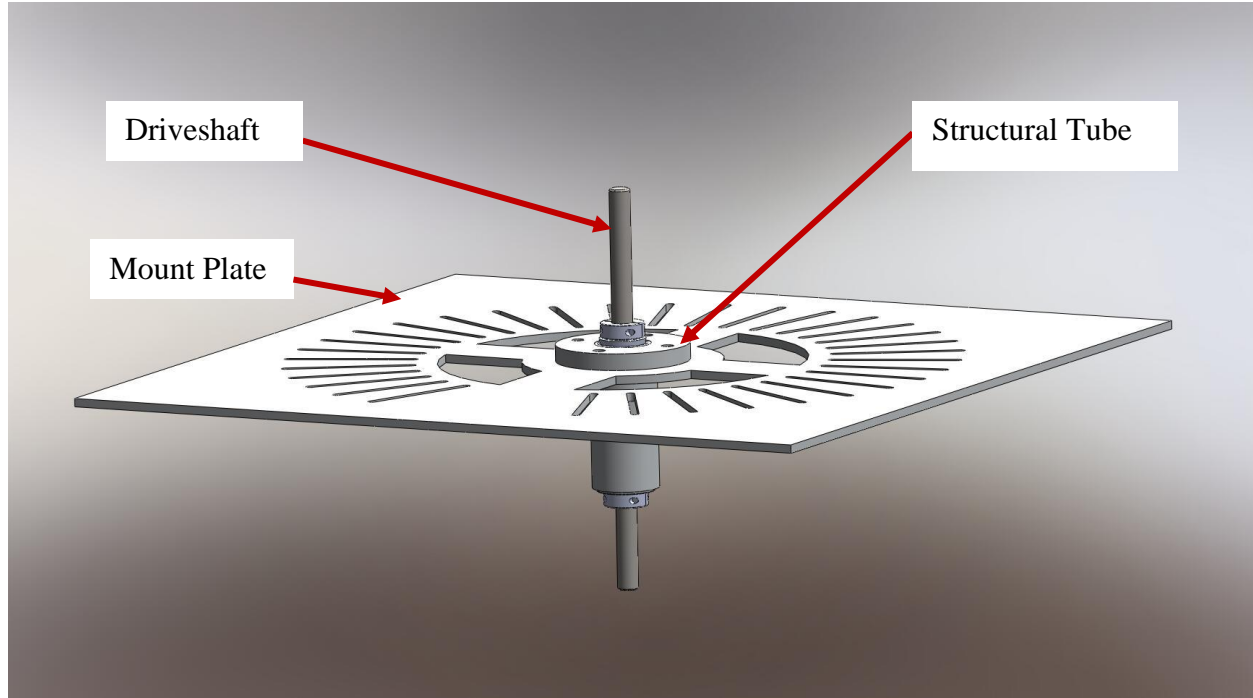

Figure 7.12: Assembly of the drive shaft, structural tube, and mounting plate.



The driveshaft is supported by two bearings in the structural tube. An angled thrust bearing in the top of the structural tube resists axial motion, and the top bearing and a roller bearing in the bottom of the structural tube absorb moments. These bearings are spaced 4 shaft diameters apart to handle the loads placed upon them. Collars on the shaft on each side of the structural tube restrict axial motion of the shaft. This design transfers the weight and forces which the substrate may impose on the drive shaft to the mounting plate through the structural tube. This is beneficial because it decreases the stress on the coupled drive shafts and the motor mount.

The motor connects directly to the computer with an integrated controller and is controlled by supplied software (LinControl). The motor is powered through a DC power supply.

7.2 Bill of Materials

A detailed bill of materials is given in Appendix C, and below is an abbreviated list of costs for the different parts of the system.

Figure 7.13: Summarized Cost Breakdown (Full Bill of Materials in Appendix C)

System Area	Cost
Substrate	\$433.30
Plate Assembly	\$1,684.04
Drip Plate	\$123.24
Air Knives	\$434.76
Water Nozzles	\$127.59
Roller Assemblies	\$217.70
Fluid Delivery System	\$1,940.14
Frame	\$1,311.00
Total	\$6,302.75

Many of the parts for the system assembly will be machined by our team. These include: the mounting plate, the roller assemblies, the substrate holding rim, the peristaltic pump housing, and the electrical component housing. The structural tube is being outsourced to another machine shop to reduce our machining time; however we will need to bore it on the lathe when we receive it to put the bearings in.

7.3 Design Parameter Analysis

7.3.1 Motor

In our design, a critical part is the choice of the correct motor. This is critical because we need to be able to accurately control the speed of the substrate so that the rollers apply the solution at the correct rate. From our bench-level experiments, we have shown that the rollers apply a bi-layer when moving at 3 inches per second, which converts to roughly 6 rpm for our substrate. Using the equation below (Eqn. 1), we are able to determine the required torque [T], based primarily on the weight [W] and radius [R] of the substrate and the substrate holder, the change in speed [ΔN], and the time [t].

$$T = \frac{WR^2 \Delta N}{612t} \tag{Eqn. 1}^2$$
$$T = \frac{(12 \text{ lbs})(.8167 \text{ ft})^2(6 \text{ rpm})}{616(1 \text{ s})} = 14.976 \text{ oz. in}$$

² Torque Calculator. Engineers' Edge.

http://www.engineersedge.com/motors/solid_cylinder_axis_torque_force_equation.htm. Retrieved November 5th, 2008

Here, we estimated the desired torque using the speed determined from our bench-level experiments and estimated weights. We estimated the weight of the substrate and its holder to be 6 lbs and the change in speed is 6 rpm. The outer radius of the substrate will be approximated to be 9.8 inches and the time will be 1 second.

In order to find a motor that met all of our torque, speed, and cycle time requirements, we decided on a Lin Engineering stepper motor along with a planetary gear box to reduce the speed while increasing torque.

7.3.2 Inner Tube Pressure

The inner tube is responsible for inflating to create contact with the inner wall of the substrate and turn the substrate as the drive shaft rotates. The entire holding device is rather simple and was modeled after a tire rim, which can be seen in Figure 7.8. When mounting the substrate, the device is inserted within the cavity of the substrate and the inner tube is inflated. When the inner tube reaches the appropriate pressure, the entire assembly can be lifted and mounted to the drive shaft.

From our force analysis, we were able to determine the pressure [P] needed to spin the substrate based primarily on the torque [T] applied from the motor, the distance from the drive shaft [R], the static coefficient of glass on rubber [μ_{static}], and the inner tube area of contact [A]. It should be noted that we neglected the rotational contribution of the rim to get a conservative estimate on the pressure needed.

Figure 7.14: Representation of Forces on Substrate and Inner Tube

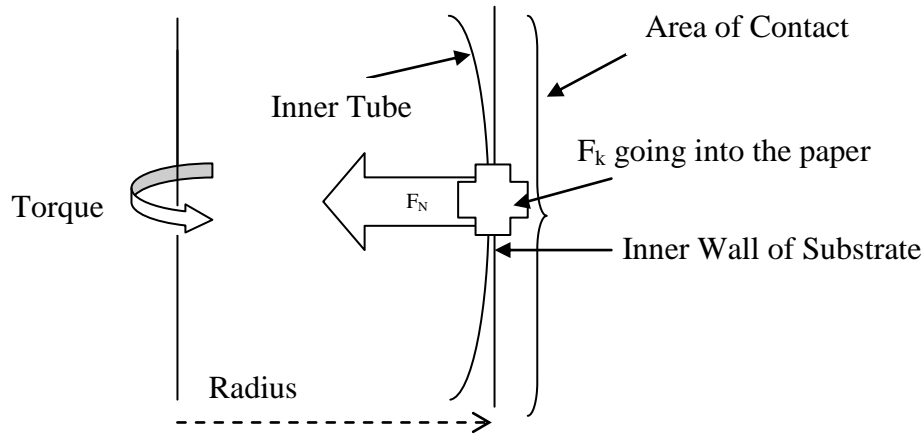

(Eqn. 2)

$$F_{applied} = \frac{T}{R}$$

$$F_{applied} = \frac{15 \text{ oz} \cdot \text{in}}{4.75 \text{ in}} = 3.16 \text{ oz}$$

(Eqn. 3)

$$F_{normal} = \frac{F_{applied}}{\mu_{static}}$$

$$F_{normal} = \frac{3.16 \text{ oz}}{0.87} = 3.63 \text{ oz}$$

(Eqn. 4)

$$P = \frac{F_{normal}}{A}$$

$$P = \frac{3.63 \text{ oz}}{2 * \pi * 120.5 \text{ in} * 3 \text{ in}} = 0.0016 \text{ oz}/\text{in}^2$$

Here, we approximated the contact area between the inner tube and the glass substrate to be the same as the area the inner tube is confined to. This approximation is slightly larger than the actual contact region which gives us a lower estimate for the required pressure.

We also estimated the coefficient of friction using coefficients between similar materials from an engineering data book. When our parts have arrived, we will conduct a simple inclination test to get a more accurate result for the required pressure in the inner tube. The pressure in the inner tube should be equal to the pressure required to inflate the inner tube to contact with the cylinder and the pressure calculated above.

7.3.3 Gear Box

A stepper motor is used to rotate the assembly. The holding torque of the motor is 100 oz.-in. at 450 RPM. However, this application requires much slower speeds. Due to this, a gear reduction system will be used to eliminate any irregularity in the rotational motion caused by running a stepper motor at very slow speeds. An analysis was completed to determine the proper reduction ratio (R) for the motor for a target rotation speed of approximately 6 RPM. To determine the reduced speed of the driveshaft (V_r) this equation was used:

(Eqn. 5)

$$V_r(RPM) = \frac{V_s(RPM)}{R}$$

The original velocity (V_s) was assumed to be 450 RPM (holding torque) because motors tend to run most efficiently near the holding torque speed. A graph reduced speed versus reduction ratio is shown below.

Figure 7.15: Graph Showing Reduction Ratios of 50 to 1 through 75 to 1 Would Achieve the Desired Speed of 6 RPM

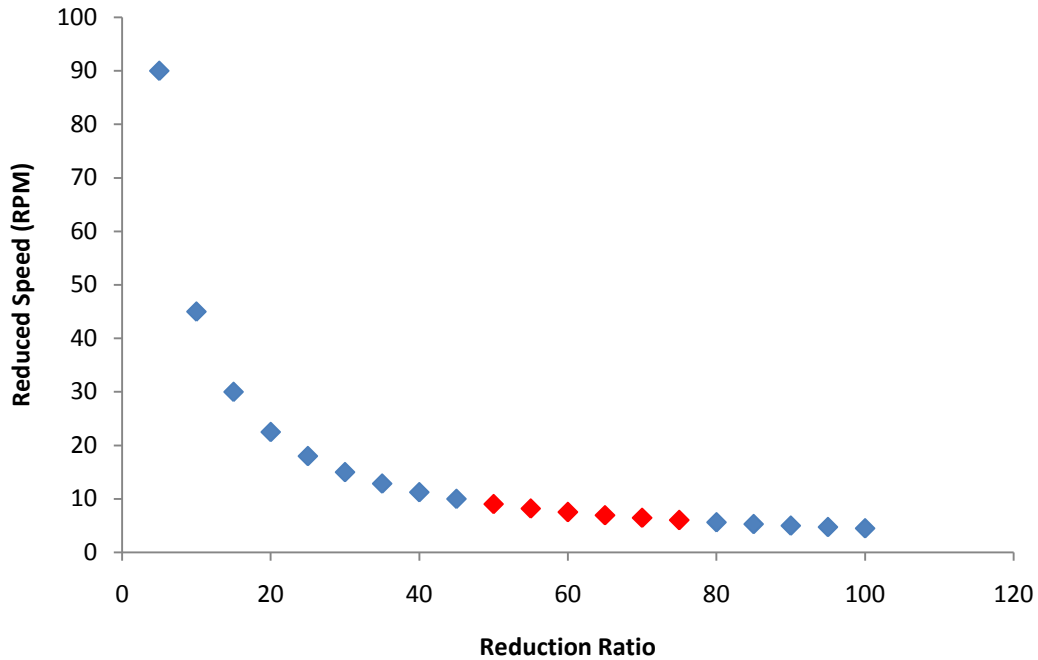

As the graph shows, reduction ratios of 50 to 1 through 75 to 1 would allow the machine to be run at approximately 6 RPM while the motor runs at 450 RPM. This would allow the motor to run efficiently, yet smoothly, while still allowing for sufficient adjustment of roller speed above or below 6 RPM.

7.4 Material Selection

7.4.1 Aluminum

For the inside of the device, we needed a material that could withstand a pH range of 4 to 10 because the parts will be coated with the solution for the entire assembly time. To simplify the machine, we decided to make the device with a minimum amount of materials because the majority of parts will require the same characteristics and the most critical one is the ability to resist acidic and basic solutions.

Because the parts will be machined it should have a moderate Young's modulus so that it can be easily machined but will be able to resist deflection. The mounting plate, for example, should also have moderate yield strength so that it can support the weight without fracture. The constraints on each selection criteria for the material are shown in Table 7.14 below.

Figure 7.16: Selection Criteria Constraints for Metal

Selection Criteria	Constraint
Weak Acid	Good or Very Good
Weak Alkalis	Good or Very Good
Young's Modulus	10.0 – 11.5 x 10 ⁶ psi
Yield Strength	10.0 – 20.0 ksi

Below is a graph from CES of metals that only includes those that have strong resistances to acids and alkalis and represents the metals' yield strength versus Young's modulus (Figure 7.15).

Figure 7.17: Yield Strength vs. Young's Modulus for Very Good Acid Resistance for Metals

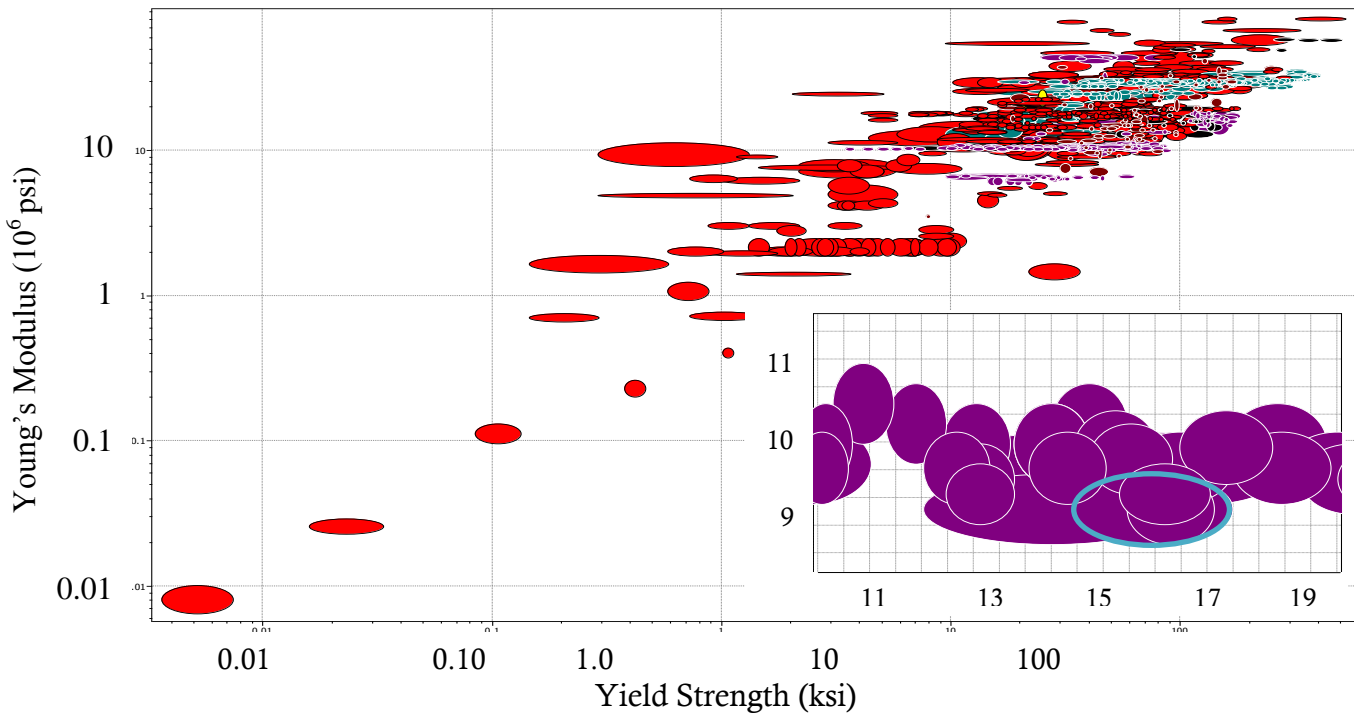

The most common material that fits our constraints is Aluminum. Following the suggestion from Bob Coury, we decided to choose Aluminum 6061 because it was easily weldable and readily available.

7.4.2 Polyethylene

A part that will not be made out of the aluminum is where the roller is held. This part needs to be very flexible so that the roller shaft can snap into place and be held without any other hardware. The constraints for this material can be seen in Table 7.16 below.

Figure 7.18: Selection Criteria Constraints for Polymer

Selection Criteria	Constraint
Weak Acid	Good or Very Good
Weak Alkalis	Good or Very Good
Young's Modulus	$0.08 - 0.16 \times 10^6$ psi
Fracture Toughness	$1 - 6 \text{ ksi} \cdot (\text{in})^{1/2}$

The material needs to have a small Young's modulus so that it can deflect easily. The Fracture toughness also needs to be relatively high so that the material resists the propagation of a crack since it will go under a number of loading cycles from placing and removing the roller. Below is a graph of polymers that only includes those that have strong resistances to acids and alkalis and represents the materials Young's modulus versus Fracture Toughness (Figure 7.16).

Figure 7.19: Young's Modulus vs. Fracture Toughness for Very Good Acid Resistance for Polymers

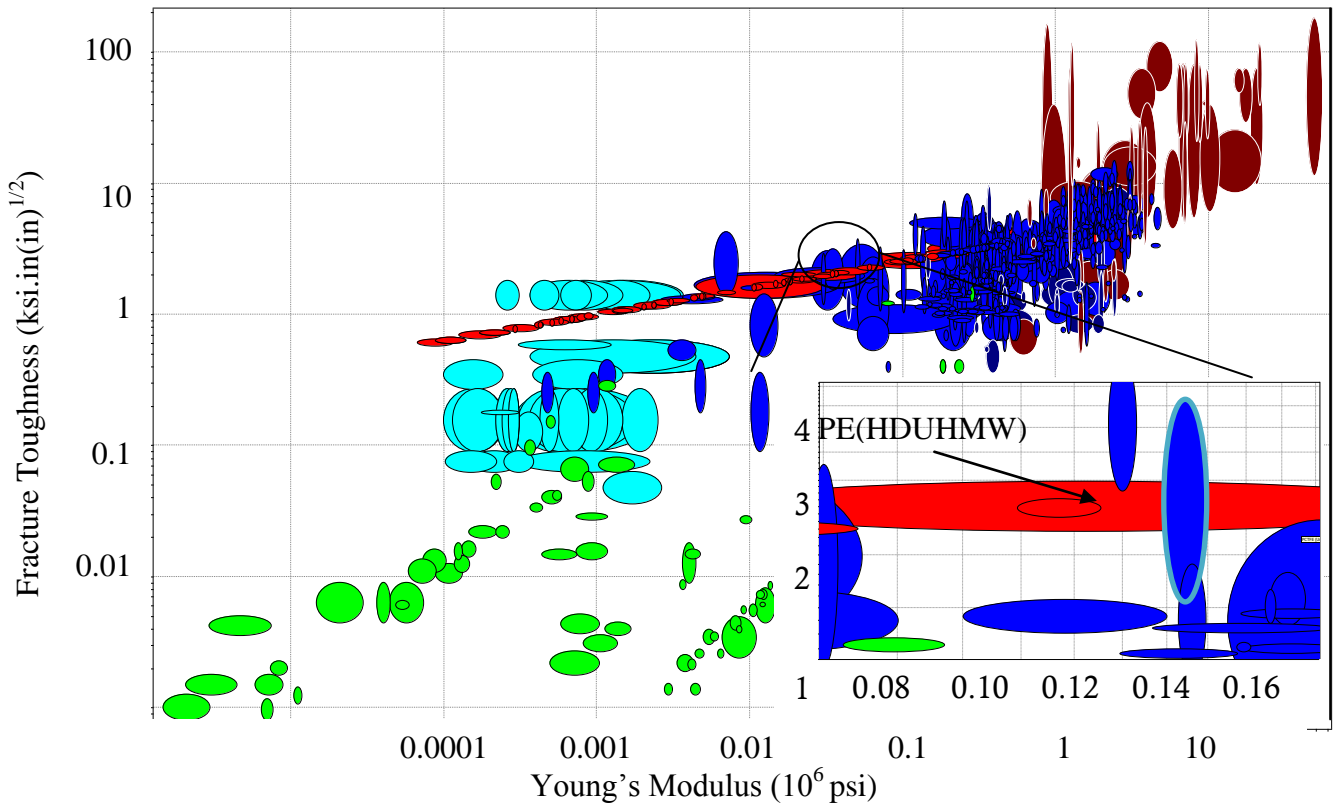

A number of different Polyethylenes fit our constraints. We have chosen Polyethylene (High Density Ultra High Molecular Weight) because it fits our constraints and is readily available.

7.5 Safety/Failure Mode

For our device there are several possible failure modes and a general list is given below in Figure 7.20:

Figure 7.20: List of Possible Failure Modes

Function/Component	Potential Failures	Effects
Supporting Substrate	<ul style="list-style-type: none"> • Lack of friction • Misalignment 	<ul style="list-style-type: none"> • Substrate does not spin correctly • Lack of vertical support causes substrate to fall/break
Holding/Transporting Solutions	<ul style="list-style-type: none"> • Leaking • Corrosion 	<ul style="list-style-type: none"> • Wastes solutions • Damages machine/environment • Hazardous for user
Door	<ul style="list-style-type: none"> • Leaking • Hinge Wear 	<ul style="list-style-type: none"> • Wastes solutions • Difficult to operate device
Roller	<ul style="list-style-type: none"> • Wear • Misalignment • Loose 	<ul style="list-style-type: none"> • Does not apply solutions • Applies solutions unevenly
Air Knife	<ul style="list-style-type: none"> • Misalignment • Deformation 	<ul style="list-style-type: none"> • Does not dry film • Dries unevenly
Water Sprayer	<ul style="list-style-type: none"> • Misalignment • Wear • Clogging 	<ul style="list-style-type: none"> • Irregular water flow • Does not remove excess
Drive Shaft/Bearings	<ul style="list-style-type: none"> • Wear • Fracture 	<ul style="list-style-type: none"> • Transmits power inefficiently • Damages motor • Hazardous for user
Mounting Plate	<ul style="list-style-type: none"> • Misalignment • Deflections • Loose 	<ul style="list-style-type: none"> • Prevents rollers from contacting substrate correctly • Refrains substrate from spinning correctly
Motor	<ul style="list-style-type: none"> • Wear • Burn Out • Jamming 	<ul style="list-style-type: none"> • Cannot spin substrate

Holding the substrate correctly poses our most serious potential failure. The task is to hold a fragile glass substrate and spin it as the rollers apply a solution by contact. The substrate may fall from the grips or may even break during the process. If this occurs, it can cause serious damage to the device because there will be shattered glass within the device. The user will be safe because the glass will be contained within the device. Conducting an FMEA on the device, we will determine the Risk Priority Number (RPN) of the function, which is a numerical product used to prioritize items³. We will take into account the potential severity (S), the possibility of occurrence (O), and the likelihood of detection (D), and then we give them numerical values. We assessed the severity to be pretty tremendous; we gave it a 9 in that the device will become inoperable since the substrate would have broken. The possibility of occurrence is relatively low because of the inner tube that will be inflated to grip the substrate from inside; we assigned it a 2. The likelihood of detection is given a 9 because it will most likely go undetected since the glass

³ Crow, Kenneth. "Failure Modes and Effects Analysis." <http://www.npd-solutions.com/fmea.html>. 2002. Retrieved November 7th, 2008.

is so fragile it can break without any signs of wear or fatigue. These assessments give the function an RPN of 162, see Equation 6 below.

$$\text{RPN} = \text{S} \times \text{O} \times \text{D} \quad (\text{Eq. 6})$$

We then redesigned the way the substrate was held to help reduce this number. Before, our design strictly on the rubber inner tube to hold the substrate vertically, but now we installed a disk that will be attached to the inner rim that holds the inner tube. The diameter of this disk will extend so that the substrate can rest on the disk. This ensures that incase the inner tube fails, the substrate will not fall. This redesign will only affect the occurrence, which will become 1, creating a new RPN of 81.

Another possible failure mode is water removal. Because water is consistently running, we need to ensure that it is removed to avoid it building up. Draining below the substrate has been addressed with the mounting plate and the drip pan below it. The slots used for mounting the rollers will be used as drainage holes for the water, which will then be collected in the drip pan. The bigger issue will be water collecting at the top of the substrate because if it flows over the edge across the film, it will disrupt the uniformity by creating streaks. The issue was addressed with a cap design that will be placed on the substrate. The cap will have holes punched in it that will allow the water to drain falling through the substrate into the drip pan. We assessed the severity of water collecting to be a 6 in that the water will disrupt the film uniformity but the device will still be operable. The possibility of occurrence is expected to be relatively low, assigned a 2, because of the new designs that are installed to address the problems. Because the housing will be constructed using transparent walls, water collecting will easily be seen making it almost certainly detected, giving it a 1. These assessments give the function an RPN of 12.

A safety hazard that has not yet been addressed is the shielding of exposed wiring on the motor. The power supply puts out 40 Volts of electricity to the motor, and if any of the wires get crossed or wet, a dangerous short could cause harm. This is very unlikely, however, because the drip pan collects any excess fluid for disposal and the wiring is tucked deep beneath the assembly.

7.6 Environmental Analysis

An environmental analysis was performed on the usage of the prototype machine. No analysis was done on the manufacturing of a commercial version, since it is currently only going to be used in a research lab setting. Also, many of the environmental factors are variable and won't be determined until testing is done on the finished prototype.

The environmental impact of the LBL assembly machine contains contributions from several different factors. The first and most obvious environmental factor is the water usage. While the machine is operating, a constant flow of water will be streamed over the substrate. This means the water will be running constantly while the machine is on, potentially wasting a significant amount of water and energy. Minimizing the impact of this will consist of positioning the nozzles and adjusting the rotation speed to allow for the lowest water flow rate possible while still achieving an adequate rinse.

Another area of environmental impact is the electricity usage of the machine. Many different components use electricity to run, including the computer, motor, power supply, and peristaltic pumps. Most of these components need to be running the entire time the machine is running as well.

The solutions being used to form the layers could also impact the environment. Many of them are acidic and contain different particles in them that could be harmful to the environment or the operators. To counteract this, the machine is designed to use as little solution as possible. The flow rates can be adjusted to just enough solution is fed through to saturate the foam applicators. Any excess solution falls into a drip pan, where it flows into a disposal container. Also, a cap on top of the roller assembly will prevent any spill over solutions to drop to the table under the machine. The sides and top of the housing are all enclosed by polycarbonate to prevent anything from spraying or spilled out of the housing.

8 Prototype Manufacturing Plan

The rim that will hold the substrate will be made up of two lips, an inner rim with a smaller disk inside, a cap and an inner tube. The cap will be made out of 1/16" 6061-T4 Aluminum sheet that will be bent to form a shape of a pie pan and the holes will then be drilled out of the sheet. The two lips and the smaller disk will be machined out of Aluminum 6061-T4 using a water jet. A polyethylene tube will be purchased to become the inner rim. The smaller disk will be attached to the inside of the inner rim using small screws. The two lips will be attached to the top and bottom of the inner rim using small screws. The inner tube will then slide over the top lip and rest on the inner rim. It can be inflated and will be constrained by the top and bottom lip. The structural tube will mostly be machined in Malaysia from a piece of 4" rod stock of Aluminum 6061-T4. Once the tube arrives, we will finish machining the tube according to the proper dimensions of the bearings since the bearing tolerance will vary. The bearings will then be pressed into the ends of the structural tube. The mounting plate will be made of the same type of Aluminum and will be machined using the water jet. The structural tube will then be bolted directly to the mounting plate. The drive shaft is coupled to the motor and slide through the bearings in the structural tube. Shaft collars are place above and below the structural tube to prevent any axial movement. The drip pan will be constructed out of the 1/16" Aluminum 6061-T4 sheet. The pan will be bent and welded into the desired shape.

The roller mounts will be constructed of several pieces. Soft, rubber rollers will be purchased as the rollers. They will be snapped into place on Polyethylene parts that will be cut to size using a band saw and the mill will be used to drill the desired holes because the tolerance need to be low. The tube that supplies the solution to the foam will be the same bioprene tubing that will deliver the solutions to the roller from the pumps. But this section will have holes that will be drilled. The wall where the spring is attached on the hinged part will be made out of Polyethylene that will be cut to size using a band saw. The 1/4" aluminum parts on the mount will be cut using the mill or the water jet to ensure correct tolerances. The aluminum block the holds the spring will be cut using the mill. The top and bottom aluminum parts and the aluminum block will be drilled and tapped (1/4-20). The slot for the spring will also be drilled and tapped (1/4 -28). The shaft that

holds the torsion string will be purchased and then the top and bottom will be machined so that it can be clipped in place using the purchased clips.

The air knives will be purchased as well as the stay-set tubing to hold it in place. The air knife tubing will come up through the mounting plate. The rigid tubing will be attached to a male through-wall where the tubing from the air-regulator can be attached to the other end. The water nozzles will be attached to 1/4" Acid Resistant Loc-Line tubing that will keep the nozzles in place. The water tubing will come through the mounting plate in a similar fashion to the air line.

The housing will be constructed out of 80/20 aluminum T-slotted profiles, which are Aluminum 6501-T5. We are currently waiting to hear back from the company which is helping us design a housing structure. The modular product is based upon the T-slot concept of their profiles⁴. The shaped slots run along the profile and allow any type of positioning. Once the order is arrived, we will assemble the parts to construct the housing.

Figures 8.1: Dimensioned 80/20 Profile in mm (left) and Example of Profiles Fitting Together (right)

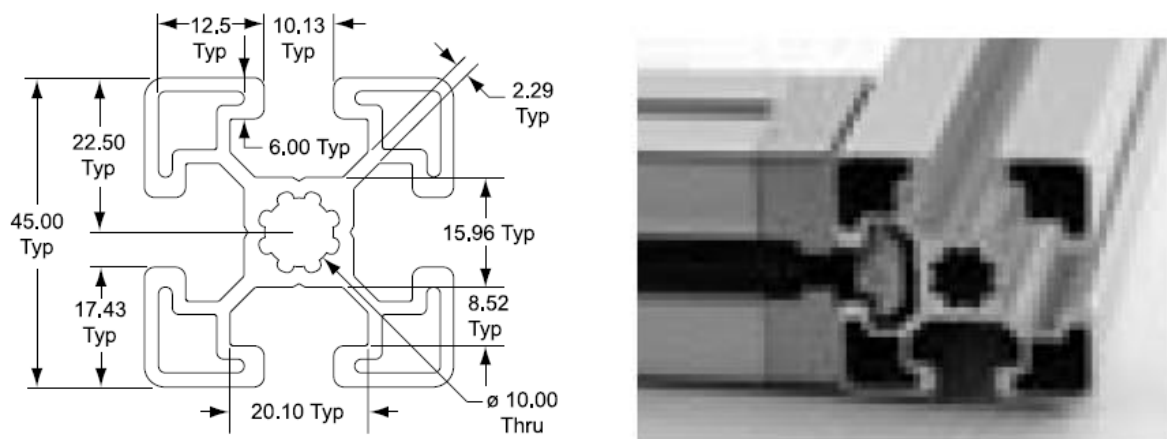

The challenging part of manufacturing will be ensuring the alignments of the machined parts are correct with tight tolerances. Using the water jet will create the biggest challenge because the machine cannot be zeroed and so it will be difficult to create the correct references for it.

9 Usability Analysis

This section contains sets of preliminary instructions for making an LBL film using the machine, as well as performing basic tasks such as cleaning and disassembling the machine. Analyzing the step by step processes needed to operate the machine allowed the design to be tweaked to ensure its overall user friendliness.

⁴ 80/20 Inc. <http://8020.net/>. Retrieved November 9th, 2008.

9.1 Making a Film

1. Fill proper reservoirs with desired solutions/colloids
2. Attach tape to glass cylinder using double-sided tape
3. Place glass cylinder onto mounting wheel by sliding over inner tube
4. Confirm glass cylinder resting on lip of bottom plate and spins true
5. Shim glass cylinder on wheel to prevent any “high spots”
6. Slide mounting wheel assembly over driveshaft
7. Insure correct number and placement of rollers around substrate
8. Release locking loops from rollers to create contact with substrate
9. Direct air nozzles and water nozzles to correct orientation
10. Correctly place partitioning walls between air and rinse sections
11. Using LinControl, turn substrate several cycles to insure proper alignment of components without any fluid flow
12. Make any necessary corrections
13. Turn on peristaltic pumps at correct flow rate setting
14. Spin rollers by hand several cycles to get initial solution coating
15. Close assembly lid
16. Start cylinder rotation in LinControl at desired speed
17. After assembly is complete, open lid and insure everything is turned off
18. Pull back rollers and lock in place
19. Carefully lift cylinder assembly off of driveshaft
20. Remove tape from cylinder

9.2 Machine Maintenance

1. Removing rollers:

- a. Verify all machine components are turned off
- b. Verify all rollers are pulled away from substrate and locked
- c. Lift substrate assembly off of driveshaft
- d. Unbolt roller assemblies from underneath mounting plate (two bolts per assembly)
- e. Remove roller assemblies

2. Remove mount plate:

- a. Verify all machine components are turned off
- b. Remove substrate assembly and all rollers from mount plate
- c. Loosen and remove upper shaft collar from driveshaft
- d. Unbolt structural tube from mount plate
- e. Remove structure tube by sliding tube upwards along driveshaft
- f. Unbolt mount plate from housing
- g. Lift mount plate from housing

3. Cleaning drip plate:

- a. Verify the all machine components are turned off
- b. Carefully slide drip plate out from housing
- c. Pour all excess liquid from drip plate into waste bucket
- d. Clean and dry drip plate
- e. Slide drip plate back into position in housing

10 Validation Plan

In order to validate the correct operation of the machine, several different tests will be performed after assembly to make sure that it conforms to the customer requirements and engineering specifications. This includes testing the basic operation of the machine, cycle time (rotation > 0.625 RPM), film assembly time (300 bilayers, time < 8 hours), film size (film > 50 cm²), film uniformity, and versatility of the machine.

10.1 Basic Operation

Testing the basic operation of the machine is simply confirming that it will do what is intended, which is assembling an LBL film. To test this, the machine will be properly set up as if under normal operating conditions. The machine will then be run very slowly to provide more than required time for rinsing and drying. While it is running, we will visually confirm the following: even and complete solution deposition on the rollers and substrate, rinse stream flowing over entire assembly area on substrate, air nozzles removing all moisture from side of substrate, and bi-layers assemble properly during operation.

Many adjustments can be made for this if any of the criteria are not met. If the solutions are not deposited completely onto the substrate and rollers, the flow rate from the peristaltic pumps can be changed or a different type of foam can be attached to the feed tube. If the rinsing or drying cycles are inadequate or excessive, the water or air flow rates can be changed, or the number and position of nozzles could be changed. An air compressor can also be added to increase the air flow for drying. If the bi-layers don't assemble properly, the water and air flow rates could be decreased and the solution flow rates, rotation speeds, and roller forces could be adjusted.

10.2 Cycle Time

Proper validation of the machine requires confirming that it can complete a single cycle (one bi-layer) in a set amount of time. The total time for 300 bi-layers must be less than 8 hours, which means a single cycle should take less than 1.6 minutes (or greater than .625 RPM). To test this, the machine will be set up and run as normal. The rotation speed will then be adjusted until the maximum speed is reached that still achieves complete drying, since drying time will be the limiting aspect. Once this speed is reached, a point on the cylinder will be marked and a single revolution will be timed, and it should be less than 1.6 minutes.

If the cycle time requirement is not met, several changes can be made to achieve it. The maximum speed can be increased by repositioning the air or water nozzles or adding more nozzles. We can also reduce the solution flow rate to deposit less material onto the substrate.

10.3 Assembly Time

The total time to assemble a film must also be validated, even if the single cycle time is met since the speed required for a single cycle may not be correct for a film consisting of 300 bilayers. To test this, the machine will be run with the same settings and speed that were used for the single cycle test. After 300 cycles, the final film will be visually inspected for complete coverage. The time required for 300 cycles must be less than eight hours.

If the assembly time is too long, adjustments can be made which are similar to the adjustments for the single cycle time. These include increasing the speed by reducing the solution flow rates or increasing the air and water flows.

10.4 Film Size

The overall size of the film must meet the engineering specifications of greater than 50 cm² to exceed the size of the films made by the Spin Grower. This will be validated by measuring the size of the complete film after assembly. Due to the sheer size of the machine, this specification should be easily met. However, if the size is inadequate, the rotation speed and flow rates could be adjusted to utilize the maximum amount of substrate surface area.

10.5 Film Uniformity

In order to be usable for future research, the assembled films must be uniform in thickness. To measure the uniformity, the thickness of a complete film will be measured using ellipsometry. Measurements will be taken at several points on the film for comparison varying the location in both the vertical and horizontal directions. The standard deviation of the measurements taken will be compared to that of the bench level testing performed earlier in the lab of ± 0.9 nm to determine if the film is acceptable.

If the film is not uniform enough, the machine will be tweaked to increase uniformity. The force of the roller on the substrate would be adjusted using the torsion spring screw and adjusting the position of the roller assembly on the mounting plate. Also, the rotation speed could be adjusted assuming it would still fit the time requirements. The solution deposition could be changed by adjusting the flow rate or using a different roller material.

10.6 Versatility

Validation of the versatility of the machine is simply confirming that the machine will assemble films in a variety of configurations. This will be tested by first moving the rollers to different

locations, and running the machine for approximately twenty cycles. The cycle and assembly times will be checked to ensure they are still acceptable. The film will then be visually inspected for completeness and size. The uniformity will also be checked using ellipsometry. Finally, the tests will be run again using different numbers of rollers.

11 Risks and Counter Risks

A manufacturing challenge will be creating a structural tube with a perfectly flat bottom that can be attached perpendicularly to the mounting plate. The solution is to send the piece to be machined in Malaysia. A major manufacturing risk will be ensuring proper alignment across the device. If there is misalignment in the mounting plate for example, the roller will not create the proper contact against the substrate, creating uneven films. For misalignments, our counter measure will be to replace the rollers with sprayers. Another risk will be rotation speed of the substrate. The motor may be too powerful and spin the substrate faster than the rollers can apply an even layer. A solution to this issue would be to install gears that reduce the rotation speed of the substrate. The flow rates of the solution will pose another risk. If the flow rates of the solution are not high enough, then the rollers won't be able to apply an even layer, but if the flow rates are too high, then there may be too much excess solution that collects within the device. To counteract an excessive flow rate, a pump can be installed into the drip pan to help remove the excess solution. The flow rate of the water is also an issue that can be solved in the lab. The flow rate has to be adjusted that the film is properly rinsed without wasting a great deal of water.

Appendix B: Engineering Drawings

Figure B.1: Arm Mount (Roller Assembly)

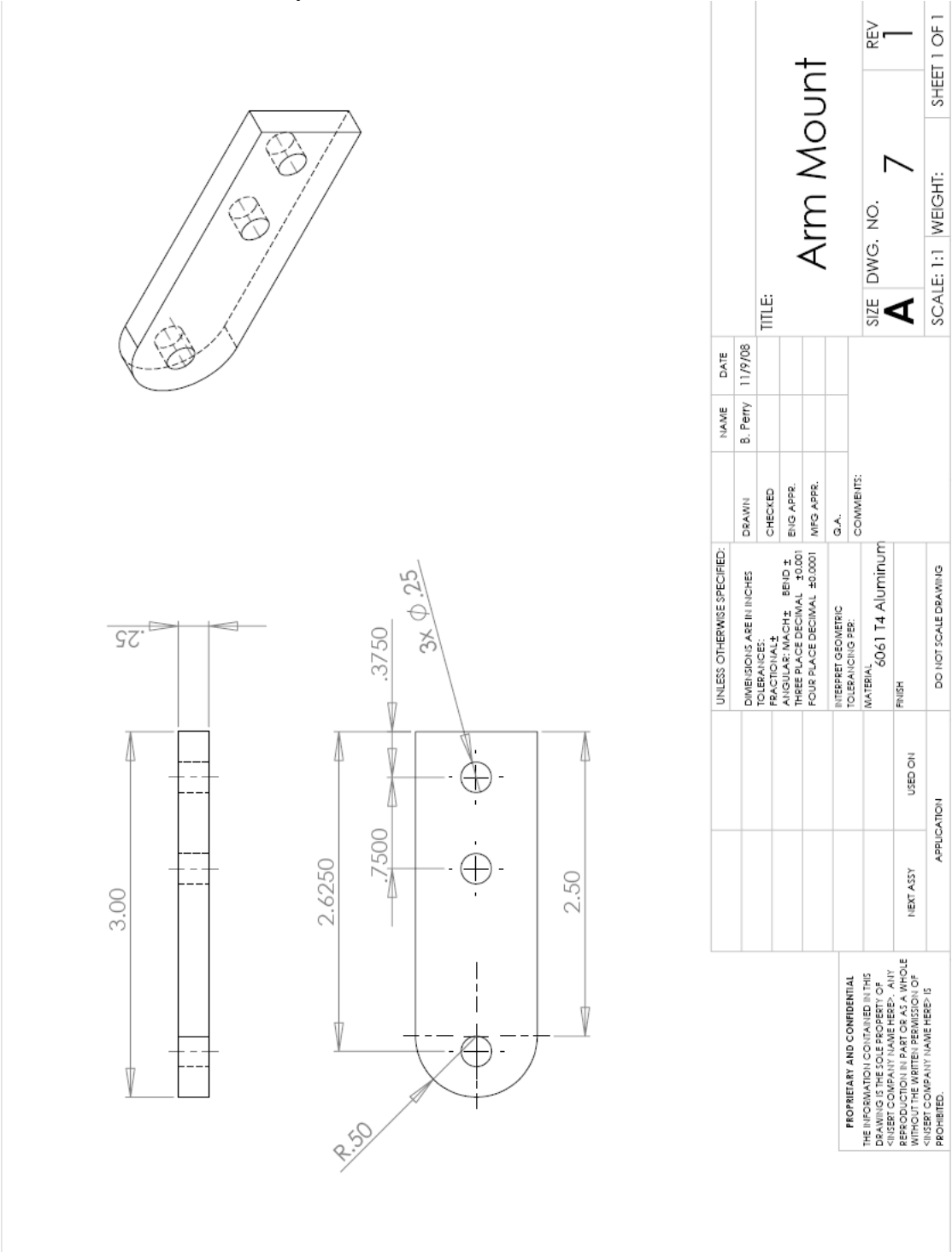

Figure B.2: Mount Block (Roller Assembly)

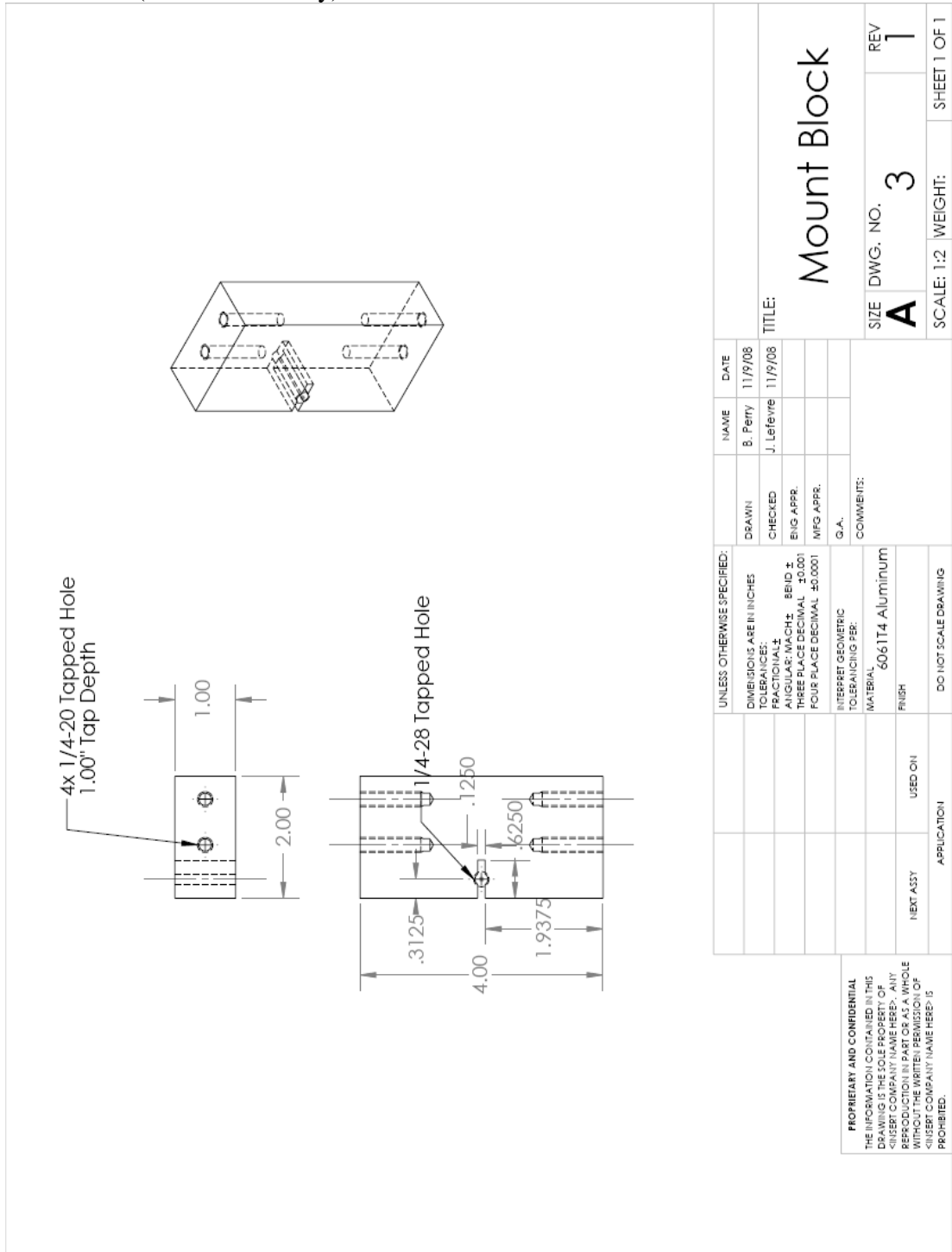

Figure B.3: Arm Mount Spacer (Roller Assembly)

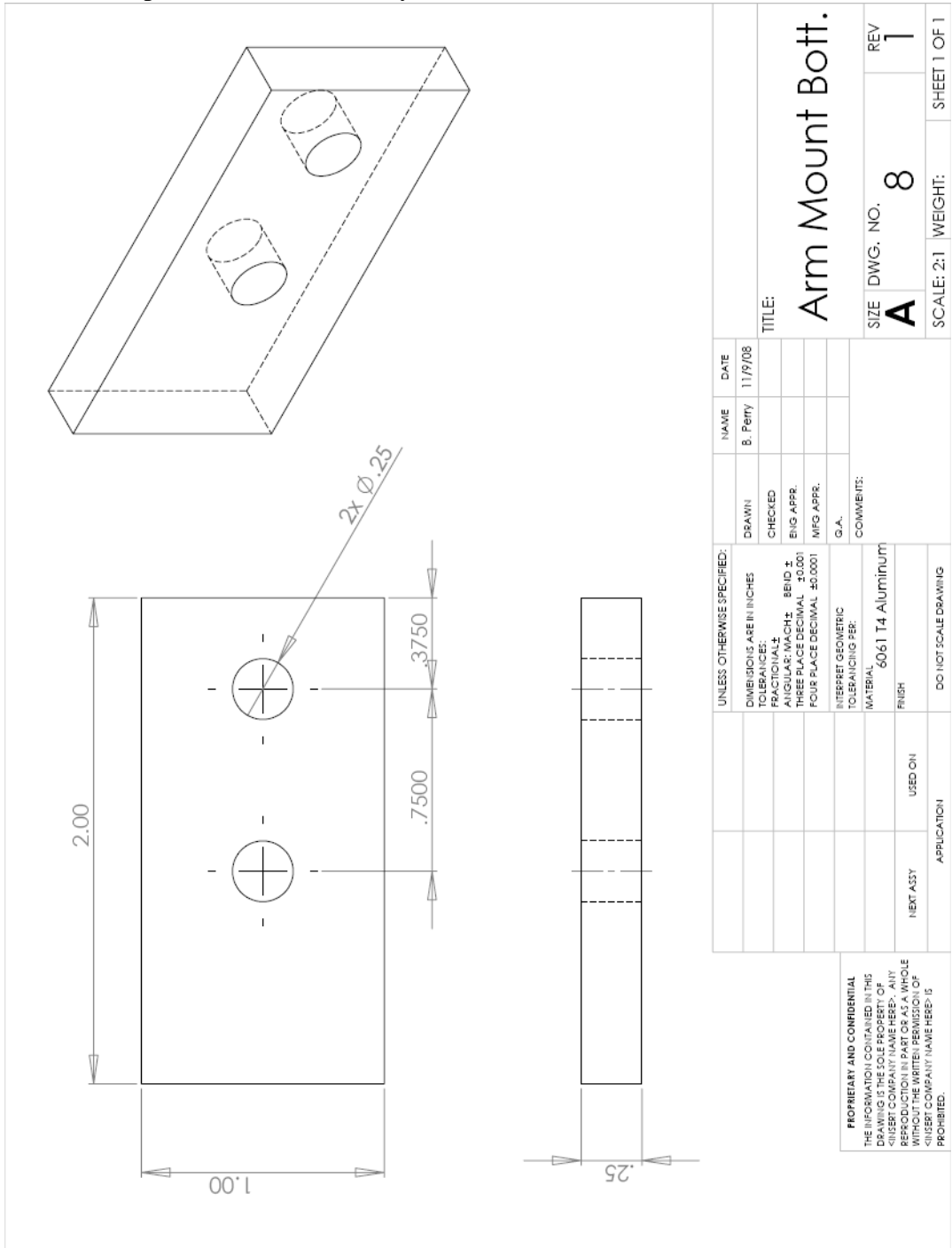
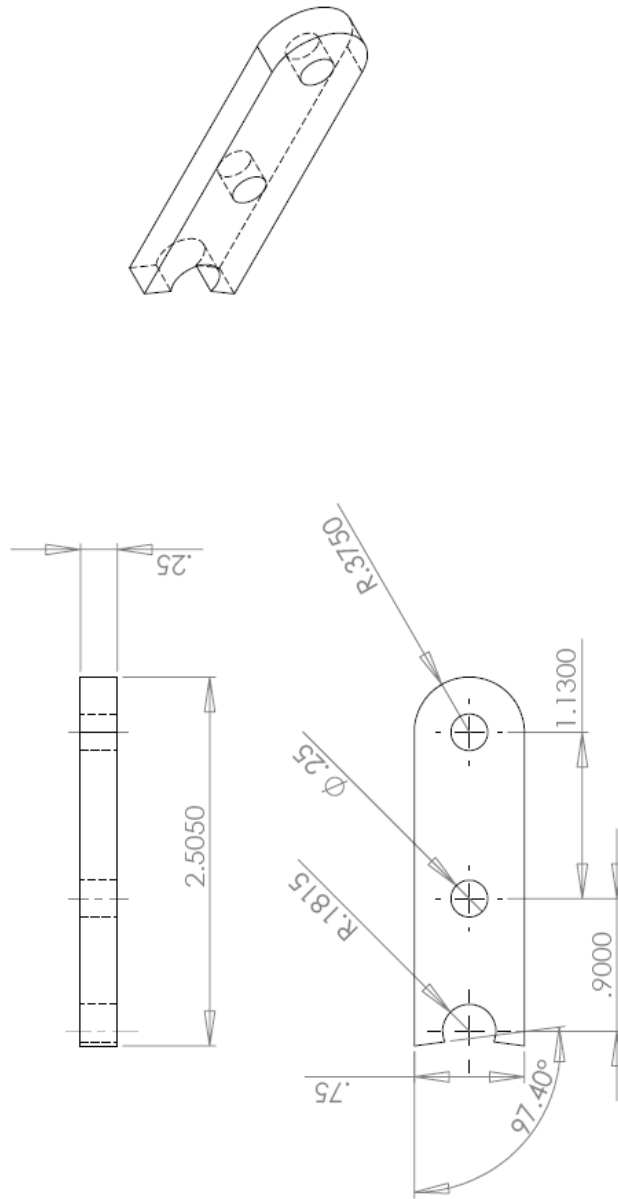

Figure B.6: Roller Arm (Roller Assembly)



UNLESS OTHERWISE SPECIFIED:		NAME	DATE
DIMENSIONS ARE IN INCHES	DRAWN	B. Peiry	11/9/08
TOLERANCES:	CHECKED		
FRACTIONAL ±	ENG APPR.		
ANGULAR: MACH ±	MFG APPR.		
THREE PLACE DECIMAL ±0.001	G.A.		
FOUR PLACE DECIMAL ±0.0001	COMMENTS:		
INTERPRET GEOMETRIC TOLERANCING PER:	MATERIAL		
	FINISH		
	DO NOT SCALE DRAWING		
	APPLICATION		
	USED ON:		
	NEW ASSY		

<p>PROPRIETARY AND CONFIDENTIAL THE INFORMATION CONTAINED IN THIS DRAWING IS THE SOLE PROPERTY OF <INSERT COMPANY NAME HERE>. ANY REPRODUCTION IN PART OR AS A WHOLE WITHOUT THE WRITTEN PERMISSION OF <INSERT COMPANY NAME HERE> IS PROHIBITED.</p>			
TITLE:		Roller Arm	
SIZE	DWG. NO.	REV	
A	6	1	
SCALE: 1:1	WEIGHT:	SHEET 1 OF 1	

Figure B.7: Structural Tube

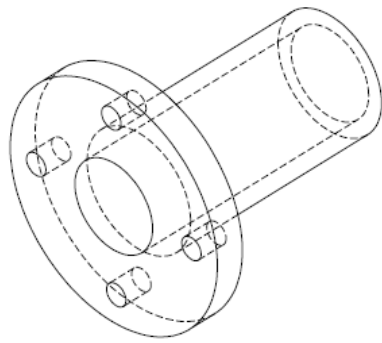
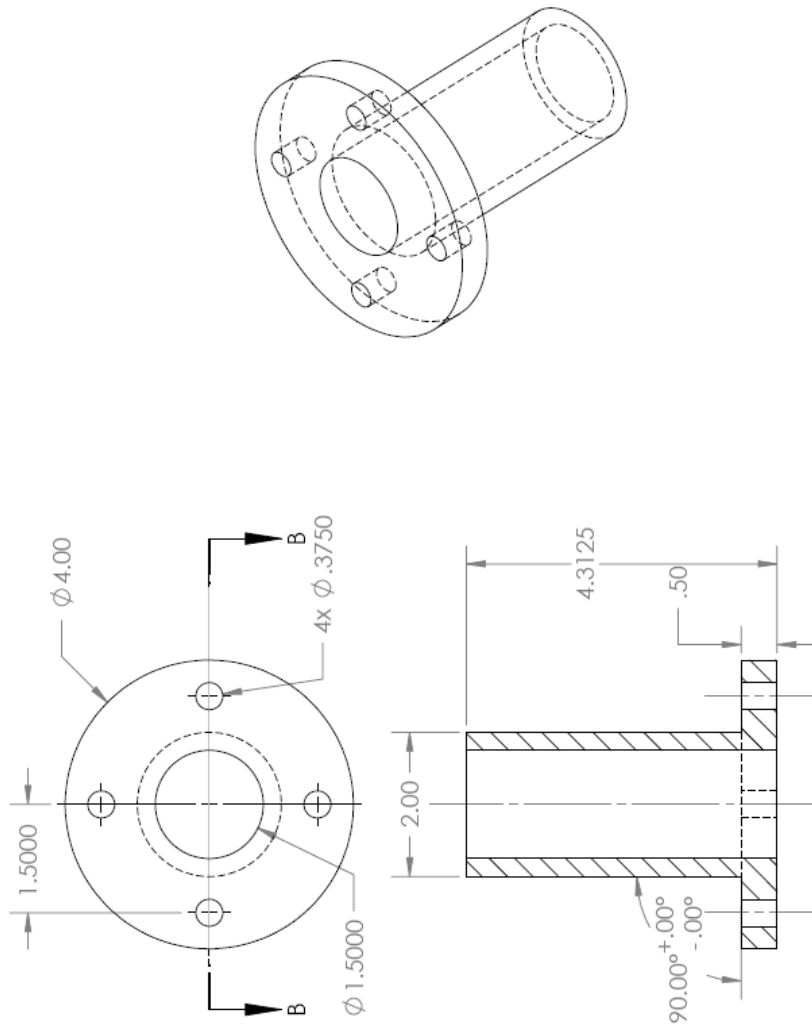

UNLESS OTHERWISE SPECIFIED:		NAME	DATE
DIMENSIONS ARE IN INCHES		B. Perry	11/9/08
TOLERANCES:		J. Lefevre	11/9/08
FRACTIONAL: \pm			
DECIMAL: \pm			
ANGULAR: MACH: BEND \pm			
THREE PLACE DECIMAL: ± 0.001			
FOUR PLACE DECIMAL: ± 0.0001			
INTERPRET GEOMETRIC TOLERANCING PER:			
MATERIAL:		Machine from 4" Rod Stock	
FINISH:			
HEAT ASY			
APPLICATION			
DO NOT SCALE DRAWING			

PROPRIETARY AND CONFIDENTIAL THE INFORMATION CONTAINED IN THIS DRAWING IS THE SOLE PROPERTY OF SIMBERT COMPANY. ANY REPRODUCTION OR TRANSMISSION OF THIS DRAWING WITHOUT THE WRITTEN PERMISSION OF SIMBERT COMPANY IS PROHIBITED.			
SIZE	DWG. NO.	REV	
A	1	1	
TITLE:			SHEET 1 OF 1
Structure Tube			
SCALE:	1:2	WEIGHT:	

Appendix C: Bill of Materials

Item	Supplier	Lead Time	Description	Qty	Unit	Unit Price	Total Price
Substrate							
Quartz substrate	United Silica	5 day	241 X 251 X 150mm	1	ea	\$380.00	\$380.00
Rim Top	Alro Metals	next day	12"*12"*1/4" 6061 T4 aluminum	1	ea	\$20.00	\$20.00
Rim Bottom	Alro Metals	next day	12"*12"*1/4" 6061 T4 aluminum	1	ea	\$20.00	\$20.00
Rubber inner tube	McMaster-Carr	next day	for 6" Rim	2	ea	\$6.65	\$13.30
Plate assembly							
Thrust Bearings	McMaster-Carr	next day	5/8" Shaft Tapered Bearing	1	ea	\$24.18	\$24.18
Thrust Bearing outer ring	McMaster-Carr	next day	Outer ring for thrust bearing	1	ea	\$9.87	\$9.87
Shielded Ball Bearings	McMaster-Carr	next day	5/8" Shaft Roller Bearing	1	ea	\$9.73	\$9.73
Two piece clamp on shaft collar	McMaster-Carr	next day	5/8" Shaft collars	2	ea	\$6.22	\$12.44
5/8" D-Profile Steel Shaft	McMaster-Carr	next day	Driveshaft	1	ea	\$16.27	\$16.27
3/8-24 nuts	McMaster-Carr	next day	Structure tube mounting	1	pack	\$12.79	\$12.79
3/8-24 Cap Screw	McMaster-Carr	next day	Structure tube mounting	1	pack	\$9.39	\$9.39
Coupling Hubs	McMaster-Carr	next day	5/8" Bore Diameter, Stainless St.	1	ea	38.14	\$38.14
Coupling Hubs	McMaster-Carr	next day	1/2" Bore Diameter, Stainless St.	1	ea	38.14	\$38.14
Solid Spider	McMaster-Carr	next day	Size D	1	ea	10.09	\$10.09
SilverPak 23CE, Integrated Motor	Lin Engineering	1-2 weeks	CE-5718X-01P	1	ea	\$304.00	\$304.00
SilverPak USB Designer's Kit	Lin Engineering	1-2 weeks	USB485 Designer's Kit	1	ea	\$99.00	\$99.00
CGI Planetary Gear Box	CGI	1-2 weeks	NEMA 23 70:1	1	ea	\$625.00	\$625.00
Aluminum Plate	Alro Metals	next day	36"*36"*1/4" 6061 T4 Alum.	1	ea	\$100.00	\$100.00
Structural Tube		2 weeks	Machined in Malaysia	1	ea	\$150.00	\$150.00
40V DC Power Supply	Acopian	3-5 days	W40FT300 Switching Regulated	1	ea	\$225.00	\$225.00
Drip Plate							
Aluminum sheet 6061	Alro Metals	next day	14 Gauge 6061 T4 Alum. 48"x48"	1	ea	\$100.00	\$100.00
Durable PVC Through Wall	McMaster-Carr	next day	1/2" Tube ID	1	ea	\$12.78	\$12.78
PVDF Single Barbed Tube fitting	McMaster-Carr	next day	1/2" ID X 1/2" OD	1	ea	\$2.86	\$2.86
Polyethylene Tubing	McMaster-Carr	next day	1/2" ID	10	ft	\$0.76	\$7.60
Air Knives							
2" Air Nozzle	Exair	2-3 day	with 12" Stay-Set Hose	4	ea	\$82.00	\$328.00
Regulator mounting bracket	McMaster-Carr	next day		2	ea	\$5.01	\$10.02
Air Pressure Regulator	McMaster-Carr	next day	1/4" NPT	2	ea	\$29.15	\$58.30
Aluminum Pipe Tee	McMaster-Carr	next day	1/4" NPT	2	ea	\$4.84	\$9.68
Pipe to Tube Male Adapter	McMaster-Carr	next day	1/4" ID, 1/4" NPT	4	ea	\$3.46	\$13.84
Pipe to Tube Female Adapter	McMaster-Carr	next day	1/4" ID, 1/4" NPT	4	ea	\$3.73	\$14.92

Water nozzle							
1/4" Acid Res. Segment(2)	Modular Hose	2-3 day		3	pack	\$6.62	\$19.86
1/4" Acid Res. Swivel Nozzle 40 (2)	Modular Hose	2-3 day		2	pack	\$10.50	\$21.00
1/4" Acid Res. Y Fitting (2)	Modular Hose	2-3 day		1	pack	\$7.35	\$7.35
1/4" Acid Res. NPT Connector (4)	Modular Hose	2-3 day		1	pack	\$4.90	\$4.90
1/4" Hose Assembly Pliers	Modular Hose	2-3 day		1	ea	\$9.86	\$9.86
Ultra-Clear Tygon PVC Tubing	McMaster-Carr	next day	1/4" ID	40	ft	\$1.32	\$52.80
Barbed Reducer Coupling	McMaster-Carr	next day	1/4" to 3/8"	4	ea	\$2.31	\$9.24
Aluminum Nipple	McMaster-Carr	next day	1/4" NPT	2	ea	1.29	\$2.58
Roller Assembly							
1/4-20 x 1" Bolt	McMaster-Carr	next day		1	pack	\$11.54	\$11.54
1/4-20 x 1.5" Bolt	McMaster-Carr	next day		2	pack	\$8.35	\$16.70
Speedball replacement roller	Speedball	Local	4" soft rubber roller replacement	6	each	\$8.00	\$48.00
6061 T4 Aluminum	Alro Metals	next day	sheet .25"*12"*12 "	1	ea	\$25.00	\$25.00
180 Deg Torsion Spring	McMaster-Carr	next day	.404" Coil OD,.048" Wire, Cw/Lh	8	ea	\$5.68	\$45.44
6061 T4 Aluminum	Alro Metals	next day		1	ea	\$30.54	\$30.54
.25" Stainless steel shaft 36" long	McMaster-Carr	next day	Roller arm mount shafts	1	ea	\$24.76	\$24.76
Shaft Clip	McMaster-Carr	next day	Roller arm mount shaft clips	1	pack	\$7.00	\$7.00
Spring Adjusting Cap Screw	McMaster-Carr	next day	1/4"-28 Thread, 1" Length	1	pack	\$8.72	\$8.72
Fluid Delivery System							
Hose Clamps	McMaster-Carr	next day	5/16" Band Width	1	pack	\$5.80	\$5.80
Hose-Tube Connector	McMaster-Carr	next day	hose to tube connector	1	pack	\$5.34	\$5.34
High Pressure Peristaltic Pump	McMaster-Carr	next day	Stenner 85MPH40	2	ea	395.06	\$790.12
High Viscosity Peristaltic Pump	McMaster-Carr	next day	Anko Series 4000	2	ea	566.04	\$1,132.08
High-Flex White PVC Tubing			3/16" ID, 5/16" OD	20	ft	0.34	\$6.80
Frame Materials							
80/20 Aluminum Housing	Midwest Fluid Power	1-2 weeks		1	ea	\$1,311.00	\$1,311.00
Misc.							
Power Strip		none		1	ea	\$7.99	\$7.99
Cellulose Acetate Film		none	26" x 12' x .007" thick	1	ea	\$22.99	\$22.99
						TOTAL:	\$6,302.75

Appendix D: Component Specifications

Figure D.1: Electrical and Operating Specs for Lin Engineering SilverPak 23CE

2. ELECTRICAL SPECIFICATIONS

Supply Voltage: +12 to +40 VDC
Peak Current: 0.3 to 3.0 Amps

Digital I/O Specifications

Number of I/O 4
Number of Inputs 2
Input Voltage +0 VDC to +5 VDC (0 to 24V tolerant, but 5V recommended)
Input Current 700 mA
Pull-up Resistors 20k Ω
Protection Static Protection to the microprocessor

Motor Specifications

Any 5718 series step motor that is rated at 3.0 Amps/Phase or less can be combined into a Silverpak 23C or CE product. General torque specifications are listed below:

Holding Torque (max of 1.5 Amp Holding Current, winding specific)
CO-5718S 50 to 100 oz-in
CO-5718M 86 to 170 oz-in
CO-5718L 140 to 294 oz-in

Steps per Revolution: 400, 800, 1600, 3200, 6400, 12800, 25600, 51200

3. OPERATING SPECIFICATIONS

Maximum Step Frequency 2[^]24 (pps) or 16.7MHz
Operating Temperature Range 0° to 50° C
Storage Temperature Range -20° to 70° C

Communication Specifications

Interface Type RS485 (RS232 or USB with a converter card)
Baud Rate 9600*, 19200, or 38400 bps
Bits per character 8 Data
Parity None
Stop Bit 1
Flow Control None
*default

Figure D.2: Mechanical Specs of Lin Engineering SilverPak 23CE

4. MECHANICAL SPECIFICATIONS

Dimensions

A. Overall Body Length

Motor body length is available in various lengths

Model 5718X (3.41")

Model 5718M (3.85")

Model 5718L (4.78")

B. Motor Front Shaft Extension Length

Standard length is 0.81". Customized length is available.

C. Motor Shaft Diameter

Standard shaft diameter is 0.2500". Customized diameter length is also available.

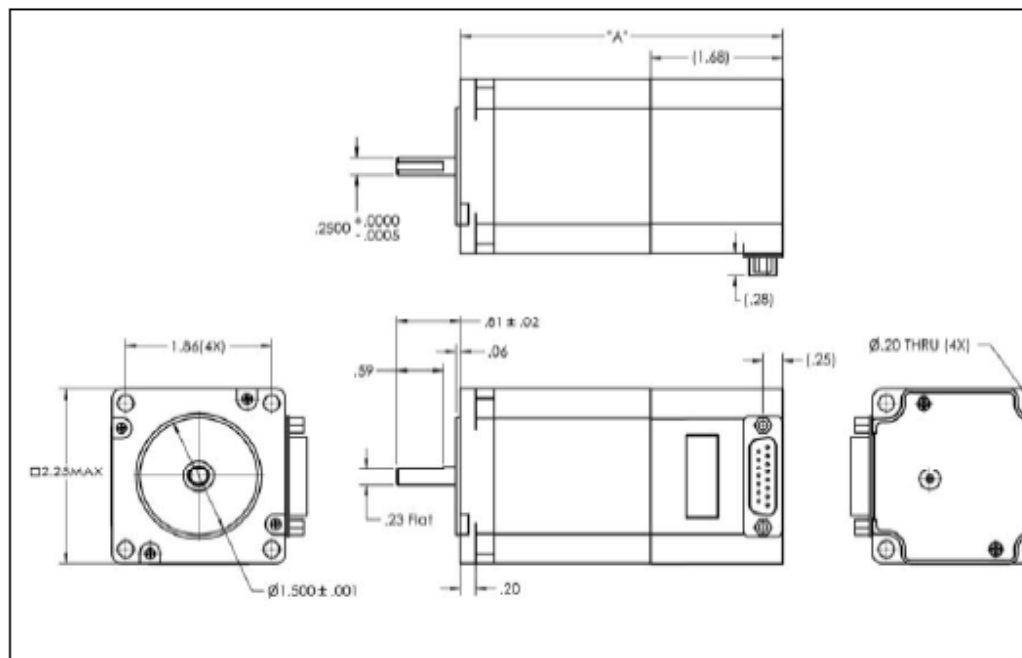



Figure 1: Dimensions

Figure D.3: Specs for Stenner 85MHP40 Peristaltic Pump

Product	Technical	Company
Product Line Markets & Applications	Support Specifications	Profile Stenner Advantages
<p>85MHP40 Specifications Summary</p> <p>100 psi (6.9 bar) Single Head Adjustable Output Pump max 40 gpd (151 lpd)</p>		
<p>Outputs @ 60Hz Gallons per day: 2.0 to 40.0 Gallons per hour: 0.08 to 1.67 Liters per day: 7.6 to 151.4 Liters per hour: 0.32 to 6.31 Ounces per minute: 0.18 to 3.55 Milliliter per minute: 5.27 to 105.14</p> <p>Outputs @ 50Hz Liters per day: 6.1 to 121.1 Liters per hour: 0.25 to 5.05 Milliliters per minute: 4.24 to 84.10</p>	<p>Discharge Pressure 26-100 psi (1.7-6.9 bar)</p> <p>Voltage 120V 60Hz; 220V 60Hz 230V 50Hz; 250V 50Hz International</p> <p>Motor shaded pole; 44 rpm; 1/30 HP</p> <p>Suction Lift 25' (7.6 m)</p> <p>Maximum Operating Temperature 125° F (52° C)</p> <p>Amp Draw 1.7 120V; 0.9 220V, 230V, 250V</p> <p>Dimensions (l x w x h) 10.6 x 5.3 x 6.0 in (26.9 x 13.4 x 15.2 cm)</p> <p>Shipping Weight 9 lbs (4 kg)</p>	<p>Materials of Construction All Housings: Lexan® polycarbonate plastic Pump tube & check valve duckbill: Santoprene® FDA approved Suction/discharge tubing & ferrules (1/4" & 6 mm): LDPE polyethylene, NSF/FDA approved Tube fittings, connecting nuts, check valve fitting, weighted strainer: Type 1 Rigid PVC-NSF listed All fasteners: Stainless Steel Lexan® is a registered trademark of General Electric. Santoprene® is a registered trademark of Advanced Elastomer system Refer to the chemical resistance guide for pump tube material, PVC, LDPE compatibility</p> <p>Agency listings UL, CSA, CE, NSF-50, NSF-61</p> <p>Accessories shipped with each pump 3 connecting nuts 1/4" or 3/8" 3 ferrules 1/4" & 6 mm OR 2 ferrules 3/8" 1 injection check valve 1 weighted strainer 1 20' roll of suction/discharge tubing 1/4" or 3/8" white or UV black OR 6 mm (Europe) white 1 spare pump tube 1 mounting bracket 1 installation manual</p>
		
<p>STENNER PUMP COMPANY Jacksonville, FL U.S.A. 800.683.2378 804.841.1666 Copyright © 2007-2008 Stenner Pump Company. All Rights Reserved.</p>		
		<p>Information Download</p> <p>Contact Us</p>

<http://www.stenner.com/specs-85mhp40-summary.htm>

Figure D.4: Specs for Anko Series 4000 Peristaltic Pump



ABOUT ANKO \ APPLICATIONS \ PUMPS \ MOTORS \ FIND-A-REP \ CONTACT US



PERISTALTIC PUMPS

OUR PUMPS MOVE MATERIALS CLEANLY, EFFICIENTLY, QUIETLY AND COST EFFECTIVELY.

SERIES 4000

4000-Variable Speed-Features

ELECTRICAL:	115 VAC / 60 Hz. CW/OFF/CCW switch. 6' power cord.
FLOW RATE:	Variable up to 2,000 ml/min. (78.6 oz).
MOUNTING:	Thermofil plastic case. Flanges.
DIMENSIONS:	6.2 W X 7.3 H X 10.3 D
SHIPPING WEIGHT:	6.8 lbs.

SCHEMATIC
A
B
C

WARNING
Anko Products assumes no responsibility or liability for chemical compatibility of our tubing or pumps in specific applications. ALWAYS pretest tubing in accordance with tubing manufacturers specifications. Tubing that shows signs of swelling, embrittlement or other deterioration should NOT be used.

LIMITED WARRANTY
See the complete limited warranty for each model, incorporated into each packing list and invoice. The full text of the written warranty can be obtained free upon written request.

<http://www.ankoproducts.com/pumpdetail.asp?ID=15>

Figure D.5: Spec Sheet for CGI Paragon Gear head

PN SERIES: PARAGON™ PLANETARY GEARHEADS

SINGLE, DOUBLE, TRIPLE STAGE PRECISION GEARHEADS

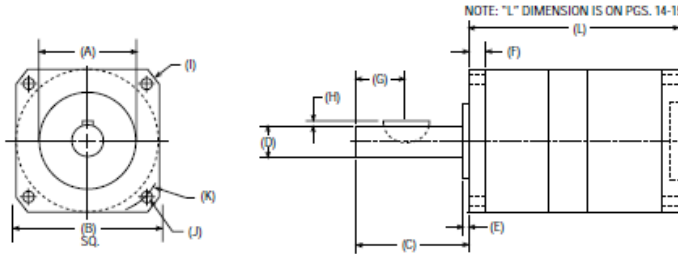

PART NUMBER	A PILOT DIAMETER (in.)	B SQUARE FLANGE (in.)	C SHAFT LENGTH (in.)	D SHAFT DIAMETER (in.)	E PILOT LENGTH (in.)	F FLANGE THICKNESS (in.)	G KEY LOCATION (in.)
017PNX	.864/.866	1.65	1.25	.4995/.5000	0.062	0.187	0.56
023PNX	1.498/1.500	2.25	1.25	.4995/.5000	0.062	0.250	0.56
034PNX	2.873/2.875	3.25	1.50	.7495/.7500	0.062	0.375	0.56
042PNX	2.185/2.187	4.20	2.00	.9995/1.0000	0.062	0.500	0.63
056PNX	4.498/4.500	5.75	2.50	1.4995/1.5000	0.125	0.750	0.94
075PNX	5.998/6.000	7.48	3.50	1.9995/2.0000	0.187	0.875	3.00 Lg

PART NUMBER	H KEY HEIGHT (in.)	I HOUSING DIAMETER (in.)	J BOLT HOLE DIAMETER (in.)	K BOLT HOLE CIRCLE (in.)	KEY WIDTH/ WOODRUFF KEY (in.)	RADIAL & AXIAL SHAFT LOADING (LBS.)
017PNX	0.063	2.05	0.125	1.725	0.125 / #404	SEE PAGE 17
023PNX	0.063	2.95	0.205	2.625	0.125 / #404	
034PNX	0.094	4.38	0.220	3.875	0.187 / #606	
042PNX	0.125	5.51	0.280	4.950	0.250 / #808	
056PNX	0.187	7.87	0.410	7.000	0.375 / #1212	
075PNX	0.157	9.64	0.560	8.465	3/8" x 5/8" RECT.	

AVAILABLE RATIOS	EFFICIENCY	SPECIFICATIONS
SINGLE STAGE : 3:1 / 4:1 / 5.5:1 / 7:1 / 10:1	90%	Input RPM: 5000 Max.
DOUBLE STAGE: 16:1 / 22:1 / 28:1 / 40:1 / 49:1 / 55:1 / 70:1 / 100:1	85%	Operating Temperature Range -60°F to +255°F Motor Mounting Hardware Supplied

A CGI EXCLUSIVE...

Developed for CGI by

UTS
Software
www.uts.com

**Gear sizing software to help you
get the right product for your project.**

SIZE IT...GEAR SIZING MADE EASY!

CGI, INC.

SIZE IT
Gear Sizing Software
www.cgimotion.com

ALL SPECIFICATIONS SUBJECT TO CHANGE.

CGI, INC. • 3400 Arrowhead Drive • Carson City, NV 89706 • Tel 775.882.3422 • Fax 775.882.9599 • www.cgimotion.com

http://www.cgimotion.com/pdf/inline_pn.pdf

Figure D.6: Spec Sheet for Acopian DC Power Supply



**Narrow Profile
SWITCHING REGULATED (to 120 watts)**

AC-DC single output
DC-DC (DC input can be used on 230 VAC input models)

- Shipped Within 3 Days
- Five Year-Warranty (trans-one year)

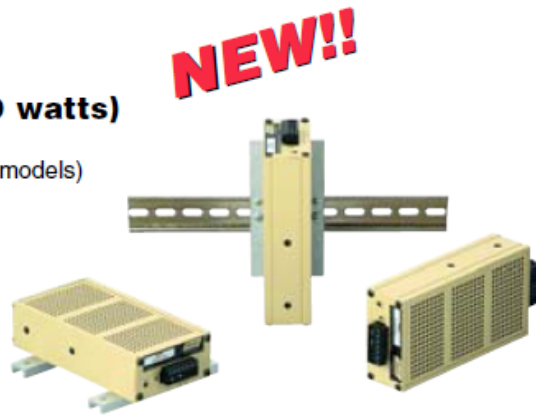

NEW!!

This newest group of Narrow Profile switchers includes convection cooled models less than 7" long that

provide outputs up to 75 watts and fan cooled models less than 8" long that provide outputs to 120 watts.

STANDARD FEATURES

- Internal EMI Filter and Shielding
- Pluggable Input/output Terminal Block
- Excellent Load/line Regulation
- Overcurrent, Overvoltage Protection
- No Minimum Load Required

SPECIFICATIONS

Input Voltage: 90-132 VAC, 47-420 Hz, single phase. 180-265 VAC input is also available (see Options).

DC Input: Not applicable on 115 VAC models. On 230 VAC models, 200-375 Vdc input can be used. DC input may be connected without regard to polarity.

Inrush current: Cold start, (thermistor limiter) 15A peak @ 115 VAC; 30A peak @ 230 VAC.

Startup Time: 1 second typical.

Input Undervoltage: An input of less than 90 VAC (180 VAC with "-230" option) will not damage power supply.

Regulation:

Line: $\pm 0.05\%$
Load: $\pm 0.05\%$

Output Voltage Remote Adjustment: The output voltage may be controlled by means of an external 1K potentiometer.

Polarity: Output is floating and may be used in either polarity.

Drift: $\pm 0.1\%$ maximum over 8 hours, after 30 minute warmup.

Temperature Coefficient: $\pm 0.02\%/^{\circ}\text{C}$ (Typical).

Holdup Time: 20 mS minimum.

Transient Response: 300 μS to return to $\pm 1\%$ of output setting. Maximum of $\pm 3\%$ output excursion following a load step change from 50% to 100%.

Remote Sensing: Compensates up to 0.5 volt drop per output line, within the limits of the output voltage adjustment range.

Overload/Short Circuit Protection: Current limiting with automatic recovery.

Overvoltage Protection: Latches power supply OFF, reset by momentarily removing AC input power.

EMI: Designed to meet FCC Part 15 and EN55022, Class A.

Output Indicator (DC on): Green LED.

Efficiency: See table. (Typical, at nominal input voltage, with full load.)

Ambient Operating Temperature: 0 to $+71^{\circ}\text{C}$.

Storage Temperature: -40 to $+85^{\circ}\text{C}$.

Cooling: Case size WN6A: forced-air cooled; air enters rear of power supply and exits from top. Case size WN6B: convection cooled.

Switching Frequency: 100 kHz (Typical).

Dielectric Withstand Voltage Isolation

Input to output:	4242 Vdc	500 VAC
Input to case:	2121 Vdc	500 VAC
Output to case:	750 Vdc	300 VAC

Internal Failure Protection: Provided by internal fuse.

Mounting: Threaded mounting holes permit mounting to a chassis, cabinet wall or bracket. To mount from the power supply side of the mounting surface or for DIN rail mounting, see accessory Mounting Kits on page 78.

OPTIONS

230 Volt Input: For applications where operation on an input of 180-265 VAC, 47-420 Hz, is desired. To order, add suffix "-230" to the model number. No increase in price.

On 230 VAC models, 200-375 Vdc input can also be used.



Appendix E: 80/20 Frame Information

Figure E.1: Price Quotation on Frame



FROM: MIDWEST FLUID POWER LLC
 5702 OPPORTUNITY DRIVE PHONE: 419-478-0015
 TOLEDO OH 43612 FAX: 419-478-3461

TO: UNIVERSITY OF MICHIGAN
 3006 HH DOW BUILDING
 2300 HAYWARD
 ANN ARBOR MI 48109-2136

ATTN: NEIL PATEL
 C.C.

QUOTATION

PAGE: 1
 DATE: 11/18/08
 QUOTE NO. 164104
 PLEASE REFER TO ABOVE WHEN ORDERING
 REPLY TO YOUR INQUIRY:

EO# 31098A1REVA

WHEN REPLYING, CONTACT:
 CAROLINE MILLER

LINE NO.	QUANTITY	DESCRIPTION	UNIT PRICE	UNITS
30	1	80/20 ENCLOSURE KIT EO# 31098A1REVA ** ABOVE PRICE INCLUDES ALL ITEMS SHOWN ON MIDWEST FLUID POWER DRAWING EO# 31098A1REVA. THIS KIT WILL BE SHIPPED UNASSEMBLED FROM 80/20 DIRECT TO CUSTOMER. A BALLOON DRAWING WILL BE PROVIDED TO EASE THE ASSEMBLY AFTER RECEIPT OF THE ORDER. THIS PRICE DOES NOT INCLUDE ASSEMBLY LABOR OR FREIGHT. DELIVERY WILL BE 1-2 WEEKS AFTER RECEIPT OF THE ORDER. THANK YOU, CAROLINE	1311.0000	EA
*** TOTALS *** EXTENDED AMOUNT			2997.00	

F.O.B. PREPAY & ADD

PAYMENT TERMS * * * * *

+ CREDIT CARD *
 + PAYMENT *
 * * * * *

BY _____
 AUTHORIZED SIGNATURE

Figure E.2: CAD Drawing of Frame (from 80/20)

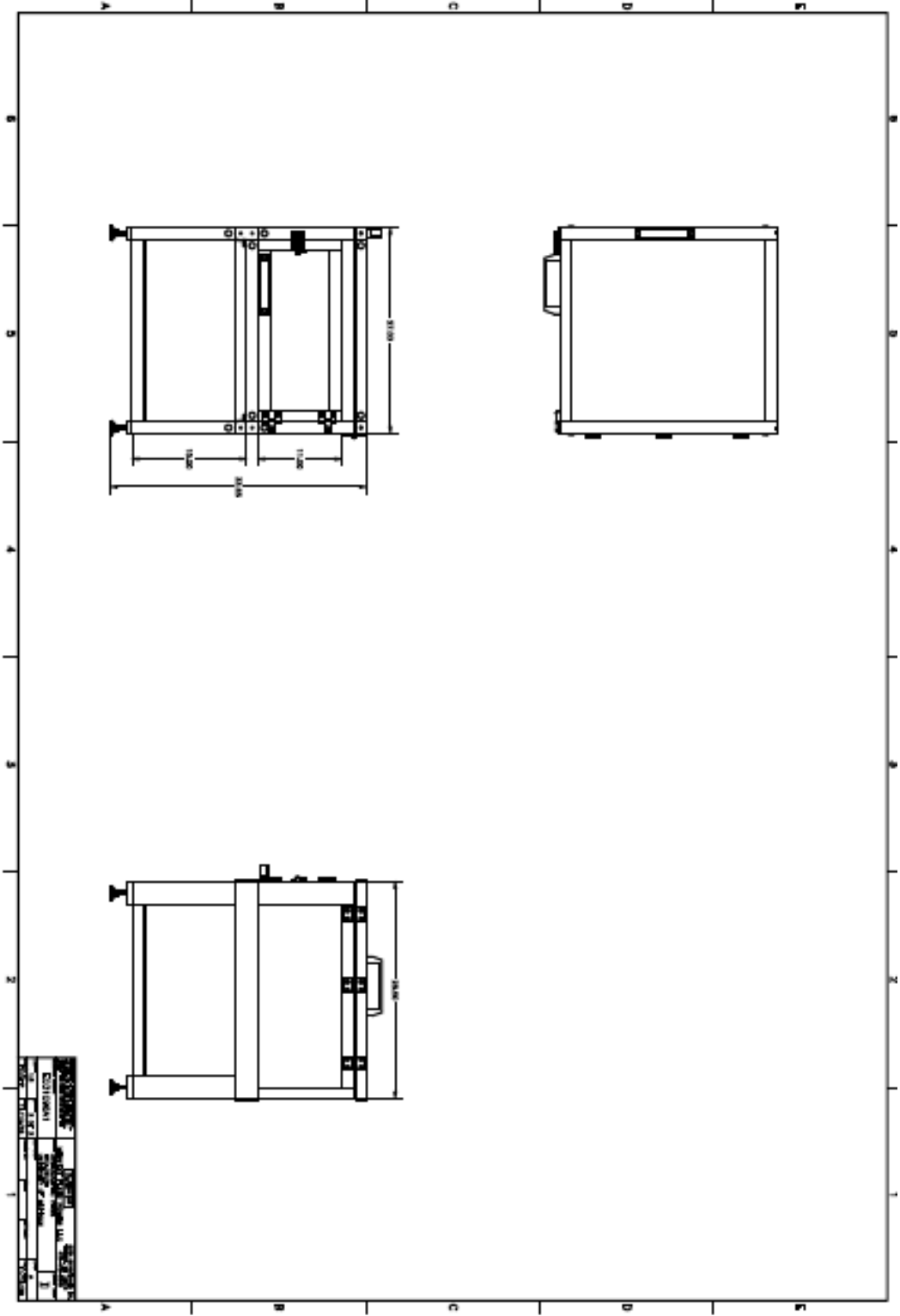
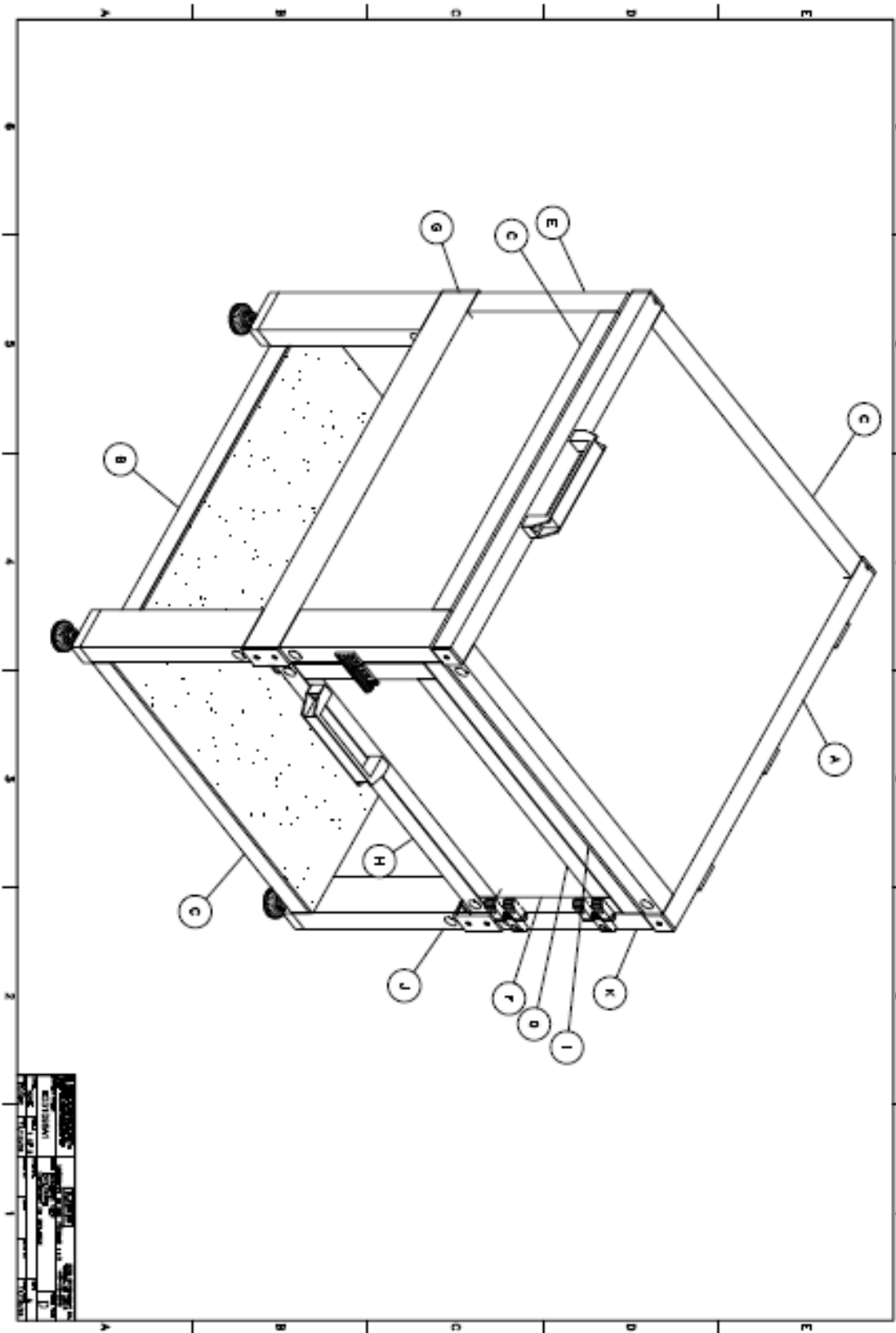

Figure E.3: 3D Model of Frame (from 80/20)



Appendix F: Changes Since DR3

Summary of design changes since Design Review #3

- 1) Manually controlled AC peristaltic pumps replaced DC Watson Marlow pumps due to long lead time and high cost
- 2) Direct solution application to rollers replaced foam applicators due to difficulty controlling the foam saturation and application
- 3) LinControl computer software used to control motor instead of LabView

Appendix G: Additional Images

Figure G.1: CAD Model Front View for Added Clarity

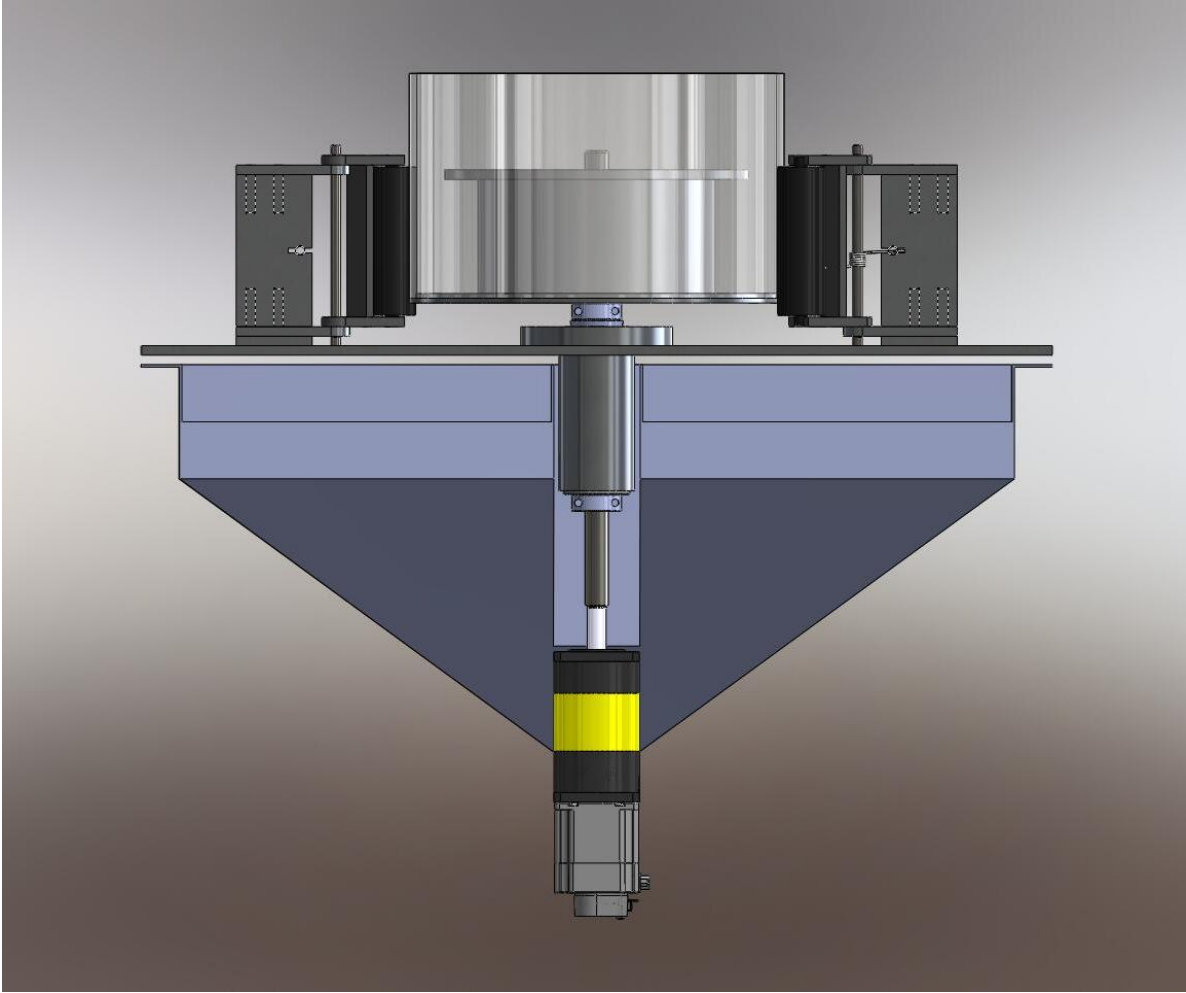

Figure G.2: Photo of Assembled Prototype with 80/20 Frame

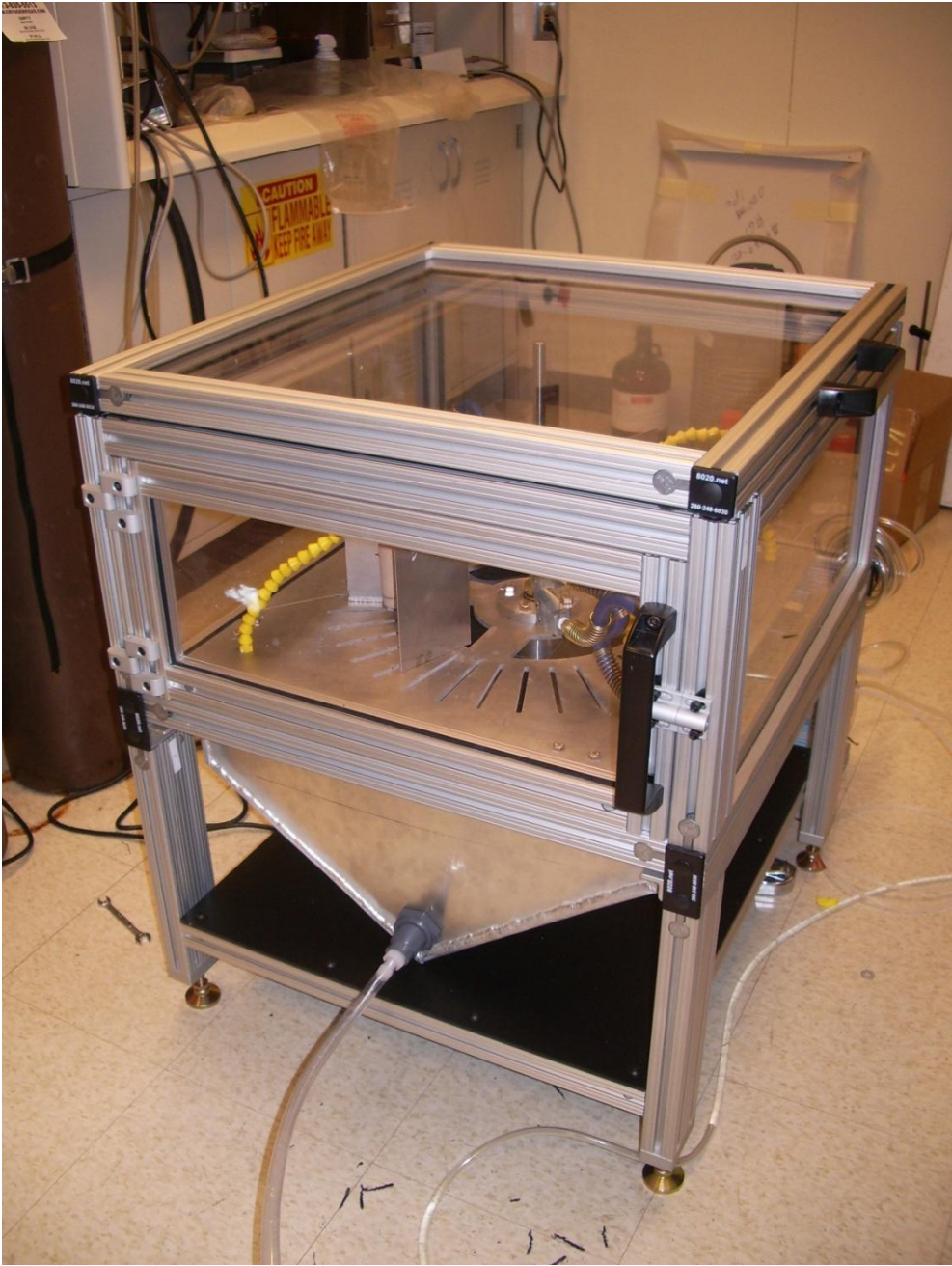

Figure G.3: Photo of Peristaltic Pump Set-Up in Rear of Prototype

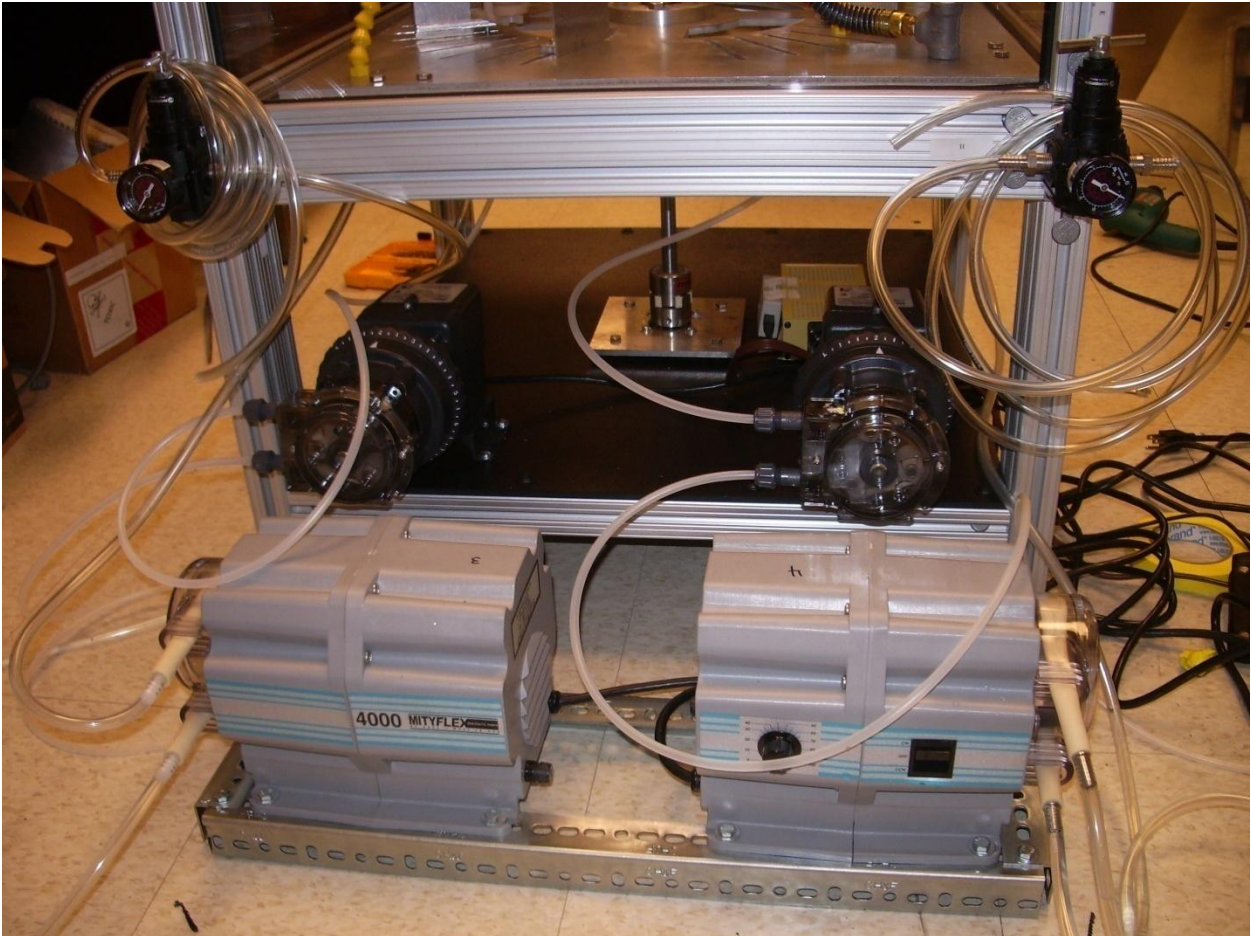

Figure G.4: Top View Photo Showing Air and Water Nozzles and Rollers

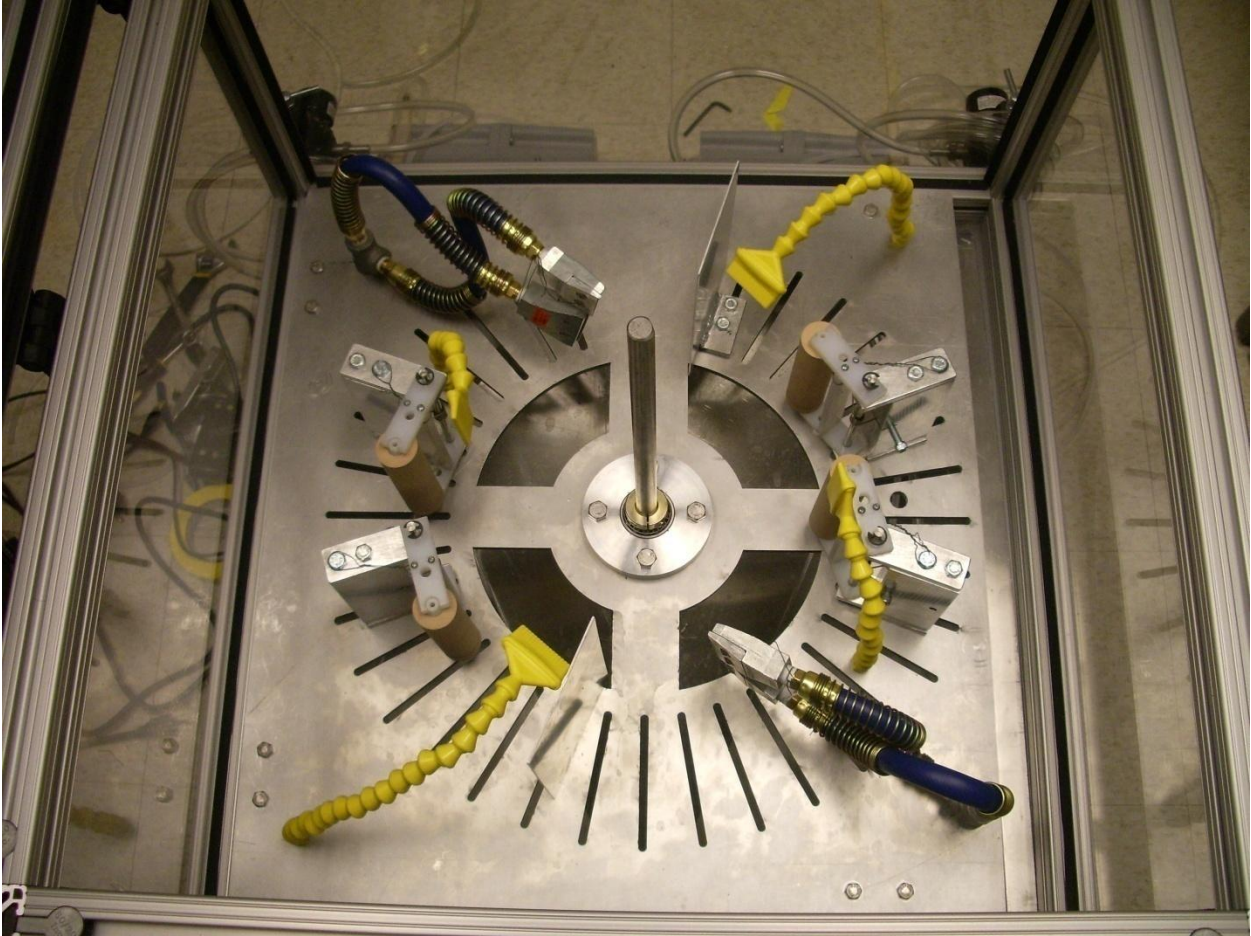

Figure G.5: Detailed Photo of Prototype Inside Housing Showing All Inner Components and Substrate

