

**The Effects of Parental Mental Illness on Children:
Pathways to Risk to Resilience from Infancy to Adulthood**

by

Lisa J. Slominski

A dissertation submitted in partial fulfillment
of the requirements for the degree of
Doctor of Philosophy
(Psychology)
in the University of Michigan
2010

Doctoral Committee:

Professor Arnold J. Sameroff, Chair
Professor Sheryl L. Olson
Associate Professor Susan C. McDonough
Assistant Research Scientist Katherine L. Rosenblum

This dissertation is dedicated to the memory of my father.
So much of who I am today is because of him.

Acknowledgements

I would like to thank my family, particularly my mother, for supporting me in everything that I ever set out to accomplish. I never could have done this without you. I would also like to thank Arnold Sameroff for his unfailing guidance as my graduate advisor. I learned so much through our interactions these past five years, and I can never thank you enough for all of the time you devoted to teaching me. I feel truly honored to have been your student. Thank you to the rest of my dissertation committee- Susan McDonough, Kate Rosenblum, and Sheryl Olson. You all have helped me in numerous ways throughout the years, and I have benefited so much from my training with each of you. To Aaron, for your constant encouragement, your distracting phone calls, and for making me laugh at times when I didn't think it was possible. Finally, to the best graduate cohort that anyone could ask for- Amanda, Jerel, and Jen. In so many ways, both personally and professionally, I never could have made it through graduate school without your friendship.

Table of Contents

| | |
|--|-----|
| Dedication..... | ii |
| Acknowledgments..... | iii |
| List of Figures..... | v |
| List of Tables..... | vi |
| List of Appendices..... | vii |
| Chapter | |
| 1. Introduction..... | 1 |
| 2. Developmental Pathways between Maternal Mental Health and Offspring Adult Outcomes: Study 1..... | 7 |
| 3. A Narrative Analysis of Family of Origin Representations and Adaptive Functioning Outcomes: Study 2..... | 56 |
| 4. A Qualitative Analysis of Adult Offspring’s Representations of Parental Mental Illness: Study 3..... | 104 |
| 5. Conclusion..... | 134 |
| Figures..... | 141 |
| Tables..... | 155 |
| Appendices..... | 167 |
| Bibliography..... | 195 |

List of Figures

| | |
|--|-----|
| 2.1. Associations between Maternal Mental Health and Offspring 30 year Mental Health Outcomes..... | 141 |
| 2.2. Mediated Pathways from Maternal Mental Health in Early Childhood to Offspring Mental Health in Adulthood..... | 142 |
| 2.3. Associations between Maternal Mental Health and Offspring 30 year Socioeconomic Outcomes..... | 143 |
| 2.4. Mediated Pathways from Maternal Mental Health in Early Childhood to Offspring 30 year Socioeconomic Outcomes..... | 144 |
| 2.5. Associations between Maternal Mental Health and Offspring 30 year Romantic Relationship Outcomes..... | 145 |
| 2.6. Mediated Pathways from Maternal Mental Health in Early Childhood to Offspring 30 year Relationship Outcomes..... | 146 |
| 3.1. Associations between Maternal Mental Health and Offspring 30 year Narrative Coherence and Relationship Beliefs..... | 147 |
| 3.2. Mediated Pathways from Maternal Mental Health in Early Childhood to Narrative Coherence and Relationship Beliefs..... | 148 |
| 3.3. Narrative Variables as Mediators of the Associations between Maternal Mental Health and Offspring Mental Health..... | 149 |
| 3.4. Narrative Variables as Mediators of the Links between Maternal Mental Health and Offspring Relationship Outcomes..... | 150 |
| 3.5. Narrative Variables as Mediators of the Associations between Maternal Mental Health and Offspring SES..... | 151 |
| 3.6. Final Model Depicting Pathways from Early Maternal Mental Health to Offspring Adult Mental Health..... | 152 |
| 3.7. Final Model Depicting Pathways from Early Maternal Mental Health to Offspring Adult Romantic Relationship Outcomes..... | 153 |

3.8. Final Model Depicting Pathways from Early Maternal
Mental Health to Offspring Adult Socioeconomic Status.....154

List of Tables

| | | |
|-----|--|-----|
| 2.1 | Descriptive Statistics for Maternal Mental Health and Offspring Adaptive Functioning Variables..... | 155 |
| 2.2 | Descriptive Statistics for Individual and Family Variables in Adolescence..... | 156 |
| 2.3 | Correlations between Maternal Mental Health in Early Childhood and Offspring Adaptive Functioning at age 30..... | 157 |
| 2.4 | Correlations between Maternal Mental Health, Offspring Adaptive Functioning, and Adolescent Predictors..... | 158 |
| 2.5 | Intercorrelations among the Adolescent Variables..... | 160 |
| 2.6 | Means (and Standard Deviations) of Outcomes as a Function of Maternal Mental Health Status..... | 161 |
| 3.1 | Descriptive Statistics for Study 2 Family Narrative Codes..... | 162 |
| 3.2 | Correlations between Study 2 Family Narrative Codes..... | 163 |
| 3.3 | Correlations between Study 2 Narrative Codes, Maternal Mental Health, and Offspring Adaptive Functioning..... | 164 |
| 3.4 | Correlations between Study 2 Narrative Codes and Adolescent Individual and Family Variables..... | 165 |
| 3.5 | Means (and Standard Deviations) of Narrative Codes as a Function of Maternal Mental Health Status..... | 166 |

List of Appendices

| | |
|--|-----|
| A Family Narrative Codebook (Study 2)..... | 167 |
| B Mental Health Interview (Study 3)..... | 185 |

CHAPTER 1

Introduction

Mental health problems are common in the United States and internationally. In the U.S. alone, an estimated 26.2 percent of Americans ages 18 and older—about one in four adults—suffer from a diagnosable mental disorder in a given year (Kessler et al., 2005). When applied to the 2009 U.S. Census population estimate for ages 18 and older, this figure translates to 80 million people. Moreover, nearly half (45 percent) of those with any psychiatric disorder meet criteria for 2 or more disorders, and mental health problems are the leading cause of disability in the U.S. and Canada for individuals between the ages of 15 and 44 (WHO, 2004). Research over the past century has provided unequivocal evidence that mental health problems influence many aspects of individual functioning, and can exert negative effects on a person's cognitions, motivations, and behaviors across situations and over time. Yet it has only been in the past several decades that researchers and clinicians have begun to consider effects of mental illness not only on the individual, but also on the individual's family.

Millions of children and adolescents are exposed to parental mental health problems at any given time (Creswell & Brereton, 2000). Over the past century, a primary question in psychological research has been how parents influence the behavior and development of offspring. Parental mental illness as an influence has emerged as a special case within this larger domain. Yet although understanding the impact of parental mental illness on offspring is without question a matter of great social and theoretical significance, relatively little attention has been paid in the research literature to the experiences of offspring of mentally ill parents.

The research that has been conducted has shown that children who have a parent with a mental illness are at significantly greater risk for multiple psychosocial problems

(Beardslee et al., 1996). Studies have noted that offspring of mentally ill parents have higher rates of psychiatric diagnoses in childhood (Friedman et al., 1996), and are more likely to show developmental delays, lower academic competence, and difficulty with social relationships (Sameroff & Seifer, 1983; Oyserman et al., 2000). In addition, these offspring are more likely to have mental health problems in adolescence and adulthood (Beardslee et al., 1998; Weissman et al., 1997). What is missing from this body of work is a focus not only on the *outcomes* of offspring of mentally ill parents, but also the *processes* through which parental psychopathology influences children.

The primary aim of this dissertation was to examine the effects of early maternal mental illness on children across development. A sample of parents and offspring were followed over the course of 40 years, and pathways from maternal psychopathology during the first three years to offspring adaptive functioning in adulthood were examined. The three studies of this dissertation attempt to address several gaps in the current research literature, and also build off each other in order to add to our current understanding of how parental psychopathology affects offspring adaptive functioning.

Study 1: Pathways between Maternal Mental Health and Offspring Adult Outcomes

The primary goal of Study 1 was to examine direct and indirect associations between maternal mental illness in early childhood and offspring adaptive functioning almost three decades later. Using structural equation modeling, associations between maternal mental illness at 30 months and measures of offspring adult mental health, romantic relationship functioning, and socioeconomic status at 30 years were tested. In addition, a number of individual and family variables from early and late adolescence were tested as mediators of these pathways.

This study adds to the current research literature in several ways. First, most of the research examining the impact of parental mental health on offspring has been cross-sectional. From a developmental psychology perspective, a primary question of interest is not only how parental mental illness affects children concurrently, but also how earlier experiences with parental psychopathology are related to later development. The long-term pathways explored in Study 1 are of particular interest because childhood, particularly early childhood, is the developmental period in which most children are not only living with parents, but are also almost completely dependent on parents for their

emotional and physical needs. Thus, early childhood may be a period in which offspring are especially sensitive to parental mental illness, and these effects may be long-lasting.

Study 1 also adds to the current research literature by considering multiple domains of adult competence. Most of the existing research on parental mental illness has focused exclusively on the intergenerational transmission of psychopathology (Beardslee, 1998). Particularly in studies of adult offspring, the majority of research studies have conceptualized “adult outcomes” as either absence or presence of psychopathology. Yet, if most people were asked to define successful adult functioning, many variables would likely contribute to this definition. Adult competence unquestionably includes good mental health, but it also may include completion of a high school diploma, attainment of a job, and the ability to maintain stable and satisfying intimate relationships with others. Study 1 will address the question of whether, in addition to its effects on offspring mental health, parental mental illness also has an effect on these other domains of adult functioning. Specifically, associations will be tested between maternal mental health measured during children’s first three years of life and offspring’s adult functioning in the areas of mental health, educational attainment, occupational attainment, income, romantic relationship status, relationship attachment security, and relationship satisfaction. A question of interest is whether the pathways from early maternal mental illness to offspring adaptive functioning differ based on the domain of competence.

Study 2: Representations of the Family and Adult Adaptive Functioning

As described above, the goal of Study 1 was to examine a number of variables throughout childhood and adolescence that help explain the associations between maternal mental illness in early childhood and offspring adaptive functioning in adulthood. However, another relatively unexplored possibility is that it is not only an individual’s actual experiences that are important, but also the ways in which an individual understands and makes sense of those experiences. Some variables that may be particularly important to explaining the link between parental mental illness and offspring outcomes are children’s representations of their experiences and relationships within their families of origin.

It has been suggested that how an individual makes sense of or understands an experience may be as, or even more, important than the actual experience itself (Emde,

2003; Bowlby, 1980). An individual's representations of growing up in his or her family of origin may provide important insights into how a person navigates his or her current interpersonal relationships, and may also be related to functioning outcomes in other domains, such as mental health. Family narratives can be considered across two dimensions: narrative coherence, or how an individual organizes and constructs a story, and relationship beliefs, or an individual's internal representations of interpersonal relationships. These codes have been found to be related to a number of outcomes, including observable behavior within the family and psychological functioning of the individual (Fiese et al., 1999).

It has yet to be examined how these general aspects of family narratives and representations of interpersonal relationships are related to both early experiences with maternal mental health and adult adaptive functioning outcomes. Study 2 of this dissertation will address this gap by examining offspring's representations of relationships, their perceptions of their experiences with their families of origin, and the ways in which they speak about these experiences in adulthood. This dissertation will explore not only how representations of interpersonal relationships develop over time, but also how these representations might contribute to outcomes of mental health, romantic relationships, and socioeconomic status in adulthood. Finally, Study 2 will assess participants' representations of relationships as additional mediators of the links between maternal mental illness and offspring adult competence.

Study 3: Offspring's Representations of Parental Mental Illness

As described above, Study 2 examines offspring's representations of relationships in general, and also assesses offspring's overall experiences within their families of origin. Study 3 expands upon this research by exploring in more depth adult offspring's experiences and perceptions of growing up with a mentally ill parent. Currently, there is very little research examining offspring's perceptions of parental psychopathology, their current and past understanding of symptoms and diagnoses, and their perceptions of their own coping behaviors both as children and as adults. Because a basic premise of this dissertation is that representations of the past are important to current levels of functioning, how offspring think about and organize their experiences with parental

mental illness may play a role in how this risk factor influences their adaptive functioning in adulthood.

The main goal of Study 3 was to explore how adult offspring conceptualize past experiences with parental mental illness. One aspect of this was to examine offspring's perceptions and understanding of parental mental illness both looking back as adults, as well as retrospective accounts of what they perceived and how they felt as children and adolescents. A second aspect was to examine offspring's methods of coping with parental mental illness at different points in development and attempt to relate this coping to their self-described level of adaptive functioning. Finally, Study 3 investigates offspring's perceptions of the effects of parental psychopathology on their lives growing up, as well as on multiple aspects of their adult functioning. Because these are relatively unexplored topics of research, these issues were examined through in-depth qualitative analyses of a small number of interviews with adult offspring who had experienced parental psychopathology while growing up.

Dissertation Methods and Goals

As will be described in more depth in Chapters 2 through 4, the research for this dissertation utilizes multiple methods to examine the impact of maternal mental illness on offspring. Because the goal of Study 1 was to examine overall patterns of data in the entire sample, several quantitative statistical methods were used. The goal of Study 2 was to move beyond the study of individuals' objective outcomes and explore how these individuals represented their earlier experiences with their families of origin. In order to do this, a mixed methods approach was used, in which open-ended interviews were coded for specific family narrative outcomes, and these codes were then used in quantitative analyses to test statistical associations. The goal of Study 3 was to explore the relatively under-researched topic of adult offspring's representations of their experiences with parental mental illness specifically. This goal was accomplished by administering open-ended interviews to a small group of participants who had dealt with parental mental illness while growing up, and then conducting qualitative analyses on these narratives. This allowed for an in depth exploration into how adult offspring actually think about and cope with their experiences with parental mental illness in a way that was not possible with the quantitative analyses of Studies 1 and 2.

In sum, the overarching goal of this dissertation was to add to the understanding of how parental psychopathology affects children across development. The focus of this dissertation was to not only elaborate sources of risk for these offspring, but also attempt to identify sources of resilience. Little is known currently about why some offspring of mentally ill parents do well in adulthood whereas others have problems. The three studies in this dissertation explore a number of pathways from early maternal mental health to offspring adult competence with the goal of not only explaining why some offspring in this sample are having trouble functioning in adulthood, but also why some offspring are resilient.

CHAPTER 2

Developmental Pathways between Maternal Mental Health and Offspring Adult Outcomes: Study 1

Introduction

Approximately half of the men and women in the United States report a lifetime prevalence of psychiatric disorder, and one-third report the prevalence of at least one disorder in the previous 12 months. Two-thirds of these women and over half of these men are parents (Kessler et al., 2005). Because a significant number of children are exposed to parental psychopathology, researchers within the past several decades have begun to examine the effects of parental mental health problems on offspring functioning and development.

Developmental Outcomes for Offspring of Mentally Ill Parents

The first psychological research on parental disorders and offspring outcomes occurred in the 1970s and 1980s, and focused almost exclusively on the intergenerational transmission of psychopathology. Since that time, a large body of research has confirmed that children of parents with mental illness are at greater risk for psychiatric disorders compared to children from homes with non-ill parents. It has been reported that between 25-50% of these children will experience some level of psychiatric disorder in their lifetimes, compared with 10-20% of children whose parents are not affected by mental illness (Beardslee, 1998).

In one of the first longitudinal studies designed to examine the effects of parental psychiatric illness on children, Beardslee and colleagues (1988) followed a sample of children ages 6 to 19 over the course of four years. At initial assessment, 30% of the children with an affectively ill parent met criteria for at least one episode of an affective illness during their lifetime, compared with just 2% of the children of non-ill parents. At

the 4-year follow-up, greater rates of disorder continued to be observed in the offspring of affectively ill parents (26%) compared to the children of non-ill parents (10%). In addition, children of affectively ill parents experienced episodes of longer duration and earlier onset and had a greater number of comorbid diagnoses compared to control children.

Hammen and colleagues (1990) conducted a similar study examining the effects of severe unipolar maternal depression and chronic mental illness on offspring. The children in this study were ages 8 to 16, and were followed up over a three year period. These researchers found that children of affectively ill mothers had higher rates of observed disorders compared to children of non-ill mothers, and that multiple disorders were common among this group, with an average of 2.6 diagnoses per child. More specifically, 45% of the children of depressed mothers met criteria for major depressive disorder (MDD), whereas only 11% of the children with non-ill mothers had MDD. More recent studies have shown that, from the earliest ages when psychiatric disorders can reliably be measured in children, rates of psychopathology are significantly higher in children with depressed mothers relative to children of non-depressed mothers, and rates range from 41 to 77%. Rates of depression alone in the school-age and adolescent children of depressed mothers are at least three times as high as those of non-depressed mothers, and have been estimated at between 20 and 41% (Goodman et al., 1994; Radke-Yarrow & Klimes-Dougan, 2002; Brennan et al., 2002).

After relations between parental mental disorder and offspring psychopathology were well established in the literature, the focus of research then turned to further impacts of parental mental illness on children. In addition to experiencing higher rates of psychopathology, children of parents with mental illness were also found to be at risk for a number of cognitive, social, and developmental problems. For example, maternal depression in the postnatal period has been associated with wide-ranging and persistent impairments in child functioning (Field, 1998; Murray, Cooper, & Hipwell, 2003). In infancy, cognitive, neurological, and regulatory disturbances have been observed among children of depressed mothers (Field, 1995; Murray, 1992). In addition, research has shown that the quality of parent-child attachment is negatively affected by parental mental health problems. Children of mentally ill mothers have been shown to have higher

rates of insecure attachment compared to children of mothers without mental illness (Murray et al., 1996). In childhood, there appears to be a continuity of cognitive impairments, at least in the presence of other environmental risk factors. Children of mentally ill parents exhibit problems with expressive language development in preschool (Cox et al., 1987), and are more likely to have special education needs or display problems in school than children of parents without mental health concerns (Hay et al., 2001).

The one period of development for which multiple offspring outcomes have not been considered to any great extent is that of adulthood. With a few exceptions, the majority of studies of adult offspring of parents with mental health problems have only reported outcomes related to psychiatric diagnoses or symptoms. In one of the few studies to report additional outcomes, adult offspring of depressed parents were found to have lower levels of functioning at home, at work, and within their marriages and families as compared to the offspring of non-ill parents (Weissman et al., 1997).

This dissertation will address a gap in the current literature by examining not only mental health outcomes, but also functioning in the areas of school, work, and romantic relationships among adult offspring of mentally ill parents. In addition to providing a multifaceted view of the individual as a way of characterizing current functioning, examining such diverse outcome variables will help to determine the areas of functioning in offspring that are at least partially attributable to parental mental illness. Thus, if we can learn what gaps in competencies exist, we can not only understand better how diagnosable disorders emerge, but also consider what areas need to be treated or subjected to preventive interventions.

Parental Mental Illness and Child Outcomes: Mediators and Moderators

As evidenced by the literature just reviewed, a large body of research has examined the impacts of parental mental health problems on offspring. Much of the research and theory to date has been from a pathological or problem-oriented perspective, whereby the focus has been on the potential negative consequences for children. Yet outcomes for children of parents with even severe mental illness are heterogeneous, and parental psychopathology may interact with a number of variables to influence child outcomes (Beardslee et al., 1998). For this reason, researchers within the past two

decades have begun to investigate a number of variables that are thought to either confer risk or enhance resilience among children of parents with mental health problems. In this discussion, mediators explain the mechanisms through which parental mental illness is related to child outcomes, whereas moderators influence the degree to which parental mental illness influences child outcomes (Baron & Kenny, 1986). Moderating factors can also interact with mediating variables to increase risk for child vulnerability and negative outcomes. Potential mediators and moderators of the associations between parental mental illness and offspring adaptive functioning outcomes are described below.

Genetic Transmission. Research clearly indicates that certain mental illnesses run in families (Kendler & Diehl, 1993). This is true whether studies begin with a cohort of adults with psychiatric diagnoses and examine rates of diagnosis among their children, or with a cohort of children with diagnoses and examine rates of mental illness among parents. There may also be specificity for transmission of diagnosis from parents to children. Children of parents with affective disorders are more likely to manifest affective disorders than other disorders, children of parents with anxiety disorders are more likely to manifest anxiety disorders, and children of parents with both depression and anxiety are more likely to manifest similar comorbidity (Biederman et al., 2001).

Family studies, twin studies, and adoption studies have supported a unique role for heredity in the transmission of mental illness from parent to child. Twin studies have shown that monozygotic twins show significantly higher concordance rates for schizophrenia (Hanson, Gottesman, & Meehl, 1977) and anxiety (Andrews et al., 1990) compared to dizygotic twins. Adoption studies reveal that children of parents with schizophrenia (Kendler & Gardner, 1997) and antisocial personality disorder (Mason & Frick, 1994) who were adopted away from their parents were at greater risk for these or related diagnoses than were adopted-away children whose parents did not have these diagnoses.

Family studies (Weissman, 1997), twin studies (e.g., Kendler et al., 1993), and adoption studies (e.g., Gatz et al., 1992) of adults with affective disorder and their first degree relatives also support a genetic connection between parental affective disorder and psychopathology in children. Heritability has been estimated at approximately 37% (Sullivan et al., 2000). Family studies reveal that the incidence of affective disorders in

relatives of depressed individuals is higher than the incidence of disorder in the general population, and that more closely related relatives are at an increased risk for disorder relative to family members who are more distantly related to the target individual (McGuffin & Katz, 1989; Weissman, 1997). Twin studies suggest that there is a 50% concordance rate of unipolar depression among monozygotic twin pairs; for bipolar illness the concordance rate is 70% (Tsuang & Faraone, 1990).

Although the study of genetics will not be a focus of this dissertation, genetic contributions are implicit in many of the variables that were examined. Genetic factors may elicit different environments, or they may mediate responses to different environments. In families where genes and environments are shared, risk for diagnoses or poor adaptive functioning among children may result from the stressful and disruptive environment created by a parent's illness or the multiple stressors that co-occur with psychiatric diagnoses (Silverman, 1989). Thus, research has shown that genetic and other biological vulnerabilities interact with contextual factors to influence child adjustment, and that the individual impact of genes and environment often cannot be separated.

Parenting. An emerging literature highlights the negative effects of mental illness, particularly depression, on parenting (Oyserman et al., 2000). Depression has been found to impact the ability of parents to effectively guide, support, and nurture their children as they negotiate important developmental tasks (Beardslee et al., 1997) and as they attempt to cope with life events and daily hassles (Hammen et al., 1991). Specifically, depressed mothers have been found to be more negative (Frankel & Harmon, 1996), less encouraging (Scherer et al., 1996), and more harsh and punitive in their discipline practices (Berg-Nielsen et al., 2002) compared to non-depressed mothers. Furthermore, depressed mothers are less sensitive and responsive in their parenting skills (Field et al., 1998), are less available to their children, and display more self-preoccupation compared to mothers without depression (Duncan & Reder, 2000). These less effective parenting practices have been found to be related to children's increased vulnerability to affective disturbances and interpersonal struggles.

Much of the information that we know about the effects of mental illness on parenting has come from observational studies of parent-child interactions, particularly in the context of maternal depression. These studies have consistently shown difficulties in

parent-child interactions when mothers have depression (Carter et al., 2001; Teti et al., 1995). Studies of mothers who experience postpartum depression indicate that these women exhibit less positive behavior toward their infants, who, in turn, exhibit less positive behavior in interactions with their mothers (Campbell et al., 1995). In addition, interaction studies of young children and their depressed parents have demonstrated that these parents attend less to their children and express more negative affect in their speech patterns (Murray et al., 1993). With older children, maladaptive interpersonal patterns between mothers and children have also been described (Gordon et al., 1989), as have higher levels of irritability in verbal exchanges (Tarullo et al., 1994).

One influential study of mother-child interactions examined the social interactions of depressed and non-depressed mothers and their preschool children, and also assessed mother's perceptions of their children's behavior within the interaction (Lovejoy, 1991). This study found that depressed mothers as a group exhibited more negative behavior than controls; however, there were no differences found for maternal positive behavior or contingent responding. There was also a high degree of reciprocity between mothers and children in both groups. In addition, there was a trend for children of the depressed mothers to be more negative than the control children, and for depressed mothers to recall more negative child behaviors compared to non-depressed mothers. However, these authors stressed that maternal behavior was highly variable within the depressed group, and that a negative interaction style was not characteristics of all, or even most, of the depressed mothers. These findings suggest that, although parental depression is a risk factor for negative parent-child relationships, parent-child difficulties are not necessarily ubiquitous correlates of maternal depression.

When testing negative parenting specifically as a mediator between parental mental illness and child psychopathology, some studies have found support for this association, whereas others have not. Bifulco and colleagues (2002) showed that the relation between maternal history of depression and depression in children was almost entirely mediated by child-rated neglect and abuse. Leinonen et al. (2002) found that fathers' punitiveness mediated the relation between paternal depressive symptoms and internalizing symptoms in children. In contrast, in a sample of boys at risk for behavior problems, Kim and colleagues (2003) found that observed parenting practices did not

mediate the effects of either maternal or paternal depressive symptoms on the development of depressive symptoms in offspring 10 years later, controlling for their earlier anti-social behavior. Thus, although theorists (e.g., Garber & Martin, 2002; Goodman & Gotlib, 1999) have suggested that the high rates of psychopathology found among offspring of depressed parents are partially the results of dysfunctional parenting, empirical evidence supporting this mediation model has been inconsistent.

Family Conflict. In addition to problematic parenting practices, one variable that may mediate the link between parental mental illness and child outcomes is family discord. Research shows that marital and family difficulties are risk factors associated with parental mental illness (Rutter, 1990; Weissman et al., 1997). At the family level, lower family cohesion, a chaotic home environment, poorer communication, and increased parent-child discord are more prevalent among families with a parent with a mental health problem (Warner et al., 1995). These features of family functioning are, in turn, associated with increased risk for behavioral and emotional problems in children (Davies & Windle, 1997; Warner et al., 1995). For example, in a study comparing different levels of family relationships, researchers found that family-level interactions were more influenced by the presence of parental mental illness than by individual parent-child or spousal relationships (Dickstein et al., 1998).

Family discord exposes children to stressful conditions and to poor models for handling interpersonal conflict (Hammen, Brennan, & Shih, 2004). Marital discord may also compromise children's sense of mastery by exposing them to stressful interpersonal circumstances over which they have little control, yet still may feel responsible (Grych & Fincham, 1993; Haines, 1999). This may then undermine children's sense of social competence and expectations of the world as being contingent and responsive, and may contribute to difficulties in coping with stressful situations that trigger depression or other disorders (Rudolph et al., 2001).

In addition, depression in a parent is frequently associated with depression and other psychopathology in spouses (Merikangas et al., 1988), as well as with disturbances in the marital relationship (Fendrich et al., 1990). Children in families with parental mental illness are also more likely to experience parental divorce than children in families without parental mental illness (Downey & Coyne, 1990). It has been reported

that the combination of parental affective illness and divorce is associated with poor outcomes in the offspring of affectively ill adults, with greater rates of depression being observed in children from divorced families versus those from dual-parent homes where parental psychiatric illness was present (Beardslee et al., 1993).

The link between mental illness and marital difficulties may be especially pronounced for individuals with severe mental health problems. Results of one study show that individuals, particularly males, with schizophrenia are less likely to be married than individuals without schizophrenia (Rushing, 1979). Recently, Danish registry data revealed that schizophrenia decreased the likelihood that individuals got married over a 25-year period (Agerbo et al., 2004). In a study that used broader clinical diagnoses, affective disorders (particularly depression) and conduct disorder reduced the likelihood of marriage for both men and women (Forthofer et al., 1996). In contrast, in studies that have examined depressive symptoms rather than depressive diagnoses, there is little evidence that risk for depression affects transition to marriage (Simon, 2002; Lamb et al., 2003).

In addition to marital status, mental illness has also been found to be negatively associated with quality of romantic relationships. In one study, married inpatients of a psychiatric clinic were compared to matched controls in the same community (Merikangas et al., 1985). The patients met criteria for non-bipolar major depression, and their spouses also served as participants. Results were that the patient couples rated their marriages as significantly worse than those of the control couples. Patients and spouses reported double the number of specific complaints about their marriages as those reported by the control couples, and reported that their sexual relationships were significantly less satisfying. In another study, Gotlib and Whiffen (1989) found that the perceptions and interactions of depressed couples were significantly more negative than in the control couples. The effects of the disorder were evident in the functioning and appraisals of both spouses, even when only one spouse was depressed.

Family conflict may thus serve as an additional risk factor for children of parents with mental health problems. Given that discord negatively impacts the family environment (Fendrich et al., 1990), the disturbances in family functioning associated with parental depression may decrease parents' ability to provide children with the

support they require to achieve competence and overcome the adversity often associated with parental mental illness. Conversely, supportive relationships among parents and between parents and children may contribute to resilient outcomes in children (Oyserman et al., 2000).

Chronicity, Severity, and Timing of Parental Mental Illness. Characteristics of the parent's illness may also help explain associations between parental psychopathology and offspring adaptive functioning. Research on familial-environmental factors associated with the cross-generational transmission of affective illness suggests that children who grow up in homes with more severe, chronic parental affective illness are at more significant risk for psychopathology compared to children whose parents are less seriously affectively ill. In fact, total duration of parental depressive disorder, number of episodes, and severity of disorder all have been associated with poor child outcomes (Hammen et al., 1990). In addition, more chronic parental affective illness has been associated with more disorder in children, as the negative effects of depression on parenting have been found to persist even after the remission of an episode (Stein et al., 1991).

An additional aspect of parental mental illness that may be important to child outcomes is the timing of the illness in relation to the child's development. Although there is mixed evidence in the literature, some researchers argue that parental mental illness has the largest effect on children when it occurs during infancy and early childhood, rather than later in development. There is evidence that, in general, the younger the age of onset of parental depression, the greater the risk for psychopathology in their offspring (Grigoriu-Serbanescu et al., 1991). Murray and Cooper (2003) found that children of mothers with depression showed cognitive, emotional, and biological disturbances, and that these disturbances were particularly related to maternal depression occurring within the first years of life, rather than to maternal depression occurring later in development or to overall exposure to maternal depression. Maternal anxiety during pregnancy has also been associated with biological and emotional disturbances in children, even after accounting for postnatal maternal disorder (Glover et al., 2004).

A number of processes may contribute to the observed links between early maternal disorder and adverse child outcomes (Murray & Cooper, 2003). The link

between maternal disorder during pregnancy and later child disturbances may be explained by fetal exposure to maternal stress hormones and placental insufficiency (O'Connor et al., 2005). In addition, the presence of early maternal depression has been associated with alterations in cortisol secretion in children (Essex et al., 2002) and adolescents (Halligan et al., 2004) that are consistent with biological risk for depression. Animal research has shown sustained biological and behavioral disturbances in offspring in association with disruptions in the early maternal environment, and has emphasized the primacy of environmental insults to the organism during the early stages of development (Weaver et al., 2004). As early maternal mental illness is also associated with disturbances in the provision of early care (Murray et al., 1996), a pre-programming hypothesis may explain the transmission of disorder from mother to offspring; this holds that, as the environmental disturbances associated with early maternal disorder occur while the infant is maturing, they may shape developing cognitive and biological systems, with sustained consequences.

Halligan and colleagues (2007) followed children who had been exposed to postnatal depression (PND) over the course of 13 years. They found that maternal PND was associated with higher rates of disorder in offspring at age 13. However, mothers who had PND were also substantially more likely than those who did not to experience depression subsequently, a fact that contributed to the development of depression in offspring. Maternal PND was associated with increased risk for depression in adolescent offspring only if there had also been later episodes of maternal depression. In contrast, anxiety disorders in offspring were elevated in the maternal PND group regardless of the occurrence of subsequent maternal illness. In other words, this research suggests the primacy of early maternal mental illness for some disorders, but perhaps not for all.

Thus, there is support in the literature for the argument that exposure to parental (particularly maternal) mental illness early in life has more of an effect on children than parental mental illness that occurs later in childhood or adolescence. Yet the question of the impact of timing of exposure to parental mental illness on offspring vulnerability to disorder is complicated to address in practical terms, as individuals exposed to parental mental illness early in development are also likely to be exposed to subsequent episodes of parental mental illness. Furthermore, the broader literature on maternal depression has

indicated associations with both family disturbances and wider environmental adversity (Cummings & Davies, 1994). To the extent that early parental disorder is associated with higher rates of subsequent disorder in mothers (Cooper & Murray, 1995), any association between maternal and child disorder may also be a function of ongoing environmental disturbances.

Socioeconomic Stress. Chronic and/or acute stressors outside the family, specifically those regarding socioeconomic status, have also been found to mediate or moderate the impact of parental mental illness on children. Specifically, the stress associated with poverty, single parenthood, social isolation, low levels of education, and minority status all may increase the likelihood of behavioral and emotional problems in children of parents with mental illness (Sameroff & Seifer, 1983; Beidel & Turner, 1997). Epidemiological and longitudinal studies (Johnson et al., 1999) have shown a relation between lower family socioeconomic status and depression. Possible mediators between SES disadvantage and depression include lack of access to adequate health care and educational opportunities, fewer social resources, greater exposure to violence, and an increased risk for being the victims of abuse (Buka et al., 2001).

Child Characteristics. Much of the original research examining associations between parental mental illness and child outcomes presumed unidirectional influence (i.e., parental illness affects children). More recent work has shown that effects may be bidirectional or transactional, with parents and children mutually influencing each other in dynamic and reciprocal relationships (Sameroff & MacKenzie, 2003; Goodman & Gotlib, 1999). Children's temperament and related affect and behaviors can impact their parents' attitudes and responses to them, which in turn can affect children's subsequent emotional and behavioral development. These transactions can sustain and exacerbate difficulties in the parent-child relationship.

Mutual influences between parental mental illness and child functioning are particularly noteworthy. Parental mental illness such as depression may have dysfunctional effects on the quality of the mother-child relationship, elicit various forms of child maladjustment, and over time, such child behaviors in turn may provoke and maintain negative maternal attitudes and behaviors (e.g., Cummings & Davies, 1994; Goodman & Gotlib, 1999). In addition, child maladjustment can impact maternal

functioning and increase the risk of or exacerbate her depression. For example, problematic child behavior creates stress for parents that can exacerbate parents' symptoms and elicit poor parenting practices that can, in turn, increase child conduct problems (Keitner & Miller, 1990), and child hyperactivity can contribute to maternal depression, which can then enhance child hyperactivity (Harrison and Sofronoff, 2002).

Child characteristics such as temperament, intelligence, social skills, and cognitive processes have also been shown to modify the risk for psychopathology among children of parents with mental health problems. Strong social skills and higher levels of intelligence have been found to protect children of parents with mental health problems in both the short and long-term from adverse outcomes (Radke-Yarrow & Sherman, 1990; Beardslee & Podorefsky, 1988). Because parental mental illness often seriously impairs relationships within the family (Billings et al., 1983), strong interpersonal skills may help children develop positive relationships with non-familial adults, which may contribute to adaptive functioning.

Studies linking temperament with resilience in children (Garmezy, 1983) have suggested further ways in which child characteristics may elicit or maintain particular parental behaviors. One option is that temperamentally easygoing children are more impervious to their depressed mother's behavior than are more irritable children. These children may be less likely to elicit negative behaviors from their depressed mother, and may thus impede the development of the reciprocal pattern of negativity often seen in the interactions of depressed mothers and their children.

Child gender also appears to be an important and complex moderating factor in the association between parental mental illness and child outcome. Some studies have shown that boys are more adversely affected by a parent's depression (Gross et al., 1995), whereas other studies have shown that girls fare worse (Davies & Windle, 1997). Research has also shown that boys and girls often exhibit divergent responses to parental mental illness, with girls more likely to develop depression and boys more likely to develop conduct problems (Cummings & Davies, 1994).

Cognitive characteristics such as a positive attribution style, good problem solving abilities, and a positive and coherent self-concept have also been associated with good outcomes among children with a mentally ill parent (Radke-Yarrow et al., 1995).

The theory behind these findings is that children of mentally ill parents show evidence of relatively negative schemas about themselves, and that such negative self-schemas might predict future development of psychopathology. Several theories, including attachment (Ainsworth, 1979; Bowlby, 1980), object relations (Baldwin, 1992), cognitive (Beck, 1976; Ingram, Miranda, & Segal, 1998), and cognitive-interpersonal (Haines et al., 1999), have suggested that harsh, critical, punitive, rejecting, and/or neglectful parenting lead to the development of depressive “working models” or “cognitive schema” about the self and others. Bowlby (1980) asserted that early insecure attachments contribute to children’s developing inferences about their acceptability and “loveableness”. The nature and quality of children’s experiences with attachment figures are internalized into cognitive working models, which are later used to appraise new situations and guide behavior.

Cognitive models of depression similarly assert that an important consequence of early adverse life experiences is the formulation of negative cognitive schemas (Abramson et al., 1989; Beck, 1976; Ingram et al., 1998). Thus, consensus across these theories is that early adverse experiences and insecure attachments to primary caregivers can create psychological vulnerability in the form of negative self-schema and mistrust of others, which then increase risk of developing psychiatric disorders, such as depression (Beck, 1987; Blatt & Homann, 1992; Segal, 1988).

Summary and Hypotheses

In summary, there is a large body of research on the effects of parental mental illness on children. The literature just reviewed shows that parental mental health problems place children at risk for a number of emotional, behavioral, and developmental problems. In addition, a number of mediators and moderators of the association between parental mental illness and child outcomes have been explored, most of which have focused on the environment, particularly the parent. Yet despite the surge in research on this topic that has occurred over the past 30 years, there remain several important gaps in the literature that must be addressed if we are to more completely understand the impact of parental mental illness on offspring. Study 1 of this dissertation will attempt to address these gaps and contribute to the existing body of literature in several ways.

First, most studies that have been conducted to look at the impact of parental mental health on children have been cross-sectional, and most of those that have been longitudinal have included only two or three time points over a relatively short period of time. If a question of interest is how parental mental illness experienced during childhood affects how a person ends up in adulthood, then long term longitudinal research is needed. Study 1 of this dissertation examines a longitudinal sample of mothers and children followed from the time children were born until children were 30 years old. These long term effects are important to study because childhood, particularly early childhood, is the developmental period in which most children are not only living with parents, but are also almost completely dependent on parents for their emotional and physical needs. Thus, early childhood may be a period in which offspring are particularly sensitive to parental mental illness, and these effects may be long-lasting.

Second, although many researchers have studied parental mental illness and its effects on offspring, most of this research has focused exclusively on the intergenerational transmission of psychopathology. Particularly in studies of adult offspring, the majority of research studies have conceptualized “adult outcomes” as either absence or presence of psychopathology. This dissertation will address this gap in the literature by examining associations between early parental mental illness and multiple offspring adult outcomes using a longitudinal sample of parents and children followed over the course of 30 years. Specifically, associations will be tested between maternal mental health measured during children’s first three years of life and offspring’s adult functioning in the areas of mental health, educational attainment, occupational attainment, income, romantic relationship status, relationship attachment security, and relationship satisfaction.

A third limitation in the existing literature is that relatively few studies have attempted to explain relations between maternal mental illness and offspring outcomes by examining mechanisms or moderators. Moreover, studies that have examined mediators or moderators have typically only examined one at a time, and have not included multiple variables to test for their relative influences on multiple outcomes. The primary analyses of Study 1 of this dissertation will include structural equation models that test multiple individual, family, and social variables across offspring’s early and late adolescence as

mediators of the predicted associations between early maternal mental illness and offspring adult outcomes. These analyses will not only determine whether there are diverse pathways to different adult outcomes, but will also determine the relative strength of each variable as a mediator.

Finally, existing research has focused primarily on elaborating sources of risk, rather than identifying sources of resilience. Little is known currently about why some offspring of mentally ill parents do well in adulthood whereas others have problems. The longitudinal sample that will be used for this dissertation contains a relatively large sample of adult offspring of mothers who had mental health problems during their early childhoods. Some of these offspring exhibit resilient functioning at age 30 whereas others exhibit poor functioning. The proposed research will explore a number of individual, family, and contextual variables throughout development that might explain the predicted association between early parental mental illness and offspring adult functioning, with a focus on not only explaining why some children do poorly, but also why some children in the same sample do well.

The analyses for Study 1 will test the following hypotheses:

- 1) Maternal mental illness during early childhood will be related to offspring adaptive functioning in adulthood as measured by their mental health, socioeconomic status, and romantic relationship outcomes.
 - (a) Overall, offspring of mentally ill mothers will have more mental health problems, be of lower socioeconomic status, and have more problems in their romantic relationships in adulthood compared to offspring of mothers without mental health problems.
- 2) Associations between maternal mental illness during early childhood and offspring outcomes in adulthood will be mediated by a number of individual and family variables that are thought to place offspring of mentally ill parents at risk for future problems.
 - (a) Parenting, family conflict, offspring self-esteem, offspring mental health, family SES, peer relationships, parental relationship status, and offspring academic achievement measured in early and late adolescence will

differentially mediate relations between maternal mental illness and offspring outcomes.

Method

Participants

The data for Study 1 of this dissertation comes from a 30-year, three-generation longitudinal study of mental health. This study was initiated in 1970, and included families with an over-representation of maternal psychopathology. Thus, this sample is particularly well suited to explore the effects of maternal and child mental health. Because the intent of this study was to recruit a community sample of women with mental health problems, these women were checked against a county-wide psychiatric register that provided information about psychiatric contacts and diagnoses of mental illness. This register had been in existence since 1959 and included approximately 95% of all individuals receiving mental health services in a metropolitan area with a population of about 850,000. A sample of women without mental health problems was obtained by matching these women to other pregnant women scheduled to deliver at the same hospital on the demographic variables of SES, race, age, marital status, and number of children. SES was computed using a modified version of the Hollingshead two-factor index of social position (ISP), which is a combination of mother's education, father's education, and head of household's occupation as described in the measures section. Race was self-identified as European American (63%), African America (34%), or Puerto Rican (3%). The final sample had approximately half of the mothers displaying no mental health problems, and approximately half of the mothers having a psychiatric diagnosis before participant children were three years old.

This study followed offspring from the time mothers were pregnant until offspring were 30 years old. The current study utilizes data collected from mothers and children when offspring were 30 months old, 13 years, 18 years, and 30 years (Sameroff, Seifer, & Zax, 1982; Gutman, Sameroff, and Cole, 2003). At 30 months, 234 families were assessed, and 139 participants remained in the study at age 30 (51% female, 71% European American, 29% African American). As is usual in longitudinal studies, families who dropped out between 30 months and age 30 ($n = 95$) scored lower on measures of parent education, parent occupation, parent and child mental health, and child GPA

compared to families who remained in the study. However, a high degree of variability remained in this sample on all variables after attrition.

Procedure

Shortly following children's birth and at 30 months old, mothers came to the laboratory and were assessed for mental health using a structured psychiatric interview. At 13 years mothers and children were brought into the laboratory and administered a variety of self-report questionnaires and interviews. At 18 years, adolescents were brought into the laboratory on two separate occasions and interviewed by two different researchers who then made independent ratings on the adolescents' mental health status. One interviewer made mental health ratings after administering a DSM-based structured psychiatric interview. The other interviewer made mental health ratings after administering a variety of psychometric assessments tapping personality, IQ, and social context variables. Because of the geographic distribution of the participants, at age 30 all data were collected through several phone interviews and a survey packet mailed to participants. One interview included a two-hour structured diagnostic assessment. A second interview included a two-hour structured and open-ended interview about family environment, parenting behavior, and personal aspirations and values.

Measures: Maternal Mental Health and Offspring Adult Outcomes

Study 1 examines associations between early maternal mental health and offspring adult outcomes in the areas of mental health, socioeconomic status, and romantic relationships. In addition, a number of individual, family, and contextual variables are tested as mediators of these predicted associations. Descriptions of all variables are below. Descriptive statistics for maternal mental health and the 30-year outcomes are presented in Table 2.1, and descriptive statistics for the adolescent variables used in these analyses are presented in Table 2.2.

Maternal Mental Health- Early Childhood. When children were 30 months old, mothers came to the laboratory and were assessed for mental health using a DSM-based psychiatric interview based on the Current and Past Psychopathology Scales (CAPPS; Spitzer & Endicott, 1972). The CAPPS is a structured clinical interview that evaluates both current psychiatric functioning and past history. In addition to diagnoses, a score for overall severity of illness based on number of diagnoses both concurrently and since the

child's birth was obtained from the CAPPS. This score was rated by clinicians on a 5-point scale, with higher numbers corresponding to clinician's perceptions of more severe mental health problems. Inter-rater reliability for this measure exceeded .80. For the purposes of this study scores were reversed so that higher numbers correspond to better mental health. In this sample 50.3% of mothers had good or superior mental health, 15.6% displayed some impairment, and 34.2% had moderate to severe mental health problems during their offspring's first two and a half years of life.

Mental Health- Adulthood. Mental health of participants at age 30 was measured by two variables: (1) an observer rating of participants' overall mental health status (Global Assessment of Functioning scale); and (2) a clinical interview that provided diagnoses of DSM-IV disorders (CIDI).

The first rating of mental health was the Global Assessment of Functioning scale (GAF) from the DSM-IVR. The GAF is a 100-point scale that is routinely used as a measure of overall mental health functioning in adults, and provides a continuous measure of mental health. Scores of below 70 on the GAF generally indicate poor mental health. In studies that have used the GAF, standard deviations range from 8 to 20, and tend to be higher in clinical samples (Hay et al., 2003; Jones et al., 1995). Ratings were made by two interviewers who had independent contact with participants during lengthy phone interviews, and were then averaged. Ratings between interviewers were highly correlated ($r = .70$; $p < .001$). Participants in this study had mean GAF ratings of 79.2 ($SD = 9.82$), which corresponds to some impairment in mental health. In addition, 51.2% had good mental health at age 30, 43.2% showed some impairment in mental health, and 5.6% had moderate or severe mental health problems.

Participants were also interviewed at age 30 with the Composite International Diagnostic Interview (CIDI). The CIDI is a comprehensive structured interview designed to be used by trained lay interviewers for the assessment of mental disorders according to the definitions and criteria of the ICD-10 and DSM-IV. The inter-rater reliability of the CIDI has been demonstrated to be excellent, the test-retest reliability good, and the validity good (Andrews & Peters, 1998). A total score was computed for each participant by adding together the number of diagnostic categories (mood, anxiety, substance, and psychoses) for which individuals met criteria. Forty three percent of participants in this

sample did not meet criteria for any disorder, 35% met criteria for one category of disorders, 18% met criteria for two categories of disorders, and 4% met criteria for three categories of disorders.

Socioeconomic Status- Adulthood. Offspring socioeconomic status in adulthood was measured by the following three variables: (1) occupational attainment; (2) educational attainment; and (3) household income. Each of these measures was gathered from a phone interview from offspring at age 30.

Occupational attainment was coded based on the Hollingshead 9-point occupation scale. A score of 1 corresponded to menial workers and a score of 9 corresponded to highest executives. In this sample, the large majority of participants were employed ($n = 111$). Of these participants, 30.2% were unskilled or semi-skilled workers, 41% were skilled or technical workers, and 28.8% were business owners or professionals. Unemployed participants ($n = 28$; 17 females, 11 males) were given Hollingshead ratings based on the last job that they had held. Of these unemployed participants, 9 (4 males, 5 females) were actively looking for a job, and the average Hollingshead rating of their last occupation was 2.9. Six female participants classified themselves as full-time homemakers, and reported an average Hollingshead rating of 3.5 for their last job held. In addition, 2 participants were on maternity leave, 4 were in recovery from physical injuries or surgeries, 1 was unemployed because of unidentified health problems, 1 was in jail, 1 was in school, and 1 was retired.

Education level was coded on the Hollingshead 7-point scale, with a score of 1 corresponding to less than high school, a score of 4 corresponding to attainment of a high school diploma, and a score of 7 corresponding to attainment of a graduate or professional degree. In this sample, 7.9% of participants had not completed high school, 20.1% had high school diplomas only, 59.7% had completed at least some college, and 12.2% had completed graduate degrees. Income was measured as total household annual income, and was coded on a scale in increments of \$5,000. A score of 1 corresponded to less than \$5,000 each year, and a score of 40 corresponded to an income of more than \$200,000 each year. Participants in this sample had a mean annual income of 11.41 (\$57,000 per year; $SD = 6.63$).

Romantic Relationships- Adulthood. Romantic relationship functioning was measured by the following three variables: (1) romantic relationship status; (2) romantic relationship satisfaction; and (3) attachment insecurity in romantic relationships.

Romantic relationship status was obtained through a phone interview when participants were age 30. Relationship status was rated on a four-point scale, with a score of 1 corresponding to “not in a romantic relationship”, a score of 2 corresponding to “casually dating”, a score of 3 corresponding to “in a committed relationship”, and a score of 4 corresponding to “married”. In this sample 11% of 30-year-old participants were not in relationships, 10% were casually dating, 33% were in committed dating relationships, and 46% were married.

Relationship satisfaction was a measure of how participants were experiencing their current most stable romantic relationship on a dimension from satisfying and supportive to unsatisfying and conflict-ridden. The measure of relationship satisfaction was a composite score based on thirteen questions presented to participants through a phone interview when participants were age 30. Examples of questions include “My partner lets me know he/she cares about me” and “My partner ignores me”. Participants were asked to rate each item on a five point scale ranging from “never happens” to “almost always happens”, and these items were then averaged to create a total measure of relationship satisfaction. If participants were not in a romantic relationship they did not fill out this measure. Mean ratings of relationship satisfaction were 4.2 ($SD = .55$), which indicates that individuals who were in romantic relationships were generally satisfied with the quality of these relationships.

Romantic relationship insecurity was assessed with the Experiences in Close Relationships- Revised (ECR-R) questionnaire (Fraley, Waller, & Brennan, 2000), which was mailed to participants at age 30. The ECR-R measures the extent to which people experience attachment-related anxiety and attachment-related avoidance. The *attachment anxiety* scale is comprised of 18 items, and includes items such as “I’m afraid that I will lose my partner’s love”, “I often worry that my partner doesn’t really love me”, and “I often wish that my partner’s feelings for me were as strong as my feelings for him or her”. The *attachment avoidance* scale is also comprised of 18 items, and includes items such as “I prefer not to be too close to romantic partners”, “I find it difficult to allow

myself to depend on romantic partners”, and “I am nervous when partners get too close to me”. Participants rated each item on a 7 point scale, and items for each scale were summed to create measures of attachment-related anxiety and attachment-related avoidance. These scales were significantly correlated ($r = .67, p < .001$). To create an overall measure of attachment insecurity, these two measures were then added together. The mean attachment insecurity in this sample was 44.85 ($SD = 20.18$), and scores ranged from 18 to 96.

Measures: Mediating Variables from Offspring’s Adolescence

Mental Health- Adolescence. Offspring mental health was measured at 13 years and 18 years. At 13 years adolescents were interviewed using the Community Mental Health Interview (CMHI; Ikle et al., 1983). The CMHI is composed of 88 behaviorally oriented multiple choice items relevant to the functioning of children during early to late adolescence, and the items focus on the adolescent’s functioning during the past 30 days. The interview is administered verbally, and generates scales reflecting both adaptive and maladaptive behavior, with higher scores reflecting better mental health. For the purposes of the present study, item-level factor analysis of the CMHI at 13-years was used to derive internalizing (20 items; $\alpha=.79$) and externalizing (18 items, $\alpha=.81$) scales. Scales were reverse coded so that higher scores would reflect greater internalizing or externalizing problem behaviors, and internalizing and externalizing scales were standardized and combined to create an overall measure of adolescent mental health at 13 years. Participants in this study had mean 13 year mental health scores of 3.27 ($SD = 0.32$).

Mental health of offspring at age 18 was measured by both observer rating and diagnostic interview. The Children’s Global Assessment Scale (C-GAS; Shaffer et al., 1983) is a rating scale for individuals 18 years of age and younger based on the Global Assessment of Functioning (GAF) scale from the Diagnostic Statistical Manual (DSM-IVR). The C-GAS is routinely used as part of DSM assessments for overall ratings of mental health, and the psychometric soundness of the C-GAS has been supported in a number of studies (Bird et al., 1987). This score ranges on a scale from 0 to 100 and assesses participants’ general psychological functioning in several areas of life (e.g., home, school, and work). Scores of below 70 generally indicate poor psychological

functioning. In studies that have used the C-GAS, standard deviations range from 7 to 16 and tend to be higher in clinical samples (Bird et al., 1987; Asarnow et al., 2001). C-GAS ratings were obtained by two independent interviewers, and were then averaged. Ratings by these two interviewers were highly correlated ($r = .79, p < .001$). In this sample, 36.6% of participants displayed good or superior mental health, 42% displayed some impairment, and 21.4% displayed moderate to severe mental health problems at age 18. Mean GAS scores were 73.17 ($SD = 15.35$).

Mental health of offspring at age 18 was also measured with the Diagnostic Interview for Children and Adolescents (DICA; Herjanic & Reich, 1982). The DICA is a standardized clinical interview designed to provide diagnoses and number of symptoms for individuals 18 years of age and younger on 25 disorders. These disorders include internalizing problems (e.g., depression, anxiety, post-traumatic stress disorder, eating disorders) as well as externalizing problems (e.g., conduct disorder, oppositional disorder). Disorders also include behaviors such as alcohol abuse, marijuana abuse, and cigarette use. Agreement between child psychiatrists and lay interviewers on child symptoms and diagnoses has been found to be strong, with estimates of sensitivity at 65%, estimates of specificity at 70%, and agreement (kappa) at .55. Test-retest reliability over 2- to 3-month intervals has also found to be strong, with estimates ranging from 80%-90% (Boyle et al., 1993). A DICA total problems score was computed for each participant by adding together the number of problems participants endorsed during the entire interview. Mean DICA scores were 34.01 ($SD = 23.26$).

These three indicators were highly correlated ($p < .001$), and were standardized and summed to create one measure of mental health in adolescence. The CMHI and DICA scores were first reversed so that in the measure higher scores would indicate better mental health for offspring.

Parenting- Adolescence. When participants were 13 and 18 years old, mothers were administered the Camberwell Family Interview (CFI). The CFI is an open-ended interview based on the expressed emotion interviews developed by Leff & Vaughn (1985). The interviewer rates the mother on four-point scales based on the number of negative and positive utterances the mother makes about the child during the interview. Negative utterances included hostile, critical, and dissatisfied comments. Positive

utterances included statements expressing enthusiasm, enjoyment, and warmth toward the child. Variables for 13 and 18 year parenting were created by reverse-coding negative items and averaging scores on the comments, with high scores indicating more positive parenting, and low scores indicating more negative parenting. Parenting scores at 13 years and 18 years were added together to create one measure of parenting in adolescence.

Family Relationships- Adolescence. At 18 years participants completed the short version of the McMaster Family Assessment Device (FAD; Epstein, Baldwin, & Bishop, 1983). The FAD is a 12-item self-report measure designed to measure the family atmosphere. In this measure statements were given that describe families and the adolescent was asked to indicate how well the statement described his or her family on a four point scale. Examples of items include “We don’t get along well together”, “In times of crisis we turn to each other for support”, “There are lots of bad feelings in my family”, and “Individuals are accepted for what they are”. This measure has been found to demonstrate adequate reliability and validity when used in nonclinical, psychiatric, and medical samples (Kabacoff et al., 1990). High scores on the FAD indicate good family functioning, and low scores indicate poor family functioning.

Family Conflict- Adolescence. At ages 13 and 18 participants and mothers were interviewed with the Community Mental Health Interview (CMHI; Ikle et al., 1983). Six items on four-point scales addressed issues of family relationships, particularly the level of conflict between parents and children. On this scale, higher scores indicate more family conflict, and lower scores indicate better perceptions of family relationships by the adolescent. Examples of questions for adolescents are “In the last month, how often did your parents hit or slap you?” and “How often did you feel that your parents were dissatisfied or unhappy with the things you did?”. Examples of questions for mothers were “How often does your child have verbal arguments with you?” and “How often have you hit or slapped your child in the last month?”. At age 13 scores for adolescents ranged from 6 to 21, and the mean score was 17.00 ($SD = 2.68$). Scores for mothers ranged from 8 to 21, and the mean score was 16.39 ($SD = 2.86$). At age 18 scores for adolescents ranged from 12 to 24, and the mean score was 20.52 ($SD = 2.63$). Scores for mothers ranged from 7 to 24, and the mean score was 19.69 ($SD = 2.88$). The four family

conflict scores for adolescents and mothers at 13 and 18 were added together to create one adolescent family conflict variable. The alpha for these four variables was .62.

Peer Relationships- Adolescence. At ages 13 and 18 participants and mothers were interviewed with the Community Mental Health Interview (CMHI; Ikle et al., 1983). Seven items asked adolescents and mothers to rate the quality of the adolescent's relationships with peers on four-point scales, with a focus on measuring interpersonal isolation. Examples of questions for adolescents are "How many close friends do you have?" and "In the last month, how often did you feel you could not trust people your own age?". Examples of questions for mothers are "How many close friends does your child have?" and "How often do you think your adolescent feels left out of things by other people his own age?". At age 13 scores for adolescents ranged from 5 to 21, and the mean score was 15.31 ($SD = 2.97$). Scores for mothers ranged from 6 to 21, and the mean score was 15.22 ($SD = 3.19$). At age 18 scores for adolescents ranged from 9 to 36, and the mean score was 31.82 ($SD = 3.94$). Scores for mothers ranged from 9 to 36, and the mean score was 31.48 ($SD = 5.00$). The four scores for mothers and adolescents at 13 and 18 were added together to create one adolescent peer relationships variable. The alpha for these four variables was .51.

Self-concept- Adolescence. Adolescent self-concept was measured at ages 13 and 18 through the Self-Perception Profile for Adolescents (Harter, 1988). The SPPA is a 45-item questionnaire that assesses adolescents' perceptions of competence in 9 areas: social acceptance, romantic appeal, behavioral conduct, close friendship, scholastic competence, athletic competence, physical appearance, job competence, and global self-worth. Items are rated on a 4-point scale, and each subscale contains 5 items. Harter has reported good internal consistency for each of the SPPA subscales. Composite self-worth scores were created by summing the average scores of each scale, with high scores indicating more positive self-concepts. At age 13 composite scores ranged from 9.67 to 22, and the mean score was 17.50 ($SD = 2.29$). At age 18 composite self worth scores ranged from 7 to 20, and the mean score was 16.18 ($SD = 2.78$).

Academic Competence- Adolescence. Three variables were used as indicators of offspring's academic competence at age 18: (1) grade point average, (2) mathematics

achievement, and (3) verbal IQ. These three indicators were standardized and combined to create one measure of academic competence in adolescence.

School records containing grade point averages on a 4-point scale for grades 1 through 12 were obtained, and an average GPA across the school years was calculated (Gutman et al., 2003). Participants had an average GPA of 2.26 ($SD = 0.74$), and GPAs ranged from 0.70 to 3.94.

At age 18 participants completed the Wide Range Achievement Test (WRAT) (Jastak & Jastak, 1978) Arithmetic Level II portion. The Level II WRAT is a brief achievement test normed for individuals ages 12 through 64 with a mean of 100 and a standard deviation of 15. Split-half reliability for the Arithmetic section was 0.94 in the norming sample. Participants in our sample received a mean score of 97 ($SD = 17.2$) on the WRAT Arithmetic portion, and scores ranged from 51 to 136.

Participants also completed the Quick Test (QT) of intelligence (Ammons & Ammons, 1962) at age 18. The QT is a brief, 15-minute test designed to assess intelligence based on visual-perceptual vocabulary performance. For this test, subjects were shown four drawings and given 50 test words of increasing difficulty, each of which related to one picture. Participants were then asked to point to the picture that corresponded to each word. This word-picture matching test has been found to correlate highly with WAIS IQ and Stanford-Binet scores (Mortimer & Bowen, 1999). Norms include standard scores with a mean of 100 and a standard deviation of 15. Participants in our sample received a mean score of 91 ($SD = 12.1$) on the QT, and scores ranged from 43 to 120.

Family Socioeconomic Status- Adolescence. At ages 13 and 18 family SES was computed using the Hollingshead scales, which are based on paternal and maternal education and occupation. Data was obtained from questionnaires filled out by mothers. At age 13 SES scores ranged from 8 to 66 ($M = 37.73$, $SD = 15.66$), and at 18 SES scores ranged from 6 to 66 ($M = 39.78$, $SD = 16.41$). The 13 and 18 year SES scores were highly correlated ($r = .851$, $p < .001$), and were therefore averaged and combined to create an overall family SES score for adolescence. This average score was then reversed so that higher scores corresponded to higher SES in adolescence.

Parental Relationship Status- Childhood and Adolescence. At children's birth, 4 years, 13 years, and 18 years mothers were asked to indicate whether they were currently married or romantically involved with their child's father. At each point, a score of 1 indicated that mothers and fathers were romantically involved, whereas a score of 0 indicated that mothers and fathers were not together. These scores were then summed for the purposes of this study so that a score of 0 indicated that parents were not together at any point during offspring's childhood or adolescence, and a score of 4 indicated that parents were married or romantically involved at all points from offspring's birth through age 18.

Results

The purpose of this study was to examine associations between early maternal mental illness and offspring adult functioning, as well as test a number of individual, family, and social variables as mediators of these predicted relations. Associations between all variables were tested with correlations. Mean differences between study variables based on maternal mental health status were tested using analysis of variance (ANOVAs). Finally, mediating relations were examined with structural equation modeling.

Associations between Variables

Correlations were first computed between maternal mental health in early childhood and offspring outcomes at 30 years (see Table 2.3). Early maternal mental health was found to be associated with both offspring 30 year GAF scores ($r = .41, p < .001$) and 30 year CIDI diagnoses ($r = -.27, p < .01$). Individuals who had mothers with mental health problems during their first three years of life had poorer overall mental health functioning and more psychiatric diagnoses at age 30 compared to individuals whose mothers did not have mental health problems.

Significant correlations were also found between maternal mental health and offspring adult relationship status ($r = .30, p < .001$) and relationship attachment insecurity ($r = -.27, p < .01$). Individuals whose mothers had mental health problems while they were children were less likely to be in stable intimate relationships as adults and were more likely to be anxious and avoidant in their attachment relationships. The

correlation between maternal mental health and offspring relationship satisfaction was not significant ($r = .10, p = .310$).

Maternal mental health was also significantly correlated with offspring educational attainment ($r = .26, p < .01$) and income ($r = .28, p < .001$). Participants whose mothers had mental health problems during their early childhoods attained fewer years of education and had lower incomes at age 30 compared to participants whose mothers did not have mental health problems. Maternal mental health was not significantly correlated with offspring 30 year occupation ($r = .13, p = .137$).

Because several individual and family variables were hypothesized to mediate the associations found between maternal mental health and offspring adaptive functioning, correlations were computed between maternal mental health and the adolescent variables of offspring mental health, parenting, offspring self-concept, offspring academic achievement, offspring peer relationships, family functioning, family conflict, family SES, and parental relationships status, as well as between all of these variables and the 30-year outcomes. These correlations are shown in Table 2.4. Correlations among the adolescent variables are shown in Table 2.5.

As can be seen in Table 2.4, maternal mental health in early childhood was significantly correlated with all but one of the adolescent variables measured. These correlations ranged from a low of $.19 (p < .01)$ for offspring self-concept and a high of $.36 (p < .001)$ for family SES in adolescence. Maternal mental health in early childhood was not significantly correlated with adolescent peer relationships ($r = .07, p = .400$).

These adolescent individual and family variables were also significantly correlated with almost all measures of adult adaptive functioning. Adolescent mental health was significantly correlated with all adult outcomes ($p < .05$), with the exception of romantic relationship satisfaction. Adolescent mental health was most strongly related to 30-year GAF scores ($r = .59, p < .001$) and 30-year educational attainment ($r = .57, p < .001$). Adolescent self-concept was also significantly correlated with all adult outcomes ($p < .05$), with the exception of romantic relationship satisfaction. Self-concept was most strongly related to 30-year attachment insecurity ($r = -.49, p < .001$), as individuals with better self-concepts at 13 and 18 showed less attachment-related anxiety and avoidance in their romantic relationships at age 30.

Parenting in adolescence was associated with all 30-year outcomes ($p < .05$), with the exception of offspring adult relationship satisfaction. Parenting was most strongly correlated with offspring 30-year GAF scores ($r = .47, p < .001$) and 30-year educational attainment ($r = .57, p < .001$). Peer relationships in adolescence were also associated with all 30 year outcomes ($p < .05$), with the exception of 30-year relationship satisfaction. Peer relationships were most strongly associated with 30-year GAF scores ($r = .49, p < .001$).

Adolescents' and mothers' perceptions of family conflict in adolescence were associated with all offspring adult outcomes, and were most strongly correlated with 30-year GAF scores ($r = .46, p < .001$) and 30-year attachment insecurity scores ($r = -.46, p < .001$). In contrast, adolescents' overall perceptions of their family relationships at 18 years were not correlated with 30-year diagnoses, romantic relationship quality, or any of the three measures of socioeconomic status in adulthood. Parental relationship status throughout offspring's childhood and adolescence was related to offspring's relationship status at 30 years ($r = .29, p < .01$), as well as to offspring's socioeconomic status and mental health at age 30 ($p < .001$).

Adolescent academic achievement was strongly correlated with adult occupation ($r = .52, p < .001$), educational attainment ($r = .73, p < .001$), and annual income ($r = .37, p < .001$). Adolescent academic achievement was also significantly correlated with adult mental health outcomes, although less strongly. Adolescent academic achievement was not significantly correlated with any of the measures of adult romantic relationships. Finally, family SES in adolescence was significantly correlated with all 30-year outcomes, with the exception of 30-year relationship satisfaction ($r = .15, p = .149$). Family SES in adolescence was most strongly correlated with the three measures of offspring SES in adulthood, with correlations ranging from .50 to .69 ($p < .001$).

Maternal Mental Health Effects

The next step in determining the long-term effects of maternal mental illness on offspring adaptive functioning in adulthood was to examine whether there were overall mean differences in the 30 year outcomes between offspring of mothers with and without mental health problems. A multivariate analysis of variance (MANOVA) was computed because many of the 30-year outcomes were correlated with each other. For this test all of

the 30 year outcomes (psychiatric diagnoses, overall mental health, occupational status, educational attainment, annual income, relationship status, relationship quality, and attachment insecurity) were entered into the equation as dependent variables and maternal mental health was entered as the fixed factor. A dichotomous measure of maternal mental health was created for this analysis by recoding the maternal mental health measure into no mental health problem versus presence of any mental health problem during children's first three years of life.

The omnibus test revealed that there were mean differences in these adult outcomes based on history of maternal mental illness [Hotelling's Trace = .313, $F(8,72) = 2.82, p < .01$]. Results of individual ANOVAs are shown in Table 2.6. As was predicted by hypothesis 1, offspring adult mental health status differed by earlier maternal mental health status. Participants whose mothers had mental health problems when they were growing up had significantly lower GAF mental health scores ($M = 75.21$, which corresponds to some mental health impairment) compared to participants whose mothers did not have mental health problems ($M = 83.20$, which corresponds to good mental health). In addition, participants of mothers with mental health problems scored positive in more psychiatric diagnosis categories at age 30 ($M = 1.10$) compared to participants of mothers without mental health problems ($M = 0.58$).

ANOVAs also revealed that offspring differed in both their relationship statuses and their levels of relationship attachment insecurity based on their mothers' mental health status thirty years earlier. Offspring of mothers with mental health problems were less likely to be married or in committed dating relationships compared to offspring of mothers without mental health problems ($M = 2.85$ vs. $M = 3.44$). Offspring of mothers with mental health problems were also more insecure in their romantic attachments, and were more likely to endorse anxious and avoidant feelings about their intimate relationships than were offspring of mothers without mental health problems ($M = 50.46$ vs. $M = 38.91$). Levels of satisfaction with current romantic relationships did not differ between offspring of mothers with mental health problems ($M = 4.15$) and offspring of mothers without mental health problems ($M = 4.15$).

Finally, adult offspring of mentally ill mothers were lower on several measures of socioeconomic status than were adult offspring of mothers without mental health

problems. Offspring of mothers with mental health problems attained fewer years of education ($M = 4.87$, which corresponds to between high school graduate and some college) compared to offspring of mothers without mental health problems ($M = 5.33$, which corresponds to between some college and college graduate). Offspring of mothers with mental health problems early in their lives also had lower annual incomes 30 years later ($M = \$47,730$ per year) compared to offspring of mothers without mental health problems ($M = \$66,210$ per year). Occupational status did not differ significantly between adult offspring of mothers with mental health problems ($M = 4.84$) and adult offspring of mothers without mental health problems ($M = 5.26$).

Structural Equation Analyses

Now that it was established that early maternal mental health was related to offspring adult outcomes, and that a number of adolescent variables were related to both early maternal mental health and offspring adult adaptive functioning, the next step was to determine whether these variables served as actual mediators. Structural equation modeling (SEM) was used for these analyses. Statisticians generally recommend that for use in SEM sample sizes exceed 100 cases (Hoyle, 1995). Some rules of thumb in the literature are that there should be at least 10 to 20 times as many cases as variables in the model (Mitchell, 1993), and there should be at least 15 cases per measured variable or indicator (Stevens, 1996). Although our sample size for this study was relatively small, it meets these three recommendations and was sufficient for estimating the models that were tested.

The gap between the observed and the estimated covariance matrix, produced according to the specified models, was used by the program to compute goodness-of-fit indices that help determine the extent to which the conceptual model provides an acceptable representation of the data. The widely used goodness-of-fit indices known as the normed fit index (NFI), the Tucker-Lewis index (TLI), and the comparative fit index (CFI) were used in this study to indicate the extent of fit. A value of .90 and higher was regarded as indication of a good fit of the model. In addition, the root-mean-square error of approximation (RMSEA) misfit index was used, and its recommended value of .06 or lower (Hu & Bentler, 1999) indicated acceptable fit.

Missing data were handled using full information maximum likelihood (FIML) methods. These procedures have been found to yield the least biased estimates when all available data are used for longitudinal analyses (versus listwise deletion of missing data) (Enders, 2001; Raykov, 2005). Thus, the full sample of participants whose mothers provided mental health data at 30 months were utilized for these analyses. This full sample provides the best possible variance/covariance estimates and was least likely to be biased by missing data. Alternative longitudinal analyses using just those participants without missing data (i.e., listwise deletion) yielded results that were substantially identical to those reported below.

Early Maternal Mental Health and Offspring Adult Mental Health

The first structural equation models were designed to test associations between maternal mental health in offspring's early childhood and offspring's mental health outcomes in adulthood. The initial model tested these direct associations, with pathways drawn from maternal mental health to offspring 30 year CIDI diagnoses and 30 year global assessment of functioning mental health scores (Figure 2.1). As expected from the significant correlations discussed earlier, this model shows that maternal mental health is significantly related to both offspring adult diagnoses ($\beta = -.26, p < .01$) and offspring adult overall mental health ($\beta = .42, p < .001$). Offspring of mothers with better mental health during their early childhood had fewer psychiatric diagnoses and better overall mental health in adulthood. In addition, 30-year CIDI diagnoses were significantly related to 30-year GAF scores ($r = -.55, p < .001$), as individuals with more psychiatric diagnoses were rated by trained observers as having poorer overall mental health. Because this model was fully saturated, fit indices are not relevant here. However, it should be noted that maternal mental health alone explained .07 of the variance in 30 year CIDI diagnoses and .17 of the variance in 30 year GAF scores.

The next step was to test whether any of the potential mediators described in the measures section help to explain the associations found between maternal mental health and offspring mental health 30 years later. Based on the body of literature described above on the intergenerational transmission of psychopathology, it was determined that offspring mental health, offspring self-concept, parenting, family relationships, parental relationship status, and family conflict in adolescence were all potential mediators of the

relations between severity of maternal mental illness in early childhood and offspring mental health problems in adulthood. A structural equation model was first tested with all possible pathways drawn from maternal mental health to each of the mediators and from each of the mediators to both offspring mental health outcomes. In addition, direct pathways from maternal mental health to offspring mental health continued to be tested, and covariances between the mediators and between the outcomes were also tested. In order to obtain the most parsimonious model, pathways that were not significant were then removed from the model in a series of steps. Because the pathways from family relationships, family conflict, and parental relationship status to offspring CIDI diagnoses and GAF mental health scores were not significant, these variables were completely removed from this model. In addition, the direct pathway from maternal mental health to offspring CIDI diagnoses was not significant when the mediators were included in the model, and was therefore removed.

The final model is shown in Figure 2.2. This model fits the data well, $\chi^2(3, n = 234) = 2.945, p = .400$; with normed fit index = .984, Tucker-Lewis index = 1.00, comparative fit index = 1.00, and root-mean-square error of approximation = .000. As can be seen from this model, adolescent mental health, adolescent self-concept, and parenting in adolescence partially mediated the significant associations found between maternal mental health and offspring mental health. The pathway between maternal mental health and offspring adolescent mental health was significant ($\beta = .27, p < .001$), as mothers with better mental health early on had offspring with better mental health at ages 13 and 18. Offspring mental health in adolescence then went on to predict both offspring psychiatric diagnoses ($\beta = -.43, p < .001$) and observer ratings of offspring overall mental health ($\beta = .40, p < .001$). Individuals with better mental health in adolescence had fewer psychiatric diagnoses and better overall mental health at age 30.

Maternal mental health in early childhood was also significantly related to adolescent self-concept ($\beta = .20, p < .05$), as individuals whose mothers had better mental health early on had better self-perceptions in adolescence compared to individuals whose mothers had more mental health problems during their first three years. Adolescent self-concept was then related to offspring overall mental health in adulthood ($\beta = .17, p < .05$), with better self-concept related to better GAF scores more than a decade later.

Parenting in adolescence mediated the association between maternal mental health and offspring overall mental health 30 years later. Maternal mental health was related to adolescent parenting ($\beta = .23, p < .01$), with better maternal mental health during early childhood predicting better parenting in early and late adolescence. Adolescent parenting was then related to offspring adult GAF scores ($\beta = .23, p < .001$), with better parenting predicting better adult mental health among offspring.

Finally, even with adolescent mental health, adolescent self-concept and adolescent parenting serving as mediators of the associations between early maternal mental health and offspring 30-year GAF scores, this direct pathway between maternal mental health and offspring mental health remained significant in this final model ($\beta = .14, p < .05$). Mothers with mental health problems during their children's first three years of life were more likely to have offspring with mental health problems three decades later. In addition, the covariances between adolescent mental health and adolescent self-concept ($r = .43, p < .001$), between adolescent mental health and adolescent parenting ($r = .31, p < .001$), and between adult CIDI diagnoses and adult GAF scores ($r = -.27, p < .001$) were all significant. The covariance between adolescent self-concept and adolescent parenting was not significant ($r = .06, p = .312$). Together, maternal mental health, adolescent mental health, adolescent self-concept, and parenting explained .44 of the variance in offspring 30 year GAF scores. Adolescent mental health alone explained .18 of the variance in 30 year CIDI diagnoses.

Early Maternal Mental Health and Offspring Adult Socioeconomic Status

The second set of structural equation models tested associations between maternal mental health and offspring adult socioeconomic status. The first model in this series tested direct associations between maternal mental health and offspring educational attainment, occupational attainment, and income at 30 years (Figure 2.3). As was expected from the correlation analyses, significant relations were found between maternal mental health in early childhood and offspring educational attainment in adulthood ($\beta = .27, p < .01$) as well as between maternal mental health and offspring annual income in adulthood ($\beta = .28, p < .001$). Maternal mental health explained .07 of the variance in offspring adult educational attainment and .08 of the variance in offspring adult income. Individuals whose mothers had better mental health in their early childhoods attained

more years of education and had higher annual incomes at age 30. The direct pathway between maternal mental health and offspring occupational attainment was not significant ($\beta = .13, p = .121$). All covariances between the 30-year socioeconomic outcomes were significant ($p < .001$).

Because the intent of this study was to explore mediators between maternal mental health and offspring outcomes, 30 year occupational attainment was removed from further analyses. A structural equation model was developed that tested all potential mediating pathways between maternal mental health and offspring educational attainment and income. The mediators tested were offspring mental health, offspring academic achievement, offspring self-concept, parenting, family conflict, family relationships, parental relationship status, and family socioeconomic status. All mediators were measured during offspring's early and late adolescence. A structural model was tested with all possible pathways drawn from maternal mental health to each of the mediators and from each of the mediators to both offspring socioeconomic outcomes. In addition, direct pathways from maternal mental health to offspring mental health continued to be tested, and covariances between the mediators and between the outcomes were also tested. In order to obtain the most parsimonious model, pathways that were not significant were then removed from the model in a series of steps. Because adolescent self-concept, parenting, family relationships, parental relationship status, and family conflict did not significantly predict offspring socioeconomic status in this model, these variables were removed from the model. In addition, because the direct pathways between maternal mental health and offspring socioeconomic status were not significant when the mediators were included in the model, these pathways were removed.

The final model is shown in Figure 2.4. This model fits the data well, $\chi^2(4, n = 234) = 4.895, p = .298$; with normed fit index = .986, Tucker-Lewis index = .985, comparative fit index = .997, and root-mean-square error of approximation = .026. As can be seen from Figure 2.4, offspring mental health, offspring academic achievement, and family socioeconomic status as measured in adolescence all mediated the relations found between maternal mental health and offspring adult socioeconomic status. Maternal mental health was significantly related to adolescent mental health ($\beta = .28, p < .001$) and adolescent mental health was then related to 30-year educational attainment (β

= .21, $p < .001$). Thus, offspring of mothers with mental health problems were more likely to have their own mental health problems in adolescence, and these problems were then related to their educational attainment in adulthood.

In addition, maternal mental health in offspring's early childhood was associated with family socioeconomic status in adolescence ($\beta = .37, p < .001$), as mothers with more mental health problems were also more likely to be of lower socioeconomic status several decades later. Family SES then predicted offspring 30-year educational attainment ($\beta = .29, p < .001$) and 30-year income ($\beta = .51, p < .001$), as individuals from lower SES families attained fewer overall years of education and earned lower annual incomes compared to individuals from higher SES families. Finally, adolescent academic achievement mediated the relation between maternal mental health and offspring adult educational attainment. Mothers with more mental health problems early on were more likely to have adolescents with lower grade point averages and IQ scores in adolescence ($\beta = .20, p < .01$), and adolescents with lower academic achievement measures in adolescence attained fewer years of education on average than did adolescents with better grades and IQ scores ($\beta = .45, p < .001$). The covariances between all three mediators were significant ($p < .001$). The covariance between 30-year income and 30-year educational attainment was not significant in this model ($r = .12, p = .177$). Together, adolescent academic achievement, mental health, and family SES explained .67 of the variance in adult educational attainment, and adolescent family SES alone explained .26 of the variance in adult annual income.

Early Maternal Mental Health and Offspring Adult Romantic Relationships

The final series of structural equation models examined associations between maternal mental health in early childhood and offspring romantic relationship outcomes in adulthood. A model was first calculated that tested direct associations between maternal mental health in early childhood and offspring relationship status, relationship quality, and relationship attachment insecurity at age 30 (Figure 2.5). As can be seen from this model, maternal mental health was significantly associated with offspring adult relationship status ($\beta = .31, p < .001$) and adult relationship attachment insecurity ($\beta = -.26, p < .01$). Offspring of mothers with mental health problems in their early childhoods were less likely to be married or in committed romantic relationships in adulthood and

were more likely to show higher levels of attachment-related anxiety and avoidance in regards to their romantic relationships. Maternal mental health explained .10 of the variance in offspring adult relationship status and .07 of the variance in offspring attachment insecurity. Maternal mental health was not significantly related to 30-year relationship quality ($\beta = .10, p = .323$). All covariances between the 30-year relationship outcomes were significant ($p < .05$).

Because the intent of this study was to explore mediators between maternal mental health and offspring outcomes, 30 year relationship quality was removed from further analyses. A structural equation model was developed that tested all potential mediating pathways between maternal mental health and offspring relationship status and relationship attachment insecurity. The mediators tested were offspring mental health, offspring self-concept, parenting, family relationships, parental relationship status, and family conflict. All mediators were measured during offspring's early and late adolescence. A structural model was tested with all possible pathways drawn from maternal mental health to each of the mediators and from each of the mediators to both offspring socioeconomic outcomes. In addition, direct pathways from maternal mental health to offspring mental health continued to be tested, and covariances between the mediators and between the outcomes were also tested. Because parenting, mental health, and family relationships in adolescence did not significantly predict offspring romantic relationship status or attachment insecurity in this model, these variables were removed. In addition, because the direct pathways between maternal mental health and offspring attachment insecurity and relationship status were not significant when the mediators were included in the model, these pathways were removed.

The final model is shown in Figure 2.6. This model fits the data well, $\chi^2(4, n = 234) = 6.399, p = .171$; with normed fit index = .945, Tucker-Lewis index = .868, comparative fit index = .975, and root-mean-square error of approximation = .042. As can be seen from Figure 2.6, adolescent family conflict and parental relationship status during childhood and adolescence mediated the association between maternal mental health and offspring adult relationship status. Maternal mental health was significantly associated with adolescent family conflict ($\beta = -.23, p < .01$), and adolescent family conflict significantly predicted adult relationship status ($\beta = -.21, p < .05$), with more

family conflict in adolescence associated with less committed romantic relationships in adulthood. In addition, maternal mental health was significantly associated with parental relationship status ($\beta = .33, p < .001$), as mothers with better mental health were more likely to be romantically involved with children's fathers. Parental relationship status from birth through age 18 then predicted offspring relationship status at age 30 ($\beta = .23, p < .01$), as offspring whose parents were together while they were growing up were more likely to be married or in stable dating relationships as adults.

In addition, adolescent family conflict and adolescent self-concept mediated the association between maternal mental health and offspring adult attachment insecurity. Maternal mental health predicted adolescent self-concept ($\beta = .19, p < .05$), and adolescent self-concept then predicted adult attachment insecurity ($\beta = -.25, p < .01$). Better self-concept in adolescence was related to lower levels of attachment insecurity in adulthood. In addition, adolescent family conflict was related to adult attachment insecurity ($\beta = .32, p < .001$), as individuals with higher levels of family conflict in adolescence had higher levels of attachment-related anxiety and avoidance in adulthood. Finally, the covariances between adolescent family conflict and adolescent self-concept ($r = .34, p < .001$) and between adult relationship status and adult attachment insecurity ($r = -.33, p < .001$) were significant. Together, parental relationship status and adolescent family conflict explained .12 of the variance in adult relationship status, and adolescent family conflict and self-concept explained .23 of the variance in attachment insecurity.

Discussion

The primary goal of Study 1 was to examine direct and indirect associations between maternal mental illness in early childhood and offspring adaptive functioning almost three decades later. Using a sample of mothers and children followed over the course of 30 years, associations between early maternal mental illness and measures of offspring adult mental health, romantic relationship functioning, and socioeconomic status were tested. In addition, a number of individual and family variables from early and late adolescence were tested as mediators of these significant relations.

This study had several strengths that addressed gaps in the existing literature on the effects of parental mental illness on offspring. First, this study examined long-term longitudinal effects of early parental mental illness on offspring adult adaptive

functioning. These long-term effects are particularly important to study because infancy and early childhood are developmental periods in which children are completely dependent upon parents for their emotional and physical needs. Thus, the effects of parental mental illness experienced during this time period may be particularly harmful and long-lasting. Second, this study expanded upon existing research by examining associations between early maternal mental illness and multiple offspring adult outcomes, including mental health, educational attainment, occupational attainment, income, romantic relationship status, romantic relationship security, and romantic relationship satisfaction. Third, this study examined multiple individual, family, and social variables across offspring's early and late adolescence as mediators of the predicted associations between early maternal mental illness and offspring adult outcomes with the aim of identifying pathways of risk and resilience for offspring of mentally ill mothers.

Maternal Mental Illness and Offspring Competence

Results of Study 1 revealed that there were significant associations between maternal mental health during offspring's early childhood and several measures of offspring adaptive functioning 30 years later. As expected from the literature, individuals with a history of maternal mental illness were more likely to display their own mental health problems in adulthood compared to individuals without a history of early maternal mental illness. In addition, individuals whose mothers had mental health problems when they were young were more likely to be in less secure romantic relationships as adults, and were more likely to be anxious and avoidant in their intimate relationships. Finally, individuals with a history of maternal mental illness were more likely to attain fewer years of education and to have lower annual incomes compared to individuals without a history of maternal mental illness. Group differences confirmed these findings, suggesting that participants with and without a history of maternal mental illness could be reliably distinguished based on their functioning on these measures of adult competence. These findings lend support to the hypothesis that early maternal mental illness is a risk factor for a range of maladaptive outcomes among offspring in adulthood. It is especially notable that maternal mental health measured during children's first three years of life significantly predicted aspects of offspring mental health, romantic relationships, and socioeconomic status up to 30 years later.

Somewhat surprisingly, early maternal mental illness was not found to be associated with either levels of satisfaction within current romantic relationships or adult occupational status. One possible reason for this first finding is that only participants who were currently in a romantic relationship answered questions about their satisfaction with that relationship. Because analyses just described suggest that individuals with a history of maternal mental illness are less likely overall to be in romantic relationships, this would have excluded a substantial number of participants from this group. For occupational status, it is likely that the pathway from maternal mental illness to occupational attainment is an indirect one. For example, the literature on socioeconomic attainment highlights the importance of educational attainment to occupational status (Jencks et al., 1972; Ceci, 1991). It is likely that maternal mental illness more directly influences educational attainment, and that this educational achievement then influences the types of jobs that individuals attain.

The individual and family variables as measured in adolescence were also significantly associated with almost all measures of maternal mental health and offspring adaptive functioning in adulthood. Maternal mental illness in early childhood was associated with more mental health problems, poorer self-concepts, and lower levels of academic achievement among offspring in adolescence. Maternal mental illness was also associated with less positive parenting, less positive family relationships, more family conflict, less stable parental relationships, and lower socioeconomic status among families in adolescence. The only variable that was not associated with early maternal mental health was offspring adolescent peer relationships, perhaps because adolescents strive to keep their relationships with peers separate from their relationships and experiences within the family during these adolescent years.

The adolescent variables were also associated with many of the 30-year outcomes for offspring. Consistent with earlier findings for the adult outcomes, only one adolescent individual or family variable was associated with adult relationship satisfaction. Participants who had experienced higher levels of family conflict in adolescence were less satisfied with their romantic relationships in adulthood. As expected, characteristics of the adolescent, including their mental health and overall self-concept, as well as characteristics of the family, including parenting quality, level of family conflict, and

parental relationship status, were highly associated with 30-year mental health and romantic relationship outcomes. The adolescent variables of academic achievement and family SES were highly associated with 30-year socioeconomic outcomes.

Pathways from Maternal Mental Health to Offspring Outcomes

The primary aim of this study was to test direct and indirect pathways from maternal mental health in early childhood to multiple offspring adaptive functioning outcomes in adulthood. This research filled an important gap in the current literature because, although a large body of research has shown that parental psychopathology often leads to adverse outcomes in offspring, we currently know very little about the processes through which maternal mental illness during a child's first years of life could affect the child's adaptive outcomes many years later, after the child has become an adult. Moreover, although research has shown that parental mental illness is linked to offspring psychopathology, we currently know much less about other areas of offspring functioning that are also important to successful adult adaptation, particularly those involving school, work, and interpersonal relationships.

Pathways to Offspring Mental Health. The first set of analyses explored pathways from early maternal mental health to two measures of offspring adult mental health. These analyses revealed that the direct pathways between maternal mental health in early childhood and offspring mental health in adolescence were explained by several individual and family variables in adolescence. In describing the development of adult mental health, two pathways that emerged were from early maternal mental health to offspring mental health in adolescence, and from offspring mental health in adolescence to adult psychiatric diagnoses and global mental health functioning in adulthood. These findings are in keeping with a body of research that supports the intergenerational transmission of psychopathology from parents to children (Radke-Yarrow & Klimes-Dougan, 2002; Brennan et al., 2002). These results suggest that individuals who experience maternal mental illness early in their lives are more likely to have mental health problems in adolescence, and that these problems remain stable into adulthood.

The second variable that helped explain the links between early maternal psychopathology and offspring adult mental health was warmth and sensitivity of parenting in adolescence. Mothers who had mental health problems when children were

born displayed more negative parenting during their adolescence, and this negative parenting then predicted lower overall mental health scores for offspring in adulthood. Although the current research literature has been mixed (Bifulco et al., 2002; Leinonen et al., 2002; Kim et al., 2003), these findings support the role of parenting as a mediator. They also suggest that early maternal mental illness may contribute to negative patterns of interaction between mothers and children that can persist for years afterward, even into adolescence.

The final pathway through which maternal mental health appears to influence offspring mental health is through its impact on offspring self-concept. These results show that adolescents with a history of maternal mental illness have more negative perceptions of themselves in areas such as their physical appearance, their behavioral conduct, and their ability to successfully navigate school, work, friendships, and romantic relationships. More negative self-concepts in adolescence are then associated with poorer overall mental health in adulthood. This finding supports the relatively unexplored theory that parental mental illness contributes to negative cognitions within the child, and that such negative self-schemas then predict the future development of psychopathology (Radke-Yarrow et al., 1995). A closer examination of the importance of cognitive processes of the offspring in these contexts will be given in Studies 2 and 3 of this dissertation.

Finally, these analyses reveal that even with adolescent mental health, adolescent self-concept and adolescent parenting taken into account, the direct pathway between maternal mental health in early childhood and offspring mental health at age 30 remained significant in this model. This suggests that there are other variables, perhaps biological or genetic factors, which also help to explain the intergenerational transmission of psychopathology. Another option is that offspring's representations of their experiences growing up with maternal mental illness serve as additional mediators of the link between maternal and child psychopathology. This possibility will be explored in Chapter 3.

Pathways to Offspring Socioeconomic Status. The second set of analyses explored direct and indirect pathways from maternal mental illness in early childhood to two measures of offspring adult socioeconomic attainment. Consistent with correlational findings, early maternal mental health was associated with offspring 30-year educational

attainment and income, but not occupational status. These direct associations between maternal mental health and offspring education and income were then explained by several individual and family variables measured in adolescence.

Based on a large body of research on status attainment, it was expected that the two variables that would be most strongly related to adult educational attainment and income would be offspring academic achievement in adolescence and family socioeconomic status (Strenze, 2007). Researchers in a number of fields have supported the link between IQ and status attainment, and have consistently found that people with higher IQ scores attain more education, hold more prestigious occupations, and earn higher incomes compared to people with lower test scores (Gottfredson, 2003; Schmidt & Hunter, 2004). In fact, a number of researchers have found that the correlation between IQ scores and educational attainment generally exceeds .50 (Jencks, 1972; Neisser et al., 1996). In addition, grades in school, even those obtained as early as elementary school, have been found to strongly predict educational attainment in adulthood (Entwisle, Alexander, & Olson, 2005).

For family SES, the achievement literature has consistently shown that parental education is an important factor in predicting children's education and occupation in adulthood (Corwyn & Bradley, 2002). In his work with white males, Jencks (1972) reported that the most important determinant of educational attainment was family SES as measured by father's occupation and income, and that educational attainment was in turn the most important determinant of occupational attainment. A more recent study by Entwisle, Alexander, and Olson (2005) found that family SES as measured by the education and occupational status of both parents in first grade had the largest direct effect on educational attainment at age 22, even compared with individual variables like school achievement and with later measures of SES.

Thus, both family SES and individual academic achievement as measured by IQ scores and grades in school have been found to be important to adult socioeconomic attainment. In this study, family SES in adolescence was indeed a mediator of the links between maternal mental health at 30 months and offspring educational attainment and income at 30 years. Mothers with more mental health problems at 30 months were of lower socioeconomic status when children were adolescents, and lower family SES in

adolescence then predicted lower educational attainment and lower income for offspring in adulthood. This is in keeping with previous work by Jencks (1972) and Entwisle, Alexander, and Olson (2005) that reported earlier family SES as an important predictor of offspring socioeconomic attainment in adulthood.

Offspring academic achievement also served as a mediator of the path between maternal mental health and offspring educational attainment. Mothers with more mental health problems at 30 months had offspring with lower IQ scores and poorer grades in adolescence. Adolescent academic achievement was then strongly associated with years of overall education attained by adulthood. In contrast to expectations, academic achievement did not serve as a mediator of the pathway between maternal mental health and offspring income.

One somewhat surprising finding was that, in addition to the expected roles of family SES and academic achievement as mediators of the relations between maternal mental health and offspring SES, adolescent mental health also emerged as an important mediator. Specifically, offspring of mothers with early mental health problems were found to have their own mental health problems at ages 13 and 18, and these adolescent problems then predicted fewer years of education attained by age 30. The fact that adolescent mental health significantly predicted adult socioeconomic attainment was notable; however, the fact that this association was significant even with the more established predictors of academic achievement, IQ scores, and family SES included and accounted for in the model was even more interesting.

Overall, these results suggest that individual academic achievement and family socioeconomic status in adolescence are related to participants' socioeconomic attainment in adulthood, and that these variables mediate associations between early maternal mental illness and offspring adult socioeconomic status. In addition, these results highlight that mental health in adolescence is an important predictor of socioeconomic attainment twelve years later, and that the links between early maternal psychopathology and later offspring psychopathology helps explain the long-term impact of maternal mental health on offspring educational attainment. Thus, although mental health has been largely ignored in the status attainment literature, this is a construct that may be important for predicting socioeconomic success in adulthood.

Pathways to Offspring Romantic Relationships. The final set of analyses explored the role of maternal mental health in early childhood in predicting aspects of offspring adult romantic relationships. Similar to results found in preliminary analyses, the first model showed that early maternal mental health was associated with offspring relationship status and relationship attachment insecurity in adulthood, but not level of satisfaction within romantic relationships. As described above, this is likely because a substantial number of participants with a history of maternal mental illness were not in romantic relationships at age 30, and thus did not complete this measure.

The association between maternal mental health and the types of adult romantic relationships that offspring were involved in was explained by family conflict in adolescence and parental relationship status throughout childhood and adolescence. Families in which mothers had mental health problems early on had higher levels of conflict as reported by both offspring and mothers in adolescence. This is in keeping with a body of research that has shown that family and marital discord are common risk factors associated with parental mental illness (Rutter, 1990; Weissman et al., 1997). High family conflict in adolescence was then associated with less committed romantic relationships for offspring in adulthood. One explanation for this finding may be that family conflict exposes children to poor models for handling interpersonal conflict (Hammen, Brennan, & Shih, 2004), and these children may grow up to be less able to navigate romantic relationships in adulthood. Children in families with parental mental illness are also more likely to experience parental divorce than children in families without parental mental illness (Downey & Coyne, 1990), and this may make children less likely to engage in long-term committed romantic relationships in adulthood.

Another pathway from maternal mental health in early childhood to offspring romantic relationship status in adulthood was through parental relationship status. Mothers with better mental health early on were more likely to be involved with offspring's fathers over the following 18 years. Offspring whose parents were married or romantically involved with each other while they were growing up were then more likely to be married or in serious dating relationships as adults. This is consistent with research that has found that children of divorced parents are more likely to experience divorce themselves (Amato, 1996). However, it should be noted that length of parental

relationship is not necessarily a measure of quality of relationship. For example, a warm and loving relationship between parents will likely have a different impact on offspring adult relationship status than will an abusive or cold relationship between parents that lasted the same amount of time. Because data on parental relationship quality was not gathered in the current study, this issue could not be addressed here. In addition, no information was gathered about other possible parental relationships, such as those between parents and step-parents. Regardless, these analyses suggest that parents who stay married while their children are growing up are more likely to have children who are married in adulthood.

Finally, the pathway between early maternal mental health and offspring relationship attachment insecurity was explained by family conflict and adolescent self-concept. Offspring from families with higher levels of conflict appear to develop more negative beliefs about romantic relationships in adulthood. Offspring with poorer self-concepts in adolescence also grow up to endorse more avoidant and anxious beliefs about romantic relationships in adulthood. These associations are in keeping with adult attachment theory. According to this theory, individuals construct internal working models of close relationships that are based on their past experiences. These models provide the basis for expectations about the behavior of self and others in current and future relationships, and serve as scripts for guiding behavior within relationships (Bowlby, 1980; Fraley, 2002). If participants' beliefs about themselves and their abilities to form interpersonal relationships in adolescence are negatively affected by their experiences with maternal mental illness in early childhood, then these beliefs may be carried over into their beliefs about romantic relationships in adulthood.

Limitations

There are several limitations to this study that must be acknowledged when interpreting these results. First, as discussed earlier, although the sample size was sufficient for running the statistics used in this study, the overall sample size was not large. Participants were part of a longitudinal study that they had entered into at birth, and although analyses indicated that a great deal of variability was present in all key variables at each time point in this study, attrition was an issue of concern.

Second, this study examined maternal mental health measured during offspring's first three years, as opposed to maternal mental health at later points in children's development. The main reason for this is that the overall aim of this study was to examine long-term developmental pathways between offspring's experiences with maternal mental illness at their earliest point in development and their overall levels of functioning in adulthood. Early childhood is a period of development in which children may be particularly susceptible to parental influences, as they are completely dependent upon caregivers for their every need. As described in the literature review, a body of research exists that supports the idea that parental mental illness has the largest effect on children when it occurs during infancy and early childhood, rather than later in development (Grigoriu-Serbanescu et al., 1991; Murray & Cooper, 2003). Moreover, as the question of how early maternal mental illness affects offspring's adult outcomes can only be answered with long-term longitudinal samples of mothers and children, this sample was particularly well suited to address this issue.

Moreover, in-depth psychiatric interviews were only given to mothers at children's birth and at 30 months. At all later waves of data collection mothers completed self-report questionnaires as measures of their mental health. Although these later measures were not used in these dissertation analyses, correlations between all maternal mental health measures revealed that maternal mental health was stable across time from children's birth through age 18. In particular, maternal CAPPS scores at children's birth and 30 months were significantly correlated with maternal self-report anxiety scores (IPAT) at birth ($r = .48, p < .001$), self-report anxiety scores (IPAT) at 30 months ($r = .49, p < .001$), self-report depression scores (Rutter) at 4 years, self-report depression scores (Rutter and Beck) at 13 years ($r = .37, p < .001$; $r = .29, p < .001$), and self-report overall mental health scores (SCL-90) at 18 years ($r = .35, p < .001$). Thus, it is reasonable to conclude that children who experienced maternal mental illness during their infancy and early childhoods also experienced maternal mental health problems later in their development.

Implications and Conclusion

The overall aim of this study was to examine a group of individuals followed over the course of 30 years and test whether experiences with maternal mental illness during

infancy and early childhood would be related to how individuals ended up in adulthood. The overarching finding of this study was that maternal mental health in early childhood is important to offspring adaptive functioning in adulthood. Previous research has shown that maternal mental illness has significant concurrent effects on children throughout development, but this study adds to this research by finding that maternal mental health measured during children's first three years is significantly associated with their own mental health, their feelings and behaviors within romantic relationships, and their socioeconomic status in adulthood.

Results from this study can be used to identify several possible intervention strategies for offspring of parents with mental health problems. First, these results highlight the importance of maternal mental health to child functioning, and suggest that maternal mental health measured even at the earliest point in a child's life may have consequences for children's outcomes decades later. Interventions focused on alleviating these early maternal mental health problems are thus crucial, and may help to impede negative trajectories of functioning that can extend into adolescence and adulthood. Early childhood may be a developmental period in which children are particularly vulnerable to parental mental illness, perhaps because of their total dependence upon caregivers during this period.

Second, these findings suggest that there are different pathways from maternal mental health in early childhood to the diverse outcomes of offspring mental health, romantic relationships, and socioeconomic status in adulthood. Moreover, these pathways reveal multiple intervention points that have not been focused on to any great extent in the existing literature. For example, traditional research on the intergenerational transmission of psychopathology asserts that to prevent offspring of mentally ill parents from developing problems in adulthood, clinicians should focus on preventing development of psychopathology in offspring early on. Results of Study 1 show that preventing or alleviating adolescent mental health problems is one possible means of breaking the cycle from maternal mental illness to offspring mental illness in adulthood. These results also show, however, that improving parenting of mothers with a history of mental illness and enhancing the self-concepts of their adolescents may also help in breaking this cycle.

Similarly, traditional research on socioeconomic attainment has suggested that the two variables most important to adult socioeconomic status are family socioeconomic status and individual academic achievement. Indeed, the results of this study suggest that two pathways through which early maternal mental illness may negatively affect offspring adult educational attainment and income are through family SES and offspring's academic competence as measured in adolescence. Interventions focused on improving the grades of offspring of mentally ill parents, or family interventions aimed at job training or finding employment for parents in these families, may therefore lead to improved socioeconomic outcomes among these offspring in adulthood. From this research it appears as though another pathway to foster socioeconomic success in adulthood is to improve mental health in adolescence. Because mental health has been found to be stable from adolescence to adulthood (Schulenberg & Zarrett, 2006), by alleviating mental health problems in adolescents we may be able to not only lower their chances of having mental health problems in adulthood, but also improve their chances of educational success years later. Although possible influences of family SES and academic competence should not be overlooked, this research supports the idea that adolescence may be an especially important period in which to focus on mental health and its consequences for later functioning.

Finally, traditional research on romantic relationship outcomes in adulthood has suggested that children learn how to navigate romantic relationships through their experiences with their families of origin (Hammen, Brennan, & Shih, 2004). Results of this study support this idea, as maternal mental illness was linked to higher levels of conflict within the family, and family conflict then predicted less committed romantic relationships and higher levels of attachment-related anxiety and avoidance in adulthood among offspring. Maternal mental illness in early childhood also predicted less stable relationships with children's fathers over time, and parental relationship status from childhood through adolescence was then associated with offspring relationship status in adulthood. One possible intervention point to break these cycles may therefore be aimed at strengthening relationships within the family, and teaching both parents and children constructive ways of dealing with conflict. Results of this study also reveal that another important factor that helps explain the link between early maternal mental health and

offspring adult romantic relationships is offspring self-concept in adolescence.

Individuals who experienced maternal mental health problems early in their lives tend to have negative perceptions about their competence in a range of areas, including their romantic appeal, their ability to form close friendships, their social acceptance, and their physical appearance. By targeting these negative perceptions in adolescence and improving the self-concepts of offspring of mentally ill parents, these results suggest that their beliefs about romantic relationships in adulthood may also be improved.

As with all non-experimental studies of human behavior, the results of this study do not imply causation. These results do not indicate that all offspring of mentally ill mothers develop problems in adulthood, or that all offspring of mentally healthy mothers display positive adaptation in adulthood. Instead, these results show that maternal mental illness is a risk factor for negative outcomes in offspring, even when this experience with maternal illness occurs very early in development. In addition, these results suggest that a number of individual and family variables throughout adolescence may also be impacted by early maternal mental illness, and that these variables may then have an influence on adaptive functioning in adulthood.

In conclusion, results of this study support the notion that success in adulthood is multi-determined. Individuals must be regarded as totalities, with cognitive functioning, environmental influences, and emotional health all contributing in some measure to adaptive functioning in adulthood. By taking a developmental approach to the study of adult adaptive functioning, we can conclude that the mental health of an individual, his or her level of socioeconomic success, and the ways in which the individual navigates romantic relationships are shaped not only by current characteristics of the individual and his or her context, but also by the nature and course of his or her developmental history. By understanding these developmental pathways, particularly regarding earlier mental health issues in the individual and in the mother, we may better understand the processes through which individuals become successful adults in our society.

CHAPTER 3

A Narrative Analysis of Family of Origin Representations and Adaptive Functioning Outcomes: Study 2

Introduction

The goal of this dissertation is to explore the effects of parental mental health on offspring development. As demonstrated in Study 1, a number of variables throughout childhood and adolescence help explain the link between maternal mental illness in early childhood and offspring adaptive functioning in adulthood. However, another relatively unexplored possibility is that it is not only an individual's actual experiences that are important, but also the ways in which an individual understands and makes sense of those experiences. Some variables that may be particularly important in explaining the link between parental mental illness and offspring outcomes are children's representations of their experiences and relationships within their families of origin. The primary focus of Study 2 of this dissertation will be to examine these representations and explore how they develop over time, as well as how they might contribute to adaptive functioning in adulthood.

Representations of Relationships

An individual's representations of growing up in his or her family of origin may provide important insights into how a person navigates his or her current interpersonal relationships, and may also be related to functioning outcomes in other domains, such as mental health. Two theoretical approaches that are based around the concept of internal representations and their importance to adaptive functioning are the theories of meaning making and adult attachment.

The theory of meaning making asserts that humans organize experiences in an ongoing, moment by moment fashion, and attempt to extract meaning from life events

(Emde, 2003). These can include everyday events, routines, and practices, as well as highly significant, emotionally charged situations, such as the experience of having a parent with a mental health problem. These meaning making processes impact the internal representations individuals form about an event or situation, and in turn, are impacted by these representations. The meanings that individuals make embody interpretations of events and interactions and reflect their understandings about the past as well as their expectations about the future.

At every developmental level of the child, the capacity to generate coherent and constructive meaning and make sense of emotional events is thought to contribute to emotional regulation and integration, with profound implications for the child's emotional well-being and subsequent development (Cole et al., 1994). Affective meaning making processes are an integral part of normative development, with important implications for the child's view of self, others, and the broader social environment (Bretherton & Munholland, 1999). Such processes can promote growth, adaptation, and resilience, or can have a negative developmental impact. In addition, they can act as mediating and moderating variables that determine the short- and long-term impact of stress or trauma on the child (Fivush et al., 2004; Main, 2000).

Meaning making in the family has been found to be associated with family adaptations to stressful conditions, such as chronic illness (Patterson & Garwick, 1994), alcoholism (Wolin, Bennett, Noonan, & Teitelbaum, 1980), or having a child kidnapped or mysteriously missing (Fravel & Boss, 1992). Meaning-making has also been found to be associated with normal transition points, such as the development of adolescent identity (Fiese, 1992; Grotevant, 1993) and relationship formation (Wamboldt & Reiss, 1989). Thus, this theory suggests that the ways in which offspring make sense of and think about their past experiences with their families could impact their current levels of functioning.

Closely related to meaning making, adult attachment theory places a great deal of importance on cognitive representations of relationships and events. Drawing on cognitive information theory, Bowlby (1980) proposed that the organization of the attachment behavioral system involves cognitive components- specifically, mental representations of the attachment figure, the self, and the environment, all of which are

largely based on experiences. Bowlby referred to these representations as “representational models” and as “internal working models”. According to Bowlby, these models allow individuals to anticipate the future and make plans, thereby operating more efficiently.

According to attachment theory, as an individual develops, attachment relations come to be governed by internal (or mental) working models that individuals construct from the experienced interaction patterns with their principal attachment figures (Bowlby, 1980). These internal working models are conceived as “operable” models of the self and of the attachment partner, and are based on a joint history. Internal working models serve to regulate, interpret, and predict both the attachment figure’s and the self’s attachment-related behavior, thoughts, and feelings. If appropriately revised in line with developmental and environmental changes, internal working models can also enable reflection and communication about past and future attachment situations and relationships.

Because internal working models are believed to reflect experienced interaction patterns between an attached individual and his or her attachment figures, the developing working models of self and of the attachment figures are complementary. According to this view, a working model of self as valued and competent is constructed in the context of a working model of parents as emotionally available. Conversely, a working model of self as devalued and incompetent is the counterpart of a working model of parents as rejecting or ignoring of attachment behavior and interfering with exploration (Bretherton & Mulholland, 1999).

Family Narratives and Representations

Together, these theories suggest that representations of the family are formed through a process of meaning making, and that these representations may be important to current and future functioning. It is only within the past several decades that researchers have developed methods for operationalizing and measuring these representations. One method is through the assessment of narratives. By definition, narratives are integrally linked to the meaning making process. Narratives afford the opportunity to examine implicit and sometimes unexamined beliefs that individuals hold about relationships and critical events. Narratives can also reflect how the individual makes sense of the world,

how the individual expresses rules of interaction, and how the individual views the trustworthiness of relationships. When individuals are asked to recount a personal event, they set an interpretive frame that reflects how the individual has struggled and sometimes resolved emotionally evocative circumstances. In this regard, narrative analysis allows for a glance at the inner workings of the individual and how the meaning making process is associated with adaptation (Fiese & Spagnola, 2005).

Narratives are complex entities that convey meaning on multiple levels. Linguists suggest that in order to interpret meaning in a story it is essential to consider how it is constructed, its actual content, and how relationships are depicted within the narrative (Halliday, 1973). Although self-report measures and behavioral coding schemes can reveal important facets of individual functioning, narrative methods take as their starting point the individual's or family's unique experiences and consider whether the reflected beliefs are coherent and dominated by particular themes.

Much of the current interest in narrative psychology stems from using talk as a window into cognitive processes of the individual (Bruner, 1987). How the individual puts together the pieces of his or her life story may reflect important aspects of personal identity (McAdams, 1993). It is important to keep in mind, however, that the recounting of personal events is not necessarily a factual accounting of person, place, and time. Rather, it is a constructive process in which past events are viewed in light of current context (Riessman, 1993). When an individual is asked to recount an experience, he or she sets an interpretive frame reflecting how he or she grapples with understanding events and how the ascription of meaning is linked to beliefs about relationships in the family and social world.

Personal narratives have received increasing amounts of attention as reflections of important psychological processes. Recently, researchers have turned to the examination of narratives as a window into beliefs about the family. Narratives may serve as markers of family relationship functioning and can provide important information about how family members make sense of family experiences. In addition, these narratives may reveal how family experiences are related to expectations for relationships in other domains. Attachment researchers first examined individuals' narratives about their families with the intent to relate these narratives to parent-infant attachment relationships.

Adult attachment was assessed with the Adult Attachment Interview (AAI; Main & Goldwyn, 1993), which is a semi-structured, hour-long interview that asks participants to speak about their experiences within their families of origin. Participants are asked to give specific episodic memories that support statements about their families, and are also asked about possible effects of family of origin experiences on relationships in their new family.

According to attachment researchers, the central task presented to the participant by the AAI is that of producing and reflecting upon memories related to attachment while simultaneously maintaining coherent discourse with the interviewer (Hesse, 1996). Attachment researchers have argued that, when individuals speak about their experiences with their parents, it is not only the content of the representation that is important, but also the overall organization of an individual's internal working model. For example, in a study by Main and colleagues (1985) it was not the reported content of attachment experiences in childhood, but the overall organization of the parents' narratives about these experiences that predicted infant-parent attachment in the next generation.

In later years, researchers began to move beyond the use of family narratives as simply a means of predicting parent-infant attachment relationships, and began to examine aspects of family narratives as predictors of outcomes in other areas, including mental health and aspects of interpersonal relationships. In 1999, the Family Narrative Consortium (Fiese, Sameroff, Grotevant, Wamboldt, Dickstein, & Fravel, 1999) was formed by a group of family researchers with the goal of testing the use of family narratives as markers of family relationship functioning that directly affect offspring development. In order to accomplish this goal the consortium devised a system by which family stories could be analyzed and reliably coded, and then applied this coding system to several diverse studies.

In their development of a coding scheme, the Family Narrative Consortium identified two important dimensions of family narratives: (1) narrative coherence and (2) relationship beliefs. *Narrative coherence* reflects how individuals organize and construct a story. On the individual level, the relative coherence of each family member's narrative may be related to his or her individual identity and life history. *Relationship beliefs* refers to the content of the narrative that includes reflections on relationships and whether

relationships are depicted as trustworthy or as sources of discontent. As a set of beliefs, family narratives reflect how much trust can be placed in relationships within and outside the family. Another way of looking at these two codes is that the relationship beliefs code captures the semantics of the narrative, or what an individual actually says in the narrative, whereas narrative coherence captures the syntax of the narrative, or how the individual says it. More detailed descriptions of these narrative dimensions are provided below.

Narrative Coherence and Relationship Beliefs

Narrative Coherence. This narrative dimension refers to how well the individual is able to construct and organize a story. The ways in which an individual's story makes sense, how clauses and thoughts are organized, the willingness of the individual to consider differing perspectives, and the match between affect and content are all considered part of the narrative's coherence. Coherence implies the pulling together of different domains or the glue that holds the pieces together (Fiese et al., 1999). For example, when considering resilience of the self, the domains of adverse past events, future expectations, and coping strategies are integrated into a coherent whole (Cohler, 1991). Regardless of the domain being examined, the coherence of the narrative is seen as pivotal to the integrity of the story.

Coherence is regarded as an integration of different aspects of an experience that provides a sense of unity and purpose. The transformation of individual sequences into a unified whole creates the coherent plot of the story (Polkinghorne, 1991). There have been a variety of ways to evaluate coherence, including discourse analysis, linguistic approaches based on story grammars, and computational models based on computer simulation (McCabe & Peterson, 1991). However, when the focus of the study is on meaning making, as it is in this dissertation, coherence analysis focuses on how the story is put together, the steps taken to present a unified whole, and the degree to which the story makes sense. Therefore, the three qualities of narrative coherence that will be considered in this study are the relative consistency of the narrative, how the narrative is organized, and the incorporation of multiple perspectives.

Internal consistency refers to the completeness of the narrative (Fiese et al., 1999). A coherent narrative is considered to be internally consistent when the different

parts of the story “hang together” to form a whole. A coherent narrative includes an internally consistent theory that is supported by sufficient detail to allow the listener to determine whether actions were justified and conclusions warranted. Narrators of internally consistent stories often use synthesizing statements that draw together information about physical laws, personal dispositions and character, responses to actions, and the process of deliberation in making decisions (Polkinghorne, 1991). Narratives that include contradictions are less internally consistent and often leave the listener confused. An example of a contradiction would be an individual reporting that her childhood was “perfect”, and then later providing multiple examples of feeling abandoned by her parents or dealing with poor parenting practices. Internal consistency contributes to coherence by integrating and synthesizing details to support the theory inherent in the story.

The second quality of narrative coherence, organization, refers to how the individual structures the narrative. A sense of order is considered a key component to a coherent narrative (Polkinghorne, 1991). An organized narrative provides the listener with a sense of orientation of context and a clear sense of referents (who, what, when, where, and why). Organized narratives also follow recognized rules of speech, and include the ordering of thoughts in a clear chronology so that the listener can understand the point the storyteller is trying to make. Well organized narratives often use orienting statements to create a context for the listener to understand the meaning of the story. These statements are typically succinct and to the point, whereas poorly organized narratives include incomplete thoughts, stops and starts, or excessive repetitive language. Organization contributes to the coherence of the story by ordering sequences and orienting the listener.

The third quality of narrative coherence is flexibility, which refers to the narrator’s ability to explore new ideas and alternatives. The flexible storyteller is able to view issues as they might be seen by others and recognizes that there is more than one side to a story. The coherence of a narrative includes the degree to which the individual holds convictions about his or her statements (Cohler, 1991), but convictions need not be rigid to be coherent. The more flexible the individual is in considering multiple viewpoints, the more likely elaboration will lead to a coherent life story. The recognition

of two or more alternatives indicates a willingness to consider the complexity of relationships, while maintaining personal integrity. Flexibility contributes to the coherence of the narrative by including multiple perspectives.

Relationship Beliefs. From a narrative perspective, the ways in which the family views the relative safety and rewarding features of relationships are expressed in the tone of the narrative and statements of satisfaction with relationships. When relationships are seen as manageable, reliable, and safe, the beliefs that are constructed include an expectation that relationships will bring rewards and provide opportunities to feel successful and satisfied. Reiss (1981) proposed that families differ in their perceptions about the relative safety of relationships within the family as well as relationships with the outside world. Reiss also proposed that these beliefs may then moderate interactions, which reaffirm the constructed belief system. For example, a family member who expects relationships to be dangerous and threatening may be more likely to withdraw from social relationships, which may then elicit negative reactions from others and thereby reaffirm his or her original beliefs.

Two aspects of relationships are considered important in understanding relationship expectations and beliefs: safety and mastery. Relationships may be seen as relatively safe or threatening and dangerous. Relationships may also be seen as something that can be mastered and rewarding or as overwhelming and confusing. Narratives with negative expectations of relationships will include statements of confusion and dissatisfaction in regard to relationships. At the other end of the dimension, relationships are regarded as rewarding, safe, reliable, and fulfilling. These narratives may include statements about the creation of opportunities to form and maintain relationships and a sense of confidence about the durability of relationships. Relationship expectations add to the understanding of narrative beliefs by highlighting the relative safety and mastery of interpersonal relationships.

Correlates of Narrative Codes

The multiple dimensions of narratives may impact directly on the individual's development through proximal interaction, or may reflect processes that are more distal to the individual's experience but serve to regulate development. Researchers do not propose that family narratives cause adaptive functioning. Rather, the idea is that family

narratives provide a window into how families come to define themselves and that the active process of storytelling is linked to important parameters of the family system.

The narrative dimensions of coherence and relationship beliefs have been linked to various aspects of individual and family functioning. As mentioned earlier, the concept of narrative coherence is a major component of adult attachment theory, and is used to determine attachment classifications. Main (2000) suggested that what is most significant about adults' childhood narratives is not the nature of the experiences they describe (i.e., whether they were positive or negative) but rather the state of mind of the individual in the present with regard to their childhood experiences. Attachment researchers have shown that scores for overall coherence on the Adult Attachment Interview are strongly related to infant security of attachment (Main & Goldwyn, 1998). In other words, mothers who speak in less coherent ways about their own experiences with parents tend to have infants who are less securely attached to them.

In addition to this association with parent-infant attachment, the structure and content of internal representations have also been linked to the development and maintenance of psychopathology (Grych et al., 2002; Page & Bretherton, 2001). For example, Oppenheim (2006) showed that children who had more positive maternal representations in their narratives about their mothers exhibited fewer behavior problems, and Warren, Emde, and Sroufe (2000) found that children's narratives that were characterized by themes of negative relationship expectations predicted more internalizing symptoms at ages 5 and 6. In a meta-analysis of 33 studies using the Adult Attachment Interview, van Ijzendoorn and Bakermans-Kranenburg (1996) found significant relations between insecure attachment representations (which were classified by less coherent narratives) and clinically significant psychological problems.

As part of the Family Narrative Consortium, Dickstein and colleagues (1999) interviewed a sample of mothers with a lifetime diagnosis of depression and their husbands, and compared the family narratives of mothers currently displaying depressive symptoms to mothers without current depressive symptoms. These researchers found that mothers currently experiencing depressive symptoms created less coherent narratives about their families compared to mothers not currently experiencing depressive symptoms. Husbands of depressed women also created less coherent family narratives,

independent of their wives' symptom severity. In addition, depressed mothers and their husbands displayed significantly less positive views of the immediate family relationship compared to non-depressed women and their husbands.

One important goal of the Family Narrative Consortium was to examine whether the family narrative codes described above would be related to additional measures of family functioning, as well as outcome measures of individual adaptive functioning (Fiese et al., 1999). As part of this consortium, Wamboldt (1999) collected narratives from couples in serious romantic relationships, and found that narrative coherence and relationship beliefs were related to other aspects of the couples' families of origin and developing relationships. Dickstein (1999) found that more coherent narratives produced by both wives and husbands were associated with self-report of marital satisfaction, clinician-based judgments of family functioning, and rater-based observations of family interaction. Husbands' and wives' positive relationship beliefs about both their current family and their families of origin were also associated with marital satisfaction and healthy family functioning. Moreover, representations about family relationships that participants' produced in narrative form were found to be consistent with family functioning assessed using clinical and direct observation strategies.

Finally, Fiese and Marjinsky (1999) found that relationship beliefs and narrative coherence in parents were related to behavior problems in their children, and that parents' expectations for rewarding relationships were related to more marital satisfaction and positive affect at the dinner table. Of interest in these results were the differential findings according to which narrative dimension was examined, which lends support to the idea that the dimensions of narrative coherence and relationship beliefs may be related to different predictors and outcomes.

Summary and Goals of Study 2

In summary, there have been several theories that have suggested that how an individual makes sense of or understands an experience may be as, or even more, important than the actual experience itself. An individual's representations of growing up in his or her family of origin may provide important insights into how a person navigates his or her current interpersonal relationships, and may also be related to functioning outcomes in other domains, such as mental health. Family narratives can be considered

across two dimensions: narrative coherence, or how an individual organizes and constructs a story, and relationship beliefs, or an individual's internal representations of interpersonal relationships in general and family relationships specifically. These codes have been found to be related to a number of outcomes, including observable behavior within the family and psychological functioning of the individual.

Results of Study 1 identified pathways between early maternal mental health and multiple measures of adult competence. Study 2 will extend these results by considering the role of representations in addition to actual experiences. The goal of Study 2 will be to examine adult offspring's representations of their families of origin through the use of family narratives, and explore not only predictors of offspring's representations of their family, but also links between these representations and measures of adaptive functioning. Because the overall aim of this dissertation is to examine pathways from early maternal mental illness to offspring adult adaptive functioning, offspring's adult representations of their families will also be examined as possible mediators of the links between maternal mental health and offspring adult outcomes found in Study 1. The specific aims of Study 2 are as follows:

- 1) To measure adult offspring's representations of their experiences growing up in their families of origin through the use of family narratives.
- 2) To examine prior predictors of individuals' narrative coherence and relationship beliefs at 30 years.
- 3) To examine associations between narrative coherence and relationship beliefs and the adult outcomes of mental health, socioeconomic status, and romantic relationships.
- 4) To test narrative coherence and relationship beliefs as possible mediators of the associations found between maternal mental health in early childhood and offspring adaptive functioning in adulthood.

Method

Participants

The data for Study 2 of this dissertation draws from the same 30-year, three-generation longitudinal study of mental health analyzed in Study 1. See Chapter 2 for a complete description of the participants in this study.

Procedure

At age 30 participants were interviewed over the phone and asked a series of open-ended questions about their experiences growing up in their family of origin. These questions included: (1) “Describe in general what it was like growing up in your family”; (2) “Choose two words or phrases that best describe what it was like growing up in your family”; (3) “Explain why you chose these two words to describe growing up in your family, and provide specific examples”; (4) “Do you think your family affected who you are as a person today, and, if so, how?” (5) “Do you think your family affected the way you relate to other people, and, if so, how?” and (6) “Do you think growing up in your family affected the way you are as a parent, and, if so, how?”.

Participants were allowed to respond as little or as much as they liked to each question, and questions were repeated or rephrased as prompts if the participant answered “I don’t know”. All interviews were recorded on cassette tapes and transcribed. Interviews were then coded by the first author, with each interview read twice through before coding. A subset of interviews (10%) was also coded for reliability by a second coder, and reliability exceeded 80%. Reliabilities were lower for the narrative coherence scales (80%-84%) and higher for the relationship belief scales (83%-96%). Aside from subject ID numbers, coders were blind to all information about participants, including history of maternal mental illness or past or current functioning. A total of 105 participants completed the family of origin interview and had tapes that were able to be coded.

Coding Scheme

The coding scheme for Study 2 was designed for use with the family of origin interview (described above). The Family Narrative Consortium (FNC) coding system (Fiese, Sameroff, Grotevant, Wamboldt, Dickstein & Fravel, 1999) was developed by a group of family researchers who were interested in how families make sense of personal experiences and find meaning in their collective lives. Four of the codes (internal consistency, organization, flexibility, and relationship expectations) for this study were

taken directly from the FNC coding system. The other three codes (experiences with family, feelings toward family, and acceptance of family) were developed to specifically measure participants' meaning making processes regarding their memories of growing up in their families of origin.

All codes were on five point scales, with a score of "5" indicating a strong presence of that particular dimension. The codes used in Study 2 are described below, and more detailed descriptions are included in the coding manual in the appendix.

Narrative Coherence Codes

Internal Consistency. The internal consistency of the narrative reflects the completeness of the narrative. Narratives that are low on internal consistency typically include multiple contradictions, and it is often difficult for the coder to identify the actual story. Narratives that are high on internal consistency include a complete story with a theory that includes specific and personalized examples, and it is easy to identify an underlying theme. For this code, raters were asked to identify a theme in the narrative and decide whether or not the theme was supported by the individual's story and statements. Coders were also asked to identify unrecognized, recognized, and explained contradictions, personalized examples, and synthesized explanations.

The scale points for this code include: (1) no theory—none can be identified; (2) unsupported theory—may include some minor unacknowledged contradictions; (3) theory with some support—respondent makes generalizations; (4) theory in process—emergent theory, supported evidence but not integrated; and (5) well-documented theory—must have all indicators of integration.

Organization. Organization refers to the participant's management of the narrative, with particular attention paid to statements that convey information and how points are made within the narrative. Organization includes how the individual is able to self-correct if his or her narrative wanders, how he or she manages the transitions evident in narratives, and whether the individual's thoughts are complete or left hanging. An organized narrative provides the listener with a sense of orientation of context, a clear sense of referents, and meta-statements that identify for the listener what is coming next. Highly organized narratives initially respond on topic, flow smoothly with completed thoughts, and are direct and to the point. Poorly organized narratives may not initially

respond on topic, may be full of stops and starts, and may consist of over-elaborations that stray further and further from the original point. In a poorly organized narrative the interviewer often struggles to follow the participant, and multiple clarification questions are often asked.

The scale points for this code include: (1) poor organization—rater has no clear picture of the story; (2) moderately poor organization—rater understands most of narrative, based on efforts of the interviewer to clarify meaning during the interview; (3) moderate organization—rater can understand story, but there may still be some markers of disorganization; (4) moderately good organization—rater can understand story clearly with rare incidence of markers of disorganization; and (5) good organization—individual puts story together in succinct and direct fashion.

Flexibility. Flexibility refers to the respondent's ability to explore new ideas and alternatives. The flexible respondent is able to view issues as others might see them, and recognizes that there is more than one side to every story. Positive referents for flexibility include elaboration of alternatives with possibility of action, whereas negative referents for flexibility include rigid statements of conviction. For example, a narrative scoring low on flexibility might include statements such as "My mother was always perfect" and "My mother never got stressed out".

The scale points for this code include: (1) low flexibility (rigid)—individual narrative strongly adheres to one perspective; (2) moderately low flexibility—individual narrative adheres to one perspective with minimal recognition of alternative views; (3) moderate flexibility—individual clearly recognizes more than one perspective; (4) moderately high flexibility—individual elaborates two or more perspectives to issues; and (5) high flexibility (balanced)—individual integrates and resolves two or more perspectives.

Relationship Belief Codes

Relationship Expectations. The Relationship Expectations code assesses how participants view interpersonal relationships as manageable, reliable and safe based on the ways in which they talk about their experiences within their families of origin. Narratives that are high on relationship expectations portray relationships as safe, reliable, rewarding, and fulfilling. The individual feels confident and positive enough

about his or her understanding of relationships to embrace opportunities to establish relationships with others. Narratives that are low on relationship expectations depict relationships as dangerous, threatening, or overwhelming. The individual often talks about relationships as a source of fear and may believe that others willfully harm him or her. When discussing the family of origin, the narrative is marked by statements of confusion about relationships and dissatisfaction with relationships in general based on experiences within the family.

Scale points include: (1) very low—expectations that relationships are dangerous, threatening, or overwhelming; (2) low—relationships are seen as precarious, trying, or unreliable; (3) moderate—relationships may be met with success, but individual tends to categorize into good or bad, black or white; (4) high—relationships are relatively understandable, safe, successful, usually rewarding, and reliable; and (5) very high—relationships are safe, reliable, and fulfilling.

Experience with Family. This code specifically measures participants' perceptions of their overall experience growing up in their family of origin. Individuals who score high on this code describe their experience with their family as being very positive, and make very few or no negative statements about their family. Individuals who score low on this code describe their family experience as very negative, and very few positive statements about the family are made. In this sample, very negative experiences often included abuse by one or both parents and/or abandonment.

The scale points for this code include: (1) very negative—almost no positive statements made; (2) slightly negative—more negative statements than positive; (3) neutral—neither positive nor negative; (4) slightly positive—more positive statements than negative; (5) very positive—family experience described as very positive or perfect.

Affective Tone of Statements about Family. This code refers to the emotional tone of the individual when discussing the family of origin, with both type of affect expressed and intensity of affect considered in scoring. Narratives that score high on this scale are almost exclusively positive in content, and express clear joy when talking about the family. Narratives that are low in affective tone are almost exclusively negative in content, and contain many statements that express clear anger and/or sadness.

The scale points for this code were: (1) mostly negative—clear anger or sadness expressed throughout narrative; (2) slightly negative—some anger or sadness expressed; (3) neutral—affectively neutral throughout narrative; (4) slightly positive—mostly positive affect, some expressions of joy; and (5) mostly positive—clear expressions of happiness/joy throughout narrative.

Acceptance of Family. This code assesses participants' current acceptance of his or her family of origin. For example, two participants may describe similarly negative experiences with their family while growing up, but one might still feel anger about the situation while the other has come to terms with or accepted the past. Individuals who score high on this code show complete acceptance of their family and past experiences, and articulate that they have “come to terms” with their past when describing negative memories. Individuals who score low on this code express clear anger toward their family as an adult.

Scale points include: (1) anger—participant expresses current feelings of anger and no acceptance of past events; (2) mostly negative—some expressions of anger and sadness, little acceptance of past events; (3) neutral—participant expresses little emotion when discussing the family, but does not express feelings of acceptance of past events; (4) mostly positive—participant is mostly accepting of family memories; and (5) complete acceptance—participant is completely accepting of family, and if negative memories are expressed, participant explicitly conveys that they have “come to terms” with these memories as an adult.

Longitudinal Predictors and Adult Outcome Variables

All 30 year outcome variables (CIDI diagnoses, GAF scores, relationship status, attachment insecurity, educational status, and income) as well as all adolescent individual and family variables (mental health, parenting, family relationships, family conflict, peer relationships, self-concept, academic achievement, family SES, and parental relationship status) that were analyzed in Study 1 were also included in Study 2. See Chapter 1 for a complete list and description of all variables. In addition, the same maternal mental health measure used in Study 1 was also used in Study 2.

Results

Preliminary Analyses

Descriptive statistics were first calculated for the seven Study 2 narrative codes (Table 3.1). As can be seen from this table, the ranges for each variable were from 1 to 5, and the means ranged from 3.39 to 4.03 out of a score of 5. Correlations were then calculated for all combinations of codes (Table 3.2). As can be seen in this table, the codes were highly correlated. In particular, the correlations between the narrative codes of internal consistency, organization, and flexibility exceeded .56 ($p < .001$) and the correlations between the codes that were designed to measure participants' perceptions of family relationships exceeded .83 ($p < .001$). These high correlations lent support to theoretical background for combining these codes into the two categories most commonly used in family narrative coding: (1) narrative coherence and (2) relationship beliefs. The measure of narrative coherence was created by summing the codes of internal consistency, organization and flexibility. Reliability for these three codes was .83. A measure of relationship beliefs was created by summing the codes of relationship expectations, experience with family, affective tone of statements about family, and acceptance of family. Reliability between these four codes was .97. The correlation between the summary codes of narrative coherence and relationship beliefs was .51 ($p < .001$).

Associations between Variables

Correlations were first calculated between offspring narrative coherence and relationship beliefs and their 30-year adaptive functioning outcomes (Table 3.3). As can be seen from this table, correlations ranged from .21 to .54, and all correlations were statistically significant ($p < .05$), with the exception of those involving relationship quality. Thus, individuals who successfully constructed coherent narratives about their families of origin and individuals who displayed more positive perceptions of family relationships through their narratives had better mental health, were of higher socioeconomic status, were in more stable intimate relationships, and had lower levels of attachment insecurity compared to individuals with less coherent narratives or more negative beliefs about relationships.

The next step in these analyses was to examine whether history of maternal mental illness was related to offspring narrative coherence and relationship beliefs in adulthood. Correlations were calculated, and maternal mental health in early childhood

was found to be associated with both offspring narrative coherence ($r = .27, p < .01$) and relationship beliefs ($r = .33, p < .001$). As expected, individuals with a history of maternal mental illness had less coherent narratives and had more negative beliefs about their families and relationships in general in adulthood.

Finally, associations between the two narrative codes and individual and family variables in adolescence were calculated. As can be seen from Table 3.4, all correlations between the narrative codes and the adolescent variables were significant. Adolescents with better mental health ($p < .001$), more positive self-concepts ($p < .05$), and better peer relationships ($p < .001$) had more coherent family narratives and more positive relationship beliefs in adulthood. More positive parenting ($p < .001$), better family functioning ($p < .01$), lower levels of family conflict ($p < .001$) and more stable parental relationships ($p < .01$) also predicted more coherent narratives about the family and more positive relationship beliefs in adulthood. Finally, individuals with higher IQ and achievement scores ($p < .05$), and from higher SES families in adolescence ($p < .001$) had more coherent narratives and more positive perceptions of family relationships compared to individuals with lower achievement scores and those from lower SES families.

Maternal Mental Health Effects

The next step was to examine whether there were overall mean differences in either of the narrative codes between offspring of mothers with and without mental health problems. A multivariate analysis of variance (MANOVA) was computed because the measures of narrative coherence and relationship beliefs were correlated. For this test these two variables were entered into the equation as dependent variables and maternal mental health was entered as the fixed factor. The dichotomous measure of maternal mental illness described in Study 1 was also used for this analysis.

The omnibus test revealed that there were mean differences in these two narrative codes based on history of maternal mental illness [Hotelling's Trace = .206, $F(2, 92) = 9.49, p < .001$]. Results of individual ANOVAs are shown in Table 3.5. As was predicted, offspring narrative coherence differed by earlier maternal mental health status. Participants whose mothers had mental health problems when they were growing up had significantly less coherent narratives ($M = 10.89, SD = .39$) compared to participants

whose mothers did not have mental health problems ($M = 12.98$, $SD = .44$). Offspring relationship beliefs as depicted in their family narratives also differed by earlier maternal mental health status. Participants of mothers with mental health problems had less positive beliefs about relationships ($M = 12.33$, $SD = .69$) compared to participants of mothers without mental health problems ($M = 16.44$, $SD = .79$).

Structural Equation Models

Structural equation models were used to examine pathways predicting to narrative coherence and relationship beliefs, as well as from narrative coherence and relationship beliefs to 30-year adaptive functioning. Statisticians generally recommend that for use in SEM sample sizes exceed 100 cases (Hoyle, 1995). Some rules of thumb in the literature are that there should be at least 10 to 20 times as many cases as variables in the model (Mitchell, 1993), and there should be at least 15 cases per measured variable or indicator (Stevens, 1996). Although our sample size for this study was relatively small, it meets these three recommendations and was sufficient for estimating the models that were tested. The gap between the observed and the estimated covariance matrix, produced according to the specified models, was used by the program to compute goodness-of-fit indices that help determine the extent to which the conceptual model provides an acceptable representation of the data. The widely used goodness-of-fit indices known as the normed fit index (NFI), the Tucker-Lewis index (TLI), and the comparative fit index (CFI) were used to indicate the extent of fit. A value of .90 and higher was regarded as indication of a good fit of the model. In addition, the root-mean-square error of approximation (RMSEA) misfit index and its recommended value of .06 or lower (Hu & Bentler, 1999) was used to indicate acceptable fit.

Missing data were handled using full information maximum likelihood (FIML) methods. These procedures have been found to yield the least biased estimates when all available data are used for longitudinal analyses (versus listwise deletion of missing data) (Enders, 2001; Raykov, 2005). Thus, the full sample of participants whose mothers provided mental health data at 30 months were utilized for these analyses. This full sample provides the best possible variance/covariance estimates and was least likely to be biased by missing data. Alternative longitudinal analyses using just those participants

without missing data (i.e., listwise deletion) yielded results that were substantially identical to those reported below.

Predicting Narrative Coherence and Relationship Beliefs

As revealed in the correlation analyses above, the codes of narrative coherence and relationship beliefs were significantly associated with maternal mental health in early childhood as well as a number of individual and family variables in adolescence. In order to determine which variables contributed most to the coherence of participants' narratives and their beliefs about their families of origin, a series of structural equation models were tested. The first model tested only associations between early maternal mental health and offspring 30-year narrative coherence and relationship beliefs. As can be seen in Figure 3.1, maternal mental health in early childhood was significantly related to both offspring narrative coherence ($\beta = .28, p < .01$) and offspring relationship beliefs ($\beta = .33, p < .001$) at 30 years. Individuals with a history of maternal mental illness had less coherent narratives about their families of origin and more negative beliefs about relationships in adulthood. Maternal mental health alone explained .08 of the variance in offspring narrative coherence and .11 of the variance in offspring relationship beliefs.

The second model added all possible adolescent predictors to the model just described. These predictors were adolescent academic achievement, mental health, peer relationships, self-concept, parenting, family conflict, family relationships, and parental relationship status. This intermediate model included the direct pathways between maternal mental health in early childhood and offspring 30-year narrative coherence and relationship beliefs, and also examined the adolescent variables as possible mediators of these significant associations. Finally, covariances between narrative coherence and relationship beliefs and between all of the adolescent variables were also included.

In order to develop a parsimonious model, all non-significant pathways were dropped. In this preliminary model, adolescent mental health, adolescent self-concept, parenting, and family relationships did not significantly predict either narrative coherence or relationship beliefs, and were therefore removed from the model. In addition, the non-significant pathways from academic achievement and family conflict to relationship beliefs and from peer relationships and parental relationship status to narrative coherence

were removed. Finally, the non-significant direct pathways from maternal mental health to narrative coherence and relationship beliefs were removed.

The final model predicting to narrative coherence and relationship beliefs is shown in Figure 3.2. This model fits the data well, $\chi^2(6, n = 234) = 4.608, p = .595$; with normed fit index = .978, Tucker-Lewis index = 1.04, comparative fit index = 1.00, and root-mean-square error of approximation = .000. As can be seen from this model, the pathway between maternal mental health and offspring narrative coherence was mediated by the variables academic achievement in adolescence and family conflict in adolescence. Maternal mental health predicted adolescent academic achievement ($\beta = .20, p < .05$), and, in turn, adolescents with better grades and higher IQ scores had more coherent narratives when speaking about their families of origin in adulthood ($\beta = .28, p < .001$). Maternal mental health also predicted family conflict ($\beta = -.26, p < .01$), and individuals with higher levels of family conflict then had less coherent narratives about their family relationships in adulthood ($\beta = -.45, p < .001$). Together, adolescent academic achievement and adolescent family conflict explained .33 of the variance in offspring adult narrative coherence.

This model also shows that the association between early maternal mental health and offspring relationship beliefs was mediated by the stability of parental relationship status. Mothers with better mental health during children's first three years of life were more likely to be with children's fathers for longer periods of time ($\beta = .33, p < .001$). More stable parental relationships while growing up then predicted more positive relationship beliefs in adulthood for offspring ($\beta = .40, p < .001$). Peer relationships in adolescence also significantly predicted offspring's relationship beliefs in adulthood ($\beta = .44, p < .001$). Individuals with better peer relationships in adolescence as rated by adolescents and their mothers tended to view interpersonal relationships as manageable, reliable, and safe, and spoke more positively about their families of origin in adulthood. Together, adolescent peer relationships and parental relationship stability explained .46 of the variance in offspring adult relationship beliefs.

Finally, all covariances in this model were significant, with the exception of the covariance between adolescent academic achievement and adolescent family conflict ($r =$

.15, $p = .08$) and the covariance between parental relationship status and adolescent family conflict ($r = .15, p = .08$).

Narrative Coherence and Relationship Beliefs as Mediators

As indicated from the analyses thus far, the ways in which individuals made sense of their experiences with their families of origin were related to maternal mental illness in early childhood as well as earlier measures of individual and family functioning. Correlations also revealed that both narrative coherence and relationship beliefs were significantly correlated with the 30-year mental health, romantic relationship, and socioeconomic status outcomes. The next step in this study was to examine whether participants' narrative coherence and relationship beliefs mediated associations between maternal mental illness in early childhood and offspring adaptive functioning in adulthood. For these analyses, a series of structural equation models were tested.

30 year Mental Health. Results of Study 1 showed that maternal mental health in early childhood significantly predicts offspring 30-year CIDI diagnoses and 30-year GAF scores. Study 2 tested narrative coherence and relationship beliefs as mediators of these associations. As can be seen in Figure 3.3, this model tested direct pathways between maternal mental health in early childhood and offspring 30-year CIDI diagnoses and GAF scores. This model also tested pathways from maternal mental health to narrative coherence and relationship beliefs, and from narrative coherence and relationship beliefs to each of the 30-year mental health outcomes. Finally, covariances between narrative coherence and relationship beliefs and between 30-year CIDI diagnoses and 30-year GAF scores were also included. Because this model tested all possible pathways and was fully saturated, the overall fit of the model is not relevant.

As can be seen from Figure 3.3, offspring's relationship beliefs as revealed in their narratives about their families of origin fully mediated associations between maternal mental health in early childhood and offspring 30-year psychiatric diagnoses. This model shows that the pathway between maternal mental health and offspring relationship beliefs was significant ($\beta = .34, p < .001$), as individuals with a history of maternal mental health problems had less positive relationship beliefs compared to individuals without a history of maternal mental illness. In addition, the pathway between offspring relationship beliefs in adulthood and offspring 30-year psychiatric diagnoses

was significant ($\beta = -.45, p < .001$), as individuals with more positive relationship beliefs displayed fewer psychiatric diagnoses in adulthood. With these pathways included in the model, the pathway between maternal mental health in early childhood and offspring diagnoses in adulthood became non-significant ($\beta = .13, p = .148$). Narrative coherence did not serve as a mediator of the association between maternal mental health and offspring adult diagnoses. The pathway between maternal mental health and offspring narrative coherence was significant ($\beta = .29, p < .01$), as individuals with a history of maternal mental illness displayed less coherent narratives compared to individuals without a history of maternal mental illness. However, the pathway between narrative coherence and psychiatric diagnoses was not significant ($\beta = .07, p = .506$), indicating that narrative coherence was not a mediator. Together, maternal mental health and relationship beliefs explained .23 of the variance in 30 year CIDI diagnoses.

Both relationship beliefs and narrative coherence served as partial mediators of the relation found between maternal mental health in early childhood and offspring overall mental health in adulthood. As can be seen in Figure 3.3, maternal mental health significantly predicted relationship beliefs, and relationship beliefs then predicted 30-year GAF scores ($\beta = .31, p < .001$), with individuals displaying more positive beliefs about family relationships in their narratives also displaying better overall mental health at age 30. Maternal mental health also significantly predicted narrative coherence, which then went on to predict 30-year GAF scores ($\beta = .27, p < .01$), as individuals with more coherent narratives about their families also had better mental health scores in adulthood. Even with these two narrative variables serving as mediators, the direct pathway between maternal mental health in early childhood and offspring 30-year GAF scores remained significant but dropped in strength ($\beta = .23, p < .01$). Together, maternal mental health, relationship beliefs, and narrative coherence explained .40 of the variance in 30 year GAF scores. Finally, the covariances between narrative coherence and relationship beliefs ($r = .47, p < .001$) and between 30-year CIDI diagnoses and 30-year GAF ratings ($r = -.48, p < .001$) were significant.

30 year Romantic Relationships. Results of Study 1 also revealed that maternal mental health in early childhood significantly predicts offspring 30-year romantic relationship status and 30-year relationship attachment insecurity. Study 2 tested

narrative coherence and relationship beliefs as mediators of these associations. As can be seen in Figure 3.4, this model tested direct pathways between maternal mental health in early childhood and offspring 30-year relationship status and relationship attachment insecurity. This model also tested pathways from maternal mental health to narrative coherence and relationship beliefs, and from narrative coherence and relationship beliefs to each of the 30-year romantic relationship outcomes. Finally, covariances between narrative coherence and relationship beliefs and between 30-year relationship status and 30-year attachment insecurity were also included. Because this model tested all possible pathways and was fully saturated, the overall fit of the model is not relevant.

As can be seen from Figure 3.4, offspring's relationship beliefs as revealed in their narratives about their families of origin fully mediated associations between maternal mental health in early childhood and offspring 30-year relationship attachment insecurity. This model shows that the pathway between maternal mental health and offspring relationship beliefs was significant ($\beta = .36, p < .001$), as individuals with a history of maternal mental health problems had less positive relationship beliefs compared to individuals without a history of maternal mental illness. In addition, the pathway between offspring relationship beliefs in adulthood and offspring 30-year attachment insecurity was significant ($\beta = -.29, p < .001$). Individuals with more positive relationship beliefs displayed less anxiety and avoidance in their attachment relationships in adulthood. With these pathways included in the model, the pathway between maternal mental health in early childhood and offspring diagnoses in adulthood became non-significant ($\beta = .13, p = .166$). Narrative coherence did not serve as a mediator of the association between maternal mental health and offspring attachment insecurity in adulthood. The pathway between maternal mental health and offspring narrative coherence was significant ($\beta = .30, p < .01$), as individuals with a history of maternal mental illness displayed less coherent narratives compared to individuals without a history of maternal mental illness. However, the pathway between narrative coherence and attachment insecurity was not significant ($\beta = .16, p = .170$), indicating that narrative coherence was not a mediator.

Neither relationship beliefs nor narrative coherence served as mediators of the relation found between maternal mental health in early childhood and offspring overall

relationship status in adulthood, although narrative coherence was marginally significant as a partial mediator. As can be seen in Figure 3.4, although maternal mental health significantly predicted relationship beliefs, relationship beliefs was not significantly related to romantic relationship status ($\beta = .01, p = .893$). In addition, although maternal mental health significantly predicted narrative coherence, the association between narrative coherence and relationship status was only marginally significant ($\beta = .19, p = .09$). Individuals with more coherent narratives about their families were slightly more likely to be in stable intimate relationships in adulthood. With the two variables of narrative coherence and relationship beliefs in this model, the direct pathway between early maternal mental health and offspring 30-year relationship status remained significant ($\beta = .25, p < .01$). All together, .13 of the variance in 30 year relationship status was explained by this model, and .21 of the variance in attachment insecurity was explained. Finally, the covariances between narrative coherence and relationship beliefs ($r = .47, p < .001$) and between relationship status and relationship attachment insecurity ($r = -.36, p < .001$) were significant.

30 year Socioeconomic Status. As revealed in Study 1, maternal mental health in early childhood significantly predicts offspring 30-year educational attainment and 30-year annual income. Study 2 tested narrative coherence and relationship beliefs as mediators of these associations. As can be seen in Figure 3.5, this model tested direct pathways between maternal mental health in early childhood and offspring 30-year educational attainment and annual income. This model also tested pathways from maternal mental health to narrative coherence and relationship beliefs, and from narrative coherence and relationship beliefs to each of the 30-year socioeconomic outcomes. Finally, covariances between narrative coherence and relationship beliefs and between 30-year educational attainment and 30-year income were also included. Because this model tested all possible pathways and was fully saturated, the overall fit of the model is not relevant.

As can be seen from Figure 3.5, offspring's narrative coherence when discussing experiences growing up in their family of origin mediated associations between maternal mental health in early childhood and offspring 30-year income. This model shows that the pathway between maternal mental health and offspring narrative coherence was

significant ($\beta = .30, p < .001$), as individuals with a history of maternal mental health problems had less positive coherent narratives about their families compared to individuals without a history of maternal mental illness. In addition, the pathway between narrative coherence and annual income was also significant ($\beta = .35, p < .001$), as individuals with more coherent narratives earned higher incomes in adulthood. With this pathways included in the model, the pathway between maternal mental health in early childhood and offspring annual income in adulthood dropped to marginal significance ($\beta = .14, p = .091$). Relationship beliefs did not serve as a mediator of the association between maternal mental health and offspring annual income in adulthood. The pathway between maternal mental health and offspring relationship beliefs was significant ($\beta = .30, p < .001$), however, the pathway between relationship beliefs and annual income was not significant ($\beta = .16, p = .134$), indicating that relationship beliefs was not a mediator.

Both relationship beliefs and narrative coherence served as mediators of the association found between maternal mental health in early childhood and offspring educational attainment in adulthood. As can be seen in Figure 3.5, maternal mental health significantly predicted relationship beliefs, and relationship beliefs then predicted 30-year educational attainment ($\beta = .27, p < .01$), with individuals displaying more positive beliefs about family relationships in their narratives also attaining more years of education by age 30. Maternal mental health also significantly predicted narrative coherence, which then went on to predict educational attainment ($\beta = .39, p < .001$), as individuals with more coherent narratives about their families also had higher levels of education in adulthood. With these two narrative variables serving as mediators, the direct pathway between maternal mental health in early childhood and offspring adult educational attainment became non-significant ($\beta = .09, p = .256$). Together, this model explained .37 of the variance in educational attainment and .26 of the variance in annual income. Finally, the covariances between narrative coherence and relationship beliefs ($r = .48, p < .001$) and between 30-year educational attainment and 30-year annual income ($r = .23, p < .05$) were significant.

Extending Findings from Study 1

The final step in these analyses was to extend the results of the structural equation models tested in Study 1 examining individual and family variables in adolescence as

mediators by including the results described above testing narrative coherence and relationship beliefs as mediators. The purpose of these final analyses was to determine which variables most strongly mediate the pathways from maternal mental health at 30 months and offspring adaptive functioning outcomes at 30 years. A question of interest was whether individuals' current representations of their experiences growing up with their families of origin or their actual characteristics and experiences while growing up more strongly predicted their adaptive functioning outcomes.

Predicting 30 year Mental Health Outcomes. The first set of structural equation models tested longitudinal pathways to overall mental health and number of psychiatric diagnoses at 30 years. In Study 1, the adolescent variables that emerged as significant mediators of the associations between early maternal mental illness and offspring adult mental health were adolescent mental health, self-concept, and parenting. A structural equation model was tested with these three variables as mediators, as well as the Study 2 variables of narrative coherence and relationship beliefs. Only pathways that were significant in the models tested in Study 1 and the models tested earlier in Study 2 were included in this combined model. All covariances between mediators and between the 30 year outcomes were also tested. After the model was calculated, all non-significant pathways were removed. In this model, the pathways from adolescent self-concept to 30 year GAF scores and from narrative coherence to 30 year GAF scores were non-significant, and were thus removed. The more parsimonious adult mental health model was then calculated, and results are shown in Figure 3.6.

As can be seen in Figure 3.6, adult relationship beliefs, adolescent mental health, and adolescent parenting remained as significant mediators of the associations between early maternal mental health and offspring adult mental health. This model fits the data well, $\chi^2(3, n = 234) = 2.951, p = .399$; with normed fit index = .984, Tucker-Lewis index = 1.00, comparative fit index = 1.00, and root-mean-square error of approximation = .000. As can be seen from this model, participants' relationship beliefs mediated the associations between maternal mental health and 30 year CIDI diagnoses ($\beta = -.34, p < .001$) and 30 year GAF mental health scores ($\beta = .31, p < .001$). The ways in which adult offspring perceived their experiences growing up in their families of origin explained part

of the link between experiences with maternal mental illness in childhood and offspring mental illness in adulthood.

In addition, adolescent mental health mediated the associations between maternal mental health and 30 year CIDI diagnoses ($\beta = .28, p < .01$) and 30 year GAF mental health scores ($\beta = .41, p < .001$). As expected, part of the link between maternal mental health and offspring adult mental health was explained by offspring earlier mental health at ages 13 and 18. Finally, parenting remained as a significant mediator ($\beta = .21, p < .01$). In addition to participants' perceptions of their experiences growing up with their families, participants' actual experiences with parents in adolescence helped explain the link between early maternal mental illness and offspring mental health problems in adulthood. Although not shown in Figure 3.6, all covariances were tested between the mediators and between the 30 year outcomes. Results were that all covariances were significant.

In comparing the final model from Study 1 to this model, the amount of explained variance in the outcome variables was improved with the addition of the representation variables in Study 2. The amount of variance in 30 year CIDI diagnoses explained by these mediators increased from .18 in Study 1 (Figure 2.2) to .28 in Study 2 (Figure 3.6). The amount of variance in 30 year GAF scores explained by these variables increased from .44 in Study 1 (Figure 2.2) to .51 in Study 2 (Figure 3.6).

Predicting 30 year Romantic Relationship Outcomes. The second set of structural equation models tested longitudinal pathways to offspring relationship status and relationship attachment insecurity at 30 years. In Study 1, the adolescent variables that emerged as significant mediators of the associations between early maternal mental illness and aspects of offspring adult romantic relationships were adolescent family conflict, self-concept, and parental relationship status. A structural equation model was tested with these three variables as mediators, as well as the Study 2 variables of narrative coherence and relationship beliefs. Only pathways that were significant in the models tested in Study 1 and the models tested earlier in Study 2 were included in this combined model. All covariances between mediators and between the 30 year outcomes were also tested. After the model was calculated, all non-significant pathways were removed. In this model, the pathways from narrative coherence to 30 year romantic relationship

outcomes were non-significant, and this variable was removed. The more parsimonious adult romantic relationships model was then calculated, and results are shown in Figure 3.7.

As can be seen in Figure 3.7, parental relationship status, adolescent family conflict, adolescent self-concept, and adult relationship beliefs remained as significant mediators of the associations between early maternal mental health and aspects of adult offspring romantic relationships. This model fits the data well, $\chi^2(5, n = 234) = 5.171, p = .395$; with normed fit index = .967, Tucker-Lewis index = .993, comparative fit index = .999, and root-mean-square error of approximation = .010. As can be seen from this model, participants' relationship beliefs mediated the associations between maternal mental health and 30 year attachment insecurity ($\beta = -.21, p < .001$). As expected, beliefs about relationships as gathered from narratives about the family of origin explained part of the link between experiences with maternal mental illness in childhood and feelings of anxiety and avoidance regarding romantic relationships in adulthood. In addition, parental relationship status mediated the association between maternal mental health and 30 year relationship status ($\beta = .25, p < .01$). As hypothesized, part of the link between maternal mental health and offspring adult relationship status was explained by parental relationship status while offspring were growing up.

In addition, family conflict in adolescence mediated associations between maternal mental health and both offspring 30-year relationship status ($\beta = -.20, p < .05$) as well as 30-year attachment insecurity ($\beta = .26, p < .01$). This suggests that part of the reason offspring of mothers with mental health problems develop problems with their romantic relationships in adulthood is that they also experienced high levels of family conflict throughout adolescence. Finally, adolescent self-concept remained a significant mediator ($\beta = -.22, p < .01$) of the pathway from maternal mental health to offspring attachment insecurity. As described earlier, offspring of mothers with mental health problems are more likely to have negative beliefs in adolescence about their competence in several areas related to interpersonal relationships in adolescence, and these negative self-concepts appear to transfer over to higher levels of anxiety and avoidance about romantic relationships in adulthood.

Although not shown in Figure 3.7, all covariances were tested between the mediators and between the 30 year outcomes. The covariances between parental relationship status and adolescent self concept ($r = -.09, p = .285$) and between parental relationship status and adolescent family conflict ($r = .15, p = .085$) were not significant. All other covariances were significant.

In comparing the final model from Study 1 to this model, the amount of explained variance in the outcome variables was improved for 30 year attachment insecurity with the addition of the representation variables in Study 2. The amount of variance in 30 year attachment insecurity explained by these mediators increased from .23 in Study 1 (Figure 2.6) to .27 in Study 2 (Figure 3.7). The amount of variance in 30 year relationship status did not change because the mediators remained the same.

Predicting 30 year Socioeconomic Status Outcomes. The third set of structural equation models tested longitudinal pathways to offspring socioeconomic status at 30 years. In Study 1, the adolescent variables that emerged as significant mediators of the associations between early maternal mental illness and adult socioeconomic status were adolescent family SES, academic achievement, and mental health. A structural equation model was tested with these three variables as mediators, as well as the Study 2 variables of narrative coherence and relationship beliefs. Only pathways that were significant in the models tested in Study 1 and the models tested earlier in Study 2 were included in this combined model. All covariances between mediators and between the 30 year outcomes were also tested. After the model was calculated, all non-significant pathways were removed. In this model, the pathway from narrative coherence to 30 year educational attainment was non-significant, and this pathway was removed. The more parsimonious adult socioeconomic status model was then calculated, and results are shown in Figure 3.8.

As can be seen in Figure 3.8, adolescent SES, academic achievement, and mental health, as well as adult narrative coherence and relationship beliefs, were significant mediators of the associations between early maternal mental health and measures of adult offspring socioeconomic status. This model fits the data well, $X^2(6, n = 234) = 7.886, p = .247$; with normed fit index = .982, Tucker-Lewis index = .972, comparative fit index = .995, and root-mean-square error of approximation = .031. As can be seen from this

model, family SES in adolescence mediated the associations between maternal mental health and 30 year educational attainment ($\beta = .25, p < .001$) and 30 year annual income ($\beta = .38, p < .001$). Offspring of mothers with mental health problems in early childhood lived in lower SES families in adolescence, and this was related to lower educational attainment and income for these offspring in adulthood.

As expected, academic achievement in adolescence also mediated the pathway to offspring educational attainment ($\beta = .45, p < .001$), as higher IQ scores and better grades in school led to higher attainment by age 30. In addition, adolescent mental health remained as a significant mediator of the association between maternal mental health and offspring educational attainment ($\beta = .15, p < .05$). Offspring whose mothers had mental health problems early on experienced their own mental health problems in adolescence, and completed fewer years of school by adulthood.

Finally, relationship beliefs mediated the pathway to educational attainment ($\beta = .20, p < .001$) and narrative coherence mediated the pathway to annual income ($\beta = .27, p < .01$). Individuals who produced more organized and coherent narratives about their families of origin had higher incomes compared to individuals with less coherent narratives. Individuals with more positive beliefs about relationships attained more years of education compared to individuals with more negative beliefs. These associations were significant even with family SES, individual IQ, grades in school, and earlier mental health accounted for. Although not shown in Figure 3.8, all covariances were tested between the mediators and between the 30 year outcomes. The only covariance not significant was between 30 year educational attainment and 30 year annual income ($r = .04, p = .674$)

In comparing the final model from Study 1 to this model, the amount of explained variance in the outcome variables was improved with the addition of the representation variables in Study 2. The amount of variance in 30 year educational attainment explained by these mediators increased from .67 in Study 1 (Figure 2.4) to .70 in Study 2 (Figure 3.8). The amount of variance in 30 year annual income explained by these variables increased from .26 in Study 1 (Figure 2.4) to .32 in Study 2 (Figure 3.8).

Gender Comparisons. Posthoc analyses examined possible gender differences in the associations found within the final three final models presented above. Analyses of

variance were conducted with all of the variables in this study, and these analyses revealed that the only mean gender difference was in adolescent self-concept, with females ($M = 32.87$, $SD = 4.27$) having lower self-concepts than males ($M = 34.27$, $SD = 3.67$). There were no other mean gender differences in any of the study variables.

Multiple group analyses were then conducted in SEM to determine whether the models in Figures 3.6 through 3.8 fit equally well for males and females in our sample. In these analyses, one model was run in which all parameters were constrained to be equal for males and females, and a second model was run in which these parameters were allowed to be freely estimated (Vandenberg, 2002).

The first model compared the fit of the 30-year mental health model (Figure 3.6) for males and females. Results from the model comparison ($X^2 = 7.60$, $df = 8$, $p = .473$) suggest that imposing the additional restrictions of equal factor loadings across the two sexes of participants did not result in a statistically significant worsening of overall model fit. Thus, we can conclude that our original model presented in Figure 3.6 fit equally well for males and females in our sample.

The second model compared the fit of the 30-year romantic relationships model (Figure 3.7) for males and females. Results from the model comparison ($X^2 = 2.36$, $df = 9$, $p = .985$) suggest that imposing the additional restrictions of equal factor loadings across the two sexes of participants did not result in a statistically significant worsening of overall model fit. Thus, we can conclude that our original model presented in Figure 3.7 fit equally well for males and females in our sample.

The third model compared the fit of the 30-year socioeconomic status model (Figure 3.8) for males and females. Results from the model comparison ($X^2 = 20.72$, $df = 11$, $p = .036$) suggest that imposing the additional restrictions of equal factor loadings across the two sexes of participants did in fact result in a statistically significant worsening of overall model fit. This indicates that there were gender differences in the SES model presented in Figure 3.8. Upon close examination of this model by gender, two significant differences were found. First, the pathway between maternal mental health and academic achievement was not significant for males ($\beta = .01$, $p = .857$) but was significant for females ($\beta = .42$, $p < .001$). Thus, girls' grades in school appeared to be more affected by maternal mental illness than boys' academic achievement. Second, the

pathway between relationship beliefs and educational attainment was significant for males ($\beta = .38, p < .001$) but not for females ($\beta = .07, p < .456$). Males who had better perceptions of relationships attained more years of school, but this association was not present for females. All other pathways that were significant in Figure 3.8 were significant for both males and females in the model comparison.

Discussion

The primary aim of this dissertation has been to examine how maternal mental health influences offspring across the course of development. Results from Study 1 suggest that maternal mental health measured in early childhood is related to offspring mental health, socioeconomic status, and romantic relationship outcomes in adulthood, and that these associations are partially explained by several individual and family variables across childhood and adolescence. Study 2 expands upon this question by asking whether offspring's adult representations of growing up in their families of origin are also important.

In Study 2 of this dissertation, narratives were examined in order to capture individuals' meaning making processes concerning their experiences growing up in their families of origin. These narratives offer a glimpse into how individuals make sense of family experiences, as well as how their family experiences may be related to expectations for relationships in other domains. Retrospective narratives about the family of origin have been used extensively by researchers to predict parent-child attachment relationships and child problems. In addition, narratives about families formed in adulthood have been linked to various aspects of concurrent functioning, and have been found to be related to marital satisfaction, family functioning, and parental psychopathology. The current study fills a gap in the research literature by examining participants' retrospective narratives about their families of origin and linking aspects of these representations to multiple domains of adult adaptive functioning. Moreover, this study is one of the first of its kind to examine long-term longitudinal relations between maternal mental illness during early childhood and offspring representations about their families of origin in adulthood, as well as possible mediators of these pathways.

Narrative Coherence, Relationship Beliefs, and 30 year Adaptive Functioning

The two variables that were obtained from offspring's family narratives were narrative coherence, or how well an individual was able to construct and organize his or her family story, and relationship beliefs, or the extent to which an individual regarded intimate relationships, particularly those within the family of origin, as manageable, reliable, and safe. The first step in this study was to examine associations between offspring's narrative coherence and relationship beliefs and their 30-year outcomes of mental health, romantic relationships, and socioeconomic status. In this sample, individuals who were able to successfully construct coherent and organized narratives about their experiences growing up in their families of origin had better overall mental health and fewer psychiatric diagnoses compared to individuals with less coherent narratives. This association between mental health and coherence was expected, and is consistent with findings from the adult attachment literature. For example, one study by van Ijzendoorn and Bakermans-Kranenburg (1996) found significant associations between less coherent narratives and clinically significant psychological problems. Another study by Dickstein (1999) found that mothers currently experiencing depressive symptoms created less coherent narratives about their families compared to mothers not currently experiencing depressive symptoms.

Offspring with more positive relationship beliefs also had better mental health than offspring with more negative relationship beliefs. Participants who had more positive experiences growing up with their families and who tended to regard intimate relationships as rewarding and safe had fewer mental health problems. This link between family of origin experiences and beliefs and adult mental health is also consistent with a body of research literature that emphasizes the importance of interpersonal relationships to adult mental health. For example, Costell and colleagues (1981) found that individual's beliefs about the relative trustworthiness of relationships were related to engagement in psychotherapy and psychiatric status. Although the directions of these associations cannot be determined from this study, these results suggest that individuals with poorer mental health tend to have more negative representations of their families of origin, more negative beliefs about interpersonal relationships in general, and are less able to construct coherent narratives about their experiences growing up in their families.

Similarly, participants with more coherent narratives and more positive beliefs about relationships were more likely to be in stable romantic relationships and to have lower levels of attachment insecurity in adulthood. In many ways, it makes sense that an individual's experiences with his or her most important interpersonal relationships while growing up would influence that individual's relationships with romantic partners in adulthood. According to attachment theory, experiences with parents shape offspring's internal working models about how relationships in general function, and these working models persist into adulthood (Bowlby, 1980). If an individual had negative experiences with their parents growing up, he or she may be less able or likely to enter into close romantic relationships in adulthood.

The measure of attachment insecurity at age 30 may also measure very similar underlying constructs as the narrative measure of relationship beliefs. If offspring's experiences with their families of origin led them to view interpersonal relationships in general as dangerous and unreliable, these experiences may also have contributed to their feelings of anxiety and avoidance within romantic relationships specifically. Overall, these findings are consistent with Dickstein's (1999) study on romantic relationships that found that husbands' and wives' positive relationship beliefs about their families of origin were associated with marital satisfaction and healthy family functioning.

Associations were also found between narrative coherence and relationship beliefs and the two measures of adult socioeconomic status used in this study. First, individuals with higher annual incomes and more years of education by age 30 displayed more coherent narratives about their families of origin. This could be explained by general IQ effects, as it is likely that individuals who are more intelligent are also better able to create an organized and complete narrative compared to individuals who are less intelligent. This hypothesis was tested in later analyses. The link between relationship beliefs and socioeconomic status was less intuitive, but supports the findings from Study 1 that individuals who are doing well in one domain of functioning (e.g., romantic relationships) also tend to do well in other domains (e.g., SES). Thus, offspring who have positive representations of their families of origin and positive beliefs about relationships in general also tend to make more money and attain more education by adulthood. Another explanation could be that individuals with less positive relationship beliefs are

also more likely to be from lower SES families. Living in poor economic circumstances can be considered a major stress factor for families, and could lead to less optimal parenting practices or family functioning. As results of Study 1, as well as numerous other studies, have found links between parental SES and offspring SES, it could be that family SES is the factor that explains both offspring SES and their relationship beliefs.

Narrative Coherence, Relationship Beliefs, and Maternal Mental Health

A primary aim of Study 2 was to examine the impact of early maternal mental health problems on the ways in which adult offspring organize their representations about their families of origin. Preliminary analyses revealed that participants whose mothers had mental health problems when they were growing up had significantly less coherent narratives compared to participants whose mothers did not have mental health problems. In addition, participants of mothers with mental health problems had less positive beliefs about relationships compared to participants of mothers without mental health problems. These associations lend support to the idea that early experiences between children and their primary caregivers are important to the formation of children's internal working models about not only their families of origin, but also interpersonal relationships in general (Bowlby, 1980). In this study, even though children would not have been able to recall their experiences with parents during their first three years of life, exposure to maternal mental illness during this time appears to somehow contribute to offspring's internal working models of relationships in adulthood. The next obvious step was to identify more proximal variables related to narrative coherence and relationship beliefs that may also serve as mediators of these associations.

Narrative Variables and Adolescent Variables

Associations were examined between the narrative variables of coherence and relationships beliefs and a number of individuals and family variables measured in childhood and adolescence. As expected, all aspects of family functioning were highly associated with offspring adult representations of their family and of interpersonal relationships in general. Individuals with more positive parenting, better family functioning, lower levels of family conflict, and more stable parental relationships in childhood and adolescence had more coherent narratives about the family and more positive beliefs about relationships in adulthood. Thus, it appears as though offspring's

representations of their experiences growing up in their families of origin were consistent with actual experiences assessed while they were growing up.

In addition, participants' relationships with peers in adolescence were also associated with their narrative coherence and relationship beliefs in adulthood. Because peer relationships are regarded as among the most important interpersonal relationships in adolescence (Collins, 2006), it is not surprising that experiences within peer relationships would also help shape beliefs about relationships in adulthood. One study that had similar findings assessed representations of parent-child attachment using the AAI and representations of friendship and peer relations in adolescence, and found that secure attachment representations with parents were significantly related to assessments of close friendships, friendship concept, integration in a peer group, and emotion regulation within close friendships (Zimmerman, 2004). Coherency during the AAI was also associated with friendship quality and friendship concept. These results highlight the close associations between attachment representations and friendship relationships during adolescence. Study 2 of this dissertation adds a longitudinal component to this research by finding that peer relationships during adolescence are related to representations of the family and of relationships in general during adulthood.

Narrative coherence and relationship beliefs were also found to be associated with adolescent mental health. Adolescents with better mental health had more coherent narratives about the family and more positive relationship beliefs in adulthood. This is consistent with research that has shown that the structure and content of internal representations about the family are linked with psychopathology (Fonagy et al., 1997; Lyons-Ruth, et al., 1999). For example, Oppenheim (2006) showed that children who had more positive maternal representations in their narratives about their mothers exhibited fewer behavior problems, and Costell and colleagues (1981) found that participants' relationship beliefs were related to engagement in psychotherapy and psychiatric status (Costell, Reiss, Berkman, & Jones, 1981). In addition, van Ijzendoorn and Bakermans-Kranenburg (1996) found significant relations between insecure attachment representations (which were classified by less coherent narratives) and clinically significant psychological problems. Because all of these studies were cross-sectional in design, the current research adds to this body of research by suggesting that earlier

mental health problems may lead to later negative representations of interpersonal relationships.

Individuals with more positive self-concepts in adolescence also tended to have more coherent narratives about the family and more positive relationship beliefs in adulthood. This measure assesses adolescents' perceptions of competence in several areas related to interpersonal relationships, including social acceptance, close friendships, and romantic appeal. Thus, one would expect that adolescents who believe themselves to be more competent in social relationships in adolescence would have more positive beliefs about relationships in adulthood.

Finally, individuals with higher IQ and achievement scores and from higher SES families in adolescence had more coherent narratives and more positive perceptions of family relationships compared to individuals with lower achievement scores and those from lower SES families. As described above, individuals with higher IQ scores may be better able to produce coherent and organized narratives compared to individuals with lower IQ scores. Family SES may be related to higher levels of stress within the family, which may contribute to negative experiences growing up in the family, and subsequently influence offspring's adult relationship beliefs. Together, these findings suggest that representations of the family are products not only of direct experiences with the family, but also of a number of other experiences, as well as individual characteristics of the child.

Pathways to Representations about the Family of Origin

The next set of analyses examined which individual or family variables in childhood or adolescence are most important to predicting narrative coherence and relationship beliefs in adulthood. Although the two dimensions of relationship beliefs and narrative coherence were without question related, they were also regarded as two distinct constructs. In the literature, the dimension of narrative coherence is believed to reflect process-level aspects of narrative construction, and is also believed to be a property of the individual. The dimension of relationship beliefs, on the other hand is more strongly content-based, and more closely linked to actual experiences within relationships. Thus, it was hypothesized that narrative coherence would be most strongly predicted by measures of individual competence, particularly academic achievement, and

that relationship beliefs would be most strongly predicted by measures of earlier family functioning, such as family conflict and parenting.

Actual results differed from these predictions. As hypothesized, although narrative coherence and relationship beliefs were significantly related, there were different pathways leading to these two variables. As predicted, narrative coherence in adulthood was predicted by academic achievement in adolescence. Individuals with higher IQ scores and better grades in school in adolescence had more coherent narratives about their families of origin in adulthood. One possible reason for this is that higher levels of intelligence make it easier to produce organized and coherent narratives. Also, as both narrative coherence and academic achievement are considered aspects of the individual, it makes sense that these two variables are related.

In addition family conflict predicted narrative coherence, with higher levels of family conflict throughout adolescence related to less coherent narratives about the family at age 30. There are several possible reasons for this association. Coherence refers to the ways in which an individual's story makes sense, how clauses and thoughts are organized, the willingness of the individual to consider differing perspectives, and the match between affect and content in the narrative. In many ways, the production of a coherent narrative requires focusing on the task at hand and organizing thoughts in clear and logical ways. High levels of family conflict, particularly discord between parents, are often confusing for children, and produce environments of chaos (Amato, 1994). These feelings of confusion can often combine with contradictory feelings of loving their parents while at the same time being angry with them. This sense of chaos and these contradictory emotions could then contribute to lower levels of coherence when speaking about their families of origin in adulthood.

The family variables of family functioning, family conflict, and parenting did not emerge as the strongest predictors of offspring's relationship beliefs in adulthood. This was somewhat surprising given that the narratives being analyzed for relationship beliefs were entirely about experiences growing up in the families of origin. Instead, the two variables that predicted relationship beliefs were parental relationship status through the age of 18 and peer relationships in adolescence. These results showed that participants whose parents stayed married or romantically involved throughout their childhood and

adolescence had more positive beliefs about relationships in adulthood. Participants whose parents had never been involved or who divorced or split up before participants turned 18 had more negative beliefs about relationships. This is consistent with a body of literature that shows that divorce often has negative effects on offspring. Compared with those raised in intact two-parent families, one meta-analysis showed that adults who experienced a parental divorce had lower psychological well-being, more behavioral problems, less education, lower job status, a lower standard of living, lower marital satisfaction, a heightened risk of divorce, a heightened risk of being a single parent, and poorer physical health (Amato, 1994). As the negative effects of divorce appear to be intensified when divorce coincides with parental mental illness (Beardslee et al., 1993), it stands to reason that parental relationship status in this sample would be associated with offspring relationship beliefs.

In addition, peer relationships in adolescence emerged as an important predictor of adult relationship beliefs. Adolescence is a critical period in social development, marked by an expansion of peer networks and increased importance of close friendships. As adolescents make the transition to middle school and then high school, peer networks increase and peer crowd affiliation becomes an important aspect of peer relations (La Greca & Prinstein, 1999). Also during adolescence, close friends begin to surpass parents as adolescents' primary source of social support and contribute in important ways to adolescents' self-concept and well-being (Furman & Buhrmester, 1992). Problems in adolescents' peer relationships (e.g., peer rejection) have been associated with internal distress for both boys and girls (Inderbitzen et al., 1997). For example, La Greca and Harrison (2005) found that positive peer-crowd affiliations and positive qualities in best friendships protected adolescents against feelings of social anxiety. Longitudinal associations have also been found between quality of peer relationships at age 13 and romantic relationship styles at age 21 (Dhariwal, et al., 2009). These results add to the existing literature by showing that peer relationships in early and late adolescence are related to individual's beliefs about relationships more than a decade later. Moreover these results are evidence that the measure of relationship beliefs used in this study does in fact measure beliefs about relationships in general, and not simply beliefs about the family of origin.

Family Narrative Representations as Mediators

Results of Study 1 revealed that several individual and family variables in childhood and adolescence mediated associations found between early maternal mental health and offspring adaptive functioning outcomes. Because the narrative codes of coherence and relationship beliefs were found in Study 2 to be related to both maternal mental illness and all 30-year outcomes, the next logical step was to test whether individuals' representations of growing up in their families of origin served as additional mediators of the relations found between early maternal mental illness and offspring adult outcomes. In other words, would the ways in which individuals conceptualize and organize their thoughts about their families of origin help further explain the links between early maternal mental illness and poor adaptive functioning among offspring in adulthood?

Results indicated that the narrative variables of coherence and relationship beliefs helped explain the pathways between maternal mental health during offspring's first three years and offspring's adaptive functioning outcomes in adulthood. Adult offspring of mothers with mental health problems had less coherent narratives when speaking about their families of origin, more negative experiences with family growing up, and more negative beliefs about the safety and reliability of relationships in general. These individuals also had more concurrent mental health problems. Thus, these findings suggest that one explanation for the link between parental mental illness and offspring mental illness more than three decades later could be the ways in which offspring think about and deal with their experiences growing up with their families. Although participants were not directly asked about their experiences with parental mental illness specifically, the codes of narrative coherence and relationship beliefs together pick up on participants' general representations of both their families of origin and interpersonal relationships. Representations of experiences growing up with parental mental illness specifically will be addressed in Study 3 of this dissertation.

In addition to these findings about the intergenerational transmission of psychopathology, findings from Study 2 also indicate that the narrative code of relationship beliefs helps explain the association between early maternal mental health and offspring adult attachment insecurity. Offspring of mothers with mental health

problems early on tend to be more anxious and avoidant in their romantic attachments in adulthood. These results show that one possible reason for this link is that experiences with maternal mental illness often contribute to both negative experiences within the family of origin as well as beliefs that relationships in general are dangerous and unreliable. These negative beliefs about interpersonal relationships then appear to be related to more specific negative beliefs about the safety and security of romantic relationships.

Finally, the pathways from maternal mental health in early childhood to offspring educational attainment and annual income at age 30 were partially explained by the offspring's representations of growing up in their families of origin. Individuals with more coherent and organized narratives about their families of origin also had higher levels of education and higher annual incomes compared to individuals with less coherent narratives. It thus appears as though individual who are able to clearly construct a story about their own past, consider multiple sides of an issue, and provide episodic memory examples for their statements about their families are also more successful in the areas of education and income. Although the common factor underlying all of these associations could be general level of intelligence, it is also possible that there is something specific to being able to produce a coherent narrative about one's own experiences in the family that is related to overall success in adulthood. In addition, relationship beliefs mediated the association between maternal mental health and offspring educational attainment, as offspring with better experiences in the family and more positive beliefs about relationships in general were more likely to achieve higher levels of education. One possible explanation for this is that negative experiences in the family could lead to higher levels of high school drop-out. Another explanation is that parents who contribute to negative relationship beliefs in offspring may be less likely to encourage offspring to attain higher levels of education or to pay for college.

Integrating Study 1 and Study 2 Findings

It was important to then examine the impact of these narrative variables as mediators of the associations found between maternal mental health and offspring adaptive functioning in relation to the variables found to be significant as mediators in Study 1. These analyses combined the findings of Study 1 and Study 2, and tested

whether individuals' concurrent representations of their experiences growing up with their families of origin were weaker or stronger predictors of adaptive functioning than individuals' actual characteristics and experiences while growing up.

These final analyses suggest that there are multiple pathways from maternal mental health in early childhood to offspring mental health in adulthood. It comes as no surprise that one variable along this path is offspring mental health in early and late adolescence. Numerous studies have found links between maternal mental health and offspring mental health, and from earlier mental health to later mental health. These results add to this body of literature by showing a longitudinal pathway from maternal mental health in early childhood to offspring mental health in adolescence, and from offspring mental health in adolescence to offspring mental health in adulthood.

In addition, two variables related to the family also explained associations between early maternal mental health and offspring mental health three decades later. The first was parenting, as offspring of mothers with mental health problems experienced more negative parenting in adolescence, and more negative parenting was related to poorer mental health among these offspring in adulthood. In addition, offspring's relationship beliefs in adulthood were negatively influenced by maternal mental health problems in early childhood, as offspring of mothers with mental illness reported more negative experiences with their families growing up and had more negative beliefs about relationships in general in adulthood. Together, these findings indicate that both experiences with parents growing up as well as later representations of these experiences as adults are influenced by early maternal mental illness, and that both actual experiences and representations contribute to mental health functioning.

Multiple pathways were also found from maternal mental health in infancy to offspring relationship status and attachment insecurity in adulthood. Mothers with mental health problems during children's first few years were less likely to be involved with or stay involved with children's fathers over the following 18 years. Parental relationship status was then related to offspring relationship status in adulthood, as participants whose parents were married or together while they were growing up were more likely to be married or in stable dating relationships at age 30. Family conflict also emerged as an important variable that explained the links between early maternal mental health and

aspects of offspring's adult romantic relationships. Maternal mental illness early on leads to higher levels of family conflict as reported by both parents and children in adolescence, and higher levels of family conflict make offspring less likely to be in stable romantic relationships in adulthood. In addition, higher levels of family conflict in adolescence lead to higher levels of anxiety and avoidance in romantic relationships at age 30.

In addition, two different measures of beliefs or perceptions emerged as significant mediators of the associations between maternal mental illness and offspring adult attachment insecurity. Adolescents whose mothers had mental health problems when they were young held less positive beliefs about their competence in areas including interpersonal relationships in adolescence, and these negative self-concepts were then related to later negative beliefs about romantic attachment relationships in adulthood. In addition, maternal mental illness was associated with negative relationship beliefs in adulthood, and these relationship beliefs were associated with negative beliefs about romantic relationships. These findings make sense in that all three variables in some way include participants' perceptions of relationships or of their role in relationships.

Finally, similar to the findings for mental health and romantic relationship outcomes, several pathways were found from maternal mental illness in early childhood to offspring socioeconomic status in adulthood that included both actual experiences and representations as measured through the narrative codes. As expected from prior research and analyses, family SES and adolescent academic achievement played significant roles in these pathways. Maternal mental illness was associated with lower family SES and lower academic achievement for offspring in adolescence, and these variables then predicted adult SES. In addition, adolescent mental health remained as a predictor of adult educational attainment.

Somewhat surprisingly, level of coherence as obtained from family of origin narratives in adulthood explained part of the link between maternal mental health in early childhood and offspring annual income in adulthood. The fact that this variable remained significant even with IQ scores and grades in school controlled for in the model suggests that the influence of narrative coherence on adult SES is not simply an effect of

intelligence. Offspring's relationship beliefs in adulthood also helped explain the association between maternal mental health and offspring adult educational attainment. Again, the fact that this variable remained significant even with academic achievement, family SES, and earlier mental health controlled for suggests that adult offspring's representations of their experiences growing up in their families of origin have effects not only on their mental health or their current relationships, but also on more distal measures of adaptive functioning, such as their socioeconomic status.

Limitations

There are several potential limitations that must be considered when interpreting the results of this study. First, the two family of origin narrative codes were gathered concurrently with the 30 year adaptive functioning outcomes. As a result, directions of associations between family of origin representations and 30 year mental health, romantic relationships, and socioeconomic outcomes cannot be determined. In particular, mental illness may uniquely influence the manner in which experiences are cognitively constructed, the salience of particular experiences that comprise the cognitive construction of relationships, and/or the extent to which certain experiences might be differentially disclosed during the course of narrative production. For example, depressed individuals may more often provide negatively distorted perceptions of their relationships by virtue of the immediate severity of their illness. Alternatively, the cognitive construction of the narrative and disclosure of salient experiences may have a significant impact on expressed symptoms (Peterson & Seligman, 1984). In addition, aspects of current relationship functioning may influence how individuals think about their experiences growing up in their families.

In this research, the important issue is that any "distortions" adults might have about their family relationships are a valid (and accurate) indication of their current sense of those relationships. Indeed, such "distorted" perceptions may be a fundamental process in the etiology or maintenance of mental health problems, as well as in the development of maladaptive relationship patterns (Wamboldt & Gavin, 1992). Thus, although it cannot be determined whether representations influence outcomes or vice versa, this question was not a primary focus of this study.

Second, another possible limitation of this study is that individuals were asked to retrospectively report on their experiences with their families while growing up. Because these experiences occurred up to several decades earlier, issues of memory could be a concern. However, for this study, retrospective self-reports were regarded as a valid means of assessing family functioning for several reasons. Self-reports are advantageous given that it is possible to assess subtle parenting behaviors and subjective cognitive and emotional experiences which would be hard to measure through direct observation (Spence, Barrett, & Turner, 2003). Adult reports of perceptions of childrearing have also been found to yield both reliable and consistent results. For example, several studies have shown that anxious adults accurately report their parents as having been more controlling, rejecting, overprotective, low in socialization, and low in caring, findings that are consistent with cross-sectional studies of anxious parents (Lieb et al., 2000; Rapee & Melville, 1997).

Related to the first limitation, although there is some evidence to suggest that recall of significant past events is not affected by mood states (Brewin, Andrews, & Gotlib, 1993), most researchers agree that retrospective data are affected by reporting bias from the offspring's perspective. Self-report questionnaires and retrospective interviews reflect perceptions of family functioning, which may be unintentionally distorted by participants, who may reframe their early lives in terms of current psychological status (Laraia et al., 1994). In other words, when asking people about their family experiences to assess cognitive perceptions, it must be acknowledged that the information provided in narrative form reflects individuals' current understanding of events, not what may (or may not) have actually happened (Zeanah & Barton, 1989). However, because the primary research questions of this study revolve around individuals' perceptions of their experiences, rather than their actual experiences, these issues of memory and accuracy are not as much of a concern.

Implications and Conclusion

Overall, the results of this study show that, in addition to offspring's actual experiences growing up in their families of origin, offspring's representations of these experiences are also important in predicting their adaptive functioning at age 30. In addition, offspring's representations of relationships, their perceptions of their

experiences with their families of origin, and the ways in which they speak about these experiences in adulthood help explain the pathways between maternal mental illness at 30 months and offspring mental health, romantic relationship, and socioeconomic outcomes at age 30.

These results have several implications for treatment. If offspring's adult representations of their experiences growing up are related to their resilient functioning, then targeting negative representations could be a goal of intervention or treatment. Results of this study suggest that it is not only what an individual says that is important, but also how that individual organizes his or her story and provides coherent examples to back up statements. Family narrative interviews, such as the one used in this study, could thus be employed by practitioners as an assessment tool to measure the internal working models of their clients.

Taking a step back from the quantitative analyses of this study, it was clear simply from reading the interviews that there were important individual differences in narratives that were almost certainly associated with adaptation. As an example, several participants spoke about experiences with abuse. However, the ways in which these participants integrated these experiences into a coherent and organized working model varied greatly. In responding to the interview questions of this study, one participant spoke at length in a positive tone about the love that he had felt from his mother.

My mother loved the shit out of me. I mean, she would do anything in her power to do for me... I pretty much got to do whatever I wanted when I was a little kid, but it was within reason, like have a friend over and do whatever I wanted. Like I said, my mother would do anything for me.

One question later, he responded:

Well, my mother, like, fired a cable box at me. And smacked me with an old cable box. Um, and I got stabbed in the freaking leg by her with a screwdriver. Um, and my father poured boiling water on my leg.

In contrast, another participant spoke about her experiences with abuse in the following way:

We had what I guess you would call a dysfunctional family. Our father was extremely abusive, and our mother was more indifferent. It was a very, very hard time. My childhood is full of very painful memories. As children my siblings and I were pretty much terrified of everything. I mean, it was like in our household you didn't breathe without permission. Always afraid that something you did or said would trigger the abuse."

When asked how her experiences with her family affected her today, she responded:

The things I lived through helped determine the things that I didn't want to do as an adult. They influenced my personality and how I deal with situations. It has a lot to do with my being able to trust people and my ability to be loved or feel loved and appreciated. It also steered me in the direction that I don't believe in spanking children. I don't believe in that kind of cruelty. I remember the terror that I lived in as a child and I go out of my way trying to prevent that from happening to my children.

It is easy to recognize the difference in coherence between these two narratives, and it is also easy to see how these two people with very similar traumatic experiences may have developed along two very different pathways, and ended up in two very different places in adulthood. Although results of Study 2 provide evidence that representations of experiences are important, these results are at the level of the group, and do not provide information about the contents of these representations for specific individuals with specific experiences. The focus of Study 3 of this dissertation will be to examine adult offspring's representations of growing up with a mentally ill parent, with the goal of more fully understanding the contributions of cognitive representations to adult competence.

CHAPTER 4

A Qualitative Analysis of Adult Offspring's Representations of Parental Mental Illness: Study 3

Introduction

Results of Studies 1 and 2 suggest that there are multiple sources of risk and resilience for children of parents with mental health problems. In particular, offspring's adult representations of their experiences growing up in their families of origin help explain associations between early maternal mental health and offspring adult adaptive functioning. Family narratives analyzed in Study 2 revealed that individuals who had more negative experiences within their families of origin and more negative perceptions of relationships in general had more maladaptive outcomes in the areas of mental health, romantic relationships, and socioeconomic status in adulthood. Yet although the interviews in Study 2 asked participants to discuss their overall experiences in their families of origin, these interviews did not contain specific questions about experiences with parental mental illness. Currently, there is very little research examining offspring's perceptions of parental psychopathology, their current and past understanding of symptoms and diagnoses, and their perceptions of their own coping behaviors both as children and as adults. Because results of Study 2 suggested that representations of the past are related to current adaptive functioning, how offspring think about and organize their experiences with parental mental illness may play a role in how this risk factor influences their adaptive functioning in adulthood.

The main goal of Study 3 will be to explore how adult offspring conceptualize past experiences with parental mental illness. One aspect of this will be to examine offspring's perceptions and understanding of parental mental illness both looking back as adults, as well as retrospective accounts of what they perceived and how they felt as children and adolescents. A second aspect will be to examine offspring's methods of

coping with parental mental illness at different points in development and attempt to relate this coping to their self-described level of adaptive functioning. Finally, Study 3 will investigate offspring's perceptions of the effects of parental psychopathology on their lives growing up, as well as on multiple aspects of their adult functioning.

Offspring's Representations of Parental Mental Illness

A small body of research has specifically addressed associations between offspring's representations of parental mental illness and their own level of functioning (Goodman, 2007). This literature explains that offspring's understanding of parental mental illness may include the extent to which offspring perceive threat in their assessment of the situation, their causal attributions regarding parental mental illness (including possible self-blame), and their perceptions of their own capacity to respond or cope with the problem. The hypothesis is that, as children become aware of the signs and symptoms of their parent's problem, they conceptualize their observations and experiences in particular ways. The adaptiveness or maladaptiveness of these cognitions is expected to guide children's emotional and coping responses, and thereby influence the impact of the parent's disorder on the child's development.

This hypothesis is supported by three cognitive developmental theories. First, Dodge's (1986) social information processing model proposes that individuals respond to social stimuli based on the ways in which they encode and interpret the information they are given. These responses are then related to their adjustment. For example, in the case of offspring of depressed mothers, offspring may encode a particular situation by selectively attending to negative cues and ignoring positive interactions, which could then be associated with individual well-being. Offspring could also show errors in representation by blaming themselves for their parent's mental health problem or over-interpreting the threat of the situation, which could lead to problems in adjustment. Second, cognitive theories of depression emphasize the role of thinking patterns on emotions and behavior (Beck, 1976; Meichenbaum, 1977; Alloy et al., 2006). For example, if offspring of mentally ill parents tell themselves that they are unable to deal with their parent's problem, this may negatively impact their coping skills and resources. Finally, stress and coping theories propose that an individual's interpretations of a stressor play a mediating role in the association between the degree of distress that an

individual feels in relation to the stressor and the impact of the stressor on the individual (Compas et al., 2001). Together, these theories suggest that it is important to assess offspring's perceptions and understanding of their parent's mental health problem in order to understand the impact that parental mental illness has on offspring.

Despite this theoretical support, however, only a few research studies have examined offspring's representations of parental mental illness. Early studies examined children's understanding of mental illness in general. These studies were conducted among children who did not have a parent with a mental health problem. For example, a few cognitive developmental studies investigated children's ability to identify and classify deviant behaviors, define causality, and identify treatment options (Adler & Wahl, 1998; Spitzer & Cameron, 1995). These studies indicated normative developmental changes in children's understanding of mental health problems, whereby younger children were found to experience more difficulties in understanding such concepts compared to older children. Qualitative studies suggest that children are unclear about mental health problems and have difficulty defining the term (Armstrong et al., 2000). The mass media, personal experience of someone with a mental illness, friends, family, and especially parents were reported as being important sources of children's understandings of mental health problems.

Most relevant to this dissertation are a small number of studies that have focused on children's representations or meaning making in the context of parental mental illness. Research has indicated that the extent to which children are affected by parental mental illness is dependent on their understanding of the condition (Beardslee & Podorefsky, 1988). There is some evidence that children of mentally ill parents struggle to understand parental illness (Garley et al., 1997), and that increased knowledge of their parent's condition can assist children in learning to cope more effectively (Cogan et al., 2004).

In one of the first studies of its kind, Beardslee and Podorefsky (1988) examined the self-understanding of children of mentally ill parents. They conceptualized self-understanding as having three components: (1) awareness of the parent's illness; (2) specific response to parental illness; and (3) the capacity to observe and reflect on the experience of parental mental illness. Their sample was composed of 18 children who were examined first in adolescence and then followed up two and a half years later. These

researchers found that participants who were functioning well at the follow-up were characterized by considerable self-understanding, a deep commitment to relationships, and the ability to think and act separately from their parents. These adolescents were aware of their parent's mental health problem, expressed feelings of confusion and helplessness, and often took on caretaking roles for their ill parent.

A second study that assessed the understanding of children of mentally ill parents examined a sample of 20 children of mentally ill parents and 20 control children (Cogan, Riddell, & Mayes, 2005). This qualitative study found that control children based their understanding of mental health problems on media representations, whereas children of mentally ill parents based their understanding on personal experiences. Affected children conveyed fewer stigmatizing views of people with mental health problems compared to control children. In addition, when children were asked to identify the causes of mental illness, the explanations given by the majority of the control and affected children were largely social and environmental in nature (e.g., caused by homelessness or experiences with abuse). For example, 13 out of 20 of the affected children thought that their parent's mental health problem was a consequence of a painful or traumatic life event. Seven out of 20 blamed themselves for their parent's problem, and only 4 out of 20 cited biological explanations for mental illness.

A final study examined children's perceptions of their mentally ill parent and how these perceptions impacted children's psychological adjustment (Scherer et al., 1996). Fifty seven child-mother dyads were assessed. Half of these children lived with a mother with a severe, chronic mental illness and half lived with a non-ill mother. This study was unique in the fact that, in addition to researchers asking parents to assess their own psychiatric symptoms, they also asked children to describe their parent's symptoms. Results of this study showed that children who perceived their mothers to have higher levels of psychiatric symptoms reported lower levels of self-competence and lower levels of social support. Children of ill mothers did not rate their mothers as having more psychiatric distress than children of well mothers, but did rate them higher on psychiatric symptoms. In addition, greater degrees of disparity between maternal perceptions of their own symptoms and child perceptions of maternal symptoms predicted child behavior

problems. The authors concluded that children of mentally ill mothers have a limited ability to perceive or comprehend symptoms of their mother's mental illness.

Offspring's Coping with Parental Mental Illness

One aspect of offspring's representations that may be important in explaining the association between parental mental illness and offspring adaptive functioning outcomes is their beliefs about their ability to cope. Related to these beliefs, individuals' actual methods of coping with stressful situations, particularly with parental mental illness, may help explain adaptive or maladaptive outcomes among these offspring.

The identification of coping strategies used by individuals has led to the development of several theories for coping with stressors in general. In one of the original theories, Lazarus and Folkman (1991) differentiated between problem-focused coping and emotion-focused coping. Problem-focused coping includes attempts to act directly on the stressor (e.g., problem solving), whereas emotion-focused coping includes attempts to deal with the problem emotionally (e.g., avoidance, distancing).

A second model of coping proposed by Rothbaum, Weisz, and Snyder (1982) introduced the concept of primary- versus secondary-control strategies. Primary-control is defined as attempts to enhance, reward, or reduce punishment by changing objective environmental conditions (e.g., altering the stressor), whereas secondary-control refers to attempts to enhance, reward, or reduce punishment by changing oneself (e.g., altering one's beliefs about a stressor). Problem solving, emotion regulation, denial, avoidance, and emotional expression are considered primary-control coping strategies. Cognitive restructuring (i.e., changing the way one thinks about a problem), distraction, positive thinking, wishful thinking, and acceptance are referred to as secondary-coping strategies.

A third, more recent, coping model emphasizes the importance of assessing a broad range of responses to stress, including both voluntary or controlled coping responses and involuntary or automatic reactions (Compas et al., 1997). Voluntary coping efforts are within conscious awareness and are oriented toward regulating one's cognitive, behavioral, emotional, or physiological responses to a stressor or toward the stressor itself. Involuntary responses to stress include temperamentally based and conditioned reactions that may or may not be within conscious awareness and are not under volitional control, such as emotional and physiological arousal, intrusive thoughts

and rumination, and emotional numbing. Both voluntary and involuntary stress responses are further distinguished on a second dimension of engagement with or disengagement from the stressor or one's reactions to the stressor. Engagement responses are directed toward a stressor and include approach responses; disengagement responses are oriented away from a stressor or one's reactions and include avoidant responses.

Together, these coping theories suggest that there are adaptive and maladaptive strategies for coping with stressful life events. Past research concerning children's methods of coping with stressful events in families has tended to focus on the effects of parental physical illness (Compas et al., 1994), parental divorce (Sandler et al., 1994), and parental quarrels (Jenkins et al., 1989). Recently, some attention has been paid to offspring coping responses to parental mental illness.

A study by Polkki and colleagues (2004) examined coping and resilience in the children of mentally ill parents. For this study, six 9- to 11-year-old children and 17 female grown up offspring of mentally ill parents were interviewed. Results showed that children used both practical problem solving and emotional coping mechanisms to deal with their situation. Another study by Langrock and Compas (2002) investigated the ways in which children aged 7 to 18 years coped with parental depression. Results based on parental reports of children's coping indicated that involuntary engagement responses, secondary control coping, and disengagement responses were used more frequently than primary control coping and involuntary disengagement responses.

Specific coping strategies among children of parents with mental health problems may be linked to their adaptive functioning. Children's constructive coping strategies are believed to buffer the effects of stressful experiences, and, consequently, foster psychological well-being. In general, active coping has been positively related to adjustment, whereas avoidant coping is negatively related (Compas et al., 2001). More specifically, avoidant coping has been associated with higher rates of depression, anxiety, and conduct problems in children (Sander et al., 1994). Maybery and colleagues (2005) found that children of parents with mental illness tend to use the coping strategies of withdrawing, avoiding, and distancing. In the coping literature, these strategies are commonly referred to as emotion-focused (Lazarus & Folkman, 1991) and are regularly labeled as "unhealthy" if maintained as long-term strategies. In the study by Langrock

and Compas (2002), children's use of secondary control coping (e.g., acceptance, positive thinking, distraction) was associated with fewer anxiety/depression and aggression symptoms. In contrast, involuntary engagement responses (e.g., rumination, intrusive thoughts) were associated with more anxiety/depression and aggression symptoms.

In thinking about coping skills and risk and resilience, it is important to also consider the potential impact that parental mental illness may have on children's coping skills, rather than simply conceptualizing coping as a stable skill or behavior that the child brings into the situation. One possibility is that dealing with a stressful situation like parental mental illness leads to an individual employing less efficient coping strategies. Another possibility, however, is that some children who are continually exposed to chronic parental affective illness may develop coping skills that ultimately lead them to more adaptive social functioning than they otherwise may have developed (Rutter, 1990). In fact, several theories of adaptation to multiple stressors (Peterson et al., 1995) suggest that "steeling" effects do occur in some children, thereby enabling them to use adversity to their advantage.

Grounded Theory

The small body of research reviewed above suggests that children often have trouble understanding parental mental illness, at least during childhood and adolescence. In addition, children of parents with mental illness who successfully avoid psychopathology have been found to employ a number of effective coping skills (Kinsella, Anderson, & Anderson, 1996). Very few studies, however, have examined adult offspring's representations of their experiences living and dealing with parental mental illness. Furthermore, very few studies have asked adult offspring to reflect upon their perceptions of parental mental illness both concurrently and during childhood, or have attempted to relate these representations to current adaptive functioning. An important task, therefore, is to examine the content of adult offspring's representations of their experiences growing up with parental mental illness, and examine whether there are differences in overall levels of functioning based on differences in these representations.

In order to describe offspring's representations, grounded theory qualitative analyses will be used. Grounded theory was developed by Glaser and Strauss (1967), and its main goal is to generate theories regarding social phenomena based on data. In other

words, the goal of these analyses is to develop an understanding of how adult offspring conceptualize experiences with parental mental illness that is “grounded” in, or derived from, a systematic analysis of narrative data. Grounded theory is regarded as having considerable value in the science of human development, as it allows for the conceptualization of complex phenomena. Grounded theory is considered an appropriate methodology when the study of social interactions or experiences aims to explain a process, not to test or verify an existing theory. Instead, the theory emerges through a close and careful analysis of the data.

The central principle of data analysis is constant comparison (Kennedy & Lingard, 2006). As issues of interest are noted in the data, they are compared with other examples for differences and similarities. Through this process of constant comparison, emerging theoretical constructs are continually being refined through comparisons with new examples. The main analytic technique of grounded theory is coding. Coding can be defined as a fundamental analytical process that plays a vital role in analyzing, organizing, and making sense of rich, textual data. When using grounded theory, the researcher starts by coding each incident, which refers to each identifiable unit of meaning. This unit can be a line of text, a sentence, a clause, a few sentences, or very occasionally a paragraph. The researcher then compares the code with other codes given both within that narrative and across the narratives of other subjects and attempts to identify themes among these codes. These themes are then combined and reduced to form a theory based on what emerges from the data.

Grounded theory coding consists of “substantive coding”, which involves comparing incident to incident to generate categories and comparing new incidents to these categories, and “theoretical coding” which involves conceptualizing how the substantive codes may relate to each other as parts of a theory. This type of open coding is regarded as the initial step of theoretical analysis that pertains to the discovery of categories and their properties (Glaser & Strauss, 1967). Some researchers have also referred to this type of coding as “axial coding”, because coding occurs around the axis of a category and the analysis process links categories at the level of properties and dimensions (Strauss & Corbin, 1998). This coding asks researchers to systematically

develop, understand, and relate categories and their subcategories, and, in the last phase, integrate the data around a central theme.

Grounded Theory and Parental Mental Illness

Grounded theory is regarded as particularly appropriate to the study of families' process of dealing with mental illness in the social and interpersonal contexts of their daily lives (Benoliel, 1996). Several qualitative researchers have used grounded theory in their studies of mental illness and families. Examples are described below.

Rose, Mallinson, and Moss (2002) conducted a grounded theory study to describe the experience of living with a family member with severe mental illness. Researchers interviewed 17 families 3 times over 2 years, and found that, among these families, living with the ambiguity of mental illness was the central concern. Individuals spoke most often about pursuing normalcy, confronting the ambiguity of mental illness, attempting to control aspects of the illness, and seeing possibilities for the future. The goals that these families spoke about were managing crises, crafting a notion of "normal", and containing and controlling symptoms. Strategies for achieving these goals were being vigilant, setting limits on patients, dealing with sense of loss, taking on roles, and acknowledging patients' strengths. Overall, results of this qualitative study illustrated the complex and difficult process that families go through in accepting the social implications of mental illness.

Gavois, Paulsson, and Fridlund (2006) used grounded theory to develop a model of mental health professional support based on the needs of families with a member suffering from severe mental illness. They interviewed 12 family members about their needs of support by mental health professionals, and analyzed these interviews using grounded theory methods. They found that four strategies by mental health professionals met the family members' needs of support in the different stages of dealing with mental health problems. These four strategies included: (1) being present at the onset of the illness as well as during relapses, (2) listening, which included assessing burden and maintaining contact, (3) sharing information between mental health professionals and family members, and (4) empowering family members through counseling and encouragement.

A third grounded theory study on mental illness was conducted by Abrams and Curran (2009), and investigated low-income mothers' experiences of postpartum depression, particularly their explanatory frameworks for their symptoms. These researchers interviewed 19 mothers using open-ended qualitative interviews and coded the interviews using the constant comparative method associated with grounded theory. Results of this study uncovered five main categories that linked the participants' postpartum depression symptoms with their experiences of mothering in poverty. These categories were: (1) ambivalence, (2) caregiving overload, (3) juggling, (4) mothering alone, and (5) real-life worry. This study also located the core experience of postpartum depression for low-income mothers as "feeling overwhelmed" due to mothering in materially and socially stressful conditions, and situated maternal symptoms in the context of the material hardships associated with living in poverty.

A fourth grounded theory study involving family responses to mental illness was conducted by Franz and colleagues (2010) with family members of individuals with schizophrenia. For this study 12 family members were interviewed with a semi-structured interview assessing family members' perceptions of the stigma associated with mental illnesses and the possible effects of stigma on treatment delay. The four main themes generated by the data analysis included: (1) society's beliefs about mental illnesses; (2) families' beliefs about mental illnesses; (3) fear of the label of a mental illness; and (4) a raised threshold for the initiation of treatment. Overall, results of this study suggest that due to fear of the official label of a mental illness, certain coping mechanisms may be adopted by families, which may result in treatment delay for the family member experiencing schizophrenia.

Finally, a group of qualitative researchers (Polkki, Ervast, & Huupponen, 2004) examined the narratives of 17 female adult children of mentally ill parents. These narratives were gathered from a writing competition arranged by a child welfare agency in which contestants wrote on the theme "How my life changed after a member of my family became mentally ill". Thus, the researchers did not ask specific questions of participants, and participants selected whether or not they wanted to enter into the competition. Researchers coded these narratives using grounded theory methods, and arrived at a number of themes. Participants' wrote about the fact that they had received

little information about their parents' illness, and that the illness often caused a change of roles within the family, with children taking on caretaker roles. These adult children described a variety of emotions, particularly fear and guilt, and reported that social support was very important in their abilities to cope with parental mental illness. Study 3 of this dissertation will expand upon this research by asking more specific questions about adult offspring's understanding of their parent's illness both while growing up and as an adult, as well as how they coped with this stressful situation as a child and currently.

Summary and Study Goals

The literature just reviewed suggests that offspring's perceptions and understanding of their parent's mental health problems may be important in explaining the associations found throughout this dissertation between parental mental health and offspring adaptive functioning. In addition, the ways in which offspring cope with parental mental health problems may be related to risk and resilience. Although a small number of studies have considered these issues, to date no studies have examined offspring's perceptions and coping behaviors both as adults, as well as their retrospective accounts of when they were growing up. The primary aim of Study 3 will be to develop a grounded theory model describing how adult offspring conceptualize past experiences with parental mental illness. Specific aims are as follows:

- (1) Describe offspring's perceptions and understanding of parental mental illness as adults, as well as retrospective accounts of what they perceived and how they felt as children and adolescents.
- (2) Identify offspring's methods of coping with parental mental illness at different points in development and attempt to relate this coping to their self-described level of adaptive functioning.
- (3) Investigate offspring's perceptions of the effects of parental psychopathology on their lives growing up, as well as on multiple aspects of their adult functioning.

Method

Participants

The 8 participants in Study 3 had been participants in the 30-year, three generation longitudinal study of mothers and children described and analyzed in Studies 1 and 2 of this dissertation. Participants for Study 3 were recruited based on information they had provided at age 30 in their family of origin interview described in Study 2. Each participant had mentioned or described a stressful experience growing up in their family of origin that mentioned or alluded to experience with parental mental health problems.

The average age of participants was 39 years, and there were seven females and one male. All participants were married at the time of the interview, however three participants were separated from their spouses and living with their boyfriends. All participants had two or three children between the ages of 3 and 18, with the exception of one participant who had three children between the ages of 18 and 24. In this sample, one participant had completed a GED only, two participants had high school diplomas, four had attended one or two years of college, and one had a master's degree. Five participants were employed full time at occupations ranging from manufacturing jobs to a school counselor, and one participant was self-employed in a cleaning business. One participant was unemployed due to a physical disability and one was unemployed due to a mental health problem. Average annual family incomes for these participants was \$71,000, with two participants making less than \$20,000 a year, two participants making between \$45,000 and \$75,000, three participants making between \$75,000 and \$100,000 and one participant making over \$150,000 per year.

Procedure

Participants were first sent a letter explaining this wave of the study and asking for their participation. Consent was also obtained through the mail. Participants were then contacted for a phone interview. These interviews lasted from 45 minutes to 90 minutes, and were on average 1 hour. Interviews were conducted by the dissertation author, recorded, and transcribed verbatim. Phone interviews consisted of a short demographics questionnaire that included questions about housing, marital status, educational attainment, current occupation, and income. In addition, a short questionnaire about participants' children and their academic achievement and mental health was administered, as well as a short questionnaire asking participants to rate their current mental and physical health and identify any major problems in these areas. All of these

questions together took approximately 10 minutes to administer. In addition, immediately following the interview the researcher rated each participant's current mental health status using the DSM Global Assessment of Functioning score described in Studies 1 and 2. The majority of the interview was comprised of the mental health interview described below.

Mental Health Interview

A mental health interview was developed for the purposes of this dissertation (the complete interview is included in the Appendix). There were three sections of this interview. The first section asked participants to reflect on their own mental health while growing up, the second section asked participants to reflect on their mother's mental health while growing up, and the third section asked participants to reflect on their father's mental health while growing up. Within each of these sections were three sub-sections. The first sub-section dealt with perceptions of mental health problems and diagnoses, the second sub-section dealt with understanding and coping with mental health problems, and the third sub-section dealt with stressful experiences in general.

Descriptions of these sub-sections are below.

The first section dealt with perceptions of mental health problems and diagnoses for the self as a child and adolescent, as well as for both parents in childhood and adolescence. Participants were first asked to rate their own and their parents' mental health on a five point scale during their childhood (before the age of 13) and during adolescence (between the ages of 13 and 18). Participants were asked specifically whether they or their parents had dealt with problems with sadness, anxiety, anger, or substance abuse, and to give specific examples for any affirmative answers. Participants were also asked if they or their parents had ever been diagnosed with a mental health problem and when that diagnosis occurred.

The second section dealt with understanding of mental health problems and perceptions of coping. Individuals were first asked what they think caused the mental health problems either they or their parent had experienced. They were asked what they thought caused the problem when they were a child or adolescent, as well as what they think caused the problem now, looking back as an adult. Next, they were asked how having problems themselves or having a parent with mental health problems affected

their lives growing up, and how it affects various aspects of their lives today. Participants were asked whether they had ever talked to a mental health professional about these issues, whether they or their parents had ever taken medication to help with feelings and emotions, and how they remember coping with either having mental health problems themselves or living with a mentally ill parent.

The third section of the interview asked participants to identify a period of time while growing up that was particularly stressful for them (or particularly stressful for their mother or father in the parent sections of the interview). They were asked what was happening at the time, what this experience was like for them (or for their parent), and to give an example of what they did to cope with that stressful time.

Grounded Theory Analysis

Grounded theory analysis includes the development of a theory within a paradigm of contexts, conditions, strategies, and consequences. This process encourages “density and precision” in the resultant theory. Data analysis for this study was conducted using constant comparative methods described by Strauss and Corbin (1998). Each interview was transcribed and read twice through prior to coding. Additional information on participants’ current families, work status, and mental health were also collected at the time of the interview. These notes were reviewed along with transcribed interview data

Grounded theory affords a systematic approach to the collection, organization, and analysis of data (Strauss & Corbin, 1998). The principal author was able to compare the qualitative data and the emerging theory in three stages following the paradigmatic model proposed by grounded theory: (1) open coding, (2) coding for categories, (3) axial coding, and (4) selective coding.

Open coding. Open coding involved reading the entire transcript and labeling discrete units (usually several sentences) according to their meaning and importance. This stage involved initially underlining significant events, facts, and incidents in the text that assist in the identification of themes or key words.

Coding for Categories. In this stage relationships were identified among like groupings of these initial codes, and more abstract labels were attached to the categories. Repeated comparisons and modifications were made to achieve similarity in wording and in the definition of the categories and relations between them.

Axial Coding. Axial coding was the process of exploring variations within a category (Strauss & Corbin, 1998). This axial-coding stage allowed the researcher to refine the coding categories described above and begin to advance a theoretical explanation by relating the categories to each other in accordance with different types of “conditions” (i.e., causal conditions, interactional and structural contexts, action strategies, and consequences). These conditions reflect actions in terms of the 6 C’s of grounded theory coding: *causes, consequences, contingencies, contexts, covariances, and conditions*. According to Strauss and Corbin the term “condition” refers to a series of events that create situations or problems associated with a phenomenon and explain why and how people respond to these circumstances. Such explanations can involve both microscopic factors (i.e., intrinsic characteristics of individuals) and macroscopic or contextual factors.

Selective Coding. In the final step of coding the researcher used the categories derived from axial coding to develop an overarching theory to explain the data. Researchers in grounded theory have described this step as extracting the essence of the story, or the common thread that binds all codes together and attempts to answer the main research question.

Results

Several themes were extracted from participants’ narratives about their experiences with parental mental illness. These themes, as well as examples of each theme, are described below.

Perceptions of Parental Mental Health Problem

The first aim of this analysis was to examine offspring’s perceptions and understanding of parental mental illness both as adults, as well as retrospective accounts of what they perceived as children and adolescents. Analyses of these narratives revealed that all participants reported having experiences with parental mental health problems when they were children or adolescents. The degree of recognition and the severity of the problem varied across the 8 participants. At the low end of the severity spectrum was one participant who described a depressive episode that her mother went through as a reaction to the participant’s brother dying from cancer. She talked about how her mother “was tearful much of the time” and “got a little withdrawn at that point”. She also recognized

the transient nature of this episode, and described it as “a typical type of depression that anybody would go through at that point”. One other participant described his mother’s episode of depression while going through a separation and divorce from the participant’s father. He spoke about how his mother went through “a very dark period” and depended upon him in many ways for support. He also described how this depressive episode ceased when his mother became romantically involved with another man.

In contrast, five participants described particularly severe forms of parental mental illness in their narratives. For example, when asked whether her mother had ever been diagnosed with a mental health problem, one participant listed split personality disorder, depression with suicidal tendencies, and substance abuse. She described how during periods of stress her mother’s “other personality” would emerge.

She was hospitalized several times when I was a kid. She went through a period where they said she had split personality, and the other personality they named Maggie, and Maggie was, um, suicidal, and if you got in her way and tried to stop her... she threw me down a flight of stairs just so she could- she had this thing about walking down to the lake, she was going to throw herself in the lake.

Another participant described how her parents had met while being treated as inpatients in the psychiatric ward of the hospital, and had suffered from clinical depression and anxiety for as long as she could remember. Still another described her father as having clinical depression, problems with alcohol and drugs, and “possibly schizophrenia”.

Together, all eight participants described either their mother or father as having symptoms of sadness or depressive disorder for either a brief episode or significant period of time. Seven participants described symptoms of anxiety or anxiety disorder in at least one parent. Five participants reported substance abuse problems in parents. In general, the participants who described the most severe forms of parental mental illness also described having their own mental health problems as adults. In addition, these participants described a range of difficulties in other areas of functioning, including marital problems, problems with keeping a job, and problems with their own children. The participants who described their parents’ mental health problems as fleeting or a normal response to traumatic life events were in general doing well in adulthood. These participants reported no current mental health problems, were in stable marital

relationships, were satisfied in their current jobs, and reported that their children were happy and doing well in school.

Labeling and Recognizing Mental Illness

One common theme within the category of recognition that appeared in several of the narratives was not having a label for the symptoms or behaviors that the participants recognized. For example, one participant described her mother's behavior in the following way:

I don't think she ever took medication for it or was diagnosed as having any particular depressive state, but- oh, how do I describe it? I don't know. I used to describe my mom as clicking, like one minute very, very happy, and then one minute just really distraught. She would go from one state to the next. Really, really happy, or really, really sad, or really, really anxious. She was all over the place.

Another described her mother as:

She would be happy too. She played and danced with us, and took us for walks...But yeah, there were a lot of times that she slept and she laid on the couch a lot. She didn't work, you know. She didn't do a whole lot.

Although both participants were clearly concerned about their mothers' behavior, neither participant had a label for the mental health problem. Another common term used by participants to describe an acute depressive episode was that of "nervous breakdown". Three participants described a parent as having had a "nervous breakdown" while they were growing up, and none of these participants also used a clinical or diagnostic term like depression to describe their mother's problem.

Another common theme that appeared in three narratives was not recognizing the parent's problem as a child or adolescent. For example, one participant described her sense of shock when her mother was hospitalized for mental health issues when she was 18, and stated that, "For her it was a period of years building up, but for me, it came on kind of quick." Another participant describes her father's mental health as "excellent" when she was a child and adolescent, but later speaks about how she found out as an adult that he had suffered from both major depression and substance abuse problems. In fact, this participant did not know that her father had mental health problems until he committed suicide when she was in her mid-twenties. A third says,

I know better now that she probably wasn't that good, but she gave me the perception of being OK. She was always a really good mom to me and

stuff. But, you know, there was obviously some stuff going on. She had been seeing psychiatrists, been on I think just about every antidepressant that's come down the pipe. She was always heavily medicated, and had no social skills.

Understanding Parental Mental Illness

A primary aim of this study was to describe how offspring's understanding of parental mental illness may change from childhood to adulthood. Several participants mentioned that they had not received information about their parent's problem as a child, and that the parent often kept the problem a secret. For example, one participant said, "She would keep her emotions and stuff inside, like to herself. I think it was because she didn't want me and my brother to see it." Another said, "I know she went to different psychiatrists throughout the years, but she never really discussed any of that with us."

Almost all participants in this study expressed feeling confused about their parents' problems when they were children or adolescents. When asked what she thought caused her father's problem as a child, one participant responded, "When I was a kid I didn't know. I just knew he was either going to beat me or he was going to want me to perform [referring to sexual abuse]." As children, 4 out of 8 participants blamed themselves for their parent's problem. One participant described how she often got into trouble as a child, and when asked about the cause of her mother's depression she responded, "Well, she couldn't have been happy about the way I was being." A second participant said,

I figured it was just the way he was. It was just life in general that, you know, life was just stressful and he was trying to raise a kid on his own for a while and I thought I probably caused some of it at the time.

Another participant blamed herself for her father's problems, and said:

Well, to me, at the time when I was growing up, I thought his issues were just that he didn't want to be my dad. You know what I mean? Like I just thought that's how it was. So I figured it was just me. But as I got older I realized what it was.

This last quote highlights the premise of developmental changes in offspring understanding, which was a central theme that emerged from these interviews. Seven out of 8 participants had different causal attributions for their parent's mental health problem as adults compared to when they were children or adolescents. As described above, several participants blamed themselves for their parent's mental illness when they were

children. As adults, however, none of these participants still blamed themselves. Instead, most began to see the mental health problem as something intrinsic to the parent or a result of the parent's past experiences. The two most common explanations for parental mental illness given by the adult offspring in this study were past negative experiences or biological imbalances. One participant stated,

Well, I think she had issues her whole life. Yeah, I just think it was probably just a chemical imbalance from even when she was real young. They just didn't deal with that kind of stuff back then.

Another says, "It was just him. It was probably the way he was raised, because his dad wasn't the greatest dude in the world either". A third talks about the role of parenting, and says, "My mother's problems with anger? It was her mother. The way she was raised by her mother. My grandmother is psycho." A fourth links a past experience with trauma and low levels of education to later mental illness:

I think it was trying to protect herself... I always thought it was because she had too many kids when she was younger. She was raped when she was 16 and her parents made her give that child up for adoption. You know, as I got older and learned more about her history, I just always assumed because she was just so overwhelmed and so very... she wasn't educated at all. She only went through 8th grade.

Another participant explains,

Financial was part of it, but she also has a lot of physical ailments and, um, she would keep her emotions and stuff, you know, inside, like to herself. And I think everything just built up and she couldn't handle it anymore.

As indicated from these quotes, almost all participants in this study had arrived at some sort of explanation for their parent's mental health problem as an adult. Only one participant, a female who had experienced severe levels of abuse in her family of origin, expressed current confusion about what caused her parents to act the way that they did while she was growing up. She also appeared to have unresolved issues with her past experiences that were significantly affecting her current level of functioning. During the interview she asked the interviewer several times of her father, "Do you have to have some kind of mental problem to do the stuff he did?". About her mother, she also expressed mixed feelings and confusion.

I love my mother, OK... but I consider her to be very weak. She knew a lot of the things my father was doing, she knew how cruel he was, she saw

the beatings that he gave... it's like he was having sex with us one minute and beating us the next. I just can't understand how she could live in that situation for so long. And there were times when she did things that we got beat for and she just stood by and let him beat us instead of just saying that she did it. And there are just some things I can never forgive her for.

This participant attributed her past experiences with her parents to the struggles that she was currently experiencing at age 40. She spoke about having severe depression that kept her from leaving the house except on rare occasions, and described frequent suicide attempts as an adult. In addition, she was on permanent disability due to her mental health problems, had experienced a string of destructive romantic relationships, and was currently estranged from her adult children. Although this is only the story of one participant, this does suggest that some sort of understanding of past experiences with parental mental illness as an adult may be important to current level of functioning.

Coping with Parental Mental Illness as Children

The next aim of these analyses was to identify themes related to offspring's methods of coping with parental mental illness at different points in development. Analyses revealed that participants fell into two groups based on their coping behaviors. Four participants reported using coping strategies that have been identified as more adaptive by coping researchers, and 4 participants reported using more maladaptive coping strategies (Compas et al., 1997). Examples of adaptive strategies used by participants while growing up were talking to friends or relatives about their parent's problem and staying busy with school activities. One participant described her coping behaviors as, "I had a group of friends who were really supportive. And I played sports in school... and I worked, so that kind of kept me busy." Another said, "I'd be doing stuff with my friends a lot. As long as I kept busy I was all right." Several of these participants described staying busy as a means of avoiding less positive home environments. For example, one stated "I would just go to school and be sociable with my friends so I wouldn't have to deal with going home."

Several participants also mentioned talking to people as a coping mechanism. One participant spoke to other members of the family about her mother's problems:

I would talk a lot with my brother or call my dad and talk to him. My family is really close, so if I needed somebody to talk to there was always somebody there I could call that could discuss things and get things out.

Three participants described the importance of maintaining a positive attitude even when they were dealing with the difficult aspects of parental mental illness. One said,

Just trying to find happiness in everything, trying to always be happy. And I think that's what led me into, as I was getting older, when I would get stressed I would find friends and people that looked like they were having fun and doing things.

Another said:

I think that's pretty much my coping mechanism. I mean, I just have to joke about everything. Really, like, how do you deal with this stuff? I'm like, if I don't laugh I'm gonna be absolutely miserable about everything.

The third stressed acceptance of the situation, and stated, "That's just the way life is. I mean, everybody's not dealt the perfect cards, and I know a lot of people have had a lot worse."

In contrast to the strategies used by the above participants, 4 participants in this study reported using more maladaptive methods of coping with parental mental illness. Three described turning to drugs or alcohol as a coping mechanism during their adolescent years. "In my teenage years I went through quenching it with alcohol mostly, drugs and alcohol", one participant said. Another stated, "I coped by taking drugs and drinking. Abusing myself in any way possible." The third described his coping as,

I became a party machine at a really young age. You know, getting into smoking, drugs. I got into some minor vandalism as well. You know, teenage boy kind of stuff. Nothing too excessive.

Other maladaptive coping strategies described by these four participants were attempting suicide ("I just wanted to die. I just wanted out.") and early risk-taking behaviors, such as sexual activity at a young age.

When these eight participants were asked whether or not they had ever talked to a mental health professional about these issues as children or adolescents, only one participant stated that she had talked to a counselor. This experience happened after she had been removed from her home as a child, and was described as follows:

I was in a foster home as a child and I did have counseling when I was really young. And I don't, I honestly, from when I was a child I never felt it was really helpful. It wasn't like counseling because I had any emotional problems or anything like that. It was just at that time they forced us to go to like, it's called a convalescence group. We had to go and talk to say if

we had any problems. And basically I never talked. I would kind of answer yes and no questions, but I think I shut down at that point. Because I think I was more afraid.

Thus, although this participant had contact with a mental health professional as a child, it did not appear as though this contact was specifically to address issues of parental mental illness, and the participant did not find it helpful. Although several participants had contact with mental health professionals as adults to address their past experiences with parental mental illness, none had received help as children, when they were actually living with these experiences.

In general, the four participants who had employed the more adaptive coping strategies were doing well on various measures of adaptive functioning in adulthood. Although two participants had experienced mental health problems during adulthood, these participants had received treatment and were currently experiencing good mental health. In contrast, 3 out of 4 of the participants who reported using maladaptive coping strategies, particularly substance abuse that started in adolescence and lasted into adulthood, were not doing as well as evidenced by their own self-reports. For example, the participant who had long-term substance abuse problems and also identified suicide attempts as a coping mechanism had very poor mental health as well as significant problems in the areas of work, children, and romantic relationships. The one participant in this group who did not identify as having any mental health problems in adulthood was a participant who engaged in drinking behaviors to cope with his mother's depressive episode, but stopped drinking when his mother's depressive state ceased. Overall, these results suggest that maladaptive coping strategies may have particularly negative consequences when they extend over long periods of time, especially into adulthood.

Connection with the Past

When participants spoke about how they dealt with their earlier experiences with parental mental illness as adults, one common theme that emerged was a distancing of the self from negative past experiences. Three participants claimed not to remember very much from their childhoods. For example, one said "I don't really remember anything else about that time. I really remember very little before age 13 or 14. Except for a few bad things." Another described her memories as, "I don't have any feelings attached to it,

to be honest with you. It's just like a photograph." One participant described how her method of coping with her traumatic past was to distance herself from those memories:

Honestly, I don't really tend to relate too much, you know, on my past. A lot of it, um, I think I've kind of drowned it out and just made my own life with my own family. I just don't use anything for an excuse, because I have too many family members that do that. So I've always tried to just stay away from even relating to a lot of stuff that happened in my childhood.

Another emphasized that the person she is today is not a direct result of her experiences growing up with a mentally ill mother. She asserted:

Anything I do now in my adult life, or the mistakes I made, those are ultimately the choices I made. So I don't want to sound like it's all coming back to my mother. You know, I've accepted that.

In general, participants who were able to separate themselves from their past experiences were doing well in adulthood, whereas the two participants who seemed to relive their past experiences daily and who blamed much of their current state on their past experiences had poor mental health and low levels of adaptive functioning.

Effects of Parental Mental Illness While Growing Up

The final aim of these analyses was to investigate offspring's perceptions of the effects of parental psychopathology on their lives growing up, as well as on multiple aspects of their adult functioning. All 8 participants named at least one negative effect that parental mental illness had on their lives while growing up. Most of these negative effects involved choices made by participants during adolescence that they later regretted. For example, when asked how her parent's mental health problems affected her life growing up, one participant said,

I made a lot of bad choices. I ran away from home when I was 15 and got involved with an alcoholic and drug addict who beat me regularly, got pregnant by him, had my first kid at 15 years old, and I've made a lot of poor decisions when it comes to relationships ever since.

Another participant had similar experiences and stated,

I couldn't wait to get away from her so I ran away and got involved with my first son's father and I left school, I did drugs and alcohol, and I just had one bad relationship after another.

A third described his experience as,

Well. I think it made me do a lot of things I shouldn't have been doing at the age I was doing things. I never got really, really bad, but I definitely got way off course.

In addition, two participants described how their experiences with parental mental illness led them to take on caretaking responsibilities in the family. For example, one participant stated, "It made me become an adult quick. I went from being a teen to making sure bills got paid and taking care of the house". Another said, "I ended up being somewhat of a counselor to my mother at times. You know, not like I was giving her advice or anything. I was just, you know, comforting her." Together, these statements suggest that parental mental health problems often lead offspring to take on more adult roles, particularly during adolescence, for which they may not be developmentally prepared.

Effects of Parental Mental Illness on Offspring in Adulthood

Participants were asked how their experiences growing up with parental mental illness affected their lives as adults. Several themes emerged from their responses to this question. The first theme was a fear of turning into their parents. Five out of 8 participants expressed worry about developing a mental health problem similar to their parent's. One participant said, "I grew up saying that I never wanted to be anything like her". Another explained how her own feelings of anger were very similar to what she had observed in her mother while growing up:

I think it's made it really hard for me to learn how to deal with my anger because it's what I've always seen, anger. I can be a patient, very patient person, but once my anger comes on me it's very hard to get rid of it. And that's how she always was. It's like I'm becoming my mother.

Three participants expressed that their fear of turning into their parent actually led them to seek help for their own mental health problems. For example, one said:

It's actually helped me because I, you know, saw the signs in myself that I was getting depressed. So I went and got counseling when I needed it because I was getting overwhelmed with my feelings and emotions.

Another said, "It was like, well, I'm kind of going down the path of my mom. I need to get it squared away before it screws up everything." A third stated:

I'm more aware of that kind of stuff. I was more willing to... you know, when I started noticing that I was having some issues a couple of years ago I think I was more willing to deal with them because I knew where she was and I didn't want to be like that.

Related to this theme was the theme of reliving the past or “repeating the cycle”. For example, several participants made the connection between their experiences with their parents and their experiences with their romantic partners as adults. One participant who had experienced abuse at the hands of her alcoholic father described her first romantic relationship:

I went from that abuse into a relationship with my first boyfriend who had his own drug and alcohol problems and he beat me up pretty good a few times and almost killed me. He ended up in prison.

Another participant stated that she “ended up dating a lot of people who were drinkers because I figured I could save them from their ill ways like I couldn’t save my father.” A third participant who also had a parent with substance abuse problems ended up marrying a recovering alcoholic and substance abuser.

Related to this last theme is the general theme of the effects of parental mental illness on adult romantic relationships. Six out of 8 participants felt that their experiences with parental mental illness affected their relationships in adulthood. Most believed that these experiences negatively affected their romantic relationships. One attributed her many failed relationships to her experiences with her family of origin. Another said,

I was quite young starting out my romantic relationship, with the person I’m actually still with right now. And I think my life would have been a lot different if I had a structured family like I’m giving my children. I wouldn’t have felt the need to be in a relationship I wasn’t ready for. And I’ll always feel that way. I don’t dwell on it, but I know that it would definitely be different.

One participant talked about how her experience with her father’s alcoholism helped dictate the type of person she wanted to become romantically involved with as an adult. She reported:

I let my husband know when we were dating that I wasn’t going to deal with the drinking. It kind of helped me decide what kind of relationship I was going to be in and what I was going to tolerate.

In contrast, one participant reported that his experiences caring for his mother during her depressive episode helped him be a better husband to his wife:

I’m more aware of the emotions, you know, that life brings up with my spouse. And, you know, to be able to sit there and listen and let her talk and cry when she needs to.

The final theme that emerged from participants' descriptions of the effects of their parents' mental health problem on their current functioning dealt with parenting. Specifically, the majority of participants stated that their experiences with parental mental illness helped them learn about the type of parent that they did not want to be. For example, one participant said:

She affected me in the way I'm always constantly paying attention to how I act to others and how I act to my children because I don't ever want to hurt them in those negative ways.

Another talked about how she would not repeat the same parenting practices that she had experienced as a child, and that ultimately led to problems with substance abuse in adulthood.

It's like, my mom handed me a roach when I was 13. Like, "Here you go. Take a hit!". And I vowed it would not be like that with my kids. I'm a bad mom in a lot of other ways, but I wouldn't do that.

Finally, one participant stated that she paid close attention to her own mental health symptoms, and made sure to get help before the problem started influencing her children. She said, "I try to keep on top of myself and notice if I'm starting to feel funky or something, that I make sure I'm not projecting all that onto them".

Discussion

Overall, the goal of this dissertation has been to examine the impact of early maternal mental illness on offspring adult competence. Results of Studies 1 and 2 suggest that there are multiple pathways from maternal psychopathology to offspring adaptive functioning that are explained by a number of individual and family variables, including characteristics of the child, experiences with the family, and adult representations of these experiences. Study 3 expands upon these results by focusing on representations of experiences with parental mental illness specifically, and exploring how these representations may change over time and be related to overall adult functioning.

Perceptions and Understanding of Parental Mental Illness

The first goal of Study 3 was to describe offspring's perceptions and understanding of parental mental illness as adults, as well as retrospective accounts of what they perceived and how they felt as children and adolescents. Based on the narratives of the participants in this study, analyses suggest that, although some participants did not recognize a problem when they were children or adolescents, by

adulthood offspring are able to identify and describe past mental health problems in their parents. However, although they are often able to describe symptoms and behaviors, many do not have information about actual diagnoses. According to this group of offspring, part of the reason for this is that parents may be reluctant to discuss mental health problems with children, and may try to hide the problem. Another possible reason for the lack of diagnostic labels used by participants may be due to the stigma attached to psychiatric diagnoses, at least during the 1970's and 1980's when these participants were growing up. As children and adolescents, the overarching feeling that emerged from the reports of these offspring was one of confusion, and a desire to have known more about what their parent was going through at the time.

These results suggest that a lack of information about and understanding of parental mental illness may lead to children blaming themselves for their parent's problem. These causal attributions also change over time, and vary widely in adulthood. In this sample, participants' current explanations for their parents' mental health problems included genetic factors, financial difficulties, bad marriages, and past experiences with abuse or trauma. Regardless of the explanation, the one thing that may be important is that the individual has arrived at some sort of explanation by adulthood. Overwhelming feelings of confusion and unresolved questions concerning parental mental illness may be particularly maladaptive in adulthood, and may prevent individuals from moving on with their lives. In contrast, individuals with a clear understanding or explanation for their parent's problem, whether this explanation is in fact correct or not, tend to do better on various measures of adult competence. In addition, individuals who are able to in a sense separate themselves from the negative experiences in their past and who do not define themselves based on these experiences also appear to be more competent as adults.

Coping with Parental Mental Illness

The second goal of Study 3 was to identify offspring's methods of coping with parental mental illness at different points in development and attempt to relate this coping to their self-described levels of adaptive functioning. These data suggest that individuals employ a wide range of coping strategies when dealing with parental mental illness as children and adolescents. In general, those who employ more adaptive coping strategies,

such as staying busy with sports and talking to friends, grow up to be relatively competent adults. Those who employ more maladaptive coping strategies in childhood and adolescence tend to have problems with adaptive functioning in adulthood, particularly if these maladaptive behaviors extend over long periods of time. For example, substance abuse that begins as a coping behavior in adolescence and then continues throughout adulthood may be linked with particularly negative outcomes. These results suggest that potentially destructive coping behaviors should be targeted early on to ensure that they do not become lasting behaviors.

Results from this sample also suggest that children and adolescence coping with parental mental illness are not necessarily being treated by mental health professionals. Although several participants in this study sought help with dealing with these past experiences as adults, none had received professional help during or immediately following the actual experience. This could also be a cohort effect, as 20 or 30 years ago requesting help from a mental health professional for these types of issues may have been less common. However, these accounts also highlight the in many ways continuing focus in the mental health field on the individual experiencing the mental health problem, with less focus on the effects of this problem on the individual's family. Early intervention for the offspring of parents with mental health problems could have significant benefits for these offspring, and could also prevent negative outcomes that then need to be treated in adulthood.

Effects of Parental Mental Illness on Offspring

The final goal of this study was to investigate offspring's perceptions of the effects of parental psychopathology on their lives growing up, as well as on multiple aspects of their adult functioning. The overarching theme of these accounts is that experiences with parental mental illness have a number of negative consequences for offspring, both as children and adolescents, as well as later in adulthood. In childhood and adolescence, offspring report engaging in various risk-taking behaviors, including early engagement in sexual relationships and problems with substance abuse. In adulthood, although almost all participants expressed fear about turning into their parent, many were repeating the same patterns of behavior that they had experienced with their mentally ill parent. In particular, parental mental illness appears to have significant

effects on offspring adult relationships, with offspring sometimes becoming romantically involved with individuals having similar mental health problems as their parent. The largest effect of parental mental illness on parenting appears to be that offspring learn “how not to parent” from their experiences with parental mental illness.

Limitations

One obvious limitation of these qualitative analyses is that they were conducted with interviews from only 8 individuals. Thus, relationships between the themes extracted from these interviews and measures of adult adaptive functioning could not be tested statistically, nor can these results be applied to all offspring of parents with mental health problems. However, the goal of these analyses was to examine the stories of a small number of participants in order to develop an emergent theory as to how adult offspring think about and cope with their earlier experiences with parental mental illness. Although quantitative analyses would have allowed for the testing of statistical associations, they would have prevented an in-depth look into individuals’ narratives and experiences. So little is known about how adult offspring think about and cope with their past experiences with parental mental illness that this is an important first step in exploring these issues.

Another potential limitation is that these interviews were conducted at age 40, several decades after participants actually experienced living with parental mental illness. As mentioned above, some participants had made a conscious effort to block out past negative memories, and thus may have been reluctant to answer some of the sensitive questions in this interview. Others may have forgotten their perceptions or behaviors as children or adolescents, which may have led to the finding that several participants did not recognize their parent’s mental health problem while growing up. Memories of coping behaviors could also have been affected by the passage of time. However, similar to the issues raised in Study 2, the main question of Study 3 was how offspring of parents with mental health problem represent their past experiences as adults, and how these representations may impact their current functioning. Thus, whether accurate or not, offspring’s retrospective accounts of their experiences and feelings are important indicators of their current representations.

Implications and Conclusion

In summary, the interviews examined in this study offer a glimpse into how adult offspring think about and cope with earlier experiences with parental mental illness. Although experiences and current levels of functioning vary widely, there were some common themes that could be extracted across accounts. Overall, the theory derived from this study is that parental mental illness has negative effects on offspring both during the actual experience, as well as decades later. In addition, the impact of parental mental health problems on offspring are influenced by a number of factors, including the adaptiveness of past and current coping behaviors, causal attributions regarding the parent's mental health problem, and an ability to separate the adult self from past traumatic experiences.

This theory may guide researchers and clinicians who are interested in understanding the complex phenomenon of growing up with parental mental illness. Future research should examine each of these factors separately, and explore whether the associations suggested by these interviews hold up with a larger sample of participants. Results from this study also suggest several implications for intervention with children of parents with mental health problems. First, it is important to give these children information about their parent's illness, particularly so that children will not blame themselves for their parent's behavior. Second, intervention should occur early on, both to provide needed information and support, as well as to prevent the adoption of maladaptive coping behaviors that could continue into adulthood. Third, because adult romantic relationships appear to be particularly influenced by experiences with parental mental illness, this is one domain that should be focused on in interventions.

On the whole, the results of Study 3 lend support to the hypothesis that perceptions of parental mental illness as well as methods of coping with parental mental illness play important roles in predicting risk or resilience among this group of offspring, and support findings from Studies 1 and 2 about the importance of parental mental illness to offspring adult functioning. Moreover, the stories of these participants emphasize the need stressed throughout this dissertation for more of a focus on the families of mentally ill individuals in research and practice if we are to prevent negative outcomes for these children later on.

CHAPTER 5

Conclusion

The overarching goal of this dissertation was to examine the effects of early maternal mental illness on multiple domains of offspring adult competence. The three studies in this dissertation followed a group of parents and children over the course of 40 years, and investigated how experiences with parental psychopathology during the first 30 months were associated with a range of adaptive functioning outcomes for offspring more than three decades later. A main focus of this dissertation was to not only examine long-term associations between parental mental health and offspring competence, but to also describe the processes through which offspring of mentally ill parents develop adaptive or maladaptive outcomes in adulthood.

The primary goal of Study 1 was to test direct and indirect associations between maternal mental illness in early childhood and offspring 30-year functioning in the areas of mental health, romantic relationships, and socioeconomic status. The first main finding of this study, and perhaps the central finding of this dissertation, was that early maternal mental health is an important predictor of offspring adult competence. Previous research has shown that maternal mental illness has significant concurrent effects on children throughout development. This study adds to this body of research by finding that maternal mental health measured during children's first three years is significantly associated with their own mental health, their feelings and behaviors within romantic relationships, and their socioeconomic status in adulthood.

Although the finding that maternal mental health is associated with offspring adjustment in general is not surprising, the discovery that a mental health assessment given to mothers shortly after offspring's birth predicts offspring's outcomes three decades later across a wide range of domains is certainly noteworthy. Researchers and

clinicians have long noted the association between parental psychopathology and child psychopathology, but results of this dissertation also show that maternal mental illness experienced during the first few years of life can have long-ranging implications for a number of outcomes, in everything from the types of romantic relationships that offspring engage in to the amount of money that they make in their occupations. The fact that the participants in this study were followed longitudinally from birth through adulthood make these associations even more notable. These results support the notion that early childhood is a period of development in which children may be particularly vulnerable to the effects of maternal mental illness, and underscore the importance of early intervention for mothers with mental health problems and their children during this period.

The second main finding of Study 1 was that, although in general early maternal mental health predicts offspring adult outcomes, the pathways to these outcomes differ based on the domain of functioning. Results of Study 1 revealed that the pathways from maternal mental health to offspring mental health were explained by offspring mental health and self-concept in adolescence, as well as quality of parenting. The pathways from maternal mental health to offspring romantic relationships included parental relationship status, level of family conflict, and adolescent self-concept. The variables that were important to explaining the associations between maternal mental health and offspring adult socioeconomic status were family SES and adolescent academic achievement and mental health. Together, these results highlight the complexity of maternal mental illness as a predictor of offspring functioning.

These findings also have implications for intervention, and suggest that it is not enough to alter or alleviate a single risk factor associated with parental mental illness in the hope of improving outcomes among their offspring. For example, a number of interventions have attempted to improve the parenting practices of individuals with mental health problems with the goal of improving outcomes for offspring (e.g., Musick et al., 1987). Results of this dissertation suggest that, although this parenting intervention might help in the area of offspring mental health, a number of different factors would need to be focused on in order to improve outcomes in other domains. In order to improve romantic relationship outcomes among offspring of mentally ill parents, interventions may need to focus on alleviating levels of conflict in the family or

improving relationships between parents. In order to improve socioeconomic outcomes among these children, effective interventions might focus on improving grades in school or the overall mental health of these offspring in adolescence. If, as suggested, adult competence must be regarded as multidimensional, then these results also suggest that interventions must be multidimensional as well.

The goal of Study 2 was to build upon the results of Study 1 and examine whether it is not only an individual's actual experiences that are important, but also the ways in which an individual understands and makes sense of these experiences. Although representations have been found to be related to a number of outcomes, particularly in the attachment literature (Ainsworth, 1979; Bowlby, 1980), this study was the first of its kind to examine long-term longitudinal relations between maternal mental illness during early childhood and offspring representations about their families of origin in adulthood. This study was also the first to test the role of representations as mediators between maternal mental health in early childhood and offspring adaptive functioning in adulthood.

The first finding of Study 2 was that individuals' representations about their families of origin and about interpersonal relationships in general are related not only to their experiences with maternal mental illness 30 years earlier, but also to a range of other individual and family variables, as well as adaptive outcomes. For example, narrative coherence and relationship beliefs were predicted by the adolescent variables of academic achievement and peer relationships, as well as the family variables of family conflict and parental relationship status. These representations were also associated with offspring's functioning in the areas of mental health, romantic relationships, and socioeconomic status. Overall, these results suggest that representations are not only reflections of direct experiences with the family, but are also a result of a number of other experiences, as well as individual characteristics of the child.

The second main finding of Study 2 was that these representations were important mediators of the link between maternal mental health and offspring adaptive functioning. Analyses that integrated the results of Studies 1 and 2 showed that both actual experiences and characteristics measured throughout childhood and adolescence, as well as offspring's adult representations of these experiences, were important steps along the pathways from early maternal mental illness to offspring adult competence. In the final

mental health model, three variables emerged as mediators: adolescent mental health, adolescent parenting, and adult relationship beliefs. Thus, in order to prevent negative mental health outcomes among offspring of mothers with early mental health problems, these results suggest that two areas on which interventions should focus in childhood and adolescence are improving the emotional health of offspring and improving parenting practices among the mentally ill parent. By adulthood, one area which could be targeted by therapeutic interventions could be individuals' beliefs and representations of relationships, particularly how past experiences with the family origin contributed to these beliefs.

In the final romantic relationships model, four variables emerged as important mediators of the links between early maternal mental illness and offspring romantic relationship outcomes: parental relationship status, adolescent family conflict, adolescent self-concept, and adult relationship beliefs. Thus, in order to foster stable relationships among offspring of mentally ill parents, interventions should focus on improving relationships between parents, as well as alleviating levels of conflict within the family. In order to foster adult security of attachment in these offspring, interventions should also focus on improving offspring beliefs about the self in adolescence, as well as their adult beliefs about interpersonal relationships in relation to their experiences with their families of origin.

Finally, the integrated socioeconomic status model reveals that adolescent family SES, academic achievement, and mental health are all important mediators. In addition, the representation variables of relationship beliefs and narrative coherence also play important roles in explaining associations between maternal mental health and offspring socioeconomic status. These results suggest that the ways in which offspring think about their past experiences can have an impact on a range of outcomes, even those that appear to be less closely related to mental health. Overall, these combined models highlight the importance of both actual experiences and representations, and suggest that both are important to study when examining the effects of parental mental illness on children.

Study 3 was designed to build off of the results found in Studies 1 and 2, and explore in more depth adult offspring's experiences and perceptions of growing up with a mentally ill parent. Although research has shown that offspring of parents with mental

health problems are at risk for myriad negative outcomes, very little is known about offspring's representations and understanding of parental psychopathology, nor the roles that these representations might play in how offspring cope with and adapt to their parent's problem. Study 3 is unique in that it addressed these issues with a sample of adult offspring, which allowed for the examination of both offspring's current perceptions and coping behaviors, as well as their retrospective accounts of when they were growing up.

The interviews conducted for Study 3 explored in depth the experiences and representations of one small group of individuals who had a parent with a mental health problem while they were growing up. Analyses of their narratives revealed that, even at age 40, experiences with parental mental illness during childhood can play a salient role in the lives of offspring. Overall, results of Study 3 support results from Studies 1 and 2 that suggest that parental mental illness has significant negative effects on offspring's lives, both during the actual experience, as well as decades later. Individual reports suggest that some of the most prominent issues for offspring as children were dealing with a lack of information about their parent's problem, a tendency to blame themselves for their parent's illness, and a risk of engaging in maladaptive coping behaviors, such as substance abuse. As adults, offspring regarded their experiences with parental mental illness as significantly affecting their lives, particularly in the realm of romantic relationships.

One advantage of the qualitative analyses in Study 3 was that the researcher was able to obtain a complex profile of each interview participant. These profiles included their responses to questions about their current and past perceptions and coping behaviors, but they also included information about how individuals were functioning in their overall mental health, their romantic relationships, as parents, and at work. Thus, although statistical analyses could not be used in this study, patterns could be discerned between certain perceptions and coping behaviors and individual outcomes. For example, in this group it became clear that the impact of parental mental illness on offspring adjustment was influenced by a number of factors. Offspring who had engaged in more maladaptive behaviors, such as substance abuse, to cope with their parent's problem in adolescence tended to have less adaptive functioning in adulthood. Similarly, offspring

who expressed high levels of confusion regarding their parent's problem or who were unable to separate themselves from their past experiences also had poor outcomes. In contrast, offspring who engaged in adaptive coping behaviors while growing up, who had arrived at some sort of explanation for their parent's mental health problem as adults, and who were able to in a sense move on from their past were in general doing well as adults.

These results are an important first step in lending support to the hypothesis that perceptions of parental mental illness as well as methods of coping with parental mental illness play important roles in predicting risk or resilience among offspring. These results can be used to inform future studies of the domains that should be assessed when studying adult offspring of parents with mental illness. They can also be used to inform interventions about the types of perceptions and coping behaviors that, when fostered, could lead to positive outcomes among offspring of mentally ill parents. Future research should examine the issues raised in Study 3 with a larger sample, which would allow for quantitative analyses to test whether these associations hold. Future work should also examine the issues of perceptions of and coping with parental mental illness across various points in development, particularly in childhood and adolescence when these issues are actually occurring.

Conclusion

Millions of children and adolescents are exposed to parental mental health problems at any given time (Kessler et al., 2005; Creswell & Brereton, 2000). Understanding the impact of parental mental health on offspring is therefore a matter of great social as well as theoretical significance. As a whole, this dissertation research has highlighted the importance of parental mental health to offspring adaptive functioning. From maternal mental health at birth to multiple domains of offspring competence 40 years later, these results support the view that parental mental illness is a risk factor for a range of maladaptive outcomes among offspring.

This dissertation research also supports the view that there are multiple pathways to risk and resilience, and that there are a number of risk and protective factors that contribute to the development of offspring of mentally ill parents. In the midst of one of the interviews conducted for Study 3, one participant asked the interviewer, "Are we pretty much all messed up in this study? I have a feeling we're pretty much all messed

up. I think we're all about in the same boat." The answer, if given, would have been no. In contrast to this participant's belief that all offspring of parents with mental health problems develop problems themselves, the outcomes of the participants in this study were incredibly diverse. Results of this dissertation have elucidated some of the individual and family factors that contribute to adaptive or maladaptive outcomes among offspring of mentally ill parents, and provide a basis for the development of prevention and intervention programs for this risk group of individuals. As a whole, these results stress a growing need for more of a focus on the families of mentally ill individuals in research and practice if we are to prevent negative outcomes for offspring later on.

Figure 2.1. Associations between Maternal Mental Health and Offspring 30 year Mental Health Outcomes

141

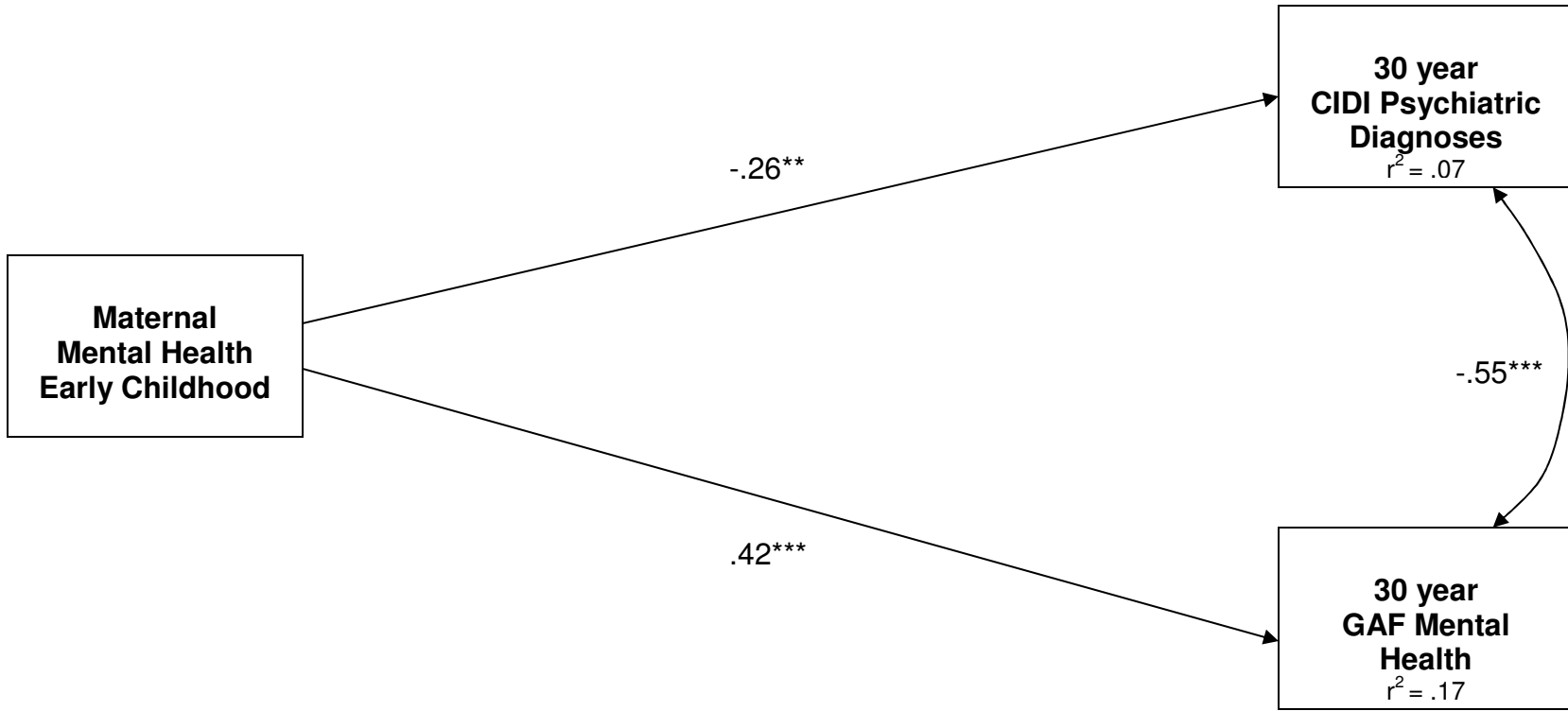

Figure 2.2. Mediated Pathways from Maternal Mental Health in Early Childhood to Offspring Mental Health in Adulthood

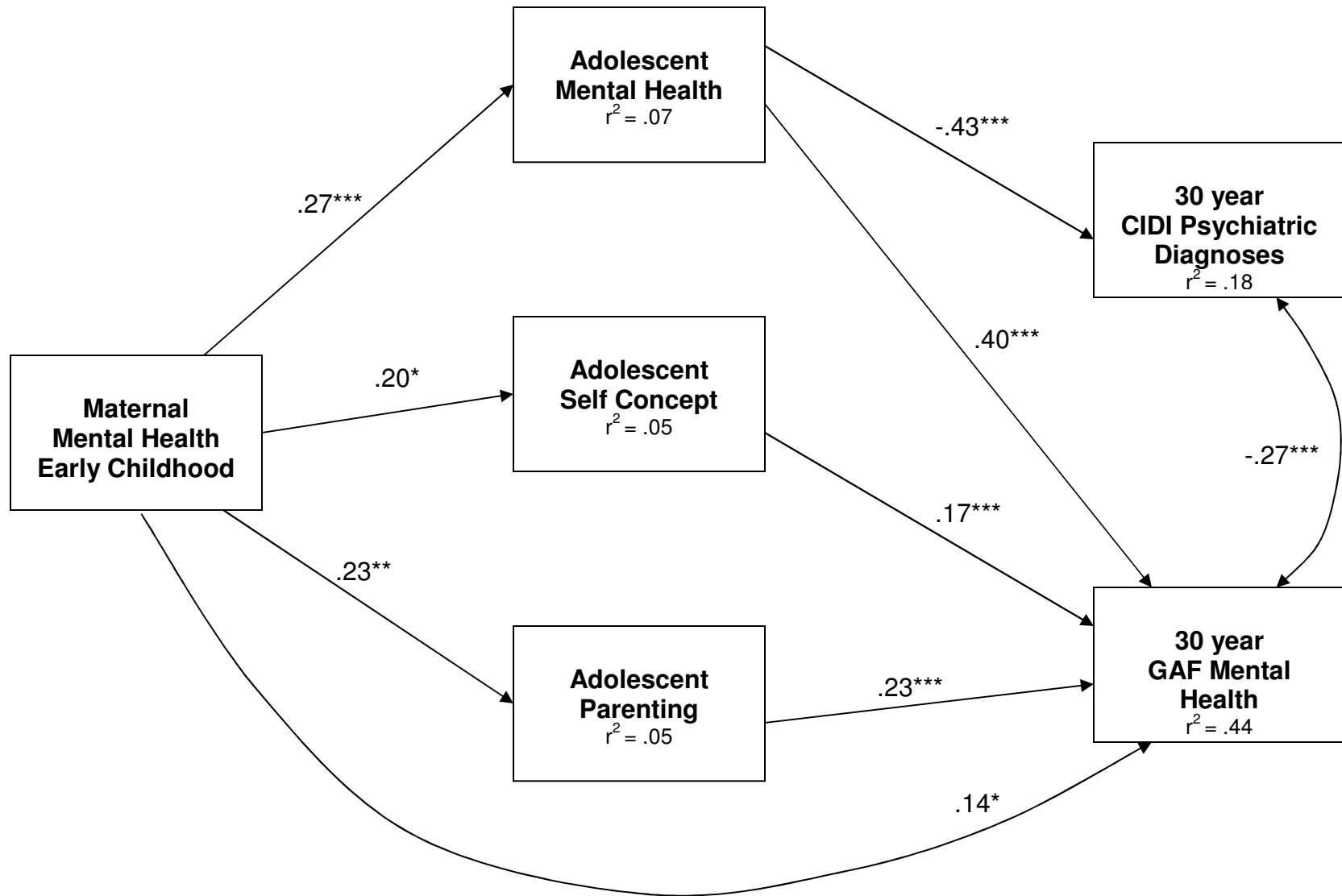

Figure 2.3. Associations between Maternal Mental Health and Offspring 30 year Socioeconomic Outcomes

143

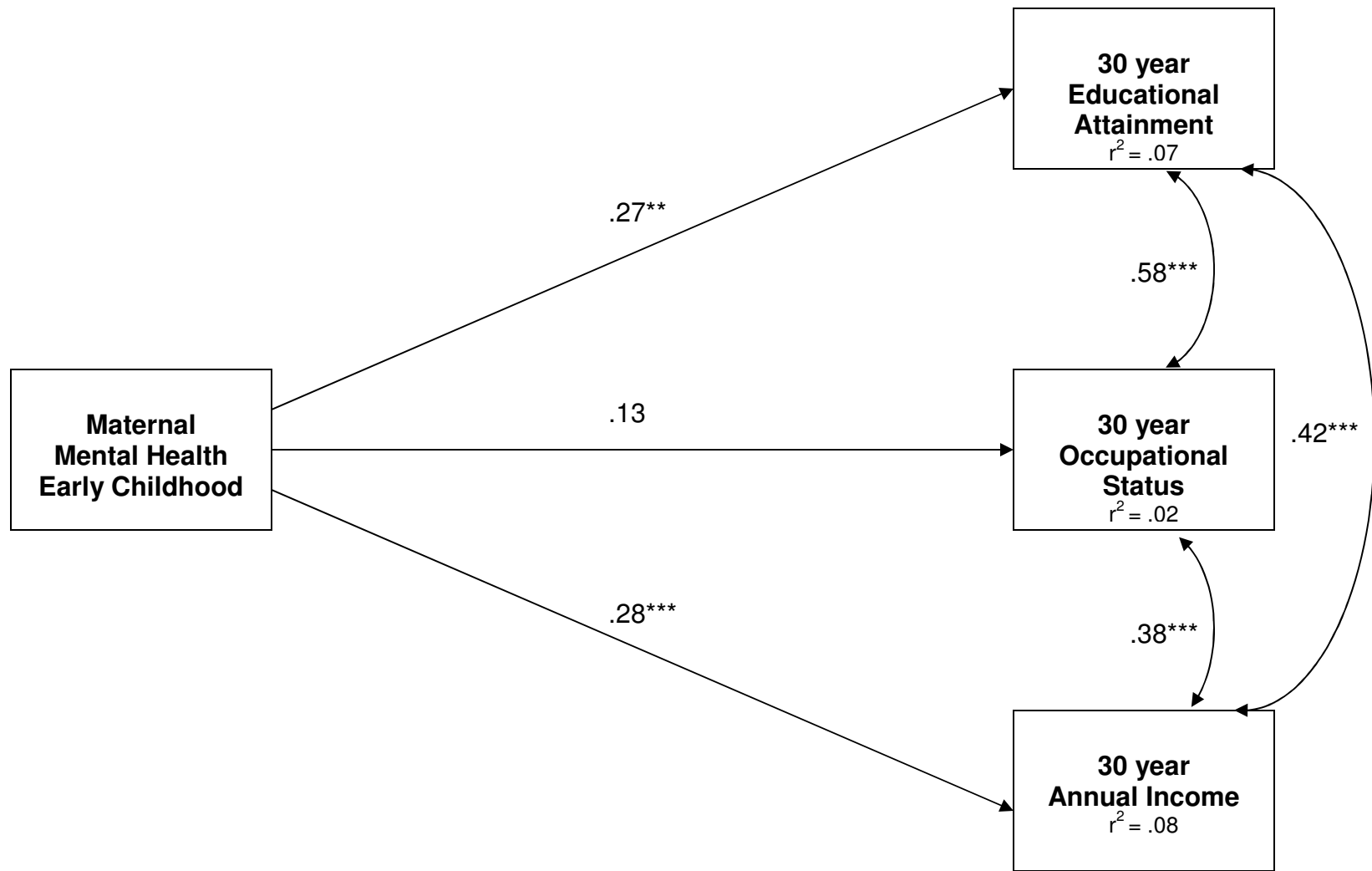

Figure 2.4. Mediated Pathways from Maternal Mental Health in Early Childhood to Offspring 30 year Socioeconomic Outcomes

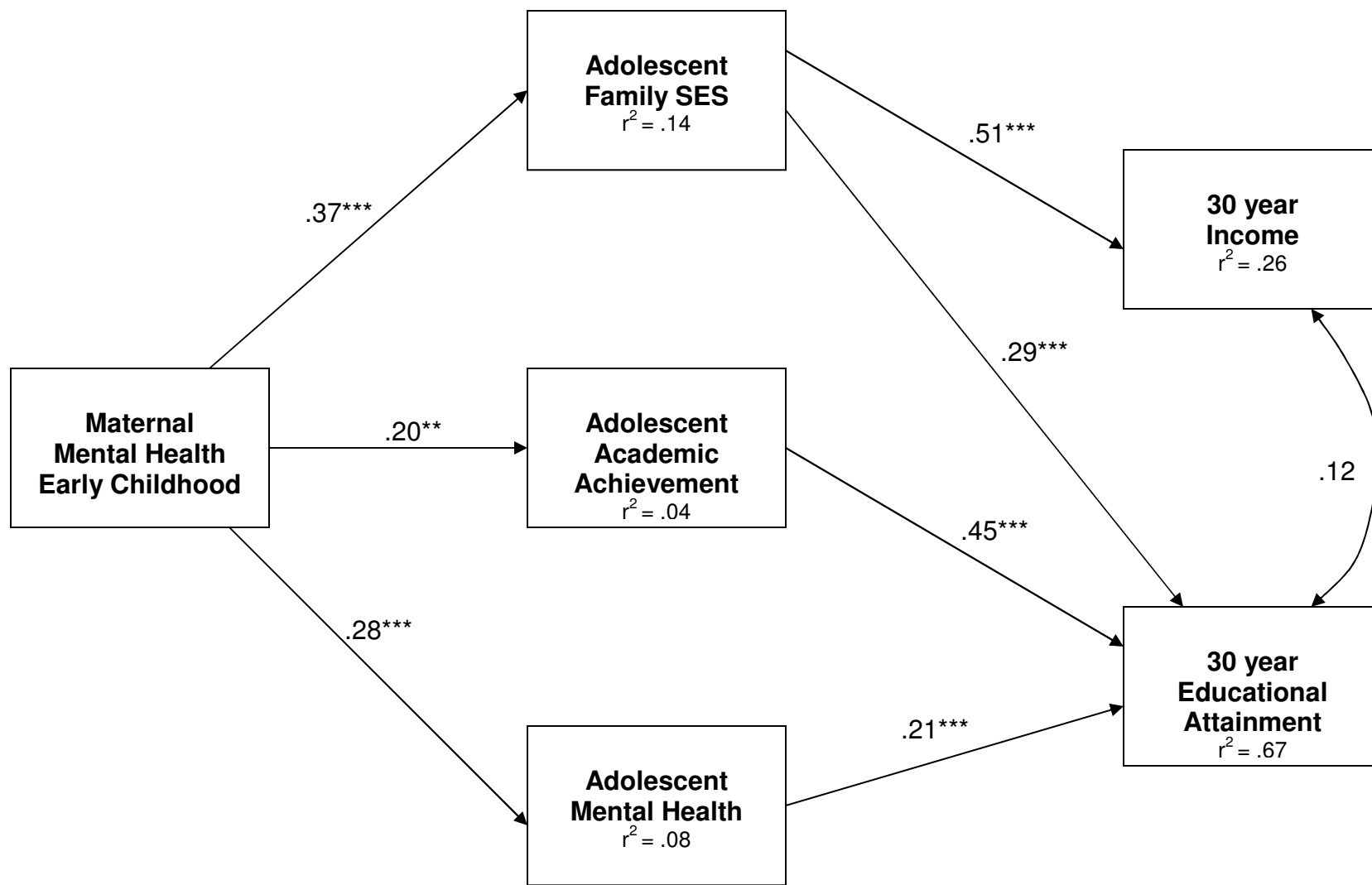

Figure 2.5. Associations between Maternal Mental Health and Offspring 30 year Romantic Relationship Outcomes

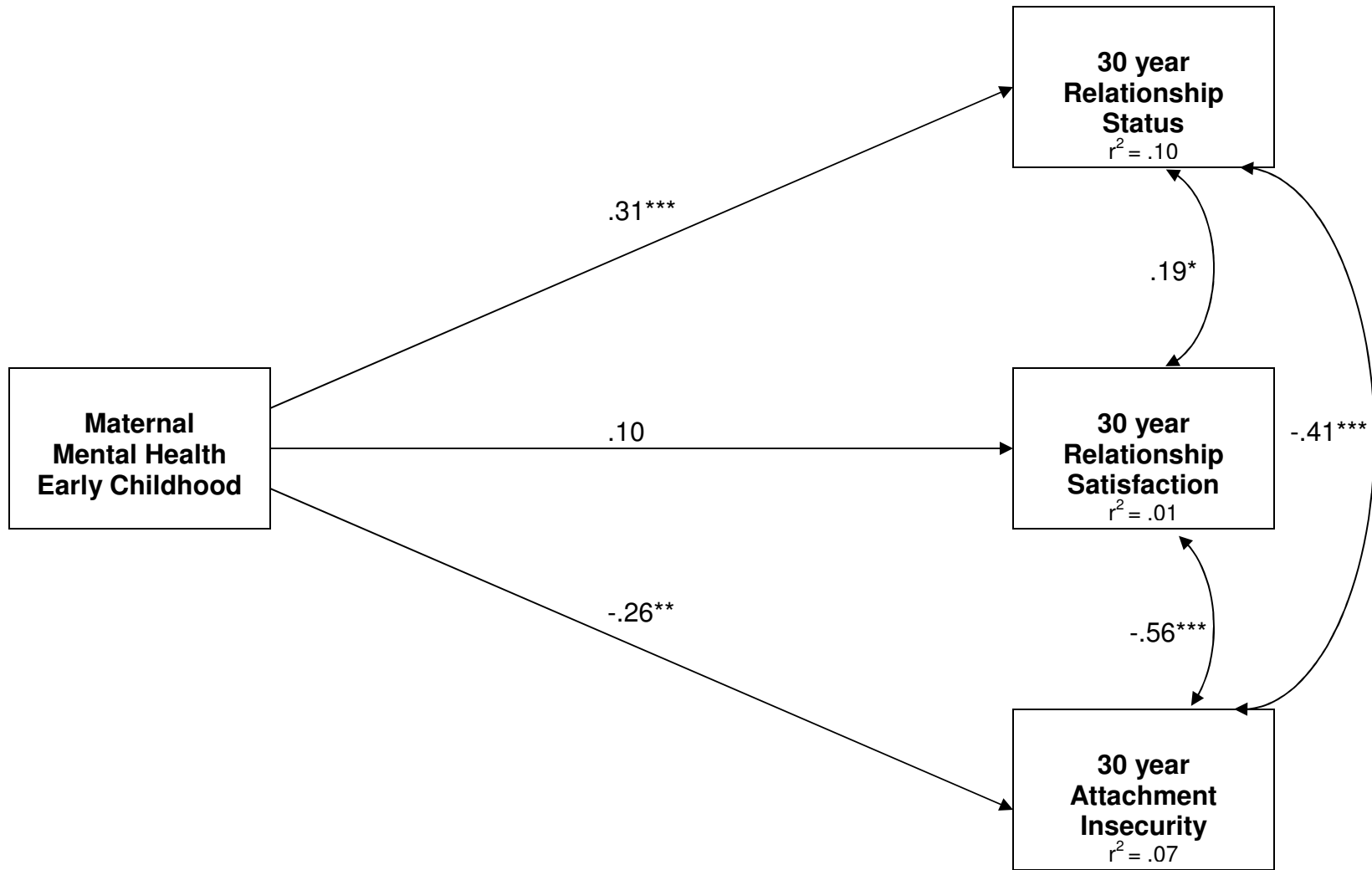

Figure 2.6. Mediated Pathways from Maternal Mental Health in Early Childhood to Offspring 30 year Relationship Outcomes

146

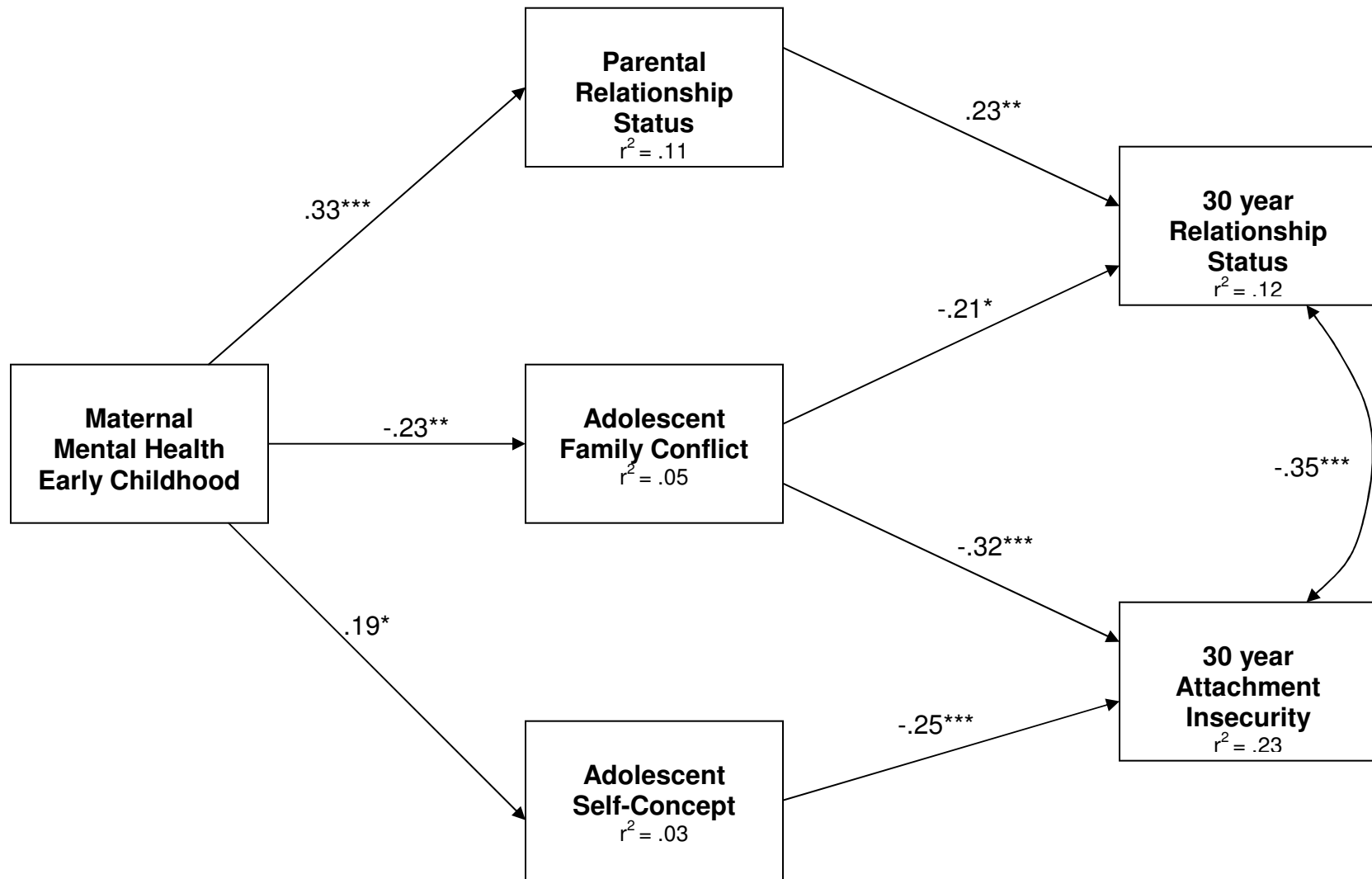

Figure 3.1. Associations between Maternal Mental Health and Offspring 30 year Narrative Coherence and Relationship Beliefs

147

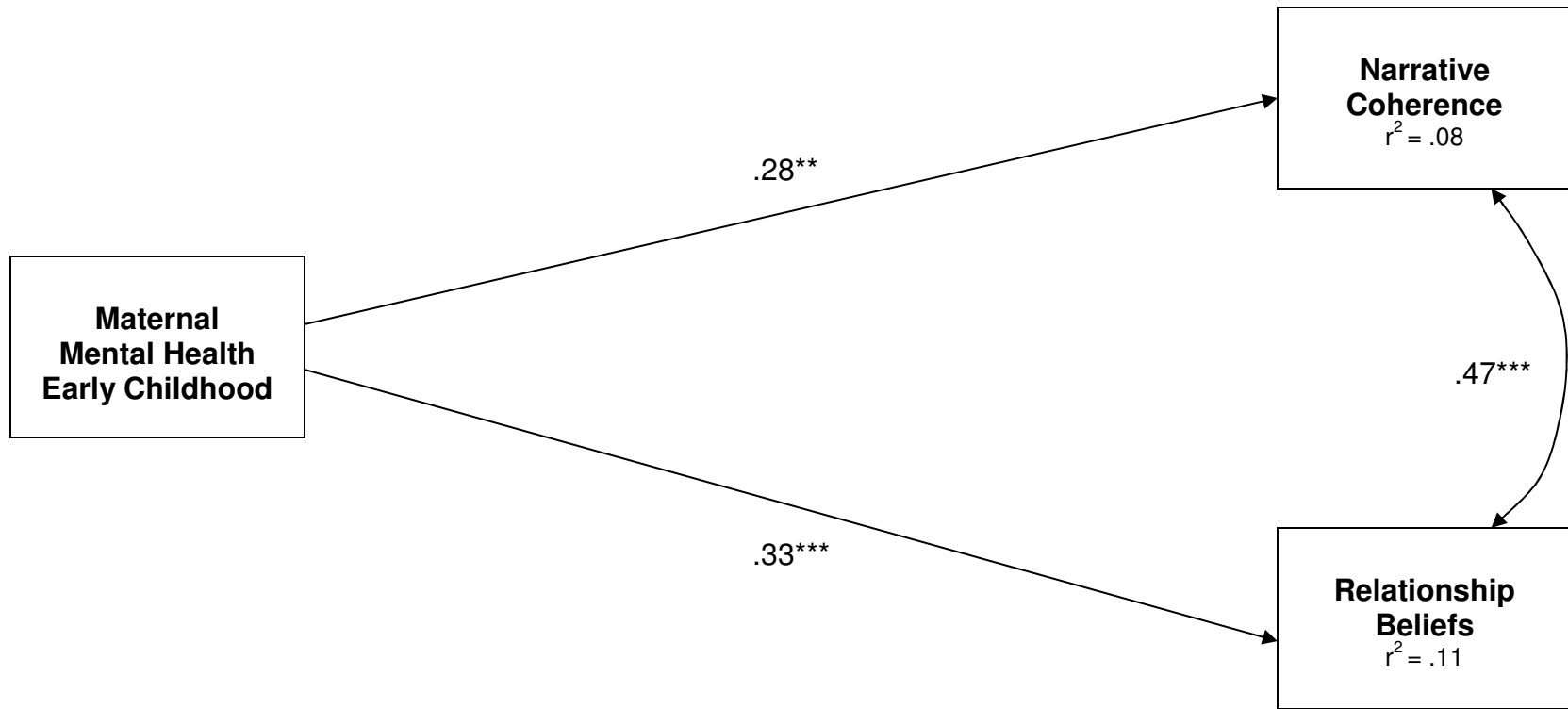

Figure 3.2. Mediated Pathways from Maternal Mental Health in Early Childhood to Narrative Coherence and Relationship Beliefs

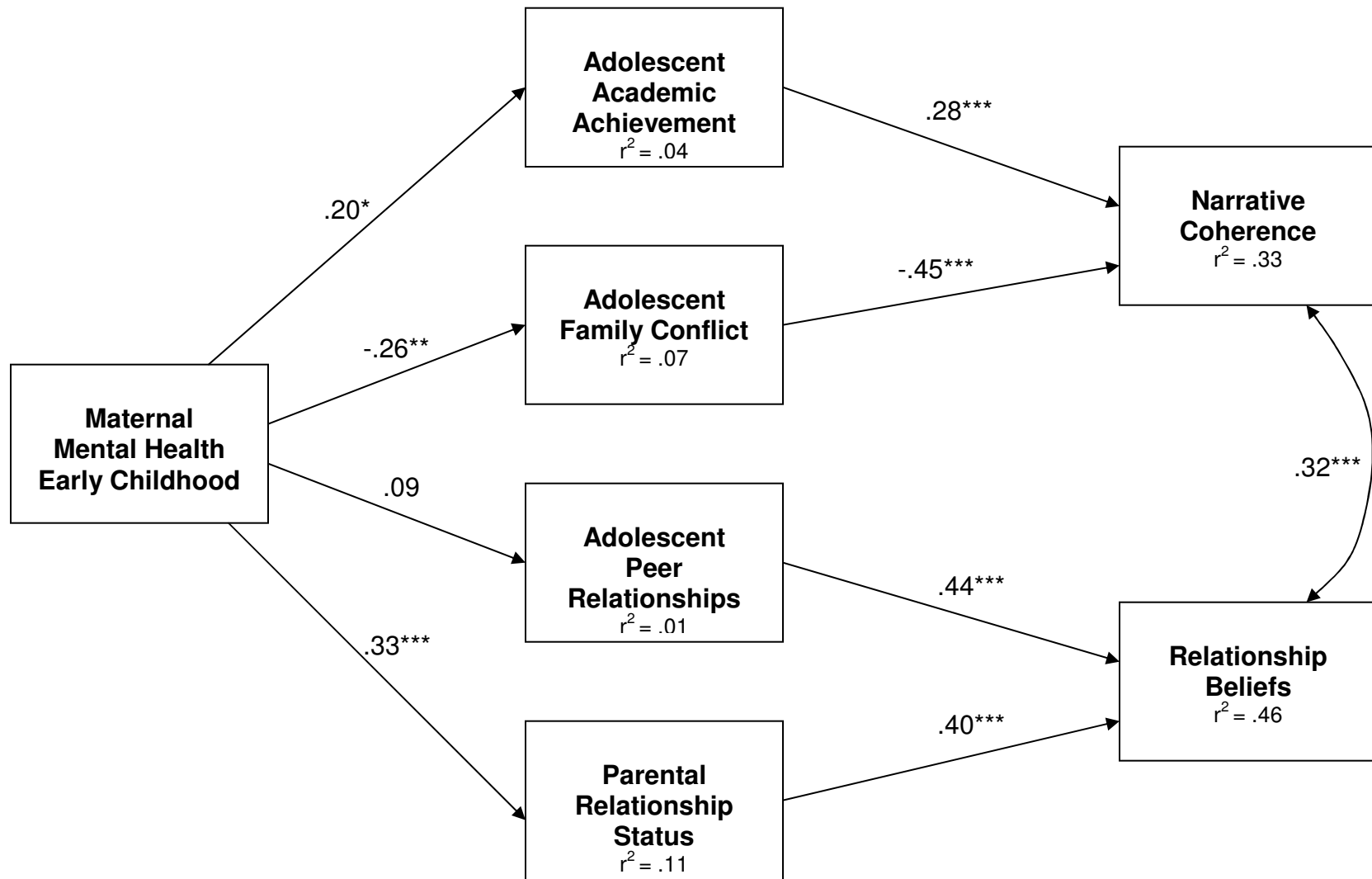

Figure 3.3. Narrative Variables as Mediators of the Associations between Maternal Mental Health and Offspring Mental Health

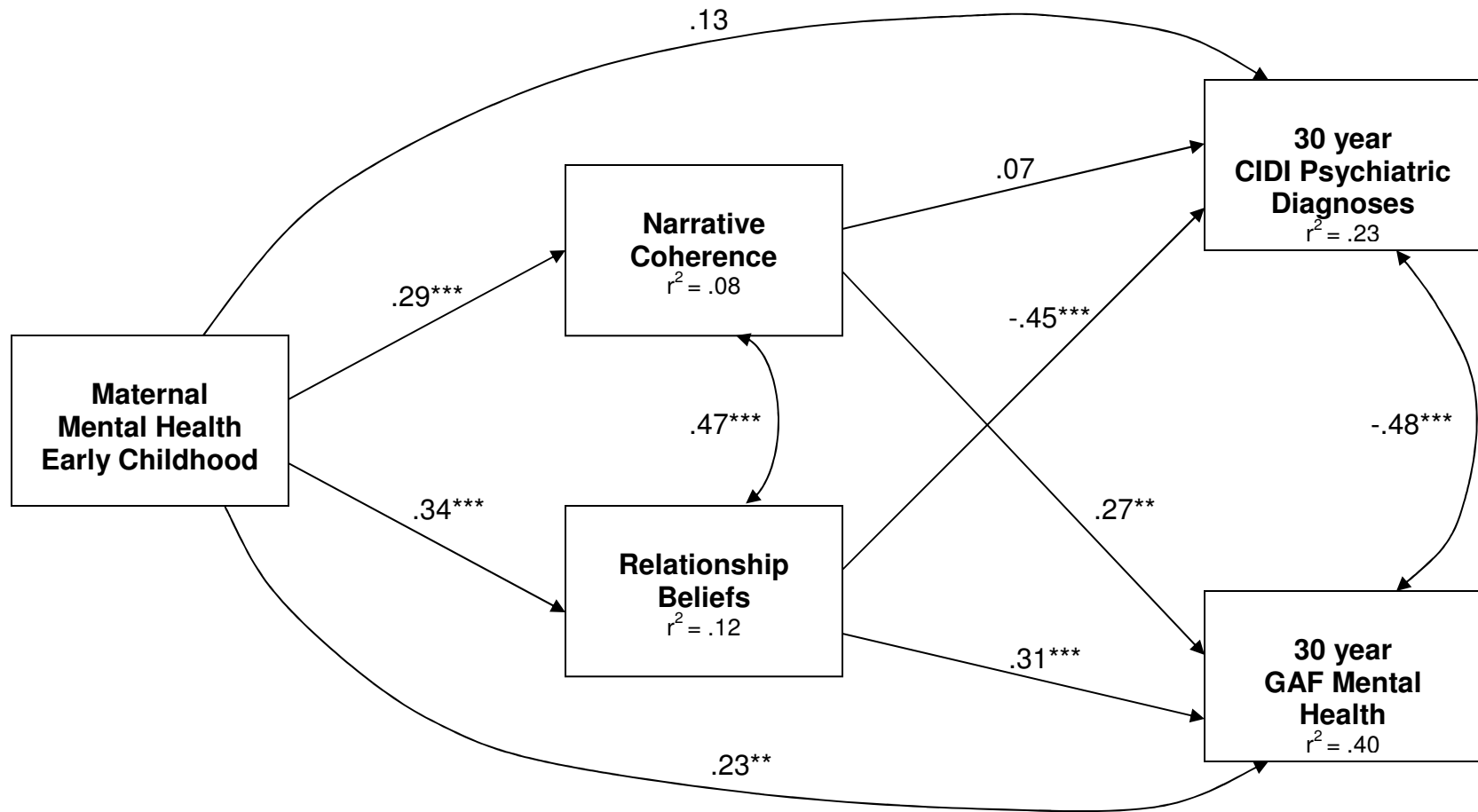

Figure 3.4. Narrative Variables as Mediators of the Links between Maternal Mental Health and Offspring Relationship Outcomes

150

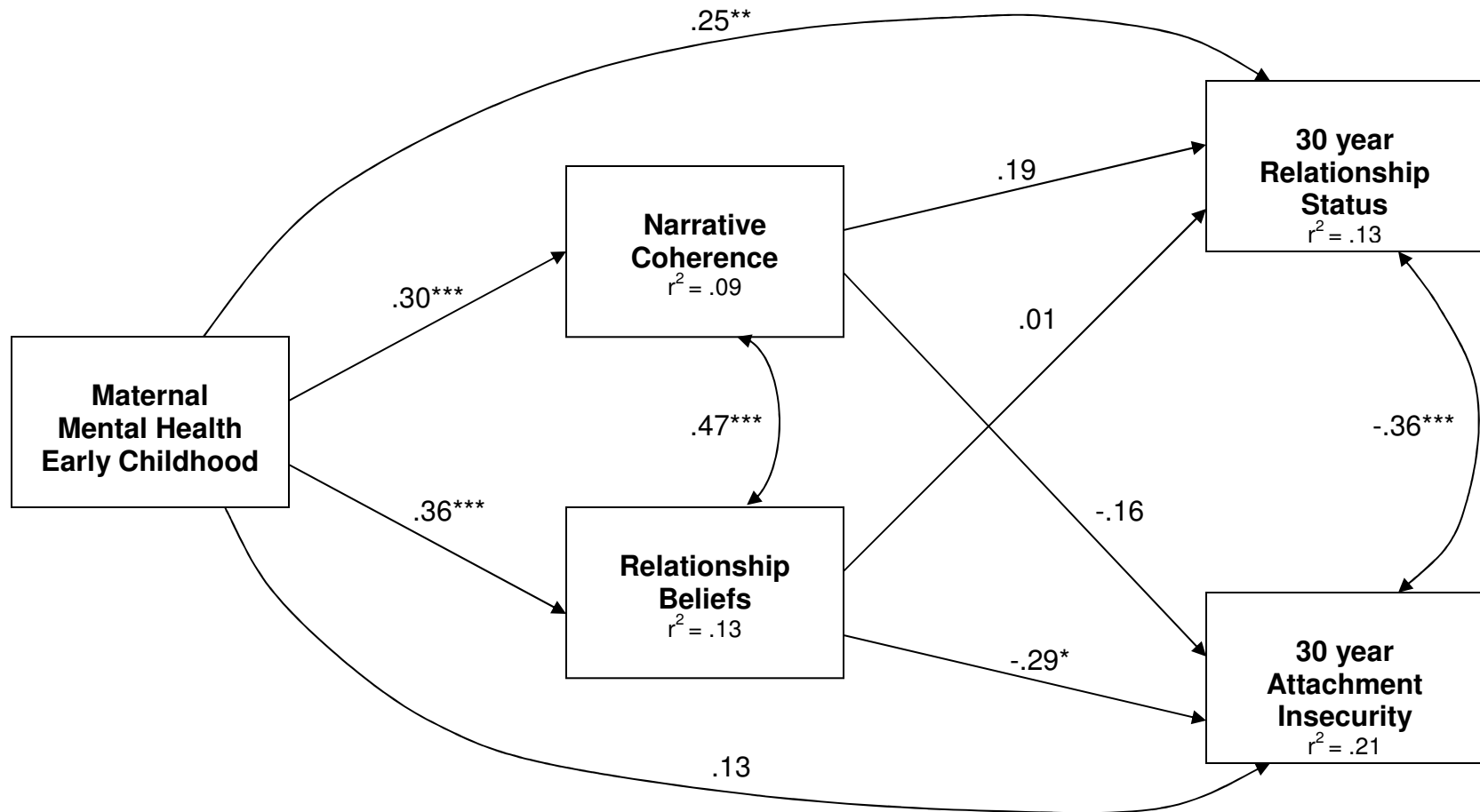

Figure 3.5. Narrative Variables as Mediators of the Associations between Maternal Mental Health and Offspring SES

151

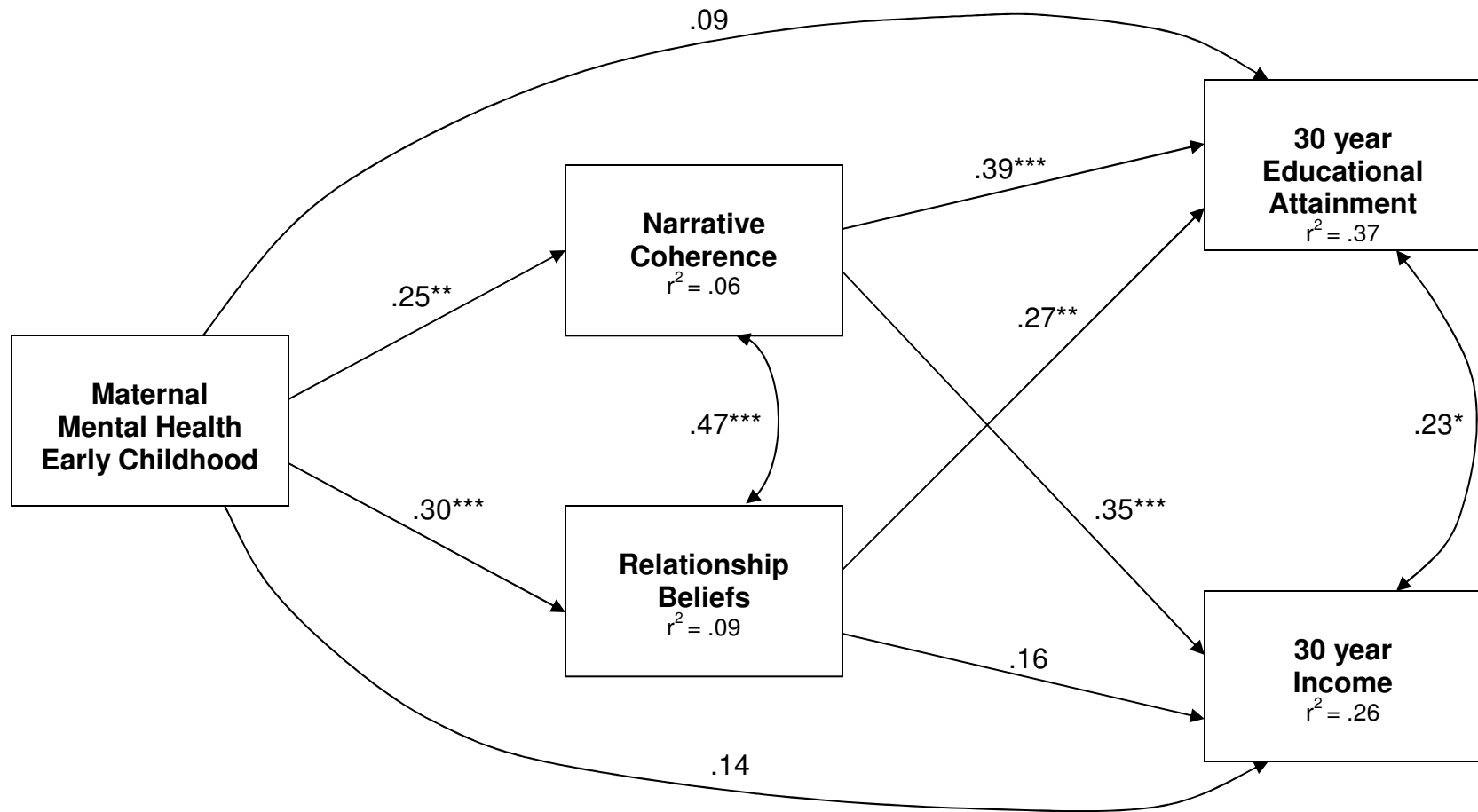

Figure 3.6. Final Model Depicting Pathways from Early Maternal Mental Health to Offspring Adult Mental Health

152

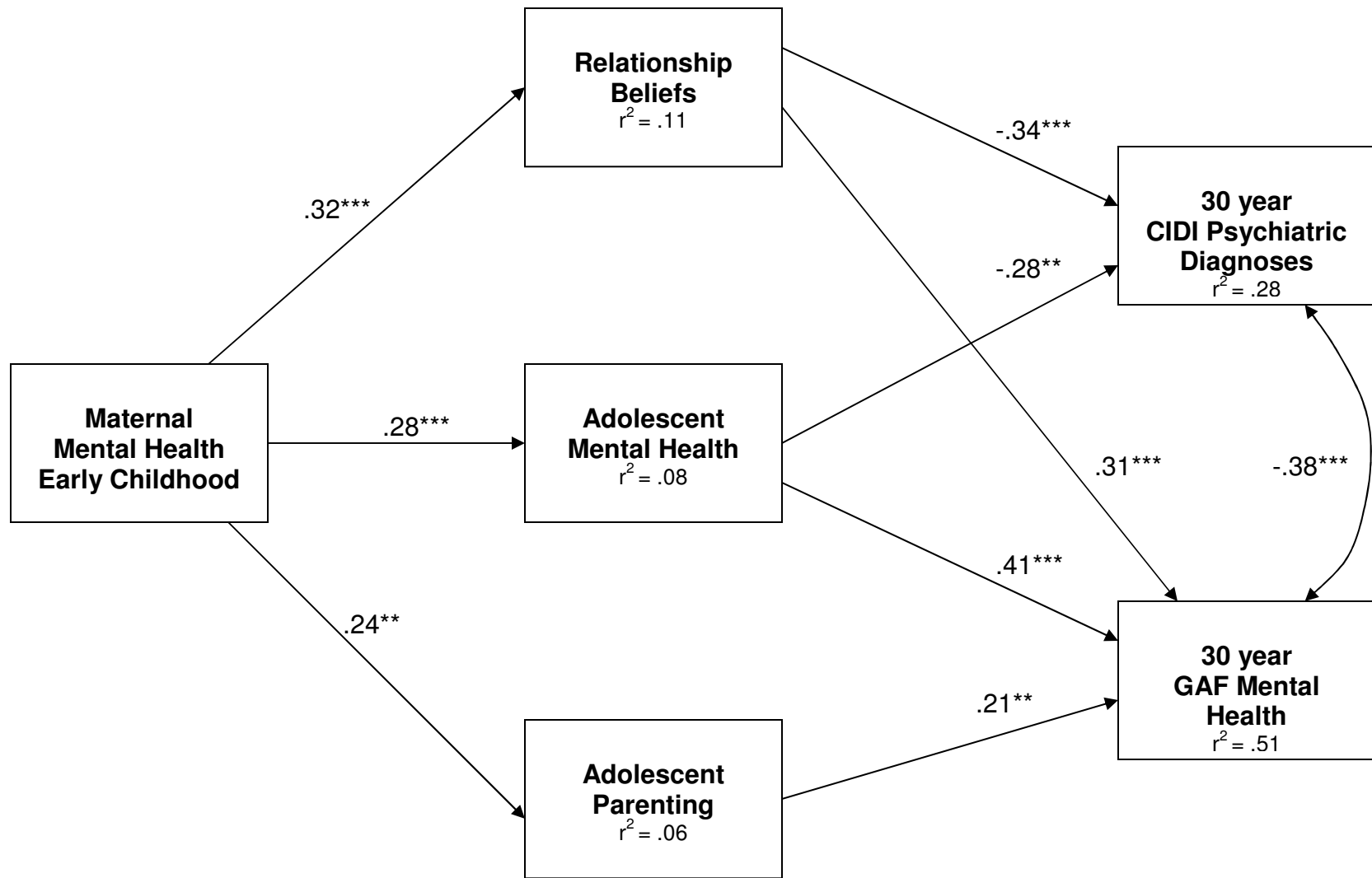

Figure 3.7. Final Model Depicting Pathways from Early Maternal Mental Health to Offspring Adult Romantic Relationship Outcomes

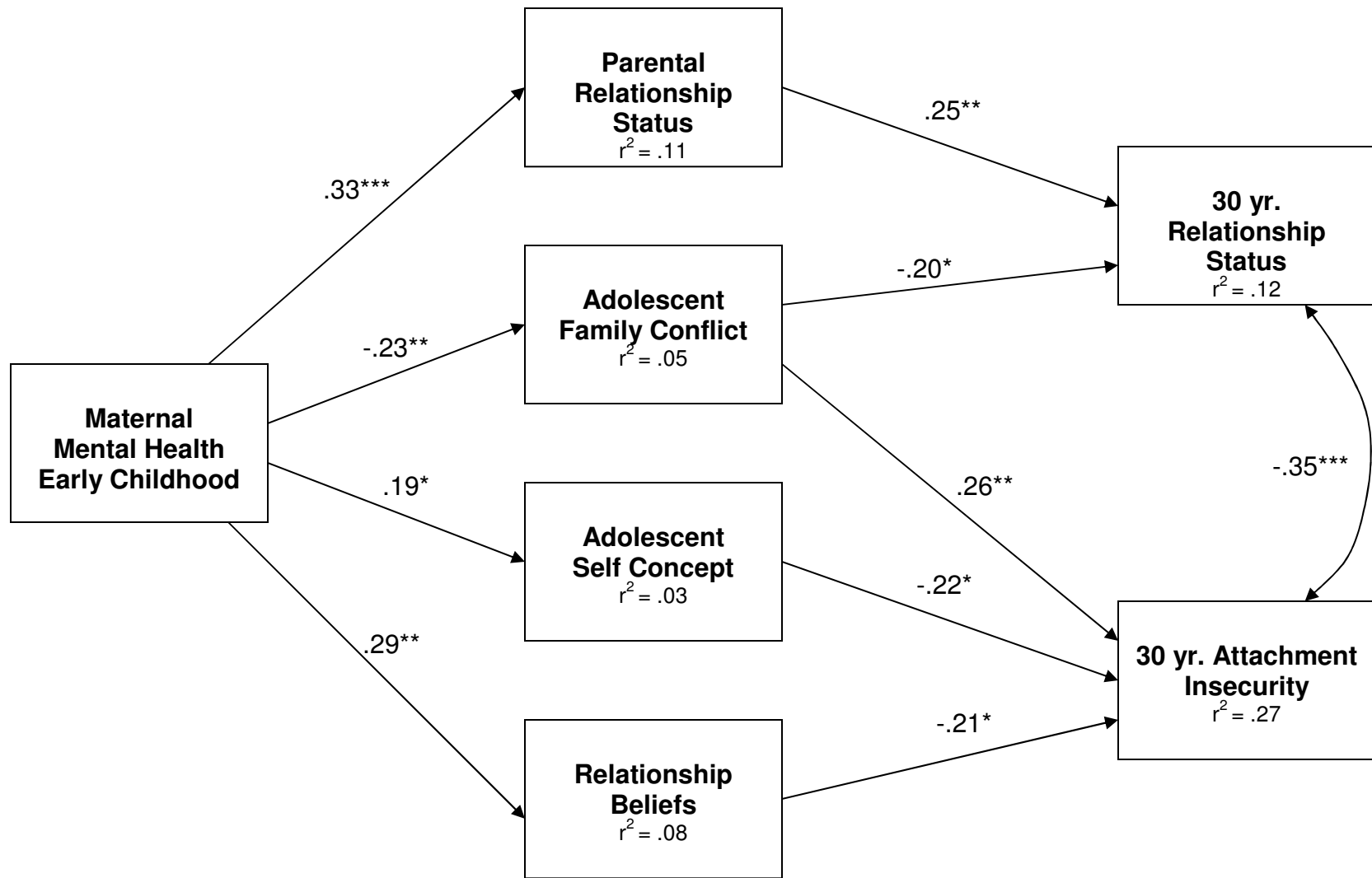

Figure 3.8. Final Model Depicting Pathways from Early Maternal Mental Health to Offspring Adult Socioeconomic Status

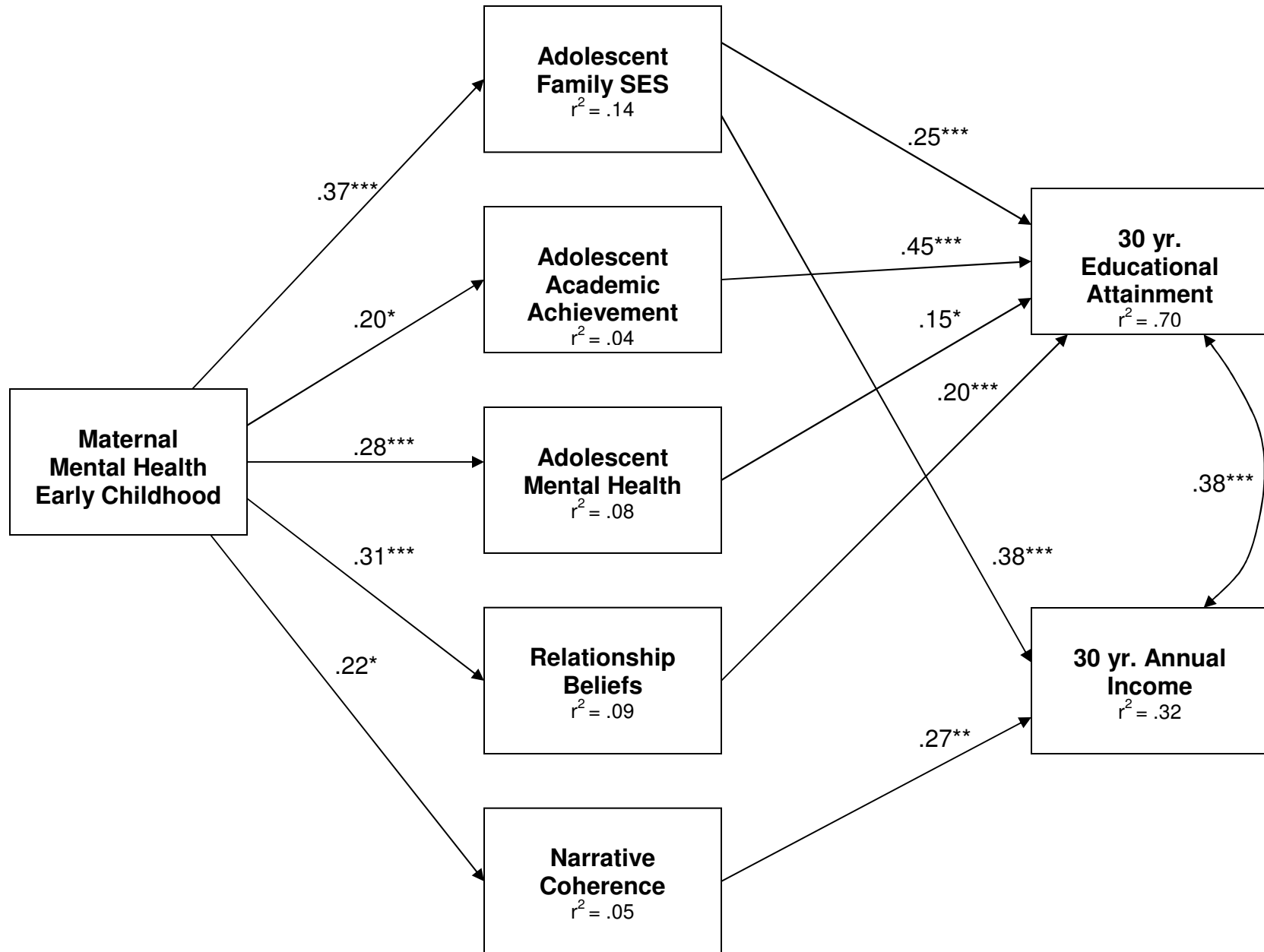

Table 2.1

Descriptive Statistics for Maternal Mental Health and Offspring Adaptive Functioning Variables

| | N | Min. | Max. | Mean | SD |
|----------------------------------|-----|-------|-------|-------|-------|
| Maternal Mental Health (0-3 yrs) | 234 | 1.00 | 4.00 | 3.01 | 1.17 |
| GAF Scores (30 yrs) | 125 | 47.00 | 93.50 | 79.17 | 9.82 |
| CIDI Diagnoses (30 yrs) | 120 | 0.00 | 3.00 | 0.84 | 0.87 |
| Relationship Status (30 yrs) | 121 | 1.00 | 4.00 | 3.15 | 0.99 |
| Relationship Quality (30 yrs) | 99 | 1.92 | 4.92 | 4.21 | 0.55 |
| Attachment Insecurity (30 yrs) | 107 | 18.00 | 96.00 | 44.85 | 20.17 |
| Occupational Status (30 yrs) | 139 | 1.00 | 9.00 | 5.05 | 2.21 |
| Educational Attainment (30 yrs) | 139 | 3.00 | 7.00 | 5.10 | 1.11 |

Table 2.2

Descriptive Statistics for Individual and Family Variables in Adolescence

| | N | Min. | Max. | Mean | SD |
|--|-----|-------|--------|-------|------|
| Mental Health (13 & 18 yrs) | 137 | -4.01 | 6.57 | 0.00 | 2.43 |
| Self-Concept (13 & 18 yrs) | 137 | 19.67 | 42.00 | 33.60 | 4.02 |
| Parenting (13 & 18 yrs) | 132 | -5.84 | 2.86 | 0.04 | 1.67 |
| Family Relationships (18 yrs) | 153 | 5.00 | 36.00 | 24.01 | 6.63 |
| Family Conflict (13 & 18 yrs) | 135 | 49.70 | 87.00 | 73.72 | 7.54 |
| Peer Relationships (13 & 18 yrs) | 135 | 51.00 | 108.00 | 93.85 | 9.93 |
| Academic Ach. (13 & 18 yrs) | 143 | -6.59 | 5.99 | 0.11 | 2.61 |
| Family SES (13 & 18 yrs) | 165 | 1.00 | 5.00 | 2.77 | 1.32 |
| Parental Relationship Status (Birth through 18 yrs) | 156 | 0.00 | 4.00 | 2.45 | 1.41 |

Table 2.3

Correlations between Maternal Mental Health in Early Childhood and Offspring Adaptive Functioning at age 30

| | 2 | 3 | 4 | 5 | 6 | 7 | 8 | 9 |
|---------------------------|---------|----------|---------|-------|----------|---------|---------|---------|
| 1. Maternal Mental Health | .413*** | -.266** | .304*** | .103 | -.266** | .127 | .259** | .282*** |
| 2. GAF Scores | | -.595*** | .423*** | .209* | -.513*** | .364*** | .465*** | .516*** |
| 3. CIDI Diagnoses | | | -.254** | .012 | .324*** | -.199* | -.226* | -.211* |
| 4. Relationship Status | | | | .117 | -.451*** | .306*** | .238** | .410*** |
| 5. Relationship Quality | | | | | -.536*** | -.057 | .177 | .122 |
| 6. Attachment Insecurity | | | | | | -.208* | -.300** | -.253** |
| 7. Occupational Status | | | | | | | .592*** | .382*** |
| 8. Educational Attainment | | | | | | | | .456*** |
| 9. Annual Income | | | | | | | | |

*p < .05, **p < .01, ***p < .001

Table 2.4

Correlations between Maternal Mental Health, Offspring Adaptive Functioning, and Adolescent Predictors

| | Mental Health (13 & 18 yrs) | Parenting (13 & 18 yrs) | Academic Ach. (18 yrs) | Self-Concept (13 & 18 yrs) | Family Conflict (13 & 18 yrs) |
|---------------------------|--------------------------------|----------------------------|---------------------------|-------------------------------|----------------------------------|
| 1. Maternal Mental Health | .243** | .216* | .204* | .186* | .223** |
| 2. GAF Scores | .590*** | .471*** | .354*** | .402*** | .463*** |
| 3. CIDI Diagnoses | -.403*** | -.260** | -.239* | -.187* | -.208* |
| 4. Relationship Status | .278** | .240* | .114 | .199* | .276*** |
| 5. Relationship Quality | .073 | .207 | .151 | .031 | .266* |
| 6. Attachment Insecurity | -.416*** | -.234* | -.147 | -.448*** | -.458*** |
| 7. Occupational Status | .405** | .227* | .520*** | .180* | .202* |
| 8. Educational Attainment | .572*** | .430*** | .729*** | .252** | .348*** |
| 9. Annual Income | .353*** | .354*** | .369*** | .189* | .303*** |

*p < .05, **p < .01, ***p < .00

Table 2.4 (cont.)

Correlations between Maternal Mental Health, Offspring Adaptive Functioning, and Adolescent Variables

| | Peer Relations (13 & 18 yrs) | Family Function. (18 yrs) | Family SES (13 & 18 yrs) | Parental Relationship (Birth-18 yrs) |
|---------------------------|---------------------------------|---------------------------------|-----------------------------|--|
| 1. Maternal Mental Health | .073 | .219** | .363*** | .320*** |
| 2. GAF Scores | .493*** | .278** | .507*** | .348*** |
| 3. CIDI Diagnoses | -.317*** | -.170 | -.316*** | -.379*** |
| 4. Relationship Status | .287** | .237* | .304*** | .287*** |
| 5. Relationship Quality | .067 | .095 | .146 | .099 |
| 6. Attachment Insecurity | -.388*** | -.314*** | -.212* | -.187 |
| 7. Occupational Status | .375*** | .152 | .539*** | .380*** |
| 8. Educational Attainment | .423*** | .099 | .685*** | .474*** |
| 9. Annual Income | .253*** | .096 | .500*** | .409*** |

*p < .05, **p < .01, ***p < .001

Table 2.5

Intercorrelations among the Adolescent Variables

| | 2 | 3 | 4 | 5 | 6 | 7 | 8 | 9 |
|--|---------|---------|---------|----------|----------|----------|---------|---------|
| 1. Mental Health (13 & 18 yrs.) | .321*** | .403*** | .483*** | -.541*** | .498*** | .234** | .422*** | .216* |
| 2. Parenting (13 & 18 yrs.) | | .356*** | .085 | -.542*** | .416*** | .145 | .442*** | .332*** |
| 3. Academic Achievement (18 yrs) | | | .050 | -.171* | .333*** | -.038 | .689*** | .475*** |
| 4. Self-Concept (13 & 18 yrs.) | | | | -.371*** | .373*** | .371*** | .104 | -.029 |
| 5. Family Conflict (13 & 18 yrs.) | | | | | -.445*** | -.461*** | -.267** | -.212* |
| 6. Peer Relationships (13 & 18 yrs.) | | | | | | .254** | .392*** | .298*** |
| 7. Family Relationships (18 yrs.) | | | | | | | .092 | -.020 |
| 8. Family SES (13 & 18 yrs.) | | | | | | | | .587*** |
| 9. Parental Relationship (Birth – 18 yrs.) | | | | | | | | |

*p < .05. **p < .01. ***p < .001

Table 2.6

Means (and Standard Deviations) of Outcomes as a Function of Maternal Mental Health Status

| 30 year Outcome | Maternal Mental Health Status | | F (1, 137) |
|----------------------------|-------------------------------|---------------|------------|
| | No Problem | Problem | |
| GAF Mental Health Scores | 83.20 (7.06) | 75.21 (10.56) | 13.06*** |
| CIDI Diagnostic Categories | 0.58 (0.79) | 1.10 (0.88) | 11.30*** |
| Occupational Attainment | 5.26 (2.29) | 4.84 (2.12) | 2.11 (ns) |
| Educational Attainment | 5.33 (1.12) | 4.87 (1.05) | 6.83* |
| Annual Income | 13.24 (6.30) | 9.55 (6.48) | 4.17* |
| Relationship Status | 3.44 (0.83) | 2.85 (1.05) | 4.19* |
| Relationship Satisfaction | 4.26 (0.51) | 4.15 (0.59) | 1.56 (ns) |
| Attachment Insecurity | 38.91 (19.84) | 50.46 (19.01) | 11.30*** |

*p < .05, **p < .01, ***p < .001

Table 3.1

Descriptive Statistics for Study 2 Family Narrative Codes

| | N | Min. | Max. | Mean | SD |
|---------------------------|-----|------|------|------|------|
| Internal Consistency | 105 | 1.00 | 5.00 | 4.00 | 1.10 |
| Organization | 105 | 1.00 | 5.00 | 4.03 | 1.13 |
| Flexibility | 105 | 1.00 | 5.00 | 3.76 | 1.25 |
| Relationship Expectations | 105 | 1.00 | 5.00 | 3.67 | 1.32 |
| Experience with Family | 105 | 1.00 | 5.00 | 3.42 | 1.51 |
| Affective Tone | 105 | 1.00 | 5.00 | 3.39 | 1.45 |
| Acceptance of Family | 105 | 1.00 | 5.00 | 3.72 | 1.47 |

Table 3.2

Correlations between Study 2 Family Narrative Codes

| | 2 | 3 | 4 | 5 | 6 | 7 |
|------------------------------|---------|---------|---------|---------|---------|---------|
| 1. Internal Consistency | .764*** | .563*** | .388*** | .304** | .366*** | .269** |
| 2. Organization | | .587*** | .388*** | .375*** | .403*** | .346*** |
| 3. Flexibility | | | .580*** | .505*** | .605*** | .584*** |
| 4. Relationship Expectations | | | | .855*** | .886*** | .830*** |
| 5. Experience with Family | | | | | .923*** | .905*** |
| 6. Affective Tone | | | | | | .908*** |
| 7. Acceptance of Family | | | | | | |

*p < .05, **p < .01, ***p < .001

Table 3.3

Correlations between Study 2 Narrative Codes, Maternal Mental Health, and Offspring Adaptive Functioning

| | Narrative Coherence | Relationship Beliefs |
|--|---------------------|----------------------|
| 1. Maternal Mental Health | .274** | .326*** |
| 2. Offspring GAF Scores (30 yrs) | .501*** | .543*** |
| 3. Offspring CIDI Diagnoses (30 yrs) | -.211* | -.481*** |
| 4. Offspring Relationship Status (30 yrs) | .279** | .209* |
| 5. Offspring Attachment Insecurity (30 yrs) | -.303** | -.397*** |
| 6. Offspring Relationship Quality (30 yrs) | .108 (ns) | .008 (ns) |
| 7. Offspring Educational Attainment (30 yrs) | .540*** | .503*** |
| 8. Offspring Annual Income (30 yrs) | .442*** | .375*** |
| 9. Offspring Occupational Status (30 yrs) | .323*** | .308*** |

*p < .05, **p < .01, ***p < .001

Table 3.4

Correlations between Study 2 Narrative Codes and Adolescent Individual and Family Variables

| | Narrative Coherence | Relationship Beliefs |
|---|---------------------|----------------------|
| 1. Adolescent Mental Health (13 yrs & 18 yrs) | .410*** | .418*** |
| 2. Adolescent Parenting (13 yrs & 18 yrs) | .506*** | .323*** |
| 3. Adolescent Academic Competence (13 yrs & 18 yrs) | .404*** | .300*** |
| 4. Self-Concept (13 yrs & 18 yrs) | .259** | .270* |
| 5. Family Functioning (18 yrs) | .303** | .303** |
| 6. Family Conflict (13 yrs & 18 yrs) | -.554*** | -.379*** |
| 7. Peer Relationships (13 yrs & 18 yrs) | .443*** | .549*** |
| 8. Family SES (13 yrs & 18 yrs) | .509*** | .359*** |
| 9. Parental Relationship Status (Birth – 18 yrs.) | .336** | .504*** |

*p < .05, **p < .01, ***p < .001

Table 3.5

Means (and Standard Deviations) of Narrative Codes as a Function of Maternal Mental Health Status

| | Maternal Mental Health Status | | F (1, 104) |
|----------------------|-------------------------------|--------------|------------|
| | No Problem | Problem | |
| Narrative Coherence | 12.98 (0.45) | 10.89 (0.39) | 12.45*** |
| Relationship Beliefs | 16.44 (0.79) | 12.33 (0.69) | 15.22*** |

*p < .05, **p < .01, ***p < .001

APPENDIX A

Family Narrative Codebook (Study 2)

Family Narrative Codebook: Introduction

This codebook was designed for use with the Family of Origin interview of the Rochester Longitudinal Study. Four of the scales (internal consistency, organization, flexibility, and relationship expectations) were adapted from the Family Narrative Consortium (FNC) coding system (Fiese, Sameroff, Grotevant, Wamboldt, Dickstein & Fravel, 1999). The FNC coding system was developed by a group of family researchers who were interested in how families make sense of personal experiences and find meaning in their collective lives. The stories that families tell during the course of an interview provide a window into the interpretive process and belief system of the family. The consortium defined family stories as the verbal accounts of personal experiences that are important to the family and typically involve the creation and maintenance of relationships. They depict rules of interaction and reflect beliefs about family and other social institutions.

The FNC codebook was revised for use with the Family of Origin Interview of the Rochester Longitudinal Study based on more recent coding by Fiese and colleagues. During this interview participants were asked questions about their family of origin while growing up. Three codes were developed by the doctoral candidate for the purposes of this study. These codes (experiences with family, feelings toward family, acceptance of family) were designed to specifically measure participants' meaning making of their experiences growing up in their families of origin.

Sections of Codebook

The codebook is divided into two sections: Narrative Coherence Codes and Relationship Belief Codes.

Narrative Coherence Codes. The narrative coherence codes assess internal consistency of the narrative, how well the narrative is organized, and the extent to which the individual explores new ideas or alternatives. The Narrative Coherence Codes are:

- Internal Consistency
- Organization
- Flexibility

Relationship Beliefs. The Relationship Beliefs dimension assesses how the individual's views of interpersonal relationships, particularly within the family of origin, are reflected in his or her narrative. These codes assess not only what the individual says about his or her family, but also the emotions behind the statements.

- Relationship Expectations
- Experience with Family
- Acceptance of Family
- Feelings toward Family

Coding Procedures

General Coding Procedures

Most scales include five scale points, with “5” indicating a strong presence of that particular dimension. Detailed descriptions are provided for each scale point. Codes of “8” and “9” exist for all scales. Code “8” indicates that the coder is unable to rate this particular scale due to a mechanical problem. Code “9”, however, means that the coder is unable to rate a specific scale due to unclearness in the content of the interview or the respondent did not answer the question adequately to code the response.

Decision Rules

If a coder has difficulty deciding between two points, the coder should code the **lower** scale point. If a coder has difficulty deciding between two scale points on the Relationship Belief scales, the coder should push the code **away from a mid-point** (3) rating. For example, in the case where there is some question between a “2” and “3” then code “2” or if there is a question between a ‘3” and “4” then code “4”.

Section I: Narrative Coherence Codes

Overview of Narrative Codes

The narrative coherence codes measure how well the individual is able to construct and organize a story. The following codes are used:

- Internal Consistency
- Organization
- Flexibility

The ways in which an individual's story makes sense, how clauses and thoughts are organized, the extent to which the individual explores new ideas or alternatives, and the overall affective tone of the narrative are all considered part of the coherence of an individual's story or narrative. A given individual may vary across the various narrative codes. For example, it is possible for an individual to have a highly organized story and be very flexible, but to have an inconsistent underlying theory.

Coders should consider each narrative code separately, recognizing that high scores on one scale do not necessarily indicate high scores on another scale. Narrative codes are to be reflective of the total interview.

Coding Guidelines

Narrative scales are coded from 1 to 5. Preceding each scale point is a list of anchor points to aid the coder. The anchor points list examples of portions of each scale. The coder is to consider the narrative in light of the anchor points and then determine the relative weight of the narrative. Each narrative may not possess all qualities given in the anchor points. The coder is to refer to point descriptions for each scale when making the rating.

Internal Consistency

Scale Description

The internal consistency of the narrative reflects the completeness of the narrative. Narratives that are low on internal consistency typically include multiple contradictions and it is difficult to identify what is the actual story. Narratives that are high on internal consistency include a complete story with a theory that includes specific and personalized examples. It is often easy to identify an underlying theme in those narratives that are high on internal consistency.

The coder should initially attempt to identify a theme in the narrative. After identifying a theme, the coder should then decide whether or not the theme is supported by the individual's story and statements. If a theme is indeed present, the coder should find evidence for it. The coder should also look for contradictions to the apparent theme. To identify the theme, the coders should repeatedly ask themselves the questions "what was it like growing up in your family" and "how has your family affected your life?" while reading the transcript of the interview. Below are some common themes:

1. "My experiences with my family of origin were difficult"
2. "My family of origin has/has not affected the person I am today"

Anchor Points

It is helpful to consider high and low anchor points when coding for internal consistency. Typically, these anchor points will cluster together. However, the presence of only one low anchor point with several high anchor points would suggest a higher score on this scale.

| <u>High</u> | <u>Low</u> |
|---------------------------|--------------------------------------|
| Absence of Contradictions | Contradictions |
| Consistency With Theme | Inconsistency With Theme |
| Recognized Contradictions | Unrecognized Contradictions |
| Explained Contradictions | Unexplained Contradictions |
| Detailed Examples | Vague or Global Examples |
| Personalized Examples | No Personal Details |
| Synthesizing Explanations | Absence of Synthesizing Explanations |

Coding Chart

Once the coder has determined whether a story line exists in the narrative, the balance between contradictions and examples needs to be considered before assigning a score. In the following chart, a “-“ signifies that a particular attribute is absent and a “+” signifies the presence of a particular attribute.

| Scale Level | Personalized Examples | Specific Examples | Synthesized Statements | Contradictions | Consistency With Theme |
|--------------------|------------------------------|--------------------------|-------------------------------|---------------------------------------|-------------------------------|
| 1 | - | - | - | ++ (multiple, recognized or thematic) | - |
| 2 | +/- | - | - | + (minor, unrecognized) | - |
| 3 | +/- | - | + | + (recognized, not explained) | +/- |
| 4 | +/- | -/+ | +/- | +/- | + |
| 5 | + | + | + | Explained if Present | + |

Definitions and Examples

Personalized Examples: Directly relating to their own experience.

Explained Contradiction: “ My mother was very hard on me growing up, but that was how she was raised herself.”

Recognized Contradiction: “I know it’s strange, but even though my dad walked out on us I still loved him.”

Synthesizing Explanations: Two or more pieces of the story that are connected with a concluding explanation. Tying together parts; how you make sense of an event. “But I mean I think all the things, the ways that it affects me, directly go back and affect my children.”

Internal Consistency Scale

| Scale Level | Indicators |
|---|--|
| 1. Thematic Contradictions/ No Story | No story can be identified. Multiple unrecognized contradictions without personalized examples. Listener cannot make summary statement about interview. |
| 2. Unsupported Story/Minor unrecognized contradictions | May include minor unacknowledged contradictions. Descriptive statements without generalizations or synthesizing explanations. |
| 3. Vague Themes/ Recognized Contradictions | Respondent may make generalizations about his/her experience. Contradictions may be recognized, but not explained. Multiple points may be made, including comparisons but no theory is evident. |
| 4. Theory in process/ Explained contradictions | Emergent theory; supported evidence but not integrated. Usually does not include unexplained contradictions. Examples can be either personalized or specific, but not both. |
| 5. Well Documented Theory | Must have all indicators. No unexplained contradictions. Specific and personal examples; synthesizing explanations. |
| 8. Can't code due to mechanical problems | |
| 9. Unclear; can't code | |

Organization of the Narrative

Scale Description

Organization refers to the respondent's management of the narrative, with particular attention to statements that convey information and how points are made within the narrative. Individuals differ in how they manage the transitions evident in narratives and whether thoughts are completed or left hanging. Organization also includes how the individual is able to self-correct if their narrative wanders.

An organized narrative provides the listener with a sense of orientation of context, and a clear sense of referents (who, what, where). Orienting statements include meta-statements that identify for the listener what is coming next. Highly organized narratives initially respond on topic, flow smoothly with completed thoughts and are direct and to the point. Interviewer has minimal work as respondent answers questions. Few, if any clarification questions required. Poorly organized narratives may not initially respond on topic and be full of stops and starts; occasionally consisting of over-elaborations, which stray further and further from the original point. Interviewer is working hard and multiple clarification questions are asked.

Anchor Points

Prior to assigning a final score, the coder should consider the degree to which the narrative falls along these anchor points.

| <u>High</u> | <u>Low</u> |
|---|---|
| Sense of order/Initial response on topic | Scattered or unclear chronology/Initial response off topic. |
| Complete | Incomplete or blocked thoughts |
| Succinct | Excessive Detail |
| Free flowing description | Description is full of starts and stops |
| Specific referents (who, what, where) | Ambiguous or missing referents |
| Isolated markers of disorganization; inconsistent throughout narrative. | Repetitive markers of disorganization; consistent throughout narrative. |
| Interviewer conducts interview with ease, minimal or no clarification required. | Interviewer experiences great difficulty in conducting interview. Multiple clarifications required. |

Definitions and Examples

Orienting Statements: Info that will help you makes sense of something the family is just about to talk about/background to help you understand the details.

Organization of the Narrative Scale

| Scale Level | Indicators |
|--|---|
| 1. Poor Organization | Rater has no clear picture of story. Individual does not put pieces of narrative together. Many/mostly markers of disorganization; especially stops and starts, scattered with no transitions, thought blockage, and ambiguous referents. Interviewer is working hard and multiple clarification questions are asked. Initial response off topic. |
| 2. Moderately Poor Organization | Rater understands most of narrative, with effort or with assistance from interviewer or other family member. Individual puts some of the story together but not all of story. Some markers of disorganization, typically stops and starts, or incomplete thoughts. Markers tend to be more repetitive and consistent throughout narrative, rather than isolated. |
| 3. Moderate Organizations | Rater can understand story but there may still be some markers of disorganization. Individual does put story together but with difficulty. However, markers should not be consistent throughout the narrative. 2 or 3 markers are allowed, but they should be isolated and not repetitive. |
| 4. Moderately Good Organization | Rater can understand story clearly with rare incidences of markers of disorganization. Individual puts story together and self-corrects. Minimal effort required of interviewer. Initial responses typically should be on topic. |
| 5. Good Organization | Individual puts story together in succinct and direct fashion. Use of orienting statements. Interviewer is able to conduct assessment with ease. Initial response and all future questions should be on topic. |
| 8 Mechanical Problem | |
| 9 Unclear/Can't Code | |

Flexibility of the Narrative

Scale Description

Flexibility refers to the respondent's ability to explore new ideas and alternatives. The flexible respondent is able to view issues as others might see them, and recognizes that there is more than one side to every story. Positive referents for flexibility include elaboration of alternatives with possibility of action, whereas negative referents for flexibility include rigid statements of conviction.

Anchor Points

Prior to assigning a final score, the coder should consider the degree to which the narrative falls along these anchor points.

| <u>High</u> | <u>Low</u> |
|--|--------------------------------------|
| Multiple perspectives integrated and resolved. | Strong adherence to one perspective. |
| Both sides evaluated and elaborated. | Issues are all one-sided. |
| No rigid statements. | Rigid statements. |

Flexibility Scale

| Scale Level | Indicators |
|---|--|
| 1. Low Flexibility/Rigid | Individual narrative strongly adheres to one perspective. Issues are all one-sided. |
| 2. Moderately Low Flexibility | Individual narrative adheres to one perspective with minimal recognition of alternative views. Alternatives may be mentioned but dismissed as not valid or wrong. |
| 3. Moderate Flexibility | Individual clearly recognizes more than one perspective. Valid alternatives mentioned. |
| 4. Moderately High Flexibility | Individual elaborates two or more perspectives to issue. (Possible alternatives elaborated if appropriate). |
| 5. High Flexibility/Balanced | Individual integrates and resolves two or more perspectives. May discuss implications for action, if appropriate given the interview. Both sides evaluated and elaborated. No rigid statements. |
| 8. Can't code due to mechanical problems | |
| 9. Unclear; can't code | |

Section II. Relationship Beliefs

Overview of Relationship Beliefs

Relationship beliefs tap into how the family's narrative reflects representations about the social world. Relationship beliefs are evident in the content of the story and the style used by the family to share information. These scales are drawn, in part, from Reiss's (1981) model of family paradigms. Family paradigms are a family's assumptions about reality, which become evident as the family works together in creating and sharing their stories. Families differ in how safe they perceive the world and social relationships and how likely they are to share information with the outside world. Inherent in this framework is the notion that families hold beliefs about relationships and develop rules of interaction to conform to these beliefs.

The relationship beliefs scales are:

- Relationship Expectations
- Experience with Family
- Affective Tone of Statements about the Family
- Acceptance of Family

The ways in which the family views the relative safety and rewarding features of relationships are expressed in the tone of their stories and statement of satisfaction with relationships. Relationships can be seen as safe, rewarding and manageable. The beliefs that are expressed in the narrative include an expectation that relationships will bring rewards and are opportunities to feel successful and satisfied.

Relationship Expectations

The Relationship Expectations scale assesses how the individual views relationships as manageable, reliable and safe. Individuals differ in how they view relationships in the social world. For some people, the social world is seen as dangerous, often evoking feelings of being overwhelmed and discouraged. For other people, the social world is seen as trustworthy, safe and full of opportunities for success and satisfaction, and there is a strong motivation to connect with other people, both inside the family and outside in the social world.

Anchor Points

Prior to assigning a score, the coder should consider anchor points for this scale. Two aspects of relationship expectations are important to consider: the relative safety of relationships and the degree to which relationships are understandable and can be mastered. Other aspects to consider are the components of the family's beliefs and approach toward trust and reliance on others. What did they experience when they interacted with other family members? Did they look forward to the interaction and expect it to be rewarding or did they avoid interaction, dread it and expect it to be frustrating or overwhelming?

| | High | Low |
|----------------|-----------------------------|--------------------------------|
| Safety | Relationships are safe | Relationships are dangerous |
| Mastery | Relationships are rewarding | Relationships are overwhelming |

Relationship Expectations Scale

| Scale Level | Indicators |
|---|--|
| 1. Very Low | Expect relationships to be dangerous, threatening, or overwhelming. Individual talks about relationships as a source of fear and may believe that others willfully harm each other. Individual cannot understand motives of others. Talk of relationships is marked by statements of confusion and dissatisfaction. |
| 2. Low | Relationships are seen as precarious, trying, or unreliable. Individual talks about past disappointments in relationships and considers almost everyone not to be worthy of trust. The individual's general tone regarding relationships is dissatisfaction. |
| 3. Moderate | Relationships may be met with success, but individual tends to categorize into good or bad, black or white. There are still instances of being dissatisfied, and the sense that some people can be trusted but others cannot. |
| 4. High | Relationships are relatively understandable, safe, successful, usually rewarding and reliable. There may be isolated references to dissatisfying relationships. Dissatisfying relationships tend to have been resolved. |
| 5. Very High | Relationships are safe, reliable, rewarding and fulfilling. The individual feels confident and positive enough about his/her understanding of relationships to embrace opportunities to establish relationships with others. Relationships are seen as opportunity to feel successful and satisfied. |
| 8. Can't code due to mechanical problems | |
| 9. Unclear; can't code | |

Experience with Family Scale

| Scale Level | Indicators |
|--|---|
| 1. Very negative | Family experience described as very negative. Very few positive statements about the family experience are made. |
| 2. Slightly negative | More negative statements than positive statements are made about experiences with the family. |
| 3. Neutral | Experience with the family of origin is related as neither positive nor negative. Equal number of positive and negative statements. |
| 4. Slightly positive | More positive statements than negative statements are made about experiences with the family. |
| 5. Very positive/Perfect | Family experience described as very positive or “perfect”. No negative statements are made. |
| 8.Can’t code due to mechanical problems | |
| 9. Unclear; can’t code | |

Affective Tone of Statements about the Family

This code refers to the emotional tone of the individual when discussing the family of origin, with both type of affect expressed and intensity of affect considered in scoring. Narratives that score high on this scale are almost exclusively positive in content, and express clear joy in talking about the family. Narratives that are low in affective tone are almost exclusively negative in content, and contain many statements that express clear anger and/or sadness.

Anchor Points

Prior to assigning a final score, the coder should consider the degree to which the narrative falls along these anchor points.

| <u>Negative</u> | <u>Positive</u> |
|-------------------------------|--|
| Clear anger expressed. | Clear joy expressed. |
| Clear sadness expressed. | Turns negative statements into positive. |
| Very few positive statements. | Very few negative statements. |

Affective Tone of Statements about Family Scale

| Scale Level | Indicators |
|---|--|
| 1. Mostly negative | The narrative almost exclusively negative in its content. Clear anger or sadness is expressed throughout the narrative. |
| 2. Slightly negative | The narrative is more negative than positive . |
| 3. Neutral | The narrative is affectively neutral , and cannot be classified as either positive or negative. |
| 4. Slightly positive | The narrative is more positive than negative . |
| 5. Mostly positive | The narrative is almost exclusively positive in its content. Almost no negative statements are made. |
| 8. Can't code due to mechanical problems | |
| 9. Unclear; can't code | |

Acceptance of Family

This code is designed to assess participants' current acceptance of his or her family of origin. For example, two participants may describe similarly negative experiences with their family while growing up, but one might still feel anger about the situation while the other has come to accept the situation for what it was.

| Scale Level | Indicators |
|--|---|
| 1. Anger | Participant expresses clear anger toward family as an adult. |
| 2. Mostly Negative | Participant expresses some anger or sadness toward family. |
| 3. Neutral | Participant expresses little emotion, but does not express feelings of acceptance of past events. |
| 4. Mostly Positive | Participant is mostly accepting of family memories. |
| 5. Complete Acceptance | Participant is completely accepting of family; if expressed negative memories, has "come to terms" with these memories as an adult. |
| 8.Can't code due to mechanical problems | |
| 9. Unclear; can't code | |

APPENDIX B

Mental Health Interview (Study 3)

MENTAL HEALTH INTERVIEW

I would like to ask you some questions about your life growing up with your parents. You probably know that a large number of people report having emotional issues, like feelings of sadness or anxiety, or problems with managing their anger. Another common problem is substance abuse. In fact, 1 out of every 2 Americans report having serious concerns about at least one of these issues at some point in their lives. These problems are so common that, as we have conducted this study over the past 40 years, we have heard from many participants that they noticed that either they or their parents had dealt with some of these emotional problems while they were growing up. Because we are very interested in how families deal with stress and emotional issues, I'm going to ask you a few questions about these topics.

SELF INTERVIEW

First, how would you rate your own mental health while you were a child (before the age of 13)?

___ poor ___ fair ___ good ___ very good ___ excellent

How would you rate your own mental health while you were a teenager (between the ages of 13 and 18)?

___ poor ___ fair ___ good ___ very good ___ excellent

IF THEY SAY GOOD, VERY GOOD, OR EXCELLENT:

You said that your mental health was _____. Would you say that it was always _____, or was there a time when it wasn't _____?

Was there ever a time when you felt sad or depressed growing up?

How about anxious or tense?

Can you think of a time when you were especially angry or irritated or in trouble with authorities a lot?

Was there a time when you had substance abuse problems?

****If participant answers positively to any of the above questions, proceed to the questions below. If no mental health problem is indicated, proceed to Stressful Experiences section****

Was anyone concerned about these behaviors? If yes, what did they do?

Were you ever diagnosed as having a mental health problem? If yes, who diagnosed you and what was the diagnosis?

How old were you when you were diagnosed?

IF THEY SAY FAIR OR POOR:

Can you tell me more about that? Why would you describe your mental health as _____? Can you give me a specific example from your childhood or adolescence that illustrates when your mental health was _____?

Was there ever a time when you were sad or depressed?

How about anxious or tense?

Can you think of a time when you were especially angry or irritated or in trouble with authorities a lot?

Was there a time when you had substance abuse problems?

Was anyone concerned about these behaviors? If yes, what did they do?

Were you ever diagnosed as having a mental health problem? If yes, who diagnosed you and what was the diagnosis?

How old were you when you were diagnosed?

Understanding and Coping with Mental Health Problems

INCLUDE "GOOD" GROUP ONLY IF THEY INDICATED THAT THERE WAS EVER A PROBLEM

Sometimes people have different understandings of the mental health issues we just talked about when they are young versus when they are older. When you were growing up and were having some problems with *[use participant's own words]*, what did you think was causing *[the problem- use participant's own words]*?

Now that you are an adult looking back, what do you think caused *[the problem- participant's own words]*?

How do you think having problems with *[participant's own words]* affected your life growing up? Can you give me a specific example?

How do you think having *[emotional problems- use participant's own words]* while you were growing up affected the person you are today? Can you give me an example?

In your romantic relationships?

With your children?

In your work or professional life?

Did you ever talk to someone at the time about these issues? Who did you talk to, and what was it like?
(Note: If not specifically mentioned, did you talk to your parents about these issues? What was that like?)

Did you talk to a mental health professional, like a doctor, therapist, or counselor, at the time? What was that like?

As an adult, have you ever talked to a mental health professional about these experiences? When? What was that like?

Have you ever taken medication to help with your feelings or emotions? When?

How do you remember coping with these *[problems- use participant's own words]*?

Stressful Experiences

INCLUDE BOTH GROUPS

OK, let's move on to the next set of questions that deal with stress in general. We know that most people have periods of time when they experiences stress or difficulty coping. I would like for you to think of a time when you were growing up when you went through a particularly stressful period.

What was happening at the time?

What was this experience like for you?

Can you give me an example of what you did to cope with this stressful time?

MOTHER INTERVIEW

Now that we have talked about your own feelings and experiences growing up, I am going to ask you the same types of questions about your parents. I am first going to ask you some questions about your mother, and I will then move on and ask the same questions about your father.

Recognizing Mental Health Problems

How would you rate your mother's mental health while you were a child (before the age of 13)?

___ poor ___ fair ___ good ___ very good ___ excellent

How about when you were an adolescent (between the age of 13 and 18)?

___ poor ___ fair ___ good ___ very good ___ excellent

IF THEY SAY GOOD, VERY GOOD, OR EXCELLENT:

You said that your mother's mental health was _____. Would you say that it was always _____, or was there a time when it wasn't _____?

Was there ever a time when your mother was sad or depressed?

How about anxious or tense?

Can you think of a time when your mother was especially angry or irritated or in trouble with the authorities a lot?

Was there a time when your mother had substance abuse problems?

****If participant answers positively to any of the above questions, proceed to the questions below. If no mental health problem is indicated, proceed to Stressful Experiences section****

How old were you when you noticed that your mother was having problems with [participant's own words]? _____

Was anyone else concerned about these problems?

Do you know if your mother was ever diagnosed as having a mental health problem?

How old were you when you found out about this diagnosis?

How did finding out about your mother's diagnosis affect your life?

IF THEY SAY FAIR OR POOR:

Can you tell me more about that? Why would you describe your mother's mental health as _____?

What did your mother act like to make you think that her mental health was _____? Can you give me a specific example from your childhood or adolescence that illustrates when your mother's mental health was _____?

Was there ever a time when your mother was sad or depressed?

How about anxious or tense?

Can you think of a time when your mother was especially angry or irritated or in trouble with the authorities a lot?

Was there ever a time when your mother had problems with substance abuse?

How old were you when you noticed that your mother was having problems with [*participant's own words*]? _____

Was anyone else concerned about these problems?

Do you know if your mother was ever diagnosed as having a mental health problem?

How old were you when you found out about this diagnosis?

How did finding out about your mother's diagnosis affect your life?

Understanding and Coping with Mental Health Problems

INCLUDE "GOOD" GROUP ONLY IF THEY INDICATED THAT THERE WAS EVER A PROBLEM

Sometimes people have different understandings of the mental health issues we just talked about when they are young versus when they are older. When you were growing up and noticed that your mother was having some problems [*use participant's own words*], what did you think was causing [*the problem- use participant's own words*]?

Now that you are an adult looking back, what do you think caused your mother's problems with [*participant's own words*]?

How do you think having a mother with [*participant's own words*] affected your life growing up? Can you give me a specific example?

Was there an age when your mother's *[participant's own words]* were most difficult for you?

How do you think having a mother with *[participant's own words]* affected the person you are today? Can you give me an example?

In your romantic relationships?

With your children?

In your work or professional life?

Did you ever talk to someone at the time about your mother's *[participant's own words]*? Who did you talk to, and what was it like? (Note: If not specifically mentioned, did you talk to your parent about these issues? What was that like? Did you talk to a mental health professional? What was that like?)

How do you remember coping with having a mother with *[participant's own words]*?

Stressful Experiences

INCLUDE BOTH GROUPS

OK, let's move on to the next set of questions that deal with stress in general. We know that most people have periods of time when they experiences stress or difficulty coping. I would like for you to think of a time when you were growing up when your mother went through a particularly stressful period.

What was happening at the time?

What was this experience like for her?

Can you give me an example of what your mother did to cope with this stress?

What was this experience like for you?

Can you give me an example of what you did to cope with this stressful time?

FATHER INTERVIEW

Now I am going to ask you the same set of questions about your father.

Recognizing Mental Health Problems

How would you rate your father's mental health when you were a child (before the age of 13)?

___ poor ___ fair ___ good ___ very good ___ excellent

How about when you were an adolescent (between the age of 13 and 18)?

___ poor ___ fair ___ good ___ very good ___ excellent

IF THEY SAY GOOD, VERY GOOD, OR EXCELLENT:

You said that your father's mental health was _____. Would you say that it was always _____, or was there a time when it wasn't _____?

Was there ever a time when your father was sad or depressed?

How about anxious or tense?

Can you think of a time when your father was especially angry or irritated or in trouble with the authorities a lot?

Was there a time when your father had substance abuse problems?

****If participant answers positively to any of the above questions, proceed to the questions below. If no mental health problem is indicated, proceed to Stressful Experiences section****

How old were you when you noticed that your father was having problems with [participant's own words]? _____

Was anyone else concerned about these problems?

Do you know if your father was ever diagnosed as having a mental health problem?

How old were you when you found out about this diagnosis?

How did finding out about your father's diagnosis affect your life?

IF THEY SAY FAIR OR POOR:

Can you tell me more about that? Why would you describe your father's mental health as _____?

What did your father act like to make you think that his mental health was _____? Can you give me a specific example from your childhood or adolescence that illustrates when your father's mental health was _____?

Was there ever a time when your father was sad or depressed?

How about anxious or tense?

Can you think of a time when your father was especially angry or irritated or in trouble with the authorities a lot?

Was there a time when your father had substance abuse problems?

How old were you when you noticed that your father was having problems with [*participant's own words*]? _____

Was anyone else concerned about these problems?

Do you know if your father was ever diagnosed as having a mental health problem?

How old were you when you found out about this diagnosis?

How did finding out about your father's diagnosis affect your life?

Understanding and Coping with Mental Health Problems

INCLUDE "GOOD" GROUP ONLY IF THEY INDICATED THAT THERE WAS EVER A PROBLEM

Sometimes people have different understandings of the mental health issues we just talked about when they are young versus when they are older. When you were growing up and noticed that your father was having some problems [*use participant's own words*], what did you think was causing [*the problem- use participant's own words*]?

Now that you are an adult looking back, what do you think caused your father's problems with [*participant's own words*]?

How do you think having a father with [*participant's own words*] affected your life growing up? Can you give me a specific example?

Was there an age when your father's *[participant's own words]* were most difficult for you?

How do you think having a father with *[participant's own words]* affected the person you are today? Can you give me an example?

In your romantic relationships?

With your children?

In your work or professional life?

Did you ever talk to someone at the time about your father's *[participant's own words]*? Who did you talk to, and what was it like? (Note: If not specifically mentioned, did you talk to your parent about these issues? What was that like? Did you talk to a mental health professional? What was that like?)

How do you remember coping with having a father with *[participant's own words]*?

Stressful Experiences

INCLUDE BOTH GROUPS

OK, let's move on to the next set of questions that deal with stress in general. We know that most people have periods of time when they experiences stress or difficulty coping. I would like for you to think of a time when you were growing up when your father went through a particularly stressful period.

What was happening at the time?

What was this experience like for him?

Can you give me an example of what your father did to cope with this stress?

What was this experience like for you?

Can you give me an example of what you did to cope with this stressful time?

Bibliography

- Abrams, L. S., & Curran, L. (2009). 'And you're telling me not to stress?' A grounded theory study of postpartum depression symptoms among low-income mothers. *Psychology of Women Quarterly*, 33(3), 351.
- Abramson, L. Y., Metalsky, G. I., & Alloy, L. B. (1989). Hopelessness depression: A theory-based subtype of depression. *Psychological Review*, 96(2), 358-372.
- Adler, A. K., & Wahl, O. F. (1998). Children's beliefs about people labeled mentally ill. *American Journal of Orthopsychiatry*, 68(2), 321-326.
- Agerbo, E., Byrne, M., Eaton, W. W., & Mortensen, P. B. (2004). Marital and labor market status in the long run in schizophrenia. *Archives of General Psychiatry*, 61(1), 28-33.
- Ainsworth, M. S. (1979). Infant-mother attachment. *American Psychologist*, 34(10), 932-937.
- Alloy, L. B., Abramson, L. Y., Walshaw, P. D., & Neeren, A. M. (2006). Cognitive vulnerability to unipolar and bipolar mood disorders. *Journal of Social and Clinical Psychology*, 25(7), 726.
- Amato, P. R. (1994). Life-span adjustment of children to their parents' divorce. *The Future of Children*, 4(1), 143.
- Amato, P. R. (1996). Explaining the intergenerational transmission of divorce. *Journal of Marriage and Family*, 58(3), 628.
- Ammons, R.B. (1962). The Quick Test: Provisional Manual. *Psychological Reports*, 11(1), 111-161.
- Andrews, G. (1990). The genetics of six neurotic disorders: A twin study. *Journal of Affective Disorders*, 19(1), 23.
- Andrews, G., & Peters, L. (1998). The psychometric properties of the composite international diagnostic interview. *Social Psychiatry and Psychiatric Epidemiology*, 33(2), 80-88.
- Arbuckle, J. (2006). *Amos 7.0 user's guide*. Chicago, IL.: SPSS Inc.
- Armstrong, M. I., Evans, M. E., & Wood, V. (2000). The development of a state policy on families as allies. *Journal of Emotional and Behavioral Disorders*, 8(4), 240-248.
- Asarnow, J. R., Jaycox, L., & Tompson, M. (2001). Depression in youth: Psychosocial interventions. *Journal of Clinical Child Psychology*, 30(1), 33.
- Baldwin, M. (1992). Relational schemas and the processing of social information. *Psychological Bulletin*, 112(3), 461-484.

- Baron, R. M., & Kenny, D. A. (1986). The moderator–mediator variable distinction in social psychological research: Conceptual, strategic, and statistical considerations. *Journal of Personality and Social Psychology*, *51*(6), 1173-1182.
- Bartholomew, K., & Horowitz, L. M. (1991). Attachment styles among young adults: A test of a four-category model. *Journal of Personality and Social Psychology*, *61*(2), 226-244.
- Beardslee, W. (1988). Resilient adolescents whose parents have serious affective and other psychiatric disorders: Importance of self-understanding and relationships. *The American Journal of Psychiatry*, *145*(1), 63.
- Beardslee, W. (1993). The impact of parental affective disorder on depression in offspring: A longitudinal follow-up in a nonreferred sample. *Journal of the American Academy of Child Adolescent Psychiatry*, *32*(4), 723.
- Beardslee, W. (1997). Examination of preventive interventions for families with depression: Evidence of change. *Development and Psychopathology*, *9*(1), 109.
- Beardslee, W. (1988). Psychiatric disorder in adolescent offspring of parents with affective disorder in a non-referred sample. *Journal of Affective Disorders*, *15*(3), 313.
- Beardslee, W., Keller, M. B., Seifer, R., & Lavori, P. W. (1996). Prediction of adolescent affective disorder: Effects of prior parental affective disorders and child psychopathology. *Journal of the American Academy of Child & Adolescent Psychiatry*, *35*(3), 279-288.
- Beardslee, W., Versage, E. M., & Gladstone, T. R. G. (1998). Children of affectively ill parents: A review of the past 10 years. *Journal of the American Academy of Child & Adolescent Psychiatry*, *37*(11), 1134-1141.
- Beck, A. (1976). *Cognitive therapy and emotional disorders*. New York: International Universities Press.
- Beck, A. (1987). Cognitive models of depression. *Journal of Cognitive Psychotherapy*, *1*(1), 5.
- Beidel, D. (1997). At risk for anxiety: I. psychopathology in the offspring of anxious parents. *Journal of the American Academy of Child Adolescent Psychiatry*, *36*(7), 918.
- Benoliel, J. (1996). Grounded theory and nursing knowledge. *Qualitative Health Research*, *6*, 406-428.
- Berg-Nielsen, T. S., Vikan, A., & Dahl, A. A. (2002). Parenting related to child and parental psychopathology: A descriptive review of the literature. *Clinical Child Psychology and Psychiatry*, *7*(4), 529.
- Biederman, J. (2001). Patterns of psychopathology and dysfunction in high-risk children of parents with panic disorder and major depression. *The American Journal of Psychiatry*, *158*(1), 49.
- Bifulco, A., Moran, P. M., Ball, C., Jacobs, C., Baines, R., Bunn, A., & Cavagin, J. (2002). Childhood adversity, parental vulnerability and disorder: Examining inter-generational transmission of risk. *Journal of Child Psychology and Psychiatry and Allied Disciplines*, *43*(8), 1075.
- Billings, A. G., & Moos, R. H. (1983). Comparisons of children of depressed and nondepressed parents: A social-environmental perspective. *Journal of Abnormal Child Psychology*, *11*(4), 463.

- Bird, H. (1987). Further measures of the psychometric properties of the children's global assessment scale. *Archives of General Psychiatry*, 44(9), 821.
- Blatt, S. (1992). Parent-child interaction in the etiology of dependent and self-critical depression. *Clinical Psychology Review*, 12(1), 47.
- Bookwala, J. (2003). Being 'single and unattached': The role of adult attachment styles. *Journal of Applied Social Psychology*, 33(8), 1564-1570.
- Bowen, A. M. M., K. (1999). Measuring IQ in schizophrenia research: An update of the quick test in estimating IQ decline. *Cognitive Neuropsychiatry*, 4(2), 81.
- Bowlby, J. (1980). *Attachment and loss*. New York, NY US: Basic Books.
- Boyle, M. H., Offord, D. R., Racine, Y., & Sanford, M. (1993). Evaluation of the diagnostic interview for children and adolescents for use in general population samples. *Journal of Abnormal Child Psychology: An Official Publication of the International Society for Research in Child and Adolescent Psychopathology*, 21(6), 663-681.
- Brennan, P. A., Hammen, C., Katz, A. R., & Le Brocque, R. M. (2002). Maternal depression, paternal psychopathology, and adolescent diagnostic outcomes. *Journal of Consulting and Clinical Psychology*, 70(5), 1075-1085.
- Bretherton, , I. (1999). Internal working models in attachment relationships: A construct revisited. In (J. Cassidy & P. Shaver, (Eds.), *Handbook of Attachment: Theory, Research, and Clinical Applications*. (pp. 89-111). New York, Guilford Press.
- Brewin, C. R., Andrews, B., & Gotlib, I. H. (1993). Psychopathology and early experience: A reappraisal of retrospective reports. *Psychological Bulletin*, 113(1), 82-98.
- Bruner, J. (1987). *Making sense: The child's construction of the world*. New York: Methuen.
- Buka, S. L., Stichick, T. L., Birdthistle, I., & Earls, F. J. (2001). Youth exposure to violence: Prevalence, risks and consequences. *American Journal of Orthopsychiatry*, 71(3), 298-310.
- Burman, B., & Margolin, G. (1992). Analysis of the association between marital relationships and health problems: An interactional perspective. *Psychological Bulletin*, 112(1), 39-63.
- Campbell, S. B., Cohn, J. F., & Meyers, T. (1995). Depression in first-time mothers: Mother-infant interaction and depression chronicity. *Developmental Psychology*, 31(3), 349-357.
- Carnelley, K. B., Pietromonaco, P. R., & Jaffe, K. (1994). Depression, working models of others, and relationship functioning. *Journal of Personality and Social Psychology*, 66(1), 127-140.
- Carter, A. S., Garrity-Rokous, F. E., Chazan-Cohen, R., Little, C., & Briggs-Gowan, M. J. (2001). Maternal depression and comorbidity: Predicting early parenting, attachment security, and toddler social-emotional problems and competencies. *Journal of the American Academy of Child Adolescent Psychiatry*, 40(1), 18.
- Carver, K., Joyner, K., & Udry, J. R. (2003). National estimates of adolescent romantic relationships. In P. Florsheim, & P. Florsheim (Eds.), *Adolescent romantic relations and sexual behavior: Theory, research, and practical implications*. (pp. 23-56). Mahwah, NJ US: Lawrence Erlbaum Associates Publishers.

- Ceci, S. J. (1991). How much does schooling influence general intelligence and its cognitive components? A reassessment of the evidence. *Developmental Psychology, 27*(5), 703-722.
- Christensen, T., & Brooks, M. (2001). Adult children of divorce and intimate relationships: A review of the literature. *The Family Journal, 9*, 289-294.
- Cogan, N. (2004). Children caring for parents with mental illness: Perspectives of young carers, parents and professionals and children of disabled parents: New thinking about families affected by disability and illness. *Child and Family Social Work, 9*(3), 313-315.
- Cogan, N., Riddell, S., & Mayes, G. (2005). The understanding and experiences of children affected by parental mental health problems: A qualitative study. *Qualitative Research in Psychology, 2*(1), 47.
- Cohler, B. (1991). The life story and the study of resilience and response to adversity. *Journal of Narrative and Life History, 1*(2-3), 169.
- Cole, P. (1994). The development of emotion regulation and dysregulation: A clinical perspective. *Monographs of the Society for Research in Child Development, 59*(2-3), 73-100,250.
- Collins, W.A. (2006). *The influence of family and peer relationships in the development of competence during adolescence*. Cambridge: Cambridge University Press.
- Collins, N. L., & Read, S. J. (1990). Adult attachment, working models, and relationship quality in dating couples. *Journal of Personality and Social Psychology, 58*(4), 644-663.
- Compas, B., Connor, J., Osowiecki, D., & Welch, A. (1997). Effortful and involuntary responses to stress: Implications for coping with chronic stress. In B. Gottlieb (Ed.) *Coping with Chronic Stress* (pp. 105-130). New York: Plenum Press.
- Compas, B. E., Connor-Smith, J., Saltzman, H., Thomsen, A. H., & Wadsworth, M. E. (2001). Coping with stress during childhood and adolescence: Problems, progress, and potential in theory and research. *Psychological Bulletin, 127*(1), 87-127.
- Compas, B. E., Worsham, N. L., Epping-Jordan, J., Grant, K. E., Mireault, G., Howell, D. C., & Malcarne, V. L. (1994). When mom or dad has cancer: Markers of psychological distress in cancer patients, spouses, and children. *Health Psychology, 13*(6), 507-515.
- Conger, R. D., Cui, M., Bryant, C. M., & Elder, G. H. J. (2000). Competence in early adult romantic relationships: A developmental perspective on family influences. *Journal of Personality and Social Psychology, 79*(2), 224-237.
- Cooper, P. J., & Murray, L. (1995). Course and recurrence of postnatal depression: Evidence for the specificity of the diagnostic concept. *The British Journal of Psychiatry, 166*(2), 191.
- Corwyn, R., & Bradley, R. (2002). Stability of maternal socioemotional investment in young children. *Parenting, Science and Practice, 2*(1), 27.
- Costell, R. (1981). The family meets the hospital: Predicting the family's perception of the treatment program from its problem solving style. *Archives of General Psychiatry, 38*(5), 569.
- Cox, A. D., Puckering, C., Pound, A., & Mills, M. (1987). The impact of maternal depression in young children. *Journal of Child Psychology and Psychiatry and Allied Disciplines, 28*(6), 917.

- Creswell, C., & Brereton, J. (2000). Community mental health services and the children of service users. *Clinical Psychology Forum*, 144, 4-6.
- Crittenden, P. M., & Ainsworth, M. D. S. (1989). Child maltreatment and attachment theory. In D. Cicchetti, V. Carlson, D. Cicchetti & V. Carlson (Eds.), *Child maltreatment: Theory and research on the causes and consequences of child abuse and neglect*. (pp. 432-463). New York, NY US: Cambridge University Press.
- Cummings, E. M., & Davies, P. T. (1999). Depressed parents and family functioning: Interpersonal effects and children's functioning and development. In T. Joiner, J. C. Coyne, T. Joiner & J. C. Coyne (Eds.), *The interactional nature of depression: Advances in interpersonal approaches*. (pp. 299-327). Washington, DC US: American Psychological Association.
- Cummings, E. M., Keller, P. S., & Davies, P. T. (2005). Towards a family process model of maternal and paternal depressive symptoms: Exploring multiple relations with child and family functioning. *Journal of Child Psychology and Psychiatry*, 46(5), 479-489.
- Cummings, E. M., & Davies, P. T. (1994). Maternal depression and child development. *Journal of Child Psychology and Psychiatry and Allied Disciplines*, 35(1), 73.
- Davies, P. T., & Windle, M. (1997). Gender-specific pathways between maternal depressive symptoms, family discord, and adolescent adjustment. *Developmental Psychology*, 33(4), 657-668.
- Dhariwal, A., Connolly, J., Paciello, M., & Caprara, G. V. (2009). Adolescent peer relationships and emerging adult romantic styles: A longitudinal study of youth in an Italian community. *Journal of Adolescent Research*, 24(5), 579.
- Dickstein, S., St. Andre, M., Sameroff, A., Seifer, R., & Schiller, M. (1999). Maternal depression, family functioning, and child outcomes: A narrative assessment. In B. Fiese, & A. Sameroff (Eds.), *The stories that families tell: Narrative coherence, narrative interaction, and relationship beliefs* (pp. 84-104). Monographs of the Society for Research in Child Development.
- Dickstein, S., Seifer, R., Hayden, L. C., Schiller, M., Sameroff, A. J., Keitner, G., Miller, I., Rasmussen, S., Matzko, M., & Magee, K. D. (1998). Levels of family assessment: II. impact of maternal psychopathology on family functioning. *Journal of Family Psychology*, 12(1), 23-40.
- Dodge, K. (1986). Social competence in children. *Monographs of the Society for Research in Child Development*, 51(2), 1.
- Downey, G., & Coyne, J. C. (1990). Children of depressed parents: An integrative review. *Psychological Bulletin*, 108(1), 50-76.
- Dozier, M., Stovall, K. C., & Albus, K. E. (1999). Attachment and psychopathology in adulthood. In J. Cassidy, P. R. Shaver, J. Cassidy & P. R. Shaver (Eds.), *Handbook of attachment: Theory, research, and clinical applications*. (pp. 497-519). New York, NY US: Guilford Press.
- Duncan, S. (2000). Children's experience of major psychiatric disorder in their parent: An overview. In P. Reder, M. McClure, & A. Jolley (Eds.) *Family Matters: Interfaces between Child and Adult Mental Health* (pp. 83-95). New York, Routledge.
- Emde, R. (2003). Early narratives: A window to the child's inner world. In R. Emde, D. Wolf & D. Oppenheim (Eds.), *Revealing the inner worlds of young children* (pp. 3-26). Oxford, England: Oxford University Press.

- Enders, C., & Bandalos, D. (2001). The relative performance of full information maximum likelihood estimation for missing data in structural equation models. *Structural Equation Modeling*, 8(3), 430.
- Entwisle, D. R., Alexander, K. L., & Olson, L. S. (2005). First grade and educational attainment by age 22: A new story. *The American Journal of Sociology*, 110(5), 1458.
- Epstein, N. B., Baldwin, L. M., & Bishop, D. S. (1983). The McMaster family assessment device. *Journal of Marital and Family Therapy*, 9(2), 171.
- Essex, M. (2002). Maternal stress beginning in infancy may sensitize children to later stress exposure: Effects on cortisol and behavior. *Biological Psychiatry*, 52(8), 776.
- Feldman, S. S., Gowen, L. K., & Fisher, L. (1998). Family relationships and gender as predictors of romantic intimacy in young adults: A longitudinal study. *Journal of Research on Adolescence*, 8(2), 263-286.
- Fendrich, M., Warner, V., & Weissman, M. M. (1990). Family risk factors, parental depression, and psychopathology in offspring. *Developmental Psychology*, 26(1), 40-50. doi:10.1037/0012-1649.26.1.40
- Field, T. (1995). Infants of depressed mothers. *Infant Behavior Development*, 18(1), 1.
- Field, T. (1998). Maternal depression effects on infants and early interventions. *Preventive Medicine*, 27(2), 200.
- Fiese, B., & Marjinsky, K. (1999). Dinnertime stories: Connecting family practices with relationship beliefs and child adjustment. In B. Fiese, & A. Sameroff (Eds.), *The stories that families tell: Narrative coherence, narrative interaction, and relationship beliefs* (pp. 52-68) Monographs of the Society for Research in Child Development.
- Fiese, B. H. (1992). Dimensions of family rituals across two generations: Relation to adolescent identity. *Family Process*, 31(2), 151-162.
- Fiese, B. H., & Sameroff, A. J. (1999). The stories that families tell: Narrative coherence, narrative interaction, and relationship beliefs. *Monographs of the Society for Research in Child Development*, 64(2), 1.
- Fiese, B. H., & Spagnola, M. (2005). Narratives in and about families: An examination of coding schemes and a guide for family researchers. *Journal of Family Psychology*, 19(1), 51-61.
- Fivush, R. (2004). *Children's memories of emotional events*. New York: Oxford University Press, USA.
- Folkman, S., & Lazarus, R. S. (1988). Coping as a mediator of emotion. *Journal of Personality and Social Psychology*, 54(3), 466-475.
- Forthofer, M. S., Kessler, R. C., Story, A. L., & Gotlib, I. H. (1996). The effects of psychiatric disorders on the probability and timing of first marriage. *Journal of Health and Social Behavior*, 37(2), 121-132.
- Fraley, R. C. (2002). Attachment stability from infancy to adulthood: Meta-analysis and dynamic modeling of developmental mechanisms. *Personality and Social Psychology Review*, 6(2), 123-151.

- Fraley, R. C., Waller, N. G., & Brennan, K. A. (2000). An item response theory analysis of self-report measures of adult attachment. *Journal of Personality and Social Psychology*, 78(2), 350-365.
- Frankel, K. (1996). Depressed mothers: They don't always look as bad as they feel. *Journal of the American Academy of Child Adolescent Psychiatry*, 35(3), 289.
- Franklin, K. M., Janoff-Bulman, R., & Roberts, J. E. (1990). Long-term impact of parental divorce on optimism and trust: Changes in general assumptions or narrow beliefs? *Journal of Personality and Social Psychology*, 59(4), 743-755.
- Franz, L., Carter, T., Leiner, A. S., Bergner, E., Thompson, N. J., & Compton, M. T. (2010). Stigma and treatment delay in first-episode psychosis: A grounded theory study. *Early Intervention in Psychiatry*, 4(1), 47.
- Fravel, D. (1992). An in-depth interview with the parents of missing children. In J. Gilgun, K. Daly, & G. Handel (Eds.) *Qualitative Methods in Family Research* (pp. 126-145). Thousand Oaks, CA: Sage Publications, Inc.
- Furman, W., & Buhrmester, D. (1992). Age and sex differences in perceptions of networks of personal relationships. *Child Development*, 63(1), 103.
- Garber, J. (2002). Negative cognitions in offspring of depressed parents: Mechanisms of risk. In S. Goodman & I. Gotlib (Eds.) *Children of Depressed Parents: Mechanisms of Risk and Implications for Treatment* (pp. 121-153). Washington, DC: American Psychological Association.
- Garley, D., Gallop, R., Johnston, N., & Pipitone, J. (1997). Children of the mentally ill: A qualitative focus group approach. *Journal of Pediatric and Mental Health Nursing*, 4(2), 97-103.
- Garmezy, N. (1983). Stressors of childhood. In N. Garmezy & M. Rutter (Eds.) *Stress, Coping, and Development in Children* (pp. 43-84). Baltimore, MD: Johns Hopkins University Press.
- Gatz, M., Pederson, N. L., Plomin, R., & Nesselroade, J. R. (1992). Importance of shared genes and shared environments for symptoms of depression in older adults. *Journal of Abnormal Psychology*, 101(4), 701-708.
- Gavois, H., Paulsson, G., & Fridlund, B. (2006). Mental health professional support in families with a member suffering from severe mental illness: A grounded theory model. *Scandinavian Journal of Caring Sciences*, 20(1), 102.
- Glaser, B., & Strauss, A. (1967). *Discovery of grounded theory: Strategies for qualitative research*. New York: Sociology Press.
- Glenn, N. D., & Kramer, K. B. (1987). The marriages and divorces of the children of divorce. *Journal of Marriage & the Family*, 49(4), 811-825.
- Glover, , Vivette. (2004). The biology and pathophysiology of peripartum psychiatric disorders. *Primary Psychiatry*, 11(3), 37.
- Goodman, S. (1994). Mothers' expressed attitudes: Associations with maternal depression and children's self-esteem and psychopathology. *Journal of the American Academy of Child Adolescent Psychiatry*, 33(9), 1265.
- Goodman, S. H. (2007). Depression in mothers. *Annual Review of Clinical Psychology*, 3, 107.

- Goodman, S. H., & Gotlib, I. H. (1999). Risk for psychopathology in the children of depressed mothers: A developmental model for understanding mechanisms of transmission. *Psychological Review*, *106*(3), 458-490.
- Gordon, D. (1989). Observations of interactions of depressed women with their children. *The American Journal of Psychiatry*, *146*(1), 50.
- Gotlib, I. H., & Whiffen, V. E. (1989). Depression and marital functioning: An examination of specificity and gender differences. *Journal of Abnormal Psychology*, *98*(1), 23-30.
- Gottfredson, L. (2003). Dissecting practical intelligence theory: Its claims and evidence. *Intelligence*, *31*(4), 343.
- Greenberg, E. F., & Nay, W. R. (1982). The intergenerational transmission of marital instability reconsidered. *Journal of Marriage & the Family*, *44*(2), 335-347.
- Grigoriu-Serbănescu, M., Christodorescu, D., Măgureanu, S., & Jipescu, I. (1991). Adolescent offspring of endogenous unipolar depressive parents and of normal parents. *Journal of Affective Disorders*, *21*(3), 185-198.
- Gross, D., Conrad, B., Fogg, L., & Willis, L. (1995). A longitudinal study of maternal depression and preschool children's mental health. *Nursing Research*, *44*(2), 96-101.
- Grotevant, H. (1993). The integrative nature of identity: Bringing the soloists to sing in the choir. In J. Kroger (Ed.) *Discussions on Ego Identity* (pp. 121-146). Hillsdale, NJ: Lawrence Erlbaum Associates.
- Grych, J. H., & Fincham, F. D. (1993). Children's appraisals of marital conflict: Initial investigations of the cognitive-contextual framework. *Child Development*, *64*(1), 215.
- Grych, J. H., Wachsmuth-Schlaefler, T., & Klockow, L. L. (2002). Interparental aggression and young children's representations of family relationships. *Journal of Family Psychology*, *16*(3), 259-272.
- Gutman, L. M., Sameroff, A. J., & Cole, R. (2003). Academic growth curve trajectories from 1st grade to 12th grade: Effects of multiple social risk factors and preschool child factors. *Developmental Psychology*, *39*(4), 777-790.
- Haines, B., Metalsky, G., Cardamone, A. & Joiner, T. (1999). Interpersonal and cognitive pathways into the origins of attributional style: A developmental perspective. In T. Joiner & J. Coyne (Eds.) *The Interactional Nature of Depression: Advances in Interpersonal Approaches* (pp. 65-92). Washington, DC: American Psychological Association.
- Halliday, M. A. K. (1973). *Explorations in the function of language*. London: Edward Arnold.
- Halligan, S. (2004). Exposure to postnatal depression predicts elevated cortisol in adolescent offspring. *Biological Psychiatry*, *55*(4), 376.
- Halligan, S., Murray, L., Martins, C., & Cooper, P. (2007). Maternal depression and psychiatric outcomes in adolescent offspring: A 13-year longitudinal study. *Journal of Affective Disorders*, *97*(1-3), 145.
- Hammen, C. (1990). Longitudinal study of diagnoses in children of women with unipolar and bipolar affective disorder. *Archives of General Psychiatry*, *47*(12), 1112.

- Hammen, C. (1991). Generation of stress in the course of unipolar depression. *Journal of Abnormal Psychology, 100*(4), 555-561.
- Hammen, C., Brennan, P. A., & Shih, J. H. (2004). Family discord and stress predictors of depression and other disorders in adolescent children of depressed and nondepressed women. *Journal of the American Academy of Child Adolescent Psychiatry, 43*(8), 994.
- Hanson, D. R., Gottesman, I. I., & Meehl, P. E. (1977). Genetic theories and the validation of psychiatric diagnoses: Implications for the study of children of schizophrenics. *Journal of Abnormal Psychology, 86*(6), 575-588.
- Harrison, C., & Sofronoff, K. (2002). ADHD and parental psychological distress: Role of demographics, child behavioral characteristics, and parental cognitions. *Journal of the American Academy of Child Adolescent Psychiatry, 41*(6), 703.
- Harter, S. (1988). Developmental and dynamic changes in the nature of the self-concept: Implications for child psychotherapy. In S. Shirk (Ed.) *Cognitive Development and Child Psychotherapy* (pp. 119-160). New York: Plenum Press.
- Hay, D., McStephen, M. & Levy, F. (2001). The developmental genetics of ADHD. In F. Levy & D. Hay (Eds.) *Attention, Genes, and ADHD* (pp. 58-79). New York: Brunner-Routledge.
- Hay, P. (2003). A two-year follow-up study and prospective evaluation of the DSM-IV axis V. *Psychiatric Services, 54*(7), 1028.
- Hazan, C., & Shaver, P. (1987). Romantic love conceptualized as an attachment process. *Journal of Personality and Social Psychology, 52*(3), 511-524.
- Herjanic, B., & Reich, W. (1982). Development of a structured psychiatric interview for children: Agreement between child and parent on individual symptoms. *Journal of Abnormal Child Psychology, 10*, 307-324.
- Hesse, E. (1996). Discourse, memory, and the adult attachment interview: A note with emphasis on the emerging cannot classify category. *Infant Mental Health Journal, 17*(1), 4.
- Hoyle, R. (1995). *Structural equation modeling: Concepts, issues, and applications*. Thousand Oaks, CA: Sage Publications.
- Hu, L., & Bentler, P. (1999). Cutoff criteria for fit indexes in covariance structure analysis: Conventional criteria versus new alternatives. *Structural Equation Modeling, 6*(1), 1-55.
- Ikle, D., Lipp, E., Butters, J., & Ciarlo, J. (1983). *Development and validation of the adolescent community mental health interview*. Denver, CO: Mental Systems Evaluation.
- Inderbitzen, H. M., Walters, K. S., & Bukowski, A. L. (1997). The role of social anxiety in adolescent peer relations: Differences among sociometric status groups and rejected subgroups. *Journal of Clinical Child Psychology, 26*(4), 338-348.
- Ingram, R., Miranda, J., & Segal, Z. (1998). *Cognitive vulnerability to depression*. New York: Guilford Press.
- Jastak, J., & Jastak, S. (1978). *Wide range achievement test*. Wilmington, DE: Jastak Associates.

- Jencks, C. (1972). *Inequality: A reassessment of the effect of family and schooling in America*. New York: Basic Books
- Jenkins, J. M., Smith, M. A., & Graham, P. J. (1989). Coping with parental quarrels. *Journal of the American Academy of Child Adolescent Psychiatry*, 28(2), 182.
- Johnson, J. G., Cohen, P., Dohrenwend, B. P., Link, B. G., & Brook, J. S. (1999). A longitudinal investigation of social causation and social selection processes involved in the association between socioeconomic status and psychiatric disorders. *Journal of Abnormal Psychology*, 108(3), 490-499. d
- Johnston, S., & Thomas, A. (1996). Divorce versus intact parental marriage and perceived risk and dyadic trust in present heterosexual relationships. *Psychological Reports*, 78, 387-390.
- Jones, S. H., Thornicroft, G., Coffey, M., & Dunn, G. (1995). A brief mental health outcome scale: Reliability and validity of the global assessment of functioning (GAF). *The British Journal of Psychiatry*, 166(5), 654.
- Kabacoff, R. I., Miller, I. W., Bishop, D. S., Epstein, N. B., & Keitner, G. I. (1990). A psychometric study of the McMaster family assessment device in psychiatric, medical, and nonclinical samples. *Journal of Family Psychology*, 3(4), 431-439.
- Keitner, G. (1990). Family functioning and major depression: An overview. *The American Journal of Psychiatry*, 147(9), 1128.
- Kelley, M. L., Nair, V., Rawlings, T., Cash, T. F., Steer, K., & Fals-Stewart, W. (2005). Retrospective reports of parenting received in their families of origin: Relationships to adult attachment in adult children of alcoholics. *Addictive Behaviors*, 30(8), 1479-1495.
- Kendler, K. (1993). Twin studies of psychiatric illness: Current status and future directions. *Archives of General Psychiatry*, 50(11), 905.
- Kendler, K. S., & Diehl, S. R. (1993). The genetics of schizophrenia: A current, genetic-epidemiologic perspective. *Schizophrenia Bulletin*, 19(2), 261-285.
- Kendler, K.S., & Gardner, C.O. (1997). The risk for psychiatric disorder in relatives of schizophrenic and control probands: A comparison of three independent studies. *Psychological Medicine*, 27(2), 411.
- Kennedy, T., & Lingard, L. (2006). Making sense of grounded theory in medical education. *Medical Education*, 40(2), 101-108.
- Kessler, R. C., Berglund, P., Demler, O., Jin, R., Merikangas, K. R., & Walters, E. E. (2005). Lifetime prevalence and age-of-onset distributions of DSM-IV disorders in the national comorbidity survey replication. *Archives of General Psychiatry*, 62(6), 593-602.
- Kim, H. (2003). Depressive symptoms across adolescence and young adulthood in men: Predictions from parental and contextual risk factors. *Development and Psychopathology*, 15(2), 469.
- Kim, I. J., Ge, X., Brody, G. H., Conger, R. D., Gibbons, F. X., & Simons, R. L. (2003). Parenting behaviors and the occurrence and co-occurrence of depressive symptoms and conduct problems among African American children. *Journal of Family Psychology*, 17(4), 571-583.
- Kinsella, K. (1996). Coping skills, strengths, and needs as perceived by adult offspring and siblings of people with mental illness: A retrospective study. *Psychiatric Rehabilitation Journal*, 20(2), 24.

- Kirkpatrick, L. A., & Hazan, C. (1994). Attachment styles and close relationships: A four-year prospective study. *Personal Relationships, 1*(2), 123-142.
- La Greca, A., & Harrison, H. M. (2005). Adolescent peer relations, friendships, and romantic relationships: Do they predict social anxiety and depression? *Journal of Clinical Child and Adolescent Psychology, 34*(1), 49.
- La Greca, A. (1999). Peer group. In W. Silverman & T. Ollendick (Eds.) *Developmental Issues in the Clinical Treatment of Children* (pp. 171-198). Needham Heights, MA: Allyn & Bacon.
- Lamb, K. A., Lee, G. R., & DeMaris, A. (2003). Union formation and depression: Selection and relationship effects. *Journal of Marriage and Family, 65*(4), 953-962.
- Langrock, A. (2002). Coping with the stress of parental depression: Parents' reports of children's coping, emotional, and behavioral problems. *Journal of Clinical Child and Adolescent Psychology, 31*(3), 312.
- Laraia, M. (1994). Childhood environment of women having panic disorder with agoraphobia. *Journal of Anxiety Disorders, 8*(1), 1.
- Larson, J. H., & Holman, T. B. (1994). Premarital predictors of marital quality and stability. *Family Relations, 43*(2), 228-237.
- Lazarus, R. S., & Folkman, S. (1991). The concept of coping. In R. S. Lazarus (Ed.), *Stress and coping: An anthology (3rd ed.)*. (pp. 189-206). New York, NY US: Columbia University Press.
- Leff, J., & Vaughn, C. (1985). *Expressed emotion in families: Its significance for mental illness*. New York: Guilford Press.
- Leinonen, J. A., Solantaus, T. S., & Punamäki, R. (2003). Parental mental health and children's adjustment: The quality of marital interaction and parenting as mediating factors. *Journal of Child Psychology and Psychiatry, 44*(2), 227-241.
- Lieb, R. (2000). Parental psychopathology, parenting styles, and the risk of social phobia in offspring: A prospective-longitudinal community study. *Archives of General Psychiatry, 57*(9), 859.
- Lovejoy, M. C., Graczyk, P. A., O'Hare, E., & Neuman, G. (2000). Maternal depression and parenting behavior: A meta-analytic review. *Clinical Psychology Review, 20*(5), 561-592.
- Lovejoy, M. C. (1991). Maternal depression: Effects on social cognition and behavior in parent-child interactions. *Journal of Abnormal Child Psychology, 19*(6), 693.
- Lussier, Y., Sabourin, S., & Turgeon, C. (1997). Coping strategies as moderators of the relationship between attachment and marital adjustment. *Journal of Social and Personal Relationships, 14*(6), 777-791.
- Main, M., & Goldwyn, R. (1998). *Adult attachment scoring and classification system*. Unpublished manuscript.
- Main, M. (2000). Attachment theory. In A. Kazdin (Ed.) *Encyclopedia of Psychology, Vol. 1*. (pp. 289-293). Washington, DC: American Psychological Association.

- Main, M., Kaplan, N., & Cassidy, J. (1985). Security in infancy, childhood, and adulthood: A move to the level of representation. *Monographs of the Society for Research in Child Development*, 50(1-2), 66.
- Mason, D. A., & Frick, P. J. (1994). The heritability of antisocial behavior: A meta-analysis of twin and adoption studies. *Journal of Psychopathology and Behavioral Assessment*, 16(4), 301.
- Maybery, D. (2005). Children of a parent with a mental illness: Perspectives on need. *Australian e-Journal for the Advancement of Mental Health*, 4(2).
- McAdams, D. P. (1989). The many-splendored self. *PsycCritiques*, 34(7), 676-677.
- McCabe, A., & Peterson, C. (1991). *Developing narrative structure*. Hillsdale, NJ: Lawrence Erlbaum Associates.
- McGuffin, P. (1989). The genetics of depression and manic-depressive disorder. *The British Journal of Psychiatry*, 155, 294.
- Merikangas, K. (1988). Assortative mating and affective disorders: Psychopathology in offspring. *Psychiatry*, 51(1), 48.
- Merikangas, K. R., Prusoff, B. A., Kupfer, D. J., & Frank, E. (1985). Marital adjustment in major depression. *Journal of Affective Disorders*, 9(1), 5-11.
- Mitchell, R. (1993). Path analysis: Pollination. In S. Schneider, & J. Gurevitch (Eds.) *Design and analysis of ecological experiments* (pp. 211-232). New York: Chapman and Hall.
- Murray, L. (2003). Controlled trial of the short- and long-term effect of psychological treatment of postpartum depression: Impact on the mother-child relationship and child outcomes. *The British Journal of Psychiatry*, 182(5), 420.
- Murray, L., Cooper, P., & Hipwell, A. (2003). Mental health of parents caring for infants. *Archives of Women's Mental Health*, 6(2), 71.
- Murray, L. (1992). The impact of postnatal depression on infant development. *Journal of Child Psychology and Psychiatry and Allied Disciplines*, 33(3), 543.
- Murray, L., Fiori-Cowley, A., Hooper, R., & Cooper, P. (1996). The impact of postnatal depression and associated adversity on early mother-infant interactions and later infant outcomes. *Child Development*, 67(5), 2512.
- Murray, L., Kempton, C., Woolgar, M., & Hooper, R. (1993). Depressed mothers' speech to their infants and its relation to infant gender and cognitive development. *Journal of Child Psychology and Psychiatry and Allied Disciplines*, 34(7), 1083.
- Musick, J. et al. (1987). Maternal factors related to vulnerability and resiliency in young children at risk. In A. James (Ed.) *The Invulnerable Child* (pp. 229-252). New York: Guilford Press.
- Neisser, U., Boodoo, G., Bouchard, T. J., Jr., Boykin, A. W., Brody, N., Ceci, S. J., Halpern, D. F., Loehlin, J. C., Perloff, R., Sternberg, R. J., & Urbina, S. (1996). Intelligence: Knowns and unknowns. *American Psychologist*, 51(2), 77-101.

- O'Connor, T., Benschlomo, Y., Heron, J., Golding, J., Adams, D., & Glover, V. (2005). Prenatal anxiety predicts individual differences in cortisol in pre-adolescent children. *Biological Psychiatry*, *58*(3), 211.
- Oppenheim, D. (2006). Child, parent, and parent-child emotion narratives: Implications for developmental psychopathology. *Development and Psychopathology*, *18*(3), 771.
- Oyserman, D., Mowbray, C. T., Meares, P. A., & Firinginger, K. B. (2000). Parenting among mothers with a serious mental illness. *American Journal of Orthopsychiatry*, *70*(3), 296-315.
- Page, T. (2001). Mother- and father-child attachment themes in the story completions of pre-schoolers from post-divorce families: Do they predict relationships with peers and teachers? *Attachment Human Development*, *3*(1), 1.
- Patterson, J. & Garwick, A. (1994). Levels of meaning in family stress theory. *Family Process*, *33*(3), 287.
- Peterson, C., Maier, S., & Seligman, M. (1995). *Learned helplessness: A theory for the age of personal control*. New York: Oxford University Press.
- Polkinghorne, D. (1991). Narrative and self-concept. *Journal of Narrative and Life History*, *1*(2-3), 135.
- Pölkki, P. (2004). Coping and resilience of children of a mentally ill parent. *Social Work in Health Care*, *39*(1-2), 151.
- Radke-Yarrow, M. (1990). Hard growing: Children who survive. In J. Rolf, A. Masten, D. Cicchetti, K. Nuechterlein, & S. Weintraub (Eds.) *Risk and Protective Factors in the Development of Psychopathology*. (pp. 97-119). New York: Cambridge University Press.
- Radke-Yarrow, M. & Klimes-Dougan, B. (2002). Parental depression and offspring disorders: A developmental perspective. In S. Goodman & I. Gotlib (Eds.) *Children of Depressed Parents: Mechanisms of Risk and Implications for Treatment* (pp. 155-173). Washington, DC: American Psychological Press.
- Radke-Yarrow, M., McCann, K., DeMulder, E., Belmont, B., Martinez, P., & Richardson, D. T. (1995). Attachment in the context of high-risk conditions. *Development and Psychopathology*, *7*(2), 247.
- Rapee, R., & Melville, L. (1997). Recall of family factors in social phobia and panic disorder: Comparison of mother and offspring reports. *Depression and Anxiety*, *5*, 7-11.
- Raykov, T. (2005). Analysis of longitudinal studies with missing data using covariance structure modeling with full-information maximum likelihood. *Structural Equation Modeling*, *12*(3), 493.
- Reiss, D. (1981). *The family's construction of reality*. Cambridge, MA: Harvard University Press.
- Rose, L. (2002). A grounded theory of families responding to mental illness. *Western Journal of Nursing Research*, *24*(5), 516.
- Rothbaum, F., Weisz, J. R., & Snyder, S. S. (1982). Changing the world and changing the self: A two-process model of perceived control. *Journal of Personality and Social Psychology*, *42*(1), 5-37.

- Rudolph, K. D., & Clark, A. G. (2001). Conceptions of relationships in children with depressive and aggressive symptoms: Social-cognitive distortion or reality? *Journal of Abnormal Child Psychology*, 29(1), 41.
- Rushing, W. (1979). Marital status and mental disorder: Evidence in favor of a behavioral model. *Social Forces*, 58, 540-556.
- Rushing, W. A., & Ortega, S. T. (1979). Socioeconomic status and mental disorder: New evidence and a sociomedical formulation. *The American Journal of Sociology*, 84(5), 1175.
- Russell, R. J. H., & Wells, P. A. (1994). Predictors of happiness in married couples. *Personality and Individual Differences*, 17(3), 313-321.
- Rutter, M. (1990). Psychosocial resilience and protective mechanisms. In J. Rolf, A. Masten, D. Cicchetti, K. Nuechterlein, & S. Weintraub (Eds.) *Risk and Protective Factors in the Development of Psychopathology*. (pp. 181-214). New York: Cambridge University Press.
- Sameroff, A.J. (2003). Research strategies for capturing transactional models of development: The limits of the possible. *Development and Psychopathology*, 15(3), 613.
- Sameroff, A. J., & MacKenzie, M. J. (2003). Research strategies for capturing transactional models of development: The limits of the possible. *Development and Psychopathology*, 15(3), 613-640.
- Sameroff, A. J., & Seifer, R. (1983). Familial risk and child competence. *Child Development*, 54(5), 1254.
- Sameroff, A. J., Seifer, R., & Zax, M. (1982). Early development of children at risk for emotional disorder. *Monographs of the Society for Research in Child Development*, 47(7), 82-82.
- Sanders, M. R., Halford, W. K., & Behrens, B. C. (1999). Parental divorce and premarital couple communication. *Journal of Family Psychology*, 13(1), 60-74.
- Sandler, I. N., Tein, J., & West, S. G. (1994). Coping, stress, and the psychological symptoms of children of divorce: A cross-sectional and longitudinal study. *Child Development*, 65(6), 1744.
- Scherer, D., Melloh, T., Buyck, D., Anderson, C., & Foster, A. (1996). Relation between children's perceptions of maternal mental illness and children's psychological adjustment. *Journal of Clinical Child Psychology*, 25(2), 156.
- Schmidt, F. L., & Hunter, J. (2004). General mental ability in the world of work: Occupational attainment and job performance. *Journal of Personality and Social Psychology*, 86(1), 162-173.
- Schulenberg, J. E., & Zarrett, N. R. (2006). Mental health during emerging adulthood: Continuity and discontinuity in courses, causes, and functions. In J. J. Arnett, J. L. Tanner, J. J. Arnett & J. L. Tanner (Eds.), *Emerging adults in america: Coming of age in the 21st century*. (pp. 135-172). Washington, DC US: American Psychological Association.
- Segal, Z. V. (1988). Appraisal of the self-schema construct in cognitive models of depression. *Psychological Bulletin*, 103(2), 147-162.
- Seifer, R., Sameroff, A. J., Baldwin, C. P., & Baldwin, A. L. (1992). Child and family factors that ameliorate risk between 4 and 13 years of age. *Journal of the American Academy of Child & Adolescent Psychiatry*, 31(5), 893-903.

- Shaffer, D., & Gould, M., Brasic, J., Ambrosini, P., Fisher, P., Bird, H., Aluwahlia, S. (1983). A children's global assessment scale (CGAS). *Arch.Gen.Psychiatry*, 40(11), 1228-1231.
- Silverman, M. (1989). Children of psychiatrically ill parents: A prevention perspective. *Hospital Community Psychiatry*, 40(12), 1257.
- Simon, R. W. (2002). Revisiting the relationships among gender, marital status, and mental health. *American Journal of Sociology*, 107(4), 1065-1096.
- Spence, S. (2003). Psychometric properties of the spence children's anxiety scale with young adolescents. *Journal of Anxiety Disorders*, 17(6), 605.
- Spitzer, R., & Endicott, J. (1972). Current and past psychopathology scales (CAPPS). *Archives of General Psychiatry*, 27, 678-680.
- Spitzer, A., & Cameron, C. (1995). School-age children's perceptions of mental illness. *Western Journal of Nursing Research*, 17(4), 398.
- Stein, A., Gath, D. H., Bucher, J., Bond, A., Day, A., & Cooper, P. J. (1991). The relationship between post-natal depression and mother-child interaction. *The British Journal of Psychiatry*, 158, 46.
- Stevens, J. (1996). Applied multivariate statistics for the social sciences. In L. Grimm, & P. Yarnell (Eds.), *Reading and understanding more multivariate statistics* (pp. 261-284). Washington, D.C.: American Psychological Association.
- Strauss, A. & Corbin, J. (1998). *Basics of qualitative research: Techniques and procedures for developing grounded theory* (2nd ed.). Sage Publications.
- Strenze, T. (2007). Intelligence and socioeconomic success: A meta-analytic review of longitudinal research. *Intelligence*, 35(5), 401.
- Sullivan, P. F. (2000). Genetic epidemiology of major depression: Review and meta-analysis. *The American Journal of Psychiatry*, 157(10), 1552.
- Tarullo, L. B., DeMulder, E. K., Martinez, P. E., & Radke-Yarrow, M. (1994). Dialogues with preadolescents and adolescents: Mother-child interaction patterns in affectively ill and well dyads. *Journal of Abnormal Child Psychology*, 22(1), 33.
- Teti, D. M., Gelfand, D. M., Messinger, D. S., & Isabella, R. (1995). Maternal depression and the quality of early attachment: An examination of infants, preschoolers, and their mothers. *Developmental Psychology*, 31(3), 364-376.
- Tsuang, M. & Faraone, S. (1990). *The genetics of mood disorders*. Baltimore: Johns Hopkins University Press.
- van IJzendoorn, M. H., & Bakermans-Kranenburg, M. (1996). Attachment representations in mothers, fathers, adolescents, and clinical groups: A meta-analytic search for normative data. *Journal of Consulting and Clinical Psychology*, 64(1), 8-21.
- Vandenberg, R. J. (2002). Toward a further understanding of an improvement in measurement invariance methods and procedures. *Organizational Research Methods*, 5(2), 139-158.

- Volling, B. L., Notaro, P. C., & Larsen, J. J. (1998). Adult attachment styles: Relations with emotional well-being, marriage, and parenting. *Family Relations, 47*(4), 355-367.
- Wallerstein, J., & Blakeslee, S. (1989). *Second chances: Men, women, and children a decade after divorce*. New York: Ticknor & Fields.
- Wamboldt, F. (1999). Co-constructing a marriage: Analyses of young couples' relationship narratives. In B. Fiese, & A. Sameroff (Eds.), *The stories that families tell: Narrative coherence, narrative interaction, and relationship beliefs* (pp. 37-51) Monographs of the Society for Research in Child Development.
- Wamboldt, F. S., & Reiss, D. (1989). Defining a family heritage and a new relationship identity: Two central tasks in the making of a marriage. *Family Process, 28*(3), 317.
- Warner, V. (1995). Offspring at high and low risk for depression and anxiety: Mechanisms of psychiatric disorder. *Journal of the American Academy of Child Adolescent Psychiatry, 34*(6), 786.
- Warren, S. L., Emde, R. N., & Sroufe, L. A. (2000). Internal representations: Predicting anxiety from children's play narratives. *Journal of the American Academy of Child Adolescent Psychiatry, 39*(1), 100.
- Weaver, I. C. G., Cervoni, N., Champagne, F. A., D'Alessio, A. C., Sharma, S., Seckl, J. R., Dymov, S., Szyf, M., & Meaney, M. J. (2004). Epigenetic programming by maternal behavior. *Nature Neuroscience, 7*(8), 847.
- Weissman, Myrna M. (1997). Offspring of depressed parents: 10 years later. *Archives of General Psychiatry, 54*(10), 932.
- Wendel, P. (1997). Counseling children of divorce. *Counseling Today, 40*(30), 35-56.
- Westervelt, K., & Vandenberg, B. (1997). Parental divorce and intimate relationships of young adults. *Psychological Reports, 80*(31), 923-926.
- Wolin, S., Bennett, L., Noonan, D., & Teitlebaum, M. (1980). Disrupted family rituals: A factor in the intergenerational transmission of alcoholism. *Journal of Studies on Alcohol, 41*.
- World Health Organization. (2004). *Changing history, annex table 3: Burden of disease in DALYs by cause, sex, and mortality stratum in WHO regions*. Geneva: WHO.
- Zeanah, C. H., & Barton, M. L. (1989). Introduction: Internal representations and parent-infant relationships. *Infant Mental Health Journal, 10*(3), 135.
- Zimmermann, P. (2004). Attachment representations and characteristics of friendship relations during adolescence. *Journal of Experimental Child Psychology, 88*(1), 83.