

Parametric Design within an Atomic Design Process (ADP) applied to Spacecraft Design

by

Rafael Ramos Alarcon

A dissertation submitted in partial fulfillment
of the requirements for the degree of
Doctor of Philosophy
(Design Science)
in The University of Michigan
2011

Doctoral Committee:

Professor Brian E. Gilchrist, Co-Chair
Professor Colleen M. Seifert, Co-Chair
Professor Richard D. Gonzalez
Associate Professor Peter D. Washabaugh

© Rafael Ramos Alarcon

2011

A mi mamá y mi papá, con cariño.

Acknowledgements

I have been very fortunate to have numerous individuals that have helped me throughout the research presented here. No endeavor this large can be accomplished without the involvement and support from many people.

I would like to express my profound gratitude to my advisor and co-chair, Dr. Brian Gilchrist. Your guidance and support were invaluable throughout this journey, and I feel privileged to have worked with you during this time. I look forward to future collaborations. I also thank Dr. Colleen Seifert, my other co-chair, for your feedback, encouragement and helpful advice. Thank you Dr. Peter Washabaugh, I am grateful for you giving me the opportunity to be part of your teaching world. The inspirational experiences I shared with you fueled my passion for engineering. Thank you Dr. Ixchel Faniel and Dr. Richard Gonzalez, for your assistance in the completion of this thesis.

Many members of the Space Electrodynamics and Tether Systems (SETS) group over the years have set very high working standards. You have not only provided support and companionship, but also friendship. Thank you Dave Morris, Keith Fuhrhop, Chris Deline, Louis Musinski, Iverson Bell and David Liaw.

The Student Space Systems Fabrication Laboratory (S3FL) has been my research home for many years. Being part of the laboratory's expansion and embracing new

challenges has been a privilege and source of personal joy. Hannah Goldberg, Tom Liu, Julie Bellerose, Steven Sandoval, Yang Li, Kiko Dontchev, Michael Heywood, Vikram Ivatury and everyone else, thank you for being there and your friendship. I learned a great deal from all of you.

The success of this effort was possible thanks to the funding provided by Consejo Nacional de Ciencia y Tecnología de México (CONACYT), NASA Jet Propulsion Laboratory's Strategic University Research Partnership program and the College of Engineering Multidisciplinary Program at the University of Michigan.

My gratitude also goes to all of the EMTs, police officers and firefighters that I have worked with over the years. Working with you as a paramedic has been an honor. It has brought balance to my life and constantly renews my appreciation for it.

On a personal note, I would like to thank my family. Thank you for your faith, patience and care.

Rafael Ramos Alarcon

April 10, 2011

Table of Contents

Dedication	ii
Acknowledgements.....	iii
List of Figures.....	vii
List of Tables	xiii
List of Appendices.....	xvii
Abstract.....	xviii
Chapter 1 Motivation and Introduction	1
1.1 Motivation.....	1
1.2 Introduction	8
1.3 Summary of Research Contributions	9
1.4 Dissertation Overview	11
Chapter 2 Some Existing Design Models	13
2.1 Introduction	13
2.2 Design Concepts	14
2.3 Design Models.....	16
2.3.1 The Space Mission Analysis and Design model.....	16
2.3.2 Pugh's Total Design Model (Pugh, 1991)	22
2.3.3 Hammond's Multidisciplinary Design Model (Hammond W.E., 1999)..	25
2.3.4 Hammond's Conceptual Design Wheel and Design Process (Hammond, W. E., 2001).....	29
2.4 Criteria for Good Design.....	34
2.4.1 Common design elements	35
2.4.2 Design elements that enable good design.....	43
Chapter 3 Relevant Disciplines and a Design Model.....	49
3.1 Introduction	49
3.2 Space Systems Engineering.....	50
3.2.1 The Space Systems environment	50
3.2.2 Current Space Systems design paradigm	54
3.2.3 Risk inherent to Space Systems	56
3.3 Information Science.....	56
3.3.1 User centered approach.....	58
3.4 A Design Model	60
3.4.1 An Atomic Design Process.....	60
3.4.2 Update to an atomic Design Process.....	64
3.5 Comparison between ADP and other Models.....	67

3.5.1	ADP and the Space Mission Analysis and Design (SMAD) process (Section 2.3.1)	67
3.5.2	ADP and Pugh's design model (Section 2.3.2).....	68
3.5.3	ADP and Hammond's Multidisciplinary Design Model (Section 2.3.3) .	70
3.5.4	ADP and Hammond's Conceptual Design Process (Section 2.3.4).....	71
3.6	Systems Engineering Concepts	72
3.6.1	Requirements	73
3.6.2	System budgets.....	73
Chapter 4	Implementation of the Design Model	80
4.1	Introduction	80
4.2	The Student Space Systems Fabrication Laboratory	81
4.3	Supporting Information Technology for the ADP.....	85
4.3.1	S3FL Information Management System (SIMS).....	85
4.3.2	Other information processing tools.....	97
4.4	Human Factors	101
4.4.1	Culture of learning.....	101
4.4.2	Culture of leading.....	105
Chapter 5	Applying the Design Model in a Design Task	109
5.1	Method	109
5.1.1	Participants	111
5.1.2	The design task: Cansat.....	111
5.1.3	Procedure.....	117
5.2	Results.....	120
5.2.1	Team 1 design process	122
5.2.2	Team 2 design process	143
5.2.3	Design questionnaire analyses.....	161
5.3	Discussion	200
Chapter 6	Long Term Case Study: Primary Payload for Imaging Spacecraft.....	205
6.1	Introduction	205
6.2	ADP Experiment Design	206
6.2.1	The CubeSat standard.....	210
6.2.2	M-Cubed mission.....	212
6.3	ADP Study Results	217
6.3.1	M-Cubed primary payload design	218
6.4	Discussion	241
6.4.1	M-Cubed spacecraft	245
6.4.2	Engineering design unit.....	284
Chapter 7	Conclusions.....	288
7.1	Summary of Findings.....	289
7.2	Recommendations for Future Work	291
Appendices.....		294
Bibliography.....		376

List of Figures

Figure 1.1 The University of Michigan's first student-built satellite, Icarus, was fully qualified for NASA's ProSEDS space tether mission (Goldberg & Fuhrhop, 2004).	4
Figure 1.2 The Field Emission Get-Away-Special Investigation (FEGI) project CAD model of the faceplate (top view) showing payloads including three Small Vacuum Protective Enclosures with field emitters, current collectors, miniature electrostatic analyzer, pressure sensor, photodiode and Langmuir probe (Ramos & Liu, 2005).	5
Figure 1.3 The Field Emission Get-Away-Special Investigation proto-flight unit NASA GAS Reservation G-187 (left) with close up of Small Vacuum Protective Enclosure (right) (Ramos & Liu, 2005).	7
Figure 2.1 The Space Mission Analysis and Design (SMAD) Model (Wertz & Larson, 1999).	17
Figure 2.2 Concept exploration flow associated with SMAD model (Wertz & Larson, 1999).	21
Figure 2.3 Pugh's total design model (Pugh, 1991).	23
Figure 2.4 Hammond's four basic components of a design process (Hammond W. E., 1999).	26
Figure 2.5 Hammond's Multidisciplinary Design Model (MDM) (1999).	27
Figure 2.6 Hammond's Conceptual Design Wheel (Hammond W. E., 2001).	30
Figure 2.7 Hammond's Conceptual Design Process (Hammond W. E., 2001).	32
Figure 3.1 A fundamental or atomic design process with process detail (Washabaugh, 1999) the numbers simply represent the sequential steps: 1. Specifications, 2. Configurations, 3. Trades and 4. Drivers.	61
Figure 3.2 Updated atomic design process, with iterative component between configurations and trade studies elements.	66
Figure 3.3 Example of a system block diagram for an unmanned space system. Black lines indicate power routing and red lines indicates data flow.	78

Figure 4.1 The Student Space Systems Fabrication Laboratory’s organization chart. Asterisks denote previous projects..... 83

Figure 4.2 Student characterizing solar panel grid (left) and students presenting at design review with industry sponsors (right). 84

Figure 4.3 S3FL Information Management System (SIMS) standard member general information section. 89

Figure 4.4 SIMS standard member current term information section. 90

Figure 4.5 SIMS member certifications and awards section example..... 90

Figure 4.6 SIMS member summary of roles in S3FL example. 91

Figure 4.7 SIMS standard member summary of events while in S3FL..... 91

Figure 4.8 SIMS member attendance record example..... 92

Figure 4.9 SIMS member outreach events example. 92

Figure 4.10 SIMS member's comments from S3FL community example. 93

Figure 4.11 SIMS standard member hours and weekly reports section example. 94

Figure 4.12 S3FL’s information management system (SIMS) thermal vacuum module interface showing results for survivability and thermal testing for a component..... 96

Figure 4.13 Google Docs main interface. (A) Allows documents to be managed in collections, (B) shows the user’s documents and (C) shows details of each document (Google, 2010). 99

Figure 4.14 Google Wave main interface. (A) Contains the user’s inbox, tools and contacts, (B) shows inbox details and participants of each wave and (C) shows a wave’s content (Google Wave, 2010). 100

Figure 5.1 Cansat payload shown as found post-flight, with the parachute attached (Hitsquad Team, 2009). 113

Figure 5.2 Cansat launch stages and separation sequence (AAS/AIAA, 2011). 116

Figure 5.3 Team 1 System block diagram (Cansat Team 1, 2010) – Iteration 1. 136

Figure 5.4 Team 1 carrier block diagram (Cansat Team 1, 2010) - Iteration 2. 137

Figure 5.5 Team 1 lander block diagram (Cansat Team 1, 2010) - Iteration 2. 138

Figure 5.6 Team 1 carrier sensor block diagram (Cansat Team 1, 2010) - Iteration 3... 139

Figure 5.7 Team 1 lander sensor block diagram (Cansat 1, 2010) - Iteration 3.	140
Figure 5.8 Team 1 system configuration diagram (Cansat 1, 2010) - Iteration 1.	140
Figure 5.9 Team 1 lander system CAD model (Cansat 1, 2010) - Iteration 1.	141
Figure 5.10 Team 1 final system CAD model in launch configuration (Cansat 1, 2010).	143
Figure 5.11 Team 2 configurations A (left) and B (right) for the design task during iteration 1. L = "Lander" and C = "Carrier" in both configurations.	151
Figure 5.12 Team 2 top-level system block diagram (Cansat Team 2, 2010) - Iteration 1.	156
Figure 5.13 Team 2 top-level circuit block diagram (Cansat Team 2, 2010) - Iteration 1.	156
Figure 5.14 Team 2 sensors diagram showing data transmitted detail - Iteration 2.	157
Figure 5.15 Team 2 final system CAD models of launch configuration (left) and deployed configuration (right).	160
Figure 5.16 Team 2 final system configurations of carrier (left) and lander (right).	160
Figure 5.17 Box plot distribution for element "Exploring problem representation" Stage 1 is pre-ADP and stage 2 is post-ADP.	166
Figure 5.18 Box plot distribution for element "Using interactive, recursive and iterative design methodology" Stage 1 is pre-ADP and stage 2 is post-ADP.	168
Figure 5.19 Box plot distribution for element "Search the space" Stage 1 is pre-ADP and stage 2 is post-ADP.	171
Figure 5.20 Box plot distribution for element "Use functional decomposition" Stage 1 is pre-ADP and stage 2 is post-ADP.	173
Figure 5.21 Box plot for element "Explore graphic representation" Stage 1 is pre-ADP and stage 2 is post-ADP.	176
Figure 5.22 Box plot distribution for element "Redefine constraints" Stage 1 is pre-ADP and stage 2 is post-ADP.	178
Figure 5.23 Box plot distribution for element "Explore scope of constraints" Stage 1 is pre-ADP and stage 2 is post-ADP.	181
Figure 5.24 Box plot distribution for element "Validate assumptions and constraints" Stage 1 is pre-ADP and stage 2 is post-ADP.	183

Figure 5.25 Box plot distribution for element "Examine existing designs" Stage 1 is pre-ADP and stage 2 is post-ADP.....	185
Figure 5.26 Box plot distribution for element "Explore user perspective" Stage 1 is pre-ADP and stage 2 is post-ADP.....	188
Figure 5.27 Box plot distribution for element "Build normative model" Stage 1 is pre-ADP and Stage 2 is post-ADP.....	191
Figure 5.28 Box plot distribution for element "Explore engineering facts" Stage 1 is pre-ADP and stage 2 is post-ADP.....	193
Figure 5.29 Box plot distribution for element "Explore issues of measurement" Stage 1 is pre-ADP and stage 2 is post-ADP.....	195
Figure 5.30 Box plot distribution for element "Conduct failure analysis" Stage 1 is pre-ADP and stage 2 is post-ADP.....	197
Figure 5.31 Box plot distribution for element "Encourage reflection on process" Stage 1 is pre-ADP and stage 2 is post-ADP.....	199
Figure 6.1 Organizational structure of M-Cubed personnel.....	207
Figure 6.2 M-Cubed team management, systems and subsystems relationship diagram.....	208
Figure 6.3 Artistic rendition of a CubeSat in low Earth orbit (NASA CubeSat, 2010)..	213
Figure 6.4 M-Cubed graphical representation of mission nominal operations. T is the time from launch and M denotes nominal mission lifetime.....	217
Figure 6.5 Sentech C202 USB CCD camera (Sentech America, 2006).....	221
Figure 6.6 Front (left) and side view (right) of M-Cubed CAD model showing camera lens and carbon fiber shutter.....	222
Figure 6.7 IDS UI1646LE-C CMOS camera (IDS Systems, 2007).....	228
Figure 6.8 M-Cubed payload system block diagram (2009).....	230
Figure 6.9 IDS CMOS camera resolution test image capture (top) and corresponding MTF plot (bottom).....	232
Figure 6.10 M-Cubed first subsystem prototypes.....	233
Figure 6.11 M-Cubed primary payload final selection, the OV2655 CMOS based sensor.....	238

Figure 6.12 M-Cubed primary payload and command and data handling interfacing block diagram.	239
Figure 6.13 M-Cubed payload thermal test data plot to -17 °C in less than one hour to verify system survivability.....	240
Figure 6.14 M-Cubed primary payload's image captured during vacuum test at 4.03E-05 Torr. The target observed in the image is a resolution chart at 55 cm.....	241
Figure 6.15 M-Cubed CAD model top view showing major elements.	246
Figure 6.16 M-Cubed CAD model isometric expanded view.	247
Figure 6.17 M-Cubed System block diagram.	248
Figure 6.18 M-Cubed system level requirements summary.	249
Figure 6.19 M-Cubed Mass budget (Jan 2011).	250
Figure 6.20 M-Cubed Power budget (Jan 2011).....	251
Figure 6.21 M-Cubed Cost Summary.....	253
Figure 6.22 OV2655 camera and location of lens on side panel of the spacecraft.....	254
Figure 6.23 M-Cubed Camera mounted within the spacecraft (left side view).....	255
Figure 6.24 OV2655 CMOS sensor point spread function with respect to pixel size.	259
Figure 6.25 OV2655 CMOS sensor ground resolution as a function of altitude.....	260
Figure 6.26 OV2655 CMOS sensor cut off frequency as a function of altitude.	261
Figure 6.27 M-Cubed's secondary payload, JPL's Xilinx Virtex-5 FPGA that hosts the algorithm to meet MSPI's on-board processing requirements (ESTO, 2010).	263
Figure 6.28 JPL's COVE payload design diagram (ESTO, 2010).....	265
Figure 6.29 CAD model with JPL's COVE payload location in M-Cubed spacecraft. .	266
Figure 6.30 M-Cubed command and data handling block diagram.....	268
Figure 6.31 M-Cubed main computer board Stamp9260.	269
Figure 6.32 M-Cubed power and electrical block diagram.	271
Figure 6.33 M-Cubed power and electrical system prototype.....	272
Figure 6.34 M-Cubed batteries (left) and batteries mounted on EPS prototype (right).	273

Figure 6.35 M-Cubed communications block diagram. 274

Figure 6.36 Antenna located on the top of the electrical engineering building at UM facilities used for ARC operations. 275

Figure 6.37 Sun-synchronous orbit diagram (NASA Landsat, 2011). 277

Figure 6.38 Configuration of passive magnetic attitude control system (left) and location of magnet in M-Cubed CAD model (right). 278

Figure 6.39 STK simulation view of M-Cubed spacecraft approaching Ann Arbor ground station showing the swath coverage. 280

Figure 6.40 M-Cubed CAD model front view (top left), isometric view in deployed configuration (bottom left) and front cross section view showing major elements (right). 282

Figure 6.41 CAD model of M-Cubed in the CubeSat integration stand. 283

Figure 6.42 Computational thermal analysis on a M-Cubed electronics board rev. 2.0 showing a maximum of 0.5 °C temperature variation between warmest (power regulators, red) and coolest (top edge of board, blue) elements in atmospheric pressure conditions. 284

Figure 6.43 M-Cubed engineering design unit top view. 286

Figure 6.44 M-Cubed engineering design unit side view. 286

List of Tables

Table 2.1 Sub-process for characterizing the sixth step in SMAD, the mission architecture (Wertz & Larson, 1999).....	18
Table 2.2 Mehalik and Schunn's five tiers for good design (2006).....	44
Table 3.1 The four main stages of the Space Mission Analysis and Design paradigm (Wertz & Larson, 1999).....	55
Table 3.2 An example of a payload team's partial list of requirements.	73
Table 3.3 Spacecraft mass budget example (showing contingency).	75
Table 3.4 Summary of spacecraft power electrical budget example (showing contingency).....	76
Table 3.5 Example of a space system cost budget summary.....	77
Table 4.1 The Student Space Systems Fabrication Laboratory Information Management System (SIMS) user categories and description of their privileges.....	87
Table 4.2 S3FL's information management system (SIMS) operations modules and their description.....	95
Table 5.1 Design questionnaire question example showing seven-point scale option... ..	118
Table 5.2 Participant statistics for design task using ADP, including (a) academic level and (b) field of study.....	121
Table 5.3 Summary of information technology elements used by the teams during the design task.....	122
Table 5.4 Team 1 mission specifications - Iteration 1.....	123
Table 5.5 Team 1 carrier and lander specifications– Iteration 1.....	124
Table 5.6 Team 1 communications, data and sensors specifications– Iteration 1.	126
Table 5.7 Team 1 configurations created for the carrier – Iterations 1 through 3.	128
Table 5.8 Team 1 configurations created for the lander – Iterations 1 through 2.....	129

Table 5.9 Team 1 configurations created for the deployment mechanism – Iterations 1 through 2.	130
Table 5.10 Team 1 configurations created for computing needs – Iteration 1.	132
Table 5.11 Team 1 summary of trade studies conducted for the GPS, barometric sensor, accelerometer, buzzer, voltage regulators, flash memory unit and rotary solenoid.	134
Table 5.12 Team 1 list of drivers identified by using the ADP model.	135
Table 5.13 Team 1 summary of final system design.	142
Table 5.14 Team 2 mission specifications – Iterations 1 through 2.	144
Table 5.15 Team 2 system level specifications – Iteration 1.	146
Table 5.16 Team 2 communications specifications – Iterations 1 through 2.	146
Table 5.17 Team 2 power specifications – Iterations 1 through 3.	147
Table 5.18 Team 2 partial list of sensors specifications – Iteration 1 through 2.	148
Table 5.19 Team 2 structures list of specifications - Iteration 1 through 2.	149
Table 5.20 Team 2 command and data handling list of specifications – Iteration 1 through 2.	150
Table 5.21 Team 2 configurations created for the system's descent – Iteration 1.	152
Table 5.22 Team 2 configurations created for deployment purposes – Iteration 1.	153
Table 5.23 Team 2 configurations considered for environmental sensing – Iteration 1.	154
Table 5.24 Team 2 summary of trade studies conducted for the structure material, structure shape, temperature sensors, pressure sensors, GPS, accelerometer and batteries.	155
Table 5.25 Team 2 drivers identified by using the ADP model.	158
Table 5.26 Team 2 summary of final system design.	158
Table 5.27 Mann-Whitney U test results for element "Explore problem representation".	167
Table 5.28 Mann-Whitney U test results for element "Using interactive, recursive and iterative design methodology".	169
Table 5.29 Mann-Whitney U test results for element "Search the space".	172

Table 5.30 Mann-Whitney U test results for element "Use functional decomposition".	174
Table 5.31 Mann-Whitney U test results for element "Explore graphic representation".	177
Table 5.32 Mann-Whitney U test results for element "Redefine constraints".	179
Table 5.33 Mann-Whitney U test results for element "Explore scope of constraints".	182
Table 5.34 Mann-Whitney U test results for element "Validate assumptions and constraints".	184
Table 5.35 Mann-Whitney U test results for element "Examine existing designs".	186
Table 5.36 Mann-Whitney U test results for element "Explore user perspective".	189
Table 5.37 Mann-Whitney U test results for element "Build normative model".	192
Table 5.38 Mann-Whitney U test results for element "Explore engineering facts".	194
Table 5.39 Mann-Whitney U test results for element "Explore issues of measurement".	196
Table 5.40 Mann-Whitney U test results for element "Conduct failure analysis".	198
Table 5.41 Mann-Whitney U test results for element "Encourage reflection on process".	200
Table 5.42 Summary of mean changes for good design elements from using ADP in the design task.	202
Table 6.1 M-Cubed mission nominal timeline where T is time leading to launch, and spacecraft operational time is denoted by M.	216
Table 6.2 M-Cubed primary payload initial major design parameters.	219
Table 6.3 Imaging technology comparison summary.	220
Table 6.4 Summary of M-Cubed primary payload main trade study (2008).	220
Table 6.5 M-Cubed primary payload requirements at first design iteration (2008).	223
Table 6.6 Summary of M-Cubed primary payload trade study (2009).	227
Table 6.7 M-Cubed primary payload requirements at second design iteration (2009).	228
Table 6.8 M-Cubed payload team's risk assessment summary.	231
Table 6.9 M-Cubed primary payload requirements (final revision).	236

Table 6.10 M-Cubed primary payload's camera sensor trade study summary.	237
Table 6.11 Summary of information technology elements used by the M-Cubed payload team.....	244
Table 6.12 M-Cubed data consumers and storage capability.	252
Table 6.13 Time to transmit picture calculations.....	253
Table 6.14 OV2655 CMOS camera input parameters.....	256
Table 6.15 OV2655 CMOS camera pixel parameters at low perigee (350 km).....	257
Table 6.16 OV2655 CMOS camera pixel parameters at apogee (810 km).	257
Table 6.17 OV2655 sensor parameters at perigee (350 km).	258
Table 6.18 OV2655 sensor parameters at apogee (810 km).....	258
Table 6.19 M-Cubed orbital parameters.	276
Table A.1 SIMS summary of system usage to date.....	295
Table A.2 SIMS database definition of types.	296
Table A.3 SIMS database tables definitions for (a) announcements, (b) attendance, (c) categories of users, (d) certifications, (e) types of certifications and (f) comments.	297
Table A.4 SIMS database tables definitions for (a) system configuration, (b) courses, (c) events, (d) types of events, (e) history of users and (f) industry contacts.....	298
Table A.5 SIMS database tables definitions for (a) history of industry contacts, (b) inventory, (c) history of inventory, (d) outreach, (e) types of outreach and (f) projects.	299
Table A.6 SIMS database tables definitions for (a) technical reports, (b) user status and (c) thermal vacuum test.....	300
Table A.7 SIMS database tables definition for (a) thermal vacuum testing history and (b) system users.	301
Table B.1 Team 2 complete list of specifications – Iteration 1. All rationale added during iteration 2.	370

List of Appendices

Appendix A SIMS Code.....	295
Appendix B Design Task Additional Material	355

Abstract

Parametric Design within an Atomic Design Process (ADP) applied to Spacecraft Design

by

Rafael Ramos Alarcon

Co-Chairs: Brian E. Gilchrist and Colleen M. Seifert

This thesis describes research investigating the development of a model for the initial design of complex systems, with application to spacecraft design. The design model is called an atomic design process (ADP) and contains four fundamental stages (specifications, configurations, trade studies and drivers) that constitute the minimum steps of an iterative process that helps designers find a feasible solution. Representative design models from the aerospace industry are reviewed and are compared with the proposed model.

The design model's relevance, adaptability and scalability features are evaluated through a focused design task exercise with two undergraduate teams and a long-term design exercise performed by a spacecraft payload team. The implementation of the design model is explained in the context in which the model has been researched. This context includes the organization (a student-run research laboratory at the University of

Michigan), its culture (academically oriented), members that have used the design model and the description of the information technology elements meant to provide support while using the model. This support includes a custom-built information management system that consolidates relevant information that is currently being used in the organization. The information is divided in three domains: personnel development history, technical knowledge base and laboratory operations.

The focused study with teams making use of the design model to complete an engineering design exercise consists of the conceptual design of an autonomous system, including a carrier and a deployable lander that form the payload of a rocket with an altitude range of over 1000 meters. Detailed results from each of the stages of the design process while implementing the model are presented, and an increase in awareness of good design practices in the teams while using the model are explained.

A long-term investigation using the design model consisting of the successful characterization of an imaging system for a spacecraft is presented. The spacecraft is designed to take digital color images from low Earth orbit. The dominant drivers from each stage of the design process are indicated as they were identified, with the accompanying hardware development leading to the final configuration that comprises the flight spacecraft.

Chapter 1

Motivation and Introduction

1.1 Motivation

During a historical speech at the National Aeronautics and Space Administration (NASA) Kennedy Space Center (KSC) in Florida on April 15th 2010, President Barack Obama recognized that what is needed for beyond Low Earth Orbit (LEO) exploration are revolutionizing technologies and strategic collaborative efforts, making the fundamental investments that will provide the foundation for the next half century of leadership in space exploration. He said,

"...as President, I believe that space exploration is not a luxury, it's not an afterthought in America's quest for a brighter future -- it is an essential part of that quest. Fifty years after the creation of NASA, our goal is no longer just a destination to reach. Our goal is the capacity for people to work and learn and operate and live safely beyond the Earth for extended periods of time, ultimately in ways that are more sustainable and even indefinite" (Obama, 2010).

This speech came only a few months after Charlie Bolden presented the President's budget request for NASA in fiscal year 2011, his first budget as NASA Administrator. It was received with great controversy due to the cancellation of the

Constellation Program, including the Ares I and V rockets and the Orion Crew Exploration Vehicle (Bolden, 2010a).

On February 25, 2010, Bolden addressed the Committee on Science and Technology to discuss the President's FY 2011 budget request for NASA. He stated:

"...if you gave NASA unlimited resources today, we could not take a human safely to Mars in the near future, because we have not solved the interrelated problems of shielding humans from radiation in space, providing consumables to last the distance, and constructing a rocket to take all of those items into space." (Bolden, 2010b).

This highlighted the need for developing technologies and infrastructure to enable safe human space exploration at a more sustainable rate. Discussion of partnerships between the United States and its allies to accomplish long term plans in a more cost effective manner is not optional, but essential to sending humans safely on missions beyond low Earth orbit.

A few weeks later, Congress sent a letter back to Mr. Bolden urging him to assemble a team of NASA experts to review how exploration spacecraft and launch vehicle development may be maintained with the proposed budget, ensuring that there would be uninterrupted independent United States human spaceflight access to the international space station and beyond (Congress of the United States, 2010).

The final response was a statement from Mr. Bolden dated May 26, 2010 (Bolden, 2010c) including a much more realistic description of the restructuring of the Orion crew capsule program, heavy lift technologies, as well as a description of the assistance for continuity of the workforce in Florida's Space Coast, through the establishment of a task

force on space industry workforce and economic development plan. NASA was forthright about taking input from new initiatives to comply with the goals set within the 2011 budget. By doing this, the agency was ensuring that it received important feedback from industry, academia, and all relevant partners before it began to finalize the implementation plan for the new technology demonstrations in human spaceflight systems development activities.

The author has observed firsthand how NASA sometimes struggles to keep academia included in their overall goals. In 2002, the University of Michigan was well on its way to conducting relevant science through student built space instruments and satellite projects. These were experiments of cold cathode electron emission technology for space. Figure 1.1 shows the completed hardware of the Icarus spacecraft, which was within 60 days of launching when the Space Shuttle Columbia disaster occurred, resulting in the eventual cancellation of the program on which it would fly.

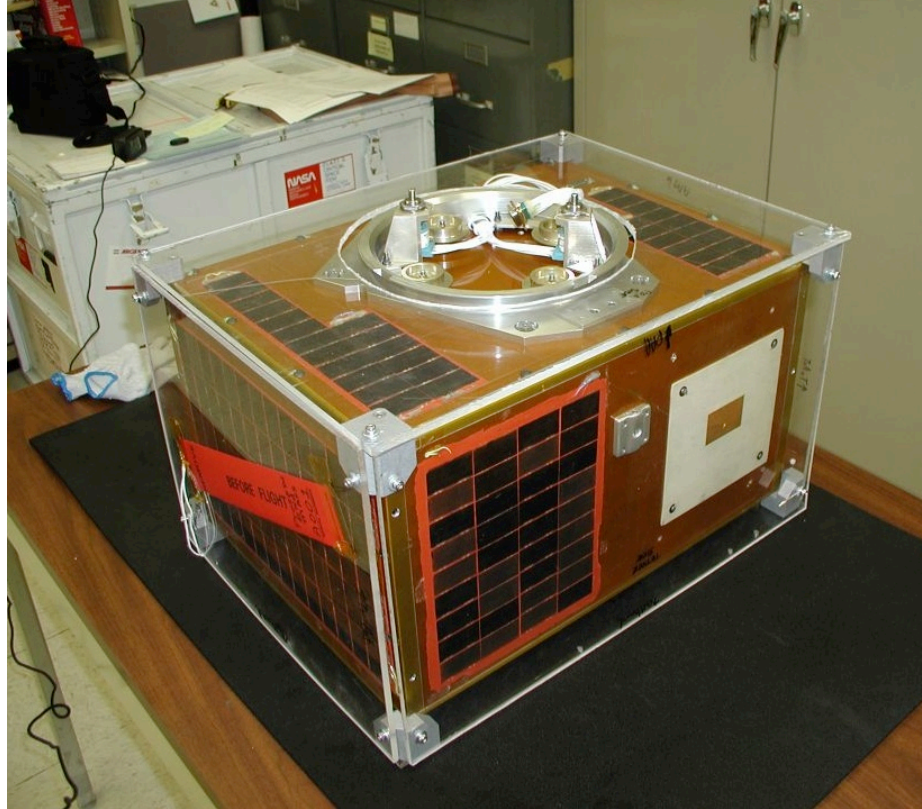

Figure 1.1 The University of Michigan's first student-built satellite, Icarus, was fully qualified for NASA's ProSEDS space tether mission (Goldberg & Fuhrhop, 2004).

A follow on program, the Field Emission Get-Away-Special Investigation (FEGI) was nearing completion of its proto-flight unit by the spring of 2005. The FEGI project was on track to test experimental nano-structured electron emission devices provided from government, industry and university partners (Ramos & Liu, 2005). They were eager to see the flight results to improve next-generation propulsion technologies and spacecraft charging remediation techniques.

The Field Emission Get-Away-Special (GAS) Investigation project was originally baselined as a NASA GAS Small Shuttle payload with the Motorized Door Assembly (MDA) added (Reservation G-187). The GAS canister is a 5-ft³ (0.1416 m³) canister capable of supporting 200 lbm (91 kg) payloads and is located in high bay area of any of

the Space Shuttles. The MDA accounts for 40 lbm of the total mass, leaving 160 lbm (72.3 kg) allocated for the payload. Once the Space Shuttle reaches orbit, the NASA-provided MDA opens, exposing a 15-inch diameter experiment faceplate to the local plasma. The faceplate contains a suite of instruments including three Small Vacuum Protective Enclosures (SVPE), a pressure sensor, Langmuir probe, photodiode, current collectors and a Miniature Electrostatic Analyzer (MESA) as shown in the Computer Aided Design (CAD) model in Figure 1.2.

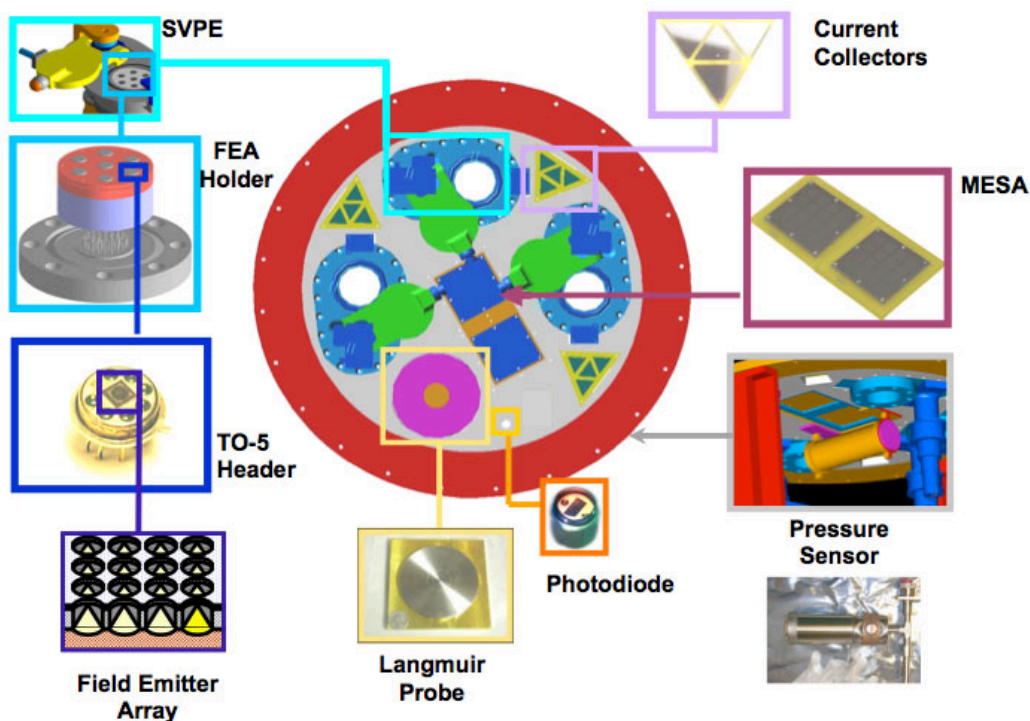

Figure 1.2 The Field Emission Get-Away-Special Investigation (FEGI) project CAD model of the faceplate (top view) showing payloads including three Small Vacuum Protective Enclosures with field emitters, current collectors, miniature electrostatic analyzer, pressure sensor, photodiode and Langmuir probe (Ramos & Liu, 2005).

The SVPEs contain the electron emitters under test, protecting them both before and after the mission.

The author had been directly involved with the project for over three years, (working first as a systems engineer and as project manager during the final two years), as were many other undergraduate, graduate students, engineers, technicians and faculty members, when NASA canceled the Getaway Special Program (GAS) completely. This left many payloads that already had a reservation to fly on the Space Shuttle without means to access space.

FEGI continued being developed at the University of Michigan through the Student Space Systems Fabrication Laboratory (S3FL) and The Pennsylvania State University until formal notification was received of the cancellation of the Get-Away-Special program. The FEGI proto-flight unit and a close up of the SVPE are shown in Figure 1.3. Other organizations also contributed to this effort including the U.S. Air Force Academy, NASA's Jet Propulsion Laboratory and Marshall Space Flight Center. Programs of this nature span many years, and hundreds of engineering students are very involved, spending tremendous amounts of time and effort to see them to completion.



Figure 1.3 The Field Emission Get-Away-Special Investigation proto-flight unit NASA GAS Reservation G-187 (left) with close up of Small Vacuum Protective Enclosure (right) (Ramos & Liu, 2005).

The fact that NASA cancelled the only means to see these programs to completion enabled very negative reactions, particularly in the younger engineers to-be. It was a decision hard to understand, especially since NASA's Administrator at the time, Sean O'Keefe, had indicated that NASA was struggling with a workforce crisis with three times as many science and technology workers over 60 years of age than are under 30 years of age.

In order for the U.S. to maintain and grow the technical capabilities required for effective workforce development in many industries beyond aerospace, not only must young engineers be attracted to different engineering fields, but also they have to develop a solid foundation for multi-disciplinary engineering design and development. The study

of such fundamental design algorithms and processes is at the center of the author's professional interests.

The revolutionizing technologies and strategic collaborative efforts that President Obama was referring to will require the development of many complex systems. The knowledge domains that are involved in today's complex systems developments (i.e. telecommunication infrastructures, modern energy systems, spacecraft development, etc.) are numerous, including engineering, engineering management, systems engineering, natural science, social sciences, and the list continues. The human capacity to predict the behavior of simple systems differs greatly from the capacity to predict that of complex systems. Wide-ranging literature can be found about systems analysis and design, and the intricate characteristics and convoluted nature of complex systems is quickly evident (Gibson, 1992; Hammond, 2001; INCOSE, 1998; Patel, 2003; Shishko, 1995; Wertz & Larson, 1999). Developing a clear understanding of existing design models and the application of a specific design model in space systems are underlying motivations for the research presented in this thesis.

1.2 Introduction

Today's modern space systems are examples of truly complex engineering systems, both as individual or constellations of systems. An important aspect of the complexity is the vast amount of information that needs to be managed, distributed, and updated during the early design phases of these systems. It becomes critical to have a

reliable information management framework that facilitates knowledge sharing and reuse across disciplinary boundaries. This is tangible due to the coupling of many sciences and personnel with various backgrounds and experiences, all coexisting in an environment with several restrictions.

Thesis:

To develop a model for initial design of complex systems, with application to spacecraft.

The goal is to develop an initial design model for the complex systems design process, with application to small spacecraft. The model is expected to be able to capture first order constraints and their relationships by coupling the knowledge domains of space systems engineering and information science for effective information utilization and prioritization.

1.3 Summary of Research Contributions

Previous work done on models for design can be so comprehensive that it can be overwhelming for inexperienced engineers to understand or follow (Pugh, 1991). Some authors attempt to capture all existing relationships between the stages of design through a complex set of algorithms, making it hard to identify what are the most relevant decisions during the process that will enable a feasible design (Hammond W. E., 1999).

In recognizing that the concept of design model is very broad, a specific focus has been selected for investigation. The questions that will be investigated in this thesis include – Is there a model that can help one to understand the central steps in design? What are the minimum stages in a design process to find a feasible solution? How flexible is the model studied?

There are three specific aspects of a design model that will help answer these questions: the model's *relevance*, that is understanding when the model works; *adaptability*, having an understanding of what kind of design problems it is good for, and what kind of organizational culture can promote a better usage of the model; and *scalability*, understanding differences between applying the model to small or large problems. Research topics and contributions of this investigation include the following:

- Representative design models and their features are presented, as well as a framework for what constitutes good design. A proposition is made for a design model for initial systems design. The model suggests it contains the central steps for design, being in essence the minimum stages for a process in finding a feasible solution.
- The usage of the design model is investigated by first explaining the context in which the model is expected to be implemented, including the description of a custom-built information management system. Second, by showcasing how novice design teams make use of the design model to complete a design task. Experimental results measuring changes in the awareness of good design practices while using the model are presented.

- The long-term process of finding a feasible solution for a spacecraft imaging system is investigated. The dominant design drivers that govern the design are indicated as they were identified; with the corresponding hardware development leading to the original spacecraft configuration that constitutes the flight unit. It is currently scheduled for launch into low Earth orbit later this year.

1.4 Dissertation Overview

This thesis is composed of seven chapters, which together address the research topic discussed in the previous section.

Chapter 1 Describes the motivation behind this research and a summary of the contributions.

Chapter 2 Explains existing design models and relevant aspects of their processes. It also includes a summary of a criterion for good design.

Chapter 3 Describes two relevant disciplines that are fundamental for the research performed (space systems engineering and information science). This chapter also includes an explanation of the design model.

Chapter 4 Provides a detailed explanation for the implementation of the design model studied, including aspects of the supporting information technology and relevant human factors considered.

Chapter 5 Describes the application of the design model in a specific design task, including details about the task, method and procedure used to characterize the impact of its usage.

Chapter 6 Explains a long-term case study, the primary payload selection for a low Earth orbit imaging spacecraft, in which all aspects of the design model were applied.

Chapter 7 Concludes the research presented in this thesis and suggests a path for future development.

Chapter 2

Some Existing Design Models

2.1 Introduction

Many authors have developed algorithms to try to define different design processes. Most of the early design models were developed in Europe (Doordan, 1996) and some date back to ancient Egypt, Greece, Rome and other similar civilizations. Studying the modern engineering design processes became more common after the industrial revolution, when the products being developed became more complex. To work with these more complex systems, a more organized approach to their development was required, which in turn required more sophisticated algorithms and processes. A much better use of mathematics, materials selection, manufacturing processes, inventory control and robust design techniques were required to follow these algorithms and enable the processes.

This chapter begins by defining important concepts that will be used in subsequent chapters. Some existing design models are explained in the following

sections, including the space mission analysis and design model by Wertz and Larson (1999), Pugh's total design model (1991), and Hammond's multidisciplinary design model (1999) and conceptual design process (2001). Finally, a summary of the work conducted by Mehalik and Schunn (2006) is explained to provide a frame of reference for what constitutes good design.

2.2 Design Concepts

There are many definitions of *design*, from “art with a purpose” (Getlein, 2008) to “the process of originating and developing a plan for a product, structure, system, or component with intention” (Cambridge Dictionary of American English, 2010). The following working definition will be used in this thesis. *Design* is the execution of a methodical process that enables the finding of a feasible solution to a particular problem (it may also prove infeasibility).

The most relevant concepts of design include:

- Goal or Objective – What a system to be designed is meant to accomplish.
- Specifications – How well the system must perform to meet its objectives. They include the following:
 - Requirements – The formal set of functional and operational technical expectations (directly from the specifications) that the system shall meet.
 - Constraints – Hard limit on a value like accuracy, cost, schedule, etc.

- Budgets – Repositories of information critical to the design, such as system mass, power, etc.
- Design space – The entirety of the set of possible designs.
- Decision hierarchy – The tree of choices in which each node represents a class of related options that satisfy a goal.
- Design drivers – These are the dominant system parameters or characteristics that directly influence the system’s performance and can be clearly identified. Some authors define drivers as those defining parameters, which most strongly affect the cost, performance and system design (Wertz & Larson, 1999). Typically system drivers are not system requirements. By explicitly identifying the design drivers, the team can concentrate the efforts on these parameters to obtain the best performance.

There are some design processes that have similar stages or characteristics, starting from an objective through the implementation. The focus of the research presented in this thesis is to capture the *core steps* to enable a designer to methodically understand the key *design drivers* that govern the system.

2.3 Design Models

Some industries are remarkably complex due to the nature of their elements and the relationships between these elements. One of these is the aerospace industry. Once in orbit, space systems typically cannot be repaired, so full functionality must be guaranteed without ever completing a single test of the vehicle in its actual operational environment. Thus, space mission success is highly associated with effective design. In 1992 a survey was published of 2,500 spacecraft failures between 1962 and the early nineties, allocating up to 24.8% of mission failures to a problem directly associated with the design of the vehicle itself (Harland & Lorenz, 2006). Therefore, it is easy to see how programs for spacecraft design are typically high cost and take a considerable amount of time. Practically all space programs schedules are measured in years.

Four design models from the aerospace industry that are representative of typical industry processes are described in the following sections.

2.3.1 The Space Mission Analysis and Design model

The Space Mission Analysis and Design (SMAD) process has gained widespread use as a text and reference throughout the aerospace community and is considered the design paradigm. Released seven years after the 2nd edition SMAD textbook, SMAD 3rd edition was meant to make the process as useful and practical as possible. Because of the growing interest among the aerospace community in low Earth orbiting (LEO) spacecraft, the SMAD process is illustrated by designing a hypothetical weather monitoring LEO spacecraft. A summary of this process is shown in Figure 2.1.

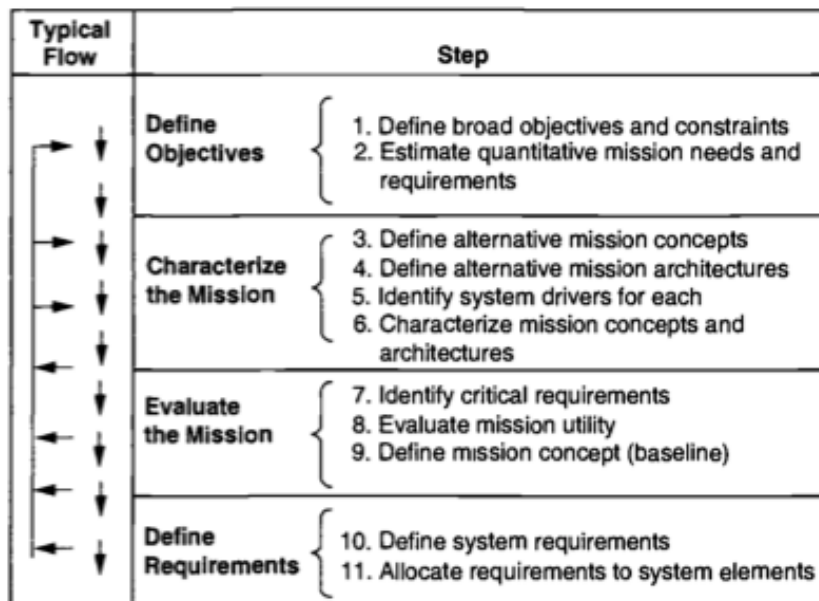

Figure 2.1 The Space Mission Analysis and Design (SMAD) Model (Wertz & Larson, 1999).

Intended to be applicable to any space mission, the authors of SMAD anticipate that new users of the process will be able to design a space mission to meet a set of broad objectives at minimum cost and risk. The iterative algorithm encompasses eleven steps. The first step is to define mission objectives and constraints, which are the broad goals that the system must achieve and the constraints. These are derived from what is known as a *mission statement*, which is a broad description of the origin and purpose of the system. The second step entails quantifying how well the broad objectives need to be achieved. There is an assessment of what the requirements are, although a formal definition of them is not specified until much later in the process. In the third step a mission concept is defined. This is expected to be a broad statement of how the mission will work in practice, for example including elements such as how the data will be collected and delivered to the end user. Different ideas generated during this step are

preferably conceptually distinct approaches to the problem. The practicality of available technology at a given time can be very restricting for the generation of different concepts. The next step involves the generation of a *mission architecture*. This is defined as the mission concept from the previous step plus a definition of elements including launch element, mission operations facilities and personnel, orbits definition, a communications architecture and a spacecraft. Step five is identifying system drivers. It is expected that there is an identification of the principal cost and performance drivers for each mission concept. The benefit of identifying these is that there will be an improvement of the chances of getting the best possible design within the available budget. Step six is described by the authors as the most involved in mission design because it defines in detail what the system is and does. The level of detail should be such that the outcomes of this stage allow meaningful evaluations of effectiveness. Although there is very complex algorithm that describes this step in depth, a summary of the series of sub-steps expected to guide this effort is shown in Table 2.1.

Table 2.1 Sub-process for characterizing the sixth step in SMAD, the mission architecture (Wertz & Larson, 1999).

Step	Description
A	Define the preliminary mission concept
B	Define the subject characteristics
C	Determine the orbit and constellation characteristics
D	Determine the payload size and performance

E	Select the mission operations approach
F	Design the spacecraft to meet payload, orbit and communications requirements
G	Select a launch and orbit transfer system
H	Determine logistics, deployment, replenishment, and spacecraft disposal strategies
I	Provide costing support for the concept-definition activity

The activities in step seven are identifying *critical requirements*. These requirements are those that dominate the space mission's overall design and affect performance and cost. This leads to performing a mission utility analysis that quantifies how well the requirements and objectives are being met in step eight. Having evaluated alternative designs and performed the required trade studies and assessments on mission utility, a baseline system design is selected in step nine. The decomposition of every subsystem aspect into progressively lower levels of design by defining lower level functions, will help formally consolidate the top level requirements. The formal definition of these system requirements happens in the tenth step. Internal to the system, the documentation of interfaces between segments is key to integrating and maintaining clarity between these segments. These documents also help in allocating numerical requirements to the components of the entire space mission, a task that is fulfilled in the eleventh and final step.

There are many options by which missions can fulfill a set of goals, such as the different types of launch vehicles, spacecraft subsystems technology available, combination of orbits, etc. Therefore, there are many associated algorithms to the SMAD

process to help make the system design more manageable, such as the one shown in Figure 2.2. Each concept that is generated per level of this algorithm must be traceable to the original requirements and constraints. Wertz and Larson point out that at the same time, designers must keep track of the systems costs, at a minimum with techniques of *rough order of magnitude* (ROM) cost. This level of detailed algorithm is called the concept exploration flow.

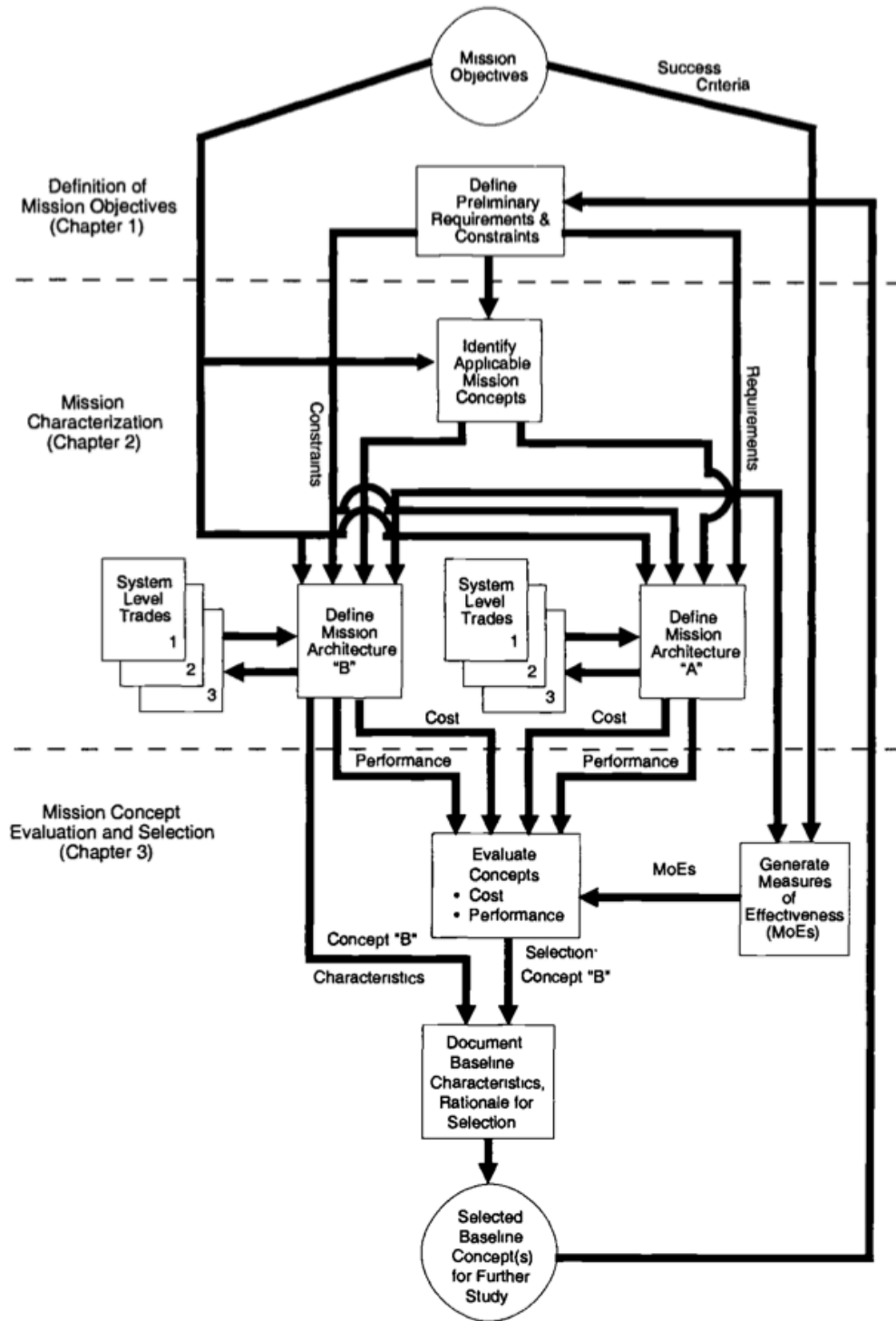

Figure 2.2 Concept exploration flow associated with SMAD model (Wertz & Larson, 1999).

It should be noted, that there is significant recognition that with the compilation of contributions over years by many engineers and managers throughout the space systems community, sometimes there are disagreements among experts regarding certain topics. The authors state, "...[SMAD] reflects the insight gained from engineers and managers practical experience, and suggests how things might be done better in the future. From time to time the views of authors and editors conflict, as must necessarily occur given the broad diversity of experience." (Wertz & Larson, 1999).

2.3.2 Pugh's Total Design Model (Pugh, 1991)

Pugh's total design model has six connected elements (see Figure 2.3 for reference). It begins with the component of *market*, which is intended to capture a need from society for the development of a system. This stage leads to the definition of *specifications*, which will be used for the development of a *concept design*, *detailed design*, and *manufacture*. It is only until the last element, *sell*, is achieved that the entire design process is complete (Pugh, 1991).

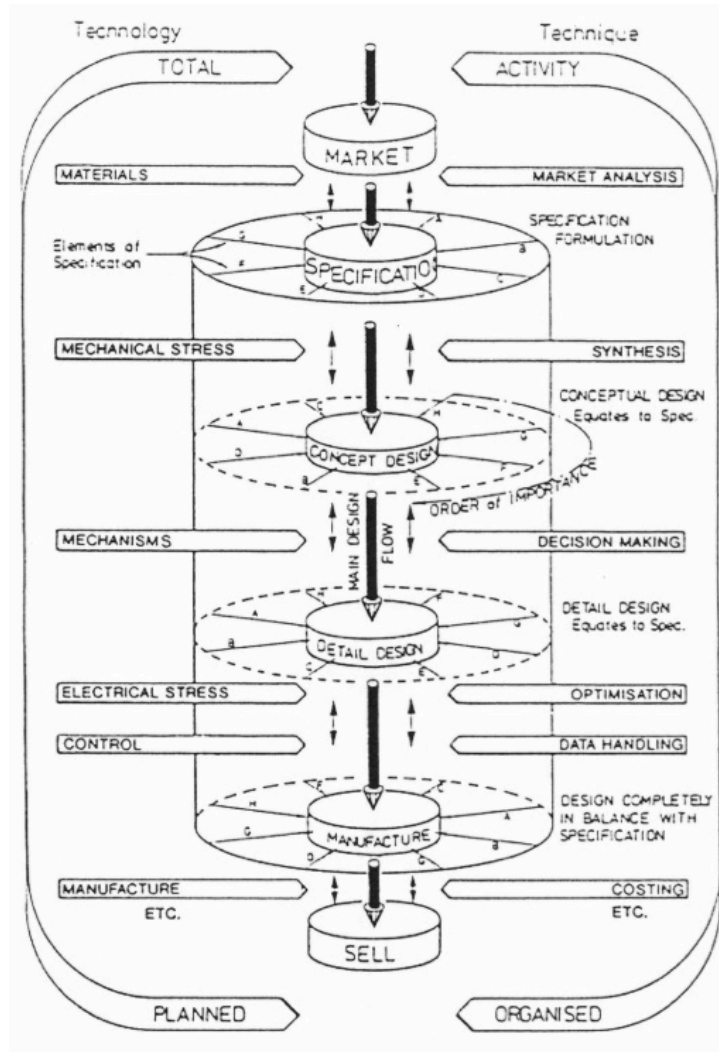

Figure 2.3 Pugh's total design model (Pugh, 1991).

Between each of these stages there are decisions and information flow that enable the designer to go back and forth between each stage. There are some identified activities through very specific techniques that allow this to happen, for instance, the proper market analysis conducted in order to determine the overall goals the system will be capable of, is defined early on in the process between *market* and *specifications*. Once the initial set of specifications has been established, the *concept design* matures into a *detail design*

through a process of synthesis and decision-making. Pugh describes the main design flow as that between the *concept design* and the *detailed design* phases.

As the system matures within the *concept design*, so will the relationships within the team, the knowledge about the system and ideally the awareness of the functionality limitations of the system in order to achieve the *detailed design* expected from the next stage. The *detailed design* outcome should meet the original *specifications*, and only until this is the case can the designer proceed to optimization and data handling techniques. It is interesting to note that the model suggests that the design can be out of balance with *specifications* up until the stage in which it can actually be built, which is the *manufacturing* stage. At this point, costing techniques to determine its best selling value come into play.

A technological dimension is also part of this model. In between the *market* and *specifications*, the materials that will be part of the system are to be defined. It seems there is an attempt to create a balance between materials that are available to a particular designer and the activities of market analysis such that the available technology is maximized to deliver information from *marketing* into *specifications*.

Once the first batch of *specifications* is complete, the designer can transition into the *concept design* phase by implementing mechanical stress analysis techniques. Similarly, between *concept design* and *detail design*, the designer should recognize the “mechanisms” that function properly to facilitate a better transition between stages. This is an element of heritage which can help iterate faster between *conceptual design* and *detail design* and which can be easily documented.

Electrical stress and control properties of the system are required before moving into the manufacturing processes. Although the model depicts that there can be more specific activities related to the techniques that will enable the maturity of the design throughout the process, (including other technological considerations such as materials selection), this vertical iterative design process allows limited access to the original specifications from other stages.

2.3.3 Hammond's Multidisciplinary Design Model (Hammond W.E., 1999)

Hammond's model begins with a schematic that shows how *decision makers*, using human expertise and *expert systems* drive the design process, as illustrated in Figure 2.4. These decisions can be made in an environment of “variable uncertainty and different risk levels”, according to Hammond (1999), where the design team faces adversity in an environment where there is schedule slippage and sometimes uncontrolled cost increases.

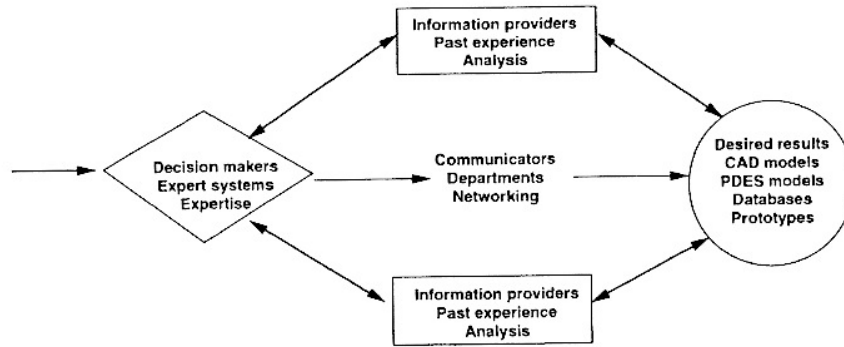

Figure 2.4 Hammond's four basic components of a design process (Hammond W. E., 1999).

Hammond's design process is an approach to analysis and design of space transportation systems. This model recognizes that ultimately the systems performance depends on the integration of many disciplines. Hammond states, "The engineering design process can be viewed as a series of decisions that gradually define a new product in more and more detail" (1999). All of these elements constitute the basis for what is called Hammond's Multidisciplinary Design Model (MDM), shown in Figure 2.5.

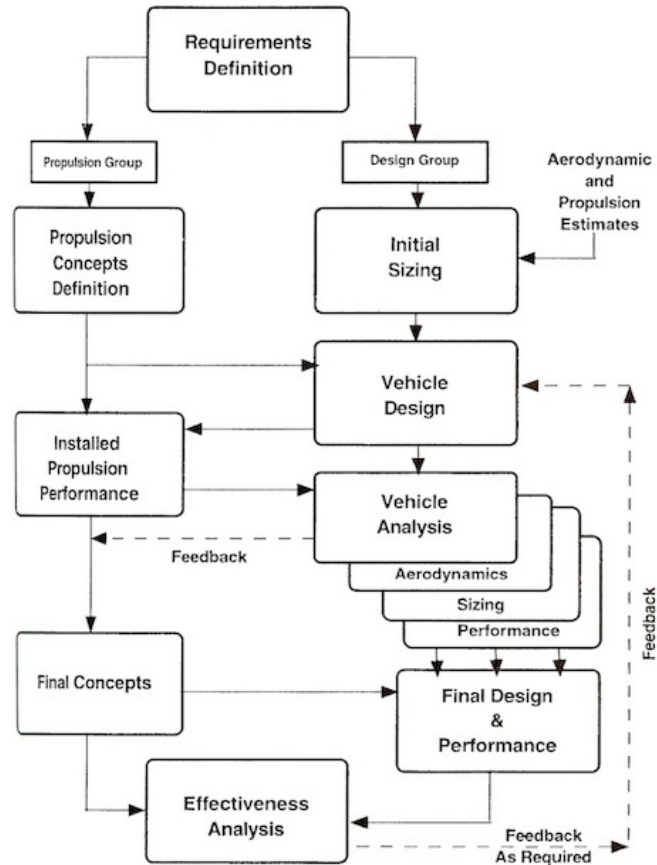

Figure 2.5 Hammond's Multidisciplinary Design Model (MDM) (1999).

In describing the process, Hammond explains that the *decision making* action is at the core of the design process. Many different types of decisions must be made and decision makers, expert systems, engineers and other required expertise should be involved throughout the design process at all times. The design consists of a sequence of steps, starting from a group of *ideas* (initially problem definition related) that turn into *concepts* that, after fully understanding through testing prototypes, will shed light on design uncertainties.

For space systems, the design activities are based on achieving a balance between the required *fuel* to achieve the mission and the *minimum weight configuration* that

allows them to be operational in orbit. There are models that are very specific in trying to capture the aerospace design process for aircraft, missiles, or other goal specific systems. Hammond claims that because *aerodynamics* and *propulsion* are two of the critical disciplines in achieving a fuel balance, and ultimately vehicle performance, they are the primary features constituting a balanced multidisciplinary design process. The beginning of the process is depicted by a *requirements definition* stage. There are two main paths that this design process algorithm follows. In the first one, the “propulsion group” will define relevant *propulsion concepts*. There is a wide range of propulsion roles that need to be studied. Some distinctive roles include launch vehicles, which are engines or “boosters” that develop a high thrust for extended periods of time, apogee and perigee motors for spacecraft orbit circularization, inclination changing and orbit placement, and attitude and station keeping orbit control (lowest thrust levels). The design process moves forward into understanding *propulsion performance* related metrics and how these concepts will ultimately be integrated into the final design of the vehicle. The other main path is taken by a “design group”, in which an *initial sizing* of the system takes place. This is equivalent to creating different concepts or architectures that satisfy the requirements defined previously. There is the inclusion of aerodynamic and other propulsion estimates that ultimately enable different options for the mission. The first time the two development paths intersect is at a stage called *vehicle design*. Different concepts supported by associated technologies help evaluate potential solutions for the statements defined in the requirements. This model encourages the generation of a large number of concepts, each of which should meet the given mission objectives.

The model is intended to emphasize design requirements throughout the process since it helps to control lifecycle costs. Hammond describes these lifecycle costs as largely determined early on by the design concepts and therefore very difficult to change past this stage. The *vehicle design* stage provides input into the *propulsion performance* effort that is needed for the overall system. Only through multiple trades having to do with the aerodynamics, sizing of different subsystems and components, and further study of the performance will there be a successful *vehicle analysis* stage completion. It is left to the discretion of the systems engineers and technical leaders that the results of these analyses are complete enough to enable feedback into the *final concepts* stage and a *final design and performance* completion.

As a designer works throughout this process there are different points in which the configuration is frozen. Some design characteristics or specific hardware design elements begin to dominate, for example the system structure. Following the different iterative paths over time will allow the team's knowledge of the design concept to mature. However, as more time is spent within the design process, the more likely that the design freedom will be reduced.

2.3.4 Hammond's Conceptual Design Wheel and Design Process (Hammond, W. E., 2001)

Hammond's Conceptual Design Wheel (CDW) is shown in Figure 2.6. The outermost circle containing *requirements* and *objectives* are coupled with *technology*

infusion from different disciplines in the middle circle to drive the core *conceptual design process* of the inner circle. The *requirements* and *objectives* delimit the entire process, including elements such as *design criteria*, *selection criteria*, *aerospace roles*, *mission profiles*, *payload definition* (that Hammond couples with *weapons integration*) and *specific requirements*.

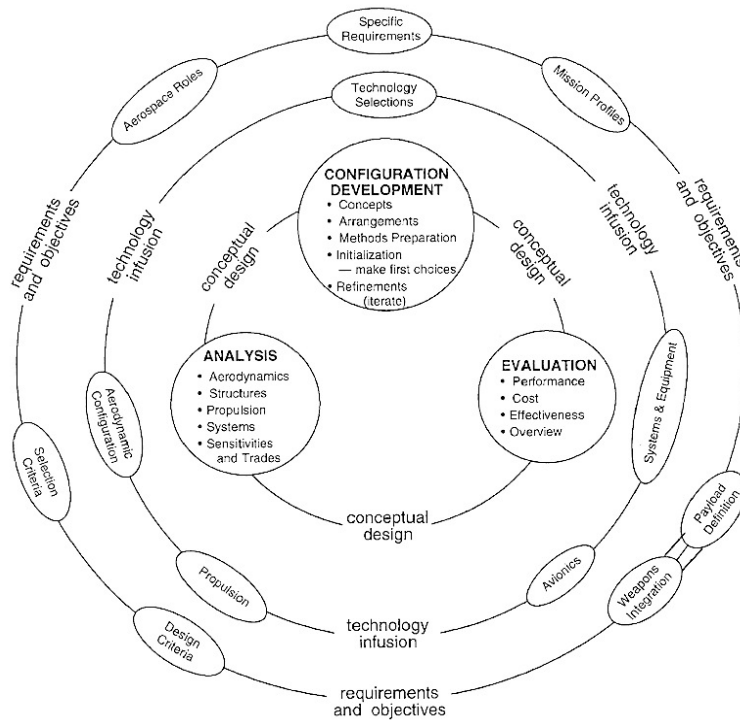

Figure 2.6 Hammond's Conceptual Design Wheel (Hammond W. E., 2001).

The design synthesis stages (shown in more detail in Figure 2.7) include *configuration synthesis*, *identification of candidate configuration types*, *design development*, filtering of selected *design concepts*, *concept refinement*, and the filtering out of a *final concept*. The “configuration development” tasks include diverse methods to compare, arrange, and evaluate the different concepts. Refinements are expected

throughout iterations. All the analysis is backed up by rigorous studies in *aerodynamics*, *structures*, etc. Ultimately an “evaluation” takes into account performance, cost and effectiveness.

The Conceptual Design Process (CDP) is meant to show a more comprehensive algorithm to design and develop a system. The process is oriented towards the aircraft industry, and this model is intended to capture all the critical elements needed for a basic configuration, system operating characteristics and mission capabilities of a system. At the core of this design process there are five stages. Hammond states “the detailed design is just conducting additional refinements, solving a myriad of technical problems, and establishing a benchmark vehicle design that meets the system specifications and requirements, backed by a series of design drawings (all on the computer)” (Hammond W. E., 2001).

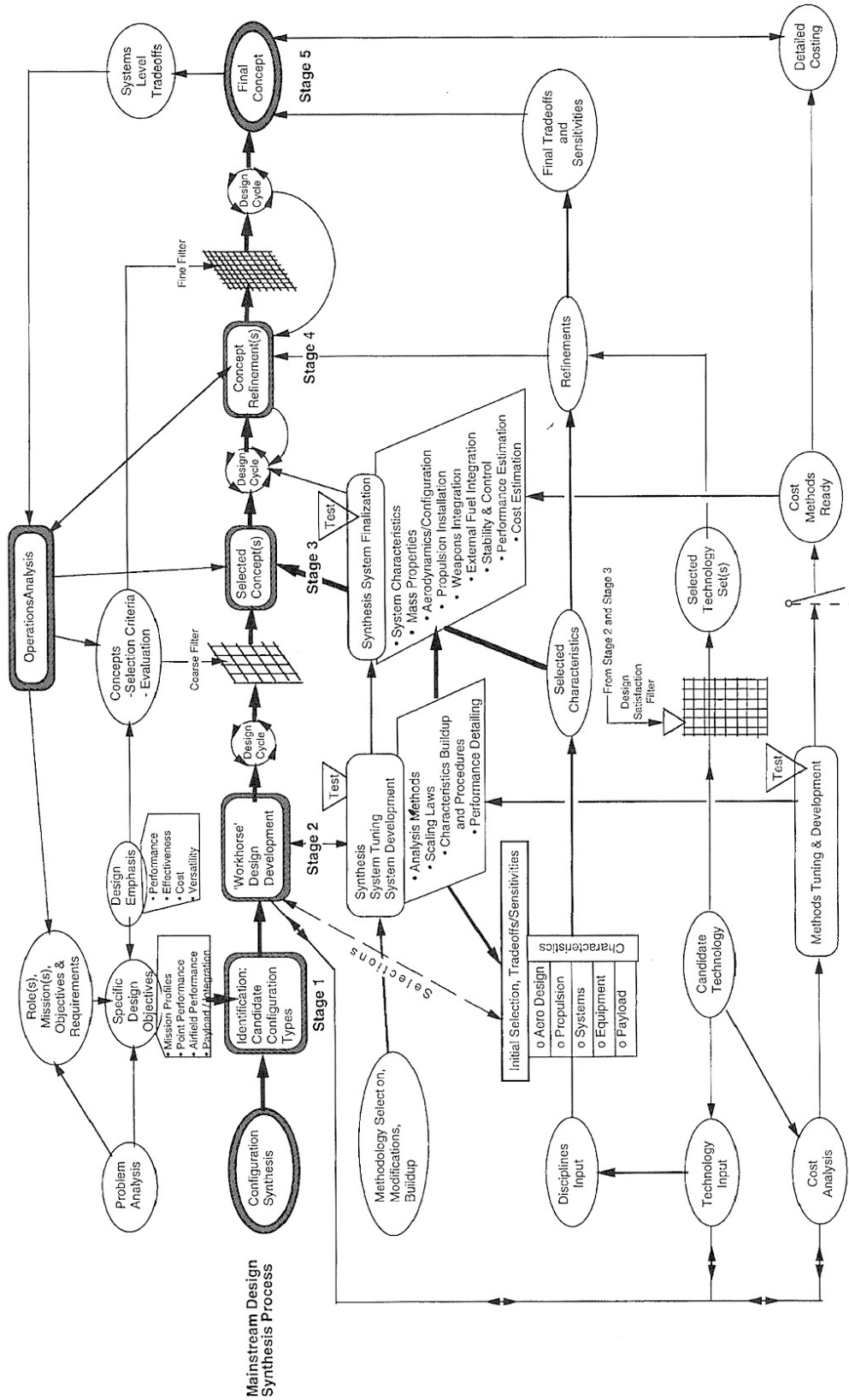

Figure 2.7 Hammond's Conceptual Design Process (Hammond W. E., 2001).

For a given problem there is an initial analysis that, through the documentation of mission objectives goals and requirements, will generate specific design objectives. Elements like mission profiles, pointing performance, airfield performance, payload integration components, etc. are all part of these specific design objectives. There is a design emphasis input on four levels: performance, effectiveness, cost and versatility. By going through this stage there should be a clear identification of different configuration types, which is why this stage is called *Identification: candidate configuration types*. This is considered Stage 1.

Stage 2 is the *design development*. This is the stage with the highest number of inputs due to the different dimensions that affect its constitution. The main path to follow during this stage is one of “system tuning” through explicit activities of tuning and development. Using analysis methods, scaling laws and performance detailing, there is a series of initial selections that will outline trade-offs with different sensitivities on different subsystems. These subsystems are the aerodynamic element, propulsion, specialized payload, and overall systems aspect. By understanding thoroughly what is the technology available to the organization and using cost analysis, the model suggests it is possible to identify the candidate technology that, through testing, will determine the output of the cycle. This is the link to the next stage, Stage 3.

Stage 3 is where the selection of components is performed. In the design model it is called *selected concepts*. This comes directly from characteristics selected through the synthesis of a system including all the relevant aspects (mass properties, aerodynamics features, command and data handling systems, propulsion installations, weapons integration, external fuel integration, stability and control, performance estimation and

cost estimation) that through testing constitute the design cycle for the stage. The process includes what it calls a “design satisfaction filter” from Stage 2 and Stage 3, which enables the designer to select particular technology sets that, through refinements, constitute the *concept refinement* stage, also known as Stage 4. A “fine filter” that comes directly from the selection criteria and evaluation metrics from a *concepts* element precedes the design cycle to the final stage, the *final concept*, which is Stage 5. Final trade-offs and sensitivities analyses feed into Stage 5 that come directly from all preceding stages in which selected concepts have been studied and specific concepts have been refined. Cost methods that have been applied from earlier stages (like stage 2 and 3) are detailed into this last design phase. All stages of this model have a relationship with an “Operations Analysis” aspect of this process, which helps verify that all the requirements and constraints are being met throughout the process.

2.4 Criteria for Good Design

With numerous design models in existence, it is crucial to be able to establish a frame of reference for what actually constitutes good design. This context will be used extensively in the following chapters when we are trying to understand the relevance and scalability of the original model researched here.

It is useful to consider the work of Mehalik and Schunn (2006) who conducted a meta-analysis by sampling over 40 articles from 16 different journals describing

empirical studies of the design process. They began the process by identifying and clustering design process elements and stages from their past experiences in cognitive studies of design and systems engineering design. The findings and earlier frameworks of Simon (1996) and Gibson (1992) constitute the disciplinary origins of Mehalik and Schunn's research. The authors conducted the review and coding of the journal articles. After completing this, an additional expert in engineering design reviewed a sample of 11 articles from the set of 40 to validate the coding. This expert reviewed one sample article (not included in the original group of articles) as practice after which he was given feedback through discussion with the authors. This process was repeated until the additional reviewer completed a review of ten randomly selected articles from the original group and the degree of correspondence of coding was shown to exceed 80% across all coding dimensions. The dimensions consisted of level of expertise in design, level of expertise in domain, type of task examined, etc. Mehalik and Schunn show in detail, which elements of the design process have been studied most frequently and, of those that have been studied, which have actually contributed to an effective design outcome. The following paragraphs describe these common design elements.

2.4.1 Common design elements

Each of the common design elements that Mehalik and Schunn (2006) identified represents a specific aspect of design activity. Each is mutually exclusive in terms of a specific describable aspect of the design process. However, it is possible for more than one of these elements to be applicable at any given time.

2.4.1.1 Explore problem representation

Exploring the problem representation should begin by examining the goal defined and having the team work together to understand what needs to be accomplished. What are the qualitative goals, and why? The way in which the design space is perceived will have an impact on different aspects of the design, chosen solution paths, and the goals and constraints by which designers are bound.

2.4.1.2 Explore graphical representation or visualization

This element involves using visual means to construct a representation. Sketches that designers may use, or graphics software such as CAD programs, fall under this element. This does not include verbal representations, such as lists of specifications, or quantitative representations, such as list of different measurements. Ultimately, visual representations also help a team communicate better, since they can agree on spatial relationships based on the graphical representations.

2.4.1.3 Use functional decomposition

Breaking down a complex system into several more function oriented aspects is a common approach taught in engineering schools. This helps isolate specific problems in different stages that are simpler to delimit, through simpler definitions that can be

designed and sometimes tested as components separately, and then reassembled into an overall design.

2.4.1.4 Explore engineering facts

Aspects that can be investigated by the designer from a specific knowledge domain can help support the decision of a feature of the design. It is good practice for designers to explore engineering facts whenever possible to make sure that the underlying assumptions, especially early on in the design, are correct.

If there is a laboratory- or company-wide knowledge database, pursuing activities related to exploring engineering facts can help to discover heritage in the design process that either the team or another design team has worked on previously.

2.4.1.5 Explore issues of measurement

This element involves examining the way in which quantitative information is gathered with relation to some aspect of the design. Typically this requires what is known as “performance parameters”, in other words how well the system works, without explicitly measuring how well it meets mission objectives. An increase in system performance can generally only be achieved by increasing cost, stretching project schedules, accepting a higher level of risk, or a combination of these according to Shishko et al. (1995). Measures that quantify directly how well the system meets the

mission objectives are called *measures of effectiveness* or *figures of merit*. Measures of effectiveness (MoEs) generally fall into one of three broad categories associated with discrete events, coverage of a continuous activity or timeliness of the information of other indicator of quality (Wertz & Larson, 1999). Metrics are robust for analysis, test and evaluations but defining them sometimes can be challenging.

2.4.1.6 Build normative model

An ideal system constitutes a normative representation or model of the design. By relaxing the limitations and constraints, the designers are able to represent a feasible solution much quicker. There are certain steps to respond to a developing normative model. Here, the designers systematically identify top-level system performance parameters and associated requirements and proceed to decompose them into a set of lower-level quantifiable and assessable elements. This needs to be done carefully, because relaxing constraints can cause unintended introduction of variability and uncertainty that can lead to poor decision making.

2.4.1.7 Explore scope of constraints

System design requirements have an existence that is dependent on the mission to be performed. There are many ways in which the designer can decide to document which initial specifications describe the mission success criteria. There are always constraints

that limit how this system can fulfill those goals. Constraints may be conceptual, physical, economical or practical.

2.4.1.8 Redefine constraints

There can be multiple interpretations when it comes to redefining constraints. The authors describe this element as an activity in which the designer decides to investigate further what is involved with the constraint or set of constraints to reconfigure the way that the constraint primarily affects the design. Instead of focusing on a specific constraint to examine the extent it governs the design, the designer may temporarily redefine the constraint in order to achieve an original goal, temporarily using a design that may not otherwise conform to the original constraint.

2.4.1.9 Conduct failure analysis

Commercial ventures accurately predict expected revenues from systems operations: they know what a failure will cost them in terms of lost hardware and income. Failure analysis tasks begin with designers early in the process. Designers should be systematic in investigating the reasons a design can fail, document this and learn from previous mistakes.

2.4.1.10 Validate assumptions and constraints

Validation of assumptions and constraints can be done through a number of ways. In inexperienced teams during early design phases, periodical reviews with experts in the different fields provide the perfect opportunity to check that some of the initial assumptions are legitimate. Another way to validate constraints is through the development of simple prototypes. Sometimes these prototypes are specifically built to gain knowledge on one or two constraints that some of the more experienced engineers identify early on. Particularly in the educational setting, sometimes engineering students may not get the opportunity to have the experience of developing prototypes to validate assumptions as a part of a design process, and they miss out on the opportunity to understand the importance of this activity.

2.4.1.11 Search the space (evaluate design alternatives)

The element of searching the space is likely to be the most creative of all the design elements. There are no limitations on how far a particular designer may wish to explore to ensure that different design alternatives have been considered. The best designers develop their own approach for complex system design. They may use various strategies and specific procedures that have worked for them to guide them systematically through the design process.

Available resources, as well as the culture of the place where the system is being designed are important dimensions that can help make this a rich activity. An

infrastructure that allows the designer to guide this effort can eventually be used when a particular concept that turned out to be more complicated than originally anticipated is no longer feasible, allowing the team to quickly focus on an alternative and resume the design process.

2.4.1.12 Examine existing designs

The authors state that this element describes a subset of activities of the *search the space* criterion (Section 2.4.1.11). In many industries, the ability to state that a particular design has heritage (meaning certain subsystems or features have been built in the past and performed successfully) immediately boosts the team's confidence in their approach. This is because a particular component or even an entire subsystem has already gone through the rigorous process of understanding its points of failure, limitations, strengths and overall design maturity.

2.4.1.13 Follow interactive, recursive and iterative design methodology

When going through the design process, it is rare that the designer will go through a fixed sequential model design only one time and find the desired solution. Typically, designers have to interact with other designers and, as they advance throughout the process, there are multiple transitions to various design stages, and iterative methodologies are common (as seen in the design models presented in Section 2.3).

The introduction of new requirements from a customer, changes in the environment, and budget alterations are examples of some of the realities that sometimes force designers to have to iterate through their design methodology a greater number of times than they originally anticipated.

2.4.1.14 Explore user perspectives

To begin the design of any system, the designers must address the system's purpose and the questions that need answering. The design model they follow will help them go through a process in which they will adequately describe the system, so that ultimately they can build it and finally test it, ideally in its operating environment. However, many designers concentrate only on acquiring information from the user at the beginning of the process, resulting in errors due to the omission of important points. Some engineers believe that constant interaction and validation from the user will improve results.

A common difficulty in any design process is that the problem is not properly defined. Designers can mitigate this by engaging the users of the system regularly, keeping them informed of matters relevant to the project that is designing it. Having the users directly involved throughout the design process with reviews, prototype presentations, relevant testing milestones and proper documentation avoids disappointments once the system is complete.

2.4.1.15 Encourage reflection on design process

Reflection on the design process can be an individual or a team experience. Groups that habitually practice self-reflection in the process of solving problems will help increase the team's level of expertise over time. This is not only relevant when there is a failure, but also when the system has met its original specifications.

2.4.2 Design elements that enable good design

The ultimate goal of Mehalik and Schunn was to have a strong context by which it might be determined what enables good design, particularly through the elements used in the design process (explained in Section 2.4.1).

Mehalik and Schunn classify the elements into five tiers, from the highest impact on design to the least, as shown in Table 2.2 and described in the following sections.

Table 2.2 Mehalik and Schunn's five tiers for good design (2006).

Tier	Elements	Impact on Design	
I	Explore problem representation	Most Impact	
	Use interactive and iterative design methodology		
	Search the space (explore alternatives)		
II	Use functional decomposition		
III	Explore graphic representation		
	Redefine constraints		
	Explore scope of constraints		
	Validate assumptions and constraints		
	Examining existing designs		
	Explore user perspective		
IV	Build normative model		
V	Explore engineering facts		Least Impact
	Explore issues of measurement		
	Conduct failure analysis		
	Encourage reflection on process		

2.4.2.1 Tier I: Design elements significant for good design (High reporting frequency)

The design elements that are reported with a high degree of frequency among the best designs in the study conducted by Mehalik and Schunn (2006) are:

- Explore problem presentation
- Use interactive/iterative design methodology
- Search the space (explore alternatives)

The authors conclude that people who used at least one of these three strategies in their design process showed the most positive design outcomes. Incidentally, it is recognized that the three design elements are associated with expert design practices that are effective.

2.4.2.2 Tier II: Design elements may be significant for good design (High reporting frequency)

Only one element is categorized as significant for good design in this tier:

- Use functional decomposition

The authors state that although this element was mentioned throughout the articles they studied, it was not always mentioned in association with the design. One reason they insinuate could be that functional decomposition is a necessary aspect of design, but the strategy is not perceived to make a large difference in achieving what is ultimately thought to be good design.

2.4.2.3 Tier III: design elements significant for good design (Moderate reporting frequency)

Six of the fifteen design process elements are associated with being significantly good, but this designation is worth less than the prior tier because these elements were mentioned less frequently overall in the database or articles.

- Explore graphic representation
- Redefine constraints
- Explore scope of constraints
- Examine existing designs
- Explore user perspective

The authors explain that confidence in this categorization can likely be increased if the database they use for their study included a larger number of articles.

2.4.2.4 Tier IV: design elements may be significant for good design (Moderate reporting frequency)

One of the elements that was mentioned overall less frequently as associated with good design is:

- Build normative model

Although some of the experts who have technical backgrounds derived from academia suggest that building a normative model provides confidence throughout the design process, Mehalik and Schunn discuss that it is not as critical as the other elements when conducting preliminary design of a system.

2.4.2.5 Tier V: items requiring further study (Low reporting frequency)

The authors describe that the low reporting frequency categories which are associated the least with good design are good candidates for further study. These categories are:

- Explore engineering facts
- Explore issues of measurement
- Conduct failure analysis
- Encourage reflection on process

Although the authors explain that the reporting of these items may be due to the types of journals considered in their analysis, they observed that there tended to be less emphasis on engineering content and facts in the empirical studies themselves. More specific engineering content and particularly measurements, techniques, knowledge and tools used tend to be reported in engineering journals for specific disciplines, rather than as a focus in the design process study. They also note, that few studies focus on the importance of design failures for improving design outcomes, and also represent possible areas for additional study for how the design processes can be better. The authors explain that from an educational standpoint, teaching of design ought to focus on the first tiers that have been documented to have higher levels of impact for achieving effective design.

There is already some research that is taking advantage of this classification. In a very interesting study of a case of robotics design teams, Noel Titus from Purdue University and Christian Schunn from the University of Pittsburgh conducted a study

with US high school robotics teams in order to determine which design activities that a team engages in has a bearing on the design (Titus & Schunn, 2008). The goal of this particular study was to provide a broad integrated perspective of the design process. There are some remarkable conclusions, for instance, making *simplicity* (as a method used for selecting among design ideas) part of the design strategy is an activity that has a positive impact on the system outcome. The other notable finding of this study was that too few or too many ideas during the exploration of the design space negatively affect design success. One thing that authors who have performed research related to this agree on is that there is definitely more work that can be done to take advantage of the fifteen common design elements.

Chapter 3

Relevant Disciplines and a Design Model

3.1 Introduction

Design models are intended to capture a system's components and their relationships. As seen in Chapter 2, different models have varied approaches to enable the designer to perform his job, for example from a functional perspective, an operational perspective or modifying an existing design.

This chapter includes the description of a design model called an atomic design process (ADP) that addresses systemic problems first rather than individual pieces of technology. The first sections describe two disciplines essential to its development: space systems engineering and information science. Following a detailed explanation of ADP, there are some similarities and differences with other models discussed. The last section in this chapter includes relevant engineering concepts that are complementary to the practical implementation of the model.

3.2 Space Systems Engineering

Space systems are composed of all the applied technology, organizations and personnel forming the entirety of the space industry network, including: spacecraft, ground stations, data links among spacecraft, mission or user terminals, launch systems and all related supporting infrastructure.

Typically spacecraft are designed for a variety of missions, including communications, Earth observation, meteorology, navigation, planetary exploration or warfare. While there is heritage in the design, there are often unique features to each mission that require innovation from engineers, scientists and technicians as they go through some part or variation of a design process to ensure that the mission is a success.

3.2.1 The Space Systems environment

The environment in which space systems operate is exceptional compared to any other man-made systems' environment. The protective characteristics of the Earth's atmosphere quickly fade as the altitude increases. The Sun, solar wind, interplanetary magnetic field, planetary magnetosphere, ionospheres and upper atmospheres all affect the environment in which space systems operate. Some studies have shown that the effects of the space environment alone cause about 25% of spacecraft failures (Anderson & Smith, 1994). The elements that make this setting unique are discussed in the following sections.

3.2.1.1 Pre-launch environment

Since the design and fabrication of spacecraft is a process that usually takes years, components and subsystems of the spacecraft may be stored for extended periods of time prior to launch. It is important that there is adequate environmental control during such periods to avoid potentially harmful degradations. This is particularly an important consideration if the assembly of the launch vehicle takes place in locations like Kennedy Space Center in Florida, where there is a higher concentration of oxidants because of its proximity to the ocean.

3.2.1.2 Launch

The placement of any spacecraft into its intended operational environment is considered the launch. It imposes a highly stressful environment on the spacecraft during its ascent, where the vehicle is subjected to significant axial loads by the acceleration of the launch vehicle, as well as lateral loads from steering and wind gusts. There are significant vibration and acoustic energy inputs throughout the entire system for the duration of the transport.

Spacecraft are mounted rigidly to the launch vehicles; therefore, they need to be designed to withstand the vibration and expected loads for the corresponding launch vehicle that they will be mounted on.

3.2.1.3 Vacuum

Designing for operation in a vacuum is an intrinsic part of spacecraft design. To control a spacecraft temperature, heat must radiate to and from space and move by

conduction to all elements of the vehicle. Different materials will outgas to some extent in a vacuum environment, and metals will usually have a thin film in their outer layer composed of gases that have been absorbed during the fabrication period of the vehicle.

3.2.1.4 Solar radiation

Solar radiation is naturally occurring and dominates particularly at what are considered high altitudes (above 800 km). It is comprised of impingement of solar photons upon the spacecraft surfaces. The pressure exerted on the vehicle is dependent on these types of surfaces, which can be transparent, absorbent or reflective. The solar radiation pressure $p(\text{N/m}^2)$ on a given surface of the satellite (in the vicinity of the Earth) exposed to the sun can be determined as (NASA SP 8027, 1969):

$$p = 4.5 \times 10^{-6} \cos \theta [(1 - k_s) \cos \theta + 0.67k_d] \quad (3.1)$$

where θ is the angle (degrees) between the incident radiation vector and the normal to the surface, and k_s and k_d are the specular and diffuse coefficients of reflectivity. The worst case solar radiation torque is (Wertz & Larson, 1999):

$$T_{sp} = F(C_{ps} - cg), \quad F = \frac{F_s}{c} A_s (1 + q) \cos i \quad (3.2)$$

where F_s is the solar constant, $1,367 \text{ W/m}^2$, c is the speed of light $3 \times 10^8 \text{ m/s}$, A_s is the surface area, C_{ps} is the location of the center of solar pressure, cg is the center of gravity, q is the reflectance factor (ranges from 0 to 1) and i is the angle of incidence of the Sun.

3.2.1.5 Microgravity

Microgravity is the nearly complete absence of the effect of gravity. It is also called weightlessness. In low Earth orbit, the gravitational force is about 90% of its value at the Earth's surface. The term microgravity is used in the space environment because in practice, zero gravity cannot actually be achieved. A rotating spacecraft can produce “artificial gravity” due to centrifugal forces, and *tidal forces* (sometimes called *gravity-gradient forces*) come about because of very small differences in the force of gravity over an extended object (Wertz & Larson, 1999).

3.2.1.6 Magnetic field

The Earth's magnetic field is roughly dipolar, described by Wertz & Larson (1999):

$$B(R, \lambda) = (1 + \sin^2 \lambda)^{1/2} B_0 / R^3 \quad (3.3)$$

where B is the local magnetic field intensity, λ is the magnetic latitude, R is the radial distance measured in Earth radii (R_E), and B_0 is the magnetic field at the equator at the Earth's surface [$B_0 = B(R = R_E, \lambda = 0) = 0.30$ gauss].

The Earth's magnetic field and any magnetic moment within the satellite interact to produce torque. The Earth's magnetic field in general is very weak (0.63 and 0.30 gauss at poles and equator, respectively) (NASA SP 8018, 1969).

3.2.1.7 Plasma

The plasma environment consists of charged particles (electrons and positively ionized atoms or molecules) that have kinetic energies in the range eV-keV. These particles penetrate into materials very little, and rather predominantly deposit a charge on the surface. Because spacecraft materials have different conductivities, they charge to different potentials when subjected to identical fluxes of charged particles. If great enough, this potential difference may cause surface arcing.

Spacecraft must be designed to either keep the differential charging caused by this plasma well below breakdown potentials, or be able to tolerate the resulting electrostatic discharges (Wertz & Larson, 1999). Engineers can select candidate materials and conductive coatings, applying numerical or analytical models based on their characteristics, so that their differential potentials in space can be determined.

3.2.2 Current Space Systems design paradigm

In Chapter 2, one of the design models presented is the Space Mission Analysis and Design model by Wertz and Larson (1999). It is used in many aerospace engineering departments throughout universities in the country as a guide for new students to learn about space systems design, particularly in senior level courses.

In summary, the spacecraft system design paradigm is represented by four stages, including a *definition of objectives* stage as a starting point, followed by a systems design series of activities to *characterize the mission*. This is accomplished by generating

alternative mission concepts and architectures. The *evaluation* of the mission follows, in which critical requirements are identified and an attempt is made to have a baseline concept as the outcome. The process ends with formal *requirements definition*, in which the overall system specifications are captured and allocated to the various system elements.

Table 3.1 shows the four main stages that constitute the current space systems design paradigm.

Table 3.1 The four main stages of the Space Mission Analysis and Design paradigm (Wertz & Larson, 1999).

Typical Flow	Stage	Description
	1	Define objectives
	2	Characterize the mission
	3	Evaluate the mission
	4	Define requirements

3.2.3 Risk inherent to Space Systems

The nature of the space industry is inherently expensive and involves significant risk, especially when there are humans aboard these vehicles. The consequences of failing to understand the implications of a critical design characteristic of a small element can be catastrophic, as with the o-ring that failed to seal in a solid rocket booster during launch due to cold temperatures and led to the loss of the Space Shuttle Challenger and its crew in 1986. After about 70 seconds of flight, on Tuesday, January 28, while traveling at a Mach number of 1.92 at an altitude of 46,000 feet, the Challenger was totally enveloped in an explosive burn. The Challenger's reaction control system ruptured and a hypergolic burn of its propellants occurred as it exited the oxygen-hydrogen flames. The reddish brown colors of the hypergolic fuel burn were visible on the edge of the main fireball. The Orbiter, under severe aerodynamic loads, broke into several large sections which emerged from the fireball - leading to the deaths of its seven crew members (Rogers Commission, 1986).

3.3 Information Science

Information Science is an interdisciplinary science concerned with the collection, classification, manipulation, storage, retrieval and dissemination of information (Pemberton, 1990). It has been perceived for a long time as a discipline that investigates the properties and behavior of information, the forces governing the flow of information,

and the means of processing information for optimum accessibility and usability. It is concerned with that body of knowledge relating to the origination, collection, organization, storage, retrieval, interpretation, transmission, transformation, and utilization of information (Borko, 1968). It includes the study of the application and usage of knowledge in organizations, along with the interaction between people, organizations and any existing information systems. It also incorporates diverse fields such as cognitive science, commerce, law, management and social sciences.

Information that is documented regarding findings of a design activity can be a largely passive by-product of the design process, as when design teams or groups of projects generate weekly reports of their action items assigned, which can later be searched in an information system. There is another type of information that has to do with the formulas and calculations that help each team member verify their theories on engineering matters. The value of this information lies in the adequate placement of the findings of said calculations. It should be noted that documenting in the context of this research will mean creating structured records (for example, of technical reports or design review material) as part of a deliberate, intrinsic design process activity. Successful consideration of the work that has been done previously will be proportionate to the effectiveness of the information technology elements that support the process.

Saracevic (1999) explains that a technological imperative is compelling and guiding the evolution of information science, as in the evolution of a number of other fields. He indicates that information science has a framework based on the past, present and future that include the *information retrieval* (IR) domain, an idea that emerged in the 1950s (defined as the main objective being retrieval of most pertinent information), the

relevance, directly orienting and associating the process with human information needs and assessments (though the relevance as defined by the user) and finally the action of *interaction*, which enables direct exchanges and feedback between systems and people engages in IR processes. More recently it is notable that due to the evolution of computing technology and the associated services, Saracevic (1999) suggests information science is inexorably connected to information technology (IT), therefore having an active participation on information-based organizations. This is particularly true for organizations that are technologically oriented, since people in these organizations have a strong intuitive understanding of what constitutes relevant information for their processes, thus, they are likely to intuitively understand the benefits that an information technology infrastructure can provide.

3.3.1 User centered approach

One of the key elements in successful information sharing is the role of information technology, particularly in the transfer of knowledge between those who have it and those who do not (Markus, 2001). It will be important for the research performed on a design model to have an information management component that enables the capture of an adequate level of detail and accessibility. This will help identify and prioritize critical couplings within the system. This information technology platform can also facilitate knowledge sharing between members of a group that have different backgrounds and levels of expertise. Because of the dynamic aspect of the design environment in the space industry, there should be elements within the design

model that promote retention and adequate distribution of information. In addition, these elements will facilitate early identification and understanding of critical decisions with conflicts of different value.

A valuable contribution from information science to other disciplines in recent years is the intention to understand the underlying problems that the information systems developed are meant to address from the perspective of the users or stakeholders (Wersig, 1993). In the case of design process models, these stakeholders can be engineers, technicians or managers that are involved in the process. The influence from this discipline comprises supporting information flow throughout the model, and applies information-supporting concepts as needed. The effective use of information technology to address the needs of the users is considered a user-centered approach. A method to gain a better understanding of user needs is to be an active user (Beyer & Holtzblatt, 1995). In this approach, system developers either already have or develop the same training, experience, and perform the same task as the people who will use the system. There have been a number of instances in which this approach has been successful in the development of customized information systems, where the information provided into the systems by users also assisted other users with similar needs (Petrelli et al. 2004; Heidorn et al. 2002).

3.4 A Design Model

There are many documented models (some presented in Chapter 2) that are extensive in attempting to capture all the details that go into complex systems design. Additional models range from over all system design through subsystem selection using physical programming (Patel & Lewis, 2003), to new methods for rapid architecture selection that are heavily computational like the ones described by McManus et al. (2004). Mawson (2003) however, argues that models of the design process tend to be misrepresentations of the way practitioners actually do design, and they do not offer a useful structure for the way that new designers learn. The intention here is to study a working model that captures the critical design steps that allow an organized approach for finding a feasible solution.

3.4.1 An Atomic Design Process

In an attempt to capture the fundamental steps required for solving complex problems, Washabaugh (1999), at the University of Michigan, proposed an atomic design process (ADP) concept. This notion is the cornerstone for this research. Fundamentally, the basic algorithm consists of the repetition of four sequential core elements in search of a viable answer to a practical problem. The elements are *specifications*, *configurations*, *trades* and *drivers*. They are shown in Figure 3.1.

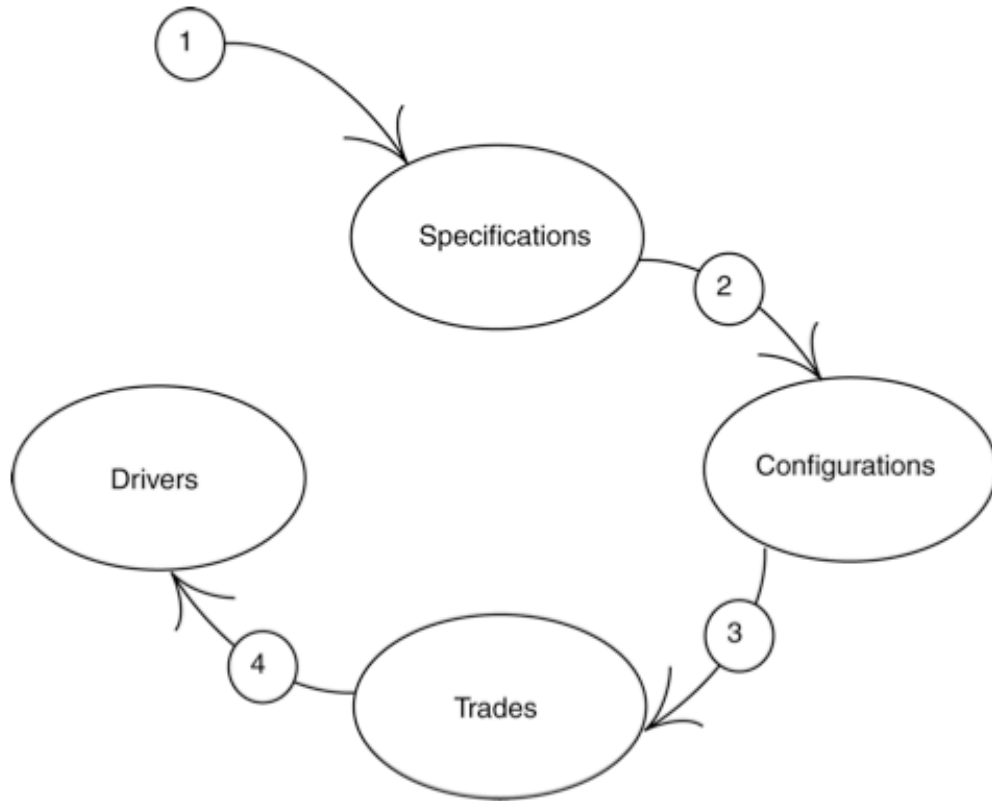

Figure 3.1 A fundamental or atomic design process with process detail (Washabaugh, 1999) the numbers simply represent the sequential steps: 1. Specifications, 2. Configurations, 3. Trades and 4. Drivers.

The ADP model entails a systematic approach to finding the initial design of a complex system. A description of each of its elements (Washabaugh, 1999), is included in the following paragraphs.

- **Specifications.** The first element consists of capturing the statements that define what the customer is trying to accomplish. The specifications include how well the resulting system should perform. From an individual need, societal need,

customer request, etc., the process begins in the specifications phase by trying to understand and organize openly what will ultimately become the project's definition of success. If what is built and operated accomplishes the specifications to the minimum degree of qualifiable performance expected, then there is success. Although it can take a certain degree of expertise to be able to recognize whether there is enough content and clarity in the specifications to fully understand the customer need, they can be modified to reflect newly acquired information as iterations occur.

- **Configurations.** The configurations stage is the second stage of ADP. During this stage, as many architectures leading to potential solutions as possible are considered deriving from the set of specifications. A team's collective creativity enhances the activities of this stage. This is an opportunity to consider all viable architectures that allow the designer to identify where values are placed within the elements of the total solution and the nature of the relationships between them.
- **Trades.** Trades (interchangeably used with *trade studies*) are performed through quantifiable evaluations (i.e., physics, engineering, accounting, etc.) to help identify relevant relationships between parameters. The trades help the designer understand how sensitive the alternatives are to variations in the baseline performance of the proposed architecture elements. The goal for any designer at this stage is to obtain the best compromise among the choices available, to meet

the specifications presented. The trades help to expose underlying assumptions and expected performance in a quantifiable way. It should be noted that the proper documentation of these become a crucial tool especially when the specifications have changed.

- **Drivers.** Drivers are the design parameters that influence system performance the most. If possible, it is necessary to identify these parameters that govern the design, since they relate directly to the quality of the design's implementation. During the initial iterations of ADP, it is likely that there is not enough information to fully determine what are the drivers. As more configurations and trade studies are performed, the team can collectively make an assessment to determine with higher certainty what are the system drivers. If a driver isn't identified during an iteration of ADP, a team can document what they contemplate is likely to be the driver at a certain point, but not consider it as part of the feedback into the next iteration of the design process. This is the best approach, since it has been observed in industry that misidentifying system drivers and allowing them to influence the evolution of a design is one of the most common causes of mission error (Wertz & Larson, 1999).
- **Iteration.** A team that proceeds methodically through an atomic design process iteratively is likely to find a feasible design solution. The team will progressively identify the critical couplings within the system leading to the key design drivers.

3.4.2 Update to an atomic Design Process

The configurations and trades elements in ADP have a strongly coupled and special relationship. It is heavily influenced by a number of factors. Some of these include an organization design's culture, financial budgets, the number of people in the design team, their level of expertise, the resources available, etc. The configurations and trades are stages in which a team's knowledge reuse and design innovation are most likely to take place. According to Liefer and McDemott (2000), the more complex a system is, the stronger the need for a harmonious balance between knowledge reuse and innovation, which is, by its very nature unique. Majchrzak et al. (2004) show that there are identifiable and repeatable actions performed (sometimes inadvertently) to try to attain a balance between knowledge reuse and innovation. There are a series of actions that have been observed in design teams that consist of a staged process, including: a brief scanning of broad searches that can sometimes be non-traditional, a brief evaluation, and a quick in-depth analysis that shows to have relevance, credibility, and adaptability. As part of this research, an updated version of ADP is proposed by the author to capture a new iterative sub-process between configurations and trade studies to facilitate the actions described by Majchrzak. Understanding this relationship will help characterize ADP's relevance, so that it can be seen with what circumstances it works.

In addition, part of the research aim is to capture different mechanisms to cope with the complexity of understanding the decisions made during all these phases. There are studies that support the premise that when accessing cross-domain knowledge, there

are specific characteristics that affect the degree to which knowledge will be used. An example of this is the formal association of the knowledge to a specific expert, since it can serve as a cue to the quality of the knowledge via the source's credibility, and a point of contact for help during the use of that knowledge (Faniel & Majchrzak, 2007). Having a good information sharing platform helps in this endeavor, by managing the documentation of choices and rationale that designers have while taking different actions.

Emphasizing the need for an alternative iteration between creating configurations and performing trades, in addition to an underlying awareness of the need for effective information sharing, the final design model is the iteration of the updated atomic design process shown in Figure 3.2

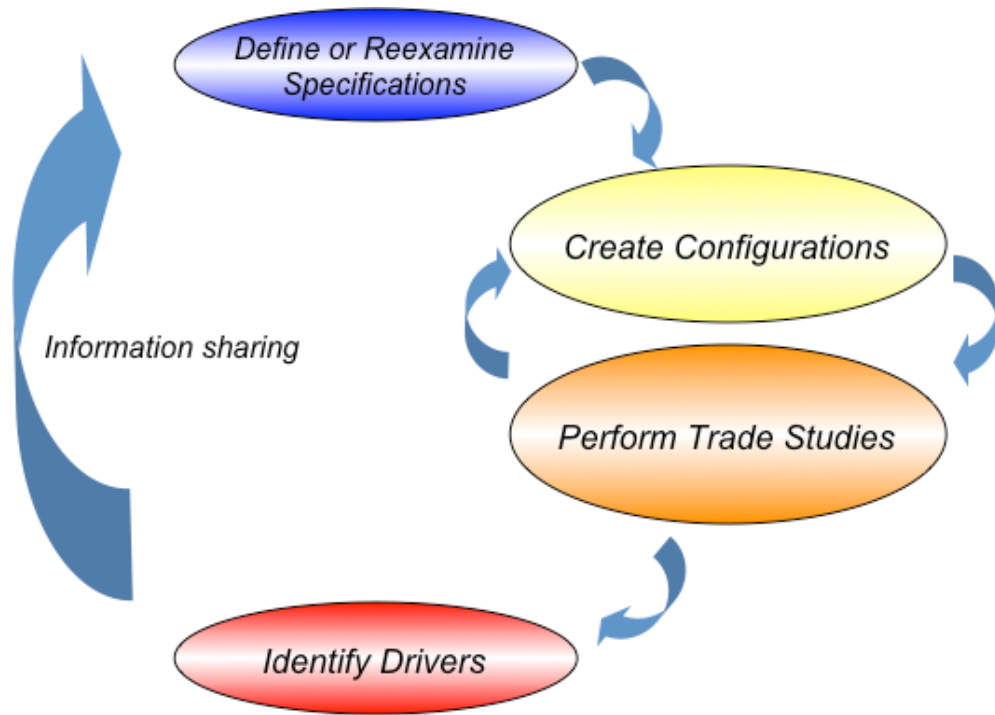

Figure 3.2 Updated atomic design process, with iterative component between configurations and trade studies elements.

Once a design is mature due to iterations through the ADP, it will become relevant to pursue processes that can optimize a specific set of parameters of the system without violating active constraints.

3.5 Comparison between ADP and other Models

To help understand the applicability of a model that captures the central steps of design, the following sections contain a description of similarities and differences between the ADP and the design models explained in Chapter 2.

3.5.1 ADP and the Space Mission Analysis and Design (SMAD) process (Section 2.3.1)

As summarized in Space Mission Analysis and Design (Wertz & Larson, 1999) the SMAD design process is a comprehensive process for design of space missions. It is recognized by the book's authors/editors that no single algorithm could fully cover all possible design options, but it is a process that seeks to be able to formally allocate requirements to system elements. Most of the eleven design steps have one or several sub-processes to help accomplish their purpose. Important design team members including users, developers, planning and budgeting personnel all have key roles throughout the entire process, but it is not obvious within the steps when their input is more valuable for the process. Overall the SMAD process is one that intends to promote designing a mature system at the expense of the complexity of the process. This is the major difference with the ADP model. The ADP model focuses on swiftly finding feasible designs by trying to identify system drivers. Identifying system drivers is only one of the eleven steps of the SMAD process (the fifth). For an implementation using ADP, finding the system drivers is one of the main focuses of the designer.

The complexity of SMAD also means that learning the process can be quite challenging for the inexperienced individual. Through basic design exercises used as examples, inexperienced undergraduate students have shown the ability to grasp the fundamental concepts involving the application of the ADP model (See Chapter 5).

Both processes are similar in their iterative nature. The common philosophy is that design is an iterative process, in which gradually there is a refining of the specifications that document what is expected from the system. It is noticeable that the ADP iterations are much faster, but this also is related to the nature of the model, which in this context has a focus of finding preliminary feasible solutions.

In many cases, these two approaches for systems design are complementary. After the basic mission concept and elements have been identified using ADP, specialized algorithms introduced by the SMAD process could be used. For example the process for defining specific mission characteristics (i.e. orbital elements, optical system field of view, launch vehicle, etc.) that a designer is expected to use in step six of SMAD (characterize the mission architecture) would be ideal to complement the first order design that a team has generated by using ADP.

3.5.2 ADP and Pugh's design model (Section 2.3.2)

Pugh's model has a strong marketing and selling philosophy that emphasizes the ultimate goal of capitalizing on the development of a system. ADP does not have stages explicitly designed for economic purposes. Clearly defined needs of a product meant to

be sold can, however, be captured within ADP's first stage of specifications. As the design matures, the iterative process guarantees that the system meets a particular financial requirement.

The fundamental sciences and engineering elements that Pugh's model has laid out throughout the entire process takes place within the *trade studies* stage in ADP. Pugh's model has organized activities that bound the techniques used throughout the design process. The ADP model does not have these techniques forced into specific elements. The synthesis and decision-making are integrated throughout the transition of all ADP's stages, and the optimization element comes from additional iterations within ADP's model after a feasible design has been found.

It is difficult for a designer following Pugh's model to identify a system driver since there is not an output that would allow him to clearly recognize it as such. While using an optimization technique after the *detailed design* has been accomplished, there could be insight into elements that are intimately related to the system's performance, suggesting a system driver. However, this is not emphasized and may easily be missed.

Pugh's model suggests the designers have a moderate-to-high level of expertise, which allows them to understand the precise steps that would have to be taken within the *concept design* phase and the *detailed design* phase to trace back the results of each of the stages to the original *specifications*. With a comprehensive description of each of ADP's stages, it is expected that inexperienced engineers are able to understand the steps needed for finding a first-order feasible design.

3.5.3 ADP and Hammond's Multidisciplinary Design Model (Section 2.3.3)

The Multidisciplinary Design Model (MDM) of Hammond (1999) and ADP have a very similar first stage, which is *requirements* or *specification's* definition. Focusing on the “design group” lobe of the MDM design process (see Figure 2.5), the two stages of *initial sizing* and *vehicle design* would be equivalent to ADP's *configurations* stage and partially the *trade studies* stage. If both the propulsion group and the design group in Hammond's model were to define the propulsion concepts and other elements (like aerodynamic propulsion estimates) within the first stage, then there would be a direct path towards the *vehicle design* stage from which they can go into the *vehicle analysis* later on.

However, once in Hammond's *vehicle design* stage, there is no defined path to go back to *initial sizing*. Through iterations of the ADP model, however, it is explicitly expected to return to the initial *specifications* and reassess if changes need to be made (or if design success has been achieved). It is possible that in Hammond's *vehicle design* stage, there is an expectation of having a mature enough set of requirements such that only going from there into *vehicle analysis* and *final design and performance* will there be ultimately a system that meets the functional and operational requirements in the *requirements definition*.

Somewhere unspecified within the *vehicle design* and *vehicle analysis* phases of MDM there are rigorous trade studies conducted to refine the vehicle. The nature of ADP enables unmistakably a singular phase where trade studies are conducted. These provide a solid foundation for the analysis (the *trade studies* stage), and they help understand how

different configurations can be justified across the board. Beyond the *final concepts*, *final design and performance* stages in Hammond's model there is an additional stage called *effectiveness analysis*. It is only from this stage that clear feedback is given to the *vehicle design* stage, which is the earliest stage from within the process a designer can come back to after passing the first two stages. Finally, in MDM, the overall conceptual design phase is very short compared to the other activities for systems development.

3.5.4 ADP and Hammond's Conceptual Design Process (Section 2.3.4)

The reader can appreciate that, as shown in Section 2.3.4, the Hammond (2001) Conceptual Design Process (CDP) is an extensive and complex algorithm to follow. There are five interconnected stages, most of which have several inputs and outputs, and there isn't a unique starting point in the algorithm. Similarities with ADP include the constituent of *configuration types*, where the designer has an opportunity to explore the design space throughout different architectures that could host the feasible solution. The iterative nature is another similarity, although in CDP there are far more paths through which the designer can iterate between parts.

The main differences with ADP include the size of the models and their scope. The information flow in CDP is enormous, and the assumptions of synthesized information between features make it difficult to comprehend at a top level. A designer trying to learn this algorithm has no choice but to break it down into manageable sub-algorithms. It is a concern that without having gone through many design processes

before, a designer may have difficulty understanding what constitute suitable outputs from these sub-algorithms that feed into subsequent stages.

It is also inherent in Hammond's CDP process that there is an element of *performance detailing* that is expected to be applied early in the design cycles, to comply with a "satisfaction filter" that is promoting an optimization element into the process.

3.6 Systems Engineering Concepts

When considering systems with many components it is convenient to subdivide them into functional elements or subsystems. Systems engineering is a multidisciplinary approach to develop balanced system solutions in response to diverse stakeholder needs. It includes the application of both management and technical processes to achieve this balance and mitigate risks that can impact the success of a project (Friedenthal & Moore, 2008). Systems engineering ultimately involves the broad series of activities required to ensure that the overall system meets the objectives defined. Some pertinent systems engineering concepts, especially appropriate for space systems design applications, are described in the following sections.

3.6.1 Requirements

The formal and official set of technical expectations (functional, operational and hard constraints) that a system shall meet, that are derived from the specifications in ADP are the *requirements*. During the first iterations of ADP it is likely there is not enough information about the system to be able to define requirements. But once a designer is able to iterate through ADP enough times that there is enough information to formalize the technical performance expectation then they become requirements. Through each iteration of the ADP requirements are assessed, challenged, and updated as needed. The proper documentation of these in itself becomes valuable knowledge that can help the design team understand historically how the priorities have been established.

Below is an example of an initial set of requirements:

Table 3.2 An example of a payload team’s partial list of requirements.

ID	Requirement
PLD-001	Payload mass shall not exceed 100 g
PLD-002	Payload should operate on 1.8V, 3V or 5V regulated voltage line
PLD-003	Payload hardware interface shall be via SPI, TWO. USB or UART/RS-232C/Serial Port

3.6.2 System budgets

There are a number of documents that are created during the design of a complex system. Some of the most updated ones, due to their impact across all the engineering

disciplines, are *system budgets*, which include the *mass budget*, the *power electrical budget* and the *cost budget*. Each of them is explained in the following sections.

3.6.2.1 Mass budget

This budget allows for tracking of the subsystem elements mass throughout the design process. It is common that there are contingencies (or *margins*) allocated per subsystem. The contingency is the additional trade space available to designers allocated. It has the purpose of providing some flexibility in the design in case there are unexpected changes. As the design matures, the contingencies are expected to be methodically reduced. The size of these contingencies is dependent on a number of factors, including knowledge of the system, component heritage, etc. As the design matures over time, the expectation is that the values reflected in the mass budget are more representative of the real values for the system. Table 3.3 is an example of a mass budget.

Table 3.3 Spacecraft mass budget example (showing contingency).

	Quantity		Mass				
	(#)	Component Mass (g)	Total w/o Contingency (g)	Contingency	Total w/ Contingency	Alloted Mass	% of Alloted Subsystem Mass
Systems					100	100	100%
Payload			49	13%	55	100	55%
Digital Camera	1	17.33	17.33	5%	18		18%
Toradex	1	11.4	11.4	5%	12		12%
Camera Mount	4	5	20	30%	26		26%
ADCS			12	10%	13	20	65%
Magnet	1	9	9	5%	9		47%
Hysteresis Material	2	1	2	5%	2		11%
Magnet Holders	2	0.5	1	20%	1		6%
P&E			269.4	22%	328	300	109%
Battery	1	52	52	5%	55		18%
Battery Case	1	9	9	30%	12		4%
Solar Cells	12	2.2	26.4	5%	28		9%
Boards	6	12	72	30%	94		31%
Power Distribution Board	1	90	90	30%	117		39%
Wiring and Harnesses	1	20	20	30%	26		9%
C&DH			100	30%	130	220	59%
C&DH Board	1	100	100	30%	130		59%
Telemetry			18	30%	23	30	78%
Antenna	1	18	18	30%	23		78%
Mount	1	5	5	30%	7		22%
Structures			199	13%	225	230	98%
Side Panels	3	18.04	54.12	5%	57		25%
Camera Panel	1	18.18	18.18	5%	19		8%
End Panels	2	22.29	44.58	5%	47		20%
Rails	4	18.11	72.44	5%	76		33%
Brackets	4	1.7	6.8	30%	9		4%
Fasteners	64	0.04	2.56	30%	3		1%
M-Cubed Total			646.81	20%	875	1,000	87%

3.6.2.2 Power electrical budget

Similar to the mass budget, this document allows tracking of the power for each component that requires it throughout the project’s design lifecycle. When estimating a spacecraft power budget Wertz & Larson (1999) suggest there are three major steps involved. First, an operating power budget is determined by estimating the power required by the payload and the spacecraft subsystems. If the spacecraft has several operating modes that differ in power requirements, there must be a separate one made for each mode, paying attention to the peak power needs for each subsystem. The second

step is battery *sizing*, or selecting a battery with the appropriate capacity to meet the power requirements. Finally, the third step is to account for power-subsystem degradation over the mission life by computing radiation, vacuum, atomic oxygen and other space environment elements to the system. An example of a power budget is shown in Table 3.4.

Table 3.4 Summary of spacecraft power electrical budget example (showing contingency).

Load Characteristics: Component:	Orbit Average Duty Factor:	Power Contingency	Peak Sub-system Power (W):	Avg. Sub-system Power (W):	Orbit Avg. Energy (W-min):
Antenna Release	0.005	30%	14.81	0.07	7.05
Camera	0.01	30%	2.41	0.02	2.29
Transceiver Tx	0.06	30%	0.12	0.01	0.66
Transceiver Rx	1	30%	0.09	0.09	0.76
Power Amplifier	0.5	30%	2.06	1.03	97.99
Processor - C&DH	0.05	30%	0.32	0.09	0.76
Total Output Power/Energy Per Regulator:			19.80	1.31	109.50
Total Input Power/Energy Per Regulator:			21.27	1.47	139.91

3.6.2.3 Cost budget

The nature of the cost budget is influenced tremendously by the early conceptual design. Maier and Rehtin (2000) found cost to be one of the four main tensions during system development (the other being performance, schedule and risk). It is not uncommon for costs to increase in space programs due to the extreme complexity of the systems being developed, schedule slips and the inherent risk. In the example below (shown in Table 3.5, costs in U.S. dollars), there are four main categories for the budget of a space system: Personnel/Labor (which can include all Management Overhead costs), CubeSat Development (the actual hardware and software of the system), Launch (launch vehicle associated costs, sometimes including the costs of qualification processes to meet

the provider's standards) and Reserve. The last category can be used in a similar fashion as the contingencies in the technical budgets.

Table 3.5 Example of a space system cost budget summary.

Subsystem	Estimated Cost	Money Spent
Personnel/Labor	\$30,000	\$12,000
CubeSat Development	\$30,000	\$2,000
Prototype*	\$5,000	\$2,000
Engineering Design Unit*	\$5,000	N/A
Flight Unit*	\$10,000	N/A
Testing and Qualification*	\$10,000	N/A
Launch	\$40,000	N/A
System Reserve	\$20,000	N/A
Total	\$120,000	\$14,000

3.6.2.4 Additional system level documents

There are many schematics that will be developed during the design of a space system. A very important one is the *system block diagram*, as the example shown in Figure 3.3. This diagram presents a top-level perspective of the major subsystems and their relationships that together constitute the complex space system.

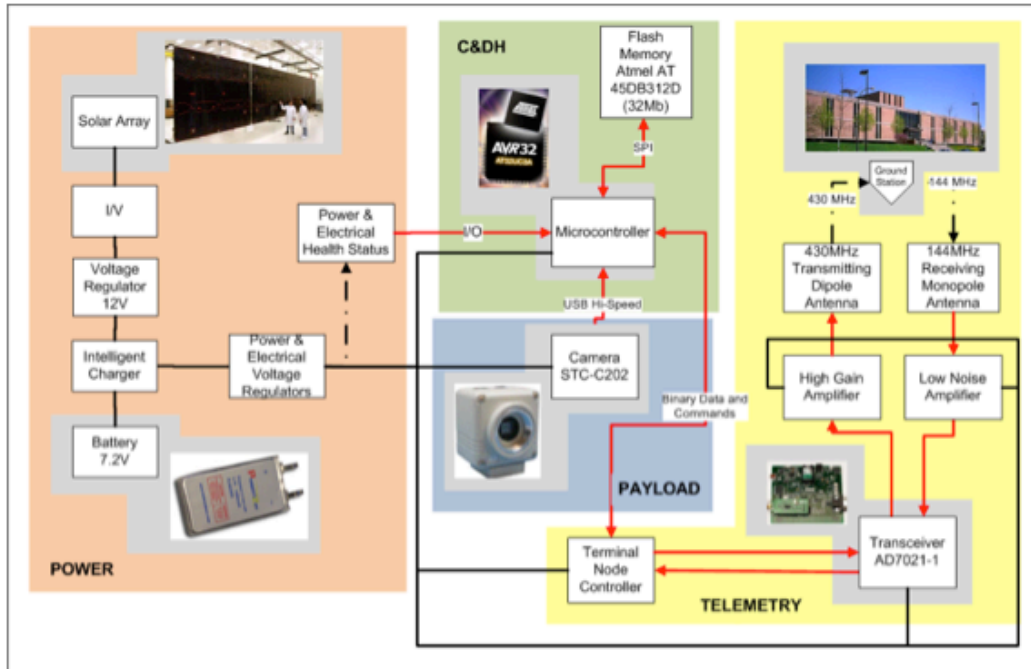

Figure 3.3 Example of a system block diagram for an unmanned space system. Black lines indicate power routing and red lines indicates data flow.

Configuration drawings are required as early as possible. The drawings should show nominal and worst-cases. In the case of many structures elements, these configuration drawings will constitute the basis for the drawings that machinist will require to fabricate the components.

Documentation pertinent to the nature of the interfaces of the subsystems is always critical, so that there is a clear understanding of the technical boundaries. The collection of this documentation is often referred to as Interface Control Documentation (ICD). At the system level, project managers or system engineers control these documents, while internally to each subsystem, having these up to date and accurate is the responsibility of the technical team leads. Although the content and format of ICD's may vary significantly with systems developed and the organizations, typical elements

always addressed include physical and data or signal interfaces and interactions (INCOSE, 1998).

Chapter 4

Implementation of the Design Model

4.1 Introduction

Each application of an atomic design process (ADP) explained in Section 3.4 should be thought of as unique. The interaction of the various disciplines involved may inadvertently leave open to interpretation many characteristics of the process. Because of this distinctiveness and due to the information sharing philosophy of the ADP model, it is necessary to explain under what context the potential advantages for such an approach exist.

This chapter begins by describing the environment where the research for understanding ADP is performed, the Student Space Systems Fabrication Laboratory (S3FL). Subsequently, there is an explanation of the supportive information technology used to reveal the strengths of the ADP model. This information technology platform includes an original customized implementation (considering the user-centered approach described in Section 3.3) and widely used web based tools. Finally, at the end of the

chapter some of the most relevant human factors that are to be considered when implementing ADP are also discussed.

4.2 The Student Space Systems Fabrication Laboratory

The Student Space Systems Fabrication Laboratory (S3FL) at the University of Michigan (UM) is part of the College of Engineering and is a student run and operated laboratory with the goal of developing systems that will operate in or near space (Bilén et al. 1999; Liu et al. 2006; Liu et al. 2007).

S3FL originally began as a small group of students whose purpose was to develop a single experiment, to be flown on NASA's KC135 program, the vortex ring transit experiment (VORTEX). Vortex had the designation of NASA payload G-093, and was flown on the Space Shuttle mission STS-89 in January 1998 and again on STS-88 in December 1998. G-093 was designed to answer some basic questions about fluid atomization; the process whereby a liquid is converted into small droplets (Bilén & Bernal, 1999). The group of students realized by the time they had finished building the small instrument that if all the resources they had used (including facilities, relationships built with experienced engineers from SPRL, documentation practices, etc.) could be somehow standardized in an organized environment, a formal laboratory could be created.

The laboratory has successfully designed and built other KC-135 microgravity experiments (Smetana et al., 2007), designed a Get Away Special Space Shuttle

experiment (Ramos & Liu, 2005), developed award winning nano-satellite concepts (Ramos, 2008), and with the help of the UM Space Physics Research Laboratory (SPRL), delivered a functional spacecraft to NASA Marshall Space Flight Center (MSFC) for their ProSEDS electrodynamic tether demonstration mission (Goldberg & Gilchrist, 2003). The laboratory provides a valuable learning experience to both graduate and undergraduate students and its immediate goal is to provide for students' practical, hands-on, interdisciplinary experience through the design and development of space systems projects, while advancing the state of art in space technology.

There are two groups that constitute S3FL, students and faculty. The faculty advisors support in many critical ways the laboratory, from reviewing designs to acting as points of contact with industry and other faculty members from UM. All day-to-day activities in S3FL are student-run, with administrative and technical guidance provided by the student Executive Committee (Excom). On average, there are about one hundred students per academic term working in S3FL. Figure 4.1 shows the organization of the laboratory, including projects that are directly overseen by Excom members, who are qualified graduate or upper-level undergraduate students with prior project lead experience.

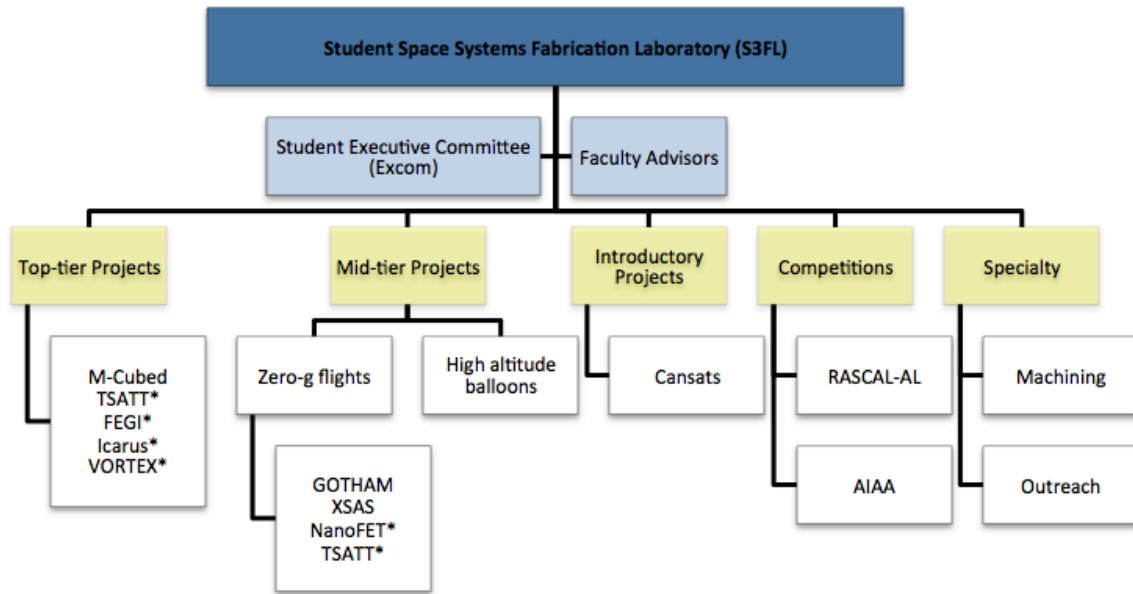

Figure 4.1 The Student Space Systems Fabrication Laboratory’s organization chart. Asterisks denote previous projects.

The projects range from top-tier, multi-year efforts involving dozens of students on satellites and Space Shuttle payloads, to months-long design projects (e.g., microgravity flights (NASA Microgravity, 2011), high altitude balloon experiments, etc.) and introductory level projects (e.g., Cansats) intended as training programs for newer students and test platforms for prototype design development. S3FL teams also participate in various aerospace systems competitions (e.g., NASA’s Revolutionary Aerospace Systems Concepts – Academic Linkage (NASA RASC-AL 2011)), undergraduate competitions from the American Institute of Aeronautics and Astronautics (AIAA, 2010), etc.).

The student body includes some graduate students but it is mainly composed of undergraduates with majors including, for example, mechanical engineering, materials

engineering, electrical engineering, computer science, physics, aerospace engineering and industrial and operations engineering. Throughout their participation in S3FL, students are involved in the development and management of aerospace projects, sub-orbital rocket payloads and high-altitude balloon experiment initiatives, etc. The fundamental group in S3FL is the *integrated product team*, which consists of six to eight students with a well-defined functional objective within a project. These teams may be involved in the technical development of experimental science payloads, electrical and/or computer systems, structures or mechanical components, communications systems or software development and support. The most experienced users take the role of *team lead* and *assistant lead*, which guide the team through technical growth, and serve as liaison with the chief engineer and project manager of each program.



Figure 4.2 Student characterizing solar panel grid (left) and students presenting at design review with industry sponsors (right).

Finally, teams of students also participate in specialty groups to support S3FL activities, including outreach programs to help increase awareness of members of the community and children about various engineering topics.

4.3 Supporting Information Technology for the ADP

Information technology (IT) is a branch of information science (see Section 3.3) that deals with the use of electronic computers and computer software to store, process, transmit, and retrieve information. This is intended to occur in a secure manner, and adhering to the organizations protocols for user accessibility and manipulation. The information technology solutions that have supported research regarding the implementation of the ADP are described in the following sections. Section 4.3.1 describes a customized information technology implementation developed for S3FL (introduced in Section 4.2) and Section 4.3.2 provides details on additional tools.

4.3.1 S3FL Information Management System (SIMS)

The author designed, coded, and implemented an information management system to help consolidate and streamline relevant information within S3FL. The intent was to create a sustainable long-term solution for capturing information regarding three domains:

- **Personnel development.** Information regarding members' participation in projects within the laboratory, including different projects they have worked on (history in the laboratory), attendance to regular working meetings, events (including design reviews, competitions, etc.), certifications (e.g. machining

certification, recognitions of work, technical trainings, etc.). Research has shown that the cost involved in creating and using information systems (such as SIMS) would not be necessarily a problem if they were balanced by appropriate incentives (Markus, 2001; Shapira et al. 2001). A detailed file that includes member's acquired skills, design reviews attendance, recognitions, etc. and that is documented in their SIMS account are intended to be good incentive for members to pursue them, in addition to being a motivation for writing better technical reports, which is the next domain.

- **Knowledge base.** A laboratory-wide collection of information representing technical experiences, problems and results captured by all members on a weekly basis in addition to all previous projects documentation.
- **Laboratory operations.** The laboratory's inventory, thermal-vacuum system operations database and the catalog of interaction with industry partners are the three major laboratory operations that are managed by the information system. This domain is relevant since research has shown that the design of information systems should be shaped by user's needs and typical situations of use, since these factors are significant determinants for the regular use of the system (Suchman, 1987; Bowker et al. 1997).

A dedicated server hosts a reliable open source database, MySQL®, that is accessed through the Internet by using an open-source HTTP¹ server, Apache®. The information system is a custom built PHP based information management system (PHP is

¹ Hypertext Transfer Protocol (HTTP) is the networking protocol that is the foundation of data communication for the world wide web.

a widely-used general-purpose scripting language that is especially suited for web development). The information system is called S3FL Information Management System (SIMS) (Ramos, 2007).

Fifteen students were asked to use SIMS during four months to work out the initial software bugs. During the following academic term it was officially launched for the entire laboratory with more than 80 registered active users during the first term. By the subsequent academic term it became mandatory for all members of the organization to submit weekly technical reports, as well as documenting all the other information categories expected by the information system as described in the S3FL Standard Operating Procedures manual (S3FL, 2010).

The system provides the users with personalized information depending on the type of user account. Table 4.1 summarizes SIMS user’s categories.

Table 4.1 The Student Space Systems Fabrication Laboratory Information Management System (SIMS) user categories and description of their privileges.

SIMS user categories	Description
Engineer	This category corresponds to the standard user. This is the default category that new S3FL members are assigned to when they sign up to work in S3FL. This category enables the user to be able to access all the features on SIMS.
Assistant Lead	These accounts are engineer accounts with additional privileges of capturing other member’s attendance on SIMS. The users of these accounts are expected to work closely with team leads (or fill in for them as needed).
Team Lead	The team lead account provides engineer level access to the system. In addition, it allows the user to see detailed profiles of all the users that are part of that team.

Chief Engineer	This account is reserved for members of a team that are technical chief engineers of a project. It provides access to all the technical teams that form part of that project.
Excom	Accounts with the highest authorization that give access to information regarding all teams and members in S3FL.
Faculty	These accounts have the same level of access as an Excom account, but these are reserved for faculty advisors of S3FL projects. It enables a faculty member to access all SIMS users and laboratory modules.
Recruiter	The recruiter account was created to provide low-level accessibility to users that are not part of S3FL and are potential recruiters from industry. They have only access to the basic information, project association and recognitions of standard SIMS users. If the recruiter wishes to contact a SIMS user, a link to send a message to that user is available.
Administrator	Unique account with only one master user, which administers the entire system.

The most common member category in SIMS is the *engineer*. The engineer category will be used as an example to illustrate the information that is provided to the standard user. When an engineer logs into SIMS they are presented with information regarding official S3FL records as follows:

- **General Information.** This includes the date the member started in S3FL, gender, academic level, academic major, other university organizations they are affiliated with and special engineering skills information. A snapshot of this section is shown in Figure 4.3.

Welcome **Monica!** << [Logout](#)



Name: **Monica K Orange**
Start Date: **2007-11-30**. Gender: **Female**. Year: **Sophomore**. Major: **MECH**.
Cell: **345-8998**. Other UM Groups: **Solar Car**. Notes: **Machining experience**.

Figure 4.3 S3FL Information Management System (SIMS) standard member general information section.

- **Current Term Information.** This consists of member category information, which university credited course they are enrolled in, their status and the project they are associated with. The status of a member is their official standing with regards to S3FL member's criteria. It includes *interview stage* (designated for potential members), *active* (standard for all working S3FL members), *dropped* (potential members that did not pursue involvement in S3FL), *former members* of S3FL and *temporarily inactive* (denoting members that are under investigation due to violation of policies). Figure 4.4 shows a snapshot of this section as it appears on SIMS.

<p>Category: Engineer</p> <p>UM Course: AERO390 Credits: 1</p> <p>Status: Active</p> <p>Project: Tethered Satellite Testbed – Structures</p>

Figure 4.4 SIMS standard member current term information section.

- Certifications and Awards.** This section displays information about certifications the student has earned including OSEH certificates of safety, skills like mill and lathe certifications, etc. It also displays the recognitions this individual has received during their time with the laboratory, for instance *Most Valuable Engineer*, *Most Valuable Freshman student*, and *Engineering Leadership* recognition. An example of the recognitions section is shown in Figure 4.5.

<p>Certifications & Awards</p> <ul style="list-style-type: none"> > OSEH Certification Date obtained: 2007-01-18 Comments: FALL07 Special session for S3FL. > WSPC - Mill Certification. Date obtained: 2007-02-02 > Team Most Valuable Freshman Student Recognition Date obtained: 2007-12-01

Figure 4.5 SIMS member certifications and awards section example.

- History.** This section includes a summary of the role, number of credits and projects that S3FL members have had in the laboratory over time. An example is shown in Figure 4.6. This section was added during the second revision of the system, with the intention of helping S3FL management to be able to keep track of students’ involvement during the span of all the academic terms they are enrolled at the university (some top-tier projects can span multiple years in development).

History
Winter 2007 , Engineer, Volunteer 1 credits, Active, TSIX - Structures, , Machining, Mon 1 Jan 2007 01:00 - arramos
Spring 2007 , Engineer, Volunteer 2 credits, Active, TSIX - Structures, , Machining, Wed 21 Mar 2007 19:05 - arramos
Fall 2007 , Assistant Lead, Volunteer 2 credits, Active, TSIX - Structures, , Machining, Wed 21 Sep 2007 19:10 - arramos
Winter 2008 , Chief Engineer, Volunteer 2 credits, Active, TSIX - Structures, , Machining, Wed 2 Jan 2008 19:10 - arramos
[...]

Figure 4.6 SIMS member summary of roles in S3FL example.

- **Events.** This section shows all the information pertaining major engineering events. Some of these events include presentation dry runs, formal design reviews, workshops, etc. An example is shown in Figure 4.7.

Events
> Design Review Presentation - PDR Status: Presenter Location: SRB Date: 2006-12-01 Verified By: Ashley Comments: Well done!
> S3FL Workshop - Unigraphics Status: Assisted Location: SRB Date: 2006-12-01 Verified By: Tom
> S3FL Workshop - SPICE/electronics Status: Assisted Location: SRB Date: 2007-01-09 Verified By: Tom Comments: Included prototype development.
> Dry Run with Excom Status: Reviewer Location: SRB Date: 2007-01-09 Verified By: Tom Comments: Remember to print out material for review.

Figure 4.7 SIMS standard member summary of events while in S3FL.

- **Attendance.** This is the section where the team leads or Excom can capture detailed attendance information for each member. An example showing justified and unjustified absences documentation is shown in Figure 4.8.

<p>Attendance</p> <ul style="list-style-type: none"> > Regular Team Meeting Unjustified Absence Location: SRB Date: 2007-01-04 Verified By: arramos > Regular Team Meeting Justified Absence - Exam Location: SRB Date: 2007-01-04 Verified By: tom Comments: Physics 101 exam > Regular Team Meeting Unjustified Absence Location: SRB Date: 2007-01-04 Verified By: liutm
--

Figure 4.8 SIMS member attendance record example.

- **Outreach.** It has become increasingly important to have proper records of outreach efforts that many S3FL members are involved in, since there is a strong desire by S3FL’s executive committee to have a positive influence with the local community. This section shows details corresponding to internal and external events, S3FL outreach events, conferences, facilities tours, etc. An example is shown in Figure 4.9.

<p>Outreach</p> <ul style="list-style-type: none"> > Internal - Other UM personnel Tour Status: Setup + Manned Booth Location: On Campus Date: 2007-11-30 Verified By: tom Comments: Presentation at campus event including tour. This student helped setup the booth and also manned the booth for the first day. > External - Middle School visit Status: Setup + Manned Booth full time Location: Off Campus Date: 2007-12-01 Verified By: Tom Comments: Good event.
--

Figure 4.9 SIMS member outreach events example.

- **Comments from S3FL community.** This section is a public bulletin board where any member of SIMS can leave feedback for the user. It is intended as a space where team leads, senior members and faculty advisors can also comment on achievements by the individual. An example is shown in Figure 4.10.

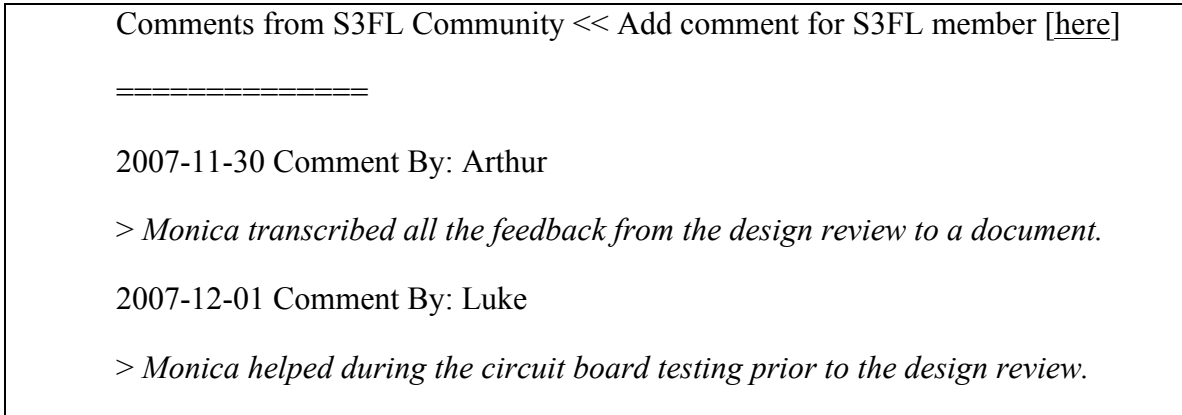

Figure 4.10 SIMS member's comments from S3FL community example.

- **Hours and weekly reports.** This is the most dynamic section of SIMS. It provides the mechanism for members to log their worked hours on a weekly basis, in addition to their technical reports. These consist of a brief description of the action items completed during this time. The interface displays customized values for *minimum hours expected* according to the members official requirements (as shown in the example in Figure 4.11) derived from the number of course credits they are enrolled in.

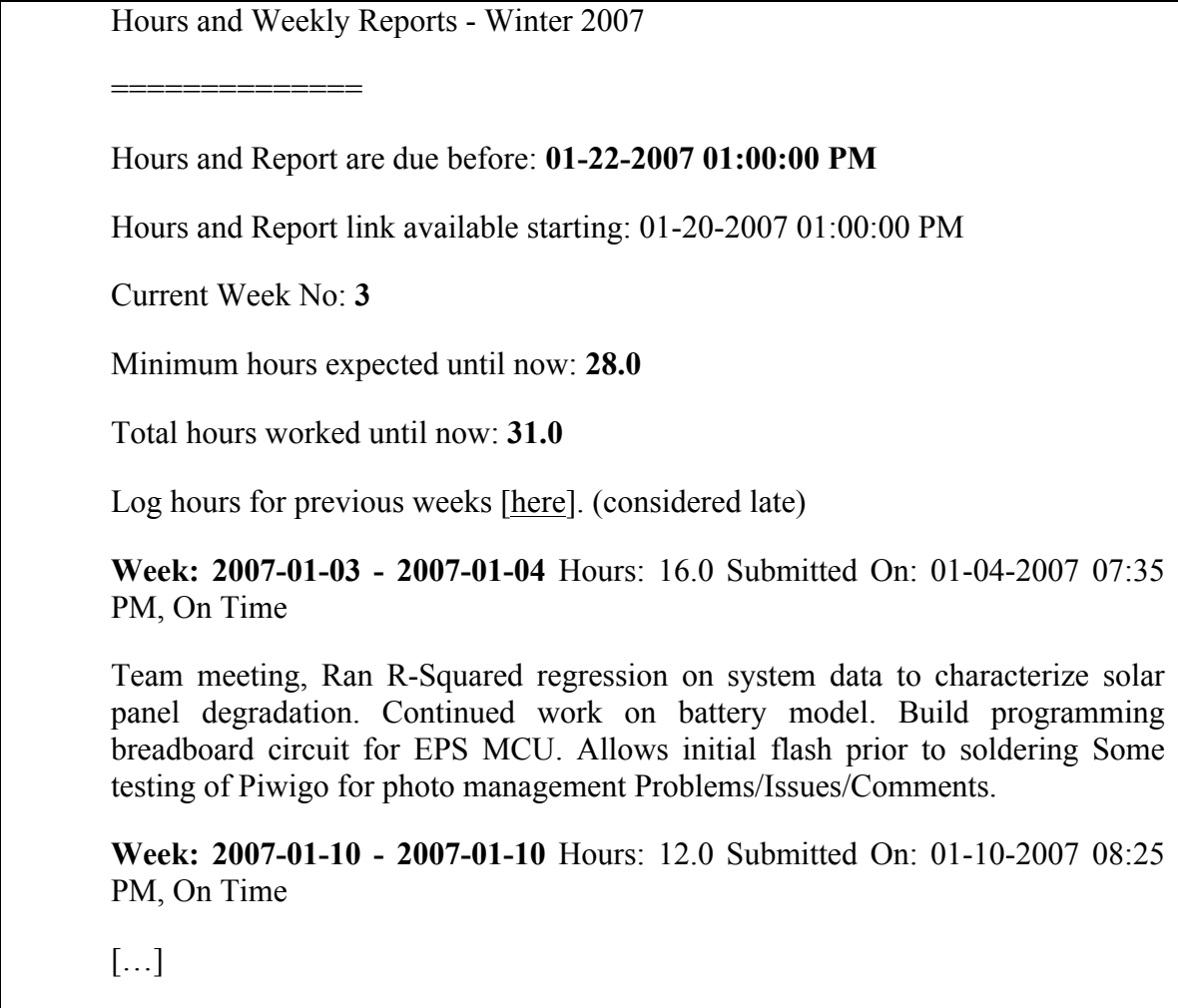

Figure 4.11 SIMS standard member hours and weekly reports section example.

Other members (e.g. team leads and assistant leads) have a similar home page, but in addition they have the option to manage group information concerning engineering events, outreach, etc., or in the case of S3FL’s executive committee, to view snapshots of all the hours worked by the engineers of the entire laboratory as described earlier in Table 4.1. When Excom members log into SIMS, in addition to the standard sections for all members, there are also links to all the active projects in S3FL that are displayed, and the users can navigate to each team and members to review specific details on their profiles.

There are three modules (accessible to anyone with a SIMS account) that have been developed to document operations in the laboratory that include: an inventory module, a thermal vacuum and an industry interactions module, summarized in Table 4.2.

Table 4.2 S3FL's information management system (SIMS) operations modules and their description.

SIMS Module	SIMS Link	Description
Laboratory Inventory	<i>Lab Inventory</i>	A global dynamic inventory of the entire laboratory (including remote locations).
Thermal Vacuum System	<i>Thermal Vac</i>	A repository of all thermal vacuum associated testing, with specifics on survivability testing, thermal testing and thermal bake-out operations.
Industry Interactions	<i>Industry</i>	Catalogs of different companies from which donations have been received or products have been purchased. It also documents interactions during reviews or off site visits.

The thermal vacuum module contains important information regarding the testing of the components. The logged in operator documents functionality parameters including pre-test characterizations and post-test results. The operator also documents values corresponding to percentage lost from component's outgassing and any other relevant technical logs of the test. In the results section there is a category for pass or fail that is shown in the top-level summary of the entire setup. There is also an area for comments, that allows the operator or any other person involved in the test to capture pertinent notes as shown in Figure 4.12. It was determined that in order for someone that was not present during thermal vacuum testing to understand clearly what happened, this module

would have a history-like feature that allows a reader to step through each of the individual operations as they were captured by the operator.

History of STAMP Board

<< Previous | 1 | 2 | 3 | 4 | 5 | 6 | 7 | 8 | Next >>

ID	Item	Team	Date of Last Activity	Timestamp	Survivability	Thermal	Bakeout	Notes	Modified By
14	STAMP Board	Cubesat - CDH	2010-10-04	21:48:34	PASSED	PASSED	INCOMPLETE		mjregan

Survivability Test

Operations		Functionality			Outgassing			Results		
Test Date	Operator	Characterization Test Unit	Pre-Test Characterization	Post-Test Characterization	Pre-Test Mass (g)	Post-Test Mass (g)	% Lost from Outgassing	Time in Vacuum	Lowest Pressure Achieved (Torr)	Pass/Fail
2010-10-03	kgmerek	Operational	Functioning	Functioning	7.82	7.82	0.0	45 mins	1.5 x 10 ⁻⁴	PASSED

Thermal Test

Operations		Functionality			Outgassing			Results				
Test Date	Operator	Characterization Test Unit	Pre-Test Characterization	Post-Test Characterization	Pre-Test Mass (g)	Post-Test Mass (g)	% Lost from Outgassing	Time in Vacuum	Lowest Pressure Achieved (Torr)	Highest Temperature Achieved (C)	Lowest Temperature Achieved (C)	Pass/Fail
2010-10-04	mjregan	Operational	Functioning	Functioning	7.82	7.80	.256	4:52	1.6*10 ⁻⁶	70	28	PASSED

Thermal Bakeout

Operations		Outgassing			Results		Status
Test Date	Operator	Pre-Test Mass (g)	Post-Test Mass (g)	% Lost from Outgassing	Lowest Pressure Achieved (Torr)	Highest Temperature Achieved (C)	Complete/Incomplete
							INCOMPLETE

<< Previous | 1 | 2 | 3 | 4 | 5 | 6 | 7 | 8 | Next >>

Figure 4.12 S3FL’s information management system (SIMS) thermal vacuum module interface showing results for survivability and thermal testing for a component.

Additional details pertaining to the overall usage of SIMS, the corresponding database data dictionary and source code are included in Appendix A.

4.3.2 Other information processing tools

In addition to the customized information system described in Section 4.3.1, there are other commercially available information processing tools that can be used to support design. They are described in the following sections.

4.3.2.1 Wikis

The *wiki* can be defined as software on the server side that allows web users (clients) to freely create and edit web page content through their web browsers, independent of operating system platform (Britannica, 2007). The first ever wiki site was created for the Portland Pattern Repository in 1995 (PPR, 1995) and since then, it has grown to be used worldwide, being *Wikipedia* one of the most recognizable websites, with 18 million articles (over 3.6 million in English) that have been written collaboratively by volunteers around the world, and almost all of its articles can be edited by anyone with access to the site (Wikipedia, 2011). Because of the nature of storing and manipulation of data, many perceive it as a very simple online database.

The usage of the web based information processing tool known as the wiki is expected to aid significantly early in a process like the ADP since it has been observed that wikis enable extremely rich, flexible collaborations that have positive psychological consequences for their participants and powerful competitive ones for their organizations (Evans & Wolf, 2005). A wiki can provide a friendly dynamic platform for critical information collection of all the components of a space mission including:

- a) Spacecraft – including top-level information like current mass, maximum power required, etc.
- b) Orbit – Current orbit parameters that the system is being designed for.
- c) Mission Operations – Including launch vehicle details, ground station elements information, etc.

By receiving input from all members in a design team, it can allow for a comprehensive single point collection of all the top-level information of the system designed. One of the advantages expected includes minimizing miscommunication among all team members. Features like history tracking can allow for examination of previous design point revisions to understand its evolution. In an environment in which complex systems have changing requirements, this would facilitate designers to reference the most updated information concerning the design.

4.3.2.2 Google products

Google Docs is a free, Web-based word processor, spreadsheet, presentation, and form application offered by Google (Google, 2010). It allows users to create and edit documents online while collaborating in real-time with other users that also have Gmail accounts. The main screen for Google Docs is shown in Figure 4.13.

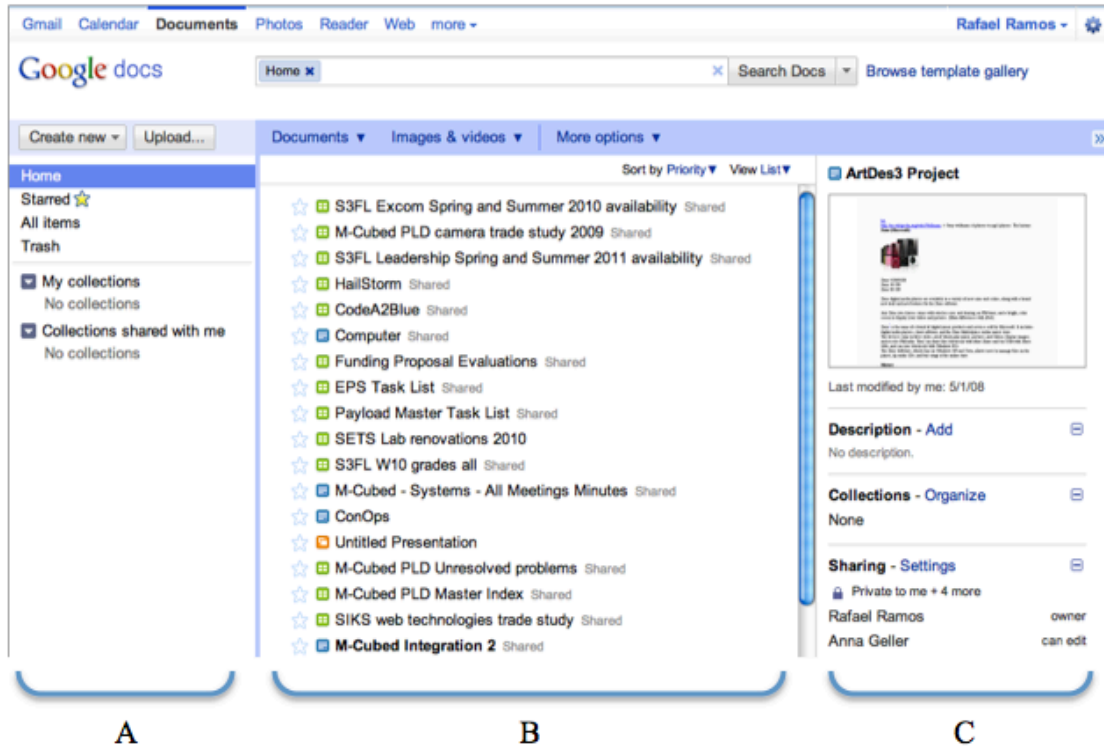

Figure 4.13 Google Docs main interface. (A) Allows documents to be managed in collections, (B) shows the user’s documents and (C) shows details of each document (Google, 2010).

System budgets are examples of documents that can be used in this platform due to the need of input from many sources simultaneously, in addition to *tracking changes* features, which allows users to follow the evolution of a particular document.

Google Wave is a web application and computing platform designed to bring together e-mail, instant messaging, wiki and social networking. It has a strong collaborative focus, mixed with spellchecker and translator extensions, in real-time (Google Wave, 2010). There are components called “waves” that are equal parts conversation and document. People can communicate and work together with richly formatted text, photos, videos, maps, and third party developed components. A wave is shared. Any participant can reply anywhere in the message, edit the content and add

participants at any point in the process. The playback feature allows any user to go through the historical changes of each wave.



Figure 4.14 Google Wave main interface. (A) Contains the user’s inbox, tools and contacts, (B) shows inbox details and participants of each wave and (C) shows a wave’s content (Google Wave, 2010).

Even though introductory work was performed to support the research in this thesis using the Google Wave platform, just over a year after launching it in beta Google decided to shut it down. This admittedly is a risk associated with using new information technology tools. In a blog post, Senior VP of Operations Urs Holzle said that while the company had high hopes for the product, and despite the fact that it had numerous loyal

fans, Google was canceling any further development of the feature, which the Google executive admitted had not seen the user adoption they would have liked (Holzle, 2010).

4.4 Human Factors

There are different types of human factors that influence the process of design. The research presented in this dissertation was conducted at the Student Space Systems Fabrication Laboratory (S3FL) at the University of Michigan introduced in Section 4.2, so human factors regarding the laboratory's culture of learning and leadership are presented in the following sections. Understanding this context is relevant for the work presented in Chapters 5 and 6.

4.4.1 Culture of learning

The purpose of the laboratory is simple to comprehend by new incoming students each term, explained to them as an opportunity to either learn about the nature of complex engineering systems (in the case of freshmen students who have not decided completely if they want to go into engineering) or to apply some of the theoretical knowledge that they (sophomore, junior and senior students) have acquired throughout their years in the college into a “real life” engineering project.

The first term for students in the laboratory has a great impact on their return the following academic term, either through undergraduate research programs that can sponsor their work, where students receive credits towards their program, or as volunteers (status which is associated with unstable time commitments and sometimes not the best performances). If students enjoy their stay the first term, not only does they return the next term but also can refer other classmates to the activities in the laboratory, which is good for continuity. On the other hand, if it was a disappointing experience, then they are less likely to return (in addition to the potential negative publicity they can disseminate to other potential future members of the laboratory).

According to Schein, “the strength of culture can be defined in terms of the homogeneity group membership and the length and intensity of shared experiences of the group” (Schein, 1984). In S3FL, the length of time that students spend in the laboratory (on average) may not seem enough to provide meaningful experiences as a team. This is not always the case; there are occasions where the intensity of the group experience is enhanced dramatically by events like an integrated systems test or the accomplishment of a critical technical milestone in the development of a project.

The cultural paradigm that best fits S3FL is strongly associated to an accelerated academic learning and teaching environment. After only a few weeks students may acquire a set of basic skills that they might teach to someone else before the academic term is over. Early on, students observe their more experienced peers explaining procedures and teaching in the laboratory. Many students soon realize that becoming a subsystem team lead involves learning while educating others and being responsible for real deadlines throughout the term.

When talking about S3FL culture, it can be said that there is an on going creation of organizational reality. As Morgan (1997) describes in regard to what shared meanings and understandings in a group promote: "...it is a process of reality construction that allows people to see and understand particular events, actions, objects, utterances or situations in distinctive ways". This construction in S3FL has to find strong support from the reinforcement of good qualities in everyone in the group, seeking the eradication of bad engineering practices and trying to build new relationships between students in order to promote the development of many projects. S3FL's management works diligently to share information and encourage multiple-level participation from everyone involved in activities within the laboratory, to reinforce a sharing environment. Those students on the shop floor (the machining group) are encouraged to be involved in design processes, as they are most familiar with the limitations and reality of their trade. From providing basic guidelines on how to format the files that are then interpreted by them, to acting as design reviewers, the experience of having an active group in the shop has proven to be very helpful. Considering that students in S3FL have a relatively short productive lifespan (two academic terms on average), they must be integrated efficiently and quickly into the complicated system of capturing and processing of information.

All students are expected to face a variety of engineering challenges (whether in theoretical work or physical implementations) and be able to deliver results with the allocated human resources, facilities and frequently limited time. Unavoidably, every four months at the change of terms, all students will start a completely new class schedule with different professors, subject material, class times and class requirements. This requires that students to be able to adapt very quickly, or they will not keep up with the

development of their project in S3FL. So all factors considered, as an innovative organization, S3FL must adapt swiftly to change, although naturally sometimes people can be resistant to it.

The concept of positive feedback that measures whether or not the purpose and goals of each project within the laboratory are aligned with dynamic environmental needs, known as deviation-amplifying feedback (Hanna, 1988), is realized through the continuous verification of the milestones accomplished in fine resolution timescales, taking into account the broader milestones that need to be finished by the end of the month or term. In multiple occasions it has been seen that in order to reach these broader milestones there is an important need for management and team leads to have the ability of understanding the development of major technology trades and availability. For instance, on a much larger scale in industry, when NASA released the FY04-08 budget plan division among its centers (influenced heavily by the announcement from former-President Bush regarding the new initiative of space exploration), there had to be a reassessment of some of the primary technology development goals so that future projects would be aligned with them. This enables better relations with potential contractors and sponsors. A strategic operation of cooperative work between key service providers of this nature helps preserve an organization's responsiveness to a very dynamic environment.

4.4.2 Culture of leading

Open-systems theory provides the perception of a systems level appreciation for the laboratory and its processes, what some authors simply describe as the “big picture” Morgan (1997), and helps avoid situations in which the system is not considered as a whole. In open systems terms it is also necessary to understand the importance of creating the appropriate conditions in which the group members’ energy and interests can be inspired by the work to be done. Since they are affiliated with an academic institution, an assumption can be made that students are seeking skills that complement the learning from their classes, either to be well prepared for industry or for graduate school. The paradigm culture of good engineering practices early on in the projects, in addition to the environment of cooperative learning, often awakens the interest of students who realize the opportunity that their work in the laboratory can be as meaningful to them as they are willing to invest time in it.

A student that wishes to become subsystem team lead or chief engineer of a project in the laboratory must be able to see the big picture of his team, and also possess several key qualities in order to be successful. Initially, the student must be able to adapt quickly to change, due to the dynamic environment. Second, the student must be able to attend to several different tasks in parallel. Since students typically take several classes per term, they must be able to juggle the demands of their classes with those of any class laboratory projects, and sometimes balance these with a part-time job. Only a well organized and highly committed student would be able to balance priorities that can often shift, and more attention is needed for a specific class or the project in S3FL. Many

times, several of these demands facing a student must be attended to at the same time, and the student must find a way to address these demands as efficiently as possible.

Being decisive and persuasive are commonalities to a few experienced leads, especially those who have older students (or a graduate student) working for them who are used to solving technological problems in a certain way because of their technical background and overall experience. Ability to synthesize existing information by team members in reliable ways and quickness to act are productive qualities that can be considered strengths in many scenarios that require low level modifications to a design, in order for the interface between subsystems to be up to date and reliable.

Excom is insistent in nurturing an atmosphere tolerant of diversity of ideas, experimentation and methodical implementation. It can be seen that a great number of trade studies are created per project, as well as other design documentation generated by the teams. S3FL management also promotes positive personal relationships between students, encouraging them to attend other team's design reviews and outreach events. It is said often to the students that their work contributes to both personal development and the growth in multiple dimensions of the laboratory, and that it should be performed professionally and following industry standards (in recent years primarily Lockheed Martin and NASA's Jet Propulsion Laboratory) as much as possible. The results include tangible functioning systems and a sustainable environment that has fostered the creation of many independent engineering programs within the laboratory.

According to open systems theory, the environment provides the inputs and must accept the outputs, must support the purpose and provides feedback to the system

(Morgan, 1997). Within this framework, the inputs to the system (laboratory) on the personnel side consist of the new students starting out each term, the contribution of the executive committee (Excom) regarding projects selected to be worked on during the school year, and the contribution from the faculty advisors. Another important input is the effort from existing programs or industry partners that have already been established from previous years.

The process of going from some of these inputs and parameterization to presentation of desired output is done on a term-by-term basis. The immediate output takes the form of a series of timelines with defined objectives, or integrated master schedules, per project, which is information of high interest to the team leads of the laboratory and discussed with Excom at the beginning of each term. The tangible output by the end of an academic term are the schematics, documents, prototypes and final systems that get developed within a specific project. The intangible products are the personal experiences and knowledge that the students take with them at the end of each term.

Inexperienced new members of the laboratory's executive committee often believe that once a project and term has started, the rest of the term is less complex, and that all internal flow of information can be processed effortlessly and automatically once the project and its subsystems are up and running, but this is not the case. Due to the nature of the laboratory as student based, there are challenging aspects that management faces each term: the departing of experienced students and the introduction of new students. Excom has to regularly manage changes as a result of the unavoidable inconsistency of know-how distributed throughout the laboratory, projects, and teams.

Even before an academic term begins, senior Excom members identify candidate replacements for them within the group of experienced team leads. They are invited to be guests at the committee's meetings so they can gradually be introduced to the processes, with the expectation that they will consider participating in that role for at least one full academic year.

Excom persistently works to remain informed and aware of the way knowledgeable students perform their assessment of critical changes according to what they perceive are the changes that support the purpose of each project. These students sometimes have to push forward with making such changes with not much immediate feedback received, in order to try to fit as quickly as possible the right set of activities within an environment marked by inconsistent participation and performance due to vacation periods, exams, schoolwork, etc. S3FL's Excom is particularly aware of the importance of continually improving all the processes students go through. From the way the team's tasks are documented early on, to more complicated human factors dealing with the intricacies that are part of a culture of learning and leading.

Chapter 5

Applying the Design Model in a Design Task

This chapter presents an empirical study of ADP by applying it in a design task. The goal is to examine its relevance by identifying what elements of *good design* according to Mehalik and Schunn's (2006) classification (Section 2.4.2) are fostered by using ADP.

5.1 Method

The central hypothesis of this chapter is that an atomic design process (ADP) can be useful for the creation of good designs. It is of interest to understand under what conditions the ADP is beneficial. In other words, to see if good design elements can be identified when a team uses the process. This provides insight into the model's relevance. There is also interest in understanding the general category of design problems the model is good for and how different levels of designer expertise affect the outcome. For the scope of this research, an engineering design task that is sufficiently short to fit within the

time available and utilizing novice designers will be studied. Novice designers are of special interest to evaluate since this population is anticipated to be especially receptive to learning a new design model compared to seasoned experts.

In summary, with this design activity the author seeks to answer the following research question: What elements of good design are promoted in a newly formed novice design team by using the ADP model? This study, in particular, focuses on the impact of the model in a controlled environment over a short term, but based on a real engineering design task.

Two new student teams in Michigan's S3FL organization were formed (Section 4.2). The students were asked to complete a design questionnaire to document their understanding in design processes. Then, they were introduced to the ADP model and some examples to understand how it works. A new design task and a timeline for completion were presented to them. Throughout the design activity information relevant to the design process followed by the teams was collected. This information consisted of design documents that captured their design adoptions as each team documented them. In addition, there were weekly reports submitted by the teams to S3FL's information system (Section 4.3.1). At the end of the new design task, the teams completed once again the design questionnaire that was applied initially. Additional details of each of these steps are explained in the following sections.

5.1.1 Participants

Fourteen volunteer undergraduate engineering students from a mid-western university were placed into two working teams. These students were seeking involvement in the laboratory to gain engineering experience. They earned course credit by their participation in the design task. It was explained to the teams that a *team lead* and an *assistant lead* would guide the teams throughout the design exercise making sure that they achieve their technical goals. From the fourteen students, four of them volunteered for the lead and assistant lead roles. The use of these undergraduate students to perform the design task is appropriate for a number of reasons. First, as an effective method to understand if ADP plays a role in design success, a pool of individuals was needed in which subjects have no extensive design process experience prior to the instructions provided. Research has shown that first year students have not developed design skills nearly as good as senior students (Atman et al. 1999, 2005), so there was a preference to populating the teams with as many first year students as possible. By choosing subjects with little training in design or engineering, the question of prior training is avoided. In addition, these individuals have never worked together before, creating the need for the development of communication mechanisms, decision handling, and the assumption that everyone is reliable in their work.

5.1.2 The design task: Cansat

For several years, the American Astronautical Society (AAS) and American Institute of Aeronautics and Astronautics (AIAA) have conducted an annual student

design-build-launch competition for space-related topics. Although similar competitions exist for other fields of engineering (robots, radio-control airplanes, racing cars, etc.), most space-related competitions are paper design competitions. While paper design studies are worthwhile, they do not give students the satisfaction of being involved with the end-to-end design process of a complex engineering project, from conceptual design, through integration and test, actual operation of the system, concluding with a post-mission summary and debrief.

This annual competition is open to teams from universities and colleges. Teams must be able to design and build a space-type system, following the approved competition guide, and then compete against each other at the end of two semesters to determine the winners. Rockets are provided, but teams are responsible for funding the construction of their Cansat and all travel/lodging expenses (AAS/AIAA, 2011). An example of a previous year's Cansat payload is shown in Figure 5.1 after successfully being launched, operating, and recovered after parachute landing.



Figure 5.1 Cansat payload shown as found post-flight, with the parachute attached (Hitsquad Team, 2009).

The design team's competition goals were to launch an autonomous Cansat with a deployable lander containing one large raw hen egg. It must be made of two parts: the carrier and lander. The carrier holds and releases the lander. Cansat refers to the complete system containing the carrier and lander. The Cansat is deployed from a rocket at an altitude range of 900 meters to 1130 meters. The Cansat must transmit GPS position and telemetry every two seconds until landing. The design of the Cansat to a conceptual level is the design task being studied here.

When the Cansat reaches about 500 meters after deployment, the carrier must deploy the lander containing one large raw hen egg. The lander must land without damaging the egg. The descent rate of the Cansat carrier after deployment must be between 3 and 5 meters per second. Sensor data other than GPS must be used to determine the descent rate. The lander containing the large raw hen egg must have a

descent rate of 4 to 7 meters per second. In the lander, a sensor must be used to determine the descent rate of the payload. The data can be recorded and retrieved after recovery.

Based on the GPS data collected, there needs to be a prediction of the landing position, before recovering the payload. Descent telemetry from the carrier is to be displayed, in real-time, on a team-developed ground-control station, to predict the landing position of the lander.

According to the competition guidelines (AAS/AIAA, 2011), each team shall select one (and only one) of the following options as part of their mission design (considered optional objective requirements):

1. The Cansat lander shall measure the impact force. Data shall be collected at a rate of at least 100 Hz and stored on-board for post processing.
2. Following separation of the lander, the carrier shall obtain images in the nadir direction, with at least one image containing the lander in it. The images shall be stored on-board the carrier for post-processing following recovery. The team is free to telemeter the images to the ground; however, no points will be awarded for this.

There are also performance bonuses to be awarded to Cansat teams that meet all of the base mission requirements and the stated bonus criteria.

1. The Cansat with the lowest mass shall receive a 100 point bonus (to be confirmed by competition organizers) applied to the flight day scores.

2. The team that best predicts the landing coordinates of the deployed lander shall receive a TBD point bonus applied to the flight day scores.

The competition also requires the team to go through rigorous design reviews including a Preliminary Design Review (PDR), Critical Design Review (CDR), Demo Flight and a Post Flight Review (PFR) to ensure that the system designed is appropriate, and can meet the stated performance requirements within cost, schedule, and risk constraints. These requirements are not part of the study here.

Figure 5.2 illustrates a typical launch and separation sequence. Due to this nominal deployment sequence, the organizers recommend that the system be integrated with the payload section upside down, such that the folded Cansat parachute rests on the payload section bulk plate. The Cansat then rests on the parachute and the folded cone parachute rests on the Cansat. Once ejection charge burn is completed, the payload section and nose cone separate from the rocket and tip over. The nose cone slides out of the top of the payload section and the Cansat then falls out of the payload section due to gravity.

Ejection charge separates payload/nose section from rocket. When front section separates from rocket the shock chord between them pulls the rocket parachute from the rocket.

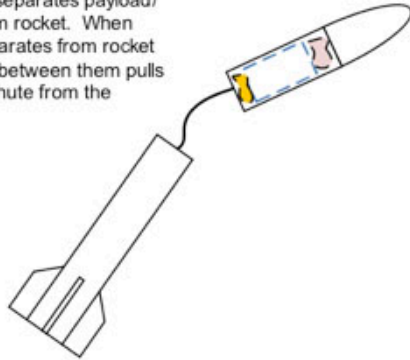

When the front section tips over, the nose cone falls off and the cansat falls out of the payload section. The cansat parachute now inflates over the cansat.

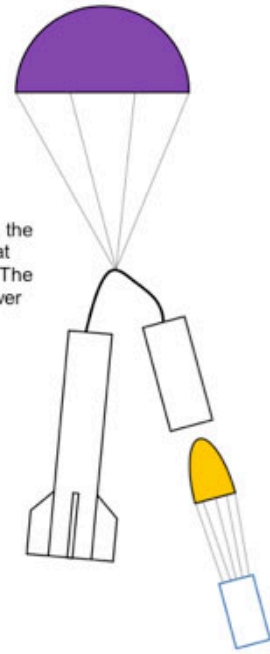

Cansat rests on its parachute. The nose cone parachute rests on the bottom of the cansat.

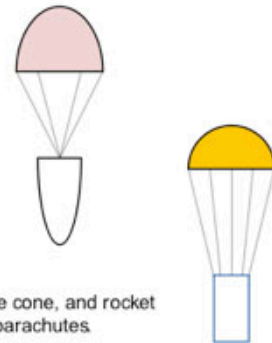
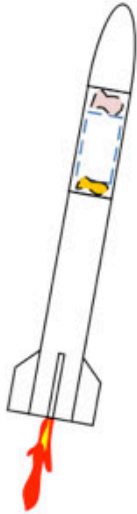

The cansat, nose cone, and rocket descend under parachutes.

Figure 5.2 Cansat launch stages and separation sequence (AAS/AIAA, 2011).

5.1.3 Procedure

This is a detailed explanation of the teams' introduction to the ADP model and the procedure for completing the design task.

I. Week 1: Background data collection to understand team's current design knowledge.

a. Design questionnaire

The purpose of the questionnaire is to gather enough information about the current understanding of each team member regarding principles relevant to good design.

The questionnaire consisted of the following sections:

i. Instructions

Clear and concise instructions about the purpose of the questionnaire are provided in this section. The team members are informed that there are no right or wrong answers and that although some questions may sound repetitive, they do not have to give different answers if they feel they have already answered a particular question, though all questions must be answered.

ii. Background questions

This section contains questions to collect information regarding gender and academic level (undergraduate year). The team members are also asked if they have taken any formal design methodology class.

iii. Design questions

These questions capture information regarding Mehalik and Schunn’s categories for effective design (2006) and are similar to comparable research (Titus, 2008). The questions have answer options using a seven-point Likert-scale (1932), where “Strongly Disagree” has a value of 1 and "Strongly Agree" a value of 7. An example of the questions is shown in Table 5.1.

Table 5.1 Design questionnaire question example showing seven-point scale option.

Category: Exploring graphical representation/visualization (this line is not shown to student)

Question 15. You use representation tools (like graphics, sketches, etc.) during your design process.

Strongly Disagree			Neutral			Strongly Agree
<input type="checkbox"/>	<input type="checkbox"/>	<input type="checkbox"/>	<input type="checkbox"/>	<input type="checkbox"/>	<input type="checkbox"/>	<input type="checkbox"/>

II. Week 2: Introduction to ADP and design task setup

During a focused seminar for the teams (material included in Appendix B), there is an introduction presented about the basic ADP model and the vocabulary relevant to

understanding the different stages. Each of the stages of the ADP model is explained in detail. There is also an engineering example used to help explain the practical aspects of each stage, associating each element discussed with the relevant vocabulary. Finally, the seminar ends with a session of questions and answers.

III. Week 3 – 8: Designing using ADP

The teams are informed of the design task described in Section 5.2.2. They are instructed to complete the design task following the ADP model. It is required that the teams meet as a group at a minimum one time per week for one hour, but if the group wants to work more hours together they may do so. Three specific media of communication were designated for capturing their design evolution, including: individual weekly reports (and hours worked) that are submitted electronically to S3FL via SIMS (only required element) (Section 4.3.1), emails within the team (as considered necessary), and a master shared Google document (Section 4.3.2) that keeps track of the changes throughout each stage of their design (also, for the team to modify when they consider necessary). The shared Google document is used to keep track of:

- a. Specifications
- b. Configurations created over time
- c. Trade studies documentation
- d. Drivers identified and documented

IV. Week 8: End of exercise questionnaire

The same questionnaire from week 1 is given to all team members to assess adjustments in their understanding of practices of good design.

For the scope of the task, the teams are expected to complete the design to what is considered a Mission Definition Review (MDR) level. At this level it is expected the proposed overall concept design is complete, feasible and consistent with the original mission statement. This level is a precursor to the PDR level. The teams have eight weeks until completion, and each team has an allocation of \$1000 USD that they can use towards the future development of their design hardware and software. The end of the design task deliverables include a presentation of specifications, configurations, identified trade studies per subsystem, engineering schematics that support their rationale, and outline of items to complete towards PDR.

5.2 Results

An empirical study was performed to understand the advantages or disadvantages of using the ADP model. Ultimately the goal was to assess the impact of the model in a controlled environment over a short term, on a real engineering design task. By understanding in depth the problem and the qualities of the culture in which the teams performed the design task, it can be understood how adaptable the ADP model is, providing insight into the model's effectiveness. The relevance of the model will be determined by the ability of the teams to identify solutions that meet the system specifications.

Two newly formed student teams (Team 1 and Team 2) were given an engineering design task to complete. Table 5.2 shows the distribution of students by academic level and field of study.

Table 5.2 Participant statistics for design task using ADP, including (a) academic level and (b) field of study.

(a)		(b)	
Academic level	Percentage	Field of study	Percentage
Freshman	58%	Aerospace Engineering	29%
Sophomore	14%	Atmospheric, Oceanic, & Space Science	7%
Junior	14%	Electrical & Computer Science Engineering	7%
Senior	14%	Mechanical Engineering	7%
		Undecided	50%

With exception of the senior students (who were concurrently enrolled in a senior level design course, and is purely theoretical, in other words without the building of a system), none of the students had taken any formal design classes.

Table 5.3 shows the information technology elements that the teams used for the design task. Most of the required SIMS weekly reports were documented, with only a few missing per each team due to students forgetting to submit them. Each team documented working more than three hundred hours during the span of the design task. Although each team had a designated email list to be used, very few emails were actually sent to it, and all of the emails (for both teams) were only reminders about meeting times.

No design related discussions were addressed via email. All members of each team accessed the Google documents at some point during the design task at least once.

Table 5.3 Summary of information technology elements used by the teams during the design task.

	Information required to be documented		Information documented as deemed necessary	
	SIMS weekly reports	SIMS hours worked reported	Team emails	Google document changes
Team 1	50	318	3	9
Team 2	52	326	6	11

Team 1 and Team 2 had distinct creative approaches for their design task, and Sections 5.2.1 and 5.2.2 highlight their design processes. Section 5.2.3 describes in detail the findings associated to the design questionnaire.

5.2.1 Team 1 design process

During the first design iteration using ADP, Team 1 defined specifications for the task in five categories. These are *mission* (pertaining to specifications at the highest level of design), *carrier*, *lander*, *communications and data* and *sensors*. They are shown in the following tables.

It should be noted that Team 1 derived many of the specifications (in Table 5.4) from the competition guidelines, with the addition imposed for cost development given for this design task.

Table 5.4 Team 1 mission specifications - Iteration 1.

Spec. #	Mission
1	Total mass of the cansat system, excluding the egg payload, shall not exceed 500g (1.1lb)
2	Cansat including descent control devices shall fit inside the cylindrical envelope 72mm in diameter and 279mm in length
3	The rocket airframe cannot be used to restrain any deployable parts of the cansat, and shall not be used as part of the cansat operations
4	The descent control system shall not use any flammable or pyrotechnic devices
5	The average descent rate of the Cansat carrier after deployment shall be 4 meters per second
6	The average descent rate of the Cansat lander after deployment shall be 5.5 meters per second
7	The cansat shall activate an audible locating device upon landing and operate for at least one hour
8	Prior to lander deployment, the cansat (carrier + lander) shall descend as a single unit
9	The cansat communications radio shall be the Laird AC4790-200 and shall use the Laird AC4790 API packet format
10	The cansat radio shall not use the broadcast mode
11	The cansat radio shall autonomously terminate telemetry transmissions within 5 minutes of landing, to be verified by ground control
12	The ground control station antenna shall be elevated a minimum of 3.5m (11.5') from ground level to ensure adequate coverage and range

13	The cansat and associated operations shall comply with all field safety regulations as outlined in the Field Safety Rules section
14	The cansat shall be launched within the assigned launch window. Failure to do so will result in loss of points
15	The cansat and lander shall have an external power switch and indication of being on/off
16	The cansat shall not utilize lithium polymer (LiPo) batteries
17	The cost of the cansat flight hardware shall be under \$500 (US). Ground support and analysis tools are excluded
18	The team shall develop their own ground station, all telemetry shall be displayed in real-time during launch and descent using engineering units
19	The lander shall interface with the carrier in a method such that it is easily deployable at an altitude of 500m (1640.4')

The specifications documented by Team 1 for the carrier and lander, are shown in Table 5.5.

Table 5.5 Team 1 carrier and lander specifications– Iteration 1.

#	Carrier	Lander
1	Total mass of the cansat system, excluding the egg payload, shall not exceed 500g (1.1lb)	The lander shall safely land a single large Grade A hen's egg from an altitude of 500m (1640.4')
2	Cansat including descent control devices shall fit inside the cylindrical envelope 72mm in diameter and 279mm in length	The lander descent control system shall not use any flammable or pyrotechnic devices
3	The GPS and transceiver antennae shall be placed such that transmission and reception errors are minimized	The average descent rate of the lander after deployment shall be 5.5 ± 1.0 m/s, determined by descent telemetry stored on board

4	The carrier descent control system shall not use any flammable or pyrotechnic devices	During descent, the lander shall sample altitude as measured using a pressure sensor every 2 seconds
5	The average descent rate of the carrier after deployment shall be 4.0 ± 1.0 m/s, determined by data telemetered to the ground	During descent, the lander shall sample battery voltage every 2 seconds
6	The carrier shall activate an audible locating device upon landing, operating for at least one hour following activation	All lander descent telemetry shall be stored on-board for post-processing following retrieval of the lander
7	During descent, the carrier shall transmit UTC time once every 2 seconds	The lander shall measure the force of impact with the ground. Data shall be collected at a rate of at least 100Hz and stored on-board for post-processing
8	During descent, the carrier shall transmit latitude/longitude once every 2 seconds	The lander shall not utilize lithium polymer (LiPo) batteries
9	During descent, the carrier shall transmit mean sea level altitude once every 2 seconds	The lander shall have an external power switch and indication of being on/off
10	During descent, the carrier shall transmit the number of satellites being tracked once every 2 seconds	The lander shall be entirely self-contained and capable of deploying from the carrier
11	During descent, the carrier shall transmit altitude in meters, determined by a non-GPS sensor, once every 2 seconds	The lander shall interface with the carrier in a method such that it is easily deployable at an altitude of 500m (1640.4')
12	During descent, the carrier shall transmit air temperature in celsius once every 2 seconds	The lander shall descend under controlled conditions using a proven descent control system
13	During descent, the carrier shall transmit battery voltage in volts once every 2 seconds	
14	The carrier shall not utilize lithium polymer (LiPo) batteries	
15	The carrier shall have an external power switch and indication of being on/off	

16	The carrier shall descend under controlled conditions using a proven descent control system
----	---

The communications and sensors specifications are shown in Table 5.6. These did not change throughout iterations of their design.

Table 5.6 Team 1 communications, data and sensors specifications– Iteration 1.

#	Communications & Data	Sensors
1	During descent, the carrier shall transmit UTC time once every 2 seconds	Carrier shall record UTC time once every 2 seconds
2	During descent, the carrier shall transmit latitude/longitude once every 2 seconds	Carrier shall record latitude/longitude once every 2 seconds
3	During descent, the carrier shall transmit mean sea level altitude once every 2 seconds	Carrier shall record mean sea level altitude using a GPS device once every 2 seconds
4	During descent, the carrier shall transmit the number of satellites being tracked once every 2 seconds	Carrier shall record number of satellites being tracked once every 2 seconds
5	During descent, the carrier shall transmit altitude in meters, determined by a non-GPS sensor, once every 2 seconds	Carrier shall record altitude in meters, determined by a non-GPS sensor, once every 2 seconds
6	During descent, the carrier shall transmit air temperature in celsius once every 2 seconds	Carrier shall record air temperature in celsius once every 2 seconds
7	During descent, the carrier shall transmit battery voltage in volts once every 2 seconds	Carrier shall record battery voltage in volts once every 2 seconds
8	Data shall be backed up on-board the carrier in case of communications failure for post-processing	Lander shall sample altitude using a pressure sensor every 2 seconds

9	During descent, the lander shall sample altitude as measured using a pressure sensor every 2 seconds	Lander shall sample battery voltage every 2 seconds
10	During descent, the lander shall sample battery voltage every 2 seconds	Lander shall measure the force of impact with the ground at a rate of at least 100Hz
11	All lander descent telemetry shall be stored on-board for post-processing following retrieval of the lander	
12	The lander shall measure the force of impact with the ground. Data shall be collected at a rate of at least 100Hz and stored on-board for post-processing	
13	The cansat communications radio shall be the Laird AC4790-200 and shall use the Laird AC4790 API packet format	
14	The cansat radio shall not use the broadcast mode	
15	The cansat radio shall autonomously terminate telemetry transmissions within 5 minutes of landing, to be verified by ground control	
16	The carrier shall activate an audible locating device upon landing, operating for at least one hour following activation	
17	The ground control station antenna shall be elevated a minimum of 3.5m (11.5') from ground level to ensure adequate coverage and range	
18	The team shall develop their own ground station, all telemetry shall be displayed in real-time during launch and descent using engineering units	

During the second stage of design, Team 1 created configurations that were divided by major components of the system. They include: *carrier*, *lander*, *deployment mechanism* and *microcontroller*. Numbers in parenthesis are used to denote the ADP iteration in which elements were identified (e.g. no number indicates first iteration, 2 indicates second iteration, 3 third iteration, etc.). The configurations are summarized in the following tables.

Table 5.7 highlights that Team 1 identified two major configurations for the carrier, including a design with a thick or thin shell for the structure. For the parachute deployment sub-system they considered options of attachment and types of stitching cap.

Table 5.7 Team 1 configurations created for the carrier – Iterations 1 through 3.

Carrier		
	Configuration	Notes
Superstructure	Thick Shell	Stresses are shared in shell
		Inefficient
	Skeleton with thin Skin (2)	Normal Stresses in Skeleton
		Shear in Skin
		Efficient
Parachute deployment	Conical Top; packed Chute	Does not meet Specification
	Cylinder w/ attached cap	Danger: Dangling parts
	Stitched Cap, "Full Circle" (2)	Less mass-efficient
		Lower success rate
Stitched Cap, "Jar" (3)	Mass-efficient	

		High success rate
--	--	-------------------

Team 1 assessed four different configurations for the lander, including the structure, parachute deployment, egg protection and a connection method between systems, as shown in Table 5.8.

Table 5.8 Team 1 configurations created for the lander – Iterations 1 through 2.

Lander		
	Configuration	Notes
Substructure	Thick Shell	Stresses are shared in shell
		Inefficient
	Skeleton with thin Skin	Normal Stresses in Skeleton
		Shear in Skin
		Efficient
Parachute Deployment	Conical Top; packed Chute	Meets Specification
		Easy to assemble
	Separate Deployment (2)	Excess work
		Added difficulty
Egg Protection	Polyurethane Foams	Excellent Impact Resistance
		Lightweight
		Excellent Tear/Abrasion Resistance
	Gels (2)	Excellent Impact Resistance
		Heavier than most foams

	Other Packing Materials	Moderate Impact Resistance
		Lightweight
		Easily destroyed
Connection Method	Spring Pins	Easy to machine
		Efficient
	Threading (2)	Difficult to machine
		Complex

The deployment aspect of the system promoted a series of configuration concepts that looked at different moving parts, timing for release of the lander elements and specific connection methods. These are shown in Table 5.9.

Table 5.9 Team 1 configurations created for the deployment mechanism – Iterations 1 through 2.

Deployment Mechanism		
	Configuration	Notes
Moving Parts	Rotary Solenoid	Requires high Voltage
		Best powered solution
	Servo	Requires high Voltage
		Excess moving parts
		Questionable reliability
	Pre-tensed Spring	Difficult to configure
		Questionable reliability
		Non-powered solution

		Needs creative release timing
Release Timing	Pressure Switch	Best option
		Analog spring release
		Versatile
	CMD from Micro	Additional work
		Added data handling
		Inefficient
Connection Method	Dual Pins	Secure during liftoff
		Many moving parts
		Questionable reliability
	Single Pin/Wire	Questionable security
		Easy to release
		Setup required for multiple launches
	Rotary Bar (2)	Best Option
		Highly Secure
		High Reliability
		Versatile
	Electromagnet (2)	Dangerous: EE Components
		Requires understanding of magnets
		High-power

There were two configurations considered for computational needs. One included a standard microcontroller with a custom built printed circuit board (PCB). The other

consisted in using an Arduino™ electronics board. Some of the notes that the team documented to help understand the advantages of each option are shown in Table 5.10.

Table 5.10 Team 1 configurations created for computing needs – Iteration 1.

Microcontroller	
Configuration	Notes
Micro + PCB	Tailored to our Specifications
	More precise EE configuration
	Directly incorporated into frame
	Very difficult
	High Risk
Arduino™ Board	Stock Parts
	Requires attachment to frame
	Limited configuration options
	Easy
	Parts on hand
	Low Risk

Even though there are non-quantifiable notes regarding the major configurations (e.g. easy, very difficult), it can be seen that there was an attempt to maintain consistency in the adjectives used to compare the configurations. For example, the team denotes that the microcontroller and printed circuit board layout entails a higher degree (likely due to difficulty associated with the manufacturing and integration steps and time involved with that configuration).

A summary of the most relevant hardware options evaluated by Team 1 during the trade studies stage is shown in Table 5.11. The trades are the result of a methodical approach to document all the technical features of the items to be compared. By including characteristics like dimensions, mass, operational voltages etc. the team members are able to identify the best options considering the specifications of a given ADP cycle. Sometimes these characteristics are found in the item's technical spec sheets, but some times it was necessary for the team members to contact the manufacturer to obtain additional details. Elements identified by the team as best candidates to meet specifications in the trade studies are highlighted.

Table 5.11 Team 1 summary of trade studies conducted for the GPS, barometric sensor, accelerometer, buzzer, voltage regulators, flash memory unit and rotary solenoid.

GPS Sensor									
Radio	Supplier	Dim. (mm)	Mass (g)	Op. Voltage	Current	Update Rate	Channels	Error	Cost
SUP500F	SparkFun	22x22x6	9	3-5.5V	33 mA	10Hz	65	±2.5m	\$59.95
EM406	GlobalSat	30x30x10.5	16	4.5-6.5V	70 mA	5Hz	20	±10m	\$59.95
Ls 20031	Locosys	30x30x6.4	10	3.3V	41 mA	5Hz	66	±3m	\$59.95
GTGPS10	MediaTek	16x16x6	5	3.3V	37mA	10Hz	66	±3m	\$38.95
IT500	Fastrax (PWS)	16.2x18.8x2.3	3	3-4.2V	≈30mA	10Hz	66	±1.8m	Inquire

Barometric Sensor										
Sensor	Supplier	Dim. (mm)	Mass (g)	Op. Voltage	Op. Current	Interface	Update Rate	Temp?	Error	Cost
SCP1000-D01	VTI	D-6.1, H-1.7	<5	2.4-3.3V	25µA	Serial (SPI)	9Hz	Yes	±1.5Pa	\$24.95
MPL115A1	Freescale Semi	5x3x1.2	<5	2.4-5.5V	10µA	Serial (SPI)	1Hz	Yes	±1kPa	\$11.95
BMP085	Bosch	5x5x1.2	<5	1.8-3.6V	5µA	I2C	1Hz	Yes	±0.5m	\$8.95

Accelerometer											
Sensor	Supplier	Dim. (mm)	Axes	Mass (g)	Range (g)	Op. Voltage	Op. Current	Interface	Update Rate	Error	Cost
ADXL335	Analog Devices	17x17x3	3	≈15g	±3	1.8-3.6V	350µA	Analog	550Hz	±1.5%	\$24.95
ADXL345	Analog Devices	14x21x3	3	≈15g	±16	2.0-3.6V	40µA	SPI, I2C	3200Hz	±1.5%	\$27.95
BMA180	Bosch	11x21x3	3	≈15g	±16	1.6-3.6V	650µA	SPI, I2C	1200Hz	±1.0%	\$29.95

Audible Sensing Device (Buzzer)									
Sensor	Supplier	Dim. (mm)	dB	Mass (g)	fRES (Hz)	Op. Voltage	Op. Current	Interface	Cost
AB2020B-2-LW1	PUI Audio	D-20,H-1	70	≈15g	2k	3V	1mA	Analog	\$1.18
254-PB163-ROX	Kobitone	16x16x2.5	70	≈15g	4k	3V	3mA	SMD/SMT	\$3.11
254-PB145-ROX	Kobitone	14x14x10.7	80	≈25g	3.3k	5V	8mA	SMD/SMT	\$2.85
254-PB119-ROX	Kobitone	11x9x1.7	70	≈10g	4.1k	5V	5mA	SMD/SMT	\$2.41

Voltage Regulators									
Regulator (595 family)	Supplier	Out Voltage	Dim(mm)	Mass (g)	Max Input (V)	Op. Current	Interface	Error	Cost
LM4040C30IDCKR	TI	3V	≈5x5	<2	10V	.06-15mA	SMD/SMT	±0.5%	\$0.93
LM4040A30IDBZTG4	TI	3V	≈5x5	<2	10V	.062-15mA	SMD/SMT	±0.1%	\$3.18
LM4040D30IDCKR	TI	3V	≈5x5	<2	10V	.065-15mA	SMD/SMT	±1%	\$0.86
LM4040C30ILPR	TI	3V	≈3x3	<2	10V	.06-15mA	Thru Hole	±0.5%	\$0.99
LM4040D50QDBZT	TI	5V	≈5x5	<2	10V	.079-15mA	SMD/SMT	±1%	\$1.57
LM4040B50IDCKR	TI	5V	≈5x5	<2	10V	.074-15mA	SMD/SMT	±0.2%	\$2.07
LM4040D50ILP	TI	5V	≈3x3	<2	10V	.079-15mA	Thru Hole	±1%	\$0.94
LM4040C50ILPR	TI	5V	≈3x3	<2	10V	.074-15mA	Thru Hole	±0.5%	\$0.99

Flash Memory Unit									
Unit	Supplier	Dim. (mm)	Mass (g)	Size	Bus Width	Op. Voltage	Op. Current	Interface	Cost
804-26VF0168IQAE	Microchip Tech	≈5x5	<2	16Mb	8b	2.7-3.6V	18mA	SPI	\$1.99
804-25WF0204ISAF	Microchip Tech	≈5x5	<2	2Mb	8b	1.65-1.95	2mA	SPI	\$1.62
804-25VF080B8IS2AE	Microchip Tech	≈5x5	<2	8Mb	8b	2.7-3.6V	10mA	SPI	\$1.29

Rotary Solenoid									
Unit	Supplier	Dimensions (in)	Mass	Res. (ohms)	Stroke	Power (W)	Voltage (V)	Type	Cost
C8-14C12DC-AY	Electroswitch	7/8 by 1/2	14.2	60	1	2.4	12	continuous	\$16.94
C8-141012DC-AY	Electroswitch	7/8 by 1/2	14.2	20.6	0.25	7	12	intermittent	\$16.94
C12-24C12DC-AY	Electroswitch	1.5 by 3/4	85	41	0.75	3.5	12	continuous	\$17.90
C12-241012DC-AY	Electroswitch	1.5 by 3/4	85	6.5	1	22	12	intermittent	\$18.41
C16-321012DC-AY	Electroswitch	2 by 1	156	3.8	1	38	12	intermittent	\$23.11

The drivers identified by the team per ADP iteration are shown in Table 5.12.

Table 5.12 Team 1 list of drivers identified by using the ADP model.

ADP Iteration	Dominant Driver	Notes
1	Electrical Components	Must house and power several EE Components
		Configuration will determine CANSAT shape
2	Deployment	Most complex portion of operations
		Must be simple, reliable, low mass and power
3	Data Precision	Data is vital to mission success, must ensure accuracy

Team 1 created the system block diagram shown in Figure 5.3. They identified three major elements, the *carrier*, the *lander* and finally all the *electronics*.

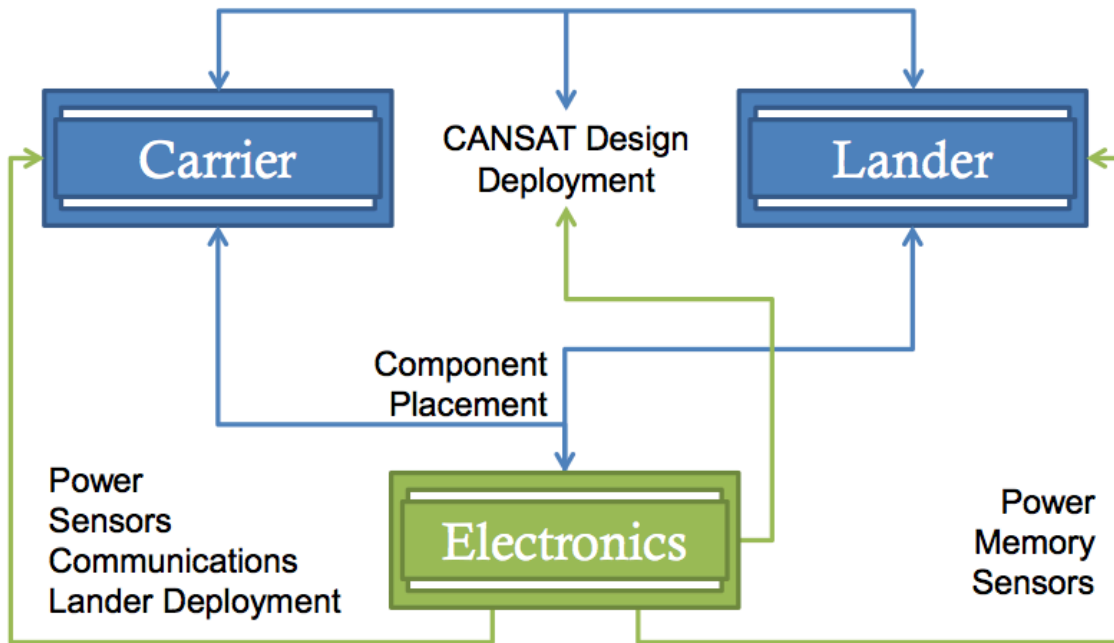

Figure 5.3 Team 1 System block diagram (Cansat Team 1, 2010) – Iteration 1.

It should be noted that in their system block diagram they had elements from the functional and operational perspective (the carrier and lander elements) and also a very specialized area of electrical engineering, which is the electronics. The connections between all of these elements range from electrical components (memory) to actions (design deployment) so it is not easy to understand the nature of these relationships.

During the second major design iteration, the diagrams created by Team 1 were divided between carrier electronics and lander electronics as shown in Figure 5.4 and Figure 5.5 respectively.

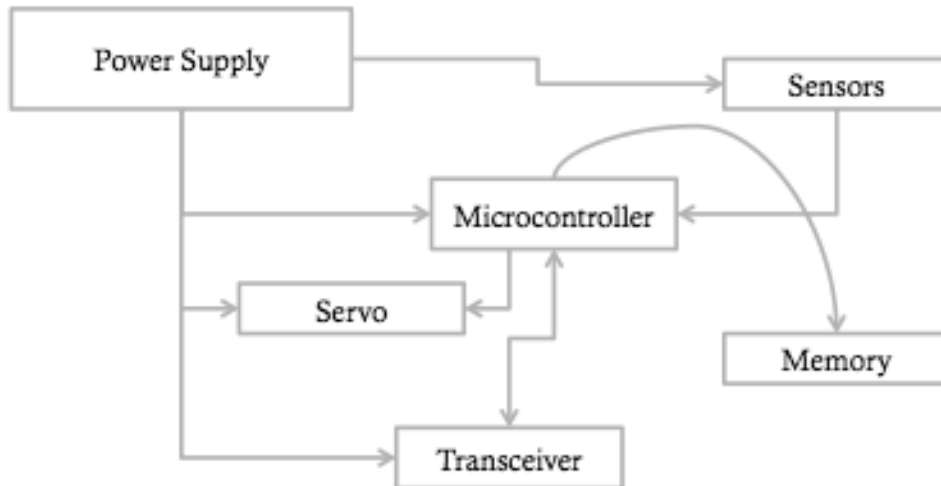

Figure 5.4 Team 1 carrier block diagram (Cansat Team 1, 2010) - Iteration 2.

In Figure 5.4 the power supply is indicated to provide power to the microcontroller, servo, transceiver and all sensors. The level of detail has increased from the first into the second iteration considering more specific functions of the elements involved.

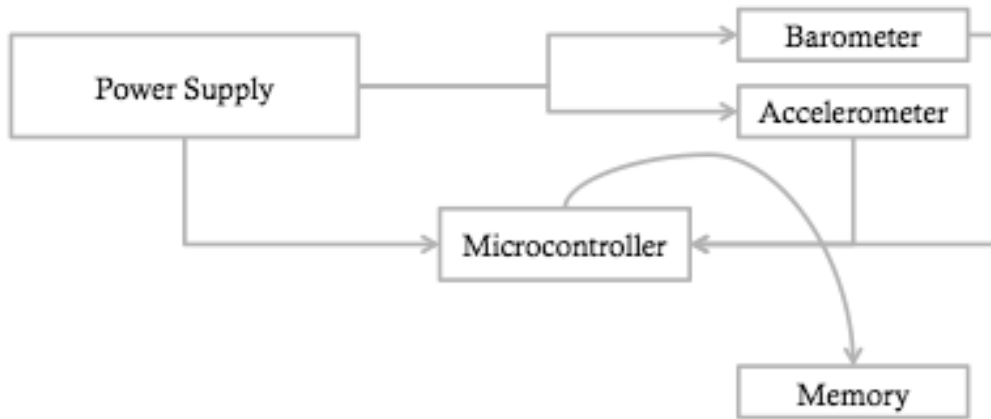

Figure 5.5 Team 1 lander block diagram (Cansat Team 1, 2010) - Iteration 2.

Similar to the carrier block diagram, the lander block diagram in Figure 5.5 shows greater level of detail corresponding to each of the elements. Since trade studies had been performed by the team, in the next major design iteration they incorporated details of the system configuration corresponding to the elements that were considered would meet the specifications. This is illustrated in Figure 5.6 and Figure 5.7 below.

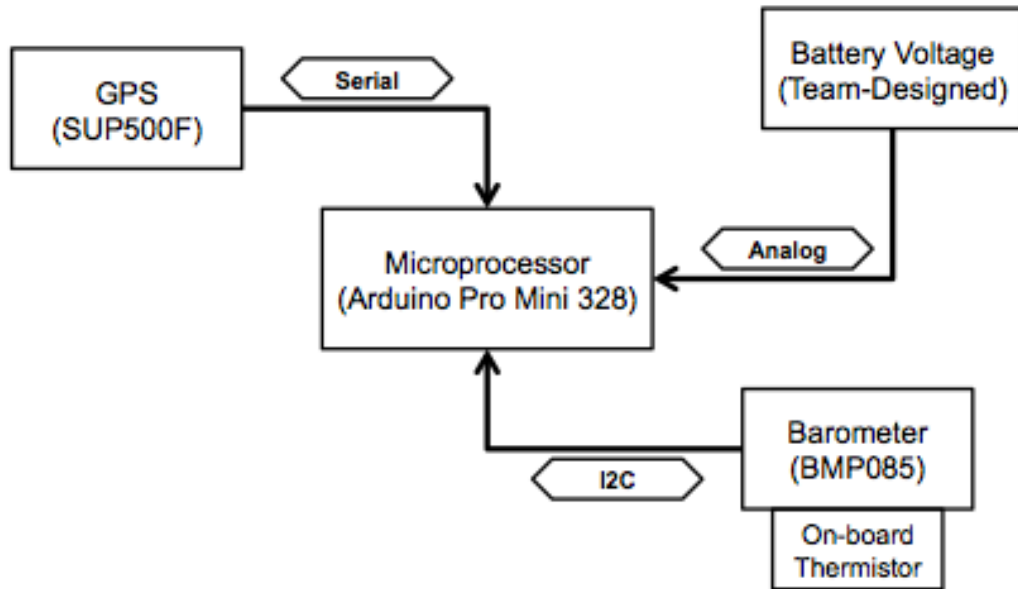

Figure 5.6 Team 1 carrier sensor block diagram (Cansat Team 1, 2010) - Iteration 3.

Figure 5.6 incorporates the names of specific components to perform functions that can be traced back to specifications. By this iteration the team incorporated specific interface protocols (e.g. serial, I2C, etc.) that had to be verified to be compatible with the main microprocessor. Even though they had identified the Arduino™ microprocessor to have more configuration limitations than other microcontrollers used with customized electronic PCB boards, it is currently perceived as the best alternative.

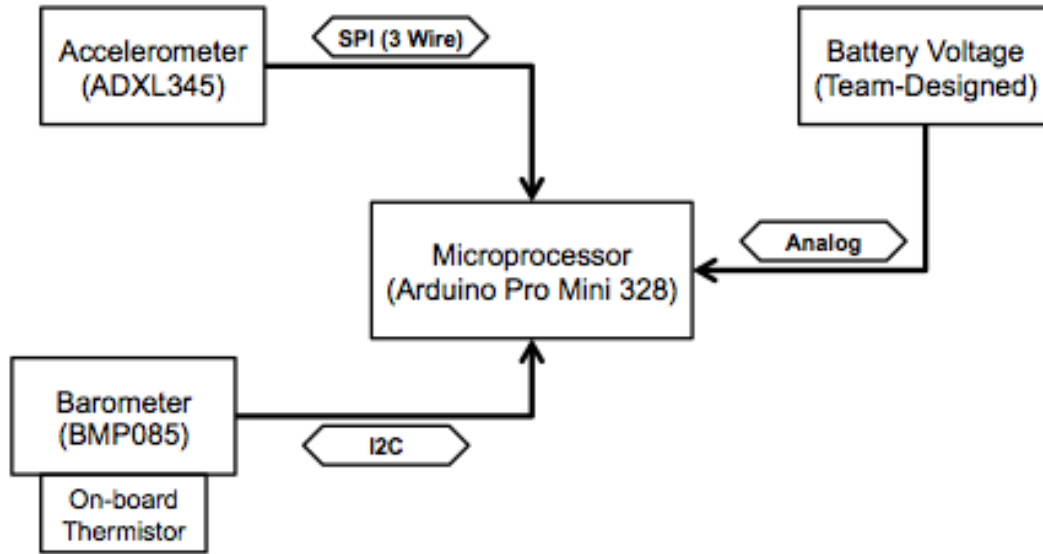

Figure 5.7 Team 1 lander sensor block diagram (Cansat 1, 2010) - Iteration 3.

Figure 5.7 shows how the team selected (similar to Figure 5.6 for the carrier) explicit components to be able to collect in-flight data from the lander.

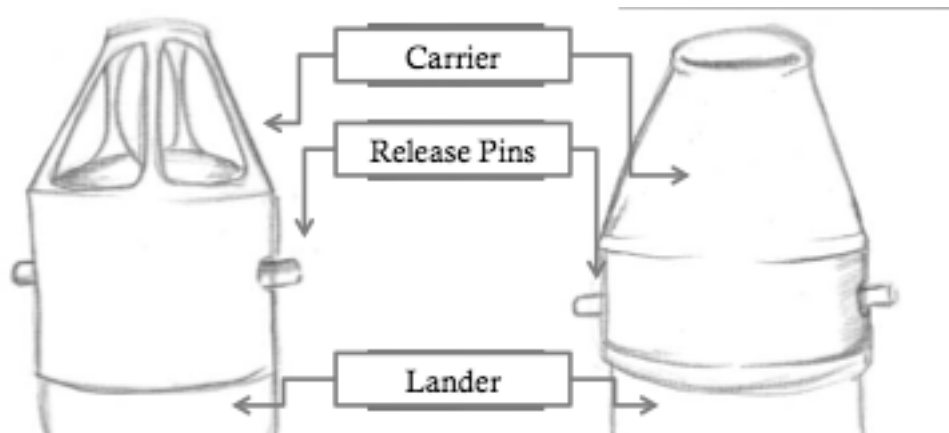

Figure 5.8 Team 1 system configuration diagram (Cansat 1, 2010) - Iteration 1.

Team 1 designed a conical shape carrier with a cylindrical lander underneath it as shown in Figure 5.8. During the second design iteration, the team identified the need for a reliable release mechanism (it was perceived as the dominant design driver). During

this iteration they were leaning towards a release pin deployment solution, although by the end of the design iteration they considered a rotating bar lock alternative.



Figure 5.9 Team 1 lander system CAD model (Cansat 1, 2010) - Iteration 1.

An example of the CAD models generated by Team 1 is shown in Figure 5.9. This model is a more accurate representation of the relative sizes between the carrier and the lander compared to the diagram shown in Figure 5.8.

A summary of the design by Team 1 is shown in Table 5.13 and a system CAD model is illustrated in Figure 5.10.

Table 5.13 Team 1 summary of final system design.

Carrier		Lander	
Processor	Arduino™ Pro Mini 328	Processor	Arduino™ Pro Mini 328
Memory	8 MB	Memory	8 MB
GPS	GPS SUP500F	Accelerometer	ADXL345
Barometer	BMP085 (with thermistor)	Barometer	BMP085 (with thermistor)
Descent mechanism	X-form parachute	Descent mechanism	X-form parachute
Transceiver	Laird AC4790-200A (specified by competition)	Egg protection	SR Foam
Locator	Buzzer AB2020B-2-LW1	Locator	Buzzer AB2020B-2-LW1
Power required	1137 mW	Power required	498 mW
Power source	9V lithium battery U9VL-BP	Power source	9V lithium battery U9VL-BP
Mass	116 g	Mass	24 g
Cost	\$202	Cost	\$104
		Carrier-Lander interface	Rotating bar lock mechanism

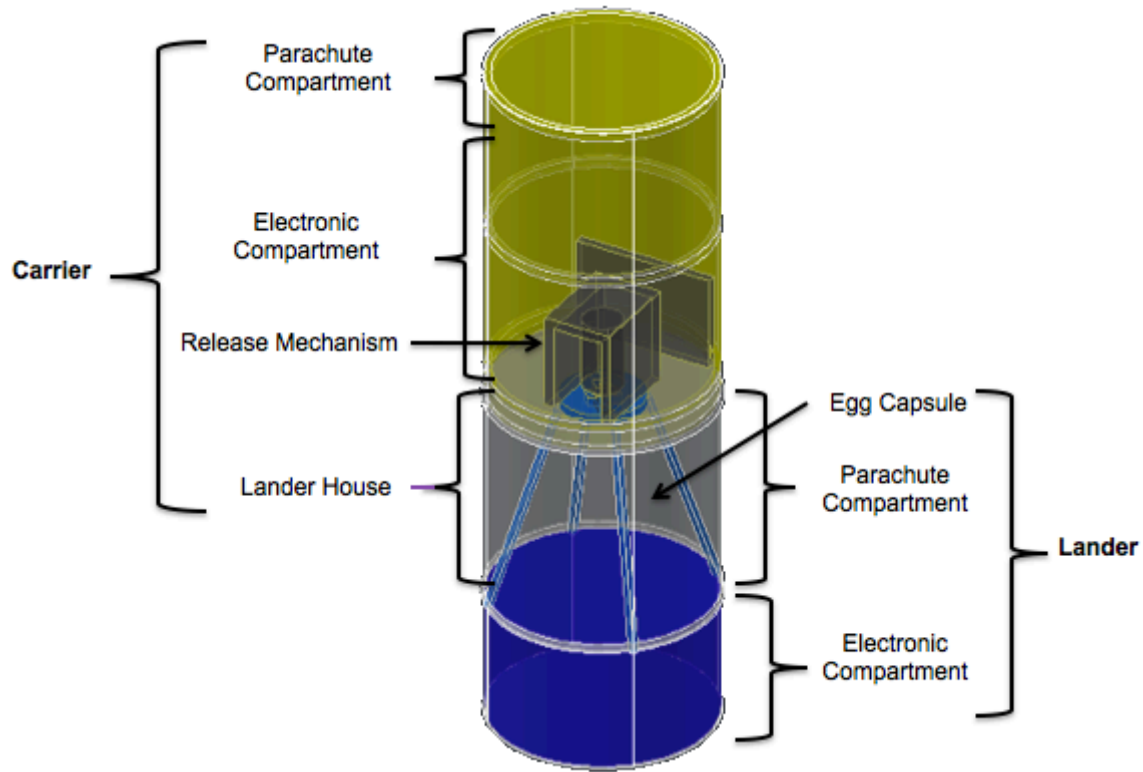

Figure 5.10 Team 1 final system CAD model in launch configuration (Cansat 1, 2010).

5.2.2 Team 2 design process

During the first design iteration using ADP, Team 2 defined specifications for the task in seven categories. These are *mission*, *systems*, *communications*, *power*, *sensors*, *structures* and *command and data handling* (shown in Table 5.14 through Table 5.20). The mission level specifications are shown in Table 5.14. It should be noted that they had significant changes between the first and second iteration in their design specifications, particularly in the sensors category. Numbers in parenthesis are used to

denote the ADP iteration in which elements were documented (e.g. no number indicates first iteration, 2 indicates second iteration, 3 third iteration, etc.).

Table 5.14 Team 2 mission specifications – Iterations 1 through 2.

Spec. #	Mission	Rationale (2)
1	The Cansat shall be an autonomous vehicle.	Cannot be externally controlled once it is loaded into the launch vehicle. (2)
2	The Cansat shall be composed of a carrier containing a deployable lander holding a hen egg.	Must be composed of these stages to meet Competition Guidelines. (2)
3	The Cansat shall descend as a single unit before separation.	Must remain carrier and lander after deployment from launch vehicle until separation. (2)
4	The Cansat shall be capable of deploying a lander payload.	Must be deployed to meet Competition Guidelines. (2)
5	The Cansat shall be deployed at 1021 +/- 107 m.	Must be deployed at this altitude to meet Competition Guidelines. (2)
6	The Cansat shall be capable of communicating with a ground station.	Must maintain communication to display telemetry in real time. (2)
7	The Cansat shall be capable of landing a hen egg without cracking.	Must land safely to satisfy Competition Guidelines. (2)
8	The Cansat shall have the capability to measure its descent rate.	Must take data to satisfy Competition Guidelines. (2)
9	The Cansat shall have the ability to control its descent rate.	Must have control over Cansat to safely land hardware. (2)
10	The Cansat shall be capable of tracking the coordinates using GPS.	Must have knowledge of where the Cansat lands adhering to Competition Guidelines. (2)

11	The lander shall be capable of measuring the impact force.	Must measure impact force adhering to Competition Guidelines (2)
12	The carrier shall be capable of transmitting telemetry data to the ground station in real time.	The carrier location must be known for retrieval adhering to the Competition Guidelines. (2)
13	The Cansat shall have a maximum mass of 500 g.	Must adhere to the Competition Guidelines. (2)
14	The Cansat shall safely fit inside the inner fairing of the Loc/Precision Forte Rocket provided.	The Cansat must fit inside the rocket to launch. (2)
15	The Cansat carrier shall emit an audible tone after landing.	Must give off audible tone to easily find lander once it has landed. (2)
16	The Cansat and personnel must adhere to the safety procedures outlined in Field Safety Rules section in 2011 Competition Guide.	The design, build, and fly process must be conducted in a safe manner. (2)
17	The Cansat shall be launched within the acceptable launch window specified by on-site Judges.	The specified launch window allows for other teams to launch on the same day. (2)
18	The Cansat hardware shall be under \$500 USD.	Must comply with funding restraints. (2)

The system level specifications identified by Team 2 are shown in Table 5.15. It is notable how many of these specifications are concerning the command and data handling subsystem.

Table 5.15 Team 2 system level specifications – Iteration 1.

Spec. #	System
1	The power subsystem shall deliver the correct power to all electronic components
2	The command and data handling subsystem shall collect all generated data, format, and deliver to communication subsystem for downlink
3	The structures subsystem shall support and contain all other subsystems
4	The command and data handling subsystem shall incorporate software to automatically control every action of the CanSat during descent
5	The sensors subsystem shall interface with the command and data handling subsystem
6	The communications subsystem shall be able to accept data from the command and data handling subsystem

It appears there was an awareness increase in the team regarding mission data flow. This is assumed since during the second iteration of the design model the team documented the rationale for communication related specifications, as seen in Table 5.16.

Table 5.16 Team 2 communications specifications – Iterations 1 through 2.

Spec. #	Communications	Rationale (2)
1	The carrier shall have an antenna for the radio.	Necessary for radio to transmit. (2)
2	The antenna should be able to transmit data to a transceiver more than 1000 m away.	CANSAT will be transmitting data starting at 1000 m in the air and Ground Station will be on the ground. (2)
3	The antenna should be 902-928 MHz.	This is the frequency range that the radio needs. (2)

4	The antenna should have at least 2dBi (Removed in 2)	
---	---	--

All of the rationale criteria shown in Table 5.17 relating to power specifications of the system were incorporated during the second iteration of the design model. Specifications 2 through 8 were also added during the second iteration, since during the first iteration there was only one generic specification of having a battery power supply.

Table 5.17 Team 2 power specifications – Iterations 1 through 3.

Spec. #	Power	Rationale (2)
1	The carrier and lander shall have a battery power supply.	Competition Safety Guidelines (2)
2	The carrier and lander batteries shall have independent power systems. (2)	Competition Safety Guidelines (2)
3	The carrier must use a 9-volt battery. (2)	The 9-volt battery is the most volume effective while providing a good voltage. (2)
4	Convertors must be used to provide the correct voltages to sensors. (2)	The voltage cannot be too high for the sensors. (2)
5	The circuit should be in parallel. (3)	The other sensors must work even if one becomes damaged. (2)
6	The microcontroller will be supplied power through a convertor. (2)	The microcontroller must be able to accept a specific voltage. (2)
7	The battery must be rechargeable. (2)	The battery must be reusable for testing purposes. (2)

8	The battery must provide power for the entire mission plus contingency. (2)	The battery has to power the entire mission plus account for time the cansat is on stand by to prevent data loss. (2)
---	---	---

Specifications concerning power needs were documented mainly during the second ADP iteration.

A partial list of the sensors' specifications from the first ADP iteration of Team 2 are shown in Table 5.18. Because of the extensive list this team generated, the full set of specifications including details of subsequent iterations is located in Appendix B.

Table 5.18 Team 2 partial list of sensors specifications – Iteration 1 through 2.

Spec. #	Sensors	Rationale (2)
1	The Cansat should have a GPS sensor	Satisfy Competition Guidelines. (2)
2	"GPS data: UTC time, latitude (degrees), longitude (degrees), mean sea level altitude, no. of satellites tracked"	Satisfy Competition Guidelines. (2)
3	The GPS data shall be transmitted once every 2 seconds (0.5 Hz)	Satisfy Competition Guidelines. (2)
4	The GPS should have an error <1m	The team most closely predicting the landing coordinates of the lander shall receive a 10% point bonus to the flight day scores. (2)
5	The GPS should work in optimal conditions at the Cansat's temperature	The sensors cannot fail during the mission. (2)

The list of structures specifications from Team 2 is shown in Table 5.19.

Table 5.19 Team 2 structures list of specifications - Iteration 1 through 2.

Spec. #	Structures	Rationale (2)
1	The CanSat shall have a height less than 279mm and a diameter less than 72mm.	Satisfy Competition Guidelines. (2)
2	The CanSat lander shall be at least 51mm in height and at least 41mm in diameter. (size of a large hen egg)	CanSat lander must be large enough to contain a large hen egg. (2)
3	The CanSat carrier shall descend at a rate of 4 m/s.	Satisfy Competition Guidelines. (2)
4	The CanSat lander shall descent at a rate of 5.5 m/s	Satisfy Competition Guidelines. (2)
5	The diameter of the carrier's parachute shall be around 688mm.	In order to achieve a terminal velocity of 4 m/s for the CanSat system. (2)
6	The diameter of the lander's parachute shall be around 328mm.	In order to achieve a terminal velocity of 5.5 m/s for the lander system. (2)
7	The mass of the CanSat shall be less than 500g.	Satisfy Competition Guidelines. (2)
8	The mass of the CanSat structure shall be less than 250g.	In order to comply with competition guidelines after taking into account the mass of interior components of the CanSat. (2)

The list of the command and data handling specifications is shown in Table 5.20.

Table 5.20 Team 2 command and data handling list of specifications – Iteration 1 through 2.

Spec. #	Command and data handling	Rationale (2)
1	The carrier shall monitor the data (at a rate of 1Hz) from all sensors starting from before launch until shortly after landing.	The carrier needs to be able to read and process the data for the entirety of the mission so that commands can go through and data can be stored/telemetered. (2)
2	The carrier shall activate the deployment mechanism on descent when it reaches 500m.	Specified altitude to deploy lander. (2)
3	The lander shall monitor the data (at a rate of 1Hz) from all sensors starting from before launch until shortly after landing.	The lander needs to be able to read and process the data for the entirety of the mission so that data can be stored. (2)
4	The carrier shall begin to store/telemeter data when it reaches 914m until landing. (2)	Minimum altitude of the range to store/telemeter data. (2)
5	The carrier shall activate the buzzer when it reaches 10m. (2)	Buffer height for resolution of altitude(2)
6	The lander shall begin to store data when it reaches 914m until landing. (2)	Minimum altitude of the range to store data. (2)
7	The lander shall activate the accelerometer when it reaches 10m. (2)	Begin to measure acceleration before landing. (2)
8	The carrier MCU shall have enough memory space to store all data. (2)	
9	The lander MCU shall have enough memory space to store all data. (2)	

The initial configurations created by Team 2 were mainly focused on identifying a configuration for the carrier and lander with respect to each other in the system, as shown in Figure 5.11. The electronics components in both configurations are stacked. It is also relevant to note that they had different positions for the egg in each configuration, one in horizontal position with respect to the egg's main axis and the other in vertical position.

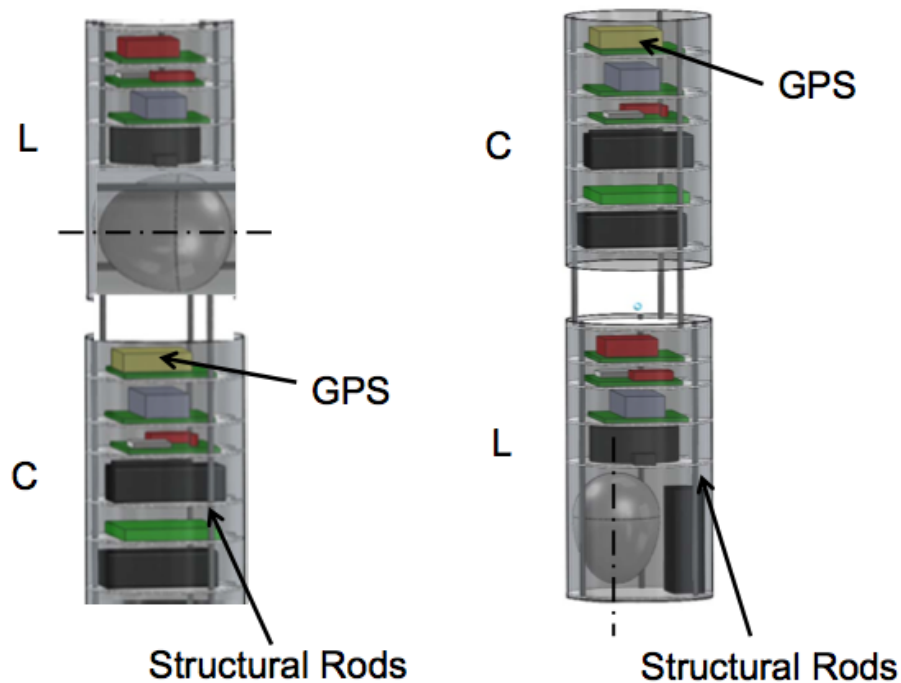

Figure 5.11 Team 2 configurations A (left) and B (right) for the design task during iteration 1. L = “Lander” and C = “Carrier” in both configurations.

In addition, more details of the configurations were oriented to address difficulties with the descent control system, deployment mechanism and the sensors, as shown in the following tables.

Table 5.21 shows how Team 2 considered two configuration concepts during their first iteration to address the systems descent, via parachute or using autorotation lift. Their preliminary calculations discouraged them from pursuing the autorotation lift.

Table 5.21 Team 2 configurations created for the system's descent – Iteration 1.

Descent	
Configuration	Notes
Parachute	High manufacturability
	Density approx. 58.9 g/m ²
	Size approx. 0.17 m ²
Autorotation lift	Low manufacturability
	Density NA
	Size approx. 0.40 m ²

The deployment feature of the system designed by Team 2 had five configurations according to their documentation of the first iteration. They included the use of a timer, using GPS, using a pressure sensor, a spring based solution and a fuse as shown in Table 5.22. The table shows features of what enables the deployment (trigger) and mechanical interfaces.

Table 5.22 Team 2 configurations created for deployment purposes – Iteration 1.

Deployment		
Feature	Configuration	Notes
Trigger	Timer	Pros: Easy to do
		Cons: Not very accurate, possibility of release at wrong altitude
	Using GPS	Pros: GPS already in vehicle, more accurate.
		Cons: Potentially more programming
	Using Pressure Sensor	Pros: Already in lander, accurate, easy to use
		Cons: Need to transfer data from lander to launch mechanism in carrier
Mechanical Interface	Spring based	Pros: Easier to manage, low power
		Cons: program spring release
	Fuse	Pros: More reliable, easier to program
		Cons: One time use (for testing), high power necessary.

The elements considered for environmental sensing are of two different categories, altitude or impact, as listed in Table 5.23.

Table 5.23 Team 2 configurations considered for environmental sensing – Iteration 1.

Sensors	
Configuration	Options
Altitude	Mass flow sensor
	Altimeter
	Pressure sensor
Impact	Accelerometer
	Piezoelectric accelerometer
	Sudden motion sensor

A summary of the trade studies performed by Team 2 is shown in Table 5.24. The teams captured the information from each element starting from the left-most column down to the one on the far right. Observation and analysis (performed by using the Google documents history tracking tool) of the gradual population of these tables revealed that often times there would not be enough distinction between the elements when only a few columns appeared in the first drafts of the trade study. But as they found more information they were able to justify a particular selected component, depending on the specifications of the current ADP cycle. In some instances, the teams were not able to find exact values for parameters that would have helped make a decision (for example GPS element’s weight values), but in those cases it was not too difficult to expect that the elements would have similar weight to other products from different companies with similar technical characteristics.

Table 5.24 Team 2 summary of trade studies conducted for the structure material, structure shape, temperature sensors, pressure sensors, GPS, accelerometer and batteries.

Structure material			
Type	Cost	Weight	Ultimate Tensile Strength
Cor-Ten Steel	Least	Most	36,000 psi
Aluminum	Medium	Least	34,000 psi
Titanium	Most	Medium	120,000 psi

Structure shape		
Cross Section	Volume (of max usable)	Machinability
Circle	100%	Easiest(Soda Cans)
Hexagon	82.70%	Hardest
Square	62.40%	Medium

Temperature sensors					
Model	Manufacturer	Dimensions (mm)	Range (°C)	Op Voltage (V)	Accuracy (°C)
LM20	National Semiconductor	2.4 x 1.3	-0.42	2.4-5.5	~2.5
LM 35	National Semiconductor	2.4 x 1.3	-0.37	4-30	~0.5
LM94022	National Semiconductor	2.4 x 1.3	-0.33	1.5-5.5	~2.1

Pressure sensors						
Model	Vendor	Op Voltage (V)	Op. Current (mA)	Accuracy	Range (kPa)	Cost
MPL115A1	Sparkfun	'2.4-5.5	0.0035	±1 kPa	'50-150	\$25.00
SCP1000	Sparkfun	'2.4-3.3	0.0035	±1.5 kPa	'30-10	\$35.00
HSCMANN 100PGAA3	Digikey	'3-3.6	2	±1 kPa	'0-690	\$40.00
BMP085	Sparkfun	'1.8-3.6	0.003-0.012	±1 kPa	'30-110	\$20.00

GPS							
Model	Manufacturer	Dimensions (mm)	Weight (g)	Max. Update	Op. Voltage (V)	Error	Channels
GTGPS10	MeadiaTek	16x16	5	10Hz	3.3-5		66
LS20033_10	Locosys	34x16	7	10Hz	3.3-4.2		66
MC-1513	Locosys	15x13		1-10Hz		<3m	66
AR1520	Atheros	4.2x4.2				<1m	
EM-318-02	SIRF	30x30			3.3-5.5		20
StarIII GSC3f/LPx-7989	SIRF	27x23	10			3.3 <5m	20
OEM GPS 15H/15L	Garmin	30x30	15		8-40 (15H)		
EM-406	Global Sat	30x30	23	10Hz	4.5-6.5	<5m	20
EM-410	GlobalSat	30x28	N/A	10Hz		3.3 <5m	20
EM-411	GlobalSat	30x30	N/A	10Hz	3.3-4.2	<5m	20
IT500	Fastrax	18x16.3	3	1-10Hz		3 <1.8m	66

Accelerometer						
Model	Vendor	Op. Voltage (V)	Op. Current (mA)	Axis	Accel. range (g)	Cost
BMA180	Sparkfun	'1.2-3.6	0.65	3	±16	\$15.00
ADXL320	Digikey	'2.4-5.25	0.35	2	±5	\$30.00
ADXL335	Digikey	'1.8-3.6	0.35	3	±3.6	\$25.00
MMA7260Q	Sparkfun	'2.2-3.6	0.5	3	±1.5-6	\$20.00

Batteries			
Type	mAh	Voltage	Mass (g)
Nickel-Metal Hydride	250	7.2	47
Lithium Ion	700	9.6	45
Alkaline	565	9	42
Carbon Zinc	850	9	43

Team 2 created the top-level block diagram shown in Figure 5.12 and the top-level circuit block diagram shown in Figure 5.13 during the first major design iteration.

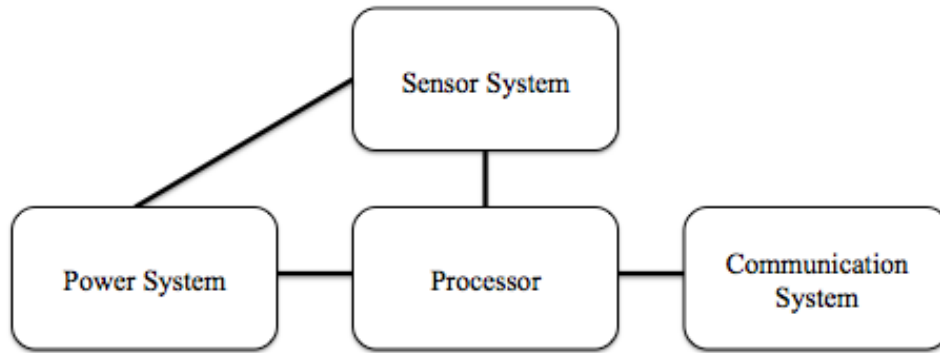

Figure 5.12 Team 2 top-level system block diagram (Cansat Team 2, 2010) - Iteration 1.

The system block diagram shows four major functional elements of the system, but there is no detail on what the lines connecting these elements represent.

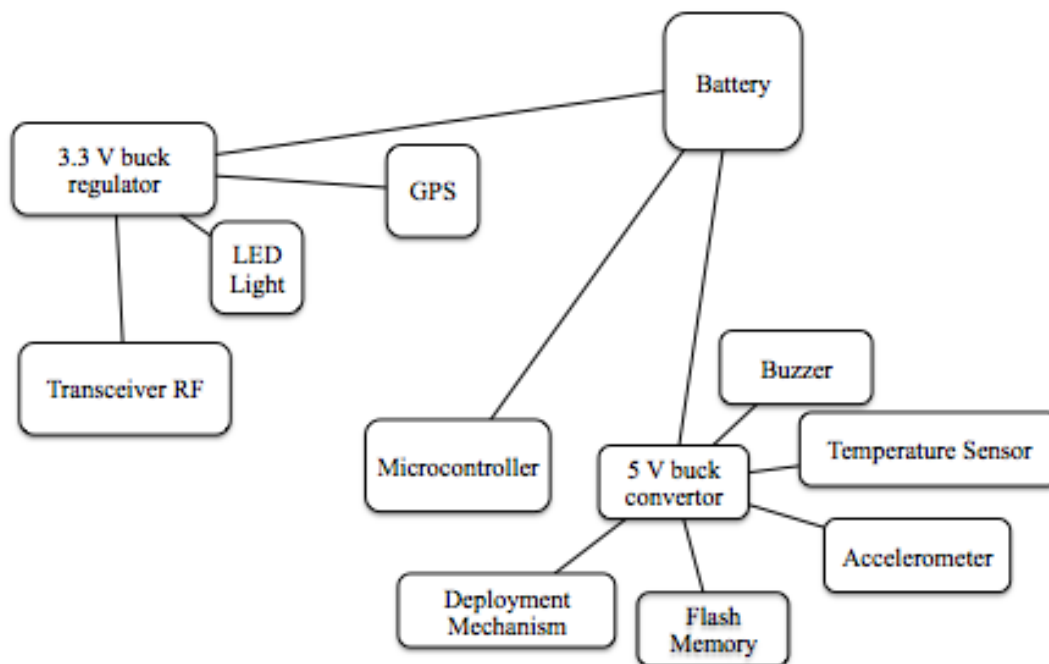

Figure 5.13 Team 2 top-level circuit block diagram (Cansat Team 2, 2010) - Iteration 1.

The two elements that stand out from their top level circuit block diagram are the buck regulator at 3.3 V and converter at 5 V, since they have the largest number of

identified relationships with other elements, creating two groups. Both of these groups are linked through the battery. The team had a strong inclination during the first design iteration for the cansat to be a power subsystem driven system.

During the second design iteration, the team created diagrams like the one shown in Figure 5.14, where functionality of each sensor is more specific, focusing on the type of data that is being transmitted. Since all the data needs to be handled by the command and data handling system, this was prompting Team 2 to consider the command and data handling of the system to be a dominant design driver.

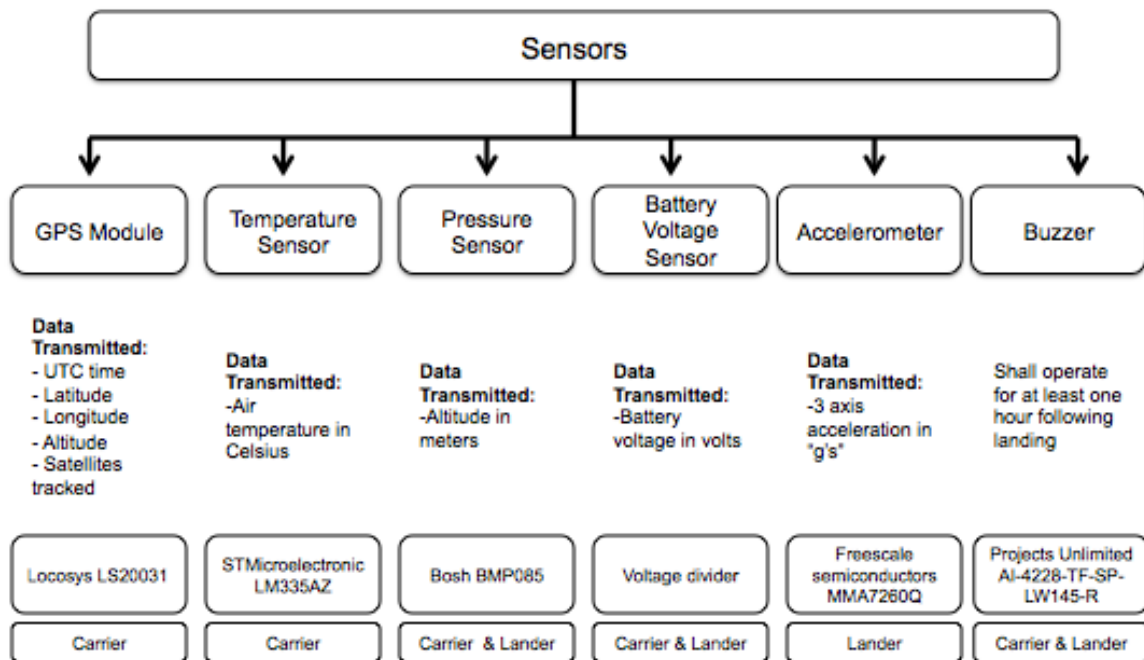

Figure 5.14 Team 2 sensors diagram showing data transmitted detail - Iteration 2.

The drivers identified by the team per ADP iteration are shown in Table 5.25.

Table 5.25 Team 2 drivers identified by using the ADP model.

ADP Iteration	Dominant Driver	Notes
1	Power	The power system must last the entire duration of the mission, plus extra time in case of errors or delays.
		The power system must be able to supply the correct amount of voltage to each sensor as well as the deployment mechanism and buzzer.
2	Command and Data handling system	Both MCU's shall collect all data from all sensors.
		Both MCU's shall have enough memory space to store all data.
		The Carrier MCU shall transfer data to transceiver.
		The Carrier MCU shall activate deployment mechanism.
		Both MCU's shall collect all data from all sensors.

Although there is documentation that the team generated (in the form of informal notes) suggesting their activities involved a third iteration of the ADP model, it is not complete to be able to identify another driver.

A summary of the design by Team 2 is shown in Table 5.26.

Table 5.26 Team 2 summary of final system design.

Carrier		Lander	
Processor	Arduino TM Nano Atmel ATmega 328	Processor	Arduino TM Nano Atmel ATmega 328
Memory	8 MB	Memory	8 MB

GPS	Sparkfun LS20031	Accelerometer	Sparkfun MMA7260Q
Barometer	BMP085 (with thermistor)	Barometer	BMP085 (with thermistor)
Descent mechanism	Parachute	Descent mechanism	Parachute
Transceiver	Laird AC4790-200A (specified by competition)	Egg protection	Impact gel
Locator	Buzzer AI-4228-TF-SP-LW145-R	Locator	Buzzer AI-4228-TF-SP-LW145-R
Power required	683 mW	Power required	317 mW
Power source	9V lithium battery	Power source	9V lithium battery
Mass	301 g	Mass	195 g
Cost	\$686 (both carrier and lander)	Carrier-Lander interface	Nichrome wire

The final system CAD model is illustrated in Figure 5.15 and Figure 5.16.

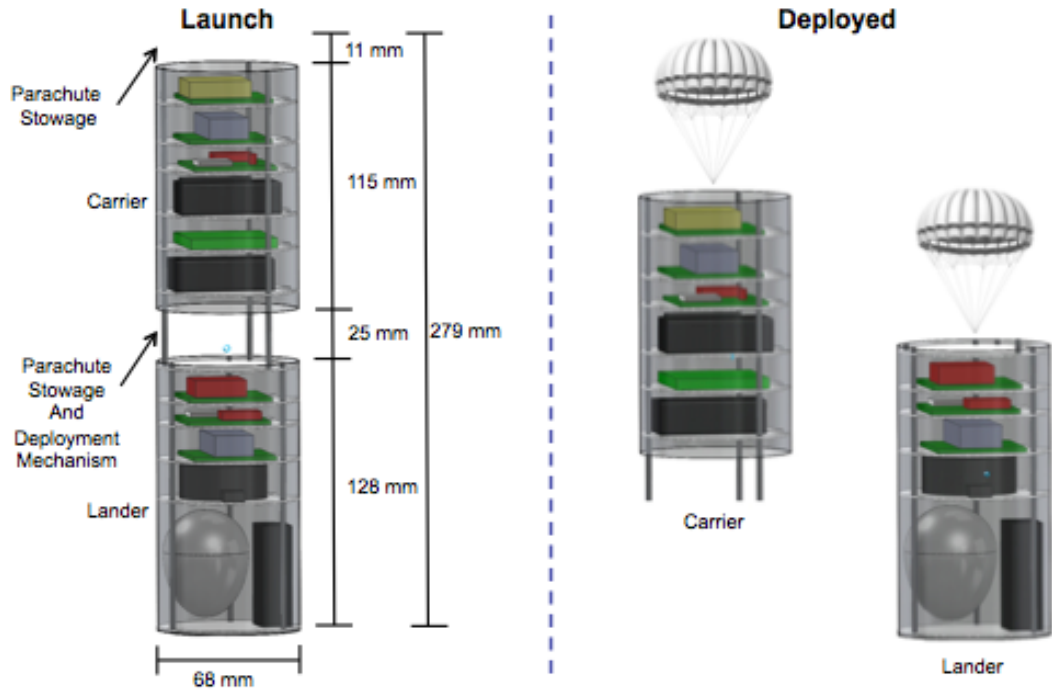

Figure 5.15 Team 2 final system CAD models of launch configuration (left) and deployed configuration (right).

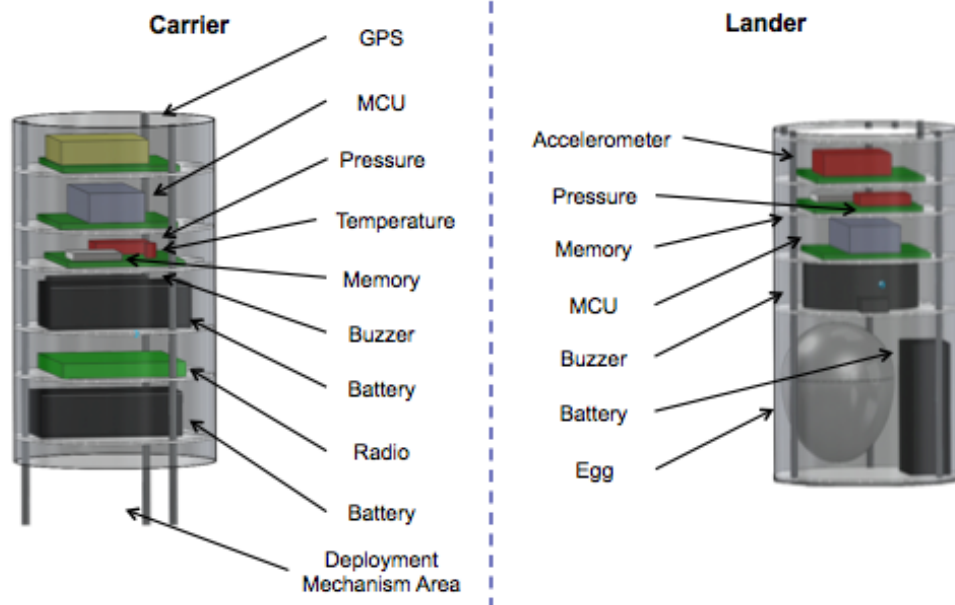

Figure 5.16 Team 2 final system configurations of carrier (left) and lander (right).

Both teams design processes have been explained in depth in this section. In designing the systems, both teams developed their baseline specifications and identified constraints. They proposed different configurations that encompassed functionality or operational characteristics. When they pursued the search for components that would support those configurations they sometimes found that not all information of the components was available, so they needed to assume values or use typical values for those elements presented in the same category. The development of their system by using the ADP helped them quickly understand in greater depth what was driving the system. When they evaluated intermediate designs and realized that the specifications were not met, they reconfigured and reallocated as needed until subsequent major design iterations produced feasible designs. It should be noted that these designs helped demonstrate ADP's success in a fast paced culture of learning, all while using the documentation tools provided and the custom build information system.

The following section presents in detail specifically the design questions analysis associated to the teams performing the design task.

5.2.3 Design questionnaire analyses

The students were asked to complete a design questionnaire to document their understanding in design processes before and after the design task. This section contains the detailed analysis of the design questionnaires, to help identify what elements of good design, according to Mehalik and Schunn's (2006) classification (Section 2.4.2), are promoted by using ADP.

The environment in which the design task took place for both teams permitted the observation of changes associated to problem representation, graphical representation and visualization, functional decomposition, exploration of engineering facts, exploration and redefinition of constraints, validation of assumptions and constraints, search of the design space (exploring alternatives), examination of existing artifacts and designs, and utilization of iterative design methodology during the design process. From the work that was conducted by Mehalik and Schunn (2006) assessing a body of literature, they concluded that the *problem representation*, *iterative design methodology*, and *exploring alternatives* were reported most frequently as the most significant for achieving a good design. These constitute the first tier (Tier I) of categories presented in Chapter 2 (See Table 2.2). As summarized in Table 2.2, there are three other category tiers. These are briefly reviewed below before considering their connections with Teams 1 and 2.

How designers use *functional decomposition* stands out in its own tier (Tier II), and it is intended to simplify complex aspects of the design by isolating them to discover which have the most impact on the overall functionality. Intuitively, it seems that this element requires a certain degree of experience in design.

The use of diagrams and schematics to invent *graphical representations*, the *redefinition of constraints* and *exploring the scope* of these, as well as *validating assumptions* are all part of the next tier, Tier III. *Examining existing designs* and *exploring user perspectives* are also part of this tier, but they were reported at a lower frequency in the literature, so their impact is much less. One of the elements mentioned less frequently in all studies was related to projecting normative outcomes, when you can

momentarily suspend constraints to construct models that would generate an ideal outcome. This element is called *building a normative model*, and it is Tier IV.

Even though a designer can be thorough in *exploring engineering facts* from different knowledge domains regarding some characteristic of a design, it actually forms part of the fifth and final tier. In addition to this activity, *exploring issues of measurement, conducting failure analysis* and *encouraging reflection process* are also within Tier V. This tier overall has the least impact on design.

Two different designs were created by the teams within the defined schedule, and all the data collected from the design questionnaires was analyzed. The questionnaire contained Likert-scale questions (1 = strongly disagree, 7 = strongly agree) asking the participant about all the elements of design. It was of interest to verify the reliability of the scale for this questionnaire. Internal consistency reliability estimators are very flexible and appropriate for a wide variety of circumstances in which an estimate of reliability is needed (Osburn, 2000). Cronbach's alpha (Cronbach, 1951) is a reliability coefficient that normally ranges between 0 and 1. The closer Cronbach's alpha coefficient is to 1.0 the greater the internal consistency of the items in the scale. It is used as a test reliability technique that requires only a single test administration to provide a unique estimate of the reliability for a given test (for more on the subject see Nunnally (1978), Hattie (1985) and Cortina (1993)). George and Mallery (2003) provide the following rules of thumb for alpha values: "alpha > 0.9 – Excellent, alpha > 0.8 – Good, alpha > 0.7 – Acceptable, alpha > 0.6 – Questionable, alpha > 0.5 – Poor, and alpha < 0.5 – Unacceptable". For the design questionnaire presented here, all questions showed to have an acceptable level of consistency with a Cronbach's alpha = 0.78.

Because the number of participants was small (sample n is small), parametric statistical procedures that require interval data, such as linear regression would not necessarily yield the best information. Those tests can be used if there is certainty that the variable is normally distributed, and there is no way to test this assumption if the sample is small.

Some studies suggest that only non-parametric statistics should be used on Likert scale data (Jamieson, 2004) but others disagree, stating that Likert response formats may logically be ratio scales with the correct anchoring terms (Carifio & Perla, 2007). The debate is beyond the scope of this research. For the analysis of the data collected in this setup, non-parametric methods that do not rely on the estimation of parameters (and that have independent samples of observations) are used, in particular the Mann-Whitney U (1947) test. Research aimed at understanding students' perception has revealed that valuable findings can be supported by using the Mann-Whitney U test (Davies, 2002; Carle et al. 2009; Ismail et al. 2010).

The results shown below present the experiment and questionnaire results with notable findings. They examine design elements mentioned above for the teams' practices and their importance in design performance.

The Tier I elements in Mehalik and Schunn's (2006) for good design include 1) *exploring problem representation*, 2) *using an iterative design methodology* and 3) *searching the space* – that is exploring different alternatives. Sections 5.2.3.1, 5.2.3.2 and 5.2.3.3 describe specific findings for this tier.

5.2.3.1 Element: Exploring problem representation (Tier I)

Exploring the problem representation can have an impact on the path selected to find the solutions to a design problem. In an ideal scenario, a team would have unlimited time to pursue this activity, but in reality there are scheduling and cost constraints that force a group to work within a deadline. It is important that at the end of this activity the team has defined an appropriate goal, so they can work together to understand what needs to be accomplished.

The hypothesis is that students will score higher in the element of *exploring problem representation*, after applying the ADP model in their design.

The graph shown in Figure 5.17 is a box plot displaying the distribution (minimum, 25th percentile, 50th percentile, 75th percentile, maximum and outliers) for the *exploring problem representation* element. Stage 1 represents the results before starting the design project and using ADP and stage 2 after completing the 8-week experience based on the using ADP.

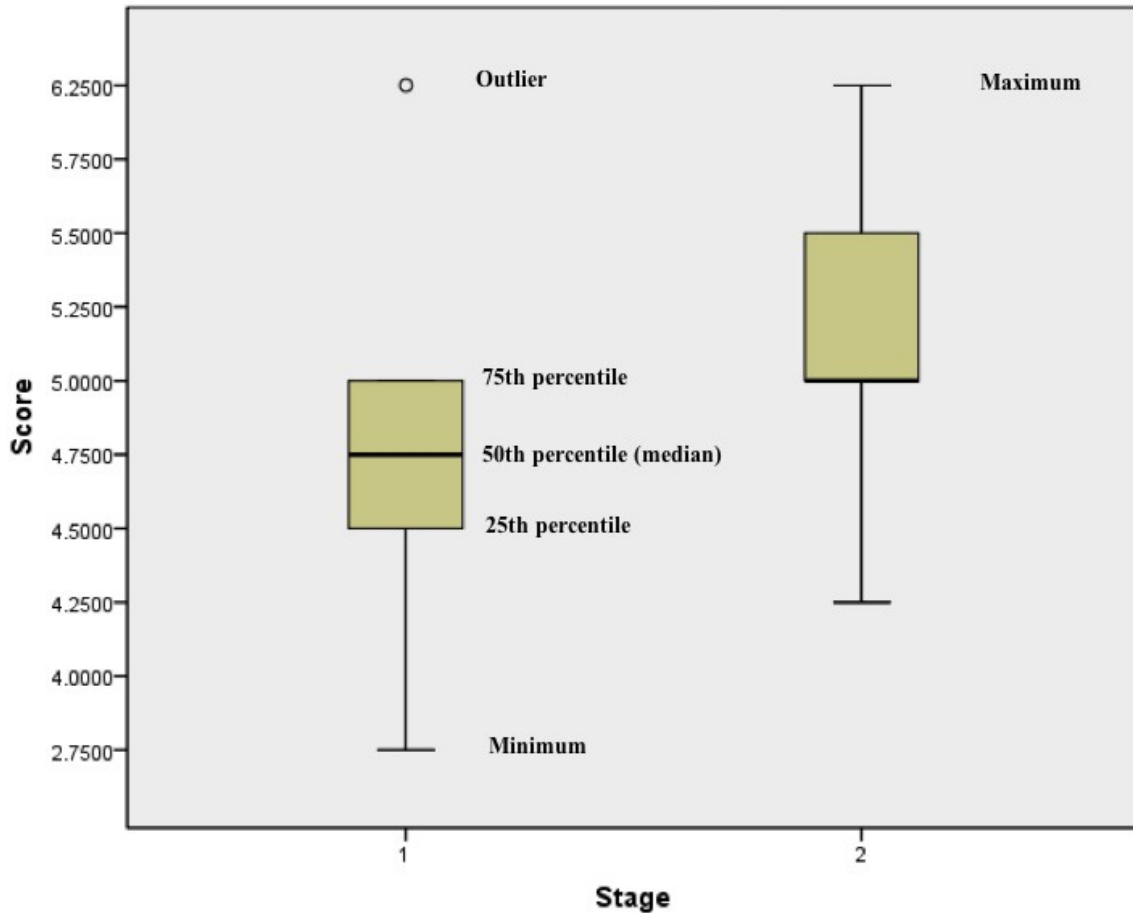

Figure 5.17 Box plot distribution for element "Exploring problem representation" Stage 1 is pre-ADP and stage 2 is post-ADP.

A Mann-Whitney U test was conducted to evaluate the hypothesis that students would score higher in the element of *exploring problem representation*, on average, after applying the ADP model for design. At the $\alpha = 0.05$ level of significance, the results were in the expected direction and significant, $Z = -2.12$, $p = 0.034 < 0.05$, $U = 36$, $r = 0.43$. Post ADP (Stage 2) values had an average rank of 15.50, while Pre ADP (Stage 1) values had an average rank of 9.50, as shown in Table 5.27.

Table 5.27 Mann-Whitney U test results for element "Explore problem representation".

	Stage	N	Mean Rank	Sum of Ranks
Score	1	12	9.50	114.00
	2	12	15.50	186.00
	Total	24		

	Score
Mann-Whitney U	36.000
Wilcoxon W	114.000
Z	-2.122
Asymp. Sig. (2-tailed)	.034
Exact Sig. [2*(1-tailed Sig.)]	.039 ^a

a. Not corrected for ties.

b. Grouping Variable: Stage

5.2.3.2 Element: Follow interactive, recursive, and iterative design methodology (Tier I)

To study the effects on this element, the questions needed to be carefully selected since these actions are different in nature. The interactive aspect related to the ability of the subject to interact with other subjects within the team, while the recursive and iterative aspects related to the transitions through design stages in order to move towards a feasible solution.

The hypothesis is that students will score higher in the element of *using interactive, recursive and iterative design methodology*, after applying the ADP model in their design.

The graph shown in Figure 5.18 is a box plot displaying the distribution (minimum, 25th percentile, 50th percentile, 75th percentile, maximum and outliers) for the *using interactive, recursive and iterative design methodology* element. Stage 1 represents the results before using ADP and stage 2 after using ADP.

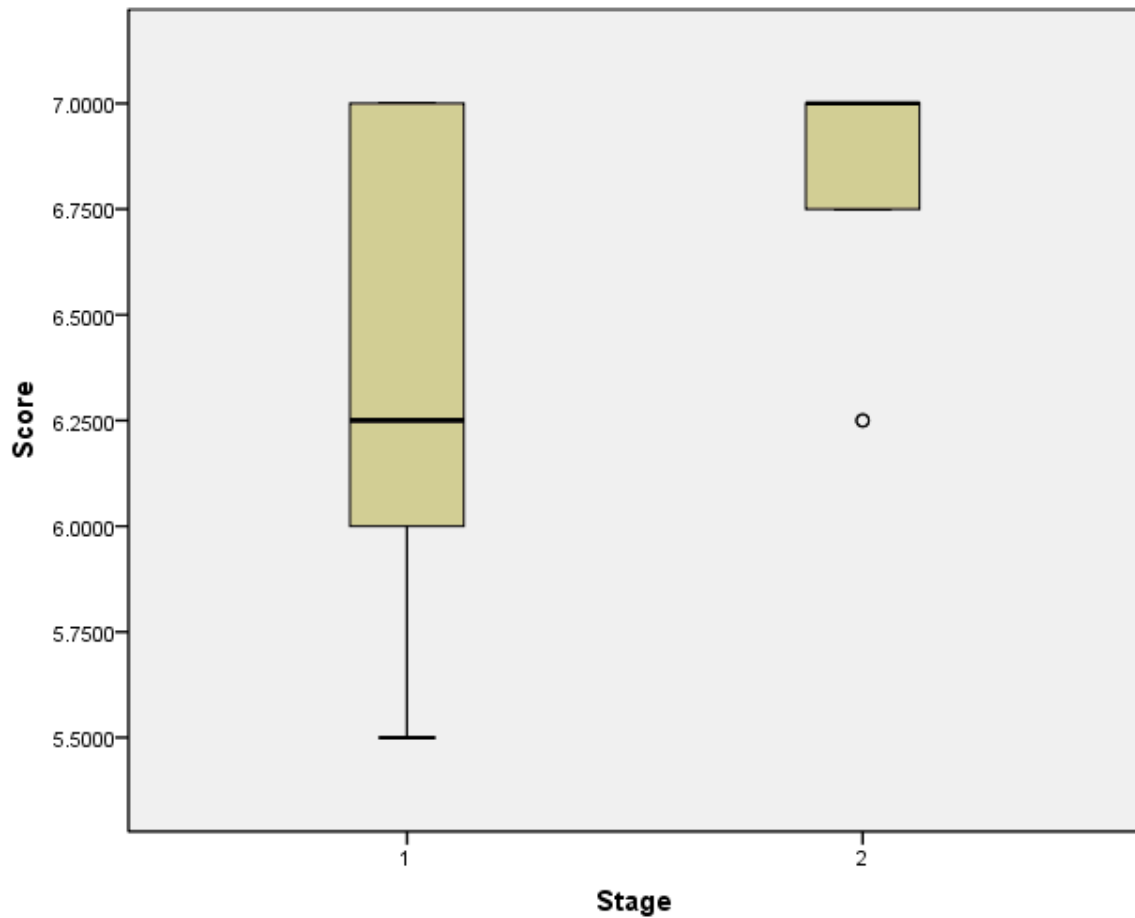

Figure 5.18 Box plot distribution for element "Using interactive, recursive and iterative design methodology" Stage 1 is pre-ADP and stage 2 is post-ADP.

A Mann-Whitney U test was conducted to evaluate the hypothesis that students would score higher in the element of using interactive, recursive and iterative design

methodology, on average, after applying the ADP model for design. At the $\alpha = 0.05$ level of significance, the results were in the expected direction and significant, $Z = -1.98$, $p = 0.048 < 0.05$, $U = 39.5$, $r = 0.40$. Post ADP (Stage 2) values had an average rank of 15.21, while Pre ADP (Stage 1) values had an average rank of 9.79, as shown in Table 5.28.

Table 5.28 Mann-Whitney U test results for element "Using interactive, recursive and iterative design methodology".

Ranks				
	Stage	N	Mean Rank	Sum of Ranks
Score	1	12	9.79	117.50
	2	12	15.21	182.50
	Total	24		

Test Statistics ^b	
	Score
Mann-Whitney U	39.500
Wilcoxon W	117.500
Z	-1.981
Asymp. Sig. (2-tailed)	.048
Exact Sig. [2*(1-tailed Sig.)]	.060 ^a

a. Not corrected for ties.

b. Grouping Variable: Stage

5.2.3.3 Element: Search the space (Tier I)

Defining clearly a performance criterion to search for potential solutions in a design can help bound this activity, since it largely depends on the size and expertise of the group. Experienced designers develop their own approach for complex system

design, and it will include some period of searching the space, and using the resources available to them.

The hypothesis is that students will score higher in the element of *searching the space*, after applying the ADP model in their design.

The graph shown in Figure 5.19 is a box plot displaying the distribution (minimum, 25th percentile, 50th percentile, 75th percentile, maximum and outliers) for the *searching the space* element. Stage 1 represents the results before using ADP and stage 2 after using ADP.

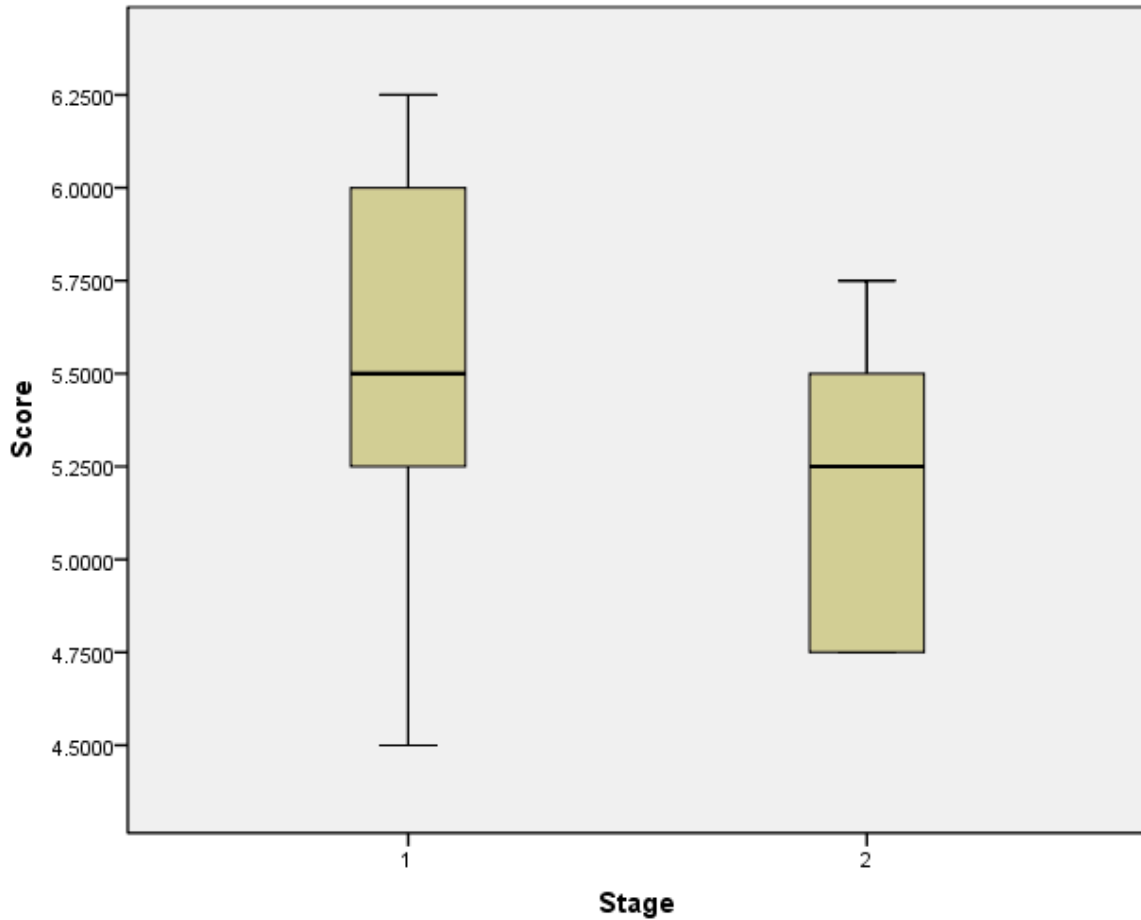

Figure 5.19 Box plot distribution for element "Search the space" Stage 1 is pre-ADP and stage 2 is post-ADP.

A Mann-Whitney U test was conducted to evaluate the hypothesis that students would score higher in the element of *searching the space*, on average, after applying the ADP model for design. With an $\alpha = 0.05$ level of significance, the results were not enough to verify the hypothesis ($p = 0.144 > 0.05$). Post ADP (Stage 2) values had an average rank of 10.42, while Pre ADP (Stage 1) values had an average rank of 14.58, as shown in Table 5.29.

Table 5.29 Mann-Whitney U test results for element "Search the space".

Ranks				
	Stage	N	Mean Rank	Sum of Ranks
Score	1	12	14.58	175.00
	2	12	10.42	125.00
	Total	24		

Test Statistics ^b	
	Score
Mann-Whitney U	47.000
Wilcoxon W	125.000
Z	-1.462
Asymp. Sig. (2-tailed)	.144
Exact Sig. [2*(1-tailed Sig.)]	.160 ^a

a. Not corrected for ties.

b. Grouping Variable: Stage

5.2.3.4 Element: Use functional decomposition (Tier II)

The practice of decomposing a complex system into its functions helps to isolate the important sections of it, typically allowing engineers to discover which ones have the most impact. Although not always easy to accomplish due to the relationships of elaborate systems, in this design task it was expected that the subjects would be receptive to the benefits that ADP can bring by helping understand the functions per subsystem. This is the only element of Tier II and is considered of high impact on overall performance.

The hypothesis is that students will score higher in the element of *use functional decomposition*, after applying the ADP model in their design.

The graph shown in Figure 5.20 is a box plot displaying the distribution (minimum, 25th percentile, 50th percentile, 75th percentile, maximum and outliers) for the *use functional decomposition* element. Stage 1 represents the results before using ADP and stage 2 after using ADP.

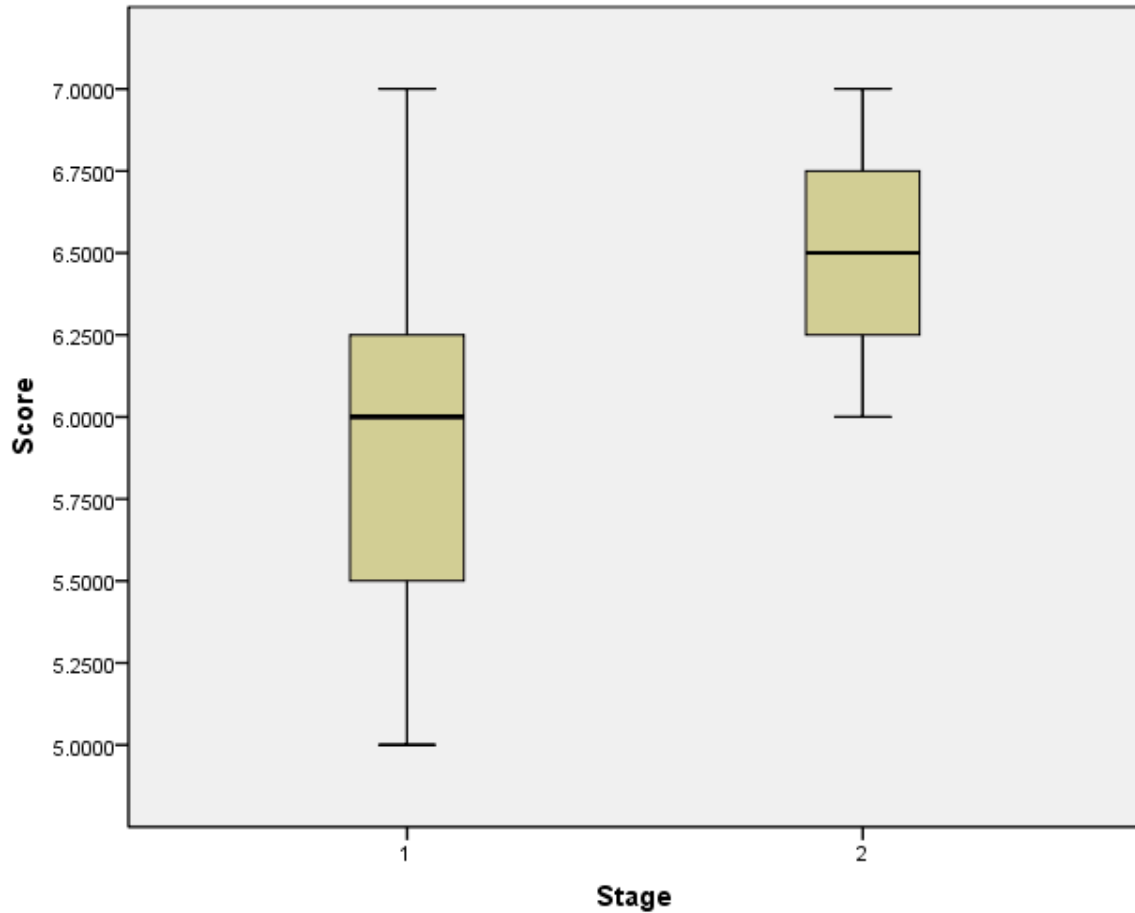

Figure 5.20 Box plot distribution for element "Use functional decomposition" Stage 1 is pre-ADP and stage 2 is post-ADP.

A Mann-Whitney U test was conducted to evaluate the hypothesis that students would score higher in the element of *use functional decomposition*, on average, after applying the ADP model for design. At the $\alpha = 0.05$ level of significance, the results were in the expected direction and significant, $Z = -3.033$, $p = 0.002 < 0.05$, $U = 20$, $r = 0.62$.

Post ADP (Stage 2) values had an average rank of 16.83, while Pre ADP (Stage 1) values had an average rank of 8.17, as shown in Table 5.30.

Table 5.30 Mann-Whitney U test results for element "Use functional decomposition".

Ranks				
	Stage	N	Mean Rank	Sum of Ranks
Score	1	12	8.17	98.00
	2	12	16.83	202.00
	Total	24		

Test Statistics ^b	
	Score
Mann-Whitney U	20.000
Wilcoxon W	98.000
Z	-3.033
Asymp. Sig. (2-tailed)	.002
Exact Sig. [2*(1-tailed Sig.)]	.002 ^a

a. Not corrected for ties.

b. Grouping Variable: Stage

5.2.3.5 Element: Explore graphical representation (Tier III)

There are six elements in Tier III, making it the biggest tier with a *moderate* impact on design performance. The elements are: *explore graphical representation*, *redefine constraints*, *explore scope of the constraints*, *validate assumptions and constraints*, *examine existing designs*, and *explore user perspectives*.

Graphical representations are used heavily in the beginning stages of design. They range from sketches drawn in engineering logbooks to sophisticated CAD models that can perform elaborate simulations. These models also help an entire team understand agreements. It was not expected that there would be much variation between pre-ADP and post-ADP due to a common acceptance even among young engineering students that simple graphical representations can be very useful for any design process. Nonetheless, the intent was to verify if changes could be observed regarding the importance of these representations through the following hypothesis:

The hypothesis is that students will score higher in the element of *explore graphical representation*, after applying the ADP model in their design.

The graph shown in Figure 5.21 is a box plot displaying the distribution (minimum, 25th percentile, 50th percentile, 75th percentile, maximum and outliers) for the *explore graphical representation* element. Stage 1 represents the results before using ADP and Stage 2 after using ADP.

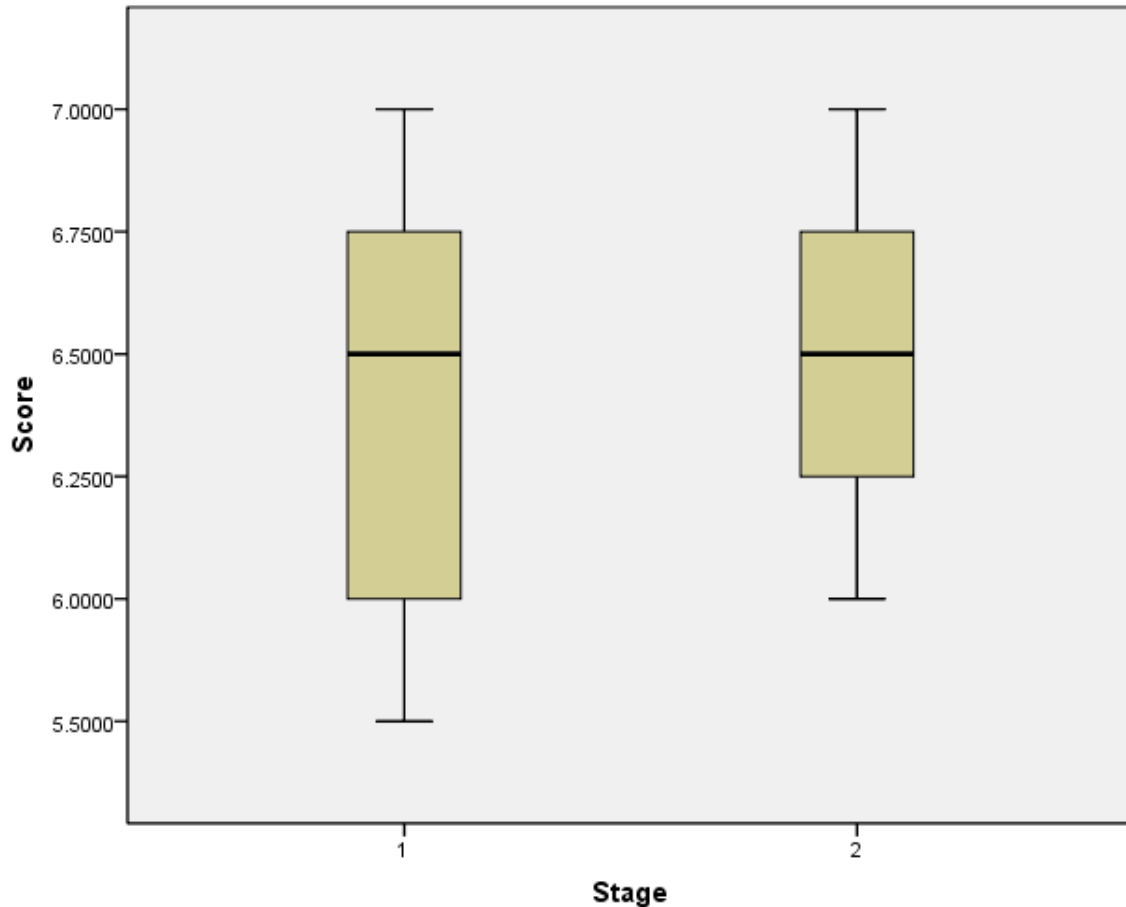

Figure 5.21 Box plot for element "Explore graphic representation" Stage 1 is pre-ADP and stage 2 is post-ADP.

A Mann-Whitney U test was conducted to evaluate the hypothesis that students would score higher in the element of *explore graphic representation*, on average, after applying the ADP model for design. With an $\alpha = 0.05$ level of significance, the results were not enough to verify the hypothesis ($p = 0.676 > 0.05$). Post ADP (Stage 2) values had an average rank of 13.08, while Pre ADP (Stage 1) values had an average rank of 11.92, as shown in Table 5.31.

Table 5.31 Mann-Whitney U test results for element "Explore graphic representation".

	Stage	N	Mean Rank	Sum of Ranks
Score	1	12	11.92	143.00
	2	12	13.08	157.00
	Total	24		

	Score
Mann-Whitney U	65.000
Wilcoxon W	143.000
Z	-.418
Asymp. Sig. (2-tailed)	.676
Exact Sig. [2*(1-tailed Sig.)]	.713 ^a

a. Not corrected for ties.

b. Grouping Variable: Stage

5.2.3.6 Element: Redefine constraints (Tier III)

To understand aspects that may make the definition of a system early in a design process too complex, a designer may temporarily alter one or more constraints in order to succeed in achieving an original goal, possibly with a lower performance expectation. This practice is referred to as *redefining constraints*.

The hypothesis is that students will score higher in the element of *redefine constraints*, after applying the ADP model in their design.

The graph shown in Figure 5.22 is a box plot displaying the distribution (minimum, 25th percentile, 50th percentile, 75th percentile, maximum and outliers) for the *redefine constraints* element. Stage 1 represents the results before using ADP and stage 2 after using ADP.

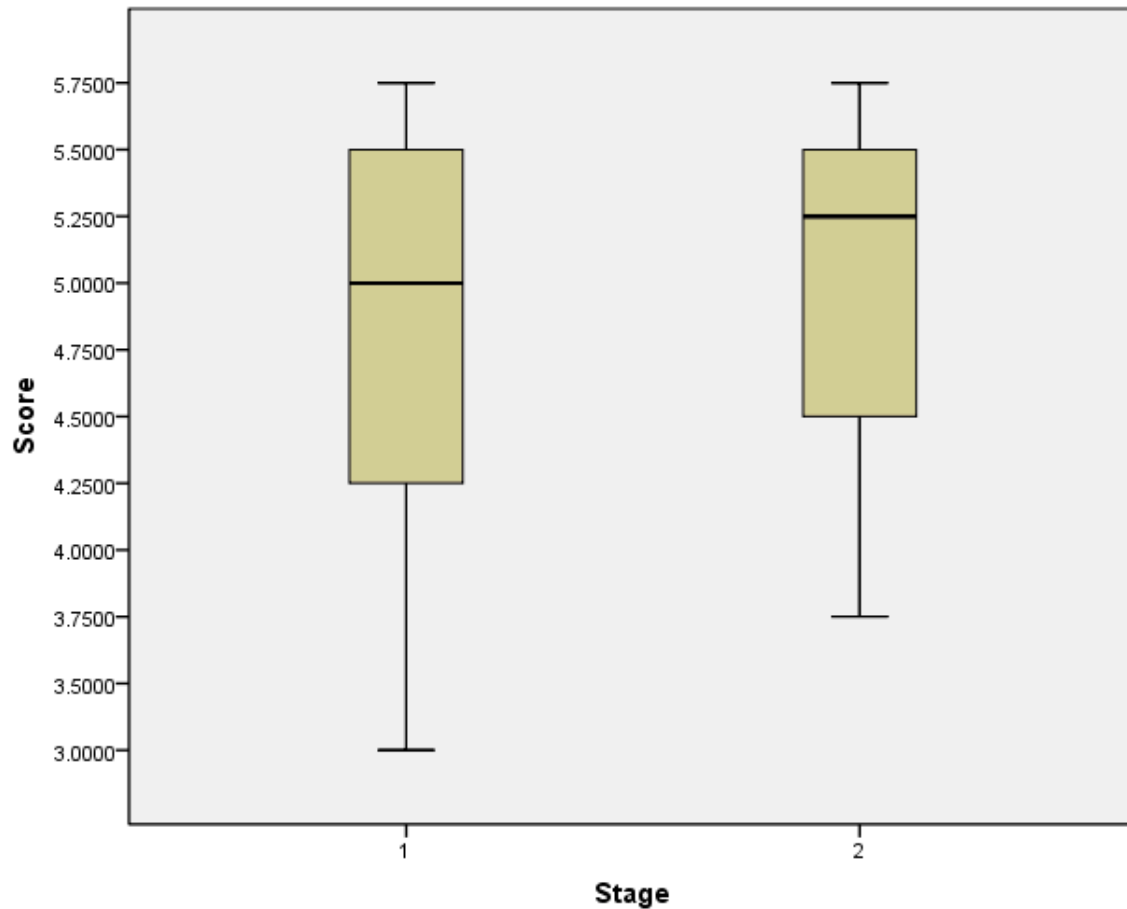

Figure 5.22 Box plot distribution for element "Redefine constraints" Stage 1 is pre-ADP and stage 2 is post-ADP.

A Mann-Whitney U test was conducted to evaluate the hypothesis that students would score higher in the element of *redefine constraints*, on average, after applying the ADP model for design. With an $\alpha = 0.05$ level of significance, the results were not enough to verify the hypothesis ($p = 0.485 > 0.05$). Post ADP (Stage 2) values had an

average rank of 13.50, while Pre ADP (Stage 1) values had an average rank of 11.50, as shown in Table 5.32.

Table 5.32 Mann-Whitney U test results for element "Redefine constraints".

Ranks				
	Stage	N	Mean Rank	Sum of Ranks
Score	1	12	11.50	138.00
	2	12	13.50	162.00
	Total	24		

Test Statistics ^b	
	Score
Mann-Whitney U	60.000
Wilcoxon W	138.000
Z	-.699
Asymp. Sig. (2-tailed)	.485
Exact Sig. [2*(1-tailed Sig.)]	.514 ^a

a. Not corrected for ties.

b. Grouping Variable: Stage

5.2.3.7 Element: Explore scope of constraints (Tier III)

Exploring the *scope of constraints* refers to the actions taken by a designer to learn more about how constraints affect the design. Thorough documentation of the exploration of the scope of constraints in a project can be beneficial when integrating different subsystems, since commonly there are interface problems that can illuminate hidden constraints. It was not expected of the members of the design exercise to

document this exploration in depth. Preferably, subjects gain a newfound appreciation for this activity that comes from following the ADP model.

The hypothesis is that students will score higher in the element of *explore scope of constraints*, after applying the ADP model in their design.

The graph shown in Figure 5.23 is a box plot displaying the distribution (minimum, 25th percentile, 50th percentile, 75th percentile, maximum and outliers) for the *explore scope of constraints* element. Stage 1 represents the results before using ADP and stage 2 after using ADP.

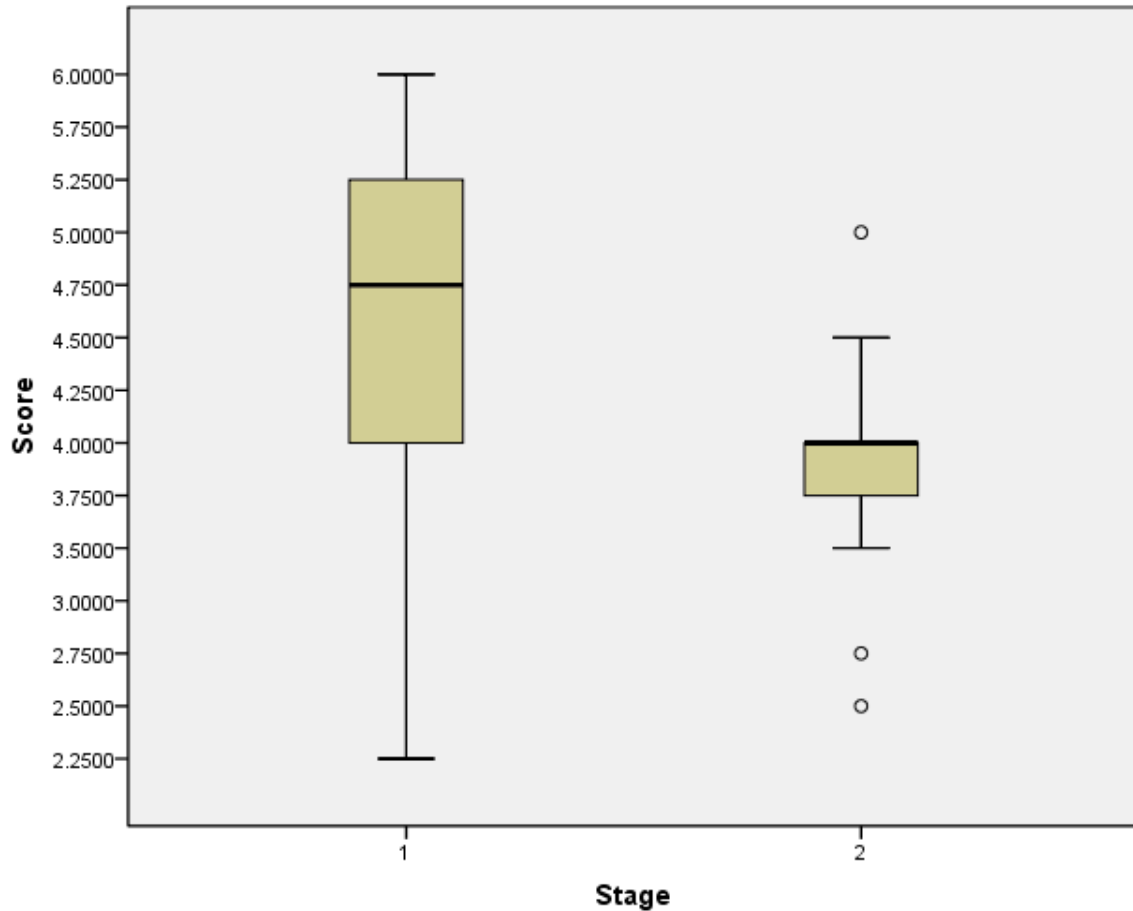

Figure 5.23 Box plot distribution for element "Explore scope of constraints" Stage 1 is pre-ADP and stage 2 is post-ADP.

A Mann-Whitney U test was conducted to evaluate the hypothesis that students would score higher in the element of *explore scope of constraints*, on average, after applying the ADP model for design. At the $\alpha = 0.05$ level of significance, the results were significant, but in reduction instead of increase, with $Z = -2.156$, $p = 0.031 < 0.05$, $U = 35$, $r = 0.44$. Post ADP (Stage 2) values had an average rank of 9.42, while Pre ADP (Stage 1) values had an average rank of 15.58, as shown in Table 5.33.

Table 5.33 Mann-Whitney U test results for element "Explore scope of constraints".

	Stage	N	Mean Rank	Sum of Ranks
Score	1	12	15.58	187.00
	2	12	9.42	113.00
	Total	24		

	Score
Mann-Whitney U	35.000
Wilcoxon W	113.000
Z	-2.156
Asymp. Sig. (2-tailed)	.031
Exact Sig. [2*(1-tailed Sig.)]	.033 ^a

a. Not corrected for ties.

b. Grouping Variable: Stage

5.2.3.8 Element: Validate assumptions and constraints (Tier III)

Validating the assumptions that the subjects made in the design exercise might be correlated to the number of iterations they can perform of ADP advancing to stages of testing. Even though the teams have limited time for their designs to evolve, there is an expectation that the model will increase their responsiveness to this element.

The hypothesis is that students will score higher in the element of *validate assumptions and constraints*, after applying the ADP model in their design.

The graph shown in Figure 5.24 is a box plot displaying the distribution (minimum, 25th percentile, 50th percentile, 75th percentile, maximum and outliers) for the *validate assumptions and constraints* element. Stage 1 represents the results before using ADP and stage 2 after using ADP.

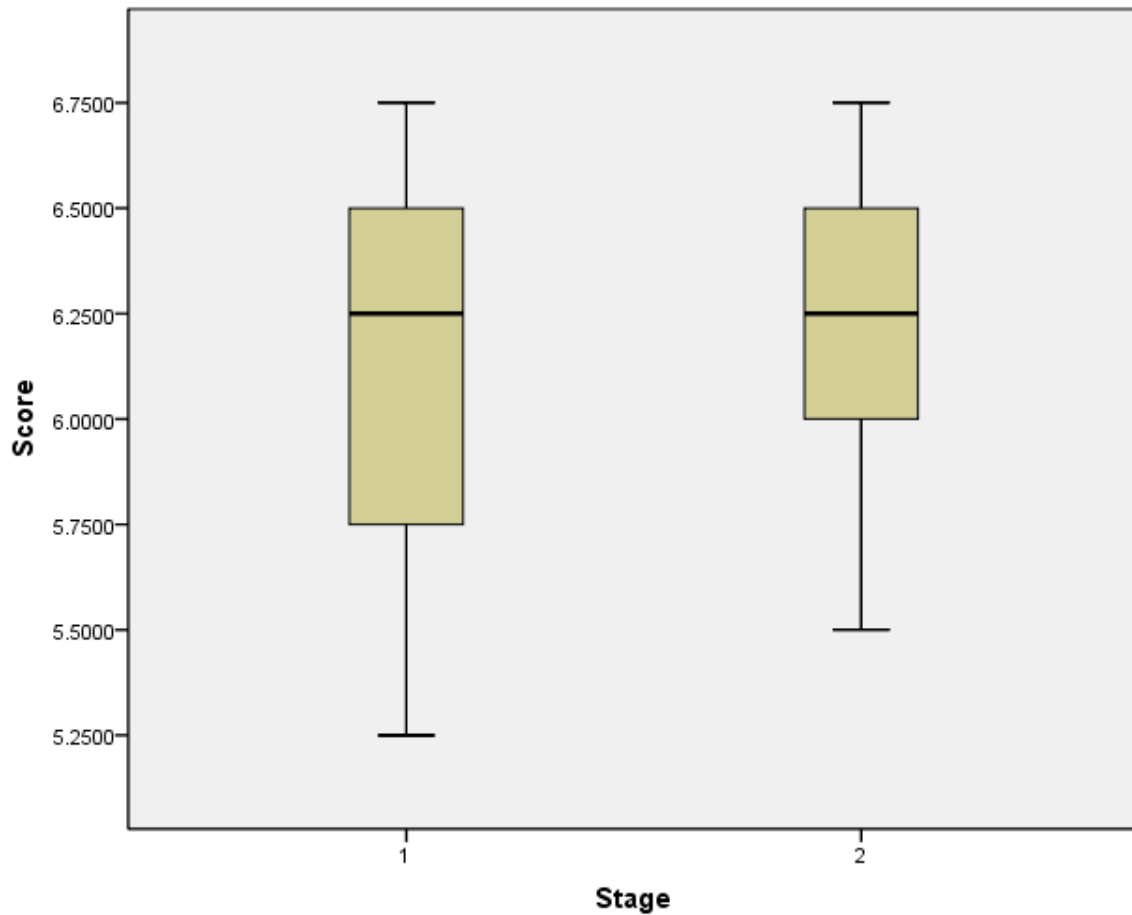

Figure 5.24 Box plot distribution for element "Validate assumptions and constraints" Stage 1 is pre-ADP and stage 2 is post-ADP.

A Mann-Whitney U test was conducted to evaluate the hypothesis that students would score higher in the element of *validate assumptions and constraints*, on average, after applying the ADP model for design. With an $\alpha = 0.05$ level of significance, the results were not enough to verify the hypothesis ($p = 0.481 > 0.05$). Post ADP (Stage 2)

values had an average rank of 13.50, while Pre ADP (Stage 1) values had an average rank of 11.50, as shown in Table 5.34.

Table 5.34 Mann-Whitney U test results for element "Validate assumptions and constraints".

Ranks

	Stage	N	Mean Rank	Sum of Ranks
Score	1	12	11.50	138.00
	2	12	13.50	162.00
	Total	24		

Test Statistics^b

	Score
Mann-Whitney U	60.000
Wilcoxon W	138.000
Z	-.704
Asymp. Sig. (2-tailed)	.481
Exact Sig. [2*(1-tailed Sig.)]	.514 ^a

a. Not corrected for ties.

b. Grouping Variable: Stage

5.2.3.9 Element: Examine existing designs (Tier III)

It can be conducive to finding a feasible solution much faster if there are systems with similar requirements and constraints that have been previously developed. The purpose of this element is to characterize the degree by which designers explore the designs already in existence.

The hypothesis is that students will score higher in the element of *examine existing designs*, after applying the ADP model in their design.

The graph shown in Figure 5.25 is a box plot displaying the distribution (minimum, 25th percentile, 50th percentile, 75th percentile, maximum and outliers) for the *examine existing* element. Stage 1 represents the results before using ADP and stage 2 after using ADP.

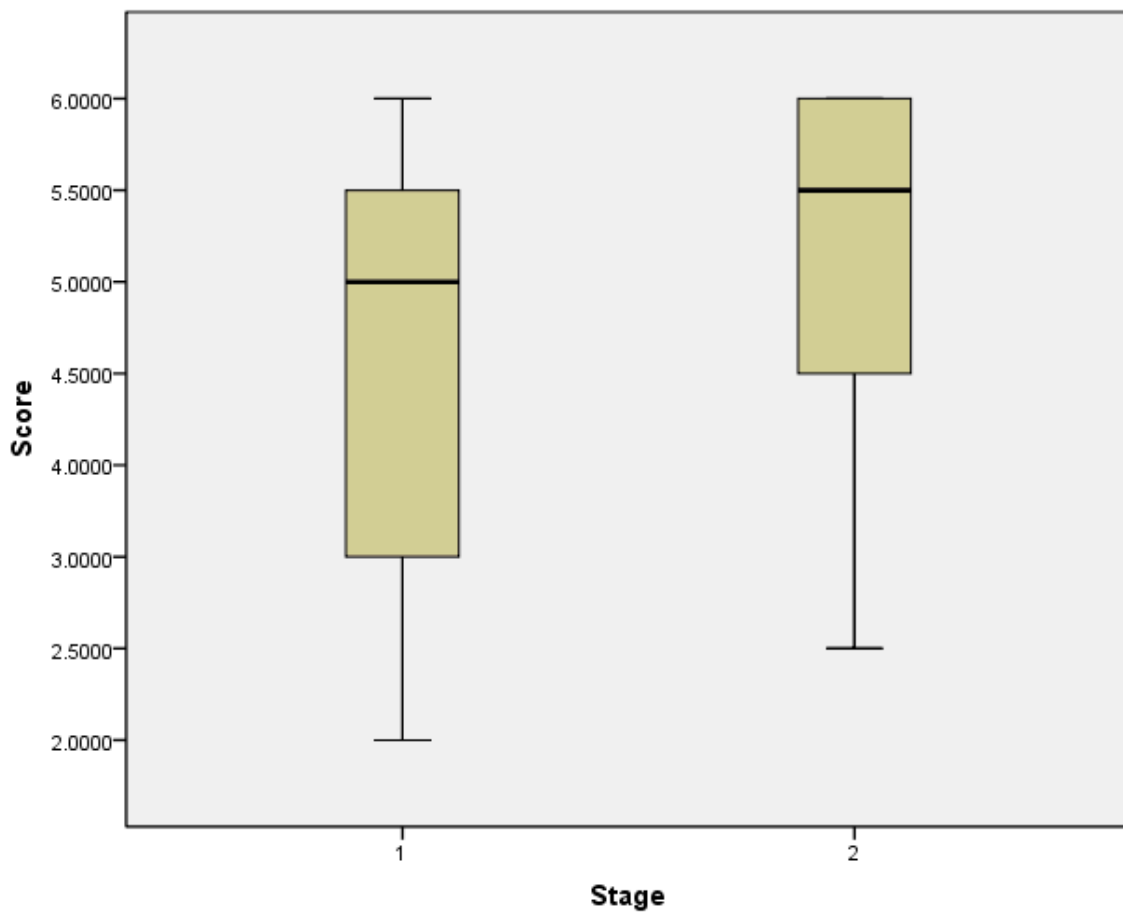

Figure 5.25 Box plot distribution for element "Examine existing designs" Stage 1 is pre-ADP and stage 2 is post-ADP.

A Mann-Whitney U test was conducted to evaluate the hypothesis that students would score higher in the element of *examine existing designs*, on average, after applying

the ADP model for design. With an $\alpha = 0.05$ level of significance, the results were not enough to verify the hypothesis ($p = 0.446 > 0.05$). Post ADP (Stage 2) values had an average rank of 13.58, while Pre ADP (Stage 1) values had an average rank of 11.42, as shown in Table 5.35.

Table 5.35 Mann-Whitney U test results for element "Examine existing designs".

Ranks				
	Stage	N	Mean Rank	Sum of Ranks
Score	1	12	11.42	137.00
	2	12	13.58	163.00
	Total	24		

Test Statistics ^b	
	Score
Mann-Whitney U	59.000
Wilcoxon W	137.000
Z	-.762
Asymp. Sig. (2-tailed)	.446
Exact Sig. [2*(1-tailed Sig.)]	.478 ^a

a. Not corrected for ties.

b. Grouping Variable: Stage

5.2.3.10 Element: Explore user perspective (Tier III)

Keeping the users engaged with the team in a design process assures that they have no disappointments with the system's performance once it has been completed. In

the design task the subjects need to act both as designers and as users. Even though there are no externally defined users, the team leads often seized the role of primary user and would question regularly the entirety of the design.

The hypothesis is that students will score higher in the element of *explore user perspective*, after applying the ADP model in their design.

The graph shown in Figure 5.26 is a box plot displaying the distribution (minimum, 25th percentile, 50th percentile, 75th percentile, maximum and outliers) for the *explore user perspective* element. Stage 1 represents the results before using ADP and stage 2 after using ADP.

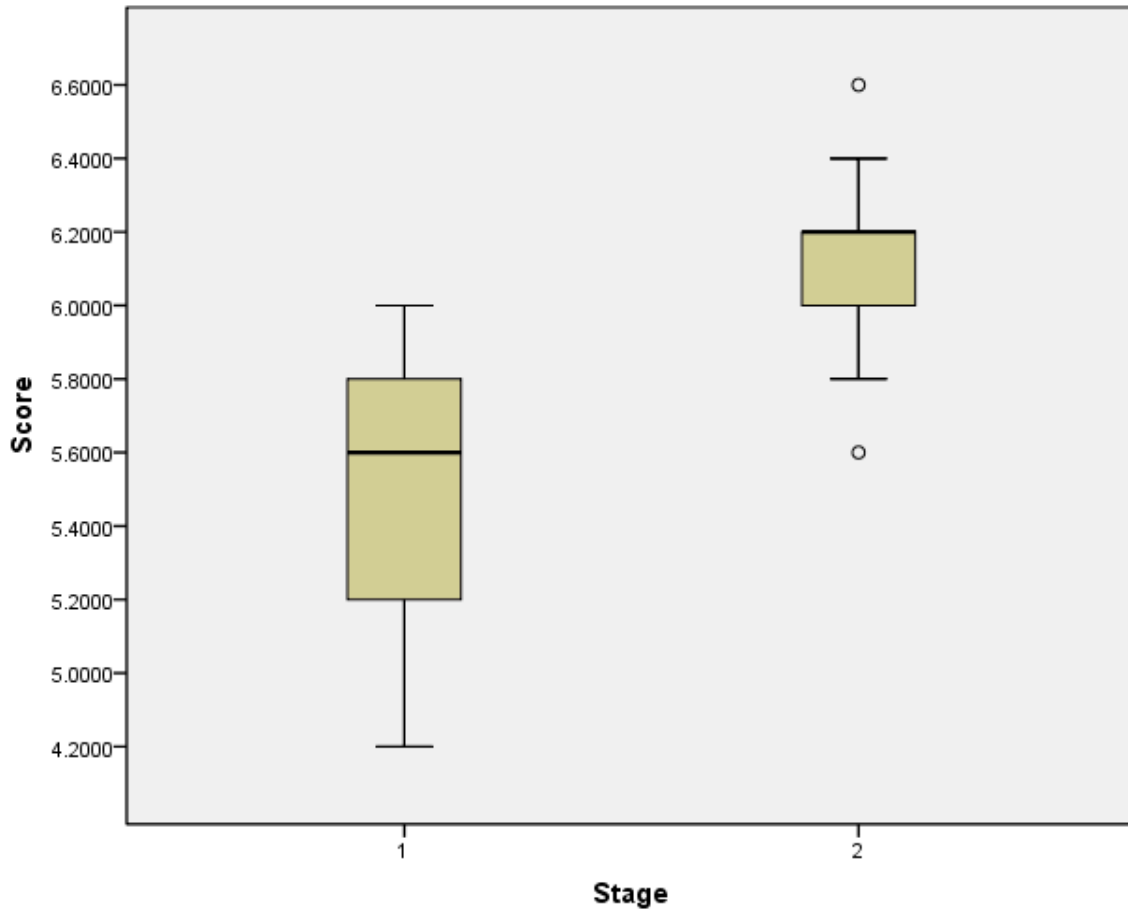

Figure 5.26 Box plot distribution for element "Explore user perspective" Stage 1 is pre-ADP and stage 2 is post-ADP.

A Mann-Whitney U test was conducted to evaluate the hypothesis that students would score higher in the element of *explore user perspective*, on average, after applying the ADP model for design. At the $\alpha = 0.05$ level of significance, the results were in the expected direction and significant, $Z = -3.662$, $p = 0.000 < 0.05$, $U = 9.5$, $r = 0.75$. Post ADP (Stage 2) values had an average rank of 17.71, while Pre ADP (Stage 1) values had an average rank of 7.29, as shown in Table 5.36.

Table 5.36 Mann-Whitney U test results for element "Explore user perspective".

	Stage	N	Mean Rank	Sum of Ranks
Score	1	12	7.29	87.50
	2	12	17.71	212.50
	Total	24		

	Score
Mann-Whitney U	9.500
Wilcoxon W	87.500
Z	-3.662
Asymp. Sig. (2-tailed)	.000
Exact Sig. [2*(1-tailed Sig.)]	.000 ^a

a. Not corrected for ties.

b. Grouping Variable: Stage

5.2.3.11 Element: Build normative model (Tier IV)

Building a normative model represents the opportunity to formalize the desired outcomes of a design process. There are different paths to performing normative models. For example, some studies attempt to introduce and describe processes to capture decision maker preferences and use them to generate and evaluate a multitude of designs, while providing a common metric that can be easily communicated throughout the design enterprise (Ross, Hastings, & Warmkessel, 2004). These endeavors can consume much time and many resources. Other studies suggest an approach to investigating the problem of selecting discrete concepts from multiple, coupled subsystems by using physical

programming (Patel & Lewis, 2003). *Building a normative model* is the only element in Tier IV.

The hypothesis is that students will score higher in the element of *build normative model*, after applying the ADP model in their design.

The graph shown Figure 5.27 in is a box plot displaying the distribution (minimum, 25th percentile, 50th percentile, 75th percentile, maximum and outliers) for the *build normative model* element. Stage 1 represents the results before using ADP and stage 2 after using ADP.

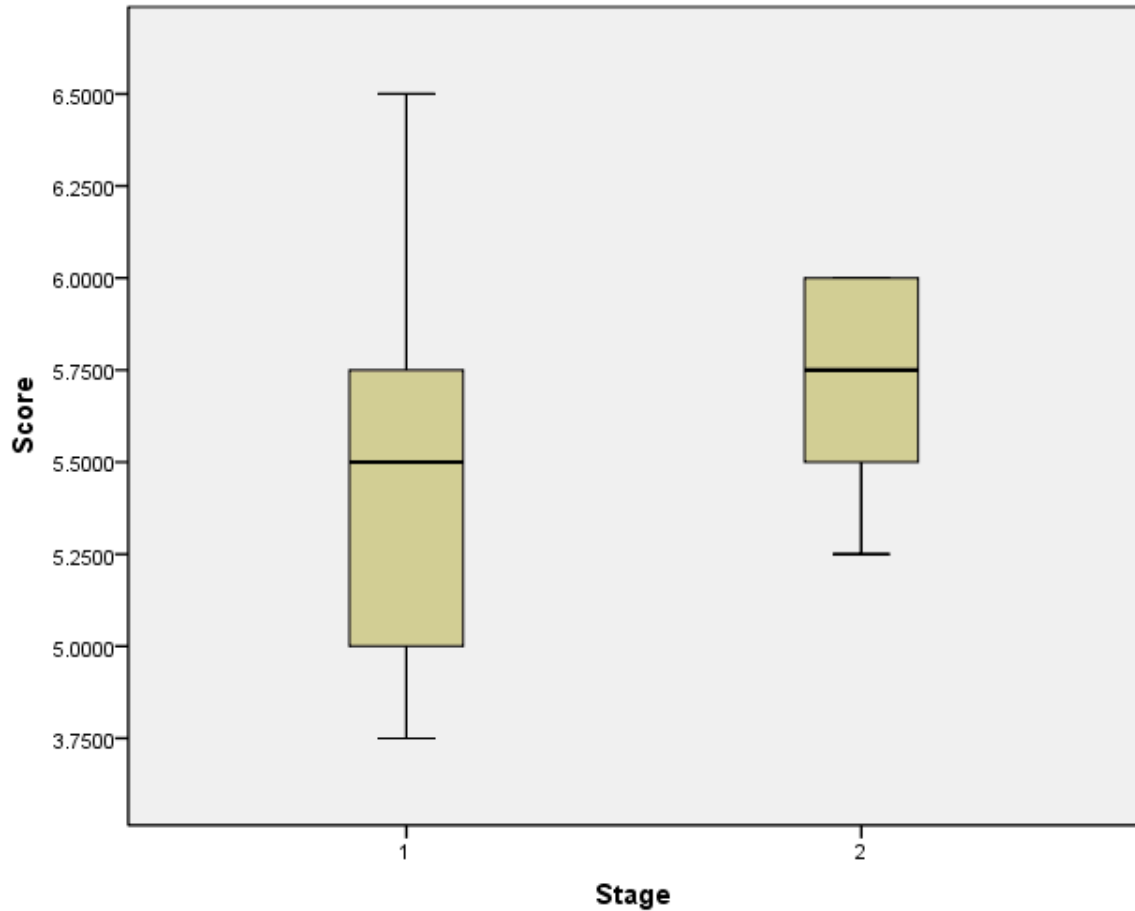

Figure 5.27 Box plot distribution for element "Build normative model" Stage 1 is pre-ADP and Stage 2 is post-ADP.

A Mann-Whitney U test was conducted to evaluate the hypothesis that students would score higher in the element of *build normative model*, on average, after applying the ADP model for design. With an $\alpha = 0.05$ level of significance, the results were not enough to verify the hypothesis ($p = 0.079 > 0.05$). Post ADP (Stage 2) values had an average rank of 15.00, while Pre ADP (Stage 1) values had an average rank of 10.00, as shown in Table 5.37.

Table 5.37 Mann-Whitney U test results for element "Build normative model".

Ranks				
	Stage	N	Mean Rank	Sum of Ranks
Score	1	12	10.00	120.00
	2	12	15.00	180.00
	Total	24		

Test Statistics ^b	
	Score
Mann-Whitney U	42.000
Wilcoxon W	120.000
Z	-1.755
Asymp. Sig. (2-tailed)	.079
Exact Sig. [2*(1-tailed Sig.)]	.089 ^a

a. Not corrected for ties.

b. Grouping Variable: Stage

5.2.3.12 Element: Explore engineering facts (Tier V)

There are four elements in Tier V, which is considered the tier with elements with the least impact on design performance. The elements are: *explore engineering facts*, *explore issues of measurement*, *conduct failure analysis*, and *encourage reflection on process*.

The pursuit of *exploring engineering facts* has to do with the unambiguous verification through a knowledge domain regarding some element of the design. Verifying the tensile strength of a material that is being considered for the structure of a system is an example of this activity.

The hypothesis is that students will score higher in the element of *explore engineering facts*, after applying the ADP model in their design.

The graph shown in Figure 5.28 is a box plot displaying the distribution (minimum, 25th percentile, 50th percentile, 75th percentile, maximum and outliers) for the *explore engineering facts* element. Stage 1 represents the results before using ADP and stage 2 after using ADP.

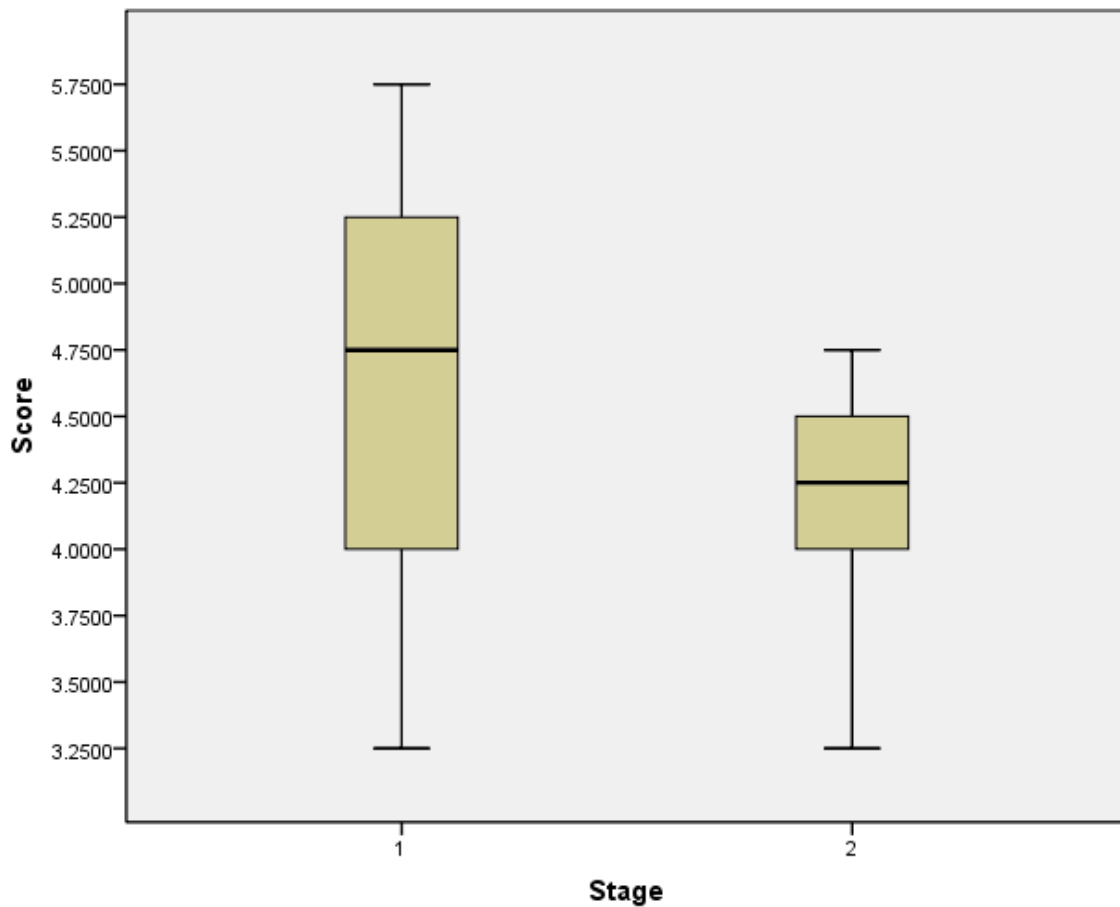

Figure 5.28 Box plot distribution for element "Explore engineering facts" Stage 1 is pre-ADP and stage 2 is post-ADP.

A Mann-Whitney U test was conducted to evaluate the hypothesis that students would score higher in the element of *explore engineering facts*, on average, after

applying the ADP model for design. With an $\alpha = 0.05$ level of significance, the results were not enough to verify the hypothesis ($p = 0.075 > 0.05$). Post ADP (Stage 2) values had an average rank of 9.96, while Pre ADP (Stage 1) values had an average rank of 15.04, as shown in Table 5.38.

Table 5.38 Mann-Whitney U test results for element "Explore engineering facts".

Ranks				
	Stage	N	Mean Rank	Sum of Ranks
Score	1	12	15.04	180.50
	2	12	9.96	119.50
	Total	24		

Test Statistics ^b	
	Score
Mann-Whitney U	41.500
Wilcoxon W	119.500
Z	-1.780
Asymp. Sig. (2-tailed)	.075
Exact Sig. [2*(1-tailed Sig.)]	.078 ^a

a. Not corrected for ties.

b. Grouping Variable: Stage

5.2.3.13 Element: Explore issues of measurement (Tier V)

This action encompasses examining how quantitative information is collected regarding aspects of the design.

The hypothesis is that students will score higher in the element of *explore issues of measurement*, after applying the ADP model in their design.

The graph shown in Figure 5.29 is a box plot displaying the distribution (minimum, 25th percentile, 50th percentile, 75th percentile, maximum and outliers) for the *explore issues of measurement* element. Stage 1 represents the results before using ADP and stage 2 after using ADP.

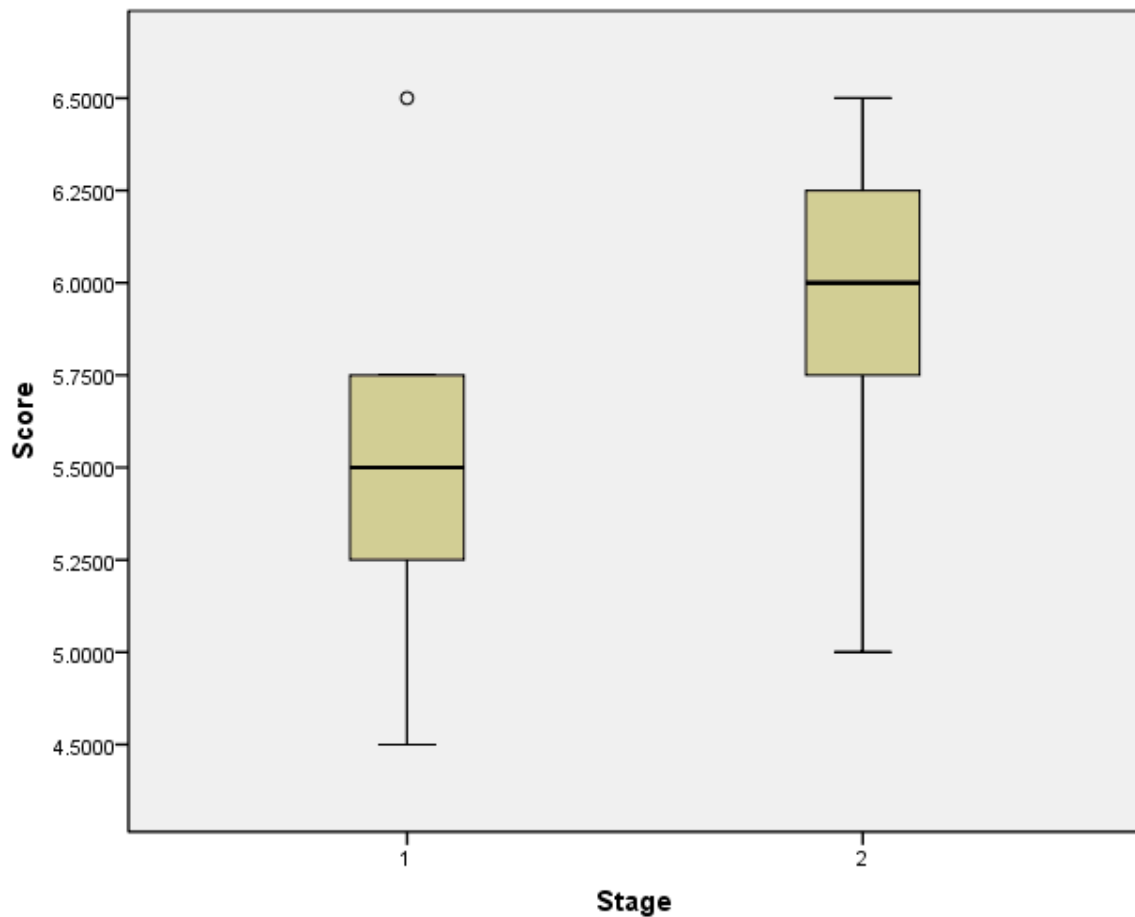

Figure 5.29 Box plot distribution for element "Explore issues of measurement" Stage 1 is pre-ADP and stage 2 is post-ADP.

A Mann-Whitney U test was conducted to evaluate the hypothesis that students would score higher in the element of *explore issues of measurement*, on average, after

applying the ADP model for design. At the $\alpha = 0.05$ level of significance, the results were in the expected direction and significant, $Z = -2.6$, $p = 0.009 < 0.05$, $U = 27.5$, $r = 0.53$. Post ADP (Stage 2) values had an average rank of 16.21, while Pre ADP (Stage 1) values had an average rank of 8.79, as shown in Table 5.39.

Table 5.39 Mann-Whitney U test results for element "Explore issues of measurement".

Ranks				
	Stage	N	Mean Rank	Sum of Ranks
Score	1	12	8.79	105.50
	2	12	16.21	194.50
	Total	24		

Test Statistics ^b	
	Score
Mann-Whitney U	27.500
Wilcoxon W	105.500
Z	-2.600
Asymp. Sig. (2-tailed)	.009
Exact Sig. [2*(1-tailed Sig.)]	.008 ^a

a. Not corrected for ties.

b. Grouping Variable: Stage

5.2.3.14 Element: Conduct failure analysis (Tier V)

Designers are interested to learn when their design fails to meet the performance expectations. Sometimes it is only a partial failure if only a few system level requirements are not met. In either case, seeking out the cause of design failure or the reason of the deficiency is what conducting failure analysis entails.

The hypothesis is that students will score higher in the element of *conduct failure analysis*, after applying the ADP model in their design.

The graph shown in Figure 5.30 is a box plot displaying the distribution (minimum, 25th percentile, 50th percentile, 75th percentile, maximum and outliers) for the *conduct failure analysis* element. Stage 1 represents the results before using ADP and stage 2 after using ADP.

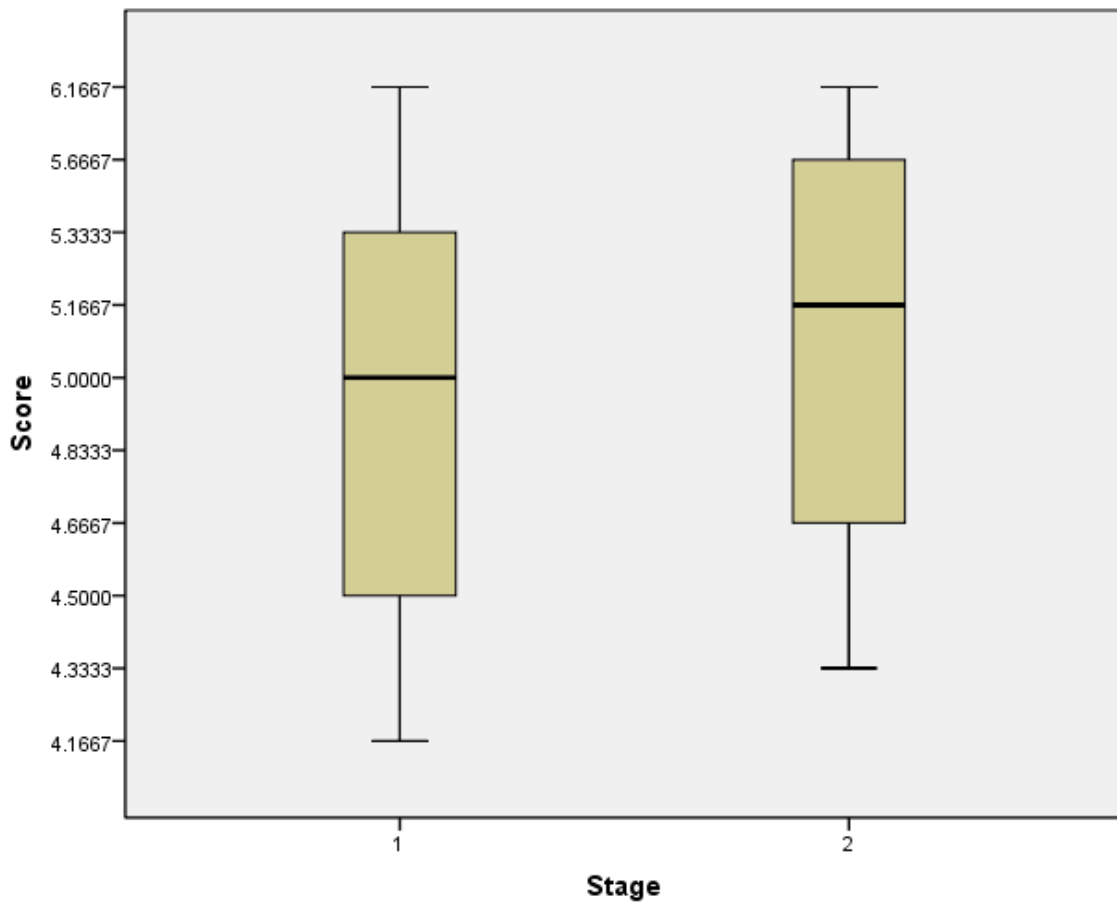

Figure 5.30 Box plot distribution for element "Conduct failure analysis" Stage 1 is pre-ADP and stage 2 is post-ADP.

A Mann-Whitney U test was conducted to evaluate the hypothesis that students would score higher in the element of *conduct failure analysis*, on average, after applying

the ADP model for design. With an $\alpha = 0.05$ level of significance, the results were not enough to verify the hypothesis ($p = 0.601 > 0.05$). Post ADP (Stage 2) values had an average rank of 13.25, while Pre ADP (Stage 1) values had an average rank of 11.75, as shown in Table 5.40.

Table 5.40 Mann-Whitney U test results for element "Conduct failure analysis".

Ranks				
	Stage	N	Mean Rank	Sum of Ranks
Score	1	12	11.75	141.00
	2	12	13.25	159.00
	Total	24		

Test Statistics ^b	
	Score
Mann-Whitney U	63.000
Wilcoxon W	141.000
Z	-.523
Asymp. Sig. (2-tailed)	.601
Exact Sig. [2*(1-tailed Sig.)]	.630 ^a

a. Not corrected for ties.

b. Grouping Variable: Stage

5.2.3.15 Element: Encourage reflection on process (Tier V)

Reflection about a design process can occur at any time, but it seems to be that during formal design review events the methodology for justifying engineering decisions can be put under scrutiny.

The hypothesis is that students will score higher in the element of *encourage reflection on process*, after applying the ADP model in their design.

The graph shown in Figure 5.31 is a box plot displaying the distribution (minimum, 25th percentile, 50th percentile, 75th percentile, maximum and outliers) for the *encourage reflection on process* element. Stage 1 represents the results before using ADP and stage 2 after using ADP.

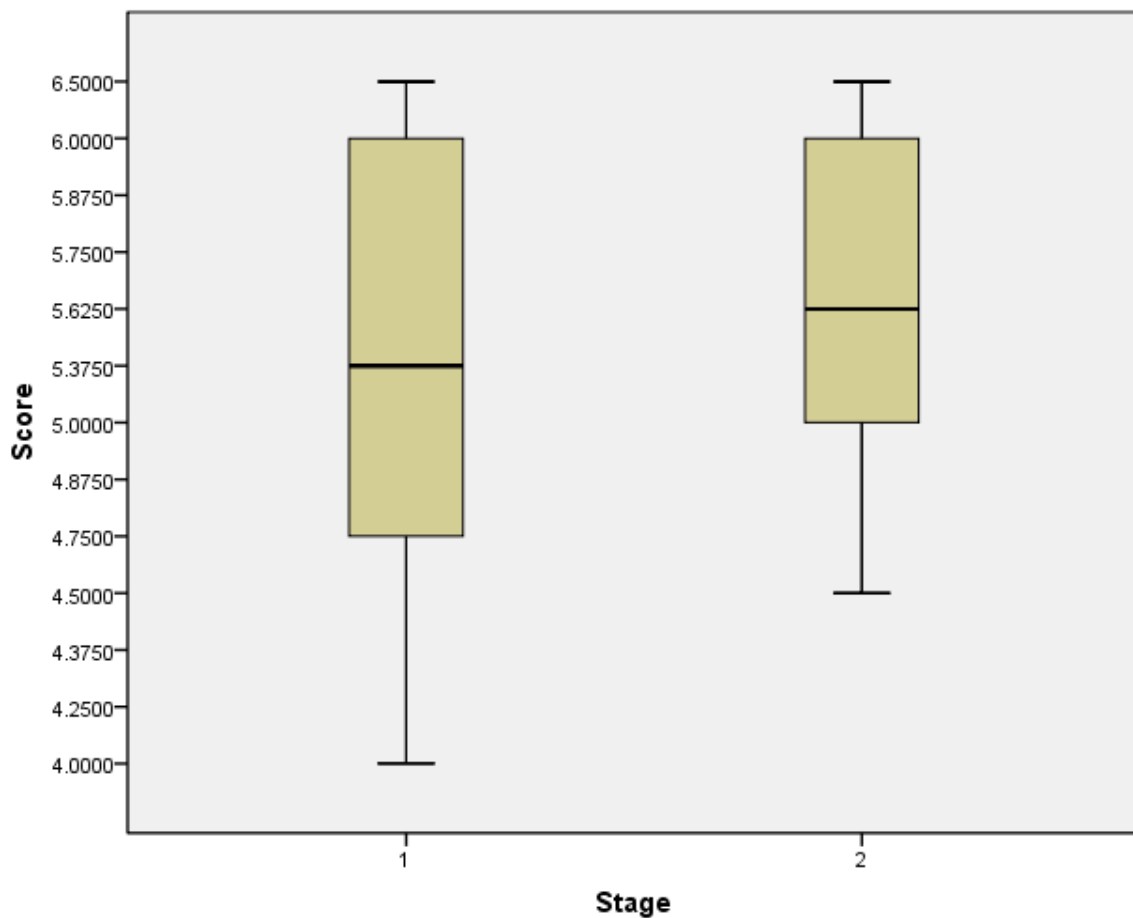

Figure 5.31 Box plot distribution for element "Encourage reflection on process" Stage 1 is pre-ADP and stage 2 is post-ADP.

A Mann-Whitney U test was conducted to evaluate the hypothesis that students would score higher in the element of *encourage reflection on process*, on average, after

applying the ADP model for design. With an $\alpha = 0.05$ level of significance, the results were not enough to verify the hypothesis ($p = 0.504 > 0.05$). Post ADP (Stage 2) values had an average rank of 13.46, while Pre ADP (Stage 1) values had an average rank of 11.54, as shown in Table 5.41.

Table 5.41 Mann-Whitney U test results for element "Encourage reflection on process".

Ranks				
	Stage	N	Mean Rank	Sum of Ranks
Score	1	12	11.54	138.50
	2	12	13.46	161.50
	Total	24		

Test Statistics ^b	
	Score
Mann-Whitney U	60.500
Wilcoxon W	138.500
Z	-.667
Asymp. Sig. (2-tailed)	.504
Exact Sig. [2*(1-tailed Sig.)]	.514 ^a

a. Not corrected for ties.

b. Grouping Variable: Stage

5.3 Discussion

In the context of this empirical study of design using the ADP model with novice engineers, the intent was to answer the following research question: what elements of

good design are promoted in a newly formed novice design team by using the ADP model?

Fourteen engineering undergraduate students were formed into two new design teams and a design task was given to them. They were instructed in the basic principles of ADP to be followed throughout the time that they would be working as a group. Since the subjects have not had the opportunity to develop their own engineering processes to follow, this model helped the groups organize their ideas and consolidate their design rationale. This was done using the information technology platform described, so they could ultimately generate a first order solution to their design task (providing insight into the ADP's adaptability).

This empirical study suggests the effectiveness of using ADP on a specific design task. For inexperienced subjects, an explanation of the fundamentals of the design model and the application of the principles throughout the task led to an increase in the expected direction for five elements as shown in the summary in Table 5.42.

Table 5.42 Summary of mean changes for good design elements from using ADP in the design task.

Impact on Design	Tier	Elements	Percentage Mean change with ADP
Most Impact	I	Explore problem representation	10.8
		Use interactive and iterative design methodology	7.2
		Search the space (explore alternatives)	Non conclusive
	II	Use functional decomposition	11
	III	Explore graphic representation	Non conclusive
		Redefine constraints	Non conclusive
		Explore scope of constraints	-15.7
		Validate assumptions and constraints	Non conclusive
		Examining existing designs	Non conclusive
		Explore user perspective	13.2
IV	Build normative model	Non conclusive	
Least Impact	V	Explore engineering facts	Non conclusive
		Explore issues of measurement	9.2
		Conduct failure analysis	Non conclusive
		Encourage reflection on process	Non conclusive

The results of this design task suggest that at least three elements within Tier I and II, which are the tiers with the most impact on design (including *explore problem representation*, *use interactive and iterative design methodology* and *use functional decomposition*), can be promoted in a novice team by using the ADP model, which provides insight into the model’s adaptability and relevance.

Within the activities that a designer will conduct to understand constraints, ideally there is an establishment of the absolute minimum threshold such that any performance that does not meet the set of specifications is unacceptable. In the case of many systems, the minimum threshold values will not satisfy the overall system requirements, but establishing the minimum level of usefulness for the task does allow flexibility for the configurations and trade studies activities. A possible reason why in this particular design task the exploration of the scope of constraints decreased instead of the expected increase in the percentage mean change, could be that there was enough definition on the minimum thresholds from the beginning that constituted the design constraints. For the newly formed teams it would seem it could have created the misconception that there wasn't a need for pursuing this activity as part of a design process. Another explanation can be found in the rapid iterative nature of the applied ADP model itself. By iterating faster in a process that is oriented to find the design drivers, it could be an unintended consequence that there is not much opportunity to explore the scope of constraints. Even though this finding was unexpected, the *explore scope of constraints* element alone isn't critical in determining the viability of using good design practices by the teams. Future studies could focus on the three elements that relate exclusively to constraints to try to identify which one has greater impact.

With regard to the trade studies conducted by the teams, it should be noted that there were a large variety of commercially available products. Looking through many catalogs to identify them and selecting the ideal component can be overwhelming for the inexperienced designer. This is an activity within the design process that can be organized by following a design model like ADP that promotes the immediate reference

to the configurations (proposed by the designer) that are tied back to the specifications of the major design cycle. In an environment with many vendors to choose from, it can be seen that undertaking a methodic approach to organizing the elements in tables with all their technical features helped the inexperienced designers to select candidates for the system. This provides insight into the adaptability nature of ADP.

As seen in this chapter, the ADP model, applied to a defined task, can help streamline the process to identify the elements that drive the system. The newly formed teams created various design configurations and corresponding trade studies that lead them to find a feasible solution for their task. Overall, for this design task, the teams worked for eight weeks as a group, and there are notable findings in the increase of the team's sensitivity for the usage of elements for good design. Through this exercise we have observed benefits of using the model in a small-scale task, which provides partial insight into the model's scalability. Additional research that supports the ADP model is able to work for design tasks of a larger scale can be seen in Chapter 6.

Chapter 6

Long Term Case Study: Primary Payload for Imaging Spacecraft

6.1 Introduction

The main premise of this chapter is that the atomic design process (ADP) can be useful for spacecraft design. In particular, it is of interest to understand if following the ADP model can help characterize the primary payload to be flown on an imaging spacecraft, called the Michigan Multipurpose Mini-satellite (M-Cubed). Through the Student Space Systems Fabrication Laboratory (S3FL) at the University of Michigan (described in Section 4.2), an engineering team has been developing the 1 kg imaging spacecraft (CubeSat) since 2008. The team has gone through several major design iterations of the spacecraft and is building it, testing it and planning on operating it in space in late 2011. The experience of designing, building and operating a system has been referred to in academia as the design-build-test-flight (DBTF) cycle. In mid 2008 the M-Cubed program was awarded a grant in conjunction with the Jet Propulsion Laboratory (JPL) for funding leading to launch activities.

In summary, with active involvement in the design team the author seeks to answer the following research question: Can the preliminary design for a spacecraft imaging system be defined by using the ADP model? This study in particular focuses on following the ADP model in a long-term engineering design task. Section 6.2 describes the ADP experiment design setup, including the definitions of the CubeSat standard and the M-Cubed mission. Section 6.3 describes the process used to define the primary payload and corresponding findings of the study, affecting directly the entire spacecraft configuration, which is presented in detail in Section 6.4.

6.2 ADP Experiment Design

Seeking to understand human activity from the perspective of the people who live and work within them is known as ethnography (Hammersley & Atkinson, 1993) and is characterized by the immersion of the researcher in the normal day-to-day activities of the people under study. In studying design processes, Bucciarelli (1988) undertook two studies with two separate engineering design firms during which participant observation was the dominant technique used. The conclusions of the studies were that design should be seen as a social process, in that different participants work on the design in quite different ways. Baird et al. (2000) studied engineering design teams in the United Kingdom. The study in particular aimed to gain a further understanding of teamwork in design. And once again a technique of participant observation was relied upon. These are

some examples where using an ethnographic approach to research provided an in-depth understanding of a group, a wealth of information, and a rich description of their processes through intense interaction and observation.

The M-Cubed program employs a team organization consisting of a project manager, systems team (which ensures compliance with CubeSat standards, explained in detail in the following section), and subsystem teams each with a respective team lead, as shown in Figure 6.1.

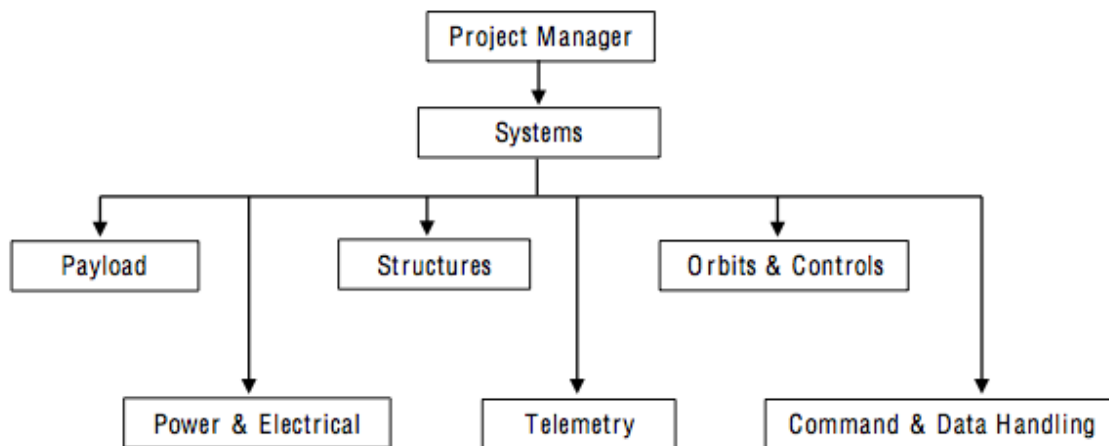

Figure 6.1 Organizational structure of M-Cubed personnel.

The author was the team lead for the payload group, as well as a systems engineer for the entire project. The most experienced individuals of the project provide managerial and technical oversight to all the spacecraft subsystems as members of the systems team (the relationship of the systems team with all the teams is represented in Figure 6.2). They are responsible for enabling consistent and reliable design practices within the entire program. The systems engineer role requires attention to system issues before other teams can build prototypes. Both of these roles enabled the possibility for

the author to document over the years the different stages of ADP when critical design decisions were made.

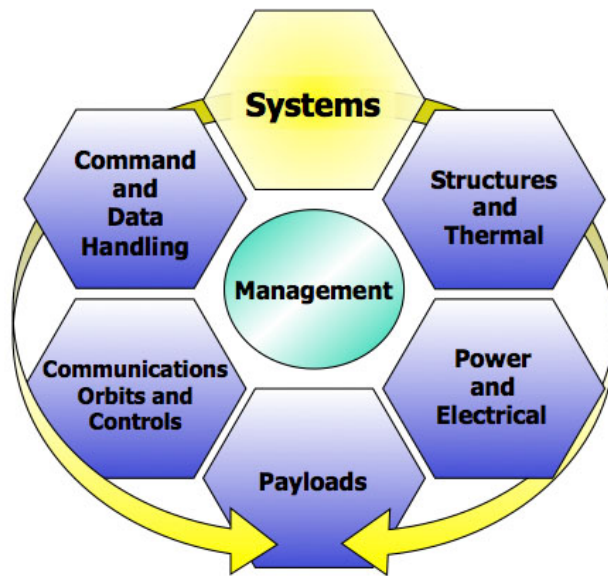

Figure 6.2 M-Cubed team management, systems and subsystems relationship diagram.

There were three areas of interest to help understand the ADP model over time that included:

- **Requirements evolution.** Observing changes in the requirements can identify iterations of ADP. It was of interest to observe how the overall system requirements would change over time, and what prompted these changes. It is expected that as the design matures, there are less modifications to the requirements.
- **Information sharing mechanisms.** It was of interest to observe what information technology elements enable adequate communication within the team.

- **Design solution.** Achieving a feasible system that meets the specifications is the ultimate goal of the design process. The results from each major ADP cycle conducted were documented to understand the intermediate design solutions, leading to the final configuration of the system.

The payload team implemented three major design iterations that concluded with the definition of the flight unit. It should be noted that each of these iterations significantly impacted the entire space system design. The payload team met regularly as a group at a minimum one time per week for one hour, but each team member worked individually anywhere from eight to forty hours a week depending on their time availability for the project. The work performed during the week was assessed at the weekly meeting and potential problems addressed by the entire team. Updated or new technical action items were assigned to each member by the team lead. The mediums of documentation that were used for capturing the design evolution included: individual weekly reports and hours worked that are submitted electronically to S3FL via SIMS (only required element) (Section 4.3.1), emails within the team (as considered necessary), a team wiki-page for capturing top-level information and a master shared Google document (Section 4.3.2) that kept track of changes throughout the design. The team had experience in using Microsoft Office PowerPoint™ and is used within the laboratory, so it was used for creating design summaries when presenting technical updates at design reviews.

The M-Cubed spacecraft is considered a CubeSat due to its volume and mass. Section 6.2.1 describes the CubeSat standard and the implications of developing space

systems using commercial components. Section 6.2.2 explains in detail the M-Cubed mission, objectives, concept and operations.

6.2.1 The CubeSat standard

The CubeSat concept was originally developed by Stanford University's Space Systems Development Laboratory (SSDL) in conjunction with California Polytechnic State University, in order to provide standardized, low-cost access to space for nano-satellites (Cubesat Community, 2010).

This standard sets limits on mass at 1 kg and volume at 10 cm x 10 cm x 10 cm, but provides for a common secondary launch solution through the P-POD deployment system. The 1 kg spacecraft are referred to as "1U" systems. Since 2003, over 30 nano-satellites have been launched under this standard. A number of companies have developed components for CubeSat subsystems such as power, communications, onboard processing, and attitude control. The number of non-experimental missions under the CubeSat standard has historically been limited due to the tight packaging requirements and scarcity of on-board power.

6.2.1.1 Building spacecraft with commercial components

In an attempt to mitigate costs during the development of space systems, there has been a tendency to use existing "commercial off the shelf" or COTS components.

Spacecraft production requires more sophisticated technology development to achieve significant cost savings if they utilize COTS components in their systems.

The typical mission qualification requirements (or relevant considerations) for COTS components include compliance with:

- Vacuum
- Shock
- Vibration
- Acoustics
- Radiation
- Magnetic fields
- Electrostatic fields
- Outgassing contamination
- Solar UV (Elements mounted external to the spacecraft)
- Thermal conditions
- Dynamics considerations
- Chemical reactions
- Radio frequency transmissions
- Micro-meteoroids (Elements mounted external to the spacecraft)

Organizations that develop space systems using low-cost COTS components typically do not have large budgets to work with (for example, S3FL). Similarly, the available facilities may not be capable of evaluating all the characteristics listed above.

Thus, robust design practices can be especially valuable to mitigate some of the risk associated with developing the systems.

6.2.2 M-Cubed mission

The Michigan Multipurpose Mini-satellite (M-Cubed) is a nano-satellite under development by students at the University of Michigan in the Student Space Systems Fabrication Laboratory (S3FL). The satellite meets the California Polytechnic Institute's (CalPoly's) specifications for a 1U CubeSat.

The M-Cubed mission is to obtain high resolution color images of Earth from Low Earth Orbit (LEO) with at least 60% land mass and a maximum of 20% cloud coverage from a single CubeSat platform. M-Cubed is also the spacecraft bus for the CubeSat On-Board Processing Validation Experiment (COVE). COVE is a technology demonstration project for NASA's Jet Propulsion Laboratory (JPL) of a Xilinx Virtex-5 FPGA to be flown on a future NASA mission.

S3FL is also developing the M-Cubed bus with the intention of making it a heritage design, thus allowing for future missions to be flown on the same bus.



Figure 6.3 Artistic rendition of a CubeSat in low Earth orbit (NASA CubeSat, 2010).

6.2.2.1 Mission objectives

The primary mission objectives of M-Cubed are as follows:

1. Develop the first generation S3FL CubeSat to take high-resolution color images of Earth from LEO.
2. Cultivate S3FL capability to develop, build, and operate a CubeSat system.
3. Promote development of S3FL students through a multidisciplinary design, built, test, fly environment.
4. Deliver COVE payload data to JPL to increase TRL and provide flight heritage.

M-Cubed's secondary mission objective includes: Develop a CubeSat standard bus for future missions that can encompass more complex payloads.

6.2.2.2 Mission concept

M-Cubed is designed to fly in low Earth orbit with a CMOS camera in order to fulfill the objective of taking a 200 meter-per-pixel color picture, and to flight qualify the JPL COVE payload. M-Cubed will be powered by battery that is charged by solar cells attached on the outside of the structure. A microcontroller will process and send the photo image to the telemetry system for transmittal to ground, and the ground station will receive the picture over a period of time. JPL's COVE payload will operate at predefined intervals, and then data will be sent down to the ground station for analysis.

The attitude of the satellite will be controlled by a passive attitude control system and will be oriented based on the Earth's magnetic field. The spacecraft structure has specified requirements from Cal Poly for launch vehicle integration.

6.2.2.3 M-Cubed operations

The National Polar-Orbiting Operational Environmental Satellite System (NPOESS) Preparatory Project (NPP) is a joint mission involving the National Aeronautics and Space Administration's (NASA) and the NPOESS Integrated Program Office (IPO). The NPP mission that is currently being developed will collect and distribute remotely-sensed land, ocean, and atmospheric data to the meteorological and global climate change communities as the responsibility for these measurements transitions from existing Earth-observing missions such as Aqua, Terra and Aura, to the

NPOESS. It will provide atmospheric and sea surface temperatures, humidity sounding, land and ocean biological productivity, and cloud and aerosol properties (NASA NPOESS ICD, 2011).

The vehicle that carries NPP into orbit will have a CubeSat Poly Pico-satellite Orbital Deployer (PPOD) mounted, where M-Cubed will be located. Once in LEO, the PPOD will eject M-Cubed into its operational orbit.

The NPP satellite will be launched from the Western Range at Vandenberg Air Force Base from SLC-2, California, by a Boeing Delta II-7920-10 launch vehicle. It will be launched on October 18, 2011² into an 824 km circular, sun-synchronous orbit with a 10:30 a.m. local-time descending node crossing.

The nominal M-Cubed mission timeline and operations are shown in Table 6.1 and Figure 6.4 respectively:

² As of April 2011.

Table 6.1 M-Cubed mission nominal timeline where T is time leading to launch, and spacecraft operational time is denoted by M.

T-2mo ³	Final University of Michigan checkout. Ship M-Cubed to launch site. Testing of M-Cubed at site.
T-2d	Placement of M-Cubed into PPOD.
T = 0	Launch
T+60m	PPOD ejected from launch vehicle
T+90m; M = 0	M-Cubed ejected from PPOD, turns on.
M+30m	Passive system de-tumbles spacecraft
M+2d	Pictures 1,2 and 3 captured on board.
M+2d+90m	Download of Pictures 1..3 from ground station.
M+2d+120m	COVE payload turns on. Executes algorithm.
M+2d+210m	Download of COVE results from ground station

³ mo = month, d = days, h = hours, m = minutes

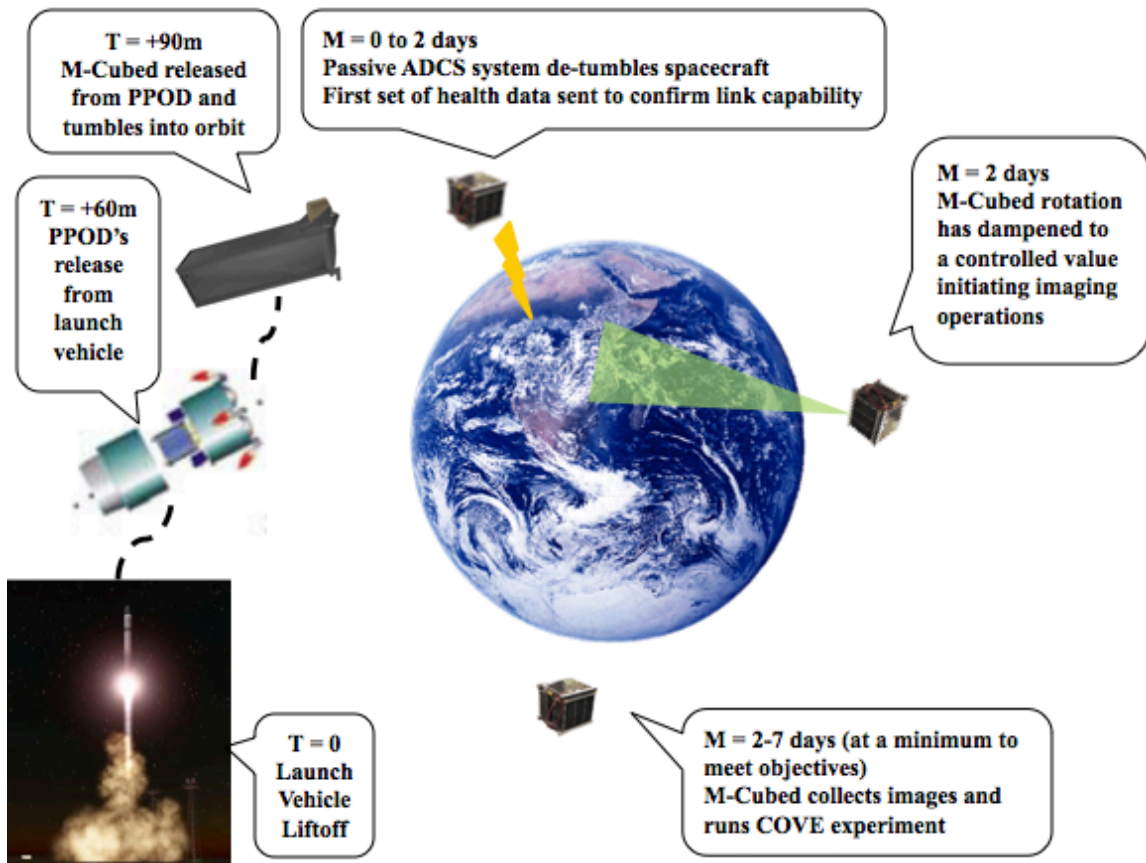

Figure 6.4 M-Cubed graphical representation of mission nominal operations. T is the time from launch and M denotes nominal mission lifetime.

6.3 ADP Study Results

Over the course of an extended period of time, three major design iterations of the spacecraft were completed supporting the research presented here. Each of the stages of ADP that were associated to these design iterations were documented. This included

changes in the specifications, the configurations, trade studies, and what were perceived as the design drivers. Details of the findings of the major design iterations are documented in this section.

6.3.1 M-Cubed primary payload design

The three major ADP iterations that enabled the selection of the M-Cubed primary payload were prompted by not having a feasible system at the end of the first two iterations. The first design iteration provided the team with an introductory awareness of the technologies available for commercial imaging systems. A limitation with the sensitivity of the sensor in addition to problems with controlling the camera prompted a re-design. Low-level software glitches and integration difficulties with the command and data handling system prompted yet another re-design, as explained below.

6.3.1.1 Iteration 1. Fall 2008 - Sentech C202 camera

At the beginning of the project, the payload team derived from the mission objectives, and in agreement with the systems team, the major design parameters shown in Table 6.2.

Table 6.2 M-Cubed primary payload initial major design parameters.

Imaging payload major design parameters	
Image Size	>1 Megapixel
Resolution Goal	< 200 meter/pixel
Image Type	Full Color
Mass Allotment	~100 grams

After considering the initial set of specifications for the primary payload, the *configurations* stage in ADP (see Figure 3.2) prompted a technology comparison activity, in order to understand which alternatives were available. The technology options that were accessible are summarized in Table 6.3. Charge coupled devices (CCD) were preferred initially for superior image quality.

Table 6.3 Imaging technology comparison summary.

Charge Coupled Device (CCD)	Complementary Metal Oxide Semiconductor (CMOS)	Off the Shelf Digital Camera
Less noise Higher sensitivity Better resolution Power ~ 3 W Mass ~ 100 g	Smaller Lighter Cheaper Lower resolution Lower sensitivity Power ~ 1.5 W Mass ~ 60 g	Difficult to interface <ul style="list-style-type: none"> • Operating controls • Data retrieval Not flexible Power ~ 2 W Mass ~ 100 g

A summary of the trade study conducted is shown in Table 6.4.

Table 6.4 Summary of M-Cubed primary payload main trade study (2008)

Model	Company	Resolution	Price	Power	Mass	Bits	Size (W,H,D)	Interface	Temp.
STC-C202USB	Sentech	1600X1200	\$835	1.75	145g	8	51X51X44mm	USB	-
STC-C33USB-A5	Sentech	640X480	\$599	1.75	145g	8	51X51X42mm	USB	14-113F
STC-C33USB-BTCS	Sentech	640X480	\$527	1.75	45g	8	45X45 (Board)	USB	14-113F
STC-CLC1500	Sentech	1360X1040	\$2100	3.84	113g	10	44X29X90mm	CameraLink	14-113F
A102kc	Basler	1360X1040	\$3450	3.5	292g	24	38X62X62mm	CameraLink	-
EC1350C	Prosilica	1360X1024	\$1850	2.5	84g	12	46X33X56mm	IEEE-1394	32-122F

The official selection from the payload team was the Sentech C202 USB CCD camera, which is typically used in video surveillance. The image sensor is a 1/1.8”

Interline CCD (ICX274AQ) and the trigger method consists of a *software trigger* (Free-run / Edge preset / Pulse Width / Start & Stop). The 1600 (H) x 1200 (V) pixel resolution would provide the required images on the average LEO. It was built to operate within the 0 °C - 40 °C temperature range. The input voltage is +5 Vdc and the video output is USB 2.0 high-speed. The lens has a mount type "C", and the power consumption is 2.80 W, at less than 560 mA. The camera specification document showed that this particular camera could operate with both Linux and Windows drivers (Sentech America, 2006). The camera is shown in Figure 6.5.



Figure 6.5 Sentech C202 USB CCD camera (Sentech America, 2006).

It was determined by the payload team that the CCD chip being used in the camera was very sensitive to damage due to thermal radiation from the sun, because of the open optical path of the system. Considerable amount of time was invested in finding a solution to this problem, which consisted in the design of an opaque shutter, which would block the optical path from direct sunlight and would not interfere with any other systems. The approach presented in itself an opportunity to perform an ADP design cycle, in which the goal was to have as minimal impact on the rest of the spacecraft; therefore a tendency for simplicity in the mechanism was preferred, as well as a low

power for operation solution. These specifications prompted a search for configurations with corresponding trade studies that enabled the creation of the shutter design made of carbon fiber that is set in its open position by rotating on a shoulder bolt with the applied force of a torsion spring. The optical shutter mechanism is shown in Figure 6.6.

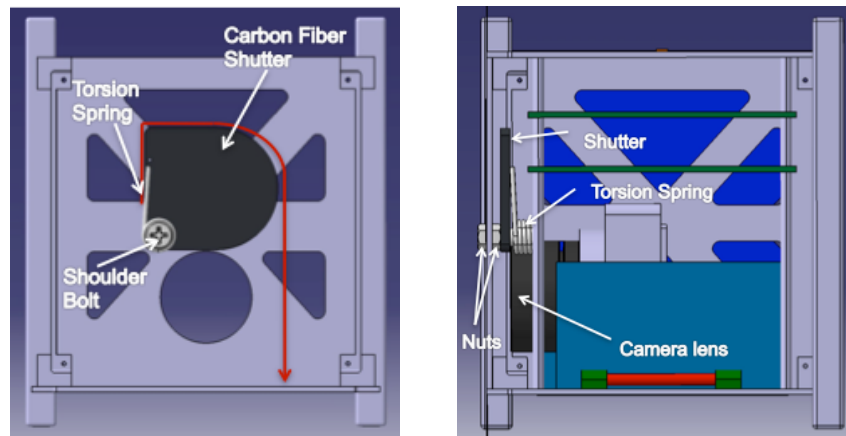

Figure 6.6 Front (left) and side view (right) of M-Cubed CAD model showing camera lens and carbon fiber shutter.

The expectation of the payload team was that through extensive testing it would be possible to determine if the rest of the camera hardware would survive the temperature extremes indicated in the initial specifications. This is typical characterization testing performed on COTS components. If the camera were to have performance problems because of thermal problems, then supporting hardware would be considered to maintain the payload within its operational temperature range. In terms of the ADP model, after understanding the different technology options and performing the corresponding trade studies, the driver for the payload at the end of this major design iteration was considered to be the image quality.

At this point, the specifications were formally documented in the following payload requirements, and these served as a baseline for future design iterations:

Table 6.5 M-Cubed primary payload requirements at first design iteration (2008).

ID	Requirement
PLD-001	The payload shall color image the Earth with a resolution of 200 meters per pixel
PLD-002	The payload shall have a power requirement of 1.8 V, 3 V, or 5 V.
PLD-003	The payload shall not exceed 100 grams in mass.
PLD-004	The payload volume dimensions shall not exceed 50 x 50 x 50 mm.
PLD-005	The payload shall operate within the temperature range of -30 to 60 °C
PLD-006	The payload shall interface adequately to C&DH
PLD-007	The payload detector shall be protected from direct sunlight and radiation
PLD-008	The payload detector shall account for TBD image blur

It should be noted that the team had also determined that there was a need for specifying an image “blurring” requirement (PLD-008 on Table 6.5). This was prompted by doing some preliminary testing with the camera, and developing a better understanding of optical systems by the design team. Although the need was identified, quantifying it formally in a requirement was not possible immediately until there was

better understanding of the implications of this performance parameter. An indication of “TBD” (To be determined) was documented.

6.3.1.2 Iteration 2. Winter 2009 - IDS UI1646LE-C camera

M-Cubed’s primary payload, the Sentech C202 USB CCD camera was procured by the payload team to begin understanding first hand its operations. From the time it arrived to the laboratory there were significant delays in its integration to the system that controls the camera, an Atmel 1649 microcontroller that runs Linux as an operating system. This microcontroller was the main component of the command and data handling (C&DH) system, which is responsible for managing all system level computational needs of the spacecraft. After many weeks working with the camera it became evident by the systems team that knowledge on the use of the camera was taking too long to develop. After three months, the project manager requested a formal assessment and recommendation to mitigate the risk associated with the delays that were impacting the critical path of the program’s master schedule.

After a problem was discovered with the sensitivity of the CCD sensor and a mechanical shutter was implemented, a larger problem was discovered coupled to the Linux software driver architecture delivered by the manufacturer and the lack of customer support in mitigating this issue. The software driver, in this case, is very important since it controls the camera at the operating system level. Every device connected to the microcontroller must have a driver. In the case of consumer electronics, many drivers, such as keyboard drivers, come with the operating system. For other

devices, like this camera, users need to load a new driver when you connect the device to a system. A driver acts like a translator between the device and programs that make use of the device. Each device has its own set of specialized commands that only its corresponding driver can interpret. However, during integration of the payload to the microcontroller it became noticeable that there were major flaws in the Linux driver provided by the company. The camera would work appropriately when operating in a windows environment, but would not even turn on consistently when using Linux. The flaws were deep in the architecture of the Linux driver, which resulted in the driver not working reliably.

After further investigation by the team, it was discovered that Sentech (the company that sells the cameras) is a small company consisting of two engineers and a couple managers. Customer support with technical problems was difficult to find, and when there was communication with them they were not helpful. The team spent three months working with the camera driver to understand it and trying to improve communication with the company that had provided it, on a task that was scheduled originally to take only one month. Eventually, Sentech sent the team a camera *beta* driver. Beta in this context means the software had not yet been released officially to the product's users, but has endured preliminary testing and still has more "bugs" (errors or flaws in a computer program that prevents it from operating as intended) than a regular release. However, after similar problems occurred with the new driver, and when the company declined to share with us the detailed product specifications documents, the decision was officially made to change the payload completely. This denotes the beginning of the second ADP iteration.

After revising the systems specifications to incorporate more detail about performance characteristics of the system, the payload team expanded the search to companies that were previously not considered, either due to cost or lack of knowledge about the company. The results were then compiled with an emphasis on establishing direct contact with the company to ensure that the new requirements in an overall system were met. The types of companies considered broke down into three groups: research oriented, standard industry and hobby board cameras.

Research oriented companies manufacture robust cameras capable of high resolution imaging with little noise ratio. Some of these cameras have been operated in vacuum chambers, but they are bulky and require cooling to stay at low operating temperatures. Most of them are also above the power and mass requirements allocated for the spacecraft. The research cameras are expensive but also carry a large amount of customer support with the cost. These cameras would work if they could be scaled down and if we could afford to only take pictures during limited periods in orbit. Due to the limited information about the orbit at the time, it was not feasible to assume that this would allow for the operational requirements to be met.

Industry based companies manufacture robust small cameras capable of adequate resolution imaging quickly. These cameras do not have vacuum operations heritage, but their sensors are manufactured in a vacuum. The cameras are typically less than \$1,500 USD and carry a significant amount of customer support with the cost. These cameras could work if functionality in a vacuum environment could be verified. Hobby board cameras are not manufactured by one company in particular and are sold from warehouses that specialize in hobby components. These cameras are very cost efficient

and some do have vacuum heritage, but customer support relies primarily on Internet blog boards for trouble-shooting. These cameras could be used if customer support is not needed. The type of company that suited best the technical needs were perceived to be the industry ones.

Of the companies that were examined, one company had a camera that met the requirements established. The company is Image Development Systems (IDS) based in Germany. Even though the company is based overseas, there are a significant number of distributors within the US, all of which have their own customer support centers. The trade study focused on determining which one would best fit the systems needs. A summary of this trade is shown in Table 6.6.

Table 6.6 Summary of M-Cubed primary payload trade study (2009).

Model	Resolution	Interface	Software	Power	Price	Mass	Sensor	(W,H,D)	Temp	Shutter
IDS-UI-1225LE-C	752 x 480	C/CS-Mount	Linux	5 V	\$340	32 g	CMOS	44x44x25.4 mm	-40 to 85 °C	Global
IDS-UI-1228LE-C	752 x 480	Board Level S-Mount M12	Linux	5 V	\$315	12 g	CMOS	36x36x20 mm	-40 to 85 °C	Global
IDS-UI-1645LE-C	1280 x 1024	C/CS-Mount	Linux	5 V	\$340	32 g	CMOS	44x44x25.4 mm	-40 to 85 °C	Rolling
IDS-UI-1646LE-C	1280 x 1024	Board Level S-Mount M12	Linux	5 V	\$315	12 g	CMOS	36x36x20 mm	-40 to 85 °C	Rolling

Relevant differences in the cameras shown in the trade study are the resolution and the type of shutter being used. For applications in which the object being imaged is moving it is better to use a global shutter since it instantly images objects. Using a rolling shutter will cause there to be some blurring depending on the properties of the camera. These particular cameras have a maximum shutter speed of 980 μ s, which preliminary analyses showed that it would be adequate to ensure that significant blurring does not occur.

The camera selected was the IDS-UI-1646LE-C Color CMOS Camera, with a resolution of 1280x1024 pixels, each with a size of 3.6 x 3.6 micrometers. It has a mass of 12 grams and is 36x36x20 mm (IDS Systems, 2007), shown in Figure 6.7.



Figure 6.7 IDS UI1646LE-C CMOS camera (IDS Systems, 2007).

The requirements were updated as shown in Table 6.7

Table 6.7 M-Cubed primary payload requirements at second design iteration (2009).

ID	Requirement
PLD-001	The payload shall color image the Earth with a resolution of 200 meters per pixel
PLD-002	The payload shall have a power requirement of 1.8 V, 3 V, or 5 V.
PLD-003	The payload shall not exceed \$2000 in cost.

PLD-004	The payload shall not exceed 100 grams in mass.
PLD-005	The payload volume dimensions shall not exceed 50 x 50 x 50 mm.
PLD-006	The payload shall operate within the temperature range of -30° C to 60°C
PLD-007	The payload shall operate on a Linux based driver
PLD-008	The payload manufacturer shall provide significant customer support
PLD-009	The payload shall compress the image by a factor of 10
PLD-010	The payload detector shall be able to operate even after exposed to direct sunlight
PLD-011	The payload detector shall account for TBA image blur

The payload team had migrated from CCD technology to CMOS, which would be beneficial since there was not as much sensitivity to thermal radiation by making this change. There was also the need to connect this camera through a microprocessor, the Colibri Toradex ARM PXA270 processor, that would act as an intermediate with the main spacecraft computer as shown in the system block diagram in Figure 6.8.

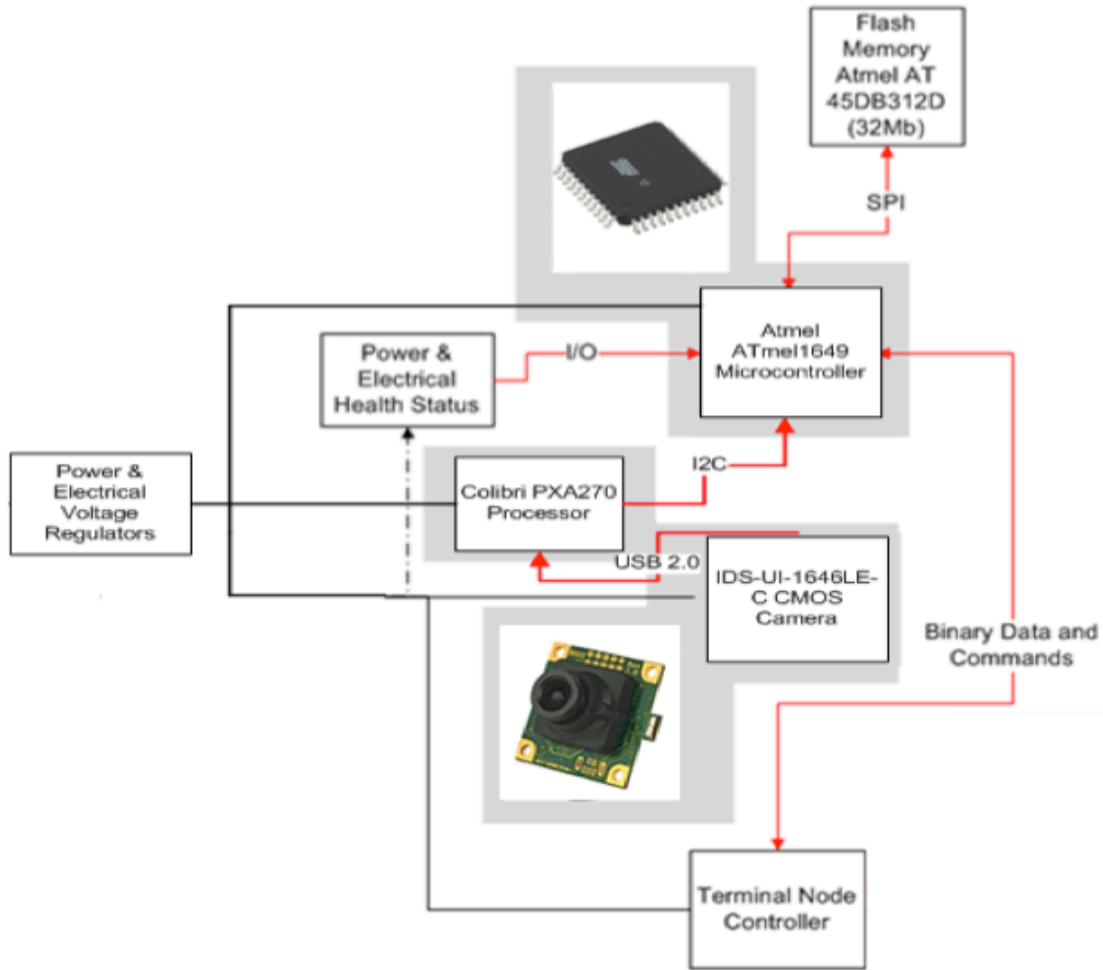

Figure 6.8 M-Cubed payload system block diagram (2009).

Risk analysis performed by the team determined five items that needed to be addressed. They are shown in Table 6.8.

Table 6.8 M-Cubed payload team's risk assessment summary.

Rank	Risk Item	Description	Mitigation Plan
High	Data Acquisition	Interface with Microcontroller not completed	Investigation of details of the interface between Colibri Processor and microcontroller
Medium	Space Survivability	Camera functionality in space environment	Validate space-qualification of components (thermal vacuum)
High	Lens mis-alignment	Lens gets misaligned during launch	Vibe testing
Medium	Lens protection from depositing	Outgassed materials deposit on lens	Further vacuum testing and bake-out
High	Resolution Verification	Resolution of picture less than goal resolution	Extensive testing on ground and post-process to determine resolution loss

With the IDS camera, the payload team was able to start conducting more testing to address the risk items identified. One of these was the much-anticipated imaging testing, including modular transfer function (MTF) and rotation testing. MTF is a method used to quantify image resolution in optical systems.

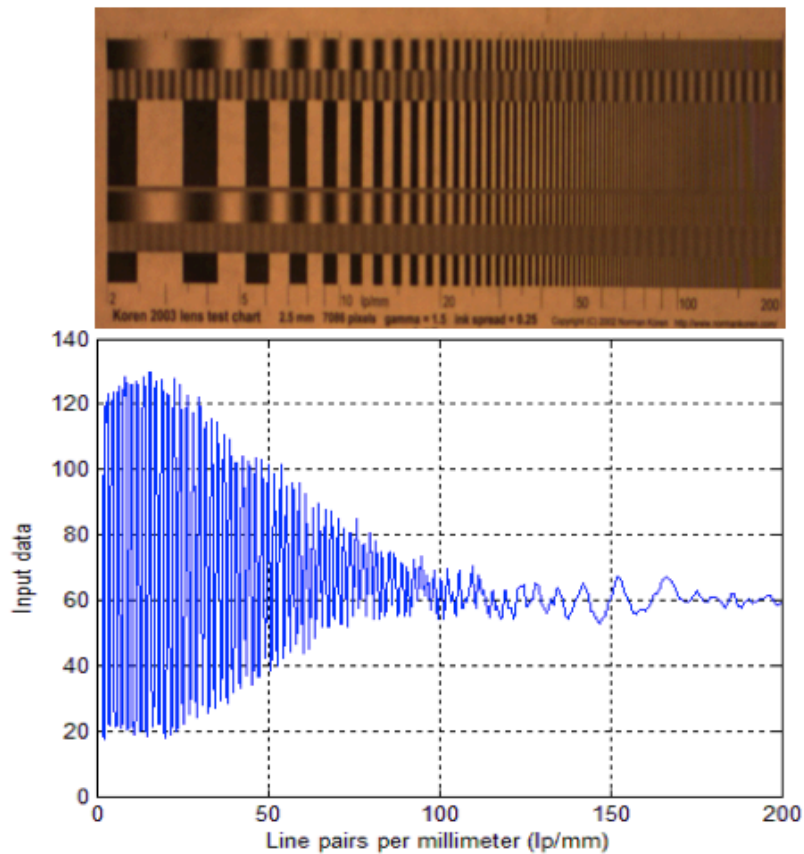

Figure 6.9 IDS CMOS camera resolution test image capture (top) and corresponding MTF plot (bottom).

Figure 6.9 shows a resolution test image and the corresponding MTF plot. The 50% MTF is equivalent to about 60 line pair/mm, which is considered a good picture. There was also rotation testing performed with a rotation table to quantify blurring. The testing revealed negligible blurring effects due to anticipated spin rates of up to 7 degrees per second.

Other subsystems on M-Cubed were steadily making progress as well. The structures team had machined the first prototype, and the electrical power system was characterizing the first version of their system. The command and data handling group

had the first revision of their main board and for the first time many of the components were being observed side by side, as shown in Figure 6.10.

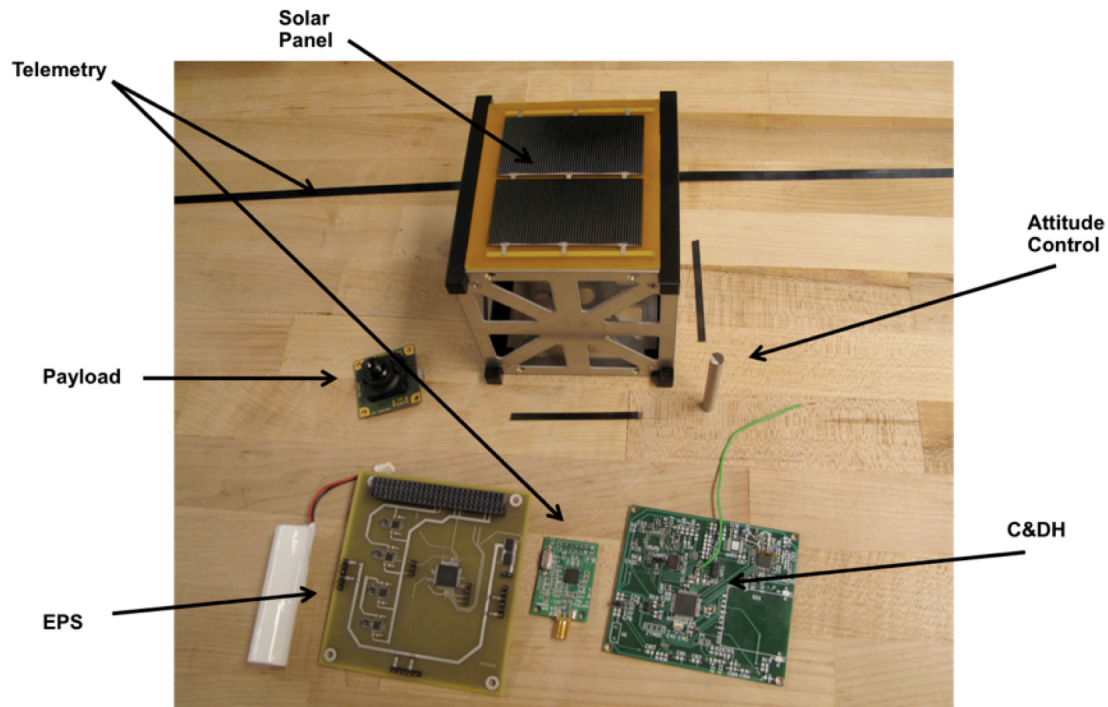

Figure 6.10 M-Cubed first subsystem prototypes.

In terms of the ADP model, it was observed that the design driver during this iteration was the control capability (camera driver), in other words, having the capability of complete control of the device selected for imaging purposes.

6.3.1.3 Iteration 3. Fall 2009 – Omnivision OV2655 camera (Final)

The UI-1646LE-C Camera was integrated with the proprietary software to run on scientific Linux. However, during integration with the Toradex Colibri processor there were problems with it recognizing the low level drivers that control the camera. After compiling the software, there is a "linking" phase, where all the compiled files get linked together. This particular software relies on an object called *common.o*. This is shipped already compiled, but is compiled specifically for an x86 architecture (an Intel® or AMD® processor). In other words, there was no way to compile specifically for the existing command and data handling system architecture, and it isn't possible to reverse engineer it. The team's research showed this driver/software absolutely cannot run on any other type of processor like AVR32, ARM, SPARC, etc. (Toradex Colibri is a XScale, an implementation of ARM). Even though there was already an awareness of the importance of the control capability for the camera, the team was not able to predict that there would *only* be certain architectures that their software would work on, until we received the camera.

If the source files had to be accessed (directly from the manufacturer) then compilation in the required architecture would be possible and would allow it to run in the selected processor. Since the research team only acquired one of their products, compared to their other customers, who typically order in the hundreds, this was perceived as unlikely. An alternative strategy entailed asking the company to compile the module (using the AVR32 tool-chain, which would output compatible files). It was thought they would consider this option and that it would appeal to them so they could avoid revealing their proprietary code.

Unfortunately, after various interactions with the company it was clear that there was not going to be support for the needed architecture. The decision to change the payload was considered once again, and it was not easy since there had already been a number of decisions made before examining the other possible sources of the delays, and other subsystems in the spacecraft were also making progress. During this intense design period, the most qualified members of the organization were working on getting the driver operational. At one point, it was considered to outsource the specific task, but it proved to be too expensive.

The laboratory setup used to complete the integration had been upgraded by a collaborative effort between the C&DH and payload team and was operating very efficiently. Protocols for documentation that included more detailed descriptions of engineering logs, testing and weekly reports were also in place. The camera itself was operating adequately in a windows environment; so there was discussion in regards to the microcontroller being changed to accommodate a windows driver. However, significant work and integration had already taken place with the microcontroller, changing this component would cause too many significant design changes.

The systems team in conjunction with payload and C&DH determined that another major design iteration to determine the best suitable system concept would be required. This was the equivalent to another major design cycle (ADP) with the corresponding updates in requirements.

The requirements for payload were updated as follows:

Table 6.9 M-Cubed primary payload requirements (final revision).

ID	Requirement
PLD-001	Payload shall take a color image of Earth with a Ground Resolution of at least 200 m per pixel
PLD-002	Payload shall take a color image of at least 1 Megapixel in size
PLD-003	Payload mass shall not exceed 100 g
PLD-004	Payload volume dimensions shall not exceed 50*50*50 mm
PLD-005	Payload should operate on 1.8 V, 3 V or 5 V regulated voltage line
PLD-006	Payload shall account for Image Blur, by taking 8-bit color images with a 50% Modulation Transfer Function (MTF) of at least 60 lp/mm.
PLD-007	Payload hardware interface shall be via SPI, TWI, USB or UART/RS-232C/Serial Port
PLD-008	Payload low level software interface shall consist of a Linux based driver
PLD-009	Payload manufacturer shall provide significant customer support as determined by payload team
PLD-010	Payload subsystem cost shall not exceed \$2000
PLD-011	Payload shall be able to operate in a vacuum of at least 5 E-04 Torr
PLD-012	Payload shall be able to operate within the temperature range of -20 to 60 °C (stby of -40 to 70 °C)
PLD-013	Payload shall demonstrate a structural natural frequency of 100 Hz or higher (Sweep from 0 – 2000 Hz at 2.2 Hz/sec sweep rate and 0.25 g)
PLD-014	Payload shall demonstrate survivability to worst case scenario in flight operations including exposure to direct sunlight

It should be noted in particular the creation of a requirement (PLD-007 in Table 6.9) that indicated technical specifications to guarantee appropriate connectivity to the command and data handling system. A summary of the final trade study of the CMOS sensors for the cameras is shown in Table 6.10. (The cost only includes the sensor; the actual pricing can be a few hundred dollars each depending on requested support boards).

Table 6.10 M-Cubed primary payload's camera sensor trade study summary.

Image Sensor	Company	Pixel Size (um)	Res. (pixels)	Cost (USD)	Vol. (mm)	Mass (g)	Op. Temp (°C)	Voltage (V)	Interface
OV7640	Omnivision	5.6	640* 480	\$25	11.43 * 11.43	5	0 to 50	2.5	SCCB
MT9M131	Micron Technology	3.6	1280* 1024	\$35	5.78 * 5.78	5	-30 to 70	2.8	2 wire serial
KAC1310	Kodak	6	1280* 1024	\$25	7.68* 6.14	7	0 to 40	3.3	I2C
OVO3640-V56A	Omnivision	1.75	2048* 1536	\$15	5.2 * 5.2	5	0 to 50	3.3	SCCB
OVO3642-V67A	Omnivision	1.75	2048* 1536	\$15	4.8 * *4.8	5	0 to 50	3.3	SCCB
OV02655	Omnivision	1.75	1600* 1200	\$15	4.8 * 4.8	5	0 to 50	3.3	SCCB

The final camera selection as the primary payload for M-Cubed is the Omnivision OV2655 CMOS based sensor camera shown in Figure 6.11. The camera and associated breakout board shown in the picture is 26.45 grams. The camera breakout board is used because the OV2655 is difficult to mount and sensitive to board routing near it. The complexity associated with creating a board to interface with the sensor directly is beyond the scope of the team's technical and manufacturing abilities. The sensor, mounted lens and breakout board are referred to simply as the camera.

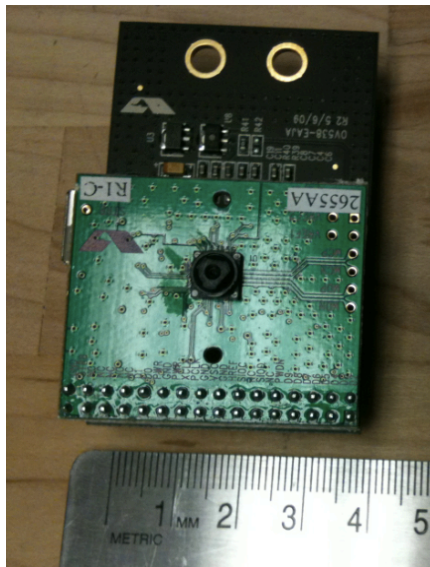

Figure 6.11 M-Cubed primary payload final selection, the OV2655 CMOS based sensor.

For configuration and control the camera uses a Serial Camera Control Bus (SCCB), which is essentially the I2C (Inter-Integrated Circuit) protocol. I2C is a multi-master serial single-ended computer bus invented by Philips that is used to attach low-speed peripherals to a motherboard, embedded system, or cellphone (Philips NXP, 2007). The payload requirement PLD-007 denotes a specific list of interfaces that the spacecraft flight computer can use, including TWI (Two Wire Interface). TWI or TWSI (Two-Wire

Serial Interface) is the same bus called I2C by Philips, but that term is sometimes avoided due to patenting issues. The payload-flight computer interface definition (represented in Figure 6.12) is considered a design driver, since it was the only way to ensure that the flight computer and the camera would operate effectively.

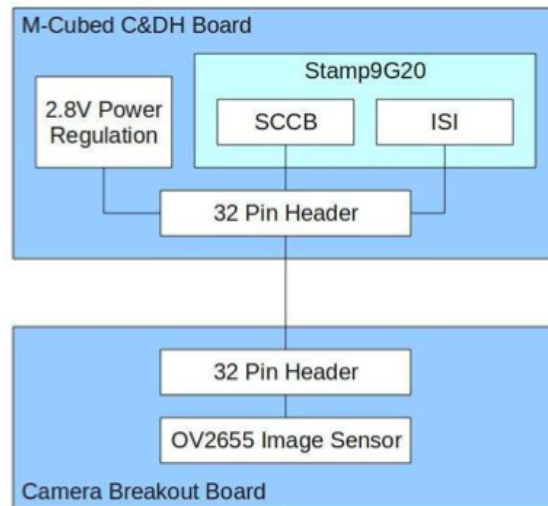

Figure 6.12 M-Cubed primary payload and command and data handling interfacing block diagram.

Environmental testing has been performed to ensure the camera’s survivability. For example, Figure 6.13 shows the results of a cold test to verify the stability of the image taken by the sensor at lower than 0 °C local temperature. The supporting electronics maintained a temperature (indicated as *camera temperature*) on average of 10 degrees above the local temperature during this test that went to -17 °C in less than one hour. Images were taken at 5-minute intervals verifying that the system was able to perform nominally.

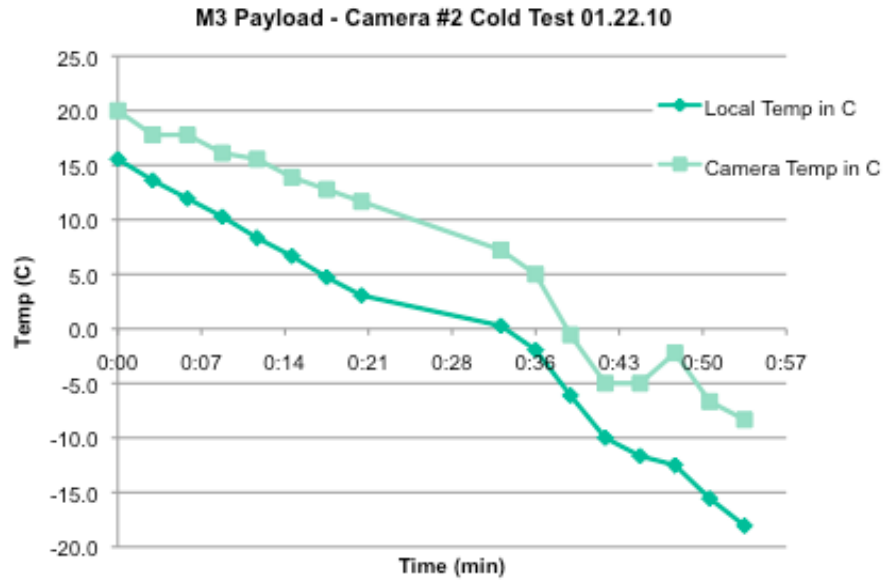

Figure 6.13 M-Cubed payload thermal test data plot to -17 °C in less than one hour to verify system survivability.

The camera has also been placed in a vacuum environment to determine survivability. During one test the camera was in a 4.3E-05 Torr pressure environment for ten hours. A mass loss (due to outgassing of the camera system) was observed of 0.02 grams. An image taken by the camera during this test is shown in Figure 6.14. The image shows the template sheet used to characterize image resolution at 55 cm., placed on the glass dome on the topside of the vacuum chamber (where the camera is pointing).



Figure 6.14 M-Cubed primary payload's image captured during vacuum test at $4.03E-05$ Torr. The target observed in the image is a resolution chart at 55 cm.

Additional information of the camera regarding its location within the spacecraft as well as the optics characterization of the sensor can be found in the M-Cubed spacecraft description section of this chapter (Section 6.4.1).

6.4 Discussion

It is of interest to understand if following the ADP model can help characterize the primary payload to be flown on an imaging spacecraft. The intent was to answer the

following research question: Can the preliminary design for a spacecraft imaging system be defined by using the ADP model?

Space systems are by their nature very complex, since there are many subsystems that must perform effectively for the entire system to meet its objective. This performance is expected from a system that is operating in a very harsh environment (Section 3.2.1) and the designers do not have the opportunity to test the spacecraft in the environment that it is meant for. As seen in the different aerospace design models presented earlier (Section 2.3) the complexity is easily noticed and the associated algorithms can be overwhelming for any inexperienced engineer.

During the first major design iteration for the primary payload, image quality was considered the dominant driver by the payload team. After having found numerous difficulties integrating with the operating system of the command and data handling system the decision was made to perform a second major design iteration. It was found after the procurement of the selected camera system that there was a lack of payload to flight-computer working interface. The third and final major design iteration addressed this problem and it was this interface, which was considered a dominant driver. At the end of this iteration the system met the requirements. This endorses the ADP model's relevance. Through the development of the M-Cubed program, it has been observed that for the initial design of the spacecraft, following the ADP design model has been very important in finding the system drivers that lead to a feasible system. In addition to the complex environment with many changes, it has been observed that the ADP is able to adapt efficiently to a dynamic environment (externally with part suppliers and internally with rotation of personnel every year) in which the levels of expertise of the team were

varied. The effort in the development of the spacecraft was a multi-year effort, in contrast with other smaller, contained design tasks (Section 5.1). This supports that the ADP model is able to scale adequately between small and large tasks. All the design iterations happened in a culture of learning (Section 4.4.1) and a culture of leading (Section 4.4.2) which is very fast paced, supporting also the adaptability characteristics of ADP.

This study effectively shows the value of using ADP for the design of space systems using commercial off the shelf components. Over the course of three major iterations the M-Cubed primary payload was successfully identified and a full spacecraft configuration was defined. The camera selected to be the primary payload is the Omnivision OV2655 CMOS Image sensor, and it drives the design of the entire CubeSat. Most of the design trades and engineering decisions for the entire spacecraft were direct consequences of the iterations to select the primary payload.

Table 6.11 shows a top-level summary of the information technology elements that the payload team used for design activities. It should be noted that these values are meant to provide an overall idea of what platforms were used. Most of the required SIMS (Section 4.3.1) technical weekly reports were submitted, but there were a few missing per each team due to students forgetting to submit them. The entire team documented more than four thousand hours of work during the span of the design task, and these hours also included documented hours of work interacting with other subsystems to understand interface related issues. A wiki page was created for the team to capture design updates, but was only edited four times and was not accessed often, so after the second major design iteration it was abandoned. However, the systems team adopted the wiki medium, and a wiki page for the entire spacecraft system level

configuration was created and is currently being used by the entire program. At the beginning of each academic term, some emails were sent regarding administrative matters for the team (e.g. weekly meeting time and location, required paperwork to submit for the laboratory, etc.) but soon after they would be oriented to addressing technical issues that the team was dealing with during each week. Although Microsoft Office™ PowerPoint was used to showcase the design updates during major technical reviews, the most up to date information regarding the design was contained in the SIMS technical reports and a shared Google document created for the team. All members of the payload team accessed at some point the shared Google document to capture design process elements (e.g. requirements, trade studies, etc.). Design reviews and technical milestones throughout the design of the spacecraft prompted twelve major revisions of this shared document.

Table 6.11 Summary of information technology elements used by the M-Cubed payload team.

	Information Technology medium	Total
Information required to be documented	SIMS weekly reports	216
	SIMS hours worked reported	4060
Information documented as deemed necessary	Wiki edits	4
	Team emails	212

	Google document changes	12
	Microsoft Office PowerPoint™ presentations	4

The spacecraft architecture and final configuration is discussed in detailed in the following section.

6.4.1 M-Cubed spacecraft

6.4.1.1 Systems overview

M-Cubed's primary payload is the Omnivision OV2655 CMOS Imaging sensor. This allows for moderate to high-resolution images of the Earth after post-processing. Figure 6.15 shows a top view with the distribution of main elements within the satellite. Each side of the spacecraft is 10 cm.

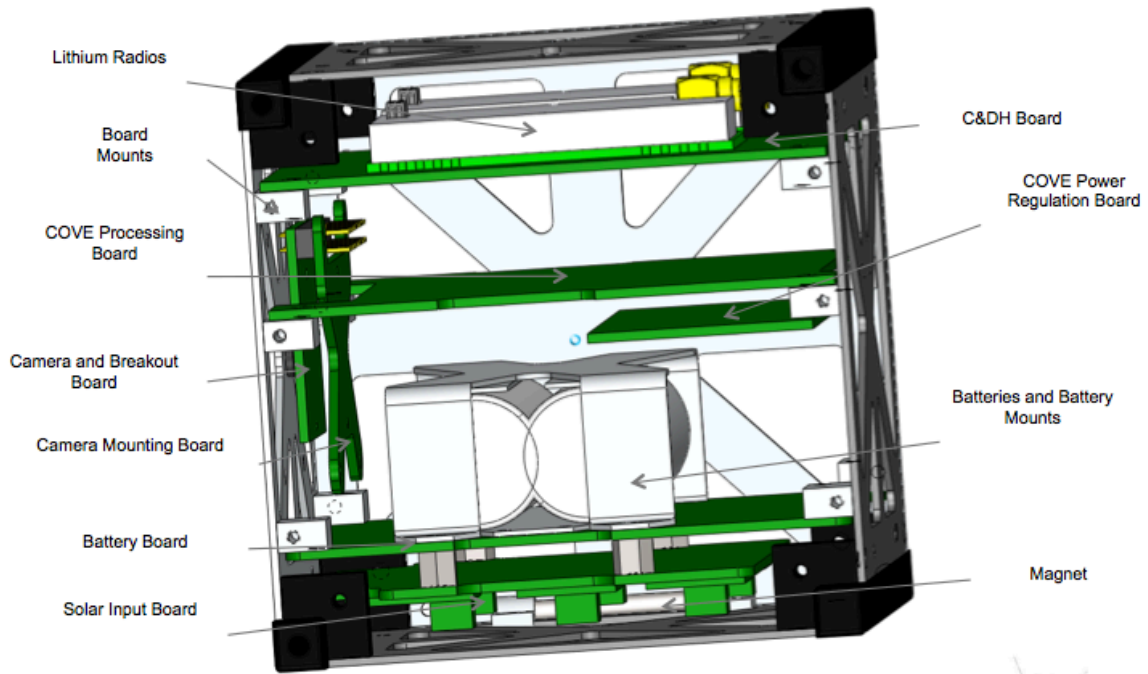

Figure 6.15 M-Cubed CAD model top view showing major elements.

Figure 6.16 shows the M-Cubed expanded view, with the antennas in deployed configuration.

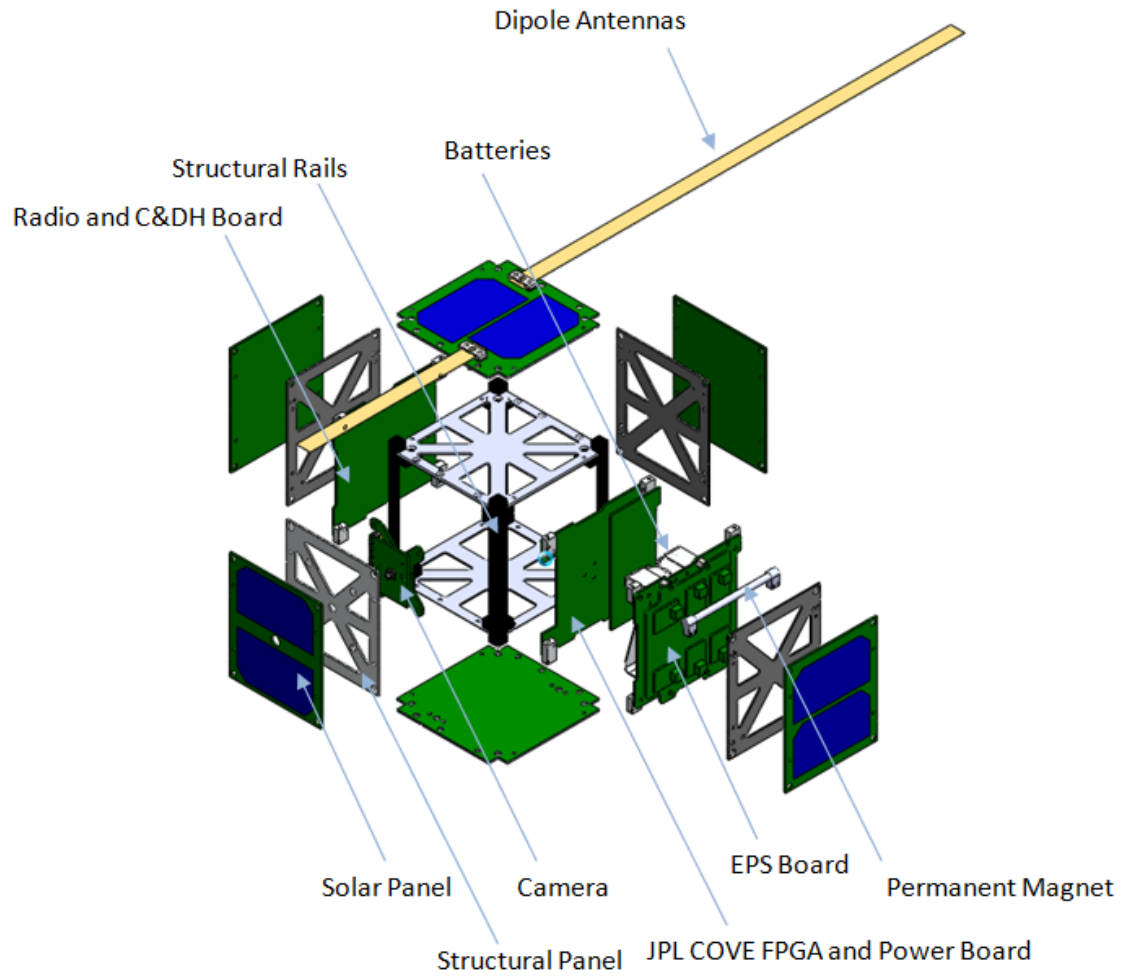

Figure 6.16 M-Cubed CAD model isometric expanded view.

Figure 6.17 is the system block diagram for M-Cubed.

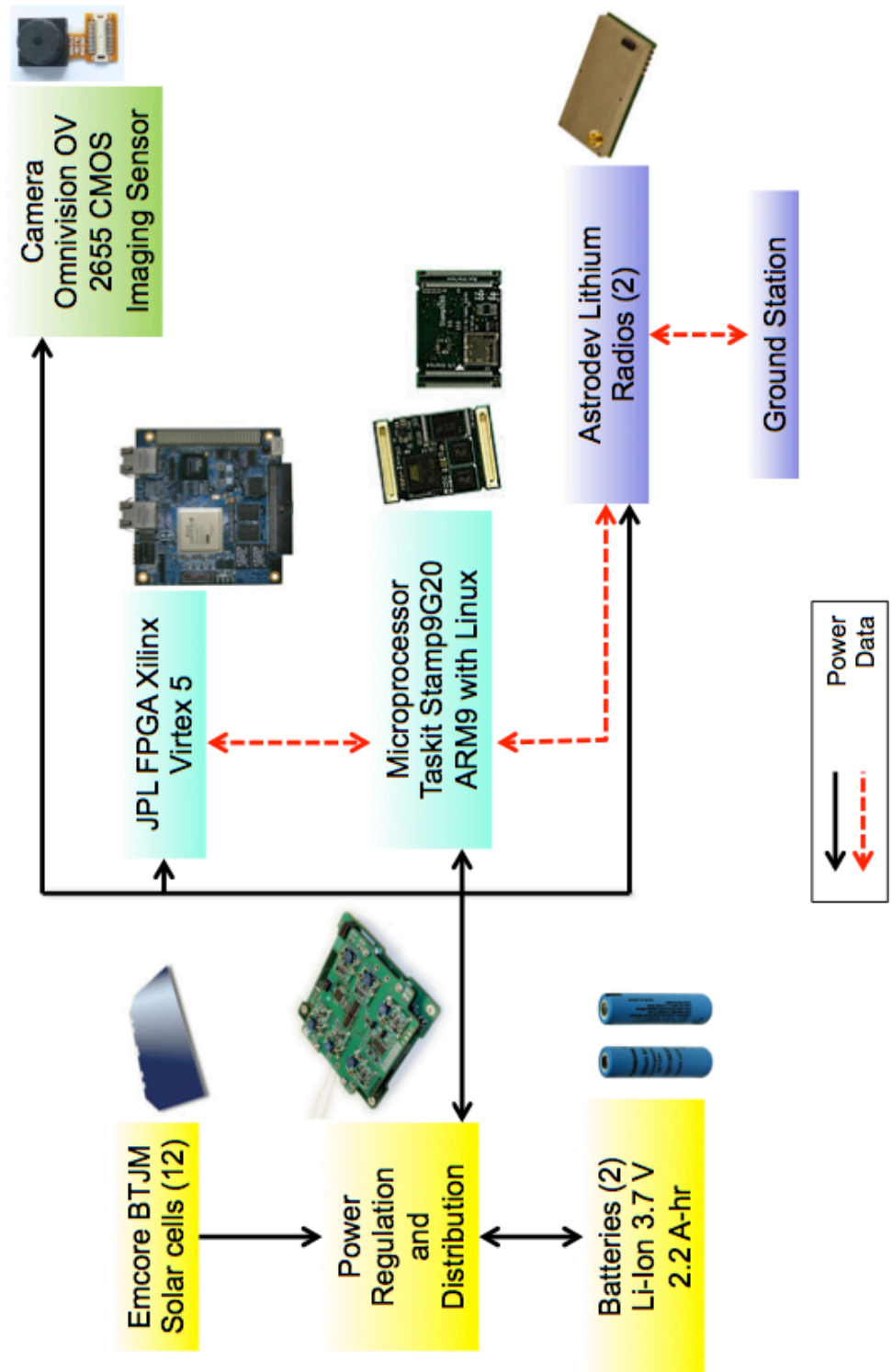

Figure 6.17 M-Cubed System block diagram.

6.4.1.2 Requirements

System-level requirements for M-Cubed are shown below in Figure 6.18. The M-Cubed Requirements Verification Document (M-Cubed RFD) lists the complete set of project requirements.

SYSTEMS		
ID	CubeSat Basic Requirements	Source
SYS-001	The total mass shall not exceed 1 kg	Cal Poly
SYS-002	M-Cubed shall have a remove before flight (RBF) pin to deactivate before integration with P-POD	Cal Poly
SYS-003	M-Cubed shall not employ pyrotechnics	Cal Poly
SYS-004	M-Cubed shall be fully deactivated in launch phase	Cal Poly
SYS-005	M-Cubed shall withstand launch loading of 10 G's	Cal Poly
SYS-006	M-Cubed shall not present any danger to neighboring CubeSats in the P-POD, the LV, or primary payloads	Cal Poly
SYS-007	M-Cubed shall fit within a square volume with sides measuring 100 square mm	Cal Poly
SYS-008	M-Cubed shall keep all parts attached during launch, ejection, and operation.	Cal Poly
SYS-009	M-Cubed structure must be compatible with the P-POD.	Cal Poly
SYS-010	M-Cubed shall provide one deployment switch at a designated point per CubeSat.	Cal Poly
SYS-011	M-Cubed developers shall provide documentation of approval of an orbital debris mitigation plan obtained from the FCC.	Cal Poly
SYS-012	M-Cubed shall undergo thermal vacuum bakeout testing according to the MTP.	Cal Poly
SYS-013	M-Cubed shall not be disassembled or modified after qualification testing.	Cal Poly
ID	Functional Requirements	Source
SYS-014	The CubeSat shall downlink one 8-bit color image with at least 60% land mass and maximum of 20% cloud coverage with less than 25% dark pixels at a resolution of at least 200 meters per pixel	Functional
SYS-015	The CubeSat's orbit shall not degrade within 1 month	Functional

Figure 6.18 M-Cubed system level requirements summary.

6.4.1.3 System Budgets

The following system budgets are from M-Cubed's last technical design review. Wherever possible, the design unit seeks to adhere to these system budgets. The final version of these budgets will be compiled after building an engineering design unit and systems testing can be performed.

M-Cubed is limited to a mass of 1 kg., Figure 6.19 shows the mass budget for M-Cubed.

	Quantity		Mass				
	(#)	Component Mass (g)	Total w/o Contingency (g)	Contingency	Total w/ Contingency	Alloted Mass	% of Alloted Subsystem Mass
Systems					130	130	100%
JPL FPGA					100	120	83%
Payload			37	13%	42	100	42%
Camera Payload	1	17.33	17.33	5%	18		18%
Camera Mount	4	5	20	20%	24		24%
ADCS			12	10%	13	20	66%
Magnet	1	9	9	5%	9		47%
Hysteresis Material	2	1	2	5%	2		11%
Magnet Holders	2	0.5	1	20%	1		6%
EPS			325.4	15%	374	380	98%
Battery	2	52	104	5%	109		29%
Battery Case	1	9	9	20%	11		3%
Solar Cells	12	2.2	26.4	5%	28		7%
Solar Panel Boards	6	12	72	20%	86		23%
Power Distribution Board	1	90	94	10%	103		27%
Wiring and Harnesses	1	20	20	30%	26		7%
C&DH			52.7	5%	55	140	40%
C&DH Board	1	52.7	52.7	5%	55		40%
Comms			161	15%	176	150	117%
Antenna	2	5	10	10%	11		7%
Coax and adapters	1	37	37	15%	43		28%
Mount	2	5	10	30%	13		9%
Lithium radios	2	52	104	5%	109		73%
Structures			222	12%	249	260	96%
Side Panels	3	18.04	54.12	5%	57		22%
Camera Panel	1	18.18	18.18	5%	19		7%
End Panels	2	22.29	44.58	5%	47		18%
Rails	4	18.11	72.44	5%	76		29%
Deployment Switch	2	5	10	5%	11		4%
Board Mounts	12	1.7	20.4	30%	27		10%
Fasteners	64	0.04	2.56	30%	3		1%
M-Cubed Total			810.71	12%	1,140	1,300	88%

Figure 6.19 M-Cubed Mass budget (Jan 2011).

The power budget for M-Cubed is shown in Figure 6.20.

Subsystem Modes	8.2 V		5.0 V		3.3 V		Power (W)		Total		Startup Orbit		Standby Orbit		Picture Orbit									
	Current (A)	Power (W)	Current (A)	Power (W)	Current (A)	Power (W)	Power (W)	w/contingency	w/inefficiency	Duration (s)	Duty Cycle	Energy (J)	Duration (s)	Duty Cycle	Energy (J)	Duration (s)	Duty Cycle	Energy (J)						
Antenna Release	1.250	10.250	0.000	0.000	0.000	0.000	10.250	12.300	14.471	30	1%	434.118	0	0%	0.000	0	0%	0.000						
Camera	0.050	0.410	0.000	0.000	0.000	0.000	0.410	0.492	0.579	0	0%	0.000	0	0%	0.000	10	0%	4.100						
Lithium Transmitt LOW	0.220	1.804	0.000	0.000	0.000	0.000	1.804	2.165	2.547	600	10%	1528.094	600	10%	1082.400	600	10%	1082.400						
Lithium UHF Receive	0.027	0.221	0.000	0.000	0.000	0.000	0.221	0.266	0.313	5800	100%	1812.875	5800	100%	1284.120	5800	100%	1284.120						
Lithium Transmitt HIGH	0.570	4.674	0.000	0.000	0.000	0.000	4.674	5.609	6.599	0	0%	0.000	0	0%	0.000	0	0%	0.000						
Flight Computer	0.000	0.000	0.000	0.000	0.040	0.132	0.132	0.158	0.186	5800	100%	1080.847	5800	100%	765.600	5800	100%	765.600						
Power System	0.000	0.000	0.040	0.200	0.000	0.000	0.200	0.240	0.282	5800	100%	1637.647	5800	100%	1160.000	5800	100%	1160.000						
COVE Standby	0.000	0.000	0.000	0.000	0.000	0.000	0.000	0.000	0.000	0	0%	0.000	0	0%	0.000	0	0%	0.000						
COVE MCU	0.000	0.000	0.000	0.000	0.075	0.248	0.248	0.287	0.349	0	0%	0.000	0	0%	0.000	180	3%	44.550						
COVE FPGA	0.850	6.970	0.000	0.000	0.000	0.000	6.970	8.364	9.840	0	0%	0.000	0	0%	0.000	10	0%	69.700						
CONSTANTS																								
Solar flux	0.1321 W/cm ²		SOLAR CELL		Series		2 #		Orbit energy consumed		6484 J		Orbit energy consumed		4292 J		Orbit energy generated		4410 J					
Earth average albedo	0.3 %		Parallel		Voc		2.69 V		Orbit energy generated		5278 J		Orbit energy generated		5278 J		Net energy		5278 J					
Earth infrared flux	0.0237 W/cm ²		Isc		Vmp		0.453 A		Net energy		-1216 J		Net energy		986 J		Net battery capacity		1.6%					
Earth radius	6378200 m		Imp		Pmp		0.434 A		Net battery capacity		-2.2%		Net battery capacity		1.8%		Net battery capacity		1.6%					
Earth mass	5.972E+24 kg		Average power in sunlight		Area		26.6 cm ²		BATTERY CELLS		Capacity		2.1 Ahr		Efficiency		0.85 %		Consumption contingency					
Gravitational constant	6.6743E-11 m ³ /kg/s		Panels per side		Average incidence angle		0 deg		Nominal voltage		Series cells		2 #		Parallel cells		1 #		Energy		54432 J			
SOLAR CELL	26.6 cm ²		2 #		Efficiency		0.28 %		Reference temperature		28 degC		Preferred depth of discharge		0.2 %		DC-DC CONVERTERS		Efficiency		0.85 %			
Area	26.6 cm ²		2 #		Average power in sunlight		1.97 W		ORBIT		Semimajor axis		6905000 m		Eccentricity		0 deg		Inclination		90 deg			
Panels per side	2 #		Efficiency		Reference temperature		28 degC		Average power in sunlight		1.97 W		Period		5800 seconds		Sun duty cycle		0.63 %		Orbit Average Power		1.82 watts	
Average incidence angle	0 deg		Efficiency		Reference temperature		28 degC		Average power in sunlight		1.97 W		Solar Array Orbit Avg Energy Output:		10556 J		Solar cell generation contingency		-0.5 %					

Figure 6.20 M-Cubed Power budget (Jan 2011).

It was defined early on that the typical image size that would be stored on the spacecraft would be approximately 5 MB. After understanding some basic values associated to the vehicle's health, a data budget was created. It contains a storage overhead consideration for data that is reserved for programs as shown in Table 6.12. The C&DH architecture has defined a flash memory of 64 MB in addition to an SD card that is 2048 MB.

Table 6.12 M-Cubed data consumers and storage capability.

Data Consumers		Data Storage	
Payload Data		Total Available Storage	
Individual Image Size (MB)	5.8	Flash (MB)	64
Cove Compressed Size (MB)	0.06	SD Card (MB)	2048
Telemetry Data			
Num Health Values	24		
Size Health Values (bits)	8		
Health Period (sec)	5		
Health Data Per Day (MB)	3.16		
Storage Overhead			
Operating System (MB)	2		
Reserved for Programs (MB)	2		

Considering the overall data rate (which is the number of bits per seconds, *bps*) available due to the telemetry system limitations, as well as the packet size, an estimated transmit time for one picture is estimated to be 138 minutes, as shown in Table 6.13. This is considering a compression factor of 1. If a standard compression algorithm (like JPEG) is used, then the size of the image can be reduced to around 10%, which would enable the transmit time to be reduced considerably.

Table 6.13 Time to transmit picture calculations.

Effective Data Rate Calculations					
	Typical	Worst Case	Best Case	1200bps	Worst+compress
Overall Data Rate (bps)	9600	9600	9600	1200	9600
Protocol bits per packet	160	160	160	160	160
Data bits per packet (8-2048)	256	128	2048	128	128
Effective Data Rate (bps)	5908	4267	8904	533	4267

Time To Transmit One Picture					
	Typical	Worst Case	Best Case	1200bps	Worst+compress
Data Size (Bits)	49140465.66	49140465.66	49140465.66	49140465.66	49140465.66
Effective Data Rate (bps)	5908	4267	8904	533	4267
Downlink Duration/Orbit (s)	600	60	600	600	60
Orbits per day	6	6	6	6	6
Data Compression Factor	1	1	1	1	10
Raw Transmit Time(min)	138.6	192.0	92.0	1536.6	19.2
Transmit Time (days)	2.3	32.0	1.5	25.6	3.2

A summary of M-Cubed cost is shown in Figure 6.21.

Type	Cost (USD)
Travel	6,000.00
Testing	6,600.00
Reviews / Consult.	10,560.00
Fab. Services	2,400.00
Hardware	37,500.00
Misc. Material	10,000.00
Launch Costs	50,000.00
Total Direct Costs	123,060.00
Modified Direct	35,560.00
Overhead Amount	7,823.20
Grand Total*	130,883.20

Figure 6.21 M-Cubed Cost Summary

6.4.1.4 Primary payload - Omnivision OV2655 CMOS camera

A payload has been chosen such that it will fulfill the mission objective and provide color images of Earth in the visual spectrum with a size of at least one megapixel, at a ground resolution of better than 200 meters per pixel. To achieve this, the payload subsystem is a commercial off the shelf (COTS) CMOS camera described in this section.

The primary payload is the Omnivision OV2655 CMOS Camera. This camera is a 2 megapixel CMOS image sensor with an active array size of 1600 x 1200 pixels. The small form factor of the image sensor will allow it to sit on a small camera breakout board, which provides additional circuitry required to form a camera. This is then interfaced to the flight computer. The camera and its location on the spacecraft is shown in Figure 6.22.

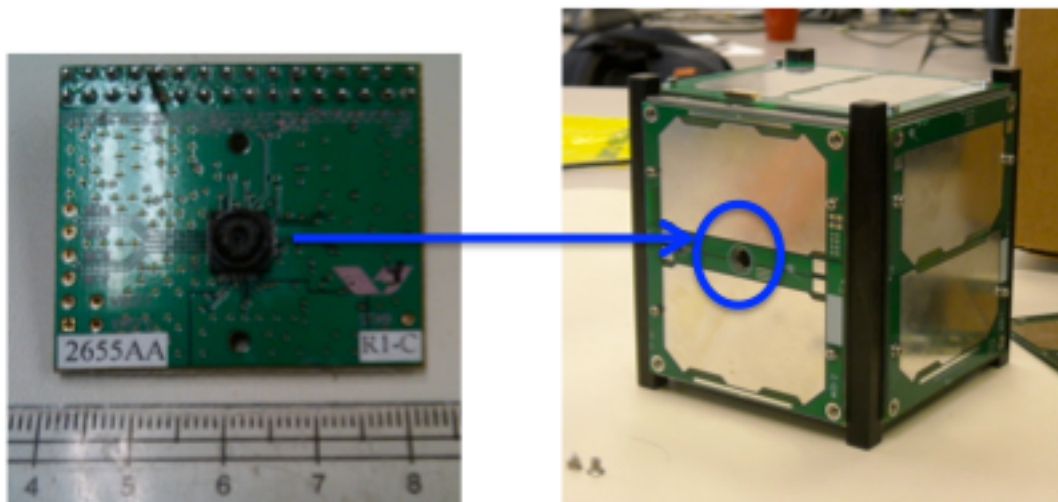

Figure 6.22 OV2655 camera and location of lens on side panel of the spacecraft.

The camera board as well as the supporting board that holds the camera in place within the spacecraft is shown in the side view of Figure 6.23.

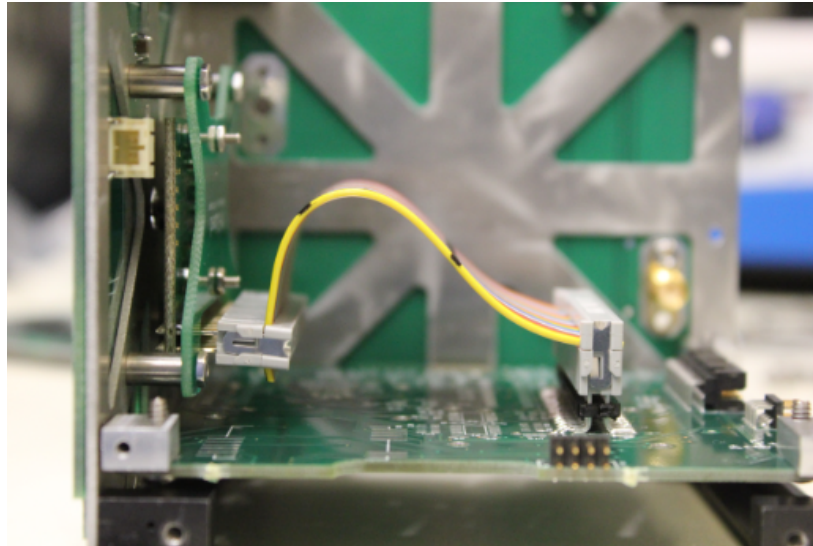

Figure 6.23 M-Cubed Camera mounted within the spacecraft (left side view).

Table 6.14 shows the camera initial conditions that were provided in documentation from Omnivision (2008). They are used to determine pixel and sensor optics parameters. The OV2655 is based on Omnivision's 1.75 micron OmniPixel3-HS architecture which uses Ultra Low Stack Height (ULSH) pixels to produce low-light sensitivity, vital for high frame rate video applications. The OV2655 operates up to 15 frames per second.

Table 6.14 OV2655 CMOS camera input parameters.

Parameter	Value
Array Size	1600 x 1200 pixels
Output Format	YUV(422/420), YCbCr422, RGB565/555
Chief Ray Angle	25 deg
Field of View	50 deg
Lens Size/Type	1/5 inch Polycarbonate
Sensitivity	1030 mV/(Lux-sec)
Pixel Size	1.75 x 1.75 micrometers
Image Area	2842 x 2121 micrometers
S/N ratio	37 dB
Image Transfer Rate	UXGA: 15 fps
Maximum Exposure Level	1235 x Trow
Bytes per pixel	3 bytes
Sensor Area	0.00602 square meters
Focal Length	31.94 mm

The pixel parameters at perigee corresponding to about 350 km are shown in Table 6.15. The IFOV is the instantaneous field of view. It is the solid angle subtended by a single pixel of the imaging system. It is assumed to be the width of one pixel, measured in degrees. The number of cross track pixels assumes that ground pixel size varies along with the swath. This number reflects the number of columns (samples) of the strip of image.

Table 6.15 OV2655 CMOS camera pixel parameters at low perigee (350 km).

Parameter	Symbol	Value
Instantaneous Field of View (one pixel width)	IFOV	0.0010 deg
Cross track ground pixel resolution at nadir	X	9.57 m
Along track ground pixel resolution at nadir	Y	9.57 m
Number of cross track pixels	Zc	1.73e3 pixels
Number of pixels in one second	Z	1.32e3 pixels
Swath Width	SW	307.76 km
Spatial Resolution	Ymax	141.5 m

The pixel parameters corresponding to apogee at 810 km are shown in Table 6.16.

Table 6.16 OV2655 CMOS camera pixel parameters at apogee (810 km).

Parameter	Symbol	Value
Instantaneous Field of View (one pixel width)	IFOV	0.0062 deg
Cross track ground pixel resolution at nadir	X	141.24m
Along track ground pixel resolution at nadir	Y	141.24 m
Number of cross track pixels	Zc	275.19 pixels
Number of pixels in one second	Z	14.78 pixels
Swath Width	SW	764.74 km
Spatial Resolution	Ymax	873.73 m

Sensor parameters at low perigee of 350 km shown in Table 6.17.

Table 6.17 OV2655 sensor parameters at perigee (350 km).

Parameter	Symbol	Value
Diffraction-limited aperture	D	27.55 m
F-number	F/#	1.15
Numerical aperture	NA	24.2 deg
Cut-off frequency	Fc	167.1 lp/mm

Sensor parameters at high apogee of 810 km are shown in Table 6.18.

Table 6.18 OV2655 sensor parameters at apogee (810 km).

Parameter	Symbol	Value
Diffraction-limited aperture	D	28.08 m
F-number	F/#	1.15
Numerical aperture	NA	24.2 deg
Cut-off frequency	Fc	67.21 lp/mm

The point spread function (PSF) is a spread function of the sensor with respect to the pixel size. The point spread function is the imaging system's response to an ideal, point-like source (Popescu & Hellicar, 2010). It shows how the camera is blurring the images upon capture. It is based on a Gaussian distribution. The Full Width at Half Max (FWHM) of the PSF shows the detector pixel width which in this case is 0.37 mm, essentially the diameter of the seeing disk. The PSF diameter is a reference to the best

angular resolution achieved by a telescope with a long exposure. Figure 6.24 is a plot of the expected PSF of the imaging system.

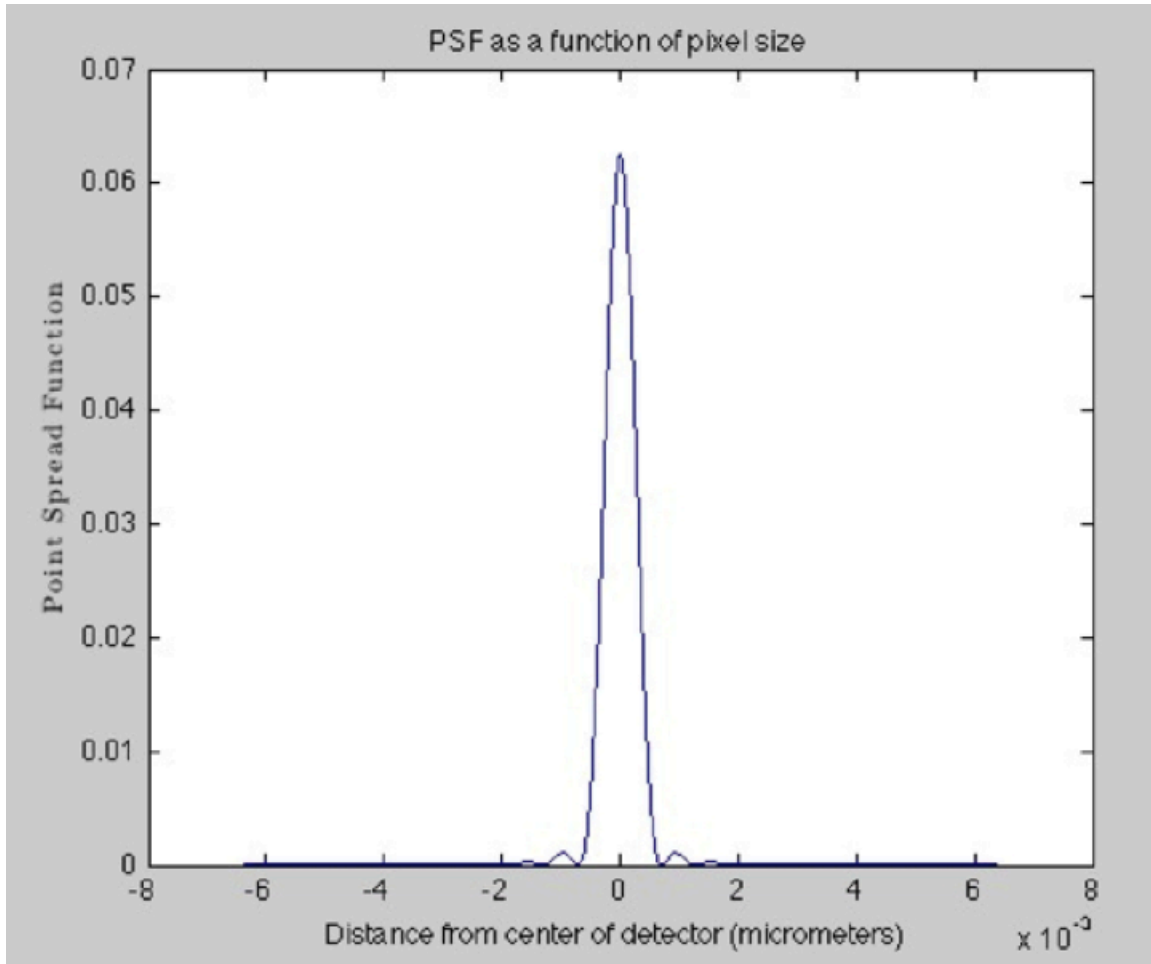

Figure 6.24 OV2655 CMOS sensor point spread function with respect to pixel size.

For the M-Cubed spacecraft, the ground resolution requirement for the imaging system states that the resolution must be better than (less than) 200 meters per pixel when the camera is pointing nadir. Figure 6.25 shows a plot ground resolution values as a

function of orbital altitude, where it can be seen that the resolution requirement is satisfied for the current orbital parameters.

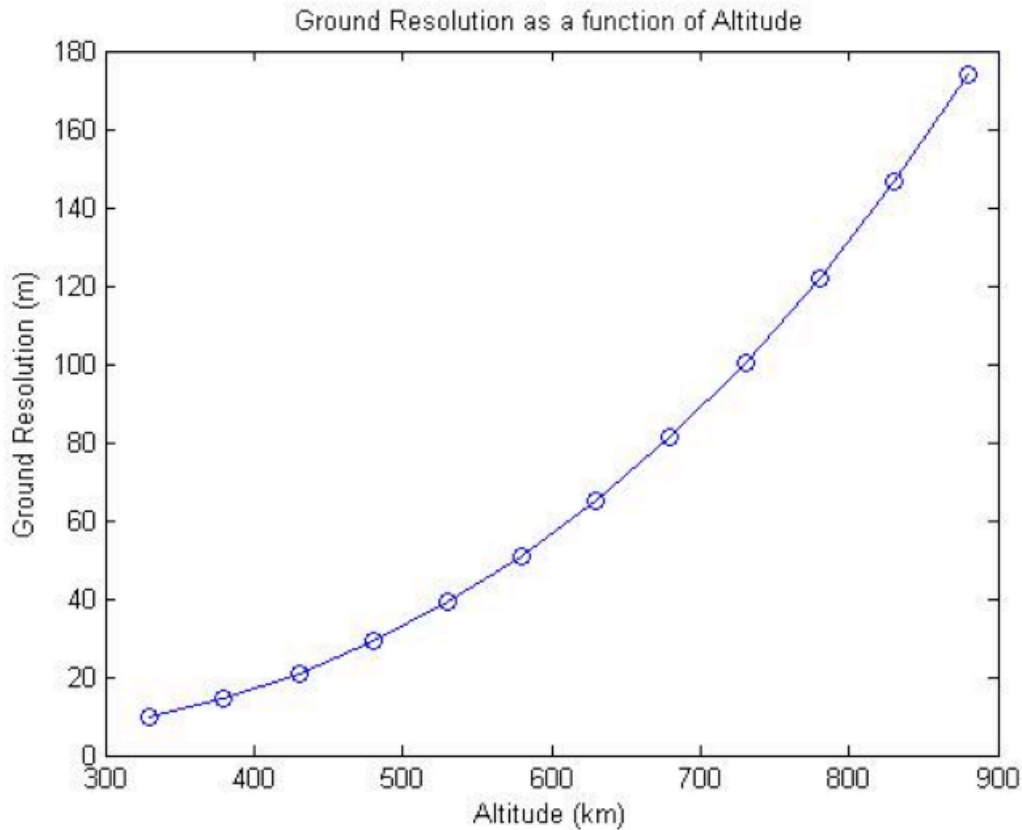

Figure 6.25 OV2655 CMOS sensor ground resolution as a function of altitude.

In addition, there is a requirement placed on the cut-off frequency for the M-Cubed camera at 60 line pairs per millimeter (referring to image blurring). Figure 6.26 shows a plot of cut-off frequency as a function of orbital altitude. With the exception at the highest altitude in orbit, all other altitude values indicate that the imaging system complies with the requirement.

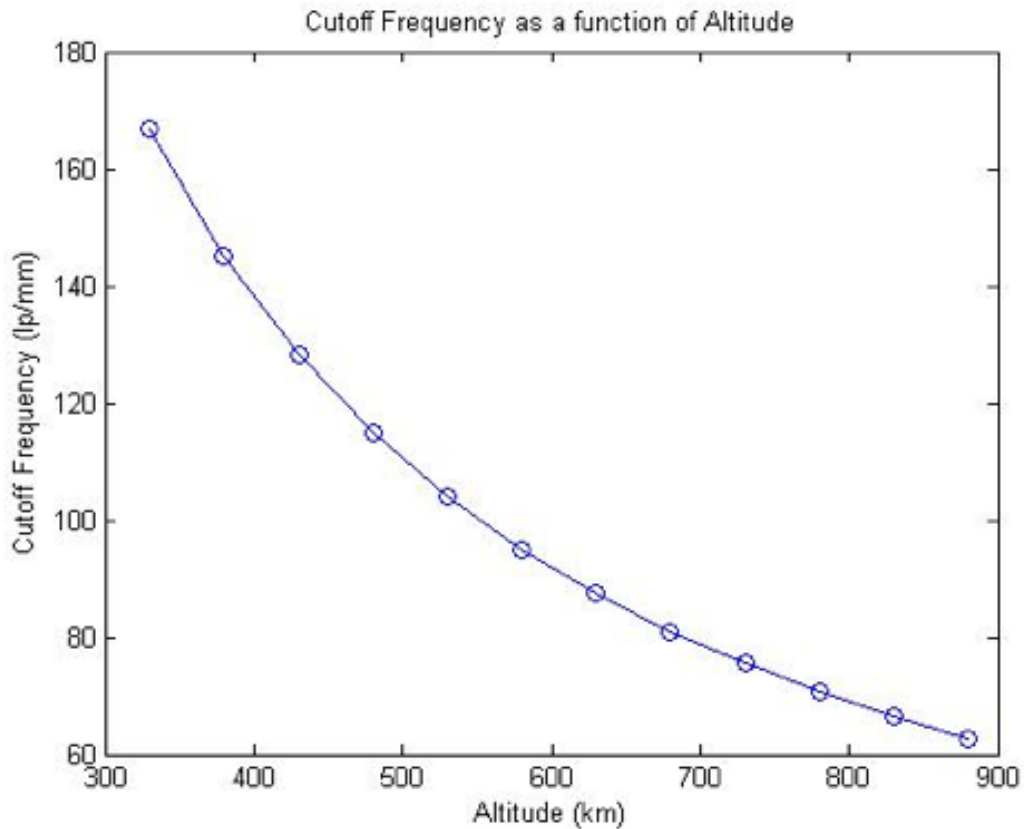

Figure 6.26 OV2655 CMOS sensor cut off frequency as a function of altitude.

6.4.1.5 Secondary payload – Jet Propulsion Laboratory’s COVE payload

The Earth Sciences Decadal Survey identifies a multiangle, multispectral, high-accuracy polarization imager as one requirement for the Aerosol-Cloud-Ecosystem (ACE) mission. JPL has been developing a Multiangle SpectroPolarimetric Imager (MSPI) as a candidate to fill this need. A key technology development needed for MSPI

is on-board signal processing to calculate polarimetry data as imaged by each of the 9 cameras forming the instrument.

With funding from NASA's Advanced Information Systems Technology (AIST) Program, JPL is solving the real-time data processing requirements to demonstrate, for the first time, how signal data at 95 Mbytes/sec over 16-channels for each of the 9 multi-angle cameras in the space-borne instrument can be reduced on-board to 0.45 Mbytes/sec. This will produce the intensity and polarization data needed to characterize aerosol and cloud microphysical properties.

Using the Xilinx Virtex-5 FPGA platform (shown in Figure 6.27) a polarimetric processing least squares fitting algorithm is under development to meet MSPI's on-board processing (OBP) requirements. The Virtex-5 FPGA is not yet space-flight qualified, therefore in-flight validation of this technology on M-Cubed through what is called the CubeSat On-Board Processing Validation Experiment (COVE) is valuable toward advancing the technology readiness level for MSPI and the ACE mission.



Figure 6.27 M-Cubed's secondary payload, JPL's Xilinx Virtex-5 FPGA that hosts the algorithm to meet MSPI's on-board processing requirements (ESTO, 2010).

The COVE payload objectives are to demonstrate an on-board processing system to optimize the data processing and instrument design of a multi-angle SpectroPolarimetric Imager (MSPI) for the ACE Decadal Survey mission. It will achieve a two-orders of magnitude reduction in data rate.

A second objective is the validation of the Xilinx Virtex-5QV rad-hard-by-design (RHBD) FPGA and MSPI on-board processing polarimetry algorithm to advance the TRL for MSPI camera development and the ACE mission.

Finally, a third objective is to grow collaborations among NASA and university partners to engage students and faculty in spaceborne technology validation by flying science payloads on small satellites. The COVE payload has the following parts (ESTO, 2010):

1. SPI Flash (Numonyx P5QPCM) - This is a phase change memory (PCM) device known from previous designs to work with Xilinx FPGAs. Flash devices trap electrons to store information; therefore they are susceptible to data corruption from radiation. However, PCM exhibits higher resistance to radiation effects, which is an advantage for this application. The SPI chip supports legacy-mode and bit-alterable writes; bit-alterable writes are used that do not require sector erase commands prior to rewrite.

2. Muxes and tri-state buffers. They need to be quick to support fast Flash read-write. The currently selected components exhibit a measured propagation delay of 2-3 ns.

3. Xilinx PROM (XQF32P). This is a selection by JPL for the Virtex-5 design.

4. ADC (AD7714). This is selected for its SPI interface to FPGA, low pin count, and low power consumption. It will provide telemetry on FPGA temperature, and 3 other selected board measurements.

5. MRAM (Everspin MR4A16B). This is a non-volatile memory chip (better for radiation) and has previously flown on a Japanese satellite.

6. Oscillator. It has a minimum frequency of 50 MHz

The COVE payload block diagram is shown in Figure 6.28.

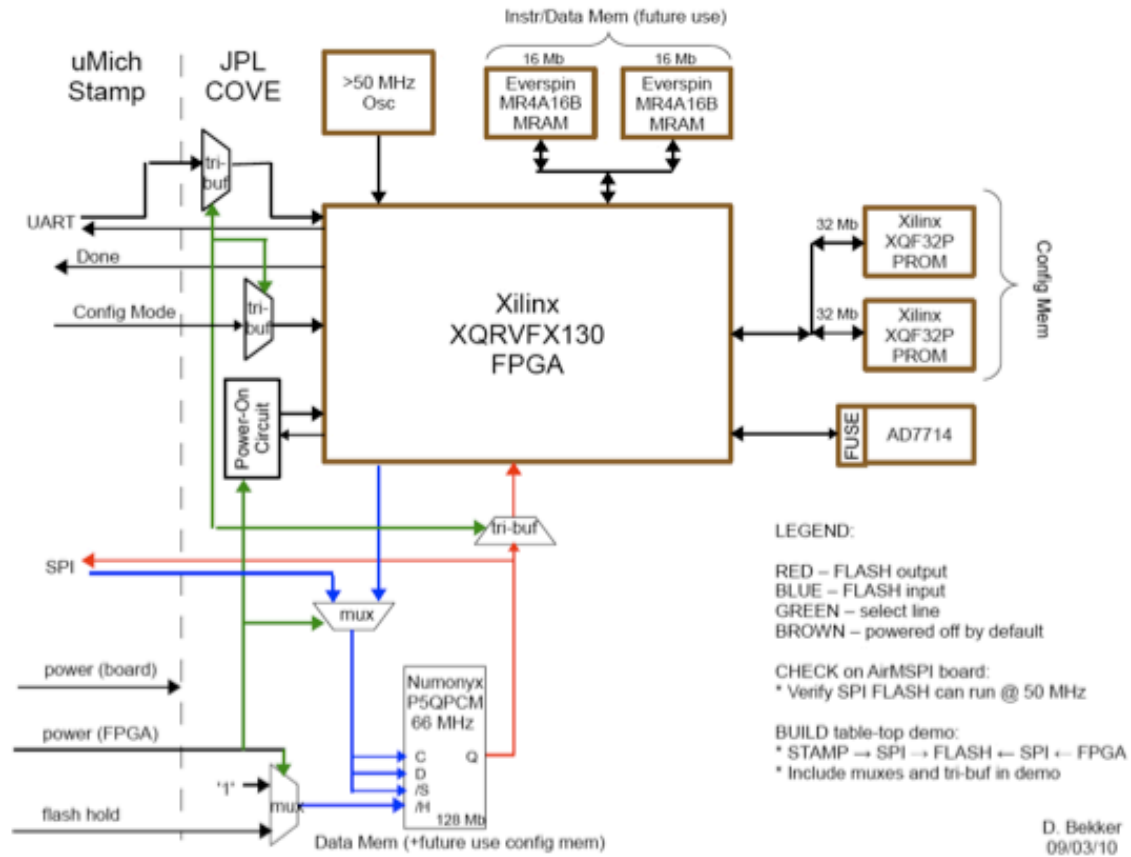

Figure 6.28 JPL's COVE payload design diagram (ESTO, 2010).

The location of the COVE payload within M-Cubed is shown in Figure 6.29.

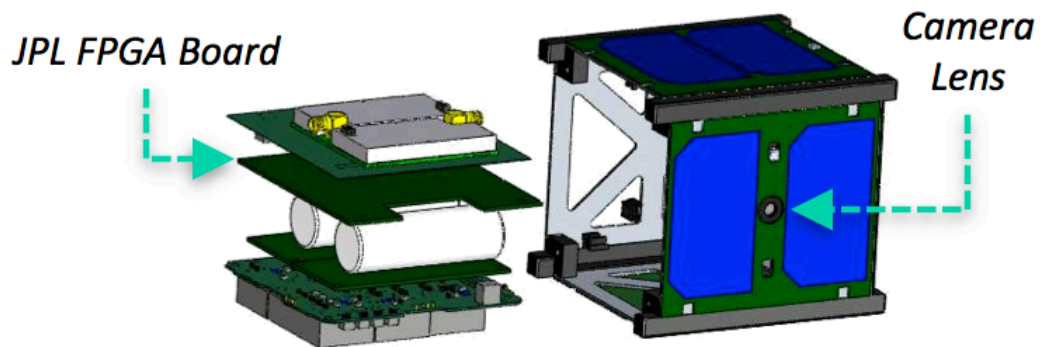

Figure 6.29 CAD model with JPL’s COVE payload location in M-Cubed spacecraft.

The COVE payload has the following concept of operations:

- STEP 1. Stamp9G20 commands COVE board to power on (the FPGA and Flash Hold remain off).
- STEP 2. Stamp9G20 writes image and auxiliary data to SPI flash memory (Flash Hold on, write data on SPI, Flash Hold off)
- STEP 3. Stamp9G20 commands FPGA to turn on and process data
 - Set Configuration Mode (to XQF32P PROM)
 - Power (FPGA) - on
 - FPGA reads SPI flash, processes data, writes results back into SPI flash
 - Simultaneously with c, FPGA communicates with Stamp9G20 via UART
 - Done – on; Stamp9G20 detects done signal
 - Power (FPGA) – off

- STEP 4. Stamp reads data back from SPI flash (Flash Hold on, read data on SPI, Flash Hold off)

Additionally, a new bit-stream can be uploaded to the SPI flash instead of image data in STEP 2. The FPGA can boot from this new bit-stream in SPI flash by having the Config Mode set to SPI flash (instead of XQF32P PROM). The FPGA can even transfer the new bit-stream to the XQF32P PROM since it is reprogrammable (ESTO, 2010).

6.4.1.6 Command and data handling

The command and data handling (C&DH) design team has three main objectives: to designate a flight computer architecture, to program the flight computer to communicate and control all subsystems, and to write and maintain the ground station software which communicates with the satellite.

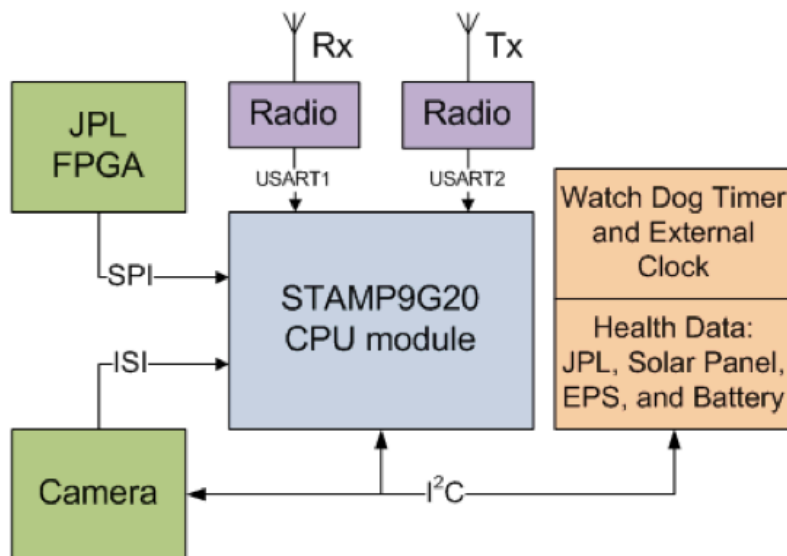

Figure 6.30 M-Cubed command and data handling block diagram.

The M-Cubed flight computer is the Stamp9G20 computer on module (shown in the block diagram of Figure 6.30). It is based on a 32-bit, ARM9, Atmel ATSAM9G20 processor. This processor has a hardware Image Sensor Interface (ISI) for capturing and buffering images from CMOS image sensors like the OV2655. All image data is transferred over the ISI interface.

For configuration and control the OV2655 uses a Serial Camera Control Bus (SCCB), which is essentially the I2C protocol. The Stamp9G20 sends commands to the OV2655 over this SCCB bus. Running a real-time Linux operating system, the Stamp9G20 is extensible for future missions. Initial tests show successful operation in vacuum conditions. A picture of the board is shown in Figure 6.31.

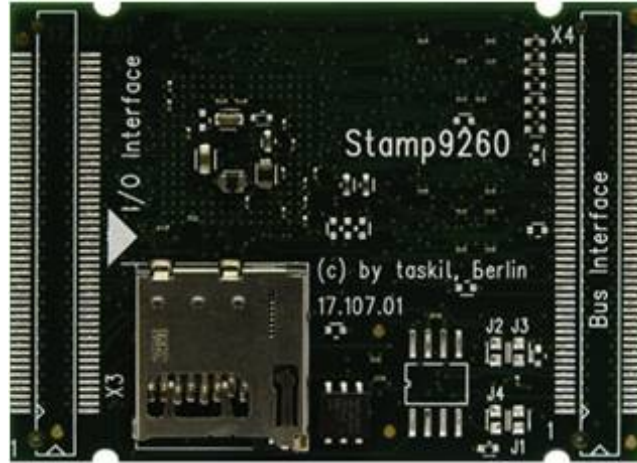

Figure 6.31 M-Cubed main computer board Stamp9260.

A driving factor in the selection of a flight computer was ease of programming and scalability. All software can be written in C/C++ and tested on development work stations before being applied to the embedded flight computer. The flight computer runs a distribution of real-time Linux provided by the manufacturer. This significantly reduces the amount of custom software development for the C&DH team. Independent kernel module drivers were written for both COVE and the OV2655. M-Cubed command scheduling is performed by a custom scheduler with 1 second resolution. Commands transferred from the ground station to the satellite are parsed by a dedicated application, and then sent to the command scheduler. Commands are Linux command line arguments, and are interpreted as such by the system.

6.4.1.7 Electrical power system

The purpose of the electrical power system is to distribute adequate power to all of the subsystems. To accomplish this, M-Cubed uses solar cells to convert solar power into electrical power, secondary batteries to provide energy storage and DC-DC converters that provide constant voltage buses to the CubeSat. The power collected by the solar cells is regulated through the solar input board, where it is dispersed between active buses on the battery board as shown in Figure 6.32. When M-Cubed is in *discharge mode*, the solar cell power is supplemented by the battery power through either a 3.3 V or 8.2 V voltage converter to power other buses. In *charge mode*, the microcontroller opens all switches to remove power from all other subsystems and directs all solar power through the battery charger. The entire satellite is expected to require ~1.2 watts of average power.

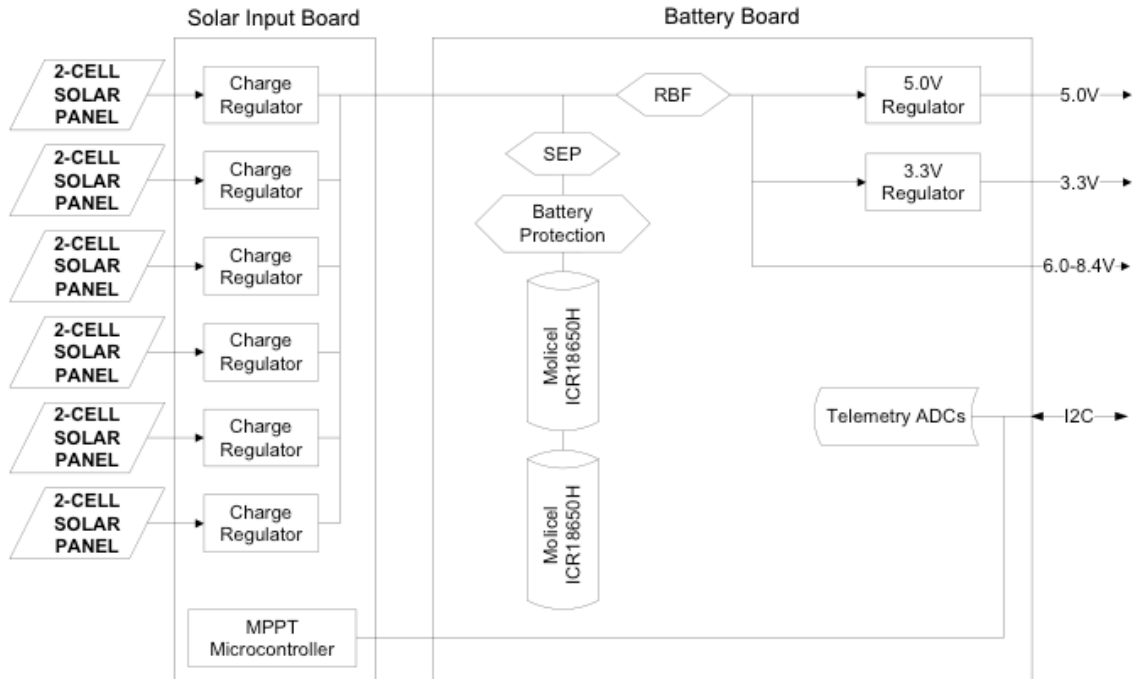

Figure 6.32 M-Cubed power and electrical block diagram.

The electrical power system has to accommodate a variety of power needs. While M-Cubed is in eclipse, all components will be in low-power or standby mode. If the spacecraft is in sunlight and takes a picture, the camera and microcontroller will need full power to operate. After a useable picture is taken, M-Cubed will wait again in low-power mode until it enters the ground station coverage area at which point the transmitter will be switched to full power mode. An effective and versatile power system requiring the use of a rechargeable battery system is necessary to accomplish these tasks. After several board layout design iterations the team has been able to generate a working system prototype (shown in Figure 6.33). It is being used in preliminary activities of integration with the rest of the subsystems.

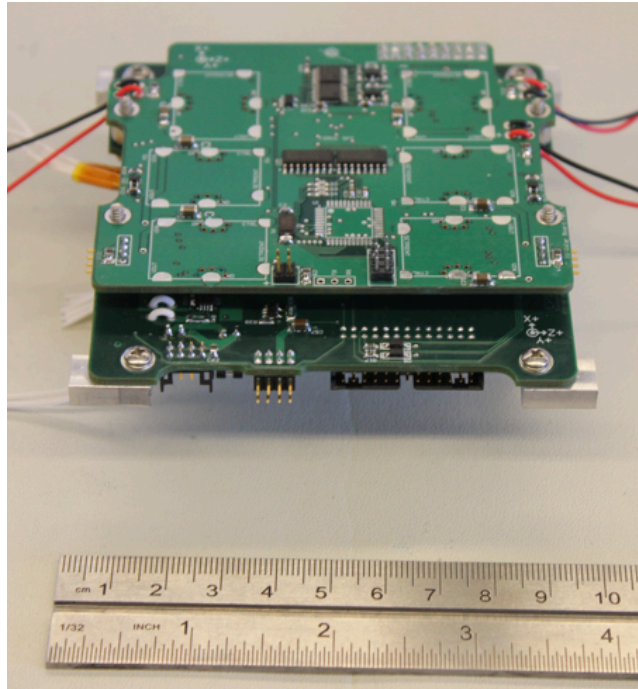

Figure 6.33 M-Cubed power and electrical system prototype.

There are two Emcore BTJM solar cells that cover each side of M-Cubed and send power through the main circuit board to be sent to various components on the satellite in 3.3 V, 5 V and 8.2 V power-buses. Combined they result in 26.6 cm² of solar cell area and they have an efficiency of 28%. On the way to the main circuit board, the power is passed through a charging circuit, where the power is either stored in the batteries during the charging phase or, if necessary, supplemented with power from the batteries.

In addition to solar arrays, M-Cubed receives power from two small Li-ion batteries onboard. The batteries are Molicel 18650 each have a capacity of 5.3 Watt-hours (W-h) and were chosen over a larger battery due to their higher discharge rate and

energy density. The CubeSat requires batteries for the mission because the solar cells alone cannot produce enough power when peak power is needed. The batteries also provide power to subsystems that cannot be turned off while M-Cubed is in eclipse. Although it is anticipated M-Cubed will have a sun-synchronous orbit, there is a small possibility that M-Cubed could have periods of eclipse. The batteries (shown in Figure 6.34) have been the primary design driver of the thermal subsystem due to the small range of temperatures in which the batteries can operate.

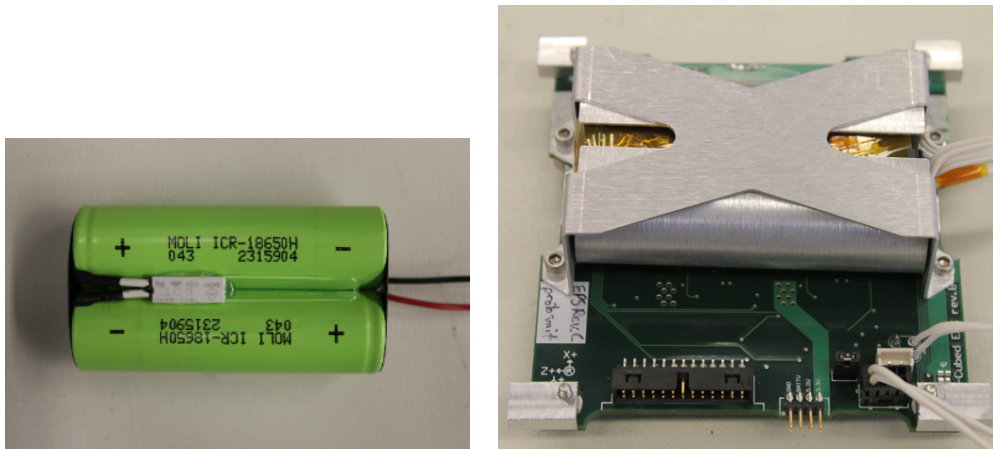

Figure 6.34 M-Cubed batteries (left) and batteries mounted on EPS prototype (right).

6.4.1.8 Communications

The communication system's main objective is to transmit the data from onboard M-Cubed to the ground station. Using a 144 MHz uplink and a 430 MHz downlink, amateur radio bands will be used to control and receive data from the satellite. A basic

beacon signal containing satellite health data will be transmitted intermittently throughout operations. Data and commands will be transmitted using Lithium Astrodev™ radios as shown in the communication block diagram in Figure 6.35.

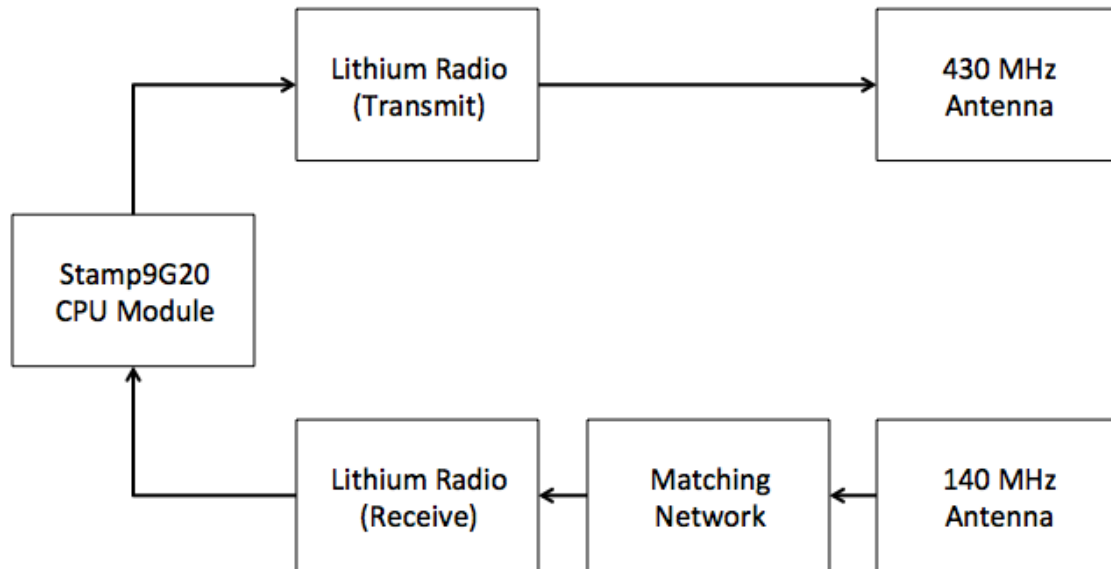

Figure 6.35 M-Cubed communications block diagram.

A dedicated receiver will operate at all times, while the dedicated transmitter will be operated only to send a beacon signal or transmit picture data. Both receiver and transmitter have been used in other CubeSat missions. An example is the Radio Aurora Explorer (RAX) spacecraft, a joint venture between the University of Michigan and SRI International, which had the objective of studying large plasma formations in the ionosphere (RAX, 2010). From the transmitter, the signal will be amplified to 1 W, the calculated necessary transmit power. A 0.16 m. monopole and a 0.40 m. monopole are the respective antennas for uplink and downlink.

A ground station will be able to autonomously receive data from M-Cubed throughout the day, reducing the human oversight required. S3FL members are working closely with the University of Michigan Amateur Radio Club (ARC) on this task. The ARC's facilities (antenna used for downlink operations shown in Figure 6.36) will be utilized for the duration of the mission and include a dedicated ground computer, IC-910H transmitter, a tracking 13.1 dBi circularly polarized Yagi antenna, preamps, and supporting cabling. This equipment is adequate for M-Cubed's purposes and provides future CubeSat missions with facilities resources that can be used as well.



Figure 6.36 Antenna located on the top of the electrical engineering building at UM facilities used for ARC operations.

6.4.1.9 Orbits and controls

The orbits and controls team is in charge of all the orbital and down linking simulation for the mission operations of the spacecraft. This team also has performed on orbit power simulations. The team's objective is to be able to determine the appropriate

material, characteristics and the material's placement within M-Cubed for a passive attitude control system designed to enable the spacecraft to point in a predictable direction.

Since M-Cubed will be launched as a secondary payload, its precise orbital trajectory is dictated by the requirements of the primary mission, the NPP program. Currently NPP is expected to be in a sun-synchronous orbit with a 10:30 a.m. local-time descending node crossing. The orbit details are shown in Table 6.19.

Table 6.19 M-Cubed orbital parameters.

Orbital parameter	Value
Altitude	350 x 810 km
Inclination	102 degrees
Local Time Descending Node	10:30 am
Argument of Periapse	339 degrees

Even before M-Cubed's launch vehicle was confirmed, research had been performed to characterize the attitude control elements for a sun-synchronous orbit. This is mainly because previous CubeSat missions have had a similar type of orbit. A sun-synchronous orbit has a polar orbital plane that remains fixed with respect to the Sun, as shown in Figure 6.37.

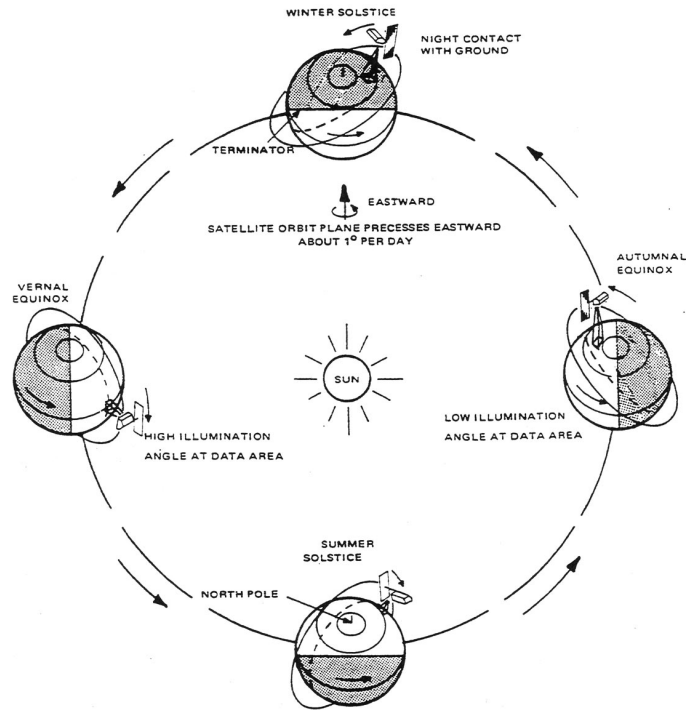

Figure 6.37 Sun-synchronous orbit diagram (NASA Landsat, 2011).

M-Cubed utilizes a passive magnetic attitude control system to achieve a proper orientation for Earth-imaging. The system consists of a single permanent magnet aligned on one CubeSat body axis, along with additional magnetic hysteresis materials aligned on each additional perpendicular body axis, as shown in Figure 6.38. In this configuration, the permanent magnet aligns one body axis of the CubeSat with the local Earth magnetic field direction. Since the magnet still permits CubeSat rotation about this single axis, the hysteresis materials are added to dampen unwanted rotation. Chosen for their high magnetic permeability, the Hymu80 hysteresis materials create internal current as they are rotated through the local magnetic field. This dissipates rotational energy as heat, effectively damping the rotational motion of the CubeSat. If each magnetic component of

the passive attitude system is properly sized, a controlled spin rate can be achieved about the local magnetic field direction.

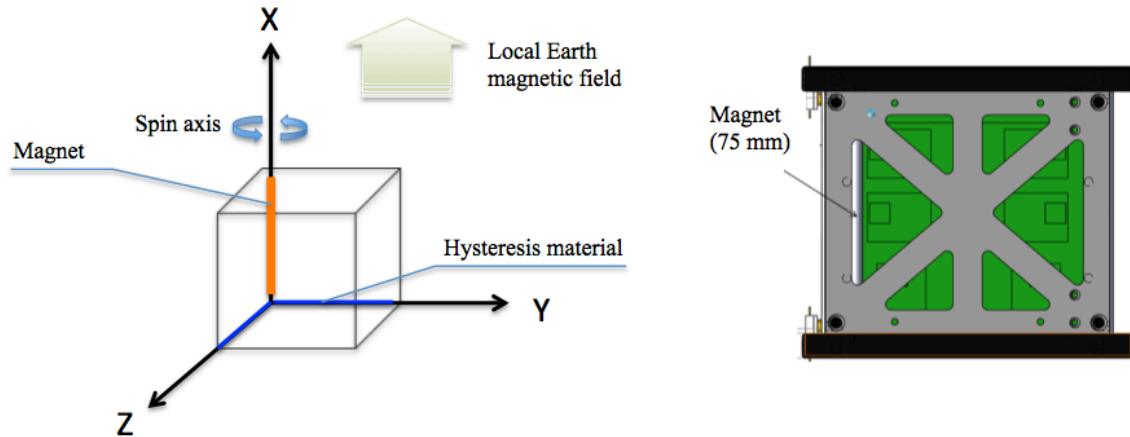

Figure 6.38 Configuration of passive magnetic attitude control system (left) and location of magnet in M-Cubed CAD model (right).

During flight, this passive attitude control system allows for Earth-imaging throughout only a designated portion of the M-Cubed orbit. The camera will continuously point in the nadir direction or straight down towards Earth. Due to Earth's magnetic field configuration, the passive magnetic control system will allow for ground coverage over a significant portion of the Northern Hemisphere. As M-Cubed passes over the North Pole, the permanent magnet and camera will be aligned in the nadir direction, due to the vertical direction of the local Earth magnetic field. As the M-Cubed orbit continues toward the Southern Hemisphere, the camera-nadir angle will increase until the Earth leaves the camera field of view. The Earth will then reenter the camera field of view after M-Cubed crosses the equator into the Northern Hemisphere. On average, this control strategy will allow for approximately 15 picture opportunities of the Northern Hemisphere per day (once per each 90 minute orbit). Although the Northern Hemisphere

will remain in the camera field of view for approximately 40 minutes during each overpass, the window of opportunity will vary depending on ground lighting conditions.

This type of passive control system was chosen for several reasons. When compared with active attitude control systems, such as magnetic torque coils, passive systems of this type require less mass and no power consumption. Furthermore, passive attitude systems offer a robust, simple control strategy that boasts extensive flight heritage in similar Earth-imaging CubeSat missions.

With the use of computer simulation tools such as Satellite Tool Kit (STK), it has been possible to verify orbital calculations to be able to size an adequate attitude control system. Simulations (like the snapshot shown in Figure 6.39) take into account the spacecraft mass, position, relative velocity and orientation. It has been determined that the spacecraft will have an average of 10 to 13 minutes of coverage time per pass over the main Ann Arbor station.

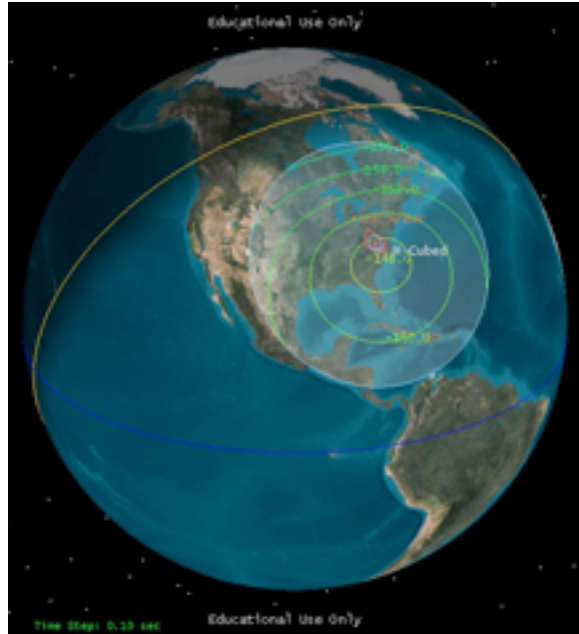

Figure 6.39 STK simulation view of M-Cubed spacecraft approaching Ann Arbor ground station showing the swath coverage.

6.4.1.10 Structures

The structure of the spacecraft has the primary job of creating a suitable bus for all of M-Cubed's components. The structure must hold all of its components safely during launch and in space. It has been designed under Cal Poly's CubeSat specification in order to fit in the PPOD, the interface with the launch vehicle. All physical interfaces between components are relevant to the structure, since any connecting cables within the spacecraft need to be routed efficiently. This can be particularly challenging for CubeSats since there is very little volume available. As for the thermal aspect, all components must always be kept within their survival temperatures to ensure reliability of operations.

The main structure is composed of six rectangular isogrid panels attached to four rails at each corner. The isogrid panels provide rigidity while being lower in mass than a solid panel. This reduction in mass allows for thicker panels that become a better medium through which necessary holes can be drilled. All panels minus one contain similar patterns. That one special panel is slightly modified to provide a circular opening for the camera lens as shown in Figure 6.40. The rails to which these panels are attached will be hollowed out from the bottom face to reduce mass as well as provide a channel through which the power and electrical subsystem can access the spring-loaded plunger necessary to indicate M-Cubed's release from the PPOD.

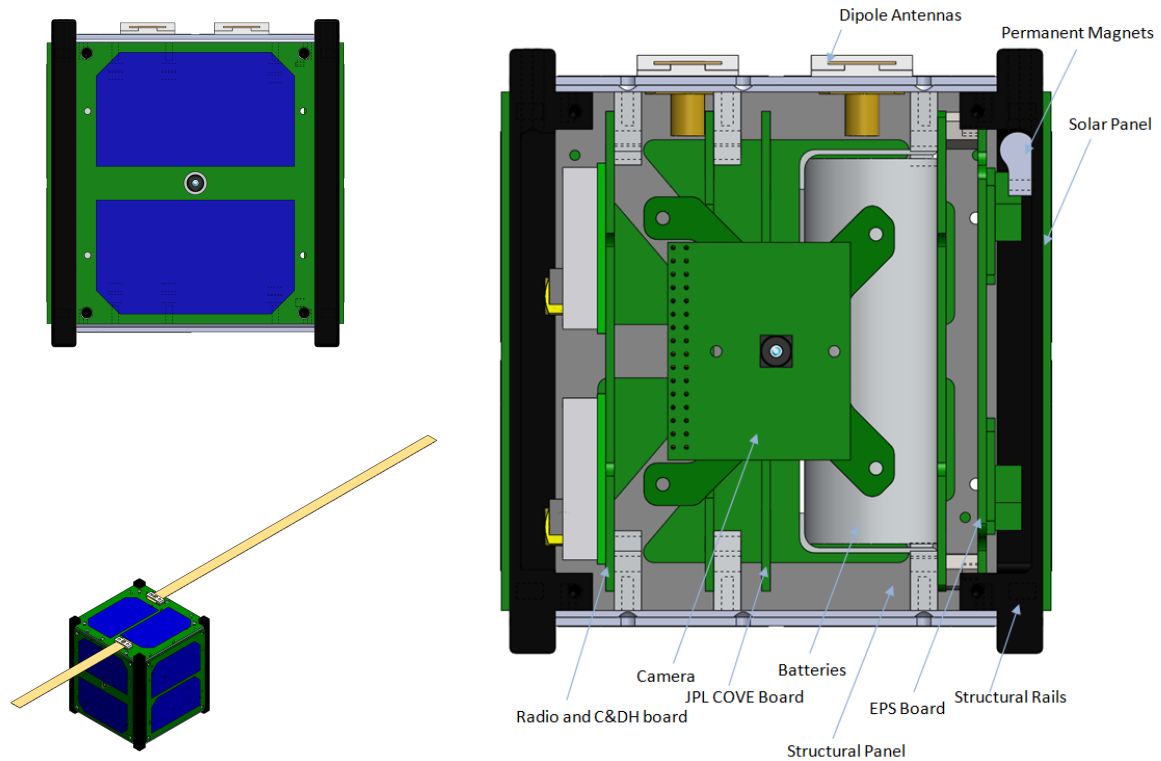

Figure 6.40 M-Cubed CAD model front view (top left), isometric view in deployed configuration (bottom left) and front cross section view showing major elements (right).

To be compatible with the PPOD, the M-Cubed rails must be hard anodized and have a height of 113.5 mm to allow distance between different CubeSats. Another feature required is the incorporation of the Remove Before Flight (RBF) pin. This pin must face the access panels on the side of the PPOD. In order for testing to be performed in the unit, an integration stand was designed, shown in Figure 6.41. It has the capability of attaching to the vibration table that will allow testing and qualification of the flight unit.

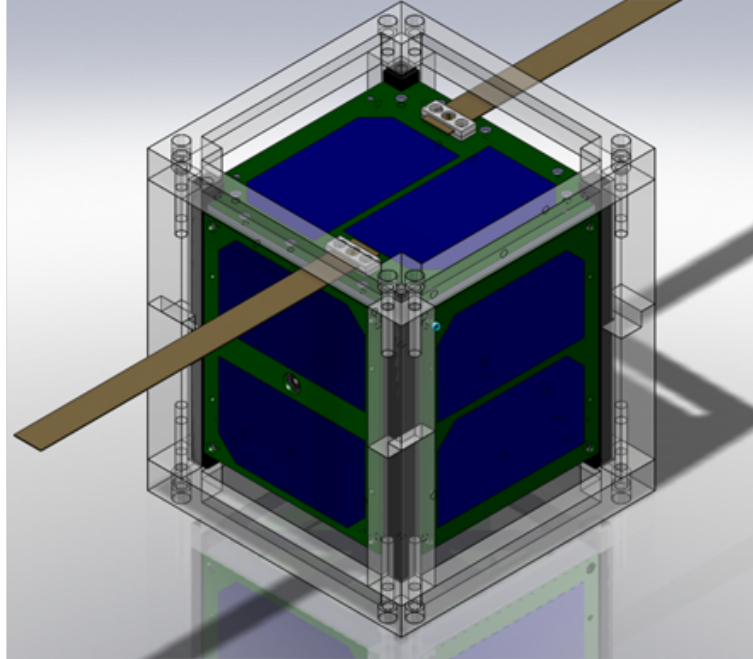

Figure 6.41 CAD model of M-Cubed in the CubeSat integration stand.

6.4.1.11 Thermal control

To provide proper protection from radiation and heat fluxes, a passive thermal protection system consisting of proper insulation is being used. The insulation consists of a layer of *kapton* outside the panels (which will also act as an adhesive for the solar panels) and multi-layer-insulation (MLI) inside the structure. Since solar panels will be covering most of the panels, the layer will be acting as additional insulation. Additional thermal covering will be used around the batteries, which are the most thermally sensitive components. There have been preliminary computational analyses performed on the electronics boards. Findings show a variation of a maximum of half a degree Celsius (as shown in Figure 6.42) between cold and warm elements during standard operations, but

additional thermal analysis is required, as well as testing with the prototypes in the vacuum chamber.

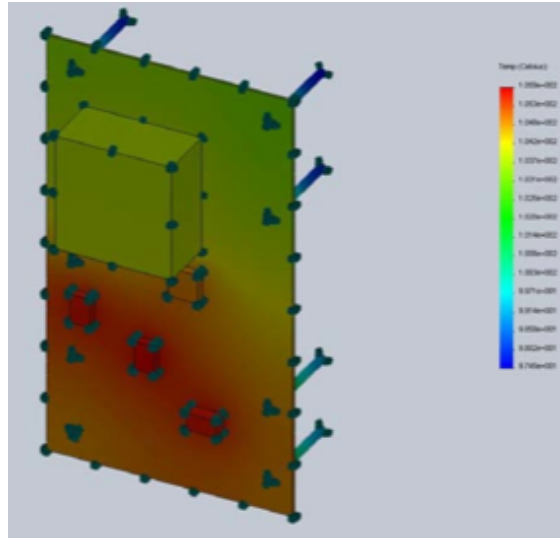

Figure 6.42 Computational thermal analysis on a M-Cubed electronics board rev. 2.0 showing a maximum of 0.5 °C temperature variation between warmest (power regulators, red) and coolest (top edge of board, blue) elements in atmospheric pressure conditions.

6.4.2 Engineering design unit

In order to decrease mission risk due to non-space qualified COTS components, an emphasis has been placed on space qualification through extensive testing. A vacuum facility that achieves a pressure of 1.0 E-06 Torr along with a 2x2x2 meter Helmholtz Cage that can simulate the Earth's magnetic field at different altitudes have been developed recently in the laboratory where M-Cubed is being built. Various functional and survivability tests of critical components have been conducted in the vacuum

chamber, and notable findings have been documented in the thermal vacuum module of SIMS.

Each M-Cubed subsystem has been fully developed as an operational prototype that will be used for integration and testing, as part of an Engineering Design Unit (EDU). A top view and side view are shown in Figure 6.43 and Figure 6.44 respectively.

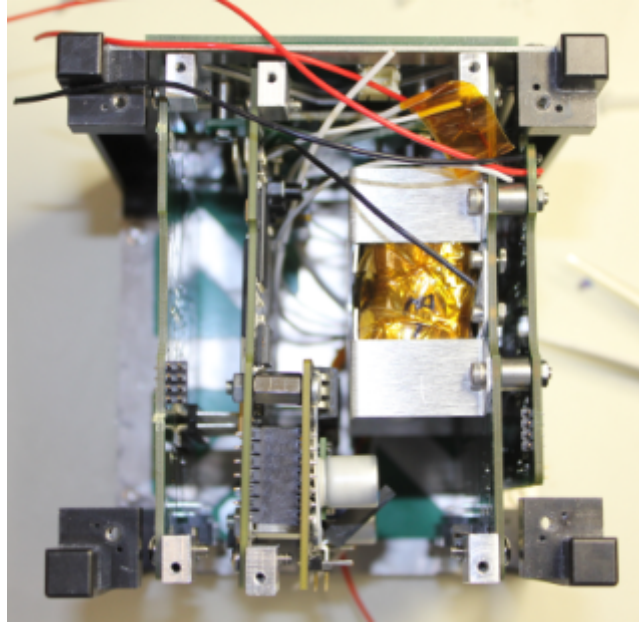

Figure 6.43 M-Cubed engineering design unit top view.

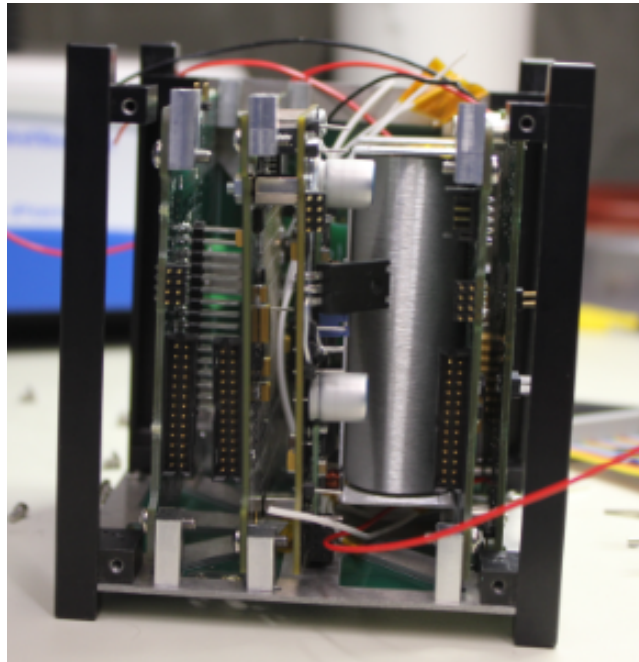

Figure 6.44 M-Cubed engineering design unit side view.

Over the next few months, qualification operations consisting of thermal and vibration testing will be conducted on the EDU.

Chapter 7

Conclusions

A common problem in the early stages of the design of a system often include the lack of consideration of factors that are critical for the first order design that eventually becomes the final system. Spacecraft systems in particular have certain distinctiveness; in space journeying, and pursuit of planetary science space systems often deal with fundamental new problems each time an application is conceived.

To accomplish the next generation of space missions not only single spacecraft will be used, but also organized sets of space systems that pursue a common goal. Cutting edge technologies will be developed and combined, used as part of a broader space exploration initiative. There are already steps taken in this direction, evident in the constellations of satellites to deepen the understanding of Earth, multipurpose observation and detection defense arrays, and other smaller spacecraft through the New Millennium missions program. In all these applications spacecraft systems are submitted to extreme and very severe environments; it is this uniqueness of the conditions in which they operate and the complexity of their tasks that suggest a need to expand our ability to learn how we develop a one-of-a-kind product used for unique applications. This will

invariably lead to an increment in the sophistication of the design process, and tools that help capture adequately the initial design parameters are needed. Requirements are dynamic not only because they are constantly changing, but also because sometimes they are not completely defined. Since we are developing something new and unique that is difficult to test in its final operations setting, understanding the nature of requirements becomes of particular relevance when there is a performance expectation of a system greater than what has been developed before. Increased complexity in the lower level components that eventually assemble a complete system, in addition to the organizational and human elements, may make it difficult for engineers to consider all potential problems initially. Determining their boundaries and interfaces properly as early as possible is justified.

The purpose of the research presented in this thesis is the development of an initial model for systems design that helps identify these boundaries early on. It is focused on being able to capture first order constraints and their relationships, providing insight into what are the design drivers as a design team follows the process. A summary of the findings is shown in the following section.

7.1 Summary of Findings

In this dissertation the development of a design model with application to spacecraft has been investigated. A particular design task aimed to understand details of

the model's relevance and adaptability with a newly formed team. In addition, application of the model in a long-term design of a spacecraft imaging system was investigated, resulting in major design modifications of the entire spacecraft. This research provided insight of the model's relevance, adaptability and scalability.

Qualitative research has shown to be useful for understanding the rationale or theory underlying relationships revealed in the quantitative data, or may directly suggest theory which can then be strengthened by quantitative support (Jick, 1979). Mintzberg (1979) explains that while systematic data creates the foundation for our theories, it is the anecdotal data that enable us to do the theory building. The intent with the quantitative results corresponding to the usage of the ADP model in the particular design task (Chapter 5) are meant to strengthen the theory supporting the ADP model by the findings of the long term design exercise (Chapter 6). In summary, the findings of the research conducted include:

- An initial design model for systems design process with application to small spacecraft is introduced. A comparison with other existing design models is also presented. It is observed that iteration is a critical feature of design models, and that the user's perspective is a distinctive approach in modern design models.
- Results of the increase in the awareness of good design practices while using the ADP model with a novice team in a design task are presented. The model allowed swift design iterations for the teams to be able to discover feasible solutions, showing the model's relevance. It is noticed that agreement in design process concepts enables an efficient work environment, and that

distinct and objective steps in a design process are easier to understand. The adaptability of the model is demonstrated by the new team's ability to rapidly learn and use the ADP, in a fast paced culture of learning where they used a custom build information system to document their work.

- The usage of ADP for finding a feasible architecture for a spacecraft imaging system is explained in detail, showcasing what design drivers were identified by the team while the design matured, with the corresponding hardware development leading to the final spacecraft configuration. This showed ADP's relevance and demonstrated its adaptability, while indicating the model's scalability, since this task was substantially different in complexity and development time.

7.2 Recommendations for Future Work

The research presented in this thesis helps illuminate a sustainable path for the preliminary design of systems. The impact of the atomic design process model is in providing a basic framework to expand the manageability of complexity in the design of the systems. The intent is that even inexperienced designers can build systems with confidence in their performance, considering all the existing constraints (cost, schedule, etc.), and to manufacture systems with potential benefits including applicability to other

complex engineering systems in areas like energy production and distribution, transportation, and more.

Recommendations specifically in regards to the design model include:

- Further in-depth analysis of elements of good design that are promoted by using ADP. It may be of interest to understand with other design teams and different design tasks which specific elements of good design are promoted. There may also be value in researching the implications of using the ADP model with an established team of experts.
- Verification of the model in non-engineering problems. The nature of the model suggests that it is flexible enough to help in finding feasible solutions in problems that are not engineering oriented (i.e., social sciences, economics, etc.).
- Verification of model in implementations beyond design. Verifying the design process implemented by using the ADP model in other system's development stages may be relevant to characterize further its relevance. For example, in the stage of an integrated system's testing activities. After a system has been designed and built, there may be applicability of the ADP when there are certain needs that are expected to be met on a given test setup.

The author perceives as important to continue enabling the creation of tools and environments that promote robust planning for organizations, information flow and products at the early phase of design. These tools should build on reliable engineering philosophies and practices, as part of a serious attempt to vigorously contribute to the

new course into the cosmos that NASA (and recently the aerospace private sector) are in the process of charting, in a journey that will take humans back to the Moon and eventually to Mars and beyond.

Appendices

Appendix A

SIMS Code

The computer code created for the S3FL Information Management System (SIMS) described in Chapter 4 and utilized in Chapters 5 and 6, is presented here. The SIMS software architecture consists of a dedicated server that hosts an open source relational database, MySQL® version 5.5, that is accessed through the Internet by using an open-source HTTP server, Apache®. SIMS is currently installed on an Apple Power Mac G4 computer with an 867 MHz PowerPC processor with 1.12 GB SDRAM. The server has a Mac OS X Panther (version 10.3.9) operating system. SIMS processing programs are a collection of custom-built PHP Version 5 based scripts. Since the system was implemented, active users have helped point out software bugs to help improve the system over time. A summary of the usage of SIMS to date is shown in Table A.1.

Table A.1 SIMS summary of system usage to date.

SIMS action	Total
Announcements for users posted on the system	101
Certifications and recognitions assigned to users	316

Technical design reviews documented	59
Assignations of users to a team, category and UM course	3,773
Outreach events documented	26
Technical reports submitted	8,342
Users that have registered and used the system	528

Section A.1 explains the setup of the SIMS database. Section A.2 contains the main PHP scripts that were built to implement the system’s functionality.

A.1 SIMS Database

The relational database used in SIMS has a collection of 23 tables. The database data dictionary (the catalog of organization and content of the database) is summarized through the definition of types (shown in Table A.2 derived from MySQL Reference (2010)) and the tables constructed (shown in Table A.3 through Table A.7). The data dictionary presented here contains all the pieces necessary to replicate the SIMS database.

Table A.2 SIMS database definition of types.

Type	Description
int(X)	Denotes a field that is a 4-byte integer, where X indicates the maximum display width. The unsigned range is 0 to 4294967295.

varchar(Y)	A variable length string, where Y represents the maximum column length in characters. In MySQL 5, the range of Y is 0 to 255.
text	A text field with a maximum length of 65,535 characters.
date	A field corresponding to a date. The supported range is '1000-01-01' to '9999-12-31'.
longtext	A text field with a maximum length of 4,294,967,295 characters.
mediumint(Z)	A medium-sized integer, where Z indicates the maximum display width. The unsigned range is 0 to 16777215.

Note that in all the tables shown next the *id* field is the table key.

Table A.3 SIMS database tables definitions for (a) announcements, (b) attendance, (c) categories of users, (d) certifications, (e) types of certifications and (f) comments.

(a)

announcements	
Field	Type
id	int(11)
studentid	int(11)
stamp	int(11)
title	varchar(80)
eventtypeid	int(11)
datefrom	int(11)
dateto	int(11)
location	varchar(50)
comments	text
term	varchar(20)

(b)

attendance	
Field	Type
id	int(11)
eventtypeid	int(11)
status	varchar(50)
location	varchar(50)
date	date
verifiedby	varchar(80)
comments	varchar(250)
studentid	int(11)

(c)

categories	
Field	Type
id	int(11)
name	varchar(40)

(d)

certifications	
Field	Type
id	int(11)
certificationtypeid	int(11)
date	date
status	varchar(35)
location	varchar(35)
verifiedby	varchar(15)
comments	varchar(250)
studentid	int(11)

(e)

certificationtypes	
Field	Type
id	int(11)
name	varchar(50)

(f)

comments	
Field	Type
id	int(11)
date	date
body	longtext
madeby	varchar(50)
madebyreal	int(11)
studentid	int(11)

Table A.4 SIMS database tables definitions for (a) system configuration, (b) courses, (c) events, (d) types of events, (e) history of users and (f) industry contacts.

(a)

configuration	
Field	Type
id	int(11)
termstart	int(11)
currentterm	varchar(20)

(b)

courses	
Field	Type
id	int(11)
name	varchar(40)

(c)

events	
Field	Type
id	int(11)
eventtypeid	int(11)
status	varchar(50)
location	varchar(50)
date	date
verifiedby	varchar(80)
comments	varchar(250)
studentid	int(11)

(d)

eventtypes	
Field	Type
id	int(11)
name	varchar(80)

(e)

history	
Field	Type
id	mediumint(9)
stamp	int(11)
studentid	mediumint(9)
notes	varchar(250)
categoryid	int(11)
courseid	int(11)
statusid	int(11)
projectid	int(11)
credits	int(11)
term	varchar(20)
grade	varchar(5)
madebyreal	int(11)

(f)

industry	
Field	Type
id	int(11)
stamp	int(11)
date	date
companyname	varchar(120)
address	varchar(250)
phone	varchar(20)
email	varchar(120)
website	varchar(180)
studentid	int(11)
description	longtext
smallinteraction	varchar(120)
interaction	longtext

Table A.5 SIMS database tables definitions for (a) history of industry contacts, (b) inventory, (c) history of inventory, (d) outreach, (e) types of outreach and (f) projects.

(a)

industryhistory	
Field	Type
id	int(11)
industryid	int(11)
stamp	int(11)
date	date
companyname	varchar(120)
address	varchar(250)
phone	varchar(20)
email	varchar(120)
website	varchar(180)
studentid	int(11)
description	longtext
smallinteraction	varchar(120)
interaction	longtext

(b)

inventory	
Field	Type
id	int(11)
stamp	int(11)
date	date
item	varchar(120)
location	varchar(250)
locationext	varchar(20)
quantity	int(11)
status	varchar(20)
studentid	int(11)
description	longtext

(c)

inventoryhistory	
Field	Type
id	int(11)
inventoryid	int(11)
stamp	int(11)
date	date
item	varchar(120)
location	varchar(250)
locationext	varchar(20)
quantity	int(11)
status	varchar(20)
studentid	int(11)
description	longtext
madebyreal	int(11)

(d)

outreach	
Field	Type
id	int(11)
outreachtypeid	int(11)
status	varchar(50)
location	varchar(50)
date	date
verifiedby	varchar(20)
comments	varchar(250)
studentid	int(11)

(e)

outreachtypes	
Field	Type
id	int(11)
name	varchar(55)

(f)

projects	
Field	Type
id	int(11)
name	varchar(40)
description	varchar(250)
email	varchar(80)
status	varchar(10)
term	varchar(20)

Table A.6 SIMS database tables definitions for (a) technical reports, (b) user status and (c) thermal vacuum test.

(a)

reports	
Field	Type
Id	int(11)
Studentid	int(11)
Stamp	int(11)
datefrom	date
dateto	date
hours	double
report	longtext
ontime	varchar(10)
term	varchar(20)

(b)

status	
Field	Type
id	int(11)
name	varchar(30)

(c)

thermalvac	
Field	Type
id	int(11)
stamp	int(11)
date	date
item	varchar(120)
projectid	int(11)
notes	longtext
studentid	int(11)
stdate	date
ststudentid	int(11)
stunits	varchar(20)
stprec	varchar(12)
stpostc	varchar(12)
stprem	varchar(12)
stpostm	varchar(12)
stoutgassing	varchar(12)
sttimein	varchar(12)
stlowestp	varchar(12)
stresult	varchar(20)
stcomments	longtext
tdate	date
ttstudentid	int(11)
ttunits	varchar(20)
ttprec	varchar(12)
ttpostc	varchar(12)
ttprem	varchar(12)
ttpostm	varchar(12)
ttoutgassing	varchar(12)
tttimein	varchar(12)
ttlowestp	varchar(12)
tthighestt	varchar(12)
ttlowestt	varchar(12)
ttresult	varchar(20)
ttcomments	longtext
tdate	date
tbstudentid	int(11)
tbprem	varchar(12)
tbpostm	varchar(12)
tboutgassing	varchar(12)

tblowestp	varchar(12)
tbhighestt	varchar(12)
tbresults	varchar(20)
tbcomments	longtext

Table A.7 SIMS database tables definition for (a) thermal vacuum testing history and (b) system users.

(a)		(b)	
thermalvachistory		users	
Field	Type	Field	Type
id	int(11)	id	mediumint(9)
thermalvacid	int(11)	username	varchar(60)
stamp	int(11)	password	varchar(60)
date	date	first	varchar(40)
item	varchar(120)	middle	varchar(30)
projectid	int(11)	last	varchar(80)
notes	longtext	startdate	date
studentid	int(11)	gender	varchar(6)
stdate	date	citizenship	varchar(20)
ststudentid	int(11)	country	varchar(20)
stunits	varchar(20)	ethnicity	varchar(20)
stprec	varchar(12)	year	varchar(20)
stpostc	varchar(12)	major	varchar(20)
stpremi	varchar(12)	cellphone	varchar(20)
stpostmi	varchar(12)	otherumgroups	varchar(250)
stoutgassing	varchar(12)	notes	varchar(250)
sttimein	varchar(12)	categoryid	int(11)
stlowestp	varchar(12)	courseid	int(11)
stresult	varchar(20)	statusid	int(11)
stcomments	longtext	projectid	int(11)
ttdate	date	credits	int(11)
ttstudentid	int(11)	grade	varchar(5)
ttunits	varchar(20)		
ttprec	varchar(12)		
ttpostc	varchar(12)		
ttpremi	varchar(12)		
ttpostmi	varchar(12)		
ttoutgassing	varchar(12)		
tttimein	varchar(12)		

ttlowestp	varchar(12)
tthighestt	varchar(12)
ttlowestt	varchar(12)
ttresult	varchar(20)
ttcomments	longtext
tbdate	date
tbstudentid	int(11)
tbprem	varchar(12)
tbpostm	varchar(12)
tboutgassing	varchar(12)
tblowestp	varchar(12)
tbhighestt	varchar(12)
tbresults	varchar(20)
tbcomments	longtext

A.2 SIMS PHP scripts

There are 86 scripts and library files that interact with the SIMS database that together form the entire framework of operations for the system. For practical reasons, only the ten essential scripts that provide the system's mainstay are presented here. In all the scripts there are embedded comments placed by the author to help understand their functionality. They are marked with // at the beginning of a line.

Users log into SIMS via the *login.php* script shown next. The script verifies that the user is registered in the system and allows for one-hour usage before it requests the username and password again.

```

<?php
// Connects to Database
require_once('connection.php');
mysql_select_db("mydb") or die(mysql_error());

//Checks if there is a login cookie
if(isset($_COOKIE['ID_my_site']))

//if there is, it logs you in and directes you to the members page
    {
        //echo "There is a cookie!";
        $username = $_COOKIE['ID_my_site'];
        $pass = $_COOKIE['Key_my_site'];
        $check = mysql_query("SELECT * FROM users WHERE username =
'$username'") or die(mysql_error());

        while($info = mysql_fetch_array( $check ))
            {
                if ($pass != $info['password'])
                    {
                    }
                else
                    {header("Location: members.php");
                    }
            }
    }
else
    {
        //echo "<br>No cookie found!";
    }

//if the login form is submitted
if (isset($_POST['submit']))
    {
        //form has been submitted
        //echo "<br>Form has been submitted.";
        // makes sure they filled it in
        if(!$_POST['username'] | !$_POST['pass'])
            {die('You did not fill in a required field.');
```

```

//gives error if the password is wrong
if ($_POST['pass'] != $info['password'])
    {die('Incorrect password, please try again.')}
}

else
    {
//echo "<br>User authentic!";
// if login is ok then we add a cookie
$_POST['username'] =
stripslashes($_POST['username']);
// Time it takes for cookie to expire: 3600 s is 1
hr.

$hour = time() + 3600;
setcookie("ID_my_site", $_POST['username'], $hour);
setcookie("Key_my_site", $_POST['pass'], $hour);

//then redirect them to the members area
header("Location: members.php");
}
} // while
}

else
{
// if they are not logged in
?>

<style type="text/css">body {font: smaller Verdana}</style>

<form action="<?php echo $_SERVER['PHP_SELF']?>" method="post">
<b>S3FL Information Management System [S.I.M.S.] 2.1</b>
<table border="0">
<tr><td colspan=2></td></tr>
<tr><td>Uniquename:</td><td>
<input type="text" name="username" maxlength="40">
</td></tr>
<tr><td>SIMS Password:</td><td>
<input type="password" name="pass" maxlength="50">
</td></tr>
<tr><td colspan="2" align="right">
<input type="submit" name="submit" value="Login">
</td></tr>
<tr>
<td></td>
</tr>
</table>
Please use lastest version of Internet Explorer, Netscape or
Safari.<br>
Forgot password? Request it at: <a href="mailto:s3fl-
sims@umich.edu?subject=SIMS Password Request">s3fl-
sims@umich.edu</a><br><br>
<b>Recruiters Welcome!</b> Request your username and password at
<a href="mailto:s3fl-info@umich.edu?subject=SIMS Recruiter user
request">s3fl-info@umich.edu</a>
</form>
<?php
}

```

?>

Connectivity to the database is performed through the *connection.php* script. Practically all of the scripts in the system make reference to this script, since it contains information regarding the specific name, user and password of the database management system.

```
<?php
# FileName="connection.php"
# Type="MYSQL"
# HTTP="true"
$hostname_database = "localhost";
$database_database = "mydb"; //database name
$username_database = "username"; // username to the database
$password_database = "*****"; // password associated with that
username
$database = @mysql_connect($hostname_database, $username_database,
$password_database)
    or die("Fatal Error: ".mysql_error());

mysql_select_db($database_database, $database);
$formMethod = "POST"; // this establishes the method value that is used
in all forms

function safe_query ($query = "") {
    global $database_database;
    global $database;
    global $debugMethod;

    if (empty($query)) { return FALSE; }
    mysql_select_db($database_database, $database);
    $result = mysql_query($query) or die("Query failed: <li>errorNo:
".mysql_errno()."<li>error: ".
    mysql_error()."<li>query: ".$query."<br>"); return $result;
}

function get_current_term ()
{
    return "Winter 2011"; // Denotes the current term for SIMS.
}

function get_term_start ()
{
    return "1294092000"; // Sets the start of the term to 1.3.11 1700
hrs
```

```

}

function get_viewer_category ($the = "")
{
    global $hostname_database;
    global $database_database;
    global $username_database;
    global $password_database;
    global $database;
    global $debugMethod;

    if (empty($the)) { return FALSE; }

    mysql_connect($hostname_database, $username_database,
    $password_database) or die(mysql_error());
    mysql_select_db($database_database) or die(mysql_error());

    $resultcategoryid = mysql_query("SELECT * FROM users WHERE
    users.id='$the'") or die(mysql_error());
    $array = mysql_fetch_array( $resultcategoryid );
    $localcategoryid = $array["categoryid"];

    $resultcategoryname = mysql_query("SELECT * FROM categories WHERE
    categories.id='$localcategoryid'") or die(mysql_error());
    $array = mysql_fetch_array( $resultcategoryname );
    $theviewercategory= $array["name"];

    return $theviewercategory;
}
?>

```

The file that displays the user's information depending on what category of user they are is the *members.php* script shown next.

```

<?php
// File members.php

require_once('connection.php');
require_once('DatabaseSearch.php');

// Connects to Database
//mysql_connect("localhost", $username,$password) or
die(mysql_error());
mysql_select_db("mydb") or die(mysql_error());

//checks cookies to make sure they are logged in
if(isset($_COOKIE['ID_my_site']))
{
    $username = $_COOKIE['ID_my_site'];
    $pass = $_COOKIE['Key_my_site'];
}

```

```

        $check = mysql_query("SELECT * FROM users WHERE username =
'$username'") or die(mysql_error());
        while($info = mysql_fetch_array( $check ))
        {
            //if the cookie has the wrong password, they are taken to
the login page
            if ($pass != $info['password'])
                { header("Location: login.php");
                }

            //otherwise they are shown the members area
            else
                {
                    echo "<style type=\"text/css\">body {font: smaller
Verdana}</style>";
                    echo "<b>Welcome ".$username."! </b> << <a
href=logout.php>Logout</a><br><br>";

                    // Announcements
                    $stampnow = strtotime('now');

                    //echo "now is: $stampnow<br>";

                    $theviewerid = $info["id"];
                    $theviewercategory =
get_viewer_category($theviewerid);

                    printf("<font face=\"Verdana\" size=\"1\">");
                    printf("<table border=\"0\">");

                    $anns = mysql_query("SELECT * FROM announcements
ORDER BY datefrom ASC"); // WHERE datefrom =>'$stampnow'
                    while ($row = mysql_fetch_array($anns))
                        {
                            // making sure its a future event (event
stays on member page for 2 hrs after datefrom)

                            if (($row["datefrom"] + 7200) >
$stampnow)

                                {
                                    printf("<tr>");

                                    printf("<td><font face=\"Verdana\"
size=\"1\">%s</td> ",date("D j M Y H:i",$row["datefrom"]));
                                    printf("<td><font face=\"Verdana\"
size=\"1\"><b>%s</b></td> ",$row["title"]);

                                    // getting event here
                                    $temp = $row["eventtypeid"];
                                    $localevent = mysql_query("SELECT name
FROM eventtypes WHERE eventtypes.id ='$temp'");
                                    while ($rowin =
mysql_fetch_array($localevent))
                                        {printf("<td><font
face=\"Verdana\" size=\"1\">%s</td>",$rowin["name"]);
                                        }
                                }
                        }

```

```

                                printf("<td><font face=\"Verdana\"
size=\"1\"><b>%s</b></td> ",$row["location"]);
                                printf("<td><font face=\"Verdana\"
size=\"1\">%s</td> ",$row["comments"]);

                                $temp = $row["studentid"];
                                $resultusername = mysql_query("SELECT *
FROM users WHERE users.id='$temp'") or die(mysql_error());
                                $array = mysql_fetch_array(
$resultusername );
                                $who_posted = $array["username"];
                                printf("<td><font face=\"Verdana\"
size=\"1\">- %s</td> ",$who_posted);

                                // $theviewerid = $info["id");//echo
                                $theviewerid";
                                // $theviewercategory =
                                get_viewer_category($theviewerid);
                                $localid = $row["id"];

                                if (($theviewercategory == 'Excom') or
                                ($theviewercategory == 'Administrator') or ($theviewercategory == 'Team
                                Lead'))
                                { echo "<td><font face=\"Verdana\"
                                size=\"1\"> < <a
                                href=edit_announcement.php?theid=".$localid."&theusr=".$theviewerid.">E
                                dit</a></td> ";
                                }

                                if (($theviewercategory == 'Excom') or
                                ($theviewercategory == 'Administrator'))
                                { echo "<td><font face=\"Verdana\"
                                size=\"1\"> < <a
                                href=delete_announcement.php?theid=".$localid."&theusr=".$theviewerid."
                                >Delete</a></td> ";
                                }

                                printf("</tr>");
                                }

                                printf("</table></font>");

                                echo "<br><img src='usrpics/$username.jpg'><br>";

                                // SIMS Messages section (possible messages shown
                                below).
                                //echo "<br><font color=red>*** SIMS MSG: GOING
                                OFFLINE IN 5 MIN FOR MAINTENANCE Please log out to avoid loosing
                                information on your file **** </font><br><br>";
                                //echo "<br>*** SIMS MSG: If your profile is missing
                                your picture, please send a picture with the name uniquename.jpg to
                                your Excom advisor **** </font><br><br>";
                                echo " <br><font color=green> SIMS MSG: SIMS will be
                                underdoing testing of S3FL's Inventory module over the next few weeks.

```

Please do not interact with any of the Inventory links in your homepage unless requested directly by an Excom Advisor. Thank you!

";

```
        if ($info["statusid"] == "1")    // Interview Stage
            {echo "<br>*** SIMS MSG: Welcome to SIMS!";}

<br><br>

        You will be contacted by S3FL Management within
two days to setup an interview.<br>
        If you do not hear from S3FL in 3 days please
send an email
            to: <a href=\"mailto:s3fl-
sims@umich.edu?subject=SIMS Interview Request\">s3fl-
sims@umich.edu</a><br><br>";
    }

    if ($info["statusid"] == "3")    // Dropped
        {echo "<br><font color=red>*** SIMS MSG: You
have dropped S3FL activities. If you think this is a mistake please
send an email to: <a href=\"mailto:s3fl-sims@umich.edu?subject=SIMS
Interview Request\">s3fl-sims@umich.edu</a> **** </font><br><br>";}

    }

    if ($info["statusid"] == "4")    // Former
        {echo "<br><font color=red>*** SIMS MSG: Your
current status is \"Former\" S3FL member. If you think this is a
mistake please send an email to: <a href=\"mailto:s3fl-
sims@umich.edu?subject=SIMS Interview Request\">s3fl-sims@umich.edu</a>
**** </font><br><br>";}

    }

    if ($info["statusid"] == "5")    // Temporarily
Inactive
        {echo "<br><font color=red>*** SIMS MSG: Your
current status is \"Temporarily Inactive\" S3FL member. If you think
this is a mistake please send an email to: <a href=\"mailto:s3fl-
sims@umich.edu?subject=SIMS Interview Request\">s3fl-sims@umich.edu</a>
**** </font><br><br>";}

    }

    $localid = $info["id"];
    $localteam = $info["projectid"];
    $localcredits = "0";

    //printf("id: %s", $info["id"]); echo "<br>";
    //printf("Uniquename: %s", $info["username"]); echo
"<br>";
    printf("Name: <b>%s %s
%s</b>", $info["first"], $info["middle"], $info["last"]); echo "<br>";

    // If Recruiter or Guest
```

```

        if (($info["categoryid"] == "7") or
($info["categoryid"] == "9"))
            { // stuff only for recruiters
                if ($info["categoryid"] == "7")
                    {echo "<br>This site provides information
about S3FL members to recruiters.<br><br>";
                    echo " << <a
href=output_mvs.php?theid=2&theusr=".$localid.">View All Active Members
With Engineering Recognitions</a> (List format)<br>";
                    echo "<br>";
                    }
                }

            echo "<br> << <a
href=output_all_byproject_public.php?theid=2&theusr=".$localid.">View
All Active Members By Project</a> (Public List format)<br>";

                // *****
                // Inventory Module access
                // *****

            echo "<br> << <a
href=output_all_inventory_public.php?theid=2&theusr=".$localid.">Lab
Inventory</a> <br>";

                // *****
                // ThermalVac Module access
                // *****

            echo "<br> << <a
href=output_all_thermalvac_public.php?theid=2&theusr=".$localid.">Therm
alVac</a> <br>";

            echo "<br><br><hr>";

            echo "Please visit our website for more
information about the projects: <a
href=\"http://aoss.engin.umich.edu/s3fl\"
target=\"_blank\">http://aoss.engin.umich.edu/s3fl</a> <br><br>";

            echo "If you require further information from
any student in S3FL please email: <a href=\"mailto:s3fl-
excom@umich.edu?subject=SIMS Recruiter Request for Info\">s3fl-
excom@umich.edu</a><br><br>";
            echo "Please email any suggestions about SIMS
to: <a href=\"mailto:s3fl-sims@umich.edu?subject=SIMS Recruiter
Comment\">s3fl-sims@umich.edu</a>";

        }

        if ((($theviewercategory != 'Recruiter') and
($theviewercategory != 'Guest') and ($info["statusid"] == "2")) or
($info["categoryid"] == "6"))

            // else
            // It is not recruiter or guest
            {

```

```

        printf("Start Date: %s. Gender:
%s.", $info["startdate"], $info["gender"]);
        echo "Year: <a
href=edit_year.php?theid=". $localid. "&theusr=". $theviewerid. ">". $info["
year"]. ".</a> ";

        printf("Major: %s. Cell:
%s.", $info["major"], $info["cellphone"]); echo "<br>";
        printf("Other UM Groups: %s. Notes:
%s.", $info["otherumgroups"], $info["notes"]); echo "<br><br>";

        //Getting Member Category
        $temp = $info["categoryid"];
        $category = mysql_query("SELECT name FROM categories
WHERE categories.id ='$temp'");
        while ($row = mysql_fetch_array($category))
        {printf("Category: <font
color=\"blue\">%s</font> <a href=\"help/info.html\" target=\"_blank\"
><b>?</b></a>", $row["name"]);
        }

        // If user is a lead, then present the option to
manage that team via the link
        if ($info["categoryid"] == "2") // Team Lead
        {echo " << <a
href=output_team.php?theid=". $localteam. "&theusr=". $localid. ">Manage
Team</a>";
        echo " << <a
href=sendannouncement.php?theusr=". $localid. ">Post Upcoming Event</a>";
        }
        else
        {
        if ($info["categoryid"] == "6") // Only for
Administrator
        {echo "<hr>";
        echo "Links<br>";
        echo "< <a
href=create_password.php>Create a random password</a>";
        echo "<hr>";
        }

        // Faculty or Excom or Administrator
        if (($info["categoryid"] == "3") or
($info["categoryid"] == "4") or ($info["categoryid"] == "6"))
        {echo "<br><br>";

        echo " << <a
href=sendannouncement.php?theusr=". $localid. ">Post Upcoming
Event</a><br>";

        echo "<br>";

        echo " << View Active Members";
        echo " < <a
href=output_all_byproject.php?theid=2&theusr=". $localid. ">By
Project</a>";

```

```

        echo " < <a
href=output_all_bycourse.php?theid=2&theusr=".$localid.">By
Course</a>";

        echo " < <a
href=output_all_underhrs.php?theid=2&theusr=".$localid.">Under
Hrs</a>";

        echo " < <a
href=output_mvs.php?theid=2&theusr=".$localid.">With Engineering
Recognitions</a><br>";

        echo "<br>";

        //echo " << <a
href=output_all.php?theid=2&theusr=".$localid.">View All Active
Members</a> (Detailed profile format, large file)";
        //echo "<br><br>";

        echo " << View Members By Status ";
        echo " < <a
href=output_all_byproject.php?theid=1&theusr=".$localid.">Interviewees<
/a>";

        echo " < <a
href=output_all_aslist.php?theid=2&theusr=".$localid.">Active</a>";
        echo " < <a
href=output_all_aslist.php?theid=3&theusr=".$localid.">Dropped</a>";
        echo " < <a
href=output_all_aslist.php?theid=4&theusr=".$localid.">Former</a>";
        echo " < <a
href=output_all_aslist.php?theid=5&theusr=".$localid.">Temporarily
Inactive</a><br><br>";

        if ($info["categoryid"] == "4") //
Only for Faculty
                {echo "<br><br><font color=red>***
SIMS MSG FOR FACULTY: Please verify that All Active Members Course
Information matches UofM Wolverineaccess official listings. Please
email discrepancies to: <a href=\"mailto:s3fl-
sims@umich.edu?subject=SIMS Faculty Request Course Update\">s3fl-
sims@umich.edu</a> **** </font>";

                }

        if ($info["categoryid"] == "3") //
Only for Excom
                {//echo " << <a
href=output_all_underhrs.php?theid=2>View Only Active Members Under
Hrs</a>";

                }

        // Retrieving all Teams
        echo "<br>";
        echo "<br>S3FL Teams (showing Active
Teams/members)";

        echo "<br>=====<br>";

```

```

                                $teams = mysql_query("SELECT * FROM
projects WHERE status='active' ORDER BY name ASC")or
die(mysql_error());

                                while($info2 = mysql_fetch_array( $teams
))

                                {$minteam = $info2["id"];
                                printf("> <b><a
href=output_team.php?theid=".$minteam."&theusr=".$localid.">%s</a></b>
%s", $info2["name"], $info2["email"]);echo "<br>";

                                $temp = $info2["id"];
                                $certstype =
mysql_query("SELECT id,username,first,last,categoryid FROM users WHERE
projectid ='$temp' AND statusid ='2' ORDER BY username ASC")or
die(mysql_error());

                                while($row =
mysql_fetch_array($certstype))

                                {$miniid=$row["id"];

                                if
                                ($row["categoryid"] == "2") // Team Lead printed, adding (L)
                                {echo " (L)
";

                                }

                                if
                                ($row["categoryid"] == "5") // Asst Lead printed, adding (AL)
                                {echo "
(AL) ";

                                }

                                if
                                ($row["categoryid"] == "8") // Chief Engineer (CE)
                                {echo "
(CE) ";

                                }

                                printf("<a
href=output_single.php?theid=".$miniid."&theusr=".$localid.">%s, %s
%s</a> | ", $row["username"], $row["first"], $row["last"]);

                                }

                                //printf("Date obtained: %s
Comments: %s", $info2["date"], $info2["comments"]);
                                echo "<br>";echo "<br>";
                                }

                                echo "<br>";
                                echo "<hr>";
                                } // end of Faculty or Excom or
Administrator

                                } // end of else

                                echo "<br>";

```

```

        if ($info["categoryid"] == "4") // faculty
            {
            //Additional Information for Faculty here That is
shown at the bottom!!!
            //echo "<br><font color=red>*** NOTE: SIMS GOING
OFFLINE IN 15 MIN FOR MAINTENANCE **** </font><br><br>";
            }

        else
        {
        //Getting Course (and credits are direct from table)
        $temp = $info["courseid"];
        $category = mysql_query("SELECT name FROM courses
WHERE courses.id ='$temp'");
        while ($row = mysql_fetch_array($category))
            {
            {$localcredits=$info["credits"];
            printf("UM Course: %s Credits:
%s", $row["name"], $info["credits"]);
            }
            }
        echo "<br>";

        //Getting Status
        $temp = $info["statusid"];
        $category = mysql_query("SELECT name FROM status
WHERE status.id ='$temp'");
        while ($row = mysql_fetch_array($category))
            {
            printf("Status: <font
color=\"green\">%s</font>", $row["name"]);
            }
        echo "<br>";

        //Getting Project
        $temp = $info["projectid"];
        $category = mysql_query("SELECT name FROM projects
WHERE projects.id ='$temp'");
        while ($row = mysql_fetch_array($category))
            {
            printf("Project: <b>%s</b>", $row["name"]);
            }
        echo "<br>";

        $the_current_term = get_current_term();
        printf("Current Term:
<b>%s</b><br>", $the_current_term);

        if ($info["statusid"] == "2") // Active Members only
            {
            echo "<br> << <a
href=output_all_byproject_public.php?theid=2&theusr=".$localid.">View
All Active Members By Project</a> (Public List format)<br>";

            // *****
            // Inventory Module access
            // *****

            echo "<br> << <a
href=output_all_inventory_public.php?theid=2&theusr=".$localid.">Lab
Inventory</a> <br>";
            }
    }
}

```

```

// *****
// ThermalVac Module access
// *****

echo "<br> << <a
href=output_all_thermalvac_public.php?theid=2&theusr=".$localid.">Therm
alVac</a> <br>";

// *****
// Industry Contacts Module access
// *****

echo "<br> << <a
href=output_all_industry_public.php?theid=2&theusr=".$localid.">Industr
y Interactions</a> <br><br><br>";

print <<<HTML

<b>S3FL Bluestream (Media
Archive)</b><br>

>> <a
href="http://bluestream.dc.umich.edu"
target="_blank">Bluestream</a><br><br>

<b>S3FL Document Archive Search</b>
<form
action="http://www.engin.umich.edu/search/query" method="get"
target="_blank">
<input type="hidden" name="restrict"
id="restrict" value='CoE-res-S3FL' />

<input type="text" name="q" id="q"
size="40" maxlength="255" value="" />
<input type="submit" value="Search
Archive" alt="Search" />
</form>

HTML;

echo "<b>S3FL Weekly Reports Search</b>";
$DBSearch = new
DatabaseSearch('localhost', 'mydb', 'root', 'salmon', false);
$DBSearch->DrawForm("search_reports.php?theusr=$localid",40,"","submit","Search
Reports",true);

}

// *****
// Retrieving students information.
// *****

```

```

echo "<br>History";

if (($theviewercategory == "Administrator") or
($theviewercategory == "Excom"))
    { //echo " << <a
href=sendcertification.php?theid=". $localid."&theusr=". $theviewerid.">A
dd</a>";
    }

echo "<br>=====<br>";

$certs = mysql_query("SELECT * FROM history WHERE
history.studentid ='$localid'") or die(mysql_error());

while($info2 = mysql_fetch_array( $certs ))
    { // getting term
        printf("<font face=\"Verdana\"
size=\"1\">%s, ", $info2["term"]);

        $h_localcategoryid = $info2["categoryid"];
        // getting category
        $category =
mysql_query("SELECT name FROM categories WHERE categories.id
='$h_localcategoryid'");
        while ($row =
mysql_fetch_array($category))
            { printf("%s,
", $row["name"]); }

        $h_localcourseid = $info2["courseid"];
        // getting umcourse and credits
        $course = mysql_query("SELECT
name FROM courses WHERE courses.id ='$h_localcourseid'");
        while ($row =
mysql_fetch_array($course))
            { printf("%s %s credits,
", $row["name"], $info2["credits"]); }

        $h_localstatus = $info2["statusid"];
        // getting status
        $course = mysql_query("SELECT
name FROM status WHERE status.id ='$h_localstatus'");
        while ($row =
mysql_fetch_array($course))
            { printf("%s,
", $row["name"]); }

        $h_localproject = $info2["projectid"];
        // getting status and grade
        $course = mysql_query("SELECT
name FROM projects WHERE projects.id ='$h_localproject'");
        while ($row =
mysql_fetch_array($course))
            { printf("%s,
", $row["name"]); }

```



```

        $h_localdatefrom = $info2["stamp"];

        // getting grade and notes
        printf("%s, %s, %s -
", $info2["grade"], $info2["notes"], date("D j M Y
H:i", $h_localdatefrom));

        $h_localmadebyreal = $info2["madebyreal"];
        // getting madebyreal
        $course = mysql_query("SELECT
username FROM users WHERE users.id ='$h_localmadebyreal'");
        while ($row =
mysql_fetch_array($course))
            {printf("%s
</font>", $row["username"]);}

            echo "<br>";

        }

        // Getting students certifications
        *****
        echo "<br>Certifications (OSEH, WSPC) / Recognitions
(Engineering) / Training (EPB, SPRL) <a
href=\"help/certifications.html\" target=\"_blank\" ><b>?</b></a>";
        echo "<br>=====<br>";

        $certs = mysql_query("SELECT * FROM certifications
WHERE certifications.studentid ='$localid'") or die(mysql_error());

        while($info2 = mysql_fetch_array( $certs ))
            {$temp = $info2["certificationtypeid"];
            $certstype = mysql_query("SELECT name FROM
certificationtypes WHERE certificationtypes.id ='$temp'") or
die(mysql_error());

            while($row = mysql_fetch_array($certstype))
                {printf("> <b>%s</b> ", $row["name"]);
                }

            printf("Date obtained: %s    Comments:
%s", $info2["date"], $info2["comments"]);
            echo "<br>";
            }

        // Getting students Events
        *****
        echo "<br>Events <a href=\"help/events.html\"
target=\"_blank\" ><b>?</b></a>";
        echo "<br>=====<br>";

        $certs = mysql_query("SELECT * FROM events WHERE
events.studentid ='$localid'") or die(mysql_error());

```

```

while($info2 = mysql_fetch_array( $certs ))
    {$temp = $info2["eventtypeid"];
    $certstype = mysql_query("SELECT name FROM
eventtypes WHERE id ='$temp'")or die(mysql_error());

    while($row = mysql_fetch_array($certstype))
        {printf("> <b>%s</b> ",$row["name"]);
        }

    printf("Status: %s Location: %s Date: %s
Verified By: %s Comments:
%s",$info2["status"],$info2["location"],$info2["date"],$info2["verified
by"],$info2["comments"]);
    echo "<br>";
    }

// Getting students Attendance
*****
echo "<br>Attendance <a href=\"help/attendance.html\"
target=\"_blank\" ><b>?</b></a>";
echo "<br>=====<br>";

$certs = mysql_query("SELECT * FROM attendance WHERE
attendance.studentid ='$localid'")or die(mysql_error());

while($info2 = mysql_fetch_array( $certs ))
    {$temp = $info2["eventtypeid"];

    $certstype = mysql_query("SELECT name FROM
eventtypes WHERE id ='$temp'")or die(mysql_error());
    while($row = mysql_fetch_array($certstype))
        {printf("> <b>%s</b> ",$row["name"]);
        }

    if ($info2["status"] == "Unjustified Absence")
// hours were late, marking in red
        {echo "<font color=\"red\">Unjustified
Absence</font> ";
        }
    else {printf(" %s ",$info2["status"]);
    }

    printf("Location: %s Date: %s Verified By: %s
Comments:
%s",$info2["location"],$info2["date"],$info2["verifiedby"],$info2["comm
ents"]);
    echo "<br>";
    }

// Getting students Outreach
*****

```

```

        echo "<br>Outreach <a href=\"help/outreach.html\"
target=\"_blank\" ><b>?</b></a>";
        echo "<br>=====

```

```

        $availabilitybeforedue = "291600"; // W2010 Excom
decided to expand window.  time available in sec for submitting hrs
before they due.

        $hrsexpected = "0";
        //$credits = "3";  for testing purposes
        $currentspan = "1";
        $tic = "0";  // week 0 is the real week for the first
week (because of division below)

        $stampnow = strtotime('now');
        //printf("stampnow: %s which is: %s", $stampnow, date('m-
d-Y h:i:s A', $stampnow)); echo "<br>";

        $tic = ($stampnow - $startofterm) / $timespan;
        settype($tic, "integer");
        //printf("tic: %s", $tic); echo "<br><br>";

        // generation of log hrs link

        $reportdue = (($tic + 1) * $timespan) +
$startofterm;
        $available = $reportdue - $availabilitybeforedue;

        if ($info["categoryid"] == "4")  // faculty
        { //printf("Additional Information for Faculty here");
        echo "<br>";
        }
        else
        {

                echo "<br>Hours and Weekly Reports - <a
href=\"help/hours.html\" target=\"_blank\" ><b>How do I log
hours?</b></a>";  // needs updating from configuration table
                if ($stampnow < $available)
                { // reports are not yet available
                        //printf("not yet...");
                        echo " << Log hours link not yet available for
this week.";
                }
                else
                { //printf("Log hours link now available! ");
                        // to other file
                        $calculatedweekstart = (($tic + 0) *
$timespan) + $startofterm;
                        echo " << <a
href=sendhrs.php?theid=".$localid."&theweek=".$calculatedweekstart.">Lo
g hours here (considered ON TIME)</a>";
                }

                echo "<br>=====<br>";
                printf("Hrs and Report are due before:
<b>%s</b>", date('m-d-Y h:i:s A', $reportdue)); echo "<br>";
                printf("Hrs and Report link available starting:
%s", date('m-d-Y h:i:s A', $available)); echo "<br>";

```

```

// end of generation log hrs link

printf("Current Week No: %s", $tic + 1); echo "<br>";

$totalhrsexpected = $localcredits * $tic * 3; // 3
represents 3 hrs per credit.
printf("Minimum hours expected until now:
<b>%2.1f</b>", $totalhrsexpected);
echo "<br>";
// Getting total of hours worked directly from
db

$certs = mysql_query("SELECT SUM(hours) as
\"totalhours\" FROM reports WHERE (reports.studentid ='$localid' and
reports.term='$the_current_term')") or die(mysql_error());
while($info2 = mysql_fetch_array( $certs ))
{printf("Total hrs worked current term until
now: <b>%2.1f</b>", $info2["totalhours"]);
echo "<br>";
if ($info2["totalhours"] < $totalhrsexpected)
{printf("<font color =\"red\">--- Note:
<b>You are currently under hours.</b> ---</font>");
}
}
echo "<br>";

/***** this code was copied and pasted so it would
show next to title hours, delete if stable in the future.
$reportdue = (($tic + 1) * $timespan) + $startofterm;
$available = $reportdue - $availabilitybeforedue;

printf("Hrs and Report are due before:
<b>%s</b>", date('m-d-Y h:i:s A', $reportdue)); echo "<br>";
printf("Hrs and Report link available starting:
%s", date('m-d-Y h:i:s A', $available)); echo "<br>";

if ($stampnow < $available)
{ // reports are not yet available
//printf("not yet...");
}
else
{printf("Log hours link now available! ");
// to other file
$calculatedweekstart = (($tic + 0) *
$timespan) + $startofterm;
echo "<a
href=sendhrs.php?theid=".$localid."&theweek=".$calculatedweekstart.">Lo
g hours</a>.<br>";
} *****/

if ($stampnow > $reportdue) // will never go into this
code
{printf("You are late submitting hours!");
}

```

```

        $calculatedweekstart2 = (($tic + 0) * $timespan) +
$startofterm;
        echo "<a
href=sendhrsrate.php?theid=". $localid."&theweek=". $calculatedweekstart2
."&thestartofterm=". $startofterm."&thetic=". $tic.">Log hours for
previous weeks here</a> (considered LATE)<br>";

        echo "<br>"; echo "<br>";

        // Getting all hours and reports for current term
        // shows only current term: $certs =
mysql_query("SELECT * FROM reports WHERE (reports.studentid ='$info[0]'
and reports.term='$the_current_term')")or die(mysql_error());
        $certs = mysql_query("SELECT * FROM reports WHERE
(reports.studentid ='$info[0]')")or die(mysql_error());

        while($info2 = mysql_fetch_array( $certs ))
        {
                if ($info2["term"] == "$the_current_term") //
marking bold current term in reports
                        {printf("<b>%s</b>", $info2["term"]);
                        }
                else {printf("%s", $info2["term"]);
                }

                printf(" [%s - %s] Hours: %2.1f Submitted
On: %s, ", $info2["datefrom"], $info2["dateto"], $info2["hours"], date('m-
d-Y h:i A', $info2["stamp"]));

                if ($info2["ontime"] == "Late") // hours were
late, marking in red
                        {echo "<font
color=\"red\"><b>Late</b></font> ";
                        }
                else {echo "On Time";
                }

                echo "<br>";
                printf("%s", $info2["report"]);
                echo "<br><br>";
        }

        }// end if faculty stuff

        } // end else If Recruiter or Guest

        } // end otherwise they are shown the members area
    } // end 1st. while($info = mysql_fetch_array( $check ))
}
else
//if the cookie does not exist, they are taken to the login screen
{

```

```
header("Location: login.php");
}
?>
```

To change a member's status the script *edit_status.php* is used. It is a similar script for editing a member's category, university course, number of credits and project association.

```
<?php
// edit_status.php allows changing a SIMS member status

require_once('connection.php');

mysql_select_db("mydb") or die(mysql_error()); // uses connection.php

//Checks if there is a login cookie
if(isset($_COOKIE['ID_my_site']))

//if there is, it logs you in and directes you to the members page
    { //echo "There is a cookie!";

        $username = $_COOKIE['ID_my_site'];
        $pass = $_COOKIE['Key_my_site'];
        $check = mysql_query("SELECT * FROM users WHERE username =
'$username'") or die(mysql_error());
        while($info = mysql_fetch_array( $check ))
            { $tip = $info['projectid'];
              if ($pass != $info['password'])
                {
                }
              else
                {
                // if already submitted maybe ?
                // header("Location: members.php");

                echo "<font face=\"Verdana\" size=\"2\"><< <a
href=members.php>Back to Members Area</a>";

                }
            }
        }
    }
else
    { //echo "<br>No cookie found!";
    }

//if the login form is submitted
if (isset($_POST['submit']))
```

```

{

$localfid = $_POST['fid'];
$localfstatusid = $_POST['feventtypeid'];
$localtheviewerid = $_POST['ftheviewerid'];

$stampnow = strtotime('now');

$check = mysql_query("UPDATE users SET statusid =
'$localfstatusid' WHERE id = '$localfid'")or die(mysql_error());

// insert into history
// get the original values from users table
$certs = mysql_query("SELECT * FROM users WHERE users.id
='$localfid'")or die(mysql_error());

        while($info2 = mysql_fetch_array( $certs ))
        {
            $localnotes = $info2["notes"];
            $localcategoryid = $info2["categoryid"];
            $localcourseid = $info2["courseid"];
            //$localstatusid = $info2["statusid"];
            $localprojectid = $info2["projectid"];
            $localterm = get_current_term();

            $localgrade = $info2["grade"];
            $localcredits = $info2["credits"];
        }

        $check = mysql_query("INSERT INTO history (id, stamp, studentid,
notes, categoryid, courseid, statusid, projectid, credits, term, grade,
madebyreal) VALUES (\\"\", '$stampnow', '$localfid', '$localnotes',
'$localcategoryid', '$localcourseid', '$localfstatusid',
'$localprojectid', '$localcredits', '$localterm', '$localgrade',
'$localtheviewerid'")or die(mysql_error());

        printf(" << <a
href=output_single.php?theid=".$localfid."&theusr=".$localtheviewerid."
>Back to Member View</a>");
            echo "<br>";

            echo "<br>SIMS: Update made successfully!<br>";

            //echo "<br>check values: ";
            //print_r($check);

        }
else
{

// if they are going to provide hours and report

//echo "\$the value:";

```



```

    $the = $_REQUEST['theid']; // this parameter was passed from
other file
    $theviewerid = $_REQUEST['theusr'];
    //printf($the);

    $query="SELECT * FROM status";
    $result=mysql_query($query);
    $num=mysql_numrows($result);
    $stampnow = strtotime('now');
    $todaydate=date('Y/m/d',$stampnow);

    // getting members current statusid
    $resultstatusid = mysql_query("SELECT * FROM users WHERE
users.id='$the'") or die(mysql_error());
    $array = mysql_fetch_array( $resultstatusid );
    $localstatusid= $array["statusid"];

    $resultstatusname = mysql_query("SELECT * FROM status WHERE
status.id='$localstatusid'") or die(mysql_error());
    $array = mysql_fetch_array( $resultstatusname );
    $localstatusname= $array["name"];

?>

<style type="text/css">body {font: smaller Verdana}</style>

<form action="<?php echo $_SERVER['PHP_SELF']?>" method="post">
<input type="hidden" name="fid" value="<?php echo $the?>">
<input type="hidden" name="ftheviewerid" value="<?php echo
$theviewerid?>">

<table border="0">
<tr><td colspan=8><font face="Verdana" size="2"><b>Edit
Status</b></td></tr>

<tr><td><font face="Verdana" size="2">Current
Status:</td><td><font face="Verdana" size="2" color="green"><?php
printf("$localstatusname"); ?></font></td></tr>

<tr><td><font face="Verdana" size="2">New Status:</td><td>

<select name="feventtypeid">

    <?php
        $k=0;
        while ($k<$num)
            {$eventlist=mysql_result($result,$k,"name");

$eventlistnumber=mysql_result($result,$k,"id");
            echo "<option
value=".$eventlistnumber.">".$eventlist."";
            $k++;
            }
    ?>

</select>

```

```

</td></tr>

<tr><td colspan="2" align="right">
<input type="submit" name="submit" value="SEND">
</td></tr>
</table>
</form>

<?php
}
?>

```

The code used to capture a member's attendance will be used to illustrate the template that is also used for adding certifications, recognitions, events, outreach and comments from other members. The script is called *sendattendance.php* and is shown next.

```

<?php
// sendattendance.php Sends the attendance of a member as captures by
a team lead into SIMS.

// Connects to Database
require_once('connection.php');
mysql_select_db("mydb") or die(mysql_error());

//echo "Connected to DB...";

//Checks if there is a login cookie
if(isset($_COOKIE['ID_my_site']))

//if there is, it logs you in and directes you to the members page
    {//echo "There is a cookie!";

        $username = $_COOKIE['ID_my_site'];
        $pass = $_COOKIE['Key_my_site'];
        $check = mysql_query("SELECT * FROM users WHERE username =
'$username'") or die(mysql_error());
        while($info = mysql_fetch_array( $check ))
            { $tip = $info['projectid'];
              if ($pass != $info['password'])
                {
                }
              else
            }

```

```

        {
            echo "<< <a href=members.php>Back to Members
Area</a><br>";
        }
    }
}
else
    { //echo "<br>No cookie found!";
    }

//if the login form is submitted
if (isset($_POST['submit']))
    {
        echo "<br>Absence captured successfully!<br>";

        $localfid = $_POST['fid'];
        $localfeventtypeid = $_POST['feventtypeid'];
        $localfstatus = $_POST['fstatus'];
        $localflocation = $_POST['flocation'];
        $localfdate = $_POST['fdate'];
        $localfverifiedby = $_POST['fverifiedby'];
        $localfcomments = $_POST['fcomments'];

        $stampnow = strtotime('now');

        $check = mysql_query("INSERT INTO attendance (id, eventtypeid,
status, location, date, verifiedby, comments, studentid) VALUES (\"\",
'$localfeventtypeid', '$localfstatus', '$localflocation',
'$localfdate', '$localfverifiedby', '$localfcomments', '$localfid')") or
die(mysql_error());

    }
else
    {

        // if they are going to provide hours and report

        //echo "\$the value:";
        $the = $_REQUEST['theid']; // this parameter passed from other
file
        //printf($the);

        $query="SELECT * FROM eventtypes ORDER BY name ASC";
        $result=mysql_query($query);
        $num=mysql_numrows($result);
        $stampnow = strtotime('now');
        $todaydate=date('Y/m/d', $stampnow)

        ?>

        <style type="text/css">body {font: smaller Verdana}</style>

        <form action="<?php echo $_SERVER['PHP_SELF']?>" method="post">
        <input type="hidden" name="fid" value="<?php echo $the?>">
        <table border="0">
        <tr><td colspan=8><b>Add Absence</b></td></tr>

```

```

<tr><td>Event Type:</td><td>
<select name="feventtypeid">
    <?php
        $k=0;
        while ($k<$num)
            {$seventlist=mysql_result($result,$k,"name");
$seventlistnumber=mysql_result($result,$k,"id");
            echo "<option
value=" . $seventlistnumber . ">" . $seventlist . " ";
            $k++;
            }
    ?>
</select>
</td></tr>
<tr><td>Type:</td><td>
    <select name="fstatus">
        <option value="Unjustified Absence">Unjustified
Absence
        <option value="Justified Absence - Exam">Justified
Absence - Exam
        <option value="Justified Absence - Class
conflict">Justified Absence - Class conflict
        <option value="Justified Absence -
Personal">Justified Absence - Personal
        <option value="Justified Absence - Other">Justified
Absence - Other
    </select>
</td></tr>
<tr><td>Location:</td><td>
    <select name="flocation">
        <option value="SRB">SRB
        <option value="Off Campus">Off Campus
    </select>
</td></tr>
<tr><td>Date:</td><td>
    <input type="text" name="fdate" maxlength="40" value="<?php echo
$todaydate?>">(Use format: 2006/12/31)
</td></tr>
<tr><td>Verified By:</td><td>
    <input type="text" name="fverifiedby" maxlength="40">(Type
uniquename)
</td></tr>
<tr><td>Comments:</td><td>
<textarea name="fcomments" rows="15" cols="40"></textarea>
</td></tr>
<tr><td colspan="2" align="right">
<input type="submit" name="submit" value="SEND">

```

```
</td></tr>
</table>
```

Note for Leads: Please document Exam Information, Class Code or detailed narrative for personal absence when selecting "Justified absence".

```
</form>
```

```
<?php
}
```

```
?>
```

SIMS enables the functionality for members to capture reports and hours on a weekly basis. The script that allows the users to capture these reports and worked hours is called *sendhrs.php* and is shown next.

```
<?php
// sendhrs.php Sends hours to the database from users script.
require_once('connection.php');

// Connects to Database
//mysql_connect("localhost", "mydbadmin", "noadmin") or
die(mysql_error());
mysql_select_db("mydb") or die(mysql_error());

//echo "Connected to DB...";

//Checks if there is a login cookie
if(isset($_COOKIE['ID_my_site']))

//if there is, it logs you in and directes you to the members page
{
    //echo "There is a cookie!";
    $username = $_COOKIE['ID_my_site'];
    $pass = $_COOKIE['Key_my_site'];
    $check = mysql_query("SELECT * FROM users WHERE username =
'$username'") or die(mysql_error());
    while($info = mysql_fetch_array( $check ))
    {
        if ($pass != $info['password'])
        {
        }
    }
    else
    {
        // if already submitted maybe ?
        // header("Location: members.php");
    }
}
}
```

```

        echo "<< <a href=members.php>Back to Members
Area</a><br>";
    }
}
else
    {  
    //echo "<br>No cookie found!";  
    }

//if the login form is submitted
if (isset($_POST['submit']))
    {  
    //form has been submitted  
    //echo "<br>Form has been submitted."  
    // makes sure they filled it in

    // verify data from user
    if(!$_POST['fhours'] | !$_POST['freport'])
        {die('You did not fill in a required field.')}

    if($_POST['fhours']<0)
        {die('Invalid numbers of hours. Hours should be between 0
and 40.')}

    if($_POST['fhours']>40)
        {die('Invalid numbers of hours. Hours should be between 0
and 40.')}

    // checks it against the database

    echo "<br>Hours and Report captured successfully!<br>";

    $localfhours = $_POST['fhours'];
    $localfreport = $_POST['freport'];
    $localfid = $_POST['fid'];
    $localftheweek = $_POST['ftheweek'];
    $localftheweekend = $_POST['ftheweekend'];
    $stampnow = strtotime('now');

    $local_currentterm = get_current_term();

    $check = mysql_query("INSERT INTO reports (id, studentid, stamp,
datefrom, dateto, hours, report, ontime, term) VALUES (\",
'$localfid', '$stampnow', '$localftheweek', '$localftheweekend',
'$localfhours', '$localfreport', 'On Time', '$local_currentterm')")or
die(mysql_error());

    }
else
    {

    // if they are going to provide hours and report

```

```

    $the = $_REQUEST['theid']; // this parameter was passed from
other file
    //printf($the);

    $theweek = $_REQUEST['theweek']; // this parameter was passed
from other file
    //printf(date('Y/m/d h:i:s',$theweek));

    $stampnow = strtotime('now');
    $todaydate=date('Y/m/d',$stampnow);

    $timespan = "604800"; // standard range for submitting
hours: 1 week. Modify accordingly if protocol changes.

    $theweekend = $theweek + $timespan;

?>

<style type="text/css">body {font: smaller Verdana}</style>

<form action="<?php echo $_SERVER['PHP_SELF']?>" method="post">
<input type="hidden" name="fid" value="<?php echo $the?>">
<table border="0">
<tr><td colspan=8><b>Hours and Weekly Report</b></td></tr>

<tr><td>Week start:</td><td>
<input readonly type="text" name="ftheweek" maxlength="40"
value="<?php echo date('Y/m/d',$theweek)?>">
</td></tr>

<tr><td>Week end:</td><td>
<input readonly type="text" name="ftheweekend" maxlength="40"
value="<?php echo date('Y/m/d',$theweekend)?>">
</td></tr>

<tr><td>Hours:</td><td>
<input type="text" name="fhours" maxlength="40"><font
size=2>(format: 10.0 Do not include word hours)</font>
</td></tr>
<tr><td>Report:</td><td>
<textarea name="freport" rows="10" cols="50"></textarea>
</td></tr>
<tr><td colspan="2" align="right">
<input type="submit" name="submit" value="SEND">
</td></tr>
</table>

<font size=2>It has been noticed that some browsers have problems
with the characters <b>"</b> and <b>'</b>. Please avoid using them
when submitting your report.</font>

<input type="hidden" name="ftheweekendhidden" value="<?php echo
$theweekend?>">

</form>
<?php

```

```

    }

?>

```

Displaying all of the projects members with relevant information about each individual is a feature accomplished through the *output_allbyproject.php* script shown below. It is used to exemplify similar scripts that also display all the members by university course they are enrolled in or members with engineering recognitions. In addition, potential members that are considered *interviewees* or *former members* can be displayed with their corresponding details.

```

<?
// output_all_byproject.php  Displays all the active members by
projects

require_once('connection.php');

$the = $_REQUEST['theid']; // this parameter was passed from other
file here used to select status of members
$theviewerid = $_REQUEST['theusr'];

echo "<style type=\"text/css\">body {font: smaller Verdana}</style>";
echo "<b><center>";

if ($the == '1')
{echo "All Interviewees By Project ";}

if ($the == '2')
{echo "All Active Members By Project ";}

echo "<< <a href=members.php>Back to Members Area</a> << <a
href=logout.php>Logout</a></center></b><br>";

        //mysql_connect("localhost","mydbadmin","noadmin") or
die(mysql_error());
        mysql_select_db("mydb") or die(mysql_error());

        $startofterm = get_term_start();
        $timespan = "604800"; // standard for
submitting hours: 1 week (also in sendhrs.php)

```



```

        $availabilitybeforedue = "172800"; // time available
in sec for submitting hrs before they due.

        $hrsexpected = "0";
        //$credits = "3"; for testing purposes
        $currentspan = "1";
        $tic = "0"; // week 0 is the real week for the first
week (because of division below)

        $stampnow = strtotime('now');
        //printf("stampnow: %s which is: %s", $stampnow, date('m-
d-Y h:i:s A', $stampnow));echo "<br>";

        $tic = ($stampnow - $startofterm)/$timespan;
        settype($tic, "integer");
        //printf("tic: %s", $tic); echo "<br><br>";

        $the_current_term = get_current_term();
        printf("Current Term:
<b>%s</b><br>", $the_current_term);

$counter = 0;

$teams = mysql_query("SELECT * FROM projects WHERE (status='active')
ORDER BY name ASC") or die(mysql_error());

        printf("<font face=\"Verdana\" size=\"1\">");
        printf("<table border=\"0\">");
        printf("<tr><td><font face=\"Verdana\"
size=\"2\"></td> <td><font face=\"Verdana\"
size=\"2\"><b>First</b></td> <td><font face=\"Verdana\"
size=\"2\"><b>Last</b></td> <td><font face=\"Verdana\"
size=\"2\"><b>Year</b></td> <td><font face=\"Verdana\"
size=\"2\"><b>Major</b></td> <td><font face=\"Verdana\"
size=\"2\"><b>Project</b></td> <td><font face=\"Verdana\"
size=\"2\"><b><a
href=output_all_bycourse.php?theid=$the&theusr=$theviewerid>By
Course</a></b></td> <td><font face=\"Verdana\"
size=\"2\"><b>Credit</b></td> <td><font face=\"Verdana\"
size=\"2\"><b>Hrs Exp</b></td> <th><font face=\"Verdana\"
size=\"2\"><b>Hrs Work</b></td> <td><font face=\"Verdana\"
size=\"2\"><b></b></td> </tr>");
        while($info2 = mysql_fetch_array( $teams ))
                {$miniteam = $info2["id"];

                                printf("<tr
bgcolor='#f1f1f1'><td><font face=\"Verdana\" size=\"2\">");
                                //printf("><b><a
href=output_team.php?theid=".$miniteam.">%s</a></b> ", $info2["name"]);
                                printf("><b>%s</b>
", $info2["name"]);

                                printf("</td></tr>");
                                $temp = $info2["id"];

```

```

                                $certsttype =
mysql_query("SELECT * FROM users WHERE projectid ='$temp' AND statusid
='$the' ORDER BY username ASC")or die(mysql_error());

                                while($row =
mysql_fetch_array($certsttype))
                                {
                                        if
((($row["projectid"] == 19) or ($row["id"] == 39))
                                        { //printf("FACULTY
HERE");
                                        }
                                        else // all users
                                        {
                                                printf("<tr>");

                                                $localcredits =
                                                $localid =
                                                $localprojectid =
                                                $localcourseid =

                                                $totalhrsexpected =
$localcredits * $tic *3; // 3 represents 3 hrs per credit.

                                                // Getting total of hours worked
directly from db
                                                $certs = mysql_query("SELECT SUM(hours)
as \"totalhours\" FROM reports WHERE (reports.studentid ='$localid' and
reports.term='$the_current_term')")or die(mysql_error());
                                                while($info2 = mysql_fetch_array( $certs
))
                                                {
                                                        printf("<td><font
face=\"Verdana\" size=\"2\">");
                                                        $miniid=$row["id"];
                                                        if
($row["categoryid"] == "2") // Team Lead printed, adding (L)
                                                        {echo "(L)
";
                                                        }
                                                        if
($row["categoryid"] == "5") // Asst Lead printed, adding (AL)
                                                        {echo "(AL)
";
                                                        }

                                                        printf("<a
href=output_single.php?theid=".$miniid."&theusr=".$theviewerid."> %s

```

```

</a></td> <td><font face=\"Verdana\" size=\"2\"> %s </td> <td><font
face=\"Verdana\" size=\"2\"> %s </td> <td><font face=\"Verdana\"
size=\"2\"> %s </td> <td><font face=\"Verdana\" size=\"2\"> %s
</td>\", $row["username"], $row["first"], $row["last"], $row["year"], $row["m
ajor"]);

                                                                    //Getting Project
direct from table                                                                    // $temp =
$info["courseid"];                                                                    // $category =
mysql_query("SELECT name FROM projects WHERE projects.id
=' $localprojectid'");                                                                    while ($row
= mysql_fetch_array($category))
    { // $localcredits = $temp2;
printf("<td><font face=\"Verdana\" size=\"2\">%s</td>", $row["name"]);
    }

                                                                    //Getting Course (and credits
are direct from table)                                                                    // $temp =
$info["courseid"];                                                                    // $category =
mysql_query("SELECT name FROM courses WHERE courses.id
=' $localcourseid'");                                                                    while ($row
= mysql_fetch_array($category))
    { // $localcredits = $temp2;
printf("<td><font face=\"Verdana\" size=\"2\">%s</td> <td><font
face=\"Verdana\" size=\"2\">%s</td> ", $row["name"], $localcredits);
    }

                                                                    printf("<td><font
face=\"Verdana\" size=\"2\">%2.1f</td>", $totalhrsexpected);
                                                                    printf("<td><font
face=\"Verdana\" size=\"2\">%2.1f</td>", $info2["totalhours"]);
                                                                    if
($info2["totalhours"] < $totalhrsexpected)
    {
        // Member is under hours
        printf("<td><font
face=\"Verdana\" size=\"2\"> <font color=\"red\"><b>Under
Hours</b></font> </td>");
    }
    else
        { printf("<td><font
face=\"Verdana\" size=\"2\"><b>Hours OK</b></font> </td>");

```

```

        }
    }
    $counter = $counter + 1;
} // end for all users ok to
print
    } // end while there are users
    printf("</tr>");

        //printf("Date obtained: %s
Comments: %s", $info2["date"], $info2["comments"]);
        //echo "<br>";
    } // end while there are
teams to print

    printf("</table>");
    printf("</font>");

    printf("<br> <font face=\"Verdana\" size=\"2\">Total
Users: <b>$counter</b> </font>");

// end other option
?>

```

Searching is a critical feature that is implemented in the system. Searches can be performed on all the major information categories including weekly reports, previous projects in the laboratory, industry interactions notes, technical reports generated by using the thermal-vacuum system, etc. The script used to perform searches on members' reports is shown next to illustrate the coding. It is called *search_reports.php*.

```

<?php
// search_reports.php

session_start();
require_once("DatabaseSearch.php");

```

```

$DBSearch = new DatabaseSearch('localhost', 'mydb', 'root', 'salmon',
false);
if (isset($_SESSION["DatabaseSearchNeedle"]))
{
    $joins = "LEFT OUTER JOIN users ON reports.studentid = users.id";
    $search_result = $DBSearch-
>DoSearch("reports","reports.id",array("report", "reports.id",
"users.username"), "", "", $joins);
}
else echo "No query yet.";

require_once('connection.php');

$databse="mydb";

$the = $_REQUEST['theid']; // this parameter used to define status:
Interview, Active, etc.
$theviewerid = $_REQUEST['theusr'];
$the_current_term = get_current_term();

mysql_select_db($databse) or die( "Unable to select database");

$resultcategoryid = mysql_query("SELECT * FROM users WHERE
users.id='$theviewerid'") or die(mysql_error());
$array = mysql_fetch_array( $resultcategoryid );
$localcategoryid = $array["categoryid"];

if($search_result){
    $orclause="";
    foreach($search_result as $result_id){
        $orclause .= "reports.id = $result_id OR ";
    }
    $orclause .= "reports.id = ''";

    if($_REQUEST['sort'] == "usersort"){ $query="SELECT reports.*,
users.first, users.last, users.projectid, users.username, projects.name
FROM reports LEFT OUTER JOIN users
ON reports.studentid = users.id LEFT OUTER JOIN projects ON
users.projectid = projects.id WHERE $orclause ORDER BY users.first,
users.last, reports.stamp ASC";}
    else if($_REQUEST['sort'] == "namesort"){ $query="SELECT reports.*,
users.first, users.last, users.projectid, users.username, projects.name
FROM reports LEFT OUTER JOIN users
ON reports.studentid = users.id LEFT OUTER JOIN projects ON
users.projectid = projects.id WHERE $orclause ORDER BY users.username,
reports.stamp ASC";}
    else if($_REQUEST['sort'] == "projectsort"){ $query="SELECT reports.*,
users.first, users.last, users.projectid, users.username, projects.name
FROM reports LEFT OUTER JOIN users
ON reports.studentid = users.id LEFT OUTER JOIN projects ON
users.projectid = projects.id WHERE $orclause ORDER BY projects.name,
reports.stamp ASC";}
    else if($_REQUEST['sort'] == "idsort"){ $query="SELECT reports.*,
users.first, users.last, users.projectid, users.username, projects.name
FROM reports LEFT OUTER JOIN users

```

```

ON reports.studentid = users.id LEFT OUTER JOIN projects ON
users.projectid = projects.id WHERE $orclause ORDER BY reports.id
ASC";}
else {$query="SELECT reports.*, users.first, users.last,
users.projectid, users.username, projects.name FROM reports LEFT OUTER
JOIN users
ON reports.studentid = users.id LEFT OUTER JOIN projects ON
users.projectid = projects.id WHERE $orclause ORDER BY reports.stamp
DESC";}

$result=mysql_query($query);

$num=mysql_numrows($result); // number of rows in table

echo "<style type=\"text/css\">body {font: smaller Verdana}</style>";
echo "<b><center>Search Results << <a href=members.php>Back to Members
Area</a> << <a href=logout.php>Logout</a></center></b><br>";

$results_per_page = 10;

$pages = ceil($num/$results_per_page);

$javascript = "\n <script type=\"text/javascript\">";
$javascript .= "\n     var showed_page = 1;";
$javascript .= "\n     var total_pages = " . $pages . " . "; // last
value assigned to $page is equal to the total of pages
$javascript .= "\n";
$javascript .= "\n     function show_page(id) {";
$javascript .= "\n         hide_page(showed_page);";
$javascript .= "\n         document.getElementById('page_' +
id).style.display = 'block';";
$javascript .= "\n         showed_page = id;";
$javascript .= "\n     }";
$javascript .= "\n";
$javascript .= "\n     function hide_page(id) {";
$javascript .= "\n         document.getElementById('page_' +
id).style.display = 'none';";
$javascript .= "\n     }";
$javascript .= "\n";
$javascript .= "\n     function show_pages_links(page_number) {";
$javascript .= "\n         document.write('<div
class=\"pages_links\">');";
$javascript .= "\n";
$javascript .= "\n         if (page_number > 1) {";
$javascript .= "\n             document.write('<a href=\"javascript:
scroll(0, 0);\" onclick=\"javascript: show_page(' + (page_number-1) +
');\">');";
$javascript .= "\n         }";
$javascript .= "\n         document.write(' &lt;&lt; Previous ');";
$javascript .= "\n         if (page_number > 1) {";
$javascript .= "\n             document.write('</a>');";
$javascript .= "\n         }";
$javascript .= "\n";
$javascript .= "\n         document.write(' | ');";
$javascript .= "\n";
$javascript .= "\n         for (var i = 1; i <= total_pages; i++) {";
$javascript .= "\n             if (page_number != i) {";

```

```

$javascript .= "\n
                document.write('<a href=\"javascript:
scroll(0, 0);\" onclick=\"javascript: show_page(' + i + ');\">');";
$javascript .= "\n
                }";
$javascript .= "\n
                document.write(i);";
$javascript .= "\n
                if (page_number != i) {";
$javascript .= "\n
                    document.write('</a>');";
$javascript .= "\n
                }";
$javascript .= "\n
                document.write(' | ');";
$javascript .= "\n
            }";
$javascript .= "\n";
$javascript .= "\n";
$javascript .= "\n
                if ((total_pages > 1) && (page_number <
total_pages)) {";
$javascript .= "\n
                    document.write('<a href=\"javascript:
scroll(0, 0);\" onclick=\"javascript: show_page(' + (page_number+1) +
');\">');";
$javascript .= "\n
                }";
$javascript .= "\n
                document.write(' Next &gt;&gt; ');";
$javascript .= "\n
                if ((total_pages > 1) && (page_number <
total_pages)) {";
$javascript .= "\n
                    document.write('</a>');";
$javascript .= "\n
                }";
$javascript .= "\n";
$javascript .= "\n
                document.write('</div>');";
$javascript .= "\n
            }";
$javascript .= "\n";
$javascript .= "\n </script>";

```

```
echo $javascript;
```

```
$DBSearch-
```

```
>DrawForm("$_SERVER[PHP_SELF]?theusr=$theviewerid",40,"","","Search
Reports",true);
```

```
// ADMIN FUNCTION possible
```

```
//echo "\n<a href=\"add_user.php?theusr=$theviewerid\">Add New
Item</a>";
```

```
echo "\n<br>$num Result(s) Found!";
```

```
$printing_page = $page = 1;
```

```
$html = "\n\n <div id=\"page_1\" style=\"display: block;\">";
```

```
$i=0;
```

```
while ($i < $num) {
```

```
$page = ceil(($i+1)/$results_per_page);
```

```
if ($i == 0)
```

```
{
```

```
    $html .= "\n\n <script type=\"text/javascript\">\n
```

```
show_pages_links(" . ($page) . ");\n    </script>\n";
```

```
}
```

```
else if ($page != $printing_page)
```

```
{
```

```
    $printing_page = $page;
```

```
    $html .= "\n\n    <script type=\"text/javascript\">\n
```

```
show_pages_links(" . ($page-1) . ");\n    </script>\n";
```

```

        $html .= "\n </div>";
        $html .= "\n <div id=\"page_\" . $page . "\"" style=\"display:
none;\">";
        $html .= "\n\n    <script type=\"text/javascript\">\n
show_pages_links(" . ($page) . ");\n    </script>\n";
    }

$localid=mysql_result($result,$i,"id");
$localdateto=mysql_result($result,$i,"dateto");
$localdatefrom=mysql_result($result,$i,"datefrom");
$localhours=mysql_result($result,$i,"hours");
$localreport=mysql_result($result,$i,"report");
$localontime=mysql_result($result,$i,"ontime");
$localterm=mysql_result($result,$i,"term");
$localusername=mysql_result($result,$i,"username");
$firstname=mysql_result($result,$i,"first");
$lastname=mysql_result($result,$i,"last");
$localproject=mysql_result($result,$i,"name");
$timestamp=mysql_result($result,$i,"stamp");
$time= date('m-d-Y h:i A', $timestamp);

if ($localterm == $the_current_term) // marking bold current term in
reports
{$submitinfo="<b>$localterm</b>";}
else {$submitinfo="<b>$localterm</b>";}
$submitinfo .= " [$localdatefrom - $localdateto]    Hours: $localhours
Submitted On $time";
if ($localontime == "Late") // hours were late, marking in red
{$submitinfo .="<font color=\"red\"><b>Late</b></font> ";}
else {$submitinfo .="On Time";}

if($i % $results_per_page == 0){
$html .= <<<HTML
<table border="1" cellspacing="0" cellpadding="2">
<tr>
<th><font face="Arial, Helvetica, sans-serif" size="2"><a
href="$_SERVER[PHP_SELF]?theusr=$theviewerid&sort=idsort">Report
ID</a></font></th>
<th><font face="Arial, Helvetica, sans-serif" size="2"><a
href="$_SERVER[PHP_SELF]?theusr=$theviewerid&sort=usersort">User</a></f
ont></th>
<th><font face="Arial, Helvetica, sans-serif" size="2"><a
href="$_SERVER[PHP_SELF]?theusr=$theviewerid&sort=username sort">Usernam
e</a></font></th>
<th><font face="Arial, Helvetica, sans-serif" size="2"><a
href="$_SERVER[PHP_SELF]?theusr=$theviewerid&sort=projectsort">Project<
/a></font></th>
<th><font face="Arial, Helvetica, sans-serif"
size="2">Report</font></th>
<th><font face="Arial, Helvetica, sans-serif" size="2"><a
href="$_SERVER[PHP_SELF]?theusr=$theviewerid&sort=">Submit
Info</a></font></th>
</tr>
HTML;
}

$html .= <<<HTML

```



```

<tr>
<td><font face="Arial, Helvetica, sans-serif" size="2"> $localid
</font></td>
<td><font face="Arial, Helvetica, sans-serif" size="2"> $firstname
$lastname </font></td>
<td><font face="Arial, Helvetica, sans-serif" size="2"> $localusername
</font></td>
<td><font face="Arial, Helvetica, sans-serif" size="2"> $localproject
</font></td>
<td><font face="Arial, Helvetica, sans-serif" size="2"><textarea
cols=75 rows=10 readonly="readonly"> $localreport
</textarea></font></td>
<td><font face="Arial, Helvetica, sans-serif" size="2"> $submitinfo
</font></td>
</tr>
HTML;

if($i % $results_per_page == ($results_per_page - 1)){
    $html .= "</table>";
}

$i++;
}
$html .= "\n </table>";
$html .= " <script type=\"text/javascript\">\n  show_pages_links(" .
$page . ");\n</script>\n";
$html .= "</div>";

echo $html;
}
else{
echo "<style type=\"text/css\">body {font: smaller Verdana}</style>";
echo "<b><center>Search Results << <a href=members.php>Back to Members
Area</a> << <a href=logout.php>Logout</a></center></b><br>";

$DBSearch-
>DrawForm("$_SERVER[PHP_SELF]?theusr=$theviewerid",40,"","","Search
Reports",true);

echo "\n<b><font face=\"Verdana\" size=\"4\">No Results Found!</b>";
}

mysql_close() or die (mysql_error());

?>

```

Displaying the system's modules of the thermal vacuum system, laboratory inventory and industry interactions require dynamic scripts that allow users input and editing. The thermal vacuum system main script used by the system (*output_all_thermalvac_public.php*) is shown below to exemplify the code for all three modules.

```

<?php
//output_all_thermalvac_public.php  scripts that enables users to
access the thermal //vacuum module, make new entries and edit existing
entries.

require_once('connection.php');
require_once("DatabaseSearch.php");

$database="mydb";

if(isset($_COOKIE['ID_my_site']))

    //echo "There is a cookie!";
    $username = $_COOKIE['ID_my_site'];
    $pass = $_COOKIE['Key_my_site'];
    $check = mysql_query("SELECT * FROM users WHERE username =
'$username'") or die(mysql_error());
    while($info = mysql_fetch_array( $check ))
        {$tip = $info['projectid'];
        if ($pass != $info['password'])
            {
                header("Location: login.php");
            }
        }

$theid = $_REQUEST['theid']; // this parameter used to define status:
Interview, Active, etc.
$theviewerid = $_REQUEST['theusr'];

mysql_select_db($database) or die( "Unable to select database");

if($_REQUEST['sort'] == "itemsort"){ $orderby = "thermalvac.item ASC";}
else if($_REQUEST['sort'] == "teamsort"){ $orderby = "projects.name,
thermalvac.item ASC";}
else if($_REQUEST['sort'] == "datesort"){ $orderby = "thermalvac.stamp
DESC";}
else if($_REQUEST['sort'] == "survivesort"){ $orderby =
"thermalvac.stresult, thermalvac.item ASC";}
else if($_REQUEST['sort'] == "thermalsort"){ $orderby =
"thermalvac.ttresult, thermalvac.item ASC";}
else if($_REQUEST['sort'] == "bakeoutsort"){ $orderby =
"thermalvac.tbresults, thermalvac.item ASC";}

```

```

else if($_REQUEST['sort'] == "usersort"){ $orderby = "users.username,
thermalvac.item ASC";}
else { $orderby = "thermalvac.id ASC";}

$query="SELECT thermalvac.id, thermalvac.item, thermalvac.projectid,
thermalvac.date, thermalvac.stamp, thermalvac.stresult,
thermalvac.ttresult, thermalvac.tbresults, thermalvac.notes,
thermalvac.studentid, users.username, projects.name
FROM thermalvac LEFT OUTER JOIN users ON users.id =
thermalvac.studentid
LEFT OUTER JOIN projects ON thermalvac.projectid = projects.id ORDER BY
$orderby";

$result=mysql_query($query);

$num=mysql_numrows($result); // number of rows in table

$resultcategoryid = mysql_query("SELECT * FROM users WHERE
users.id='$theviewerid'") or die(mysql_error());
$array = mysql_fetch_array( $resultcategoryid );
$localcategoryid = $array["categoryid"];

echo "<style type=\"text/css\">body {font: smaller Verdana}</style>";
echo "<b><center>ThermalVac << <a href=members.php>Back to Members
Area</a> << <a href=logout.php>Logout</a></center></b><br>";

$results_per_page = 20;

$pages = ceil($num/$results_per_page);

$javascript = "\n <script type=\"text/javascript\">";
$javascript .= "\n     var showed_page = 1;";
$javascript .= "\n     var total_pages = " . $pages . ";"; // last
value assigned to $page is equal to the total of pages
$javascript .= "\n";
$javascript .= "\n     function show_page(id) {";
$javascript .= "\n         hide_page(showed_page);";
$javascript .= "\n         document.getElementById('page_' +
id).style.display = 'block';";
$javascript .= "\n         showed_page = id;";
$javascript .= "\n     }";
$javascript .= "\n";
$javascript .= "\n     function hide_page(id) {";
$javascript .= "\n         document.getElementById('page_' +
id).style.display = 'none';";
$javascript .= "\n     }";
$javascript .= "\n";
$javascript .= "\n     function show_pages_links(page_number) {";
$javascript .= "\n         document.write('<div
class=\"pages_links\">');";
$javascript .= "\n";
$javascript .= "\n         if (page_number > 1) {";
$javascript .= "\n             document.write('<a href=\"javascript:
scroll(0, 0);\" onclick=\"javascript: show_page(' + (page_number-1) +
');\">');";
$javascript .= "\n         }";
$javascript .= "\n         document.write(' &lt;&lt; Previous ');";

```

```

$javascript .= "\n        if (page_number > 1) {";
$javascript .= "\n            document.write('</a>');";
$javascript .= "\n        }";
$javascript .= "\n";
$javascript .= "\n        document.write(' | ');";
$javascript .= "\n";
$javascript .= "\n        for (var i = 1; i <= total_pages; i++) {";
$javascript .= "\n            if (page_number != i) {";
$javascript .= "\n                document.write('<a href=\"javascript:
scroll(0, 0);\" onclick=\"javascript: show_page(' + i + ');\">');";
$javascript .= "\n            }";
$javascript .= "\n                document.write(i);";
$javascript .= "\n            if (page_number != i) {";
$javascript .= "\n                document.write('</a>');";
$javascript .= "\n            }";
$javascript .= "\n        document.write(' | ');";
$javascript .= "\n    }";
$javascript .= "\n";
$javascript .= "\n";
$javascript .= "\n        if ((total_pages > 1) && (page_number <
total_pages)) {";
$javascript .= "\n            document.write('<a href=\"javascript:
scroll(0, 0);\" onclick=\"javascript: show_page(' + (page_number+1) +
')\">');";
$javascript .= "\n        }";
$javascript .= "\n        document.write(' Next &gt;&gt; ');";
$javascript .= "\n        if ((total_pages > 1) && (page_number <
total_pages)) {";
$javascript .= "\n            document.write('</a>');";
$javascript .= "\n        }";
$javascript .= "\n";
$javascript .= "\n        document.write('</div>');";
$javascript .= "\n    }";
$javascript .= "\n";
$javascript .= "\n </script>";

```

```
echo $javascript;
```

```
$DBSearch = new DatabaseSearch('localhost', 'mydb', 'root', 'salmon',
false);
```

```
$DBSearch-
```

```
>DrawForm2("search_thermalvac.php?theusr=$theviewerid",40,"Search
ThermalVac","Search ThermalVac History",true);
```

```
echo "\n<a href=\"add_thermalvac.php?theusr=$theviewerid\">Add New
Item</a>";
```

```
$printing_page = $page = 1;
```

```
$html = "\n\n <div id=\"page_1\" style=\"display: block;\">";
```

```
$i=0;
```

```
while ($i < $num) {
```

```
$page = ceil(($i+1)/$results_per_page);
```

```
if ($i == 0)
```

```
{
```

```

        $html .= "\n\n <script type=\"text/javascript\">\n
show_pages_links(" . ($page) . ");\n    </script>\n";
    }
else if ($page != $printing_page)
{
    $printing_page = $page;
    $html .= "\n\n    <script type=\"text/javascript\">\n
show_pages_links(" . ($page-1) . ");\n    </script>\n";
    $html .= "\n </div>";
    $html .= "\n <div id=\"page_\" . $page . \"\" style=\"display:
none;\">";
    $html .= "\n\n    <script type=\"text/javascript\">\n
show_pages_links(" . ($page) . ");\n    </script>\n";
}

$localid=mysql_result($result,$i,"id");
$localitem=mysql_result($result,$i,"item");
$localteam=mysql_result($result,$i,"name");
$localdate=mysql_result($result,$i,"date");
$timearray=getdate(mysql_result($result,$i,"stamp"));
$timestamp=
$timearray['hours'].":".$timearray['minutes'].":".$timearray['seconds']
;
$localsurvive=mysql_result($result,$i,"stresult");
$localthermal=mysql_result($result,$i,"ttresult");
$localbakeout=mysql_result($result,$i,"tbresults");
$localnotes=mysql_result($result,$i,"notes");
$localusername=mysql_result($result,$i,"username");

if($localcategoryid == 6){
$removeheader = "<th><font face=\"Arial, Helvetica, sans-serif\"
size=\"2\">Remove Item</font></th>";
$remove = "<th><font face=\"Arial, Helvetica, sans-serif\" size=\"2\">
<a
href=\"delete_thermalvac.php?thermalvacid=$localid&theusr=$theviewerid&
name=$localitem\">X</a></font></th>";
}

//color cells according to pass/fail/complete
if($localsurvive == "PASSED"){ $survivecolor = "bgcolor = \"33FF00\"";}
else if($localsurvive == "FAILED"){ $survivecolor = "bgcolor =
\"red\"";}
else { $survivecolor = "";}
if($localthermal == "PASSED"){ $thermalcolor = "bgcolor = \"33FF00\"";}
else if($localthermal == "FAILED"){ $thermalcolor = "bgcolor =
\"red\"";}
else { $thermalcolor = "";}
if($localbakeout == "COMPLETE"){ $bakeoutcolor = "bgcolor =
\"33FF00\"";}
else { $bakeoutcolor = "";}

if($i % $results_per_page == 0){
$html .= <<<HTML
<table border="1" cellspacing="0" cellpadding="2">
<tr>

```

```

<th><font face="Arial, Helvetica, sans-serif" size="2"><a
href="$ _SERVER[PHP_SELF]?theusr=$theviewerid&sort=idsort">ID</a></font>
</th>
<th><font face="Arial, Helvetica, sans-serif" size="2"><a
href="$ _SERVER[PHP_SELF]?theusr=$theviewerid&sort=itemsort">Item</a></f
ont></th>
<th><font face="Arial, Helvetica, sans-serif" size="2"><a
href="$ _SERVER[PHP_SELF]?theusr=$theviewerid&sort=teamsort">Team</a></f
ont></th>
<th><font face="Arial, Helvetica, sans-serif" size="2"><a
href="$ _SERVER[PHP_SELF]?theusr=$theviewerid&sort=datesort">Date of
Last Activity</a></font></th>
<th><font face="Arial, Helvetica, sans-serif"
size="2">Timestamp</font></th>
<th><font face="Arial, Helvetica, sans-serif" size="2"><a
href="$ _SERVER[PHP_SELF]?theusr=$theviewerid&sort=survivesort">Survivab
ility</a></font></th>
<th><font face="Arial, Helvetica, sans-serif" size="2"><a
href="$ _SERVER[PHP_SELF]?theusr=$theviewerid&sort=thermalsort">Thermal<
/a></font></th>
<th><font face="Arial, Helvetica, sans-serif" size="2"><a
href="$ _SERVER[PHP_SELF]?theusr=$theviewerid&sort=bakeoutsort">Bakeout<
/a></font></th>
<th><font face="Arial, Helvetica, sans-serif"
size="2">Notes</font></th>
<th><font face="Arial, Helvetica, sans-serif" size="2"><a
href="$ _SERVER[PHP_SELF]?theusr=$theviewerid&sort=usersort">Modified
By</a></font></th>
<th><font face="Arial, Helvetica, sans-serif" size="2">Edit
Item</font></th>
$removeheader
</tr>
HTML;
}
$html .= <<<HTML
<tr>
<td><font face="Arial, Helvetica, sans-serif" size="2"> $localid
</font></td>
<td><font face="Arial, Helvetica, sans-serif" size="2"> <a
href="thermalvac_history.php?thermalvacid=$localid&name=$localitem"
target="_blank">$localitem </a></font></td>
<td><font face="Arial, Helvetica, sans-serif" size="2"> $localteam
</font></td>
<td><font face="Arial, Helvetica, sans-serif" size="2"> $localdate
</font></td>
<td><font face="Arial, Helvetica, sans-serif" size="2"> $timestamp
</font></td>
<td $survivecolor><font face="Arial, Helvetica, sans-serif" size="2">
$localsurvive </font></td>
<td $thermalcolor><font face="Arial, Helvetica, sans-serif" size="2">
$localthermal </font></td>
<td $bakeoutcolor><font face="Arial, Helvetica, sans-serif" size="2">
$localbakeout </font></td>
<td><font face="Arial, Helvetica, sans-serif" size="2"> $localnotes
</font></td>
<td><font face="Arial, Helvetica, sans-serif" size="2"> $localusername
</font></td>

```

```

<td><font face="Arial, Helvetica, sans-serif" size="2"><a
href="edit_thermalvac.php?thermalvacid=$localid&theusr=$theviewerid">Ed
it</a></font></td>
$remove
</tr>
HTML;

if($i % $results_per_page == ($results_per_page - 1)){
    $html .= "</table>";
}

$i++;
}
$html .= "\n </table>";
$html .= " <script type=\"text/javascript\">\n  show_pages_links(" .
$page . ");\n</script>\n";
$html .= "</div>";

echo $html;
}
else
    { //echo "<br>No cookie found!";
      header("Location: login.php");
    }

mysql_close() or die (mysql_error());

?>

```

The code required for registering a new user on SIMS is part of the *new.php* script, shown next.

```

<?php

// new.php is intended for new SIMS users registration

require_once('connection.php');

// Connects to Database
mysql_select_db("mydb") or die(mysql_error());

//This code runs if the form has been submitted
if (isset($_POST['submit'])) {

//This makes sure they did not leave any fields blank
if (!$_POST['username'] | !$_POST['pass'] | !$_POST['pass2'] |
!$_POST['first'] | !$_POST['last'] )
    {die('You did not complete all of the required fields');

```

```

    }

    // checks if the username is in use
    if (!get_magic_quotes_gpc())
        {$_POST['username'] = addslashes($_POST['username']);
        }
    $usercheck = $_POST['username'];
    $check = mysql_query("SELECT username FROM users WHERE username
    ='$usercheck'");
    or die(mysql_error());
    $check2 = mysql_num_rows($check);

    //if the name exists it gives an error
    if ($check2 != 0)
        {die('Sorry, the username '.$_POST['username'].' is already in
    use.');
```

```

        }

    // this makes sure both passwords entered match
    if ($_POST['pass'] != $_POST['pass2']) {
    die('Your passwords did not match.');
```

```

    }

    // here we encrypt the password and add slashes if needed
    $_POST['pass'] = md5($_POST['pass']);
    if (!get_magic_quotes_gpc()) {
    $_POST['pass'] = addslashes($_POST['pass']);
    $_POST['username'] = addslashes($_POST['username']);
    }

    // now we insert it into the database
    $insert = "INSERT INTO users (username, password, first, middle, last,
    startdate, gender, citizenship, country, ethnicity, year, major,
    cellphone, otherumgroups, notes, categoryid, courseid, statusid,
    projectid, credits) VALUES ('".$_POST['username'].",
    '".$_POST['pass'].", '".$_POST['first'].", '".$_POST['middle'].", '".$_P
    OST['last'].", '".$_POST['startdate'].", '".$_POST['gender'].", '".$_P
    OST['citizenship'].", '".$_POST['country'].", '".$_POST['ethnicity'].",
    '".$_POST['year'].", '".$_POST['major'].", '".$_POST['cellphone'].", '
    '".$_POST['otherumgroups'].", '".$_POST['notes'].", '".$_POST['categoryi
    d'].", '".$_POST['courseid'].", '".$_POST['statusid'].", '".$_POST['pro
    jectid'].", '".$_POST['credits'].")";
    $add_member = mysql_query($insert);

    // insert into history (first record for new students)

    $stampnow = strtotime('now');

    // get the original values from users table
    $certs = mysql_query("SELECT * FROM users WHERE users.username
    ='$usercheck'") or die(mysql_error());

    while($info2 = mysql_fetch_array( $certs ))
        {$localfid = $info2["id"];
        $localtheviewerid = $info2["id"];

        $localnotes = $info2["notes"];

```



```

        $localcategoryid = $info2["categoryid"];
        $localcourseid = $info2["courseid"];

        $localstatusid = $info2["statusid"];

        $localprojectid = $info2["projectid"];
        $localterm = get_current_term();

        $localgrade = $info2["grade"];
        $localcredits = $info2["credits"];
    }

    $check = mysql_query("INSERT INTO history (id, stamp, studentid,
notes, categoryid, courseid, statusid, projectid, credits, term, grade,
madebyreal) VALUES (\\"\\", '$stampnow', '$localfid', '$localnotes',
'$localcategoryid', '$localcourseid', '$localfstatusid',
'$localprojectid', '$localcredits', '$localterm', '$localgrade',
'$localtheviewerid')")or die(mysql_error());

?>

<h1>Registered</h1>
<p>Thank you, you have registered - you may now <a
href=login.php>login</a> to S.I.M.S.</p>

<?php
}
else
{
    //$stampnow = strtotime('now');
    //$todaydate=date('Y/m/d',$stampnow)

?>

<style type="text/css">body {font: small Verdana}</style>
<body>
<form action="<?php echo $_SERVER['PHP_SELF']; ?>" method="post">

<b>S.I.M.S. Registration - New Members</b><br><br>

Hi! Welcome to S3FL's Information Management System.   People in S3FL
call me "SIMS".  <br>
Here you can register so that you may begin the process of joining
S3FL.<br>
<br>Filling out and submitting this form DOES NOT guarantee that you
have been placed in a project within the lab,  it is only the mechanism
used to setup interviews with your program advisors. <br>
<br>Important: This registration DOES NOT substitute your registration
through Wolverine Access,  it is each student's responsibility to make
sure you have your SIMS records matching what you have on Wolverine
Access.  For further questions please contact your S3FL Excom Program
Advisor.<br>

```

Students are officially enrolled in S3FL when their "SIMS status" is set to "Active".

Please use Internet Explorer or Netscape, and make sure you remember your password since there is no automatic recovery mechanism in place.

For questions about this form, please send an email to s3fl-sims at umich dot edu

```
<table border="0">
```

```
<tr><td>Username:</td><td>
```

```
<input type="text" name="username" maxlength="60">(use your um  
uniquename here, since automatic emails are sent to it)  
</td></tr>
```

```
<tr><td>Password:</td><td>
```

```
<input type="password" name="pass" maxlength="10">(this will be your  
"SIMS" password, you WILL need this on a weekly basis)  
</td></tr>
```

```
<tr><td>Confirm Password:</td><td>
```

```
<input type="password" name="pass2" maxlength="10">  
</td></tr>
```

```
<tr><td>First Name:</td><td>
```

```
<input type="text" name="first" maxlength="40">  
</td></tr>
```

```
<tr><td>Middle Name:</td><td>
```

```
<input type="text" name="middle" maxlength="30">  
</td></tr>
```

```
<tr><td>Last Name:</td><td>
```

```
<input type="text" name="last" maxlength="80">  
</td></tr>
```

```
<tr><td>Start in S3FL:</td><td>
```

```
<input type="text" name="startdate" value="2007/09/12">(please type  
todays date)  
</td></tr>
```

```
<tr><td>Gender:</td><td>
```

```
<input type="radio" name="gender" value="Male" checked>Male <input  
type="radio" name="gender" value="Female">Female  
</td></tr>
```

```
<tr><td>Citizenship:</td><td>
```

```
<select name="citizenship">  
<option value="US">US  
<option value="Non-US">Non-US  
</select>  
</td></tr>
```

```
<tr><td>Country of Origin:</td><td>
```

```
<select name="country">
```

```

        <option value="US">US
        <option value="Non-US">Non-US
    </select>
</td></tr>

<tr><td>Ethnicity:</td><td>
    <select name="ethnicity">
        <option value="White, non-Hispanic">White, non-
Hispanic
        <option value="Hispanic or Latino">Hispanic
        <option value="African-American">African-American
        <option value="Korean">Korean
        <option value="Japanese">Japanese
        <option value="Chinese">Chinese
        <option value="Indian">Indian
        <option value="Arab">Arab
        <option value="Native American">Native American
        <option value="Other">Other
    </select>
</td></tr>

<tr><td>Year:</td><td>
    <select name="year">
        <option value="Freshman">Freshman
        <option value="Sophomore">Sophomore
        <option value="Junior">Junior
        <option value="Senior">Senior
        <option value="First Yr Grad">First Yr Grad
        <option value="Second Yr Grad">Second Yr Grad
        <option value="Third Yr Grad">Third Yr Grad
    </select>
</td></tr>

<tr><td>Major:</td><td>
    <select name="major">
        <option value="AERO">AERO
        <option value="MECH">MECH
        <option value="EE">EE
        <option value="CS">CS
        <option value="CE">CE
        <option value="AOSS">AOSS
        <option value="IOE">IOE
        <option value="CHEM">CHEM
        <option value="NUCLEAR">NUCLEAR
        <option value="OTHER">OTHER

    </select>
</td></tr>

<tr><td>Cellphone:</td><td>
<input type="text" name="cellphone" maxlength="80">
</td></tr>

<tr><td>Other UM Groups:</td><td>
    <select name="otherumgroups">
        <option value="None">None
        <option value="Solar Car">Solar Car

```

```

        <option value="Mars Rover">Mars Rover
        <option value="Michigan microgravity">Michigan
microgravity
        <option value="AERO modeling Club">AERO modeling Club
        <option value="Other">Other
    </select> (Academic)
</td></tr>

<tr><td>Engineering skills (optional):</td><td>
    <select name="notes">
        <option value="None">None
        <option value="Advanced CAD">Advanced CAD
        <option value="Machining">Machining
        <option value="Advanced Machining">Advanced Machining
        <option value="Circuit board development">Circuit
board development
        <option value="Software Development">Software
Development
    </select>
</td></tr>

<tr><td>Your role in S3FL:</td><td>
<input type="radio" name="categoryid" value="1"
checked>Engineer</td></tr>

<tr><td>UM Course:</td><td>
<select name="courseid">
    <?php
        $query="SELECT * FROM courses";
        $result=mysql_query($query);
        $num=mysql_numrows($result);

        $k=0;
        while ($k<$num)
            {$eventlist=mysql_result($result,$k,"name");

$eventlistnumber=mysql_result($result,$k,"id");
            echo "<option
value=".$eventlistnumber.">".$eventlist."";
            $k++;
            }
    ?>
</select>(This is NOT signing you up for it, its just so we know
what you WOULD like to take)
</td></tr>

<tr><td>Credits:</td><td>
    <select name="credits">
        <option value="1">1
        <option value="2">2
        <option value="3">3
        <option value="4">4
        <option value="5">5
    </select> <font size=2> *Volunteers: 1 credit min</font>
</td></tr>

```

```

<tr><td>Current Status:</td><td>
<select name="statusid">
  <?php
    $query="SELECT * FROM status";
    $result=mysql_query($query);
    $num=mysql_numrows($result);

    $k=0;
    while ($k<$num)
      {$eventlist=mysql_result($result,$k,"name");

$eventlistnumber=mysql_result($result,$k,"id");
      if (($eventlist != "Active") and ($eventlist
!= "Former member") and ($eventlist != "Dropped") and ($eventlist !=
"Temporarily Inactive"))
        {echo "<option
value=".$eventlistnumber.">".$eventlist."";
          }
          $k++;
        }
      ?>
</select> <font size=2>(Right now you are in the "Interview
Stage")</font>
</td></tr>

<tr><td>Requested S3FL Project or team:</td><td>
<select name="projectid">
  <?php
    $query="SELECT * FROM projects";
    $result=mysql_query($query);
    $num=mysql_numrows($result);

    $k=0;
    while ($k<$num)
      {$eventlist=mysql_result($result,$k,"name");

$eventlistnumber=mysql_result($result,$k,"id");
      // old version //if (($eventlist != "< Faculty
>") and ($eventlist != "< ExCom >") and ($eventlist != "Special
Projects") and ($eventlist != "Unassigned"))
        if ($eventlist == "Unassigned")
          {echo "<option
value=".$eventlistnumber.">".$eventlist."";
            }
            $k++;
          }
        ?>
</select> <font size=2>(Right now Unnasigned is OK)</font>
</td></tr>

<tr><th colspan=2>
By clicking Register you are confirming that you have read carefully
this page and are certifying that you have filled out the application
accurately.<br>
<input type="submit" name="submit" value="Register">

</th></tr> </table>

```

```
</form>
```

```
</body>
```

```
<?php
```

```
}
```

```
?>
```

Appendix B

Design Task Additional Material

Additional material from the design task described in Chapter 5 is included in this appendix.

B.1 ADP seminar material

The material used to explain the ADP model to the teams is shown in this section. The presentation consisted of a detailed explanation of each of the stages of ADP, an example and opportunity for questions from the teams.

A design process

Outline



-
- A design process
 - Example
 - Questions

A design process

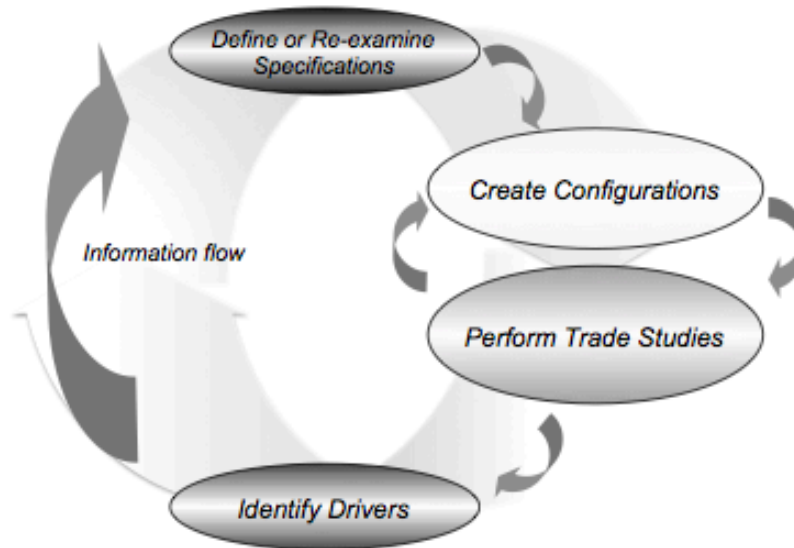

A design process



- Define **Specifications** – It is capturing statements that define what you are trying to achieve and how well it should perform
- Create **Configurations** – As many possible solution architectures are considered, based on the specifications and being as creative as possible
- Perform **Trade Studies** – Through rigorous disciplines (i.e. physics, engineering, etc.) relevant relationships between parameters are identified
 - *Iterate* between configurations and trade studies – identify what configuration to pursue
- Identify **Drivers** – If possible, try to identify parameters that govern the design, since they are in direct relationship with the performance
- *Iterate* this process until a feasible design is found

An example using the design process



- **Goal:**
 - Design of an imaging payload for a Low Earth Orbit small spacecraft

Step 1 – Define or re-examine specifications



- **Specifications (first design iteration)**
 - Payload shall take a color image of Earth with a Ground Resolution of at least 200 m per pixel
 - Payload shall take a color image of at least 1 Megapixel in size
 - Payload mass shall not exceed 100 g
 - Payload volume dimensions shall not exceed 50*50*50 mm
- **Notes**
 - Be thorough
 - Be descriptive
 - Be as specific as possible
 - During iterations it is ok to re-write, delete or add specifications

Step 1 – Define or re-examine specifications



• Specifications (after 3 design iterations)

- PLD-001 Payload shall take a color image of Earth with a Ground Resolution of at least 200 m per pixel
- PLD-002 Payload shall take a color image of at least 1 Megapixel in size
- PLD-003 Payload mass shall not exceed 100 g
- PLD-004 Payload volume dimensions shall not exceed 50*50*50 mm
- PLD-005 Payload should operate within the temperature range of range of -20 to 60 C (standby of -30 to 70 C)
- PLD-006 Payload should operate on 1.8V, 3V or 5V regulated voltage line
- PLD-007 Payload shall account for Image Blur, by taking 8-bit color images with a 50% Modulation Transfer Function (MTF) of at least 60 lp/mm.
- PLD-008 Payload hardware interface shall be via SPI, TWI, USB or UART/RS-232C/Serial Port
- PLD-009 Payload low level software interface shall consist of a Linux based driver
- PLD-010 Payload manufacturer shall provide significant customer support as determined by payload team
- PLD-011 Payload subsystem cost shall not exceed \$2000
- PLD-012 Payload shall be able to operate in a vacuum of at least 5.0 E-04 Torr
- PLD-013 Payload shall demonstrate a structural natural frequency of 100 Hz or higher (Sweep from 0 – 2000 Hz at 2.2 Hz/sec sweep rate and 0.25 g TBC)

Step 2 – Create configurations



- Some configurations include:
 - Single camera concept
 - Multiple low resolution cameras to create one high resolution image
 - Single space qualified high resolution camera
 - Image composition from two cameras in two separate spacecraft
- Notes
 - Keep in mind the specifications from the previous step
 - Create various configurations
 - Be innovative
 - Involve the entire team

Step 2 – Create configurations



- For this example:
 - A single camera configuration is selected
 - For a camera there are three different technologies available:

Charge Coupled Device (CCD)	Complementary Metal Oxide Semiconductor (CMOS)	Off the Shelf Digital Camera
Less Noise Higher Sensitivity Better Resolution Power ~3W Mass ~100g	Smaller/Lighter Cheaper Lower Resolution Lower Sensitivity Power ~1.5W Mass ~60g	Difficult to Interface: (Operating Controls, Data Retrieval, Analysis) Not Flexible

- For each of these technologies there should be trade studies performed

Step 3 – Perform trade studies



Trade study for CMOS technology single camera (summary)

Camera Model	Company	Interface	Resolution	Mass (g)	Volume (mm)	Power Req	Driver
PL-B958U-BL	Pixelink	USB	1600*1200	80	44x35x28	4.9 W	Linux & Windows
LU120	Lumenera	USB	1280*1024	150	50.8x 63.5x 41.4	2.5 W	Linux & Windows
VCC-F32529CL	CIS America	RS232	1392*1040	140	44*29*71.5	4 W	Windows
VCC-F32519CL	CIS America	RS232	1392*1040	140	44*29*71.5	4 W	Windows
TCM8240MD	Toshiba	Data/I2C	1300*1040	-	24*16*16	-	Windows

Sensor Model	Company	Interface	Resolution	Pixel Size	Volume (mm)	Power Req	Operating Temp (C)
OV-9655	Omnivision	I2C/SI	1280*960	3.0*3.0	12*12	40mW	-10-70
OVO-2655	Omnivision	I2C/SI	1600*1200	1.75*1.75	12*12	40mW	-10-70
OVO-3642	Omnivision	I2C/SI	2048*1536	1.75*1.75	12*12	40mW	-10-70

The highlighted areas are denoting the best candidates of the trade study

Step 4 – Identify drivers



- Drivers
 - Mass (first design iteration)
 - Power (second design iteration)
 - Specific hardware interface (third design iteration)
- *Iteration*
 - Until a feasible solution is found
- Notes
 - Seeking design drivers helps focus on parameters that influence performance the most
 - Sub-iteration between configurations and trades can help characterize which of the configurations is viable to lead to a solution

A design process



Example to help understand **trade studies**:*

- How can the largest hole be made using a typical hydraulic punch press? (maximum diameter)

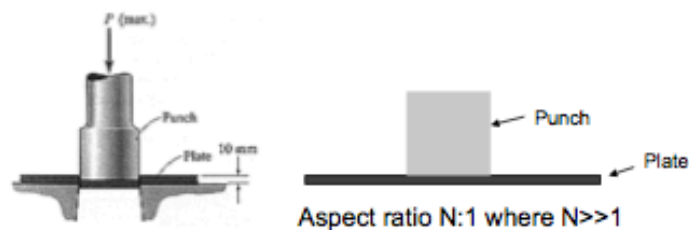

A typical press can have the following characteristics:

- A 800 kN punch press hydraulic capacity
- Used to punch circular holes in a 10 mm thick aluminum plate
- Average punching shear resistance of the plate is 230 MPa

* from Mechanics of materials, A. Craig, 2nd edition

A design process



- One option is to equate the load applied in the punch with the shearing resistance of the material.

$$P(\max) = \pi r t \sigma_s$$

$P(\max)$ - load in punch
 r - radius
 t - material thickness
 σ_s - shear stress

$$r = \frac{P(\max)}{\pi \sigma_s t} = \frac{800 \cdot 10^3 \text{ N}}{\pi 230 \cdot 10^6 \frac{\text{N}}{\text{m}^2} 10 \cdot 10^{-3} \text{ m}} \approx 110 \text{ mm}$$

- If we now have a load *specification*, for instance:
The load is 8 kN,
what would be our new guess of the radius?
 - The hole radius becomes 1.1 mm (?)

A design process



- BUT the aspect ratio of the design has changed so dramatically that the original assumptions of the hole radius being much bigger than the thickness is lost!

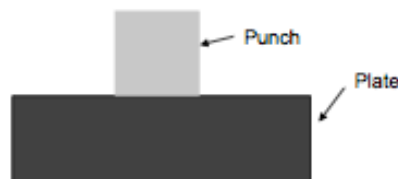

Schematic of a punch and a plate at a scale of about 1:1

- A preferred approach: a *trade study* that indicates where various combinations of radii and thicknesses are feasible...

A design process



- A trade study reveals a *feasible* region

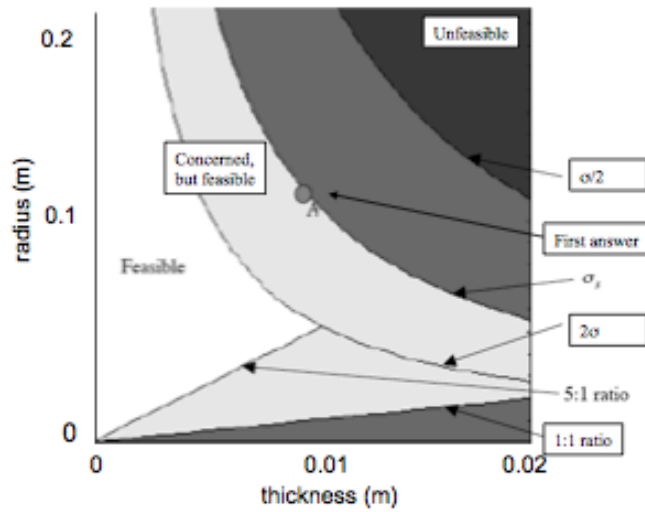

Trade study showing relationship between punch radii, r , and material thickness, t



Questions?

B.2 Design questionnaire

The full questionnaire used to collect information regarding the teams understanding of design processes is shown in this section. This was a questionnaire filled out online.

The first screen shows the introduction below:

Introduction

Thank you for taking the time to fill this questionnaire. This is a voluntary activity to help understand your design background. Here are some instructions.

- The purpose of this questionnaire is to understand your background and your experience in design.
- Your answers will provide valuable insight into design methods research.
- There are no right or wrong answers to any of the questions.
- Some of the questions may sound repetitive. Do not feel like you have to give a different answer if you feel you've already answered that question. We are asking so many questions because we want to make sure we understand your perspective clearly.

(Note to reader: From here on, each question is presented one at a time).

Background questions

1. Male/Female?
2. Graduate/Undergraduate?
3. What is your academic major?
4. What is your academic year?
5. In what engineering team are you working now?
6. Have you had experience working in industry?
7. If so, where?
8. In what capacity?
9. For how long?
10. During your academic career you have taken a formal design methodology class.

Design questions

Exploring problem representation (From here on, these titles not shown)

11. When designing, you follow a structured method

Strongly Disagree			Neutral			Strongly Agree
<input type="checkbox"/>	<input type="checkbox"/>	<input type="checkbox"/>	<input type="checkbox"/>	<input type="checkbox"/>	<input type="checkbox"/>	<input type="checkbox"/>

Note: each of the design questions present a similar seven-point scale option for collecting answers from the users.

12. When designing, defining a problem is always first
13. You finish a design when you find one solution to a problem
14. When designing, exploring the problem representation is the most important part of your method

Exploring graphical representation/visualization

15. You use representation tools (like graphics, sketches, etc.) during your design process

16. It is common for you to attempt to “visualize” elements of what you are designing
17. A list of specifications helps you visualize your design
18. A prototype or mock-up helps you visualize your design

Use functional decomposition

19. Instead of focusing on what the final product should be, you break down a design into several more detailed aspects to investigate
20. Complex systems can be decomposed into simpler systems
21. In a complex system design, if you are able to decompose into smaller components that you can test you gain insight into the overall design
22. Being able to design and test subsystems of a product independently is the most important part of your method

Explore engineering facts

23. You verify engineering facts (i.e. the magnetic property of a material that is being considered for a system) as needed during a design
24. Only after verifying engineering facts can you move along in a design
25. It is the team lead’s responsibility to verify engineering facts
26. Exploring engineering facts is the most important aspect of your design process

Explore issues of measurement

27. In your experience, you have discovered strategies for collecting information (i.e. documenting) that have improved your own ability to design
28. Standardization of information capture across a team is very useful for design
29. The way quantitative information is gathered relating to some aspect of the design is the most important part of a design process
30. Collecting quantitative information improves the quality of a design

Build normative model

- 31. There is value in creating normative models (a model of what the design might look like if you were not constrained or limited, that can be visual, physical, etc.)
- 32. Normative model building can also apply to design process management, not just artifact representation
- 33. Temporarily suspending your constraints while you design can be of value
- 34. Building a normative model is different from redefining constraints

Explore scope of constraints

- 35. Constraints are limitations of how a design can fulfill the goals within a problem frame
- 36. Constraints are physical
- 37. Constraints are conceptual
- 38. You as an engineer dictate what are the design constraints

Redefine constraints

- 39. Constraints are flexible
- 40. Constraints can change during a design process
- 41. Constraints can be re-defined
- 42. Spending effort to learn more about how constraints are affecting the design is the most important aspect of your methodology

Conduct failure analyses

- 43. When a design does not fulfill their goals or desired outcomes it is a failure
- 44. When a design does not meet the performance expectations it is a failure
- 45. When there is only a few aspects of under-performance in a design it is not considered a failure

- 46. Treating failed designs as disconfirming cases of performance can be a learning experience
- 47. You learn more from your own design failures
- 48. You learn more from other designers failures

Validate assumptions and constraints

- 49. Investigation of a success is as relevant of investigation of a failure
- 50. You test your designs in order to confirm that they are falling within constraints as expected
- 51. You test your designs in order to confirm that the assumptions you made are holding true
- 52. There should always be an engagement of the product users or other stakeholders in the design process to validate assumptions made

Search the space – evaluation of design alternatives

- 53. You have a standard approach for evaluating design alternatives
- 54. When starting a design, you methodically survey what has been done before similar to what you will be doing
- 55. Evaluating alternatives is the most important step in design
- 56. It is best to have as much design alternatives as possible

Examine existing designs

- 57. Design is a goal oriented heuristic search process in which the goals are not necessarily fixed
- 58. When you design, you spend most of your effort looking for existing solution ideas from design that already exist

Follow interactive/recursive/iterative design methodology

- 59. Design is an iterative process
- 60. All iterations in a design process are important
- 61. You as a designer can borrow solution ideas from designs that already exist
- 62. Interacting with other engineers has helped your own design process

Explore user perspective(s)

- 63. Everyone's involvement is equally important when designing
- 64. Everyone should know what the design requirements are
- 65. Everyone's involvement is important when creating requirements
- 66. You have learned (or follow) standard procedures for tracing requirements
- 67. Requirements are always flexible

Encourage reflection on design process

- 68. Design reviews are always needed in a program
- 69. You have reflected in the past about your own engineering design process
- 70. You have been a part of a full design process
- 71. The success of a design depends on the quality of the interactions between team members
- 72. The success of a design depends on the level of expertise of the team members
- 73. You have had more successful designs than failures
- 74. You understand everything that engineering design entails
- 75. You have an interest in improving your design skills

B.3 Additional material generated by the teams while implementing ADP

The full specifications list from Team 2 is shown in Table B.1.

Table B.1 Team 2 complete list of specifications – Iteration 1. All rationale added during iteration 2.

Spec. #	Sensors	Rationale (2)
1	The CanSat should have a GPS sensor	Satisfy Competition Guidelines
2	"GPS data: UTC time, latitude (degrees), longitude (degrees), mean sea level altitude, no. of satellites tracked"	Satisfy Competition Guidelines
3	The GPS data shall be transmitted once every 2 seconds (0.5 Hz)	Satisfy Competition Guidelines
4	The GPS should have an error <1m	"The team most closely predicting the landing coordinates of the lander shall receive a 10% point bonus to the flight day scores"
5	The GPS should work in optimal conditions at the Cansat's temperature	The sensors cannot fail during the mission
6	The GPS should work in optimal conditions at altitudes >500m	The sensors cannot fail during the mission
7	The GPS should have dimensions not greater than 30x30x30 mm	All the devices shall fit inside the cylindrical payload
8	The GPS shouldn't weight more than 20 grams	The CanSat with the lowest mass shall receive a 10% point bonus applied to the flight day scores
9	The GPS shouldn't cost more than \$50.	The cost of the CanSat should be less than \$500
10	The GPS should be located in the Carrier	Satisfy Competition Guidelines
11	The GPS module should operate with low voltage (2)	The power should be distributed to many devices

12	The CanSat should have a non GPS sensor to measure altitude in the carrier (2)	Satisfy Competition Guidelines
13	The CanSat should have a pressure sensor to measure altitude in the lander	Satisfy Competition Guidelines
14	The CanSat should have two pressure sensors (to measure altitude) (2)	We thought that a pressure sensor is the best non-GPS sensor to measure altitude
15	The altitude can be calculated in the CanSat or on the ground station (2)	Satisfy Competition Guidelines
16	The altitude data shall be transmitted on every 2 seconds (0.5 Hz) (2)	Satisfy Competition Guidelines
17	The altitude should be given in meters (2)	Satisfy Competition Guidelines
18	The pressure sensor should have an error <0.2m (2)	"The team most closely predicting the landing coordinates of the lander shall receive a 10% point bonus to the flight day scores"
19	The pressure sensor should work in optimal conditions at Cansat's temp (2)	The sensors cannot fail during the mission
20	The pressure sensor should work in optimal conditions at altitudes >500m (2)	The sensors cannot fail during the mission
21	The pressure sensor should have dimensions not greater than 30x30x30 mm (2)	All the devices shall fit inside the cylindrical payload
22	The pressure sensor shouldn't weight more than 20 grams (2)	The CanSat with the lowest mass shall receive a 10% point bonus applied to the flight day scores
23	The pressure sensor shouldn't cost more than \$5 (3)	The cost of the CanSat should be less than \$500
24	The pressure sensor should operate with low voltage (2)	The power should be distributed to many devices
25	The CanSat Should have a Temperature sensor (2)	Satisfy Competition Guidelines

26	The temperature data shall be transmitted onve every 2 seconds (0.5 Hz) (2)	Satisfy Competition Guidelines
27	Air temperature should be measured in Celsius (2)	Satisfy Competition Guidelines
28	The temperature sensor should have an error <1°C (2)	Measurements should be accurate
29	The temperature sensor should work in optimal conditions at Cansat's temperature (2)	The sensors cannot fail during the mission
30	The temperature sensor should work in optimal conditions at altitudes >500m (2)	The sensors cannot fail during the mission
31	The temperature sensor should have dimensions not greater than 30x30x30 mm (2)	All the devices shall fit inside the cylindrival payload
32	The temperature sensor shouldn't weight more than 20 grams (2)	The CanSat with the lowest mass shall receive a 10% point bonus applied to the flight day scores
33	The temperature sensor shouldn't cost more than \$5 (3)	The cost of the CanSat should be less than \$500
34	The temperature sensor should be calibrated in °Celsius (2)	Advantage over linear temperature sensors calibrated in ° Kelvin, as the user is not required to subtract a large constant voltage from its output to obtain convenient Centigrade scaling
35	The temperature sensor should be located in the carrier (2)	Satisfy Competition Guidelines
36	The temperatue sensor should operate with low voltage (2)	The power should be distibuted to many devices
37	The CanSat should have a device to measure the battery voltage (2)	Satisfy Competition Guidelines
38	The CanSat should have two voltage sensors (2)	One for the carrier and one for the lander

39	The battery voltage should be given in volts (2)	Satisfy Competition Guidelines
40	The voltage sensor should have an error < 0.01V (2)	Measurements should be accurate
41	The voltage sensor should work in optimal conditions at Cansat's temperature (2)	The sensors cannot fail during the mission
42	The voltage sensor should work in optimal conditions at altitudes >500m (2)	The sensors cannot fail during the mission
43	The voltage sensor should have dimensions not greater than 30x30x30 mm (2)	All the devices shall fit inside the cylindrical payload
44	The voltage sensor shouldn't weight more than 20 grams (2)	The CanSat with the lowest mass shall receive a 10% point bonus applied to the flight day scores
45	The voltage sensor shouldn't cost more than \$5. (3) (2)	The cost of the CanSat should be less than \$500
46	The voltage sensor might be custom-built (2)	We can save money and it may be a bonus for our design
47	One voltage sensor should be located in the carrier (2)	Satisfy Competition Guidelines
48	One voltage sensor should be located in the lander (2)	Satisfy Competition Guidelines
49	The voltage data shall be transmitted once every 2 seconds (2)	Satisfy Competition Guidelines
50	The CanSat should have an audible locating device (2)	Satisfy Competition Guidelines
51	The audible locating device should be a buzzer (2)	This seems to be the best option
52	The audible locating device should be activated during prelaunch and launch activities (2)	Satisfy Competition Guidelines
53	The audible device shall operate for at least one hour following activation (2)	Satisfy Competition Guidelines

54	The audible device should be located in the carrier (2)	Satisfy Competition Guidelines
55	The lander CanSat shall measure the force of impact with the ground (2)	Satisfy Competition Guidelines
56	The force of impact data shall be collected at a rate of at least 100 Hz (2)	Satisfy Competition Guidelines
57	The force of impact data shall be stored on-board for post processing (2)	Satisfy Competition Guidelines
58	The CanSat should have an accelerometer (2)	We are going to use the accelerometer to measure the force of impact
59	The acceleration sensor should have an error <1°C (2)	The measurement should be as accurate as possible
60	The acceleration sensor should work in optimal conditions at the CanSat's temperature (2)	The sensors cannot fail during the mission
61	The acceleration sensor should work in optimal conditions at altitudes >500m (2)	The sensors cannot fail during the mission
62	The acceleration sensor should have dimensions not greater than 30x30x30 mm (2)	All the devices shall fit inside the cylindrical payload
63	The acceleration sensor shouldn't weight more than 20 grams (2)	The CanSat with the lowest mass shall receive a 10% point bonus applied to the flight day scores
64	The acceleration sensor shouldn't cost more than \$5 (2)	The cost of the CanSat should be less than \$500
65	The acceleration sensor should be located in the carrier (2)	Satisfy Competition Guidelines
66	The acceleration sensor should operate with low voltage (2)	The power should be distributed to many devices
67	All the devices shall fit inside the cylindrical payload (2)	Satisfy Competition Guidelines

68	The CanSat shall not have flammable or pyrotechnic devices (2)	Satisfy Competition Guidelines
----	--	--------------------------------

Bibliography

- AAS/AIAA. (2011). Cansat Competition. Retrieved from <http://cansatcompetition.com>.
- AIAA. (2010). Retrieved from American Institute of Aeronautics and Astronautics (AIAA): <http://www.aiaa.org/content.cfm?pageid=224>
- Anderson, B., & Smith, R. (1994). Natural Orbital Environment Guidelines for Use in Aerospace Vehicle Development. NASA Technical Memorandum.
- Anderson, B., & Smith, R. (1994). Natural Orbital Environment Guidelines for Use in Aerospace Vehicle Development. Washington, DC: NASA Technical Memorandum.
- Atman, C., Cardella, M., Turns, J., & Adams, R. (2005). Comparing freshman and senior engineering design processes: an in-depth follow-up study. *Design Studies* , 26 (4), 325-357.
- Atman, C., Chimka, J., Bursic, K., & Nachtman, H. (1999). A comparison of freshman and senior engineering design processes. *Design Studies* , 20 (2), 131-152.
- Baird, F., Moore, C., & Jagodzinski, A. (2000). An ethnographic study of engineering design teams at Rolls-Royce Aerospace. *Design Studies* , 21 (1), 333-355.
- Beyer, H., & Holtzblatt, K. (1995). Apprenticing with the customer. *Communications of the ACM* , 38 (5), 45-52.
- Bilen, S., & Bernal, L. (1999). Get Away Special Payload G-093: The VOrtex Ring Transit EXperiment (VORTEX) Flights. 1999 Shuttle Small Payloads Symposium (pp. 129-138). Annapolis, MD: NASA/CP- 1999-209476.

Bilen, S., Bernal, L., Gilchrist, B., & Gallimore, A. (1999, April 8-10). The Student Space Systems Fabrication Laboratory: Enhancing Engineering Education Through Student-Run, Real-World Projects. ASEE-NCS Spring Conference , pp. 68-72.

Bolden, C. (2010a). NASA Budget Press Conference, February 1. NASA.

Bolden, C. (2010b). Statement before the Committee on Science and Technology, February 25. NASA.

Bolden, C. (2010c). Statement before the Committee on Science and Technology, May 26. NASA.

Borko, H. (1968). Information Science: What is it? *American Documentation* , 3-5.

Bowker, G., Star, S., Turner, W., & Gasser, L. (1997). *Social science, technical systems and cooperative work: Beyond the great divide*. Hillsdale, NJ: Erlbaum.

Britannica. (2007). Retrieved 04 10, 2008, from Encyclopedia Britannica online: <http://www.britannica.com/EBchecked/topic/1192819/wiki>

Bucciarelli, L. (1988). An ethnographic perspective on engineering design. *Design Studies* , 9 (3), 159-168.

Cambridge Dictionary of American English. (2010).

Cansat Team 1. (2010). MDR Report. Student Space Systems Fabrication Laboratory, University of Michigan, Ann Arbor, MI.

Cansat Team 2. (2010). MDR Report. Student Space Systems Fabrication Laboratory, University of Michigan, Ann Arbor, MI.

Carifio, J., & Perla, R. (2007). Ten Common Misunderstandings, Misconceptions, Persistent Myths and Urban Legends about Likert Scales and Likert Response Formats and their Antidotes. *Journal of Social Sciences* , 3 (3), 106-116.

Carle, A., Jaffee, D., & Miller, D. (2009). Engaging college science students and changing academic achievement with technology: A quasi-experimental preliminary investigation. *Computers and Education* , 52 (1), 376-380.

Cohan, L., Miller, D., & Uebelhart, S. (2006). Design Exploration for a Modular Optical Space Telescope Architecture Using Parameterized Integrated Models. 14th AIAA/ASME/AHS Adaptive Structures Conference. Newport, Rhode Island.

Congress of the United States. (2010, March 11). Letter to Charles Bolden. Washington, D.C.

Cortina, J. M. (1993). What Is Coefficient Alpha? An Examination of Theory and Applications. *Journal of Applied Psychology* , 78 (1), 98-104.

Cronbach, L. (1951). Coefficient alpha and the internal structure of tests. *Psychometrika* , 16 (3), 297-334.

Cubesat Community. (2010). From CubeSat.org: <http://www.cubesat.org>

Davies, C. (2002). Student engagement with simulations: a case study. *Computers and Education* , 39 (1), 271-282.

Doordan, D. (1996). *Design History: An Anthology*. The MIT Press.

ESTO. (2010). Earth Science Technology Office (ESTO) & M-Cubed Interim Review, University of Michigan, Ann Arbor, MI.

Evans, P., & Wolf, B. (2005). Collaboration rules. *Harvard Business Review* , 83 (7), 96-104.

Faniel, I., & Majchrzak, A. (2007). Innovation by accessing knowledge across departments. *Decision Support Systems* , 43, 1684-1691.

Friedenthal, S., & Moore, A. (2008). *A practical guide to SysML*. Burlington, MA: Morgan Kaufmann Publishers.

From, J., Kramer, S., & Pohl, E. (1997). A Small Satellite System Design Process. IEEE National Aerospace and Electronics Conference. Ohio.

George, D., & Mallery, P. (2003). SPSS for Windows step by step: A simple guide and reference (4th Edition ed.). Boston: Allyn & Bacon.

Getlein, M. (2008). Living with art (8th ed.). New York.

Gibson, J. (1992). How to Do A Systems Analysis. Charlottesville, VA: University of Virginia Department of Systems Engineering.

Goldberg, H., & Fuhrhop, K. (2004). Icarus (ProSEDS) Engineering Report. University of Michigan, Space Physics Research Laboratory.

Goldberg, H., & Gilchrist, B. (2003). The Icarus Student Satellite Project. IAA-B4-0601 4th IAA Symposium on Small Satellites for Earth Observation. Berlin, Germany.

Google Wave. (2010). Google Wave. From <http://wave.google.com>

Google. (2010). Google Documents. Retrieved from <http://docs.google.com>

Hammersley, M., & Atkinson, P. (1993). Ethnography: Principles in Practice. London, U.K.: Routledge.

Hammond, W. E. (1999). Space Transportation: A Systems Approach to Analysis and Design. American Institute of Aeronautics and Astronautics.

Hammond, W. E. (2001). Design Methodologies for Space Transportation Systems. Reston, VA: American Institute of Aeronautics and Astronautics.

Hanna, D. (1988). Designing Organizations for High Performance. Addison-Wesley.

Harland, D., & Lorenz, R. (2006). Space Systems Failures: Disasters and Rescues of Satellites. New York: Springer.

Hattie, J. (1985). Methodology review: Assessing unidimensionality of tests and items. *Applied Psychological Measurement*, 9, 139-164.

Heidorn, P., Mehra, B., & Lokhaiser, M. (2002). Complementary user-centered methodologies for information seeking and use: System's design in the biological information browsing environment (BIBE). *Journal of the American Society for Information Science and Technology* , 53 (14), 1251-1258.

Hitsquad Team. (2009). Cansat 2009 Final Report. University of Michigan.

Holzle, U. (2010, 8 4). The Official Google Blog. Retrieved from <http://googleblog.blogspot.com/2010/08/update-on-google-wave.html>

Hu, Z., Guo, J., You, Z., & Ren, D. (2003). A New System Engineering Method for Spacecraft Design. AIAA Space 2003 Conference and Exposition. Long Beach, CA.

IDS Systems. (2007). IDS Imaging Systems CMOS USB 2.0 Cameras. Obersulm.

INCOSE. (1998). *Systems Engineering Handbook*. San Diego, CA: International Council on Systems Engineering.

Ismail, A., Hussain, R., & Jamaluddin, S. (2010). Assessment of students' learning styles preferences in the faculty of science, Tishreen University, Syria. *Social and Behavioral Sciences* , 2 (1), 4087-4091.

Jamieson, S. (2004). Likert scales: how to (ab)use them. *Medical Education* , 38 (12), 1217-1218.

Jick, T. (1979). Mixing qualitative and quantitative methods: Triangulation in action. *Administrative Science Quarterly* , 24, 602-611.

Kerne, A., Smith, S., & Koh, E. (2008). An experimental method for measuring the emergence of new ideas in information discovery. *International Journal of Human-Computer Interaction* , 24 (5), 460-477.

Leifer, R., & McDemott, G. (2000). *Radical Innovation*. Harvard Business School Press .

Likert, R. (1932). A Technique for the Measurement of Attitudes. *Archives of Psychology* .

Liu, T., Deline, C., Ramos, R., Sandoval, S., Bellerose, J., Washabaugh, P., et al. (2007). Challenges Facing the Student Space Systems Fabrication Laboratory and Lessons Learned. ASEE-2007-1409 114th ASEE Conference .

Liu, T., Deline, C., Ramos, R., Sandoval, S., Smetana, A., Gilchrist, B., et al. (2006). The Student Space Systems Fabrication Laboratory: An Approach to Space Systems Engineering Education. ASEE-2006 Conference and Exposition .

Mahler, J. (2004). Management of groups. *Engineering Education* , 3-5.

Maier, M., & Rechtin, E. (2000). *The art of systems architecting* (2nd Edition ed.). Boca Raton, FL: CRC Press.

Majchrzak, A., Cooper, L. P., & Neece, O. E. (2004). Knowledge Reuse for Innovation. *Management Science* , 50 (2).

Mann, H., & Whitney, D. (1947). On a test of whether one of two random variables is stochastically larger than the other. *Annals of Mathematical Statistics* , 18 (1), 50-60.

Markus, M. (2001). Toward a theory of knowledge reuse: Types of knowledge reuse situations and factors in reuse success. *Journal of Management Information Systems* , 18 (1), 57-91.

Mawson, B. (2003). *Breaking the Shackles: Beyond the Design Process*. Auckland, New Zealand: Center for Technology Education.

McManus, H., Hastings, D., & Warmkessel, J. (2004). New Methods for Rapid Architecture Selection and Conceptual Design. *Journal of Spacecraft and Rockets* , 41 (1).

Mehalik, M. M., & Schunn, C. (2006). What constitutes good design? A review of empirical studies of design processes. *International Journal of Engineering Education* , 22 (3), 519-532.

Mintzberg, H. (1979). An emerging strategy of "direct" research. *Administrative Science Quarterly*, 24, 580-589.

Morgan, G. (1997). *Images of Organization* (2nd Edition ed.). Thousand Oaks, CA: SAGE Publications, Inc.

MySQL Reference. (2010). *MySQL Reference Manual 5*.

NASA Cubesat. (2010). Retrieved from NASA's Cubesat Launch Initiative: http://www.nasa.gov/directorates/somd/home/CubeSats_initiative.html

NASA Landsat. (2011). Seasonal Illumination Variations. Retrieved from <http://landsat.gsfc.nasa.gov/images/seasons.html>

NASA Microgravity. (2011). Retrieved from NASA Reduced Gravity Student Flight Opportunities Program: <http://microgravityuniversity.jsc.nasa.gov/theProgram/index.cfm>

NASA NPOESS ICD. (2011). National Polar-Orbiting Operational Environmental Satellite System (NPOESS) Interface Control Document Vol 1. NASA DoD Raytheon Norhtrop Grumman.

NASA RASC-AL. (2011). Retrieved from Revolutionary Aerospace Systems Concepts – Academic Linkage: <http://www.nianet.org/RASCAL/index.aspx>

NASA SP 8018. (1969). Spacecraft magnetic torques.

NASA SP 8027. (1969). Spacecraft radiation torques.

Nunnally, J. (1978). *Psychometric theory* (2nd Edition ed.). New York: McGraw-Hill.

Obama, B. (2010, April 15). Remarks by the President on Space Exploration in the 21st Century. Kennedy Space Center, FL.

Omnivision. (2008). OV2655 Product Specifications sheet Version 1.0. Omnivision, Santa Clara, CA.

Osburn, H. G. (2000). Coefficient alpha and related internal consistency reliability coefficients. *Psychological Methods* , 5 (3), 343-355.

Patel, M., & Lewis, K. (2003). System Design Through Subsystem Selection Using Physical Programming. *AIAA Journal* , 41 (6).

Pemberton, M. (1990). *Information Science: The interdisciplinary context*. New York, NY: Neal-Schuman.

Petrelli, D., Beaulieu, M., Sanderson, M., Diemetriu, G., Herring, P., & Hansen, P. (2004). Observing users, designing clarity: A case study on the user-centered design of a cross-language information retrieval system . *Journal of the American Society for Information Science and Technology* , 55 (10), 923-934.

Philips NXP. (2007). I2C Bus specification and user manual. NXP Semiconductors.

Popescu, D., & Hellicar, A. (2010). Point spread function estimation for a terahertz imaging system. *Journal on Advances in Signal Processing* , 2010.

PPR. (1995). Portland Pattern Repository. Retrieved from <http://c2.com/cgi/wiki?WikiHistory>

Pugh, S. (1991). *Total Design: Integrated Methods for Successful Product Engineering*.

Ramos, R. (2007). S3FL Information Management System definition documentation. Student Space Systems Fabrication Laboratory. University of Michigan, Ann Arbor.

Ramos, R. (2008). Tethered Satellite Ionospheric eXplorer Concept. 6th International Academy of Astronautics Symposium on Small Satellites. Berlin, Germany: 1st place, Graduate Student Paper.

Ramos, R., & Liu, T. (2005). Field Emission Get-Away-Special Investigation (FEGI) Final Technical Report. University of Michigan, Student Space Systems Fabrication Laboratory.

RAX. (2010). Radio Aurora Explorer spacecraft. Retrieved from <http://rax.engin.umich.edu>

Rogers Commission. (1986). Report of the Presidential Commission on the Space Shuttle Challenger Accident.

Ross, A., Hastings, D., & Warmkessel, J. (2004). Multi-Attribute Tradespace Exploration as Front End for Effective Space System Design. *Journal of Spacecraft and Rockets* , 41 (1).

S3FL. (2010). S3FL Standard Operating Procedures. S3FL.

Saracevic, T. (1999). Information Science. *Journal of the American Society for Information Science* , 50 (12), 1051-1063.

Schein, E. (1984). Coming to a new awareness of organizational culture. *Management Review* , 25 (1), 3-16.

Sentech America. (2006). Sentech C202 USB CCD Camera specifications document. Sentech America.

Shapira, B., Kantor, P., & Melamed, B. (2001). The effect of extrinsic motivation on user behavior in a collaborative information finding system. *Journal of the American Society for Information Science and Technology* , 52 (11), 879-887.

Shishko, R., & Chamberlain, R. (1995). *NASA Systems engineering handbook*, SP-610S. NASA, Washington, D.C.

Simon, H. (1996). *The Sciences of the Artificial*. MIT Press.

Smetana, A., Liu, T., Ramos, R., Gilchrist, B., & Washabaugh, P. (2007). Microgravity Flight Testing as a Case Study for the Student Space Systems Fabrication Laboratory. ASEE-2007-1442 Conference. Honolulu, HI.

Suchman, L. (1987). *Plans and situated actions: The problems of human-machine communication*. Cambridge University Press.

Titus, N., & Schunn, C. (2008). What design processes predict better design outcomes? The case of robotics design teams. Proceedings of the TMCE. Izmir: TMCE.

Washabaugh, P. (1999). A Design Process. Rudiments of a Design Process Notes . Ann Arbor.

Wersig, G. (1993). Information science: the study of postmodern knowledge usage. Information Processing and Management , 29, 229-239.

Wertz, J., & Larson, W. (1999). Space Mission Analysis and Design (3rd ed.). El Segundo, CA: Microcosm Press.

Wikipedia. (2011). Retrieved from Wikipedia: <http://en.wikipedia.org/wiki/Wikipedia>