

Effects of Age and Peripheral Neuropathy on Responses
to an Unexpected Underfoot Perturbation during Gait

by

Hogene Kim

A dissertation submitted in partial fulfillment
of the requirements for the degree of
Doctor of Philosophy
(Biomedical Engineering)
in The University of Michigan
2012

Doctoral Committee:

Research Professor James A. Ashton Miller, Co-Chair
Professor James K. Richardson, Co-Chair
Professor Thomas J Armstrong
Associate Professor Susan Brooks Herzog

© Hogene Kim

All rights reserved 2012

To Yul

Acknowledgements

At one point during my doctoral studies, I was really doubtful that I could complete this dissertation. Then my advisor, Dr. James Ashton-Miller, continued to offer encouragement with a warmth that I treasure. My thanks also to Dr. James K. Richardson for all his clinical help and support with this project.

I thank my fellow graduate students in the Biomechanics Research Laboratory for their companionship and help over the years.

I am grateful to the National Institute on Aging for their financial support through Public Health Service grant R01 AG 026569.

I thank my Mom and Dad, Young-A Shin and Kyu-Soo Kim, who have been waiting for this day for a long time. Their endless support has made this possible.

Last, but not least, I thank my family for all their support. My wife, Yul, has been a tower of strength and source of love through thick and thin. And our daughter, Sian, born during this period and now 5 years old, is provided both of us joy and motivation. Thank you both.

Table of Contents

Dedication	ii
Acknowledgements	iii
List of Figures	vii
List of Tables	xii
Abstract	xiv

Chapter

1. Introduction	1
2. Frontal Plane Hip and Ankle Sensorimotor Function, not Age, Predicts Unipedal Stance Time	14
2.1. Introduction	
2.2. Methods	
2.3. Results	
2.4. Discussion	
3. Which Lower Limb Sensory and Motor Functions are Required for Functional Gait on Uneven Surfaces in Older Persons with Diabetic Neuropathy?	33
3.1. Introduction	
3.2. Materials and Methods	
3.3. Results	
3.4. Discussion	
4. A Novel Clinical Test of Simple and Recognition Reaction Time in Healthy Adults	49

4.1. Introduction	
4.2. Method	
4.3. Results and Discussion	
5. A Shoe Sole-based Apparatus and Method for Randomly Perturbing the Stance Phase of Gait: Test-Retest Reliability in Young Adults	64
5.1. Introduction	
5.2. Methods	
5.3. Results	
5.4. Discussion	
6. Effect of Age on the Ability to Recover from a Single Unexpected Underfoot Perturbation During Level Gait: Kinematic Responses.....	74
6.1. Introduction	
6.2. Methods	
6.3. Results	
6.4. Discussion	
7. Effect of Peripheral Neuropathy on the Ability to Recover from an Unexpected Underfoot Perturbation while Walking: Kinematic, Kinetic and EMG Responses	89
7.1 Introduction	
7.2 Methods	
7.3 Results	
7.3.1 The First Medially Perturbed Recovery Step Responses	
7.3.2 The First Laterally Perturbed Recovery Step Responses	
7.4 Discussion	
8. The Relationship between Lower Extremity Frontal Plane Muscle Capacities and Step Width Responses to an Underfoot Perturbation in Older Subjects with and without Peripheral Neuropathy	107
8.1 Introduction	
8.2 Methods	
8.3 Results	
8.4 Discussion	

9. Effect of a Vocal Choice Reaction Time Task on the Kinematics of the First Recovery Step after a Sudden Underfoot Perturbation during Gait	120
9.1. Introduction	
9.2. Subjects and Methods	
9.3. Results	
9.4. Discussion	
10. General Discussion	136
11. Conclusions	145
Appendix	148

List of Figures

Figure 1-1 Gradient loss of sensory function in patient with peripheral neuropathy. (black)	2
Figure 1-2. Conceptual neuromusculo-skeletal system model for studying the effects of a single underfoot perturbation (disturbance), age and disease, lower extremity muscle strength, and ankle proprioception on the response of an upright human in single leg stance.	3
Figure 1-3. A forward dynamics frontal plane model simulation showing the effect of applying a solitary positive or negative 50 Nm moment at each of six major joints on the magnitude and direction of the resulting ground reaction force direction during unipedal balance on a fulcrum.	5
Figure 2-1 Scatterplots illustrating the relationship between hip strength and ankle proprioception. The equation for the curvilinear regression is $y = 0.0098e^{0.067x}$	23
Figure 2-2 A comparison of (a) hip strength and (b) ankle proprioceptive thresholds in subjects who demonstrated shorter (left) and longer (right) USTs.....	24
Figure 3-1. Apparatus for determining frontal plane ankle proprioceptive thresholds ...	36
Figure 3-2. Experimental set-up for determining gait speed and step width to step length ratio on an irregular surface.....	38
Figure 4-1. The clinical reaction time apparatus and testing procedure: (a) the apparatus, (b) predrop examiner and test subject positions, and (c) post drop examiner and test subject positions. For the purpose of this illustration, neither the subject nor testing apparatus is instrumented with optoelectronic markers. The lightemitting diode can be	

seen at far right in (a) as the small light-colored hemisphere mounted on the circular shaped transparent plastic top cover to the finger spacer, here seen in side view.....52

Figure 4-2a Boxplots with scatter plots of mean and variabilities in simple RT_{clin} and variability, recognition RT_{clin} and its variability, Overall and OFF accuracy.....57

Figure 4-2b Boxplots with scatter plots of mean and variabilities in RT_{clin} and accuracy for gender effect.57

Figure 5-1. Sample anterior view of the modified 11 ½ mens sandal showing the shoe orientation with undeployed flap (middle), a 18.4 mm high medial flap deployed in the parasagittal plane so as to invert the foot during midstance (right), and 18.4 mm high lateral flap deployed in the parasagittal plane to evert the foot during midstance (left). Two actuators and flaps are concealed within each shoe sole.....67

Figure 6.1. Anterior view of the modified 11 ½-sized Mens sandal showing the shoe orientation with : (Right) a 18.4 mm high medial flap (dotted circle) deployed in the parasagittal plane so as to invert the foot during midstance, and (center) undeployed flap, (Left) 18.4 mm high lateral flap (dotted circle) deployed in the parasagittal plane to evert the foot during midstance. Two actuators and flaps are concealed within each shoe sole.....77

Figure 6-2. Box- and scatter plots of ΔSW (first row) and ΔSL (second row) in MP (first and second columns) and LP (third and fourth columns) recovery steps for HY (first and third columns) and HO (second and fourth columns) subjects.82

Figure 6-3. Box and scatter plots of the peak torso inclination and lateral pelvic displacement kinematic responses, $\Delta\theta_{trunk}$ (+: more lateral rotation than UnP) and ΔLPD (+: more lateral movement than UnP) in the frontal plane over the first recovery steps..... 82

Figure 7-1. Boxplots and scatter plots of step width (SW) and lateral pelvic displacement (LPD) for the 1st medially-perturbed (MP_1) steps.....94

Figure 7-2. Pearson’s linear correlation coefficients and least-square regression line between Δ Step Kinematics (Δ SW, Δ SL, Δ ST) and Δ LPD in the 1st MP (MP_1) recovery step.....95

Figure 7-3. Pearson’s linear correlation coefficients and least-square regression line (top) severity of PN vs vertical ground reaction force of the perturbed stance limb, (2-4th rows) delta step kinematics, and (5th row) delta lateral pelvic displacement against horizontal (F_{hor}) and vertical (F_{ver}) components of ground reaction forces for the first medially-perturbed (MP_1) recovery steps.....96

Figure 7-4. Boxplots with scatter plots of Δ rms EMG amplitude and Delta raw RMG onset in ankle muscle groups (Per-L: Peroneus Longus, m-SOL: medial soleus) in the first medially-perturbed (MP_1) recovery step in HO and PN.97

Figure 7-5. Boxplots and scatter plots of step width (SW) and lateral pelvic displacement (LPD) for the 1st laterally-perturbed (LP_1) steps.....98

Figure 7-6. Pearson’s linear correlation coefficients and least-square regression line between Δ Step Kinematics (Δ SW, Δ SL, Δ ST) and Δ LPD in the 1st LP (LP_1) recovery step.98

Figure 7-7. Pearson’s linear correlation coefficients and least-square regression line (top) severity of PN vs vertical ground reaction force of the perturbed stance limb, (2-4th rows) delta step kinematics, and (5th row) delta lateral pelvic displacement against horizontal (F_{hor}) and vertical (F_{ver}) components of ground reaction forces for the first laterally-perturbed (LP_1) recovery steps.99

Figure 7-8. Boxplots with scatter plots of Δ rms EMG amplitude and Delta raw RMG onset in ankle muscle groups (Per-L: Peroneus Longus, m-SOL: medial soleus) in the first laterally-perturbed (LP_1) recovery step in HO and PN.100

Figure 8-1 Bar graphs with scatter plots of maximum rate of torque development (MRTD) in ankle (Inversion/Eversion) and hip (Abduction/Adduction) movement in frontal plane. HO denotes healthy old with Michigan Diabetic Neuropathy Score (MDNS) = 0, mPN denotes mild Peripheral Neuropathy with $0 < MDNS < 10$, and PN denotes

peripheral neuropathy with MDNS ≥ 10 . p-values in brackets were calculated using rm-ANOVA.111

Figure 8-2 Boxplots with scatter plots of recovery Δ step kinematics

($\Delta X = \bar{X}_{1st\ recovery\ step} - \bar{X}_{unperturbed\ step}$) following a single underfoot medial perturbation (MP) or lateral perturbation (LP) in three groups (HO (MDNS =0), mild PN ($0 < MDNS < 10$), PN (MDNS ≥ 10)).112

Figure 8-3. Boxplots and scatter plots of Δ EMG ($\Delta X = \bar{X}_{1st\ recovery\ step} - \bar{X}_{unperturbed\ step}$)

(rms) amplitude (left three columns) and Δ EMG (rms) onset (right three columns) in ankle muscle groups (Per-L: Peroneus Longus, m-SOL: medial soleus) in the first medially-perturbed (MP₁) and laterally-perturbed (LP₁) recovery step in three groups (HO (MDNS =0), mild PN ($0 < MDNS < 10$), PN (MDNS ≥ 10)).113

Figure 8-4 Scatter plot with regression line (left) calculated from Pearson correlation

coefficients. Ankle inversion maximum rate of torque development (MRTD) estimated the first medially perturbed (MP₁) Step width (SW) ($R = -0.354$ ($p = 0.002$)). Bar graphs with scatter plots of normalized ankle inversion MRTD in three groups (HO, mPN, PN)114

Figure 8-5 Pearson linear correction between the second medially perturbed Δ SW (i.e.

Perturbed – Unperturbed Step Width (cm)) and off accuracy in manual reaction time measurement (%).116

Figure 9-1. Top figure (A) shows the anterior view of the perturbing shoe in three

orientations during midstance: left - lateral flap (dotted circle) deployed; middle - no flap deployed; right - medial flap (dotted circle) deployed. Note eversion at left and inversion at right. Lower figure (B) illustrates the change in stance phase ankle inversion angle in a sample unperturbed trial (middle solid line), with medial perturbation (upper dotted line) and with lateral perturbation (lower dashed line).123

Figure 9-2. Definition of the first recovery step width and length. The first recovery step time was defined as the time between heel strikes of the perturbed and the first recovery step.125

Figure 9-3. A sample trial from the left foot of a single subject. Data from unperturbed trials (left column) are compared with data from a medial perturbation trial (“LM”, right column). The center of pressure (CoP) tracings are shown at top. Also shown from top to bottom are the ground reaction force vs. time plots (second row), CoP tracing in the horizontal plane (third row), and peroneal muscle responses (fourth row). The arrow denotes the onset of ground contact of the flap, and the bars underline the response to the LM perturbation.....126

Figure 9-4. Summary box- and scatter-plots of the change in recovery step kinematics (ΔSL , ΔSW , ΔST) from the unperturbed step values for single task and dual task tests.127

Figure 9-5. Effect of posture and gait (unperturbed and perturbed) on median, upper and lower quartiles, and 95th percentile vocal choice reaction time (vCRT) in healthy young subjects.129

Figure 10-3. Simulation results for changes in resulting ankle inversion angle for (at left) different duration (ms) ankle and (at right) different magnitude (Nm) eversion torque responses (see different curve types within text boxes) to reach maximum range of motion (35 degrees) of ankle inversion.139

List of Tables

Table 2-1. Mean (SD) demographic and neuromuscular capacity results.....	21
Table 2-2. Bivariate correlations between UST and neuromuscular capacities, age and BMI.....	22
Table 2-3 Regression model	22
Table 3-1 Subject information	39
Table 3-2a Correlation coefficients between sensorimotor functions and gait speed	40
Table 3-2b Correlation coefficients between sensorimotor functions and step width to step length ratio	40
Table 3-3a Sensorimotor functions predicting gait speed on the irregular surface RTD Hip Add = Rate of torque development of Hip Adductors; RTD Ankle Inv = Rate of torque development of Ankle inversion; Confidence (ABC scale); MVC Hip Abd = Maximum voluntary contraction of Hip Abduction	41
Table 3-3b. Sensorimotor functions predicting step width to step length ratio RTD Hip Add = Rate of torque development of Hip Adductors	41
Table 5-1 Mean (SD) values of each of the gait parameters by walking speed and visit. The medial and lateral perturbation each significantly affected the first recovery step width at each speed.....	69
Table 5-2 Intraclass correlation coefficients (ICC) illustrating the test-retest reliability for each kinematic gait parameter measured at each gait speed.	70
Table 6-1. Subject demographics.....	76

Table 6-2. Main and interaction effects from single factor repeated measures ANOVA for comparing presence of perturbation (UnP/Ptb), perturbation type (MP/LP), and recovery steps (RS1/RS2) in HY and HO groups.....81

Table 9-1 Kinematics of the first recovery step after medial and lateral perturbation without (MP and LP respectively) and with vocal choice reaction task (vMP and vLP respectively). UnP: step kinematics during unperturbed gait.....128

Table 10-1. Comparison between the mediolateral ground reaction shear force developed by maximum ankle and hip muscle strengths. (Ankle: data are measured values during maximum rate of inversion/eversion torque development tests; Hip: direct calculation found by dividing measured maximum hip abduction/adduction strengths by leg length)141

ABSTRACT

Advancing age and diabetic peripheral neuropathy (PN) are both associated with an increased risk of fall-related injuries, especially when walking on uneven surfaces, but little is known about the effect of even a single unexpected underfoot perturbation on gait kinematics. The challenge of establishing the effects of such a perturbation arises from the difficulty of isolating the stimulus-response relationships due to carryover effects from earlier perturbations. To address this challenge a custom perturbing shoe was invented to present a single unexpected medial or lateral underfoot perturbation during level gait. The shoe was used to test the primary hypotheses that both age and increasing severity of PN would affect the kinematic response to these perturbations, chiefly by affecting myoelectric latencies, ankle proprioceptive thresholds, and ankle and hip muscle strength capacities.

We recruited 42 older subjects with and without PN and 26 healthy young subjects. We measured manual reaction times, unipedal balance times, lower extremity strength capacities, gait kinematics, lower extremity electromyographic latencies and ground reaction forces during gait trials with underfoot perturbations randomly presented in 16 of 60 gait trials. The results showed that hip strength was a significant predictor of unipedal stance time ($R^2 = 0.73$). Hip abduction/adduction and ankle inversion strengths explained almost 70% of the variation in gait speed over an uneven surface. The perturbing shoe

proved a reliable method for affecting step kinematics following an unexpected underfoot perturbation. In healthy young adults, the single perturbation affected the kinematics of up to four of recovery steps but not pelvic displacements. Despite exhibiting EMG responses on the first recovery step, healthy older adults chose to alter their lateral pelvic displacements, but not recovery step kinematics. Subjects with moderate PN did not display early EMG or step kinematic responses, but larger lateral pelvic displacements than the healthy older adults. These results suggest that with advancing age and PN, subjects employ a stance limb hip response rather than an ankle response to recover from a single underfoot perturbation.

These results suggest that future interventions for patients with moderate PN should aim to increase maximum hip strength and rate of strength development.

Chapter 1

Introduction

1.1 Overview

Falls among older persons are costly to society in financial and human terms.

One in three adults 65 years and older falls each year (Hausdorf et al., 2001, Hornbrook et al., 1994). Among those who fall, 20% to 30% suffer moderate to severe injuries that make it hard to live independently (Alexander et al., 1992). The cause of numerous injuries and social dysfunction, falls are responsible of a majority of accidental deaths being the fifth leading cause of death among persons 65 years and older (Rubenstein and Josephson, 1996). In 2000, the total direct cost of all fall injuries for people 65 years and older exceeded \$19 billion (Stevens et al., 2006). The financial cost of falls in older adults is expected to reach \$54.9 billion by 2020 (Englander et al., 1996). Clearly, falls in the elderly engender serious socioeconomic costs both on an individual and societal level.

Peripheral neuropathy due to diabetes and other causes leads to balance impairment and is a potential risk factor for falls.

About 25.8 million people in United States (18.8 million diagnosed and 7.0 undiagnosed people) – 8.3 percent of the population – have diabetes. Among U.S residents ages 65 years and older, 10.9 million (26.9%) had diabetes in 2010. About 60 to 70 percent of people with diabetes have some form of neuropathy (NIDDK Publication No.11-3892 Feb 2011). The most common type of neuropathy is peripheral neuropathy (PN). PN is known to adversely affect the longest nerve axons of the peripheral nerves bilaterally (Dumitru et al. 2002).

Figure 1-1 shows PN's distal-to-proximal gradient loss of sensory and motor function. The nerves in feet and legs are likely to be affected before the arms and hands. So PN may cause muscle weakness, loss of reflexes, especially in the feet and at the ankle. As a result, it is not surprising that PN has been found to impair bipedal and unipedal balance (Uccioli et al., 1995; Simoneau et al., 1994; Richardson et al., 1996; Ashton-Miller et al., 1996; Gutierrez et al., 2001).

Time delay and influences the stability of a system.

Impairments of nerve function could lead to an increase in time delay in a closed loop neural system or neuromuscular system. In any closed loop feedback control system a time delay reduces the stability of a feedback controlled system (Franklin 1994). The most effective way to understand the effect of time delay is to perturb the system, measure its response and then compare it with the unperturbed response. So, for gait, one can quantify the response to postural perturbations during gait by studying the change in variability in step kinematics (i.e., step width, step length, step time) from that in unperturbed gait.



Figure 1-1 Gradient loss of sensory function in patient with peripheral neuropathy. (black)

Do afferent and efferent impairments in the elderly and patients with PN lead to time delay in neuromuscular feedback system?

In this thesis we aim to study the effect of age and PN on step kinematics during gait over a single perturbation or series of perturbations, because patients with PN remark that their balance feels most threatened when walking on uneven surfaces, particularly at dusk or in the dark (Thies 2005). Thus they feel that they are most likely to fall on an uneven surface, so if we understood better why, we may be able to help them better prevent falls.

If a fall is due to a loss of stability in the balance control system, then it would make sense to study how an individual with PN responds to a single unexpected perturbation during gait on a flat surface. In this way we could examine how robust the feedback loop

system is to the single perturbation. A longer time delay is anticipated to adversely affect the system stability. As shown in Figure 1-2, the components of the loop (a-d) include: a) reaching the sensory threshold necessary for activation of the afferent nerves; b) sensory nerve conduction time; c) motor nerve conduction time; d) rate of muscle force generation. If the time delay and signal strength become longer and/or weaker with age and/or disease, it may be due to 1) conduction delays in damaged sensory nerves, 2) conduction delays in damaged motor nerves, and/or 3) decreased joint torque from decreased number of muscle fibers. The effect of time delay and the importance of different components of the delay, on the postural responses to a single perturbation during gait variability are presently unknown, but will be addressed in this dissertation.

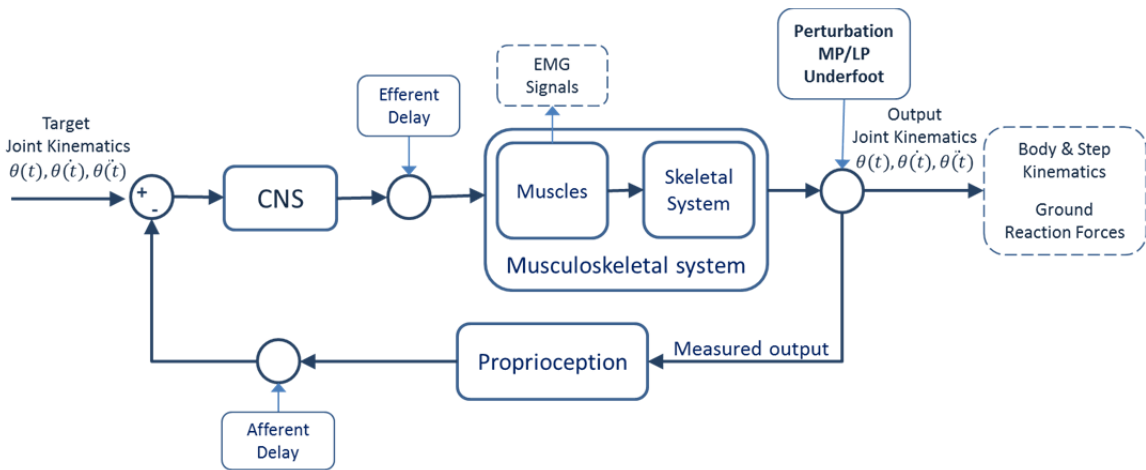

Figure 1-2. Conceptual neuromusculo-skeletal system model for studying the effects of a single underfoot perturbation (disturbance), age and disease, lower extremity muscle strength, and ankle proprioception on the response of an upright human in single leg stance. (--- output measurements)

In this dissertation we shall focus on frontal plane stability. This is because Bauby and Kuo (2000) demonstrated in healthy adults that adjustments in step width (SW) are important for maintaining frontal plane stability during locomotion, and this is important because bipedal gait is otherwise unstable in the frontal plane. In addition, patients with PN describe problems with walking on uneven surfaces and they have shown evidence of

less stable gait in the frontal plane on such surfaces – greater SW, SWV and range of SW (Thies 2005). So, in the PN patients's neuromusculo-skeletal system (Figure 1-4), one might anticipate that a difficulty in responding to an underfoot perturbation might be due to a longer time delay in the feedback loop caused by the lower extremity neural impairments engendered by PN.

A Useful Conceptual Model

Otten (1999) simulated the forward dynamics of a balancing movement on a fulcrum while standing on one leg. He calculated the theoretical effect of introducing either a +50 Nm or -50 Nm moment at each of the six main body joints in the frontal plane. Then he calculated the resultant changes in the horizontal component of the ground-reaction force due to applying this moment at the joint. He found that stance limb hip joint moments are the most effective locations to apply the 50 Nm moment in order to change the direction of the horizontal component of the ground reaction force, thereby changing the direction of the restoring moment about the whole body center of mass. Otten found that the stance limb hip joint was the most effective joint to apply the corrective or recovery moment to in order to balance unipedally on a narrow fulcrum. We surmise that the same might be true for an individual wishing to recover from a single underfoot perturbation.

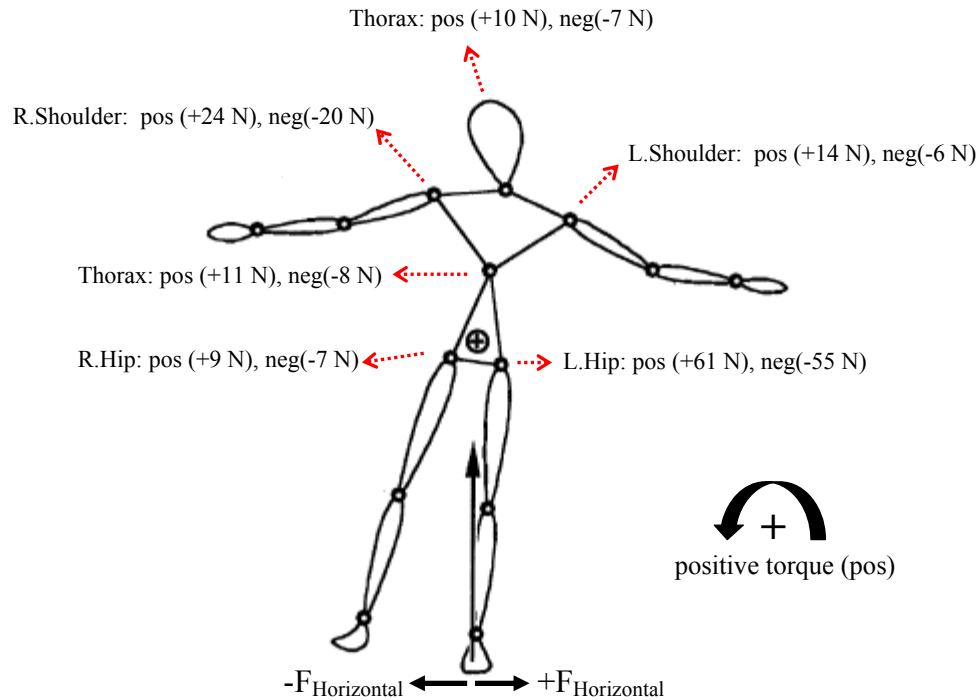

Figure 1-3. A forward dynamics frontal plane model simulation showing the effect of applying a solitary positive or negative 50 Nm moment at each of six major joints on the magnitude and direction of the resulting ground reaction force direction during unipedal balance on a fulcrum. The six joints are the Left (L) and Right (R) Hip, Head, Thorax, Left (L) and Right (R) Shoulder. The numbers in parentheses show the resultant magnitude and direction of the horizontal shear force (in N) under the stance foot. This shear force helps redirect the ground reaction force (shown by the vertical arrow) to the one or the other side of the center of mass (shown by the cross symbol within a circle), thereby applying a restoring moment to recover balance, even though the center of gravity might be outside the base of support provided by the narrow fulcrum. Figure and data are redrawn from Otten (1999).

1.2 Knowledge gaps

Previous research on the effect of perturbations on human gait and knowledge gaps

The effect of perturbations on human locomotion have been studied by studying responses when stepping over obstacles (for example, Chen et al. 1994), as well as

responses to a trip (for example, Pavol et al. 1999, Pijnappels et al. 2001), sagittal plane slips (for example, Cham et al., 2001), frontal plane support surface movements (for example, Oddsson et al. 2004), galvanic stimulation (Cass et al. 1996), lateral forces applied to the hip (Redfern & Schumann 1994) and when attention is distracted (for example, Chen et al. 1996). In 2004, Thies completed a doctoral dissertation at the University of Michigan on the effects of age and PN on the step kinematics (i.e., step width, time, length) while volunteers walked on even and uneven surfaces (Thies 2004). She studied locomotion on uneven surfaces because PN subjects often report balance difficulties while walking on irregular surfaces, particularly in the dark when visual feedback is limited (Richardson et al. 2007, Thies et al. 2007). Then, in a single study, Thies and collaborators examined how a single underfoot perturbation affected the recovery step width, time and length (Thies et al. 2008). This is the only study we are aware of its type. Their results suggested that a medial perturbation caused a step narrowing. But limitations of that experiment include the fact that only young females were studied, subjects had to carry a tray in front of them to avoid their viewing their gait path, and that one could not control where under the foot the perturbation acted (fore- or midfoot, medial or lateral foot). Hence the magnitude of the moment developed by the surface protruberance about the ankle was not controlled. Finally, subjects knew that they might step on a ground surface irregularity on that trial. So a better way of delivering an unexpected, intermittent medial or lateral underfoot perturbation is needed that always applies the perturbation at the same location under the shoe so that its moment arm about the ankle is known (Chapter 5).

Currently, a major knowledge gap in the field of locomotion on uneven surfaces is how age and disease affect the ability of humans to recover from a single unexpected underfoot perturbation during gait. How might this single perturbation affect step width, step length or step time of the first or subsequent recovery steps? Increased stride width deviation in response to an underfoot perturbation is important because an extremely narrow step width, or even a cross-over step, can cause a subject's swing leg toe to contact the stance phase heel just after toe-off, thereby causing a trip over their own foot (Thies et al. 2007). So if PN causes time delays and decreased strength that affects step

width variability, this could be one mechanism by which PN could cause falls (and fall-related injuries). This is a working hypothesis underlying the current research.

Chapter 2 is a study of how PN affects the capacities of the lower limb musculature that affect postural stability in frontal plane during unipedal balance. Then the capacities are compared with simple but powerful clinical measures of postural balance in frontal plane – Unipedal Stance Time. So the main object in Chapter 2 is to clarify the relationships between UST and lower limb neuromuscular capacities relevant to frontal plane postural control in the elderly with various rates of neuromuscular function.

Use of an irregular surface is a simple yet effective means to analyze gait under more challenging conditions than a flat surface. Lower limb sensory and motor capacity measures in PN have not been compared with human gait in terms of lateral stability. So Chapter 3 explores how sensorimotor capacities affect gait speed and gait efficiency while walking on an irregular surface.

In Chapter 4 we introduce a new simple, but practical, clinical method for determining simple and recognition reaction time as a potential evaluative tool. We also examine how age affects these manual reaction times.

Despite of many advantages of irregular surface on gait research shown in Chapter 3, it is methodologically limited to verify causal effect on kinematic responses due to possible carryover effects from multiple previous irregularities. So we designed and developed a custom perturbing shoe to simulate the condition in which the swing foot unexpectedly lands once on a single pebble with the midfoot during level gait. The method allows the pebble to appear under the medial or the lateral foot, under either the left or right foot, as needed. Chapter 5 evaluates the test-retest reliability of the method in young adults on two separate visits.

In Chapter 6, we use the experimental device and method developed in Chapter 5 to study the effect of age on gait. We tested the hypothesis that recovery step kinematics are not adversely affected by age following an underfoot perturbation. The difference in

carryover effects from a single underfoot perturbation in the young and older adult group is investigated in this chapter.

In Chapter 7 we extend the methods of Chapter 5 & 6 to study the gait of older adults with the presence or absence of peripheral neuropathy. We explore the neuromuscular, kinematic and kinetic responses to a single perturbed stance limb. A body kinematic parameter (Lateral pelvic displacement) is used to describe frontal plane movement and this is also compared with the first recovery step kinematics and severity of PN.

Chapter 8 investigates whether it is possible to use lower limb physiological capacities like proprioception and/or strength to distinguish between recovery steps in PN from healthy controls using a generalized linear model.

In daily life it is not uncommon to divide one's attention between two tasks. The dogma in the field suggests that when attention is divided, one prioritizes 'posture first', namely that when two tasks are to be carried out simultaneously, the task associated with maintaining gait or posture will be prioritized and the accuracy of completing the other, secondary, task will suffer (Cordo 1982). In Chapter 9, we study the effect of divided attention on the ability to recover from a single underfoot perturbation during gait. As a new application of the perturbing shoe method, Chapter 9 investigates the reciprocal effect of the vocal choice reaction time task and perturbed gait responses.

In Chapter 10, the General Discussion, we discuss what is new in the dissertation, how the dissertation extends what is known in the current literature, what insights may be gained by combining insights from two or more chapters, as well as the strengths and limitations of the approach used in this dissertation.

1.3 Overall Structure of the Dissertation with Hypotheses (H) to be Tested in Each Chapter

Chapter 2 Frontal Plane Hip and Ankle Sensorimotor Function, Not Age, Predicts Unipedal Stance Time

H2-1: Hip motor function would be an independent predictor of unipedal stance time.

Chapter 3 Which Lower Limb Sensory and Motor Functions are Required for Functional Gait on Uneven Surfaces in Older Persons with Diabetic Neuropathy?

H3-1: Greater hip and ankle motor function, and more precise ankle sensory function, would be associated with increased gait speed and efficiency on the irregular surface.

Chapter 4 A Novel Clinical Test of Recognition Reaction Time in Healthy Adults

H4-1: Recognition RT_{clin} test results would be prolonged compared with simple RT_{clin} results

H4-2: The majority of the recognition RT_{clin} result prolongation would be attributable to PMT

H4-3: Recognition RT_{clin} results would positively correlate with age.

H4-4: Recognition RT_{clin} response accuracy would negatively correlate with age

Chapter 5 A Shoe Sole-based Apparatus and Method for Randomly Perturbing the Stance Phase of Gait: Test-Retest Reliability in Young Adults

H5-1: A single medial or lateral underfoot perturbation would alter the step width of the first recovery step at both a comfortable gait speed and a faster gait speed.

H5-2: This method is reliable and repeatable in the kinematic responses.

Chapter 6 Effect of Age on the Response to an Unexpected Underfoot Perturbation during Level Gait

H6-1: Medial and lateral perturbations have similar effects on recovery step kinematics

H6-2: Age will not affect recovery step kinematics to these perturbations.

Chapter 7 Effect of Peripheral Neuropathy on the Ability to Recovery from an Unexpected Underfoot Perturbation while walking: About underlying relationships among kinematic, kinetic and neuromuscular responses of perturbed limb.

H7-1: There is peripheral neuropathy effect on the response in step width and lateral pelvic displacement.

H7-2: Horizontal and vertical ground reaction forces during perturbed stance phase of limb are positively correlated with step kinematics and lateral pelvic displacements in the first recovery step.

H7-3: raw EMG activation onset and rms EMG magnitude of ankle muscle distinguish medial and lateral underfoot perturbations.

Chapter 8. The Relationship between Frontal Lower Limb Capacities and Step Width Responses to an Underfoot Perturbation in Older Subjects with and Without Peripheral Neuropathy.

H8-1: response latencies in frontal lower limb muscles may change, not the first, but the second recovery step width

H8-2: Decreased hip and ankle rate of strength development in people with peripheral neuropathy adversely affects the recovery step width following a single underfoot perturbation.

Chapter 9 Effect of a Vocal Choice Reaction Time Task on the Kinematics of the First Recovery Step after a Sudden Underfoot Perturbation during Gait

H9-1: Greater attentional demand of controlling gait in a challenging dual-task situation would significantly affect recovery step kinematics following the underfoot perturbation, as well as the vocal choice reaction during that recovery, compared to the case when attention is not divided.

1.4 References

- Ahmed A.A., Ashton-Miller J.A., “Is a “loss of balance” a control error signal anomaly? Evidence for three-sigma failure detection in young adults,” *Gait and Posture*, 2004;19:252-262
- Alexander B.H., Rivara F.P., and Wolf M.E., “The cost and frequency of hospitalization for fall-related injuries in older adults,” *American Journal of Public Health*, 1992;82(7):1020–3.

- Ashton-Miller J.A., Kim H., “Apparatus and Method for Analyzing the Response to Gait Perturbations using Convertible Foot Ware,” TMO #4134, University of Michigan Invention Disclosure, Aug 2008.
- Ashton-Miller J.A., Kim H., Eckner J.T., Richardson J.K., “Device and Method for Measuring Reaction Time”, United States Patent Application Publication #US 2010/0324443A1.
- Bauby CE, Kuo AD., “Active control of lateral balance in human walking,” *J Biomech* 2000;33:1433-40.
- Dumitru D., Amato A.A., and Zwarts M., “Nerve Conduction Studies” *Electrodiagnostic Medicine*, 2nd Edition, Philadelphia: Hanley & Belfus 2002, p.889.
- Englander F., Hodson T.J., and Terregrossa R.A., “Economic dimensions of slip and fall injuries,” *Journal of Forensic Sciences*, 1996;41(5):733–746.
- Feldman E.L., Stevens M.J., Thomas P.K., Brown M.B., Canal N., Greene D.A., “A practical two-step quantitative clinical and electrophysiological assessment for the diagnosis and staging of diabetic neuropathy,” *Diabetes Care*, 1994;17(11):1281-89.
- Franklin G.F., Power J.D., and Emami-Naeini A., “Time Delay,” *Feedback Control of Dynamic Systems: Control Engineering*, 3rd Edition, Addison-Wesley 1994, pp.300-304
- Gilting, M.G., Van Den Bosch, C.G., Lee SG., Ashton-Miller J.A., Alexander, N.B., Schultz, A.B., and Ericson, W.A., “Association of age with the threshold for detecting ankle inversion and eversion in upright stance,” *Age and Ageing*, 1995;24 (1): 58-66
- Gutierrez E.M., Helber M.B., Dealva D., Ashton-Miller J.A., Richardson J.K., “Mild diabetic neuropathy affects ankle motor function,” *Clinical Biomechanics*, 2001; 16(6):522-8
- Hausdorff J.M., Rios D.A., and Edelberg H.K., “Gait variability and fall risk in community-living older adults: a 1-year prospective study,” *Archives of Physical Medicine and Rehabilitation*, 2001;82(8):1050–1056.

- Hornbrook M.C., Stevens V.J., and Wingfield D.J., Hollis J.F., Greenlick M.R., Ory M.G., “Preventing falls among community-dwelling older persons: results from a randomized trial,” *The Gerontologist*, 1994;34(1):16–23.
- Otten E., “Balancing on a narrow ridge: biomechanics and control,” *Phil. Trans. R. Soc. Lond. B*, 1999;354:869-875.
- Pavol, M.J., Owings T.M., Foley, K.T., Grabiner, M.D., “The sex and age of older adults influence the outcome of induced trips,” *Journal of Gerontology: Medical Sciences*, 54A:M103-M108, 1999.
- Cordo P, Nashner L., “Properties of postural adjustments associated with rapid arm movements,” *J Neurophysiol* 1982;47:287-302.
- Redfern, M.S., Schumann, T., “A model of foot placement during gait,” *Journal of Biomechanics*: 1994;27(11): 1339-46.
- Richardson J.K., Ching C., and Hurvitz E.A., “The relationship between electromyographically documented peripheral neuropathy and falls,” *Journal of American Geriatric Society*, 1992; 40(10):1008-12
- Rubenstein L.Z., and Josephson K.R., “The epidemiology of falls and syncope,” *Clinical Geriatric Medicine*, 2002 May; 18(2):141-58
- Simoneau G.G., Ulbrecht J.S., Derr J.A., Becker M.B., and Cavanagh P.R., “Postural instability in patients with diabetic sensory neuropathy,” *Diabetes Care* 1994; 17(12):1411-21
- Son, J., Ashton-Miller, J.A., and Richardson, J.K., “Frontal plane ankle proprioceptive thresholds and unipedal balance,” *Muscle & Nerve* 2009; 39(2): 150-157
- Stevens, J. A., Corso, P.S., Finkelstein E.A., and Miller T.R., “The costs of fatal and non-fatal falls among older adults,” *Injury Prevention*, 2006;12:290–295.
- Thies S.B, “Human Gait on an Irregular Surface: Effects of Age and Peripheral Neuropathy on Step Variability,” Doctoral dissertation, Department of Biomedical Engineering, University of Michigan, Ann Arbor, October, 2004.

Thies S.B, Richardson J.K., DeMott T, Ashton-Miller J.A., “Influence of an irregular surface and low light on the step variability of patients with peripheral neuropathy during level gait,” *Gait Posture*, 2005;22:40-45.

Thelen, D.G., Schultz, A.B., Alexander N.B., and Ashton-Miller J.A., “Effects of Age on Rapid Ankle Torque Development,” *The Journals of Gerontology*; Sep 1996; 51A,(5) M226-M232

Uccioli L., Giacomini P.G., Monticone G, Magrini A., Durola L., Bruno E., Parisi L., Di Girolamo S., and Menzinger G., “Body sway in diabetic neuropathy,” *Diabetes Care* 1995; 18(3):339-44

Vaughan C.L., Davis B.L., and O’Connor J.C., “Dynamics of human gait,” Champaign: Human Kinetics Publishers, 1992

Chapter 2

Frontal plane hip and ankle sensorimotor function, not age, predicts unipedal stance time

[Published in *Muscle & Nerve*, April 2012]

2.1 Introduction

Quantitative and qualitative changes occur in muscles and nerves with aging (Narici et al., 2005). These include a decrease in the number of alpha motoneurons, reduced motoneuron excitability, and loss of type II muscle fibers leading to decreased muscle mass and slower muscle response latencies (Barry and Carson, 2004). Such changes, which adversely affect motor control and balance in older persons, are even more marked among older persons with peripheral neuropathy (PN), a common complication of diabetes mellitus. In such patients, the neuropathy is usually length dependent and results in distal sensorimotor dysfunction of varying severity. As a result, diabetic patients have decreased balance (Kanade et al., 2008; Turcot et al., 2009; Son et al., 2009; Richardson et al., 1996), altered gait (Allet et al., 2008) and increased fall risk (Wallace et al., 2002; Maurer et al., 2005) when compared to healthy controls.

Control of frontal plane stability is particularly important given that lateral falls are associated with hip fractures in older adults (Make et al., 1994; Cummings and Nevitt, 1994). Biomechanical models and human studies suggest that control at the hip is of greater importance to equilibrium in the frontal plane than control at the ankle. For example, a whole-body inverted pendulum model of medial-lateral control during human walking, suggests that the hip exerts the primary influence, and that minor errors in hip

motion are compensated by adjustments at the subtalar joint (MacKinnon and Winter, 1993). Similarly, a second model demonstrated that foot placement in the frontal plane, which is regulated by hip abduction/adduction, was the most efficient method for controlling frontal plane balance while walking (Bauby and Kuo, 2000). Other studies have provided experimental support for these models and demonstrated the importance of hip frontal plane strength for balance control in elderly subjects when they negotiate obstacles (Chou et al., 2000) and for fall prevention (Hilliard et al., 2008; Mille et al., 2005).

However, no study has evaluated the relationship between lower limb afferent and efferent neuromuscular capacities relevant to frontal plane control in older subjects with a demonstrably significant range of peripheral neurologic function. For example, none of the above biomechanical models or experimental studies have addressed the role of distal afferent function (i.e., ankle proprioception). Similarly, evaluations of lower limb neuromuscular capacities associated with balance deficits in subjects with PN studied either ankle proprioception or ankle joint motor function (Gutierrez et al., 2001; Giacomozzi et al., 2008), but not both, and no study evaluated hip motor function in this high risk population.

Unipedal stance time (UST) is a convenient clinical measure of balance that evaluates frontal plane postural control. It is the most challenging activity within the widely used Berg Balance Scale (Wang 2006). Moreover, UST is associated with frailty (Hurvitz 2000, Vellas 1997), PN (Hurvitz 2001), activity level (Bulbalian 2000), falls in older persons with (Richardson 2002) and without PN (Vellas 1997, Bohannon 2006) and decreases markedly with age (Bohannon 1984, Potvin 1980). Therefore, the objective of this study was to explore the relationships between UST and lower limb neuromuscular capacities relevant to frontal plane postural control in older subjects with a spectrum of neuromuscular function. The primary hypothesis was that hip motor function would be an independent predictor of UST. Support for this hypothesis has clinical relevance, given the fact that PN predominantly affects distal function, which leaves the potential for strengthening of hip musculature (Narici 2005).

2.2 Materials and Methods

Forty-one subjects (16 healthy old and 25 subjects with PN due to diabetes) were recruited under a protocol approved by the Institutional Review Board. Written informed consent was obtained from all participants. Subjects were recruited from the University of Michigan Orthotics and Prosthetics Clinic, Endocrinology Clinic and the Older Americans Independence Center Human Subjects Core.

Inclusion criteria for PN subjects were:

- Age 50 - 85 years
- Weight < 136 kg
- Known history of diabetes.
- Able to walk household distances without assistance/assistive device
- Strength of ankle dorsiflexors, invertors, and evertors at least anti-gravity (grade>3 by manual muscle testing)
- Symptoms and signs consistent with PN: symmetrically altered sensation in lower extremities, Michigan Diabetes Neuropathy Score (MDNS) >10; (Richardson 2010)
- Electrodiagnostic evidence of a diffuse PN as evidenced by bilaterally abnormal fibular motor nerve conduction studies (absent or amplitude < 2 mV and/or latency > 6.2 msec and/or conduction velocity < 41.0 m/s) stimulating 9 centimeters from recording site over the extensor digitorum brevis distally, and distal to the fibular head proximally.

Exclusion criteria for PN subjects were:

- Accidental fall one month or less prior to testing
- History or evidence of any significant central nervous system dysfunction (i.e. hemiparesis, myelopathy or cerebellar ataxia)
- Neuromuscular disorder other than PN (e.g. myopathy or myasthenia gravis)
- Evidence of vestibular dysfunction
- Angina or angina-equivalent symptoms with exercise
- Plantar skin sore or joint replacement within the previous year

- Symptomatic postural hypotension
- Significant musculoskeletal deformity (i.e. amputation or Charcot changes)
- Lower limb or spinal arthritis or pain that limits standing to less than 10 minutes, or walking to less than one block

The healthy older adults were without neuropathic symptoms, had an MDNS<10 and had normal electrodiagnostic studies. They otherwise met the same inclusion criteria as the PN subjects.

2.2.1 Entrance Evaluation:

During the physical examination that focused on neurologic and musculoskeletal findings, inclusion and exclusion criteria were verified. Neuropathy severity was further determined using the 46 point scale MDNS (Richardson et al., 2002; Feldman et al., 1994), (higher score reflecting more severe neuropathy) evaluating distal sensory impairment, distal muscle strength and muscle stretch reflexes. Finally, all subjects underwent nerve conduction studies of the fibular nerve, as described above.

2.2.2 UST

Subjects performed three trials of UST on each foot (Richardson, 2002, 2010). Subjects started with an intra-malleolar distance of approximately 15 cm, and then transferred weight to one foot. To standardize the test sequence and timing of weight transfer to the extent possible the examiner asked, “Ready?” and upon receiving assent from the subject, gave the cadence command, “one, two, up”. Subjects were required to raise their non-stance limb at the “up” command. UST maximum was set at 30 s.

2.2.3 Neuromuscular Capacity Testing

Hip abduction and adduction muscle strength

A custom, whole-body dynamometer (BioLogic Engineering, Inc.) was used to measure the maximum voluntary contraction (MVC) and maximum rate of torque development (RTD) in the frontal plane at the hip (Smeesters et al., 2001). This dynamometer was found to be sensitive to the effects of age, gender and hip angle when isometric hip

strength was measured in a group of 24 young and 24 older subjects. In addition, the apparatus demonstrated the ability to resolve torque with a precision of 0.5 Newtonmeters. Retest reliability has not been evaluated; however, it is anticipated that reliability would be similar to that found with isometric testing in other populations (e.g., with a mean day-to-day difference of 10% and a coefficient of repeatability of 11 to 33%) (Ylinen et al., 2004). The dynamometer features a horizontal bench on which the subject lies fully supported, allowing all measurements to be made in a gravity-free plane. The pelvis and upper body were immobilized using adjustable harness straps at multiple points. During maximum voluntary abduction strength tests, subjects progressively increased their isometric effort from rest to their maximum over a count of three, held it for two seconds, and relaxed. Patients were encouraged verbally. To quantify rate of isometric strength development, subjects performed an abduction against the lever arm as fast and as hard as possible for three seconds (Thelen et al., 1996). Three trials were performed with one minute rest between trials. Subjects performed analogous maneuvers in the opposite direction for hip adduction strength and rate of isometric strength testing.

Ankle muscle strength

During ankle rate of strength development testing, subjects stood on the test foot on a force plate (Advanced Mechanical Technology, Inc. OR-6) and moved the center of ground support reaction from the lateral margin of the foot to the medial margin as quickly as possible, then again to the lateral margin, as previously described (Gutierrez et al., 2001) . Three trials, each trial with five medial-lateral movements, were performed. Subjects were allowed to touch a horizontal railing to keep their balance.

During maximum voluntary strength testing, subjects stood on the force platform touching the hand rails on both sides as needed. Subjects were then asked to lift one leg, shift their center of gravity as far lateral under their foot as they could and lift their hands from the rails for three seconds. The test was repeated three times for the lateral, and then likewise repeated for the medial margin of the foot.

Ankle proprioception threshold

Subjects stood with the test foot in a 40 x 25 cm cradle that was rotated by an Aerotech 1000 servomotor equipped with an 8,000 line rotary encoder as described by Son et al. (2009). After an audible cue, a single ankle inversion or eversion rotation of 0.1 to 3° magnitude was randomly presented at 5°/s. The subject then pressed a joystick handle in the direction of the perceived foot rotation. Four blocks of 25 trials (randomly, 10 eversion, 10 inversion, and 5 dummy trials) were presented interspersed with 2 to 5 minute rest intervals. The outcome measure was the ankle proprioception threshold (TH100), defined as the smallest rotational displacement of the ankle that a subject could reliably detect with 100% accuracy (Son et al., 2010).

2.2.4 Data Processing

Signals were amplified to volt levels before being acquired using a 12 bit analog-to-digital converter sampling at 100 Hz. The MVC efforts at the hip and ankle, as well as the maximal RTD, were normalized by individual body size defined as the parameter body height multiplied by weight in units of Nm. Strength data were processed using a Labview second-order least squares polynomial fit to determine the peak value. The mean peak value obtained from the three trials for each test type was used for the statistical analyses. To determine each proprioceptive threshold, the mean TH100 from the four blocks of 25 trials in each test direction was calculated. A summary measure of ankle proprioception was found from the sum of the inversion and eversion proprioception threshold.

2.2.5 Statistics

Statistics were conducted using SPSS (SPSS for Windows, Rel.11.0.1.2001. Chicago). Descriptive statistics were calculated for all measures, including a composite score of frontal plane 'hip strength', calculated as the mean of the mean peak abduction and adduction MVCs. Data were examined for normality and screened for outliers. Pearson product-moment correlation coefficients were calculated to assess relationships between neuromuscular capacities and UST.

A regression model determined independent predictors of UST. Variables were entered stepwise in the order of their strength of correlation. To reduce the number of independent variables, only the best predictor variable for ankle motor function and the best predictor variable for hip motor function were retained in the final regression model, along with the identified co-variables (age and body mass index).

To determine whether hip strength might compensate for distal afferent deficiencies (less precise ankle proprioceptive thresholds), the residuals of the regression model using UST as the outcome variable and proprioceptive threshold and age as predictor variables were saved and ranked by magnitude. The hip strength of the 12 subjects with the highest residuals was then compared with the hip strength of the 12 subjects with the lowest residuals using a two-sided, student t-test. A similar analysis was performed to determine whether more precise ankle proprioceptive thresholds might compensate for decreased hip strength. The significance level for all tests was set at 0.05.

3. Results

Of 91 potential subjects, 21 did not pass the telephone screening, and 18 elected to not participate. Of the 52 remaining subjects, three had scheduling conflicts, and five failed the screen. Of the remaining 44, one was lost to follow-up, and 2 dropped out due to medical concerns. Therefore, 41 subjects were enrolled. The means and standard deviations of age, body mass index (BMI) and MDNS, together with the participants' neuromuscular capacities and UST, are shown in Table 1.

Table 2-1. Mean (SD) demographic and neuromuscular capacity results

		Non diabetic subjects (N=16)			Diabetic patients (N=25)			
		All	Men	Women	All	Men	Women	
Subjects	Age (yrs)	67.8 (8.97)	67.8 (11.02)	67.8 (8.16)	70.0 (8.16)	71.5 (7.17)	67.8 (9.39)	
	BMI (kg/m ²)	28.4 (7.18)	26.2 (3.25)	29.6 (8.68)	32.4 (6.44)	30.3 (5.36)	35.7 (6.81)	
	UST (s)	22.3 (11.1)	21.9 (12.0)	22.6 (11.19)	6.9 (6.91)	15.1 (11.03)	9.52 (9.36)	
	MDNS†	1.69 (3.77)	2.5 (6.12)	1.2 (1.48)	13.6 (6.04)	14.1 (6.5)	12.7 (5.48)	
Hip	Abduction	MVC	0.041 (0.024)	0.051 (0.028)	0.035 (0.02)	0.031 (0.01)	0.032 (0.011)	0.03 (0.009)
		MRTD	0.26 (0.19)	0.31 (0.22)	0.22 (0.17)	0.154 (0.10)	0.155 (0.10)	0.15 (0.09)
	Adduction	MVC	0.047 (0.018)	0.051 (0.018)	0.045 (0.02)	0.033 (0.01)	0.035 (0.013)	0.030 (0.01)
		MRTD	0.29 (0.226)	0.40 (0.224)	0.22 (0.211)	0.20 (0.15)	0.19 (0.18)	0.21 (0.11)
Ankle	Inversion	MVC*	1.28 (0.50)	1.50 (0.67)	1.14 (0.35)	1.02 (0.44)	1.01 (0.54)	1.03 (0.26)
		MRTD*	0.19 (0.10)	0.23 (0.09)	0.16 (0.10)	0.10 (0.06)	0.11 (0.07)	0.09 (0.06)
	Eversion	MVC*	2.19 (0.50)	2.54 (0.38)	1.93 (0.43)	1.60 (0.66)	1.59 (0.73)	1.61 (0.56)
		MRTD*	0.24 (0.11)	0.33 (0.14)	0.19 (0.06)	0.14 (0.07)	0.15 (0.08)	0.13 (0.05)
	Proprioception	0.99 (0.76)	1.15 (1.09)	0.89 (0.51)	2.39 (1.31)	2.21 (0.83)	2.67 (1.84)	

MVC, maximum voluntary contraction (N.m/N.m); RTD, rate of torque development

(N.m/N.m.s). *N = 13 valid cases for non-diabetic subjects; N = 24 valid cases for

diabetic patients, and N = 12 for non-diabetic subjects; † score from 0 to 46, 0 best value

3.1 Correlations

Correlations between UST and frontal plane lower limb neuromuscular function were strong, and many of the functions explained more than a third of the variability in UST (Table 2-2). This includes all of the functions measured except for ankle inversion and eversion MVC, and hip abduction and ankle eversion RTD. Age and BMI were substantially less strongly associated with UST than were the majority of neuromuscular RTD variables.

Table 2-2. Bivariate correlations between UST and neuromuscular capacities, age and BMI.

		Correlation coefficient with UST	p	
Subject	Age	-.492	.001	
	BMI	-.392	.009	
Hip	Strength	.672	.000	
	Adduction	MVC	.664	.000
		MRTD	.645	.000
	Abduction	MVC	.619	.000
		MRTD	.481	.001
	Ankle	Inversion	MVC	.350
MRTD			.644	.000
Eversion		MVC	.351	.018
		RTD	.490	.001
Proprioceptive threshold		-.643	.000	

All values calculated based on the 36 subjects who had valid results for all variables.

3.2 Multivariate Analyses

The final regression model included UST as the outcome variable and hip strength (as defined in Methods), ankle inversion RTD, ankle proprioception and the covariates age and BMI as independent variables (Table 3). Maximum hip strength was the most important predictor of UST, explaining almost half of its variability.

Table 2-3 Regression model

Model	R	R ²	Dependent variable	US*	95% CI bound		t	p
					Lower	Upper		
1	0.676	0.456	Hip MVC	460.9	290.9	631.0	5.50	0.000
2	0.834	0.696	Hip MVC	386.5	254.2	518.7	5.93	0.000
			Ank. Proprio. Th.	-4.18	-5.79	-2.56	-5.25	0.000
3	0.856	0.733	Hip MVC	339.5	205.9	473.1	5.17	0.000
			Ank. Proprio. Th.	-3.87	-5.43	-2.30	-5.02	0.000
			Age	-0.26	-0.52	-0.02	-2.16	0.038

MVC=maximum voluntary contraction; US* = unstandardized coefficients.

Ankle proprioceptive thresholds and age also contributed to the model in a significant manner. The former explained an additional 25% of the variance in UST, and age explained just 3%. Overall, the model explains nearly three quarters of the variability in UST.

UST and the Ratio of a Composite Variable of Hip Strength to Ankle Proprioception

After observing the relationship between hip strength and UST and the inverse relationship between proprioceptive threshold and UST, we formed a new variable, the ratio of hip strength to proprioceptive threshold. This variable was found to explain more than 70% of the variability of UST (Figure 2-1).

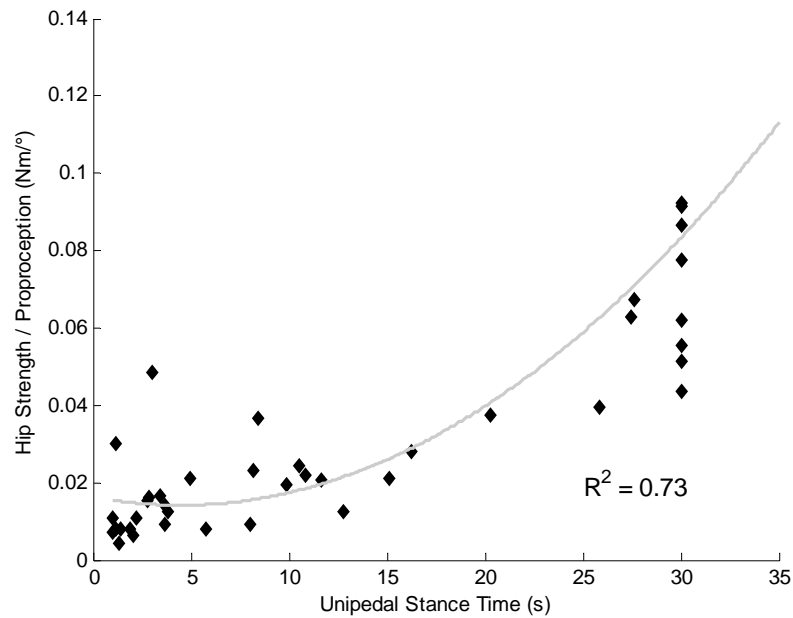

Figure 2-1 Scatterplots illustrating the relationship between hip strength and ankle proprioception. The equation for the curvilinear regression is $y = 0.0098e^{0.067x}$

Hip Strength Can Compensate for Imprecise Ankle Proprioception

After performing regression of ankle proprioceptive threshold and age on UST the residuals for all subjects were ranked, and the hip strength of the upper one-third (representing subjects who had longer USTs than would be expected for proprioceptive threshold and age) was compared to that of the lower one-third. The former had

significantly greater hip strength than the latter (Figure 2-2a), suggesting that hip strength was able to compensate for less precise ankle proprioception. When the analogous analysis was performed for ankle proprioceptive thresholds, subjects with greater UST had significantly more precise (smaller) proprioceptive thresholds (Figure 2-2b).

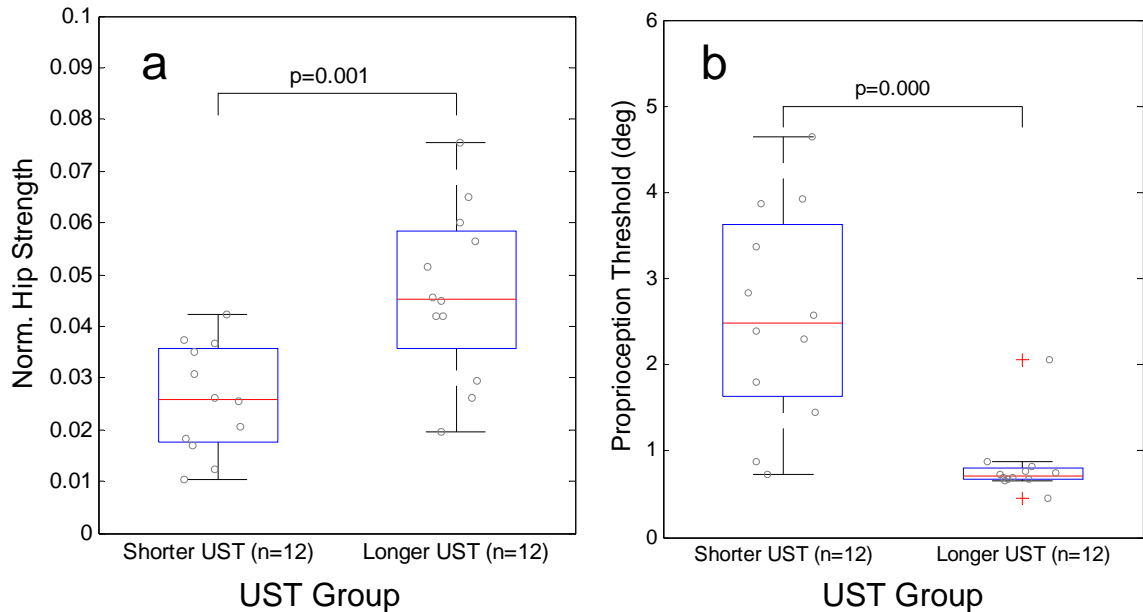

Figure 2-2. A comparison of (a) hip strength and (b) ankle proprioceptive thresholds in subjects who demonstrated shorter (left) and longer (right) USTs. Hip strength was calculated as the mean of the mean peak abduction and adduction maximal voluntary contractions (Nm/Nm). UST, unipedal stance time. Proprioceptive threshold = smallest rotational displacement of the ankle that a subject could reliably detect with 100% accuracy.

4. Discussion

We have quantified sensory and motor lower limb neuromuscular capacities in a group of older subjects with a spectrum of peripheral neurologic health. There are three novel, clinically significant findings: 1) Maximum voluntary hip strength in the frontal plane was the single best predictor of UST, a result consistent with the primary hypothesis; 2) Maximum voluntary hip strength and ankle proprioceptive thresholds explained the

majority of the variance in UST, with age playing a trivial role; 3) Increased hip strength appears to compensate for less precise ankle proprioception.

Although frontal plane hip strength is not routinely evaluated in studies of postural control, there is evidence supporting its importance. For example during bipedal stance, anterior-posterior balance is under ankle control (plantar and dorsiflexors), whereas medio-lateral balance is controlled via frontal plane motion at the hip (Winter et al., 1998). Other studies have found significant correlations between hip abduction RTD and performance of reactive and voluntary frontal plane balance in older adults (Chang et al., 2005). A study of slips noted that older persons used frontal plane mechanisms for recovery, whereas young subjects did not (Liu and Lockhart, 2009). One way to interpret the importance of abductor and adductor muscles with regard to unipedal stance is to suggest that a cocontraction of these muscles allows a transient, voluntary increase in hip rotational stiffness. Given that an inverted pendulum is a commonly used model for human standing balance, this stiffness creates a longer pendulum, which requires more time to fall than a shorter pendulum. As a result, there is more time available for postural adjustments, which renders the task of one legged balance less challenging (Reeves et al., 2011). However, once balance is disturbed, it is likely that the availability of a rapid rate of strength development would be more important, given that balance restoration occurs within fractions of a second (Thelen et al., 1996).

The independent contribution of ankle proprioception for balancing on one leg is consistent with previous work (Son et al., 2009) in which ankle inversion/eversion proprioceptive thresholds explained approximately half the variance in UST ($R^2 = 0.514$) in older subjects with a range of peripheral neurologic function. More precise ankle proprioceptive thresholds may reduce the lateral distance the center of mass (COM) can travel prior to detection. Early detection of a displaced COM would then require only moderate strength that a majority of older persons likely possess. In contrast, less precise ankle proprioception would require greater intensity of motor function for appropriate repositioning of the COM. Supporting this explanation, healthy subjects demonstrate increased center of pressure velocities when the plantar aspect of the foot is anesthetized, which is consistent with the greater motor function requirement (Meyer et al., 2004).

Ankle motor function did not show a significant independent influence on UST, despite the fact that ankle inversion and eversion rates of torque generation explained approximately 40% and 25%, respectively, of its variance. These findings are consistent with those of Gutierrez et al. (2001) who found that ankle inversion RTD explained over half of the variance in UST ($R^2 = 0.575$). In contrast, ankle maximum isometric inversion and eversion strengths each explained only 12% of UST. When observing subjects successfully balance on one foot there are rapid postural adjustments in ankle inversion and eversion as the center of pressure is quickly manipulated to control the movements of the whole body COM. The rapid speed with which these changes occur in the subject who can reliably stand on one foot is consistent with ankle maximum RTD being an important motor function for the maintenance of unipedal stance. These findings are in line with other studies that have found that the ability of the lower limbs to create force quickly is of greater importance than the total force a muscle group can generate (Bean et al., 2002; Bento et al., 2010). Although highly correlated with UST, ankle RTD had no independent influence on UST in the presence of ankle proprioception and hip strength. This is of clinical interest, given the challenge of strengthening distal musculature in PN subjects.

Given the established relationships between a diminished UST and frailty, activity level and falls, strategies to increase UST have clinical relevance. There is no clear evidence that ankle proprioceptive thresholds can be improved by therapeutic exercise (Ashton-Miller et al., 2001) and recent work showed that an ankle orthosis, which had decreased the temporal and spatial variability of neuropathic gait on an irregular surface, did not improve ankle proprioceptive thresholds (Son et al., 2010). Given these findings, frontal plane hip strengthening appears the best strategy for improving UST. This strengthening should be pursued most aggressively in persons with decreased distal afferent neurologic function, as it appears that increased frontal plane hip strength can compensate for distal sensory impairment at the ankle. Given the fact that the majority of polyneuropathies are distal, this strategy can be used in a large proportion of patients with lower limb neuromuscular disease. Conversely, persons with PN and proximal weakness that cannot be improved may be best served by an assistive device, appropriate upper limb strengthening, environmental modification and instruction (Ashton-Miller et al., 1996;

Richardson et al., 2004). Finally, it should be noted that diminished UST need not be viewed as a natural consequence of aging, despite research which notes the inverse association between the two and even work which suggests offering age-adjusted norms for UST (Bohannon et al., 1984; Springer et al., 2007). Instead, a decreased UST should, in the absence of obvious musculoskeletal and/or central neurologic disorder, be considered a function of diminished lower limb neuromuscular competence.

A recent study (Suri et al., 2011) found that improvements in trunk extension endurance, but not lower limb strength or power, were independently associated with clinically meaningful change in balance in older adults. However, the protocol measured lower limb strength while subjects performed a double leg press maneuver while seated, and so sagittal plane strength of multiple muscle groups within the lower limbs was simultaneously measured. This technique contrasts with our study which measured frontal plane sensorimotor functions discretely at the hip and ankle. Therefore, although trunk extension endurance may be more important to balance than sagittal plane lower limb strength, the relative importance of trunk endurance and lower limb frontal plane sensorimotor function with reference to balance has yet to be explored.

The strengths of this study include the fact that sensory and motor control mechanisms were quantified simultaneously in subjects with a spectrum of neuromuscular dysfunction. The correlations and multiple regression analyses were unusually strong. Given the complexity of any human behavior it is remarkable that just two lower limb neuromuscular characteristics explain nearly 75% of UST. Limitations include the fact that UST is unlikely to perfectly reflect a variety of relevant mobility characteristics such as gait speed and the ability to recover from a perturbation while walking. The lower limb sensorimotor function(s) responsible for these deserves further attention. Additionally, only frontal plane neuromuscular functions were evaluated. It is possible that sagittal plane muscle strength also influences UST. It should also be mentioned that the ankle motor function measures assumed the ankle center of rotation to be mid-way between the malleoli. This is an estimation and therefore a study limitation, and an important one to note given that ankle motor function was not identified as an independent predictor of UST. It is possible that evaluation of ankle motor function by another means, for example

an open chain technique, would have led to an alternative conclusion. However, we have used the closed chain technique in the past, and its validity is supported by the relationship between ankle strength determined in this fashion to the presence of neuropathy and unipedal stance time (Gutierrez et al., 2001). Due to technical difficulties in the early stages of the study, a portion of the ankle motor data could not be analyzed for 5 subjects, and so the final regression model was performed on 36 subjects. Finally, UST was cut off at 30 seconds, likely creating a ceiling effect for the most able subjects.

In conclusion, increased frontal plane hip strength and/or decreased (more precise) ankle proprioceptive thresholds strongly influenced UST. Age, in contrast, had a trivial influence when these neuromuscular functions were taken into account. Frontal plane hip strength was the single best predictor of UST and appeared to compensate for less precise ankle proprioceptive thresholds. This finding is clinically relevant, given the possibility of strengthening the hip even in the setting of significant PN.

5. References

- Allet L, Armand S, Golay A, Monnin D, de Bie RA, de Bruin ED. Gait characteristics of diabetic patients: a systematic review. *Diabetes Metab Res Rev* 2008;24(3):173-191.
- Ashton-Miller JA, Yeh MW, Richardson JK, Galloway T. A cane reduces loss of balance in patients with peripheral neuropathy: results from a challenging unipedal balance test. *Arch Phys Med Rehabil* 1996;77(5):446-452.
- Ashton-Miller JA, Wojtys EM, Huston LJ, Fry-Welch D. Can proprioception really be improved by exercises? *Knee Surg Sports Traumatol Arthrosc* 2001;9(3):128-136.
- Barry BK, Carson RG. The consequences of resistance training for movement control in older adults. *J Gerontol A Biol Sci Med Sci* 2004;59(7):730-754.
- Bauby CE, Kuo AD. Active control of lateral balance in human walking. *J Biomech* 2000;33(11):1433-1440.
- Bean JF, Kiely DK, Herman S, Leveille SG, Mizer K, Frontera WR, Fielding RA. The relationship between leg power and physical performance in mobility-limited older people. *J Am Geriatr Soc* 2002;50(3):461-467.

- Bento PC, Pereira G, Ugrinowitsch C, Rodacki AL. Peak torque and rate of torque development in elderly with and without fall history. *Clin Biomech* 2010;25(5):450-454.
- Bohannon RW, Larkin PA, Cook AC, Gear J, Singer J. Decrease in timed balance test scores with aging. *Phys Ther* 1984;64(7):1067-1070.
- Bohannon R. Single limb stance times. A descriptive meta-analysis of data from individuals at least 60 years of age. *Topics in Geriatric Rehabil* 2006;22:70-77.
- Bulbulian R, Hargan ML. The effect of activity history and current activity on static and dynamic postural balance in older adults. *Physiol Behav* 2000;70(3-4):319-325.
- Chang SH, Mercer VS, Giuliani CA, Sloane PD. Relationship between hip abductor rate of force development and mediolateral stability in older adults. *Arch Phys Med Rehabil* 2005;86(9):1843-1850.
- Chou L, Kaufman K, Brey R. Correlation between muscle strength and balance control when negotiating obstacles. 46th Annual Meeting, *Orthopaedic Research Society. Orlando, Florida; 2000.* p 0315.
- Cummings SR, Nevitt MC. Non-skeletal determinants of fractures: the potential importance of the mechanics of falls. *Study of Osteoporotic Fractures Research Group. Osteoporos Int* 1994;4 Suppl 1:67-70.
- Feldman EL, Stevens MJ, Thomas PK, Brown MB, Canal N, Greene DA. A practical two-step quantitative clinical and electrophysiological assessment for the diagnosis and staging of diabetic neuropathy. *Diabetes Care* 1994;17(11):1281-1289.
- Giacomozzi C, D'Ambrogi E, Cesinaro S, Macellari V, Uccioli L. Muscle performance and ankle joint mobility in long-term patients with diabetes. *BMC Musculoskeletal Disord* 2008;9:99.
- Gutierrez EM, Helber MD, Dealva D, Ashton-Miller JA, Richardson JK. Mild diabetic neuropathy affects ankle motor function. *Clin Biomech (Bristol, Avon)* 2001;16(6):522-528.

- Hilliard MJ, Martinez KM, Janssen I, Edwards B, Mille ML, Zhang Y, Rogers MW. Lateral balance factors predict future falls in community-living older adults. *Arch Phys Med Rehabil* 2008;89(9):1708-1713.
- Hurvitz EA, Richardson JK, Werner RA, Ruhl AM, Dixon MR. Unipedal stance testing as an indicator of fall risk among older outpatients. *Arch Phys Med Rehabil* 2000;81(5):587-591.
- Hurvitz EA, Richardson JK, Werner RA. Unipedal stance testing in the assessment of peripheral neuropathy. *Arch Phys Med Rehabil* 2001;82(2):198-204.
- Kanade RV, Van Deursen RW, Harding KG, Price PE. Investigation of standing balance in patients with diabetic neuropathy at different stages of foot complications. *Clin Biomech* 2008;23(9):1183-1191.
- Liu J, Lockhart TE. Age-related joint moment characteristics during normal gait and successful reactive-recovery from unexpected slip perturbations. *Gait Posture* 2009;30(3):276-281.
- MacKinnon CD, Winter DA. Control of whole body balance in the frontal plane during human walking. *J Biomech* 1993;26(6):633-644.
- Maki BE, Holliday PJ, Topper AK. A prospective study of postural balance and risk of falling in an ambulatory and independent elderly population. *J Gerontol* 1994;49(2):M72-84.
- Maurer MS, Burcham J, Cheng H. Diabetes mellitus is associated with an increased risk of falls in elderly residents of a long-term care facility. *J Gerontol A Biol Sci Med Sci* 2005;60(9):1157-1162.
- Meyer PF, Oddsson LI, De Luca CJ. The role of plantar cutaneous sensation in unperturbed stance. *Exp Brain Res* 2004;156(4):505-512.
- Mille ML, Johnson ME, Martinez KM, Rogers MW. Age-dependent differences in lateral balance recovery through protective stepping. *Clin Biomech* 2005;20(6):607-616.
- Narici MV, Maganaris C, Reeves N. Myotendinous alterations and effects of resistive loading in old age. *Scand J Med Sci Sports* 2005;15(6):392-401.

- Potvin AR, Sydulko K, Tourtellotte WW, Lemmon JA, Potvin JH. Human neurologic function and the aging process. *J Am Geriatr Soc* 1980;28(1):1-9.
- Reeves NP, Narendra KS, Cholewicki J. Spine stability: lessons from balancing a stick. *Clin Biomech* 2011;26(4):325-330.
- Richardson JK, Ashton-Miller JA, Lee SG, Jacobs K. Moderate peripheral neuropathy impairs weight transfer and unipedal balance in the elderly. *Arch Phys Med Rehabil* 1996;77(11):1152-1156.
- Richardson JK. Factors associated with falls in older patients with diffuse polyneuropathy. *J Am Geriatr Soc* 2002;50(11):1767-1773.
- Richardson JK. The clinical identification of peripheral neuropathy among older persons. *Arch Phys Med Rehabil* 2002;83(11):1553-1558.
- Richardson JK, Thies SB, DeMott TK, Ashton-Miller JA. Interventions improve gait regularity in patients with peripheral neuropathy while walking on an irregular surface under low light. *J Am Geriatr Soc* 2004;52(4):510-515.
- Richardson JK, Tang C, Nwagwu C, Nnodim J. The influence of initial bipedal stance width on the clinical measurement of unipedal balance time. *PMR* 2010;2(4):254-258.
- Smeesters C, Ashton-Miller JA, Cole N, NB. A. Effect of age and gender on maximum hip flexor power. *International Association of Gerontology. Vancouver, BC; 2001.*
- Son J, Ashton-Miller JA, Richardson JK. Frontal plane ankle proprioceptive thresholds and unipedal balance. *Muscle Nerve* 2009;39(2):150-157.
- Son J, Ashton-Miller JA, Richardson JK. Do ankle orthoses improve ankle proprioceptive thresholds or unipedal balance in older persons with peripheral neuropathy? *Am J Phys Med Rehabil* 2010;89(5):369-375.
- Springer BA, Marin R, Cyhan T, Roberts H, Gill NW. Normative values for the unipedal stance test with eyes open and closed. *J Geriatr Phys Ther* 2007;30(1):8-15.
- Suri P, Kiely DK, Leveille SG, Frontera WR, Bean JF. Increased trunk extension endurance is associated with meaningful improvement in balance among older adults with mobility problems. *Arch Phys Med Rehabil* 2011;92(7):1038-1043.

- Thelen DG, Schultz AB, Alexander NB, Ashton-Miller JA. Effects of age on rapid ankle torque development. *J Gerontol A Biol Sci Med Sci* 1996;51(5):M226-232.
- Turcot K, Allet L, Golay A, Hoffmeyer P, Armand S. Investigation of standing balance in diabetic patients with and without peripheral neuropathy using accelerometers. *Clin Biomech* 2009;24(9):716-721.
- Vellas BJ, Wayne SJ, Romero L, Baumgartner RN, Rubenstein LZ, Garry PJ. One-leg balance is an important predictor of injurious falls in older persons. *J Am Geriatr Soc* 1997;45(6):735- 738.
- Vellas BJ, Rubenstein LZ, Ousset PJ, Faisant C, Kostek V, Nourhashemi F, Allard M, Albarede JL. One-leg standing balance and functional status in a population of 512 community-living elderly persons. *Aging (Milano)* 1997;9(1-2):95-98.
- Wallace C, Reiber GE, LeMaster J, Smith DG, Sullivan K, Hayes S, Vath C. Incidence of falls, risk factors for falls, and fall-related fractures in individuals with diabetes and a prior foot ulcer. *Diabetes Care* 2002;25(11):1983-1986.
- Wang CY, Hsieh CL, Olson SL, Wang CH, Sheu CF, Liang CC. Psychometric properties of the Berg Balance Scale in a community-dwelling elderly resident population in Taiwan. *J Formos Med Assoc* 2006;105(12):992-1000.
- Winter DA, Patla AE, Prince F, Ishac M, Gielo-Perczak K. Stiffness control of balance in quiet standing. *J Neurophysiol* 1998;80(3):1211-1221.
- Ylinen J, Salo P, Nykanen M, Kautiainen H, Hakkinen A. Decreased isometric neck strength in women with chronic neck pain and the repeatability of neck strength measurements. *Arch Phys Med Rehabil* 2004;85(8):1303-1308.

Chapter 3

Which lower limb sensory and motor functions are required for functional gait on uneven surfaces in older persons with diabetic neuropathy?

[Accepted in *Journal of Physical Medicine and Rehabilitation*, April 2012]

3.1. Introduction

The prevalence of type 2 diabetes mellitus is increasing worldwide (Wild et al., 2004). It is therefore anticipated that the prevalence of one of its common complications, a distal symmetric peripheral neuropathy (DSPN), will increase as well. It is broadly recognized that a DSPN leads to a decrement in distal lower limb sensory function; however, there is also a neuropathy-related decrease in distal motor function, even among those with relatively mild disease (Gutierrez et al., 2001). The degradation in lower limb sensorimotor function often results in balance and gait impairment among older persons with diabetic DSPN (Allet et al., 2009; Allet et al., 2008; DeMott et al., 2007; Richardson et al., 1996, 2004). These gait abnormalities are accentuated when subjects with DSPN walk on uneven surfaces (Allet et al., 2009; DeMott et al., 2007). Accordingly, the majority of falls in older subjects with neuropathy occur when they are walking on an

irregular surface (DeMott et al., 2007). Despite this link between walking surface irregularity and falls, the great majority of gait research is performed on smooth surfaces (Allet et al., 2008), and so the lower limb sensorimotor features that allow safe and effective gait on irregular surfaces have not been determined. The question is of clinical relevance given that exercise, often in the form of walking, is fundamental to the management of type 2 diabetes mellitus (Matheson et al., 2011).

There is increasing recognition of the importance of lateral (or frontal plane) control during ambulation. In addition to the markedly increased injury potential associated with lateral falls (Greenspan et al., 1998), there is a growing appreciation of the importance of frontal plane sensory and motor function with respect to fall risk and fall prevention (Brauer et al., 2000; Hilliard et al., 2008; Liu and Lockhart, 2009; Rogers and Mille, 2003). However the relative importance of lower limb sensory and motor functions involved in lateral control with respect to functional gait, as defined by speed and efficiency, on an uneven surface has not been explored. Speed and efficiency of gait are relevant measures given that a slower gait speed is associated with increased fall risk (Espy et al., 2010), increased morbidity and mortality (Afilalo et al., 2010), reduced overall health status and increased duration of hospital stay (Purser et al., 2005), and that an efficient gait allows greater ease in daily activities that involve accessing the community. Optimal efficiency occurs when the step-width-to-step-length ratio is 0.14 (Kuo 2001 2002, Donelan et al., 2001), with greater ratios leading to greater energy costs.

Therefore the objective of this research was to identify the lower limb sensory and/or motor functions involved in frontal plane control that most powerfully influence gait speed and efficiency on an uneven surface in older persons with diabetic DSPN. To achieve this objective ankle and hip motor functions, and ankle sensory function, relevant to frontal plane control were measured in a group of older persons with a spectrum of peripheral neurologic disease ranging from normal to moderate/severe diabetic DSPN. Subsequent determination of gait speed and efficiency on an uneven surface allowed the exploration of relationships between lower limb sensorimotor functions and these gait characteristics. It was hypothesized that greater hip and ankle motor function, and more

precise ankle sensory function, would be associated with increased gait speed and efficiency on the irregular surface.

3.2. Materials and Methods

Subjects

Subjects were recruited from the University of Michigan Orthotics and Prosthetics Clinic, Endocrinology Clinic and the Older Americans Independence Center Human Subjects Core. The research protocol was approved by the University of Michigan Institutional Review Board and all subjects provided written informed consent. Inclusion criteria included: age between 50 and 85; weight not greater than 136 kilograms; a history of type 2 diabetes mellitus for subjects with DSPN; the ability to walk household distances without assistance or assistive devices; ankle strength at least against gravity (grade ≥ 3 by manual muscle testing). The history of type 2 diabetes mellitus was confirmed by medical record review of elevated fasting glucose and the ongoing use of oral hypoglycemic agents or insulin. The presence of DSPN was confirmed by: a) symptoms consistent with neuropathy (subject reported altered sensation in the distal lower limbs; b) signs consistent with neuropathy (Michigan Diabetes Neuropathy Score; MDNS) ≥ 10 (Feldman et al., 1994); c) electrodiagnostic evidence of neuropathy (bilaterally abnormal peroneal motor responses recording over the extensor digitorum brevis, defined as amplitude < 2 mV and/or latency > 6.2 milliseconds and/or conduction velocity < 41.0 m/s). Subjects without DSPN had no history of diabetes mellitus, no symptoms or signs of DSPN (MDNS < 10), and normal peroneal nerve conduction studies. Subjects were excluded if they reported a fall within one month of testing or had history or clinically evident central nervous system dysfunction (for example, hemiparesis, myelopathy or cerebellar ataxia). Additional exclusion criteria included: neuromuscular disorders other than DSPN (for example, myopathy or neuromuscular junction disorders), evidence of vestibular dysfunction, history of angina or angina-equivalent symptoms with exercise, plantar skin sore or joint replacement within the previous year, symptomatic postural hypotension, significant musculoskeletal deformity (for example, amputation or Charcot

changes), lower limb or spinal pain that limited standing to less than 10 minutes, or walking to less than one block. Subjects meeting criteria provided answers to a validated balance confidence scale (ABC Scale) (Powell et al., 1995).

Evaluation of Lower Limb Sensorimotor Function

Ankle Sensory Function: Ankle proprioception thresholds were determined as previously described (Son et al., 2010). In brief, subjects stood with the foot/ankle being tested in a 40 x 25 cm cradle that rotated in the frontal plane (inversion and eversion; Figure 3-1). The cradle was rotated by a servomotor equipped with an 8,000 line rotary encoder (Aerotech 1000 servomotor, Aerotech, Inc., Pittsburgh, PA, United States). The subject responded to the direction of the rotation with a hand held joystick. Four blocks of 25 trials (randomly 10 eversion, 10 inversion, and 5 dummy trials) were presented. Each block was interspersed with 2 to 5 minutes rest intervals. The ankle proprioception threshold was defined as the smallest rotational displacement of the ankle that a subject could detect with 100% accuracy.



Figure 3-1. Apparatus for determining frontal plane ankle proprioceptive thresholds. Figure from Son et al. (2010).

Ankle Motor Function: During maximum voluntary strength testing, subjects stood on a force plate (Model #OR6-7 Force Plate, AMTI, Inc., Watertown, Massachusetts, United States) touching hand rails on both sides as needed. Subjects then lifted one leg, shifted their center of gravity as far laterally under their foot as possible and lifted their hands from the rails for three seconds. The test was repeated three times for the lateral margin of the foot (maximum voluntary inversion), and repeated for the medial margin of the foot (maximum voluntary eversion). To measure ankle rate of torque development (RTD), subjects stood on the test foot on the force plate and moved the center of ground support reaction from the lateral margin of the foot to the medial margin as quickly as possible, and then back again to the lateral margin, as previously described (Gutierrez et al., 2001). Three trials, each trial with five medial-lateral movements, were performed. Subjects were allowed to touch horizontal hand rails as needed.

Hip Motor Function: A custom, whole-body dynamometer (BioLogic Engineering, Inc. Dexter, MI.) was used to measure maximum voluntary strength and RTD of frontal plane hip musculature (Allet et al., 2011). The subject lay on a horizontal bench with the pelvis and upper body immobilized with adjustable harness straps, and the limb being tested secured with straps against a lever, allowing all measurements to be made in a gravity-free plane. During maximum voluntary strength tests subjects progressively increased their isometric effort to their maximum over a count of three seconds, held it for two seconds, and relaxed. To quantify rate of isometric strength development, subjects increased their effort as rapidly as possible for 3 s. Three trials were performed with 1 minute rest between trials. Subjects had a real time visual display of the force generated to allow them to evaluate their efforts. Ankle and hip motor functions were normalized for body size, defined as body height multiplied by weight in units of Newton-m.

Gait Analysis

All subjects wore flat-soled athletic shoes (New Balance Athletic Shoe Inc., Boston, Massachusetts) as well as a full-body safety harness which was adjusted so that their knees or other body parts could not touch the floor in the event of a fall. Subjects walked on a 1.5 m*10 m irregular surface which was created by randomly placing triangular

wooden prisms under a strip of industrial carpeting (Figure 2). An optoelectronic camera system measured kinematic data at 100 Hz (Optotrak 3020, Northern Digital Corp., Waterloo, Ontario.) (Richardson et al., 2004). These data were then processed using a custom MATLAB algorithm to quantify walking speed, step width, and step length as previously described (Richardson et al., 2004).



Figure 3-2. Experimental set-up for determining gait speed and step width to step length ratio on an irregular surface. A Figure from Richardson et al. (2005)

Statistics

Statistical analyses used SPSS (SPSS for Windows, Rel.11.0.1.2001 Chicago). Descriptive statistics were determined for all measures. Data were examined for normality and screened for outliers. Pearson product-correlation coefficients were calculated to assess relationships between lower limb sensorimotor functions, gait speed, and step width to step length ratio. Multiple regression models were used to determine

the independence and relative influence of sensorimotor functions (independent variables) and gait speed and step-width-to-step-length ratio (dependent variables). Sensorimotor functions with significant relationships to gait speed or efficiency were introduced in the regression model as potential predictors, using age, BMI and ABC scale results as co-variables. The significance level for all tests was set at 0.05.

3.4 Results

Subjects: Thirty three subjects were enrolled (14; 42.4% female and 21; 63.6% with diabetic DSPN). Means and standard deviations of age, BMI, MDNS, and ABC scale results are presented in Table 1.

Table 3-1 Subject information

Parameter (N=33)	Minimum	Maximum	Mean (SD)
Age (years)	52.0	85.0	69.67 (8.89)
Height (cm)	150.0	188.0	171.72 (10.09)
Weight (kg)	49.5	125.0	88.74 (19.04)
BMI (m ² /kg)	19.2	46.5	30.11 (6.30)
MDNS (0-46)	0.0	31.0	9.49 (8.39)
ABC-Scale (0-100)	30.0	100.0	88.40 (15.40)

Univariate Analyses: Correlation coefficients between lower limb sensorimotor functions and gait speed, as well as gait efficiency are listed in Table 2. The data indicate that all of the sensorimotor functions were significantly associated with gait speed with correlations (r) ranging from .412 to .665. Additionally, all sensorimotor functions except ankle eversion RTD were significantly associated with gait efficiency with significant correlations ranging from .385 to .648. The ABC scale results were directly related to gait speed (r = .523; p = .002) but not gait efficiency (r = - .236, p = .187). Age was indirectly related to speed and efficiency (r = -.447; p = .009; respectively r = .425; p = .014) whereas BMI correlated with neither gait speed nor efficiency.

Table 3-2a Correlation coefficients between sensorimotor functions and gait speed

Variable	N	Correlation coefficient	p-value
Ankle inversion Rate of Torque development	31	0.665	0.000
Hip Add Rate of Torque development	33	0.626	0.000
Hip Abd Rate of Torque development	33	0.504	0.003
Hip Add Maximum Voluntary Strength	33	0.475	0.005
Ankle Inversion Maximum Voluntary Strength	31	0.491	0.007
Ankle Eversion Maximum Voluntary Strength	31	0.447	0.012
Ankle Eversion Rate of Torque development	31	0.441	0.013
Hip Abd Maximum Voluntary Strength	33	0.422	0.015
Ankle proprioceptive threshold	33	-0.412	0.017

Table 3-2b Correlation coefficients between sensorimotor functions and step width to step length ratio

	N	Correlation coefficient	p-value
Hip Add Maximum Voluntary Strength	33	-0.648	0.000
Ankle inversion Rate of Torque development	31	-0.636	0.000
Ankle proprioceptive threshold	33	0.503	0.003
Ankle eversion Rate of Torque development	31	-0.514	0.003
Hip Abd Rate of Torque development	33	-0.486	0.004
Hip Abd Maximum Voluntary Strength	33	-0.475	0.005
Hip Add Rate of Torque development	33	-0.471	0.006
Ankle Inversion Maximum Voluntary Strength	29	-0.385	0.039
Ankle Eversion Maximum Voluntary Strength	31	-0.326	0.074

Multivariate Analyses: Regression analyses identified four significant predictors of gait speed on the irregular surface (Table 3.a.). These predicted nearly 70% of the variance in gait speed, with hip adductor RTD accounting for greater than 40%. The only significant predictor of gait efficiency (step-width-to-step-length ratio) was ankle inversion RTD which accounted for 46% of the variance (Table 3.b.).

Table 3-3a Sensorimotor functions predicting gait speed on the irregular surface

RTD Hip Add = Rate of torque development of Hip Adductors; RTD Ankle Inv = Rate of torque development of Ankle inversion; Confidence (ABC scale); MVC Hip Abd = Maximum voluntary contraction of Hip Abduction

(N=33) Parameters	R	R ²	Adj. R ²	SE Estimate	R ² Change	F Change	Sig. F Change
RTD Hip Add	.610	.436	.416	.129	.436	20.907	.000
RTD Ankle Inv	.735	.540	.504	.119	.103	5.826	.023
Confidence	.792	.628	.583	.109	.088	5.915	.023
MVC Hip Abd	.833	.694	.643	.101	.067	5.220	.031

Table 3-3b. Sensorimotor functions predicting step width to step length ratio

RTD Hip Add = Rate of torque development of Hip Adductors

(N=33) Parameter	R	R ²	Adj. R ²	SE Estimate	R ² Change	F Change	Sig. F Change
RTD Hip Add	.678	.460	.440	.061	.460	22.960	.000

3.4 Discussion

The most important finding was that frontal plane motor function at the hip and ankle (adduction and inversion, respectively) explained nearly three quarters of the variance in gait speed and nearly half of the variance in gait efficiency among older subjects with varying degrees of DSPN walking on an irregular surface. Moreover it was RTD of these muscles, rather than their maximal strength, that was critical to gait speed and efficiency under the experimental conditions. In contrast, ankle proprioceptive function did not appear to influence gait when frontal plane motor function and confidence were taken into account. Finally, age independently influenced neither gait speed nor efficiency on the irregular surface.

Although the importance of frontal plane motor function relative to that more routinely studied in the sagittal plane (i.e., knee extensors and plantar flexors) was not determined,

comparisons with other work are useful. For example in prior work we found that frontal plane hip strength explained about 45% of unipedal balance time (Allet et al., 2011), whereas a separate study found that knee extensor and flexor strength explained only 10% (Citaker et al., 2011). Similarly, in a study of older adults with diabetic DSPN, sagittal plane muscle strength predicted about one fifth of gait speed change when subjects transitioned from smooth to uneven terrain (Allet et al., 2009), substantially less than our study in which frontal plane motor function predicted almost three quarters of the variance in gait speed. These comparisons suggest that motor function in the frontal plane, rather than that in the more frequently studied sagittal plane, exerts the dominant influence when balance is challenged.

Rates of torque generation at the hip and ankle were more important than the maximum strengths of these same muscle groups, a point supported by other research which emphasizes motor response speed for successful recovery from a perturbation. Jumping distance (Hernandez and Rose, 2008) and gluteus medius onset latency (Brauer et al., 2000) in response to a perturbation were the best predictors of prospectively identified falls among community-dwelling older persons. Similarly, jump height was the best clinical measure of ability to recover from an induced trip (Pijnappels et al., 2008), and subjects routinely recovered from trip durations less than 700 milliseconds, but could not recover from longer trip durations (Smeester et al., 2001). Our results add to current research suggesting that successful response to a balance challenge, including gait on an irregular surface, is time dependent and so requires short response latencies and rapid generation of force. The greater importance of hip adduction and ankle inversion RTD, rather than abduction and eversion, is likely related to the ability of the former movements to generate a laterally directed ground reaction force which allows control of a laterally displaced center of mass (Otten, 1999).

The absence of a significant, independent age effect implies that aging does not intrinsically contribute to difficulty navigating an irregular surface. It is likely that age is a marker for decrements in RTD in frontal plane muscles, along with reductions in plantar flexor power (Graf et al., 2005) which are the true sources of apparent age-related gait change. Although a greater number of subjects might reveal an independent age

effect, our data suggest that such an effect would be minor in comparison to lower limb motor function.

The apparent lack of influence of frontal plane proprioceptive sensory function at the ankle was not anticipated given their importance to unipedal stance time (Son et al., 2010; Allet et al., 2011). However, this finding is consistent with other analyses of these same subjects which found that hip motor function compensates for imprecise ankle proprioception during one-legged balance (Allet et al., 2011). The apparent lack of ankle sensory contribution may also be related to subjects seeing the walking surface irregularities which could have allowed visual compensation for somatosensory deficits. In support, lower field visual information is important to adapting to varying walking surfaces (Marigold and Patla, 2008) and so proprioceptive thresholds might have played a measurable role if lower field vision was occluded.

The study has strengths in comparison with prior work. Among these is the simultaneous quantification of sensory and motor function relevant to frontal plane control within each subject, a novel feature of the study. In addition the subjects were selected to represent a spectrum of peripheral sensorimotor function, and the presence and severity of PN were determined by history, physical examination and nerve conduction studies as has been recommended (England et al., 2005). In contrast, studies often use a single modality such as vibratory perception threshold or monofilament testing to determine the presence and severity of PN. The measurement of RTD is infrequently determined, but is an advantage given other work finding that diabetic neuropathy is associated with selective dropout of Type II motor neurons and reduced rate of force generation (Andersen and Mogensen, 1997; Narici 2005). The use of an uneven walking surface is more functionally relevant than gait analysis on a smooth surface, as is typically used, particularly given the fall risk associated with irregular surfaces (DeMott et al., 2007).

One of the study's limitations is the combining of subjects with diabetic DSPN with subjects who have neither diabetes nor neuropathy. This concern is mitigated by evidence that a DSPN, rather than the presence of diabetes mellitus, is primarily responsible for impairments in ankle motor function and balance (for example (Gutierrez

et al., 2001; Turcot et al., 2009)). Another limitation involves the method for determining ankle motor function which assumed the ankle center of rotation to be midway between the malleoli. However this technique has been used previously and its validity is supported by the relationship between ankle strength determined in this manner, and the presence of neuropathy and unipedal stance time (Gutierrez et al., 2001). The method for determining hip strength applied a varus/valgus stress on the knee. Although no subjects reported pain they may have not given maximal effort for fear of causing discomfort. In addition, it has recently been demonstrated that the knee has frontal plane proprioceptive function (Cammarata et al., 2011), something we did not account for. The number of subjects was reasonable given the quantitative nature of the study, but the 33 subjects allow the reliable consideration of just 3 to 4 potential predictors within a multiple regression analysis.

The results of this research have potential clinical application. Specifically, it appears that strengthening regimens in older persons with diabetic DSPN should focus on the capacity to develop strength quickly, rather than on maximal strength generated gradually. In addition, training should involve muscles of frontal plane control, rather than focusing exclusively on muscles involved in sagittal plane control; however, this is not routinely recommended (Woo et al., 2007; Korpelainen et al., 2006). The dominant effect of the proximally located hip muscles on gait speed on an uneven surface suggests that even patients with more severe PN can benefit from training, given the distal nature of neuropathic disease. It is less clear that patients with PN, particularly those with more severe impairments, can increase ankle inversion rate of torque generation. However some strengthening is likely possible in most cases given that both the anterior and posterior tibialis muscles perform this function, with the latter muscle innervated by the tibial nerve which takes a shorter route to its target, rendering it relatively less affected in a length dependent neuropathic process.

Our results suggest that a future trial examining the effect of a training program designed to increase rate of torque generation in frontal plane muscles in older persons with diabetic PN is reasonable, using gait speed and the ability to tolerate perturbations while walking as outcomes. It is tempting to suggest that increasing frontal plane rate of torque

generation will reduce fall risk in older patients with diabetic PN when walking on an uneven surface. Although this is likely true, that specific hypothesis was not explored and is a question that merits further study. The absence of influence of ankle proprioceptive function is surprising but may, as suggested above, show influence if the lower visual field is obscured. Such a study has special relevance to the diabetic population given the likelihood that some patients will have visual impairment from retinopathy.

3.5 References

- Afilalo J, Eisenberg M, Morin J, et al. (2010) Gait Speed as an Incremental Predictor of Mortality and Major Morbidity in Elderly Patients Undergoing Cardiac Surgery. *J Am Coll Cardiol* 56:1668-1676
- Allet L, Armand S, Golay A, Monnin D, de Bie RA, and de Bruin ED (2008) Gait characteristics of diabetic patients: a systematic review. *Diabetes Metab Res Rev* 24:173-91
- Allet L, Armand S, de Bie RA, et al. (2009) Gait alterations of diabetic patients while walking on different surfaces. *Gait Posture* 29:488-93
- Allet L, Armand S, de Bie RA, et al. (2009) Clinical factors associated with gait alterations in diabetic patients. *Diabet Med* 26:1003-9
- Allet L, Kim H, Ashton-Miller JA, DeMott T, Richardson JK, (2012) Frontal plane hip and ankle sensorimotor function, not age, predicts unipedal stance time. *Muscle & Nerve* 45:578-585
- Andersen H and Mogensen PH (1997) Disordered mobility of large joints in association with neuropathy in patients with long-standing insulin-dependent diabetes mellitus. *Diabet Med* 14:221-7
- Brauer SG, Burns YR, and Galley P (2000) A prospective study of laboratory and clinical measures of postural stability to predict community-dwelling fallers. *J Gerontol A Biol Sci Med Sci* 55:M469-76

- Cammarata ML, Schnitzer TJ, and Dhaher YY (2011) Does knee osteoarthritis differentially modulate proprioceptive acuity in the frontal and sagittal planes of the knee? *Arthritis Rheum* 63:2681-9
- Citaker S, Kaya D, Yuksel I, et al. (2011) Static balance in patients with patellofemoral pain syndrome. *Sports Health: A Multidisciplinary Approach* 3:524-527
- DeMott TK, Richardson JK, Thies SB, and Ashton-Miller JA (2007) Falls and gait characteristics among older persons with peripheral neuropathy. *Am J Phys Med Rehabil* 86:125-32
- Donelan JM, Kram R, and Kuo AD (2001) Mechanical and metabolic determinants of the preferred step width in human walking. *Proc Biol Sci* 268:1985-92
- England JD, Gronseth GS, Franklin G, et al. (2005) Distal symmetrical polyneuropathy: a definition for clinical research. A report of the American Academy of Neurology, the American Association of Electrodiagnostic Medicine, and the American Academy of Physical Medicine and Rehabilitation. *Arch Phys Med Rehabil* 86:167-74
- Espy DD, Yang F, Bhatt T, and Pai YC (2010) Independent influence of gait speed and step length on stability and fall risk. *Gait Posture* 32:378-82
- Feldman EL, Stevens MJ, Thomas PK, Brown MB, Canal N, and Greene DA (1994) A practical two-step quantitative clinical and electrophysiological assessment for the diagnosis and staging of diabetic neuropathy. *Diabetes Care* 17:1281-9
- Graf A, Judge JO, Ounpuu S, and Thelen DG (2005) The effect of walking speed on lower-extremity joint powers among elderly adults who exhibit low physical performance. *Arch Phys Med Rehabil* 86:2177-83
- Greenspan SL, Myers ER, Kiel DP, Parker RA, Hayes WC, and Resnick NM (1998) Fall direction, bone mineral density, and function: risk factors for hip fracture in frail nursing home elderly. *Am J Med* 104:539-45
- Gutierrez EM, Helber MD, Dealva D, Ashton-Miller JA, and Richardson JK (2001) Mild diabetic neuropathy affects ankle motor function. *Clin Biomech (Bristol, Avon)* 16:522-8

- Hernandez D and Rose DJ (2008) Predicting which older adults will or will not fall using the Fullerton Advanced Balance scale. *Arch Phys Med Rehabil* 89:2309-15
- Hilliard MJ, Martinez KM, Janssen I, et al. (2008) Lateral balance factors predict future falls in community-living older adults. *Arch Phys Med Rehabil* 89:1708-13
- Kuo AD (2001) A simple model of bipedal walking predicts the preferred speed-step length relationship. *J Biomech Eng* 123:264-9
- Korpelainen R, Keinanen-Kiukaanniemi S, Heikkinen J, Vaananen K, and Korpelainen J (2006) Effect of exercise on extraskeletal risk factors for hip fractures in elderly women with low BMD: a population-based randomized controlled trial. *J Bone Miner Res* 21:772-9
- Kuo AD (2002) Energetics of actively powered locomotion using the simplest walking model. *J Biomech Eng* 124:113-20
- Liu J and Lockhart TE (2009) Age-related joint moment characteristics during normal gait and successful reactive-recovery from unexpected slip perturbations. *Gait Posture* 30:276-81
- Marigold DS and Patla AE (2008) Visual information from the lower visual field is important for walking across multi-surface terrain. *Exp Brain Res* 188:23-31
- Matheson GO, Klugl M, Dvorak J, et al. (2011) Responsibility of sport and exercise medicine in preventing and managing chronic disease: applying our knowledge and skill is overdue. *Br J Sports Med* 45:1272-82
- Otten E (1999) Balancing on a narrow ridge: biomechanics and control. *Philos Trans R Soc Lond B Biol Sci* 354:869-75
- Narici MV, Maganaris C, and Reeves N (2005) Myotendinous alterations and effects of resistive loading in old age. *Scand J Med Sci Sports* 15:392-401
- Pijnappels M, van der Burg PJ, Reeves ND, and van Dieen JH (2008) Identification of elderly fallers by muscle strength measures. *Eur J Appl Physiol* 102:585-92
- Powell LE and Myers AM (1995) The Activities-specific Balance Confidence (ABC) Scale. *J Gerontol A Biol Sci Med Sci* 50A:M28-34

- Purser JL, Weinberger M, Cohen HJ, et al. (2005) Walking speed predicts health status and hospital costs for frail elderly male veterans. *J Rehabil Res Dev* 42:535-46
- Richardson JK, Ashton-Miller JA, Lee SG, and Jacobs K (1996) Moderate peripheral neuropathy impairs weight transfer and unipedal balance in the elderly. *Arch Phys Med Rehabil* 77:1152-6
- Richardson JK, Thies SB, DeMott TK, and Ashton-Miller JA (2004) A comparison of gait characteristics between older women with and without peripheral neuropathy in standard and challenging environments. *J Am Geriatr Soc* 52:1532-7
- Rogers MW and Mille ML (2003) Lateral stability and falls in older people. *Exerc Sport Sci Rev* 31:182-7
- Smeesters C, Hayes WC, and McMahon TA (2001) The threshold trip duration for which recovery is no longer possible is associated with strength and reaction time. *J Biomech* 34:589-95
- Son J, Ashton-Miller JA, and Richardson JK (2010) Do ankle orthoses improve ankle proprioceptive thresholds or unipedal balance in older persons with peripheral neuropathy? *Am J Phys Med Rehabil* 89:369-75
- Turcot K, Allet L, Golay A, Hoffmeyer P, and Armand S (2009) Investigation of standing balance in diabetic patients with and without peripheral neuropathy using accelerometers. *Clin Biomech (Bristol, Avon)* 24:716-21
- Wild S, Roglic G, Green A, Sicree R, and King H (2004) Global prevalence of diabetes: estimates for the year 2000 and projections for 2030. *Diabetes Care* 27:1047-53
- Woo J, Hong A, Lau E, and Lynn H (2007) A randomised controlled trial of Tai Chi and resistance exercise on bone health, muscle strength and balance in community-living elderly people. *Age Ageing* 36:262-8

Chapter 4

A Novel Clinical Test of Simple and Recognition Reaction Time in Healthy Adults

[Published in *Psychological Assessment*, 2011]

4.1 Introduction

Simple reaction time (RT), a measure of how quickly a person performs a uniform response to a specific stimulus, is of clinical relevance with regard to function and health. It is evident that a prolonged RT would influence function, for example by increasing risk for accidental falls (e.g., Lord et al., 1991) and motor vehicle accidents (e.g., McKnight and McKnight, 1999). Less obvious, however, is the strong relationship between simple RT and measures of cognitive and physical health. Simple RT has been linked to intelligence (Jensen and Munro, 1979) and biomarkers such as forced expiratory volume at 1 s (FEV1), grip strength, visual acuity, and systolic blood pressure (Anstey et al., 2005). Furthermore, a prolonged simple RT and greater declines in simple RT over a 7-year span have been independently associated with mortality (Shipley et al., 2006; 2007).

Despite the clear potential of RT as an evaluative tool, it is not commonly used by most clinicians because its measurement typically requires a computer and dedicated software, for example, CANTAB (Cambridge Cognition Ltd., Cambridge, United Kingdom) or CogState (CogState Ltd., Melbourne, Australia). In an effort to make the determination of simple RT available to all health care practitioners, we developed a clinical method of determining RT (RT_{clin}). We defined simple RT_{clin} as the time required to catch a suspended vertical shaft by pinch grip. The device is released at random intervals through

the subject's open hand. As soon as the subject perceives the apparatus to be falling, he or she grasps it as quickly as possible (Figure 4-1). The fall distance is measured, and the RT is calculated with the knowledge that the acceleration is due to gravity.

Previous work has found simple RT_{clin} test scores to be reliable over a wide range of time and their interpretation valid in two distinct populations. In a healthy adult population, short term test–retest and interrater reliabilities were intraclass correlation coefficient (ICC) = 0.860 and ICC = 0.915, respectively (Eckner et al., 2009). Furthermore, significant correlations were present between RT_{clin} scores and those of a computerized RT measure written in E-Prime ($R = 0.570$), as well as with participant age ($R = 0.430$). A follow-up study involving collegiate athletes found test–retest reliabilities for simple RT_{clin} test scores of ICC = 0.645 over a 1-year retest interval (Eckner et al., 2011). The validity of RT_{clin} test score interpretation was further supported by a second collegiate athlete study, which demonstrated a significant correlation between RT_{clin} test scores and simple RT scores obtained during valid CogState– Sport test sessions ($R = 0.445$; Eckner et al., 2010). In addition, simple RT_{clin} test scores correlate strongly with the time required to perform a functional head-protective task ($R = 0.725$; Eckner et al., 2011). Simple RT_{clin} scores also appear to be sensitive to the effects of mild traumatic brain injury. Simple RT_{clin} scores were 13.5% slower in nine concussed collegiate athletes tested within 72 hr of injury, compared with each athlete's own baseline during the preseason (Eckner et al., 2011).

A complex RT occurs when the stimuli and responses vary. There is evidence that complex forms of RT may be of greater clinical utility than simple RT. For example, compared with simple RT tasks, complex RT tasks have been found to relate more strongly with cognition and mortality across the adult age range (Shipley et al., 2006), a measure of fluid intelligence (Thoma et al., 2006), cognitive ability (Deary et al., 2010), death from all causes (Shipley et al., 2007), and death from cardiovascular diseases, stroke, and respiratory diseases (Shipley et al., 2008). In addition simple RT is relatively unchanging until individuals reach the age of 50 years, after which it increases, whereas complex RT tasks increase steadily throughout the lifespan (Der and Deary, 2006), suggesting the latter is a more sensitive marker of change. Last, complex RT tasks mirror

the complexities of daily life more effectively than does simple RT. For example, a driver may have to choose between braking and rapidly turning the wheel in response to an object in the vehicle's path. In fact, a complex RT has been shown to be a better predictor of on-road driving than simple RT (Mathias and Lucas, 2009).

Given these apparent advantages of a complex RT, we modified the simple RT_{clin} apparatus to allow the clinical measurement of a complex RT task, referred to as *recognition RT_{clin}* . In this condition, the subject responds, or withholds response, on the basis of the stimuli presented. The modifications to the apparatus include the addition of a light-emitting diode (LED), accelerometer, digital timing circuit, and microcontroller (Figure 4-1a). The LED is programmed to illuminate upon the onset of acceleration after the device is dropped in 50% of trials, with the presentation of those trials being randomized. The subject is instructed to catch the device only when the LED illuminates, but to let the apparatus drop to the floor if the LED remains off.

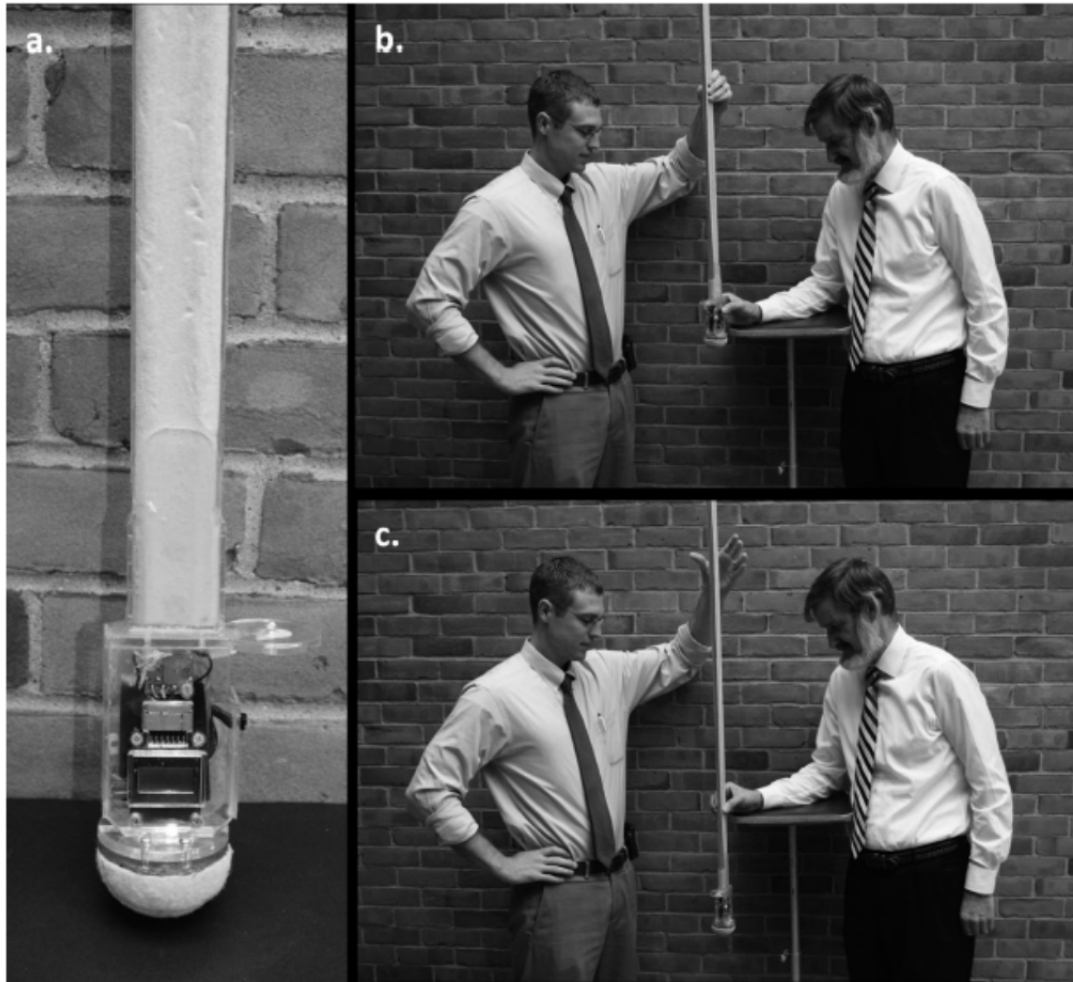

Figure 4-1. The clinical reaction time apparatus and testing procedure: (a) the apparatus, (b) predrop examiner and test subject positions, and (c) postdrop examiner and test subject positions. For the purpose of this illustration, neither the subject nor testing apparatus is instrumented with optoelectronic markers. The lightemitting diode can be seen at far right in (a) as the small light-colored hemisphere mounted on the circular shaped transparent plastic top cover to the finger spacer, here seen in side view. (Figure appears in Psychological Assessment, 2011)

The essential difference between recognition RT_{clin} and simple RT_{clin} is that the former requires the subject to recognize and interpret additional information not included in the latter and to use this additional information to decide whether to catch the falling device. We anticipated that the additional central nervous system processing required during the

recognition RT_{clin} task would increase the utility of the task for evaluating neurocognitive dysfunction.

Researchers commonly divide RT into two intervals: the time required by the nervous system to interpret and process the input stimulus and plan a motor response, referred to in this article as *premovement time (PMT)*, and the time required to perform the response, referred to here as *movement time (MT)*; e.g., McMorris et al., 2005). The reader should note that an alternative definition of *reaction time* is synonymous with *PMT*, as used in this article. Using this definition, *response time* is synonymous with *reaction time*, as used in this article. To distinguish PMT, which includes central processing and decision making (Sternberg, 1969; Spirduso, 1975), from MT, an optoelectronic camera system quantified the motions of the apparatus and the subject's fingers.

This camera and the measurement of PMT and MT do not ordinarily form part of the recognition RT_{clin} measurement but are used here only for the purposes of testing a specific hypothesis.

The purpose of the study was to determine the feasibility of using the modified RT_{clin} apparatus to measure simple and recognition RT_{clin} across an age spectrum. More specifically, we tested the hypotheses:

Hypothesis 1: Recognition RT_{clin} test results would be prolonged compared with simple RT_{clin} results.

Hypothesis 2: The majority of the recognition RT_{clin} result prolongation would be attributable to PMT.

Hypothesis 3: Recognition RT_{clin} results would positively correlate with age.

Hypothesis 4: Recognition RT_{clin} response accuracy would negatively correlate with age.

4.2 Method

We recruited a gender-balanced sample of 93 volunteers (mean age 40.1 ± 21 years, range 18–83 years). The sample was skewed toward a younger population, with 44 participants ages 18–27 years, nine ages 28–37 years, four ages 38–47 years, nine ages 48–57 years, seven ages 58–67, twelve ages 68–77, and eleven whose ages were 78 years and older.

Healthy active adults 18–85 years old were eligible to participate. Potential subjects were excluded if they were pregnant, had corrected vision 20/40, or had any significant disease or injury limiting the function of their upper extremities. An additional exclusion criterion was current use of any medications known to affect RT. All participants provided informed written consent that was approved by the institutional review board at the authors' institution prior to participation.

Simple and recognition RT_{clin} scores were measured with an RT_{clin} apparatus (Figure 4-1a; Eckner, Lipps, et al., 2011) that was modified from an earlier simple RT_{clin} assessment device (Eckner et al., 2009). The device is a rigid, lightweight 117-cm elongated biconcave shaft; affixed to the bottom is a rectangular thumb–finger “spacer” that houses an accelerometer, timing circuit, microprocessor, and LED. A half tennis ball on the bottom of the housing dissipated energy upon ground contact. The device was programmed so that the LED randomly illuminated in green during 50% of the recognition RT_{clin} trials. The linear accelerometer sensed the onset of device movement and instantaneously triggered the illumination of the LED.

Simple RT_{clin} was assessed first. Participants stood with their dominant forearm resting on an adjustable table such that their hand was positioned at the edge of the surface. The examiner suspended the device vertically from its upper end such that the top of the device spacer was collinear in the horizontal plane with the superior-most aspect of the participant's open first and second digits (Figure 4-1b). The purpose of the spacer was to standardize the initial distance between the participant's thumb and fingers to be at least 25 mm. Participants were instructed to hold their thumb and fingers so they just did not touch the spacer. The examiner released the apparatus after randomly assigned delay times between 2 and 5 s so that participants were unable to anticipate the instant of release. As soon as the device began to fall, the participant used a pinch grip to catch the narrowest portion (measuring 10 mm) of its biconcave-sectioned handle as quickly as possible (Figure 4-1c). The elapsed time between the instant when, after examiner release, device downward acceleration reached 0.5g until the instant when the subject's pinch grip slowed device acceleration to 0.5 g again was defined as the total RT_{clin} score. Each participant completed four practice trials followed by eight data acquisition trials.

Next, recognition RT_{clin} scores were measured using a “go/no go” testing paradigm in a manner identical to simple RT_{clin} , except that participants were instructed to catch the device only during trials when the green LED illuminated. For trials when the LED did not illuminate, participants were instructed to allow the device to fall to the ground. Participants were given two go trials during which the LED illuminated and two no-go trials during which the LED remained unlit to practice the recognition RT_{clin} task. During data acquisition trials, the recognition RT_{clin} task was repeated with the LED randomly illuminating for 50% of trials over a minimum of 16 trials. Trials were then added until the participant successfully completed eight go trials.

The movements of the apparatus and the participant’s first and second digits were recorded in three dimensions with optoelectronic markers and an optoelectronic camera system (Certus; Northern Digital Inc., Waterloo, ON, Canada). It should be noted that these measurements allowed RT_{clin} scores to be divided into PMT and MT components for this study, but are not necessary for RT_{clin} measurement. PMT was defined as the elapsed time between onset of downward device acceleration and the instant when the speed of participant digit movement reached 10 cm/s. MT was defined as the elapsed time from the onset of the participant’s digit movement response until the instant when device acceleration had decreased to 0.5g due to the pinch grip of the participant. Threedimensional kinematic data were measured at 1 kHz at a resolution of 0.1 mm. Signal processing was performed using MATLAB (Version 2009b; The MathWorks, Natick, MA).

Trials with ambiguous kinematic data that could not be interpreted were excluded from analysis. This occurred in 4.1% (34 of 832) of trials. Mean (SD) simple and recognition RT_{clin} values were calculated for each participant, as were the mean (SD) of the PMT and MT subintervals and overall go and no-go recognition RT_{clin} accuracies. Overall accuracy was defined as the number of correct responses divided by the total number of trials. The go and no-go accuracies were defined as the number of times the device was appropriately caught during go trials and the number of times the device was appropriately allowed to fall during no-go trials divided by the total number of go trials and no-go trials, respectively.

Visual inspection of the raw data histograms demonstrated right-skewing, so a log transformation was applied to the raw data prior to all parametric analyses. We compared continuous variables using paired t tests. Proportions were used to describe the amount of change between total simple and recognition RT_{clin} attributable to PMT. Pearson correlation coefficients were calculated to assess the relationships between continuous variables. A Bonferroni correction was applied to account for multiple comparisons. Statistical analysis was conducted using SAS (Version 9.1; SAS Institute, Inc., Cary, NC) and SPSS (Version 16.0; SPSS Inc., Chicago, IL).

4.3 Results and Discussion

Recognition RT_{clin} test scores were significantly longer than simple RT_{clin} scores (243 ± 20 ms vs. 168 ± 28 ms, $p < 0.001$; Hypothesis 1), as were the PMT and MT subintervals (194 ± 26 ms vs. 141 ± 19 ms, $p < 0.001$ and 64 ± 14 ms vs. 43 ± 9 ms, $p < 0.001$, respectively) (Figure 4-2a and 4-2b). The forced-choice paradigm prolonged total RT_{clin} by proportionately lengthening both PMT and MT, with PMT accounting for 76.3% and 75.0% of total simple and recognition RT_{clin} , respectively ($p < 0.090$). This equates to 71% of the overall prolongation in recognition RT_{clin} scores being attributable to PMT (Hypothesis 2), which includes the time required for central signal processing and decision making. Age was positively associated with simple RT_{clin} test scores ($R = 0.500$, $p < 0.001$) and their PMT subinterval ($R = 0.591$, $p < 0.001$), but not with the corresponding recognition RT_{clin} indices (Hypothesis 3) or simple MT. A weaker association was present between age and the PMT subinterval of recognition RT_{clin} ($R = 0.315$, $p < 0.023$) that did not reach statistical significance after Bonferroni correction.

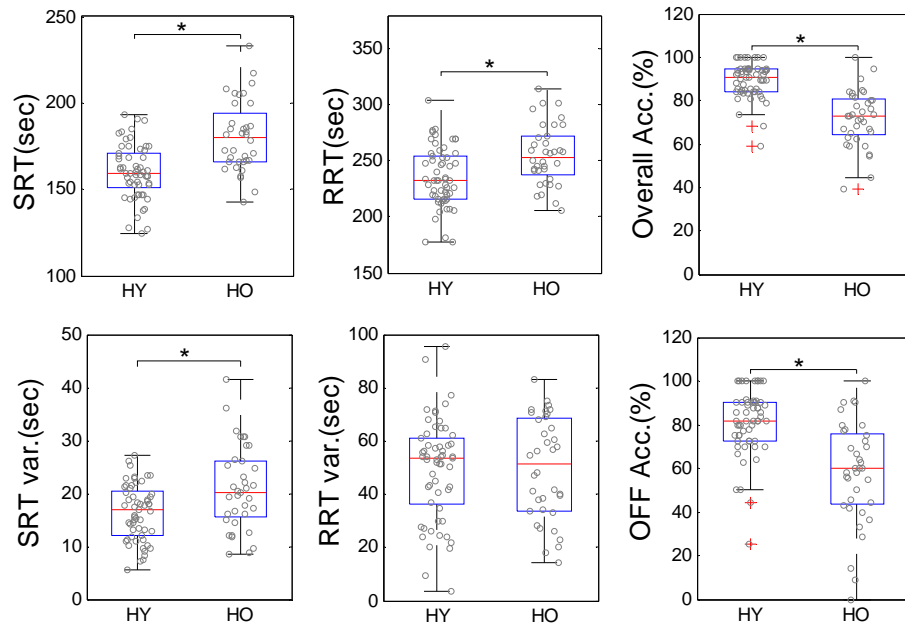

Figure 4-2a Boxplots with scatter plots of mean and variabilities in simple RT_{clin} (SRT) and variability (SRT var.), recognition RT_{clin} (RRT) and its variability (RRT var.), Overall and OFF accuracy. * denotes significant age effect on the corresponding category ($\alpha < 0.001$) HY denotes healthy young adults and HO denotes healthy old adults.

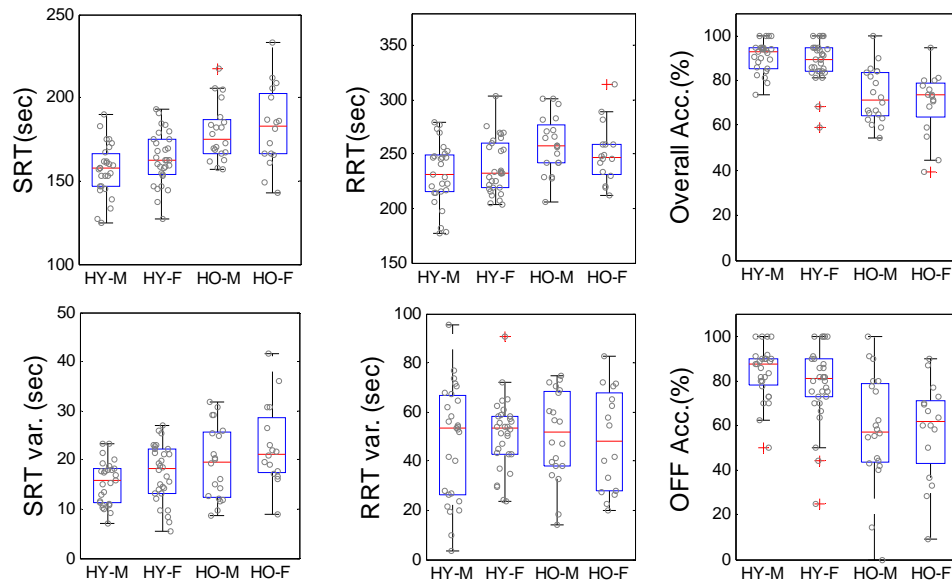

Figure 4-2b Boxplots with scatter plots of mean and variabilities in RT_{clin} and accuracy for gender effect. M denotes male and F denotes female.

Overall recognition RT_{clin} accuracy was 80.4%. Participants were more successful in catching the falling device during go trials than they were in allowing the device to fall during no-go trials (91.8% vs. 68.4%, $p < 0.001$). This indicates that response inhibition during no-go trials was the more difficult task during the forced-choice paradigm. All three recognition RT_{clin} accuracy measures decreased with age ($R = -0.603$, $p < 0.001$, for overall accuracy; $R = -0.481$, $p < 0.001$ for go accuracy; $R = -0.596$, $p < 0.001$ for no-go accuracy; Hypothesis 4), with the greatest decrement in accuracy observed in participants older than 40 years old.

This study explored the feasibility of testing a measure of complex RT using a simple and relatively rapid portable method. None of the subjects dropped out, and all were able to complete all the trials, suggesting that this form of testing is feasible, at least in a healthy adult population. As hypothesized (Hypothesis 1), the data confirmed prolonged recognition RT_{clin} scores compared with simple RT_{clin} scores. This finding is consistent with prior studies (see Introduction) and thus supports the construct validity of test score interpretation for this novel method of measuring recognition RT. Also as hypothesized (Hypothesis 2), the majority of the recognition RT_{clin} test score prolongation was attributable to PMT, suggesting that recognition RT_{clin} predominantly reflects cognitive processes rather than digital movement.

As expected, and as has been the case in previous work using computerized RT assessment methods (Der and Deary, 2006), simple RT_{clin} test scores were significantly and positively associated with age. In contrast, recognition RT_{clin} latency was not associated with age (Hypothesis 3). However, recognition RT_{clin} accuracy was highly and significantly associated with age (Hypothesis 4), demonstrating that as subjects' ages increased, their decision making became less accurate. This effect was relatively strong, with age explaining over a third of the variance in error rate.

One possible explanation for these findings involves that fact that the maximal possible response latency for RT_{clin} is the time it takes the apparatus to strike the floor after its release (about 400 ms). In contrast, computerized complex RT tests allow for a prolonged or even indefinite latency. Therefore, during recognition RT_{clin} testing, older subjects may

have felt that they did not have sufficient time to make an accurate decision. In support of this, other work demonstrates that older subjects require approximately 190 ms to inhibit perceptual and motor impulses, whereas young subjects take 35 ms (Mendelson et al., 2009). Given the natural tendency to catch a falling object, there is a clear need for the subjects being tested with recognition RT_{clin} to inhibit the impulse to catch the apparatus during the no-go trials. When the 190 ms of inhibition time for older persons is added to the mean simple RT_{clin} score of 185 ms, the sum is nearly equal to 400 ms, at which point the apparatus will strike the floor. However, the sum of simple RT_{clin} scores and response inhibition for younger persons is about 220 ms, which would leave sufficient time for them to make an accurate decision and execute a response before the apparatus strikes the floor. This idea is supported by a significant negative correlation between the PMT component of simple RT_{clin} and recognition RT_{clin} response accuracy ($R = -0.424$, $p = 0.002$), suggesting that subjects who needed little time to initiate motion for simple RT_{clin} had greater time during recognition RT_{clin} testing to make an accurate decision.

If this reasoning is correct, then recognition RT_{clin} accuracy may be evaluating inhibitory function. One domain of inhibitory function is “inhibition of a prepotent response (the ability to withhold the most obvious reaction to a stimulus)” (Boonstra et al., 2010). This appears to apply to recognition RT_{clin} given the natural tendency to catch the device, a point underscored by the fact that no-go accuracy was significantly lower than go accuracy. Inhibitory function is of clinical relevance given that it is recognized as being fundamental to effective executive function, and in the view of some affects all other executive domains (Barkley, 1997). Accordingly, impairment of inhibition is thought to underlie cognitive deficiencies in older persons (Andre’s and Van der Linden, 2000), be responsible for some kinds of psychopathology (Patterson and Newman, 1993), and be one of the earliest and most prominent findings in Alzheimer’s type dementia (Collette et al., 2009). Abnormal inhibitory responses have also been noted in stimulant users and alcohol-dependent subjects (Lawrence et al., 2009; Monterosso et al., 2005), as well as in patients with traumatic brain injury (Leblanc et al., 2005; Stewart and Tannock, 1999). Moreover, recent findings suggest that inhibitory proficiency is critical to the ability of older persons to maintain balance while receiving multiple sensory inputs (Mendelson et

al., 2009). Therefore, a clinical tool that can quantify inhibitory function quickly may have clinical utility.

However, further work is needed before recognition RT_{clin} can be applied in the clinical setting. The present study included a relatively small number of healthy subjects, and so further testing is indicated. Moreover, the investigators were not blinded and were aware of the hypotheses. This is likely rendered less relevant given that the outcomes were in the millisecond range and were determined with objective kinematic measurement techniques. Furthermore validation with a proven method for determining recognition RT and testing in specific populations with pathologies of clinical concern are necessary before application can be considered. In addition, recognition RT_{clin} scores should be compared with simple RT_{clin} scores to determine whether the former provides incremental diagnostic precision or greater clinical inference and, if so, with regard to which clinical populations. Last, the optimal number of trials necessary to make clinically relevant distinctions should be explored.

In conclusion, this pilot study demonstrated that a novel, clinically available technique for evaluating recognition RT is feasible in a healthy population across a broad RT_{clin} age range. The study also suggests that when using this technique recognition, RT_{clin} accuracy, rather than latency, is of greater importance with regard to the cognitive consequences of aging. When the results are taken in the context of previous work, they suggest that recognition RT_{clin} may be a measure of inhibitory capacity, an internal act of control that broadly affects executive function. An inexpensive bedside or office tool that can measure with relative precision short-latency cognitive processes might have a wide range of clinical applicability.

4.4 References

Andre's, P., & Van der Linden, M. (2000). Age-related differences in supervisory attentional system functions. *The Journals of Gerontology, Series B: Psychological Sciences and Social Sciences*, 55, P373–P380.

- Anstey, K. J., Dear, K., Christensen, H., & Jorm, A. F. (2005). Biomarkers, health, lifestyle, and demographic variables as correlates of reaction time performance in early, middle, and late adulthood. *The Quarterly Journal of Experimental Psychology, A: Human Experimental Psychology*, 58, 5–21.
- Barkley, R. A. (1997). Behavioral inhibition, sustained attention, and executive functions: Constructing a unifying theory of ADHD. *Psychological Bulletin*, 121, 65–94.
- Boonstra, A. M., Kooij, J. J., Oosterlaan, J., Sergeant, J. A., & Buitelaar, J. K. (2010). To act or not to act, that's the problem: Primarily inhibition difficulties in adult ADHD. *Neuropsychology*, 24, 209–221.
- Collette, F., Schmidt, C., Scherrer, C., Adam, S., & Salmon, E. (2009). Specificity of inhibitory deficits in normal aging and Alzheimer's disease. *Neurobiology of Aging*, 30, 875–889.
- Deary, I. J., Johnson, W., & Starr, J. M. (2010). Are processing speed tasks biomarkers of cognitive aging? *Psychology and Aging*, 25, 219–228.
- Der, G., & Deary, I. J. (2006). Age and sex differences in reaction time in adulthood: Results from the United Kingdom Health and Lifestyle Survey. *Psychology and Aging*, 21, 62–73.
- Eckner, J. T., Kutcher, J. S., & Richardson, J. K. (2010). Pilot evaluation of a novel clinical test of reaction time in National Collegiate Athletic Association Division I football players. *Journal of Athletic Training*, 45, 327–332.
- Eckner, J. T., Kutcher, J. S., & Richardson, J. K. (2011). Effect of concussion on clinically measured reaction time in nine NCAA Division I collegiate athletes: A preliminary study. *PM&R: The Journal of Injury, Function, and Rehabilitation*, 3, 212–218.
- Eckner, J. T., Kutcher, J. S., & Richardson, J. K. (in press). Between season test–retest reliability of clinically measured reaction time in NCAA Division I collegiate athletes. *Journal of Athletic Training*.

- Eckner, J. T., Lipps, D. B., Kim, H., Richardson, J. K., & Ashton-Miller, J. A. (2011). Can a clinical test of reaction time predict a functional head-protective response? *Medicine and Science in Sports and Exercise*, *43*, 382–387.
- Eckner, J. T., Whitacre, R. D., Kirsch, N., & Richardson, J. K. (2009). Evaluating a clinical measure of reaction time: An observational study. *Perceptual and Motor Skills*, *108*, 717–720.
- E-prime [Computer software]. Pittsburgh, PA: Psychology Software Tools. Jensen, A., & Munro, E. (1979). Reaction time, movement time, and intelligence. *Intelligence*, *3*, 121–126.
- Lawrence, A. J., Luty, J., Bogdan, N. A., Sahakian, B. J., & Clark, L. (2009). Impulsivity and response inhibition in alcohol dependence and problem gambling. *Psychopharmacology*, *207*, 163–172.
- Leblanc, N., Chen, S., Swank, P. R., Ewing-Cobbs, L., Barnes, M., Dennis, M., . . . Schachar, R. (2005). Response inhibition after traumatic brain injury (TBI) in children: Impairment and recovery. *Developmental Neuropsychology*, *28*, 829–848.
- Lord, S. R., Clark, R. D., & Webster, I. W. (1991). Physiological factors associated with falls in an elderly population. *Journal of the American Geriatrics Society*, *39*, 1194–1200.
- Mathias, J. L., & Lucas, L. K. (2009). Cognitive predictors of unsafe driving in older drivers: A meta-analysis. *International Psychogeriatrics*, *21*, 637–653.
- McKnight, A. J., & McKnight, A. S. (1999). Multivariate analysis of age-related driver ability and performance deficits. *Accident Analysis and Prevention*, *31*, 445–454.
- McMorris, T., Hill, C., Sproule, J., Potter, J., Swain, J., Hobson, G., & Holder, T. (2005). Supramaximal effort and reaction and movement times in a noncompatible response time task. *Journal of Sports Medicine and Physical Fitness*, *45*, 127–133.
- Mendelson, D. N., Redfern, M. S., Nebes, R. D., & Jennings, J. R. (2009). Inhibitory processes relate differently to balance/reaction time dual tasks in young and older adults. *Aging, Neuropsychology, and Cognition*, *17*, 1–18.

- Monterosso, J. R., Aron, A. R., Cordova, X., Xu, J., & London, E. D. (2005). Deficits in response inhibition associated with chronic methamphetamine abuse. *Drug and Alcohol Dependence, 79*, 273–277.
- Patterson, C. M., & Newman, J. P. (1993). Reflectivity and learning from aversive events: Toward a psychological mechanism for the syndromes of disinhibition. *Psychological Review, 100*, 716–736.
- Shiple, B. A., Der, G., Taylor, M. D., & Deary, I. J. (2006). Cognition and all-cause mortality across the entire adult age range: Health and Lifestyle Survey. *Psychosomatic Medicine, 68*, 17–24.
- Shiple, B. A., Der, G., Taylor, M. D., & Deary, I. J. (2007). Association between mortality and cognitive change over 7 years in a large representative sample of U.K. residents. *Psychosomatic Medicine, 69*, 640–650.
- Shiple, B. A., Der, G., Taylor, M. D., & Deary, I. J. (2008). Cognition and mortality from the major causes of death: The Health and Lifestyle Survey. *Journal of Psychosomatic Research, 65*, 143–152.
- Spiriduso, W. W. (1975). Reaction and movement time as a function of age and physical activity level. *Journal of Gerontology, 30*, 435–440.
- Sternberg, S. (1969). Memory scanning: Mental processes revealed by reaction time experiments. *American Scientist, 57*, 421–457.
- Stewart, J. A., & Tannock, R. (1999). Inhibitory control differences following mild head injury. *Brain and Cognition, 41*, 411–416.
- Thoma, R. J., Yeo, R. A., Gangestad, S., Halgren, E., Davis, J., Paulson, K. M., & Lewine, J. D. (2006). Developmental instability and the neural dynamics of the speed-intelligence relationship. *NeuroImage, 32*, 1456–1464.

Chapter 5

A Shoe Sole-based Apparatus and Method for Randomly Perturbing the Stance Phase of Gait: Test-Retest Reliability in Young Adults

[Accepted in Journal of Biomechanics, 2012]

5.1 Introduction

Walking on an irregular surface is associated with an elevated risk for a trip or loss of balance, especially for the elderly (Berg et al., 1997). For example, elderly persons with peripheral neuropathy (PN) have significantly worse ankle proprioception than the healthy old (Van den Bosch et al., 1995) and are at a significantly higher risk for fall-related injuries (Richardson et al., 1992), particularly on uneven ground at dusk or in the dark. However, analyzing the foot perturbation stimulus–response relationships when a subject walks across serial underfoot perturbations (Menant et al., 2008) is complicated by carryover effects confounding how each irregularity perturbs the kinematics of subsequent steps. In a previous study we analyzed how young adult gait changed after stepping on a single ground protuberance with the stance foot, akin to stepping on a single pebble (Thies et al., 2007). We found that it did cause an alteration in the subsequent location and timing of the next step, and even a cross-over step. However, a limitation was that subjects could see and therefore prepare for the protuberance, something they would not be able to do in the dark.

We designed and tested a custom shoe to simulate the condition in which the swing foot unexpectedly lands once with the mid-forefoot on a small medially-located or a laterally-located protuberance while walking across a flat surface. Following Thies et al. (2007), we tested the hypothesis that a single medial or lateral underfoot perturbation would alter the step width of the first recovery step at both a comfortable gait speed and a faster gait speed. We also measured the between-visit test-retest reliability of the kinematic responses on two separate occasions, one week apart.

5.2. Method

Subjects

Six healthy young subjects (3 females, mean (SD) age: 23.0 (3.9) yr, height: 173.1 (8.4) cm, mass: 78.5 (23.3) kg) were recruited via the University of Michigan volunteer network (UMClinicalStudies.org). Participants passed a telephone screen excluding known neurological and musculoskeletal pathologies. The study was approved by the institutional review board.

Perturbing shoes

Five pairs of commercially available sandals (ACG Rayong, Nike, Inc., Beaverton, OR; men's size 10, 12 and 13; women's size 8, and 9) were equipped with electronically controlled linear actuators (Model PQ-12, Firgelli Technologies, Inc., Victoria, BC, Canada) each of which deployed a small rectangular (25.4×30.5×9.5 mm) aluminum flap hinged in the parasagittal plane and concealed in a recess under the medial and lateral aspects of the custom shoe sole, just behind the metatarsal bases. When neither flap was deployed, the shoe felt normal to walk in. When one of the concealed flaps was deployed, it rotated down about a parasagittal plane axis such that the resultant medial or lateral men's size 11 shoe sole inclination was nominally plus or minus 16° to the horizontal in the frontal plane, corresponding to a 18.4 mm-high perturbation under the medial or lateral foot with no weight bearing on the shoe (Figure 5-1). To guarantee subject's safety, the inclination of non-weight bearing perturbing shoe in frontal plane was designed to 16°, at which ankle inversion resistance was significantly increased by 20.4% (Ottaviani et al.,

1995) and where ankle everter muscle group increased the passive resistance regardless of shoe types (Ashton-Miller et al., 1996).

After three or more steps of normal gait, a flap could be covertly deployed within 400 ms starting in the midswing phase of gait, using a linear actuator embedded in the sole. The actuator was attached to a drive shaft and mechanism that transformed the linear motion of the actuator into a 100° rotation of the flap in the manner of the mechanism of a push screw driver (Furbish, 1905). Because the flap rotated over the top dead center to a mechanical stop, no extra power was required to maintain its deployed position under the ground reaction forces acting during stance phase. After heel strike, as the subject's stance foot rolls toward a foot flat posture, the edge of the flap contacts the ground, causing an immediate medial or lateral shift of the usual center of pressure (COP) trajectory, as well as a medial (or lateral) inclination of the stance fore-midfoot. This is COP shift and unexpected stance foot orientation is the stimulus to which the subject must react during that stance phase, if possible, and during subsequent steps, if necessary. The instant that the flap contacts the ground is detected by an infrared contact sensor, installed in the inferior edge of the flap. After toe off, the flap was covertly retracted during the subsequent swing phase, so that no perturbation is present during any of the subsequent stance phases (although this could have been the case, if so programmed). A rear foot and forefoot force sensing resistor switch sensor (FlexiForce, Tekscan Inc., South Boston, MA) were used to update the computer algorithm on heel strike, toe off, and current step number. The onset and trigger mechanism of each perturbation types was automated so as to be controlled by a custom-developed C++ program (Visual Studio 2008, Microsoft Cooperation, Redmond, WA), which cooperates with an optoelectric motion tracking system and foot switches via Optotrak Application Programming Interface (Northern Digital Inc., Waterloo, ON, Canada).

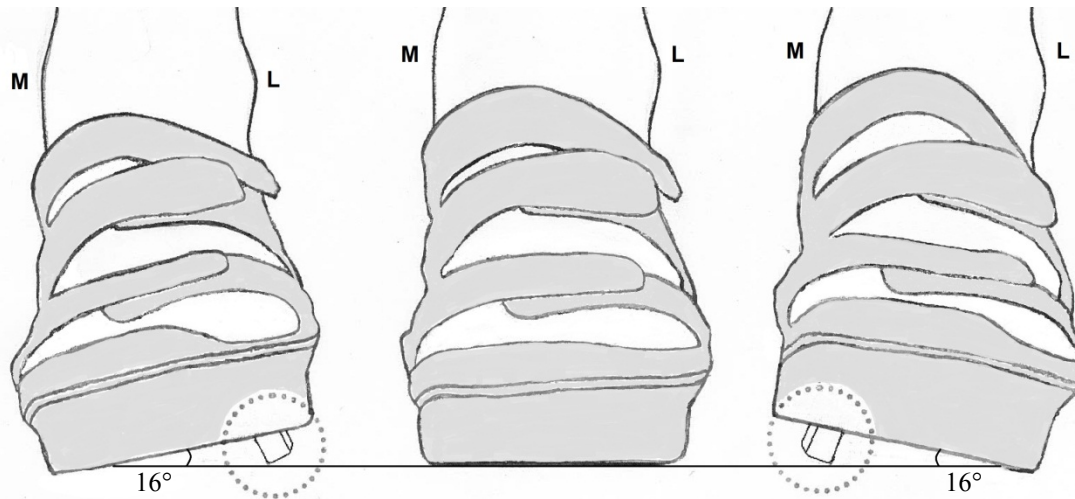

Figure 5-1. Sample anterior view of the modified 11 ½ mens sandal showing the shoe orientation with undeployed flap (middle), a 18.4 mm high medial flap deployed in the parasagittal plane so as to invert the foot during midstance (right), and 18.4 mm high lateral flap deployed in the parasagittal plane to evert the foot during midstance (left). Two actuators and flaps are concealed within each shoe sole. (Figure appears in *Journal of Biomechanics* 2012)

Experimental design

Subjects performed a total of 60 walking trials at two walking speeds along a 6 m level walkway. The first block of 30 trials was performed at a comfortable walking speed (WS), “as though they were walking to mail a letter”. The second block of 30 trials was performed at a faster walking speed, “as though they were crossing a busy street”. Six trials each were conducted with either a medial or a lateral perturbation (MP or LP, respectively) presented randomly under the left or right foot, and randomized among 18 additional unperturbed (UnP) dummy trials at each speed. Subjects were told that, when it occurred, the stance phase perturbation would happen only once per gait trial; but they could not know if, when or where a left or right shoe MP or LP was to be deployed in that trial. Before the trials began, subjects practiced several times without the perturbation to familiarize themselves with the apparatus and experimental environment.

The 3-D kinematics of foot, leg, pelvis and trunk (including ankle inversion angle, step width (SW), step time (ST), and step length (SL)) were collected at 100 Hz using an

Optotrak optoelectric motion analysis system (Northern Digital Inc., Waterloo, ON, Canada) in the manner we used in Thies et al. (2007). Each subject repeated the same test protocol seven days later.

Statistical analysis

A one-way repeated measures analysis of variance (rm-ANOVA) was used to test the hypotheses that (a) any perturbation (presence vs absence of perturbation), and (b) perturbation location (medial vs lateral) significantly affect the first recovery SW at each of the two walking speeds. Under the assumption of normality, a p-value less than 0.05 was considered significant. The recovery step time, width and length were measured on two separate occasions one week apart to evaluate test-retest reliability using MATLABTM (Statistics Toolbox v. 2009b, The Math Works, Inc., Natick, MA, U.S.A.). The intra-rater correlation between two visits was assessed using one-way random model of the intraclass correlation coefficient (ICC; type 1,1; Shrout and Fleiss, 1979). Coefficients of variation (CVs) of the method error were also calculated (Portney and Watkins, 1993). The inter-rater correlation was assessed from the 95% limits of agreement statistics (Bland and Altman, 1986).

5.3 Results

The mean (SD) ankle-foot subtalar angle of the perturbed stance foot was inverted by a medial perturbation through 10.2 (2.3)^o and everted by a lateral perturbation through 9.2 (2.0)^o. The first each type of perturbation significantly affected the first recovery SW at the faster WS (Table 5-1).

Table 5-1 Mean (SD) values of each of the gait parameters by walking speed and visit. The medial and lateral perturbation each significantly affected the first recovery step width at each speed.

Gait parameter	Condition	Comfortable Walking Speed		Faster Walking Speed	
		Visit 1	Visit 2	Visit 1	Visit 2
WS (m/s)	UnP	1.28 (0.06)	1.29 (0.07)	1.61 (0.07)	1.55 (0.08)
	MP	1.30 (0.08)	1.29 (0.08)	1.58 (0.09)	1.56 (0.09)
	LP	1.31 (0.06)	1.31 (0.08)	1.61 (0.06)	1.54 (0.10)
SW (cm)	UnP	15.8 (3.2)	13.7(2.3)	16.4 (3.5)	14.6 (3.9)
	MP	15.4 (5.7)	11.7 (5.3)	21.1 (4.0)*	16.5 (3.7)* ^α
	LP	16.1 (5.1)	11.9 (4.5)	21.3 (3.9)*	12.8 (4.3)*
SL (cm)	UnP	69.9 (4.9)	70.6 (4.9)	78.7 (5.1)	77.6 (3.7)
	MP	70.7 (6.3)	70.0 (4.7)	76.8 (7.4)	75.0 (6.9)
	LP	71.0 (7.6)	67.2 (6.6)	76.6 (5.7)	75.2 (4.1)*
ST (ms)	UnP	579.6 (30.5)	588.8 (33.7)	519.8 (29.1)	536.4 (39.8)
	MP	573.3 (30.8)	610.0 (39.5)	520.0 (16.7)	521.7 (36.6)
	LP	593.3 (30.1)	600.0 (44.3)	523.3 (18.6)	530.0 (30.0)*

In this and the following table SW, SL and ST denote step width, length and time, respectively; UnP: Unperturbed step, MP: first recovery step in response to a medial perturbation, LP: first recovery step in response to a lateral perturbation.

* Denotes a significant change between UnP SW and the first recovery SW from either a MP or LP trial using one-way repeated measure ANOVA ($p < 0.05$).

^α Denotes a significant difference in MP and LP first recovery SW via one-way rm-ANOVA ($p < 0.05$).

The ICCs, CVs, and 95% limits of agreement for the step kinematics between Visit 1 and Visit 2 are shown in Table 5-2. Both unperturbed and the first recovery step kinematics showed acceptable reliability in both comfortable and faster WS, MP and LP.

Table 5-2 Intraclass correlation coefficients (ICCs), coefficients of variation (CVs) and Bland-Altman limits of agreement (LoA) assessing the the test-retest reliability between visits for unperturbed (UnP) gait and first recovery step width (SW), step length (SL), and step time (ST) at each gait speed. CI denotes confidence interval, while Δ denotes the mean difference between visits.

Gait parameter	Cond	Comfortable Walking Speed			Faster Walking Speed		
		ICC (95%CI)	CV(%)	Δ Mean (95%LoA)	ICC (95%CI)	CV(%)	Δ Mean (95%LoA)
SW (cm)	UnP	0.78 (0.05 ~ 0.97)	8.5	1.57 (-1.09 ~ 4.25)	0.96 (0.74 ~ 1.00)	11.6	0.84 (-0.67 ~ 2.37)
	MP	0.52 (-0.40 ~ 0.93)	8.1	3.38 (-0.26 ~ 7.02)	0.75 (0.10 ~ 0.96)	13.5	1.50 (-4.50 ~ 7.50)
	LP	0.64 (-0.23 ~ 0.95)	11.7	2.35 (-1.95 ~ 6.66)	0.90 (0.44 ~ 0.99)	15.3	0.76 (-2.79 ~ 4.33)
SL (cm)	UnP	0.94 (0.68 ~ 0.99)	1.7	-0.68 (-4.06 ~ 2.70)	0.90 (0.55 ~ 0.99)	1.5	1.11 (-2.23 ~ 4.47)
	MP	0.91 (0.47 ~ 0.99)	5.1	-1.13 (-5.44 ~ 3.16)	0.85 (0.37 ~ 0.98)	2.5	0.78 (-4.68 ~ 6.24)
	LP	0.80 (0.22 ~ 0.97)	3.0	1.24 (-4.60 ~ 7.09)	0.79 (0.18 ~ 0.97)	2.6	1.71 (-4.01 ~ 7.43)
ST (ms)	UnP	0.90 (0.53 ~ 0.99)	1.5	-9.2 (-32.9 ~ 1.45)	0.78 (0.14 ~ 0.96)	2.5	-16.6 (-53.5 ~ 20.3)
	MP	0.49 (-0.35 ~ 0.91)	3.6	-28.1 (-85.5 ~ 29.4)	0.78 (0.14 ~ 0.96)	2.5	-15.1 (-51.9 ~ 21.7)
	LP	0.89 (0.47 ~ 0.98)	2.0	-6.1 (-38.4 ~ 26.3)	0.80 (0.20 ~ 0.97)	2.0	-15.8 (-45.0 ~ 13.3)

Δ Mean and LoA denote mean difference between two visits and Bland-Altman Limits of Agreement, respectively. CI denotes the confidence interval.

5.4 Discussion

This is the first description of a method for randomly perturbing the stance phase of gait in a repeatable manner while walking on an otherwise flat surface. The actual inclinations of the perturbed stance foot in the frontal plane (see Results) were less than when the sandal is unloaded (Fig.1, left or right) because the sole deformed under body weight. It is also novel that the location of the perturbation can be varied spatially under a foot, and also between feet. The results corroborate and extend the results of Thies et al. (2007) because in that study there was no control over where the perturbation acted under the foot.

The method holds promise for measuring the effect of age or disease on the sensory and motor latencies of the response to a single underfoot perturbation. It also has potential for training patients to practice dealing with perturbations while protected by a full body safety harness, as well as evaluating the efficacy of a clinical intervention such as the use of an assistive device such as a cane or orthoses on uneven surfaces (Richardson et al., 2005). The apparatus also allows one to perturb more than one step in a gait trial: for

example, in a more challenging test sequential steps might be perturbed. Indeed, by triggering the perturbation on sequential steps, one can simulate stepping on serial underfoot perturbations, thereby establishing a link with the uneven surface studies of Thies et al. (2005a, 2005b), Richardson et al. (2004, 2005) and Menz et al. (2003).

The ICCs were in good to excellent range. There is a possibility that the ICCs were strong because either (1) there is no washout effect with Day 1 strongly influencing Day 2, or (2) that there is a strong washout effect and response itself is a stereotyped, overlearned and present when a subject is challenged by such a perturbation.

By designing the flap height to invert or evert the foot through less than half the available range of motion (Ashton-Miller et al., 1996), the risk of an ankle sprain was minimized. This approach should also be acceptable for testing older subjects or those with disease. If there is any doubt, then smaller height flaps can be installed, as would be the case for testing children.

Possible vibrational or audible cues signaling an impending underfoot perturbation were minimized. Noise from the rollers in the ceiling-mounted rail supporting the whole-body safety harness and protecting the subject from a fall during gait completely masked any sound emanating from the linear actuators mounted in the shoe insole. Furthermore, linear actuator was mounted to the frame supporting the flipper, so there was no direct contact of the actuator with the shoe sole. This helped minimize the transmission of possible vibrational cues to the subject.

The greater variability in recovery SW at the “faster” walking speed likely reflects the task being physically more challenging at that speed than at the comfortable gait speed. So, with healthy aging one would expect to first notice a change in SW at the faster gait speed. But given the diminished sensorimotor capacities associated with aging and especially neuromuscular disease, SW changes may become apparent at a comfortable WS as well.

We chose not to control comfortable gait speed to an absolute value, say 1.5 m/s during this experiment. Instead we instructed subjects to walk at their self-selected walking

speed (2). This proved to be a reliable strategy, since there were no significant differences in step kinematics at either speeds. Experiments could also be conducted at a given absolute speed (i.e., Chen et al., 1991), but we would not expect the reliability to be affected, based on the present results unless the speed was unusually slow (<1.0 m/s).

5.5 References

- Ashton-Miller, J.A., Ottaviani, R.A., Hutchinson, C., Woytys, E.M., 1996. What best protects the inverted weightbearing ankle against further inversion? Evertor muscle strength compares favorably with shoe height, athletic tape, and three orthoses. *American Journal of Sports Medicine* 24, 800-809
- Berg, W.P., Alessio, H.M., Mills, E.M., Tong, C., 1997. Circumstances and consequences of falls in independent community-dwelling older adults. *Age and Ageing* 26, 261-268
- Bland, J.M., Altman, D.G., 1986. Statistical methods for assessing agreement between two methods of clinical measurement. *Lancet* 1, 307-310.
- Chen, H-C., Ashton-Miller, J.A., Alexander, N.B., Schultz, A.B., 1991. Stepping over obstacles: Gait patterns of healthy young and old adults. *Journal of Gerontology* 46, 196-203.
- Furbish, Z.T., 1905. Push Screw Driver or Drill, US Patent No.791766.
- Menant, J.C., Perry S.D., Steele, J.R., Menz, H.B., Munro, B.J., Lord, S.R., 2008. Effects of shoe characteristics on dynamic stability when walking on even and uneven surfaces in young and older people. *Archives Physical Medicine and Rehabilitation* 89,1970-1976.
- Ottaviani, R.A., Ashton-Miller, J.A., Kothari, S.U., Wojtys, E.M., 1995, basketball shoe height and the maximal muscular resistance to applied ankle inversion and eversion moments, *American Journal of Sports Medicine* 23, 418-423
- Portney, L.G., Watkins, M.P.O., 1993. Foundations of clinical research: applications to practice. Norwalk, Appleton & Lange, Inc..

- Richardson, J.K., Ching, C, Hurvitz, E.A., 1995. The relationship between electromyographically documented peripheral neuropathy and falls. *Journal of the American Geriatrics Society* 1992; 40, 1008-1012.
- Richardson, J.K., Thies, S.B., DeMott, T.K., Ashton-Miller, J.A., 2005. Interventions improve gait regularity in patients with peripheral neuropathy while walking on an irregular surface under low light. *Arch Phys Med Rehabil.* 86,1539-44.
- Shrout, P.E., Fleiss, J.L., 1979. Intraclass correlation: uses in assessing rater reliability. *Psychol. Bull.* 86, 420-428
- Thies, S.B., Richardson, J.K., Ashton-Miller, J.A., 2005a. Effects of surface irregularity and lighting on step variability during gait: a study in healthy young and older women. *Gait and Posture* 22, 26-31
- Thies, S.B., Richardson, J.K., DeMott, T., 2005b, Influence of an irregular surface and low light on the step variability of patients with peripheral neuropathy during level gait, *Gait and Posture* 22, 40-45
- Thies, S.B., Richardson, J.K., Ashton-Miller, J.A., 2007. What causes a crossover step when walking on uneven ground? A study in healthy young women. *Gait and Posture* 26, 156-160
- Van den Bosch, C.G., Gilsing, M.G., Lee, S-G., Richardson, J.K., Ashton-Miller, J.A., 1995, Peripheral neuropathy effect on ankle inversion and eversion detection thresholds, *Archives of Physical Medicine and Rehabilitation* 76, 850-856.

Chapter 6

Effect of Age on the Ability to Recover from a Single Unexpected Underfoot Perturbation During Level Gait: Kinematic Responses

6.1 Introduction

Walking outside on level ground often necessitates having to cross an uneven surface the geometry of which can cause unexpected variations in the orientation of a stance foot in both the frontal and sagittal planes. Such perturbations can then alter the anticipated center of pressure (COP) trajectory beneath the stance foot and thereby the familiar relationship between the COP and the whole body center of mass during gait (Jian et al., 1993; Thies et al. 2007). One might speculate that the ability to compensate for such under-stance foot perturbations might be an important capacity for crossing such surfaces reliably without stumbling and falling. In older adults, for example, walking on uneven surfaces is associated with falls (for example, Berg et al., 1997; Milisen et al., 2004). But relatively little is known about how and why these falls occur, or even how humans deal with underfoot perturbations during gait, or how advancing age affects this ability.

It is known that humans increase their step width variability when walking across uneven surfaces by about 20% in healthy young adults and 35% in healthy elderly (Thies et al. 2005). This adjustment of step width (SW) is consistent with the SW adjustments

humans are known to use to maintain their dynamic balance during bipedal gait on an even surface (Bauby and Kuo, 2000). On the other hand, on a level surface at least, increased variability in step kinematics is known to be a marker of an elevated falls risk (for example, Hausdorff et al., 2001). So, when is a change in step kinematics on an uneven surface reasonable and how is it affected by age? The present study addresses these questions.

The analysis of serial stepping on an irregular surface (Thies et al., 2005; Menz et al., 2003; Richardson et al., 2004, 2008) provides a useful test of humans' ability to walk across such surfaces without falling. But such studies provide limited insight for understanding how a human responds to just one underfoot perturbation. This is because carryover effects from preceding underfoot perturbations confound the analysis of anyone one step on an irregular surface. Besides which, there is also the difficulty of defining precisely what the magnitude and location of the underfoot perturbation really is given that it is hidden under the shoe; and differences in foot and shoe sole compliance will likely affect how much the foot is actually perturbed by a perturbation of a given geometric size and location under the foot. During gait, being able to prescribe a single underfoot perturbation having a predefined location and magnitude would make it easier to examine the relationship between that underfoot stimulus and the recovery step kinematics; by definition, any carryover effects from preceding perturbations would thereby be eliminated.

In a prior investigation we did indeed study how young adults alter their gait after stepping on a single discrete perturbation (Thies et al., 2007). However, a limitation of that experiment was that subjects could see the surface protruberance from afar, so they knew it was there and could anticipate its effect as affecting a particular foot even if they could not predict how it would affect that foot. This contrasts with many daily situations when such visual cues often go unnoticed because of poor lighting or contrast, or divided attention.

So, we developed a pair of custom instrumented shoes to simulate the condition in which the mid swing foot unexpectedly lands on an unseen medially-located or laterally located protuberance while walking across a flat surface (Kim and Ashton-Miller, in press). In

this study we use these shoes to test whether age adversely affects recovery step kinematics following such a perturbation. We tested the hypotheses that (a) medial and lateral perturbations have similar effects on recovery step kinematics, and (b) age will not affect recovery step kinematics to these perturbations.

6.2 Methods

Subjects

A total of 41 healthy subjects (23 young and 18 old subjects) participated in this research. Elderly subjects were recruited from University of Michigan Older Americans Independence Center (OAIC) Human Subjects Core and young subjects were recruited from University of Michigan volunteer network (UN Clinical Studies – Engage). Old and young groups were screened by a telephonic questionnaire for absence of known neurological or musculoskeletal pathologies including stroke, diabetes, neuropathy, lower limb joint replacement, and spinal surgery. Test procedures and devices were approved by institutional review board of the University of Michigan and all subjects completed a written informed consent form.

Table 6-1. Subject demographics. N, M and F denote number of participants, male and female respectively.

	HY	HO
N (M/F)	23 (13/10)	18 (7/11)
Age (yr)	22.7 (3.35)	68.0 (7.19)
WT (kg)	70.0 (14.0)	74.0 (16.7)
HT (cm)	172.9 (8.47)	169.8 (6.64)
BMI (kg/m ²)	23.3 (3.65)	25.7 (6.11)

Entrance Evaluation

Before the gait tests began a neuromuscular examination was performed on each participant to screen out abnormalities of the peripheral and central nervous system, or distal sensation and muscle strengths in lower extremity.

Perturbing Shoes

Since the custom instrumented sandals designed to perturb gait during the stance phase have been described elsewhere (Kim and Ashton-Miller, in press) only a brief description will be given here. Each sandal is equipped with two electronically-controlled hinged flaps concealed within the medial and lateral inferior aspects of the shoe sole near the base of the metatarsal bones. When one of the concealed flaps is deployed, the resultant medial-lateral inclination of the non-weight bearing shoe is 16° , but under weight bearing the inclination of the midfoot is about 2/3rds this value because of foot and shoe sole compliance (see Results). The flap may or may not be deployed in the late swing phase of a gait trial conducted on a level surface. The computer took timing cues from heel switches and the optoelectronic markers on each shoe and randomly issued the perturbation on certain trials.

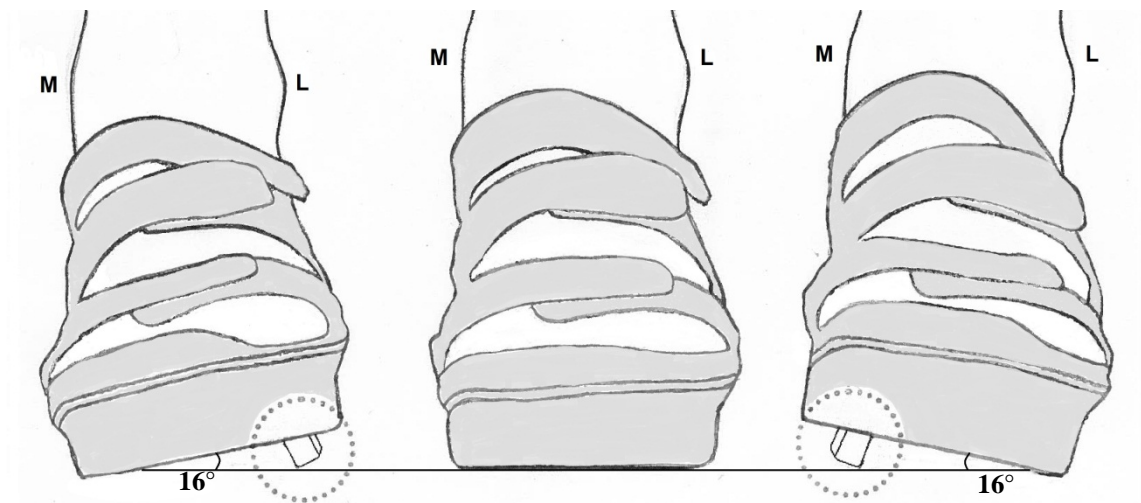

Figure 6-1. Anterior view of the modified 11 ½-sized Mens sandal showing the shoe orientation with : (Right) a 18.4 mm high medial flap (dotted circle) deployed in the parasagittal plane so as to invert the foot during midstance, and (center) undeployed flap, (Left) 18.4 mm high lateral flap (dotted circle) deployed in the parasagittal plane to evert the foot during midstance. Two actuators and flaps are concealed within each shoe sole (see text). (Figure appears in J. Biomech. 2012)

Experiment and instrumentation

Wearing a pair of the perturbing shoes, each subject performed a total of 60 walking trials at a purposeful walking speed (WS) along a 6-m level walkway “as though they were crossing a busy street”. Eight trials each with a medial perturbation (MP) or a lateral perturbation (LP) and 44 unperturbed (UnP) dummy trials were presented in randomized order.

Subjects were told the perturbation would happen only once per gait trial but because the presentation was randomized by the computer, they could not know if, when or where a perturbation might occur: under the left or the right shoe, or under the medial or lateral aspect of a particular shoe. They were not told that after three or more steps of normal gait, one flap might be covertly deployed during the latter part of the swing phase. After the heel strike of that swing foot, the subject has to counter the sudden and unexpected effect of the perturbation during the weight acceptance phase as the stance foot begins to roll towards foot-flat. After toe-off, the flap is then retracted immediately for the rest of that gait trial. Before the trials began, the subject practiced several times without the perturbation to familiarize themselves with wearing the shoes and with the experimental environment.

One optoelectronic camera system (Optotrak Certus, Northern Digital Inc., Waterloo, Ontario, Canada) sampled three-dimensional kinematic data from 28 infrared-emitting diodes at 100 Hz. A marker triad was secured on the mid-section of each foot, including two markers on the bony landmarks of the foot over the 1st and 5th metatarsal joints, the anterolateral aspects of each lower and upper leg, and over the pelvis midway between the anterior superior iliac spines, and over the mid-sternum on the thorax. A C++ program (Visual Studio 2008, Microsoft, Inc., Redmond, WA) was developed using the Optotrak Application Programming Interface (OAPI, Northern Digital Inc., Waterloo, Ontario, Canada) to register the 3-D marker data, control the linear flap actuators and acquire sensor data at 2 kHz from the flap ground contact sensor and two foot switches that detected each heel strike. All data were post-processed to calculate walking speed (WS), step width (SW), step time (ST) and step length (SL), the timing of the heel strike

and flap ground contact using a custom Matlab algorithm (Matlab 2011a, The Mathworks, Inc., Natick, MA).

Data Analysis

Step kinematics (SW, SL, ST) were calculated at every heel strike. We defined step kinematic variability from the standard deviation of each step kinematic variable. WS was calculated from the first derivative of the position of the pelvis marker to represent the gait speed of the subject.

The change (or delta) in each kinematic variable (ΔSW , ΔSL , ΔST) was defined as the difference between the mean of the MP or LP first recovery step kinematics and the mean unperturbed (UnP) step kinematics for each subject as shown in (1).

$$\Delta Step = \overline{Step}_{1st\ post\ perturbation} - \overline{Step}_{unperturbed} \dots (1)$$

Thus the delta step kinematics variables indicate how much the first recovery step differs from a subject's normal gait. To calculate the mean step kinematics for each subject, a minimum of 20 UnP steps were used to define a steady mean WS (Thies et al. 2005) and a total of eight recovery steps were used to calculate the average recovery step kinematics for each of the MP and LP responses.

Torso kinematic responses were calculated as the change in the frontal plane trunk rotation ($\Delta\theta_{trunk}$: delta trunk rotation) calculated via the waist and sternum markers, and the change in the frontal plane mediolateral waist marker displacement (ΔLPD : delta lateral pelvic displacement) from the UnP steps during the first recovery step.

Six separate two factors repeated measures analyses of variance (ANOVA) were run to assess the between-subjects effect of age (young, old), within-subjects effect of perturbation type (LP vs MP), and the number of recovery steps (1st, 2nd) on recovery SW and SL changes from UnP values, with $p < 0.05$ being considered significant. Two-sided post-hoc t-tests were used to study directly differences. Matlab (Matlab 2011a Statistics Toolbox™, The Mathworks, Inc., Natick, MA) was used for all statistical analysis.

6.3 Results

No significant group differences were found in height, weight or BMI (Table 6-1). There was no significant perturbation effect on the WS across all subjects, whereas there was a significant age effect in the WS. The WS at the first MP recovery step in HY decreased by 2.98 cm/s whereas that in HO increased 1.20 cm/s; the same phenomenon was observed in the LP trials (HY: -1.75 cm/s, HO: +0.49 cm/s).

Rm-ANOVA results on the two main outcomes: SW and SL (Table 6-2)

The presence of a perturbation altered the recovery SL ($p=0.005$) but not SW ($p=0.304$), with the number of such recovery steps being affected by age ($p=0.017$, Tables 6-2 & 6-3, and Fig. 6-2). The SW and SL used to recover from each type of perturbation (MP vs LP) did not differ significantly, but they were both affected by age ($p=0.013$ and $p=0.031$, respectively, Table 6-2). Across all subjects, the SL was significantly different between first and second recovery steps ($p=0.017$), and age affected the difference in SW and SL between first and second steps ($P=0.002$, Table 6-2).

Post-hoc tests showed that a MP caused young adults to increase the first and second recovery SW and shorten the first, third and fourth recovery steps ($p<0.05$), whereas older adults shortened only their fourth step ($p<0.05$).

The LP also caused young adults to widen their first recovery SW and also shorten the first, third and fourth recovery steps ($p<0.05$). The older adults did not significantly alter their first recovery step, but narrowed their second recovery SW; again, only the fourth recovery SL was shortened by the older adults ($p<0.05$).

We analyzed whether widening or narrowing the first step influenced the direction of the change in the succeeding step. For the MP, 56.2% of the young adults who widened their first recovery step also widened their second recovery step. For the LP, the corresponding value was 69.6%. For the MP, 52.6% of the older adults who narrowed their first step also narrowed their second step. For the LP, the corresponding value was 84.2%, so it was only for the LP that the directional change in the first step really influenced the second step.

Figure 6-3 shows the torso inclination and lateral pelvic displacement responses, $\Delta\theta_{trunk}$ and ΔLPD , during the first recovery step for each group. HY maintained their trunk rotation in the first recovery step for MP and LP as they did in the UnP trials, whereas HO rotated their trunk significantly less laterally in response to MP, but more laterally in response to LP. During the first recovery step for MP, HO significantly decreased their WS, but that for HY was unchanged. For LP, both young and old significantly shifted waist more laterally than their UnP kinematics.

Table 6-2. Main and interaction effects from single factor repeated measures ANOVA for comparing presence of perturbation (UnP/Ptb), perturbation type (MP/LP), and recovery steps (RS1/RS2) in HY and HO groups.

Effect		SW		SL	
		F	Prob>F	F	Prob>F
Presence of Perturbation	UnP/Ptb	1.21	0.304	2.17	0.121
	Age	3.10	0.086	8.85	*0.005
	Interaction	Perturbation x Age	3.13	*0.049	1.18
Perturbation Type	MP/LP	1.38	0.247	1.64	0.208
	Age	4.98	*0.031	6.74	*0.013
	Interaction	Perturbation x Age	1.08	0.305	1.45
Recovery Step	RS1/RS2	3.24	0.076	5.88	*0.017
	Age	8.18	*0.005	9.75	*0.002
	Interaction	Perturbation x Age	0.11	0.744	1.90

* denotes significant ($p < 0.05$) difference for rm-ANOVA comparing perturbation presence/type/recovery steps in healthy young (HY) and old (HO) groups. In this and the following table UnP denotes unperturbed steps, Ptb: medially and laterally perturbed steps, MP: medial perturbation, LP: lateral perturbation, RS1: first recovery step, and RS2: second recovery step.

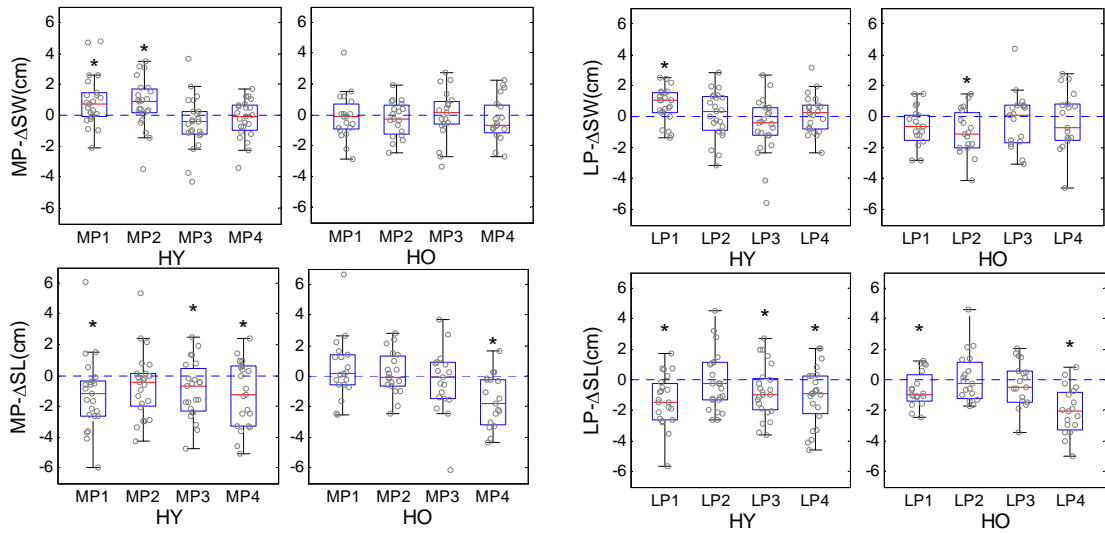

Figure 6-2. Box- and scatter plots of ΔSW (first row) and ΔSL (second row) in MP (first and second columns) and LP (third and fourth columns) recovery steps for HY (first and third columns) and HO (second and fourth columns) subjects

($\Delta Step = \overline{Step}_{1st\ post\ perturbation} - \overline{Step}_{unperturbed}$). MP_n and LP_n denotes the nth MP/LP

recovery step, where n can take a value of 1 - 4. * denotes a significant kinematic change ($\alpha < 0.05$) in recovery SW, compared to UnP SW.

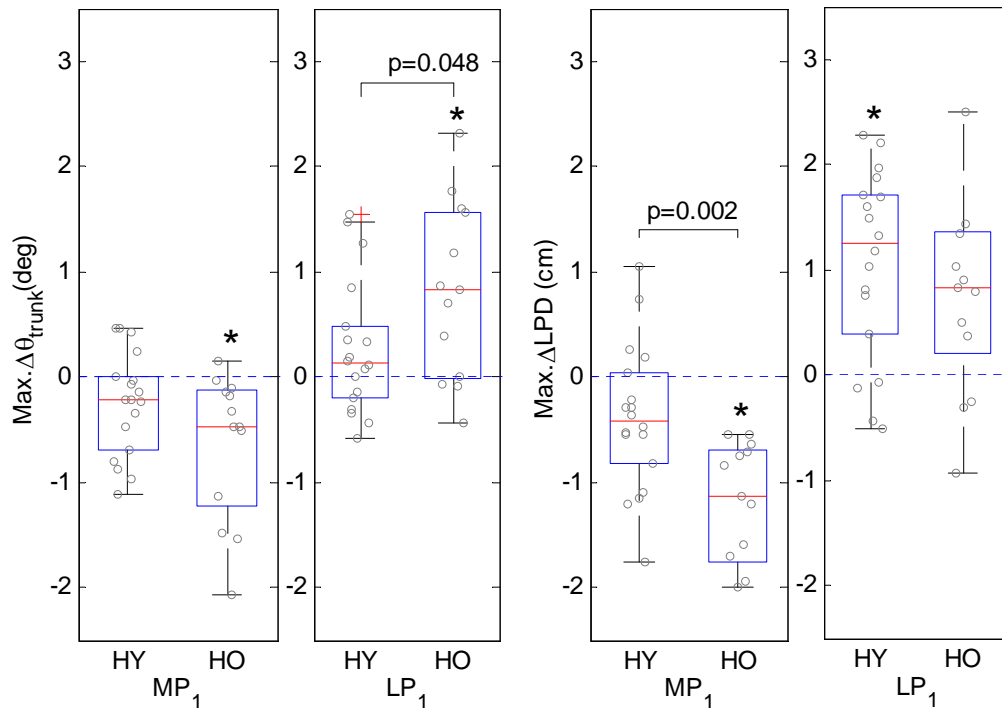

Figure 6-3. Box and scatter plots of the peak torso inclination and lateral pelvic displacement kinematic responses, $\Delta\theta_{trunk}$ (+: more lateral rotation than UnP) and ΔLPD (+: more lateral movement than UnP) in the frontal plane over the first recovery steps. * denotes significant difference in the first recovery step compared with unperturbed joint kinematics ($\alpha < 0.01$). Δ kinematics denotes $\Delta X = \overline{X}_{1st\ post\ perturbation} - \overline{X}_{unperturbed}$ where X is corresponding body kinematics.

6.4 Discussion

This is the first systematic study of how humans respond to an unpredictable, yet standardized, eversional or inversional mid-stance foot perturbation during gait on a level surface. No subjects lost their balance, fell, or required support from their safety harness as a result of the unpredictable 10 degree eversional or inversional perturbation, so we deem the perturbations a safe challenge to gait in these subjects.

One novel finding is that HY were able to respond quickly by altering the kinematics of their first recovery step following the single underfoot perturbation. Furthermore, they continued to adjust their recovery steps for at least four steps post-perturbation. That young subjects should require up to four recovery steps following a relatively small underfoot perturbation is a surprise, since one might expect them to be able to recover in a single step, given their capacities.

On the other hand, the healthy older adults either would not or, more likely, could not alter the kinematics of their first step after an underfoot perturbation. Furthermore, when older adults did respond to alter their stepping pattern, it was on the second and fourth post-perturbation steps, but interestingly not the third step. However, older adults did respond with their upper body on the first post-perturbation step, moving it significantly less far laterally for an MP perturbation, and further laterally for the LP perturbation than for the UnP trials. Both of these responses are likely to have been due to a proximal response made using the hip ab- and adductors rather than the ankle muscles, because the hip muscles have been shown to play a direct biomechanical role in righting the body over the hip in the frontal plane (Otten, 1999). In addition, the hip muscles have

considerably shorter reflex pathways than the ankle muscles. So a hip muscle response can be initiated three times faster than with the ankle muscles, just based on the difference in the neural transmission distances from the spinal cord for the hip and ankle muscles (for example, 33 cm vs. 99 cm, say, for a 1.80 m-tall individual). Hence, these data suggest that these healthy older adults chose a hip strategy, rather than an ankle strategy, moving their torso to maintain their balance on the first post-perturbation step, after which they change the kinematics of the second step post-perturbation in order to continue their recovery.

Hence, it is clear that a small underfoot perturbation results in significant carryover effects on the kinematics of the foot placement during gait of both younger and older adults for at least four steps after the perturbation has been vanished. That a single perturbation can affect gait so many steps later has not been demonstrated before. The source of the carryover is presently unknown, but one might speculate that it represents dynamic interactions between the responses of the feet and torso.

The underfoot perturbation was shown to cause a kinematic response in terms of torso inclination and lateral pelvic displacement. It is well known that healthy adults choose a hip strategy when responding to a more proximal perturbation such as a tug on the torso, but an ankle strategy when responding to a distal perturbation such as a support surface that is moved unexpectedly (for example, Woollacott et al., 1993; Rogers et al., 2001). When support platform was suddenly swayed, the typical strategy adopted by healthy young adults is ankle strategy (Woollacott, 1993). However, Manchester et al. (1989) found hip strategies were more favorable in the elderly for the platform sway, possibly due to distal muscle weakness and peripheral neuropathy. The hip strategy is dominant for the larger perturbation when the base of support is limited, whereas the ankle strategy is used when the perturbation is smaller. (Shumway-Cook and Woollacott, 2001) So torso inclination and lateral pelvic displacement would seem to represent a hip strategy in healthy young and old.

The early recovery step response of the HY on their first post-perturbation step indicates that (1) they detected the perturbation, (2) sensed its direction, and (3) immediately chose a wider (and therefore more stable) gait pattern in response to the single unexpected

underfoot perturbation, while adjusting their torso attitude to minimize the change in gravitational moment caused by the perturbation about their center of mass.

The early upper body response of the healthy older adults post-perturbation is also evidence that they detected the perturbation when it happened. The differential nature of their response also demonstrates that they correctly determined the direction of the change in gravitational moment it caused about their center of mass. Their use of the hip strategy to help recovery in the first step is logical from a biomechanical perspective because it keeps the system feedback loop delay as short as possible. The fact that they narrowed their second step in response to an LP is reminiscent of the narrowed cross-over step recorded in young adults by Thies et al. (2007) in response to an MP, but it may here be the result of an interaction with carryover from their hip strategy response on the first step.

Two possible reasons might explain the age-related changes in recovery step kinematics. First, the unexpected nature of a single underfoot perturbation does not allow any subjects to anticipate the upcoming perturbation. The slower muscle rate of strength development of the elderly (Thelen et al., 1996) may have precluded older subjects from being able to move the foot that had been perturbed during its next swing phase far enough within the time available before the next heel strike occurs. Second, age-related changes in the neural sensory musculoskeletal systems and/or a reduction in stability of the first recovery step may necessitate additional steps to recover stability from the underfoot perturbation (Maki, 2000).

Strengths and Limitations

There are several strengths to this experimental paradigm. First, the perturbing shoes allow systematic comparison between UnP steps and MP/LP recovery steps in response to a standardized onset and magnitude of an unpredictable underfoot perturbation. The onset of the perturbation occurs at the same angle of inversion or eversion each time, something that cannot be guaranteed on uneven surfaces in use to date (for example, Menz et al., 2003; Thies et al., 2005). Second, neither right or left foot, nor which step along the walkway that is to be perturbed, can be predicted by a subject a priori. The fact

that 44 dummy trials were randomized among the 16 perturbation trials meant that subjects likely did not walk in a guarded fashion. Third, the perturbation contains the element of surprise that one so often must deal with when walking on outdoor surfaces. Yet, the perturbation is still both natural and familiar for anyone who walks outdoors, and so the response is likely overlearned and that is why it demonstrates little practice effect. Fourth, the experimental paradigm allowed the effect of age to be explored in a safe manner since no one tripped, stumbled or fell or needed to rely on the whole body safety harness they wore. Lastly, the calculation of the delta step kinematics is a change score that is normalized to each person's own unperturbed gait kinematics. This is based on an average of eight medial or lateral recovery steps and more than 20 UnP steps at a steady WS. Thus the kinematic changes in the first and second recovery steps can be considered reliable.

We believe that this method of measuring locomotory responses to an underfoot perturbation is generalizable to other planes, such as the sagittal plane. Indeed, even though the primary perturbations used in this study were either medial or lateral perturbations to a foot, they both also applied a sagittal plane perturbation to gait by altering the timing of foot flat following heel strike. So, it would be possible to use our method to place a perturbation at the same location in the frontal plane relative to the mid-line of the foot, but place it at different locations in the sagittal plane under the foot, thereby delaying or advancing the timing of first mid- or forefoot foot ground contact during the foot flat phase of gait.

We chose not to control WS by asking subjects to walk in time to a metronome, or at a certain walking speed. This is because we wanted each subject to feel comfortable with their walking speed given the upcoming perturbation. However, after each trial, the custom C++ program provided instantaneous feedback of the mean WS during the mid portion of each trial when a steady state WS had been achieved. If the WS deviated too much from the initial trial, the subject was given verbal feedback to increase or decrease WS slightly for the next trial. The difference in WS between subjects or groups was not significant. The WS we asked for was a little faster than comfortable gait speed, but still well within the range of normal gait speed (Bohannon 1997; Oberg et al., 1993).

6.5 References

- Bauby CE, Kuo AD, Active control of lateral balance in human walking. *J Biomech* 2000;33:1433-1440
- Berg WP, Alessio HM, Mills EM, Tong C. Circumstances and consequences of falls in independent community-dwelling older adults. *Age Ageing* 1997;26:261-268.
- Bohannon RW. Comfortable and maximum walking speed of adults aged 20-79 years: reference values and determinants. *Age Ageing* 1997;26:15-9
- Davis CS, Statistical methods for the analysis of repeated measurements. New York: Springer Publishing; 2002
- Hausdorff JM, Rios DA, Edelberg HK. Gait variability and fall risk in community-living older adults: a 1-year prospective study. *Arch Phys Med Rehabil* 2001; 82:1050-6
- Jian Y, Winter DA, Ishac MG, Gilchrist L. Trajectory of the body COG and COP during initiation and termination of gait. *Gait & Posture* 1993; 1:9-22.
- Kim H, Ashton-Miller JA. A shoe sole-based apparatus and method for randomly perturbing the stance phase of gait: test-retest reliability in young adults. *J Biomech* 2012; submitted
- Maki BE. Gait changes in older adults: predictors of falls or indicators of fear? *J American Geriatrics Society* 1997;45(3):313-320.
- Maki BE, Edmondstone MA, McIlroy WE, Age-related differences in laterally directed compensatory stepping behavior, *J Geron: MED SCI* 2000;55A(5):M270-M277
- Menz HB, Lord SR, Fitzpatrick RC. Age-related differences in walking stability. *Age Ageing* 2003;32:137-42
- Milisen K, Detroch E, Braes T, Dierickx K, Smeulders W, Teughels S, Dejaeger E, Boonen S, Pelemans W. Falls among community-dwelling elderly: a pilot study of prevalence, circumstances and consequences in Flanders. *Tijdschr Gerontol Geriatr* 2004;35(1):15-20

- Nnodim JO, Kim H, Ashton-Miller JA. Effect of a vocal choice reaction time task on the kinematics of the first recovery step after a sudden underfoot perturbation during gait. *Gait Posture* 2012; submitted
- Manchester D, Woollacott M, Zederbauer-Hylton N, Marin O . Visual, vestibular and somatosensory contributions to balance control in the older adult. *J Gerontol Med Sci* 1989;44:M118-27.
- Oberg T, Karznia A, Oberg K. Basic gait parameters: reference data for normal subjects, 10-79 years of age, *J Rehabil Res Dev* 1993;30(2):210-23.
- Otten E., Balancing on a narrow ridge: biomechanics and control *Phil. Trans. R. Soc. Lond. B* 1999;354:869-875
- Richardson JK, Thies SB, DeMott TK, Ashton-Miller JA. Interventions Improve Gait Regularity in Patients with Peripheral Neuropathy While Walking on an Irregular Surface Under Low Light. *J Am Geriatr Soc* 2004;52:510-515.
- Richardson JK, Thies S, Ashton-Miller JA. An exploration of step time variability on smooth and irregular surfaces in older persons with neuropathy. *Clinical Biomechanics* 2008;23:249056
- Rogers MW, Hedman LD, Johnson ME, Cain TD, Hanke TA, Lateral stability during forward-induced stepping for dynamic balance recovery in young and older adults, *J Gerontol: MED SCI*, 2001;56A(9):589-594
- Thelen DG, Schultz AB, Alexander NB, Ashton-Miller JA. Effects of age on rapid ankle torque development. *J Gerontol a Biol Sci Med Sci* 1996;51A(5):226-32
- Thies SB, Richardson JK, Ashton-Miller JA. Effects of surface irregularity and lighting on step variability during gait: a study in healthy young and older women. *Gait Posture* 2005;22:26-31
- Thies SB, Ashton-Miller JA, Richardson JK. What causes a crossover step when walking on uneven ground? A study in healthy young women. *Gait Posture* 2007;26:156-160.
- Woollacott MH, Age-Related Changes in Posture and Movement, *J Gerontol Med Sci* 1993;48:M56-60

Chapter 7

Effect of Peripheral Neuropathy on the Ability to Recover from an Unexpected Underfoot Perturbation while Walking: Kinematic, Kinetic and EMG Responses

7.1 Introduction

Peripheral neuropathy (PN) causes gait instability (Ojala 1985; Krebs 1998; Lord 1991, 1993, 1994; Corriveau 2000; Menz 2004). Patients with PN are 20 times more likely to fall (Richardson et al. 1992; Richardson and Hurvitz 1995) and 15 times to sustain fall-related injury than age-matched controls (Cavanagh et al. 1992)

Step width (SW) is a key factor in maintaining frontal plane stability (Bauby and Kuo 2000). Greater step width variability (SWV) has been linked to a higher fall risk in community dwelling elderly (Hausdorff et al., 2001). And several studies have evaluated the frontal plane stability of patients with PN during gait. PN patients exhibit increased SW, SWV, and SW range as well as ST and SL when walking at a comfortable gait speed on an irregular surface (Richardson et al., 2004).

Although the construction of an irregular surface in the laboratory or clinic is relatively straightforward, it takes up considerable storage space and so is not very practical in a clinic or hospital setting. Furthermore, the underlying mechanisms by which surface irregularities affect step kinematics during gait are currently not well understood. This is

because of the difficulty of associating any particular kinematic response with the effect of a particular underfoot irregularity because of the possibility of carryover effects from perturbation to one or more preceding steps. Thies et al (2007) were the first to study how a single static medial underfoot perturbation affected inversional acceleration of the stance foot and recorded a decrease in the SW of the first recovery step. However, there were methodological limitations in the control of the location of the underfoot perturbation. In addition, a subject was able to see the perturbation from afar and prepare a response strategy if their foot should land on the perturbation. So we developed a shoe-based underfoot perturbation method with better reliability and unpredictability (Chapter 5, Kim and Ashton-Miller, 2012).

The three most common metrics of human gait are include step and body kinematics during gait, ground reaction kinetics during the stance phase, and electromyographic (EMG) activity in the lower limbs (Winter, 1990). It is known that lateral pelvic displacement (LPD) during gait is a unique personal gait characteristics and one determinant of how disease affects gait (Saunders, 1953). Second, ground reaction forces and torques of the stance limb permit center of pressure (COP) traces to be measured under the stance foot so that they may be compared to whole body center of gravity trajectories in order to evaluate, for example, mediolateral gait stability in the elderly (Krebs et al., 1998). Otten (1999) showed that hip joint torques of the stance limb are very important for varying the horizontal component of the ground reaction force under the stance foot while balancing on a fulcrum in order to bring the whole body center of gravity back over the base of support in the frontal plane. The EMG of ankle frontal muscle groups (m-SOL, PER-L) have commonly been used to evaluate the onset and root-mean-square (rms) muscle activity during gait (Sinkjaer et al., 2000; Santilli et al., 2005).

There are several knowledge gaps understanding the maintenance of lateral stability during gait. Firstly, no one has systematically investigated the relationships between the kinetic, kinematic and neuromuscular responses following a single underfoot perturbation. Secondly, this information is lacking in patients with PN, even though it might shed light on why they have a difficult time walking on uneven surfaces (Richardson et al., 2005).

Thirdly, the timing (onset, offset) and magnitude of EMG muscle activity in patients with PN have been studied in only a few studies (Kwon et al., 2003). However, gait stability has not been directly evaluated using the frontal muscle EMG activities yet, and its relationship with recovery step kinematics remains unknown. Fourthly, there are no quantitative measurements of LPD following an unexpected single underfoot perturbation or its relation with the severity of PN or step kinematic responses. One study has reported the effect of stroke on LPD and another has given a qualitative description of the possible relationship between foot placement and LPD (Dodd et al., 2003).

So the purpose of this chapter was to investigate: 1) the relationships between the first recovery step kinematics, changes in LPD, and ground reaction forces following a perturbation to the stance phase of gait, 2) the effect of PN on the neuromuscular and kinematic recovery from a single underfoot perturbation, and 3) EMG activation onset and EMG magnitude of ankle muscle responses to that perturbation.

7.2 Methods

Subjects

Forty-one old adults with and without peripheral neuropathy (PN) were recruited (16 healthy old and 25 with PN due to diabetes, age 50-85 yrs, Weight<136 kg) from University of Michigan Orthotics and Prosthetics Clinic, Endocrinology Clinic, and the Older American Independence Center Human Subjects Core. The test protocol was approved by Institutional Review Board and written informed consent forms were collected from each subject. Participants passed a telephone screening for both HO and PN groups including the following criteria:

- No accidental fall in the last month
- No history of significant central nervous system and vestibular dysfunction, musculoskeletal deformity.
- No joint replacements within the last year.
- No significant musculoskeletal deformity (i.e., amputation or Charcot changes),

- Normal electrodiagnostic studies.
- No evidence of vestibular dysfunction

From initial in-hospital screening, subjects were categorized according to severity of PN according to the Michigan Diabetes Neuropathy Score (MDNS) ≥ 10 (Feldman et al. 1994).

The Perturbation Shoes

The Perturbation Shoes are described in detail in Chapter 5 (Kim and Ashton-Miller, 2012), so they will only be described briefly here. They are based on a modification of a commercial sandal (ACG RayongTM, Nike Inc., Beaverton, OR) and built by a state-certified orthotist. A flap under the medial or lateral mid-forefoot was silently deployed during the swing phase of gait using a linear motor (Fergelli, Inc. Victoria, BC, Canada). Once the subject stepped on the perturbation in the next stance phase, the flap was then abruptly retracted during the following swing phase. This unpredictable underfoot perturbation method has been proven to be reliable, repeatable (Kim and Ashton-Miller, 2012) and approved by Institutional Review Board for the safety in people at a higher risk of falls, such as these subjects with PN.

Measurement Methods (See Chapter 5)

A total of eight double differential, wireless, surface EMG electrodes were placed over the mid-belly of the right and left hip abductor/adductor (GM:Gluteus Medius, ADD-L: Hip Adductor Longus) and ankle inverter/everter muscle groups (PER-L: peroneus longus, m-SOL: medial soleus), and sampled at 2 kHz (TrignoTM wireless EMG system Delsys Inc., Boston, MA). A optoelectronic triad was formed from three Certus system markers to define the 3 translational and 3 rotational movements of the rigid body (i.e. triad). A total of six Certus optoelectronic triads were placed on the chest (bottom of the sternum), on the midline between the anterior superior iliac spines, on the anterior aspect of the mid-upper and mid-lower leg, and on the midfoot bilaterally. In addition one Certus marker was placed on the first metatarsal and another on the fifth metatarsal bilaterally and sampled at 100 Hz (Optotrak Certus system, Northern Digital Inc., Waterloo, ON, Canada). Two AMTI 6-axis force platforms measured ground reaction

forces under right or left stance foot, when perturbed (OR6-7-2000, AMTI Inc., Watertown, MA).

Human Test Procedures

Subject were asked to walk at a faster than normal speed as “if they were crossing a busy street”. Verbal feedback was given to subjects to adjust their walking speed so that it matched their speed on the first trial throughout test session. The force plate was hidden underneath a 3 mm-thick black natural rubber mat (1m wide x 9.15 m long) to prevent any unintentional slips during perturbed trials. Detailed instructions and practice trials were given before the main test started. The baseline measurements were collected before the test from 1) force plate with and without the subject standing quietly, 2) baseline EMG levels from both relaxed and maximally contracted ankle and hip muscles, and 3) relative marker triad locations during quiet standing with respect to 20 body landmarks (Acromion, Anterior Superior Iliac Spine, Head of Fibula, Medial and Lateral Maleolus, 1st and 5th metatarsal, Calcaneus (Left and right), and Bottom and top of Sternum (center)). The subject then performed 60 walking trials which included a total of 16 perturbed trials (4 right foot - medial (RM), 4 right foot - lateral (RL), 4 left foot - medial (LM), and 4 left foot - lateral (LL) perturbations) presented in a randomized order.

Data Analysis

The change (or “delta”) variables were defined to show the difference between the mean of the first medially-perturbed (MP₁) or first laterally-perturbed (LP₁) recovery step outputs and the mean unperturbed (UnP) step outputs for each subject, as shown in (1).

$$\Delta X = \overline{X}_{1st\ recovery\ step} - \overline{X}_{unperturbed\ step} \quad \dots (1)$$

where X denotes each kinematic (SW, SL, ST), kinetic (F_{horizontal} and F_{vertical}), body kinematic (LPD) and electromyographic (raw and rms EMG_{Per-L}, EMG_{m-SOL}) measurements.

Thus the delta parameters indicate how much the first recovery step changes during a perturbed stance phase from unperturbed gait. Pearson linear correlation coefficients and, on the assumption of normality, repeated measures ANOVA were used to study

relationships and differences among gait trials (Matlab 2011a Statistical Toolbox™, The Mathworks, Inc., Natick, MA). A p-value less than 0.05 was considered significant.

7.3 Results

7.3.1 The First Medially Perturbed Recovery Step Responses

Step Width and Lateral Pelvic Displacements

In the first medially perturbed (MP_1) recovery steps, PN had significantly wider SW ($p = 0.028$, HO: 16.4 (2.9) cm, PN:19.7 (3.9) cm), and larger LPD ($p=0.026$, HO: 4.0 (1.3) cm, PN: 5.6 (1.8) cm) in the first recovery medially perturbed gait than HO did. There were no significant difference ΔSW , ΔSL and ΔST in the first MP step, compared to unperturbed steps in either HO or PN. Lateral pelvic displacement during medially perturbed stance limb was significantly different between HO and PN, as shown in Figure 7-1.

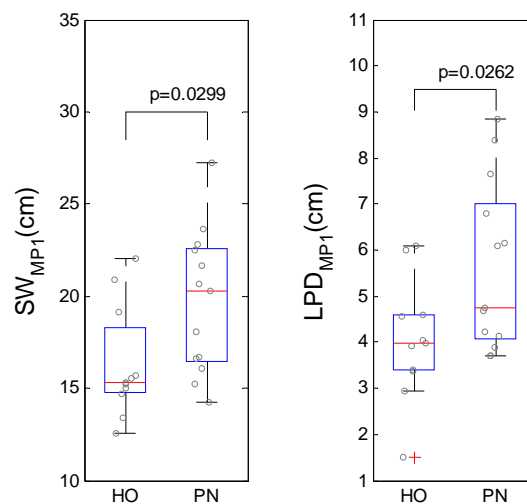

Figure 7-1. Boxplots and scatter plots of step width (SW) and lateral pelvic displacement (LPD) for the 1st medially-perturbed (MP_1) steps.

Body Kinematics in Frontal Plane

As shown in Figure 7-2, in MP₁, there was a strong positive correlation between Δ LPD and Δ SL ($R=0.554$, $p<0.003$) and Δ ST ($R=0.695$, $p<0.001$) in the 1st MP recovery step.

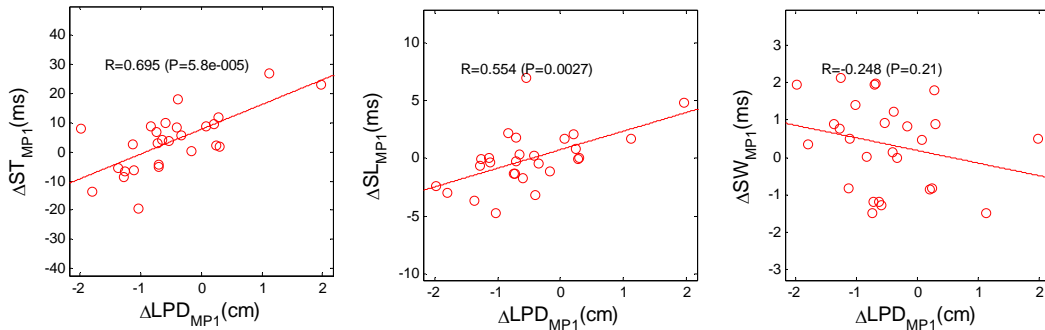

Figure 7-2. Pearson’s linear correlation coefficients and least-square regression line between Δ Step Kinematics (Δ SW, Δ SL, Δ ST) and Δ LPD in the 1st MP (MP₁, A) recovery step.

Kinetic Responses

The severity of PN correlated negatively with the off-loading of the perturbed stance limb, as shown in Figure 4 than HO. ($R = -0.46$ ($p=0.018$)) Horizontal (F_{hor}) and vertical (F_{ver}) components of the ground reaction force (GRF) in the frontal plane during perturbed stance phase correlated significantly with Δ Step Kinematics (Δ ST (ΔF_{ver} : $R=0.54$ ($p=0.004$), ΔF_{hor} : $R=0.42$ ($p=0.030$)) and Δ SL (ΔF_{hor} : $R=0.55$ ($p=0.003$)), and strongly correlated with Δ LPD (ΔF_{hor} : $R=0.57$ ($p=0.002$)). Both ΔF_{hor} and ΔF_{ver} were little correlated with Δ SW.

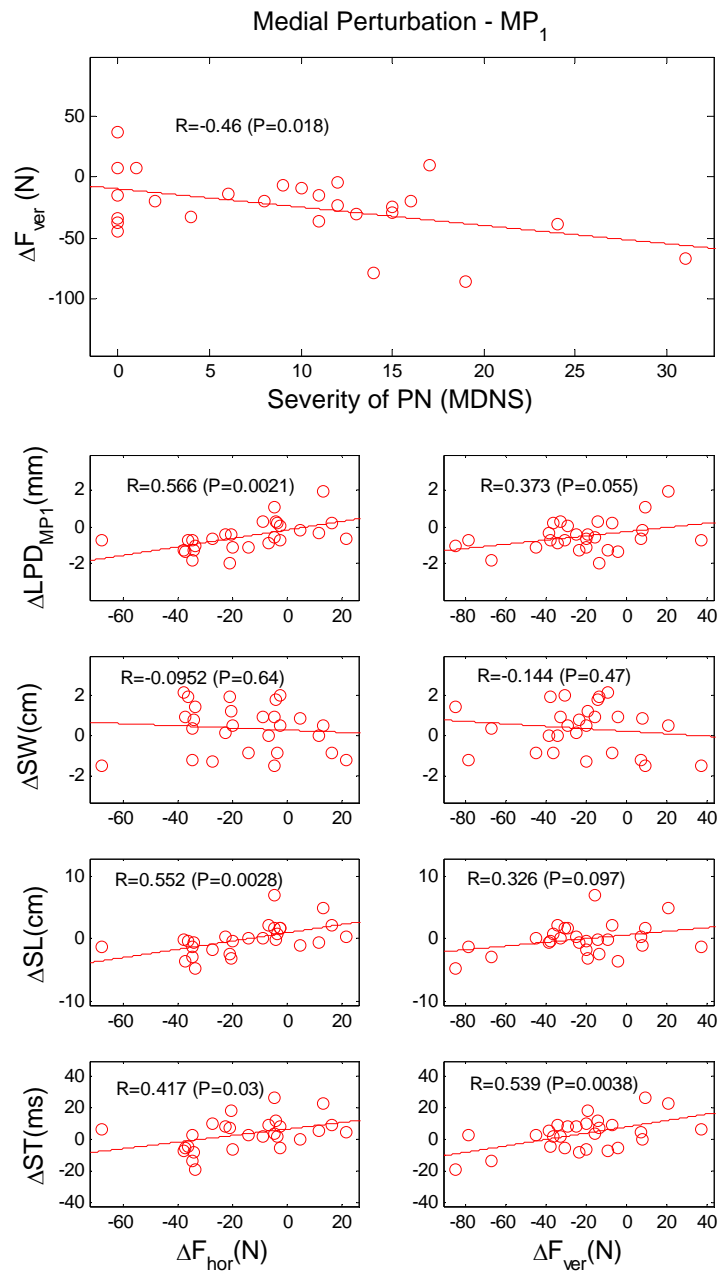

Figure 7-3. Pearson’s linear correlation coefficients and least-square regression line (top) for severity of PN vs vertical ground reaction force of the perturbed stance limb, (2-4th rows) delta step kinematics, and (5th row) delta lateral pelvic displacement against horizontal (F_{hor}) and vertical (F_{ver}) components of ground reaction forces for the first medially-perturbed (MP₁) recovery steps.

Neuromuscular Responses

There was a significant effect of disease on rms peroneal EMG levels. In medially perturbed (MP_1) stance limb, the peroneal rms EMG strength in HO was significantly larger than for an unperturbed step (mean +29.7 % for HO). Per-L for both PN and HO was activated earlier in MP_1 than in the unperturbed stance limb (mean -28.5 ms for HO, -36.6 ms for PN). No significant changes were observed in m-SOL activation onset time and rms EMG strength for either HO or PN groups.

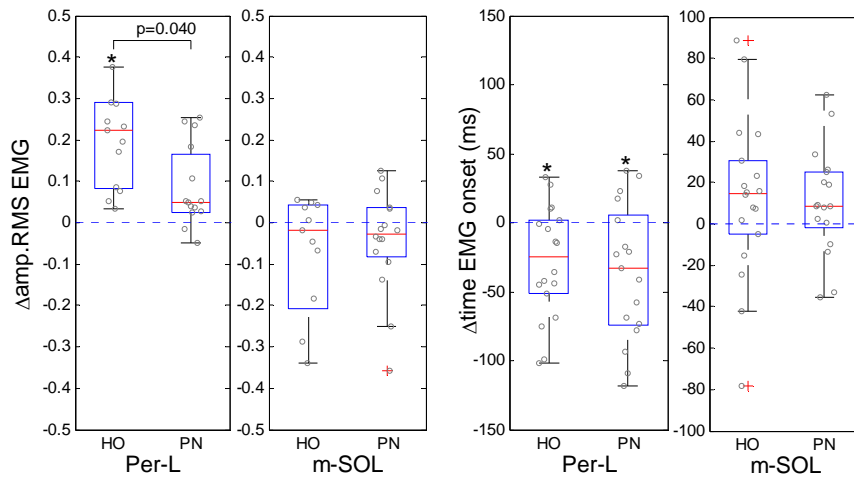

Figure 7-4. Boxplots with scatter plots of Δ rms EMG amplitude and Delta raw RMG onset in ankle muscle groups (Per-L: Peroneus Longus, m-SOL: medial soleus) in the first medially-perturbed (MP_1 : A) and laterally-perturbed (LP_1 : B) recovery step in HO and PN. * denotes the significant difference from unperturbed (UnP) outputs. Bracket denotes the significant difference between groups (HO vs PN).

7.3.2 The First Laterally Perturbed Recovery Step Responses

Step Width and Lateral Pelvic Displacements

In the first laterally-perturbed (LP_1) recovery steps, PN patients exhibited significantly wider SW ($p = 0.028$, HO: 16.1 (3.1) cm, PN:19.7 (4.0) cm), and a larger LPD ($p=0.026$, HO: 5.5 (1.3) cm, PN: 7.0 (1.8) cm) than HO in the first recovery following a lateral

perturbation. The lateral pelvic displacement after a medially perturbed stance limb was significantly different between HO and PN, as shown in Figure 7-5.

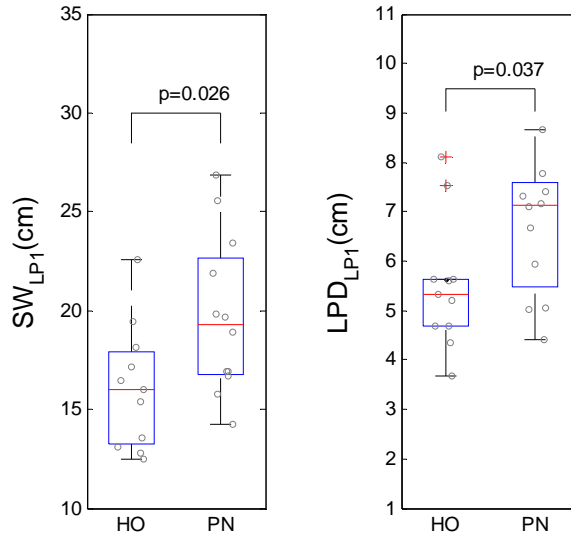

Figure 7-5. Boxplots and scatter plots of step width (SW) and lateral pelvic displacement (LPD) for the 1st laterally-perturbed (LP1) steps.

Body Kinematics in Frontal Plane

For LP₁, there was no significant correlation between Δ LPD and Δ Step kinematics in the first laterally-perturbed (LP₁) responses.

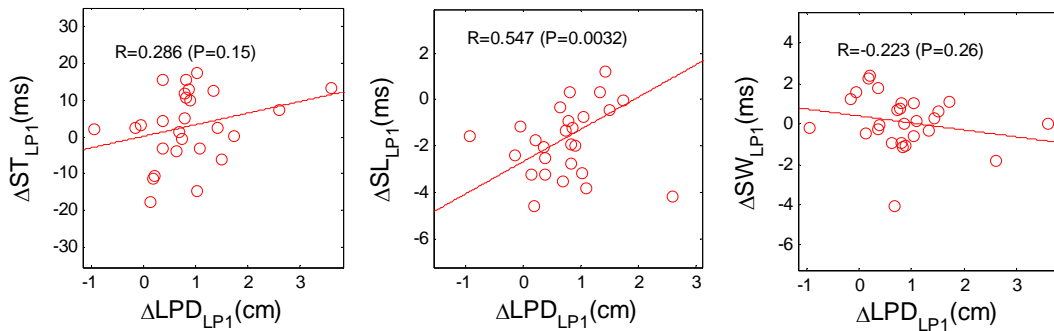

Figure 7-6. Pearson’s linear correlation coefficients and least-square regression line between Δ Step Kinematics (Δ SW, Δ SL, Δ ST) and Δ LPD in the 1st LP (LP₁, B) recovery step.

Kinetic Responses

There was no significant correlation observed between severity of PN and horizontal (F_{hor}) and vertical (F_{ver}) components of ground reaction force (GRF) in frontal plane during perturbed stance phase. There was a significant correlation between horizontal GRF and step length changes in the first laterally perturbed (LP_1) recovery step.

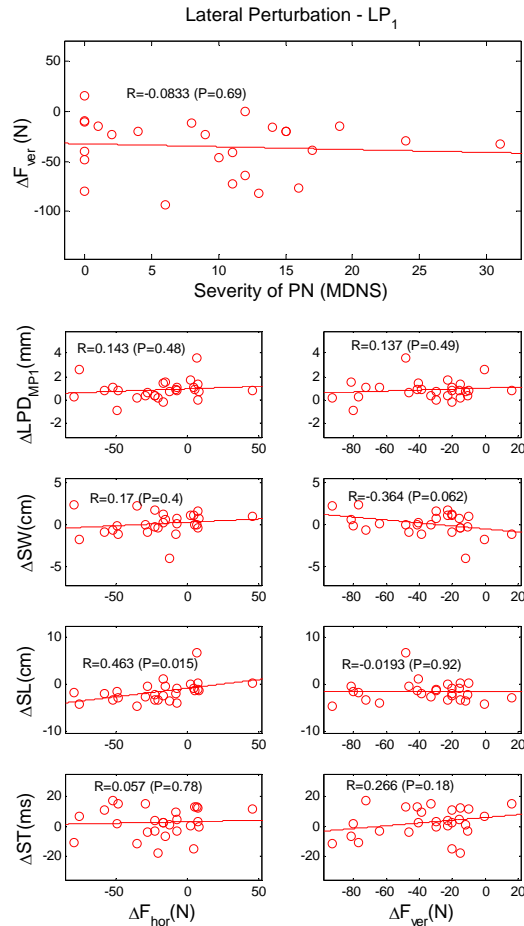

Figure 7-7. Pearson's linear correlation coefficients and least-square regression line (top) severity of PN vs vertical ground reaction force of the perturbed stance limb, (2-4th rows) delta step kinematics, and (5th row) delta lateral pelvic displacement against horizontal (F_{hor}) and vertical (F_{ver}) components of ground reaction forces for the first laterally-perturbed (LP_1) recovery steps.

Neuromuscular Responses

In the laterally perturbed (LP_1) HO stance limb, Per-L was activated significantly more strongly and m-SOL activated significantly less strongly than in unperturbed stance limb (Per-L: ave +9.1%, m-SOL: ave -10.7%). In PN, however, there no significant changes in activation onset time in Per-L and m-SOL (Per-L: ave +3.6%, m-SOL: ave -4.4%). In HO, Per-L was activated significantly later during a LP_1 than in unperturbed gait (+39.1 ms).

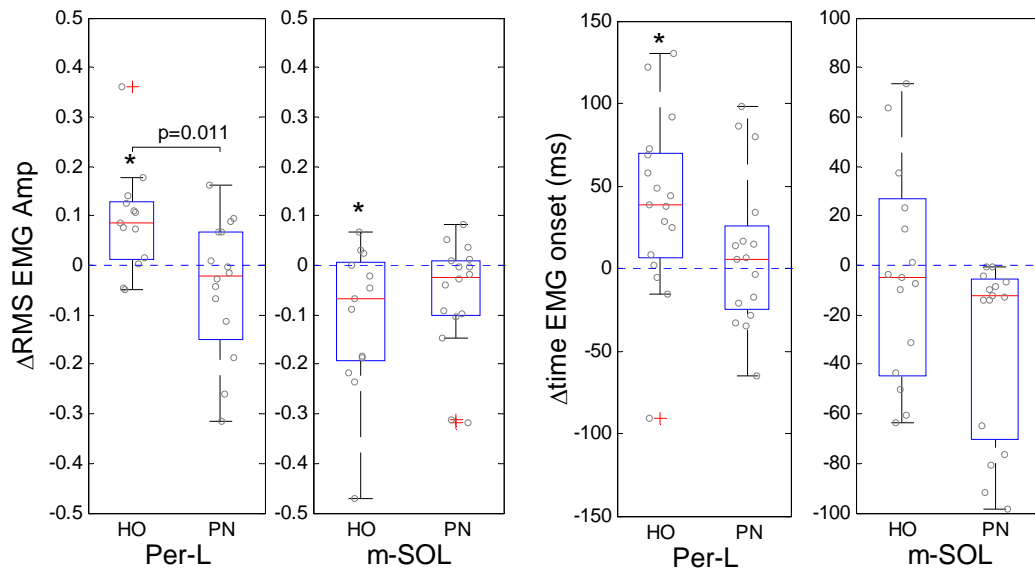

Figure 7-8. Boxplots with scatter plots of Δ rms EMG amplitude and Delta raw RMG onset in ankle muscle groups (Per-L: Peroneus Longus, m-SOL: medial soleus) in the first medially-perturbed (MP_1 : A) and laterally-perturbed (LP_1 : B) recovery step in HO and PN. * denotes the significant difference from unperturbed (UnP) outputs. Bracket denotes the significant difference between groups (HO vs PN).

7.4 Discussion

We have systematically investigated the relationships between LPD and step kinematics (especially SW), step dynamics, and neuromuscular responses in the perturbed stance

limb within the context of increasing PN severity. We have demonstrated a possible explanation for LPD based on the placement of the recovery foot following an unexpected single underfoot perturbation.

The main finding in this chapter is the effect of PN on LPD and SW during perturbation of the stance foot. The two primary findings are 1) the relationships between LPD, the kinematic step parameters, and the stance limb ground reaction shear forces, and 2) the effects of PN effects on EMG responses during the first recovery step following a MP or LP.

PN patients exhibited considerably wider SW and larger LPD than the controls during MP₁ and LP₁ recovery steps compared to unperturbed steps. This finding is consistent with PN having a wider SW both on smooth and irregular surfaces. As Chen et al. (1994) showed in a virtual obstacle avoidance task, the success rate achieved in avoiding the obstacle decreased as the available reaction time (ART) was decreased. If PN slows the response to an underfoot perturbation, there will systematically be less time for PN patients than HO to organize a suitable response during the time available before their recovery foot heel strikes the ground.

Wider SW and a larger LPD were commonly observed both in MP₁ and LP₁ recovery steps. However, the underlying relationships for MP₁ among delta step kinematics, delta ground reaction force, and delta step kinematics were quite different from those in LP₁. ΔLPD_{MP1} had strong positive correlation with ΔST and ΔSL in step kinematics, $\Delta F_{horizontal}$ and $\Delta F_{vertical}$ in GRF of perturbed stance limb, whereas no such relationship was observed for LP₁. One explanation might be that the lateral underfoot perturbation was located near the trajectory of the underfoot COP during the perturbed stance phase, so additional muscles (i.e., anterior tibialis, hamstring, and calf muscles) can be used to control gait in the sagittal plane without affecting mediolateral stability.

The vertical component of delta ground reaction force (ΔF_{ver}) in perturbed stance limb was closely related to limb kinematics. Indeed ΔF_{ver} was significantly correlated with the severity of PN. Apparently PN subjects compensated for their loss of ankle muscle control by simply offloading the perturbed foot as quickly as possible.

Considering the onset and magnitude of ankle EMG responses, it is a reasonable assumption that PN generate less ankle eversion torque in medially perturbed (MP_1) stance limb than HO. There was no significant difference between HO and PN in the onset activation time of Per-L after heel strike of perturbed limb. However, as shown in Figure 7-4, the rms EMG magnitude of medially perturbed Per-L in PN was significantly less than that in HO. And m-SOL exhibited no significant MP_1 changes in the magnitude and onset time for both HO and PN. Consequently, we can infer that PN patients generated relatively less force in Per-L than HO for MP, even if there was no direct measurement of ankle torques.

EMG in the laterally perturbed (LP_1) stance limb (Figure 7-8) showed that Per-L was activated rapidly and strongly compared to the unperturbed case. The onset of Per-L in LP_1 has the opposite trend than for a MP_1 perturbation – faster in MP_1 and slower in LP_1 . By controlling the activation onset, HO seemed to successfully generate the counter torque when reacting to an everted ankle, yet PN did not do so. This is the first time that an ankle response strategy has been shown clearly in HO and its absence has been shown in PN patients.

In order to react to an underfoot perturbation successfully during stance, the required torques in the target joint (i.e., ankle inversion/eversion torque) depends on the activation onset and activation of target muscle group. In the case of the medially perturbed limb, for example, to generate sufficient ankle eversion torque, the onset and magnitude of Per-L should either be earlier or stronger or both than in normal gait in order to prevent an ankle sprain.

However, the available reaction time (ART) to generate ankle torque is limited during perturbed stance. It is known that the muscle activation duration during one gait cycle is around 15 to 35% for Per-L and SOL (Prince 1997). Based on data from the present study ($v_{\text{mean}} = 1.26$ m/s), the ART window is only 92 to 214 ms for Per-L and m-SOL before the next heel strike. If the activation was postponed or tardy within the given ART for the perturbed limb, then the perturbed ankle would fail to generate sufficient torque to

overcome the underfoot perturbation. If PN uses an ankle response strategy, there will be higher probability of failing to respond in time to an underfoot perturbation because of nerve damage to the largest fastest and longest neurons in the lower extremity. As seen in the EMG activation responses, the PN patient exhibited the loss of an effective ankle response to the underfoot perturbation

The changes (“delta”) in step kinematics, dynamics and myography (Δ Step, Δ Force, Δ EMG) were quite effective in demonstrating the magnitude of changes in responses to an underfoot perturbation compared to unperturbed gait. In neuropathic gait, for example, a greater LPD and wider SW in the first recovery step helped illustrate the disease effect.

Since the swing limb dynamics offer relatively little potential for helping to recover frontal plane balance (Otten, 1999), the changes in the kinematics of the swing limb were not considered in this study. Is it possible that the balance problems that patients with PN describe when walking on uneven ground might simply be attributable to a different locomotion strategy adopted to compensate for the PN, rather than an increased feedback loop delay due to loss of afference and muscle strength? It seems unlikely. For example, Thies et al. (2005) did not find evidence that PN tripped more than healthy controls when walking on a standardized uneven surface, so their foot clearance would not appear to be less than normal. And in the present study, PN subjects did not trip more than the healthy older adults when the underfoot foot was deployed.

Strengths and Limitations

Strengths of this study are the well characterized nature of the PN in these patients, the innovative method for perturbing gait using randomized single perturbations, and the set of measures used to quantify the responses to the perturbation.

Weaknesses include the use of only a self-controlled gait speed (to which a subject had to adhere via verbal feedback from the experimenter based on the measured speed of the first trial). But it would have been desirable to run the same MP and LP tests at fixed gait speeds such as 1.0, 1.25 and 1.5 m/s. But this would have risked inducing both mental and physical fatigue in these subjects given the number of trials, and that would have confounded interpretation of the results. For simplicity, we only considered frontal plane

body kinematics; it is a weakness that sagittal and transverse plane kinematics and dynamics were not studied. It is also a limitation that a full whole body kinematic and dynamic study of gait was not conducted. Moreover it is a pity that we could not record reliable EMG activity in the gluteus medius (hip abductor) or adductor longus (hip adductor) muscles, because this would have helped with interpreting how disease affects hip and ankle responses to the MP and LP perturbations.

Nonetheless, the study provides useful insights into how PN affects the ability to respond to underfoot perturbations during gait. The results will have to be replicated by other researchers before one can be certain of the interpretation of the EMG data in particular.

7.5 References

- Bauby CE, Kuo AD. Active control of lateral balance in human walking. *J Biomech* 2000;33:1433–40.
- Cavanagh PR, Derr JA, Ulbrecht JS, Maser RE, Orchard TJ. Problems with gait and posture in neuropathic patients with insulin-dependent diabetes mellitus. *Diabet Med* 1992;9:469–74.
- Chen HS, Ashton-Miller JA, Alexander NB, Schultz AB, Effect of Age and Available Response Time on Ability To Step Over an Obstacle. *J Gerontol: Med SCI* 1994;49(5):M227-M233
- Corriveau H, Prince F, Hebert R. Evaluation of postural stability in elderly with diabetic neuropathy. *Diabetes Care* 2000;23:1187-
- Grabiner PC, Biswas T, Grabiner M, Age-related changes in spatial and temporal gait variables, *Arch Phys Med Rehab* 2001;82(1):31-35.
- Dodd KJ, Morris ME, Lateral pelvic displacement during gait: abnormalities after stroke and changes during the first month of rehabilitation. *Arch Phys Med Rehabil* 2003;84(8):1200-1205

- Feldman EL, Stevens MJ, Thomas, PK, Brown MB, Canal, N Greene DA, A practical two-step quantitative clinical and electrophysiological assessment for the diagnosis and staging of diabetic neuropathy. *Diabetes Care* 1994;17(11):1281-1289
- Hausdorff JM, Rios DA, Edelberg HK. Gait variability and fall risk in community-living older adults: a 1-year prospective study. *Arch Phys Med Rehabil* 2001;82:1050–6.
- Kim H., Ashton-Miller JA, A shoe-based apparatus and method for randomly perturbing the stance phase of gait: test-retest reliability in young adults, *J Biomech* [Accepted]
- Krebs D.E., Jette A.M., Assmann S.F., “Moderate exercise improves gait stability in disabled elders,” *Arch Phys Med Rehabil* 79 (12), 1998 Dec., 1489-1495
- Kwon O.Y., Minor S.D., Maluf K.S., Mueller M.J., Comparison of muscle activity during walking in subjects with and without diabetic neuropathy, *Gait Posture* 2003;18(1):105-113
- Lafond D, Corriveau H, Prince F: Postural control mechanisms during quiet standing in patients with diabetic sensory neuropathy. *Diabetes Care* 2004;27:173–8
- Lord SR, Clark RD, Webster IW. Postural stability and associated physiological factors in a population of aged persons. *J Gerontol* 1991;46:M69-76
- Lord SR, Caplan GA, Colagiuri R, Ward JA. Sensori-motor function in older persons with diabetes. *Diabet Med* 1993;10:614-8.
- Lord SR, Ward JA. Age-associated differences in sensori-motor function and balance in community dwelling women. *Age Ageing* 1994;23:452-60.
- Menz HB, Lord SR, Fitzpatrick RC. Acceleration patterns of the head and pelvis when walking on level and irregular surfaces. *Gait Posture* 2003;18:35–46.
- Menz HB, Pod B, Lord SR, St. George R, Fitzpatrick RC: Walking stability and sensorimotor function in older people with diabetic peripheral neuropathy. *Arch Phys Med Rehabil* 2004;85:245–52
- Ojala J, Matikainen E, Groop L. Body sway in diabetic neuropathy [abstract]. *J Neurol* 1985;232(Suppl):3.

- Otten E., Balancing on a narrow ridge: biomechanics and control, *Phil.Trans. R.Soc.Lond.* B(1999) 354, 869-875
- Owings TM, Grabiner MD, Measuring step kinematic variability on an instrumented treadmill: how many steps are enough? *J Biomech* 2003; 36(8):1215-1218.
- Richardson JK, Ching C, Hurvitz EA. The relationship between electromyographically documented peripheral neuropathy and falls. *J Am Geriatr Soc* 1992;40:1008–12.
- Richardson JK, Hurvitz EA. Peripheral neuropathy: a true risk factor for falls. *J Gerontol A Biol Sci Med Sci* 1995;50:M211–5.
- Richardson JK, Thies SB, DeMott TK, Ashton-Miller JA, A Comparison of Gait Characteristics Between Older Women with and without Peripheral Neuropathy in Standard and Challenging Environments *J Amr Geriat Soc* 2004;52(9):1532-1537
- Santilli V., Frascarelli M.A., Paoloni M., Frascarelli F., Camerota F., Natale L.D., Santis F.D., Peroneus longus muscle activation pattern during gait cycle in athletes affected by functional ankle instability: A surface electromyographic study., 2005; 33(8):1183-1187
- Saunders J.B.M., Inman V.T., Eberhardt H.D., The major determinants in normal and pathological gait, *J Bone Joint Surg* 1953;35-A: 543-558
- Sinkjaer T., Andersen J.B., Ladouceur M., Christensen L.O.D., Nielsen J.B., Major role for sensory feedback in soleus EMG activity in the stance phase of walking in man., *J Physiology*, 2000;523(3);817-827
- Winter DA, Biomechanics and motor control of human movement, 4th ed. Wiley and Sons, New York, 1990

Chapter 8

The Relationship between Lower Extremity Frontal Plane Muscle Capacities and Step Width Responses to an Underfoot Perturbation in Older Subjects with and without Peripheral Neuropathy

8.1 Introduction

Peripheral neuropathy (PN) is known to adversely affect the longest nerve axons of the peripheral nerves (Dumitru, 2002). The loss of type II muscle fibers leads to decreased muscle mass and longer muscle response latencies in the elderly with PN (for example, Barry et al., 2004). Reduced ankle rate of torque development (RTD) in PN decreases the ability to recover from lateral balance perturbation (for example, Gutierrez et al., 2001).

Step width (SW) is known to be a key gait parameter in maintaining frontal plane stability during locomotion (Bauby and Kuo, 2000). PN with distal sensory and motor loss have shown unstable gait in frontal plane when crossing uneven surfaces, displaying greater SW, SWV and range of SW (Menz, 2003; Thies et al., 2005). A larger lateral pelvic displacement and wider first recovery step width following an underfoot perturbation in PN is suggestive of unstable frontal plane gait responses (Chapter 7).

One might posit that elderly with PN, who have longer latencies in muscle strength development, should may fail to respond to an unexpected underfoot perturbation within the given available response time (ART) after their stance phase is perturbed. However no studies have been published on the relationship between lower limb motor capacities and recovery step widths to a single unexpected underfoot perturbation.

So our working hypotheses are that 1) rate of strength development in frontal plane lower limb musculature decreases as symptoms of PN progress, and 2) peroneal EMG muscle response decreases as PN gets more severe when a medial underfoot perturbation affects the stance phase. Specifically, we tested the hypothesis that 3) response latencies in PN frontal plane lower limb musculature may change but not the first recovery SW, and 4) decreased hip and ankle rate of strength development in PN adversely affects the second recovery SW following a single underfoot perturbation.

8.2 Methods

Subjects

Forty-one old adults were recruited from University of Michigan Orthotics and Prosthetics Clinic, Endocrinology Clinic, and the Older American Independence Center Human Subjects Core. Participants passed telephone screening as described in Chapter 7. Based on Michigan Diabetes Neuropathy Score (MDNS) measured from initial in-hospital screening, they were categorized into three groups (11 healthy old (HO: MDNS=0), 9 mild PN (mPN: MDNS<10) and 22 with distal symmetric peripheral neuropathy (PN: MDNS \geq 10) due to diabetes, (Age 50-85 yrs, Weight<136kg) (Feldman et al., 1994), Test protocol was approved by Institutional review board and written consent forms were collected at site.

Physical Capacities (See Chapter 2 and 3)

Ankle inversion/eversion proprioception threshold were measured while subjects were standing using a foot cradle system (40 x 25cm) that rotated in frontal plane (Inversion/Eversion) and a staircase series of 100 rotational stimuli (Son 2010). Ankle

muscle maximum strength and rate of strength development were measured when subjects stood on the test foot on a force plate (Advanced Mechanical Technology, Inc. OR-6) and moved as quickly as possible the center of pressure from the lateral to medial side of the foot, then to the lateral side (Gutierrez et al., 2001) and repeated five times on each verbal cue from test administrator. For hip motor function, a custom, whole-body dynamometer (BioLogic Engineering, Inc. Dexter, MI) was used to measure maximum voluntary strength and rate of torque development of hip musculature in the frontal plane (Smeesters et al., 2001). Strength data were normalized by subject's height and weight.

The Perturbing Shoe (see Chapter 5)

The perturbing shoe method were developed using commercial sandal (ACG Rayong™, Nike Inc., Beaverton, OR). Before beginning of the main test, detail instructions and practice trials were presented to the subject and baseline measurements were collected from muscle EMG, ground reaction force, and optoelectric markers in relaxed and maximal ankle and hip muscles (Chapter 7). Subjects were asked to walk at a 'faster than normal speed' as if they are crossing busy street. Spontaneous verbal feedback was given for subjects to adjust walking speed throughout test session. A flap under the medial or lateral mid-forefoot shoe sole was silently deployed during a single swing phase using a linear miniature actuator (Fergelli, Inc. Victoria, BC, Canada). Once the subject stepped on the perturbation in the following stance phase, then the flap is retracted in the next swing phase. Among 60 walking trials, a total of 8 medially (4 for right foot/4 for left foot) and 8 laterally (4 for right foot/4 for left foot) perturbed trials were presented in a randomized order. This unpredictable underfoot perturbation method has been proven to be reliable, repeatable (Kim and Ashton-Miller, 2012) and approved by Institutional Review Board as safe to test people with an elevated risk of falls, such as subjects with PN. All subjects completed written informed consent forms.

Statistical Analysis

The change (or delta) variables were defined to show the difference between the mean of the first medially-perturbed (MP₁) or first laterally-perturbed (LP₁) recovery step outputs and the mean unperturbed (UnP) step outputs for each subject as shown in (1).

$$\Delta X = \overline{X}_{1st\ recovery\ step} - \overline{X}_{unperturbed\ step} \quad \dots (1)$$

where X denotes each kinematic (SW, SL, ST), kinetic (F_{horizontal} and F_{vertical}), body kinematic (LPD), and electromyographic (EMG_{Per-L}, EMG_{m-SOL}) measurements. Thus the delta parameters indicate how much the first recovery step changes during a perturbed stance phase from unperturbed gait.

A generalized linear model was used to study contributions of physical capacities (Independent variables: Ankle inversion/eversion, hip adduction/abduction MRTD and MVC, Ankle proprioception threshold) and kinematic responses (first and second recovery SW and ΔSW) in response to an unexpected underfoot perturbation (Matlab 2011a Statistical Toolbox™, The Mathworks, Inc., Natick, MA). Independent repeated measures ANOVA analyses were also run. A p-value less than 0.05 was considered significant.

8.3 Results

Ankle and Hip Maximum Rate of Torque Development

Normalized hip and ankle maximum rate of torque development (MRTD) showed a significant difference between HO and PN groups (PN and mild PN) (Figure 8-1): (Hip abduction MRTD (HO: 0.648 (0.309), mild PN: 0.344 (0.193), PN: 0.342 (0.152)), Hip adduction MRTD (HO: 0.750 (0.290), mild PN: 0.363 (0.267), PN: 0.413 (0.188)), Ankle inversion MRTD (HO: 0.235 (0.096), mild PN: 0.096 (0.051), PN: 0.105 (0.067)), Ankle eversion MRTD (HO: 0.279 (0.140), mild PN: 0.155 (0.062), PN: 0.144 (0.078)).

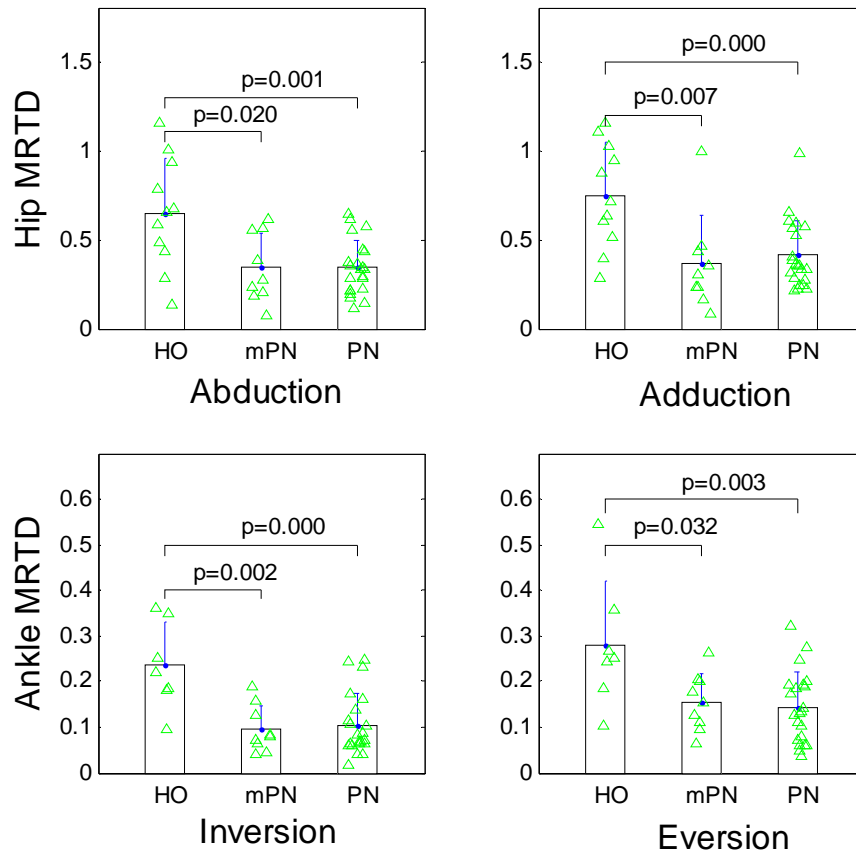

Figure 8-1 Bar graphs with scatter plots of maximum rate of torque development (MRTD) in ankle (Inversion/Eversion) and hip (Abduction/Adduction) movement in frontal plane. HO denotes healthy old with Michigan Diabetic Neuropathy Score (MDNS) = 0, mPN denotes mild Peripheral Neuropathy with $0 < \text{MDNS} < 10$, and PN denotes peripheral neuropathy with $\text{MDNS} \geq 10$. P-values in brackets were calculated using rm-ANOVA.

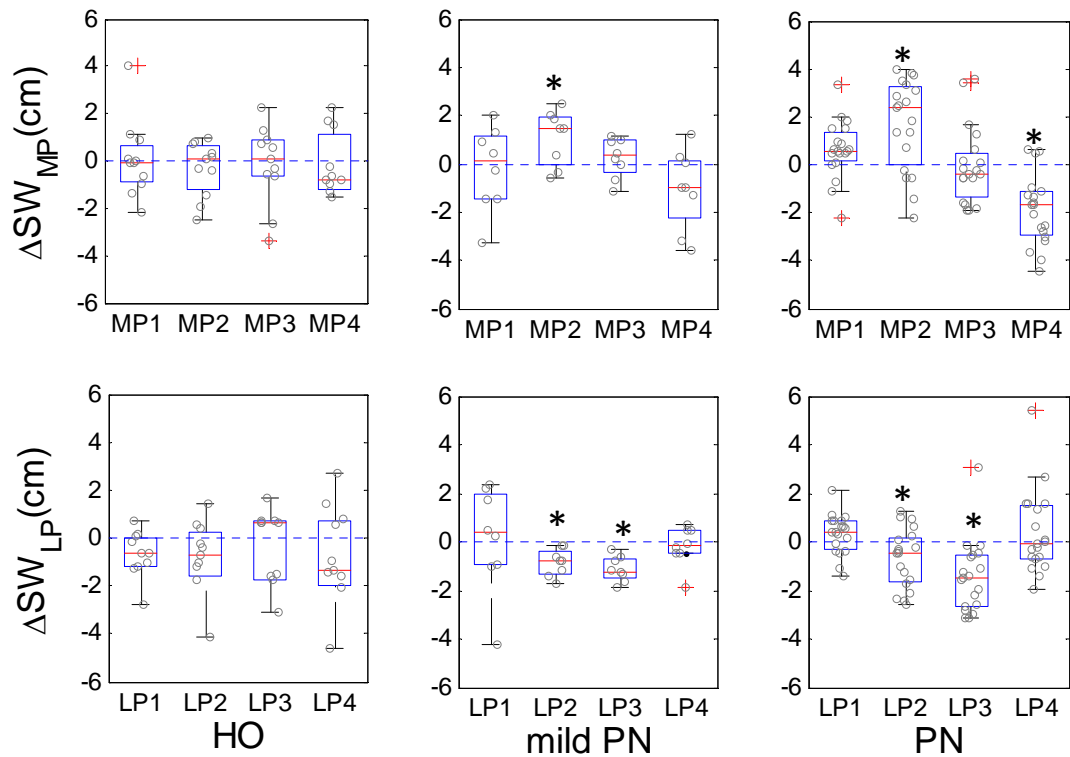

Figure 8-2 Boxplots with scatter plots of recovery Δ step kinematics

($\Delta X = \bar{X}_{1st\ recovery\ step} - \bar{X}_{unperturbed\ step}$) following a single underfoot medial perturbation (MP) or lateral perturbation (LP) in three groups (HO (MDNS =0), mild PN ($0 < MDNS < 10$), PN ($MDNS \geq 10$)). * denotes significantly different recovery step width compared to unperturbed step width using rm-ANOVA ($\alpha < 0.03$). MP_n or LP_n denotes n^{th} recovery step following a MP or LP.

Recovery Step Widths

Figure 8-2 shows recovery step width changes following either medial (first row) or lateral (second row) underfoot perturbation. There were no significant changes in HO up to fourth recovery step widths. The recovery step widths in PN groups were altered in wider second (mild PN and PN) and narrower fourth step width (PN) for MP and narrower second and third step widths (mild PN and PN) for LP.

Peroneal Responses

The peroneal responses in rms EMG amplitude and raw EMG onset were different on the first MP recovery step in three groups with respect to severity of PN (Figure 8-3). HO and subjects with mild PN had significantly larger rms EMG amplitudes during the perturbed step than unperturbed step (mean (sd): HO: 0.15 (0.12), mPN: 0.20 (0.13); PN: 0.05 (0.09)). HO had significantly earlier raw EMG onset than unperturbed muscle (mean (sd): HO: -46.3 (44.9) ms; mPN: -18.1 (38.2) ms, PN: -21.5 (45.9) ms). In PN, there were no significant changes in peroneal EMG amplitude and activation onset during the first and second recovery steps, compared to unperturbed step. In the second recovery step, the peroneal EMG activities were not significantly changed for any of the three subject groups.

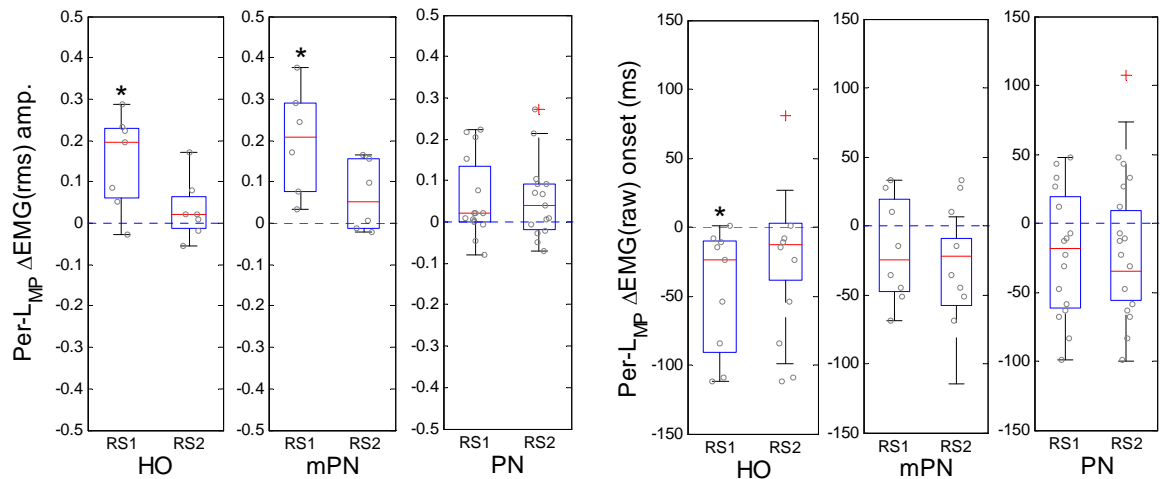

Figure 8-3. Boxplots and scatter plots of ΔEMG ($\Delta X = \bar{X}_{1st\ recovery\ step} - \bar{X}_{unperturbed\ step}$) (rms) amplitude (left three columns) and ΔEMG (rms) onset (right three columns) in ankle muscle groups (Per-L: Peroneus Longus, m-SOL: medial soleus) in the first medially-perturbed (MP_1) recovery step in three groups (HO (MDNS =0), mild PN ($0 < MDNS < 10$), PN (MDNS ≥ 10)). * denotes the significant difference from unperturbed (UnP) outputs. Bracket denotes the significant difference between groups (HO vs PN) using rm-ANOVA ($\alpha < 0.03$).

Generalized Linear Model

Using a generalized linear regression model, the first and second step widths (SW and Δ SW) were predicted from physical capacities such as hip abduction/adduction MVC and MRTD, ankle inversion/eversion MVC and MRTD, and ankle proprioception thresholds. Hip abduction and ankle inversion MVCs estimated the change in the second medially perturbed step width (Hip Abduction MVC beta:-60.8 (p=0.039), Ankle inversion MVC: beta:-200.6 (p=0.025)). Ankle inversion MRTD is the most important predictor of the first medially perturbed step width (R= -0.354 (p=0.002)) and there was a significant peripheral neuropathy effect on normalized ankle inversion MRTD (HO vs mPN: p=0.002, HO vs PN: p=0.001) as shown in Figure 8-4.

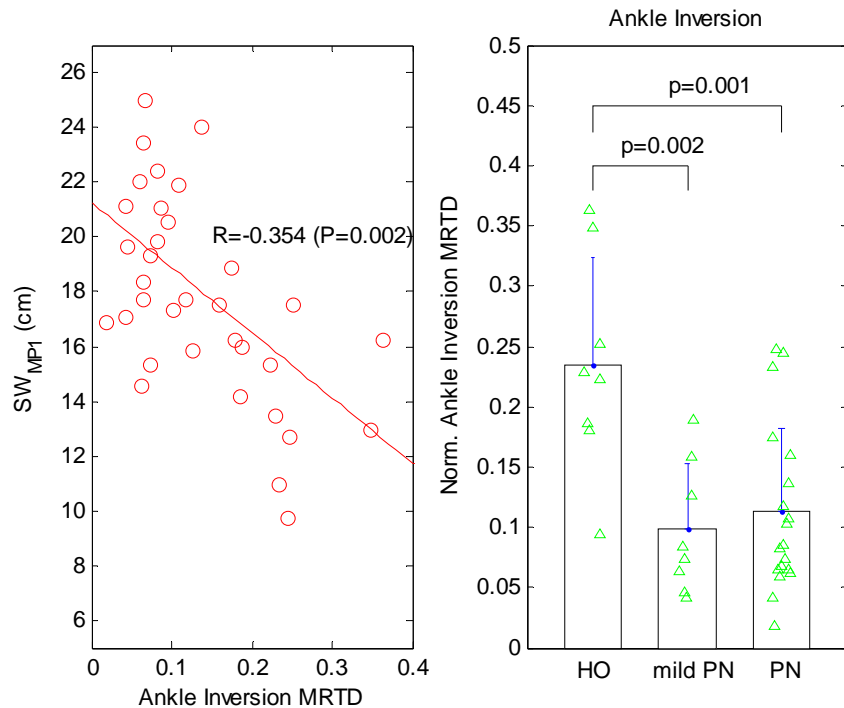

Figure 8-4 Scatter plot with regression line (left) calculated with Pearson correlation coefficients. Ankle inversion maximum rate of torque development (MRTD) significantly predicted the first medially perturbed (MP₁) step width (SW) (R=-0.354 (p=0.002)). Bar graphs with scatter plots are shown at right for normalized ankle inversion MRTD in

three groups (HO: healthy old (MDNS=0), mPN: mild peripheral neuropathy (MDNS<10), PN: peripheral neuropathy (MDNS \geq 10)).

8.4 Discussion

This study showed that decreased physical capacities in the PN lower limb significantly affected recovery step width responses to an underfoot perturbation. We showed that an absence in peroneal responses to an underfoot perturbation altered the recovery SW pattern in PN groups. PN subjects also had a slower rate of strength development in hip and ankle muscles than HO. So the PN subjects took longer than HO did to generate a given torque to counteract rolling an ankle in response to a medial or lateral underfoot perturbation. These muscle latencies in PN may result in a failure to respond within the available response time following the perturbed stance phase and before the upcoming heel strike. PN had noticeably weak and slow peroneal EMG responses for the medially perturbations of the stance phase.

In addition, using a generalized linear regression model, the ankle inversion maximum rate of torque development was found to be the most important predictor for the first post-MP recovery step width. For the changes in the second recovery step width, compared to an unperturbed step width, maximum hip abduction strength and ankle inversion strength were the two most significant lower limb physical capacity predictors of step width in the subjects with and without peripheral neuropathy.

Ankle muscle strength development is the most important predictor of first recovery SW. Then for changes in the second recovery SW, maximum strength ankle and hip strengths are the two most important predictors among all the lower extremity sensory and motor capacities.

Otten showed that when balancing unipedally on a narrow sagittal fulcrum, the frontal plane moment at the hip is more effective than the contralateral swing limb hip torque or torque about the spine, neck or shoulder in developing the largest horizontal component of the ground-reaction force to direct the recovery moment about the whole body center

of mass (Otten 1999). The findings from our generalized linear model were consistent with Otten’s finding. When PN loses distal sensory and motor capacities in ankle, the most significant capacity turned out to be hip joint muscle strength to maintain frontal plane stability for the second recovery step.

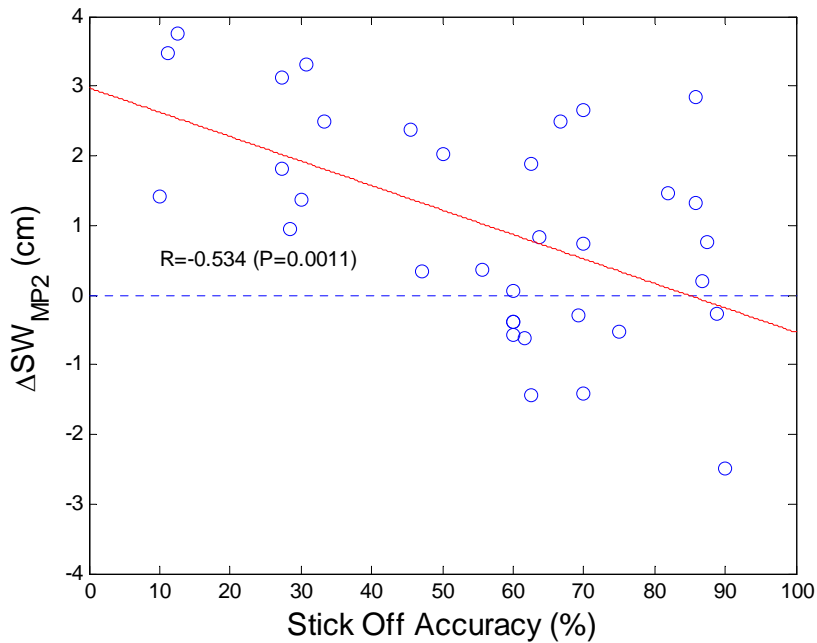

Figure 8-5 Pearson linear correction between the “second” medially perturbed (MP₂) ΔSW (i.e. $\Delta Step = \overline{Step}_{1st\ post\ perturbation} - \overline{Step}_{unperturbed}$ in Step Width (cm)) and the “off” accuracy in the manual recognition reaction time measurement (%).

During gait, the lower limb muscle response to an underfoot perturbation must preferably be executed before the next heel strike (Chapter 5-8). So the ‘available response time’ (ART) arguably is the time from the underfoot perturbation to the next heel strike measuring about half a second (e.g., mean step time of medially perturbed gait (ST_{MP1}), HO: 500.9 (ms), mPN: 518.6 (ms), PN: 518.1 (ms)).

Chen et al (1994) showed that the rate of success (RS) to avoid a gait perturbation decreases as available response time (ART) is decreased. Older adults had a significantly lower rate of success (RS) in avoiding a virtual underfoot obstacle than young adults at

the same ART. Using the same rationale, PN may have lower RS than HO at the same ART since PN takes more time to generate a certain level of torque to an underfoot perturbation than HO, due to slower rate of torque development in lower limb. The slower muscle response latencies to an underfoot perturbation may explain the absence of PN peroneal EMG responses during perturbed steps. The latencies certainly resulted in evidence of frontal plane gait instability in the second recovery step (Figure 8-2 and 8-3).

Similarly, in the manual reaction time test (Chapter 4), the time it takes the apparatus to strike the floor after its release by the examiner is also the ART (about 400 ms in this case). As the ‘off’ accuracy in the manual reaction time test is indicative of inhibitory function (Chapter 4), the ‘off’ accuracy could be a simple indicator of the inhibitory function during gait perturbation task if the gait task involves a cognitive response. Figure 8-5 showed one possible application of the manual reaction time test. There was strong correlation between the second recovery step width change and the ‘off’ accuracy of manual reaction time. Besides, all subjects who had less than 50% ‘off’ accuracy took significantly wider SW in the second recovery step following a medial underfoot perturbation and 91.7% of those subjects had symptoms of PN.

Strengths and Limitations

By presenting precisely controlled underfoot perturbation and collecting synchronized EMG and optoelectric measurements, we successfully presented an underfoot perturbation to all subjects with or without peripheral neuropathy.

To present an identical ART to every subject, it was a weakness that we used self-selected gait speed. However, there was no significant difference in walking speed between subject groups (i.e. HO, mPN, PN), so this may not be a significant limitation. Since delta step kinematics gave the same relative difference between unperturbed and perturbed gait responses in each subject, we successfully described the kinematic changes from perturbed gait for all subjects with and without peripheral neuropathy.

Group sizes were relatively modest, and not large enough to assess gender differences reliably, so this study and its results should be replicated by other investigators before the findings are accepted.

8.5 References

- Amato AA, Dumitru D. Approach to Peripheral Neuropathy. In: DumitruD, AmatoAA, ZwartsMJ, eds. *Electrodiagnostic Medicine*. Philadelphia: Hanley & Belfus, 2002, pp 885–898.
- Barry BK, Carson RG. The consequences of resistance training for movement control in older adults. *J Gerontol A Biol Sci Med Sci* 2004;59(7):730-754.
- Bauby CE, Kuo AD. Active control of lateral balance in human walking. *J Biomech* 2000;33:1433-40.
- Chen HS, Aston-Miller JA, Alexander NB, Schultz AB, Effect of Age and Available Response Time on Ability to Step over an Obstacle. *J Gerontol: Med Sci* 1994;49(5):M227-M233
- Dumitru D., Amato A.A., and Zwarts M., “Nerve Conduction Studies” *Electrodiagnostic Medicine*, 2nd Edition, Philadelphia: Hanley & Belfus 2002, p.889.
- Feldman EL, Stevens MJ, Thomas PK, Bron MB, Canal N, Green DA, A practical two-step quantitative clinical and electrophysiological assessment for the diagnosis and staging of diabetic neuropathy. *Diabetes Care* 1994;17(11):1281-1289
- Gutierrez EM, Helber MD, Dealva D, Asthon-Miller JA, Richardson JK. Mild diabetic neuropathy affects ankle motor function. *Clin Biomech* 2001;16(6):522-528
- Kim H., Ashton-Miller JA, A shoe-based apparatus and method for randomly perturbing the stance phase of gait: test-retest reliability in young adults, *J Biomech*, in-press
- Menz HB, Lord SR, Fitzpatrick RC. Acceleration patterns of the head and pelvis when walking on level and irregular surfaces. *Gait Posture* 2003;18:35-46
- Otten E., “Balancing on a narrow ridge: biomechanics and control,” *Phil. Trans. R. Soc. Lond. B*, 1999;354:869-875.

- Richardson JK, Thies SB, DeMott TK, Ashton-Miller JA., A Comparison of gait characteristics between older women with and without peripheral neuropathy in standard and challenging environments. *J Am Geriat Soc* 2004;52(9);1532-1537
- Smeesters C, Cole N.M., Ashton-Miller JA, Effect of age and gender on maximum hip flexion power. *International Association of Gerontology*. Vancouver, BC Canada; 2001.
- Son J, Ashton-Miller JA, Richardson JK. Frontal plane ankle proprioceptive thresholds and unipedal balance, *Muscle Nerve* 2009;39:150-157

Chapter 9

Effect of a Vocal Choice Reaction Time Task on the Kinematics of the First Recovery Step after a Sudden Underfoot Perturbation during Gait.

[Accepted in *Gait and Posture*, 2012]

9.1 Introduction

Stepping unexpectedly on a discrete raised object can destabilize gait to a significant degree, even in young adults (Thies et al., 2007). Since natural gait surfaces are typically uneven, such occurrences are not uncommon. As such, balance during walking is often challenged and trips, as well as slips, have been implicated in the causation of the majority of falls (Berg et al., 1997).

It is not uncommon to have to divide one's attention during gait (Chen et al., 1996). Several lines of evidence support a connection between attention and gait. Measures of executive function, of which attention is a specific example (Stuss et al., 2002), show a correlation with changes in gait performance. In the InCHIANTI study, the gait speed of participants with poor scores in trail-making, was significantly slower over an obstacle course than that of those with good scores (Ble et al., 2005). Gait derangements have been consistently reported in pathological states characterized by the deterioration of attention. Thus, children suffering from attention-deficit hyperactivity disorder walk with greater stride-to-stride variability and this deficit is alleviated by treatment with attention-enhancing medication (Keitner 2007). In demented older adults, slower gait speed and

shorter step length have been documented, in comparison with age-matched healthy controls (Tanaka et al., 1995).

Perhaps the most common investigative approach to the question of the interplay between attention and gait is the dual-task experimental paradigm in which attentional resources are challenged by requiring the simultaneous performance of an attention-demanding task during gait (Chen et al., 1996). Since attention is a finite resource, interference would be expected to occur between both tasks if gait too utilized attention, the so-called dual-task cost or decrement (Chen et al., 1996; Perry et al., 1999; Tombu et al., 2003). In everyday life, it is common for human beings to engage in multitasking, such as chatting and watching out for traffic while crossing a street with a friend. Indeed, the seminal studies of Lundin-Olson and colleagues showed that talking, for example, does interfere with walking (Lundin-Olsson et al., 1997). In general, the more complex the gait task, the greater the demand on attentional resources (Lajoie et al., 1993; Verhaeghen et al., 2002).

In dual task studies, participants have usually walked on a regular or instrumented walkway while performing such tasks as carrying on a conversation (Lundin-Olsson et al., 1997), responding to auditory or visual stimuli (Sparrow et al., 2002), reciting animal names (Dubost et al., 2006), spelling (Hollman et al., 2007) or counting backwards (Beauchet et al., 2005). To the extent that we are aware, only one method, namely obstacle negotiation, has been used to complicate the gait task in the presence of divided attention (Chen et al., 1996; Schrodts et al., 2004; Siu et al., 2008AB; Harley et al., 2009). However, with the exception of Chen et al. (1996) the obstacles were fixed in position and foreseeable. In the present study, we report a novel method for challenging gait which has the added merit of unpredictability.

The purposes of the investigation were to examine the stepping responses of young adults to an unexpected gait challenge posed by a sudden underfoot perturbation and to better understand the interaction between the performance of such a complex gait task and simultaneous vocal choice reaction. It was hypothesized that the greater attentional demand of controlling gait in a challenging dual-task situation would significantly affect

recovery step kinematics following the underfoot perturbation, as well as the vocal choice reaction during that recovery, compared to the case when attention is not divided.

9.2. Subjects and Methods

Subjects

Thirty-two healthy young subjects (17 males, 15 females; age: 22.1 ± 3.3 years; height: 172.9 ± 7.5 cm; weight: 72.6 ± 17.5 kg; body mass index: 24.1 ± 4.7) were recruited through the University of Michigan Clinical Studies Volunteer Network. They were screened by telephone for neurological or musculoskeletal disorders such as stroke, peripheral neuropathy, head trauma, persistent dizziness, visual impairment not correctible with prescription glasses, diabetes mellitus, flaring osteoarthritis, amputation, spinal surgery, muscle and bone mineral disease. Pregnant female volunteers were also excluded.

Before the walking trials, a written informed consent to participate was obtained and a focused physical examination of the neuromuscular system was performed. Peripheral neurological integrity was clinically evaluated as described by Richardson²¹.

Outstretched upper extremities were assessed for pronator drift. Unipedal stance and Romberg tests were also performed.

For safety during the walking trials, subjects wore a harness attached to a track in the ceiling. In addition, a staff member walked alongside as spotter. Approval to use human subjects was obtained from the University of Michigan Institutional Review Board (HUM 00016379).

Perturbing Shoes

Participants wore specially designed footwear (Fig. 9-1) (Kim 2012). Nike sandals (ACG Rayong) were modified by an orthotist who replaced the sole with a customized sole. Hidden in a recess under the intermetatarsal joints of the forefoot were two retractable aluminum flaps, each 18.4 mm high, centered 20 mm on either side of the foot axis. Each flap was connected via a flexible shaft to a low-voltage DC linear actuator (Firgelli,

Inc., PQ-12) housed in a heel recess. In any particular swing phase, either flap could be remotely triggered to emerge and deploy into a quasi-parasagittal plane during the swing phase of the gait cycle within 400 ms. The trigger mechanism was automated so as to be controlled by a custom-developed C++ program (Visual Studio 2008, Microsoft, Inc., Redmond) which uses Optotrak Application Programming Interface (Northern Digital Inc., Waterloo, Canada).

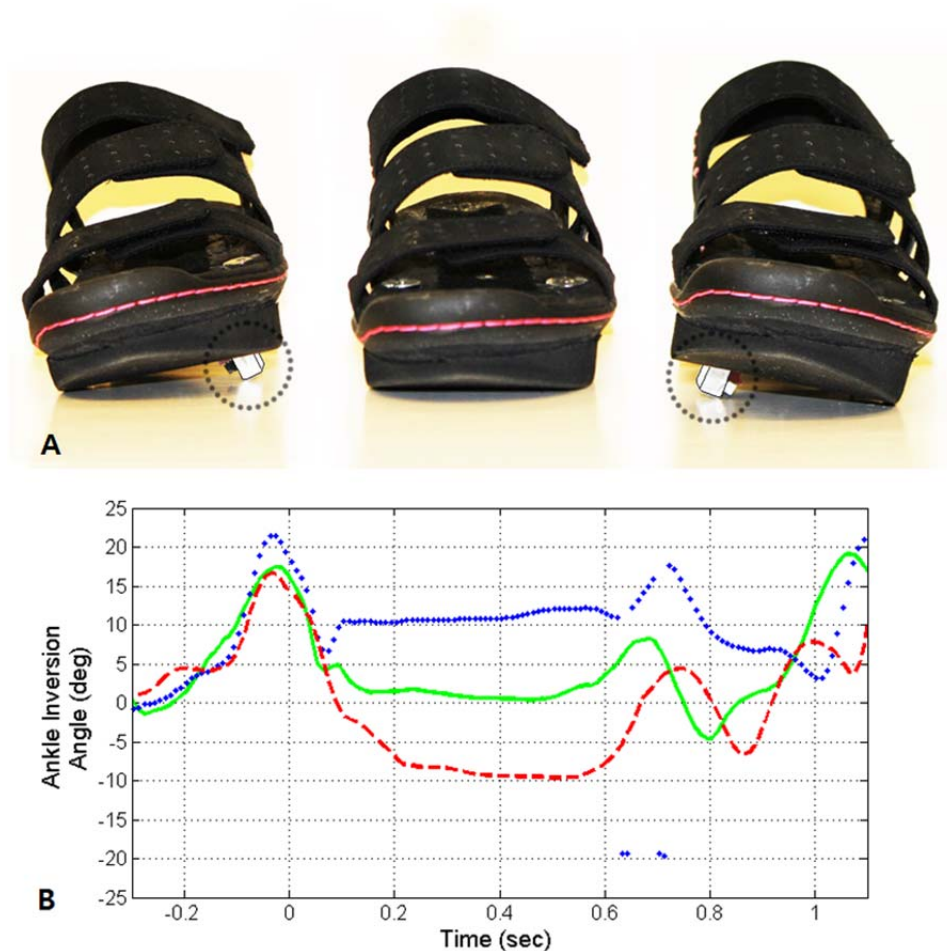

Figure 9-1. Top figure (A) shows the anterior view of the perturbing shoe in three orientations during midstance: left - lateral flap (dotted circle) deployed; middle - no flap deployed; right - medial flap (dotted circle) deployed. Note eversion at left and inversion at right. Lower figure (B) illustrates the change in stance phase ankle inversion angle in a sample unperturbed trial (middle solid line), with medial perturbation (upper dotted line) and with lateral perturbation (lower dashed line). (0 degrees denotes neutral; + denotes inversion; and - denotes eversion).

When the subject stepped on the midfoot during the next stance phase with the flap deployed, the medial or lateral foot sole would be perturbed to a 16-degree inclination in the frontal plane, depending on the flap deployed. The usual center of pressure (CoP) path under the shoe shifts abruptly as a result. A sample tracing of inversion and eversion angles is shown in Fig. 9-1.

The change in CoP trajectory often elicited a response consisting of a change in the length, width or time of the first post-perturbation (recovery) step from the kinematics of unperturbed gait. The flap is fitted with a ground contact sensor and retracts at toe-off, not to be deployed again in the remainder of that gait trial. In a pilot study, the perturbing shoes showed good test-retest reliability (average intraclass correlation coefficient: 0.834) (Kim, 2012).

Experiment

Three tests were administered: gait perturbation, vocal choice reaction, and gait perturbation with vocal choice reaction. The gait perturbation tests (with and without vocal choice reaction) each comprised a total of 30 walking trials along a 6-m level walkway. The subjects were told to ambulate at purposeful speed (“as though you were going to mail a letter”) and that a single perturbation would be presented to one foot or the other during trials randomly selected by a computer. In the event, 12 of the 30 trials were perturbed, three each for right foot-medial (RM), right foot-lateral (RL), left foot-medial (LM) and left foot-lateral (LL), in randomized order. Baseline step parameters were obtained from 4 steps at steady-state gait speed during the unperturbed trails. Data collection was preceded by 30 practice trials, with and without perturbation.

An Optotrak Certus motion analysis system (Northern Digital, Inc.) was used to acquire three-dimensional data at 100 Hz from 28 infrared-emitting diode markers placed at bony landmarks in each foot (5), leg (3), thigh (3); the pelvis (3) and mid-sternum (3). Foot switches on the perturbing shoe detected every heel strike. Two force plates along the walkway measured ground reaction force. Foot switch and force plate data were collected at 2 kHz. In addition, surface electrodes were placed on ankle invertors and

evertors as well as hip abductors and adductors to record the temporal onset and offset of muscle firing sequences relative to the perturbation.

In the vocal choice reaction time test, the participants listened to ten 200 ms-long tones of either high (1,047 Hz) or low (33 Hz) frequency, delivered randomly at 2-second intervals through a headphone fitted with a microphone. Participants were required to respond with a loud "yes" only when they heard a high tone. Additionally, data were obtained from 6 trials of eight subjects (4 female) while standing still and during comfortable gait, to examine the effect of gait on vocal choice reaction time.

In the gait perturbation with vocal choice reaction test, there was also a total of 30 walking trials, 12 of which were perturbed using the same setup described above. The tone was phase-locked to sound 174.9±47.8 ms prior to the heel-strike of the stance phase in which the flap was deployed. The vocal response was recorded and synchronized with the optoelectric marker and force plate measurements.

Data processing and statistical analysis

Data collected at 2 kHz from the foot switches, flap sensor and force plates were low-pass filtered (5th-order Butterworth). A custom MATLAB algorithm (MATLAB® 2011a; The MathWorks, Inc., Natick) was used to post-process all the data and calculate kinematic parameters (step length, and step width and step time, Fig. 2). Sample kinematic tracings, CoP and EMG responses are shown in Fig 9-3.

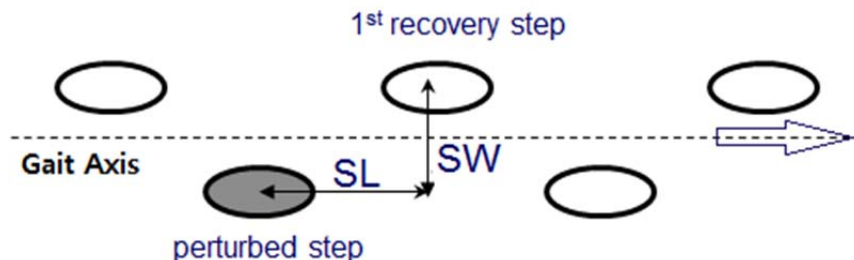

Figure 9-2. Definition of the first recovery step width and length. The first recovery step time was defined as the time between heel strikes of the perturbed and the first recovery step.

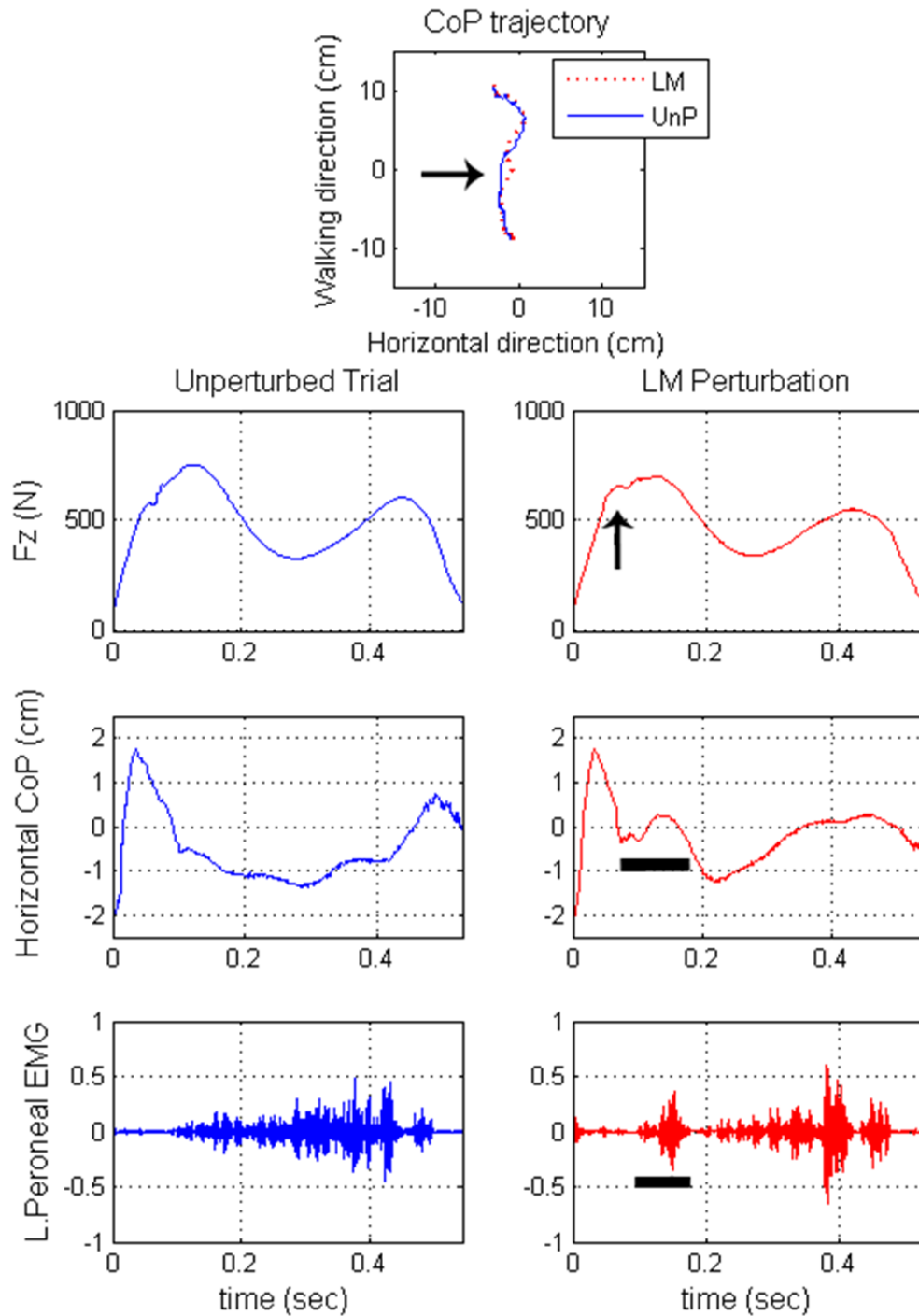

Figure 9-3. A sample trial from the left foot of a single subject. Data from unperturbed trials (left column) are compared with data from a medial perturbation trial (“LM”, right column). The center of pressure (CoP) tracings are shown at top. Also shown from top to bottom are the ground reaction force vs. time plots (second row), CoP tracing in the

horizontal plane (third row), and peroneal muscle responses (fourth row). The arrow denotes the onset of ground contact of the flap, and the bars underline the response to the LM perturbation.

The following outcome variables were used: step length; step time, step width (normalized to mean unperturbed step width) and vocal choice reaction time. A one-way repeated measures analysis of variance (rm-ANOVA) was used to estimate the effect of the three gait conditions (one independent variable with three levels: unperturbed, perturbed, perturbed gait with auditory distraction) on the width, length and time of the first recovery step as well as vocal choice reaction time (dependent variables) during that step. Statistical significance was set at $\alpha = 0.05$.

9.3 Results

The differences between step parameters during unperturbed gait (UnP) on one hand, and first recovery step kinematics after perturbation with (vMP, vLP) or without (MP, LP) auditory distraction on the other, are shown as box- and scatter- plots in Fig. 9-4.

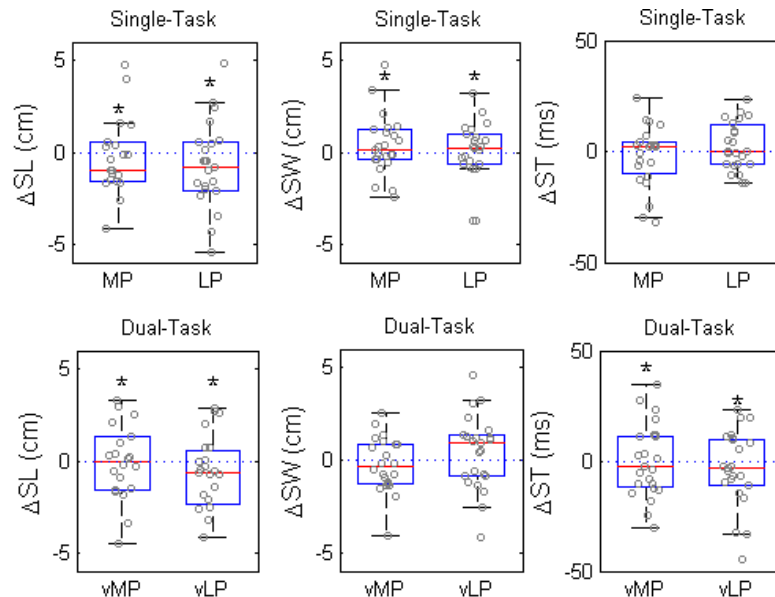

Figure 9-4. Summary box- and scatter-plots of the change in recovery step kinematics (ΔSL , ΔSW , ΔST) from the unperturbed step values for single task and dual task tests. *

denotes significantly different step kinematics compared to unperturbed steps at $\alpha = 0.05$ level.

In testing the primary hypothesis, the rm-ANOVA showed no significant change in the recovery step length, width or time following a perturbation during dual-tasking (vMP, vLP) compared to the single-task gait condition when gait was perturbed in the absence of a vocal reaction time task (MP, LP). Similarly, there was no effect of attention division on vocal choice reaction time ($p > 0.05$) during recovery stepping.

A significant decrement in first recovery step length occurred under both single-task (MP, LP) and dual-task (vMP, vLP) conditions. Compared to step width during unperturbed gait, the first recovery step width increased with perturbation (UnP vs MP; UnP vs LP); however, the change with dual-tasking (UnP vs vMP; UnP vs vLP) was not significant. The change in first recovery step time was significant only with dual-tasking, but the direction of the effect was not consistent, increasing in vMP and decreasing in vLP. Significant interactions were found between gait condition and first recovery step kinematics (Table 9-1, Fig. 9-4).

Table 9-1 Kinematics of the first recovery step after medial and lateral perturbation without (MP and LP respectively) and with vocal choice reaction task (vMP and vLP respectively). UnP: step kinematics during unperturbed gait.

	UnP	MP	vMP	LP	vLP
	Mean (SD)	Mean (SD)	Mean (SD)	Mean (SD)	Mean (SD)
SW (cm)	15.1 (2.3)	*15.5 (2.4)	14.8 (2.4)	*15.2 (2.6)	15.5 (2.2)
SL (cm)	71.2 (3.1)	*70.5 (3.2)	*71.1 (3.3)	*70.2 (3.4)	*70.0 (2.6)
ST (ms)	578.6 (26.4)	576.3 (26.1)	*578.7 (21.8)	580.8 (25.8)	*575.2 (22.8)

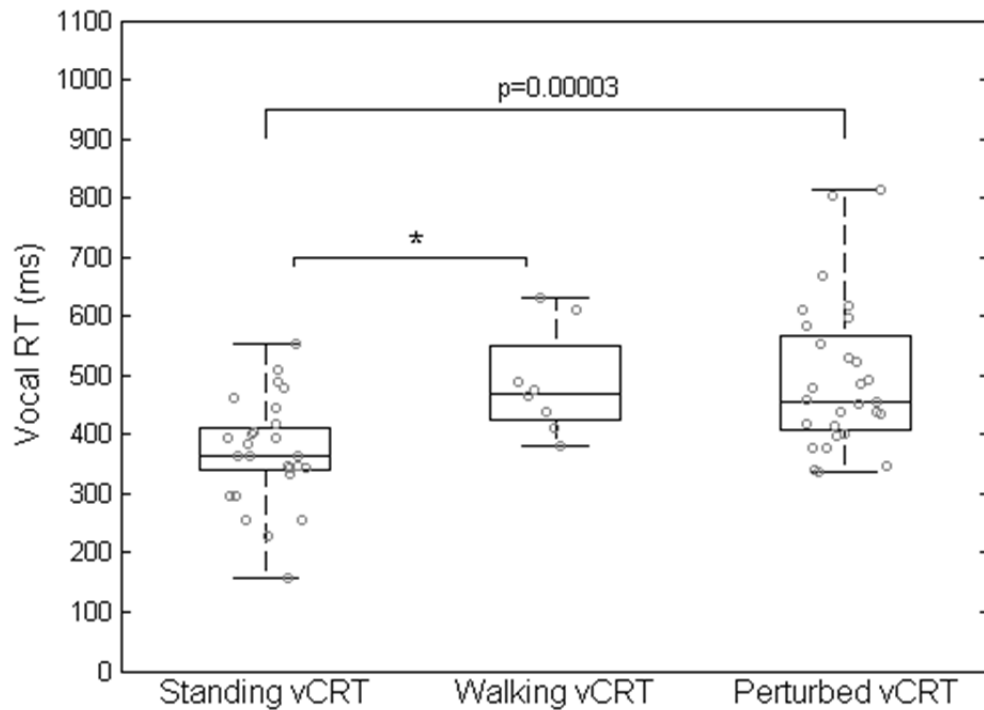

Figure 9-5. Effect of posture and gait (unperturbed and perturbed) on median, upper and lower quartiles, and 95th percentile vocal choice reaction time (vCRT) in healthy young subjects. “*” denotes significantly prolonged vCRT ($P < 0.005$, rm-ANOVA).

Significant interaction was also obtained between gait condition and vocal choice reaction time. While standing still, mean (SD) vocal choice reaction time was 368.9 ± 87.0 ms. It increased significantly to 487.4 ± 89.4 ms and 494.7 ± 125.3 ms, respectively, during unperturbed and perturbed comfortable gait (Fig. 9-5).

Vocal response accuracy was excellent in these healthy young adults: out of a total of 1,184 vocal choice reaction trials, subjects were incorrect in only four trials, yielding an error rate of 0.34%. In three trials, no response was given to the high tone and, in one trial, an incorrect response was given.

9.4 Discussion

This is the first study to examine the interaction between a vocal reaction time task and execution of the response to a sudden yet familiar, underfoot perturbation of gait. The perturbation has the element of surprise in regard to if, when (which step) and where (under which foot, and medial vs. lateral aspect of that foot) it occurs. It is felt but never seen. In the absence of the vocal reaction time task, the spatial kinematics of the first recovery step following the perturbation were significantly different from those of unperturbed gait, there being an increase in step width and a decrease in step length. But the primary hypothesis was not supported because there was no significant effect of divided attention on first recovery step kinematics following the perturbation. This suggests that the recovery step kinematics, being different from normal gait, were a natural response to the perturbation, and that these were not altered by this dividing attention task. The lack of an interaction with vocal reaction time suggests that the gait perturbation task was apparently not demanding enough in these healthy young adults to affect the stimulus-response relationship in the separate sensorimotor system controlling the vocal response to an auditory stimulus.

The typical outdoor walking surface is uneven, so during gait, the foot can be expected to land on raised projections of the surface, as well as loose bodies such as a pebble on a rigid surface. Such an event can cause a sudden rotational acceleration of the foot and ankle, thereby destabilizing gait. Our shoe replicates this scenario in a controlled and reproducible way, with the extended flap representing a raised object 18.4 mm high. Its remotely controlled deployment and retraction ensure surprise while its location on either side of the foot axis simulates an inversional or eversional perturbation.

Other investigators have found an interaction of gait with the competing secondary non-gait task (Gage et al., 2003; Yogev-Seligmann et al., 2008). However, regarding the effect of the non-gait task on gait performance, comparison of our findings with those of other studies are vitiated somewhat by methodological differences. Our experiment is perhaps the only one that has focused on the properties of the first recovery step as a marker for the postural response to a familiar but unexpected gait challenge. For the gait task, most

studies have reported on unperturbed gait and measured such parameters as gait velocity, stride length and time, rather than step properties (Hollman et al., 2007; Beauchet et al., 2005). Commenting on such studies, Yogev-Seligmann and colleagues remarked that in general, healthy young adults slowed down during gait when performing a concurrent cognitive task (2008). Nevertheless, there are investigations that have shown that healthy young adults maintain their stride pattern during dual-tasking (Gage et al., 2003; Regnaud et al., 2006). The experimental design of Siu et al. (2008B) incorporates obstacle negotiation as a gait challenge and is therefore more comparable to ours. They found that healthy young adults stepping over a bar 10% their height while performing an auditory Stroop task, increased their step width and stride length. In our study subjects could not see the perturbation in advance, and auditory distraction had no significant additional effect on the first recovery step response to the sudden underfoot perturbation.

The properties of the first recovery step after unexpected base-of-support destabilization has implications for the potential loss of balance and fall. In the earlier investigation which inspired the design of our special perturbing footwear, the swing limb trajectory actually crossed the gait axis while taking the first recovery step in 12% of trials (Thies et al., 2007). Such cross-over stepping obviously increases the chances of limb entanglement which could result in a fall.

The increase in width of the first recovery step in response to a postural challenge is clearly adaptive. Since the plane of instability during gait is the frontal plane, mediolateral adjustments in foot placement are a means of achieving stabilization (Donelan et al., 2004). The reduction in step length is probably driven by the rapid unloading of the perturbed stance limb to minimize the risk of an ankle inversion sprain (Santos and Liu, 2007). Unlike the spatial kinematics, the change in recovery step time was significant only with dual-tasking, decreasing with distracted, medially perturbed gait but increasing with its distracted, laterally perturbed counterpart. While the decrease in recovery step time is consistent with a rapid unloading of the inverted stance foot, it is not yet clear why the lateral perturbation would lengthen recovery step time.

Our experimental design introduces two innovations to the dual-task paradigm for studying gait under conditions of divided attention, namely a means to reliably administer a discrete base-of-support perturbation precisely and unexpectedly, and the analysis of the recovery step. The study by Thies and colleagues showed that stepping on a protuberance 1.2 cm-high provoked a recovery step with altered kinematics (2007). However, the location of the underfoot perturbation in that experiment could not be accurately controlled and subjects had to carry a tray to partially obscure the location of the underfoot perturbation. With our perturbing footwear, the flap plays the role of a protuberance when lowered and its remotely controlled random deployment ensures an element of surprise and unpredictability. With the exception of step time, the effects of medial and lateral perturbation were indistinguishable. In all the perturbed gait trials, electromyographic data confirmed the absence of anticipatory muscle activation.

All the dual task studies on young adults but ours have consistently shown a non-gait task performance deficit. This decrement has been explained on the basis of a shifting of attentional resources away from the non-gait task in order to optimize the response to the gait challenge. This apparent unconscious prioritization of the exigencies of balance control over the execution of activities unrelated to gait or balance, is in conformity with the "posture-first" strategy identified with healthy young adults (Bloem et al., 2006). The adaptive benefit of such a strategy is obvious: it prevents the individual from falling, which is a hazardous event. Minimizing danger is a core motivation and the significance of a stimulus is defined by its relevance to that purpose (Williams et al., 2006). Significance processing forms the basis of prioritization. On this principle, dealing with a threat to balance, such as a sudden unexpected underfoot perturbation during gait, would understandably be accorded preference over the other competing demands on finite attentional resources. While our results clearly show altered step kinematics in response to the perturbation, this response was not further altered by adding the auditory reaction time task. This is consistent with control of posture continuing to be important even when attention was divided. The absence of a non-gait task performance deficit in our data suggests that the perturbation was both familiar and brief enough so as not to slow the vocal response to an auditory stimulus in these young adults.

Study limitations include the modest sample size. We did not control for gait speed because we wanted to retain ecological validity by asking each subject to walk ‘purposefully’. This was not a limitation because when subjects were divided into those walking at 1.39 m/s or above, and those walking at 1.28 m/s or below, no significant effect of speed was found on any of the recovery step kinematic responses.

9.5 References

- Beauchet O, Duost V, Herrmann FR, Kressig RW. Stride-to-stride variability while backward counting among healthy young adults. *J Neuroeng Rehabil* 2005; 2:26.
- Berg WP, Alessio HM, Mills EM, Tong C. Circumstances and consequences of falls in independent community-dwelling older adults. *Age Ageing* 1997; 26(4): 261-268.
- Ble A, Volpato S, Zuliani G, Guralnik JM, Bandinelli S, Lauretani F, Bartali B, Maraldi C, Fellin R, Ferrucci L. Executive function correlates with walking speed in older persons: the InCHIANTI study. *J Am Geriatr Soc.* 2005 Mar;53(3):410-415.
- Bloem BR, Grimbergen YA, van Dijk JG, Munneke M. The "posture second" strategy: a review of wrong priorities in Parkinson's disease. *J Neurol Sci* 2006;248(1-2): 196-204.
- Chen H-C, Schultz AB, Ashton-Miller JA, Giordani BJ, Alexander NB, Guire KE. Stepping over obstacles: dividing attention impairs performance of old more than young adults, *J Gerontol: Med Sci* 1996;51(3):M116-122.
- Donelan JM, Shipman DW, Kram R, Kuo AD. Mechanical and metabolic requirements for active lateral stabilization in human walking. *J Biomech* 2004;37(6): 827-835.
- Dubost V, Kressig RW, Gonthier R, Herrmann FR, Aminian K, Najafi B, Beauchet O. Relationships between dual-task related changes in stride velocity and stride time variability in healthy older adults. *Hum Mov Sci* 2006; 25(3): 372-382.
- Gage WH, Sleik RJ, Polych MA, McKenzie NC, Brown LA. The allocation of attention during locomotion is altered by anxiety. *Exp Brain Res* 2003; 150(3): 385-394.
- Harley C, Wilkie RM, Wann JP. Stepping over obstacles: attention demands and aging. *Gait Posture.* 2009 Apr;29(3):428-432.

- Hollman JH, Kovash FM, Kubik JJ, Linbo RA. Age-related differences in spatiotemporal markers of gait stability during dual task walking. *Gait Posture* 2007; 26(1): 113-119.
- Kim H and Ashton-Miller JA. A shoe sole-based apparatus and method for randomly perturbing the stance phase of gait: Test-retest reliability in young adults. (Submitted for publication to the *J. Biomechanics*).
- Lajoie Y, Teasdale N, Bard C, Fleury M. Attentional demands for static and dynamic equilibrium. *Exp Brain Res* 1993; 97(1): 139-144.
- Leitner Y, Barak R, Giladi N, Peretz C, Eshel R, Gruendlinger L, Hausdorff JM. Gait in attention deficit hyperactivity disorder : effects of methylphenidate and dual tasking. *J Neurol.* 2007 Oct;254(10):1330-1338.
- Lundin-Olsson L, Nyberg L, Gustafson Y. "Stops walking while walking" as a predictor of falls in elderly people. *Lancet* 1997; 349(9052): 617.
- Perry RJ, Hodges JR. Attention and executive deficits in Alzheimer's disease. A critical review. *Brain* 1999; 122 (Pt 3): 383-404.
- Regnaux JP, Roberston J, Smail DB, Daniel O, Bussel B. Human treadmill walking needs attention. *J Neuroeng Rehabil.* 2006 Aug 21;3:19.
- Richardson JK. The clinical identification of peripheral neuropathy among older persons. *Arch Phys Med Rehabil* 2002; 83(11): 1553-1558.
- Santos MJ, Liu W. Unloading reaction to electrical stimulation at neutral and supinated ankle positions. *Gait Posture* 2007; 26:106-112.
- Schrodt LA, Mercer VS, Giuliani CA, Hartman M. Characteristics of stepping over an obstacle in community dwelling older adults under dual-task conditions. *Gait Posture.* 2004 Jun;19(3):279-287.
- Siu KC, Chou LS, Mayr U, Donkelaar P, Woollacott MH. Does inability to allocate attention contribute to balance constraints during gait in older adults? *J Gerontol A Biol Sci Med Sci* 2008A; 63(12): 1364-1369.

- Siu KC, Lugade V, Chou LS, van Donkelaar P, Woollacott MH. Dual-task interference during obstacle clearance in healthy and balance-impaired older adults. *Aging Clin Exp Res* 2008B; 20(4): 349-354.
- Sparrow WA, Bradshaw EJ, Lamoureux E, Tirosh O. Ageing effects on the attention demands of walking. *Hum Mov Sci.* 2002 Dec;21(5-6):961-972.
- Stuss DT, Levine B. Adult clinical neuropsychology: lessons from studies of the frontal lobes. *Ann Rev Psychol.* 2002;53:401-433.
- Tanaka A, Okuzumi H, Kobayashi I, Murai N, Meguro K, Nakamura T. Gait disturbance of patients with vascular and Alzheimer-type dementias. *Percept Mot Skills.* 1995 Jun;80(3 Pt 1):735-738.
- Thies SB, Ashton-Miller JA, Richardson JK. What causes a crossover step when walking on uneven ground? A study in healthy young women. *Gait Posture* 2007;26(1): 156-160.
- Tombu M, Jolicoeur P. A central capacity sharing model of dual-task performance. *J Exp Psychol Hum Percept Perform.* 2003 Feb;29(1):3-18.
- Verhaeghen P, Cerella J. Aging, executive control, and attention: a review of meta-analyses. *Neurosci Biobehav Rev* 2002; 26(7): 849-857.
- Williams LM. An integrative neuroscience model of "significance" processing. *J Integr Neurosci.* 2006 Mar;5(1):1-47.
- Yogev-Seligmann G, Hausdorff JM, Giladi N. The role of executive function and attention in gait. *Mov Disord.* 2008 Feb 15;23(3):329-342.

Chapter 10

General Discussion

On the Introduction of the Perturbing Shoe Method

One of the novel contributions of this dissertation is the invention, design, development and testing of the perturbing shoe as a method for challenging gait stability on a level surface with a single unexpected underfoot perturbation (Chapter 5). The method proved reliable and repeatable on the first recovery step kinematics following an underfoot perturbation in healthy young adults (Chapters 5 and 6). We then successfully used this method to measure the effects of age and peripheral neuropathy on the sensory and motor latencies of the response to the single underfoot perturbation and the kinematic responses used in the recovery steps (Chapters 6, 7 and 8). The apparatus and method proved safe because no adverse events occurred during testing, even to the vulnerable subjects with a known higher risk of a fall (i.e., the elderly with peripheral neuropathy). To ensure that subjects would not hurt themselves we instituted two safety measures: a thin natural rubber mat on the ground to prevent the possibility of slipping between the perturbing shoe metal ‘flipper’ and tile flooring upon deployment, and the use of a full body safety harness to prevent a subject from hurting themselves should they inadvertently slip or trip. The laboratory found over 20 years ago that without the ceiling harness spotters are unable to react fast enough to save the subject, unless the spotter is actually walking behind the subject and holding onto a gait belt in the manner of a physical therapist. But having the spotter hold onto a gait belt also affects the gait of the test subject. So we felt

the use of the ceiling safety harness was the better option for getting better quality data while providing a level of support that prevents the hands and knees from ever touching the ground in a fall.

The analysis of serial underfoot perturbations on uneven surface presents useful information on gait stability (Thies et al., 2005; Menz et al., 2003; Richardson et al., 2004, 2008). However, the present studies (Chapters 5, 6, 7, 8 and 9) clearly demonstrate that a single underfoot perturbation can affect the first recovery step, as we had expected, but also carried over to as many as three more recovery steps, which we had not expected in the young. Furthermore, it was sometimes observed that the carryover effect affected only the second and fourth recovery step, for example, clearly demonstrating asymmetry in the carryover effect. This is a novel finding. These results on carryover effects mean that it is not possible to associate a kinematic response during human gait with any individual perturbation on an irregular surface, because of the carryover effect. By eliminating multiple perturbations, the perturbing shoe method allows one to analyze and disease effects on the recovery steps.

The perturbing shoe method has potential in applications such as: 1) evaluating the efficacy of a clinical intervention or the progress in post-surgery rehabilitation (e.g., cane or orthoses, knee or hip replacement), 2) presenting different underfoot locations on any number of successive steps (e.g., direct comparison with uneven surface), and 3) studying the mutual effects of combined stimuli on gait stability.

From a training perspective, the perturbing shoe also offers the possibility of varying what would otherwise be highly stereotyped foot and ankle loadings when walking on flat hard surfaces such as concrete or asphalt roads. This might be useful for varying the training of competitive distance walkers or runners in urban environments.

A new test was developed for studying the effect of dividing attention on the ability to successfully respond to an unexpected underfoot perturbation (Chapter 9). This shows potential for studying the effect of physical and cognitive impairments on the ability to recover from unexpected underfoot perturbations.

On the Changes in Recovery Step Kinematics

A new method was introduced for analyzing time-critical response to an underfoot perturbation (Delta Parameters, Chapters 6, 7, 8 and 9).

$$\Delta X = \overline{X}_{recovery\ step} - \overline{X}_{unperturbed\ step}$$

Effects of underfoot perturbation on kinematics, ground reaction forces and EMG activities were effectively described perturbed changes using delta parameters (ΔSW , ΔSL , ΔST , ΔLPD , $\Delta\theta_{torso}$, $\Delta\theta_{pelvis}$, ΔEMG , ΔF).

Δ Step Kinematics are effective gait parameter to analyze the post-perturbation effect of an underfoot perturbation. ΔSW and its pattern in recovery steps successfully showed a significant difference between groups (HY: 1st recovery step wider, HO: no changes, PN: 2nd recovery step wider) in the response to a given underfoot perturbation (Chapters 6, 7 and 8). This suggests that each group may have different motor strategy (i.e., ankle vs hip) given the limited resources afforded by the lower limb physical capacities. ΔLPD was found to be a useful body kinematics parameter to identify significant age and PN effects during the first MP recovery step (Chapter 7 and 8). As Saunders (1953) suggested, weak hip muscle strength increases LPD during the medially perturbed stance phase. A larger ΔLPD may suggest hip strategy (primarily using hip torque to recover from gait perturbation) to respond to an underfoot perturbation (e.g., the elderly or PN group).

The peroneal ΔEMG activity presented important information to evaluate gait stability in frontal plane (Chapters 7 and 8). For example, in PN, there were no peroneal activity changes in rms EMG magnitude and raw EMG onset. It makes sense then that there were no SW changes in the corresponding 1st recovery step.

On the Significance of the Feedback Loop Delay

As the elderly with PN lose distal sensory and motor capacities, the peroneal muscle ΔEMG activity was found to diminish during frontal balancing activities (Chapter 8). An effective ankle torque was generated against an underfoot perturbation by controlling

onset and magnitude of peroneal muscle Δ EMG activity (Chapter 8). An absence of peroneal responses during perturbed stance phase in PN resulted in significant SW alterations in the second and later recovery step kinematics, both for medial and lateral perturbations (Chapter 8).

We ran a simulation of the ankle response strategy using a triple inverted pendulum model (Prince-Dormond 8th order ordinary differential equation solver, Matlab Inc.). We assumed an initial ankle perturbation of 16 degree inversion, and using the author's stature and estimated segmental mass distribution, we found that the available response time (ART) significantly decreases as the duration and magnitude of the available ankle torque decreases. A greater feedback loop delay in the ankle sensorimotor pathway precludes the earlier onset of ankle muscle (i.e., peroneus longus) and there is no time difference (duration) between ankle agonist and antagonistic muscle onsets. So we attribute the lack of peroneal Δ EMG activity in the elderly with PN during medially perturbed stance phase (Chapter 8) as evidence of the PN having lengthened the feedback loop delay and decreased the loop gain to the point that no response is possible.

This ankle feedback loop dysfunction in the elderly with PN means that they are forced to adopt a hip response strategy as the only way to combat the underfoot perturbation.

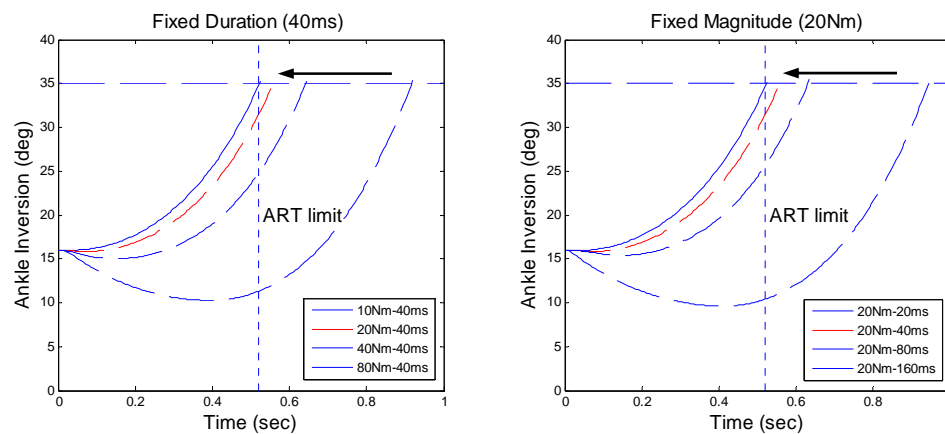

Figure 10-3. Simulation results for changes in resulting ankle inversion angle for (at left) different duration (ms) ankle and (at right) different magnitude (Nm) eversion torque responses (see different curve types within text boxes) to reach maximum range of motion

(35 degrees) of ankle inversion (vertical dashed line (:). The available response time (ART) is limited by the time from sensing the underfoot perturbation to the time of the following heel strike, horizontal dashed line (---) denotes ankle inversion upper threshold: 35 deg). ← denotes the direction of ART decrease with smaller duration and magnitude.

On the Importance of Frontal Plane Hip Muscle Strength Capacities

The four ankle and hip muscle physical capacity measures (Ankle Inversion/Eversion and Hip Abduction/Adduction maximum strength and rate of torque development) turned out to be valuable parameters for evaluating the effect of distal sensory and motor loss on frontal plane balance activities. For example, unipedal stance time and gait speed on uneven surface were both successfully predicted by lower limb physical capacities in subjects with and without peripheral neuropathy (Chapters 2 and 3).

Among the lower limb physical capacity measures, hip muscle strength was the single most important predictor for unipedal stance time (Chapter 2), a main contributor for gait speed and step efficiency on irregular surface (Chapter 3), and one of the two significant predictors for the delta step width of the second recovery step in the medially perturbed trials (Chapter 8).

In order to better compare the relative efficacies of a hip response and an ankle response strategy, we assembled that data in Table 10-1 for three subjects. For the ankle response it shows the measured peak maximum (mediolateral) horizontal component of foot ground reaction force in frontal plane during maximum ankle joint torque generation. For the hip response it shows the maximum theoretical mediolateral horizontal component of the foot-ground reaction force calculated by dividing the measured peak hip ab- and adduction strengths by the individual's leg length. The results show that the maximum ground reaction shear force developed by the hip muscles is, on average, 3.5 times larger than corresponding shear force developed by during the maximum ankle rate of torque development test (Table 10-1). This means the hip response strategy is nearly four times more effective than the ankle response strategy for both maintaining unipedal balance and recovering from an unexpected under foot perturbation. This is because that shear force inclines the vertical ground reaction so that it can act to cause a moment to act

about the whole body center of mass so as to restore balance. Developing a hip moment will also cause a LPD to occur, so this may explain why PN subjects tend to exhibit a LPD strategy in Chapter 7.

Table 10-1. Comparison between the mediolateral ground reaction shear force developed by maximum ankle and hip muscle strengths. (Ankle: data are measured values during maximum rate of inversion/eversion torque development tests; Hip: direct calculation found by dividing measured maximum hip abduction/adduction strengths by leg length)

Subject	Gender	BW (kg)	BW (N)	Max. Ankle on shear force (N)		Hip Strength (Nm)		Leg length (m)	Max. Hip on shear force (N)	
				Inv	Ev.	ABD	ADD		ABD	ADD
PN	M	127	1246	40	30	117	100	0.71	165	141
HO	F	64	628	39	25	73	63	0.58	125	109
PN	M	70	687	22	29	48	48	0.82	59	59

Therefore, maintaining hip strength is particularly important for the elderly to maintain frontal plane stability during unipedal stance and gait, especially those with distal sensory and motor loss.

On the Responses of Healthy Young Adults

This study showed for the first time that young adults take up to four recovery steps from an underfoot perturbation (Chapter 6). Especially, step lengths were significantly shortened in the first, third and fourth recovery steps. This is a surprising result given that the perturbation was only a 10 degree underfoot inclination. But the immediate EMG responses seem to be evidence that healthy young adults were attempting to counter the perturbation distally, at its source, through the use of an ankle response strategy, whereas healthy older adults were more variable in whether they used an ankle or hip response, so their responses were less clear.

On the Development of a New Device for Measuring Manual Reaction Times

The reaction time measurement apparatus was invented to test manual simple and go/no-go reaction times (Chapter 4), and “ON” and “OFF” accuracies in recognition reaction time tasks. Because the task is attentionally engaging, this device and method lends itself for testing eye-hand reaction times using less than a tenth of the trials required by computer-based methods. It therefore provides a useful capacity measure to characterize neuromuscular performance and frontal lobe function in healthy individuals of different ages, as well as patients of various types. For example, it could be used to quantify changes in reaction time in post-concussion patients, and those with sleep disorders. It might even make a practical screening test for elderly drivers at Secretary of State’s offices.

Strengths and Weaknesses of the Perturbing Shoe Approach

Strengths of the general approach used in this thesis include the ability to challenge the robustness of gait with a discrete unexpected underfoot perturbation whose location can be varied under one foot, or between feet, as desired. When these trials are embedded in sufficient dummy trials, it makes it difficult or impossible for a subject to guess when or where a perturbation will occur during a gait trial. Obviously, the more dummy trials are prescribed, the more difficult it is to guess. Our use of 16 perturbation trials embedded in 60 gait trials was a tradeoff between having enough trials for each of the four types of perturbations (i.e., medial, lateral, left foot, right foot) to be able to average responses across, while still retaining the element of surprise. We could have used a single underfoot perturbation trial among the 60 trials in order to retain the element of complete surprise. But we chose not to because outdoor surfaces typically involve more than one random perturbations, so they are a familiar form of perturbation during locomotion. Indeed, a strength of the approach is the very familiarity of the perturbation, meaning that the responses are overlearned and few practice effects were observed.

A limitation was that we only used one height of flipper for each of the perturbing shoes, which ranged from size 8 in women to size 13 in men. With male subjects ranging from

164 to 188 cm in height, and female subjects ranging from 150 to 186 cm in height, this seems reasonable. But it does mean that the perturbation might have tended to be systematically larger for individuals with smaller feet. The trend is for those with larger feet to be heavier, so the maximum shoe sole inclination induced by the fixed-height flipper would be less due to bending of the sole under body weight (i.e., an unloaded shoe sole inclination of 16 degrees was found to correspond to a body-weight loaded shoe inclination of 9 – 10 degrees during the stance phase). In the future, one might adjust the vertical height of the deployed flipper to be a fixed percentage of the height of the subject, or the width of their foot, in order to be able to titrate the magnitude of the perturbation it induces. This would be necessary in children, for example, just as it would be for very short or tall individuals.

A second limitation was that the MP and LP were located at only one point along the foot in the sagittal plane. Therefore one does not know how perturbations at other locations affect gait kinematics or dynamics. It would be instructive to be able to vary this sagittal location and study the effect that this sagittal location has on the response. Certainly, the more posterior a fixed height flipper is located, the more challenging it is likely to be because the foot is narrower, and the ground reaction force larger. Indeed, the most challenging location would be a MP under the rearfoot because of the risk of an ankle sprain. Indeed, because of this risk, such a test location is contraindicated from a safety point-of-view except for the use of very small flippers.

A third limitation was that we only chose to deploy the perturbation under one foot in these studies. We could have programmed the perturbation under a second foot immediately following the first perturbation or on a later step during gait. We chose to study the effect of a single underfoot perturbation as a start. But it would be worthwhile to study the effect of two and more successive perturbations on gait kinematics. This should probably be carried out on healthy subjects first, so as not to place PN subjects at undue risk of injury, because it is likely more challenging to recover from.

A fourth limitation was that we elected to use a thin natural rubber mat over the tiled floor to ensure that subjects did not slip during a perturbation. We considered the use of a rubber tip on the metal flipper to prevent the foot slipping, but considered the rubber

mat would be safer because of less localized wear, given the high forces involved. This would mean that a clinic would have to store the rubber mat when not in use. Obviously, a non-skid flooring surface would solve this problem, but the more compliant the floor surface, the higher the flipper that would be needed in order to induce a given frontal plane perturbation of, say, 10 degrees.

A last limitation was that we elected to only use a given flipper height for simplicity. It would be interesting to systematically vary the height of the flipper in the same individual so that one could study the effect of perturbation magnitude on gait.

Chapter 11

Conclusions

1. In subjects with and without peripheral neuropathy, maximum hip muscle strength and ankle frontal plane ankle proprioception thresholds are strong predictors of unipedal balance time (Chapter 2).
2. In subjects with and without peripheral neuropathy, those in the lower tertile in the unipedal stance time test had significantly weaker hip muscle strength and larger ankle proprioception thresholds than those in the upper tertile (Chapter 2).
3. In subjects with and without peripheral neuropathy, gait speed and step efficiency are strongly correlated to lower extremity muscle strengths, rate of strength developments, ankle proprioceptive thresholds when walking across uneven ground at a comfortable gait speed (Chapter 3).
4. A novel manual test of simple and recognition reaction times showed significant age differences within eight trials (Chapter 4).
5. A novel test for perturbing gait using a single underfoot perturbation demonstrated acceptable test-retest reliability healthy in young adults. Reliabilities were better at the faster gait speed (Chapter 5).
6. The single underfoot perturbation resulted in an alteration of step width and length for at least four steps beyond the perturbation in healthy young adults (Chapter 6).

7. Healthy old adults failed to respond in the first step following an underfoot perturbation, instead often responding on the second and fourth steps (Chapter 6).
8. Both single medial and lateral underfoot perturbations increased the step width of healthy young adults for up to two steps beyond the perturbations (Chapter 6)
9. During the first recovery step following an underfoot perturbation, healthy older adults responded by significantly increasing their torso lateral inclination and lateral pelvic displacement (Chapter 6).
10. In a sample of subjects with and without peripheral neuropathy, those with peripheral neuropathy significantly unweighted the perturbed stance foot. For a medial or lateral underfoot perturbation, those with peripheral neuropathy significantly increased the width of the first recovery step and associated lateral pelvic displacement (Chapter 7).
11. Following a medial underfoot perturbation, healthy older adults demonstrated a shorter latency and greater amplitude of their peroneal EMG responses. Following a lateral underfoot perturbation, healthy older adults demonstrated a longer latency and greater amplitude of their peroneal EMG responses, compared to subjects with peripheral neuropathy who showed no significant responses (Chapter 7).
12. When subjects with and without peripheral neuropathy were divided into tertiles of neuropathy severity, those in the lower tertile exhibited no changes in the widths of the four recovery steps following the single underfoot perturbation. They did however display significant changes in peroneal latency and amplitude in the first recovery step. Those with mild and moderate peripheral neuropathy changed the second and sometimes later recovery step widths following both medial and lateral underfoot perturbations; they displayed no significant changes in peroneal latency or amplitude in the first recovery step (Chapter 8).
13. In healthy young adults walking at a comfortable gait speed, their vocal reaction time was significantly prolonged by an unexpected single underfoot perturbation compared to when standing still. In this dual task, the first recovery step width was unaffected by a distraction (Chapter 9).

14. Because a single underfoot perturbation can affect step kinematics for up to four recovery steps, carryover effects confound the interpretation of step kinematics on uneven surfaces (Chapters 3,6,8).
15. Age and peripheral neuropathy preclude a step width change of the first recovery step following a single underfoot perturbation; the kinematic response first appears on the second recovery step. This appears to be partly due to an inability to organize the peroneal muscle activation in the time available before the next heel strike (Chapters 6 and 8).
16. A single underfoot perturbation which resulted in a 10 degree inversion or eversion forefoot inclination (in the frontal plane) proved to be a safe gait provocation test in adults with and without moderate peripheral neuropathy (Chapters 7 and 8).

APPENDIX A

Patent Application Publication:

Pub.No.: US 2010/0324443 A1

Device and Method for Measuring Reaction Time



(19) **United States**

(12) **Patent Application Publication**
ASHTON-MILLER et al.

(10) **Pub. No.: US 2010/0324443 A1**

(43) **Pub. Date: Dec. 23, 2010**

(54) **DEVICE AND METHOD FOR MEASURING REACTION TIME**

Publication Classification

(76) Inventors: **James A. ASHTON-MILLER**,
Ann Arbor, MI (US); **Hogene KIM**,
Ann Arbor, MI (US); **James T.**
ECKNER, Ann Arbor, MI (US);
James K. RICHARDSON, Ann
Arbor, MI (US)

(51) **Int. Cl.**
A61B 5/05 (2006.01)

(52) **U.S. Cl.** **600/554**

Correspondence Address:
HARNESS, DICKEY & PIERCE, P.L.C.
P.O. BOX 828
BLOOMFIELD HILLS, MI 48303 (US)

(57) **ABSTRACT**

A manual neurological testing device for measuring a subject's reaction time comprising: a releasable holding member operable to be grasped by the subject; a stimulus device coupled with the releasable holding member, the stimulus device outputting a perceivable stimulus; and a measurement device coupled with the releasable holding member, the measurement device measuring the subject's reaction time for grasping the releasable holding member relative to the perceivable stimulus.

(21) Appl. No.: **12/815,619**

(22) Filed: **Jun. 15, 2010**

Related U.S. Application Data

(60) Provisional application No. 61/187,749, filed on Jun. 17, 2009.

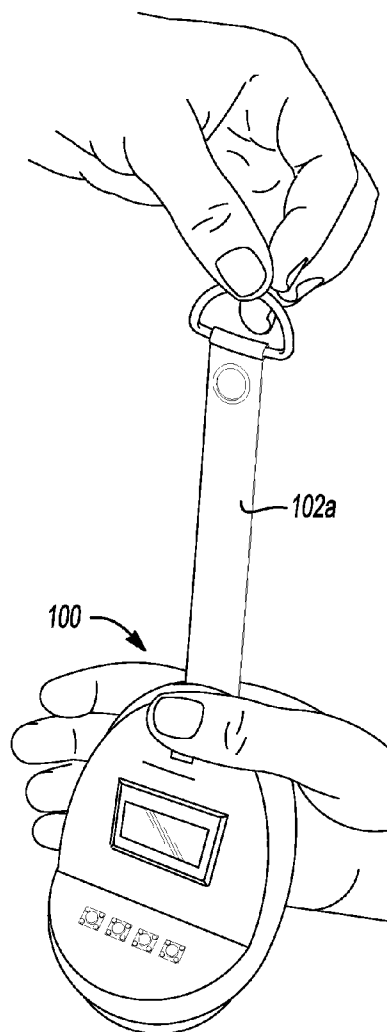

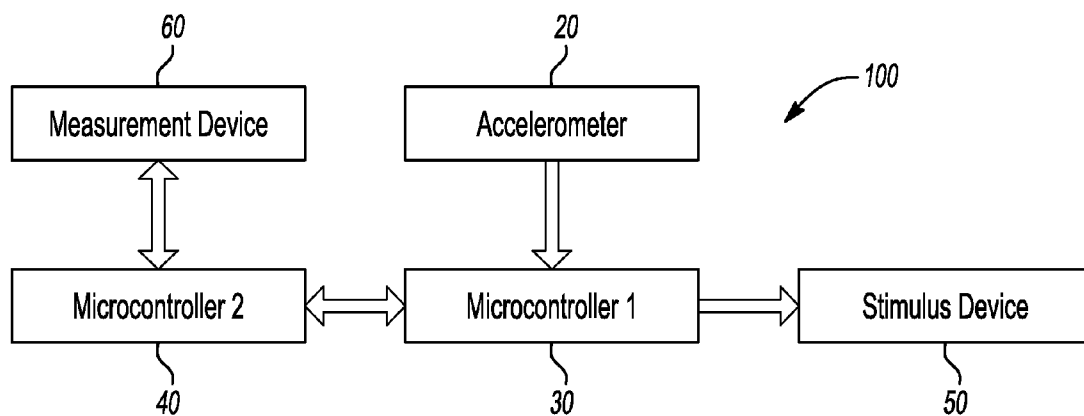

Fig-1

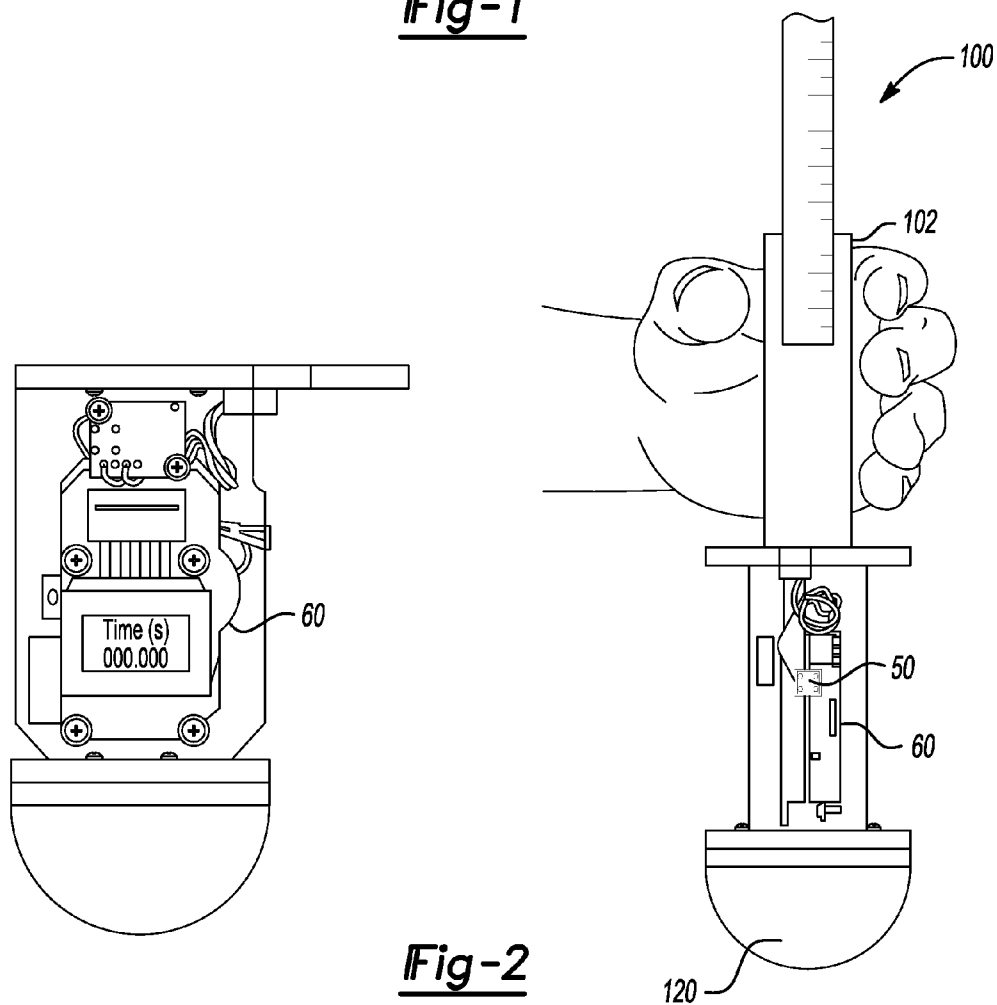

Fig-2

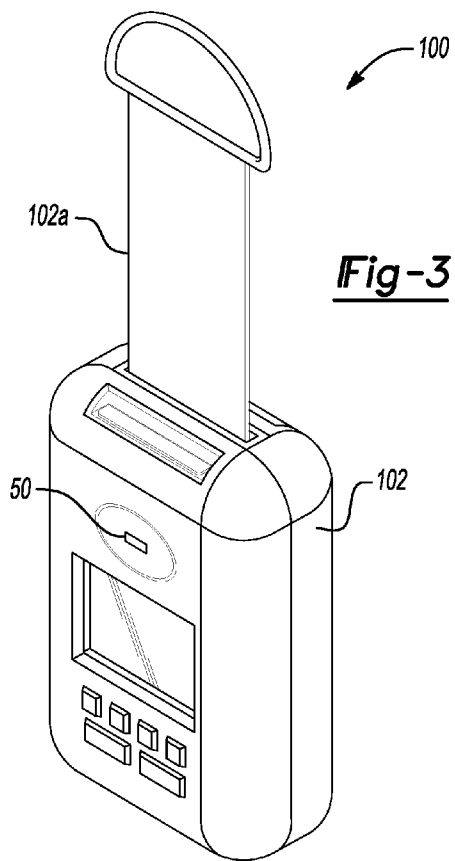

Fig-3

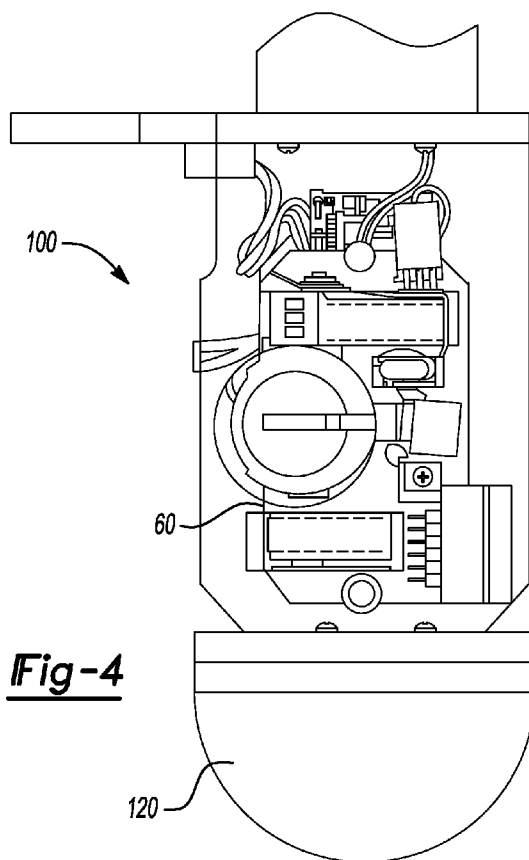

Fig-4

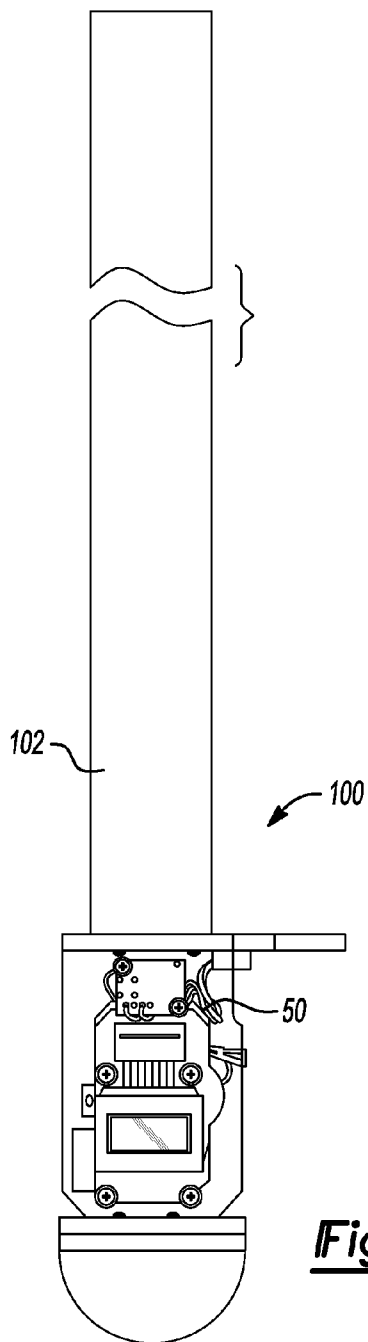

Fig-5

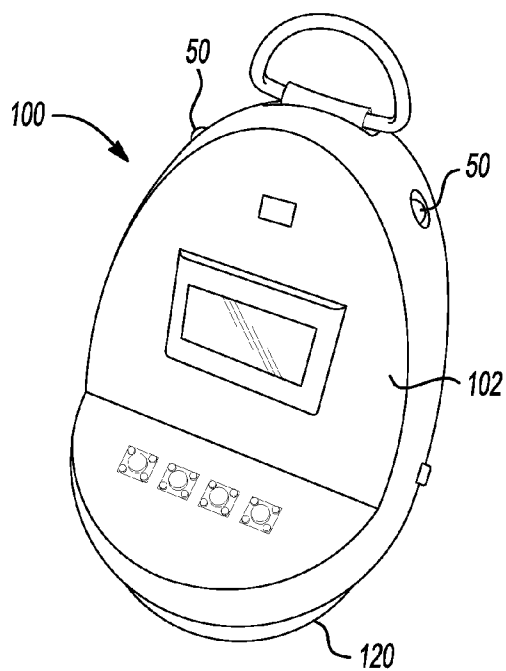

Fig-6A

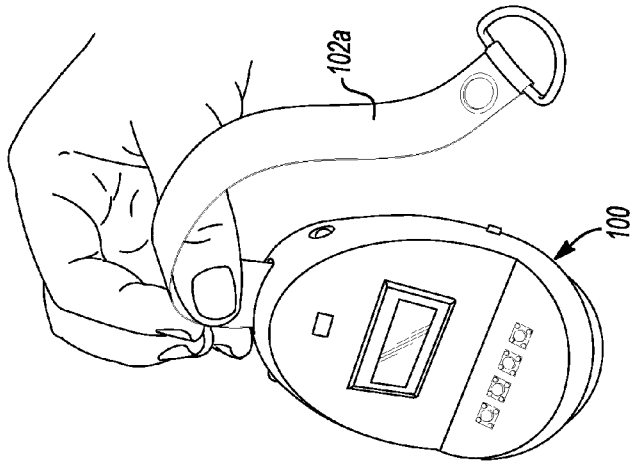

Fig-6C

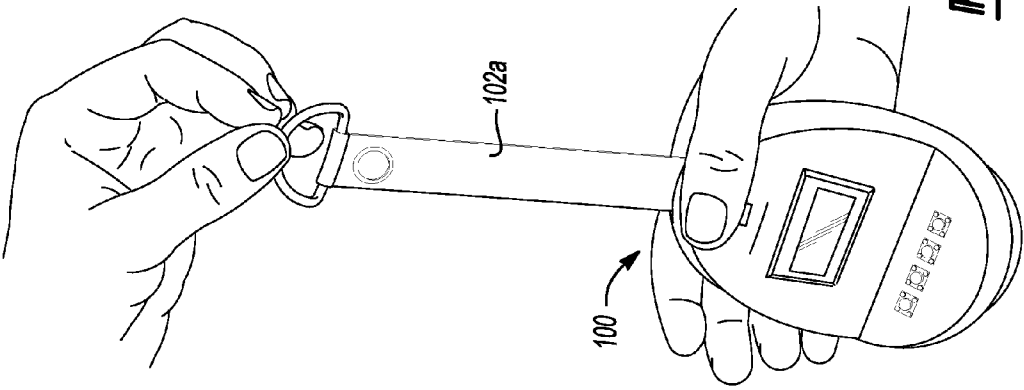

Fig-6B

DEVICE AND METHOD FOR MEASURING REACTION TIME

CROSS-REFERENCE TO RELATED APPLICATIONS

[0001] This application claims the benefit of U.S. Provisional Application No. 61/187,749, filed on Jun. 17, 2009. The entire disclosure of the above application is incorporated herein by reference.

GOVERNMENT RIGHTS

[0002] This invention was made under Grant number AG024824 awarded by the National Institutes of Health. The government has certain rights in the invention.

FIELD

[0003] The present disclosure relates to a manual reaction time measuring device and methods for determining a subject's simple, recognition and choice reaction time.

BACKGROUND

[0004] This section provides background information related to the present disclosure which is not necessarily prior art.

[0005] Sport-related concussion is understood to be a significant public health concern which may be underreported. Studies have suggested that >5% of high school and college football players sustain a concussion during a single season. An athlete who has sustained an initial concussion is more susceptible to repeated concussions, and the athlete with multiple concussions is at increased risk for abnormalities in neuropsychological testing and ongoing symptoms. Premature return to play is of particular concern to society in general, and it appears to be associated with increased likelihood of further injury, prolonged experience of cognitive symptoms, and even death on rare occasions. The last concern refers to the "second impact syndrome", a catastrophic outcome in child and adolescent athletes.

[0006] Prolongation of reaction time after sports-related concussion has been recognized for many years. Importantly, concussed football athletes have shown impairments in reaction time as compared to controls several days after complete symptom resolution and clearance to return to play. However, present practice for determining reaction time typically includes a personal computer and specialized software-equipment not usually immediately available because of the associated cost (typically \$500 per football team per year) — and is not available to the great majority of high school, and younger, athletes. This is especially important given evidence that the adolescent brain, as compared to that of the adult, is more vulnerable to sports-related concussion.

[0007] Reaction time can be partitioned into three intervals: a) Pre-motor time: from the onset of the stimulus to the onset of increased myoelectric activity in the response musculature; b) Electromechanical delay: from the depolarization of the response musculature to the acceleration of the response limb; and c) Movement time: from the initial acceleration of the response limb to completion of the task. A prolongation of any of these intervals can increase reaction time; e.g., a delay in upper extremity limb acceleration was the major source of delay in older women asked to move their hands quickly into position to break a fall. In some examples, a clinical reaction time can be defined as a measure of the speed with which a

functional task relevant to sport, prevention of a blow to the head or face, is performed. However a clinical measure of reaction time would be of greatest use in evaluating sports-related concussion if it measures pre-motor events, since that interval includes central neurologic processing time.

[0008] Scientists define at least three types of reaction time including simple reaction time, recognition (or "Go/No Go") reaction time, and choice reaction time. Simple reaction time (SRT) is the reaction time obtained when the subject has to respond in a similar way to the same stimulus. In one example, one could obtain a simple reaction time by simply dropping an object at random intervals and asking the subject to catch it each time as quickly as possible. The time taken to catch the object from when it was dropped is the SRT. No decision-making is involved by the subject. Recognition reaction time (RRT) is the reaction time obtained when the subject recognizes the presence/absence of a stimulus at the time the object is dropped and takes the appropriate action as quickly as possible. So in one example, the subject will have been asked to catch the object that is dropped using a pinch grip if a light comes on, but to let it drop if the light does not come on. Here the stimulus to catch the object occurs only intermittently and a decision has to be made as to whether to catch it or not. Choice reaction time (CRT) is the reaction time obtained when the subject interprets the stimulus that is presented at the time the object is dropped so as to make one of at least two different responses as quickly as possible. An example would be that the subject is asked to catch the object when it is dropped using their thumb and first finger if the light is green, but with their thumb and third finger if it is red. Here the stimulus varies, every trial and subject is burdened with making the choice between the two different motor responses or catching actions when responding to the stimulus as quickly as possible. It is known that the reaction time (RT) increases as a function of the number of choices according to the formula $RT = a + b \log_2(n+1)$, where a and b are constants representing the intercept and slope of the function, and n is the number of choices.

[0009] Therefore an inexpensive clinical measure of reaction time would be welcomed in the evaluation of sports- and age-related neurological disorders or conditions, including sports-related concussion. Moreover, such a measure would be of even greater use if it was found to predict a sports-related protective reaction time (SPRT). The immediate availability of this information could influence return to play decision-making, and prevent repeat sports-related concussion or other injury.

SUMMARY

[0010] This section provides a general summary of the disclosure, and is not a comprehensive disclosure of its full scope or all of its features.

[0011] The present disclosure provides in exemplary aspects, a manual neurological testing device for measuring a subject's reaction time. In some embodiments, the device comprises a releasable holding member operable to be grasped by the subject; a stimuli output device coupled to the releasable holding member, the stimuli output device outputting a perceivable stimulus; and a measurement device coupled to the releasable holding member. The measurement device can be configured to measure the subject's reaction time for grasping the releasable holding member relative to the perceivable stimulus.

[0012] In other exemplary aspects, the present disclosure also provides a method for manually measuring the reaction time in a subject, the method comprising: (a) positioning a manual neurological testing device within grasp of the subject, operable to measure the reaction time of subject, said manual testing device having a releasable holding member operable to be grasped by the subject; a stimuli output device coupled with the releasable holding member, the stimuli output device outputting a perceivable stimulus; and a measurement device coupled with the releasable holding member; (b) releasing the holding member with or without the perceivable stimulus; and (c) determining the time taken for the subject to grasp the releasable holding member after releasing the releasable holding member.

[0013] In a further aspect of the present disclosure, the perceivable stimulus can include a visual stimulus, for example, an off or on light, one or more colored lights, for example, a red light and a green light. Other perceivable stimuli can include one or more sounds, music or alerts similarly used to register an on-off stimuli and also recognition stimuli where one sound indicates to the subject to grab the testing device and a different sound indicates not to grab the testing device.

[0014] The manual neurological testing device offers several advantages over computer-based methods including face validity—intrinsically motivating subjects to exert significant effort to react because it replicates a time-critical situation where all used to having to respond to—catching a fragile object that falls off a table before it strikes the ground, thus an excellent measure of reaction time.

[0015] Motivation is an important factor to consider when measuring reaction time in a clinical setting because of its effect on subject performance. Current methods of accurately measuring recognition or choice reaction time require a computer with specialized software. These computer-based methods fail to provide the same physical level of motivation because the physical stimulus is not a sudden movement of a physical body that has to be physically caught as soon as possible (rather a key has to usually be depressed on a computer keyboard according to a sense of urgency that is entirely reliant on the testee self-generating, not imposed upon him or her by the laws of physics of a falling body). The present device is also more motivating than computer testing to determine reaction times because the present testing device imposes the sense of urgency upon the testee while providing instant dissemination of results to both the subject and the examiner. The present method can be well controlled and results in higher reproducibility than computerized testing.

[0016] The portability and simplicity of the manual neurological testing device renders the device better suited for routine clinical use than computerized assessment methods. Other uses of the manual neurological testing device can include monitoring medication effects, establishing fall risk, return to driving testing, the effects of sleep apnea, dementia screening, return to work in hazardous occupations testing and sobriety testing, as well as evaluating symptoms from many conditions to be specified later.

[0017] The device has an order of magnitude lower cost than a computerized PC-based testing system. It can be made for less than \$50. This puts the devices of the present technologies in a price range that every professional team, college, high-school, middle school and elementary school and would be able to afford for their football, basketball, lacrosse, field hockey, baseball, softball, soccer, gymnastics, and ice

hockey teams as well as participants of martial arts, teams that are exposed to the danger of a concussion every time they participate. The same is true for military medics needing to test or evaluate military personnel who have been exposed to concussion from the detonation of nearby explosive devices.

[0018] Further areas of applicability will become apparent from the description provided herein. The description and specific examples in this summary are intended for purposes of illustration only and are not intended to limit the scope of the present disclosure.

DRAWINGS

[0019] The drawings described herein are for illustrative purposes only of selected embodiments and not all possible implementations, and are not intended to limit the scope of the present disclosure.

[0020] FIG. 1 shows a block diagram of the signal paths between various components used in an exemplary manual neurological testing device in accordance with the present disclosure.

[0021] FIG. 2 is a photograph of a partial view of the manual neurological testing device with the subject's hand in position at, but not touching, the spacer portion of the holding member ready to react to a stimulus and grasp the manual neurological testing device in accordance with the present disclosure. The inset shows a photograph of the front view of the distal portion of the manual neurological testing device. A digital clock and display is shown indicating a reaction time result in milliseconds.

[0022] FIG. 3 shows a schematic illustration of the portable manual neurological testing device and a retractable leash holding member in accordance with the present disclosure.

[0023] FIG. 4 is a photograph of the rear side of the distal portion of the manual neurological testing device showing the various components described in FIG. 1.

[0024] FIG. 5 is a photograph of an illustrative example of a manual neurological testing device having a biconcave holding member in accordance with the present disclosure.

[0025] FIG. 6A is a photograph of an illustrative example of a manual neurological testing device in accordance with the present disclosure.

[0026] FIG. 6B is a photograph of the illustrative example of the manual neurological testing device of FIG. 6A in a pre-release position.

[0027] FIG. 6C is a photograph of the illustrative example of the manual neurological testing device of FIG. 6A in a caught position.

[0028] Corresponding reference numerals indicate corresponding parts throughout the several views of the drawings.

DETAILED DESCRIPTION

[0029] Example embodiments are provided so that this disclosure will be thorough, and will fully convey the scope to those who are skilled in the art. Numerous specific details are set forth such as examples of specific components, devices, and methods, to provide a thorough understanding of embodiments of the present disclosure. It will be apparent to those skilled in the art that specific details need not be employed, that example embodiments may be embodied in many different forms and that neither should be construed to limit the scope of the disclosure. In some example embodiments, well-known processes, well-known device structures, and well-known technologies are not described in detail.

[0030] The terminology used herein is for the purpose of describing particular example embodiments only and is not intended to be limiting. As used herein, the singular forms “a”, “an” and “the” may be intended to include the plural forms as well, unless the context clearly indicates otherwise. The terms “comprises,” “comprising,” “including,” and “having,” are inclusive and therefore specify the presence of stated features, integers, steps, operations, elements, and/or components, but do not preclude the presence or addition of one or more other features, integers, steps, operations, elements, components, and/or groups thereof. The method steps, processes, and operations described herein are not to be construed as necessarily requiring their performance in the particular order discussed or illustrated, unless specifically identified as an order of performance. It is also to be understood that additional or alternative steps may be employed.

[0031] When an element or layer is referred to as being “on”, “engaged to”, “connected to” or “coupled to” another element or layer, it may be directly on, engaged, connected or coupled to the other element or layer, or intervening elements or layers may be present. In contrast, when an element is referred to as being “directly on,” “directly engaged to”, “directly connected to” or “directly coupled to” another element or layer, there may be no intervening elements or layers present. Other words used to describe the relationship between elements should be interpreted in a like fashion (e.g., “between” versus “directly between,” “adjacent” versus “directly adjacent,” etc.). As used herein, the term “and/or” includes any and all combinations of one or more of the associated listed items.

[0032] Although the terms first, second, third, etc. may be used herein to describe various elements, components, regions, layers and/or sections, these elements, components, regions, layers and/or sections should not be limited by these terms. These terms may be only used to distinguish one element, component, region, layer or section from another region, layer or section. Terms such as “first,” “second,” and other numerical terms when used herein do not imply a sequence or order unless clearly indicated by the context. Thus, a first element, component, region, layer or section discussed below could be termed a second element, component, region, layer or section without departing from the teachings of the example embodiments.

[0033] Spatially relative terms, such as “inner,” “outer,” “beneath”, “below”, “lower”, “above”, “upper” and the like, may be used herein for ease of description to describe one element or feature’s relationship to another element(s) or feature(s) as illustrated in the figures. Spatially relative terms may be intended to encompass different orientations of the device in use or operation in addition to the orientation depicted in the figures. For example, if the device in the figures is turned over, elements described as “below” or “beneath” other elements or features would then be oriented “above” the other elements or features. Thus, the example term “below” can encompass both an orientation of above and below. The device may be otherwise oriented (rotated 90 degrees or at other orientations) and the spatially relative descriptors used herein interpreted accordingly.

[0034] The present disclosure provides a manual testing neurological device that when used in a controlled neurological procedure is capable of quickly and accurately measuring human reaction time.

[0035] Manual Neurological Testing Device

[0036] As used herein, the term “manual” can include devices that can be released by the clinician and grasped by the subject using any part of the human body, including for example, the hand, knees, legs, arms, elbows, feet and the like. The body part can also be on the dominant side or the non-dominant side, or both. Hence, contacting a mouse, keyboard key, or computer display to measure reaction time is not contemplated in the present disclosure.

[0037] In some exemplary embodiments as illustrated in FIGS. 1-6C, the manual neurological testing device **100** (herein referred to as the “testing device **100**”) can include: a) a releasable holding member **102** operable to be grasped by the subject; b) a stimuli output device **50** coupled with the releasable holding member **102**, the stimuli output device **50** outputs a perceivable stimulus to the subject; and c) a measurement device **60** coupled with the releasable holding member **102**, the measurement device measures the subject’s reaction time for grasping the releasable holding member **102** relative to the perceivable stimulus.

[0038] In some embodiments the present disclosure, testing device **100** includes a holding member **102** that can serve as a structural component of the testing device **100** to mount the various components as shown in FIGS. 2 and 5. The holding member **102** can be elongated, measuring from about 20 cm to about 200 cm. The holding member **102** can be configured to be grasped by the subject’s hand during the testing procedure as shown in FIGS. 2 and 6C. While the overall geometry of the holding member **102** can be varied, depending on the subject being tested, the holding member **102** can illustratively have a cross-section shaped like an hour-glass or biconcave, a rectangular shape having circular segments completing the ends, circular, triangular, square, rectangular and oval. In some embodiments, the biconcave shape of the holding member **102** cross-section promotes reproducible pinch grip grasping movements. The biconcave shape of the holding member **102** also facilitates the subject to use a pinch grip rather than a palm grip to actually grasp or catch the device. This reduces the time needed for the subject’s fingers to close onto the surface of the device.

[0039] In some embodiments, the holding member **102** can be configured to have a range of lengths and cross-section widths, i.e. at the center of the concave surface, for example from about 0.5 cm to about 10 cm to accommodate varying subject hand sizes (i.e. juvenile, adolescent and adult). The holding member **102** can be manufactured from any solid material including plastic, polymer, metal, wood, ceramic, glass and combinations thereof. In some embodiments, the holding member **102** can be made from a dense plastic material.

[0040] In some embodiments, the testing device **100** can include the components shown in FIG. 1 attached to a retractable or pivotable holding member **102**. With reference to FIGS. 1 and 3, the accelerometer **20**, microcontrollers **30** and/or **40**, stimulus device **50** and measurement device **60** can be incorporated into a unitary device shown in FIG. 3 having the size relative to a cell phone or even as small as a key fob. The unitary testing device **100** is attached to a holding member **102** shown in FIG. 3 as a retractable leash and can measure from about 20 cm to about 100 cm. Alternatively, the holding member **102** may be designed to telescope, in the manner of a radio antenna, be foldable in the manner of a segmented tent post whose disassembled parts are held together by a thin bungee cord, and pivotable or hinged pole

segments much like a carpenter's ruler. As shown in FIG. 3, the testing device 100 can be made to be compact by replacing the elongated solid holding member 102 with a flexible structure 102a such as a woven nylon tape that is retracted on a take-up spool inside the device when not in use. The tape can have a cross-section that is like that of a ribbon or like that of a closed tube or stocking for increased resistance to rotation.

[0041] In some embodiments, the testing device 100 can also provide added functionality, such as being able to automatically score the recognition or choice reaction time response accuracy (i.e., the percentage of trials wherein the subject only catches the testing device 100 when the LED lights, but correctly allows it to fall when the LED does not light upon the device being released by the clinician, recognition, or catches the testing device 100 using their thumb and index finger when the LED is green and their thumb and middle finger when the LED is red, choice). Additional optoelectronic, wireless and infra red sensors, diodes and adapters contained within the unitary testing device 100 for receipt and transmission of various data and other programmable instructions to and from the device are contemplated. The testing device 100 can also provide the means to store reaction time performance results made at an earlier time, or baseline, so that they may be rapidly compared with the results of tests made at a later time, or follow up.

[0042] In some embodiments, the holding member 102 can be fitted with various components that permit the measurement and determination of the subject's reaction time, including simple reaction time and recognition reaction time. As shown in FIG. 1, an exemplary testing device 100 can include an accelerometer 20, one or more of microcontrollers 30 and 40, stimulus device 50 and a measurement device 60. FIGS. 2, 4 and 5 show a holding member 102 having the accelerometer 20, microcontrollers 30 and 40, stimulus device 50 and measurement device 60 located at the distal end of the testing device 100. Best illustrated in FIG. 2, the holding member 102 can include a region called a spacer 50. The spacer 50 maintains the subject's distal digits a fixed distance apart so that the fingers must travel a uniform distance before they touch the holding member 102 after release. The spacer 50 can be shaped differently to the rest of the holding member 102 or may be similarly shaped.

[0043] In some embodiments, the testing device 100 can include an accelerometer 20 that is integrated and coupled with the testing device 100 to sense movement of the testing device 100 after it has been released by the clinician, i.e. the accelerometer 20 can measure the onset and offset of motion of the testing device 100. The accelerometer 20 can be any linear accelerometer capable of sending a signal to at least one of the microcontrollers 30 and 40 when it senses both onset and offset of motion. The accelerometer 20 is an illustrative example of a displacement sensor, other displacement sensors known in the art can also be used to detect onset of acceleration and deceleration of the testing device 100 when released by the clinician, and caught by the subject respectively. An accelerometer 20 useful in the present disclosure can include the Model ADXL202 accelerometer manufactured by Analog Devices, Inc. Norwood, Mass.

[0044] In some embodiments, the testing device 100 can include a displacement-measuring device that is not integrated or coupled with the testing device 100 but is disposed at a remote location to sense movement of the testing device 100 after it has been released by the clinician, i.e. the accelerometer or displacement-measuring device can measure the

onset and offset of motion of the testing device 100 remotely. The displacement-measuring device can be any optoelectronic sensor capable of sensing both onset and offset of motion. An example of such a displacement measuring sensor would be a Northern Digital Inc., Certus system or any video-based motion capture system such as the VICON system. The sensor would then send a signal to at least one of the microcontrollers 30 and 40 to signal the onset and offset of motion.

[0045] In some embodiments, the testing device 100 also includes at least one microcontroller, illustratively shown in FIG. 1 as microcontroller 30 and microcontroller 40. Microcontrollers 30 and/or 40 can be configured to perform a variety of functions including: determine the test mode program (simple reaction time or "Go-No-Go" recognition reaction time), measure the onset of acceleration of the testing device 100, send a signal to a stimulus device 50 upon determining a threshold acceleration, send a signal to a stimulus device 50 to activate one of two different stimuli from stimulus device 50, senses a significant deceleration signal from the accelerometer 20 as when the testing device 100 is grasped by the subject and send a signal to stop the measurement device 60. The microcontrollers 30 and 40 can include RISC type of microcontrollers, commercially available as Model PIC16F84A manufactured by Microchip Technology Inc., Chandler, Az., USA.

[0046] The testing device 100 of the present disclosure can further comprise a measurement device 60 that can be used to ultimately measure and determine the subject's reaction time. Moreover, in some embodiments, measurement device 60 can be used for determining response accuracy. The measurement device 60 can be automated and in data and electronic communication with the microcontrollers 30 and/or 40 or the measurement device 60 can be a ruler. In some embodiments, the measurement device 60 can include a digital time recording device that is programmable and/or that is in electrical communication with at least one of the microcontrollers 30 and 40 and is capable of reporting the elapsed time measured from the onset of acceleration and stimulus delivery to the time the testing device 100 has been grasped by the subject. In some embodiments, the measurement device 60 can include a crystal oscillator. Although many crystal oscillators would be suitable for use in the present disclosure, one such exemplary oscillator can include Model HC49US (4.096 MHz) manufactured by Citizen Holdings Co., LTD., Tokyo, JP. A microcontroller similar to that mentioned above can be arranged to count pulses from the oscillator and transfer the number to a second microcontroller which controls an LCD display unit so as to display a number—the reaction time in, say, units of msec. An LCD display useful in the present disclosure can include the Model MDL(S)-82603 manufactured by Varitronix LTD, Kwun Tong, Hong Kong. In some embodiments, the measurement device 60 can work in concert with microcontrollers 30 and 40 to determine and report the number of correct (incorrect) response in the Recognition Reaction Time test.

[0047] As noted above, the measurement device 60 can include a set of ruler markings imprinted on the holding member 102 operable to indicate the distance the testing device 100 has moved since the testing device 100 has been released and before it was caught. The ruler markings can be marked in millimeters and the holding member 102 can have a roughened surface to prevent slippage between the member and fingers when it is caught by the test subject. The measurement device 60 can include the digital clock and/or the

ruler markings. In some embodiments the ruler markings can represent the elapsed time the member has been in free-fall (in ms) since release rather than using metric measure for conversion to time.

[0048] In some embodiments, the reaction time testing device 100 of the present disclosure requires the use of a perceivable stimulus to indicate to the subject, upon the release of the holding member 102 by the examiner, to resist catching the testing device 100 or to catch the testing device 100. The stimulus device 50 produces a stimulus that is perceivable to the subject. The stimulus itself is not limited to any one physical form. In some embodiments, the stimulus device 50 outputs a perceivable stimulus detectable by the subject. The perceivable stimulus can include a single light, for example, as produced from a single LED that when turned on signals to the subject that the released testing device 100 is to be caught. If the LED is not turned on, and the testing device 100 is released then the subject is meant to let the testing device 100 fall to the ground. This type of testing method is designed to test and measure the recognition reaction time of the subject. Alternatively, for choice reaction time determination, the stimulus device 50 must be capable of outputting at least two different perceivable stimuli. In some embodiments, the stimulus device 50 can be a single LED that is capable of displaying, for example, two different colors, two different light intensities, two different light frequencies, for example, one continuous light and one light that flickers repetitively, or strobe. Alternatively, the stimulus device 50 can include two or more LEDs, each operable for providing a perceivable stimulus that are different to the other. In some embodiments, the stimulus device 50 can also output a perceivable stimulus that is not visual, but rather aural. As with the description of LEDs, the aural signal generator can be a single sound generator or a multi-sound generator, since the sounds may be perceived by the subject as an indicator of whether to grasp the testing device 100 after being released or whether to let the testing device 100 fall. Alternatively, the stimulus device could trigger (wirelessly) a tactile (vibratory) (sensory) feedback at two or more locations on the skin.

[0049] In some embodiments, the testing device 100 can have an optional output device that electronically displays the subject's reaction time. The output device can be integrated with the measurement device and display the subject's reaction time as shown in FIG. 2 (inset).

[0050] In some embodiments, the testing device 100 can have a weight 120 or other stabilizing device such as a weighted ballast. The weighted ballast 120 can be attached to the lower end or distal portion of the holding member 102 to increase its inertia as a pendulum thereby helping to maintain the device in a vertical position prior to being released. In other embodiments, the various components described in FIG. 1 can serve as the weight to help maintain the testing device 100 in a vertical position without the need for a weighted ballast 120.

[0051] The testing device 100 can include: a) a releasable elongated holding member 102 configured to be grasped by the subject; b) a control module coupled with the releasable elongated holding member 102, the control member comprising: i) a displacement sensor operable to determine a predetermined onset and an offset of motion of the releasable elongated holding member 102 in a vertical direction; ii) a controller connected to the displacement sensor, the controller comprising: a stimulus driving output and a timer on/off output; and iii) a timing device in communication with the

timer on/off output, the timing device measures the period of time elapsed between the predetermined onset and the offset of motion of the releasable elongated holding member 102, the timing device sends the period of time elapsed to the controller; and c) a stimuli output device coupled with the releasable elongated holding member 102 to be perceived by the subject, the stimuli output device being in electronic communication with the controller and is operable to output a stimulus in response to the stimulus driving output.

Methods For Determining A Subject's Reaction Time

[0052] The above described testing device 100 can be employed to determine at least three patterns of reaction time that provide valuable neurological information as to the condition or status of the subject being tested. These at least three reaction times can include simple reaction time, recognition reaction time, and choice reaction time.

[0053] In some embodiments, a method for determining the subject's simple, recognition and/or choice reaction time can include: positioning a neurological manual testing device 100 within the grasp of the subject. The manual testing device 100 can have a releasable holding member 102 which is configured to be grasped by the subject and a stimuli output device which can be coupled with the releasable holding member 102. The stimuli output device is capable of outputting a perceivable stimulus. The testing device 100 also includes a measurement device which can be coupled with the releasable holding member 102. The holding member 102 is then released with or without the perceivable stimulus; and the time taken for the subject to grasp the releasable holding member 102 in a specified manner after being releasing is measured.

[0054] In some embodiments, a method to determine a simple reaction time of a subject is provided. Generally, the subject being tested can be positioned sitting in an upright position with their dominant or non-dominant forearm resting on a horizontal surface such that their hypothenar eminence is positioned at the edge of the surface. The clinician or examiner can suspend the device vertically with the holding member 102 spacer region near and the hand and horizontal surface on which the subject's forearm is resting. Subjects can hold their dominant or non-dominant hand open around the "spacer" portion of the device as shown in FIG. 2 such that their first and second digits are close to, but not touching the spacer in a pinch grip.

[0055] To determine a simple reaction time, subjects can be instructed to direct and maintain their gaze at the light-emitting diode shown on the top left hand corner of FIG. 4 and, when the testing device 100 is released, to catch the device as quickly as possible after its release. Direction of gaze is specified because it is understood that the threshold for the subject to visually detect the onset of the release of the testing device 100 is better when using foveal vision than when using peripheral vision: in the former case it is on the order of 0.017 to 0.033 deg/sec as an angular velocity subtended at the retina. At pre-determined random time intervals, the examiner releases the device and the subject catches it as quickly as possible. For an electronic readout, the device measures reaction time internally via an accelerometer and displays the reaction time in milliseconds on a digital output screen.

[0056] To determine a recognition reaction time measured as a "Go or No-Go" paradigm, the method for the above simple reaction time determination method is slightly modified. In an exemplary method for determining a recognition

reaction time, the subject can also be positioned sitting in an upright position with their forearm resting on a horizontal surface such that their hypothenar eminence is positioned at the edge of the surface. The clinician or examiner can suspend the testing device **100** vertically with the holding member **102** near the hand and horizontal surface on which the subject's forearm is resting. Subjects hold their hand open around the "spacer" portion of the device as shown in FIG. 2 such that their first and second digits are close to, but not touching the spacer in a pinch grip.

[0057] To determine recognition reaction time, subjects can be instructed to direct their attention to the stimulus device **50**, for example, a colored light from a light source attached to the testing device **100**, such as a light-emitting diode (LED) or an audible stimulus from a speaker attached to the testing device **100**. In some embodiments, the subject can direct and maintain their gaze at the stimulus device **50** if it is a visible stimulus. To measure the reaction time, the testing device **100** is released by the clinician and if the stimulus device **50**, for example, having a LED on the testing device **100** illuminates contemporaneously as the device is released, the subject catches the device as quickly as possible. If the LED does not illuminate, the subject allows the device to fall to the ground without catching it. At pre-determined random time intervals, the clinician releases the device and the subject catches it as quickly as possible when the test condition is satisfied. In some embodiments circuitry connected to stimulus device **50** can either randomize whether the LED stimulus is illuminated on a trial or presents a pre-recorded test sequence. For an electronic readout, the testing device **100** measures reaction time internally via an accelerometer and temporal recording device and displays the reaction time in milliseconds on a digital output screen. It should be appreciated that other stimulus can be used.

[0058] In some embodiments, the spacer can have two or more proximity sensors **100** (see FIGS. 6A-6C), each for example consisting of an infrared emitter and detector pair connected to some circuitry, located on opposing surfaces of the spacer, that sense whether distances to the finger on one side of the space and the thumb on the other side of the spacer are within tolerance: in other words neither touching the spacer directly nor being so far away that the time required by the subject to move the fingers through that distance materially affects the measured reaction time needed to catch the device. When the distance from the spacer is within tolerance, a signaling device can be used to transmit that information to the examiner thereby indicating that conditions are right to be able to release the device when he/she so chooses. An example of a suitable proximity sensor is the Osram SFH 7741 short range proximity sensor.

[0059] In some embodiments, the measurement device **60** disposed on the testing device **100** can consist of markings approximating a ruler that can be used to measure the distance the testing device **100** has traveled towards the ground before it has been grasped. In the "ruler" method, the top of the subject's finger or hand when held close to the spacer region of the holding member **102** as shown in FIG. 2 is noted and read from the rule as the initial measurement point. Then the device is released and grasped as appropriately indicated by the stimulus device **50**. Then, the top of the same subject's finger or hand grasping the testing device **100** is measured on the ruler and is noted as the final measurement point of the ruler. The difference between the first and second measurement points is therefore the distance the holding member **102**

has traveled. The resting position of the subject's hand after the device has been grasped can be used to determine the delta, i.e. the distance the testing device **100** has traveled. This distance can be used to calculate the reaction time of the subject. The reaction time as measured by the "ruler" method is the square root of twice the distance traveled in meters divided by the acceleration caused by gravity on the Earth of 9.8 m/s^2 . So for example, if the subject were to let the testing device **100** fall 8.0 cm after receiving the appropriate stimulus to grasp the falling testing device **100**, the reaction time can be calculated as the square root of (two times 0.08 m divided by 9.8) which is 0.1278 seconds or approximately 128 milliseconds. Or in other embodiments the markings could be in ms instead of mm, with the above calculation already performed to determine the location of the markings in the first place.

[0060] To determine choice reaction time, subjects can be instructed to direct their attention to the stimulus device **50**, for example, a colored light from a light source attached to the testing device **100**, such as a light-emitting diode (LED) or an audible stimulus from a speaker attached to the testing device **100**. In some embodiments, the subject can direct and maintain their gaze at the stimulus device **50** if it is a visible stimulus. To measure the choice reaction time, the testing device **100** is released by the clinician and if the stimulus device **50**, for example, having a LED on the testing device **100** illuminates in green contemporaneously as the device is released, the subject catches the device as quickly as possible using one kind of pinch grip: for example, using thumb and forefinger. If the LED illuminates in red, the subject catches the device as quickly as possible using another kind of pinch grip: for example, using thumb and third finger. At pre-determined random time intervals, the clinician releases the device and the subject catches it as quickly as possible when the test condition is satisfied. In some embodiments one of more than two colors may be displayed; for example, one of up to four colors could be displayed calling for one of four pinch grips to be used comprised of using the thumb with one of the four fingers on the same hand. In some embodiments circuitry connected to stimulus device **50** can either randomize the color of the stimulus to be presented on each trial or present a pre-recorded sequence. For an electronic readout, the testing device **100** measures reaction time internally via an accelerometer and temporal recording device and displays the reaction time in milliseconds on a digital output screen. In some embodiments, the measurement device **60** can work in concert with microcontrollers **30** and **40** to determine and report the number (or percent) correct (incorrect) responses in a binary, 3-choice or more reaction time test.

[0061] In some embodiments the holding member **102** can be of sufficient width to allow its being caught by either the left hand or the right hand using a pinch grip. In a simple or recognition reaction time it can then be caught using either the left or the right hand, or both, as specified by the experimenter. But in a choice reaction time test if the LED lights green, the subject can be instructed to catch it with one hand. If the LED lights red, the subject can be instructed to catch it with the other hand. In some embodiments the subject will wear a glove with sensors on the digits that can be sensed by the member such that the device can "score" whether or not the correct digit closure pattern was used.

Applications for the Manual Neurological Testing Device

[0062] In some embodiments, the testing device **100** of the present disclosure can be used to determine a clinical measure

of the recognition and/or choice reaction times of a subject. In some embodiments, the testing device **100** can be used to gather evidence of a sports-related concussion. A prolonged simple reaction time is a sign of sport-related concussion immediately following head trauma. A prolonged simple reaction time in the days following sport-related concussion can be a sub-clinical finding (i.e., is present when the athlete otherwise appears normal) indicating that complete recovery has not occurred; a prolonged simple reaction time places the athlete at increased risk for further injury. The reaction time data obtainable with the testing device **100s** of the present disclosure provides objective data for the first time in the form of an inexpensive, yet accurate and intrinsically engaging, low-technology test. Furthermore, by subtracting the simple reaction time from the recognition reaction time one can calculate how much time the central nervous system required to perform the recognition process (between the Go-No Go and simple option). Likewise, subtracting the simple reaction time from the choice reaction time allows one to calculate how long the subject's central nervous system takes to make the choice between the two motor responses. Therefore being able to measure both simple and recognition reaction times, or simple and choice reaction times, with the same device gives the examiner a direct measure of central nervous system function that is not available with only simple, recognition or choice reaction time alone. The device's use would be indicated when an athlete has sustained head trauma and the diagnosis of concussion is in question, or after all clinical signs and symptoms of concussion have abated for an appropriate period of time in an athlete who has been diagnosed as having sustained a concussion, and the physician or athletic trainer is trying to decide whether the athlete should return to play. This decision currently involves subjective evaluation with few, if any, objective data (absent computerized neuropsychologic testing programs which are rarely available in the pediatric population).

[0063] The present disclosure provides a manual neurological testing device **100** that can be inexpensive and simple to use, relatively compact, e.g., no larger than a key fob, and to be able to measure simple reaction time and recognition reaction time and choice reaction time, forms of choice reaction time known to be impaired following concussion, and to confirm their relationship to the ability of the athlete to protect him- or herself during sport using a "sport-specific reaction time" (SPRT) measure.

[0064] In addition to the testing device **100** being an important diagnostic tool to determine in real time, the presence of some form of concussion, in a child, adolescent or adult, the testing device **100** can also be used as a screening device to determine whether a subject can return to a particular sport that may be physically demanding and probabilistic of a repeated neurological injury. Similarly, subjects undergoing medical treatment for a neurological condition may have their reaction time tested as a prognostic indicator whether or not a subject is able to return to some level of physical exposure. Subjects having overcome a neurological problem with medication may confirm recuperation by providing a reaction time result with the devices of the present disclosure that is indicative and correlates with neurological recovery. In one application, the post-concussion reaction time would have to equal the reaction time measured at the start of the playing season before a concussion was sustained, plus/minus a given margin

of error. The preconcussion value of reaction time could be stored in the device memory and directly compared with the post-concussion value.

[0065] Other exemplary uses of the testing device **100** can include broader clinical applicability of the testing device **100** within the pediatric population and in adults. For example, it is well established that children with attention-deficit hyperactivity disorder (ADHD) have more prolonged and variable simple reaction time as compared to children without the disorder. Moreover, children with ADHD have diminished ability to stop an activity when cued as compared to other children, an ability that is restored with methylphenidate. The testing device **100** of the present disclosure also has application in assisting in the diagnosis of ADHD and monitoring response to therapy. Similarly, anti-epileptic drugs and anti-histamines have known effects on reaction time and are commonly used in the pediatric population; therefore the testing device **100** could be used with these children requiring these therapies to determine reaction time. In adults, the ability to accurately measure reaction time in the office setting would allow for the evaluation of patients with central neurologic disorders such as sleep apnea syndrome, traumatic brain injury, stroke, Parkinson's disease and dementia. In addition, the device could be used to monitor the effects of psychoactive medications commonly used such as neuroleptics, benzodiazepines, anti-epileptics, anti-depressants, hypnotics and opioids. The device could also be used to monitor function, and guide decisions regarding driving, return to work and fall risk in the setting of disease, polypharmacy and/or old age. Still further, the present teachings may find utility in connection with:

[0066] Central Neurological/Psychiatric Conditions, such as concussion/TBI, depression, dementia, distractions, stroke, ADHD (particularly monitoring response to medication), MS, psychologic stress, and Parkinson's Syndrome;

[0067] Peripheral Neurologic Conditions, such as polyneuropathy, demyelinating disease (AIDP, CIDP), myopathy, and diseases of neuromuscular junction (e.g., myasthenia gravis);

[0068] Metabolic Conditions, such as hyper/hypothyroid, renal failure/dialysis, menstrual cycle, hyper/hypocalcemia or hyper/hyponatremia, and hyper/hypoglycemia ;

[0069] General Conditions, such as normal aging, OSA, sleep deprivation, alcohol intoxication, other drug effects, medication side effects, caffeine effects, exercise effects, pain effects, temperature effects, deconditioning, malnutrition, fever effects, and hypo/hypertension.

[0070] Moreover, the present teachings may find utility in connection with functional testing, such as in connection with sport protective response, driving, falls, occupational safety (machinery, etc), military protective response, fall protective response, and predicting athletic reaction time (e.g., track or swimming start).

EXAMPLES

Example 1

[0071] Manual Neurological Testing device **100** With Digital Measurement Device

[0072] By way of example only and not for purposes of limitation, a testing device **100** as shown in FIGS. 3 and 5 includes an elongate holding member **102** similar to a wooden ruler having a biconcave shape measuring approximately 100 cm in length. The holding member **102** has a surface with

ruler markings spaced in centimeters and millimeters. The holding member **102** has a roughened surface to prevent slippage between the holding member **102** and fingers when it is caught by the test subject. A weighted ballast **120** is attached to the lower end of the holding member **102** to help maintain the device in a vertical position prior to being released. Housed either within the holding member **102** or on the ballast are a spacer element, a linear accelerometer, two microcontroller chips, one or more light emitting diodes (LED), where one or both may have different colors, and a digital display screen as shown in FIGS. **2** and **4**. The spacer maintains the subject's distal digits a fixed distance apart so they just do not touch the member prior to release. The linear accelerometer measures both onset and offset of motion of the member. The computer chip as shown in the inset of FIG. **2** is programmed to either a.) illuminate or fail to illuminate the bicolor LED at the onset of motion, or b.) illuminate the red LED or illuminate the green LED at the onset of motion. The microcontroller chip also records elapsed time (in milliseconds) from onset of motion to arrest of motion and outputs this information to the digital output screen shown in the inset of FIG. **2**.

[0073] A first microcontroller initializes all I/O ports and timer and then checks the test mode (simple reaction time or "Go-No Go"). Then the first microcontroller measures the onset of the acceleration when the stick is dropped by the clinician. When the acceleration exceeds a set threshold, the circuit turns on one color in the bicolor LED and sends a signal to a second microcontroller to start the clock. If the stick experiences a sudden acceleration change, such as being slowed or halted by the fingers or striking the ground, then the first microcontroller sends a signal to the second microcontroller to stop the clock. (The second microcontroller initializes the LCD module and waits for a signal from the first microcontroller to start or stop the clock.) The testing device **100** has a unit which displays the reaction time on a display unit (screen) which is the calculated time between the onset and offset of acceleration of the testing device **100** and therefore the measured reaction time. The LED can be bicolored, having a green and a red LED in one module.

[0074] It should be appreciated that in some embodiments, the measurement and display of response accuracy in the measurement of Recognition Reaction Time and Choice Reaction Time can be provided. In the case of Recognition Reaction Time, it can be incorporated into circuitry **60** and apparatus described herein. In the case of a binary (two-choice) Choice Reaction Time, the present teachings can comprise one or more (such as two) thimble or other sensor disposed on a finger that is capable of detecting when the finger touches the "handle" and the other does not. A touch could be indicated by a pressure-sensitive switch or pressure sensor or proximity sensor. In some embodiments, such as a three-choice Choice Reaction Time system, the thimble or other sensor can be placed on three finger tips. Response accuracy would be calculated for the RRT as the number of correct responses versus the total number of responses, the number of incorrect responses versus the total number of responses, and/or the total number of correct responses versus the total number of incorrect responses. In some embodiments, the response accuracy for the binary (2-choice) Choice Reaction Time could be calculated as the 'number of correct responses for Choice **1**' versus the 'total number of trials with

Choice **1**', and the 'number of correct responses for Choice **2**' versus 'total number of trials with Choice **2**', and so on for additional choices.

[0075] The foregoing description of the embodiments has been provided for purposes of illustration and description. It is not intended to be exhaustive or to limit the invention. Individual elements or features of a particular embodiment are generally not limited to that particular embodiment, but, where applicable, are interchangeable and can be used in a selected embodiment, even if not specifically shown or described. The same may also be varied in many ways. Such variations are not to be regarded as a departure from the invention, and all such modifications are intended to be included within the scope of the invention.

What is claimed is:

1. A manual neurological testing device for measuring a subject's reaction time comprising:

- a) a releasable holding member operable to be grasped by the subject;
- b) a stimulus device coupled with said releasable holding member, said stimulus device outputting a perceivable stimulus; and
- c) a measurement device coupled with said releasable holding member, said measurement device measuring the subject's reaction time for grasping said releasable holding member relative to said perceivable stimulus.

2. The manual neurological testing device according to claim **1** wherein said releasable holding member is a rigid member.

3. The manual neurological testing device according to claim **1** wherein said releasable holding member is a flexible member.

4. The manual neurological testing device according to claim **1** wherein said releasable holding member is a telescoping member.

5. The manual neurological testing device according to claim **1** wherein said measurement device determines a recognition reaction time response accuracy.

6. The manual neurological testing device according to claim **1** wherein said measurement device comprises an accelerometer detecting acceleration of at least one of said releasable holding member and said measurement device.

7. The manual neurological testing device according to claim **1** wherein said stimulus device comprises a visual cue device.

8. The manual neurological testing device according to claim **1** wherein said stimulus device comprises an audible cue device.

9. The manual neurological testing device according to claim **1** wherein said stimulus device outputs a plurality of distinct cues for eliciting a corresponding unique response by the subject.

10. The manual neurological testing device according to claim **1** wherein said stimulus device outputs a plurality of distinct cues for eliciting a corresponding unique response by the subject, a first of said plurality of cues indicating a catch command to the subject, a second of said plurality of cues indicating a no-catch command to the subject.

11. The manual neurological testing device according to claim **1**, further comprising:

- a spacer system for positioning the subject's appendage in a pre-test position.

12. The manual neurological testing device according to claim **1**, further comprising:

a spacer system for positioning the subject's appendage in a pre-test position, said spacer system having a proximity sensor detecting positioning of the subject's appendage.

13. The manual neurological testing device according to claim **1**, further comprising:

a spacer system for positioning the subject's appendage in a pre-test position, said spacer system having a body defining a predetermined dimension for positioning of the subject's appendage.

14. A manual neurological testing device for measuring a subject's reaction time comprising:

- a) a releasable holding member configured to be grasped by the subject;
- b) a control module coupled with said releasable holding member, said control module comprising:
 - i) a displacement sensor operable to determine a predetermined onset and an offset of motion of said releasable holding member in a vertical direction;
 - ii) a controller connected to said displacement sensor, said controller comprising: a stimulus driving output and a timer on/off output; and
 - iii) a timing device in communication with said timer on/off output, said timing device measuring a period of time elapsed between said predetermined onset and said offset of motion of said releasable holding member and sending said period of time elapsed to said controller; and

c) a stimulus device coupled with said releasable holding member to be perceived by the subject, said stimulus device in electronic communication with said controller and operable to output a stimulus in response to said stimulus driving output.

15. A method for manually measuring the reaction time in a subject, the method comprising:

- (a) positioning a manual neurological testing device operable to measure the reaction time of the subject, said manual neurological testing device having a releasable holding member operable to be grasped by the subject; a stimulus device coupled with said releasable holding member, said stimulus device outputting a perceivable stimulus;
- and a measurement device coupled with said releasable holding member;
- (b) releasing said releasable holding member with or without said perceivable stimulus; and
- (c) determining the time taken for the subject to grasp said releasable holding member after releasing said releasable holding member.

16. The method according to claim **15** wherein said determining the time taken for the subject to grasp said releasable holding member comprises determining the time taken for the subject to grasp said releasable holding member using a plurality of sensors disposed on the subjects fingers.

* * * * *