

## Oxygen concentrator tube storage and sanitation device

ME 450 Section 02  
Team 5

Peter Chun  
Tyler Greene  
Nathan Matheny  
Steve Schell

Final Report  
December 11, 2012

### **Project Abstract**

Portable oxygen concentrators are often used to deliver supplemental oxygen to people who suffer from respiratory ailments. Tubing used to deliver oxygen from these concentrators can sometimes be as long as 50 feet, resulting in tripping hazards and damage from entanglement. This affects the concentrator's ability to supply oxygen to the user. Sanitation issues can also arise if the tubing is left lying on the ground for an extended period of time, leading to user infection and other health concerns. The project objective is to design and develop a prototype device to mitigate these issues listed above.

## Table of Contents

Executive Summary	2
Project Description	4
Information Source	4
Customer Requirements	5
Technical Requirements	6
Competitive Products	7
Concept Generation	8
Concept Selection Process	12
Alpha Design Description	13
Concept Subsystem Selection	15
Engineering Analysis	16
Parameter Analysis	18
Force Measurements	18
Bearing Normal Force Calculation	19
Bearing Selection	20
Spring Force Calculation	21
Beam Stress Calculation	23
Tipping Calculation	24
Material Selection	25
Environmental Performance	26
Final Design Description	26
Initial Fabrication Plan	32
Validation Approach	33
Validation Results	34
Design Critique	34
Recommendations	35
Specific Challenges	36
Project Plan	37
Conclusions	38
Acknowledgements	39
References	40

## Executive Summary

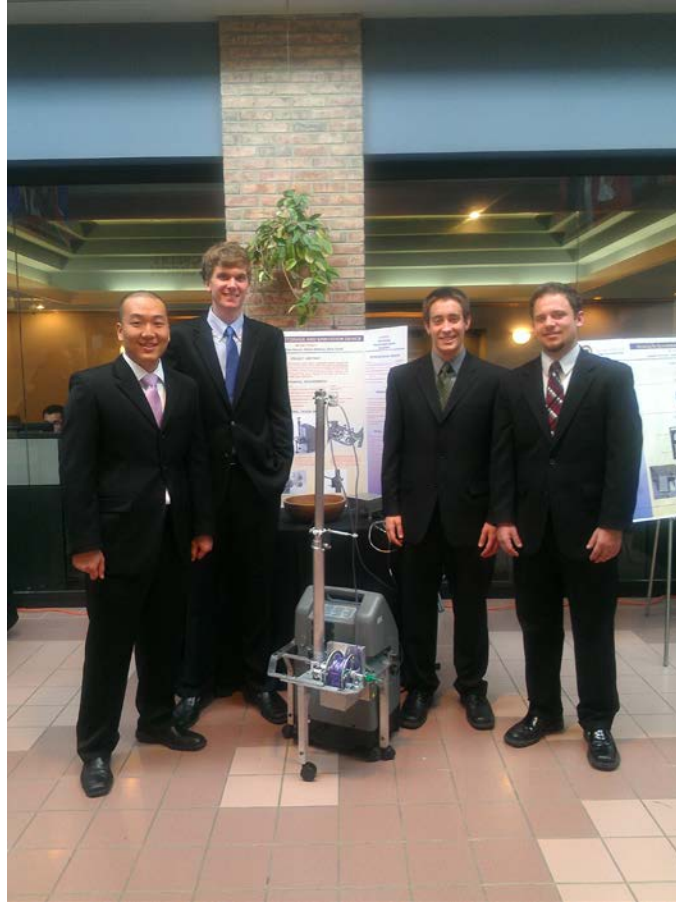
For oxygen concentrator users, long tubing causes dangerous tripping and entanglement hazards to the user as well as sanitation issues if left on the floor for any period of time. These were the two most important problems to our sponsor, Scott Kellman of American Eagle Life Care Corporation, a patient that we spoke with, and other health care professionals who work with patients that have chronic obstructive pulmonary disease (COPD) and other respiratory issues. Our group also determined that the user's mobility was an extremely important factor for whatever design we choose, that the device needed to be easy to use, and maintenance should be low. We then used a QFD chart, and based on these issues, determined technical requirements that our design will be required to meet.

From these technical requirements, our team generated twelve concepts that would meet the user requirements for our device. Requirements for our device were then determined and given weights based on the QFD that our group had previously completed, and the nine feasible concepts were then scored in Pugh charts using these requirements. Each member completed a Pugh chart individually, and the results of our Pugh charts were consistent between all group members. The selected concept was then iterated and our Alpha design was created.

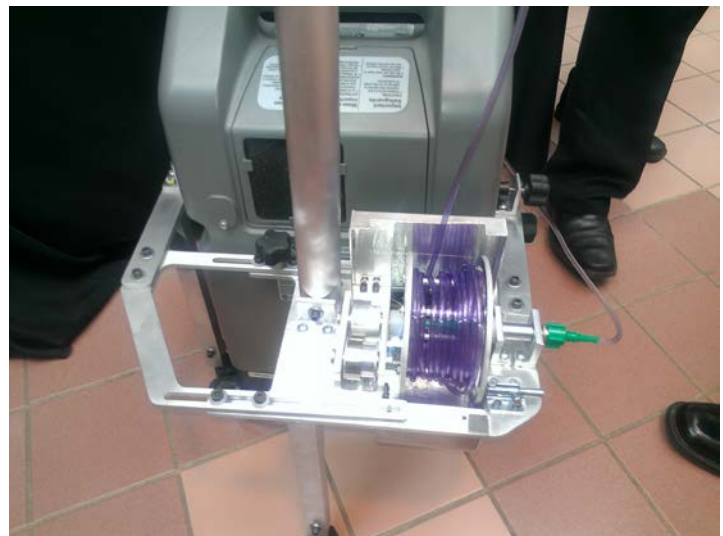
The final design features a retraction spool mounted on an adjustable base plate as well as a UV sanitation system inside the spool cover. This sanitation system is time-limited so that the oxygen tubing is sanitized after a prescribed amount of time. An adjustable pole extends vertically so that tubing passes over household objects to allow high user mobility. Engineering analyses were done on the critical components of the device such as the spool, base plate, pole, pole topper, and spool cover. Next, material selection was performed for each of these major components using CES EduPack 2012. A final design was modeled in SolidWorks 3D CAD software and part drawings created. The parts and materials required to assemble the prototype were compiled into a bill of materials which yielded a total prototype cost of \$357.47.

A manufacturing plan was generated to ensure that the prototype was assembled in a timely and efficient manner. Once the prototype was assembled, validation and testing began to benchmark the prototype against the engineering specifications established in Design Review 1. From the validation, it was observed that the technical requirements of human inputs required for general use and accessible height of components requiring maintenance were met. The technical specification of time between regular maintenance was determined to be met through engineering analysis since this could not be measured. The percent of oxygen tubing length sanitized by device exceeded the set target, and the maximum distance the user can be from concentrator failed to meet the specification. After, a less stiff, and therefore a shorter, spring was needed.

Although the design provides a solution to the issues of reducing the tripping hazard of the oxygen tubing and sanitizing the tubing, it has several weaknesses. The majority of these weaknesses surround the spool, constant force spring system, and UV light. For future development it is recommended to further test the UV system effectiveness, design a custom spring for the constant force spring system, reduce the number of fasteners, and include a wheel brake.



From left to right: Peter Chun, Tyler Greene, Nathan Matheny, Steve Schell



Oxygen concentrator tube storage and sanitation device



## **Project Description**

Respiratory conditions, such as chronic obstructive pulmonary disease (COPD), affect a large part of the population. According to the CDC/NCHS, in 2007-2009, 5.1% of adults ages 18 and over in the United States had COPD (Akinbami 2). To help subdue such conditions, supplemental oxygen is often provided for these patients. Outside of hospitals, in both nursing communities and private homes, oxygen concentrators are widely used to facilitate supplemental oxygen delivery to people who need respiratory help.

These oxygen concentrators deliver oxygen to the user via plastic tubing connected to a nasal cannula. To provide the user with as much mobility as possible, sometimes these oxygen tubes can be 50 feet in length, but 20 foot tubing is most commonly used (Emberton). This long oxygen tubing can drag and pile up on the floor, causing many issues for the user and care providers.

The tubing acts as a tripping hazard when left on the ground and can become entangled with other objects. For users in wheelchairs, the extra tubing is difficult to maneuver around and becomes tangled in the wheels of the chair (Baker). These issues may cause crimping or other damage to the tubing that could affect the amount of oxygen that is supplied to the user from the concentrator.

Sanitation issues can also arise from excess tubing lying on the ground or other surfaces. This is a key problem in assisted living communities and nursing homes, where many people occupy the same living area. Bacteria can grow on the tubing which can potentially spread infection and illness to users and care providers.

Scott Kellman from American Eagle Life Care Corporation first brought this issue to the University of Michigan and will be sponsoring the project. The goal of this project will be to design and develop a prototype device that helps mitigate the previously stated issues that arise from uncontrolled oxygen tubing.

## **Information Sources**

There are multiple oxygen concentrator tube retraction devices on the market today. These range from a simple coil-spring system, which winds up tubing around a spool (Pierce), to a ceiling-mounted counterweight system (*Oxygen ceiling hose reel, 2012*). In addition, numerous patents have been filed for similar systems that coil tubing into a device that is either handheld or attached to the patient's hip or other common items (Vinding).

An issue that our team researched was flow restriction for oxygen tubing in a spool-like device. However, a team from the University of Pittsburgh evaluated oxygen flow rate for 45 feet of coiled tubing and they found that the pressure dropped only 0.24% from the tubing inlet to the outlet using COSMOSFloWorks software. Thus, it is known that flow rate will not become a serious problem for this type of design (Haney).

Speaking with healthcare professionals, Tom Emberton and Jackie Strader, provided us with

insight as to which techniques are used to reduce trip incidents and infection issues. Often, short oxygen tubing (about 9 feet long) is currently used to prevent tubing from contacting the ground. As a result, this short tubing severely limits the patient’s mobility. More often than not, the user must disconnect the oxygen tubing to move around a room or use the restroom (Emberton). This was also seen during our group’s visit with Emily Baker at University Living in Ann Arbor, Michigan. Emily Baker is an oxygen concentrator user who, because she is confined to a wheelchair, uses shorter tubing in order to ensure it does not tangle in her wheelchair wheels. Each time she wants to use the restroom, she must page for someone to help carry her oxygen tubing with her (Baker).

Temporarily, a plastic bag that stores excess tubing reduces tripping hazards for oxygen concentrator users. When the patient moves around a room, excess tubing exits the bag, but the user must manually place the tubing back into the bag when that excess tubing is no longer needed. Another interesting fact we learned was that a majority of oxygen concentrator users are confined to a wheelchair. However, there are also people that use a wheelchair in conjunction with a cane or walker. This information allowed us to broaden our concept generation to accommodate multiple user groups (Emberton).

### Customer Requirements

After completing our initial background research, our team created a list of user requirements that our device should meet. Since concentrators are used in both assisted living communities and private homes, our team focused on designing our oxygen tube device for both patient care providers and users of oxygen concentrators. We took into account five major customer requirements, and they can be seen in Table 1 below.

Rank	Customer Requirement	Weight (Scaled from 1-10)
1	Reduce tripping and entanglement hazards	10
2	User mobility	9
3	Sanitary oxygen tubing	8
4	Easy to use	8
5	Easily maintained	6

**Table 1:** User requirements are ranked based on importance to customer. Each requirement was given a scaled weight, with 10 being most important, and 1 being least important

After speaking with our team sponsor and other health care professionals, tripping and entanglement hazards were found to be the most common issues with oxygen tubing (Emberton). Therefore, we wanted to make sure that our highest valued user requirement was to mitigate risks that come along with oxygen tubing getting tangled and piling on the floor.

Our team ranked user mobility as an important customer requirement, so that users of our device

could still live as independently as possible. This requirement also resulted from issues we had discovered by talking with healthcare professionals (Emberton) and speaking with oxygen concentrator user, Emily Baker (Baker).

Another significant issue with oxygen tubing is keeping the tubing sanitized. When tubing is allowed to contact the floor, bacteria can be transmitted to the tubing and aids the spread of illness. This disease transmission is especially an issue in nursing homes and assisted living communities, where multiple people use the same living spaces.

Our device must be easy to use and require a low level of maintenance. Most oxygen concentrator users cannot live without assistance, are confined to a wheelchair, or are elderly. Therefore, one of our user requirements is to make the device as easy to use as possible so that they can use the device without having to change their daily routines.

### Technical Requirements

Technical requirements were then determined to help our device meet these customer requirements. Each requirement was given a target value that our device will meet. Prior research and interviews were used to help determine target values for each technical requirement. A QFD chart was then used to help determine which technical requirements were of highest importance. Table 2 shows the results of this QFD chart, which can be seen in its entirety in Appendix B.

Rank	Technical Requirement	Target
1	Oxygen tube distance below concentrator connection point	Less than 6 inches
2	Maximum distance user can be from concentrator	20-25 feet
3	Percent of oxygen tubing length sanitized by device	40-70%
4	Accessible height of components requiring maintenance	4 feet off ground or lower
5	Human inputs required for general use	1-3 human inputs
6	Time between regular maintenance	7-14 days

**Table 2:** Results of a QFD chart are shown, ranking the device’s technical requirements in order of highest importance. Target values for each requirement are also shown. See Appendix B for entire QFD

When determining a technical requirement that helps mitigate tripping hazards, it was first necessary to define a tripping hazard. Our group determined a tripping hazard is any object more than six inches below the user’s hip. Therefore, our device will ensure that oxygen tubing rests above this target. However, after looking further into the issue, it was found that the average oxygen concentrator is about two feet tall, and where the oxygen tubing connects to the concentrator is about one and a half feet tall. This connection point is below the previously stated tripping threshold and therefore any device we design would inherently violate this requirement

at the point where the tubing connects to the concentrator. Our technical requirement was thus changed to ensure oxygen tubing rests no more than six inches below the tubing connection point.

Speaking with assisted living community clinician, Jackie Strader, and assisted living community executive, Tom Emberton, our group learned that the average oxygen tube length used is about 20 feet long (Emberton). Therefore, we are hoping to maximize user mobility with our device by using 25 foot tubing since some tubing will be devoted to connecting the concentrator to the device and the nasal cannula to the patient. Our group determined a range of 20-25 feet from the concentrator to better serve user mobility.

According to the FDA (Food and Drug Administration), CDC (Center for Disease Control), and OSHA (Occupational Safety and Health Administration), there are no current standards or regulations for oxygen tube sanitation. When talking with Jackie Strader and Tom Emberton, they also said that no regulations exist, but nursing homes and assisted living communities can be given citations for tubing that is deemed to be in an unsanitary state (Emberton). Currently, care providers and assisted living community auditors subjectively determine whether tubing is sanitary, making it difficult to determine a technical requirement that dealt with oxygen tube sanitation. Our team did determine, however, that the section of the tube that will need to be sanitized the most will be the section that can rest on the floor or other surfaces. This was taken to be the middle 40-70% of the oxygen tubing. Our device will be required to sanitize this amount of tubing.

There is also no regulation on how often oxygen tubing needs to be changed. Jackie Strader stated that it is typical for assisted living communities to change oxygen tubing every 7 days (Emberton). Since our device will employ some sort of sanitation to the tubing, we will be able to improve this standard time between oxygen tube maintenance. Our device will only require regular maintenance every 7-14 days.

With regards to maintenance, we wanted to ensure that both caregivers and the oxygen concentrator users could perform regular maintenance on the device. Regular maintenance is defined as replacing the tubing to ensure sanitary conditions. Wheelchair users will have the hardest time performing regular maintenance on the device if it is a higher distance off the ground. According to *Accessibility for the Disabled: A Design Manual for a Barrier Free Environment*, the maximum vertical reach of the typical wheelchair user is between 1.47 and 1.79 meters (or 4.8 and 5.9 feet) (Solidere, 105). Therefore, our device will have components that require maintenance be accessible at a height no higher than 4 feet, in order to stay within a comfortable range for wheelchair users.

## **Competitive Products**

One current device in the market, the “O2 Ceiling Hose Reel” allows the user a high range of user mobility (*Oxygen ceiling hose reel*, 2012). It also keeps the oxygen tubing above the user’s hip by employing a 40 or 50 foot oxygen tube that is not replaceable. Since it cannot be replaced, sanitation issues can arise from bacteria growth. Serviceable parts do not appear to be less than 4 feet off the ground, so users who are confined to a wheel chair may have difficulty using this

device. Along with the sanitation issues, the “O2 Ceiling Hose Reel” requires the human to actively participate during general use.

Another device that works to solve some of the issues we have proposed is Tidy Tubing (*Captive technologies tidy tubing*, 2012). This device meets the user input requirements that we have created, as it only takes one input (the user walking to and from the device) to either expand or retract the oxygen tubing. It does not, however, meet our requirement of keeping the tubing a maximum of 6 inches below the user’s hip or sanitizing the tubing.

The “Oxy-Reel” also helps mitigate some problems with oxygen tubing (*Premier remote controlled oxygen tubing spool*, 2011). The electric powered motor allows the user to unwind more oxygen tubing with the simple press of a button. This device meets technical requirements of being accessible for maintenance, using a 20-25 foot oxygen tube, and allowing the user to move the 20-25 feet away from the concentrator. However, it fails other technical requirements. The spool rests on the floor, and tubing that is left out still poses a tripping hazard since it is lower than 6 inches below the user’s hip. The device also employs no method of sanitizing any part of the oxygen tubing.

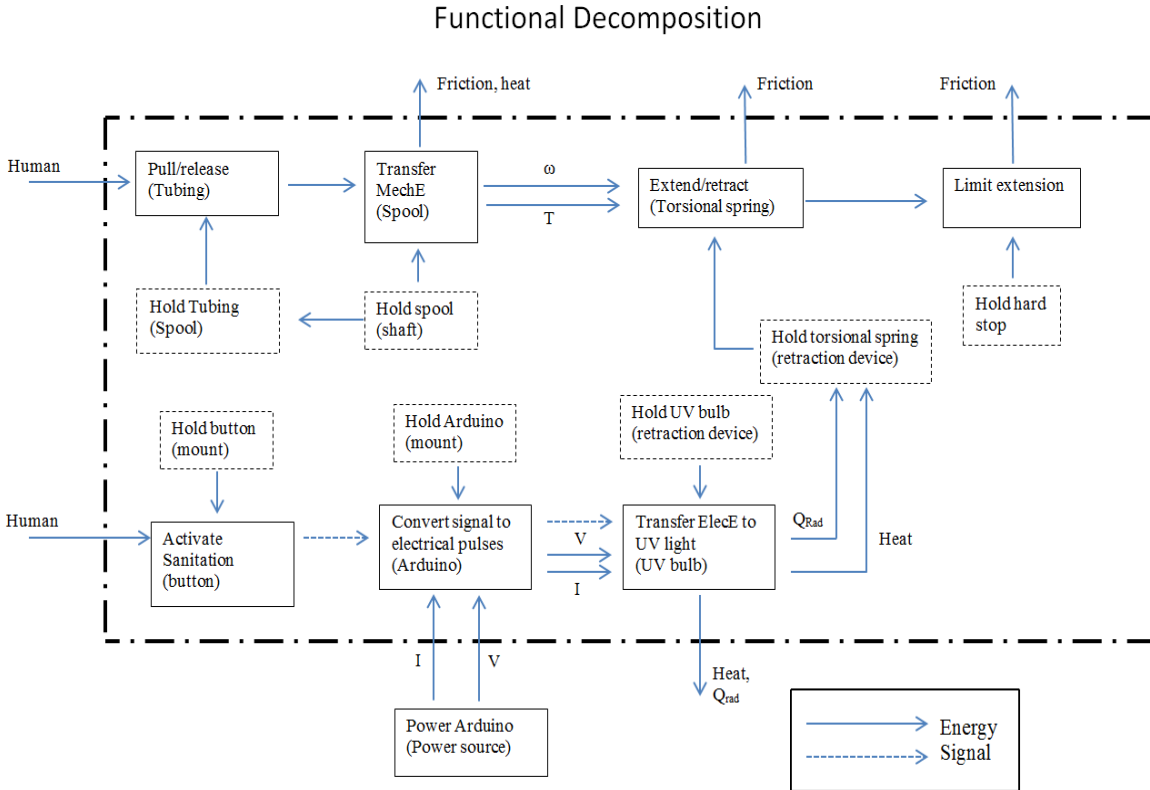
## **Concept Generation**

After determining our technical requirements and researching prior products, our group completed a functional decomposition to determine how our design would meet the customer requirements. Our group completed a functional decomposition for the general tasks our device must accomplish (see Figure 1, p. 9). From this functional decomposition, our group then began generating design concepts that would meet our technical requirements.

First, our group looked at the various environments where oxygen concentrators would be used (such as nursing homes and other residential housing) to find consistencies between them. We found three features that are always present in environments where oxygen concentrators are used: room walls, room ceilings, and an oxygen concentrator. We generated these concepts so that, if our device was to mount to anything, it would mount to one of these three features. We generated a total of twelve concepts: three mounted onto the oxygen concentrator, three mounted to the ceiling, three mounted to the wall, and three that required no mounting to anything other than the user.

Our first category included devices that mounted to the ceiling. An example of a ceiling-mounted device is the “fisherman” concept. This design uses a retraction reel with a hook and track system attached to the ceiling in order to guide the tubing as the user walks toward or away from the concentrator. One of the advantages of ceiling-mounted devices is that it keeps the tubing at a large distance above the ground. This not only reduces tripping hazards, but also helps prevent tubing from becoming tangled or snagged on other furniture in the room. One of the disadvantages of ceiling-mounted devices, such as the “fisherman”, is that maintenance of the tubing will be hard to implement. Also, obstructions mounted to the ceiling of the room, such as fans and lighting fixtures, will severely limit where this device could be employed. The device, since it is attached to the ceiling, will also not be able to easily be moved from room to room if the user would like to move it. Figure 2, p. 10, shows a sketch of the “fisherman” concept.

Our second category of devices featured retraction devices that were mounted to the wall of a room. One of the concepts in this category was called the “scissor.” This concept uses an extendable arm attached to a wall-mounted rolling track system (see Figure 3, p. 10, for a visual depiction of the device). As the user walks parallel to the wall, the track system is able to follow



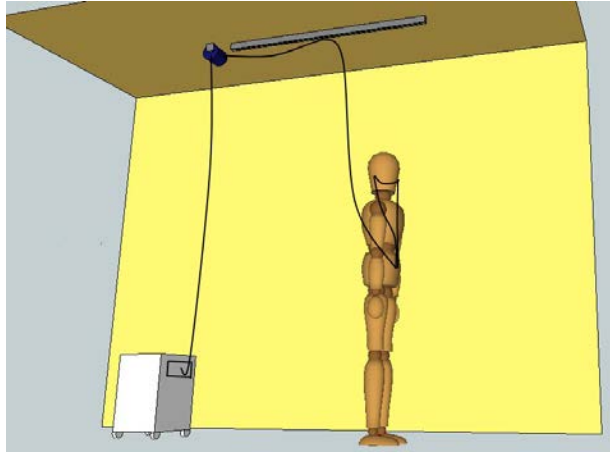
**Figure 1:** The final functional decomposition for the Alpha design illustrating a more detailed breakdown of the subsystems during general use.

the user. When the user walks perpendicular to the wall, the arm is able to extend and retract, allowing for more user mobility. The tubing is attached to the sections of the extendable arm, so when the arm folds in on itself, the tubing also folds together. Like the “fisherman”, the “scissor” is confined to the room and cannot be moved, but since it is mounted to the wall and not the ceiling, the device is much easier to maintain. However, the device does not allow for much user mobility, as the user is kept along the wall that the device attaches to.

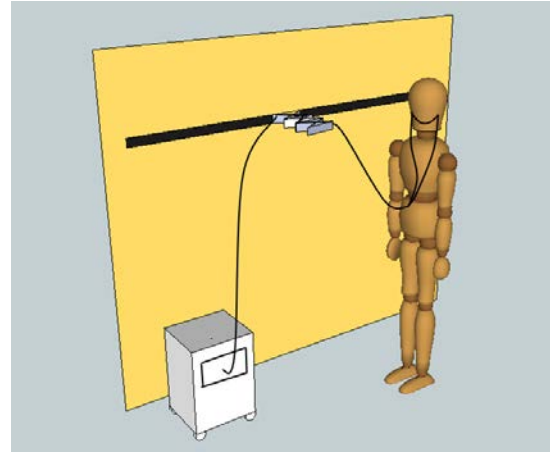
Figure 4, p. 10, shows a sketch of a wall-mounted concept called the “mobile wall mount.” This concept utilizes a portable bracket system, where multiple brackets can be placed in various rooms. The wall mount itself will hold a tubing retraction device, and can be moved to and from the different mounting brackets. This concept will allow the user to move their retraction device and their oxygen concentrator, to another room, as long as there is a bracket mounted there.

This device would be relatively easy to manufacture, and would be easy to access for regular maintenance. However, it will not be as easy to use because the user will have to physically carry the “mobile wall mount” when they move the oxygen concentrator to a new room.

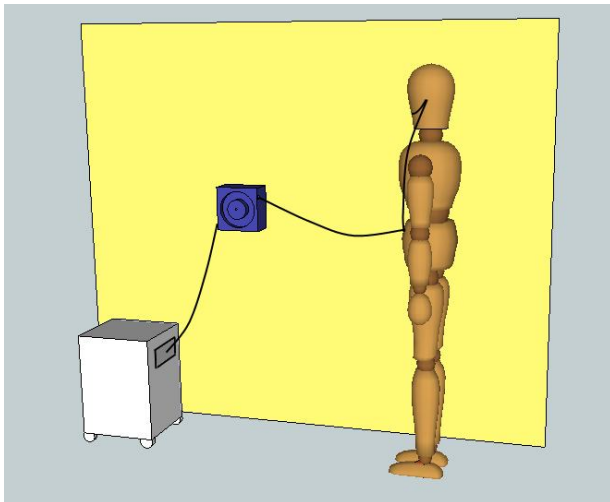
Our third category of concept generation was concentrator-mounted devices. When our group was researching oxygen concentrators, we noticed that concentrators came in all shapes and sizes (*Home Oxygen Concentrators*, 2011). Therefore, mounting to the concentrator was going to be a challenge. One of our group’s concepts in this category is the “IV pole”. This concept attaches to



**Figure 2:** The “fisherman” concept features a ceiling-mounted tubing retraction device, using a track system that the tubing slides along.



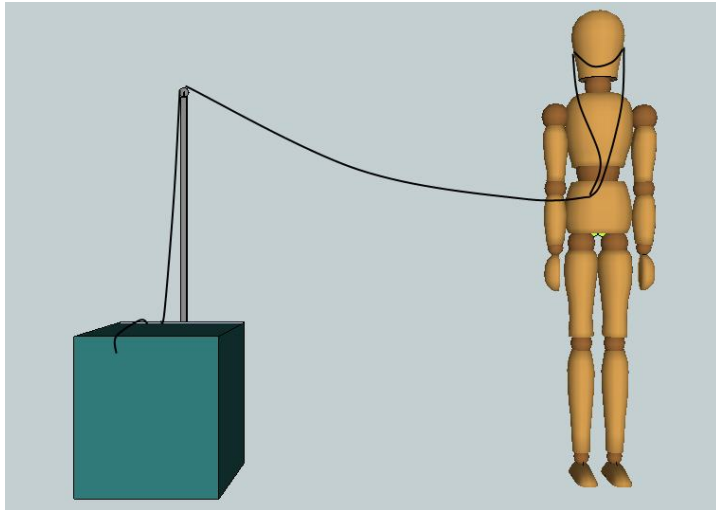
**Figure 3:** The “scissor” concept moves along the wall on a track system, and can extend out toward the user as he/she moves away from the wall.



**Figure 4:** The “mobile wall mount” device is portable and can be mounted to various wall-fixed brackets around in different rooms.

the concentrator using a box that slides over the top. The sides of the box would be adjustable, so that you could slide the box over the concentrator and “clamp” it to the sides. The box would still allow the wheels of the oxygen concentrator to be used so it could still easily be moved. The concept has an extendable pole that allows for varying heights. The retraction device would be located at the base of the pole, on the box that attaches to the concentrator. One of the advantages of this device is its portability. Also, the tubing is high enough off the floor to avoid entanglement with furniture or other obstacles, while the pole adjustability still allows the device

to be easily accessible for maintenance. However, one disadvantage of this system is the potentially high material cost, as the attachment “box” would require a lot of material. Figure 5 shows a physical representation of this concept.

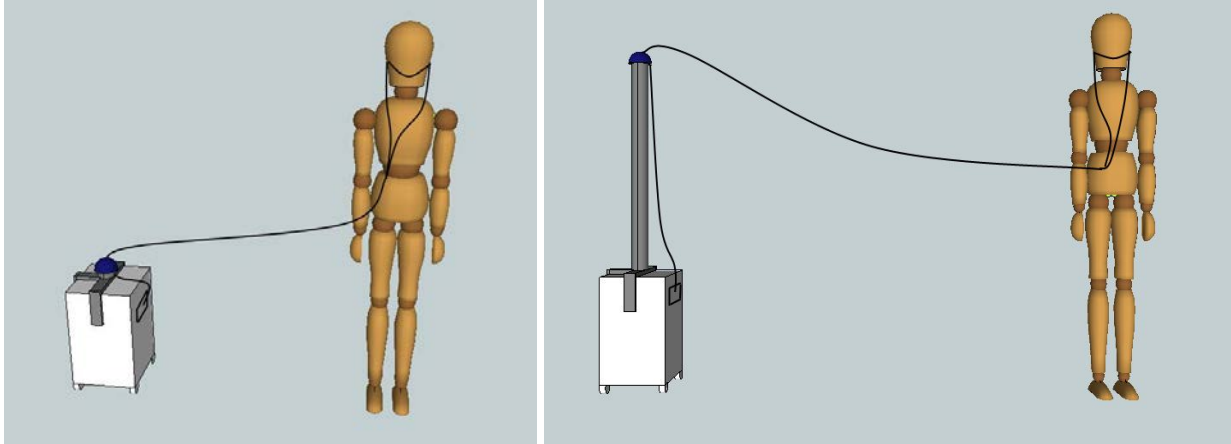


**Figure 5:** The “IV Pole” concept is an oxygen concentrator-mounted device that extends the height of the tubing and uses the concentrator for stability.

Another concept which mounts to the oxygen concentrator is called the “swivel tube clamp”. This system clamps on top of the concentrator, with a retraction device that rests on top of the clamp (see Figure 6, p. 12, for an image of this concept). The reel is able to swivel three hundred sixty degrees, allowing the user to walk all the way around the concentrator. As the user walks away from the concentrator, the pole will rise in order to keep the tubing from snagging on furniture. When the user walks towards the device, and the tubing retracts, the pole would lower to make it more convenient for the user. Another advantage of this device is the use of clamps, which will allow direct connection to the concentrator. Disadvantages of this device include manufacturing difficulties and robustness concerns, as there are many moving parts in the system.

For more information on all of our group’s generated concepts, Appendix D shows all of our concepts, not only the ones shown in the section above. Concepts were also created that do not mount to any external object or mount to the concentrator themselves.





**Figure 6:** The “swivel tube clamp” is shown in both its raised and lowered positions. This automatically happens when the user moves closer or further from the device.

### Concept Selection Process

Once the concepts had been generated, selecting which design to move forward with was the next step. First, our group established requirements for a Pugh Chart and weighed the requirements based off the QFD that was previously completed. These requirements and weights are shown in Table 3.

<b>Requirement</b>	<b>Weight</b>
Reduce tripping hazard	0.20
User mobility	0.15
Ability to utilize sanitizing agent	0.15
Easy to use	0.15
Easy to maintain	0.10
Portability of device	0.10
Ease of manufacturing	0.10
Durability	0.05

**Table 3:** Each concept was rated based on how well it met these requirements. The QFD chart used to help guide these requirement weights can be found in Appendix B.

Next, our group looked at the feasibility of each concept, and eliminated designs that our team would not be able to produce due to budget or time constraints, or the technology was not fully developed. This narrowed our twelve concepts down to nine concepts to be scored based on the above requirements.

Each member of the team then separately completed a Pugh Chart that included all concepts deemed feasible with the “fisherman” concept as the reference (Appendix E). The results for all four members were similar, with the ceiling-mounted concepts scoring lower than wall- and concentrator-mounted concepts. Also, two team members scored the “I.V. pole” concept as the

highest and the other two scored the “swivel tube clamp” the highest. The team then came together, discussed, and completed a final Pugh chart shown below in Table 4.

The team decided to move forward with the “I.V. pole” concept, as this was the highest scoring concept from the team Pugh chart. After looking further into the selected concept, the large box the concentrator set in was thought to be too large, weighed too much, and was an inefficient use of materials. For these reasons, the box was replaced by a wheeled, side-clamping base. The idea of this base was pulled from both the “side reel” and “swivel tube clamp” concepts, and was thought to be a much more efficient way to attach the device to the oxygen concentrator. After incorporating this new clamping mechanism into the design, our team then had a final concept on which to base our Alpha design.

		Concepts								
Requirement	Weight	“Fisherman” (Reference)	“Shower curtain”	“Scissor”	“Cross tracks”	“Tele- mag arm”	“Mobile wall mount”	“I.V. pole”	“Side reel”	“Swivel tube clamp”
Reduce tripping hazard	0.20	3	3	2	3	2	2	2	1	2
User mobility	0.15	3	3	2	4	3	4	4	4	4
Ability to utilize sanitizing agent	0.15	3	1	1	3	2	4	4	4	4
Easy to use	0.15	3	3	3	3	2	3	3	3	3
Easy to maintain	0.10	3	3	4	3	3	4	4	4	4
Portability of device	0.10	3	3	3	3	3	4	5	5	5
Ease of manufacturing	0.10	3	4	2	1	1	3	2	3	1
Durability	0.05	3	3	1	2	1	3	4	4	2
<b>Total</b>		<b>3</b>	<b>2.8</b>	<b>2.25</b>	<b>2.9</b>	<b>2.2</b>	<b>3.3</b>	<b>3.35</b>	<b>3.25</b>	<b>3.15</b>

**Table 4:** The team Pugh chart shows exactly what our individual Pugh charts did; the ceiling-mounted concepts scored much lower than the wall- and concentrator-mounted concepts.

### Alpha Design Description

Adding the new clamping system onto the “I.V. pole” concept allowed our group to move forward with this project. This design, depicted in Figure 7, p. 14, has many of the same features as the “I.V. pole” concept our team originally created, while incorporating some features from other high scoring concepts as well.

Initial research showed that there are many different, widely used concentrators with a unique shape, size, and surface type (*Home Oxygen Concentrators*, 2011). However, every unit had at

least two parallel surfaces on its side. Thus, an obvious solution to mounting the device onto the concentrator is to clamp onto these parallel surfaces. Our Alpha design originally was



**Figure 7:** Alpha design on the left and close-up of clamping system and retraction device on the right.

going to feature a rack and pinion system so that a nurse or user simply rotated a knob to tighten or loosen the clamp, but after further research, we determined it would be too costly and complex for an initial prototype. The new system still allows the device to clamp onto concentrators of various sizes.

This design also includes a tubing retraction system that will ensure the oxygen tubing remains off the ground and does not get tangled. This retraction device will also be able to implement an ultraviolet light sanitizing agent. The user will be able to turn on the UV sanitizer in order to kill bacteria on the oxygen tubing. The next feature that stands out is the pole system (Figure 8, p. 15). At its highest point of extension, the pole ensures that oxygen tubing does not catch any household furniture such as tables and chairs. However, the pole can be lowered using a detent locking mechanism, allowing a caregiver or user to easily access and maintain the top portion of the pole under the 4' limit that was established in the engineering specifications.

The tripod-like base structure enables a person to easily install and remove the device if necessary (Figure 9, p. 15). When the clamp is loosened, the user is not expected to exert any force in holding or carrying the device to or away from the concentrator; they must simply roll it.



**Figure 8:** The pole system allows 360° rotation for increased user mobility and adjusts to allow for accessibility below 4 feet from the ground.



**Figure 9:** The three-wheeled base structure makes installing and removing the device simple.

### **Concept Subsystem Selection**

We evaluated how each of the three subsystems: tubing retraction, tubing sanitation, and a concentrator clamping system could be optimized. During this process, we came up with three different concepts for each subsystem. Starting with the retraction system, one concept implemented a motorized spool. Motivated by designs like the “Oxy-Reel” (*Premier remote controlled oxygen tubing spool, 2011*), the user would press a button to retract excess tubing. However, when the user extended the range of the tubing, the device would be free-wheeling. Also, a motorized spool would require the device to be plugged into an electrical outlet. The next two concepts used a spring-loaded mechanism to retract tubing. One of the concepts was motivated by a fishing rod. A vertical fixed spool would have a secondary arm that would rotate about the same axis. As the arm rotated clockwise, the tubing would be extracted, whereas when the arm rotated counterclockwise, the tubing would be retracted back into the spool. The

problems with this concept are the complexity as well as the need for gears and bearings to rotate the secondary arm. Our final concept was selected, which uses a spool with a constant force spring to control the tubing. As the user extends the tubing, the spring would exert a force on the spool, keeping tension on the tubing, and when returning to the concentrator, the tubing would be wound up.

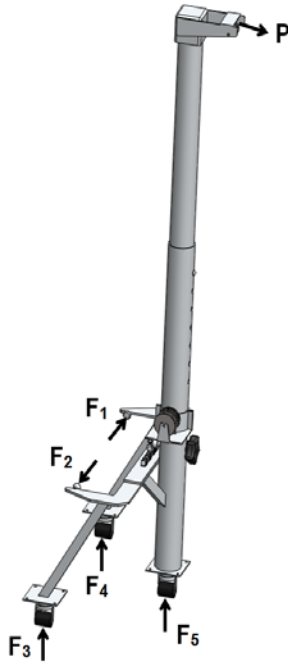
The three categories of sanitation ranged from materials to applications. The first concept would use a bleach solution to sanitize the tubing. This process would be implemented when the tubing entered the spool. As more tubing was retracted, the solution would be sprayed on the tubing. As the tubing left the spool, the bleach would be dried off the tubing. The problems with this concept are that the user would need to refill the solution after a period of time, the solution may not be entirely dried off the tubing, and a mechanism would be needed to apply the solution. The second concept would use a material with anti-bacterial properties specifically for the components in contact with the tubing. This concept does solve the complexity of applying a sanitizing agent, but finding a coating with these properties is limited in the current market. The concept we selected for this subsystem uses ultraviolet (UV) radiation. UV light would shine on the tubing, killing microorganisms and sanitizing the tubing. The benefit of UV sanitation is that unlike the bleach solution, the tubing does not need to be dried because it is not sprayed. Also, UV light is easier to maintain compared to using a bleach solution.

The clamping system was important for the stability of our design. We needed an effective clamping system that would not loosen once clamped onto the concentrator. The first concept would use a worm drive to power a rack which would extend and tighten the arms of the clamps. Another gear system concept would use ratchets and pawls to power a rack which would then extend and tighten the clamps. Both these concepts are very costly. Therefore, a concept using slots was implemented. Two plates, one stationary and one moving, would be able to extend and tighten on a concentrator. After it was clamped, the use of feet would then be able to grip down on the concentrator and prohibit lateral movement.

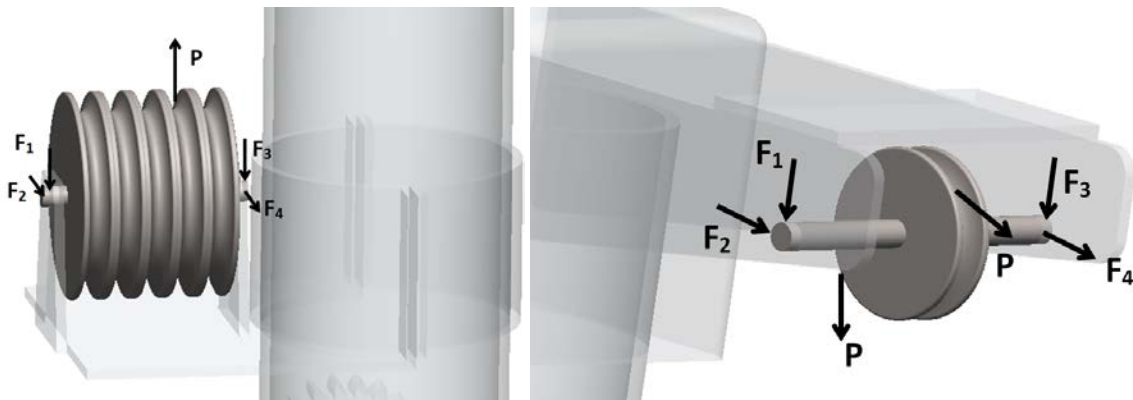
## **Engineering Analysis**

Looking at our selected concept, we have multiple components to our device, both moving and stationary, to meet our technical requirements. Therefore, static and dynamic analyses will need to be performed. An analysis of the external forces placed on our device and the moments caused by these forces will help determine the exact dimensions we need to design a physically stable device (see Figure 10, p. 17).

Internal forces on individual components will also be analyzed to determine what stresses each component will sustain. This analysis will be required for material selection, ensuring a durable device. See Figure 11, p. 17 for examples of internal force diagrams that will be analyzed.



**Figure 10:** The large extendable pole adds flexibility to our design, but also causes a large bending moment from the user's pull force,  $P$ . Based on our force analysis, the leg positions will have to be arranged such that this bending moment is stabilized.



**Figure 11:** Examples of force diagrams on individual components. These diagrams show forces on the tubing spool and upper pulley of our design when the tubing is at its full extension, so that the cable is in static tension.

Material selection will be important for durability, manufacturability, and the ability of the device to meet the technical requirements. From these force calculations, the required material strength used for each component can be determined. Our group is aiming to minimize cost and weight of our device, while still making it strong enough to withstand the stresses on each component. Also, certain materials or material coatings may prevent bacterial growth better than others. To determine which material will be best for each component, we will first determine a material index from the properties our team wants to maximize. Then, we will use this index to determine what would be the best material to use for each part, using material selection charts.

The Alpha design has many rotating parts which will require the use of bearings and gears. To select the correct bearings for our design, we will be using both bearing load and life calculations. Our mounting clamp uses a rack and pinion design, so we will need to determine the most efficient gear design, both from a tooth count and strength standpoint, to create the best design. Both of these tasks will be completed using methods from *Shigley's Mechanical Engineering Design* (Budynas).

Since a timed UV sanitation method is preferred, we will need to incorporate a simple timer switch. We plan to use a button to turn on the light, and then have the light automatically turn off after a set time limit. To accomplish this, we will use a processing unit, like an Arduino Duemilanove processor (See Appendix G for circuit diagram and code).

## **Parameter Analysis**

To turn our Alpha design into our final design, the team analyzed the critical components that would be the main design drivers. Our team determined the most critical components of our device to be the spool, pole, and base plate of our device. Some of our analyses include maximum stress calculations, force balance equations, and bearing load calculations.

### *Force Measurements*

Before our design parameter analyses were performed, our team first had to determine what magnitude of forces our device would experience during use. We were interested in finding two force values: the maximum amount of pull force that the user would feel from our device and the maximum pull force the user could exert on our device. Since it was difficult to find research data for this force, our team determined these values from experimentation.

First, we wanted to find the minimum pull force from the tubing that the user begins to “feel.” This value was set as the maximum pull force of our device to ensure the user will feel little to no force during general use of our device. To determine this pull force, one end of the oxygen tubing was fixed to a wall and the other end attached to a force gauge attached to the user’s hip (see Figure 12, p. 19 for experiment set-up). The user then slowly walked away from where the tubing was attached at the wall, and stopped when they began to feel the tubing tugging at their waist. The amount of force was then measured from the force gauge and was recorded. This procedure was repeated for twelve trials and the average of these trials, 2.39 lbs, was taken to be the maximum force the device exerts on the user during normal use.

The maximum pull force the user can exert on the device was then found using a similar set-up. However, the user walked away at an average pace and continued to walk until just after they felt a force from the tubing. This process was designed to simulate a user “forgetting” that the tubing is connected to the concentrator, and continue to walk at a normal pace until the user realizes they are out of tubing. This force represents the maximum pull force a user would apply to the device. After taking multiple trials, the largest pull force from all trials was 7.61 lbs. It was noted that the variation between these force readings was high. Therefore, we cannot say that 7.61 lbs is a reasonable estimate for the maximum force exerted onto the concentrator. Therefore, our team will design for a safety factor of five, meaning the maximum force the user will place on

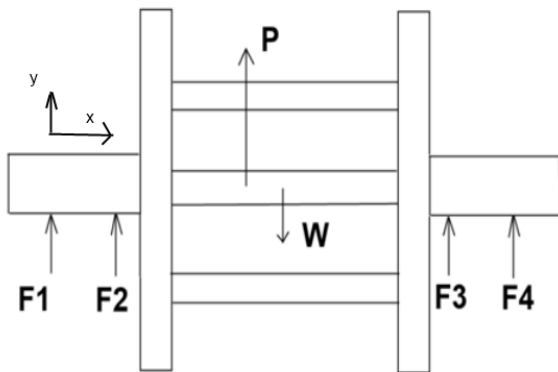
the device is 38 lbs.



**Figure 12:** Set-up used for testing both minimum force felt on user and maximum force experienced by device.

#### *Bearing Normal Force Calculation*

After the maximum pull force was found that the user will apply to the tubing during regular use, the reaction forces on the retraction spool shafts from the bearings can be calculated. The force decomposition of the spool can be seen in Figure 13 below.



**Figure 13:** Force diagram of the tubing retraction spool. In this diagram, **P** represents the maximum pull force exerted on the tubing, **W** is the weight of the spool, and **F<sub>1</sub>**, **F<sub>2</sub>**, **F<sub>3</sub>**, and **F<sub>4</sub>** are the normal reaction forces from the 4 bearings on the spool shaft.

When the spool is at rest, the resulting force and moments on the spool sum to zero. This relationship physically represents when the user is exerting a maximum pull force of 38 lbs at the maximum length of tubing extension. Equations 1 and 2 show the balance of forces at this equilibrium position.

$$\sum F_y = 0$$



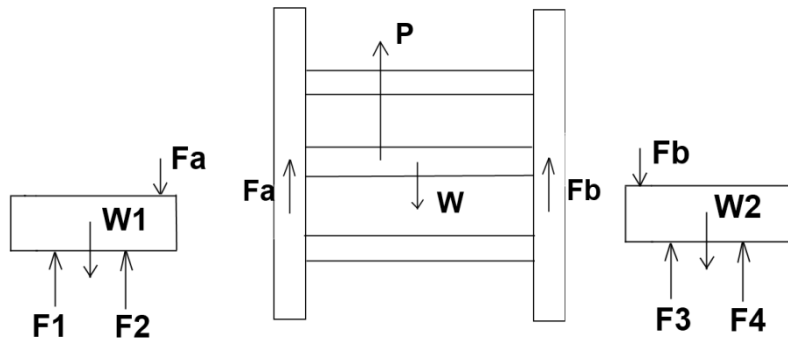
$$F_1 + F_2 + F_3 + F_4 + P = W \quad (\text{Eq. 1})$$

$$\sum M_1 = 0$$

$$F_2x_2 + F_3x_3 + F_4x_4 + Px_p = Wx_p \quad (\text{Eq. 2})$$

Summing forces and moments from the force diagram yield the above equations, with  $x_1$ ,  $x_2$ ,  $x_3$ ,  $x_4$  and  $x_p$  measured from the left hand side in Figure 13, p. 19. This system is statically indeterminate since there are too many unknown variables.

To solve for the bearing reaction forces, the spool was broken down into its individual components, seen in Figure 14 below.



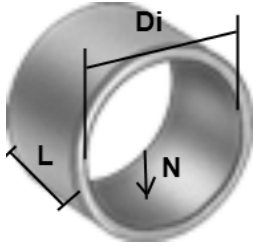
**Figure 14:** Breaking down the spool into its components allows for solving the reaction bearing forces.

Using the same method listed above in Figure 14, the forces and moments were summed to zero in each individual component. The bearing normal forces,  $F_1$ ,  $F_2$ ,  $F_3$ , and  $F_4$ , were then found to be 4.55 lbs, -26.08 lbs, -19.67 lbs, and 3.84 lbs, respectively. For these calculations in their entirety, see Appendix F.

### *Bearing Selection*

After finding the normal reaction forces on the shafts, our group then needed to determine which type of bearings would be best for our spool shaft mounts. Our group wanted to use SAE 841 bronze sleeve bearings because these are much cheaper than ball bearings. To verify bronze bearings would be acceptable for this application, we calculated the PV rating for SAE 841 sleeve bearings. A bearing's PV rating relates pressure on the projected bearing area,  $P$ , and the linear velocity of the bearing's wear surface,  $V$  (Bunting Bearings). Calculations for these design parameters can be seen below in Figure 15, p. 21.

To calculate the rotational speed of the shafts, the rate at which tubing will be pulled out of the spool needs to be found. According to a study done on pedestrian walking speeds, the average walking speed of people 65 years and older is 4.11 feet/second (Knoblauch). Most of our users will probably be around this age, so this was taken to be the rate at which the tubing is pulled out of the spool. Then, taking the radius of the spool,  $R$ , to be 2 inches, the average rotational speed of the shaft was found to be 235.5 RPM. The results of the pressure, linear velocity, and PV rating calculations can be seen in Table 5, p. 21 below.



$$P = \left( \frac{N}{D_i \cdot L} \right) \text{ (Eq. 3)} \quad V = \frac{\pi}{12} \cdot RPM \cdot D_i \text{ (Eq. 4)} \quad PV = P \cdot V \text{ (Eq. 5)}$$

**Figure 15:** Pressure, linear velocity, and PV calculations are shown for bronze SAE 841 sleeve bearings, where  $N$  is the magnitude of the normal force exerted on the bearing by the shaft,  $D_i$  is the inner diameter of the bearing,  $L$  is the length of the bearing, and  $RPM$  is the rotational speed of the shaft. Appendix F shows full PV parameter calculations.

	Maximum in Design	SAE 841 Maximum
$P$ (psi)	222.5	2,000
$V$ (sfpm)	38.53	1,200
$PV$ (psi·sfpm)	8,572.9	50,000

**Table 5:** From looking at the pressure, linear velocity, and PV ratings for the bearings, all values are well below the acceptable values for SAE 841 bronze (*Bunting Bearings*). Therefore, SAE 841 bearings can be used in our device.

### Spring Force Calculation

Next, we determined the frictional forces acting on the shafts from the bearings. These bearing normal reaction forces,  $F_1$ ,  $F_2$ ,  $F_3$ , and  $F_4$ , were shown how they were calculated previously in this report, using the force diagram in Figure 14, p. 20. A published value of the coefficient of static friction between lubricated bronze and aluminum was unable to be found, so this value was approximated to be the coefficient between lubricated bronze and steel,  $\mu_s=0.16$  (*Friction and Coefficients of Friction*). Using these values, the total frictional force due to all four bearings on the shaft was found from Equation 6:

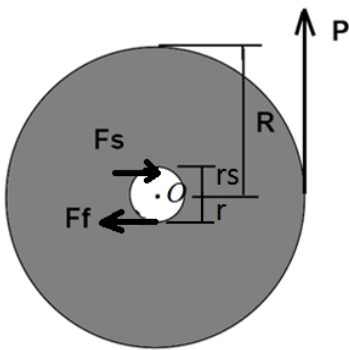
$$F_f = (F_1 + F_2 + F_3 + F_4)\mu_s \quad \text{(Eq. 6)}$$

This frictional force was found at two states: when the user is pulling on the tubing with the maximum force of 38 lbs (representing the worst case scenario of friction) and when tubing is being retracted and the user pull force is zero. This analysis was done to find a range of spring forces necessary to move the spool. The minimum value was the force the device needs to exert to overcome friction and the maximum value is the force limit the pull force felt on the user by the device to 2.39 lbs (the maximum allowable force, determined from lab testing previously mentioned in report).

To fully retract the tubing, the constant-force spring needs to be a certain length at its full

extension. Since we are retracting a large amount of tubing (258 inches, or 21.5 feet) and we want to keep the size of the spool down, the extended length of the spring has to be relatively long. To retract this amount of tubing, the spring length at maximum extension must be 40.3 inches (see Appendix F for this calculation). When looking at standard constant force springs that are readily available to us through convenient suppliers, there are only a handful of springs that we could choose from. Therefore, we selected a 7.00 lb constant spring force,  $F_s$ , that, at full extension, is 43 inches long (*McMaster-Carr*).

Once these values were determined, the torques created about the center of the spool by forces acting on the spool and shaft were calculated and evaluated at equilibrium. Figure 16 shows a force diagram on the side view of the spool and the equilibrium equations that were derived from the diagram.



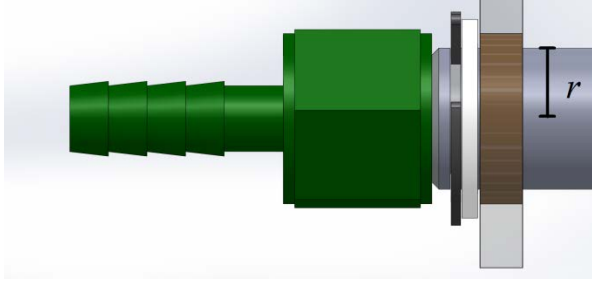
$$\sum \tau_o = 0$$

$$F_s r_s + F_f r = PR$$

**Figure 16:** Seen above is a force diagram for all forces that create torques about the center of the shaft (point  $O$ ). In this figure,  $R$  represents the radius of the spool,  $r$  is the shaft radius, and  $r_s$  is the radius from the center of the shaft at which the spring force is applied.

The shaft radius,  $r$ , is already fixed because of the oxygen tubing swivel connector; the radius must be at least 5/16". To optimize the weight, the shaft radius was set to that minimum value of 5/16" (see Figure 17, p. 23).

After setting the friction force, shaft radius, and pull force, the spring force radius can be found. This spring force radius was found for both maximum and minimum values of the force of friction to determine a range of values that would work for the radius where the force is applied. After performing these calculations, it was determined that the shaft radius would need to be between 0.005 inches and 0.3 inches. The low end of that shaft radius is extremely small, which makes sense because the frictional forces on the spool are so small when the user is not pulling on the device; not much torque is required to overcome these small frictional forces.

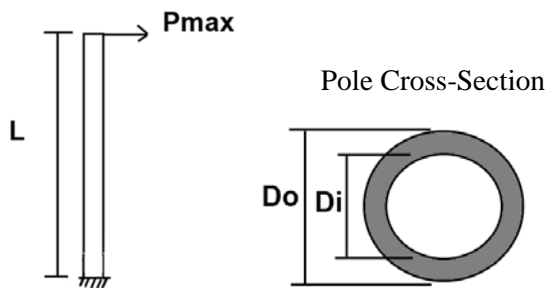


**Figure 17:** The oxygen tubing swivel connector threads onto the spool shaft. The shaft diameter must be at least as large as the threads of the swivel connector, thus the radius of the shaft,  $r$ , is fixed.

To fasten the constant force spring to the shaft, a larger diameter is required. Therefore, for these reasons, our group has chosen the spring force radius to be 0.25 inches. Using this spring force and radius at which it is applied, the user will feel a pull force of 2.23 lbs, which is below our maximum threshold of 2.39 lbs. Like before, the full calculation is done in Appendix F.

#### *Beam Stress Calculation*

One of the other critical components of our device is the pole which extends and guides the oxygen tubing. To determine which material the pole will be made of, we first determined what maximum stresses the pole would experience during use. The pole was modeled as a beam in simple bending as shown in Figure 18 below.



**Figure 18:** The pole was modeled as a cylindrical beam in bending with the bottom end constrained (fixed to the device mounting plate) and the top end of the beam unconstrained. The pole is a hollow cylinder, with cross-sectional area shown to the right, an outer diameter  $D_o$ , an inner diameter  $D_i$ , and a length  $L$ . The pull force,  $P_{max}$ , was taken to be the maximum loading calculated from lab testing, 38 lbs.

The maximum stress in a cylindrical beam can be found from Equation 7.

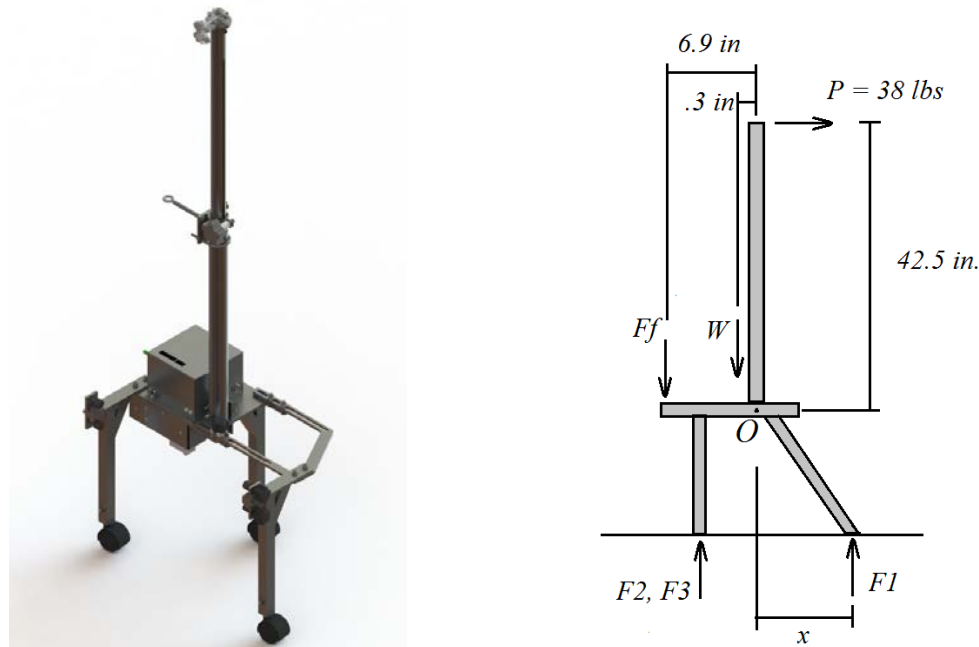
$$\sigma = \frac{PL(D_o/2)}{(\pi/64)(D_o^4 - D_i^4)} \quad (\text{Eq. 7})$$

Schedule 40 tube will be used for the top section of the pole, which will have a length of 21.4 inches, an outer diameter of 1.313 inches, and an inner diameter of 1 inch. Using the equation above, the top section will experience a maximum stress of 5,515 psi at the bottom of the upper section. The bottom section of the pole's bending length is 40.6 inches, with an outer diameter of 1.66 inches and an inner diameter of 1.38 inches. According to Equation 7, the lower section of

the pole will have a maximum stress of 6,576 psi.

### Tipping Calculation

To ensure that the device will not tip over, the team looked at how the device attaches to the concentrator and where the support legs rest on the ground. The team determined the worst case scenario as pulling from the direction depicted in figure 19. They then solved for the distance that the rear leg is from the back of the concentrator so that the device will not tip over at the maximum pull force. Figure 19 below shows a free body diagram of forces external forces on our device.



**Figure 19:** The entire device (shown on the left) can be represented by a simplified, in-plane force diagram on the right. In this diagram,  $F_f$  is the frictional force from both sides of the clamp rubber feet against the concentrator,  $F_2$  and  $F_3$  are the reaction normal forces from the ground to the front two legs of the device,  $F_1$  is the reaction force from the ground on the rear leg,  $W$  is the weight of the entire device, and  $P$  is the maximum user pull force. Distances shown are horizontal distances from the force to the center of the pole on the mounting plate (point  $O$ ).

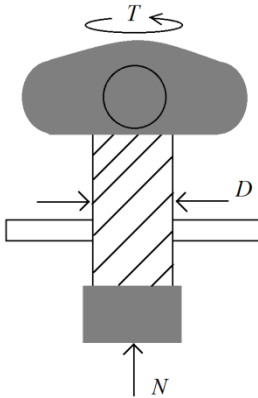
When the concentrator just begins to tip over due to the horizontal force of  $P$ , both  $F_2$  and  $F_3$  would be zero. Then, applying the equilibrium equations to the device at the point right before it tips over, the following equations are obtained:

$$\sum F_y = 0 \rightarrow F_1 = W + F_f \quad (\text{Eq. 8})$$

$$\sum M_O = 0 \rightarrow 6.9F_f + 0.3W + xF_1 = 42.5P \quad (\text{Eq. 9})$$

To solve for  $x$ , we first determined the friction forces from the concentrator on the foot pads of the clamp. This was found using the relationship between installation torque and tension in a fastener (*Machinery's Handbook 28<sup>th</sup> Edition*). Figure 20, pg. 25, shows how the foot clamp can

be modeled as a fastener with a given installation torque and the equation that was used to solve for  $N$ , the normal force between the foot pads and the concentrator.



$$N = \frac{T}{0.2 \times D} \quad (\text{Eq. 10})$$

**Figure 20:** The foot pad with screw-in handle can be modeled as a fastener of major diameter,  $D$ , installed with an installation torque,  $T$ , with a resulting bolt tension force of  $N$ .

The amount of torque,  $T$ , that the user places on the device was taken as 1.22 N·m (or 10.80 in·lbs), which is the lowest range of torque that persons between the ages of 30-51 can exert on a circular knob (*Human Strength / Endurance Notes*). Using the lowest range would be the worst case scenario, giving us the lowest frictional force between the foot pads and the concentrator. Using this torque, and a fastener major diameter of 0.25 inches (for a 1/4"-20 fastener), the normal force on one of the footpads is 216 pounds per foot. The force of friction,  $F_f$ , was then found from Equation 11.

$$F_f = 2N\mu_s \quad (\text{Eq.11})$$

The factor of 2 was put into the equation because there are two foot pads that are pressed against the concentrator using the torque knobs. The coefficient of static friction,  $\mu_s$ , was estimated to be 0.5, which is the coefficient of friction for rubber on cardboard, which was the closest published value we could find.

From our SolidWorks 3D model, the approximate weight of our device,  $W$ , was 10.8 pounds. Using the force of friction found above, and Equations 8 and 9 on page 24, the distance  $x$  away from the concentrator that the leg needs to be in order to avoid tipping is 0.54 inches. This value is the minimum distance to stabilize the device, so any distance greater than this will also keep the device stable. The distance was chosen to be 4.5 inches in order to make the part easier to fabricate.

### *Material Selection*

The major components that were analyzed for material selections were the pole, spool supports, housing, base plate, and legs. First the function of each component had to be determined, then the objective for each component was determined, and lastly the constraints of each component were defined which would affect the material chosen. Once the function, objective, and

constraints of each component were determined, the material indices for the components were determined so the material selection could be optimized. These steps were completed to screen and rank possible materials for each component, leaving a small number to choose from. To choose the correct material for each component, supporting information such as corrosion behavior, price, availability, and other factors were researched allowing the team to make an informed and correct decision. See Appendix L for the full CES material selection process and analyses.

### *Environmental Performance*

Aluminum 6061-T6 alloy and polypropylene (PP) were chosen from the material selection process because these materials are the most prevalent in the final design. SimaPro (version 7.3.3) was used to determine the environmental effects for these materials, and the full analysis can be seen in Appendix L. Aluminum, partly because it makes up nearly the entire device, has the greatest impact on the environment compared to polypropylene. However, aluminum can be easily recycled at the end of its life; PP currently has limited possibilities in terms of recycling.

### **Final Design Description**

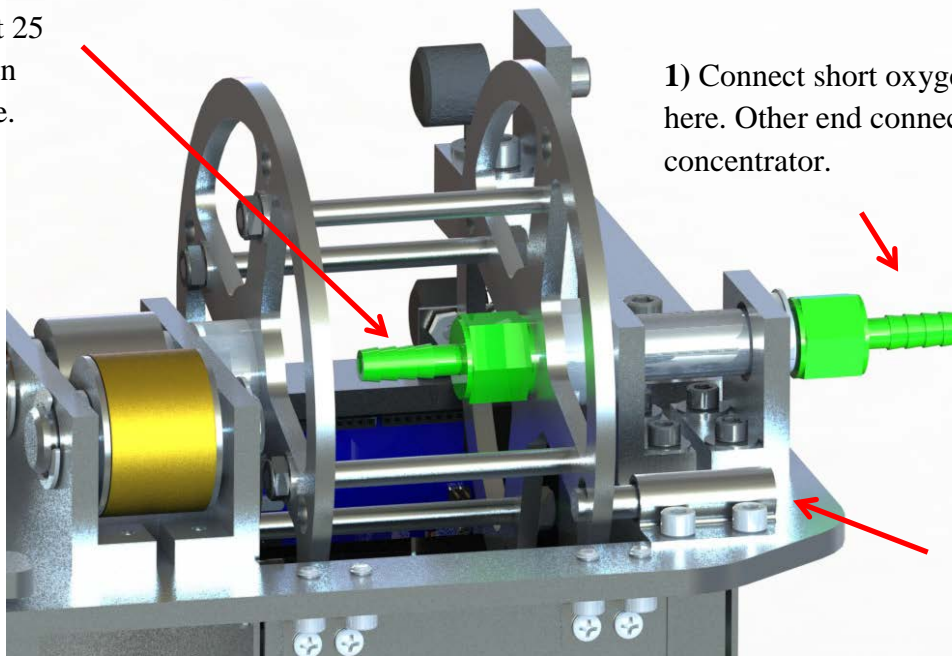
With the parameter analysis completed, components and subcomponents could then be fully designed and finalized for the final design.

The spool is arguably the most complicated, intricate, and important component in the device because multiple functions are being performed simultaneously. Thus, it is important to note that tolerances of the machined parts are very important. There are press fits, shafts, and bearings, all which must be perfectly aligned to achieve the desired operation. Starting from when the user first interacts with the device, the spool will be empty and in its locked position, ready for oxygen tubing to be installed. First, one end of a short oxygen tube will be attached to the fitting on the oxygen concentrator and the other end of the tubing to a swivel fitting on the device. This fitting is connected to another swivel fitting that is located on the central axis of the spool via a hollow shaft. The two fittings are free to swivel independently to eliminate any twisting and binding of the tubing that would result if the fittings were permanently fixed. The user would then remove the top spool housing, attach the longer 25 foot tubing to the inside fitting, unlock the spool, and allow the spool to wind up the tubing through a constant force spring. The first part of the tube installation is illustrated below in Figure 26, p. 27.

The force felt by the user at the maximum distance away from the concentrator is the same as the force experienced at the minimum distance. The shaft that supports the spool must be able to spin freely, so oil-impregnated SAE 841 bronze sleeve bearings are placed in the spool mounts that support the shaft. The spring also doubles as a hard stop so that the oxygen tubing does not come off the fitting in the spool; i.e. the end of the spring is reached before the tubing is extended to its full length.

2) Connect 25 foot oxygen tubing here.

1) Connect short oxygen tubing here. Other end connects to concentrator.



3) Disengage slide bolt after 25 foot tube installation.

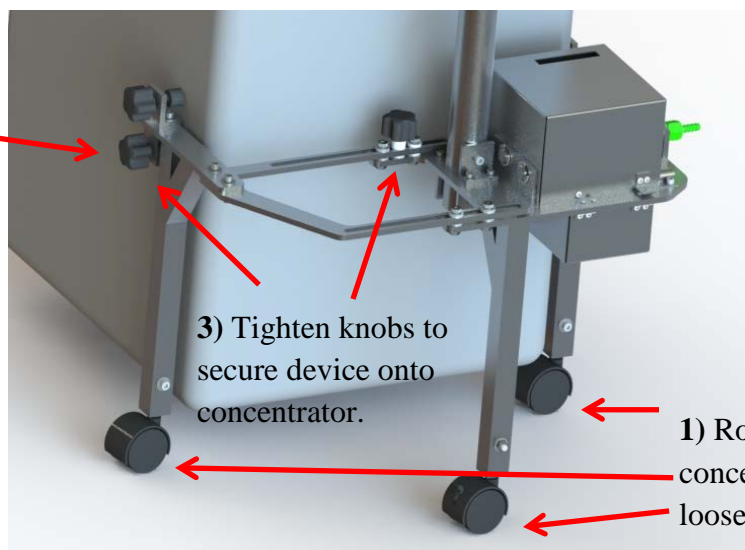
**Figure 26:** Installation procedure for oxygen tubing onto retraction spool

The spool is recessed and mounted into a base plate. There are two parts to the plate, one half that the components are mounted to, and the other half that is free to have translational motion relative to the other via shoulder bolts. As previously discussed, this plate movement allows the device to be mounted on a wide variety of oxygen concentrators. To attach the device to a concentrator, the user rolls the device up to the concentrator with the plates spread apart, pushes the plates together, and turns a knob that restrains any further translational motion between the plates. Then, the user turns another knob on the side of the device that presses a “foot” or “pad” against the wall of the concentrator to secure the device completely. This procedure is illustrated below in Figure 27.

2) Push clamp so that it contacts the side of concentrator.

3) Tighten knobs to secure device onto concentrator.

1) Roll device to concentrator with clamp loosened.

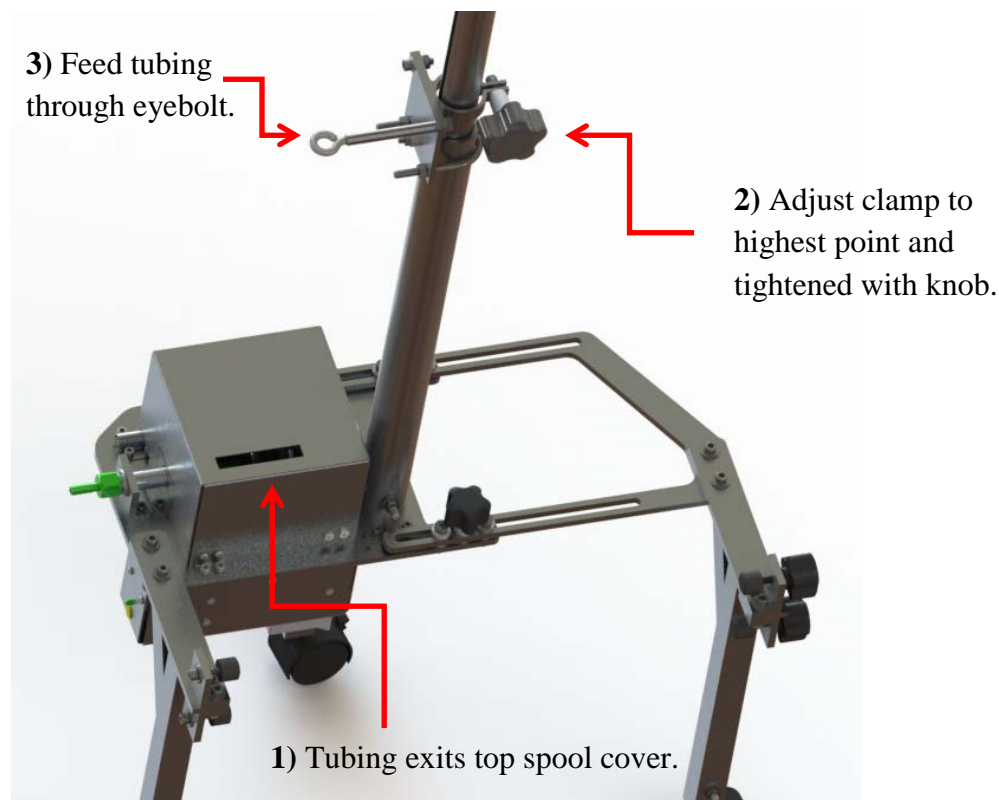


**Figure 27:** Process of clamping device onto concentrator



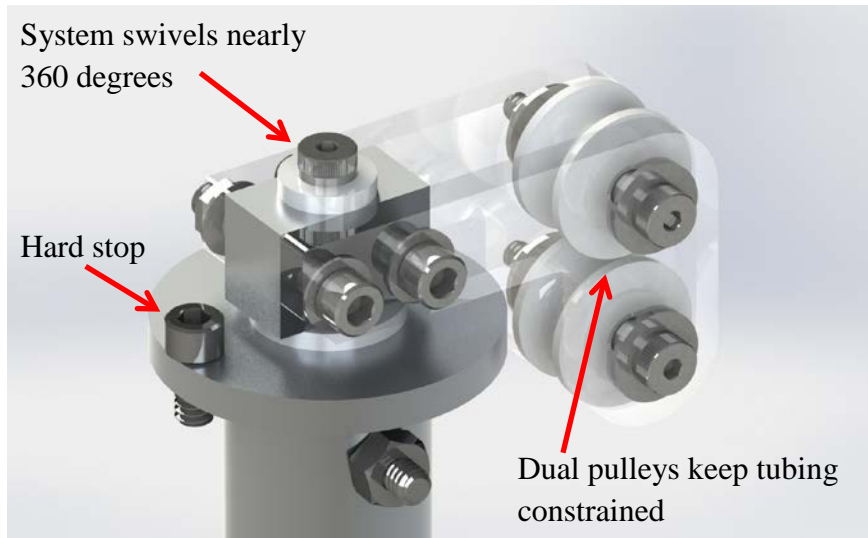
This base plate acts as a foundation with which most of the components are mounted. Thus, the material that this component is made from is important because of the many different forces it will be experiencing.

Continuing with the tubing attachment process, the tubing is fed up the pole through an eyebolt. The eyebolt is positioned so as to guide the tubing away from entanglement hazards with the pole clamp as well as to facilitate even tube distribution on the spool during retraction. The pole itself is divided into two parts, the top part being able to slide down inside the bottom part so that all components on the device are accessible under the four foot limit established in our technical requirements from DR1. The top half of the pole has two slots symmetrically spanning most of this part's length so that it hard stops on a bolt in the bottom half of the pole. The top half can be locked into position by turning a knob that clamps down onto this piece. The inside face of the clamp is lined with a rubber seal to prevent the top half of the pole from sliding down too fast and fingers getting pinched between the two parts of the pole. Figure 28 shows how these steps are performed.



**Figure 28:** The oxygen tubing exits the top spool cover and is fed through the eyebolt located on the adjustable pole clamp

The final component that the tubing passes through is located at the top of the pole. The pole topper contains two pulleys vertically orientated so that the tubing passes between them, constraining the tubing, as shown in Figure 29, p. 29 and doesn't "jump" off the bottom pulley. This pulley system can swivel about the vertical axis nearly 360 degrees; it has a hard stop because of the possibility of the user wrapping the tubing around the pole by walking around the



**Figure 29:** Tubing is fed through dual pulley system, which itself swivels nearly 360 degrees.

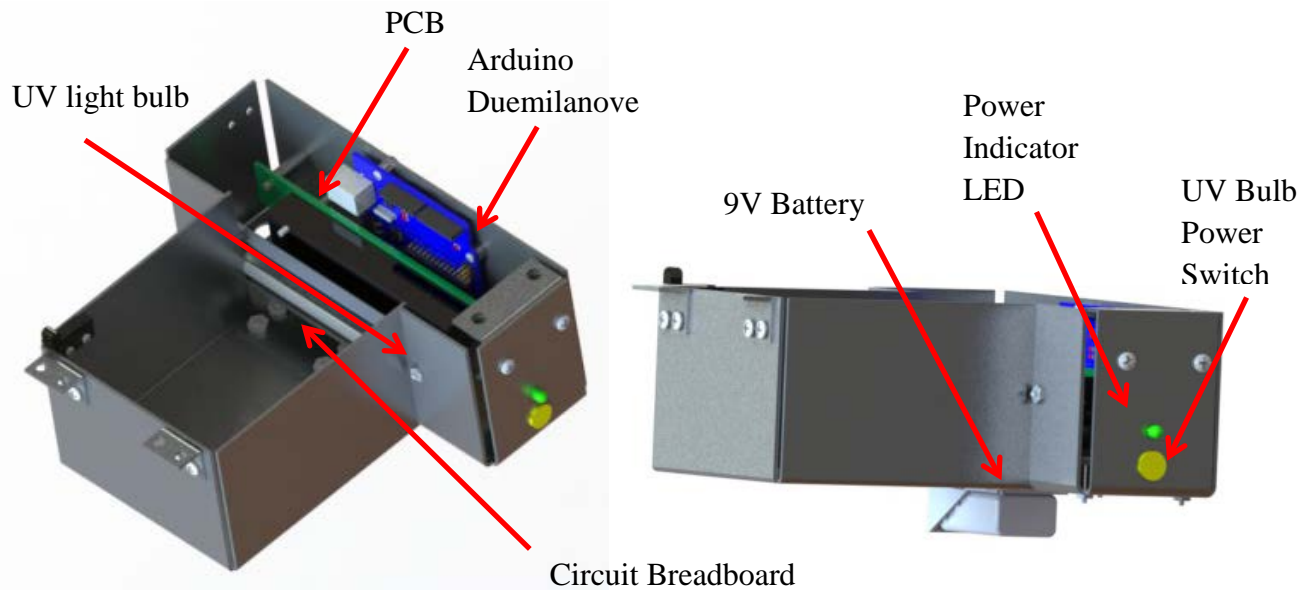
device too many times. The supports holding the two pulleys in place are made from 0.25 inch acrylic because of its cost-effectiveness and low density. Calculations were performed earlier and it was determined that the acrylic could withstand the forces experienced when the system is against the hard stop. Likewise, the pulleys are made from Nylon polymer because of its low friction properties. Also, the unique profile of the pulley can be turned on a lathe to the exact specifications needed.

Lastly, the entire spool will be enclosed by two covers because direct exposure of UV light can be harmful to human skin. Both housing pieces can be seen below in Figure 30.



**Figure 30:** Both covers house the entire spool

These housing pieces were originally planned to be 3D printed out of ABS plastic, but due to project budget constraints, they were manufactured from bent sheet metal. Sheet metal was used because it is an inexpensive way to create the desired geometry for the cover designs. The top cover is made of two components: one permanently attached to the baseplate and one that is removable to replace oxygen tubing. The UV sanitation system is located in the bottom spool housing. The circuit components for this system include: the printed circuit board (PCB) and UV light bulb from the purchased UV sanitizing wand, Arduino Duemilanove microprocessor, 9 volt battery, power switch, LED power indicator, and the circuit breadboard. The layout of the internals of the bottom spool cover is shown below in Figure 31.



**Figure 31:** Location of circuit components in bottom spool cover.

After the user has set up the device and is using it regularly, the UV sanitation method may be employed by simply engaging a push-button switch. This action sends a signal to the Arduino microprocessor, which simultaneously begins a timer and supplies power to the UV bulb. After the predetermined time has elapsed, the UV bulb is turned off by the Arduino. It is important to note that pushing the button while the UV bulb is on will not turn off the bulb. The time required to sanitize the tubing is calculated based on the light intensity of the UV wand, which is 897  $\mu\text{W}/\text{cm}^2$  (*Clean Wave Sanitizing Wand*). A calculation of the time required to kill 99% of microorganisms is shown below (*UV Irradiation Dosage Table*).

$$time, t = \frac{UV\ dose}{UV\ intensity} \quad (\text{Eq. 12})$$

where UV dose is in  $\mu\text{Ws}/\text{cm}^2$ , UV intensity is in  $\text{W}/\text{cm}^2$ , and time is in seconds. The microorganism that affects humans the most is the *Aspergillus niger* mold, with a UV dose need for 99% kill factor of 330,000  $\mu\text{Ws}/\text{cm}^2$  (*UV Irradiation Dosage Table*). Substituting into the equation above,

$$t = \frac{330,000 \frac{\mu W s}{cm^2}}{897 \frac{\mu W}{cm^2}}$$

$$t = 6.1 \text{ minutes}$$

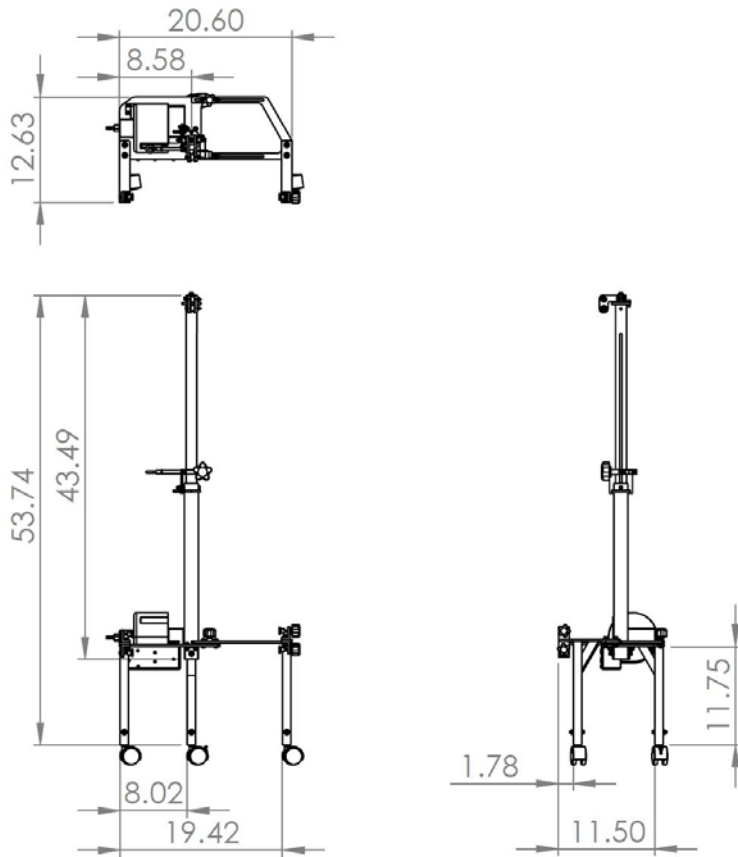
Thus, the Arduino is programmed to supply power to the UV bulb for 6.1 minutes. The circuit diagram and Arduino code can be found in Appendix G.

Light intensity is determined by five factors: lamp power, distance from lamp to product, type of reflector, lamp age, and transmission characteristics of substrate (*Light Cure Technology Guide*). Obviously, the closer the lamp is to the contaminated surface, the higher the light intensity. Reflector material is also critical in distributing the UV light throughout the spool. For this device, reflective tape is used to enhance the effectiveness of the UV bulb intensity. According to Henkel, “lamps with electrodes are expected to last 1,000 hours with loss of no more than 15%-25% of original intensity” (*Light Cure Technology Guide*). Assuming the sanitation system will be used once a day for the aforementioned 6.1 minutes, the bulb will lose 15%-25% intensity after about 27 years.

Figure 32, p. 32 shows some of the key dimensions of the device. The height of the device allows the user to move about a room without the oxygen tubing entangling with chairs, tables, or other household items of similar height. The clamping arms were designed with multiple different oxygen concentrators in mind; this device is more or less universal across all concentrators.

A majority of the parts required to create the Alpha prototype will be made in-house while the rest will be bought from various suppliers. Due to the number of parts required for the device, the bill of materials for all bought parts as well as the material list for all manufactured parts can be seen in Appendix H. The total cost of the purchased items needed for this device is \$357.47. This number represents the cost to someone who wanted to build the device from scratch. Our team has been lent a few items, notably the Arduino Duemilanove and 25 foot oxygen tubing. Stock material has also been salvaged from the scrap piles in the machine shop, so that decreases the cost of the device for our team.

The final design and prototype are intended to be theoretically identical. The device dimensions are of a magnitude that is relatively easy to manufacture. The device is designed in such a way so as to meet the engineering specifications, which ultimately solve the sponsor’s original problem of oxygen tube sanitation and control. The UV sanitation system sanitizes the oxygen tubing while it is stored in the retraction spool. This spool serves as a control system for the tubing. These actions are performed with hardly any human input or awareness of these processes.



**Figure 32:** Important dimensions of the device

### Initial Fabrication Plan

The first system to be fabricated will be the support legs. The legs will be cut to proper lengths. Threaded inserts will be bolted into the bottom of the legs; therefore the interior of the base of the legs will need to be milled to meet tight tolerances. The legs are aluminum 6061-T6 and therefore will be milled at a speed of 400-1000 ft/min and a feed of 2.4-4 in/min. The aluminum 6061-T6 inserts that attach the wheels to the legs will then be drilled on the mill at 300 ft/min. The sides will be milled and the hole reamed at 150 ft/min for tight tolerance, and then tapped. While this is done, the two pieces of the back leg will be welded together using a TIG welder because the pieces are aluminum. The inserts will then be bolted to the legs. The wheels will not be attached until the legs are attached to the clamping system.

For the pole topper, the base will be turned at a speed of 150-400 ft/min and a feed rate of 2.5-4 in/min since it is aluminum, and then drilled on the mill. The pulleys will be turned out of Nylon cylinders using a forming tool and then drilled on the mill. While the pulleys are being fabricated the pulley covers will be cut out on the laser cutter at 100% power, 4% speed, and 5000 ppi frequency (assuming 35 W) and the top block will be drilled with the mill. The holes and slots in the pole will be fabricated using the mill.

The actual design of the housing calls for polypropylene and would most likely be fabricated

using injection molding. Since injection molding is not available, too costly for one part, and would take too much time to design a mold, a 3D printed ABS+ housing was intended to be used for the prototype. For prototype purposes, the housing was to be made from ABS+ and 3D printed using a Dimension Elite FDM machine. However, the ABS+ 3D printed housing would have put the prototype over budget. Thus, the prototype housing was changed to bent sheet metal. Aluminum 6061-T6 alloy sheet metal, 0.064" (14 gauge) thick, was used. First, all holes and slots were located. The shape for each piece was then cut using the band saw. The location of each hole was then center-punched before each hole was drilled on the drill press at a speed of 1540 rpm. The sheets were then annealed by shop faculty to prevent cracking from residual forces cause by bending. Finally, the sheets were bent with a manual bending press to bend the parts into shape.

The two plates for the clamping system will be first cut out using the water jet. All the slots and holes will then be fabricated using the mill for tight tolerances. All the brackets associated with the plates will then be cut and drilled on the mill. Once the plates are complete, the legs and support beams for the legs will be welded to the underside of the plates using a TIG welding machine.

The two aluminum wheels of the spool will be cut out using the water jet cutter since the tolerance is not of importance and it is a quick process. They will then be drilled, reamed to ensure tight tolerances for the shafts, and tapped. The spool supports will be turned and then tapped. See Appendix I for safety reports concerning manufacturing procedures. Appendix J illustrates all drawings for parts to be manufactured in-house.

## **Validation Approach**

For the six technical requirements (Table 2, p. 6), a plan was made to validate the engineering specifications. Starting with reducing tripping hazard, we determined that the tubing had to be no more than 6" below the concentrator connection point. To validate this specification, we would extend the tubing to its full length and measure the lowest point of the tubing to the concentrator connection port. To maximize user mobility, we determined a radial distance of 20 to 25 feet from the concentrator. Therefore, we would extend the tubing to its full length and measure the radial distance from the oxygen concentrator. To sanitize our tubing, we wanted to target 40-70% of the tubing that would be exposed to a sanitary agent. To validate this technical requirement, we will ensure the UV light turns on when the user presses the button and the spool houses 40-70% percent of the tubing when the user is standing no more than 3 feet radially from the concentrator. To validate the height requirement for accessible maintenance, the pole will be lowered to its lowest point and measure from the ground to the top of the pole with a target value of 4 feet or less. For the engineering specification of human inputs required for general use, we will validate this by counting the number of human inputs for each subsystem during general use with a target of 1-3 inputs. By maximizing the number of days between maintenance, we are not able to test this engineering specification; however, we will use engineering analysis to validate it. Engineering analysis has shown that tubing will be kept off the floor as well as utilize a sanitation method which, compared to current applications, will extend the life of the tubing from 7 to 14 days. See Appendix I for safety reports concerning testing/experimental procedures.

## Validation Results

For validation testing, two technical requirements were not tested. To test the time between regular maintenance, consultation with healthcare professionals would have been required due to the lack of standards regarding oxygen tube replacement. For long-term testing, a device could be sent to focus groups and allow them to determine when tubing should be replaced. The second requirement that was not tested was the tube distance below the concentrator connection point. All concentrators have different connection points; therefore the result will be variable based on the concentrator that is used. The technical requirement should have been more specific, such as measuring the distance the tubing is from the ground instead of a variable location such as the connection point.

The maximum distance the user can be from the concentrator was measured at 14 feet, which does not meet the requirement of 20 to 25 feet. The percent of oxygen tubing sanitized by the device was measured at 71%. Although this does not meet the target of 40 to 70%, it exceeds expectations. The engineering specification should have allowed for more than 70% of oxygen tubing to be sanitized; as sanitizing more tubing increases device performance. For the tested value of accessible height, the highest point was measured on the device to be 3 feet, 4.25 in. This result meets the targeted value of 4 feet off the ground. The result from the human inputs required for general use was measured at two human inputs. The two human inputs for general use were walking away from or toward the concentrator and pressing the power switch to activate the sanitation system. Out of all six technical requirements, two measured values met the technical requirements. The only technical requirement that was not met was the maximum distance the user can be from the concentrator. Out of the remaining technical requirements, one technical requirement exceeded our targeted value, and the other two need more evaluation.

## Design Critique

This device addresses two key issues: the tripping hazard from the tubing lying on the floor and the tube sanitization issue. Although these issues were addressed, many of the weaknesses of this design come from the most complicated sub-assembly: the spool. A hard stop is needed for the spool retraction when the user reaches the maximum allowed distance away from the concentrator. This hard stop would prevent spring deformation from excessive force. One solution is to place two hard stops on the tubing, one to limit the tubing as it is being retracted into the spool and the other to limit the extension of the tubing.

Another weakness in the design is that the tubing winds on one place of the spool, instead of distributing itself over the width of the spool. As tubing collects in one spot, tubing begins to rub against the side of the spool housing and eventually prevents spool rotation. This problem can be solved by having a mechanism that guides the tubing along the width of the spool as the tubing is retracted into the spool.

The third weakness in this design is that the technical requirement for distance away from the concentrator was not met due to the shorter constant force spring. The original constant force spring was not used because it would deform upon retraction (See *Spring Force Calculation*, p. 21); the stiffness of the spring was believed to be too high. To compensate for this deformation, a

weaker constant force spring was used. A weaker spring could not be found in the necessary length, so a shorter spring length was used. As a result, the user could only move 14 feet away from the concentrator. In the future, a custom-built spring with a longer spring length could mitigate this problem.

The fourth weakness in this design is the sanitation effectiveness. Although the technical requirement of 40 to 70% of tubing housed in the spool during sanitization was exceeded with 71%, the entire tubing inside the spool might not have been sanitized. To evaluate the effectiveness of the UV light, tests need to be conducted to calculate the amount of bacteria that can be killed in the spool. The amount of bacteria per length of tubing before the sanitization would be compared to the amount of bacteria after sanitization. Although this test would have been more thorough in validating the amount of tubing sanitized, the amount of time and resources needed to perform these tests were outside the team's project timeline. If testing results showed that the UV light did not sanitize the required amount of tubing, more UV bulbs could be installed.

The fifth weakness in this design is the difficulty that lies in replacing the tubing. To fix this problem, a new spool design is suggested to allow easier access to the tubing. One change that could be made would be to increase the spacing between the spool beams. This change would increase the radius of the spool, which would allow larger hands to reach in between the spool beams to replace tubing.

The final weakness in the design is the amount of force the user felt when they walked away from the concentrator. This force can be attributed to many things such as the friction between the tubing and system components. To reduce force, a smoother oxygen tube may help, but using rollers along the edges of the guiding eyebolt and the pulley covers might also reduce friction.

## **Recommendations**

The most important part of the device is the constant force spring system, so ensuring that this part of the device is designed correctly is critical. The output shaft, or the shaft that the spring winds around when tubing is being extracted from the spool, and the storage shaft must have a diameter at least as large as the inside diameter of the constant torque spring in its fully wound state. The two shaft diameters are allowed to have a ratio of 1:1 (McGuire), however we discovered that this might not always be the case. The 7 pound spring was installed on the storage shaft, but when wound on the output shaft and then returned to its original position, the spring was severely deformed. A weaker spring, about 2.49 pounds, was then installed on the same two shafts, such that the shafts had diameters about twice that of the inside diameter of the spring. The spring behaved normally, meaning that it did not deform when it returned to its steady state position on the storage shaft. The disadvantage to using this spring was its decrease in length from the 7 pound spring, as stated earlier. To achieve the necessary tubing extension, a custom spring could be designed to meet exacting specifications or two standard springs could be joined together in series to essentially create a spring twice as long as the original, but with the same strength. More testing and research needs to be done to accurately predict the behavior of constant force springs.



Many components in the device are attached using fasteners such as screws and bolts. This attachment process was utilized so that problems that arose during the manufacture and assembly of the prototype could be quickly diagnosed. However, some components could be permanently fastened together by welding or other processes to reduce the overall cost of the device.

In redesigning the device, tolerances must be accounted for very well. This recommendation focuses mainly on the retraction spool because there are press fits and bearings in this subsystem. If tolerances are not taken into consideration, the spool might not rotate smoothly, if at all. Friction must be reduced to a minimum in the spool because the lowest possible spring strength is preferable so that the user does not need to exert much force to extend the tubing.

Another consideration for a device redesign is the material of the spool shafts. Currently, oxygen is set up to flow through one oxygen connector, through the aluminum shaft of the spool, and into the other tubing via another connector. This setup would need to be thoroughly tested to determine if oxygen that has come into contact with this aluminum shaft would be safe for users to inhale. If not, then the shaft would need to be redesigned using either an entirely different material or using a lining or coating for the inside of the shaft to ensure no oxygen contact with aluminum.

A feature that would be beneficial in the redesigned device is a wheel brake. Currently, the prototype has three caster wheels so that the device and oxygen concentrator may be moved to a new location as a whole unit. However, most concentrators do not have wheel brakes because they were not designed to experience any force from the user. With the device attached to the concentrator, there is a force distributed through the concentrator to the floor, so a brake is a strongly recommended feature to prevent the device from rolling during general use.

### **Specific Challenges**

To conceive a successful design, the two major issues of tripping hazards and tube sanitation were addressed. Certain challenges arose when designing with these issues in mind.

First, reducing tripping hazards was a challenge since oxygen tubing must be kept above our determined tripping threshold of 6 inches below the user hip. This requirement was difficult to accomplish while still trying to maximize user mobility between 20 and 25 feet. One way it was addressed was to ensure constant tension in the tubing. An added benefit was that it helped prevent entanglement with the tubing itself and other objects, allowing the user to utilize the full length of tubing.

One of the constraints of ME 450 is the limited time and budget to define the problems, develop technical requirements, and build a prototype to meet those specifications. For example, advances in nanotechnology to combat bacterial growth could be valuable in this project. However, time and budget constraints limit the exploration of this new innovative field. Our group developed a design that focused on mechanical engineering principles with which the team is familiar with.

The team's Alpha design included a rotating element that allowed the user to move around the

pole easily without the tubing binding up. However, the team needed to be careful with how this feature was implemented, because if the top portion of the tubing was allowed to swivel three hundred sixty degrees, it may have become tangled with the extendable pole.

This project required special equipment, including oxygen tubing and an oxygen concentrator. Currently, state laws dictate that oxygen tubing can only be purchased with an oxygen prescription. Thus, the team worked with healthcare professionals to obtain tubing for our device. An oxygen concentrator was acquired from our sponsor, Scott Kellman, which greatly aided in prototype validation.

## **Project Plan**

The team divided the project into seven main milestones. These milestones of the project included: the initial meeting with the sponsor, Scott Kellman, Design Review 1 through Design Review 4, Design Expo, and the Final Report. Initial tasks for this project included meeting with the sponsor from American Eagle Life Care Corporation, visiting an oxygen concentrator user, and partaking in a conference call with the sponsor, a lead clinician, and an assisted living executive. By completing these tasks, along with additional oxygen concentrator research and product benchmarking, the team determined customer needs and technical requirements.

There were several known tasks that needed to be accomplished after Design Review 1. After Design Review 1, the team brainstormed several concepts that lead to a single concept for the team to pursue. Then, in preparation for the third milestone, Design Review 2, the chosen concept was designed and a mock-up fabricated. For the fourth milestone, Design Review 3, the design was finalized with changes from Design Review 2 feedback. Concept selection processes were applied for the spool, sanitation system, clamping mechanism, and the swiveling top. After the subsystems were determined, force analysis was completed to select dimensions and materials. The CAD model of the device was then created and bearing selection to begin. Finalizing the design allowed safety analysis to begin. Before the team entered the shop to build the Alpha prototype, the prints were finalized and approved. Once in the shop, a strict schedule was followed to finish all the parts and assemble them on time for Design Review 4. Although they were not all completed for Design Review 4, these parts were completed by the following dates to keep the project on schedule for Design Expo: the legs were completed by November 7<sup>th</sup>, the housing by November 8<sup>th</sup>, the pole topper by November 9<sup>th</sup>, the pole by November 14<sup>th</sup>, and the clamping system by November 16<sup>th</sup>. By Design Review 4, Alpha prototype was not completely assembled, but assembling was completed by December 3<sup>rd</sup> with validation testing completed by December 5<sup>th</sup>.

The final two milestones were the Design Expo and the Final Report. At the Design Expo, the final prototype was displayed, demonstrated, and testing results presented. All information, observations, and experiences were gathered and published for the final report. Details, projected deadlines, and task assignments can be found in the project Gantt chart (see Appendix C).

## Conclusions

After initially meeting with the sponsor, visiting an assisted living community resident, and speaking with healthcare providers, the team was able to determine user requirements for the project (Table 1, p. 5). From these, technical requirements were determined based on competitive analysis and prior research (Table 2, p. 6). These technical requirements will serve as benchmarks that the device prototype will be tested against for design validation. For a full QFD chart that shows how each technical requirement was ranked, see Appendix B.

The team then generated twelve concepts that would meet the customer requirements, and this list was narrowed down to feasible concepts that were rated against the specific requirements. A Pugh chart was then completed to score these concepts (see Table 4, p. 13), and the final concept was determined based on these results. The group then finalized this design, and has decided to move forward with this as the Alpha design (see p. 14 for images of this design). With the Alpha design chosen, the team completed a concept subsystem selection process for the final design. The concept subsystem selection was based on the tubing retraction, tubing sanitation, and clamping system. For each subsystem, three different concepts were created. The final design featured a retraction spool using a constant force spring, a UV sanitation system, and an adjustable pole with two plates, one stationary and one moving that would extend and tighten on a concentrator (see p. 15-16 for concept subsystem selection).

With the final design chosen, a parameter analysis of the critical components was completed. These critical components were determined to be the spool, pole, and base plate of the device, with an analysis on maximum stress calculations, force balance equations, and bearing load calculations. After the parameter analysis, material selection for the critical components followed. The final design was then fabricated with the spool housing being fabricated by sheet metal instead of ABS+ plastic (See Figure 28 on p. 28).

The final design was ready for Design Expo and validation testing. From the tests, two of our technical requirements were validated through measured values; human inputs and accessible height. Two of the requirements need further evaluation and the other requirement should be reconsidered. The only technical requirement that was measured and not met was the maximum distance the user can be from the concentrator, with a value of 14 feet. (See p. 34 for full validation results)

All challenges were met to produce a device ready for Design Expo and validation. The team produced a device that met the initial sponsor's concern of the tripping hazard from the tubing lying on the floor and the sanitization issue. However, there are six design critiques that can be made. A hard stop would be needed for the spool retraction to protect the constant force spring from deforming. Second, a mechanism would be needed in the redesign to guide the tubing along the width of the spool. Third, the distance that the user can walk away should be increased from 14 feet to the target value of 20 to 25 feet. Fourth, the UV sanitation should be analyzed thoroughly to prove that the sanitation is working on the entire length of the tubing that is housed in the spool. Also, tube replacement should be more user-friendly and finally, the force the user experiences when moving away from the concentrator should be reduced.

## **Acknowledgements**

We would like to thank our sponsor, Scott Kellman, for all his support this semester as well as Marcie Greenfield, Tom Emberton, and Jackie Strader from American Eagle Life Care Corporation for their help and insight. We would also like to thank Professor Gordon Krauss, Michael Wang, and especially Professor Elijah Kannatey-Asibu for their guidance through this daunting endeavor. For help with all our manufacturing we would like to thank Bob Coury, Mark Stock, and Toby Donajkowski. Without the contribution of these people we would never have accomplished all that we have this semester.

## References

Budynas, Richard G.; Nisbett, Keith J. *Shigley's Mechanical Engineering Design, 9<sup>th</sup> Edition*. 2010. McGraw-Hill. Chapters 11, 13 and 14.

Bunting Bearings. (2012). Retrieved from <http://www.buntingbearings.com/data.html>

*Captive technologies tidy tubing*. (2012). Retrieved from <http://www.oxygenconcentratorstore.com/tidy-tubing/>

*Clean Wave Sanitizing Wand*. (2012). Retrieved from [http://www.needs.com/product/Verilux\\_CleanWave\\_Sanitizing\\_Wand/ee\\_Sanitizer](http://www.needs.com/product/Verilux_CleanWave_Sanitizing_Wand/ee_Sanitizer)

Emberton, Tom; Strader, Jackie; Kellman, Scott. (2012, September 17). Telephone interview.

Falcone, V. (2000). *US Patent No. 6,065,490*. Washington, DC: U.S. Patent and Trademark Office.

*Friction and Coefficients of Friction* (2012). Retrieved from [http://www.engineeringtoolbox.com/friction-coefficients-d\\_778.html](http://www.engineeringtoolbox.com/friction-coefficients-d_778.html)

*Granta CES 2012 Version 11.9.9*. Granta Design Limited. Cambridge, UK

*Granta CES EduPack 2008*. "Resources Book 2: Material and Process Selection Charts". Granta Design Limited. Cambridge, UK

Haney, J., Smithula, M., Sendgikoski, N., & Vidokle, A. (2008). *Verification and validation retractable oxygen tubing device*. Manuscript submitted for publication, University of Pittsburgh, Pittsburgh, PA, p.1. Accessed from: [www.pitt.edu/~gartnerm/08/RetractableIVtubingsystem/Tube.html](http://www.pitt.edu/~gartnerm/08/RetractableIVtubingsystem/Tube.html)

*Human Strength / Endurance Notes*. (2011). Retrieved from [http://www.roymech.co.uk/Useful\\_Tables/Human/Human\\_strength.html](http://www.roymech.co.uk/Useful_Tables/Human/Human_strength.html)

Knoblauch, R. L., Pietrucha, M.T., Nitzburg M. (1997). *Field Studies of Pedestrian Walking Speed and Start-Up Time*. Accessed from: <http://www.usroads.com/journals/p/rej/9710/re971001.htm>

*Machinery's Handbook 28<sup>th</sup> Edition*, p. 1428. Copyright 2008, Industrial Press Inc., New York, NY. Accessed from: <http://pbadupws.nrc.gov/docs/ML1213/ML12138A215.pdf>

*Light Cure Technology Guide*. (2011). Retrieved from [http://www.henkeln.com/us/content\\_data/232945\\_LT2730\\_Light\\_Cure\\_Technology\\_Guide\\_lo\\_res.pdf](http://www.henkeln.com/us/content_data/232945_LT2730_Light_Cure_Technology_Guide_lo_res.pdf)

Longo, Carina, Savaris, Michele, Zeni, Mára, Brandalise, Rosmary Nichele, & Grisa, Ana Maria Coulon. (2011). Degradation study of polypropylene (PP) and bioriented polypropylene (BOPP) in the environment. *Materials Research*, 14(4), 442-448. Retrieved from [http://www.scielo.br/scielo.php?script=sci\\_arttext&pid=S1516-14392011000400003&lng=en&tlng=en](http://www.scielo.br/scielo.php?script=sci_arttext&pid=S1516-14392011000400003&lng=en&tlng=en). <http://dx.doi.org/10.1590/S1516-14392011005000080>

McGuire, J. R., Yura, J. A. *Advances in the Analysis and Design of Constant-Torque Springs*. Retrieved from [http://ntrs.nasa.gov/archive/nasa/casi.ntrs.nasa.gov/19960025610\\_1996050443.pdf](http://ntrs.nasa.gov/archive/nasa/casi.ntrs.nasa.gov/19960025610_1996050443.pdf)

*Oxygen ceiling hose reel*. (2012). Retrieved from <http://oxygeninhome.com/>

Penn, A. (2011). *US Patent Application Publication No. US 2011/0017856 A1*. Washington, DC: U.S. Patent and Trademark Office.

Petrovick, P.R., Carlini, E. (1999). *US Patent No. 1,123,445*. Washington, DC: U.S. Patent and Trademark Office.

Pierce, E. (1995). *US Patent No. 5,392,808*. Washington, DC: U.S. Patent and Trademark Office.

Pierce, E. (1998). *US Patent No. 5,826,608*. Washington, DC: U.S. Patent and Trademark Office.

*Premier remote controlled oxygen tubing spool*. (2011). Retrieved from <http://www.oxy-reel.com/>

*Study Compares Older and Younger Pedestrian Walking Speeds*. (2012). Retrieved from <http://www.usroads.com/journals/p/rej/9710/re971001.htm>

*UV Irradiation Dosage Table*. (2012). Retrieved from <http://www.americanairandwater.com/uv-facts/uv-dosage.htm>

Vinding, D. (2006). *US Patent No. 7,104,491 B2*. Washington, DC: U.S. Patent and Trademark Office.

*Home Oxygen Concentrators*. (2011). Retrieved from <http://www.vitalitymedical.com/home-oxygen-concentrator.html>

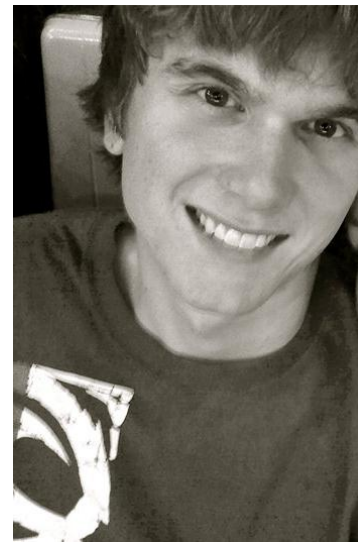
### **Peter Chun**

Peter Chun is from Baltimore, MD. His interest in Mechanical Engineering began as an 8 year old watching his grandfather build prototypes to aid his paraplegic grandmother. After a scary accident, his grandmother sustained severe brain damage, and so his grandfather became the primary caretaker. His grandfather immediately converted his garage into a machine shop after the accident and became obsessed with building devices to aid his grandmother in walking and moving. Exposed to his grandfather's commitment, Peter caught on to his passion of design and redesign. Luckily through his grandfather's caretaking and prototypes, Peter's grandmother made small, yet miraculous, improvements with her mobility. He is now in his fourth year at the University of Michigan, pursuing both a Bachelor's in Mechanical Engineering and a commission as a second lieutenant in the United States Army. After graduation, Peter hopes to become an engineering officer in the Army Corps of Engineers.



### **Tyler Greene**

Tyler was born and raised in Florida and moved up to Michigan in 2008 to attend the College of Engineering at the University of Michigan. Ever since he was a kid playing with LEGO he has had a fascination of taking individually dull parts or pieces and assembling them to create a unique and useful device. Studying Mechanical Engineering allows him to further refine this fascination into practical applications, especially in ME 250, ME 350, and now ME 450. After school, he would like to be part of a company that offers a breadth of interesting projects. This summer he had the opportunity to intern at Universal Orlando Resort in Florida, and virtually every facet of mechanical engineering is employed throughout the parks, be it a water ride utilizing fluid dynamics in its pumps or overhead signs that require extensive solid mechanics to ensure they don't endanger guests for a couple decades. While working there he enjoyed the diversity of projects he was involved with and hopes that the company he works for after school has that same diversity.



## **Nathan Matheny**

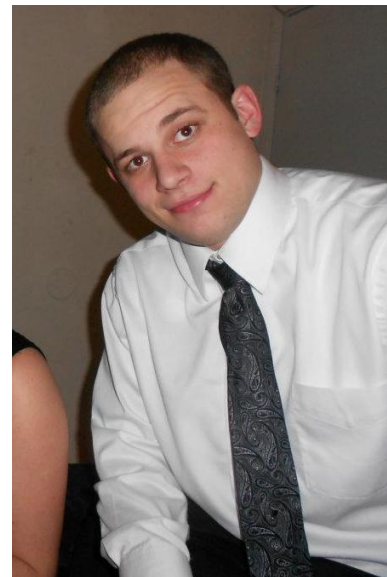
Nathan Matheny will be graduating in May 2013 from the University of Michigan with a Bachelor's degree in mechanical engineering. Nathan is from Lake Orion, Michigan, where he had spent his entire life prior to coming to Ann Arbor for his undergraduate degree. Nathan has always been interested in mechanical engineering since he can remember. He loved math and science since he was a kid, and enjoyed seeing what his father, who is also a mechanical engineer, worked on. Nathan knew then that wanted to do something similar with his future.



Nathan has also always been interested in working in the medical industry because it is easy to see the direct and meaningful impact your work makes. Whether it is creating a new hospital bed or designing new surgical tools, the work being done is used to improve the lives other people. He spent the past summer working at Stryker Medical in Kalamazoo as a design engineer intern in their EMS business unit. Nathan really enjoyed my time spent at Stryker, and it made him positive that a career as a design engineer was what he wanted to pursue. The internship also made Nathan certain of his desire to work in the medical industry, as he was able to see the powerful impact that Stryker's products have on peoples' lives.

## **Steve Schell**

Steve Schell was born and raised in Lake Orion, Michigan. His interest in engineering began in middle school with Modern Technology 1&2 classes where the students dabbled in several different fields. Once in high school he took drafting and CAD courses as well as an Engineering Tech class for electives because they were fun and he enjoyed them. During his first semester in the College of Engineering at the University of Michigan he imagined himself going into electrical engineering but as the semester continued it became clear that was not what he wanted to do and was unsure of engineering as a whole. Second semester Steve took an Engineering 100 course that was more design and mechanical based. He loved the hands on aspect of the course, the real world problems solving, and working with objects that he could see and touch (or at least imagine easily if on paper). By the end of that first year Steve knew that he wanted to go into mechanical engineering and declared the major the following fall semester. This semester is his last as an undergraduate and will be graduating this December. After graduation he will be employed at American Axle and Manufacturing as a Product Engineer in the GM full-frame axle team. Steve plans to start working towards obtaining his MBA in a few years and eventually open his own engineering/manufacturing firm down the road.





1	Maximum distance user can be from concentrator (+)							
2	Oxygen tube distance below waistline (-)	-						
3	Human inputs required for general use (-)							
4	Time between regular maintenance (-)							
5	Accessible height of components requiring maintenance (-)							
6	Percent of oxygen tubing length sanitized by the device (+)							
		<b>Technical Requirements</b>						
	<b>Customer Needs</b>	<b>Customer Weights</b>	Maximum distance user can be from concentrator (+)	Oxygen tube distance below waistline (-)	Human inputs required for general use (-)	Time between regular maintenance (-)	Accessible height of components requiring maintenance (-)	Percent of oxygen tubing length sanitized by the device (+)
1	Reduce Tripping and Entanglement Hazards	10	1	9				
2	User Mobility	9	9	3				
3	Easy to Use	8			9	1	3	
4	Sanitary Oxygen Tube	8		3				9
5	Easily Maintained	6				9	9	3
		<b>Raw score</b>	91	141	72	62	78	90
		<b>Scaled</b>	0.6454	1	0.5106	0.4397	0.5532	0.6383
		<b>Relative Weight</b>	17%	26%	13%	12%	15%	17%
		<b>Rank</b>	2	1	5	6	4	3
	<b>Technical Requirement Units</b>		15ft	6in	3#	7 days	4 feet	60%
	<b>Technical Requiriement Targets</b>		15ft	6in	3#	7 days	4 feet	60%

Relationships

- ++ Strong Positive
- + Positive
- Negative
- Strong Negative

- (+) Increasing quantity improves score
- (-) Decreasing quantity improves score

Appendix C: Gantt Chart

ID	Task Name	Start	Finish	Predecessors	September				October			November			December	
					E	B	M	E	B	M	E	B	M	E	B	M
1	Initial Meeting with Sponsor	Mon 9/10/12	Mon 9/10/12			◆ 9/10										
2	DR1 - Report	Fri 9/21/12	Fri 9/21/12	14												
3	DR1 - Presentation	Thu 9/20/12	Thu 9/20/12	12												
4	Research oxygen concentrator use	Mon 9/10/12	Tue 9/18/12													
5	Research patented tube storage and control devices	Mon 9/10/12	Tue 9/18/12													
6	Meet with Sponsor and Associates	Fri 9/14/12	Mon 9/17/12													
7	Project statement and description	Mon 9/10/12	Tue 9/18/12													
8	Determine project requirements and engineering specs	Mon 9/17/12	Tue 9/18/12	6												
9	Summarize research and background	Mon 9/10/12	Tue 9/18/12													
10	Determine possible design challenges	Mon 9/17/12	Tue 9/18/12	6												
11	Prepare DR1 presentation	Wed 9/19/12	Wed 9/19/12	4,5,6,7												
12	Practice DR1 presentation	Wed 9/19/12	Thu 9/20/12	11												
13	Prepare DR1 Rough Draft	Tue 9/18/12	Thu 9/20/12	4,5,6,7												

Project: 450_GANTT_CHART Date: Thu 11/1/12	Task		External Milestone		Manual Summary Rollup	
	Split		Inactive Task		Manual Summary	
	Milestone		Inactive Milestone		Start-only	
	Summary		Inactive Summary		Finish-only	
	Project Summary		Manual Task		Deadline	
	External Tasks		Duration-only		Progress	

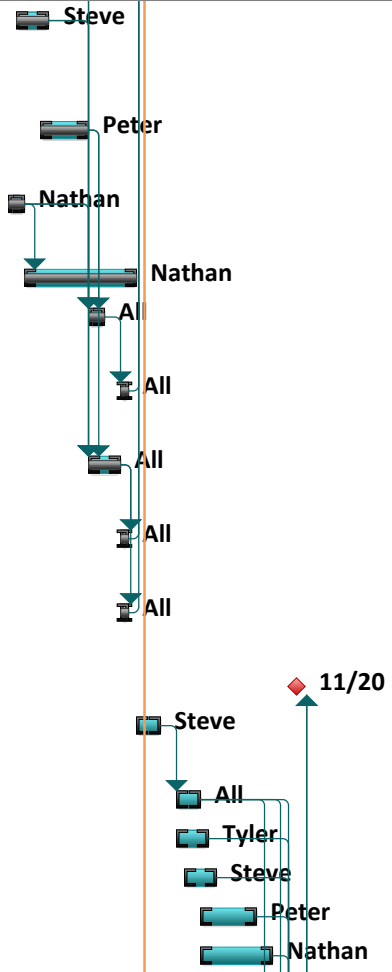
Appendix C: Gantt Chart

ID	Task Name	Start	Finish	Predecessors	September				October			November			December	
					E	B	M	E	B	M	E	B	M	E	B	M
14	Look over Rough Draft w/ Prof	Thu 9/20/12	Fri 9/21/12	13				All								
15	DR2 - Alpha and Mock-up	Tue 10/9/12	Tue 10/9/12	21,23												
16	Concept Brainstorming	Tue 9/25/12	Wed 9/26/12					All								
17	Choose Concept	Thu 9/27/12	Thu 9/27/12	16				All								
18	Design/CAD chosen concept	Fri 9/28/12	Tue 10/2/12	17				Nathan								
19	Build Mock-up	Wed 10/3/12	Wed 10/3/12	18				Steve								
20	Prepare DR2 presentation	Thu 10/4/12	Fri 10/5/12	18,19				All								
21	Practice DR2 presentation	Mon 10/8/12	Mon 10/8/12	20				All								
22	Prepare DR2 Rough Draft	Fri 10/5/12	Sun 10/7/12	18,19				All								
23	Look over Rough Draft w/ Prof	Mon 10/8/12	Mon 10/8/12	22				All								
24	DR3 - Final Design Analysis Safety Report	Tue 10/30/12	Tue 10/30/12	36,38,39												
25	Implement design changes from feedback	Tue 10/9/12	Thu 10/11/12													
26	Subsystems Concept Selection	Fri 10/12/12	Wed 10/17/12													
27	Force Analysis	Wed 10/17/12	Fri 10/19/12													
28	Material Selection	Thu 10/11/12	Sun 10/14/12													
29	Finalize CAD	Mon 10/15/12	Fri 10/19/12													
30	Bearings and Gears Selected	Fri 10/19/12	Wed 10/24/12													

Project: 450_GANTT_CHART Date: Thu 11/1/12	Task		External Milestone		Manual Summary Rollup	
	Split		Inactive Task		Manual Summary	
	Milestone		Inactive Milestone		Start-only	
	Summary		Inactive Summary		Finish-only	
	Project Summary		Manual Task		Deadline	
	External Tasks		Duration-only		Progress	

Appendix C: Gantt Chart

ID	Task Name	Start	Finish	Predecessors	September				October			November			December	
					E	B	M	E	B	M	E	B	M	E	B	M
31	Determine Manufacturing process needed	Tue 10/16/12	Fri 10/19/12													
32	Analysis of Safety Measures	Fri 10/19/12	Wed 10/24/12													
33	Determine design tolerances	Mon 10/15/12	Tue 10/16/12													
34	Produce Prints	Wed 10/17/12	Tue 10/30/12	33												
35	Prepare DR3 presentation	Thu 10/25/12	Fri 10/26/12	25,31,32,33												
36	Practice DR3 presentation	Mon 10/29/12	Mon 10/29/12	35												
37	Prepare DR3 Rough Draft and Safety Rough Draft	Thu 10/25/12	Sun 10/28/12	25,31,32,33												
38	Look over Rough Draft w/ Prof	Mon 10/29/12	Mon 10/29/12	37												
39	Look over Safety Draft w/ GSI	Mon 10/29/12	Mon 10/29/12	37												
40	DR4 - Alpha Prototype	Tue 11/20/12	Tue 11/20/12	52,54												
41	Finalize and get Alpha prints approved	Wed 10/31/12	Fri 11/2/12													
42	Fabricate legs	Mon 11/5/12	Wed 11/7/12	41												
43	Fabricate Housing	Mon 11/5/12	Thu 11/8/12													
44	Fabricate pole topper	Tue 11/6/12	Fri 11/9/12													
45	Fabricate pole	Thu 11/8/12	Wed 11/14/12													
46	Fabricate spool	Thu 11/8/12	Fri 11/16/12													



Project: 450_GANTT_CHART Date: Thu 11/1/12	Task		External Milestone		Manual Summary Rollup	
	Split		Inactive Task		Manual Summary	
	Milestone		Inactive Milestone		Start-only	
	Summary		Inactive Summary		Finish-only	
	Project Summary		Manual Task		Deadline	
	External Tasks		Duration-only		Progress	

Appendix C: Gantt Chart

ID	Task Name	Start	Finish	Predecessors	September				October			November			December	
					E	B	M	E	B	M	E	B	M	E	B	M
47	Fabricate clamping system	Thu 11/8/12	Fri 11/16/12													
48	Fabricate brackets	Mon 11/5/12	Fri 11/16/12													
49	Assemble Alpha Prototype	Mon 11/19/12	Tue 11/20/12	42,43,44,45,46,												
50	Alpha Prototype Testing and Validation	Sun 11/18/12	Mon 11/19/12	42												
51	Prepare DR4 presentation	Fri 11/16/12	Mon 11/19/12	50												
52	Practice DR4 presentation	Mon 11/19/12	Mon 11/19/12	51												
53	Prepare DR4 Rough Draft	Fri 11/16/12	Mon 11/19/12	42												
54	Look over Rough Draft w/ Prof	Mon 11/19/12	Mon 11/19/12	53												
55	Design Expo - Final Prototype	Thu 12/6/12	Thu 12/6/12	61												
56	Finalize Design Changes	Tue 11/20/12	Wed 11/21/12													
57	Finalize and get final prints approved	Thu 11/22/12	Fri 11/23/12	56												
58	Build Final Prototype	Sat 11/24/12	Sun 12/2/12	57												
59	Final Prototype Testing and Validation	Mon 12/3/12	Tue 12/4/12	58												
60	Prepare Expo presentation	Mon 12/3/12	Wed 12/5/12	59												
61	Practice for Expo	Wed 12/5/12	Wed 12/5/12	60												
62	Final Report	Tue 12/11/12	Tue 12/11/12	64												
63	Prepare DR4 Rough Draft	Thu 12/6/12	Sun 12/9/12													

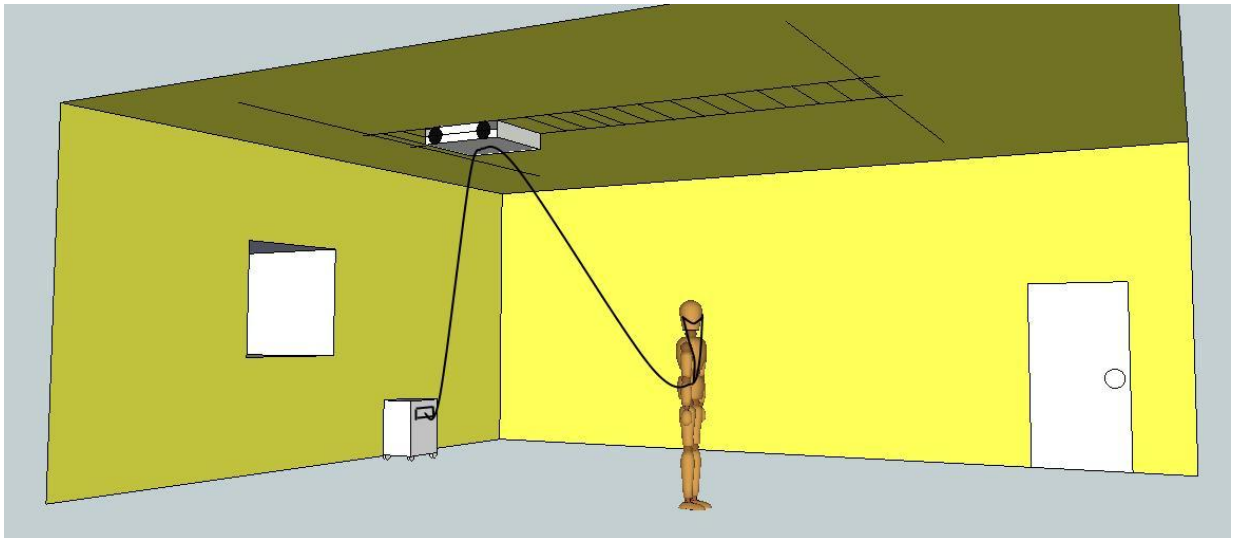
Project: 450\_GANTT\_CHART  
Date: Thu 11/1/12

Task		External Milestone		Manual Summary Rollup	
Split		Inactive Task		Manual Summary	
Milestone		Inactive Milestone		Start-only	
Summary		Inactive Summary		Finish-only	
Project Summary		Manual Task		Deadline	
External Tasks		Duration-only		Progress	



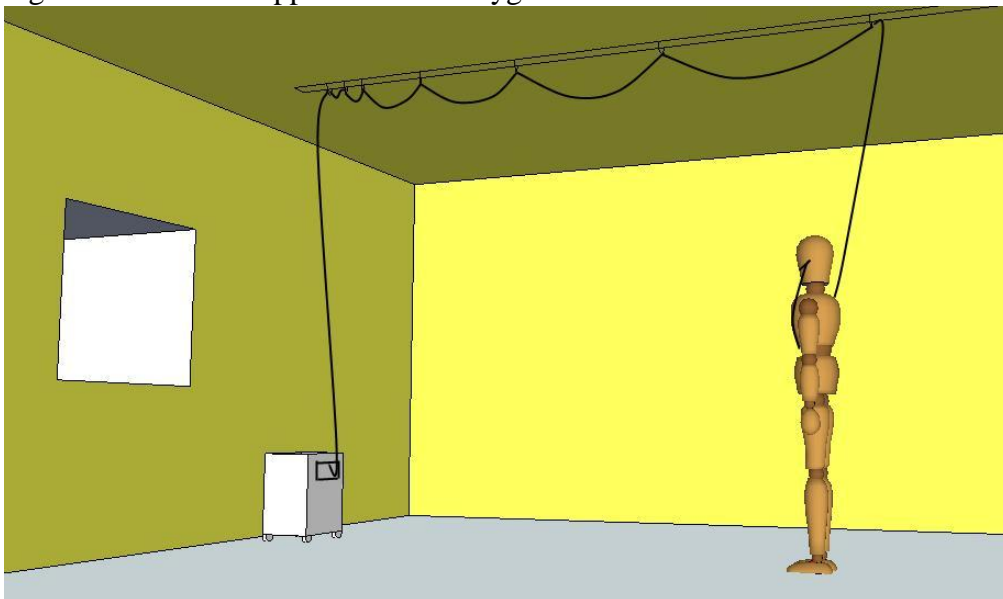
Ceiling-mounted devices

1) “Cross Tracks”: This concept is a ceiling mounting system with a trolley that can move on the x-y plane using a dual track design. The trolley allows the user great mobility throughout the entire room. A spool, located on the trolley, feeds and retracts tubing as the user moves around the room. Constant tension is exerted on the user via the torsional spring in the spool.



**Figure 1:** A ceiling mounted device that uses a two-axis track system.

2) “Shower Curtain”: This design consists of hook that can slide along a track mounted on the ceiling. No retraction device is utilized because the excess tubing will collapse together as the user approaches the oxygen concentrator.

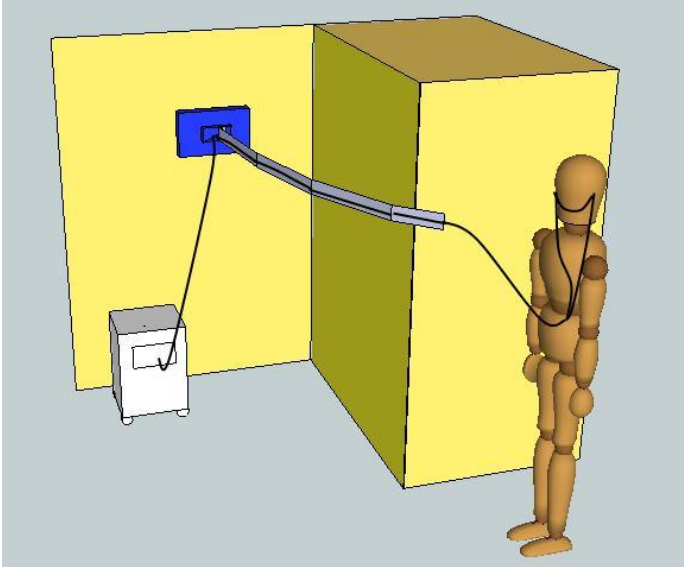


**Figure 2:** A ceiling mounted concept that utilizes no retraction device.

## Appendix D: Concept drawings

### Wall-mounted devices

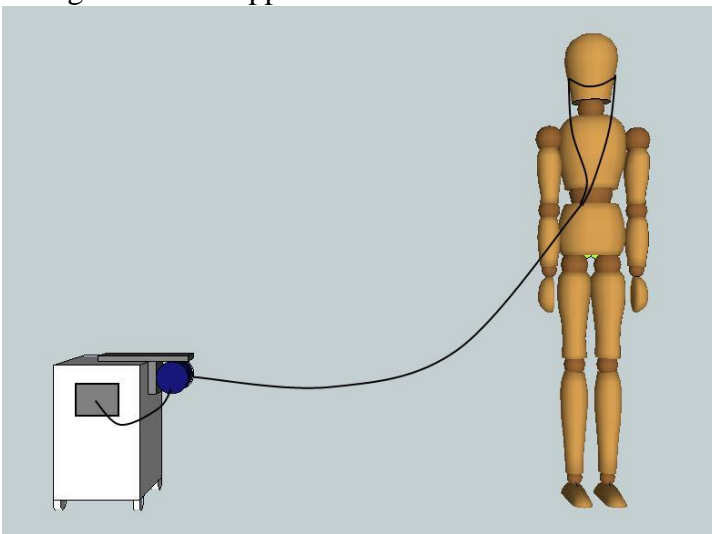
3) “Tele-mag Arm”: The tubing is housed in an arm that is able to break and bend through the use of magnets in the joints. This design will be helpful as the user walks around corners. When the user returns to the concentrator, the arm will be able to retract upon itself much like a telescope.



**Figure 3:** A wall mounted device that breaks and bends around corners of the room.

### Concentrator-mounted devices

4) “Side Reel”: This system will be clamped on the side of concentrator with a retraction device. The retraction device will house a spool and a torsional spring to collect excess tubing as the user approaches the concentrator.



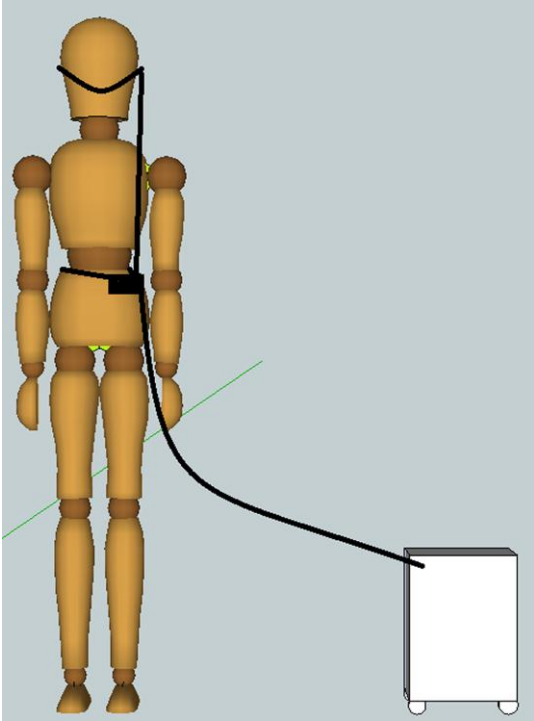
**Figure 4:** A concentrator-mounted device that utilizes a clamping system to fasten to the concentrator.



## Appendix D: Concept drawings

### Non-mounted devices

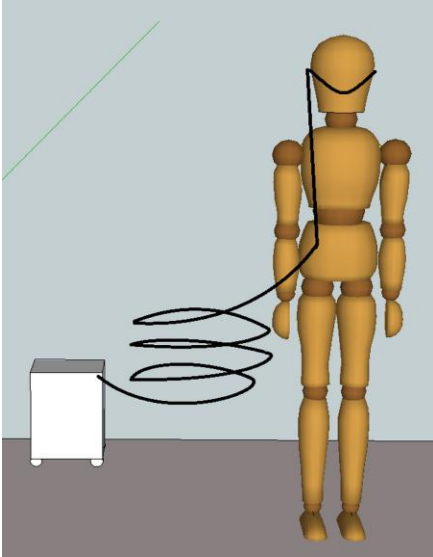
5) “Belt Spinner”: This device will be fastened to the user’s belt or waist. It consists of a retraction device housing a torsional spring and a spool. The retraction device is also able to swivel around the person’s belt line as he/she walks around the room.



**Figure 5:** A retraction device that can swivel around the person’s beltline.

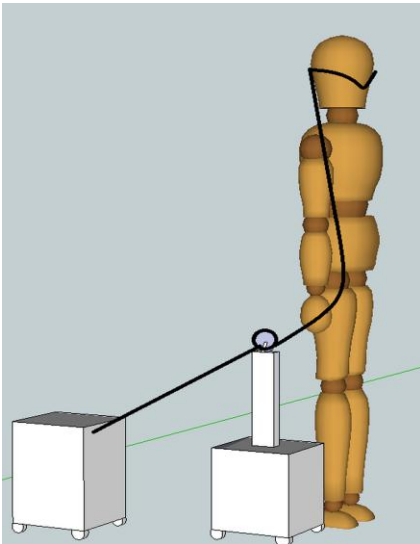
## Appendix D: Concept drawings

6) “Levatube”: For this concept, a magnetic plate is placed on the floor and the tubing is coated with magnets. This system allows the tube to levitate above the floor and would eliminate the need for a retraction device to house excess tubing.



**Figure 6:** The tubing can levitate due to the magnetic floor and coating on the tubing.

7) “Trolley System”: The retraction device is placed on top of a trolley, which can follow the user as he/she walks around the room collecting and extending the tubing as needed.



**Figure 7:** A trolley will follow the user as he/she walks around the room. It will also carry the retraction device for the excess tubing.

Appendix E: Individual Pugh charts

			Concepts								
PETER	Requirement	Weight	Fisherman (Ref.)	Shower curtain	Scissor	Cross tracks	Tele-mag arm	Mobile wall mount	I.V. pole	Side reel	Swivel tube clamp
	Reduce tripping hazard	0.20	3	3	3	4	2	3	2	1	2
	User mobility	0.15	3	3	2	2	4	4	3	2	4
	Ability to utilize sanitizing agent	0.15	3	1	4	2	2	4	4	4	4
	Easy to use	0.15	3	3	4	4	3	1	3	3	3
	Easy to maintain	0.10	3	1	4	2	2	4	4	4	4
	Portability of device	0.10	3	3	3	1	4	4	4	4	4
	Ease of manufacturing	0.10	3	3	2	2	2	4	4	5	4
	Durability	0.05	3	3	3	4	2	4	4	4	3
<b>Total</b>			3	2.5	3.15	2.7	2.65	3.35	3.3	3.05	3.4

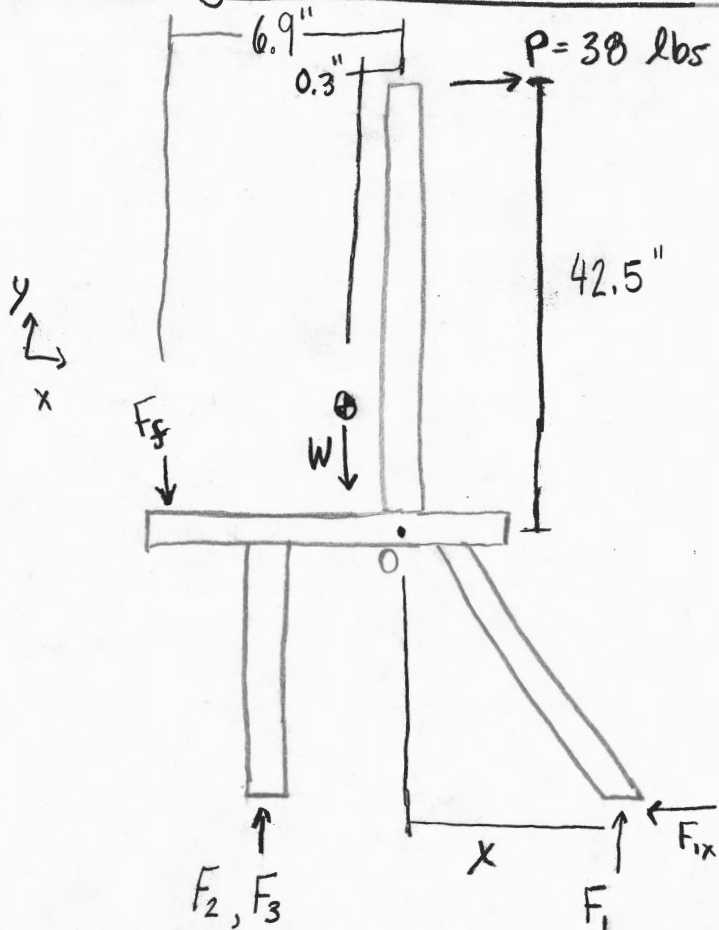
TYLER	Requirement	Weight	Fisherman (Ref.)	Shower curtain	Scissor	Cross tracks	Tele-mag arm	Mobile wall mount	I.V. pole	Side reel	Swivel tube clamp
	Reduce tripping hazard	0.20	3	3	3	3	3	3	3	2	3
	User mobility	0.15	3	3	3	4	4	5	5	5	5
	Ability to utilize sanitizing agent	0.15	3	2	2	3	3	3	3	3	3
	Easy to use	0.15	3	3	3	3	3	2	2	3	3
	Easy to maintain	0.10	3	3	3	1	1	4	3	4	4
	Portability of device	0.10	3	3	3	3	3	5	5	5	5
	Ease of manufacturing	0.10	3	3	2	2	1	3	3	4	3
	Durability	0.05	3	5	3	3	2	4	4	3	3
<b>Total</b>			3	2.95	2.75	2.85	2.7	3.5	3.4	3.5	3.6

NATHAN	Requirement	Weight	Fisherman (Ref.)	Shower curtain	Scissor	Cross tracks	Tele-mag arm	Mobile wall mount	I.V. pole	Side reel	Swivel tube clamp
	Reduce tripping hazard	0.20	3	3	2	3	2	2	3	2	2
	User mobility	0.15	3	3	3	4	4	4	4	4	5
	Ability to utilize sanitizing agent	0.15	3	1	3	3	3	3	3	3	3
	Easy to use	0.15	3	3	3	4	3	3	3	3	3
	Easy to maintain	0.10	3	1	4	1	4	4	4	4	4
	Portability of device	0.10	3	1	2	1	2	4	4	4	4
	Ease of manufacturing	0.10	3	4	2	1	1	4	3	3	2
	Durability	0.05	3	3	2	3	3	3	3	3	3
<b>Total</b>		<b>3</b>	<b>2.4</b>	<b>2.65</b>	<b>2.7</b>	<b>2.75</b>	<b>3.25</b>	<b>3.35</b>	<b>3.15</b>	<b>3.2</b>	

STEVE	Requirement	Weight	Fisherman (Ref.)	Shower curtain	Scissor	Cross tracks	Tele-mag arm	Mobile wall mount	I.V. pole	Side reel	Swivel tube clamp
	Reduce tripping hazard	0.20	3	3	2	3	2	2	2	1	2
	User mobility	0.15	3	3	2	4	4	4	4	4	4
	Ability to utilize sanitizing agent	0.15	3	1	1	3	4	4	4	5	4
	Easy to use	0.15	3	3	2	3	2	3	3	3	3
	Easy to maintain	0.10	3	4	3	2	4	4	5	5	5
	Portability of device	0.10	3	3	3	3	3	4	5	5	5
	Ease of manufacturing	0.10	3	4	2	2	1	5	5	5	4
	Durability	0.05	3	4	1	3	1	4	5	5	4
<b>Total</b>		<b>3</b>	<b>2.95</b>	<b>2</b>	<b>2.95</b>	<b>2.75</b>	<b>3.55</b>	<b>3.8</b>	<b>3.75</b>	<b>3.65</b>	

**Table 1:** Pugh charts completed by each team member show that ceiling- and wall-mounted concepts scored low compared to concentrator-mounted concepts

# Rear Leg horizontal distance calculation



$$\sum F_y = 0$$

$$\sum M_o = 0$$

When just beginning  
to tip backwards,  
 $F_2 = F_3 = 0$

$$F_1 = W + F_f$$

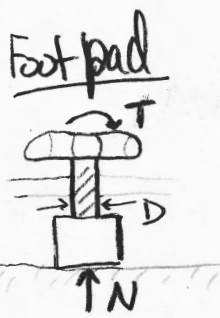
$$(6.9)F_f + (0.3)W + F_1 x = (42.5)P$$

( $F_2$  is other foot reaction located in the same x-y coordinate, only z-dimension, into the page, is different.)

## Estimating $F_f$

$F_f = 2N\mu_s$  where  $N$  is the normal force (out of the page) on the device from the concentrator, per foot pad

(from Machinery's Handbook 29th Edition)



$$N = \frac{T}{(0.2)(D)}$$

$T \approx 1.22 \text{ N}\cdot\text{m} = 10.80 \text{ in}\cdot\text{lbs}$  (from Human Factors study)

$D = \frac{1}{4}''$  ( $\frac{1}{4}''$ -20 fastener)

$$N = \frac{10.80 \text{ in}\cdot\text{lbs}}{(0.2)(0.25 \text{ in})} = 216 \text{ lbs per foot pad}$$

$\mu_s \approx 0.5$  (Rubber on cardboard, closest to situation that we could find)

$$F_f = 2 N \mu_s = 2(216 \text{ lbs})(0.5) = \underline{216 \text{ lbs}}$$

$$F_i = W + F_f \quad (W \text{ from SolidWorks} \rightarrow \underline{W = 10.8 \text{ lbs}})$$

$$F_i = 10.8 \text{ lbs} + 216 \text{ lbs} = \underline{226.8 \text{ lbs}}$$

$$(6.9)F_f + (0.3)W + F_i x = (42.5)P$$

$$x = \frac{-(6.9)(216) - (0.3)(10.8) + (42.5)(38)}{226.8}$$

$$\boxed{x = 0.54}$$

## Length of spring needed

Tubing length wound  $\rightarrow L = 258''$

$R = 2.00''$  (spool radius)

$r \equiv$  diameter of shaft =  $0.3125''$

shaft =  $0.3125''$

## Appendix F: Engineering Analysis Calculations

$$\Delta\theta \text{ for full rotation} \rightarrow \Delta\theta = \frac{L}{R} = \frac{258''}{2.00''} = 129 \text{ rads}$$

$$l_{\text{spring}} = (\Delta\theta)(r) = (129 \text{ rads})(.3125'') = \underline{40.3''}$$



Maximum tubing in the spool  $\rightarrow (25') \left( \frac{12''}{ft} \right) - 42'' = 258'' = L$  Appendix F: Engineering Analysis Calculations tubing OD = 0.25'' = d

3 wraps around spool  $\rightarrow$  10 wraps long

$$l = 10 \text{ wraps} \times 0.25''/\text{wrap} = 2.5'' \quad (\text{spool length})$$

1st wrap =  $D_1$

2nd wrap =  $D_1 + 0.5''$

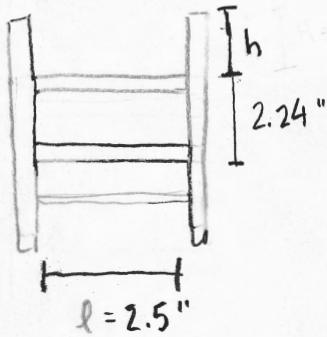
3rd wrap =  $D_1 + 1''$

$$L = (\pi D_1 + \pi(D_1 + 0.5'')) + \pi(D_1 + 1'') (\# \text{ of wraps})$$

$$258'' = 10\pi(3D_1 + 1.5)$$

$$D_1 = 2.24'' \rightarrow \text{minimum diameter required}$$

$$S_D = \text{Spool diameter} = D_1 - 0.5'' = 1.74''$$



$h =$  height of wrapped tubing

$$h = (\# \text{ of wraps})(d) = (3)(0.25'') = 0.75''$$



# Bearing Selection For Spool Shaft mounts

Appendix F: Engineering Analysis Calculations

to use SAE 841 bushings, the PV value for the loading and rotational speed of the bearing must be less than 50,000 psi·sfpm

$P$  = pressure on "projected area" of the bearing (using max bearing force seen of 26.08 lbs)



$$P = F/A_{\text{projected}} = F/(l \times ID)$$

$$P = 26.08 \text{ lbs} / (.1875 \times .625) = \underline{222.5 \text{ psi}}$$

$V$  = linear velocity of projected area

average walking speed of 65 years and older  $\rightarrow V_w = 4.11 \text{ ft/s}$

$$\omega_{\text{spool}} = \omega_{\text{shaft}} = \frac{V_w}{r_{\text{spool}}} = \frac{4.11 \text{ ft/s}}{(2.00 \text{ in}) \left(\frac{1 \text{ ft}}{12 \text{ in}}\right)} = (24.66 \text{ rad/s}) \left(\frac{1 \text{ rev}}{2\pi \text{ rad}}\right) \left(\frac{60 \text{ sec}}{1 \text{ min}}\right) = 235.5 \text{ RPM}$$

$$V = \frac{\pi}{12} \cdot (\text{RPM}) \cdot ID = \pi (235.5 \text{ RPM}) (.625 \text{ in}) \left(\frac{1 \text{ ft}}{12 \text{ in}}\right) = \underline{38.53 \text{ sfpm}}$$

$$PV = (222.5 \text{ psi})(38.53 \text{ sfpm}) = \underline{8572.9 \text{ psi} \cdot \text{sfpm}}$$

According to McMastercar.com, for SAE 841, the following parameters should be met for sleeve bearings:

$$P < 2000 \text{ psi}$$

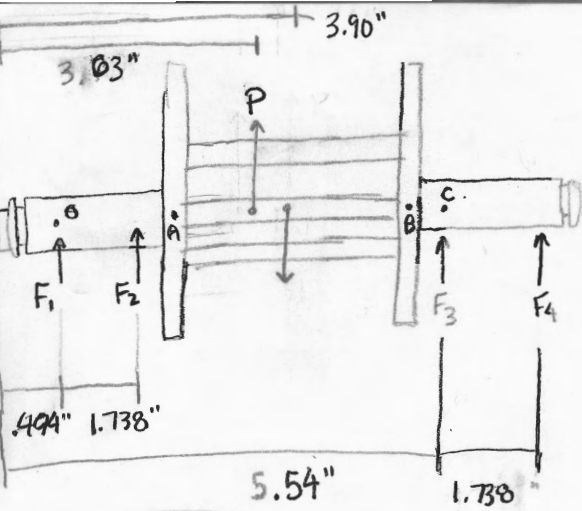
$$V < 1,200 \text{ sfpm}$$

$$PV < 50,000 \text{ psi} \cdot \text{sfpm}$$

All these conditions are met, so SAE 841 Bronze sleeve Bearings will be acceptable.

From Solid Works,  $W = 0.61$  lbs

$P = 38$  lbs (max pull from user)  
(measured in Lab)



Break into components.

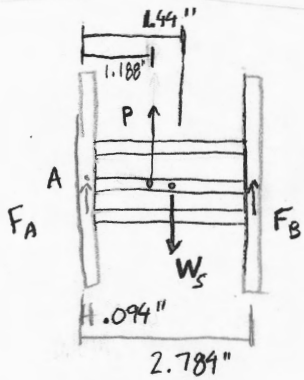
$W_s =$  weight of spool from Solid works  $= 0.47$  lbs

$$\sum F_y = 0 \quad F_A + F_B + P = W_s$$

$$\sum M_A = 0 \quad 1.188 P + 2.784 F_B = 1.44 W_s$$

$$F_B = \frac{(1.44)(.47) - (1.188)(38)}{2.784} = -15.9 \text{ lbs}$$

$$F_A = W_s - P - F_B = .47 - 38 + 15.9 \text{ lbs} \quad F_A = -21.63 \text{ lbs}$$



$W_1 = 0.10$  lbs (from Solid Works)

$$\sum F_y = 0 \quad F_1 + F_2 = W_1 + F_A$$

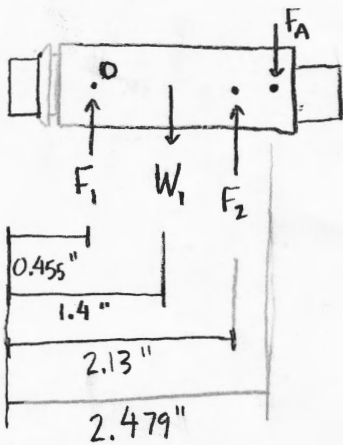
$$\sum M_B = 0 \quad (1.675)F_2 = (.945)W_1 + (2.024)F_A$$

$$F_2 = \frac{(.945)(.10) + (2.024)(-21.63)}{1.675}$$

$$F_2 = -26.08 \text{ lbs}$$

$$F_1 = W_1 + F_A - F_2 = .10 + (-21.63) + 26.08$$

$$F_1 = 4.55 \text{ lbs}$$



$W_2 = .07$  lbs from solid works

$$\sum F_y = 0 \quad F_3 + F_4 = F_B + W_2$$

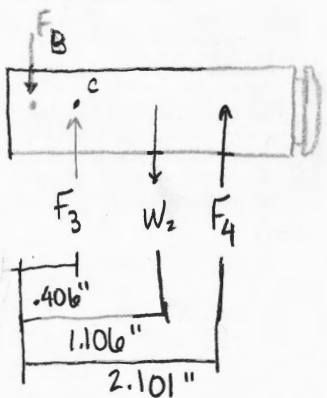
$$\sum M_c = 0 \quad (.406)F_B + (2.101 - .406)F_4 = (1.106 - .406)W_2$$

$$F_4 = \frac{(.67)(.07) - (.406)(-15.9)}{1.695}$$

$$F_4 = 3.84 \text{ lbs}$$

$$F_3 = F_B + W_2 - F_4 = (-15.9) + (.07) - (3.84)$$

$$F_3 = -19.67 \text{ lbs}$$



Appendix G: Circuit Diagram for UV Sanitation

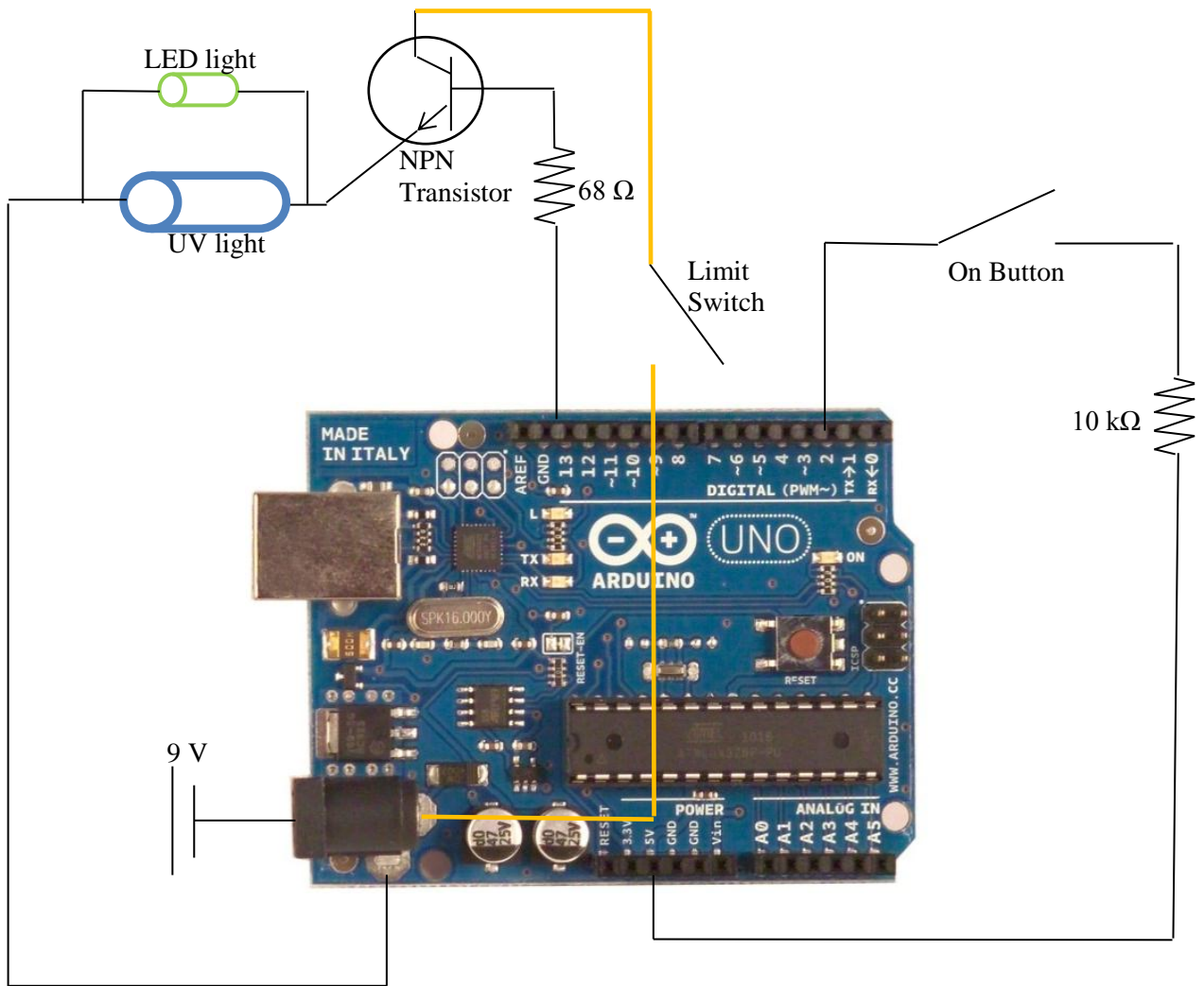


Figure 1: The circuit diagram for the Alpha design UV sanitation subsystem.

## Appendix G: Circuit Diagram for UV Sanitation

### Arduino Code

```
// ME 450 (Peter Chun, Nathan Matheny, Tyler Greene, Stepehn Schell)
// UV Sanitation Light

//set the values of variables to represent the pin numbers
const int buttonPin = 2;
const int pwmPin = 13;
// set the button to off
int buttonState = 0;

void setup(){
  // declare which digital pins are inputs and outputs
  pinMode(buttonPin, INPUT);
  pinMode(pwmPin, OUTPUT);
  // set the initial state of the UV sanitation to off
  digitalWrite(pwmPin, LOW);
}

void loop(){
  // read the state of the button value;
  buttonState = digitalRead(buttonPin);

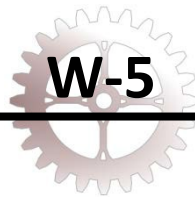
  if (buttonState == HIGH) {
    // button is pressed and UV Sanitation Light and LED light turns on
    digitalWrite(pwmPin, HIGH);
    // turns on UV light and LED light for 3 minutes
    delay(180000);
    // turn off UV light and LED light after 3 minutes
    digitalWrite(pwmPin, LOW);
    // set the button to low
    buttonState == LOW;
  }
  else {
    // button is not pressed on for UV Sanitation
    digitalWrite(pwmPin, LOW);
  }
}
```

# Appendix H: Bill of Materials

Bill of Materials  
ME 450 Team 5

Purchased Components	Use	Vendor	Part number	Cost/Part	Number	Part Cost
Bronze Sleeve Busing, .25" ID, .3125 OD, .75" Length	TOP_BUSHING	McMaster-Carr	6391K401	\$ 0.65	1 \$	0.65
1/4" Shoulder Bolt - 1 1/4" Length	Pivot for top pulley	McMaster-Carr	91259A544	\$ 1.22	2 \$	2.44
1/4" Shoulder Bolt - 1" Length	Pulley Shaft, Rotating arm	McMaster-Carr	91259A542	\$ 1.13	1 \$	1.13
10 kOhm resistor	UV Circuit	Radioshack	N/A	\$ 0.24	1 \$	0.24
68 Ohm resistor	UV Circuit	Radioshack	N/A	\$ 0.24	1 \$	0.24
Arduino Uno Processing Board REV 3	Control of UV Light Sanitation	Radioshack	N/A	\$ 34.99	1 \$	34.99
Black Comfort-Grip Knob with Threaded Stud, 3/8"-16 Thread, 1 3/4" Length	Pole Clamp Turn Knob	McMaster-Carr	61125K69	\$ 2.74	1 \$	2.74
Black Comfort-Grip Polypropylene with Steel Stud	Moves clamping feet to clamp to concentrator	McMaster-Carr	61125K43	\$ 1.95	3 \$	5.85
Black Plastic 9 Volt Battery Holder	Hold 9V power supply for circuit	Mammothelectronics.com	4SJK-9V-BH	\$ 1.25	1 \$	1.25
9V battery	Power circuit	Duracell	N/A	\$ 2.98	2 \$	5.96
Bronze Sleeve Busing, ID 5/8", OD 3/4", 1 1/2" Length	Allows shaft Rotation (cut to length)	McMaster-Carr	6391K415	\$ 1.94	2 \$	3.88
Caster Wheels	Allows wheels to roll	McMaster-Carr	24215T67	\$ 1.60	3 \$	4.80
Constant-Force Spring, 2.63 lbs	Provides required torque to retract tubing	McMaster-Carr	9293K52	\$ 7.56	1 \$	7.56
E-Clip, 5/8" diameter shaft, groove: .046" W, .485" D	Constrains spool and spring shafts	McMaster-Carr	97431A350	\$ 0.15	4 \$	0.60
Eyebolt, Light Duty, .5" ID, 1/4"-20 Threads, 1 3/8" I Thread	Pole Clamp Tubing Guide	McMaster-Carr	9489T47	\$ 2.25	1 \$	2.25
LED	Alert user when UV bulb is on	Mammothelectronics.com	4SLED3MMGR	\$ 0.17	1 \$	0.17
Limit Switch	Does not allow user to turn on UV bulb without top cover on	McMaster-Carr	7658K12	\$ 3.33	1 \$	3.33
Metalic Tape	Reflect UV light	Home Depot	N/A	\$ 5.79	1 \$	5.79
NPN Transistor	UV Circuit	Radioshack	276-1617	\$ 0.20	1 \$	0.20
Nut, #10-24	General Fastening	General Fastener	N/A	\$ 0.03	19 \$	0.57
Nut, #2-56	Fasten Electrical components to spool housing	General Fastener	N/A	\$ 0.03	16 \$	0.48
Nut, #6-32	Fasten tabs to cover components	General Fastener	N/A	\$ 0.02	18 \$	0.36
Nut, 1/4"-20	Fasten pivot pulley sides together	General Fastener	N/A	\$ 0.03	26 \$	0.78
Oxygen tubing swivel connection	Attach tubing to SPOOL_SHAFT_TUBING	BP Medical Supplies	N/A	\$ 2.00	2 \$	4.00
Oxygen tubing, 25' length	Deliver oxygen from concentrator to user	US Medical Supplies	64232	\$ 2.42	1 \$	2.42
Pan Head Machine Screw, #10-24, 1/2" Length	Fasten spool mounts on spring side	General Fastener	N/A	\$ 0.20	4 \$	0.80
Pan Head Machine Screw, #2-56, 1" Length	Fasten UV printed circuit board to spool housing	General Fastener	N/A	\$ 0.17	2 \$	0.34
Pan Head Machine Screw, #2-56, 3/8" Length	Fasten battery holder, Arduino to spool housing	General Fastener	N/A	\$ 0.11	8 \$	0.88
Pan Head Machine Screw, #2-56, 5/8" Length	Fasten breadboard, UV light to spool housing	General Fastener	N/A	\$ 0.13	6 \$	0.78
Pan Head Machine Screw, #6-32, 1/4" Length	Fasten tabs to cover components	General Fastener	N/A	\$ 0.17	19 \$	3.23
Press Button Switch	Turns on UV bulb	Adafruit Industries	1009	\$ 0.40	1 \$	0.40
Prototyping Bread Board	Holds circuit components	Radioshack	276-150	\$ 2.49	1 \$	2.49
Rubber Feet	Allows clamping to concentrator	McMaster-Carr	9546K79	\$ 3.87	4 \$	15.48
Rubber Stripping, 1/8" thick, 1/4" wide	Attach to pole clamp to lock clamp in	Home Depot	N/A	\$ 6.24	1 \$	6.24
SHCS, #10-24, 3/4" Length	Fasten spool mounts on connection side, Pole bracket to baseplate	General Fastener	N/A	\$ 0.12	8 \$	0.96
SHCS, #10-24, 3/8" Length	Fasten tabs to base plate, slide bolt to baseplate	General Fastener	N/A	\$ 0.11	12 \$	1.32
SHCS, 1/4"-20, 1 1/2" Length	Fasten Top mount, top pulley sides together, foot insert to leg	General Fastener	N/A	\$ 0.17	6 \$	1.02
SHCS, 1/4"-20, 1 1/4" Length	Fasten foot clamps to side arms	General Fastener	N/A	\$ 0.22	4 \$	0.88
SHCS, 1/4"-20, 1 3/4" Length	Fasten Pole Top	General Fastener	N/A	\$ 0.20	1 \$	0.20
SHCS, 1/4"-20, 1" Length	Fasten arm to baseplate, stationary feet to bracket	General Fastener	N/A	\$ 0.14	6 \$	0.84
SHCS, 1/4"-20, 1/2" Length	Pulley hard stop	General Fastener	N/A	\$ 0.13	1 \$	0.13
SHCS, 1/4"-20, 2 1/2" Length	Fasten pole to pole brackets	General Fastener	N/A	\$ 0.28	2 \$	0.56
SHCS, 1/4"-20, 3/4" Length	Pole Clamp Mount	General Fastener	N/A	\$ 0.14	1 \$	0.14
Shoulder Bolt, 1/4" D, 2 1/4" Length	Pole Hard Stop	McMaster-Carr	91259A104	\$ 1.78	1 \$	1.78
Shoulder Bolts, 5/16" Diameter, 1/2" Length shoulder	Allow for slide between plates	McMaster-Carr	91259A578	\$ 1.20	4 \$	4.80
Slide Bolt	Lock tubing retraction spool when replacing tubing	Home Depot	N/A	\$ 1.99	1 \$	1.99
U-Bolt, Pipe Size 1 1/4", 3" Length, 1/4"-20 Thread	Pole Clamp Mounting	McMaster-Carr	3201T15	\$ 0.88	1 \$	0.88
Velcro, 1/8" thick	Attach removable top spool cover to baseplate	Carpenter Brothers	N/A	\$ 0.99	1 \$	0.99
Verilux CleanWave Sanitizing Wand	Apply UV Light Sanitation	Walgreens.com	N/A	\$ 39.99	1 \$	39.99
Washer, #10	General Fastening	General Fastener	N/A	\$ 0.08	28 \$	2.24
Washer, 1/4"	General Fastening	General Fastener	N/A	\$ 0.15	41 \$	6.15
Purchased Stock Materials	Use	Vendor	Part Number	Cost/Unit	# of units	
6061 Aluminum Angle, 1-1/2" x 1-1/2" x .25", 12"	Clamping pad brackets and spool mount brackets	Speedy Metals	N/A	\$ 3.67	1 \$	3.67
6061 Aluminum Angle, 1-1/2" x 1-1/2" x 3/16", 12"	Pole mounting brackets	Alro Metals	N/A	\$ 12.98	1 \$	12.98
6061 Aluminum bar, 1"x1", 12" long	Foot inserts and rotating pulley	Alro Metals	N/A	\$ 5.32	1 \$	5.32
6061 Aluminum bar, 1/2" x 2-1/2" (priced by inch)	Bending clamps	Speedy Metals	N/A	\$ 0.73	7 \$	5.11
6061 Aluminum plate, 0.25" thick, 1'x1'	Baseplate and armplates	McMaster-Carr	9246K13	\$ 20.11	2 \$	40.22
6061 Aluminum Round Stock (1.5" D, 12")	Spool shafts	Speedy Metals	N/A	\$ 8.71	1 \$	8.71





**Semester:** Fall  
**Year:** 2012  
**Project Number:** Team 5  
**Project Title:** Oxygen tube concentrator storage and control device

**Task Category:**  
 Manufacturing/Prototyping

### **Who:**

Who will be present when you perform this task? Please include teammates and any observers.  
 Group members Stephen Schell, Tyler Greene, Peter Chun, and Nathan Matheny.

### **When:**

List the date and time you intend to start this task, as well as an estimate of the duration.  
 Novemeber 5th, 2012. 12:00 PM – November 14th, 2012

### **Where:**

Describe the exact location where you intend to conduct this task.

**On-campus locations:** List the building and room.

*Note:* If you are using the G.G. Brown Undergraduate Machine Shop, just write “Undergrad. Machine Shop”.

**Off-campus locations:** List the address.

Undergrad. Machine Shop

### **What:**

- List and describe all important and potentially-dangerous equipment you will be using for your task.
- Describe all potentially-dangerous energy, material, and environmental requirements for your task. **Include inputs and outputs.**  
Examples: High voltage/current, extreme temperatures, toxic chemicals, fluids (circulating water, etc.), dust/particulates.
- Summarize your planned procedure.
- If possible, please attach a photograph/drawing of your setup.  
**For Experiment/Validation:** Show your experimental setup, especially the equipment described in #1. Include labels.  
**For Manufacturing/Prototyping:** Show the part(s) you will be manufacturing. Line drawings or CAD images are acceptable.
- List methods to reduce safety risk (protective equipment, safe practices, etc.)

#### **1) Equipment:**

Laser cutter machine, Acrylic workpiece

#### **2) Inputs & Outputs**

Inputs: High voltage/current, high temperatures, intense brightness

Output: potentially sharp workpiece

#### **3) Procedure Summary**

We will bring the proper part file to the machine and open it. We will then insert the workpiece into the machine, start the machine, and wait for the part to be finished.

#### **4) Setup Figure**



**5) Mitigation Steps**

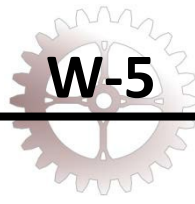
Only trained individuals are allowed to be in the shop. Must wear safety glasses, tuck in shirt, shirt must have short sleeves, wear long pants, and shoes that completely cover the foot.

**Why:**

Why are you doing this particular task? What results/data do you hope to obtain? Is everything you listed in the previous section (equipment, procedures, etc.) *really* necessary?

We are doing this to manufacture our prototype. We hope to obtain parts that are made to print. Everything is completely necessary to manufacture our parts





**Semester:** Fall  
**Year:** 2012  
**Project Number:** Team 5  
**Project Title:** Oxygen tube concentrator storage and control device

**Task Category:**  
 Manufacturing/Prototyping

**Who:**

Who will be present when you perform this task? Please include teammates and any observers.  
 Group members Stephen Schell, Tyler Greene, Peter Chun, and Nathan Matheny.

**When:**

List the date and time you intend to start this task, as well as an estimate of the duration.  
 Novemeber 5th, 2012. 12:00 PM – November 20th, 2012

**Where:**

Describe the exact location where you intend to conduct this task.

**On-campus locations:** List the building and room.

*Note:* If you are using the G.G. Brown Undergraduate Machine Shop, just write “Undergrad. Machine Shop”.

**Off-campus locations:** List the address.

Undergrad. Machine Shop

**What:**

- List and describe all important and potentially-dangerous equipment you will be using for your task.
- Describe all potentially-dangerous energy, material, and environmental requirements for your task. **Include inputs and outputs.**  
Examples: High voltage/current, extreme temperatures, toxic chemicals, fluids (circulating water, etc.), dust/particulates.
- Summarize your planned procedure.
- If possible, please attach a photograph/drawing of your setup.  
**For Experiment/Validation:** Show your experimental setup, especially the equipment described in #1. Include labels.  
**For Manufacturing/Prototyping:** Show the part(s) you will be manufacturing. Line drawings or CAD images are acceptable.
- List methods to reduce safety risk (protective equipment, safe practices, etc.)

**1) Equipment:**

Lathe, tool block, spindle, workpiece, boring bar, parting tool, facing tool, forming tool

**2) Inputs & Outputs**

Inputs: High voltage/current, sharp tool edges, high velocities  
 workpiece, UFOs

Output: High temperatures, potentially sharp

**3) Procedure Summary**

The the lathe with the tool block, spindle, workpiece, boring bar, parting tool, facing tool, and/or forming tool will be used to fabricate the workpiece into our desired geometer. The speed will be set depending on the material used. Attach the workpiece to the spindle and then turn the mill on. Multiple levers and knobs are then used to shape the workpiece.

**4) Setup Figure**



### **5) Mitigation Steps**

Only trained individuals are allowed to be in the shop. Must wear safety glasses, tuck in shirt, shirt must have short sleeves, wear long pants, and shoes that completely cover the foot.

### **Why:**

Why are you doing this particular task? What results/data do you hope to obtain? Is everything you listed in the previous section (equipment, procedures, etc.) *really* necessary?

We are doing this to manufacture our prototype. We hope to obtain parts that are made to print. Everything is completely necessary to manufacture our parts



**Semester:** Fall  
**Year:** 2012  
**Project Number:** Team 5  
**Project Title:** Oxygen tube concentrator storage and control device

**Task Category:**  
 Manufacturing/Prototyping

**Who:**

Who will be present when you perform this task? Please include teammates and any observers.  
 Group members Stephen Schell, Tyler Greene, Peter Chun, and Nathan Matheny.

**When:**

List the date and time you intend to start this task, as well as an estimate of the duration.  
 Novemeber 5th, 2012. 12:00 PM – November 20th, 2012

**Where:**

Describe the exact location where you intend to conduct this task.

**On-campus locations:** List the building and room.

*Note:* If you are using the G.G. Brown Undergraduate Machine Shop, just write “Undergrad. Machine Shop”.

**Off-campus locations:** List the address.

Undergrad. Machine Shop

**What:**

- List and describe all important and potentially-dangerous equipment you will be using for your task.
- Describe all potentially-dangerous energy, material, and environmental requirements for your task. **Include inputs and outputs.**  
Examples: High voltage/current, extreme temperatures, toxic chemicals, fluids (circulating water, etc.), dust/particulates.
- Summarize your planned procedure.
- If possible, please attach a photograph/drawing of your setup.  
**For Experiment/Validation:** Show your experimental setup, especially the equipment described in #1. Include labels.  
**For Manufacturing/Prototyping:** Show the part(s) you will be manufacturing. Line drawings or CAD images are acceptable.
- List methods to reduce safety risk (protective equipment, safe practices, etc.)

**1) Equipment:**

Mill, bit, chuck, workpiece

**2) Inputs & Outputs**

Inputs: High voltage/current, sharp tool edges, high velocities  
 workpiece, UFOs

Output: High temperatures, potentially sharp

**3) Procedure Summary**

The mill with the chuck and bit will be used to fabricate the workpiece into our desired geometry. The correct bit will be selected and attached to the chuck and the chuck into the mill. The speed will be set depending on the material used. Attach the workpiece to the fixture and then turn the mill on. Multiple levers and knobs are then used to shape the workpiece.

**4) Setup Figure**



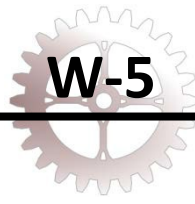
#### **5) Mitigation Steps**

Only trained individuals are allowed to be in the shop. Must wear safety glasses, tuck in shirt, shirt must have short sleeves, wear long pants, and shoes that completely cover the foot.

#### **Why:**

Why are you doing this particular task? What results/data do you hope to obtain? Is everything you listed in the previous section (equipment, procedures, etc.) *really* necessary?

We are doing this to manufacture our prototype. We hope to obtain parts that are made to print. Everything is completely necessary to manufacture our parts



**Semester:** Fall  
**Year:** 2012  
**Project Number:** Team 5  
**Project Title:** Oxygen tube concentrator storage and control device

**Task Category:**  
 Manufacturing/Prototyping

### **Who:**

Who will be present when you perform this task? Please include teammates and any observers.  
 Group members Stephen Schell, Tyler Greene, Peter Chun, and Nathan Matheny.

### **When:**

List the date and time you intend to start this task, as well as an estimate of the duration.  
 November 5th, 2012. 12:00 PM – November 14th, 2012

### **Where:**

Describe the exact location where you intend to conduct this task.

**On-campus locations:** List the building and room.

*Note:* If you are using the G.G. Brown Undergraduate Machine Shop, just write "Undergrad. Machine Shop".

**Off-campus locations:** List the address.

S. M. Wu Manufacturing Research Center

### **What:**

- List and describe all important and potentially-dangerous equipment you will be using for your task.
- Describe all potentially-dangerous energy, material, and environmental requirements for your task. **Include inputs and outputs.**  
Examples: High voltage/current, extreme temperatures, toxic chemicals, fluids (circulating water, etc.), dust/particulates.
- Summarize your planned procedure.
- If possible, please attach a photograph/drawing of your setup.  
**For Experiment/Validation:** Show your experimental setup, especially the equipment described in #1. Include labels.  
**For Manufacturing/Prototyping:** Show the part(s) you will be manufacturing. Line drawings or CAD images are acceptable.
- List methods to reduce safety risk (protective equipment, safe practices, etc.)

#### **1) Equipment:**

Water Jet Machine, workpiece

#### **2) Inputs & Outputs**

Inputs: High voltage/current, high pressures, fluids at high velocity

Output: potentially sharp workpiece

#### **3) Procedure Summary**

We will bring the proper part file to the machine and open it. We will then give the workpiece to the technician, stand back, and wait for the part to be finished.

#### **4) Setup Figure**



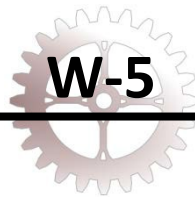
**5) Mitigation Steps**

Only trained individuals are allowed to use the machine and the trained technician will be handling the machine for us. Must wear safety glasses, tuck in shirt, shirt must have short sleeves, wear long pants, and shoes that completely cover the foot.

**Why:**

Why are you doing this particular task? What results/data do you hope to obtain? Is everything you listed in the previous section (equipment, procedures, etc.) *really* necessary?

We are doing this to manufacture our prototype. We hope to obtain parts that are made to print. Everything is completely necessary to manufacture our parts



**Semester:** Fall  
**Year:** 2012  
**Project Number:** 5  
**Project Title:** Oxygen concentrator tube storage and control device

**Task Category:**  
 Experiment/Validation

### Who:

Who will be present when you perform this task? Please include teammates and any observers.

Tyler Greene, Nathan Matheny, Peter Chun and Steve Schell

### When:

List the date and time you intend to start this task, as well as an estimate of the duration.

November 18th from 1:00 PM to 2:00 PM

### Where:

Describe the exact location where you intend to conduct this task.

**On-campus locations:** List the building and room.

*Note:* If you are using the G.G. Brown Undergraduate Machine Shop, just write "Undergrad. Machine Shop".

**Off-campus locations:** List the address.

GG Brown x50 assembly room

### What:

- List and describe all important and potentially-dangerous equipment you will be using for your task.
- Describe all potentially-dangerous energy, material, and environmental requirements for your task. **Include inputs and outputs.**  
*Examples:* High voltage/current, extreme temperatures, toxic chemicals, fluids (circulating water, etc.), dust/particulates.
- Summarize your planned procedure.
- If possible, please attach a photograph/drawing of your setup.  
**For Experiment/Validation:** Show your experimental setup, especially the equipment described in #1. Include labels.  
**For Manufacturing/Prototyping:** Show the part(s) you will be manufacturing. Line drawings or CAD images are acceptable.
- List methods to reduce safety risk (protective equipment, safe practices, etc.)

#### 1) Equipment:

Tape measure, oxygen concentrator tube storage and control device

#### 2) Inputs & Outputs

Inputs: user retracts the pole      Outputs: The pole is retracted, heat, dust/particles

#### 3) Procedure Summary

The user will retract the pole to its lowest length. A team member will then measure from the ground to the top of the pole with a target value of 4' or less. This is to validate that easy to use by measuring the height of 4' or less.

#### 4) Setup Figure



#### 5) Mitigation Steps

The user of the tape measure will not place their fingers near the opening of the tape measurer to insure that they do not pinch nor further injure themselves. All members will not be touching the pole when it is retracted to its lowest

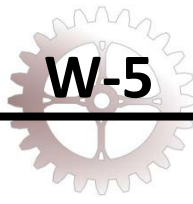
point.

**Why:**

Why are you doing this particular task? What results/data do you hope to obtain? Is everything you listed in the previous section (equipment, procedures, etc.) *really* necessary?

We are hoping to validate our technical requirement of accessible height required for maniteance. All equipment and procedures are necessary for this validation.





**Semester:** Fall  
**Year:** 2012  
**Project Number:** 5  
**Project Title:** Oxygen concentrator tube storage and control device

**Task Category:**  
 Experiment/Validation

**Who:**

Who will be present when you perform this task? Please include teammates and any observers.

Tyler Greene, Nathan Matheny, Peter Chun and Steve Schell

**When:**

List the date and time you intend to start this task, as well as an estimate of the duration.

November 18th from 1:00 PM to 2:00 PM

**Where:**

Describe the exact location where you intend to conduct this task.

**On-campus locations:** List the building and room.

*Note:* If you are using the G.G. Brown Undergraduate Machine Shop, just write "Undergrad. Machine Shop".

**Off-campus locations:** List the address.

GG Brown x50 assembly room

**What:**

- List and describe all important and potentially-dangerous equipment you will be using for your task.
- Describe all potentially-dangerous energy, material, and environmental requirements for your task. **Include inputs and outputs.**  
*Examples:* High voltage/current, extreme temperatures, toxic chemicals, fluids (circulating water, etc.), dust/particulates.
- Summarize your planned procedure.
- If possible, please attach a photograph/drawing of your setup.  
**For Experiment/Validation:** Show your experimental setup, especially the equipment described in #1. Include labels.  
**For Manufacturing/Prototyping:** Show the part(s) you will be manufacturing. Line drawings or CAD images are acceptable.
- List methods to reduce safety risk (protective equipment, safe practices, etc.)

**1) Equipment:**

oxygen concentrator tube storage and control device, UV light, oxygen tubing/concentrator, belt clip

**2) Inputs & Outputs**

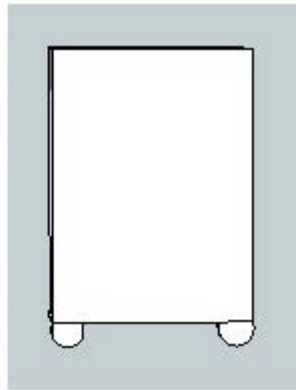
Inputs: user extends/retracts the tubing, high voltage/current  
 exerted on the torsional spring, heat

Outputs: UV light, extension of the tubing, load

**3) Procedure Summary**

The user will be observed by team members during general use. The team members will observe the number of human inputs for each subsystem during general use with a target of 1-3 inputs. This is to validate easy to us by limiting the number of human interactions with the device.

**4) Setup Figure**



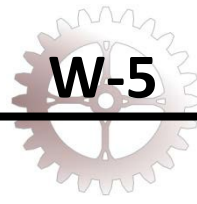
### **5) Mitigation Steps**

Team members will not touch the circuits of the UV light when it is plugged in the outlet. Team members will not stand near the user during general use. They will observe at a distance that does not interfere with the tubing, the device, concentrator, or the user.

### **Why:**

Why are you doing this particular task? What results/data do you hope to obtain? Is everything you listed in the previous section (equipment, procedures, etc.) *really* necessary?

We are hoping to validate our technical requirement of human inputs required for general use. All equipment and procedures are necessary for this validation.



**Semester:** Fall  
**Year:** 2012  
**Project Number:** 5  
**Project Title:** Oxygen concentrator tube storage and control device

**Task Category:**  
 Experiment/Validation

### Who:

Who will be present when you perform this task? Please include teammates and any observers.

Tyler Greene, Nathan Matheny, Peter Chun and Steve Schell

### When:

List the date and time you intend to start this task, as well as an estimate of the duration.

November 18th from 1:00 PM to 2:00 PM

### Where:

Describe the exact location where you intend to conduct this task.

**On-campus locations:** List the building and room.

*Note:* If you are using the G.G. Brown Undergraduate Machine Shop, just write "Undergrad. Machine Shop".

**Off-campus locations:** List the address.

GG Brown x50 assembly room

### What:

- List and describe all important and potentially-dangerous equipment you will be using for your task.
- Describe all potentially-dangerous energy, material, and environmental requirements for your task. **Include inputs and outputs.**  
Examples: High voltage/current, extreme temperatures, toxic chemicals, fluids (circulating water, etc.), dust/particulates.
- Summarize your planned procedure.
- If possible, please attach a photograph/drawing of your setup.  
**For Experiment/Validation:** Show your experimental setup, especially the equipment described in #1. Include labels.  
**For Manufacturing/Prototyping:** Show the part(s) you will be manufacturing. Line drawings or CAD images are acceptable.
- List methods to reduce safety risk (protective equipment, safe practices, etc.)

#### 1) Equipment:

Tape measure, oxygen tubing/concentrator, belt clip, oxygen concentrator tube storage and control device

#### 2) Inputs & Outputs

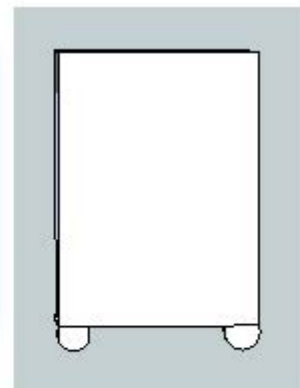
Inputs: user extends the tubing to its full length  
 spring in the retraction device

Outputs: Tubing is extended, force is exerted on the torsional

#### 3) Procedure Summary

The tubing will be extended to its full length from the retraction device with the other end of the tubing being attached to the user's hip. Then, a team member will measure the lowest point of the tubing to the concentrator connection port. This is to validate that the tripping hazard has been reduced by measuring if the lowest point of the tubing to the connection port is less than 6".

#### 4) Setup Figure



#### 5) Mitigation Steps

## Appendix I: Safety Reports

The user of the tape measure will not place their fingers near the opening of the tape measurer to insure that they do not pinch nor further injure themselves.

### **Why:**

Why are you doing this particular task? What results/data do you hope to obtain? Is everything you listed in the previous section (equipment, procedures, etc.) *really* necessary?

We are hoping to validate our technical requirement of reducing tripping hazard. All equipment and procedures are necessary for this validation.



**Semester:** Fall  
**Year:** 2012  
**Project Number:** 5  
**Project Title:** Oxygen concentrator  
 tube storage and control device

**Task Category:**  
 Experiment/Validation

**Who:**

Who will be present when you perform this task? Please include teammates and any observers.

Tyler Greene, Nathan Matheny, Peter Chun and Steve Schell

**When:**

List the date and time you intend to start this task, as well as an estimate of the duration.

November 18th from 1:00 PM to 2:00 PM

**Where:**

Describe the exact location where you intend to conduct this task.

**On-campus locations:** List the building and room.

*Note:* If you are using the G.G. Brown Undergraduate Machine Shop, just write "Undergrad. Machine Shop".

**Off-campus locations:** List the address.

GG Brown x50 assembly room

**What:**

- List and describe all important and potentially-dangerous equipment you will be using for your task.
- Describe all potentially-dangerous energy, material, and environmental requirements for your task. **Include inputs and outputs.**  
*Examples:* High voltage/current, extreme temperatures, toxic chemicals, fluids (circulating water, etc.), dust/particulates.
- Summarize your planned procedure.
- If possible, please attach a photograph/drawing of your setup.  
**For Experiment/Validation:** Show your experimental setup, especially the equipment described in #1. Include labels.  
**For Manufacturing/Prototyping:** Show the part(s) you will be manufacturing. Line drawings or CAD images are acceptable.
- List methods to reduce safety risk (protective equipment, safe practices, etc.)

**1) Equipment:**

Tape measure, oxygen tubing/oxygen concentrator, UV sanitation system, oxygen concentrator tube storage and control device

**2) Inputs & Outputs**

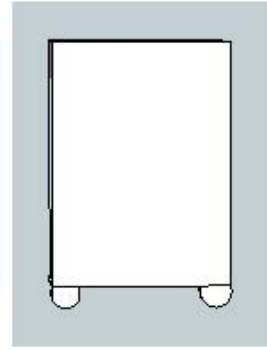
Inputs: high voltage/current, pulling of the tubing  
 the torsional spring, heat

Outputs: UV light, extension of the tubing, load exerted on

**3) Procedure Summary**

The user will stand no greater than 3 feet radially from the concentrator with the tubing attached to the hip. The user will then press the button for sanitation. Team members will observe that the UV light turns on for 2-3 minutes and measure the length of tubing that sits outside the spool. This is to measure the percent of tubing that is sanitized by the UV light in the spool, which we will target at 40 to 70% of the tubing. This is to validate that the device sanitizes 40 to 70% of the tubing.

**4) Setup Figure**



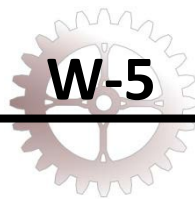
### **5) Mitigation Steps**

The user of the tape measure will not place their fingers near the opening of the tape measurer to insure that they do not pinch nor further injure themselves. Team members will also not touch the circuits of the UV light when it is plugged in the outlet.

### **Why:**

Why are you doing this particular task? What results/data do you hope to obtain? Is everything you listed in the previous section (equipment, procedures, etc.) *really* necessary?

We are hoping to validate our technical requirement of sanitizing the tubing. All equipment and procedures are necessary for this validation.



**Semester:** Fall  
**Year:** 2012  
**Project Number:** 5  
**Project Title:** Oxygen concentrator tube storage and control device

**Task Category:**  
 Experiment/Validation

### Who:

Who will be present when you perform this task? Please include teammates and any observers.

Tyler Greene, Nathan Matheny, Peter Chun and Steve Schell

### When:

List the date and time you intend to start this task, as well as an estimate of the duration.

November 18th from 1:00 PM to 2:00 PM

### Where:

Describe the exact location where you intend to conduct this task.

**On-campus locations:** List the building and room.

*Note:* If you are using the G.G. Brown Undergraduate Machine Shop, just write "Undergrad. Machine Shop".

**Off-campus locations:** List the address.

GG Brown x50 assembly room

### What:

- List and describe all important and potentially-dangerous equipment you will be using for your task.
- Describe all potentially-dangerous energy, material, and environmental requirements for your task. **Include inputs and outputs.**  
Examples: High voltage/current, extreme temperatures, toxic chemicals, fluids (circulating water, etc.), dust/particulates.
- Summarize your planned procedure.
- If possible, please attach a photograph/drawing of your setup.  
**For Experiment/Validation:** Show your experimental setup, especially the equipment described in #1. Include labels.  
**For Manufacturing/Prototyping:** Show the part(s) you will be manufacturing. Line drawings or CAD images are acceptable.
- List methods to reduce safety risk (protective equipment, safe practices, etc.)

#### 1) Equipment:

Tape measure, oxygen tubing, belt clip, oxygen concentrator tube storage and control device

#### 2) Inputs & Outputs

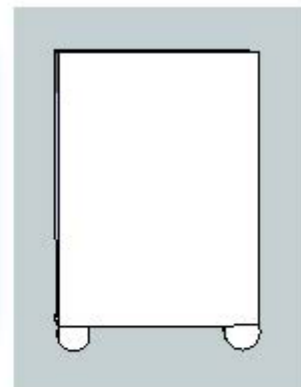
Inputs: user extends the tubing to its full length  
 spring in the retraction device

Outputs: Tubing is extended, force is exerted on the torsional

#### 3) Procedure Summary

The tubing will be extended to its full length from the retraction device with the other end of the tubing attached to the user's hip. Then, a team member will measure the radial distance from the concentrator to the user's hip. This is to validate that the user mobility is extended which is defined as a radial distance of 20 to 25 feet.

#### 4) Setup Figure



#### 5) Mitigation Steps

The user of the tape measure will not place their fingers near the opening of the tape measurer to insure that they do

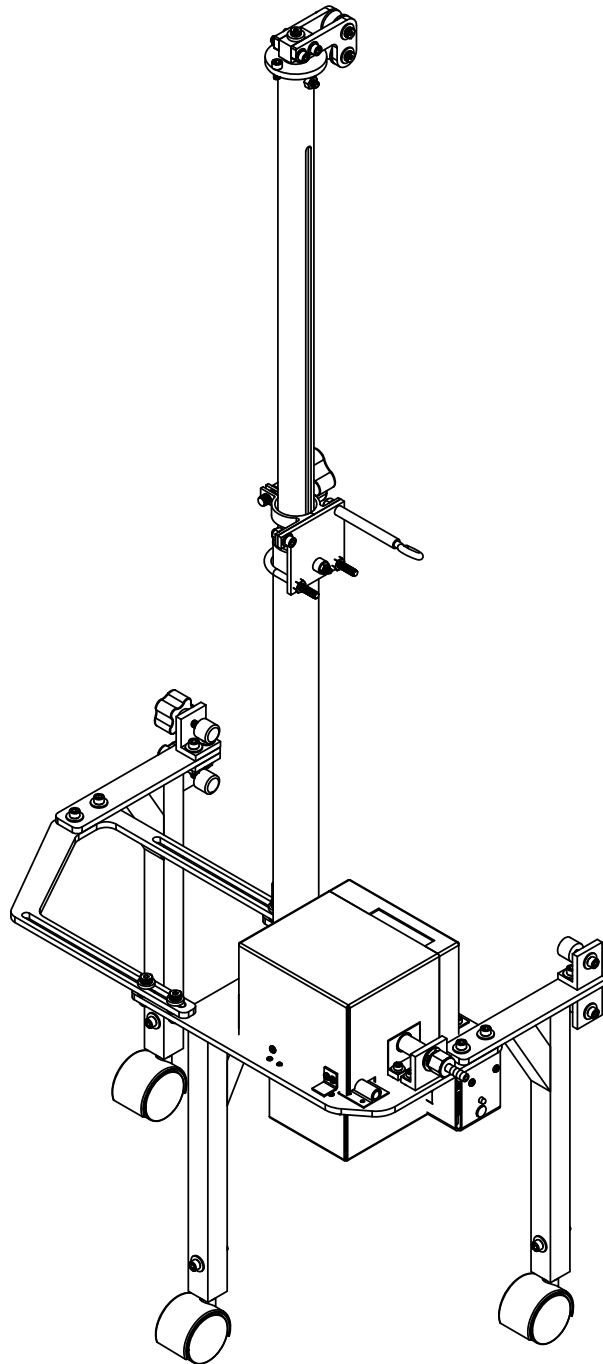
not pinch nor further injure themselves.

**Why:**

Why are you doing this particular task? What results/data do you hope to obtain? Is everything you listed in the previous section (equipment, procedures, etc.) *really* necessary?

We are hoping to validate our technical requirement of maximizing user mobility. All equipment and procedures are necessary for this validation.





ME 450 Team 5

TITLE:

FINAL DESIGN  
ASSEMBLY

SIZE

**A**

DWG. NO.

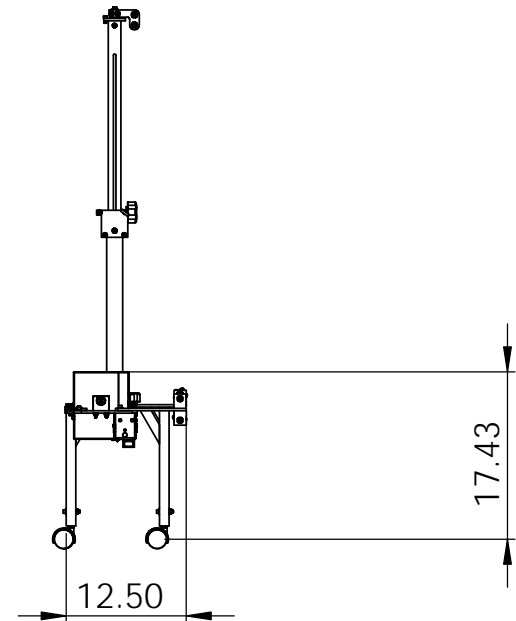
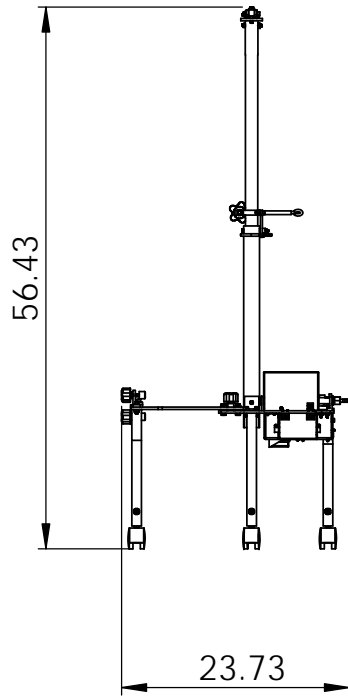
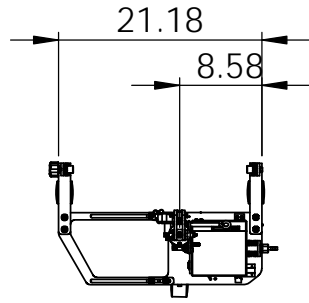
REV

SCALE: 1:20

WEIGHT:

SHEET 1 OF 3

Appendix J: Drawings



ME 450 Team 5

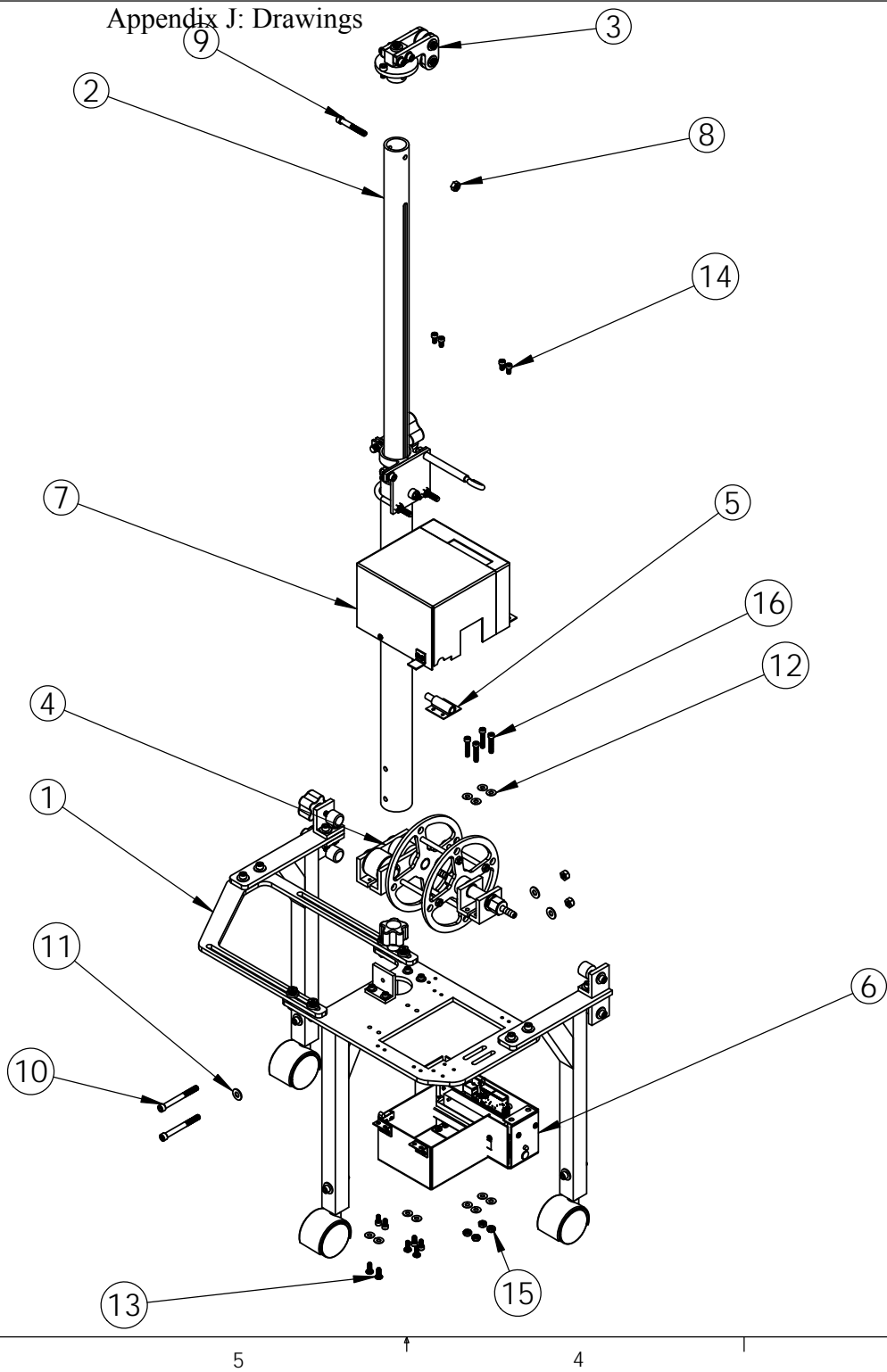
TITLE:

FINAL DESIGN  
ASSEMBLY

SIZE	DWG. NO.	REV
<b>A</b>		

SCALE: 1:20	WEIGHT:	SHEET 2 OF 3
-------------	---------	--------------

Appendix J: Drawings



ITEM NO.	PART NUMBER	QTY.
1	CLAMPING_SYSTEM	1
2	POLE_ASSEMBLY	1
3	MAST_TOPPER_ASSEMBLY	1
4	SPOOL	1
5	SLIDE_BOLT	1
6	BOTTOM_SPOOL_COVER	1
7	TOP_SPOOL_COVER	1
8	NUT, 1/4"-20	3
9	SHCS, 1/4"-20, 1 3/4" L	1
10	SHCS, 1/4"-20, 2 1/2" L	2
11	WASHER, 1/4"	3
12	WASHER, #10	12
13	PAN HEAD MACHINE SCREWS, #10-24, 1/2" L	4
14	SHCS, #10-24, 3/8" L	8
15	Nut, #10-24	4
16	91251A247	4

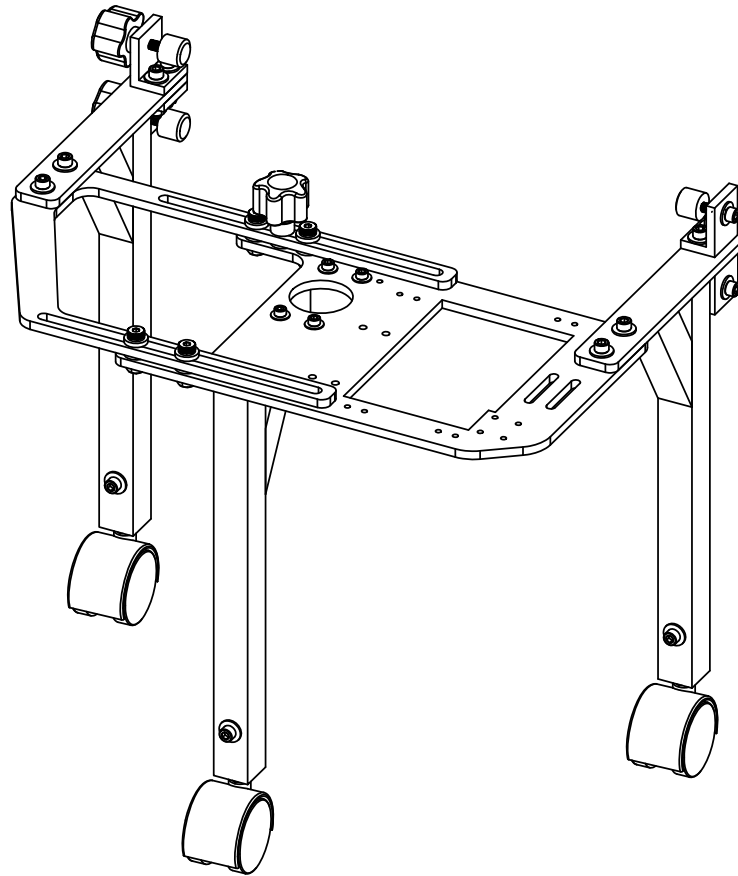
ME 450 Team 5

TITLE:

FINAL DESIGN ASSEMBLY

SIZE <b>A</b>	DWG. NO.	REV
------------------	----------	-----

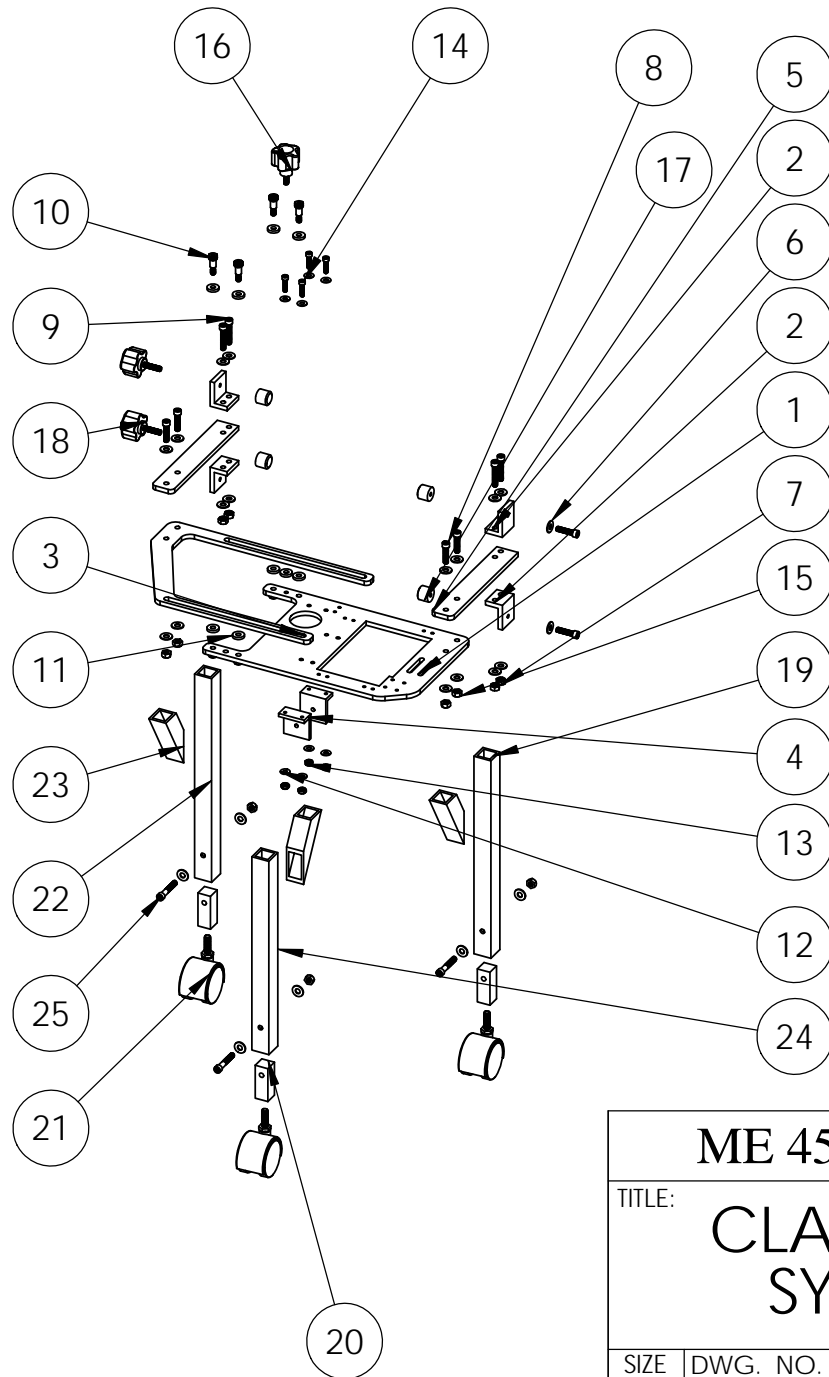
SCALE: 1:20	WEIGHT:	SHEET 3 OF 3
-------------	---------	--------------



ME 450 TEAM 5		
TITLE: CLAMPING SYSTEM		
SIZE <b>A</b>	DWG. NO. CLAMPING_SYSTEM	REV
SCALE: 1:4	WEIGHT:	SHEET 1 OF 17

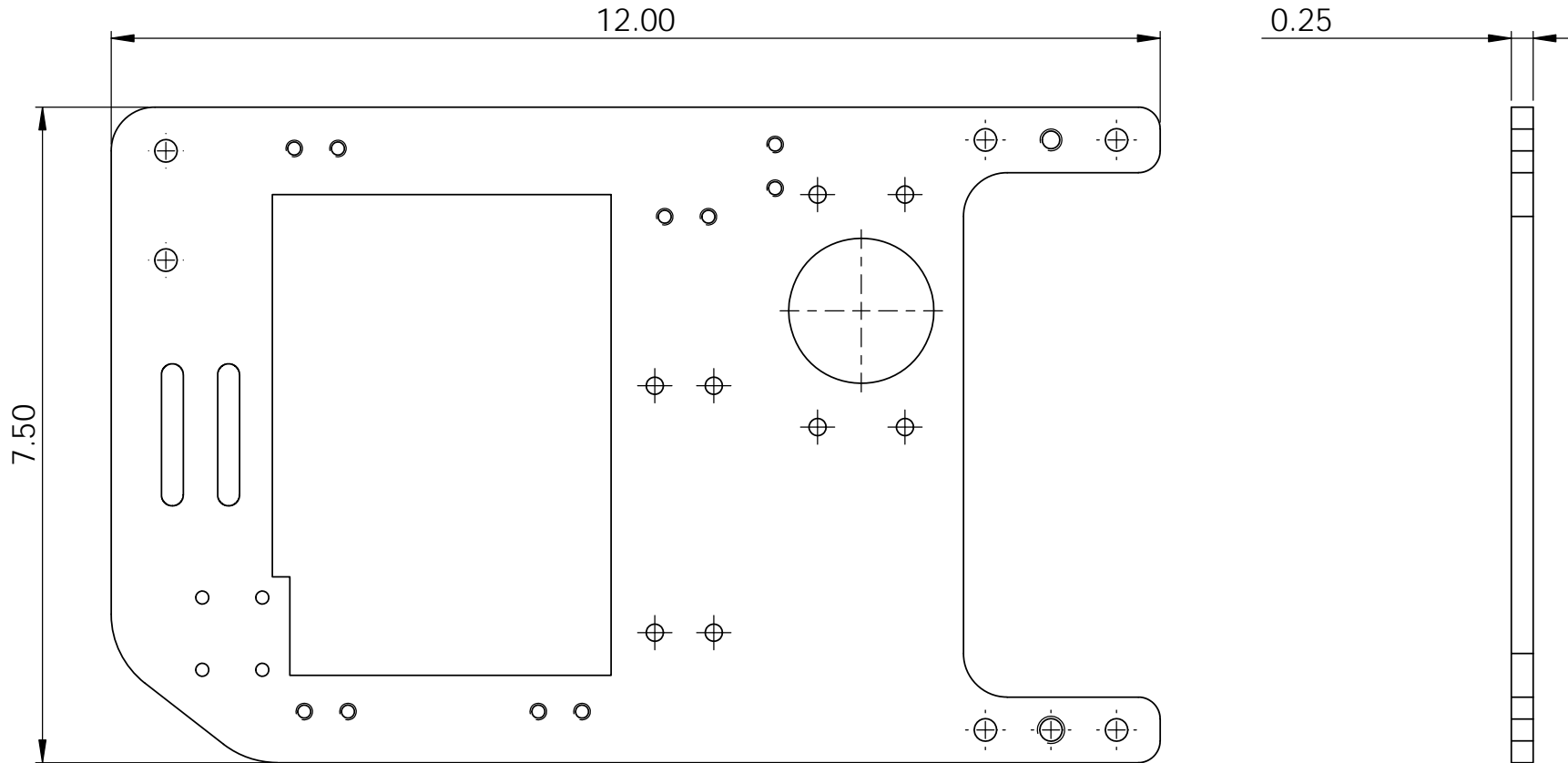
Appendix J: Drawings

ITEM NO.	PART NUMBER	QTY.
1	BASEPLATE	1
2	CLAMP_ARMS_TOP	4
3	MOVING_ARM	1
4	POLE_SUPPORT	2
5	ARM_MOVING_SIDE	2
6	Washer, 1/4"	24
7	Nut, 1/4"-20	4
8	SHCS, 1/4"-20, 1" L	6
9	SHCS, 1/4"-20, 1-1/4" L	4
10	Shoulder bolt, 5/16" D, 1/2" L	4
11	WASHER_NYLON_1-4_1-8	9
12	Washer, #10	8
13	Nut, #10-24	4
14	SHCS, #10-24, 3/4" L	4
15	Nut, 1/4"-20	11
16	WASHER_NYLON_1-4_1-4	1
17	Rubber feet	4
18	Polypropylene knob w/ comfort-grip	3
19	LEG_RIGHT	1
20	LEG_STRAIGHT_INSERT	3
21	CASTER_NO_BRAKE	3
22	LEG_LEFT	1
23	LEG_STRAIGHT_BRACE	3
24	LEG_STRAIGHT_LONG	1
25	SHCS, 1/4"-20, 1-1/2" L	3



<b>ME 450 TEAM 5</b>		
TITLE:		
<b>CLAMPING SYSTEM</b>		
SIZE	DWG. NO.	REV
<b>A</b>	CLAMPING_SYSTEM	
SCALE: 1:4	WEIGHT:	SHEET 2 OF 17

Appendix J: Drawings



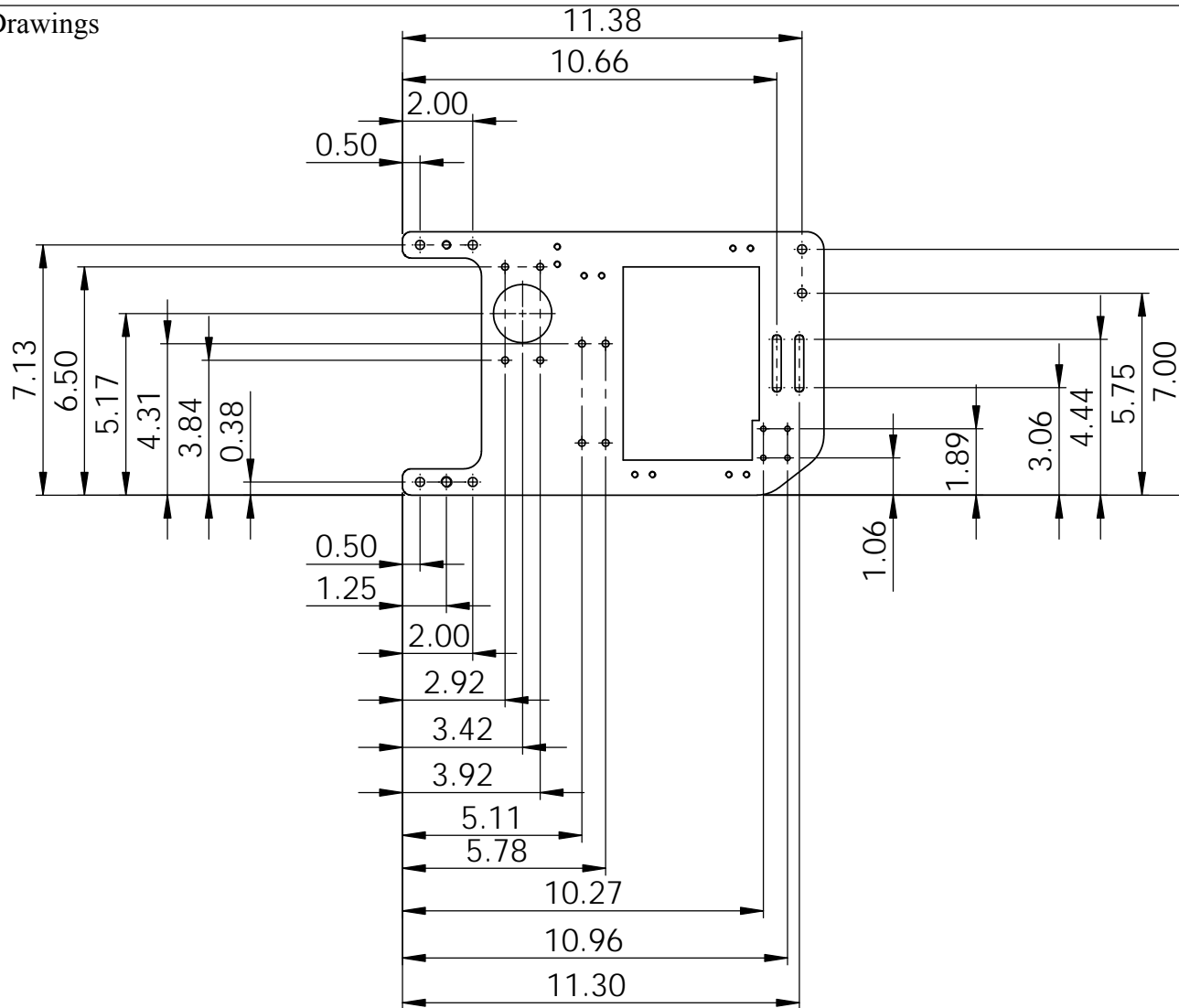
PART TO BE WATER JET  
 OVERALL DIMENSIONS SHOWN  
 HOLE LOCATIONS SHOWN ON FOLLOWING PAGES

**PROPRIETARY AND CONFIDENTIAL**  
 THE INFORMATION CONTAINED IN THIS DRAWING IS THE SOLE PROPERTY OF <INSERT COMPANY NAME HERE>. ANY REPRODUCTION IN PART OR AS A WHOLE WITHOUT THE WRITTEN PERMISSION OF <INSERT COMPANY NAME HERE> IS PROHIBITED.

		UNLESS OTHERWISE SPECIFIED:		NAME	DATE
		DIMENSIONS ARE IN INCHES	DRAWN		
		TOLERANCES:	CHECKED		
		FRACTIONAL ±	ENG APPR.		
		ANGULAR: MACH ± BEND ±	MFG APPR.		
		TWO PLACE DECIMAL ±	Q.A.		
		THREE PLACE DECIMAL ±	COMMENTS:		
		INTERPRET GEOMETRIC TOLERANCING PER:			
		MATERIAL			
		6061 ALUMINUM			
		FINISH			
NEXT ASSY	USED ON				
APPLICATION		DO NOT SCALE DRAWING			

ME 450 TEAM 5		
TITLE:		
BASEPLATE		
SIZE <b>A</b>	DWG. NO. CLAMPING_SYSTEM	REV
SCALE: 1:5	WEIGHT:	SHEET 3 OF 17

Appendix J: Drawings

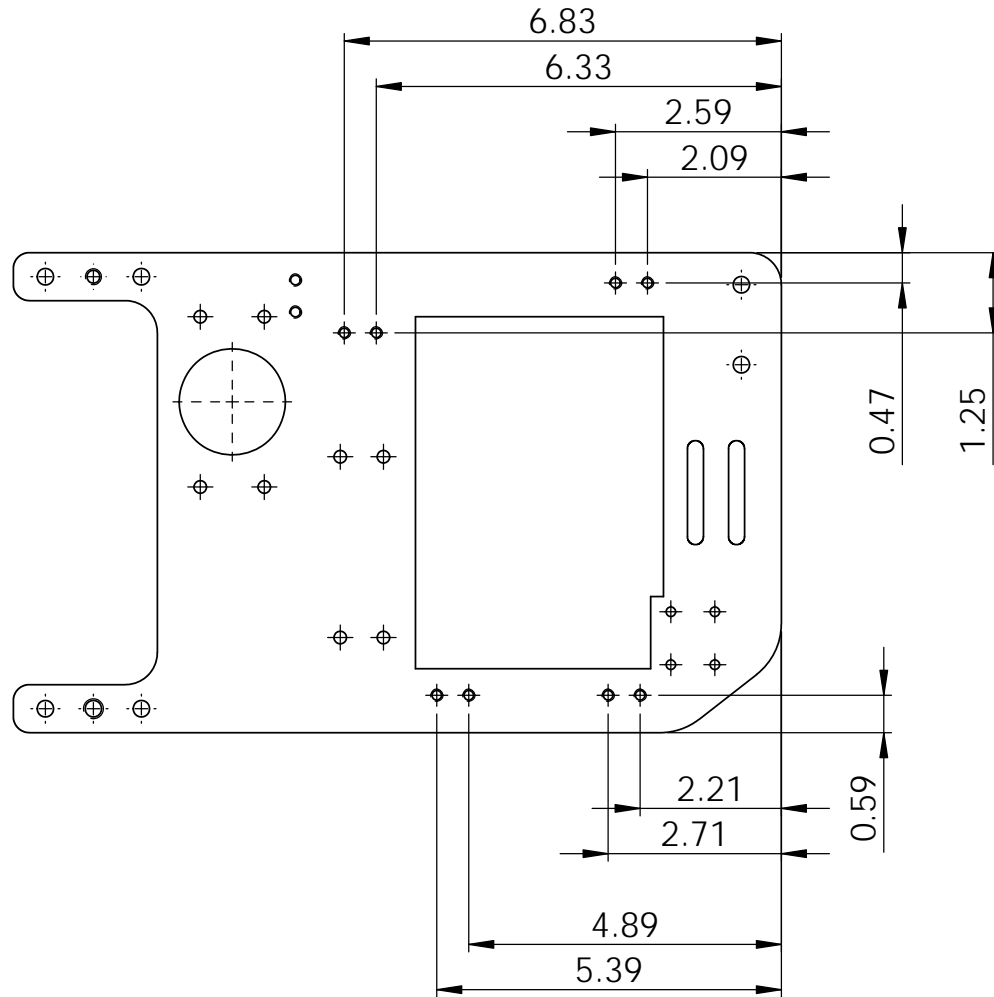


**PROPRIETARY AND CONFIDENTIAL**  
 THE INFORMATION CONTAINED IN THIS DRAWING IS THE SOLE PROPERTY OF <INSERT COMPANY NAME HERE>. ANY REPRODUCTION IN PART OR AS A WHOLE WITHOUT THE WRITTEN PERMISSION OF <INSERT COMPANY NAME HERE> IS PROHIBITED.

		UNLESS OTHERWISE SPECIFIED:		NAME	DATE
		DIMENSIONS ARE IN INCHES	DRAWN		
		TOLERANCES:	CHECKED		
		FRACTIONAL ±	ENG APPR.		
		ANGULAR: MACH ± BEND ±	MFG APPR.		
		TWO PLACE DECIMAL ±	Q.A.		
		THREE PLACE DECIMAL ±	COMMENTS:		
		INTERPRET GEOMETRIC TOLERANCING PER:			
		MATERIAL			
		6061 ALUMINUM			
		FINISH			
NEXT ASSY	USED ON				
APPLICATION		DO NOT SCALE DRAWING			

ME 450 TEAM 5		
TITLE:		
BASEPLATE		
SIZE	DWG. NO.	REV
<b>A</b>	CLAMPING_SYSTEM	
SCALE: 1:5	WEIGHT:	SHEET 4 OF 17

Appendix J: Drawings



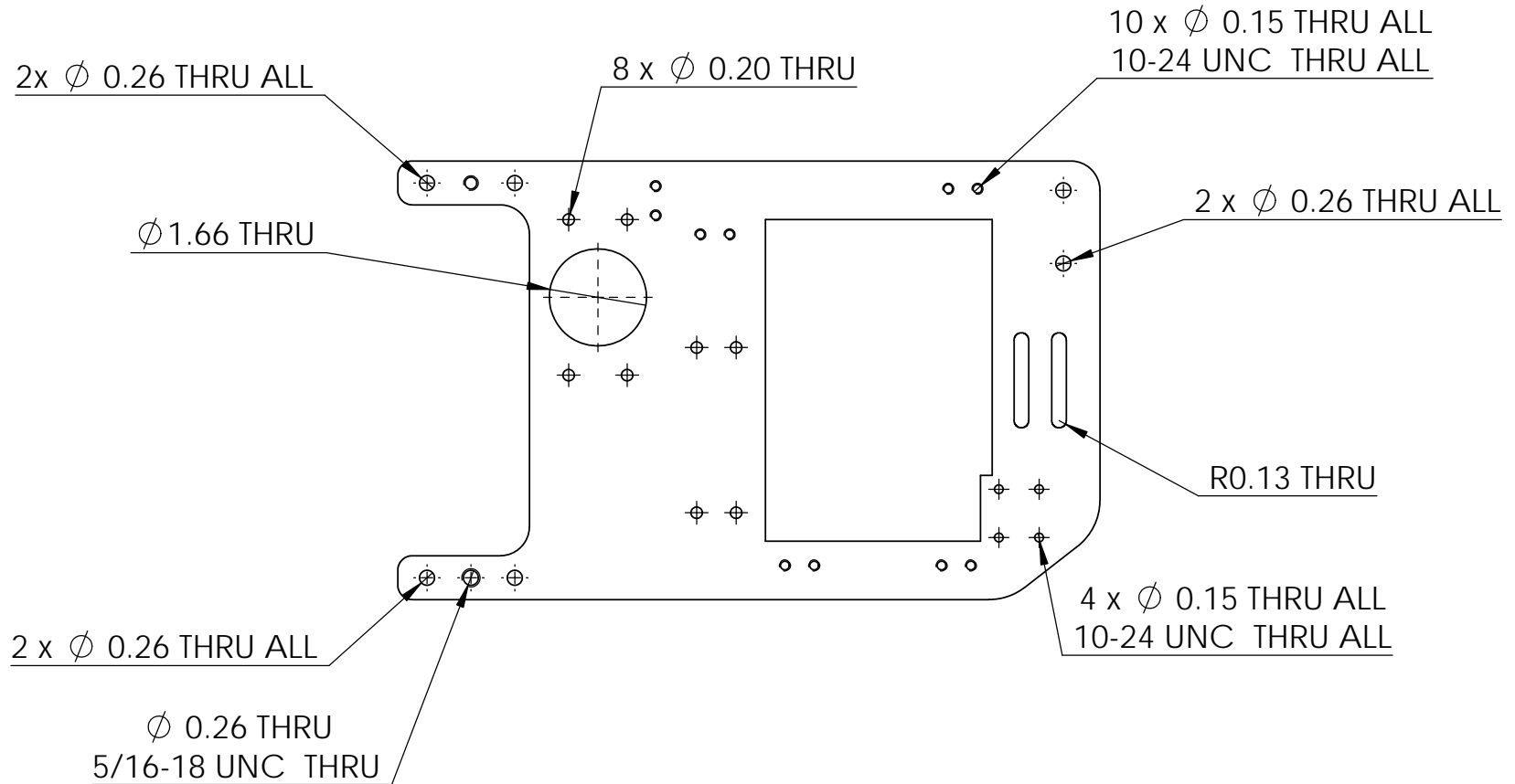
**PROPRIETARY AND CONFIDENTIAL**  
 THE INFORMATION CONTAINED IN THIS DRAWING IS THE SOLE PROPERTY OF <INSERT COMPANY NAME HERE>. ANY REPRODUCTION IN PART OR AS A WHOLE WITHOUT THE WRITTEN PERMISSION OF <INSERT COMPANY NAME HERE> IS PROHIBITED.

		UNLESS OTHERWISE SPECIFIED:		NAME	DATE
		DIMENSIONS ARE IN INCHES	DRAWN		
		TOLERANCES:	CHECKED		
		FRACTIONAL ±	ENG APPR.		
		ANGULAR: MACH ± BEND ±	MFG APPR.		
		TWO PLACE DECIMAL ±	Q.A.		
		THREE PLACE DECIMAL ±	COMMENTS:		
		INTERPRET GEOMETRIC TOLERANCING PER:			
		MATERIAL			
		6061 ALUMINUM			
		FINISH			
NEXT ASSY	USED ON				
APPLICATION		DO NOT SCALE DRAWING			

ME 450 TEAM 5		
TITLE:		
BASEPLATE		
SIZE	DWG. NO.	REV
<b>A</b>	CLAMPING_SYSTEM	
SCALE: 1:5	WEIGHT:	SHEET 5 OF 17



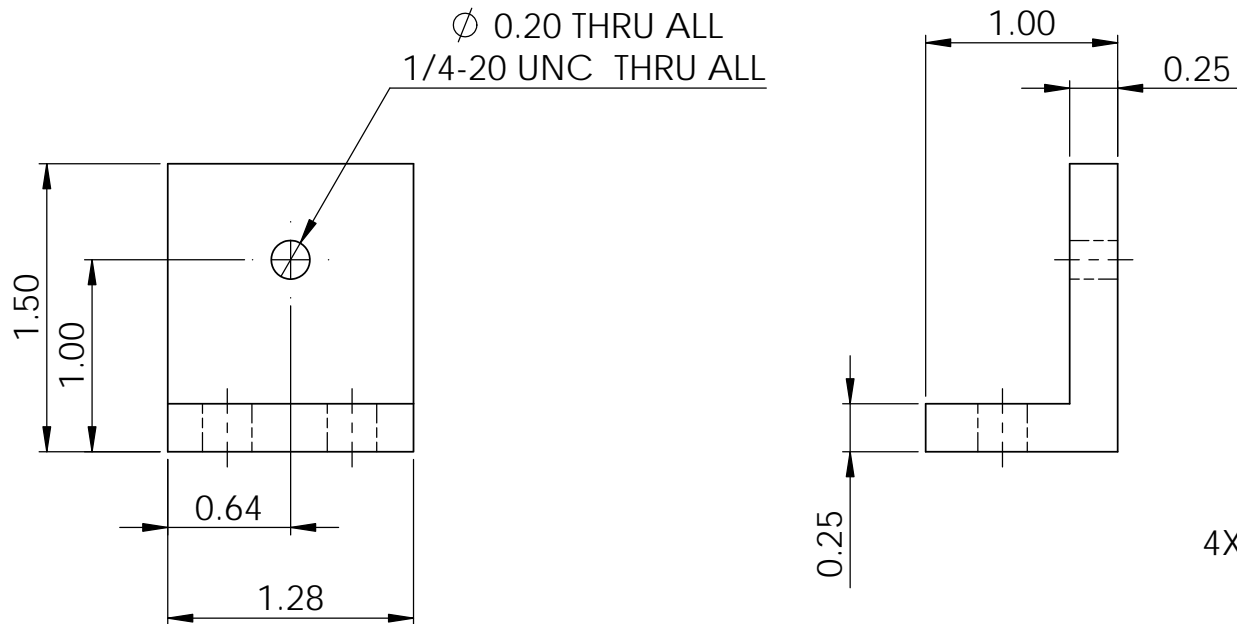
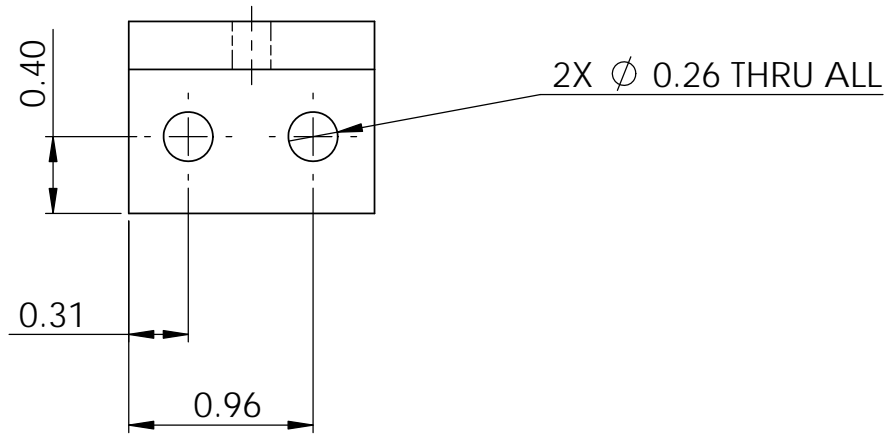
Appendix J: Drawings



**PROPRIETARY AND CONFIDENTIAL**  
 THE INFORMATION CONTAINED IN THIS DRAWING IS THE SOLE PROPERTY OF <INSERT COMPANY NAME HERE>. ANY REPRODUCTION IN PART OR AS A WHOLE WITHOUT THE WRITTEN PERMISSION OF <INSERT COMPANY NAME HERE> IS PROHIBITED.

		UNLESS OTHERWISE SPECIFIED:		NAME	DATE	<b>ME 450 TEAM 5</b>	
		DIMENSIONS ARE IN INCHES	DRAWN			TITLE:	
		TOLERANCES:	CHECKED			<b>BASEPLATE</b>	
		FRACTIONAL $\pm$	ENG APPR.				
		ANGULAR: MACH $\pm$ BEND $\pm$	MFG APPR.				
		TWO PLACE DECIMAL $\pm$	Q.A.				
		THREE PLACE DECIMAL $\pm$	COMMENTS:				
		INTERPRET GEOMETRIC TOLERANCING PER:				SIZE	DWG. NO.
		MATERIAL				<b>A</b>	CLAMPING_SYSTEM
		6061 ALUMINUM					REV
		FINISH					
NEXT ASSY	USED ON					SCALE: 1:5	WEIGHT:
APPLICATION		DO NOT SCALE DRAWING					SHEET 6 OF 17

Appendix J: Drawings



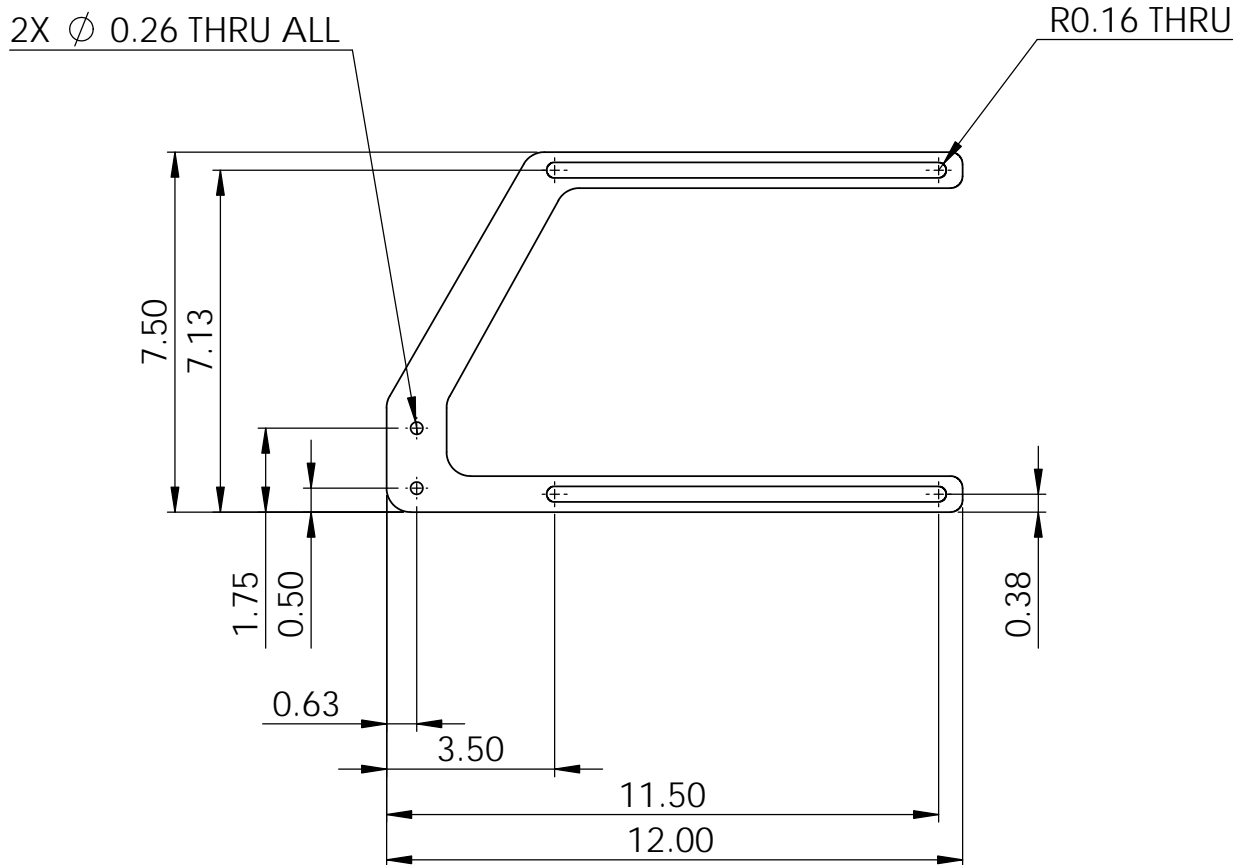
4X PART

**PROPRIETARY AND CONFIDENTIAL**  
 THE INFORMATION CONTAINED IN THIS DRAWING IS THE SOLE PROPERTY OF <INSERT COMPANY NAME HERE>. ANY REPRODUCTION IN PART OR AS A WHOLE WITHOUT THE WRITTEN PERMISSION OF <INSERT COMPANY NAME HERE> IS PROHIBITED.

		UNLESS OTHERWISE SPECIFIED:		NAME	DATE
		DIMENSIONS ARE IN INCHES	DRAWN		
		TOLERANCES:	CHECKED		
		FRACTIONAL ±	ENG APPR.		
		ANGULAR: MACH ± BEND ±	MFG APPR.		
		TWO PLACE DECIMAL ±	Q.A.		
		THREE PLACE DECIMAL ±	COMMENTS:		
		INTERPRET GEOMETRIC TOLERANCING PER:			
		MATERIAL			
		6061 ALUMINUM			
		FINISH			
NEXT ASSY	USED ON				
APPLICATION		DO NOT SCALE DRAWING			

ME 450 TEAM 5		
TITLE:		
CLAMP, FOOT MOUNT		
SIZE	DWG. NO.	REV
<b>A</b>	CLAMPING_SYSTEM	
SCALE: 1:1	WEIGHT:	SHEET 7 OF 17

Appendix J: Drawings



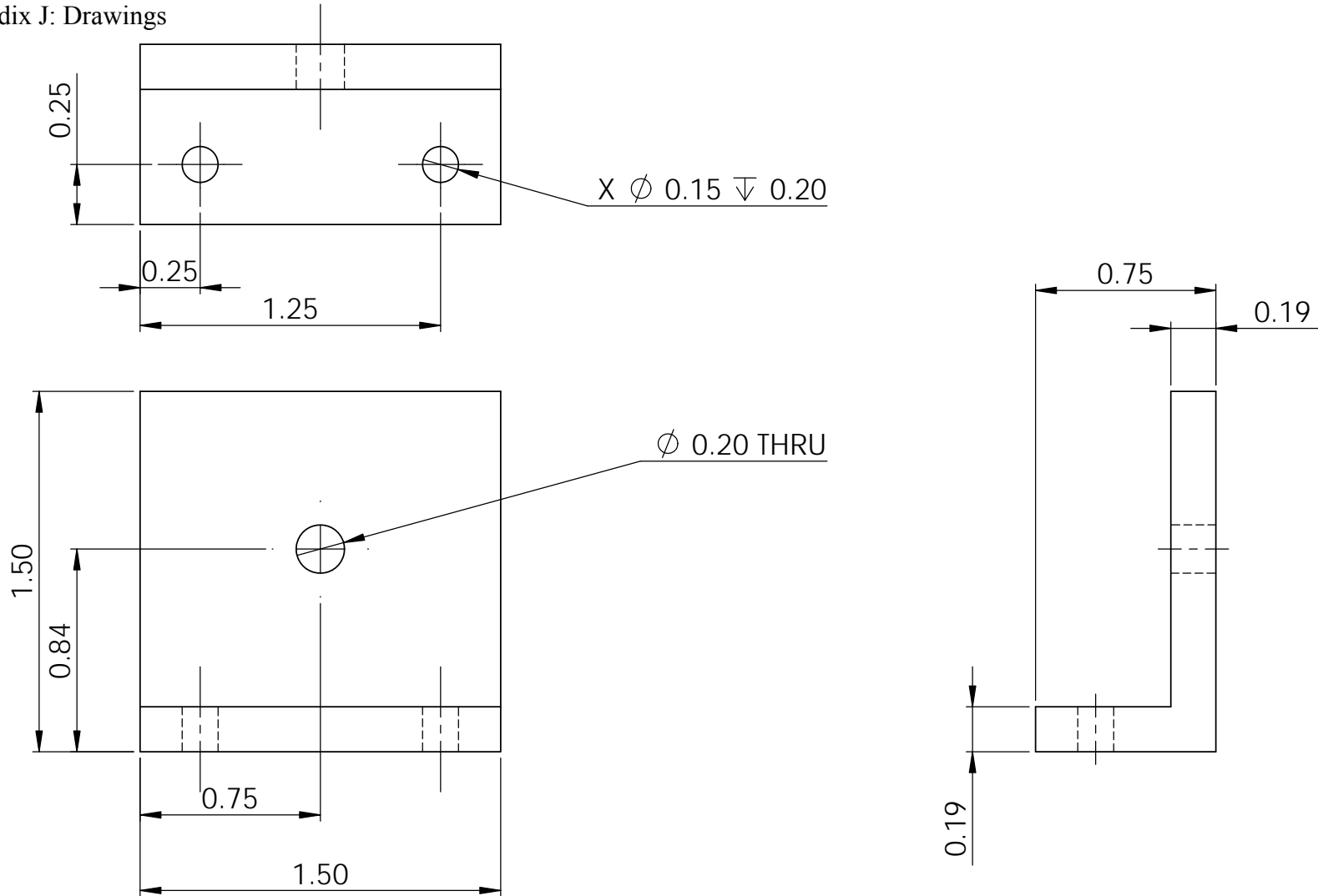
PART TO BE WATERJET MILL SLOTS AND HOLES

**PROPRIETARY AND CONFIDENTIAL**  
 THE INFORMATION CONTAINED IN THIS DRAWING IS THE SOLE PROPERTY OF <INSERT COMPANY NAME HERE>. ANY REPRODUCTION IN PART OR AS A WHOLE WITHOUT THE WRITTEN PERMISSION OF <INSERT COMPANY NAME HERE> IS PROHIBITED.

		UNLESS OTHERWISE SPECIFIED:		NAME	DATE
		DIMENSIONS ARE IN INCHES	DRAWN		
		TOLERANCES:	CHECKED		
		FRACTIONAL ±	ENG APPR.		
		ANGULAR: MACH ± BEND ±	MFG APPR.		
		TWO PLACE DECIMAL ±	Q.A.		
		THREE PLACE DECIMAL ±	COMMENTS:		
		INTERPRET GEOMETRIC TOLERANCING PER:			
		MATERIAL			
		6061 ALUMINUM			
		FINISH			
NEXT ASSY	USED ON				
APPLICATION		DO NOT SCALE DRAWING			

ME 450 TEAM 5		
TITLE: CLAMP, MOVING ARM		
SIZE <b>A</b>	DWG. NO. CLAMPING_SYSTEM	REV
SCALE: 1:4	WEIGHT:	SHEET 8 OF 17

Appendix J: Drawings

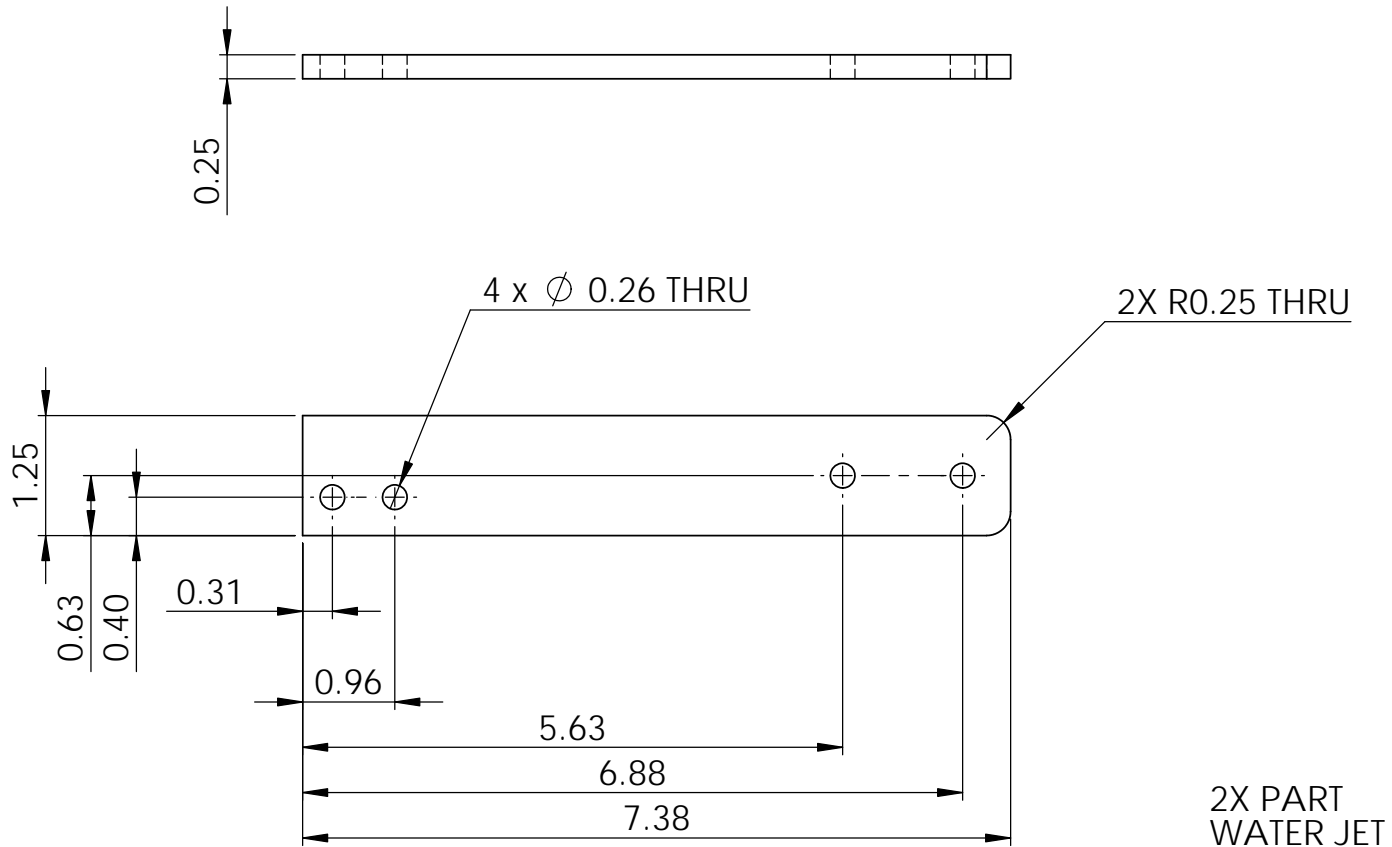


**PROPRIETARY AND CONFIDENTIAL**  
 THE INFORMATION CONTAINED IN THIS DRAWING IS THE SOLE PROPERTY OF <INSERT COMPANY NAME HERE>. ANY REPRODUCTION IN PART OR AS A WHOLE WITHOUT THE WRITTEN PERMISSION OF <INSERT COMPANY NAME HERE> IS PROHIBITED.

		UNLESS OTHERWISE SPECIFIED:		NAME	DATE
		DIMENSIONS ARE IN INCHES	DRAWN		
		TOLERANCES:	CHECKED		
		FRACTIONAL ±	ENG APPR.		
		ANGULAR: MACH ± BEND ±	MFG APPR.		
		TWO PLACE DECIMAL ±	Q.A.		
		THREE PLACE DECIMAL ±	COMMENTS:		
		INTERPRET GEOMETRIC TOLERANCING PER:			
		MATERIAL			
		6061 ALUMINUM			
		FINISH			
NEXT ASSY	USED ON				
APPLICATION		DO NOT SCALE DRAWING			

ME 450 TEAM 5		
TITLE:		
CLAMP, POLE SUPPORT		
SIZE	DWG. NO.	REV
<b>A</b>	CLAMPING_SYSTEM	
SCALE: 2:1	WEIGHT:	SHEET 9 OF 17

Appendix J: Drawings



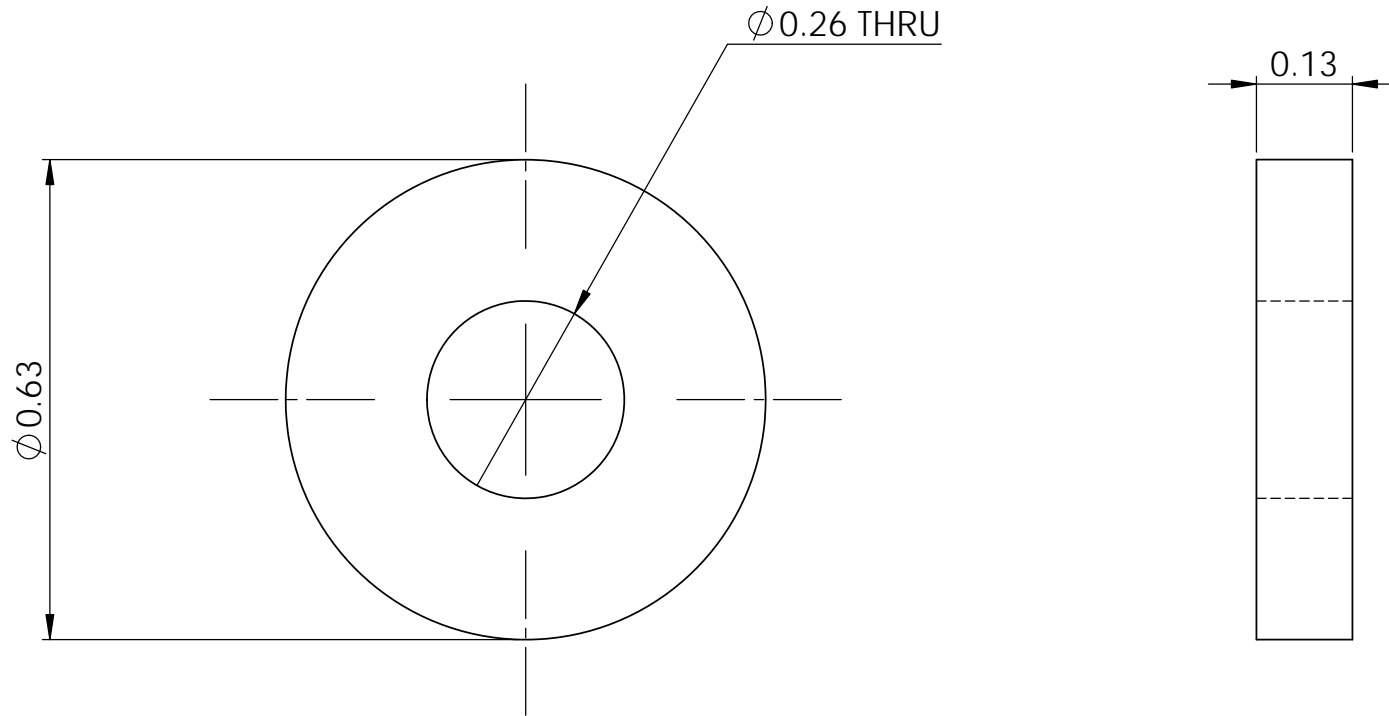
2X PART  
WATER JET

**PROPRIETARY AND CONFIDENTIAL**  
THE INFORMATION CONTAINED IN THIS DRAWING IS THE SOLE PROPERTY OF <INSERT COMPANY NAME HERE>. ANY REPRODUCTION IN PART OR AS A WHOLE WITHOUT THE WRITTEN PERMISSION OF <INSERT COMPANY NAME HERE> IS PROHIBITED.

		UNLESS OTHERWISE SPECIFIED:		NAME	DATE
		DIMENSIONS ARE IN INCHES	DRAWN		
		TOLERANCES:	CHECKED		
		FRACTIONAL ±	ENG APPR.		
		ANGULAR: MACH ± BEND ±	MFG APPR.		
		TWO PLACE DECIMAL ±	Q.A.		
		THREE PLACE DECIMAL ±	COMMENTS:		
		INTERPRET GEOMETRIC TOLERANCING PER:			
		MATERIAL			
		6061 ALUMINUM			
NEXT ASSY	USED ON	FINISH			
APPLICATION		DO NOT SCALE DRAWING			

ME 450 TEAM 5		
TITLE:		
BAESPLATE, ARM		
SIZE	DWG. NO.	REV
<b>A</b>	CLAMPING_SYSTEM	
SCALE: 1:2	WEIGHT:	SHEET 10 OF 17

Appendix J: Drawings



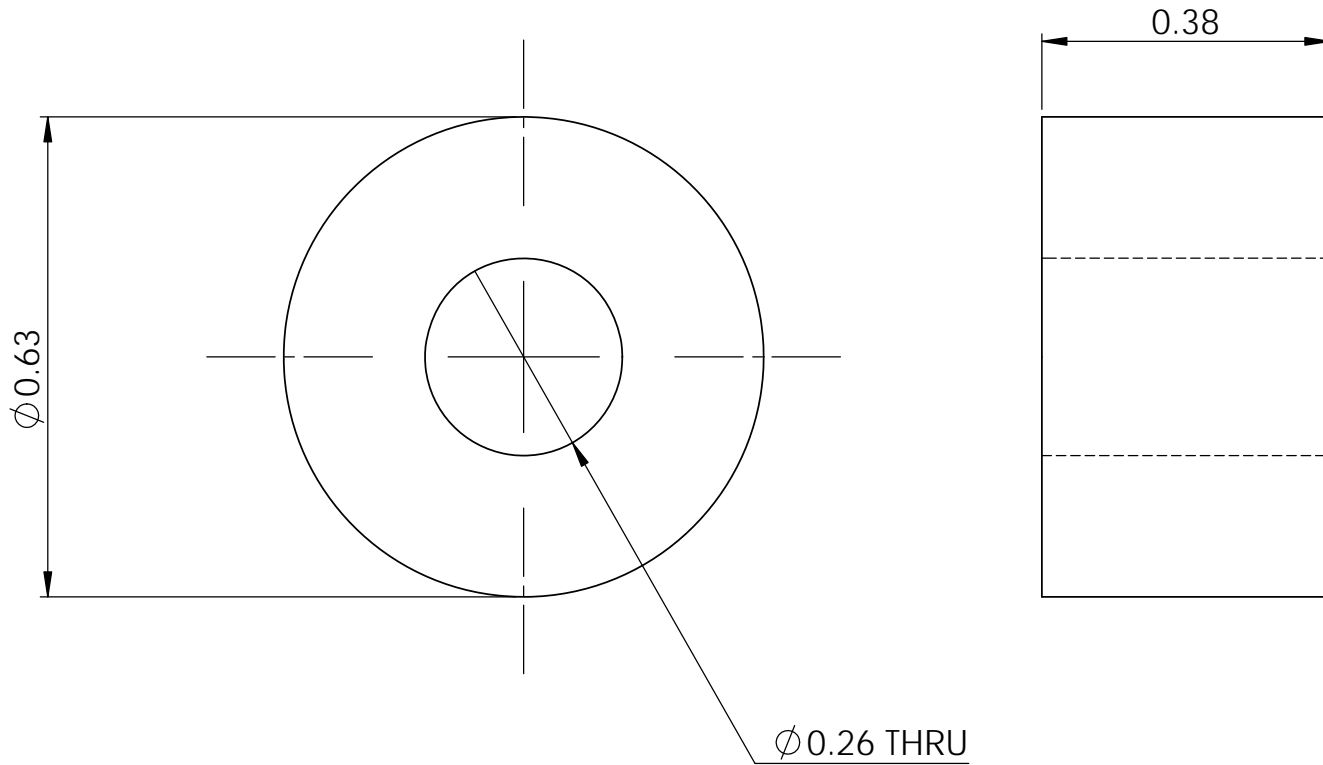
4X PART

**PROPRIETARY AND CONFIDENTIAL**  
 THE INFORMATION CONTAINED IN THIS DRAWING IS THE SOLE PROPERTY OF <INSERT COMPANY NAME HERE>. ANY REPRODUCTION IN PART OR AS A WHOLE WITHOUT THE WRITTEN PERMISSION OF <INSERT COMPANY NAME HERE> IS PROHIBITED.

		UNLESS OTHERWISE SPECIFIED:		NAME	DATE
		DIMENSIONS ARE IN INCHES	DRAWN		
		TOLERANCES:	CHECKED		
		FRACTIONAL $\pm$	ENG APPR.		
		ANGULAR: MACH $\pm$ BEND $\pm$	MFG APPR.		
		TWO PLACE DECIMAL $\pm$	Q.A.		
		THREE PLACE DECIMAL $\pm$	COMMENTS:		
		INTERPRET GEOMETRIC TOLERANCING PER:			
		MATERIAL			
		NYLON			
NEXT ASSY	USED ON	FINISH			
APPLICATION		DO NOT SCALE DRAWING			

ME 450 TEAM 5		
TITLE:		
WASHER, NYLON, SLIDING SPACERS		
SIZE	DWG. NO.	REV
<b>A</b>	WASHER_NYLON_ 1-4_1-8	
SCALE: 4:1	WEIGHT:	SHEET 11 OF 17

Appendix J: Drawings

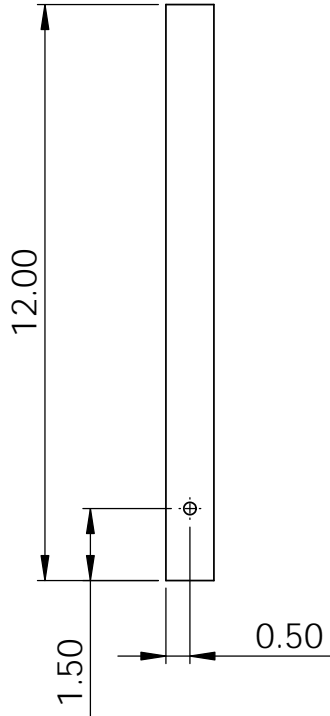
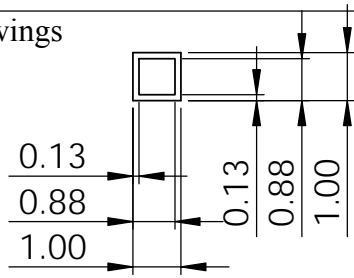


**PROPRIETARY AND CONFIDENTIAL**  
 THE INFORMATION CONTAINED IN THIS DRAWING IS THE SOLE PROPERTY OF <INSERT COMPANY NAME HERE>. ANY REPRODUCTION IN PART OR AS A WHOLE WITHOUT THE WRITTEN PERMISSION OF <INSERT COMPANY NAME HERE> IS PROHIBITED.

		UNLESS OTHERWISE SPECIFIED:		NAME	DATE
		DIMENSIONS ARE IN INCHES	DRAWN		
		TOLERANCES:	CHECKED		
		FRACTIONAL ±	ENG APPR.		
		ANGULAR: MACH ± BEND ±	MFG APPR.		
		TWO PLACE DECIMAL ±	Q.A.		
		THREE PLACE DECIMAL ±	COMMENTS:		
		INTERPRET GEOMETRIC TOLERANCING PER:			
		MATERIAL			
		NYLON			
		FINISH			
NEXT ASSY	USED ON				
APPLICATION		DO NOT SCALE DRAWING			

ME 450 TEAM 5		
TITLE:		
CLAMP, NYLON SPACER, KNOB		
SIZE	DWG. NO.	REV
<b>A</b>	WASHER_NYLON_1-4_1-4	
SCALE: 4:1	WEIGHT:	SHEET 12 OF 17

Appendix J: Drawings



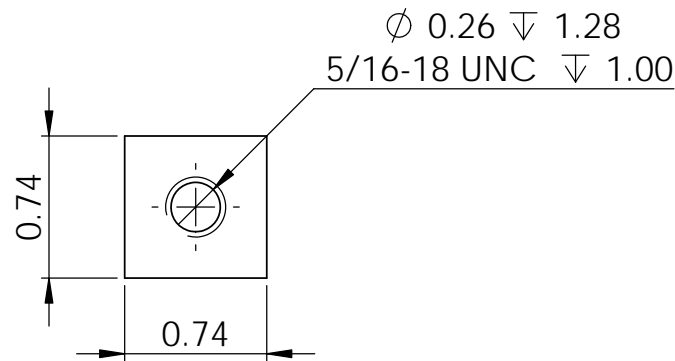
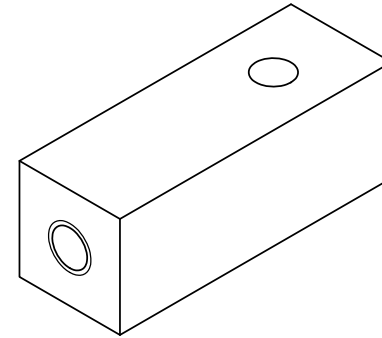
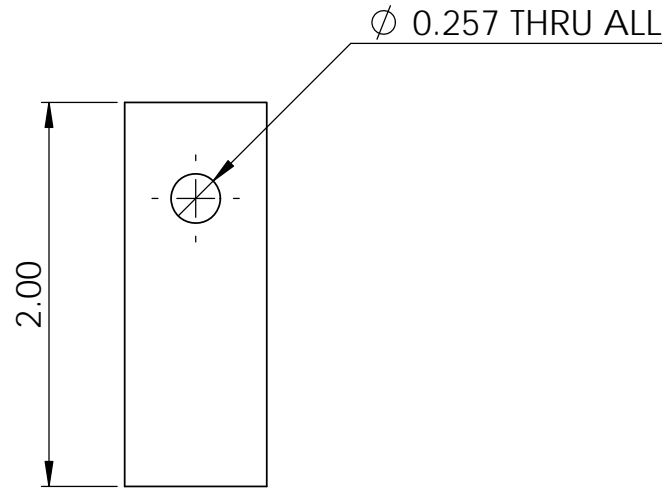
**PROPRIETARY AND CONFIDENTIAL**  
 THE INFORMATION CONTAINED IN THIS DRAWING IS THE SOLE PROPERTY OF <INSERT COMPANY NAME HERE>. ANY REPRODUCTION IN PART OR AS A WHOLE WITHOUT THE WRITTEN PERMISSION OF <INSERT COMPANY NAME HERE> IS PROHIBITED.

		UNLESS OTHERWISE SPECIFIED:		NAME	DATE
		DIMENSIONS ARE IN INCHES	DRAWN		
		TOLERANCES:	CHECKED		
		FRACTIONAL ±	ENG APPR.		
		ANGULAR: MACH ± BEND ±	MFG APPR.		
		TWO PLACE DECIMAL ±	Q.A.		
		THREE PLACE DECIMAL ±	COMMENTS:		
		INTERPRET GEOMETRIC TOLERANCING PER:			
		MATERIAL			
		6064 ALUMINUM			
		FINISH			
NEXT ASSY	USED ON				
APPLICATION		DO NOT SCALE DRAWING			

ME 450 TEAM 5		
TITLE:		
LEG, RIGHT		
SIZE	DWG. NO.	REV
<b>A</b>	LEG_STRAIGHT	
SCALE: 1:4	WEIGHT:	SHEET 13 OF 17



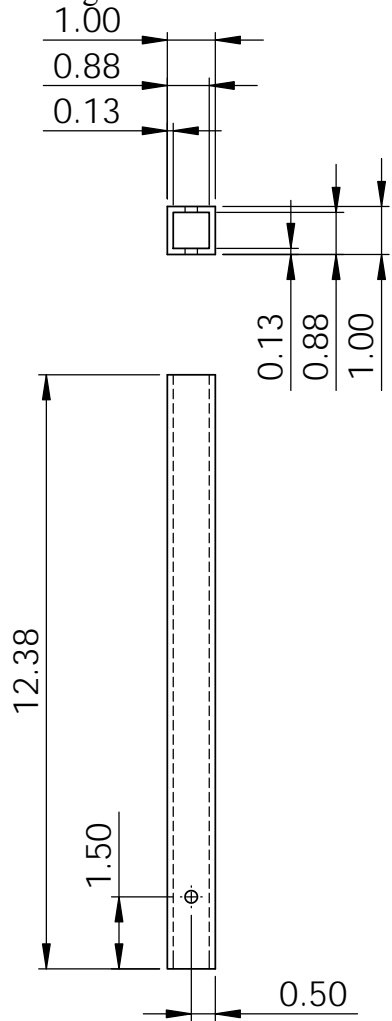
Appendix J: Drawings



**PROPRIETARY AND CONFIDENTIAL**  
THE INFORMATION CONTAINED IN THIS DRAWING IS THE SOLE PROPERTY OF <INSERT COMPANY NAME HERE>. ANY REPRODUCTION IN PART OR AS A WHOLE WITHOUT THE WRITTEN PERMISSION OF <INSERT COMPANY NAME HERE> IS PROHIBITED.

		UNLESS OTHERWISE SPECIFIED:		NAME	DATE	<b>ME 450 TEAM 5</b>	
		DIMENSIONS ARE IN INCHES	DRAWN			TITLE:	
		TOLERANCES:	CHECKED			<b>LEG, INSERT</b>	
		FRACTIONAL $\pm$	ENG APPR.			SIZE	DWG. NO.
		ANGULAR: MACH $\pm$ BEND $\pm$	MFG APPR.			<b>A</b>	<b>CLAMPING_SYSTEM</b>
		TWO PLACE DECIMAL $\pm$	Q.A.				REV
		THREE PLACE DECIMAL $\pm$	COMMENTS:				
		INTERPRET GEOMETRIC TOLERANCING PER:				SCALE: 1:1	WEIGHT:
		MATERIAL					SHEET 14 OF 17
		<b>6061 ALUMINUM</b>					
		FINISH					
NEXT ASSY	USED ON						
APPLICATION		DO NOT SCALE DRAWING					

Appendix J: Drawings

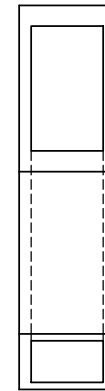
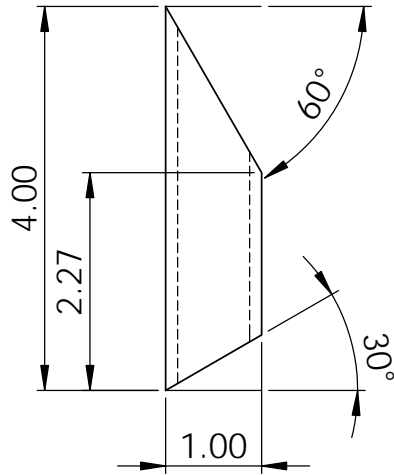
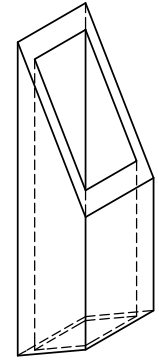
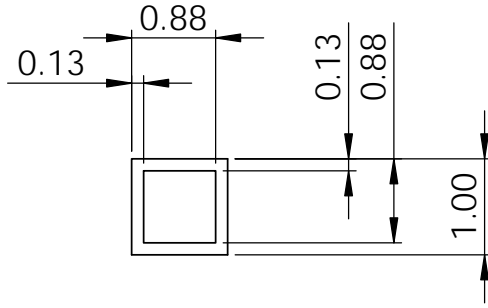


**PROPRIETARY AND CONFIDENTIAL**  
 THE INFORMATION CONTAINED IN THIS DRAWING IS THE SOLE PROPERTY OF <INSERT COMPANY NAME HERE>. ANY REPRODUCTION IN PART OR AS A WHOLE WITHOUT THE WRITTEN PERMISSION OF <INSERT COMPANY NAME HERE> IS PROHIBITED.

		UNLESS OTHERWISE SPECIFIED:		NAME	DATE
		DIMENSIONS ARE IN INCHES	DRAWN		
		TOLERANCES:	CHECKED		
		FRACTIONAL ±	ENG APPR.		
		ANGULAR: MACH ± BEND ±	MFG APPR.		
		TWO PLACE DECIMAL ±	Q.A.		
		THREE PLACE DECIMAL ±	COMMENTS:		
		INTERPRET GEOMETRIC TOLERANCING PER:			
		MATERIAL			
		6061 ALUMINUM			
		FINISH			
NEXT ASSY	USED ON				
APPLICATION		DO NOT SCALE DRAWING			

ME 450 TEAM 5		
TITLE:		
LEG, LEFT		
SIZE	DWG. NO.	REV
<b>A</b>	CLAMPING_SYSTEM	
SCALE: 1:4	WEIGHT:	SHEET 15 OF 17

Appendix J: Drawings

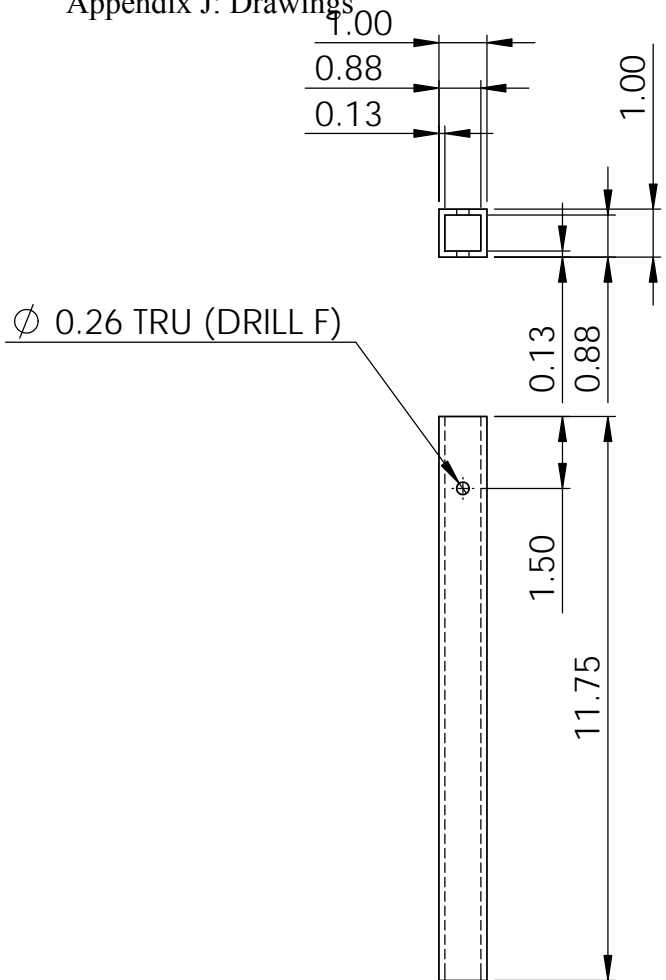


3X PART

**PROPRIETARY AND CONFIDENTIAL**  
 THE INFORMATION CONTAINED IN THIS DRAWING IS THE SOLE PROPERTY OF <INSERT COMPANY NAME HERE>. ANY REPRODUCTION IN PART OR AS A WHOLE WITHOUT THE WRITTEN PERMISSION OF <INSERT COMPANY NAME HERE> IS PROHIBITED.

		UNLESS OTHERWISE SPECIFIED:		NAME	DATE	<b>ME 450 TEAM 5</b>	
		DIMENSIONS ARE IN INCHES	DRAWN			TITLE:	
		TOLERANCES:	CHECKED			<b>LEG SUPPORT</b>	
		FRACTIONAL ±	ENG APPR.			SIZE	DWG. NO.
		ANGULAR: MACH ± BEND ±	MFG APPR.			<b>A</b>	LEG_STRAIGHT_
		TWO PLACE DECIMAL ±	Q.A.				BRACE
		THREE PLACE DECIMAL ±	COMMENTS:				REV
		INTERPRET GEOMETRIC TOLERANCING PER:				SCALE: 1:2	WEIGHT:
		MATERIAL					SHEET 16 OF 17
		<b>6061 ALUMINUM</b>					
		FINISH					
NEXT ASSY	USED ON						
APPLICATION		DO NOT SCALE DRAWING					

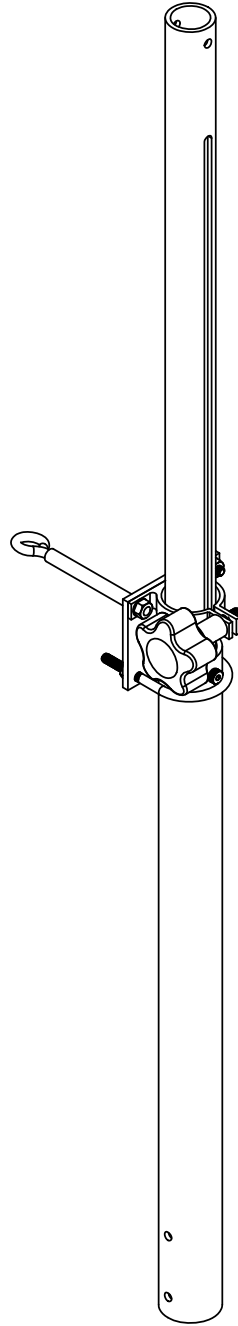
Appendix J: Drawings



1X PART

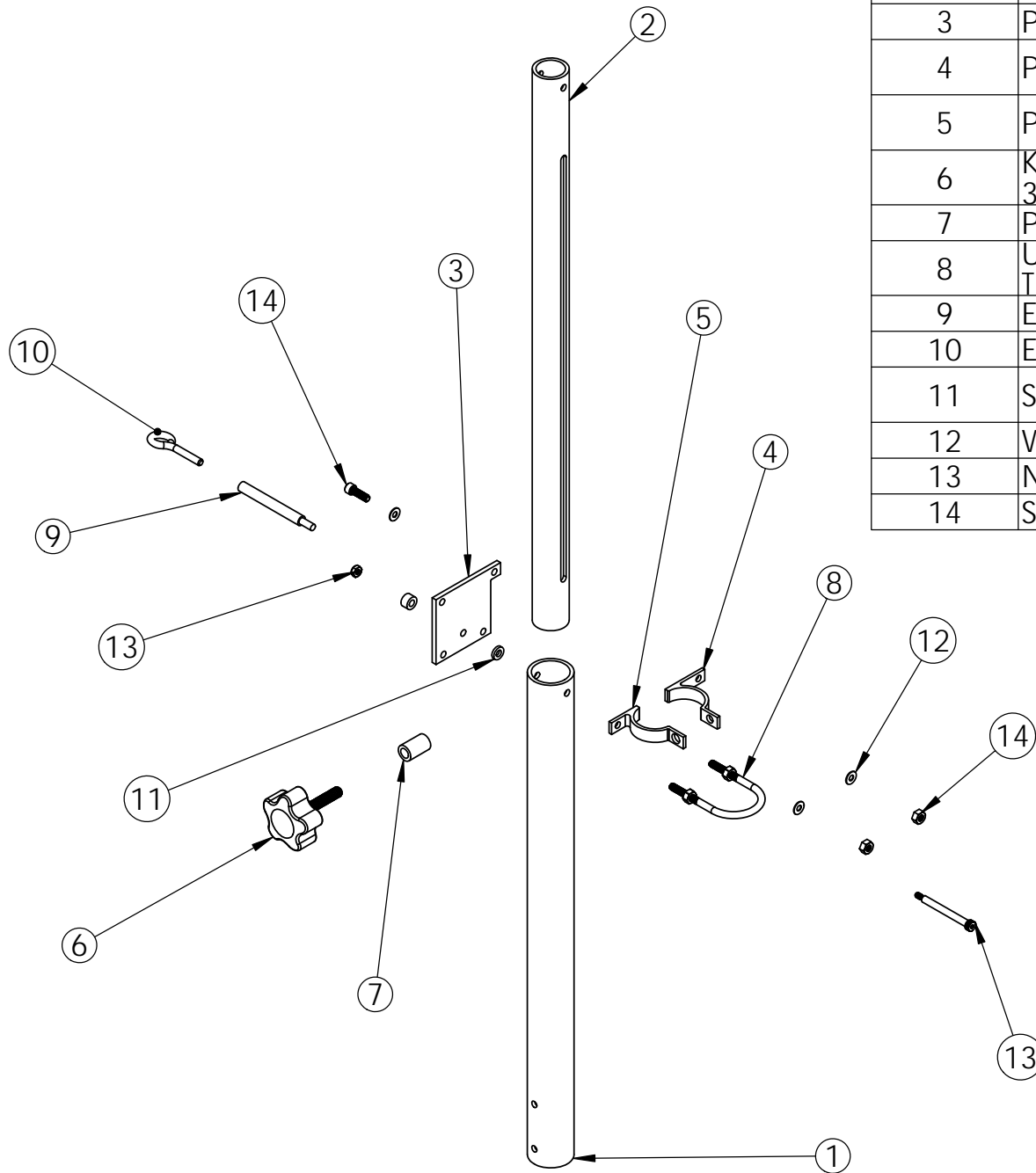
**PROPRIETARY AND CONFIDENTIAL**  
 THE INFORMATION CONTAINED IN THIS DRAWING IS THE SOLE PROPERTY OF <INSERT COMPANY NAME HERE>. ANY REPRODUCTION IN PART OR AS A WHOLE WITHOUT THE WRITTEN PERMISSION OF <INSERT COMPANY NAME HERE> IS PROHIBITED.

		UNLESS OTHERWISE SPECIFIED:		NAME	DATE	<b>ME 450 TEAM 5</b>	
		DIMENSIONS ARE IN INCHES TOLERANCES: FRACTIONAL ± ANGULAR: MACH ± BEND ± TWO PLACE DECIMAL ± THREE PLACE DECIMAL ±	DRAWN			<b>REAR LEG</b>	
			CHECKED				
			ENG APPR.				
			MFG APPR.				
		INTERPRET GEOMETRIC TOLERANCING PER:	Q.A.			TITLE:  SIZE <b>A</b> DWG. NO. LEG_STRAIGHT_LONG REV SCALE: 1:4 WEIGHT: SHEET 17 OF 17	
		MATERIAL	COMMENTS:				
		6061 ALUMINUM					
NEXT ASSY	USED ON	FINISH					
APPLICATION		DO NOT SCALE DRAWING					



ME 450 TEAM 5		
TITLE: POLE ASSEMBLY		
SIZE <b>A</b>	DWG. NO. POLE_ASSEMBLY	REV
SCALE: 1:20	WEIGHT:	SHEET 1 OF 9

Appendix J: Drawings



ITEM NO.	PART NUMBER	QTY.
1	POLE_BOTTOM	1
2	POLE_TOP	1
3	POLECLAMP_PLATE	1
4	POLECLAMP_CLAMP_THREAD	1
5	POLECLAMP_CLAMP_THRU	1
6	KNOB WITH THREADED STUD, 3/8"-16, 1 3/4" L	1
7	POLECLAMP_STUD	1
8	U-BOLT, PIPE SIZE 1 1/4", 3" L, 1/4"-20 THREAD	1
9	EYE_SHAFT	1
10	EYEBOLT, 1/2" ID, 1/4"-20 X 1 3/8" THREAD	1
11	SPACER_POLE_SHOULDER_BOLT	2
12	WASHER, 1/4"	3
13	NUT, 1/4"-20	3
14	SHOULDER BOLT, 1/4" D, 2 1/4" L	1

ME 450 TEAM 5

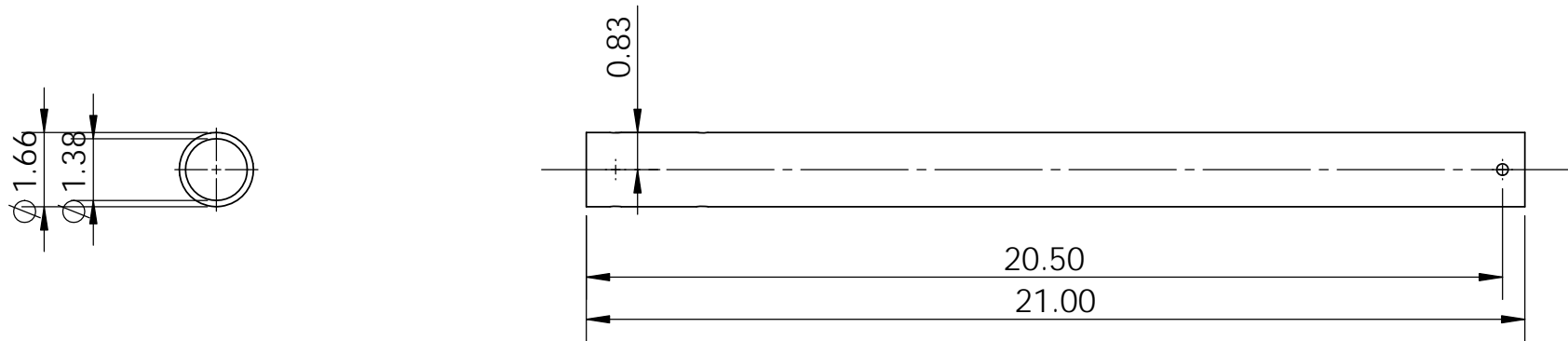
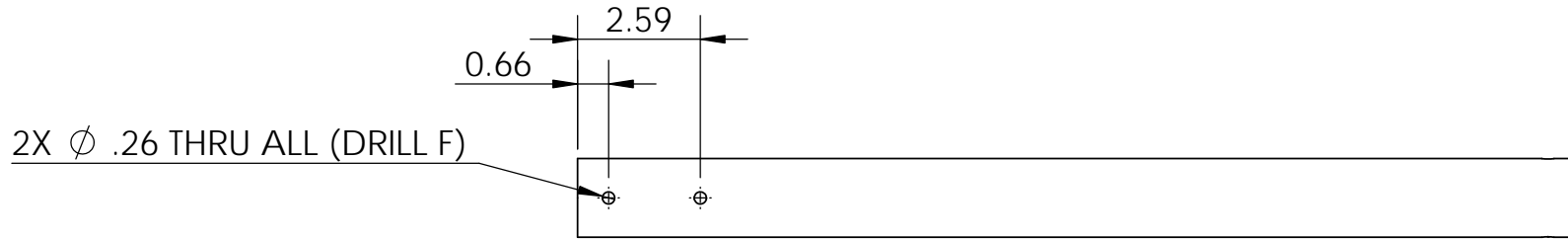
TITLE:

POLE ASSEMBLY

SIZE	DWG. NO.	REV
<b>A</b>	POLE_ASSEMBLY	

SCALE: 1:20 WEIGHT: SHEET 2 OF 9

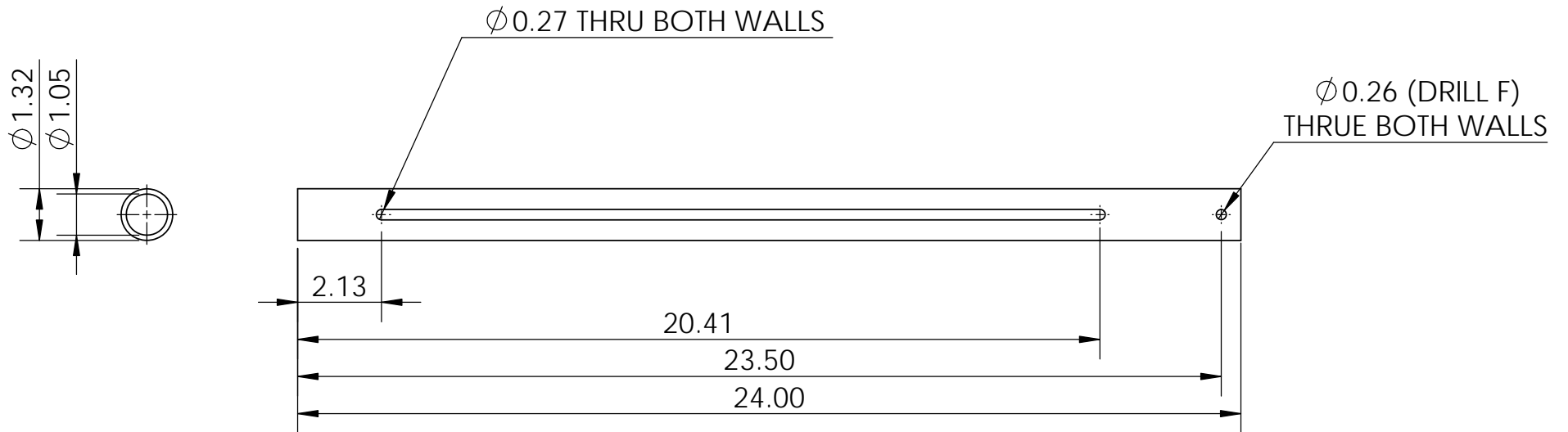
Appendix J: Drawings



**PROPRIETARY AND CONFIDENTIAL**  
 THE INFORMATION CONTAINED IN THIS DRAWING IS THE SOLE PROPERTY OF <INSERT COMPANY NAME HERE>. ANY REPRODUCTION IN PART OR AS A WHOLE WITHOUT THE WRITTEN PERMISSION OF <INSERT COMPANY NAME HERE> IS PROHIBITED.

		UNLESS OTHERWISE SPECIFIED:		NAME	DATE	<b>ME 450 TEAM 5</b>	
		DIMENSIONS ARE IN INCHES	DRAWN			TITLE:	
		TOLERANCES:	CHECKED			<b>BOTTOM POLE</b>	
		FRACTIONAL ±	ENG APPR.			SIZE	DWG. NO.
		ANGULAR: MACH ± BEND ±	MFG APPR.			<b>A</b>	<b>POLE_ASSEMBLY</b>
		TWO PLACE DECIMAL ±	Q.A.			SCALE: 1:8	WEIGHT:
		THREE PLACE DECIMAL ±	COMMENTS:			SHEET 3 OF 9	REV
		INTERPRET GEOMETRIC TOLERANCING PER:					
		MATERIAL					
		<b>ALUMINUM</b>					
		FINISH					
NEXT ASSY	USED ON	DO NOT SCALE DRAWING					
APPLICATION							

Appendix J: Drawings



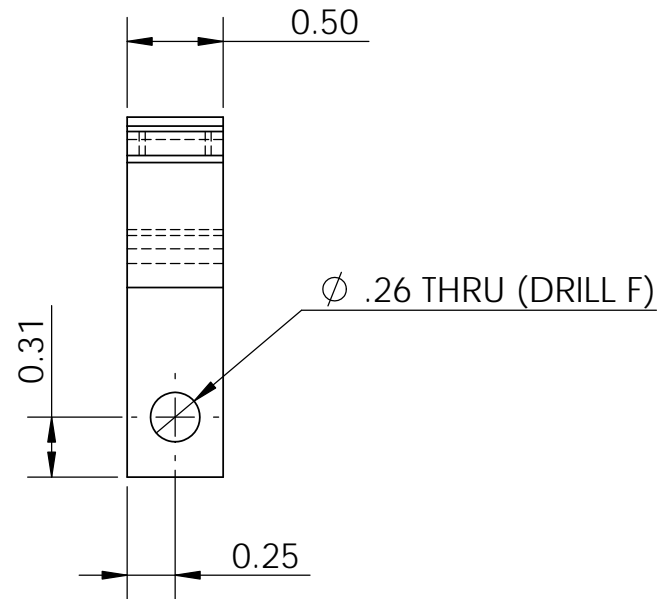
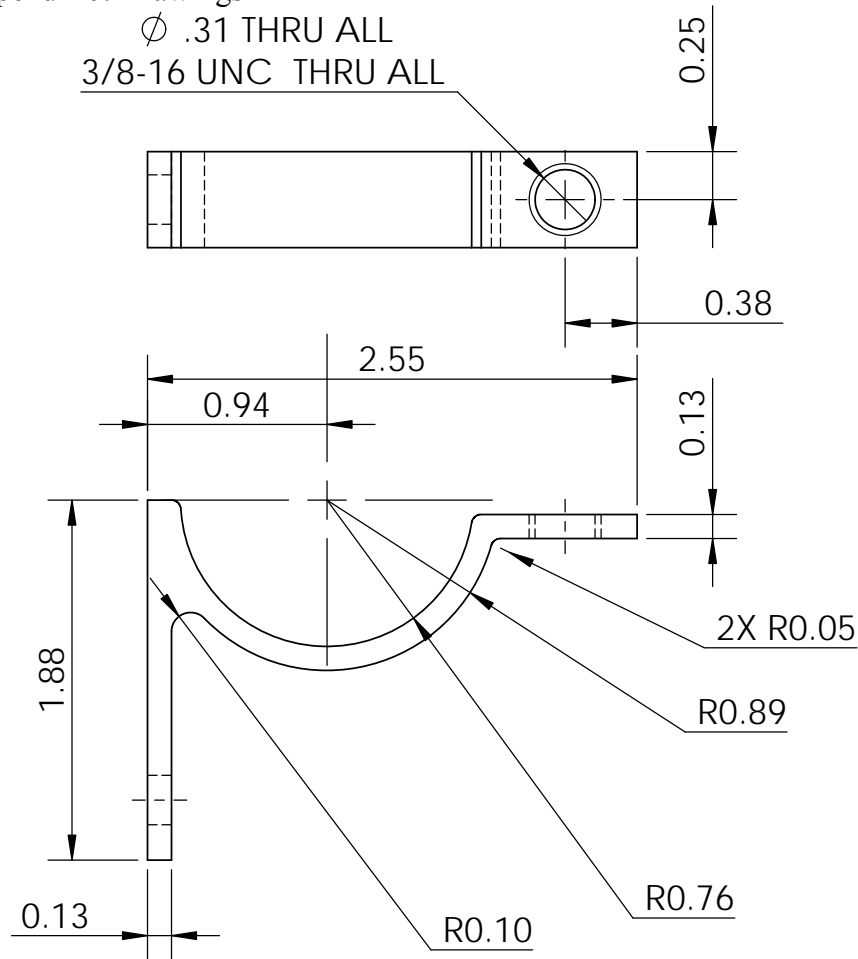
**PROPRIETARY AND CONFIDENTIAL**  
 THE INFORMATION CONTAINED IN THIS DRAWING IS THE SOLE PROPERTY OF <INSERT COMPANY NAME HERE>. ANY REPRODUCTION IN PART OR AS A WHOLE WITHOUT THE WRITTEN PERMISSION OF <INSERT COMPANY NAME HERE> IS PROHIBITED.

		UNLESS OTHERWISE SPECIFIED:		NAME	DATE	<b>ME 450 TEAM 5</b>	
		DIMENSIONS ARE IN INCHES	DRAWN			TITLE:	
		TOLERANCES:	CHECKED			<b>TOP POLE SECTION</b>	
		FRACTIONAL ±	ENG APPR.			SIZE	
		ANGULAR: MACH ± BEND ±	MFG APPR.			DWG. NO.	
		TWO PLACE DECIMAL ±	Q.A.			POLE_ASSEMBLY	
		THREE PLACE DECIMAL ±	COMMENTS:			REV	
		INTERPRET GEOMETRIC TOLERANCING PER:				SCALE: 1:8	
		MATERIAL				WEIGHT:	
		ALUMINUM				SHEET 4 OF 9	
		FINISH				J24	
NEXT ASSY	USED ON	DO NOT SCALE DRAWING					
APPLICATION							



Appendix J: Drawings

Ø .31 THRU ALL  
3/8-16 UNC THRU ALL

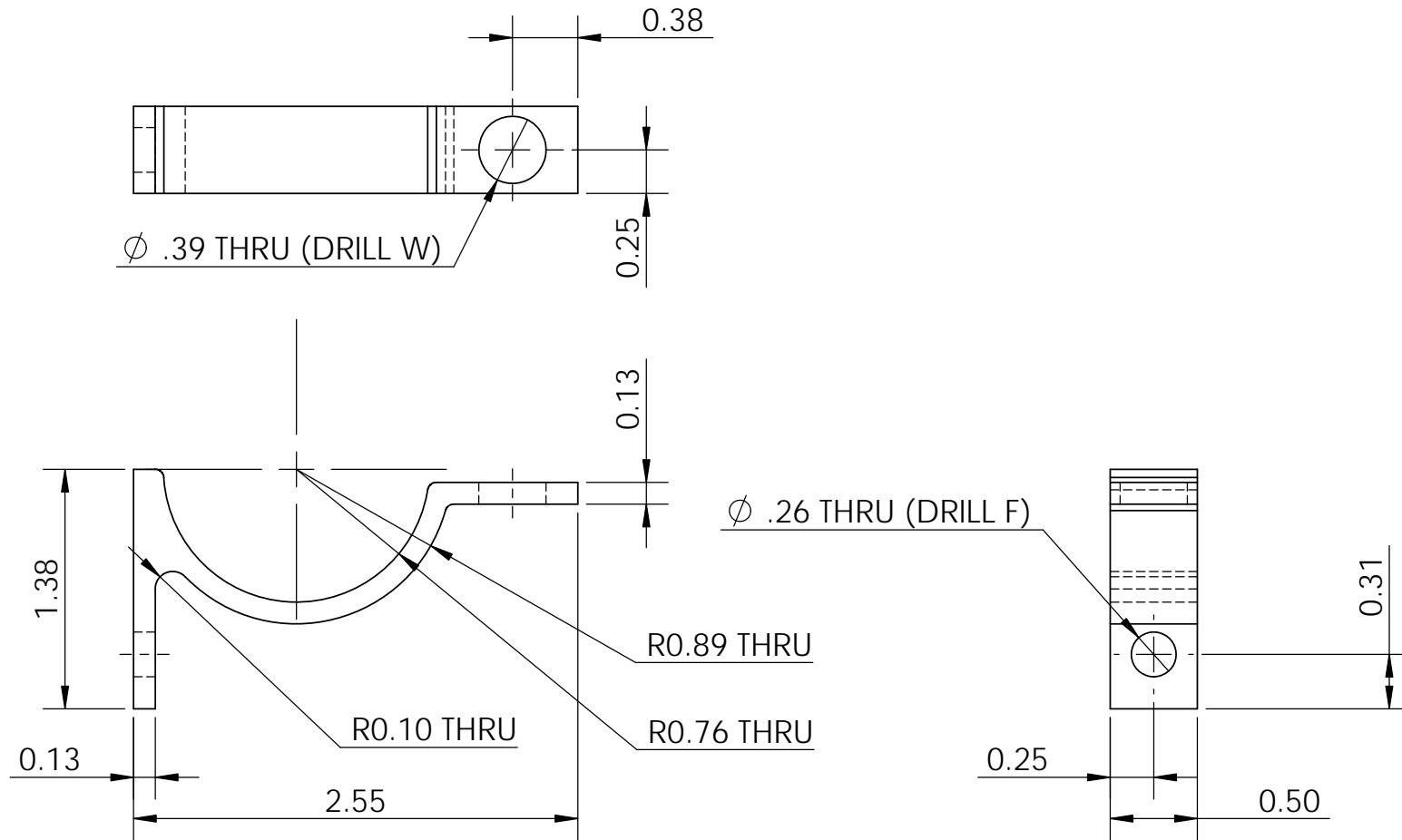


**PROPRIETARY AND CONFIDENTIAL**  
THE INFORMATION CONTAINED IN THIS DRAWING IS THE SOLE PROPERTY OF <INSERT COMPANY NAME HERE>. ANY REPRODUCTION IN PART OR AS A WHOLE WITHOUT THE WRITTEN PERMISSION OF <INSERT COMPANY NAME HERE> IS PROHIBITED.

		UNLESS OTHERWISE SPECIFIED:		NAME	DATE
		DIMENSIONS ARE IN INCHES	DRAWN		
		TOLERANCES:	CHECKED		
		FRACTIONAL ±	ENG APPR.		
		ANGULAR: MACH ± BEND ±	MFG APPR.		
		TWO PLACE DECIMAL ±	Q.A.		
		THREE PLACE DECIMAL ±	COMMENTS:		
		INTERPRET GEOMETRIC TOLERANCING PER:			
		MATERIAL			
		6061 ALUMINUM			
		FINISH			
NEXT ASSY	USED ON				
APPLICATION		DO NOT SCALE DRAWING			

ME 450 TEAM 5		
TITLE:		
POLECLAMP, THREAD SIZE		
SIZE <b>A</b>	DWG. NO. POLECLAMP_ CLAMP_THREAD	REV
SCALE: 1:1	WEIGHT:	SHEET 5 OF 9

Appendix J: Drawings



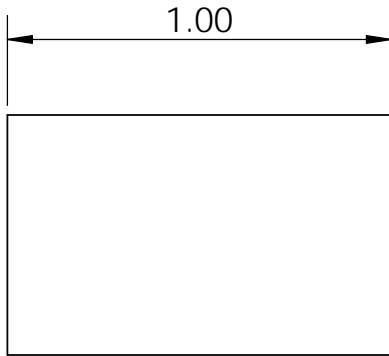
WATERJET PART

**PROPRIETARY AND CONFIDENTIAL**  
 THE INFORMATION CONTAINED IN THIS DRAWING IS THE SOLE PROPERTY OF <INSERT COMPANY NAME HERE>. ANY REPRODUCTION IN PART OR AS A WHOLE WITHOUT THE WRITTEN PERMISSION OF <INSERT COMPANY NAME HERE> IS PROHIBITED.

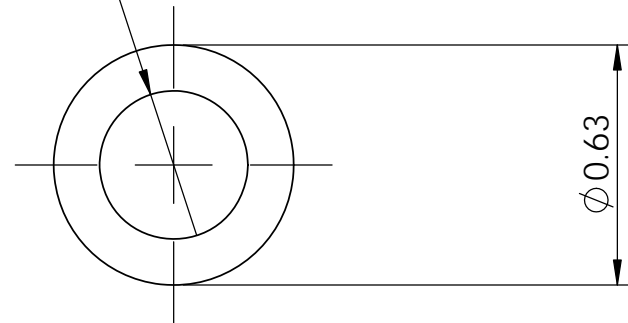
		UNLESS OTHERWISE SPECIFIED:		NAME	DATE
		DIMENSIONS ARE IN INCHES	DRAWN		
		TOLERANCES:	CHECKED		
		FRACTIONAL ±	ENG APPR.		
		ANGULAR: MACH ± BEND ±	MFG APPR.		
		TWO PLACE DECIMAL ±	Q.A.		
		THREE PLACE DECIMAL ±	COMMENTS:		
		INTERPRET GEOMETRIC TOLERANCING PER:			
		MATERIAL			
		6061 ALUMINUM			
		FINISH			
NEXT ASSY	USED ON				
APPLICATION		DO NOT SCALE DRAWING			

ME 450 TEAM 5		
TITLE:		
POLE CLAMP, THRU SIDE		
SIZE	DWG. NO.	REV
<b>A</b>	POLECLAMP_CLAMP_THRU	
SCALE: 1:1	WEIGHT:	SHEET 6 OF 9

Appendix J: Drawings



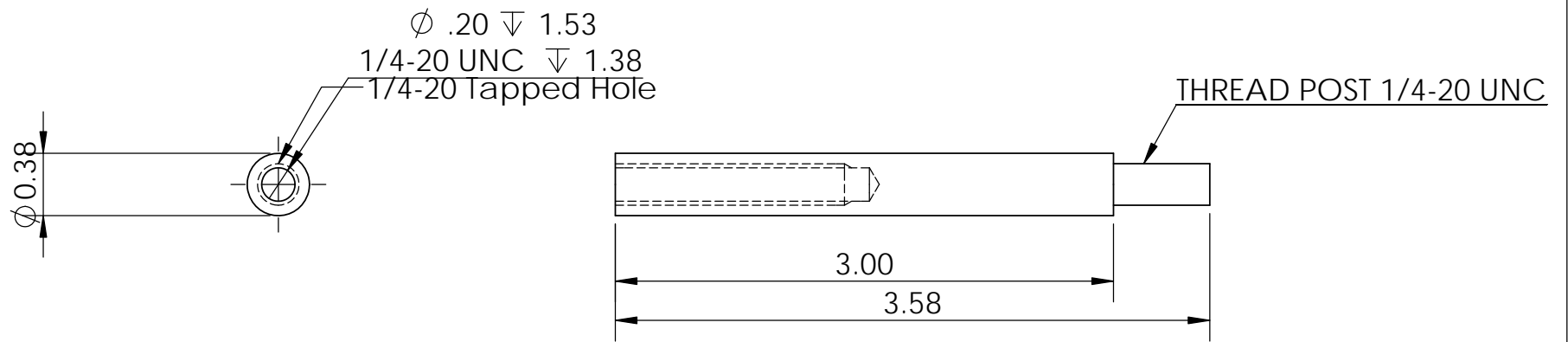
Ø .39 THRU (DRILL W)



**PROPRIETARY AND CONFIDENTIAL**  
 THE INFORMATION CONTAINED IN THIS DRAWING IS THE SOLE PROPERTY OF <INSERT COMPANY NAME HERE>. ANY REPRODUCTION IN PART OR AS A WHOLE WITHOUT THE WRITTEN PERMISSION OF <INSERT COMPANY NAME HERE> IS PROHIBITED.

		UNLESS OTHERWISE SPECIFIED:		NAME	DATE	<b>ME 450 TEAM 5</b>		
		DIMENSIONS ARE IN INCHES TOLERANCES: FRACTIONAL ± ANGULAR: MACH ± BEND ± TWO PLACE DECIMAL ± THREE PLACE DECIMAL ±	DRAWN			TITLE:		
			CHECKED			<b>SPACER, POLE CLAMP</b>		
			ENG APPR.					
			MFG APPR.					
		INTERPRET GEOMETRIC TOLERANCING PER:	Q.A.					
		MATERIAL <b>NYLON</b>	COMMENTS:			SIZE <b>A</b>	DWG. NO. POLE_ASSEMBLY	REV
NEXT ASSY	USED ON	FINISH				SCALE: 2:1	WEIGHT:	SHEET 7 OF 9
APPLICATION		DO NOT SCALE DRAWING						

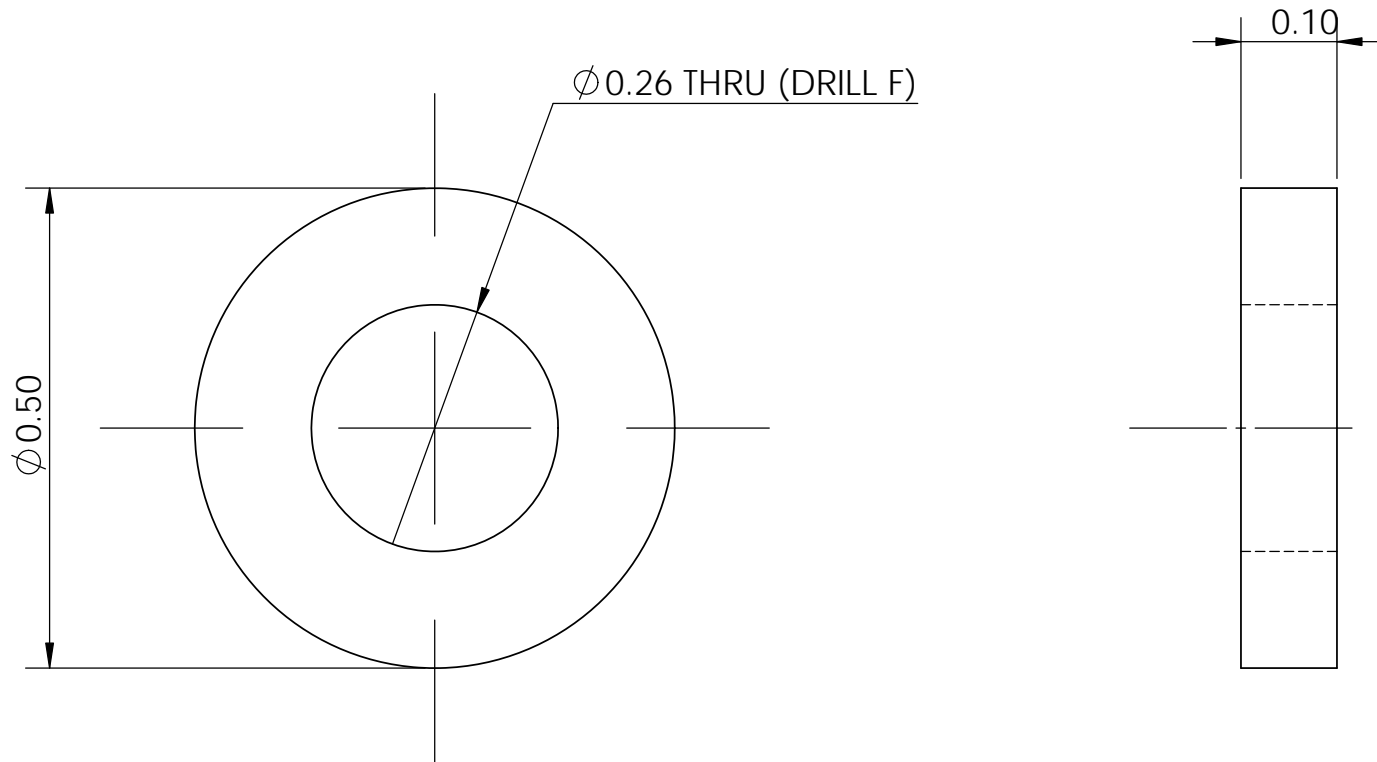
Appendix J: Drawings



**PROPRIETARY AND CONFIDENTIAL**  
 THE INFORMATION CONTAINED IN THIS DRAWING IS THE SOLE PROPERTY OF <INSERT COMPANY NAME HERE>. ANY REPRODUCTION IN PART OR AS A WHOLE WITHOUT THE WRITTEN PERMISSION OF <INSERT COMPANY NAME HERE> IS PROHIBITED.

		UNLESS OTHERWISE SPECIFIED:		NAME	DATE	<b>ME 450 TEAM 5</b>	
		DIMENSIONS ARE IN INCHES TOLERANCES: FRACTIONAL ± ANGULAR: MACH ± BEND ± TWO PLACE DECIMAL ± THREE PLACE DECIMAL ±	DRAWN			TITLE:	
		INTERPRET GEOMETRIC TOLERANCING PER:	CHECKED			<b>POLE CLAMP, EYE SHAFT</b>	
		MATERIAL <b>6061 ALUMINUM</b>	ENG APPR.			SIZE	DWG. NO.
NEXT ASSY	USED ON	FINISH	MFG APPR.			<b>A</b>	<b>POLE_ASSEMBLY</b>
APPLICATION		DO NOT SCALE DRAWING	Q.A.				REV
			COMMENTS:			SCALE: 1:1	WEIGHT:
							SHEET 8 OF 9

Appendix J: Drawings



2X PART

**PROPRIETARY AND CONFIDENTIAL**  
 THE INFORMATION CONTAINED IN THIS DRAWING IS THE SOLE PROPERTY OF <INSERT COMPANY NAME HERE>. ANY REPRODUCTION IN PART OR AS A WHOLE WITHOUT THE WRITTEN PERMISSION OF <INSERT COMPANY NAME HERE> IS PROHIBITED.

		UNLESS OTHERWISE SPECIFIED:		NAME	DATE	<b>ME 450 TEAM 5</b>	
		DIMENSIONS ARE IN INCHES	DRAWN			TITLE:	
		TOLERANCES:	CHECKED			<b>POLE CLAMP, SPACER</b>	
		FRACTIONAL ±	ENG APPR.			SIZE	DWG. NO.
		ANGULAR: MACH ± BEND ±	MFG APPR.			<b>A</b>	SPACER_POLE_SHOULDER_BOLT
		TWO PLACE DECIMAL ±	Q.A.				REV
		THREE PLACE DECIMAL ±	COMMENTS:				
		INTERPRET GEOMETRIC TOLERANCING PER:				SCALE: 5:1	WEIGHT:
		MATERIAL					SHEET 9 OF 9
		<b>NYLON</b>					
		FINISH					
NEXT ASSY	USED ON						
APPLICATION		DO NOT SCALE DRAWING					

5

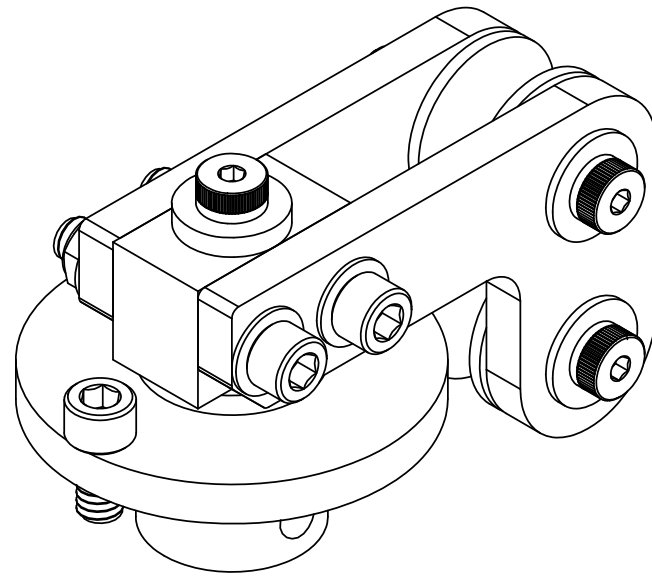
4

3

2

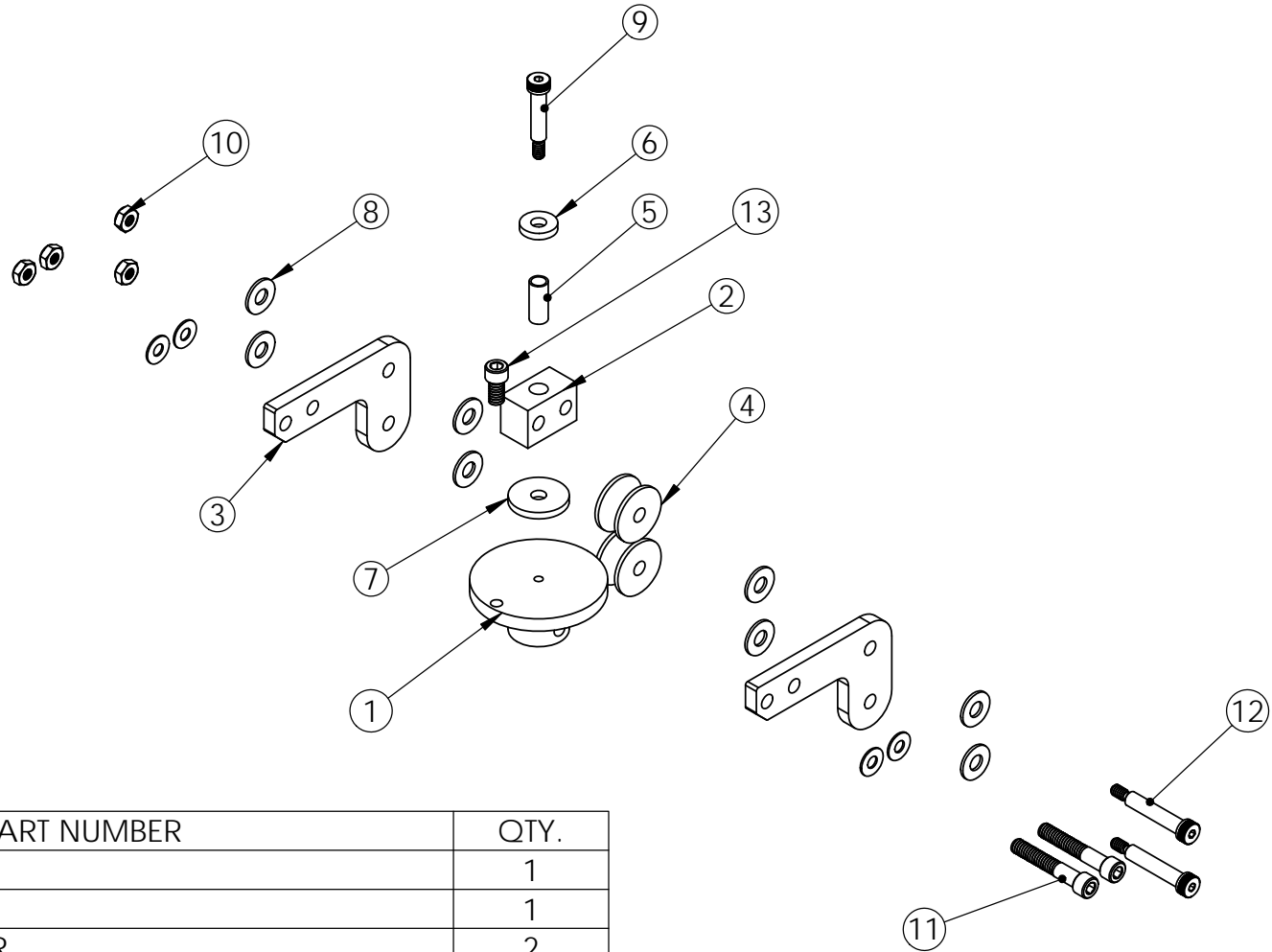
1

129



ME 450 TEAM 5		
TITLE: POLE TOPPER, ASSEMBLY		
SIZE <b>A</b>	DWG. NO. POLE TOPPER	REV
SCALE: 1:4	WEIGHT:	SHEET 1 OF 8

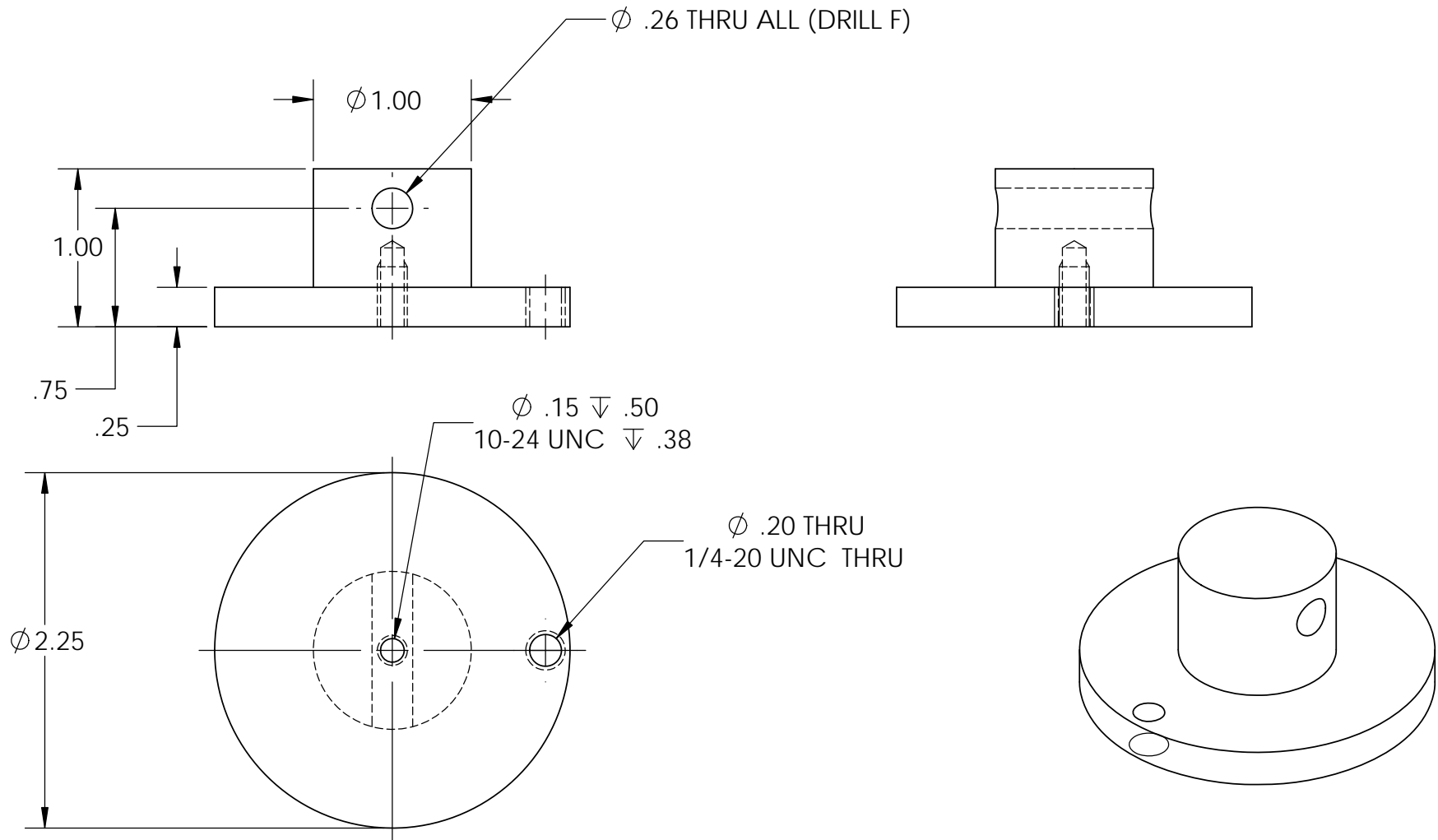
Appendix J: Drawings



ITEM NO.	PART NUMBER	QTY.
1	TOP_BODY	1
2	TOP_CUBE	1
3	TOP_PULLEY_COVER	2
4	TOP_PULLEY	2
5	BRONZE SLEEVE BUSHING, 1/4" ID, 3/8" OD, 3/4" L	1
6	SPACER_TOP_SHOULDER_BOLT	1
7	SPACER_BOTTOM_SHOULDER_BOLT	1
8	WASHER, 1/4"	12
9	SHOULDER BOLT, 1/4" SHOULDER, 1 1/4" L	1
10	NUT, 1/4"-20	4
11	SHCS, 1/4"-20, 1 1/2" L	2
12	SHOULDER BOLT, 1" L	2
13	SHCS, 1/4"-20, 1/2" L	1

<b>ME 450 TEAM 5</b>		
TITLE:		
<b>POLE TOPPER, ASSEMBLY</b>		
SIZE	DWG. NO.	REV
<b>A</b>	<b>POLE TOPPER</b>	
SCALE: 1:4	WEIGHT:	SHEET 2 OF 8

Appendix J: Drawings



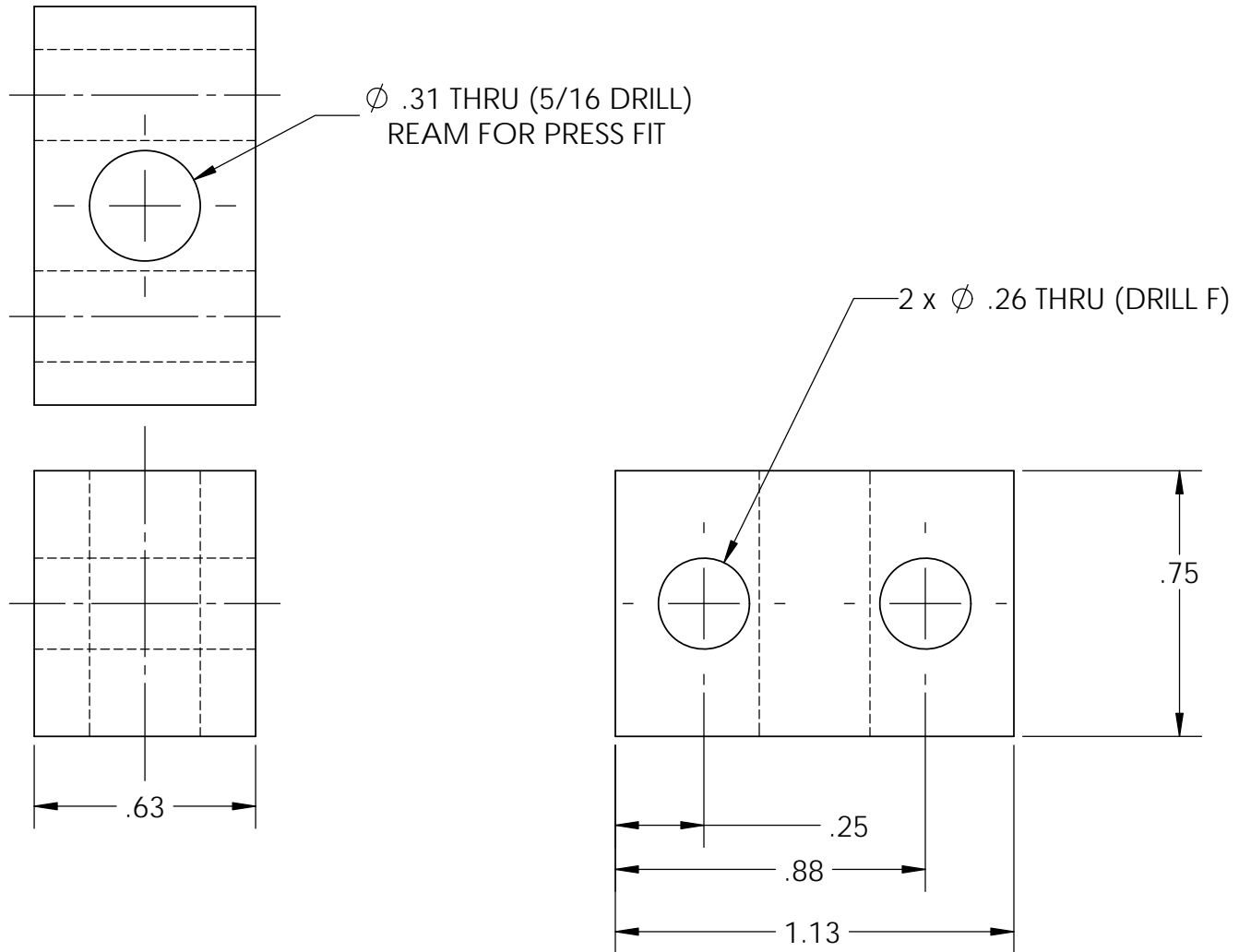
**PROPRIETARY AND CONFIDENTIAL**  
 THE INFORMATION CONTAINED IN THIS DRAWING IS THE SOLE PROPERTY OF <INSERT COMPANY NAME HERE>. ANY REPRODUCTION IN PART OR AS A WHOLE WITHOUT THE WRITTEN PERMISSION OF <INSERT COMPANY NAME HERE> IS PROHIBITED.

		UNLESS OTHERWISE SPECIFIED:		NAME	DATE
		DIMENSIONS ARE IN INCHES	DRAWN		
		TOLERANCES:	CHECKED		
		FRACTIONAL $\pm$	ENG APPR.		
		ANGULAR: MACH $\pm$ BEND $\pm$	MFG APPR.		
		TWO PLACE DECIMAL $\pm$	Q.A.		
		THREE PLACE DECIMAL $\pm$	COMMENTS:		
		INTERPRET GEOMETRIC TOLERANCING PER:			
		MATERIAL			
		6061 ALUMINUM			
NEXT ASSY	USED ON	FINISH			
APPLICATION		DO NOT SCALE DRAWING			

ME 450 TEAM 5		
TITLE:		
POLE TOP BODY		
SIZE	DWG. NO.	REV
<b>A</b>	<b>TOP_BODY</b>	<b>A</b>
SCALE: 1:1	WEIGHT:	SHEET 3 OF 8



Appendix J: Drawings

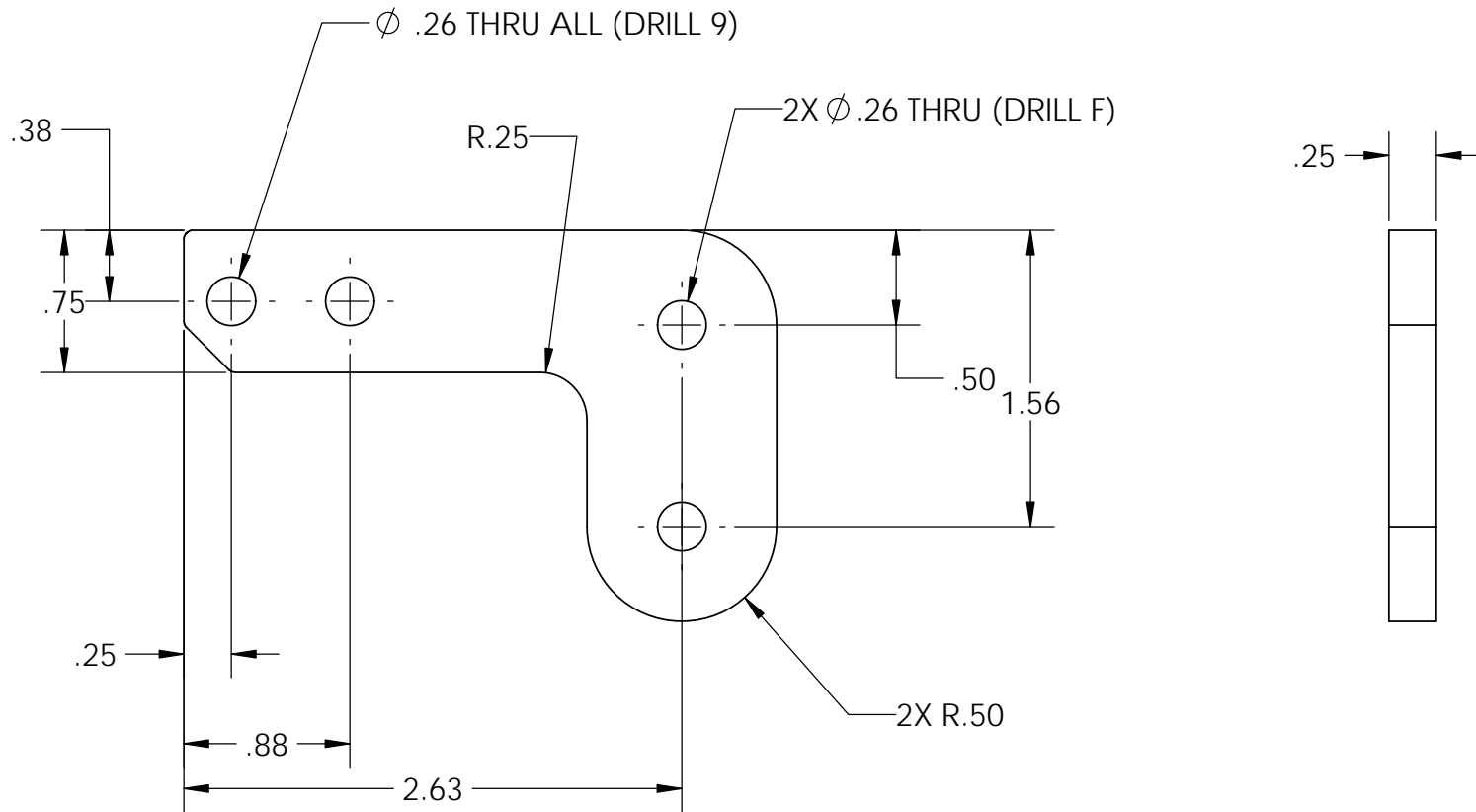


**PROPRIETARY AND CONFIDENTIAL**  
 THE INFORMATION CONTAINED IN THIS DRAWING IS THE SOLE PROPERTY OF <INSERT COMPANY NAME HERE>. ANY REPRODUCTION IN PART OR AS A WHOLE WITHOUT THE WRITTEN PERMISSION OF <INSERT COMPANY NAME HERE> IS PROHIBITED.

		UNLESS OTHERWISE SPECIFIED:		NAME	DATE
		DIMENSIONS ARE IN INCHES	DRAWN		
		TOLERANCES:	CHECKED		
		FRACTIONAL $\pm$	ENG APPR.		
		ANGULAR: MACH $\pm$ BEND $\pm$	MFG APPR.		
		TWO PLACE DECIMAL $\pm$	Q.A.		
		THREE PLACE DECIMAL $\pm$	COMMENTS:		
		INTERPRET GEOMETRIC TOLERANCING PER:			
		MATERIAL			
		6061 ALUMINUM			
NEXT ASSY	USED ON	FINISH			
APPLICATION		DO NOT SCALE DRAWING			

ME 450 TEAM 5		
TITLE:		
POLE TOP, CUBE		
SIZE	DWG. NO.	REV
<b>A</b>	TOP_CUBE	
SCALE: 2:1	WEIGHT:	SHEET 4 OF 8

Appendix J: Drawings



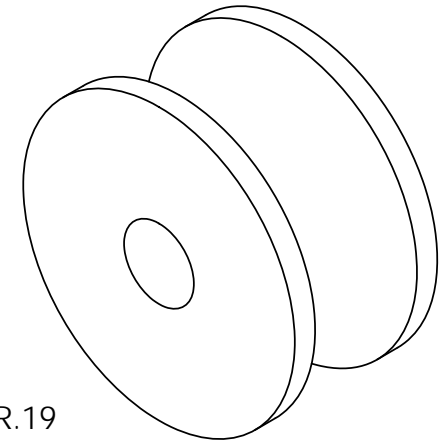
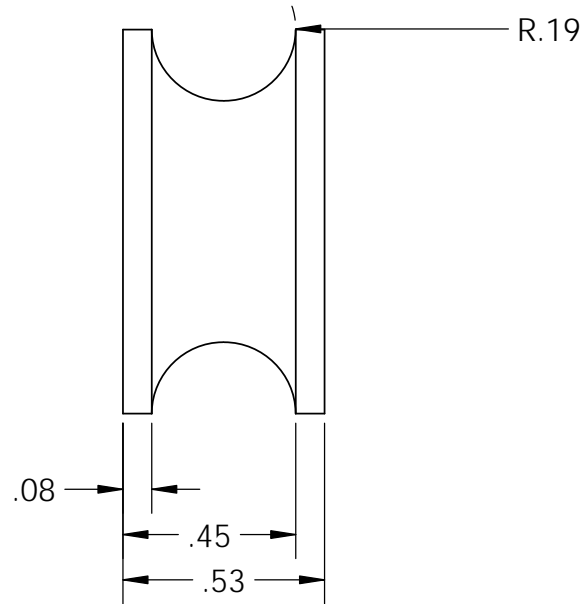
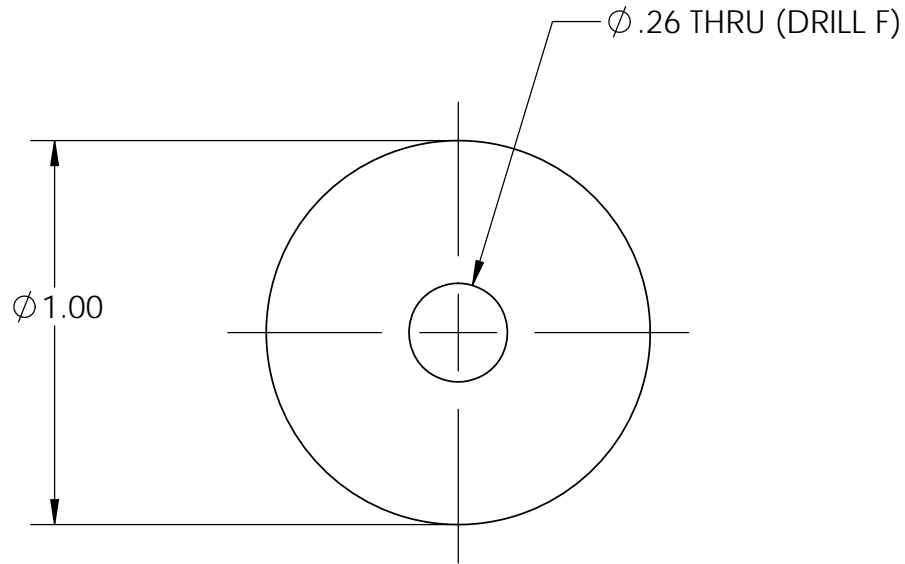
2X PART  
LASER CUT ACRYLIC, DRILL HOLES

**PROPRIETARY AND CONFIDENTIAL**  
THE INFORMATION CONTAINED IN THIS DRAWING IS THE SOLE PROPERTY OF <INSERT COMPANY NAME HERE>. ANY REPRODUCTION IN PART OR AS A WHOLE WITHOUT THE WRITTEN PERMISSION OF <INSERT COMPANY NAME HERE> IS PROHIBITED.

		UNLESS OTHERWISE SPECIFIED:		NAME	DATE
		DIMENSIONS ARE IN INCHES	DRAWN		
		TOLERANCES:	CHECKED		
		FRACTIONAL ±	ENG APPR.		
		ANGULAR: MACH ± BEND ±	MFG APPR.		
		TWO PLACE DECIMAL ±	Q.A.		
		THREE PLACE DECIMAL ±	COMMENTS:		
		INTERPRET GEOMETRIC TOLERANCING PER:			
		MATERIAL			
		ACRYLIC			
NEXT ASSY	USED ON	FINISH			
APPLICATION		DO NOT SCALE DRAWING			

ME 450 TEAM 5		
TITLE:		
TOP_PULLEY_COVER		
SIZE	DWG. NO.	REV
<b>A</b>	MAST_TOPPER_ASSEMBLY	
SCALE: 1:1	WEIGHT:	SHEET 5 OF 8

Appendix J: Drawings

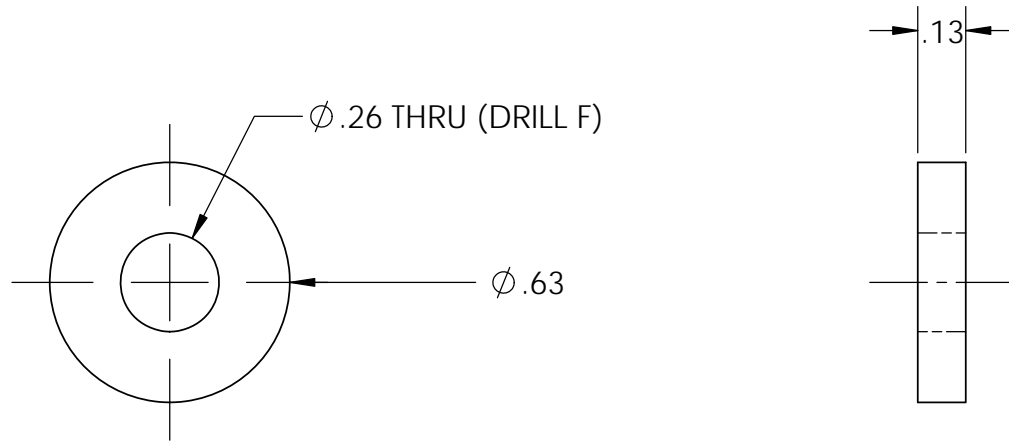


2X PART

**PROPRIETARY AND CONFIDENTIAL**  
 THE INFORMATION CONTAINED IN THIS DRAWING IS THE SOLE PROPERTY OF <INSERT COMPANY NAME HERE>. ANY REPRODUCTION IN PART OR AS A WHOLE WITHOUT THE WRITTEN PERMISSION OF <INSERT COMPANY NAME HERE> IS PROHIBITED.

		UNLESS OTHERWISE SPECIFIED:		NAME	DATE	<b>ME 450 TEAM 5</b>	
		DIMENSIONS ARE IN INCHES	DRAWN			TITLE:	
		TOLERANCES:	CHECKED			<b>TOP PULLEY</b>	
		FRACTIONAL $\pm$	ENG APPR.				
		ANGULAR: MACH $\pm$ BEND $\pm$	MFG APPR.				
		TWO PLACE DECIMAL $\pm$	Q.A.				
		THREE PLACE DECIMAL $\pm$	COMMENTS:				
		INTERPRET GEOMETRIC TOLERANCING PER:				SIZE	DWG. NO.
		MATERIAL				<b>A</b>	<b>TOP_PULLEY</b>
		<b>NYLON</b>					REV
		FINISH					
NEXT ASSY	USED ON					SCALE: 2:1	WEIGHT:
APPLICATION		DO NOT SCALE DRAWING					SHEET 6 OF 8

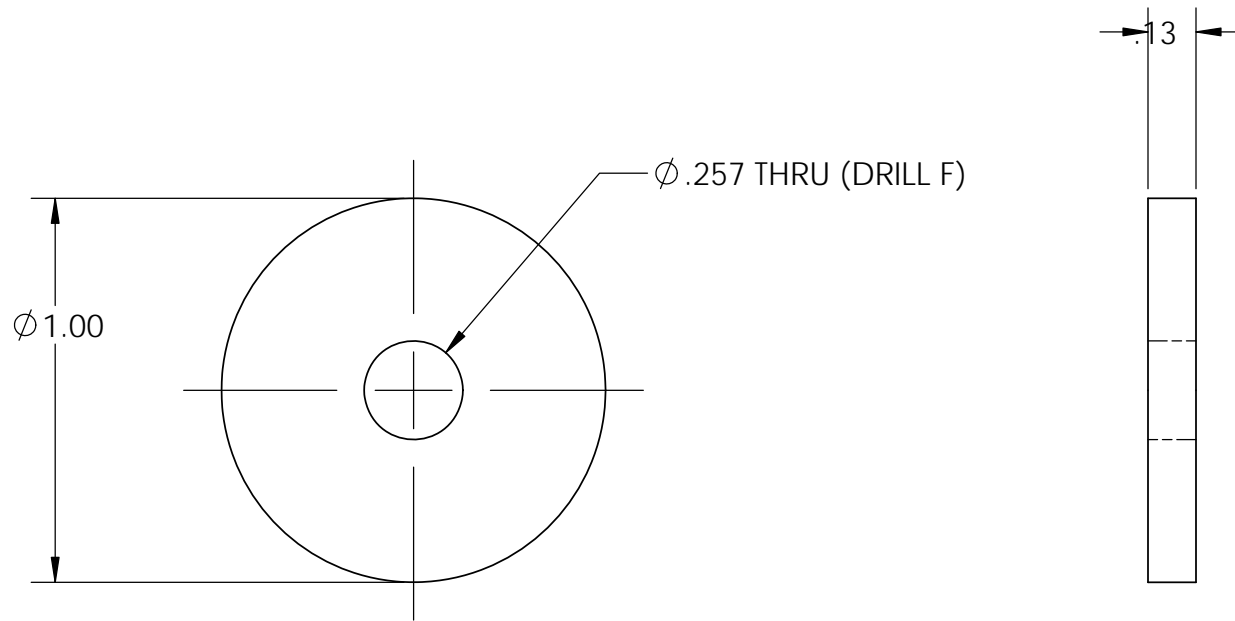
Appendix J: Drawings



**PROPRIETARY AND CONFIDENTIAL**  
 THE INFORMATION CONTAINED IN THIS DRAWING IS THE SOLE PROPERTY OF <INSERT COMPANY NAME HERE>. ANY REPRODUCTION IN PART OR AS A WHOLE WITHOUT THE WRITTEN PERMISSION OF <INSERT COMPANY NAME HERE> IS PROHIBITED.

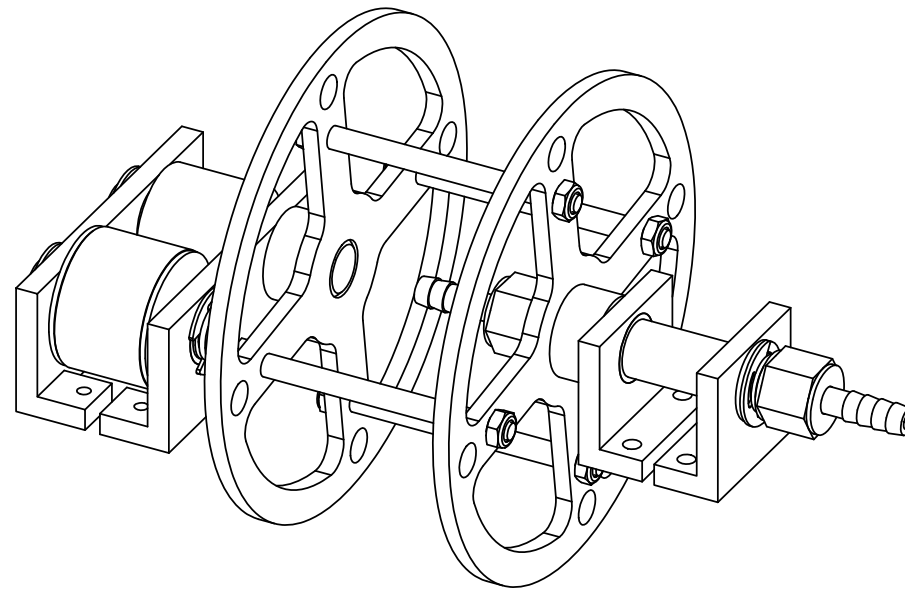
		UNLESS OTHERWISE SPECIFIED:		NAME	DATE	<b>ME 450 TEAM 5</b>		
		DIMENSIONS ARE IN INCHES TOLERANCES: FRACTIONAL ± ANGULAR: MACH ± BEND ± TWO PLACE DECIMAL ± THREE PLACE DECIMAL ±	DRAWN			TITLE:  <b>SPACER, TOP SHOULDER BOLT</b>		
			CHECKED					
			ENG APPR.					
			MFG APPR.					
		INTERPRET GEOMETRIC TOLERANCING PER:	Q.A.			SIZE DWG. NO. REV <b>A</b> <b>TOP SPACER</b>		
		MATERIAL <b>NYLON</b>	COMMENTS:					
		FINISH						
NEXT ASSY	USED ON					SCALE: 2:1	WEIGHT:	SHEET 7 OF 8
APPLICATION		DO NOT SCALE DRAWING						

Appendix J: Drawings



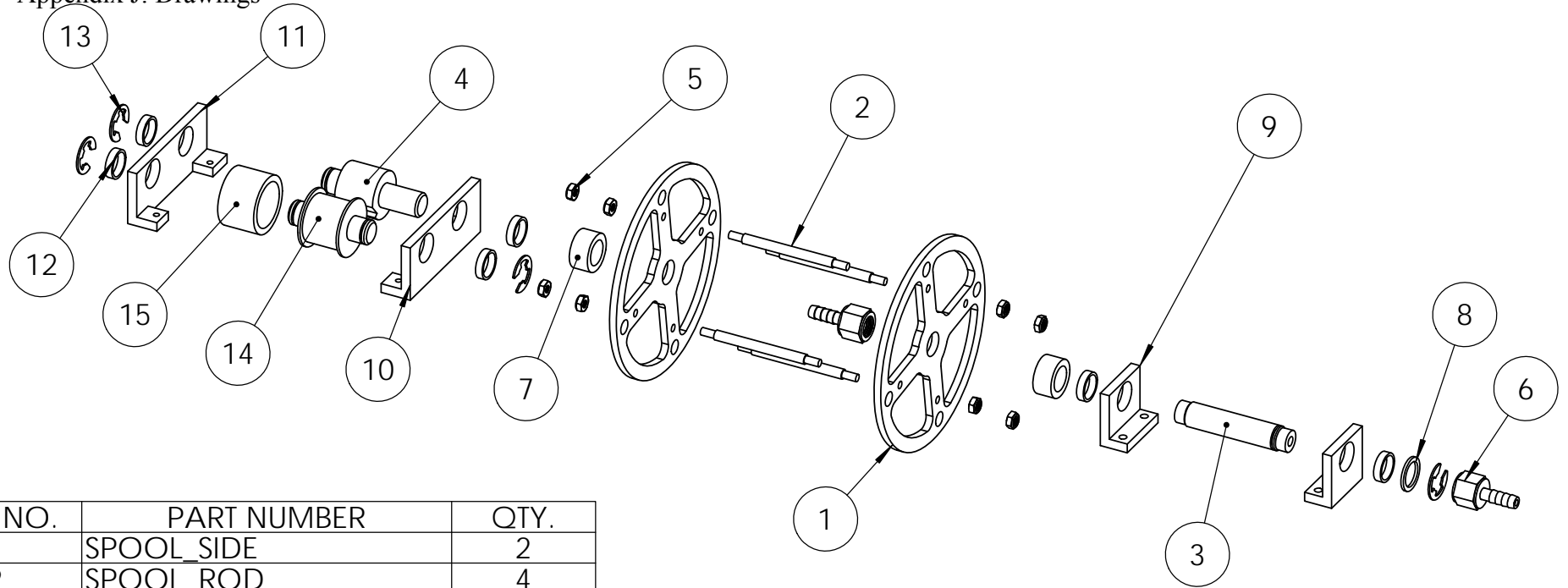
**PROPRIETARY AND CONFIDENTIAL**  
 THE INFORMATION CONTAINED IN THIS DRAWING IS THE SOLE PROPERTY OF <INSERT COMPANY NAME HERE>. ANY REPRODUCTION IN PART OR AS A WHOLE WITHOUT THE WRITTEN PERMISSION OF <INSERT COMPANY NAME HERE> IS PROHIBITED.

		UNLESS OTHERWISE SPECIFIED:		NAME	DATE	<b>ME 450 TEAM 5</b>	
		DIMENSIONS ARE IN INCHES	DRAWN			TITLE:	
		TOLERANCES:	CHECKED			<b>SPACER_BOTTOM</b>	
		FRACTIONAL ±	ENG APPR.			<b>SHOULDER_BOLT</b>	
		ANGULAR: MACH ± BEND ±	MFG APPR.			SIZE	DWG. NO.
		TWO PLACE DECIMAL ±	Q.A.			<b>A</b>	<b>SPACER BOTTOM</b>
		THREE PLACE DECIMAL ±	COMMENTS:			SCALE: 2:1	WEIGHT:
		INTERPRET GEOMETRIC TOLERANCING PER:				SHEET 8 OF 8	REV
		MATERIAL					
		<b>NYLON</b>					
		FINISH					
NEXT ASSY	USED ON						
APPLICATION		DO NOT SCALE DRAWING					



ME 450 TEAM 5		
TITLE: SPOOL ASSEMBLY		
SIZE <b>A</b>	DWG. NO. SPOOL	REV
SCALE: 1:2	WEIGHT:	SHEET 1 OF 13

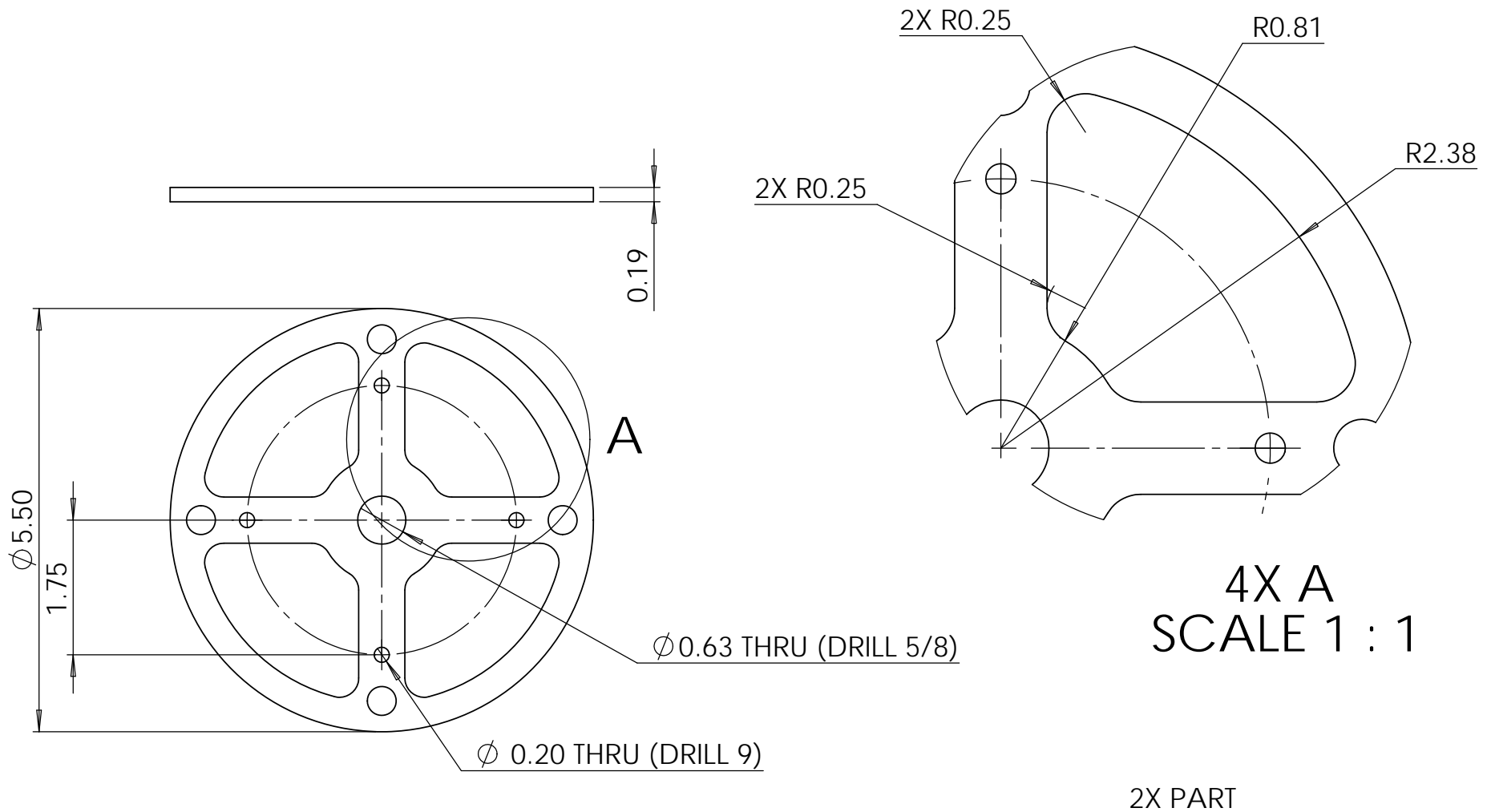
Appendix J: Drawings



ITEM NO.	PART NUMBER	QTY.
1	SPOOL_SIDE	2
2	SPOOL_ROD	4
3	SPOOL_SHAFT_TUBING	1
4	SPOOL_SHAFT_SPRING	1
5	Nut, #10-24	8
6	Oxygen tube swivel connection	2
7	SPOOL_PLASTIC_SPACER	2
8	WASHER_NYLON_5-8	1
9	SPOOL_MOUNT_TUBING	2
10	SPOOL_MOUNT_SPRING	1
11	SPOOL_MOUNT_SPRING_B	1
12	SPOOL_MOUNT_BEARING	6
13	E-clip, 5/8" diameter shaft	4
14	SPRING_SHAFT	1
15	SPOOL_SPRING	1

<b>ME 450 TEAM 5</b>		
TITLE:		
<b>SPOOL ASSEMBLY</b>		
SIZE	DWG. NO.	REV
<b>A</b>	<b>SPOOL</b>	
SCALE: 1:4	WEIGHT:	SHEET 2 OF 13

Appendix J: Drawings



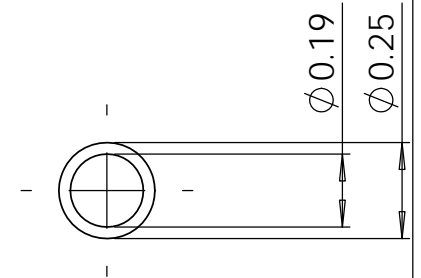
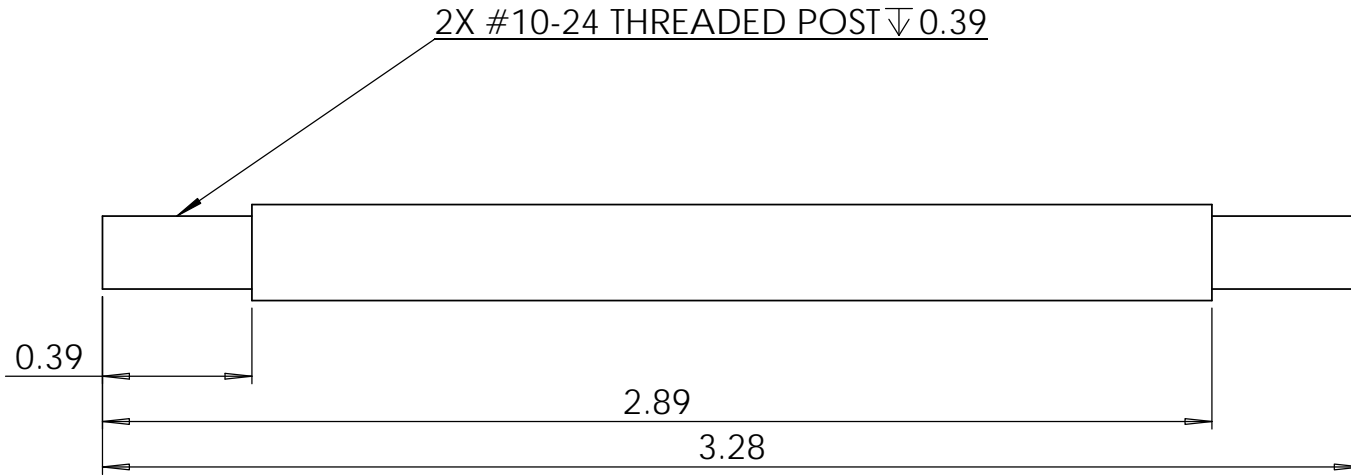
**PROPRIETARY AND CONFIDENTIAL**  
 THE INFORMATION CONTAINED IN THIS DRAWING IS THE SOLE PROPERTY OF <INSERT COMPANY NAME HERE>. ANY REPRODUCTION IN PART OR AS A WHOLE WITHOUT THE WRITTEN PERMISSION OF <INSERT COMPANY NAME HERE> IS PROHIBITED.

		UNLESS OTHERWISE SPECIFIED:		NAME	DATE
		DIMENSIONS ARE IN INCHES	DRAWN		
		TOLERANCES:	CHECKED		
		FRACTIONAL $\pm$	ENG APPR.		
		ANGULAR: MACH $\pm$ BEND $\pm$	MFG APPR.		
		TWO PLACE DECIMAL $\pm$	Q.A.		
		THREE PLACE DECIMAL $\pm$	COMMENTS:		
		INTERPRET GEOMETRIC TOLERANCING PER:			
		MATERIAL			
		6061 ALUMINUM			
NEXT ASSY	USED ON	FINISH			
APPLICATION		DO NOT SCALE DRAWING			

ME 450 TEAM 5		
TITLE:		
SPOOL, SIDE		
SIZE	DWG. NO.	REV
<b>A</b>	SPOOL	
SCALE: 1:2	WEIGHT:	SHEET 3 OF 13



Appendix J: Drawings

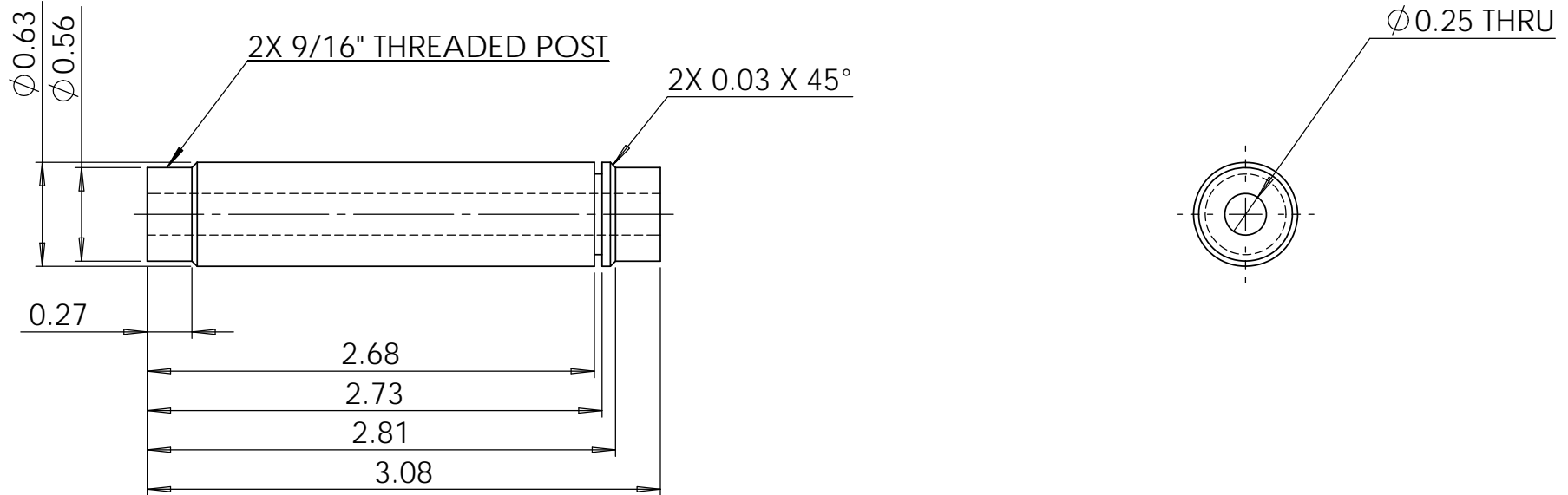


4X PART

**PROPRIETARY AND CONFIDENTIAL**  
 THE INFORMATION CONTAINED IN THIS DRAWING IS THE SOLE PROPERTY OF <INSERT COMPANY NAME HERE>. ANY REPRODUCTION IN PART OR AS A WHOLE WITHOUT THE WRITTEN PERMISSION OF <INSERT COMPANY NAME HERE> IS PROHIBITED.

		UNLESS OTHERWISE SPECIFIED:		NAME	DATE	<b>ME 450 TEAM 5</b>		
		DIMENSIONS ARE IN INCHES TOLERANCES: FRACTIONAL ± ANGULAR: MACH ± BEND ± TWO PLACE DECIMAL ± THREE PLACE DECIMAL ±		DRAWN		TITLE:		
				CHECKED		<b>SPOOL, ROD</b>		
				ENG APPR.				
				MFG APPR.				
		INTERPRET GEOMETRIC TOLERANCING PER:		Q.A.		COMMENTS:		
		MATERIAL				SIZE	DWG. NO.	REV
		6061 ALUMINUM				<b>A</b>	<b>SPOOL</b>	
		FINISH						
NEXT ASSY	USED ON					SCALE: 1:1	WEIGHT:	SHEET 4 OF 13
APPLICATION		DO NOT SCALE DRAWING						

Appendix J: Drawings

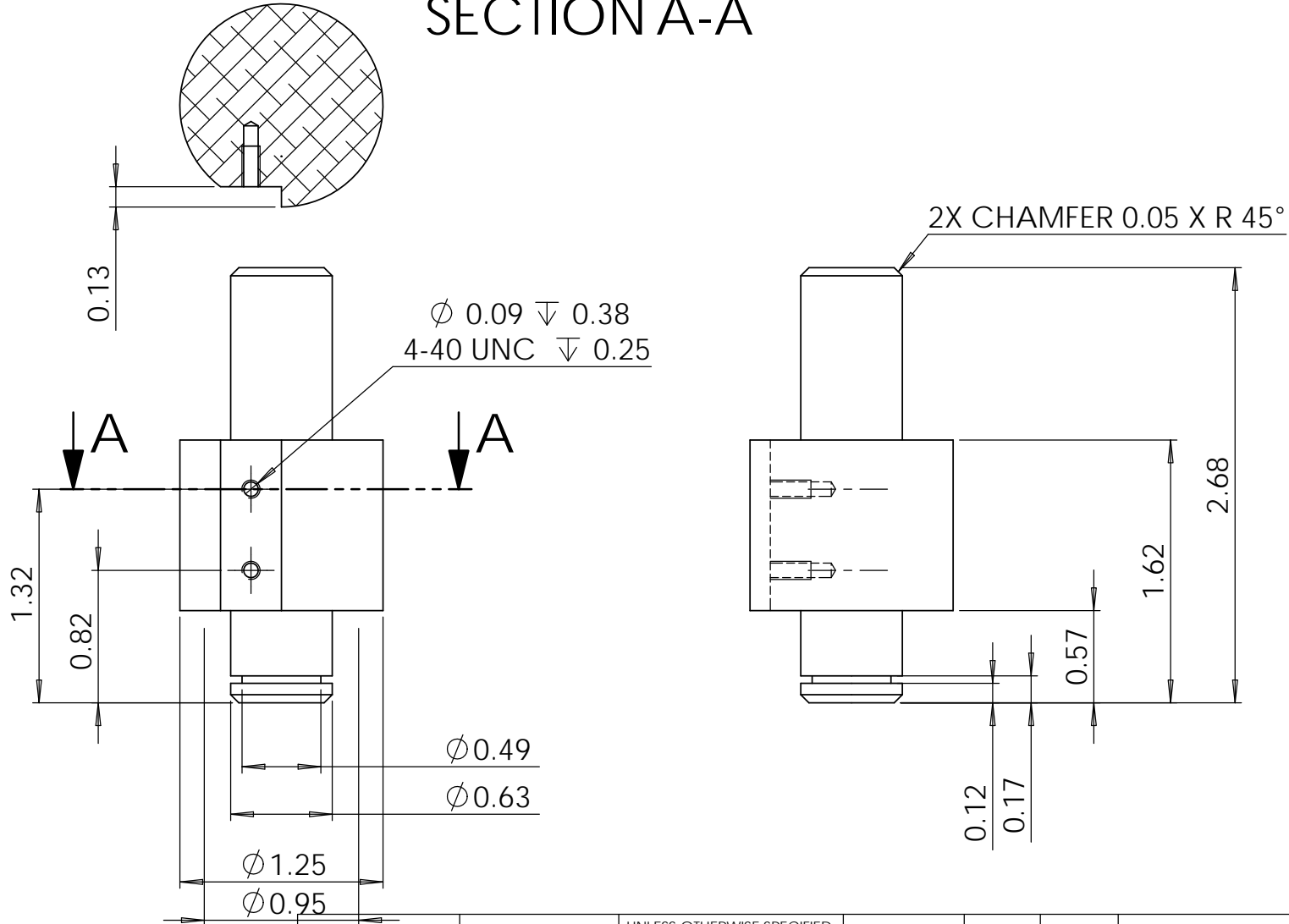
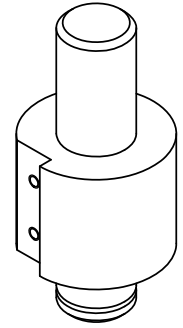


**PROPRIETARY AND CONFIDENTIAL**  
 THE INFORMATION CONTAINED IN THIS DRAWING IS THE SOLE PROPERTY OF <INSERT COMPANY NAME HERE>. ANY REPRODUCTION IN PART OR AS A WHOLE WITHOUT THE WRITTEN PERMISSION OF <INSERT COMPANY NAME HERE> IS PROHIBITED.

		UNLESS OTHERWISE SPECIFIED:		NAME	DATE
		DIMENSIONS ARE IN INCHES	DRAWN		
		TOLERANCES:	CHECKED		
		FRACTIONAL $\pm$	ENG APPR.		
		ANGULAR: MACH $\pm$ BEND $\pm$	MFG APPR.		
		TWO PLACE DECIMAL $\pm$	Q.A.		
		THREE PLACE DECIMAL $\pm$	COMMENTS:		
		INTERPRET GEOMETRIC TOLERANCING PER:			
		MATERIAL			
		6061 ALUMINUM			
		FINISH			
NEXT ASSY	USED ON				
APPLICATION		DO NOT SCALE DRAWING			

<b>ME 450 TEAM 5</b>		
TITLE:		
<b>SPOOL SHAFT, TUBING SIDE</b>		
SIZE	DWG. NO.	REV
<b>A</b>	SPOOL_SHAFT_TUBING	
SCALE: 1:1	WEIGHT:	SHEET 5 OF 13

# SECTION A-A

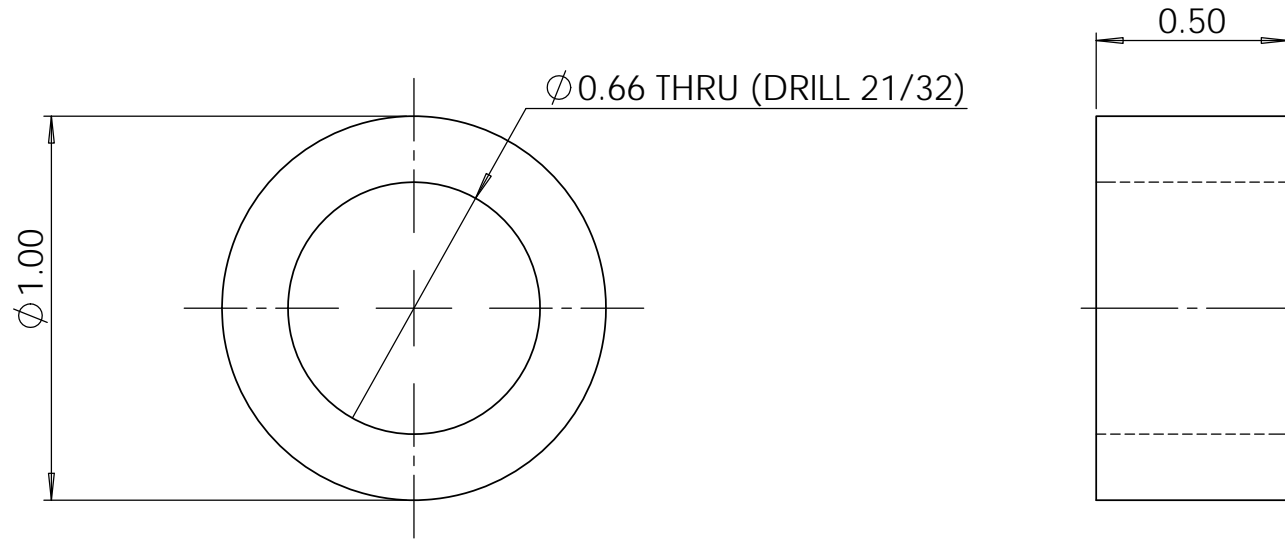


**PROPRIETARY AND CONFIDENTIAL**  
 THE INFORMATION CONTAINED IN THIS DRAWING IS THE SOLE PROPERTY OF <INSERT COMPANY NAME HERE>. ANY REPRODUCTION IN PART OR AS A WHOLE WITHOUT THE WRITTEN PERMISSION OF <INSERT COMPANY NAME HERE> IS PROHIBITED.

		UNLESS OTHERWISE SPECIFIED:	NAME	DATE
		DIMENSIONS ARE IN INCHES	DRAWN	
		TOLERANCES:	CHECKED	
		FRACTIONAL $\pm$	ENG APPR.	
		ANGULAR: MACH $\pm$ BEND $\pm$	MFG APPR.	
		TWO PLACE DECIMAL $\pm$	Q.A.	
		THREE PLACE DECIMAL $\pm$	COMMENTS:	
		INTERPRET GEOMETRIC TOLERANCING PER:		
		MATERIAL		
		6061 ALUMINUM		
		FINISH		
NEXT ASSY	USED ON			
APPLICATION		DO NOT SCALE DRAWING		

ME 450 TEAM 5		
TITLE:		
SPOOL SHAFT, SPRING SIDE		
SIZE	DWG. NO.	REV
<b>A</b>	SPOOL_SHAFT_ SPRING	
SCALE: 1:1	WEIGHT:	SHEET 6 OF 13

Appendix J: Drawings

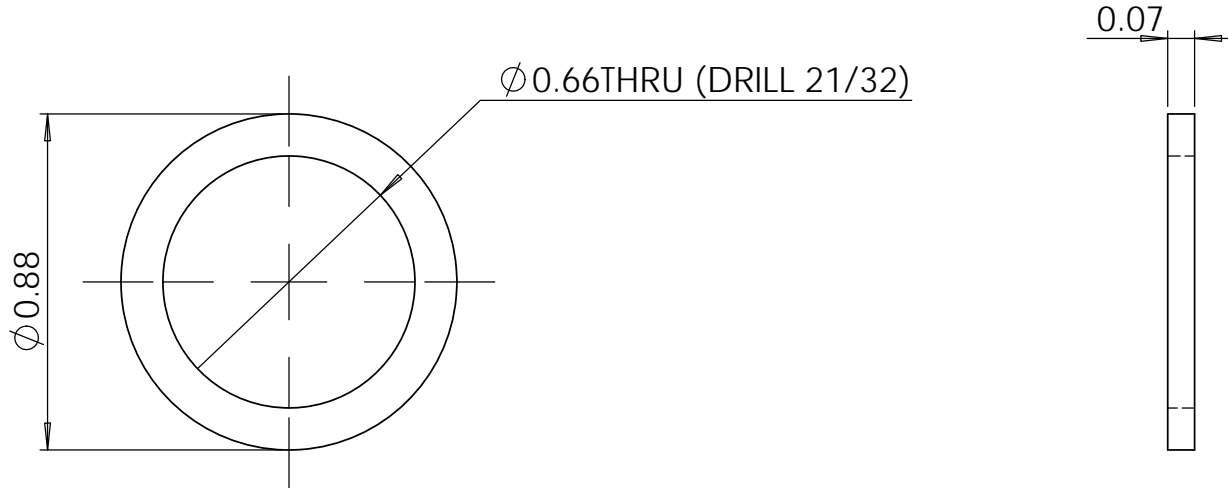


2X PART

**PROPRIETARY AND CONFIDENTIAL**  
 THE INFORMATION CONTAINED IN THIS DRAWING IS THE SOLE PROPERTY OF <INSERT COMPANY NAME HERE>. ANY REPRODUCTION IN PART OR AS A WHOLE WITHOUT THE WRITTEN PERMISSION OF <INSERT COMPANY NAME HERE> IS PROHIBITED.

		UNLESS OTHERWISE SPECIFIED:		NAME	DATE	<b>ME 450 TEAM 5</b>	
		DIMENSIONS ARE IN INCHES TOLERANCES: FRACTIONAL ± ANGULAR: MACH ± BEND ± TWO PLACE DECIMAL ± THREE PLACE DECIMAL ±	DRAWN			TITLE:  <b>SPACER,          SPOOL SHAFTS</b>	
			CHECKED				
			ENG APPR.				
			MFG APPR.				
		INTERPRET GEOMETRIC TOLERANCING PER:	Q.A.			SIZE <b>A</b> DWG. NO. SPOOL_PLASTIC_SPACER REV SCALE: 2:1 WEIGHT: SHEET 7 OF 13	
		MATERIAL <b>NYLON</b>	COMMENTS:				
		FINISH					
NEXT ASSY	USED ON						
APPLICATION		DO NOT SCALE DRAWING					

Appendix J: Drawings

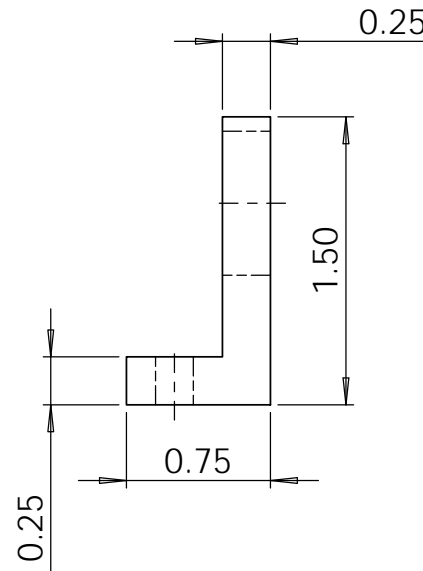
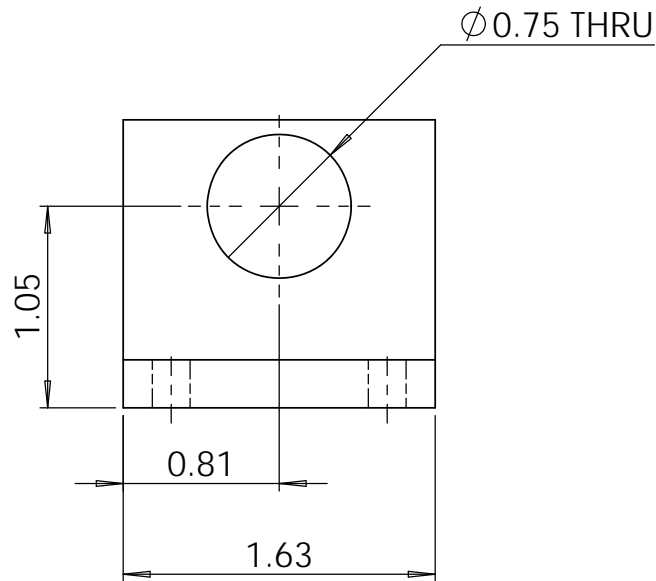
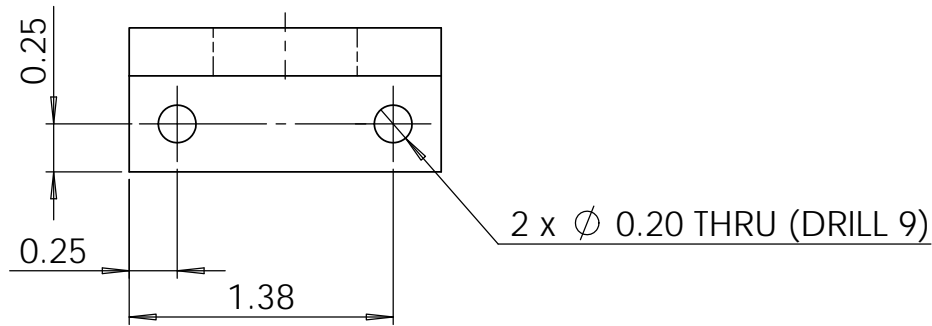


8X PART

**PROPRIETARY AND CONFIDENTIAL**  
 THE INFORMATION CONTAINED IN THIS DRAWING IS THE SOLE PROPERTY OF <INSERT COMPANY NAME HERE>. ANY REPRODUCTION IN PART OR AS A WHOLE WITHOUT THE WRITTEN PERMISSION OF <INSERT COMPANY NAME HERE> IS PROHIBITED.

		UNLESS OTHERWISE SPECIFIED:		NAME	DATE	<b>ME 450 TEAM 5</b>		
		DIMENSIONS ARE IN INCHES TOLERANCES: FRACTIONAL ± ANGULAR: MACH ± BEND ± TWO PLACE DECIMAL ± THREE PLACE DECIMAL ±	DRAWN			TITLE:  <b>SPOOL, SHAFT WASHER</b>		
			CHECKED					
			ENG APPR.					
			MFG APPR.					
		INTERPRET GEOMETRIC TOLERANCING PER:	Q.A.			SIZE DWG. NO. REV <b>A</b> SPOOL		
		MATERIAL <b>NYLON</b>	COMMENTS:					
		FINISH						
NEXT ASSY	USED ON					SCALE: 5:1	WEIGHT:	SHEET 8 OF 13
APPLICATION		DO NOT SCALE DRAWING						

Appendix J: Drawings



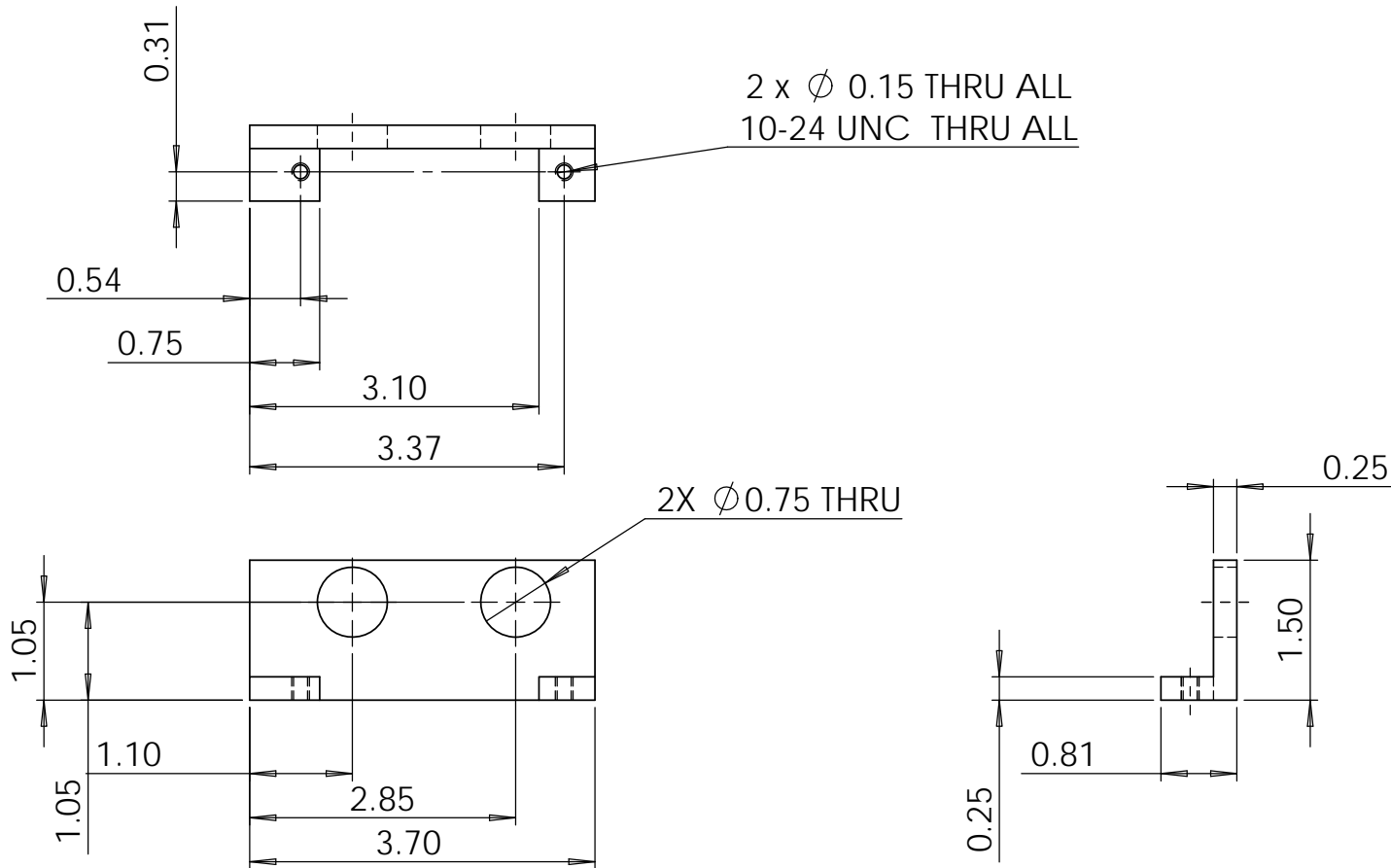
2X PART

**PROPRIETARY AND CONFIDENTIAL**  
THE INFORMATION CONTAINED IN THIS DRAWING IS THE SOLE PROPERTY OF <INSERT COMPANY NAME HERE>. ANY REPRODUCTION IN PART OR AS A WHOLE WITHOUT THE WRITTEN PERMISSION OF <INSERT COMPANY NAME HERE> IS PROHIBITED.

		UNLESS OTHERWISE SPECIFIED:		NAME	DATE
		DIMENSIONS ARE IN INCHES	DRAWN		
		TOLERANCES:	CHECKED		
		FRACTIONAL ±	ENG APPR.		
		ANGULAR: MACH ± BEND ±	MFG APPR.		
		TWO PLACE DECIMAL ±	Q.A.		
		THREE PLACE DECIMAL ±	COMMENTS:		
		INTERPRET GEOMETRIC TOLERANCING PER:			
		MATERIAL			
		6061 ALUMINUM			
NEXT ASSY	USED ON	FINISH			
APPLICATION		DO NOT SCALE DRAWING			

ME 450 TEAM 5		
TITLE:		
SPOOL MOUNT, TUBING SIDE		
SIZE <b>A</b>	DWG. NO. SPOOL_MOUNT_ TUBING	REV
SCALE: 1:1	WEIGHT:	SHEET 9 OF 13

Appendix J: Drawings



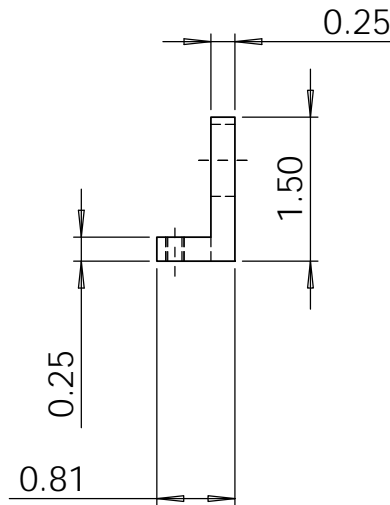
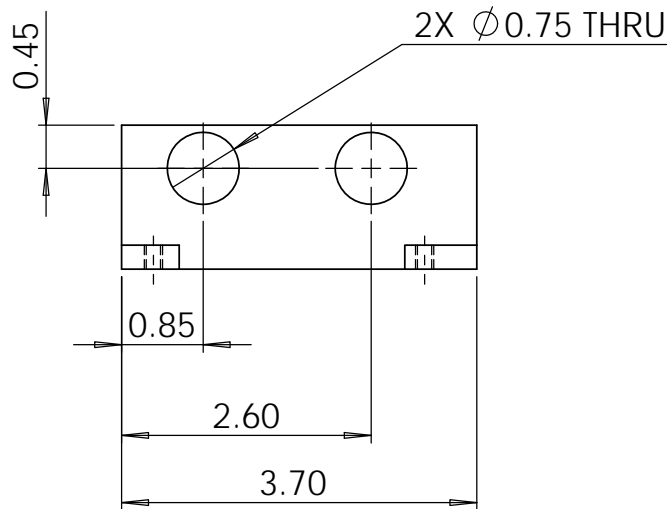
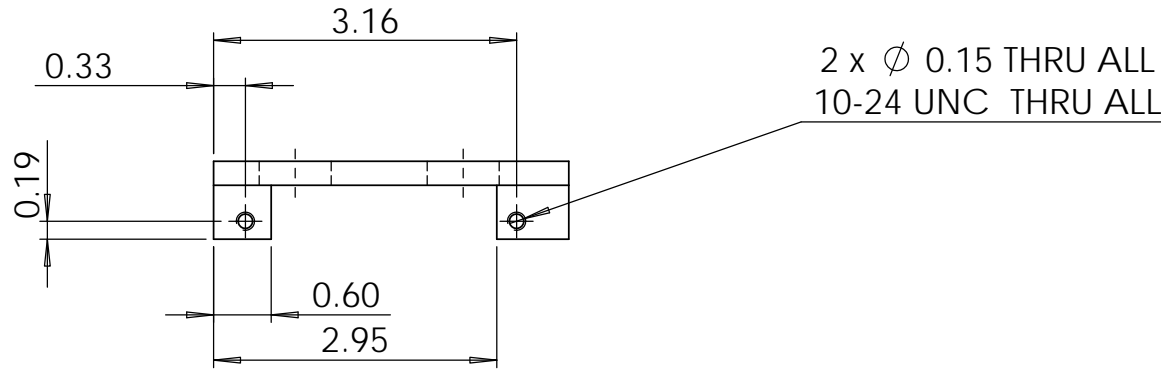
1X PART

**PROPRIETARY AND CONFIDENTIAL**  
 THE INFORMATION CONTAINED IN THIS DRAWING IS THE SOLE PROPERTY OF <INSERT COMPANY NAME HERE>. ANY REPRODUCTION IN PART OR AS A WHOLE WITHOUT THE WRITTEN PERMISSION OF <INSERT COMPANY NAME HERE> IS PROHIBITED.

		UNLESS OTHERWISE SPECIFIED:		NAME	DATE
		DIMENSIONS ARE IN INCHES	DRAWN		
		TOLERANCES:	CHECKED		
		FRACTIONAL ±	ENG APPR.		
		ANGULAR: MACH ± BEND ±	MFG APPR.		
		TWO PLACE DECIMAL ±	Q.A.		
		THREE PLACE DECIMAL ±	COMMENTS:		
		INTERPRET GEOMETRIC TOLERANCING PER:			
		MATERIAL			
		6061 ALUMINUM			
NEXT ASSY	USED ON	FINISH			
APPLICATION		DO NOT SCALE DRAWING			

ME 450 TEAM 5		
TITLE:		
SPOOL MOUNT, SPRING SIDE		
SIZE <b>A</b>	DWG. NO. SPOOL_MOUNT_ SPRING	REV
SCALE: 1:2	WEIGHT:	SHEET 10 OF 13

Appendix J: Drawings



1X PART

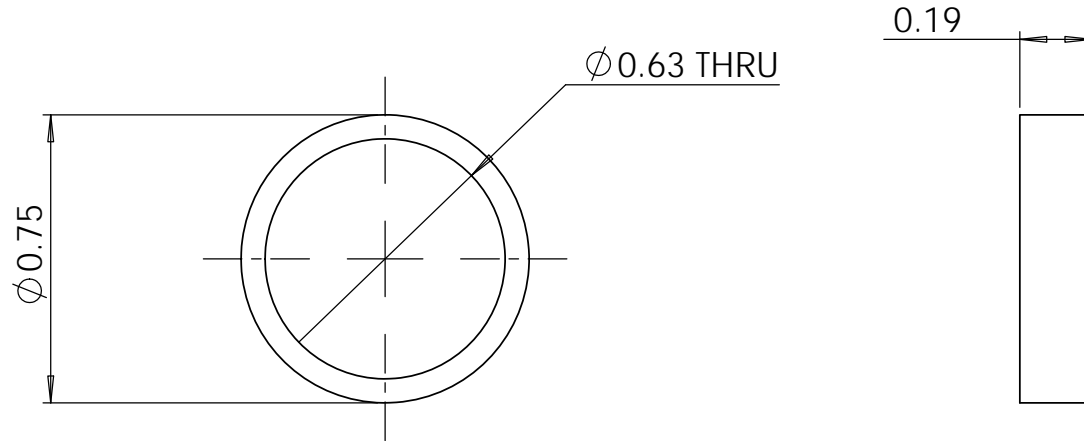
**PROPRIETARY AND CONFIDENTIAL**  
 THE INFORMATION CONTAINED IN THIS DRAWING IS THE SOLE PROPERTY OF <INSERT COMPANY NAME HERE>. ANY REPRODUCTION IN PART OR AS A WHOLE WITHOUT THE WRITTEN PERMISSION OF <INSERT COMPANY NAME HERE> IS PROHIBITED.

		UNLESS OTHERWISE SPECIFIED:		NAME	DATE
		DIMENSIONS ARE IN INCHES	DRAWN		
		TOLERANCES:	CHECKED		
		FRACTIONAL ±	ENG APPR.		
		ANGULAR: MACH ± BEND ±	MFG APPR.		
		TWO PLACE DECIMAL ±	Q.A.		
		THREE PLACE DECIMAL ±	COMMENTS:		
		INTERPRET GEOMETRIC TOLERANCING PER:			
		MATERIAL			
		6061 ALUMINUM			
NEXT ASSY	USED ON	FINISH			
APPLICATION		DO NOT SCALE DRAWING			

ME 450 TEAM 5		
TITLE:		
SPOOL MOUNT, SPRING SIDE B		
SIZE <b>A</b>	DWG. NO. SPOOL_MOUNT_ SPRING_B	REV <b>B</b>
SCALE: 1:2	WEIGHT:	SHEET 11 OF 13



Appendix J: Drawings

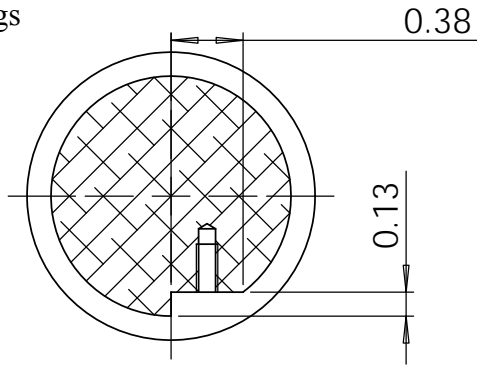


6X PART

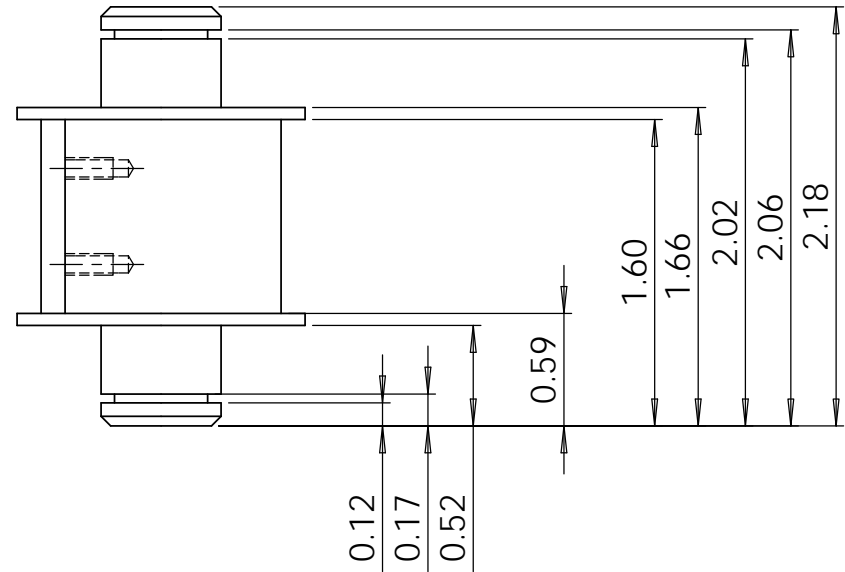
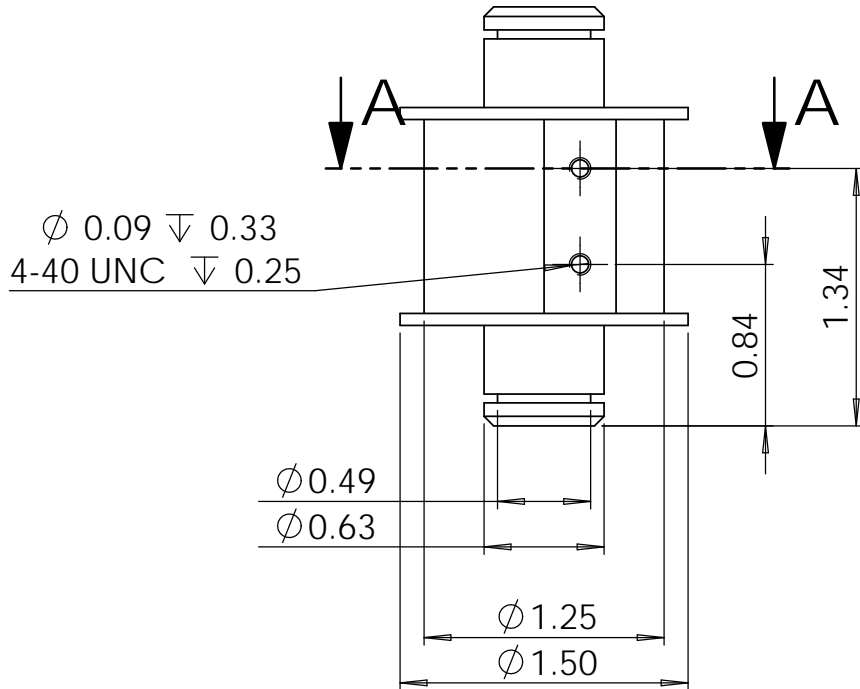
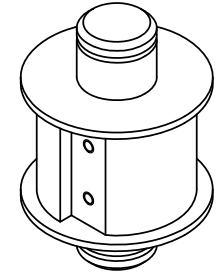
MODIFIED MCMMASTER-CARR 6391k243  
CUT TO LENGTH

**PROPRIETARY AND CONFIDENTIAL**  
THE INFORMATION CONTAINED IN THIS DRAWING IS THE SOLE PROPERTY OF <INSERT COMPANY NAME HERE>. ANY REPRODUCTION IN PART OR AS A WHOLE WITHOUT THE WRITTEN PERMISSION OF <INSERT COMPANY NAME HERE> IS PROHIBITED.

		UNLESS OTHERWISE SPECIFIED:		NAME	DATE	<b>ME 450 TEAM 5</b>		
		DIMENSIONS ARE IN INCHES TOLERANCES: FRACTIONAL $\pm$ ANGULAR: MACH $\pm$ BEND $\pm$ TWO PLACE DECIMAL $\pm$ THREE PLACE DECIMAL $\pm$	DRAWN			TITLE:  <b>BEARING, SPOOL MOUNT</b>		
			CHECKED					
			ENG APPR.					
			MFG APPR.					
		INTERPRET GEOMETRIC TOLERANCING PER:	Q.A.			SIZE <b>A</b> DWG. NO. SPOOL_MOUNT_BEARING REV		
		MATERIAL SAE 841 BRONZE	COMMENTS:					
		FINISH						
NEXT ASSY	USED ON					SCALE: 2:1	WEIGHT:	SHEET 12 OF 13
APPLICATION		DO NOT SCALE DRAWING						



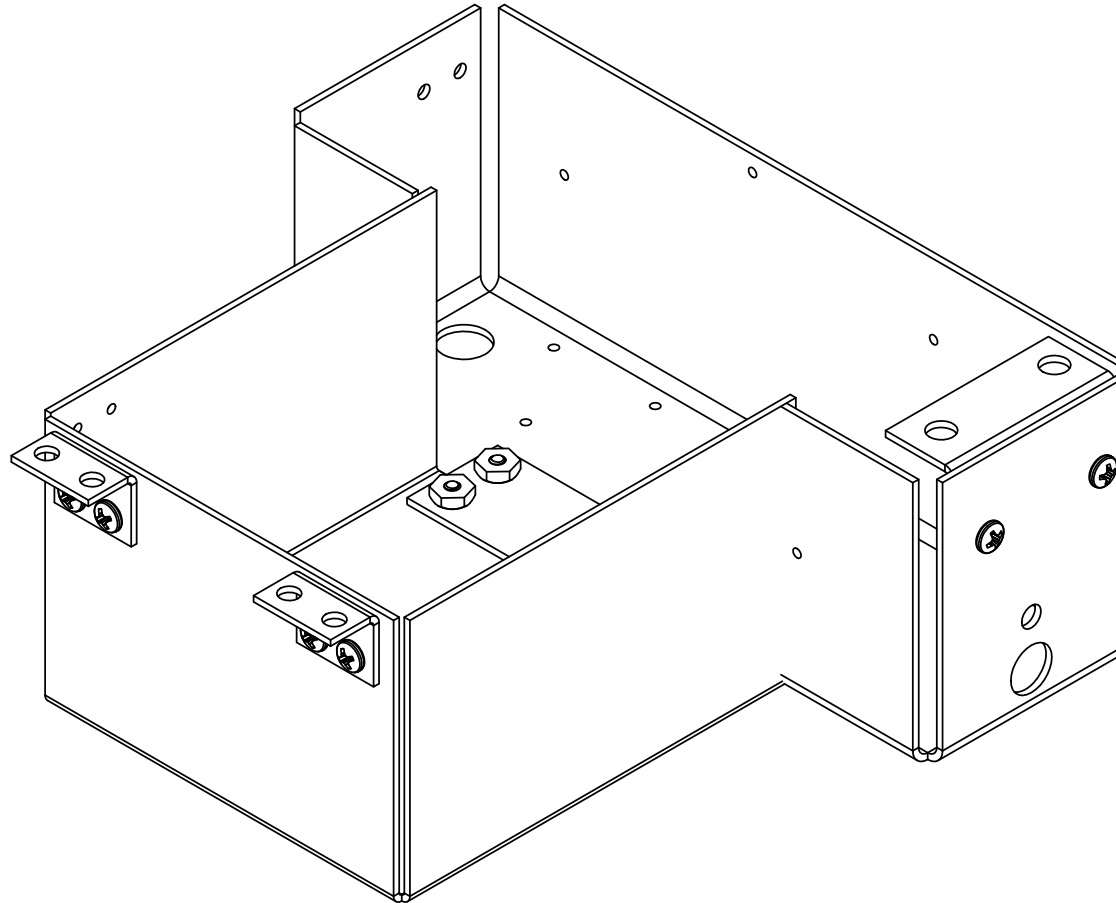
SECTION A-A



**PROPRIETARY AND CONFIDENTIAL**  
 THE INFORMATION CONTAINED IN THIS DRAWING IS THE SOLE PROPERTY OF <INSERT COMPANY NAME HERE>. ANY REPRODUCTION IN PART OR AS A WHOLE WITHOUT THE WRITTEN PERMISSION OF <INSERT COMPANY NAME HERE> IS PROHIBITED.

		UNLESS OTHERWISE SPECIFIED:		NAME	DATE
		DIMENSIONS ARE IN INCHES	DRAWN		
		TOLERANCES:	CHECKED		
		FRACTIONAL ±	ENG APPR.		
		ANGULAR: MACH ± BEND ±	MFG APPR.		
		TWO PLACE DECIMAL ±	Q.A.		
		THREE PLACE DECIMAL ±	COMMENTS:		
		INTERPRET GEOMETRIC TOLERANCING PER:			
		MATERIAL			
		6061 ALUMINUM			
		FINISH			
NEXT ASSY	USED ON				
APPLICATION		DO NOT SCALE DRAWING			

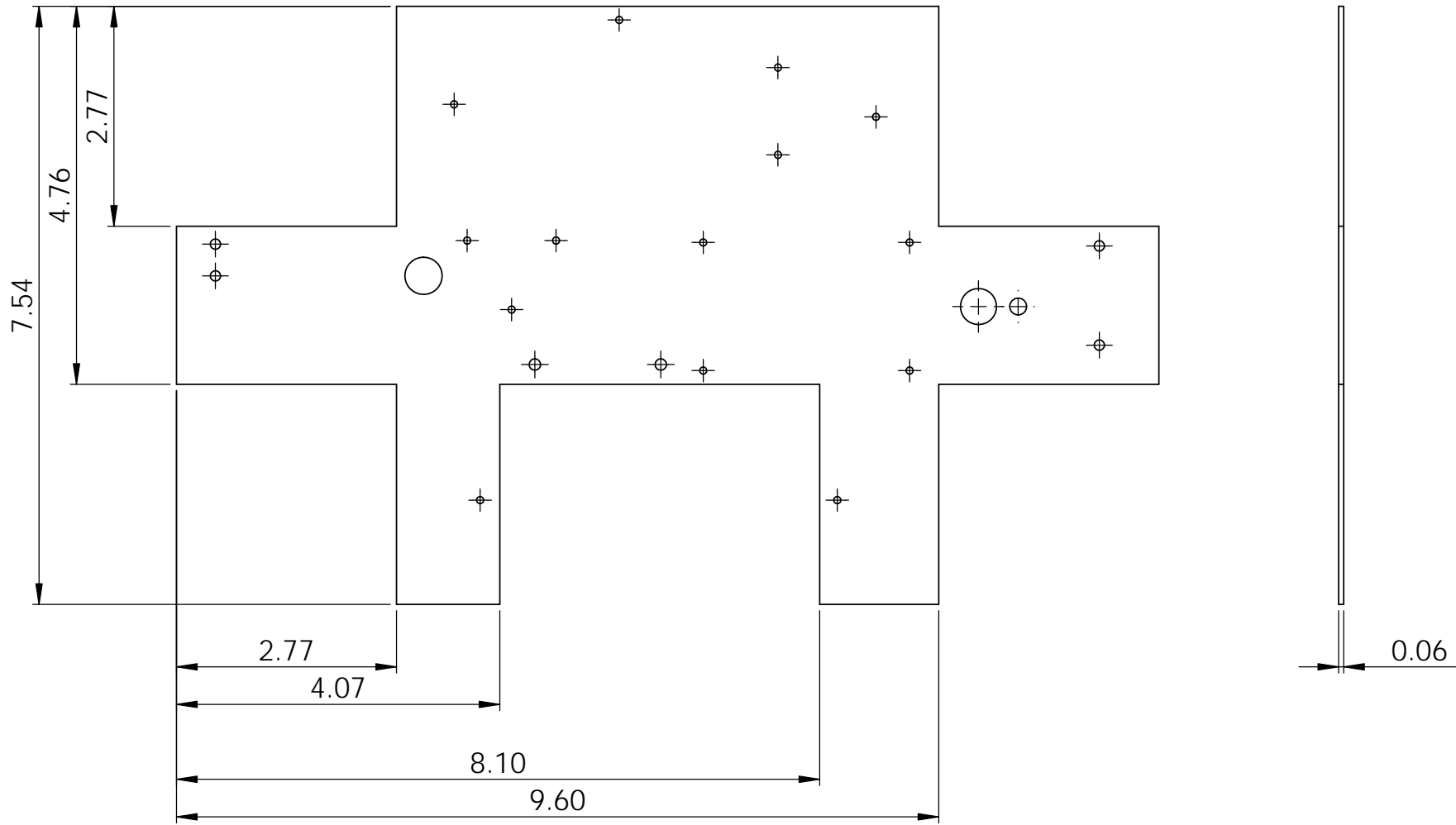
ME 450 TEAM 5		
TITLE:		
SHAFT, SPRING		
SIZE	DWG. NO.	REV
<b>A</b>	SPOOL	
SCALE: 1:1	WEIGHT:	SHEET 13 OF 13



<b>ME 450 TEAM 5</b>		
TITLE:		
<b>BOTTOM COVER ASSEMBLY</b>		
SIZE	DWG. NO.	REV
<b>A</b>	BOTTOM_SPOOL_COVER ASSEMBLY	
SCALE: 1:10	WEIGHT:	SHEET 1 OF 14



Appendix J: Drawings

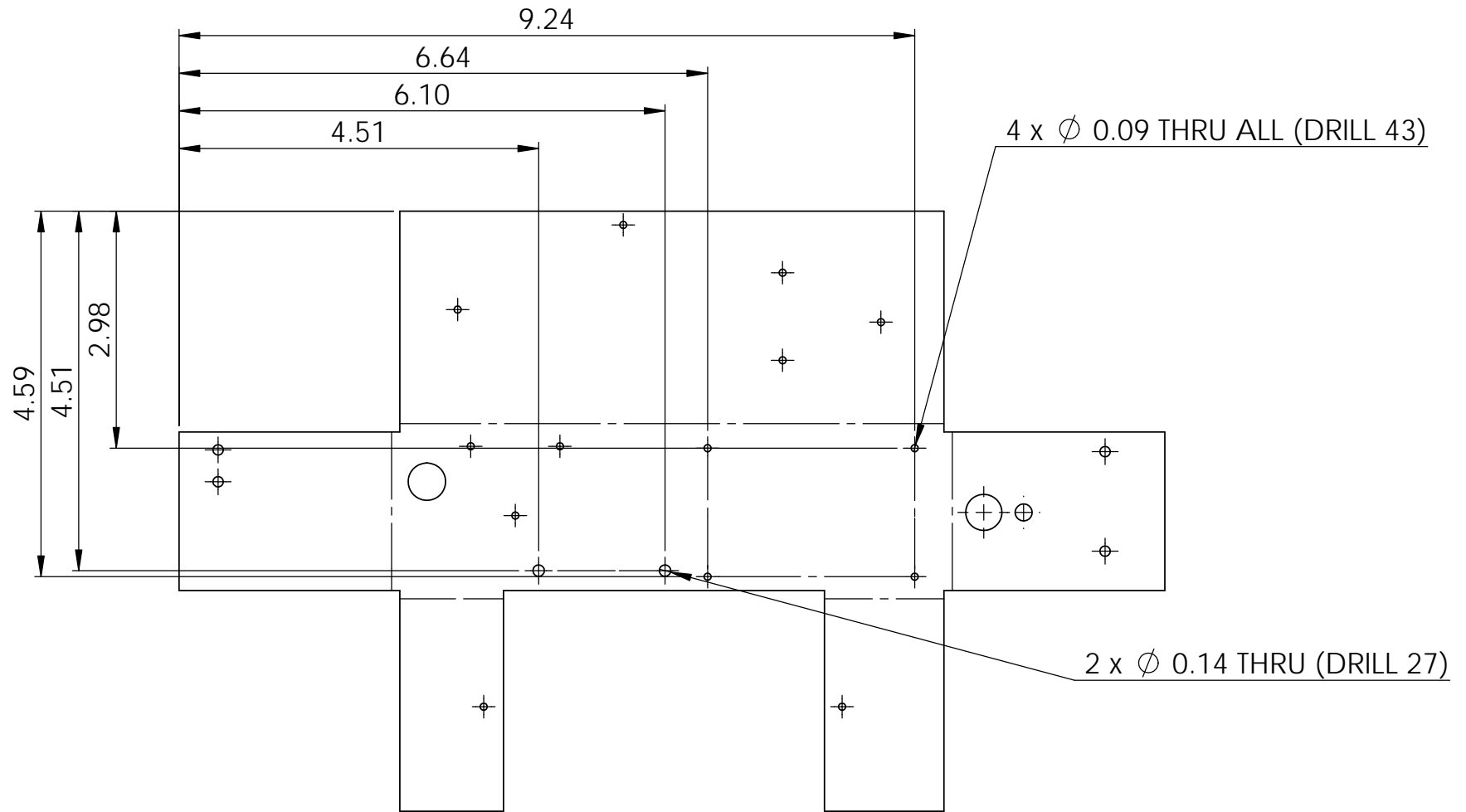


**PROPRIETARY AND CONFIDENTIAL**  
 THE INFORMATION CONTAINED IN THIS DRAWING IS THE SOLE PROPERTY OF <INSERT COMPANY NAME HERE>. ANY REPRODUCTION IN PART OR AS A WHOLE WITHOUT THE WRITTEN PERMISSION OF <INSERT COMPANY NAME HERE> IS PROHIBITED.

		UNLESS OTHERWISE SPECIFIED:		NAME	DATE
		DIMENSIONS ARE IN INCHES	DRAWN		
		TOLERANCES:	CHECKED		
		FRACTIONAL ±	ENG APPR.		
		ANGULAR: MACH ± BEND ±	MFG APPR.		
		TWO PLACE DECIMAL ±	Q.A.		
		THREE PLACE DECIMAL ±	COMMENTS:		
		INTERPRET GEOMETRIC TOLERANCING PER:			
		MATERIAL			
		6061 ALUMINUM			
		FINISH			
NEXT ASSY	USED ON				
APPLICATION		DO NOT SCALE DRAWING			

ME 450 TEAM 5		
TITLE:		
BOTTOM COVER, CIRCUIT		
SIZE	DWG. NO.	REV
<b>A</b>	BOTTOM_SPOOL_COVER SM_CIRCUIT	
SCALE: 1:2	WEIGHT:	SHEET 3 OF 14

Appendix J: Drawings

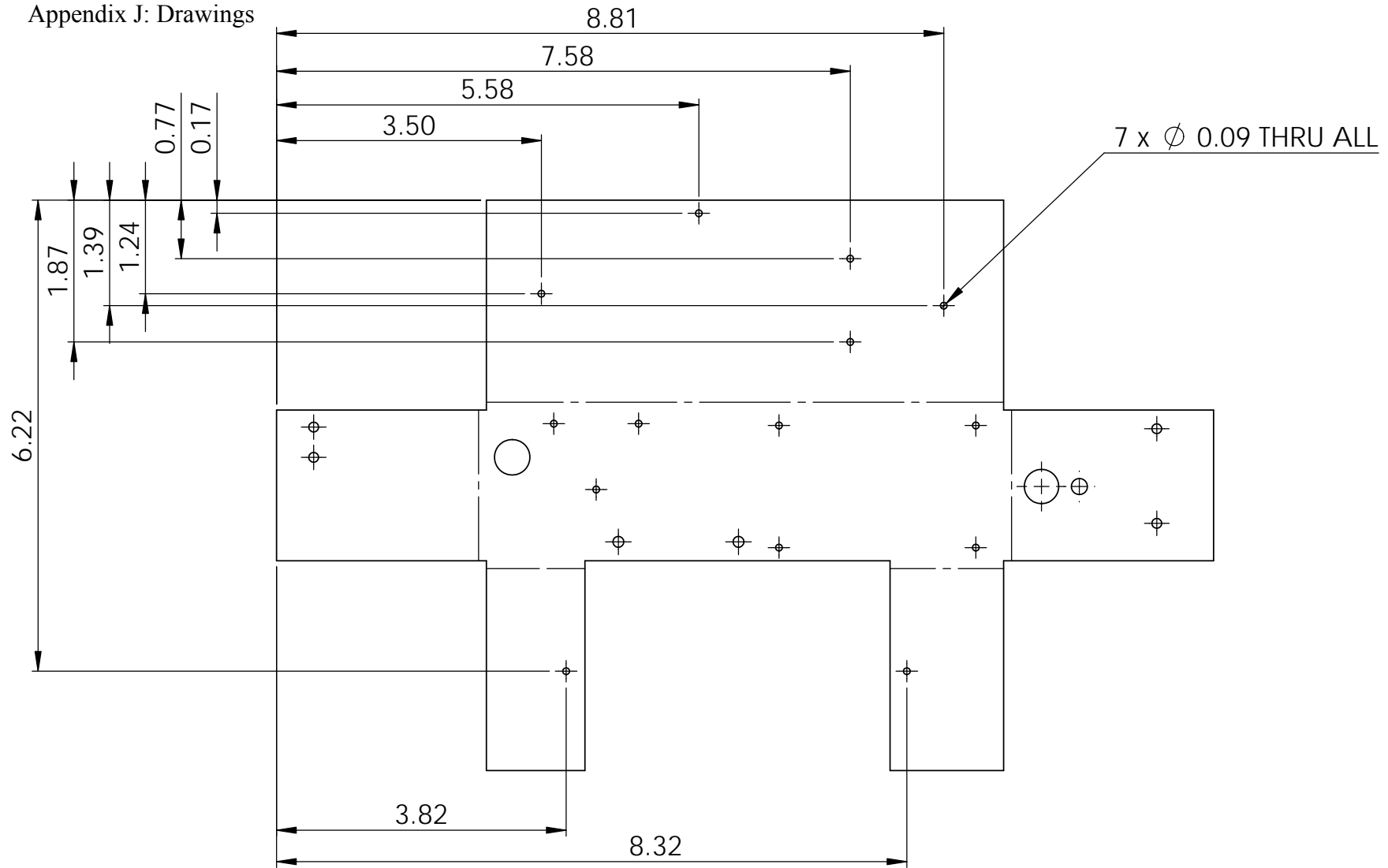


**PROPRIETARY AND CONFIDENTIAL**  
THE INFORMATION CONTAINED IN THIS DRAWING IS THE SOLE PROPERTY OF <INSERT COMPANY NAME HERE>. ANY REPRODUCTION IN PART OR AS A WHOLE WITHOUT THE WRITTEN PERMISSION OF <INSERT COMPANY NAME HERE> IS PROHIBITED.

		UNLESS OTHERWISE SPECIFIED:		NAME	DATE
		DIMENSIONS ARE IN INCHES	DRAWN		
		TOLERANCES:	CHECKED		
		FRACTIONAL ±	ENG APPR.		
		ANGULAR: MACH ± BEND ±	MFG APPR.		
		TWO PLACE DECIMAL ±	Q.A.		
		THREE PLACE DECIMAL ±	COMMENTS:		
		INTERPRET GEOMETRIC TOLERANCING PER:			
		MATERIAL			
		6061 ALUMINUM			
		FINISH			
NEXT ASSY	USED ON				
APPLICATION		DO NOT SCALE DRAWING			

ME 450 TEAM 5		
TITLE:		
BOTTOM COVER, CIRCUIT		
SIZE	DWG. NO.	REV
<b>A</b>	BOTTOM_SPOOL_COVER SM_CIRCUIT	
SCALE: 1:2	WEIGHT:	SHEET 4 OF 14

Appendix J: Drawings



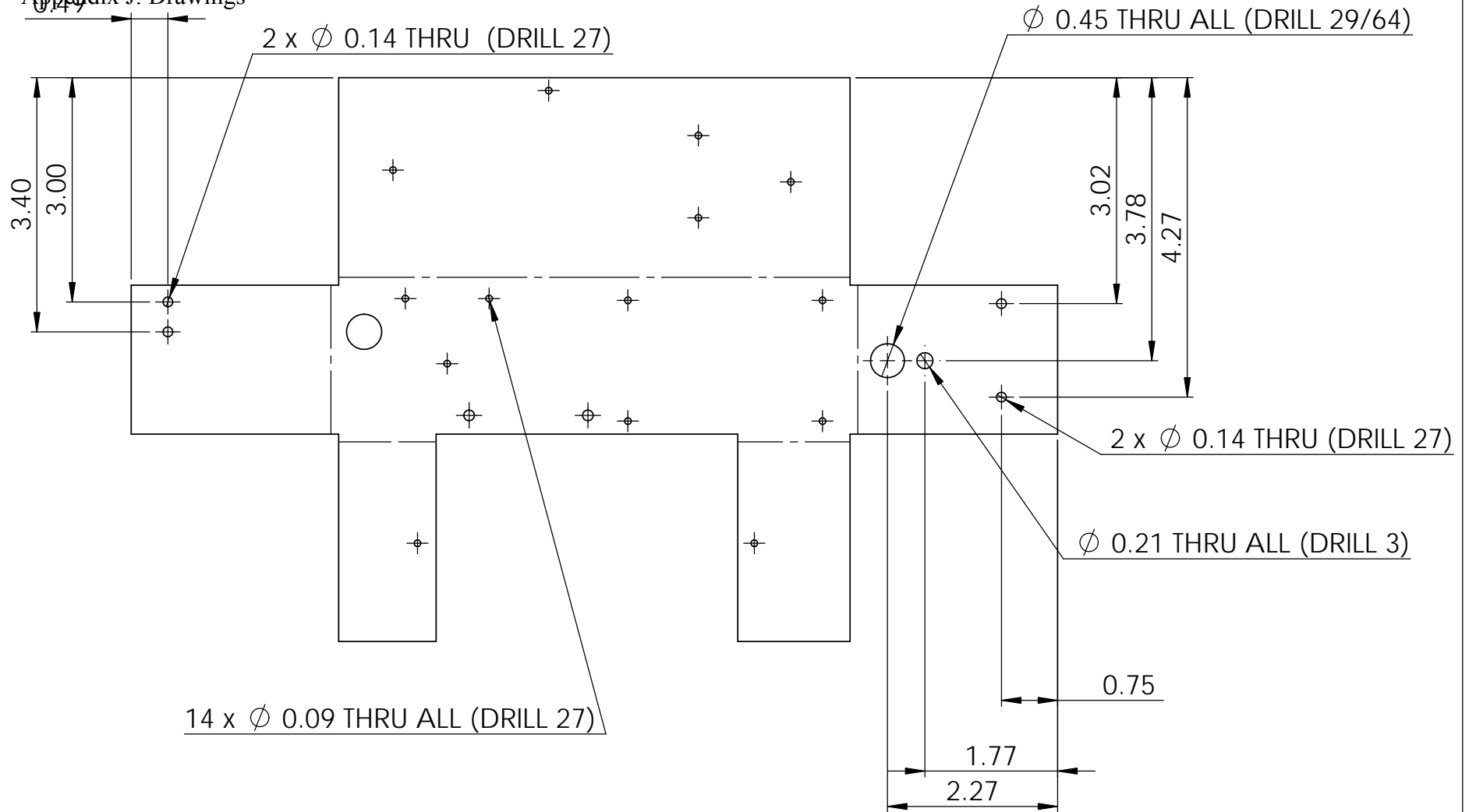
7 x  $\phi$  0.09 THRU ALL

**PROPRIETARY AND CONFIDENTIAL**  
 THE INFORMATION CONTAINED IN THIS DRAWING IS THE SOLE PROPERTY OF <INSERT COMPANY NAME HERE>. ANY REPRODUCTION IN PART OR AS A WHOLE WITHOUT THE WRITTEN PERMISSION OF <INSERT COMPANY NAME HERE> IS PROHIBITED.

		UNLESS OTHERWISE SPECIFIED:		NAME	DATE
		DIMENSIONS ARE IN INCHES	DRAWN		
		TOLERANCES:	CHECKED		
		FRACTIONAL $\pm$	ENG APPR.		
		ANGULAR: MACH $\pm$ BEND $\pm$	MFG APPR.		
		TWO PLACE DECIMAL $\pm$	Q.A.		
		THREE PLACE DECIMAL $\pm$	COMMENTS:		
		INTERPRET GEOMETRIC TOLERANCING PER:			
		MATERIAL			
		6061 ALUMINUM			
		FINISH			
NEXT ASSY	USED ON				
APPLICATION		DO NOT SCALE DRAWING			

ME 450 TEAM 5		
TITLE:		
BOTTOM COVER, CIRCUIT		
SIZE	DWG. NO.	REV
<b>A</b>	BOTTOM_SPOOL_COVER SM_CIRCUIT	
SCALE: 1:2	WEIGHT:	SHEET 5 OF 14

Appendix J: Drawings



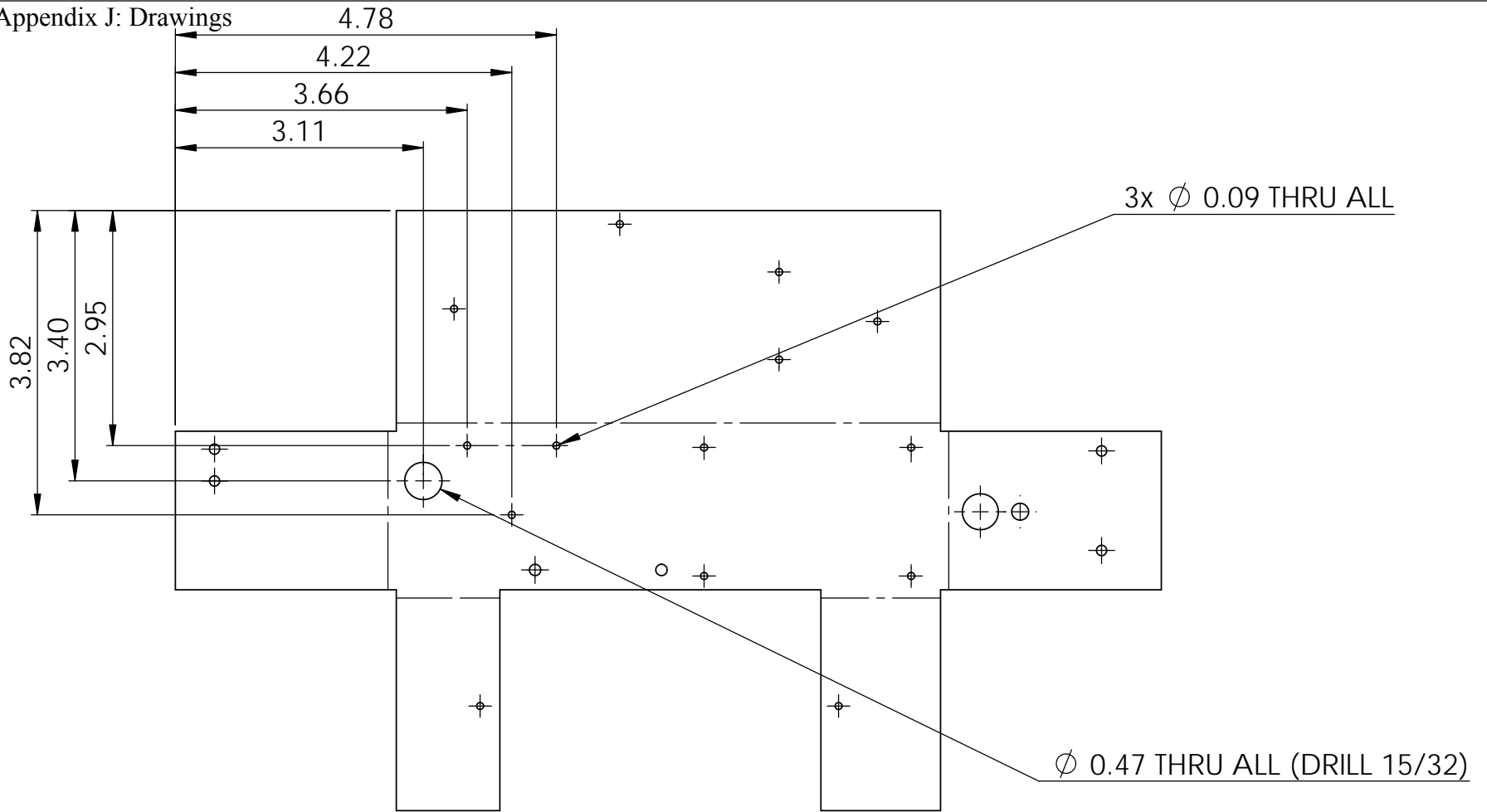
**PROPRIETARY AND CONFIDENTIAL**  
 THE INFORMATION CONTAINED IN THIS DRAWING IS THE SOLE PROPERTY OF <INSERT COMPANY NAME HERE>. ANY REPRODUCTION IN PART OR AS A WHOLE WITHOUT THE WRITTEN PERMISSION OF <INSERT COMPANY NAME HERE> IS PROHIBITED.

		UNLESS OTHERWISE SPECIFIED:		NAME	DATE
		DIMENSIONS ARE IN INCHES	DRAWN		
		TOLERANCES:	CHECKED		
		FRACTIONAL ±	ENG APPR.		
		ANGULAR: MACH ± BEND ±	MFG APPR.		
		TWO PLACE DECIMAL ±	Q.A.		
		THREE PLACE DECIMAL ±	COMMENTS:		
		INTERPRET GEOMETRIC TOLERANCING PER:			
		MATERIAL			
		6061 ALUMINUM			
		FINISH			
NEXT ASSY	USED ON				
APPLICATION		DO NOT SCALE DRAWING			

<b>ME 450 TEAM 5</b>		
TITLE:		
<b>BOTTOM COVER, CIRCUIT</b>		
SIZE <b>A</b>	DWG. NO. BOTTOM_SPOOL_COVER SM_CIRCUIT	REV
SCALE: 1:2	WEIGHT:	SHEET 6 OF 14



Appendix J: Drawings

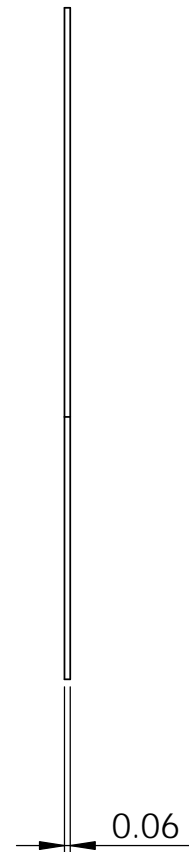
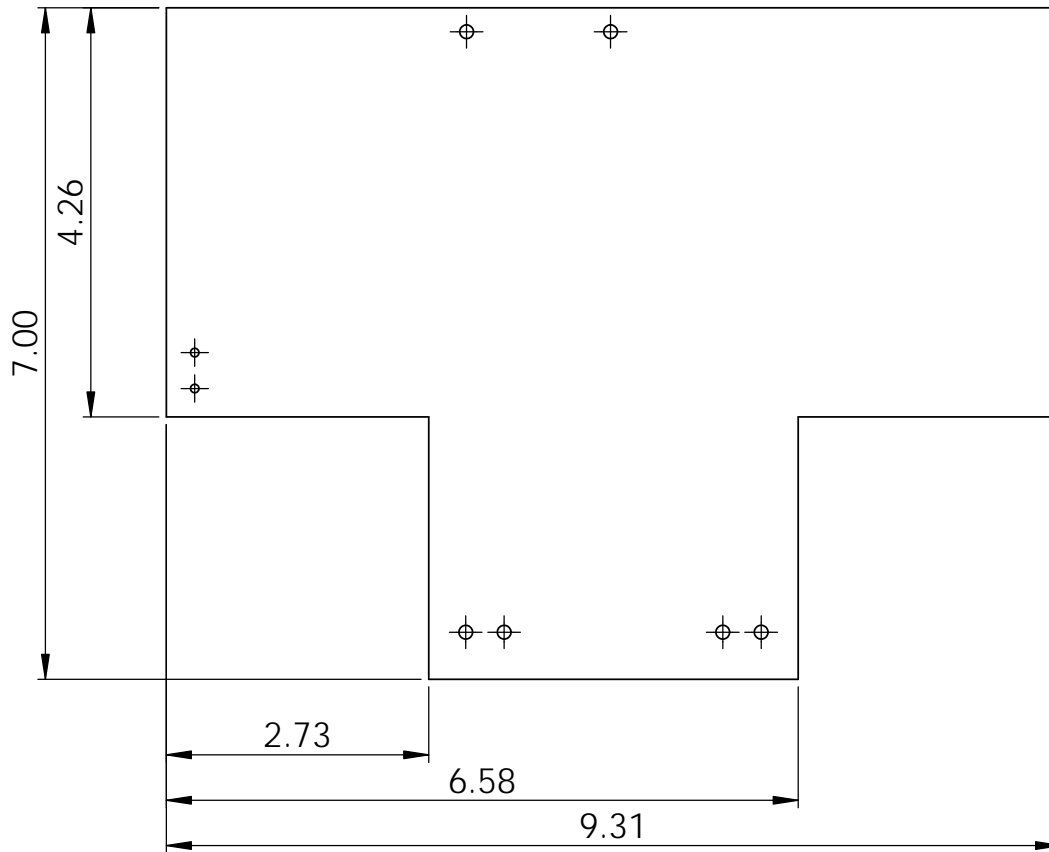


**PROPRIETARY AND CONFIDENTIAL**  
 THE INFORMATION CONTAINED IN THIS DRAWING IS THE SOLE PROPERTY OF <INSERT COMPANY NAME HERE>. ANY REPRODUCTION IN PART OR AS A WHOLE WITHOUT THE WRITTEN PERMISSION OF <INSERT COMPANY NAME HERE> IS PROHIBITED.

		UNLESS OTHERWISE SPECIFIED:		NAME	DATE
		DIMENSIONS ARE IN INCHES	DRAWN		
		TOLERANCES:	CHECKED		
		FRACTIONAL $\pm$	ENG APPR.		
		ANGULAR: MACH $\pm$ BEND $\pm$	MFG APPR.		
		TWO PLACE DECIMAL $\pm$	Q.A.		
		THREE PLACE DECIMAL $\pm$	COMMENTS:		
		INTERPRET GEOMETRIC TOLERANCING PER:			
		MATERIAL			
		6061 ALUMINUM			
		FINISH			
NEXT ASSY	USED ON				
APPLICATION		DO NOT SCALE DRAWING			

ME 450 TEAM 5		
TITLE:		
BOTTOM COVER, CIRCUIT SIDE		
SIZE	DWG. NO.	REV
<b>A</b>	BOTTOM_SPOOL_COVER SM_CIRCUIT	
SCALE: 1:2	WEIGHT:	SHEET 7 OF 14

Appendix J: Drawings

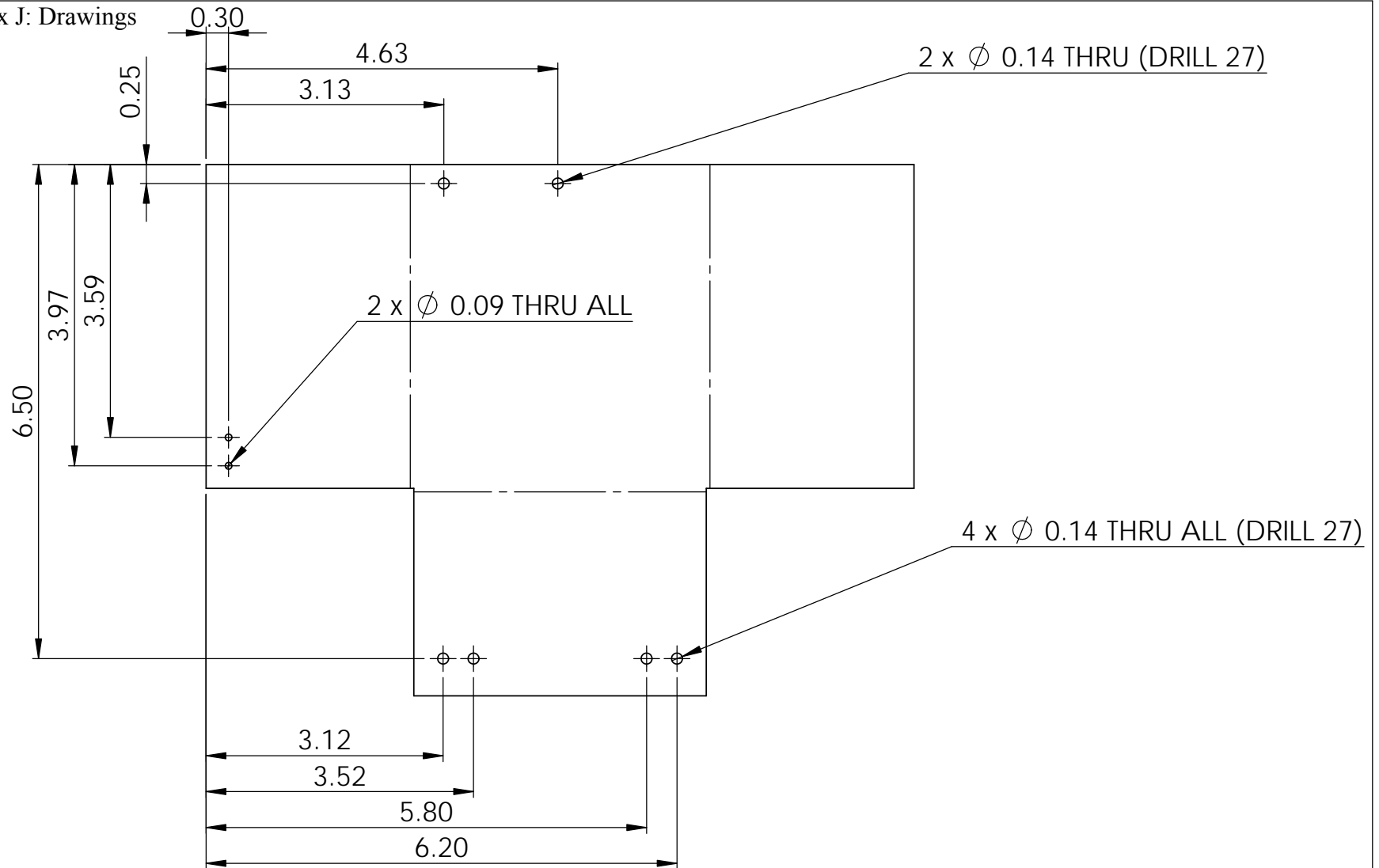


**PROPRIETARY AND CONFIDENTIAL**  
 THE INFORMATION CONTAINED IN THIS DRAWING IS THE SOLE PROPERTY OF <INSERT COMPANY NAME HERE>. ANY REPRODUCTION IN PART OR AS A WHOLE WITHOUT THE WRITTEN PERMISSION OF <INSERT COMPANY NAME HERE> IS PROHIBITED.

		UNLESS OTHERWISE SPECIFIED:		NAME	DATE
		DIMENSIONS ARE IN INCHES TOLERANCES: FRACTIONAL ± ANGULAR: MACH ± BEND ± TWO PLACE DECIMAL ± THREE PLACE DECIMAL ±	DRAWN		
		INTERPRET GEOMETRIC TOLERANCING PER:	CHECKED		
		MATERIAL 6061 ALUMINUM	ENG APPR.		
		FINISH	MFG APPR.		
NEXT ASSY	USED ON		Q.A.		
APPLICATION		DO NOT SCALE DRAWING	COMMENTS:		

ME 450 TEAM 5		
TITLE:		
BOTTOM COVER, SPOOL SIDE		
SIZE <b>A</b>	DWG. NO. BOTTOM_SPOOL_COVER SP_SPOOL	REV
SCALE: 1:2	WEIGHT:	SHEET 8 OF 14

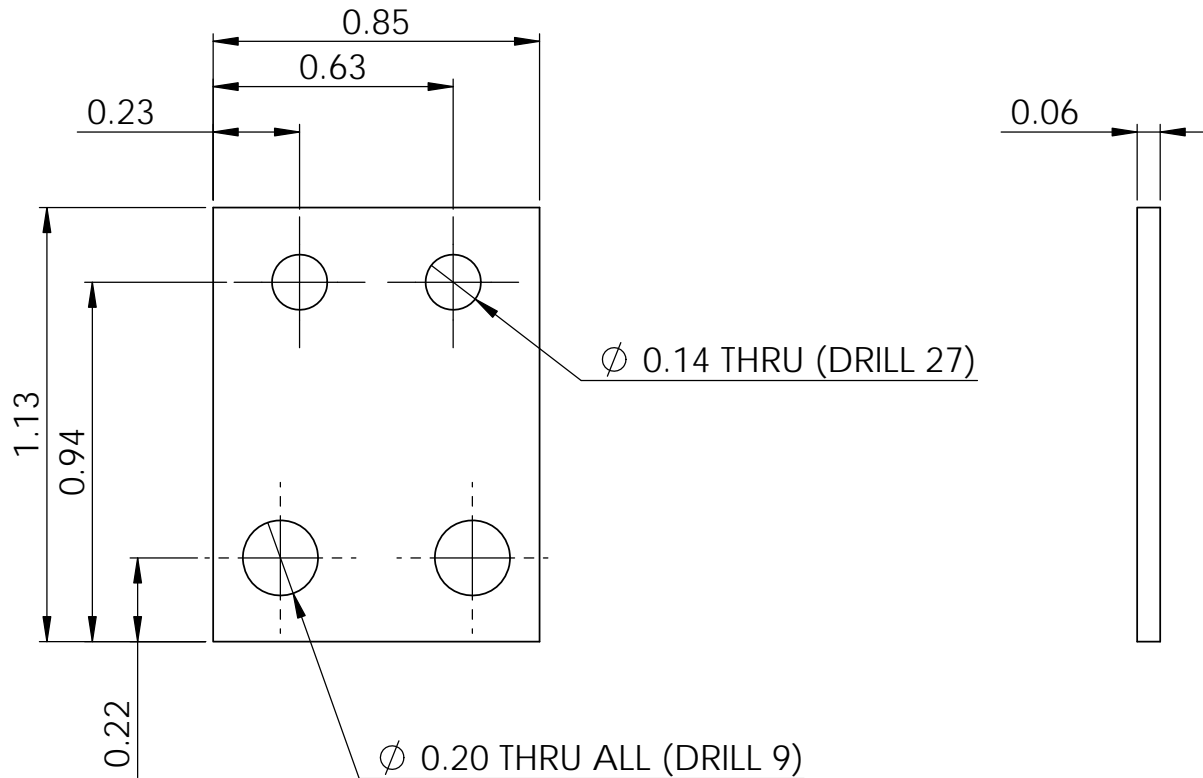
Appendix J: Drawings



**PROPRIETARY AND CONFIDENTIAL**  
 THE INFORMATION CONTAINED IN THIS DRAWING IS THE SOLE PROPERTY OF <INSERT COMPANY NAME HERE>. ANY REPRODUCTION IN PART OR AS A WHOLE WITHOUT THE WRITTEN PERMISSION OF <INSERT COMPANY NAME HERE> IS PROHIBITED.

		UNLESS OTHERWISE SPECIFIED:		NAME	DATE	<b>ME 450 TEAM 5</b>	
		DIMENSIONS ARE IN INCHES	DRAWN			TITLE:	
		TOLERANCES:	CHECKED			<b>BOTTOM COVER, SPOOL SIDE</b>	
		FRACTIONAL $\pm$	ENG APPR.			SIZE	DWG. NO.
		ANGULAR: MACH $\pm$ BEND $\pm$	MFG APPR.			<b>A</b>	<b>BOTTOM_SPOOL_COVER</b>
		TWO PLACE DECIMAL $\pm$	Q.A.				REV
		THREE PLACE DECIMAL $\pm$	COMMENTS:				<b>SM_SPOOL</b>
NEXT ASSY	USED ON	INTERPRET GEOMETRIC TOLERANCING PER:				SCALE: 1:2	WEIGHT:
		MATERIAL					SHEET 9 OF 14
		<b>6061 ALUMINUM</b>					
		FINISH					
APPLICATION		DO NOT SCALE DRAWING					

Appendix J: Drawings

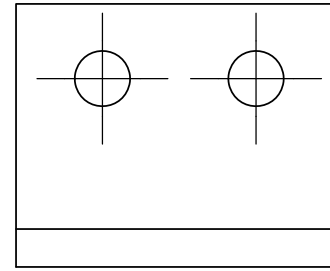
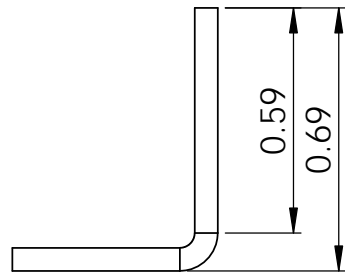


3X PART

**PROPRIETARY AND CONFIDENTIAL**  
 THE INFORMATION CONTAINED IN THIS DRAWING IS THE SOLE PROPERTY OF <INSERT COMPANY NAME HERE>. ANY REPRODUCTION IN PART OR AS A WHOLE WITHOUT THE WRITTEN PERMISSION OF <INSERT COMPANY NAME HERE> IS PROHIBITED.

		UNLESS OTHERWISE SPECIFIED:		NAME	DATE	<b>ME 450 TEAM 5</b>	
		DIMENSIONS ARE IN INCHES TOLERANCES: FRACTIONAL ± ANGULAR: MACH ± BEND ± TWO PLACE DECIMAL ± THREE PLACE DECIMAL ±	DRAWN			TITLE:	
			CHECKED			<b>BOTTOM COVER, EXTERIOR TAB</b>	
			ENG APPR.				
			MFG APPR.				
		INTERPRET GEOMETRIC TOLERANCING PER:	Q.A.			REV	
		MATERIAL	COMMENTS:			SIZE	DWG. NO.
		6061 ALUMINUM				SCALE: 2:1	WEIGHT:
NEXT ASSY	USED ON	FINISH					
APPLICATION		DO NOT SCALE DRAWING					

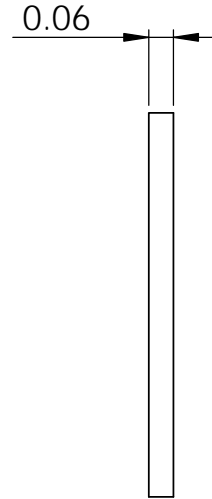
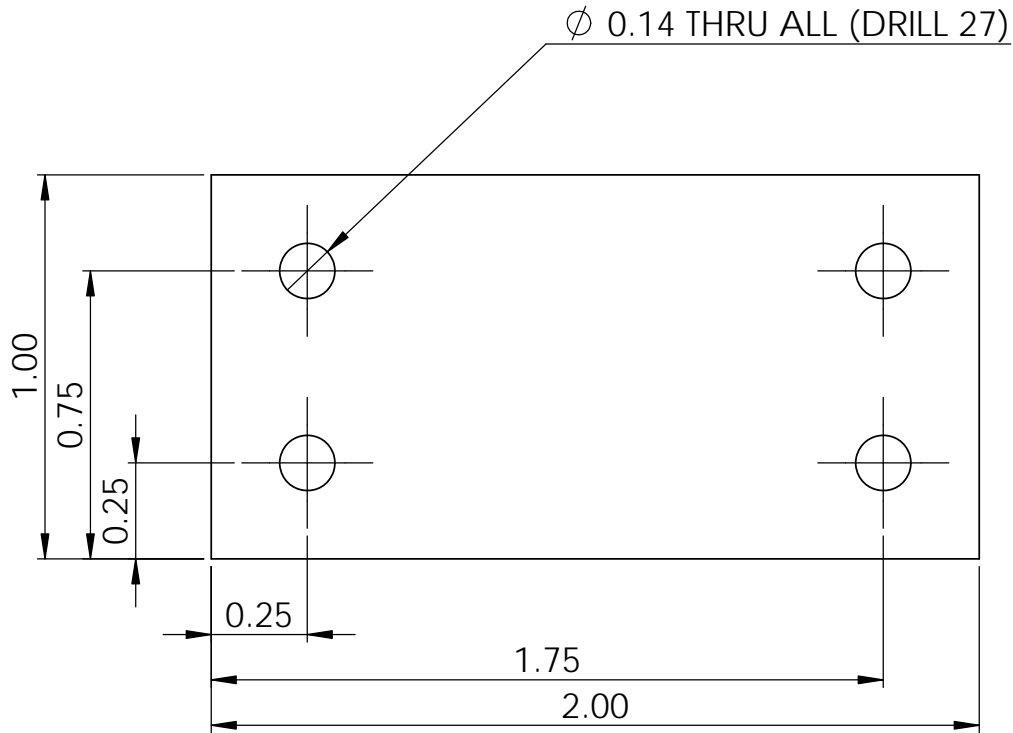
Appendix J: Drawings



**PROPRIETARY AND CONFIDENTIAL**  
 THE INFORMATION CONTAINED IN THIS DRAWING IS THE SOLE PROPERTY OF <INSERT COMPANY NAME HERE>. ANY REPRODUCTION IN PART OR AS A WHOLE WITHOUT THE WRITTEN PERMISSION OF <INSERT COMPANY NAME HERE> IS PROHIBITED.

		UNLESS OTHERWISE SPECIFIED:		NAME	DATE	<b>ME 450 TEAM 5</b>		
		DIMENSIONS ARE IN INCHES TOLERANCES: FRACTIONAL ± ANGULAR: MACH ± BEND ± TWO PLACE DECIMAL ± THREE PLACE DECIMAL ±	DRAWN			TITLE:		
			CHECKED			<b>BOTTOM COVER, EXTERIOR TAB</b>		
			ENG APPR.					
			MFG APPR.					
		INTERPRET GEOMETRIC TOLERANCING PER:	Q.A.			SIZE	DWG. NO.	REV
		MATERIAL	COMMENTS:			<b>A</b>	BOTTOM_SPOOL_COVER SM_BATTERY_TAB	
		6061 ALUMINUM						
		FINISH				SCALE: 2:1	WEIGHT:	SHEET 11 OF 14
NEXT ASSY	USED ON							
APPLICATION		DO NOT SCALE DRAWING						

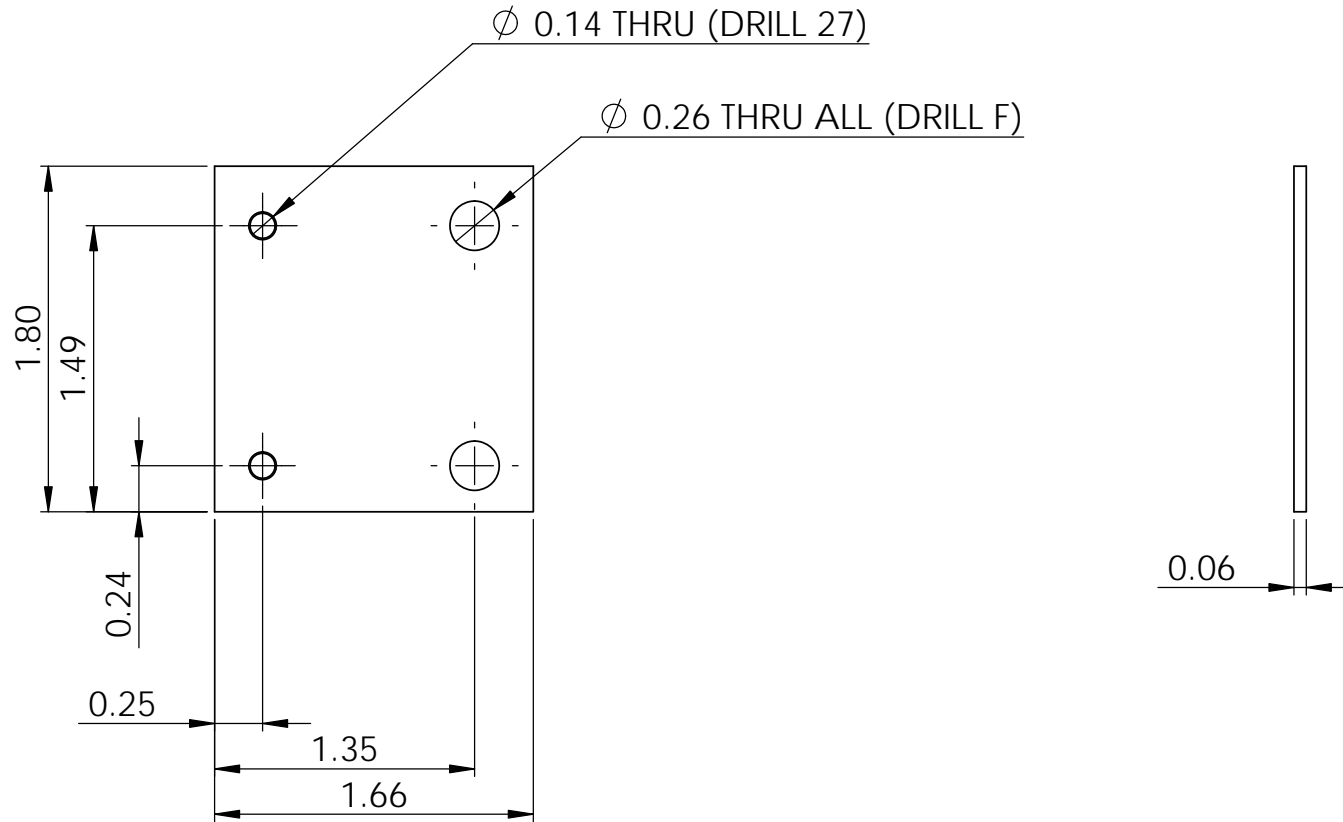
Appendix J: Drawings



**PROPRIETARY AND CONFIDENTIAL**  
 THE INFORMATION CONTAINED IN THIS DRAWING IS THE SOLE PROPERTY OF <INSERT COMPANY NAME HERE>. ANY REPRODUCTION IN PART OR AS A WHOLE WITHOUT THE WRITTEN PERMISSION OF <INSERT COMPANY NAME HERE> IS PROHIBITED.

		UNLESS OTHERWISE SPECIFIED:		NAME	DATE	<b>ME 450 TEAM 5</b>	
		DIMENSIONS ARE IN INCHES TOLERANCES: FRACTIONAL $\pm$ ANGULAR: MACH $\pm$ BEND $\pm$ TWO PLACE DECIMAL $\pm$ THREE PLACE DECIMAL $\pm$		DRAWN		TITLE:	
				CHECKED		<b>BOTTOM COVER, CONNECTOR</b>	
				ENG APPR.			
				MFG APPR.			
		INTERPRET GEOMETRIC TOLERANCING PER:		Q.A.		REV	
		MATERIAL	COMMENTS:			SIZE	DWG. NO.
		<b>6061 ALUMINUM</b>				SCALE: 2:1	WEIGHT:
NEXT ASSY	USED ON	FINISH					
APPLICATION		DO NOT SCALE DRAWING					

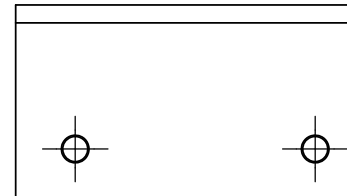
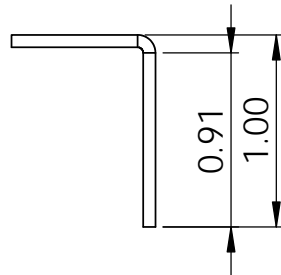
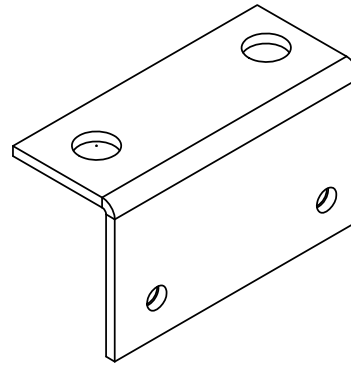
Appendix J: Drawings



**PROPRIETARY AND CONFIDENTIAL**  
 THE INFORMATION CONTAINED IN THIS DRAWING IS THE SOLE PROPERTY OF <INSERT COMPANY NAME HERE>. ANY REPRODUCTION IN PART OR AS A WHOLE WITHOUT THE WRITTEN PERMISSION OF <INSERT COMPANY NAME HERE> IS PROHIBITED.

		UNLESS OTHERWISE SPECIFIED:		NAME	DATE	<b>ME 450 TEAM 5</b>	
		DIMENSIONS ARE IN INCHES TOLERANCES: FRACTIONAL ± ANGULAR: MACH ± BEND ± TWO PLACE DECIMAL ± THREE PLACE DECIMAL ±		DRAWN		TITLE:	
				CHECKED		<b>BOTTOM COVER, INTERIOR TAB</b>	
				ENG APPR.			
				MFG APPR.			
		INTERPRET GEOMETRIC TOLERANCING PER:		Q.A.		REV	
		MATERIAL	COMMENTS:			SIZE	DWG. NO.
		<b>6061 ALUMINUM</b>				SCALE: 1:1	WEIGHT:
NEXT ASSY	USED ON	FINISH					
APPLICATION		DO NOT SCALE DRAWING					

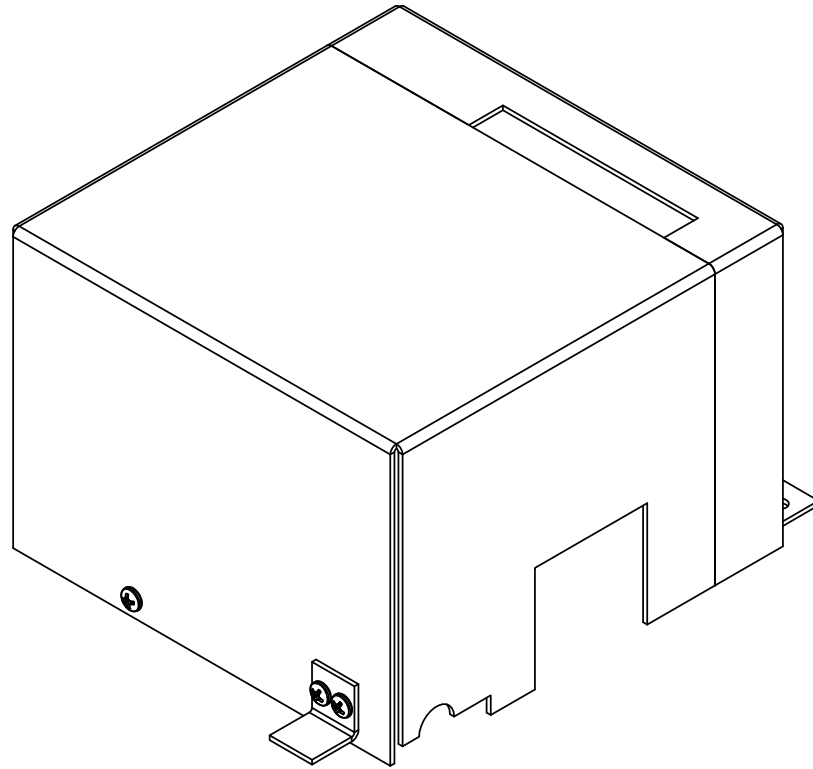
Appendix J: Drawings



**PROPRIETARY AND CONFIDENTIAL**  
 THE INFORMATION CONTAINED IN THIS DRAWING IS THE SOLE PROPERTY OF <INSERT COMPANY NAME HERE>. ANY REPRODUCTION IN PART OR AS A WHOLE WITHOUT THE WRITTEN PERMISSION OF <INSERT COMPANY NAME HERE> IS PROHIBITED.

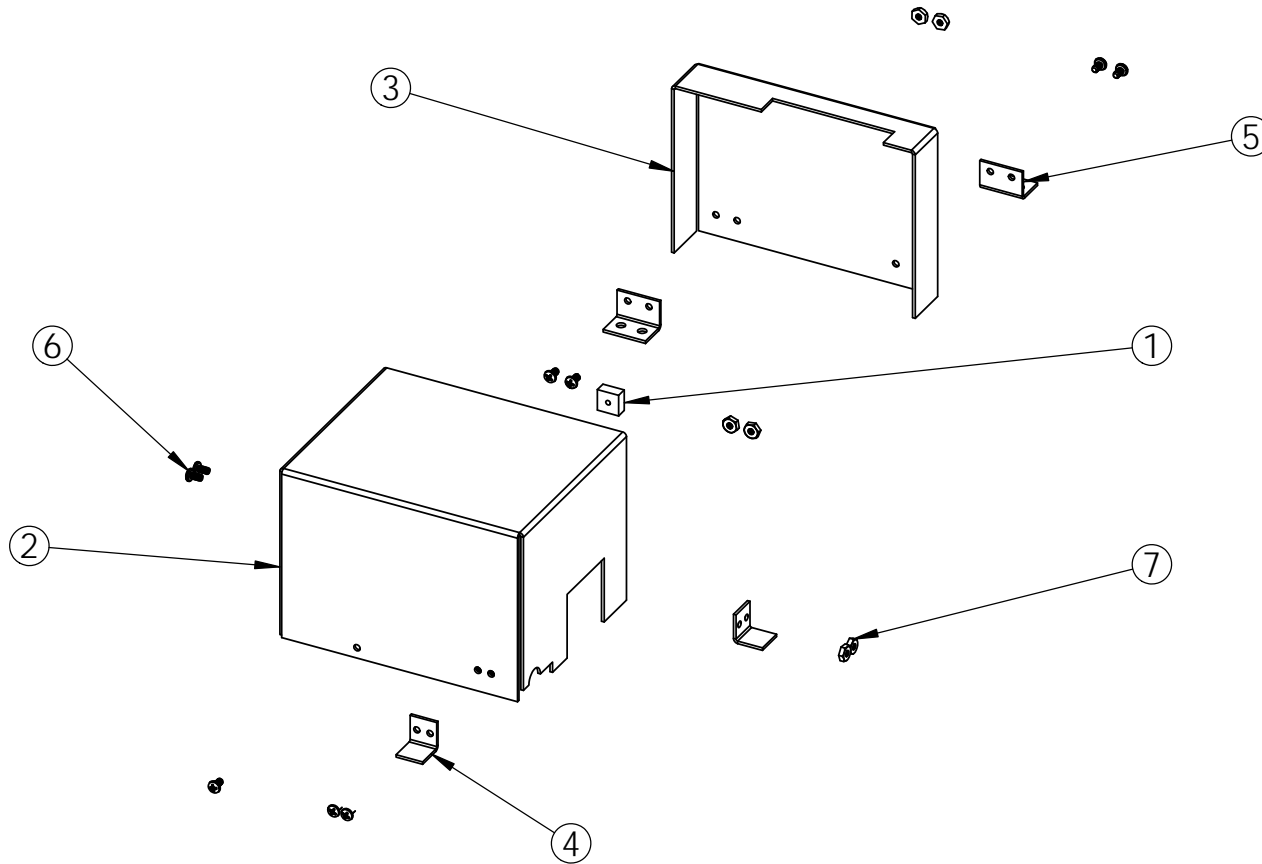
		UNLESS OTHERWISE SPECIFIED:		NAME	DATE	<b>ME 450 TEAM 5</b>		
		DIMENSIONS ARE IN INCHES TOLERANCES: FRACTIONAL ± ANGULAR: MACH ± BEND ± TWO PLACE DECIMAL ± THREE PLACE DECIMAL ±	DRAWN			TITLE:		
			CHECKED			<b>BOTTOM COVER, INTERIOR TAB</b>		
			ENG APPR.					
			MFG APPR.					
		INTERPRET GEOMETRIC TOLERANCING PER:	Q.A.			SIZE <b>A</b>	DWG. NO. BOTTOM_SPOOL_COVER SM_BUTTON_TAB	REV
		MATERIAL <b>6061 ALUMINUM</b>	COMMENTS:					
		FINISH				SCALE: 1:1	WEIGHT:	SHEET 14 OF 14
NEXT ASSY	USED ON							
APPLICATION		DO NOT SCALE DRAWING						





ME 450 TEAM 5		
TITLE:		
TOP COVER ASSEMBLY		
SIZE	DWG. NO.	REV
<b>A</b>	TOP_SPOOL_COVER ASSEMBLY	
SCALE: 1:10	WEIGHT:	SHEET 1 OF 11

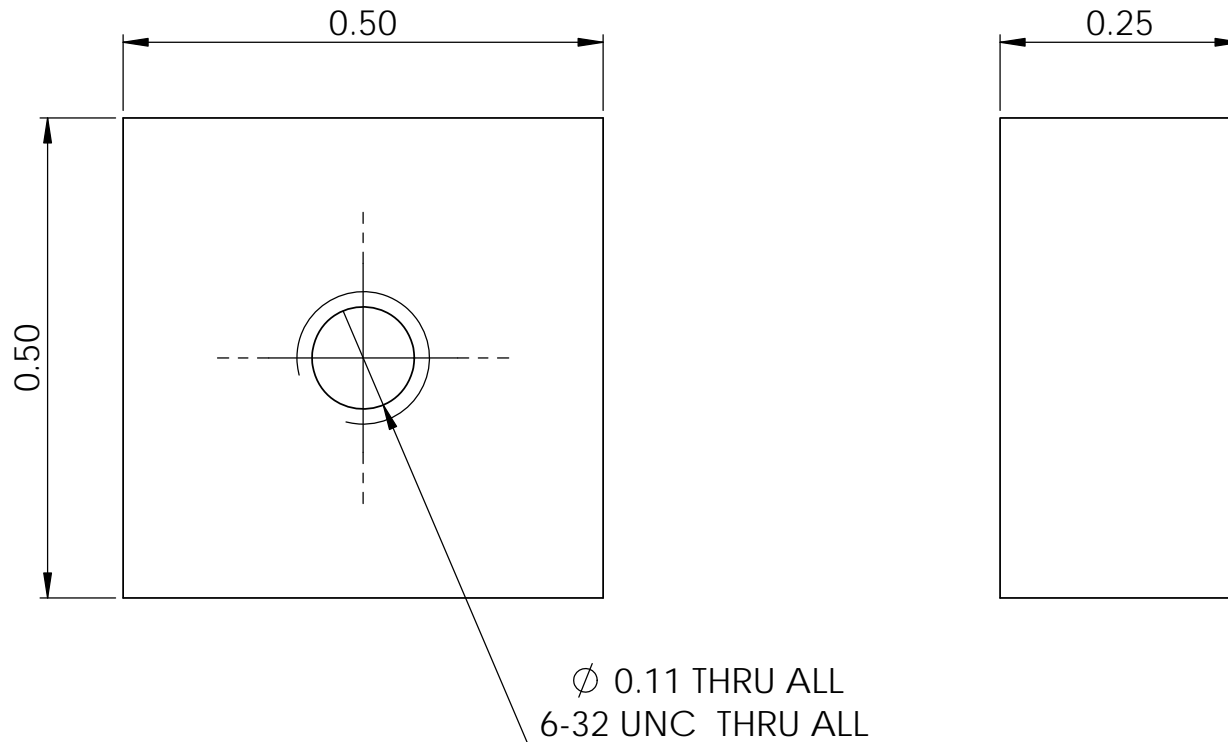
Appendix J: Drawings



ITEM NO.	PART NUMBER	QTY.
1	TOP_COVER_LIMIT_SWITCH_2	1
2	TOP_COVER_MAIN	1
3	TOP_COVER_SECONDARY	1
4	TOP_COVER_VALCRO_TAB_2	2
5	TOP_COVER_TAB_2	2
6	PAN HEAD MACHINE SCREW, #6-32, 1/4" L	9
7	NUT, #6-32	8

<b>ME 450 TEAM 5</b>		
TITLE:		
<b>TOP COVER ASSEMBLY</b>		
SIZE <b>A</b>	DWG. NO. TOP_SPOOL_COVER ASSEMBLY	REV
SCALE: 1:10	WEIGHT:	SHEET 2 OF 11

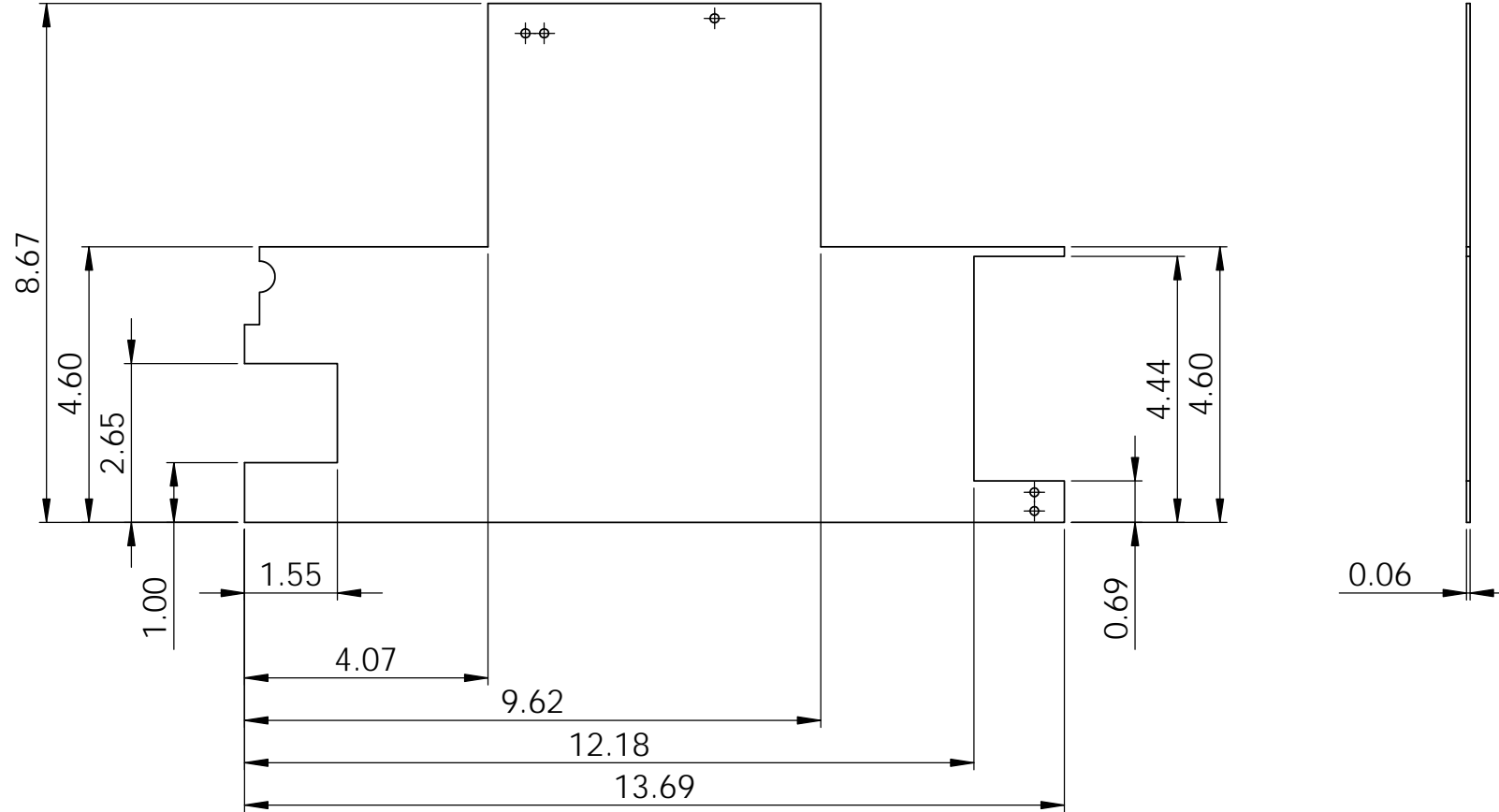
Appendix J: Drawings



**PROPRIETARY AND CONFIDENTIAL**  
 THE INFORMATION CONTAINED IN THIS DRAWING IS THE SOLE PROPERTY OF <INSERT COMPANY NAME HERE>. ANY REPRODUCTION IN PART OR AS A WHOLE WITHOUT THE WRITTEN PERMISSION OF <INSERT COMPANY NAME HERE> IS PROHIBITED.

		UNLESS OTHERWISE SPECIFIED:		NAME	DATE	<b>ME 450 TEAM 5</b>		
		DIMENSIONS ARE IN INCHES TOLERANCES: FRACTIONAL ± ANGULAR: MACH ± BEND ± TWO PLACE DECIMAL ± THREE PLACE DECIMAL ±	DRAWN			TITLE:		
			CHECKED			<b>TOP COVER, LIMIT SWITCH TAB</b>		
			ENG APPR.					
			MFG APPR.					
		INTERPRET GEOMETRIC TOLERANCING PER:	Q.A.			SIZE	DWG. NO.	REV
		MATERIAL	COMMENTS:			<b>A</b>	TOP_COVER LIMIT_SWITCH_2	
		6061 ALUMINUM						
		FINISH				SCALE: 5:1	WEIGHT:	SHEET 3 OF 11
NEXT ASSY	USED ON							
APPLICATION		DO NOT SCALE DRAWING						

Appendix J: Drawings

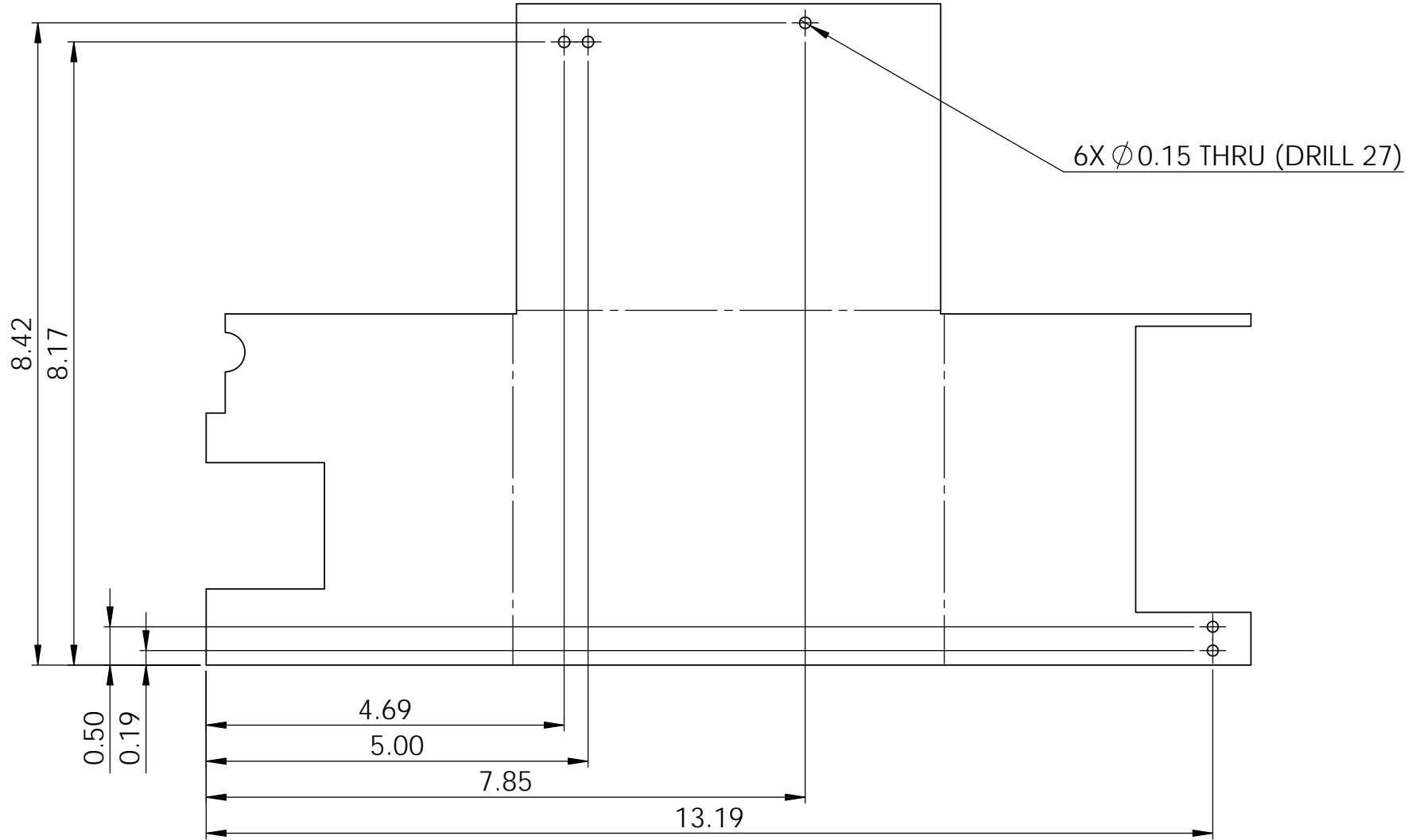


**PROPRIETARY AND CONFIDENTIAL**  
 THE INFORMATION CONTAINED IN THIS DRAWING IS THE SOLE PROPERTY OF <INSERT COMPANY NAME HERE>. ANY REPRODUCTION IN PART OR AS A WHOLE WITHOUT THE WRITTEN PERMISSION OF <INSERT COMPANY NAME HERE> IS PROHIBITED.

		UNLESS OTHERWISE SPECIFIED:		NAME	DATE
		DIMENSIONS ARE IN INCHES	DRAWN		
		TOLERANCES:	CHECKED		
		FRACTIONAL ±	ENG APPR.		
		ANGULAR: MACH ± BEND ±	MFG APPR.		
		TWO PLACE DECIMAL ±	Q.A.		
		THREE PLACE DECIMAL ±	COMMENTS:		
		INTERPRET GEOMETRIC TOLERANCING PER:			
		MATERIAL			
		6061 ALUMINUM			
		FINISH			
NEXT ASSY	USED ON				
APPLICATION		DO NOT SCALE DRAWING			

ME 450 TEAM 5		
TITLE:		
TOP COVER, REMOVABLE		
SIZE	DWG. NO.	REV
<b>A</b>	TAP_SPOOL_COVER_ASSEMBLY	
SCALE: 1:5	WEIGHT:	SHEET 4 OF 11

Appendix J: Drawings

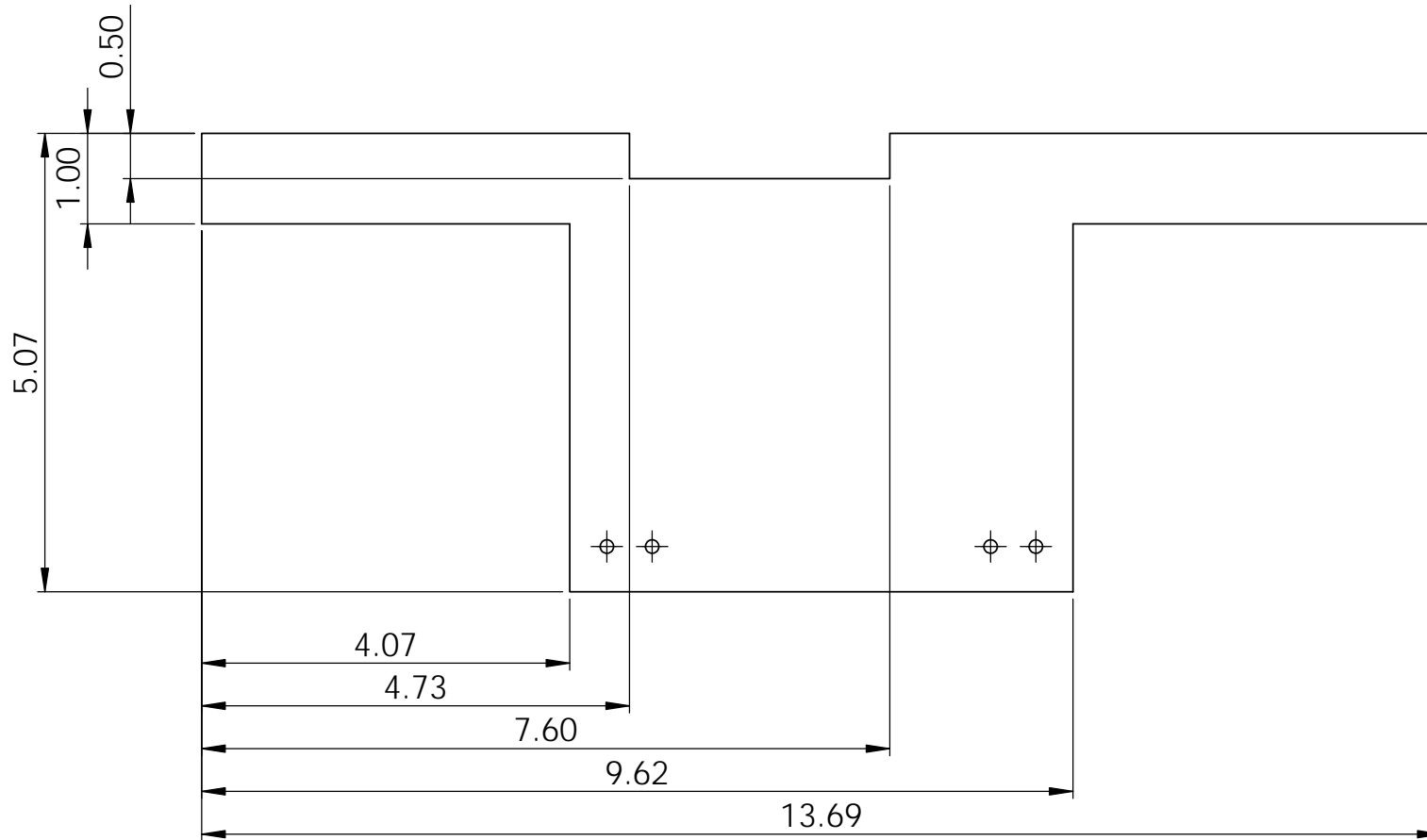


**PROPRIETARY AND CONFIDENTIAL**  
 THE INFORMATION CONTAINED IN THIS DRAWING IS THE SOLE PROPERTY OF <INSERT COMPANY NAME HERE>. ANY REPRODUCTION IN PART OR AS A WHOLE WITHOUT THE WRITTEN PERMISSION OF <INSERT COMPANY NAME HERE> IS PROHIBITED.

		UNLESS OTHERWISE SPECIFIED:		NAME	DATE
		DIMENSIONS ARE IN INCHES	DRAWN		
		TOLERANCES:	CHECKED		
		FRACTIONAL ±	ENG APPR.		
		ANGULAR: MACH ± BEND ±	MFG APPR.		
		TWO PLACE DECIMAL ±	Q.A.		
		THREE PLACE DECIMAL ±	COMMENTS:		
		INTERPRET GEOMETRIC TOLERANCING PER:			
		MATERIAL			
		6061 ALUMINUM			
		FINISH			
NEXT ASSY	USED ON				
APPLICATION		DO NOT SCALE DRAWING			

ME 450 TEAM 5		
TITLE:		
TOP COVER, REMOVABLE		
SIZE	DWG. NO.	REV
<b>A</b>	TOP_SPOOL_COVER_ASSEMBLY	
SCALE: 1:5	WEIGHT:	SHEET 5 OF 11

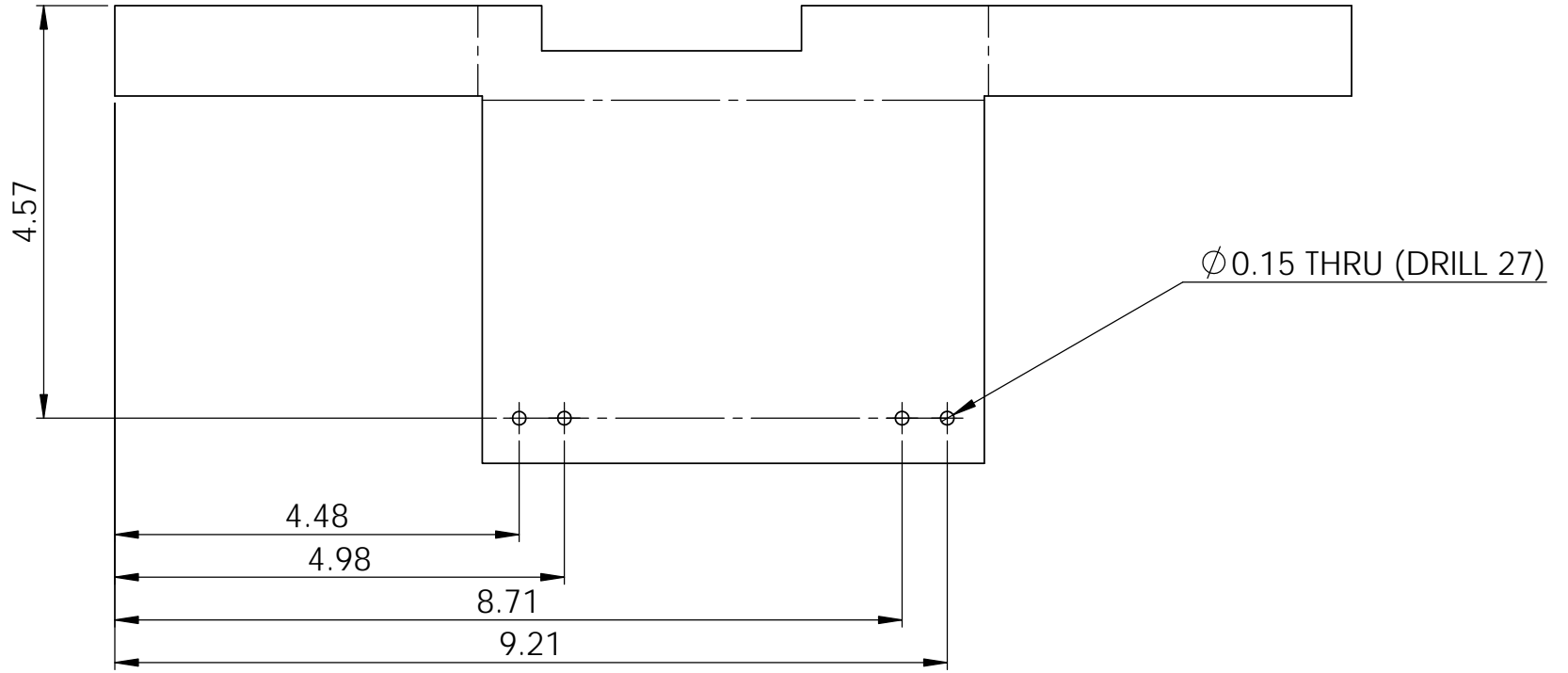
Appendix J: Drawings



**PROPRIETARY AND CONFIDENTIAL**  
 THE INFORMATION CONTAINED IN THIS DRAWING IS THE SOLE PROPERTY OF <INSERT COMPANY NAME HERE>. ANY REPRODUCTION IN PART OR AS A WHOLE WITHOUT THE WRITTEN PERMISSION OF <INSERT COMPANY NAME HERE> IS PROHIBITED.

		UNLESS OTHERWISE SPECIFIED:		NAME	DATE	<b>ME 405 TEAM 5</b>	
		DIMENSIONS ARE IN INCHES TOLERANCES: FRACTIONAL ± ANGULAR: MACH ± BEND ± TWO PLACE DECIMAL ± THREE PLACE DECIMAL ±	DRAWN			TITLE:	
		INTERPRET GEOMETRIC TOLERANCING PER:	CHECKED			<b>TOP COVER, FIXED</b>	
		MATERIAL <b>6061 ALUMINUM</b>	ENG APPR.				
		FINISH	MFG APPR.			SIZE	DWG. NO.
NEXT ASSY	USED ON		Q.A.			<b>A</b>	<b>TOP_COVER SECONDARY</b>
APPLICATION		DO NOT SCALE DRAWING	COMMENTS:			SCALE: 1:2	WEIGHT:
							REV
							SHEET 6 OF 11

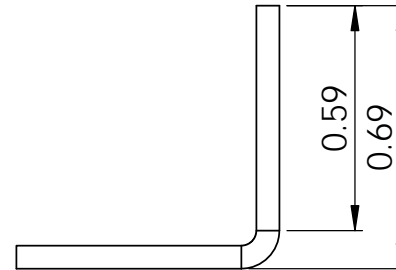
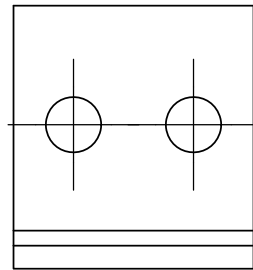
Appendix J: Drawings



**PROPRIETARY AND CONFIDENTIAL**  
 THE INFORMATION CONTAINED IN THIS DRAWING IS THE SOLE PROPERTY OF <INSERT COMPANY NAME HERE>. ANY REPRODUCTION IN PART OR AS A WHOLE WITHOUT THE WRITTEN PERMISSION OF <INSERT COMPANY NAME HERE> IS PROHIBITED.

		UNLESS OTHERWISE SPECIFIED:		NAME	DATE	<b>ME 450 TEAM 5</b>	
		DIMENSIONS ARE IN INCHES TOLERANCES: FRACTIONAL ± ANGULAR: MACH ± BEND ± TWO PLACE DECIMAL ± THREE PLACE DECIMAL ±	DRAWN			TITLE:	
		INTERPRET GEOMETRIC TOLERANCING PER:	CHECKED			<b>TOP COVER, FIXED</b>	
		MATERIAL <b>6061 ALUMINUM</b>	ENG APPR.				
		FINISH	MFG APPR.			SIZE	DWG. NO.
NEXT ASSY	USED ON		Q.A.			<b>A</b>	<b>TOP_COVER SECONDARY</b>
APPLICATION		DO NOT SCALE DRAWING	COMMENTS:			SCALE: 1:2	WEIGHT:
							SHEET 7 OF 11

# Appendix J: Drawings

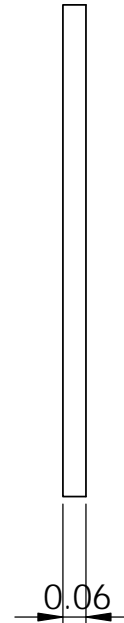
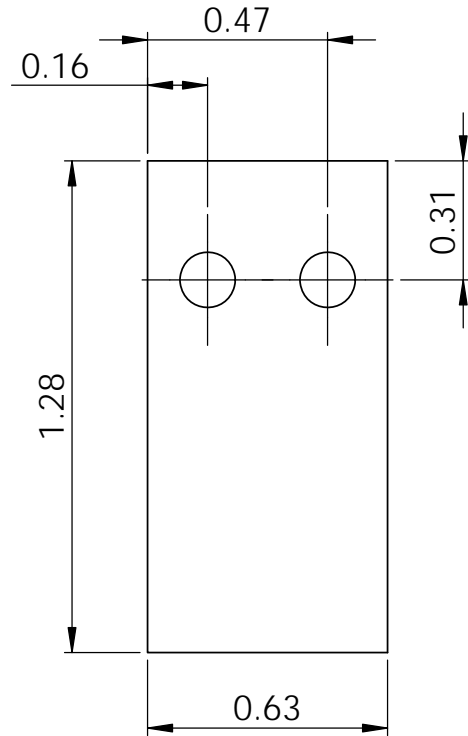


**PROPRIETARY AND CONFIDENTIAL**  
 THE INFORMATION CONTAINED IN THIS DRAWING IS THE SOLE PROPERTY OF <INSERT COMPANY NAME HERE>. ANY REPRODUCTION IN PART OR AS A WHOLE WITHOUT THE WRITTEN PERMISSION OF <INSERT COMPANY NAME HERE> IS PROHIBITED.

		UNLESS OTHERWISE SPECIFIED:		NAME	DATE	<b>ME 450 TEAM 5</b>		
		DIMENSIONS ARE IN INCHES TOLERANCES: FRACTIONAL ± ANGULAR: MACH ± BEND ± TWO PLACE DECIMAL ± THREE PLACE DECIMAL ±				TITLE:		
						<b>TOP COVER, VELCRO TAB BENT</b>		
			INTERPRET GEOMETRIC TOLERANCING PER:				SIZE	DWG. NO.
		MATERIAL	COMMENTS:			<b>A</b>		
		<b>6061 ALUMINUM</b>						
		FINISH						
NEXT ASSY	USED ON							
APPLICATION		DO NOT SCALE DRAWING				SCALE: 2:1	WEIGHT:	SHEET 8 OF 11



Appendix J: Drawings

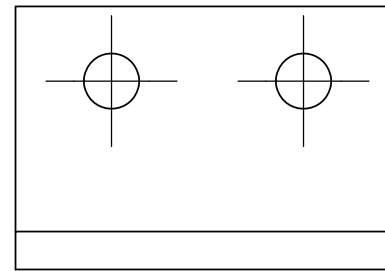
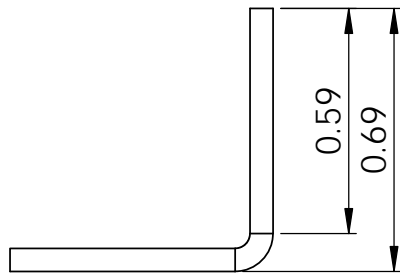


2X PART

**PROPRIETARY AND CONFIDENTIAL**  
 THE INFORMATION CONTAINED IN THIS DRAWING IS THE SOLE PROPERTY OF <INSERT COMPANY NAME HERE>. ANY REPRODUCTION IN PART OR AS A WHOLE WITHOUT THE WRITTEN PERMISSION OF <INSERT COMPANY NAME HERE> IS PROHIBITED.

		UNLESS OTHERWISE SPECIFIED:		NAME	DATE	<b>ME 450 TEAM 5</b>		
		DIMENSIONS ARE IN INCHES TOLERANCES: FRACTIONAL ± ANGULAR: MACH ± BEND ± TWO PLACE DECIMAL ± THREE PLACE DECIMAL ±	DRAWN			TITLE:  <b>TOP COVER, VELCRO TAB</b>		
			CHECKED					
			ENG APPR.					
			MFG APPR.					
		INTERPRET GEOMETRIC TOLERANCING PER:	Q.A.			SIZE <b>A</b> DWG. NO. TOP_COVER_VELCRO TAB_2 REV		
		MATERIAL <b>60601 ALUMINUM</b>	COMMENTS:					
		FINISH						
NEXT ASSY	USED ON					SCALE: 2:1	WEIGHT:	SHEET 9 OF 11
APPLICATION		DO NOT SCALE DRAWING						

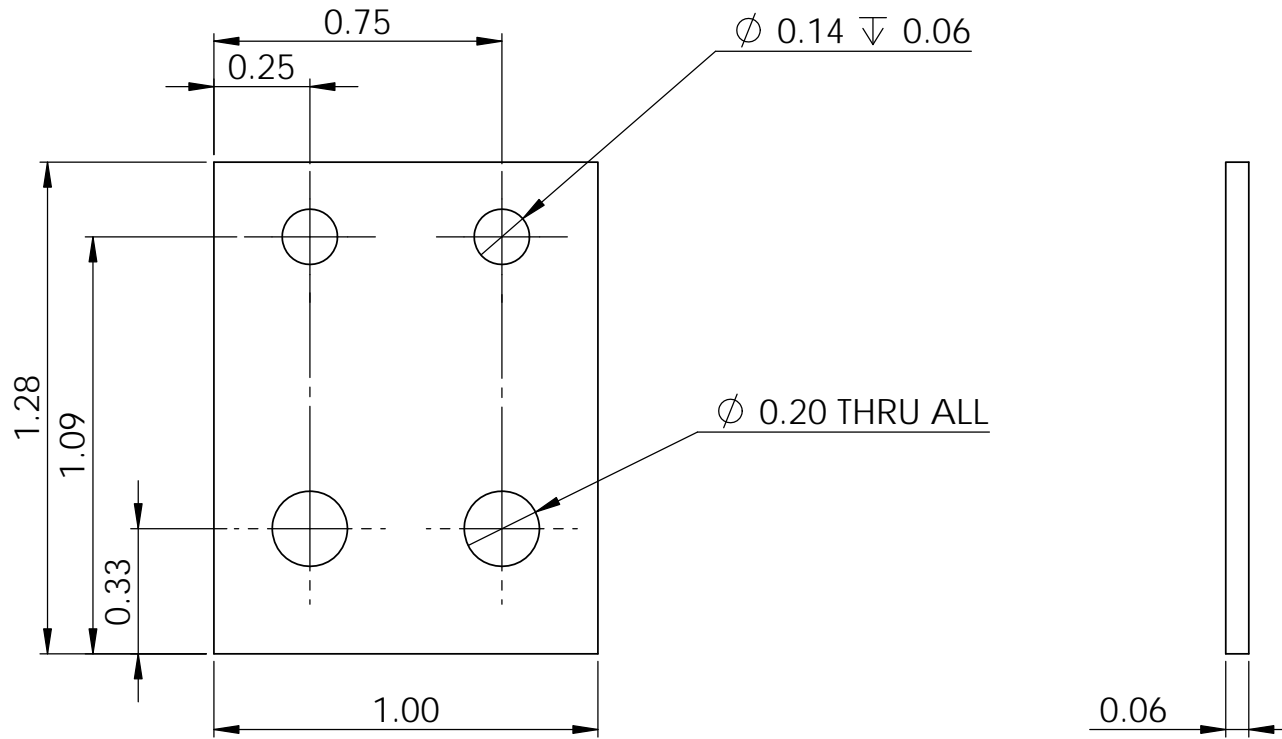
# Appendix J: Drawings



**PROPRIETARY AND CONFIDENTIAL**  
 THE INFORMATION CONTAINED IN THIS DRAWING IS THE SOLE PROPERTY OF <INSERT COMPANY NAME HERE>. ANY REPRODUCTION IN PART OR AS A WHOLE WITHOUT THE WRITTEN PERMISSION OF <INSERT COMPANY NAME HERE> IS PROHIBITED.

		UNLESS OTHERWISE SPECIFIED:		NAME	DATE	<b>ME 450 TEAM 5</b>	
		DIMENSIONS ARE IN INCHES TOLERANCES: FRACTIONAL ± ANGULAR: MACH ± BEND ± TWO PLACE DECIMAL ± THREE PLACE DECIMAL ±	DRAWN			TITLE:  <b>TOP COVER, FIXED TAB</b>	
			CHECKED				
			ENG APPR.				
			MFG APPR.				
		INTERPRET GEOMETRIC TOLERANCING PER:	Q.A.			SIZE DWG. NO. REV <b>A</b> TOP_COVER TAB_2	
NEXT ASSY	USED ON	MATERIAL <b>6061 ALUMINUM</b>	COMMENTS:				
		FINISH					
APPLICATION		DO NOT SCALE DRAWING	SCALE: 2:1	WEIGHT:	SHEET 10 OF 11		

Appendix J: Drawings



2X PART

**PROPRIETARY AND CONFIDENTIAL**  
 THE INFORMATION CONTAINED IN THIS DRAWING IS THE SOLE PROPERTY OF <INSERT COMPANY NAME HERE>. ANY REPRODUCTION IN PART OR AS A WHOLE WITHOUT THE WRITTEN PERMISSION OF <INSERT COMPANY NAME HERE> IS PROHIBITED.

		UNLESS OTHERWISE SPECIFIED:		NAME	DATE	<b>ME 450 TEAM 5</b>		
		DIMENSIONS ARE IN INCHES TOLERANCES: FRACTIONAL ± ANGULAR: MACH ± BEND ± TWO PLACE DECIMAL ± THREE PLACE DECIMAL ±	DRAWN			TITLE:		
			CHECKED			<b>TOP COVER, FIXED TAB</b>		
			ENG APPR.					
			MFG APPR.					
		INTERPRET GEOMETRIC TOLERANCING PER:	Q.A.			SIZE	DWG. NO.	REV
		MATERIAL	COMMENTS:			<b>A</b>	<b>TOP_COVER TAB_2</b>	
		6061 ALUMINUM						
NEXT ASSY	USED ON	FINISH				SCALE: 2:1	WEIGHT:	SHEET 11 OF 11
APPLICATION		DO NOT SCALE DRAWING						

## Appendix K: Engineering Change Notifications

### Engineering Change Notification #1

ME 450 Team 5

Change of Hole on Baseplate, change of slot in Moving Arm, and change of Baseplate Fasteners

Parts Affected by change: Baseplate and Moving Arm (See drawings on following pages for details)

What has been changed:

Holes on the baseplate for mounting the spool lock (Slide Bolt) were change to #10-24 threaded holes from #4-40 threaded holes. This was done to accommodate the larger than expected holes in the slide bolt on the item that was purchased from Home Depot (see Figure 1 attached). Holes were also changed to be through holes in order to more easily find #10-24 fasteners that would fit the part. The four (4) #40-40 bolts used to fasten the Slide Bolt to the plate will be changed on the bill of materials to reflect this change, and new fasteners will be ordered accordingly.

The hole location and type was changed for the Moving Arm locking knob. This knob is used to adjust the clamping width of our device, in order to accommodate different types of oxygen concentrators. The hole was called out to the wrong size and thread type in the original drawings of the Baseplate. After drilling and tapping the hole, it was determined this was the incorrect size and thread type for the turn knob specified in the bill of materials. Ordering a new knob to fit the hole would provide too costly and would create long lead times in receiving the new knob. Changing the size and thread type of the hole while leaving the hole in the same location would require the Baseplate to be remade, which is too costly and requires too much time to remanufacture the part, so the hole location will be changed to the opposite side of the Baseplate to allow the same Baseplate to be used in the device. (see Figure 1 attached)

The hole type for the four (4) shoulder bolts on the baseplate were originally specified to be 0.257" diameter for a 1/4"-20 fastener clearance hole. Holes in the Baseplate were drilled to meet this spec. However, the shoulder bolt used in these holes had a shoulder diameter of 1/4", so the shoulder did not rest on the hole, but instead slide through the hole. The Baseplate hole diameter could be changed, but this would have required a new Baseplate and moving arm to have been made. This would be too costly for new material costs, and would create too long of a lead time in order to manufacture the new parts. Instead, new shoulder bolts, of shoulder diameter 5/16" will be purchased to be used in replacement of the 1/4" shoulder diameter bolts (see Figure 2 attached). New hex nuts will be purchased to be used with these new shoulder bolts (1/4"-20 threads). The bill of materials has been updated to make this change, as well as all CAD drawings. The slots in Moving Arm that allow the part to slide along the Baseplate were widened from 0.257" to 0.323" (clearance hole for a 5/16" fastener) to accommodate the wider shoulder bolts (see Figure 3 attached). Drawings shown will reflect manufactured parts.

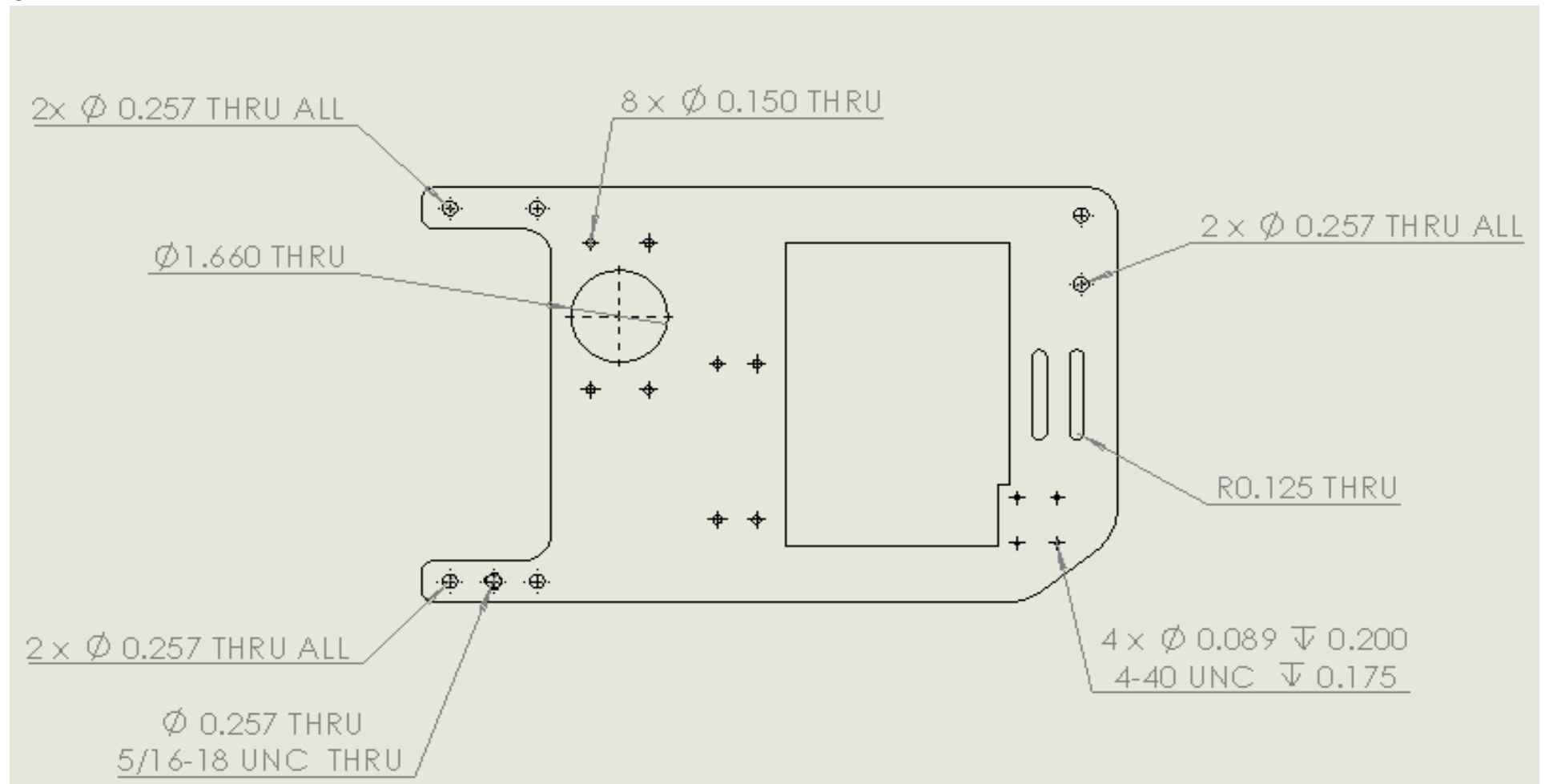
Change Initiated by: Nathan Matheny

Date: 11/18/12

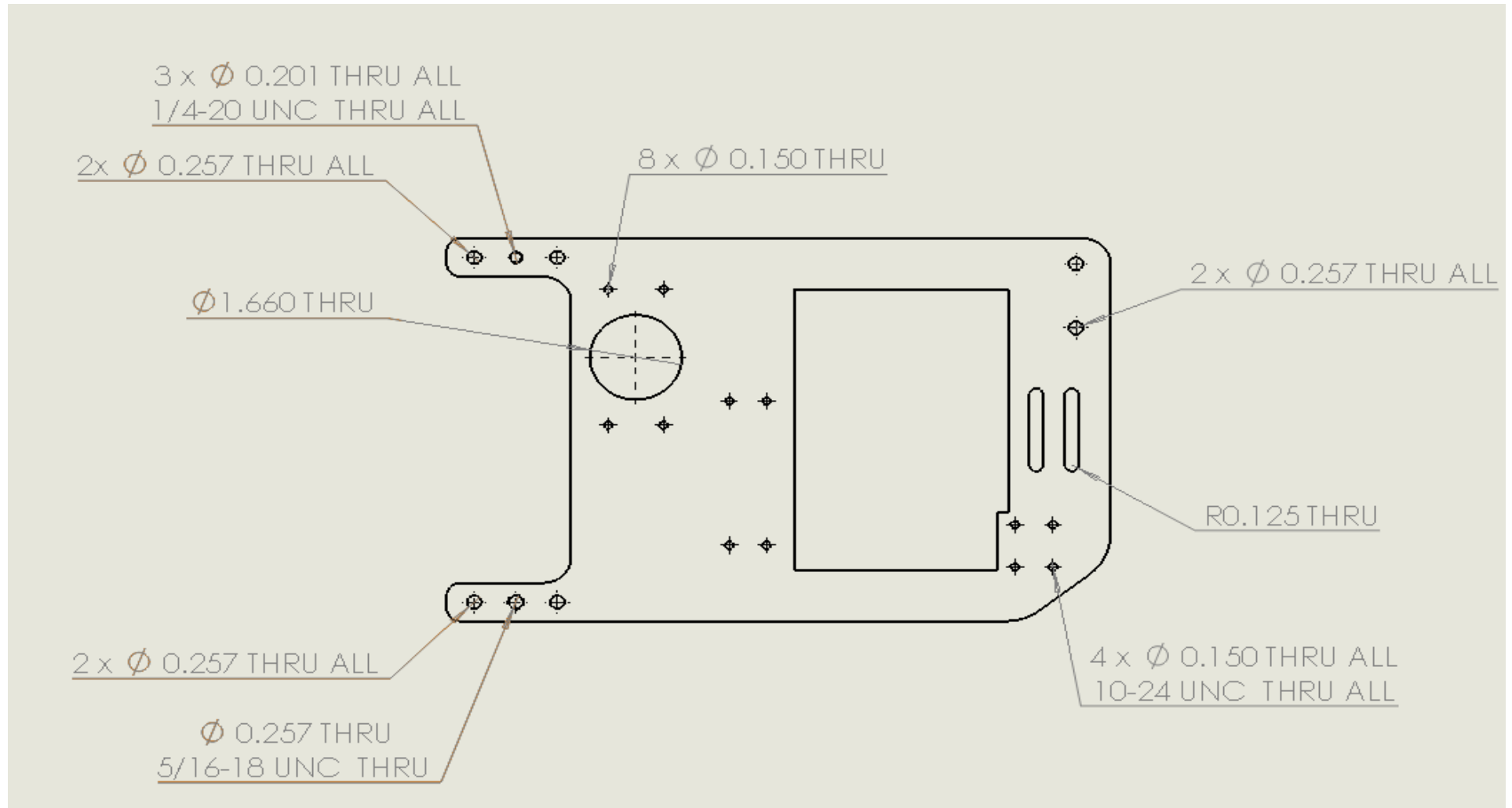
Change Approved By:

Figure 1: Changes made to Baseplate print and part

OLD

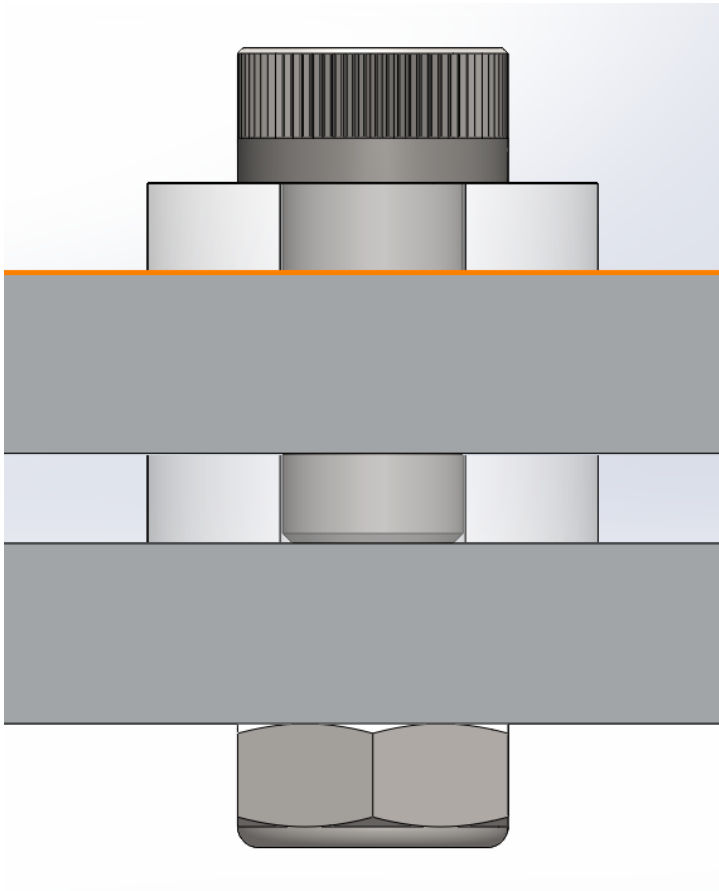


NEW

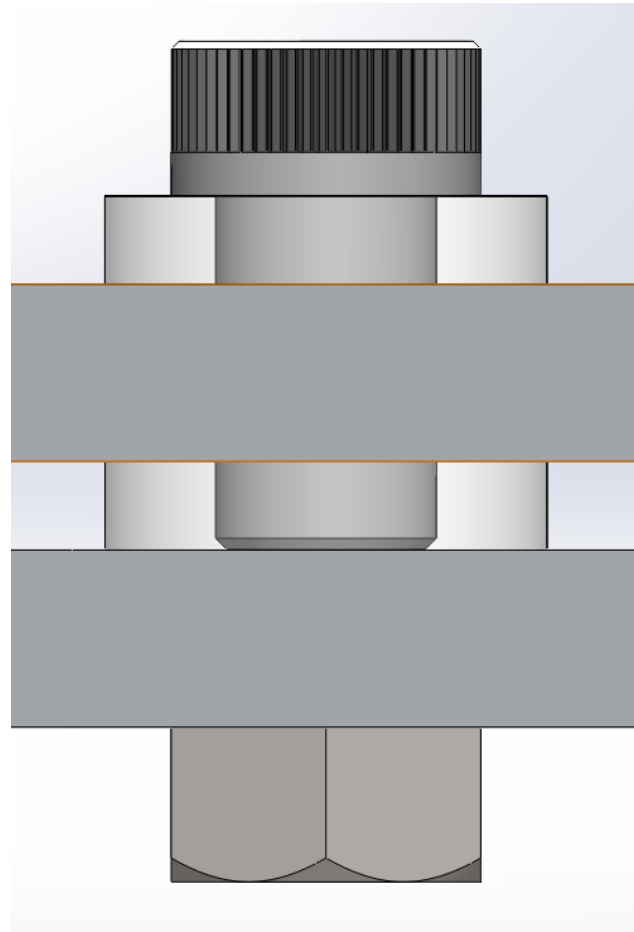


**Figure 2: New shoulder bolt in Baseplate design**

**OLD**



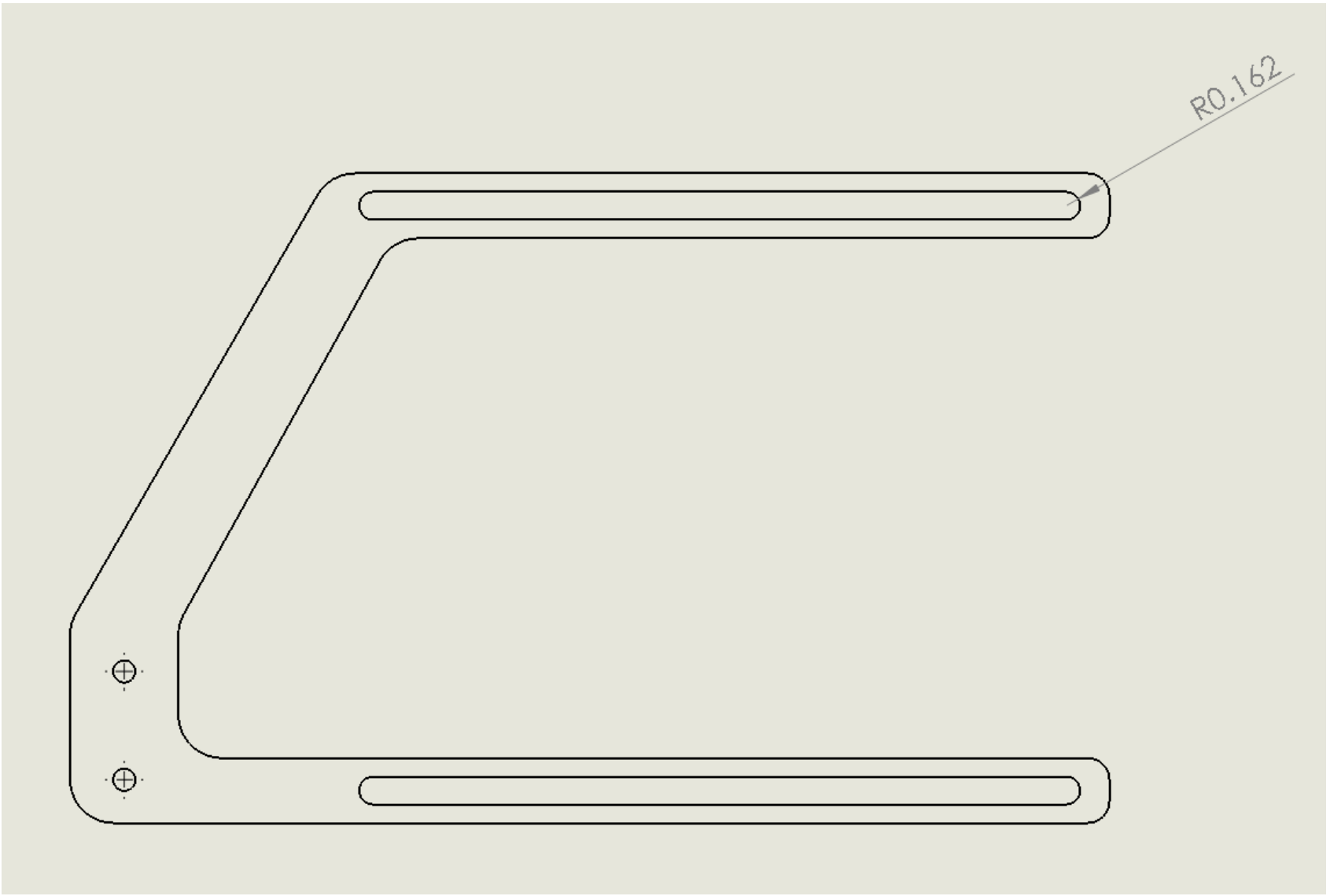
**NEW**







NEW



## Appendix K: Engineering Change Notifications

### **Engineering Change Notification #2**

ME 450 Team 5

Change of Bottom Spool Housing in order to accommodate finalized circuit and 3D printing cost savings

Parts Affected by change: Bottom Spool Cover

What has been changed:

In order to complete the UV sanitation circuit so that the user turns on the sanitation system then it automatically turns off, certain components needed to be added to the circuit. These components included: a breadboard (to house resistors and transistors needed for the new circuit), a button switch to turn on the circuit, an LED light (to alert the user when the sanitation device is on), and a limit switch to prevent the UV light from being on when the top cover is taken off of the spool.

To house these components in the bottom spool cover, the orientation of the circuit component supports needed to be changed (see Figure 1). Holes were added to the side of the bottom spool cover to accommodate the new button switch, LED light, and limit switch (see Figure 1).

A few features of the bottom housing were changed in order to make the bottom spool cover cheaper in order to meet our team's budget constraints. First, the curved radius of the housing was removed and the spool cut-out height increased in order to remove the amount of support material required to 3D print this part (see Figure 2). Second, one of the side cut-outs on the part was removed so that it would not need to be supported while printing. The UM 3D printing lab charges for the amount of support material used, so cutting down on the amount of support material required will cut down on the cost of printing our part.

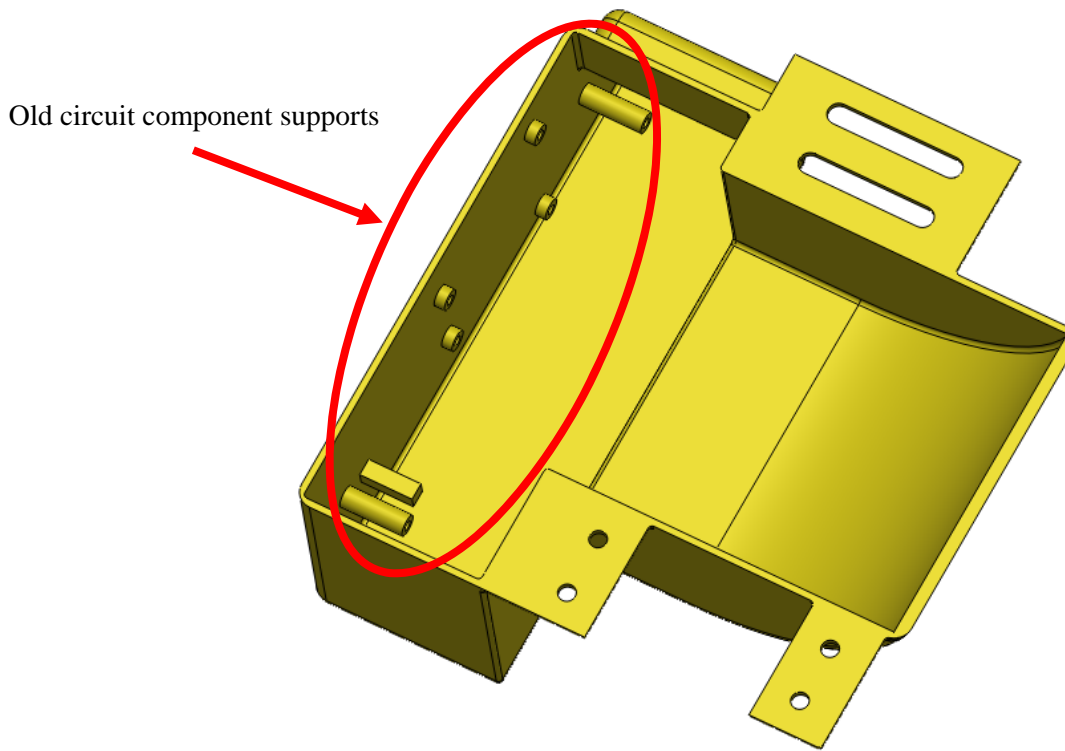
Change Initiated by: Nathan Matheny

Date: 11/25/12

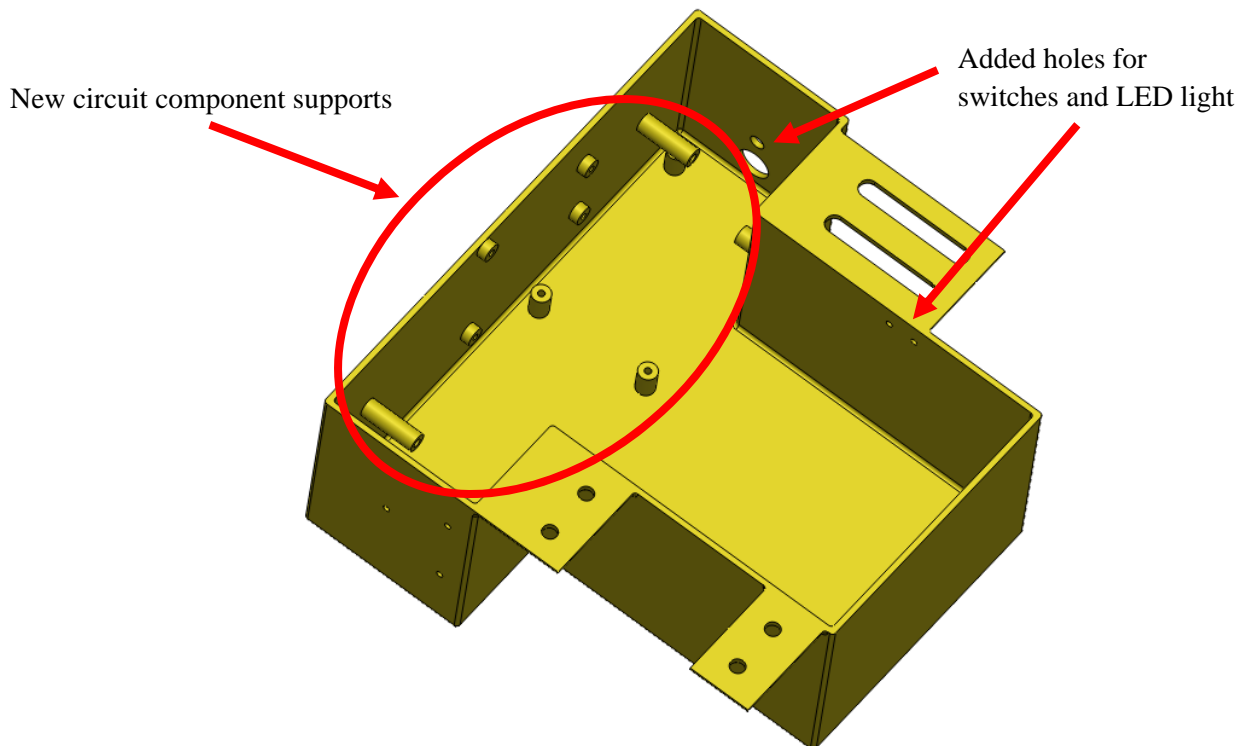
Change Approved By:

**FIGURE 1**

**Old Bottom Spool Cover**

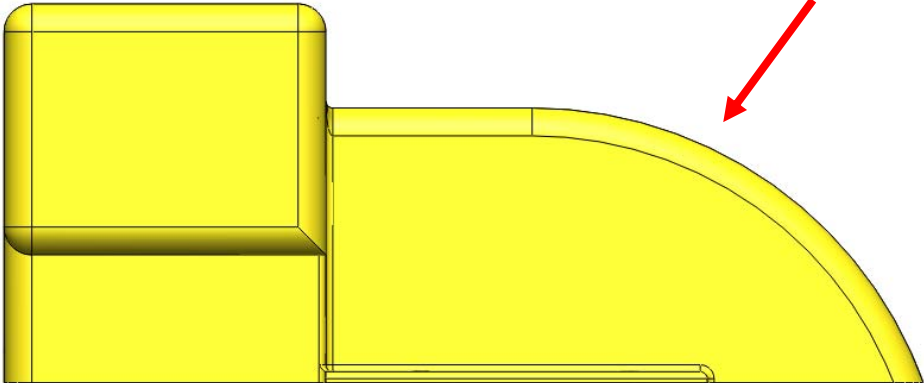


**Revised Bottom Spool Cover**



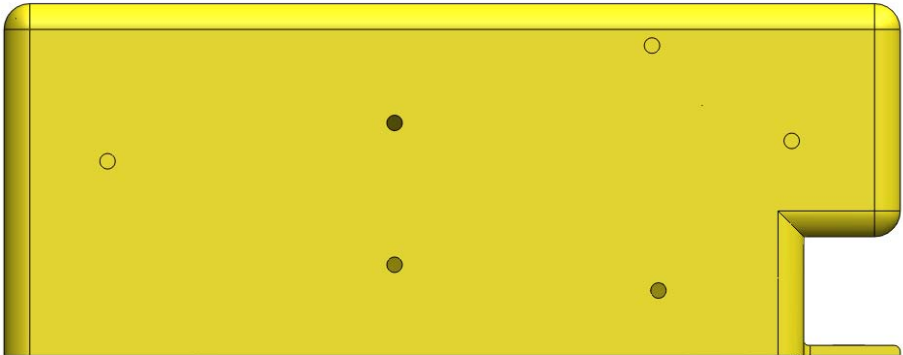
**FIGURE 2**

**Old Bottom Spool Cover Side**



Old bottom cover radius

**Old Bottom Spool Cover Rear View**

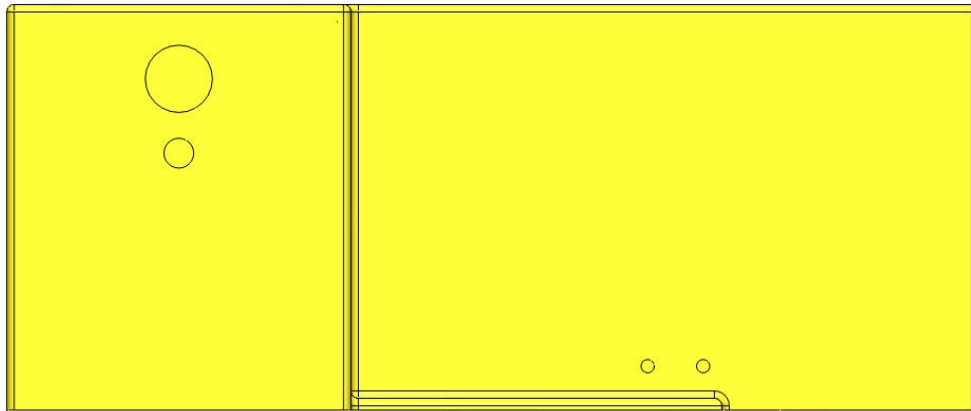


Old bottom side cut-out

(new bottom spool cover pictures on next page)

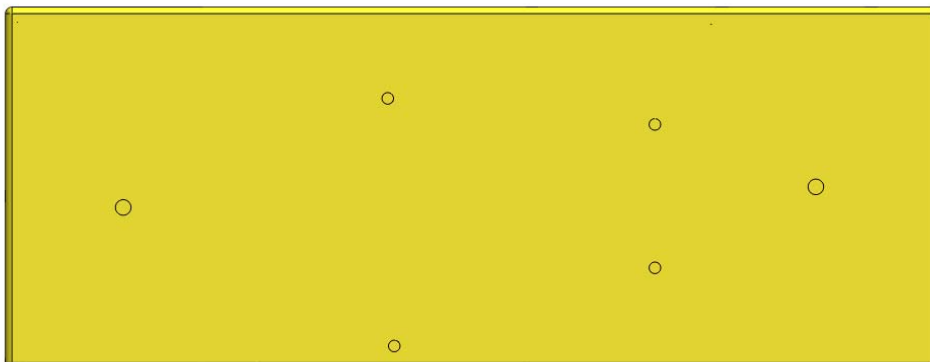
**New Bottom Spool Cover Side**

New flat side, depth of cut-out increased



**Old Bottom Spool Cover Rear View**

New flat side, no cut-out



## Appendix K: Engineering Change Notifications

### Engineering Change Notification #3

ME 450 Team 5

Change of spool mounts and spool spring side shaft in order to allow constant torque spring to work

Parts Affected by change: Spool Mount, Tubing Side; Spool Mount, Spring Side; Spool Mount, Spring Side B; Spool Shaft, Spring Side

What has been changed:

When assembling our device, it was found that the constant torque spring would not work with the current output shaft diameter (on part “Spool Shaft, Spring Side”). It was incorrectly assumed that the spring would conform to the diameter of the output shaft, even though the output shaft was much smaller than the wound inner diameter of the spring. However, this diameter difference caused the spring to bend and bind on itself when the spool was turned. After further research, it was found that the output shaft diameter for a constant torque spring should equal to or greater than the wound inner diameter of the constant torque spring (according to *Advances in the Analysis and Design of Constant-Torque Springs*, [http://ntrs.nasa.gov/archive/nasa/casi.ntrs.nasa.gov/19960025610\\_1996050443.pdf](http://ntrs.nasa.gov/archive/nasa/casi.ntrs.nasa.gov/19960025610_1996050443.pdf)). Therefore, the output shaft diameter was changed to be 1.25”, which is larger than the wound inner diameter of the constant-torque spring, 1.19” (see Figure 1). This should allow the constant-torque spring to correctly wind around the output shaft when the spool is turned.

Because the output shaft for the constant torque spring was increased, the distance between the two shafts needed to be increased to avoid interference between the spring and spring shafts. This was done by moving the placement of the spring storage spool hole further from the spool shaft mounting holes on parts, “Spool Mount, Spring Side” and “Spool Mount, Spring Side B” (see Figure 2). The hole for the spool shafts was also raised further from the spool shafts on each of these parts (see Figure 2) so that the shaft did not come into contact with the bottom of the mount.

In order to move the spring shaft further from the spool shaft and to increase the diameter of the spool shaft on the spring side, the fasteners must be changed in order to allow room for clearance. New holes would need to be drilled in the baseplate in order to accommodate for new hole locations on the mounts in order to fasten using the same fasteners. However, since the rear leg has already been welded onto the baseplate so that the baseplate can no longer be fixed onto a mill, the only way to drill new holes in the baseplate would be to hand drill them, which would not meet the accurate tolerance needed for these hole locations. Therefore, instead of using a #10-24, 1” long bolt to fasten through mount and baseplate from the top, a #10-24, 5/8” long both will be used from the bottom of the baseplate and threaded into the spool mount. This is not an ideal situation, to be threading into the mount, but is the best solution to the problem seeing as we cannot accurately drill new holes in the baseplate (see Figure 3).

Since the spool shaft height was raised, the spool shaft mounts on the other side of the spool (parts “Spool Mount, Tubing Side”) would also need to be raised to the same height so that the spools shafts remain aligned (see Figure 4).

Since we are out of the material our team purchased to make these mounts originally, different aluminum angle stock was found to make these parts. This stock has the same leg dimensions (1.5”x1.5”) but different wall thickness (0.25” instead of 3/16” originally specified). New prints will be made (see Figure 5) for all changed parts, and the bill of materials will be changed to reflect changes to the shaft mounts.

Change Initiated by: Nathan Matheny

Date: 11/26/12

Change Approved By:

Figure 1

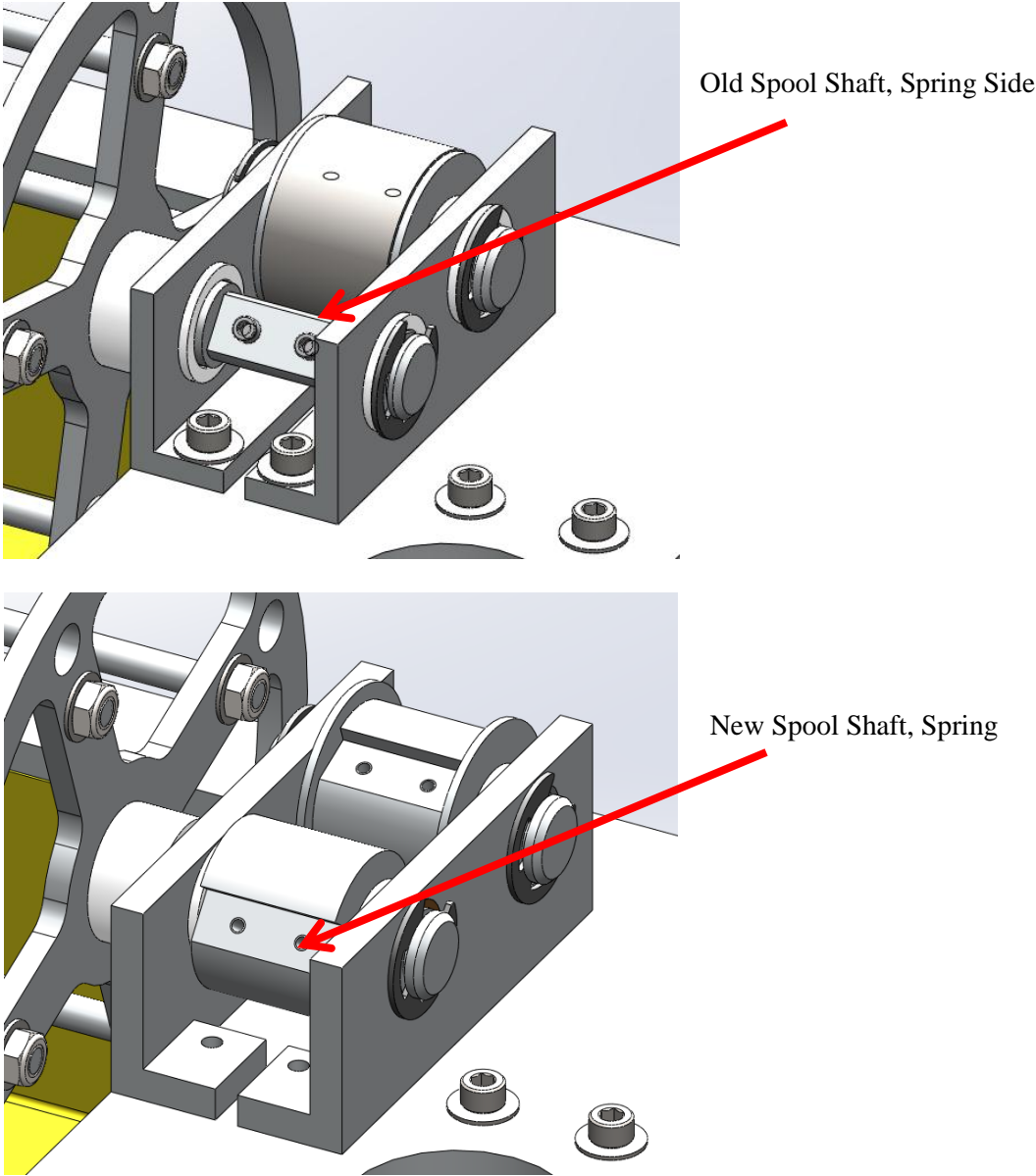
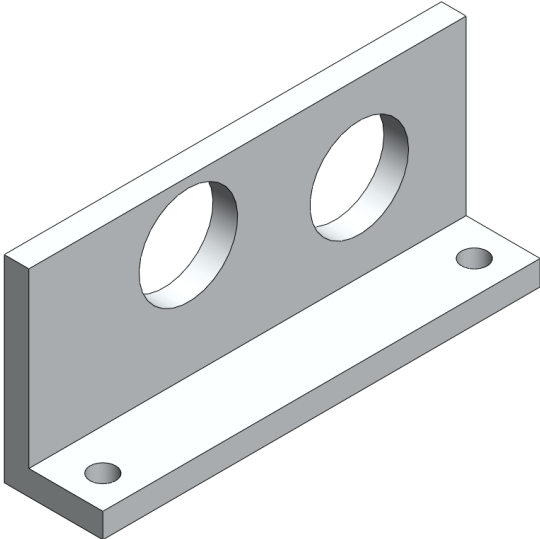
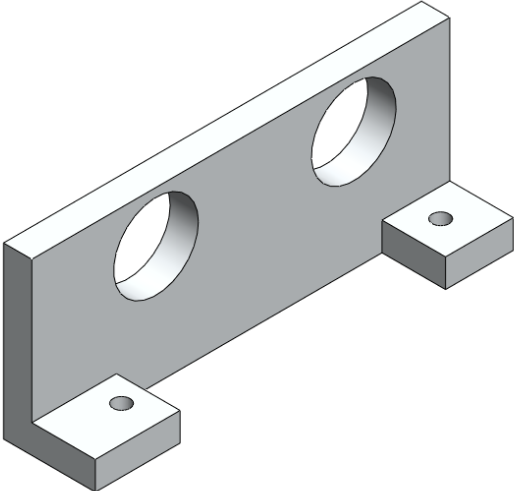


Figure 2



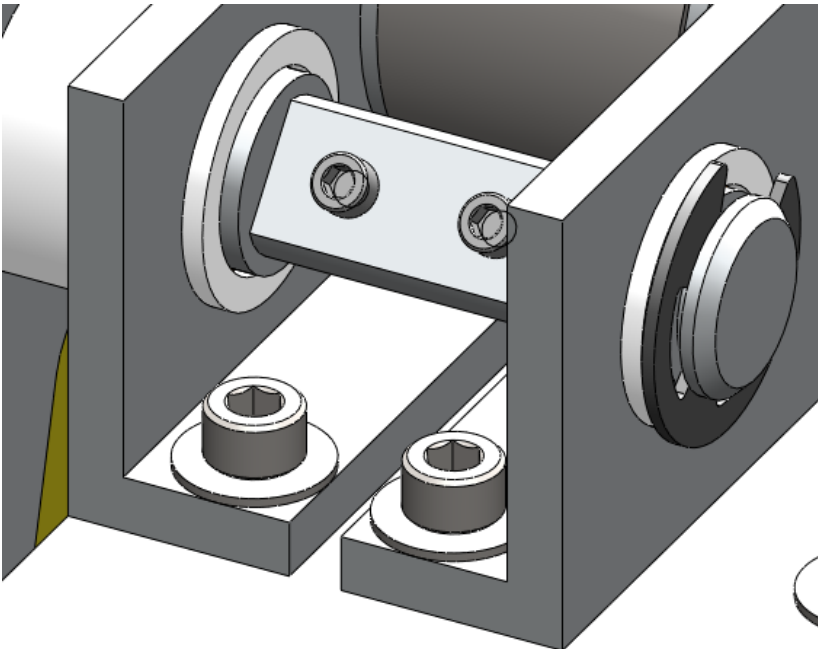
Old spool and spring shaft hole placement in “Spool Mount, Spring Side” and “Spool Mount, Spring Side, B”



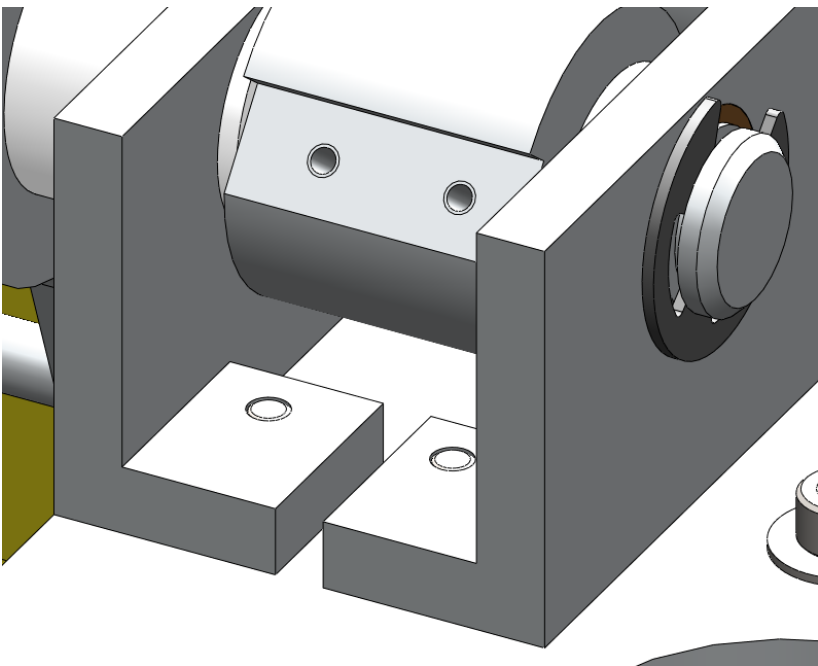
New spool and spring shaft hole placement in “Spool Mount, Spring Side” and “Spool Mount, Spring Side, B”. Changes include new shaft hole placement, new fastening holes, removed material to allow room for spring, and thicker angle stock.



**Figure 3**

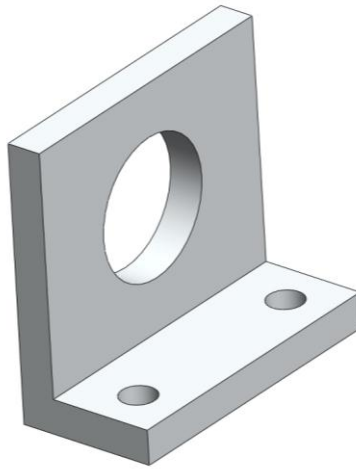


Old fastening method for “Spool Mount, Spring Side” and “Spool Mount, Spring Side, B”.

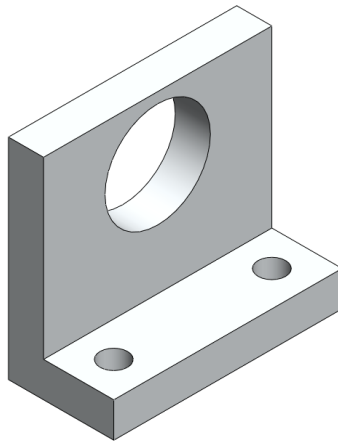


New fastening method for “Spool Mount, Spring Side” and “Spool Mount, Spring Side, B”. Mounts are threaded into to avoid fastener interference with spring.

**Figure 4**

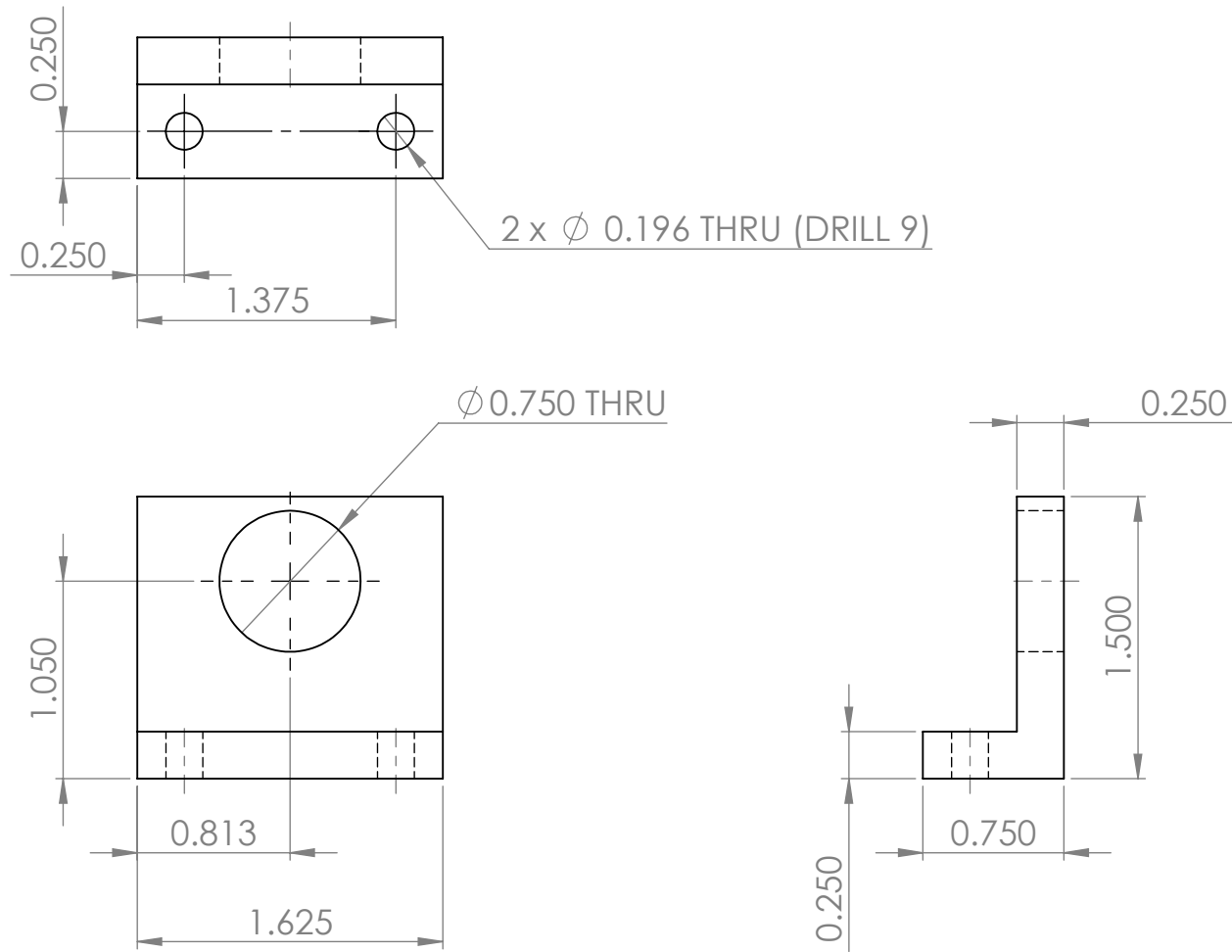


Old spool shaft hole placement in “Spool Mount, Tubing Side”



New spool shaft hole placement in “Spool Mount, Tubing Side”. Hole is higher up to account for increase in spool height.

# Appendix K: Engineering Change Notifications



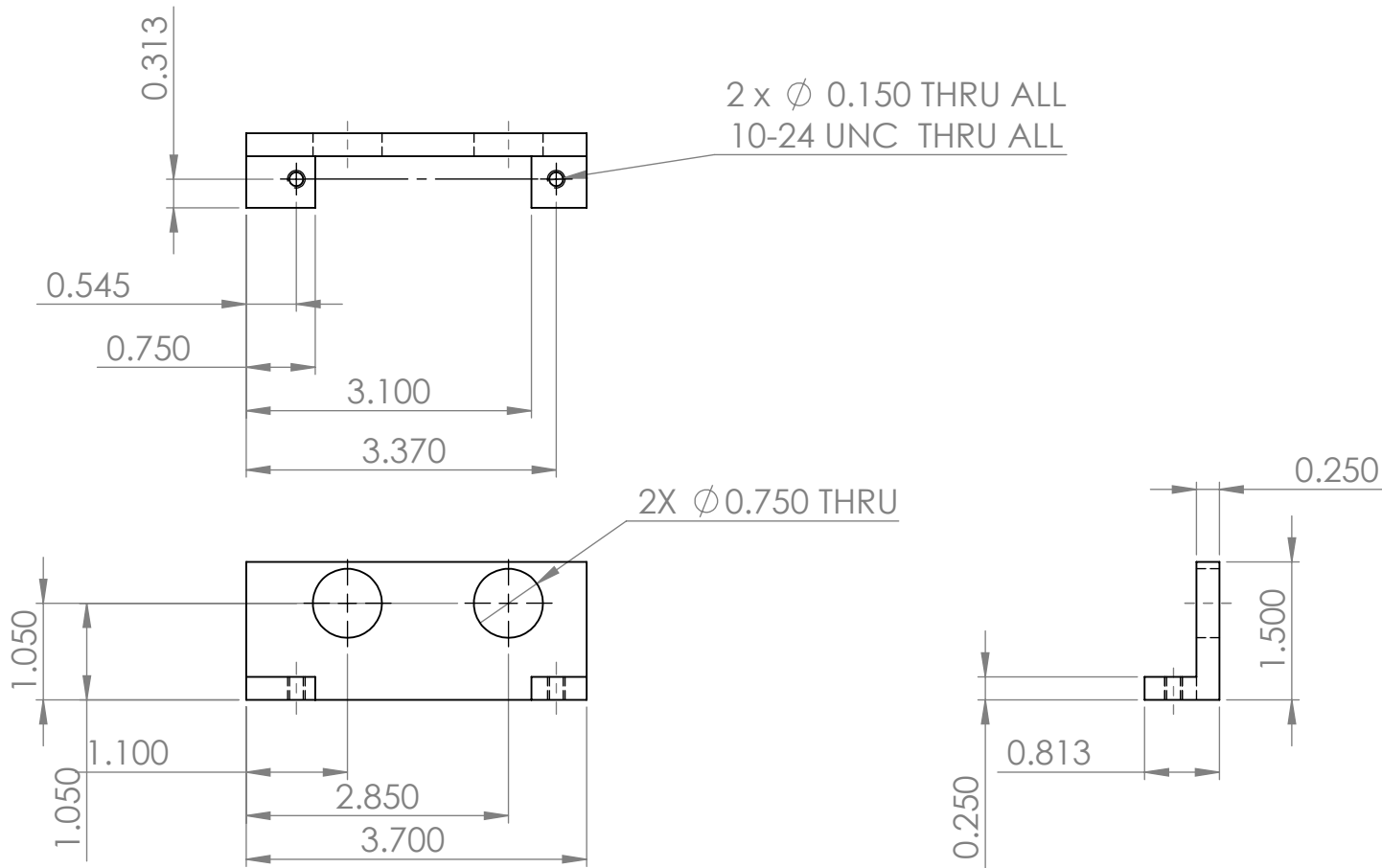
2X PART

**PROPRIETARY AND CONFIDENTIAL**  
 THE INFORMATION CONTAINED IN THIS DRAWING IS THE SOLE PROPERTY OF <INSERT COMPANY NAME HERE>. ANY REPRODUCTION IN PART OR AS A WHOLE WITHOUT THE WRITTEN PERMISSION OF <INSERT COMPANY NAME HERE> IS PROHIBITED.

		UNLESS OTHERWISE SPECIFIED:		NAME	DATE
		DIMENSIONS ARE IN INCHES	DRAWN		
		TOLERANCES:	CHECKED		
		FRACTIONAL ±	ENG APPR.		
		ANGULAR: MACH ± BEND ±	MFG APPR.		
		TWO PLACE DECIMAL ±	Q.A.		
		THREE PLACE DECIMAL ±	COMMENTS:		
		INTERPRET GEOMETRIC TOLERANCING PER:			
		MATERIAL			
		6061 ALUMINUM			
		FINISH			
NEXT ASSY	USED ON				
APPLICATION		DO NOT SCALE DRAWING			

ME 450 TEAM 5		
TITLE:		
SPOOL MOUNT, TUBING SIDE		
SIZE	DWG. NO.	REV
<b>A</b>	SPOOL_MOUNT_TUBING	
SCALE: 1:1	WEIGHT:	SHEET 1 OF 1

Appendix K: Engineering Change Notifications

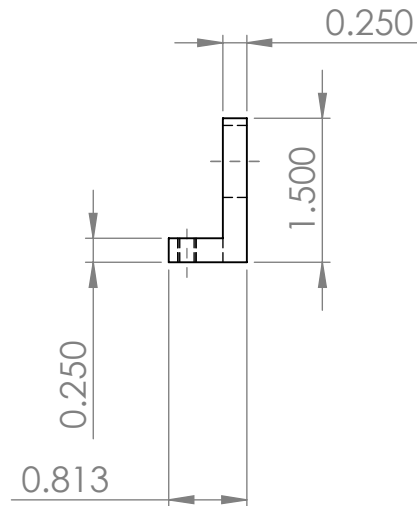
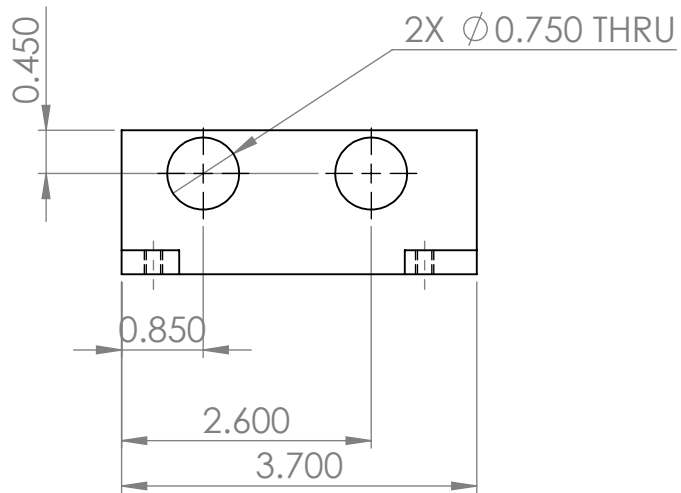
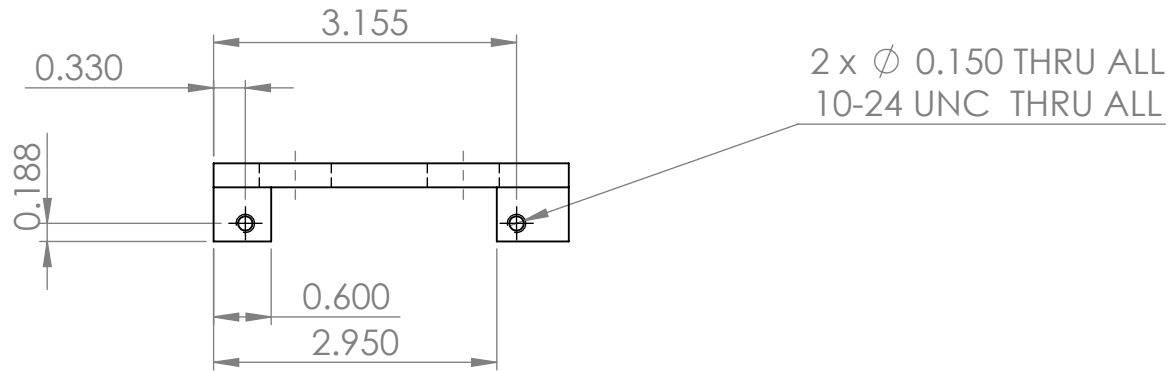


1X PART

**PROPRIETARY AND CONFIDENTIAL**  
THE INFORMATION CONTAINED IN THIS DRAWING IS THE SOLE PROPERTY OF <INSERT COMPANY NAME HERE>. ANY REPRODUCTION IN PART OR AS A WHOLE WITHOUT THE WRITTEN PERMISSION OF <INSERT COMPANY NAME HERE> IS PROHIBITED.

		UNLESS OTHERWISE SPECIFIED:		NAME	DATE	<b>ME 450 TEAM 5</b>	
		DIMENSIONS ARE IN INCHES TOLERANCES: FRACTIONAL $\pm$ ANGULAR: MACH $\pm$ BEND $\pm$ TWO PLACE DECIMAL $\pm$ THREE PLACE DECIMAL $\pm$	DRAWN			TITLE:	
		INTERPRET GEOMETRIC TOLERANCING PER:	CHECKED			<b>SPOOL MOUNT, SPRING SIDE</b>	
		MATERIAL <b>6061 ALUMINUM</b>	ENG APPR.			SIZE <b>A</b>	DWG. NO. SPOOL_MOUNT_ SPRING
		FINISH	MFG APPR.				REV
NEXT ASSY	USED ON		Q.A.			SCALE: 1:2 WEIGHT: SHEET 1 OF 1	
APPLICATION		DO NOT SCALE DRAWING	COMMENTS:			K17	

# Appendix K: Engineering Change Notifications



1X PART

**PROPRIETARY AND CONFIDENTIAL**  
 THE INFORMATION CONTAINED IN THIS DRAWING IS THE SOLE PROPERTY OF <INSERT COMPANY NAME HERE>. ANY REPRODUCTION IN PART OR AS A WHOLE WITHOUT THE WRITTEN PERMISSION OF <INSERT COMPANY NAME HERE> IS PROHIBITED.

		UNLESS OTHERWISE SPECIFIED:		NAME	DATE
		DIMENSIONS ARE IN INCHES	DRAWN		
		TOLERANCES:	CHECKED		
		FRACTIONAL ±	ENG APPR.		
		ANGULAR: MACH ± BEND ±	MFG APPR.		
		TWO PLACE DECIMAL ±	Q.A.		
		THREE PLACE DECIMAL ±	COMMENTS:		
		INTERPRET GEOMETRIC TOLERANCING PER:			
		MATERIAL			
		6061 ALUMINUM			
		FINISH			
NEXT ASSY	USED ON				
APPLICATION		DO NOT SCALE DRAWING			

ME 450 TEAM 5

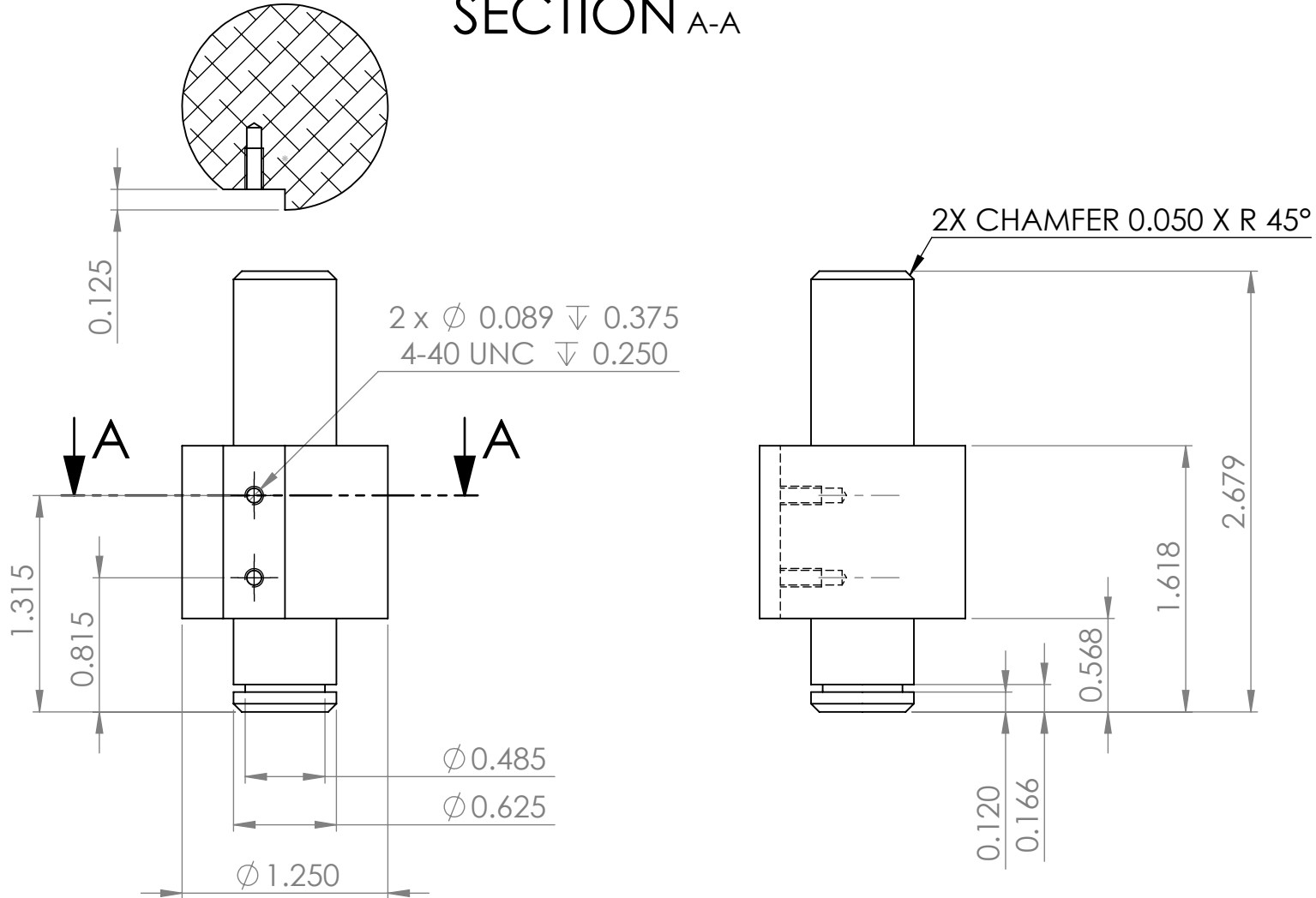
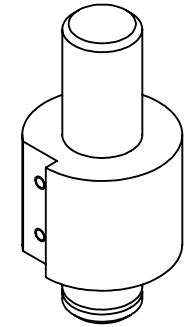
TITLE:

SPOOL MOUNT,  
 SPRING SIDE B

SIZE <b>A</b>	DWG. NO. SPOOL_MOUNT_ SPRING_B	REV <b>B</b>
------------------	-----------------------------------	-----------------

SCALE: 1:2 WEIGHT: SHEET 1 OF 1

# SECTION A-A



**PROPRIETARY AND CONFIDENTIAL**  
THE INFORMATION CONTAINED IN THIS DRAWING IS THE SOLE PROPERTY OF <INSERT COMPANY NAME HERE>. ANY REPRODUCTION IN PART OR AS A WHOLE WITHOUT THE WRITTEN PERMISSION OF <INSERT COMPANY NAME HERE> IS PROHIBITED.

		UNLESS OTHERWISE SPECIFIED:	NAME	DATE
		DIMENSIONS ARE IN INCHES	DRAWN	
		TOLERANCES:	CHECKED	
		FRACTIONAL $\pm$	ENG APPR.	
		ANGULAR: MACH $\pm$ BEND $\pm$	MFG APPR.	
		TWO PLACE DECIMAL $\pm$	Q.A.	
		THREE PLACE DECIMAL $\pm$	COMMENTS:	
		INTERPRET GEOMETRIC TOLERANCING PER:		
		MATERIAL		
		6061 ALUMINUM		
NEXT ASSY	USED ON	FINISH		
APPLICATION		DO NOT SCALE DRAWING		

ME 450 TEAM 5		
TITLE:		
SPOOL SHAFT, SPRING SIDE		
SIZE	DWG. NO.	REV
<b>A</b>	SPOOL_SHAFT_ SPRING	
SCALE: 1:1	WEIGHT:	SHEET 1 OF 1

## Appendix K: Engineering Change Notifications

### **Engineering Change Notification #4**

ME 450 Team 5

Change of top spool cover from 3D printed part to fabricated aluminum sheet metal part

Parts Affected by change: Top Spool Cover

What has been changed:

After submitting the top spool cover for 3D printing from the UM 3D lab, the quoted price for printing both the top and bottom spool covers was much larger than the team anticipated. Our team only had room in the budget for one 3D printed part. The bottom spool cover, because all of the circuit components are fastened to the bottom cover, needed to be 3D printed. Thus, the top spool cover was revised so that it could be fabricated using other means.

The new design of the top spool cover includes 2 pieces: one piece that is permanently attached to the baseplate and another that is removable to allow the user to replace oxygen tubing in the device (see Figure 1 for a comparison between the old top spool cover and the new top spool cover). Both pieces are fabricated from bent sheet metal parts (see attached prints of these parts) and will be bent into “boxes”.

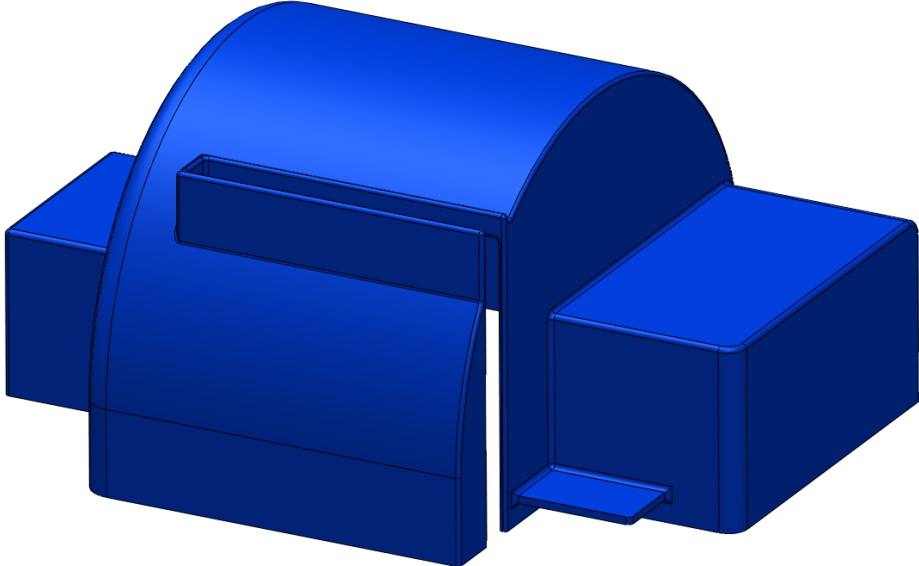
#6-32 by 3/8” bolts with #6-32 nuts will be used to fasten tabs to the bent “boxes”. These tabs will be used to fasten the cover to the baseplate (see attached prints for drawings of these parts). Velcro adhesive will be used to attach the removable component to the baseplate of the device. #10-24 by 3/8” long bolts will be used to fasten the permanent section of the cover to the baseplate. Holes were added to the baseplate to make this possible (see attached print). The bill of materials will be updated to reflect both new stock materials and fasteners required for this change.

Change Initiated by: Nathan Matheny

Date: 11/26/12

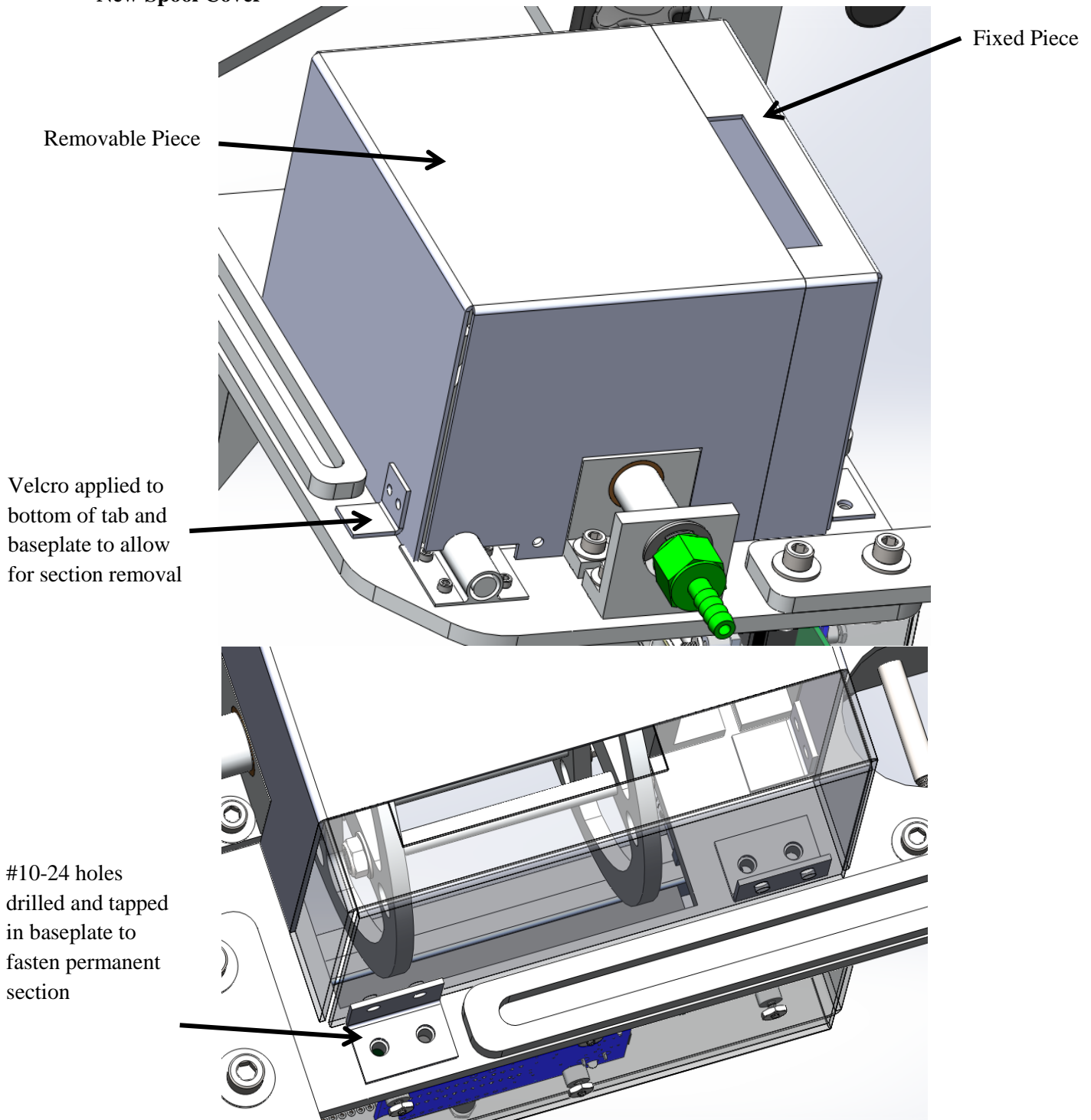
Change Approved By:

**Old Spool Cover**

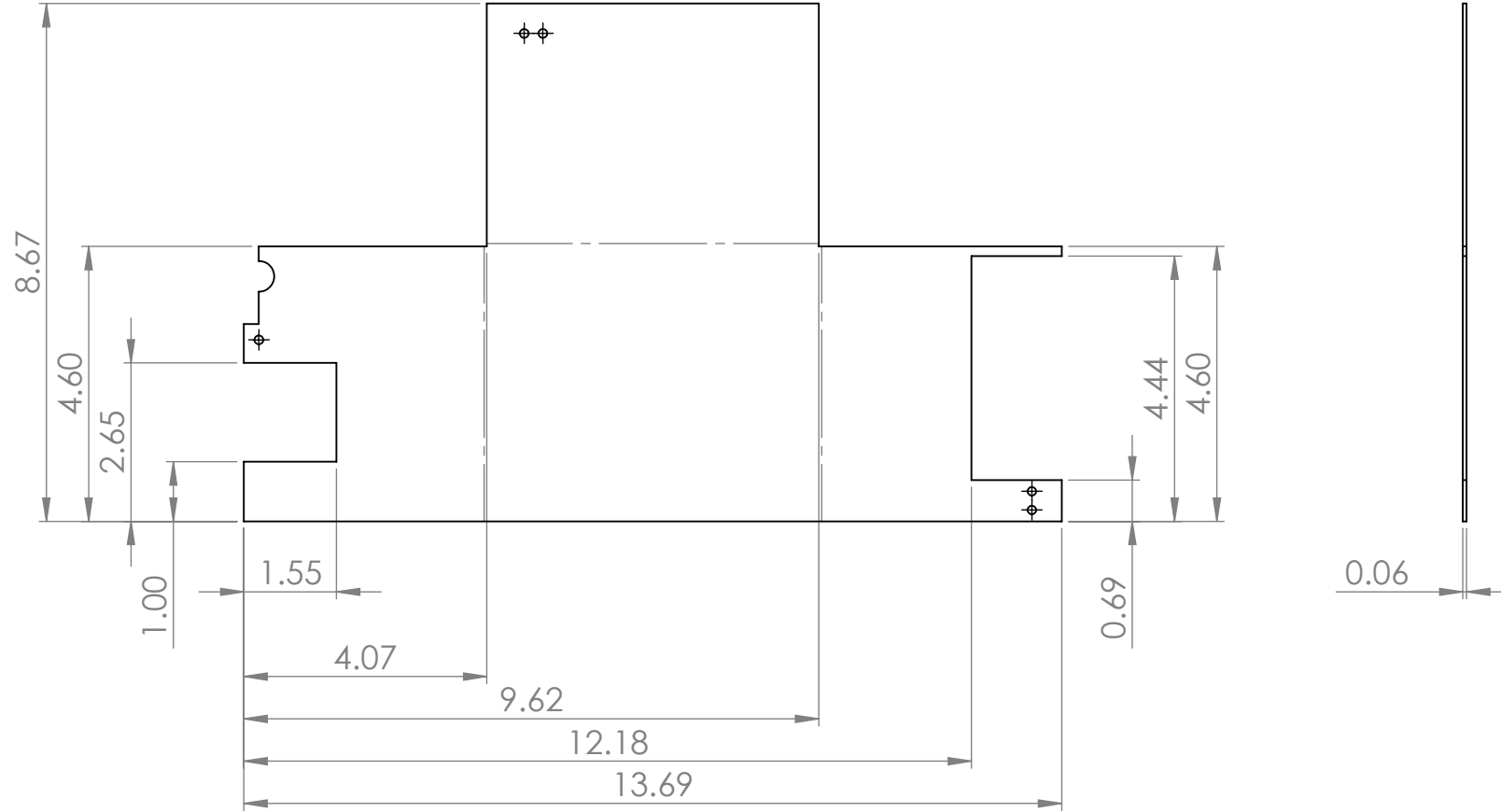




**New Spool Cover**



# Appendix K: Engineering Change Notifications

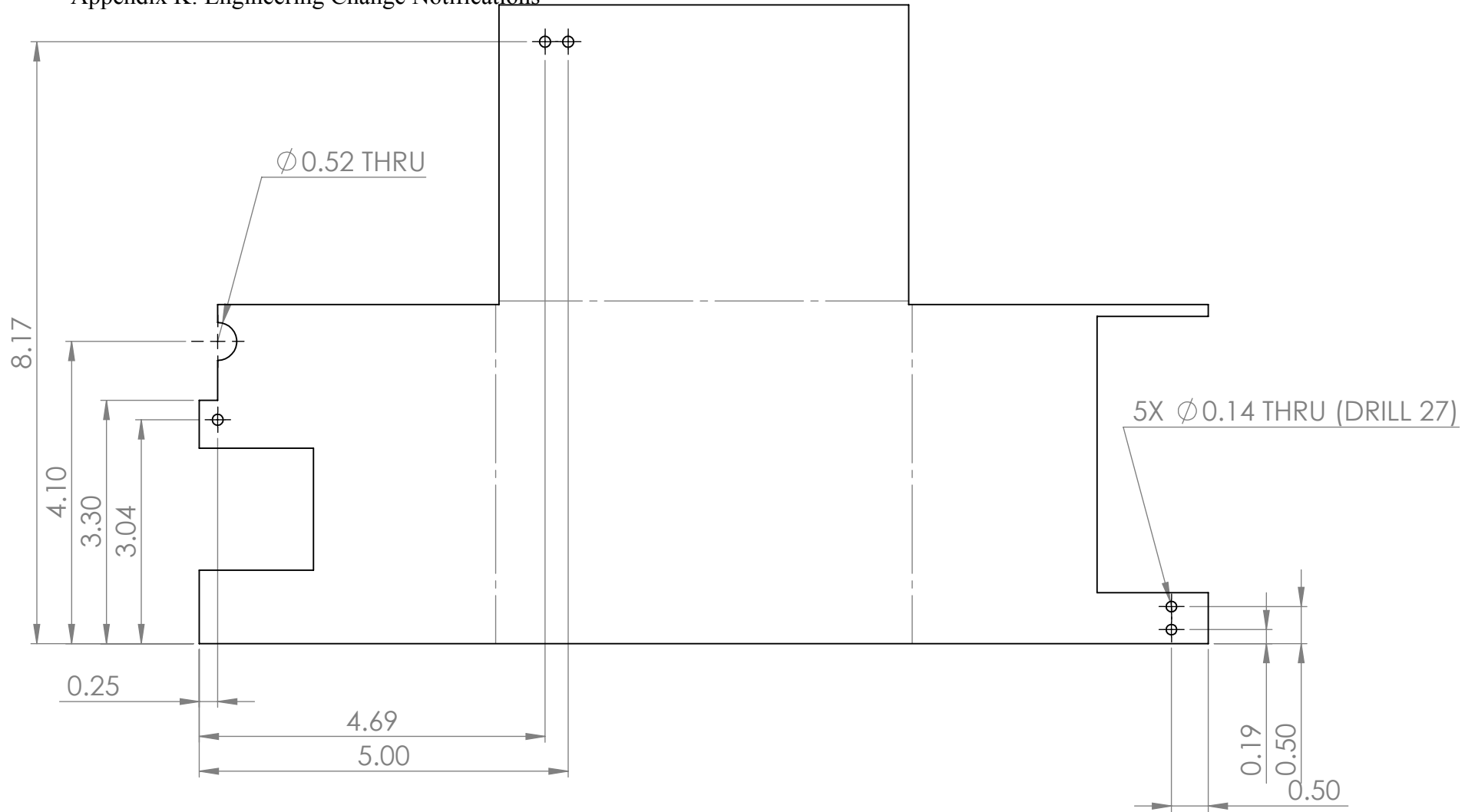


**PROPRIETARY AND CONFIDENTIAL**  
 THE INFORMATION CONTAINED IN THIS DRAWING IS THE SOLE PROPERTY OF <INSERT COMPANY NAME HERE>. ANY REPRODUCTION IN PART OR AS A WHOLE WITHOUT THE WRITTEN PERMISSION OF <INSERT COMPANY NAME HERE> IS PROHIBITED.

		UNLESS OTHERWISE SPECIFIED:		NAME	DATE
		DIMENSIONS ARE IN INCHES	DRAWN		
		TOLERANCES:	CHECKED		
		FRACTIONAL ±	ENG APPR.		
		ANGULAR: MACH ± BEND ±	MFG APPR.		
		TWO PLACE DECIMAL ±	Q.A.		
		THREE PLACE DECIMAL ±	COMMENTS:		
		INTERPRET GEOMETRIC TOLERANCING PER:			
		MATERIAL			
		6061 ALUMINUM			
		FINISH			
NEXT ASSY	USED ON				
APPLICATION		DO NOT SCALE DRAWING			

<b>ME 450 TEAM 5</b>		
TITLE:		
<b>TOP COVER, REMOVABLE</b>		
SIZE	DWG. NO.	REV
<b>A</b>	TOP_COVER_MAIN	
SCALE: 1:5	WEIGHT:	SHEET 1 OF 2

# Appendix K: Engineering Change Notifications



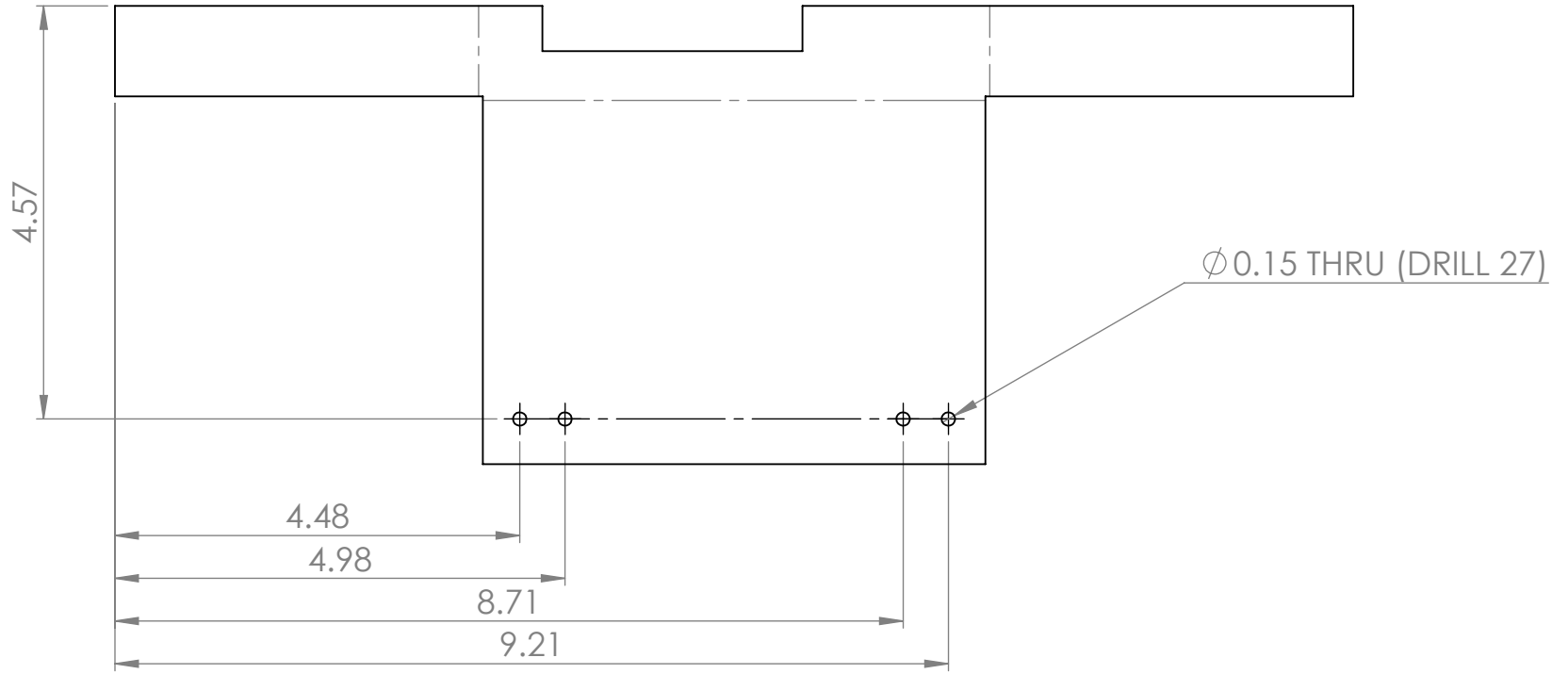
**PROPRIETARY AND CONFIDENTIAL**  
 THE INFORMATION CONTAINED IN THIS DRAWING IS THE SOLE PROPERTY OF <INSERT COMPANY NAME HERE>. ANY REPRODUCTION IN PART OR AS A WHOLE WITHOUT THE WRITTEN PERMISSION OF <INSERT COMPANY NAME HERE> IS PROHIBITED.

		UNLESS OTHERWISE SPECIFIED:		NAME	DATE
		DIMENSIONS ARE IN INCHES	DRAWN		
		TOLERANCES:	CHECKED		
		FRACTIONAL ±	ENG APPR.		
		ANGULAR: MACH ± BEND ±	MFG APPR.		
		TWO PLACE DECIMAL ±	Q.A.		
		THREE PLACE DECIMAL ±	COMMENTS:		
		INTERPRET GEOMETRIC TOLERANCING PER:			
		MATERIAL			
		6061 ALUMINUM			
		FINISH			
NEXT ASSY	USED ON				
APPLICATION		DO NOT SCALE DRAWING			

ME 450 TEAM 5		
TITLE:		
TOP COVER, REMOVABLE		
SIZE	DWG. NO.	REV
<b>A</b>	TOP_COVER_MAIN	
SCALE: 1:5	WEIGHT:	SHEET 2 OF 2



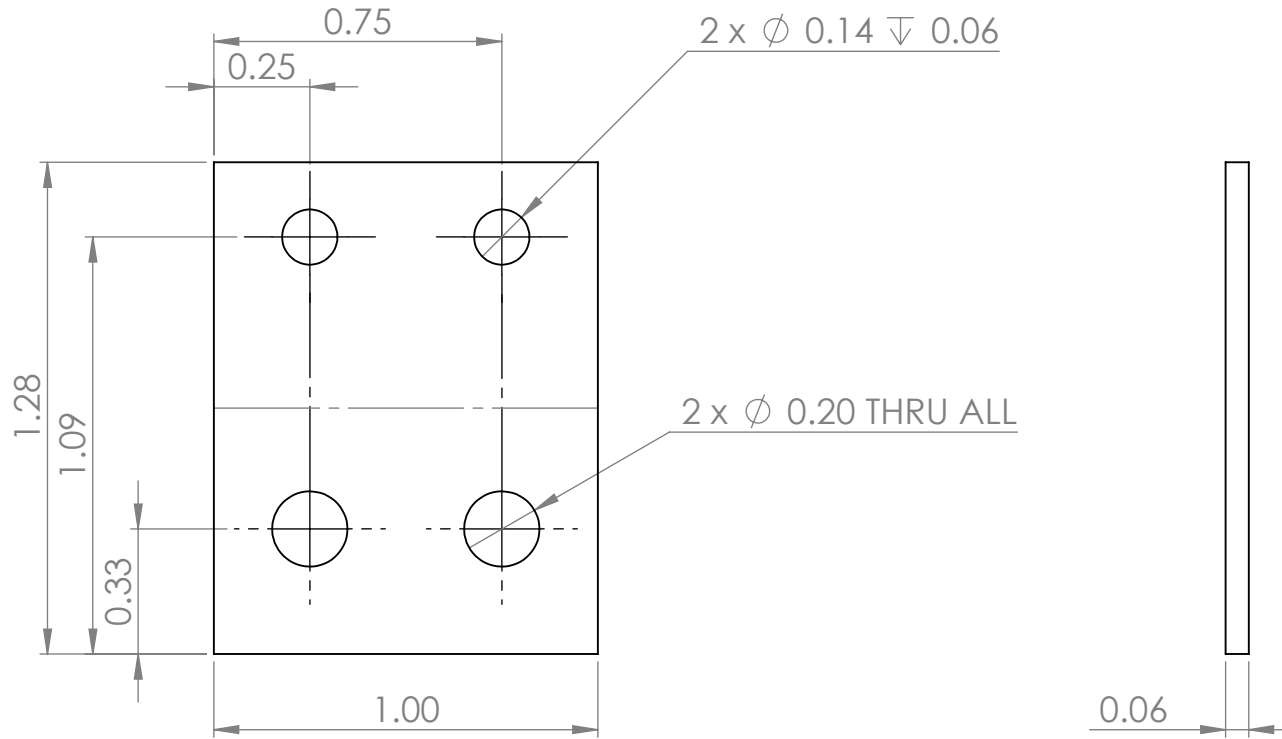
Appendix K: Engineering Change Notifications



**PROPRIETARY AND CONFIDENTIAL**  
 THE INFORMATION CONTAINED IN THIS DRAWING IS THE SOLE PROPERTY OF <INSERT COMPANY NAME HERE>. ANY REPRODUCTION IN PART OR AS A WHOLE WITHOUT THE WRITTEN PERMISSION OF <INSERT COMPANY NAME HERE> IS PROHIBITED.

		UNLESS OTHERWISE SPECIFIED:		NAME	DATE	<b>ME 450 TEAM 5</b>	
		DIMENSIONS ARE IN INCHES TOLERANCES: FRACTIONAL ± ANGULAR: MACH ± BEND ± TWO PLACE DECIMAL ± THREE PLACE DECIMAL ±	DRAWN			TITLE:	
		INTERPRET GEOMETRIC TOLERANCING PER:	CHECKED			<b>TOP COVER, FIXED</b>	
		MATERIAL <b>6061 ALUMINUM</b>	ENG APPR.			SIZE	DWG. NO.
		FINISH	MFG APPR.			<b>A</b>	<b>TOP_COVER SECONDARY</b>
NEXT ASSY	USED ON		Q.A.				REV
APPLICATION		DO NOT SCALE DRAWING	COMMENTS:			SCALE: 1:2	WEIGHT:
							SHEET 2 OF 2

Appendix K: Engineering Change Notifications

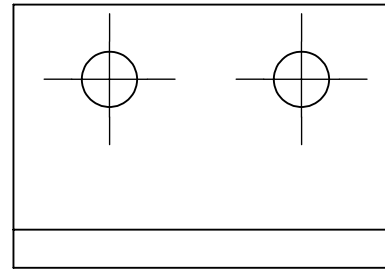
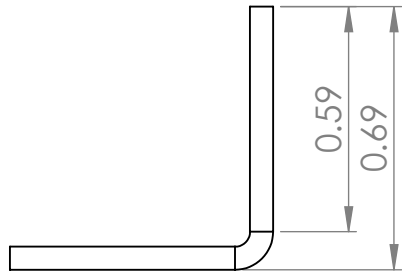


2X PART

**PROPRIETARY AND CONFIDENTIAL**  
 THE INFORMATION CONTAINED IN THIS DRAWING IS THE SOLE PROPERTY OF <INSERT COMPANY NAME HERE>. ANY REPRODUCTION IN PART OR AS A WHOLE WITHOUT THE WRITTEN PERMISSION OF <INSERT COMPANY NAME HERE> IS PROHIBITED.

		UNLESS OTHERWISE SPECIFIED:		NAME	DATE	<b>ME 450 TEAM 5</b>	
		DIMENSIONS ARE IN INCHES		DRAWN		TITLE:	
		TOLERANCES:		CHECKED		<b>TOP COVER, FIXED TAB</b>	
		FRACTIONAL ±		ENG APPR.		SIZE	DWG. NO.
		ANGULAR: MACH ± BEND ±		MFG APPR.		<b>A</b>	<b>TOP_COVER</b>
		TWO PLACE DECIMAL ±		Q.A.			<b>TAB_2</b>
		THREE PLACE DECIMAL ±		COMMENTS:			REV
		INTERPRET GEOMETRIC TOLERANCING PER:				SCALE: 2:1	WEIGHT:
		MATERIAL					SHEET 1 OF 2
		<b>6061 ALUMINUM</b>					<b>K27</b>
		FINISH					
NEXT ASSY	USED ON	APPLICATION	DO NOT SCALE DRAWING				

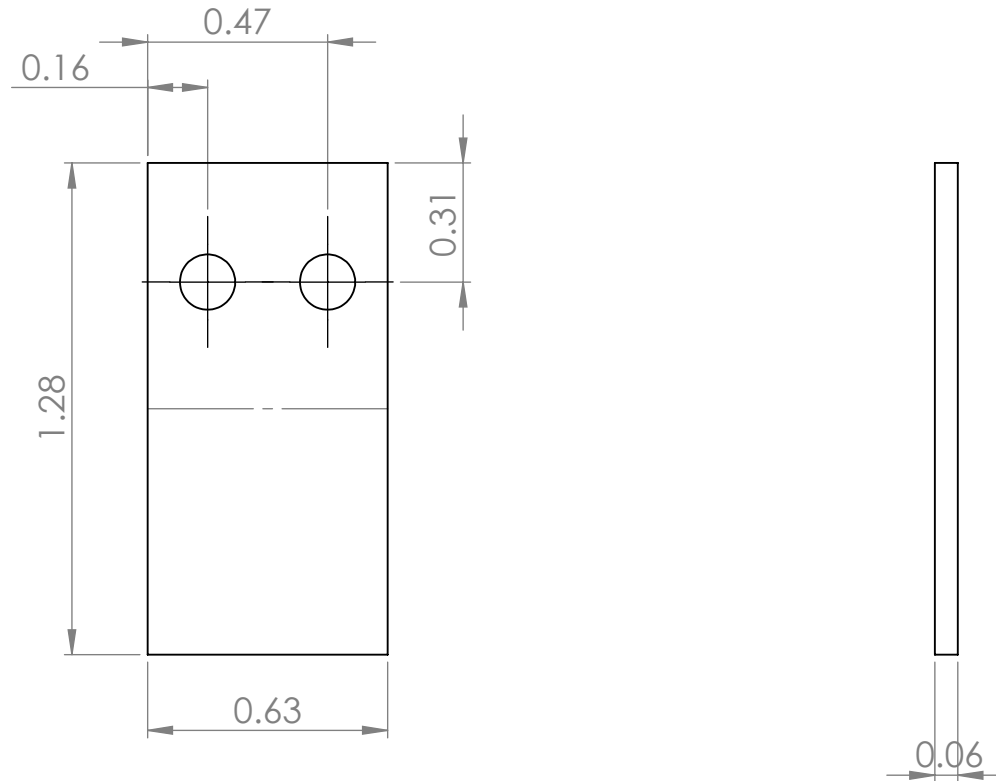
# Appendix K: Engineering Change Notifications



**PROPRIETARY AND CONFIDENTIAL**  
 THE INFORMATION CONTAINED IN THIS DRAWING IS THE SOLE PROPERTY OF <INSERT COMPANY NAME HERE>. ANY REPRODUCTION IN PART OR AS A WHOLE WITHOUT THE WRITTEN PERMISSION OF <INSERT COMPANY NAME HERE> IS PROHIBITED.

		UNLESS OTHERWISE SPECIFIED:		NAME	DATE	<b>ME 450 TEAM 5</b>	
		DIMENSIONS ARE IN INCHES TOLERANCES: FRACTIONAL ± ANGULAR: MACH ± BEND ± TWO PLACE DECIMAL ± THREE PLACE DECIMAL ±	DRAWN			TITLE:	
		INTERPRET GEOMETRIC TOLERANCING PER:	CHECKED			<b>TOP COVER, FIXED TAB</b>	
		MATERIAL <b>6061 ALUMINUM</b>	ENG APPR.				
		FINISH	MFG APPR.			SIZE	DWG. NO.
NEXT ASSY	USED ON		Q.A.			<b>A</b>	<b>TOP_COVER TAB_2</b>
APPLICATION		DO NOT SCALE DRAWING	COMMENTS:			SCALE: 2:1	WEIGHT:
							SHEET 2 OF 2

Appendix K: Engineering Change Notifications



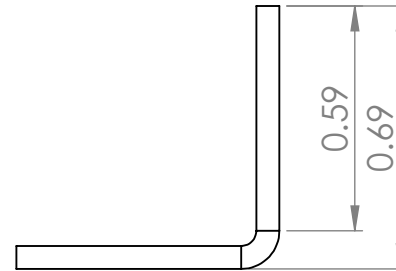
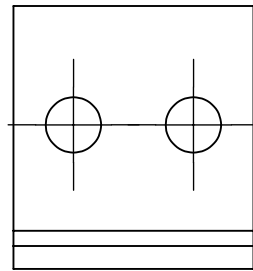
2X PART

**PROPRIETARY AND CONFIDENTIAL**  
 THE INFORMATION CONTAINED IN THIS DRAWING IS THE SOLE PROPERTY OF <INSERT COMPANY NAME HERE>. ANY REPRODUCTION IN PART OR AS A WHOLE WITHOUT THE WRITTEN PERMISSION OF <INSERT COMPANY NAME HERE> IS PROHIBITED.

		UNLESS OTHERWISE SPECIFIED:		NAME	DATE	<b>ME 450 TEAM 5</b>		
		DIMENSIONS ARE IN INCHES	DRAWN			TITLE:		
		TOLERANCES:	CHECKED			<b>TOP COVER, VELCRO TAB</b>		
		FRACTIONAL ±	ENG APPR.					
		ANGULAR: MACH ± BEND ±	MFG APPR.			SIZE	DWG. NO.	REV
		TWO PLACE DECIMAL ±	Q.A.			<b>A</b>	TOP_COVER_VELCRO	
		THREE PLACE DECIMAL ±	COMMENTS:				TAB_2	
		INTERPRET GEOMETRIC TOLERANCING PER:				SCALE: 2:1	WEIGHT:	SHEET 1 OF 2
		MATERIAL						<b>K29</b>
		<b>60601 ALUMINUM</b>						
		FINISH						
NEXT ASSY	USED ON							
APPLICATION		DO NOT SCALE DRAWING						



# Appendix K: Engineering Change Notifications

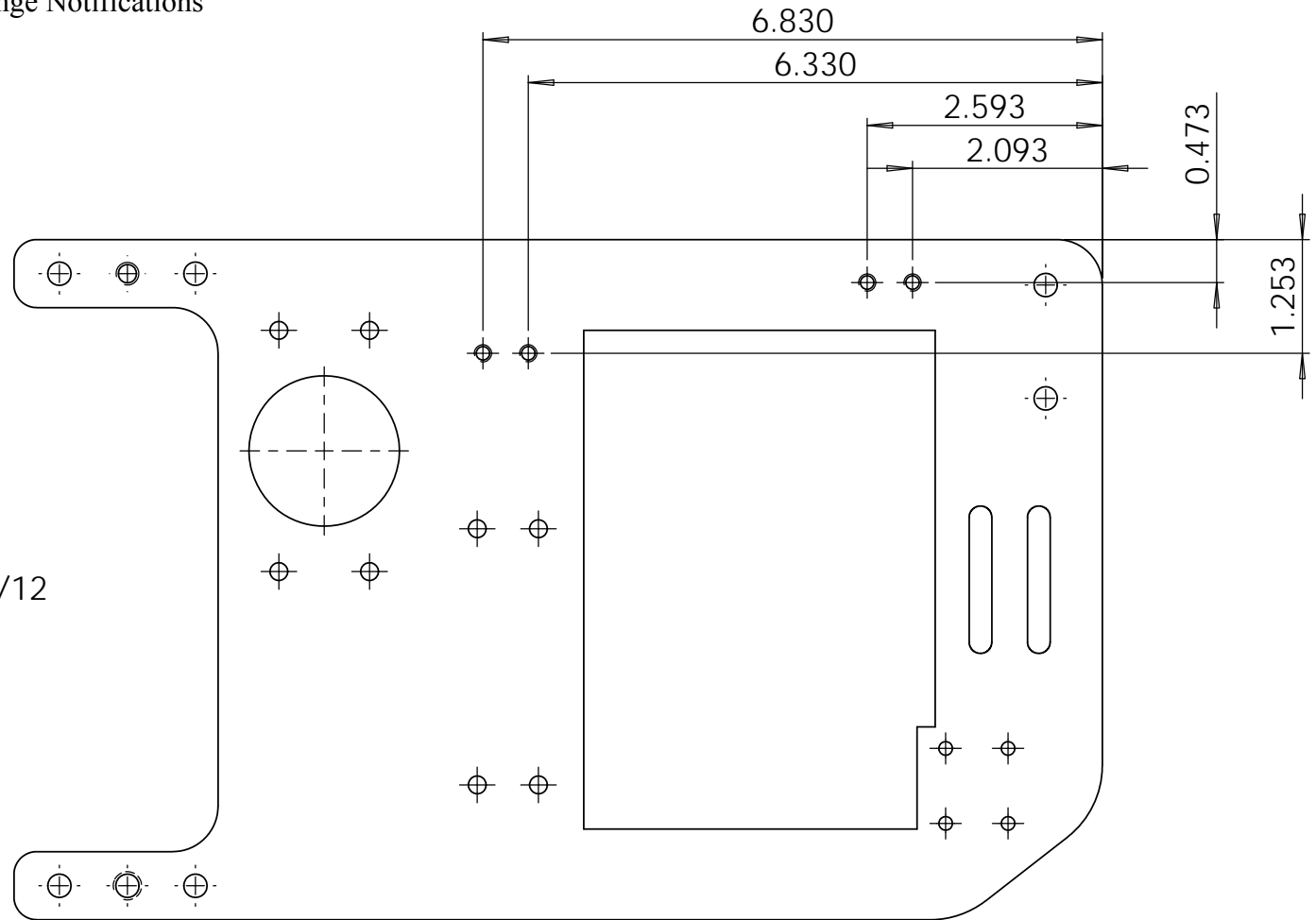


**PROPRIETARY AND CONFIDENTIAL**  
 THE INFORMATION CONTAINED IN THIS DRAWING IS THE SOLE PROPERTY OF <INSERT COMPANY NAME HERE>. ANY REPRODUCTION IN PART OR AS A WHOLE WITHOUT THE WRITTEN PERMISSION OF <INSERT COMPANY NAME HERE> IS PROHIBITED.

		UNLESS OTHERWISE SPECIFIED:	NAME	DATE	<b>ME 450 TEAM 5</b>	
		DIMENSIONS ARE IN INCHES TOLERANCES: FRACTIONAL ± ANGULAR: MACH ± BEND ± TWO PLACE DECIMAL ± THREE PLACE DECIMAL ±	DRAWN			
		INTERPRET GEOMETRIC TOLERANCING PER:	CHECKED		<b>TOP COVER, VELCRO TAB BENT</b>	
		MATERIAL <b>6061 ALUMINUM</b>	ENG APPR.			
		FINISH	MFG APPR.		SIZE	DWG. NO.
NEXT ASSY	USED ON		Q.A.		<b>A</b>	REV
APPLICATION		DO NOT SCALE DRAWING	COMMENTS:			SCALE: 2:1
					SHEET 2 OF 2	



Appendix K: Engineering Change Notifications



MODIFICATIONS MADE 11/28/12

**PROPRIETARY AND CONFIDENTIAL**  
 THE INFORMATION CONTAINED IN THIS DRAWING IS THE SOLE PROPERTY OF <INSERT COMPANY NAME HERE>. ANY REPRODUCTION IN PART OR AS A WHOLE WITHOUT THE WRITTEN PERMISSION OF <INSERT COMPANY NAME HERE> IS PROHIBITED.

		UNLESS OTHERWISE SPECIFIED:		NAME	DATE	<b>ME 450 TEAM 5</b>	
		DIMENSIONS ARE IN INCHES	DRAWN			TITLE:	
		TOLERANCES:	CHECKED			<b>BASEPLATE</b>	
		FRACTIONAL ±	ENG APPR.				
		ANGULAR: MACH ± BEND ±	MFG APPR.				
		TWO PLACE DECIMAL ±	Q.A.				
		THREE PLACE DECIMAL ±	COMMENTS:			SIZE	DWG. NO.
		INTERPRET GEOMETRIC TOLERANCING PER:				<b>A</b>	<b>BASEPLATE</b>
		MATERIAL					REV
		<b>6061 ALUMINUM</b>					
		FINISH					
NEXT ASSY	USED ON					SCALE: 1:5	WEIGHT:
APPLICATION		DO NOT SCALE DRAWING					SHEET 4 OF 4

## Appendix K: Engineering Change Notifications

### **Engineering Change Notification #5**

ME 450 Team 5

Change bottom spool cover to be made of sheet metal and no longer require 3D printing

Parts Affected by change: Bottom Spool Cover

What has been changed:

After submitting the top spool cover for 3D printing from the UM 3D lab, there was some miscommunication with the staff of the lab, and the part did not get placed into the queue until 11/27/12. There are a lot of parts waiting to be printed, and it was estimated that we would receive the parts on the evening of Wednesday, December 5<sup>th</sup>, which is one day before Design Expo. This would not be enough time to assemble the bottom cover and test the device, so a change had to be made. This change will also save us a lot of money, as the 3D printing was very costly and we will be using stock material already available to us.

The bottom spool cover will now be made from 2 parts, both bent sheet metal “boxes” (see figures for a view of the cover attached to the baseplate). They will be made from 14 gauge aluminum sheet metal (as this stock is available to our team at no extra cost). These boxes will be fastened to the baseplate using bent tabs and #10-24, 3/8” long fasteners. These will be threaded into the baseplate, and the baseplate will need to be updated to include these threaded holes. The tabs will be attached to the “boxes” with #6-32 bolts and nuts. For prints of these cover parts, fastening tabs, and updated baseplate holes, see the attached drawings.

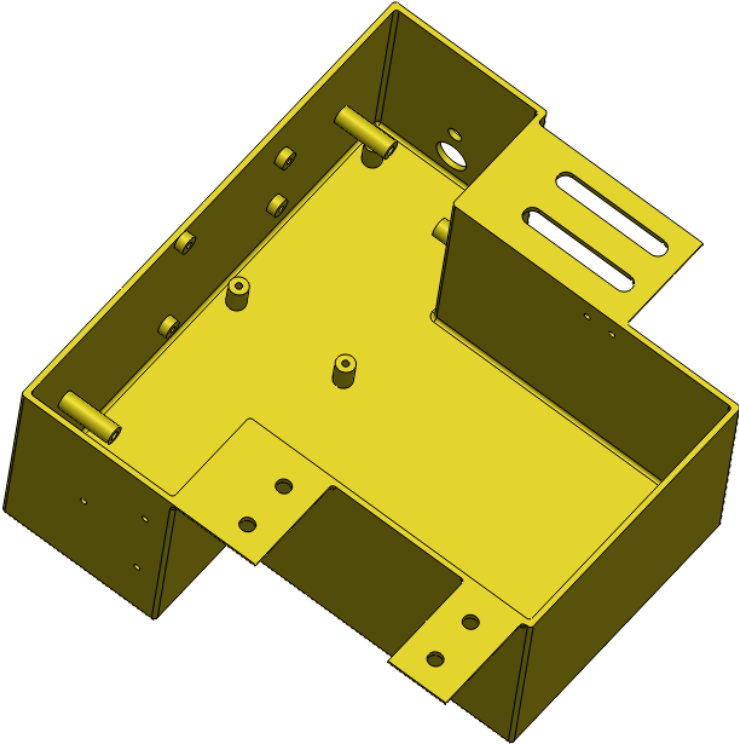
The circuit components will be attached to the walls of these covers using #2-56 machine screws and nuts. Spacers will be created to offset these components from the cover walls so that there is room for the circuit wiring and other components to fit in the cover (see figures for how circuit components will be fastened to the cover walls). For prints of these spacers, see attached drawings.

Change Initiated by: Nathan Matheny

Date: 11/30/12

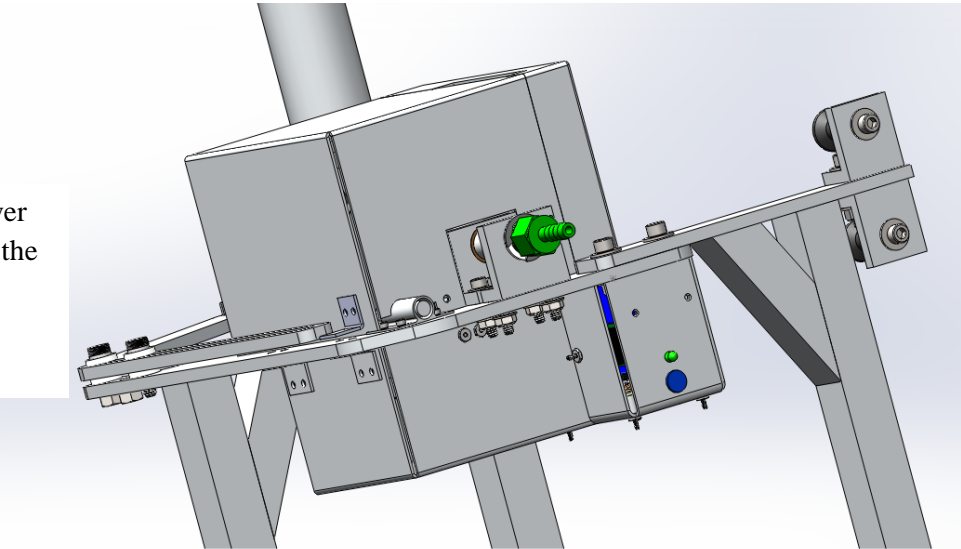
Change Approved By:

**Old Bottom Cover**



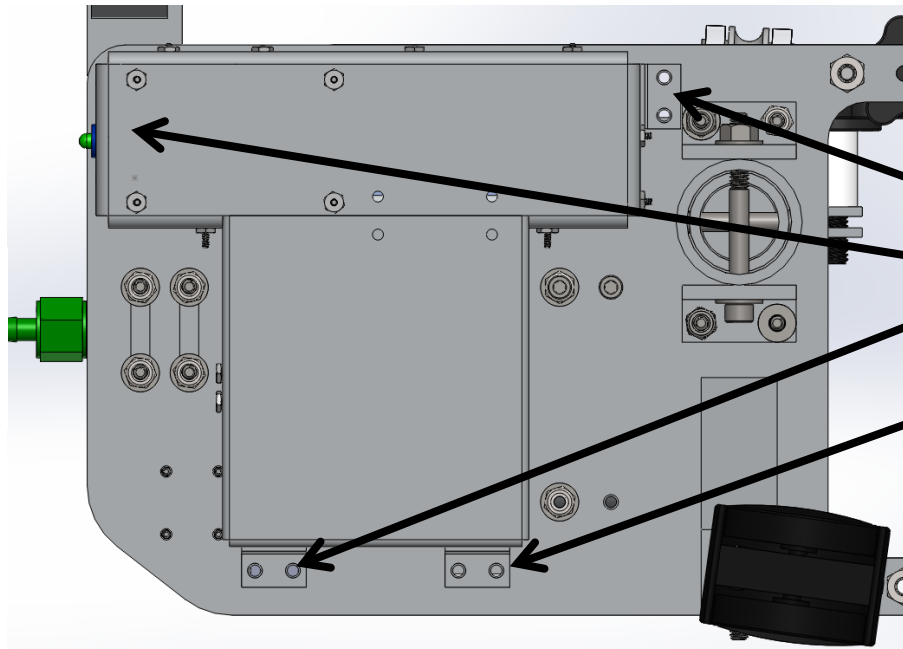
**New Bottom Cover**

Bottom cover attached to the baseplate

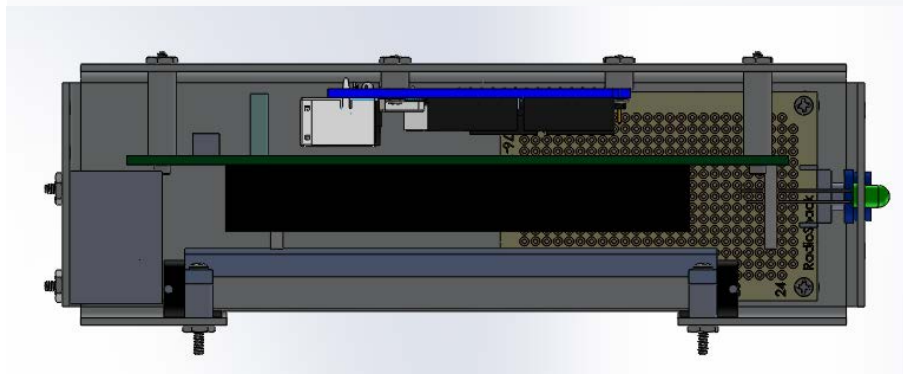


Appendix K: Engineering Change Notifications

Bottom view of bottom cover attached to baseplate

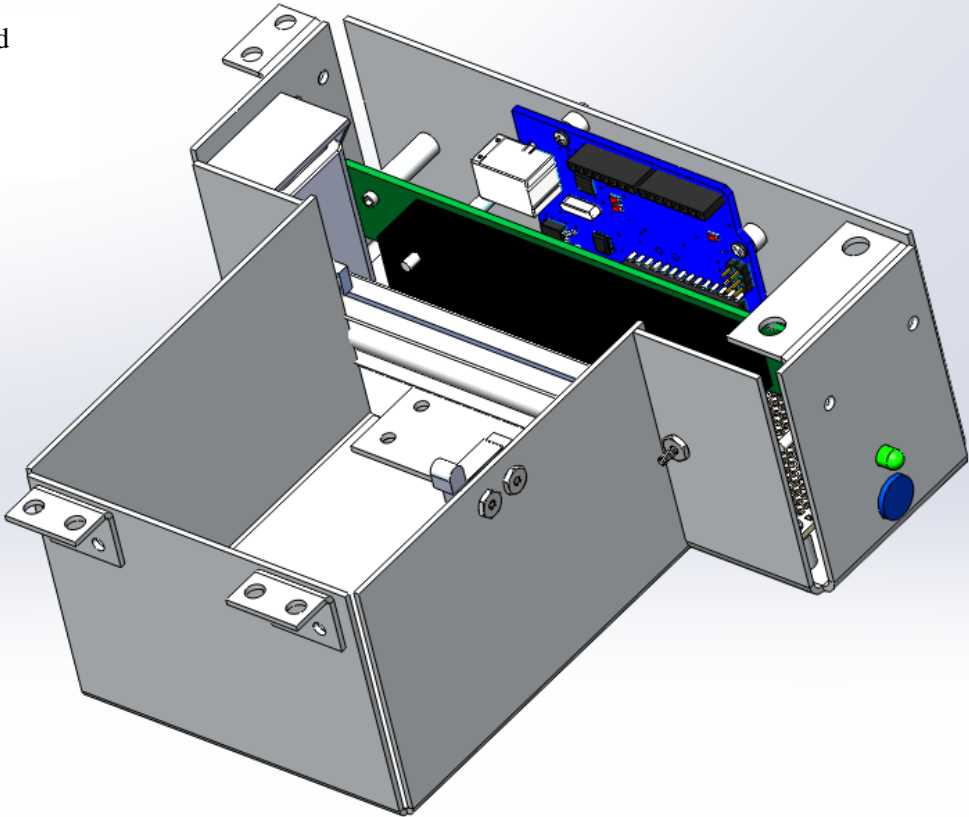


Tabs for fastening to baseplate (one mounted on interior of cover, fastener to be reached from top)

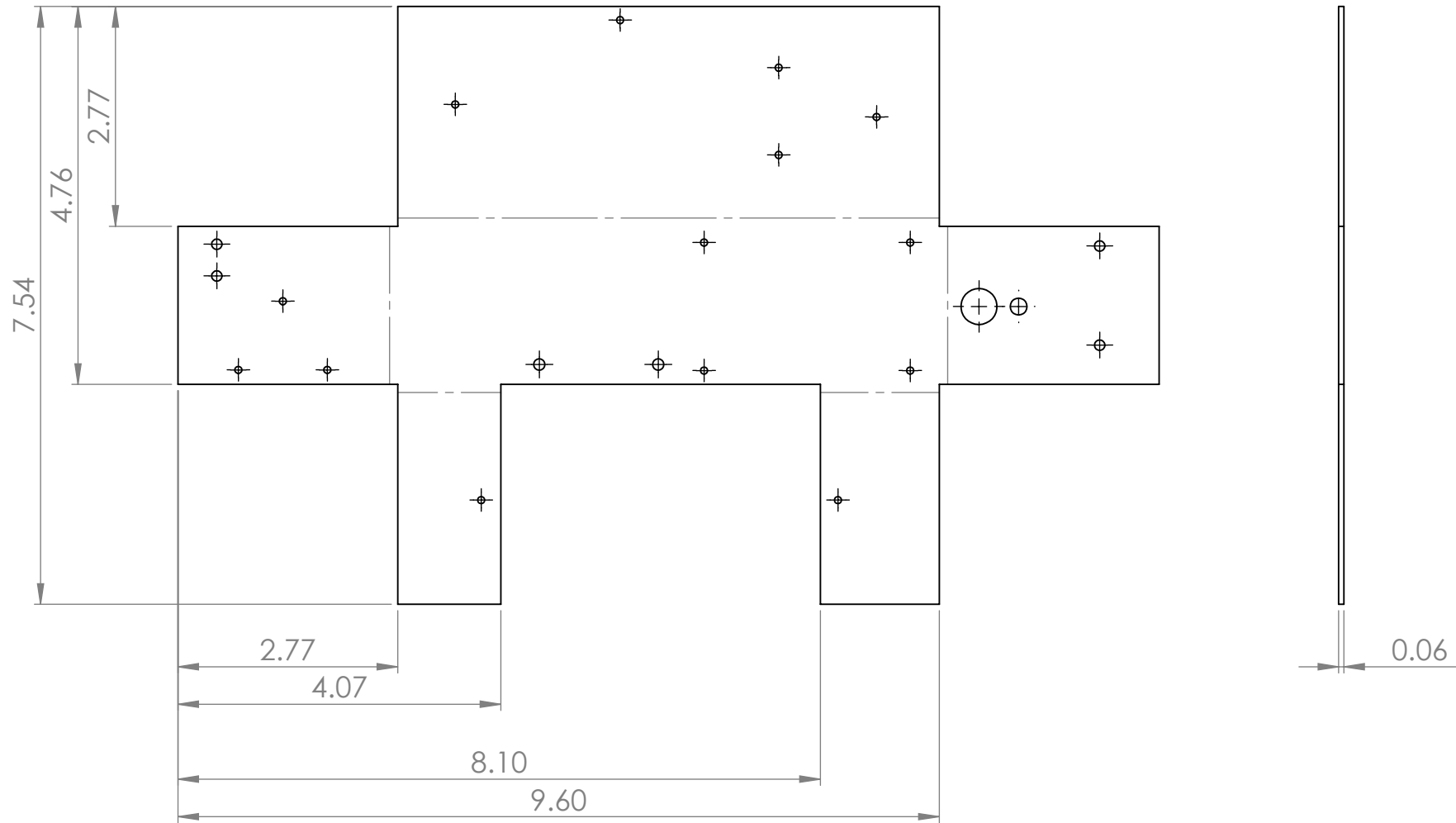


Circuit components fastened in bottom housing using spacers as "posts"

Assembled  
Bottom  
Housing



# Appendix K: Engineering Change Notifications



**PROPRIETARY AND CONFIDENTIAL**  
 THE INFORMATION CONTAINED IN THIS DRAWING IS THE SOLE PROPERTY OF <INSERT COMPANY NAME HERE>. ANY REPRODUCTION IN PART OR AS A WHOLE WITHOUT THE WRITTEN PERMISSION OF <INSERT COMPANY NAME HERE> IS PROHIBITED.

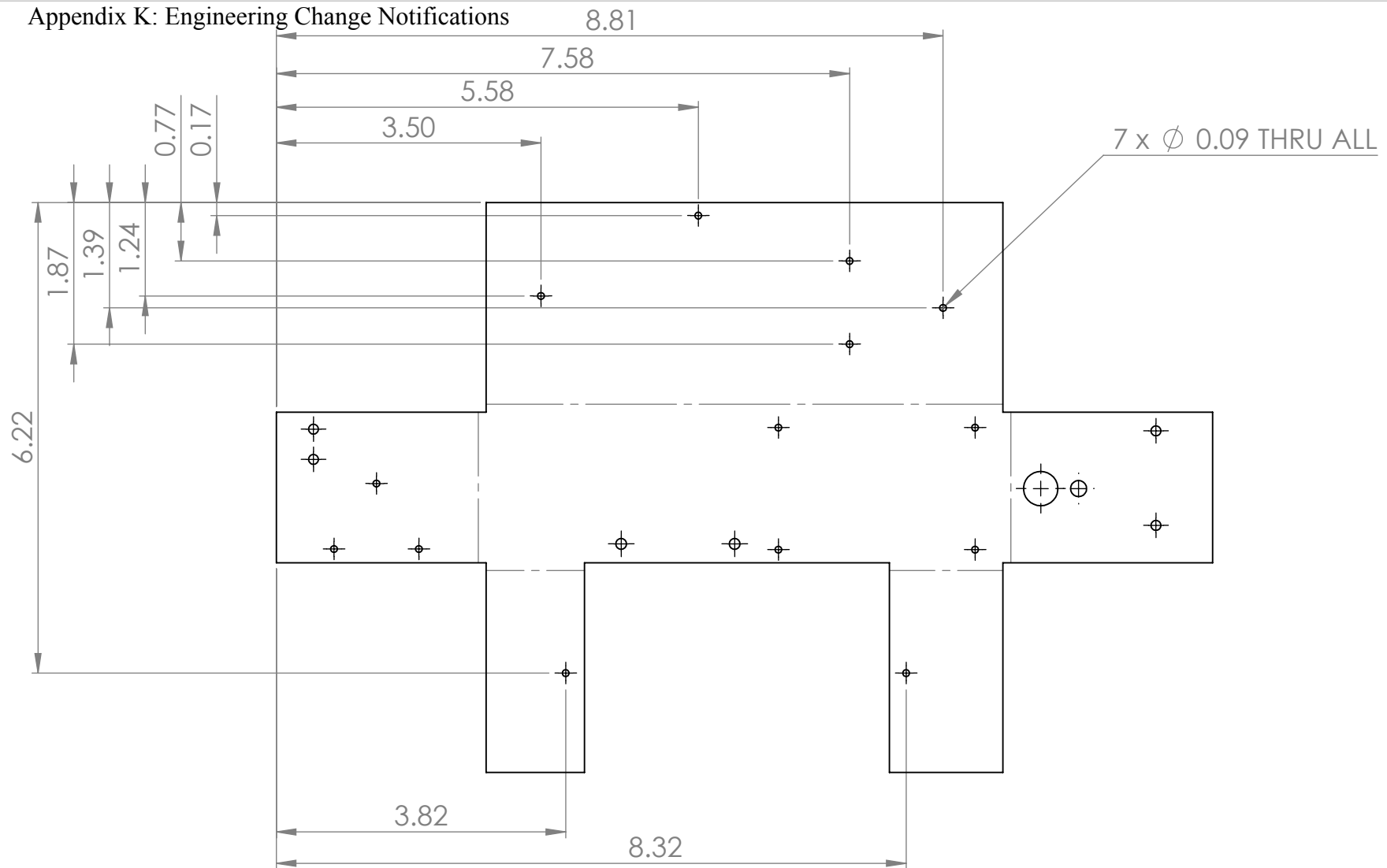
		UNLESS OTHERWISE SPECIFIED:		NAME	DATE
		DIMENSIONS ARE IN INCHES	DRAWN		
		TOLERANCES:	CHECKED		
		FRACTIONAL ±	ENG APPR.		
		ANGULAR: MACH ± BEND ±	MFG APPR.		
		TWO PLACE DECIMAL ±	Q.A.		
		THREE PLACE DECIMAL ±	COMMENTS:		
		INTERPRET GEOMETRIC TOLERANCING PER:			
		MATERIAL			
		6061 ALUMINUM			
		FINISH			
NEXT ASSY	USED ON				
APPLICATION		DO NOT SCALE DRAWING			

ME 450 TEAM 5		
TITLE:		
BOTTOM COVER, CIRCUIT		
SIZE	DWG. NO.	REV
<b>A</b>	BOTTOM_SPOOL_COVER SM_CIRCUIT	
SCALE: 1:2	WEIGHT:	SHEET 1 OF 4





Appendix K: Engineering Change Notifications



**PROPRIETARY AND CONFIDENTIAL**  
 THE INFORMATION CONTAINED IN THIS DRAWING IS THE SOLE PROPERTY OF <INSERT COMPANY NAME HERE>. ANY REPRODUCTION IN PART OR AS A WHOLE WITHOUT THE WRITTEN PERMISSION OF <INSERT COMPANY NAME HERE> IS PROHIBITED.

		UNLESS OTHERWISE SPECIFIED:		NAME	DATE
		DIMENSIONS ARE IN INCHES	DRAWN		
		TOLERANCES:	CHECKED		
		FRACTIONAL ±	ENG APPR.		
		ANGULAR: MACH ± BEND ±	MFG APPR.		
		TWO PLACE DECIMAL ±	Q.A.		
		THREE PLACE DECIMAL ±	COMMENTS:		
		INTERPRET GEOMETRIC TOLERANCING PER:			
		MATERIAL			
		6061 ALUMINUM			
		FINISH			
NEXT ASSY	USED ON				
APPLICATION		DO NOT SCALE DRAWING			

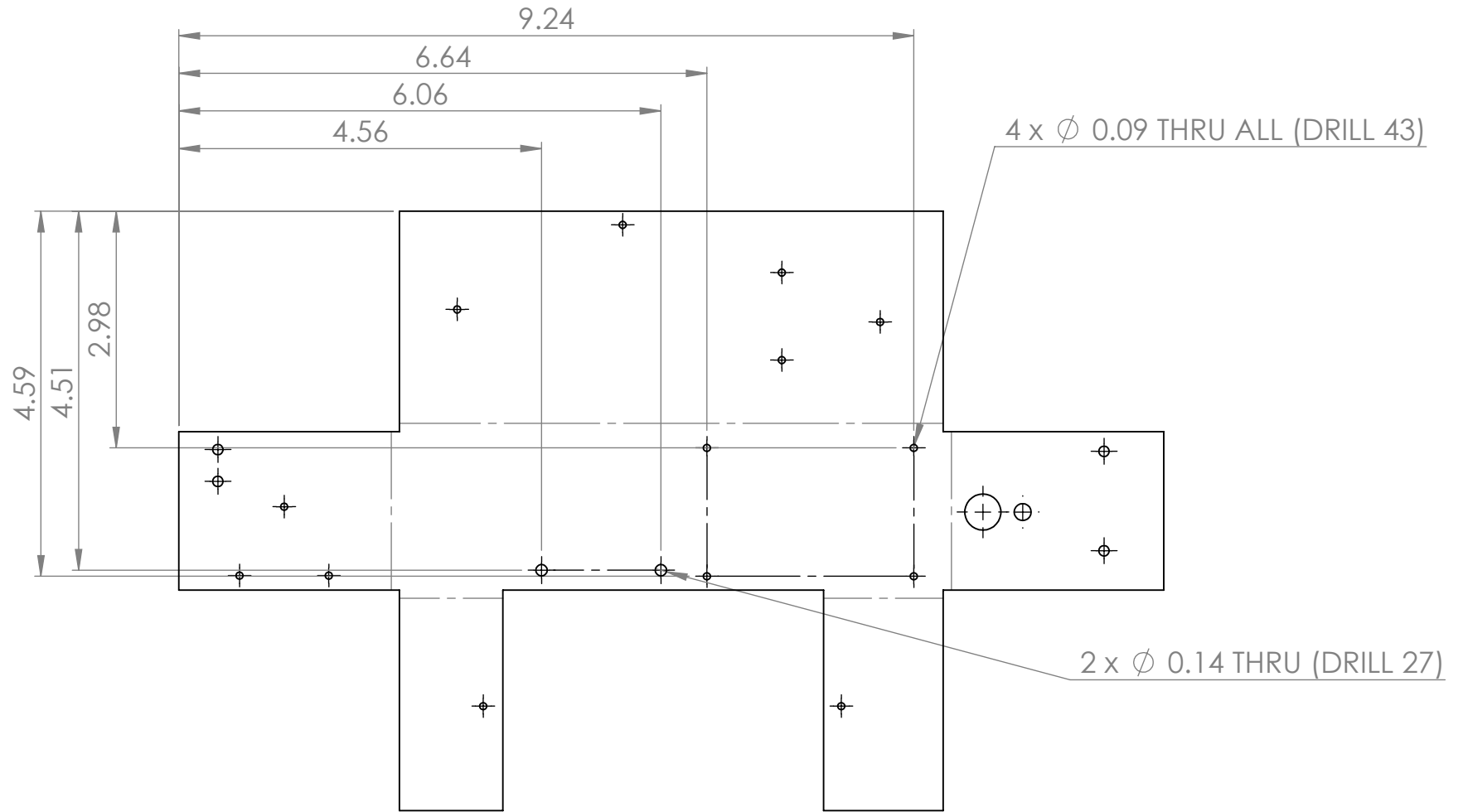
ME 450 TEAM 5

TITLE:  
**BOTTOM COVER, CIRCUIT**

SIZE <b>A</b>	DWG. NO. BOTTOM_SPOOL_COVER SM_CIRCUIT	REV
------------------	--	-----

SCALE: 1:2	WEIGHT:	SHEET 3 OF 4
------------	---------	--------------

# Appendix K: Engineering Change Notifications

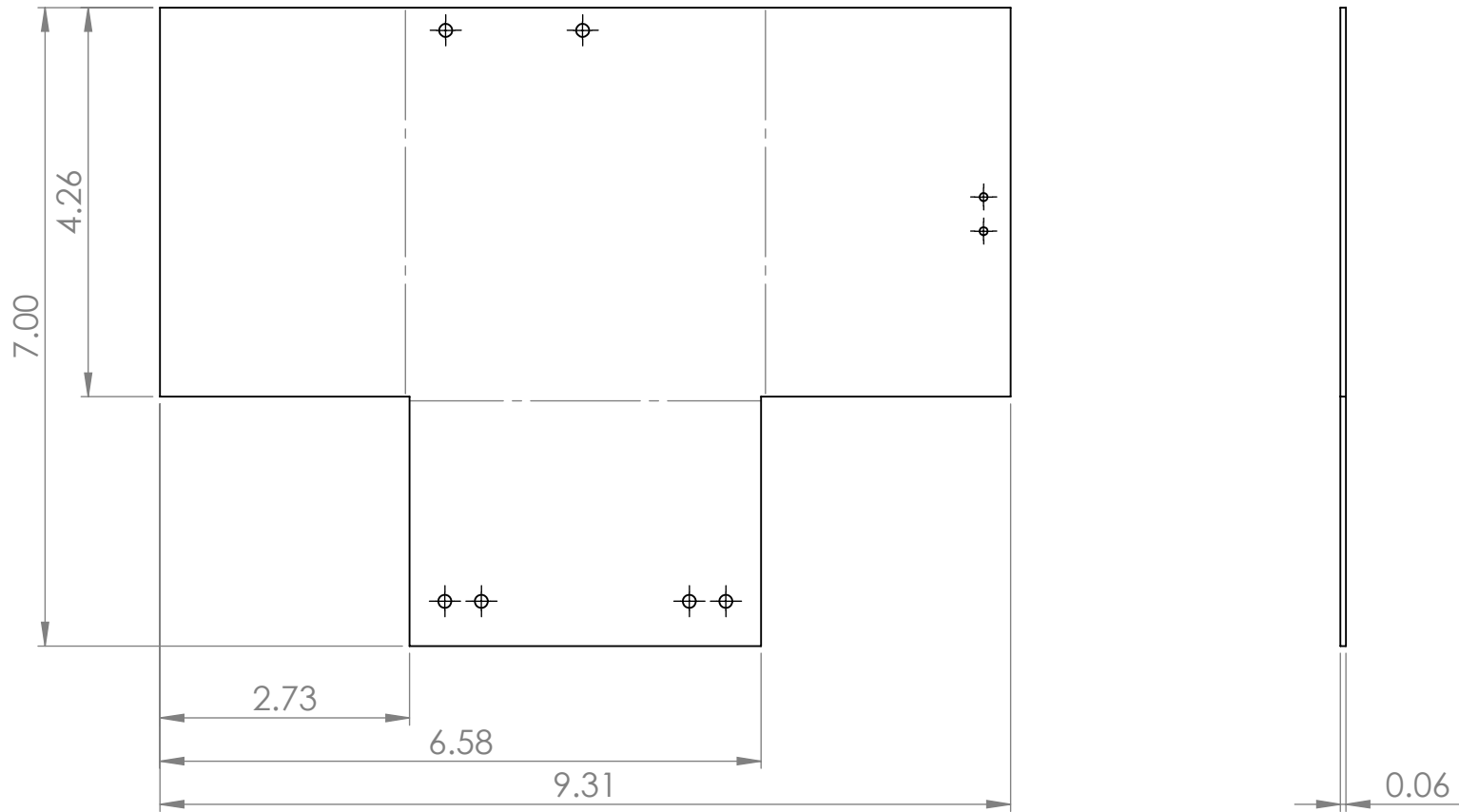


**PROPRIETARY AND CONFIDENTIAL**  
 THE INFORMATION CONTAINED IN THIS DRAWING IS THE SOLE PROPERTY OF <INSERT COMPANY NAME HERE>. ANY REPRODUCTION IN PART OR AS A WHOLE WITHOUT THE WRITTEN PERMISSION OF <INSERT COMPANY NAME HERE> IS PROHIBITED.

		UNLESS OTHERWISE SPECIFIED:		NAME	DATE
		DIMENSIONS ARE IN INCHES	DRAWN		
		TOLERANCES:	CHECKED		
		FRACTIONAL ±	ENG APPR.		
		ANGULAR: MACH ± BEND ±	MFG APPR.		
		TWO PLACE DECIMAL ±	Q.A.		
		THREE PLACE DECIMAL ±	COMMENTS:		
		INTERPRET GEOMETRIC TOLERANCING PER:			
		MATERIAL			
		6061 ALUMINUM			
		FINISH			
NEXT ASSY	USED ON				
APPLICATION		DO NOT SCALE DRAWING			

ME 450 TEAM 5		
TITLE:		
BOTTOM COVER, CIRCUIT		
SIZE	DWG. NO.	REV
<b>A</b>	BOTTOM_SPOOL_COVER SM_CIRCUIT	
SCALE: 1:2	WEIGHT:	SHEET 4 OF 4

# Appendix K: Engineering Change Notifications

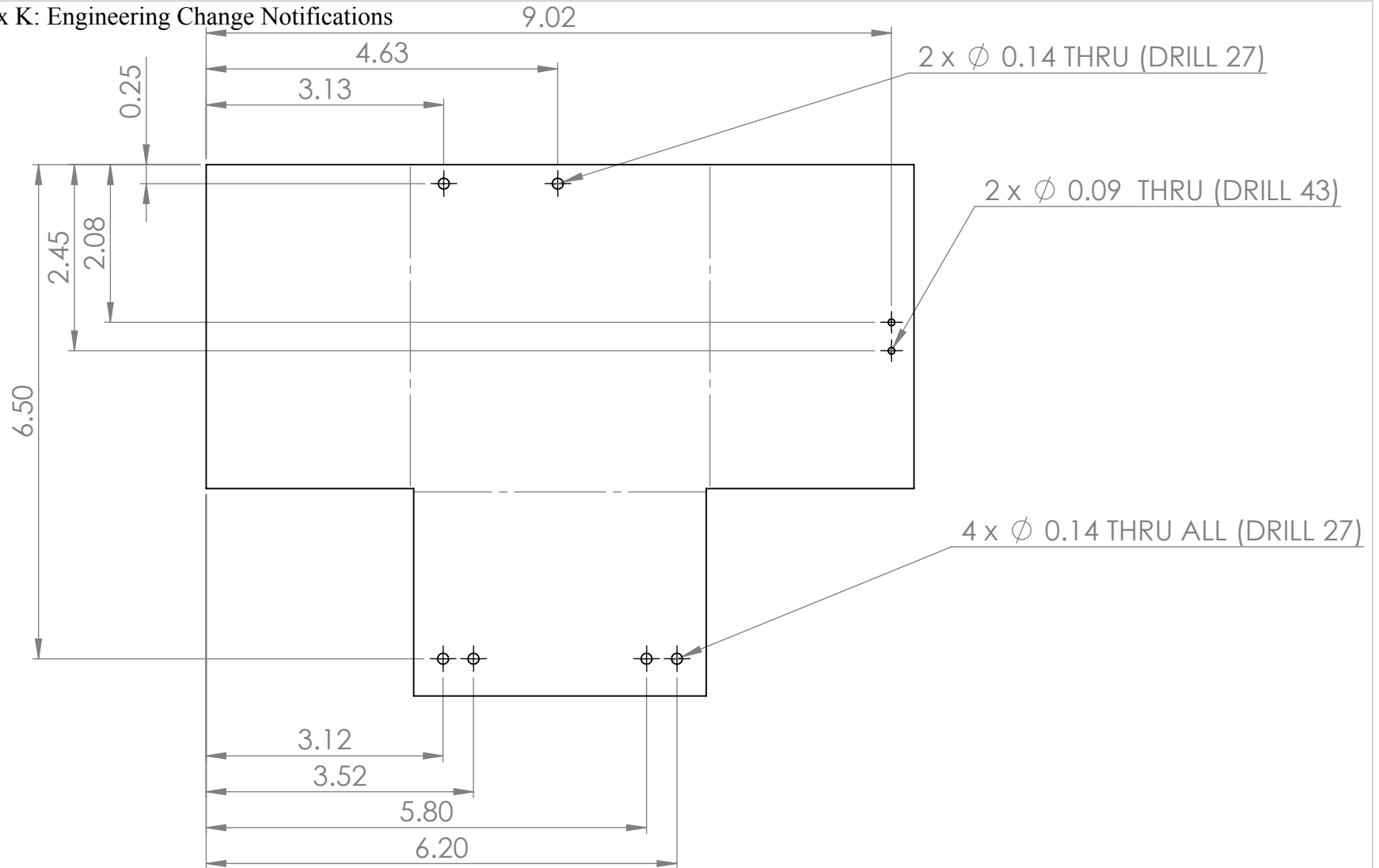


**PROPRIETARY AND CONFIDENTIAL**  
 THE INFORMATION CONTAINED IN THIS DRAWING IS THE SOLE PROPERTY OF <INSERT COMPANY NAME HERE>. ANY REPRODUCTION IN PART OR AS A WHOLE WITHOUT THE WRITTEN PERMISSION OF <INSERT COMPANY NAME HERE> IS PROHIBITED.

		UNLESS OTHERWISE SPECIFIED:		NAME	DATE
		DIMENSIONS ARE IN INCHES	DRAWN		
		TOLERANCES:	CHECKED		
		FRACTIONAL ±	ENG APPR.		
		ANGULAR: MACH ± BEND ±	MFG APPR.		
		TWO PLACE DECIMAL ±	Q.A.		
		THREE PLACE DECIMAL ±	COMMENTS:		
		INTERPRET GEOMETRIC TOLERANCING PER:			
		MATERIAL			
		6061 ALUMINUM			
		FINISH			
NEXT ASSY	USED ON				
APPLICATION		DO NOT SCALE DRAWING			

ME 450 TEAM 5		
TITLE:		
BOTTOM COVER, SPOOL SIDE		
SIZE	DWG. NO.	REV
<b>A</b>	BOTTOM_SPOOL_COVER SP_SPOOL	
SCALE: 1:2	WEIGHT:	SHEET 1 OF 2

Appendix K: Engineering Change Notifications

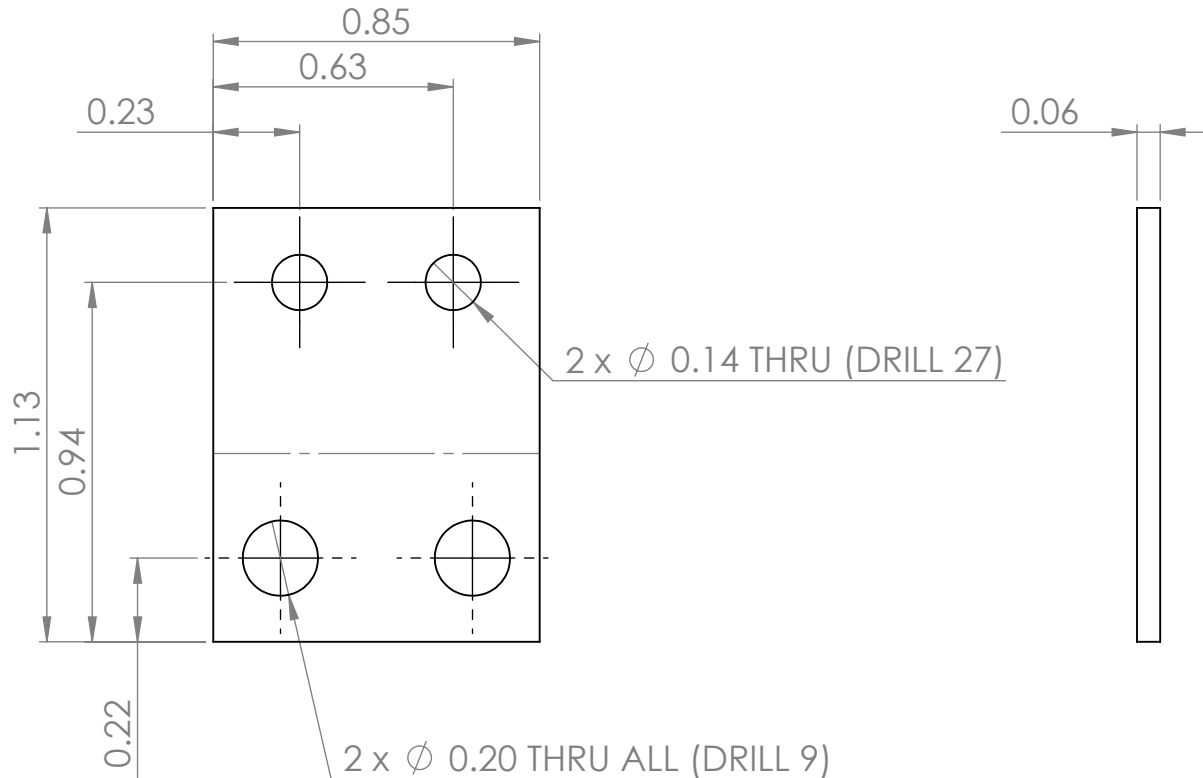


**PROPRIETARY AND CONFIDENTIAL**  
 THE INFORMATION CONTAINED IN THIS DRAWING IS THE SOLE PROPERTY OF <INSERT COMPANY NAME HERE>. ANY REPRODUCTION IN PART OR AS A WHOLE WITHOUT THE WRITTEN PERMISSION OF <INSERT COMPANY NAME HERE> IS PROHIBITED.

		UNLESS OTHERWISE SPECIFIED:		NAME	DATE
		DIMENSIONS ARE IN INCHES	DRAWN		
		TOLERANCES:	CHECKED		
		FRACTIONAL ±	ENG APPR.		
		ANGULAR: MACH ± BEND ±	MFG APPR.		
		TWO PLACE DECIMAL ±	Q.A.		
		THREE PLACE DECIMAL ±	COMMENTS:		
		INTERPRET GEOMETRIC TOLERANCING PER:			
		MATERIAL			
		6061 ALUMINUM			
		FINISH			
NEXT ASSY	USED ON				
APPLICATION		DO NOT SCALE DRAWING			

ME 450 TEAM 5		
TITLE:		
BOTTOM COVER, SPOOL SIDE		
SIZE	DWG. NO.	REV
<b>A</b>	BOTTOM_SPOOL_COVER SM_SPOOL	
SCALE: 1:2	WEIGHT:	SHEET 2 OF 2

Appendix K: Engineering Change Notifications

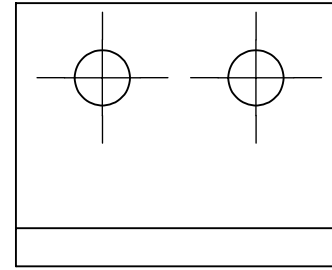
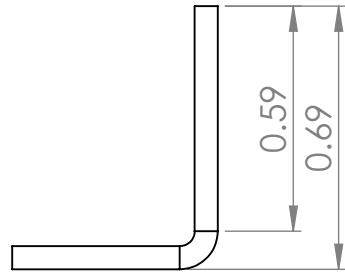


3X PART

**PROPRIETARY AND CONFIDENTIAL**  
 THE INFORMATION CONTAINED IN THIS DRAWING IS THE SOLE PROPERTY OF <INSERT COMPANY NAME HERE>. ANY REPRODUCTION IN PART OR AS A WHOLE WITHOUT THE WRITTEN PERMISSION OF <INSERT COMPANY NAME HERE> IS PROHIBITED.

		UNLESS OTHERWISE SPECIFIED:	NAME	DATE	<b>ME 450 TEAM 5</b>	
		DIMENSIONS ARE IN INCHES TOLERANCES: FRACTIONAL ± ANGULAR: MACH ± BEND ± TWO PLACE DECIMAL ± THREE PLACE DECIMAL ±	DRAWN		TITLE:	
		INTERPRET GEOMETRIC TOLERANCING PER:	CHECKED		<b>BOTTOM COVER, EXTERIOR TAB</b>	
		MATERIAL <b>6061 ALUMINUM</b>	ENG APPR.		SIZE <b>A</b>	DWG. NO. BOTTOM_SPOOL_COVER SM_BATTERY_TAB
NEXT ASSY	USED ON	FINISH	MFG APPR.			REV
APPLICATION		DO NOT SCALE DRAWING	Q.A.		SCALE: 2:1 WEIGHT:	
			COMMENTS:		SHEET 1 OF 2	

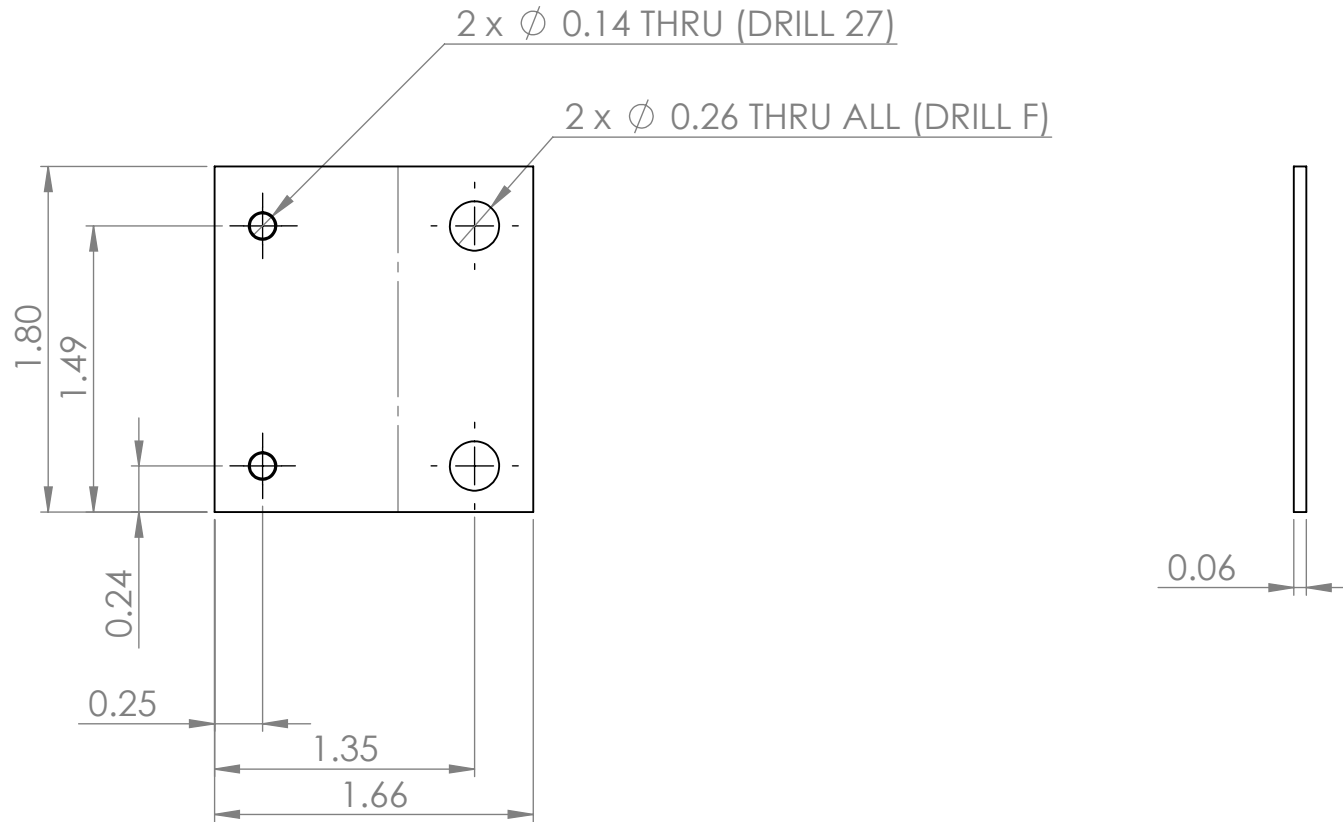
# Appendix K: Engineering Change Notifications



**PROPRIETARY AND CONFIDENTIAL**  
 THE INFORMATION CONTAINED IN THIS DRAWING IS THE SOLE PROPERTY OF <INSERT COMPANY NAME HERE>. ANY REPRODUCTION IN PART OR AS A WHOLE WITHOUT THE WRITTEN PERMISSION OF <INSERT COMPANY NAME HERE> IS PROHIBITED.

		UNLESS OTHERWISE SPECIFIED:		NAME	DATE	<b>ME 450 TEAM 5</b>	
		DIMENSIONS ARE IN INCHES TOLERANCES: FRACTIONAL ± ANGULAR: MACH ± BEND ± TWO PLACE DECIMAL ± THREE PLACE DECIMAL ±	DRAWN			TITLE:	
		INTERPRET GEOMETRIC TOLERANCING PER:	CHECKED			<b>BOTTOM COVER, EXTERIOR TAB</b>	
		MATERIAL <b>6061 ALUMINUM</b>	ENG APPR.			SIZE	DWG. NO.
		FINISH	MFG APPR.			<b>A</b>	<b>BOTTOM_SPOOL_COVER SM_BATTERY_TAB</b>
NEXT ASSY	USED ON		Q.A.				REV
		DO NOT SCALE DRAWING	COMMENTS:			SCALE: 2:1	WEIGHT:
	APPLICATION						SHEET 2 OF 2

Appendix K: Engineering Change Notifications



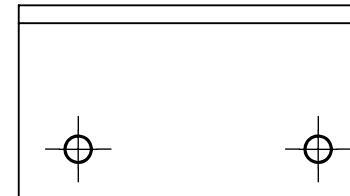
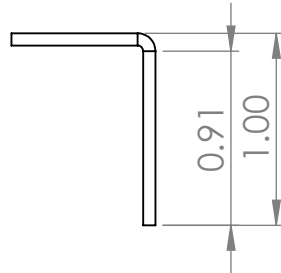
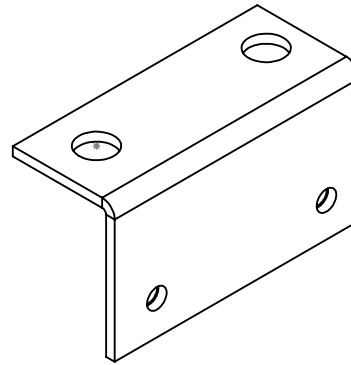
**PROPRIETARY AND CONFIDENTIAL**  
 THE INFORMATION CONTAINED IN THIS DRAWING IS THE SOLE PROPERTY OF <INSERT COMPANY NAME HERE>. ANY REPRODUCTION IN PART OR AS A WHOLE WITHOUT THE WRITTEN PERMISSION OF <INSERT COMPANY NAME HERE> IS PROHIBITED.

		UNLESS OTHERWISE SPECIFIED:		NAME	DATE
		DIMENSIONS ARE IN INCHES	DRAWN		
		TOLERANCES:	CHECKED		
		FRACTIONAL ±	ENG APPR.		
		ANGULAR: MACH ± BEND ±	MFG APPR.		
		TWO PLACE DECIMAL ±	Q.A.		
		THREE PLACE DECIMAL ±	COMMENTS:		
		INTERPRET GEOMETRIC TOLERANCING PER:			
		MATERIAL			
		6061 ALUMINUM			
		FINISH			
NEXT ASSY	USED ON				
APPLICATION		DO NOT SCALE DRAWING			

ME 450 TEAM 5		
TITLE:		
BOTTOM COVER, INTERIOR TAB		
SIZE	DWG. NO.	REV
<b>A</b>	BOTTOM_SPOOL_COVER SM_BUTTON_TAB	
SCALE: 1:1	WEIGHT:	SHEET 1 OF 2



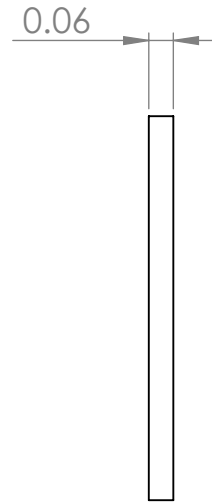
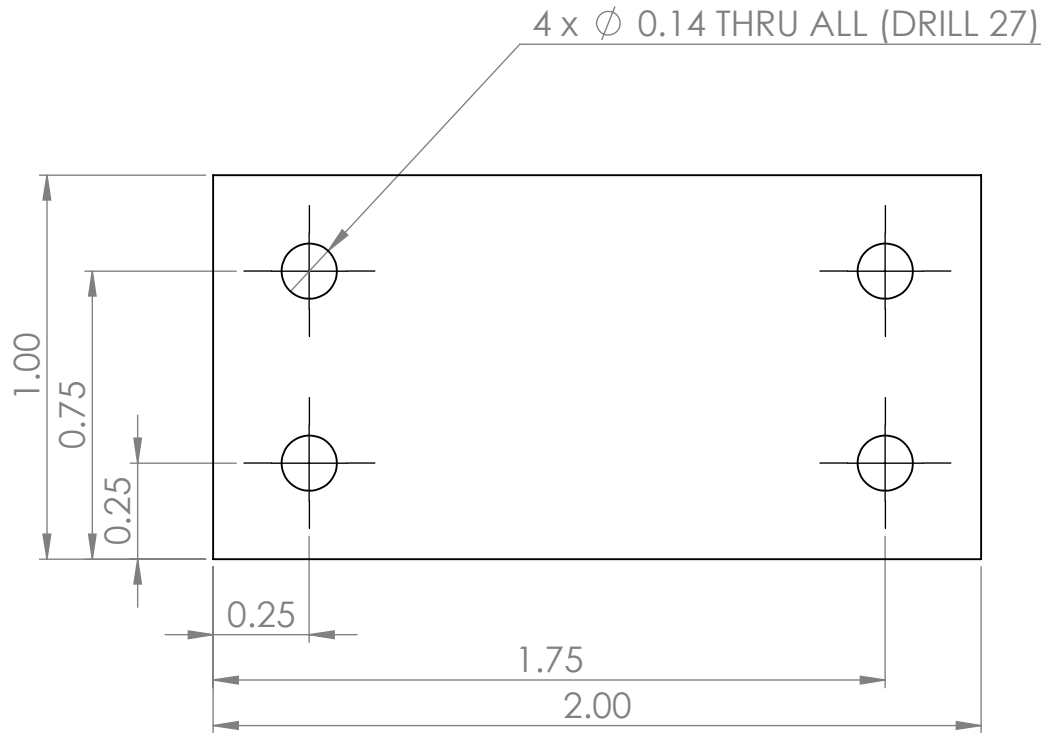
# Appendix K: Engineering Change Notifications



**PROPRIETARY AND CONFIDENTIAL**  
 THE INFORMATION CONTAINED IN THIS DRAWING IS THE SOLE PROPERTY OF <INSERT COMPANY NAME HERE>. ANY REPRODUCTION IN PART OR AS A WHOLE WITHOUT THE WRITTEN PERMISSION OF <INSERT COMPANY NAME HERE> IS PROHIBITED.

		UNLESS OTHERWISE SPECIFIED:		NAME	DATE	<b>ME 450 TEAM 5</b>	
		DIMENSIONS ARE IN INCHES		DRAWN		TITLE:	
		TOLERANCES:		CHECKED		<b>BOTTOM COVER, INTERIOR TAB</b>	
		FRACTIONAL ±		ENG APPR.		SIZE	DWG. NO.
		ANGULAR: MACH ± BEND ±		MFG APPR.		<b>A</b>	<b>BOTTOM_SPOOL_COVER</b>
		TWO PLACE DECIMAL ±		Q.A.			REV
		THREE PLACE DECIMAL ±		COMMENTS:			<b>SM_BUTTON_TAB</b>
		INTERPRET GEOMETRIC TOLERANCING PER:				SCALE: 1:1	WEIGHT:
		MATERIAL					SHEET 2 OF 2
		<b>6061 ALUMINUM</b>					<b>K46</b>
		FINISH					
	NEXT ASSY	USED ON					
	APPLICATION		DO NOT SCALE DRAWING				

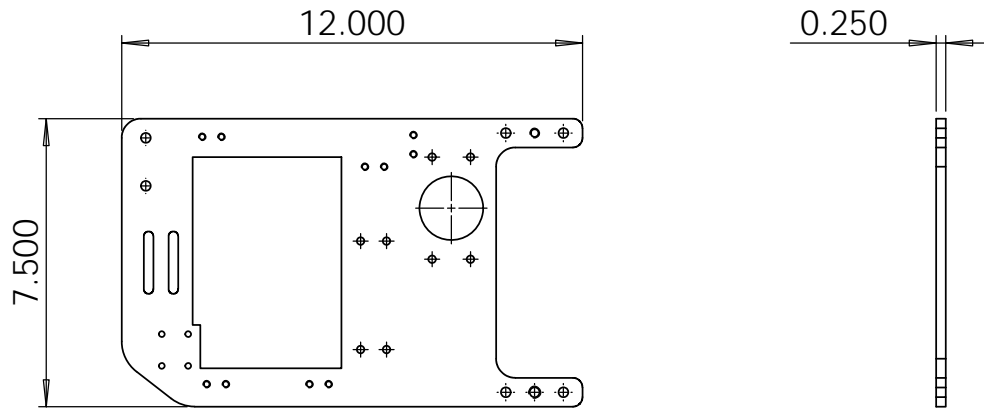
# Appendix K: Engineering Change Notifications



**PROPRIETARY AND CONFIDENTIAL**  
 THE INFORMATION CONTAINED IN THIS DRAWING IS THE SOLE PROPERTY OF <INSERT COMPANY NAME HERE>. ANY REPRODUCTION IN PART OR AS A WHOLE WITHOUT THE WRITTEN PERMISSION OF <INSERT COMPANY NAME HERE> IS PROHIBITED.

		UNLESS OTHERWISE SPECIFIED:	NAME	DATE	<b>ME 450 TEAM 5</b>	
		DIMENSIONS ARE IN INCHES	DRAWN		TITLE:	
		TOLERANCES:	CHECKED		<b>BOTTOM COVER, CONNECTOR</b>	
		FRACTIONAL ±	ENG APPR.		SIZE	DWG. NO.
		ANGULAR: MACH ± BEND ±	MFG APPR.		<b>A</b>	<b>BOTTOM_SPOOL_COVER CONNECTOR</b>
		TWO PLACE DECIMAL ±	Q.A.		SCALE: 2:1	WEIGHT:
		THREE PLACE DECIMAL ±	COMMENTS:		SHEET 1 OF 1	REV
		INTERPRET GEOMETRIC TOLERANCING PER:				
		MATERIAL				
		<b>6061 ALUMINUM</b>				
		FINISH				
NEXT ASSY	USED ON	DO NOT SCALE DRAWING				
APPLICATION						

Appendix K: Engineering Change Notifications

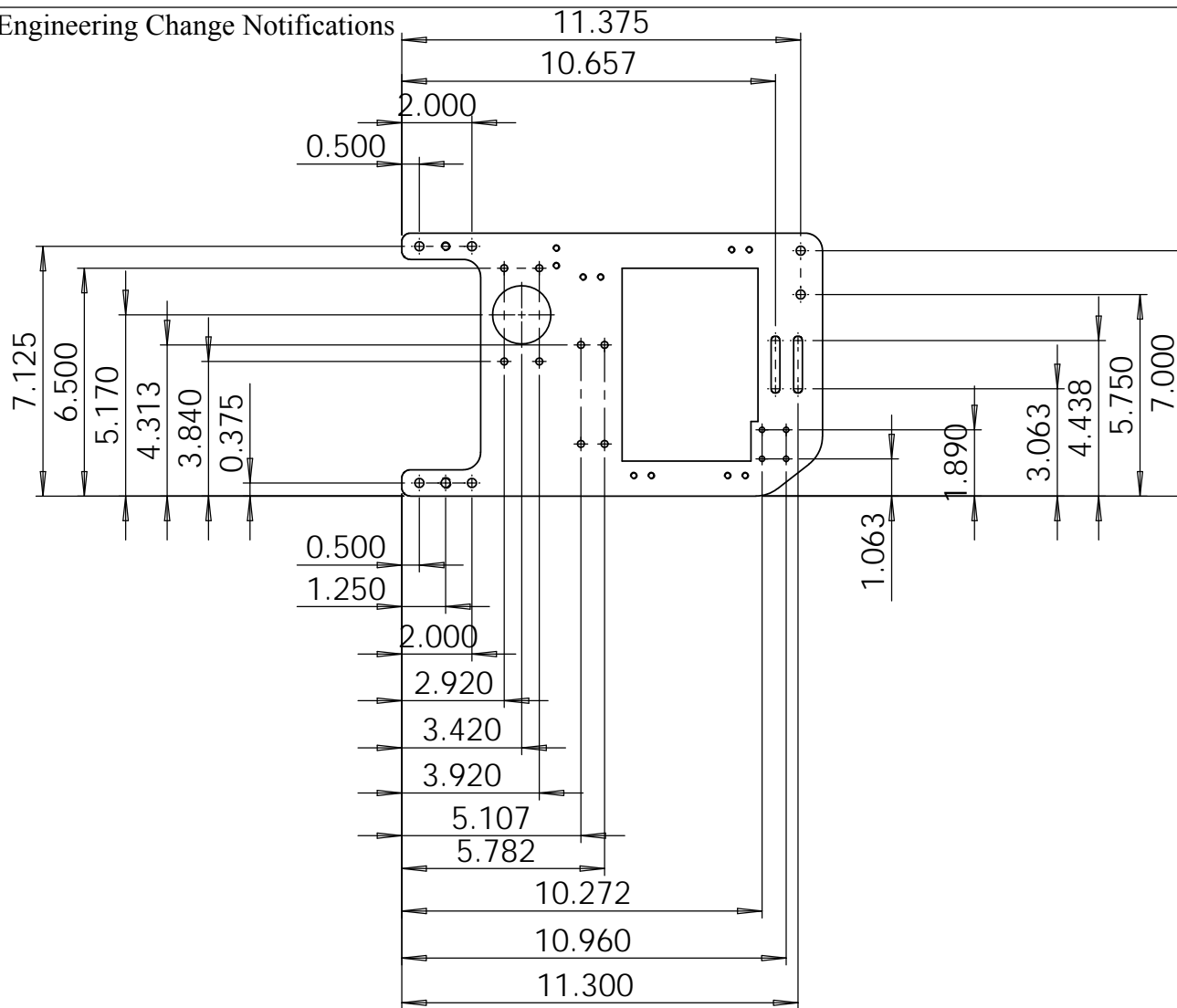


PART TO BE WATER JET  
 OVERALL DIMENSIONS SHOWN  
 HOLE LOCATIONS SHOWN ON FOLLOWING PAGES

**PROPRIETARY AND CONFIDENTIAL**  
 THE INFORMATION CONTAINED IN THIS DRAWING IS THE SOLE PROPERTY OF <INSERT COMPANY NAME HERE>. ANY REPRODUCTION IN PART OR AS A WHOLE WITHOUT THE WRITTEN PERMISSION OF <INSERT COMPANY NAME HERE> IS PROHIBITED.

		UNLESS OTHERWISE SPECIFIED:		NAME	DATE	<b>ME 450 TEAM 5</b>		
		DIMENSIONS ARE IN INCHES TOLERANCES: FRACTIONAL ± ANGULAR: MACH ± BEND ± TWO PLACE DECIMAL ± THREE PLACE DECIMAL ±	DRAWN			TITLE:		
		INTERPRET GEOMETRIC TOLERANCING PER:	CHECKED			<b>BASEPLATE</b>		
		MATERIAL <b>6061 ALUMINUM</b>	ENG APPR.			SIZE	DWG. NO.	REV
NEXT ASSY	USED ON	FINISH	MFG APPR.			<b>A</b>	<b>BASEPLATE</b>	
APPLICATION		DO NOT SCALE DRAWING	Q.A.			SCALE: 1:5	WEIGHT:	SHEET 1 OF 4
			COMMENTS:					<b>K48</b>

Appendix K: Engineering Change Notifications



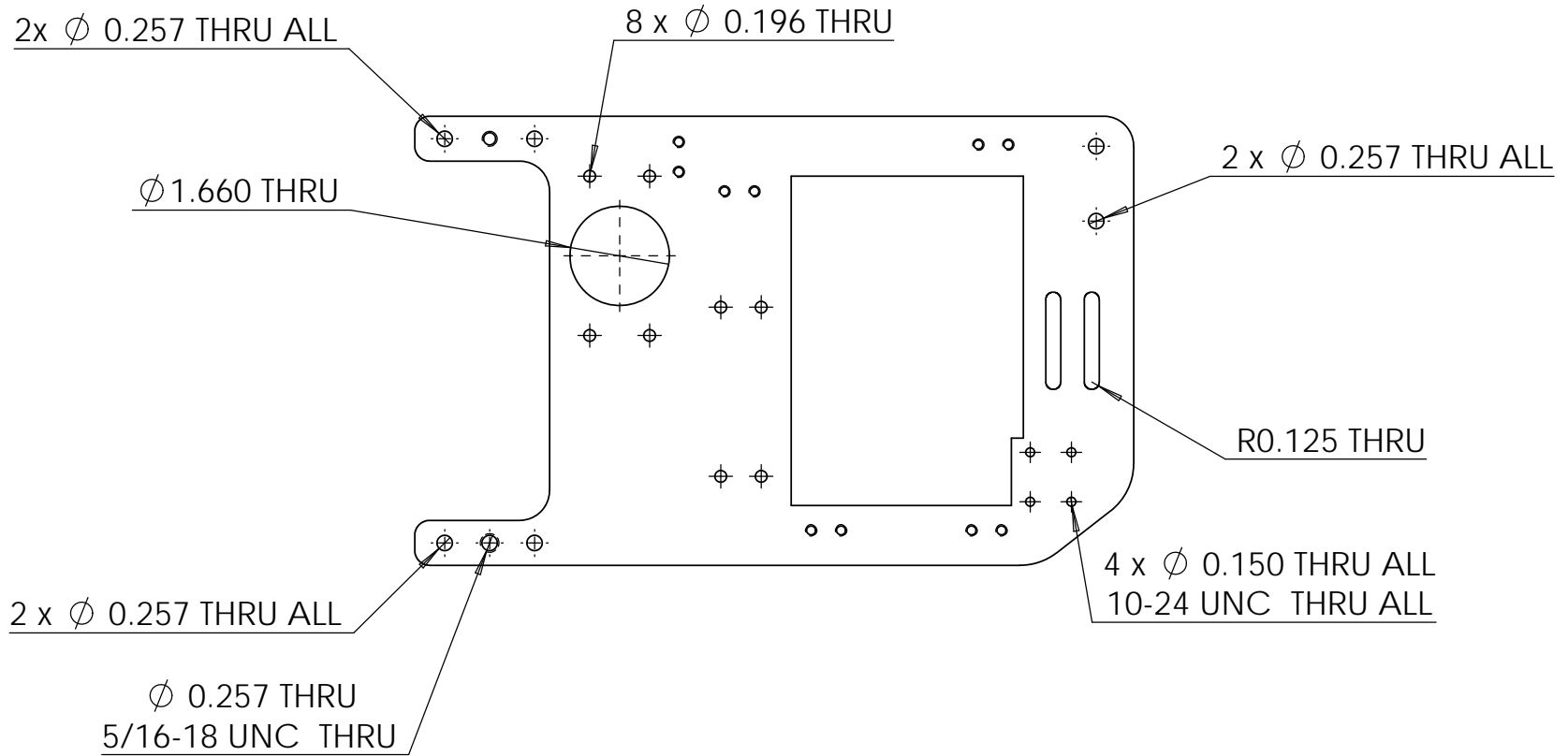
**PROPRIETARY AND CONFIDENTIAL**  
 THE INFORMATION CONTAINED IN THIS DRAWING IS THE SOLE PROPERTY OF <INSERT COMPANY NAME HERE>. ANY REPRODUCTION IN PART OR AS A WHOLE WITHOUT THE WRITTEN PERMISSION OF <INSERT COMPANY NAME HERE> IS PROHIBITED.

		UNLESS OTHERWISE SPECIFIED:		NAME	DATE
		DIMENSIONS ARE IN INCHES	DRAWN		
		TOLERANCES:	CHECKED		
		FRACTIONAL ±	ENG APPR.		
		ANGULAR: MACH ± BEND ±	MFG APPR.		
		TWO PLACE DECIMAL ±	Q.A.		
		THREE PLACE DECIMAL ±	COMMENTS:		
		INTERPRET GEOMETRIC TOLERANCING PER:			
		MATERIAL			
		FINISH			
NEXT ASSY	USED ON				
APPLICATION		DO NOT SCALE DRAWING			

TITLE:		
SIZE	DWG. NO.	REV
<b>A</b>	<b>BASEPLATE</b>	
SCALE: 1:5	WEIGHT:	SHEET 2 OF 4

K49

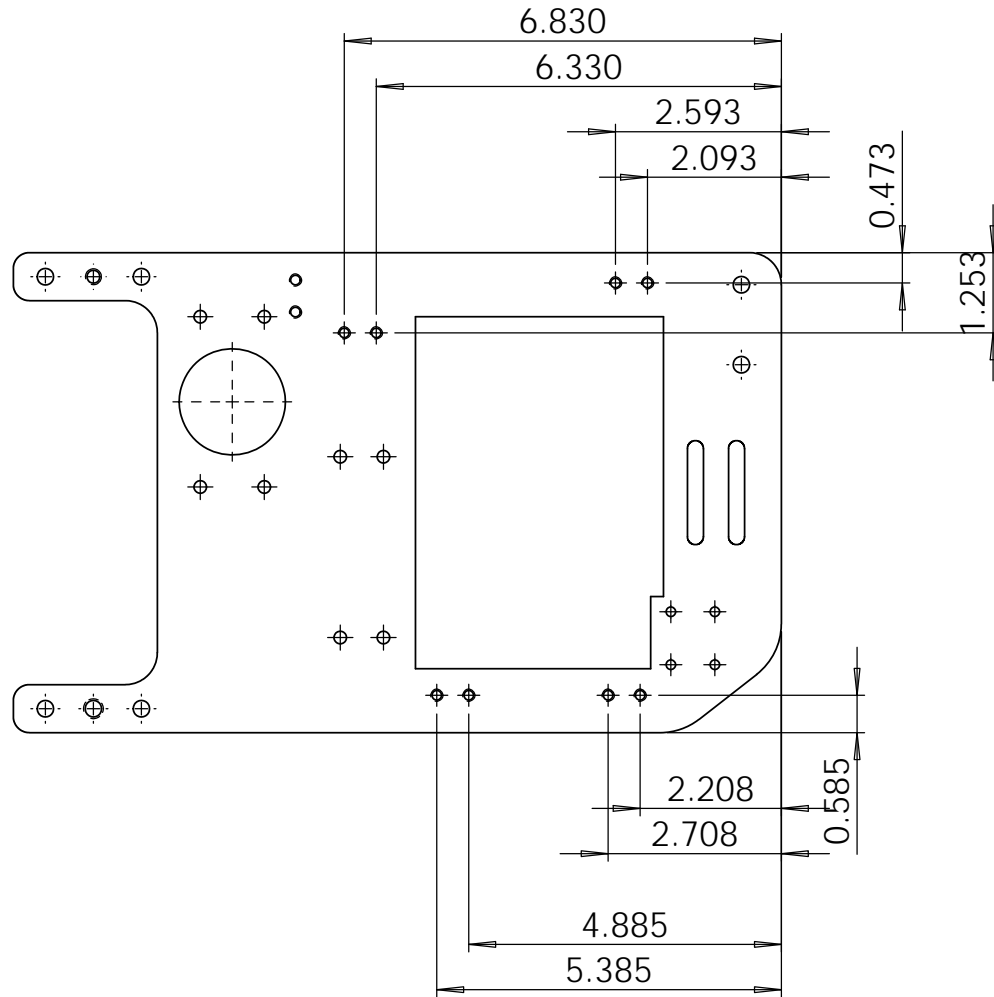
Appendix K: Engineering Change Notifications



**PROPRIETARY AND CONFIDENTIAL**  
 THE INFORMATION CONTAINED IN THIS DRAWING IS THE SOLE PROPERTY OF <INSERT COMPANY NAME HERE>. ANY REPRODUCTION IN PART OR AS A WHOLE WITHOUT THE WRITTEN PERMISSION OF <INSERT COMPANY NAME HERE> IS PROHIBITED.

		UNLESS OTHERWISE SPECIFIED:		NAME	DATE	
		DIMENSIONS ARE IN INCHES	DRAWN			TITLE:
		TOLERANCES:	CHECKED			
		FRACTIONAL $\pm$	ENG APPR.			
		ANGULAR: MACH $\pm$ BEND $\pm$	MFG APPR.			
		TWO PLACE DECIMAL $\pm$	Q.A.			
		THREE PLACE DECIMAL $\pm$	COMMENTS:			
		INTERPRET GEOMETRIC TOLERANCING PER:				SIZE DWG. NO. REV
		MATERIAL				<b>A</b> <b>BASEPLATE</b>
NEXT ASSY	USED ON	FINISH				SCALE: 1:5 WEIGHT: SHEET 3 OF 4
APPLICATION		DO NOT SCALE DRAWING				<b>K50</b>

Appendix K: Engineering Change Notifications

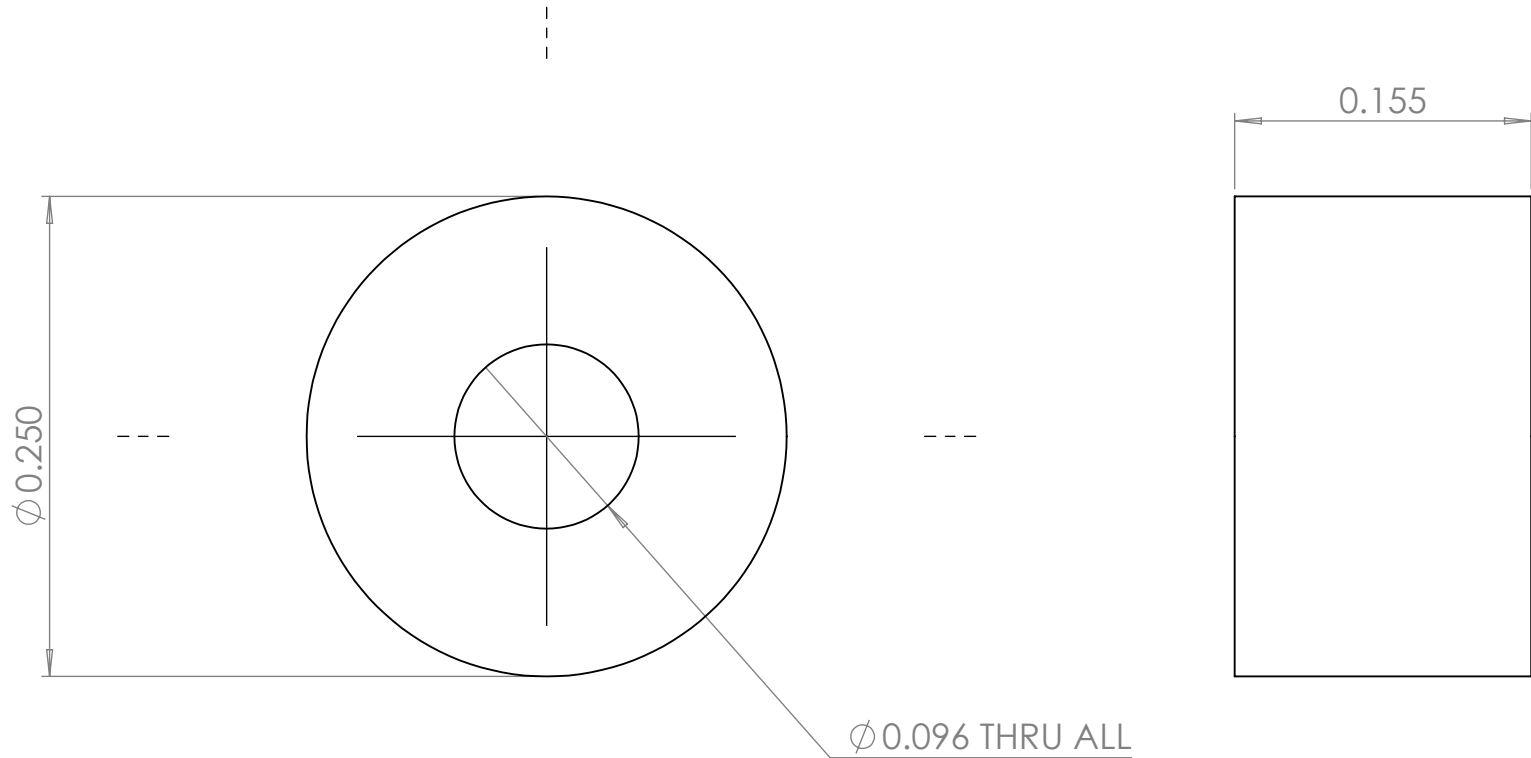


MODIFICATIONS MADE 11/29/12

**PROPRIETARY AND CONFIDENTIAL**  
 THE INFORMATION CONTAINED IN THIS DRAWING IS THE SOLE PROPERTY OF <INSERT COMPANY NAME HERE>. ANY REPRODUCTION IN PART OR AS A WHOLE WITHOUT THE WRITTEN PERMISSION OF <INSERT COMPANY NAME HERE> IS PROHIBITED.

		UNLESS OTHERWISE SPECIFIED:		NAME	DATE	<b>ME 450 TEAM 5</b>		
		DIMENSIONS ARE IN INCHES TOLERANCES: FRACTIONAL ±	DRAWN			TITLE:		
		ANGULAR: MACH ± BEND ±	CHECKED			<b>BASEPLATE</b>		
		TWO PLACE DECIMAL ±	ENG APPR.					
		THREE PLACE DECIMAL ±	MFG APPR.					
		INTERPRET GEOMETRIC TOLERANCING PER:	Q.A.					
		MATERIAL <b>6061 ALUMINUM</b>	COMMENTS:			SIZE	DWG. NO.	REV
NEXT ASSY	USED ON	FINISH				<b>A</b>	<b>BASEPLATE</b>	
APPLICATION		DO NOT SCALE DRAWING				SCALE: 1:5	WEIGHT:	SHEET 4 OF 4

# Appendix K: Engineering Change Notifications



3X PART

**PROPRIETARY AND CONFIDENTIAL**  
 THE INFORMATION CONTAINED IN THIS DRAWING IS THE SOLE PROPERTY OF <INSERT COMPANY NAME HERE>. ANY REPRODUCTION IN PART OR AS A WHOLE WITHOUT THE WRITTEN PERMISSION OF <INSERT COMPANY NAME HERE> IS PROHIBITED.

		UNLESS OTHERWISE SPECIFIED:	NAME	DATE	<b>ME 450 TEAM 5</b>	
		DIMENSIONS ARE IN INCHES	DRAWN		TITLE:	
		TOLERANCES:	CHECKED		<b>BOTTOM COVER, ARDUINO SPACER</b>	
		FRACTIONAL $\pm$	ENG APPR.		SIZE	DWG. NO.
		ANGULAR: MACH $\pm$ BEND $\pm$	MFG APPR.		<b>A</b>	<b>BOTTOM_SPOOL_COVER</b>
		TWO PLACE DECIMAL $\pm$	Q.A.			ARDUINO_SPACER
		THREE PLACE DECIMAL $\pm$	COMMENTS:		SCALE: 10:1	WEIGHT:
NEXT ASSY	USED ON	INTERPRET GEOMETRIC TOLERANCING PER:				SHEET 1 OF 1
		MATERIAL				<b>K52</b>
		<b>ALUMINUM 6061</b>				
		FINISH				
APPLICATION		DO NOT SCALE DRAWING				

5

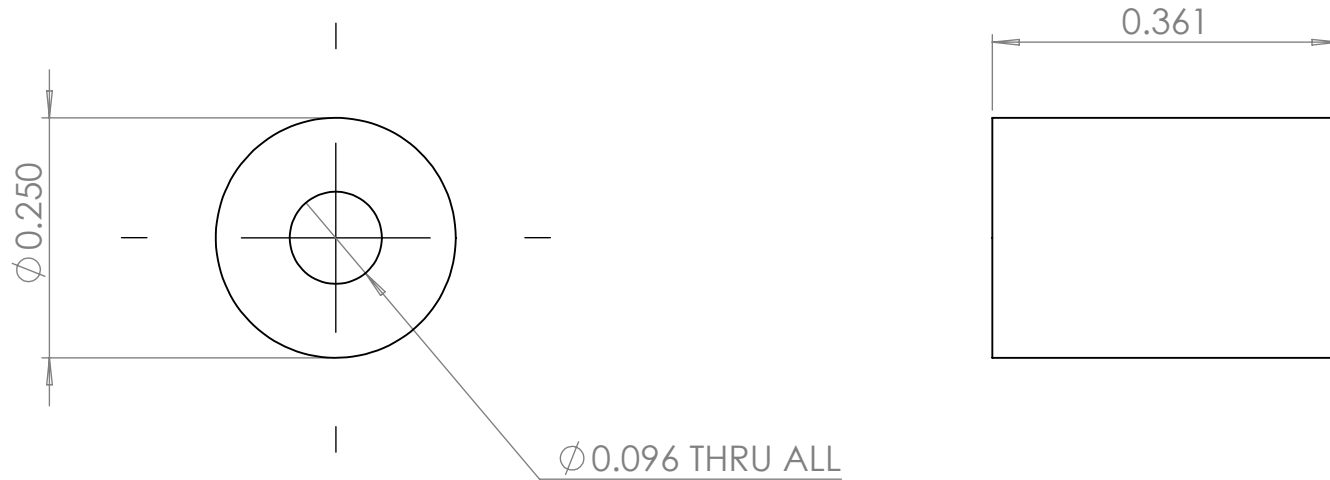
4

3

2

1

# Appendix K: Engineering Change Notifications



4X PART

**PROPRIETARY AND CONFIDENTIAL**  
 THE INFORMATION CONTAINED IN THIS DRAWING IS THE SOLE PROPERTY OF <INSERT COMPANY NAME HERE>. ANY REPRODUCTION IN PART OR AS A WHOLE WITHOUT THE WRITTEN PERMISSION OF <INSERT COMPANY NAME HERE> IS PROHIBITED.

		UNLESS OTHERWISE SPECIFIED:		NAME	DATE	<b>ME 405 TEAM 5</b>	
		DIMENSIONS ARE IN INCHES TOLERANCES: FRACTIONAL $\pm$ ANGULAR: MACH $\pm$ BEND $\pm$ TWO PLACE DECIMAL $\pm$ THREE PLACE DECIMAL $\pm$	DRAWN			TITLE:	
		INTERPRET GEOMETRIC TOLERANCING PER:	CHECKED			<b>BOTTOM COVER, BREADBOARD SPACER</b>	
		MATERIAL <b>ALUMINUM 6061</b>	ENG APPR.			SIZE	DWG. NO.
		FINISH	MFG APPR.			<b>A</b>	<b>BOTTOM_SPOOL_COVER BREADBOARD_SPACER</b>
NEXT ASSY	USED ON		Q.A.				REV
		DO NOT SCALE DRAWING	COMMENTS:			SCALE: 5:1	WEIGHT:
APPLICATION							SHEET 1 OF 1

5

4

3

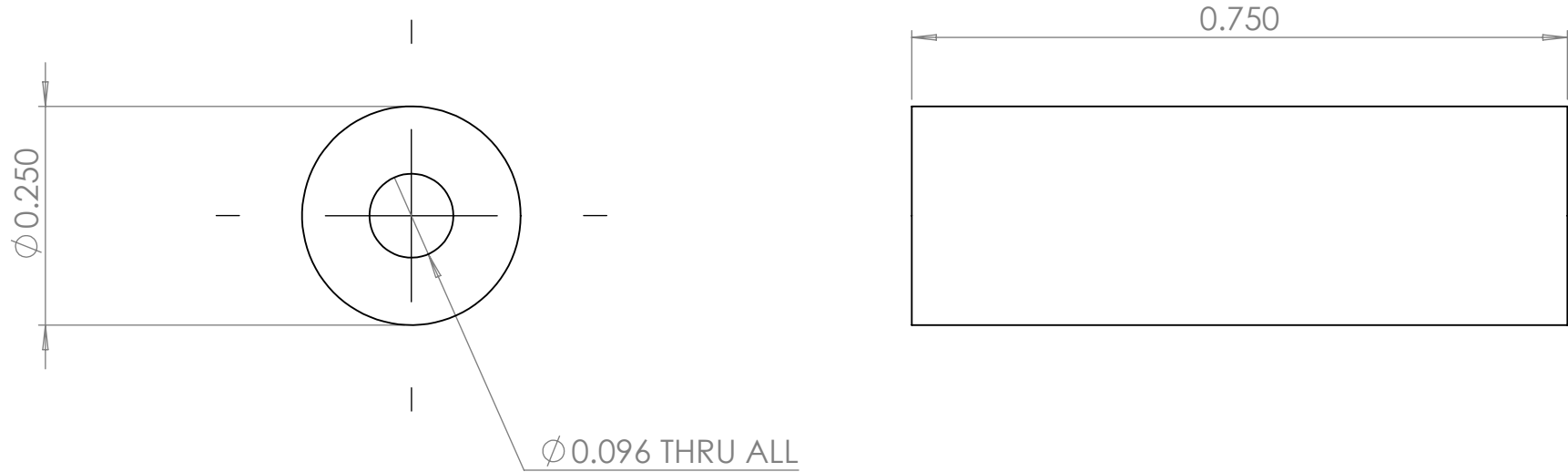
2

1

K53



# Appendix K: Engineering Change Notifications



2X PART

**PROPRIETARY AND CONFIDENTIAL**  
 THE INFORMATION CONTAINED IN THIS DRAWING IS THE SOLE PROPERTY OF <INSERT COMPANY NAME HERE>. ANY REPRODUCTION IN PART OR AS A WHOLE WITHOUT THE WRITTEN PERMISSION OF <INSERT COMPANY NAME HERE> IS PROHIBITED.

		UNLESS OTHERWISE SPECIFIED:		NAME	DATE	<b>ME 450 TEAM 5</b>	
		DIMENSIONS ARE IN INCHES		DRAWN		TITLE:	
		TOLERANCES:		CHECKED		<b>BOTTOM COVER, PCB SPACER</b>	
		FRACTIONAL ±		ENG APPR.		SIZE	DWG. NO.
		ANGULAR: MACH ± BEND ±		MFG APPR.		<b>A</b>	<b>BOTTOM_SPOOL_COVER</b>
		TWO PLACE DECIMAL ±		Q.A.			PCB_SPACER
		THREE PLACE DECIMAL ±		COMMENTS:			REV
		INTERPRET GEOMETRIC TOLERANCING PER:				SCALE: 2:1	WEIGHT:
		MATERIAL					SHEET 1 OF 1
		<b>6061 ALUMINUM</b>					<b>K54</b>
		FINISH					
NEXT ASSY	USED ON						
APPLICATION		DO NOT SCALE DRAWING					

5

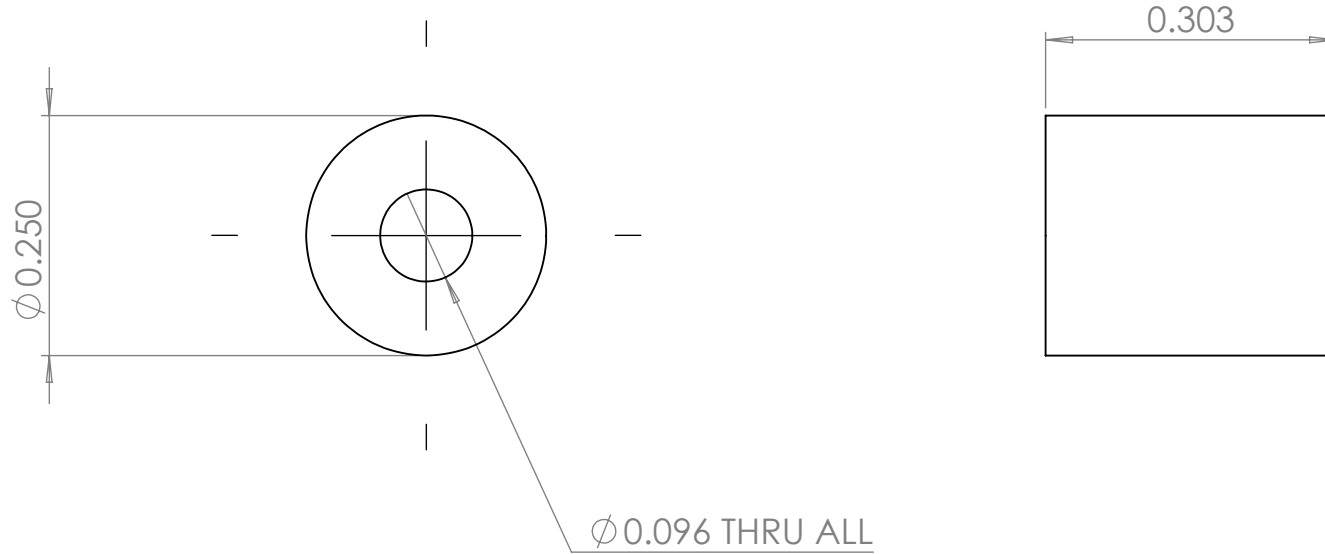
4

3

2

1

Appendix K: Engineering Change Notifications



2X PART

**PROPRIETARY AND CONFIDENTIAL**  
 THE INFORMATION CONTAINED IN THIS DRAWING IS THE SOLE PROPERTY OF <INSERT COMPANY NAME HERE>. ANY REPRODUCTION IN PART OR AS A WHOLE WITHOUT THE WRITTEN PERMISSION OF <INSERT COMPANY NAME HERE> IS PROHIBITED.

		UNLESS OTHERWISE SPECIFIED:		NAME	DATE	<b>ME 450 TEAM 5</b>	
		DIMENSIONS ARE IN INCHES TOLERANCES: FRACTIONAL $\pm$ ANGULAR: MACH $\pm$ BEND $\pm$ TWO PLACE DECIMAL $\pm$ THREE PLACE DECIMAL $\pm$	DRAWN			TITLE:	
		INTERPRET GEOMETRIC TOLERANCING PER:	CHECKED			<b>BOTTOM COVER, UV BULB SPACER</b>	
		MATERIAL <b>ALUMINUM 6061</b>	ENG APPR.			SIZE <b>A</b>	DWG. NO. BOTTOM_SPOOL_COVER UVBULB_SPACER
NEXT ASSY	USED ON	FINISH	MFG APPR.				REV
APPLICATION		DO NOT SCALE DRAWING	Q.A.			SCALE: 5:1	WEIGHT:
			COMMENTS:				SHEET 1 OF 1 <b>K55</b>

5

4

3

2

1

## Appendix K: Engineering Change Notifications

### Engineering Change Notification #6

ME 450 Team 5

Addition of another pole support

Parts Affected by change: Pole Support, Bottom Pole

What has been changed:

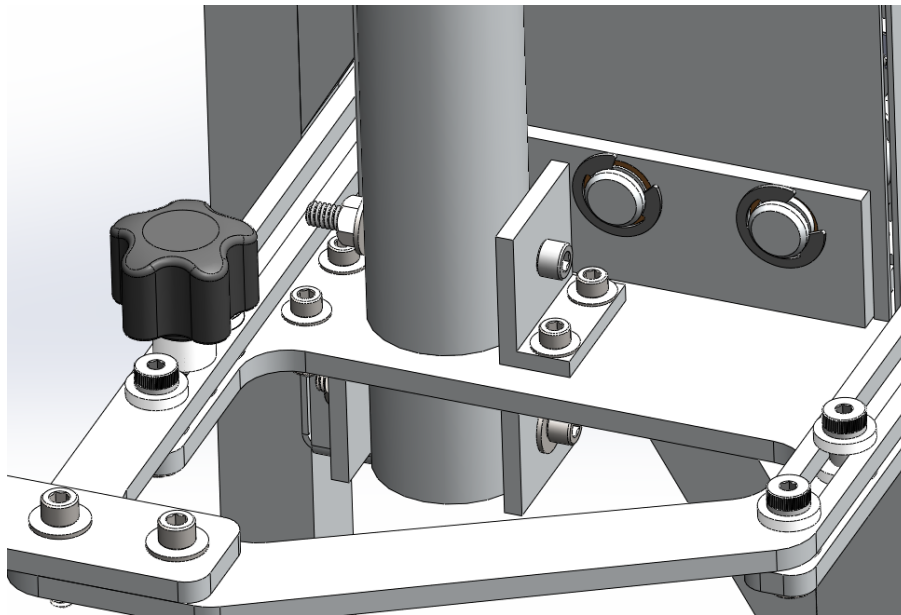
There is a lot of “wobble” in the pole where it connects to the base. The pole the hole fits into is a little too large for the pole. Another support (same part and drawing as the other pole supports) will be added to the assembly in order to add two points of contact between the pole and the baseplate to mount to. This will prevent the pole from deflecting as much during use.

Another ¼”-20, 2” long fastener with washer and nut will be used to fasten the pole to the new pole support and the bill of materials will be adjusted to meet this change. A new hole will be drilled in the bottom pole to accommodate the new pole support (see attached print for updated bottom pole prints).

Change Initiated by: Nathan Matheny

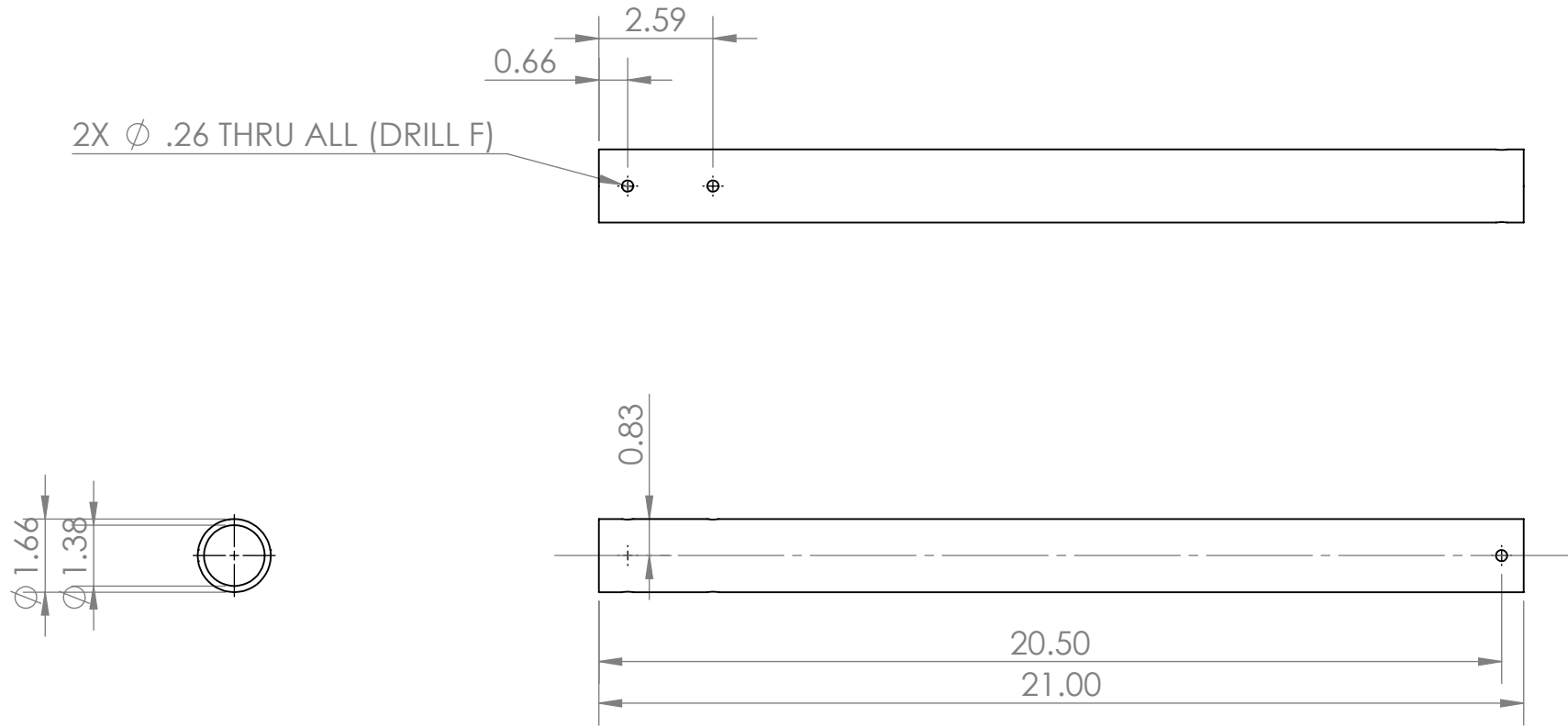
Date: 11/30/12

Change Approved By:



2.59375

Appendix K: Engineering Change Notifications



**PROPRIETARY AND CONFIDENTIAL**  
 THE INFORMATION CONTAINED IN THIS DRAWING IS THE SOLE PROPERTY OF <INSERT COMPANY NAME HERE>. ANY REPRODUCTION IN PART OR AS A WHOLE WITHOUT THE WRITTEN PERMISSION OF <INSERT COMPANY NAME HERE> IS PROHIBITED.

		UNLESS OTHERWISE SPECIFIED:	NAME	DATE	ME 450 TEAM 5	
		DIMENSIONS ARE IN INCHES	DRAWN		TITLE:	
		TOLERANCES:	CHECKED		BOTTOM POLE	
		FRACTIONAL ±	ENG APPR.		SIZE DWG. NO. REV	
		ANGULAR: MACH ± BEND ±	MFG APPR.		A POLE_BOTTOM	
		TWO PLACE DECIMAL ±	Q.A.		SCALE: 1:8 WEIGHT: SHEET 1 OF 1	
		THREE PLACE DECIMAL ±	COMMENTS:		K57	
		INTERPRET GEOMETRIC TOLERANCING PER:				
		MATERIAL				
		ALUMINUM				
		FINISH				
NEXT ASSY	USED ON					
APPLICATION		DO NOT SCALE DRAWING				

## Appendix K: Engineering Change Notifications

### Engineering Change Notification #6

ME 450 Team 5

Move Limit Switch to different location on bottom cover

Parts Affected by change: Bottom Cover, Spool Side; Top Cover, Removable

What has been changed:

As the limit switch was attached to the bottom cover, the nuts holding the spool sides to the spool supports would rub on the limit switch as the spool was turned. This prevented the spool from rotating freely, so the limit switch needed to be moved.

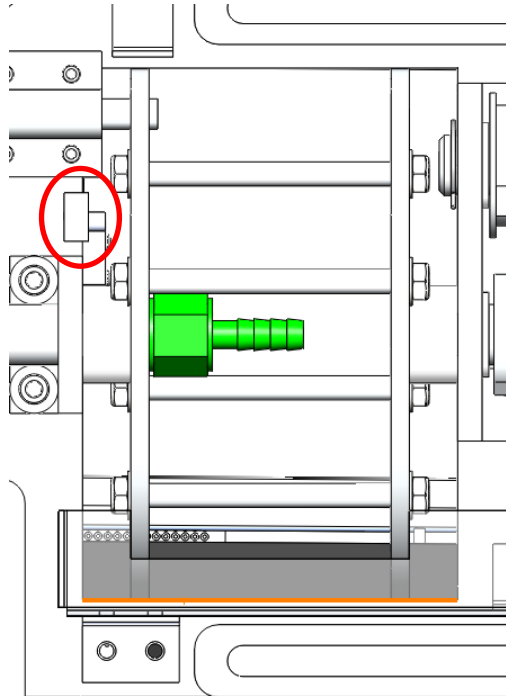
All fasteners and parts remained the same, but the holes for the limit switch mounting and the top cover limit switch tab placement. See attached prints for both the changed Bottom Cover, Spool Side and Top Cover, Removable parts.

Change Initiated by: Nathan Matheny

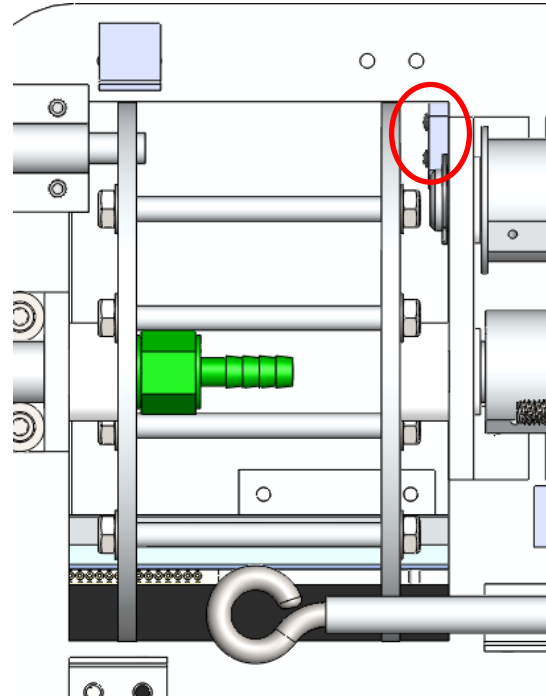
Date: 12/4/12

Change Approved By:

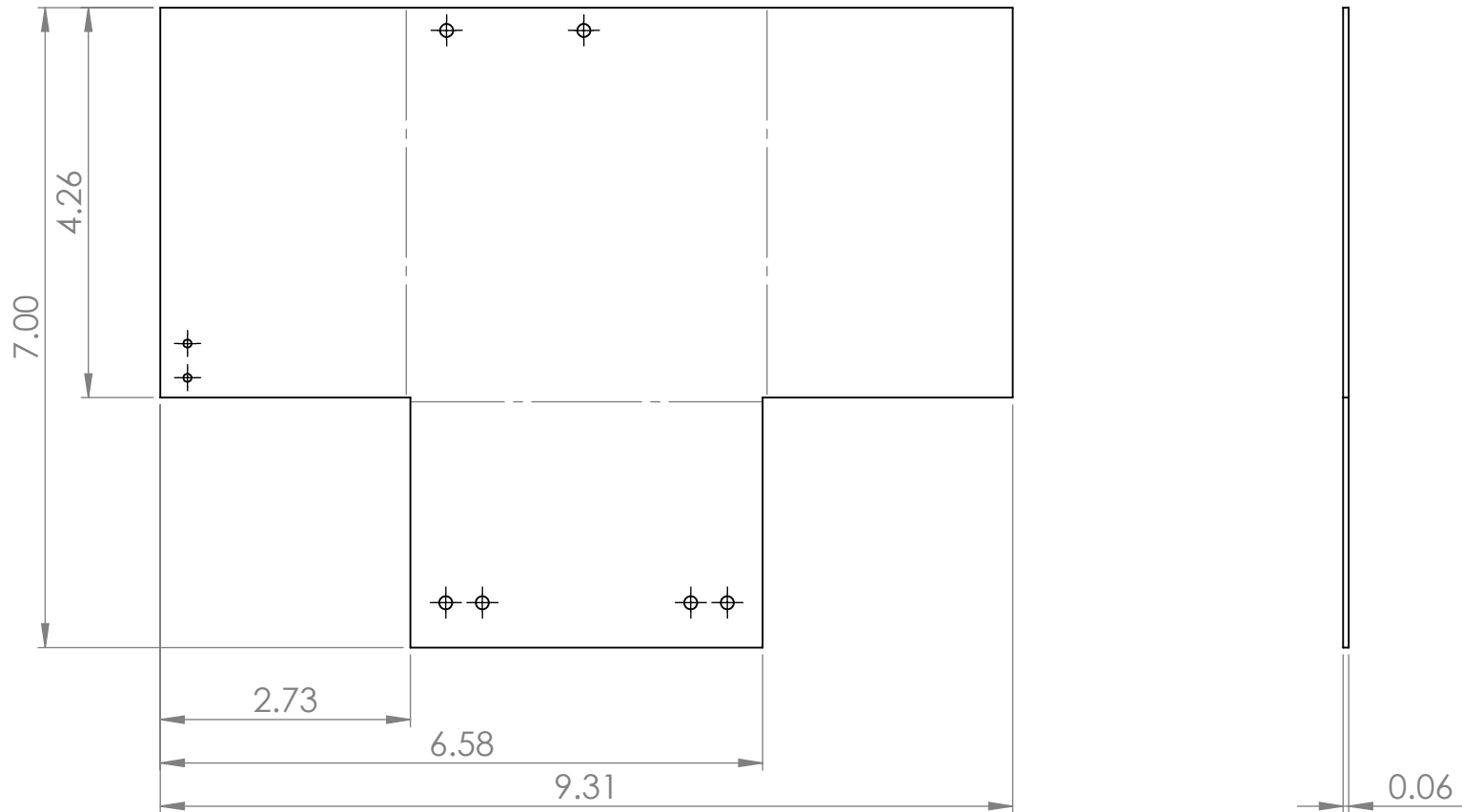
**OLD**



**NEW**



# Appendix K: Engineering Change Notifications

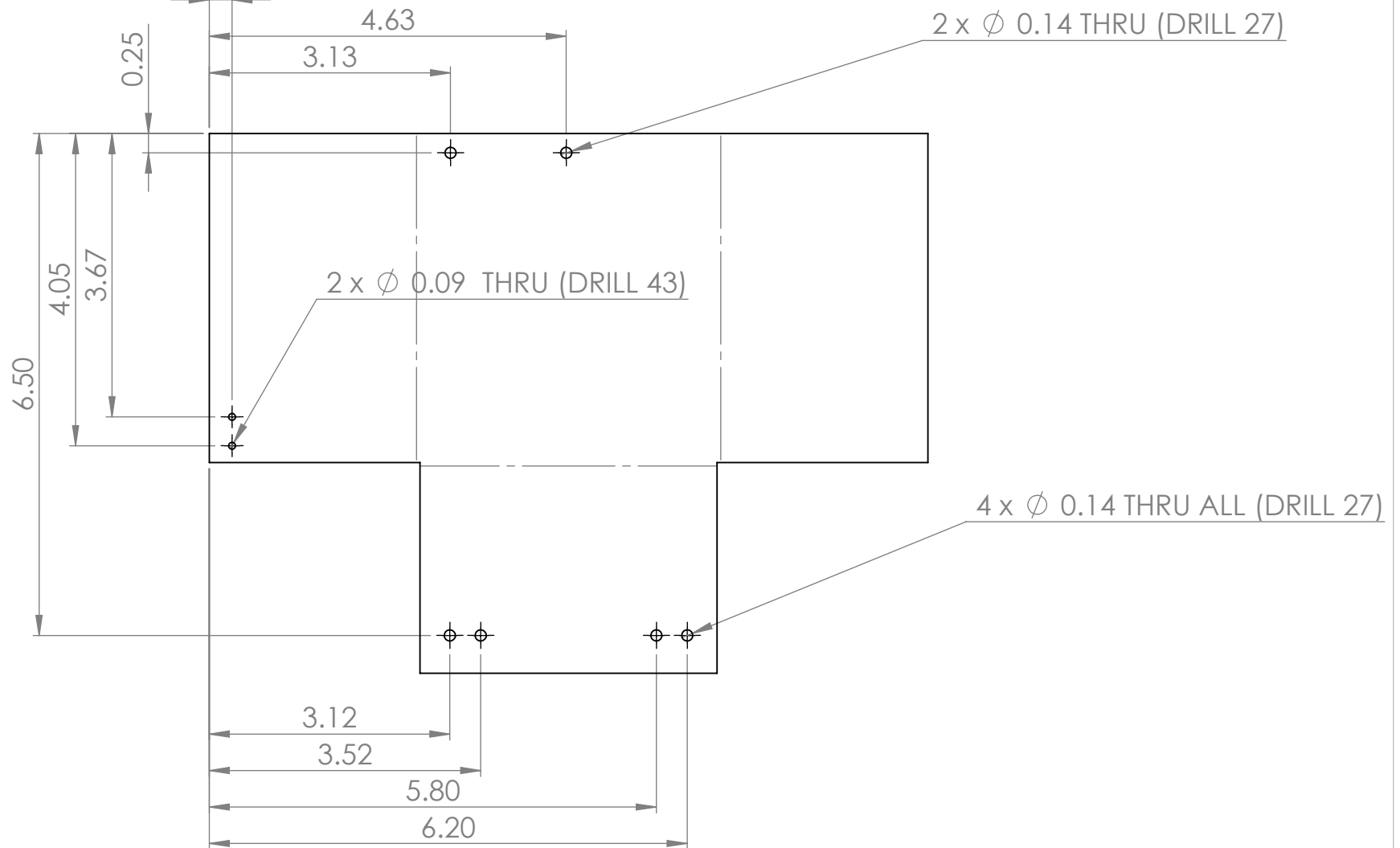


**PROPRIETARY AND CONFIDENTIAL**  
 THE INFORMATION CONTAINED IN THIS DRAWING IS THE SOLE PROPERTY OF <INSERT COMPANY NAME HERE>. ANY REPRODUCTION IN PART OR AS A WHOLE WITHOUT THE WRITTEN PERMISSION OF <INSERT COMPANY NAME HERE> IS PROHIBITED.

		UNLESS OTHERWISE SPECIFIED:	NAME	DATE
		DIMENSIONS ARE IN INCHES	DRAWN	
		TOLERANCES:	CHECKED	
		FRACTIONAL ±	ENG APPR.	
		ANGULAR: MACH ± BEND ±	MFG APPR.	
		TWO PLACE DECIMAL ±	Q.A.	
		THREE PLACE DECIMAL ±	COMMENTS:	
		INTERPRET GEOMETRIC TOLERANCING PER:		
		MATERIAL		
		6061 ALUMINUM		
		FINISH		
NEXT ASSY	USED ON			
APPLICATION		DO NOT SCALE DRAWING		

ME 450 TEAM 5		
TITLE:		
BOTTOM COVER, SPOOL SIDE		
SIZE	DWG. NO.	REV
<b>A</b>	BOTTOM_SPOOL_COVER SP_SPOOL	
SCALE: 1:2	WEIGHT:	SHEET 1 OF 2

# Appendix K: Engineering Change Notifications

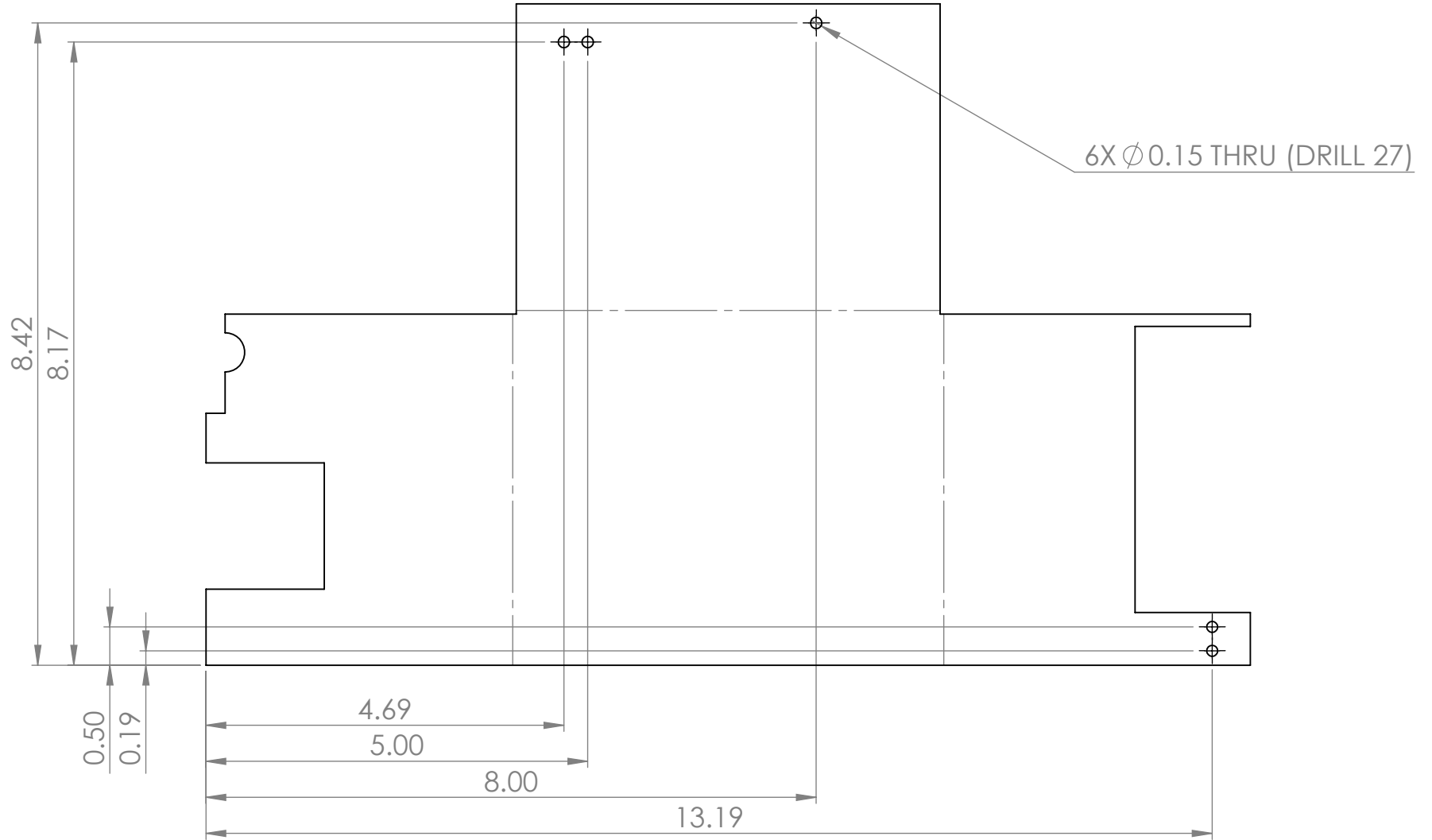


**PROPRIETARY AND CONFIDENTIAL**  
 THE INFORMATION CONTAINED IN THIS DRAWING IS THE SOLE PROPERTY OF <INSERT COMPANY NAME HERE>. ANY REPRODUCTION IN PART OR AS A WHOLE WITHOUT THE WRITTEN PERMISSION OF <INSERT COMPANY NAME HERE> IS PROHIBITED.

		UNLESS OTHERWISE SPECIFIED:		NAME	DATE
		DIMENSIONS ARE IN INCHES	DRAWN		
		TOLERANCES:	CHECKED		
		FRACTIONAL ±	ENG APPR.		
		ANGULAR: MACH ± BEND ±	MFG APPR.		
		TWO PLACE DECIMAL ±	Q.A.		
		THREE PLACE DECIMAL ±	COMMENTS:		
		INTERPRET GEOMETRIC TOLERANCING PER:			
		MATERIAL			
		6061 ALUMINUM			
		FINISH			
NEXT ASSY	USED ON				
APPLICATION		DO NOT SCALE DRAWING			

ME 450 TEAM 5		
TITLE:		
BOTTOM COVER, SPOOL SIDE		
SIZE	DWG. NO.	REV
<b>A</b>	BOTTOM_SPOOL_COVER SM_SPOOL	
SCALE: 1:2	WEIGHT:	SHEET 2 OF 2
		<b>K60</b>

Appendix K: Engineering Change Notifications



**PROPRIETARY AND CONFIDENTIAL**  
 THE INFORMATION CONTAINED IN THIS DRAWING IS THE SOLE PROPERTY OF <INSERT COMPANY NAME HERE>. ANY REPRODUCTION IN PART OR AS A WHOLE WITHOUT THE WRITTEN PERMISSION OF <INSERT COMPANY NAME HERE> IS PROHIBITED.

		UNLESS OTHERWISE SPECIFIED:		NAME	DATE
		DIMENSIONS ARE IN INCHES	DRAWN		
		TOLERANCES:	CHECKED		
		FRACTIONAL ±	ENG APPR.		
		ANGULAR: MACH ± BEND ±	MFG APPR.		
		TWO PLACE DECIMAL ±	Q.A.		
		THREE PLACE DECIMAL ±	COMMENTS:		
		INTERPRET GEOMETRIC TOLERANCING PER:			
		MATERIAL			
		6061 ALUMINUM			
		FINISH			
NEXT ASSY	USED ON				
APPLICATION		DO NOT SCALE DRAWING			

ME 450 TEAM 5		
TITLE:		
TOP COVER, REMOVABLE		
SIZE	DWG. NO.	REV
<b>A</b>	TOP_COVER_MAIN	
SCALE: 1:5	WEIGHT:	SHEET 2 OF 2
		<b>K61</b>



## Appendix K: Engineering Change Notifications

### **Engineering Change Notification #8**

ME 450 Team 5

Use different constant force spring for spool retraction

Parts Affected by change: Constant Force Spring

What has been changed:

After assembly of the device, the spring that was initially ordered (McMaster-Carr part number 9293K58) was found to be too stiff and behaved differently than expected when the tubing was extended and then retracted. The constant force spring became deformed after tubing extension and would not wind properly back around the storage shaft when the tubing was retracted. This caused the spring to bind on the supports and not allow the spool to rotate.

A new spring was ordered (McMaster-Carr part number 9293K52) and used to replace this spring. This spring is a lot less stiff (2.63 lbs of force compared to 7.00 lbs of force from the old spring) and wound much easier around both shafts during extension and retraction. However, this limited the length of tubing that could be extended from the device, as this spring is shorter. We could not order a less stiff spring in a longer length. Another spring was ordered, and the two will be welded together in an attempt to create a longer spring. If this does not work, then one spring will be used and the tubing will not be able to extend as far as our team initially hoped. However, the new spring will allow the device to work, unlike the old spring. See attached specification sheets for all differences between springs.

Change Initiated by: Nathan Matheny

Date: 12/4/12

Change Approved By:

## Constant-Force Springs



Typically used as retractors in tape measures and cable reels, these springs are wound into a tight coil to provide uniform force throughout extension and retraction. They can be wrapped around a shaft, spool, or rod; allow for 1 1/2 extra coils on the shaft at full extension to hold the spring in place. All of these springs are made of Type 301 stainless steel. The free end has one hole for attaching a load to the spring. Wound ID, wound OD, and load tolerances are ±10%.

Thickness	Extended Lg.	Wd.	Wound		End Hole Dia.	Load, lbs.		Each	
			ID	OD					
<b>4,000-Cycle Life</b>									
0.004"	15"	0.250"	0.28"	0.40"	0.130"	0.66	9293K42	\$6.35	
0.005"	17"	0.312"	0.37"	0.50"	0.130"	1.03	9293K44	7.41	
0.006"	22"	0.370"	0.51"	0.62"	0.131"	1.12	9293K46	9.67	
0.007"	26"	0.500"	0.59"	0.75"	0.131"	1.62	9293K48	9.93	
0.008"	30"	0.500"	0.59"	0.82"	0.196"	2.63	9293K52	7.56	
<div style="border: 1px solid black; padding: 5px;"> <a href="#">Catalog Page</a>   <a href="#">Bookmark</a> </div>									
Stainless Steel Constant-Force Spring 4000 Cycle Life, .008" Thick, 30.0" L, .5" Wide							<input type="checkbox"/>	Each	
							<b>ADD TO ORDER</b>		
							In stock		
0.010"	33"	0.625"	0.73"	0.99"	0.196"	4.12	9293K54	7.56	
0.012"	39"	0.750"	0.88"	1.19"	0.196"	5.94	9293K56	7.85	
0.014"	43"	1.000"	1.19"	1.50"	0.187"	7.00	9293K58	16.55	
<div style="border: 1px solid black; padding: 5px;"> <a href="#">Catalog Page</a>   <a href="#">Bookmark</a> </div>									
Stainless Steel Constant-Force Spring 4000 Cycle Life, .014" Thick, 43.0" L, 1" Wide							<input type="checkbox"/>	Each	
							<b>ADD TO ORDER</b>		
1 each was ordered 11/05/12 11/3/2012 ME 450.							In stock		
0.016"	40"	1.000"	1.20"	1.52"	0.196"	10.60	9293K12	10.83	
0.025"	52"	1.500"	1.77"	2.23"	0.265"	24.80	9293K13*	18.58	
0.031"	60"	2.000"	2.50"	3.03"	0.265"	40.90	9293K14*	29.81	

## Appendix K: Engineering Change Notifications

### **Engineering Change Notification #9**

ME 450 Team 5

Change of fastener types

Parts Affected by change: Most fasteners used for assembly

What has been changed:

Certain fasteners were changed in the prototype based on what was put in the CAD and bill of materials for the device. This was done in order to use fasteners that were readily available to us. This was done to cut down on prototype cost by not making our team purchase fasteners in order to match the bill of materials and CAD. Lengths and sizes of fasteners were not changed, only the type of fastener. For example, certain socket head cap screws were changed to machine head screws. This was done throughout the prototype when other fasteners were available to save money. The bill of materials will be updated to make these changes, including an estimated cost of the new fasteners.

Change Initiated by: Nathan Matheny

Date: 12/4/12

Change Approved By:

## Appendix K: Engineering Change Notifications

### **Engineering Change Notification #10**

ME 450 Team 5

Move battery to outside of bottom spool cover for easy battery replacement of UV sanitation circuit

Parts Affected by change: Bottom Spool Cover, Circuit Side

What has been changed:

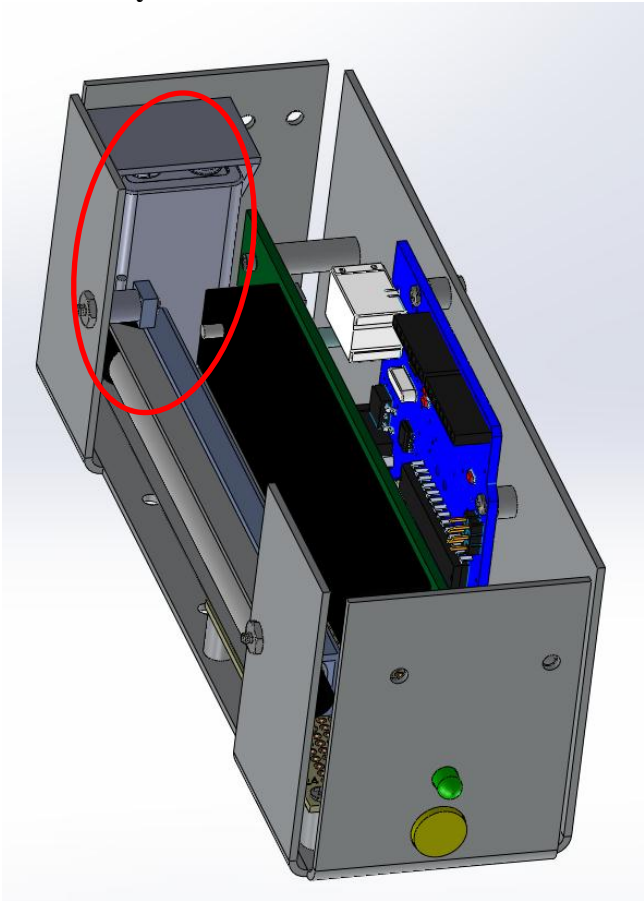
The 9 volt battery and holder will be moved to the outside of the housing to allow for easy changing of the battery for the UV sanitation circuit. If the battery was kept in the old location inside of the cover, then the entire cover would need to be removed whenever a new battery was needed. By moving the battery outside, the user will not remove the entire cover, and just replace the battery on the outside of the cover. All fasteners stay the same. The only part that needs to be changed is the “Bottom Spool Cover, Circuit Side”, which will have the battery mounting holes moved from the side of the cover to the bottom and a hole for the battery mount cable to go through. Please see the attached figures and drawings for new parts and battery location

Change Initiated by: Nathan Matheny

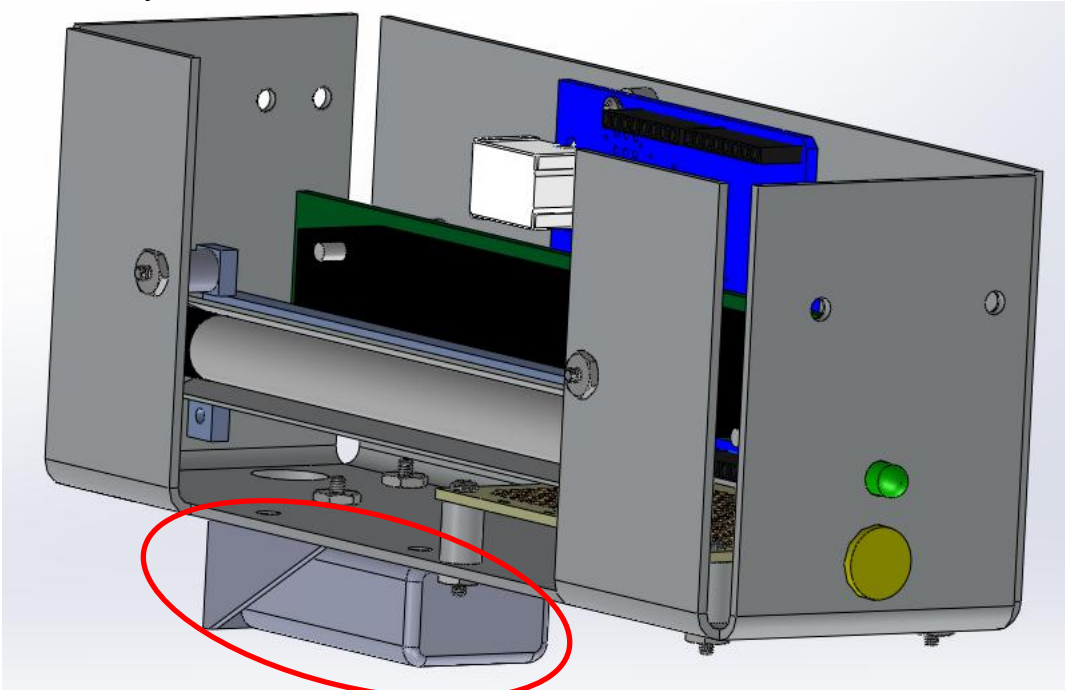
Date: 12/7/12

Change Approved By:

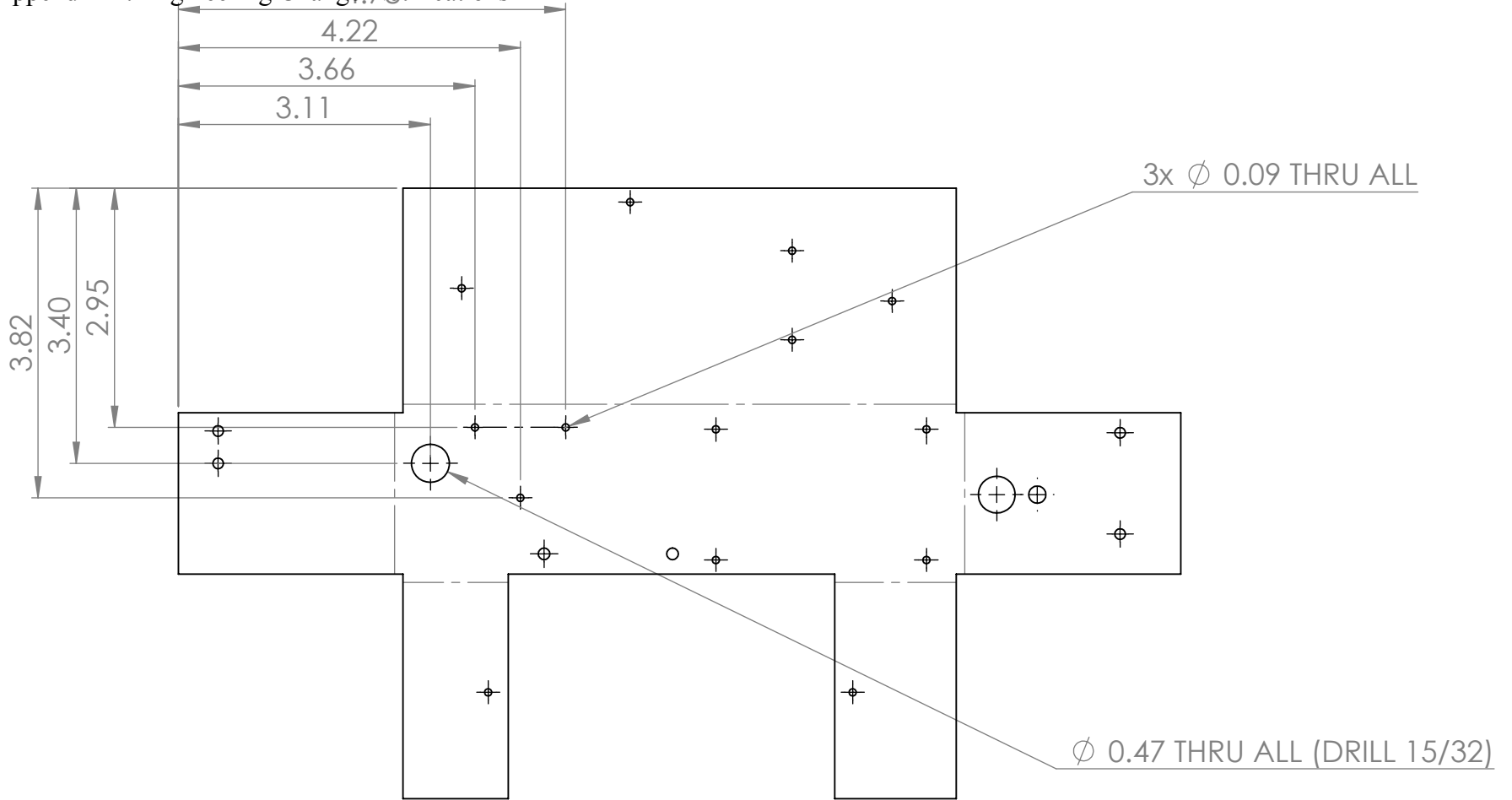
**Old Battery Location**



**New Battery Location**



# Appendix K: Engineering Change Notifications



**PROPRIETARY AND CONFIDENTIAL**  
 THE INFORMATION CONTAINED IN THIS DRAWING IS THE SOLE PROPERTY OF <INSERT COMPANY NAME HERE>. ANY REPRODUCTION IN PART OR AS A WHOLE WITHOUT THE WRITTEN PERMISSION OF <INSERT COMPANY NAME HERE> IS PROHIBITED.

		UNLESS OTHERWISE SPECIFIED:	NAME	DATE	<b>ME 450 TEAM 5</b>	
		DIMENSIONS ARE IN INCHES TOLERANCES: FRACTIONAL $\pm$ ANGULAR: MACH $\pm$ BEND $\pm$ TWO PLACE DECIMAL $\pm$ THREE PLACE DECIMAL $\pm$	DRAWN			
		INTERPRET GEOMETRIC TOLERANCING PER:	CHECKED		<b>BOTTOM COVER, CIRCUIT SIDE</b>	
		MATERIAL <b>6061 ALUMINUM</b>	ENG APPR.			
NEXT ASSY	USED ON	FINISH	MFG APPR.		SIZE <b>A</b>	DWG. NO. BOTTOM_SPOOL_COVER SM_CIRCUIT
APPLICATION		DO NOT SCALE DRAWING	Q.A.		REV	
			COMMENTS:		SCALE: 1:2	WEIGHT:
					SHEET 5 OF 5	

## Functional Performance

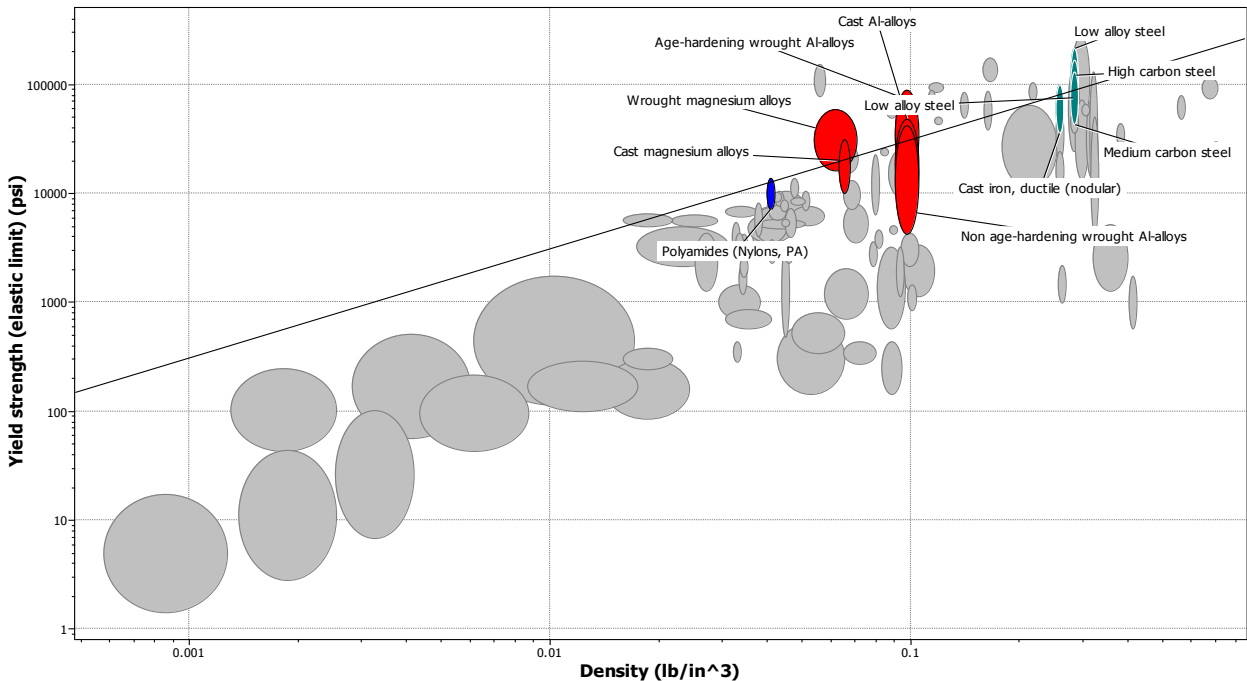
### Pole

The pole requires a material that has high yield strength to overcome the large moment created from the long length of the pole and the force at the top of the pole from the user input. Force analysis provided that the pole has to have yield strength,  $\sigma_f$ , greater than 9,330 psi to operate under expected loads with a safety factor of five taken into account. The determined function, objective, and constraints of the pole are shown below in Table 1.

Function	Beam
Objective	Minimize mass and cost
Constraints	Height and diameter defined Thickness free $\sigma_f > 9,330\text{psi}$

**Table 1:** These factors dictate what material index to use for the pole to find the optimal material for the desired objective.

From these factors the material index was found to be  $M = \frac{\sigma_f}{\rho}$  (Granta 2008, p. 35). Using the constraints in the CES EduPack 2012 program and inputting the specific material index to optimize for mass the chart below was produced (Figure 1).



**Figure 2:** The line that's slope is the inverse of the exponent in the material index, shows the optimal materials for selection for the pole.

The colored materials are the ones available after screening and optimization. Supporting information was researched for each of the materials and Age-hardening wrought Al-alloys were chosen for the pole. Specifically, 6061-T6 aluminum alloy was chosen because of its yield

strength meeting the requirements, its low cost, light weight, machinability, and its properties that protect against corrosion.

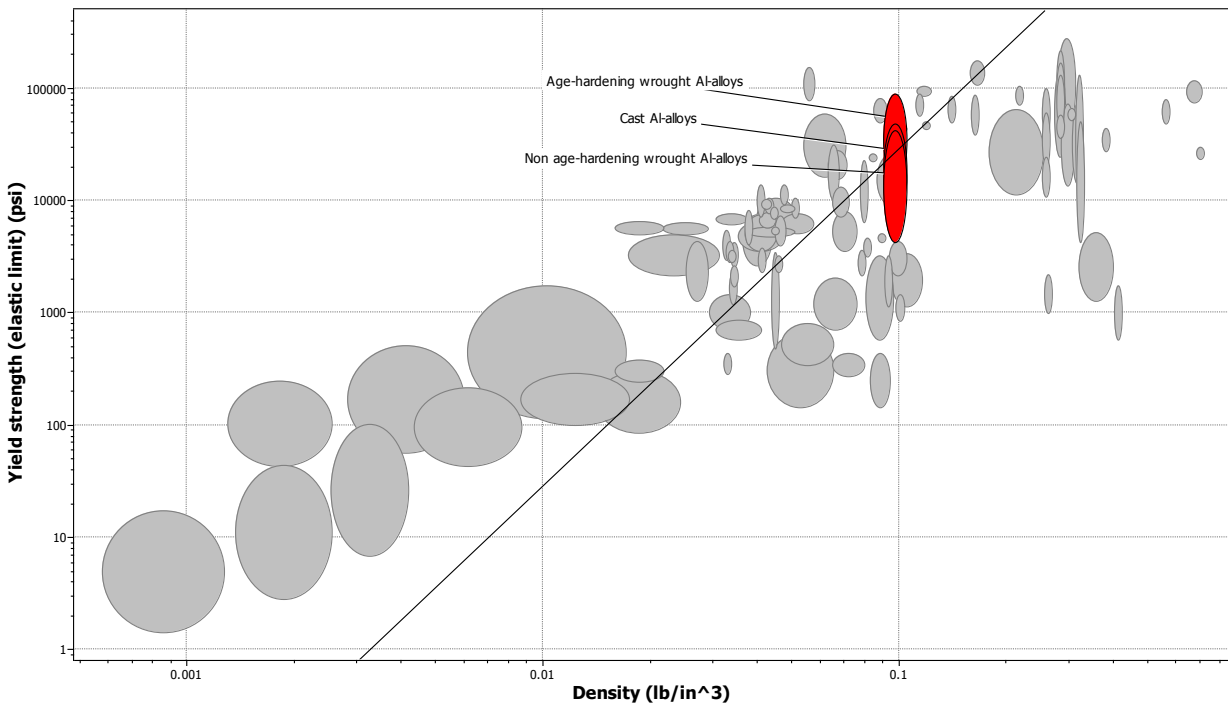
*Spool Supports*

The spool supports also require a material that has high yield strength to oppose failure in bending from the 38 lbs force of the tubing being pulled out by the user. Force analysis provided that the spool supports have to have yield strength greater than 15,482 psi to operate under expected loads, again with a safety factor of five taken into account. The determined function, objective, and constraints of the spool supports are shown below in Table 2.

Function	Beam
Objective	Minimize mass and cost
Constraints	Length defined Diameter free $\sigma_f > 15482\text{psi}$

**Table 2:** These factors dictate what material index to use for the spool supports to find the optimal material for the desired objective.

From these factors the material index was found to be  $M = \frac{\sigma_f^{2/3}}{\rho}$  (Granta 2008, p. 35). Using the constraints in the CES EduPack 2012 program and inputting the specific material index to optimize for mass the chart below was produced (Figure 3).



**Figure 3:** The line that’s slope is the inverse of the exponent in the material index, shows the optimal materials for selection for the spool supports.

Through supporting information, age-hardening wrought Al-alloys was chosen over the other types of aluminum for the spool supports. More specifically, aluminum 6061-T6 was chosen for the same reason as previously stated for the pole.



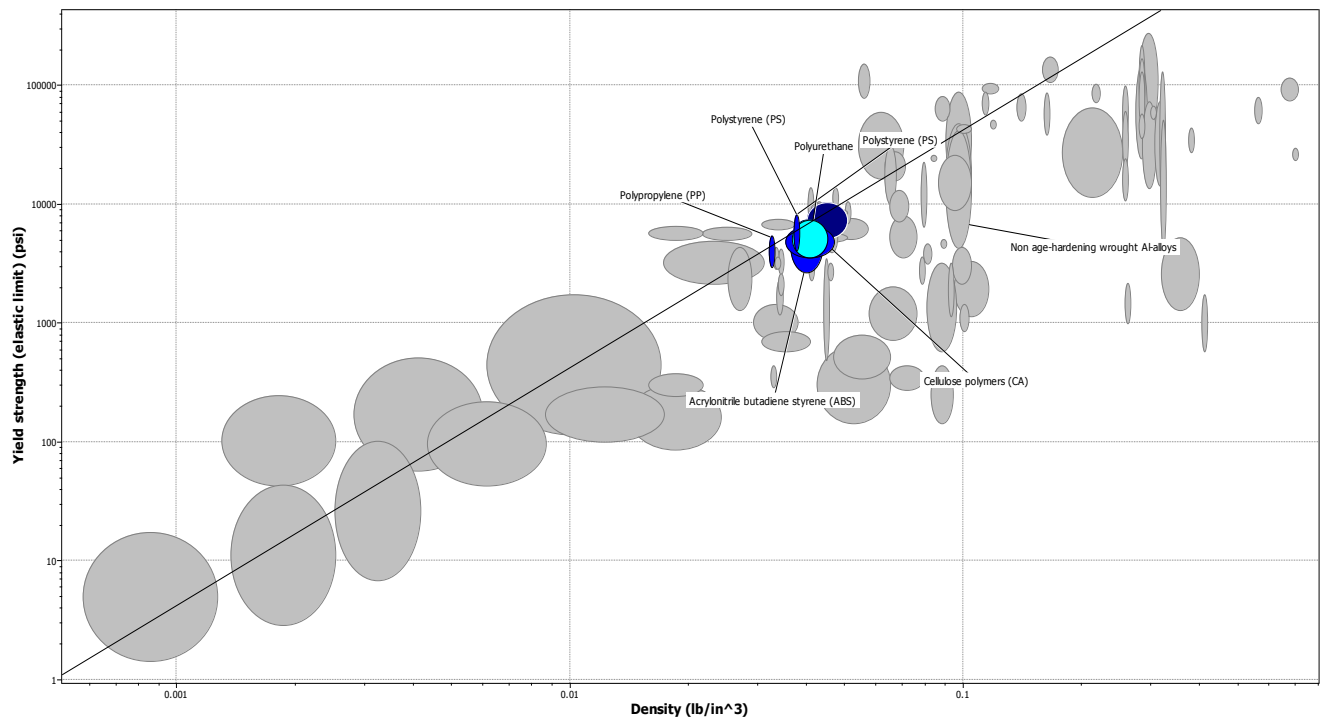
*Housing*

The maximum load felt by the housing will be in tension with an estimated force, including a safety factor of two, of 7 lbs. Designing against yield, the force analysis provided that the housing must have yield strength greater than 112 psi to operate under expected loads. The determined function, objective, and constraints of the housing are shown below in Table 3.

Function	Plate
Objective	Minimize mass and cost
Constraints	Length and width defined Thickness free $\sigma_f > 112\text{psi}$

**Table 3:** These factors dictate what material index to use for the housing to find the optimal material for the desired objective.

From these factors the material index was found to be  $M = \frac{\sigma_f^{1/2}}{\rho}$  (Granta 2008, p. 35). Using the constraints in the CES EduPack 2012 program and inputting the specific material index to optimize for mass the chart below was produced (Figure 4).



**Figure 4:** The line that's slope is the inverse of the exponent in the material index, shows the optimal materials for selection for the housing.

The best material for the housing was found to be polypropylene (PP) through supporting information. PP meets the yield strength requirement, is the cheapest of the material choices, is easily molded, and with additives is extremely stable to UV light, which is important since UV

light will be used within the housing.

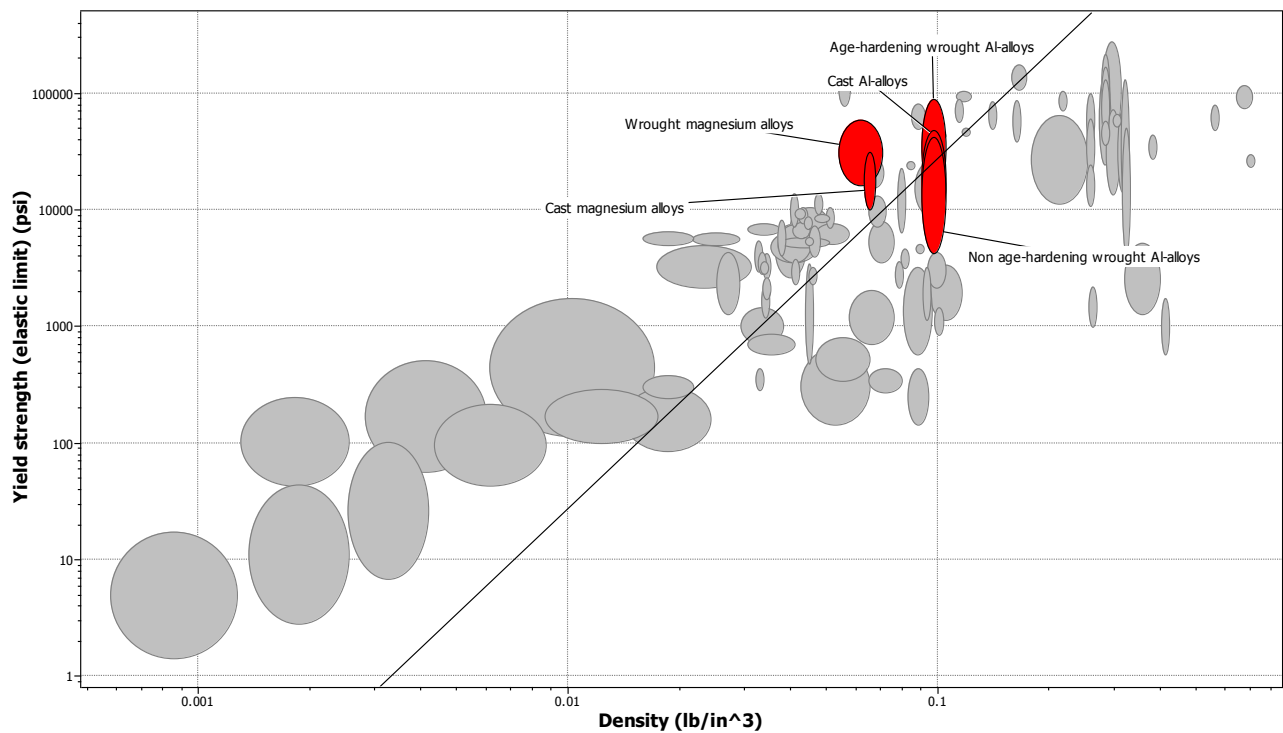
*Base Plate*

A material needed to be selected for the base plate that would ensure stiffness. With a load of 16 lbs, including safety factor, and a desired maximum deflection of 0.1in., force analysis provided that a material with a Young’s Modulus,  $E$ , of  $2.9 \times 10^6$  psi is necessary. The determined function, objective, and constraints of the housing are shown below in Table 4.

Function	Panel
Objective	Minimize mass and cost
Constraints	Length and width defined Thickness free $E > 2.9 \times 10^6$ psi

**Table 4:** These factors dictate what material index to use for the base plate to find the optimal material for the desired objective.

From these factors the material index was found to be  $M = \frac{E^{1/3}}{\rho}$  (Granta 2008, p. 35). Using the constraints in the CES EduPack 2012 program and inputting the specific material index to optimize for mass the chart below was produced (Figure 5).



**Figure 5:** The line that’s slope is the inverse of the exponent in the material index, shows the optimal materials for selection for the base plate.

Thus, aluminum 6061-T6 aluminum alloy was chosen for this application for the same reasons as previously stated.

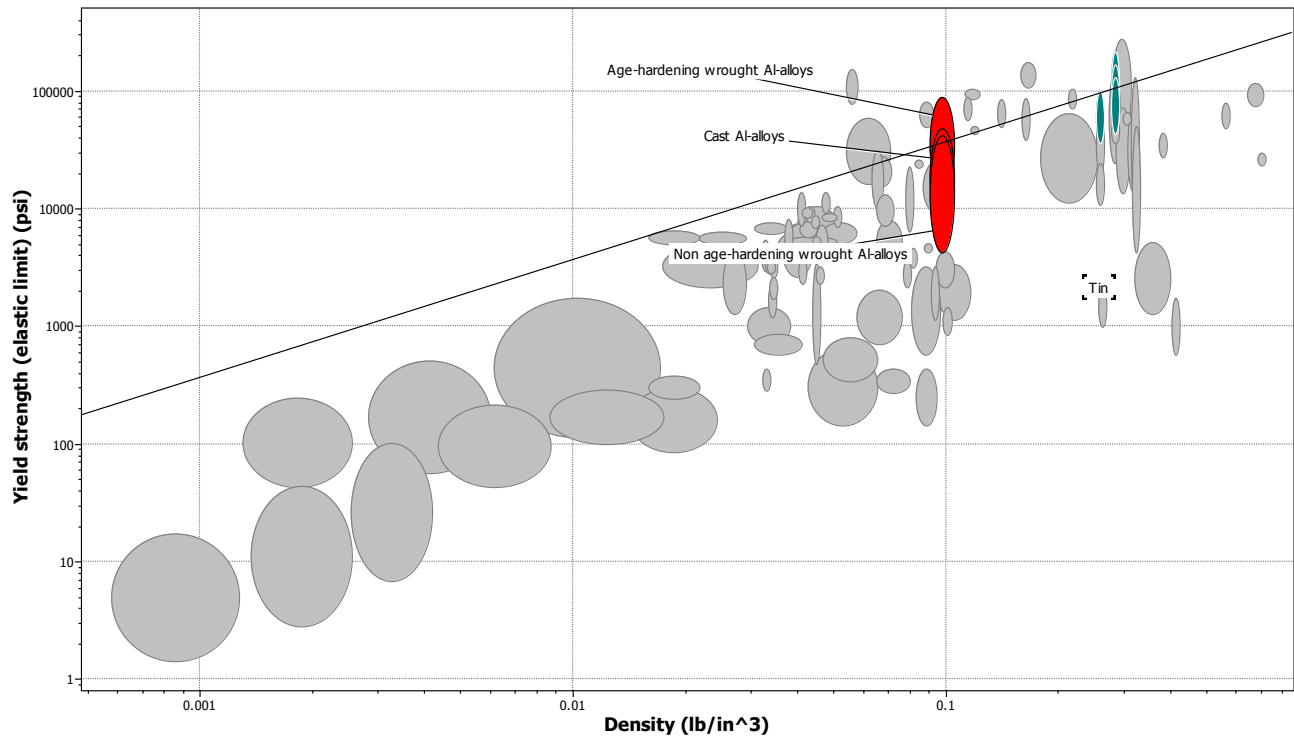
*Legs*

The legs needed to be designed against failure in yield and the maximum load one leg would experience is 20 lbs in compression. It was calculated that the yield strength needed to handle this load must be greater than 86.96 lbs. The determined function, objective, and constraints of the housing are shown below in Table 5.

Function	Column
Objective	Minimize mass and cost
Constraints	Height and shape defined Sectional area free $\sigma_f > 86.96\text{psi}$

**Table 5:** These factors dictate what material index to use for the legs to find the optimal material for the desired objective.

From these factors the material index was found to be  $M = \frac{\sigma_f}{\rho}$  (Granta 2008, p. 35). Using the constraints in the CES EduPack 2012 program and inputting the specific material index to optimize for mass the chart below was produced (Figure 6).



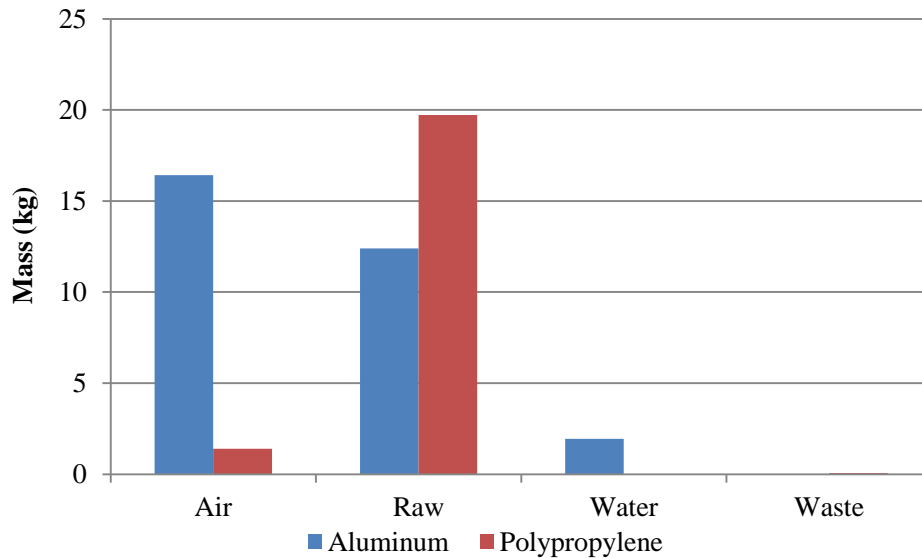
**Figure 6:** The line’s slope is the inverse of the exponent in the material index shows the optimal materials for leg selection.

**Environmental Performance**

From the CES Material Selection process above, the two major components in the final design are 6061-T6 aluminum alloy and injection molded polypropylene (PP). Using SolidWorks 2012 it was determined that the required weights of materials for the final design are 4.71 kg and 0.358 kg for aluminum and PP,

## Appendix L: Design Analysis

respectively. SimaPro (version 7.3.3) was used to determine the environmental impacts of these two materials in the final design. The materials chosen in the software were “aluminum alloy, AlMg<sub>3</sub>,” and “polypropylene injection molding E” because they closely resembled the mechanical properties of 6061-T6 aluminum alloy and PP. The analysis method used was EcoIndicator 99. Figure 7 below illustrates the amount of constituents that are needed to produce each material with the aforementioned weights.



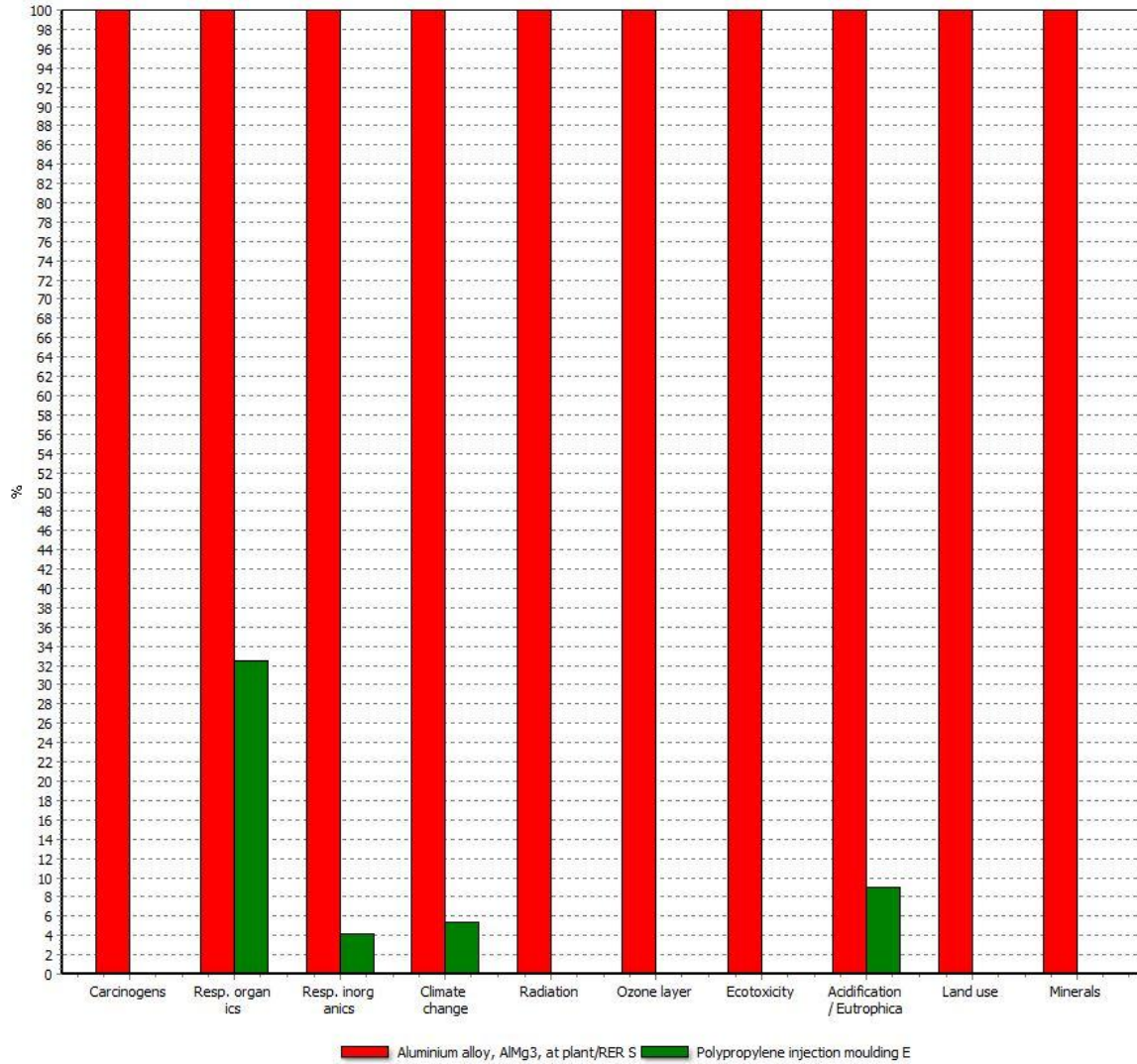
**Figure 7:** Comparison of emissions produced by 4.71 kg 6061-T6 aluminum and 0.358 kg polypropylene. Overall, aluminum produces more emissions than polypropylene in the device

The total mass of air emissions, raw materials, water emissions, and solid waste required to produce the aluminum is 30.8 kg and for PP, 21.1 kg. Strictly observing the total amount of waste and emissions for each of the materials, aluminum is more environmentally damaging than PP. However, more analysis is required to understand how exactly these two materials affect the environment. Figure 8, p. L7 categorizes the impacts each material has on the environment.

In this figure, PP is being compared against aluminum because aluminum has the highest emissions in each category. From this figure it is clear that PP produces less harmful emissions than the manufacture of aluminum.

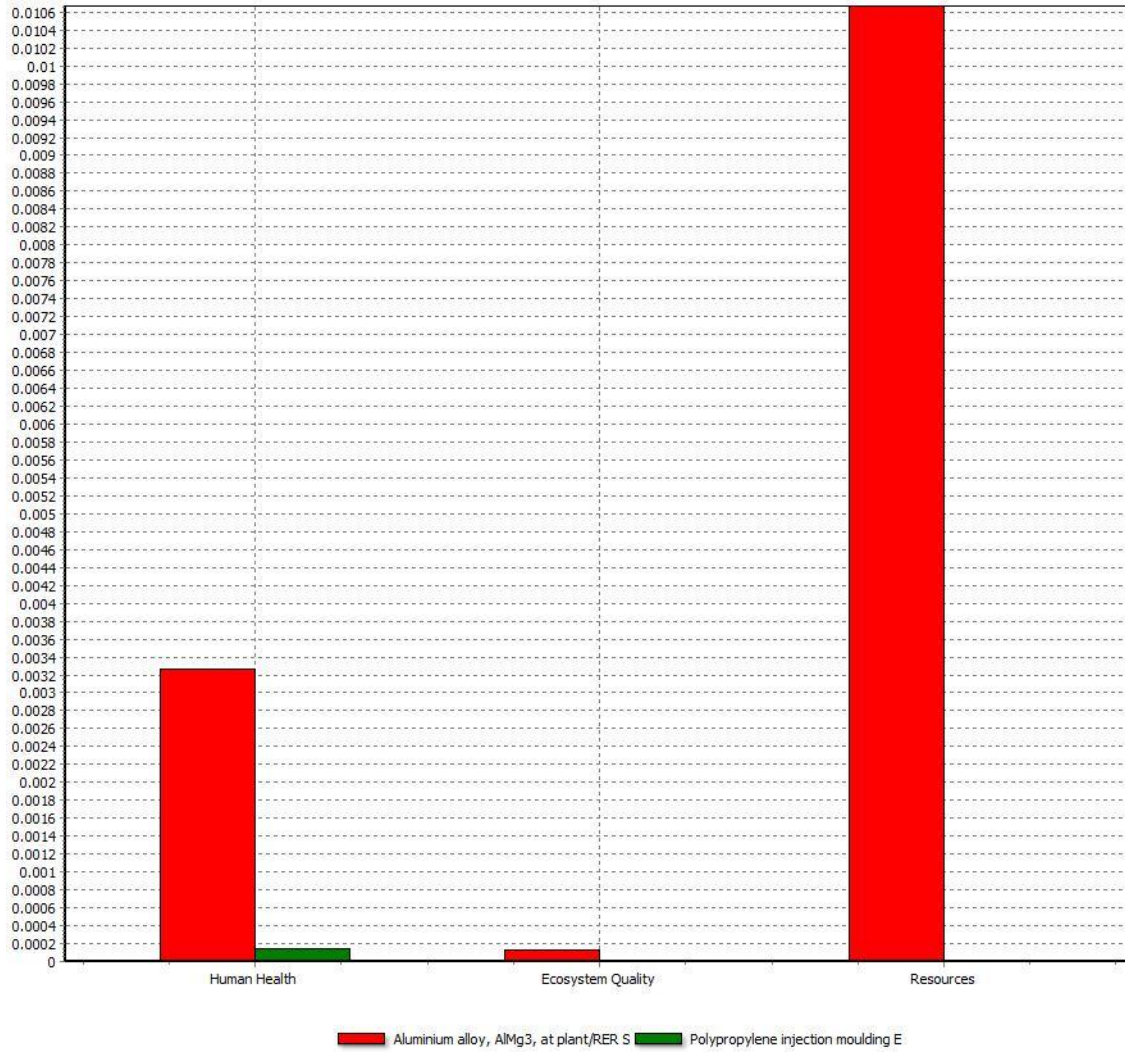
Figure 9, p. L8 normalizes the emission data for aluminum and PP with the average damage caused by the average European person over one year. Figure 10, p. L9 scores each material on a “points” system; the material with the lowest score is that which has the lowest environmental impact out of the two materials. However, the full life cycle of the device must be taken into consideration. PP is a petroleum based product, and with world energy demands on the rise, petroleum reserves will be depleted at faster and faster rates. Recycling the PP components also becomes an issue because it has “resistance to biodegradation since it is highly hydrophobic, has high molecular weight, lacks of an active functional group and has a continuous chain of repetitive methylene units” (Longo). Whereas aluminum can be melted down and reformed to make different products, there are currently limited recycling possibilities for polypropylene.

Appendix L: Design Analysis



**Figure 8:** Comparison of the effects that the amount of each material has on the environment. Aluminum has greater emissions than PP in each category, thus it is normalized to 100%, and PP is compared to this value.

Appendix L: Design Analysis



**Figure 9:** The effects on the environment from aluminum and PP are lumped into three main categories and compared to the average environmental damage cause by the average European person over one year





**Figure 10:** The results from the previous figure are combined and displayed for each material. The emission effects for each material are scored on a points system. PP has a much lower point value than aluminum, thus it has less impact on the environment

### Manufacturing Process Selection

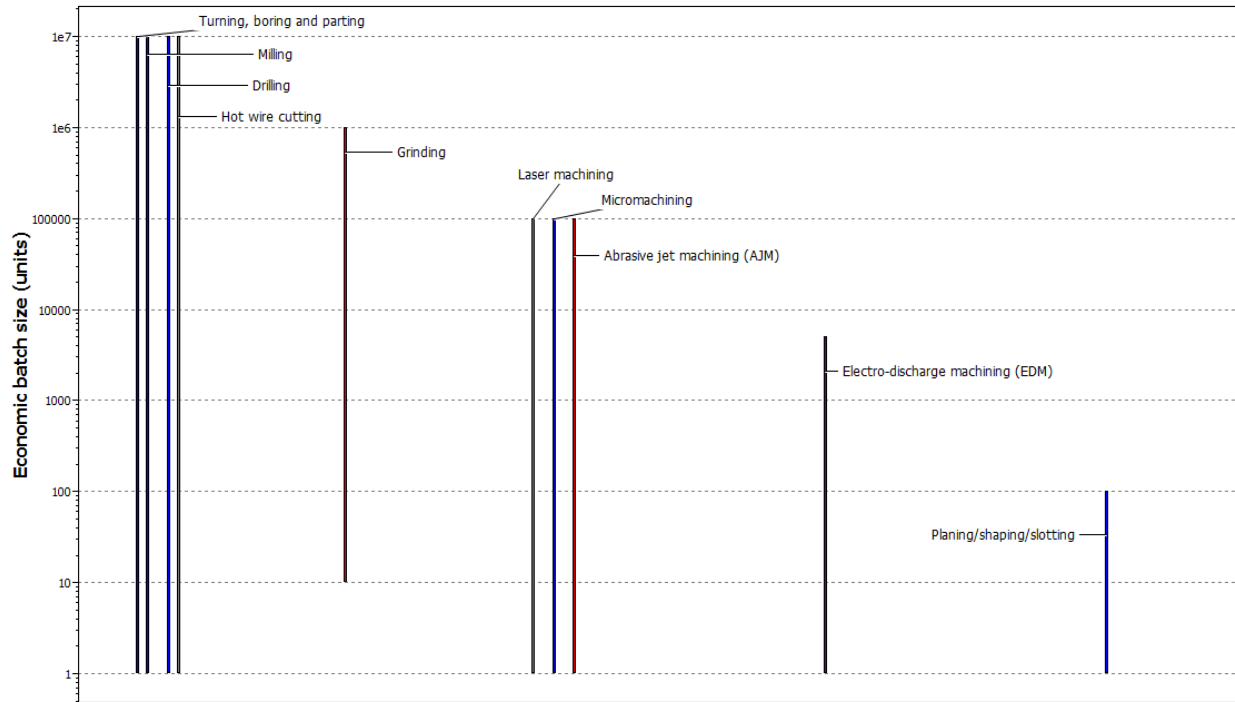
There are an estimated 1.5 million people in the United States that use oxygen due to respiratory ailments. This device is capable of being sold to one third of that population and therefore the production volume for this product is 500,000 units. To meet this production volume and to keep costs and waste low with lean manufacturing, the batch size was determined to be between 1,000 and 5,000 units. Using this batch size and the CES EduPack 2012 program, the manufacturing processes for the aluminum base plate and the Polypropylene housing were determined.

#### *Base Plate*

Previously, the base plate was determined to be produced from 6061-T6 aluminum alloy. Because the base plate is 0.25 in thick aluminum, it was assumed to be a solid 3D that is needed to be manufactured through machining. The tightest tolerances in the base plate are 0.005 in.

## Appendix L: Design Analysis

These constraints were used to limit the number of manufacturing choices. The possible processes with their range of batch sizes were then plotted (Figure 11).



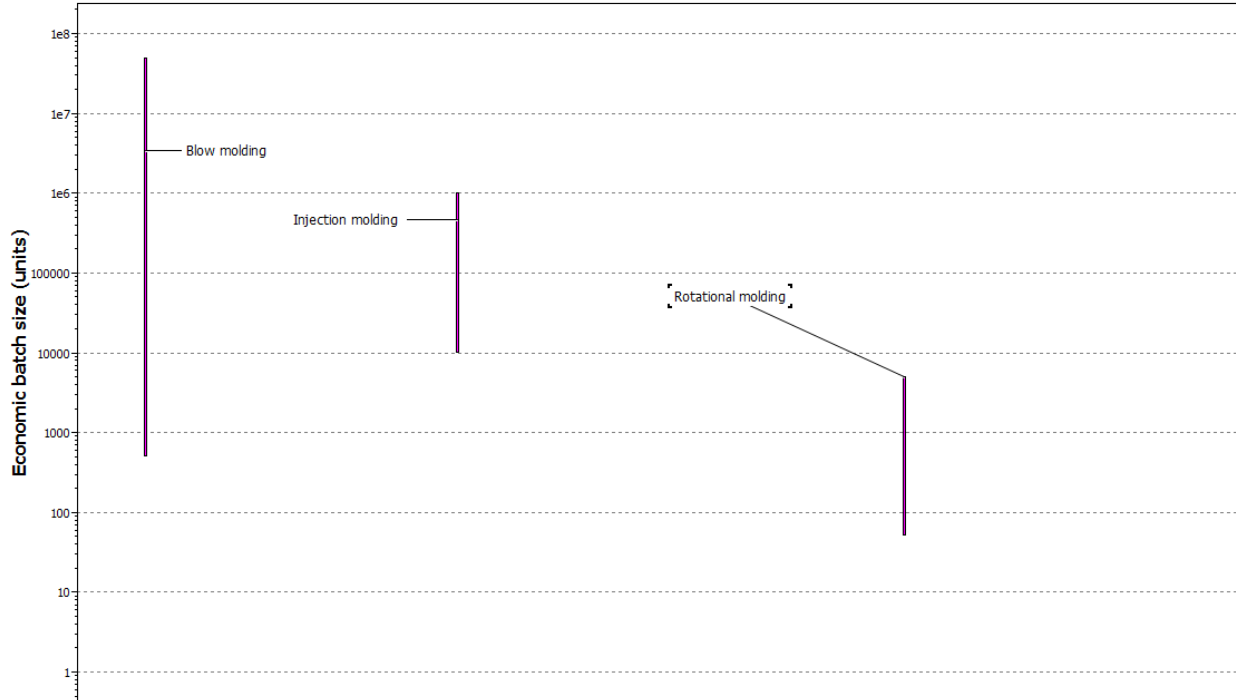
**Figure 11:** Comparison of manufacturing processes that meet base plate constraints and their economic batch sizes

After eliminating the processes that do not produce the correct batch size, each process was researched to determine the best match. It was determined that the process that met all the requirements of the base plate and is most practical to use is Laser Beam Machining.

### *Housing*

The housing had previously been determined to be manufactured from Polypropylene. It was assumed that the housing is a dished sheet since the thickness is 1/16 in and that it will be manufactured through a molding process. The tightest tolerances in the housing are 0.01 in. These constraints were used to limit the number of manufacturing choices. The possible processes with their range of batch sizes were then plotted (Figure 12, L11).





**Figure 12:** Comparison of manufacturing processes that meet housing constraints and their economic batch sizes

After eliminating the processes that do not produce to correct batch size, each process was researched to determine the best match. It was determined that the process that met all the requirements of the housing and is most practical to use is injection molding.