

## TECHNICAL NOTE

*A CUEING DEVICE FOR THE ACCELERATION OF THE RATE OF POSITIVE INTERACTION*

This paper describes and illustrates the use of an apparatus<sup>1</sup> that might be used to extend a therapeutic force into home settings while at the same time generating data on the effectiveness of the procedure. It is believed that the economies of time that could result from such an instrument will prove valuable in extending the resources of behavior modifiers.

The instrument is designed to permit the cueing of positive interactions between two or more persons. The importance of the exchange of positives in parent-child interactions has been suggested by Stuart (in press, *a*), who has shown that families producing delinquents can be differentiated from families that do not produce delinquents by determining the proportion of positive social exchanges made during structured interview situations. In this work, a feedback apparatus (Stuart, in press, *b*) was used to permit parents and adolescents to signal to each other—via lights, sounds and/or tally counts—their positive and negative reactions to each other's behavior simultaneously and immediately. While wide within-group variations were noted, between-group comparisons demonstrated that the families of nondelinquents used more than three times as many positively as opposed to negatively perceived maneuvers; the families of delinquents relied upon approximately equal numbers of positive and negative maneuvers. The subsequent pilot study then suggested that it may be possible to interrupt the delinquent careers of certain adolescents by accelerating the rate of positive exchanges during family interactions.

As an outgrowth of this work, an apparatus was constructed that may permit the cueing and monitoring of positive exchanges in natural home and school environments. The apparatus<sup>2</sup> consists of a recycling interval timer (Industrial Timer Corp. Model TDAF) that can be set to sound an "aversive" buzz at intervals of from 1 to 60 min, a button located at the top of the timer, which automatically resets the timer at a pre-determined interval (forestalling the buzz), tally counters (Allied Electronics Model CE50, 115 vac) to measure both the number of times the buzzer is

sounded and the number of times the reset button is pressed, and a lapsed-time indicator (Heydon Model EN3010) showing the total time that the apparatus is used. An output is also available, permitting the attachment of a Rustrak (Model 292-4) four-channel event recorder to obtain data pertaining to the sequence of buzzes and resets. A schematic diagram and photograph of the apparatus are presented in Fig. 1 and 2.

The timer is placed before one or more members of the family. Each time that the operator wishes to record receipt of what he defines as a positive action by any other person, he presses the button on the timer. This records the positive event and resets the timer. If the operator does not press the button before a preset interval expires, e.g., 5 min, a loud buzz is sounded continually until the button is pressed again. The sound of the buzz is intended to serve both as a cue that a positive should be emitted and as a negatively reinforcing stimulus for the other person, who is instructed that he should terminate the buzz by emitting a response that the operator defines to be positive and that stimulates the operator to press the reset button. In the present context, a "positive" is described as "any interpersonal response emitted by the other person that the operator would like to have to have him continue or repeat."

It has been estimated from Stuart's earlier studies that a rate of seven or more positives, approximately evenly distributed between parents and adolescents, during each half hour of interaction would differentiate families that do and do not produce delinquent adolescents. It was decided to try out the apparatus with one family which, when asked to code tapes of dinner-table conversation, demonstrated a rate of 0.90 positives per 30-min meal, a rate well below that considered to be minimally adequate. The 14-yr-old girl in this upper-middle-class family had been referred for treatment by a neighbor to whom the parents had confided their knowledge that the girl had been shoplifting several times weekly over a two- to three-month period. During the first session, the parents and daughter discussed the need for positive interaction and attention to positive rather than negative actions. This was followed by training in interaction coding, in which each was instructed to base his assessment upon his personal reaction to the content of the conversation, limiting, as much as possible, reactions based upon things that had happened in the past and that were essentially unrelated to the current interaction. The family was then asked to code separately reactions to cassette tapes of

<sup>1</sup>The prototype of this equipment was developed by the Family and School Consultation Project and Behavior Change Systems, Inc., with funds provided by the State of Michigan Department of Mental Health through the United States Public Health Service 314 (d) program.

<sup>2</sup>All parts can be ordered from Allied Electrical Corp., 100 N. Western Avenue, Chicago, Illinois 60602.

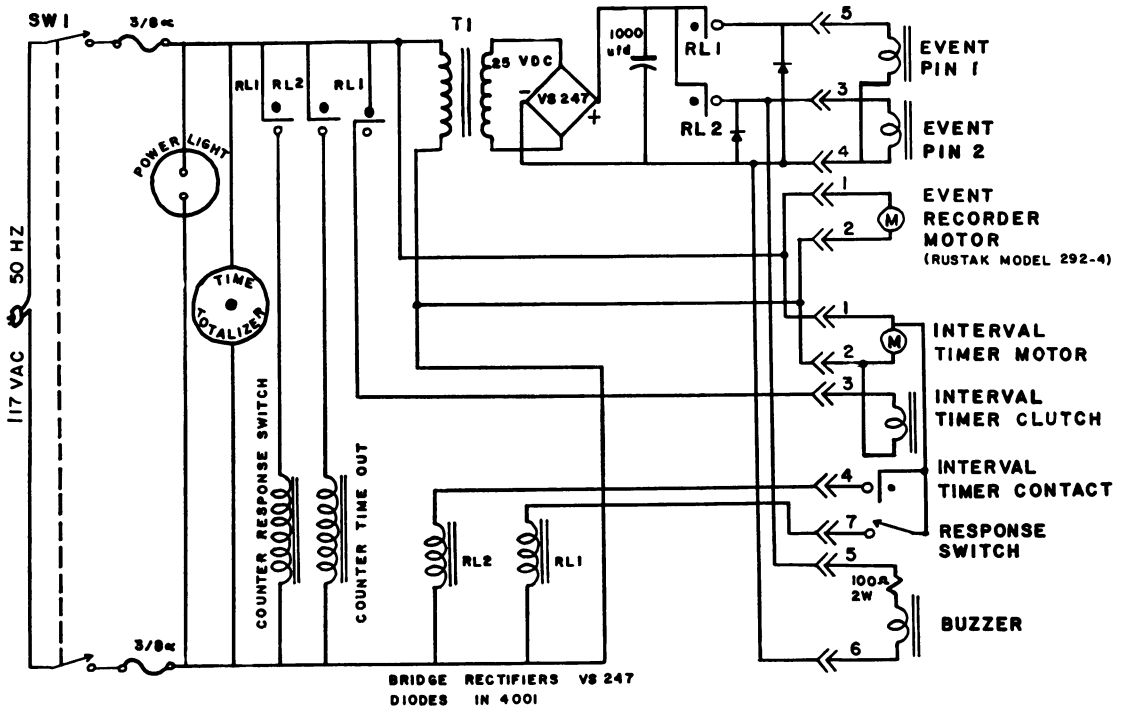

Fig. 1. Schematic of the interval timer recorder.

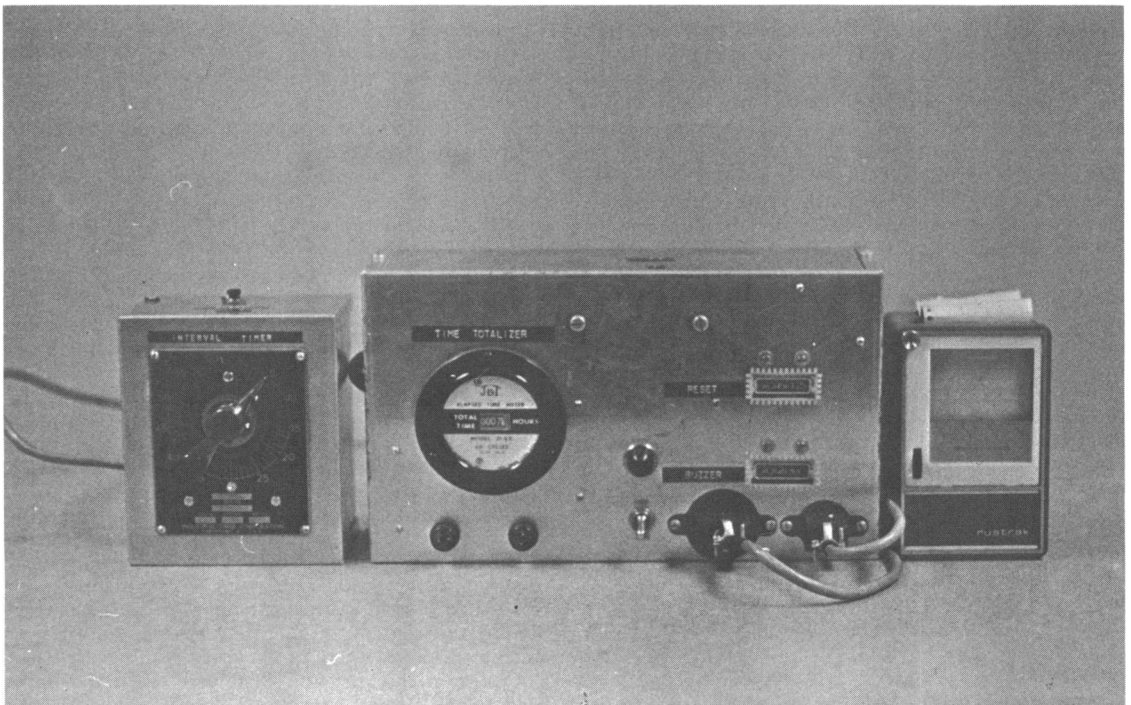

Fig. 2. The cueing apparatus.

dinner-table conversation and to telephone in the results of this coding daily, mailing the cassettes to the author every second day. The daily taped sessions were limited to the 30-min tape provided.

No effort was made to cross-validate the baseline data because, as Stuart (in press *a*) found, responses scored by an observer who is unfamiliar with the idiosyncracies and nuances that words, expressions, and mannerisms have acquired in families over time are subject to considerable interpretive error. It is therefore assumed that the most valid means of collecting such data is to allow the subjects themselves to score each other's behavior. This approach does create a new source of error stemming from the possibility that responses may be tempered because of fear of negative social consequences following normal actions. Insofar as this intensifies but does not alter interaction messages, however, it is in the author's judgment a less

serious error than that which would result from interpretive bias by an outside observer who would not be able to score the action on the basis of its function for the members of the family.

The second session was held after the 11-day baseline was completed. At this time, the cueing apparatus was introduced with the suggestion that it might be useful in providing periodic reminders to family members that positive maneuvers were needed. It was agreed that 5-min intervals between positives was minimally tolerable and that the daughter would have the first opportunity to cue her parents for one week, to be followed by a return to baseline condition for one week. Placement of the tape-recorder microphone next to the timer permitted synchronization of the tape and event-recorder chart by merely sounding a 10-sec buzz; it also permitted audio recording of each button press as the resetting of the timer was associated with a

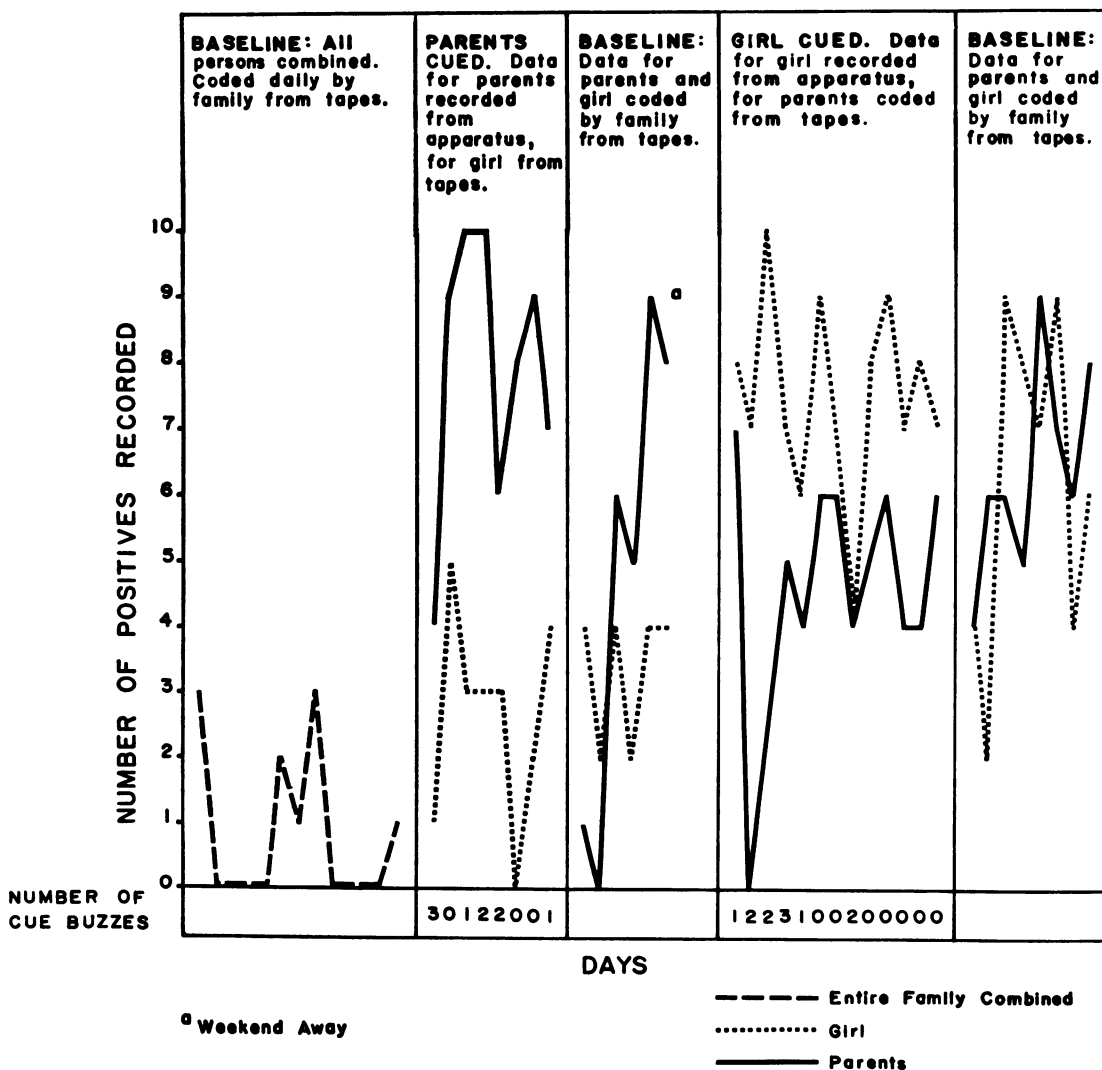

Fig. 3. Number of positive interactions recorded during dinner conversations by a predelinquent girl and her parents.

distinct click. Synchronization of the event-recorder chart with the tape made possible the cross-validation of the use of the timer. An independent observer was instructed to listen to the tapes and to judge whether the button presses were associated with actions that the observer would describe as statements of "agreement, appreciation, approval and/or encouragement." By telephone, the family was asked to reverse the procedure for the next two weeks, the parents cueing their daughter for seven days followed by a terminal baseline.

The data generated in association with use of the apparatus are shown in Fig. 3.<sup>3</sup> It will be seen that the rate of positive interaction increased during this period, reaching an overall average of 9.26 positives for all three members of the family during the final baseline interval. It can also be seen that while the positive behavior of the individual cued was consistently higher than that of the person doing the cueing, the positive response rate of all persons rose during the times that the apparatus was in use. This is to be expected if the positives of one family member have a cueing function for the positives of others (Stuart, 1969). Finally, the independent observer concurred with the appropriateness of button presses at the level of 0.95 giving ample assurance that the apparatus was used as intended, although the observer indicated that approximately 140% more of the family's responses met the observer's criterion for positive statements than were recorded by the family members. It is interesting to note that overall, the girl recorded 89% of the positives that the observer attributed to her parents, while the latter recorded only 73% of the positives attributed to the girl by the observer.

While it is still too soon to determine whether the cueing apparatus has helped in reversing the antisocial

<sup>3</sup>The baseline data produced by the parents and girl are combined due to the fact that the low frequencies and similarities in response patterns would make separate graphing difficult to understand.

behavior of the girl, it is reasonable to suppose that use of this apparatus contributed to the gains made by each family member in achieving positive control over the behavior of the other members. The family reported that they regarded the use of the apparatus as a nuisance initially, but in a termination session they asked about its availability at subsequent periods "just to keep everyone honest".

With this family and others like it, the apparatus has been used for a total of 108 hr without malfunction. The total amount of professional time expended with this family (excluding the time devoted to cross-validating the tapes) was 3 hr. It appears that the use of this and similar equipment (Schwitzgebel, 1969) is worthy of continued exploration as a means of both increasing the effectiveness of behavior modification activities and of extending their usefulness into natural environments at nominal cost.

#### REFERENCES

- Schwitzgebel, R. L. Survey of electromechanical devices for behavior modification. *Psychological Bulletin*, 1968, **70**, 444-459.
- Stuart, R. B. Operant-interpersonal treatment for marital discord. *Journal of Consulting and Clinical Psychology*, 1969, **33**, 675-682.
- Stuart, R. B. Assessment and change of the communicational patterns of juvenile delinquents and their parents. In R. D. Rubin, A. A. Lazarus, and C. M. Franks (Eds.), *Advances in behavior therapy*, 1969. New York: Academic Press, *in press*. (a)
- Stuart, R. B. An apparatus for the assessment and change of communicational patterns. In R. D. Rubin, A. A. Lazarus, and C. M. Franks (Eds.), *Advances in behavior therapy*, 1969. New York: Academic Press, *in press*. (b)

RICHARD B. STUART  
University of Michigan