

**Phi-Agree, A-movement, and  
Complementizer-Tense Relations in Chinese**

By

Chao-Ting Chou

A dissertation submitted in partial fulfillment  
of the requirements for the degree of  
Doctor of Philosophy  
(Linguistics)  
in The University of Michigan  
2013

Doctoral Committee:

Professor Samuel David Epstein, Co-chair

Associate Professor Acrisio M. Pires, Co-chair

Professor Richard L. Lewis

Assistant Professor Ezra Russel Keshet

Professor T. Daniel Seely, Eastern Michigan University

© Chao-Ting Chou

All rights reserved

2013

## **Dedication**

*To my wife Shu-Ching Yang and my son Ethan Chou*

*獻給我的老婆舒晴與兒子牧齊*

## Acknowledgments

It is 1pm, June 13th 2013, and I am sitting in front of my desk, trying to finish the most challenging task in this dissertation – to fully and properly express my thanks to all the remarkable individuals for what they have done for me to help me finish my Ph.D. degree.

The first person I would like to thank is my advisor, mentor, and friend Sam Epstein. The email exchanges with him in early 2008 made joining the University of Michigan an easy decision. He selflessly devotes his time to supporting every aspect of my graduate life in Ann Arbor. As an advisor and a cognitive scientist, his scrutinizing questions and enlightening comments redefine my understanding of what counts as an “explanation” in the linguistic theory. As a person, Sam’s kindness and leniency always make me speechless with gratitude. No one expresses it better than Hamid Ouali did: “Sam is the most caring human being I have ever met”. Indeed, he is a role model for me in multiple respects. He is that kind of advisor and friend that everybody wants. I feel sorry for not having enough time and space here to thank Sam for every little amazing thing he has done for me. To Sam I say: Thank you! I hope when you overcome airplane phobia and visit Miki in Japan someday, don’t forget to swing by Taiwan then (it’s JUST another 4 hours from Tokyo).

I am also immensely grateful to Acrisio Pires, an all-around linguist, for his guidance throughout my graduate career. It is a privilege to work with him for multiple times as a teaching assistant of *Introduction to Syntax* and *Aspects of Meaning*. He is also incredibly generous to invite me to work with him on the bilingual acquisition project since the summer in 2011. As his TA and RA, I got the opportunity to closely observe and learn how he carefully plans each class and carries out his own research. In spite of his tight and hectic schedule, he is a truly remarkable advisor who gives meticulous and penetrating comments on everything I have ever written and provides very useful suggestions at every single meeting we have ever had. I learned a lot from him about time

management and how to strike a balance between teaching, research, and life. Working with him provides me with an invaluable opportunity to broaden my horizon by learning how to design an experiment and carry out statistical analysis, both of which would play important roles in my future research agenda. To Acrisio I say: I greatly appreciate what you have generously shared with me in the past five years, both academically and personally (and you need to take a break).

Each of the members of my dissertation committee deserves special thanks. Ezra Keshet has given comprehensive comments and suggestions on my dissertation from his point of view as a semanticist. Rick Lewis, a computational psycholinguist, raised many critical and deep questions about the notion of economy in the linguistic theory. Daniel T. Seely is the master of presenting complicated syntactic analyses and problems. Watching his presentation of syntactic derivations is like watching a surgeon performing a delicate dissection. I am grateful to all these three members for their professional assistance beyond the call of duty.

My gratitude extends to the professors, colleagues and friends at the Department of Linguistics at Michigan. I thank especially Marlyse Baptista (for your heartfelt encouragement whenever I ran into you on the campus), Pam Beddor (for your lucid teaching of categorical perception and other concepts in Phonetics), Sujewa Hettiarachchi (for inviting me to work with you on Sinhala syntax), Jae-Young Shim (for being a good friend with whom I could talk about anything), Mike Opper (for being one of the most easygoing persons I know of), David Medeiros (for being a good company at the Song Bird Café), Miki Obata (for your outstanding research that always inspires me), Tridha Chatterjee (for giving me the opportunity to know more about India), and Jon Yip (for being a friend who is always willing to share).

I also have to thank linguists outside the University of Michigan. Thanks Prof. Chen-Sheng Liu, Jonah Lin, Jowang Lin for being encouraging and caring teachers/friends when I was a master student at the National Chiao Tung University in Hsinchu, Taiwan. I would also like to thank Prof. Jim Huang at the Harvard University for his pioneering work on Chinese syntax.

Last but not least, I thank my wife Shu-Ching for her never-failing love, my son Ethan for the joy he brings to our family, and my parents for their financial support.

## Table of Contents

Dedication	ii
Acknowledgments	iii
List of Abbreviation	viii
<b>Chapter 1 Introduction and Theoretical Background</b>	<b>1</b>
1.1 The Framework: Minimalism Program and Feature Inheritance	1
1.2 Feature Inheritance in Chinese?	10
1.3 Overview of the Dissertation	17
<b>Chapter 2 A-movement in Chinese</b>	<b>20</b>
2.1 Introduction	20
2.2 Raising Modal Constructions	23
2.3 Object Raising in RMC	30
2.3.1 Against the base-generation analysis	32
2.3.2 A- or A'- movement?	37
2.4 The (Apparent) Underivability of Object A-movement in RMC	44
2.4.1 Topicality and A-movement in RMC	44
2.4.2 The incompatibility between PIC and feature inheritance	52
2.5 Two Views of the Syntactic Visibility of “Discourse” Features	57
2.5.1 Horvath (2010)	57
2.5.2 Aboh (2010)	62
2.6 Analysis	64
2.6.1 Feature valuation/interpretability biconditional	64
2.6.2 A fine-grained characterization of the Topic feature	66
2.6.3 Remarks on Lin (2011) and Case-motivated A-movement in Chinese	68
2.6.4 A novel argument for Case-driven A-movement without	

	$\phi$ -features on T	77
	2.6.5 The derivation of topic A-movement in RMC	87
2.7	Summary and Concluding Remarks	95
<b>Chapter 3</b>	<b><math>\phi</math>-Agree in Chinese</b>	<b>99</b>
3.1	Introduction	99
3.2	Chinese <i>Wh-the-hell</i> Questions	102
3.3	Previous Analyses of the Long-distance Construal of <i>Ziji</i>	108
	3.3.1 The pragmatic analysis	108
	3.3.2 The syntactic analysis	111
	3.3.3 The non-uniform analysis	117
3.4	A Fine-grained Theory of $\phi$ -features	122
3.5	$\phi$ -features and $\phi$ -Agree in Korean	125
3.6	A Unified Analysis	131
	3.6.1 The negative attitude of <i>wh-the-hell</i> questions	132
	3.6.2 Deriving the logophoric ascription of Chinese <i>wh-the-hell</i> questions and its BE	134
	3.6.3 Deriving the long-distance construal of <i>ziji</i> and its Agree-based BE	140
3.7	Extension: the Incompatibility between Causal <i>Zenme</i> and <i>Daodi</i>	144
	3.7.1 Previous studies of <i>how come</i>	145
	3.7.2 <i>Wh-the-hell</i> phrases as polarity items	148
	3.7.3 The negative attitude of causal <i>zenme</i>	149
	3.7.4 Deriving the incompatibility between <i>daodi</i> and causal <i>zenme</i>	152
3.8	Summary	156
<b>Chapter 4</b>	<b><math>\phi</math>-features on T and Intra-phase Rule Ordering</b>	<b>157</b>
4.1	Introduction	157
4.2	T-to-C Raising in Locative Inversion	161
4.3	The Derivation of Locative Inversion	164
	4.3.1 Locality	165
	4.3.2 A, A-bar, or both?	169

4.3.3	Proposal: locative inversion as topic A-movement	180
4.4	Explaining the (In)compatibility between T-to-C raising and Locative Inversion	188
4.4.1	The timing of intra-phase rule application	189
4.4.2	Two ways of labeling {XP, YP}	190
4.4.3	Ruling out/in T-to-C raising in locative inversion	195
4.5	Summary and Concluding Remarks	198
<b>Chapter 5</b>	<b>Thesis Summary and Theoretical Implications</b>	<b>205</b>
5.1	Thesis Summary	205
5.2	Theoretical Implications	211
5.2.1	A/A'-distinction	211
5.2.2	A CI interface free from featural crash	221
	Bibliography	230



## List of Abbreviation

ACC: Accusative Case  
ASP: Aspectual marker  
BA: disposal marker  
BEI: passive marker  
COMP: complementizer  
DAT: Dative Case  
DEC: Declarative  
DOU: universal quantification marker  
DUR: Durative marker  
EXH: Exhortative marker  
EXP: Experiential marker  
FOC: Focus marker  
[iF]: interpretable features  
IMP: Imperative marker  
LOC: Localizer  
MOD: Modifier  
NOM: Nominative Case  
PERF: Perfective marker  
PRM: Promissive marker  
PROG: Progressive marker  
Q<sub>yes-no</sub>: *Yes-no* question marker  
Q<sub>wh</sub>: *Wh*-question marker  
SG: Singular  
TOP: Topic marker  
[uF]: Uninterpretable features

## Chapter 1 Introduction and Theoretical Background

### 1.1 The Framework: Minimalism Program and Feature Inheritance

This thesis is developed within the framework of the minimalist program. In particular, I examine different aspects of Chinese syntax under Chomsky's (2007, 2008) feature inheritance hypothesis. The feature inheritance hypothesis maintains that  $\phi$ -features are no longer inherent features of T. Rather, T inherits  $\phi$ -features from C. Consequently, T cannot initiate  $\phi$ -probing on its own until C is introduced into the derivation (and passes down its  $\phi$ -features to T). A strong piece of evidence for the association between  $\phi$ -features and C comes from the C-agreement paradigm in West Flemish (see Haegeman 1992, Haegeman and van Koppen 2012, and Carstens 2013) illustrated in (1).

- (1) C-agreement in West Flemish
- |  |                  |
|--|------------------|
| a. K weten <b>dan-k (ik)</b> goan wegoan.      | [C + 1SG]        |
| I know that-I (I) go leave                     |                  |
| 'I know that I am going to leave.'             |                  |
| b. K weten <b>da-j (gie)</b> goat weggoan.     | [C + 2SG]        |
| I know that-you (you) go leave                 |                  |
| 'I know that you are going to leave.'          |                  |
| c. K weten <b>da-se (zie)</b> goat weggoan.    | [C + female 3SG] |
| I know that-she (she) go leave                 |                  |
| 'I know that she is going to leave.'           |                  |
| d. K weten <b>da-tje (jij)</b> goat weggoan.   | [C + male 3SG]   |
| I know that-he (he) go leave                   |                  |
| 'I know that he is going to leave.'            |                  |
| e. K weten <b>da-me (wunder)</b> goan weggoan. | [C + 1PL]        |

- I know that-we (we) go leave  
 ‘I know that we are going to leave.’
- f. K weten **da-j** (**gunder**) goat weggoan. [C + 2PL]  
 I know that-you (you) go leave  
 ‘I know that you are going to leave.’
- g. K weten **dan-ze** (**zunder**) goan weggoan. [C + 3PL]  
 I know that-they (they) go leave  
 ‘I know that they are going to leave.’

The paradigm of C-agreement in West Flemish is determined by the embedded subject and distinguishes all person and number combinations.<sup>1</sup> In view of the C-agreement paradigm, Chomsky (2007, 2008) suggests that C is the source of  $\phi$ -features, and T manifests morphological realization of  $\phi$ -features because of the operation of feature inheritance that passes C’s  $\phi$ -features to T.

Taking C to be the origin of  $\phi$ -features has an important advantage: it explains the correlation between the occurrence of C and the agreement in the TP domain. Specifically, in English, environments lacking agreement (evidenced by the realization of T as *to* in English), such as the ECM (exceptional Case-marking) and raising constructions as in (2), involve a “bare” TP that does not have a CP (Chomsky 2005, 2008). This correlation between the occurrence of C and the availability of agreement in the TP receives a straightforward explanation if it is C that provides the  $\phi$ -features, the source that triggers the agreement operation. Therefore, in the absence of C, the embedded T in (2) by itself cannot bear agreement.

- (2) a. John believes [<sub>TP</sub> Mary to be the suspect].  
 b. John seems [<sub>TP</sub> t<sub>John</sub> to like Mary].

A question arises as to whether the C-to-T inheritance of the unvalued  $\phi$ -features is an obligatory operation. That is, is C able to retain its unvalued  $\phi$ -features instead of

---

<sup>1</sup> Zwart (1997, 2001) argues that the C-agreement paradigm results from T-to-C movement of the  $\phi$ -features on T. By contrast, on the basis of C-agreement in West Germanic, Carstens (2003) refutes Zwart’s movement analysis, and contends that C-agreement is based on C’s own  $\phi$ -features.

passing them down to T?<sup>2</sup> Richards (2007) argues that this option inevitably leads to a crash at the CI interface because if valued uninterpretable features remain at the phase head position, the derivation will crash at the next phase. To understand his argument for the necessity of C-to-T feature inheritance as a necessary precondition for convergence, we need to introduce Chomsky's (2001) Valuation/Interpretability Biconditional in (3).

(3) Valuation/Interpretability Biconditional (Chomsky 2001:5)

A feature F is uninterpretable [at the Conceptual-Intentional/CI interface, CTC]  
iff F is unvalued [in the lexicon, CTC].

Chomsky (2001:5) further states that “the uninterpretable features, and only these, enter the derivation without values, and are distinguished from interpretable features by virtue of this property.” This biconditional is based on the theory that narrow syntax, which is a computational system rather than an interpretive one, is not able to inspect a feature and “see” whether the CI interface will be able to interpret it later. This involves look-ahead. However, Transfer (i.e. transfer of syntactic objects to the interfaces for interpretation) must remove uninterpretable features for convergence (see e.g. Epstein et al. 1998 for an early discussion). To deal with this problem, Chomsky proposes (3) to encode interpretability of a feature at the CI interface as valuation in the lexicon, allowing narrow syntax to further change feature values (from unvalued to valued) without violating the Inclusiveness Condition.<sup>3</sup> The rationale behind this correlation is that although narrow syntax is blind to semantics, hence featural interpretability, the lexical valuation of a feature is a formal property that can be detected by narrow syntax. This proposal provides a computationally transparent way for Transfer to detect and delete uninterpretable features (thanks to their unvalued property) to ensure the convergence of the derivation.

---

<sup>2</sup> See Ouali (2006, 2008, 2010, 2011) for a proposal regarding the option and consequences of leaving  $\phi$ -features on C.

<sup>3</sup> The Inclusiveness Condition states that “no new features are introduced by  $C_{HL}$  [=the computational procedure of human language, CTC]” (Chomsky 2000:113). Given that the value/unvalued property of a feature is an independent property of a feature specified in the lexicon, Chomsky's encoding of feature interpretability at the CI interface as feature valuation in the lexicon does not introduce new features in the course of syntactic derivation.

However, this valuation/interpretability correspondence does not guarantee that Transfer is able to detect and remove all uninterpretable features in the syntactic object it sends to the interface. Given that valuation of a certain feature is its only formal property that Transfer relies on to distinguish interpretable features from uninterpretable ones (henceforth  $[iF]$  and  $[uF]$ , respectively), once an  $[uF]$  syntactically gets a value (via Agree), Transfer can no longer distinguish it from  $[iF]$ . This leads to crash of the derivation because Transfer fails to remove uninterpretable, but now valued  $[uF]$  from syntactic objects that are sent to the semantic component (see Chomsky 2001, 2007 and Epstein and Seely 2002).

In view of this problem, Richards (2007) reasons that Transfer and feature valuation must occur simultaneously for convergence so that Transfer can see which feature goes from lexically unvalued to syntactically valued, and thereby is able to remove these features to ensure CI convergence. Nevertheless, problems arise for this solution when we take into consideration the assumption that  $\phi$ -features can originate from C, given the cyclic nature of Transfer (i.e., there are multiple applications of Transfer to different chunks of syntactic objects throughout the course of syntactic derivation). This is because Transfer of a phase edge (including the phase head C) is suspended until the domain of the next higher phase is transferred, based on the multiple Transfer/Spell-out system suggested in Chomsky (2000). If unvalued  $\phi$ -features on C are not passed to T but instead probe for valuation directly on C, the resultant syntactically valued  $[u\phi]$  is stranded on C (part of the CP phase edge) and is indistinguishable from inherently interpretable features  $[iF]$  in the next phase. Because Transfer has only one-phase memory, it will not know that the syntactically valued uninterpretable features  $[u\phi]$  must be removed at the next phase level, therefore the derivation will crash. As a result, Richards argues that convergence is impossible if any valued  $[uF]$  is stranded at the phase edge. This is precisely what C-to-T feature inheritance avoids, and so Richards (2007) suggests that feature inheritance of  $[uF]$  on C to T is a necessary precursor operation to the convergence of a derivation.

If the C-to-T inheritance of unvalued  $\phi$ -features, as argued by Richards (2007), is an obligatory operation, the C-agreement morphology noted in (1) needs to be explained. If C cannot retain any  $\phi$ -features, how could it display any  $\phi$ -agreement morphology? Even

though the C-agreement morphology suggests that the agreement features start out as a property of C, it also casts doubt on the obligatoriness in the application of feature inheritance. Some contend that the C-agreement morphology does not result from syntactic Agree, and thus does not challenge Richards' (2007) deduction of feature inheritance as an obligatory operation. For example, Chomsky (2008:159, fn. 26) states "sometimes the  $\phi$ -features of C are morphologically expressed, as in the famous West Flemish examples". In addition, Chomsky (2013:47, fn. 47) states that "inheritance has to be understood as copying [...] For  $\phi$ -features it may mean that they are deleted or given a phonetic form (as in West Flemish), hence invisible at the next phase." In other words, Chomsky seems to maintain that the C-agreement morphology is just either a morphological residue or the phonetic form of the inherited  $\phi$ -features. Along the same line of reasoning, Miyagawa (2010:56) claims that the C-agreement morphology is just the result of string adjacency of C and the subject at PF. Specifically, he states "...the complementizer portion of the agreement receives its valuation not in narrow syntax but in PF" and "...in complementizer agreement, the probe-goal relation is established strictly through string adjacency, of the type similar in phrasal phonology" (see also Ackema and Neeleman 2004 for a similar approach based on prosodic phrasing). Therefore, Chomsky (2008, 2013) and Miyagawa (2010) hold that the C-agreement morphology does not challenge the obligatoriness of application of feature inheritance.

On the other hand, Haegeman and van Koppen (2012), on the basis of C-agreement in West Flemish, argue against not only Miyagawa's (2010) analysis of C-agreement as the result of string adjacency of C and the subject at PF, but also the C-T  $\phi$ -dependency presupposed by Richards' (2007) deduction of feature inheritance. First, note that C-agreement in West Flemish is not determined by string adjacency, as evidenced by the contrast between (4a) and (4b).

- (4) a. Kpeinzen **dat/ \*da-n** [zelfs Vale`re] zukken boeken niet leest.  
 I.think that/that-PL even Vale`re such books not reads  
 'I think that even Vale`re would not read such books.'
- b. Kpeinzen **dat/\*da-n** zukken boeken [zelfs Vale`re] niet leest.

I.think that/that-PL such books even Vale`re not reads

In (4b), even though the focused plural object NP *zukken boeken* ‘such books’ is preposed to be linearly adjacent to C, C-agreement does not reflect this PF property on its agreement morphology: it resists plural agreement with the linearly adjacent plural object. Miyagawa’s (2010) PF linear adjacency analysis of C-agreement would wrongly predict that (4b) cannot exhibit C-agreement with the singular subject because the subject is not linearly adjacent to C. Haegeman and van Koppen (2012) further note that the linear adjacency approach to C-agreement fails to predict the distribution of external possessor agreement in (5).

(5) C-agreement with external possessors in West Flemish

a. . . . **omdat/\*omda-n** [Andre´ en Vale`re underen computer] toen juste  
because/because-PL Andre´ and Vale`re their computer then just  
kapot was.

broken **was**

‘ . . . because just then Andre´ and Vale`re’s computer was broken.’

b. . . . **omda-n/\*omdat** [Andre´ en Vale`re] toen juste [underen computer]  
because-PL/because Andre´ and Vale`re then just their computer  
kapot was.

broken **was**

‘ . . . because just then Andre´ and Vale`re’s computer was broken.’

Note that even though the possessor is linearly adjacent to C in both (5a) and (5b), C agrees with the plural possessor only in (5b) where the possessor is syntactically separated from the rest of the subject NP.<sup>4</sup> The linear adjacency approach would predict that the plural agreement with the plural possessor should be allowed in both (5a) and (5b), given that linear adjacency between C and the plural possessor holds in both cases.

In addition, the mismatch between verbal agreement and C-agreement in the context of externalized possessors in West Flemish shown in (5b) constitutes a strong argument

---

<sup>4</sup> The syntactic position of the discontinuous subject NP in (5b) is not relevant for the current purposes. See Haegeman and van Koppen (2012) for a tentative analysis.

against the C-T  $\phi$ -dependency presupposed by Richards' (2007) deduction of feature inheritance. In particular, Haegeman and van Koppen (2012) reason that if feature inheritance is an obligatory operation due to the reasons elucidated by Richards (2007), then C cannot have its own discrete  $\phi$ -feature valuation relation. Otherwise, the syntactically valued uninterpretable  $\phi$ -features on C would not be removed by Transfer at the next phase, contra Richards' (2007) deduction of the necessity of feature inheritance. Note that in (5a), the C-agreement is consistent with the verbal agreement in that both exhibit singular agreement with the singular subject NP *Andre' en Vale're underen computer* 'Andre' and Vale're's computer'. Interestingly, in (5b) where the subject *Andre' en Vale're underen computer* 'Andre' and Vale're's computer' is discontinuous, C agrees with the plural external possessor, whereas the verb agrees with the singular subject NP. This suggests that C and T cannot share the same unique valuation relation of unvalued  $\phi$ -features with a  $\phi$ -complete NP. Therefore, Haegeman and van Koppen (2012) conclude that C is able to have its own discrete  $\phi$ -feature valuation relation, and thus C-to-T inheritance of the  $\phi$ -features cannot be regarded as a necessary precondition for derivation convergence.

Turning to an additional issue, C's agreement valuation relation on the basis of its own discrete set of unvalued  $\phi$ -features is not the only problem for Richards' (2007) deduction of feature inheritance as a necessary precondition to convergence. As Obata (2010) and Obata and Epstein (2011) insightfully point out, *wh*-movement as in (6) also causes a serious challenge to the base of Richards' deduction: no [*uF*] can occur in the phase edge. The structure in (7) shows the relevant steps of the derivation of (6).

(6) Whom does John think Mary likes?

(7) [<sub>CP1</sub> Whom<sub>[*uCase*]</sub> does John [<sub>v\*P1</sub> t<sub>[*uCase*]</sub> think [<sub>CP2</sub> t<sub>[*uCase*]</sub> Mary [<sub>v\*P2</sub> t<sub>[*uCase*]</sub> likes t<sub>[*uCase*]</sub> ]]]]]?

The [*uCase*] feature on the *wh*-object is derivationally valued as accusative in the lowest v\*P phase. However, the successive-cyclic *wh*-movement carries with it a [*uCase*] feature now derivationally valued as accusative. Consequently, at each phase edge in (7), there



exists a derivationally valued [*uCase*] feature that is indistinguishable from inherently valued [*iF*], which should cause a crash of derivation (to be precise, when  $v^*P_2$  is transferred when the assembly of  $CP_2$  is completed), according to Richards' (2007) deduction.<sup>5</sup>

In sum, even though it is both conceptually and empirically motivated to assume that  $\phi$ -features start out as a property of C, the base of Richards' (2007) deduction of feature inheritance as a necessary precondition to convergence is doubtful. This is because (i) C is able to retain unvalued  $\phi$ -features to initiate its own  $\phi$ -Agree relation with a  $\phi$ -complete NP (see also Carstens 2003 for the same conclusion), and (ii) *wh*-movement brings derivationally valued [*uCase*] to the phase edge. Therefore, in this dissertation, I explore the hypothesis that feature inheritance is not motivated by the ban on unvalued features on the phase edge (see also Chomsky 2005, 2008).

If the ban on the presence of unvalued features on the phase edge is not the motivation of feature inheritance, what else could trigger C's discharge of unvalued  $\phi$ -features to T, which is overtly manifested in a wide array of agreement languages? Chomsky (2005, 2008) makes a different proposal as motivation for feature inheritance: it enables languages to have A-chains. In particular, if  $\phi$ -features originate from C and stay on C, all NP-movement related to  $\phi$ -feature valuation would target the left periphery (=the CP level of phrase structure; see Rizzi 1997). As a consequence, there would exist no A-chains in human languages. Following this line of reasoning, Miyagawa (2010) extends feature inheritance to the Topic/Focus features. Specifically, Miyagawa (2010:19) argues that "without inheritance by T, all movement would be A'-movement [i.e. operator movement to the left periphery, CTC]." He further contends that in agreement languages such as English, A-chains are created based on the inheritance of  $\phi$ -

---

<sup>5</sup> In view of this problem, Obata (2010) and Obata and Epstein (2011), in an attempt to maintain Richards' (2007) deduction of feature inheritance, propose feature-splitting internal Merge which allows the moving *wh*-phrase to carry only the relevant feature driving *wh*-movement on its way up to the matrix spec-CP, leaving the derivationally valued [*uCase*] behind in the lowest VP in (7). This allows Transfer to detect the valuation process of this [*uCase*] and thereby remove it when it sends the lowest VP to the CI interface in (7). Readers are referred to the work above for details and further consequences of a derivational system assuming a feature-splitting mechanism. Notice that the feature-splitting mechanism is not the only possibility to approach the problem *wh*-movement brings to Richards' (2007) deduction of feature inheritance. The other possibility is to admit the unavoidable presence of uninterpretable features on the phase edge (as shown by the C-agreement paradigm in West Flemish and derivations involving *wh*-movement), and assume that their presence at the CI interface does not cause crash at the CI interface for some reason. This possibility is examined by Epstein, Kitahara and Seely (2010), which will be discussed in Chapter 5.

features, whereas in discourse-configurational languages like Finnish and Japanese, the inheritance of the Topic/Focus features is the basis of the creation of A-chains (see the Finnish examples in (21) below, which led Miyagawa to propose the Topic feature inheritance for discourse-configurational languages). The conceptual underpinning of Miyagawa's proposal is an attempt to unify the agreement and A-movement operations in both discourse-configurational languages and agreement-based languages. To achieve this goal, Miyagawa (2010) argues for the Strong Uniformity hypothesis in (9) based on Chomsky's Uniformity hypothesis in (8):

(8) Uniformity Principle (Chomsky 2001:2)

In the absence of compelling evidence to the contrary, assume language to be uniform, with varieties restricted to easily detectable properties of utterances.

(9) Strong Uniformity (Miyagawa 2010:12)

All languages share the same set of grammatical features, and every language overtly manifests these features.

In particular, Miyagawa argues that all languages make use of the same set of grammatical features to drive syntactic operations (see also Sigurðsson 2004 for a similar proposal). These include  $\phi$ -features and Topic/Focus features. Moreover, in his proposal the Topic/Focus features in discourse-configurational languages are computationally equivalent to  $\phi$ -features in agreement-based languages in forcing A-movement to spec-TP and both kinds of features originate from C under Chomsky's (2007, 2008) feature inheritance hypothesis. The inheritance of Topic/Focus features from C to T makes a language discourse-configurational (Miyagawa 2010:29). In essence, this approach maintains that Topic/Focus features as well as  $\phi$ -features are both syntactically active and serve as the trigger of syntactic operations in the narrow syntax computational system. Notice that Miyagawa (2010:11) emphasizes that his system does not exclude the possibility that agreement languages have topic or focus, or that discourse-configurational languages have  $\phi$ -features. Rather, both agreement languages and

discourse-configurational languages overtly manifest topic/focus as well as  $\phi$ -Agree in some fashion.

Last, notice that even though Chomsky (2005, 2008) and Miyagawa (2010) provide another motivation of feature inheritance, their proposal is not different from Chomsky's (2007) and Richards' (2007) in that feature inheritance is an obligatory operation: either  $\phi$ -features or Topic/Focus features are inherited from C to T. In the next section, I examine some preliminary Chinese data that appear to show that Chinese is a language that does not seem to manifest feature inheritance, understood under either Richards' (2007) deduction or Miyagawa's (2010) extension to the Topic feature. However, as I later discuss extensively in Chapter 2, I will show that Chinese is in fact compatible with Miyagawa's feature inheritance approach to syntax, by proposing an economy-based approach to feature inheritance.

## 1.2 Feature Inheritance in Chinese?

The major goal of this thesis is to examine the empirical validity of Miyagawa's (2010) proposal by investigating A-movement and  $\phi$ -Agree in Chinese. The reason for choosing Chinese as the empirical focus of this study is that it is a language that does not seem to manifest feature inheritance, understood under either Richards' (2007) deduction or Miyagawa's (2010) extension to the Topic feature. First, even though Chinese does not show overt verbal morphological agreement, one may argue that T has phonologically null  $\phi$ -features and that the associated syntactic agreement operation is still operative in Chinese. However, the distribution of subject anaphors presents a serious empirical impediment to this line of reasoning. Note that English does not allow subject anaphors in a finite clause as illustrated in (10):

- (10) a. \*John thinks that **himself** is hard-working.  
b. \*They think that **each other** are nice.

There are various proposals regarding the ungrammaticality of (10) in the Government-Binding era (see e.g. Chomsky 1981, 1986; Everaert 1986, 1990, 2000; Lebeaux 1986; Kayne 1984; Aoun 1985, 1986; Piccolo 1985; Rizzi 1990; Woolford 1999). For

expository purposes, I focus on one particular set of proposals whose central unifying idea is to attribute the ungrammaticality of (10) to the fact that anaphors cannot be agreed with (cf. Rizzi 1990, following Picallo 1985). In particular, Rizzi (1990) proposes the anaphor agreement effect in (11) and argues that the reason why anaphors are barred from the subject position of tensed clauses as in (10) is that anaphors cannot agree.

(11) The anaphor agreement effect<sup>6</sup>

Anaphors do not occur in syntactic positions construed with agreement.

Rizzi (1990) argues that neither nominative Case (see Brame 1977, Koster 1978, Anderson 1982, Maling 1984, Everaert 1991) nor the subject position (see Kayne 1984, 1994, Chomsky 1986b) accounts for the ban on subject anaphors. Rather, it is agreement that causes the ungrammaticality (cf. Chomsky 1981, George and Kornfilt 1981, Johnson 1985, Picallo 1985). Rizzi supports this line of analysis with Icelandic and Italian data and argues that it “holds quite systematically in natural languages” (Rizzi 1990:26). First, notice that subjects in Icelandic can take a lexical Case such as dative whose assignment is not dependent upon agreement, and a dative subject can be an anaphor as in (12a). By contrast, when the subject bears nominative which requires agreement, it cannot be an anaphor, as in (12b).

- (12) a. Hún sagði að sré pætti vænt um mig.  
       she<sub>i</sub> said that **self<sub>i</sub>(DAT)** was(SUBJUNCTIVE) fond of me [Maling 1984:(8b)]
- b. \*Jón segir að sig elski Maria.  
       Jon<sub>i</sub> says that **self<sub>i</sub>(NOM)** loves(SUBJUNCTIVE) Maria [Rizzi 1990:(15b)]

Furthermore, what (11) predicts is that the ban on subject anaphors in English in (10) should extend to objects in languages with object agreement. This prediction is borne out by the Italian data in (13).

---

<sup>6</sup> There are several analyses aiming at deriving (11). For example, Chomsky (1981:209) regards agreement on T as an accessible SUBJECT for the purposes of determining the binding domain, so a subject anaphor exhibiting agreement must be bound by the agreement on T; however, this leads to an *i*-within-*i* violations where the subject anaphor and the agreement on T enter into an infinitive regression relation due to dependence on each other for reference (see also Johnson 1985 for a similar proposal).

- (13) a. A loro importa solo di se stessi.  
to them(DAT) matters(3SG) only of themselves(GEN)  
‘All that matters to them is themselves.’ [Rizzi 1990:(15a)]
- b. \*A loro interessano solo se stessi.  
to them(DAT) interest(3PL) only themselves(NOM)  
‘They are interested only in themselves.’ [Rizzi 1990:(15b)]

Note that the genitive object in (13a) does not trigger agreement, and can be an anaphor. By contrast, when the object is in nominative Case which triggers agreement as in (13b), an anaphor is prohibited in this position. This suggests that the ban on anaphors has nothing to do with syntactic positions or grammatical relations like being a subject or an object in a sentence. It is the presence of agreement that rules out the occurrence of anaphors in different positions in different languages.

In addition, if it is the presence of nominative Case, rather than the presence of agreement, that rules out the occurrence of anaphors, we predict that anaphors are always incompatible with the nominative Case, even when there is no agreement. However, this prediction is not borne out. The following examples cited by Woolford (1999) show that nominative anaphors are allowed in languages without agreement like Korean and Japanese.

- (14) John-ga kare-ga **zibun-ga** tensai da to omotte iru to itta (koto)  
John-NOM he-NOM **self-NOM** genius is COMP think PROG COMP said (fact)  
‘John said that he thinks that self is a genius.’ [Japanese; Woolford 1999:280]
- (15) Kitil-in **selo-ka** kyengcaengha-nin-kes-il calangh-n-ta  
They-TOP **each.other-NOM** compete-ASP-COMP-ACC boast-ASP-DEC  
‘They boast that each other are competing.’ [Korean; Yang 1983:4]

In addition, Japanese also exhibits the dative subject constructions with nominative objects like Italian in (13) above, but Japanese differs from Italian in one crucial aspect –

nominative objects do not trigger agreement in Japanese. Consequently, a nominative object anaphor is allowed in Japanese, as evidenced by (16).

- (16) Sensei-ni (wa) zibun-ga wakar-ani-i.  
teacher-DAT (TOP) **self-NOM** understand-not-PRES  
'The teacher does not understand himself.' [Shibatani 1977:(33a)]

In view of these data, Woolford (1999) argues that the anaphor agreement effect is universal and can be a diagnostic for the presence or absence of (covert) agreement.<sup>7</sup> With this conclusion, consider the Chinese example in (17). Like other East Asian languages lacking overt verbal agreement morphology including Japanese and Korean, subject anaphors are allowed in Chinese. Huang (1982) argues that subject anaphors are allowed in Chinese precisely because of the absence of (covert)  $\phi$ -features on T.

- (17) Akiu renwei **taziji** zui congming  
Akiu think himself most smart  
'Akiu thinks that himself is the smartest.'

A clarification is in order before we proceed. Note that one may argue that the embedded clause in (17) is a small clause, rather than a full finite clause. If it is a small clause, then the occurrence of the subject anaphor *ziji* in (17) could be treated on a par with the occurrence of *himself* in (18), and the grammaticality of (17) does not constitute an argument for the lack of (covert)  $\phi$ -features on T in Chinese.

- (18) John thinks [**himself** quite smart].

---

<sup>7</sup> Therefore, the contrast between (10) and other examples showing subject anaphors in the absence of agreement can be compared to that between (ia) and (ib) in English:

- (i) a. \*John believes himself is smart.  
b. John believes himself to be smart.

The subject anaphor *himself* is allowed in (ib) precisely because of the lack of  $\phi$ -features on T (morphologically realized by *to*) of the embedded TP selected by the ECM verb *believe*.

The occurrence of various kinds of aspectual markers in the embedded clauses in (19) refutes this small clause analysis of the embedded clause in (17) (see Huang 1982, Li 1990, Tang 1990, Tsai 1995, Tang 2000, Paul 2002, Lin 2011 among others, for arguments for the finite-nonfinite distinction in Chinese). Therefore, the grammatical occurrence of subject anaphors in (17) can be treated on a par with the Japanese and Korean examples in (14) and (15) to argue for the lack of covert  $\phi$ -features/Agree on T in Chinese. Consequently, the anaphor agreement effect suggests that T in Chinese does not inherit unvalued  $\phi$ -features from C in Chinese,<sup>8</sup> contra Richards' (2007) deduction of feature inheritance.

- (19) a. Akiu renwei [taziji     **zai** bangzhu dajia]  
           Akiu think    himself PROG help     everyone  
           ‘Akiu thinks that himself is helping everyone.’
- b. Akiu renwei [taziji    nian **guo** henduo shu]  
           Akiu think    himself read.EXP many books  
           ‘Akiu thinks that himself has read many books.’
- c. Akiu renwei [taziji    xie.wang kongke    **le**]  
           Akiu think    himself write.done assignment PERF  
           ‘Akiu thinks that himself has finished the assignment.’

Now, if  $\phi$ -features are not inherited by T to establish A-chains in Chinese, Miyagawa's (2010) proposal predicts that it is the Topic feature that is inherited by T to achieve this goal in Chinese. However, even though Chinese is a topic-prominent language which, as the term suggests, heavily uses structures involving topics and comments (cf. Li and Thompson 1976, 1981; Tsao 1979, 1990), as opposed to subject-prominent languages, the topic phrase occupies the left periphery as shown in (20), rather

---

<sup>8</sup> In spite of the grammatical occurrence of anaphors as subjects in Chinese, I will reject the possibility that Chinese lacks  $\phi$ -features/Agree altogether. I will argue in Chapter 3 that the presence of  $\phi$ -features/Agree can be detected in the left periphery in Chinese when we examine the two types of “Blocking Effects” associated with the long-distance construal of the bare anaphor *ziji* ‘self’ and the formation of Chinese *wh-the-hell* questions.

than spec-TP.<sup>9</sup> This means the Topic feature, if present, can stay in the left periphery, rather than being inherited by T to trigger A-movement of the topic phrase.

- (20) a. **Na-chang da-huo** (a), xingkui xiaofang-dui lai-de-kuai.  
 that-CL big-fire (TOP) fortunately fire-brigade come-MOD-quickly  
 Lit. 'That big fire, fortunately the fire brigade came quickly.'
- b. **Zhe-ci kaoshi** (a), jushuo Akiu yiding hui renzhen zhunbei.  
 this-CL exam (TOP) allegedly Akiu definitely will serious prepare  
 Lit. 'This exam, allegedly Akiu definitely will prepare for it seriously.'
- c. **Shuiguo** (a), laoshishuo ta zhi xihuan xiangjiao.  
 fruit (TOP) frankly she only like banana  
 Lit. 'Fruit, frankly she only likes bananas.'

Moreover, Holmberg and Nikanne (2002) show that Finnish is a topic-prominent language in the sense that any category that can serve as the topic of the sentence can surface as the external argument. Note that both (21a) and (21b) are grammatical active sentences with *Graham Greene* as the thematic subject of the predicate *on kirjoittanut* 'has written' in Finnish, but the topics differ in these two sentences – *Graham Greene* is the topic in the former, while *taman kirjan* 'this book' is the topic in the latter. Holmberg and Nikanne (2002) notice that (21b) in Finnish can be used whenever the book is the topic, with specific reference that has been previously introduced in the discourse, while the identity of the author, *Graham Greene*, carries new information.

- (21) a. **Graham Greene** on kirjoittanut tllman kirjan.  
 Graham Greene has written this book
- b. **Taman kirjan** on kirjoittanut Graham Greene.  
 this book has written Graham Greene

---

<sup>9</sup> The speaker-oriented adverbs *xingkui* 'fortunately', *jushuo* 'allegedly', and *laoshishuo* 'frankly' in (20), according to Cinque's (1999) work on the position of adverbs and functional projections, occupy the specifiers of different functional projections in the left periphery. Thus, the topics *na-chang da huo* 'that big fire', *zhe-ci kaoshi* 'this test', and *shuiguo* 'fruit' preceding these speaker-oriented adverbs must occupy the left periphery, rather than spec-TP.



This property of Finnish leads Miyagawa (2010) to propose that it is the inheritance of the Topic feature that allows for A-movement of either the subject or the object in discourse-configurational languages such as Finnish. Now notice that unlike Finnish, Chinese does not allow topic A-movement of the object NP in mono-clausal structures, as evidenced by (22b).

- (22) a. Akiu jingchang zhunbei wancan  
Akiu often prepare dinner  
'Akiu often prepares the dinner.'
- b. \***Wancan** jingchang Akiu zhunbei  
dinner often Akiu prepare  
Intended: 'As for the dinner, it is often prepared by Akiu.'

The contrast between (22b) and (21b), together with the A'-topics in (20), suggests that the Topic feature in Chinese, when present, stays in the left periphery and is not inherited by T. Taken together, Chinese appears to be a language where neither  $\phi$ -features nor the Topic feature is inherited by T, casting doubt on the motivations of feature inheritance provided by either Richards (2007) or Miyagawa (2010). This dissertation aims to investigate this apparent paradox presented by Chinese for the feature inheritance hypothesis. I propose an economy-based motivation of feature inheritance, as in (23).

- (23) Economy-driven feature inheritance
- Feature inheritance takes place to yield a more economical derivation with a shorter derivational path, and its application cannot run afoul of other independent principles in the grammar.

Importantly, unlike previous approaches to feature inheritance, the operation of feature inheritance as formulated in (23) is an optional operation that applies only if it can lead to a derivation with a shorter derivational path without violating other independent principles. In other words, feature inheritance does not occur at the cost of the violation of other independent principles in the grammar. For example, I will argue in Chapter 2

that Topic feature inheritance as proposed by Miyagawa (2010) exists in Chinese, but its application cannot bleed the valuation of the unvalued Case feature on the subject NP, which requires the subject move to spec-TP to c-command a finite T bearing the valued (yet uninterpretable) Case feature.<sup>10</sup> This is the reason why (22b) is ungrammatical where the object NP moves to spec-TP for the valuation of its Topic feature at the cost of failure in the valuation of the Case feature on the subject NP. On the other hand, the Finnish counterpart (21b) is grammatical because Case valuation in Finnish does not require movement of the NP bearing the unvalued Case feature: Chomsky's (2001, et seq.) probe-goal Agree suffices for Case valuation in Finnish. I will explore in Chapter 2 the possibility that this cross-linguistic movement vs. Agree contrast with respect to how Case valuation can be accomplished is due to the existence (or lack thereof) of  $\phi$ -features on T in a language.

### 1.3 Overview of the Dissertation

This dissertation has four main goals: [1] I contend that Chinese displays A-movement motivated by two distinct forces: the valuation of the Case feature on NPs (see Epstein and Seely 2006, Bošković 2002) and the Topic feature on T inherited from C (à la Miyagawa 2010); crucially the A-movement triggered by the latter exemplifies the application of Topic feature inheritance in conformity with the economy considerations in (23). [2] I propose a fine-grained featural theory of topic A-movement based on the hypothesis that feature interpretability and feature valuation can be lexically dissociated (see also Pesetsky and Torrego 2007; Carstens 2010, 2011; Bošković to appear). [3] I argue that Chinese exhibits  $\phi$ -Agree in the left periphery, despite the lack of morphological realization of  $\phi$ -features. [4] I study the derivation of locative inversion in English and Chinese, particularly focusing on why T-to-C inversion is not allowed in English locative inversion, whereas the counterpart operation is allowed in Chinese.

---

<sup>10</sup> Notice that I am not suggesting that a “representational” requirement like spec-head relation exists for Case valuation in Chinese. Rather, the unvalued Case feature in Chinese, as a probe, requires movement of the subject NP bearing it to move to c-command a goal bearing the valued counterpart (=the finite T). Therefore, the spec-head configuration is the “resultant representation”, rather than the cause of the observed movement (see Chapter 2 for details and Bošković 2002, 2007, to appear for the original proposal of this line of analysis).

Based on the logical connection of these four main goals, this dissertation is divided into four major components. [1] Chapter 2 of this dissertation is an in-depth investigation of the distribution, motivation and derivation of A-movement in Chinese. In particular, I propose that there is neither a universal EPP requirement on T nor the need to postulate a null expletive in Chinese; rather, there are two distinct driving forces of A-movement in this language – the unvalued uninterpretable Case feature and the unvalued interpretable Topic feature. In addition, my examination of the derivation of object topic A-movement will provide support for (i) the lexical dissociation of feature interpretability and feature valuation (contra Chomsky 2001; see Pesetsky and Torrego 2007, Bošković to appear, Carstens 2010, 2011 for the same suggestion based on different conceptual/empirical grounds), (ii) the moving-element-driven approach to A-movement (see Bošković 2007), and (iii) the proposal that Topic feature inheritance is an optional operation that aims to yield a more economical derivation with a shorter movement path, without violating other independent principles like Case valuation in the grammar. [2] Even though there is no morphological manifestation of  $\phi$ -features in Chinese, I argue in Chapter 3 that  $\phi$ -feature agreement can be detected at the CP level in this language. In particular, I investigate two types of “Blocking Effects” (BE) observed with the long-distance construal of Chinese bare reflexive *ziji* ‘self’ (see Huang and Liu 2001, among many others) and the formation of *wh-the-hell* questions in Chinese (see Chou 2012). I contend that these two types of BE receive a unified analysis if we assume (i)  $\phi$ -features exist in Chinese but stay at the CP level, unlike agreement languages where  $\phi$ -features are inherited by T, and (ii)  $\phi$ -probe in Chinese takes the form of unvalued person features including [Speaker] and [Participant], as in a fine-grained theory of the sub-components of  $\phi$ -features (see Harley and Ritter 2002; Béjar and Rezac 2003, 2009; Nevins 2007, 2008, 2011, among many others). [3] Chapter 4 takes stock of the discussion in chapters 2 and 3 to argue that the fronting of the locative phrase in locative inversion constructions is topic A-movement; in addition, I propose that the possible presence of  $\phi$ -features on T (inherited from C) and the categorial status of the locative phrase jointly determine whether a language can implement T-to-C inversion in locative inversion. [4] Chapter 5 discusses the theoretical implications of the previous three chapters, including (i) the A/A'-distinction in languages without  $\phi$ -features on T, and (ii) a featurally crash-proof

grammar where uninterpretable features present in the CI interface do not cause crash (see Frampton and Guttman 2002; Putman 2010; Carstens 2010, 2011; Epstein, Kitahara and Seely 2010, 2012;).

## Chapter 2 A-movement in Chinese

### 2.1 Introduction

In Chapter 1, I discussed how the occurrence of anaphors as embedded subjects provides a strong argument against the presence of  $\phi$ -features on T in Chinese. In this connection, consider one prominent hypothesis in the literature on A-movement that it is motivated by the presence and valuation of the unvalued  $\phi$ -features on T (e.g., Chomsky 2000, 2005, 2007, 2008; Kuroda 1988; Pesetsky and Torrego 2001; Miyagawa, 2005; among many others). One important question arises as to what else could motivate A-movement to spec-TP in languages with a  $\phi$ -less T. Could these languages lack A-movement to spec-TP altogether? This problem does not arise for researchers who maintain that the driving force of A-movement to spec-TP is actually either an unvalued Case feature on DPs/NPs (see Epstein and Seely 1999, 2006; Alexiadou and Anagnostopoulou 1998; Bošković 2002, 2007) or an EPP/edge feature on T (Chomsky 1995, 2000, 2001; Lasnik 1995, 1999, 2001; Nevins 2005), rather than involving the unvalued  $\phi$ -features on T.

Aside from  $\phi$ -features, unvalued Case feature, and EPP on T, Miyagawa (2010), assuming the feature inheritance hypothesis in Chomsky (2005, 2007, 2008), proposes that in discourse-configurational languages like Finnish and Japanese, Topic or Focus features can be inherited from C to T to motivate A-movement. The conceptual underpinning of Miyagawa's proposal is an attempt to unify the agreement and A-movement operations in both discourse-configurational languages and agreement-based languages. To achieve this goal, Miyagawa (2010) argues for the Strong Uniformity hypothesis in (2) based on Chomsky's Uniformity hypothesis in (1):

(1) Uniformity Principle (Chomsky 2001:2)

In the absence of compelling evidence to the contrary, assume language to be uniform, with varieties restricted to easily detectable properties of utterances.

(2) Strong Uniformity (Miyagawa 2010:12)

All languages share the same set of grammatical features, and every language overtly manifests these features.

In particular, Miyagawa argues that all languages make use of the same set of grammatical features to drive syntactic operations. These include  $\phi$ -features and Topic/Focus features. Moreover, in his proposal the Topic/Focus features in discourse-configurational languages are computationally equivalent to  $\phi$ -features in agreement-based languages in forcing A-movement to spec-TP. That is, this approach maintains that Topic/Focus features as well as  $\phi$ -features are both syntactically active and serve as the trigger of syntactic operations in the narrow syntax computational system.

Miyagawa's proposal provides still another answer to the question as to what motivates A-movement in languages without  $\phi$ -features on T: in these languages, Topic/Focus features can be inherited from C to T to drive A-movement.<sup>1</sup> Now, the motivation of A-movement in languages with  $\phi$ -less T turns out to be an issue of potential conceptual and empirical redundancy involving the overlap of Topic/Focus features, the unvalued Case feature, and the EPP /edge feature on T as triggers of A-movement to spec-TP. In Miyagawa (2010), he denies the relevance of Case in driving A-movement and rejects EPP as an independent feature (though for him there are EPP "effects"), so his proposal amounts to the claim that it is either  $\phi$ -features or Topic/Focus features that motivate A-movement cross-linguistically. This chapter aims to examine the empirical adequacy of Miyagawa's claim and argues that (i) there are two distinct driving forces of A-movement in Chinese – Case feature and Topic feature, (ii) there is neither

---

<sup>1</sup> Notice that Miyagawa (2010) assumes that the unvalued  $\phi$ -features on C are always inherited by T (or a head between C and T he calls  $\alpha$ ), even in discourse-configurational languages where the Topic feature is inherited by T to trigger A-movement. However, in view of Rizzi's (1990) anaphor agreement effect reviewed in Chapter 1, I do not adopt this assumption in this dissertation. That is, I maintain that in languages like Chinese where anaphors are allowed to occur as the subject, T does not inherit the unvalued  $\phi$ -features from C (if there are any such features on C). See Chapter 3 for arguments for the existence of  $\phi$ -features and the related Agree operation in the left periphery in Chinese *wh-the-hell* questions and sentences with the long-distance anaphor *ziji* 'self'.

EPP feature on T nor the need to postulate a null expletive in this language, and (iii) feature inheritance of the Topic feature is motivated by the economy consideration in (3).

(3) Economy-driven feature inheritance

Feature inheritance takes place to yield a more economical derivation with a shorter derivational path, and its application cannot run afoul of other independent principles in the grammar.

To achieve these three major goals, I investigate the argument displacement in Chinese raising modal constructions (RMC) containing raising modals like *yinggai* ‘should/ought to’ or *keneng* ‘be likely to’, as illustrated in (4) and (5):

- (4) a. Akiu *yinggai* *zhunbei.hao* *wancan* *le*  
Akiu should prepare.done dinner PERF  
‘Akiu should have prepared the dinner.’  
b. *Wancan* *yinggai* Akiu *zhunbei.hao* *le*  
dinner should Akiu prepare.done PERF  
‘The dinner should have been prepared by Akiu.’
- (5) a. Akiu *keneng* *zhunbei.hao* *wancan* *le*  
Akiu may prepare.done dinner PERF  
‘Akiu may have prepared the dinner.’  
b. *Wancan* *keneng* Akiu *zhunbei.hao* *le*  
dinner may Akiu prepare.done PERF  
‘The dinner may have been prepared by Akiu.’

Such data show that either the subject or the object<sup>2</sup> can occur to the left of the modal in RMC. I argue that argument displacement in RMC exemplified by (4) and (5) is an instance of topic A-movement, contra Miyagawa’s (2010:46-52) claim that topic A-movement does not exist in Chinese. However, I show that object A-movement in RMC

---

<sup>2</sup> To the best of my knowledge, the possibility of the object raising in RMC in (4b) and (5b) was first observed in the generative syntax literature in Lin (2011).

like (4b) and (5b) is underivable under Miyagawa's probe-driven system of movement based on Topic feature inheritance. This is because of a timing problem regarding feature inheritance and Chomsky's (2001) Phase-Impenetrability Condition, as noted independently by Epstein, Kitahara and Seely (2012) and Richards (2011). To solve this under-generation problem, I propose a more fine-grained featural characterization of topic A-movement on the basis of: (a) the dissociation of feature interpretability and valuation (see Pesetsky and Torrego 2007; Carstens 2010, 2011 and Bošković to appear), and (b) the adoption of Bošković's (2007) moving-element-driven (= Greed) theory of movement.

This chapter, based on Chou (2013), is organized as follows. Section 2.2 introduces previous analyses of Chinese raising modals constructions (RMC) as the empirical focus of this chapter. In sections 2.3 and 2.4, I propose that A-movement in RMC is topic A-movement. I then argue that Miyagawa's (2010) probe-driven system based on Topic feature inheritance fails to generate object topic A-movement due to a timing problem regarding the external merger of C and the Transfer of VP under the feature inheritance hypothesis. In section 2.5, I compare two opposing views of the syntactic visibility of "discourse" features like the Topic feature. Section 2.6 provides a critical review of Lin's (2010) argument for an EPP-based analysis of A-movement in Chinese, and proposes that there are two distinct driving forces of A-movement in Chinese – the lexically unvalued yet interpretable Topic feature and the lexically unvalued and uninterpretable Case feature. Section 2.7 presents a summary and concluding remarks on the comparison between the proposed system and Neeleman and van de Koot's (2008) mapping-based approach to topic movement.

## 2.2 Raising Modal Constructions

Lin and Tang (1995) (henceforth L&T) argue that raising modals in Chinese are verbs that take a TP complement as in (6a).<sup>3</sup> They assume that the subject-modal word order in

---

<sup>3</sup> According to L&T's analysis, not only epistemic modals like *yinggai* 'should/ought to' and *keneng* 'be likely to' but also the deontic use of *yinggai* 'be expected/be required by some set of rules' and *keyi* 'be allowed to' are unaccusative raising predicates taking a TP complement. I refer to constructions containing a raising modal, epistemic or not, as "raising modal constructions" (see also Wurmbrand 1999 for arguments for treating both epistemic and deontic modals as raising verbs).



RMC results from A-movement of the subject targeting matrix spec-TP, as schematically shown in (6b):<sup>4</sup>

- (6) a. Yinggai/keneng [<sub>TP</sub> Akiu zhunbei.hao wancan le]  
 should/may Akiu prepare.done dinner PERF  
 ‘It should/may be the case that Akiu prepares the dinner.’
- b. [<sub>TP</sub> Akiu<sub>i</sub> yinggai/keneng [<sub>TP</sub> t<sub>i</sub> zhunbei.hao wancan le]]  
 Akiu should/may prepare.done dinner PERF  
 ‘Akiu should/may prepare the dinner.’

L&T give extensive evidence for this verbal analysis of these modals. First, being negated by *bu* and forming an *A-not-A* question are both properties shared only by predicates in Chinese, as evidenced for instance by the (un)grammaticality of the association of either of these two properties with: (i) the adverb *xinkuei* ‘fortunately’ in (7),<sup>5</sup> (ii) the verb *xihuan* ‘like’ in (8) and (iii) the adjective *congming* ‘smart’ in (9):

<sup>4</sup> Both Lin and Tang (1995) and Lin (2011) assume that EPP exists in Chinese and the matrix spec-TP in (6a) is filled by a null expletive to satisfy the EPP structural requirement. As I show in section 2.6.3, the postulation of a null expletive to satisfy the EPP cannot be maintained in Chinese and A-movement in Chinese cannot be driven by a universal EPP structural requirement on T. Rather, Chinese A-movement lends support to Epstein and Seely’s (2006) and Bošković’s (2002, 2007) checking/valuation-based approach to A-movement.

<sup>5</sup> The negation and *A-not-A* question in (i) and (ii) seem to suggest that adverbs can also be the target of negation and *A-not-A* questions.

- (i) a. Akiu bu-chang chi tofu  
 Akiu not-often eat tofu  
 ‘Akiu does not eat tofu often.’  
 b. Akiu bu-ceng qu Taipei  
 Akiu not-ever go Taipei  
 ‘Akiu has never been to Taipei.’
- (ii) a. Akiu chang-bu-chang chi tofu?  
 Akiu often-not-often eat tofu  
 ‘Does Akiu often eat tofu or not?’  
 b. Akiu ceng-bu-ceng qu Taipei?  
 Akiu ever-not-ever go Taipei  
 ‘Has Akiu ever been to Taipei or not?’

However, there is a strict constraint on when an adverb can be negated and form an *A-not-A* question - only the monosyllabic *chang* ‘often’ and *ceng* ‘ever’ can be negated and form *A-not-A* questions, while the synonymous bisyllabic forms *jingchang* and *cenjing* prohibit negation and *A-not-A* questions, as evidenced by (iii) and (iv). The fact that the bisyllabic raising modals *yinggai* ‘should’ and *keneng* ‘be likely to’ are free from this constraint (as shown in (10)-(13) in the text) suggests that they are predicates, rather than adverbs. See Tzeng (2009) for an interesting phonology-based account of why the monosyllabic adverbs *chang* ‘often’ and *ceng* ‘ever’ are exceptions to the generalization that adverbs cannot be negated and form *A-not-A* questions.

- (7) a. Xinkuei Akiu hui yoyong  
 fortunately Akiu able swim  
 ‘Fortunately, Akiu knows how to swim.’
- b. \*Bu-xinkuei Akiu hui yoyong  
 not-fortunately Akiu able swim  
 Intended: ‘Unfortunately, Akiu knows how to swim.’
- c. \*Xin-bu-xinkuei Akiu hui yoyong ne?  
 fortunately-not-fortunately Akiu able swim Q  
 Intended: ‘Is it fortunate that Akiu knows how to swim?’

- (8) a. Akiu bu-xihuan zhe-ben shu  
 Akiu not-like this-CL book  
 ‘Akiu does not like this book.’
- b. Akiu xi-bu-xihuan zhe-ben shu ne?  
 Akiu like-not-like this-CL book Q  
 ‘Does Akiu like this book or not?’

- (9) a. Akiu bu congming  
 Akiu not smart  
 ‘Akiu is not smart.’
- b. Akiu cong-bu-congming ne?  
 Akiu smart-not-smart Q  
 ‘Is Akiu smart or not?’

- 
- (iii) a. \*Akiu bu-jingchang chi tofu  
 Akiu not-often eat tofu  
 b. \*Akiu bu-cengjing qu Taipei  
 Akiu not-ever go Taipei
- (iv) a. \*Akiu jing-bu-jingchang chi tofu?  
 Akiu often-not-often eat tofu  
 b. \*Akiu ceng-bu-cengjing qu Taipei?  
 Akiu ever-not-ever go Taipei

L&T note that *yinggai* and *keneng* can be negated by *bu* as in (10) and (11) and form an A-not-A question as in (12) and (13):

- (10) a. Akiu bu-yinggai zhunbei wancan  
Akiu not-should prepare dinner  
'Akiu should not prepare the dinner.'
- b. Wancan bu-yinggai Akiu zhunbei  
dinner not-should Akiu prepare  
'The dinner should not be prepared by Akiu.'
- (11) a. Akiu bu-keneng zhunbei wancan  
Akiu not-be-likely-to prepare dinner  
'Akiu is not likely to prepare the dinner.'
- b. Wancan bu-keneng Akiu zhunbei  
dinner not-be-likely-to Akiu prepare  
'The dinner is not likely to be prepared by Akiu.'
- (12) a. Akiu ying-bu-yinggai zhunbei wancan ne?  
Akiu should-not-should prepare dinner Q  
'Should it be the case that Akiu prepares the dinner?'
- b. Wancan ying-bu-yinggai Akiu zhunbei ne?  
dinner should-not-should Akiu prepare Q  
'Should it be the case that the dinner is prepared by Akiu?'
- (13) a. Akiu ke-bu-keneng zhunbei wancan ne?  
Akiu likely-not-be-likely-to prepare dinner Q  
'Is it likely that Akiu prepares the dinner?'
- b. Wancan ke-bu-keneng Akiu zhunbei ne?  
dinner likely-not-be-likely-to Akiu prepare Q  
'Is it likely that the dinner is prepared by Akiu?'

Therefore, the capacity of *yinggai* and *keneng* to be negated and to form A-not-A questions excludes an adverbial analysis of these items<sup>6</sup>. They must be either verbs or adjectives. However, I argue that an adjectival analysis of *yinggai* and *keneng* is not tenable either, since adjectives in Chinese must be accompanied by the degree adverb *hen* ‘very’ in a sentence without contextual support, as shown by (14a). Crucially, *yinggai* and *keneng* cannot be modified by *hen*, as evidenced by (14b)<sup>7</sup>. This suggests that these modals are verbs, rather than adjectives.

- (14) a. Akiu \*(hen) congming  
           Akiu very smart  
           ‘Akiu is smart.’
- b. \*Akiu hen yinggai/keneng zhunbei wancan

<sup>6</sup> There is another line of syntactic analysis of the categorial status of Chinese modals based on the licensing of VP-preposing and VP-ellipsis. Tsai (2009), adopting a cartographic approach of adverbial placement proposed in Cinque (1999), maintains that there are dedicated functional projections hosting Chinese modals. In particular, he distinguishes modal auxiliaries/heads from modal adverbs, and only the former can license VP-preposing and VP-ellipsis. According to this descriptive criterion, *yinggai* ‘should’ and *keneng* ‘likely’ are modal adverbs occupying the specifier of certain functional projections such as an Epistemic (Necessity/Probability) Phrase, because neither of them can license VP-preposing or VP-ellipsis as shown in (ia) and (iia), respectively. By contrast, deontic modals like *neng* ‘be-able-to’ and *keng* ‘be-willing-to’ are functional heads that license VP-preposing and VP-ellipsis as in (ib) and (iib).

- (i) a. \*[Chuguo]<sub>i</sub>, Lisi bu-yinggai/bu-keneng t<sub>i</sub>  
           go-abroad Lisi not-should/not-be-likely-to
- b. [Chuguo]<sub>i</sub>, Lisi bu-neng/bu-keng t<sub>i</sub>  
           go-abroad Lisi not-be-able/willing-to  
           ‘Lisi is not able to/willing to go abroad.’ [VP-preposing]
- (ii) a. \*Lisi yinggai/keneng [chuguo] le, Akiu ye yinggai/keneng [e]  
           Lisi should/be-likely-to go-abroad PERF Akiu also should/be-likely-to
- b. Lisi neng/keng [chuguo], Akiu ye neng/keng [e]  
           Lisi be-able/willing-to go-abroad Akiu also be-able-to/be-willing-to  
           ‘Lisi is able/willing to go abroad, so is Akiu.’ [VP-ellipsis]

There are at least two problems confronting this line of analysis. First, the licensing of VP-preposing and VP-ellipsis is not a comprehensive test to define the categorial status of all Chinese modals. For example, VP-ellipsis and VP-preposing do not apply to deontic modals like *dei* ‘must’ and *bixu* ‘be-obliged-to’ either. In this connection, a reviewer points out that even though English auxiliaries are standardly taken to be functional heads, some of them don’t license ellipsis/movement, as in (iii).

- (iii) a. \*They are being noisv. and you are being too.  
        b. \* Noisy, they are being.

Second, the ability to form negation and an A-not-A question is the hallmark feature of predicates in Chinese, as shown by (6)-(8). The cartographic approach that analyzes *yinggai* ‘should’ and *keneng* ‘likely’ as modal adverbs would have a hard time explaining their ability to form negation and an A-not-A question as in (9)-(12) because adverbs in Chinese do not exhibit these two syntactic properties. In view of these two difficulties, I maintain in this paper L&T’s verbal analysis of *yinggai* ‘should’ and *keneng* ‘likely’.

<sup>7</sup> See Liu (2010) for an illuminating account of the obligatory presence of *hen* ‘very’ in (14a).

Akiu very should/be-likely-to prepare dinner

Second, (15a) shows that unlike ‘Standard English’ modals, it is possible to have multiple adjacent modals<sup>8</sup> in Chinese, and each of the adjacent modals may be negated by *bu*, as in (15b/c). L&T contend that the multiple occurrences of the modals and the negations in (15b/c) follow naturally if each of the modals in (15) is a verb taking a clausal complement.

- (15) a. Akiu yinggai keneng hui zhunbei wancan  
Akiu should likely will prepare dinner  
‘It should be likely that Akiu will prepare the dinner.’
- b. Akiu bu-yinggai bu-hui zhunbei wancan  
Akiu not-should not-will prepare dinner  
‘It should not be the case that Akiu will not prepare the dinner.’
- c. Akiu bu-keneng bu-hui zhunbei wancan  
Akiu not-likely not-will prepare dinner  
‘It is not likely that Akiu will not prepare the dinner.’

Third, in support of a verbal analysis of these modals, Huang (1990) further notes that they are raising verbs because they impose no S-selectional restriction on their surface subject. For example, either an animate NP or an inanimate NP can surface as the subject of these modals in Chinese, as shown by (16) and (17):

- (16) a. Ta chi-guo fan le  
he eat-EXP meal PERF  
‘He has eaten his meal.’
- b. Ta yinggai chi-guo fan le  
he should eat-EXP meal PERF  
‘He should have eaten his meal.’
- c. Ta keneng chi-guo fan le

---

<sup>8</sup> *Hui* ‘will’ is also analyzed as a raising modal verb by L&T. I will discuss A-movement in RMC involving *hui* in section 2.6.3

he may eat-EXP meal PERF  
'He may have eaten his meal.'

- (17) a. Shu zhang-jia le  
book increase-price PERF  
'The price of books has increased.'
- b. Shu yinggai zhang-jia le  
book should increase-price PERF  
'The price of books should have increased.'
- c. Shu keneng zhang-jia le  
book may increase-price PERF  
'The price of books may have increased.'

Huang points out that the lack of an S-selectional restriction imposed by these modals on their surface subject indicates that these modals do not assign an external theta role to their subject.<sup>9</sup> Therefore, (16b/c) and (17b/c) can be analyzed as raising constructions with the embedded subject moving to the matrix subject position as in (18). In (18), modals like *yinggai* and *keneng* behave syntactically like unaccusative verbs such as *seem* in English, by taking a TP complement as their sole argument. This explains why the subject argument of the embedded verb can raise to matrix spec-TP.

---

<sup>9</sup> In contrast to the lack of selectional restriction of epistemic modals shown in (16) and (17), L&T note that deontic modals generally impose selectional restriction on their subject and thus analyze them as control verbs. Nevertheless, they argue that the raising-control distinction does not neatly correspond to the epistemic-deontic distinction in Chinese because deontic *yinggai* 'be supposed to' and *keyi* 'be permitted to', unlike other deontic modals, show properties of raising verbs; in particular, they lack the selectional restriction on the animacy of their surface subject, as shown in (i) and (ii). This led L&T to analyze epistemic modals together with deontic *yinggai* and *keyi* as raising verbs, and all other deontic modals as control verbs.

- (i) a. Lisi yinggai lai canjia huiyi  
Lisi should come participate meeting  
'Lisi is supposed/obliged to participate in the meeting.'
- b. Shu yinggai zhang-jia  
book should increase-price  
'The price of books is supposed to increase.'
- (ii) a. Lisi keyi lai canjia huiyi  
Lisi be-permitted-to come participate meeting  
'Lisi is permitted to participate in the meeting.'
- b. Shu keyi zhang-jia  
book be-permitted-to increase-price  
'The price of books is permitted to increase.'

- (18) a. [<sub>TP</sub> Ta<sub>i</sub> yinggai/keneng [<sub>TP</sub> t<sub>i</sub> chi-guo fan le]]  
           he should/may eat-EXP meal PERF  
           ‘It should/may be the case that he has eaten his meal.’
- b. [<sub>TP</sub> Shu<sub>i</sub> yinggai/keneng [<sub>TP</sub> t<sub>i</sub> zhang-jia le]]  
           book should/may increase-price PERF  
           ‘It should/may be the case that the price of books has increased.’

Let us assume for now that subject raising in RMC is A-movement targeting matrix spec-TP; I will show in section 2.3 what distinguishes it from an alternative A'-movement analysis. Given this, the object raising in RMC in (4b) and (5b) (repeated here as (19)) poses other challenging questions. Is object raising in RMC also an instance of A-movement? If so, why doesn't it violate Chomsky's (1995) Attract Closest? Attract Closest expresses a locality restriction on the application of syntactic movement: Movement of  $\alpha$  to a target K is blocked by  $\beta$ , if  $\beta$  is closer to K and could enter the same checking relation. Given that before any overt movement operation takes place, the subject *Akiu* in (19) is structurally closer to matrix T than the object *wancan* 'dinner' is, the raising of the object *wancan* to the matrix spec-TP is prohibited by Attract Closest, contrary to fact. We turn to this question in the next section.

- (19) a. Wancan<sub>i</sub> yinggai [<sub>TP</sub> Akiu zhunbe.hao t<sub>i</sub> le]  
           dinner should Akiu prepare.done PERF  
           ‘The dinner should have been prepared by Akiu.’
- b. Wancan<sub>i</sub> keneng [<sub>TP</sub> Akiu zhunbe.hao t<sub>i</sub> le]  
           dinner may Akiu prepare.done PERF  
           ‘The dinner may have been prepared by Akiu.’

### 2.3 Object Raising in RMC

In view of the problem of Attract Closest, Lin (2011:63) suggests that object raising in (19) is actually an instance of A'-movement to the left periphery, and thus the presence of the intervening embedded subject does not interfere with the formation of this A'-

movement. However, the sole evidence he provides for this A'-movement analysis of object raising in RMC is the placement of a speaker-oriented adverb like *tanbai-shuo* 'frankly-speaking' in (20):<sup>10</sup>

- (20) Wancan<sub>i</sub>, tanbai-shuo, [<sub>TP</sub> \_\_\_ yinggai [<sub>TP</sub> Akiu zhunbei t<sub>i</sub>]]  
 dinner franky-speaking should Akiu prepare  
 'The dinner, frankly speaking, should be prepared by Akiu.'

He assumes that the EPP of the matrix T in (20) is satisfied by a null expletive, and reasons that object raising must be topicalization since it precedes the speaker-oriented adverb *tanbai-shuo*. Nevertheless, aside from the controversial existence of a null expletive in Chinese,<sup>11</sup> (20) also (in principle) allows the analysis in (21) in which the embedded object first undergoes A-movement to matrix spec-TP and then is topicalized, thereby preceding the speaker-oriented adverb:

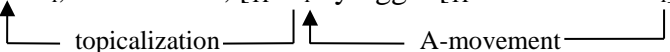
- (21) Wancan<sub>i</sub>, tanbai-shuo, [<sub>TP</sub> t<sub>i</sub> yinggai [<sub>TP</sub> Akiu zhunbe t<sub>i</sub>]]  

Crucially, the raised object can also follow the speaker-oriented adverb as in (22), so the evidence based on the placement of the speaker-oriented adverb is actually inconclusive:

- (22) Tanbai-shuo, wancan yinggai Akiu zhunbei  
 Frankly-speaking dinner should Akiu prepare  
 'Frankly speaking, it should be the case that the dinner is prepared by Akiu.'

In this section, I argue that at least the first instance of object raising in RMC, as in (21), exists in Chinese, as is supported independently by the grammaticality of (22), and is an instance of A-movement targeting spec-TP, contra Lin (2011).

<sup>10</sup> Lin assumes that *tanbai-shuo* 'frankly-speaking' occupies the specifier of a functional projection in the left periphery of the clause, following Cinque's (1999) cartographic work on the syntactic positions of different types of adverbs.

<sup>11</sup> See section 2.6.3 for arguments against postulating a null expletive to satisfy EPP in Chinese.



### 2.3.1 Against the base-generation analysis

Before presenting the evidence for an A-movement analysis of object raising in RMC, I also need to exclude a “non-movement” analyses of object raising in RMC. First, one may wonder if the raised object in RMC is actually a base-generated (i.e. first-merged) left-peripheral topic binding a null object. That is, no movement, A or A', would be involved in “object raising” in RMC. This analysis is not implausible given the fact that Chinese allows a base-generated topic not related to any gap in the comment, as exemplified in (23). Such “gapless” topic structures suggest that some sentence-initial topics are base-generated in the left periphery:<sup>12</sup>

- (23) a. Shuiguo (a), wo zui xihuan xiangjiao.  
fruit (TOP) I most like banana  
'As for fruits, I like bananas most.'

One clarification is in order regarding topics. There are three different types of topics in Chinese – the dangling/aboutness topic as in (23), a left dislocation topic as in (24), and a hanging topic as in (25):

- (24) Akiu<sub>i</sub>, Lisi bu renshi t<sub>i</sub>  
Akiu Lisi not know  
'As for Akiu<sub>i</sub>, Lisi does not know (him<sub>i</sub>).'

- (25) Zhangsan<sub>i</sub>, Lisi hen xihuan ta<sub>i</sub>  
Zhangsan Lisi very like him  
'As for Zhangsan<sub>i</sub>, Lisi likes him<sub>i</sub> very much.'

The main difference between the dangling/aboutness topic in (23) and the other two types of topics lies in whether the sentence-initial topic has syntactic integration into the rest part of the sentence, i.e. the comment clause (Jacobs 2001:641). The left dislocation topic *Akiu* in (24) and the hanging topic *Zhangsan* in (25) have a grammatical function in the

---

<sup>12</sup> A is an optional prosodic topic marker that sets the sentence-initial topic apart from its comment.

comment, which is manifested in either a gap or a co-indexed pronoun. A dangling/aboutness topic, by contrast, does not have any syntactic integration into the comment. In addition, the hanging topic (25) differs from the left dislocation topic (24) in the presence of a pronoun, instead of a gap, occupying the thematic position of the sentence-initial topic.<sup>13</sup>

Turning back to the analysis of object raising in RMC, I argue that a left-peripheral base-generation analysis of object raising in RMC is not tenable since the option of base-generating a topic is actually available in Chinese only (i) in topic structures without gaps as in the dangling/aboutness topic structure as in (23), and the hanging topic structure as in (25), and (ii) when the gap related to the topic is in an island in a (pre-)subject position as in (26)-(28):

(26) Akiu<sub>i</sub>, [[e<sub>i</sub> baba] hen congming] [Left Branch Condition]  
 Akiu father very smart  
 ‘Akiu<sub>i</sub>, [his<sub>i</sub>] father is smart.’

(27) Akiu<sub>i</sub>, [[ e<sub>i</sub> xihuan de] ren] hen duo [Complex NP Condition]  
 Akiu like DE people very many  
 ‘Akiu<sub>i</sub>, people who [he<sub>i</sub>] likes are many.’

(28) Akiu<sub>i</sub>, [yinwei e<sub>i</sub> qipian le dajia], suoyi meiren xihuan ta [Adjunct Condition]  
 Akiu because lie PERF everyone so nobody like him  
 ‘(As for) Akiu<sub>i</sub>, because [he<sub>i</sub>] lied to everyone, nobody likes him.’

According to Huang (1984, *et seq.*), the gaps in the islands in the (pre-)subject position in (26)-(28) are immune to island constraints because they are not traces left by movement; rather, they are empty pronouns subject to his Generalized Control Rule in (29):

---

<sup>13</sup> The general analysis of topic structures in Chinese is that there is no movement involved in the dangling topic and hanging topic structures in Chinese and the topic is base-generated at its surface sentence-initial position. I do not review in detail the corresponding argumentation in the literature. Please see Huang et al. 2009 and Kuo 2010 for detailed discussion.

(29) Generalized Control Rule (GCR)

An empty pronoun is coindexed with the closest potential antecedent.

Thus, the gaps/empty pronouns in (26)-(28) are coindexed with the closest potential antecedent, which is the base-generated topic *Akiu*. Nevertheless, this analysis is prohibited when the island does not appear at the (pre-)subject position. Compare (26)-(28) with (30)-(32):

(30) \**Akiu<sub>i</sub>*, *Lisi kanjian le* [*e<sub>i</sub>* *baba*]

*Akiu Lisi see perf father*

Intended: ‘*Akiu<sub>i</sub>*, *Lisi* saw [*his<sub>i</sub>*] father.’

(31) \**Akiu<sub>i</sub>*, *Lisi jianguo henduo* [[*e<sub>i</sub>* *xihuan de*] *ren*]

*Akiu Lisi see-EXP many like MOD people*

Intended: ‘*Akiu<sub>i</sub>*, *Lisi* has seen many people who [*he<sub>i</sub>*] likes.’

(32) \**Akiu<sub>i</sub>*, *meiren xihuan ta* [*yinwei e<sub>i</sub> qipian le* *dajia*]

*Akiu nobody like him because lie PERF everyone*

Intended: ‘(As for) *Akiu<sub>i</sub>*, nobody likes him because [*he<sub>i</sub>*] lied to everyone.’

The GCR cannot establish the intended coreference relation between the base-generated topic *Akiu* and the empty pronouns in the islands because there exists a closer potential antecedent interrupting this relation (i.e., *Lisi* in (30)/(31) and *meiren* in (32)).

Therefore, the pre-modal object in RMC cannot be a base-generated topic because a base-generated topic is available in Chinese only in topic structures without gaps or when the gap appears in an island in a (pre-)subject position.<sup>14</sup> Object raising in RMC as in (19) cannot be analyzed as a base-generated topic because the preposed object leaves a gap in its theta position and the gap does not appear in a (pre-)subject position.

Another way to maintain the base-generation analysis of the pre-modal object would be to analyze the gap within the TP complement in RMC as a gap left by a null operator

---

<sup>14</sup> Note that this restriction on the occurrence of a base-generated topic in Chinese does not take into consideration the controversial licensing configuration of parasitic gaps in Chinese. See footnote 23.

movement that establishes a predication relation with the pre-modal object, as illustrated in (33).

- (33)  $\left[ \begin{array}{c} \text{predication} \\ \left[ \begin{array}{c} \text{movement} \\ \left[ \begin{array}{c} \text{Wancan}_i \text{ yinggai} \text{ } \text{OP}_i \text{ } \text{Akiu} \text{ zhunbei} \text{ } t_i \end{array} \right] \end{array} \right] \end{array} \right]$   
 dinner should Akiu prepare  
 ‘The dinner should be prepared by Akiu.’

This analysis of the pre-modal object in RMC is analogous to Chomsky’s (1982) treatment of *tough*-constructions in English. Chomsky (1982) analyzes the complement of *tough* as containing a null operator (NOP) that undergoes A'-movement and then gets strongly bound (Chomsky 1986) by the surface subject of *tough* constructions, as in (34):

- (34)  $\left[ \begin{array}{c} \text{John}_i \text{ is easy} \text{ } \text{OP}_i \text{ PRO to please } t_i \end{array} \right]$   
 $\left[ \begin{array}{c} \text{predication} \\ \left[ \begin{array}{c} \text{movement} \end{array} \right] \end{array} \right]$

The relation between the OP and the embedded object position is one of A'-movement, and the relation between the OP and the matrix subject is one of predication (a case of strong binding in the terms of Chomsky 1986).

Note that the NOP movement analysis of object raising in RMC would assume that the relation between the object in the surface position and the gap in its theta position is established via predication, rather than movement. However, there is evidence against this assumption. Consider the object raising in (35b) and (36b):

- (35) a. Yinggai shi Chen Yishi lai kai-zhe-tai-dao  
 should FOC Chen Doctor come open-this-CL-knife  
 ‘It should be the case that Dr. Chen (rather than someone else) performs this surgery.’  
 b. Zhe-tai-dao<sub>i</sub> yinggai shi Chen Yishi lai kai-t<sub>i</sub>

this-CL-knife should FOC Chen Doctor come open

‘This surgery should be performed by Dr. Chen (rather than by someone else).’

- (36) a. Keneng Akiu bu-gai dui Lisi kai-zhe-ge-wan.xiao  
likely Akiu not-should to Lisi open-this-CL-play.laugh  
‘It is likely that Akiu should not have made fun of Lisi.’
- b. Zhe-ge-wan.xiao<sub>i</sub> keneng Akiu bu-gai dui Lisi kai-t<sub>i</sub>  
this-CL-play.laugh likely Akiu not-should to Lisi open  
‘It is likely that Akiu should not have made fun of Lisi.’

*Kai-dao* “perform surgery” and *kai-wan.xiao* “make fun of” are idioms, which may be regarded as one unit at some level of lexical-semantic analysis. If some part of an idiom is separated from the rest of it and the idiomatic interpretation is still available, the apparent separation must be a result of movement of an idiom chunk. Therefore, Chomsky (1980) notes that *care* in the idiom “take care of” can be separated from the rest of the idiom chunk, via A-movement, while maintaining the idiomatic interpretation, as exemplified in (37).

- (37) a. Excellent care was taken of the orphans.  
b. Excellent care seems to have been taken of the orphans.

Crucially, he also notes the contrast between (37) and (38a). He argues that the ungrammaticality of (38a) can be explained if we assume that unlike (37), *excellent care* in (38a) is base-generated at its surface position in *tough*-constructions, but only a movement relation as in (37) can license separation of an idiom chunk (i.e. not the combination of NOP movement and strong binding as in the analysis of *tough*-constructions). (38b) is the base-line example showing a grammatical non-idiomatic counterpart to (38a).

- (38) a. \*Excellent care is hard to take of the orphans.  
b. Food is hard to take from the orphans.

Given that the idiomatic interpretations are available with object raising in (35b) and (36b), I propose that the relation between the fronted object and the gap in the embedded clause in RMC must be one of A-movement<sup>15</sup>, rather than the combination of predication (via strong binding) and NOP movement.<sup>16</sup>

### 2.3.2 A- or A'-movement?

With this much said, we can now turn to the arguments for an A-movement analysis of object raising in RMC. First, there is evidence against Lin's (2011:63) claim that object raising in RMC is A'-movement, specifically A'-topicalization. A'-topicalization in Chinese, like other instances of A'-movement, exhibits reconstruction<sup>17</sup> (cf. Chomsky

<sup>15</sup> Based on the same idiom chunk test, Huang et al. (2009: ch.6) argue that relative clauses in Chinese are formed via direct movement when the relativized element is an idiom chunk.

<sup>16</sup> Huang (1999) argues convincingly for a null operator movement analysis of Chinese passive sentences with agent NPs (i.e., long passives, in his terms) like (ia). In particular, there is null operator movement in the clausal complement of the passive marker *bei* and the raised null operator establishes a predication relation with the base-generated subject *Akiu*, as in (ib).

- (i) a. *Akiu bei Lisi da le*  
       *Akiu bei Lisi hit PERF*  
       ‘Akiu was hit by Lisi.’  
       b. *Akiu bei [OP<sub>i</sub> Lisi da t<sub>i</sub> le]*

One reviewer of Chou (2013) suggested that the validity of the idiom chunk test shown in (35) and (36) is arguably challenged by the sentences in (ii), in which idioms like *you-muo* ‘make-humor’ and *chui-niu* ‘boast’ is separated in a long passive construction involving null operator movement. However, both my consultants’ and my own intuition are that (iia) is ungrammatical, and (iib) is at least marginal. In addition, as shown in (iii), the idioms *kai-dao* ‘perform surgery’ and *kai-wan.xiao* ‘make fun of’ used in (35) and (36) cannot be separated in a long passive construction, either.

- (ii) a. \**Zhe-ge muo bei ta you huai le.*  
       this-CL humor bei s/he make bad PERF  
       ‘This humor is badly made by her/him.’  
       b. ??*Zhe-ge niu bei ta chui da le.*  
       this-CL boast bei s/he boast big PERF  
       ‘This boast is too much boasted by her/him.’
- (iii) a. \**Zhe-tai dao bei Chen yishi kai huai le*  
       this-CL knife bei Chen doctor open bad PERF  
       Intended: ‘This surgery was performed badly by Dr. Chen.’  
       b. \**Zhe-ge wan.xiao bei Akiu kai-da le*  
       this-CL play.laugh bei Akiu open-big PERF  
       Intended: ‘This joke is badly made by Akiu.’

I leave for future research the apparent dialectal variation regarding whether an idiom can be separated in a Chinese long passive.

<sup>17</sup> An example of reconstruction associated with A'-movement is (i). (iia) and (iib) show that A'-movement is not forced to reconstruct:

- (i) [Which of his<sub>i</sub> students]<sub>j</sub> do you think [every professor]<sub>i</sub> talked to t<sub>j</sub>? (Fox 1999:172)

1993, Fox 1999, and Lasnik 1999), as evidenced by the binding of reflexive *taziji* ‘himself’ in (39). If object raising in RMC were A'-topicalization, we would expect it to display reconstruction as well; nevertheless, (40a) shows that the object does not reconstruct, indicating that it cannot be A'-topicalization:

(39) [Taziji<sub>i</sub>-de pengyou]<sub>j</sub> a, Akiu renwei Lisi<sub>i</sub> bu hui beipan t<sub>j</sub>  
 himself-DE friend TOP Akiu think Lisi not will betray  
 ‘As for his own<sub>i</sub> friend, Akiu thinks that Lisi<sub>i</sub> will not betray (him).’

(40) a. \*[Taziji<sub>i</sub>-de pengyou]<sub>j</sub> yinggai/keneng [<sub>TP</sub> Akiu<sub>i</sub> bu hui beipan t<sub>j</sub>]  
 himself-DE friend should/ may Akiu not will betray  
 Intended: ‘It should/may be the case that Akiu<sub>i</sub> will not betray his own<sub>i</sub> friend.’  
 b. Yinggai/keneng [<sub>TP</sub> Akiu<sub>i</sub> bu hui beipan [taziji<sub>i</sub>-de pengyou] ]  
 should/ may Akiu not will betray himself-DE friend  
 ‘It should/may be the case that Akiu<sub>i</sub> will not betray his own<sub>i</sub> friend.’  
 c. Akiu<sub>i</sub> yinggai/keneng [<sub>TP</sub> t<sub>i</sub> bu hui beipan [taziji<sub>i</sub>-de pengyou] ]  
 Akiu should/ may not will betray himself-DE friend

Second, if object raising in RMC is indeed A-movement targeting matrix spec-TP, as I argue, then we expect it to feed binding condition A (as in *John<sub>i</sub> seems to himself<sub>i</sub> t<sub>i</sub> to be a diligent student*). This prediction is borne out<sup>18</sup>:

- 
- (ii) a. [The claim that John<sub>i</sub> was asleep] seems to him<sub>i</sub> to be correct.  
 b. [John<sub>i</sub>'s mother] seems to him<sub>i</sub> to be wonderful. (Lebeaux 1988:23)

<sup>18</sup> A reviewer challenges the universal validity of the A-movement test based on binding condition A. S/he notes that binding condition A is satisfied in an RMC sentence like (i) by the A'-moved topic *Xiaoming*:

- (i) Xiaoming<sub>i</sub> a, zhiyou [taziji<sub>i</sub>-de mama]<sub>j</sub> cai keneng t<sub>j</sub> guan-de-zhu t<sub>i</sub>  
 Xiaoming TOP only himself-DE mother then likely control-DE-hold  
 ‘As for Xiaoming<sub>i</sub>, it is likely that only his<sub>i</sub> own mother can control him<sub>i</sub>.’

First, note that the binding of *taziji* ‘himself’ by an A'-moved topic is not limited to RMC, as shown in (ii). However, this is allowed only when there is a focus marker like *zhiyou* ‘only’ or *lien* ‘even’. Crucially, this restriction does not apply to RMC, as evidence by (41):

- (ii) a. Xiaoming<sub>i</sub> a, \*(zhiyou) [taziji<sub>i</sub>-de mama] guan-de-zhu t<sub>i</sub>  
 Xiaoming TOP (only) himself-DE mother control-DE-hold  
 ‘As for Xiaoming<sub>i</sub>, (only) his<sub>i</sub> own mother can control him<sub>i</sub>.’  
 b. Xiaoming<sub>i</sub> a, \*(lien) [taziji<sub>i</sub>-de mama] dou guan-bu-zhu t<sub>i</sub>  
 Xiaoming TOP (even) himself-DE mother all control-not-hold  
 ‘As for Xiaoming<sub>i</sub>, (even) his<sub>i</sub> own mother cannot control him<sub>i</sub>.’

- (41) [Akiu<sub>i</sub>-de wancan] yinggai/keneng [taziji<sub>i</sub>-de mama] zaojiu zhunbei.hao le<sup>19</sup>  
 Akiu- DE dinner should/may himself-DE mother early prepare.done PERF  
 ‘Akiu<sub>i</sub>’s dinner should/may have been prepared by his<sub>i</sub> own mother early on.’

Note that I am not saying that the object in RMC can never undergo topicalization to the left periphery. Object fronting in RMC *is* topicalization when the subject undergoes A-movement to matrix spec-TP, as in (42). Crucially, when this does occur, the raised object shows reconstruction and fails to feed binding condition A, as evidence by (43) and (44), in sharp contrast to (40a) and (41), where the object undergoes A-movement to matrix spec-TP.

- (42) Wancan<sub>j</sub> (a), [TP Akiu<sub>i</sub> yinggai/keneng [TP t<sub>i</sub> zhunbei.hao t<sub>j</sub> le]]  
 dinner (TOP) Akiu should/may prepare.done PERF  
 ‘As for the dinner, Akiu should/may have prepared it.’
- (43) [Taziji<sub>i</sub>-de pengyou]<sub>j</sub> (a), Akiu<sub>i</sub> yinggai/keneng [TP t<sub>i</sub> bu hui beipan t<sub>j</sub>]  
 himself-DE friend (TOP) Akiu should/may not will betray  
 ‘As for his<sub>i</sub> own friend, It should/may be the case that Akiu<sub>i</sub> will not betray him.’
- (44) \*[Akiu<sub>i</sub>-de wancan]<sub>k</sub> (a) [taziji<sub>i</sub>-de mama]<sub>j</sub> yinggai/keneng [TP t<sub>j</sub> zaojiu  
 Akiu- DE dinner (TOP) himself- DE mother should/may early  
 zhunbei.hao t<sub>k</sub> le]

---

The effects of focus on the satisfaction of binding condition A by an A'-moved antecedent deserves further research. However, given that the feeding of binding condition A in RMC shown in (41) does not rely on the presence of a focus marker, the argument presented in the text is not rendered invalid by the reviewer's example in (i).

<sup>19</sup> Chinese reflexives allow for a sub-commanding antecedent contained in an inanimate subject (Tang, 1989):

- (i) [John<sub>i</sub>-de wenchang] hai-le taziji<sub>i</sub>  
 John-DE article harm-PERF himself  
 ‘John’s article harmed himself.’



prepare.done PERF

Intended: ‘As for Akiu<sub>i</sub>’s dinner, it should/may have been prepared by his<sub>i</sub> own mother early on.’

Third, Wu (2008: 56) notes that the ungrammatical A'-topicalization of both direct and indirect objects in (45) suggests that stacking of topic phrases via syntactic movement in Chinese is prohibited, possibly due to minimality effects. Note that the ungrammaticality of (46d) and (46e) shows that this constraint also applies to A'-topicalization of both subject and direct object.<sup>20</sup>

(45) \*Lisi<sub>j</sub> (a), zhe-ben shu<sub>i</sub> (a), Zhangsan gei-le t<sub>j</sub> t<sub>i</sub>

Lisi (TOP) this-CL book (TOP) Zhansan give-PERF

Intended: ‘As for Lisi, as for this book, Zhangsan has given it to him.’

(46) a. Akiu yijing zhunbei.hao wancan le

Akiu already prepare.done dinner PERF

‘Akiu has already prepared the dinner.’

b. Wancan<sub>i</sub> a, Akiu yijing zhunbei.hao t<sub>i</sub> le

dinner TOP Akiu already prepare.done PERF

‘As for the dinner, Akiu has already prepared it.’

c. Akiu<sub>i</sub> a, t<sub>i</sub> yijing zhunbei.hao wancan le

Akiu TOP already prepare.done dinner PERF

‘As for Akiu, he has already prepared the dinner.’

d. \*Akiu<sub>i</sub> a, wancan<sub>j</sub> a, t<sub>i</sub> yijing zhunbei.hao t<sub>j</sub> le

Akiu TOP dinner TOP already prepare.done PERF

Intended: ‘As for Akiu, as for the dinner, he has already prepared it.’

e. \*Wancan<sub>j</sub> a, Akiu<sub>i</sub> a, t<sub>i</sub> yijing zhunbei.hao t<sub>j</sub> le

---

<sup>20</sup> The ban on the stacking of topic phrases via syntactic movement to the left periphery in Chinese raises interesting questions about restrictions on the multiple Topic Phrases in the left periphery proposed by Rizzi 1997. This is beyond the scope of this dissertation, and I leave it for future research.

dinner TOP Akiu TOP already prepare.done PERF

Intended: 'As for the dinner, as for Akiu, he has already prepared it.'

Now, consider the fronting of both the subject and direct object in RMC as in (47) and (48). The lack of minimality effect in (47) and (48) lends further support to the A-movement analysis under investigation of object raising in (47) and subject raising in (48). Specifically, the grammaticality of (47) and (48) suggests that if both the subject NP and the object NP undergo raising across the raising modal in RMC, they must be different types of syntactic movement. Otherwise, (47) and (48) should be as bad as (46d) is. In particular, the sentence-initial subject *Akiu* in (47) and the object *zhe-ben shu* in (48) must be derived via A'-topicalization, whereas the object in (47) and the subject in (48) must be A-movement targeting matrix spec-TP.

(47) Akiu<sub>i</sub> (a) zhe-ben shu<sub>j</sub> yinggai/keneng [TP t<sub>i</sub> mei kang-guo t<sub>j</sub>]  
Akiu (TOP) this-CL book should/may not read-EXP  
'As for Akiu, it should/may be the case that he has not read this book.'

(48) Zhe-ben shu<sub>j</sub> (a) Akiu<sub>i</sub> yinggai/keneng [TP t<sub>i</sub> mei kang-guo t<sub>j</sub>]  
this-CL book (TOP) Akiu should/may not read-EXP  
'As for this book, it should/may be the case that Akiu has not read it.'

The fourth argument for an A-movement analysis of object raising in *yinggai/keneng*-RMC is related to argument raising in another type of RMC containing *hui* 'will'. Note that unlike *yinggai/keneng*-RMC, the object raising option is generally prohibited in the *hui*-RMC, as shown in (49a); besides, the subject raises to spec-TP obligatorily, as shown by the contrast between (49b) and (49c):

(49) a. \*[TP Wancan<sub>i</sub> hui [TP Akiu zhunbei t<sub>i</sub>]]  
dinner will Akiu prepare  
Intended: 'The dinner will be prepared by Akiu.'  
b. [TP Akiu<sub>i</sub> hui [TP t<sub>i</sub> zhunbei wancan]]

Akiu will prepare dinner  
 ‘Akiu will prepare the dinner.’

c. \*[<sub>TP</sub> Hui [<sub>TP</sub> Akiu zhunbei wancan]]

will Akiu prepare dinner

Intended: ‘It will be the case that Akiu prepares the dinner.’

I will present an analysis of why subject raising is obligatory in RMC involving *hui* ‘will’ as in (49c) but optional in RMC involving *yinggai/keneng* ‘should/likely’ in section 2.6.3. For now, let’s focus on (50). Interestingly, the subject raising requirement shown in (49b/c) can be violated if we add the focus marker *shi* before the subject, as evidenced by (50):<sup>21</sup>

(50) a. [<sub>TP</sub> Wancan<sub>i</sub> hui [<sub>TP</sub> shi Akiu zhunbei t<sub>i</sub>]]

dinner will FOC Akiu prepare

‘The dinner will be prepared by AKIU.’

b. [<sub>TP</sub> Hui [<sub>TP</sub> shi Akiu zhunbei wancan]]

will FOC Akiu prepare dinner

‘It is AKIU who will prepare the dinner.’

Now notice that (50a) can be embedded under *keneng* ‘likely’ and *yinggai* ‘should’ as in (51). Crucially, the object raising in (51) cannot be A'-movement targeting the CP periphery because there is no landing site for CP-level topicalization to take place within the bare TP complement of *keneng* and *yinggai*<sup>22</sup>.

(51) [<sub>TP</sub> Keneng/yinggai [<sub>TP</sub> wancan<sub>i</sub> hui [<sub>TP</sub> shi Akiu zhunbei t<sub>i</sub>]]]

<sup>21</sup> The contrast in obligatory subject raising in *hui*-RMC with the insertion of the focus marker *shi* was first observed by Lin and Tang (1995:62-63, fn.7). See section 2.6.3 for an explanation of this long-standing puzzle.

<sup>22</sup> The object *wancan* ‘dinner’ in (51) can undergo further raising across *keneng/yinggai* ‘likely/should’ as in (i), which is then another instance of A-movement to matrix spec-TP, under the analysis I propose in this paper.

(i) [<sub>TP</sub> Wancan<sub>i</sub> keneng/yinggai [<sub>TP</sub> t<sub>i</sub> hui [<sub>TP</sub> shi Akiu zhunbei t<sub>i</sub>]]]  
 dinner likely/should will FOC Akiu prepare

likely/should                      dinner    will    FOC Akiu prepare

‘It is likely to/should be the case that the dinner will be prepared by AKIU.’

Summing up, the lack of reconstruction and feeding of binding condition A manifested by object raising in RMC, as well as its distribution in multiple modal constructions each suggest that object raising in RMC is A-movement targeting spec-TP, rather than an instance of A'-movement,<sup>23</sup> contra Lin 2011. Thus, the raised object in RMC as in (19) must appear in its surface position via A-movement, not via A'-movement or left-peripheral base-generation, nor can this construction be analyzed as strong binding in a structure involving NOP movement. However, we have thus come to a dilemma: The data we have examined in this section indicates that object raising in

<sup>23</sup> One reviewer of Chou (2013) wonders if it is possible to use parasitic gaps (PG) to test object raising in RMC. Lin (2005) argues that PGs exist in Chinese and are licensed only by overt *wh*-movement in this language, as shown in (i):

- (i) a. \*Akiu [zai huijian e<sub>i</sub> zhichian] jiu kaichu le nei-ge yuangong<sub>i</sub>?  
       Akiu at meet before already fire PERF which-CL employee  
       ‘Which employee did Akiu fire before meeting?’  
       b. Nei-ge yuangong<sub>i</sub>, Akiu [zai huijian e<sub>i</sub> zhichian] jiu kaichu le t<sub>i</sub>?

However, Liu (2012) argues convincingly that the sentence-initial *wh*-phrase in (ib) is not transformationally related to the trace after *kaichu* ‘fire’ via overt *wh*-movement; that is, it is base-generated in the left periphery. First, he notes that weak crossover effects (WCO) should be observed if overt *wh*-movement is involved to derive the sentence-initial *wh*-phrase in (ib), but this is not borne out, as evidenced by (ii). Second, superiority effects do not arise when there is another *wh*-phrase hierarchically higher than the launch site of the assumed *wh*-movement, as shown in (iii). This suggests that there is no direct *wh*-movement relation between the sentence-initial *wh*-phrase and the trace after *kaichu* ‘fire’. Third, it is possible to replace the trace after the verb *kaichu* ‘fire’ with a pronoun *ta* ‘he/him’ as in (iv). This is contrary to the prediction of the overt *wh*-movement analysis because the position where the *wh*-phrase is assumed to be extracted should be left empty.

- (ii) Nei-ge yuangong<sub>i</sub>, Akiu [zai huijian ta<sub>i</sub> zhichian] jiu kaichu le e<sub>i</sub>?  
       which-CL employee Akiu at meet him before already fire PERF  
       ‘Which employee<sub>i</sub> did Akiu fire before meeting him<sub>i</sub>?’ [WCO]
- (iii) Nei-ge yuangong<sub>i</sub>, shei [zai huijian e<sub>i</sub> zhichian] jiu kaichu le e<sub>i</sub>?  
       which-CL employee who at meet before already fire PERF  
       ‘Which employee<sub>i</sub> did who fire before meeting him<sub>i</sub>?’ [superiority effects]
- (iv) Nei-ge yuangong<sub>i</sub>, Akiu [zai huijian e<sub>i</sub> zhichian] jiu kaichu le ta<sub>i</sub>?  
       which-CL employee Akiu at meet before already fire PERF him<sub>i</sub> [pronoun insertion]

Based on these data from Liu (2012) and Engdahl’s (1983) observation that only overt *wh*-movement can license a PG in English, I think it is difficult to justify the existence of PG in Chinese. The gap in the adverbial clause in (ib) might well be a null object bound by the base-generated *wh*-phrase in the left periphery. Therefore, even though the RMC analog of (i) in (v) is grammatical, it has no bearing on the question of whether object raising in RMC is A-movement because there is no movement, A or A', involved in (v).

- (v) Nei-ge yuangong<sub>i</sub> keneng Akiu [zai huijian e<sub>i</sub> zhichian] jiu kaichu e<sub>i</sub> le?  
       which-CL employee likely Akiu at meet before already fire PERF  
       ‘Which employee is Akiu likely to fire before meeting?’

RMC involves A-movement, but Attract Closest (henceforth AC), on the other hand, predicts that object raising, as an instance of A-movement, should be ruled out by the presence of the subject, which is closer to the matrix T and which we know can itself raise. In the next section, I show that AC is not the only problem that an adequate account of object A-movement in RMC must overcome — I argue that object raising in RMC is also underivable within Miyagawa’s (2010) probe-driven system of movement based on C-to-T Topic feature inheritance.

## 2.4 The (Apparent) Underivability of Object A-movement in RMC

### 2.4.1 Topicality and A-movement in RMC

Even though argument displacement in RMC is A-movement targeting matrix spec-TP, there is evidence showing that A-movement in RMC exhibits the semantic traits of topicalization, which is normally a product of A'-movement. First, Ko (2005) notes that in Chinese, *meige-ren* ‘everyone’ can undergo topicalization to the left periphery as in (52), whereas *henshao-ren* ‘few people’ and *meiyou-ren* ‘nobody’ cannot be topicalized as in (53) and (54), respectively:

- (52) a. *Mei.ge-ren*            a,    *dou xihuan na-ben shu*  
           every.CL-people TOP all like that-CL book  
           ‘Everyone like(s) that book.’
- b. *Mei.ge-ren<sub>i</sub>*            a,    *wo renwei [t<sub>i</sub> dou hui qu].*  
           Every.CL-people TOP I think all will go  
           ‘Everyone, I think will go.’
- (53) a. \**Henshao-ren*        a,    *xihuan na-ben shu*  
           few-people TOP like that-CL book  
           ‘Few poeple likes that book.’
- b. \**Henshao-ren<sub>i</sub>* a,    *wo renwei [t<sub>i</sub> hui qu].*

few-people TOP I think will go  
 'Few people, I think will go.'

- (54) a. \*Mei.you-ren a, xihuan na-ben shu  
 not.have-people TOP like that-CL book  
 'No one likes that book.'
- b. \*Mei.you-ren<sub>i</sub> a, wo renwei [t<sub>i</sub> hui qu].  
 not.have-people TOP I think will go  
 'No people, I think will go.'

Tsai (2010:4) notes that the same contrast is maintained in RMC – only *meige-ren* 'everyone' can raise as in (55),<sup>24</sup> while *henshao-ren* 'few people' and *meiyou-ren* 'nobody' cannot, as in (56) and (57), respectively. The parallel suggests that A-movement in RMC has semantic traits in common with topicalization to the left periphery.

- (55) a. Yinggai/keneng mei.ge-ren dou xihuan na-ben shu  
 should/may every.CL-people all like that-CL book  
 'It should/may be the case that everyone like(s) that book.'
- b. Mei.ge-ren yinggai/keneng dou xihuan na-ben shu
- (56) a. Yinggai/keneng henshao-ren xihuan na-ben shu  
 should/may few-people like that-CL book  
 'It should/may be the case that few people like that book.'
- b. \*Henshao-ren yinggai/keneng xihuan na-ben shu

- (57) a. Yinggai/keneng mei.you-ren xihuan na-ben shu

<sup>24</sup> The grammaticality of (i) shows that the raising of *mei.ge-ren* 'everyone' in (55b) is a case of A-movement, given that multiple A'-topicalization via syntactic movement is prohibited in Chinese, as shown by (45) and (46).

(i) Na-ben shu a, mei.ge-ren yinggai/keneng dou xihuan  
 that-CL book TOP every.CL-people should/may all like  
 'As for that book, everyone should/may like it.'

Should/may no.have-people like that-CL book  
'It should/may be the case that nobody likes that book.'

b. \*Mei.you-ren yinggai/keneng xihuan na-ben shu

The second argument concerns the ambiguity of weak quantifiers like *many students*. Since Milsark (1974), it is well-known that quantificational determiners are divided into categories according to whether they can occur in the environment in (58).

(58) There is/are \_\_\_\_ student(s) in the dorm.

Quantifiers which can appear here, such as *many*, *several*, and *two*, are called 'weak' quantifiers, and quantifiers which cannot, such as *most* and *every*, are called 'strong' quantifiers. Interestingly, weak quantifiers have both cardinal and proportional readings (see Milsark 1977, Partee 1988, Diesing 1992, and many others), so a sentence like (59) is ambiguous as indicated, and this ambiguity is observed with Chinese weak quantifiers as well, as in (60).<sup>25</sup>

(59) Many students are in the dorm.

- a. A lot of students are in the dorm. [Cardinal reading]
- b. A large proportion of the set of students is in the dorm (, whereas a small proportion of the set is in the café.) [Proportional reading]

(60) You henduou xuesheng qu-le Taipei  
have many student go-PERF Taipei

- a. 'A lot of students have gone to Taipei.' [Cardinal Reading]
- b. 'A large proportion of the set of students has gone to Taipei (, whereas a small proportion of this set stays at home).' [Proportional reading]

---

<sup>25</sup> (59) and (60) with the cardinal interpretation (=59a) and (60a)) can be uttered in a context where one asks "who is in the dorm?/who went to Taipei?", whereas the proportional reading can be used only in a context where one asks a question like "where did your students go?", which makes students the topic of the discourse.

Based on the prosodic profile of weak quantifiers in different contexts, Büring (1999) argues that weak quantifiers can have only the proportional reading when they function as the sentence topic.<sup>26</sup> One consequence of this claim relevant to the current purposes is that if the argument moving to the matrix spec-TP in RMC has the semantic traits of being the sentence topic, we expect a weak quantifier subject to have only the proportional reading at this position, while a cardinal-proportional ambiguity is only available for a weak quantifier subject staying in the embedded TP in RMC. The contrast between (61) and (62) corroborates this prediction: only a proportional reading is available in the former, whereas the latter is ambiguous.<sup>27</sup>

(61) You henduo xuesheng [<sub>TP</sub> yinggai/keneng qu-le Taipei]  
 have many student should/may go-PERF Taipei  
 ‘A large proportion of the set of students should/may have gone to Taipei.’  
 [Proportional reading only]

(62) Yinggai/keneng [<sub>TP</sub> you henduo xuesheng qu-le Taipei]  
 should/may have many student go-PERF Taipei  
 ‘It should/may be the case that a lot of students have gone to Taipei.’  
 ‘It should/may be the case that a large proportion of the set of students have gone to Taipei.’

The same restriction should also hold of weak quantifier objects that move to the matrix spec-TP in RMC. However, in contrast to weak quantifier subjects, weak quantifier objects staying in the embedded TP in RMC can only have the cardinal reading, as in (63) (cf. (62)):

<sup>26</sup> Thanks to Ezra Keshet (personal communication) for bringing Büring’s work to my attention.

<sup>27</sup> NPs headed by a weak quantifier are often referred to as ‘indefinites’ since they introduce new entities to the domain of discourse. One language-particular fact about Chinese indefinites is that they are generally not allowed in the subject position in this language, unless it is accompanied by *you* ‘have’ which has been analyzed as the existential quantifier that is responsible for binding the variable in the indefinite NP. See Huang (1987, 1990) for a detailed analysis of *you* and the existential construction in Chinese (see also Tsai 2001 for some exceptions to this ban and Liao 2011 for a novel analysis).



- (63) Yinggai/keneng [<sub>TP</sub> Akiu renshi henduo yundongyuan]  
 should/may            Akiu know many    athlete  
 ‘It should be the case that Akiu knows a lot of athletes.’    [Cardinal reading]  
 #’It should be the case that Akiu knows a large proportion of the set of athletes.’  
[Proportional reading]

Diesing’s (1992) mapping hypothesis in (64), based on the assumption that an LF representation is translated into a tripartite semantic structure, provides an analysis of this contrast between subject weak quantifiers and object weak quantifiers.

- (64) Material within VP is mapped into the nuclear scope of the tripartite structure, while material outside of VP is mapped into the restrictive clause of the tripartite structure.

Diesing assumes that the object weak quantifier within VP is mapped to the nuclear scope and is bound by the default existential closure at VP as in (65), yielding only the existential/cardinal reading.<sup>28</sup>

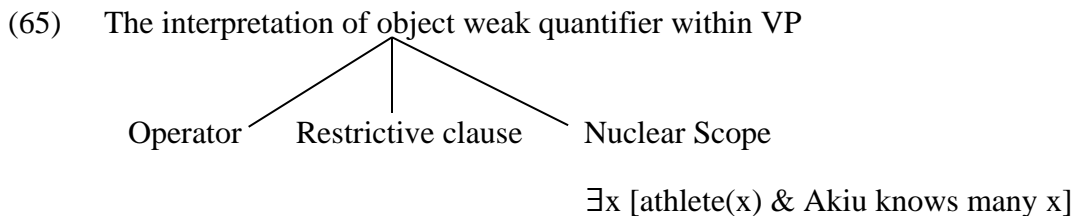

Now consider how the movement of a weak quantifier object to the matrix spec-TP in RMC as in (66) affects its interpretation: the cardinal reading in (63) is suppressed, and more importantly, the proportional reading becomes the only interpretation available, on a par with the subject weak quantifier seen in (61). This pattern, together with Büring’s (1999) association of the proportional reading of weak quantifiers with the semantics of

---

<sup>28</sup> The subject weak quantifier in cases like (59) is ambiguous, according to Diesing’s (1992) analysis, due to the fact that a subject NP can be interpreted at either spec-TP (the derived position) or spec-vP (the base-generated theta position).

the sentence topic, provides another piece of evidence for the topicality of A-movement to matrix spec-TP in RMC.

- (66) You hendou yungondyuan<sub>i</sub> yinggai/keneng [<sub>TP</sub> Akiu dou renshi t<sub>i</sub>]  
 have many athlete should/may Akiu all know  
 'It should be the case that Akiu knows a large proportion of the set of athletes.'  
 [Proportional reading only]

The third argument is related to the specificity ambiguity of indefinite NPs in Chinese, as shown by the two readings of (67):

- (67) You-yi-ge Taiwan-ren yingde-le guanjun  
 have-one-CL Taiwan-people win-PERF championship  
 (i) 'A specific Taiwanese won the championship.' (specific)  
 (ii) 'One Taiwanese won the championship.' (nonspecific)

Interestingly, (68a) and (69a) shows that the raised indefinite subject/object in RMC can receive only a specific reading, while the in situ indefinite subject/object in RMC retains the ambiguity as in (68b) and (69b):

- (68) a. You-yi-ge Taiwan-ren yinggai yingde-le guanjun  
 have-one-CL Taiwan-people should win-PERF championship  
 'One specific Taiwanese should have won the championship.'  
 b. Yinggai you-yi-ge Taiwan-ren yingde-le guanjun  
 should have-one-CL Taiwan-people win-PERF championship  
 'It should be the case that one (specific or not) Taiwanese won the championship.'
- (69) a. You yi-dao cai yinggai/keneng Akiu zhunbei

have one-CL dish should/may Akiu prepare

‘There is one specific dish that should/may be prepared by Akiu.’

b. Akiu yinggai/keneng zhunbei yi-dao cai

Akiu should/may prepare one-CL dish

‘It should/may be the case that Akiu prepares one (specific or not) dish.’

Note that the interpretation of the raised indefinite NP in RMC patterns together with that of topicalization to the left periphery – when the indefinite NP is topicalized, it has only the specific reading as in (70):

(70) a. You-yi-ge Taiwan-ren a, yingde-le guanjun

have-one-CL Taiwan-people TOP win-PERF championship

‘There is one specific Taiwanese who has won the championship.’

b. You-yi-ge Taiwan-ren<sub>i</sub>, wo renwei [<sub>t<sub>i</sub></sub> yingde-le guanjun]

have-one-CL Taiwan-people I think win-PERF championship

‘As for one specific Taiwanese, I think s/he has won the championship.’

Fourth, if the raised argument in RMC semantically exhibits topicality, we predict that it is incompatible with a focus interpretation. This is indeed what we find - neither the raised subject nor the raised object in RMC can serve as the information focus to reply to a *wh*-question, as evidenced by (71c) and (72c):

(71) a. Shei mai-le na-liang che?

who buy-PERF that-CL car

‘Who bought that car?’

b. Yinggai/keneng shi AKIU mai-le na-liang che

should/may FOC Akiu buy-PERF that-CL car

‘It should/may be the case that AKIU bought that car.’

c. #Shi AKIU yinggai/keneng mai-le na-liang che

FOC Akiu should/may buy-PERF that-CL car

- (72) a. Akiu mai-le shenme?  
 Akiu buy-PERF what  
 ‘What did Akiu buy?’
- b. Akiu yinggai/keneng shi mai-le XIEZI  
 Akiu should/may FOC buy-PERF shoes  
 ‘It should/may be the case that John bought the SHOES.’
- c. #XIEZI yinggai/keneng shi John mai-le  
 shoes should/may FOC John buy-PERF

When the question is “What happened?” as in (73) where everything is focused, the reply can only be (74a) where the focus marker *shi* scopes over the entire embedded clause of RMC and there can be neither (discourse-felicitous) subject raising nor object raising out of this focused clause, as evidenced by (74b) and (74c).

- (73) Fasheng shenme shi?  
 Happen what matter  
 ‘What happened?’
- (74) a. Yinggai/Keneng shi Akiu da-puo na-kuai buoli le  
 should/may FOC Akiu hit-break that-CL glass PERF  
 ‘It should/may be the case that Akiu broke the glass.’
- b. #Akiu yinggai/keneng shi da-puo na-kuai buoli le
- c. #Na-kuai buoli yinggai/keneng shi Akiu da-puo le

In sum, although argument raising in RMC syntactically represents A-movement targeting matrix spec-TP, semantically it patterns together with topicalization, which is otherwise normally associated with an A'-structure (via movement or base-generation).<sup>29</sup>

---

<sup>29</sup> Note that it is not uncommon to have topic interpretation associated with A-movement. In addition to the well-known A-topicalization in Finnish studied by Holmberg and Nikanne (2002), Grimm (2009) argues that in English, a typical example of a non-discourse-configurational language, A-movement from the infinitival complement clause of the unaccusative verb *seem* exhibits the properties of topicality, based on the distribution of the normative/deontic reading of singular indefinite generics like *a bishop*.

(i) It seems that a bishop moves diagonally.

In other words, there exists topic A-movement in Chinese.<sup>30</sup> In this connection, Miyagawa (2010) proposes that Chomsky's (2007, 2008) feature inheritance hypothesis can be extended to the [+Topic] feature<sup>31</sup> to derive topic A-movement in languages like Finnish and at least some of the Bantu languages. In addition, Miyagawa (2010: 46-52), contra the usual characterization of Chinese as a topic-prominent language, makes an interesting claim that Chinese is an agreement language based on the well-known blocking effects exhibited by the long-distance anaphor *ziji* 'self' in Chinese (see Chapter 3, Huang and Liu 2001, and Cole *et al.* 2006). Crucially, he maintains that the Topic feature remains in C in Chinese, and hence there is no topic A-movement in this language. Nevertheless, the data I have examined so far in this paper indicate that topic A-movement exists in Chinese,<sup>32</sup> suggesting that Miyagawa's system of topic feature inheritance can be extended to Chinese. In the next section, I explore whether Miyagawa's proposal can be reconciled with the empirical facts observed so far.

#### 2.4.2 *The incompatibility between PIC and feature inheritance*

First, under Miyagawa's [+Topic]-based feature inheritance hypothesis, the [+Topic] feature, if inherited by T, can drive A-movement to spec-TP. This can explain the topicality of A-movement in RMC. Second, although Chinese does not have morphological case, it has been argued that abstract Case exists in this language (see Li 1985; Travis 1984; Huang *et al.* 2009; Koopman 1984). However, given Chomsky's (2001) Activity Condition in (75), the object's Case feature is valued within the v\*P phase, and hence the object becomes inactive and inaccessible to further A-movement to matrix spec-TP in RMC.

---

(ii) ?A bishop seems to move diagonally.

<sup>30</sup> The topic A-movement in RMC, as motivated in this paper, can be loosely regarded as a left dislocation topic because the pre-modal argument in RMC has a direct grammatical relation to the embedded clause c-selected by the raising modal and it leaves a gap in the embedded clause. However, note that argument raising in RMC differs from the canonical left dislocation topic in Chinese as in (24) in that the former is A-movement, while the latter is A'-movement.

<sup>31</sup> Miyagawa characterizes the Topic feature as [-Focus]. As pointed out by one of the anonymous reviewers of Chou (2013), being [-Focus] does not necessarily mean [+Topic]; thus this is not a matter of a simple binary distinction. For relevant discussion, see, e.g. Şener (2010). For this reason, I use [+Topic] in this paper instead, to refer to the Topic feature.

<sup>32</sup> Note that topic A-movement of object NPs in Chinese is relatively constrained in that it cannot apply in mono-clausal structures, unlike other languages showing this movement discussed by Miyagawa. The lack of topic A-movement of object NPs in Chinese mono-clausal structures is ruled out by the failure of Case valuation, as discussed in the end of section 2.6.5.

(75) a. Inactivity of an XP:

An XP that eliminates its uninterpretable features (case, *-wh*) is rendered *inactive*.

b. The Activity Condition:

Inactive elements are not accessible for further (syntactic) operations.

However, the empirical data I discussed above indicates that the object in RMC is able to undergo further A-movement to matrix spec-TP even though its Case feature has been valued. Consequently, assuming the Activity Condition<sup>33</sup>, we are led to the conclusion that if the Activity Condition exists, then the object in RMC must contain a feature aside from the Case feature (syntactically valued at v\*P phase edge of the derivation) that renders further A-movement possible. Miyagawa's assumption of [+Topic] feature on both T and the moving element serves precisely this purpose. Even though Miyagawa's derivational system is appealing given these considerations, in this chapter I argue that Miyagawa's system cannot derive object A-movement in RMC due to an inherent incompatibility between feature inheritance and Chomsky's (2001) Phase-Impenetrability Condition.

First of all, object raising in RMC is impossible under Chomsky's (2000) version of the Phase-Impenetrability Condition (PIC) in (76) since the embedded object *wancan* 'dinner' would be Transferred as part of the complement VP as soon as the assembly of the embedded v\*P phase is completed in (77). Assignment of an EPP feature to the phase head v\* does not help derive object raising in RMC, since it yields other problems, as discussed below.

(76) In phase  $\alpha$  with head H, the domain of H is not accessible to operations outside  $\alpha$ , only H and its edge are accessible to such operations. (Chomsky 2000:108)

(77) [<sub>v\*P</sub> Akiu v\* [<sub>VP</sub> zhunbei wancan]]] (VP now Transferred)

---

<sup>33</sup> Nevins (2005) argues against the empirical validity of the Activity Condition. See Bošković (2007: 607, fn. 30) for problems in Nevins' argumentation. In section 2.6.4, I provide a novel argument for the necessity of the Activity Condition.



in (79a). Given this simultaneity of the external Merge of C and the Transfer of the embedded VP in (79a), when T inherits the Topic feature from C (necessarily only after the first-Merge of C) and is then ready to initiate probing on the basis of the [+Topic] feature inherited from C in (79b), the lower VP containing the object *wancan* ‘dinner’ has already become syntactically invisible via Transfer. Therefore, object A-movement in RMC, as a single-step A-movement operation targeting matrix spec-TP, cannot be derived under Miyagawa’s probe-driven system of movement based on the inheritance of [+Topic] from C to T, even under the delayed PIC in (78).<sup>34</sup>

One possible solution is to postulate an EPP feature on the embedded T as in (80) so that the object can be raised out of the VP to the embedded spec-TP, and thereby remain accessible to the matrix T’s probing, after escaping embedded VP:

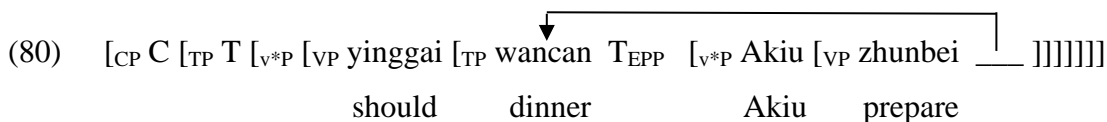

However, this movement is dubious on numerous grounds. For one thing, as argued by Epstein and Seely (1999, 2006), Epstein et al. (2005), and Bošković (2002, 2007), EPP is not an independent principle and can (or should) be reduced either to a structural requirement of agreement/Case and/or to general locality constraints on the syntactic derivation.<sup>35</sup> Nevertheless, the complement of a raising modal is a bare TP not selected by C, so the embedded T does not contain any features aside from its lexical temporal contents, under the feature inheritance hypothesis. Thus, postulating an EPP feature on such a  $\phi$ -less T is incompatible with any approach aiming to deduce the empirically correct aspects of the EPP from agreement. Second, even if EPP is to be postulated on the

<sup>34</sup> Note that this problem of under-generation is not specific to object A-movement in RMC. Under the feature inheritance hypothesis, this problem extends to other cases involving one-step A-movement from embedded object position to spec-TP if what is moving is within the embedded VP, which will be spelled-out upon the introduction of C. A case in point is the non-subject Topic A-movement in Finnish (see Holmberg and Nikanne 2002).

<sup>35</sup> This view is different from the earlier notion of EPP, in which every T (in fact, INFL) is associated with the EPP property, as in Chomsky (1981, 1995) and Alexiadou and Anagnostopoulou (1998). Later studies indicate that the so-called EPP movement only emerges when some grammatical feature is present (cf. Chomsky 2000, 2001, 2005; Kuroda 1988; Miyagawa 2005; among many others).



bare  $\phi$ -less T in RMC in (80), its attraction should abide by general locality constraints such as Attract Closest, contrary to the facts illustrated by object raising in RMC.

Assuming PIC, in order to derive object A-movement in RMC, the object needs to start moving *before* the probe (i.e. [Topic] on matrix C/T) enters the structure. A different way to implement this is to postulate an EPP property on phase heads, as in Chomsky's (2000, 2001) approach to successive-cyclic movement, such that the object can raise to the edge of the  $v^*P$  phase, and thereby remain accessible to the matrix T's probing. On this assumption, which version of PIC is adopted is not relevant, since the object remains accessible to further syntactic operations even if VP is transferred right after the completion of the  $v^*P$  phase, thanks to the EPP property on the phase head  $v^*$ .

- (81) a.  $[_{CP} C [_{TP} T [_{v^*P} [_{VP} \text{yinggai} [_{TP} T [_{v^*P} \text{wancan} [_{v^*P} \text{Akiu } v^*_{EPP} [_{VP} \text{---} ]]]]]]]]]]$   
should dinner Akiu
- 

However, as argued by Bošković (2007), such an approach inevitably requires look-ahead computation. The implementation of this local step based on assigning an EPP property to phase heads crucially depends on look-ahead into subsequent but yet unavailable derivational steps external to the  $v^*P$  phase. Thus we confront the same look-ahead problem observed by Bošković (2007) concerning Chomsky's (2000, 2001) analysis of successive-cyclic movement of Y to W across phase XP in (82a) in terms of A's EPP property whose assignment fully relies on whether W will enter the structure later, which is unknown at stage (82b).

- (82) a.  $W_{[uF, iK, EPP]} \dots [_{XP} \dots X \dots Y_{[iF, uK]}]$  (XP a phase)  
 b.  $[_{XP} Y_{[iF, uK]} \dots X_{EPP} \dots t_y]$  (XP a phase)

Summing up, the adoption of Miyagawa's probe-driven system based on T-to-C [+Topic] feature inheritance fails to derive object A-movement in RMC due to the inherent incompatibility between the delayed PIC in (78) and the feature inheritance system. To circumvent the problem, an EPP feature needs to be postulated either on the embedded bare T of RMC or on each phase head. As shown above, both options

encounter difficulties, as summarized in (83). The upshot of the discussion so far is that even though Miyagawa's system seems to provide relevant motivation for object A-movement in RMC, his approach confronts empirical problems when we take into consideration the incompatibility between the PIC and the feature inheritance hypothesis.

- (83) a. The late trigger problem: The (lower) VP containing non-subject constituents is Transferred before T is ready to probe/attract by virtue of inheriting the Topic feature from C, i.e., object movement is not generable given PIC.
- b. The early trigger problem: The assignment of spurious intermediate EPP/Edge-features on phase heads to trigger successive cyclic (= escape via small steps) movement to the phase edge is look-ahead computation.

## **2.5 Two Views of the Syntactic Visibility of “Discourse” Features**

This section reviews two opposing views of the syntactic visibility and activity of discourse features like [Topic] and [Focus]. On the one hand, Horvath (2010) argues that notions of information structure and discourse cannot be encoded as formal features active in narrow syntax and hence cannot constitute functional projections. On the other hand, Aboh (2010), based on the morphological markers associated with the obligatory topic and focus movement in Gungbe, argues that such discourse-related movement has its roots in the lexicon. This section briefly reviews the arguments and empirical data adduced by both to support their different views about the syntactic status of discourse-related notions.

### *2.5.1 Horvath (2010)*

The main goal of Horvath (2010) is to restrict the set of formal features active within the  $C_{HL}$  (i.e. the computational system of narrow syntax). Horvath proposes the Strong Modularity Hypothesis for discourse features in (84):

(84) The Strong Modularity Hypothesis for Discourse Features

No information structure notions – i.e., purely discourse-related notions – can be encoded in the grammar as formal features; hence no “discourse-related features” are present in the syntactic derivation. They are available only outside the  $C_{HL}$ .

This hypothesis is in stark contrast with the cartographic approach to syntax (see Rizzi 1997, 2004, 2007; Cinque 1999, 2002) which maintains that discourse notions like topic and focus have featural encodings as well as designated functional projections in syntax. Horvath (2010) argues that these purely discourse-related notions should be excluded from the set of features visible and active in the  $C_{HL}$ . Horvath defines purely discourse-related notions as those notions whose interpretations have no truth-conditional effect in formal semantics. Horvath (2010:1347) compares these notions to phonological features that are interpretable only at the PF component: “both should be absent, or at least inaccessible in the  $C_{HL}$ .” I suggest that another motivation for (84) is a major concept of generative linguistics that  $C_{HL}$  is an autonomous computational system, rather than an interpretive one. Therefore, the discourse-related features like [Focus] and [Topic], as purely interpretive objects without formal properties identifiable by  $C_{HL}$ , should be at least inaccessible to  $C_{HL}$ .

The empirical prediction of this hypothesis is that no syntactic movement that appears to realize a purely discourse-related notion can be driven by a corresponding formal feature encoding it in syntactic structure. The primary data Horvath examines is the well-known obligatory (alleged) focus-related movement in Hungarian (see É. Kiss 1987, 1998; Horvath 1986, 2000). Notice that (85) shows the normal particle-verb order in Hungarian (i.e. *be-mutattam*), which is reversed by the obligatory verb raising associated with the (alleged) focus-related movement, as illustrated by the contrast between (86a) and (86b).

(85) Be-mutattam Jánost az unokahúgomnak  
 in-showed-1SG John-ACC the niece-my-DAT  
 ‘I introduced John to my niece.’

(86) Q: Kinek matattad be Jánost?

‘To whom did you introduce John?’

a. [AZ UNOKAHÚGOMNAK]<sub>i</sub> mutattam be Jánost t<sub>i</sub>  
 the niece-my-DAT showed-1SG in John-ACC  
 ‘I introduce John TO MY NIECE.’

b. \*[AZ UNOKAHÚGOMNAK]<sub>i</sub> be-mutattam Jánost t<sub>i</sub>  
 the niece-my-DAT in-showed-1SG John-ACC

Horvath (2010:1352) summarizes the properties of the movement observed in (86a) in (87). Due to its similarities with other instances of feature-driven movement like *wh*-movement, the standard analysis of the movement in (86a) is that the movement in (86a) is driven by a syntactically active formal feature [Focus] (e.g. Horvath 1986, 1995; Brody 1990, 1995).

- (87) a. The moved phrase – or one of its constituents – gets interpreted as the focus of the clause it appears in,  
 b. exhibits long, successive cyclic extraction,  
 c. obeys the complex-NP and other syntactic island constraints, and  
 d. licenses parasitic gaps.

One strong piece of evidence adduced by Horvath (2010) to argue against attributing the movement in (86a) to [Focus] is the contrast between two focus-sensitive particles: *csak* ‘only’ and *még...is* ‘even’ (lit. ‘yet...also’). Only the phrase associated with *csak* undergoes obligatory movement as in (88), whereas the phrase associated with *még...is* is not allowed to move, as in (89). Importantly, an analysis that attributes the movement in (86a) to the feature [Focus] would predict that both *csak* and *még...is* must trigger obligatory fronting of the phrase associated with focus. However, the prohibition of

moving the phrase associated with *még...is* suggests that we should seek elsewhere for the motivation of movement in (86a) and (88a).

- (88) a. Mari csak [A FOGADÁSRÓL] késett el  
 Mary-NOM only the reception-from late-was away  
 ‘Mary was late only for THE RECEPTION.’
- b. \*Mari elkésett csak [A FOGADÁSRÓL]  
 Mary-NOM away-late-was only the reception-from
- c. \*Mari csak [A FOGADÁSRÓL] elkésett  
 Mary-NOM only the reception-from away-late-was
- d. \*Mari csak elkésett [A FOGADÁSRÓL]  
 Mary-NOM only away-late-was the reception-from
- (89) a. Mari elkésett még [AZ ESKÜVŐJÉRŐL] is  
 Mary-NOM away-late-was yet the wedding-her-from also  
 ‘Mary was late even for HER WEDDING.’
- b. \*Mari még [AZ ESKÜVŐJÉRŐL] is elkésett  
 Mary-NOM yet the wedding-her-from also away-late-was
- c. \*Mari még [AZ ESKÜVŐJÉRŐL] is késett el  
 Mary-NOM yet the wedding-her-from also late-was away

In view of this unexpected contrast between the two focus-sensitive particles in (88) and (89), Horvath proposes that what is responsible for the obligatory movement in (86a) and (88a) is an Exhaustive Identification Operator with the semantic import of maximality. One strong argument for this novel analysis concerns question-answer pairs. Even though functioning as the answer to a *wh*-question is a standard test for identifying focus, Horvath notes that the answer to a *wh*-question in Hungarian does not always undergo the movement seen in (86a). For example, the phrase functioning as the answer in (90) *Katit és Pétert* ‘Cathy and Peter’ does not need to undergo movement.

- (90) Q: Kiket hívott már meg Anna  
 who-PL-ACC invited-3SG already PERF.PRT Anna-NOM  
 ‘Who has Anna (already) invited?’
- A: (Valószínűleg) meghívta [KATIT ÉS PÉTERT],  
 probably PERF.PRT-invited-3SG Cathy-ACC and Peter-ACC  
 és talán Marit is  
 and perhaps Mary-ACC also  
 ‘(Probably) she has invited Cathy and Peter, and perhaps also Mary.’

The lack of movement of the phrase functioning as the answer to the *wh*-question in (90) shows that being the focus of a sentence cannot be the real cause of the observed movement in (86a) and (88a). Horvath (2010:1356) suggests that what distinguishes the answer in (86a) and that in (90) is that the latter is uttered in a context where “there is no need or possibility for exhaustive specification in the answer within a question-answer pair.” As a result, no preposing of the phrase functioning as the answer in the context of (90) is appropriate. With this observation in mind, the contrast between *csak* ‘only’ and *még...is* ‘even’ in (88) and (89) becomes explicable: only the phrase associated with *csak* undergoes obligatory fronting, whereas the phrase associated with *még...is* cannot because the meaning of *csak* ‘only’ entails exhaustivity, while *még...is* ‘even’ obviously does not.

Horvath’s (2010) re-analysis of the well-known allegedly focus-related movement in Hungarian as triggered by an Exhaustive Identification Operator with truth-conditional effects represents a case study of an ambitious project aiming at eliminating discourse-related notions like topic and focus from the set of syntactically active features. Even though the Hungarian data provides a convincing argument toward this goal, it is unclear if the hypothesis in (84) can be successfully extended to the topic/focus-related movement attested in other languages. Indeed, Aboh (2010) argues that the data in Gungbe strongly suggests the presence of [Topic] and [Focus] features in  $C_{HL}$ . I turn to the Gungbe data in the next section.

### 2.5.2 Aboh (2010)

Even though the fronting of *John* yields a topic reading in (91b), Chomsky (1995) attributes the movement of *John* in (91b) to the EPP feature under C, rather than any intrinsic property in *John*. Furthermore, he (*ibid*: 220) suggests that the topic reading in (91b) is extraneous to the computation in C<sub>HL</sub> which is based on properties of different objects in the Numeration. This amounts to excluding any discourse-related notions like topic from appearing in the C<sub>HL</sub>. Specifically, he argues that the discourse-related interpretations are imposed on the output of C<sub>HL</sub> by an additional level “internal to the phonology component, postmorphology, but prephonetic, accessed at the interface along with PF and LF.” Along this line of analysis, some researchers go as far as completely dissociating this sort of discourse-related movement from C<sub>HL</sub>, and argue that it is a purely PF operation (see Zubizarreta 1998; Szendroi 2001; Fanselow 2006).

- (91) a. I like John very much.  
 b. John, I like him very much.

By contrast, based on data from Gungbe, Aboh (2010) holds that discourse-related notions like topic, focus, and interrogative force should all be treated on a par with Case features and  $\phi$ -features as syntactically active features that drive syntactic derivation. Specifically, In Gungbe, a language of the Gbe group (Niger-Congo languages of the Kwa family), both the topic phrase and the focus phrase undergo obligatory movement to the left periphery, whose boundary is marked by the complementizer *dɔ̀* ‘that’, as in (92a) and (92b).

- (92) a. Ûn sè **dɔ̀** dàn lɔ̀ **yà** Kòfí hù ì  
 1SG hear **that** snake DET TOP Kofi kill 3SG  
 ‘I heard that, as for the snake Kofi killed it.’  
 b. Ûn sè **dɔ̀** dàn lɔ̀ **wɔ̀** Kòfí hù  
 1SG hear **that** snake DET FOC Kofi kill  
 ‘I heard that Kofi killed THE SNAKE.’

Gungbe is an SVO language and in both (92a) and (92b) the object *dàn ló* ‘the snake’ has been displaced to the left of the morphemes *yà* and *wɛ́*. Note that these two morphemes don’t have any lexical meaning apart from indicating that what is to their left is the topic or the focus of the sentence, so they are not found in any contexts other than an utterance with a fronted topic or focus constituent in the left periphery. Aboh proposes that *yà* and *wɛ́* are the overt realization of the heads of Topic and Focus functional projections in the left periphery of the phrase structure in Gungbe, and hence the Gungbe data strongly supports Rizzi’s (1997) split-CP hypothesis which maintains the featural encoding of and designated functional projections for discourse-related notions like topic and focus in  $C_{HL}$ , contra Chomsky’s (1995) approach and Horvath’s (2010) Strong Modularity Hypothesis in (84). Given the presence of *yà* and *wɛ́* in the lexicon as the heads of Topic Phrase and Focus Phrase in Gungbe, Aboh (2010) argues that [Topic] and [Focus] features must be present at the beginning of the derivation (by being selected as a member in the Numeration), rather than being assigned post-syntactically to the fronted phrase, as Chomsky’s (1995) approach would predict. Thus, Aboh (2010:14) suggests that “the Numeration pre-determines the Information Structure of a linguistic expression.”

However, being “present” in  $C_{HL}$  does not necessarily entail “accessibility” to  $C_{HL}$ . As mentioned in the last section,  $C_{HL}$  is an autonomous computational system, rather than an interpretive one. Therefore, even if discourse-related features like [Focus] and [Topic] are present in  $C_{HL}$ , as strongly supported by the data in Gungbe, as purely interpretive objects without formal properties identifiable by  $C_{HL}$ , they should be inaccessible to  $C_{HL}$ . Therefore, I suggest that Horvath’s (2010) Strong Modularity Hypothesis in (84) is too strong, but it can be modified to allow the presence of [Topic] and [Focus] features in  $C_{HL}$ . As a consequence, the major difference between a weak version of (84) and the cartographic approach boils down to the “accessibility” of these discourse-related features in  $C_{HL}$ . Now the issue is whether these discourse-related features can be modified so that they are accessible to  $C_{HL}$  to trigger syntactic operations. I propose in the next section that a modification to this effect is available if we allow the dissociation of feature valuation and feature interpretability. That is, in this chapter, I propose that a feature-based account of discourse-related movement is on the right track (at least for Chinese), but it is necessary to adopt the dissociation of feature valuation and feature



interpretability to render these discourse-related features accessible and fully operational in  $C_{HL}$ .

## 2.6 Analysis

I propose that Miyagawa's [Topic] feature on the moving phrase (which is going to be interpreted by CI as the sentence topic) should be recast as an interpretable yet unvalued feature, in the spirit of Pesetsky and Torrego (2007), Carstens (2010, 2011), and Bošković (to appear). This approach to the [Topic] feature not only solves the accessibility problem of discourse-related features in  $C_{HL}$  but also derives object topic A-movement in RMC without inducing the look-ahead problem, if we adopt Bošković's (2007) moving-element-driven approach to movement (i.e., the driving force of movement resides on the moving element itself, rather than on the final target of movement) to trigger the movement of the phrase bearing the unvalued interpretable [Topic] feature.

### 2.6.1 *Feature valuation/interpretability biconditional*

Chomsky (2001) lexically ties feature valuation and feature interpretability, arguing for the biconditional relation in (93):

(93) Valuation/Interpretability Biconditional (Chomsky 2001:5)

[In the lexicon, CTC] A feature F is uninterpretable iff F is unvalued.

This biconditional is based on the fact that narrow syntax, which is a computational system rather than an interpretive one, is not able to inspect a feature and “see” whether the CI interface will be able to interpret it later. This involves look-ahead. However, uninterpretable features need to be deleted for convergence (see e.g. Epstein et al., 1998 for an early discussion). To deal with this problem, Chomsky proposes (93) to encode interface interpretability at the CI interface, as valuation in the lexicon and narrow syntax does this without violating the Inclusiveness Condition since interpretability and value of features are independently motivated. The rationale behind this correlation is that

although narrow syntax is blind to semantics, hence feature interpretability, the lexical valuation of a feature is a formal property that can be detected by narrow syntax.

This proposal provides a computationally transparent way for syntax to detect and delete uninterpretable features (thanks to their unvalued property) to ensure the convergence of the derivation. However, Pesetsky and Torrego (2007:267) propose an interesting departure from (93) based on the consideration that this assumption is serving syntax at the cost of a stipulation about the lexicon. They note that interpretability and valuation are two distinct properties of a lexical item – the former concerns its potential contribution to semantics, whereas the latter is related to the (un)specification of a certain property. Therefore, Pesetsky and Torrego (2007) suggest that feature valuation and feature interpretability are independent concepts and should not be lexically associated. In their approach, four types of features are distinguished:

- (94) a.  $uF[ \ ]$  (uninterpretable and unvalued; e.g. Case feature)  
b.  $uF[val]$  (uninterpretable and valued)  
c.  $iF[ \ ]$  (interpretable and unvalued)  
d.  $iF[val]$  (interpretable and valued; e.g.  $\varphi$ -features on NPs)

The novelty of this approach is the new features in (94b/c) and the ability of an interpretable feature to act as a probe if it is unvalued. For example, Pesetsky and Torrego (2007) argue that the Tense feature on T is an instance of unvalued interpretable features (i.e.  $iF[ \ ]$  in (94c)), since it is the locus of tense interpretation but its value depends on the verb it co-occurs with.<sup>36</sup> In addition, based on the pattern of conjunct agreement in Serbo-Croatian (see Bošković 2009), Bošković (to appear) provides additional evidence for Pesetsky and Torrego's claim that (93) should be abandoned, arguing that the grammatical gender feature on Serbo-Croatian nouns is an instance of a valued yet uninterpretable feature (i.e.  $uF[val]$  in (94b)) since it is lexically arbitrary and its arbitrary variance does not have any semantic import. Extending this proposal further, Carstens (2010, 2011) argues that grammatical gender in general should be (lexically)

---

<sup>36</sup> Pesetsky and Torrego maintain that the Tense feature on V is valued (yet uninterpretable) based on the argument that there are tense tantum verbs like Latin *meminisse* 'remember' and *coepisse* 'began', which have only perfect-system forms. Notice that even though I adopt the dissociation of feature interpretability and feature valuation, I do not assume their characterization of the Tense feature (see footnote 37). Their characterization of the Tense feature is mentioned here and below simply for expository convenience.

valued yet uninterpretable to account for the hyperagreement and hyperactivity of A-movement in the Bantu languages.

### 2.6.2 *A fine-grained characterization of the Topic feature*

I argue that both types of new features in (94b) and (94c) predicted by Pesetsky and Torrego's (2007) system are needed for a more fine-grained and empirically adequate characterization of topic A-movement in Mandarin Chinese. Note that even though  $\varphi$ -features and the Topic feature on an NP are both interpretable, their interpretation differs in one crucial aspect – the former are inherently interpretable at the CI interface, given their lexical valuation; the interpretation of the latter by contrast is configurational, requiring a syntactic relation between an NP and another syntactic category (= a head bearing [+Topic] feature). Consequently, the NP's Topic feature, though *potentially interpretable*, is not intrinsically valued in the lexicon. Therefore, my proposal of the unvalued yet interpretable Topic feature (i.e.  $i\text{Topic}[\ ]$ ) on the moving NP is roughly similar to Pesetsky and Torrego's treatment of Tense feature on T as  $i\text{Tense}[\ ]$  (i.e. an interpretable but unvalued feature in (94c)) in the sense that both of them are *potentially interpretable* at the CI interface, but their interpretations critically rely on their syntactic relation to other elements in the derivation.<sup>37</sup>

This proposal also provides a way to render the discourse-related [Topic] feature accessible to and fully operational in  $C_{HL}$ . As mentioned above, in spite of its presence in  $C_{HL}$ , the [Topic] feature, as a discourse-related and purely interpretive object, does not have any formal/computational properties that make it “visible” to  $C_{HL}$ , and thereby trigger syntactic operations. Furthermore, the [Topic] feature on the moving constituent must be an interpretable feature for the CI interface to assign the correct topic

---

<sup>37</sup> A reviewer of Chou (2013) raises the question of the learnability of unvalued interpretable features like the Tense feature on T in Pesetsky and Torrego's (2007) system. Pesetsky and Torrego (2007) do not address learnability in general, but I agree that this type of feature is potentially difficult to acquire since there would hardly be much evidence for it in the input. Therefore, I agree that Pesetsky and Torrego's characterization of the Tense feature on T still requires justification on learnability grounds. Crucially, even though the Topic feature I propose on the moving NP is also an unvalued interpretable feature under my analysis, it does not face this learnability problem. First, there are overt (prosodic) topic markers and different sorts of topic structures in Chinese that can unambiguously suggest the presence of topic feature in the input. Second, the unvalued nature of the interpretable Topic feature on the moving NP does not need to be induced from the input; rather, as I proposed above, it follows from how topic is interpreted at the CI interface. The interpretable Topic feature on the constituent to be interpreted as the topic in the CI interface cannot be intrinsically valued because its successful interpretation depends on its syntactic relation with another category in the course of syntactic derivation, a hallmark property of unvalued features.

interpretation to this constituent.<sup>38</sup> More importantly, this interpretable [Topic] feature on the moving constituent must also be a valued feature, if we follow Chomsky’s (2001) Valuation/Interpretability Biconditional in (93). However, for the system in Chomsky (2001, *et seq.*), a syntactic object is active for syntactic operations only if it bears an unvalued feature (i.e. a purely interpretive feature without formal properties like valuation is inert in  $C_{HL}$ ). Thus, if there is anything that triggers the movement of a constituent bearing topic interpretation, it cannot be the interpretable/valued [Topic] feature in a system assuming (93). By contrast, in a system assuming the dissociation of feature valuation and feature interpretability, an interpretable [Topic] feature can be unvalued, providing the necessary formal property to motivate the movement of the phrase bearing such a feature.

With this assumption, I turn to the valuation of the unvalued but interpretable  $i$ Topic[ ] on the moving NP and how it accounts for topic A-movement in RMC. I argue that the Topic feature on T inherited from C assumed by Miyagawa (2010) should be reanalyzed under Pesetsky and Torrego’s (2007) hypothesis dissociating feature interpretability and feature valuation. Specifically, I propose that the inherited feature on T should be reanalyzed as a valued yet uninterpretable feature  $u$ Topic[+]. Given that the T inheriting Miyagawa’s [+Topic] feature from C always assigns a topic interpretation to the element moving to its specifier, the inherited feature on T must be valued. However, “a syntactic position” (either T or spec-TP) is not what is interpreted as “topic” at the CI interface (rather, the category moving to merge with T, forming spec-TP, is what is interpreted as topic at CI), suggesting the uninterpretable of the inherited feature. Taken together, Miyagawa’s inherited [+Topic] feature on T should be a valued yet uninterpretable feature  $u$ Topic[+] (i.e. an instance of  $u$ F[val] in (94b)). The Topic features on the T assigning topic interpretation and the NP undergoing topic A-movement are represented in (95):

$$(95) \quad \dots T \quad \dots NP \quad \dots$$

$$\quad \quad \quad \underline{u\text{Topic}[+]} \quad \underline{i\text{Topic}[ ]}$$

<sup>38</sup> An alternative way to derive the topic interpretation of the fronted constituent is the mapping approach suggested by Neeleman and van de Koot (2007). I will review this approach in section 2.7, and argue that the feature-based approach fares better than the mapping approach with respect to the derivation of topic A-movement in Chinese RMC.

However, note that under a valuation-driven system, it is the unvalued status of a feature that makes it an active probe/goal. Accordingly, given last resort, T in (95) cannot initiate probing since its Topic feature is valued (though uninterpretable). Consequently, under Miyagawa's probe-driven system of movement, the *i*Topic[ ] on the NP in (95) would not be valued and there would be no syntactic motivation for topic A-movement in RMC, contrary to fact. To address this question and outline the preliminaries for the discussion of the step-by-step derivation of A-movement in RMC, I argue in the next section that there is (greedy) NP-movement motivated by Case feature valuation in Chinese.

### 2.6.3 Remarks on Lin (2011) and Case-motivated A-movement in Chinese

Recall that in section 2.3.2, we discussed the distribution of argument raising in *hui*-RMC to argue for an A-movement analysis of object raising in *yinggai/keneng*-RMC. Examples relevant to the current discussion are repeated in (96) and (97). (96) shows that subject raising in *hui*-RMC is obligatory without the subject focus, whereas it is not required to produce a grammatical *yinggai/keneng*-RMC, as illustrated by (97):

- (96) a. [<sub>TP</sub> Akiu<sub>i</sub> hui [<sub>TP</sub> t<sub>i</sub> zhunbei wancan]]  
           Akiu will       prepare dinner  
           ‘Akiu will prepare the dinner.’
- b. \*[[<sub>TP</sub> Hui [<sub>TP</sub> Akiu zhunbei wancan]]  
           will   Akiu   prepare dinner  
           Intended: ‘It will be the case that Akiu prepares the dinner.’
- (97) a. [<sub>TP</sub> Akiu<sub>i</sub> yinggai/keneng [<sub>TP</sub> t<sub>i</sub> zhunbei wancan]]  
           Akiu should/likely       prepare dinner  
           ‘Akiu should/is likely to prepare the dinner.’
- b. [<sub>TP</sub> Yinggai/keneng [<sub>TP</sub> Akiu zhunbei wancan]]  
           should/likely   Akiu   prepare dinner  
           ‘It should/is likely to be the case that Akiu prepares the dinner.’

Lin (2011) argues that the major distinction between *yinggai/keneng*-RMC and *hui*-RMC is that aspectual markers such as the perfective marker *le* and the progressive marker *zai* are allowed in the clausal complement of the former, as in (98), but not in the latter, as in (99):

- (98) a. Zhangsan<sub>i</sub> yinggai/keneng [<sub>TP</sub> t<sub>i</sub> qu Taipei le]  
 Zhangsan should/likely go Taipei PERF  
 ‘Zhangsan should/may have gone to Taipei.’
- b. Akiu<sub>i</sub> yinggai/keneng [<sub>TP</sub> t<sub>i</sub> zai chi niuro-mien]  
 Akiu should/likely PROG eat beef-noodle  
 ‘It is should be the case/likely that Akiu is eating beef noodle.’
- (99) a. \*Akiu hui [<sub>TP</sub> t<sub>i</sub> qu Taipei le]  
 Akiu will go Taipei PERF  
 Intended: ‘Akiu will have gone to Taipei.’
- b. \*Akiu hui [<sub>TP</sub> t<sub>i</sub> zai chi niuro-mien]  
 Akiu will PROG eat beef-noodle  
 Intended: ‘Akiu will be eating beef noodle.’

Based on this contrast, Lin proposes that the clausal complement of *yinggai/keneng*-RMC is a finite TP, whereas that of *hui*-RMC is a non-finite TP. Therefore, the reference time needed for the interpretation of the aspectual markers is available in the former, but not in the latter (see Reichenbach 1947),<sup>39</sup> yielding the contrast between (98) and (99).

<sup>39</sup> However, Lin’s argument for the correlation between the occurrence of aspectual markers like *le* and the existence of TP in Chinese is not uncontroversial. A number of authors have used the fact that aspect determines temporal interpretation in Chinese as an argument that Chinese lacks TP (see Lin 2003, 2006; Smith and Erbaugh 2005). In view of this controversy, I suggest that the only solid conclusion one can draw from the contrast between (98) and (99) is that the clausal complement of *yinggai* ‘should’ and *keneng* ‘likely’ is an Aspectual Phrase that can host aspectual markers, while that of *hui* ‘will’ is a “deficient” Aspectual Phrase, so aspectual markers within the complement in *hui*-RMC are not allowed unless sufficient contextual information is provided to identify the reference time, as noted by Lin (2011:53) in (i):

- (i) a. Mingtien xiawu san dien, Akiu hui (yijing) qu Taipei le  
 tomorrow afternoon three o’clock Akiu will (already) go Taipei PERF  
 ‘By three o’clock tomorrow afternoon, Akiu will have (already) gone to Taipei.’
- b. Mingtien xiawu san dien, Akiu hui zai chi niuro-mien  
 tomorrow afternoon three o’clock Akiu will PROG eat beef-noodle

In addition, Lin assumes that Chinese does not have grammatical features (i.e.  $\phi$ -features and Case features), and based on this assumption, he argues that a checking-based theory of A-movement (as in Epstein and Seely 1999, 2006; Bošković 2002; Epstein et al. 2005; Bošković 2007) cannot explain the distribution of A-movement in this language. This is because a checking-based theory of A-movement would wrongly predict there is no A-movement at all in this language as it has no checking-based grammatical features that can drive A-movement. This apparently false prediction leads Lin to conclude that Chomsky' (2000, 2001) EPP feature is the sole driving force of A-movement in Chinese. This explains why A-movement is possible out of a finite clause in Chinese but not in English. The valuation of (unvalued) grammatical features in a finite clause in English renders an argument inactive for further A-movement; on the other hand, this is not a concern for Chinese due to the lack of grammatical features in this language. Rather, EPP on T is responsible for A-movement in this language. However, this analysis makes it necessary for Lin to assume that EPP on T in Chinese can be satisfied by a null expletive to account for the grammaticality of those *yinggai/keneng*-RMC without subject raising out of the finite clausal complement, as in (97b).

There are both conceptual and empirical challenges to Lin's assumption that a null expletive satisfies the EPP on the matrix T in (97b). The conceptual difficulty, as Lin himself points out, is why the option of having a null expletive satisfying the EPP feature of the matrix T is not available for the *hui*-RMC in (96b). He leaves this issue open and conjectures that Chinese null expletive has to be associated with the clausal complement of *yinggai/keneng* 'should/likely'. Furthermore, an empirical challenge comes from the successive-cyclic A-movement in *yinggai/keneng*-RMC. First, note that *yinggai*, *keneng*, and *hui* can be stacked to form a structure like (100):<sup>40</sup>

- (100) [<sub>TP1</sub> Yinggai [<sub>TP2</sub> keneng [<sub>TP3</sub> Akiu hui [<sub>TP4</sub> <Akiu> zhunbei wancan]]]]  
           should           likely           Akiu will                   prepare dinner

---

'Akiu will be eating beef noodle at 3 o'clock tomorrow afternoon.'

For a recent debate on the existence of TP in Chinese, see Sybesma 2007, Lin 2010, and Bošković 2010. Given the controversial existence of TP in Chinese, TP could be seen in this chapter as being used solely for expository convenience.

<sup>40</sup> Recall that subject raising is obligatory from the TP<sub>4</sub> complement of *hui* 'will' (cf. the contrast between (96a) and (96b)).

‘It should be the case that Akiu will prepare the dinner.’

Next, notice that the subject *Akiu* can raise to spec-TP<sub>1</sub>, as in (101):

(101) [<sub>TP1</sub> Akiu<sub>i</sub> yinggai [<sub>TP2</sub> t<sub>i</sub> keneng [<sub>TP3</sub> t<sub>i</sub> hui [<sub>TP4</sub> t<sub>i</sub> zhunbei wancan]]]]  
           Akiu should               likely               will               prepare dinner

Crucially, *Akiu* cannot stay in the embedded spec-TP<sub>2</sub>, as in (102):

(102) \*[<sub>TP1</sub> Yinggai [<sub>TP2</sub> Akiu<sub>i</sub> keneng [<sub>TP3</sub> t<sub>i</sub> hui [<sub>TP4</sub> t<sub>i</sub> zhunbei wancan]]]]  
           should       Akiu likely               will               prepare dinner

Now compare (102) with (97b). Neither has an overt lexical item filling the matrix spec-TP. If null expletive were to exist in Chinese to satisfy EPP on the matrix T in cases like these, as assumed by Lin (2011), we would expect to find both (102) and (97b) as grammatical sentences, contrary to fact. Given the contrast between (102) and (97b), I conclude that Chinese does not have a null expletive to satisfy EPP on T when there is nothing overt moving to spec-TP. This in turn argues against a universal structural requirement (= the so-called EPP) imposed by T in Chinese. In the absence of a null expletive, there simply is no matrix spec-TP position in (97b).<sup>41</sup>

<sup>41</sup> The contrast between (97b), (101), and (102) reminds one of the following contrast in English:

- (i) a. [<sub>TP</sub> A man seems [<sub>TP</sub> to be [<sub>PP</sub> <a man> outside]]]
- b. [<sub>TP</sub> There seems [<sub>TP</sub> to be [<sub>PP</sub> a man outside]]]
- c. \*[<sub>TP</sub> There seems [<sub>TP</sub> a man to be [<sub>PP</sub> <a man> outside]]]

Chomsky (1995) assumes a universal EPP on T and explains the contrast between (ib) and (ic) in terms of the “Merge over Move” principle which says that at a given stage of derivation, if both Merge and Move can satisfy a given property (e.g., EPP in (i)), Merge preempts Move because the former is “simpler”. As a consequence, given that the EPP on the embedded T in (i) can be satisfied by either merging the expletive *there* or moving *a man*, the former excludes the application of the latter. If the expletive *there* exists in the lexical array for the derivation of (i), its first-Merge site must be the embedded spec-TP to satisfy the EPP, rather than the matrix one. Therefore, *a man* is simply not allowed to move to embedded spec-TP in (ic). However, Chomsky (2000, 2001, *et seq.*) recasts Merge and Move as external Merge and internal Merge, respectively, considering them as the same kind of a generalized syntactic operation - Merge. Given this unification, the contrast between (ib) and (ic) can no longer be explained in terms of Merge-over-Move. The contrast between (ib) and (ic) now turns into supporting evidence for the checking/valuation-based approach to A-movement, argued by Epstein and Seely (2006) and Bošković (2002, 2007). Since the infinitival T is not able to check/value the unvalued Case feature on *a man* in (i), the movement of *a man* to embedded spec-TP as in (ib) simply cannot apply. As I argue in the text, the lack of null expletive in Chinese and the contrast between (97b) and (102) jointly lead one to adopt the checking/valuation-driven approach to A-movement in this language.



How do we explain then the difference between *hui*-RMC and *yinggai/keneng*-RMC with respect to the obligatory application of A-movement out of their TP complements, as shown in (96) and (97)? I argue that the valuation-based theory of A-movement can provide an analysis empirically preferable to Lin’s (2011) analysis for Chinese A-movement and one with fewer “differences” stipulated between e.g., Chinese and English. More specifically, I propose that the valuation of Case is responsible for the obligatory subject raising in *hui*-RMC like (96). Recall that the contrast between (98) and (99) suggests that the clausal complement in *yinggai/keneng*-RMC is a finite TP, whereas that of *hui*-RMC is a non-finite one (or, more precisely, a full-fledged Aspectual Phrase and a deficient Aspectual Phrase, respectively; see footnote 39). Therefore, subject NP’s unvalued Case feature can be valued in the finite TP complement in *yinggai/keneng*-RMC (97b). On the other hand, given that the TP complement in *hui*-RMC is non-finite, the obligatory subject raising in *hui*-RMC naturally follows from this analysis because the unvalued Case feature on the subject NP cannot be valued within this deficient domain. Therefore, the embedded subject NP must raise to matrix spec-TP to get its Case valued,<sup>42</sup> assuming the moving-element-driven approach to Case valuation and syntactic movement in Bošković 2007 and Bošković to appear. In other words, my proposed analysis of Case valuation in Chinese does not adopt Chomsky’s (2000, 2008) system where Case valuation can be accomplished under Agree alone. I will return to the issue of why Agree does not suffice for Case valuation in languages like Chinese and Sinhala in section 2.6.5.

On the other hand, based on the possibility of A-movement out of the clausal complement of *yinggai/keneng*-RMC, as in (97a), Lin argues that the checking/valuation of unvalued features cannot be the driving force of Chinese A-movement, and the cost of maintaining a checking/valuation-based theory of A-movement in this language would be, in his view, the postulation of a feature F that can remain active even after checking/valuation within the clausal complement of *yinggai/keneng*-RMC. However, as I argue in this chapter, the driving force of A-movement to the matrix spec-TP in

---

<sup>42</sup> Importantly, as argued by Bošković 2010, in languages without TP, nominative Case can still be valued by a separate functional category. Given an analysis under which the grammatical presence of aspectual markers would not constitute evidence for the existence of TP in Chinese (cf. fn. 39), it is possible that the head of the Aspectual Phrase takes up T’s role to value the nominative Case on the subject NP in this language. By contrast, the deficient Aspectual Phrase selected by *hui* ‘will’ cannot value the unvalued Case feature on the subject NP, rendering further A-movement to the matrix clause obligatory.

*yinggai/keneng*-RMC is the presence of the unvalued interpretable Topic feature on NPs, along the lines of Miyagawa's (2010) proposal discussed above. This Topic feature on the moving argument is precisely the missing piece that Lin does not consider in his analysis. The reason why the subject *Akiu* remains active for further A-movement to the matrix clause in (97a) is that there is no valued Topic feature on T in the TP complement in *yinggai/keneng*-RMC to value the unvalued interpretable Topic feature on *Akiu*. There is no Topic feature on the T in the TP complement of *yinggai/keneng*-RMC since T can bear the Topic feature only via inheritance from C (*à la* Miyagawa 2010), but there is no CP layer in the clausal complement of *yinggai/keneng*-RMC.<sup>43</sup>

Next, we turn to the question of how the insertion of the focus marker *shi* affects A-movement in *hui*-RMC, as in (103). I argue that the Case-theoretic approach to A-movement in Chinese developed in this section provides a straightforward account of this long-standing puzzle first observed by L&T.

- (103) a. [<sub>TP</sub> Hui [<sub>TP</sub> shi Akiu zhunbei wancan]]  
           will    FOC Akiu   prepare dinner  
           ‘It is AKIU who will prepare the dinner.’  
       b. \*[<sub>TP</sub> Hui [<sub>TP</sub> Akiu zhunbei wancan]]

---

<sup>43</sup> Nunes' (2007, 2008) and Ferreira's (2004) work on hyperraising in Brazilian Portuguese (BP) is worth mentioning in this context. They note that BP allows A-movement out of the finite clausal complement of certain impersonal predicates such as *parece* 'seem', as in (i). At first glance, hyperraising in BP looks similar to A-movement out of the embedded complement in *yinggai/keneng*-RMC, since both involve raising out of a finite clause.

- (i) a. Parece que o João comprou um carro.  
           seems that the João bought a car  
       b. O João parece que comprou um carro  
           the João seems that bought a car  
           'It seems that João bought a car.'

Ferreira's (2004) and Nunes (2007, 2008) argue that hyperraising is allowed in BP because finite Ts in BP can be associated with either a complete or an incomplete set of  $\phi$ -features. When T is associated with an incomplete set of  $\phi$ -features, it is unable to value the Case feature on the subject NP, thereby rendering hyperraising of the subject NP to the matrix spec-TP in (ib) obligatory for Case valuation. In this sense, the hyperraising in BP is a lexical option (due to whether or not a  $\phi$ -incomplete finite T is chosen to form the Numeration) restricting syntactic optionality (whether or not hyperraising takes place). However, such an analysis cannot be extended to RMC, where there is no principled motivation for optional realization of a complete set of  $\phi$ -features. The application of A-movement out of the finite clausal complement in *yinggai/keneng*-RMC, as I argue in the next section, hinges upon the presence of a Topic feature on the moving argument.

will Akiu prepare dinner

Intended: 'It will be the case that Akiu prepares the dinner.'

The contrast in (103) constitutes a serious empirical challenge to Lin's EPP-based account of A-movement in Chinese. He has to postulate that the null expletive can only be associated with *yinggai/keneng*-RMC, but crucially, not *hui*-RMC, so that (103b) is predicted to be ungrammatical. However, the grammaticality of (103a) is entirely unexpected under this account. To maintain the explanatory force of the EPP-based account, one would have to postulate another arbitrary correlation between the availability of the null expletive and the presence of the focus marker *shi*.

My analysis of (103) is based on three key assumptions. The first one concerns the syntactic analysis of the focus marker *shi*. Huang (1990) argues convincingly that the focus marker *shi* should be analyzed as a one-place raising predicate taking an IP/TP as its sole argument. Importantly, he claims that this kind of *shi* can be analyzed either as an auxiliary occupying I/T or as a main predicate/verb, because of the subtle distinction between these two categories in Chinese. He maintains that the ellipsis facts in (104) and (105) favor the auxiliary analysis of *shi*.

- (104) a. Zhangsan hen xihuan Li xiaojie, wo ye hen xihuan Li xiaojie  
Zhangsan very like Li Miss I also very like Li miss  
'Zhangsan likes Miss Li very much, and I like her very much as well.'
- b. \*Zhangsan hen xihuan Li xiaojie, wo ye  
Intended: 'Zhangsan likes Miss Li very much. So do I.'
- c. Zhangsan hen xihuan Li xiaojie, wo ye **shi**
- (105) a. Zhangsan hui kai che, wo ye hui kai che  
Zhangsan be-able-to drive car I also be-able-to drive car  
'Zhangsan is able to drive a car, and I am able to drive a car as well.'
- b. Zhangsan hui kai che, wo ye **hui**

Zhangsan be-able-to drive car I also be-able-to  
'Zhangsan is able to drive a car. So am I.'

Specifically, he notes that the insertion of *shi* is obligatory in ellipsis contexts as in (104c), unless an auxiliary like *hui* 'be-able-to' is available in the antecedent clause as in (105b). He compares the obligatory insertion of *shi* in ellipsis contexts to *do*-support in English and concludes that the auxiliary analysis of *shi* fares better empirically. Nevertheless, as argued convincingly by L&T, deontic modal *hui* 'be-able-to' in (105) should be analyzed as the main predicate/verb, so the obligatory insertion of *shi* in ellipsis contexts does not provide conclusive argument for the auxiliary analysis of *shi*. Furthermore, taking an IP/TP complement as the sole argument is a canonical property of raising predicates/verbs, rather than of auxiliaries occupying I/T. Based on these considerations, I treat *shi* as a one-place raising predicate/verb, on a par with the raising modals *yinggai* and *keneng* under investigation.

Second, the TP complement of *shi* is just like that of *yinggai/keneng* – it is also finite, as evidenced by the presence of aspectual markers in (106). Therefore, *Akiu* is able to get Case valuation in this finite TP selected by *shi*. Accordingly, *Akiu* is not forced to undergo further A-movement to matrix spec-TP for Case valuation.

- (106) a. Shi [TP Akiu chi-le tofu ]  
FOC Akiu go-PERF tofu  
'It is AKIU that ate the tofu.'
- b. Shi [TP Akiu chi-guo tofu]  
FOC Akiu eat-EXP tofu  
'It is AKIU that has eaten tofu.'
- c. Shi [TP Akiu zai zhunbei wancan]  
FOC Akiu PROG prepare dinner  
'It is AKIU that is preparing dinner.'

Third, recall that Lin (2011) argues that the clausal complement of *hui*, unlike that of *yinggai*, *keneng*, and *shi*, is a non-finite TP where Case valuation for the subject NP is not

available. As mentioned above, this is precisely why Case-driven A-movement out of the TP complement of *hui*-RMC to a finite spec-TP is obligatory.

Given these assumptions, we are ready to account for why A-movement out of the TP complement of *hui* is no longer obligatory when *shi* is added as in (107a), whose relevant structure is given in (107b). Given that the TP complement of *shi* is finite, A-movement out of the TP complement selected by *hui* is no longer obligatory precisely because the clausal complement of *shi* is a finite TP where *Akiu* has its Case valued in the embedded spec-TP, rendering further Case-motivated A-movement unnecessary.

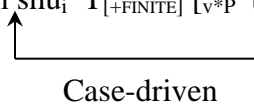
- (107) a. Hui **shi** zhe-ben shu jiang-jia. (Bu shi na-ben.)  
 will FOC this-CL book decrease-price (not FOC that-CL)  
 ‘It is THIS BOOK whose price is going to decrease. (Not that one.)’
- b. [<sub>VP</sub> Hui [<sub>TP</sub> T<sub>[-FINITE]</sub> [<sub>VP</sub> shi [<sub>TP</sub> zhe-ben shu<sub>i</sub> T<sub>[+FINITE]</sub> [<sub>V\*P</sub> t<sub>i</sub> jiang-jia]]]]]
- 

Huang (1990: 53) notes that further raising of the thematic subject to matrix spec-TP in a *hui-shi* construction is possible, as in (108). I maintain that (108) is derived in the same way as proposed for *yinggai/keneng*-RMC, based on Topic feature inheritance in the matrix clause and the unvalued interpretable Topic feature on the moving NP.<sup>44</sup>

- (108) Zhe-ben shu<sub>i</sub> hui-bu-hui shi t<sub>i</sub> mingtien cai jiang-jia?  
 this-CL book will-not-will FOC tomorrow until decrease-price  
 ‘Is it the case that it is not until TOMORROW that this book’s price is going to decrease?’

Summing up, Lin’s assumption that the EPP feature on T can be satisfied by a null expletive and is the sole driving force of Chinese A-movement is insufficient to explain

<sup>44</sup> The same analysis extends to A-movement to matrix spec-TP in *shi*-construction as in (i). Although Huang (1990: 50) notes the possibility of such cases, he does not provide the motivation for this step of movement.

(i) [<sub>CP</sub> [<sub>TP</sub> Akiu<sub>i</sub> shi [<sub>TP</sub> t<sub>i</sub> zai shuijiao]]] (bu shi zai nienshu)  
 Akiu FOC PROG sleep not FOC PROG study  
 ‘Akiu is SLEEPING (not studying).’

the obligatory subject A-movement in *hui*-RMC (and why this requirement does not hold when the focus marker *shi* is inserted). A Case-theoretic approach to the motivation of A-movement readily provides an explanation of why and when the subject raising in *hui*-RMC is obligatory. Moreover, the A-movement out of a finite TP complement of *yinggai/keneng*-RMC does not necessarily force the postulation of an EPP feature on the matrix T if the presence of an unvalued Topic feature is taken into account. The postulation of a null expletive can be abandoned as well, under the proposed system. Before I show the step-by-step derivation of topic A-movement in *yinggai/keneng*-RMC based on the unvalued interpretable Topic feature on the moving NP in section 2.6.5, I present a novel argument for Case-driven A-movement in the next section.

#### 2.6.4 A novel argument for Case-driven A-movement without $\phi$ -features on T

In the beginning of this chapter, I mentioned several proposals regarding the motivation of A-movement. There are at least four distinct driving forces identified by different researchers that are responsible for triggering A-movement to spec-TP: the unvalued  $\phi$ -features on T (e.g. Chomsky 2000, 2005, 2007, 2008; Kuroda 1988; Pesetsky and Torrego 2001; Miyagawa, 2005), the EPP feature on T (e.g. Chomsky 1995, 2000, 2001; Lasnik 1995, 1999, 2001; Nevins 2005), the unvalued Case feature on an NP (e.g. Epstein and Seely 1999, 2006; Alexiadou and Anagnostopoulou 1998; Bošković 2002, 2007; my analysis of A-movement in *hui*-RMC), and the Topic/Focus features inherited from C (Miyagawa 2010; my analysis of A-movement in *yinggai/keneng*-RMC). In this section, I present novel evidence from Sinhala, an Indo-Aryan SOV language spoken in Sri Lanka, to argue that the valuation of Case feature on an NP can be the sole driving force of A-movement in a language without  $\phi$ -features on T.

The existence of A-movement in languages without  $\phi$ -features on T (e.g., Chinese, Japanese, and Korean) poses a direct challenge on the universality of the  $\phi$ -based theory of A-movement. By analogy, Sinhala is a language without  $\phi$ -features on T, as evidenced by the grammatical occurrence of anaphors as embedded subjects in (109), so A-movement in Sinhala cannot be triggered by  $\phi$ -features on T.

- (109) a. *Siri hitənəwa* [**thaman** awankai kiyala]  
           *Siri think-PRES self honest that*  
           ‘Siri thinks that himself is honest.’
- b. *Mala kiwwa* [**thaman** parə dannəwa kiyəla]  
           *Mala say-PAST self way know that*  
           ‘Mala said that self knows the way.’

A clarification is in order before we proceed. Unlike Chinese (see Chapter 3), Sinhala does not have the bare-compound distinction of the morphological form of reflexives. It only has the bare reflexive *thaman* ‘self’. Accordingly, one may wonder whether *thaman*, as an embedded subject, is used as a logophor whose distribution has nothing to do with the presence or absence of  $\phi$ -features on T, and hence sentences in (109) do not constitute an argument for the lack of  $\phi$ -features on T in Sinhala. Note that Huang and Liu (2001) argue convincingly that the bare reflexive *ziji* in Chinese can be used either as a logophor or an anaphor. Importantly, when occurring as an embedded subject, *ziji* is not subject to various logophoric conditions (e.g. under a *de se* scenario). This observation carries over to the bare reflexive *thaman* ‘self’ in Sinhala. The sentences in (109) can be uttered under a non-*de se* scenario in which the coreference between *thaman* and *Siri/Mala* is reported purely as speaker’s knowledge from the speaker’s own perspective. This indicates that *thaman* in (109) can be an anaphor, rather than a logophor, and thus its grammatical occurrence as an embedded subject constitutes an argument against the presence of  $\phi$ -features on T in Sinhala.

The next question is whether the  $\phi$ -less T in Sinhala is endowed with a universal EPP property that drives obligatory A-movement to spec-TP. There is empirical evidence against this line of analysis. Chou and Hettiarachchi (2013), investigating the correlation between Case marking on the subject NP and the volitivity of the predicates in Sinhala, argue that the Case-based approach fares better empirically than the EPP-based approach to A-movement in Sinhala. A general assumption holds in recent (though scarce) Sinhala syntactic literature that a volitive verb denoting a volitional action assigns nominative Case (which is morphologically null) to the subject, as in (110a), while the morphologically marked involitive verb denoting an involuntary action assigns non-

nominative Case to the subject, most commonly dative Case as in (110b) (cf. Inman 1993; Janny 2006).

- (110) a. Lal            nātuwe.  
           Lal (NOM) danced (VOL)  
           ‘Lal (actively/voluntarily) danced.’            [Volitive verb → nominative]
- b. Laltə            nətune.  
           Lal (DAT) danced (INVOL)  
           ‘Lal (involuntarily) danced.’            [Involitive verb → dative]

The volitivity-based approach to Case marking in Sinhala assumes that both nominative Case and dative Case are inherent Cases assigned by volitive predicates and involitive predicates, respectively, to the subject NP at spec-v\*P. However, this approach makes a wrong prediction regarding the scopal interaction between a universal quantifier subject and negation. In particular, sentences with volitive verbs like (111) exhibit ambiguity between partial negation and total negation. By contrast, when we replace the volitive verb with an involitive counterpart as in (112), only partial negation interpretation is available.

- (111) Lamai hæmomə    nātuwe            nəhə  
       children all (NOM) danced (VOL) not  
       ‘All children did not (voluntarily) dance.’    [Total negation]  
       ‘Not all children (voluntarily) danced.’      [Partial negation]
- (112) Lamai hæmotəmə    nətune            nəhə  
       children all (DAT) danced (INVOL) not  
       #‘All children did not (voluntarily) dance.’ [Total negation]  
       ‘Not all children (involuntarily) danced.’    [Partial negation]

The effect of (in)volitivity on the scopal interpretation of the universal quantifier subject is not easily explained by the volitivity-based analyses of Sinhala Case marking because



volitive verbs are treated on a par with involitive verbs with respect to their ability to assign inherent Case under this analysis. Given that both nominative Case and dative Case are inherent Cases assigned entirely based on the volitivity of the predicates, this analysis predicts that (111) and (112) should have the same range of scopal interpretation of the subject quantifier. Specifically, suppose we assume that T in Sinhala is endowed with a universal EPP property that induces obligatory A-movement to spec-TP and follow Nevins (2005) to abandon the Activity Condition, the universal quantifier subject NPs in (111) and (112) should both raise to spec-TP, even though they have already been assigned an inherent Case by the (in)volitive predicates, as in (113).

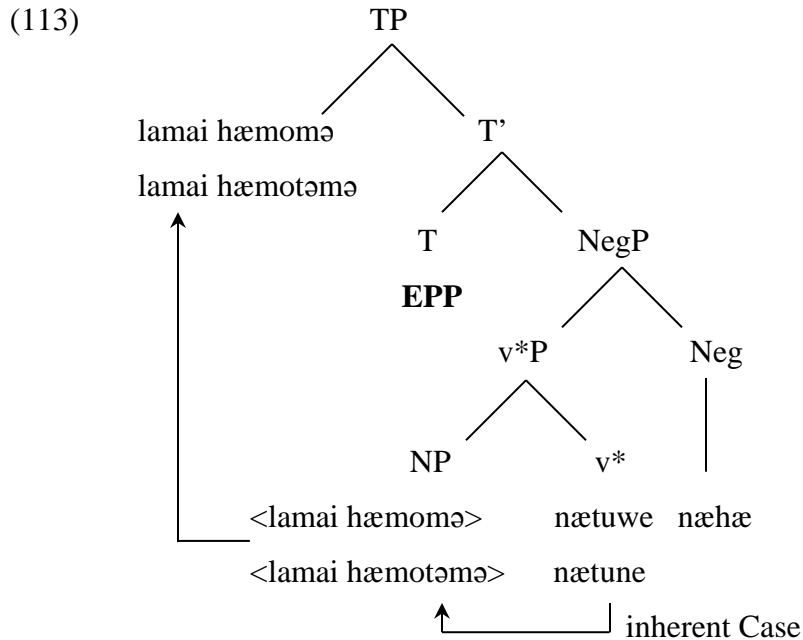

Consequently, the negation *nəhæ* c-commands the lower copy of the universal quantifier subject at spec-v\*P and is also c-commanded by the copy at spec-TP. Therefore, the standard assumption in (114) predicts that (111) and (112) should both have total and partial negation interpretations as the English sentence in (115) does, contrary to fact.

(114) For negation to take scope over  $\alpha$ , negation c-commands  $\alpha$ . (Klima 1964)

(115) Every student did not pass the exam.

The contrast between (111) and (112) suggests that the dative-marked subject quantifier *lamai hæmotəmæ* ‘all children’ stays below the negation *næhæ* ‘not’ so that only partial negation reading is available. By contrast, the nominative-marked counterpart can occupy a syntactic position c-commanding the negation to receive the total negation reading.

Note that the EPP analysis, coupled with the volitivity-based account of Case marking in Sinhala, fails to capture the asymmetry between volitive and involitive verbs in (111) and (112) even if we adopt the Activity Condition. This is because the universal quantifier subject NPs in (113) are rendered inactive by the inherent Case from the (in)volitive predicates according to the Activity Condition, and hence should stay in situ at spec-v\*P, yielding only partial negation for both (111) and (112), a wrong prediction.

A clarification is in order before we can conclude that the EPP-based approach to A-movement, coupled with the volitivity-based account of Case marking in Sinhala, fails to explain the asymmetry between (111) and (112). One possible way to maintain the EPP-based approach is to assume that Quantifier Raising (QR, see May 1985) applies at LF in Sinhala and that the application of QR in Sinhala is subject to a morphosyntactic constraint such that the presence of the dative Case restrains QR. This way, the nominative-marked quantifier subject overtly staying at spec-v\*P (assuming the Activity Condition), below negation, can outscope negation at LF via QR, whereas the dative-marked counterpart does not have QR at its disposal to yield a wide scope total negation interpretation. Even though this line of analysis would capture the contrast between (111) and (112), it relies on an incorrect assumption, the existence of QR in Sinhala. Crucially, unlike the English counterparts, the Sinhala sentences in (116) are not ambiguous: they only have the surface scope interpretation, and the inverse scope reading (available in English due to the QR of the object NP over the subject NP at LF) is not available. The lack of ambiguity in (116) provides a strong argument against the presence of QR in Sinhala, and so the above-mentioned alternative analysis assuming the EPP-based approach to A-movement in Sinhala is not viable.

- (116) a. [Kauruhari laməyek] [həmə guruwarəyatəmə] kaməti.  
 some student every teacher like  
 ‘Some student likes every professor.’ [some>every; \*every>some]
- b. [Kauruhari əmətiwarəyek] [həmə madyawediyamə] hamu-una.  
 some minister every journalist meet-PAST  
 ‘Some minister met every journalist.’ [some>every; \*every>some]

Chou and Hettiarachchi (2013) conclude that neither the EPP-based approach to A-movement (no matter whether the Activity Condition is assumed or not) nor the previous volitivity-based account of Case marking in Sinhala is on the right track. We propose that (i) only the involitive predicates in Sinhala assign inherent Case, whereas volitive predicates are not lexically related to Case marking to an external argument in any way, (ii) nominative Case is a structural Case in Sinhala valued by a finite T (just like the nominative Case in languages like English), and (iii) A-movement in Sinhala is triggered by Case valuation. These assumptions work in tandem with the Activity Condition to derive the asymmetry between (111) and (112) as in (117).

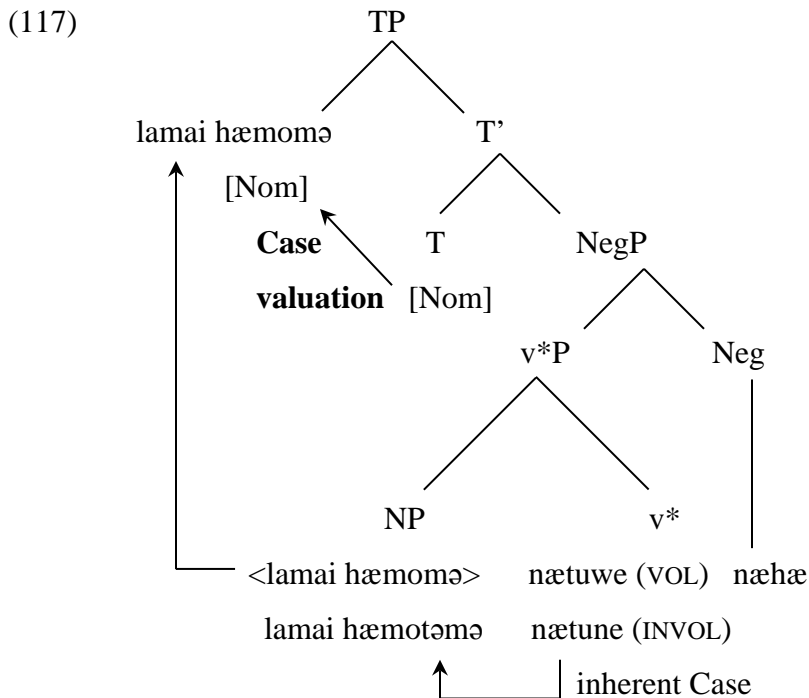

The universal quantifier subject of a volitive predicate can scope either above or below the negation because it cannot get inherent Case from the volitive predicate, and as a result has to undergo A-movement to spec-TP to get its Case feature valued as nominative by the finite T. Therefore, sentences like (111) are just like the English sentence (115) in that the scopal ambiguity results from the two interpretation positions of the subject universal quantifier: the base-generated position spec-v\*P below the negation and the derived position spec-TP above the negation. On the other hand, the universal quantifier subject of an involitive predicate has no motivation to move to spec-TP because it becomes inactive by being assigned the inherent Case from the involitive predicate.

There is empirical support for the proposed difference between volitive and involitive predicates in Sinhala with respect to their ability to assign inherent Case. Consider the following previously unnoted contrast between volitive and involitive predicates in the ECM contexts:

(118) Mamə [eya natənəwa] dannəwa.  
 I he (ACC) dance<sub>infinitival</sub> (VOL) know  
 ‘I know him to be voluntarily dancing.’

(119) \*Mamə [eya nætenəwa] dannəwa.  
 I he (ACC) dance<sub>infinitival</sub> (INVOL) know  
 Intended: ‘I know him to be involuntarily dancing.’

Curiously, only the subject of a volitive predicate can take the accusative Case from the ECM verb *dannəwa* ‘know’ as in (118), while the subject of an involitive predicate can only take the dative Case, as shown by the contrast between (119) and (120):

(120) Mamə [eyatə nætenəwa] dannəwa.  
 I he (DAT) dance<sub>infinitival</sub> (INVOL) know  
 ‘I know him to be involuntarily dancing.’

This contrast runs afoul of the prediction of the volitivity-based analysis of Sinhala case marking. Specifically, if both nominative Case and dative Case are inherent Cases assigned by the (in)volitive predicates, none of the subject NPs in (118) and (119) should be able to get the accusative Case in the ECM contexts. This is because the assignment of inherent Case renders further structural Case valuation unnecessary and hence inapplicable. The fact that this prediction does not hold casts further doubt on the uniform treatment of the assignment of nominative Case and dative Case in Sinhala.

By contrast, our analysis provides a straightforward account for this contrast. Given that volitive predicates in Sinhala do not assign inherent Case to its subject and only a finite T is able to value the structural nominative Case, the subject NP of a volitive predicate cannot get a Case, structural or inherent, within the embedded infinitival complement clause of an ECM verb, and hence has to move to the matrix vP domain to receive the accusative Case from the ECM verb *dannəwa* ‘know’, as in (121).

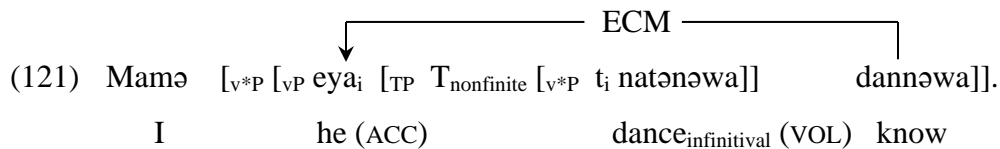

On the other hand, (122) shows that an involitive predicate in Sinhala assigns an inherent Case to its subject, regardless of the finiteness of the T upstairs; therefore, the accusative Case from the ECM verb cannot override the inherent Case on the subject NP of an involitive predicate, and hence the contrast between (119) and (120).

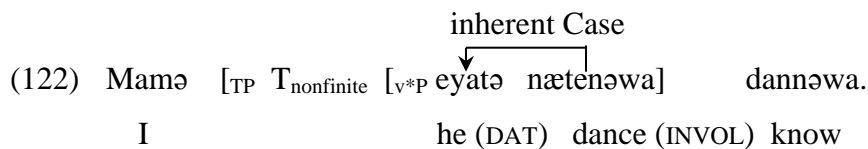

Summing up, if our novel analysis of Case marking in Sinhala is on track, the scope contrast between (111) and (112) provides a strong argument against the EPP-based approach to A-movement in a language without  $\phi$ -features on T. Instead, Case valuation is the driving force of obligatory A-movement in languages like Chinese and Sinhala.



Note that this approach dissociates Case valuation from the presence of  $\varphi$ -features. The obligatory A-movement induced by Case-valuation in Sinhala lends further support for both Bošković's (to appear) analysis of Case valuation and Bošković (2007) moving-element-driven approach to movement.

Sinhala provides another interesting argument against Chomsky's (2000, 2008) association of  $\varphi$ -features with Case valuation. Recall that the anaphor *thaman* 'self' in Sinhala is allowed to occur as an embedded subject (=109), arguing against the presence of  $\varphi$ -features on T in Sinhala. Interestingly, *thaman*, as the embedded subject, can carry either the structural nominative Case or the inherent dative Case, depending on the volitivity of its predicate, as shown by (124) and (125), respectively. The fact that *thaman* can carry inherent Dative Case as in (125) suggests that *thaman* is able to carry Case markers. Therefore, even though Nominative Case is not morphologically realized in Sinhala, we can assume that in (124), *thaman* carries Nominative Case valued by the embedded finite T, lending further support for the dissociation of Case valuation and  $\varphi$ -features.<sup>45</sup>

(124) Mala kiwwa [**thaman** parə dannəwa kiyəla]  
 Mala say-PAST self (NOM) way know (VOL) that  
 'Mala said that herself knows the way.'

(125) Mala kiwwa [**thamantə** nətenəwa kiyəla]  
 Mala say-PAST self (DAT) dance (INVOL) that  
 'Mala said that herself (involuntarily) dances.'

Summing up, this section presents novel arguments that Case valuation needs not be tied with the presence of  $\varphi$ -features and A-movement can be motivated by the moving NP's need to seek valuation of its unvalued Case feature. In the next section, with this conclusion in mind, I continue my discussion of the derivation of topic A-movement in RMC.

---

<sup>45</sup> See also Saito's (2012) argument based on the Case markers on subject prepositional phrases in Japanese that Case valuation in Japanese is independent of  $\varphi$ -features agreement.

### 2.6.5 The derivation of topic A-movement in RMC

To derive topic A-movement in RMC under Pesetsky and Torrego's (2007) system dissociating feature interpretability and valuation, I adopt Bošković's (2007) moving-element-driven approach to movement. Following Epstein and Seely 1999 and 2006, Bošković (2007:619) assumes that a probe must contain an unvalued feature, and an unvalued feature must function as a probe. Additionally, a probe must c-command its goal. On these assumptions, an element containing an unvalued feature (whether interpretable or not) functions as a probe and has the motivation to move – to move to a position to c-command a goal that contains a corresponding valued feature (whether interpretable or not). In other words, the driving force of movement now can reside on the moving element itself, rather than on the head whose specifier position represents the final landing site of (successive-cyclic) movement. Under this approach, an NP carrying an unvalued (Case or Topic) feature must raise to spec-TP to enter into an Agree relation as a probe with T, which in this case functions as a goal. First, in the case of Chinese, (126) shows that the subject NP bears the interpretable yet unvalued Topic feature, whose convergent CI interpretation depends on its valuation by a valued counterpart. Besides, it also bears the uninterpretable unvalued Case feature.<sup>46</sup>

(126) [<sub>v</sub>\*P SUBJECT<sub>[i</sub>Topic[ ], uCase] [<sub>v</sub>P VERB OBJECT]] (VP phase now transferred<sup>47</sup>)

Next, the TP c-selected by raising modals is built, as in (127). One crucial point at this stage of the derivation is that the TP c-selected by raising modals like *yinggai* 'should' and *keneng* 'likely' in Chinese is finite, as noted by Lin 2011 (see (98)). The Case feature on the subject NP can be valued by this finite T. Therefore, in (128), following Bošković 2007, the subject bearing an unvalued Case feature, functioning as a probe, must move to a spec-TP to c-command the goal T<sub>FINITE</sub> for successful valuation of its Case feature.

(127) [<sub>TP</sub> T<sub>FINITE</sub> [<sub>v</sub>\*P SUBJECT<sub>[i</sub>Topic[ ], uCase] [<sub>v</sub>P VERB OBJECT]]]

<sup>46</sup> The valuation of the Case feature on the object NP is omitted in this section since it is not relevant.

<sup>47</sup> Chomsky's (2000) PIC is adopted here since there is no reason for delaying Transfer in the proposed system. See Epstein, Kitahara and Seely (2012) for an interesting alternative analysis of T-object agreement in Icelandic without appealing to the delayed PIC in Chomsky (2001).



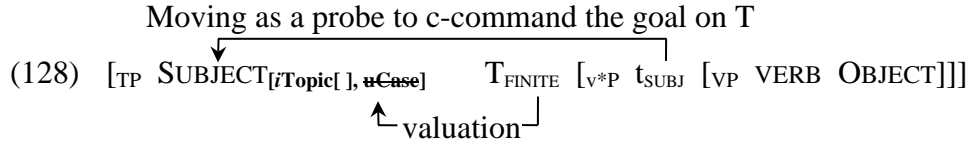

Next, in (129a), the raising modal, matrix T and C enter the derivation, and C passes down the uninterpretable valued Topic feature to T (i.e. feature inheritance, as assumed by Miyagawa 2010). Finally, the unvalued interpretable Topic feature on the subject is functioning as a probe and moving to matrix spec-TP in order to c-command the goal (= the valued uninterpretable Topic feature) on the matrix T in (129b), again following Bošković 2007 regarding the requirement for c-command by the probe.<sup>48</sup> This produces the subject raising cases of RMC, as in (129c).

- (129) a. [CP C [TP T<sub>uTopic[+]</sub> [VP MODAL [TP SUBJ<sub>[iTopic[ ], uCase]</sub> T<sub>FINITE</sub> [v\*P .....]]]]]
- b. [CP C [TP SUBJ<sub>[iTopic[+], uCase]</sub> T<sub>uTopic[+]</sub> [VP MODAL [TP t<sub>SUBJ</sub> T<sub>FINITE</sub> [v\*P .....]]]]]
- c. [CP [TP Akiu keneng [TP zhunbei wancan]]]
- Akiu likely prepare dinner
- ‘Akiu is likely to prepare the dinner.’

Now, I turn to the derivation of object topic A-movement in RMC. Recall that the central question raised by object A-movement in RMC is how it is possible, given AC, since the subject NP, which we know can raise, intervenes. First, in line with Bošković’s (2007) moving-element-driven system, the unvalued interpretable Topic feature on the object provides a computationally local and active cue for its movement to the phase edge in (130), avoiding spell-out.<sup>49</sup> Crucially, there is neither a probe nor an EPP feature on the phase head v\* involved in this step of the derivation because the driving force of the movement is on the moving element itself. Therefore, the look-ahead problem does not arise under this system.

<sup>48</sup> The subject NP might move successive-cyclically via the intermediate landing site at the edge of a VP headed by the raising modal if one treats unaccusative VPs as phases as well (see Legate 2003 and Sauerland 2003).

<sup>49</sup> I omit the representation of object movement to spec-VP for Case valuation because it is not relevant for current purposes.

(130) [<sub>v\*P</sub> **OBJECT**<sub>i,Topic[]</sub> SUBJECT<sub>[uCase]</sub> [<sub>VP</sub> VERB t<sub>OBJ</sub> ] ] (VP now Transferred)

Then, the embedded finite T of RMC enters the derivation in (131). The subject bearing an unvalued Case feature moves to spec-TP, the same step as in the derivation in (128) above.

(131) [<sub>TP</sub> **SUBJECT**<sub>[uCase]</sub> T<sub>FINITE</sub> [<sub>v\*P</sub> **OBJECT**<sub>i,Topic[]</sub> t<sub>SUBJ</sub> [<sub>VP – TRANSFERRED –</sub>]]]

Next, the raising modal, the matrix C and T enter the derivation in (132a), and the Topic feature inheritance from C to T takes place. Finally, in (132b), the unvalued interpretable Topic feature on the object triggers its movement to matrix spec-TP so that this unvalued interpretable Topic feature on the object (i.e. the probe) can c-command the valued uninterpretable Topic feature on the matrix T as its goal. This produces an instance of object topic A-movement in RMC like (132c).

(132) a. [<sub>CP</sub> C [<sub>TP</sub> **T**<sub>uTopic[+]</sub> [<sub>VP</sub> MODAL [<sub>TP</sub> **SUBJ**<sub>[uCase]</sub> T<sub>FINITE</sub> [<sub>v\*P</sub> **OBJ**<sub>i,Topic[]</sub> [<sub>VP.....</sub>]]]]]]]  
 b. [<sub>CP</sub> C [<sub>TP</sub> **OBJ**<sub>i,Topic[+]</sub> **T**<sub>uTopic[+]</sub> [<sub>VP</sub> MODAL [<sub>TP</sub> **SUBJ**<sub>[uCase]</sub> T<sub>FINITE</sub> [<sub>v\*P</sub> t<sub>OBJ</sub> .....]]]]]]]  
 c. [<sub>CP</sub> [<sub>TP</sub> Wancan keneng [<sub>TP</sub> Akiu zhunbei]]]  
     dinner    may        Akiu prepare  
     ‘The dinner is likely to be prepared by Akiu.’

Recall that the object A-movement in RMC is predicted to violate Attract Closest. But under the proposed system combining the dissociation of feature interpretability and valuation and a moving-element-driven approach to syntactic movement, the AC problem does not arise. This is because the motivation for the A-movement to the matrix spec-TP in RMC is the presence of an unvalued interpretable Topic feature on either the subject NP or the object NP. Thus, in (132b), the object A-movement does not violate AC precisely because only the object bears the unvalued interpretable Topic feature in this derivation, and the subject is rendered inactive for further A-movement for two reasons. First, its unvalued Case feature has already been valued by the finite T in the embedded

TP of RMC. Second, it does not contain the unvalued interpretable Topic feature that could keep it active in spite of the valuation of its unvalued Case feature.

The proposed analysis also explains why object A-movement is not allowed in Chinese mono-clausal structures, as shown by the contrast in (133):

- (133) a. Akiu<sub>i</sub> jinchang t<sub>i</sub> zhunbei wancan  
           Akiu often prepare dinner  
           ‘Akiu often prepares the dinner.’  
       b. \*Wancan<sub>i</sub> jinchang Akiu zhunbei t<sub>i</sub>

I argue that the reason for this restriction in mono-clausal structures is due to the unvalued Case feature on the subject NP. Let’s examine the step-by-step derivation of (133b). First, in (134), the object bearing an unvalued interpretable Topic feature moves to the edge of v\*P.

- (134) [<sub>v\*P</sub> jinchang wancan<sub>i,Topic[ ]</sub> Akiu<sub>[uCase]</sub> [<sub>VP</sub> zhunbei t<sub>i</sub>]]  
           often dinner Akiu prepare (VP now Transferred)

Then C and the finite T enter the derivation and T inherits the valued uninterpretable Topic feature from C in (135). The object bearing an unvalued interpretable Topic feature at the v\*P edge moves to spec-TP to c-command, i.e. to probe, T as its goal for Topic feature valuation. The resulting structure is ungrammatical since the unvalued Case feature on the subject NP is left unvalued, leading to CI crash. However, this is not a problem for the subject NP left in the embedded TP of RMC in (132), precisely because its unvalued Case feature is valued by the embedded finite T.

- (135) \*<sub>[CP</sub> C <sub>[TP</sub> wancan<sub>i,Topic[+]</sub> T<sub>u/Topic[+]</sub> [<sub>v\*P</sub> jinchang t<sub>i</sub> **Akiu**<sub>[uCase]</sub> [<sub>VP</sub> .....]]]]

Importantly, the distribution of topic A-movement in Chinese exemplifies the application of Topic feature inheritance in conformity with the economy considerations in (3), repeated here as (136).

(136) Feature inheritance takes place to yield a more economical derivation with a shorter derivational path, and its application cannot run afoul of other independent principles in the grammar.

Let's illustrate this idea with subject topic A-movement in RMC. Topic features are assigned to C and the subject upon the formation of the Numeration for RMC, and if the Topic feature stays on C, the subject bearing the unvalued interpretable Topic feature will undergo movement to merge with C for feature valuation, as in (137a). If, by contrast, feature inheritance applies as in (137b), the subject would target T for feature valuation, yielding a movement with a shorter movement path, a more economical derivation (compared with that in (137a)).

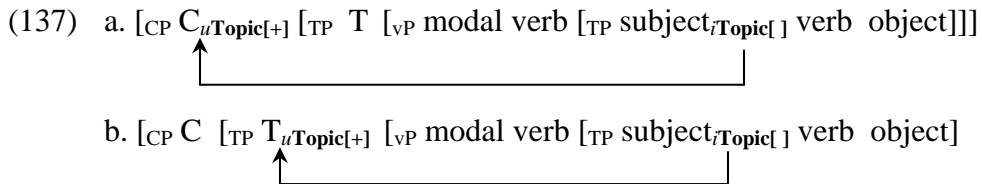

Crucially, even though the inheritance of the Topic feature could lead to a more economical derivation with a shorter movement path, its application is subject to independent principles like the requirement for Case valuation in a language. This is precisely why object topic A-movement is prohibited in mono-clausal structures in Chinese, as discussed above.<sup>50</sup>

In this connection, Finnish, as a discourse-configurational language, allows for object A-movement in mono-clausal structures, as shown by (138b).

<sup>50</sup> The approach to economy proposed here takes into account the length of movement paths, which can be computed in terms of number of nodes crossed by each movement operation. In addition, notice that different from the derivation in (137b), the one in (137a) does not have the added application of feature inheritance. This suggests that feature inheritance does not cancel out the economy yielded by the shorter derivation in (137b), and that shorter length of movement paths weighs more than less number of movement steps in a derivation with respect to the comparison of economy between competing derivations.

- (138) a. **Graham Greene** on kirjoittanut tämän kirjan.  
           Graham Greene has written this book
- b. **Tämän kirjan** on kirjoittanut Graham Greene.  
           this book has written Graham Greene

Holmberg and Nikanne (2002) show that Finnish is a topic-prominent language in the sense that any category that can serve as the topic of the sentence can surface as the external argument. They note that both (138a) and (138b) are grammatical active sentences with *Graham Greene* as the thematic subject of the predicate *on kirjoittanut* ‘has written’ in Finnish, but the topics differ in these two sentences – *Graham Greene* is the topic in the former, while *tämän kirjan* ‘this book’ is the topic in the latter. Holmberg and Nikanne (2002) notice that (138b) in Finnish can be used whenever the book is the topic, with specific reference that has been previously introduced in the discourse, while the identity of the author, *Graham Greene*, carries new information.

This property of Finnish leads Miyagawa (2010) to propose that A-chains in discourse-configurational languages such as Finnish are created on the basis of the inheritance of the Topic feature, so that either the subject or the object can undergo A-movement as long as the fronted element bears the topic reading. However, given my analysis of the ungrammaticality of the Chinese counterpart in (133b), a question arises as to why the Case feature on the in situ subject NP *Graham Greene* can be valued without movement. Notice that Chomsky’s (2000, 2008) Agree-based approach to Case valuation readily accounts for the valuation of the Case feature on the in situ subject NP in (133b). As noted by Holmberg and Nikanne (2002) and Miyagawa (2010), agreement always goes with the subject NP in Finnish even if the subject NP stays in in situ while other category bearing the Topic feature moves to the front of the sentence. Therefore, the fact that the in situ subject can get nominative Case and always controls agreement in Finnish lends a strong support for Chomsky’s (2000, 2008) association of Case valuation with  $\phi$ -feature Agree.

Now the question boils down to why Agree does not suffice for Case valuation in Chinese and Sinhala. I suggest that the reason why movement is not needed for Case valuation in languages like Finnish is that the  $\phi$ -Agree relation established between T and

the subject NP conforms to Chomsky's (2001) Maximize Matching Effects (MME) in (139) (see also Pesetsky's (1989) Earliness Principle and Poole's (1996) Total Checking Principle).

(139) Maximize Matching Effects (MME)

If local (P, G) [= probe and goal relations, CTC] match and are active, their uninterpretable features must be eliminated at once, as fully as possible; partial elimination of features under Match, followed by elimination of the residue under [another application of, CTC] Match, is not an option.

In languages with  $\phi$ -features on T, MME requires that both unvalued  $\phi$ -features on T and the unvalued Case feature on NP be valued once T establishes a probe-goal relation with the subject NP, thereby eliminating the motivation for the latter to undergo further Case-driven movement to c-command T.<sup>51</sup>

(140) Agree suffices:

T[ $\mu\phi$ , NOM] ... NP[ $\phi$ ,  $u$ Case]

By contrast, in languages like Chinese and Sinhala, T does not have  $\phi$ -features, so at the derivational stage in (141a), T cannot establish a probe-goal relation with the NP it c-commands because T, lacking an unvalued feature, does not qualify as a probe by definition. Therefore, the unvalued Case feature on the NP cannot get valued at this stage of derivation (because there exists no probe-goal relations at this stage in the first place). Next, following Epstein and Seely (1999, 2006) and Bošković (2007), the unvalued Case feature on the NP is a probe that needs to c-command a goal bearing a valued Case feature, so the NP moves to spec-TP to c-command T in (141b) for the valuation of its Case feature.

---

<sup>51</sup> Therefore, Bošković's (2002, 2007) movement approach to Case valuation cannot be regarded as a universal principle. Case valuation requires movement of the subject NP only in languages without  $\phi$ -features on T.

(141) Movement needed:

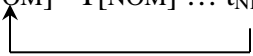
- a. T[NOM] ... NP[ $\phi$ ,  $u$ Case] [no (P, G) established at this stage ]  
 b. NP[ $\phi$ , NOM] T[NOM] ... t<sub>NP</sub> [Movement for Case valuation]
- 

My hypothesis amounts to attributing the cross-linguistic movement vs. Agree contrast with respect to how Case valuation can be accomplished to the existence of unvalued  $\phi$ -features on T in a language. Examining the cross-linguistic empirical scope of this hypothesis is beyond the scope of this dissertation, so I leave it for my future research.

Before ending this section, I turn to the issue of optionality of A-movement out of the finite TP complement in *yinggai/keneng*-RMC, as shown in (97) (repeated here as (142)).

- (142) a. [<sub>TP</sub> Akiu<sub>i</sub> yinggai/keneng [<sub>TP</sub> t<sub>i</sub> zhunbei wancan]]  
 Akiu should/likely prepare dinner  
 ‘Akiu should/is likely to prepare the dinner.’  
 b. [<sub>TP</sub> Yinggai/keneng [<sub>TP</sub> Akiu zhunbei wancan]]  
 should/likely Akiu prepare dinner  
 ‘It should/is likely to be the case that Akiu prepares the dinner.’

Recall that, since Lin (2011) argues that the driving force of Chinese A-movement is an EPP feature on T, he has to assume a null expletive satisfies the EPP in cases like (97b). We have seen the difficulty of this hypothesis when we take *hui*-RMC into consideration (cf. (103)). I argue that the apparent optionality of A-movement out of the finite TP in *yinggai/keneng*-RMC is rooted in the optional assignment of the unvalued interpretable Topic feature, which, unlike  $\phi$ -features and Case features, is not an inherent lexical property of NPs, and whose assignment is determined upon the formation of the Numeration for a syntactic derivation. Therefore, the subject/object arguments, if entering the derivation of *yinggai/keneng*-RMC without being assigned an unvalued interpretable Topic feature, would have no motivation to move to the matrix spec-TP of *yinggai/keneng*-RMC, giving the impression of optionality, because their unvalued Case feature is valued within the finite TP complement of *yinggai/keneng*-RMC.

## 2.7 Summary and Concluding Remarks

This chapter has investigated the empirical coverage of Miyagawa's (2010) probe-driven system of movement based on Topic feature inheritance. The examination of the derivation of object topic A-movement in *yinggai/keneng*-Raising Modal Constructions (RMC) reveals that the object needs to move before the probe (i.e. the Topic feature on C/inherited by T) enters the derivation. However, the implementation of this step depending on the assignment of an EPP feature to phase heads entails look-ahead computation. In addition, the characterization of the Topic feature is not precise under Chomsky's (2001) biconditional approach to feature valuation and interpretability. I argue that the Topic feature on the moving NP is an unvalued interpretable feature under the featural system of Pesetsky and Torrego's (2007), Carstens' (2010, 2011), and Bošković's (to appear). This is because the Topic feature on the NP is potentially interpretable, but its interpretation critically depends on valuation by another category in the derivation. The Topic feature inherited by T assumed by Miyagawa (2010), on the other hand, is valued yet uninterpretable because a position is not what is interpreted as the topic of the sentence, yet a consistent topic reading is assigned to the argument raising to the matrix spec-TP of *yinggai/keneng*-RMC. This analysis of the Topic feature is possible only if we abandon Chomsky's (2001) lexical association of feature interpretability and valuation, in line with proposals by Pesetsky and Torrego (2007), Carstens (2010, 2011), and Bošković (to appear). This fine-grained featural characterization of Topic feature is combined with Bošković's (2007) moving-element-driven approach to derive Topic A-movement in *yinggai/keneng*-RMC in Mandarin Chinese.

I have also arrived at a conclusion different from Lin (2011) regarding the driving force of A-movement in Chinese based on the properties of A-movement in both *yinggai/keneng*-RMC and *hui*-RMC. I argue that an EPP-based account of A-movement does not provide a satisfying analysis of A-movement in RMCs because it leaves unexplained why having a null expletive to satisfy the EPP on T is not available for *hui*-RMC. I further argue that the optionality of A-movement in *yinggai/keneng*-RMC and the obligatory A-movement in *hui*-RMC can be explained if we assume that there are two



distinct driving forces for Chinese A-movement – the unvalued uninterpretable Case feature on NPs and the unvalued interpretable Topic feature. The former is an inherent lexical feature of a NP and induces obligatory subject raising in *hui*-RMC because an unvalued Case feature would cause CI crash. By contrast, the assignment of the unvalued interpretable Topic feature to NPs is an optional morphological operation, determined by the time the Numeration is formed for a derivation. Therefore, the optionality of argument raising out of the finite TP of *yinggai/keneng*-RMC is only apparent. As long as the unvalued interpretable Topic feature is assigned to either the subject or the object NP,<sup>52</sup> topic A-movement must take place. In other words, it is a morphological featural option that restricts syntactic optionality.

I would like to end this chapter with a brief discussion of Neeleman and van de Koot's (2008) mapping approach to topic movement. This chapter adopts a feature-driven approach to topic A-movement in RMC. By contrast, Neeleman and van de Koot (2008) propose a mapping approach that says that topic movement is an interface-induced movement whose motivation is to facilitate the mapping associating syntactic representations with representations in information structure. What licenses such movements is that they yield syntactic configurations matching the required input form of a mapping rule of information structure, a discourse template, that otherwise would not be able to apply. In other words, this approach maintains that neither probe-goal relation nor feature valuation is involved in the derivation of topic movement. Horvath (2010) notes that an interface-induced movement has two distinguishing properties. First, it is an optional operation; second, it can have multiple landing sites. I contend that this line of analysis cannot be extended to argument fronting in RMC in Chinese because neither of the two above-mentioned properties holds for the derivation of topic A-movement under investigation. First, the raising of the object NP to the v\*P phase edge as an intermediate step to derive topic A-movement in RMC as in (94) is obligatory to avoid early spell-out and derivational crash. More importantly, the subject and the object in an RMC can obtain a topic interpretation only if they undergo A-movement to matrix spec-TP. Therefore, the movement to matrix spec-TP in RMC is obligatory for either the subject or

---

<sup>52</sup> It is also possible that both the subject and the object are assigned a Topic feature. However, a Numeration based on such assignment of the Topic feature could generate a grammatical sentence only if the subject and the object target different syntactic positions as in (47) and (48), but not when they compete for the same position in the left periphery, as illustrated by (46d) and (46e).

the object to acquire the topic reading, as shown by the exchanges in (143) and (144), respectively:

(143) Q: Gaosu wo yixie Akiu de shi

Tell me some Akiu MOD matter

‘Tell me something about Akiu.’

A1: **Akiu** keneng/yinggai mei kan-guo zhe-ben shu

Akiu may/should not read- EXP this-CL book

‘It may/should be the case that Akiu has not read this book before.’

A2: #Keneng/yinggai **Akiu** mei kan-guo zhe-ben shu

may/should Akiu not read- EXP this-CL book

(144) Q: Gaosu wo yixie zhe-bu dianying de shi

Tell me some this-CL movie MOD matter

‘Tell me something about this movie.’

A1: **Zhe-bu dianying** keneng/yinggai lien Akiu ye mei kan-guo

this-CL movie may/should even Akiu also not watch-EXP

‘It may/should be the case that even Akiu has not watched this movie before.’

A2: #Keneng/yinggai lien Akiu ye mai kan-guo **zhe-bu dianying**

may/should even Akiu also not watch-EXP this-CL movie

The questions in (143) and (144) set up a context in which *Akiu* and *zhe-bu dianying* ‘this movie’ are the discourse topic, and as the discourse topic, *Akiu* and *zhe-bu dianying* ‘this movie’ must be fronted to matrix spec-TP in RMC in the responses in (143-A1) and (144-A2). Leaving them in the embedded clause in (143-A2) and (144-A2) causes them to lose the topic interpretation, which creates an incoherent discourse. Therefore, as far as the acquisition of the topic reading is concerned, topic A-movement to matrix spec-TP in RMC is not an optional operation. Last, topic A-movement in RMC does not have multiple landing sites, as evidenced by (145b) and (145c). This strongly suggests that feature valuation of the Topic feature is involved in the derivation of topic A-movement in RMC. The presence of a valued Topic feature on matrix T inherited from C provides a

straightforward account for why matrix spec-TP is the only position the object can target in (145). The derivations in (145b) and (145c) are ruled out precisely because the object moves to a position where no valued Topic feature is available for feature valuation.

- (145) a. **Wancan** yinggai/keneng Akiu zhunbei  
dinner should/may Akiu prepare  
'The dinner should/may be prepared by Akiu.'
- b. \*Yinggai/keneng **wancan** Akiu zhunbei
- c. \*Yinggai/keneng Akiu **wancan** zhunbei

## Chapter 3 $\phi$ -Agree in Chinese

### 3.1 Introduction

Given that the possibility of having covert  $\phi$ -features/Agree on T is refuted for Chinese on the grounds of anaphor agreement effect, I ask a further question in (1):

- (1) Does Chinese lack  $\phi$ -features/Agree altogether or does it displays  $\phi$ -features/Agree elsewhere, say, in the left periphery?

I argue in this chapter that there are two types of Blocking Effects (BE, hereafter) in Chinese, indicating that even though there are no  $\phi$ -features on T in Chinese,  $\phi$ -Agree can still be detected in the syntactic computation in Chinese and thereby affects the grammaticality of a sentence. Specifically, in this chapter I argue for the presence of  $\phi$ -features/Agree at the CP level in Chinese, based on the investigation of these two types of BE. The first type of BE concerns the formation of *wh-the-hell* questions in Chinese. Deferring the detailed description of the syntactic structure of Chinese *wh-the-hell* questions until the next section, I simply note here that *wh-the-hell* questions in Chinese are formed with an attitudinal adverb *daodi* ‘the-hell’ and the *wh*-phrase, as in (2):

- (2) Daodi Lisi xihuan shei?<sup>1</sup>

---

<sup>1</sup> Huang and Ochi (2004) note that *daodi* can occur either before or after the (non-*wh*) subject, as shown by (2) and (i), respectively:

- (i) Lisi daodi xihuan shei?  
Lisi THE-HELL like who  
‘Who the hell does Lisi like?’

For expository purposes, I will use the word order in (2) in the text, and assume that the (non-*wh*) subject > *daodi* word order as in (i) is derived by subject’s topicalization to the left periphery.

THE-HELL Lisi like who  
 ‘Who the hell does Lisi like?’

Huang et al. (2009: 241) note that *daodi* can take matrix scope while staying overtly in the embedded clause as exemplified by (3):<sup>2</sup>

(3) Ni renwei [**daodi** Lisi xihuan shei]?  
 you think THE-HELL Lisi like who  
 ‘Who the hell do you think Lisi likes?’

Interestingly, the matrix second-person subject *ni* ‘you’ cannot be replaced by a third-person subject *Zhangsan*, as in (4), illustrating the first type of BE I investigate in this chapter.

(4) \***Zhangsan** renwei [daodi Lisi xihuan shei]?  
 Zhangsan think THE-HELL Lisi like who  
 ‘Who the hell does Zhangsan think Lisi likes?’

The second type of BE is related to the long-distance construal of the bare reflexive *ziji* ‘self’ in Chinese. The bare reflexive *ziji* in Chinese can function either as a locally bound reflexive just like *himself* or *herself* in English or as a long-distance bound anaphor (LDA, henceforth), as shown by (5).<sup>3</sup> The main concern of this chapter is the LDA usage of *ziji*.

(5) Akiu<sub>i</sub> renwei Lisi<sub>j</sub> kan-bu-qi **ziji**<sub>i/j</sub>

<sup>2</sup> By matrix scope, they mean that the negative attitude expressed by *daodi* ‘the-hell’ scopes over the matrix sentence, indicating the attitude of the speaker of the entire utterance. Notice that the matrix scope of *daodi* in (3) is not due to its indexical nature because it can take scope within an embedded interrogative like (9) below in the text.

<sup>3</sup> The bare reflexive *ziji* in Chinese differs from the compound reflexive *taziji* in that only the former is able to receive the long-distance construal, as shown by the contrast between (i) and (5).

(i) Akiu<sub>i</sub> renwei Lisi<sub>j</sub> kan-bu-qi taziji<sub>j/\*i</sub>  
 Akiu think Lisi look-not-up himself  
 ‘Akiu thinks that Lisi looks down upon himself.’

Akiu think Lisi look-not-up self

‘Akiu<sub>i</sub> thinks that Lisi<sub>j</sub> looks down upon him<sub>i</sub>/himself<sub>j</sub>.’

There is a well-known property of the LDA *ziji*, first noted by Y.-H. Huang (1984): the long-distance construal of *ziji* may be blocked under various conditions. (For a detailed review, see section 3.3, Huang and Liu 2001, and Cole et al. 2006.) Deferring the detailed discussion of the BE associated with *ziji* until section 3.3, here I focus only on the blocking induced by a first- or second-person local antecedent. Compare (5) with (6), in which the third-person embedded subject *Lisi* is replaced by a first-/second-person NP (i.e. *I* and *you*), with the result that *ziji* cannot refer to the remote antecedent as illustrated by (6):

- (6) a. Akiu<sub>i</sub> renwei [wo<sub>j</sub> kan-bu-qi ziji<sub>j</sub>/\*<sub>i</sub>]  
Akiu think I look-not-up self  
‘Akiu<sub>i</sub> thinks I<sub>j</sub> look down on \*him<sub>i</sub>/myself<sub>j</sub>.’
- b. Akiu<sub>i</sub> renwei [ni<sub>j</sub> kan-bu-qi ziji<sub>j</sub>/\*<sub>i</sub>]  
Akiu think you look-not-up self  
‘Akiu<sub>i</sub> thinks you<sub>j</sub> look down on \*him<sub>i</sub>/yourself<sub>j</sub>.’

Both types of BE presented above (illustrated by (4) and (6)) show sensitivity to the person feature (a sub-component of  $\phi$ -features) of a subject NP, suggesting the presence of  $\phi$ -Agree in Chinese. As a result, a natural question that emerges is the identity and structural locus of the probe and goal involved in  $\phi$ -Agree in Chinese, given that T does not host  $\phi$ -features in this language. The main goal of this chapter is to argue that (i) both types of BE in Chinese can be derived on the basis of  $\phi$ -Agree if we assume that  $\phi$ -features exist in Chinese but remain in the left periphery, unlike agreement languages where  $\phi$ -features are inherited by T (see Chomsky 2007, 2008; Richards 2007);<sup>4</sup> (ii) the  $\phi$ -feature bundle involved in  $\phi$ -Agree should be decomposed into more primitive subsets of features, specifically, the person feature is composed of [Speaker] and [Participant]

---

<sup>4</sup> Miyagawa (2010) proposes that the feature that is inherited from C to T is subject to parametric variation. In particular, he argues that in discourse-configurational languages like Finnish, it is the Topic feature, rather than  $\phi$ -features, that is inherited from C to T to create A-chains. See Chapter 2 for discussion of A-movement in Chinese under Miyagawa’s proposal.

features (cf. Harley and Ritter 2002; Béjar 2003; Béjar and Rezac 2003, 2009; Rezac 2008, 2011; Baker 2011; Nevins 2007, 2008, 2011, among many others); and (iii) the  $\varphi$ -Agree operation involved in these two types of BE in Chinese can be carried out either under binding by the closest c-commanding subject phrase (in the sense of Kratzer 2009) or by moving the phrase with the unvalued  $\varphi$ -features to create a spec-head relationship with the head with the valued counterparts.

The organization of this chapter is as follows. In section 3.2, I present previous analyses of Chinese *wh-the-hell* questions and then describe in more detail the BE noted in (4). Section 3.3 reviews previous analyses of the (BE of) long distance construal of *ziji* and points out the difficulties they encounter. Following Cole et al. (2006), I maintain that the BE of the long-distance construal of *ziji* is not a unified phenomenon. The BE induced by non-subjects (which are not potential antecedents of *ziji*) is due to discourse principles along the lines of avoiding perspective conflicts, as suggested by Huang and Liu (2001), while the BE induced by subjects (which are potential antecedents of *ziji*) can be explained based on  $\varphi$ -Agree and the successive-cyclic movement of *ziji*. The Agree-based BE of *ziji* is the main focus of this chapter; importantly, I argue that this type of BE should be treated on a par with the BE associated with Chinese *wh-the-hell* questions. Section 3.4 provides a brief literature review of a fine-grained theory of  $\varphi$ -features that constitutes the theoretical cornerstone of my analysis of the two types of BE associated with the long-distance construal of *ziji* and the formation of Chinese *wh-the-hell* questions. In section 3.5, I review Zanuttini et al. (2012) who argue that there exist  $\varphi$ -features and  $\varphi$ -Agree in Korean, which is also an East Asian language that lacks overt verbal agreement morphology and allows subject anaphors. Based on the assumptions introduced in 3.4 and 3.5, section 3.6 develops the unifying analysis of the two types of BE in Chinese. Section 3.7 extends this unifying analysis to the previously unnoted incompatibility between *daodi* and causal *zenme* ‘how come’ in Chinese. Section 3.8 concludes this chapter.

### **3.2 Chinese *Wh-the-hell* Questions**

This section reviews Huang and Ochi’s (2004) analysis of Chinese *wh-the-hell* questions, and describes the BE in Chinese *wh-the-hell* questions in more detail. There are several

properties of Chinese *wh-the-hell* questions worth mentioning. First, the *wh-the-hell* question in Chinese is constructed with the *wh*-question operator, the attitudinal adverb *daodi* ‘the-hell’ and the *wh*-associate as in (7). Unlike their English counterparts,<sup>5</sup> *daodi* ‘the-hell’ and its *wh*-associate both stay in situ and do not need to form a constituent, at least in overt syntax, as exemplified by (8):

(7) Q<sub>wh</sub>...*daodi*...*wh*

(8) **Daodi** ta xihuan **shenme**?  
 THE-HELL he like what  
 ‘What the hell does he like?’

Second, as noted by Kuo (1996) and Huang and Ochi (2004), in overt syntax, *daodi* ‘the-hell’ must occur in the c-command domain of the question operator in spec-CP as shown by the contrast in (9), and the *wh*-associate (*shei* ‘who’) must be c-commanded by *daodi* as evidenced by (10):

(9) a. Ta xiang-zhidao [CP Q<sub>wh</sub> [**daodi** [ni [xihuan shei]]]]  
 he wonder THE-HELL you like who  
 ‘He wonders who the hell you like.’

b. \*Ta **daodi** xiang-zhidao [CP Q<sub>wh</sub> ni xihuan shei]

(10) a. Ta xiang-zhidao [CP Q<sub>wh</sub> [**daodi** [**shei** mei lai shang ke]]]  
 he wonder THE-HELL who not come attend class  
 ‘Who the hell did not come to class?’

b. \*Ta xiang-zhidao [CP Q<sub>wh</sub> [**shei** [**daodi** mei lai shang ke]]]

---

<sup>5</sup> The *wh-the-hell* expression in English must occur as a (continuous) constituent that obligatorily moves overtly (cf. Huang and Ochi 2004:1-2):

- (i) a. \*What did you buy \_\_\_ the hell?  
 b. \*Who bought what the hell?



(9b) is ungrammatical because *daodi* is not realized overtly in the interrogative complement clause subcategorized by *xiang-zhidao* ‘wonder’, and (10b) is ill-formed since the *wh*-associate *shei* ‘who’ is not overtly c-commanded by *daodi*, even though the question operator c-commands *daodi*. Therefore, there exist two constraints on the formation of Chinese *wh-the-hell* questions, as summarized in (11):

- (11) a. The question operator needs to c-command *daodi*, and  
 b. *daodi* has to c-command the *wh*-associate overtly, forming a serial c-command relationship.

Huang and Ochi (2004:6) provide an illuminating summary of the structure of the *wh-the-hell* questions in Chinese. They note that there are two kinds of dependencies in a Chinese *wh-the-hell* question as represented in (12) – one between the null *wh*-question operator at spec-CP and the attitudinal adverb *daodi* (dependency A), and the other between *daodi* and the *wh*-associate (dependency B). These three key elements must form a successive c-command relation, as shown by (9) and (10). Importantly, the dependency A exhibits island sensitivity due to *daodi*’s covert adverbial movement observed by Kuo (1996) and Hunag and Ochi (2004),<sup>6</sup> and dependency B indicates that the *wh*-associate can occur in an island only if it is an argument, as is well-known in the literature (cf. Huang 1982 and Tsai 1994, among others).

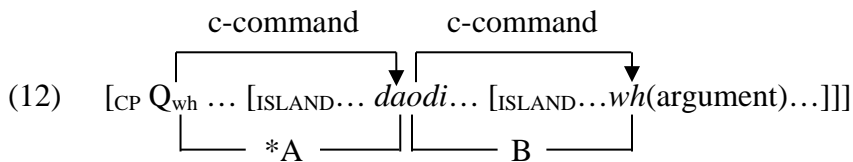

<sup>6</sup> The contrast between (ia) and (ib), adapted from Huang and Ochi (2004), shows that *daodi* cannot occur in a complex NP island:

- (i) a. Ni daodi xihuan [wo piping shei de wenzhang]?  
 you THE-HELL like I criticize who MOD article  
 ‘Who the hell is x such that you like the article in which I criticize x?’  
 b. \*Ni xihuan [wo daodi piping shei de wenzhang]?  
 you like I THE-HELL criticize who MOD article

Having introduced the basic syntactic properties of Chinese *wh-the-hell* questions, we turn to the BE associated with it. As already shown in (3) (repeated here as (13)), *daodi* can take matrix scope while appearing overtly in the embedded clause:

- (13) Ni renwei [**daodi** Lisi xihuan shei]?  
you think THE-HELL Lisi like who  
'Who the hell do you think Lisi likes?'

One clarification regarding the syntactic structure of (13) is required before we proceed. One may wonder if the embedded clause in (13) is actually a direct question with *ni renwei* "you think" simply as a parenthetical interjection meaning "in your opinion" as in (14), so that *daodi* is actually in the root clause of a direct question:

- (14) Ni renwei, daodi Lisi xihuan shei?  
you think THE-HELL Lisi like who  
'In your opinion, who the hell does Lisi like?'

The evidence against this line of analysis comes from the distribution of causal *zenme* 'how come'. As noted by Collins (1991), the construal of *how come* in (15) is not ambiguous, i.e., *how come* cannot originate from the embedded clause.

- (15) How come Bill thought Mary quit?  
(i) What is the cause of Bill's thinking that Mary quit?  
(ii) \*What is the cause of Mary's quitting that Bill thought?

Similarly, in Chinese, causal *zenme* cannot occur in the embedded clause, as in (16a), unless the embedded clause is an interrogative CP as in (16b):

- (16) a. \*Zhangsan renwei [Lisi **zenme** cizhi le]?

Zhangsan think Lisi how-come quit PERF

Intended: ‘What is the cause of Lisi’s quitting that Zhangsan thought?’

b. Zhangsan xiang-zhidao [Lisi zenme cizhi le]?

Zhangsan wonder Lisi how-come quit PERF

‘Zhangsan wonders how come Lisi quit.’

If the embedded clause of (13) is actually a direct question with *ni renwei* ‘you think’ as a parenthetical interjection, causal *zenme* should be able to occur in it; however, this is not borne out, as evidenced by (17). I take this as evidence against the direct question with a parenthetical analysis of (13).

(17) \*Ni renwei Lisi zenme cizhi le ne?

you think Lisi how-come quit PERF Q<sub>wh</sub>

Intended: ‘What is the cause of Lisi’s quitting that you thought?’

Turning to BE data, notice that the embedded distribution of *daodi* as in (13) is, in fact, highly restricted by the person feature of the matrix subject. We cannot replace the second-person matrix subject in (13) with a third-person one as in (18):<sup>7</sup>

(18) \*Zhangsan renwei [daodi Lisi xihuan shei]?

Zhangsan think THE-HELL Lisi like who

‘Who the hell does Zhangsan think Lisi likes?’

---

<sup>7</sup> The person feature of the matrix subject in (13) cannot be first-person as in (i). This is because it is pragmatically odd, and thus must be distinguished from the syntactically ill-formed (18).

- (i) #Wo renwei Lisi daodi xihuan shei?  
I think Lisi THE-HELL like who  
‘Who the hell do I think Lisi likes?’

The pragmatic oddity of (i) could be remedied as in (ii), in a context in which I lose my memory (e.g. have amnesia due to brain injury).

- (ii) Ni keyi gaosu wo [wo renwei [Lisi daodi xihuan shei]] ma?  
you can tell me I think Lisi THE-HELL like who Q<sub>yes-no</sub>  
‘Can you tell me who the hell I thought Lisi likes?’

By contrast, no context can render (18) acceptable.

Interestingly, if we put *daodi* in the matrix clause, the person feature constraint on the matrix subject is lifted with the same intended interpretation. Compare (13) and (18) with (19a) and (19b):

- (19) a. **Daodi** ni renwei [Lisi xihuan shei]? [cf. (13)]  
 ‘Who the hell do you think Lisi likes?’  
 b. **Daodi** Zhangsan renwei [Lisi xihuan shei]? [cf. (18)]  
 ‘Who the hell does Zhangsan think Lisi likes?’

Also, the person feature of the embedded subject does not affect the grammaticality of either (13) or (18), as shown by (20):

- (20) a. Ni renwei [daodi **ni/wo** xihuan shei]? [cf. (13)]  
 you think THE-HELL you/I like who  
 ‘Who the hell do you think you/I like?’  
 b. \*Zhangsan renwei [daodi **ni/wo** xihuan shei]? [cf. (18)]  
 Zhangsan think THE-HELL you/I like who  
 ‘Who the hell does Zhangsan think you/I like?’

These aspects of the distribution of *daodi* can be summarized in diagram (21). *Daodi* cannot overtly stay in the embedded clause of a direct *wh*-question when the matrix subject is a third-person NP (= (21d)):

- (21) a. Q<sub>wh</sub> **Daodi** Subject<sub>2nd</sub> ... [Subject<sub>1st/2nd/3rd</sub> ...*wh*...]?  
 b. Q<sub>wh</sub> Subject<sub>2nd</sub> ... [**daodi** Subject<sub>1st/2nd/3rd</sub> ...*wh*...]?  
 c. Q<sub>wh</sub> **Daodi** Subject<sub>3rd</sub> ... [Subject<sub>1st/2nd/3rd</sub>...*wh*...]?  
 d. \*Q<sub>wh</sub> **Subject<sub>3rd</sub>** ... [**daodi** Subject<sub>1st/2nd/3rd</sub> ...*wh*...]?

It is clear that the embedded occurrence of *daodi* in direct questions is not constrained by the person feature of the embedded subject. It is the person feature of the matrix subject that constrains the distribution of embedded *daodi*. The main goal of this chapter is to

propose an analysis that explains *both* the BE of Chinese *wh-the-hell* questions in (21d) and that of the LDA *ziji* in Chinese. In the next section, I review previous analyses of the BE associated with LDA *ziji* in Chinese.

### 3.3 Previous Analyses of the Long-distance Construal of *Ziji*

#### 3.3.1 *The pragmatic analysis*

Developing the approach in Huang et al. (1984), Huang and Liu (2001) explain the BE of the long-distance construal of *ziji* in terms of a pragmatic strategy of avoiding perspective conflicts. Let's first examine how their proposal derives the long-distance construal of *ziji* in (5), repeated here as (22).

- (22) Akiu<sub>i</sub> renwei Lisi<sub>j</sub> kan-bu-qi **ziji**<sub>i/j</sub>  
 Akiu think Lisi look-not-up self  
 'Akiu<sub>i</sub> thinks that Lisi<sub>j</sub> looks down upon him<sub>i</sub>/himself<sub>j</sub>.'

Following Kuno's (1972) proposal of a direct discourse (= quotative) representation for the interpretation of pronouns, they argue that the embedded clause containing the LDA *ziji* in (22) is translated as a direct discourse representation anchored to the matrix subject *Akiu* as the internal speaker of the embedded clause, as in (23). Crucially, they propose that the bare reflexive *ziji* with the long-distance interpretation is a logophor (cf. Sells, 1987), which is equivalent to *wo* 'I/me/my' anchored to the matrix subject *Akiu* in the direct discourse representation. It is this translation of *ziji* 'self' to *wo* 'I/me/my' in the direct discourse representation that yields the long-distance construal of *ziji*.

- (23) Akiu renwei, "Lisi kan-bu-qi **wo**."  
 Akiu think Lisi look-not-up me  
 Akiu thinks, "Lisi looks down on me."

Next, the long-distance construal of *ziji* (i.e. the translation of *ziji* to *wo*, under Huang and Liu's 2001 analysis) is blocked when the embedded subject is a first/second-person pronoun in (6), repeated here as (24).

- (24) a. Akiu<sub>i</sub> renwei [**wo**<sub>j</sub> kan-bu-qi ziji<sub>j/\*i</sub>]  
 Akiu think I look-not-up self  
 'Akiu<sub>i</sub> thinks I<sub>j</sub> look down on \*him<sub>i</sub>/myself<sub>j</sub>.'
- b. Akiu<sub>i</sub> renwei [**ni**<sub>j</sub> kan-bu-qi ziji<sub>j/\*i</sub>]  
 Akiu think you look-not-up self  
 'Akiu<sub>i</sub> thinks you<sub>j</sub> look down on \*him<sub>i</sub>/yourself<sub>j</sub>.'

Huang and Liu (2001) argue that the long-distance construal of *ziji* in (24) is blocked because the translation of *ziji* to *wo* 'I/me/my' in the direct discourse representation as in (25) produces a perspective conflict. This is because in the direct discourse representation in (25) the logophor needs to be anchored to the internal speaker (= the matrix subject) for long-distance construal, whereas the embedded first/second-person subject is anchored to the external speaker of the entire utterance, a situation that Huang and Liu claim is difficult to sort out perceptually.

- (25) #Akiu renwei, "wo/**ni**<sub>External</sub> kan-bu-qi wo<sub>Internal</sub>."  
 Akiu think I/you look-not-up me  
 Akiu thinks, "I/you look down on me."

Even though this pragmatic approach provides an explanation for the BE observed in (24), I would like to point out two deficiencies in the account. First, the core pragmatic principle of avoiding perspective conflicts underlying Huang and Liu's account wrongly allows the ungrammatical long-distance construal of *ziji* in (26a), with the direct discourse representation (26b). On their view, the underlying *wo* 'I' of *ziji* in (26b) is anchored to the first-person matrix subject, which denotes the external speaker of the entire utterance. This anchoring should not have any perspective conflict with the second-person embedded subject *ni* 'you', which is also anchored to the external speaker.

- (26) a.  $WO_i$  renwei [ $ni_j$  bu yinggai kan-bu-qi  $ziji_{j/*i}$ ]  
 I think you not should look-not-up self  
 ‘ $I_i$  think you $_j$  should not look down on yourself $_j$ / $*me_i$ .’
- b.  $WO$  renwei, “ **$ni_{External}$**  bu yinggai kan-bu-qi  **$WO_{External}$** .”  
 I think you not should look-not-up me  
 I think, “You should not look down on me.  
 (= direct discourse representation of (26a))

This indicates that the core concept of perspective conflict of Huang and Liu’s (2001) approach, which is intuitively on the right track, needs further refinements to rule out the long-distance construal of *ziji* in (26a). Specifically, I propose that the perceptual concept in Huang and Liu’s (2001) pragmatic account can be formalized as a component of the syntactic computation based on a fine-grained theory of  $\phi$ -features. A brief review of such a theory of  $\phi$ -features will be presented in section 3.4.

Second, Chen (2009) also suggests that *ziji*’s BE does not receive a complete analysis in terms of perspective conflicts in the direct discourse representation. Specifically, she argues that Huang and Liu’s direct discourse translation of the embedded clause containing *ziji* is not properly carried out. For instance, when the embedded clauses in (24a) and (24b) are translated into a direct discourse representation anchored to the matrix subject *Akiu*, the translation should be done from *Akiu*’s perspective, not that of the speaker of the entire utterance. Suppose the *Lisi* is the speaker and *Zhangsan* is the addressee of the discourse in which (24a) and (24b) are uttered, the direct discourse paraphrases of the embedded clauses of (24a/b) should be (27a/b), rather than (25).

- (27) a.  $Akiu$  renwei, ‘ **$Lisi$**  kan-bu-qi  **$WO_{Internal}$** .’  
 $Akiu$  think  $Lisi$  look-not-up me  
 $Akiu$  thinks, “ $Lisi$  looks down on me.”
- b.  $Akiu$  renwei, ‘ **$Zhangsan$**  kan-bu-qi  **$WO_{Internal}$** .’

Akiu think Zhangsan look-not-up me  
Akiu thinks, ‘‘Zhangsan looks down on me.’’

Chen (2009) reasons that when the embedded clauses containing *ziji* are properly rewritten from the matrix subject’s point of view as in (27a/b), there actually exists no perspective conflicts since the reference to *Lisi* and *Zhangsan* in the direct discourse complement must all be anchored to the internal speaker *Akiu*, causing no perspective conflicts, and predicting that (25) should be acceptable, contrary to fact. This lends further support to the conclusion based on (26) above – we should find another way to implement Huang and Liu’s (2001) approach based on the pragmatic perspective strategy.

### 3.3.2 *The syntactic analysis*

The syntactic analysis of *ziji* assumes that the non-local relationship between *ziji* and its long-distance antecedent (i.e. not conforming to Binding Principle A) is just an illusion because *ziji* undergoes successive-cyclic LF movement from its base-generated position to a position where it has a local relationship (i.e. satisfying Binding Principle A) with the ‘‘long-distance’’ antecedent. There are two approaches along this line of analysis of *ziji*. On the one hand, Pica (1989), Battistella (1987), and Cole et al. (1993) maintain that *ziji* first adjoins to the local INFL and then undergoes successive-cyclic head movement to the INFL head of the IP in which the long-distance antecedent is located, thereby explaining the possibilities of long-distance construal of *ziji*. On the other hand, Huang and Tang (1991) argues that *ziji* undergoes successive-cyclic A'-movement as an operator to adjoin to the IP immediately below the antecedent, as illustrated in (28).<sup>8,9</sup>

---

<sup>8</sup> For the head movement approach, *ziji* would undergo successive-cyclic head movement to adjoin to each head on its way up to the matrix I in (28) where it stands in a local relation (i.e. satisfying Binding Principle A) with the matrix subject *Akiu*. For space limitations, I omit the relevant derivations of *ziji*’s movement under the head movement approach here.

<sup>9</sup> Even though Huang and Liu (2001) maintain a pragmatic analysis of the BE of *ziji*, they also assume the LF A'-adjunction of *ziji*. In addition, for Huang and Tang (1991), the LF adjunction of *ziji* is just a means to make *ziji* local to its apparently remote antecedent. By contrast, the LF adjunction of *ziji* assumed by Huang and Liu (2002) has another purpose – *ziji* adjoins to the embedded CP to change the adjoined CP from a proposition to a *de se* property to be ascribed to the antecedent of LDA *ziji*. Huang and Liu suggest that this creates a direct syntactic input for the representation of *ziji*’s *de se* semantics. Following Huang and Liu’s (2001) proposal regarding the motivation of *ziji*’s LF adjunction, I further propose that the valuation of the unvalued person feature on *ziji* introduce a presupposition to the denotation of the *de se* property to be ascribed to the long-distance antecedent of *ziji* (see the discussion in 3.6.3).



- (28) [IP Akiu renwei [IP **ziji** [IP Lisi zhidao [IP t<sub>ziji</sub> [IP Zhangsan xihuan t<sub>ziji</sub>]]]]  
 Akiu think self Lisi know Zhangsan like  
 ‘Akiu<sub>i</sub> thinks that Lisi<sub>j</sub> knows that Zhangsan<sub>k</sub> likes him<sub>i/j</sub>/himself<sub>k</sub>.’

A critical property of *ziji* that favors the A'-movement approach over the head-movement approach is that *ziji*'s long-distance construal can go beyond island boundaries, as shown in (29) and (30), and as explained below.

- (29) Akiu<sub>i</sub> shuo [ruguo Lisi<sub>j</sub> taoyen ziji<sub>i/j</sub>], ta jui bu lai [Adverbial island]  
 Akiu say if Lisi hate self he then not come  
 ‘Akiu<sub>i</sub> said that if Lisi<sub>j</sub> hates him<sub>i</sub>/himself<sub>j</sub>, the he won't come.’

- (30) Akiu<sub>i</sub> taoyen [naxie kan-bu-qi ziji<sub>i/j</sub> de ren<sub>j</sub>] [Complex NP island]  
 Akiu hate those look-not-upon self MOD person  
 ‘Akiu<sub>i</sub> hates those people<sub>j</sub> who look down upon him<sub>i</sub>/themselves<sub>j</sub>.’

Note that Huang (1982) argues convincingly that *A-not-A* questions in Chinese as in (31) involve LF head movement of the *A-not-A* question operator base-generated at INFL/T to C, so the scope of an *A-not-A* question cannot go beyond island boundaries, as shown by the ungrammaticality of (32) and (33).<sup>10</sup>

- (31) Akiu xi-bu-xihuan ni?  
 Akiu like-not-like you  
 ‘Does Akiu like you or not?’

- (32) \*[Ruguo Akiu xi-bu-xihuan ni], ni jui hui nanguo? [Adverbial island]  
 If Akiu like-not-like you you then will sad  
 ‘\*If Akiu likes you or not, then you will be sad?’

<sup>10</sup> Please see Chapter 4 for further discussion of the head movement involved in Chinese *A-not-A* questions and its derivational interaction with the formation of locative inversion.

- (33) \*Ni taoyen [neixie pi-bu-piping            Akiu de ren]?    [Complex NP island]  
       you hate    those criticize-not-criticize Akiu MOD person  
       ‘\*You hate those people who criticize Akiu or not?’

Huang and Tang (1991) reason that given that LF head movement is subject to strict locality restrictions, *ziji*'s long-distance construal possibilities, if derived by successive-cyclic head movement, are predicted to be unable to go beyond syntactic islands, contrary to the facts shown in (29) and (30). By contrast, they argue that the LF A'-movement approach that assumes successive-cyclic IP-adjunction of *ziji* in the LF component does not suffer from this problem. Specifically, they argue that the LF adjunction of *ziji* across islands as in (29) and (30) does not exhibit subjacency, CED, or ECP effects because subjacency and CED do not apply in LF (see Huang, 1982, Lasnik and Saito, 1984, and Chomsky, 1986a), and ECP is not violated since *ziji*, as an argument NP, is always lexically governed. Given this superiority of the A'-movement analysis of *ziji*, I devote the rest of this section to reviewing further details of how the successive-cyclic A'-movement of *ziji* works in tandem with  $\phi$ -Agree to derive the (BE of) long-distance construal of *ziji*.

Huang and Tang's (1991) analysis has two major components – the featural makeup of *ziji* and the level at which Binding Principle A applies. First, they propose that *ziji* is “doubly anaphoric” in that it lacks both  $\phi$ -features and a reference, whereas compound reflexives like *ta-ziji* ‘him/her-self’ have inherent  $\phi$ -features but lack a reference. Therefore, in Huang and Tang's (1991: 275) words, *ziji* “needs to pick up two indices, one for its  $\phi$ -features and one for its reference, from an antecedent.” Furthermore, they assume that the  $\phi$ -index must be assigned before the referential index because an NP's  $\phi$ -features constitute the basis for its reference. Note that because Huang and Tang's (1991) paper coincides the initial development of the minimalist program, they assume that *ziji*'s  $\phi$ -index is set at S-structure and its referential index is not fixed until LF. Based on these two assumptions, the long-distance construal of *ziji* in (22) can be derived as follows. First, in (34), note that *ziji* does not have either a  $\phi$ -index or a referential index before binding applies:

- (34) Akiu<sub>( $\varphi(i)$ , R(3))</sub> renwei Lisi<sub>( $\varphi(i)$ , R(2))</sub> kan-bu-qi **ziji**<sub>( $\varphi(0)$ , R(0))</sub>  
 Akiu think Lisi look-not-up self

Next, when Binding Principle A applies at S-structure in (35), *ziji* sets its  $\varphi$ -index based on the  $\varphi$ -features of *Lisi*, the local subject.

- (35) Akiu<sub>( $\varphi(i)$ , R(3))</sub> renwei Lisi<sub>( $\varphi(i)$ , R(2))</sub> kan-bu-qi **ziji**<sub>( $\varphi(i)$ , R(0))</sub>  
 Akiu think Lisi look-not-up self

After setting the  $\varphi$ -index, *ziji* can determine its reference at LF. If *ziji* does not adjoin to the embedded IP, as in (36a), its reference will be set by the local subject *Lisi*; by contrast, if it adjoins to the embedded IP, as in (36b), it is the matrix subject *Akiu* that is closer to the adjoined *ziji* and thereby determines its (apparently long-distance) reference.

- (36) a. Akiu<sub>( $\varphi(i)$ , R(3))</sub> renwei [IP Lisi<sub>( $\varphi(i)$ , R(2))</sub> kan-bu-qi **ziji**<sub>( $\varphi(i)$ , R(2))</sub>]  
 Akiu think Lisi look-not-up self  
 ‘Akiu<sub>3</sub> thinks that Lisi<sub>2</sub> looks down upon himself<sub>2</sub>.’
- b. Akiu<sub>( $\varphi(i)$ , R(3))</sub> renwei [IP **ziji**<sub>( $\varphi(i)$ , R(3))</sub> Lisi<sub>( $\varphi(i)$ , R(2))</sub> kan-bu-qi t<sub>ziji</sub>]  
 Akiu think self Lisi look-not-up  
 ‘Akiu<sub>3</sub> thinks that Lisi<sub>2</sub> looks down upon him<sub>3</sub>.’

Huang and Tang’s (1991) analysis also captures the BE induced by the embedded subject whose person feature is different from that of the remote antecedent, as in (37a). In particular, given that *ziji*’s  $\varphi$ -index is set by the local subject *wo/ni* ‘I/you’ at S-structure in (37b) and the  $\varphi$ -index cannot be altered once set, *ziji*’s LF movement in (37c) does not allow the matrix subject *Akiu* to be an antecedent of *ziji*, since they differ in their  $\varphi$ -indices, rendering co-reference impossible.<sup>11</sup>

<sup>11</sup> Although the BE observed in (26) poses a significant difficulty for Huang and Liu’s (2001) pragmatic account, it supports Huang and Tang’s (1991) Agree-based analysis which predicts BE whenever the remote antecedent and the local antecedent have different person features. However, as I argue below, Huang and Tang’s view on the  $\varphi$ -feature bundle does not allow us to achieve the goal in (52) below.

- (37) a. Akiu<sub>3</sub> renwei [IP **wo/ni**<sub>2</sub> kan-bu-qi ziji<sub>2/\*3</sub>]  
 Akiu think I/you look-not-up self  
 ‘Akiu<sub>3</sub> thinks that I/you look down upon myself/yourself/\*himself<sub>2</sub>.’
- b. Akiu<sub>(φ(i), R(3))</sub> renwei [IP wo/ni<sub>(φ(j), R(2))</sub> kan-bu-qi **ziji**<sub>(φ(j), R(2))</sub>]  
 Akiu think I/you look-not-up self  
 ‘Akiu<sub>3</sub> thinks that I/you look down upon myself/yourself.’
- c. \*Akiu<sub>(φ(i), R(3))</sub> renwei [IP **ziji**<sub>(φ(j), R(3))</sub> wo/ni<sub>(φ(j), R(2))</sub> kan-bu-qi t<sub>ziji</sub>]  
 Akiu think self I/you look-not-up  
 Intended: ‘Akiu<sub>3</sub> thinks that I/you look down upon him<sub>3</sub>.’

The major empirical difficulty Huang and Tang’s (1991) analysis faces is the data noted by Xu (1993) who finds that there exists a person asymmetry between first-/second-person on the one hand versus third-person subject NPs on the other with respect to BE. Compare (38) with (39) and (40), where the local antecedent of *ziji* is a third-person NP and the remote antecedent is a first-/second-person NP. The first-/second-person embedded subject in (38) completely blocks the remote third-person subject as an antecedent of *ziji*, while it is marginal to have the matrix first-/second-person subjects in (39) and (40) as the antecedents of *ziji*, in spite of the intervening third-person embedded subject. The pattern of the person asymmetry is summarized in (41).

- (38) Lisi<sub>i</sub> bu danxin [wo<sub>j</sub>/ni<sub>j</sub> hui kan-bu-qi ziji<sub>j/\*i</sub>].  
 Lisi not worry I/you will look-not-up self  
 ‘Lisi<sub>i</sub> is not worried that I<sub>j</sub>/you<sub>j</sub> will look down upon myself<sub>j</sub>/yourself<sub>j</sub>/\*him<sub>i</sub>.’
- (39) Wo<sub>i</sub> bu danxin [Akiu<sub>j</sub> hui kan-bu-qi ziji<sub>j/?i</sub>].  
 I not worry Akiu will look-not-up self  
 ‘I am not worried that Akiu will look down upon himself/?me.’

(40)  $N_i$  bu danxin [Akiu<sub>j</sub> hui kan-bu-qi ziji<sub>j/?i</sub>] ma?  
 you not worry Akiu will look-not-up self  $Q_{yes-no}$   
 ‘Aren’t you worried that Akiu will look down upon himself/??you?’

- (41) Person asymmetry of *ziji*’s BE
- a. \*Subject<sub>3rd</sub> ... Subject<sub>1st/2nd</sub> ... ziji<sub>3rd</sub>
  - b. ?Subject<sub>1st</sub> ... Subject<sub>3rd</sub> ... ziji<sub>1st</sub>
  - c. ?? Subject<sub>2nd</sub> ... Subject<sub>3rd</sub> ... ziji<sub>2nd</sub>

The person asymmetry is not predicted by the Agree-based approach to BE because all of these sentences involve differences in the person feature of the subject antecedents, which in the absence of other principles incorrectly predicts the same strength of BE across all cases in (41).

Another conceptual difficulty Huang and Tang’s (1991) analysis faces is how their S-structure-LF distinction can be maintained in the current minimalist framework. Given that S-structure is abandoned in minimalism (see Chomsky 1995), there is only one cycle in the syntactic derivation, and there should not be two stages for binding to apply, which is a crucial step in Huang and Tang’s explanation of BE in (37). Aside from the problem of referring to the S-structure-LF distinction, another question arises as to why *ziji*’s  $\phi$ -index and referential index must be valued separately. It is a stipulation to prohibit “simultaneous valuation” of *ziji*’s  $\phi$ -index and referential index so that in (35), for example, when the local subject antecedent sets *ziji*’s  $\phi$ -index, why can’t it also determine *ziji*’s referential index at S-structure?

Summing up, even though Huang and Liu’s (2001) pragmatic analysis wrongly predicts the availability of the long-distance construal of *ziji* in (26) and needs refinements in how the direct discourse representation should be paraphrased, Huang and Tang’s (1991) Agree-based approach to *ziji* also requires some refinements. In addition, as suggested by Cole et al. (2006), there is considerable evidence that the BE of *ziji*’s long-distance construal is not a unitary phenomenon with a unitary (syntactic or pragmatic) analysis. In the next section, I review other supporting evidence adduced by

Cole et al. (2006) to support a non-uniform analysis of the BE in the long-distance construal of *ziji*.

### 3.3.3 *The non-uniform analysis*

Cole et al. (2006) argue that BE of *ziji* must have a major discourse component which can be summarized in (42), using the terminology of logophoricity in Sells (1987):

- (42) Discourse requirement in Chinese (= (72) in Cole et al. 2006)
- a. The antecedent for an LD reflexive must be a PIVOT.
  - b. The presence of a PIVOT (external or internal) in a sentence prevents a reflexive from taking any other distinct DP as a long-distance antecedent.

The strongest evidence for condition (42b) comes from sentences like (43) noted by Pan (1997) with multiple occurrences of *ziji*:

- (43) Akiu renwei Lisi zhidao [Wangwu ba **ziji**<sub>1</sub> de shu song-gei-le **ziji**<sub>2</sub> de pengyou]  
Akiu think Lisi know Wangwu BA self DE book gave-to-PERF self DE friend  
'Akiu thinks that Lisi knows that Wangwu gave self's books to self's friends.'

The crucial observation about cases like (43) is that although both *ziji*<sub>1</sub> and *ziji*<sub>2</sub> can take *Akiu* or *Lisi* as their long-distance antecedents, they cannot have distinct long-distance interpretations so that *ziji*<sub>1</sub> refers to *Akiu* but *ziji*<sub>2</sub> refers to *Lisi*, or vice versa. In other words, (43) has only two long-distance interpretations (disregarding the irrelevant local interpretation in which *Wangwu* binds both *ziji*<sub>1</sub> and *ziji*<sub>2</sub>): either "Akiu thinks that Lisi knows that Wangwu gave Akiu's books to Akiu's friends" or "Akiu thinks that Lisi knows that Wangwu gave Lisi's books to Lisi's friends." Therefore, the existence of one long-distance antecedent (i.e. a PIVOT, following (42a)) blocks the other (representing another PIVOT, following (42b)). Another important point is that all potential subject antecedents in (43) have the same  $\phi$ -features (i.e. third person, singular), so Huang and Tang's (1991) Agreement-based analysis of *ziji* cannot be the relevant trigger of the observed BE in (43). Cases involving multiple occurrences of *ziji* like (43) constitute a

strong piece of evidence for the relevance of Huang and Liu's (2001) pragmatic account of BE in terms of avoiding perspective conflicts.

In spite of such a strong support for the discourse component of the BE of *ziji*, there is considerable evidence for a non-uniform analysis which maintains a division of labor between discourse (i.e. avoiding perspective conflicts) and syntax (i.e.  $\phi$ -Agree) in explaining the full spectrum of *ziji*'s BE reviewed so far. In short,  *$\phi$ -Agree is only responsible for the BE triggered by different person features of subject antecedents, while all other cases of BE should be attributed to the discourse principle of avoiding perspective conflicts (=having more than one PIVOT in an utterance)*. The argumentation adduced by Cole et al. (2006) for this non-uniform analysis revolves around Cole and Wang's (1996) observation that while post-verbal objects generally cannot be *ziji*'s long-distance antecedents, as in (44), pre-verbal objects following the disposal marker *ba* are able to antecede *ziji*, as illustrated by (45):

- (44) Zhangsan<sub>i</sub> gausu **Lisi<sub>j</sub>** Wangwu<sub>k</sub> bu xihuan ziji<sub>i/\*j/k</sub>  
 Zhangsan told Lisi Wangwu not like self  
 'Zhangsan<sub>i</sub> told Lisi<sub>j</sub> that Wangwu<sub>k</sub> does not like him<sub>i/\*j</sub>/himself<sub>k</sub>.'
- (45) Akiu<sub>i</sub> yiwei Lisi<sub>j</sub> hui **ba Zhangsan<sub>k</sub>** dai hui ziji<sub>i/j/k</sub> de jia  
 Akiu think Lisi will BA Zhangsan take back self DE home  
 'Akiu<sub>i</sub> thinks that Lisi<sub>j</sub> will bring Zhangsan<sub>k</sub> back to his<sub>i/j/k</sub> home.'

Now, note that a mild BE (of the long-distance construal with the matrix subject *Akiu*) occurs when we replace the object following *ba* in (45) with a first-/second-person NP, as in (46):

- (46) Akiu<sub>i</sub> yiwei Lisi<sub>j</sub> hui **ba wo<sub>k</sub>/ni<sub>k</sub>** dai hui ziji<sub>k/j/?i</sub> de jia  
 Akiu think Lisi will BA I/you take back self DE home  
 'Akiu<sub>i</sub> thinks that Lisi<sub>j</sub> will bring me<sub>k</sub>/you<sub>k</sub> back to my/your/?his<sub>i/j</sub> home.'

In addition, if we replace the embedded subject *Lisi* in (45) with a first-/second-person NP, the long-distance construal with the matrix subject *Akiu* is entirely impossible, as in (47):

- (47) Akiu<sub>i</sub> yiwei **wo<sub>j</sub>/ni<sub>j</sub>** hui ba Zhangsan<sub>k</sub> dai hui ziji<sub>j/k/\*i</sub> de jia  
 Akiu think I/you will BA Zhangsan take back self DE home  
 ‘Akiu<sub>i</sub> thinks that I<sub>j</sub>/you<sub>j</sub> will bring Zhangsan<sub>k</sub> back to my/your/his<sub>k/\*i</sub> home.’

Cole et al. (2006) reason that these gradations of BE in (45) – (47) are explicable only if we assume that Agree-based BE is independent of discourse-based BE. The former occurs whenever there is a difference in person features between the subject antecedents; on the other hand, the discourse-based BE results from the occurrence of any first-/second-person NP in a sentence, no matter if it is a subject or not, thereby introducing an external PIVOT to the sentence. Thus, we predict a difference in the strength of BE between subject and non-subject blockers. In particular, the BE observed in (47) is stronger than that of (46) because both Agree-based BE and discourse-based BE occur in the former, while the latter only involve a discourse-based BE.

They further note that this non-uniform analysis solves the problem of person asymmetry noted by Xu (1993), summarized in (41) above (repeated here as (48)).

- (48) Person asymmetry of *ziji*'s BE  
 a. \*Subject<sub>3rd</sub> ... Subject<sub>1st/2nd</sub> ... ziji<sub>3rd</sub>  
 b. ?Subject<sub>1st</sub> ... Subject<sub>3rd</sub> ... ziji<sub>1st</sub>  
 c. ?? Subject<sub>2nd</sub> ... Subject<sub>3rd</sub> ... ziji<sub>2nd</sub>

Cole et al.'s (2006) non-uniform analysis predicts that the BE induced by the local third person subject antecedent in (48b) and (48c) is not as strong as that triggered by the local first/second person subject in (48a) because the former involves only the Agree-based BE, whereas both discourse-based BE and Agree-based BE are present in the latter. Specifically, *ziji* can marginally refer to the matrix first-/second-person subject in (41b) and (41c) because the presence of *wo/ni* ‘I/you’ forces the speaker to be the external



PIVOT, which can be the antecedent of *ziji*, following the discourse condition in (42a). However, the reference of *ziji* to the external PIVOT in (48b) and (48c) violates the grammatical condition on the long-distance construal of *ziji* – the remote and the local antecedents must have identical person features. On the other hand, the long-distance construal of *ziji* in (48a) is impossible because it violates not only the grammatical condition but also the discourse condition in (42b). Given that the presence of *wo/ni* ‘I/you’ as the embedded subject represents the external PIVOT of the utterance, the matrix subject must be the internal PIVOT to be an eligible long-distance antecedent of *ziji*; nevertheless, (42b) says that there cannot be more than one PIVOT in one utterance.

Given the independence of the Agree-based BE, I propose the question in (49):

- (49) Can the mechanism responsible for the Agree-based BE, which is divorced from the discourse-based BE, of *ziji* be extended to explain the BE involved in Chinese *wh-the-hell* questions (as summarized in (21))?

Both types of BE involve person features of subject NPs, so it is preferable to have a unifying analysis of them. However, I argue that Huang and Tang’s (1991)  $\phi$ -Agree mechanism responsible for the Agree-based BE of *ziji* cannot be extended to the BE in Chinese *wh-the-hell* questions because it treats the  $\phi$ -feature bundle involved in Agree as an atomic element without internal structure. To see why this is an impediment to the unifying analysis of these two types of BE, compare the abstract representations in (50) and (51):

- (50) Agree-based BE of the long-distance construal of *ziji*

a. \*Subject<sub>3rd</sub> ... Subject<sub>1st/2nd</sub> ... *ziji* (cf. (38))

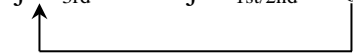

b. \*Subject<sub>1st</sub> ... Subject<sub>2nd</sub> ... *ziji* (cf. (26))



(51) BE in Chinese *wh-the-hell* questions

a. \*Q<sub>wh</sub> Subject<sub>3rd</sub> ... [*daodi* Subject<sub>1st/2nd/3rd</sub> ...*wh*...]? (cf. (18))

b. Q<sub>wh</sub> Subject<sub>2nd</sub> ... [*daodi* Subject<sub>1st/2nd/3rd</sub> ...*wh*...]? (cf. (13))

The major difficulty is why any difference in person features between the embedded subject and matrix subject would cause BE of *ziji*'s long-distance construal, while BE arises in Chinese *wh-the-hell* questions only when the matrix subject is third person (=51a), but not when the matrix subject is second person (=51b). I propose that we should adopt a fine-grained theory of the components of  $\phi$ -features to yield a difference in the featural representation between 1<sup>st</sup>/2<sup>nd</sup> and 3<sup>rd</sup> person arguments. Specifically, the  $\phi$ -feature bundle should be unpacked into person, number, and gender features, and the value of the person feature (i.e. 1<sup>st</sup>, 2<sup>nd</sup>, or 3<sup>rd</sup>) is the result of the composition of two sub-components – the [Participant] feature and the [Speaker] feature. This view of the internal structure of the  $\phi$ -feature bundle can help us achieve the major goal of this chapter:

(52) *Desideratum*: Both types of BE in Chinese should be explained by the same syntactic mechanism, differing only in the featural makeup of *ziji* 'self' and *daodi* 'the-hell'.

Thus, if successful, two phenomena (i.e. the two types of BE involved in the long-distance construal of *ziji* and the formation of Chinese *wh-the-hell* questions) that appear to be unrelated can receive a unified analysis. As preliminaries to my unifying analysis in section 3.6, I briefly review (i) Harley and Ritter's (2002) feature-geometric hierarchy of pronouns and Nevins' (2007) analysis of the Person-Case Constraint in the next section, and then (ii) the syntactic analysis of Korean jussive clause types by Zanuttini et al. (2012) in section 3.5. The former serves to establish the binary-valued representation of person features necessary for my unifying analysis of the two types of BE in Chinese, and the latter demonstrates how  $\phi$ -features and  $\phi$ -Agree can be detected and affect the grammaticality of sentences in a language that lacks overt morphological realization of  $\phi$ -features.

### 3.4 A Fine-grained Theory of $\phi$ -features

To capture both the cross-linguistic uniformity and the variation in the acquisition order and the inventory of pronouns in a wide range of languages, Harley and Ritter’s (2002) (H&R henceforth) propose the morphological feature geometry for pronouns in (53). We focus on the left branch of the geometry in (53) because it deals with the person features of pronouns, the primary focus of this chapter. One feature of H&R’s geometry crucial for the current purposes is that it is a privative, rather than binary, feature system, in which there is no explicit featural representation of the negative value of a feature. In other words, it encodes the negative value of a feature X with underspecification, i.e. absence of X in the geometry. For example, third person is not explicitly represented in this geometry – although the node [Participant] forms a natural class by grouping together [Speaker] (i.e. the first person) and [Addressee] (i.e. the second person), there is no node representing the third person. Thus, this privative view on the  $\phi$ -feature bundle entails the “invisibility” of the third person feature.

(53) Harley and Ritter’s (2002) feature geometry for pronouns

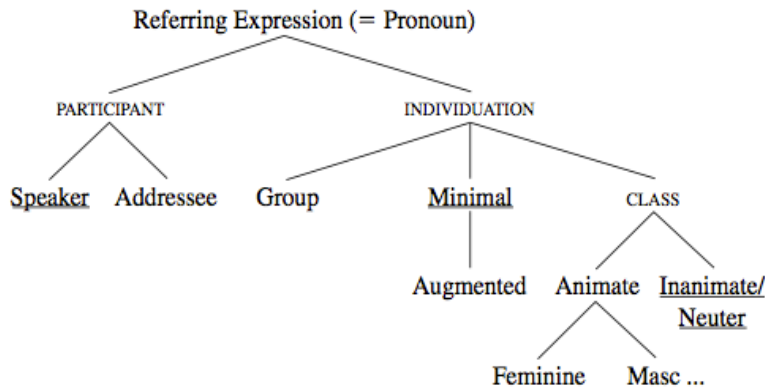

However, Nevins (2007) argues convincingly that an adequate analysis of the Person-Case Constraint (see below for a detailed description) requires (i) the syntactic presence and visibility of the third person feature, and (ii) a binary-valued representation of person features that allows for a syntactic and morphological distinction between first/second person on the one hand, and third on the other.<sup>12</sup> In addition, while this binary-valued

<sup>12</sup> By contrast, Nevins (2011) argues that the privative system provides an appropriate characterization of

system, like the privative one, groups first person and second person under the node [+Participant], what distinguishes these two systems is that only in the binary-valued system, third person is encoded as the [-Participant] feature which is visible to syntactic operations. Therefore, third person is explicitly encoded as the negative value of a binary feature [ $\pm$ Participant], rather than the absence of a unary feature [Participant].

The Person-Case Constraint (PCC) is a co-occurrence restriction on certain combinations of phonologically weak arguments (i.e. pronouns or clitics) of ditransitive verbs in a wide range of Romance languages (Perlmutter 1971; Bonet 1991; Anagnostopoulou 2003; Nevins 2007; among many others). It arises when these two pronouns or clitics fall within the same agreement domain with one single probing head (= the v head or the applicative head). Consider the following paradigm in Catalan from Bonet (1991:178-179).

- (54) \*A en Josep, me li va recomenar la Mireia  
to the Josep, **1.ACC 3.DAT** has recommended the Mireia  
'She (Mireia) recommended me to him (Josep).'
- (55) \*A en Josep, te li va recomenar la Mireia  
to the Josep, **2.ACC 3.DAT** has recommended the Mireia  
'She (Mireia) recommended you to him (Josep).'
- (56) En Josep, te 'l va recomenar la Mireia  
the Joseph, **2.DAT 3.ACC** has recommended the Mireia  
'She (Mireia) recommended him (Josep) to you.'

As shown by (54) and (55), Catalan prohibits the clitic sequence 1/2.ACC 3.DAT, where these clitics are assumed to reflect an underlying argument structure where the indirect object (marked by dative case) c-commands the direct object (marked by

---

the number feature. That is, negative values of number (e.g. the absence of [plural] for singular arguments) have no explicit featural encoding and hence are not visible to syntactic operations, yielding what he calls "the omnivorous number" in Multiple Agree.

accusative case). That is, a third-person [-Participant] dative cannot c-command a first-/second-person [+Participant] accusative in Catalan. The asymmetry between third-person and first-/second-person NPs with respect to their co-occurrence as object pronouns/clitics is unexpected under the view that treats the  $\phi$ -feature bundle as an atomic unit involved in Agree. More precisely, the combination in (56) should be as ill-formed as those in (54) and (55) because they all involve different  $\phi$ -features on both object clitics (if this is the reason for the ungrammaticality in (54) and (55)). Moreover, the privative approach to the representation of person features cannot capture the asymmetry because third person has no explicit representation in such a system (i.e. it is syntactically invisible), and should not have any effects on the grammatical formation of double clitics. Therefore, the asymmetry between (54) and (55) on the one hand and (56) on the other suggests that the  $\phi$ -feature bundle involved in Agree should be unpacked into a more articulated set of features with binary values which allows us to distinguish the third person from the first/second person. Nevins (2007) argues that the PCC receives an adequate analysis if we assume the  $\phi$ -probe on the ditransitive *v* head in languages like Catalan initiates Multiple Agree (as in Hiraiwa 2001, 2004) with both the direct object clitic and the indirect object clitic and the Multiple Agree operation is subject to a featural contiguity constraint on the path of Multiple Agree:

(57) Contiguous Agree

For a relativization *R* of a feature *F* on a Probe *P*, and  $x \in \text{Domain}(R(F))$ ,  $\neg \exists y$ , such that  $y > x$  and  $P > y$  and  $y \neg \in \text{Domain}(R(F))$  “There can be no interveners between *P* and *x* that are not in the domain of relativization that includes *x*”.

Nevins proposes that the ditransitive *v* probe in Catalan is required to agree with marked [+Participant] feature.<sup>13</sup> Accordingly, the underlying clitic sequence 3.DAT 1/2.ACC (= (54) and (55)) violates Contiguous Agree because the [-Participant] third person indirect object interrupts the Agree path of the ditransitive *v* probe relativized to [+Participant]. Note that this line of analysis is tenable only if third person has a syntactically visible representation as [-Participant] in a binary-valued system. In a privative system, by

---

<sup>13</sup> Nevins assumes that Multiple Agree may be relativized to different values of a feature. He argues that different types of PCC in different languages result from this parametric variation on the probing head.

contrast, the syntactic operation Agree simply cannot detect the third person indirect object standing in the way of its continuous span of Agree relativized to the [+Participant] feature – it does not know that it “skips” an argument that is not in the domain of the relativization.

In the next section, I review Zanuttini et al. (2012) to demonstrate how a binary featural encoding of person features explains the person feature constraint on the subjects of jussive sentences in Korean, a language without overt morphological evidence of  $\phi$ -features and  $\phi$ -Agree.

### 3.5 $\phi$ -features and $\phi$ -Agree in Korean

Zanuttini et al. (2012) investigate the interpretive constraint on subjects in Korean imperative, promissive, and exhortative sentences (grouped under the “jussive” clause type in Zanuttini et al., 2012), as in (58) (their (2)). They find that the syntax of these three types of jussive sentences in Korean differ minimally in the choice of the sentence final particle:

- (58) a. Cemsim-ul sa-**la**. (Imperative)  
lunch-ACC buy-IMP  
'Buy lunch!'
- b. Cemsim-ul sa-**ma**. (Promissive)  
lunch-ACC buy-PRM  
'I will buy lunch.'
- c. Cemsim-ul sa-**ca**. (Exhortative)  
lunch-ACC buy-EXH  
'Let's buy lunch.'

Semantically, they differ in the interpretation of the subjects – the subject of the imperative (58a) must be the addressee, the subject of the promissive (58b) can only be the speaker, and the subject of the exhortive in (58c) must refer to the speaker and the addressee together. In other words, these jussive sentences differ in which discourse participant(s) they relate to.

They argue that a purely semantic/pragmatic account cannot offer a satisfying explanation for the person feature restriction on the subjects in these three types of jussive sentences. This is because a purely pragmatics-based approach, appealing to pragmatic principles to determine the felicity of the speech act expressed by different types of jussive sentences, would face one major empirical difficulty regarding the syntactic realization of the particular discourse participant a jussive sentence relates to. For example, one could argue that the person feature constraint on the subject in Korean promissives has nothing to do with syntax but stems from the felicity condition that a promissive can express a felicitous speech act (i.e. the speaker of a promissive commits himself/herself to doing or refraining from doing something) only if it relates itself to the speaker. However, this hypothesis cannot ensure that the speaker must be realized as the subject of the promissive, rather than as other arguments in the sentence. Therefore, the pragmatic theory would predict all forms of Korean promissives in (59) are grammatical because they all refer to the speaker (= I) in some way. However, (59a) is ungrammatical, contrary to the pragmatic account, because the speaker is not syntactically realized as the subject of the promissive:

- (59) a. \*Jon-i na-lul/eykey khisuha-ma.  
 John-NOM me-ACC/DAT kiss-PROM  
 Intended meaning: ‘I promise that John will kiss me.’
- b. Nay-ka Jon-ul/eykey khisuha-ma.  
 I-NOM John-ACC/DAT kiss-PROM  
 ‘I promise to kiss John.’
- c. Nay-ka Jon-hantey khisu-lul patu-ma.  
 I-NOM John-from kiss-ACC receive-PROM  
 ‘I promise to be kissed by John.’ (Zanuttini et al. 2012: (9))

In a similar vein, they illustrate the inadequacy of a pragmatics-based account with imperatives. Specifically, such an approach does not explain why the addressee must be syntactically realized as the subject of an imperative. Assuming the pragmatic principle determining the felicity of an imperative says that an imperative must be associated with

a speech act “The addressee is to make  $p$  true”, both forms of imperative in (60) should be grammatical. However, only (60a) with the addressee realized as the subject is grammatical. This is not expected by a pragmatic theory because the speech act “The addressee is to make  $p$  true” should hold as long as the addressee is syntactically realized in the imperative.

- (60) a. (You) be kissed by John!  
b. \*John kiss you!

They further show that such a pragmatic theory would not work even if Postdam’s (1998) proposal of the core meaning of imperatives in (61) is taken into consideration.

- (61) Core meaning of an imperative

In an imperative, it is proposed that the addressee bring about an event.

(Postdam, 1998: 215)

Postdam maintains that the individual who brings about an event is the agent, and assumes a tight connection between agent and the subject position in an imperative. This assumption, together with (61), implies that the addressee should be syntactically realized as the subject. However, this revised pragmatic theory does not explain the ungrammaticality of (62) because the connection between agent and the subject position is not robust. In particular, agents are realized in *by*-phrases in passives, so an imperative like (62) should be allowed to express the core meaning in (61).

- (62) \*John be kissed by you! (meaning “You kiss John!”)

Zanuttini et al. also suggest that the pragmatic explanation of the person feature constraint faces a conceptual problem that runs counter to a major concept of generative linguistics, which assumes an autonomous syntax and a compositional theory of the association between syntactic structure and its interpretation. The pragmatic theory, in essence, appeals to the final meaning of an utterance to determine what can participate in



syntactic computation. However, the general assumption in generative linguistics is that the final meaning of an utterance is primarily based on the structure that syntax assembles (although other semantic/pragmatic principles may come into play to add additional non-compositional meaning to the syntactic structure). In other words, syntax feeds semantics/pragmatics, not the other way around.

Based on these considerations, Zanuttini et al. (2012) conclude that a pragmatic theory does not provide an adequate explanation of the person feature constraint on the subjects in jussive sentences; rather, a syntactic approach assuming the presence of  $\phi$ -features and  $\phi$ -Agree in Korean provides a comprehensive account for this interpretive constraint. Moreover, the constraint that the relevant discourse participant in different types of jussive sentences must be realized as the subject also strongly suggests that syntactic operations ( $\phi$ -Agree) and principles (e.g., minimality of  $\phi$ -Agree) must be involved in a proper characterization of jussive sentences.

It is useful to review Zanuttini et al. in detail because their proposal about the existence of  $\phi$ -features and  $\phi$ -Agree in Korean is similar to mine about Chinese (to be presented in section 3.6), though our arguments are based on empirical observations from two different East Asian languages.

They propose that the person feature constraint on the subjects of these jussive sentences in (58) is a consequence of the  $\phi$ -Agree relation between the subjects and different values of the person feature on the  $\phi$ -probe on a Jussive functional head in the left periphery of Korean phrase structure representation. They further assume that the Jussive head carries different values of the person feature and is realized by different particles (i.e. *la*, *ma*, or *ca*) in different types of jussive sentences. Importantly, they give a central role to morpho-syntax (i.e.  $\phi$ -Agree) to derive the person feature restriction on the subjects of jussive sentences.

To see how a syntactic analysis can explicitly derive the person feature constraint in Korean Jussive sentences, they make the following assumptions regarding the  $\phi$ -features on the Jussive head and formation of feature bundles as in (63) and (64), respectively:

- (63) Claims concerning the Jussive head (=17) in Zanuttini et al. 2002):
- a. The Jussive head is present in all and only jussive clauses.
  - b. The Jussive head has person features that are valued and interpretable:
    - i. All and only imperatives contain a Jussive head with a second person feature. This feature is the reason why imperatives place a requirement on the addressee.
    - ii. All and only exhortatives contain a Jussive head with a first person feature inclusive of the addressee. This feature is the reason why exhortatives place a requirement on the speaker and the addressee.
    - iii. All and only promissives contain a Jussive head with a first person feature. This feature is the reason why imperatives place a requirement on the speaker.
  - c. The Jussive head is not endowed with other  $\phi$ -features, or with a case feature.
  - d. The Jussive head is an abstraction operator that binds the argument it agrees with.
- (64) Claims about (structurally adjacent) features (=19) in Zanuttini et al. 2002):
- a. Features on structurally adjacent functional heads form a bundle and probe as a unit.
  - b. A bundle of features results from head-to-head movement.
  - c. A bundle of features can contain at most one instance of a given feature.

The relevant tree representation of a Korean imperative under these assumptions would be (65) where subscripts *i* and *u* indicate the interpretability of features. Therefore, the subject is active due to its unvalued case feature. One crucial point to note is that its person feature is also unvalued. This is because Zanuttini et al. (2012) follow Déchaine and Wiltschko's (2002) proposal that pronouns differ in whether they have inherent  $\phi$ -features, and assume that personal pronouns like *you*, *we* and *I* carry an unvalued person feature when entering the derivation of a jussive sentence (in other words, they are 'minimal pronouns' in the sense of Kratzer 2009).<sup>14</sup>

---

<sup>14</sup> The subject in (65) can be either an overt (minimal) pronoun or a null (minimal) *pro*, as in (58).

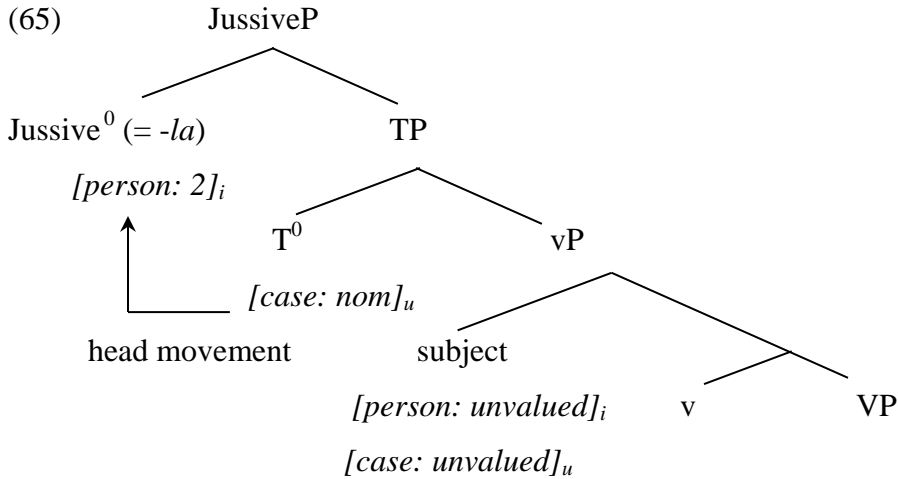

In addition, following Sigurðsson's (2009, 2010) proposal that features on adjacent heads function as a bundle of features on a single head, Zanuttini et al. (2012) assume that T undergoes head-movement to adjoin to the Jussive head in jussive sentences so that the interpretable second person feature on Jussive<sup>0</sup> and the valued uninterpretable nominative case feature on T form a feature bundle that together enter an agreement relation with the subject as in (66). The person feature constraint on the subjects in different jussive sentences now follows directly from (63b): the person feature on the minimal subject pronoun in jussive sentences is determined by different values of the interpretable person feature on the jussive head.

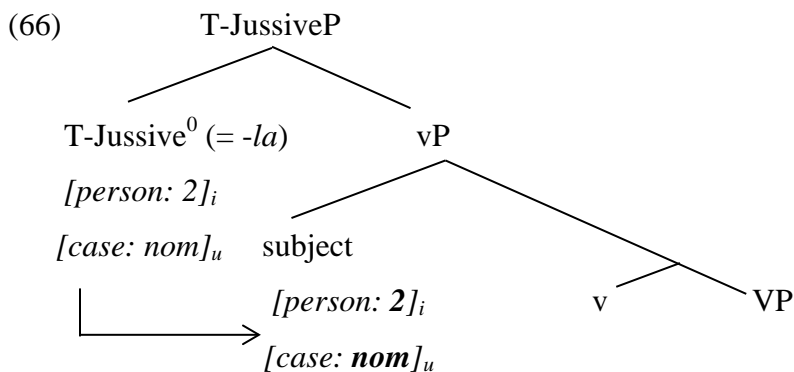

It is noteworthy that the  $\phi$ -Agree between T-Jussive and the subject Zanuttini et al. (2012) assumed in (66) depends on Kratzer's (2009) mechanism in (67):

(67) Feature Transmission under Binding:

The  $\phi$ -feature set of a locally bound pronoun unifies with the  $\phi$ -feature set of the head that hosts its binder.

Importantly, Zanuttini et al. (2012) argue that even though binding alone seems to be able to value the person feature on the subject in (66), syntactic  $\phi$ -Agree is indispensable in the derivation of jussive sentences. This is because binding alone cannot ensure that the person feature constraint falls on the subject, which is hierarchically closer to the T-Jussive head, rather than on other (hierarchically lower) arguments in the sentence. The fact that minimality plays a crucial role argues strongly for the presence of a syntactic operation like  $\phi$ -Agree.

One of the implications of Zanuttini et al.'s (2012) syntactic analysis of the person feature constraint on jussive sentences is that even though Korean does not have any overt inflectional morphology of agreement, the presence of  $\phi$ -features and  $\phi$ -Agree can still be detected. In their own words, “exhibiting person agreement is a matter of degree, not a property that a language either has or lacks completely” (Zanuttini et al. 2012: 1267). In the next section, I lend further support to this statement by proposing a unifying analysis of the two types of BE in Chinese that also invokes Agree.

### 3.6 A Unified Analysis

In this section, I marshal evidence showing that what Chinese *wh-the-hell* questions and LDA *ziji* have in common is that their interpretation restrictions are both largely determined by logophoricity. Specifically, I argue that the solution to the BE observed in Chinese *wh-the-hell* questions lies in the logophoric negative attitude carried by *daodi* ‘the-hell’ toward the propositional content of the question it occurs in. Semantically, the negative attitude of *daodi* is logophoric in the sense that it must be ascribed to either the external speaker or the internal speaker (typically the subject of certain speech-act verbs like *think*) for full interpretation of an attitude-bearing question (see Sells 1987, Chierchia 1989, and Huang and Liu 2001 for logophoricity ascription). I propose a derivational system that yields a step by step calculation of the logophoric ascription. My major assumption for this system is that the logophoric deficiency in *daodi* can be formalized as

an unvalued [Participant] feature that must be valued to yield a full interpretation of attitude-bearing *wh-the-hell* questions. Moreover, the same set of assumptions regarding the identity and structural locus of  $\phi$ -features in Chinese can be extended to derive the long-distance construal of LDA *ziji*. The Agree-based BE of *ziji* results from the failure of ascribing the *de se* property to *ziji*'s long-distance antecedent due to the person feature mismatch between the long-distance antecedent and the variable in the *de se* property created by *ziji*'s LF adjunction, as I will show below.

### 3.6.1 *The negative attitude of wh-the-hell questions*

In this section, I analyze the data showing the logophoricity of the negative attitude (i.e. attitude *de se* in the sense of Huang and Liu 2001 and Chierchia 1989) expressed by Chinese *wh-the-hell* questions and argue for the necessity of a derivational/cyclic mechanism to calculate the logophoric orientation of this semantic trait of Chinese *wh-the-hell* questions.

As pointed out explicitly by den Dikken and Giannakidou (2002: 43–44), “*wh-the-hell* in English carries a presupposition of negative attitude on the part of the speaker.” Specifically, the speaker of a *wh-the-hell* question holds a negative attitude toward the proposition expressed in the interrogative. For instance, the speaker of (68) thinks that for any *x*, such that *x* bought this book, *x* should not have done this.

(68) Who the hell bought this book?

As for the Chinese counterpart *daodi*, Huang et al. (2009: 237, fn. 2) point out that *daodi* in Chinese *wh-the-hell* questions, conveys “an urgent desire, even a sense of impatience, on the part of the speaker to get to the specific information being requested.”

I would like to provide two additional comments regarding the presupposition of the speaker's attitude of *wh-the-hell* in Chinese. First of all, den Dikken and Giannakidou's (2002) observation on the negative attitude of the speaker in a *wh-the-hell* question deserves elaboration. In particular, the ascription of this negative attitude calls for a formal mechanism. Consider (69) and (70) regarding the negative attitude ascription of *daodi*.

(69) Daodi Lisi mai le shenme?  
 THE-HELL Lisi buy PERF what  
 ‘What the hell did Lisi buy?’

(70) Akiu xiang-zhidao [daodi Lisi mai le shenme]  
 Akiu wonder THE-HELL Lisi buy PERF what  
 ‘Akiu wonders what the hell Lisi bought.’

In the direct question (69), the negative attitude of *daodi* is ascribed to the external speaker of the question, whereas it is the matrix subject referent, the “internal speaker” *Akiu*, that is holding this negative attitude in the indirect question (70).<sup>15</sup> Note that the attitude holder of *daodi* can only be determined when the syntactic derivation unfolds, given that it depends on the position of *daodi* in a sentence. Accordingly, we should have a derivational mechanism responsible for this value-setting.

Summing up thus far, the negative attitude carried by *daodi* ‘the-hell’ must be ascribed to either the external speaker of the entire utterance or the internal speaker (typically the subject of certain speech-act verbs) for full interpretation of an attitude-bearing question. Any adequate analysis of questions containing *daodi* in Chinese must take this logophoric property into consideration. In the next subsection, it will be shown how this pragmatic concept may be formalized and integrated into the syntactic computation.

---

<sup>15</sup> Note that (70) cannot mean that both the external speaker and the matrix subject referent *Akiu*, as the internal speaker of the embedded clause, hold the negative attitude. Also consider the direct questions (i) and (ii).

- (i) Who the hell did John say Bill saw?
- (ii) Ni renwei daodi Lisi xihuan shenme?  
 you think THE-HELL Lisi like what  
 ‘What the hell do you think Lisi likes?’

In direct questions like (i) and (ii), only the external speaker, rather than the matrix subject referent (*John* and *ni* ‘you’), holds the negative attitude.

### 3.6.2 Deriving the logophoric ascription of Chinese *wh-the-hell* questions and its BE

This section spells out the derivation of Chinese *wh-the-hell* questions that yields the calculation of logophoric orientation of the attitude *de se* in such questions.

To formalize the logophoric property of the negative attitude carried by *daodi*, I propose that there is an unvalued [Participant] feature in *daodi* that needs to be valued via  $\phi$ -Agree with the person feature on the closest Point-of-View operator (POV) hosted by a designated Point-of-View functional head in the left periphery of Chinese *wh-the-hell* questions, to identify “the logophoric orientation” (to quote a comment from a reviewer of Chou 2012) for full interpretation of attitude-bearing *wh-the-hell* questions.<sup>16</sup> As reviewed in 3.4, H&R propose the morphological feature geometry in (53) for pronouns to capture the cross-linguistic uniformity, variation of the acquisition order and the inventory of pronouns in a wide range of languages. Inspired by their feature geometry, I propose that POV consists of two person features, [Speaker] and [Participant], as shown in (71):

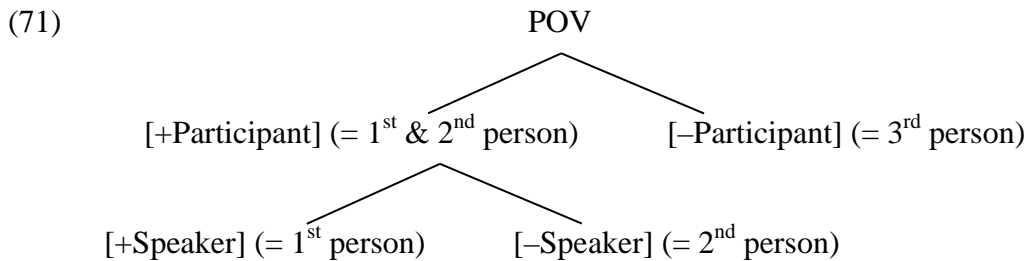



Two points are noteworthy regarding the [Participant] and [Speaker] features on *daodi* and POV are noteworthy. First, even though the person feature geometry for POV in (71) is inspired by and adapted from a portion of H&R’s geometry, (71) is different from their geometry not only in form but also in its theoretical purposes. Following Nevins (2007), I adopt a binary-valued feature system (H&R intend a unary-valued geometry) of person features, in which the features in (71) are meant to denote the logophoric orientation of point of view. Second, even though the [Participant] feature on *daodi* is unvalued, it is interpretable, because *daodi*’s [Participant] feature, when valued, contributes to the full

<sup>16</sup> In terms of Rizzi’s (1997) articulated theory of the left periphery phrase structure, this functional head must occupy a position higher than the Interrogative Phrase hosting the Question operator in the left periphery for the POV to scope over the interrogative.

interpretation of an attitude-bearing *wh-the-hell* question. In other words, the proposed featural analysis of *daodi* follows Pesetsky and Torrego’s (2007) featural system that abandons Chomsky’s (2001) Interpretability/Valuation Biconditional discussed in Chapter 2.

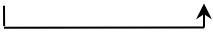
Note that there is a critical distinction between the  $\phi$ -features on the matrix POV and that on an embedded POV. The person features on the matrix POV are always [+Participant, +Speaker], which represents the point of view of the external speaker of the entire utterance, while those of the embedded POV are indeterminate with respect to “logophoric orientation,” which is determined by the person feature of the minimal c-commanding subject via binding, as shown in the diagrams in (72).<sup>17,18</sup>

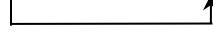
- (72) a. [Matrix POV<sub>[+p, +s]</sub>...subj<sub>1st</sub>...[POV<sub>[+p, +s]</sub>...]]  

  
 b. [Matrix POV<sub>[+p, +s]</sub>...subj<sub>2nd</sub>...[POV<sub>[+p, -s]</sub>...]]  

  
 c. [Matrix POV<sub>[+p, +s]</sub>...subj<sub>3rd</sub>...[POV<sub>[-p, -s]</sub>...]]  

Next, we turn to the unvalued person feature of *daodi* and the covert movement associated with its valuation and scope. The unvalued [Participant] feature has to be valued by the POV in the left periphery to set the logophoric orientation of an attitude-bearing *wh-the-hell* question. As noted by Kuo (1996) and Huang and Ochi (2004), the occurrence of *daodi* is island sensitive, suggesting its covert adverbial movement (see footnote 6). I propose its covert movement targets the specifier of the POV Phrase (spec-POV) in the left periphery and serves two purposes: (i) to obtain its scope over the attitude-bearing question, and (ii) to seek valuation of its unvalued [Participant] feature. Notice that I adopt Bošković’s (2007) moving-element-driven approach to movement. Following Epstein and Seely (1999, 2006), Bošković (2007:619) assumes that a probe must contain an unvalued feature, and an unvalued feature must function as a probe.

<sup>17</sup> Note that [-Participant, +Speaker] is not a possible combination since an addresser must be a discourse participant by definition.

<sup>18</sup> An anonymous reviewer of Chou (2012) points out that if the external speaker is viewed as the subject of a performative verb in some representation, the person feature valuation of the matrix POV can be assimilated to the one of the embedded POV. Both are determined by the minimal c-commanding subject.



Additionally, a probe must c-command its goal. On these assumptions, an element containing an unvalued feature functions as a probe and has the motivation to move – to move to a position to c-command a goal. Under this approach, *daodi*, carrying an unvalued feature, must raise to spec-POV to enter into an Agree relation as a probe with POV which in this case functions as a goal. Let’s see how the valuation of the [Participant] feature on *daodi* proceeds case by case. Consider (73), a direct question:

- (73) [*daodi*<sub>[+p]</sub> POV<sub>[+s, +p]</sub> [ *t* Lisi xihuan shenme]]?  
 THE-HELL Lisi like what  
 ‘What the hell does Lisi like?’

First, *daodi* moves to spec-POV to mark its scope and seek feature valuation. In addition, the unvalued [Participant] feature of *daodi* is valued as [+Participant] via  $\phi$ -Agree with the matrix POV. This identifies the logophoric orientation of *daodi* as the one belonging to the discourse participant identified by POV. Last but not least, the amalgam of the person features of *daodi* and the matrix POV, [+Participant, +Speaker], correctly identifies the attitude-bearer of *daodi* as the speaker among the discourse participant, and thereby we have a full interpretation of this attitude-bearing question.

Next, consider the derivations related to the  $\phi$ -Agree of the unvalued [Participant] feature on *daodi* in the indirect question (74).

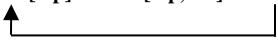
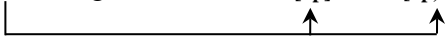
- (74) **Zhangsan** xiang-zhidao [**daodi** Lisi xihuan shenme]  
 Zhangsan wonder THE-HELL Lisi like what  
 ‘Zhangsan wonders what the hell Lisi likes.’  
 a. [*daodi*<sub>[u,p]</sub> POV<sub>[u,p, u,s]</sub> [ *t* LS xihuan shenme]  
  
 b. **ZS** xiang-zhidao [*daodi*<sub>[-p]</sub> POV<sub>[-p, -s]</sub> .....]  

In (74a), *daodi*, bearing an unvalued [Participant] feature, moves to the embedded spec-POV to take scope over the embedded question and seek feature valuation. Note that

neither *daodi* nor the embedded POV has valued person features at this stage of derivation since both of them are indeterminate with respect to their logophoric orientation. Next, in (74b), the subject NP *Zhangsan*, by c-commanding both *daodi* and the POV at *daodi*'s scope position, values the unvalued features on both *daodi* and the embedded POV via binding.<sup>19</sup> Last, the person features amalgam [-Participant, -Speaker] of *daodi* and the embedded POV in (74b) correctly identifies the bearer of the negative attitude of *daodi* as the non-discourse-participant matrix subject referent *Zhangsan*.

With the mechanism of  $\varphi$ -Agree responsible for the valuation of person features on *daodi* and POV, we are now ready to explain the person feature constraint of the matrix subject in Chinese *wh-the-hell* questions. When *daodi* occurs in the embedded clause in a direct question, the attitude-bearer of this direct *daodi* question is always the external speaker, i.e. the addresser, of the entire question. When the matrix subject of a direct question is a second-person NP, the relevant derivation of this interpretation would be as in (75a-c).

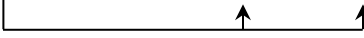
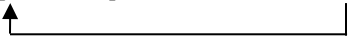
- (75) **Ni** renwei [**daodi** Lisi xihuan shenme]?  
 you think THE-HELL Lisi like what  
 ‘What the hell do you think Lisi likes?’
- a. [*daodi*<sub>[u,p]</sub> POV-op<sub>[u,p, u,s]</sub> [ t Lisi xihuan shenme]]  

- b. **Ni** renwei [*daodi*<sub>[+p]</sub> POV<sub>[+p, -s]</sub> [ .....]]?  

- c. [*daodi*<sub>[+p]</sub> POV<sub>[+p, +s]</sub> **Ni** renwei [ t POV<sub>[+p, -s]</sub> [ .....]]]  

<sup>19</sup> The derivational relation between the embedded POV/*daodi* and the minimal c-commanding subject in (74b) is similar to the one between the null operator and the local subject in the derivation of a *tough*-construction in (i) (cf. Chomsky 1982, 1986):

- (i) *Fred* said *John* is easy [*OP* PRO to please *t*]

The null operator within the embedded clause in (i) is anaphoric in the sense that its referent is indeterminate until *John* is merged in the derivation. Also, the relation is local since the antecedent can only be the closest subject *John*, rather than the remote *Fred*. Last, even though the embedded POV has no valued features to value *daodi* at the stage of (74a), *daodi* still needs to move to the embedded spec-POV because that is the only place it can move to in order to mark its scope over the embedded attitude-bearing question and participate in potential feature valuation.

(75a) and (75b) are similar to (74a) and (74b) except for the person feature of the matrix subject and the selection of the main verb. The person features of *daodi* and the embedded POV are determined by the person feature of the minimal c-commanding subject via binding, as shown in (74b) and (75b). Besides, since (75) is a direct question, *daodi* has to continue to raise to the matrix spec-POV as in (75c) to obtain matrix scope over the entire question.<sup>20</sup> Crucially the person feature of *daodi* is consistent with those of the matrix POV at its scope position, so we obtain the correct ascription of *daodi*'s negative attitude to the external speaker of the direct question in (75) with the person features amalgam [+Participant, +Speaker] of *daodi* and the matrix POV.

Next, consider the direct question (76) with a third-person matrix subject, the case illustrating the matrix subject person feature constraint. Note that like (75), (76) is a direct question in which the negative attitude carried by *daodi* should be ascribed only to the external speaker of the entire question.

(76) \***Zhangsan** renwei [**daodi** Lisi xihuan shenme]]?

Zhangsan think THE-HELL Lisi like what

‘What the hell does Zhangsan think that Lisi likes?’

a. [*daodi*<sub>[u,p]</sub> POV<sub>[u,p,u,s]</sub> [ t Lisi xihuan shenme]]

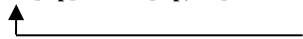

b. **ZS** renwei [*daodi*<sub>[-p]</sub> POV<sub>[-p,-s]</sub> [.....]]?



c. \*[[*daodi*<sub>[-p]</sub> POV<sub>[+p,+s]</sub> **ZS** renwei [t POV<sub>[-p,-s]</sub> [.....]]]

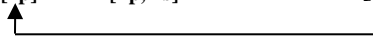

(75) and (76) differ only in the person feature of the matrix subject. This affects the logophoric orientation the embedded POV and *daodi* as seen in (75b) and (76b). The reason why (76) is ungrammatical stems from the clash of the person features of *daodi* and the matrix POV in (76c). The derivational steps in (76) yield an ill-formed CI representation that cannot identify the bearer of *daodi*'s negative attitude.

<sup>20</sup> Even though the embedded spec-POV is not *daodi*'s scope position in a direct question, it has to move successive-cyclicly via this intermediate position because of locality considerations.

Our analysis predicts that if we put *daodi* in the matrix clause rather than in the embedded clause, the sentence should be acceptable because the person feature of *daodi* would be directly valued by [+Participant, +Speaker] of the matrix POV, generating the correct interpretation. This prediction is borne out as already seen in (19b), repeated here as (77):

- (77) [***Daodi***<sub>[+p]</sub> **POV**<sub>[+p, +s]</sub> [ *t* Zhangsan renwei [Lisi xihuan shei]]?  
 THE-HELL                      Zhangsan think Lisi like who  
 ‘Who the hell does Zhangsan think Lisi likes?’

The generalization emerging from the discussion so far is (78):

- (78) Generalization of person feature valuation of *daodi*  
 a. The [Participant] feature of *daodi* must match that of the POV at its scope position to ensure correct ascription of its negative attitude.  
 b. *Daodi*’s [Participant] feature can be valued by either (i) the matrix POV via  $\phi$ -Agree, or (ii) the subject NP c-commanding *daodi* via binding.

Note that the valuation of *daodi*’s [Participant] feature in (78bii) is exemplified by the binding relation between the matrix subject and *daodi* (and the embedded POV) in (74b), (75b), and (76b). It is similar to Zanuttini et al.’s (2012) proposal for Korean jussive sentences reviewed in 3.5 in the sense that it is also based on Kratzer’s (2009) Feature Transmission under Binding in (79) (repeated from (67)):

- (79) Feature Transmission under Binding:  
 The  $\phi$ -feature set of a locally bound pronoun unifies with the  $\phi$ -feature set of the head that hosts its binder.

Specifically, I suggest that *daodi* and the embedded POV contain a minimal pronoun entering the derivation without inherent values of their person features (in the sense of Kratzer 2009; see also Déchaine and Wiltschko 2002), whose values can be set either via

binding by the matrix subject or by entering into a  $\phi$ -Agree relation with the matrix POV (by moving to spec-POV).

### 3.6.3 Deriving the long-distance construal of *ziji* and its Agree-based BE

In this section, I extend my proposal concerning the components of  $\phi$ -features in Chinese to the bare reflexive *ziji* to derive its long-distance construal and its BE. Recall that the long-distance construal of *ziji* in (26) (repeated here as (80)) is incorrectly predicted to be grammatical under Huang and Liu's (2001) analysis in terms of a pragmatic strategy of avoiding perspective conflicts.

- (80) a. Wo<sub>i</sub> renwei [ni<sub>j</sub> bu yinggai kan-bu-qi ziji<sub>j/\*i</sub>]  
 I think you not should look-not-up self  
 'I<sub>i</sub> think you<sub>j</sub> should not look down on yourself<sub>j/\*i</sub>.'
- b. Wo renwei, "ni bu yinggai kan-bu-qi wo."  
 I think you not should look-not-up me  
 I think, "You should not look down on me."  
 (= direct discourse representation of (80a))

This is because on Huang and Liu's view, the *wo* 'I' replacing *ziji* in (80b), as the underlying representation of (80a), is anchored to the first-person matrix subject, which denotes the external speaker of the entire utterance. This anchoring should not have any perspective conflict with the second-person embedded subject *ni* 'you', which is also anchored to the external speaker, in Huang and Liu's approach.

I argue that the proposed system for the derivation of the attitude ascription of Chinese *wh-the-hell* questions can be extended to the derivation of the long-distance construal of *ziji*, to capture (80) as well as the BE induced by the disparity of person features on its local and remote subject antecedents. This extension is based on three key components. First, I follow Huang and Tang's (1991) suggestion that *ziji* is "doubly anaphoric"; however, I propose that what *ziji* lacks is not a  $\phi$ -index and a referential index, which must be valued at two different stages of derivation under Huang and

Tang's (1991) analysis; rather, *ziji* is a minimal pronoun that enters the derivation without inherent values of its [Participant] and [Speaker] features. In addition, recall that one of the problems confronting Huang and Tang's (1991) analysis in the current minimalist framework is that they need to appeal to the independent existence of S-structure where the local subject antecedent sets *ziji*'s  $\phi$ -index, which in turn functions as a filter on whether a remote subject NP can determine *ziji*'s referential index (after *ziji* undergoes LF adjunction to a position close to the remote subject antecedent). A related question is why *ziji*'s  $\phi$ -index and referential index cannot be valued simultaneously. My modified approach to *ziji*'s Agree-based BE solves both problems. There is no need to assume the two-stage valuation of *ziji*'s anaphoric deficiency – both of its unvalued [Participant] and [Speaker] features are valued at once, and they cannot be valued separately because the [Participant] and the [Speaker] features are sub-components of the person feature whose valuation is subject to Chomsky's (2001) Maximize Matching Effects in (81).

(81) Maximize Matching Effects

If local (P, G) [= probe and goal relations, CTC] match and are active, their uninterpretable features must be eliminated at once, as fully as possible; partial elimination of features under Match, followed by elimination of the residue under [another application of, CTC] Match, is not an option.

Second, I follow Huang and Liu's (2001) analysis of the LF adjunction of *ziji* for creating a direct input for the semantics of attitude *de se* expressed by *ziji* (see Huang and Tang 1991 for the LF movement of *ziji*, and Chierchia 1989 for the semantics of attitude *de se*). In particular, the minimal pronoun *ziji* is a  $\lambda$ -abstraction operator that moves to adjoin to the embedded CP and changes the CP from a proposition to a *de se* property to be ascribed to the long-distance antecedent of *ziji*.

Third, following Zanuttini et al.'s (2012) assumption about person features (along the lines suggested in Cooper 1979, Schlenker 2003, Sauerland 2008, and Kratzer 2009), I assume that the unvalued [Participant] and [Speaker] features on *ziji*, once they get valued, introduce a presupposition to the denotation of the *de se* property to be ascribed to the long-distance antecedent of *ziji*.

Let's examine how the proposed system derives the long-distance interpretation of *ziji* in (82).

- (82) Akiu<sub>i</sub> renwei Lisi<sub>j</sub> kan-bu-qi **ziji**<sub>i/j</sub>  
 Akiu think Lisi look-not-up self  
 'Akiu<sub>i</sub> thinks that Lisi<sub>j</sub> looks down upon him<sub>i</sub>/himself<sub>j</sub>.'

First, the unvalued [Participant] and [Speaker] features on *ziji* are valued by the third person local subject *Lisi* via binding (=operation (79)) as [-Participant, -Speaker] as in (83).

- (83) [<sub>v\*P</sub> Lisi kan-bu-qi **ziji**<sub>[-p, -s]}]</sub>
- 

Next, *ziji* adjoins to the embedded CP in (84a) to create the syntactic input for attitude *de se* by changing the embedded CP from a proposition to a *de se* property to be ascribed to the matrix subject antecedent. The denotation of this *de se* property is (84b). Notice that the valued person features [-Participant, -Speaker] on *ziji* trigger presupposition on the variable in the *de se* property, requiring the property be ascribed to an individual who is [-Participant, -Speaker], i.e. a third person NP.

- (84) a. [<sub>CP</sub> **ziji**<sub>[-p, -s]} [<sub>CP</sub> Lisi ..... *t* ]]</sub>
- b.  $\lambda x$ :  $x = [-\text{Participant}, -\text{Speaker}]$ . [Lisi looks down upon  $x_{[-p, -s]}$ ]

The composition of this *de se* property with the matrix subject *Akiu* and the subject verb *think* yields the denotation given in (85). The long-distance construal of *ziji* is allowed in (82) precisely because there is no conflict in the person feature between the matrix subject *Akiu* and the [-Participant, -Speaker] variable in the *de se* property.<sup>21</sup>

<sup>21</sup> If *ziji* stays in the v\*P as in (83), rather than adjoining to the embedded CP as in (84) to create the syntactic input for attitude *de se*, *ziji* can only obtain the local interpretation. In other words, in the proposed system, what distinguishes local *ziji* from long-distance *ziji* is the movement of *ziji* as in (84).

(85) think (Akiu,  $\lambda x: x = [-\text{Participant}, -\text{Speaker}]$ ). [Lisi looks down upon  $x_{[-p, -s]}$ ]

The proposed system also derives the BE that emerges when the local subject and the remote subject do not have the same values of the [Participant] and [Speaker] features, as in (86a) and (86b).

- (86) a. Akiu<sub>i</sub> renwei [**w**<sub>j</sub> kan-bu-qi ziji<sub>j/\*i</sub>].  
 Akiu think I look-not-up self  
 ‘Akiu<sub>i</sub> thinks I<sub>j</sub> look down on \*him<sub>i</sub>/myself<sub>j</sub>.’
- b. Akiu<sub>i</sub> renwei [**n**<sub>j</sub> kan-bu-qi ziji<sub>j/\*i</sub>].  
 Akiu think you look-not-up self  
 ‘Akiu<sub>i</sub> thinks you<sub>j</sub> look down on \*him<sub>i</sub>/yourself<sub>j</sub>.’

In the proposed system, this type of BE results from the mismatch of the values of the [Participant] and [Speaker] features on the remote subject antecedent and those on the variable in the *de se* property created by *ziji*’s adjunction to the embedded CP. The denotations of (86a) and (86b) are shown in (87a) and (87b), respectively.

- (87) a. #think (Akiu,  $\lambda x: x = [+Participant, +Speaker]$ ). [I look down upon  $x_{[+p, +s]}$ ]  
 b. #think (Akiu,  $\lambda x: x = [+Participant, -Speaker]$ ). [you look down upon  $x_{[+p, -s]}$ ]

Note that the local subject antecedent determines the unvalued [Participant] and [Speaker] features of *ziji*, which in turn trigger the person feature presupposition of the variable in the *de se* property created by *ziji*’s adjunction to the embedded CP. The mismatch of person features between the matrix subject and the variable in the *de se* property would cause a problem for the semantic composition of the *de se* property with the matrix subject. Therefore, this type of BE, in the proposed system, turns out to be a semantic problem (failure of ascribing the *de se* property) that has a syntactic root (the  $\phi$ -Agree between *ziji* and its local subject).

As for (80) where Huang and Liu’s pragmatic account gives the wrong prediction (repeated here as (88a)), the proposed mechanism correctly rules out the long-distance



construal of *ziji* as another example of BE induced by the conflict of person features between the matrix subject and the variable in the *de se* property, as shown in (88b).

- (88) a. Wo<sub>i</sub> renwei [ni<sub>j</sub> bu yinggai kan-bu-qi ziji<sub>j/\*i</sub>].  
 I think you not should look-not-up self  
 ‘I<sub>i</sub> think you<sub>j</sub> should not look down on yourself<sub>j/\*i</sub>.’  
 b. #think (I, λx: x = [+Participant, –Speaker]. [you look down upon x<sub>[+p, –s]</sub>])

At this point, it is instructive to compare the featural makeup of *daodi* and *ziji*. I assume that *daodi* contains only the unvalued [Participant] feature, whereas *ziji* has an additional unvalued [Speaker] feature. The blocking of the remote first person antecedent by the local second person antecedent in (88) provides direct support for this assumption about *ziji* because if *ziji* contained only the unvalued [Participant] feature, which distinguishes only third person from first/second person, we would predict only the BE in (86), not the one in (88). Thus, *ziji* must contain the unvalued [Speaker] feature to draw a further distinction between first person and second person.

In this subsection, I demonstrated how the valuation mechanism of the person feature on *ziji* may explain not only the case where Huang and Liu’s (2001) analysis makes a wrong prediction, but also the blocking of the long-distance construal induced by different person features of the local and remote antecedents of *ziji*. In the next section, I extend the proposed system to explain a previously unnoted incompatibility between *daodi* and causal *zenme* ‘how come’.

### 3.7 Extension: the Incompatibility between Causal *Zenme* and *Daodi*

Although *daodi* ‘the-hell’ typically combines with a *wh*-associate to form an attitude-bearing *wh-the-hell* question in Chinese, it is not allowed to co-occur with causal *zenme* ‘how come’ to construct an attitude-bearing question, the expression of which constitutes an inquiry about cause or reason:

- (89) (\*Daodi) ta zenme zuotien mei lai shang ke?

the-hell he how-come yesterday not come attend class  
'How come (\*the hell) he did not come to class yesterday?'

This incompatibility is surprising because *daodi* can combine with *weishenme* 'why', which is also an adverb expressing an inquiry about the reason for or cause of the propositional content of the question:

(90) Daodi ta weishenme zuotien mei lai shang ke?  
the-hell he why yesterday not come attend class  
'Why the hell didn't he come to class yesterday?'

To the best of my knowledge, this incompatibility has not been previously noted or accounted for. In the next section, I will show that the previous studies of *how come* cannot provide an adequate explanation for this incompatibility in Chinese.

### 3.7.1 Previous studies of *how come*

Developing a suggestion in Collins (1991) concerning *how come*, Fitzpatrick (2005) advances a factivity analysis of *how come*-questions to explain an array of distinctions between *why* and *how come* such as the contrast with respect to rhetorical questions in (91).

(91) a. Why would John leave?  
b. \*How come John would leave?

The key idea in Fitzpatrick's analysis of the various disparities between *how come* and *why* is that only *how come* carries a genuine existential presupposition of the truth of the propositional content of the question. Also, rhetorical questions are negatively biased questions to which the speaker assumes that only a negative answer is the correct answer. Therefore, (91b) is ruled out due to the clash between the existential presupposition

carried by *how come* in (92a) and the negative bias of the rhetorical question in (92b) (the factivity-bias clash, henceforth).<sup>22</sup>

- (92) a. How come - Presupposed: He would leave.  
b. Rhetorical question - Negative bias: He would not leave.

On the basis of the contrast in (91), Fitzpatrick claims that in contrast to *how come*, *why* does not carry the existential presupposition of the truth of the propositional content of the question, and hence does not conflict with the negative bias of a rhetorical question. The apparent existential presupposition of a *why* question actually comes from the inference from the set of its possible answers as in (93) (Fitzpatrick 2005:7). The inference from all the possible answers to a *why* question like (93) is that John hit Bill (for whatever reason(s)), and this leads to the apparent factivity presupposition of a *why* question.

- (93) Why did John hit Bill?  
{John hit Bill for reason x, John hit Bill for reason y, John hit Bill for no reason}

First, I agree that *how come* presupposes the truth of the propositional content of the question it occurs in, but I do not think the factivity-bias clash can help us explain the illicit combination of causal *zenme* with *daodi* to form a *wh-the-hell* question. According to den Dikken and Giannakidou (2002: 43-44), a *wh-the-hell* question carries a negative attitude toward the propositional content of the *wh*-question (that is, the state of affairs described in the propositional content of a *wh-the-hell* question is characterized by the speaker as an event that s/he assumed should not happen). One possible way for Fitzpatrick's (2005) analysis to capture this incompatibility might be to say that the presupposition of *how come* conflicts with the negative attitude of a *wh-the-hell* question

---

<sup>22</sup> The presupposition of 'how come John left' is 'John left for *some* reason' rather than just 'John left' as assumed in Fitzpatrick's paper, and 'how come John would leave?' would be a felicitous rhetorical question only if the speaker has the expectation that 'there is *no* reason for John to leave.' This speaker's expectation conflicts with the presupposition of *how come*, and the infelicity of this rhetorical question is correctly predicted even if the speaker doesn't have a negative attitude toward the actual leaving. Although the infelicity of (91b) may be derived without assuming the negative attitude carried by *how come* argued for in this chapter, the goal of this section is to show that a factivity analysis of *how come* is not enough to explain the incompatibility between causal *zenme* 'how come' and *daodi* 'the hell' in Chinese.

as well. However, there are good reasons against this extension. Conceptually, it is perfectly reasonable and common for one to wish or think that a certain true proposition should not happen. Consider, for example, (94) with the factive verb *regret*:

(94) John regrets that he stole the book yesterday.

Factive verbs like *regret* presuppose the truth of the proposition of their complement clause. However, the verb *regret* also carries a negative attitude on the part of the referent of its subject that s/he would prefer that the event expressed by the embedded proposition were not to have happened. If factivity conflicts with negative attitude, (94) would be ungrammatical, but this is not borne out. Thus, we cannot exclude the combination of *daodi* and causal *zenme* by a constraint banning the combination of factivity and negative attitude.

Second, most semantic analyses of questions would have both ‘why did Mary leave’ and ‘how come Mary left’ presupposing the truth of “Mary left.” Even though Fitzpatrick (2005) contends that only *how come* carries the true existential presupposition of truth of the propositional content of the question, while the apparent presuppositionality of *why* questions should be viewed as the inference from the set of its possible answers,<sup>23</sup> it is not clear how this distinction can help us analyze the contrast between causal *zenme* and reason *weishenme* with respect to their combination with *daodi*, since the truth of the propositional content of a *weishenme* ‘why’ question is clearly presupposed by the speaker as well, regardless of the source of this presupposition. Therefore, I conclude that the factivity analysis does not provide an explanation for the incompatibility between *daodi* ‘hell’ and causal *zenme* ‘how come.’ In the next section, I briefly review den Dikken and Giannakidou’s (2002) analysis of *wh-the-hell* phrases in English as polarity items and argue that to account for the incompatibility problem between *daodi* and causal *zenme*, a polarity approach to *wh-the-hell*, although perhaps necessary, is not sufficient.

---

<sup>23</sup> Fitzpatrick seems to suggest that the presupposition of *how come* is based on its inherent semantics, while that of *why* questions is inferred from its set of possible answers as a pragmatic consequence. Despite this alleged underlying difference, the speaker of *why* questions clearly presupposes the truth of the propositional content in the question (cf. #*I don’t believe that John left, but I want to know why John left.*), and it is not clear why this presupposition does not conflict with the negative bias of a rhetorical question.

### 3.7.2 *Wh-the-hell* phrases as polarity items

Den Dikken and Giannakidou (2002) propose a comprehensive analysis of *wh-the-hell* phrases in English as dependent polarity items, which need to be licensed by a c-commanding nonveridical operator such as the question operator and negation. However, it is not clear how this licensing condition could rule out the combination of *daodi* ‘the hell’ and causal *zenme* ‘how come’ in Chinese. More specifically, if we combine den Dikken and Giannakidou’s polarity-licensing analysis of *wh-the-hell* phrases with Fitzpatrick’s (2005) proposal that *how come* selects a factive complementizer  $C_{FACT}$  that creates a factive island (cf. Melvold 1991), the relevant configuration involving both *daodi* and *zenme* would be as in the structure (95).

- (95) Nonveridical operator...*daodi* ... *zenme*  $C_{FACT}$ .....  
THE-HELL how-come

Notice that since *daodi* must c-command the *wh*-phrase *zenme*, the nonveridical operator, *daodi*, *zenme*, and the factive complementizer selected by *zenme* must form a successive-cyclic c-command relation. Crucially, the resultant configuration in (95) does not provide an explanation for the illicit combination of *daodi* and causal *zenme*, given that the licensing force of the nonveridical operator is not overridden by the  $C_{FACT}$  which is the lowest element in the structure.

Further, the licensing environments of *wh-the-hell* phrases noted by den Dikken and Giannakidou apply to *how come* as well, as evidenced by (96) and (97). One may also treat *how come* as a dependent polarity item based on this parallelism of licensing environments.

- (96) a. I \*(don’t) know who the hell would buy that book.  
b. He \*(didn’t) {told me/confirmed/realized} who the hell had spread those horrible rumors about me.
- (97) a. I ??(don’t) know how come John did not show up today.  
b. He ??(didn’t) {told me/confirmed/realized} how come John did not show up

yesterday.

However, the licensing condition of dependent polarity items is itself insufficient to rule out the combination of *how come* and *the hell*. This is because although it is possible to put two polarity items in one licensing environment as in (98a-b), (98c) is still ill-formed.

- (98) a. I don't know [who the hell would read any of the books].  
b. I don't know [how come anyone would spread bad rumors about me].  
c. \*I don't know [how come the hell John did not come to class yesterday].

Thus, to exclude the combination of *daodi* 'the hell' and causal *zenme* 'how come', we need to seek some other properties of *daodi* and causal *zenme* other than the licensing requirement of *wh-the-hell* phrases as polarity items proposed by den Dikken and Giannakidou (2002). In the next section, I marshal evidence for an analysis that treats causal *zenme* on a par with *daodi* in the sense that both of them are indeterminate in both their logophoric orientation and their identification of the attitude-bearer, and this property can be formalized as having an unvalued [Participant] feature.

### 3.7.3 *The negative attitude of causal zenme*

In this section, I argue that the observation about the logophoric orientation of attitude *de se* in Chinese *wh-the-hell* questions carries over to causal *zenme* questions. Therefore, the same derivational system proposed in section 3.6 applies to the interpretation of causal *zenme* questions as well.

Causal *zenme* 'how come' conveys the speaker's negative attitude toward the propositional content of the question. According to Tsai (2004:5), causal *zenme* contributes a sense of speaker's counter-expectation. More specifically, the state of affairs expressed in the propositional content of a causal *zenme* question does not match the speaker's expectation regarding what should be the real world situation. As we will see, it is precisely this speaker's negative attitude that distinguishes causal *zenme* 'how come' and reason *weishenme* 'why' with respect to their different compatibility with

*daodi* ‘the hell’. To see the mismatch between the propositional content of the causal *zenme* question and speaker’s expectation, consider (99):

- (99) Zhangsan zenme zai ku?  
Zhangsan how-come ASP cry  
‘How come Zhangsan is crying?’

The speaker of (99) holds the negative attitude that Zhangsan’s crying is contrary to his/her expectation, and hence is asking about the cause of this unexpected state of affairs.<sup>24</sup>

Chou (2012) shows that the following interrogatives that inquire about the reason for or the cause of a mathematical fact, one plus one equals two, illustrate speaker’s use of causal *zenme* to express his/her counter-expectation regarding the real world:

- (100) a. Yi jia yi **weishenme** hui denyu er?  
one plus one why would equal two  
‘Why does one plus one equal two?’  
b. #Yi jia yi **zenme** hui denyu er?  
one plus one how-come would equal two  
‘#How come one plus one equals two?’

(100a) and (100b) differ minimally in the interrogative adverb they use. However, (100b) is semantically/pragmatically odd. The subtle yet crucial distinction between them lies in speaker’s counter-expectation toward the propositional content of the question. By uttering (100b), the speaker is not only asking about the cause of the truth of the mathematical equation, but also expressing his/her negative attitude toward it, that is, the speaker thinks that the mathematical equation,  $1 + 1 = 2$ , does not match the real world

---

<sup>24</sup> Consider the contrast between *how come* and *why* in this aspect:

- (i) I expected Zhangsan to be crying, but  
a. why is he crying?  
b. \*how come he is crying?

Example (ib) is bad precisely because the speaker cannot utter a *how come* question that asks for the cause of some event or state that is consistent with his/her expectation.

fact, and asks for the cause of this mistaken equation. With this much said, it is obvious that the oddity of (100b) stems from the clash between this speaker's negative attitude induced by causal *zenme* and the real world mathematical fact, i.e., one plus one *indeed* equals two. As a result, an interrogative like (100b) is not a felicitous information-seeking question. Note that compared to causal *zenme*, reason *weishenme* 'why' is rather neutral with respect to speaker's attitude toward the propositional content of the question. The speaker of (100a) simply inquires about the principles underlying the mathematical equation, which he/she regards as the truth. The oddity of (100b), when compared with (100a), shows the contrast between causal *zenme* and reason *weishenme* in the negative attitude carried by the former. The oddity of (100b) also indicates that Fitzpatrick's (2005) factivity analysis of *how come* in English is not sufficient for causal *zenme* in Chinese. Causal *zenme*, carrying the factivity presupposition, should be able to combine with a true proposition expressing a mathematical fact to form an interrogative, but this is not borne out. Therefore, causal *zenme* 'how come' must have something more than this presupposition that is responsible for the oddity of (100b). I argue that it is the speaker's negative attitude that leads to this anomaly.

The prediction is that we can use causal *zenme* to question a proposition which is definitely false because the speaker can felicitously express his/her negative attitude that the propositional content does not match the real world fact. This prediction is borne out. Consider the contrast between (101) and (100b):<sup>25</sup>

- (101) Yi jia yi **zenme** hui denyu san?  
 one plus one how-come would equal three  
 'How come one plus one equals three?'

Since the propositional content "one plus one equals three" is not a mathematical truth, it is licit for the speaker to express his/her negative attitude that this equation does not match the real world fact, and inquire about the cause of this false equation.

---

<sup>25</sup> One context in which (101) is a felicitous question is when a young child, who is just beginning to learn basic arithmetic, thinks that one plus one equals three, and one may correct him/her by asking (101). On the other hand, one can never utter (100b) to teach or correct the child.



Additionally, the logophoric property of *daodi*'s negative attitude noted in section 3.6.1 carries over to the negative attitude of causal *zenme* as well. Compare the attitude ascription of (102) and (103):

(102) Lisi **zenme** mei lai shang ke?  
Lisi how-come not come attend class  
'How come Lisi did not attend the class?'

(103) Zhangsan xiang-zhidao [Lisi **zenme** mei lai shang ke]  
Zhangsan wonder Lisi how-come not come attend class  
'Zhangsan wonders how come Lisi did not attend the class.'

Just like the *daodi* question counterparts in (69) and (70), the ascription of the negative attitude of causal *zenme* varies according to its overt syntactic position. In direct questions such as (69) and (102), it is the external speaker holding the negative attitude, while in indirect questions such as (70) and (103), the negative attitude goes only to the matrix subject referent, i.e., the internal speaker of the embedded clause.

Summing up thus far, the negative attitudes carried by *daodi* 'the-hell' and causal *zenme* 'how come' must be ascribed to either the external speaker of the entire utterance or the internal speaker (typically the subject of certain speech-act verbs) for full interpretation of an attitude-bearing question. Any adequate analysis of questions containing *daodi* and causal *zenme* in Chinese must take this logophoric property into consideration. In the next subsection, it will be shown how the proposed unifying analysis of the two types of BE in Chinese can explain the incompatibility between *daodi* and *zenme*.

#### 3.7.4 Deriving the incompatibility between *daodi* and causal *zenme*

Based on the derivational system proposed in 3.6, I propose that the incompatibility between *daodi* and *zenme* can be explained in terms of the covert movement of *daodi* and *zenme* triggered by feature valuation. Recall that the attitude holder of the negative attitude of *daodi* depends on the overt position of *daodi* (see the discussion of (72)-(76)).

The same mechanism also applies to *zenme* questions as in (104)-(106). In a direct question like (104a), *zenme* raises to spec-POV as in (104b) to value its unvalued [Participant] feature as [+Participant], and as a result, the person feature amalgam [-Participant, -Speaker] of *zenme* and the POV in (104b) correctly identifies the bearer of the negative attitude of *zenme* as the speaker of the interrogative. For embedded *zenme* questions like (105a) and (106a), *zenme* raises to the embedded spec-POV to seek feature valuation and mark its scope as in (105b) and (106b); however, neither *zenme* nor the embedded POV has valued person features at this stage of derivation since both of them are indeterminate with respect to their logophoric orientation, which is determined by the minimal c-commanding subject as in (105c) and (106c) (=operation (79)).

(104) a. Ni zenme mei lai?  
 you how-come not come

‘How come you did not come?’

b. [CP **zenme**<sub>[+p]</sub> **POV**<sub>[+p, +s]</sub> [TP ni t mei lai]]?

(105) a. Ni xiang-zhidao [Lisi zenme mei lai] ma?  
 you wonder Lisi how-come not come Q<sub>yes-no</sub>  
 ‘Do you wonder how come Lisi did not come?’

b. [CP **zenme**<sub>[u,p]</sub> **POV**<sub>[u,p, u,s]</sub> [TP Lisi t mei lai]]

c. Ni xiang-zhidao [CP **zenme**<sub>[+p]</sub> **POV**<sub>[+p, -s]</sub> [TP Lisi t mei lai]] ma?

(106) a. Zhangsan xiang-zhidao [Lisi zenme mei lai]  
 Zhangsan wonder Lisi how-come not come  
 ‘Zhangsan wonders how come Lisi did not come.’

b. [CP **zenme**<sub>[u,p]</sub> **POV**<sub>[u,p, u,s]</sub> [TP Lisi t mei lai]]

c. Zhangsan xiang-zhidao [CP **zenme**<sub>[-p]</sub> **POV**<sub>[-p, -s]</sub> [TP Lisi t mei lai]] ma?

With the assumption of *zenme*'s movement to spec-POV for feature valuation, we are ready to explain the incompatibility between *zenme* and *daodi* in (107).

- (107) \*Daodi Lisi zenme mei lai?  
 THE-HELL Lisi how-come not come  
 Intended: 'How come the hell Lisi did not show up?'

Given that both *daodi* and *zenme* are subject to movement to the same position (=spec-POV) for feature valuation, the incompatibility between *daodi* and *zenme* in (107) can be accounted for in terms of a competition effect between *daodi* and *zenme* for the same syntactic position – spec-POV, as in (108).<sup>26</sup>

- (108) \*<sub>[CP</sub> Daodi<sub>[u,p]</sub> zenme<sub>[u,s]</sub> POV<sub>[+p, +s]</sub> [*t*<sub>daodi</sub> Lisi *t*<sub>zenme</sub> mei lai]?

This line of analysis gives the following correct prediction: if we split *zenme* 'how come' and *daodi* 'the-hell' into two interrogatives, the construction should be well-formed since each of them moves to different spec-POVs and thus their unvalued [Participant] features are each valued by a separate POV, not interfering with each other's valuation. (109a) and (109b) substantiate this prediction:

- (109) a. **Daodi** Zhangsan weishenme xiang-zhidao [Lisi **zenme** mei lai]?

---

<sup>26</sup> A reviewer of Chou (2012) suggests that ECP rules out the illicit combination in (107). Given that both *daodi* and *zenme* are adjuncts subject to movement to spec-POV, the derivation in (107) would be ruled out on a par with (i), in which by hypothesis there are also two adjuncts targeting a single syntactic landing site position (though one does so overtly, whereas the other one does it covertly).

- (i) a. \**Why* did you fix the car *how*?  
 b. \**How* did he leave early *why*?

The traditional ECP account of (i) (Lasnik and Saito 1984, 1992) is that both of the adjuncts need to be antecedent-governed, but only one of them satisfies this requirement. Given that the notion of government is not available under the minimalism framework, I do not adopt the ECP analysis, and suggest that the incompatibility results from the competition between *daodi* and *zenme* for the same syntactic position (=spec-POV) for feature valuation.

THE-HELL Zhangsan why wonder Lisi how-come not come  
 ‘Why the hell does Zhangsan wonder how come Lisi did not come?’

b. Lisi **zenme** hui xiang-zhidao [**daodi** Zhangsan xihuan shei]?  
 Lisi how-come would wonder THE-HELL Zhangsan like who  
 ‘How come Lisi would wonder who the hell Zhangsan likes?’

Notice that the success of the proposed analyses of the incompatibility of *daodi* and causal *zenme* depends on the hypothesis that what triggers the movement of *daodi* and *zenme* must be their unvalued [Participant] features. Otherwise, we cannot explain why they must target the same position, spec-POV. If the driving force of the movement were not the valuation of the [Participant] feature, we would not be able to explain why *weishenme* ‘why’, but not *zenme* ‘how come’, is compatible with *daodi*, as shown in (90) (repeated here as (110)):

(110) **Daodi** ta **weishenme** zuotien mei lai shang ke?  
 THE-HELL he why yesterday not come attend class  
 ‘Why the hell didn’t he come to class yesterday?’

Suppose that like *weishenme*, what drives the covert movement of *zenme* is its *wh*-feature, its landing position<sup>27</sup> would be different from that of *daodi*, and there would be no competition for the same syntactic position. Consequently, causal *zenme* ‘how come’ and *weishenme* ‘why’ would be both compatible with *daodi*, contrary to facts. Therefore, I conclude that *zenme* contains the unvalued [Participant] feature whose valuation requires its movement to spec-POV. Note that I am not saying the *wh*-feature on *zenme* does not motivate its covert movement. It does, but to a different position in the left periphery (see fn. 27). Therefore, causal *zenme* needs to move to two different positions in the left periphery, and the movement to one of these two positions (i.e. spec-POV) is problematic when *zenme* and *daodi* co-occur under the scope of the same question operator.

<sup>27</sup> Assuming Rizzi’s (1997) analysis of the left-periphery, the movement of the *wh*-phrase targets the specifier of either the Force Phrase or the Interrogative Phrase in the left periphery.

### 3.8 Summary

This chapter argues that what *daodi* ‘the hell’, LDA *ziji* ‘self’, and causal *zenme* ‘how come’ have in common is that they are all indeterminate (=underspecified lexically) in their logophoric orientation. For *daodi* and *zenme*, the negative attitudes conveyed by them need to be ascribed to either the external speaker or the internal speaker (the subject referent of certain speech-act verbs) to obtain the full interpretation of an attitude-bearing question. Additionally, Huang and Liu (2001) argue that the bare reflexive *ziji* with the long-distance interpretation is a logophor (cf. Sells 1987) whose reference depends on the point of view from which the sentence is uttered. I propose that their common logophoric property can be formalized as their unvalued [Participant] feature (and an additional unvalued [Speaker] feature for *ziji*) which must be valued for a full interpretation of the CI representation containing them.

For *daodi* and *zenme*, the POV valuation analysis proposed in this chapter constitutes an explicit mechanism to determine their logophoric orientation and the identification of their attitude-bearer. The logophoric orientation is determined either by entering into a  $\phi$ -Agree relation with the matrix POV as in (73) and (104) or by the minimal c-commanding subject via binding as in (74)-(76) and (105)-(106), while the attitude bearer is identified by the amalgam of the person features of *daodi*/causal *zenme* and the POV head at their scope position. Crucially, the value of the former cannot clash with the latter in Chinese *wh-the-hell* questions (=78)). This condition helps us analyze the BE associated with *wh-the-hell* questions in Chinese. That is, *daodi* cannot occur in the embedded clause of a direct question when the matrix subject is a third-person NP. In addition, this analysis also predicts that *daodi* is not compatible with causal *zenme* because their unvalued [Participant] features makes them compete for the same position, spec-POV, for feature valuation.

Formalizing logophoric orientation as unvalued person features also provides an analysis of the Agree-based BE of the long-distance construal of *ziji*. Under this analysis, the Agree-based BE of LDA *ziji* is derived as the failure of ascribing the *de se* property associated with LDA *ziji* to its long-distance antecedent. The failure results from the person feature mismatch of the long-distance subject antecedent and the variable in the *de se* property.

## Chapter 4 $\phi$ -features on T and Intra-phase Rule Ordering

### 4.1 Introduction

In the two previous chapters, under the lexical-featural hypothesis that there are no  $\phi$ -features on T in Chinese, I discussed the left-peripheral  $\phi$ -Agree operation and the Case/Topic-feature-driven A-movement in this language. In this chapter, I discuss another issue related to the presence /absence of  $\phi$ -features on T, focusing on the derivational ordering between T-to-C raising and other grammatical operations applying within a CP phase.

Chomsky (2013) identifies a new puzzle regarding the inversion in (1b) from (1a). First, notice that what (1a) requests is information which concerns swimming abilities, rather than flying abilities. Therefore, (2b), rather than (2a), can be a felicitous answer to (1b).

- (1) a. [Young eagles that fly] can swim.  
b. Can [young eagles that fly] swim?
- (2) a. Yes, they can fly.  
b. Yes, they can swim.

A well-known fact about syntactic operations like inversion in natural languages is that they are structurally dependent and hence observe structural minimality (as opposed to linear minimality). Therefore, it follows that the fronted auxiliary *can* in (1a) cannot originate from within the complex subject NP, as in (3), even though this position is linearly closer to the matrix C.

(3) \*Can [young eagles that \_\_\_ fly] swim?

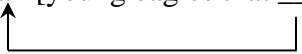

Accordingly, (1a) cannot be used to question the ability to fly, even though it is a fine thought and a legitimate question.

Given this observation, Chomsky questions another curious fact that is generally taken for granted: Why is it the case that the T head of the verbal phrase (=can) is selected for inversion, not the N head of the nominal phrase (=eagle)? Crucially, Chomsky notes that this puzzle does not arise if the schematic representation of (1b) is (4), which is built up in accordance with X-bar theory. T is the closest goal for inversion in this representation because TP, as complement of C, is the closest category to C's search. Accordingly, the T head of TP (realized by *can* in (1)) is selected for inversion.

(4) [CP C [TP NP [T' T [vP t<sub>NP</sub> ]]]]

Importantly, this view can be maintained only under X-bar theory, according to which the (raised) subject NP is located at spec-TP. However, Chomsky (2013) argues that this is a stipulation. To see this more clearly, notice that in the simpler Merge bare-phrase-structure system in Chomsky (1995, 2007, 2008), there are no notions like bar-levels or specifiers anymore, so the representation in (4) should be re-written as (5): The combination of T and vP yields a TP, rather than a T', and when the subject NP at spec-vP raises to merge with this TP, in Chomsky's words, "there is no more reason for NP to be spec-TP than for TP to be spec-NP." Therefore, the label of  $\alpha$  in (5) can be either a TP as in (5a), or an NP as in (5b).

(5) [C C [ $\alpha$  NP TP]]

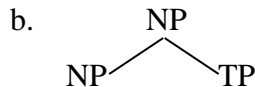
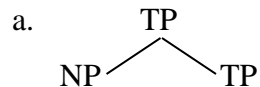

Given that there is no notion of specifier in this simpler Merge system, Chomsky argues that when C probes  $\alpha$  to select a goal for inversion, it cannot distinguish NP from TP

based on minimal structural distance. Also, since merging XP and YP in this system yields the set containing XP and YP, what C “sees” when it probes to locate a goal in (5) is actually a set-theoretic object {NP, TP} where there is no fixed order between NP and TP (since order is irrelevant to set membership, and is assumed to be solely a PF phenomenon).

Therefore, the empirical difficulty is how and when C searches and ‘finds’ T as the target of inversion. The critical question is where the subject NP is positioned when C initiates the search. Is it in spec-vP, where it is first merged, or does the subject raise to merge with TP before C initiates the search for inversion? Chomsky (2013) shows that only the former allows C to locate T as the licit goal for inversion in English. When C in (1b) ‘attracts’ T (=can) to derive (1a), the subject *young eagles that fly* must be at spec-v\*P as in (6) so that T is the uniquely closest goal for C’s probing because the closest category C “sees” in its search space at this stage of derivation is the TP produced by the combination of T and vP.

(6) T-to-C inversion precedes subject raising:

[<sub>CP</sub> C [<sub>TP</sub> can [<sub>v\*P</sub> [<sub>NP</sub> young eagles that fly] swim]]]



If by contrast, the subject is raised to spec-TP before minimal search by C as in (7), T is no longer the uniquely closest member in the minimal search space of C because what it faces is an unordered two-membered set {NP, TP} where the head of either TP or NP should be eligible for raising to C in a *yes-no* question. However, the option of raising the N head as in (8) does not yield a grammatical *yes-no* question.<sup>1</sup> Based on these observations, Chomsky argues that subject raising to spec-TP must in fact be preceding minimal search by C (as in (6)), but offers no explanation of why the other order (as in (7)) is barred, blocking (8).<sup>2</sup>

(7) T-to-C inversion follows subject raising:

<sup>1</sup> I will argue in section 4.4 that neither T nor N can be attracted for inversion to C in (7) because the principle of minimal search requires that the probe (=C) find a uniquely closest goal in its search space, but in (7), there are two eligible closest goals (=N and T) for inversion to C, a fatal ambiguity problem for C’s search.

<sup>2</sup> See section 4.5 for Kitahara’s (2011) attempt to explain the derivational order in (7).



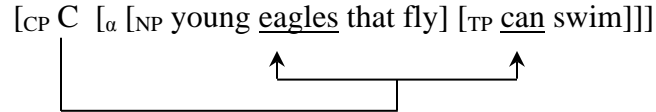

(8) \*Eagles [young that fly] can swim?

Two immediate questions arise as to whether the derivational order in (7) is ever possible and what consequences this order has for further syntactic computation. I will argue in section 4.4 that neither T nor N can be attracted for inversion to C in (7) because the principle of minimal search requires that the probe (=C) find a uniquely closest goal in its search space, but in (7), there are two eligible closest goals (=N and T) for inversion to C, a fatal ambiguity problem for C’s search. In this chapter, I investigate the empirical consequence of the derivational order in (7) by investigating the derivation of locative inversion in both English and Chinese. I argue that T-to-C raising is not allowed in the derivation of locative inversion in English as in (9) because the raising of the locative subject like “on the desk” in (9) must precede the application of T-to-C raising (=the order in (7)).

- (9) a. [On the desk] were placed a few pencils.  
 b. \*Were [on the desk] placed a few pencils?

By contrast, the Chinese counterpart does not need to adopt (7). I argue that this contrast is attributed to two factors: the presence of  $\phi$ -features on T and the categorial status of the locative phrase. This chapter is organized as follows. Section 4.2 introduces the main empirical issue this chapter is concerned with – the incompatibility between T-to-C raising in English locative inversion and the grammatical Chinese counterpart in the so-called A-not-A questions. Section 4.3 first reviews previous approaches to two prominent issues in the literature concerning the derivation of locative inversion: locality and the landing site of locative inversion. I then argue that the fronting of the locative phrase in locative inversion is topic A-movement. I develop my proposal of the (in)compatibility between locative inversion and T-to-C raising in section 4.4. The gist of my proposal is that the presence of  $\phi$ -features on T in a language can delay T-to-C raising, crucially

after some constituent raises to undergo internal Merge with T. I argue that the consequence of this delay is the formation of an opaque domain for T-to-C raising due to minimal search. Section 4.5 concludes this chapter and discusses an important difference between my analysis and Kitahara’s (2011) view of the derivational ordering in (7).

## 4.2 T-to-C Raising in Locative Inversion

The empirical focus of this chapter is locative inversion in English and Chinese as in (10) and (11), respectively.

(10) On the desk lie many books.

(11) Shuzhuo-shang bai-zhe henduo shu  
 desk-on lie-DUR many book  
 ‘On the desk lie many books.’

The major empirical question I am concerned with is why a *yes-no* question cannot be derived from English locative inversion, as shown by (12), whereas the Chinese counterpart is grammatical, as in (13).

(12) \***Do** on the desk lie many books?

(13) a. Shuzhuo-shang **shi-bu-shi** bai-zhe henduo shu?  
 desk-on FOC-not-FOC lie-DUR many book  
 b. Shuzhuo-shang bai-zhe henduo shu **ma**?  
 desk-on lie-DUR many book Q<sub>yes-no</sub>  
 ‘Is it the case that on the desk lie many books?’

Note that (13a) and (13b) represent two distinct kinds of questions in Chinese. The latter is a *yes-no* question with a *yes-no* question particle *ma* base-generated in C, whereas the former is called an “A-not-A question” (cf. Huang 1982, 1991; Hagstrom 2006). In this chapter, I focus on A-not-A questions because syntactically it is more similar to English

*yes-no* questions in that both involve establishing a syntactic relation between C and T. Specifically, auxiliary inversion in English shown by (12) is analyzed as T-to-C raising (together with *do*-support). Similarly, Huang (1982, 1991) argues convincingly that *A-not-A* questions in Chinese as in (13a) and (14) involve covert head movement of the *A-not-A* question morpheme based-generated at T/INFL to C. This head-movement analysis seeks to explain why the scope of an *A-not-A* question cannot go beyond island boundaries induced by the Head Movement Constraint (see Travis 1984), as shown by the ungrammaticality of (15) and (16).<sup>3</sup>

(14) Akiu xi-bu-xihuan ni?

Akiu like-not-like you

‘Does Akiu like you or not?’

(15) \*[Ruguo Akiu xi-bu-xihuan ni], ni jui hui nangguo?

if Akiu like-not-like you you then will sad

‘\*If Akiu likes you or not, then you will be sad?’

(16) \*Ni taoyen [neixie pi-bu-piping Akiu de ren]?

you hate those criticize-not-criticize Akiu MOD person

‘\*You hate those people who criticize Akiu or not?’

The difference between English and Chinese lies in when the C-T relation is established – auxiliary inversion in English takes place overtly, whereas the movement of the *A-not-A* question morpheme in Chinese is a covert operation. At least two possible analyses of the contrast between (12) and (13a) come to mind. First, one may argue that some peculiar properties of the derivation of locative inversion blocks overt T-to-C inversion in

<sup>3</sup> Notice that in the absence of islands, the *A-not-A* operator can be embedded, as evidenced by (i) and (ii), so the ungrammaticality of (15) and (16) is not due to any embedding restriction on the occurrence of the *A-not-A* operator.

- (i) Akiu xiangzhidao [Lisi xi-bu-xihuan zhe-ben shu]  
Akiu wonder Lisi like-not-like this-CL book  
‘Akiu wonders whether Lisi likes this book or not.’
- (ii) Ni renwei [Lisi xi-bu-xihuan zhe-ben shu] ne?  
you think Lisi like-not-like this-CL book Q<sub>wh</sub>  
Lit. ‘You think Lisi likes this book or not?’

English, while the covert counterpart in Chinese is somehow free from this ban. Therefore, the contrast boils down to the overt-covert contrast. Second, following Chomsky's (2013) observation and reasoning about (6) and (7), it is possible that the locative phrase in English raises to undergo internal Merge with T before T-to-C raising takes place, whereas the opposite order is observed in Chinese. In other words, the formation of a *yes-no* question in an English locative inversion structure exhibits the order in (7), while the Chinese counterpart follows the order in (6).

I contend that the first possibility cannot be maintained under the current minimalist framework assuming a single-cycle derivation from lexicon to the CI interface, as opposed to a derivation with multiple levels of representation (i.e. DS, SS, and LF) as in the GB era. Currently, the overt-covert distinction is determined by which member of a movement chain is pronounced (see Groat and O'Neil 1996): the pronunciation of the head of a movement chain produces an "overt" movement, whereas pronouncing the tail of a movement chain produces a "covert" movement. An immediate question arises as to why the tail, rather than the head, of the T-to-C movement chain is pronounced in Chinese. There is a principled account for this fact. The account is based on three facts about Chinese: it does not have v-to-T head movement (even though it has V-to-v raising, see the detailed argument in Huang 1997), the *A-not-A* question morpheme phonologically cannot stand alone, and there is no *do*-support in Chinese. Therefore, there is no way to pronounce the head of the T-to-C movement chain corresponding to the *A-not-A* question morpheme in Chinese, because the *A-not-A* question morpheme needs a phonological host but neither v-to-T raising nor *do*-support is available in Chinese. As a result, only the tail of the movement chain in T can be pronounced because the *A-not-A* question morpheme can be phonologically supported by the adjacent verb in this position.

Suppose the second analysis is on the right track and the order in (7) blocks T-to-C inversion (for which Chomsky does not provide an account), the next question is what is special about locative inversion that can reverse the usual order (6) in English, and why the Chinese counterpart is free from this effect. In the next section, I first review some previous analyses of the derivation of locative inversion in English and Chinese as the preliminaries to my proposal that locative inversion is topic A-movement.

### 4.3 The Derivation of Locative Inversion

Following Collins (1997) and Hale and Keyser (1993), I assume that in locative inversion construction, the locative phrase originates from a position lower than that of the theme DP as illustrated in (17).

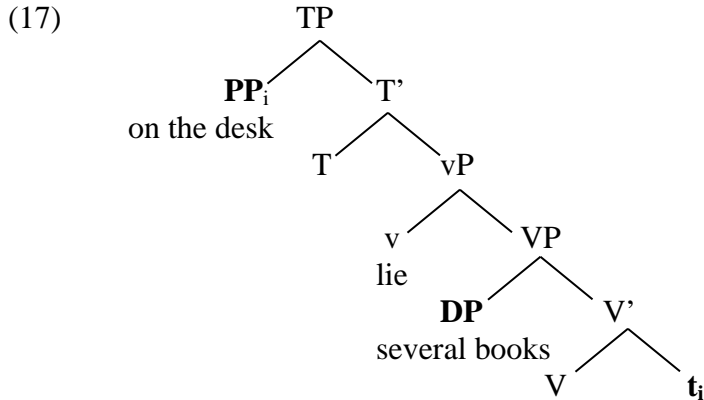

One of the most discussed issues in the literature on locative inversion is whether the movement of locative phrase across the theme DP violates locality if locality is defined based on strict c-command as in (18).

(18)  $\beta$  is closer to  $\gamma$  than  $\alpha$  is, if  $\gamma$  c-commands  $\beta$  and  $\beta$  c-commands  $\alpha$ .

Given that the theme DP is able to move to spec-TP (as in *several books lie on that desk*), if the movement of the locative phrase also targets spec-TP, then there is an apparent violation of the relativized minimality constraint banning movement of XP across a c-commanding YP in the configuration (19), where both YP and XP can move to merge with WP, and YP is closer to WP than XP is (see Rizzi 1991).

(19) \*WP ... YP ... XP

The second central issue concerns the landing site of locative inversion. The answer to this question is directly related to the first question. As noted above, the locality problem

arises only if locative inversion is A-movement. By contrast, if locative inversion is an A'-movement targeting the left periphery, then the locality concern does not arise since the movement of theme DP and that of the locative phrase target different positions and hence do not interfere with each other. In this section, I briefly review previous analyses of these two questions regarding the derivation of locative inversion. Then I argue that locative inversion is topic A-movement, and the locality problem is circumvented by the intermediate movement of the locative phrase to the vP phase edge, triggered by the unvalued interpretable Topic feature on the locative phrase.

#### 4.3.1 Locality

Assuming locative inversion is an A-movement targeting spec-TP (see the next section for evidence for this analysis) as in (20), it has been proposed that there are two ways for locative inversion to circumvent the locality constraint. First, Dogget (2004) argues that there is an EPP feature on v that raises the locative PP to outer spec-vP where it asymmetrically c-commands the theme DP and becomes closer to spec-TP (than the theme DP is) as in (21).

(20)  $[_{CP} C [_{TP} \mathbf{PP} T [_{vP} v [_{VP} \mathbf{DP} [V t_{PP}]]]]]$

(21)  $[_{TP} \_\_\_ T [_{vP} \mathbf{PP} v_{EPP} [_{VP} \mathbf{DP} [V t_{PP}]]]]]$

One clear downside of this approach is the recourse to EPP which is not an independent principle and can (or should) be reduced either to a structural requirement of agreement/Case and/or to general locality constraints on the syntactic derivation (see Epstein and Seely 1999, 2006; Epstein et al. 2005; Bošković 2002, 2007). Indeed it is desirable to have a derivational stage of locative inversion like (21) where the locality problem does not arise for the further movement of the locative phrase to spec-TP, but appealing to EPP on v makes the movement to the edge of vP a construction-specific rule. In section 4.3.3, I argue that the derivational stage in (21) indeed exists, but it is not

driven by an arbitrary assignment of an EPP feature to *v*; rather, it is triggered by the unvalued interpretable Topic feature on the locative phrase (see Chapter 2 for the same proposal for object raising in the Chinese raising modal construction).

Another approach to the locality problem appeals to Chomsky’s (1995, 2001) notion of equidistance. Some have argued that the movement of XP to WP across a c-commanding YP as in (19) does not violate the locality constraint under an appropriate condition on syntactic representations, called “minimal domain” (see Anagnostopoulou 2003, Bruening 2001, Collins 1997, and Wu 2008), as defined in (22a), associated with Chomsky’s (1995, 2001) notion of equidistance in (22b). In effect, (22b) amounts to relativizing closeness to minimal domains.

- (22) a. The minimal domain of a head H is the set of terms immediately contained<sup>4</sup> in a/any projection of H.  
 b. Terms of the same minimal domain are equidistant to the probe.

Wu (2008) argues that V-v-T raising is an obligatory precursor to the grammatical derivation of locative inversion as in (23).

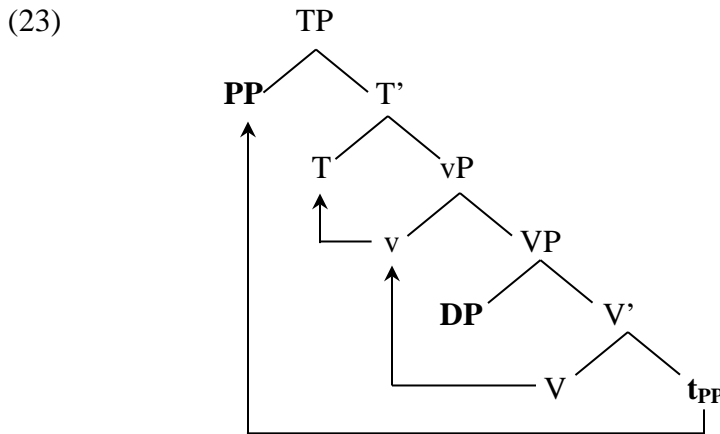

This is because the head movement can expand the minimal domain from {spec-VP (where the theme DP is located), Compl-V (where the locative phrase is located)} to

<sup>4</sup> When  $\alpha$  merges with  $\beta$ , the new object formed by this merger is  $K(\alpha, \beta)$ . The relation immediate containment holds of  $(K, \alpha)$  and  $(K, \beta)$ .

{spec-TP (=the landing site of locative inversion), spec-VP, Compl-V}. As the result of this expansion of the minimal domain, the locative phrase and the theme DP are equidistant to spec-TP, so the movement of either to spec-TP satisfies locality.

The major argument adduced by Wu (2008) to support the obligatory head raising to T in locative inversion is the auxiliary restriction in locative inversion as illustrated in (24).<sup>5</sup>

- (24) a. Down this hill rolled John.  
 b. ??Down this hill **has** rolled John.  
 c. ?? Down this hill **was** rolling John.  
 d. ?? Down this hill **will** roll John.

Wu argues that the ungrammaticality of (24b-d) is because the obligatory V-v-T raising to expand the minimal domain in (23) to license locative inversion is blocked by the presence of the auxiliary in T, as in (25).

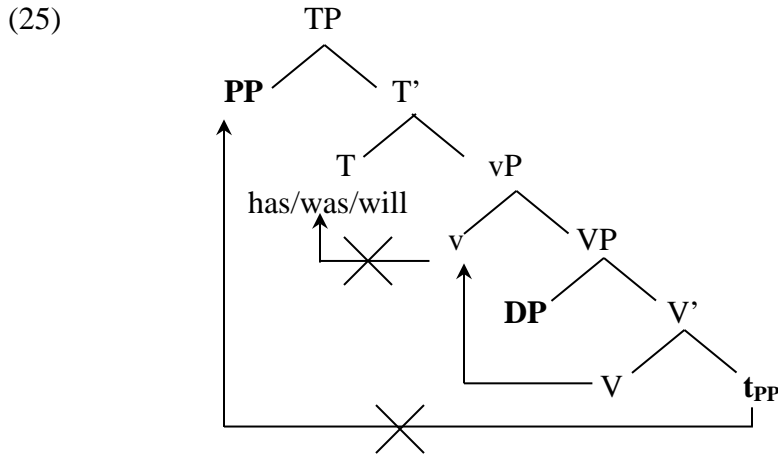

There are several conceptual and empirical difficulties facing this analysis of locative inversion based on equidistance and the prerequisite head raising. First, the notion of

<sup>5</sup> As Ezra Keshet (personal communication) points out the auxiliary restriction in (24b-d) is found (only?) with activity verbs. The following sound comparatively better:

- (i) a. On the path *had* fallen the thickest blanket of snow I had ever seen.  
 b. On the wall *was* hanging a portrait of the late king.  
 c. In front of the new house *will* stand a statue of my mother.



minimal domain in (22a) is a representational one which has a peculiar status in the current minimalist framework, which assumes that narrow syntax is a derivational computation, and there is no clear explanation for why there should be an equidistance relation applying to all the terms in a minimal domain. In other words, equidistance as defined in (22b) is a representational stipulation or an unexplained definition. As Epstein et al. (1998) insightfully point out, there could be countless conceivable syntactic relations that can be defined on tree representations, so representation-based relations are ad hoc and non-explanatory. Second, Doggets (2004) argues convincingly that equidistance is not only conceptually ad hoc and unnecessary, but it also makes wrong predictions in a variety of constructions, including passivization in applicatives, movement to multiple specifiers, and Agree with multiple specifiers.<sup>6</sup> Third, Wu argues that the fact that V-v-T raising is an obligatory precursor to the derivation of locative inversion (by expanding the minimal domain) can be generalized to derive other inversion structures like English quotative inversion and sentences with sentential subjects as in (26a) and (26b), because they all involve moving a constituent lower than the subject DP within vP and thus the expansion of the minimal domain via V-to-v-T raising as in (27) is necessary for the derivation of these inversion constructions.

- (26) a. “Where is my key?” asked John.  
 b. That John showed up annoyed Mary.

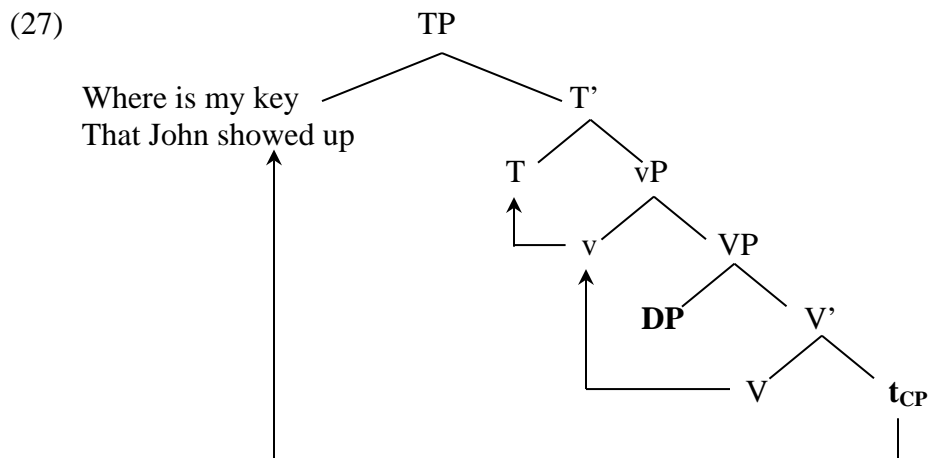

<sup>6</sup> Due to space limitations, I refer readers to Dogget (2004) for a detailed discussion of the empirical failure of the proposed theory incorporating the postulates of “minimal domain” and “equidistance”.

Even though the auxiliary restriction observed in locative inversion in (24) also holds for quotative inversion, as in (28), sentences with a sentential subject are free from this restriction, as evidenced by (29). The analysis based on the notions of minimal domains and equidistance wrongly predicts that (29) should be ungrammatical because the auxiliary prevents the verb from rising to T to expand the minimal domain. This suggests that V-v-T raising does not hold as a universal prerequisite operation for moving a phrase whose base-generated position is lower than that of the subject DP (see also the data in footnote 5). This then weakens the explanatory force of any analysis exclusively relying on the notion of minimal domain, especially if it is dependent on the application of overt v-V-to-T raising. In sum, the apparent lack of V-raising in structures involving sentential subjects suggested by (29), together with the empirical difficulties noted by Dogget (2004), weakens the validity of the equidistance-via-head raising analysis.<sup>7</sup>

- (28) a. \**“Where is my key?” has* asked John.  
 b. \**“Where is my key?” was* asking John.  
 c. \**“Where is my key?” will* ask John.
- (29) a. That John showed up *has* annoyed Mary.  
 b. That John showed up *was* annoying Mary.  
 c. That John showed up *will* annoy Mary.

#### 4.3.2 A, A-bar, or both?

Another main disagreement in the literature on the derivation of locative inversion in English concerns the correct landing site of the inverted locative phrase. Some argue that it occupies spec-TP as in (30) (i.e., it is an A-movement; see Bresnan 1994, Collins 1997, Levin and Rappaport 1995, and Dogget 2004).<sup>8</sup>

<sup>7</sup> I do not have an explanation for why the auxiliary restriction holds only in locative inversion and quotative inversion but not in structures involving sentential subjects.

<sup>8</sup> For expository convenience, I ignore the issue of locality of the derivation of locative inversion in this section. Therefore, when illustrating the movement path under different approaches to the derivation of locative inversion, I omit the edge of vP as a potential intermediate landing site in the movement of the locative phrase to either spec-TP or the left periphery.

(30) A-movement approach to English locative inversion

[<sub>TP</sub> [On the desk]<sub>i</sub> T [<sub>vP</sub> sat a frog t<sub>i</sub>]].

Some maintain that the fronted locative phrase in locative inversion raises to the topic position in the left periphery, whereas spec-TP is occupied by an expletive (i.e., the Null Expletive Hypothesis, NEH, henceforth) (see Kuno 1971, and Postal 1977, 2004, Coopmans 1989), as shown by (31).

(31) A'-movement + NEH

[<sub>CP</sub> [On the desk]<sub>i</sub> [<sub>TP</sub> **pro**<sub>there</sub> sat a frog t<sub>i</sub>]].

Wu (2008) proposes a synthesized approach, arguing that locative inversion in English is a two-step movement: it first raises to spec-TP, and then undergoes obligatory A'-movement to the left periphery, as shown by (32).

(32) Wu's (2008) approach to English locative inversion

[<sub>CP</sub> [On the desk]<sub>i</sub> [<sub>TP</sub> t<sub>i</sub> T [<sub>vP</sub> sat a frog t<sub>i</sub>]].

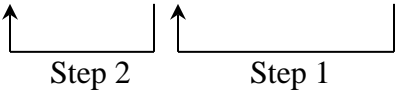

Step 2                      Step 1

In this section, I review the arguments in these previous analyses of English locative inversion. I will argue in the next section that the A-movement approach to locative inversion is on the right track and the data adduced by those maintaining the A'-movement approach can be deduced from my proposal that syntactically locative inversion is A-movement, although semantically it exhibits topicality.

The A'-movement + NEH approach shown by (31) contends that the only difference between locative inversion like (31a) and the existential-*there* construction like (33b) lies in the overt pronunciation of the expletive *there*. The NEH provides a straightforward account for why in both locative inversion and existential-*there* construction, the verb agrees with the postverbal DP, rather than with *there* or the fronted locative phrase.

- (33) a. [CP [On the desk]<sub>i</sub> [TP **pro**<sub>there</sub> sat a frog t<sub>i</sub>]].  
 b. [CP [On the desk]<sub>i</sub> [TP **there** sat a frog t<sub>i</sub>]].

However, Dogget (2004) and Wu (2008) argue that the NEH faces several difficulties. First, given that English is not a *pro*-drop language, assuming the existence of a null expletive in English locative inversion is a construction-specific stipulation because one would have to say that null subject *pro* is allowed in English locative inversion, but crucially not in other constructions in this language. Second, NEH fails to predict the contrast between (34) and (35) in the suppression of the Weak Crossover effects (WCO).

- (34) a. [Into every dog<sub>j</sub>'s pen]<sub>i</sub> peered its<sub>j</sub> owner t<sub>i</sub>.

- (35) \* [Into every dog<sub>j</sub>'s pen]<sub>i</sub> **there** peered its<sub>j</sub> owner t<sub>i</sub>.

As noted by Culicover and Levine (2000), locative inversion shows the typical property of A-movement in suppressing WCO; however, the NEH predicts that both (34) and (35) should induce WCO since NEH assumes that the locative phrase in both undergoes direct A'-movement to the left periphery and that the only difference between them is the pronunciation of the expletive *there*, which should not cause any difference in the suppression of WCO.

Third, as pointed out by Wu (2008: 57), if English locative inversion does involve a null expletive *there*, we expect locative inversion to display a Definiteness Effect, a typical property of existential-*there* construction illustrated in (36). However, this prediction is not borne out, as evidenced by the contrast in (37). Given these considerations, the A'-movement + NEH approach is not tenable.

- (36) There seems to be {a/\*the/\*every} student in the room.

- (37) a. \*Into the room **there** entered **the** student that I met at the party yesterday.  
 b. Into the room entered **the** student that I met at the party yesterday.

Moreover, there are two convincing arguments for the A-movement approach which maintains that the fronted locative phrase in locative inversion occupies spec-TP and behaves like common subject DPs. First, Bresnan (1994) notes that both common subject DPs and the fronted locative phrase can undergo raising as in (38) and (39).

(38) Mary seems \_\_\_ to like this book.

(39) a. [Over my window] seems \_\_\_ to have crawled an entire army of ants.  
b. [On that hill] appears \_\_\_ to be located a cathedral. (Bresnan 1994)

Second, the extraction of both common subject DPs and the fronted locative phrase exhibits the well-known *that*-trace effect as in (40) and (41) (cf. Bresnan 1994, Stowell 1981).

(40) a. Who<sub>i</sub> do you think t<sub>i</sub> likes Mary?  
b. \*Who<sub>i</sub> do you think that t<sub>i</sub> likes Mary?

(41) a. It's [in these villages]<sub>i</sub> that we will believe t<sub>i</sub> can be found the best examples of this cuisine.  
b. \*It's [in these villages]<sub>i</sub> that we will believe that t<sub>i</sub> can be found the best examples of this cuisine. (Bresnan 1994)

Even though the fronted locative phrase and common subject DPs have striking similarities, indicating that the former also occupies spec-TP, the fronted locative phrase still differs from common subject DPs in two important respects. First, the verb in locative inversion does not agree with the fronted locative phrase; rather, it is the postverbal DP that determines the agreement, as shown by (42).

(42) On the desk lie(\*s) several books by Chomsky.

Second, as mentioned above, the fronted locative phrase, unlike common subject DPs, cannot undergo subject-auxiliary inversion, as shown by the contrast in (43).

- (43) a. \*Do on the desk lie many books?  
b. Do many books lie on the desk?

Nevertheless, these two properties of the fronted locative phrase do not exclude the analysis of locative inversion as A-movement based on the data from (38)-(41). This is because they can be derived from other factors in the derivation of locative inversion. Anticipating the detailed discussion and analysis of the ungrammaticality of (43a) in section 4.4 below, I focus on the explanation for (42) here. The inability of the locative phrase to determine agreement follows from Grimshaw's (1991) and van Riemsdijk's (1990, 1996) proposal that locative prepositional phrases are extended nominal categories equipped with some, but not full,  $\phi$ -features (see also works on adpositional phrases by Koopman 1997, den Dikken 2003, and Svenonius 2007 that suggest locative prepositional phrases are associated with rich functional structure). Unlike genuine nominal categories, locative phrases do not contain a full set of  $\phi$ -features (i.e. they are  $\phi$ -defective). Therefore, the unvalued  $\phi$ -features on T can be valued only by the postverbal theme DP in locative inversion.

Finally, Wu (2008), adopting most of the arguments for an A-movement analysis of locative inversion, proposes that locative inversion in English, after moving to spec-TP, undergoes an obligatory A'-movement to the left periphery, as illustrated by (44). She contends that this step of movement can be regarded as topicalization to the left periphery, and notes several facts suggesting the obligatory second step of the derivation of English locative inversion in (44). The general idea of her arguments is that the fronted locative phrase in English locative inversion bears significant syntactic resemblance to an A'-moved topic phrase in English.

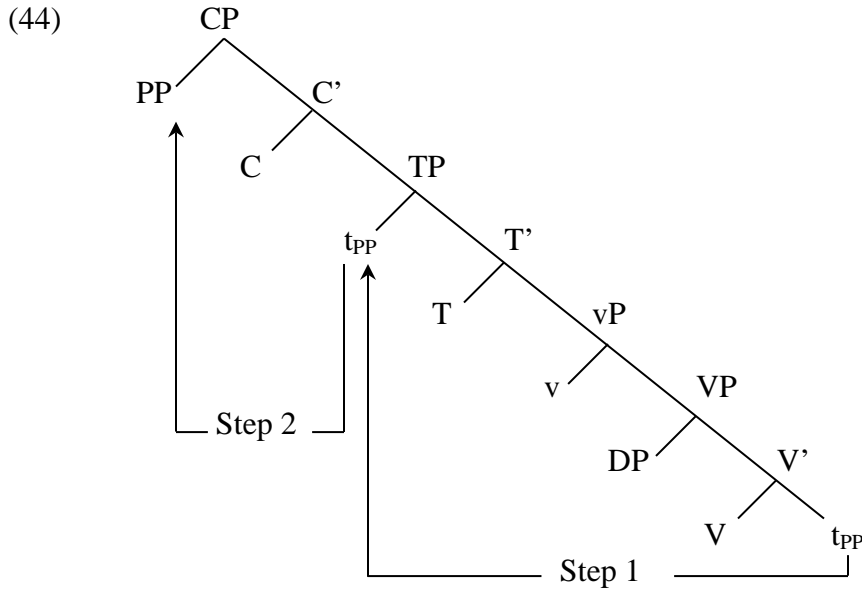

Wu reasons that the syntactic resemblance receives a straightforward account if the locative phrase in English locative inversion, like the topicalized phrase, ends up in the left periphery. The first argument has to do with Exceptional Case Marking (ECM) constructions. Given that ECM verbs like *believe* and *consider* select a TP complement, Wu's analysis predicts that English locative inversion cannot occur in the complement clause of an ECM verb because there is not enough "space" in the TP complement of an ECM verb for the second step of movement in (44). This prediction is borne out, as evidenced by (45). Note that this constraint is also observed with embedded A'-topicalization, as in (46).

(45) \*John believes/considers [[in that room]<sub>i</sub> t<sub>i</sub> to sit a frog t<sub>j</sub>].

(46) \*John believes/considers [Mary<sub>i</sub>, Bill to have killed t<sub>j</sub>].

The second argument comes from the incompatibility between the fronted locative phrase and an A'-moved topic phrase. Wu notes that the ungrammatical A'-topicalization of both direct and indirect objects in (45) suggests that stacking of topic phrases via syntactic movement in English is prohibited. Since the locative PP moves to the topic

position in the left periphery under Wu's proposal, the same incompatibility between a topicalized phrase and locative inversion is expected, as evidenced by (48).

(47) \*John<sub>i</sub>, the book<sub>j</sub>, I gave t<sub>j</sub> to t<sub>i</sub>.

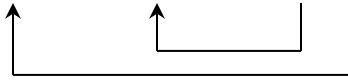

(48) \*This person<sub>i</sub>, [under the bed]<sub>j</sub> t<sub>j</sub> hid t<sub>i</sub>.

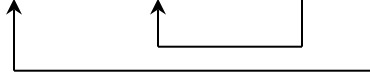

She maintains that the further topicalization of the locative phrase in English is to avoid the Intervention Constraint (IC, hereafter) in (49):

(49) The Intervention Constraint (cf. Chomsky 2000: 123)

$\alpha > \beta > \gamma$  (where the relation  $>$  designates c-command)

AGREE ( $\alpha, \gamma$ ) fails when  $\alpha$  is a probe and  $\beta$  is a closer matching goal to  $\alpha$  than  $\gamma$  is, even if  $\beta$  (i) is inactive due to a prior Agree with some probe, or (ii) is defective in the relevant features under Agree.

Her reasoning is based on three crucial assumptions. First, she adopts the feature inheritance hypothesis developed in Chomsky (2007, 2008). Nonetheless, she departs from the original proposal in that it is C that initiates  $\varphi$ -probing, rather than T inheriting the  $\varphi$ -features from C. Second, she assumes the existence of EPP on T as a universal structural requirement. Third, following Grimshaw (1991) and van Riemsdijk (1990, 1996), Wu assumes that locative prepositional phrases are  $\varphi$ -defective extended nominal categories. Given these three assumptions, Wu contends that at the derivational stage in (50), the locative PP at spec-TP induces defective intervention effect in the sense of (49ii).



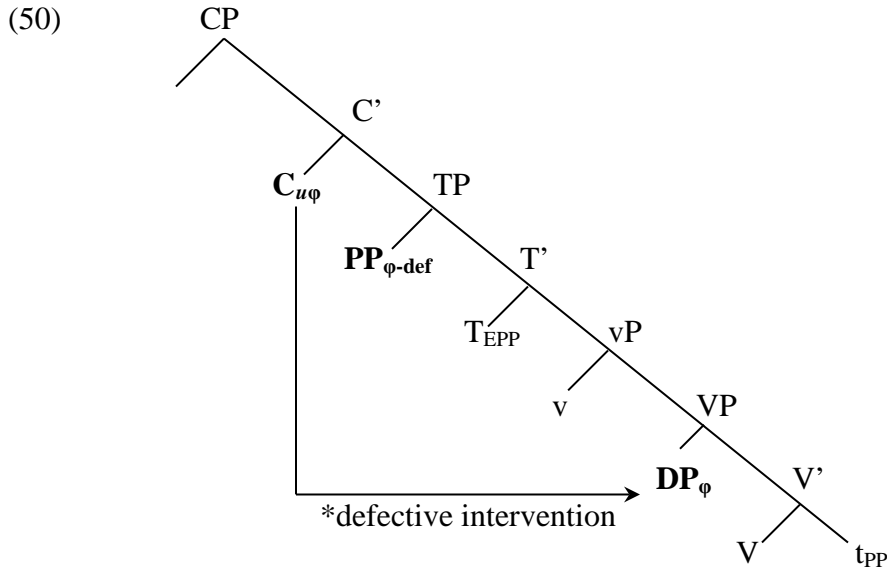

To resolve the defective intervention effect, Wu argues that the  $\phi$ -defective locative PP has to undergo obligatory movement to spec-CP as in (44) so that there is no intervener<sup>9</sup> for the  $\phi$ -Agree relation between C and the theme DP in VP.

Her proposal for the derivation of English locative inversion is summarized in (51). First, the locative PP is raised to merge with T to satisfy EPP in (51a) (under the minimal domain representation discussed in the last section). However, the  $\phi$ -features on C cannot be valued if the locative PP stays in spec-TP because the locative PP is  $\phi$ -defective and stands in the way between C and the  $\phi$ -complete subject NP staying in the vP. Therefore, the obligatory topicalization of the locative PP in (51b) can be understood as a last resort rescue strategy to avoid violating the IC. Finally, with the locative PP out of the way, C can establish the probe-goal relation with the subject NP in the vP to value its  $\phi$ -features.<sup>10</sup>

(51) [<sub>CP</sub> [On the table]<sub>i</sub> C [<sub>TP</sub> t<sub>i</sub> T [<sub>vP</sub> sits [a frog] t<sub>i</sub> ]]]

a. The locative PP raises from within vP to spec-TP (to satisfy EPP)

b. Obligatory topicalization of the locative PP (to avoid violation of the IC in (49))

<sup>9</sup> Wu assumes that the tail of a movement chain does not cause intervention. That is, only the entire chain would induce such effect.

<sup>10</sup> Even though Wu argues that  $\phi$ -features originate from C and the  $\phi$ -defective locative PP at spec-TP blocks the  $\phi$ -Agree between “C” and the  $\phi$ -complete theme DP, she states that there is a long-distance  $\phi$ -Agree relation between “T” and the theme DP after the locative PP moves to the left periphery in (51c). The same problem occurs in her analysis of Chinese locative inversion in (52). It is not clear to me what is meant here. See below for further discussion of this possible inconsistency in her analysis.

c. After the locative PP raises to CP, T initiates Agrees with the post-verbal DP

[adapted from Wu 2008: 38]

Wu points out an interesting prediction of this analysis: if the locative phrase can be a nominal phrase with a full set of  $\phi$ -features in a certain language, the topicalization in step (51b) in English is no longer necessary (hence inapplicable, given Chomsky's 1995 Last Resort) because C can value its  $\phi$ -features with the closer locative nominal phrase at spec-TP. She maintains that Chinese exemplifies such a language because the locative phrase in Chinese is a nominal phrase. Her analysis of Chinese locative inversion is summarized in (52).

(52) [TP [locative NP]<sub>i</sub> T [vP v [theme DP] t<sub>i</sub>]]

a. The locative nominal stays at spec-TP and Agrees with T

b. The postverbal DP Agrees with v

[Wu 2008: 61]

Wu notes that locative inversion in Chinese displays raising as in (53) and suppression of WCO as in (54), and both are hallmark properties of A-movement.<sup>11</sup>

(53) a. [Chuang-bian]<sub>i</sub> sihu t<sub>i</sub> pa-zhe yi-dui mayi dajun t<sub>i</sub>. [Raising]

window-LOC.by seems crawl-DUR one-CL ant army

'By the window seems to crawl an army of ants.'

b. [Cunzhuang-li]<sub>i</sub> haoxing t<sub>i</sub> zuo-luo-zhe yi-dong jiaotang t<sub>i</sub>.

village-LOC.in appear locate-DUR one-CL cathedral

'In the village appears to be located a cathedral.'

(54) [Mei-ge-ren<sub>i</sub> de shuzhuo-shang]<sub>j</sub> dou bai-zhe tade<sub>i</sub> shu t<sub>j</sub> [No WCO]

every-CL-person MOD desk-LOC.on DOU place-DUR his book

Lit. 'On everyone<sub>i</sub>'s table was placed his<sub>i</sub> book.'

<sup>11</sup> Words like *bian* 'by' and *li* 'in' are not prepositions in Chinese; rather, they are relational nouns, glossed as localizers (LOC) which specify the relative location with respect to a certain object. See Wu (2008: 61-64) for arguments that the combination of a noun and a localizer in Chinese is a nominal phrase.

Wu's (2008) proposal of how the categorial status of a locative phrase in a certain language affects the derivation of locative inversion in that language is insightful, but she leaves one important question unanswered. In particular, for Wu's analysis to go through, she must assume the feature inheritance hypothesis. This is clear in her argument that a  $\phi$ -defective locative PP at spec-TP stands in the way of the  $\phi$ -Agree relation between "C" and the  $\phi$ -complete post-verbal theme DP. This is precisely why she argues that a further A'-movement of the locative PP to the left periphery is necessary to avoid defective intervention in English. However, she only adopts the assumption that  $\phi$ -features start out on C, but never states explicitly whether the inheritance of  $\phi$ -features from C to T has to take place (see footnote 10). On the one hand, she argues that "C" needs to  $\phi$ -Agree with the theme DP; on the other, it is only after the  $\phi$ -defective locative PP moves to the left periphery that "T" is able to establish long-distance  $\phi$ -Agree with the post-verbal theme DP. I see two possibilities to proceed here, each of which has its problems. First, suppose inheritance from C to T does take place, the  $\phi$ -defective locative PP is not within the c-command domain of T's  $\phi$ -probing as in (55), so there is no need to move the locative PP further to the left periphery to avoid defective intervention effect:

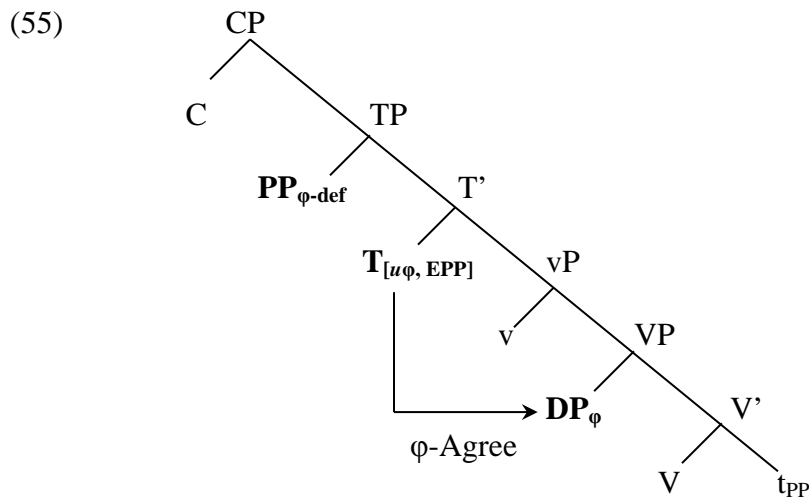

Therefore, if Wu assumes inheritance of  $\phi$ -features from C to T takes place (as suggested by (51c)), the fronted PP can remain in spec-TP, and does not need to move further to the left periphery, contradicting Wu's original analysis of English locative inversion.

The second possibility to interpret the possible inconsistency in Wu's analysis is that inheritance does not take place and C keeps the  $\phi$ -features throughout the derivation. However, this does not square with the *do*-support operation in the context of negation in English, as shown by (56).

- (56) a. John **does** not like pizza.  
b. John and Mary **do** not like pizza.

The contrast between *does* and *do* as well as their syntactic position in T shown in (56) are not expected if C does not pass down the unvalued  $\phi$ -features to T throughout the derivation. The feature inheritance hypothesis maintains that  $\phi$ -features are not inherent features on T, so if C keeps the  $\phi$ -features throughout the derivation, we do not expect to see different morphological realizations of the dummy *do* auxiliary under T, which is standardly analyzed as a reflex of  $\phi$ -Agree (in particular, the number feature) with the subject NP.

Summing up, Wu's proposal has an inconsistency concerning the locus of the  $\phi$ -probe. On the one hand, C cannot keep  $\phi$ -features throughout the derivation in English, as evidenced by (56); on the other hand, if T inherits  $\phi$ -features from C, the  $\phi$ -defective locative PP at spec-TP, being out of the probing domain of T, does not cause any defective intervention effect, and so A'-movement of the locative phrase is not forced, contra Wu's analysis. Therefore, I conclude that locative inversion in both English and Chinese is A-movement targeting spec-TP, and there is no need to postulate the further A'-topicalization to avoid defective intervention effects in English locative inversion.

The next question is how to deal with the apparent A'-properties in (45)-(48) adduced by Wu to argue for the obligatory A'-topicalization of the locative PP in English. In the next section, I will develop my analysis of locative inversion as topic A-movement and argue that the apparent A'-properties in (45)-(48) follow from the mechanics of the inheritance of the Topic feature from C to T and the discourse conditions on locative inversion. More specifically, locative inversion has A-properties because the fronted locative phrase lands at spec-TP, an A-position, whereas it has A'-properties not because

the fronted locative phrase is in an A'-position in the left periphery, but because it bears a Topic feature.

#### 4.3.3 Proposal: locative inversion as topic A-movement

Bresnan (1994) argues that the post-verbal DP in locative inversion gets a specific “presentational focus” interpretation, as exemplified in (57).

- (57) A: I'm looking for my friend John. (Bresnan 1994)  
B1: #Among the guests of honor was sitting John.  
B2: John was sitting among the guests of honor.

The response in B1 is semantically/pragmatically odd because it requires a context where (i) John would have been introduced to the discourse as a new individual and (ii) the guests of honor would have been mentioned in the previous discourse. Neither of these two discourse requirements is met in the context of a preceding utterance like A. Chinese locative inversion is also subject to these two discourse conditions, as evidenced by (58).

- (58) A: Wo zai zhao wode beibao.  
I PROG look.for my backpack  
'I am looking for my backpack.'  
B1: #Shuzhuo-shang fang.zhe nide beibao.  
desk-LOC.on place.DUR your backpack  
'On the desk was placed your backpack.'  
B2: Nide beibao fang zai shuzhuo-shang.  
Your backpack place at desk-LOC.on  
'Your backpack was put on the desk.'

Given these two discourse conditions, I propose that locative inversion in both Chinese and English is topic A-movement, the same process as the topic A-movement in Chinese raising modal constructions discussed in Chapter 2. In particular, the locative phrase, whether nominal or not, can be assigned the unvalued interpretable Topic feature upon

the formation of the Numeration. Let's examine the step-by-step derivation of the English locative inversion under this assumption. First, (59) shows the stage vP with V-to-v raising and no movement of either the theme DP or the locative phrase has taken place. Note that following Belletti (1988), the theme DP *many books* receives partitive Case within vP from the unaccusative verb *lie*.

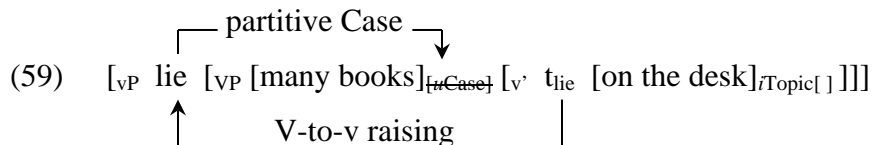

Next, recall that one of the most discussed questions regarding the derivation of locative inversion is how the A-movement of the locative phrase to spec-TP across the c-commanding theme DP at spec-VP can circumvent the locality problem. As noted, previous analyses either assume the notion of equidistance under the representational stipulation of minimal domains or postulate an EPP feature on v. Both approaches have their downside, as I discussed in section 4.3.1. I argue that the locality problem receives a straightforward account under my proposal if we assume Bošković's (2007) moving-element-driven approach to movement and the hypothesis that unaccusative vPs are also phases that induce Transfer (see Legate 2003 and Sauerland 2003). More specifically, the unvalued Topic feature on the locative phrase provides a local cue for moving the locative phrase to the edge of the vP phase to avoid early transfer of the locative phrase, as in (60). Notice that this step of movement does not appeal to an arbitrary assignment of the EPP feature to v, and crucially, the locative phrase sitting at the edge of the vP phase is hierarchically higher than the theme DP *many books* at spec-VP. Therefore, my proposal that there is an unvalued Topic feature on the fronted locative phrase entails that no locality problem arises in the derivation of locative inversion.

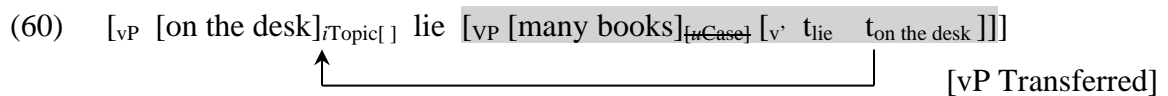

With the locative phrase at the edge of the vP phase, let's proceed to the next stage of derivation where the matrix C and T enter the derivation, as in (61a). Notice that C passes down the valued yet uninterpretable Topic feature to T in (61b) (the same Topic feature inheritance seen in the derivation of topic A-movement in Chinese raising modal construction discussed in Chapter 2). Last, the locative phrase at the edge of vP raises to spec-TP for Topic feature valuation in (61c).

- (61) a. [CP C<sub>uTopic[+]</sub> [TP T [vP [on the desk]<sub>iTopic[ ]</sub> lie [VP [many books]<sub>tuCase[ ]</sub>]]]]  
 b. [CP C [TP T<sub>uTopic[+]</sub> [vP [on the desk]<sub>iTopic[ ]</sub> lie [VP [many books]<sub>tuCase[ ]</sub>]]]]  
 c. [CP C [TP [on the desk]<sub>iTopic[+]</sub> T<sub>uTopic[+]</sub> [vP t lie [VP [many books]<sub>tuCase[ ]</sub>]]]]
- 
- The diagram in (61c) shows a bracket under the locative phrase "[on the desk]" in the TP complement, with an arrow pointing up to the T<sub>uTopic[+]</sub> feature in the TP complement. Another arrow points from the C<sub>uTopic[+]</sub> feature in the CP complement down to the T<sub>uTopic[+]</sub> feature in the TP complement, indicating feature inheritance.

If locative inversion is topic A-movement, we predict that it should exhibit other topic-like properties aside from the discourse conditions noted in (58). Recall that in Chapter 2, I appeal to the cardinal-proportional/presuppositional ambiguity of weak quantifiers like *many students* to argue that the A-movement in Chinese raising modal construction semantically exhibits topicality. The relevant examples are repeated in (62) and (63) for expository convenience.

- (62) Many students are in the dorm.  
 a. A lot of students are in the dorm. [Cardinal reading]  
 b. A large proportion of the set of students is in the dorm (whereas a small proportion of the set is in e.g. the café.) [Proportional reading]

- (63) You hendouou xuesheng qu-le Taipei  
 have many student go-PERF Taipei  
 a. 'A lot of students have gone to Taipei.' [Cardinal Reading]  
 b. 'A large proportion of the set of students has gone to Taipei (, whereas a small proportion of this set stays at home).' [Proportional reading]

Based on the prosodic profile of weak quantifiers in different contexts, Büring (1999) argues that weak quantifiers can only have the proportional reading when they function as the sentence topic. One consequence of this claim relevant to current purposes is that in locative inversion, the locative phrase containing a weak quantifier is predicted to receive only the proportional reading because it is the topic of the sentence. This prediction is borne out in both English and Chinese, as evidenced by (64) and (65). Both (64) and (65) can be uttered only in a context where a salient set of tables has been introduced in the previous discourse, and (64) and (65) serve to specify the amount of tables in this salient set where you can find a backpack.

- (64) On many desks stood vases containing wildflowers.  
 #On a lot of desks stood vases containing wildflowers. [Cardinal reading]  
 On many of the desks (in the classroom) stood vases containing wildflowers.  
 [Proportional reading]
- (65) Hendo shuzhuo-shang dou bai-zhe yi-ge huaping  
 many desk-LOC.on DOU place-DUR one-CL vase  
 #‘On a lot of desks was placed a vase.’ [Cardinal reading]  
 ‘On many of the desks (in the classroom) was placed a vase.’  
 [Proportional reading]

Notice that the topicality of the fronted locative phrase in Chinese locative inversion is not predicted by Wu’s (2008) analysis of English/Chinese locative inversion reviewed in the last section. Given that Wu (2008) argues that obligatory raising to the left periphery of English locative inversion in (44) is not needed for Chinese locative inversion, because the locative phrase in Chinese is a  $\phi$ -complete NP, her analysis wrongly predicts that only English locative phrases exhibit topicality, whereas the Chinese counterpart does not. Next, I provide further evidence that Chinese locative phrases also display topicality.

First, Ko (2005) notes that in Chinese, *meige-ren* ‘everyone’ can undergo topicalization to the left periphery as in (66), whereas *henshao-ren* ‘few people’ and *meiyou-ren* ‘nobody’ cannot be topicalized as in (67) and (68), respectively:



- (66) a. Mei.ge-ren a, dou xihuan na-ben shu  
 every.CL-people TOP all like that-CL book  
 'Everyone like(s) that book.'
- b. Mei.ge-ren<sub>i</sub> a, wo renwei [t<sub>i</sub> dou hui qu].  
 Every.CL-people TOP I think all will go  
 'Everyone I think will go.'

- (67) a. \*Henshao-ren a, xihuan na-ben shu  
 few-people TOP like that-CL book  
 'Few people like that book.'
- b. \*Henshao-ren<sub>i</sub> a, wo renwei [t<sub>i</sub> hui qu].  
 few-people TOP I think will go  
 'Few people I think will go.'

- (68) a. \*Mei.you-ren a, xihuan na-ben shu  
 not.have-people TOP like that-CL book  
 'No one likes that book.'
- b. \*Mei.you-ren<sub>i</sub> a, wo renwei [t<sub>i</sub> hui qu].  
 not.have-people TOP I think will go  
 'No people I think will go.'

If the locative phrase in locative inversion semantically bears topicality, we predict that the fronted locative phrase exhibits the same contrast between *every* and *few/no* in Chinese. This prediction is met, as shown by (69)-(71).

- (69) a. On every desk was placed a backpack.  
 b. Mei.zhang shuzhuo-shang dou bai-zhe yi-ge beibao  
 every.CL desk-LOC.on DOU place-DUR one-CL backpack  
 'On every desk was placed a backpack.'

- (70) a. \*On few desks was placed a backpack.  
 b. \*Henshao shuzhuo-shang bai-zhe yi-ge beibao  
 few desk-LOC.on place-DUR one-CL backpack  
 ‘On few desks was placed a backpack.’
- (71) a. \*On no desk was placed a backpack.  
 b. Mei.you shuzhuo-shang bai-zhe yi-ge beibao  
 not.have desk-LOC.on place-DUR one-CL backpack  
 ‘On no desk was placed a backpack.’

The second argument is related to the specificity ambiguity of indefinite NPs in Chinese, as shown by the two readings of (72).

- (72) You-yi-ge Taiwan-ren yingde-le guanjun  
 have-one-CL Taiwan-people win-PERF championship  
 (i) ‘A specific Taiwanese person won the championship.’ (specific)  
 (ii) ‘A Taiwanese person won the championship.’ (nonspecific)

The nonspecific reading disappears when the indefinite NP is topicalized, as in (73).

- (73) a. You-yi-ge Taiwan-ren a, yingde-le guanjun  
 have-one-CL Taiwan-people TOP win-PERF championship  
 ‘There is a specific Taiwanese person who won the championship.’  
 b. You-yi-ge Taiwan-ren<sub>i</sub>, wo renwei [t<sub>i</sub> yingde-le guanjun]  
 have-one-CL Taiwan-people I think win-PERF championship  
 ‘As for one specific Taiwanese person, I think s/he won the championship.’

A locative phrase containing an indefinite NP also displays the specificity ambiguity when it stays within vP, as in (74).

- (74) Akiu-de beibao bai zai yi-zhang shuzhuo-shang  
 Akiu-MOD backpack place at one-CL desk-LOC.on  
 ‘Akiu’s backpack was placed on one desk.’ (nonspecific)  
 ‘Akiu’s backpack was placed on one specific desk.’ (specific)

Interestingly, the nonspecific reading disappears when locative inversion occurs as in (75). The parallelism between (73) and (75) suggests that the fronted locative phrase semantically bears topicality.

- (75) You-yi-zhang shuzhuo-shang bai-zhe Akiu-de beibao  
 have-one-CL desk-LOC.on place-DUR Akiu-MOD backpack  
 (i) ‘On a specific desk was placed Akiu’s backpack.’ (specific)  
 (ii) #‘On one nonspecific desk was placed Akiu’s backpack.’ (nonspecific)

Third, if the fronted locative phrase in Chinese locative inversion semantically bears topicality, we predict that the fronted locative phrase cannot function as the information focus in a reply to a *wh*-question. As shown by (76), the locative phrase can serve as the information focus only when it remains within vP.

- (76) Q: Akiu-de beibao zai nail?  
 Akiu-MOD backpack at where  
 ‘Where is Akiu’s backpack?’  
 A1: #Shuzhuo-shang bai-zhe Akiu-de beibao.  
 Desk-LOC.on place-DUR Akiu-MOD backpack  
 ‘On the desk was placed Akiu’s backpack.’  
 A2: Akiu-de beibao bai zai shuzhuo-shang.  
 Akiu-MOD backpack place at desk-LOC.on  
 ‘Akiu’s backpack was placed on the desk.’

Therefore, even though syntactically locative inversion in English/Chinese is A-movement targeting spec-TP, the fronted locative phrase semantically exhibits topicality.

This mixed A/A' property of locative inversion follows from my proposal that locative inversion is topic A-movement of a Topic feature bearing element based on the C-to-T inheritance of the Topic feature, à la Miyagawa (2010). Importantly, recall that Wu (2008) argues that the locative inversion in Chinese, unlike the English counterpart, does not need to undergo a further obligatory A'-topicalization to avoid the defective intervention effect. This is because the locative phrase in Chinese is a  $\phi$ -complete nominal, whereas the English counterpart is a  $\phi$ -defective prepositional phrase. The prediction of this line of analysis is that only English locative inversion semantically exhibits topicality (due to its proposed obligatory topicalization to the left periphery), whereas the Chinese counterpart does not. However, I have shown that Chinese and English are alike, in that the fronted locative phrase in locative inversion, in spite of undergoing only A-movement targeting spec-TP, semantically displays topicality. This parallelism constitutes a direct challenge to Wu's (2008) positionally non-uniform analysis of locative inversion in Chinese vs. English, and supports previous A-movement analyses of locative inversion in English. Now, the question comes down to how to account for those examples Wu adduces to support the obligatory A'-movement of English locative inversion. I turn to this question below.

First, Wu argues that because ECM verbs like *believe* and *consider* selects a TP complement, English locative inversion cannot occur in the complement clause of an ECM verb because there is not enough "space" in the TP complement of an ECM verb for the obligatory topicalization to the left periphery, as shown by (77).

(77) \*John believes/considers [[in that room]<sub>i</sub> t<sub>i</sub> to have sat a frog t<sub>i</sub>].

Under my proposal, the ungrammatical occurrence of locative inversion in ECM contexts in (77) also follows from the lack of a CP layer in the clausal complement of ECM verbs, but I do not need to appeal to Wu's obligatory topicalization to the left periphery to explain the ungrammaticality of (77). More specifically, given the feature inheritance hypothesis of the origin of the Topic feature (see Miyagawa 2010), (77) is ungrammatical simply because there is no C in the clausal complement of ECM verbs that can pass down

the valued yet uninterpretable Topic feature to T to value the unvalued Topic feature on the fronted locative phrase.

Wu's second argument is concerned with the incompatibility between the fronted locative phrase and an A'-moved topic phrase, as in (78).

(78) \*This person<sub>i</sub>, [under the bed]<sub>j</sub> t<sub>j</sub> hid t<sub>i</sub>.

I argue that the ungrammaticality of (78) does not support the obligatory A'-movement of English locative inversion claimed by Wu. This is because (78) is bad due to the discourse conditions on locative inversion noted in (57) in the beginning of this section. Recall that Bresnan (1994) argues that the postverbal theme DP in locative inversion receives the presentational focus interpretation. Given this discourse condition on locative inversion, (78) is ungrammatical because of the topicalization of the theme DP, which must instead receive the presentational focus interpretation in locative inversion. In other words, the problem of (78) is semantic/pragmatic inconsistency: a focus phrase is forced to receive a topic interpretation via topicalization.

Summing up, in this section, I propose a uniform analysis of locative inversion in Chinese and English as topic A-movement based on Miyagawa's (2010) feature inheritance hypothesis of the Topic feature. In the next section, under this uniform analysis of locative inversion in English and Chinese, I examine issues concerning the timing of T-to-C inversion and the labeling algorithm involved in the derivation of locative inversion.

#### 4.4 Explaining the (In)compatibility between T-to-C raising and Locative Inversion

In this section, I develop my analysis of the (in)compatibility between T-to-C raising and locative inversion in English and Chinese in terms of two recent ideas in Chomsky (2013). The first one involves the timing of intra-phase rule application (see Chomsky 2008, 2013, and Obata et al. 2013), and the other concerns the labeling algorithm (as in Chomsky 2013). I discuss each of these below as preliminaries of my analysis.

#### 4.4.1 The timing of intra-phase rule application

At the derivational stage (79) after C-to-T inheritance of the unvalued  $\phi$ -features applies, there are a few operations that can take place, as indicated by (79a-c).<sup>12</sup>

- (79) [CP C [TP T<sub>[u $\phi$ ]</sub> [vP Subj<sub>[ $\phi$ ]</sub> [vP .....]]]]
- a. T-to-C raising in a *yes-no* question
  - b. Internal Merge with T
  - c. The  $\phi$ -valuation between T and the  $\phi$ -complete subject NP

As mentioned in the beginning of this chapter, Chomsky (2013) argues that T-to-C raising (79a) must precede subject raising (79b) (i.e., the order in (6)) so that T is the uniquely closest goal C can select for inversion.<sup>13</sup> I would like to propose that T's  $\phi$ -probing (79c) should also be considered in the discussion of rule ordering at the derivational stage (79). In particular, I contend that it is deducible that C cannot attract T until T completes the  $\phi$ -Agree valuation relation with a  $\phi$ -complete NP; otherwise, the agreement inflection observed with *do*-inversion as in (80) cannot be explained.

- (80) Does/\*do John like pizza?

One may wonder if the reverse order is possible. That is, T raises to C, and then C initiates  $\phi$ -probing. I argue that the morphological realizations of *do*-support in the context of a negative declarative as in (81) (repeated from (56)) suggest that this reverse order does not exist. Given that the morphological realizations of the dummy *do* auxiliary are standardly analyzed as a reflex of  $\phi$ -Agree (in particular, the number and person features) with the subject NP, the syntactic position of *do/does* in (81) suggests that the

---

<sup>12</sup> Given that the focus of this section is locative inversion in English, I ignore the possibility where unvalued  $\phi$ -features stay on C in languages like West Flemish and Bantu languages (see Chapter 1, Haegeman and van Koppen 2012, and Carstens 2003).

<sup>13</sup> Note that in contrast to Chomsky (2013), Chomsky (2008) maintains that operations within a phase apply simultaneously. See Obata et al. (2013) for empirical arguments for the need of rule ordering within a phase, and Epstein and Seely (2002) for conceptual arguments that derivational explanation is destroyed by the representational notion of simultaneity.

valuation of  $\phi$ -features takes place when  $\phi$ -features stay on T, rather than after T-to-C inversion applies as depicted in (82).

- (81) a. John **does** not like pizza.  
 b. John and Mary **do** not like pizza.

(82)  $\phi$ -valuation after T-to-C inversion applies

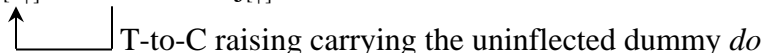
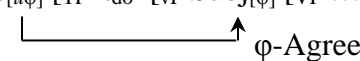
- a.  $[_{CP} do_{[u\phi]} [_{TP} t_{do} [_{VP} Subj_{[\phi]} [_{VP} \dots]]]]$   
  
 b.  $[_{CP} do/does_{[u\phi]} [_{TP} t_{do} [_{VP} Subj_{[\phi]} [_{VP} \dots]]]]$   

With this assumption, the timing of T's  $\phi$ -Agree, T-to-C raising, and internal Merge to spec-TP is summarized in (83).

- (83) T's  $\phi$ -Agree  $\rightarrow$  T-to-C raising  $\rightarrow$  internal Merge with T  
 (the relation  $\rightarrow$  designates precedence)

In this section, I develop the analysis of the incompatibility between T-to-C inversion and English locative inversion in terms of the timing of the three rules within CP, as specified in (83). I argue that in the derivation of English locative inversion the order between T-to-C raising and internal Merge with T is reversed (= the order in (7)), and the consequence of this reversed order is the formation of an opaque domain for T-to-C raising due to the labeling algorithm that works in accordance with minimal search. In the next section, I briefly review the labeling algorithm in Chomsky (2013).

#### 4.4.2 Two ways of labeling $\{XP, YP\}$

Given that the CI interpretive system must know what kind of object it is interpreting, Chomsky (2013) asks how categories created by internal/external Merge get a label to be properly interpreted at the CI interface. He discusses three possible syntactic objects

created by Merge, including the Merger between two heads, the Merger between a head and a phrase XP, and the Merger of two phrases XP and YP as in (84) (see also Rizzi 2012).

(84) XP-YP Merge:

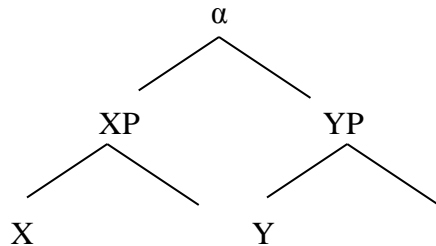

For current purposes, I review only his analysis of how the labeling algorithm in (85) labels the syntactic object  $\alpha$  created by merging XP and YP in (84).<sup>14</sup>

(85) Labeling algorithm (LA): The category created by Merge is identified as having the label of the closest head.

By the LA in (85), there is an ambiguity in (84) with respect to the label of the syntactic object  $\alpha$  created by merging XP and YP because both X and Y are an eligible label by both being the closest head to  $\alpha$ . As Rizzi (2012) points out, this ambiguity renders  $\alpha$  temporarily unlabeled, and this labeling indeterminacy must be resolved before Transfer applies to (the structure containing)  $\alpha$ , so that  $\alpha$  can be properly interpreted at the CI interface. Notice that we can infer from Chomsky's reasoning about the unlabeled (84) that LA should be modified to be more restricted, as in (86).

(86) Labeling algorithm (LA): The category created by Merge is identified as having the label of the *uniquely* closest head.

---

<sup>14</sup> Note that Rizzi (2012) assumes that labels exist in syntactic representations for CI interpretation. That is, he treats labels like  $\alpha$  in (84) as the projection of a certain head in phrase structure. By contrast, Chomsky's (2013) maintains that labels do not exist in syntactic representations (see Collins 2002 and Seely 2006 for early proposals eliminating labels); rather, labeling is an interpretive/identification process of syntactic objects that takes place at the CI interface. I remain agnostic as to which approach to labels is the correct one, and I refer to labels in the text simply for expository convenience.



One important difference between Chomsky’s (2013) LA and previous labeling assumptions is that labeling can no longer be considered a prerequisite for application of Merge. To see why, let’s examine the step-by-step assembly of a vP. First, the category created by the Merge of v and VP is identified as having the label vP as in (87) because v is the label of the uniquely closest head to this category.<sup>15</sup>

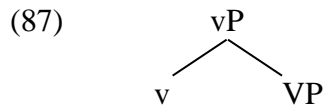

Next, the vP in (87) is merged with the subject DP as in (88), exemplifying the XP-YP structure in (84). The resultant category  $\alpha$  in (88) cannot get a label because there exist two closest heads to this category in this structure, D and v.

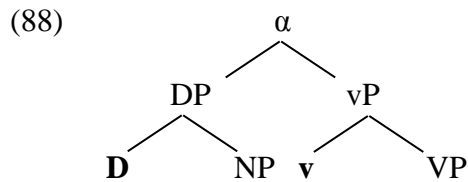

Next, T enters the derivation and merges with the structure in (88) as in (89).

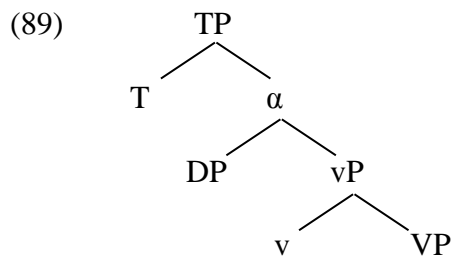

The resultant category is identified as having the label of T, the uniquely closest head to this category. Crucially, the unlabeled status of the category  $\alpha$  in (88) created by merging NP and vP does not prevent it from undergoing Merge with T. Accordingly, Merge can

---

<sup>15</sup> The label of the structure in (87) should be identified as v (the label of the uniquely closest head) rather than “vP” in the text. I maintain the XP notation in the text simply for expository convenience.

apply to unlabeled structures, and the necessity of labeling a syntactic object  $\alpha$  can be delayed until  $\alpha$  must be Transferred to the CI interface for interpretation.

Chomsky proposes that there are two ways to label the syntactic object created by XP-YP Merge, as shown in (90).

- (90) Two ways to label {XP, YP}:  
 a. Moving XP out of {XP, YP}, yielding label Y; or  
 b. the most prominent feature shared by XP and YP is the label of {XP, YP}.

Chomsky further suggests that the labeling of  $\alpha$  in (89) exemplifies the application of (90a) to save an unlabeled structure. In particular, the movement of the external argument DP from its base-generated position in vP to merge with T (i.e. commonly referred to by the cover term “subject raising for EPP”) in (91) renders  $\alpha$  labelable as vP because v is left as the closest head to  $\alpha$ . Notice that this line of reasoning goes through only if we assume that the tail of a movement chain is invisible to LA, as proposed by Chomsky (2013).

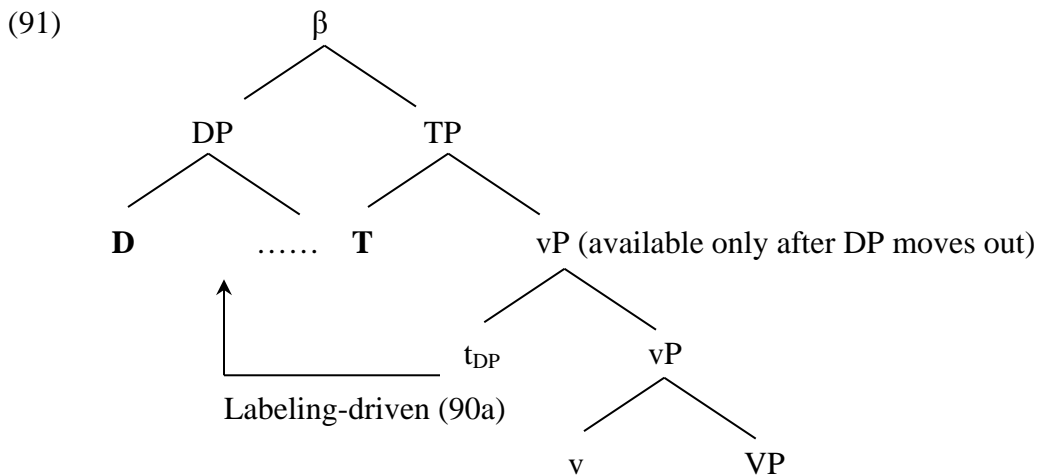

However, the solution to label  $\alpha$  by appealing to (90a) leads to yet another labeling problem for the category  $\beta$  created by merging DP and TP in (91). Now,  $\beta$  cannot be labeled because there does not exist one uniquely closest head from which  $\beta$  can inherit the label: both D and T are equally close to  $\beta$ . Again, we are faced with two solutions in

(90) to label  $\beta$ . Chomsky contends that if there exists a prominent feature  $F$  shared by two merged phrases  $XP$  and  $YP$  as in (92), then  $F$  can label the category created by merging  $XP$  and  $YP$  (=strategy (90b)).

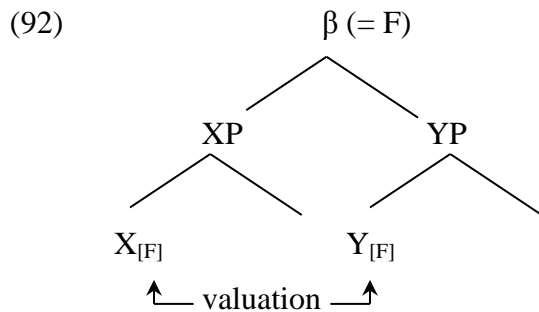

More specifically, what Chomsky means by “a prominent feature shared by  $XP$  and  $YP$ ” is that there is a valuation/Agree relation of a certain feature  $F$  between  $XP$  and  $YP$  (following a suggestion by Marcel den Dikken). Notice that although (84) and (92) differ only in the shared feature  $F$  by  $X$  and  $Y$  in the latter, this common feature has a significant effect when LA applies to (92). Recall that (84) cannot be labeled because  $X$  and  $Y$  are two distinct heads yet both are equally close to  $\alpha$ . By contrast, in (92),  $X$  and  $Y$  are no longer fully distinct from each other, thanks to the common feature  $F$ . Consequently, when LA applies to (92), it can find an unambiguous indication of a label for  $\beta$ . As a result, there is no need to appeal to the movement strategy (90a). For the structure  $\beta$  in (91), Chomsky suggests that the  $\phi$ -features shared by  $D$  and  $T$  can provide the label for  $\beta$  because both  $D$  and  $T$  contain  $\phi$ -features, which provides an unambiguous indication for the label for the whole structure.<sup>16</sup>

Importantly, given that  $\beta$  can be labeled by the common  $\phi$ -features shared by  $D$  and  $T$ ,  $DP$  can no longer undergo further raising for the sake of labeling. In other words, the application of (90b) bleeds (90a), and (90a) can be seen as a last resort strategy when (90b) is not available.<sup>17</sup>

<sup>16</sup> Rizzi (2012) suggests that it is the person feature in the  $\phi$ -feature bundle that labels  $\beta$  in (91).

<sup>17</sup> Notice that it is not the case that the application of (90b) bleeds any further movement of either  $XP$  or  $YP$  in a structure like (92). What (90b) blocks is just a (further) labeling-driven movement, which is exemplified in (91). Therefore, either  $XP$  or  $YP$  in (92) can undergo further movement for other purposes, say, topicalization to the left periphery, which is motivated independently of labeling.



What's crucial at this stage of the derivation is that after the locative PP moves “out of the way”, T's  $\phi$ -Agree can be implemented as in (95b).<sup>18</sup> Last, following Chomsky (2013), the syntactic object  $\alpha$  in (96) created by the merger of the fronted locative PP and the TP consisting of T and vP is labeled as Topic in accordance with (90b) because there is a prominent Topic feature valuation between T (whose Topic feature is inherited from C) and the locative PP.<sup>19</sup> Notice that the locative PP cannot move any further for labeling (=90a) given the bleeding relation mentioned above (= Critical Freezing in Rizzi 2010, 2012, Epstein 1992).

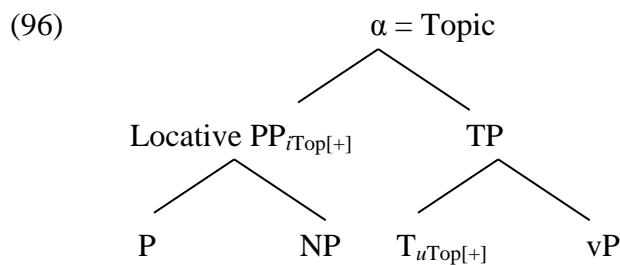

Now given that T's  $\phi$ -Agree is completed, thanks to the topic A-movement of the locative PP, T-to-C raising is allowed to take place in (97).

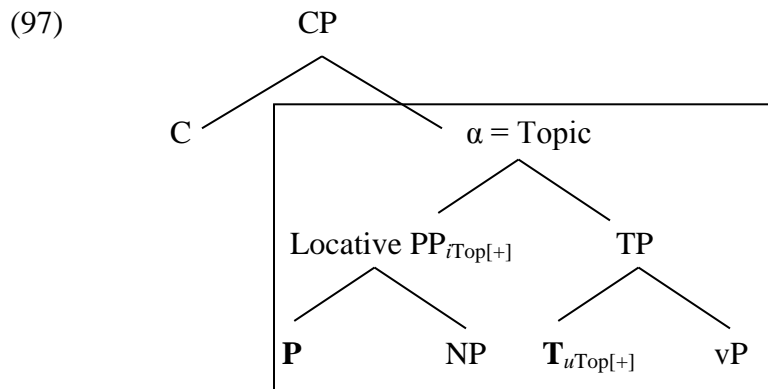

However, it is now too late for T-to-C raising to be successfully applied. This is because the boxed structure in (97) is the search space within which C looks for a head for

<sup>18</sup> I am following Bošković's (2007) assumption that Agree is not constrained by Transfer. That is, Agree can probe into a domain that has already been Transferred.

<sup>19</sup> Note the under Chomsky's (2013) labeling algorithm, the lowest VP containing the theme DP in (94)-(95) should be labeled as DP instead because both the verb and the locative PP have moved out, leaving only the theme DP in this portion of the structure. However, I ignore the label of this part of the structure here because it is not relevant for the current discussion.

inversion, and this structure cannot provide a uniquely closest goal for inversion because the two heads P and T are equally close to C. Notice that the search space of C in (97) is identical to the structure (84), where labeling cannot be determined. Even though (97) and (84) are concerned with two different operations (i.e., T-to-C raising in the former and labeling in the latter), I assume that both operations are implemented in accordance with minimal search (arguably a universal third factor principle) as defined in (85) for labeling. That is, both LA and T-to-C raising are looking for a uniquely closest head, and if there does not exist one uniquely closest head, the operation is aborted. Consequently, we derive the non-occurrence of T-to-C raising in English locative inversion from the principle of minimal search that governs both head raising and LA.

Next, I turn to the derivation of Chinese locative inversion and why T-to-C raising (= the formation of *A-not-A* questions) is allowed in Chinese locative inversion. First, Chinese and English are alike, the locative phrase bearing the unvalued yet interpretable Topic feature raises to the edge of vP to avoid being Transferred, as in (98):

(98)  $[_{VP} [_{Topic} \text{locative phrase}]_{iTop}] \nu [_{VP} DP V t_{locative}]$  (VP Transferred)

Next, C and T enter the derivation in (99).

(99)  $[_{CP} C [_{TP} T_{[A-not-A, iTop[+]]} [_{VP} [_{Topic} \text{locative phrase}]_{iTop}] \nu [_{VP} DP V t_{locative}]]]]$

Notice that T contains two features relevant to the current discussion – the valued Topic feature inherited from C and the base-generated *A-not-A* question operator. Crucially, T in Chinese is  $\phi$ -less; as a result, there does not exist an operation called T's  $\phi$ -Agree in Chinese, and T-to-C raising would be the first operation in (83) to be applied at this stage of derivation. Besides, the search space where C looks for a goal for inversion in accordance with the principle of minimal search is the boxed structure in (100), which has a uniquely closest head T. Consequently, T-to-C raising (of the *A-not-A* question operator) can be successfully applied in Chinese locative inversion.

(100)

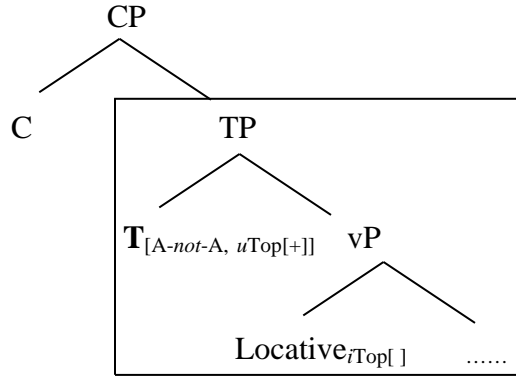

Finally, the locative phrase undergoes topic A-movement to merge with TP, and the category created by this Merge operation is labeled as a Topic Phrase by (90b).

Summing up, the distinction between Chinese and English with respect to the compatibility between T-to-C raising and locative inversion boils down to the presence of  $\phi$ -features on T and the rule ordering specified in (83). More specifically, the presence of the  $\phi$ -defective locative PP at the vP edge in the derivation of English locative inversion renders T's  $\phi$ -Agree with the  $\phi$ -complete theme DP downstairs in VP inapplicable due to the defective intervention effect (see (94b)). T's  $\phi$ -Agree with the  $\phi$ -complete theme DP downstairs in VP becomes applicable only when the locative PP undergoes topic A-movement (see (95)). This delay of T's  $\phi$ -Agree also renders T-to-C raising inapplicable momentarily, in accordance with (83). However, the topic A-movement of the locative PP out of vP, the prerequisite operation for T's  $\phi$ -Agree, creates an ambiguity in C's minimal search for a uniquely closest head for inversion (see (97)). By contrast, Chinese does not face this fatal delay problem because there are no  $\phi$ -features on T (let alone T's  $\phi$ -Agree) to begin with.

#### 4.5 Summary and Concluding Remarks

This chapter began with Chomsky's conceptual argument that T-to-C raising must take place before subject raising. From his reasoning, it can be inferred that he assumes the opposite order would render T-to-C raising inapplicable. I have shown that the derivation of English locative inversion exemplifies this reversed order blocking T-to-C raising. This is because the  $\phi$ -defective locative PP at the edge of vP triggers defective intervention effect on T's  $\phi$ -valuation with the  $\phi$ -complete theme DP. Consequently, the

intervening locative phrase has to move to spec-TP before T's  $\phi$ -valuation can proceed. The resultant configuration after the locative PP moves out of the vP is an ambiguous structure (97) that cannot provide a uniquely closest head for C's probing in accordance with the principle of minimal search, and the empirical consequence of this ambiguity is the inapplicability of T-to-C raising in English locative inversion. The upshot is that Chomsky assumes that subject raising would create a configuration like (97) which renders inapplicable T-to-C raising which is implemented on the basis of the principle of unique minimal search.

By contrast, Kitahara (2011), following Epstein, Kitahara and Seely (2012), holds a different view of the configuration created by subject raising. In particular, he argues that T is always the closest goal to C for the inversion operation regardless of the ordering between T-to-C raising and subject raising. Epstein, Kitahara and Seely (2012) and Kitahara (2011) take issue with the derivational step from (101a) to (101b). Specifically, they note that this derivational step (i.e., the movement of DP to merge with TP<sub>1</sub>, creating TP<sub>2</sub>) is a counter-cyclic application of Merge because it does not extend the CP root in (101a).

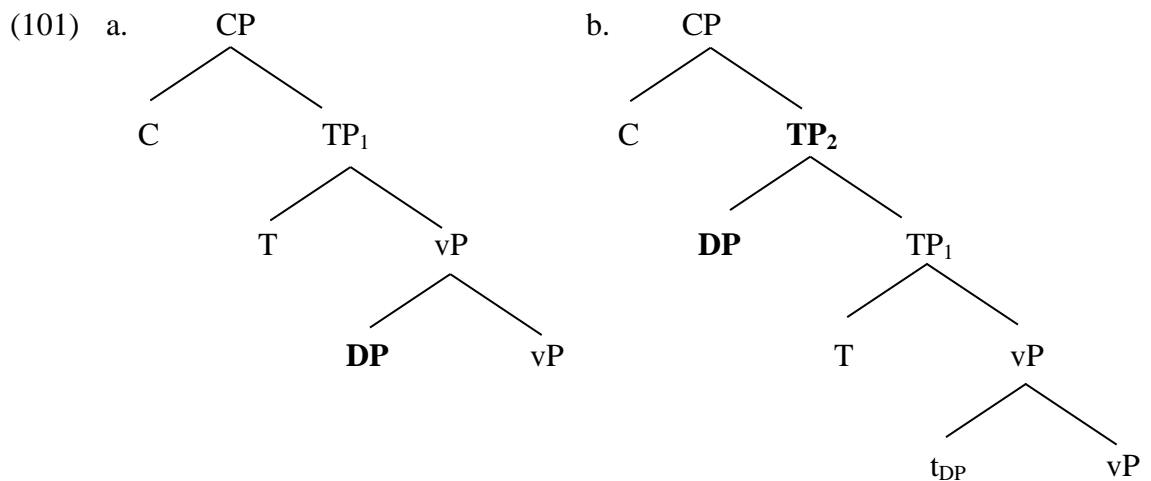

More specifically, they argue that simplest Merge cannot create such syntactic infixation or replacement. To avoid this problem of counter-cyclicity, Epstein, Kitahara and Seely (2012) and Kitahara (2011) contend that the derivational step from (101a) to (101b) is



actually creating a “double-peaked” (set-intersection) structure with two roots as graphically represented in (102).

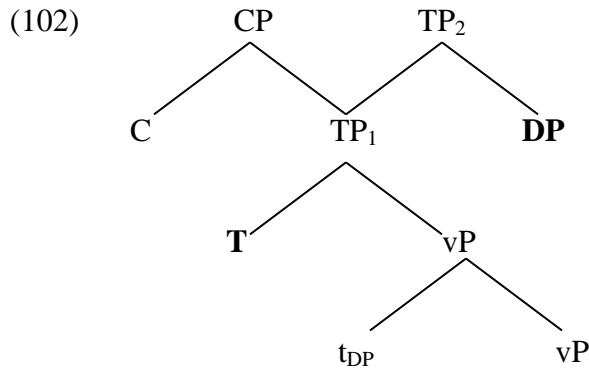

An important consequence of the double-peaked structure in (102), as opposed to (101b), is that even when subject raising precedes T-to-C raising, the head of the subject phrase does not compete with T in being the uniquely closest head in C’s search space because in this double-peaked structure, the raised DP is not even c-commanded by C and hence does not exist in C’s search domain.<sup>20</sup> In other words, the successful application of T-to-C raising is independent of the timing of subject raising – T is always the uniquely closest head to C’s minimal search for inversion throughout the derivation.

However, I have argued in this chapter that the derivation of English locative inversion exemplifies the situation where the Internal Merge of the locative subject phrase with T has to precede T-to-C raising, and following Chomsky’s (2013) reasoning, the consequence is that T-to-C raising cannot apply, contrary to the prediction of the structure in (102). In this last section, I would like to consider an alternative analysis of the ungrammatical occurrence of T-to-C raising in English locative inversion consistent with the structure proposed by Kitahara (2011) and Epstein, Kitahara and Seely (2012). Nevertheless, I will conclude that this alternative analysis faces a labeling ambiguity problem similar to that in (84) and maintain that the creation of (102) is forced only if we adopt the stringent interpretation of cyclicity as “root extension” (i.e., Chomsky’s (1993)

<sup>20</sup> Another consequence irrelevant for the current discussion which Epstein, Kitahara and Seely (2012) point out is that a double-peaked structure like (101) halts any further derivation unless one of the peaks is Transferred, hence rendered invisible to syntactic computation. They argue that the Transfer of the phase complement (i.e. TP and VP) is deduced from the necessity of continuing the derivation of a double-peaked structure, although they do not explain why it is the TP<sub>2</sub> peak that is Transferred rather than the CP peak in (101).

Extension Condition), which is abandoned in Chomsky (1995) and Richards (1997, 2001), who assume a feature-based characterization of cyclicity.

The alternative analysis is based on Chomsky’s (2013) suggestion that features cannot move independently of the feature bundle to which they belong, contra Chomsky 1995 and Obata and Epstein 2011. Therefore, the C-to-T feature inheritance is a whole-sale operation that moves the entire feature bundle (of which unvalued  $\phi$ -features are members) from C to T. This is how Chomsky (2013) explains the well-known contrast between (103a) and (103b).

- (103) a. How many cars did they ask if the mechanics fixed \_\_\_?  
 b. \*How many mechanics did they ask if \_\_\_ fixed the cars?

Given the whole-sale inheritance of the feature bundle from C to T, when the embedded C in (103) passes its unvalued  $\phi$ -features to T, its Q feature is also inherited by T. The structure in (104) specifies the position of the question feature after the whole-sale feature inheritance takes place in (103a).

- (104) \*They asked [if-Q [ <sub>$\alpha$</sub>  [how many mechanics] [TP/QP T-Q fix the cars]]]
- 

The consequence of the question feature being on T in (104) is that the *wh*-subject phrase is already in a position (i.e. the sister of TP/QP) where it agrees with the inherited Q feature on T, and  $\alpha$  is labeled as a Question Phrase, in accordance with (90b). In Rizzi’s (2010, 2012) terms, it is then already in a “criterial position” from which no further movement is allowed. This analysis explains why the movement of the *wh*-subject phrase to the matrix clause in (103b) is ungrammatical.

Now, turning back to the derivation of English locative inversion, the inapplicability of T-to-C raising in this construction also follows from Chomsky’s (2013) conjecture about the whole-sale C-to-T feature inheritance, which includes the question feature, the Topic feature, and the  $\phi$ -features in the derivation of English locative inversion as shown in (105). Consequently, one may argue that T-to-C inversion needs not (in fact cannot)

apply to produce a *yes-no* question in a locative inversion construction precisely because the question feature is already on T.

(105) [<sub>CP</sub> C [<sub>α</sub> [Locative PP]<sub>[+Top]</sub> [<sub>TP</sub> T<sub>[Q, uφ, +Top]</sub> [<sub>vP</sub> t<sub>PP</sub> [<sub>VP</sub> V DP<sub>φ</sub>]]]]]

This line of analysis would gain more empirical coverage and hence explanatory strength if it could also explain the contrast between *wh*-subject questions and *wh*-object/adjunct questions with respect to T-to-C raising, as shown by the contrast from (106) to (108).

(106) a. Who ate the pizza?  
b. \*Who did eat the pizza?

(107) a. \*What John bought?  
b. What did John buy?

(108) a. \*Why John bought the car?  
b. Why did John buy the car?

The relevant derivation of *wh*-subject questions like (106a) under this alternative is shown (109). C's unvalued  $\phi$ -features and the question feature are both inherited by T, and the *wh*-subject as the sister of TP can agree with both of these two features. As a result, one may argue that, similar to the case in English locative inversion, no T-to-C raising needs to (and hence cannot) apply in a *wh*-subject question, given that the question feature is already on T.

(109) [<sub>CP</sub> C [<sub>α</sub> Who [<sub>TP</sub> T<sub>[Q, uφ]</sub> [<sub>v\*P</sub> t<sub>who</sub> [<sub>VP</sub> .....]]]]]

Applying this line of analysis to *wh*-object/adjunct questions yields the derivation in (110).

- (110) a. [<sub>CP</sub> C [ $\alpha$  What [<sub>TP</sub> T<sub>[Q, u\phi]</sub> [<sub>v\*P</sub> t<sub>what</sub> **John**<sub>[uCase]</sub> [<sub>VP</sub> .....]]]]]  
 b. [<sub>CP</sub> C [ $\alpha$  Why [<sub>TP</sub> T<sub>[Q, u\phi]</sub> [<sub>v\*P</sub> t<sub>why</sub> **John**<sub>[uCase]</sub> [<sub>VP</sub> .....]]]]]

Notice that neither (110a) nor (110b) can be ruled out because of the unvalued Case feature on *John* left in v\*P. First, in (110a), the *wh*-object *what* has already entered into  $\phi$ -Agree within vP, also valuing its Case, so it would not be available to enter into another  $\phi$ -Agree relation with T. Consequently, T is able to probe *John* left in v\*P and both the  $\phi$ -features on T and the Case feature on *John* are valued, assuming Chomsky's (2000, et seq.) Agree-based system for Case valuation for English (see Chapter 2 for the discussion of the cross-linguistic Agree vs. movement variation with respect to Case valuation). Similarly, in (110b), the *wh*-adverb *why*, lacking  $\phi$ -features, does not enter into  $\phi$ -Agree with T, so T can enter into  $\phi$ -Agree with *who* in v\*P, valuing *who*'s unvalued Case feature as well as T's unvalued  $\phi$ -features. Therefore, both (110a) and (110b) are wrongly predicted to be grammatical derivations.

Aside from the wrong prediction about the derivations in (110a) and (110b), the whole-sale feature inheritance conjecture prompts another question regarding labeling of  $\alpha$  in (109). In the declarative counterpart of (109) (*John ate the pizza*), Chomsky suggests that  $\alpha$  is labeled as  $\phi$  (or Person, following Rizzi 2012), but it is unclear whether  $\alpha$  should be labeled as  $\phi$  or as Q in (109) because the valuation relation between the *who* and T involves both of these two "prominent features." Given Chomsky's reasoning regarding the labeling indeterminacy of the structure in (84), we can infer that under Chomsky's (2013) system, labeling ambiguity leads to an unlabeled structure. In the same vein,  $\alpha$  in (109) cannot be labeled because of the featural ambiguity. Put in another way,  $\alpha$  in (84) and in (109) are both unlabelable because of an ambiguity, if one assumes the whole-sale feature inheritance conjecture. The former involves two eligible closest heads, and the latter contains two eligible "prominent features". According to (90a), further movement of the *wh*-phrase is needed to create a labelable structure in (109); however, as mentioned above, the *wh*-phrase is frozen in its criterial position, the sister of TP, due to the inheritance of the Q feature from C. Therefore, the *wh*-question in (109) derived along the lines suggested by Chomsky's whole-sale feature inheritance conjecture should be rejected as containing an unlabeled structure. Given this labeling problem in (109) and

the the incorrect prediction about the derivations in (110) faced by Chomsky's whole-sale feature inheritance hypothesis, I do not adopt this alternative analysis of the ungrammatical occurrence of T-to-C raising in English locative inversion and argue in favor of the analysis proposed in section 4.4.3.

Finally, I would like to point out that the derivational step from (101a) to (101b) violates cyclicity only under Chomsky's (1993) Extension Condition which requires the Merge operation to "extend the tree", creating a new node which immediately dominates a previously undominated node. Notice that Chomsky's (1995) and Richards' (1997, 2001) maintain a different/less stringent conception of cyclicity. Specifically, they contend that movement operations need not extend the tree, as long as they conform to Shortest Move defined in (111) which is applied in order to contribute to the valuation of an unvalued feature.

(111) Shortest Move

Movement of  $\alpha$  to  $\beta$  is prohibited if  $\gamma$  is a potential landing site for  $\alpha$  and  $\gamma$  is closer to  $\alpha$  than  $\beta$  is.

In other words, cycles are defined in terms of unvalued features, rather than the root nodes ("feature cyclicity" in Richards' (1997, 2001) terms). Richards (1997, 2001) argues that the "tucking-in" derivation of multiple *wh*-movement in languages like Bulgarian exemplifies featural cyclicity, rather than the stringent Extension Condition. On this feature-based view of cycles, the derivation from (101a) to (101b) does not violate cyclicity because after C-to-T feature inheritance applies, the relevant unvalued features are on T, and DP's movement to merge with T is an operation conforming to featural cyclicity and Shortest Move in (111). Therefore, I conclude that whether or not the derivation from (101a) to (101b) forces the creation of a double-rooted structure in (102) depends on which version of cyclicity one adopts: Chomsky's (1993) Extension Condition or Chomsky's (1995) and Richards' (1997, 2001) featural cyclicity (coupled with the Shortest Move condition in (111)). The inapplicability of T-to-C raising in English locative inversion examined in this chapter lends empirical support to the latter.

## Chapter 5 Thesis Summary and Theoretical Implications

### 5.1 Thesis Summary

The arguments in this thesis are developed within Chomsky's (1995, et seq.) framework of the minimalist program. I examine different aspects of Chinese syntax under Chomsky's (2007, 2008) feature inheritance hypothesis and Miyagawa's (2010) extension of feature inheritance to the Topic feature. The conceptual underpinning of Miyagawa's (2010) extension of feature inheritance to the Topic feature is the Strong Uniformity hypothesis in (1), formulated on the basis of Chomsky's Uniformity Principle in (2).

(1) Strong Uniformity (Miyagawa 2010:12)

All languages share the same set of grammatical features, and every language overtly manifests these features.

(2) Uniformity Principle (Chomsky 2001:2)

In the absence of compelling evidence to the contrary, assume language to be uniform, with varieties restricted to easily detectable properties of utterances.

Miyagawa's (2010) proposal of the Strong Uniformity hypothesis is an attempt to unify the A-movement operation in both agreement languages such as English and discourse-configurational languages such as Finnish. Specifically, Miyagawa argues that all languages make use of the same set of grammatical features to drive syntactic operations. He particularly focuses on the  $\phi$ -features and the Topic feature in this uniform set of features for two reasons. First, under Chomsky's (2007, 2008) feature inheritance hypothesis, the unvalued  $\phi$ -features, like the Topic feature, start out in the left periphery. Second, A-movement to spec-TP across different languages is closely related to either

one of these two types of features. Based on these two observations, Miyagawa (2010:29) proposes that “...the difference between agreement languages and discourse-configurational languages boils down to what triggers movement at T.” In other words, in agreement languages,  $\phi$ -features are inherited by T to trigger A-movement to spec-TP, whereas the Topic feature is inherited by T and drives A-movement to spec-TP in discourse-configurational languages.

In Chapter 2, I examine the empirical validity of Miyagawa’s (2010) proposal by investigating the distribution of A-movement in Chinese. Chinese is chosen as the empirical focus because it appears at first glance to be a language that does not manifest feature inheritance. Given that T in Chinese lacks  $\phi$ -features (evidenced by the grammatical occurrence of anaphors as embedded subjects), Miyagawa’s (2010) system predicts that it is the Topic feature that is inherited by T in Chinese to trigger A-movement to spec-TP. This prediction amounts to the claim that Chinese should be treated on a par with other discourse-configurational languages such as Finnish because of such Topic feature inheritance. However, unlike Finnish where the topic of the sentence surfaces as the subject of the sentence, the topic phrase in Chinese generally occurs in the left periphery, rather than at spec-TP. This means the Topic feature in Chinese, if present, remains in the left periphery, rather than being inherited by T to trigger A-movement of the topic phrase as in Finnish. Therefore, Chinese appears to be a language where neither the  $\phi$ -features nor the Topic feature is inherited by T, posing a challenge to Miyagawa’s feature inheritance system.

However, I argue that Topic feature inheritance, similarly to what is proposed by Miyagawa (2010) for a language such as Finnish, in fact exists in Chinese as well, but unlike previous approaches to feature inheritance, its motivation is not to keep unvalued features from the phase edge (as in Richards 2007, Chomsky 2007) or to create A-chains (as in Chomsky 2005, 2008, Miyagawa 2010). Rather, I propose an economy-based motivation for feature inheritance, summarized in (3):

- (3) An economy-based motivation of feature inheritance  
 Feature inheritance takes place to yield a more economical derivation with a shorter derivational path, and its application cannot run afoul of other independent principles in the grammar.

The major results of Chapter 2 are summarized in (4):

- (4) a. The distribution of topic A-movement in Chinese exemplifies the application of Topic feature inheritance in conformity with the economy considerations in (3).  
 b. Feature valuation in the lexicon is dissociated from feature interpretability at the CI interface.  
 c. There exist two distinct driving forces of A-movement in Chinese: an unvalued Case feature and an unvalued Topic feature.  
 d. Case valuation in languages with a  $\phi$ -less T requires movement of the NP bearing the Case feature.

Let's illustrate (4a) and (4b) with object topic A-movement in Chinese raising modal constructions, the abstract representation of which is given in (5).

- (5)  $[_{CP} C_{uTopic[+]} [_{TP} T [_{VP} \text{modal verb} [_{TP} \text{subject verb object}_{iTopic[-]} ]]]]$

Topic features are assigned to C and the object upon the formation of the Numeration for RMC. Importantly, to avoid the late and early trigger problems associated with object topic A-movement (see the discussion in 2.4.2), I argued that the Topic feature on the moving object should be interpretable yet unvalued, providing a local cue for the movement of the object.

Next, notice that if the Topic feature stays on C, the object bearing the unvalued interpretable Topic feature will undergo movement to merge with C for feature valuation, as in (6a). If, by contrast, feature inheritance applies as in (6b), the object would target T for feature valuation, yielding a movement with a shorter movement path, a more economical derivation (compared with that in (6a)).

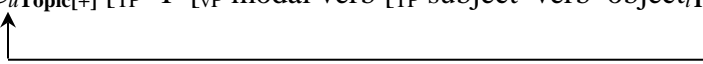
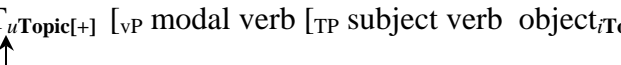

- (6) a. [CP C<sub>uTopic[+]</sub> [TP T [VP modal verb [TP subject verb object<sub>iTopic[ ]</sub>]]]]  

  
 b. [CP C [TP T<sub>uTopic[+]</sub> [VP modal verb [TP subject verb object<sub>iTopic[ ]</sub>]]]]  

Crucially, even though the inheritance of the Topic feature could lead to a more economical derivation with a shorter movement path, its application cannot run afoul of the movement requirement for Case valuation in Chinese (=4d). This is precisely why object topic A-movement in Chinese, unlike that in Finnish, is not allowed in mono-clausal structures because if object topic A-movement were to occur in Chinese mono-clausal structures, the subject would not be able to move to spec-TP to value its Case feature. Last, I suggest that the cross-linguistic movement vs. Agree contrast with respect to how Case valuation (e.g. Chinese/Sinhala vs. Finnish) is accomplished is due to the conspiracy of two factors: the presence/absence of  $\phi$ -features on T in a language and Chomsky's (2001) Maximize Matching Effects.

In Chapter 3, under the premise that there are no  $\phi$ -features on T in Chinese, I investigate the related question in (7):

- (7) Does Chinese lack  $\phi$ -features/Agree altogether, or does it manifest  $\phi$ -features/Agree somewhere else, say, the left periphery?

Question (7) is particularly important in view of Miyagawa's (2010:11) claim that all languages have  $\phi$ -features and Topic/Focus features, and "overtly manifest these features in some fashion." Although T in Chinese does not contain  $\phi$ -features, Miyagawa's system predicts that Chinese should "overtly display  $\phi$ -features/Agree in some fashion." In Chapter 3, I argue that even though there is no morphological manifestation of  $\phi$ -features in Chinese,  $\phi$ -feature agreement can be detected at the CP level in this language. In particular, I investigate two types of "Blocking Effects" (BE) observed with the long-distance construal of Chinese bare reflexive *ziji* 'self' (see Huang and Liu 2001, among many others) and the formation of *wh-the-hell* questions in Chinese (see Chou 2012). I

contend that these two types of BE receive a unified analysis if we assume: (i)  $\phi$ -features exist in Chinese but remain at the CP level, unlike agreement languages where  $\phi$ -features are inherited by T, and (ii)  $\phi$ -features in Chinese takes the form of an unvalued person feature including [Speaker] and [Participant], as in a fine-grained theory of the sub-components of  $\phi$ -features (see Harley and Ritter 2002; Béjar and Rezac 2003, 2009; Nevins 2007, 2008, 2011, among many others).

Combining the findings in Chapter 2 and Chapter 3, we find that even though at first sight Chinese appears to be a counterexample to the feature inheritance hypothesis, it in fact manifests both Topic feature inheritance and  $\phi$ -features/Agree, lending further support for Miyagawa's (2010) Strong Uniformity hypothesis.

Finally, in Chapter 4, I study question (8) which is also related to the absence of  $\phi$ -features/Agree on T in Chinese. I approach this question by investigating the ordering of the three rules in (9):

- (8) Does the existence of  $\phi$ -features/Agree on T in a language affect the timing of the application of different rules in a CP phase?
  
- (9)
  - a. T's  $\phi$ -valuation
  - b. T-to-C raising
  - c. Internal Merge with T

First, in view of the general applicability of T-to-C raising, Chomsky (2013) and Rizzi (2012) argue that T-to-C raising must take place before spec-TP is occupied by a category moving from within vP (most commonly the external argument NP first Merged into spec-vP). This is because the reverse order would create an ambiguous search space for C to locate a uniquely closest goal for head movement to C. Next, I propose that in languages with  $\phi$ -features on T, the application of T-to-C raising must wait until T completes its  $\phi$ -feature valuation with a  $\phi$ -complete NP. Taken together, the ordering of these three rules is summarized in (10):

(10) T's  $\phi$ -valuation  $\rightarrow$  T-to-C raising  $\rightarrow$  Subject raising

In Chapter 4, I investigate the question of whether the ordering in (11) is ever empirically possible.

(11) Internal Merge with T  $\rightarrow$  T's  $\phi$ -valuation  $\rightarrow$  T-to-C raising

That is, does there exist a derivation where the subject moves to spec-TP before T accomplishes its  $\phi$ -feature valuation with a  $\phi$ -complete NP and then raises to C? The empirical consequence of this ordering is that T-to-C raising will be blocked in this derivation as elucidated by Chomsky (2013) and Rizzi (2012).

I study the derivation of locative inversion in both English and Chinese, and argue that (i) locative inversion is topic A-movement, and more importantly (ii) the derivation of English locative inversion exemplifies the order in (11). Specifically, I show that the  $\phi$ -defective locative PP raising to the edge of vP causes a defective intervention effect on T's  $\phi$ -valuation with the  $\phi$ -complete theme DP. Consequently, T would not be able to complete its  $\phi$ -valuation with the  $\phi$ -complete theme DP unless the  $\phi$ -defective locative PP moves to spec-TP first. This delay of T's  $\phi$ -valuation in turn defers the subsequent application of T-to-C raising. As predicted by Chomsky's (2013) and Rizzi's (2012) reasoning, the empirical consequence of this ordering is that T-to-C raising is not allowed in the derivation of locative inversion in English as shown by (12).

- (12) a. [On the desk] were placed a few pencils.  
b. \*Were [on the desk] placed a few pencils?

By contrast, I contend that the derivation of locative inversion in Chinese is not forced to adopt (11), as evidenced by the grammatical formation of *A-not-A* questions in Chinese locative inversion. This contrast is attributed to the absence of  $\phi$ -features on T in Chinese. Given the lack of  $\phi$ -features on T in Chinese, T does not need to complete any  $\phi$ -valuation with any  $\phi$ -complete NP, and hence T-to-C raising applies as soon as C enters

the derivation of Chinese locative inversion, crucially not after the locative subject moves to spec-TP as is the case for English locative inversion.

## **5.2 Theoretical Implications**

### *5.2.1 A/A'-distinction*

The purpose of this section is to briefly review previous approaches to the distinction between A-positions/movement and the A'-counterparts and discuss this dissertation's theoretical implications for this distinction. The A/A'-distinction has been characterized in different terms in the generative literature. There exist three prominent approaches to this distinction: the position-type-based approach (e.g. Rizzi 1990), the feature-based approach (see e.g. Rizzi 2003; Chomsky 1993, 2007; Chomsky and Lasnik 1995; Obata 2010, 2012), and Miyagawa's (2010) phase-based approach. I will point out the difficulties the first two approaches face, and conclude that Miyagawa's (2010) phase-based approach fares better if our ultimate goal is to maintain an A/A'-distinction that works for both agreement languages like English and languages without agreement on T such as Chinese and Sinhala.

#### *5.2.1.1 From position types to features*

Rizzi (1990) maintains that spec-TP is an A-position (and thus movement targeting spec-TP is A-movement), whereas spec-CP is an A'-position (and thus movement targeting spec-CP is A'-movement). Rizzi's (1990) influential characterization of the A/A'-distinction in terms of position types is however both conceptually and empirically problematic. Conceptually, it appeals to stipulated representational concepts. That is, it does not explain why it is spec-TP that exhibits the so-called A-properties and why it is spec-CP that displays the so-called A'-properties, rather than the other way around. In addition, this representational approach is incompatible with the current minimalist framework which assumes a derivational approach to syntactic computation and hence abandons representational concepts like government in the GB era. Empirically, as Rizzi (2003) himself points out, this position-type-based approach is too course-grained to

distinguish different types of A'-movement. Before we discuss the relevant data indicating the empirical deficiency of the position-type-based approach, it is necessary to introduce the locality principle Relativized Minimality, as defined in (13).

(13) ...X...Z...Y

Y cannot be related to X if Z intervenes and Z has certain characteristic in common with X.<sup>1</sup> [from Rizzi 2003:89]

Therefore, Y cannot move to X across the intervening Z if Z and X are of the same structural type. Rizzi distinguishes two structural types: heads or specs, and for specs, there are A-specs (=spec-TP) and A'-specs (specs of CP and other functional projections). The locality principle in (13), when coupled with Rizzi's (1990) position-type-based approach to the A/A'-distinction, provides a straightforward account for a significant range of empirical data. For example, the A'-movement of the *wh*-adverbial *how* to the matrix spec-CP is grammatical in (14a), but not in (14b) (both from Rizzi 2003:90).

- (14) a. How did you solve the problem <how>?  
 b. \*How do you wonder *who* could solve this problem <how>?

Relativized Minimality rules out the A'-movement of *how* (=Y in (13)) to spec-CP (=Z in (13)) in (14b) because of the intervention of *who* which occupies the embedded spec-CP, also an A'-position (=X in (13)). Also, notice that the contrast between (14a) and (14b) argues strongly for the necessity of distinguishing A-positions (=spec-TP) from A'-positions (spec-CP) because the subject *you* at spec-TP in (14a), unlike *who* at the embedded spec-CP in (14b), does not block the movement of *how* to spec-CP.

Furthermore, according to Cinque's (1999) analysis of adverbial positions and functional projections, adverbs occupy the specifiers of different functional projections (=A'-specs). Thus, Relativized Minimality, in its simplest form, predicts that adverbs occupying A'-specs positions also block *wh*-movement. This prediction is borne out as

---

<sup>1</sup> Z intervenes between X and Y iff Z c-commands Y and Z does not c-command X.

shown by the French example in (15), where the amount/frequency adverb *beaucoup* ‘a lot’ blocks the movement of the *wh*-phrase *combien* ‘how many’.

- (15) a. *Combien a-t-il consulté \_\_\_ de livres?*  
‘How many has he consulted of books?’  
b. \**Combien a-t-il beaucoup consulté \_\_\_ de livres?*  
‘How many has he a lot consulted of books?’

However, not all adverbs occupying A'-specs block *wh*-movement – the manner adverb *attentivement* ‘carefully’ does not, as shown by (16).

- (16) *Combien a-t-il attentivement consulté [\_\_\_\_ de livres]?*

The contrast between (15b) and (16) suggests that the cover term “A'-spec” is not homogeneous with respect to inducing Relativized Minimality effects and hence needs to be refined to distinguish different types of “A'-specs”. This concern is one of the major motivations for Rizzi’s shift from his (1990) position-type-based approach to the A/A'-distinction to his (2003) feature-based one. In short, the position type of X and Z in (13) is not the relevant factor in formulating Relativized Minimality<sup>2</sup>; rather, it is their featural composition that matters. To achieve this goal, Rizzi proposes the four feature types in (17):

- (17) a. Argumental: person, number, gender, case  
b. Quantificational: Wh, Neg, measure, focus...  
c. Modifier: evaluative, epistemic, Neg, frequentative, measure, manner,....  
d. Topic

The feature types in (17b-d) divide A'-specs into three subclasses, and Relativized Minimality effects are expected to arise only within the same feature class, but not across

---

<sup>2</sup> A stronger interpretation is that there do not exist A-positions or A'-positions. The only cue that narrow syntax and the CI interface rely on to distinguish different types of movement is the features involved in different movement operations.

classes. Specifically, because amount/frequency adverbs like *beaucoup* ‘a lot’ and *wh*-elements are both quantificational (= (17b)), the former blocks the movement of the latter (= (15b)). By contrast, manner adverbs like *attentivement* ‘carefully’ does not block the movement of *wh*-elements since they belong to different feature types. In essence, A'-movement is not blocked by A'-positions across the board, but rather it is the sameness of feature types that induces intervention.

As for the distinction between A-positions and A'-positions, Rizzi suggests that it is the presence of the  $\phi$ -features that makes the difference (= (17a)). However, I will show in the next section that this  $\phi$ -based approach does not work for languages without  $\phi$ -features on T.

#### 5.2.1.2 *The $\phi$ -based approach*

In Chomsky (1993) and Chomsky and Lasnik (1995), the A/A'-distinction is defined on the basis of the notion of L-features and L-relatedness, defined in (18) and (19), respectively.

(18) Chomsky (1993:28-29):

The functional elements of Tense and Agr therefore incorporate features of the verb. Let us call these features *V-features*: the function of the V-features of an inflectional element is to check the morphological properties of the verb selected from the lexicon. More generally, let us call such features of a lexical item L *L-features*.

(19) Chomsky and Lasnik (1995:64):

Given a lexical head L, we say that a position is L-related if it is the specifier or complement of a feature of L. The L-related positions are the former A-positions. (i.e., The non-L-related positions are A'-positions. [CTC])

Chomsky and Lasnik (1995) maintain a feature-based characterization of the A/A'-distinction. That is, A/A'-positions are defined in terms of the features a head contains: if

a head contains an L-feature, its specifier and complement positions are both A-positions; all other positions are A'-positions. Therefore, given that T bears an L-feature but C does not, spec-TP is an A-position, whereas spec-CP is an A'-position. Chomsky (2007) extends this feature-based approach to the characterization of A/A'-movement, as defined in (20).

(20) Chomsky (2007:24):

A-movement is IM [internal merge, CTC] contingent on probe by uninterpretable inflectional features, while A'-movement is IM driven by EF [i.e. the edge feature, CTC].

In short, an A-movement is movement resulting from  $\phi$ -Agree (e.g., the movement of the subject DP to spec-TP on the basis of T's  $\phi$ -Agree with the subject DP), and the landing site of this  $\phi$ -based movement is an A-position. By contrast, a movement operation triggered purely by EF is A'-movement (i.e., movement to the vP/CP phase edge), and the landing site of such EF-triggered movement is an A'-position. Nevertheless, as Obata (2012:180) insightfully points out, this approach based on the (non-)existence of uninterpretable  $\phi$ -features on the attracting head is problematic, considering the fact that the A/A'-distinction is read off at the CI interface, but the  $\phi$ -features on an attracting head are "uninterpretable" at the CI interface. In other words, the property of the attracting head (the presence/absence of uninterpretable  $\phi$ -features) Chomsky relies on to characterize A/A'-movement/positions is lost in the CI interface representation where the A/A'-distinction is necessary for, e.g., the interpretation of binding relations. In view of this problem, Obata (2010, 2012) proposes to shift the featural cue for the A/A'-distinction from the head to the moving element, as in (21).

(21) Obata (2012:181):

A category at an A-position is reanalyzed as a category bearing  $\phi$ -features. A category at an A'-position is reanalyzed as a category lacking  $\phi$ -features.



Obata’s (2012) reformulation of Chomsky’s (2007) feature-based approach is free from the problem she identifies. This is because the  $\phi$ -features on the moving DP are interpretable at the CI interface, and hence can be used by the CI interface to distinguish A/A'-positions. This reformulation is made possible under Obata’s (2010) and Obata and Epstein (2011) proposal of Feature Splitting Internal Merge under Chomsky’s (2007, 2008) and Richards’ (2007) feature inheritance hypothesis. In particular, under the feature inheritance hypothesis,  $\phi$ -features are not inherent features of T, but originate from C, so T cannot initiate  $\phi$ -probing until C enters the derivation and passes its  $\phi$ -features to T. In addition, T and C can function as probes and attract a single element simultaneously in the derivation of “who left?” in (22).

(22) a. [<sub>VP</sub> who<sub>[\phi, uCase, Q]</sub> [<sub>VP</sub> left]]

b. C-to-T Feature inheritance of  $\phi$ -features

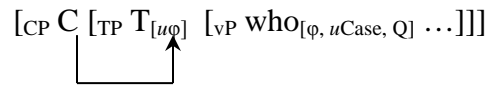

c. T  $\phi$ -Agrees with *who* and the Case on *who* is valued.

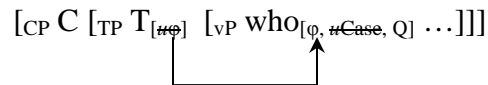

d. Feature Splitting Internal Merge

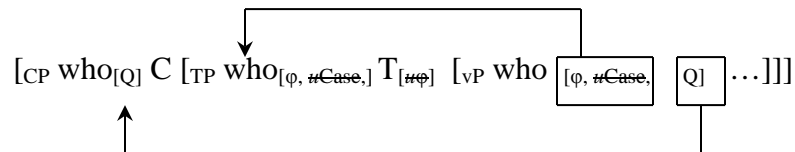

Obata (2010) and Obata and Epstein (2011) propose that in this context, features on a single attractee (=who) are split into two different landing sites, spec-TP and spec-CP as in (22d). Specifically, when T and C simultaneously attract a subject DP, T attracts only the features which it agrees with (i.e.  $\phi$  and Case) and C attracts the rest.

The major conceptual motivation for Feature Splitting Internal Merge is to maintain Richards’ (2007) deduction of feature inheritance as a necessary precondition to convergence. Recall that Richards (2007) reasons that uninterpretable/unvalued features

are prohibited from occurring in the phase edge because they will be indistinguishable from inherent valued features in the next phase, and thus feature inheritance applies to keep uninterpretable  $\phi$ -features off the phase edge. Based on this reasoning, Obata (2010) and Obata and Epstein (2008, 2011) note that feature inheritance does not keep all uninterpretable features away from the phase edge because *wh*-movement brings derivationally valued uninterpretable Case feature on the *wh*-phrase to spec-CP. To avoid this problem, they propose Feature Splitting Internal Merge in (22) so that the derivationally valued uninterpretable Case feature never reaches the CP phase edge. With respect to the A/A'-distinction, *who* at spec-TP is “at an A-position” because the copy of *who* at this position carries (interpretable)  $\phi$ -features, whereas the copy at spec-CP is “at an A'-position” because of its absence of  $\phi$ -features, according to (21). That is, position types are reanalyzed as categorical features.

Nevertheless, both (20) and (21) fail to capture the A/A'-distinction in languages without  $\phi$ -features on T such as Chinese and Sinhala. First, given that T does not contain  $\phi$ -features in Chinese, (20) predicts that movement to spec-TP is A'-movement. However, this is a wrong prediction, given the various distinct properties of the movement to spec-TP in contrast with the movement to the left periphery in Chinese noted in Chapter 2.<sup>3</sup>

The featural characterization in (21) based on Feature Splitting Internal Merge also faces difficulty in distinguishing spec-TP from spec-CP in languages without  $\phi$ -features on T. Given that T never enters into a  $\phi$ -Agree relation with any NP in Chinese because it does not contain  $\phi$ -features in the first place,  $\phi$ -features splitting along with the Case feature at spec-TP as in (22d) does not take place. Consequently, (21) predicts that spec-CP in Chinese is an A-position, a prediction unsupported by the empirical facts examined in Chapter 2.

In sum, previous approaches to the A/A'-distinction based on the presence of  $\phi$ -features, either on the landing site or on the moving element itself, do not readily provide an adequate characterization of the distinct properties of the movement operations to spec-TP and spec-CP in languages without  $\phi$ -features on T.<sup>4</sup>

---

<sup>3</sup> See also Hettiarachchi (2012) for arguments for the A/A'-distinction in Sinhala.

<sup>4</sup> Notice that Rizzi (2003) includes both the  $\phi$ -features and the case feature in (17a) to distinguish A-positions from A'-positions. For space limitations, I do not discuss why the case feature also fails to yield the desired distinction. See Miyagawa (2010: 114-115) for relevant discussion.

### 5.2.1.3 Miyagawa's (2010) phase-based approach

Even though Rizzi's (2003) feature types in (17) provide a refined approach to different types of A'-movement and the closely related Relativized Minimality effects, the reliance on the existence of  $\varphi$ -features to distinguish A-positions from A'-positions fails to maintain an A/A'-distinction that is empirically adequate for both agreement languages like English and languages without agreement on T like Chinese and Sinhala. Therefore, it is likely that the A/A'-distinction has nothing to do with features, but follows from the distinct nature of the derivations involved in A-movement and A'-movement. Miyagawa (2010) pursues this line of analysis and discusses the A/A'-distinction in the context of reconstruction. He notes that the various differences (e.g., the suppression of the Weak Crossover effect, the creation of a new binder, and Condition C suppression) between A-movement and A'-movement can be attributed to the effect of obligatory reconstruction in the latter.

For instance, the examples in (23) and (24) show that A'-movement exhibits obligatory reconstruction which explains not only the possibility of bound-variable reading of the pronoun *his* in (23) but also the Binding Principle C violation in (24).

(23) [Which of  $his_i$  students] $_j$  do you think [every professor] $_i$  talked to  $t_j$ ?  
(Fox 1999:172)

(24) \*[Which report that  $John_i$  was incompetent] $_j$  did he $_i$  submit  $t_j$ ?  
(Freidin 1986:179)

By contrast, the examples in (25) indicate that A-movement is not forced to reconstruct; otherwise, they would be ruled out by Binding Principle C.

(25) a. [The claim that  $John_i$  was asleep] $_j$  seems to  $him_i$  to  $t_j$  be correct.  
b. [ $John_i$ 's mother] $_j$  seems to  $him_i$  to  $t_j$  be wonderful. (Lebeaux 1988:23)

In view of this contrast, Fox (1999) and Lasnik (1999) maintain that A'-traces are fully structured copies, whereas A-traces are unstructured. That is, each member in an A'-

chain is identical, whereas the lower members in an A-chain are not fully specified copies, and hence not fully identical to the highest member in the chain. Although this characterization captures the empirical data, it merely restates the curious A/A'-asymmetry in other terms. Following Lasnik's (1999) and Fox's (1999) analyses, Miyagawa (2010:115) proposes (26) to derive the A/A'-asymmetry from whether a movement operation crosses a transfer domain boundary.

(26) Phase-base characterization of chains

A full copy of a moved item must be available for interpretation [at the CI interface, CTC] if the movement crosses a transfer domain boundary [i.e., the phase complement, CTC].

This “full interpretation” requirement of movement chains follows from how the CI interface interprets syntactic objects in the phase architecture of narrow syntax in which phase complements (e.g., VP and TP complements of phases vP and CP, respectively) are cyclically transferred to the interfaces for interpretation, once the assembly of a phase is completed in the bottom-up structure building procedure. Notice that under this mechanism, the CI interface receives syntactic objects in a piecemeal fashion, so the different phase complements transferred separately must be put back together for the CI interface to interpret the sentence as a whole. Now consider movement operations in this context: an item XP can either move within a transfer domain as in (27a), or move across this boundary as in (27b).

(27) a. Full lower copy unnecessary

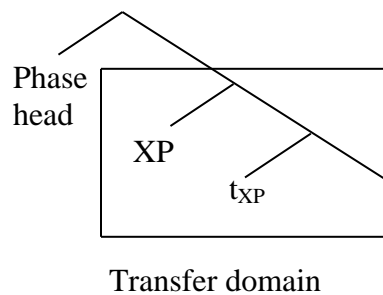

b. Full lower copy needed

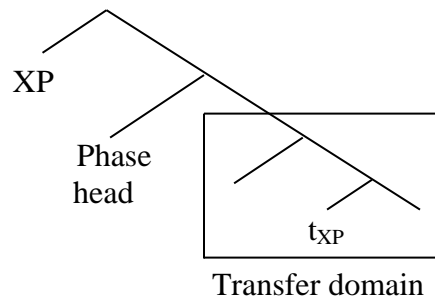

Crucially, Miyagawa (2010:116) notes that A-movement exemplifies the first scenario as illustrated by (28), whereas A'-movement always crosses a transfer domain boundary, as illustrated by (29).

(28) A-movement exemplifies (27a)

a. Subject movement from spec-vP to spec-TP

[<sub>CP</sub> [<sub>TP</sub> DP [<sub>VP</sub> t<sub>DP</sub> [<sub>VP</sub> ... ]]]]

b. Raising

[<sub>TP</sub> DP [<sub>seem</sub> [<sub>TP</sub> t<sub>DP</sub> ... ]]]<sup>5</sup>

(29) A'-movement exemplifies (27b)

[<sub>CP</sub> WH [<sub>TP</sub> ... [<sub>VP</sub> t<sub>WH</sub> ... [<sub>VP</sub> ... t<sub>WH</sub>]]]]

Notice that in (28a) and (28b), the movement of the DP stays within the same transfer domain (=the TP). On the other hand, in (29), the first step of the *wh*-movement crosses the VP transfer domain, and the second step crosses the TP transfer domain.

Based on this difference, Miyagawa (2010:116) argues that if a movement chain crosses the transfer domain boundary (= the movement chain in (27b) and (29)), “a record of the chain in its entirety must be kept [=a fully structured lower copy of the chain must be kept, CTC].” In other words, when a movement chain straddles two transfer domains, the transfer operation can be regarded as “breaking” the chain links. Therefore, when the phase complement containing the lower copy of the movement chain is transferred, the lower copy must be kept in its full form for the later assembly of different phase pieces to establish the link between phases, with respect to the movement operation. This requirement explains the observed obligatory reconstruction effect observed with A'-movement, which always crosses a transfer domain boundary. On the other hand, when a movement chain in its entirety exists in the same transfer domain as in (27a) and (28), there is no “linking problem“ between different phases at the CI

<sup>5</sup> Following Chomsky (2001), Miyagawa assumes that the vP hosting unaccusative verbs are not phases.

interface. Consequently, there is no need to keep a fully structured lower copy of such a chain, although it does not harm to do so.<sup>6</sup>

Miyagawa's (2010) novel approach to the distinction between A-movement and A'-movement retains the original insight in Fox (1999) and Lasnik (1999) with respect to the identities and structures of the copies in these two types of movement. Importantly, he shows that this contrast can be deduced from a specific derivational property of the movement itself: whether or not a movement crosses a transfer domain. Understood in this way, there do not exist terms like "A-movement" or "A'-movement"; rather, the observed disparities generally attributed to these two terms are deducible from the landing site of a movement operation in relation to a transfer domain boundary. One advantage of this approach is that it appeals to a constant property of movement which is applicable to all languages, rather than to the (non-)existence of  $\phi$ -features either on the landing site or on the moving element itself. As discussed in the last section, the latter approach would make false predictions regarding the A-/A'-distinction in languages without  $\phi$ -features on T. I conclude that Miyagawa's (2010) approach fares better if our ultimate goal is to maintain a general A/A'-distinction that works for both languages with agreement on T like English and languages without agreement on T like Chinese and Sinhala.

### 5.2.2 *A CI interface free from featural crash*

In this section, I go back to the question this dissertation starts with: the motivations for feature inheritance. Specifically, I discuss the theoretical implications of this dissertation for the conceptual underpinnings of Richards' (2007) deduction of feature inheritance as a necessary precondition for convergence. The theoretical underpinnings of Richards' (2007) deduction can be traced back to Chomsky's (1998) legibility conditions, whose definition can be summarized as follows:

---

<sup>6</sup> The bound-variable interpretation of the pronoun *his* in (i) indicates that it is possible for A-movement to leave a fully structured copy. Importantly, what distinguishes A-movement from A'-movement is that the former has the choice of not doing so, as evidenced by the grammaticality of (25).

(i) [Someone from his<sub>i</sub> class]<sub>j</sub> seems to [every professor]<sub>i</sub> to t<sub>j</sub> be a genius. (Fox 1999:161)

“To be usable, the new organ [=the faculty of language, FL, CTC] has to meet certain “legibility conditions”. Other systems of the mind/brain [e.g., the conceptual-intentional/CI system and the articulatory-perceptual/AP system, CTC] have to be able to access expressions generated by FL, to “read” them and use them as “instructions” for thought and action. We can try to formulate clearly—and if possible answer—the question of how good a solution FL is to the legibility conditions, and these alone. This is essentially the topic of the minimalist program.”

(Chomsky 1998:5-6)

Chomsky (1998:9) explores the hypothesis that “language is an optimal solution to legibility conditions.” One defining property of an optimal computational system is that it solves the problems it faces with least complexity in its generative procedure. For the design of FL to achieve this goal, Chomsky (2000) writes:

"One category [of the reduction of complexity in the generative procedure of FL, CTC] concerns 'least effort' conditions, which seek to eliminate anything unnecessary: (a) superfluous elements in representations, (b) superfluous steps in derivations."

(Chomsky 2000:99)

The legibility conditions require semantic and phonological representations to be legible by the CI and AP interfaces. One way for these representations to meet the legibility conditions is by containing only interpretable features (i.e. no superfluous elements in representations). This way, the representations are fully accessible to and interpretable by the CI and AP interfaces. Also, the derivation constructing those representations in narrow syntax must be the most economical among possible derivations based on the same lexical array/numeration (i.e. no superfluous steps in derivations), under the inclusiveness condition, which states that no new element can be added in the course of the syntactic derivation. Observing these two conditions, the legibility conditions and the inclusiveness condition, leads linguistic computation to having less computational burden (=least effort), and hence reduces the complexity in the generative procedure of FL.

However, the goal that the CI interface contain only interpretable features (as one way) to satisfy the legibility condition is impeded by the fact that uninterpretable features like  $\phi$ -features on C/T and the Case feature are indispensable in the generative procedure constructing syntactic objects to be transferred to the CI interface for interpretation. Therefore, Chomsky argues that the Transfer operation must remove uninterpretable

features from the syntactic objects sent to the CI interface. To maintain this goal without inducing look-ahead computation (see Chapter 1), Chomsky (2001:5) proposes the Valuation/Interpretability Biconditional to encode the interpretability of a feature at the not yet reached CI interface in terms of the feature's valuation in the lexicon, and maintains that the Transfer operation detects and deletes what will be uninterpretable features at the CI interface based only on their unvalued property to ensure the convergence of the derivation.

In this connection, consider my proposal concerning the derivation of topic A-movement in Chinese RMC. In view of the late trigger and early trigger problems of object A-movement in a probe-driven system based on feature inheritance, as identified in Chapter 2 (see section 2.4.2), I follow Pesetsky and Torrego (2006), Carstens (2010, 2011), and Bošković (to appear) in assuming that feature valuation (in the lexicon) and feature interpretability (at the CI interface) can be dissociated so that the interpretable Topic feature on a moving category (to be interpreted as the topic at the CI interface) can be lexically unvalued, thereby providing a local trigger for the category bearing such feature to move to the phase edge without appealing to the arbitrarily assigned EPP feature on phase heads.

Notice that one important consequence of this dissociation is that Transfer is not able to distinguish inherently valued interpretable features (like  $\phi$ -features on NPs) from inherently valued uninterpretable ones (such as the nominative Case feature on the finite T, the grammatical gender feature on NPs in Serbo-Croatian and Bantu languages, the Topic feature that C passes to T to derive topic A-movement) because the valuation of a certain feature is its only formal property that Transfer relies on to distinguish interpretable features from uninterpretable ones. Consequently, Transfer would send both to the CI interface, and the resultant representation is not fully accessible to and interpretable by the CI interface due to the presence of (inherently valued) uninterpretable features.

One may argue that Pesetsky and Torrego's (2006) proposal against Chomsky's (2001) Valuation/Interpretability Biconditional is conceptually flawed for this reason. However, a derivational system assuming Chomsky's (2001) Valuation/Interpretability Biconditional is not any less problematic in this respect. First, the C-agreement involving



external possessors in West Flemish discussed in Chapter 1 shows that C can have its own discrete  $\phi$ -feature valuation relation, and hence syntactically valued uninterpretable  $\phi$ -features can remain on the phase edge, contra Richards 1997. Second, Obata (2010) and Obata and Epstein (2011) point out that a derivational system assuming feature inheritance coupled with Chomsky's Valuation/Interpretability Biconditional fails to avoid the presence of uninterpretable features at the CI interface. Specifically, they show that *wh*-movement carries the syntactically valued uninterpretable Case feature on the *wh*-phrase to the phase edge, which would enter the CI interface because the Transfer operation cannot distinguish it from inherently valued interpretable features at the next phase level.<sup>7</sup> Therefore, not being able to prevent uninterpretable features from entering the CI interface can no longer be held as an argument undermining Pesetsky and Torrego's (2006) proposal against Chomsky's (2001) Valuation/Interpretability Biconditional: uninterpretable features enter the CI interface under both hypotheses regarding the association of feature interpretability and feature valuation. With this counter-argument removed, notice that there are at least three empirical advantages in favor of the dissociation of feature interpretability and feature valuation. Adopting the dissociation allows us to explain: (i) the hyperactivity and hyperraising in Bantu languages (see Carstens 2010, 2012), (ii) the pattern of conjunct agreement in Serbo-Croatian (see Bošković 2009, to appear), and (iii) the derivation of non-subject topic A-movement in Chinese (as discussed in Chapter 2 of this dissertation).

Given that it is inevitable for uninterpretable features to enter the CI interface, we can conclude that the CI interface does not satisfy the legibility condition by containing only interpretable features. How is the legibility condition satisfied at the CI interface then? I suggest that a promising thesis to pursue is to follow Epstein, Kitahara and Seely's (2010) proposal that uninterpretable features do not require deletion: they are simply

---

<sup>7</sup> One way to maintain Richards' (2007) deduction of feature inheritance in the face of this problem caused by *wh*-movement is to adopt the feature-splitting mechanism proposed by Obata (2010) and Epstein and Obata (2011) discussed in the last section. This mechanism allows the moving *wh*-phrase to carry only the relevant feature driving *wh*-movement on its way to the matrix spec-CP, leaving the derivationally valued [*u*Case] behind in the lower vP phase. This allows Transfer to detect the valuation process of this [*u*Case] and thereby remove it when it sends the lowest VP to the CI interface. Notice that even if the feature-splitting mechanism is on the right track and hence derivations involving *wh*-movement are no longer a problem for Richards' (2007) deduction, the C-agreement involving external possessors in West Flemish examined by Haegeman and van Koppen (2012) remains a serious challenge for Richards' (2007) deductive base. Therefore, I maintain that allowing uninterpretable features to enter the CI interface is a common problem shared by Pesetsky and Torrego's (2006) and Chomsky's (2001) hypotheses regarding the association of feature interpretability and feature valuation.

ignored at the CI interface (entailing that Richards' deduction of feature inheritance is not maintainable). In particular, they (2010:139) contend that "there is no need to stipulate that the CI interface is designed to recognize (and be crash-offended by) features that it cannot use" and propose the following assumption:

- (30) [-Int] [=uninterpretable, CTC] features (e.g. EF [=the edge feature, CTC], unvalued features such as phi on T and Case on N, phonological codes) are invisible to CI. (Epstein, Kitahara and Seely 2010:139, (16))

The CI interface, as an interpretive system, recognizes only interpretable features, and uninterpretable features, either valued or unvalued, are simply invisible in its eyes, and hence are ignored by the CI interpretative system.<sup>8</sup> Therefore, there is no need for Transfer to detect and remove uninterpretable features from CI-bound objects for semantic interpretation. They point out that this assumption greatly simplifies the internal mechanism of Transfer, which is defined in (31):

- (31) Transfer sends SO [=syntactic objects, CTC] (constructed by NS [=narrow syntax, CTC]) to the semantic component and to the phonological component, respectively. (Epstein, Kitahara and Seely 2010:139, (17))

Importantly, Transfer as defined in (31) is simplified in that the previous detect-and-delete function is no longer a "hardwired" internal mechanism. What Transfer does is simply cyclically send syntactic objects to the interfaces for semantic and phonological interpretations, and it does not care about whether or not the CI-bound objects contain CI-uninterpretable features (be they valued or not). Importantly, their illuminating understanding of how Transfer and the CI interface work does not mean that uninterpretable features do not cause any harm if transferred to the interfaces without getting a value in the course of syntactic derivation. They argue that uninterpretable features like the  $\phi$ -features on T and the Case feature, if transferred without a value,

---

<sup>8</sup> The presence of uninterpretable features at the CI interface can be roughly compared to the presence of PC viruses in a MAC operating system – the MAC operating system does not crash because of the presence of PC viruses that it cannot recognize.

terminate the derivation in the phonological component due to the under-specification of a feature value. They point out that native speakers' perception of (32) as a phonological anomaly, rather than a semantic one, supports this line of analysis.

(32) \*It is likely **Bob** to go.

Under their analysis, the unvalued Case feature on *Bob* does not cause crash at CI but constitutes a problem for the phonological coding/implementation at the S(ensory)-M(otor) interface.<sup>9</sup> Now an important question arises as to if there exist genuine semantic anomalies and if it is possible to distinguish sentences that terminate derivations at the phonological component from those that are perceived by native speakers as semantic anomalies. If not, then (32) provides nothing but a vacuous and hence invalid argument for Epstein, Kitahara and Seely's (2010) analysis of uninterpretable features. I maintain that a clear-cut distinction is available and hence (32) constitutes empirical support for their analysis. The argument is related to Epstein's (1990) paradigm in (33). He claims that the contrast in degree of ungrammaticality between (33a) and (33b) can be explicated by assuming that the Case Filter is independent of the Theta Criterion (against the goal of Chomsky's (1986b) Visibility Condition, which aims to reduce the Case Filter to theta-role assignment).

- (33) a. \*\*I hope **John** to be likely that Bill left. (\*Case Filter, \*Theta Criterion)  
 b. \*I want **John** to be likely that Bill left. (<sup>OK</sup>Case Filter, \*Theta Criterion)

---

<sup>9</sup> The fact that (32) is perceived as a phonological anomaly in spite of the invariant form of NPs like *Bob* in different contexts of case assignment suggests that such phonological anomaly is expected to be perceivable even in languages without any morphological realization of different types of case. A case in point is the following sentence discussed in Chapter 2:

- (i) \*Hui [<sub>TP</sub> Akiu zhunbei wancan]  
 will Akiu prepare dinner  
 Intended: 'It will be that case that Akiu prepares the dinner.'

As discussed in Chapter 2, (i) is excluded because *Akiu* cannot get Case within the nonfinite TP complement of *hui*. This is analyzed as a phonological anomaly by Epstein, Kitahara and Seely (2010). My brief survey of five native speakers' intuitions of (i) (including mine) is that even though it sounds odd/unacceptable, its intended interpretation is perceivable by native speakers, similar to (32).

Even though native speakers of English judge both of these sentences as deviant, they assign different degrees of ungrammaticality to them: (33a) is worse than (33b). Epstein (1990) working within the GB theory argues that (33a) violates both the Case Filter and the Theta Criterion. On the other hand, (33b) violates only the Theta Criterion. The fact that (33a) is worse than (33b) is due to the number of violations and what kind of filters are involved in excluding these sentences.

Now the contrast between (33a) and (33b), formulated and explained by Epstein (1990) within the GB theory, becomes relevant to the current discussion under the minimalist framework. Under Epstein, Kitahara and Seely's (2010) approach, a Case filter violation is recast as the failure of implementation of phonological coding in the phonological component due to the under-specification of a feature value, while the violation of the Theta Criterion constitutes a genuine semantic anomaly. In other words, (33a) is worse than (33b) because the former involves both semantic and phonological problems, while the ungrammaticality of the latter is due only to a semantic anomaly. Therefore, the explanation of the different degrees of ungrammaticality in (33a) and (33b) is still available under Epstein, Kitahara and Seely's (2010) minimalist analysis. Now, consider the ungrammaticality of (34), also formulated by Epstein (1990):

(34) \*I hope **John** to think that Bill left. (\*Case filter, <sup>OK</sup>Theta Criterion)

Notice that the ungrammaticality of (34) as well as that of (32) is attributed to the failure of phonological coding due to the under-specification of a feature value. Taking (33) and (34) together, their degree of ungrammaticality is due to whether they are just phonological/semantic anomaly, or they cause problems at both interfaces, as summarized in (35). The fact that (35a) is perceived as worse than (35b/c) suggests that there exist two types of anomalies detectable by human's linguistic cognitive capacity.

- (35) a. \*\*I hope **John** to be likely that Bill left. (\*phonology, \*semantics)  
 b. \*I want **John** to be likely that Bill left. (<sup>OK</sup>phonology, \*semantics)  
 c. \*I hope **John** to think that Bill left. (\*phonology, <sup>OK</sup>semantics)

Now the question comes down to whether native speakers perceive (35b) and (35c) differently. Crucially, even though both (35b) and (35c) are both ungrammatical, (35c) is perceived by native speakers as a sentence that “is understandable but sounds odd”. By contrast, even though (35b) “sounds fine at” *John*, it is semantically anomalous when perceived in its entirety. In sum, I conclude that a clear-cut distinction can be maintained between semantic anomalies and phonological anomalies, and hence sentences like (32) and (35c) constitute empirical support for Epstein, Kitahara and Seely’s (2010) novel approach to uninterpretable features and the properties of the CI interface. An interesting way to further investigate the issue of different types of anomalies and their detectability is to conduct experiments focusing on speakers’ acceptability judgment (say, on a scale of 7) as well as their online processing of these sentences and see if they assign different degrees of unacceptability to sentences like (35b) and (35c), and if they display different reading times at different points in (35b) and (35c) (say, at *to*). This is beyond the scope of this dissertation, and I leave it for future research. Finally, I would like to end the discussion of this section with the following quote from Chomsky (2008:135-136):

It is hardly necessary to add that the [interface, CTC] conditions that enter into principled explanation, in this sense, are only partially understood: *we have to learn about the conditions that set the problem in the course of trying to solve it. The research task is interactive: to clarify the nature of the interfaces and optimal computational principles through investigation of how language satisfies the conditions they impose – optimally, insofar as SMT holds. This familiar feature of empirical inquiry has long been taken for granted in the study of the sensorimotor interface (SM). Inquiry into acoustic and articulatory phonetics takes cues from what has been learned about phonological features and other such properties in I-language research and seeks SM correlates, and any discoveries then feed back to refine I-language inquiry. The same should hold, no less controversially, at the semantic/conceptual-intentional interface (C-I).*

[emphasis mine, CTC]

The inquiries into (i) how topic A-movement of Chinese raising modal constructions can be derived without appealing to the arbitrary assignment of EPP feature to phase heads (see Chapter 2 of this dissertation), (ii) how NPs in Bantu languages remain active throughout the derivation and hence are able to undergo hyperraising (see Carstens 2010, 2011), and (iii) how the CI interface handles the inevitable presence of uninterpretable features present in CI-bound objects (see Epstein, Kitahara and Seely 2010) feed back to

refine the inquiry into how the CI interface satisfies the legibility conditions: it satisfies the legibility conditions by ignoring uninterpretable features, and thus it is featurally crash proof.

## Bibliography

- Ackema, P. and A. Neeleman. 2004. *Beyond Morphology: Interface Conditions on Word Formation*. Oxford: Oxford University Press.
- Aboh, E.O. 2010. Information Structuring Begins with Numeration. *Iberia: An international Journal of Theoretical Linguistics* 2.1: 12-42.
- Alexiadou, A. and E. Anagnostopoulou. 1998. Parameterizing Word Order, V-movement, and EPP-checking. *Natural Language and Linguistic Theory* 16: 491-539.
- Anagnostopoulou, E. 2003. *The Syntax of Ditransitives: Evidence from Clitics*. Berlin: Mouton de Gruyter.
- Anderson, S. 1982. Types of Dependency in Anaphors: Icelandic (and other) Reflexives. *Journal of Linguistic Research* 2:1-22.
- Baker, M. 2008a. *The Syntax of Agreement and Concord*. Cambridge: Cambridge University Press.
- Baker, M. 2008b. The Macroparameter in a Microparametric World. In *The Limits of Syntactic Variation*, ed. by T. Biberauer, 351-374, Amsterdam: John Benjamins.
- Battistella, E. 1989. Chinese Reflexivization. *Linguistics* 27: 987-1012
- Béjar, S. 2003. *Phi-Syntax: A Theory of Agreement*, Doctoral dissertation, University of Toronto.
- Béjar, S and M. Rezac. 2003. Person Licensing and the Derivation of PCC Effects. In *Romance Linguistics: Theory and Acquisition*, ed. by A.T. Pérez-Leroux and Y. Roberge, 49-62. Amsterdam: John Benjamins.
- Béjar, S and M. Rezac. 2009. Cyclic Agree. *Linguistic Inquiry* 40: 35-73.
- Belletti, A. 1988. The Case of Unaccusatives. *Linguistic Inquiry* 19: 1-34.
- Bonet, Eulàlia. 1991. Morphology After Syntax: *Pronominal Clitics in Romance*, Doctoral dissertation, MIT.
- Bošković, Ž. 2002. A-movement and the EPP. *Syntax* 5: 167-218.

- Bošković, Ž. 2007. On the Locality and Motivation of Move and Agree: An Even More Minimal Theory. *Linguistic Inquiry* 38: 589-644.
- Bošković, Ž. 2009. Unifying First and Last Conjunct Agreement. *Natural Language and Linguistic Theory* 27: 455-496.
- Bošković, Z. 2010. On NP and Clauses. Ms., University of Connecticut.
- Bošković, Ž. To appear. On Valued Uninterpretable Features. In *Proceedings of NELS* 39.
- Brame, M. 1977. Alternatives to the Tensed S and Specified Subject Conditions. *Linguistics and Philosophy* 1: 381-411.
- Branigan, P. 1992. *Subjects and Complementizers*, Doctoral dissertation, MIT.
- Bresnan, J. 1994. Locative Inversion and the Architecture of Universal Grammar. *Language* 70: 72-131.
- Brody, M. 1990. Some Remarks on the Focus Field in Hungarian. In *UCL Working Papers in Linguistics, vol. 2*, University College London, pp. 201-226.
- Brody, M. 1995. Focus and Checking Theory. In *Approaches to Hungarian*, ed. by Kenesei, I., , V. JATE, Szeged, pp. 29-44.
- Bruening, B. 2001. QR Obeys Superiority: ACD and Frozen Scope. *Linguistic Inquiry* 32: 233-273.
- Büring, D. 1999. Topic. In *Focus: Linguistic, Cognitive, and Computational Perspectives*, ed. by P. Bosch and R. van der Sandt, 142-165. Cambridge: Cambridge University Press.
- Carstens, V. 2003. Rethinking Complementizer Agreement: Agree with a Case-checked Goal. *Linguistic Inquiry* 34:393-412.
- Carstens, V. 2010. Grammatical Gender and the Theory of Uninterpretable Features. In *Exploring Crash Proof Grammars*, ed. by M. Putnam, 31-57. Amsterdam: John Benjamins.
- Carstens, V. 2011. Hyperactivity and Hyperagreement in Bantu. *Lingua* 121: 721-741.
- Chen, H.-Y. 2009. Logophoricity and *Ziji*. In *Proceedings of the 21<sup>st</sup> North American Conference on Chinese Linguistics*, ed. by Y. Xiao, 464-481. Smithfield, Rhode Island: Bryant University.



- Chierchia, G. 1989. Anaphora and Attitudes *De Se*. In *Semantics and Contextual Expression*, ed. by R. Bartsch, J. van Benthem, and P. van Emde Boas, 1-31. Dordrecht: Foris.
- Chomsky, N. 1968. *Language and Mind*, Harcourt, Brace, Jovanovitch, New York.
- Chomsky, N. 1980. *Rules and Representations*. New York: Columbia University Press.
- Chomsky, N. 1981. *Lectures on Government and Binding*. Dordrecht: Foris Publications.
- Chomsky, N. 1982. Some Concepts and Consequences of the Theory of Government and Binding. Cambridge: MIT Press.
- Chomsky, N. 1986a. *Barriers*. Cambridge, Cambridge: MIT Press.
- Chomsky, N. 1986b. Knowledge of Language. New York: Praeger.
- Chomsky, N. 1993. A Minimalist Program for Linguistic Theory. In *The View from Building 20*, ed. by S. Keyser and M. Hale, 1-52. Cambridge: MIT Press.
- Chomsky, N. 1995. *The Minimalist Program*. Cambridge: MIT Press.
- Chomsky, N. 2000. Minimalist Inquiries: The Framework. In *Step by step: Essays on minimalism in honor of Howard Lasnik*, ed. by R. Martin, D. Michaels, and J. Uriagereka, 89-155. Cambridge: MIT Press.
- Chomsky, N. 2001. Derivation by Phase. In *Ken Hale: a Life in language*, ed. by M. Kenstowicz, 1-52. Cambridge: MIT Press.
- Chomsky, N. 2005. Three Factors in Language Design. *Linguistic Inquiry* 36: 1-22.
- Chomsky, N. 2007. Approaching UG from Below. In *Interfaces + Recursion = Language?*, ed. by U. Sauerland and H.-M. Gärtner, 1-30. Berlin: Mouton de Gruyter.
- Chomsky, N. 2008. On Phases. In *Foundational Issues in Linguistic Theory: Essays in Honor of Jean-Roger Vergnaud*, ed. by R. Freidin, C. P. Otero, and M. L. Zubizarreta, 133-166. Cambridge: MIT Press.
- Chomsky, N. 2010. Poverty of Stimulus: Unfinished Business. Transcription of the lecture presented at Johannes-Gutenberg University Mainz, dated March 24, 2010.
- Chomsky, N. 2013. Problems of Projection. In press in *Lingua*.
- Chou, C.-T. T. 2012. Syntax-Pragmatics Interface: Mandarin Chinese *Wh-the-hell* and Point-of-View Operator. *Syntax* 15: 1-24.

- Chou, C.-T. T. 2013. Unvalued Interpretable Features and Topic A-movement in Chinese Raising Modal Constructions. *Lingua* 123: 118-147.
- Chou, C.-T. T. and S. Hettiarachchi. 2013. Sinhala Case-marking, Modality and A-movement. In *Proceedings of GLOW in Asia IX*.
- Cinque, G. 1999. *Adverbs and Functional heads*. Oxford: Oxford University Press.
- Cinque, G. (Ed.), 2002. *Functional Structure in DP and IP: The Cartography of Syntactic Structures*. Oxford: Oxford University Press.
- Cole, P. and C. Wang. 1996. Antecedents and Blockers of Long Distance Reflexives. *Linguistic Inquiry* 27: 357–390.
- Cole, P. et al. 1993. Feature Percolation and Mandarin Reflexives. *Journal of East Asian Linguistics* 2: 91-118.
- Cole, P. et al. 2006. Long-distance Binding in Asian languages. In *The Blackwell companion to Syntax, Volume III*, ed. by Martin Everaert and Henk van Riemsdijk, 21-84. Malden, MA: Blackwell Publishing.
- Collins, C. 1991. *Why and How Come*. In *More papers on wh-Movement: MIT working papers in linguistics* 15, ed. by L. Cheng and H. Demirdache, 31-45, Cambridge: MIT Press.
- Collins, C. 1997. *Local Economy*. Cambridge: MIT Press.
- Collins, C. 2002. Eliminating Labels. In *Derivation and Explanation in the Minimalist Program*, ed. by S. D. Epstein and T. D. Seely, 42-64. Cambridge: Blackwell Publishing.
- Cooper, R. 1979. The Interpretation of Pronouns. In *Selections from the Third Groningen Round Table*, vol. 10 of *Syntax and Semantics*, ed. by F. Heny and H. Schnelle, 61–92. New York: Academic Press.
- Coopmans, P. 1989. Where Stylistic and Syntactic Processes Meet: Locative Inversion in English. *Language* 65: 728-751.
- Culicover, P. W. and R. Levine. 2001. Stylistic Inversion in English: A Reconsideration. *Natural Language and Linguistic Theory* 19: 283–310.
- Diesing, M. 1992. *Indefinites*. Cambridge: MIT Press.
- Dikken, M. den and A. Giannakidou. 2002. From Hell to Polarity: ‘Aggressively non-D-linked’ Wh-phrases as Polarity Items. *Linguistic Inquiry* 33: 31-61.

- Déchaine, R. and M. Wiltschko. 2002. Decomposing Pronouns. *Linguistic Inquiry* 33-3: 409–442.
- Dogget, T. B. 2004. *All Things Being Unequal: Locality in Movement*, Doctoral dissertation, MIT.
- É. Kiss, K. 1987. *Configurationality in Hungarian*. Reidel, Dordrecht.
- É. Kiss, K. (Ed.). 1995. *Discourse Configurational Languages*. Oxford: Oxford University Press.
- É. Kiss, K., 1998. Identificational Focus and Information Focus. *Language* 74: 245–273.
- Epstein, S.D. 1992. Derivational Constraints on A'-formation. *Linguistic Inquiry* 23 235-259.
- Epstein, S.D. 2007. On I(nternalist)-functional Explanation in Minimalism. *Linguistic Analysis* 33: 20-53.
- Epstein, S. D., E. Groat, R. Kawashima, and H. Kitahara. 1998. *A Derivational Approach to Syntactic Relations*. Oxford: Oxford University Press.
- Epstein, S. D., H. Kitahara, and T. D. Seely. 2010. Uninterpretable Features: What are They and What do They do? In *Exploring Crash-proof Grammar*, ed. by M. Putnam, 125-142. Amsterdam: John Benjamins.
- Epstein, S. D., H. Kitahara, and T. D. Seely. 2012. Structure Building that Can't be. In *Ways of Structure Building*, ed. by M. Uribe-Etxebarria and V. Valmala, 253-270 Oxford: Oxford University Press.
- Epstein, S. D., A. Pires, and T. D. Seely. 2005. EPP in T: More Controversial Subjects. *Syntax* 8: 65-80.
- Epstein, S. D. and T. D. Seely. 1999. SPEC-ifying the GF "Subject": Eliminating A-Chains and the EPP within a Derivational Model. Ms., University of Michigan and Eastern Michigan University.
- Epstein, S. D. and T. D. Seely. 2006. *Derivations in Minimalism*. Cambridge: Cambridge University Press.
- Everaert, M. 1991. Nominative Anaphors in Icelandic: Morphology or Syntax. In *Issues in Germanic Syntax*, ed. by W. Abraham, W. Kosmeijer, and E. J. Reuland, 277–305. Berlin: Mouton de Gruyter.

- Fanselow, G. 2006. On Pure Syntax (Uncontaminated by Information Structure). In *Form, structure and grammar*, ed. by P. Brandt and E. Fuss, 137–157. Berlin: Akademie Verlag.
- Ferguson, K.S. 1996. *A Feature-relativized Shortest Move Requirement*, Doctoral dissertation, Harvard University.
- Fisher, K. 1988. Agreement and the Distribution of Anaphors. In *Studies in Syntactic Typology*, ed. by M. Hammond, E. Moravcsik, and J. Wirth, 25–36. Amsterdam: John Benjamins.
- Fitzpatrick, J. 2005. The Whys and How Comes of Presupposition and NPI Licensing in Questions. In *Proceedings of the West Coast Conference on Formal Linguistics 24*. Simon Fraser University, Vancouver, BC, Canada.
- Fox, D. 1999. Reconstruction, Binding Theory, and the Interpretation of Chains. *Linguistic Inquiry* 33:63-96.
- Frampton, J. and S. Gutmann. 2002. Crash-proof Syntax. In *Derivation and Explanation in the Minimalism Program*, ed. by S. D. Epstein and T. D. Seely, 90-105. Oxford: Blackwell.
- George, L. and Jaklin K. 1981. Finiteness and Boundedness in Turkish. In *Binding and Filtering*, ed. by F. Heny, 105–127. Cambridge: MIT Press.
- Grimshaw, J. 1991. Extended Projection. Ms., Brandeis University.
- Groat, E. and J. O’Neil. 1996. Spell-Out at the LF Interface. In *Minimalist Ideas: Syntactic Studies in the Minimalist Framework*, ed. by W. Abraham et al., 113-139, Amsterdam: John Benjamins.
- Haegeman, L. 1992. *Theory and Description in Generative Syntax: A Case Study in West Flemish*. Cambridge: Cambridge University Press.
- Haegeman, L. and V. Hill. 2011. The Syntacticization of Discourse. Ms., Ghent University and University of Brunswick-SJ.
- Haegeman, L. and M. van Koppen. 2012. Complementizer Agreement and the Relation between  $C^0$  and  $T^0$ . *Linguistic Inquiry* 43-3: 441-454.
- Hagstrom, P. 2006. A-not-A Questions. In *The Blackwell companion to Syntax, Volume I*, ed. By Martin Everaert and Henk van Riemsdijk, 173-213. Malden, MA: Blackwell Publishing.

- Harbour, D., et al. 2008. *Phi Theory: Phi-features across Modules and Interfaces*. Oxford: Oxford University Press.
- Harley, H. and E. Ritter. 2002. Person and Number in Pronouns: A Feature-geometric Analysis. *Language* 78: 482-526.
- Hettiarachchi, S. 2012. Sinhala Scrambling: Topic/Focus-Driven A-bar Movement. Ms., University of Michigan, Ann Arbor.
- Hiraiwa, K. 2001. Multiple Agree and the Defective Intervention Constraint in Japanese. In *The Proceedings of the MIT-Harvard joint conference (HUMIT 2000) MITWPL 40*, ed. by O. Matushansky, 67–80. Cambridge: MIT Press.
- Hiraiwa, K. 2004. Dimensions of Symmetry in Syntax: Agreement and Clausal Architecture, Doctoral Dissertation, MIT.
- Holmberg, A and U. Nikanne. 2002. Expletives, Subjects, and EPP in Finnish. In *Subjects, Expletives, and the EPP*, ed. by P. Svenonius, 71-106. Oxford: Oxford University Press.
- Holmberg, A. and T. Hróarsdóttir. 2003. Agreement and Movement in Icelandic Raising Constructions. *Lingua* 113: 997-1019.
- Horvath, J. 1986. *FOCUS in the Theory of Grammar and the Syntax of Hungarian*. Foris, Dordrecht.
- Horvath, J. 1995. Structural Focus, Structural Case, and the Notion of Feature-Assignment. In *Discourse Configurational Languages*, ed. by K. É. Kiss, 28–64., Oxford: Oxford University Press.
- Horvath, J. 2010. “Discourse Features”, Syntactic Displacement and the Status of Contrast. *Lingua* 120: 1346-1369.
- Huang, C.-T. J. 1982. *The Logical Relations of Chinese and the Theory of Grammar*, Doctoral dissertation, MIT.
- Huang, C.-T. J. 1983. On the Representation of Scope in Chinese. *Journal of Chinese Linguistics* 11: 37-91,
- Huang, C.-T. J. 1987. Existential Sentences in Chinese and (In)definiteness. In *The Representation of (In)definiteness*, ed. by E. Reuland & A. ter Meulen, 226-253. Cambridge, Massachusetts: MIT Press.

- Huang, C.-T. J. 1990. Shuo Shi he You [On Be and Have in Chinese]. *Bulletin of the Institute of History and Philology, Academia Sinica* 59, 43-64.
- Huang, C.-T. J. 1997. On Lexical Structure and Syntactic Projection. *Chinese Languages and Linguistics* 3: 45-89
- Huang, C.-T. J. 1999. Chinese Passives in Comparative Perspectives. *Tsing Hua Journal of Chinese Studies* 29: 423-509.
- Huang, C.-T. J., Y.-H. Huang, T.-H. Teng, and R. Tiedeman. 1984. Reflexives in Chinese and the Teaching of Chinese. In *Proceedings of the First World Conference on Chinese Language*: 205-215.
- Huang, C.-T. J. and C.-C. J. Tang. 1991. The Local Nature of the Long-distance Reflexives in Chinese. In *Long-distance anaphor*, ed. by J. Koster and E. Reuland, 263-282. Cambridge: Cambridge University Press.
- Huang, C.-T. J. and C.-S. L. Liu. 2001. Logophoricity, Attitudes and *Ziji* at the Interface. In *Long distance reflexives, Syntax and semantics 33*, ed. by P. Cole, *et al.*, 141-195. New York: Academic Press.
- Huang, C.-T. J. and M. Ochi. 2004. Syntax of *the Hell*: Two Types of Dependencies. In *Proceedings of NELS 34*.
- Huang, C.-T. J., Y.-H. A. Li, and Yafei Li. 2009. *The Syntax of Chinese*. Cambridge: Cambridge University Press.
- Huang, Y.-H. 1984. Chinese Reflexives. In *Studies in English Literature and Linguistics 10*: 163-188. National Taiwan Normal University, Taipei.
- Inman, M. 1994. *Semantics and Pragmatics of Sinhala Involitives*, Doctoral dissertation, Stanford University.
- Jacobs, J. 2001. The Dimensions of Topic-Comment. *Linguistics* 39-4: 641-681
- Jany, C. 2006. The Relationship between Case marking, ans S, A, and O in Spoken Sinhala. In *Santa Barbara Papers in Linguistics 17*, ed. by R. Englebreston and C. Genetti, 68-84.
- Johnson, K. 1985. Some Notes on Subjunctive Clauses and Binding in Icelandic. In *MIT working papers in linguistics 6: Papers in theoretical and applied linguistics*, 102–134. Cambridge: MIT Press.
- Kayne, R. 1984. *Connectedness and Binary Branching*. Dordrecht: Foris.

- Kayne, R. 1989. Facets of Romance Past Participle Agreement. In *Dialect Variation and the Theory of Grammar*, ed. by Paola Beninca, 85–103. Dordrecht: Foris.
- Kayne, R. 1994. *The Antisymmetry of Syntax*. Cambridge: MIT Press.
- Kitahara, H. 2011. Can Eagles that Fly Swim?: Guaranteeing the Simplest Possible Answer to a New Puzzle. In *The proceedings of 12th Tokyo Conference on Psycholinguistics*, ed. by Y. Otsu. Hitsuji Syobo, Tokyo.
- Klima, E. 1964. Negation in English. In *The Structure of Language*, ed. by J. A. Fodor and J. J. Katz, 246-332. Englewood Cliffs, NJ: Prentice-Hall.
- Ko, H. 2005. Syntax of *Why*-in-situ: Merge into [Spec, CP] in the Overt Syntax. *Natural Language and Linguistic Theory* 23: 867-916.
- Koppen, M. van. 2005. One Probe – Two Goals: Aspects of Agreement in Dutch Dialects. Doctoral dissertation, University of Leiden. LOT Publications 105. Available at <http://www.lotpublications.nl/publish/articles/001227/bookpart.pdf>.
- Koppen, M. van. 2007. Agreement with Coordinated Subjects: A Comparative Perspective. *Linguistic Variation Yearbook* 7:121–161.
- Koopman, H. 1984. The Syntax of Verbs: From Verb Movement in the Kru Languages to Universal Grammar. Dordrecht: Foris.
- Kratzer, A. 2009. Making a Pronoun: Fake Indexicals as Windows into the Properties of Pronouns. *Linguistic Inquiry* 40-2: 187–237.
- Kuno, S. 1971. The Position of Locatives in Existential Sentences. *Linguistic Inquiry* 1: 333–378.
- Kuno, S. 1972. Pronominalization, Reflexivization, and Direct Discourse. *Linguistic Inquiry* 3: 161-195.
- Kuo, C.-M. 1996. The Interaction between *Daodi* and *Wh*-phrases in Mandarin Chinese. Ms., University of Southern California.
- Kuroda, S. Y. 1988. Whether We Agree or Not: A Comparative Syntax of English and Japanese. *Lingvisticae Investigationes* 12: 1-47.
- Lasnik, H. 1995. Case and Expletives Revisited: On Greed and Other Human Failings. *Linguistic Inquiry* 26: 615–633.
- Lasnik, H. 1999. Chains of Arguments. In *Working minimalism*, ed. by S. D. Epstein and N. Hornstein, 189–215. Cambridge: MIT Press.

- Lasnik, H. 2001. A Note on the EPP. *Linguistic Inquiry* 32: 356–362.
- Lasnik, H and M. Saito. 1984. On the Nature of Proper Government. *Linguistic Inquiry* 15-2: 235-289.
- Lebeaux, D. 1988. *Language Acquisition and the Form of the Grammar*, Doctoral dissertation, University of Massachusetts, Amherst.
- Legate, J. A. 2003. Some Interface Properties of the Phase. *Linguistic Inquiry* 34: 506-515.
- Levin, B. and H. M. Rappaport. 1995. *Unaccusativity at the Syntax-Semantics Interface*. Cambridge: MIT Press.
- Li, Y.-H.A. 1985. *Abstract Case in Chinese*, Doctoral dissertation, USC.
- Li, Y.-H.A. 1990. *Order and Constituency in Mandarin Chinese*. Dordrecht: Kluwer Academic Publishers.
- Liao, W.-W. R. 2011. *The Symmetry of Syntactic Relations*, Doctoral dissertation, University of Southern California.
- Lin, J. 2003. Temporal Reference in Mandarin Chinese. *Journal of East Asian Linguistics* 12: 259-311.
- Lin, J. 2006. Time in a Language without Tense: The Case of Chinese. *Journal of Semantics* 23:1-53.
- Lin, J. 2010. A Tense-less Analysis of Mandarin Chinese Revisited: A Response to Sybesma 2007. *Linguistic Inquiry* 41: 305-329.
- Lin, J. and C.-C. J. Tang. 1995. Modals as Verbs in Chinese: A GB Perspective. In *The Bulletin of Institute of History and Philosophy* 66. Taipei: Academia Sinica.
- Lin, T.-H. J. 2005. Does *Wh-in-situ* License Parasitic Gaps?. *Linguistic Inquiry* 36: 298-302.
- Lin, T.-H. J. 2011. Finiteness of Clauses and Raising of Arguments in Mandarin Chinese. *Syntax*: 14, 48-73.
- Liu, C.-M. L. 2012. Mandarin Parasitic Gaps. Ms., Harvard University.
- Liu, C.-S. L. 2010. The Positive Morpheme in Chinese and the Adjectival Structure. *Lingua* 120: 1010-1056.
- Maling, J. 1984. Non-clause-bounded Reflexives in Modern Icelandic. *Linguistics and Philosophy* 7: 211–241.



- May, R. 1985. *Logical Form: Its Structure and Derivation*. Cambridge: MIT Press
- Medeiros, D. In prep. *The Syntax and Semantics of Morphological Imperatives*, Doctoral dissertation, University of Michigan, Ann Arbor.
- Melvold, J. 1991. Factivity and Definiteness. In *More papers on wh-movement, MIT working papers in linguistics 15*, ed. by Lisa L. S. Cheng and H. Demirdache, 97–117. Cambridge: MIT Press
- Milsark, G. 1974. *Existential Sentences in English*, Doctoral dissertation, MIT.
- Milsark, G. 1977. Toward an Explanation of Certain Peculiarities in the Existential Construction in English. *Linguistic Analysis* 3: 1-30.
- Miyagawa, S. 2005. On the EPP. In *Perspectives on Phases, MIT Working Papers in Linguistics* 49, ed. by M. McGinnis and N. Richards, 201-236. Cambridge: MIT Press.
- Miyagawa, S. 2010. *Why Agree? Why Move?* Cambridge: MIT Press.
- Miyagawa, S. 2012. Agreements that Occur Mainly in the Main Clause. In *Main Clause Phenomena: New Horizons*, ed. by L. Aelbrecht and L. Haegeman, and R. Nye. 79-112. Amsterdam: John Benjamins.
- Moro, Andrea. 1997. *The Raising of Predicates*. Cambridge: Cambridge University Press.
- Neeleman, A. and H. van de Koot. 2008. Dutch Scrambling and the Nature of Discourse Templates. *Journal of Comparative Germanic Linguistics* 11:137-189.
- Nevins, A. 2005. Derivations without the Activity Condition. In *MIT Working Papers in Linguistics* 49, 283-306. Cambridge: MIT Press
- Nevins, A. 2007. The Representation of Third Person and its Consequences for the Person-case Effects. *Natural Language and Linguistic Theory* 25: 273-313.
- Nevins, A. 2008. Cross-modular Parallels in the Study of Phon and Phi. In *Phi Theory*, ed. by Harbour et al., 329-367. Oxford: Oxford University Press.
- Nevins, A. 2011. Multiple Agree with Clitics: Person Complementarity vs. Omnivorous Number. *Natural Language and Linguistic Theory* 29: 939-971.
- Obata, M. 2010. *Root, Successive-cyclic, and Feature-Splitting Internal Merge: Implications for Feature Inheritance and Transfer*, Doctoral dissertation, University of Michigan, Ann Arbor.

- Obata, M. 2012. Feature-splitting Internal Merge and its Implications for the Elimination of A/A'-position Types. In *Phases: Developing the Framework*, 173-194, ed. by Á. Gallego,. Berlin: Mouton de Gruyter.
- Obata, M. & S. D. Epstein. 2011. Feature-Splitting Internal Merge: Improper Movement, Intervention and the A/A'-Distinction. *Syntax* 14: 122-147.
- Obata, M, M. Baptista, and S. D. Epstein. 2013. Parameter as Third Factor Optionality. Poster presented at the *the 87th Annual Meeting of the Linguistic Society of America*.
- Ouali, H. 2006. *Unifying Agreement Relations: A Minimalist Analysis of Berber*, Doctoral dissertation, University of Michigan, Ann Arbor.
- Ouali, H. 2008. On C-to-T  $\Phi$ -feature Transfer: The Nature of Agreement and Anti-agreement in Berber. In *Agreement Restrictions*, ed. by R. D'Alessandro, G.H. Hrafnbjargarson, S. Fischer, 159-180. Berlin: Mouton de Gruyter.
- Ouali, H. 2010. Computational Efficiency and Feature Inheritance in Crash Proof Syntax. In *Exploring Crash-Proof Grammars [Language Faculty and Beyond]*, ed. by M.T. Putnam, 15-29, Amsterdam: John Benjamins.
- Ouali, H. 2011. *Agreement, Pronominal Clitics and Negation in Tamazight Berber: A Unified Analysis*. Continuum, New York.
- Oyharçabal, B. 1993. Verb Agreement with Non Arguments: On Allocutive Agreement. In *Generative Studies in Basque Linguistics*, ed. by José Ignacio Hualde and Jon Ortiz de Urbina, 89-114, Amsterdam: Jon Benjamins.
- Pak, M., P. Portner, and R. Zanuttini. 2004. Deriving Clause types: Focusing on Korean. In *Proceedings of the 2004 Linguistic Society of Korea international conference*: 359–368. Seoul: Hanshin Publishing Company.
- Pak, M., P. Portner, and R. Zanuttini. 2008a. Agreement and the Subjects of Jussive Clauses in Korean. In *Proceedings of NELS 37*, ed. by E. Elfner and M. Walkow, 127–138. Amherst: GLSA.
- Pak, M., P. Portner, and R. Zanuttini. 2008b. Agreement in Promissive, Imperative, and Exhortative Clauses. *Korean Linguistics* 14: 157–175.
- Pan, H.-H. 1997. *Constraints on Reflexivization in Mandarin Chinese*. New York: Garland.
- Partee, B. 1988. Many Quantifiers. *ESCOL* 5: 383-401.

- Paul, W. 2002. Sentence-internal Topics in Mandarin Chinese: The Case of Object Preposing. *Language and Linguistics* 3:695–714.
- Pica, P. 1987. On the Nature of the Reflexivization Cycle. In Proceedings of NELS 17, ed. by J. McDonough and B. Plunkett, 483-499, GLSA, University of Massachusetts, Amherst.
- Perlmutter, D. 1971. *Deep and Surface Structure Constraints in Syntax*. New York: Holt, Rinehart and Winston.
- Pesetsky, D. 1987. *Wh-in-situ: Movement and Unselective Binding*. In *The representation of (in)definiteness*, ed. by Eric Reuland and Alice ter Meulen, 98-129. Cambridge: MIT Press.
- Pesetsky, D. 1989. Language-particular Processes and the Earliness Principle. Ms., MIT.
- Pesetsky, D. and E. Torrego. 2001. T-to-C movement: Causes and Consequences. In *Ken Hale: A Life in Language*, ed. by M. Kenstowicz, 355–426. Cambridge: MIT Press.
- Pesetsky, D. and E. Torrego. 2007. The Syntax of Valuation and the Interpretability of Features. In *Phrasal and Clausal Architecture: Syntactic Derivation and Interpretation*, ed. by S. Karimi, et al., 262-294. John Benjamins.
- Picallo, M. C. 1985. *Opaque Domains*, Doctoral dissertation, The Graduate Center, City University of New York.
- Poole, G. 1996. Transformations across Components, Doctoral dissertation, Harvard University.
- Postal, P. 1977. About a ‘Nonargument’ for Raising. *Linguistic Inquiry* 8: 141-154.
- Postal, P. 2004. *Skeptical Linguistic Essays*. Oxford University Press.
- Putnam, M. (Ed.) 2010. *Exploring Crash Proof Grammar*. Amsterdam: John Benjamins
- Reichenbach, H. 1947. *Elements of Symbolic Logic*. New York: Macmillan.
- Reuland, E. 1981. Empty Subjects, Case and Agreement and the Grammar of Dutch. In *Binding and filtering*, ed. by Frank Heny, 159–190. Cambridge: MIT Press.
- Rezac, M. 2008. The Syntax of Eccentric Agreement: The Person Case Constraint and Absolute Displacement in Basque. *Natural Language and Linguistic Theory* 26: 61–106.
- Rezac, M. 2011. Phi-features and the Modular Architecture of Language. Berlin: Springer.

- Richards, N. 1997. *What Moves Where When in Which Language*, Doctoral dissertation, MIT.
- Richards, N. 2001. *Movement in Language: Interactions and Architectures*. Oxford: Oxford University Press.
- Richards, N. 2011. A-bar Dependencies. In *The Oxford Handbook of Linguistic Minimalism*, ed. by C. Boeckx, 173-194. Oxford: Oxford University Press.
- Richards, M. 2007. On Feature Inheritance: An Argument from the Phase Impenetrability Condition. *Linguistic Inquiry* 38: 563-572.
- Richards, M. 2011. Deriving the Edge: What's in a Phase. *Syntax* 14: 74-95.
- Riemsdijk, H.C. van. 1990. Functional Prepositions. In *Unity in Diversity: Papers presented to Simon C. Dik on his 50th birthday*, ed. by H. Pinkster and I. Genée., Dordrecht: Foris.
- Riemsdijk, H.C. van. 1996. The Extension of Projections. In *Tsuru Working Papers in Linguistics*.
- Ritter, E. and H. Harley. 1998. Meaning in Morphology: A Feature-geometric Analysis of Person and Number. Paper presented at GLOW 20, Tilburg, the Netherlands.
- Rizzi, L. 1990. On the Anaphor Agreement Effect. *Rivista di Linguistica* 2: 27-42.
- Rizzi, L. 1997. The Fine Structure of the Left Periphery. In: *Elements of Grammar*, ed. by L. Haegeman, 281-337. Dordrecht: Kluwer.
- Rizzi, L. 2004. On the Form of Chains: Criterial Positions and ECP effects. Ms., University of Siena.
- Rizzi, L., 2010. On some properties of criterial freezing. In *Complementizer Phrase*, ed. by E.P. Panagiotidis, 17-32. Oxford: Oxford University Press.
- Rizzi, L. 2012. Cartography, Criteria, and Labeling. Paper presented at Ecole d'Automne de Linguistique 2012 - Blaise Pascal Lectures, Sep 11-13.
- Rizzi, L. and Shlonsky, U. 2007. Strategies of Subject Extraction. Ms., University of Siena and University of Geneva.
- Potsdam, E. 1998. *Syntactic Issues in the English Imperative. Outstanding dissertations in linguistics*. New York: Garland Publishing, Inc.
- Sabel, J. 2000. Expletives as Features. In *Proceedings of WCCFL 19*, ed. by B. Roger and B. Danielle Lillehaugen, 411-424. Somerville: Cascadilla Press.

- Saito, M. 2012. Case Checking/valuation in Japanese: Move, Agree, or Merge? *Nanzan Linguistics* 8: 109-127.
- Sauerland, U. 2003. Intermediate Adjunction with A-movement. *Linguistic Inquiry* 34: 308-314.
- Sauerland, U. 2008. On the Semantic Markedness of Phi-features. In *Phi-theory: Phi-features across modules and interfaces*, ed. by Daniel Harbour, David Adger, and Susana Béjar. Oxford: Oxford University Press.
- Schlenker, P. 2003. A Plea for Monsters. *Linguistics and Philosophy* 26-1: 29–120.
- Seely, T. D. 2006. Merge, Derivational C-command, and Subcategorization in a Label-free Syntax. In *Minimalist Essays*, ed. by C. Boeckx. LA Series, John Benjamins.
- Sells, P. 1987. Aspects of Logophoricity. *Linguistic Inquiry* 18: 445-479.
- Shen, Li. 2004. Aspect Agreement and Light Verbs in Chinese: A Comparison with Japanese. *Journal of East Asian Linguistics* 13: 141–179.
- Sigurðsson, H. Á. 1996. Icelandic Finite Verb Agreement. In *Working Papers in Scandinavian Syntax* 57, 1–46.
- Sigurðsson, H. Á. 2004. Meaningful Silence, Meaningless sounds. In *Linguistic Variation Yearbook Volume 4*, ed. by P. Pica et al., 235–259. Amsterdam & Philadelphia: John Benjamins.
- Sigurðsson, H. Á. 2009. Language Quarks. *Iberia* 1: 169–183.
- Sigurðsson, H. Á. 2010. On EPP Effects. *Studia Linguistica* 64: 159–189.
- Smith, C. and M. Erbaugh. 2005. Temporal Interpretation in Mandarin Chinese. *Linguistics* 43: 713-756.
- Stowell, T. 1981. *Origins of Phrase Structure*, Doctoral Dissertation, MIT.
- Sybesma, R. 2007. Whether We Tense-agree Overtly or Not. *Linguistic Inquiry* 38: 580–587.
- Speas, M. 2004. Evidentiality, Logophoricity and the Syntactic Representation of Pragmatic features. *Lingua* 114: 255-276.
- Szendroi, K. 2001. *Focus and the Syntax-phonology Interface*, Doctoral dissertation, University College London.
- Takahashi, S. 2006. *Decompositionality and Identity*, Doctoral dissertation, MIT.

- Takahashi, S. & S. Hulsey. 2009. Wholesale Late Merger: Beyond the A/ $\bar{A}$  Distinction. *Linguistic Inquiry* 40: 387-426.
- Tang, C.-C. J. 1989. Chinese Reflexives. *Natural Language and Linguistic Theory* 7: 93–121.
- Tang, C.-C. J. 1990. *Chinese Phrase Structure and the Extended X'-theory*, Doctoral dissertation, Cornell University.
- Tang, T.-C. 2000. Finite and Nonfinite Clauses in Chinese. *Language and Linguistics* 1:191–214.
- Taraldsen, K. T. 1995. On Agreement and Nominative Objects in Icelandic. In *Studies in comparative Germanic syntax*, ed. by Haider, H., et al., 307-327. Dordrecht: Kluwer.
- Tenny, C. 2006. Evidentiality, Experiencers, and the Syntax of Sentience in Japanese. *Journal of East Asian Linguistics* 15: 245-288.
- Tenny, C. & M. Speas. 2003. Configurational Properties of Point of View Roles. In *Asymmetry in Grammar*, ed. by Anna Maria Di Sciullo. Benjamins.
- Travis, L. 1984. *Parameters and Effects of Word Order Variation*, Doctoral dissertation, MIT.
- Tsai, W.-T. D. 1994. *On Economizing the Theory of A-Bar Dependencies*, Doctoral dissertation, MIT.
- Tsai, W.-T. D. 1995. Visibility, Complement Selection and the Case Requirement of CP. *Journal of East Asian Linguistics* 4: 281–312.
- Tsai, W.-T. D. 2001. On Subject Specificity and Theory of Syntax-semantics Interface. *Journal of East Asian Linguistics* 10: 129-168.
- Tsai, W.-T. D. 2004. Left Periphery and *How-why* Alternations. Ms., National Tsing Hua University.
- Tsai, W.-T. D. 2009. Actuality Entailments and Topography of Chinese Modals. Paper presented at the Seventh GLOW in Asia, EFLU, Hyderabad, India.
- Tsai, W.-T. D. 2010. EPP as a Topic Feature: Evidence from Chinese Applicatives, Modals, and Refutory *Wh*'s. Paper presented at the Eighth GLOW in Asia, Beijing Language & Culture University, Beijing, China.

- Tseng, W.-H. K., 2009. A Post-Syntactic Approach to the A-not-A Questions. In UST Working Papers in Linguistics, ed. by C.Y. Hu and Y.W.K. Chiang, 107-139. National Tsing Hua University, Hsinchu.
- Woolford, E. 1999. More on the Anaphor Agreement Effect. *Linguistic Inquiry* 30: 257–287.
- Wu, H.-H. I. 2008. *Generalized Inversion and the Theory of Agree*, Doctoral dissertation, MIT.
- Wurmbrand, S. 1999. Modal Verbs must be Raising Verbs. In *Proceedings of WCCFL 18*, ed. by S. Bird, A. Carnie, J. Haugen, and P. Norquest, 599-612. Somerville, MA: Cascadilla Press.
- Xu, L. 1993. The Long-distance Binding of *Ziji*. *Journal of Chinese Linguistics* 21: 123-141.
- Xue, P., P., Carl J., and I. A. Sag. 1994. A New Perspective on Chinese Reflexive *Ziji*. In *Proceedings of the 13th West Coast Conference on Formal Linguistics*, 432-447, CSLI Publications, Stanford University.
- Yang, D-W. 1983. The Extended Binding Theory of Anaphors. *Language Research* 19:169–192.
- Zanuttini, R., M. Pak, and P. Portner. 2012. A Syntactic Analysis of Interpretative Restrictions on Imperative, Promissive, and Exhortative Subjects. *Natural Language and Linguistic Theory*: DOI 10.1007/s11049-012-9176-2.
- Zubizarreta, M. L. 1998. *Prosody, Focus and Word Order*. Cambridge: MIT Press.
- Zwart, C. J.-W. 1997. *Morphosyntax of Verb Movement*. Dordrecht: Kluwer.
- Zwart, C. J.-W. 2001. Syntactic and Phonological Verb Movement. *Syntax* 4: 34-62.