

- pore waters, p. 811-812. In B. C. Heezen et al. [eds.], Initial reports of the deep sea drilling project, v. 20.
- CULKIN, F. 1965. The major constituents of seawater, p. 121-161. In J. P. Riley and G. Skirrow [eds.], Chemical oceanography, v. 1. Academic.
- MACCHI, G., B. CESCO, AND D. MAMELI D' ERICO. 1969. A volumetric determination of sulphate in seawater. Arch. Oceanogr. Limnol. **16**: 163.
- MANGELSDORF, P. C., JR. 1966. Difference chromatography. Anal. Chem. **38**: 1540-1544.
- , AND W. M. CHANG. 1975. Direct determination of normality of electrolyte solutions. Anal. Chem. **47**: 1713-1714.
- , AND T. R. WILSON. 1971. Difference chromatography of seawater. J. Phys. Chem. **75**: 1418-1425.
- MILLERO, F. J., S. R. SCHRAGER, AND L. D. HANSEN. 1974. Thermometric titration analysis of seawater for chlorinity, sulfate, and alkalinity. Limnol. Oceanogr. **19**: 711-715.
- MURRAY, J., AND R. IRVINE. 1895. On the chemical changes which take place in the composition of seawater associated with blue muds on the floor of the ocean. Trans. R. Soc. Edinburgh **37**: 481-508.
- RICHARDS, F. A. 1965. Anoxic basins and fjords, p. 197-225. In J. P. Riley, and G. Skirrow [eds.], Chemical oceanography, v. 1. Academic.
- SAYLES, F. L., T. R. WILSON, D. N. HUME, AND P. C. MANGELSDORF, JR. 1973. In situ sampler for marine sedimentary pore waters: Evidence for potassium depletion and calcium enrichment. Science **181**: 154-156.
- THORSTENSON, D. C., AND F. T. MACKENZIE. 1974. Time variability of pore water chemistry in recent carbonate sediments, Devil's Hole, Harrington Sound, Bermuda. Geochim. Cosmochim. Acta **38**: 1-20.
- WILSON, T. R. 1975. Salinity and the major elements of seawater, p. 365-413. In J. P. Riley, and G. Skirrow [eds.], Chemical oceanography, 2nd ed., v. 1. Academic.

Submitted: 1 March 1976
Accepted: 7 June 1976

A squeezer for efficient extraction of pore water from small volumes of anoxic sediment¹

Abstract—A simple, small-volume, low pressure, diaphragm-type sediment squeezer made from inexpensive standard nylon stock material, suitable for trace metal studies, features a removable sediment cassette with prefilter which greatly facilitates loading and cleaning. Pore water is recovered rapidly through a large active area membrane filter without clogging, impermeable cake formation, or gas breakthrough. A minimal pore water dead volume significantly reduces flushing losses and facilitates online electrode measurements. The squeezer is designed to accept small quantities of unconsolidated sediment (20-100 ml) from refrigerated cores sectioned in a nitrogen-filled glove box.

Here we describe a modified version of the pistonless sediment squeezer developed by Reeburgh (1967), designed to be used on the unconsolidated, fine-grained sediments of the Great Lakes.

Several systems for the acquisition of sediment pore water described recently rep-

resent tangible improvements over earlier models (Siever 1962; Presley et al. 1967; Reeburgh 1967). However, none is entirely suited to our work with anoxic sediment cores from the Great Lakes. The hydraulic, piston squeezer of Kalil and Goldhaber (1973) is designed for use with consolidated sediments which are sectioned by cutting through the core liner. We often obtain fluid material not amenable to this type of treatment. The in situ interstitial water sampler of Barnes (1973) is designed primarily for the study of dissolved gases in deep-sea sediments. It is not appropriate for trace metal analysis and cannot provide the required vertical resolution near the sediment-water interface. The large-volume squeezer described by Sasseville et al. (1974) is unsuitable for several reasons. In the operation of their system the sediments are exposed to air during transfer from corer to squeezer. The sensitivity of concentrations of dissolved phosphate (Bray et al. 1973; Weiler 1973) and iron (Troop

¹Contribution 201 from the Great Lakes Research Division, University of Michigan.

et al. 1974) in anoxic sediments to air exposure is known to be very great. Our study of such effects has shown that traces of residual air on squeezer walls and in the filters can result in an order-of-magnitude decrease in concentrations of both dissolved iron and phosphate. Even the briefest exposure of sediments to air is unacceptable. In addition, the squeezer is simply too large for the volumes of sediment we routinely collect.

We use a Benthos gravity corer with a nominal 3-inch diameter (7.6-cm ID) or smaller diameter core liner as we have encountered appreciable skewing of sediments within larger diameter (12.7 cm) core liners. Since order-of-magnitude changes occur within the upper 2–4 cm of sediment for some elements of interest to us, such as manganese (Robbins and Callender 1975) and silica (Robbins et al. 1975; Weiler 1973), we section cores in intervals of 0.5 to 2.0 cm to preserve significant details in concentration profiles. Hence we routinely obtain a comparatively small volume (20–100 cc) of wet sediment for squeezing. Therefore we have redesigned the gas-operated diaphragm squeezer to accommodate small volumes of sediment and have eliminated previously encountered problems with cleaning, clogging, low flow rates, and gas breakthrough.

A cross-sectional view of the system is shown in Fig. 1. Like its predecessor, the squeezer is gas-operated and relies on expansion of a rubber diaphragm to compress the sediment and force the interstitial water through several filters. The sediment sample is contained in a removable prefilter cassette, about 2.5 cm deep. As a prefilter we use a standard 70-mm diameter, pre-soaked Whatman 541 cellulose fiber filter supported by No. 10 mesh Nitex, epoxied to the cassette base. The shallow tray depth minimizes the distortion of the rubber diaphragm in squeezing centimeter-thick sediment sections. We have observed incomplete squeezing of sediment near squeezer walls in smaller diameter models where the gap between the sediment and diaphragm is over several centimeters. The

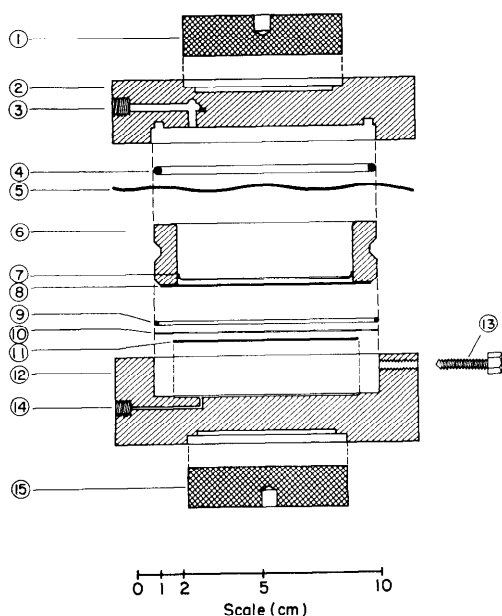

Fig. 1. Cross-sectional view of the squeezer components. 1—Top clamp plate (aluminum); 2—cap (Delrin); 3—gas inlet; 4—O-ring (Viton); 5—rubber diaphragm (Dental Dam); 6—sediment cassette (Delrin); 7—prefilter. Its diameter is slightly larger than cassette inner diameter; in operation, the prefilter is flush with the support screen. 8—Prefilter supporting screen (nylon) cemented to the cassette base with epoxy; 9—O-ring (Viton); 10—membrane filter (90-mm diam, 0.45- μ Millipore GSTF); 11—supporting screen (nylon); 12—base (Delrin); 13—one of three positioning screws (nylon); 14—pore water outlet; 15—bottom clamp plate (aluminum).

inner diameter of the cassette is made slightly smaller than the diameter of the prefilter to prevent sediment leakage. The cassette can be held in position during assembly by three nylon screws, although we have not routinely used this feature. An important advantage of this cassette-prefilter configuration is that the system is very easy to clean. No sediment can get around and under O-rings and there is little chance of contaminating the pore water side of the system with sediment particles, as there is no sediment in contact with the membrane filter.

We selected this large but standard size, 90-mm-diameter 0.45- μ Millipore, deter-

gent-free (Cahn 1967) filter to enhance pore water flow rates and for the convenience of directly loading the squeezer with sections of sediments extruded from the core liner. The combination of the large main filter (about 40-cm² active area) and pre-filter eliminates the problem of clogging that we have observed with both piston and diaphragm squeezers with appreciably smaller active filter areas. With the present system, it is not necessary to increase the pressure in a stepwise manner to avoid effects of impermeable cake formation (Reeburgh 1967). At the standard operating pressure of 6.9 atm we recover ca. 20 ml per 50 g wet wt of sediment (porosity from 0.8 to 0.9) in 10–20 min. This volume of water is typically about 50–60% of the total water in the sample. The rate of pore water recovery appears to be appreciably greater than that reported either by Reeburgh (1967) or by Weiler (1973) who squeezed Great Lakes sediments with presumably comparable porosities. Our recovery rate is similar to that reported by Sasseville et al. (1974) for their large-volume squeezer. The membrane filter is supported by a No. 10 Nitex screen. Because a reproducible, relatively low pressure is applied to the sediments, we have very infrequently encountered ruptured filters. With hydraulic piston squeezers there is a greater potential for sediment leakage resulting from the application of excessive pressure.

Since water is collected through a side port, the squeezer parts can be compressed with a standard C-clamp. In Reeburgh's (1967) diaphragm squeezer, the clamp needed modification to accommodate the pore water outlet. Not shown in Fig. 1 is a short section of polyethylene tubing which conducts the pore water to the collector. This tube is attached to the side port by a center-drilled stainless machine screw through which the tube passes. The screw presses the flared end of the tube against the Delrin seat, forming a leak-proof metal-free contact. The overall dead volume of pore water is about 1 ml with the section of tubing contributing about half the total volume. Also not shown is a small hole in

the side of the base to accommodate a copper-constantan thermocouple temperature probe, which is centered slightly below the main filter support screenbed.

Recent studies have shown the necessity for maintaining sediments at in situ temperatures during squeezing (Weiler 1973; Fanning and Pilson 1971; Bischoff et al. 1970; Mangelsdorf et al. 1969) as well as avoiding exposure to air, so we carry out core extruding, sectioning, and squeezing under refrigeration (usually at 6°C) in a nitrogen atmosphere. We routinely begin this process aboard ship within 5 min of collecting the core. However, we have found that sediment cores along with overlying water may be stored in their butyrate plastic liners under refrigeration at in situ temperatures for at least a day without detectable alteration in dissolved element concentrations. To minimize disturbance of near-surface sediments, which are often quite fluid, the cores are kept vertical at all times. For the purpose of extruding a core from its liner, we insert an aluminum plug, with an O-ring seal, into the base of the liner, obtaining a leak-proof contact with a standard hose clamp tightened against the outside of the liner. We can control the rate of upward travel of the sediment core within the liner by adjusting the rate of flow of water (at about 4.1 atm) into the liner through a connection in the base plug. After mounting the core liner vertically on the extruding stand, a set of insulated copper coils is slipped over the outside of the liner. The coils are cooled by circulating a standard automobile antifreeze-water mixture, using a constant temperature circulator (Lauda model K-2/RD). To check the effectiveness of this method of cooling we sacrificed one core, inserting a mercury thermometer at four locations within it: surface-center, surface-side, and 10-cm-deep center and side. In no case were differences >1°C. Also we found no long term (5 h) variations in the sediment temperature >1°C. We remove most of the water in the core liner immediately above the sediment with a syringe just before attaching the top of

the liner to the bottom of a small (about 55 liters) glove box. The box is purged with nitrogen, containing less than 3 ppm O_2 , derived from a 165-liter Dewar of liquid nitrogen which provides a virtually unlimited supply of gas, about 10^5 liters at STP. The remaining water (about 1-cm depth) is removed within the glove box by allowing the core to travel upward until the sediment interface is flush with the floor of the glove box. The water spreads out over the floor and is wiped away. A desired length of sediment is then obtained by extruding the core into a short section of core liner with the same diameter, accurately scribed in intervals of 0.5, 1, 2, 5, and 10 cm. This core liner section with sediment is then moved laterally across the glove box floor, without appreciable sediment loss, to another opening where the sediment section drops into the squeezer cassette. The floor of the glove box is also refrigerated at the *in situ* temperature. This method is particularly useful for precise sectioning of extremely fluid cores.

To prepare the squeezers, the screen, large membrane filter, and ungreased O-ring are added to the base. All filters are prepurged with prepurified dry nitrogen and stored in a desiccator under nitrogen. Other components of the squeezer are stored in a refrigerator in air. The membrane filter is wetted with nitrogen-purged distilled water to prevent its cracking on addition of the sediment cassette, since detergent-free membrane filters (GSTF) are relatively brittle until wet. After the prefilter is positioned in the cassette, about 30 ml of nitrogen-purged distilled water are added. A piece of Dental Dam rubber with a pinhole leak is then placed over the cassette, the top plate is added, and the completed assembly is clamped. On application of pressure the water is expelled through the system, giving the filters a final purge. The nitrogen gas which passes through the pinhole removes residual air in the system, particularly in the filters. We generally allow the system to nitrogen-purge in this way at low flow rates (≈ 100 ml min^{-1}) for about 5 min.

After this flushing with nitrogen the squeezer is opened carefully so as to preserve the seal between the diaphragm and the cassette. The unit consisting of the base and covered cassette is then transferred to the glove box. After loading, the cassette is covered in the glove box with an unperforated rubber diaphragm and transferred back to the refrigerator for clamping and squeezing. The brief exposure of the squeezer to ambient temperatures during loading results in a tolerably small sediment temperature increase ($<0.2^\circ C$) because of the mass of prerefrigerated Delrin enclosing the sediment. We customarily operate five such squeezers simultaneously with a nitrogen gas manifold.

The times required to carry out these steps are generally short. Operations of extruding, sectioning, and loading the squeezer take about 1 min in all. The overall delay between sectioning and squeezing is <2 min. The longest time is for cleaning the glove box and cleaning and reassembling the squeezers, about 15 min per unit. The overall rate of generating pore water samples is about 1 to 2 samples per hour per squeezer. At this rate, using five squeezers, we typically process one to two cores in a working day aboard ship. Note then that portions of the core 50–80 cm below the sediment–water interface are sectioned and squeezed roughly 5–10 h after the near-surface sediments. With respect to K, Na, Mg, Ca, Si, P, Mn, and Fe, we did not observe interstitial concentration changes as a result of delayed sectioning and squeezing.

Because the initial output of pore water contains some residual distilled water, we discard the first 3 or 4 ml—about 10% of the total sample volume. With thorough nitrogen flow-through purging, this flushing volume can be reduced to about 1 ml. For trace metal and nutrient chemistry studies pore water samples are collected in pre-cleaned, acid-rinsed polyethylene vials and preserved for later analysis by the addition of about 3% by volume of concentrated nitric acid (Ultrex).

The squeezer was made at the Univer-

sity of Michigan, Physics Instrument Shop, by P. Racicot. Exact specifications are available from us on request. This work is supported through Argonne National Laboratory subcontract 31-109-38-2468 and E.P.A. grant R-803086.

John A. Robbins
John Gustinis

Great Lakes Research Division
University of Michigan
Ann Arbor 48109

References

- BARNES, R. O. 1973. An in situ interstitial water sampler for use in unconsolidated sediments. *Deep-Sea Res.* **20**: 1125-1128.
- BISCHOFF, J. L., R. E. FREER, AND A. O. LUISTRO. 1970. Composition of interstitial waters of marine sediments: Temperature of squeezing effect. *Science* **167**: 1245-1246.
- BRAY, J. T., O. P. BRICKER, AND B. N. TROOP. 1973. Phosphate in interstitial waters of anoxic sediments: Oxidation effects during sampling procedure. *Science* **180**: 1362-1364.
- CAHN, R. D. 1967. Detergents in membrane filters. *Science* **155**: 195-196.
- FANNING, K. A., AND M. E. Q. PILSON. 1971. Interstitial silica and pH in marine sediments: Some effects of sampling procedures. *Science* **173**: 1228-1231.
- KALLIL, E. K., AND M. GOLDHABER. 1973. A sediment squeezer for removal of pore waters without air contact. *J. Sediment. Petrol.* **43**: 553-557.
- MANGELSDORF, P. C., T. R. WILSON, AND E. DANIELL. 1969. Potassium enrichment in interstitial waters of recent marine sediments. *Science* **165**: 171-174.
- PRESLEY, B. J., R. R. BROOKS, AND H. M. KAPPEL. 1967. A simple squeezer for removal of interstitial water from ocean sediments. *J. Mar. Res.* **25**: 355-357.
- REEBURGH, W. S. 1967. An improved interstitial water sampler. *Limnol. Oceanogr.* **12**: 163-165.
- ROBBINS, J. A., AND E. CALLENDER. 1975. Diagenesis of manganese in Lake Michigan sediments. *Am. J. Sci.* **275**: 512-533.
- , D. N. EDGINGTON, AND J. I. PARKER. 1975. Distribution of amorphous, diatom frustule and dissolved silica in a lead-210 dated core from southern Lake Michigan. *Radiol. Environ. Res. Div. Annu. Rep. Ecol. Argonne Natl. Lab. ANL-75-3 Part 3*, p. 19-31.
- SASSEVILLE, D. R., A. P. TAKACS, S. A. NORTON, AND R. B. DAVIS. 1974. A large-volume interstitial water sediment squeezer for lake sediments. *Limnol. Oceanogr.* **19**: 1001-1004.
- SIEVER, R. 1962. A squeezer for extracting interstitial water from modern sediments. *J. Sediment. Petrol.* **32**: 329-331.
- TROOP, B. N., O. P. BRICKER, AND J. T. BRAY. 1974. Oxidation effect on the analysis of iron in the interstitial water of recent anoxic sediments. *Nature* **249**: 237-239.
- WEILER, R. R. 1973. The interstitial water composition in the sediments of the Great Lakes. 1. Western Lake Ontario. *Limnol. Oceanogr.* **18**: 918-931.

Submitted: 23 December 1975

Accepted: 26 March 1976

Chemical water sampling in lakes and sediments with dialysis bags¹

Abstract—An inexpensive interstitial water sampler using dialysis bags for the in situ separation of water from particulate matter in lake waters and sediments is described, and an example of dissolved silica is given.

Natural waters frequently change in chemical composition during the period of time between sampling and analysis, through biological action or re-equilibra-

tion between water and suspended sediment. Techniques of sample preservation can usually solve problems arising from biological action, but occasionally the process of preserving a sample leads to other complications. For example, refrigeration or the addition of acid will inhibit biological action, but will also affect water and suspended sediment equilibria (Siever and Woodford 1973). Thus the in situ separation of dissolved from particulate

¹This work was supported in part by NSF-RANN grant AEN 72-03469 A03.