

## **Annual Research Report ARR-5-15-95**

This report was prepared for the  
U.S. Department of Transportation  
National Highway Traffic Safety Administration  
Office of Crash Avoidance Research  
by the University of Michigan Transportation Research Institute (UMTRI).

### **Fostering Development, Evaluation, and Deployment of Forward Crash Avoidance Systems (FOCAS)**

**Cooperative Agreement Number: DTNH22-94-Y-47016**

**UMTRI No.: 95-31**

**Reporting Period: May 1994 to May 1995**

**Paul S. Fancher  
Zevi Bareket  
James R. Sayer  
Gregory E. Johnson  
Robert D. Ervin  
Mary Lynn Mefford**

**Date: May 15, 1995  
(Revised: September 5, 1995)**

**UMTRI** The University of Michigan  
Transportation Research Institute





Technical Report Documentation Page

1. Report No. UMTRI -95-31		2. Government Accession No.		3. Recipient's Catalog No.	
4. Title and Subtitle Fostering Development, Evaluation, and Deployment of Forward Crash Avoidance Systems (FOCAS)				5. Report Date May 15, 1995	
				6. Performing Organization Code	
7. Author(s) Fancher, P., Bareket, Z., Sayer, J., Johnson, G., Ervin, R., Mefford, M.				8. Performing Organization Report No. UMTRI - 95 - 31	
9. Performing Organization Name and Address The University of Michigan Transportation Research Institute 2901 Baxter Road, Ann Arbor, Michigan 48109-2150				10. Work Unit No. (TRAIS)	
				11. Contract or Grant No.	
12. Sponsoring Agency Name and Address National Highway Traffic Safety Administration U.S. Department of Transportation 400 Seventh Street S.W. Washington, D.C.				13. Type of Report and Period Covered Annual Research Report May 1994 to May 1995	
				14. Sponsoring Agency Code	
15. Supplementary Notes					
16. Abstract <p>This work is part of a three year program to foster the development, evaluation, and deployment of forward crash avoidance systems. The efforts during this first year have focused on operational testing of a passenger car equipped with a baseline autonomous intelligent cruise control system, also known as "adaptive cruise control" (ACC). To aid in evaluating and comparing ACC with other types of speed and headway control, on-road measurements have been made while driving using conventional cruise control, manual control (normal driving), as well as with the ACC system.</p> <p>The objective and subjective results obtained this year are from a population of 36 driver-participants that was balanced for gender, age, and experience with cruise control. These results indicate that the baseline system operates well on U.S. freeways, and that the performance obtained with this system will be useful as a benchmark for comparison with the performance of future ACC systems. In general, most of the driver-participants liked driving with this baseline ACC system. Given that the results obtained with the baseline system are useful, there now exists an extensive database which contains new knowledge about driving and the intelligent control of vehicle dynamics.</p> <p>The report presents technical results and information that support preliminary conclusions and recommendations concerning:</p> <ul style="list-style-type: none"> <li>• simple design methods for speed and headway control</li> <li>• evaluation of system performance as a function of range, range rate and velocity</li> <li>• methods for evaluation of operational field experience</li> <li>• future studies aimed at obtaining improved results for ACC systems</li> </ul>					
17. Key Words Autonomous Intelligent Cruise Control, Longitudinal Control, Crash avoidance, AICC, ICC, ACC			18. Distribution Statement Unrestricted		
19. Security Classif. (of this report) None		20. Security Classif. (of this page) None		21. No. of Pages 81	22. Price



# Table of Contents

PREFACE	i
<b>1.0 INTRODUCTION AND RATIONALE</b>	<b>1</b>
<b>2.0 TECHNICAL DISCUSSION</b>	<b>5</b>
2.1 Basic Description of the Dynamics of Rear-End Crashes and Headway Speed (H&S) Control	5
2.2 Description of the ACC System Deployed This Year	11
2.2.1 Interface with the Driver	11
2.2.1.1 Driver Controls	11
2.2.1.2 Driver Displays	13
2.2.1.3 Warning Cues	12
2.2.2 Sensor	14
2.2.3 Control Algorithm	16
2.2.4 Control Authority	18
2.2.5 Summary of Operational Boundaries	19
2.3 Definitions and Symbols used in Describing Data Variables, System Parameters, Conceptual Ideas, and Measures of Performance in the Report	20
2.3.1 Measured (Acquired) Variables	20
2.3.2 Derived (Computed) Variables	24
2.4 Possibilities for Safety Benefits of ACC over Manual & CC Driving	26
<b>3.0 CONDITIONS OF DEPLOYMENT</b>	<b>31</b>
3.1 The Vehicle and its Instrumentation	31
3.2 The Route and Driving Control Modes	32
3.2.1 The Route	32
3.2.2 Control Modes	36
3.3 Participants	36
3.4 Instructions	37
<b>4.0 DESCRIPTION OF THE DATABASE</b>	<b>39</b>
4.1 Objective Data	39
4.2 Subjective Data	40
4.2.1 Comfort and Safety Questionnaires	40
4.2.2 ACC Acceptance and Comfort Questionnaire	42
4.2.3 Focus Groups	44
<b>5.0 FINDINGS</b>	<b>58</b>
5.1 Findings from Objective Data	58
5.1.1 Nature of Traffic and Roadway	58
5.1.2 Comparison of Driving Modes Based on Freeway Driving	59
5.1.3 Differences by Participant Characteristics	65
5.1.3.1 Age	65
5.1.3.2 Gender	70
5.1.3.3 Conventional Cruise Control Usage (Experience)	70
5.1.3.4 Interactions between Age, Gender & Experience	72
5.2 Findings from Subjective Data	74
5.2.1 Comfort	74
5.2.2 Acceptance	74
<b>6.0 CONCLUSIONS, RECOMMENDATIONS AND CONCLUDING REMARKS</b>	<b>75</b>
6.1 Conclusions	75
6.2 Recommendations	77
6.3 Concluding Remarks	79
REFERENCES	81



## Figure Table of Contents

	<u>Page</u>
Figure 1 - Evolutionary process for fostering forward crash avoidance systems (FOCAS) .....	1
Figure 2 - Headway control.....	5
Figure 3 - Kinematics of available reaction time and Ta*.....	7
Figure 4 - Range-rate versus range diagram.....	10
Figure 5 - Baseline ACC system structure.....	11
Figure 6 - Stalk control switches.....	12
Figure 7 - ACC control unit.....	12
Figure 8 - Driver's display unit.....	13
Figure 9 - ODIN Infra red sensor.....	14
Figure 10 - Sensor's field of view.....	14
Figure 11 - Multiple targets.....	15
Figure 12 - Autonomous cruise control algorithm.....	17
Figure 13- Target outside sensor's view.....	20
Figure 14 - Deceleration and acceleration density.....	27
Figure 15 - Available reaction time (Ta) density.....	28
Figure 16 - Accelerator pedal position time histories.....	29
Figure 17 - Accelerator pedal position density.....	30
Figure 18 - ACC instrumentation system.....	32
Figure 19 - Map of the selected route through Ann Arbor & the Metropolitan Detroit area.....	33
Figure 20 - Time histories showing ramp locations.....	34
Figure 21 - Velocity density histogram.....	35
Figure 22 - Range density histogram.....	36
Figure 23 - Density of the velocity of the preceding vehicle.....	58
Figure 24 - Approximate density for path curvature (1/radius).....	59
Figure 25 - ACC loop, headway control only, Rdot vs. R.....	60
Figure 26 - ACC loop, all modes, Rdot vs. R.....	61
Figure 27 - CC loop, CC only, Rdot vs. R.....	62
Figure 28 - CC loop, CC and N modes, Rdot vs. R.....	63
Figure 29 - Normal loop, Rdot vs. R.....	64
Figure 30 - Plot of the main effect of Age for the dependent measure Range (mean) where F(2,24) = 10.48 and p ≤ 0.01, and Student-Newman-Keuls post hoc analysis.....	66
Figure 31 - Plot of the main effect Age for the dependent measure Range Rate (mean) where F(2,24) = 14.67 and p ≤ 0.01, and Student-Newman Keuls post hoc analysis.....	67
Figure 32 - Plot of the main effect Age for the dependent measure Velocity (mean) where F(2,24) = 21.11 and p ≤ 0.01, and Student-Newman-Keuls post hoc analysis.....	68
Figure 33 - Plot of the main effect Age for the dependent measure Accelerator Pedal Position (mean) where F(2,24) = 4.20 and p ≤ 0.02, and Student -Newman -Keuls post hoc analysis.....	69
Figure 34 - Plot of the main effect Age for the dependent measure Brake Application (frequency) where F(2,24) = 96.03 and p ≤ 0.01, and Student-Newman-Keuls post hoc analysis.....	70
Figure 35 - Plot of the main effect Experience for the dependent measure Range Rate (mean) where F(1,24) = 7.68 and p ≤ 0.01.....	71
Figure 36 - Plot of the main effect Experience for the dependent measure Velocity (mean) where F(1,24) = 17.92 and p ≤ 0.01.....	71
Figure 37 - Plot of the main effect Experience for the dependent measure Accelerator Pedal Position (mean) where F(1,24) = 10.28 and p ≤ 0.01.....	72
Figure 38 - Plot of the interaction Age*Gender for the dependent measure Velocity (mean) where F(2,24) = 3.22 and p ≤ 0.05.....	73
Figure 39 - Plot of the interaction Age*Experience for the dependent measure Brake Application (frequency) for F(1,24) = 5.09 and p ≤ 0.01.....	73
Table 1 - Acquired Data.....	23
Table 2 - Derived Data.....	25
Table 3 - Annual average 24 hour traffic volumes for the selected route (Source: Michigan Dept. of Transportation, 1993 [9]).....	33





## *Preface —Preliminary Statements of Progress*

### OVERALL PROGRAM OBJECTIVES

This program's primary goal is to facilitate the development of a range of commercializeable sensors and associated application systems that supplement the forward crash avoidance performance of drivers. A secondary goal is to advance the associated evaluation tools, methodologies, and knowledge base available for expediting the development of forward crash-avoidance system (FOCAS) products and for assessing the performance of these products.

The three-year program's objectives are (1) to apply and extend an UMTRI/Leica/Michigan Department of Transportation-provided autonomous intelligent cruise control (AICC) testbed; (2) to conduct engineering and human factors testing, in concert with the development of sensor and systems design supporting the AICC application; (3) to measure a sample of longitudinal response characteristics that are practicably representative of the U.S. passenger car population and pertinent to the problem of engineering AICC packages; (4) to determine a practicably representative distribution of geometric roadway properties that cover limited-access highways in the U.S. and are pertinent to the AICC engineering problem; (5) to explore the application needs of FOCAS packages that engage higher levels of deceleration than are available in the throttle-off state — including controlled downshifting, modest braking via the traction-control system, and application of service brakes over a moderate range of deceleration levels; (6) to develop test methodologies and modeling tools as needed for evaluating the performance of FOCAS packages; and (7) to develop the technology and application-knowledge supporting FOCAS applications as broadly as possible within the scope of the cooperative agreement.

The deliverable for the first year is this annual report that provides detailed information on (1) a baseline AICC system, (2) the performance of the baseline system, and (3) the human factors and engineering aspects of problematic situations.

### WORK ACCOMPLISHED DURING THE REPORTING PERIOD

We have analyzed quantitative data from all of the tests with the ACC-equipped Saab 9000 being driven with and without the ACC system in operation. This includes complete time and histogram analyses of the basic measured variables, and then more sophisticated analyses including the use of derived variables for quantifying and evaluating performance.



A computer application for studying target losses on curves and false alarms from vehicles in adjacent lanes has been developed. We are preparing to use this application in conjunction with road curvature information in the Highway Performance Monitoring System (HPMS) database. We have used this computer application to look at the path curvature information measured during the operational tests performed on stretches of local freeways.

Work in the months of November and December 1994 involved performing a set of baseline measurements for use in characterizing human performance and headway-control system performance on the road. These tests have been completed, and a massive data set for 36 naive driver-participants is now available. During January and February 1995 we examined these data to provide results and findings concerning manual control, conventional cruise control, and adaptive cruise control during freeway driving of approximately 50 to 60 minutes for each control mode for each driver.

Our preliminary findings are not surprising in hindsight. Specifically, we found that (1) driving in the ACC mode is very orderly, with the range headway being close to the system-specified headway range for most of the time, and (2) manual driving is not characterized by anywhere near the same orderliness as that provided by ACC driving. Our preliminary observation is that the driver is not concentrating on headway control during much of his/her driving time. Perhaps a major benefit of the ACC system is that it vigilantly concentrates on headway control. It also aids the driver by autonomously performing precise and smooth modulation of the acceleration to maintain headway. However, the ACC system only has a limited scope of information and control authority, hence the driver needs to use his/her broader knowledge and information processing skills to supervise overall vehicle control during ACC operation.

The implications of these two findings have a significant bearing on our approach to data analysis. Comparing ACC driving to manual driving is not as straightforward as we had believed that it would be. It is difficult because we do not know when the driver is concentrating on controlling headway. We do not have any measurements of what the driver is thinking about. (For example, drivers could be day dreaming or talking to the passenger/experimenter.) Since drivers use learned skills for much of the driving process, it is not easy for them to tell us how they perform the headway control function. This leads us to a finding that we need to identify the driving situation pertaining to each section of the data. Given the driving situation, we can then compare driver performance in those situations with ACC performance in similar situations. Accordingly, a great deal of effort has been devoted to working out data processing means for identifying driving situations such as closing-in on a slower moving vehicle, another vehicle merging-in ahead of the ACC vehicle, steady following of a preceding vehicle, etc.



We have made considerable progress evaluating the subjective data gathered in November and December. These results have been written up in the form of a draft paper entitled "Consumer's Subjective Impressions of Adaptive Cruise Control: A Preliminary Report." The technical reporting that follows this preface includes subjective and objective results and findings concerning the influences of driver characteristics on driving performance.

#### PLANNED ACTIVITIES FOR THE NEXT YEAR

During the next year we plan to incorporate a capability for applying modest braking (less than approximately 0.1 g) in the test vehicle. This will allow us to perform engineering tests involving "low-decel-cues." After a satisfactory cue arrangement is developed, typical driver-participants will operate the vehicle in a proving-grounds setting. Given acceptable results from the proving grounds, on-road operational testing may be performed.

Also, we plan to work out an arrangement in which the driver adjusts the headway time to the preceding vehicle. Driver performance and acceptance as well as system performance will be assessed in an experimental or operational setting.

In addition, during the next reporting period (between now and July 15), we plan to employ the Highway Performance Monitoring System database to evaluate the possibilities for false alarms and missed targets for sensors with three or four degree fields of view, given the distribution of geometric roadway properties in the U.S. We also plan to conduct tests assessing the coast-down characteristics, and accelerator-pedal-to-velocity characteristics of several vehicles.



# 1. INTRODUCTION AND RATIONALE

This work is part of a three-year program to foster the development, evaluation, and deployment of forward crash-avoidance systems. The efforts during this first year have focused on operational testing of a passenger car equipped with a baseline autonomous intelligent cruise control (AICC) system. For purposes of communicating with drivers in general, we refer to the AICC system as “adaptive cruise control” to distinguish it from conventional cruise control, and we use the acronym ACC. To aid in evaluating and comparing ACC with other types of speed and headway control, on-road measurements have been made while driving using conventional cruise control (denoted as CC), manual (normal) control (denoted N), and the ACC system.

This program is seen by the researchers as an evolutionary process. Figure 1 illustrates and delineates the elements of the evolutionary process as it is envisioned by the researchers. The program started with a baseline ACC system whose features are sufficiently developed to be used by alert, normal drivers. The evolutionary process involves iterating between development and deployment stages in a reciprocating manner.

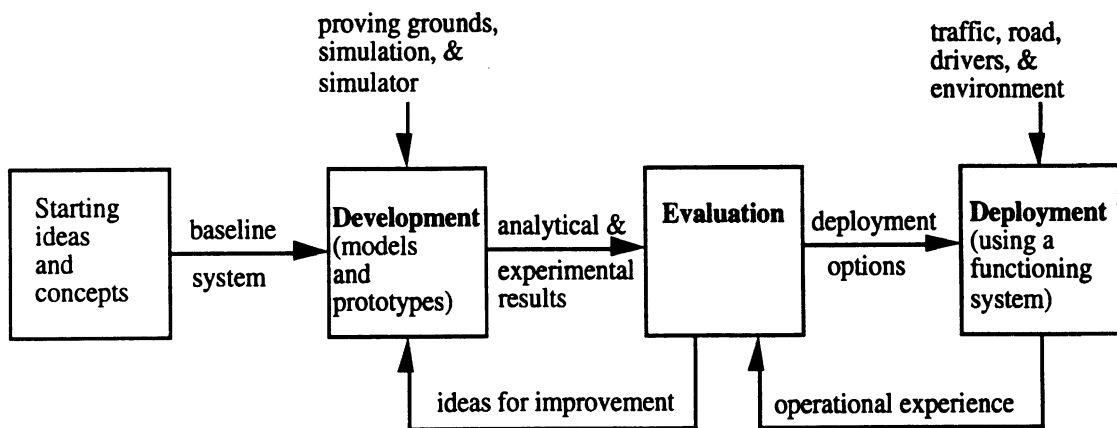

Figure 1. Evolutionary process for fostering forward crash-avoidance systems (FOCAS)

During the past year an ACC-equipped vehicle has been operated on local freeways by drivers that were accompanied by a knowledgeable experimenter. In this sense, the data resulting from this year’s work provide measures of operational experience that come from deploying the ACC system in a real driving environment involving real drivers and real roads.

An important aspect of the evolutionary process, as portrayed in figure 1, is the role of the “evaluation” stage. As new ideas are fed forward from development, they are evaluated to determine reasonable options and constraints on the type and level of deployment. For example, the original proposal was based upon ideas and concepts developed during previous research and

testing done by UMTRI with support from Leica and MDOT. In the preparation of the proposal, the researchers evaluated past work and experience, and proposed operating the baseline ACC system on real roads with real drivers. NHTSA evaluated the proposed work before funding was provided to operate the system on the road. As a result, there is now a wealth of information pertaining to the operational experience obtained by deploying the baseline system. Currently, an evaluation activity is underway, but this time the evaluation is in the feedback path of the evolutionary process. The evaluation is expected to provide new insights that will contribute to the development of an improved ACC system. This system will be analyzed and prototyped as necessary to provide information and hardware for another evaluation before returning for more operational testing. Ideally, this process evolves and reciprocates, until an evaluation of operational experience indicates that the system is ready for deployment with constraints that will not limit the utility of applying the system in practical transportation service.

The rationale for an evolutionary approach lies in the idea that we need to develop methods for obtaining the information, knowledge, and understanding necessary to evaluate ACC systems effectively. There is synergy between current objectives concerning fostering forward crash avoidance systems, and ultimate goals concerning the development of driving theory as it applies to the intelligent control of vehicle dynamics. One might say that a theory of driving that is applicable to intelligent control of vehicle dynamics is needed to evaluate proposed ACC systems. In this context, the objectives for year one have involved developing methodologies for gathering and processing information concerning the performance of the baseline ACC system.

The baseline ACC system employs an infrared sensor for detecting range and range rate. The beam is fixed, and its width is such that targets at long range on sharp curves may be missed. Also on sharp curves, vehicles in adjacent lanes may provide false targets. However, these limitations occur relatively infrequently on multilane U.S. freeways, which seldom have curves that are sharper than 3 degrees (1900 ft radius).

The fundamental functional characteristics of the baseline ACC system with regard to following a preceding vehicle are:

Initiating following — The system has automatic target acquisition. A major benefit is expected to be that the system aids inattentive drivers in preventing rear-end collisions with slower-moving vehicles. This would not happen if the driver had to initiate tracking a target.

Establishing following — Following is established automatically using a time constant to control the closing-in rate.



**The following rule** — The system use a constant headway time, such that headway distance varies in proportion to the velocity of the preceding vehicle.

**Response to momentary target loss** — The system/vehicle does not accelerate rapidly to achieve the set speed unless the driver aggressively pushes on the accelerator pedal. This means that speed doesn't change much during a momentary target loss.

**Minimum operating speed** — The minimum speed for headway control is determined by that of the inherent cruise control of the vehicle.

**Maximum operating speed** — The maximum set-speed value for the cruise control is determined by that of the inherent system of the vehicle. In headway control, the system will not follow vehicles that are going faster than the cruise speed set by the driver.

**Minimum following distance** — The constant headway time (see "The following rule") along with the minimum operating speed establish the minimum headway distance.

**Maximum following distance** — The sensor is fairly reliable out to about 160 m (about 525 ft) in good weather. Targets beyond sensor reliability are ignored. The constant headway time along with the cruise speed set by the driver establish the maximum headway distance.

**Maximum deceleration** — The maximum deceleration rate is determined by zero-throttle coast-down of the vehicle (about 0.04 g).

**Maximum acceleration** — Automatic speed increase is done using a speed command that is no more than 4 mph above the current speed. The driver can always use the accelerator pedal to get any other achievable acceleration.

**Insufficient deceleration level warning** — The warning is through the sudden switch to coast down deceleration when closing-in becomes too fast for the range involved.

Some of the characteristics of the ACC system are planned to be improved and modified during the second phase of the FOCAS study (next year). These characteristics include:

**Minimum following distance** — We plan to incorporate driver-adjustable headways.

**Maximum deceleration** — Next year we will look at down-shifting or small amounts of braking effort.

**Insufficient deceleration level warning** — We plan to incorporate an audio warning.

The objective and subjective results obtained this year indicate that the baseline system operates well on U.S. freeways, and that the performance obtained with this system will be useful as a benchmark for comparison with the performance of future ACC systems. In general, most of the driver-participants liked driving with this baseline ACC system. Given that the results obtained

with the baseline system are useful, there now exists an extensive database which contains new knowledge about driving and the intelligent control of vehicle dynamics.

The following sections of this report present technical results and information that support preliminary conclusions, and recommendations concerning:

- simple design methods for speed and headway control
- evaluation of system performance as a function of range, range rate, and velocity plus the driver's control actions and subjective ratings
- methods for evaluation of operational field experience
- future studies aimed at obtaining improvements in the development, evaluation, and deployment of ACC and other systems for performing functions involving the control of forward motion of highway vehicles.

## 2. TECHNICAL DISCUSSION

### 2.1 Basic Description of the Dynamics of Rear-End Crashes and Headway and Speed (H&S) Control

Referring to Figure 2, the following fundamental quantities are needed to describe speed and headway control:

$V_p$  — velocity of the preceding vehicle

$V$  — velocity of the ACC-equipped vehicle

$R$  — range from the ACC-equipped vehicle to the preceding vehicle

$R_h$  — desired range from the ACC-equipped vehicle to the preceding vehicle (In the situation shown in figure 2, the ACC-equipped vehicle is closer to the preceding vehicle than the desired range.)

$dR/dt$  — range-rate, the relative velocity between the vehicles (Range rate is also denoted by  $\dot{R}$  in this report.)

Knowledge of these quantities plus the accelerations of these vehicles allows a complete kinematic analysis of the relative motion between the following and preceding vehicles.

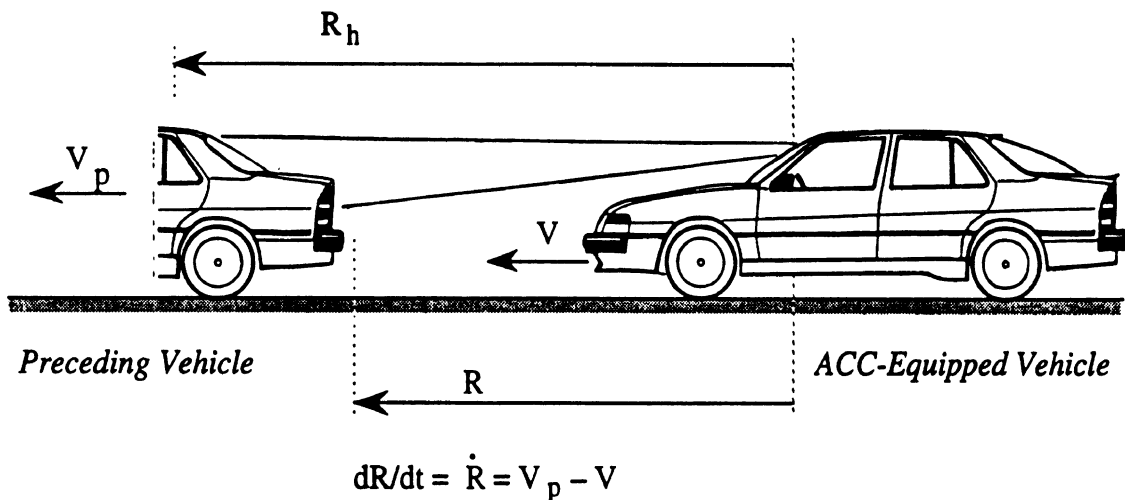

Figure 2. Headway Control

Because the sensor in figure 2 is located behind the windshield, the distance  $R$  to the front bumper is not zero. If this offset in  $R$  is compensated for in the control system, one can make  $R = 0$  occur at the front bumper. The following discussions are based on  $R$  being measured from the front bumper of the following vehicle to the rear bumper of the preceding vehicle so that a crash

occurs if  $R = 0$ . Also,  $R_h$  is measured from the front bumper of the following vehicle. (Of course, these offsets are unnecessary, if the sensor is located on or above the front bumper.)

The occurrence of a rear-end crash as a result of a deceleration by the preceding vehicle, can be determined (under most circumstances) by the reaction time of the following vehicle's driver. If the driver reacts too slowly, a rear-end crash will occur; if the driver's reaction is prompt, the crash is preventable. Reaction time is denoted here as  $T_a$ ; the particular value of reaction time which separates between crash occurrence and crash avoidance is denoted  $T_a^*$ . The scenario described below demonstrates the importance of this parameter.

Suppose that two vehicles are travelling at the same speed ( $V_o$ ) and that they are separated by a range  $R_o$  (see figure 3 for an illustration of the kinematics described here). At time point "0" the preceding vehicle starts to decelerate, but the following vehicle still maintains  $V_o$ , since its driver has not had time to react yet. At point  $T_a^*$ , a reaction time that will just prevent a collision, the driver of the following vehicle starts to slow down. The braking deceleration applied by the driver of the following vehicle, is equal to that applied by the driver of the preceding vehicle. That is, the deceleration of the following vehicle is the same as that of the preceding vehicle, except that it is delayed by  $T_a^*$  seconds. In this case, a crash will not occur, and if the maneuver is carried to a complete stop, the point  $t_c$  denotes the time when the following vehicle will come to rest with its front bumper just touching the rear bumper of the preceding vehicle .

### Rear-End Precrash Sequence Diagram

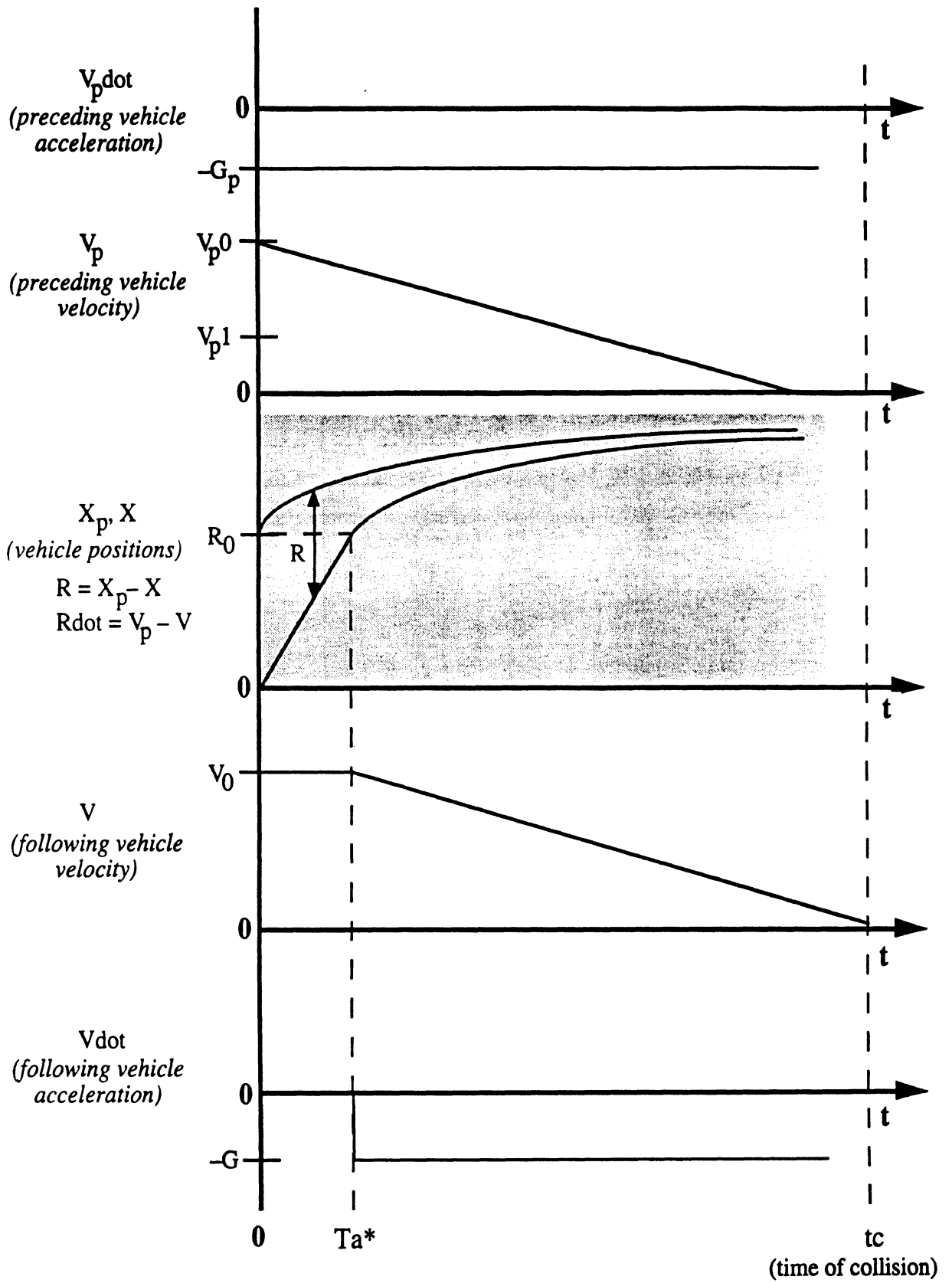

Figure 3. Kinematics of available reaction time and  $Ta^*$ .

The basic form of figure 3 was originally created for use in illustrating what the preceding and following vehicles were doing in driving situations that led to rear-end crashes. Although it has never happened, the idea was that crash investigators or people reading accident reports would use a form like this to describe precrash scenarios. Clearly, there are all sorts of arrangements of decelerations, accelerations, velocity differences, and range separations that are possible precrash scenarios, and they should be accounted for accordingly. For the purposes of this discussion, and as it was described earlier, in the case shown in figure 3 the following vehicle will come to rest barely touching the preceding vehicle. As shown in the figure, if the following vehicle starts braking after it has traveled a distance equal to  $R_0$  (the initial separation between the vehicles), the crash will be avoided. Also as shown in the figure, the distance  $R_0$  is reached by the following vehicle at time  $T_{a^*}$ . The point is, that when a car travels at a velocity  $V$  and at a range  $R$  behind a preceding vehicle, it has an available reaction time  $T_a = R/V$  to avoid a crash (assuming comparable deceleration capabilities). Ideally, one might wish that  $T_a$  be greater than  $T_{a^*}$ . However, as a practical matter, traffic streams are usually much denser than that implied by evaluating  $T_{a^*}$  for a panic stop of the preceding vehicle. It seems that both preceding and following drivers know that it is bad form (culturally unacceptable) to brake in a traffic stream. Nevertheless,  $T_a$  is a measure of available reaction time that has a physical interpretation related to describing the initial conditions if and when a pre-crash sequence starts. In subsequent sections,  $T_a$  will be one of the performance measures used in evaluating results from operational testing of ACC systems.

The type of kinematic considerations used in thinking about figure 3 has been used (along with trying ideas on the data) to arrive at definitions of various driving states that are pertinent to the speed and headway control problem. Based on these types of considerations, the following driving states have been identified:

- Cruising**—There is no preceding vehicle close enough to cause the following vehicle to change speed. The following vehicle proceeds at a nearly-constant velocity as it does when conventional cruise control is in operation.
- Closing-in**—There is a preceding vehicle ahead, and it is close enough that the following vehicle is slowing down towards a desired headway range.
- Following**—The following vehicle is following a preceding vehicle at an approximately constant headway range and the following vehicle's speed is approximately equal to the speed of the preceding vehicle.
- Chasing**—The following vehicle is trying to catch-up to a preceding vehicle that, at least initially, is travelling faster than the following vehicle.

**Sudden merge**—Either, a preceding vehicle has suddenly become a consideration in speed control of the following vehicle because the preceding vehicle cut-in or merged in front of the following vehicle, or because a following vehicle suddenly cut-in or merged behind a preceding vehicle.

**Beyond the control authority of the ACC or Too close**—The relative motion of the following vehicle is such that, with the deceleration capability (authority) given to the ACC, the following vehicle will come closer to the preceding vehicle than some safety margin would allow (if the driver does not intervene).

**Sudden slow down** - The following vehicle was following a preceding vehicle at the desired range and then the preceding vehicle suddenly slowed down.

Clearly, these definitions appear to be amenable to precise and rigorous interpretations such that computerized data processing may be used to determine whether a vehicle was in one of these states of driving. However, these qualitative definitions are a starting point for understanding the phenomena involved. They provide reason to observe that relative headway range  $R$  and range-rate  $dR/dt$  are key to identifying the driving state. In fact, a diagram displaying vehicle motions in a range-rate versus range space has been a key feature of many papers on headway control authored by UMTRI researchers (references [1] through [6]). The use of diagrams with range on the vertical axis and range-rate on the horizontal axis are used throughout this work to display results and ideas concerning headway and speed (H&S) control.

The range-rate/range diagram is useful for explaining the concepts behind the headway control algorithm used in the baseline ACC system. Conceptually, the control objective is to perform headway control in accordance with the following equation:

$$T \frac{dR}{dt} + R - R_h = 0 \quad (1)$$

This equation appears as a straight line in the range-rate/range diagram. See the line labeled “dynamics line for headway control” in figure 4. The slope of that line ( $T$  in Equation 1) serves as a control-design parameter.

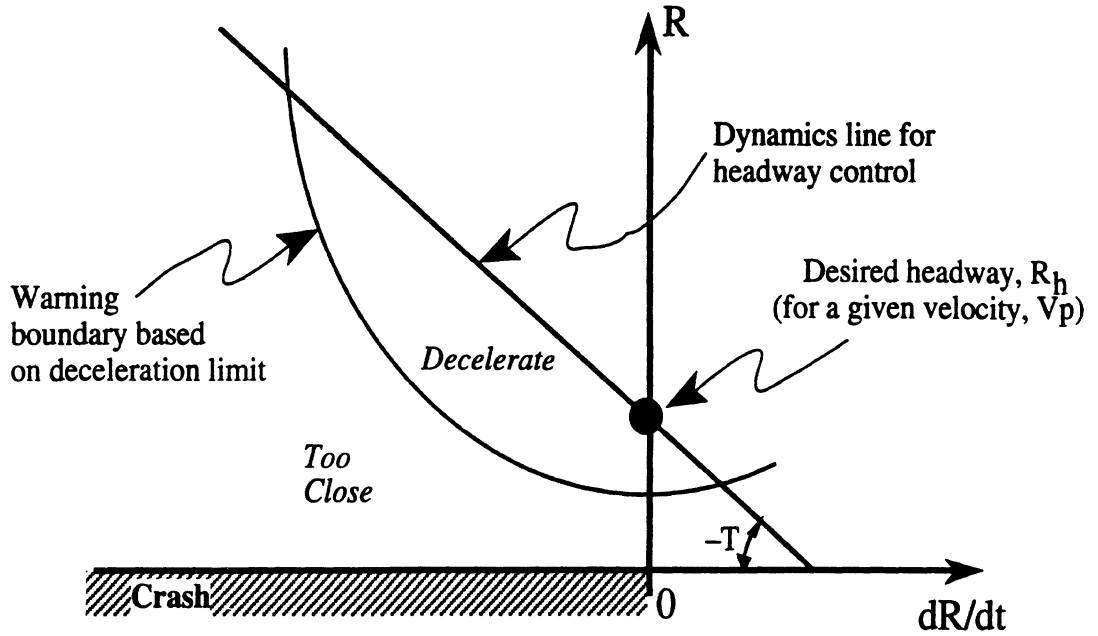

Figure 4. Range-rate versus range diagram.

The desired headway is a linear function of  $V_p$  the velocity of the preceding vehicle; viz.,

$$R_h = V_p \cdot T_h \quad (2)$$

where  $T_h$  is the desired headway time which is a control parameter.

This equation is of the form of the commonly used advice, "Allow one car length for each ten miles per hour of speed."

Since  $V_p = dR/dt + V$ , measurements of  $V$ ,  $R$ , and  $dR/dt$  are sufficient to evaluate the terms in equations 1 and 2. This means that the difference between the desired state and our current situation, expressed as an error  $e$  in velocity is as follows:

$$e = dR/dt + (R - R_h)/T \quad (3)$$

where the quantities on the right side of the equation are evaluated using inputs from the sensor and values of the control parameters.

For a vehicle with a cruise-control system, there is already an existing velocity-control system. To make a simple speed-and-headway control, one needs to send a velocity command ( $V_c$ ) to the cruise-control unit, so that the desired headway will be attained. The general idea is that if the vehicle is too far away, one must speed up, and if the vehicle is too close, one must slow down. From the above discussion, the particular velocity command ( $V_c = V_h$ ) to achieve the desired headway ( $R_h$ ) is given by:

$$V_h = V_p + (R - R_h)/T \quad (4)$$



Equation 4 is the basis for a simple design method for extending (or adapting) a speed controller to include an outer control loop that achieves a headway control function. The baseline ACC system is an example of an H&S control system of this type.

## 2.2 Description of the ACC System

This section describes the operational properties of the baseline ACC system that was deployed during the first year of the FOCAS study. The functional structure of the system is depicted in a block-diagram form in figure 5.

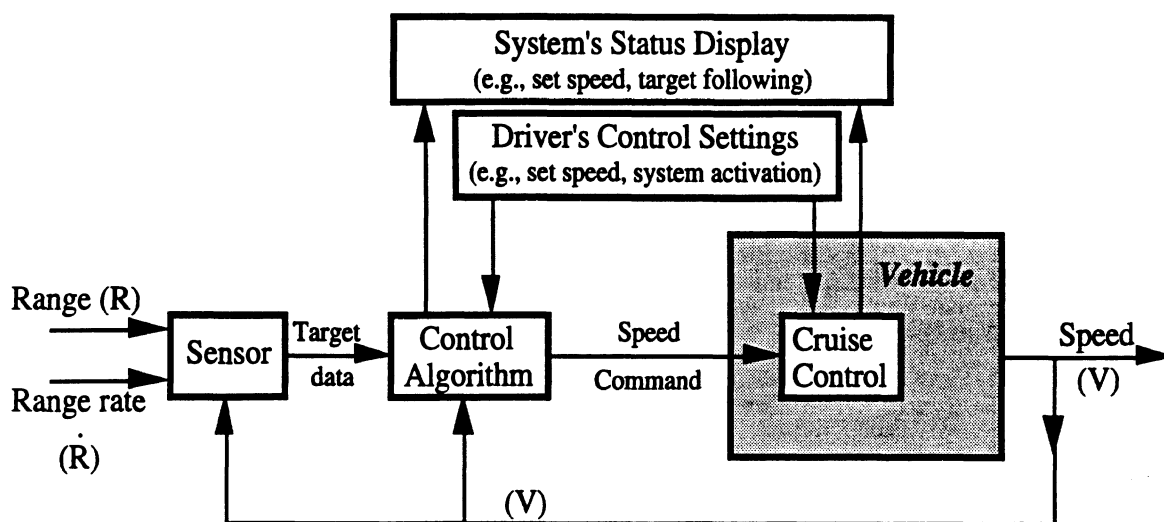

Figure 5. Baseline ACC system structure

### 2.2.1 Interface with the Driver

The ACC system that was deployed had three interfaces with the driver. Of the three, two interfaces enable the driver to provide control inputs to the system, while the third interface is informative only (to provide the driver with information regarding the status of the system).

#### 2.2.1.1 Driver Controls

Since the ACC system utilizes the original cruise-control system of the vehicle, its operation depends upon activating the cruise-control. Two main switches need to be activated for the ACC system to be operative: (1) the original cruise-control toggle switch mounted on the stalk (see figure 6), and (2) the on switch on the ACC control unit. This unit, which is conveniently mounted in the central instruments console, is shown in figure 7.

Setting and controlling the desired cruising speed is done using the original stalk-mounted switches (see figure 6). Once the system is engaged, the desired cruising speed is set like a conventional cruise control — by pushing the “SET” button when the vehicle is travelling at that speed. Reengaging the system (if it was disconnected by depressing the brake pedal — much like the conventional cruise control), is done by pushing the “RES” side of the toggle switch. The “SET” and “RES” buttons are also used to incrementally increase or decrease the value of the “set” cruising speed (again, as in the case of a conventional cruise control). During normal operation, the driver does not need to interact with the ACC unit. However, a big, visible, red button (on the lower-left side of the unit — see figure 7) allows for an immediate system shut-off.

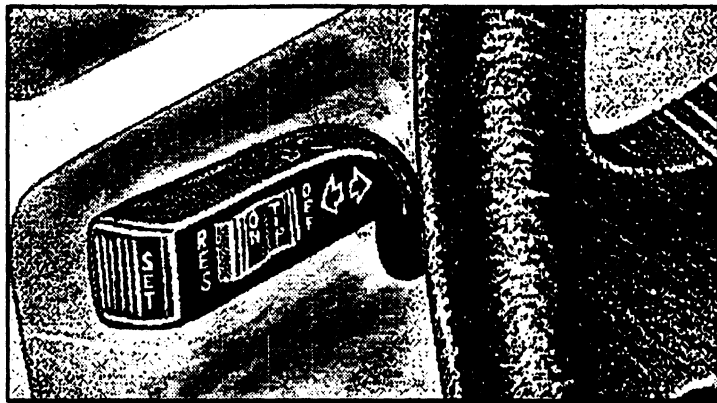

Figure 6. Stalk control switches

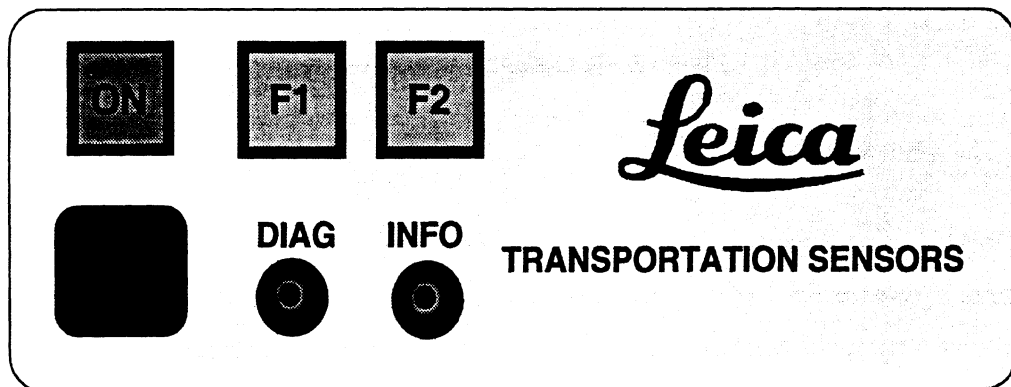

Figure 7. ACC control unit

#### 2.2.1.2 *Driver Displays*

The driver’s display unit is located above the steering column, so that it is well within the driver’s view of the instrument panel. The display is shown in figure 8.

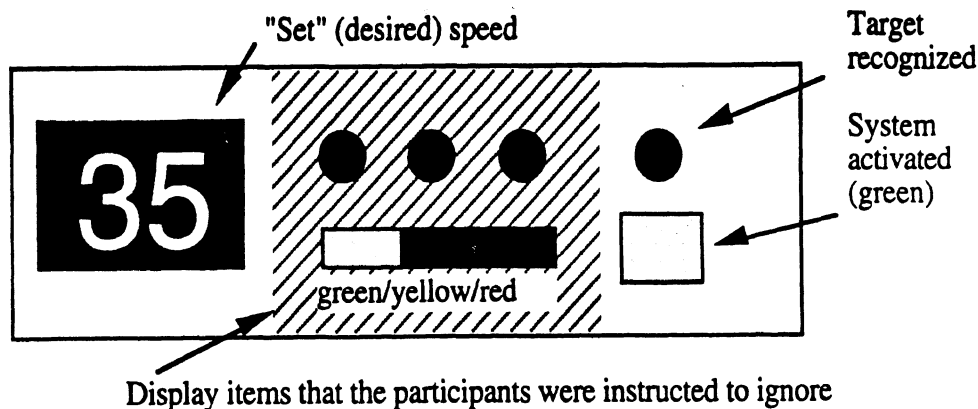

Figure 8. Driver's display unit

The desired speed, or "set" speed, is shown on the left side of the display. While in ACC mode, this speed will never be automatically exceeded by the car. The hatched area in figure 8 shows, for general information purposes only, additional display items that the participants were instructed to ignore during the deployment exercise. These items include three diagnostic LED's, and a multicolor illumination that provides some visual cue concerning deviation from the desired headway distance.

The green square LED on the right indicates when the system is engaged, and the red LED above it illuminates when a target that is "valid" to follow is detected by the sensor (see discussion in section 2.2.3 about what "valid" targets are). The system stays active until the brake pedal is pushed, or if it is switched off. The system can be overridden at any time, without being disengaged, by depressing the accelerator pedal.

### 2.2.1.3 Warning Cues

The baseline system did not provide any active warning signal to the driver. However, warning was provided implicitly through a kinesthetic cue. Under most operational conditions, the speed of the vehicle was smoothly governed by small modulations of the throttle. When the combination of range and range rate to the preceding vehicle was such that a complete dethrottling (coastdown) was called for, it caused a momentary disruption in the smoothness of the drive which was altogether noticeable. This initiation of coastdown served as a warning cue, calling the attention of the inattentive driver to all situations challenging the control authority of the ACC system.

### 2.2.2 Sensor

The infrared headway sensor (Leica-ODIN) measures the distance (range) and relative velocity (range rate) between the ACC-equipped car and the vehicle in front. These two parameters, together with the speed of the car, are imperative for a proper operation of the ACC system.

The ODIN sensor is mounted above the rear-view mirror, behind the front windshield (see figure 9). The sensor is of a fixed monobeam type, which means that its field of view is fixed in shape and dimensions, and also in its orientation relative to the bearing vehicle. Potential impediments that this characteristic might impose on system's operation are discussed in section 2.2.5. The view angle of the ODIN is shown in figure 10.



Figure 9. ODIN Infrared sensor

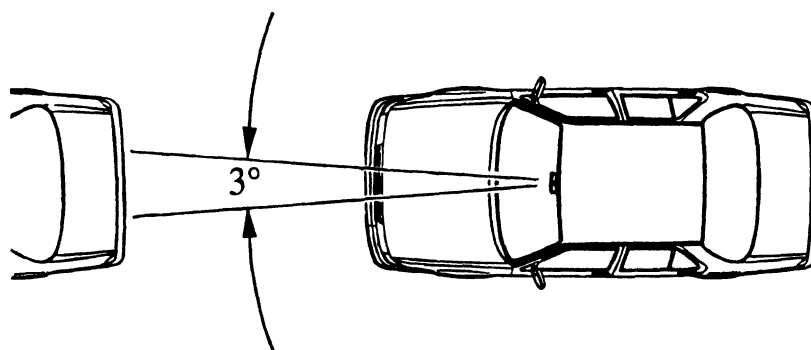

Figure 10. Sensor's field of view

The principle of range measurement employed by the ODIN sensor is called time of flight. The sensor emits a light pulse, and then measures the time until the echo of this pulse is scattered back from the target. The emitter and receiver lenses of the sensor are clearly shown in figure 9. Based on the fixed value of the speed of light, the distance to the target can be calculated from the time

lapsed between emitting and receiving the light pulse. Digital signal processing that takes place in the sensor unit enhances the reading and improves the sensor's performance. In addition, the range data is also processed to provide relative-speed, or range-rate information.

The sensor is capable of measuring distances from 2 m (6.56 ft) up to 160 m (525 ft), and relative speed values between  $-400$  kph ( $-248$  mph) and  $+200$  kph (124 mph). Measuring accuracy varies from  $\pm 0.5$  m ( $\pm 1.6$  ft) at close ranges, to  $\pm 1.0$  meter ( $\pm 3.2$  ft) at large distances. Range and range-rate data are provided by the sensor to the ACC system at a frequency of 100 Hz (every 10 msec) for targets up to 120 meters (394 ft), and at a frequency of 10 Hz (every 100 msec) for targets that are further than 120 m.

An additional data item that the sensor reports to the ACC system is tracking. Conceptually, that information can be regarded as an indication of target consistency. Momentary targets which only flash through the sensor's view for a very short brief (less than 300 milliseconds) will not be reported as tracked, or consistent targets. Furthermore, since the sensor is of a monobeam type, only one target (the one which is closest) is reported each time. If the range data indicates that the target lacks consistency, (that is, the variation between two consecutive readings is too large), that target will also not be reported as tracked. Figure 11 shows two targets that are detected. Only the closer one will be reported, and if it drops out of the sensor's view so that the distant target is now reported, it will initially not be reported as tracked.

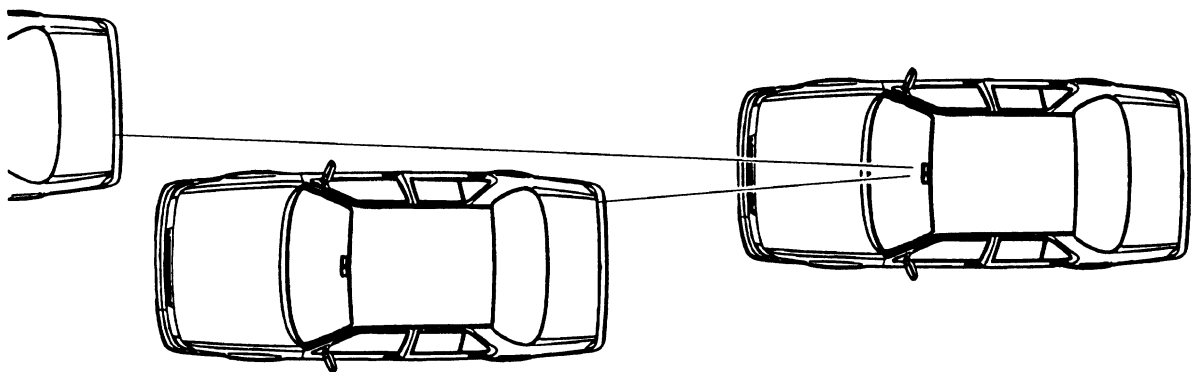

Figure 11. Multiple targets

When a target is detected by the sensor, its range, range-rate (relative speed), and also the tracking information are reported to the ACC control unit. Consequently, that data, together with additional information, are evaluated by the control algorithm to determine the course of action needed.

### 2.2.3 Control Algorithm

The control algorithm is a sequential process which begins by assembling data from the various sources, continues through processing the data to make decisions, and it ends by providing an output signal. In the baseline ACC system (see also figure 5), the input data for the control algorithm includes target data (range, range rate, and tracking), driver's setting data (set speed), and vehicle's speed. The output is a commanded speed value which is the input to the conventional cruise control.

Once the controller assembles the necessary data, the decision-making process commences. Figure 12 describes the control algorithm by way of a schematic. When the information from the sensor indicates that an object is detected within its field of view, the algorithm's first decision needs to address the "validity" of that target.

The controller discriminates between targets that should be ignored and targets that should be considered. Stationary objects (e.g., road signs), or traffic in the opposite direction are classified by the algorithm as invalid targets. Such targets will cause no control action to be taken. Vehicles that are traveling in the same direction as the host vehicle are classified as valid targets, and the necessity of a subsequent control action is considered by the controller. In addition, target data beyond practical bounds will also classify it as an invalid target. These bounds are defined by a combination of range, range rate, and speed.

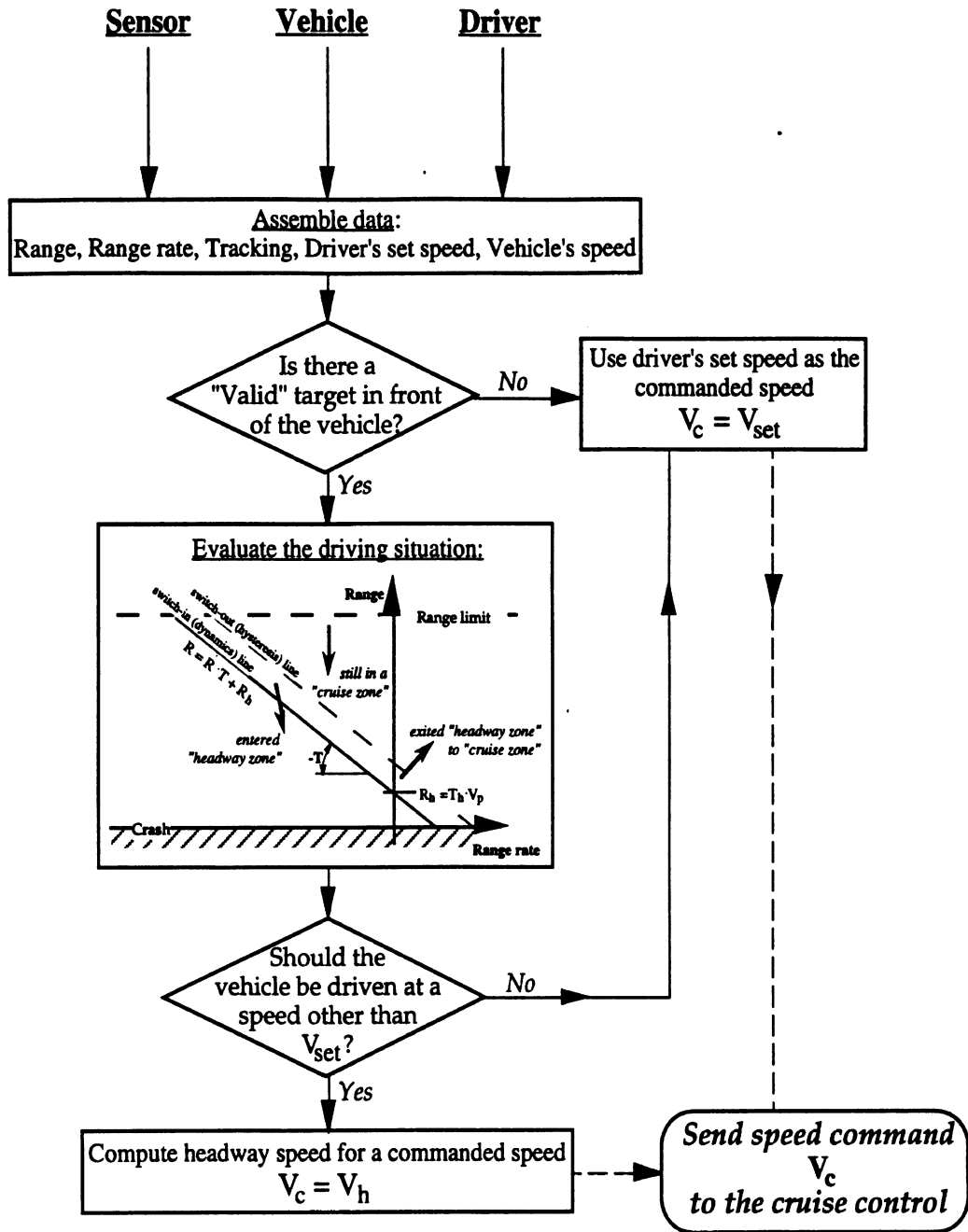

Figure 12. Autonomous Cruise Control algorithm

The process outlined below is used by the control algorithm to determine the validity of a target:

- Compute the speed of the preceding vehicle according to  $V_p = V + \dot{R}$ .
- If the target is moving at a reasonable speed, and at the same direction as the host vehicle ( $V_p > 0.3 \cdot V$ ), it is a valid target.
- If the target is close enough ( $R < 525\text{ft}$ ), but not too close so as it might be an erroneous optical reflection ( $R > 15\text{ft}$ ), it is a valid target.

All other targets are ignored by the controller.

If a valid target is detected by the sensor, the controller evaluates the driving situation, calculates the appropriate headway distance and corresponding speed, and then sends a speed command so that the headway distance is achieved. If no target is detected, or when the vehicle in front either disappears or accelerates above the desired speed, the ACC operates as a normal cruise control according to the speed set by the driver.

As shown in figure 5, the output of the control algorithm is a speed command to the cruise-control system of the vehicle. As shown in figure 12, the commanded speed can be either the driver's set speed ( $V_{set}$ , like in a conventional cruise control), or a headway speed ( $V_h$ ) that was computed by the controller. If a headway speed needs to be computed, a sliding-control approach is used [7]. Relative to the time it takes for the vehicle to close headway gaps and to reach the desired range, it is assumed that the speed response is significantly faster. That is, it is assumed that in comparison to range changes, speed variations are almost instantaneous ( $V \approx V_c$ ). Therefore, for longitudinal control purposes, the vehicle can be modeled as a first order system. Equation 5 represents such a system (see also figure 12 and discussion in section 2.1).

$$V_h = V_p + \frac{R - R_h}{T} \quad (5)$$

where  $V_p = V + \dot{R}$

and  $R_h = T_h \cdot V_p$

#### 2.2.4 Control Authority

The longitudinal control authority given to the baseline ACC system was limited to throttle manipulation. Brakes are not applied automatically by the system to control speed. Target acquisition, however, is fully automatic. Driver's input in selecting a target is not required, and the system autonomously chooses a target to follow (see also discussion in sections 2.2.2 and 2.2.3).

Since brake activation was not incorporated in the baseline system, the maximum available deceleration rate was the prevailing deceleration during zero-throttle coastdown (approximately 0.05g). During acceleration, however, not all of the available engine power was utilized. Preliminary tests showed that when the vehicle switches from "headway" operation ( $V_c < V_{set}$ ) to "cruise" ( $V_c = V_{set}$ ), the large change in commanded speed usually involves a startling level of acceleration because of the high-output engine. For that reason, a taming feature had to be applied during acceleration. This feature was in a form of speed ramps, or a moving-window. When acceleration is required, the commanded speed ( $V_c$ ) sent to the cruise control never exceeds a value which is 6 kph (3.7 mph) more than the current speed of the vehicle. This incremental speed increase using 6-kph steps at a time, continues until the desired speed is achieved. This taming



feature also possesses a safety benefit: If the preceding vehicle accidentally drops out of the sensor's view (e.g., when going around a curve) so that the system attempts to resume  $V_{set}$ , the slow acceleration level caused by the 6-kph steps significantly reduces the risk of crashing into the rear-end of the preceding vehicle. Clearly, opposing scenarios also exist. When moving to a vacant lane, drivers might feel that the vehicle is too-lame or not-responsive-enough. However, safety considerations prevailed in this case. Furthermore, the driver always has the option of overriding the throttle momentarily to get higher acceleration without disconnecting the system.

## 2.2.5 Summary of Operational Boundaries

This section presents a summary regarding the operation of the ACC system. These boundaries are a result of either the system's design, or its component's characteristics, or both. Explanations as to the cause or the rationale behind these boundaries are also provided.

### Following distance

*Maximum bound* : 160 m (525 ft)

*Minimum bound* : 4.6 m (15 ft)

*Rationale* : The maximum bound is a hardware-related limitation. The minimum bound is aimed at minimizing the potential for erroneous reflections from the hood, etc., since the sensor is mounted far behind the bumper at the top of windshield

### Operating speed

*Maximum bound* : 160 kph (100 mph)

*Minimum bound* : 24 kph (15 mph)

*Rationale* : Both bounds are established for safety reasons. The lower bound, however, is determined by the vehicle's cruise-control system. This system does not operate below 15 mph. Though the cruise-control system can operate above 100 mph, it was decided that for safety reasons the ACC should not be engaged above that value. In any case, the speed commanded by the ACC never exceeds the driver's set speed (see section 2.2.1.2).

### Acceleration/Deceleration

*Acceleration bound* : No definitive numerical value. The acceleration level depends on the instantaneous speed and gear, and it can vary between approximately 0.04 and 0.1g.

*Deceleration bound* : Similar to the acceleration, there is no definitive numerical value. Actual limit is the resultant dethrottling coastdown (approximately 0.05g, depending on instantaneous speed and gear).

Sensor's coverage

*Maximum bound* :  $\pm 1.5$  degrees relative to the centerline of the ACC vehicle

*Minimum bound* : none

*Rationale* : The sensor's limited field of view (see section 2.2.2 and figure 13)

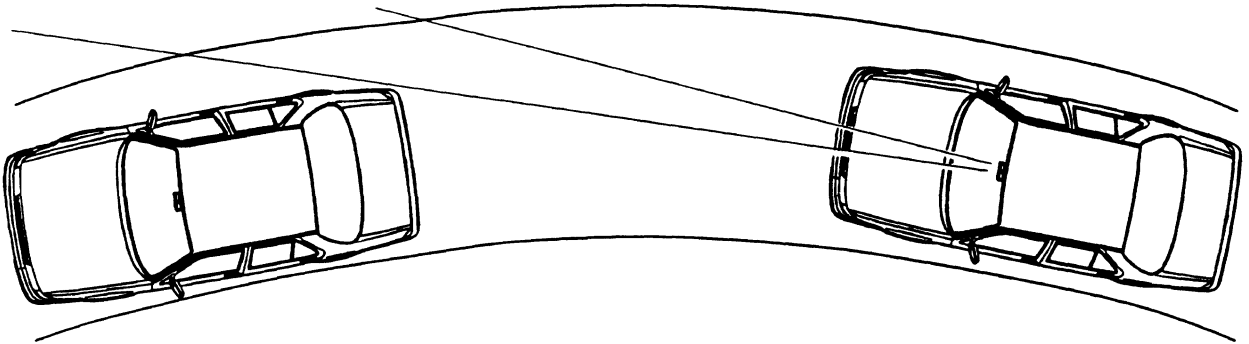

Figure 13. Target outside sensor's view

### 2.3 Definitions and Symbols Used in Describing Data Variables, System Parameters, Conceptual Ideas, and Measures of Performance in the Report

This section describes the data required for evaluating the performance of the headway-control system and characterizing the driver as the system's supervisor and operator. These data are used to identify operational parameters for the driver when he/she operates the vehicle without the assistance of any control system. Based on experience with data acquired while using a working headway-control system, it has been concluded that additional data items (that will be computed from the acquired data) are desired. These computed data, referred to as auxiliary variables, provide additional information to be used in evaluating the performance of the headway-control system and characterizing the driver.

#### 2.3.1 Measured (Acquired) Variables

The operation of the ACC system can be regarded as a combination of the following four elements: (1) the sensor, (2) the vehicle, (3) the driver, and (4) the controller. The measured variables are basic data that pertain to each of those elements. These data are used in evaluating driving operations under various modes of automatic-control assistance. This section summarizes

the measured data according to the four elements of the ACC system. In addition, ambient and monitoring data that are intended to aid in the posttesting processing were acquired.

### *Sensor Data*

The sensor measures range (R) and range-rate ( $dR/dt$ ) data regarding objects it detects. That information is fundamental to evaluating and controlling headway.

### *Vehicle Data*

In the longitudinal direction, the essential vehicle data are velocity and acceleration. Velocity data was available on the communication-buss system of the vehicle. Acceleration data was available from the electronic-throttle system of the vehicle (through the communication-buss). The same system provided data concerning the actual position of the throttle on the engine (from fully open under heavy acceleration, to almost closed at idle). In addition, the vehicle was also instrumented with an accelerometer for direct measurement of acceleration and deceleration.

To identify when the vehicle is in a turn, yaw rate was measured. This information is useful in identifying (later when processing the data) whether a target is in the sensor's field of view. These data were acquired by means of a specially installed sensor.

### *Driver Data*

“Driver data” refers to actions taken by the driver to control the vehicle. The driver can control the forward velocity and the lateral direction of motion. For that purpose, measured quantities included accelerator pedal position, brake actuation, and steering-wheel angle. The data concerning accelerator pedal position was available from the electronic-throttle system of the vehicle (through the communication-buss), which also provided boolean (yes or no) information about the activation of the brake pedal. Steering-wheel-angle data were acquired by means of a specially installed rotary potentiometer.

The desired cruise speed set by the driver and the driver's desired headway-time setting were recorded. It should be noted that even though during this phase of the study drivers did not have the ability to modify headway-time setting. This feature is planned to be incorporated in the future, therefore the data-acquisition system was designed accordingly. These data items were available at the communication-buss link.

### *Controller Data*

The controller processes the range and range-rate data from the sensor to discriminate between targets that should be ignored (e.g., road signs), and valid targets for which speed adjustment should be considered. This boolean signal (valid or not valid) was collected from the data serial port on the controller.

The controller's output command to the vehicle's cruise-control system, available at the controller's communication link, was recorded. This command signal is in a form of a commanded speed.

### *Ambient and Monitoring Data*

To identify when the vehicle is on an uphill slope or a downhill grade, an atmospheric-pressure sensor was installed. This information was intended to be used later when processing the data, to possibly identify reasons for otherwise unexplained throttle or brake activation. In addition, visual data was acquired by means of a video camera so that any driving scene could be reviewed. Synchronization between the video tape and the other data that was collected on a laptop computer, was ensured by registering the frame numbers along with the other data.

The complete array of data that was collected is listed in Table 1 below. For each data item listed in the table, its description, units, and the acquisition source are provided.

Table 1. Acquired data

Data Item	Symbol	Definition	Units	Acquisition Source
<b>Sensor Data</b>				
Range	R	Distance from the sensor to a detected object	ft	Sensor
Range Rate	Rdot	Rate of change of distance from the sensor to a detected object	fps	Sensor
<b>Vehicle Data</b>				
Velocity	V	Forward velocity of the headway controlled vehicle	fps	Comm. buss
Acceleration (measured)	Ax	Forward acceleration of the vehicle	g	Accelerometer
Throttle	Cth	Throttle position (on the engine)	%	Comm. buss
Acceleration (calculated)	Vdot	Forward acceleration of the vehicle	g	Comm. buss
Yaw Rate	YR	Yaw rate of the vehicle	deg/sec	Transducer
<b>Driver Data</b>				
Steering	Csw	Rotational position of the steering wheel	deg	Transducer
Accelerator	Cac	Accelerator pedal position	%	Comm. buss
Brake	Lbr	Boolean variable indicating brake pedal status: 0 = brake pedal <b>is not</b> depressed 1 = brake pedal <b>is</b> depressed * Note: In the future, when limited braking is incorporated, this data item will contain a continuous variable for brake intensity.	(—)	Comm. buss
Set speed	Vset	Cruise speed set by the driver	fps	Comm. buss
Headway time	Thc	Desired headway time	sec	Controller
<b>Controller Data</b>				
Valid target	Ltv	Boolean variable to filter objects: 1 = detected object <b>is</b> a valid target to consider and to possibly adjust headway to 0 = Otherwise	(—)	Controller
Command speed	V <sub>c</sub>	Velocity command for headway control	fps	Controller
<b>Ambient and Monitoring Data</b>				
Grade	Grade	Atmospheric pressure (to indicate altitude changes)	in Hg	Pressure transducer
Frame	Fn	Frame number of the VCR for data playback	(—)	VCR

### 2.3.2 Derived (Computed) Variables

In addition to the data collected during the tests, there are auxiliary variables that were computed and evaluated. These auxiliary variables were derived from the acquired data listed in Table 1. The purpose of the auxiliary variables is to enhance data processing by providing additional information concerning the driver, the vehicle, and a better understanding of driver's operating patterns. Table 2 lists the auxiliary variables that were computed and stored.

Table 2. Derived data

Symbol	Definition	Units	Condition to derive	Expression	Value if cannot be derived
Valid	Valid target	(—)	(—)	=1 if: $(525 \geq R \geq 15)$ and $(Rdot \geq -0.7V)$ and $(V > 10)$ and $(Ltv=1)$ =0 otherwise	
Rnew	Valid range	ft	Valid=1	=R	0
RdotNew	Valid range rate	fps	Valid=1	=Rdot	0
Vp	Speed of preceding vehicle	fps	Valid=1	= V + RdotNew	-10
Rh	Reference headway distance	ft	Valid=1	=Vp·Th	-10
SSPC	Steady-state path curvature	1/ft	V>10	$= \left( \frac{YR}{V} \right) \cdot \left( \frac{\pi}{180} \right)$	-0.05
Ays	Steady-state lateral acceleration	g	V>10	$= (YR \cdot V) \cdot \left( \frac{\pi}{180} \right) \cdot \left( \frac{1}{32.2} \right)$	0.5
Ta	Available reaction time	sec	Valid=1	$= \frac{Rnew}{V}$	-10
Ti	Time to impact	sec	Valid=1 and RdotNew<-1	$= \frac{-Rnew}{RdotNew}$	-10
Dreq	Deceleration to avoid crash	g	Valid=1 and RdotNew≤0	$= \left( \frac{RdotNew^2}{2 \cdot Rnew} \right) \cdot \left( \frac{1}{32.2} \right)$	-0.05
Eh	Headway difference	ft	Valid=1	=Rnew-Rh	-1000
Nh	Normalized headway	(—)	Valid=1	$= \frac{Rnew}{Rh}$	-1
VcRef	Reference speed command	fps	Valid=1	$= Vp + \frac{Rnew - Rh}{T}$	0
Lhind	Hindrance level	(—)	Valid=1 and Vset≥22	$= \frac{V}{Vset}$	0

## **2.4 Possibilities for Safety Benefits of ACC over Manual and CC Driving**

Based on experience and analysis, it appears reasonable to speculate that ACC systems might have safety benefits related to system characteristics that change the driving situation with respect to driver inattention, available reaction time, and fatigue.

In many rear-end crashes the following vehicle does not slowdown at all or perhaps it does not slowdown until it is way too late to avoid a collision. Some of these crashes are with stopped cars. As currently configured, in order to eliminate false alarms, ACC systems do not respond to stationary objects. Hence, current ACC systems, like the baseline system, will only intervene to prevent collisions with moving vehicles. Nevertheless, there could be a warning given when there is any obstacle in the path of the vehicle at a relatively short range (say less than the stopping sight distance associated with a modest level of deceleration). Whether there would be too many false alarms is not clear.

For moving vehicles, the baseline system provides a warning to drivers through the deceleration that is felt by the driver when the vehicle starts coasting down in speed. This is noticeable and drivers look around to see why the system has decided to slow the vehicle. Based on experience in this study, it appears that decelerations on the order of 0.1g will certainly send a warning message to the driver because deceleration levels at or above 0.1g seldom occur in manual driving on U.S. freeways. See figure 14. This may have a significant effect upon driver inattention to preceding vehicles.



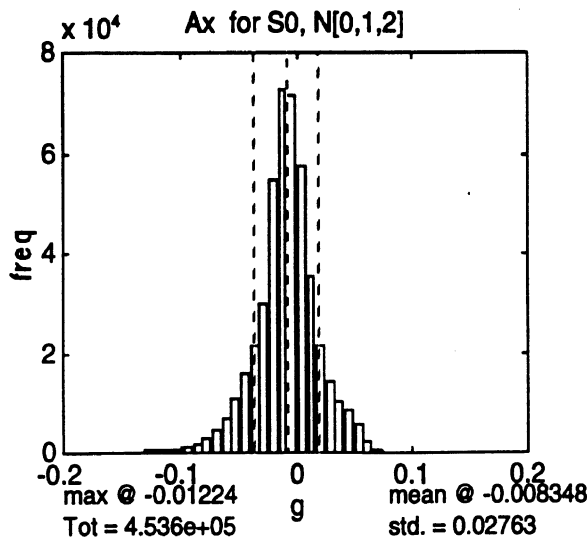

TABLE of: Ax for S0, N[0,1,2]

bin	freq	bin	freq
-0.200	13	+0.004	57722
-0.192	22	+0.012	35785
-0.184	26	+0.020	21166
-0.176	20	+0.029	14228
-0.167	18	+0.037	9908
-0.159	19	+0.045	8528
-0.151	50	+0.053	5686
-0.143	123	+0.061	2134
-0.135	246	+0.069	597
-0.127	306	+0.078	247
-0.118	416	+0.086	175
-0.110	548	+0.094	182
-0.102	683	+0.102	141
-0.094	1137	+0.110	109
-0.086	1692	+0.118	109
-0.078	2724	+0.127	119
-0.069	4244	+0.135	63
-0.061	6522	+0.143	76
-0.053	10822	+0.151	42
-0.045	15552	+0.159	30
-0.037	21613	+0.167	16
-0.029	30144	+0.176	17
-0.020	54923	+0.184	11
-0.012	72767	+0.192	26
-0.004	71799	+0.200	18

Figure 14. Deceleration and acceleration density

As explained in Section 2.1, the available reaction time ( $T_a$ ) has a bearing on whether crashes are likely to occur. Test results have shown that drivers often travel at values of  $T_a$  that are much closer than 1.4 seconds, which is the desired value of  $T_a$  used in the baseline ACC system. See figure 15. If one knew the relationship between  $T_a$  and the risk of a crash, one could estimate the benefits obtained by maintaining longer ranges (i.e., providing more reaction time when reaction time is less than 2.5 sec). Given a concern with crashes, it is of interest to estimate what might be done with more reaction time. For example, each additional 0.1 sec of available reaction time means a change of relative velocity (DV) of 0.322 ft/sec per 0.1 g of relative deceleration between the preceding and following vehicles. This means that a 0.4 sec reduction in  $T_a$  and an available relative deceleration capability of 0.5 g could reduce DV by 6.44 ft/sec (about 4.4 mph) which could mean a reduction in the number of rear-end crashes and a reduction in the severity of the accidents that did occur.

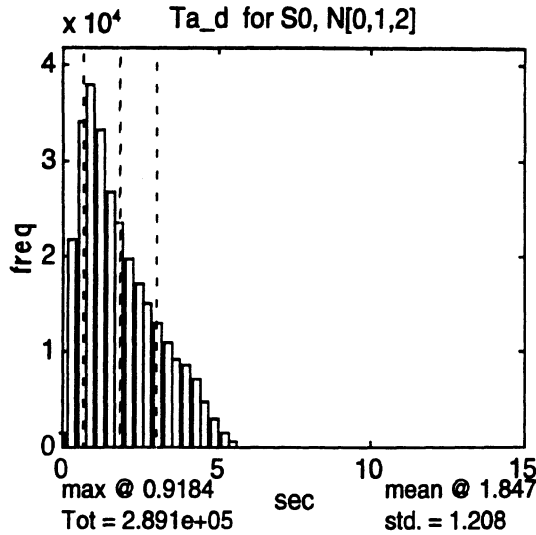

TABLE of: Ta\_d for S0, N[0,1,2]

bin	freq	bin	freq
+0.00	1586	+7.65	0
+0.31	21779	+7.96	0
+0.61	34051	+8.27	0
+0.92	37946	+8.57	0
+1.22	33338	+8.88	0
+1.53	26888	+9.18	0
+1.84	23484	+9.49	0
+2.14	19729	+9.80	0
+2.45	17002	+10.10	0
+2.76	15031	+10.41	0
+3.06	12942	+10.71	0
+3.37	10874	+11.02	0
+3.67	9229	+11.33	0
+3.98	8444	+11.63	0
+4.29	7063	+11.94	0
+4.59	4597	+12.24	0
+4.90	2958	+12.55	0
+5.20	1598	+12.86	0
+5.51	481	+13.16	0
+5.82	118	+13.47	0
+6.12	5	+13.78	0
+6.43	0	+14.08	0
+6.73	0	+14.39	0
+7.04	0	+14.69	0
+7.35	0	+15.00	0

Figure 15. Available reaction time (Ta) density

With regard to drivers being able to perceive relative velocity, it has been found that drivers become aware of relative velocity through the looming effect that occurs as an object gets closer. Studies show that people start to distinguish relative speed changes when the angular rate of change of image size exceeds 0.2 deg/sec [8]. For example, the angular width (A in degrees) of a 6 ft object at a range (R in feet) is given by:

$$A = 6.57.3/R \tag{6}$$

And the angular rate is:

$$dA/dt = - (344 dR/dt)/R^2 \tag{7}$$

For dA/dt at the 0.2 sec threshold of resolution, one obtains:

$$dR/dt = - 0.00058 \cdot R^2 \tag{8}$$

This means that at a range of 250 ft, for example, the range-rate needs to be at least 36 ft/sec (25 mph relative velocity) for the driver to notice it. This result for minimum detectable range-rate is so much bigger than one might imagine that it needs further verification. Nevertheless, presuming that the result is at least qualitatively correct, it means that the ACC system has a big advantage over drivers in detecting the rate of closing on a preceding vehicle. In essence, drivers

are nearly “blind” to range-rate until they get to within about 100 ft of range when the minimum detectable range rate is 5.8 ft/sec (4 mph). Perhaps this has something to do with why drivers tend to follow at close ranges when the relative velocities are small. In any event, it means that the ACC system is much more responsive to relative velocity than the human driver, and hence the ACC system can be expected to close in on preceding vehicles in a much more orderly and consistent manner.

Now consider fatigue. This is really a nebulous subject, but there is no doubt that ACC (as well as conventional cruise control) greatly reduces the physical and neurological effort that the driver expends in modulating the accelerator pedal. One might think that they put the accelerator pedal at a fixed position and go at the speed they desire. Measurements made in this program show that this is not the case at all. See figures 16 and 17. Drivers tend to be moving the accelerator pedal continuously with a ratio of standard deviation of the pedal motion about the mean to the mean itself of approximately 0.43 at highway speeds. To the extent that the benefits of removing this effort, and all of the decisions to increase or decrease speed that accompany it, greatly reduces the driver’s workload, the ACC system leads to safer as well as more pleasant driving.

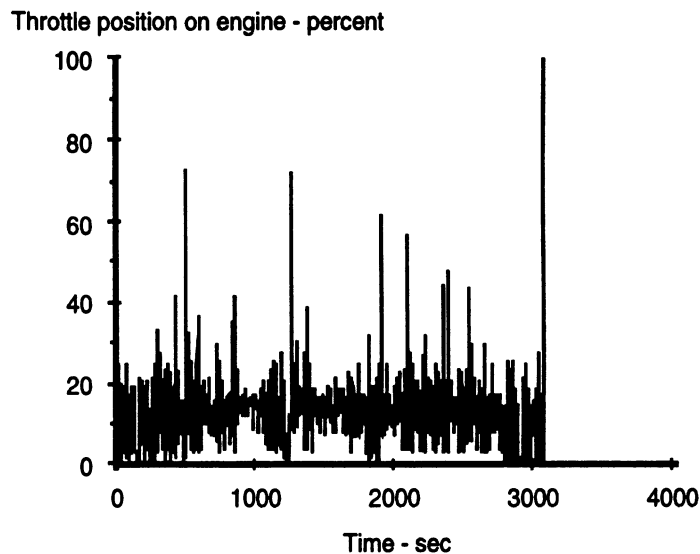

Figure 16. Accelerator pedal position time histories

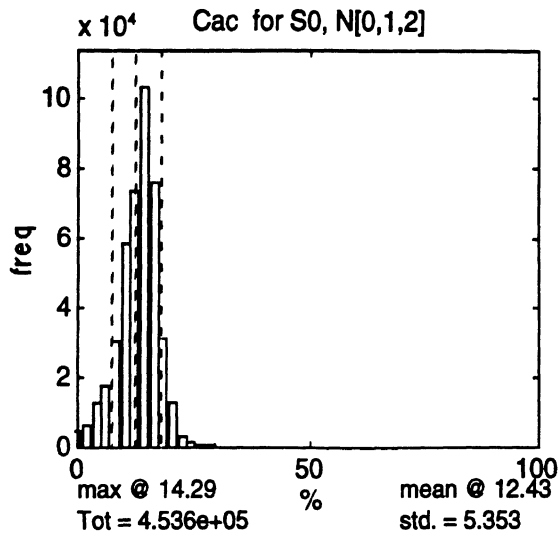

TABLE of: Cac for S0, N[0,1,2]

bin	freq	bin	freq
+0.0	4841	+51.0	14
+2.0	6587	+53.1	7
+4.1	12726	+55.1	19
+6.1	17957	+57.1	11
+8.2	30433	+59.2	4
+10.2	58223	+61.2	6
+12.2	73755	+63.3	1
+14.3	103411	+65.3	2
+16.3	76261	+67.3	3
+18.4	31008	+69.4	0
+20.4	13055	+71.4	4
+22.4	3536	+73.5	3
+24.5	1429	+75.5	0
+26.5	847	+77.6	0
+28.6	478	+79.6	0
+30.6	322	+81.6	0
+32.7	262	+83.7	0
+34.7	145	+85.7	0
+36.7	108	+87.8	0
+38.8	99	+89.8	0
+40.8	64	+91.8	0
+42.9	62	+93.9	0
+44.9	32	+95.9	0
+46.9	39	+98.0	0
+49.0	23	+100.0	0

Figure 17. Accelerator pedal position density

### **3. CONDITIONS OF DEPLOYMENT**

#### **3.1 The Vehicle and its Instrumentation**

The vehicle is equipped with a number of ancillary transducers along with the headway sensor employed (see figure 18 for a depiction of the ACC Instrumentation system). Longitudinal acceleration, yaw rate, steering wheel angle, and atmospheric pressure were transduced using analog sensors and a simple eight bit digitizer. Signal-conditioning circuitry was implemented for powering the transducers and filtering the signals prior to digitizing. These data were transmitted (via RS-232) from the digitizer to the laptop computer for storage. Range and range-rate information are also collected by the same laptop computer, also via RS-232 communications.

A color video camera, two microphones, and computer-controlled, videotape recorder were installed. The tape deck recorded the forward scene and in-vehicle sounds of the driving experience whenever the laptop was collecting data from the transducers and headway sensor. This recorder was controlled (record, stop, play, etc.) by the laptop via an RS-232 connection. While recording, the video recorder also placed SMPTE (Society of Motion Picture and Television Engineers) time-code data on an audio track and transmitted this code (as frame counts) to the laptop for storage. These data were simply treated as another serial-data stream, which serves to synchronize the engineering data with the video and sound captured. These data were permanently recorded on the video tape and stored in the data files providing the common synchronization between the two storage mediums.

Data from the headway sensor and controller were transmitted to the laptop via RS-232 at 10Hz. These data consisted of range, range-rate, and several control parameters such as set-speeds, current speed, intervention mode (if any), etc. Data from the digitizer (the ancillary transducers) and the video recorder (the time-code for synchronization) were also transmitted to the laptop at 10Hz intervals.

The entire instrumentation package is independent of the controller (i.e., the vehicle functions as an ICC system without the need for a laptop, VCR, analog transducers, etc.). All instruments are powered separately using an inverter which produces a 110V, 60Hz square wave from the vehicle's battery voltage. The vehicle's own charging system was sufficient to maintain the battery voltage levels for the duration of the study.

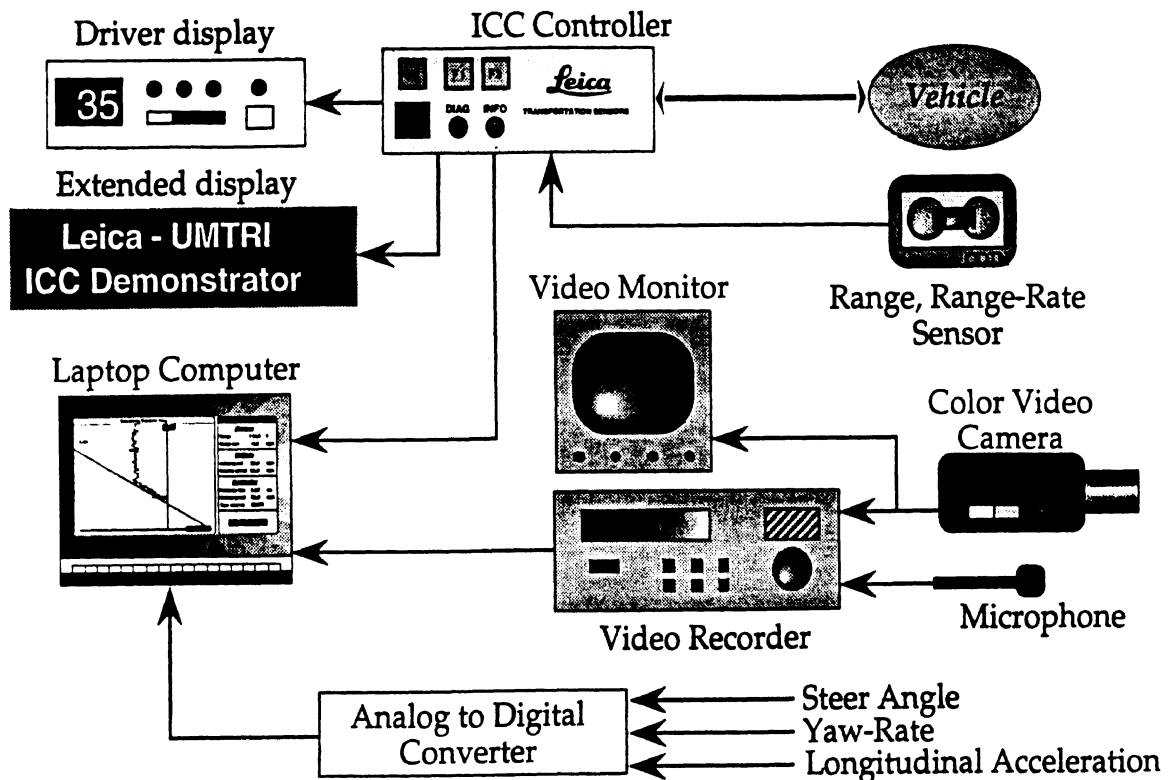

Figure 18. ACC Instrumentation system

## 3.2 The Route and Driving Control Modes

### 3.2.1 The Route

Each participant drove a predetermined route on local highways (figure 19 and table 3). The length of the route was 55 miles, and took approximately 50–60 minutes per trial to complete. This time was believed to be sufficient to allow participants to experience, and become accustomed to, controlling the vehicle. Participants drove only when weather and road conditions permitted (an experimenter was present at all times to aid participants in route guidance). Test drives only took place between the hours of 9 a.m.–noon and 1:30 p.m.–4:30 p.m. to avoid large fluctuations in traffic density associated with rush hours. At the end of each experimental trial participants returned to the UMTRI research facility to complete a questionnaire. A ten minute break was provided to participants at the end of each trial.

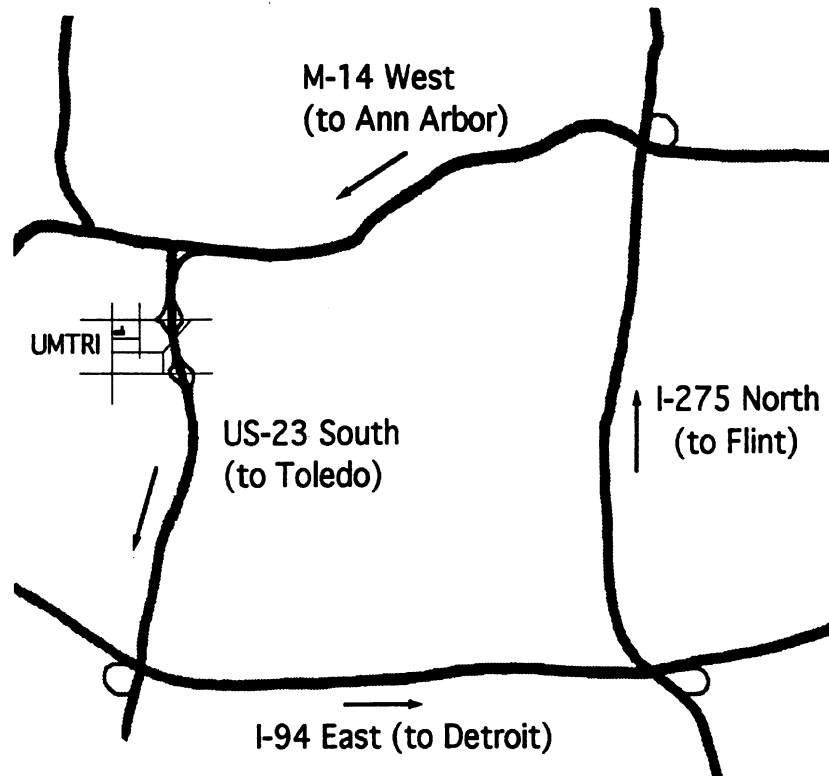

Figure 19. Map of the selected route through Ann Arbor and the Metropolitan Detroit area.

Table 3. Annual average 24-hour traffic volumes for the selected route (Source: Michigan Department of Transportation, 1993 [9])

Segment	Average Volume	Lanes
US 23 (South)	44,000 - 56,000	2
I-94 (East)	60,000 - 91,000	2-3
I-275 (North)	45,000 - 112,000	3-4
M14 (West)	43,000 - 70,000	2-3

The recorded data clearly show the locations of the ramps and the time periods when the vehicles were on the various highways. See figure 20 for an example of typical data for one subject. To obtain information pertaining to driving at highway speeds, it is convenient to use data when the velocity is greater than 55 mph. As indicated by the velocity time history shown in figure 20, the velocities on the three low-speed, short-radius, right-turn ramps are below 55 mph although the high-speed, long-radius, left-lane-to-left-lane ramp is included for subject S1.

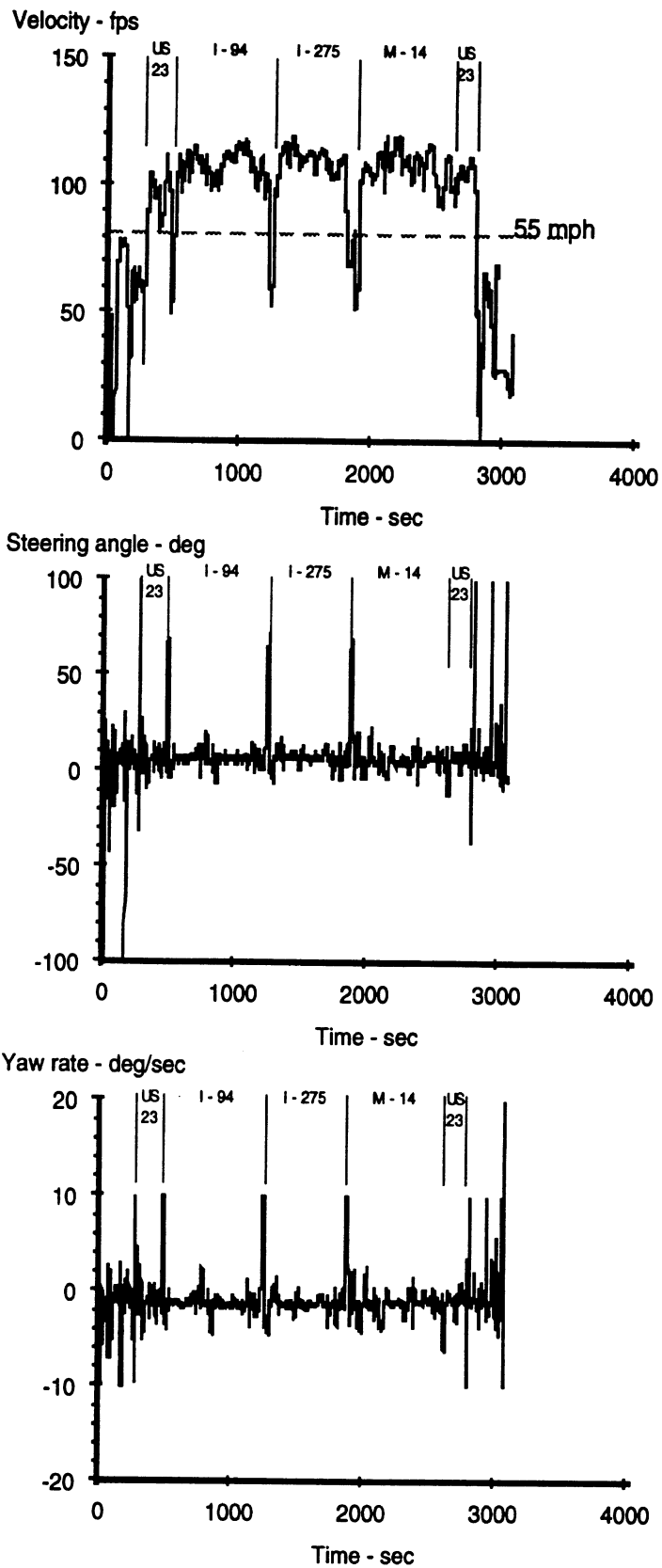

Figure 20. Time histories showing ramp locations



The recorded data also provide an indication of the traffic situation during the tests. There is a subtle way to deduce how much of the time there is a preceding vehicle within range of the sensor. Figures 21 and 22 show histograms of the frequencies of occurrence for various ranges (bins) of velocity and headway range. In these figures, the special information under the bar charts includes a quantity called Tot which is the total number of data points measured for the variable. There are fewer data points for R (that is, Rnew) than there are for V because R is only measured when there is a preceding vehicle in range of the sensor. If the frequency numbers (“freq”) in the tables were divided by the value of Tot, these frequencies would be turned into probability estimates for each bin. This is all very interesting as a matter of general knowledge, but specifically with regard to traffic the value of Tot for R divided by the value of Tot for V is the fraction of the time there is a preceding vehicle within 525 ft of the participant’s vehicle. That fraction for all subjects (also know as S0) is given by  $(289,100)/(453,600) = 0.64$ . Or in other words, the traffic can be described by saying that a preceding vehicle was within 525 ft for 64 percent of the time.

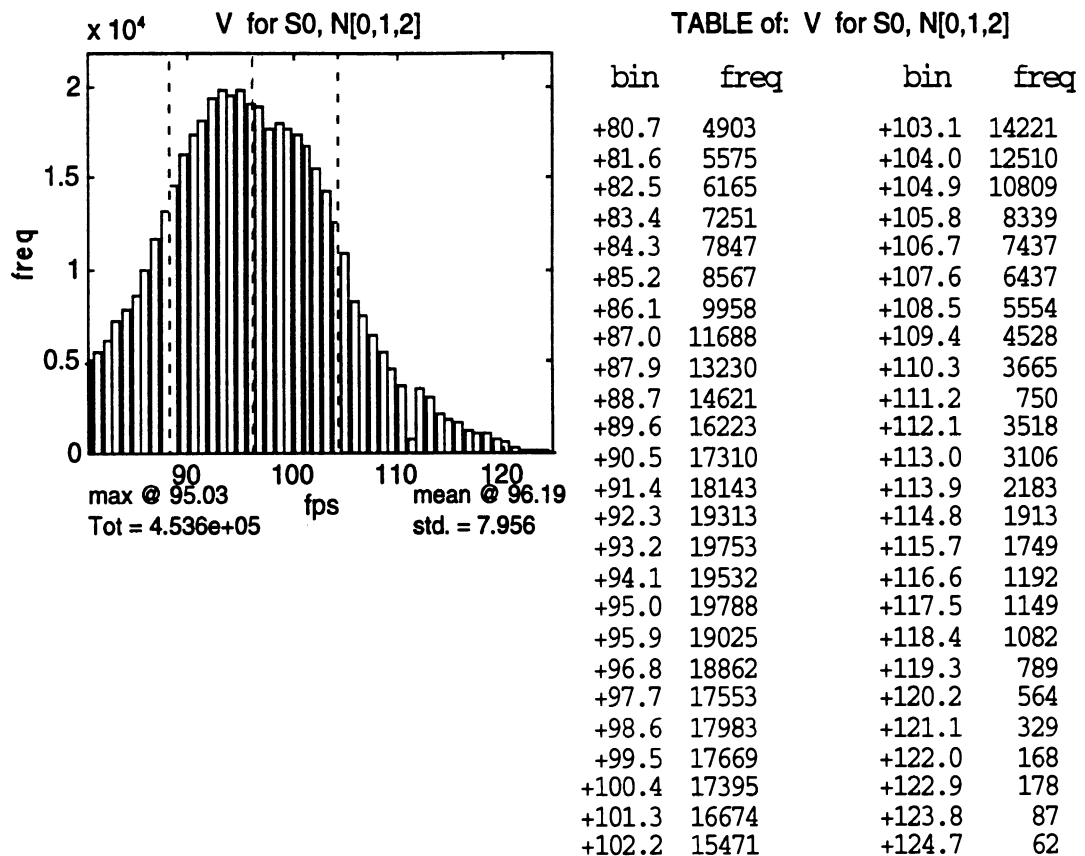

Figure 21. Velocity density histogram

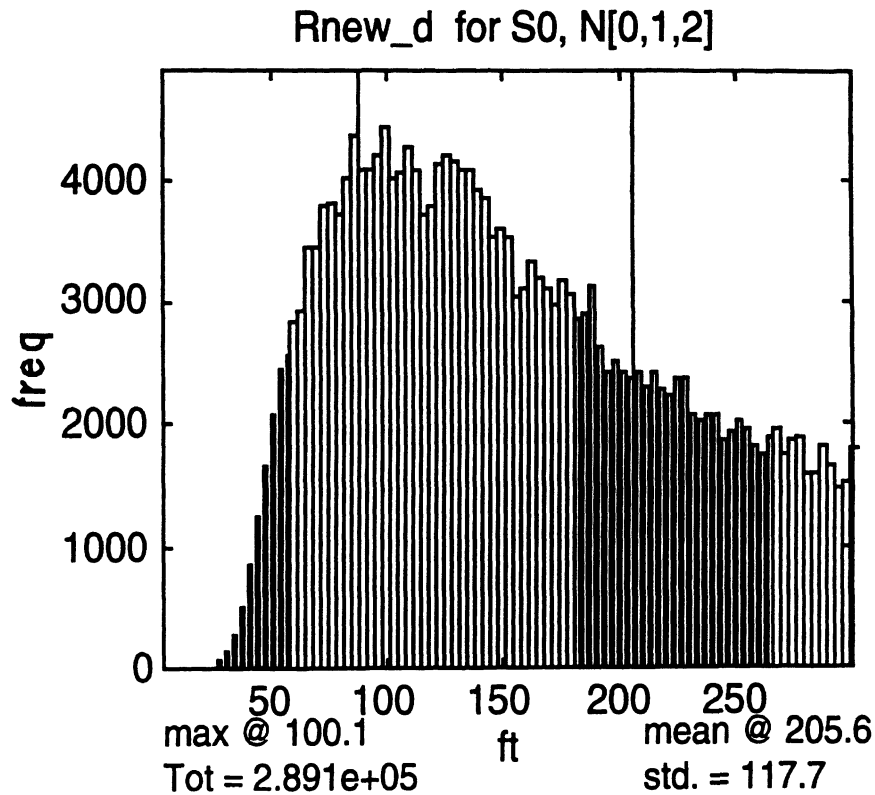

Figure 22. Range density histogram

### 3.2.2 Control Modes

Each of three experimental trials began and ended at the UMTRI facility. On each trial a different mode of speed assistance (cruise control) was evaluated: no cruise control (manual), conventional cruise control, and ACC. The same route was followed for testing each of the control modes. The orders in which participants experienced cruise control modes were counter balanced to eliminate order effects.

### 3.3 Participants

Thirty-six licensed drivers were recruited from a local Secretary of State's office (the state of Michigan's equivalent to the Department of Motor Vehicles), as well as through newspaper advertisements, to participate in the study. Prospective individuals were required to meet the following criteria:

- a. possess a valid, unrestricted, driver's license
- b. have a minimum of two year's driving experience

- c. and appear not be under the influence of alcohol, drugs, or any other substances that could impair their ability to drive

The participant population was balanced for gender, age, and experience in the use of conventional cruise control. The average, yearly mileage driven by participants was 13,500 miles. The three age groups examined were 20 to 30, 40 to 50, and 60 to 70 years of age. Experience with conventional cruise control was divided into two groups: those who frequently used cruise control and those who never, or very rarely, used cruise control. Among those who never, or rarely, used cruise control, having a car that was not equipped with cruise was cited most often as the reason it was not used (57.1percent). Among users of cruise control, reduced workload was cited most often as the reason for its use (64 percent). When the participants were asked to describe their cruising speed on the open freeway, 57.1 percent reported that they drove 5 mph above the speed limit, 22.9 percent reported driving at the speed limit, 2.9 percent reported driving 5 mph below the speed limit, and 17.1 percent reported driving at some other speed. In addition, 44.4 percent of the participants reported regularly driving at speeds consistent with the flow of traffic, while 55.6 percent drove at a speed with which they felt comfortable.

In the event participants encountered a slower moving vehicle, and the adjacent lane was free, 75 percent of the participants stated that they would pass the vehicle and return to the lane even if momentary acceleration was necessary. Another 16.7 percent claimed they would maintain their speed even if it meant moving to another lane and remaining there. While 8.3 percent reported that they would adjust their speed and remain in the lane if the other vehicle were only slightly slower.

### **3.4 Instructions**

Individuals were briefed as to the nature of the study. Prospective participants were asked to read an information letter describing the study and the associated benefits and risks. Individuals who agreed to participate, and met the previously mentioned criteria, provided informed consent.

Participants were shown the research vehicle and instructed on its operation. Specific attention was paid to locating and identifying controls and displays. Instruction on the use of the two cruise-control devices was also provided. Participants were asked to adjust the driver's seat and vehicle mirrors. All participants were required to wear safety belts.

Participants were instructed to drive as they would normally for the existing road and traffic conditions, with the exception that they were asked to employ a specific level of speed assistance (control mode) for each of the three trials. The participants were further instructed to disengage cruise control at any time they felt it was unsafe to use for the existing conditions, but to use the

**control mode requested as much as possible during the course of the trial. Participants were reminded that as the driver they must remain in control of the vehicle at all times.**

..

## 4. DESCRIPTION OF THE DATABASE

### 4.1 Objective Data

Data from the field consisted of a time sequence of samples from a variety of sources, each with its own independent timing system and phase relationship to the system as a whole. Synchronization of all data to within one sample period is possible under such a scheme. Prior to testing the subjects, the data being transmitted to the laptop computer had been validated to ensure such a phase relationship existed, and that it remained constant over the course of a test. The 10Hz transmission rate was chosen since the controller installed in the vehicle had a preprogrammed output rate of 10Hz. Also, this allows a maximum skew in channel phasing of 100ms - acceptable synchronization of each sub-system in this configuration.

Raw data exist in the data base as a 5Hz time history of each transduced variable. The bit depth of the data varies between subsystems. Digitized analog data are eight bits deep, while the controller had a variety of effects on resolution of its data output, dependent on internal representations within the microcontroller vehicle system. The video tape frame numbers are integers, and assumed to be of resolution as may be specified in the SMPTE specification.

Listings of the data items for which time histories are stored in the database, are given in Tables 1 and 2 (see pages 23 and 25).

Postprocessing efforts have been made to zero any DC offsets in steering wheel angle and longitudinal acceleration sensors, and to correct zero-drift in the yaw-rate sensor. Such analog transducers exhibit classical drift and zeroing problems. More efforts need to be made in this processing area; literature supports a plethora of techniques for doing this and they will not be discussed here. All of the data in the time histories have been calibrated and corrected for offsets, and these data exist in the files in the appropriate engineering units. Appendix A includes an example set of time histories for subject S1.

A first-level reduction approach has been to generate histograms of the raw data. Histograms for each variable for all subjects currently exist. These histograms provide immediate access to a distribution of the data and simple descriptors such as mean, mode, variance, etc. These histograms also lend themselves to easy merging (i.e., aggregate totals across a range of subjects), allowing convenient comparative analyses for different subject groups and/or driving modes. The bins selected for the histograms are somewhat arbitrary. When sensor quantization effects are known, attempts were made to locate histogram bin centers at the center of the quantization levels -

alleviating requantization problems. When the sensor's or subsystem's characterization is not known, the assignment of bin centers is simply chosen to be uniform between the minimum and maximum values in the time history. Bin center intervals were, of course, kept constant for a single variable across all subjects and driving modes.

Histograms for all 36 subjects combined and tables of means, standard deviations, variances, modes, and numbers of samples for each subject are included in Appendix B.

## 4.2 Subjective Data

### 4.2.1 Comfort and Safety Questionnaires

Following the completion of each traverse of the predetermined route, once for each of the three control modes, a brief questionnaire was completed by each of the participants. These questionnaires were used to compare the participants' sense of comfort and safety across control modes. The questions were worded identically, with the exception that reference was made to the control mode most recently experienced by the participant. Each of the questions was followed by a seven-point adjectival rating scale. The questions, and results, are provided below.

1. *How comfortable, from a safety standpoint, did you feel driving the car with no cruise control/conventional cruise control/adaptive cruise control?* The scale was anchored on either end by "Not Comfortable" (1) and "Very Comfortable" (7) respectively, as shown below.

<u>Control Mode</u>	<u>Mean</u>	<u>Std. Dev.</u>
No Cruise	6.17	1.28
Conven. Cruise	5.75	1.05
ACC	6.00	1.22

2. *How easy did you find it to maintain a safe distance between your car and other cars in front of you?* The scale was anchored on either end by "Not Easy" (1) and "Very Easy" (7).

<u>Control Mode</u>	<u>Mean</u>	<u>Std. Dev.</u>
No Cruise	5.86	1.50
Conven. Cruise	5.14	1.62
ACC	6.33	1.17

3. *How comfortable did you feel with the ability to pass other cars while driving with no cruise control/ conventional cruise control/adaptive cruise control?* The scale was anchored on either end by “Not Comfortable” (1) and “Very Comfortable” (7).

<u>Control Mode</u>	<u>Mean</u>	<u>Std. Dev.</u>
No Cruise	6.36	0.96
Conven. Cruise	5.67	1.22
ACC	5.72	1.56

4. *Using no cruise control/ conventional cruise control/adaptive cruise control, do you feel that you drove either faster or slower than you would normally?* The scale was anchored on either end by “Slower than Normal” (1) and “Faster than Normal” (7).

<u>Control Mode</u>	<u>Mean</u>	<u>Std. Dev.</u>
No Cruise	5.17	1.13
Conven. Cruise	3.86	1.15
ACC	3.69	1.43

5. *Using no cruise control/ conventional cruise control/adaptive cruise control, do you feel that you applied the brakes more or less frequently than usual for comparable traffic?* The scale was anchored on either end by “Less than Usual” (1) and “More than Usual” (7).

<u>Control Mode</u>	<u>Mean</u>	<u>Std. Dev.</u>
No Cruise	4.42	1.46
Conven. Cruise	4.39	1.52
ACC	2.47	1.52

6. *In general, how similar was your driving to the way you would normally drive under the same types of road and traffic conditions?* The scale was anchored on either end by “Not at all Similar” (1) and “Very Similar” (7).

<u>Control Mode</u>	<u>Mean</u>	<u>Std. Dev.</u>
No Cruise	5.97	1.36
Conven. Cruise	5.33	1.43
ACC	4.72	1.95

#### 4.2.2 ACC Acceptance and Comfort Questionnaire

Following the completion of all three trials, each participant was asked to complete a detailed questionnaire regarding the use of the ACC mode only. The questions, and participant responses, are provided below.

1. *When a difference in vehicle speeds would require you to use the brake, would an audible tone be useful?*

Yes = 17   Not certain = 10   No = 9

2. *Did you like the 2 mph increments for setting and reducing cruise speeds?*

Yes = 34   No = 2 (would prefer 1 and 5 mph increments)

3. *If the headway (distance the adaptive cruise control system maintained between the two vehicles) was adjustable, you would:*

like it shorter (drive closer to others) = 3

like it where it currently is = 17

like it longer (farther from others) = 2

it would depend on traffic conditions = 13

no response = 1

4. *What impact did adaptive cruise control have on your sense of safety? The scale was anchored on either end by "I felt very unsafe" (1) and "I felt very safe" (7).*

Mean = 5.97   Std. Dev. = 1.08

5. *What impact did adaptive cruise control have on you sense of comfort? The scale was anchored on either end by "I felt very uncomfortable" (1) and "I felt very comfortable" (7).*

Mean = 6.25   Std. Dev. = 1.10

6. *Did the system ever make you feel too comfortable, as if someone else had taken control of the car for you?*

Yes = 11   I am not certain = 3   No = 22

7. *How convenient did you find using adaptive cruise control? The scale was anchored on either end by "It was very inconvenient" (1) and "It was very convenient" (7).*

Mean = 6.25   Std. Dev. = 1.23



8. *When closing a gap, or when a lane becomes free, what do you think of the adaptive cruise control system's rate of acceleration? The scale was anchored on either end by "Too Slow" (1) and "Too Fast" (7).*

Mean = 4.22      Std. Dev. = 1.10

9. *How similar to your own driving behavior do you think the adaptive cruise control system operated? The scale was anchored on either end by "Not similar" (1) and "Very similar" (7).*

Mean = 4.91      Std. Dev. = 1.68

10. *Did any aspects of the adaptive cruise control system bother you? If yes, what aspects were bothersome? Values in parentheses represent the number of participants providing the same comment.*

Loss of target on curves (4)

Can't track cars entering the highway (2)

Rate of acceleration during lane change (2)

Location of controls and digital display (2)

Tracks wrong targets on curves (0)

What would indicate malfunction? (0)

Lack of brake lights during deceleration (0)

Uncertain about reliability (0)

Not for use on interchanges (0)

Difficulty in remaining awake (0)

Headway is too short (0)

Headway too long (0)

### Advantages

Very safe, reduce risk of accidents  
Good for elderly, minimum leg movement  
Safety for lane changing  
Less driving stress  
Useful and comfortable  
Convenient, unobtrusive  
Less leg cramping, less stress  
Good for elderly & drowsy drivers  
Simple override mechanism  
Improves safety  
Less braking required  
Good acceleration, safer than standard cruise  
Comfort on highway trips  
Fine for the open road or low traffic

### Disadvantages

Over dependence in poor weather  
Concern about quick cut-ins  
Too comfortable on long trips  
Needs sound  
Problem on exit ramps  
Use on exit ramps and curves  
False sense of security  
Over dependency  
Sound when braking needed  
Curves, need to eliminate wrong targets  
Prefer to control car myself  
Over dependence  
Too little acceleration for lane changing

#### 4.2.3 Focus Groups

Twenty-four of the original 36 participants returned to take part in focus groups concerning the ACC system they had experienced. Three separate focus groups were held with seven to ten participants in each, and conducted by the same researchers who accompanied participants while driving. Individuals had driven the ACC-equipped vehicle one to seven days prior to participating in the focus group. In each of the three sessions participants were asked the same sixteen questions. Each question is provided below, and most are followed by a researcher's synopsis of participants' responses. In addition, abbreviated forms of participant comments, transcribed from video tape, are also provided. Each comment is preceded by a three letter acronym that describes the participants gender, age and conventional cruise control usage (respectively). The listing below is a key to these abbreviations.

#### Gender

F = Female

M = Male

#### Age

Y = Youngest age group (20 - 30)

I = Intermediate age group (40 - 50)

E = Eldest age group (60 - 70)

## Age

Y = Youngest age group (20 - 30)

I = Intermediate age group (40 - 50)

E = Eldest age group (60 - 70)

## Conventional Cruise Control Usage

N = Never, or seldom, use conventional cruise control

F = Frequently use conventional cruise control

1. *What are the main advantages, or disadvantages of using conventional cruise control when driving your car? On what occasions do you use or avoid using conventional cruise control? When, or if, you use cruise control, do you try to "platoon" with other vehicles or try to remain isolated?*

Participants frequently responded that conventional cruise control was useful in reducing driver workload, helping to maintain posted speed limits, and resulting in better gas mileage than manual control. However, some participants expressed concern with becoming too dependent on cruise control, and ACC in particular. Specifically, participants felt that some drivers would not pay close enough attention to the task of driving when they relied too heavily on cruise control. Several participants suggested that conventional cruise control was least useful in congested traffic situations, and most useful for long trips on open highways.

### Advantages

- MEN - reduces workload on open highway driving
- MEF - maintain speed
- MEF - reduces workload; can concentrate on steering task
- MEF - looks further down the road while driving w/ cruise
- MEF - better gas mileage
- FEF - controls speed in city driving (school zones)

### Disadvantages

- FEN - over dependency
- MIF - loss of control; loss of quick response
- FEF - dangerous in rush hour traffic; constantly concentrating on turning cruise control off/on and not concentrating on the driving task
- FYF - not for use in rush hour traffic; will use driving long distances even in heavy traffic

### Platooning

- MEN - never platoon; have to worry about speed of preceding vehicle
- MIF - platoon on open highways
- FIF - don't platoon or isolate, I drive to pass slower cars, stay behind faster cars; reduces workload on long trips; prevents speeding
- MYN - tough using cruise control with people who aren't using it; they are constantly slowing down and speeding up; always having to adjust the cruise
- FIF - platooning is nice to use with other drivers who are using cruise and going at comparable speeds
- FEN - I wouldn't try to stay in a platoon
- FIN - I do; smooth riding when pulling a trailer; saves gas
- FYF - I platoon

### 2. *How convenient did you find using adaptive cruise-control? Was it difficult to learn to operate?*

While some participants were not pleased with the cruise-control interface, they almost unanimously reported that the ACC system was convenient and easy to learn.

Participants had a good conceptual understanding of how the system functioned, the system limitations, and that the ACC system was not a collision-avoidance device.

- FEN - quite easy to learn to use; poor placement of controls; set speed display useful and in a good location
- FEF - poor placement of controls; increasing/decreasing by 2 mph was confusing (opposite of her vehicle)
- FYN - found it easy to use. set speed display helpful
- FIF - wonderful; system kept a safe distance; I do a lot of night distance driving and it would be great for that; exit/entrance ramps were startling at first; learned easily; liked set speed display
- FIF - I thought that I wouldn't like it, because I like to be in control, but I would buy it as an option right now; headway was fine; similar to how I drive; easy to learn how to use it; controls placed on the steering wheel would be more convenient; have speed indicators on speedometer
- FYN - easy to learn; difficult to remember to use resume and use the 2 mph incremental change
- MYN - easy to learn; set speed display was helpful
- FYN - no difficulty in learning to use

- MIN - not difficult at all to learn; problems on curves with wrong targets and problem with accelerating on exit ramps
- MIN - very convenient; not difficult to learn; would like a signal for deceleration
- FEN - I don't always listen to instructions; once I used the system, I was OK.
- FEN - not difficult to learn
- FEF- will set speed display be in the dash? angle was bad to read it; should be on top of the dash; liked the display, didn't like the position
- FEN - had same problem with the set speed display

3. *How similar to your own driving behavior do you think the adaptive cruise-control system operated?*

Participants generally reported that the ACC system they had experienced was similar to their own driving behavior. Except for the ACC system occasionally losing targets on curves, the system headway and deceleration characteristics were reportedly similar to participant behavior under manual control. A few participants even suggested that the ACC system was safer than their normal driving behavior because it maintained a longer headway. However, participants did suggest that the acceleration levels of the ACC system were less than what they would accelerate themselves under manual control and that headway should be adjustable.

- MEF - similar
- MIF - ACC provided smoother acceleration than manual driving
- MIF - similar
- MEN - similar
- FEN - deceleration was a little slow as compared to her manual driving
- FIF - headway was similar; on curves - slowing down because of wrong targets was a problem
- FIF - on curves - originally annoying; I then realized I just needed to accelerate if the system was tracking the wrong target
- FYN - ACC had longer headway than I keep which was safer
- MYN - safer than how I drive
- FMF - the acceleration for lane changing was slightly slower than I like
- FYN - the deceleration occurred too quickly
- FYF - close except for overtaking a car; ACC gives extra time (safety zone) for passing; normally, I would brake or shut off the cruise before passing
- FEN - I would have braked sooner than the system (just a little); not uncomfortable nor frightening; concern on curves

- FEF - would need to brake for cut-ins
- MIN - quite similar

4. *Did you like the 2 mph increments for increasing and decreasing the cruise-control speed?*

The majority of participants liked the 2 mph increments used for both conventional and adaptive cruise controls. At least two participants wanted the size of the increments to be adjustable by the driver.

- MEN - yes
- MEF - yes
- MIF - yes
- FYN - bothered that she couldn't increase/decrease and be right on 55 or 65 mph;  
desires increments of 1 mph
- FYN - yes
- FYN - yes
- FEN - yes
- FIN - yes
- FYF - yes
- MYN - liked the increasing 2 mph; for decreasing the speed would like a coasting  
feature
- FIF - would like a coasting button
- FYN - yes
- FIF - rather than braking and pressing resume, it was nice to hit the button to increase  
the speed
- MYN - it would be nice to have the option of programming a control to vary the  
increment  
1 mph increments?
- FYF - no
- FIN - would be annoying
- MIN - could it be changed? Under some circumstances, 3 mph would be OK;  
suggests a programmable device for 1 - 4 mph.
- FEF - adjustable but keep it simple

5. *Did you feel comfortable with the headway distance? Should it have been longer or shorter? Should it be adjustable?*

The response of participants to the 1.4 second headway was mixed, and their responses were heavily dependent upon the density of traffic in which they felt they would be using the ACC system. Specifically, participants frequently stated that the 1.4 second headway was fine, or perhaps even a little short, for use on the open highway. However, several participants felt that the same headway was too long for use in dense traffic conditions. While several participants felt that ACC should not be used in high density traffic conditions, they were generally in favor of an ACC system that offered adjustable headways depending upon the driving environment. Some participants stated that the 1.4 second headway was longer than they would maintain driving manually, and recognized that this distance was likely safer than their behavior. Participants were also interested in knowing how much headway was required for an automobile to come to a complete stop at highway speeds.

- MEN - headway too short; wants to have enough time to react
- FYN - just right; maybe a little too long
- FEN - headway should be adjustable; too long for rush hour cut-ins

Adjustable?

- FEN - yes
- MIF - if it is too complicated, people wouldn't use it; recommend short (standard safety distance at a given speed), medium, and long
- MEF - adjustable based upon speed
- MEF - in bumper to bumper traffic: if it would work at 15-20 mph, I would use it
- MEF - will have chaos with adjustable; there would be a lack of standard following distances
- FEN - suggest No Traffic/Heavy Traffic as settings
- FIF - just perfect
- FYN - it was good, but not really comfortable, too impatient; I'd like it shorter
- MYN - safe distance, but I'm used to shorter headways in city driving
- MYN - would like it shorter
- FIF - right distance
- FYN - really safe, but too long
- MYN - for long trips, headway was fine; like shorter headway for city driving
- FYN - yes
- MYN - yes
- FIF - yes
- FEN - fine
- MIN - Is the distance a safe one?

- FEF - Is the headway tied to braking time? It should be; should be related to the ability of the car to stop
- FIN - comfortable with the headway . .
- MIN - I like the system. I tend to follow more closely than the system. It would promote safer driving.
- MIN - make adjustable for rush hour; driver experience/age; type of car
- FEF - should be a minimum/maximum

6. *Did you feel more safe or less safe when driving with adaptive cruise control as compared to manual driving? conventional cruise control?*

Several participants suggested that use of the ACC system was just as safe as driving under manual control, and one even suggested that it was safer than manual control because it prevented him from tailgating. Participants regularly reported they felt safer, or as safe, with the ACC system as they felt with conventional cruise control. Specifically, participants stated that they felt safer using ACC because it maintained a “safer” following distance (headway) and required fewer interventions by the driver than conventional cruise control. Several participants, particularly individuals from the oldest age group examined, expressed a concern with becoming too dependent on ACC systems.

Manual control

- MIF - safer w/ ACC; wouldn't let me tailgate at 75 mph
- FEF - very comfortable; uses its brain instead of mine
- FEF - didn't feel safe; traffic moving so fast had to drive faster to test ACC
- MIF - felt unsafe with merging traffic and traffic in adjacent lane. The system can't recognize what is happening laterally.
- MIN - safer than manual
- MEF - response time for deceleration was faster than I was; good for people with depth perception problems

Conventional cruise control

- FEN - safer; anticipated traffic slowing down; would not use it on entrance/exit ramps
- MIF - in heavier traffic, CC is a problem; when overtaking slower cars, the CC has to be taken off; one doesn't have to think about it w/ ACC; ACC is improving CC
- MEN - concerned about over dependency; I'm becoming a passenger in my car
- FEF - concern about over dependency
- FIF - extra safety as compared to manual and conventional cruise



- FIF - safer than cruise control; always braking and setting in conventional cruise; with manual driving I wouldn't keep a constant headway; felt safer passing in manual because you can rapidly accelerate in manual
- FYF - same as manual; safer than CC
- FIN - same as manual; safer than CC
- FYN - way safer than conventional cruise; maintains headway for safety

Did anyone feel like they relinquished control?

- FIF - can always take it back
- MYN - scary; when approaching a slower car with faster moving traffic in the passing lane; I wasn't good at overriding using the accelerator. I just tried to pull out and let the car accelerate by itself; didn't trust ACC to accelerate as quickly as it should

7. *While on a curve, did you experience the loss of a targeted vehicle resulting in the car accelerating? What was your reaction if you experienced this?*

Several participants expressed concern over the loss of targets, or even the sensing of false targets, while on curves. While some individuals stated that they simply came to accept the ACC system as it was, others felt it was unsafe. Participants regularly stated that they would not rely on the ACC system while on curves or at interchanges. One participant asked whether the vehicle's rear stoplamps illuminated in response to the vehicle slowing to maintain headway. Several of the participants felt it was necessary to have some form of warning or stoplamp to indicate deceleration to following drivers.

- FEN - yes; didn't feel safe on interchanges
- MEF - sensed a wrong target on a curve and slowed down; potential problem for following vehicles
- FEN - brake lights?; received dirty looks from people following me because I was slowing down w/o brake lights
- FIF - yes; I got used to it
- FIF - yes; tracked wrong target which produced a slow down; could pose safety problems
- MYN - no problems
- FYN - I automatically brake on curves; system was off
- FIN - yes; reaction was panic
- FEN - if you keep using the system, you would get used to it; you'd pay attention on curves
- MIN - after using it for a while, it would become second nature

8. *What impact did adaptive cruise control have on your sense of safety? comfort?*

Several of the participants stated that they felt more comfortable driving with ACC, but not necessarily safer. Some individuals expressed concern with over-dependency on the ACC system, and still others were concerned with the system reliability. Several participants felt that using ACC made them feel safer and more comfortable. A few participants expressed concern with becoming too comfortable, to the point that they could fall asleep, and stated that this would be dependent upon the driving environment.

- FEF - I would be more comfortable if it had a wider range of tracking; like CC better
- MEF - I like ACC better
- MEF - might be too comfortable; people may fall asleep on highway, country driving with no traffic
- MIF - if trip is less than 1 hour: using cruise is laziness and laziness becomes a safety issue; overtime with cruise use, run times will slow down; driving manually over time will produce better skills; liken it to a car phone — people aren't paying attention to the road. On a long trip, it would be refreshing to have.
- MEN - felt like car took care of itself; I talked excessively while driving
- MEF - provided speed control; relieved me of one responsibility
- MEF - physically comfortable; can move legs and release leg and back pain
- FIF - safer; more comfortable
- FYN - safer; more comfortable
- MYN - safer; more comfortable
- FYN - safer; less comfortable because of headway and deceleration
- MYN - a lot more comfortable; safer because I wouldn't hit preceding car; less safe because I didn't trust the system to always work
- FEF - ACC felt more comfortable than CC, not as comfortable as manual
- FIN - very comfortable, smooth ride; not jamming on the brakes; for a drowsy driver this system would be an asset.

9. *Did the system ever make you feel too comfortable? as if someone else had taken control of the car? that you might fall asleep easily?*

- MEF - no
- FEN - yes
- MEN - yes
- FEF - still had responsibility to drive
- FIF - didn't drive it long enough to find out
- MYN - yes; felt too relaxed; don't have to worry quite so much

- MYN - depends on driving conditions - wide open road, too comfortable, some traffic then it's OK
- FIF - after having it a long time, maybe I'd become too dependent on the car but I would not fall asleep; didn't feel like I gave over control
- FYN - I still felt in control; didn't feel I could get so comfortable that I would fall asleep
- MYN - right; conventional cruise more dangerous than ACC

10. *When closing a gap, or when a lane becomes free, what do you think of the adaptive cruise control system's rate of acceleration?*

- FEN - too slow
- MIF - too slow
- MIF - I liked it
- MEF - just right
- MEN - at a comfortable level
- FIF - not a problem
- FYN - too slow to pass
- MYN - accelerating is such a personal thing, I didn't want to leave it to ACC; wanted to do it based on road conditions
- FIF - wanted to get out and get by without slowing down traffic flow
- FYN - just right
- MIN - fine
- FEF - nice; CC is jerky, don't have that with ACC; deceleration was much smoother; rate was fine

11. *What do you think of the adaptive cruise-control system's rate of deceleration? in response to slower moving vehicles? in response to "cut-ins"?*

- MEN - comfortable level
- MIF - deceleration was noticeable; alerted before the visual determination to decelerate was made
- MEF - not sure when to brake; would like auto braking with ACC; with cut ins, the deceleration was too slow
- FEN - deceleration was too slow in rush hour traffic
- FIF - car responded beautifully; rate was perfect
- FYN - with cut in, I had to brake; I was unsure if the system would work or not; system responded too slowly if coming up on someone

- MYN - felt fine if approaching from the rear
- FEF - with cut-ins, system was not fast enough; no lateral sensing; needs a larger arc
- FYF - with slower moving vehicles, the system responded fine; with cut-ins - if they were moving faster than you or at the same speed, there was no problem. If they were moving slower (like when a car merges onto the highway), you'll need to watch for them anyway.
- MIN - had a truck cut-in; had to brake because the system could not respond quickly enough to the great difference in speeds for the short distance

12. *When a difference in vehicle speeds required you to use the brake, was it difficult to learn when braking was required? Would an audible tone be useful? Would you like a system that automatically applies the brakes when the distance ahead is very short given the rate of closing?*

Participants regularly stated that it was easy to learn when their intervention was required. Most participants objected to the idea that an audible tone be incorporated into the ACC system, unless an on/off switch was provided. Several individuals felt that a tone would be useful for persons just learning to use ACC, or just learning how to drive, but felt that a tone would eventually become annoying and therefore be ignored. Regarding the issue of automatic braking, participants were almost unanimous in their objection to automatic braking. Several participants stated that automatic braking crossed the line that dictates who controls the vehicle. Still others objected because they felt as though they would become a passenger in their own vehicle. Finally, other participants objected to the concept of automatic braking because the ACC system would have to consider the status of vehicles to the rear (likely adding considerable cost to an ACC system).

#### Audible tone?

- MIF - tone would be useful; digital display of preceding vehicle's speed would be helpful
- FYN - no tone; it would be distracting
- MEF - no tone; already have enough bells/whistles in the car
- MEF - tone would be helpful; alert to possible hazardous conditions
- FIF - so many bells in new cars; another bell?; I would like a voice
- FYN - only in dangerous situations; you should be aware if you are driving
- MYN - helpful if person in front of you had broken brake lights
- FEN - no; I would just tune it out
- FEF - suggested a blinking light at eye level

- FEN - shouldn't be that out of it that you need a signal
- FYF - would like a tone with an on/off switch; no blinking light
- FEN - would be helpful for learning phase; on/off switch
- MIN - tone would be good for learning phase
- FIN - would like the option of having a tone

Auto braking?

- MEF - yes
- FEN - no; at that point one becomes a passenger; I would like to retain control
- FEF - no
- FYN - no
- FYN - no, braking is a natural thing when car is in front of you
- FYN - no
- FIF - no
- FIF - no
- MYN - no
- FYF - no; takes too much control away
- FEF - need to look in the mirror to see conditions behind you
- FEN - unless sensor can sense speed of vehicles approaching from the rear
- FIN - no
- FEN - no
- MIN - undecided

What if the system could respond faster than you? How about in an emergency situation?

- FYN - that would be a positive thing to prevent accidents
- FIF - I would like that
- FYF - impulse comes in and you brake; driver must stay in control; I shut the system down whenever I felt it was necessary

13. *What features of adaptive cruise control did you find most beneficial?*

(The answers to this question are combined with those to question 14 below.)

14. *What disadvantages do you feel are associated with driving in adaptive cruise control mode?*

- FEF - would liked to have known the speed to which I had slowed down; couldn't see the controls
- MEN - helpful driving assist

- MEF - thoroughly enjoyed it; liked that the car accelerated/decelerated automatically; very convenient
- MEF - made me a better driver; didn't allow tailgating
- FEF - all right; like CC better; liked SET SPEED DISPLAY
- FEN - nice being the passenger while it drove; made me a better driver
- MEF - liked the visual displays; SET SPEED DISPLAY
- FEF - very comfortable; like magic
- FYN - comfortable; liked TARGET ACQUIRED LIGHT, SET-SPEED DISPLAY
- MIF - deceleration; digital display; suggest a display on top of dash w/ set speed, actual speed, and speed of preceding vehicle
- MIF - made me a safer driver, liked the acceleration and not having to reset the cruise
- MYN - ACC made me more relaxed than conventional cruise in medium traffic - didn't have to set/reset the cruise; I would be tempted to use it in situations in which I shouldn't, like heavy traffic, fog, and snow
- FYN - safety - keeps a safe distance; decelerated too quickly; too long of a headway
- FIF - liked it in medium traffic; like 2 mph increments; did not like control placement and the tracking of wrong targets on curves which resulted in deceleration
- MYN - liked headway; 2 mph increments; didn't like missed targets (system did not track a trailer which was being pulled by a car)
- MYN - liked safe following distance; didn't like missed targets
- FYN - liked digital readouts; more in control of setting the speed; liked the headway; didn't like that she was too relaxed and that she relied too much on the system
- FIF - enjoyed it; felt safer and more comfortable; didn't see any disadvantages that could not be overcome with overriding the system
- MIN - liked that the car automatically slowed down in moderately heavy traffic given that he couldn't change lanes; disadvantages were accelerating on exit ramps and too slow of a response to cut-ins
- FEN - I wouldn't have either one; neat that it slowed cars down; headway was fun; I would not have stayed awake with ACC driving long distances
- FYF - ACC gave extra time for reaction; problem with wrong targets on curves resulting in deceleration in the passing lane
- FIN - ACC provided safety and comfort and a smooth ride; liked 2 mph increments; problem on curves
- MIN - comfortable; didn't like not being able to tell when the car was going to decelerate

- FEF - I wouldn't have any types of cruise control unless traveling long distances frequently; on curves and exit ramps, the car was traveling too quickly; liked controls on the stalk
- FEN - felt comfortable; kept safe following distance; problem on exit ramps

15. *Given the present state of development of the adaptive cruise control (what you experienced), would you feel comfortable using it on a trip of several thousand miles?*

- MEN - yes
- MEF - yes
- FEF - yes
- FIF - yes
- MYN - yes
- FYN - feel comfortable, but would prefer to drive manually
- FIN - yes
- FYF - yes
- FEF - it would be easier than manual

16. *Please estimate the cost of the adaptive cruise control system. What would you be willing to pay for adaptive cruise control?*

Participants were frequently reluctant to estimate the cost of an ACC system. This was in part due to their lack of familiarity with the cost of conventional cruise control. To make the process easier, participants were instructed to estimate the amount, in addition to the cost of conventional cruise control, that manufacturers would charge for an ACC system (e.g., the cost to upgrade from conventional cruise to ACC). Cost estimates ranged from \$100 to \$5000, with a median value of \$350. When asked how much they, as individuals, would be willing to pay for an ACC system, participants were willing to spend considerably less than what they felt the manufacturers might charge. What participants were willing to spend on an ACC system ranged from \$0 to \$8000, with a median value of \$200. Only two participants expressed a willingness to pay more than what they believed a manufacturer would charge for a system. Four participants were not willing to purchase an ACC system at any price.

## 5. FINDINGS

### 5.1 Findings from Objective Data

#### 5.1.1 Nature of Traffic and Roadway

The results presented in section 3.2 showed that during testing there was a preceding vehicle within sensor range 64 percent of the time on these routes. Examination of the histograms and tables in Appendix B indicates that the mean speed of preceding vehicles ( $V_p$ ) was approximately 66 mph with a standard deviation of about 6 mph. The density function for  $V_p$  is not extremely skewed as can be seen by examining figure 23.

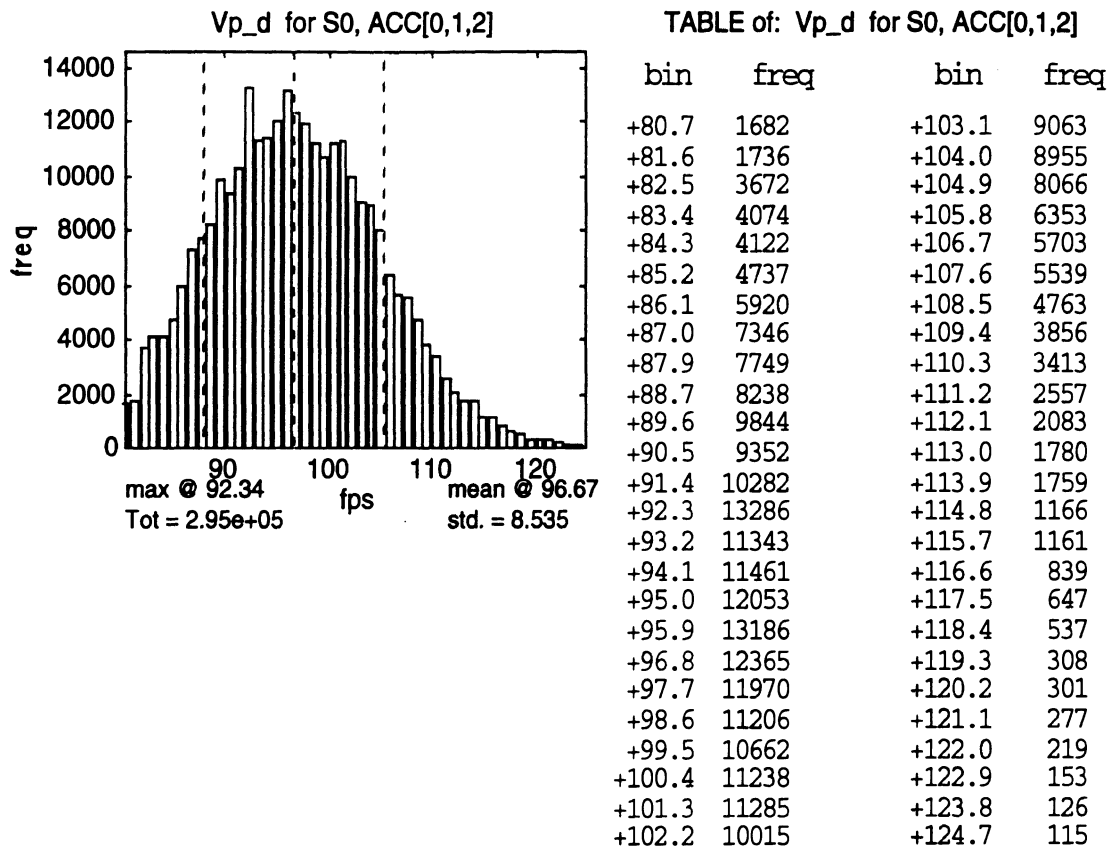

Figure 23. Density of the velocity of the preceding vehicle

The roadway is fairly straight and drivers do not make many sharp turns on these freeways. Figure 24 is a preliminary result that needs to be corrected for drift in the yaw rate sensor. Nevertheless, if one mentally adjusts so that the mean is at zero, these data show that path curvatures more than  $0.0005 \text{ ft}^{-1}$  (less than 2000 ft radius turn) are very rare. Although more data



processing using our computer application for false and missed targets needs to be done, the preliminary finding is that a monobeam sensor is not going to have many misses and false alarms on these freeways, and when it does the situation is going to be easy for drivers to recognize.

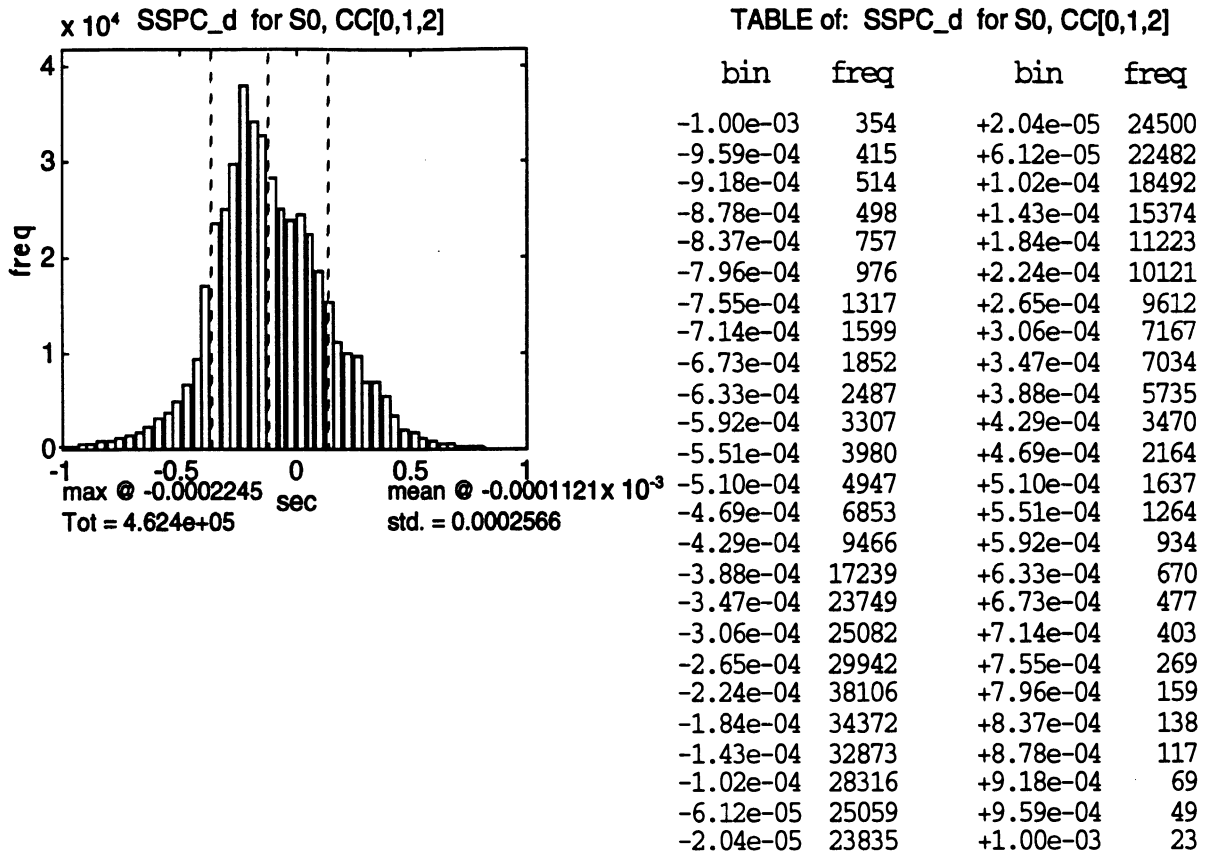

Figure 24. Approximate density for path curvature (1/radius)

### 5.1.2 Comparison of Driving Modes Based on Freeway Driving

The differences between driving with normal (manual) control, conventional cruise control, and adaptive cruise control are large. These are different modes of driving not only in name but also with regard to performance. A good qualitative understanding of these differences may be obtained by inspecting figures 25 through 29.

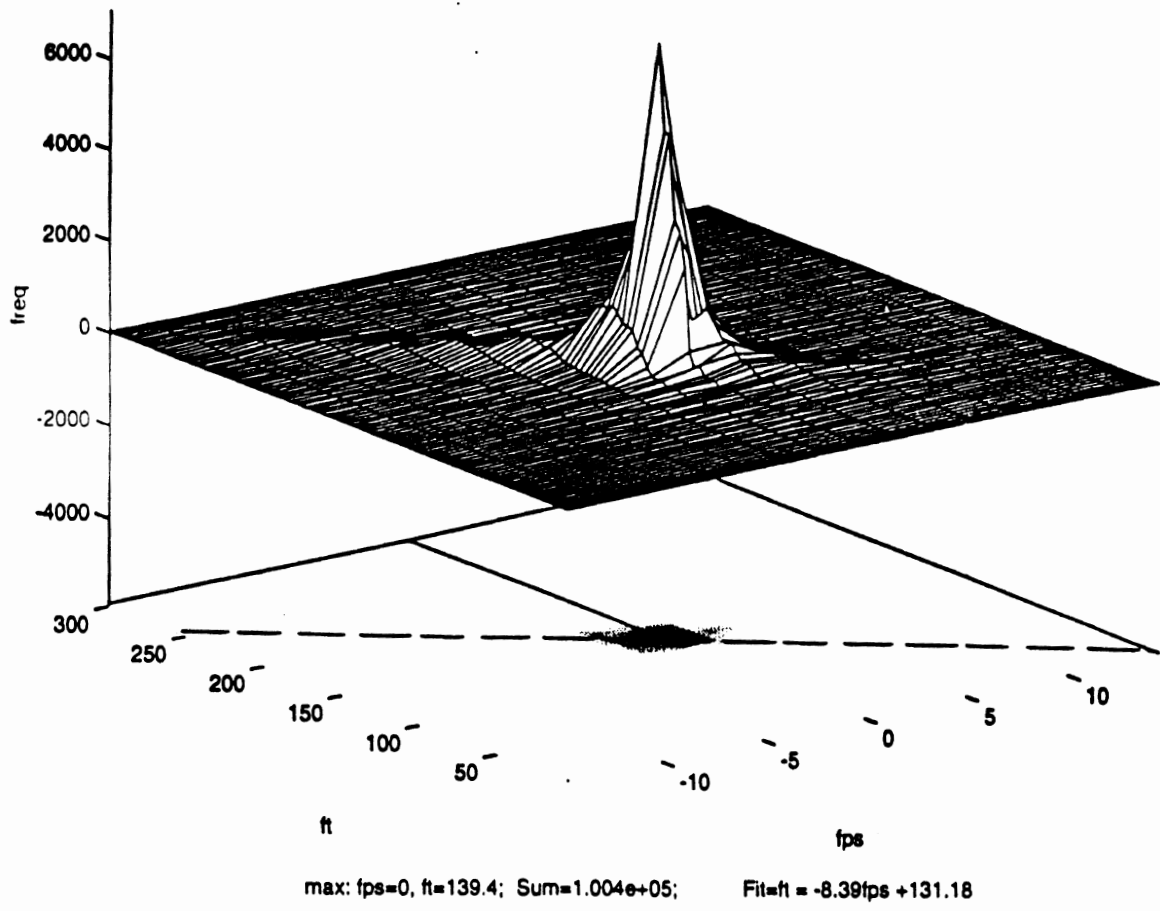

Figure 25. ACC loop, headway control only, Rdot vs. R

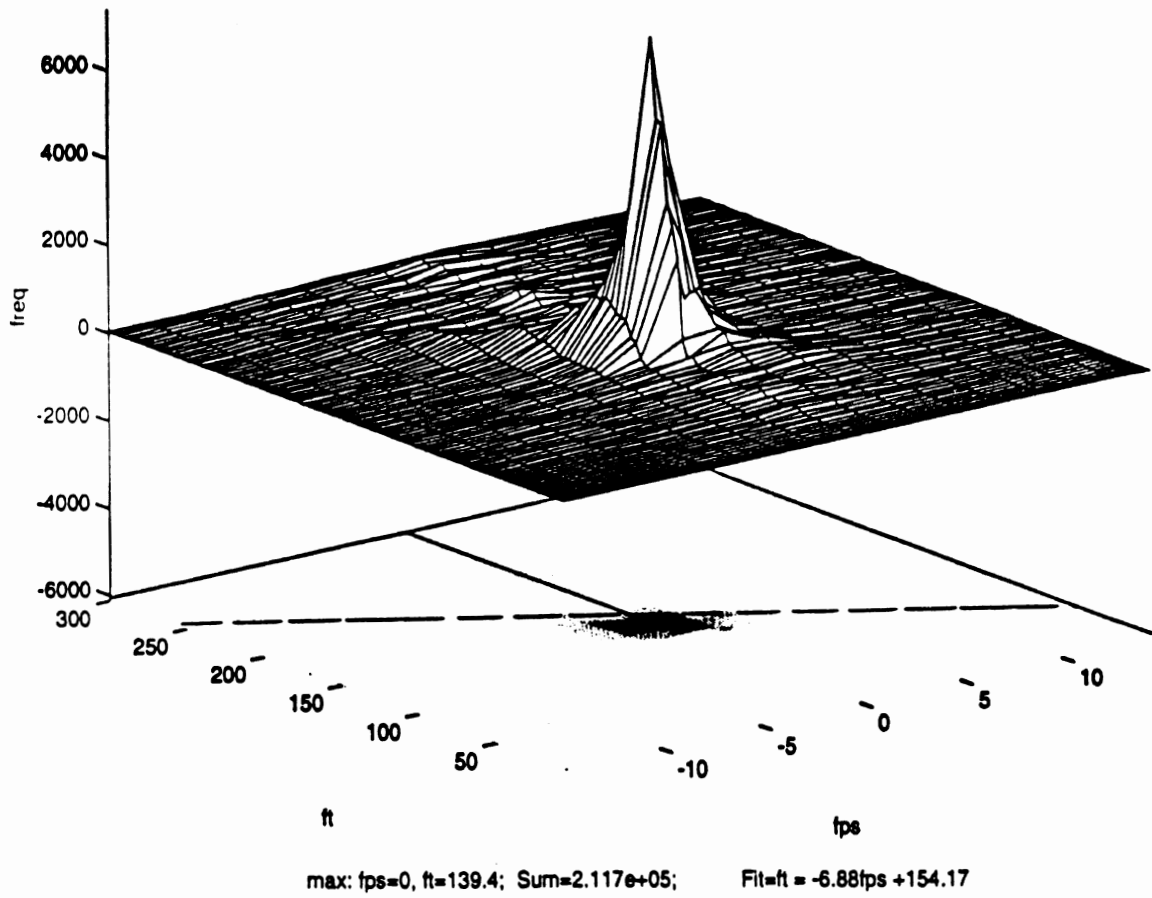

Figure 26. ACC loop, all modes, Rdot vs. R

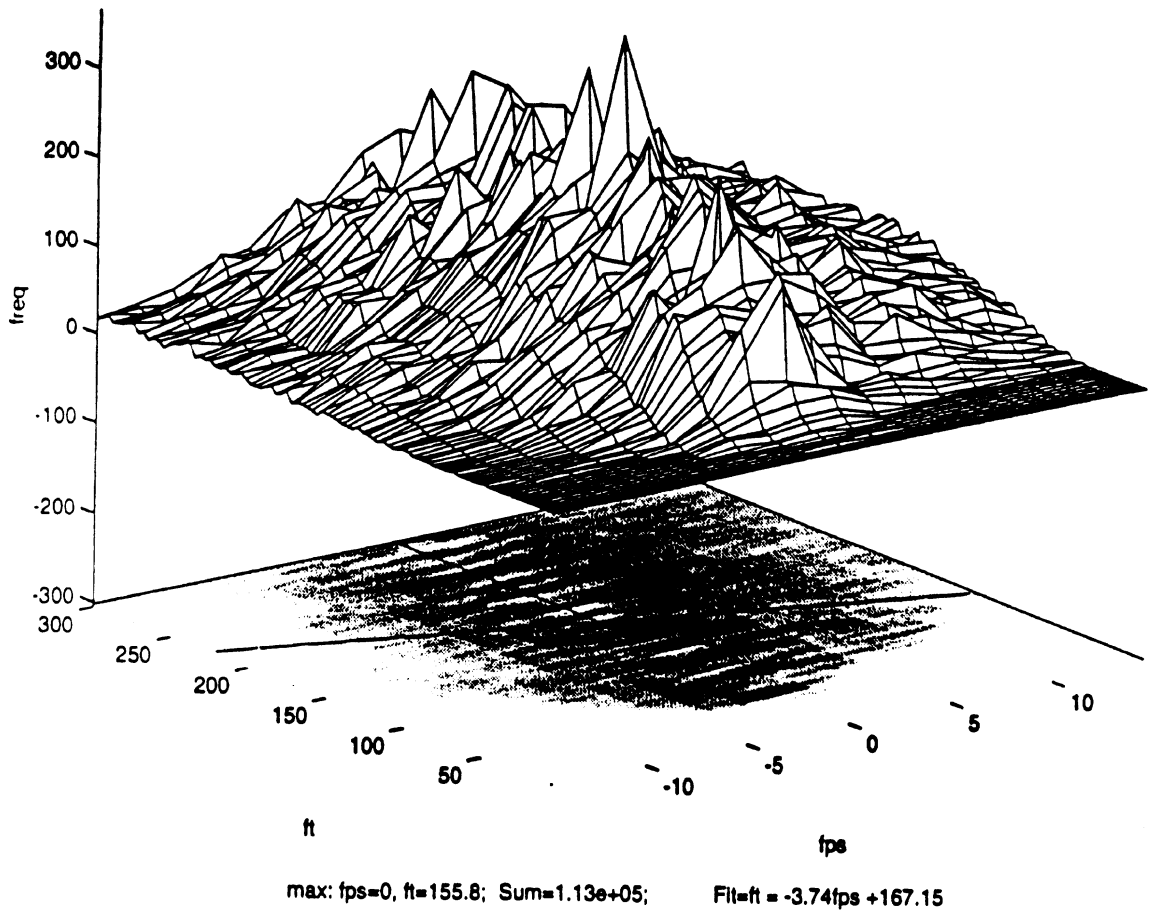

Figure 27 CC loop, CC only, Rdot vs. R

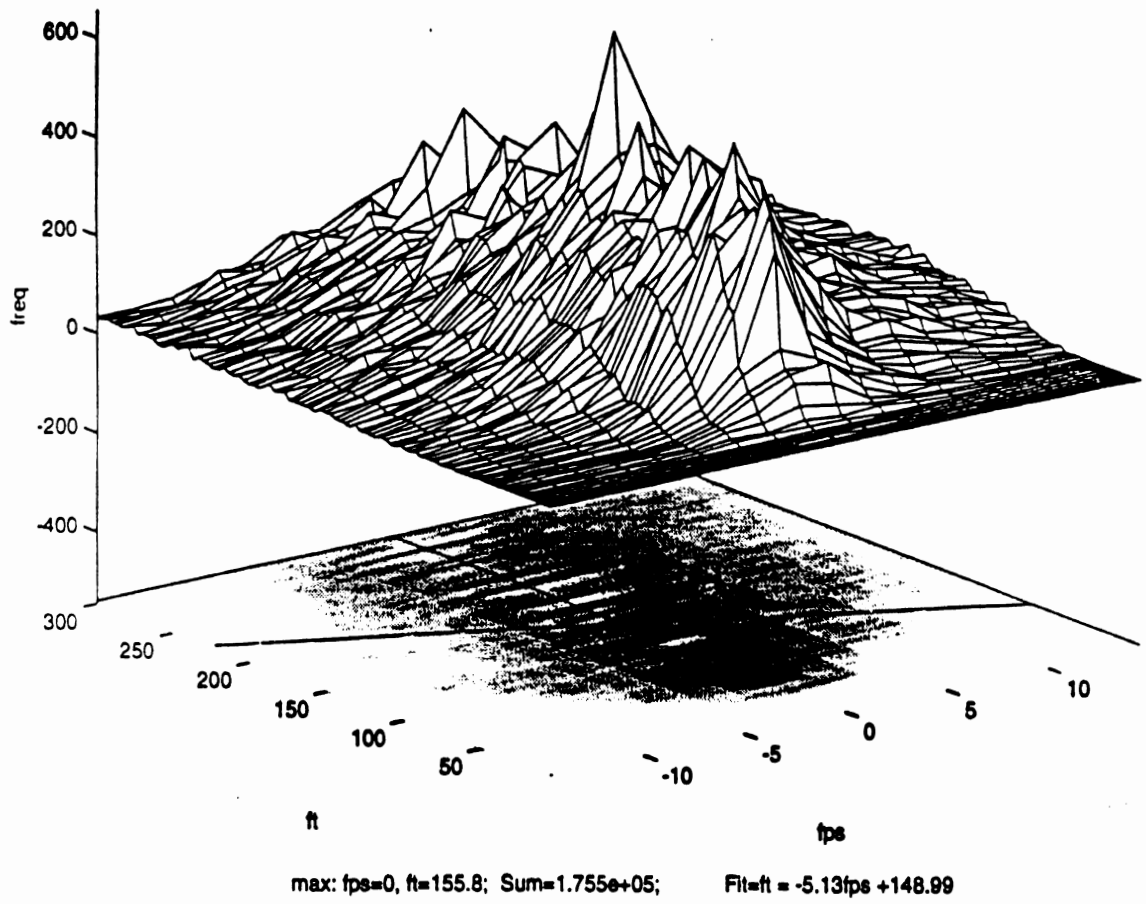

Figure 28. CC loop, CC and N modes, Rdot vs. R

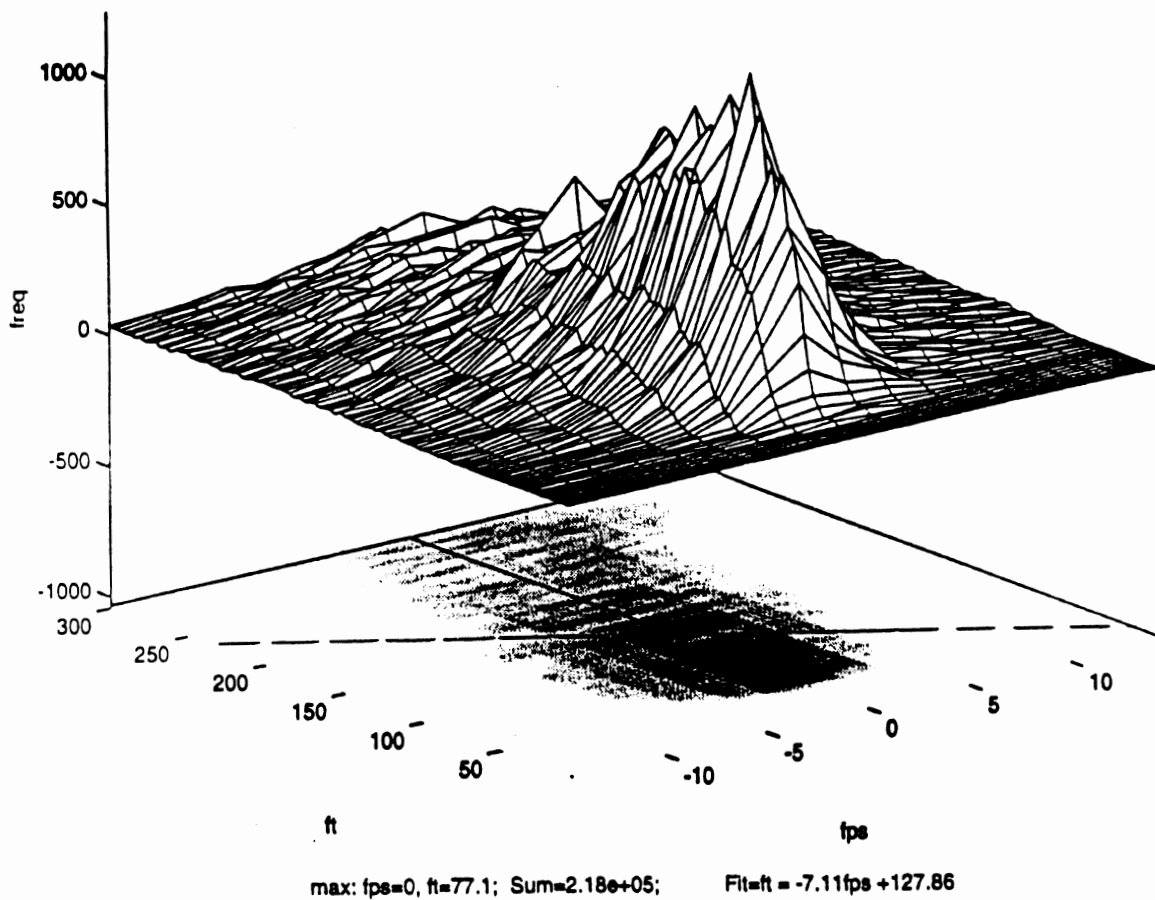

Figure 29. Normal loop, Rdot vs. R

Figure 25 shows the form or density of the distribution of R versus Rdot for when the ACC is operating and the headway algorithm is in operation determining  $V_C$ , the speed command to the cruise control. The pattern of the frequency density is just as one would expect given that the control objective is known to be as it is. The performance is very regular and conforms to the control objective as it should.

The situation does not change much for the whole loop (route) when other modes of control are included. See figure 26.

In contrast, the situation looks entirely different during the cruise-control loop. See figure 27. "Range vs. range-rate" points are spread all over. There are many points at small values of R in the range versus range-rate sample space. When all modes are included for the CC loop, the general form of the two-variable histogram (see figure 28) does not change much.

The appearance of the two-variable histogram of the N (no auxiliary control or normal) driving loop is different from any of the histograms for the ACC or CC loops around the route (see figure 29).

Further examination of the one-variable histograms indicates that there are differences in the form of the range R and Ta data for each of the control modes. These differences show up at close range as well as elsewhere. Since the density functions are greatly skewed towards zero for R and Ta, the mean value is not representative of what is happening at small values of range, which represent very small values of available reaction time. In short, drivers frequently come surprisingly close to the preceding vehicle in either manual control or cruise-control driving.

### 5.1.3 Differences by Participant Characteristics

Several four-way, mixed-factor, analyses of variance were performed, including the independent variables age, gender, and experience, using conventional cruise control. In addition to the three independent variables based upon participant characteristics, the fourth, and final, independent variable examined was control mode (a vehicle characteristic). The three participant-characteristic-based independent variables were between-subjects factors in the analyses of variance, and the remaining variable, control mode, was a within-subjects factor.

The results of analyses for each of the three independent variables based on participant characteristics for the observed cell mean values of the dependent measures range, range rate, velocity, accelerator pedal position, and brake application are presented below. Plots for statistically significant ( $p < 0.05$ ) effects are provided and include standard-deviation error bars.

#### 5.1.3.1 Age

Three ranges of participant age were examined; Young (20-30 yrs), Middle Aged (40-50 yrs), and Older (60-70 yrs). The main effect of participant age was statistically significant ( $p < 0.05$ ) for the following dependent measures: range, range rate, velocity, accelerator pedal position, and brake application (figures 30 through 34).

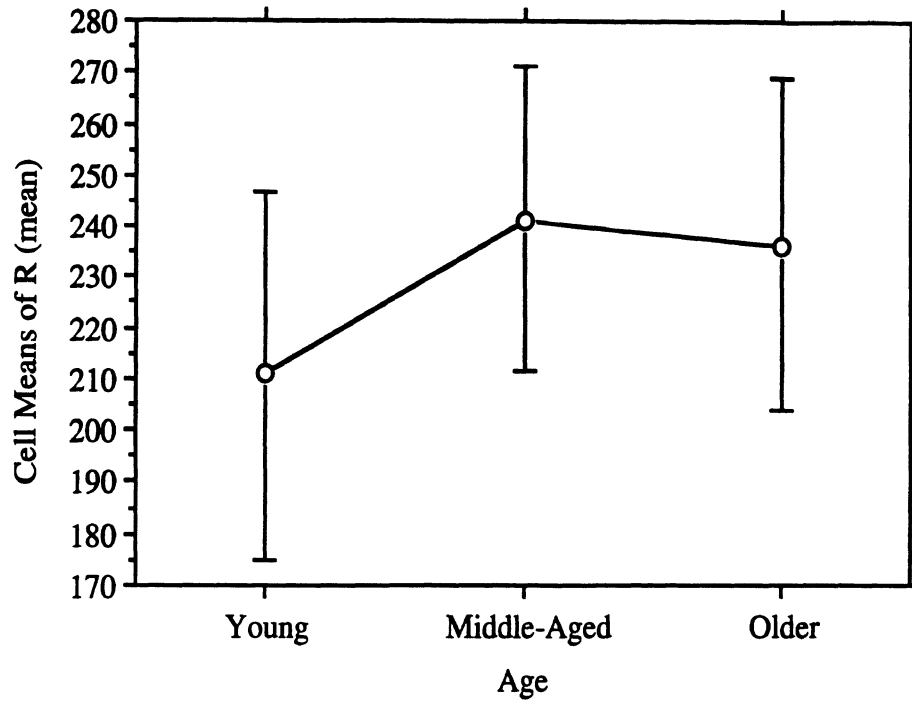

Student-Newman-Keuls post hoc analysis, S = significance level of 0.05

	Vs.	Diff.	Crit. diff.	
Young	Older	25.498	14.265	S
	Middle-Aged	30.495	17.134	S
Older	Middle-Aged	4.997	14.265	

Figure 30. Plot of the main effect of Age for the dependent measure Range (mean) where  $F(2,24) = 10.48$  and  $p \leq 0.01$ , and Student-Newman-Keuls post hoc analysis.



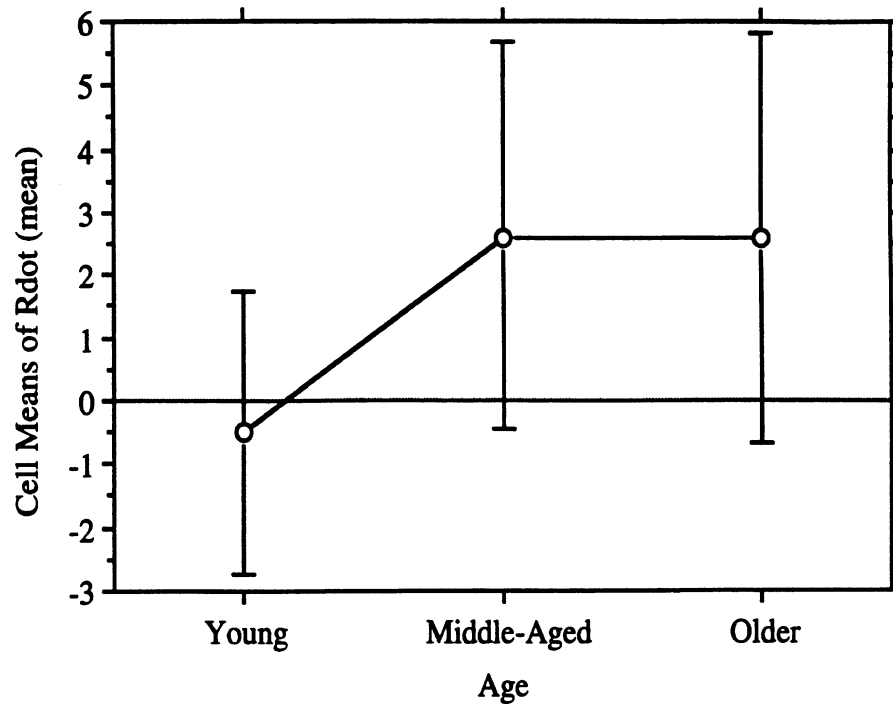

Student-Newman-Keuls post hoc analysis, S = significance level of 0.05

	Vs.	Diff.	Crit. diff.	
Young	Older	3.059	1.310	S
	Middle-Aged	3.097	1.574	S
Older	Middle-Aged	.037	1.310	

Figure 31. Plot of the main effect Age for the dependent measure Range Rate (mean) where  $F(2,24) = 14.67$  and  $p \leq 0.01$ , and Student-Newman-Keuls post hoc analysis.

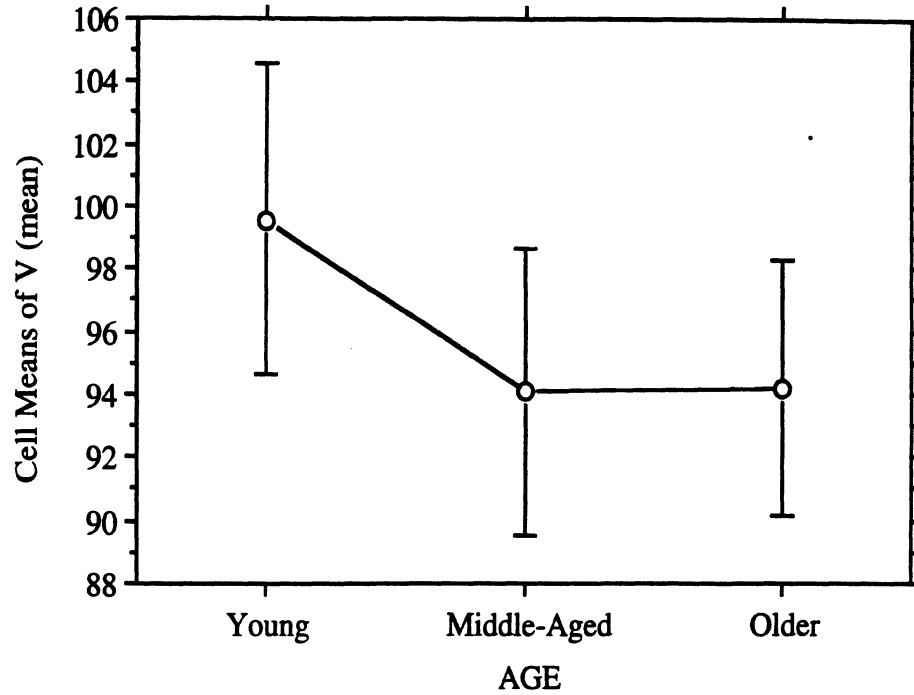

Student-Newman-Keuls post hoc analysis, S = significance level of 0.05

	Vs.	Diff.	Crit. diff.	
Middle-Aged	Older	.101	1.932	
	Young	5.494	2.320	S
Older	Young	5.392	1.932	S

Figure 32. Plot of the main effect Age for the dependent measure Velocity (mean) where  $F(2,24) = 21.11$  and  $p \leq 0.01$ , and Student-Newman-Keuls post hoc analysis.



Student-Newman-Keuls post hoc analysis, S = significance level of 0.05

	Vs.	Diff.	Crit. diff.	
Middle-Aged	Older	.358	.635	S
	Young	.914	.763	
Older	Young	.556	.635	

Figure 33. Plot of the main effect Age for the dependent measure Accelerator Pedal Position (mean) where  $F(2,24) = 4.20$  and  $p \leq 0.02$ , and Student-Newman-Keuls post hoc analysis.

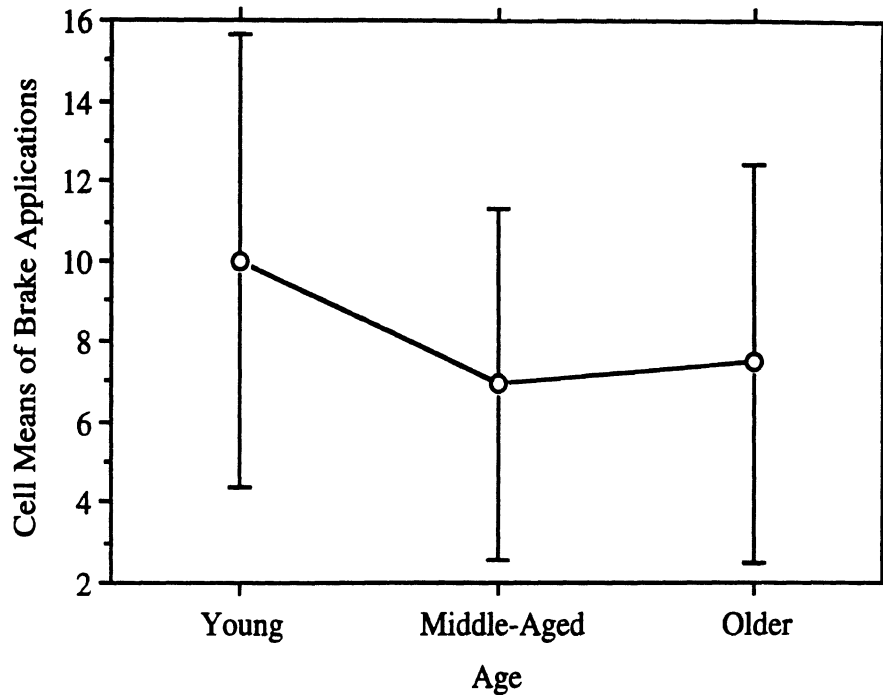

Student-Newman-Keuls post hoc analysis, S = significance level of 0.05

	Vs.	Diff.	Crit. diff.	
Middle-Aged	Older	.528	1.897	
	Young	3.056	2.278	S
Older	Young	2.528	1.897	S

Figure 34. Plot of the main effect Age for the dependent measure Brake Application (frequency) where  $F(2,24) = 96.03$  and  $p \leq 0.01$ , and Student-Newman-Keuls post hoc analysis.

### 5.1.3.2 Gender.

Two levels of participant gender were examined: male and female. The main effect of participant gender was not statistically significant ( $p < 0.05$ ) for any of the following dependent measures: range, range rate, accelerator pedal position, or brake application.

### 5.1.3.3 Conventional Cruise Control Usage (Experience).

Two levels of participant experience were examined: persons who never, or very rarely, use conventional cruise control and those who use conventional cruise control frequently, or whenever possible. The main effect of participant experience was statistically significant ( $p < 0.05$ ) for the following dependent measures: range rate, velocity, and accelerator pedal position. (See figures 35, 36 and 37.)

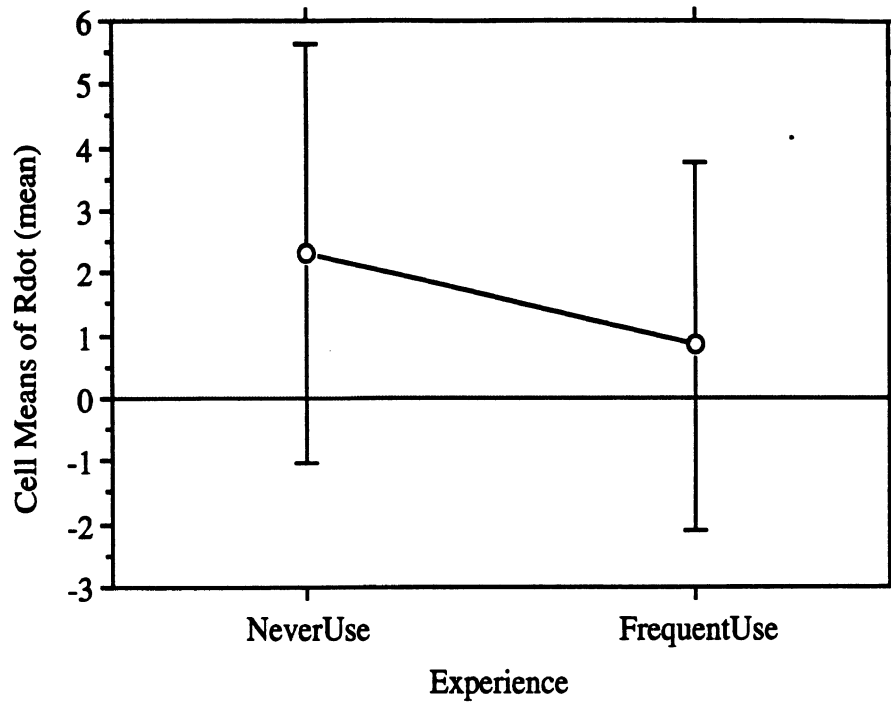

Figure 35. Plot of the main effect Experience for the dependent measure Range Rate (mean) where  $F(1,24) = 7.68$  and  $p \leq 0.01$ .

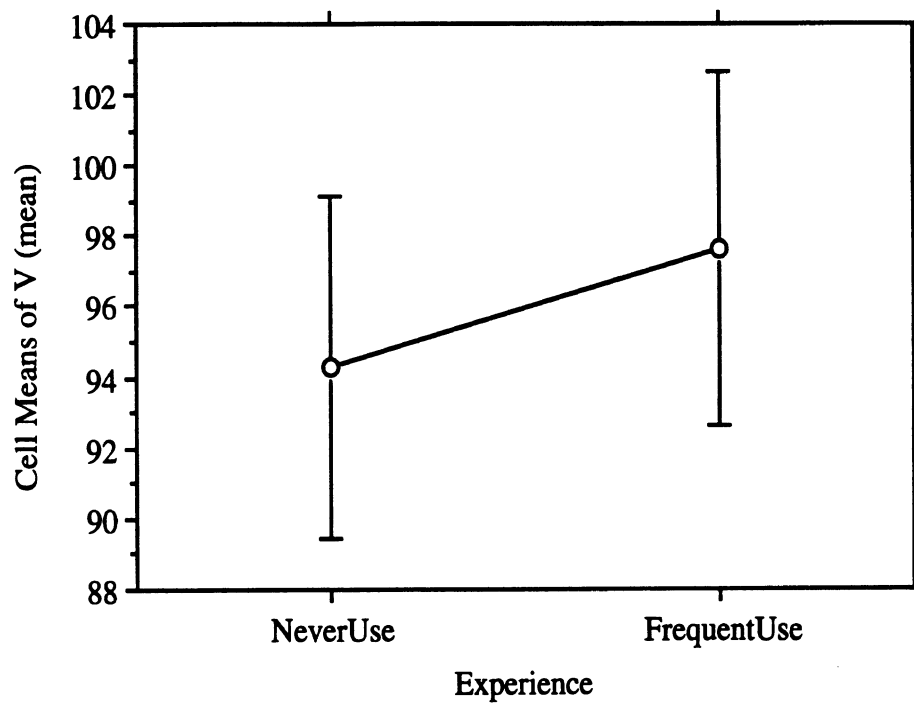

Figure 36. Plot of the main effect Experience for the dependent measure Velocity (mean) where  $F(1,24) = 17.92$  and  $p \leq 0.01$ .

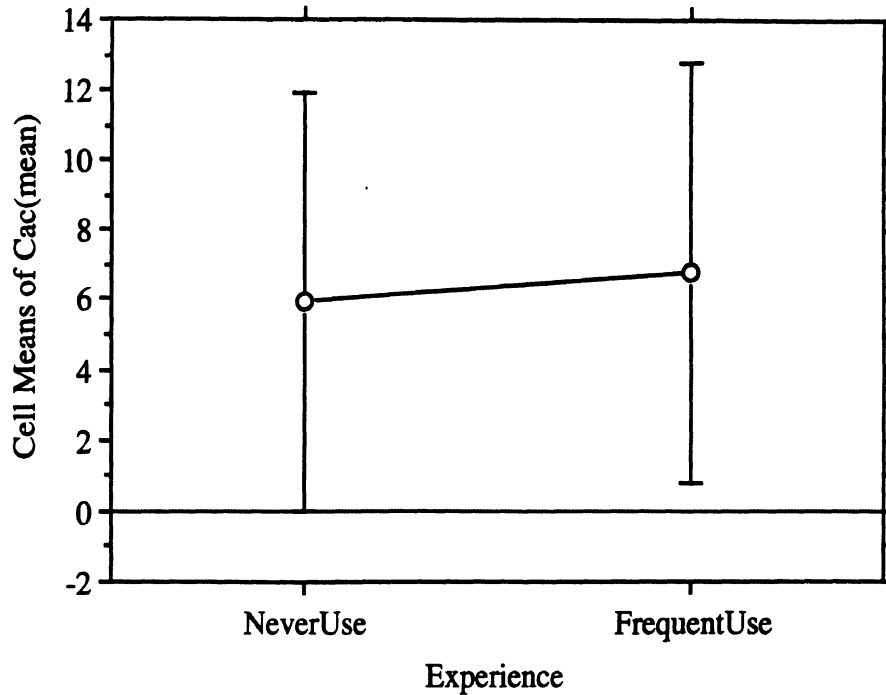

Figure 37. Plot of the main effect Experience for the dependent measure Accelerator Pedal Position (mean) where  $F(1,24) = 10.28$  and  $p \leq 0.01$ .

#### 5.1.3.4 Interactions between Age, Gender and Experience.

Statistically significant ( $p < 0.05$ ) two-way interactions were only observed between the main effects of age\*gender for the dependent measure Velocity ( $F(2,24) = 3.22$  and  $p \leq 0.05$ ), and between the main effects of age\*experience for the dependent measure Brake Application ( $F(1,24) = 5.09$  and  $p \leq 0.01$ ). These two-way interactions are shown graphically in figures 38 and 39, respectively.

The only three-way interaction observed was between the main effects of age\*experience\*gender, but this interaction was found to be statistically significant for each of the dependent measures examined. Three-way interactions of this nature are difficult to interpret, particularly due to the fact that no consistent, apparent, relationships exist for this interaction of main effects across the dependent measures. The age\*experience\*gender significant main effect warrants additional examination.

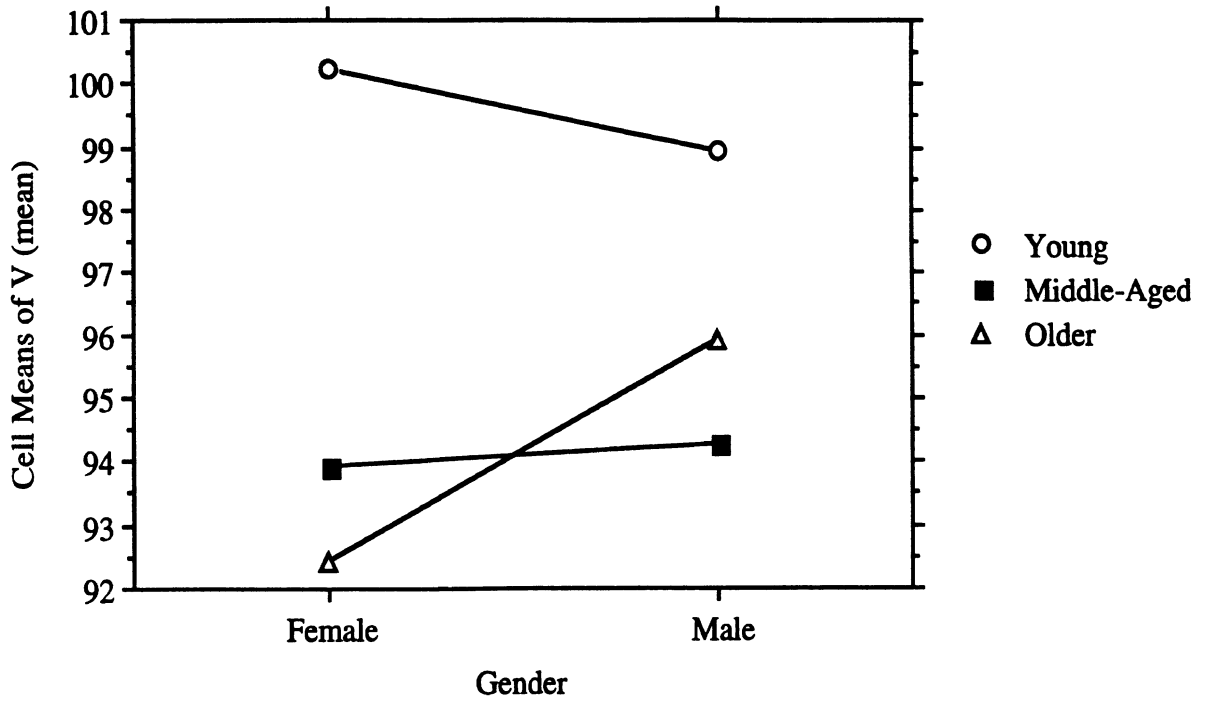

Figure 38. Plot of the interaction Age\*Gender for the dependent measure Velocity (mean) where  $F(2,24) = 3.22$  and  $p \leq 0.05$ .

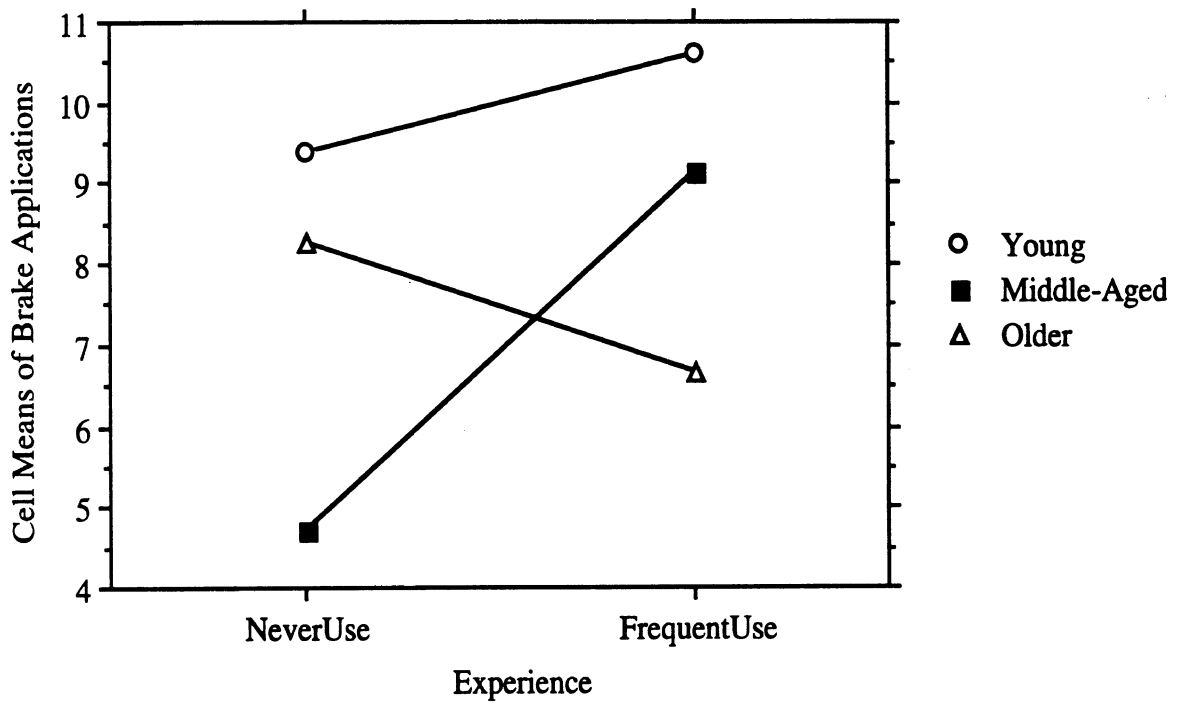

Figure 39. Plot of the interaction Age\*Experience for the dependent measure Brake Application (frequency) for  $F(1,24) = 5.09$  and  $p \leq 0.01$ .

## **5.2 Findings from Subjective Data**

### **5.2.1 Comfort**

Participants generally felt very comfortable using the ACC system under the conditions examined. Individuals who were not experienced in the use of conventional cruise control were perhaps initially more reluctant, but none the less quickly adapted to the use of ACC. Participants did not have difficulties in understanding the concept of ACC, or the limitations of the ACC system examined (i.e., they understood that there could be missed targets and false targets). Several of the participants, particularly older individuals, stated that an ACC system would make long trips physically more comfortable for them by allowing greater freedom of movement for their legs. However, approximately one-third of the participants stated that the system made them feel too comfortable at times, as if someone else had taken control of the vehicle.

### **5.2.2 Acceptance**

While participants generally reported feeling very comfortable with the ACC system, several voiced concerns over the use of ACC in traffic conditions other than those tested (i.e., how it might behave in rush hour traffic). Several participants stated that they would be reluctant to use ACC in many, if not most, traffic settings they encounter due to the density of traffic. When asked, for example, how much they would be willing to spend to purchase an ACC system, all but two stated they would not spend as much money as they believed the manufacturers would be charging. The median amount participants would be willing to spend, above the cost of conventional cruise control, was \$200, where as the median value participants believed that manufacturers would charge was \$350 above the cost of conventional cruise control. The value participants assigned to an ACC system appears to be, in part, influenced by the amount of use they would receive out of such a system, based on the types of traffic settings they normally encounter.



## **6. CONCLUSIONS, RECOMMENDATIONS, AND CONCLUDING REMARKS**

### **6.1 Conclusions**

- **The baseline ACC system performs well for a first generation system operating on U.S. roads.**

The U.S. highway system is characterized by limited-access roads with curved sections seldom exceeding 3 degrees of curvature. Frequently, in many places the traffic is such that drivers find it convenient to use conventional cruise-control systems. Under these conditions, a fixed-beam, advanced, cruise-control system provides drivers with an added measure of convenience through its headway control functionality.

The results from this study show that drivers using the ACC do not follow as closely or with as high closing rates as they do in manual driving or with conventional cruise control. The comments and reactions from drivers indicate that the operation of an advanced cruise-control system with limited control authority and limited beam width is easy to understand and supervise. Drivers are aware of the systems capabilities, and the geometric and physical limitations of the system are in keeping with the drivers' perception of the headway-control situation. Given the transparent nature of the functional capability of the baseline system, the system can provide convenience, comfort, and safety benefits to prudent drivers.

- **A pertinent ACC, CC, & M operational database now exists.**

Perhaps the major contribution of this first year's work is the database of driving behavior that has been assembled. The data contain time histories of driving for a balanced set of 36 typical drivers. Each of these subjects drove the vehicle for approximately 55 minutes in each of the three control states: manual driving (M), conventional cruise control driving (CC), and advanced cruise control driving (ACC). The data contains information on the driving situation (range, range-rate, velocity, yaw rate, and longitudinal acceleration), the driver's control actions (accelerator pedal position, brake lights on or not, and steering-wheel angle), and the control system and derived variables (commanded speed, available reaction time, set speed, time to impact, etc.).

The database provides the information needed to make within-subject and across subject comparisons between the ACC, CC, and M modes of longitudinal control of vehicle speed and headway.

- **Data from test drives are needed to classify drivers.**

The data show that drivers do differ but that driver tendencies to be aggressive or passive do not follow patterns based upon gender, age, or driving experience with cruise control. The characteristics of each experienced driver need to be examined in driving tests to determine their driving tendencies.

- **ACC, CC, & M are quite different modes of driving control.**

Figures 25, 27, and 29 show the frequency densities for range and range-rate for the different control modes (ACC, CC, and M). Examination of these data show that drivers have very different driving tasks depending upon the control mode they are using. With manual control the driver is modulating the accelerator pedal continuously. The driver commits a considerable amount of physical and neurological effort to modulating the accelerator pedal. In conventional cruise control, the driver supervises the situation and decides when to apply the brakes depending upon the driver's judgement of whether the headway is acceptable. Driving in advanced cruise control is characterized by the system slowing autonomously to provide headway. The driver feels even modest decelerations and is aware of when the system decides to slow at or near its level of control authority. The driver supervises the operation and decides to brake when the deceleration applied by the system is not acceptable.

- **ACC provides more orderly control of range and range-rate without small values of range.**

As shown by figure 25, the ACC system controls range and range-rate per its control algorithm. This means that the headway time is usually close to the design value of 1.4 seconds with the range rate at approximately zero ft/sec. Comparisons with figures 27 and 29 show that manual-and cruise-control driving are nowhere near as orderly as ACC driving. In manual driving, there are many instances of shorter headway times than those encountered with ACC driving. Also there are many instances where people do not close up the gap in manual driving. With conventional cruise control, drivers not only come closer to the preceding vehicle but they often

close at a substantial level of range-rate. To the extent that small values of available reaction time (range divided by velocity) and range-rate are unsafe, ACC driving occurs with a greater safety margin than driving in the manual or conventional cruise control modes of speed and headway control.

- **Available reaction time has interpretations that make for an attractive performance measure.**

The data have been examined using a number of quantities which might serve as performance measures. Based on the work performed so far, available reaction time (range divided by velocity) appears to be a performance measure that has physical significance as well as power for discriminating between different types of longitudinal control. Physically, available reaction time represents the length of time that the driver of the following vehicle has to do the same decelerating maneuver as that done by the preceding vehicle. If the driver applies the same level of braking as the preceding vehicle within the available reaction time there will not be a crash. The field data show that manual and conventional cruise-control driving are characterized by a considerable amount of driving with available reaction times that are well below the ability of typical drivers to react quickly. In these cases, collisions are prevented because drivers do not slow down rapidly when there is a vehicle close behind them. Nevertheless available reaction time is a performance measure that indicates the safety margin available for use in preventing collisions.

## **6.2 Recommendations**

The recommendations are aimed at (1) further enhancing the state of knowledge concerning headway control and (2) exploring new concepts to automatically control headway, as they emerge from findings of this study.

- **Study methods for selecting headway times.**

Headway time is a matter of concern to drivers as well as safety advocates. When traffic is fairly open and cut-ins and merges are not a frequent event, 1.4 seconds may be acceptable to many people, even though others may find it tolerable but too long for their styles of driving. However, in dense, high-speed traffic many people would like shorter headway times. In extremely dense traffic, experienced drivers of ACC systems say that they would like 1.0 or even 0.8 seconds for headway time.

Several approaches need to be considered for allowing drivers to try different headways. These include man-machine interfaces that provide a button for selecting the desired headway or digital choices for about three or four different headway settings. Research needs to be done to provide a rationale for the minimum headway to be used. Since people already drive at headways that are beyond their capabilities to react, there is a problem knowing the appropriate tradeoff between risk of a crash and the desire to follow closely with maximum density of traffic flow.

- **Study warnings and modest braking.**

A prototype model that incorporates braking should be developed and studied. During the first year it was evident that under certain circumstances, the coastdown deceleration capability of the test vehicle limits the performance of the ACC system. Added deceleration is needed to ensure that the performance boundaries of the prototype will better meet the driver's expectations, and will also be an advancement towards becoming a crash-avoidance system.

However, there is a limit to the control authority that the driver can readily supervise. Once the system becomes too capable, the driver will no longer be able to decide to intervene in time. There is a possibility for the system to become unsafe relative to manual driving, when the deceleration authority is too large. Research is needed to aid in deciding the appropriate level of deceleration authority to be compatible with the driver's level of supervision capability.

It appears that something on the order of 0.1 g would be a dramatic warning to drivers in a freeway setting. Experience in this year's work indicates that drivers are very sensitive to 0.04 g of deceleration and that 0.1 g of deceleration happens very infrequently on freeways. There might be some danger that 0.1 g of deceleration would be a surprise to drivers of trailing vehicles operating with manual control. In any event, a deceleration in the range from 0.05 g to 0.1 g would be plenty to warn the driver that the system perceives a situation requiring the driver's attention. The form of this warning and braking needs to be investigated.

- **Study systems with swept or multiple beams for curved roads.**

A headway-control system that employs a sensor with directional information should be studied. Lack of information regarding the lateral position of the target relative to the orientation of the ACC-equipped vehicle impedes system's performance on curved roads. The monobeam sensor can pick up false targets on adjacent lanes, or miss valid targets around the curve ahead. Possible sensing technology or sensor design that will provide such azimuth information might include (1) multi-beam sensors; (2) mechanically rotating (swept) beam sensors; or (3) an

electronically sweeping beam sensor. Using directional sensing will enhance sensing confidence as a step towards being a crash-avoidance system.

- **Examine possibilities for analytical, simulation, and proving grounds tests for prototype systems.**

Although on-road testing represents deploying the system in a real environment, there is a need to have techniques for studying these systems as they develop. The FOCAS project started with a deployable system. Now that the results and findings from deploying the baseline system are being evaluated, there is a need to have analytical, simulation (or simulator) and proving grounds techniques for examining system performance in a controlled environment. Evaluations of advanced systems with adjustable or selectable headways or with warnings and braking capabilities or with swept-beam sensors would benefit from evidence obtained from analyses, simulations, or proving grounds tests. The next deployment in the field would be more likely to be successful if the new features have received clinical examination under controlled conditions.

- **Deploy systems (such as the baseline system) allowing people to operate them unescorted and for longer periods of time.**

The baseline system performed very well in the hands of experienced drivers when the drivers were accompanied by an experimenter. The next step in deployment would be to have responsible drivers operate these systems without an experimenter present. There is a need to confirm that people will use these systems much as they currently use conventional cruise-control systems. There is a need to obtain driver reactions and opinions to assess the viability of ACC as a consumer product as well as its influence on the safety margins used by the driving public.

### **6.3 Concluding Remarks**

The data gathered during this year have received considerable attention. Nevertheless, the database needs to be penetrated further. The data certainly contain many findings that have not been uncovered yet. There is a wealth of information concerning the driving process to be obtained from the database. Some of the activities that need to be pursued in the near future are as follows:

- Normalize the data using speed so that timing is evident. For example, use the equation  
$$TLC ( Rdot/V) + (Ta - Th) = 0$$

- Work with streams (time continuous values) to study driving situations such as cruising, closing-in, following, suddenly too close, chasing, etc.
- Relate subjective and statistical results to physical understanding.
- Contribute to a theory of driving as it applies to the intelligent control of vehicle dynamics.

## REFERENCES

1. Fancher, P., Bareket, Z. and Johnson, G., "Predictive Analyses of the Performance of a Headway Control System for Heavy Commercial Vehicles." *International Association for Vehicle System Dynamics*, Proceedings to the 13th IAVSD Symposium. Chengdu, China, Swets & Zeitlinger, 1993.
2. Fancher, P., Bareket, Z. and Johnson, G., "Investigation of the performance of a headway control system for commercial vehicles." Michigan University, Ann Arbor, Transportation Research Institute, GLCTRR-27/91, UMTRI-93-2, IVHS Technical Report-93-01, 1993.
3. Fancher, P.S., Ervin, R.D., Bareket, Z., Johnson, G.E., Trefalt, M., Tiedecke, J. and Hagleitner, W., "Intelligent Cruise Control: Performance Studies Based Upon an Operating Prototype." *IVHS America Annual Meeting*, IVHS America Annual Meeting. Atlanta, Georgia, 1994.
4. Fancher, P.S. and Bareket, Z., "Evaluating Headway Control Using Range Versus Range-Rate Relationships." *Vehicle System Dynamics, International Journal of Vehicle Mechanics and Mobility*, vol. 23, no. 8, Nov. 1994, pp. 575-596.
5. Fancher, P.S. and Ervin, R.D., "Implications of Intelligent Cruise Control (ICC) Systems for the Driver's Supervisory Role," ITS World Congress, Paris, December 1994.
6. Fancher, P.S. and Bareket, Z., "Controlling Headway Between Successive Vehicles", Association for Unmanned Vehicle Systems, Symposium Proceedings Manual, May 1994, pp. 149-157.
7. Slotine, J-J.E., and Li, W.: *Applied Nonlinear Control*. Prentice Hall, Englewood Cliffs, New Jersey, 1991.
8. Hoffman, E.R., "Perception of Relative Velocity," *Studies of Automobile and Truck Rear Lighting and Signaling Systems*, Report No. UM-HSRI-HF-74-25, University of Michigan, Highway Safety Research Institute, Ann Arbor, MI, Nov. 1974.
9. Michigan Department of Transportation (1994). Michigan 1993 annual average 24-hour traffic volumes, Lansing, MI.





# APPENDIX A



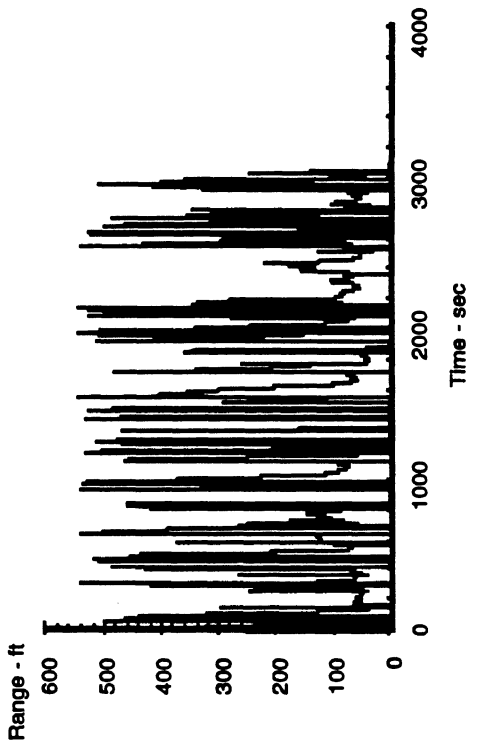

HEADAC FOCAS Data, re-binned & re-sampled from file S1\_N\_x

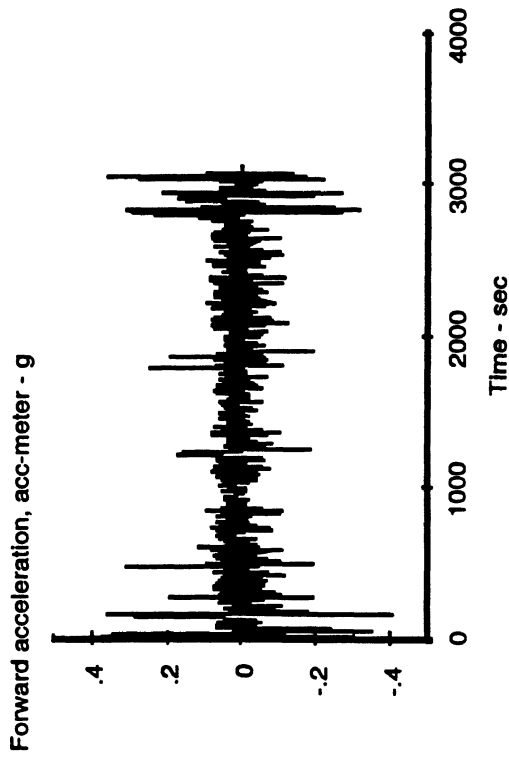

HEADAC FOCAS Data, re-binned & re-sampled from file S1\_N\_x

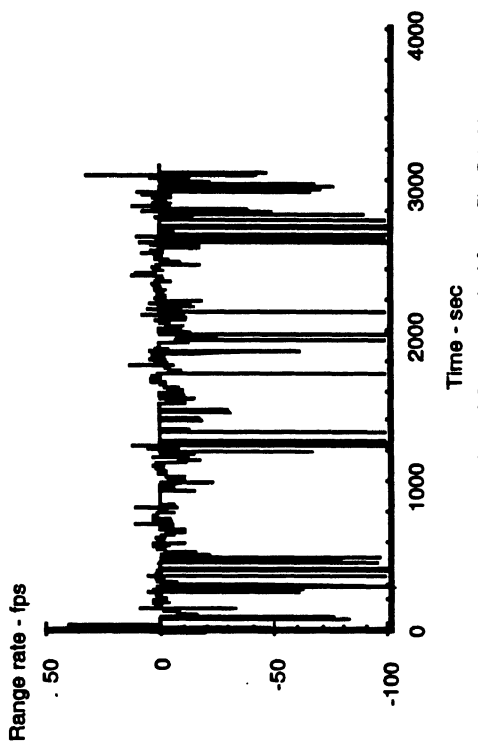

HEADAC FOCAS Data, re-binned & re-sampled from file S1\_N\_x

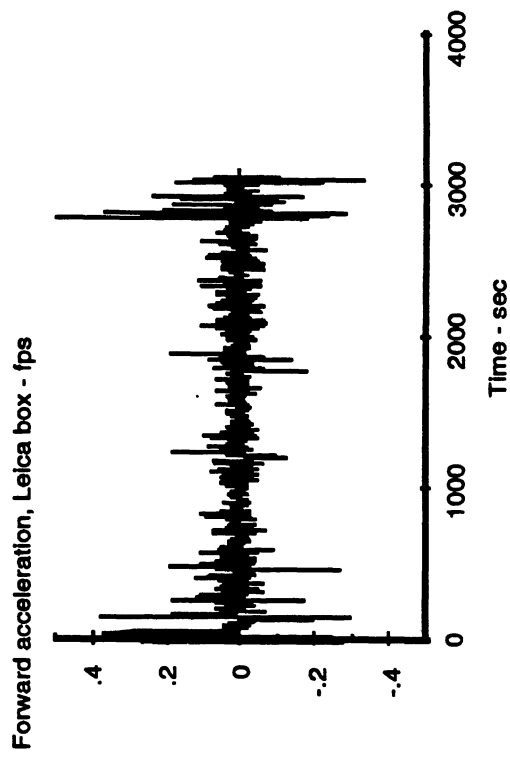

HEADAC FOCAS Data, re-binned & re-sampled from file S1\_N\_x

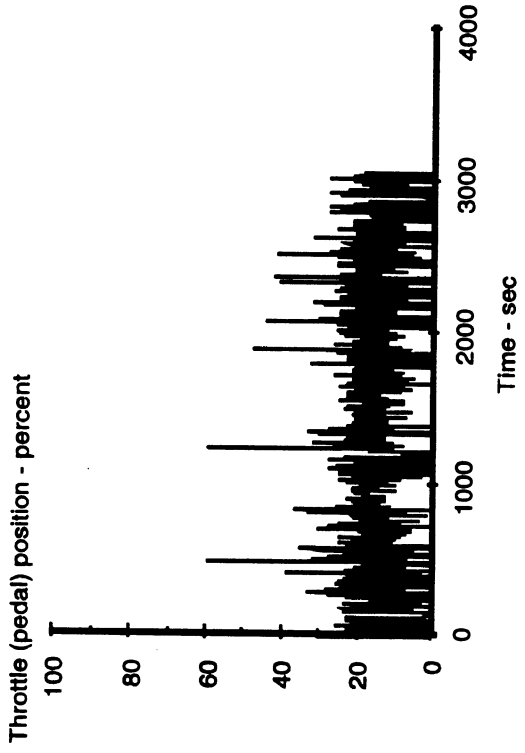

HEADAC FOCAS Data, re-binned & re-sampled from file S1\_N\_x

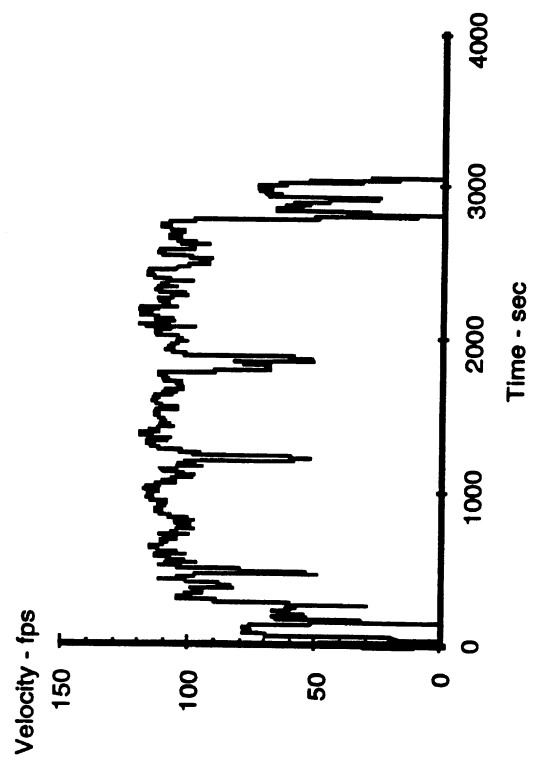

HEADAC FOCAS Data, re-binned & re-sampled from file S1\_N\_x

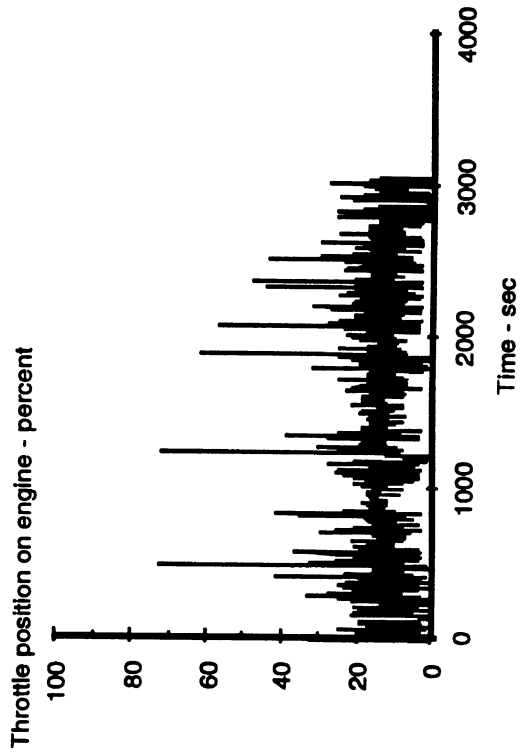

HEADAC FOCAS Data, re-binned & re-sampled from file S1\_N\_x

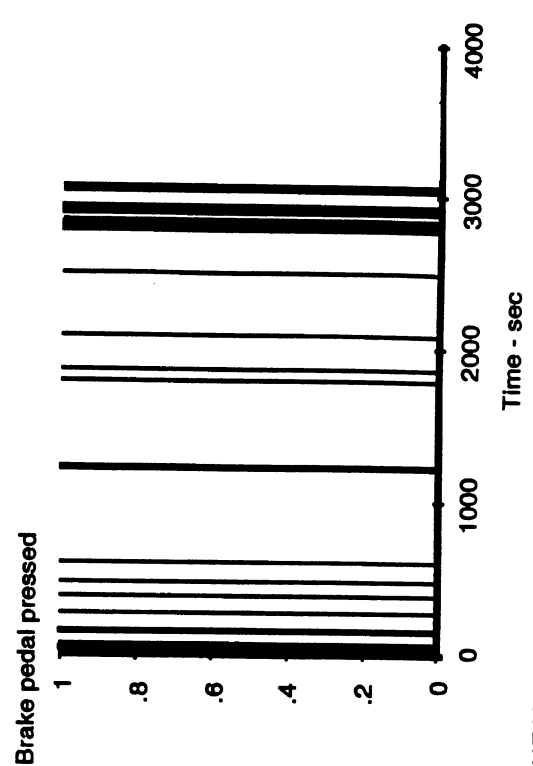

HEADAC FOCAS Data, re-binned & re-sampled from file S1\_N\_x

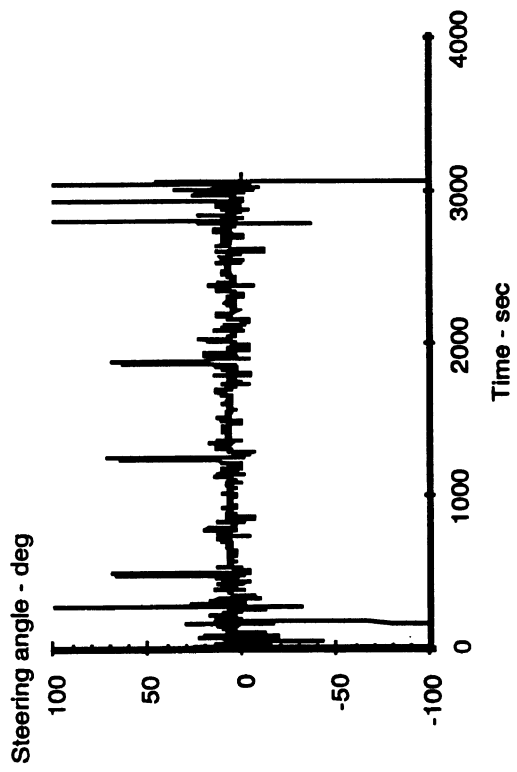

HEADAC FOCAS Data, re-binned & re-sampled from file S1\_N\_x

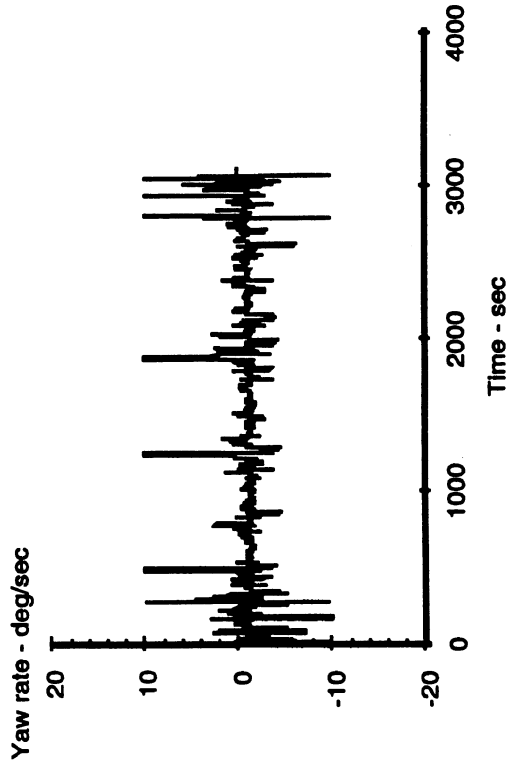

HEADAC FOCAS Data, re-binned & re-sampled from file S1\_N\_x

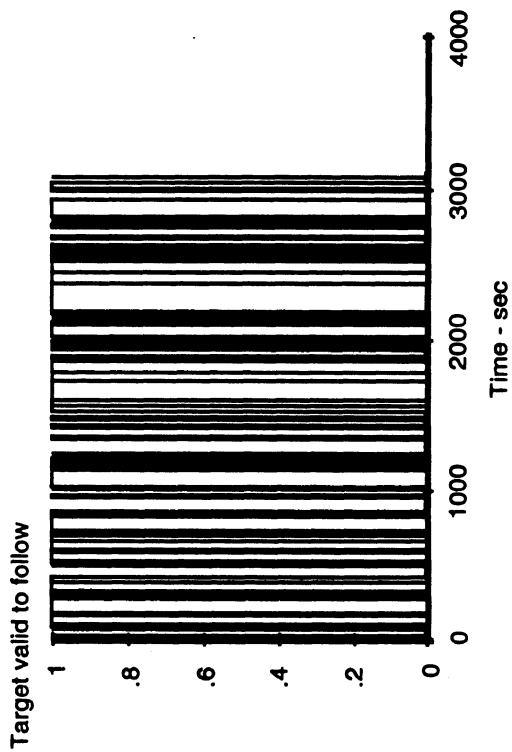

HEADAC FOCAS Data, derived channels from file S1\_N\_der

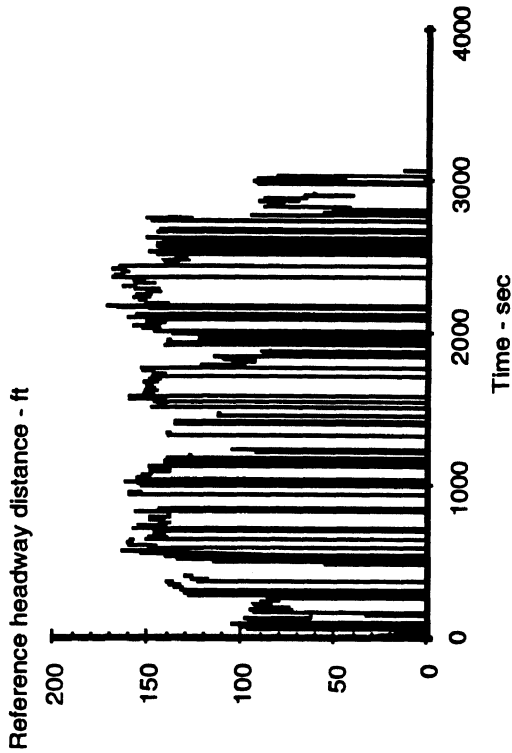

HEADAC FOCAS Data, derived channels from file S1\_N\_der

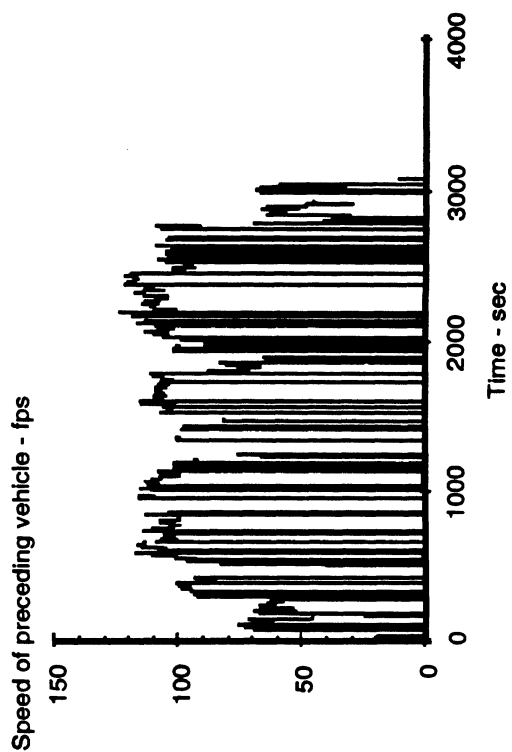

HEADAC FOCAS Data, derived channels from file S1\_N\_der

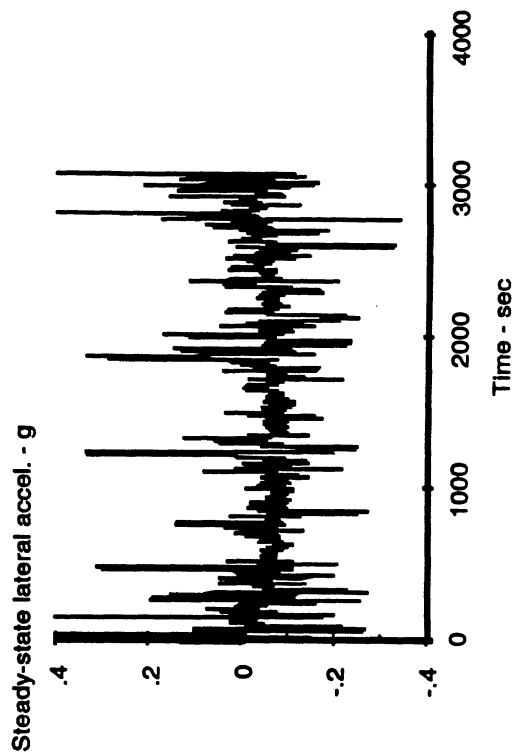

HEADAC FOCAS Data, derived channels from file S1\_N\_der

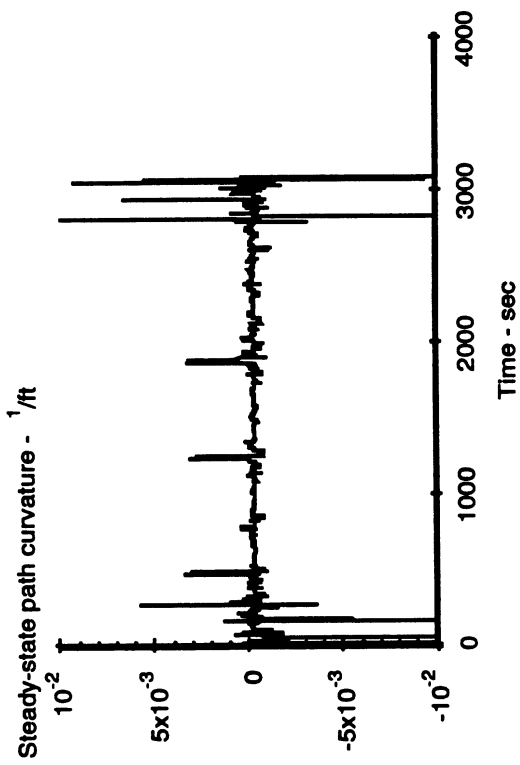

HEADAC FOCAS Data, derived channels from file S1\_N\_der

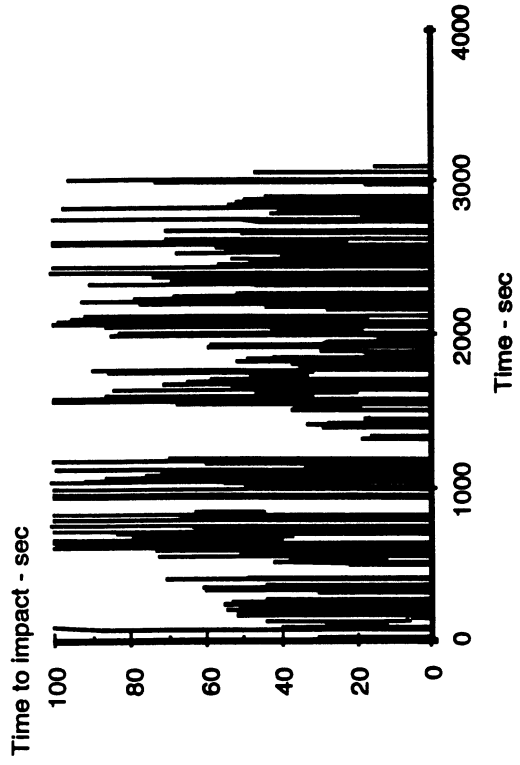

HEADAC FOCAS Data, derived channels from file S1\_N\_der

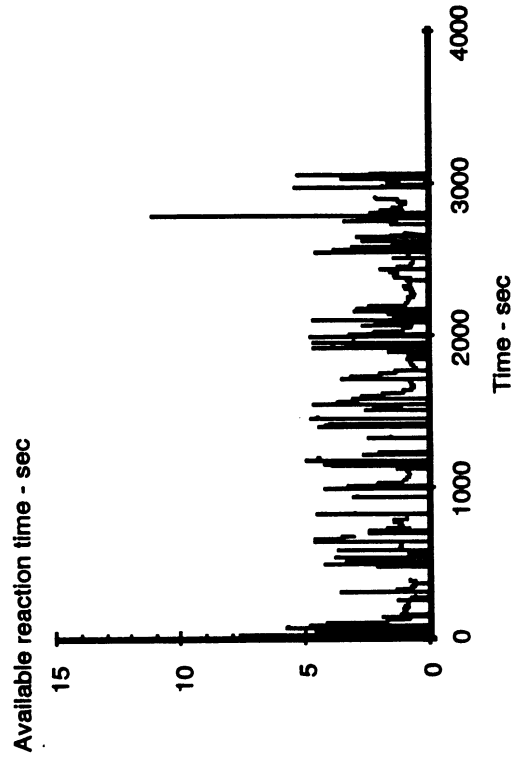

HEADAC FOCAS Data, derived channels from file S1\_N\_der

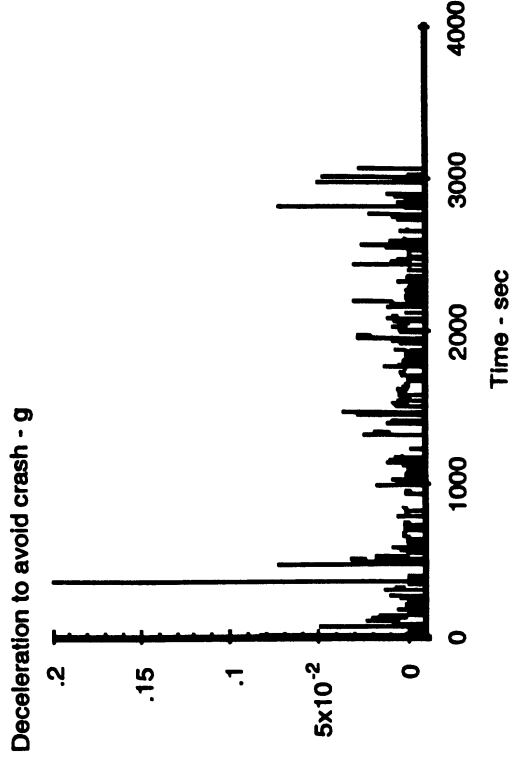

HEADAC FOCAS Data, derived channels from file S1\_N\_der

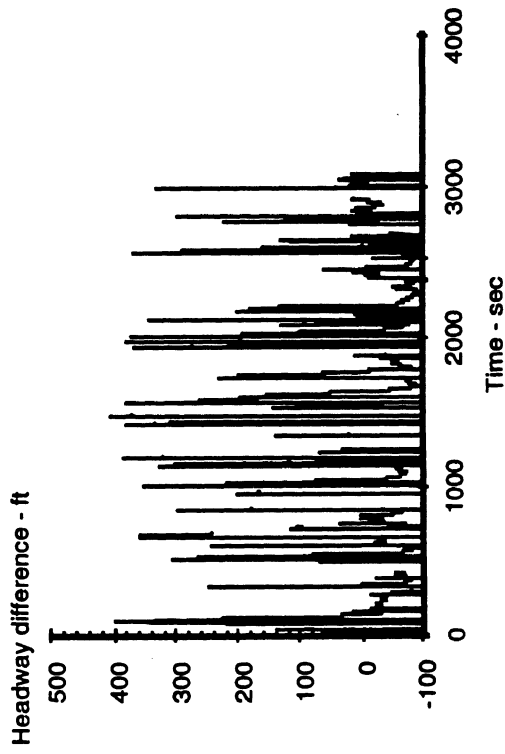

HEADAC FOCAS Data, derived channels from file S1\_N\_der

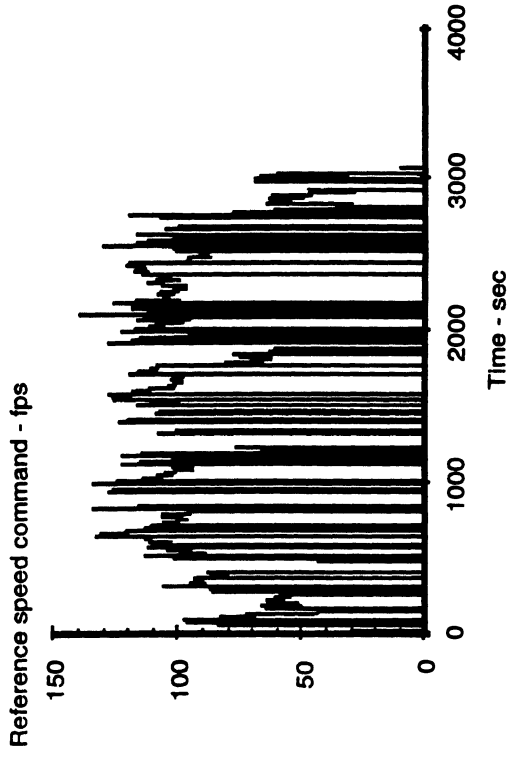

HEADAC FOCAS Data, derived channels from file S1\_N\_der

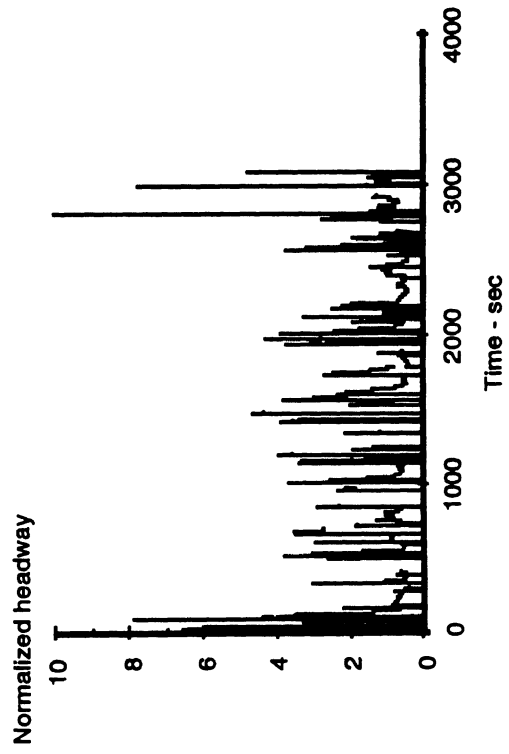

HEADAC FOCAS Data, derived channels from file S1\_N\_der

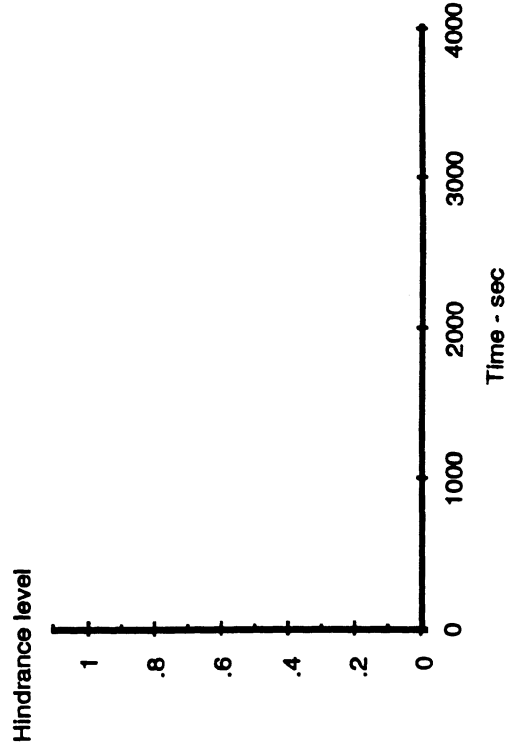

HEADAC FOCAS Data, derived channels from file S1\_N\_der



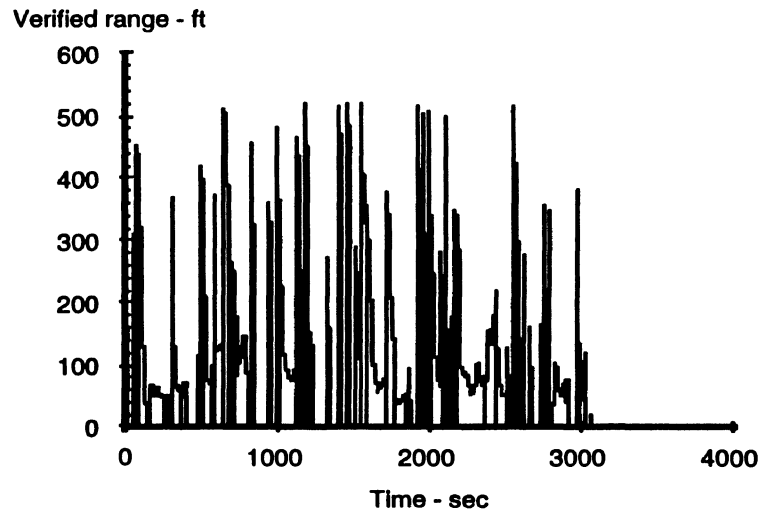

HEADAC FOCAS Data, derived channels from file S1\_N\_der

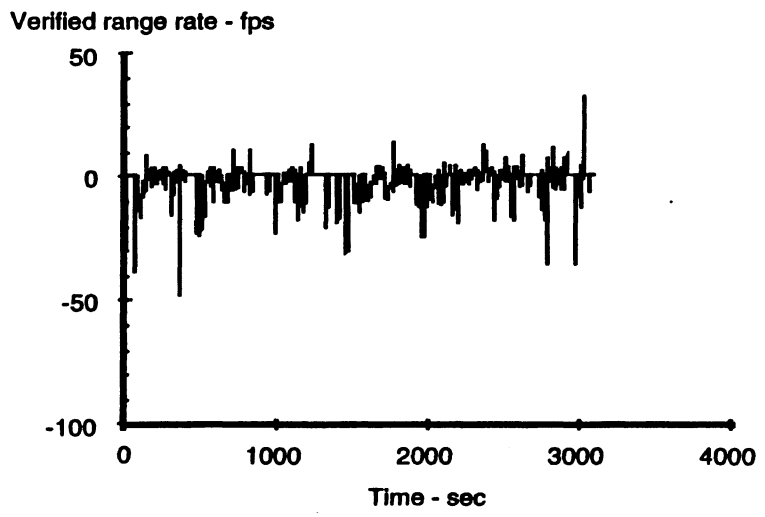

HEADAC FOCAS Data, derived channels from file S1\_N\_der

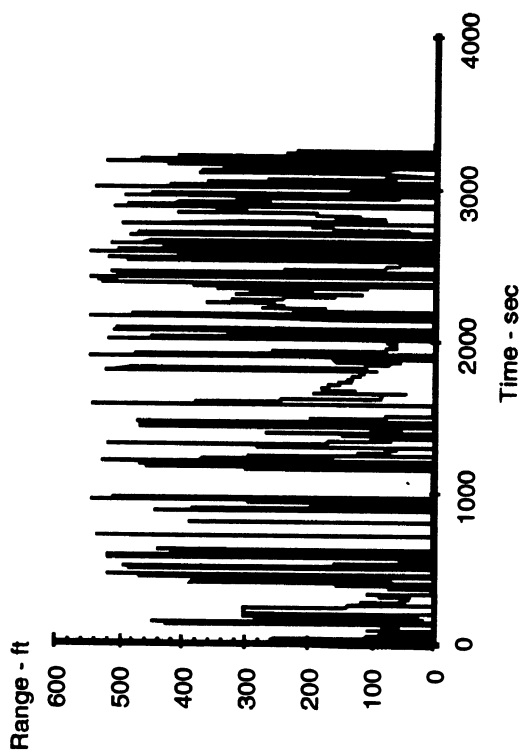

HEADAC FOCAS Data, re-binned & re-sampled from file S1\_CC\_x

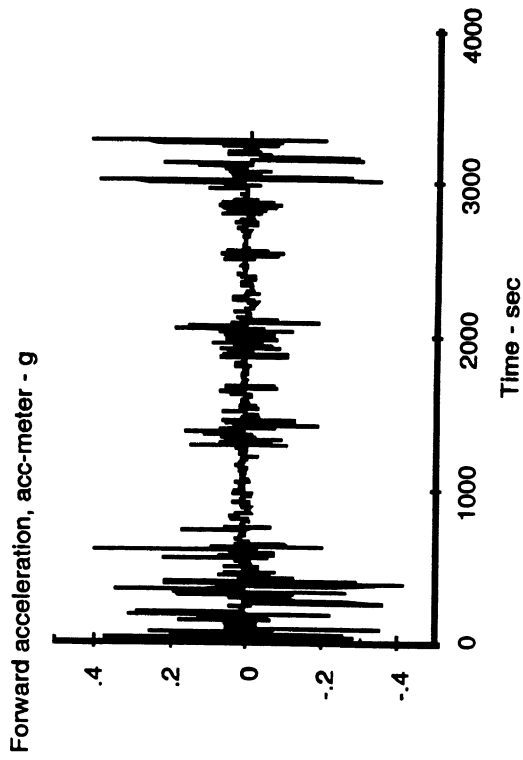

HEADAC FOCAS Data, re-binned & re-sampled from file S1\_CC\_x

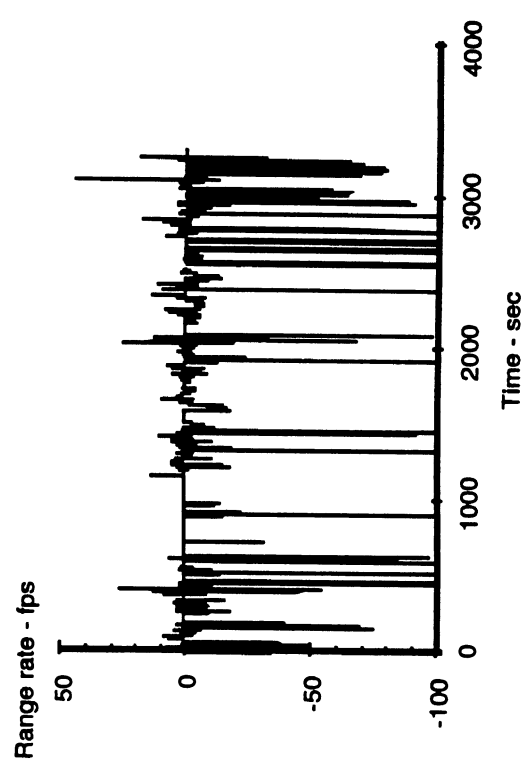

HEADAC FOCAS Data, re-binned & re-sampled from file S1\_CC\_x

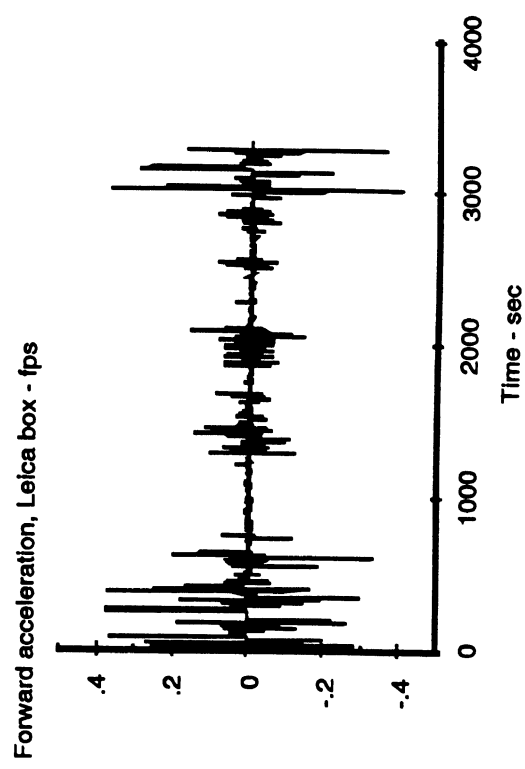

HEADAC FOCAS Data, re-binned & re-sampled from file S1\_CC\_x

Throttle (pedal) position - percent

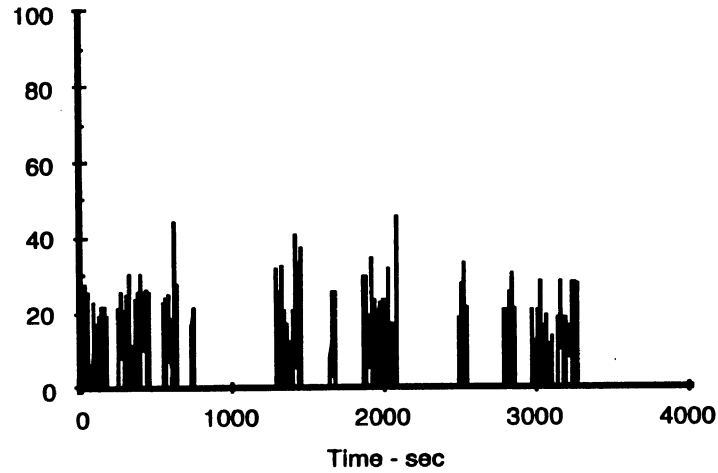

HEADAC FOCAS Data, re-binned & re-sampled from file S1\_CC\_x

Velocity - fps

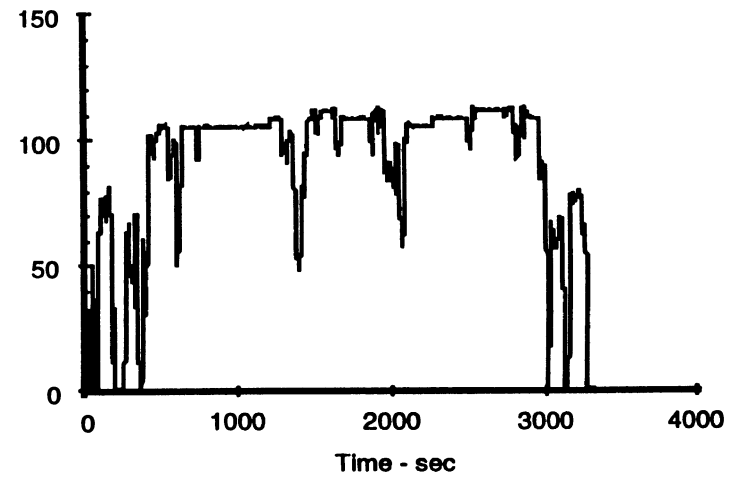

HEADAC FOCAS Data, re-binned & re-sampled from file S1\_CC\_x

Throttle position on engine - percent

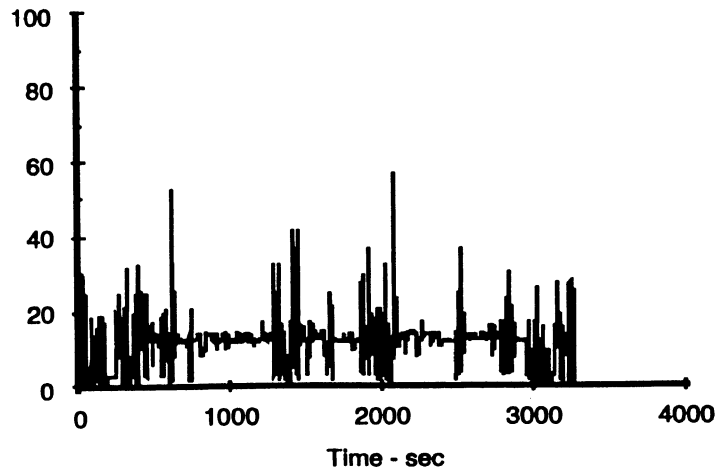

HEADAC FOCAS Data, re-binned & re-sampled from file S1\_CC\_x

Brake pedal pressed

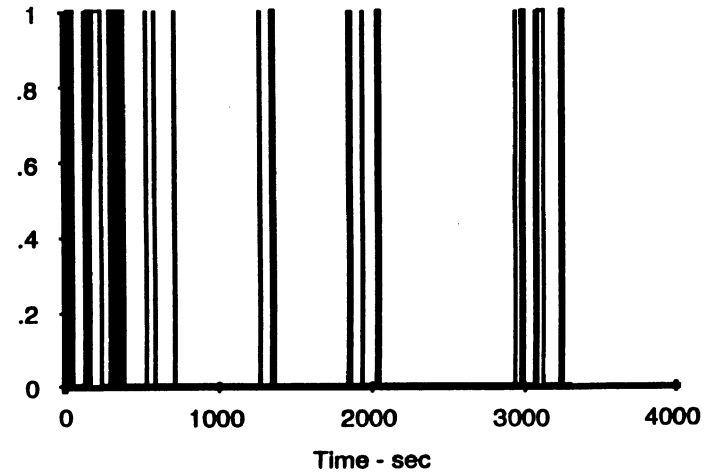

HEADAC FOCAS Data, re-binned & re-sampled from file S1\_CC\_x

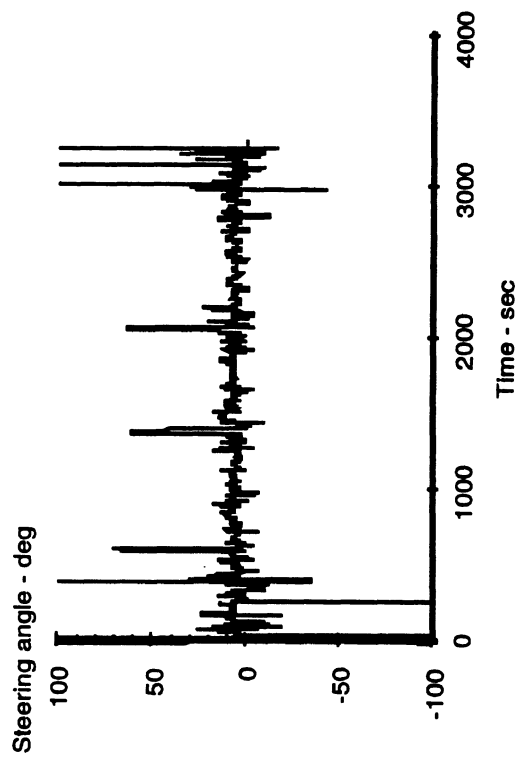

HEADAC FOCAS Data, re-binned & re-sampled from file S1\_CC\_x

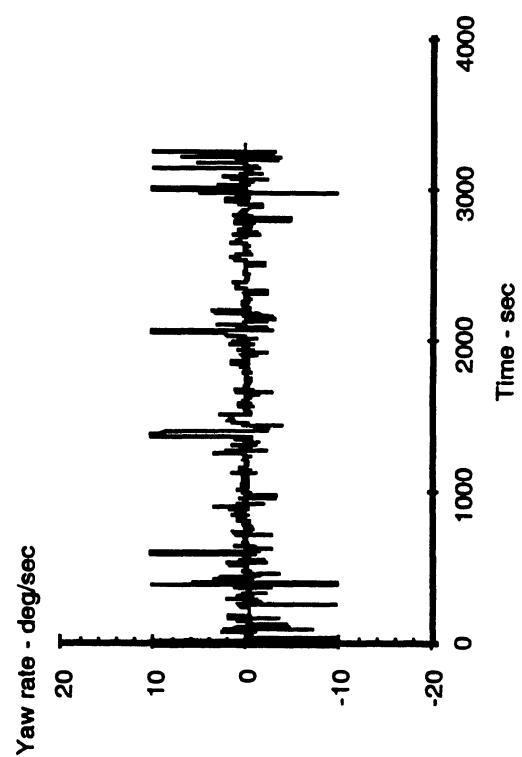

HEADAC FOCAS Data, re-binned & re-sampled from file S1\_CC\_x

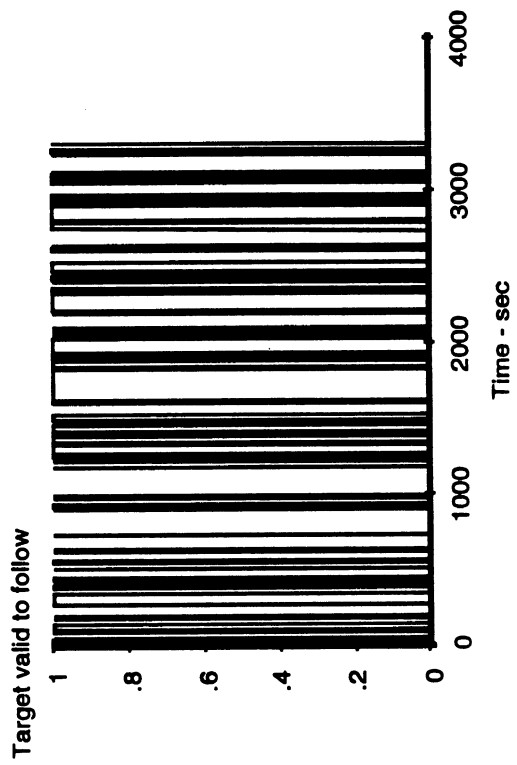

HEADAC FOCAS Data, derived channels from file S1\_CC\_der

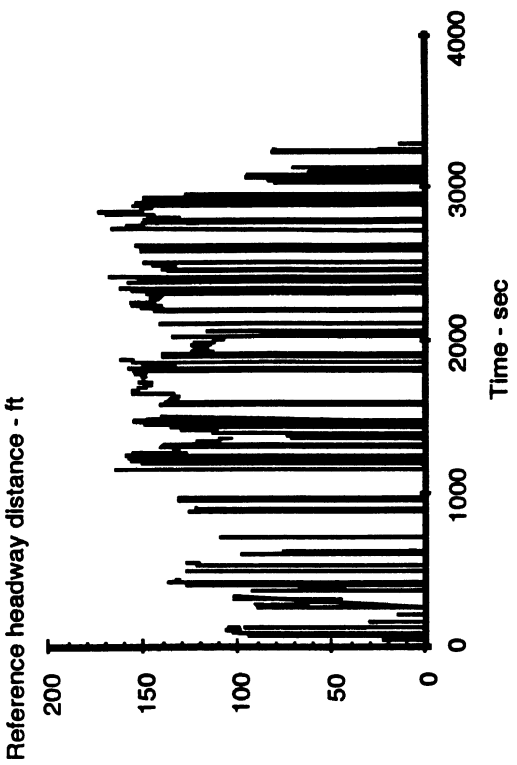

HEADAC FOCAS Data, derived channels from file S1\_CC\_der

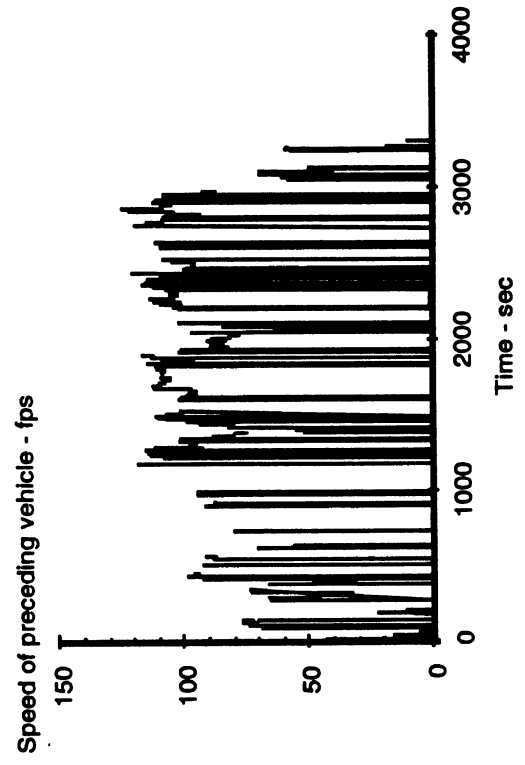

HEADAC FOCAS Data, derived channels from file S1\_CC\_der

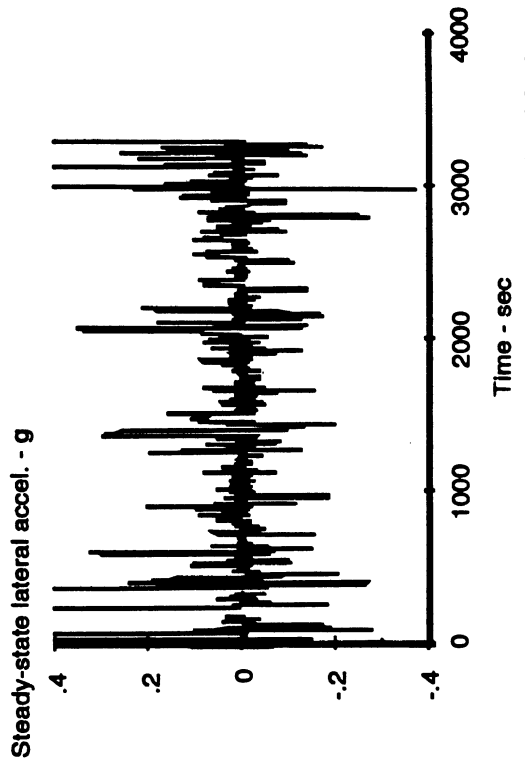

HEADAC FOCAS Data, derived channels from file S1\_CC\_der

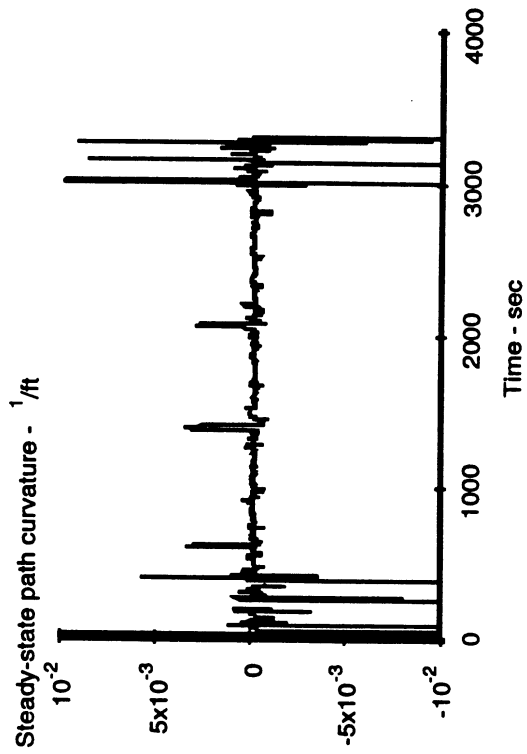

HEADAC FOCAS Data, derived channels from file S1\_CC\_der

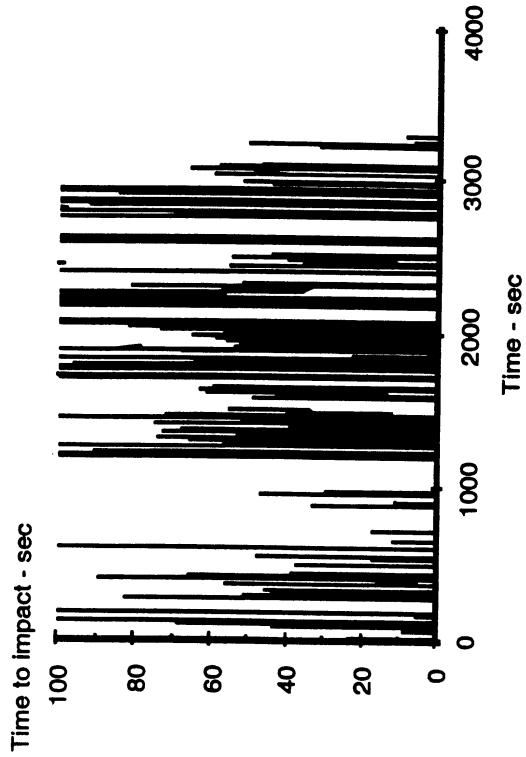

HEADAC FOCAS Data, derived channels from file S1\_CC\_der

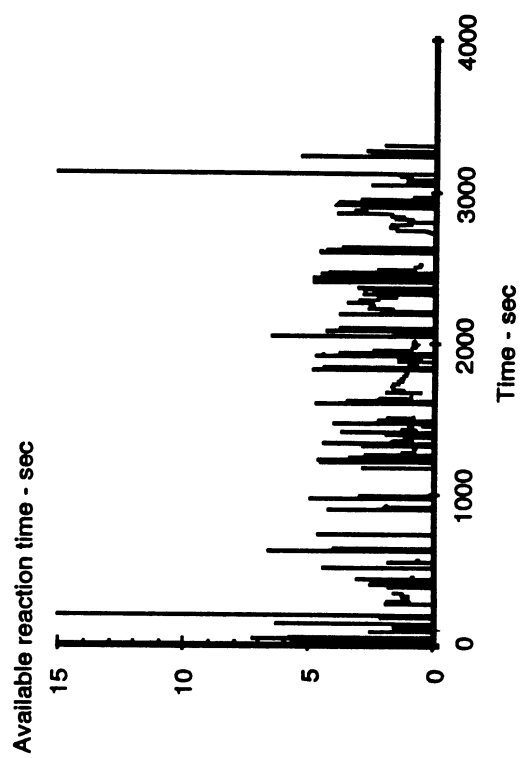

HEADAC FOCAS Data, derived channels from file S1\_CC\_der

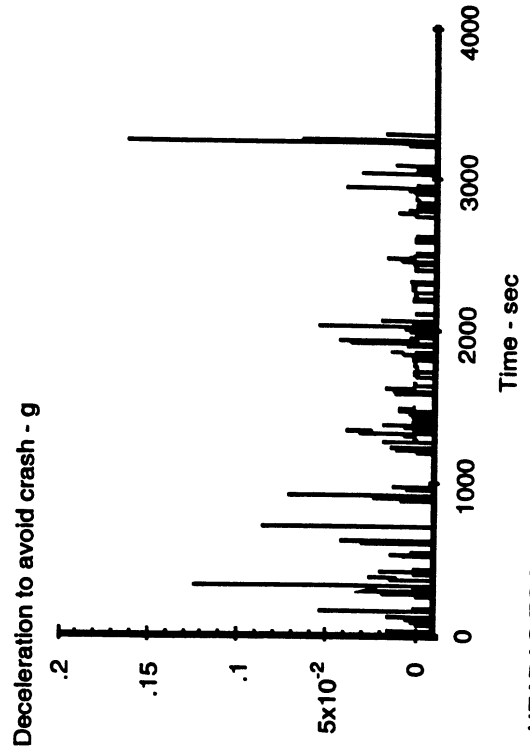

HEADAC FOCAS Data, derived channels from file S1\_CC\_der

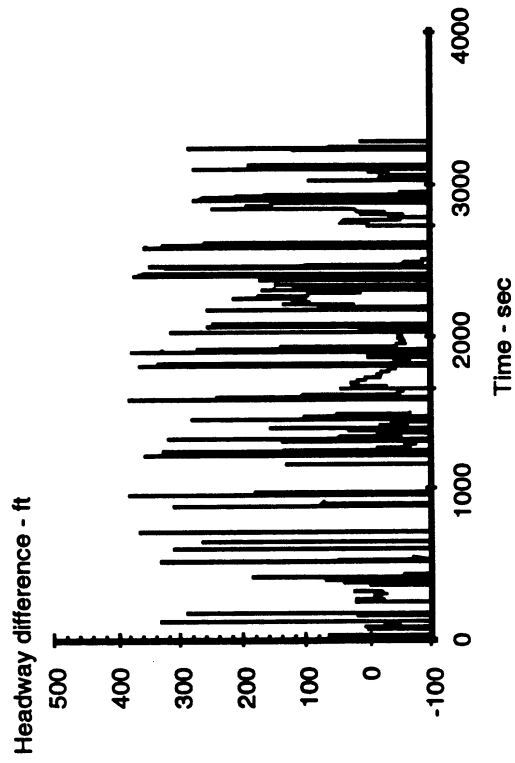

HEADAC FOCAS Data, derived channels from file S1\_CC\_der

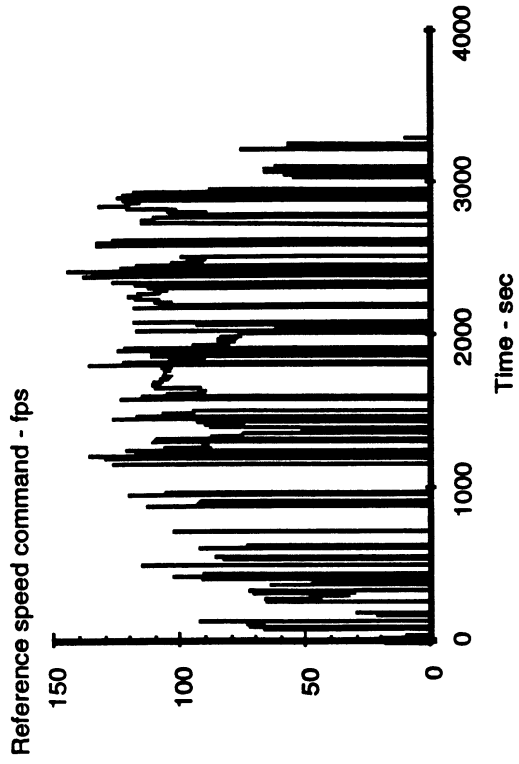

HEADAC FOCAS Data, derived channels from file S1\_CC\_der

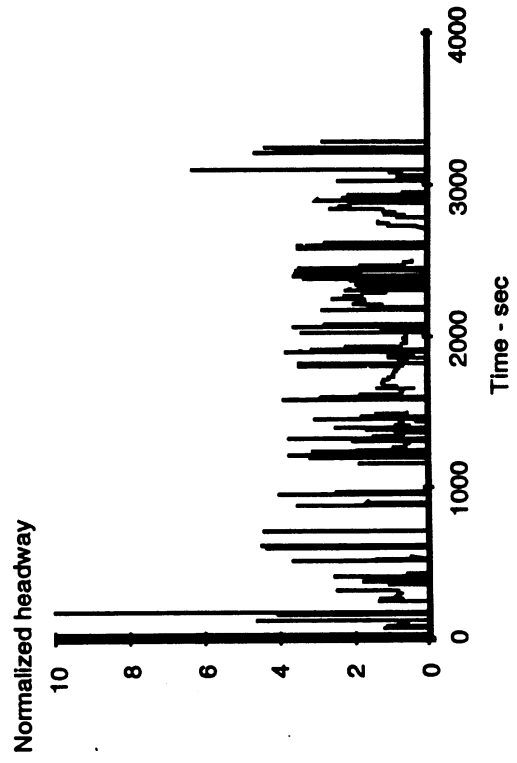

HEADAC FOCAS Data, derived channels from file S1\_CC\_der

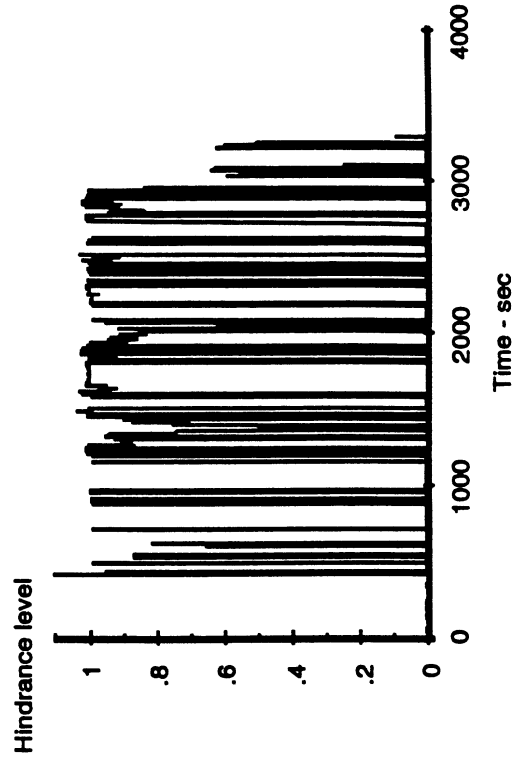

HEADAC FOCAS Data, derived channels from file S1\_CC\_der

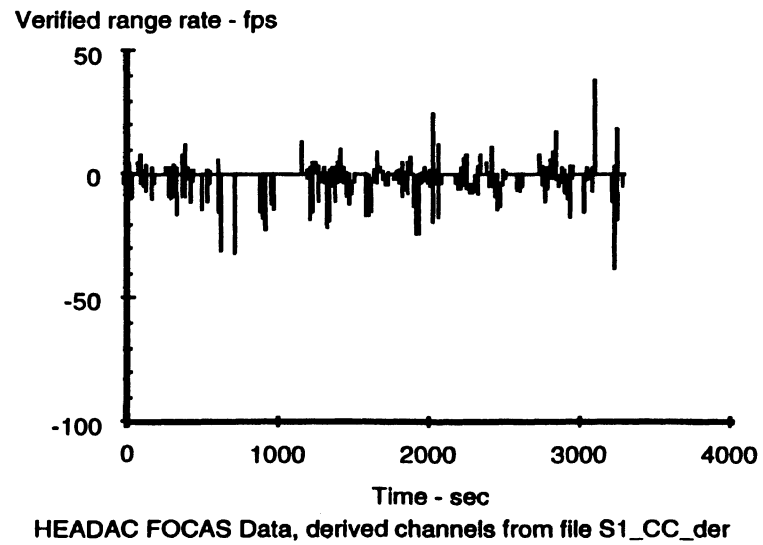
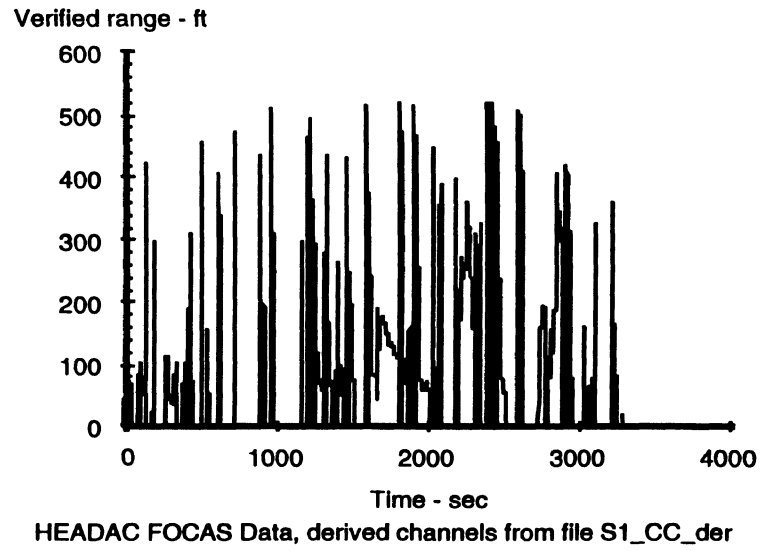



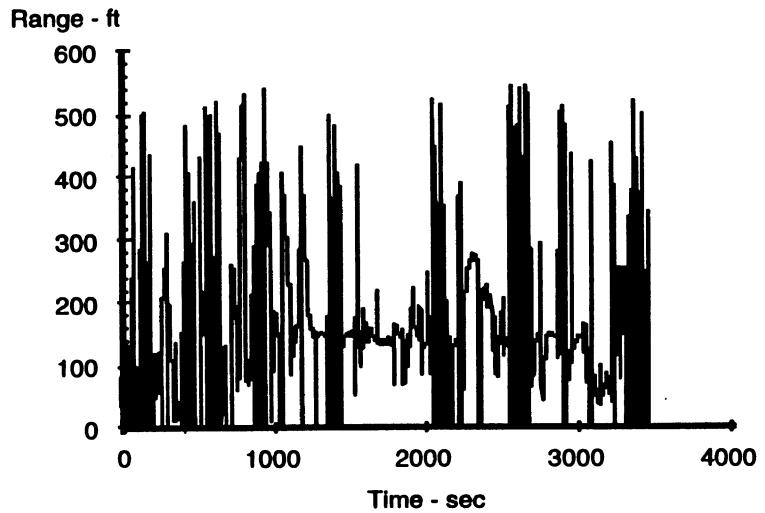

HEADAC FOCAS Data, re-binned & re-sampled from file S1\_ACC\_x

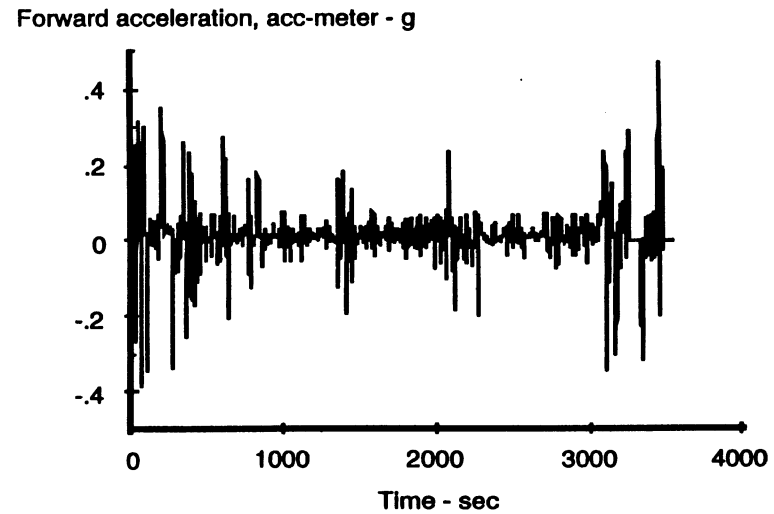

HEADAC FOCAS Data, re-binned & re-sampled from file S1\_ACC\_x

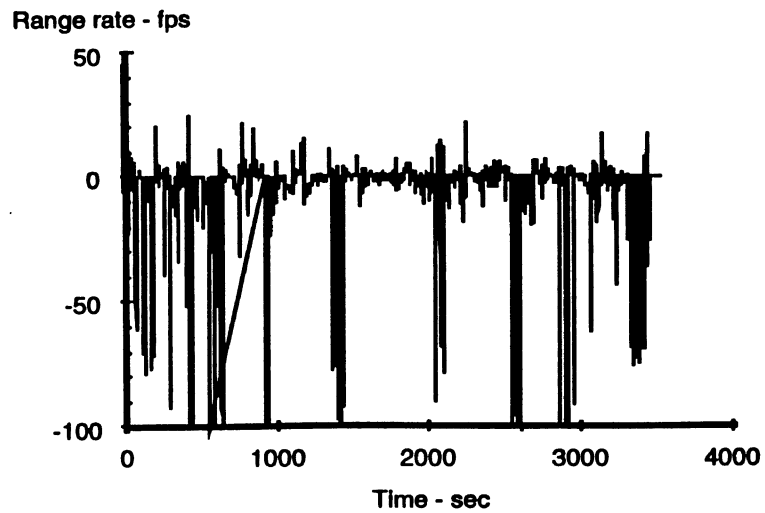

HEADAC FOCAS Data, re-binned & re-sampled from file S1\_ACC\_x

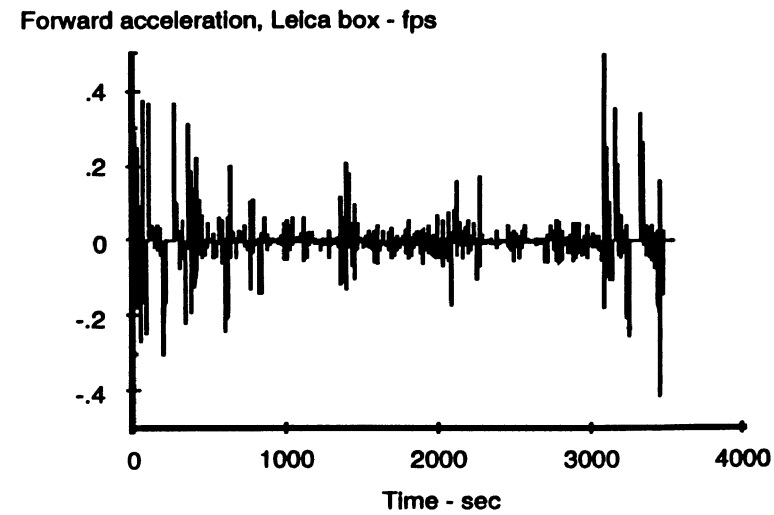

HEADAC FOCAS Data, re-binned & re-sampled from file S1\_ACC\_x

Throttle (pedal) position - percent

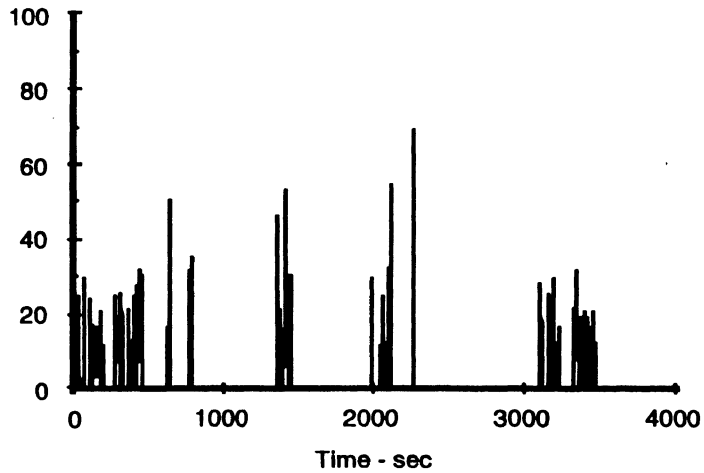

HEADAC FOCAS Data, re-binned & re-sampled from file S1\_ACC\_x

Velocity - fps

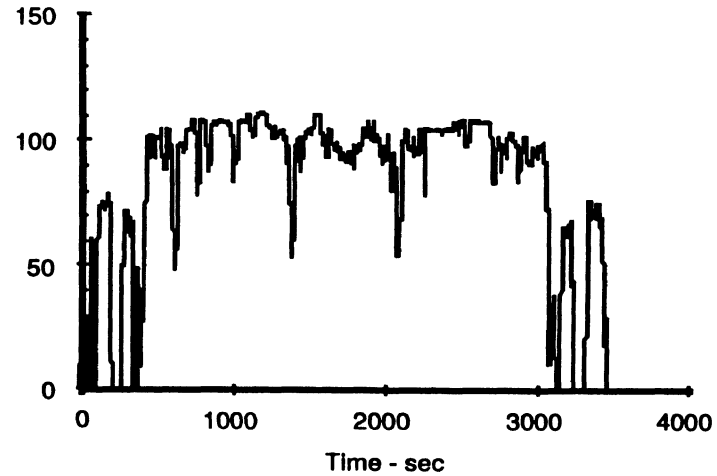

HEADAC FOCAS Data, re-binned & re-sampled from file S1\_ACC\_x

Throttle position on engine - percent

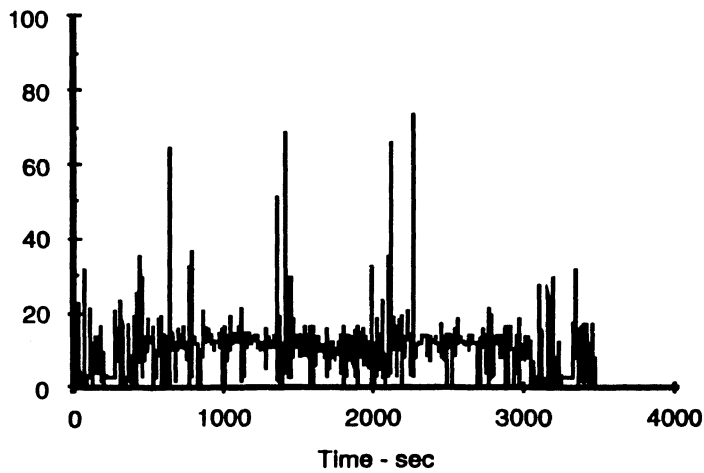

HEADAC FOCAS Data, re-binned & re-sampled from file S1\_ACC\_x

Brake pedal pressed

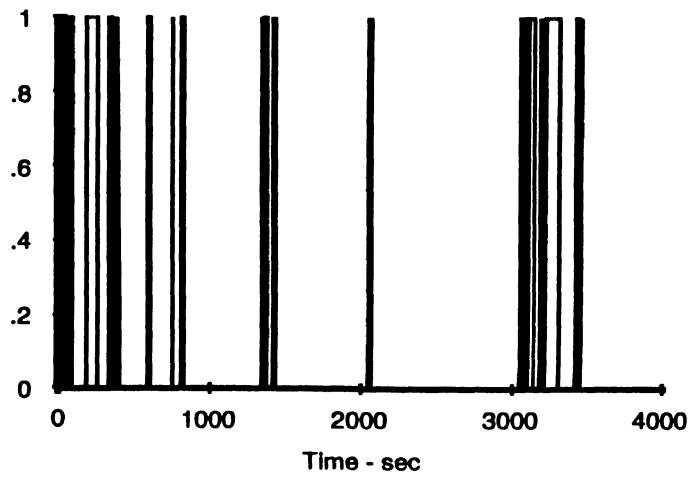

HEADAC FOCAS Data, re-binned & re-sampled from file S1\_ACC\_x

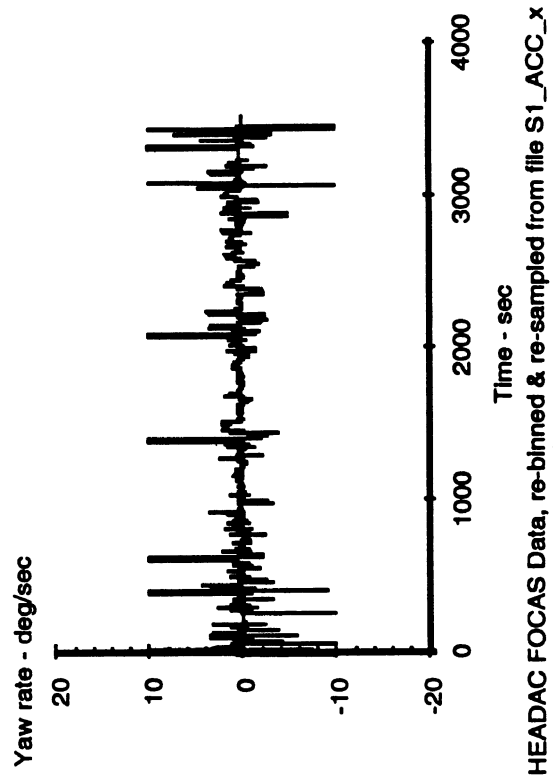
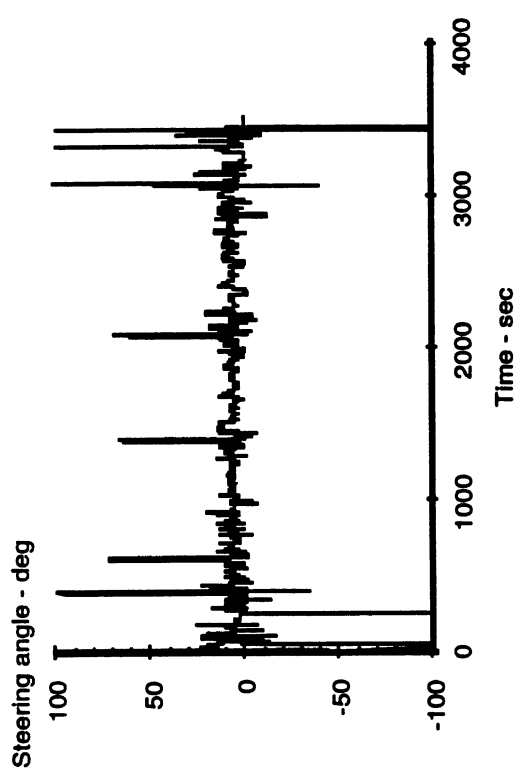

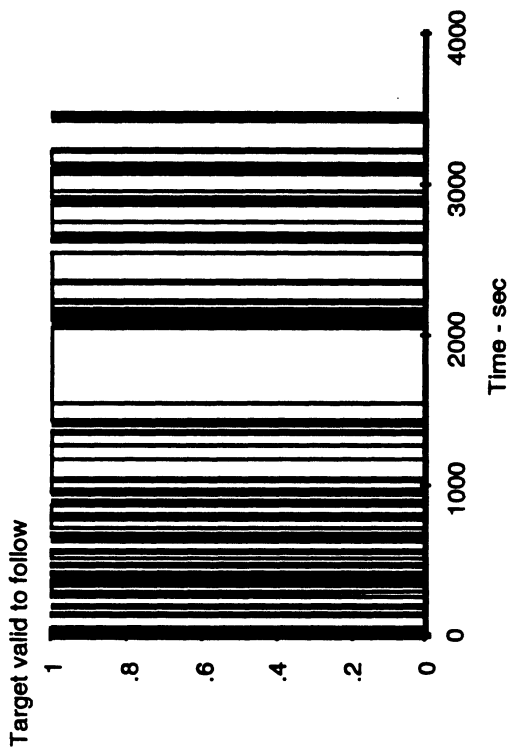

HEADAC FOCAS Data, derived channels from file S1\_ACC\_der

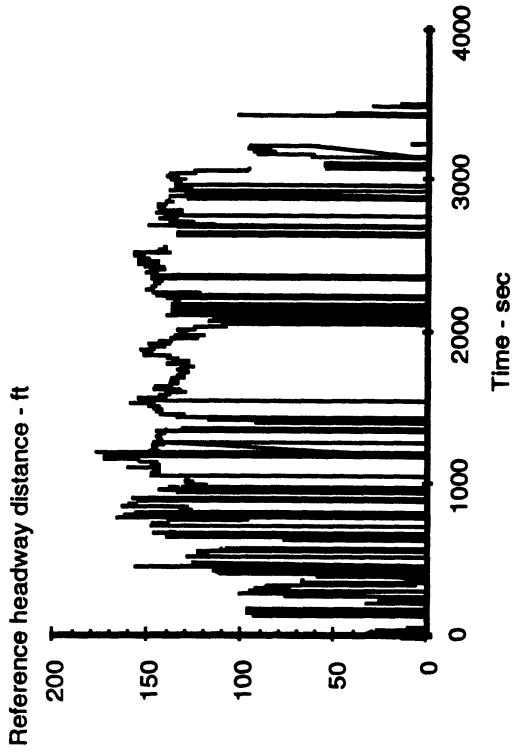

HEADAC FOCAS Data, derived channels from file S1\_ACC\_der

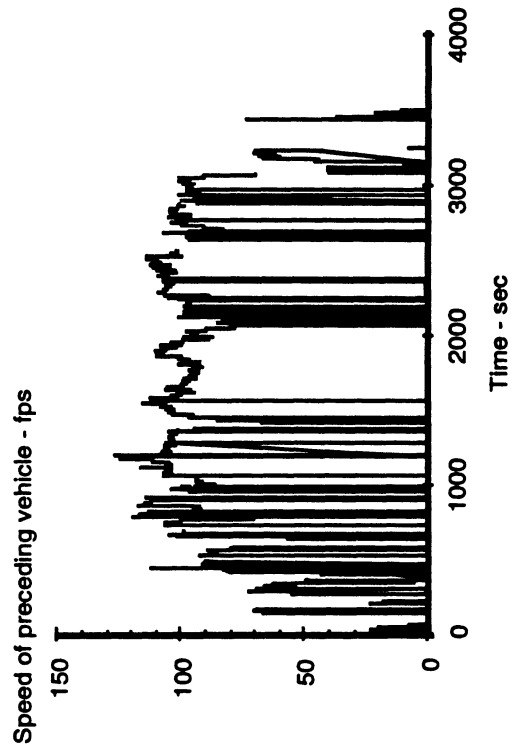

HEADAC FOCAS Data, derived channels from file S1\_ACC\_der

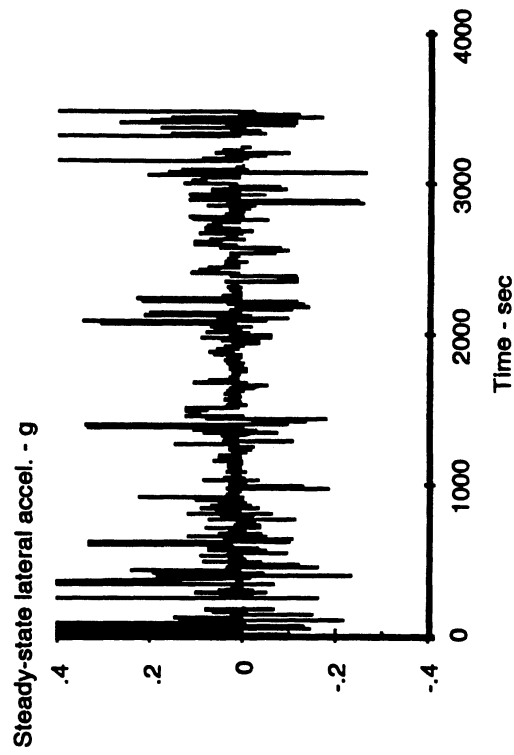

HEADAC FOCAS Data, derived channels from file S1\_ACC\_der

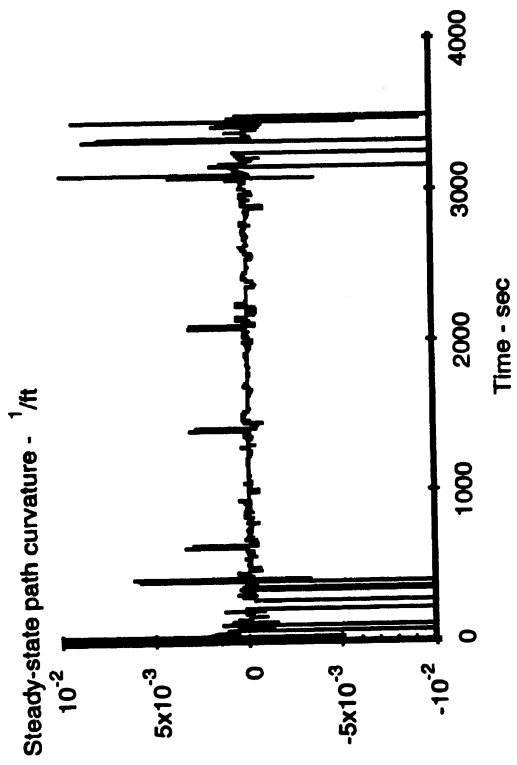

HEADAC FOCAS Data, derived channels from file S1\_ACC\_der

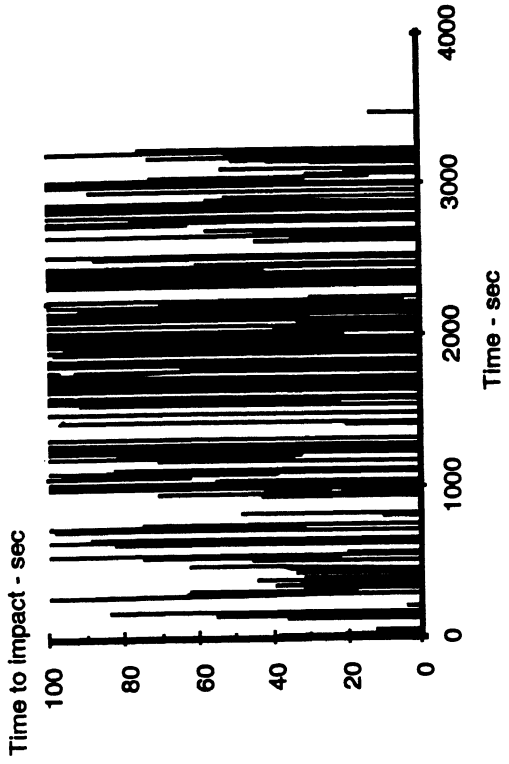

HEADAC FOCAS Data, derived channels from file S1\_ACC\_der

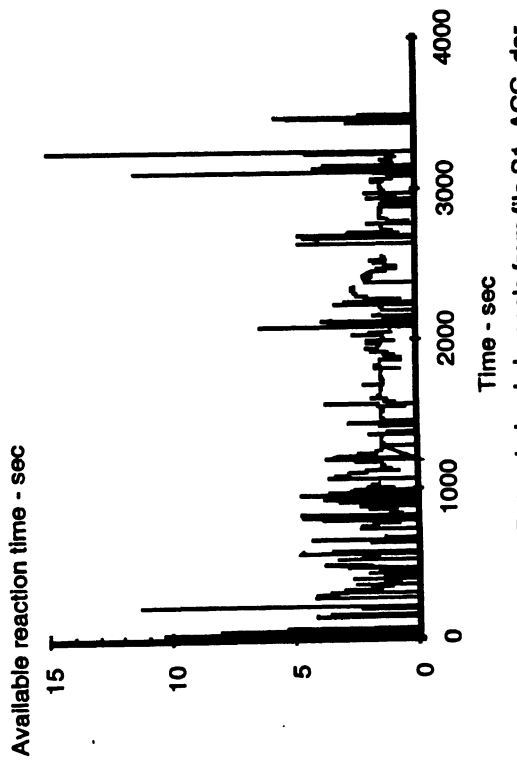

HEADAC FOCAS Data, derived channels from file S1\_ACC\_der

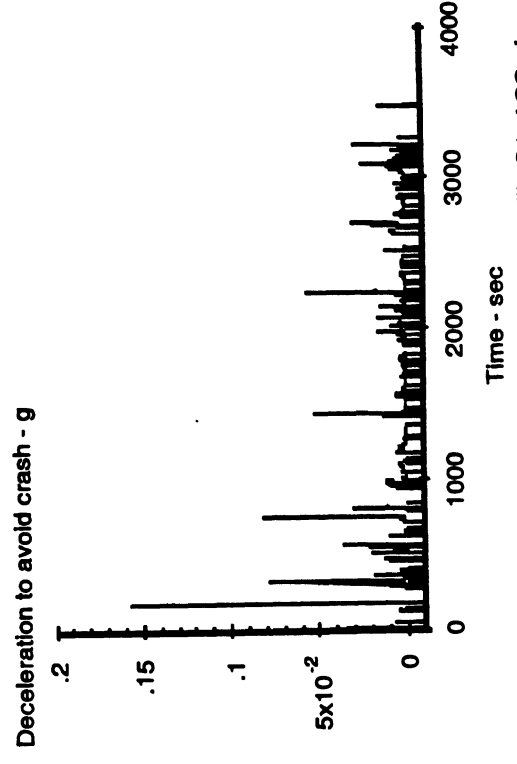

HEADAC FOCAS Data, derived channels from file S1\_ACC\_der

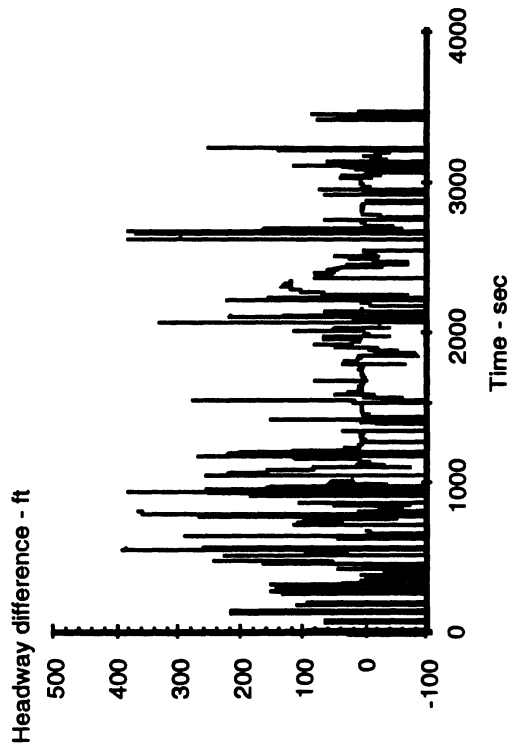

HEADAC FOCAS Data, derived channels from file S1\_ACC\_der

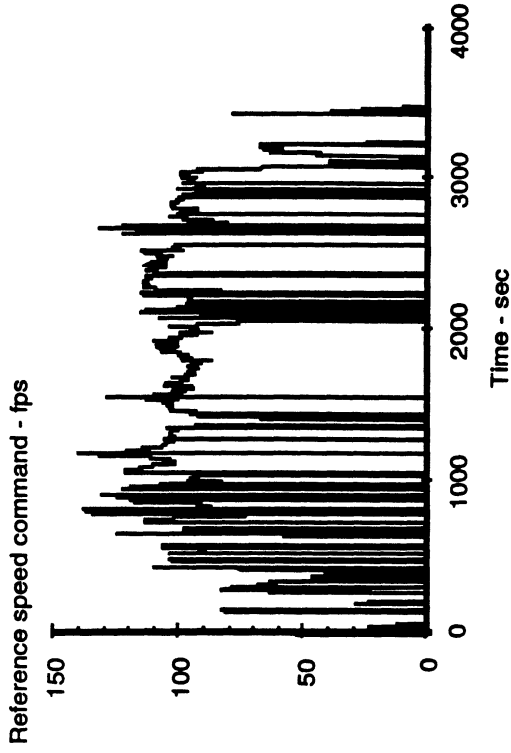

HEADAC FOCAS Data, derived channels from file S1\_ACC\_der

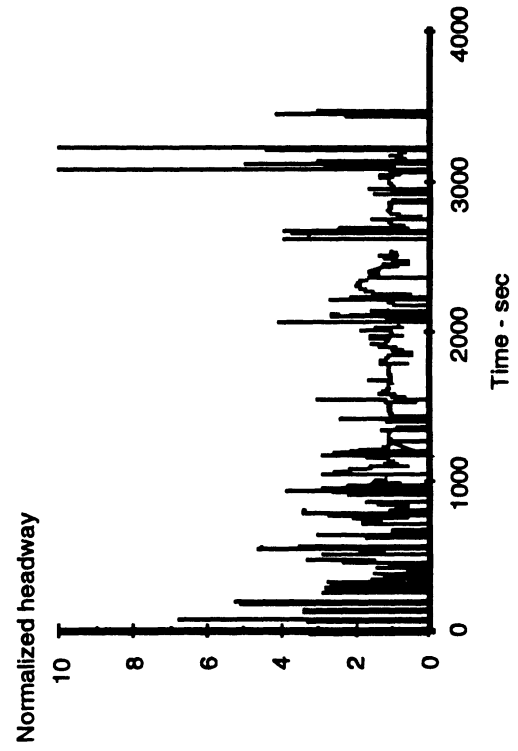

HEADAC FOCAS Data, derived channels from file S1\_ACC\_der

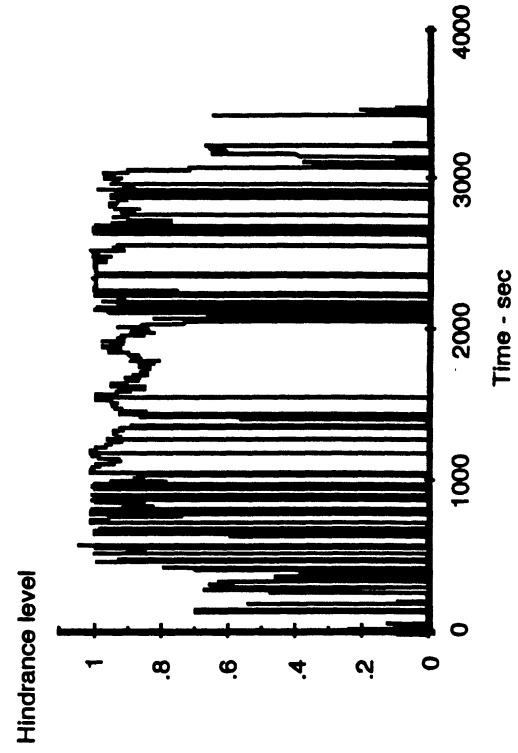

HEADAC FOCAS Data, derived channels from file S1\_ACC\_der

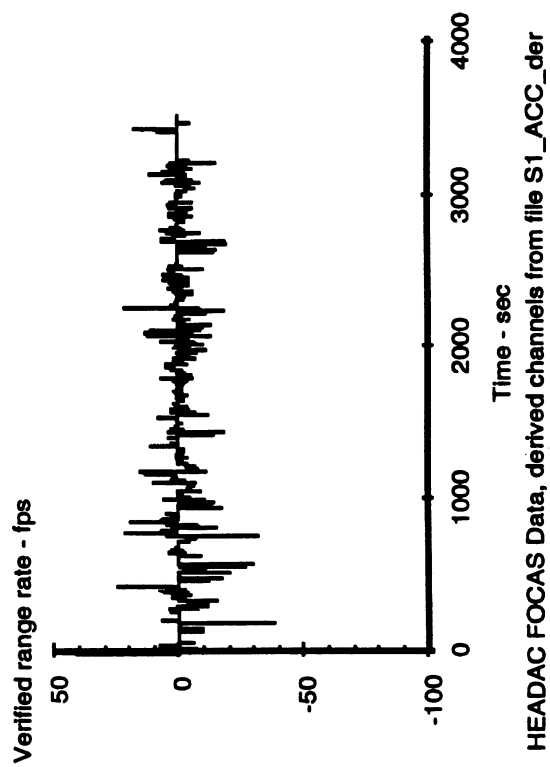
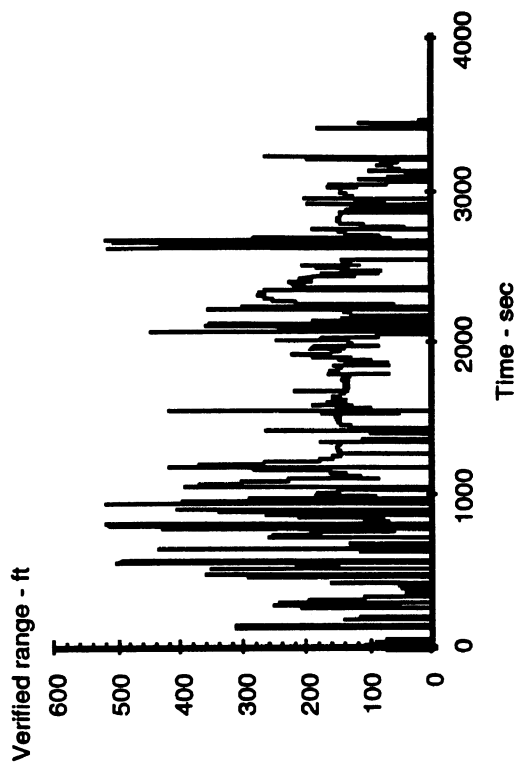





## **APPENDIX B**



## STATISTICAL DATA FOR HISTOGRAMS, NORMAL DRIVING

Var	Subj	Mean	StdDev	Variance	MLV	Total
V	1	107.75	7.37	54.25	110.30	11782
V	2	101.43	8.26	68.30	105.81	12204
V	3	101.61	5.65	31.97	104.01	12524
V	4	97.29	5.95	35.40	97.73	12916
V	5	104.47	9.56	91.41	113.89	11775
V	6	99.44	4.88	23.86	101.32	12627
V	7	93.91	3.57	12.73	94.14	13301
V	8	98.13	5.85	34.19	101.32	12618
V	9	91.05	4.51	20.30	91.44	13343
V	10	97.29	6.74	45.44	98.63	12045
V	11	107.28	10.12	102.51	105.81	11714
V	12	107.39	8.71	75.89	109.40	11857
V	13	86.46	3.29	10.84	84.26	11149
V	14	96.00	5.76	33.22	99.52	13198
V	15	95.39	5.56	30.91	90.54	13184
V	16	101.09	8.17	66.76	102.22	12583
V	17	97.50	5.19	26.95	99.52	12653
V	18	98.76	7.41	54.86	101.32	12281
V	19	98.37	8.19	67.09	103.12	12411
V	20	96.49	5.37	28.83	100.42	12949
V	21	93.60	6.86	47.06	93.24	12428
V	22	91.72	4.08	16.66	93.24	13549
V	23	93.71	4.46	19.91	95.93	13444
V	24	101.08	6.37	40.62	102.22	12287
V	25	99.66	6.83	46.66	99.52	12524
V	26	89.46	4.89	23.95	86.05	12641
V	27	90.61	4.83	23.29	87.85	12405
V	28	93.41	5.07	25.86	92.34	13282
V	29	91.62	4.70	22.08	90.54	12993
V	30	94.97	6.18	38.17	95.03	13066
V	31	99.39	6.29	39.54	103.12	12716
V	32	93.73	5.82	31.82	94.14	12557
V	33	93.67	5.58	31.14	95.03	12702
V	34	96.99	6.61	43.75	100.42	12851
V	35	95.60	5.92	35.09	95.03	13009
V	36	102.51	6.06	36.75	105.81	12081
Rnew_d	1	160.58	115.48	13334.51	76.49	7352
Rnew_d	2	138.00	109.23	11932.13	58.37	10211
Rnew_d	3	190.81	121.07	14657.49	88.57	6364
Rnew_d	4	194.28	107.80	11620.44	82.53	10032
Rnew_d	5	144.54	98.51	9704.24	58.37	9912
Rnew_d	6	221.45	130.60	17055.86	100.65	7953
Rnew_d	7	226.57	126.26	15941.88	94.61	7714
Rnew_d	8	180.40	124.57	15518.02	52.33	7300
Rnew_d	9	239.41	118.52	14047.54	124.82	7581
Rnew_d	10	222.28	97.60	9525.90	148.98	7985
Rnew_d	11	119.44	84.54	7146.67	76.49	10190
Rnew_d	12	220.60	120.26	14462.62	100.65	7447
Rnew_d	13	234.58	108.37	11743.60	161.06	4795
Rnew_d	14	192.67	95.53	9125.74	130.86	10211
Rnew_d	15	221.35	127.88	16353.38	82.53	7803
Rnew_d	16	197.87	108.86	11851.00	136.90	9545
Rnew_d	17	210.63	129.85	16859.88	94.61	4729
Rnew_d	18	177.96	106.96	11440.33	112.73	8187
Rnew_d	19	252.71	123.56	15267.28	330.20	6794
Rnew_d	20	263.87	114.11	13020.52	306.04	7037
Rnew_d	21	227.77	118.15	13959.04	167.10	7688
Rnew_d	22	229.20	114.11	13020.58	124.82	9536
Rnew_d	23	230.63	116.77	13634.68	94.61	8777
Rnew_d	24	201.99	124.53	15508.89	88.57	6176
Rnew_d	25	240.09	117.38	13777.23	130.86	6653
Rnew_d	26	261.71	122.83	15088.01	112.73	6838
Rnew_d	27	207.84	106.69	11383.33	118.78	7156
Rnew_d	28	203.27	88.61	7851.83	167.10	8130
Rnew_d	29	275.78	121.37	14731.39	179.18	7473
Rnew_d	30	240.99	106.16	11269.47	130.86	8336
Rnew_d	31	235.65	120.95	14628.86	148.98	8569
Rnew_d	32	184.86	101.64	10329.84	88.57	10838
Rnew_d	33	235.24	94.79	8985.53	173.14	8027
Rnew_d	34	203.22	113.06	12781.65	136.90	8690
Rnew_d	35	209.22	99.41	9882.22	233.55	9707

<b>Rnew_d</b>	<b>36</b>	<b>226.43</b>	<b>125.32</b>	<b>15705.84</b>	<b>88.57</b>	<b>7407</b>
RdotNew_d	1	-3.37	5.80	33.63	0.31	7352
RdotNew_d	2	-0.88	5.42	29.39	0.31	10211
RdotNew_d	3	-3.26	7.46	55.63	-0.31	6364
RdotNew_d	4	-0.14	5.17	26.75	-0.31	10032
RdotNew_d	5	-2.15	6.00	36.06	-0.31	9912
RdotNew_d	6	-1.34	7.07	50.01	-0.31	7953
RdotNew_d	7	-0.77	5.74	32.99	-0.31	7714
RdotNew_d	8	-2.72	6.06	36.71	-0.31	7300
RdotNew_d	9	1.98	8.03	64.44	-0.31	7581
RdotNew_d	10	-0.42	6.25	39.10	-0.31	7985
RdotNew_d	11	-2.73	5.97	35.70	-0.31	10190
RdotNew_d	12	-5.29	6.86	47.08	-0.31	7447
RdotNew_d	13	5.55	7.84	61.42	-0.31	4795
RdotNew_d	14	-1.09	5.40	29.18	0.31	10211
RdotNew_d	15	1.83	7.74	59.98	-0.31	7803
RdotNew_d	16	-1.73	6.04	36.52	0.31	9545
RdotNew_d	17	0.76	7.78	60.54	-0.31	4729
RdotNew_d	18	-0.77	6.26	39.14	-0.31	8187
RdotNew_d	19	1.22	7.17	51.37	0.31	6794
RdotNew_d	20	0.82	8.02	64.33	0.31	7037
RdotNew_d	21	4.34	8.79	77.25	-0.31	7688
RdotNew_d	22	1.83	6.61	43.68	-0.31	9536
RdotNew_d	23	4.19	7.17	51.43	-0.31	8777
RdotNew_d	24	-2.54	7.51	56.35	-0.31	6176
RdotNew_d	25	-1.01	7.19	51.64	-0.31	6653
RdotNew_d	26	7.98	8.40	70.61	10.71	6838
RdotNew_d	27	3.61	7.58	57.47	0.31	7156
RdotNew_d	28	1.24	6.47	41.82	0.31	8130
RdotNew_d	29	3.89	8.37	70.03	-0.31	7473
RdotNew_d	30	0.61	8.00	64.07	-0.31	8336
RdotNew_d	31	0.52	6.84	46.80	-0.31	8569
RdotNew_d	32	1.64	5.35	28.60	-0.31	10838
RdotNew_d	33	0.91	6.59	43.38	-0.31	8027
RdotNew_d	34	-1.04	5.54	30.74	-0.31	8690
RdotNew_d	35	-0.14	5.50	30.22	-0.31	9707
RdotNew_d	36	-1.32	6.62	43.78	-0.31	7407
Ta_d	1	1.47	1.04	1.08	0.61	7352
Ta_d	2	1.35	1.03	1.05	0.61	10211
Ta_d	3	1.89	1.20	1.43	0.92	6364
Ta_d	4	2.00	1.09	1.19	0.92	10032
Ta_d	5	1.37	0.87	0.76	0.61	9912
Ta_d	6	2.21	1.28	1.65	0.92	7953
Ta_d	7	2.41	1.33	1.77	1.22	7714
Ta_d	8	1.83	1.22	1.49	0.61	7300
Ta_d	9	2.62	1.27	1.61	1.53	7581
Ta_d	10	2.26	0.95	0.91	1.84	7985
Ta_d	11	1.11	0.73	0.53	0.61	10190
Ta_d	12	2.04	1.08	1.18	0.92	7447
Ta_d	13	2.71	1.26	1.58	1.84	4795
Ta_d	14	2.00	0.93	0.87	1.53	10211
Ta_d	15	2.33	1.35	1.83	0.92	7803
Ta_d	16	1.94	1.02	1.04	1.22	9545
Ta_d	17	2.17	1.33	1.76	0.92	4729
Ta_d	18	1.82	1.06	1.13	1.22	8187
Ta_d	19	2.56	1.18	1.38	3.08	6794
Ta_d	20	2.71	1.18	1.40	1.84	7037
Ta_d	21	2.42	1.29	1.67	1.84	7688
Ta_d	22	2.48	1.20	1.43	1.53	9536
Ta_d	23	2.43	1.23	1.51	1.22	8777
Ta_d	24	1.99	1.24	1.54	0.92	6176
Ta_d	25	2.40	1.17	1.37	1.22	6653
Ta_d	26	2.92	1.38	1.91	2.45	6838
Ta_d	27	2.29	1.13	1.28	1.53	7156
Ta_d	28	2.16	0.95	0.90	1.84	8130
Ta_d	29	3.00	1.31	1.71	2.14	7473
Ta_d	30	2.55	1.08	1.17	2.14	8336
Ta_d	31	2.36	1.19	1.43	1.22	8569
Ta_d	32	1.96	1.05	1.10	0.92	10838
Ta_d	33	2.53	0.96	0.92	2.14	8027
Ta_d	34	2.08	1.09	1.19	1.22	8690
Ta_d	35	2.19	1.01	1.03	2.45	9707
Ta_d	36	2.20	1.18	1.39	0.92	7407
Ays_d	1	-0.07	0.06	0.00	-0.07	11782
Ays_d	2	-0.05	0.05	0.00	-0.04	12204

Ays_d	3	-0.04	0.05	0.00	-0.04	12524
Ays_d	4	-0.06	0.05	0.00	-0.06	12916
Ays_d	5	-0.05	0.06	0.00	-0.06	11775
Ays_d	6	-0.06	0.05	0.00	-0.06	12627
Ays_d	7	-0.10	0.04	0.00	-0.11	13301
Ays_d	8	-0.07	0.05	0.00	-0.07	12618
Ays_d	9	-0.05	0.04	0.00	-0.04	13343
Ays_d	10	-0.08	0.04	0.00	-0.07	12045
Ays_d	11	0.14	0.07	0.00	0.12	11714
Ays_d	12	-0.05	0.06	0.00	-0.06	11857
Ays_d	13	-0.09	0.04	0.00	-0.09	11149
Ays_d	14	-0.03	0.05	0.00	-0.04	13198
Ays_d	15	-0.04	0.05	0.00	-0.04	13184
Ays_d	16	-0.06	0.05	0.00	-0.06	12583
Ays_d	17	-0.03	0.05	0.00	-0.02	12653
Ays_d	18	0.01	0.05	0.00	0.01	12281
Ays_d	19	-0.04	0.05	0.00	-0.04	12411
Ays_d	20	0.01	0.05	0.00	0.01	12949
Ays_d	21	-0.06	0.04	0.00	-0.06	12428
Ays_d	22	-0.12	0.05	0.00	-0.14	13549
Ays_d	23	-0.03	0.05	0.00	-0.02	13444
Ays_d	24	-0.03	0.05	0.00	-0.02	12287
Ays_d	25	0.07	0.05	0.00	0.07	12524
Ays_d	26	-0.06	0.04	0.00	-0.06	12641
Ays_d	27	-0.07	0.04	0.00	-0.07	12405
Ays_d	28	0.06	0.04	0.00	0.06	13282
Ays_d	29	0.06	0.04	0.00	0.06	12993
Ays_d	30	0.02	0.05	0.00	0.02	13066
Ays_d	31	-0.23	0.08	0.01	-0.29	12716
Ays_d	32	0.04	0.05	0.00	0.04	12557
Ays_d	33	-0.01	0.05	0.00	-0.01	12702
Ays_d	34	-0.14	0.05	0.00	-0.17	12851
Ays_d	35	0.00	0.05	0.00	0.01	13009
Ays_d	36	0.05	0.05	0.00	0.06	12081
SSPC_d	1	0.00	0.00	0.00	0.00	11782
SSPC_d	2	0.00	0.00	0.00	0.00	12204
SSPC_d	3	0.00	0.00	0.00	0.00	12524
SSPC_d	4	0.00	0.00	0.00	0.00	12916
SSPC_d	5	0.00	0.00	0.00	0.00	11775
SSPC_d	6	0.00	0.00	0.00	0.00	12627
SSPC_d	7	0.00	0.00	0.00	0.00	13301
SSPC_d	8	0.00	0.00	0.00	0.00	12618
SSPC_d	9	0.00	0.00	0.00	0.00	13343
SSPC_d	10	0.00	0.00	0.00	0.00	12045
SSPC_d	11	0.00	0.00	0.00	0.00	11714
SSPC_d	12	0.00	0.00	0.00	0.00	11857
SSPC_d	13	0.00	0.00	0.00	0.00	11149
SSPC_d	14	0.00	0.00	0.00	0.00	13198
SSPC_d	15	0.00	0.00	0.00	0.00	13184
SSPC_d	16	0.00	0.00	0.00	0.00	12583
SSPC_d	17	0.00	0.00	0.00	0.00	12653
SSPC_d	18	0.00	0.00	0.00	0.00	12281
SSPC_d	19	0.00	0.00	0.00	0.00	12411
SSPC_d	20	0.00	0.00	0.00	0.00	12949
SSPC_d	21	0.00	0.00	0.00	0.00	12428
SSPC_d	22	0.00	0.00	0.00	0.00	13549
SSPC_d	23	0.00	0.00	0.00	0.00	13444
SSPC_d	24	0.00	0.00	0.00	0.00	12287
SSPC_d	25	0.00	0.00	0.00	0.00	12524
SSPC_d	26	0.00	0.00	0.00	0.00	12641
SSPC_d	27	0.00	0.00	0.00	0.00	12405
SSPC_d	28	0.00	0.00	0.00	0.00	13282
SSPC_d	29	0.00	0.00	0.00	0.00	12993
SSPC_d	30	0.00	0.00	0.00	0.00	13066
SSPC_d	31	0.00	0.00	0.00	0.00	12716
SSPC_d	32	0.00	0.00	0.00	0.00	12557
SSPC_d	33	0.00	0.00	0.00	0.00	12702
SSPC_d	34	0.00	0.00	0.00	0.00	12851
SSPC_d	35	0.00	0.00	0.00	0.00	13009
SSPC_d	36	0.00	0.00	0.00	0.00	12081
Caw	1	0.10	4.21	17.69	-0.41	11782
Caw	2	-0.11	3.85	14.83	-0.41	12204
Caw	3	-0.20	3.58	12.78	-0.41	12524
Caw	4	-0.18	3.35	11.24	-0.41	12916
Caw	5	-0.20	4.18	17.48	-0.41	11775

Cow	6	-0.09	3.67	13.47	-0.41	12627
Cow	7	-0.14	3.80	12.96	-0.41	13301
Cow	8	-0.12	4.01	16.05	0.41	12618
Cow	9	-0.18	3.13	9.82	-0.41	19343
Cow	10	-0.19	3.31	10.94	0.41	12045
Cow	11	0.12	4.24	18.01	1.22	11714
Cow	12	0.11	4.12	16.99	-0.41	11857
Cow	13	-0.21	3.06	9.35	0.41	11149
Cow	14	-0.20	3.72	13.80	0.41	19198
Cow	15	-0.21	3.54	12.51	0.41	13184
Cow	16	-0.10	3.87	14.96	-1.22	12583
Cow	17	-0.24	3.46	11.99	-0.41	12653
Cow	18	-0.30	3.46	12.01	-1.22	12281
Cow	19	0.10	3.49	12.21	-0.41	12411
Cow	20	0.04	3.22	10.36	-0.41	12949
Cow	21	-0.08	3.47	12.07	0.41	12428
Cow	22	0.04	3.16	9.99	0.41	13549
Cow	23	0.12	3.34	11.14	-0.41	13444
Cow	24	0.09	3.76	14.16	-0.41	12287
Cow	25	-0.04	3.67	13.47	1.22	12524
Cow	26	-0.65	3.33	11.07	-0.41	12641
Cow	27	-0.20	3.18	10.09	0.41	12405
Cow	28	0.23	3.16	9.96	-0.41	13282
Cow	29	-0.13	2.97	8.81	-0.41	12993
Cow	30	-0.30	3.58	12.78	-0.41	13066
Cow	31	-0.09	3.60	12.96	0.41	12716
Cow	32	-0.31	3.30	10.90	-1.22	12557
Cow	33	-0.10	3.44	11.81	-0.41	12702
Cow	34	-0.15	3.50	12.22	0.41	12851
Cow	35	-0.23	3.36	11.31	-0.41	13009
Cow	36	0.15	3.57	12.74	1.22	12081
Cac	1	15.22	6.46	41.70	16.33	11782
Cac	2	13.52	6.96	48.41	16.33	12204
Cac	3	16.23	3.77	14.25	16.33	12524
Cac	4	14.82	4.32	18.64	16.33	12916
Cac	5	14.93	5.92	35.07	18.37	11775
Cac	6	15.27	3.81	14.54	16.33	12627
Cac	7	14.58	4.70	22.04	16.33	13301
Cac	8	15.44	4.72	22.28	16.33	12618
Cac	9	13.10	5.00	25.00	16.33	13343
Cac	10	14.94	5.65	31.94	16.33	12045
Cac	11	15.49	6.80	46.18	16.33	11714
Cac	12	16.13	5.49	30.15	16.33	11857
Cac	13	12.13	4.02	16.13	12.24	11149
Cac	14	14.56	4.48	20.06	16.33	13198
Cac	15	14.11	4.51	20.31	16.33	13184
Cac	16	14.88	7.96	63.31	16.33	12583
Cac	17	14.49	3.63	13.16	14.29	12653
Cac	18	15.29	4.89	23.92	18.37	12281
Cac	19	14.16	5.73	32.84	16.33	12411
Cac	20	13.50	4.49	20.13	14.29	12949
Cac	21	13.91	6.15	37.82	16.33	12428
Cac	22	14.28	5.27	27.74	16.33	13549
Cac	23	14.28	6.91	47.80	16.33	13444
Cac	24	15.57	5.01	25.09	16.33	12287
Cac	25	14.06	7.22	52.13	16.33	12524
Cac	26	13.34	4.86	23.65	16.33	12641
Cac	27	12.96	4.75	22.55	16.33	12405
Cac	28	14.32	4.62	21.34	16.33	13282
Cac	29	14.17	4.24	17.98	16.33	12993
Cac	30	12.86	6.12	37.40	16.33	13066
Cac	31	15.41	5.69	32.35	18.37	12716
Cac	32	13.62	4.45	19.81	16.33	12557
Cac	33	13.88	5.33	28.41	16.33	12702
Cac	34	15.26	4.31	18.57	16.33	12851
Cac	35	14.98	3.96	15.71	16.33	13009
Cac	36	15.39	3.93	15.45	16.33	12081
Vp_d	1	103.86	7.76	60.17	103.12	7352
Vp_d	2	99.75	8.89	75.44	101.32	10211
Vp_d	3	97.59	9.47	89.62	95.03	6364
Vp_d	4	97.29	7.33	53.69	93.24	10032
Vp_d	5	101.68	9.85	97.04	103.12	9912
Vp_d	6	97.93	8.71	75.92	95.03	7953
Vp_d	7	92.83	7.01	49.17	91.44	7714
Vp_d	8	94.42	8.26	68.27	92.34	7300

Vp_d	9	93.06	8.91	79.47	92.34	7581
Vp_d	10	97.29	8.91	79.34	93.24	7985
Vp_d	11	103.83	10.19	103.77	105.81	10190
Vp_d	12	101.69	8.52	72.61	103.12	7447
Vp_d	13	92.47	7.86	61.72	93.24	4795
Vp_d	14	94.46	6.88	47.27	90.54	10211
Vp_d	15	97.52	8.09	65.45	101.32	7803
Vp_d	16	99.15	8.69	75.48	98.63	9545
Vp_d	17	97.69	9.62	92.62	96.83	4729
Vp_d	18	96.48	8.02	64.39	97.73	8187
Vp_d	19	98.59	10.26	105.20	89.65	6794
Vp_d	20	98.83	8.42	70.88	103.12	7037
Vp_d	21	99.02	7.08	50.09	98.63	7688
Vp_d	22	93.92	8.22	67.55	86.95	9536
Vp_d	23	98.82	8.19	67.04	100.42	8777
Vp_d	24	98.65	8.97	80.42	104.91	6176
Vp_d	25	98.86	8.69	75.46	104.91	6653
Vp_d	26	98.13	9.51	90.48	104.91	6838
Vp_d	27	93.62	10.39	107.87	86.95	7156
Vp_d	28	95.36	7.51	56.37	95.93	8130
Vp_d	29	95.95	8.68	75.43	95.93	7473
Vp_d	30	94.92	8.64	74.63	90.54	8336
Vp_d	31	100.14	8.40	70.64	105.81	8569
Vp_d	32	95.46	7.87	61.97	91.44	10838
Vp_d	33	93.50	8.54	72.85	88.75	8027
Vp_d	34	95.75	7.53	56.76	95.93	8690
Vp_d	35	95.23	7.40	54.69	92.34	9707
Vp_d	36	100.75	9.11	83.05	100.42	7407
r	1	0.02	1.10	1.21	0.08	11782
r	2	-0.04	0.94	0.88	-0.08	12204
r	3	-0.01	0.95	0.91	-0.08	12524
r	4	-0.04	0.90	0.82	-0.08	12916
r	5	-0.03	0.99	0.99	-0.08	11775
r	6	-0.03	0.98	0.97	0.08	12627
r	7	-0.04	0.90	0.80	-0.24	13301
r	8	-0.03	0.97	0.95	-0.08	12618
r	9	-0.03	0.82	0.68	-0.08	13343
r	10	-0.02	0.83	0.70	-0.08	12045
r	11	0.01	1.21	1.47	0.08	11714
r	12	-0.01	1.04	1.08	-0.08	11857
r	13	-0.07	0.86	0.74	-0.08	11149
r	14	-0.03	0.89	0.79	-0.08	13198
r	15	-0.03	0.93	0.87	0.08	13184
r	16	-0.03	1.00	1.01	-0.08	12583
r	17	-0.03	0.89	0.79	-0.08	12653
r	18	-0.04	0.90	0.81	-0.08	12281
r	19	0.00	0.91	0.82	-0.08	12411
r	20	-0.06	0.91	0.82	-0.08	12949
r	21	-0.04	0.87	0.76	-0.08	12428
r	22	-0.09	0.93	0.87	-0.41	13549
r	23	0.01	0.93	0.86	0.08	13444
r	24	-0.03	0.97	0.94	0.08	12287
r	25	-0.05	0.97	0.95	0.08	12524
r	26	-0.12	0.85	0.72	-0.08	12641
r	27	-0.11	0.86	0.75	-0.08	12405
r	28	0.00	0.89	0.78	-0.08	13282
r	29	-0.01	0.83	0.69	-0.08	12993
r	30	-0.05	0.90	0.81	-0.08	13066
r	31	-0.01	1.41	1.99	-1.06	12716
r	32	-0.06	0.91	0.83	-0.08	12557
r	33	0.02	0.91	0.83	0.08	12702
r	34	-0.05	1.07	1.14	-0.57	12851
r	35	-0.03	0.90	0.81	-0.08	13009
r	36	-0.01	0.98	0.96	0.08	12081
Ax	1	0.00	0.03	0.00	0.01	11782
Ax	2	0.00	0.04	0.00	0.00	12204
Ax	3	0.00	0.02	0.00	0.00	12524
Ax	4	0.00	0.02	0.00	0.00	12916
Ax	5	0.00	0.03	0.00	0.00	11775
Ax	6	0.00	0.02	0.00	0.00	12627
Ax	7	0.00	0.02	0.00	0.00	13301
Ax	8	0.00	0.03	0.00	0.00	12618
Ax	9	0.00	0.03	0.00	0.00	13343
Ax	10	0.00	0.03	0.00	0.00	12045
Ax	11	0.00	0.04	0.00	0.00	11714

Ax	12	0.00	0.03	0.00	0.00	11857
Ax	13	0.00	0.02	0.00	0.00	11149
Ax	14	0.00	0.02	0.00	0.00	13198
Ax	15	0.00	0.02	0.00	0.00	13184
Ax	16	0.00	0.04	0.00	0.00	12583
Ax	17	0.00	0.02	0.00	0.00	12653
Ax	18	0.00	0.03	0.00	0.00	12281
Ax	19	0.00	0.03	0.00	0.00	12411
Ax	20	0.00	0.02	0.00	0.00	12949
Ax	21	0.00	0.03	0.00	0.01	12428
Ax	22	0.00	0.03	0.00	-0.01	13549
Ax	23	0.00	0.03	0.00	0.00	13444
Ax	24	0.00	0.03	0.00	0.00	12287
Ax	25	0.00	0.04	0.00	-0.01	12524
Ax	26	0.00	0.02	0.00	0.00	12641
Ax	27	0.00	0.02	0.00	0.00	12405
Ax	28	0.00	0.02	0.00	-0.01	13282
Ax	29	0.00	0.02	0.00	0.00	12993
Ax	30	0.00	0.03	0.00	0.00	13066
Ax	31	0.00	0.03	0.00	0.00	12716
Ax	32	0.00	0.02	0.00	0.00	12557
Ax	33	0.00	0.03	0.00	0.00	12702
Ax	34	0.00	0.02	0.00	0.00	12851
Ax	35	0.00	0.02	0.00	0.00	13009
Ax	36	0.00	0.02	0.00	0.00	12081
Cth	1	13.40	5.31	28.14	14.29	11782
Cth	2	12.74	5.50	30.24	16.33	12204
Cth	3	12.48	2.86	8.17	14.29	12524
Cth	4	11.27	3.28	10.78	10.20	12916
Cth	5	13.35	4.94	24.43	14.29	11775
Cth	6	10.85	2.61	6.84	12.24	12627
Cth	7	11.85	3.46	11.95	12.24	13301
Cth	8	12.66	3.90	15.24	14.29	12618
Cth	9	10.87	3.97	15.78	12.24	13343
Cth	10	12.29	4.41	19.42	14.29	12045
Cth	11	11.92	5.74	32.93	12.24	11714
Cth	12	12.65	4.13	17.09	14.29	11857
Cth	13	9.27	2.87	8.25	8.16	11149
Cth	14	12.72	3.48	12.14	14.29	13198
Cth	15	12.41	3.52	12.37	12.24	13184
Cth	16	12.31	7.22	52.10	14.29	12583
Cth	17	12.17	2.54	6.44	12.24	12653
Cth	18	11.95	3.64	13.22	14.29	12281
Cth	19	11.53	4.16	17.27	14.29	12411
Cth	20	10.51	3.43	11.80	12.24	12949
Cth	21	12.21	4.67	21.76	12.24	12428
Cth	22	10.16	3.73	13.93	12.24	13549
Cth	23	11.57	4.04	16.34	14.29	13444
Cth	24	11.94	4.12	17.00	12.24	12287
Cth	25	10.95	5.55	30.83	12.24	12524
Cth	26	11.68	3.61	13.00	12.24	12641
Cth	27	11.38	3.41	11.61	12.24	12405
Cth	28	10.20	3.52	12.41	12.24	13282
Cth	29	10.66	3.19	10.17	10.20	12993
Cth	30	12.30	4.69	21.96	14.29	13066
Cth	31	11.77	4.72	22.29	12.24	12716
Cth	32	8.97	3.47	12.02	8.16	12557
Cth	33	10.37	4.10	16.82	10.20	12702
Cth	34	10.90	3.25	10.58	12.24	12851
Cth	35	11.81	3.29	10.84	14.29	13009
Cth	36	10.86	2.80	7.86	12.24	12081



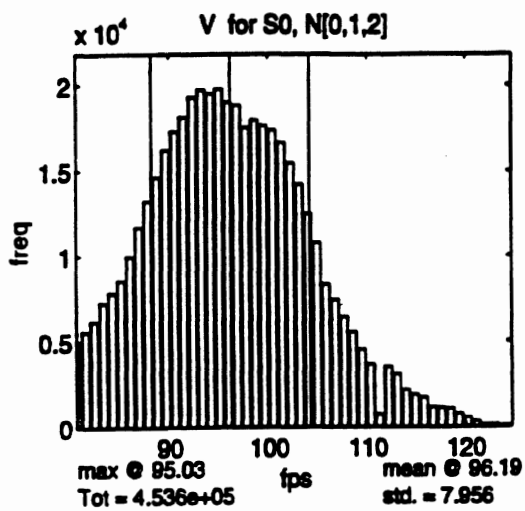

**TABLE of: V for S0, N[0,1,2]**

bin	freq	bin	freq
+80.7	4903	+103.1	14221
+81.6	5575	+104.0	12510
+82.5	6165	+104.9	10809
+83.4	7251	+105.8	8339
+84.3	7847	+106.7	7437
+85.2	8567	+107.6	6437
+86.1	9958	+108.5	5554
+87.0	11688	+109.4	4528
+87.9	13230	+110.3	3665
+88.7	14621	+111.2	750
+89.6	16223	+112.1	3518
+90.5	17310	+113.0	3106
+91.4	18143	+113.9	2183
+92.3	19313	+114.8	1913
+93.2	19753	+115.7	1749
+94.1	19532	+116.6	1192
+95.0	19788	+117.5	1149
+95.9	19025	+118.4	1082
+96.8	18862	+119.3	789
+97.7	17553	+120.2	564
+98.6	17983	+121.1	329
+99.5	17669	+122.0	168
+100.4	17395	+122.9	178
+101.3	16674	+123.8	87
+102.2	15471	+124.7	62

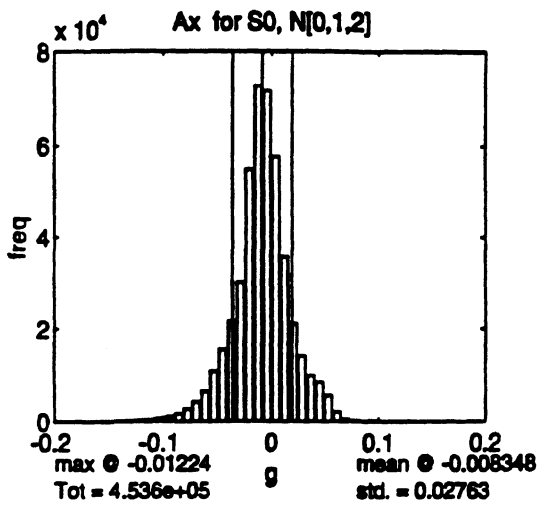

**TABLE of: Ax for S0, N[0,1,2]**

bin	freq	bin	freq
-0.200	13	+0.004	57722
-0.192	22	+0.012	35785
-0.184	26	+0.020	21166
-0.176	20	+0.029	14228
-0.167	18	+0.037	9908
-0.159	19	+0.045	8528
-0.151	50	+0.053	5686
-0.143	123	+0.061	2134
-0.135	246	+0.069	597
-0.127	306	+0.078	247
-0.118	416	+0.086	175
-0.110	548	+0.094	182
-0.102	683	+0.102	141
-0.094	1137	+0.110	109
-0.086	1692	+0.118	109
-0.078	2724	+0.127	119
-0.069	4244	+0.135	63
-0.061	6522	+0.143	76
-0.053	10822	+0.151	42
-0.045	15552	+0.159	30
-0.037	21613	+0.167	16
-0.029	30144	+0.176	17
-0.020	54923	+0.184	11
-0.012	72767	+0.192	26
-0.004	71799	+0.200	18

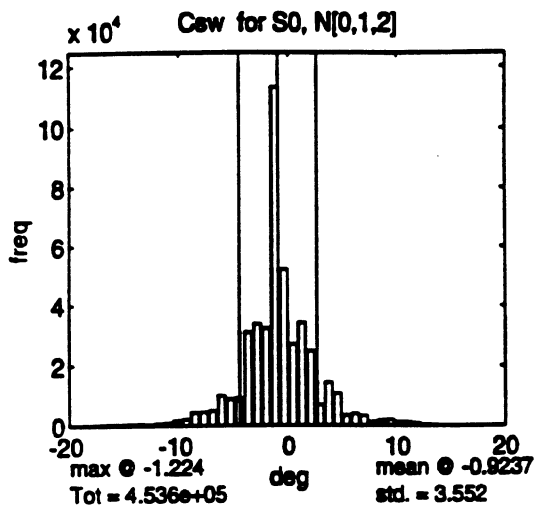

**TABLE of: Csw for S0, N[0,1,2]**

bin	freq	bin	freq
-20.00	67	+0.41	27257
-19.18	82	+1.22	34265
-18.37	104	+2.04	24967
-17.55	150	+2.86	6963
-16.73	410	+3.67	14387
-15.92	520	+4.49	10777
-15.10	437	+5.31	3369
-14.29	503	+6.12	4078
-13.47	681	+6.94	3356
-12.65	407	+7.76	1284
-11.84	744	+8.57	1863
-11.02	961	+9.39	2043
-10.20	1727	+10.20	1295
-9.39	2220	+11.02	1244
-8.57	4458	+11.84	896
-7.76	4599	+12.65	411
-6.94	5021	+13.47	255
-6.12	10159	+14.29	128
-5.31	8997	+15.10	85
-4.49	9235	+15.92	33
-3.67	31272	+16.73	51
-2.86	33938	+17.55	12
-2.04	32424	+18.37	28
-1.22	113208	+19.18	9
-0.41	52227	+20.00	3

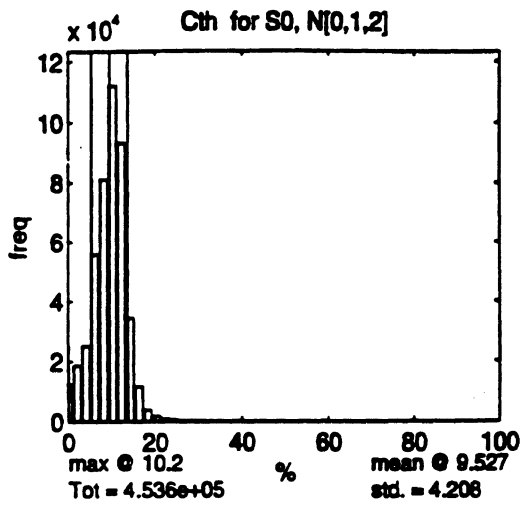

**TABLE of: Cth for S0, N[0,1,2]**

bin	freq	bin	freq
+0.0	12293	+51.0	28
+2.0	18544	+53.1	24
+4.1	25078	+55.1	19
+6.1	55629	+57.1	4
+8.2	81025	+59.2	6
+10.2	112086	+61.2	4
+12.2	93112	+63.3	9
+14.3	34392	+65.3	20
+16.3	11706	+67.3	6
+18.4	3863	+69.4	6
+20.4	1934	+71.4	6
+22.4	1029	+73.5	1
+24.5	678	+75.5	7
+26.5	396	+77.6	10
+28.6	262	+79.6	0
+30.6	242	+81.6	0
+32.7	181	+83.7	0
+34.7	133	+85.7	0
+36.7	122	+87.8	0
+38.8	98	+89.8	0
+40.8	81	+91.8	0
+42.9	65	+93.9	0
+44.9	30	+95.9	0
+46.9	41	+98.0	0
+49.0	29	+100.0	0

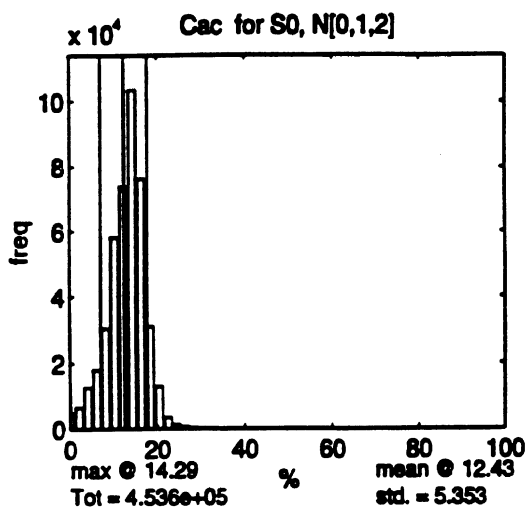

**TABLE of: Cac for S0, N[0,1,2]**

bin	freq	bin	freq
+0.0	4841	+51.0	14
+2.0	6587	+53.1	7
+4.1	12726	+55.1	19
+6.1	17957	+57.1	11
+8.2	30433	+59.2	4
+10.2	58223	+61.2	6
+12.2	73755	+63.3	1
+14.3	103411	+65.3	2
+16.3	76261	+67.3	3
+18.4	31008	+69.4	0
+20.4	13055	+71.4	4
+22.4	3536	+73.5	3
+24.5	1429	+75.5	0
+26.5	847	+77.6	0
+28.6	478	+79.6	0
+30.6	322	+81.6	0
+32.7	262	+83.7	0
+34.7	145	+85.7	0
+36.7	108	+87.8	0
+38.8	99	+89.8	0
+40.8	64	+91.8	0
+42.9	62	+93.9	0
+44.9	32	+95.9	0
+46.9	39	+98.0	0
+49.0	23	+100.0	0

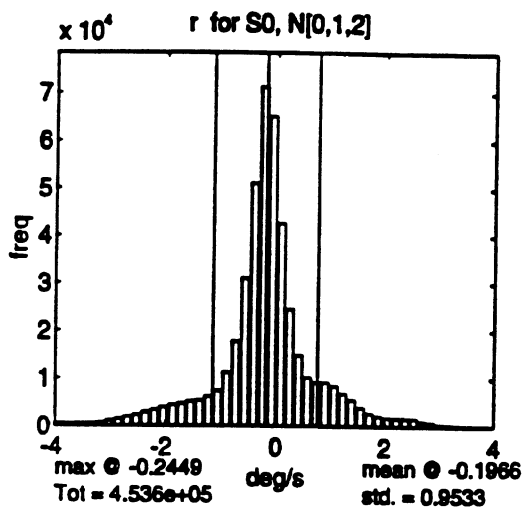

**TABLE of: r for S0, N[0,1,2]**

bin	freq	bin	freq
-4.00	516	+0.08	42588
-3.84	507	+0.24	24505
-3.67	486	+0.41	14837
-3.51	556	+0.57	10152
-3.35	569	+0.73	9164
-3.18	774	+0.90	9137
-3.02	1151	+1.06	8323
-2.86	1524	+1.22	6819
-2.69	1970	+1.39	5491
-2.53	2307	+1.55	3894
-2.37	2949	+1.71	2732
-2.20	3396	+1.88	2179
-2.04	3969	+2.04	1837
-1.88	4427	+2.20	1751
-1.71	4728	+2.37	1720
-1.55	5227	+2.53	1633
-1.39	5415	+2.69	1135
-1.22	6191	+2.86	899
-1.06	7456	+3.02	524
-0.90	11273	+3.18	337
-0.73	17768	+3.35	205
-0.57	31055	+3.51	161
-0.41	51114	+3.67	97
-0.24	71342	+3.84	74
-0.08	65218	+4.00	45

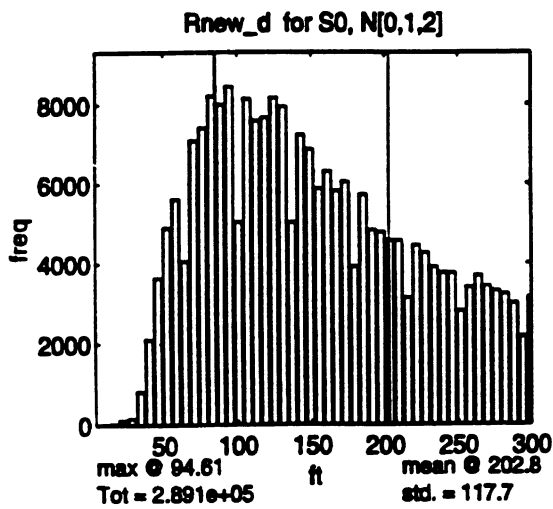

**TABLE of: Rnew\_d for S0, N[0,1,2]**

bin	freq	bin	freq
+4.0	0	+155.0	5898
+10.0	1	+161.1	6328
+16.1	14	+167.1	5832
+22.1	109	+173.1	6062
+28.2	163	+179.2	3919
+34.2	820	+185.2	5737
+40.2	2097	+191.3	4847
+46.3	3636	+197.3	4795
+52.3	4894	+203.3	4594
+58.4	5615	+209.4	4577
+64.4	4050	+215.4	3146
+70.4	7102	+221.5	4455
+76.5	7429	+227.5	4273
+82.5	8210	+233.6	3911
+88.6	7999	+239.6	3769
+94.6	8444	+245.6	3764
+100.7	5055	+251.7	2822
+106.7	8146	+257.7	3409
+112.7	7605	+263.8	3695
+118.8	7685	+269.8	3439
+124.8	8177	+275.8	3326
+130.9	7957	+281.9	3245
+136.9	5049	+287.9	3013
+142.9	7258	+294.0	2180
+149.0	6886	+300.0	3147

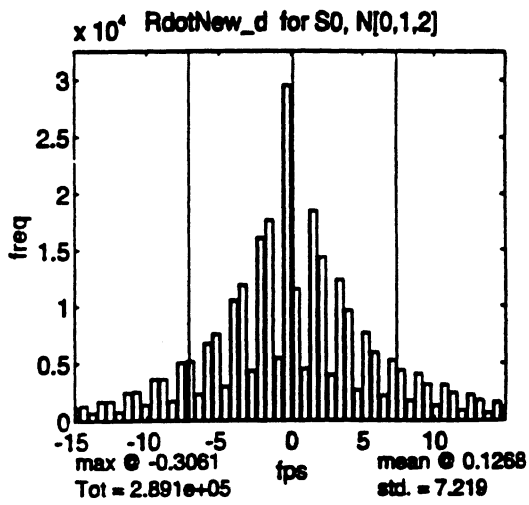
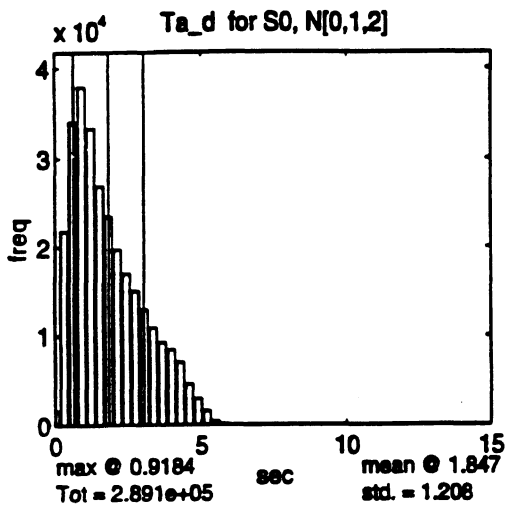

TABLE of: RdotNew\_d for S0, N[0,1,2]

bin	freq	bin	freq
-15.00	1094	+0.31	11512
-14.39	1291	+0.92	4541
-13.78	704	+1.53	18476
-13.16	1665	+2.14	14321
-12.55	1671	+2.76	3989
-11.94	778	+3.37	12314
-11.33	2436	+3.98	9587
-10.71	2530	+4.59	2674
-10.10	1395	+5.20	7627
-9.49	3603	+5.82	5940
-8.88	3611	+6.43	2177
-8.27	1705	+7.04	5240
-7.65	5025	+7.65	4401
-7.04	5155	+8.27	1746
-6.43	2308	+8.88	4083
-5.82	6718	+9.49	3157
-5.20	7520	+10.10	1337
-4.59	2987	+10.71	3108
-3.98	10479	+11.33	2453
-3.37	11851	+11.94	894
-2.76	4358	+12.55	2254
-2.14	16060	+13.16	1803
-1.53	17598	+13.78	691
-0.92	5461	+14.39	1603
-0.31	29511	+15.00	1164





**TABLE of: Ta\_d for S0, N[0,1,2]**

bin	freq	bin	freq
+0.00	1586	+7.65	0
+0.31	21779	+7.96	0
+0.61	34051	+8.27	0
+0.92	37946	+8.57	0
+1.22	33338	+8.88	0
+1.53	26888	+9.18	0
+1.84	23484	+9.49	0
+2.14	19729	+9.80	0
+2.45	17002	+10.10	0
+2.76	15031	+10.41	0
+3.06	12942	+10.71	0
+3.37	10874	+11.02	0
+3.67	9229	+11.33	0
+3.98	8444	+11.63	0
+4.29	7063	+11.94	0
+4.59	4597	+12.24	0
+4.90	2958	+12.55	0
+5.20	1598	+12.86	0
+5.51	481	+13.16	0
+5.82	118	+13.47	0
+6.12	5	+13.78	0
+6.43	0	+14.08	0
+6.73	0	+14.39	0
+7.04	0	+14.69	0
+7.35	0	+15.00	0

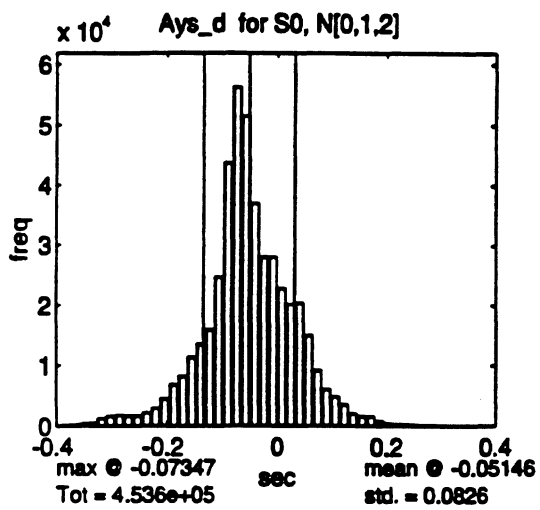

**TABLE of: Ays\_d for S0, N[0,1,2]**

bin	freq	bin	freq
-0.400	77	+0.008	22785
-0.384	95	+0.024	20091
-0.367	223	+0.041	20305
-0.351	385	+0.057	14907
-0.335	529	+0.073	9158
-0.318	1217	+0.090	6020
-0.302	1649	+0.106	4842
-0.286	1811	+0.122	3549
-0.269	1679	+0.139	2076
-0.253	1700	+0.155	1648
-0.237	2192	+0.171	1593
-0.220	2925	+0.188	877
-0.204	4502	+0.204	517
-0.188	6823	+0.220	330
-0.171	8224	+0.237	297
-0.155	11323	+0.253	186
-0.139	13493	+0.269	109
-0.122	15857	+0.286	96
-0.106	24657	+0.302	42
-0.090	43679	+0.318	21
-0.073	56265	+0.335	6
-0.057	51507	+0.351	3
-0.041	36999	+0.367	10
-0.024	28090	+0.384	13
-0.008	28039	+0.400	1

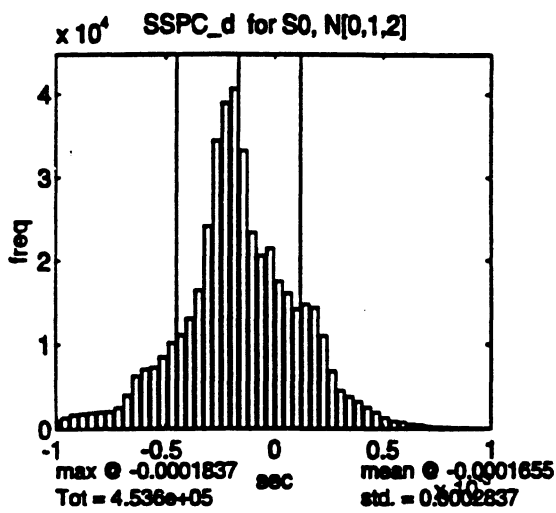

TABLE of: SSPC\_d for S0, N[0,1,2]

bin	freq	bin	freq
-1.00e-03	997	+2.04e-05	17463
-9.59e-04	1356	+6.12e-05	16046
-9.18e-04	1695	+1.02e-04	14114
-8.78e-04	1833	+1.43e-04	14722
-8.37e-04	1925	+1.84e-04	14323
-7.96e-04	1994	+2.24e-04	10977
-7.55e-04	2087	+2.65e-04	6810
-7.14e-04	2517	+3.06e-04	4568
-6.73e-04	3978	+3.47e-04	3863
-6.33e-04	6204	+3.88e-04	3272
-5.92e-04	7007	+4.29e-04	2610
-5.51e-04	7228	+4.69e-04	2014
-5.10e-04	8454	+5.10e-04	1372
-4.69e-04	10091	+5.51e-04	963
-4.29e-04	11075	+5.92e-04	824
-3.88e-04	13034	+6.33e-04	589
-3.47e-04	16409	+6.73e-04	456
-3.06e-04	24095	+7.14e-04	321
-2.65e-04	34459	+7.55e-04	217
-2.24e-04	38952	+7.96e-04	201
-1.84e-04	40588	+8.37e-04	94
-1.43e-04	33256	+8.78e-04	82
-1.02e-04	23385	+9.18e-04	59
-6.12e-05	20573	+9.59e-04	31
-2.04e-05	21448	+1.00e-03	10

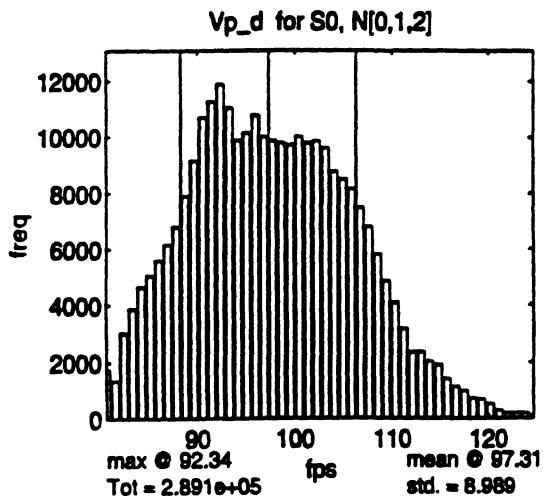

TABLE of: Vp\_d for S0, N[0,1,2]

bin	freq	bin	freq
+80.7	1755	+103.1	9608
+81.6	1344	+104.0	8771
+82.5	3020	+104.9	8492
+83.4	3858	+105.8	8155
+84.3	4646	+106.7	7489
+85.2	5061	+107.6	6797
+86.1	5591	+108.5	5830
+87.0	6162	+109.4	4861
+87.9	6789	+110.3	4093
+88.7	7889	+111.2	3172
+89.6	9156	+112.1	2347
+90.5	10693	+113.0	2360
+91.4	11269	+113.9	2029
+92.3	11888	+114.8	1902
+93.2	11047	+115.7	1407
+94.1	9889	+116.6	1133
+95.0	10150	+117.5	987
+95.9	10772	+118.4	728
+96.8	10010	+119.3	689
+97.7	9886	+120.2	521
+98.6	9804	+121.1	307
+99.5	9717	+122.0	202
+100.4	10022	+122.9	197
+101.3	9797	+123.8	206
+102.2	9871	+124.7	110

## STATISTICAL DATA FOR HISTOGRAMS, CRUISE CONTROL DRIVING

Var	Subj	Mean	StdDev	Variance	MLV	Total
V	1	103.96	6.28	39.50	104.01	12233
V	2	99.07	7.83	61.30	107.61	11927
V	3	98.36	4.10	16.79	101.32	12856
V	4	98.33	5.10	26.02	101.32	12749
V	5	100.68	5.77	33.28	102.22	12547
V	6	99.22	3.71	13.80	98.63	12330
V	7	94.63	4.52	20.39	95.93	13153
V	8	93.27	3.77	14.25	95.93	13450
V	9	91.24	5.20	27.02	89.65	13213
V	10	98.55	5.72	32.69	104.01	12598
V	11	109.33	9.26	85.66	109.40	11521
V	12	107.07	9.14	83.53	108.50	12052
V	13	86.27	5.17	26.77	81.56	13670
V	14	90.03	4.14	17.15	88.75	13273
V	15	94.82	6.18	38.15	89.65	13376
V	16	100.76	5.99	35.82	104.01	12681
V	17	93.46	3.59	12.88	95.03	13196
V	18	91.70	3.81	14.49	92.34	13182
V	19	97.45	6.83	46.62	104.01	12630
V	20	89.93	6.65	44.19	95.93	13999
V	21	93.93	6.69	44.70	86.95	12888
V	22	92.39	1.45	2.12	92.34	13374
V	23	90.27	2.31	5.33	89.65	13951
V	24	100.99	5.09	25.89	104.01	12522
V	25	95.65	4.41	19.47	98.63	11412
V	26	82.03	1.33	1.76	81.56	13495
V	27	89.36	3.21	10.28	89.65	13251
V	28	94.22	3.71	13.75	95.93	13070
V	29	90.77	5.25	27.57	94.14	11084
V	30	97.59	7.34	53.83	97.73	12562
V	31	96.92	4.65	21.58	98.63	13146
V	32	92.25	4.89	23.88	95.93	13444
V	33	94.72	4.28	18.34	95.93	12924
V	34	95.55	5.37	28.82	95.93	12964
V	35	93.76	3.13	9.80	95.93	13410
V	36	100.12	4.74	22.51	101.32	12234
Rnew_d	1	186.41	125.50	15751.40	76.49	5545
Rnew_d	2	206.21	130.50	17029.49	64.41	6757
Rnew_d	3	213.93	127.87	16351.89	130.86	6333
Rnew_d	4	244.88	113.10	12791.91	167.10	8127
Rnew_d	5	256.93	129.98	16894.49	52.33	6598
Rnew_d	6	258.16	124.07	15393.35	318.12	7975
Rnew_d	7	228.44	113.02	12773.14	88.57	8605
Rnew_d	8	246.46	118.06	13937.14	82.53	6761
Rnew_d	9	235.57	115.70	13386.35	167.10	7566
Rnew_d	10	261.35	115.15	13259.79	245.63	8433
Rnew_d	11	189.63	124.24	15435.78	58.37	7689
Rnew_d	12	165.35	98.54	9710.27	88.57	7432
Rnew_d	13	279.38	110.53	12215.88	275.84	5276
Rnew_d	14	266.17	124.63	15532.39	161.06	7050
Rnew_d	15	276.36	130.70	17083.67	251.67	8017
Rnew_d	16	224.74	106.25	11288.38	173.14	8506
Rnew_d	17	247.60	112.29	12608.22	197.31	6328
Rnew_d	18	236.34	112.59	12676.53	233.55	9551
Rnew_d	19	260.01	111.86	12512.79	203.35	6707
Rnew_d	20	284.94	123.92	15355.02	179.18	5656
Rnew_d	21	225.64	116.21	13504.79	155.02	8756
Rnew_d	22	251.48	123.49	15249.20	148.98	6888
Rnew_d	23	259.88	116.83	13650.12	275.84	8139
Rnew_d	24	248.32	129.20	16693.36	155.02	7168
Rnew_d	25	201.15	96.06	9227.94	155.02	9290
Rnew_d	26	303.09	119.01	14163.28	203.35	6455
Rnew_d	27	264.38	106.86	11420.07	203.35	9214
Rnew_d	28	236.49	107.74	11607.43	167.10	9008
Rnew_d	29	267.06	124.14	15409.76	281.88	5820
Rnew_d	30	211.65	101.64	10330.87	148.98	9328
Rnew_d	31	240.00	119.58	14299.29	161.06	7650
Rnew_d	32	234.71	117.19	13733.65	136.90	8236
Rnew_d	33	289.49	126.13	15908.53	197.31	7433
Rnew_d	34	264.84	121.05	14653.32	136.90	6399
Rnew_d	35	280.19	119.66	14319.32	124.82	8806

Rnew_d	36	263.23	122.77	15071.80	94.61	7033
RdotNew_d	1	-2.33	6.65	44.21	-0.31	5545
RdotNew_d	2	-0.16	6.57	43.13	-0.31	6757
RdotNew_d	3	-0.31	7.83	61.24	0.31	6333
RdotNew_d	4	0.83	6.49	42.18	-0.31	8127
RdotNew_d	5	-0.22	6.46	41.79	-0.31	6598
RdotNew_d	6	-0.30	7.35	54.08	-3.37	7975
RdotNew_d	7	3.60	7.36	54.17	-0.31	8605
RdotNew_d	8	1.76	7.56	57.13	-0.31	6761
RdotNew_d	9	3.66	7.70	59.28	-0.31	7586
RdotNew_d	10	0.15	6.83	46.65	-0.31	8433
RdotNew_d	11	-4.97	8.81	77.64	0.31	7689
RdotNew_d	12	-2.78	7.70	59.31	0.31	7432
RdotNew_d	13	8.16	8.63	74.45	11.33	5276
RdotNew_d	14	5.24	7.71	59.48	-0.31	7050
RdotNew_d	15	4.02	8.44	71.21	0.31	8017
RdotNew_d	16	-0.62	7.58	57.40	-0.31	8506
RdotNew_d	17	2.79	8.81	77.60	0.31	6328
RdotNew_d	18	4.27	7.01	49.18	-0.31	9551
RdotNew_d	19	0.88	7.67	58.78	-0.31	6707
RdotNew_d	20	9.48	9.20	84.61	7.04	5656
RdotNew_d	21	0.91	7.09	50.22	-0.31	8756
RdotNew_d	22	4.75	8.19	67.07	0.31	6888
RdotNew_d	23	5.39	8.20	67.18	-0.31	8139
RdotNew_d	24	-0.77	7.51	56.44	-0.31	7168
RdotNew_d	25	0.51	5.90	34.76	-0.31	9290
RdotNew_d	26	13.20	9.12	83.26	15.00	6455
RdotNew_d	27	5.78	8.09	65.46	-0.31	9214
RdotNew_d	28	4.76	7.65	58.57	0.31	9008
RdotNew_d	29	7.65	9.74	94.87	-3.37	5820
RdotNew_d	30	-0.67	7.43	55.26	-0.31	9328
RdotNew_d	31	3.21	7.22	52.09	-0.31	7650
RdotNew_d	32	4.29	6.91	47.80	-0.31	8236
RdotNew_d	33	1.37	6.92	47.85	-0.31	7433
RdotNew_d	34	2.68	6.99	48.91	-0.31	6399
RdotNew_d	35	2.83	6.83	46.66	-0.31	8806
RdotNew_d	36	0.64	7.34	53.93	-0.31	7033
Ta_d	1	1.77	1.14	1.31	0.92	5545
Ta_d	2	2.10	1.33	1.76	0.61	6757
Ta_d	3	2.17	1.29	1.67	0.92	6333
Ta_d	4	2.49	1.12	1.26	2.45	8127
Ta_d	5	2.54	1.28	1.65	2.45	6598
Ta_d	6	2.58	1.24	1.53	2.45	7975
Ta_d	7	2.41	1.17	1.37	1.84	8605
Ta_d	8	2.62	1.25	1.56	2.14	6761
Ta_d	9	2.59	1.27	1.61	1.53	7586
Ta_d	10	2.64	1.16	1.34	2.45	8433
Ta_d	11	1.70	1.07	1.15	0.61	7689
Ta_d	12	1.55	0.90	0.80	0.92	7432
Ta_d	13	3.25	1.27	1.62	3.06	5276
Ta_d	14	2.93	1.37	1.88	1.84	7050
Ta_d	15	2.94	1.42	2.00	2.45	8017
Ta_d	16	2.21	1.02	1.04	1.53	8506
Ta_d	17	2.64	1.19	1.42	2.14	6328
Ta_d	18	2.56	1.21	1.47	2.45	9551
Ta_d	19	2.67	1.10	1.20	2.45	6707
Ta_d	20	3.20	1.43	2.05	2.45	5656
Ta_d	21	2.40	1.26	1.59	1.84	8756
Ta_d	22	2.71	1.33	1.77	1.53	6888
Ta_d	23	2.87	1.31	1.71	1.84	8139
Ta_d	24	2.45	1.24	1.55	1.53	7168
Ta_d	25	2.09	0.99	0.98	1.22	9290
Ta_d	26	3.69	1.45	2.11	2.76	6455
Ta_d	27	2.95	1.19	1.42	2.14	9214
Ta_d	28	2.51	1.13	1.27	1.84	9008
Ta_d	29	2.95	1.39	1.94	1.84	5820
Ta_d	30	2.17	1.00	1.00	1.84	9328
Ta_d	31	2.47	1.24	1.54	1.53	7650
Ta_d	32	2.54	1.26	1.58	2.76	8236
Ta_d	33	3.06	1.29	1.68	2.14	7433
Ta_d	34	2.78	1.28	1.64	2.45	6399
Ta_d	35	2.97	1.26	1.58	1.53	8806
Ta_d	36	2.63	1.22	1.48	2.14	7033
Ays_d	1	0.00	0.06	0.00	-0.01	12233
Ays_d	2	-0.10	0.05	0.00	-0.11	11927

Ays_d	3	-0.03	0.05	0.00	-0.04	12856
Ays_d	4	-0.03	0.05	0.00	-0.02	12749
Ays_d	5	0.02	0.06	0.00	0.01	12547
Ays_d	6	-0.02	0.05	0.00	-0.02	12330
Ays_d	7	-0.06	0.05	0.00	-0.06	13153
Ays_d	8	-0.09	0.05	0.00	-0.09	13450
Ays_d	9	-0.02	0.04	0.00	-0.02	13213
Ays_d	10	-0.07	0.05	0.00	-0.07	12598
Ays_d	11	-0.10	0.06	0.00	-0.11	11521
Ays_d	12	0.02	0.06	0.00	0.02	12052
Ays_d	13	-0.06	0.04	0.00	-0.06	13670
Ays_d	14	-0.06	0.04	0.00	-0.07	13273
Ays_d	15	-0.05	0.05	0.00	-0.04	13376
Ays_d	16	-0.02	0.05	0.00	-0.02	12681
Ays_d	17	-0.10	0.04	0.00	-0.11	13196
Ays_d	18	0.04	0.04	0.00	0.04	13182
Ays_d	19	0.03	0.05	0.00	0.02	12630
Ays_d	20	-0.10	0.04	0.00	-0.09	13999
Ays_d	21	-0.07	0.05	0.00	-0.07	12888
Ays_d	22	-0.04	0.05	0.00	-0.04	13374
Ays_d	23	-0.08	0.05	0.00	-0.07	13951
Ays_d	24	0.01	0.05	0.00	0.01	12522
Ays_d	25	0.06	0.05	0.00	0.06	11412
Ays_d	26	-0.07	0.04	0.00	-0.07	13495
Ays_d	27	-0.04	0.04	0.00	-0.04	13251
Ays_d	28	0.11	0.05	0.00	0.12	13070
Ays_d	29	-0.03	0.04	0.00	-0.02	11084
Ays_d	30	0.03	0.05	0.00	0.04	12562
Ays_d	31	0.08	0.06	0.00	0.09	13146
Ays_d	32	-0.02	0.04	0.00	-0.02	13444
Ays_d	33	0.01	0.05	0.00	0.01	12924
Ays_d	34	0.03	0.05	0.00	0.02	12964
Ays_d	35	-0.05	0.05	0.00	-0.06	13410
Ays_d	36	0.09	0.05	0.00	0.09	12234
SSPC_d	1	0.00	0.00	0.00	0.00	12233
SSPC_d	2	0.00	0.00	0.00	0.00	11927
SSPC_d	3	0.00	0.00	0.00	0.00	12856
SSPC_d	4	0.00	0.00	0.00	0.00	12749
SSPC_d	5	0.00	0.00	0.00	0.00	12547
SSPC_d	6	0.00	0.00	0.00	0.00	12330
SSPC_d	7	0.00	0.00	0.00	0.00	13153
SSPC_d	8	0.00	0.00	0.00	0.00	13450
SSPC_d	9	0.00	0.00	0.00	0.00	13213
SSPC_d	10	0.00	0.00	0.00	0.00	12598
SSPC_d	11	0.00	0.00	0.00	0.00	11521
SSPC_d	12	0.00	0.00	0.00	0.00	12052
SSPC_d	13	0.00	0.00	0.00	0.00	13670
SSPC_d	14	0.00	0.00	0.00	0.00	13273
SSPC_d	15	0.00	0.00	0.00	0.00	13376
SSPC_d	16	0.00	0.00	0.00	0.00	12681
SSPC_d	17	0.00	0.00	0.00	0.00	13196
SSPC_d	18	0.00	0.00	0.00	0.00	13182
SSPC_d	19	0.00	0.00	0.00	0.00	12630
SSPC_d	20	0.00	0.00	0.00	0.00	13999
SSPC_d	21	0.00	0.00	0.00	0.00	12888
SSPC_d	22	0.00	0.00	0.00	0.00	13374
SSPC_d	23	0.00	0.00	0.00	0.00	13951
SSPC_d	24	0.00	0.00	0.00	0.00	12522
SSPC_d	25	0.00	0.00	0.00	0.00	11412
SSPC_d	26	0.00	0.00	0.00	0.00	13495
SSPC_d	27	0.00	0.00	0.00	0.00	13251
SSPC_d	28	0.00	0.00	0.00	0.00	13070
SSPC_d	29	0.00	0.00	0.00	0.00	11084
SSPC_d	30	0.00	0.00	0.00	0.00	12562
SSPC_d	31	0.00	0.00	0.00	0.00	13146
SSPC_d	32	0.00	0.00	0.00	0.00	13444
SSPC_d	33	0.00	0.00	0.00	0.00	12924
SSPC_d	34	0.00	0.00	0.00	0.00	12964
SSPC_d	35	0.00	0.00	0.00	0.00	13410
SSPC_d	36	0.00	0.00	0.00	0.00	12234
Caw	1	0.16	4.07	16.60	-0.41	12233
Caw	2	-0.24	3.65	13.30	-0.41	11927
Caw	3	-0.15	3.80	12.96	-0.41	12856
Caw	4	-0.11	3.50	12.26	-0.41	12749
Caw	5	0.08	3.90	15.18	1.22	12547

Csw	6	0.07	3.71	13.77	-0.41	12330
Csw	7	-0.22	3.91	15.30	-0.41	13153
Csw	8	0.08	3.63	13.18	-1.22	13450
Csw	9	-0.17	3.17	10.05	-0.41	13213
Csw	10	-0.03	3.63	13.15	0.41	12598
Csw	11	-0.08	4.22	17.81	1.22	11521
Csw	12	0.14	4.28	18.34	-0.41	12052
Csw	13	-0.27	2.77	7.67	0.41	13670
Csw	14	-0.12	3.37	11.32	0.41	13273
Csw	15	0.08	3.61	13.01	0.41	13376
Csw	16	-0.07	3.88	15.07	-1.22	12681
Csw	17	0.03	3.14	9.87	0.41	13196
Csw	18	-0.30	3.01	9.06	-1.22	13182
Csw	19	0.04	3.47	12.01	-0.41	12630
Csw	20	-0.55	3.14	9.89	-0.41	13999
Csw	21	-0.10	3.72	13.82	0.41	12888
Csw	22	-0.21	3.32	11.04	-0.41	13374
Csw	23	-0.25	3.22	10.37	-0.41	13951
Csw	24	-0.06	3.96	15.72	-1.22	12522
Csw	25	-0.09	3.46	12.00	-1.22	11412
Csw	26	-2.81	2.84	8.08	-2.04	13495
Csw	27	-0.14	2.94	8.63	0.41	13251
Csw	28	-0.25	3.25	10.55	-1.22	13070
Csw	29	0.02	2.91	8.49	0.41	11084
Csw	30	-0.14	3.80	14.46	-0.41	12562
Csw	31	-0.11	3.59	12.91	-1.22	13146
Csw	32	0.15	3.27	10.72	-0.41	13444
Csw	33	-0.12	3.26	10.65	-0.41	12924
Csw	34	-0.11	3.26	10.65	-0.41	12964
Csw	35	0.07	3.34	11.15	0.41	13410
Csw	36	-0.04	3.82	14.63	1.22	12234
Cac	1	2.81	6.66	44.32	0.00	12233
Cac	2	5.49	7.55	57.06	0.00	11927
Cac	3	1.29	4.42	19.57	0.00	12656
Cac	4	3.52	6.57	43.13	0.00	12749
Cac	5	3.88	7.04	49.50	0.00	12547
Cac	6	1.22	4.25	18.04	0.00	12330
Cac	7	3.36	6.50	42.28	0.00	13153
Cac	8	0.90	3.82	14.60	0.00	13450
Cac	9	3.08	6.35	40.35	0.00	13213
Cac	10	2.86	6.65	44.29	0.00	12598
Cac	11	5.78	9.83	96.60	0.00	11521
Cac	12	7.77	9.45	89.28	0.00	12052
Cac	13	0.93	3.69	13.65	0.00	13670
Cac	14	3.71	6.74	45.39	0.00	13273
Cac	15	1.25	4.44	19.68	0.00	13376
Cac	16	6.60	9.05	81.90	0.00	12681
Cac	17	3.76	6.45	41.59	0.00	13196
Cac	18	2.91	6.18	38.19	0.00	13182
Cac	19	0.86	3.63	13.18	0.00	12630
Cac	20	1.31	4.69	21.96	0.00	13999
Cac	21	3.45	8.29	68.73	0.00	12888
Cac	22	0.44	3.06	9.34	0.00	13374
Cac	23	1.78	5.39	29.01	0.00	13951
Cac	24	4.36	7.33	53.70	0.00	12522
Cac	25	0.86	3.83	14.70	0.00	11412
Cac	26	1.09	3.92	15.37	0.00	13495
Cac	27	2.98	5.78	33.45	0.00	13251
Cac	28	1.65	5.08	25.85	0.00	13070
Cac	29	5.10	7.32	53.57	0.00	11084
Cac	30	6.24	8.73	76.16	0.00	12562
Cac	31	2.17	6.00	35.99	0.00	13146
Cac	32	5.33	7.43	55.16	0.00	13444
Cac	33	4.43	7.08	50.18	0.00	12924
Cac	34	3.41	6.77	45.78	0.00	12964
Cac	35	2.03	5.19	26.98	0.00	13410
Cac	36	2.75	6.06	36.70	0.00	12234
Vp_d	1	100.79	9.71	94.26	107.61	5545
Vp_d	2	97.13	9.62	92.45	88.75	6757
Vp_d	3	97.91	8.48	71.84	93.24	6333
Vp_d	4	99.07	8.55	73.18	104.01	8127
Vp_d	5	100.38	7.41	54.97	99.52	6598
Vp_d	6	99.15	8.45	71.45	95.93	7975
Vp_d	7	98.07	8.57	73.51	101.32	8605
Vp_d	8	95.41	8.68	75.38	100.42	6761



Vp_d	9	94.79	7.29	53.14	85.16	7566
Vp_d	10	99.21	8.59	73.82	103.12	8433
Vp_d	11	103.67	10.83	117.23	104.01	7689
Vp_d	12	103.84	9.70	94.07	107.61	7432
Vp_d	13	94.38	8.33	69.46	97.73	5276
Vp_d	14	96.07	8.37	70.13	98.63	7050
Vp_d	15	98.84	8.63	74.56	101.32	8017
Vp_d	16	100.71	8.63	74.41	95.93	8506
Vp_d	17	96.29	9.42	88.80	97.73	6328
Vp_d	18	96.25	7.53	56.70	92.34	9551
Vp_d	19	97.59	9.45	89.32	95.93	6707
Vp_d	20	99.60	9.80	96.03	103.12	5656
Vp_d	21	96.05	7.39	54.63	98.63	8756
Vp_d	22	97.37	8.34	69.55	92.34	6888
Vp_d	23	96.09	8.23	67.67	93.24	8139
Vp_d	24	99.82	9.17	84.02	97.73	7168
Vp_d	25	96.28	6.59	43.47	92.34	9290
Vp_d	26	95.46	8.85	78.40	92.34	6455
Vp_d	27	95.35	8.54	72.98	97.73	9214
Vp_d	28	98.86	8.69	75.49	103.12	9008
Vp_d	29	98.93	8.66	74.94	100.42	5820
Vp_d	30	96.37	8.38	70.20	94.14	9328
Vp_d	31	100.40	7.42	55.08	102.22	7650
Vp_d	32	96.82	8.03	64.55	95.93	8236
Vp_d	33	95.63	8.82	77.79	95.93	7433
Vp_d	34	98.03	7.63	58.18	95.93	6399
Vp_d	35	96.99	7.33	53.78	95.93	8806
Vp_d	36	100.40	8.61	74.19	95.93	7033
r	1	0.01	1.05	1.09	0.08	12233
r	2	-0.05	0.90	0.82	-0.08	11927
r	3	-0.01	0.97	0.94	0.08	12856
r	4	-0.05	0.94	0.87	-0.08	12749
r	5	-0.01	1.13	1.28	-0.24	12547
r	6	-0.04	0.95	0.90	-0.08	12330
r	7	-0.07	0.82	0.85	-0.08	13153
r	8	0.00	0.92	0.85	0.08	13450
r	9	-0.05	0.84	0.70	-0.24	13213
r	10	-0.03	0.93	0.86	-0.08	12598
r	11	0.02	1.10	1.21	-0.24	11521
r	12	0.01	1.06	1.12	0.08	12052
r	13	-0.03	0.77	0.60	-0.08	13670
r	14	-0.03	0.83	0.69	-0.08	13273
r	15	0.01	0.95	0.90	0.08	13376
r	16	-0.02	1.01	1.01	0.08	12681
r	17	-0.04	0.84	0.70	-0.08	13196
r	18	-0.05	0.78	0.62	-0.08	13182
r	19	-0.07	0.90	0.81	-0.08	12630
r	20	-0.21	0.88	0.77	-0.41	13999
r	21	-0.05	0.91	0.82	-0.08	12888
r	22	0.00	0.91	0.82	0.08	13374
r	23	-0.03	0.93	0.86	0.08	13951
r	24	-0.01	0.99	0.98	0.08	12522
r	25	0.02	0.92	0.84	0.08	11412
r	26	-0.66	0.80	0.63	-0.73	13495
r	27	-0.06	0.81	0.65	-0.08	13251
r	28	-0.04	0.89	0.79	-0.08	13070
r	29	-0.10	0.85	0.72	0.08	11084
r	30	0.01	0.95	0.91	0.08	12562
r	31	0.00	1.10	1.22	0.24	13146
r	32	-0.01	0.88	0.77	-0.08	13444
r	33	-0.02	0.91	0.83	-0.08	12924
r	34	-0.07	0.95	0.89	-0.24	12964
r	35	-0.05	0.91	0.83	-0.08	13410
r	36	-0.03	0.98	0.97	-0.08	12234
Ax	1	0.00	0.03	0.00	0.00	12233
Ax	2	0.00	0.03	0.00	0.00	11927
Ax	3	0.00	0.02	0.00	0.00	12856
Ax	4	0.00	0.02	0.00	0.00	12749
Ax	5	0.00	0.02	0.00	0.00	12547
Ax	6	0.00	0.02	0.00	0.00	12330
Ax	7	0.00	0.02	0.00	0.00	13153
Ax	8	0.00	0.02	0.00	0.00	13450
Ax	9	0.00	0.02	0.00	0.00	13213
Ax	10	0.00	0.03	0.00	0.00	12598
Ax	11	0.00	0.04	0.00	0.00	11521

Ax	12	0.00	0.04	0.00	0.00	12052
Ax	13	0.00	0.02	0.00	0.00	13670
Ax	14	0.00	0.02	0.00	0.00	13273
Ax	15	0.00	0.02	0.00	0.00	13376
Ax	16	0.00	0.04	0.00	0.00	12881
Ax	17	0.00	0.02	0.00	0.00	13196
Ax	18	0.00	0.02	0.00	0.00	13182
Ax	19	0.00	0.02	0.00	0.00	12630
Ax	20	0.00	0.02	0.00	0.00	13999
Ax	21	0.00	0.03	0.00	0.00	12888
Ax	22	0.00	0.02	0.00	0.00	13374
Ax	23	0.00	0.02	0.00	0.00	13951
Ax	24	0.00	0.02	0.00	0.00	12522
Ax	25	0.00	0.02	0.00	0.00	11412
Ax	26	0.00	0.02	0.00	0.00	13495
Ax	27	0.00	0.02	0.00	0.00	13251
Ax	28	0.00	0.02	0.00	0.00	13070
Ax	29	0.00	0.02	0.00	0.00	11084
Ax	30	0.00	0.04	0.00	0.00	12562
Ax	31	0.00	0.02	0.00	0.00	13146
Ax	32	0.00	0.02	0.00	0.00	13444
Ax	33	0.00	0.02	0.00	0.00	12924
Ax	34	0.00	0.02	0.00	0.00	12964
Ax	35	0.00	0.02	0.00	0.00	13410
Ax	36	0.00	0.02	0.00	0.00	12234
Cth	1	12.40	4.06	16.46	12.24	12233
Cth	2	12.51	3.73	13.93	14.29	11927
Cth	3	11.27	2.59	6.72	12.24	12856
Cth	4	11.14	2.52	6.35	12.24	12749
Cth	5	12.87	2.70	7.27	12.24	12547
Cth	6	10.09	2.24	5.03	10.20	12330
Cth	7	11.42	3.13	9.79	12.24	13153
Cth	8	10.83	2.50	6.26	10.20	13450
Cth	9	10.40	3.47	12.05	10.20	13213
Cth	10	12.44	3.89	15.17	12.24	12598
Cth	11	12.34	6.54	42.74	12.24	11521
Cth	12	12.28	4.40	19.34	12.24	12052
Cth	13	9.13	2.24	5.02	8.16	13670
Cth	14	11.67	3.34	11.16	12.24	13273
Cth	15	11.78	2.75	7.58	12.24	13376
Cth	16	12.26	5.20	27.06	12.24	12681
Cth	17	11.12	2.36	5.55	12.24	13196
Cth	18	10.54	2.71	7.33	10.20	13182
Cth	19	10.74	3.22	10.39	12.24	12630
Cth	20	9.30	2.89	8.34	8.16	13999
Cth	21	11.98	4.40	19.34	12.24	12888
Cth	22	10.02	2.33	5.41	10.20	13374
Cth	23	10.13	2.87	8.24	10.20	13951
Cth	24	11.85	3.21	10.28	12.24	12522
Cth	25	9.84	3.06	9.38	10.20	11412
Cth	26	10.40	2.12	4.48	10.20	13495
Cth	27	10.82	2.73	7.47	10.20	13251
Cth	28	10.03	3.19	10.17	10.20	13070
Cth	29	9.80	2.70	7.29	10.20	11084
Cth	30	12.39	5.54	30.65	12.24	12562
Cth	31	11.08	3.49	12.15	12.24	13146
Cth	32	8.95	2.79	7.77	8.16	13444
Cth	33	10.33	2.86	8.20	10.20	12924
Cth	34	10.97	2.92	8.50	12.24	12964
Cth	35	10.18	2.18	4.77	10.20	13410
Cth	36	10.01	2.51	6.32	10.20	12234

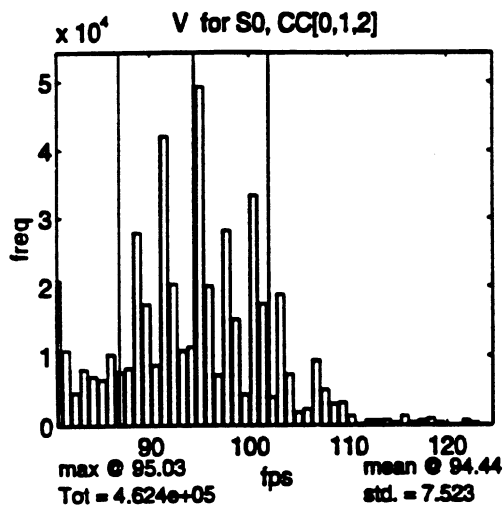

**TABLE of: V for S0, CC[0,1,2]**

bin	freq	bin	freq
+80.7	20880	+103.1	18820
+81.6	10708	+104.0	7331
+82.5	4688	+104.9	1874
+83.4	7979	+105.8	2350
+84.3	6971	+106.7	9316
+85.2	6573	+107.6	5149
+86.1	10155	+108.5	3078
+87.0	7627	+109.4	3300
+87.9	8209	+110.3	1381
+88.7	27797	+111.2	217
+89.6	17396	+112.1	754
+90.5	8629	+113.0	718
+91.4	42017	+113.9	800
+92.3	20302	+114.8	402
+93.2	10651	+115.7	1341
+94.1	11153	+116.6	440
+95.0	49221	+117.5	712
+95.9	20019	+118.4	979
+96.8	7196	+119.3	405
+97.7	28169	+120.2	69
+98.6	15170	+121.1	54
+99.5	4442	+122.0	730
+100.4	33331	+122.9	378
+101.3	17438	+123.8	116
+102.2	4052	+124.7	19

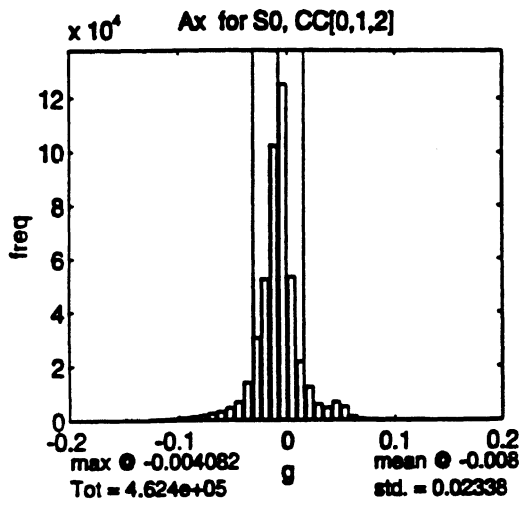

**TABLE of: Ax for S0, CC[0,1,2]**

bin	freq	bin	freq
-0.200	25	+0.004	53302
-0.192	34	+0.012	21820
-0.184	29	+0.020	12415
-0.176	17	+0.029	6028
-0.167	9	+0.037	4780
-0.159	14	+0.045	6827
-0.151	30	+0.053	5139
-0.143	77	+0.061	1757
-0.135	103	+0.069	654
-0.127	166	+0.078	348
-0.118	309	+0.086	253
-0.110	471	+0.094	194
-0.102	639	+0.102	171
-0.094	998	+0.110	128
-0.086	1411	+0.118	124
-0.078	1964	+0.127	140
-0.069	2488	+0.135	72
-0.061	3258	+0.143	62
-0.053	4609	+0.151	57
-0.045	6771	+0.159	31
-0.037	14045	+0.167	41
-0.029	30442	+0.176	27
-0.020	52335	+0.184	20
-0.012	102463	+0.192	24
-0.004	125092	+0.200	23

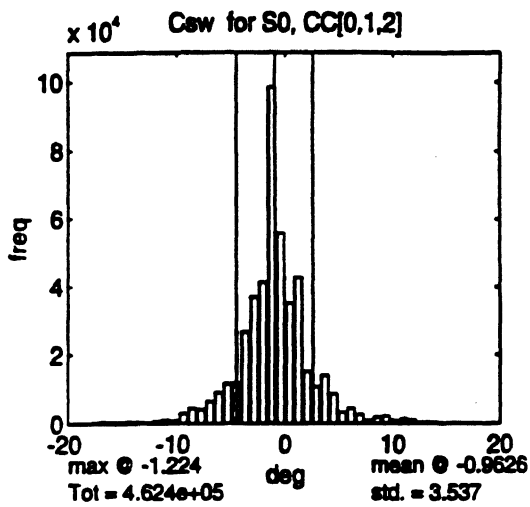
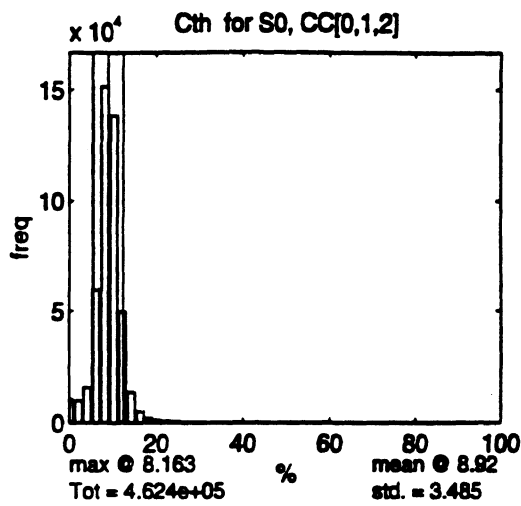

TABLE of: Caw for S0, CC[0,1,2]

bin	freq	bin	freq
-20.00	31	+0.41	35183
-19.18	101	+1.22	42653
-18.37	102	+2.04	15203
-17.55	114	+2.86	10775
-16.73	512	+3.67	14011
-15.92	554	+4.49	8589
-15.10	403	+5.31	3298
-14.29	703	+6.12	4541
-13.47	547	+6.94	2754
-12.65	366	+7.76	1011
-11.84	749	+8.57	1881
-11.02	1214	+9.39	2207
-10.20	894	+10.20	819
-9.39	2927	+11.02	1529
-8.57	4551	+11.84	1085
-7.76	4141	+12.65	286
-6.94	6433	+13.47	369
-6.12	8905	+14.29	207
-5.31	11529	+15.10	60
-4.49	11841	+15.92	100
-3.67	26556	+16.73	57
-2.86	36899	+17.55	14
-2.04	41304	+18.37	15
-1.22	98447	+19.18	3
-0.41	55853	+20.00	10



**TABLE of: Cth for S0, CC[0,1,2]**

bin	freq	bin	freq
+0.0	10827	+51.0	27
+2.0	10060	+53.1	19
+4.1	15790	+55.1	21
+6.1	59589	+57.1	11
+8.2	151254	+59.2	18
+10.2	138334	+61.2	7
+12.2	49717	+63.3	11
+14.3	13834	+65.3	11
+16.3	5095	+67.3	15
+18.4	2188	+69.4	7
+20.4	1276	+71.4	1
+22.4	898	+73.5	0
+24.5	531	+75.5	1
+26.5	238	+77.6	3
+28.6	143	+79.6	2
+30.6	178	+81.6	0
+32.7	115	+83.7	0
+34.7	77	+85.7	0
+36.7	59	+87.8	0
+38.8	43	+89.8	0
+40.8	55	+91.8	0
+42.9	26	+93.9	0
+44.9	32	+95.9	0
+46.9	40	+98.0	0
+49.0	21	+100.0	0

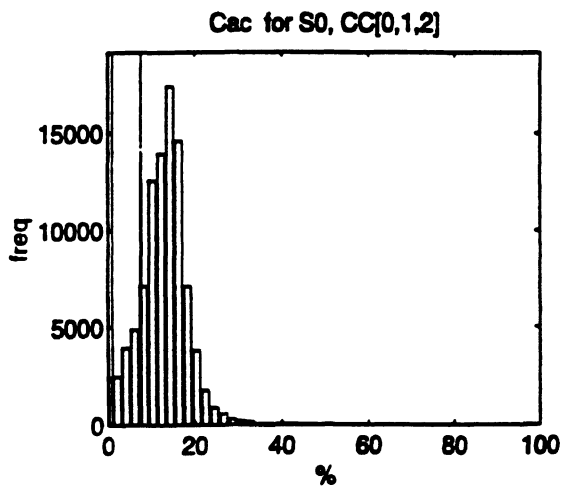

**TABLE of: Cac for S0, CC[0,1,2]**

bin	freq	bin	freq
+0.0	2346	+51.0	39
+2.0	2501	+53.1	8
+4.1	3955	+55.1	11
+6.1	4867	+57.1	11
+8.2	7102	+59.2	11
+10.2	12551	+61.2	0
+12.2	13923	+63.3	0
+14.3	17392	+65.3	0
+16.3	14567	+67.3	0
+18.4	7092	+69.4	2
+20.4	3807	+71.4	0
+22.4	1771	+73.5	0
+24.5	886	+75.5	0
+26.5	568	+77.6	0
+28.6	313	+79.6	0
+30.6	223	+81.6	0
+32.7	184	+83.7	0
+34.7	68	+85.7	0
+36.7	59	+87.8	0
+38.8	34	+89.8	0
+40.8	51	+91.8	0
+42.9	50	+93.9	0
+44.9	34	+95.9	0
+46.9	28	+98.0	0
+49.0	24	+100.0	0

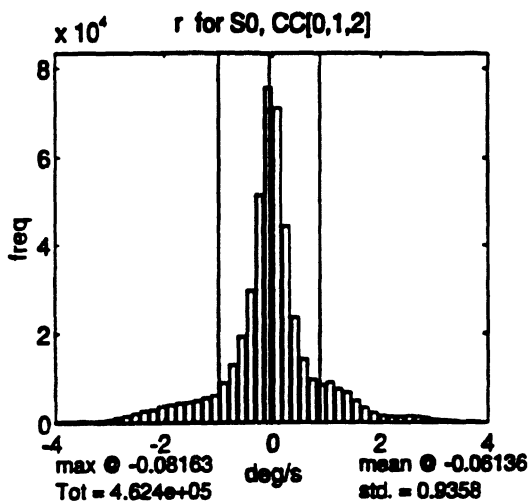

**TABLE of: r for S0, CC[0,1,2]**

bin	freq	bin	freq
-4.00	388	+0.08	71146
-3.84	465	+0.24	44248
-3.67	487	+0.41	23650
-3.51	522	+0.57	14244
-3.35	446	+0.73	9741
-3.18	585	+0.90	8517
-3.02	796	+1.06	9026
-2.86	1184	+1.22	7552
-2.69	1556	+1.39	6811
-2.53	2028	+1.55	4896
-2.37	2589	+1.71	3311
-2.20	2995	+1.88	2332
-2.04	3685	+2.04	1640
-1.88	3993	+2.20	1379
-1.71	4375	+2.37	1345
-1.55	4550	+2.53	1577
-1.39	4849	+2.69	1370
-1.22	5527	+2.86	1223
-1.06	6117	+3.02	808
-0.90	8859	+3.18	519
-0.73	12878	+3.35	400
-0.57	19175	+3.51	198
-0.41	29578	+3.67	160
-0.24	51354	+3.84	86
-0.08	75681	+4.00	60



Rnew\_d for S0, CC[0,1,2]

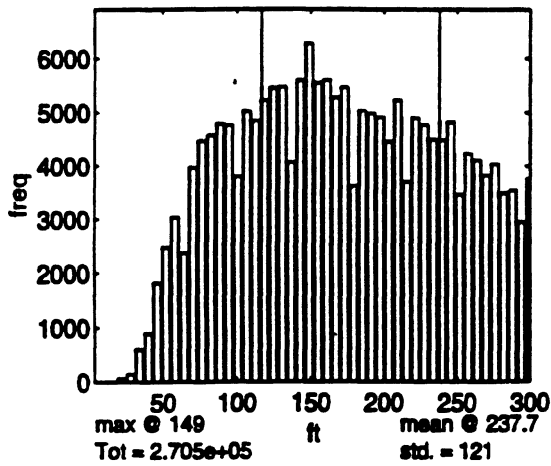
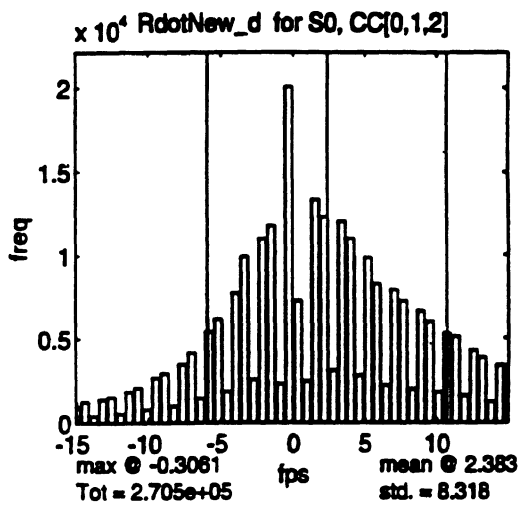

TABLE of: Rnew\_d for S0, CC[0,1,2]

bin	freq	bin	freq
+4.0	0	+155.0	5546
+10.0	3	+161.1	5603
+16.1	1	+167.1	5274
+22.1	71	+173.1	5461
+28.2	144	+179.2	3619
+34.2	604	+185.2	5031
+40.2	889	+191.3	4981
+46.3	1818	+197.3	4908
+52.3	2473	+203.3	4454
+58.4	3034	+209.4	5225
+64.4	2369	+215.4	3703
+70.4	3959	+221.5	4896
+76.5	4461	+227.5	4772
+82.5	4570	+233.6	4498
+88.6	4786	+239.6	4484
+94.6	4764	+245.6	4824
+100.7	3800	+251.7	3464
+106.7	5019	+257.7	4232
+112.7	4846	+263.8	4114
+118.8	5227	+269.8	3824
+124.8	5458	+275.8	4037
+130.9	5473	+281.9	3494
+136.9	4069	+287.9	3545
+142.9	5593	+294.0	2955
+149.0	6275	+300.0	3757



**TABLE of: RdotNew\_d for S0, CC[0,1,2]**

bin	freq	bin	freq
-15.00	967	+0.31	7261
-14.39	1242	+0.92	2495
-13.78	430	+1.53	13336
-13.16	1374	+2.14	12280
-12.55	1521	+2.76	3108
-11.94	557	+3.37	12027
-11.33	1824	+3.98	10992
-10.71	2059	+4.59	2813
-10.10	798	+5.20	9841
-9.49	2643	+5.82	8261
-8.88	2939	+6.43	2230
-8.27	999	+7.04	7904
-7.65	3461	+7.65	7241
-7.04	4158	+8.27	1990
-6.43	1452	+8.88	6642
-5.82	5417	+9.49	6006
-5.20	6160	+10.10	1813
-4.59	1852	+10.71	5335
-3.98	7742	+11.33	5123
-3.37	9922	+11.94	1632
-2.76	2574	+12.55	4300
-2.14	10977	+13.16	3874
-1.53	11764	+13.78	1259
-0.92	2321	+14.39	3417
-0.31	20077	+15.00	3377

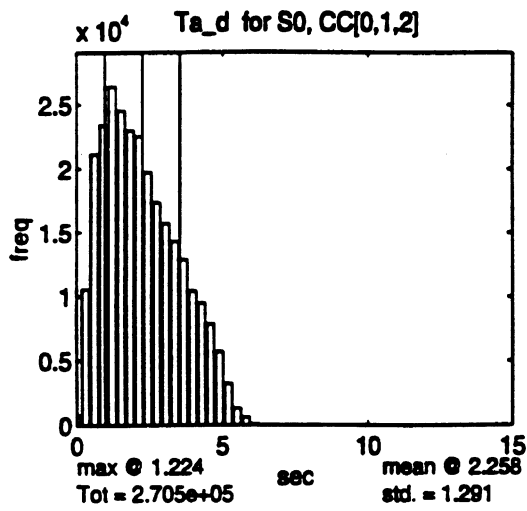

TABLE of: Ta\_d for S0, CC[0,1,2]

bin	freq	bin	freq
+0.00	809	+7.65	0
+0.31	10520	+7.96	0
+0.61	21111	+8.27	0
+0.92	23368	+8.57	0
+1.22	26354	+8.88	0
+1.53	24489	+9.18	0
+1.84	22965	+9.49	0
+2.14	22499	+9.80	0
+2.45	19705	+10.10	0
+2.76	17304	+10.41	0
+3.06	15648	+10.71	0
+3.37	14254	+11.02	0
+3.67	12823	+11.33	0
+3.98	10409	+11.63	0
+4.29	9463	+11.94	0
+4.59	7818	+12.24	0
+4.90	5698	+12.55	0
+5.20	3231	+12.86	0
+5.51	1340	+13.16	0
+5.82	632	+13.47	0
+6.12	94	+13.78	0
+6.43	0	+14.08	0
+6.73	0	+14.39	0
+7.04	0	+14.69	0
+7.35	0	+15.00	0

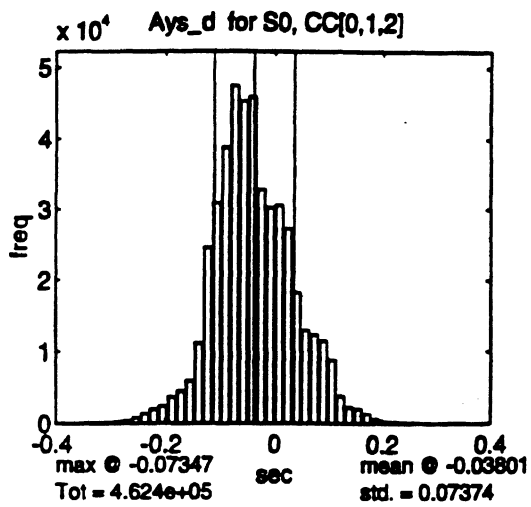

TABLE of: Ays\_d for S0, CC[0,1,2]

bin	freq	bin	freq
-0.400	0	+0.008	30652
-0.384	0	+0.024	27347
-0.367	14	+0.041	18275
-0.351	24	+0.057	12979
-0.335	73	+0.073	12309
-0.318	118	+0.090	11454
-0.302	184	+0.106	8784
-0.286	238	+0.122	3792
-0.269	391	+0.139	2295
-0.253	814	+0.155	2052
-0.237	1398	+0.171	1376
-0.220	1996	+0.188	637
-0.204	2412	+0.204	347
-0.188	3682	+0.220	281
-0.171	4518	+0.237	180
-0.155	5951	+0.253	87
-0.139	11133	+0.269	38
-0.122	24614	+0.286	11
-0.106	31002	+0.302	4
-0.090	38838	+0.318	0
-0.073	47517	+0.335	0
-0.057	45393	+0.351	0
-0.041	45974	+0.367	0
-0.024	32912	+0.384	0
-0.008	30271	+0.400	0

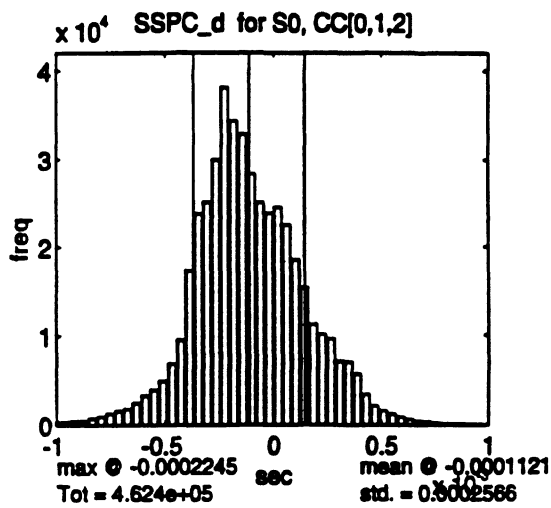
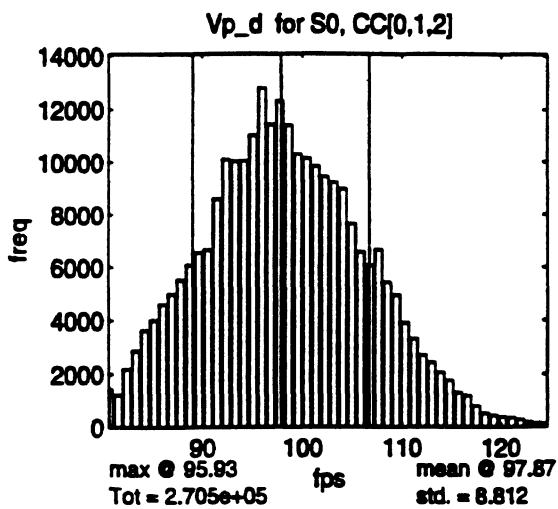

TABLE of: SSPC\_d for S0, CC[0,1,2]

bin	freq	bin	freq
-1.00e-03	354	+2.04e-05	24500
-9.59e-04	415	+6.12e-05	22482
-9.18e-04	514	+1.02e-04	18492
-8.78e-04	498	+1.43e-04	15374
-8.37e-04	757	+1.84e-04	11223
-7.96e-04	976	+2.24e-04	10121
-7.55e-04	1317	+2.65e-04	9612
-7.14e-04	1599	+3.06e-04	7167
-6.73e-04	1852	+3.47e-04	7034
-6.33e-04	2487	+3.88e-04	5735
-5.92e-04	3307	+4.29e-04	3470
-5.51e-04	3980	+4.69e-04	2164
-5.10e-04	4947	+5.10e-04	1637
-4.69e-04	6853	+5.51e-04	1264
-4.29e-04	9466	+5.92e-04	934
-3.88e-04	17239	+6.33e-04	670
-3.47e-04	23749	+6.73e-04	477
-3.06e-04	25082	+7.14e-04	403
-2.65e-04	29942	+7.55e-04	269
-2.24e-04	38106	+7.96e-04	159
-1.84e-04	34372	+8.37e-04	138
-1.43e-04	32873	+8.78e-04	117
-1.02e-04	28316	+9.18e-04	69
-6.12e-05	25059	+9.59e-04	49
-2.04e-05	23835	+1.00e-03	23



**TABLE of: Vp\_d for S0, CC[0,1,2]**

bin	freq	bin	freq
+80.7	1444	+103.1	9222
+81.6	1216	+104.0	8963
+82.5	2186	+104.9	7621
+83.4	2865	+105.8	6555
+84.3	3608	+106.7	6052
+85.2	3990	+107.6	6628
+86.1	4588	+108.5	5410
+87.0	4966	+109.4	4933
+87.9	5503	+110.3	3900
+88.7	6063	+111.2	3307
+89.6	6527	+112.1	2702
+90.5	6633	+113.0	2428
+91.4	8564	+113.9	2055
+92.3	10091	+114.8	1755
+93.2	10006	+115.7	1300
+94.1	10038	+116.6	1186
+95.0	11004	+117.5	795
+95.9	12789	+118.4	534
+96.8	11417	+119.3	449
+97.7	12317	+120.2	391
+98.6	11377	+121.1	377
+99.5	10289	+122.0	299
+100.4	10121	+122.9	191
+101.3	9831	+123.8	148
+102.2	9432	+124.7	135

## STATISTICAL DATA FOR HISTOGRAMS, ACC DRIVING

Var	Subj	Mean	StdDev	Variance	MLV	Total
V	1	100.73	6.22	38.69	107.61	12666
V	2	99.29	7.81	61.05	107.61	12153
V	3	95.15	6.71	45.01	101.32	13279
V	4	97.50	4.86	23.64	101.32	12892
V	5	101.75	7.79	60.66	104.01	12647
V	6	97.95	3.23	10.46	98.63	12912
V	7	96.89	5.06	25.64	95.93	12732
V	8	92.99	4.20	17.68	95.93	13397
V	9	92.21	5.61	31.49	95.93	13373
V	10	100.79	7.37	54.34	104.01	12132
V	11	108.52	9.37	87.78	116.59	11847
V	12	100.32	6.45	41.55	104.01	12500
V	13	88.54	4.70	22.05	92.34	11191
V	14	89.94	4.89	23.93	85.16	13742
V	15	94.59	6.45	41.60	89.65	13396
V	16	103.87	8.99	80.78	113.89	12002
V	17	93.93	3.26	10.65	95.03	12910
V	18	87.07	1.68	2.81	86.95	12987
V	19	96.01	5.47	29.93	96.83	12723
V	20	90.61	5.17	26.78	95.93	13669
V	21	89.24	5.23	27.39	95.93	14231
V	22	92.45	3.64	13.28	94.14	12635
V	23	89.53	1.42	2.02	89.65	13961
V	24	98.59	5.69	32.43	104.01	12691
V	25	96.46	6.03	36.38	98.63	12516
V	26	85.43	4.16	17.33	81.56	13065
V	27	89.54	4.81	23.10	95.93	13181
V	28	96.47	6.03	36.41	101.32	13124
V	29	91.34	4.12	16.95	95.03	13287
V	30	94.45	4.77	22.79	98.63	13166
V	31	98.06	5.92	35.06	98.63	12832
V	32	92.09	4.08	16.68	92.34	13335
V	33	91.69	4.65	21.66	91.44	13199
V	34	96.26	5.77	33.31	101.32	12747
V	35	96.53	5.49	30.11	101.32	12791
V	36	96.51	5.18	26.85	98.63	12891
Rnew_d	1	178.04	81.88	6705.11	148.98	9645
Rnew_d	2	195.09	113.71	12931.03	136.90	8779
Rnew_d	3	223.21	110.05	12112.04	130.86	8151
Rnew_d	4	219.11	99.15	9829.99	227.51	9924
Rnew_d	5	225.12	129.67	16813.96	148.98	6774
Rnew_d	6	243.69	112.43	12640.20	155.02	6530
Rnew_d	7	206.94	104.81	10986.05	148.98	9372
Rnew_d	8	247.19	108.08	11682.06	130.86	8305
Rnew_d	9	240.15	113.78	12945.95	142.94	6555
Rnew_d	10	229.10	98.22	9647.11	142.94	8839
Rnew_d	11	180.75	103.01	10610.83	155.02	8821
Rnew_d	12	251.13	116.12	13482.98	130.86	7228
Rnew_d	13	261.02	115.73	13392.28	179.18	5532
Rnew_d	14	243.75	121.95	14871.41	130.86	8202
Rnew_d	15	256.50	104.01	10818.03	136.90	8232
Rnew_d	16	183.81	92.44	8545.74	161.06	8823
Rnew_d	17	272.32	123.34	15212.46	130.86	7177
Rnew_d	18	298.84	116.29	13523.09	390.61	5392
Rnew_d	19	196.71	90.00	8100.21	136.90	9666
Rnew_d	20	251.24	126.46	15993.07	136.90	7510
Rnew_d	21	274.81	116.67	13611.59	251.67	7834
Rnew_d	22	231.26	119.92	14381.00	124.82	8453
Rnew_d	23	258.62	117.36	13773.37	130.86	8806
Rnew_d	24	257.57	113.02	12774.21	148.98	8073
Rnew_d	25	205.39	108.09	11684.05	148.98	9681
Rnew_d	26	254.84	118.13	13955.24	130.86	5961
Rnew_d	27	226.01	108.18	11702.11	124.82	8413
Rnew_d	28	156.64	48.36	2338.64	148.98	12026
Rnew_d	29	279.48	124.09	15398.59	136.90	7421
Rnew_d	30	226.69	105.40	11108.30	136.90	8738
Rnew_d	31	203.39	95.63	9145.04	136.90	9143
Rnew_d	32	199.96	101.40	10281.53	136.90	10477
Rnew_d	33	234.34	116.89	13663.58	124.82	7060
Rnew_d	34	257.68	124.32	15456.19	148.98	7669
Rnew_d	35	213.82	110.19	12142.77	138.90	9837

Rnew_d	36	270.21	120.79	14591.00	155.02	5979
RdotNew_d	1	-0.74	5.05	25.54	-0.31	9645
RdotNew_d	2	0.11	5.80	33.60	-0.31	8779
RdotNew_d	3	0.51	6.16	37.90	-0.31	8151
RdotNew_d	4	0.73	5.27	27.77	-0.31	9924
RdotNew_d	5	-0.74	7.50	56.18	-0.31	6774
RdotNew_d	6	1.66	7.18	51.55	-0.31	6530
RdotNew_d	7	1.44	5.91	34.89	0.31	9372
RdotNew_d	8	1.76	6.77	45.82	-0.31	8305
RdotNew_d	9	4.63	9.55	91.15	0.31	6555
RdotNew_d	10	-1.78	6.71	44.99	-0.31	8839
RdotNew_d	11	-2.15	6.76	45.72	0.31	8821
RdotNew_d	12	-1.57	6.99	48.92	0.31	7228
RdotNew_d	13	5.60	7.94	63.06	-0.31	5532
RdotNew_d	14	2.35	8.80	77.43	0.31	8202
RdotNew_d	15	2.67	8.56	73.26	-0.31	8232
RdotNew_d	16	-1.89	6.23	38.83	0.31	8823
RdotNew_d	17	3.13	7.21	51.92	-0.31	7177
RdotNew_d	18	9.03	9.08	82.37	-0.31	5392
RdotNew_d	19	0.52	5.23	27.39	-0.31	9666
RdotNew_d	20	0.70	7.86	61.70	0.31	7510
RdotNew_d	21	4.64	8.56	73.20	-0.31	7834
RdotNew_d	22	1.87	6.22	38.69	-0.31	8453
RdotNew_d	23	6.92	8.16	66.64	0.31	8806
RdotNew_d	24	-0.32	6.48	42.01	-0.31	8073
RdotNew_d	25	-0.20	4.69	22.00	-0.31	9681
RdotNew_d	26	10.46	9.10	82.76	-0.31	5961
RdotNew_d	27	3.82	7.41	54.91	-0.31	8413
RdotNew_d	28	-0.20	3.33	11.12	-0.31	12026
RdotNew_d	29	5.07	8.08	65.25	-0.31	7421
RdotNew_d	30	1.34	5.82	33.87	-0.31	8738
RdotNew_d	31	0.28	5.84	34.06	0.31	9143
RdotNew_d	32	2.72	6.27	39.28	-0.31	10477
RdotNew_d	33	2.20	6.76	45.71	-0.31	7080
RdotNew_d	34	1.20	7.70	59.22	-0.31	7669
RdotNew_d	35	-0.28	5.30	28.10	-0.31	9837
RdotNew_d	36	1.94	7.50	56.31	-0.31	5979
Ta_d	1	1.77	0.74	0.55	1.53	9645
Ta_d	2	1.98	1.11	1.24	1.53	8779
Ta_d	3	2.37	1.13	1.29	1.53	8151
Ta_d	4	2.23	0.98	0.96	1.53	9924
Ta_d	5	2.22	1.25	1.56	1.53	6774
Ta_d	6	2.48	1.11	1.24	1.53	6530
Ta_d	7	2.13	1.04	1.08	1.53	9372
Ta_d	8	2.65	1.11	1.24	1.53	8305
Ta_d	9	2.63	1.23	1.51	1.53	6555
Ta_d	10	2.27	0.90	0.81	1.53	8839
Ta_d	11	1.67	0.89	0.78	1.53	8821
Ta_d	12	2.49	1.08	1.18	1.53	7228
Ta_d	13	2.94	1.31	1.72	1.84	5532
Ta_d	14	2.71	1.33	1.78	1.53	8202
Ta_d	15	2.75	1.15	1.32	1.53	8232
Ta_d	16	1.78	0.83	0.70	1.53	8823
Ta_d	17	2.88	1.27	1.62	1.53	7177
Ta_d	18	3.43	1.33	1.78	3.37	5392
Ta_d	19	2.06	0.88	0.78	1.53	9666
Ta_d	20	2.74	1.37	1.87	1.53	7510
Ta_d	21	3.11	1.30	1.68	3.06	7834
Ta_d	22	2.49	1.24	1.53	1.53	8453
Ta_d	23	2.89	1.30	1.70	1.53	8806
Ta_d	24	2.62	1.14	1.29	1.53	8073
Ta_d	25	2.14	1.06	1.12	1.53	9681
Ta_d	26	3.00	1.43	2.03	1.53	5961
Ta_d	27	2.53	1.18	1.40	1.53	8413
Ta_d	28	1.63	0.45	0.21	1.53	12026
Ta_d	29	3.05	1.33	1.77	1.53	7421
Ta_d	30	2.39	1.10	1.21	1.53	8738
Ta_d	31	2.08	0.93	0.86	1.53	9143
Ta_d	32	2.18	1.07	1.13	1.53	10477
Ta_d	33	2.55	1.20	1.45	1.53	7080
Ta_d	34	2.65	1.23	1.52	1.53	7669
Ta_d	35	2.20	1.06	1.13	1.53	9837
Ta_d	36	2.83	1.26	1.58	1.53	5979
Ays_d	1	0.02	0.05	0.00	0.02	12666
Ays_d	2	-0.08	0.05	0.00	-0.07	12153



Ays_d	3	-0.05	0.05	0.00	-0.06	13279
Ays_d	4	-0.01	0.05	0.00	-0.01	12892
Ays_d	5	-0.04	0.05	0.00	-0.04	12647
Ays_d	6	-0.12	0.05	0.00	-0.12	12912
Ays_d	7	-0.03	0.05	0.00	-0.02	12732
Ays_d	8	-0.08	0.04	0.00	-0.07	13397
Ays_d	9	-0.08	0.04	0.00	-0.09	13373
Ays_d	10	-0.06	0.05	0.00	-0.06	12132
Ays_d	11	0.00	0.06	0.00	-0.01	11847
Ays_d	12	-0.12	0.05	0.00	-0.12	12500
Ays_d	13	-0.10	0.04	0.00	-0.09	11191
Ays_d	14	-0.04	0.04	0.00	-0.04	13742
Ays_d	15	-0.01	0.05	0.00	-0.01	13396
Ays_d	16	0.01	0.06	0.00	0.01	12002
Ays_d	17	-0.06	0.04	0.00	-0.06	12910
Ays_d	18	-0.04	0.04	0.00	-0.04	12987
Ays_d	19	0.04	0.05	0.00	0.04	12723
Ays_d	20	-0.05	0.04	0.00	-0.06	13669
Ays_d	21	-0.05	0.04	0.00	-0.04	14231
Ays_d	22	-0.02	0.05	0.00	-0.02	12635
Ays_d	23	-0.04	0.04	0.00	-0.04	13961
Ays_d	24	-0.09	0.05	0.00	-0.09	12691
Ays_d	25	0.10	0.05	0.00	0.09	12516
Ays_d	26	-0.07	0.03	0.00	-0.07	13065
Ays_d	27	-0.09	0.04	0.00	-0.09	13181
Ays_d	28	0.16	0.05	0.00	0.17	13124
Ays_d	29	0.03	0.04	0.00	0.04	13287
Ays_d	30	0.01	0.05	0.00	0.01	13166
Ays_d	31	0.17	0.05	0.00	0.17	12832
Ays_d	32	0.01	0.04	0.00	0.01	13335
Ays_d	33	-0.05	0.05	0.00	-0.04	13199
Ays_d	34	0.12	0.05	0.00	0.12	12747
Ays_d	35	0.00	0.05	0.00	-0.01	12791
Ays_d	36	-0.04	0.05	0.00	-0.06	12891
SSPC_d	1	0.00	0.00	0.00	0.00	12666
SSPC_d	2	0.00	0.00	0.00	0.00	12153
SSPC_d	3	0.00	0.00	0.00	0.00	13279
SSPC_d	4	0.00	0.00	0.00	0.00	12892
SSPC_d	5	0.00	0.00	0.00	0.00	12647
SSPC_d	6	0.00	0.00	0.00	0.00	12912
SSPC_d	7	0.00	0.00	0.00	0.00	12732
SSPC_d	8	0.00	0.00	0.00	0.00	13397
SSPC_d	9	0.00	0.00	0.00	0.00	13373
SSPC_d	10	0.00	0.00	0.00	0.00	12132
SSPC_d	11	0.00	0.00	0.00	0.00	11847
SSPC_d	12	0.00	0.00	0.00	0.00	12500
SSPC_d	13	0.00	0.00	0.00	0.00	11191
SSPC_d	14	0.00	0.00	0.00	0.00	13742
SSPC_d	15	0.00	0.00	0.00	0.00	13396
SSPC_d	16	0.00	0.00	0.00	0.00	12002
SSPC_d	17	0.00	0.00	0.00	0.00	12910
SSPC_d	18	0.00	0.00	0.00	0.00	12987
SSPC_d	19	0.00	0.00	0.00	0.00	12723
SSPC_d	20	0.00	0.00	0.00	0.00	13669
SSPC_d	21	0.00	0.00	0.00	0.00	14231
SSPC_d	22	0.00	0.00	0.00	0.00	12635
SSPC_d	23	0.00	0.00	0.00	0.00	13961
SSPC_d	24	0.00	0.00	0.00	0.00	12691
SSPC_d	25	0.00	0.00	0.00	0.00	12516
SSPC_d	26	0.00	0.00	0.00	0.00	13065
SSPC_d	27	0.00	0.00	0.00	0.00	13181
SSPC_d	28	0.00	0.00	0.00	0.00	13124
SSPC_d	29	0.00	0.00	0.00	0.00	13287
SSPC_d	30	0.00	0.00	0.00	0.00	13166
SSPC_d	31	0.00	0.00	0.00	0.00	12832
SSPC_d	32	0.00	0.00	0.00	0.00	13335
SSPC_d	33	0.00	0.00	0.00	0.00	13199
SSPC_d	34	0.00	0.00	0.00	0.00	12747
SSPC_d	35	0.00	0.00	0.00	0.00	12791
SSPC_d	36	0.00	0.00	0.00	0.00	12891
Caw	1	0.02	3.71	13.74	-0.41	12666
Caw	2	-0.22	3.80	14.47	-0.41	12153
Caw	3	0.06	3.54	12.54	0.41	13279
Caw	4	-0.08	3.46	11.96	-0.41	12892
Caw	5	-0.24	4.16	17.34	-0.41	12647

Cow	6	-0.23	3.77	14.18	-0.41	12912
Cow	7	-0.15	3.77	14.23	-0.41	12732
Cow	8	0.21	3.66	13.41	-1.22	13397
Cow	9	0.02	2.99	8.93	0.41	13373
Cow	10	-0.23	3.96	15.65	-0.41	12132
Cow	11	-0.23	4.27	18.19	0.41	11847
Cow	12	-0.19	3.78	14.25	-0.41	12500
Cow	13	-0.51	3.15	9.95	-2.04	11191
Cow	14	0.51	3.59	12.88	1.22	13742
Cow	15	0.10	3.68	13.55	1.22	13396
Cow	16	0.17	4.12	17.00	1.22	12002
Cow	17	-0.18	3.28	10.74	-0.41	12910
Cow	18	-0.85	2.95	8.73	-1.22	12987
Cow	19	-0.18	3.51	12.34	-0.41	12723
Cow	20	-0.43	3.26	10.64	-0.41	13669
Cow	21	-0.33	3.36	11.32	0.41	14231
Cow	22	-0.12	3.43	11.75	-0.41	12635
Cow	23	-0.20	2.99	8.91	-0.41	13961
Cow	24	-0.18	3.72	13.81	-0.41	12691
Cow	25	-0.14	3.51	12.32	-1.22	12516
Cow	26	0.35	2.59	6.73	1.22	13065
Cow	27	-0.71	3.20	10.23	-0.41	13181
Cow	28	-0.21	3.50	12.26	-1.22	13124
Cow	29	-0.10	2.84	8.07	-0.41	13287
Cow	30	0.21	3.45	11.88	0.41	13166
Cow	31	-0.14	3.68	13.57	1.22	12832
Cow	32	-0.34	3.22	10.34	-1.22	13335
Cow	33	0.04	3.23	10.41	0.41	13199
Cow	34	0.00	3.23	10.41	-0.41	12747
Cow	35	-0.23	3.39	11.48	-0.41	12791
Cow	36	-0.27	3.31	10.96	-1.22	12891
Cac	1	0.70	4.02	16.19	0.00	12666
Cac	2	3.94	7.25	52.53	0.00	12153
Cac	3	0.90	3.82	14.61	0.00	13279
Cac	4	4.22	7.07	50.05	0.00	12892
Cac	5	4.88	7.88	62.09	0.00	12647
Cac	6	0.62	3.23	10.44	0.00	12912
Cac	7	1.40	4.67	21.82	0.00	12732
Cac	8	0.23	2.01	4.03	0.00	13397
Cac	9	1.15	4.12	16.97	0.00	13373
Cac	10	0.93	4.13	17.04	0.00	12132
Cac	11	4.82	9.05	81.85	0.00	11847
Cac	12	2.35	6.63	43.96	0.00	12500
Cac	13	0.44	2.58	6.66	0.00	11191
Cac	14	0.84	3.68	13.57	0.00	13742
Cac	15	0.86	3.52	12.40	0.00	13396
Cac	16	2.75	8.58	73.68	0.00	12002
Cac	17	1.52	4.55	20.67	0.00	12910
Cac	18	0.99	3.82	14.63	0.00	12987
Cac	19	0.57	3.18	10.11	0.00	12723
Cac	20	1.45	4.87	23.73	0.00	13669
Cac	21	0.26	2.30	5.29	0.00	14231
Cac	22	0.57	3.13	9.79	0.00	12635
Cac	23	0.25	2.16	4.67	0.00	13961
Cac	24	2.09	5.54	30.71	0.00	12691
Cac	25	1.41	5.24	27.44	0.00	12516
Cac	26	0.90	3.66	13.43	0.00	13065
Cac	27	2.15	4.80	23.08	0.00	13181
Cac	28	0.48	2.90	8.39	0.00	13124
Cac	29	2.78	6.01	36.16	0.00	13287
Cac	30	0.90	3.78	14.28	0.00	13166
Cac	31	0.27	3.12	9.72	0.00	12832
Cac	32	2.34	5.63	31.74	0.00	13335
Cac	33	4.45	7.22	52.15	0.00	13199
Cac	34	0.75	3.48	12.12	0.00	12747
Cac	35	1.20	4.12	17.01	0.00	12791
Cac	36	1.83	4.99	24.87	0.00	12891
Vp_d	1	99.74	7.56	57.15	104.01	9645
Vp_d	2	98.57	9.49	90.15	94.14	8779
Vp_d	3	94.75	8.23	67.81	87.85	8151
Vp_d	4	98.32	7.44	55.32	101.32	9924
Vp_d	5	100.13	8.87	78.73	99.52	6774
Vp_d	6	99.28	8.02	64.34	96.83	6530
Vp_d	7	98.01	7.99	63.88	102.22	9372
Vp_d	8	94.64	8.44	71.21	95.93	8305

Vp_d	9	95.74	9.07	82.28	95.03	6555
Vp_d	10	98.17	9.21	84.78	95.93	8839
Vp_d	11	105.05	9.58	91.77	103.12	8821
Vp_d	12	98.14	8.80	77.52	92.34	7228
Vp_d	13	94.53	8.22	67.54	87.73	5532
Vp_d	14	92.45	8.02	64.26	89.85	8202
Vp_d	15	96.78	7.98	63.74	91.44	8232
Vp_d	16	100.51	7.88	62.17	98.63	8823
Vp_d	17	96.84	8.85	78.25	95.03	7177
Vp_d	18	96.18	9.32	86.95	88.75	5392
Vp_d	19	95.96	6.84	46.77	96.83	9666
Vp_d	20	92.54	7.66	58.64	92.34	7510
Vp_d	21	92.94	9.73	94.71	89.85	7834
Vp_d	22	93.81	8.11	65.81	85.16	8453
Vp_d	23	96.56	8.65	74.88	97.73	8806
Vp_d	24	98.12	7.32	53.64	104.91	8073
Vp_d	25	95.58	7.46	55.67	98.63	9681
Vp_d	26	96.18	7.50	56.19	94.14	5961
Vp_d	27	93.23	9.02	81.38	83.36	8413
Vp_d	28	96.57	6.14	37.64	100.42	12026
Vp_d	29	96.63	6.81	46.36	95.93	7421
Vp_d	30	96.38	7.66	58.63	93.24	8738
Vp_d	31	97.34	7.62	58.04	95.03	9143
Vp_d	32	94.89	7.41	54.90	92.34	10477
Vp_d	33	93.50	8.14	66.20	91.44	7060
Vp_d	34	97.49	9.27	85.99	92.34	7669
Vp_d	35	96.10	7.94	63.11	101.32	9837
Vp_d	36	97.82	8.95	80.18	101.32	5979
r	1	-0.01	1.00	0.99	0.08	12666
r	2	-0.04	0.97	0.94	-0.08	12153
r	3	-0.06	0.95	0.90	-0.08	13279
r	4	0.01	0.93	0.87	0.08	12892
r	5	-0.04	1.02	1.04	-0.08	12647
r	6	-0.03	0.98	0.97	-0.08	12912
r	7	-0.02	0.93	0.86	-0.08	12732
r	8	-0.02	0.90	0.81	0.08	13397
r	9	-0.11	0.82	0.68	-0.08	13373
r	10	-0.02	0.94	0.89	-0.08	12132
r	11	-0.02	1.10	1.22	-0.08	11847
r	12	0.00	1.02	1.03	-0.08	12500
r	13	-0.05	0.85	0.72	-0.08	11191
r	14	0.00	0.89	0.80	0.08	13742
r	15	0.06	1.02	1.05	-0.08	13396
r	16	-0.01	1.03	1.07	0.08	12002
r	17	-0.01	0.85	0.72	0.08	12910
r	18	-0.10	0.79	0.63	-0.24	12987
r	19	-0.03	0.95	0.91	0.08	12723
r	20	-0.09	0.86	0.74	-0.08	13669
r	21	0.02	0.83	0.68	0.08	14231
r	22	0.02	0.92	0.85	0.08	12635
r	23	-0.07	0.87	0.75	-0.08	13961
r	24	-0.01	0.98	0.95	-0.08	12691
r	25	-0.02	0.96	0.93	-0.08	12516
r	26	-0.02	0.72	0.52	-0.08	13065
r	27	-0.05	0.82	0.68	-0.08	13181
r	28	-0.01	0.94	0.88	0.08	13124
r	29	-0.05	0.83	0.68	-0.08	13287
r	30	0.01	0.89	0.79	0.08	13166
r	31	-0.04	0.98	0.96	0.08	12832
r	32	-0.05	0.87	0.75	-0.08	13335
r	33	-0.01	0.92	0.86	0.24	13199
r	34	-0.05	0.90	0.81	-0.08	12747
r	35	-0.04	0.91	0.82	-0.08	12791
r	36	-0.13	1.03	1.05	0.08	12891
Ax	1	0.00	0.03	0.00	0.00	12666
Ax	2	0.00	0.03	0.00	0.00	12153
Ax	3	0.00	0.02	0.00	0.00	13279
Ax	4	0.00	0.02	0.00	0.00	12892
Ax	5	0.00	0.03	0.00	0.00	12647
Ax	6	0.00	0.02	0.00	0.00	12912
Ax	7	0.00	0.02	0.00	0.00	12732
Ax	8	0.00	0.02	0.00	0.00	13397
Ax	9	0.00	0.02	0.00	0.00	13373
Ax	10	0.00	0.03	0.00	0.00	12132
Ax	11	0.00	0.04	0.00	0.00	11847

Ax	12	0.00	0.03	0.00	0.00	12500
Ax	13	0.00	0.02	0.00	0.00	11191
Ax	14	0.00	0.02	0.00	0.00	13742
Ax	15	0.00	0.02	0.00	0.00	13396
Ax	16	0.00	0.04	0.00	0.00	12002
Ax	17	0.00	0.02	0.00	0.00	12910
Ax	18	-0.01	0.02	0.00	0.00	12987
Ax	19	0.00	0.02	0.00	0.00	12723
Ax	20	0.00	0.02	0.00	0.00	13669
Ax	21	0.00	0.02	0.00	0.00	14231
Ax	22	0.00	0.02	0.00	0.00	12635
Ax	23	0.00	0.02	0.00	0.00	13961
Ax	24	0.00	0.02	0.00	0.00	12691
Ax	25	0.00	0.03	0.00	0.00	12516
Ax	26	0.00	0.02	0.00	0.00	13065
Ax	27	0.00	0.02	0.00	0.00	13181
Ax	28	0.00	0.03	0.00	0.00	13124
Ax	29	0.00	0.02	0.00	0.00	13287
Ax	30	0.00	0.02	0.00	0.00	13166
Ax	31	0.00	0.02	0.00	0.00	12832
Ax	32	0.00	0.02	0.00	0.00	13335
Ax	33	0.00	0.02	0.00	0.00	13199
Ax	34	0.00	0.02	0.00	0.00	12747
Ax	35	0.00	0.02	0.00	0.00	12791
Ax	36	0.00	0.02	0.00	0.00	12891
Cth	1	11.59	4.57	20.86	12.24	12666
Cth	2	12.51	4.09	16.75	14.29	12153
Cth	3	10.72	3.05	9.31	12.24	13279
Cth	4	11.00	2.94	8.64	12.24	12892
Cth	5	12.92	4.07	16.59	14.29	12647
Cth	6	9.99	2.60	6.78	10.20	12912
Cth	7	11.32	3.56	12.68	12.24	12732
Cth	8	11.36	3.13	9.81	12.24	13397
Cth	9	10.64	3.02	9.11	10.20	13373
Cth	10	12.36	4.28	18.29	14.29	12132
Cth	11	11.86	6.02	36.29	12.24	11847
Cth	12	10.44	4.41	19.45	10.20	12500
Cth	13	9.48	2.23	4.99	10.20	11191
Cth	14	11.45	2.90	8.43	12.24	13742
Cth	15	11.81	3.00	8.99	12.24	13396
Cth	16	12.39	7.78	60.58	12.24	12002
Cth	17	10.96	2.29	5.23	10.20	12910
Cth	18	10.05	2.19	4.79	10.20	12987
Cth	19	10.38	2.96	8.74	10.20	12723
Cth	20	9.23	3.24	10.49	10.20	13669
Cth	21	11.30	3.14	9.89	12.24	14231
Cth	22	9.98	2.62	6.86	10.20	12635
Cth	23	10.28	2.52	6.34	10.20	13961
Cth	24	10.57	3.07	9.45	10.20	12691
Cth	25	9.80	3.99	15.91	10.20	12516
Cth	26	10.91	2.38	5.66	10.20	13065
Cth	27	10.96	2.69	7.25	12.24	13181
Cth	28	9.91	3.62	13.07	10.20	13124
Cth	29	10.16	2.42	5.85	10.20	13287
Cth	30	11.94	2.90	8.39	12.24	13166
Cth	31	11.12	4.48	20.11	12.24	12832
Cth	32	8.42	2.67	7.15	8.16	13335
Cth	33	9.84	3.08	9.50	10.20	13199
Cth	34	10.76	3.01	9.05	12.24	12747
Cth	35	10.80	3.24	10.49	10.20	12791
Cth	36	9.58	2.82	7.96	10.20	12891

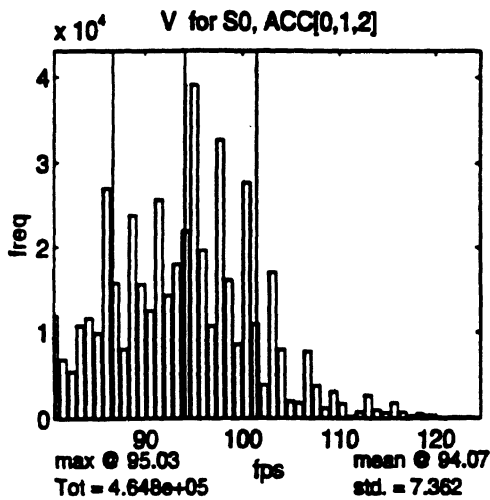

TABLE of: V for S0, ACC[0,1,2]

bin	freq	bin	freq
+80.7	11880	+103.1	17029
+81.6	6823	+104.0	7971
+82.5	5384	+104.9	1999
+83.4	10719	+105.8	1748
+84.3	11570	+106.7	7772
+85.2	9836	+107.6	3769
+86.1	26957	+108.5	1182
+87.0	15759	+109.4	3107
+87.9	7998	+110.3	1705
+88.7	23811	+111.2	256
+89.6	15612	+112.1	765
+90.5	12446	+113.0	2669
+91.4	25631	+113.9	991
+92.3	14261	+114.8	685
+93.2	17963	+115.7	1795
+94.1	21913	+116.6	758
+95.0	39087	+117.5	265
+95.9	19629	+118.4	579
+96.8	10726	+119.3	370
+97.7	32704	+120.2	154
+98.6	16101	+121.1	88
+99.5	8595	+122.0	124
+100.4	27671	+122.9	64
+101.3	10938	+123.8	41
+102.2	3860	+124.7	27

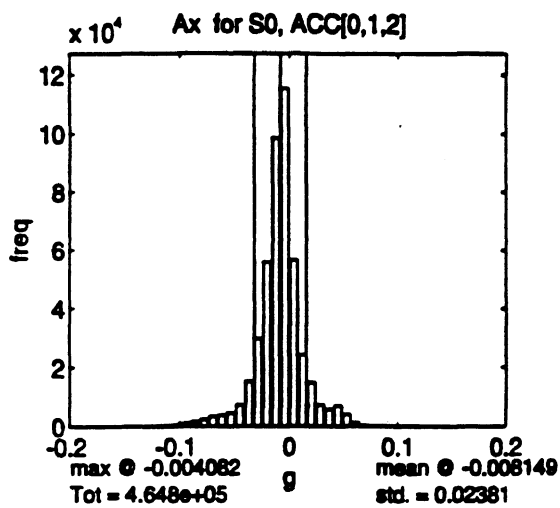
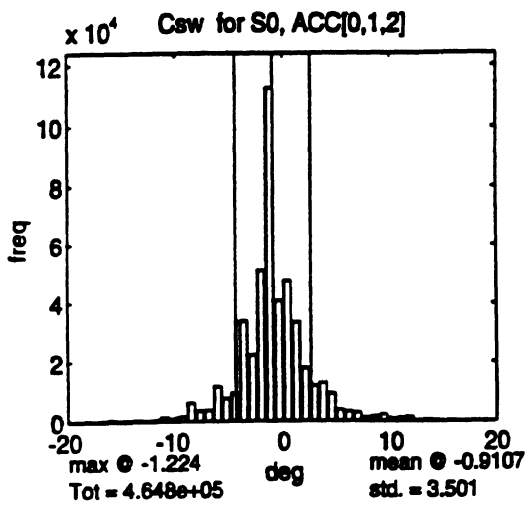

TABLE of: Ax for S0, ACC[0,1,2]

bin	freq	bin	freq
-0.200	35	+0.004	56533
-0.192	23	+0.012	24269
-0.184	17	+0.020	14961
-0.176	27	+0.029	7347
-0.167	32	+0.037	5849
-0.159	21	+0.045	6999
-0.151	20	+0.053	4220
-0.143	44	+0.061	1419
-0.135	83	+0.069	497
-0.127	278	+0.078	292
-0.118	261	+0.086	221
-0.110	367	+0.094	177
-0.102	570	+0.102	190
-0.094	1156	+0.110	161
-0.086	1661	+0.118	162
-0.078	2430	+0.127	106
-0.069	3363	+0.135	72
-0.061	3767	+0.143	75
-0.053	4631	+0.151	63
-0.045	7190	+0.159	52
-0.037	15203	+0.167	26
-0.029	29812	+0.176	27
-0.020	55854	+0.184	16
-0.012	98574	+0.192	19
-0.004	115486	+0.200	22



**TABLE of: Csw for S0, ACC[0,1,2]**

bin	freq	bin	freq
-20.00	51	+0.41	47477
-19.18	118	+1.22	33372
-18.37	134	+2.04	17906
-17.55	145	+2.86	12012
-16.73	316	+3.67	12976
-15.92	588	+4.49	9364
-15.10	325	+5.31	4004
-14.29	416	+6.12	3471
-13.47	639	+6.94	2953
-12.65	355	+7.76	1274
-11.84	531	+8.57	1659
-11.02	1564	+9.39	2314
-10.20	1000	+10.20	927
-9.39	1671	+11.02	1172
-8.57	6360	+11.84	1527
-7.76	3552	+12.65	271
-6.94	3803	+13.47	385
-6.12	11751	+14.29	201
-5.31	7721	+15.10	57
-4.49	9485	+15.92	43
-3.67	33898	+16.73	66
-2.86	22450	+17.55	11
-2.04	51061	+18.37	38
-1.22	112583	+19.18	20
-0.41	40688	+20.00	4

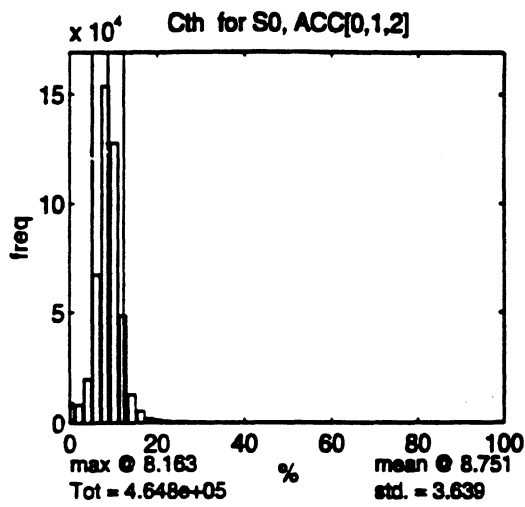

**TABLE of: Cth for S0, ACC[0,1,2]**

bin	freq	bin	freq
+0.0	9227	+51.0	15
+2.0	8347	+53.1	15
+4.1	19800	+55.1	35
+6.1	67196	+57.1	10
+8.2	153482	+59.2	24
+10.2	127753	+61.2	4
+12.2	48707	+63.3	4
+14.3	12973	+65.3	12
+16.3	5398	+67.3	16
+18.4	2242	+69.4	6
+20.4	1408	+71.4	11
+22.4	869	+73.5	8
+24.5	426	+75.5	5
+26.5	245	+77.6	29
+28.6	139	+79.6	11
+30.6	144	+81.6	0
+32.7	94	+83.7	0
+34.7	107	+85.7	0
+36.7	54	+87.8	0
+38.8	33	+89.8	0
+40.8	50	+91.8	0
+42.9	31	+93.9	0
+44.9	16	+95.9	0
+46.9	16	+98.0	0
+49.0	18	+100.0	0



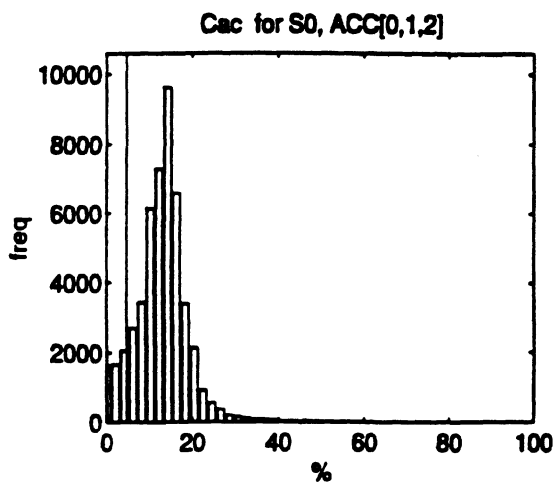

**TABLE of: Cac for S0, ACC[0,1,2]**

bin	freq	bin	freq
+0.0	1631	+51.0	25
+2.0	1664	+53.1	14
+4.1	2061	+55.1	17
+6.1	2695	+57.1	12
+8.2	3428	+59.2	12
+10.2	6142	+61.2	7
+12.2	7289	+63.3	5
+14.3	9619	+65.3	9
+16.3	6593	+67.3	14
+18.4	3408	+69.4	6
+20.4	2132	+71.4	4
+22.4	927	+73.5	8
+24.5	550	+75.5	0
+26.5	372	+77.6	0
+28.6	217	+79.6	0
+30.6	169	+81.6	0
+32.7	134	+83.7	0
+34.7	88	+85.7	0
+36.7	80	+87.8	0
+38.8	61	+89.8	0
+40.8	27	+91.8	0
+42.9	32	+93.9	0
+44.9	18	+95.9	0
+46.9	36	+98.0	0
+49.0	29	+100.0	0

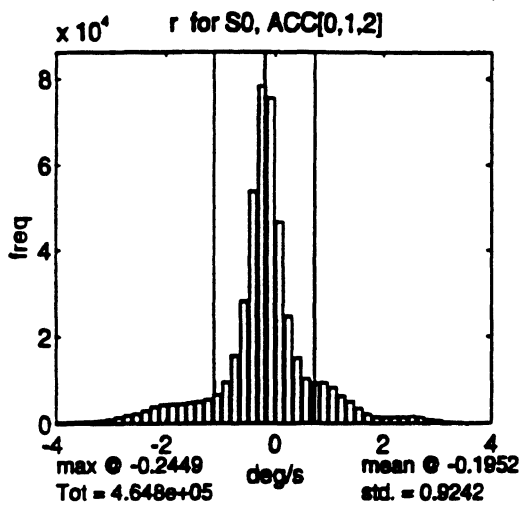

TABLE of: r for S0, ACC[0,1.2]

bin	freq	bin	freq
-4.00	434	+0.08	46582
-3.84	459	+0.24	24626
-3.67	449	+0.41	14933
-3.51	492	+0.57	10225
-3.35	561	+0.73	9187
-3.18	722	+0.90	9342
-3.02	1007	+1.06	8199
-2.86	1473	+1.22	6254
-2.69	1888	+1.39	4988
-2.53	2272	+1.55	3362
-2.37	2971	+1.71	2083
-2.20	3839	+1.88	1532
-2.04	4354	+2.04	1453
-1.88	4450	+2.20	1442
-1.71	4489	+2.37	1451
-1.55	4722	+2.53	1629
-1.39	4965	+2.69	1393
-1.22	5478	+2.86	876
-1.06	6552	+3.02	621
-0.90	9417	+3.18	330
-0.73	15418	+3.35	207
-0.57	28117	+3.51	77
-0.41	53797	+3.67	73
-0.24	78220	+3.84	57
-0.08	75544	+4.00	39

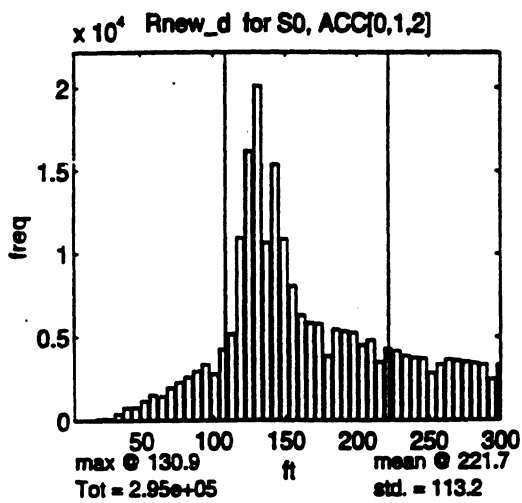
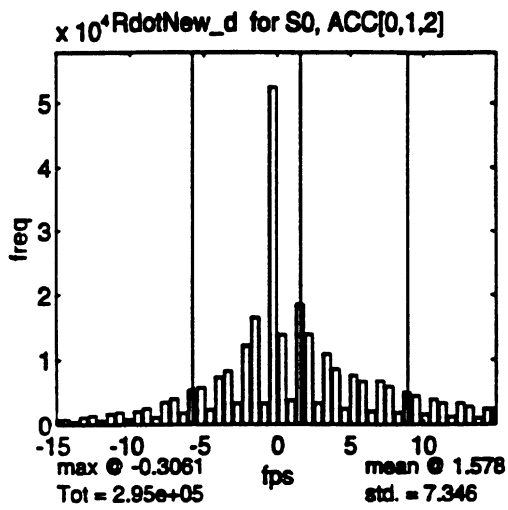

TABLE of: Rnew\_d for S0, ACC[0,1,2]

bin	freq	bin	freq
+4.0	0	+155.0	8046
+10.0	1	+161.1	6281
+16.1	8	+167.1	5821
+22.1	102	+173.1	5763
+28.2	94	+179.2	3845
+34.2	399	+185.2	5432
+40.2	764	+191.3	5341
+46.3	794	+197.3	5250
+52.3	1160	+203.3	4501
+58.4	1536	+209.4	4787
+64.4	1412	+215.4	3487
+70.4	1932	+221.5	4276
+76.5	2263	+227.5	4163
+82.5	2573	+233.6	3888
+88.6	2918	+239.6	3751
+94.6	3322	+245.6	3708
+100.7	2774	+251.7	2832
+106.7	4223	+257.7	3350
+112.7	5153	+263.8	3662
+118.8	10958	+269.8	3616
+124.8	16193	+275.8	3533
+130.9	20085	+281.9	3456
+136.9	10664	+287.9	3378
+142.9	15398	+294.0	2481
+149.0	10892	+300.0	3332



**TABLE of: RdotNew\_d for S0, ACC[0,1,2]**

bin	freq	bin	freq
-15.00	763	+0.31	13799
-14.39	802	+0.92	3735
-13.78	456	+1.53	18472
-13.16	1106	+2.14	13860
-12.55	1383	+2.76	3328
-11.94	628	+3.37	10841
-11.33	1620	+3.98	8511
-10.71	1898	+4.59	2454
-10.10	926	+5.20	7581
-9.49	2035	+5.82	6654
-8.88	2521	+6.43	2052
-8.27	1098	+7.04	6746
-7.65	3433	+7.65	5921
-7.04	3992	+8.27	1839
-6.43	1808	+8.88	5019
-5.82	5263	+9.49	4458
-5.20	5700	+10.10	1636
-4.59	2305	+10.71	3962
-3.98	7243	+11.33	3376
-3.37	8229	+11.94	1256
-2.76	3314	+12.55	3362
-2.14	12079	+13.16	2817
-1.53	16468	+13.78	1019
-0.92	3277	+14.39	2462
-0.31	52301	+15.00	2497

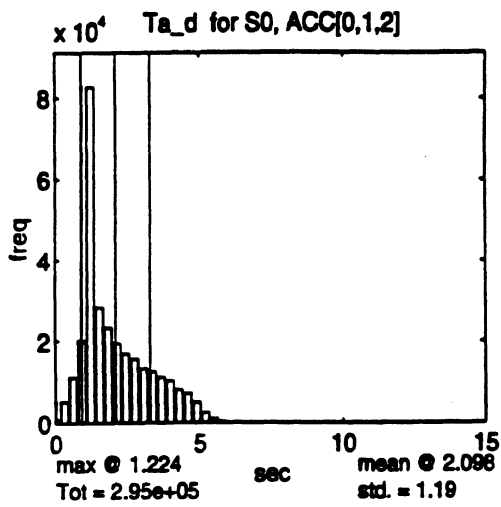

TABLE of: Ta\_d for S0, ACC[0,1,2]

bin	freq	bin	freq
+0.00	832	+7.65	0
+0.31	5196	+7.96	0
+0.61	11193	+8.27	0
+0.92	20045	+8.57	0
+1.22	82594	+8.88	0
+1.53	28300	+9.18	0
+1.84	23321	+9.49	0
+2.14	19430	+9.80	0
+2.45	16851	+10.10	0
+2.76	15609	+10.41	0
+3.06	13314	+10.71	0
+3.37	12550	+11.02	0
+3.67	11150	+11.33	0
+3.98	10316	+11.63	0
+4.29	8117	+11.94	0
+4.59	7162	+12.24	0
+4.90	5040	+12.55	0
+5.20	2486	+12.86	0
+5.51	1120	+13.16	0
+5.82	353	+13.47	0
+6.12	49	+13.78	0
+6.43	0	+14.08	0
+6.73	0	+14.39	0
+7.04	0	+14.69	0
+7.35	0	+15.00	0

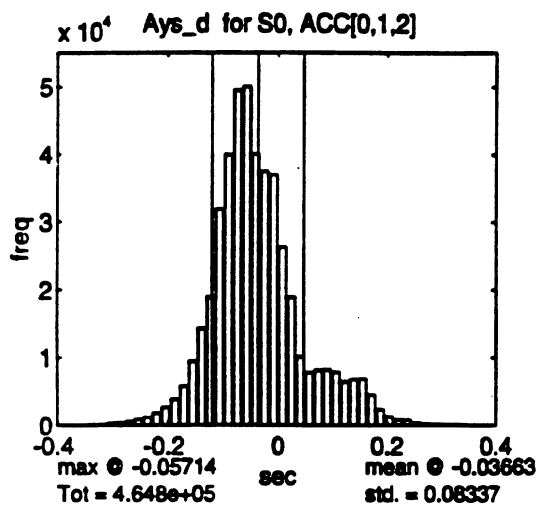

TABLE of: Ays\_d for S0, ACC[0,1,2]

bin	freq	bin	freq
-0.400	4	+0.008	26251
-0.384	6	+0.024	18858
-0.367	21	+0.041	10095
-0.351	31	+0.057	7779
-0.335	82	+0.073	8152
-0.318	118	+0.090	8248
-0.302	335	+0.106	7850
-0.286	452	+0.122	6472
-0.269	601	+0.139	6830
-0.253	946	+0.155	6846
-0.237	1192	+0.171	4517
-0.220	1823	+0.188	2337
-0.204	2673	+0.204	1305
-0.188	3808	+0.220	880
-0.171	5750	+0.237	880
-0.155	9421	+0.253	450
-0.139	14241	+0.269	249
-0.122	18862	+0.286	201
-0.106	31860	+0.302	80
-0.090	39962	+0.318	67
-0.073	49514	+0.335	51
-0.057	50053	+0.351	15
-0.041	40088	+0.367	8
-0.024	37530	+0.384	0
-0.008	37004	+0.400	0

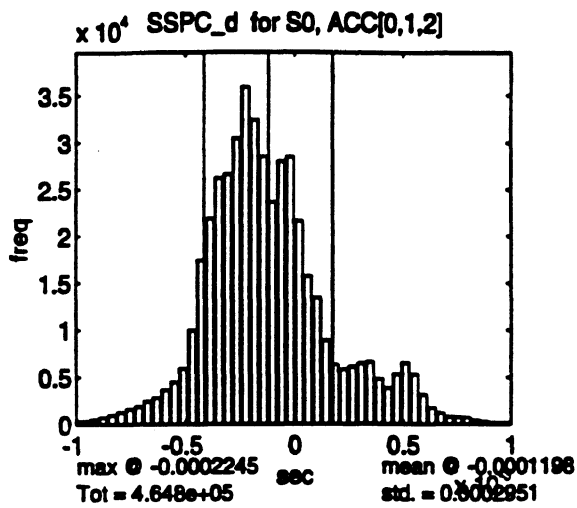
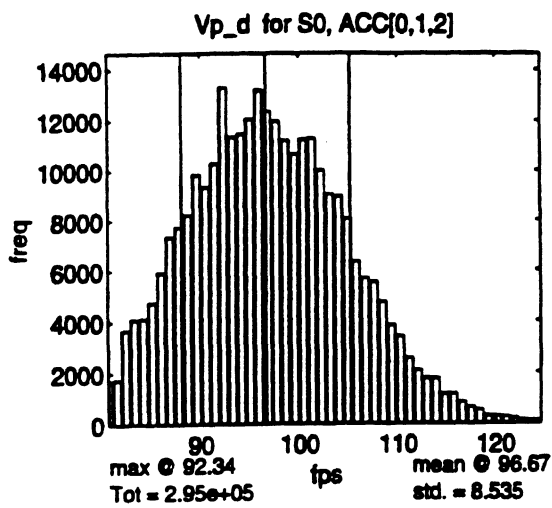

TABLE of: SSPC\_d for S0, ACC[0,1,2]

bin	freq	bin	freq
-1.00e-03	392	+2.04e-05	21629
-9.59e-04	386	+6.12e-05	15721
-9.18e-04	535	+1.02e-04	13408
-8.78e-04	743	+1.43e-04	8956
-8.37e-04	1003	+1.84e-04	6376
-7.96e-04	1306	+2.24e-04	5826
-7.55e-04	1650	+2.65e-04	6138
-7.14e-04	1915	+3.06e-04	6490
-6.73e-04	2453	+3.47e-04	6635
-6.33e-04	2827	+3.88e-04	4796
-5.92e-04	3636	+4.29e-04	3832
-5.51e-04	4452	+4.69e-04	5281
-5.10e-04	5891	+5.10e-04	6497
-4.69e-04	9935	+5.51e-04	5272
-4.29e-04	17422	+5.92e-04	3119
-3.88e-04	21855	+6.33e-04	1763
-3.47e-04	26206	+6.73e-04	1228
-3.06e-04	26623	+7.14e-04	834
-2.65e-04	30434	+7.55e-04	791
-2.24e-04	35895	+7.96e-04	736
-1.84e-04	32413	+8.37e-04	494
-1.43e-04	28538	+8.78e-04	337
-1.02e-04	23665	+9.18e-04	210
-6.12e-05	28029	+9.59e-04	148
-2.04e-05	28487	+1.00e-03	172



**TABLE of: Vp\_d for S0, ACC[0,1,2]**

bin	freq	bin	freq
+80.7	1682	+103.1	9063
+81.6	1736	+104.0	8955
+82.5	3672	+104.9	8066
+83.4	4074	+105.8	6353
+84.3	4122	+106.7	5703
+85.2	4737	+107.6	5539
+86.1	5920	+108.5	4763
+87.0	7346	+109.4	3856
+87.9	7749	+110.3	3413
+88.7	8238	+111.2	2557
+89.6	9844	+112.1	2083
+90.5	9352	+113.0	1780
+91.4	10282	+113.9	1759
+92.3	13286	+114.8	1166
+93.2	11343	+115.7	1161
+94.1	11461	+116.6	839
+95.0	12053	+117.5	647
+95.9	13186	+118.4	537
+96.8	12365	+119.3	308
+97.7	11970	+120.2	301
+98.6	11206	+121.1	277
+99.5	10662	+122.0	219
+100.4	11238	+122.9	153
+101.3	11285	+123.8	126
+102.2	10015	+124.7	115