

## Upper Group Cluster C: Closed Table Vessels, Shape Groups IX-XI

This cluster contains thirty-one upper profile types separated into three groups. These are all closed table vessels, identified by fabric, shape, and decoration combinations. They are found in a variety of fine fabrics, primarily Pink/Buff A and Pink/Buff B fabrics. Slips are common, and they are often combined with other forms of decoration, including incisions, stamps, and pattern burnishing.

The vessels in Groups X and XI are among the most problematic in this corpus. Very few profiles are preserved to the shoulder and there is a wide range of possibilities for their lower bodies. The diameter of the rim need not always have a direct correlation to the shape or volume of the vessel, but it is the greatest distinguishing factor available and it is reasonable to assume that there are frequently functional differences connected to the size of the mouth of the vessel. Hence, the major factor that divides the vessels in these groups is the diameter of the rim. There is an important bimodal distribution of the rim diameters with an overwhelming size mode of 10-12 centimeters and then a lesser number of vessels with larger rims, in the 20-35 centimeter range. I have used this size distribution to create a somewhat arbitrary distinction between vessels below 20cm in rim diameter (Group 10) and those 20cm and above (Group 11).<sup>123</sup>

- *Shape Group IX*: Small Toilet and Oil Jars, Upper Profile Types 1-3
- *Shape Group X*: Pitchers and Small Table Amphorae, Upper Profile Types 86-103
- *Shape Group XI*: Wide-mouthed Serving Jars/Table Amphorae, Upper Profile Types 104-112, 176

Group IX vessels probably held perfume, oil, or other cooking products. The

---

<sup>123</sup> Similar upper profiles at Ai Khanoum with 10 centimeter rim diameters are connected to vessels between 15 and 65 centimeters in height.

function of Group X and XI vessels is uncertain, but those in Group X were likely used for pouring or holding small amounts of liquids in dining settings. Vessels in Group XI were likely used for serving liquids in a dining setting, but perhaps with a ladle or cup and not by pouring, given their likely larger volume capacity.



## Shape Group IX: Small Toilet and Oil Jars

### Upper Profile Types 1-3

These small, closed jar types are usually 3 to 8 centimeters in diameter at the rim; fully preserved examples have plain bases, 3 to 5 centimeters in diameter (Figure 249). With rounded or angular everted rims, neckless or with very short necks, the bodies are slightly globular and occasionally have slight carinations at the lower body. Lower Profile Types 1 and 2 are associated with this shape group. No examples have handles or spouts, so they were probably used for storing toiletry liquids or perhaps oil or condiments. Vessels in this group could have had private, toilet functions or public table functions, perhaps oil serving. They are clustered with closed utilitarian vessels because most were likely utilitarian vessels. Several examples in this group have whole profiles and show plain bases, either rounded or angular, but other forms are possible, particularly the disc base, which is popular at Bactra.

Upper Profile Types 1 and 2 are rare.

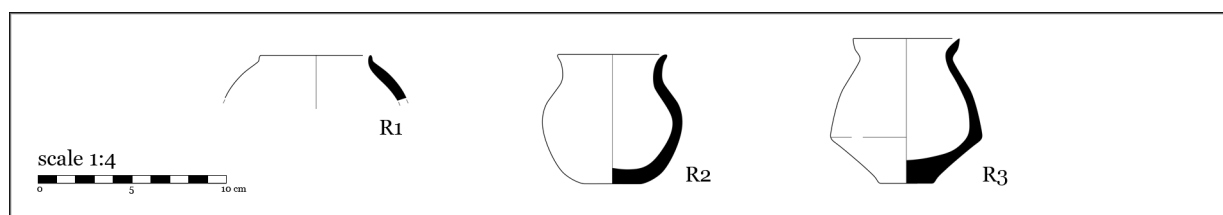

Figure 249: Compendium of Shape Group IX vessels

*Upper Profile Type 1 (n=3)*

This small closed jar type is thin-walled and neckless with widened shoulders (Figure 250). The rims vary between plain and rounded and slightly pinched. Examples are not preserved down to the belly of the vessel and its base is unknown.

Rim diameters range from 3-8 cm, but too few examples were found to determine modes. It has been found only in Pink/Buff B fabric (3 sherds). Decorations include one example of matte red slip and one example of matte eggplant colored slip.

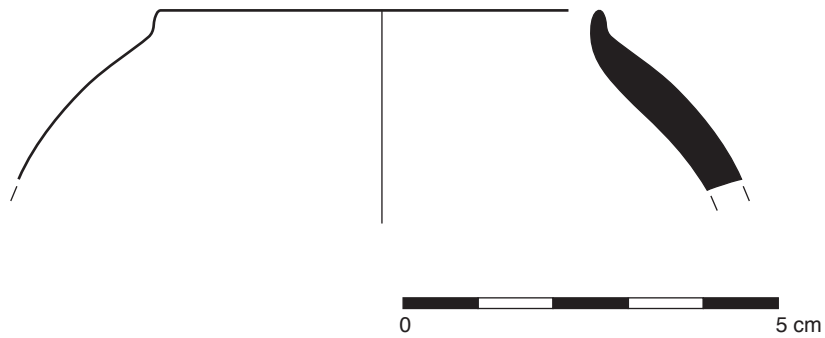

Figure 250: Rim in Pink/Buff B fabric, unslipped; TZ 2008 Ch.18 UF 15

*Upper Profile Type 2 (n=2)*

This small closed jar type is a thin-walled, pear-shaped vessel with a distinct carination (Figure 251). It has an everted rim, a rounded, plain lip, and a convex upper body and an angular carination at the widest point of the body. It has straight lower walls and a plain, angular base. Examples have a rim diameter of 6-7 cm.

It has been found in unslipped Pink/Buff B fabric (1 sherd) and Peach Cream fabric (1 sherd).

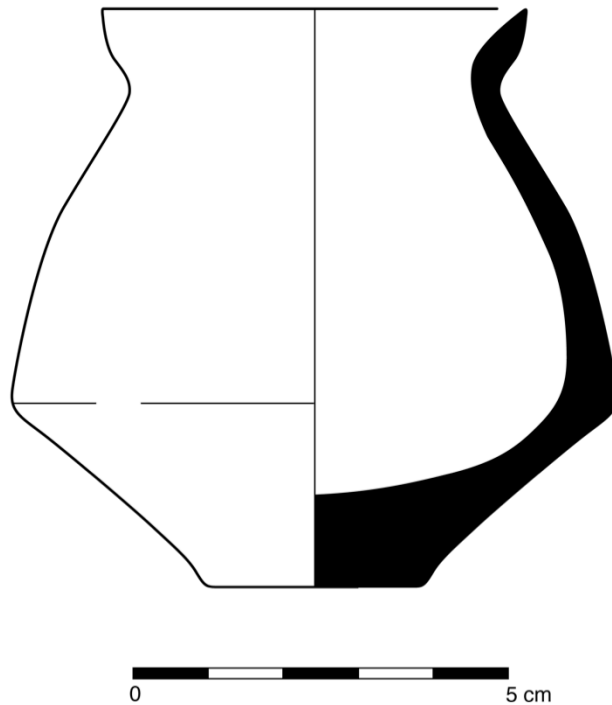

Figure 251: Whole profile in Peach Cream fabric; BH 2005 UF 52

*Upper Profile Type 3 (n=10)*

This small closed jar type is a thin-walled, globular-shaped vessel (Figure 252). It has an everted rim, a rounded, plain lip, and a rounded belly and an unarticulated base. Examples have a rim diameter of 4 to 6 centimeters. Whole profiles range in height from 7 to 8 centimeters. Some examples are wheel-made and some appear handmade.

It has been found in Pink/Buff B fabric (8 sherds), Pink/Buff A fabric (1 sherd), and an unknown coarse fabric (1 sherd). There are some unslipped examples. Others are decorated with red slip or red slip with vertically burnished stripes.

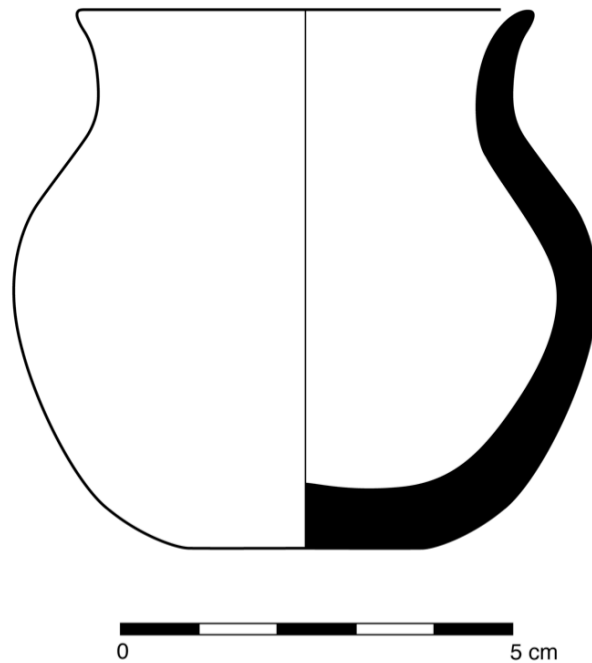

Figure 252: Whole profile in unknown gray fabric with red/brown slip and small irregular brown and gray inclusions; TZ 2005 Ch.6 UF.32

## **Shape Group X: Pitchers and Small Table Amphorae**

### **Upper Profile Types 86-103**

These are all closed vessel types, likely for serving liquids in a public dining setting (Figure 253). Usually 5 to 15 centimeters in diameter at the rim, average height is unknown. Necks are usually 10-20 centimeters tall, and extant bodies have curved, widened shoulders. Examples have mostly one, and sometimes two vertical handles, attached at the upper neck and lower neck or upper body. Due to preservation, it is usually impossible to determine whether these vessels had one handle and were pitchers or had two handles and were meant to be table amphorae or none at all. The presence of trefoil rims is diagnostic for pitchers, but small pinched spouts were often used, so unless a whole rim found, it is not possible to say that a rim does not have one. At this time, because of the very fragmentary evidence, it is only possible to determine whether a sherd is part of a pitcher or an amphorae if one has the following diagnostic features: a whole rim with no formed spout, two handles, a pinched spout, or a trefoil spout.

Upper Profile Types 89, 93, and 97 are rare. Upper Profile Types 94 and 98 are very common.

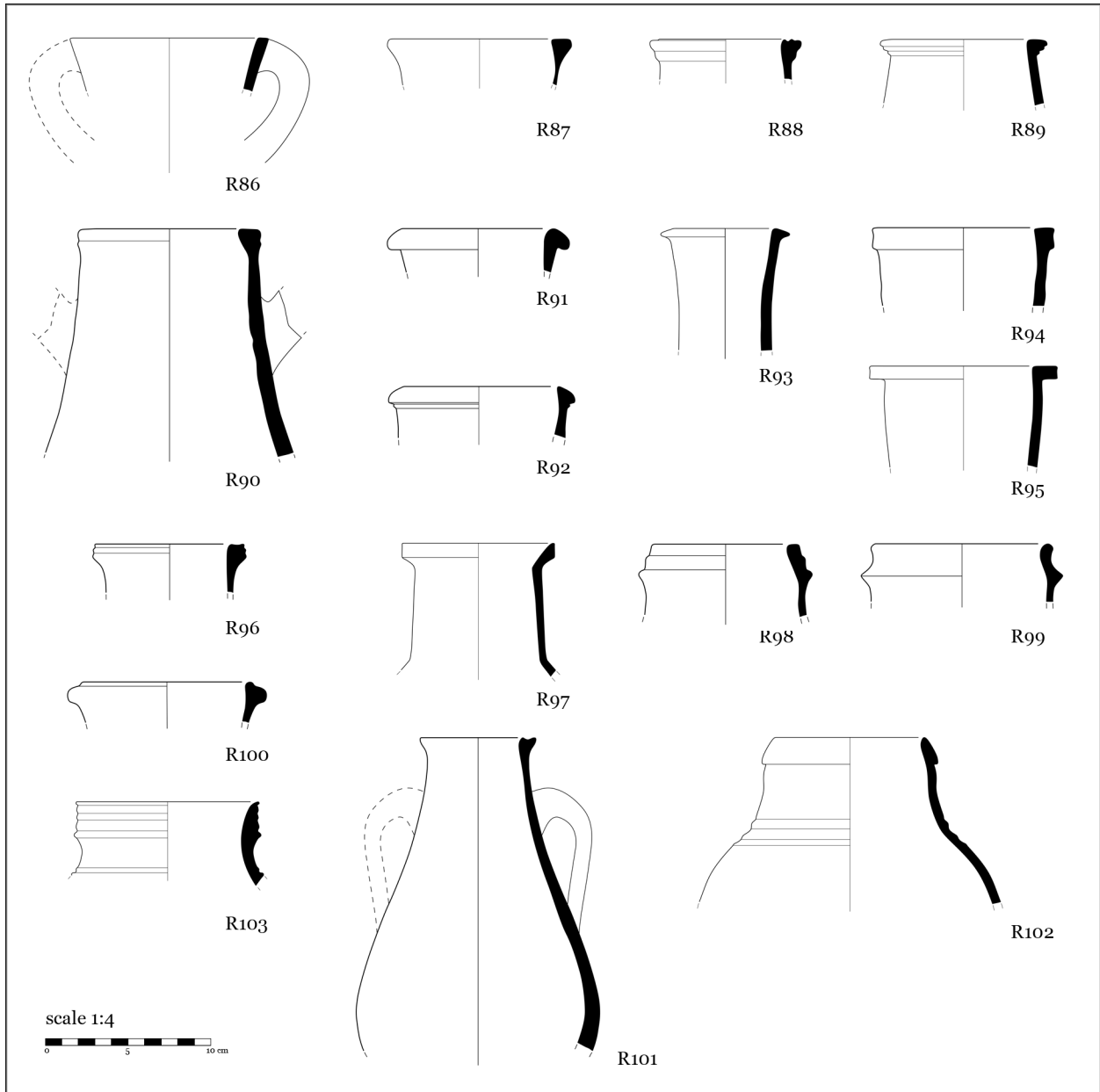

Figure 253: Compendium of Shape Group X vessels

*Upper Profile Type 86 (n=6)*

This jar type is a thin walled closed shape (Figure 254). It has a tall, vertical or slightly flanged neck and a plain rim with a squared lip. Examples are not extant to the belly. Some examples have round handles that join the body at the top of the lip. Base forms are unknown.

It has rim diameters between 5 and 10 centimeters. It is found in Pink/Buff B fabric (3 sherds), Pink/Buff A fabric (1 sherd), and coarse fabrics (2 sherds). Most examples are undecorated, but there are two examples of impressed decorations. One example shows dots in oval patterns impressed on the exterior of the neck. Another has a shallow parallel groove on the exterior of the rim.

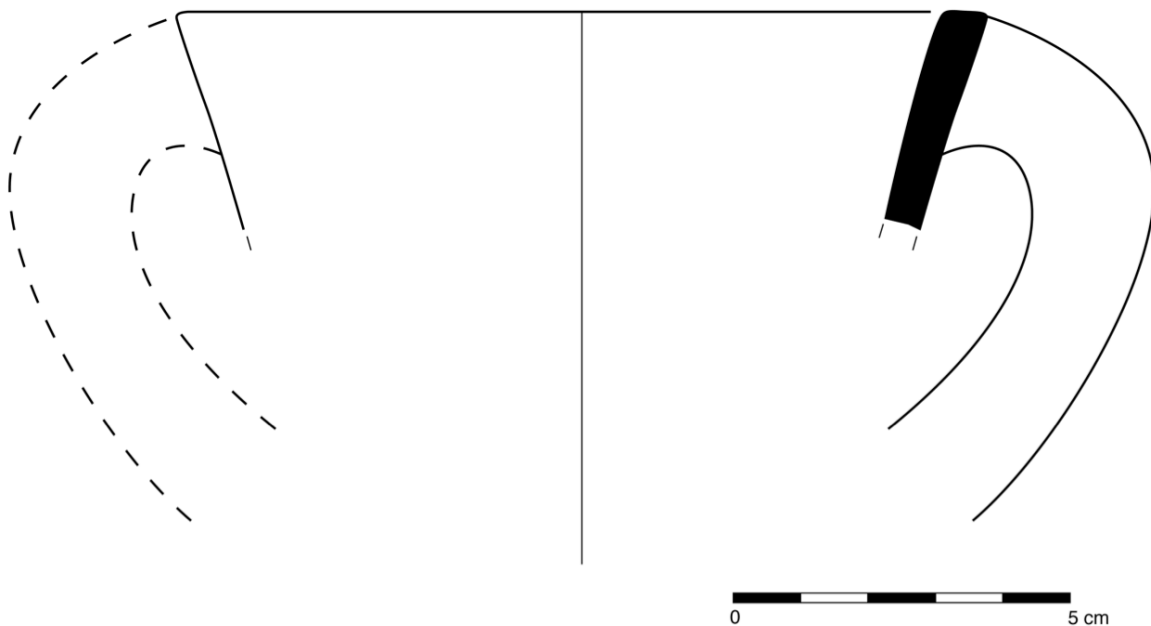

Figure 254: Rim and handle in Pink/Buff B fabric, unslipped; TZ 2004 Ch.4 Sec.2 UF 12

*Upper Profile Type 87 (n=129)*

This jar type is a thin walled closed shape (Figure 255). It has a tall, vertical neck and the rim has a triangular shaped external articulation. The lip is flat and rounded. Examples are not extant past the belly, but several show a widened shoulder and one or two handles. Base forms are unknown.

It has rim diameters between 4 and 12 centimeters. It has been found only in Pink/Buff A fabric (35 sherds) and Pink/Buff B fabric (93 sherds) and an unknown fabric (1 sherd). There are many unslipped examples, but red and eggplant colored semi-glossy slips are common and are sometimes found in conjunction with wavy or incised lines on the neck or upper body. Vertical burnishing over the slip exists, but is not as frequent in this type as it is in other types in this group.

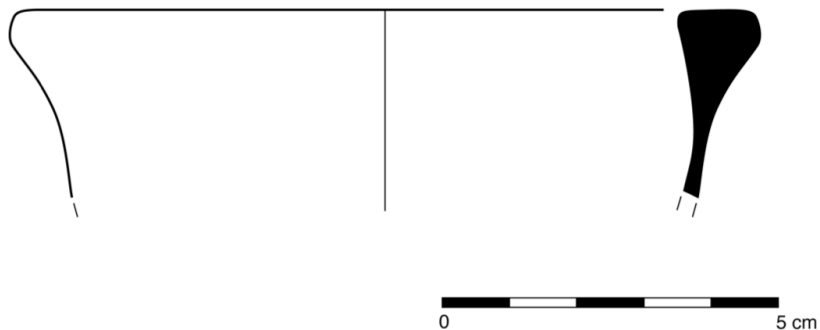

Figure 255: Rim in Pink/Buff B fabric with semi-glossy eggplant colored slip; TZ 2004 Ch.4 UF 9



*Upper Profile Type 88 (n=45)*

This jar type is a thin walled closed shape (Figures 256, 257). It has a tall, vertical neck and the rim has external articulation, mostly triangular with deep grooves in the top often the exterior. The lip is undulating and rounded. Examples are not preserved past the belly, but rare examples do show a widened shoulder. Evidence of one and two handled varieties exist, with the handle affixed just below the rim and at the shoulder. Base forms are unknown.

It has rim diameters between 7 and 15 centimeters. It has been found in Pink/Buff A fabric (13 sherds) and Pink/Buff B fabric (32 sherds), the latter being more common. Unslipped varieties are as common as those with red or eggplant colored semi-glossy slips. Other than the grooved rims, no decorated examples have been found on this type.

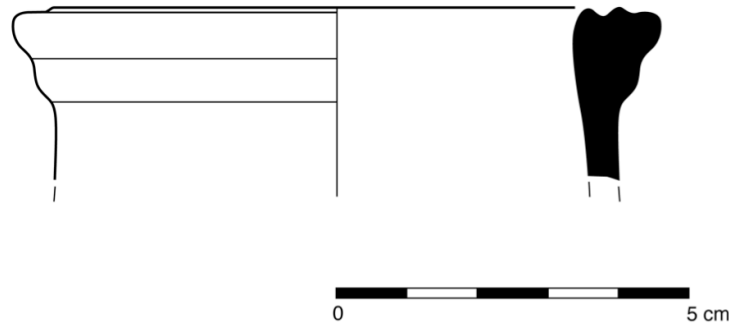

Figure 256: Rim in Pink/Buff B fabric, unslipped; TZ 2005 Ch.6 UF 4

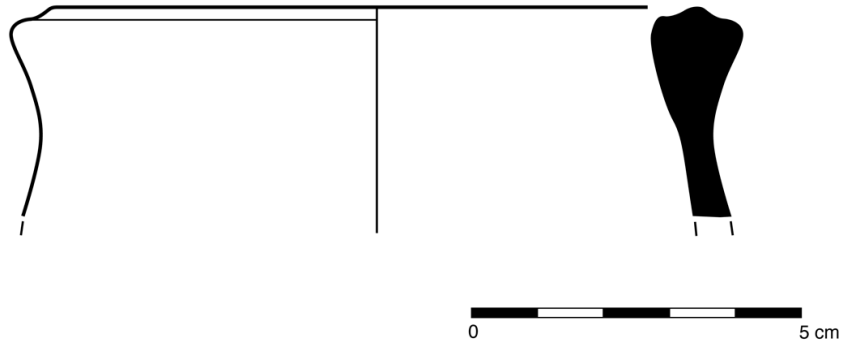

Figure 257: Rim in Pink/Buff A fabric, unslipped; TZ 2004 Ch.4 UF 15

*Upper Profile Type 89 (n=5)*

This jar type is a thin walled closed shape (Figure 258). It has a tall, vertical neck and the rim has a triangular shaped external articulation with articulated grooves on the exterior of the rim. The lip is flat and rounded. Examples are not preserved to the belly. Base forms are unknown.

A fairly rare type, it has rim diameters between 10 and 13 centimeters. It has been found in Pink/Buff A fabric (2 sherds) and Pink/Buff B fabric (3 sherds). Mostly undecorated, there is a single example of eggplant colored semi-glossy slip and one of semi-glossy red slip with vertical burnishing on the neck.

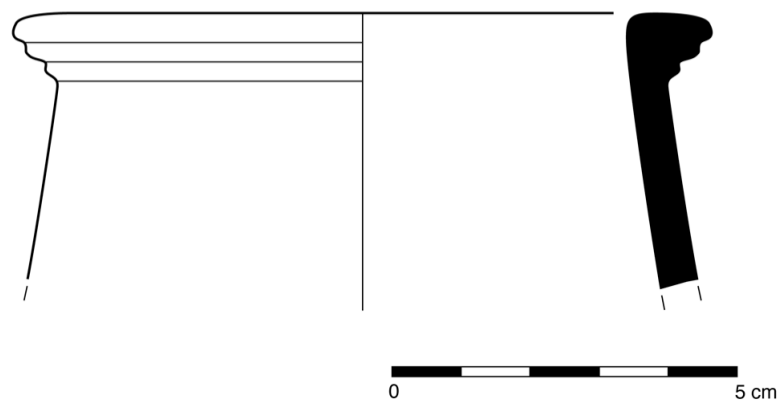

Figure 258: Rim in Pink/Buff B fabric with semi-glossy red slip; TZ 2005 Ch.6 UF 4

*Upper Profile Type 90 (n=12)*

This jar type is a thin walled closed shape (Figures 259, 260). It has a tall, vertical neck and triangular, internal articulation. Examples are not preserved to the belly. Some examples have large, rounded or flat handles that join the vessel at the neck at a flat or upwards angle and bend down to attach at the shoulder. Base forms are unknown.

It has rim diameters between 5 and 13 centimeters. It has been found primarily in Pink/Buff B fabric (9 sherds), but Pink/Buff A fabric (3 sherds) examples are also known. Often undecorated, red and eggplant colored semi-glossy slips have been found.

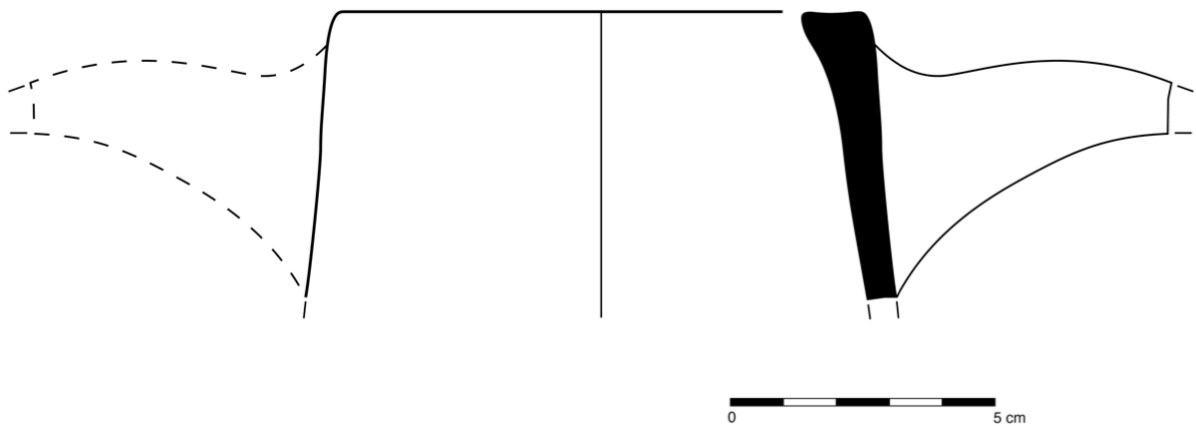

Figure 259: Rim in Pink/Buff B fabric with semi-glossy red slip; TZ 2005 Ch.6 UF 53

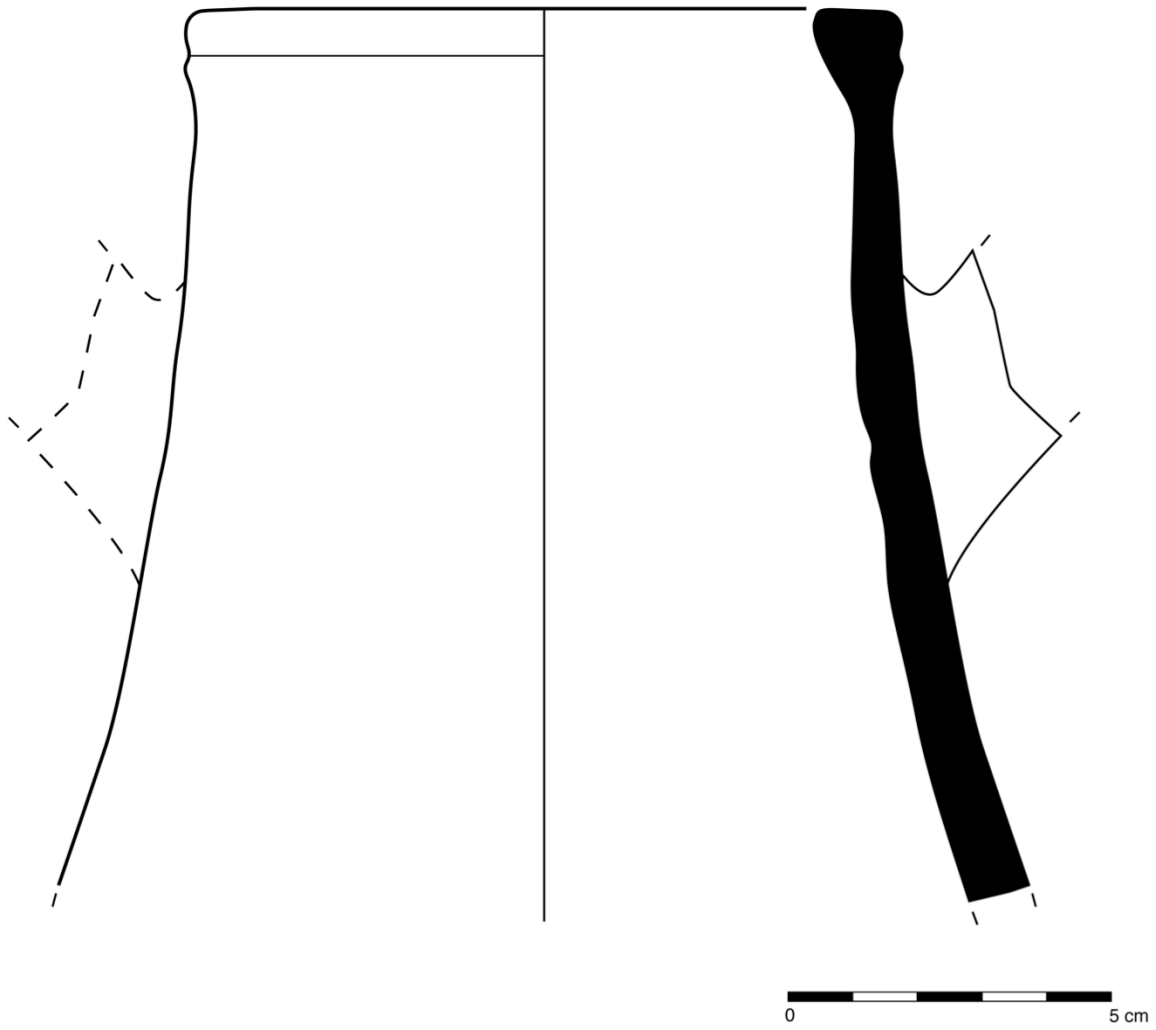

Figure 260: Rim and handle in Pink/Buff B fabric, unslipped; TZ 2004 Ch.4 Sec.2 UF 10

*Upper Profile Type 91 (n=99)*

This jar type is a thin walled closed shape (Figures 261, 262). It has a tall, vertical neck and the rim has external articulation, a rounded triangle. The rim is downturned and the lip is rounded. Examples are not extant to the belly. Base forms are unknown.

It has rim diameters between 4 and 15 centimeters. It is found primarily in Pink/Buff A fabric (43 sherds) and Pink/Buff B fabric (53 sherds), but there are rare examples in coarse fabrics (2 sherds) and a single example in Gray fabric with black slip. Undecorated varieties and those with red and eggplant colored semi-glossy slips are equally common. Slips are sometimes used in conjunction with wavy or straight incised lines, vertical burnishing on the neck, or patterned impressed dots.

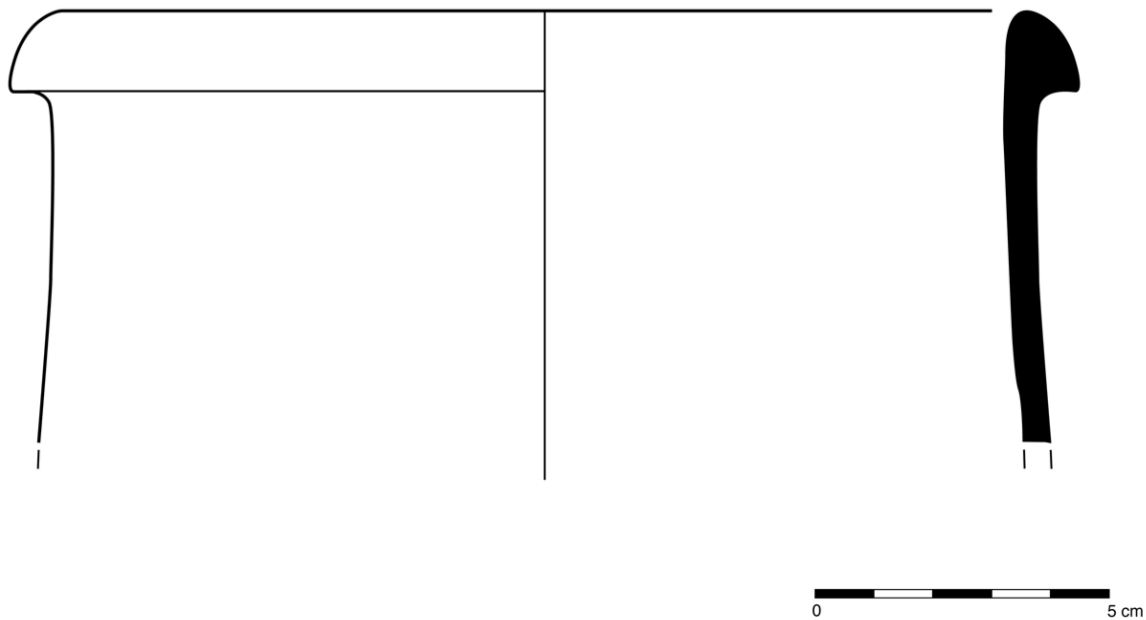

Figure 261: Rim in Pink/Buff B fabric, unslipped; TZ 2004 Ch.4 Sec.? UF 12

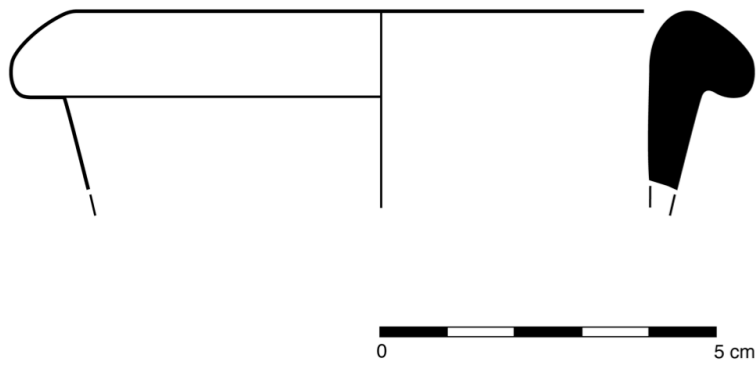

Figure 262: Rim in Pink/Buff B fabric, unslipped; TZ 2005 Ch.6 UF 4

*Upper Profile Type 92 (n=8)*

This jar type is a thin walled closed shape (Figures 263, 264). It has a tall, vertical neck and the rim has external articulation, a rounded triangle. The lip is downturned and rounded. Examples are not extant to the belly. Base forms are unknown.

It has rim diameters between 5 and 15 centimeters. It has been found in Pink/Buff A fabric (3 sherds) and Pink/Buff B fabric (5 sherds). There are unslipped examples, but two examples of red semi-glossy slip have also been found. Both slipped examples are additionally decorated with either vertical burnishing strokes on the neck or wavy incised lines.

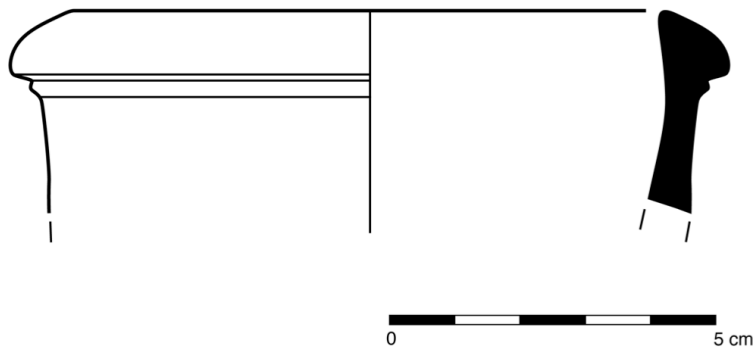

Figure 263: Rim in Pink/Buff A fabric with semi-glossy red slip; TZ 2005 Ch.6 UF 17

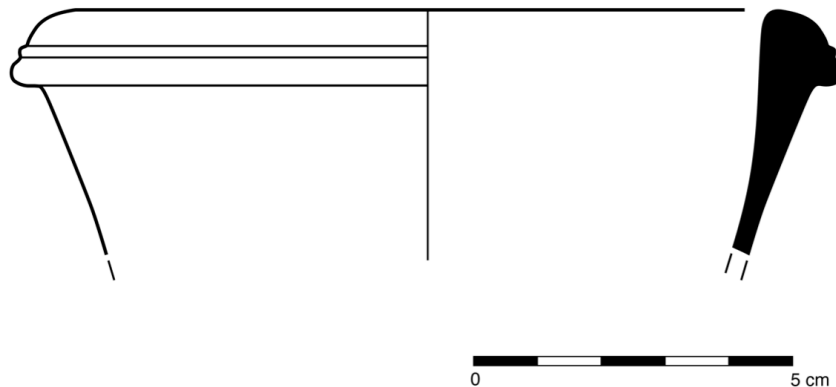

Figure 264: Rim in Pink/Buff B fabric, unslipped; TZ 2004 Ch.4 Sec.2 UF 18



*Upper Profile Type 93 (n=3)*

This narrow mouthed jar type is a thin walled, closed form (Figure 265). It has a vertical rim with a sharp external articulation. Examples have tall necks and could perhaps be lagynoi or unguentaria, but are not preserved to the belly, so it is impossible to determine. Base forms are unknown.

This rare type has rim diameters between 5 and 10 centimeters. It has been found in Pink/Buff B fabric (3 sherds) with red or eggplant colored semi-glossy slip and vertical burnishing on the neck.

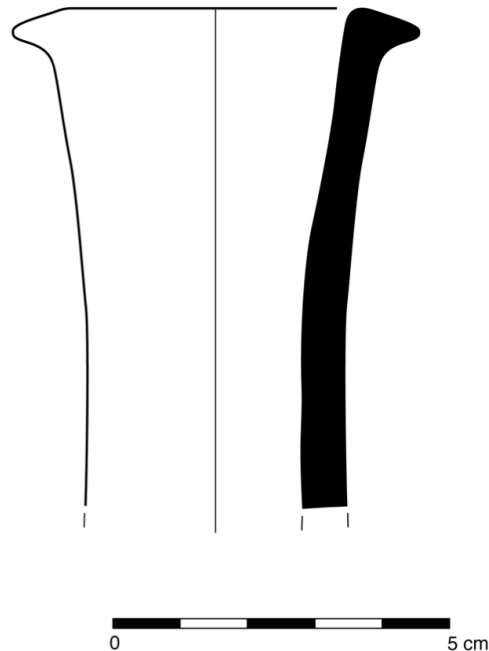

Figure 265: Rim in Pink/Buff B with semi-glossy red slip and vertical burnishing on neck; TZ 2005 Ch.6 UF 5

*Upper Profile Type 94 (n=177)*

This jar type is a thin walled closed shape (Figure 266). It has a tall, vertical neck and the rim has squared or rectangular external articulation. The top of the lip is plain and angular. Examples are not preserved to the belly. One or two handles are fairly common, usually affixed just below the rim or further down the neck. Base forms are unknown.

A very common type, it has rim diameters between 5 and 15 centimeters. It has been found in Pink/Buff B fabric (134 sherds) and Pink/Buff A fabric (43 sherds), the former far more common. Unslipped varieties are as common as red and eggplant colored semi-glossy slip, often used in conjunction with incised straight lines or patterned impressed dots on the neck. One example shows black crosshatched slipped lines on the neck.

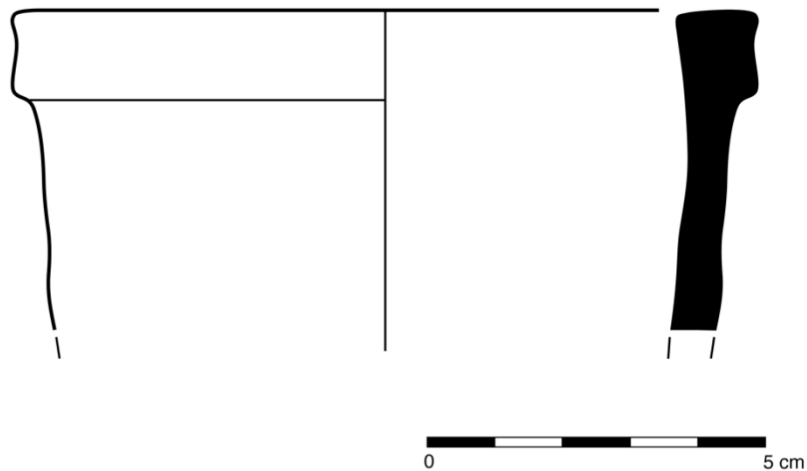

Figure 266: Rim in Pink/Buff A fabric, unslipped; TZ 2004 Ch.4 UF 9

*Upper Profile Type 95 (n=14)*

This jar type is a thin walled closed shape (Figure 267). It has a tall, vertical neck and the rim has rectangular external articulation that juts out from the top of the vessel. The top of the lip is plain and angular. Examples are not preserved to the belly. Base forms are unknown.

It has rim diameters between 8 and 12 centimeters. It has been found in Pink/Buff A fabric (6 sherds) and Pink/Buff B fabric (8 sherds). Unslipped varieties are common, sometimes with wavy or straight incised lines on the neck. Red and eggplant colored semi-glossy slips are common, sometimes used in conjunction with vertical burnishing or stamped decoration on the neck.

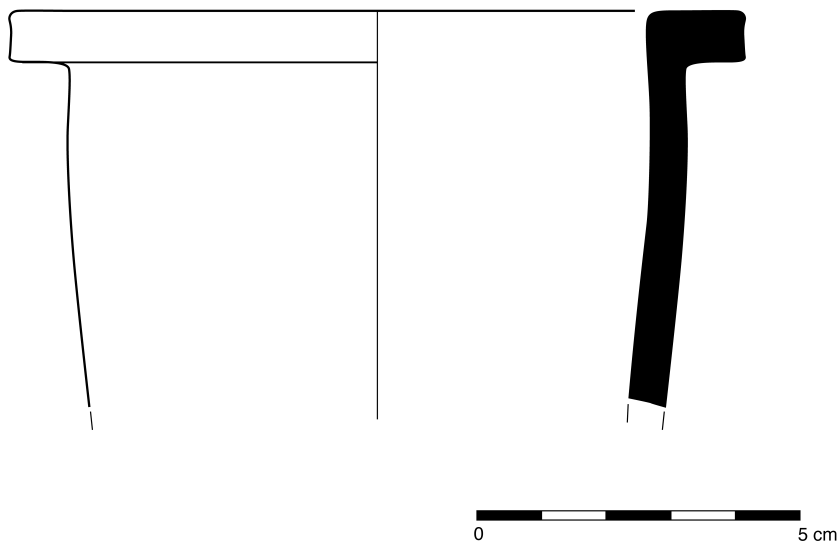

Figure 267: Rim in Pink/Buff A fabric with semi-glossy red slip and vertical burnishing on neck; TZ 2005 Ch.6 UF 4

*Upper Profile Type 96 (n=46)*

This jar type is a thin walled closed shape (Figures 268, 269). It has a tall, vertical neck and the rim has squared external articulation. The top of the lip is angular with grooves. Examples are not preserved to the belly. Some examples have large, rounded or flat handles that join the vessel at the neck at a flat or upwards angle and bend down to attach at the shoulder. Base forms are unknown. Trefoil versions have also been found.

It has rim diameters between 8 and 12 centimeters. This type has been found in Pink/Buff A fabric (11 sherds) and Pink/Buff B fabric (35 sherds). Unslipped varieties have been found, but are not common. Red and eggplant colored semi-glossy slip is common, often used in conjunction vertical burnishing or wavy incised lines on the neck. Patterned impressed dots and stamps have also been found.

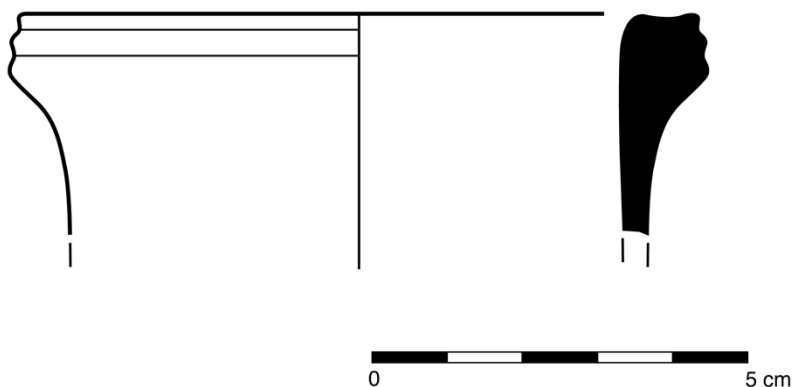

Figure 268: Rim in Pink/Buff B fabric with semi-glossy red slip; TZ 2008 Ch.18 UF 15

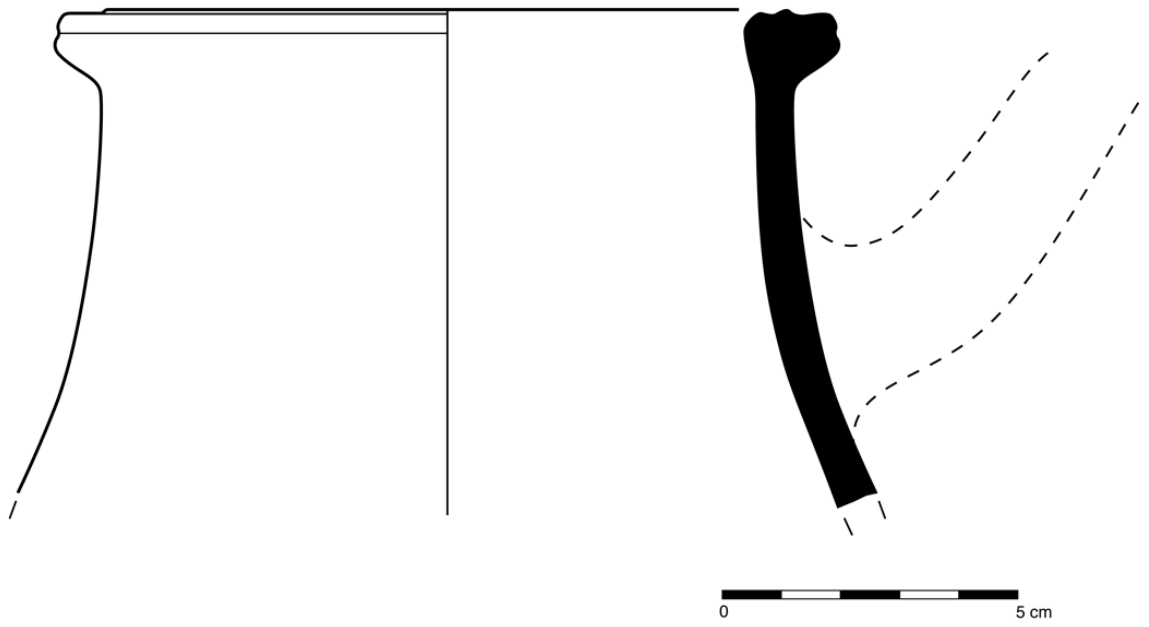

Figure 269: Rim and handle in Pink/Buff B fabric with semi-glossy eggplant colored slip; TZ 2005 Ch.6 UF 53

*Upper Profile Type 97 (n=5)*

This jar type is a thin walled closed shape (Figure 270). It has a tall, vertical neck and the rim has a diagonal upward slanting rectangular articulation. The top of the lip is angular. Examples are not preserved to the belly. Some examples have rounded handles that join the vessel at the neck. Base forms are unknown.

It has rim diameters between 6 and 13 centimeters. It has been found in Pink/Buff B fabric (4 sherds) and Pink/Buff A fabric (1 sherd). A single unslipped example has been found, but more common is red or eggplant colored semi-glossy slip.

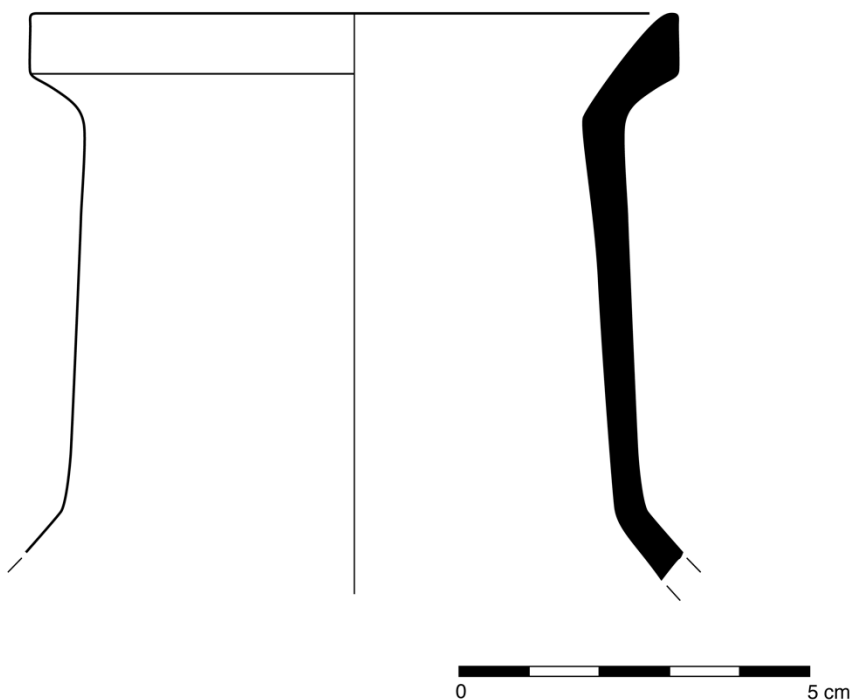

Figure 270: Rim and neck in Pink/Buff B fabric with semi-glossy eggplant colored slip; TZ 2007 Ch.6 UF 7

*Upper Profile Type 98 (n=110)*

This jar type is a thin walled closed shape (Figures 271, 272). It has a tall, vertical neck and the rim has an external articulation. The top of the lip is plain and rounded and there is frequently a lower triangular articulation at the bottom of the rim. There are grooves on the external portion of the rim. Some examples show a widened shoulder and rounded pear-shaped body. Base forms are unknown. Trefoil rims have been found.

It has rim diameters mainly from 8 to 15 centimeters, though one very small (2.5 cm) example is present, which clearly has a different purpose, though the shape itself is the same. It appears in Pink/Buff A fabric (35 sherds), Pink/Buff B fabric (73 sherds) and rarely in coarse fabrics (2 sherds). Unslipped varieties have been found, but red and eggplant colored semi-glossy slip is more common, often used in conjunction with wavy or straight incised lines or vertical burnishing on the neck.

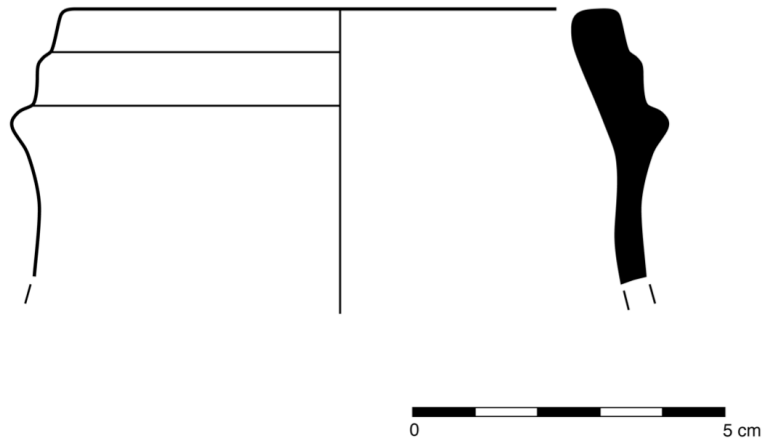

Figure 271: Rim in Pink/Buff B fabric with semi-glossy eggplant colored slip; TZ 2005 Ch.6 UF 10

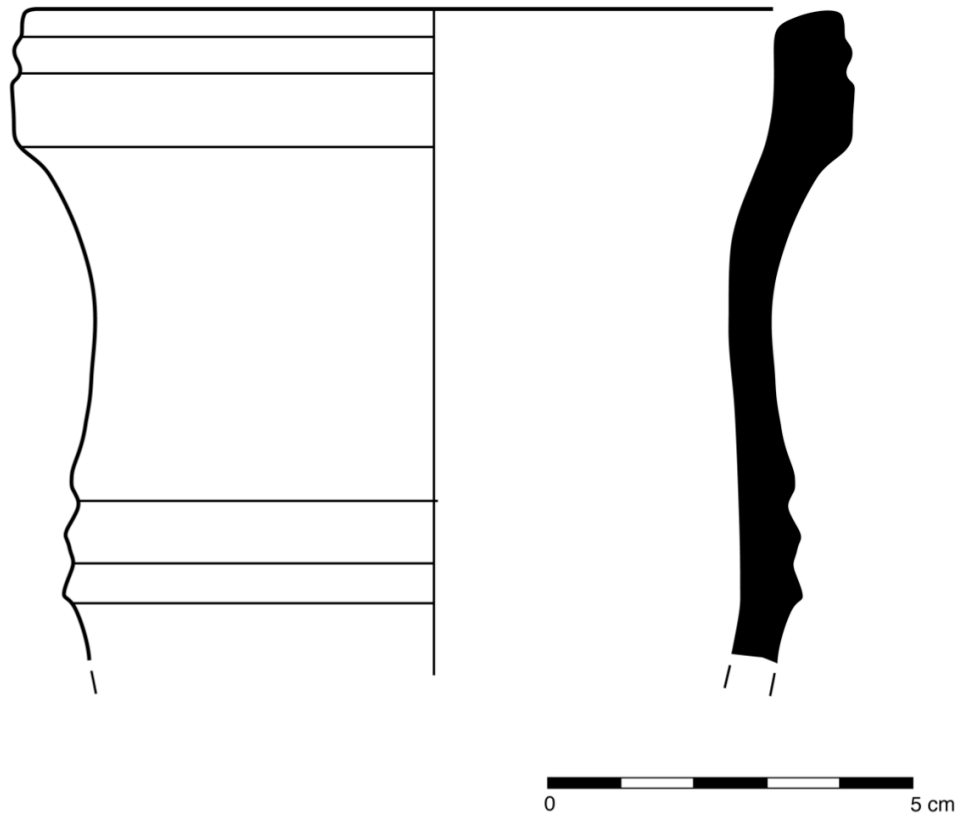

Figure 272: Rim in Pink/Buff A fabric with eggplant colored slip; TZ 2005 Ch.6 UF 4



*Upper Profile Type 99 (n=19)*

This jar type is a thin walled closed shape (Figures 273, 274). It has a tall, vertical neck and the rim has external articulation. The top of the lip is plain and rounded and there is a lower triangular articulation at the bottom of the rim. Examples are not preserved to the belly. Base forms are unknown. Trefoil mouths have been found.

It has rim diameters between 7 and 14 centimeters. It has been found in Pink/Buff B fabric (11 sherds) and Pink/Buff A fabric (8 sherds). Unslipped varieties have been found, but red or eggplant colored semi-glossy slip is more common, often used in conjunction with vertical burnishing on the neck.

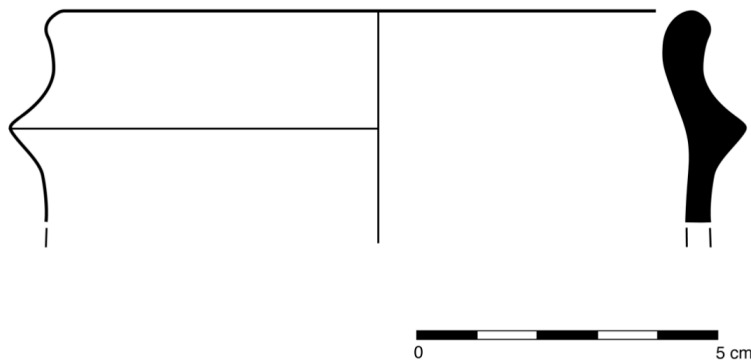

Figure 273: Rim in Pink/Buff B fabric with semi-glossy eggplant colored slip; TZ 2004 Ch.4 UF 9

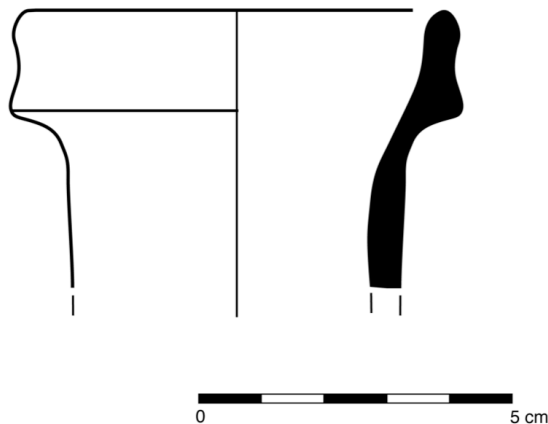

Figure 274: Rim in Pink/Buff A fabric, unslipped; TZ 2005 Ch.6 UF 5

*Upper Profile Type 100* (n=30)

This jar type is a thin walled closed shape (Figure 275). It has a tall, vertical neck and the rim has triangular external articulation. The lip is rounded with a lower external ledge. Examples are not preserved to the belly. Base forms are unknown. Trefoil mouths have been found.

It has rim diameters between 8 and 14 centimeters. It is primarily found in Pink/Buff A fabric (14 sherds) or Pink/Buff B fabric (15 sherds), but one example in a coarse fabric has been found. Unslipped varieties exist, but red or eggplant semi-glossy slip is more common, often used in conjunction with vertical burnishing on the neck.

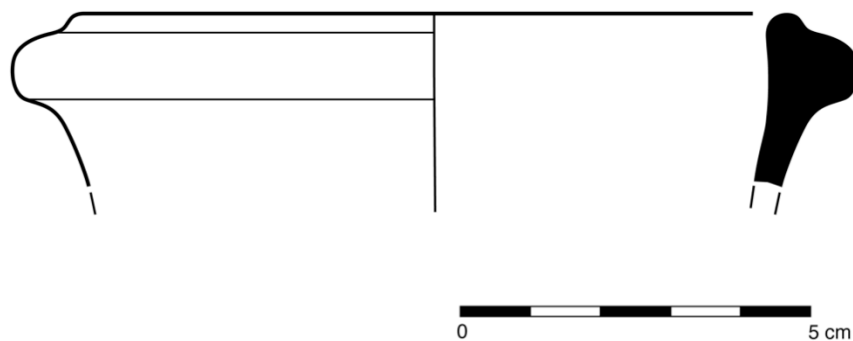

Figure 275: Rim in Pink/Buff B fabric, unslipped; TZ 2005 Ch.6 UF 5

*Upper Profile Type 101 (n=13)*

This jar type is a thin walled closed shape (Figures 276-277). It has a tall, vertical neck and the rim has triangular external articulation. The lip is rounded with a central indent. Some examples are preserved well past the belly (Figure 278), with a rounded, slightly pear shaped body. Some examples have round handles that join the body at the neck. Base forms are unknown. Trefoil rims have been found.

It has rim diameters between 7 and 12 centimeters. It has been found in Pink/Buff A fabric (3 sherds) and Pink/Buff B fabric (10 sherds). All known examples have either red or eggplant colored semi-glossy slip. Vertical burnishing is sometimes used in conjunction with the slipped decoration.

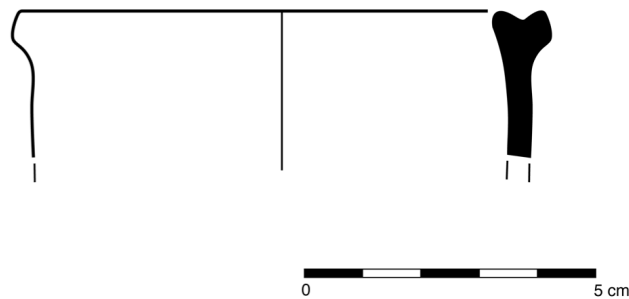

Figure 276: Rim in Pink/Buff B fabric with semi-glossy eggplant colored slip; TZ 2005 Ch.6 UF 4

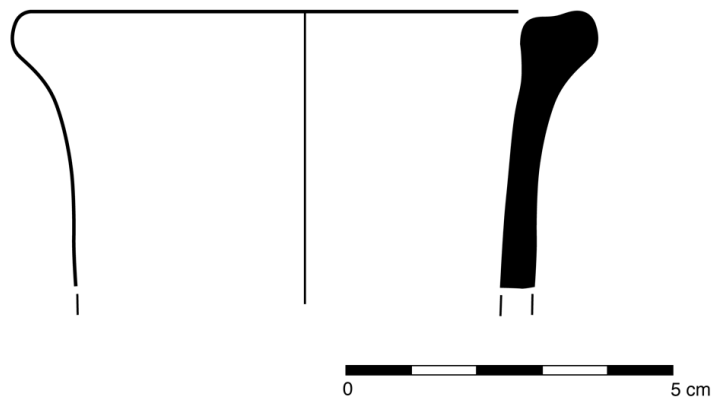

Figure 277: Rim in Pink/Buff A fabric with semi-glossy red slip; TZ 2004 Ch.4 UF 11

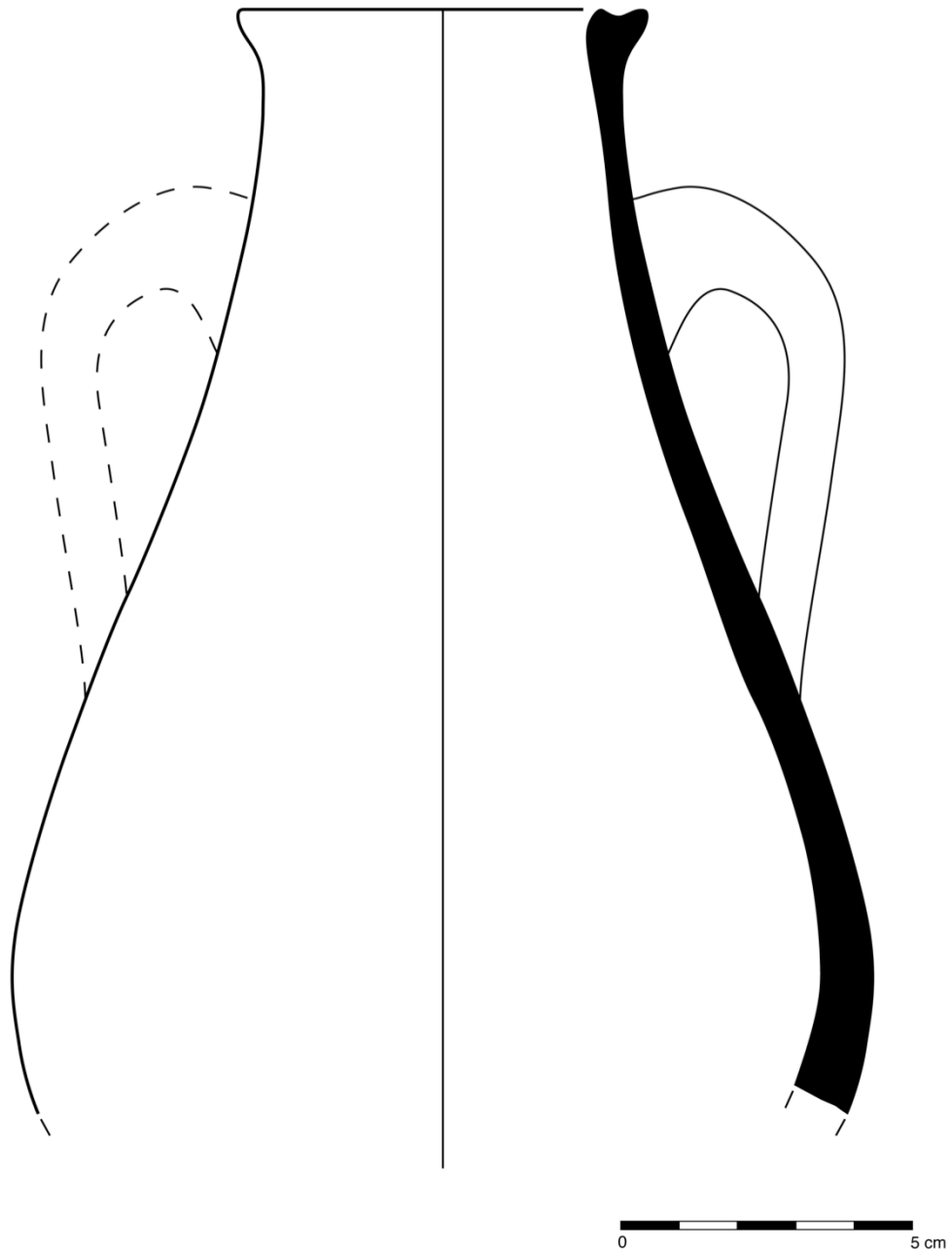

Figure 278: Rim, body, and handle in Pink/Buff B fabric with semi-glossy eggplant colored slip;  
TZ 2005 Ch.6 UF 5

*Upper Profile Type 102 (n=32)*

This jar type is a thin walled closed shape (Figures 280, 281). It has a tall, vertical neck and the rim has triangular external articulation. The rim is rounded and elongated. Examples are preserved to the belly, which is rounded. Base forms are unknown. Trefoil rims have been found.

It has rim diameters between 8 and 15 centimeters. It has been found primarily in Pink/Buff A fabric (5 sherds) and Pink/Buff B fabric (26 sherds), but one example in a coarse fabric has been found. Undecorated examples have been found, but red and eggplant colored semi-glossy slips are common. This is often used in conjunction with incised wavy or straight lines on the exterior of the rim or the neck.

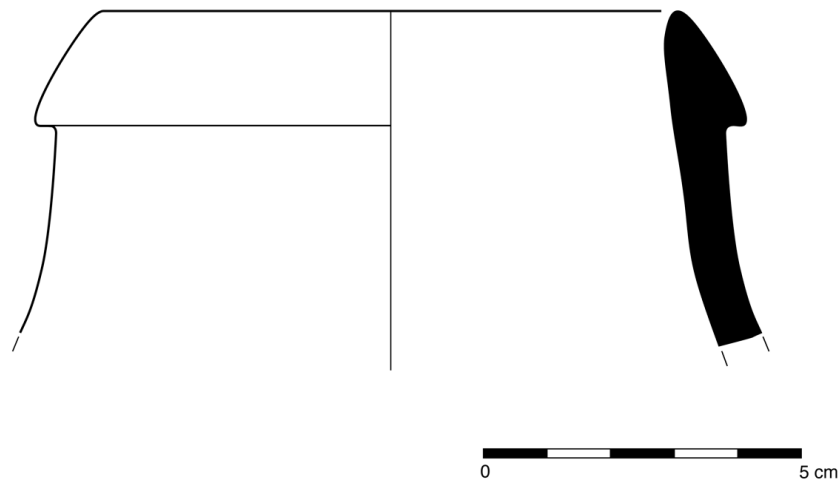

Figure 279: Rim in Pink/Buff B fabric, unslipped; TZ 2004 Ch.4 UF 15

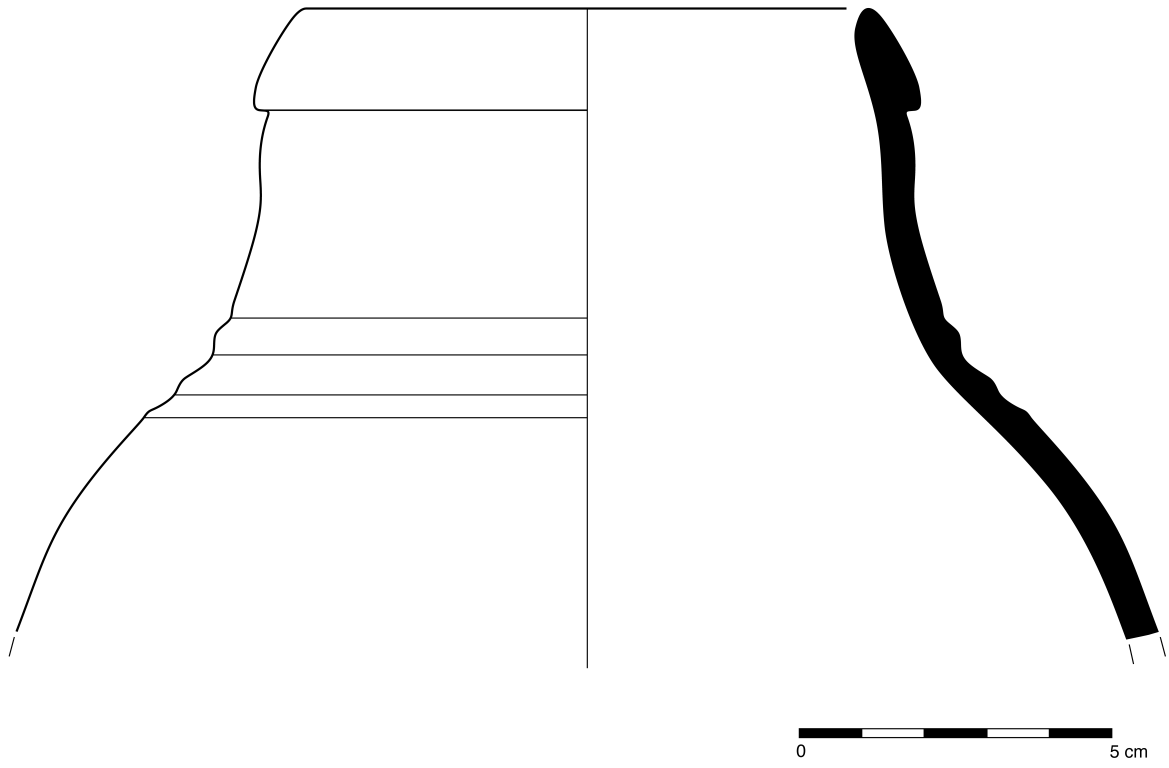

Figure 280: Rim in Pink/Buff B fabric, unslipped; TZ 2004 Ch.4 UF 15

*Upper Profile Type 103 (n=7)*

This jar type is a thin walled closed shape (Figure 281). It has a concave neck and the rim is heavily articulated and grooved on the exterior. The lip is pointed and slightly everted. Examples are not preserved past the belly, but there appear to be shoulders that slope slightly out, and those that form a right angle, creating a more bulbous body. Some examples show handles affixed at the neck. Base forms are unknown.

It has rim diameters mainly between 9 and 12 centimeters, though much smaller diameters are seen occasionally. This type has been found in Pink/Buff A fabric (3 sherds), Pink/Buff B fabric (3 sherds), and Orange fabric (1 sherd). All examples are decorated with red or eggplant colored semi-glossy slip.

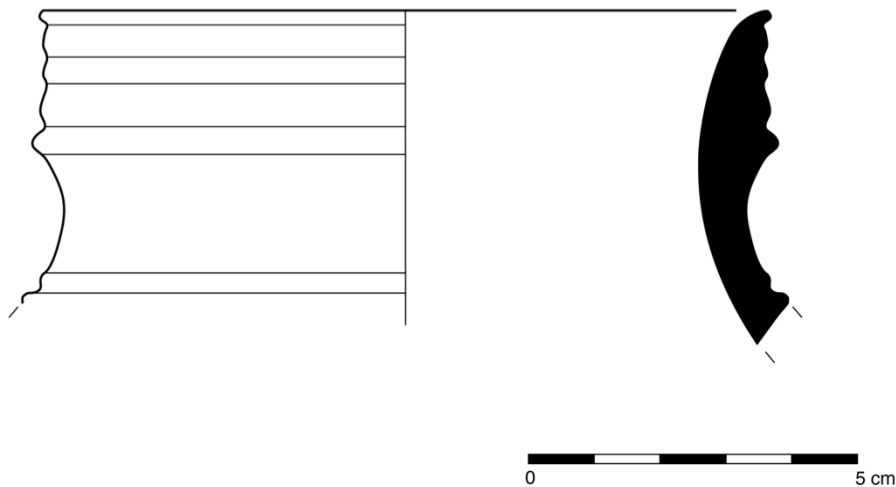

Figure 281: Rim in Orange fabric with semi-glossy eggplant colored slip; TZ 2008 Ch.18 UF 15

## **Shape Group XI: Wide-mouthed Serving Jars/Table Amphorae**

### **Upper Profile Types 104-112, 176**

These vessel types have rims ranging in diameter from 18 to 30 centimeters (Figure 282). With fairly straight necks ranging from 5 to at least 15 centimeters tall, the rims are frequently articulated in similar ways as the rims of tall-necked jars, but have markedly larger rim diameters. There is no evidence of lower body shape, but sherds preserved to the shoulder range from a rounded, pear-shaped contour to angular, right-angled bulging shoulders. There is some evidence of two handled varieties, and while these are probably common, the fragmentary nature of the evidence usually shows single handled or handle-less forms. No whole profiles are preserved, but they probably had plain or disc bases. The slipped and incised decoration frequently found on these vessels indicates some sort of table serving or presentation function.

Upper Profile Types 106, 107, 109, 111, 112, and 176 are rare.



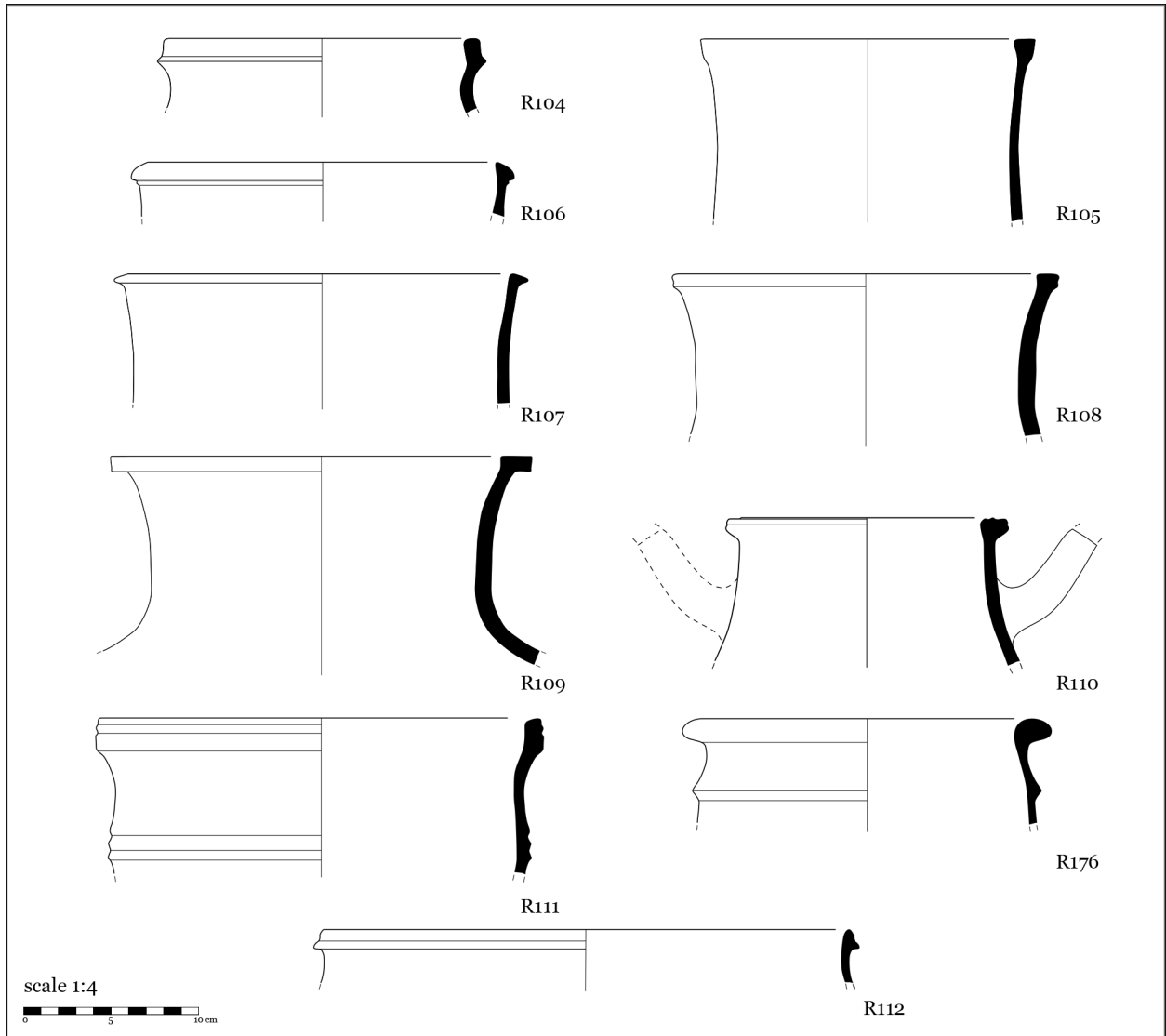

Figure 282: Compendium of Shape Group XI vessels

*Upper Profile Type 104 (n=7)*

This wide-mouthed jar type is a thin walled closed shape (Figures 283, 284). It has a tall, concave neck and irregular, thickened rims with articulated grooves. Examples are not preserved to the belly. Base forms are unknown. There is one example with a pinched, spouted pouring rim.

It has rim diameters between 17 and 25 centimeters. This type has been found in Pink/Buff A fabric (2 sherds) and Pink/Buff B fabric (5 sherds). There are four undecorated examples. Decorations include eggplant colored slip and occasional wavy incised lines on the upper body.

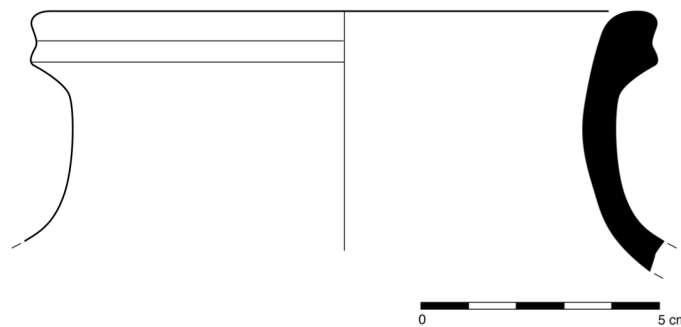

Figure 283: Rim in Pink/Buff B fabric with semi-glossy eggplant slip; TZ 2005 Ch.6 UF 3

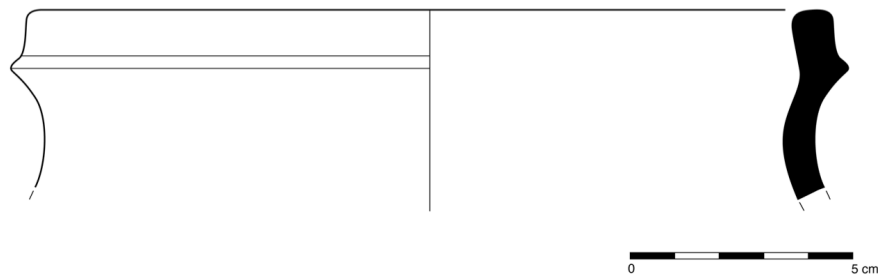

Figure 284: Rim in Pink/Buff B fabric, unslipped; TZ 2005 Ch.6 UF 4

*Upper Profile Type 105 (n=7)*

This wide-mouthed jar type is a thin walled closed shape (Figures 285, 286). It has a vertical neck and the rim has external articulation, mostly triangular. The lip is flat. Examples are not extant to the belly. Base forms are unknown.

It has rim diameters between 20 and 25 centimeters. It has been found in Pink/Buff A fabric (1 sherd) and Pink/Buff B fabric (6 sherds). Three unslipped examples have been found and four sherds have red semi-glossy slip. One sherd combines red semi-glossy slip with vertical burnishing strokes on the neck.

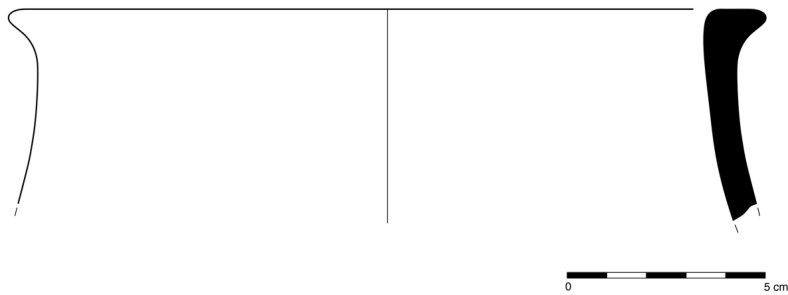

Figure 285: Rim in Pink/Buff B fabric, unslipped; TZ 2005 Ch.6 UF 5

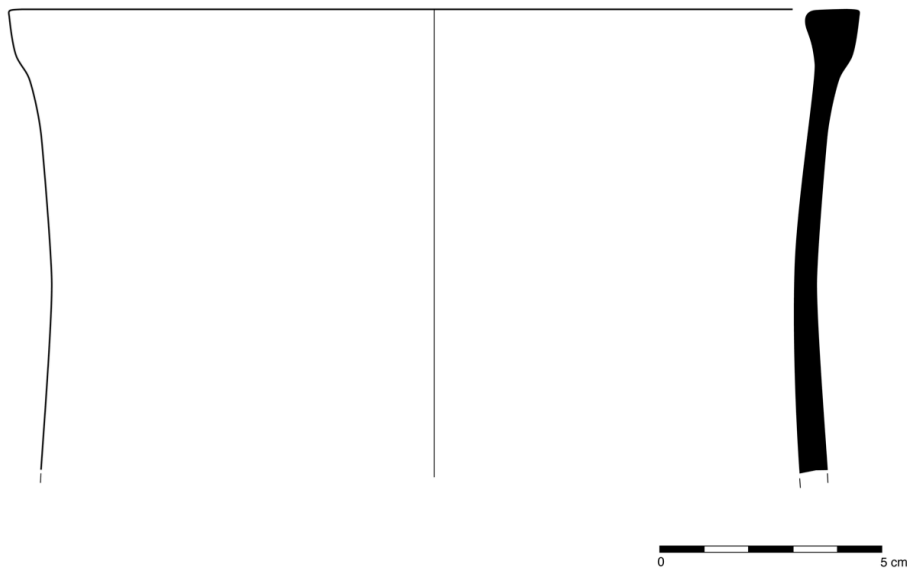

Figure 286: Rim in Pink/Buff A fabric with semi-glossy red slip on exterior; TZ 2005 Ch.6 UF 3

*Upper Profile Type 106 (n=2)*

This wide-mouthed jar type is a thin walled closed shape (Figures 287, 288). It has a vertical neck and the rim has external articulation, a rounded triangle. The lip is downturned and rounded. Examples are not extant to the belly. Base forms are unknown.

It has rim diameters between 20 and 25 centimeters. It has been found in Pink/Buff A fabric (1 sherd) and Pink/Buff B fabric (1 sherd). Both examples have red semi-glossy slip, one is used in conjunction with vertical burnishing and incised wavy lines on the neck.

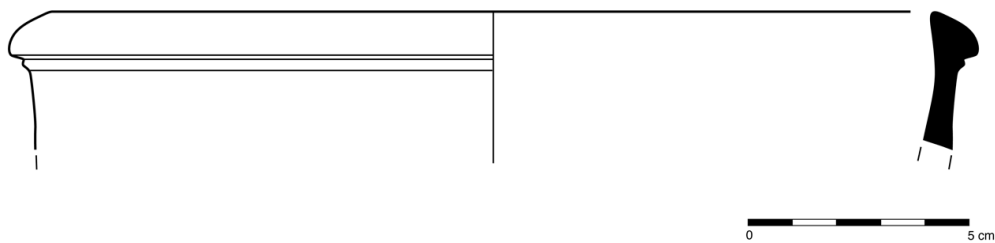

Figure 287: Rim in Pink/Buff B fabric with semi-glossy red slip on exterior; TZ 2005 Ch.6 UF 10

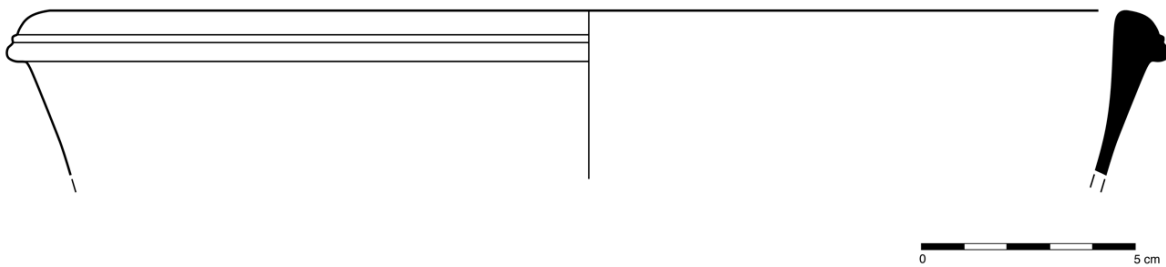

Figure 288: Rim in Pink/Buff A fabric with semi-glossy red slip on exterior and wavy burnished lines on neck; TZ 2006 Ch.6 UF 13

*Upper Profile Type 107 (n=2)*

This wide-mouthed jar type is a thin walled, closed form (Figure 289). It has a plain, mostly rounded rim and a trefoil mouth. Examples have tall necks, but are not preserved to the belly. Trefoil mouths have been found. Handles are flat and are affixed just below the rim. Base forms are unknown.

It has rim diameters between 20 and 25 centimeters. It has been found in Pink/Buff A fabric (2 sherds). Both examples have semi-glossy red slip.

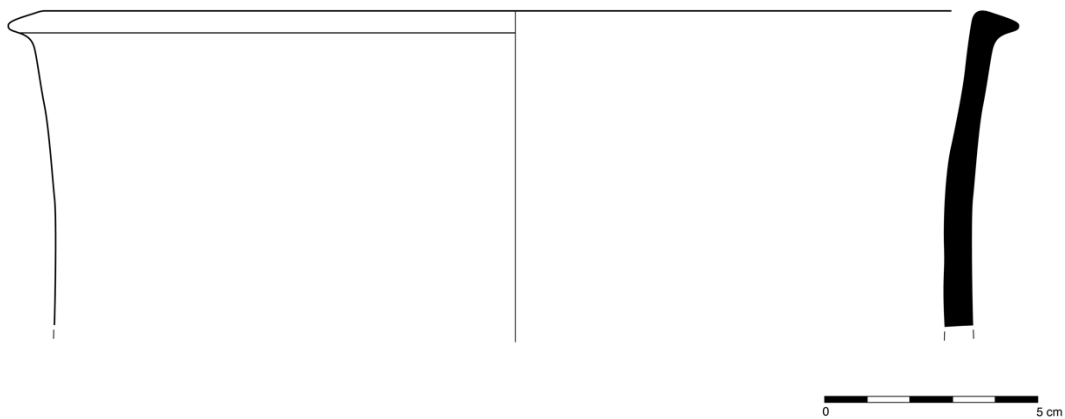

Figure 289: Rim in Pink/Buff A fabric with semi-glossy red slip; TZ 2008 Ch.6(?) UF 28

*Upper Profile Type 108 (n=7)*

This wide-mouthed jar type is a thin walled closed shape (Figure 290). It has a vertical neck and the rim has a short, squared external articulation. The top of the lip is plain and angular. Examples are not preserved to the belly. Base forms are unknown.

It has rim diameters between 20 and 25 centimeters. It has been found in Pink/Buff A fabric (3 sherds) and Pink/Buff B fabric (4 sherds). Three unslipped examples have been found, but red semi-glossy slip is more commonly used.

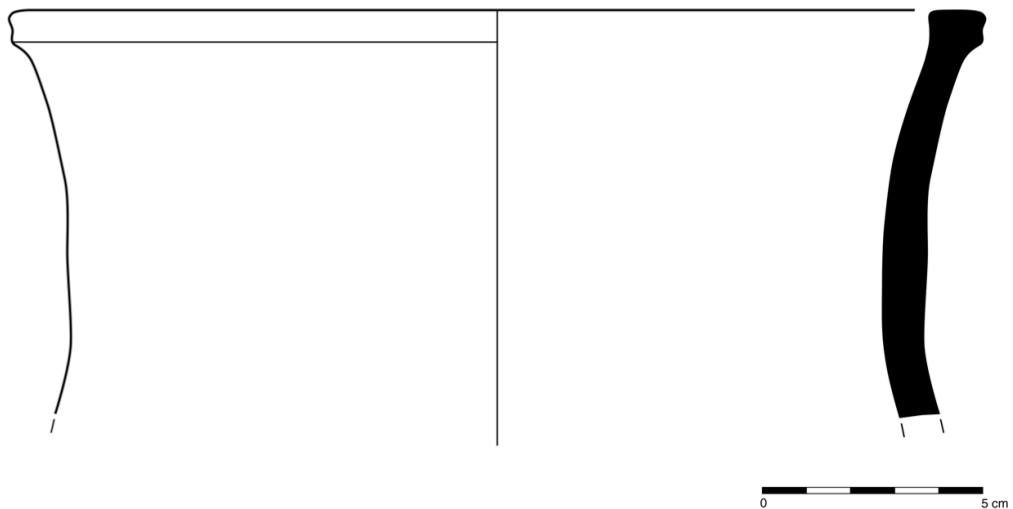

Figure 290: Rim in Pink/Buff B fabric, unslipped; TZ 2004 Ch.4 UF 12

*Upper Profile Type 109 (n=2)*

This wide-mouthed jar type is a thin walled closed shape (Figure 291). It has a vertical neck and the rim has an outward-jutting, rectangular, external articulation. The top of the lip is plain and angular. Examples are not preserved to the belly. Base forms are unknown.

This rare type has rim diameters between 25 and 30 centimeters. It has only been found in Pink/Buff A fabric (2 sherds) with red semi-glossy slip.

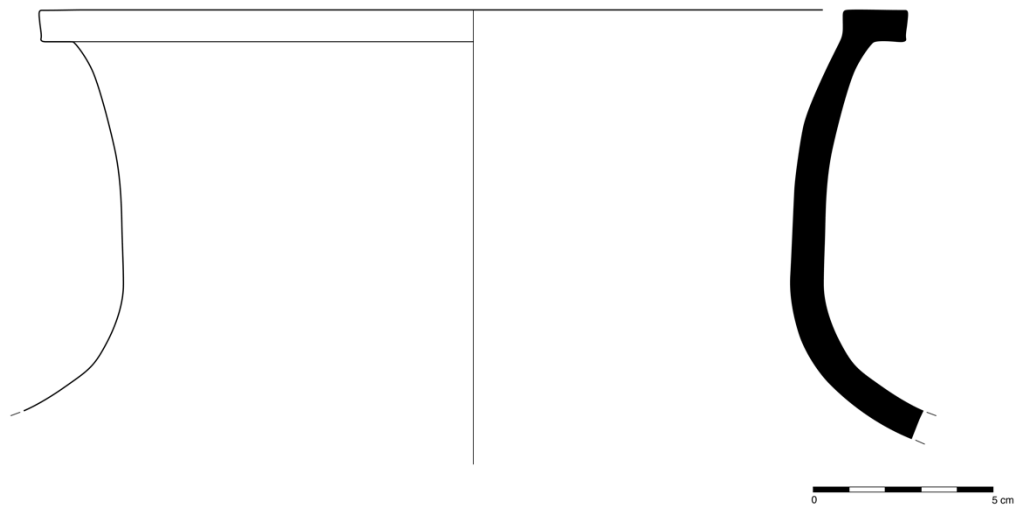

Figure 291: Rim, neck, and upper shoulder in Pink/Buff A fabric with semi-glossy red slip on exterior; TZ 2005 Ch.6 UF 56

*Upper Profile Type 110 (n=7)*

This wide-mouthed jar type is a thin walled closed shape (Figure 292). It has a vertical neck and the rim has a squared external articulation. The top of the lip is angular with grooves. Examples are not preserved to the belly. Some examples have rounded handles that are affixed at the neck. Base forms are unknown.

It has rim diameters between 15 and 25 centimeters in diameter. It has been found in Pink/Buff A fabric (3 sherds) and Pink/Buff B fabric (4 sherds). All examples have either red or eggplant colored semi-glossy slip.

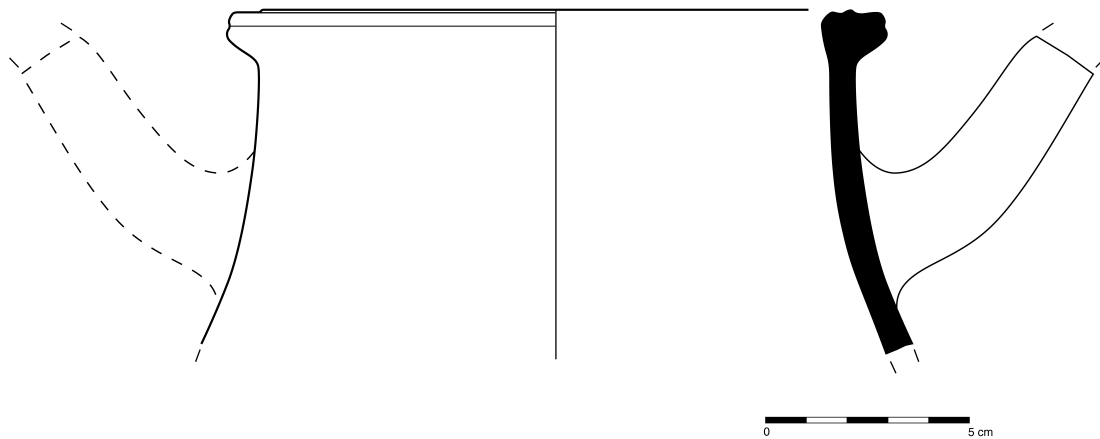

Figure 292: Rim in Pink/Buff A fabric with semi-glossy red slip and vertical burnishing on neck; TZ 2005 Ch.6 UF 4



*Upper Profile Type 111 (n=4)*

This wide-mouthed jar type is a thin walled closed shape (Figure 293). It has a vertical neck and the rim has external articulation. The top of the lip is plain and rounded and there is frequently a lower triangular articulation at the bottom of the rim. There are grooves on the external portion of the rim. Examples are not preserved to the belly. Base forms are unknown.

It has rim diameters between 18 and 32 centimeters. It has been found in Pink/Buff A (1 sherd) and Pink/Buff B fabric (3 sherds). No unslipped examples have been found. Red and eggplant colored semi-glossy slip is found on the exterior surfaces of all examples. There are occasionally sloppy drips of slip on the interior of the vessel, but the interior surfaces are not well finished, so despite the poor preservation, we can be reasonably sure these were large closed shapes.

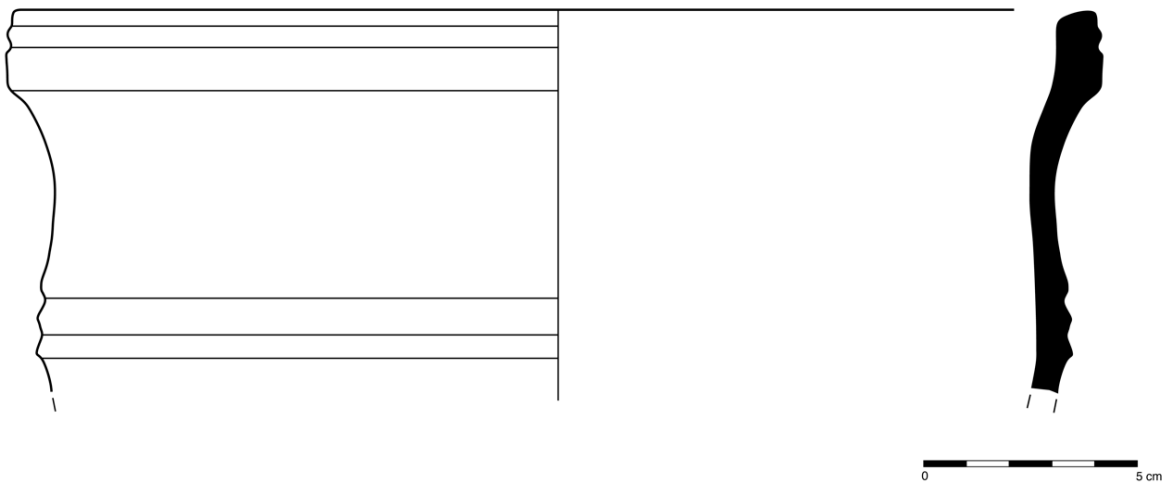

Figure 293: Rim in Pink/Buff B fabric with semi-glossy eggplant colored slip on exterior and deep, worked grooves in neck; TZ 2007 Ch.6 UF 12(?)

*Upper Profile Type 112 (n=4)*

This wide-mouthed jar type is a thin walled closed shape (Figure 294). It has a vertical neck and the rim has a triangular external articulation. The lip is rounded with a lower external ledge. Examples are not preserved to the belly. Base forms are unknown.

It has rim diameters between 30 and 35 centimeters. It has only been found in Pink/Buff B fabric (4 sherds). All examples have red semi-glossy slip.

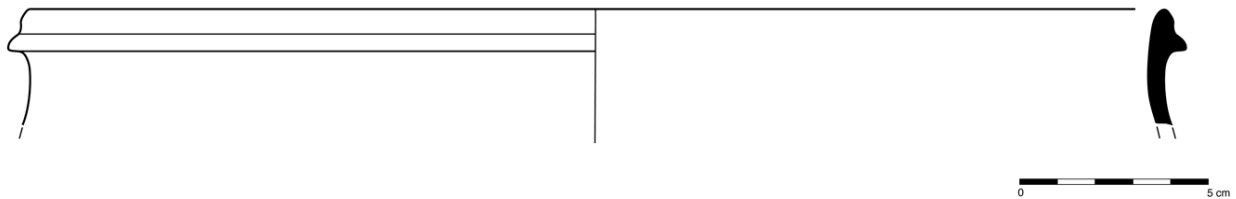

Figure 294: Rim in Pink/Buff B fabric with semi-glossy red slip on exterior; TZ 2005 Ch.6 UF 53

*Upper Profile Type 176 (n=4)*

This wide-mouthed jar type is a thin walled closed shape (Figure 295). It has a vertical neck with a rounded rolled rim and a peaked articulation just below it on the exterior of the neck. Examples are not preserved to the belly and no examples have handles. Base forms are unknown.

It has rim diameters between 14 and 16 centimeters. It has been found in Peach Cream fabric (1 sherd), Pink/Buff A fabric (1 sherd), and coarse fabrics (2 sherds). Excepting the usual slip on Peach Cream fabric, no examples are decorated.

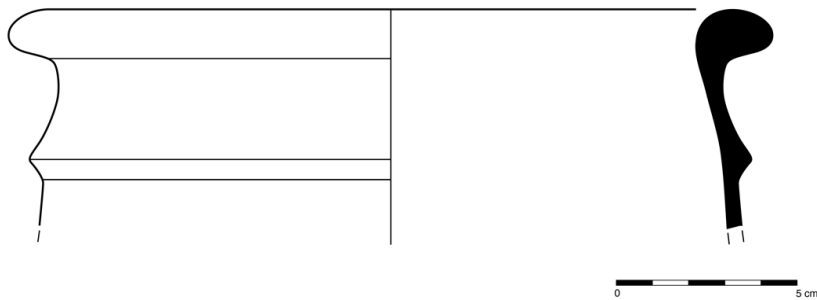

Figure 295: Rim in Peach Cream fabric; BH 2007 UF 285

## Upper Group Cluster D: Open Table Vessels, Groups XII-XVI

This cluster contains eighty-seven upper profile types separated into five groups. These are all open table vessels, found primarily in fine fabrics, primarily Pink/Buff A and Pink/Buff B fabrics, but also Peach Cream, Orange, and Gray fabrics. Very rare examples have been found in coarse fabrics. Slips are common, and they are often combined with other forms of decoration, including incisions, stamps, and pattern burnishing.

- *Shape Group XII*: Open Deep Bowls, Upper Profile Types 24-48, 177
- *Shape Group XIII*: Large Open Sloping-walled Serving Bowls, Upper Profile Types 113-134
- *Shape Group XIV*: Small Shallow Table Bowls, Upper Profile Types 135-148, 150-155, 158-163, 167, 175
- *Shape Group XV*: Small Hemispherical and Carinated Table Bowls, Upper Profile Types 149, 156-157, 164-166, 168
- *Shape Group XVI*: Straight-walled Drinking and Serving Vessels: Upper Profile Types 169-174

Group XII vessels were probably used as individual or group dining vessels, but given the relatively rough lip, they were probably not meant to be drunk from. Some Group XIII vessels were probably used for serving dry goods like bread, fruit, or nuts, as the incised decoration would be difficult to clean liquids from. Group XIV and XV vessels were probably individual serving vessels of a variety of foods and liquids. Group XVI includes several vessel types with wide and continuous rim diameter ranges, some were probably used for individual dining vessels and others were likely serving vessels. Those that were serving vessels were probably used with a ladle.

## **Shape Group XII: Open Deep Bowls**

### **Upper Profile Types 24-48, 177**

Usually 15 to 25 centimeters in diameter, the depth is likely not more than 20 centimeters, but few whole profiles are preserved (Figure 296). Rims vary from fairly plain to well articulated and there are occasionally one or two small handles on the upper body. The rims and presence or absence of handles are not good indicators of depth, and unfortunately depth is the best indicator of function with these vessels. The lack of burn marks suggests a serving or dining function.

Bases are unknown. If these vessels were meant to be used at a table, they could have had a wide variety of articulated bases. Given the typical decoration pattern on these vessels, which was slipped at the rim and unslipped elsewhere, one would expect unslipped bases. The majority of unslipped bases in fine fabrics that are an appropriate size for these bowls are disc bases, so it is likely that whole profiles would show this.

Upper Profile Types 26, 28, 47, and 177 are rare.

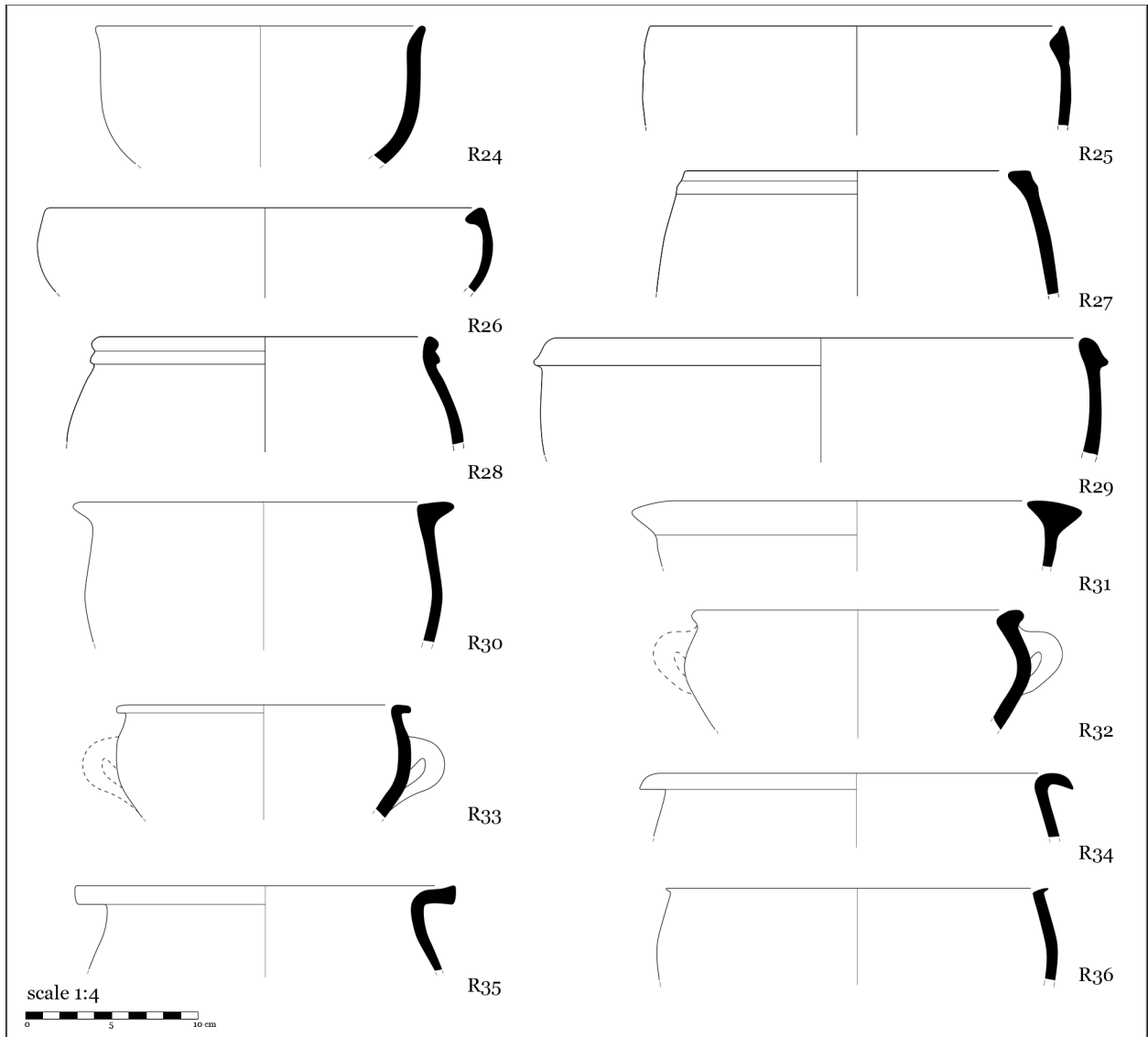

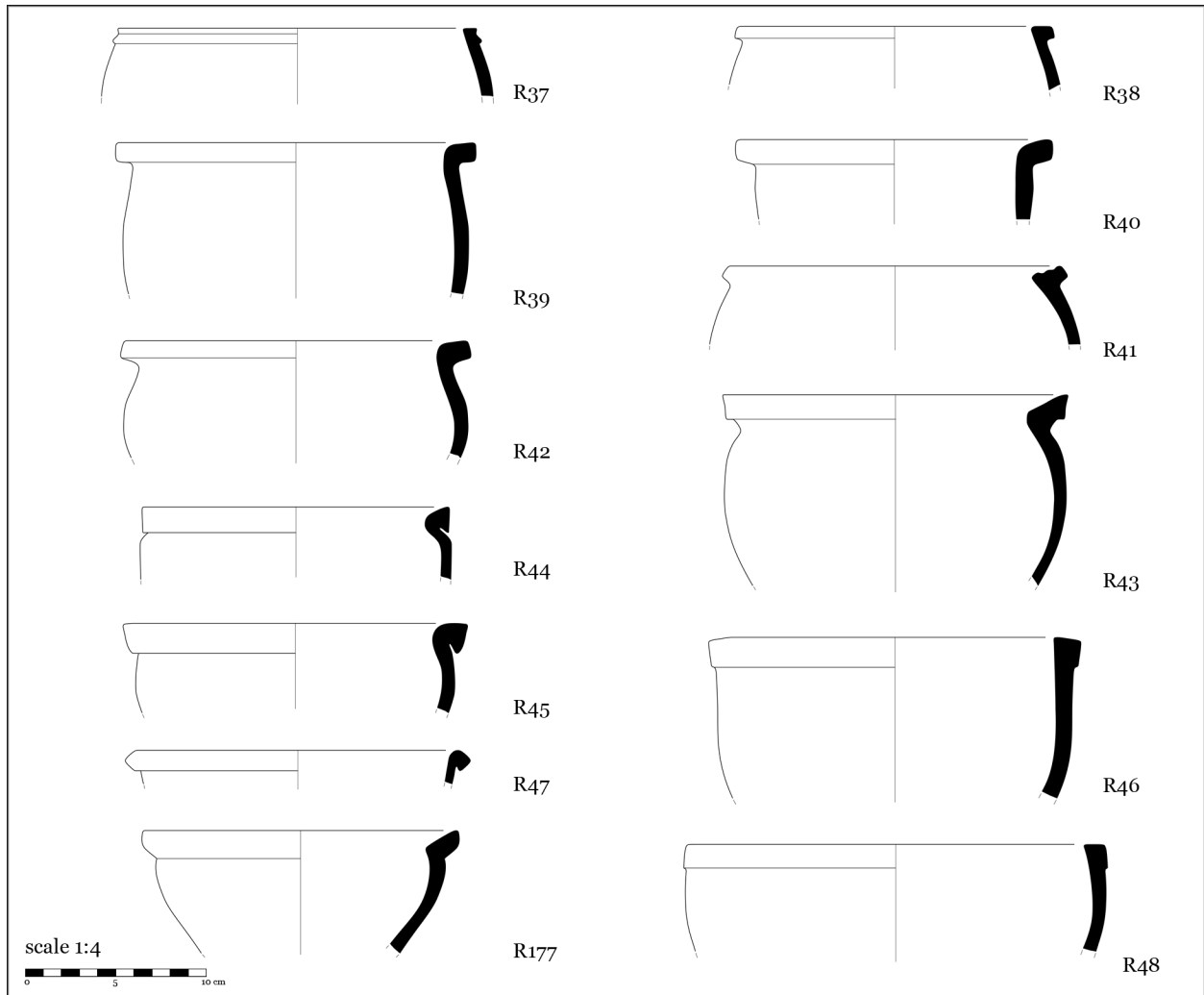

Figure 296: Compendium of Shape Group XII vessels

*Upper Profile Type 24 (n=5)*

This bowl type is a thin walled vessel with fairly vertical upper walls (Figure 297). This is a fairly deep bowl with a plain, rounded lip and convex walls. No examples are preserved to the base.

It has diameters between 15 and 20 centimeters. Most examples were found in Peach Cream fabric (4 sherds) and there is one example in an unknown coarse fabric with white fabric and dark painted geometric design, but it is too small to determine the pattern.

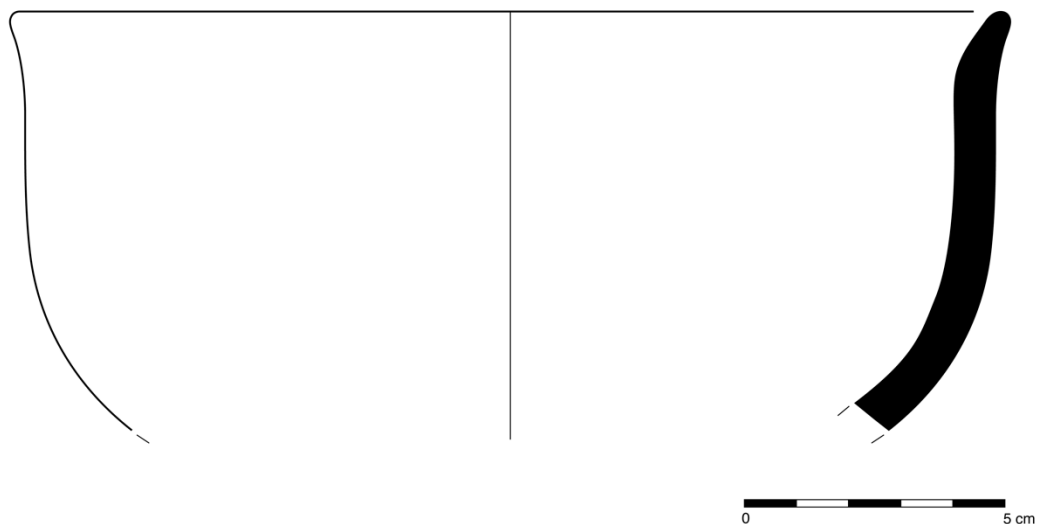

Figure 297: Rim and body in Peach Cream fabric; BH 2005 UF 37



*Upper Profile Type 25 (n=28)*

This bowl type is a thin walled vessel with fairly vertical upper walls (Figure 298). This is a relatively deep bowl with an internal triangular rim. It has a fairly angular lip and straight walls. No examples are preserved to the base.

It has rim diameters between 20 and 30 centimeters. It has been found in Pink/Buff A fabric (16 sherds) and Pink/Buff B fabric (12 sherds). There are undecorated examples, but red and eggplant colored matte slips are frequently found on the upper body and rim of the exterior and interior, probably applied by dipping.

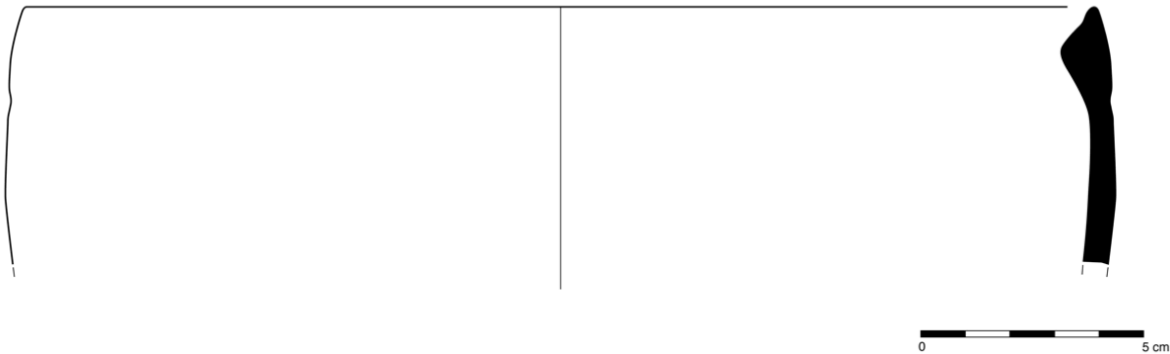

Figure 298: Rim and upper body in Pink/Buff B fabric with matte red slip on upper exterior and drips on interior; TZ 2005 Ch.6 UF 40

*Upper Profile Type 26 (n=3)*

This bowl type is a thin walled vessel with fairly vertical upper walls (Figures 299, 290). This is a relatively deep bowl with an internal articulation and rounded lip. The walls become convex in the mid-body. No examples are preserved to the base.

It has rim diameters between 25 and 30 centimeters. Found in Pink/Buff B fabric (2 sherds) and Pink/Buff A fabric (1 sherd), one example has matte red slip and one has matte brown slip.

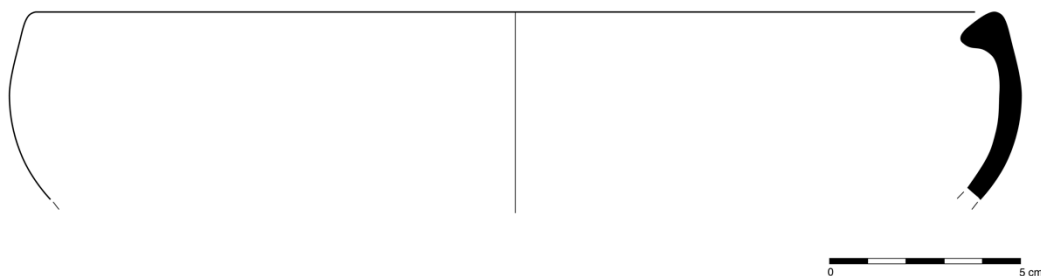

Figure 299: Rim and upper body in Pink/Buff A fabric with matte red slip on rim and upper walls; TZ 2005 Ch.6 UF 5

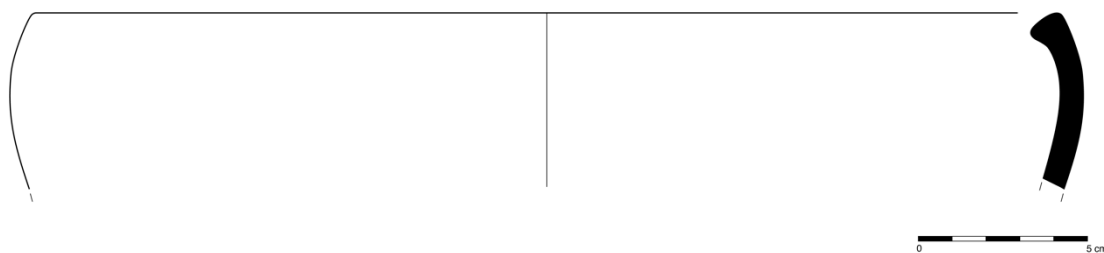

Figure 300: Rim and upper body in Pink/Buff B with matte eggplant colored slip on rim and upper walls; TZ 2005 Ch.6 UF 10

*Upper Profile Type 27 (n=41)*

This bowl type is a thin walled vessel with fairly vertical, slightly inward sloping upper walls (Figures 301, 302). This is a fairly deep bowl with a slightly thickened rim. No examples are preserved to the base.

It has rim diameters between 18 and 35 centimeters. It has been found mostly in Pink/Buff A fabric (17 sherds) and Pink/Buff B fabric (22 sherds), but there are rare examples in Peach Cream fabric (2 sherds). There are several unslipped examples. Decorations include frequent double grooves on the upper exterior rim, red and eggplant colored matte slip (sometimes on the same vessel). Incised wavy lines have been found on slipped and unslipped examples.

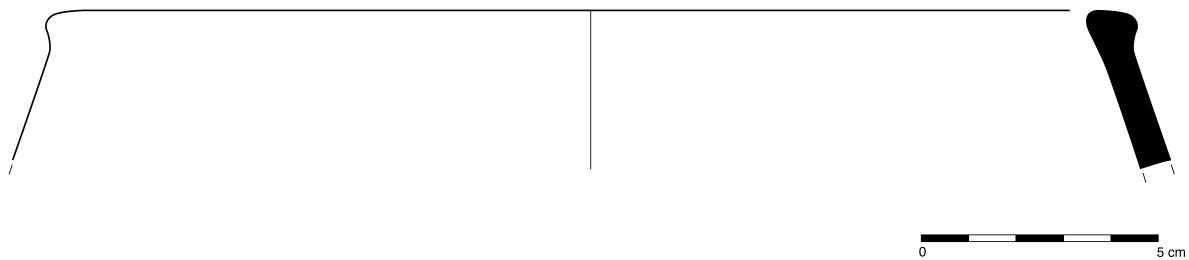

Figure 301: Rim and upper body in Pink/Buff B with matte eggplant colored slip on rim and upper walls; TZ 2008 Ch.6 UF 15

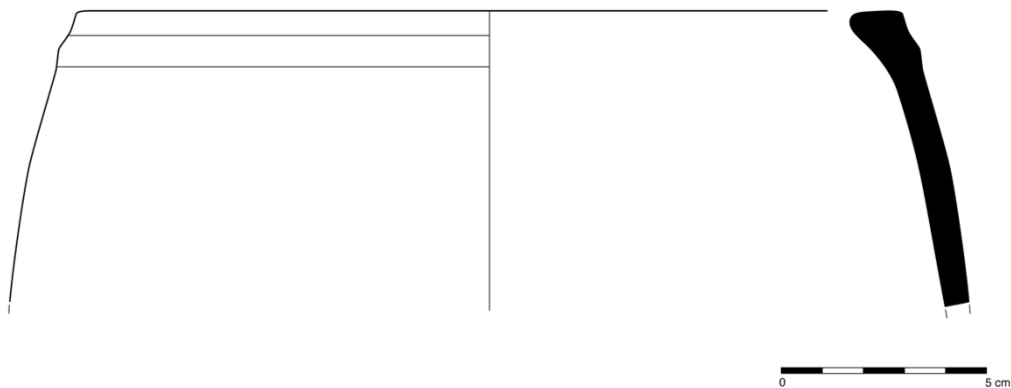

Figure 302: Rim and upper body in Pink/Buff A, unslipped; TZ 2007 Ch.14 UF 81

*Upper Profile Type 28 (n=3)*

This bowl type is a thin walled vessel with fairly vertical upper walls (Figure 303). This is a relatively deep bowl with a thickened, slightly everted rim. It has two deep grooves in the exterior rim and a rounded lip. The walls become convex, but there are no examples preserved to the base.

It has rim diameters between 19 and 25 centimeters. It has been found in Pink/Buff A fabric (2 sherds) and Pink/Buff B fabric (1 sherd). There are two unslipped examples, but one example has matte eggplant colored slip and deep grooves in the exterior rim.

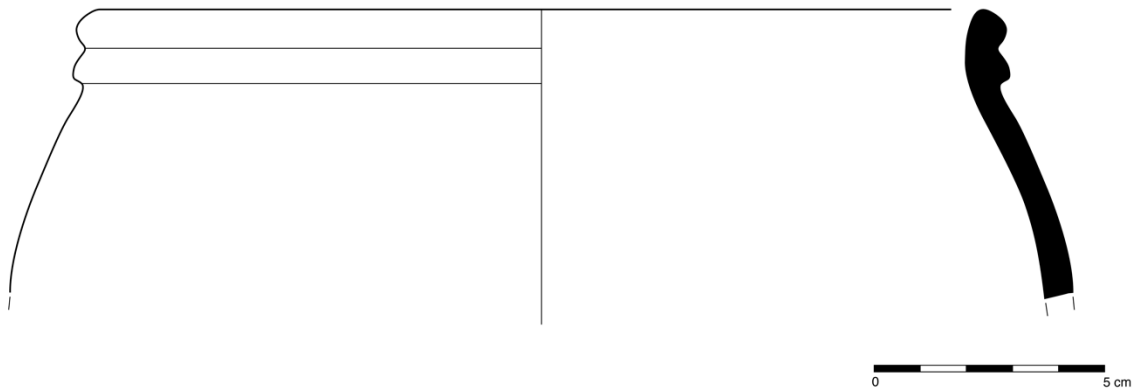

Figure 303: Rim and upper body in Pink/Buff A fabric, unslipped; TZ 2007 Ch.14 Unit 2 UF 320

*Upper Profile Type 29 (n=7)*

This bowl type is a thin walled vessel with almost vertical upper walls (Figures 304, 305). This is a fairly deep bowl with a rounded lip, a thickened, triangular, external articulation, and convex lower walls. No examples are preserved to the base.

It has rim diameters between 18 and 35 centimeters. It has been found in Pink/Buff A fabric (3 sherds), Pink/Buff B fabric (3 sherds), and an unknown dark pink fabric, possibly an import (1 sherd). Decorations include matte eggplant colored and red slip, usually only on the upper body and rim, interior and exterior.

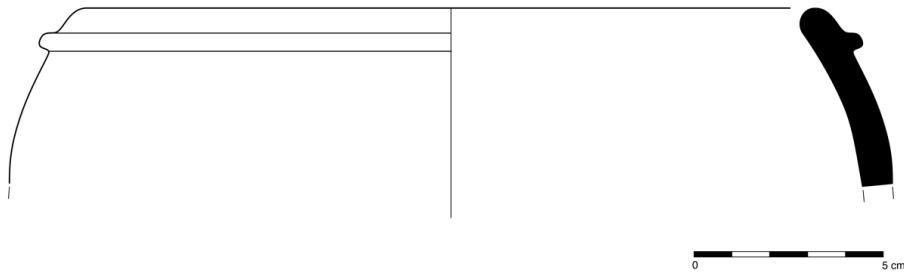

Figure 304: Rim and upper body in Pink/Buff B fabric with matte eggplant colored slip on rim and upper walls; TZ 2005 Ch.6 UF 39

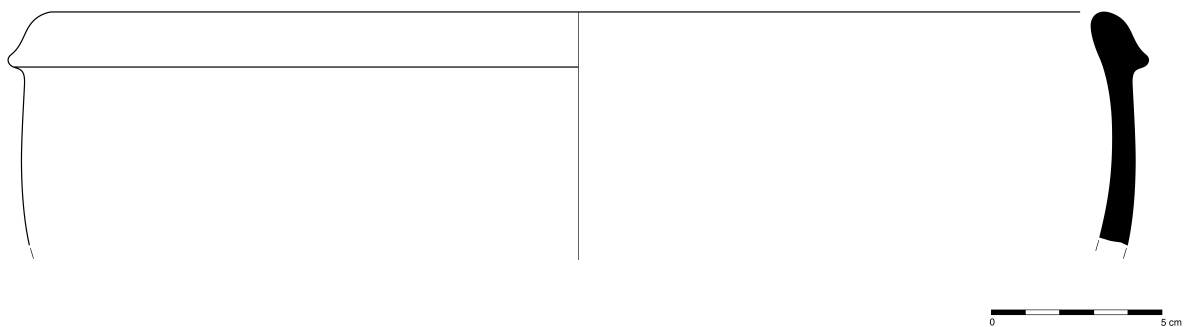

Figure 305: Rim and upper body in Pink/Buff A fabric, unslipped; TZ 2007 Ch.6 UF 122

*Upper Profile Type 30 (n=11)*

This bowl type is a thin walled vessel with fairly vertical upper walls (Figures 306, 307). This is a likely a relatively deep bowl with an everted triangular rim. It has a flat lip and the walls are vertical as far as profiles are preserved. No examples are preserved to the base.

It has rim diameters between 20 and 35 centimeters. It has been found in Pink/Buff B fabric (6 sherds), Pink/Buff A fabric (2 sherds), and Peach Cream fabric (3 sherds). The Peach Cream examples have the largest diameters. Buff and Pink/Buff A examples are usually decorated with matte red or eggplant colored slip.

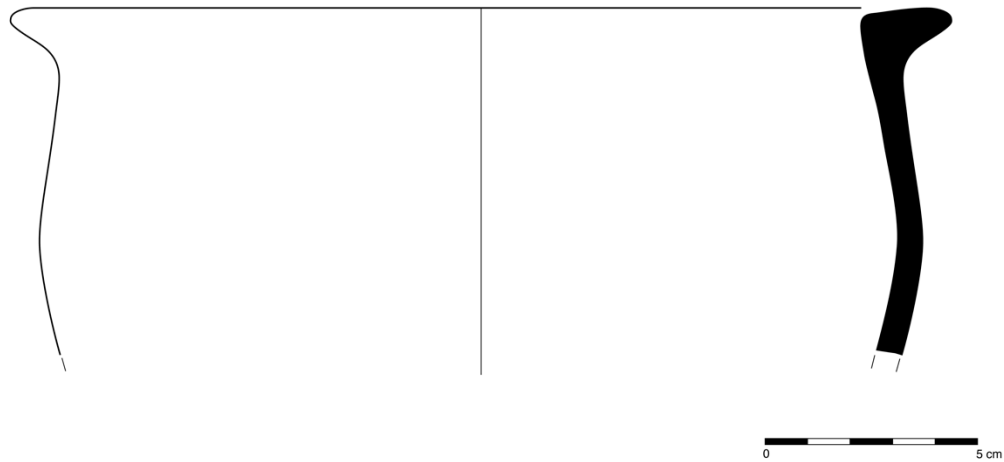

Figure 306: Rim in Pink/Buff B fabric with matte red slip; TZ 2005 Ch.6 UF 39

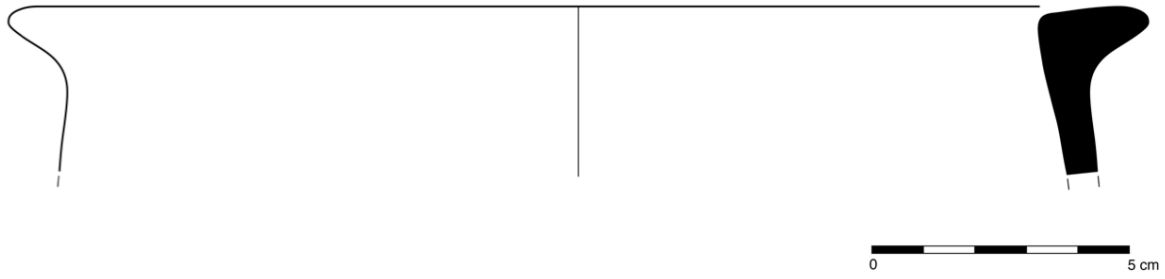

Figure 307: Rim in Pink/Buff B fabric, unslipped; TZ 2007 Ch.6 UF 25

*Upper Profile Type 31 (n=10)*

This bowl type is a thin walled vessel with fairly vertical upper walls (Figures 308, 309). This is a deep bowl with a hammerhead rim, usually slanted downwards at the exterior lip. It has a rounded lip and straight walls. No examples are preserved to the base.

It has rim diameters between 15 and 35 centimeters. It has been found in Pink/Buff A fabric (1 sherd), Pink/Buff B fabric (4 sherds), and coarse fabrics (5 sherds). Examples in Pink/Buff A and B fabrics have matte red or eggplant colored slips. Three of these examples also have shallow, straight, or wavy, incised grooves on the top of the rim. One example in a coarse fabric has a single small handle.

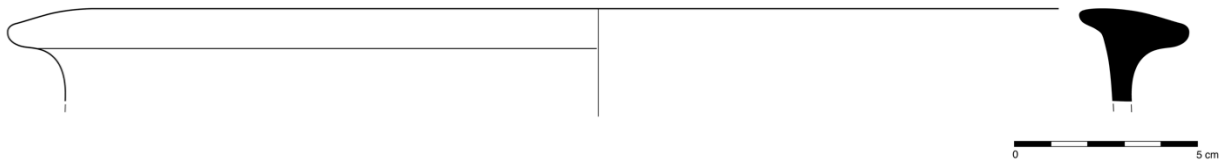

Figure 308: Rim in Gritty Black fabric; TZ 2004 Ch.4 UF 9

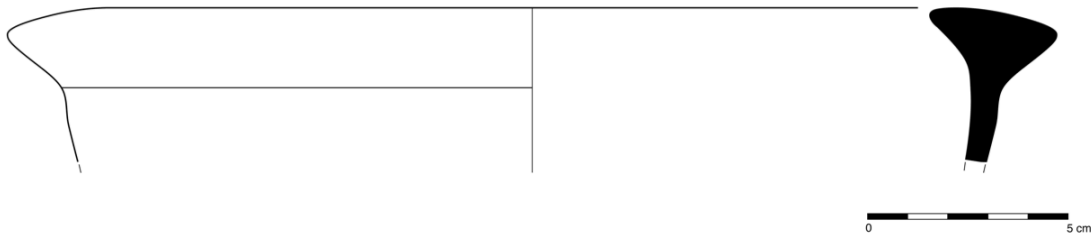

Figure 309: Rim in Gritty Black fabric; TZ 2004 Ch.4 UF 9



*Upper Profile Type 32 (n=15)*

This bowl type is a thin walled vessel with fairly vertical upper walls (Figures 310, 311). This is a deep bowl with a short, everted rim, sometimes only faintly everted. It has a rounded, upward tilted lip and convex lower walls. No examples are preserved to the base. Some examples have a rounded handle joined at the upper body.

It has rim diameters between 17 and 28 centimeters. It has been found in Pink/Buff A fabric (6 sherds) and Pink/Buff B fabric (9 sherds). There are infrequent unslipped examples, but most are either matte red or eggplant colored slipped, usually on the upper body and rim, possibly dipped.

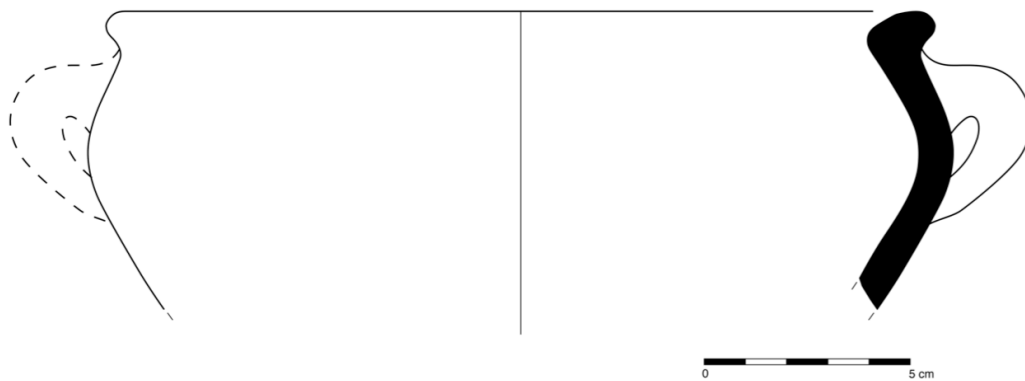

Figure 310: Rim, body, and handle in Pink/Buff B fabric with matte red slip on rim and upper walls; TZ 2005 Ch.6 UF 56

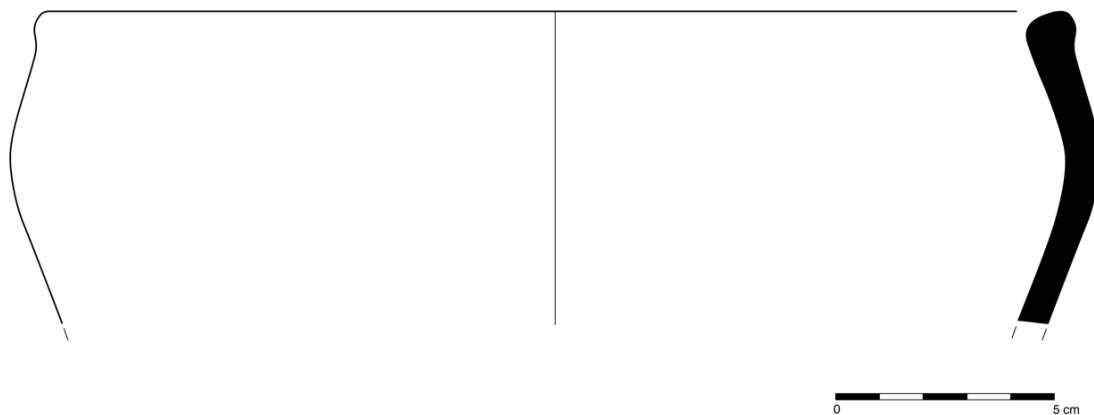

Figure 311: Rim and body in Pink/Buff A with matte red slip; TZ 2007 Ch.14 Unit 2 UF 37 (?)

*Upper Profile Type 33 (n=34)*

This bowl type is a thin walled vessel with fairly vertical upper walls (Figures 312, 313). This is a deep bowl with a short, everted rim. It has a rounded, flat lip and convex walls. No examples are preserved to the base. Several examples have one handle, but it is possible that there were two symmetrical handles.

It has a wide range of rim diameters, but most are between 15 and 25 centimeters. This type has been found primarily in Pink/Buff A fabric (16 sherds) and Pink/Buff B fabric (17 sherds).<sup>124</sup> Decorations include matte red and eggplant colored slip, frequently on the upper portions of the vessel. Shallow straight grooves in the top of the lip are infrequent and there is a single example of an affixed plastic decoration, perhaps a small animal head, on the upper exterior rim.

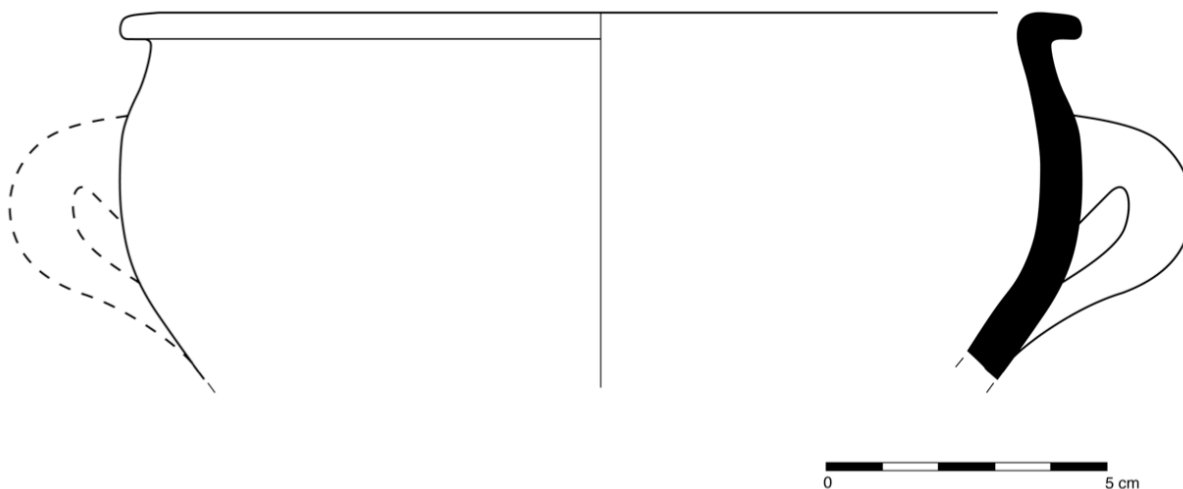

Figure 312: Rim, body, and handle in Pink/Buff B fabric with matte red slip on rim and upper walls; TZ 2007 Ch.6 UF 12 (?)

<sup>124</sup> Only one example has been found in Peach Cream fabric, and this example is between 45 and 50 centimeters in diameter, an outlier in size.



Figure 313: Rim and body in Pink/Buff B fabric, unslipped; TZ 2008 Ch.6 UF 11

*Upper Profile Type 34 (n=10)*

This bowl type is a thin walled vessel with fairly vertical upper walls (Figure 314). This is a deep bowl with a long, overhanging, everted rim, rounded lip and convex walls. No examples are preserved to the base.

It has rim diameters between 20 and 30 centimeters. It has been found in Pink/Buff B fabric (5 sherds) and Pink/Buff A fabric (5 sherds). It is usually decorated with matte red or eggplant colored slip, though there are rare unslipped examples. Occasional examples have shallow grooves on the exterior rim.

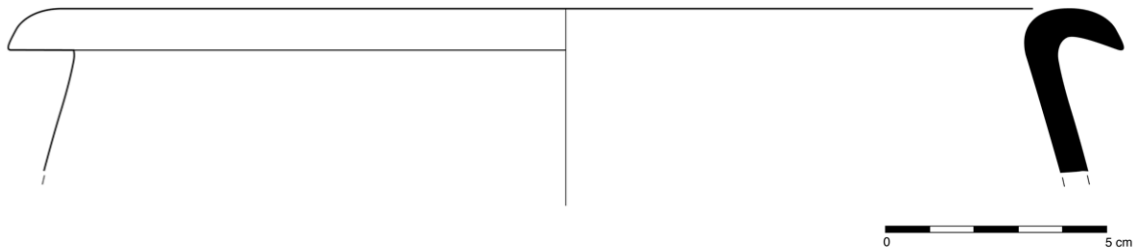

Figure 314: Rim in Pink/Buff B fabric, unslipped; TZ 2007 Ch.6 UF 107

*Upper Profile Type 35 (n=18)*

This bowl type is a thin walled vessel with inward sloping upper walls (Figure 315). This is a deep bowl with a long, overhanging, everted rim. It has a squared lip and convex walls. No examples are preserved to the base.

It has a wide range of rim diameters, but most are between 18 and 25 centimeters. This type is usually found in Pink/Buff A fabric (7 sherds) or Pink/Buff B fabric (10 sherds), with a single example in Orange Fine fabric (1 sherd).<sup>125</sup> There are several unslipped examples, but most have either matte red or eggplant colored slip. There are rare examples of semi-glossy red slip.

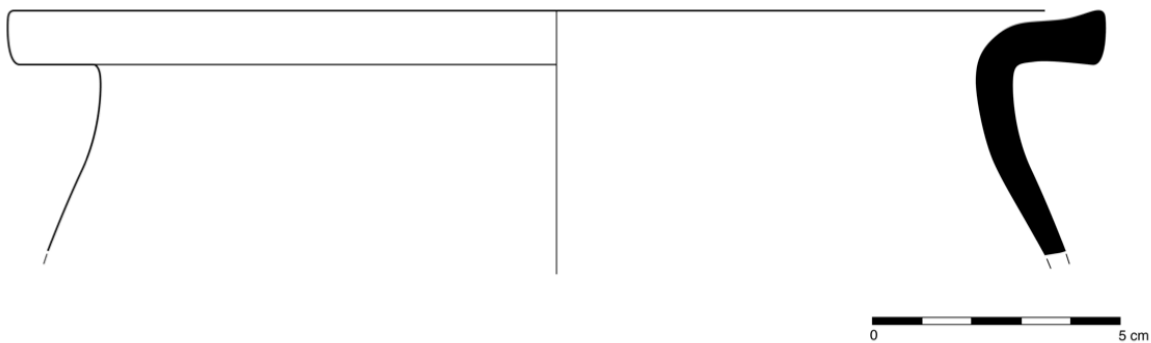

Figure 315: Rim and upper body in matte eggplant colored slip; TZ 2005 Ch.6 UF 56

<sup>125</sup> There is a single example in Peach Cream fabric that is 45 centimeters in diameter, another outlier in size in Peach Cream fabric.

*Upper Profile Type 36 (n=8)*

This bowl type is a thin walled vessel with fairly vertical upper walls (Figures 316, 317). This is a deep bowl with a short, everted rim. It has an angular, flat lip with a small, pointed extrusion on its exterior and convex lower walls. No examples are preserved to the base.

It has rim diameters between 12 and 25 centimeters, making it slightly smaller than other forms in this shape group. It has been found primarily in Pink/Buff B fabric (7 sherds) and unslipped, but there is one example in Pink/Buff A fabric (1 sherd). Matte red and eggplant colored slip are infrequent.

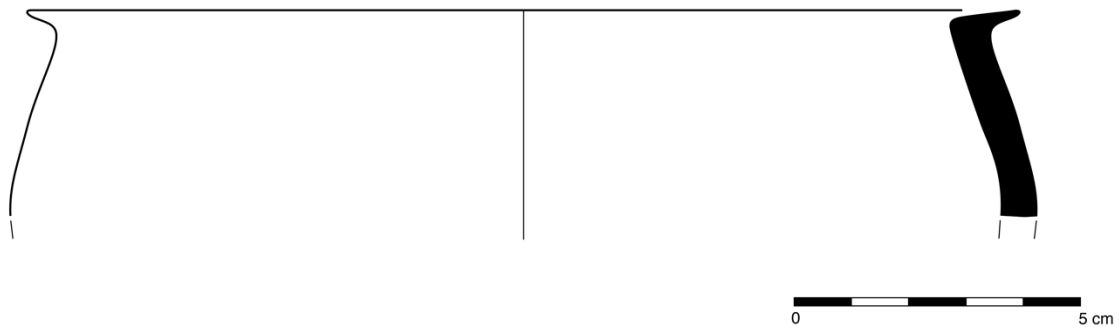

Figure 316: Rim in Pink/Buff B fabric, unslipped; TZ 2005 Ch.6 UF 10

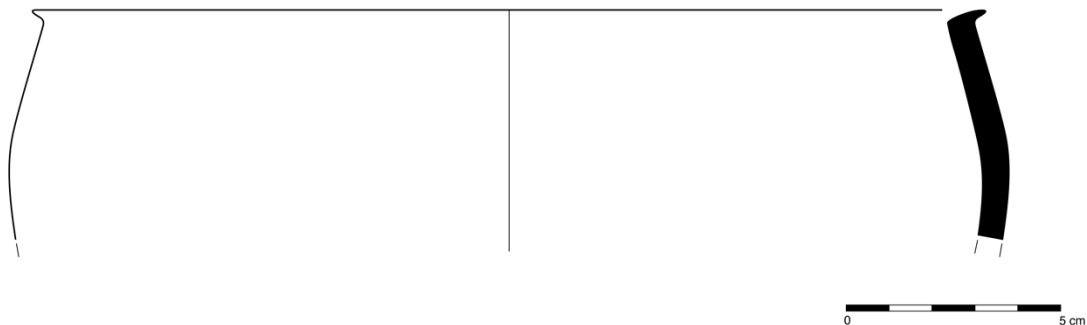

Figure 317: Rim in Pink/Buff B fabric with matte red slip; TZ 2007 Ch.6 UF 2

*Upper Profile Type 37 (n=6)*

This bowl type is a thin walled vessel with fairly vertical upper walls (Figures 318, 319). This is a deep bowl with a slightly thickened rim and flat lip. It has a shallow groove in the exterior rim and convex lower walls. No examples are preserved to the base.

It has rim diameters between 20 and 30 centimeters. It has been found in Pink/Buff A fabric (4 sherds) and Pink/Buff B fabric (2 sherds). Most examples are matte red slipped, but one example is unslipped and one has matte eggplant colored slip.

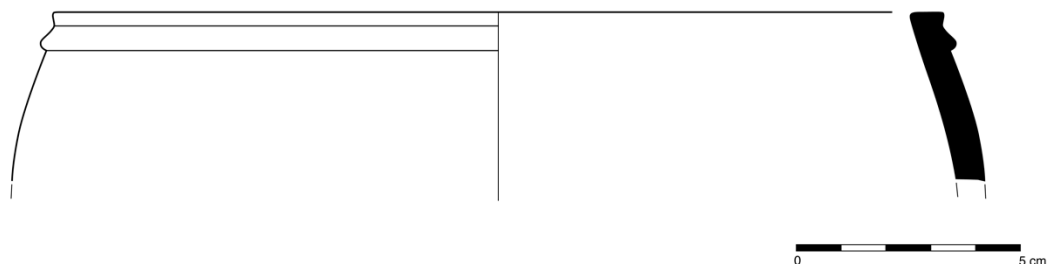

Figure 318: Rim in Pink/Buff A fabric with matte red slip; TZ 2005 Ch.6 UF 44

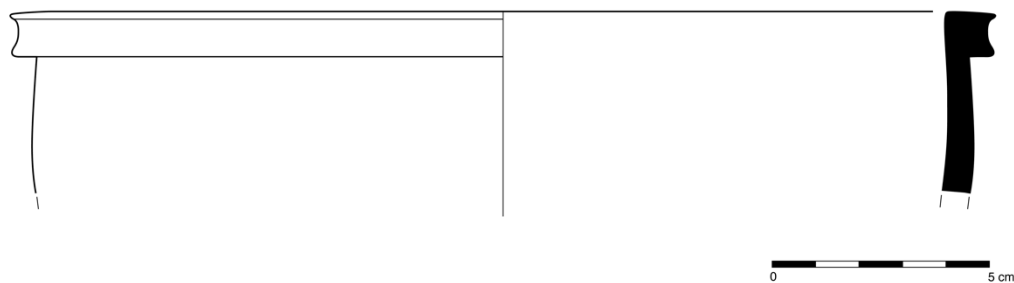

Figure 319: Rim in Pink/Buff B fabric with matte red slip; TZ 2005 Ch.6 UF 32

*Upper Profile Type 38 (n=42)*

This bowl type is a thin walled vessel with inward sloping upper walls (Figure 320). This is a deep bowl with a square rim and flat lip. No examples are preserved to the base.

It has a wide range of diameters, but most are between 15 and 25 centimeters. It has been found in Pink/Buff A fabric (23 sherds) and Pink/Buff B fabric (19 sherds). There are some unslipped examples. Decorations include matte red slip and less frequently, matte eggplant colored slip. The slip is usually on the upper body and rim, possibly dipped. As with most of this shape group, the slip extends further down the exterior, approximately 4 centimeters, than the interior, approximately 1 centimeter. There are occasional straight, incised lines on the upper exterior body.

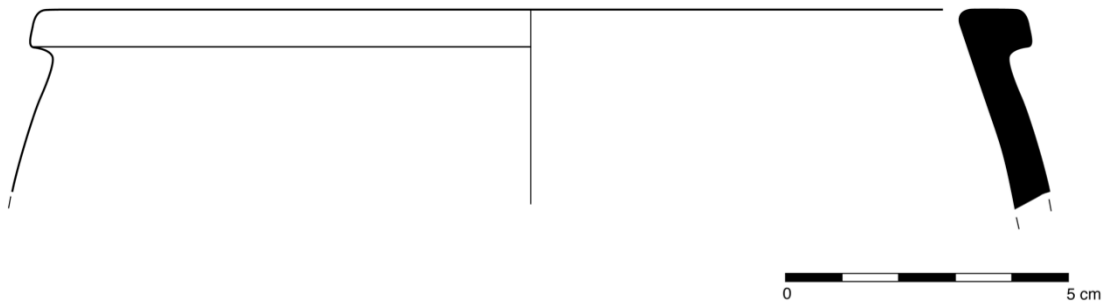

Figure 320: Rim in Pink/Buff B fabric with matte eggplant colored slip; TZ 2007 Ch.14 UF 4



*Upper Profile Type 39 (n=23)*

This bowl type is a thin walled vessel with fairly vertical upper walls (Figures 321, 322). This is a deep bowl with an everted rim. It has a flat lip and straight walls. No examples are preserved to the base.

It has rims between 19 and 25 centimeters, with occasional smaller examples. It has been found in Pink/Buff A fabric (10 sherds) and Pink/Buff B fabric (13 sherds). There are unslipped examples, but most have either matte red or eggplant colored slip.

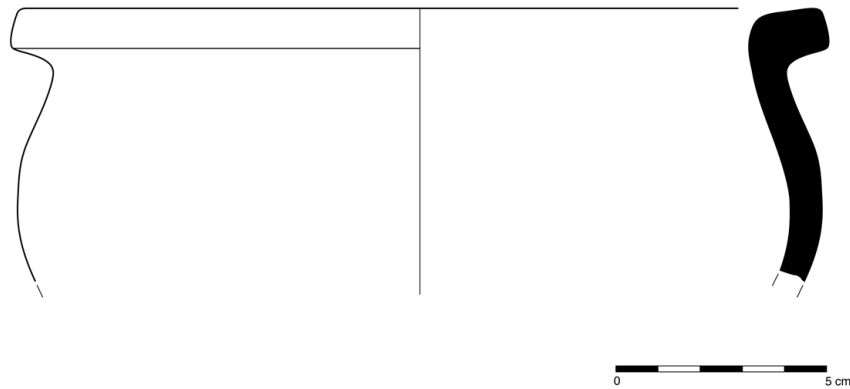

Figure 321: Rim in Pink/Buff A fabric with matte red slip on rim and upper body; TZ 2005 Ch.6 UF 4

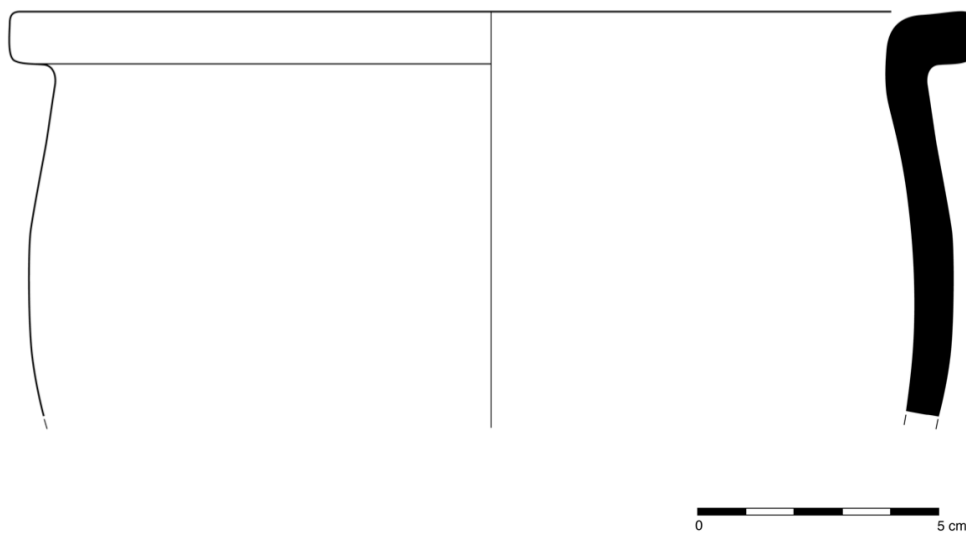

Figure 322: Rim in Pink/Buff B fabric, unslipped; TZ 2007 Ch.6 UF 25

*Upper Profile Type 40 (n=7)*

This bowl type is a thin walled vessel with fairly vertical upper walls (Figure 323). This is a deep bowl with an everted rim. It has a tilted lip and straight walls. No examples are preserved to the base.

It has rim diameters between 20 and 25 centimeters. It has been found in Pink/Buff A fabric (6 sherds) and Pink/Buff B fabric (1 sherd). Most examples have matte red slip on the upper exterior and interior, possibly dipped. There is one unslipped example.

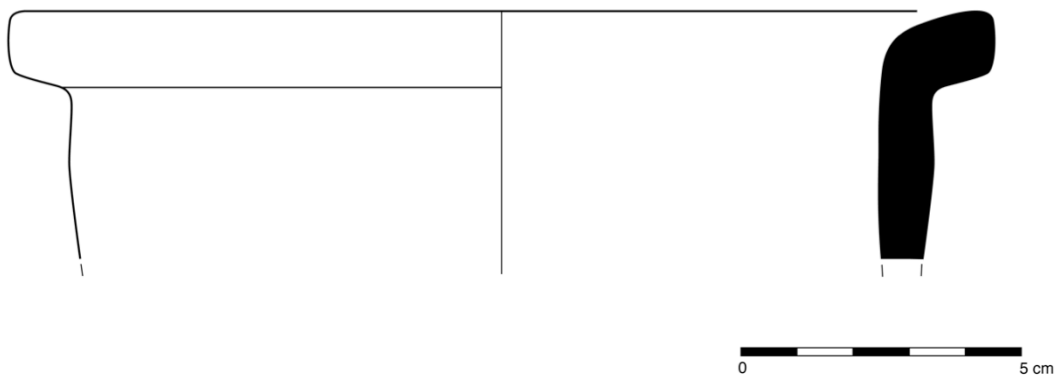

Figure 323: Rim in Pink/Buff A fabric with matte red slip; TZ 2005 Ch.6 UF 35

*Upper Profile Type 41 (n=8)*

This bowl type is a thin walled vessel with fairly incurved upper walls (Figure 324, 325). This is a deep bowl with a short, everted rim. It has an angular, upward tilted lip with a grooved top. The lower walls are convex walls. No examples have handles or are preserved to the base.

It has rim diameters between 20 and 35 centimeters. Most examples are in Pink/Buff A fabric (7 sherds), but Pink/Buff B fabric (1 sherd) is also found. There are three unslipped examples; decorations include one sherd with matte eggplant colored slip and four sherds with matte red slip.

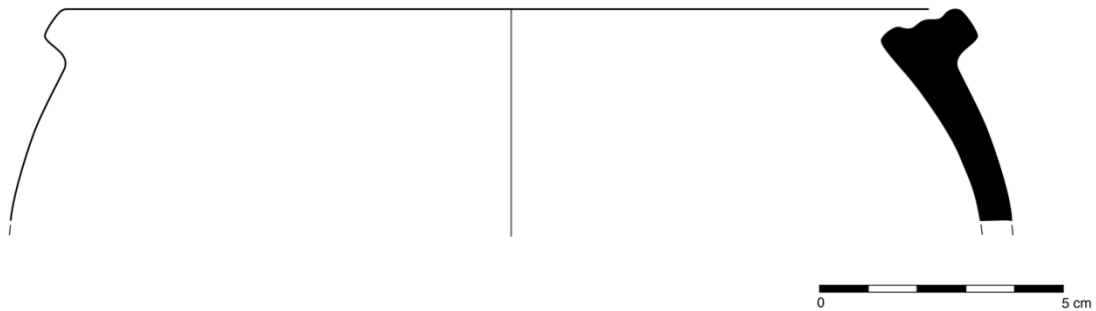

Figure 324: Rim in Pink/Buff A fabric with matte red slip; TZ 2007 Ch.14 UF 59

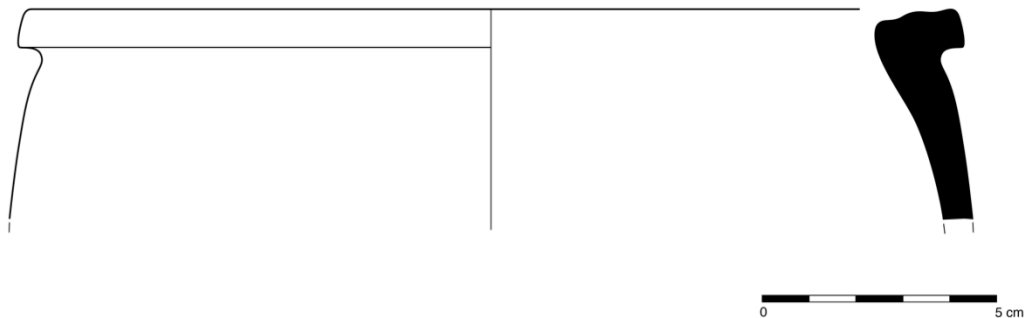

Figure 325: Rim in Pink/Buff A fabric, unslipped; TZ 2005 Ch.6 UF 107

*Upper Profile Type 42 (n=22)*

This bowl type is a thin walled vessel with fairly vertical upper walls (Figures 326-328). This is a deep bowl with a short, everted rim. It has an angular, upward tilted lip and convex lower walls. Some examples have a single small, rounded loop handle preserved, attached to the upper body. No examples are preserved to the base.

It has rim diameters between 15 and 35 centimeters. It has been found mostly in Pink/Buff A fabric (10 sherds) and Pink/Buff B fabric (11 sherds), but there is a single example in a coarse fabric. There are some unslipped examples, but most have either matte red or eggplant colored slip. Red slip is more common.

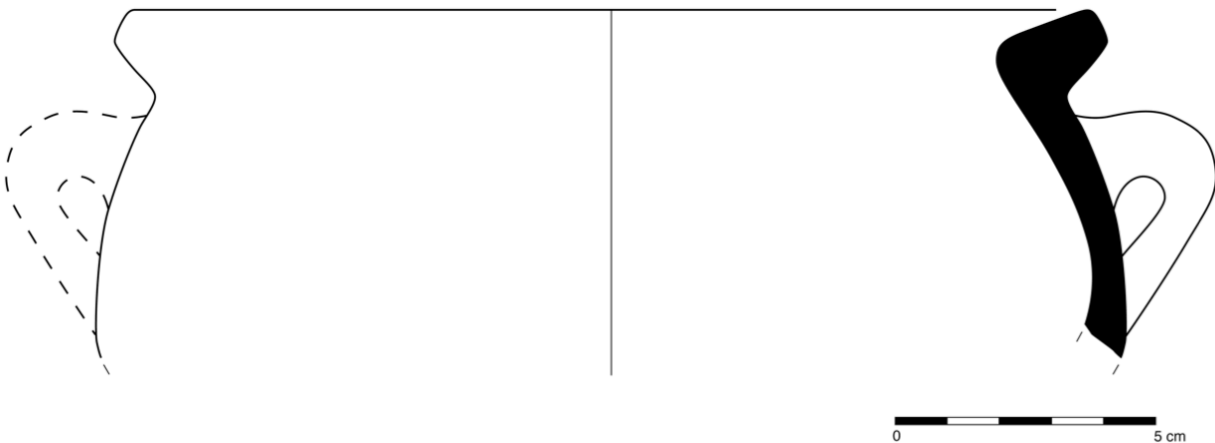

Figure 326: Rim in Pink/Buff B fabric, unslipped; TZ 2005 Ch.6 UF 9

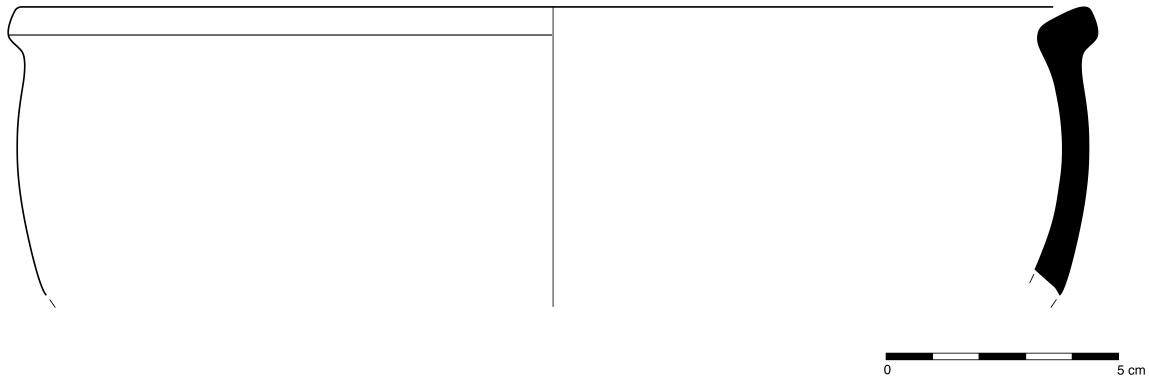

Figure 327: Rim in Pink/Buff B with matte red slip; TZ 2005 Ch.6 UF 50

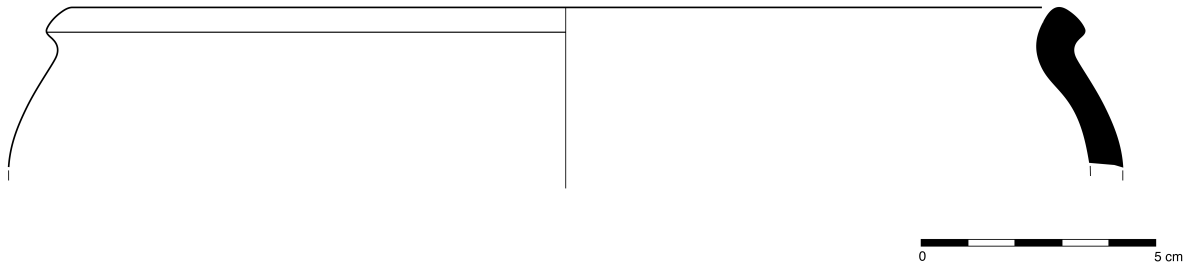

Figure 328: Rim in Pink/Buff A fabric with matte red slip; TZ 2007 Ch.6 UF 113

*Upper Profile Type 43 (n=37)*

This bowl type is a thin walled vessel with fairly vertical upper walls (Figures 329, 330). This is a deep bowl with a thickened, everted rim. It has an angular, upward tilted lip and convex lower walls. Rare examples have a single small handle, no examples are preserved to the base.

It has rim diameters between 15 and 30 centimeters. It has been found in Pink/Buff A fabric (15 sherds) and Pink/Buff B fabric (22 sherds). There are unslipped examples. Matte red and eggplant colored slip are common decorations, occasionally shallow grooves, either straight or wavy, are incised on the surface of the exterior lip.

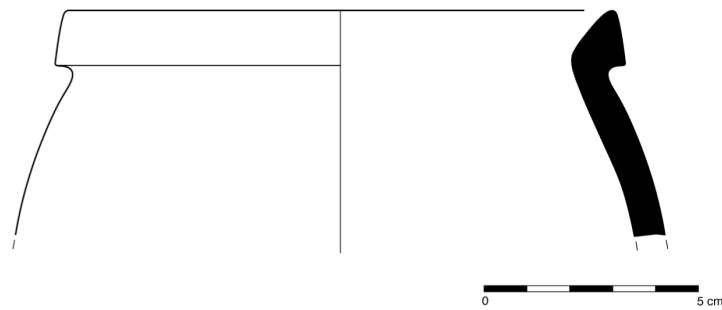

Figure 329: Rim in Pink/Buff B fabric with matte red slip; TZ 2007 Ch.14 Unit 1 UF 320/570

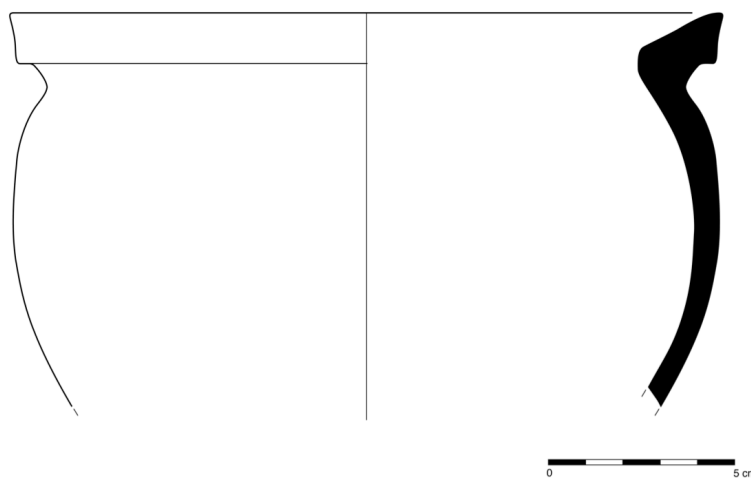

Figure 330: Rim and body in Pink/Buff B with matte eggplant colored slip; TZ 2006 Ch.6 UF 121

*Upper Profile Type 44 (n=60)*

This bowl type is a thin walled vessel with fairly vertical upper walls (Figures 331-333). This is a deep bowl with a thickened, everted rim that is folded with a hooked profile. It has an angular, upward tilted lip and convex lower walls. No examples have handles or are preserved to the base.

It has rim diameters between 19 and 31 centimeters. Pink/Buff B fabric (47 sherds) is the most common, but examples have also been found in Pink/Buff A fabric (13 sherds). There are unslipped examples. Matte red and eggplant colored slip are also common, usually on the upper body and rim.

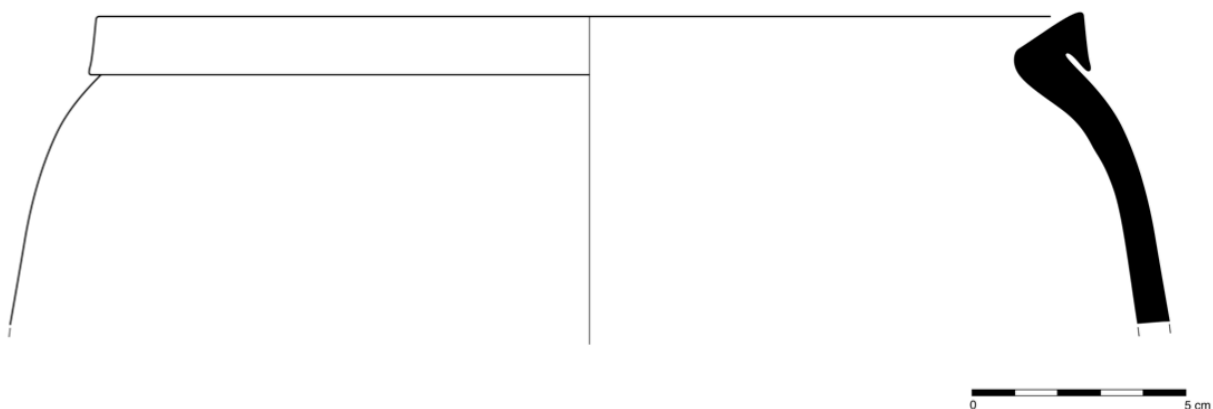

Figure 331: Rim in Pink/Buff A fabric with matte red slip; TZ 2007 Ch.14 UF 65

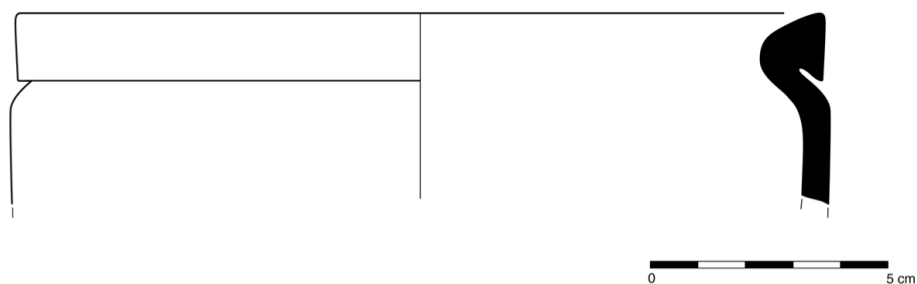

Figure 332: Rim in Pink/Buff A fabric with matte red slip; TZ 2005 Ch.6 UF 5

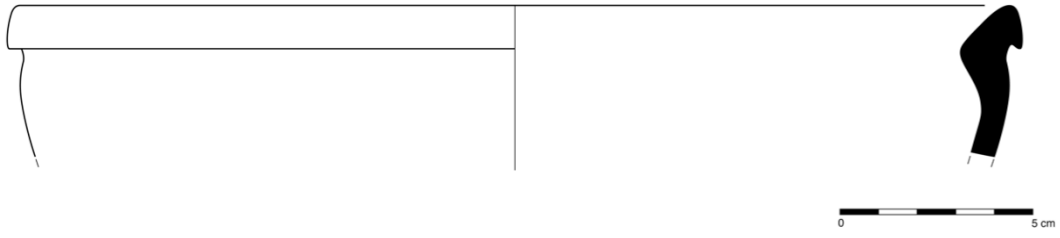

Figure 333: Rim in Pink/Buff B fabric, unslipped; TZ 2007 Ch.14 UF 60



*Upper Profile Type 45 (n=29)*

This bowl type is a thin walled vessel with fairly vertical upper walls (Figures 334-337). This is a deep bowl with a thickened, everted rim that is folded with a hooked profile. It has an angular, flat lip and convex lower walls. No examples are preserved to the base.

It has rim diameters between 16 and 28 centimeters. It is found in Pink/Buff A fabric (12 sherds) and Pink/Buff B fabric (17 sherds). There are unslipped examples, though matte red and eggplant colored slip are common. Rare examples have shallow grooves incised on the exterior of the rim.

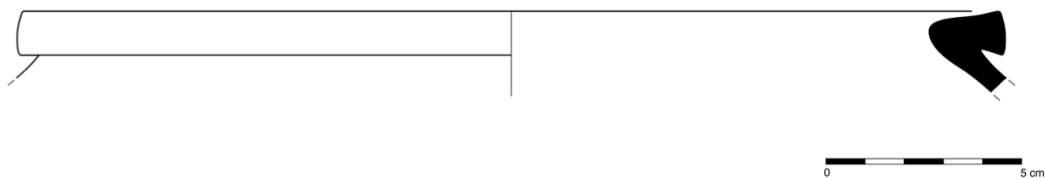

Figure 334: Rim in Pink/Buff B fabric with matte red slip; TZ 2007 Ch.14 UF 4

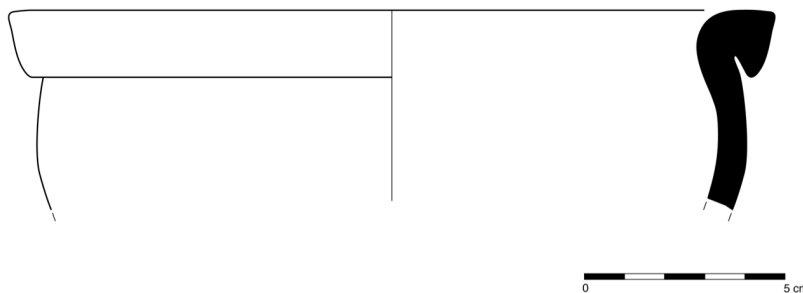

Figure 335: Rim in Pink/Buff B fabric with matte eggplant colored slip; TZ 2008 Ch.6 UF 5

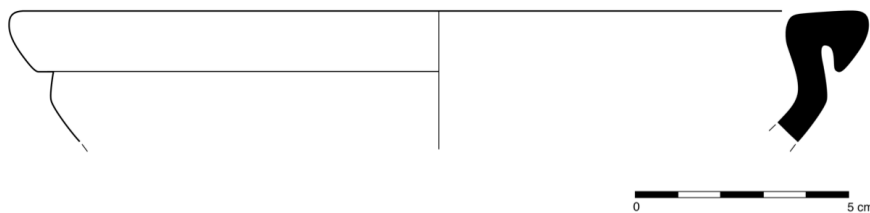

Figure 336: Rim in Pink/Buff A with matte red slip; TZ 2007 Ch.14 UF 61

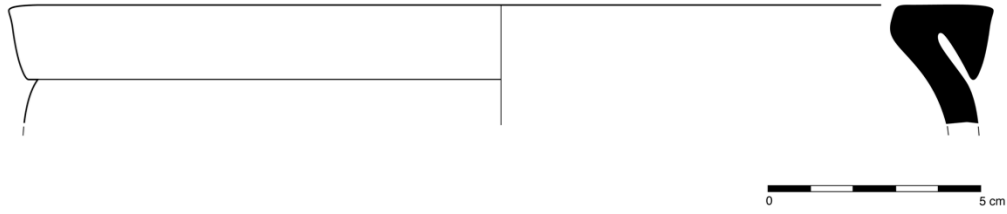

Figure 337: Rim in Pink/Buff B fabric with matte red slip; TZ 2008 Ch.6 UF 15

*Upper Profile Type 46 (n=26)*

This bowl type is a thin walled vessel with fairly vertical upper walls (Figure 338). This is a deep bowl with a thickened, short, everted rim. It has a flat lip and straight walls. Some examples have a single small, round, vertical loop handle. No examples are preserved to the base.

It has rim diameters between 17 and 28 centimeters. It has been found in Pink/Buff A fabric (9 sherds) and Pink/Buff B fabric (17 sherds). There are unslipped examples, but matte red slip and eggplant colored slip are also common decorations. Occasionally there are shallow incised lines on the exterior of the rim.

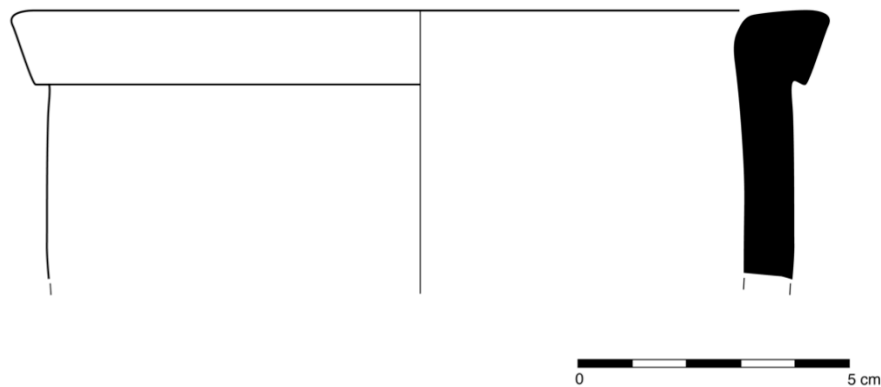

Figure 338: Rim in Pink/Buff B fabric, unslipped; TZ 2008 Ch.6 UF 15

*Upper Profile Type 47 (n=3)*

This bowl type is a thin walled vessel with fairly vertical upper walls (Figure 339). This bowl has a slightly thickened, everted rim. It has a hooked lip and straight walls. No examples are preserved past the upper body and the base forms are not known.

It has rim diameters between 12 and 19 centimeters. It has been found in Pink/Buff A fabric (2 sherds) and Pink/Buff B fabric (1 sherd). Two examples are unslipped and one example in Pink/Buff A fabric has matte red slip.

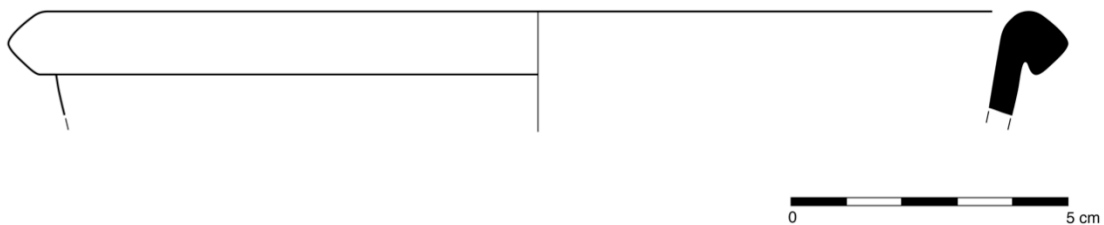

Figure 339: Rim in Pink/Buff B fabric, unslipped; TZ 2004 Ch.4 UF 20

*Upper Profile Type 48 (n=26)*

This bowl type is a thin walled vessel with fairly vertical upper walls (Figures 340, 341). This is a deep bowl with a barely articulated, squared, straight rim. It has a flat lip and convex lower walls. No examples have handles or are preserved to the base.

It has diameters between 18 and 30 centimeters. It has been found in Pink/Buff A fabric (18 sherds) and Pink/Buff B fabric (8 sherds). There are some unslipped examples. Matte red and eggplant colored slip are common decorations, particularly at the upper body and rim. These are frequently combined with straight or wavy shallow, incised grooves on the exterior of the rim or the upper body.

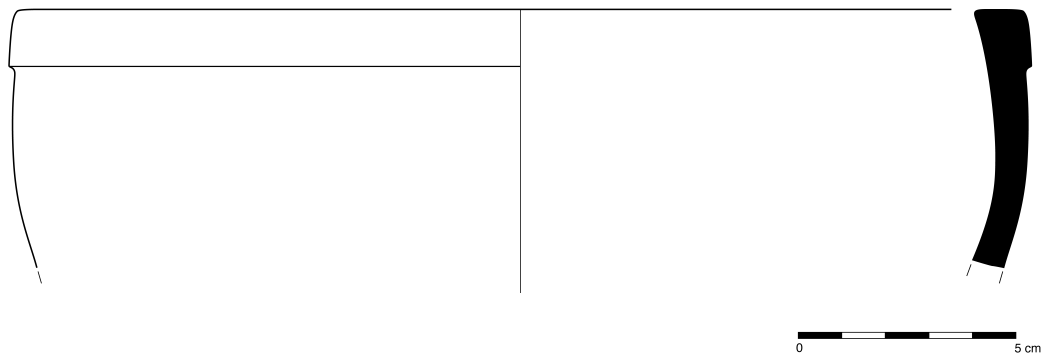

Figure 340: Rim in Pink/Buff B with matte eggplant colored slip; TZ 2008 Ch.18 UF 27

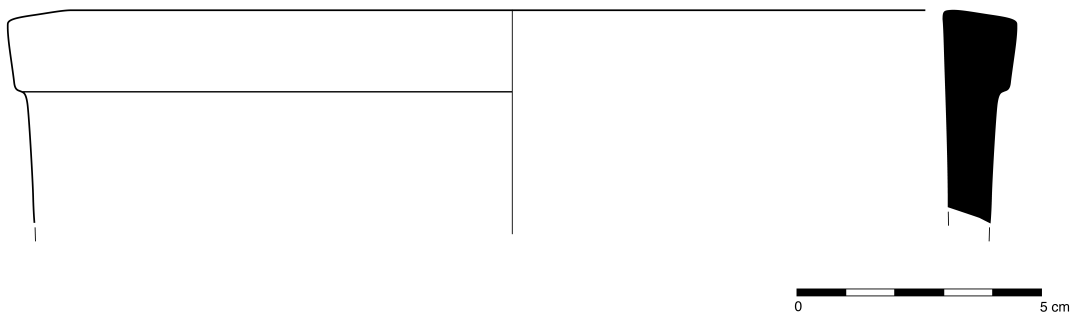

Figure 341: Rim in Pink/Buff A, unslipped; TZ 2008 Ch.6 UF 18

*Upper Profile Type 177 (n=2)*

This bowl type is a thin walled vessel with curved upper walls (Figure 342). This is a deep bowl with an articulated, everted rim that is flat on its upper surface and convex on its lower surface. The lip is fairly rounded. No examples have handles and no examples are preserved to the base.

It has rim diameters between 25 and 30 centimeters. It has been found in Pink/Buff A fabric (1 sherd) and Pink/Buff B fabric (1 sherd) with matte red slip on the upper interior and exterior walls.

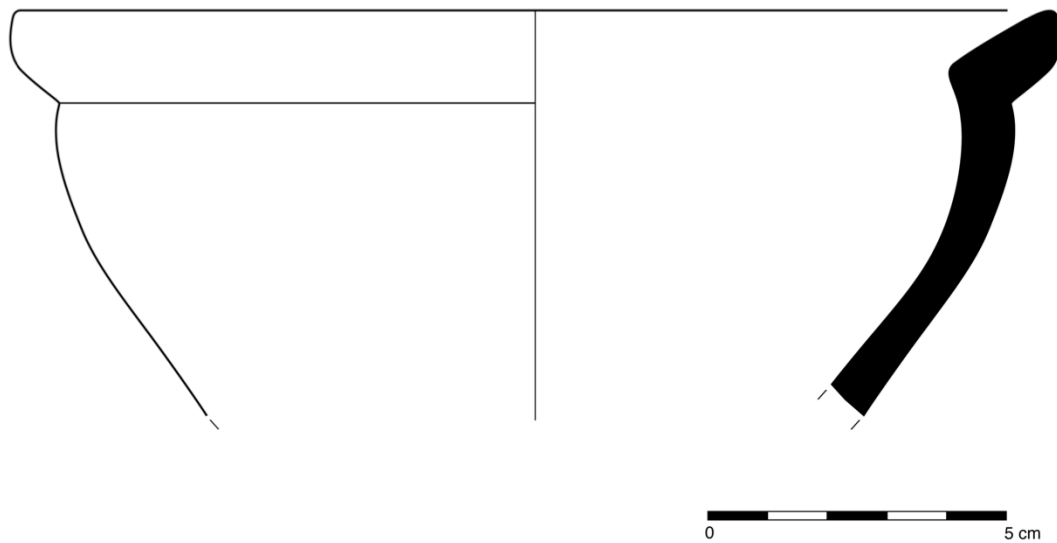

Figure 342: Rim and upper body in Pink/Buff A fabric with matte red slip on rim and upper walls; TZ 2005 Ch.6 UF 53

## Shape Group XIII: Large Open Sloping-walled Serving Bowls

### Upper Profile Types 113-134

These vessel types have rims ranging in diameter from 25 to 50 centimeters (Figure 343). With sloping walls, extant profiles of this vessel group show a depth of 15-25 centimeters and plain or simple disc bases. The rims range from plain and rounded to highly articulated with registers used for further decoration. Almost always decorated, these vessels were used for table service. Those with incised decoration were probably for dry goods, as liquid foods would make those forms difficult to clean.

Upper Profile Types 117 and 118 are rare. Upper Profile Types 113, 123, and 124 are very common.

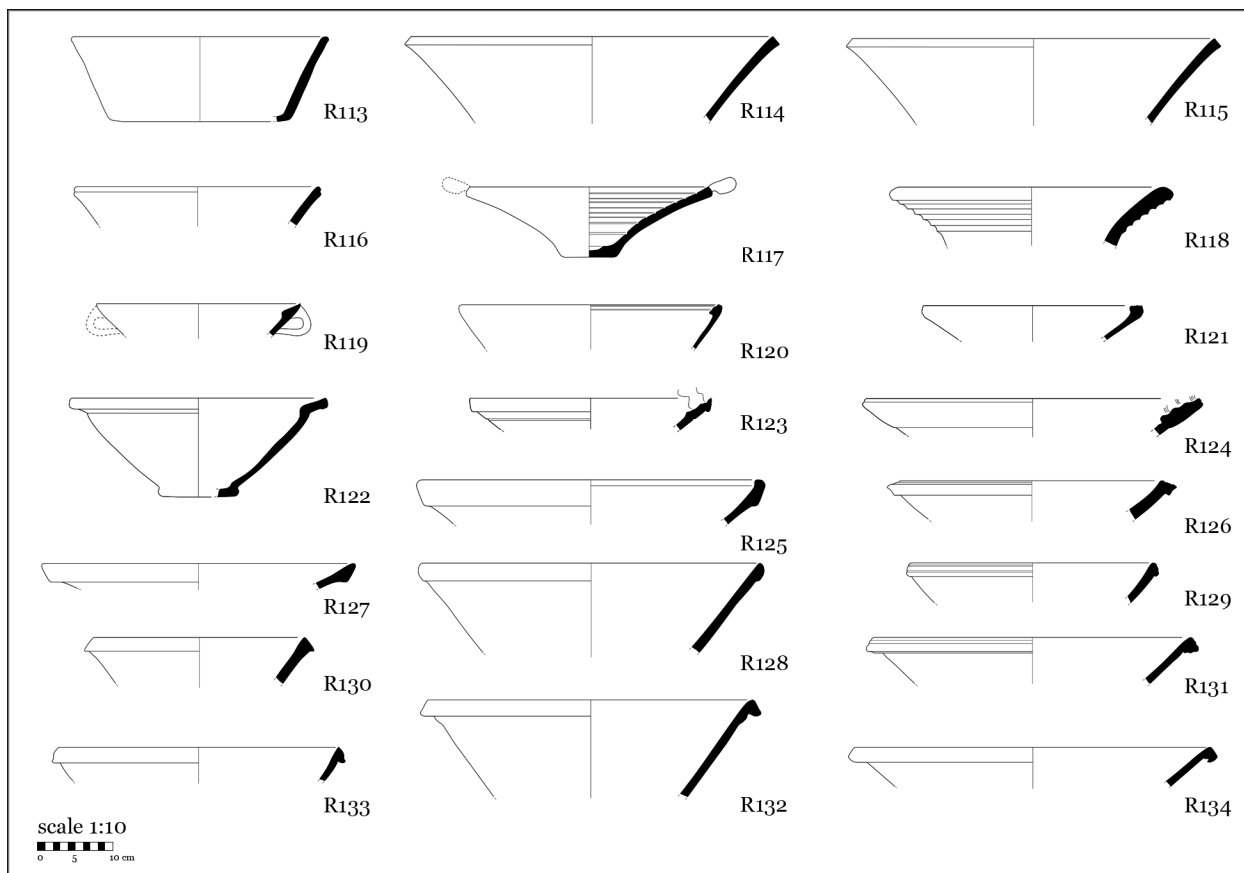

Figure 343: Table of Shape Group XIII vessels

*Upper Profile Type 113* (n=462)

This large bowl or platter type is an open, thick walled vessel with straight, open slanting walls (Figures 344, 345). The rim is plain and the lip is rounded. The base is unarticulated and angular, usually Lower Profile Type 27.

It has a wide range of rim diameters, between 15 and 42 centimeters. It has been found in primarily in Pink/Buff A fabric (222 sherds) and Pink/Buff B fabric (238 sherds), but there are rare examples in Peach Cream fabric (2 sherds). Pink and Buff examples are either undecorated or, equally as common, slipped with red or eggplant colored semi-glossy slip. This is only rarely combined with any other type of decoration, but occasionally one or more incised wavy or straight lines are found on the rim.

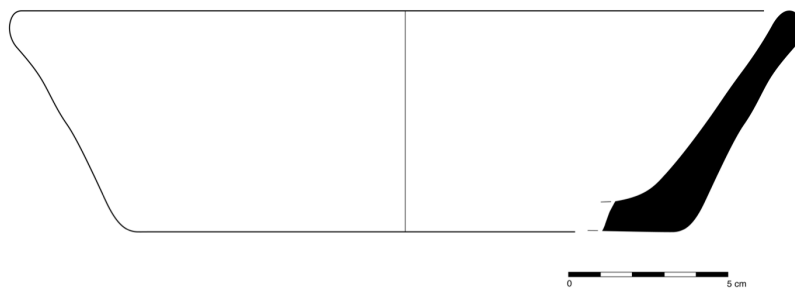

Figure 344: Whole profile in Pink/Buff B with semi-glossy red slip; TZ 2004 Ch.4 UF 20

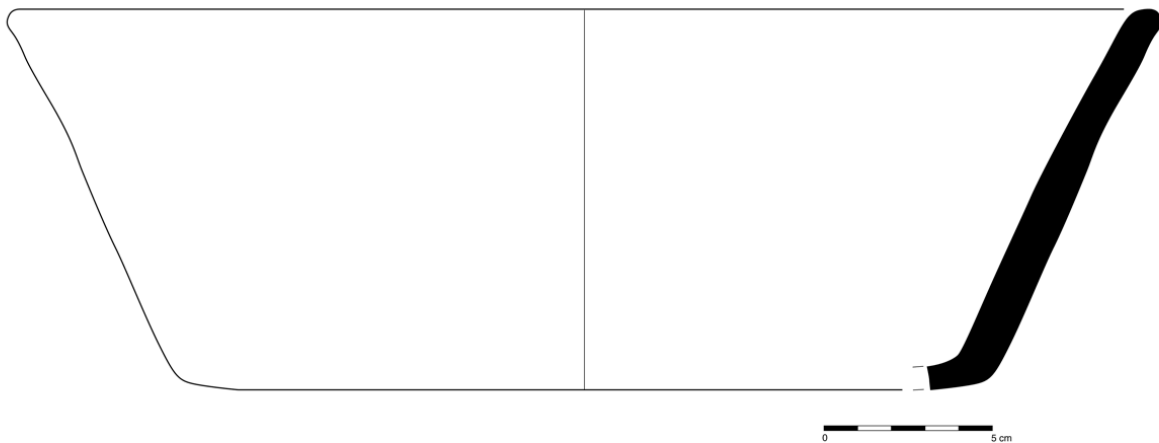

Figure 345: Whole profile in Pink/Buff A, unslipped; TZ 2005 Ch.6 UF 4



*Upper Profile Type 114 (n=29)*

This large bowl type is an open, thick walled vessel with outward sloping straight walls (Figure 346). The rim is plain and squared. There are no examples preserved to the base.

It has rim diameters from 35 to 50 centimeters. It has been found primarily in Peach Cream fabric (4 sherds), Pink/Buff A fabric (5 sherds), and Pink/Buff B fabric (20 sherds). Pink and Buff examples are undecorated or have red or eggplant colored semi-glossy slip. There is a single example of red semi-glossy slip used in conjunction with complex incised and impressed decoration.

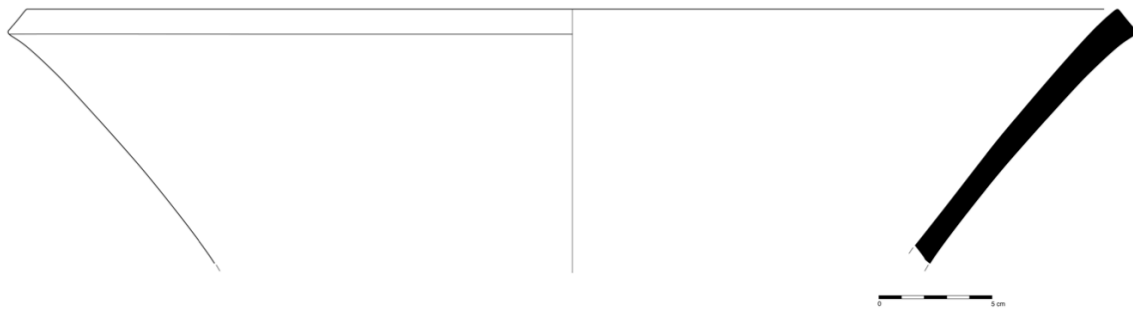

Figure 346: Rim in Pink/Buff A fabric with semi-glossy red slip; TZ 2005 Ch.6 UF 54

*Upper Profile Type 115 (n=9)*

This large bowl type is an open, thick walled vessel with outward sloping straight walls (Figure 347). The rim is plain and squared, with a single groove in the center of the lip. There are no examples preserved to the base.

It has rim diameters between 25 and 40 centimeters. It has only been found in Pink/Buff B fabric (9 sherds). Unslipped examples are just as common as red or eggplant colored semi-glossy slip. This is rarely used in conjunction with incised wavy lines on the upper interior.

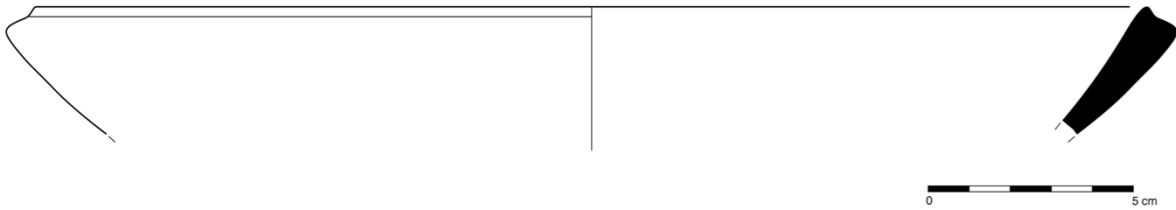

Figure 347: Rim in Pink/Buff B fabric with semi-glossy eggplant colored slip; TZ 2008 Ch.18 UF 15

*Upper Profile Type 116 (n=47)*

This large bowl type is an open, thick walled vessel with open slanting, straight walls (Figures 348, 349). The rim is rounded with a central groove in the lip. There are no examples preserved to the base.

It has rim diameters between 30 and 50 centimeters. It has been found in Pink/Buff A fabric (25 sherds) and Pink/Buff B fabric (22 sherds). There are undecorated examples, but more common is red or eggplant colored semi-glossy slip. This is sometimes used in conjunction with straight and wavy incised lines in concentric circles on the interior of the vessel.

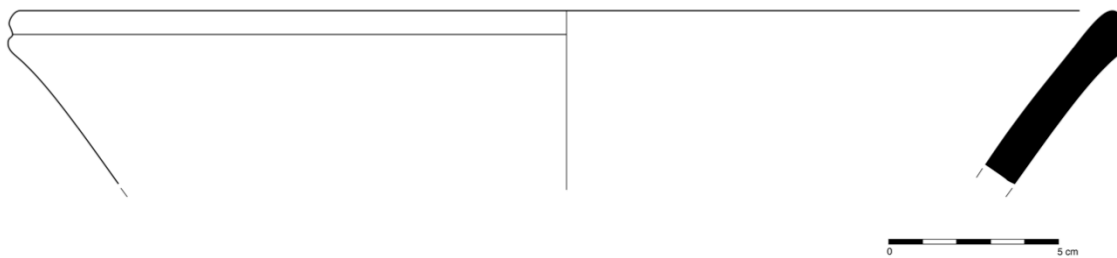

Figure 348: Rim and upper body in Pink/Buff B fabric, unslipped; TZ 2005 Ch.6 UF 5

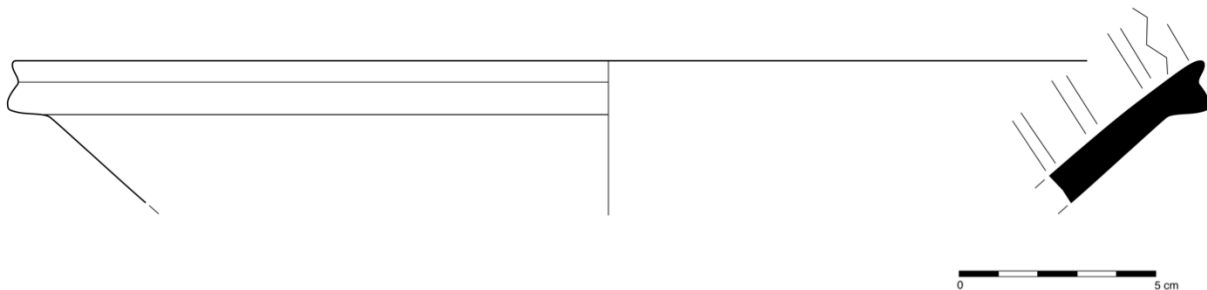

Figure 349: Rim and upper body in Pink/Buff A fabric with semi-glossy eggplant colored slip and incised decoration; TZ 2005 Ch.6 UF 17

*Upper Profile Type 117 (n=4)*

This large bowl type is an open, thick walled vessel with open slanting, straight walls (Figure 350). The rim is plain and angular. There are deep, concentric grooves spaced evenly along the interior of the vessel. The base is unarticulated and angular. There are two small hand-holds/lug handles along the top of the rim.

This rare type has rim diameters between 30 and 35 centimeters. It has only been found in Peach Cream fabric (4 sherds). The deep incised decoration with the central impression is a necessary part of this type.

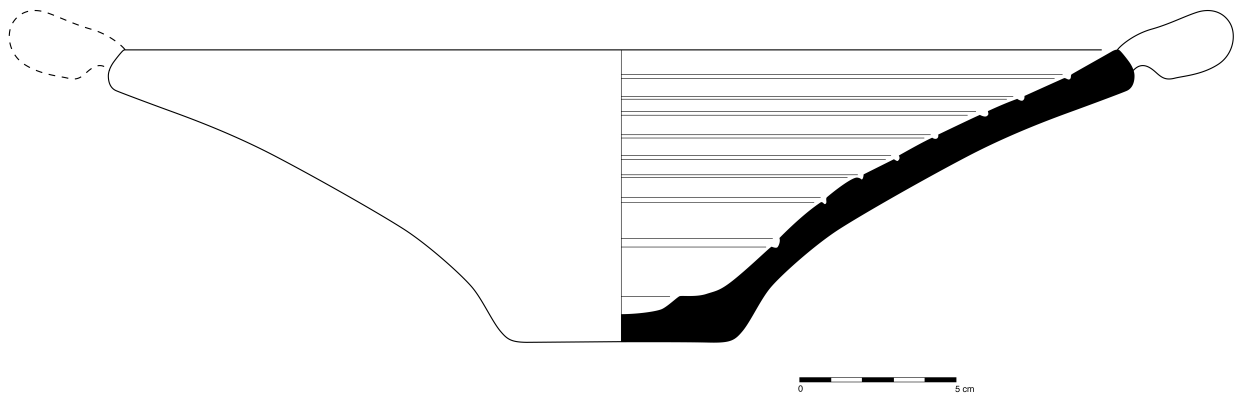

Figure 350: Whole profile in Peach Cream fabric; BH 2005 UF 52

*Upper Profile Type 118 (n=2)*

This bowl type is an open, thick walled vessel with slightly outward flaring walls (Figure 351). The rim is plain with a rounded lip. There are deep, wide, concentric ridges on the exterior walls. No examples are preserved to the base.

It has rim diameters between 25 and 30 centimeters. It has only been found in Peach Cream fabric (2 sherds).

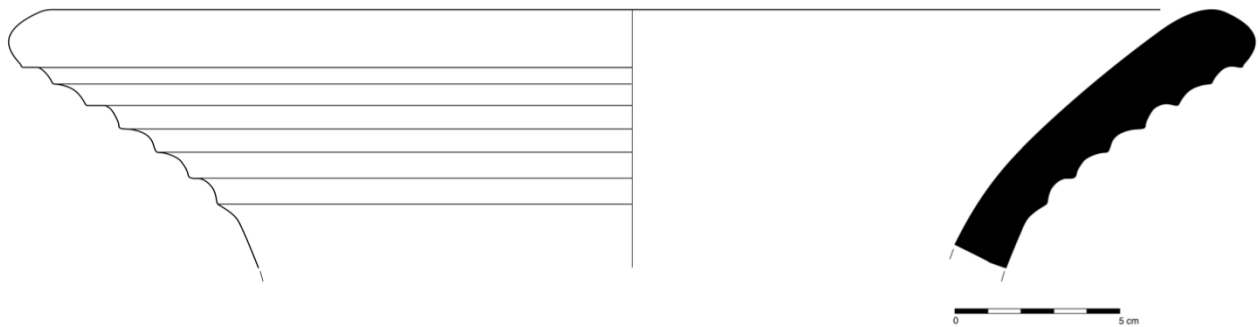

Figure 351: Rim and upper body in Peach Cream fabric; BH 2008 UF 409

*Upper Profile Type 119 (n=42)*

This bowl type is an open, thick walled vessel with outward slanting, straight walls (Figures 352, 353). The rim has an interior, triangular articulation. Some examples show straight walls connecting with a plain, rounded base. Some examples show a small rounded handle joining at the top of the rim and the upper body.

It has rim diameters between 25 and 40 centimeters. It has been found in Pink/Buff A fabric (19 sherds) and Pink/Buff B fabric (23 sherds). Undecorated examples have been found and there are some unslipped examples with incised concentric straight lines on the interior of the rim. More common is red or eggplant colored matte or semi-glossy slip. This is sometimes used in conjunction with multiple straight incised lines on the interior of the rim.

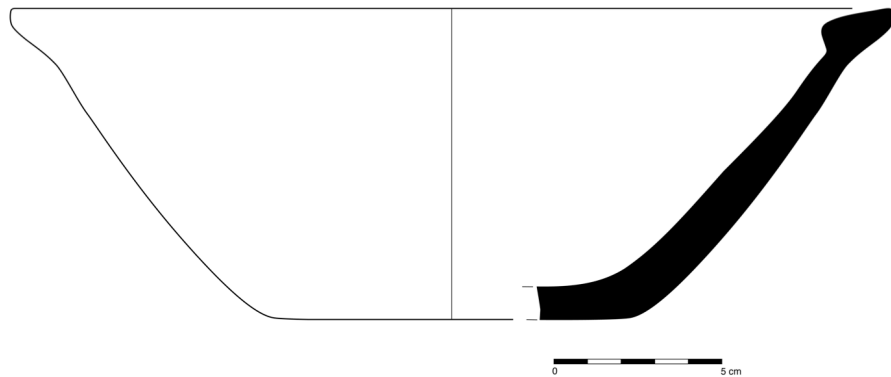

Figure 352: Whole profile in Pink/Buff B fabric with matte red slip; TZ 2008 Ch.18 UF 11

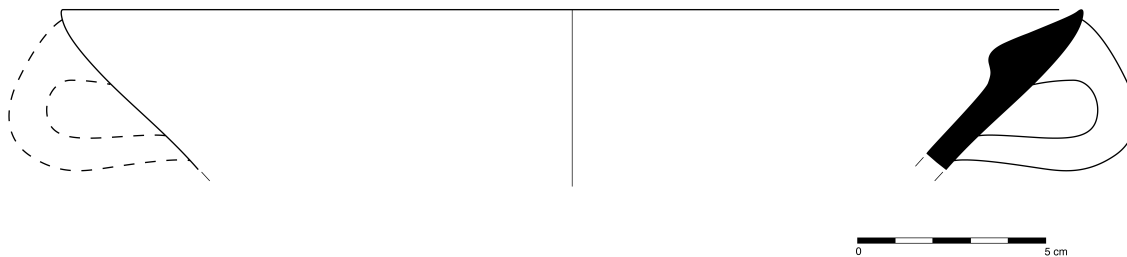

Figure 353: Rim and handle in Pink/Buff B fabric with semi-glossy red slip; TZ 2005 Ch.6 UF 10

*Upper Profile Type 120 (n=65)*

This bowl type is an open, thick walled vessel with outward slanting, straight walls (Figures 354, 355). The rim has an interior articulation, a thickened incurve with a tilted, grooved lip. Some examples show a rounded handle joining vertically at the top of the rim and the upper body. No examples are preserved to the base.

It has rim diameters between 25 and 40 centimeters. It has been found primarily in Pink/Buff A fabric (32 sherds) and Pink/Buff B fabric (32 sherds), but there is a single example in a coarse fabric (1 sherd). Some undecorated examples have been found, but more common is red or eggplant colored semi-glossy slip.

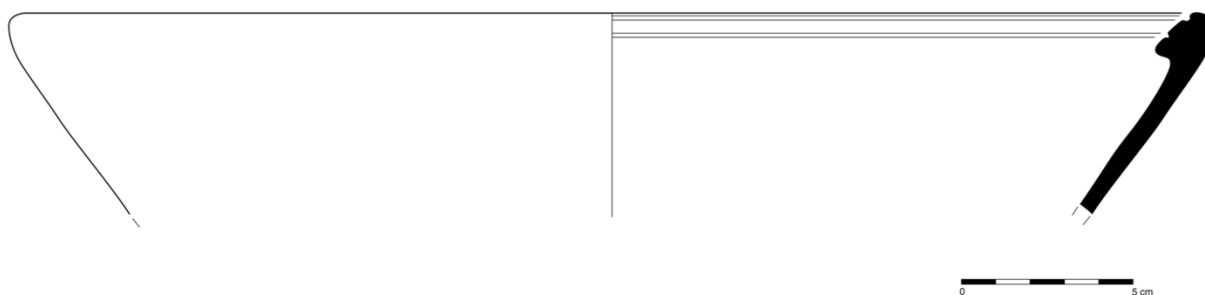

Figure 354: Rim and upper body in Pink/Buff A fabric, unslipped; TZ 2005 Ch.6 UF 9

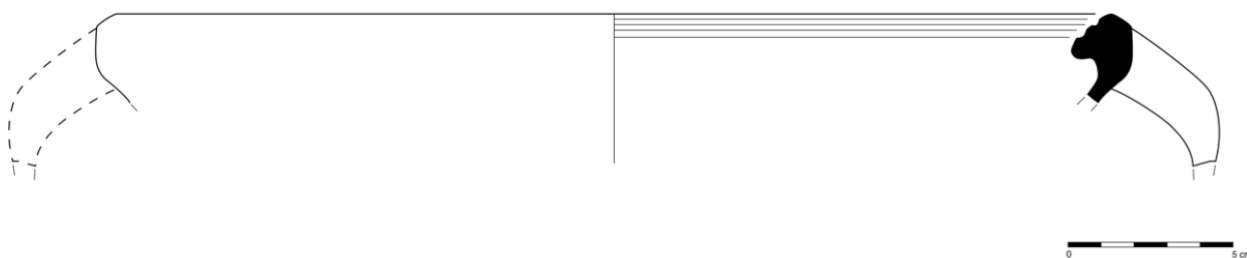

Figure 355: Rim and handle in Pink/Buff B fabric with semi-glossy red slip; TZ 2008 Ch.6 UF 15

*Upper Profile Type 121 (n=6)*

This bowl type is an open, thick walled vessel with outward slanting, straight walls (Figure 356). The rim has an interior articulation, a thickened incurve with a flat, grooved rim. Some examples show a small rounded handle joining at the top of the rim and the upper body. No examples are preserved to the base.

It has rim diameters between 25 and 40 centimeters. It has been found in Pink/Buff A fabric (4 sherds) and Pink/Buff B fabric (2 sherds). Undecorated examples are known, but more common is red or eggplant colored semi-glossy slip.

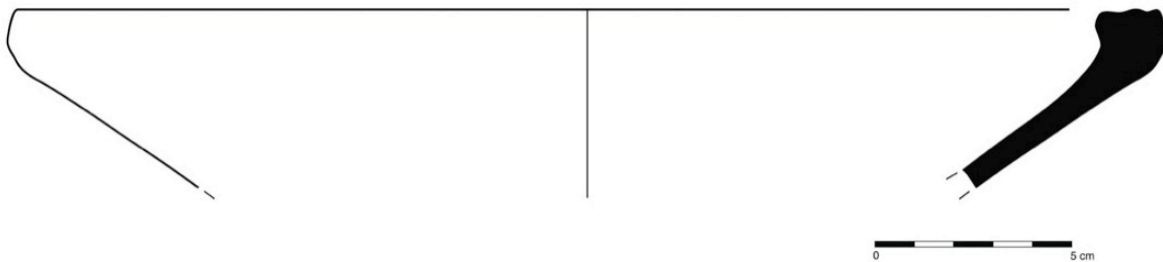

Figure 356: Rim and upper body in Pink/Buff B with semi-glossy red slip; TZ 2005 Ch.6 UF 50



*Upper Profile Type 122 (n=26)*

This bowl type is an open, thick walled vessel with outward slanting, straight walls (Figures 357-360). The rim has an interior articulation, a plain register set at a slightly lower angle. Some examples show a small rounded handle joining at the top of the rim and the upper body. Some examples show straight walls joining with a plain, rounded disc foot.

It has rim diameters between 25 and 40 centimeters. It is found primarily in Pink/Buff A fabric (7 sherds) and Pink/Buff B fabric (18 sherds), but there is one very nice example in Orange fabric with lustrous orange slip. There are unslipped examples, but more common is red or eggplant colored semi-glossy slip. This is sometimes used in conjunction with straight or wavy concentric incised lines on the interior of the rim/separated register.

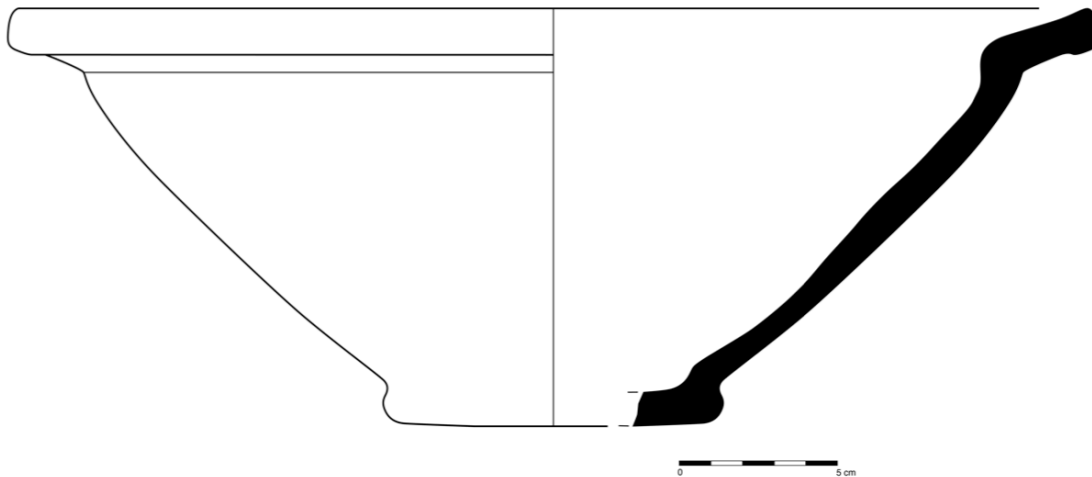

Figure 357: Whole profile in Orange fabric with lustrous orange slip; TZ 2005 Ch.6 UF 10

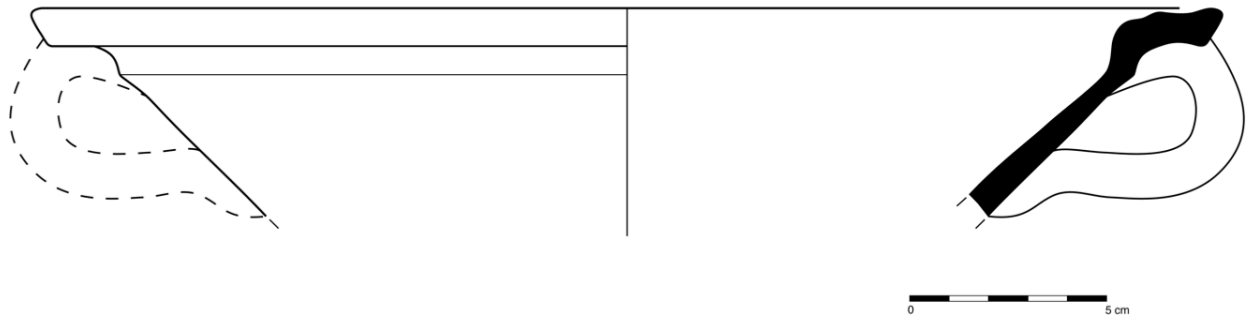

Figure 358: Rim and handle in Pink/Buff B fabric, unslipped; TZ 2005 Ch.6 UF 53

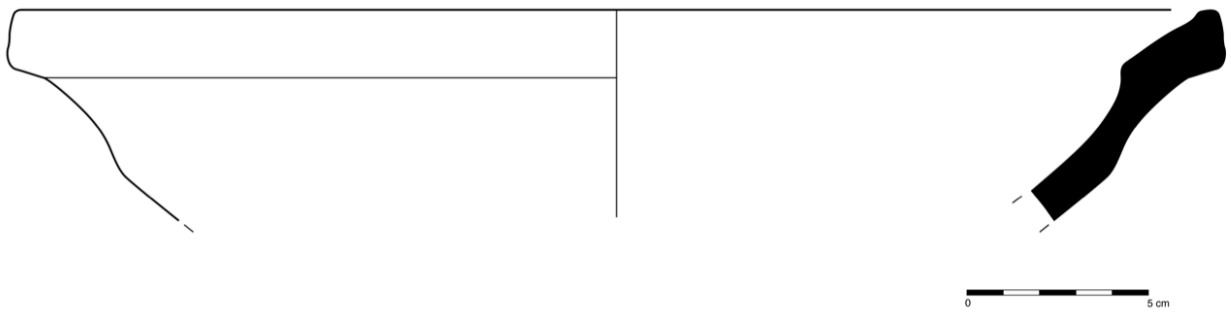

Figure 359: Rim in Pink/Buff B fabric with semi-glossy eggplant colored slip; TZ 2007 Ch.6 UF 123

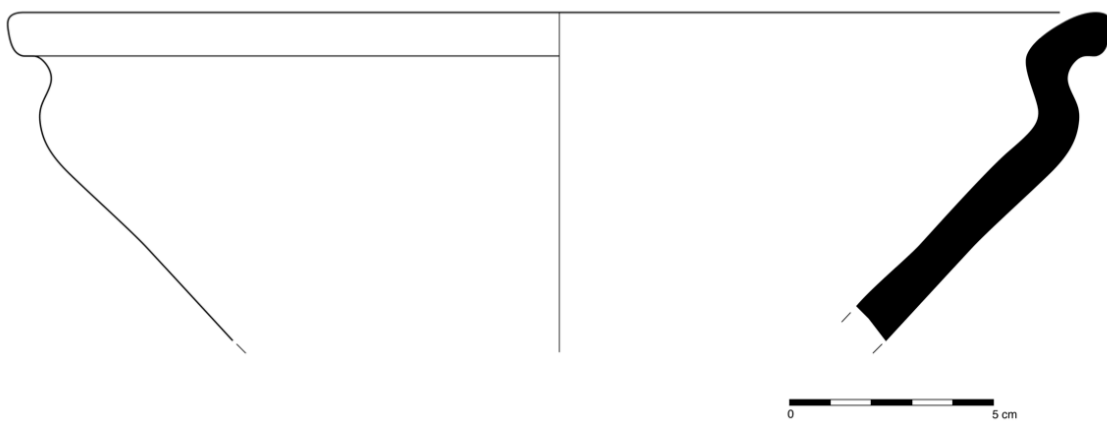

Figure 360: Rim in Pink/Buff A fabric with semi-glossy red slip; TZ 2007 Ch.14 UF 58

*Upper Profile Type 123* (n=111)

This bowl type is an open, thick walled vessel with outward slanting, straight walls (Figures 361-364). The rim has an interior articulation with two raised “registers”. This articulated rim is usually devoid of incised decoration. No examples are preserved to the base.

It has rim diameters between 30 and 40 centimeters. It has been found in Pink/Buff A fabric (37 sherds) and Pink/Buff B fabric (74 sherds). Sometimes unslipped, more commonly it has red or eggplant colored semi-glossy slip. Occasionally this is used in conjunction with wavy, straight, or dotted incised concentric lines on the interior “registers”. There is one example with matte brown slip.

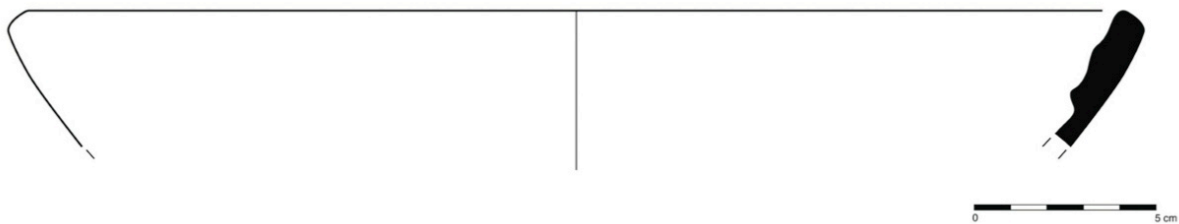

Figure 361: Rim in Pink/Buff A fabric with semi-glossy red slip; TZ 2008 Ch.6 UF 15

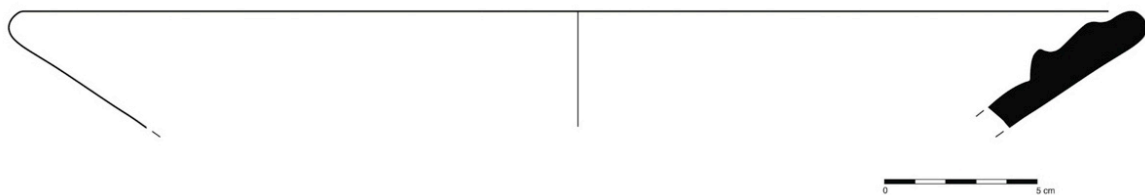

Figure 362: Rim in Pink/Buff A with semi-glossy red slip; TZ 2007 Ch.14 UF 525

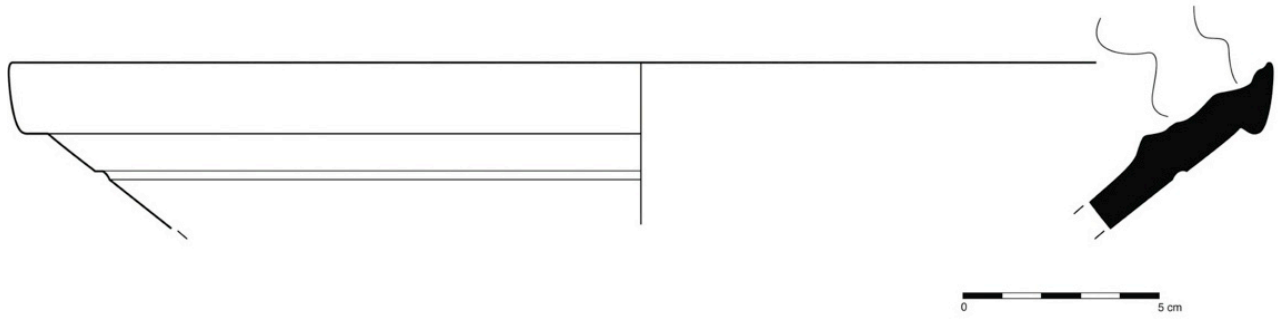

Figure 363: Rim in Pink/Buff B fabric with semi-glossy red slip and incised wavy lines; TZ 2005 Ch.6 UF 54

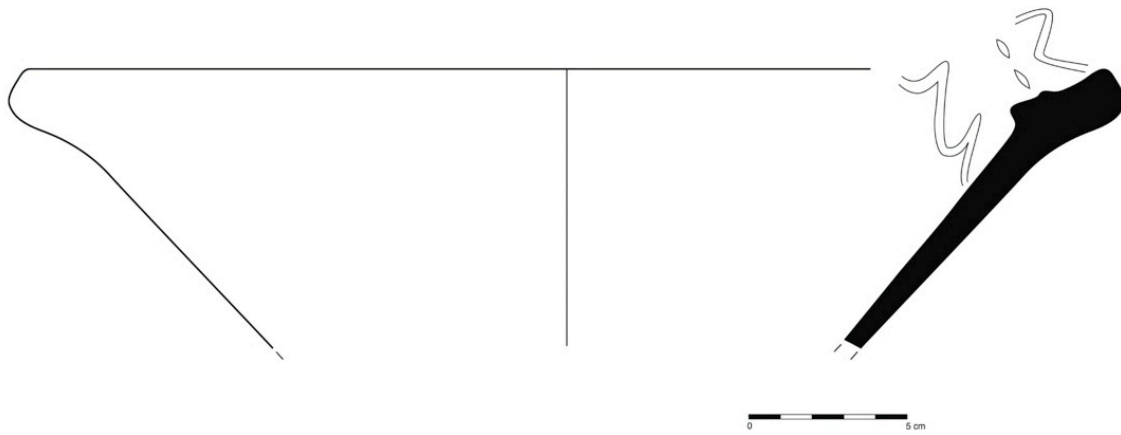

Figure 364: Rim and upper body in Pink/Buff A with semi-glossy red slip and wide incised decoration; TZ 2008 Ch.14 UF 59

*Upper Profile Type 124 (n=135)*

This bowl type is an open, thick walled vessel with outward sloping, straight walls (Figures 365-367). The rim has an interior articulation, multiple registers, often elaborately decorated. Some examples show a small, flat hand-hold attached at the top of the rim (Figure 367). Some examples show straight walls joining with a plain, rounded disc foot. Rope shaped handles are commonly found on this type, attached horizontally at the rim.

It has rim diameters between 20 and 45 centimeters. Primarily found in Pink/Buff A fabric (62 sherds) and Pink/Buff B fabric (66 sherds), there are some examples in coarse fabric (7 sherds). There are rare unslipped examples. Red and eggplant colored semi-glossy slips are ubiquitous, frequently used in conjunction with incised and stamped decoration on the registers and interior wall of the vessel. There are occasional examples of pattern burnished decoration on the interior center of the vessel. Incised decorations range from wavy to angular, straight, and scalloped lines in multiples or singly arranged on the registers of the vessel.

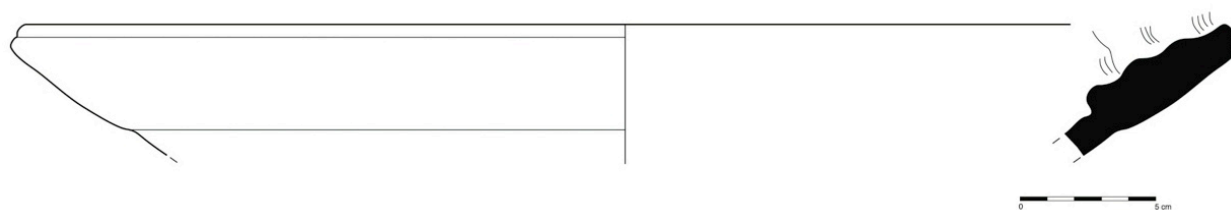

Figure 365: Rim in Pink/Buff B fabric with semi-glossy red and eggplant colored slip with incised decoration; TZ 2005 Ch.6 UF 53

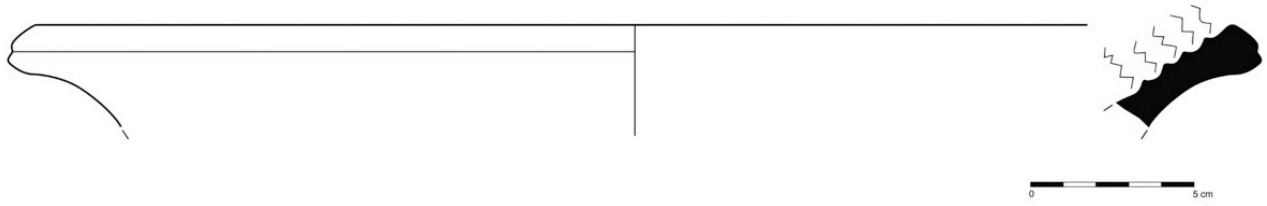

Figure 366: Rim in Pink/Buff B fabric with semi-glossy eggplant colored slip with rouletted decoration; TZ 2005 Ch.6 UF 39

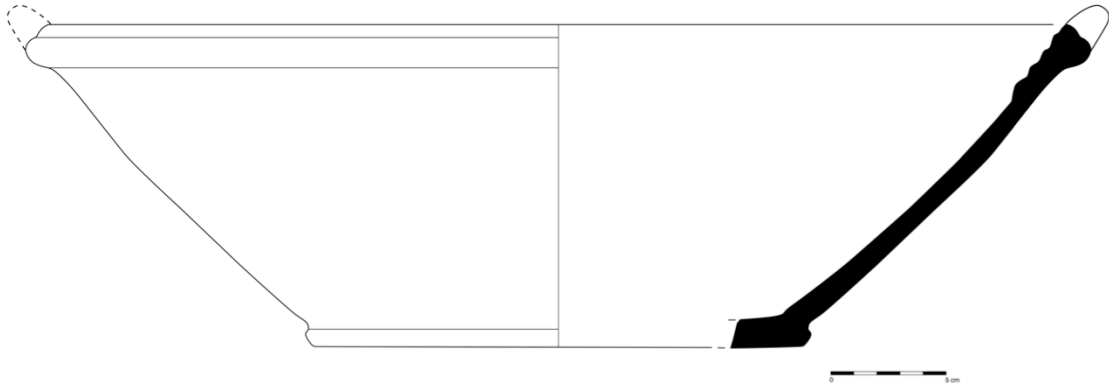

Figure 367: Whole profile in Pink/Buff B fabric with semi-glossy eggplant colored slip; TZ 2005 Ch.6 UF 17

*Upper Profile Type 125 (n=33)*

This bowl type is an open, thick walled vessel with straight, outward sloping walls (Figures 368, 369). The rim has an exterior articulation, vertically oriented and squared. No examples are preserved to the base.

It has rim diameters between 30 and 40 centimeters. It has been found in Pink/Buff A fabric (21 sherds) and Pink/Buff B fabric (12 sherds). There are rare unslipped examples, but red and eggplant colored semi-glossy slips are more common.

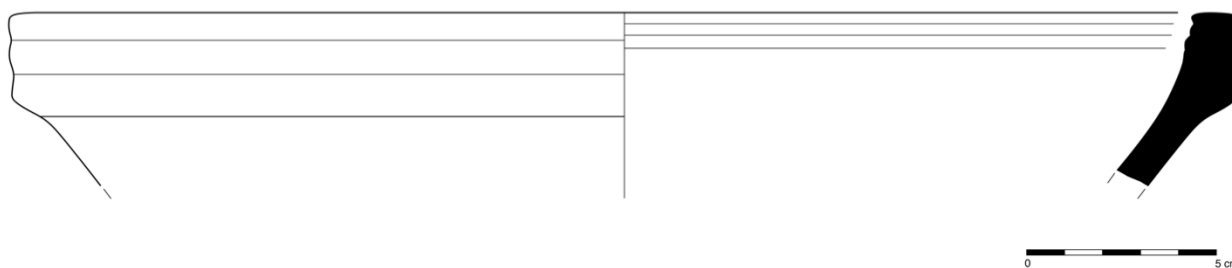

Figure 368: Rim in Pink/Buff B fabric, unslipped; TZ 2004 Ch.4 Sec.2 UF 6

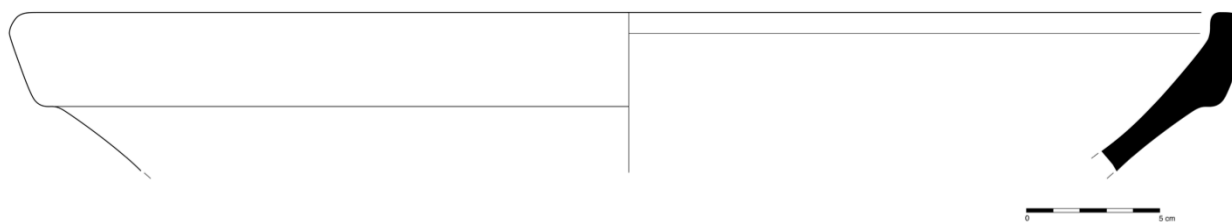

Figure 369: Rim in Pink/Buff B fabric with semi-glossy red slip; TZ 2004 Ch.4 UF 12

*Upper Profile Type 126 (n=10)*

This bowl type is an open, thick walled vessel with open slanting, straight walls (Figures 370, 371). The rim has an exterior articulation that is everted and squared. No examples are preserved to the base.

This relatively rare type has rim diameters between 35 and 45 centimeters. It has been found primarily in Pink/Buff B fabric (8 sherds), Pink/Buff A fabric (1 sherd), and Peach Cream fabric (1 sherd). Unslipped and slipped examples are equally common. Red and eggplant colored semi-glossy slip is sometimes used in conjunction with incised wavy lines in the rim. Sometimes these are found on unslipped examples.

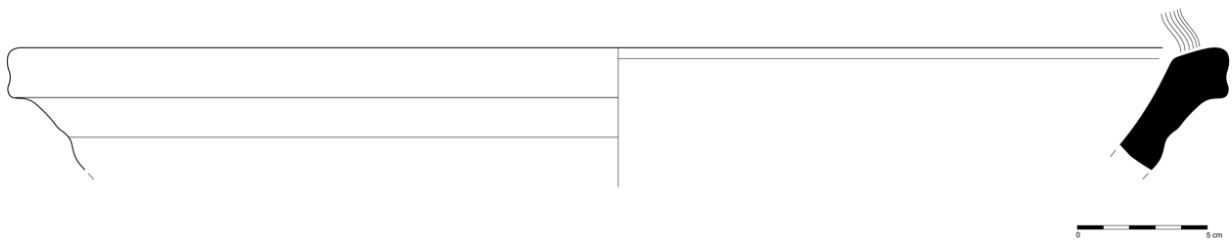

Figure 370: Rim in Pink/Buff B fabric with semi-glossy eggplant colored slip and incised decoration on rim; TZ 2008 Ch.18 UF 20

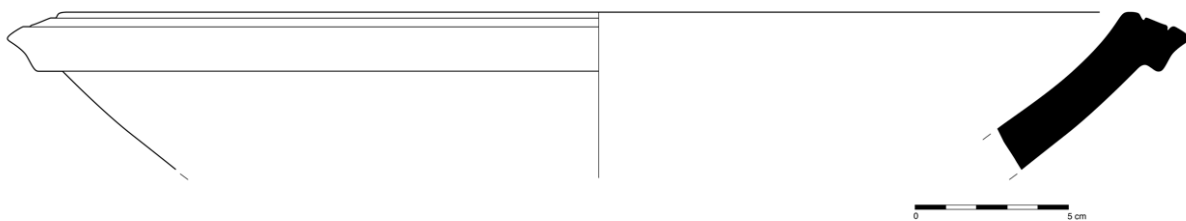

Figure 371: Rim in Pink/Buff B fabric, unslipped with incised lines in rim; TZ 2004 Ch.4 UF 18



*Upper Profile Type 127 (n=46)*

This bowl type is an open, thick walled vessel with straight, outward sloping walls (Figures 372, 373). The rim has a triangular, exterior articulation. The lip is angular. No examples are preserved to the base.

It has rim diameters from 30 to 45 centimeters. It has been found in Pink/Buff A fabric (24 sherds) and Pink/Buff B fabric (22 sherds). Undecorated examples have been found. More common is red or eggplant colored semi-glossy slip. This is occasionally used in conjunction with incised wavy lines on the exterior of the rim. There is one example in red lustrous slip.

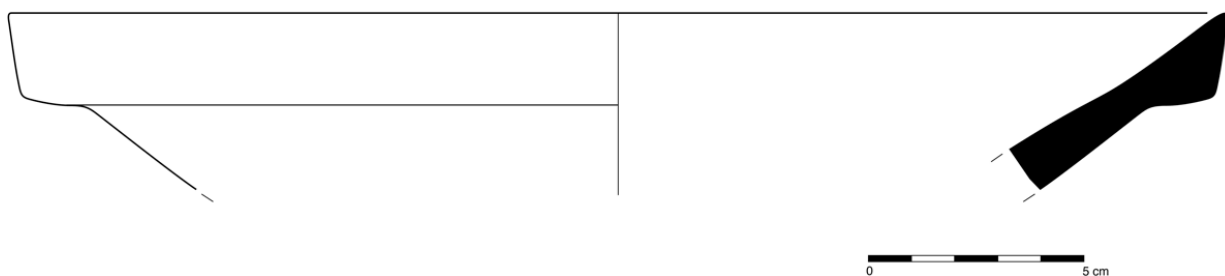

Figure 372: Rim in Pink/Buff B fabric with semi-glossy red slip; TZ 2006 Ch.6 UF 13

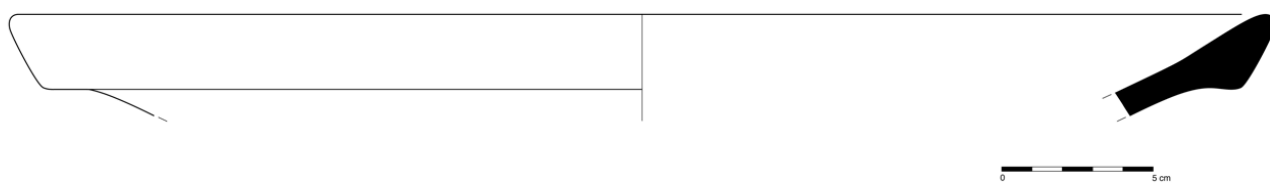

Figure 373: Rim in Pink/Buff A fabric with semi-glossy red slip; TZ 2005 Ch.6 UF 39

*Upper Profile Type 128* (n=30)

This bowl type is an open, thick walled vessel with open slanting, straight walls (Figure 374). The rim has a slightly rounded, exterior articulation. No examples are preserved to the base.

It has rim diameters between 30 and 45 centimeters. It has been found primarily in Pink/Buff A fabric (12 sherds) and Pink/Buff B fabric (16 sherds), but rare examples have been found in Peach Cream fabric (2 sherds). Undecorated examples are equally as common as red or eggplant colored semi-glossy slip.

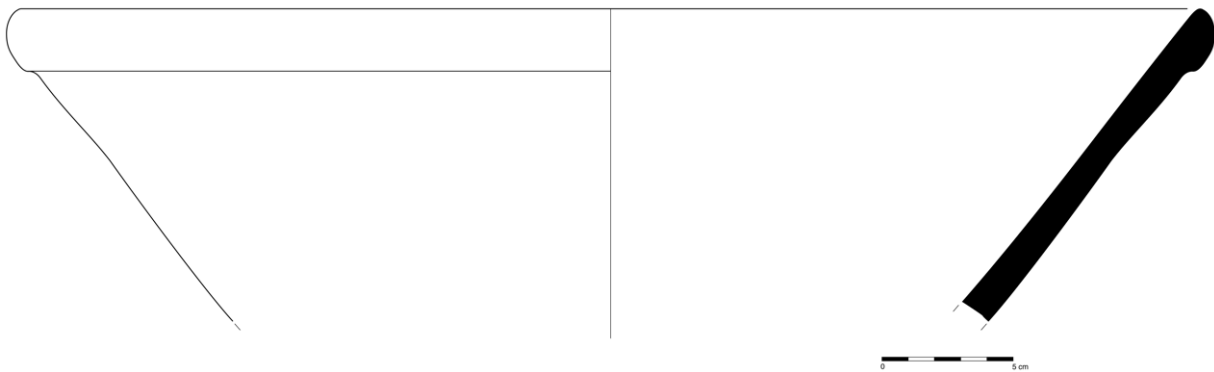

Figure 374: Rim and upper body in Pink/Buff A fabric with semi-glossy red slip; TZ 2005 Ch.6 UF 53

*Upper Profile Type 129 (n=59)*

This bowl type is an open, thick walled vessel with outward slanting, straight walls (Figure 375). The rim has a slightly rounded, exterior articulation. The rim is grooved on the exterior and the lip is rounded. No examples are preserved to the base.

It has rim diameters between 30 and 45 centimeters. It has been found in Pink/Buff A fabric (22 sherds) and Pink/Buff B fabric (37 sherds). Undecorated examples have been found. Equally common is red or eggplant colored semi-glossy slip.



Figure 375: Rim in Pink/Buff A fabric with semi-glossy red slip and deep grooves in exterior of rim; TZ 2004 Ch.4 Sec.2 UF 16

*Upper Profile Type 130 (n=84)*

This bowl type is an open, thick walled vessel with outward slanting, straight walls (Figures 376, 377). The rim has a plain, triangular, exterior articulation. No examples are preserved to the base.

It has rim diameters between 30 and 45 centimeters. It is found primarily in Pink/Buff A fabric (31 sherds), Pink/Buff B fabric (51 sherds), and occasionally Peach Cream fabric (2 sherds). Undecorated examples are as commonly found as those with red or eggplant colored semi-glossy slip.

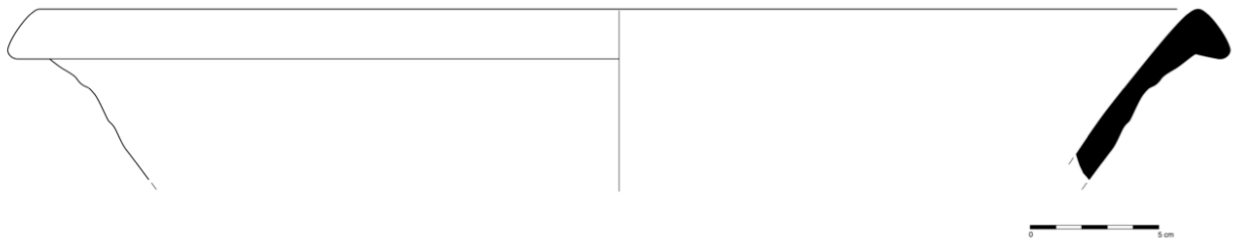

Figure 376: Rim in Pink/Buff B fabric with semi-glossy red slip; TZ 2005 Ch.6 UF 10

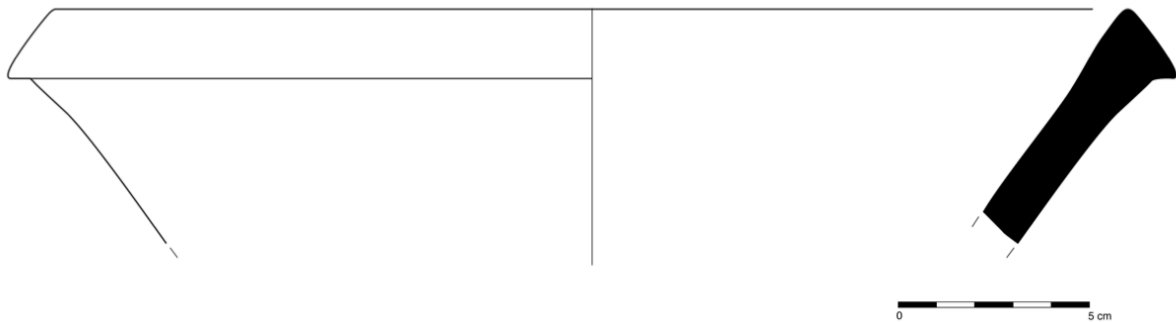

Figure 377: Rim in Pink/Buff A fabric with semi-glossy red slip; TZ 2004 Ch.4 UF 9

*Upper Profile Type 131 (n=21)*

This bowl type is an open, thick walled vessel with outward sloping, straight walls (Figures 378, 379). The rim has a triangular, exterior articulation. The exterior of the rim is grooved and the top is rounded. No examples are preserved to the base.

It has rim diameters between 25 and 45 centimeters. It has been found in Pink/Buff A fabric (11 sherds) and Pink/Buff B fabric (10 sherds). There are undecorated examples, but more common is red or eggplant colored semi-glossy slip. There is one example of red lustrous slip.

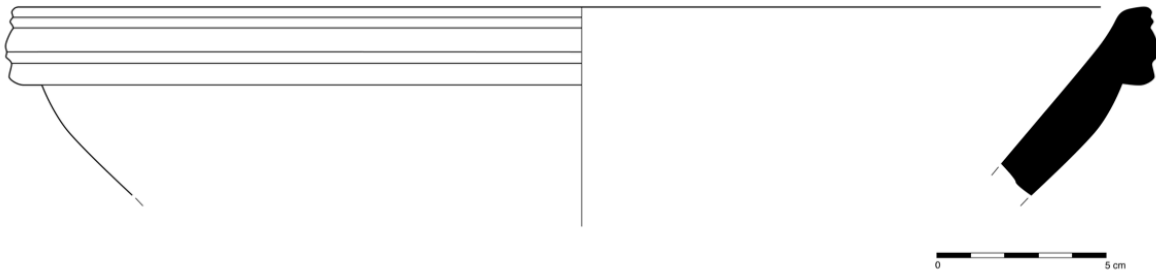

Figure 378: Rim in Pink/Buff A fabric with semi-glossy red slip; TZ 2004 Ch.4 Sec.2 UF 18

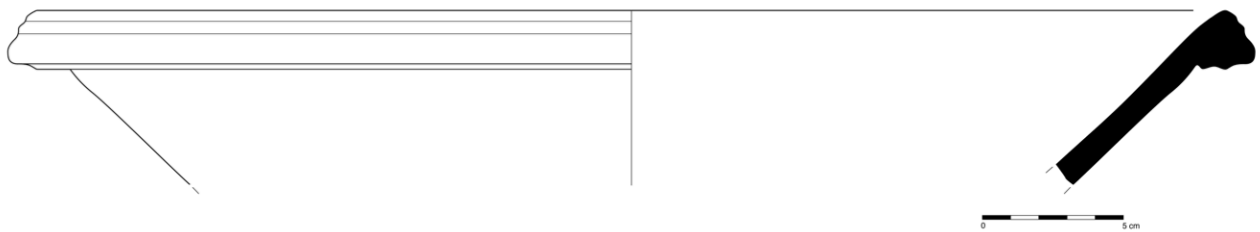

Figure 379: Rim in Pink/Buff B fabric with semi-glossy eggplant colored slip; TZ 2008 Ch.18 UF 24

*Upper Profile Type 132 (n=41)*

This bowl type is an open, thick walled vessel with outward slanting, straight walls (Figures 380, 381). The rim has a rounded, slightly overhanging rim. The lip is rounded. No examples are preserved to the base.

It has rim diameters between 35 and 45 centimeters. It is found in Peach Cream fabric (1 sherd), Pink/Buff A fabric (17 sherds) and Pink/Buff B fabric (23 sherds). Undecorated examples are very rare. Red or eggplant colored semi-glossy slip is ubiquitous. There is one example of a higher quality glossy red slip.

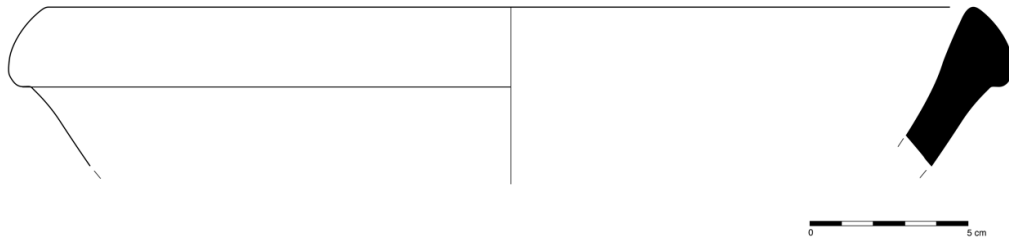

Figure 380: Rim in Pink/Buff B fabric, unslipped; TZ 2004 Ch.4 Sec.2 UF 8

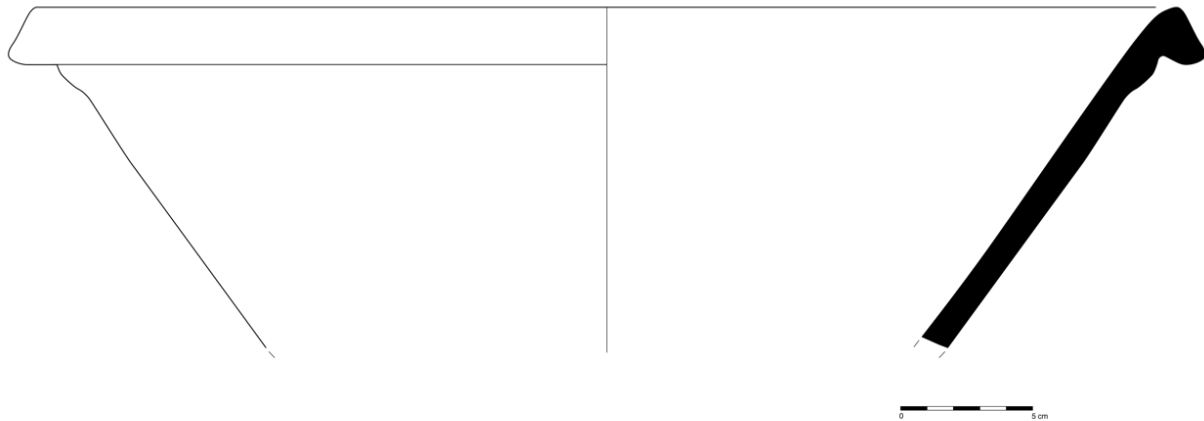

Figure 381: Rim in Pink/Buff B fabric with semi-glossy red slip; TZ 2005 Ch.6 UF 16

*Upper Profile Type 133 (n=13)*

This bowl type is an open, thick walled vessel with outward slanting, straight walls (Figures 382, 383). The rim is a rounded, overhanging triangle. The exterior of the rim is grooved and the lip is rounded. No examples are preserved to the base.

It has rim diameters between 30 and 45 centimeters. It has been found in Pink/Buff A fabric (3 sherds) and Pink/Buff B fabric (10 sherds). There are occasional undecorated examples, but more common is red or eggplant colored semi-glossy slip.

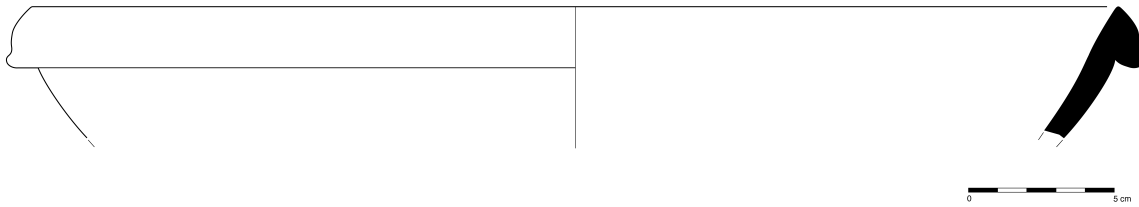

Figure 382: Rim in Pink/Buff A fabric with semi-glossy red slip; TZ 2004 Ch.4 UF 9

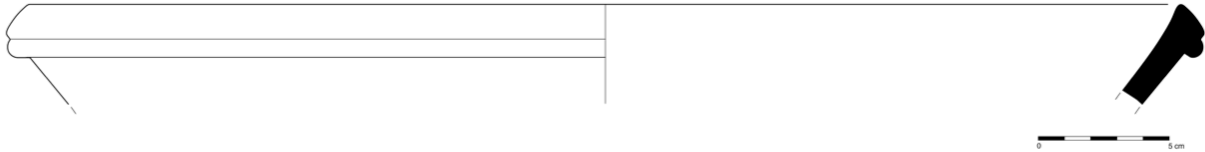

Figure 383: Rim in Pink/Buff B fabric, unslipped; TZ 2004 Ch.4 UF 18

*Upper Profile Type 134 (n=6)*

This bowl type is an open, thick walled vessel with outward slanting, straight walls (Figures 384, 385). The rim is angular and hooked. No examples are preserved to the base.

This rare type has rim diameters between 30 and 40 centimeters. It has been found in Pink/Buff B fabric (6 sherds). Three sherds are undecorated and three sherds are decorated with red or eggplant colored semi-glossy slip.

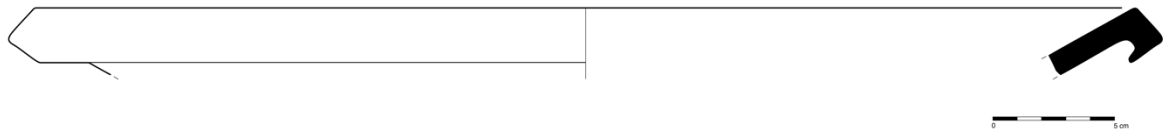

Figure 384: Rim in Pink/Buff B, unslipped; TZ 2005 Ch.6 UF 3

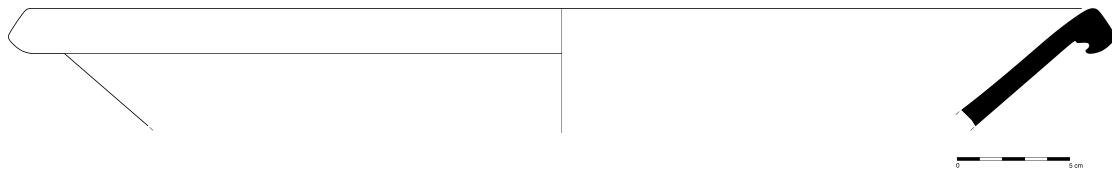

Figure 385: Rim in Pink/Buff B with semi-glossy red slip; TZ 2005 Ch.6 UF 10



## **Shape Group XIV: Small Shallow Table Bowls or Cups**

### **Upper Profile Types 135-148, 150-155, 158-163, 167, 175**

These vessel types have rims ranging from 15 to 30 centimeters in diameter and are wider than they are deep (Figure 386). These vessels have a great variety of rims, both curved and straight, sloping walls, and their bases include plain, disc, and ring formed. They are table service vessels that were probably used as individual dining vessels for a variety of foodstuffs, dry and liquid.

Upper Profile Types 147, 140, 135, 137, 151, 141, and 161 are rare. Upper Profile Types 144 and 165 are very common.

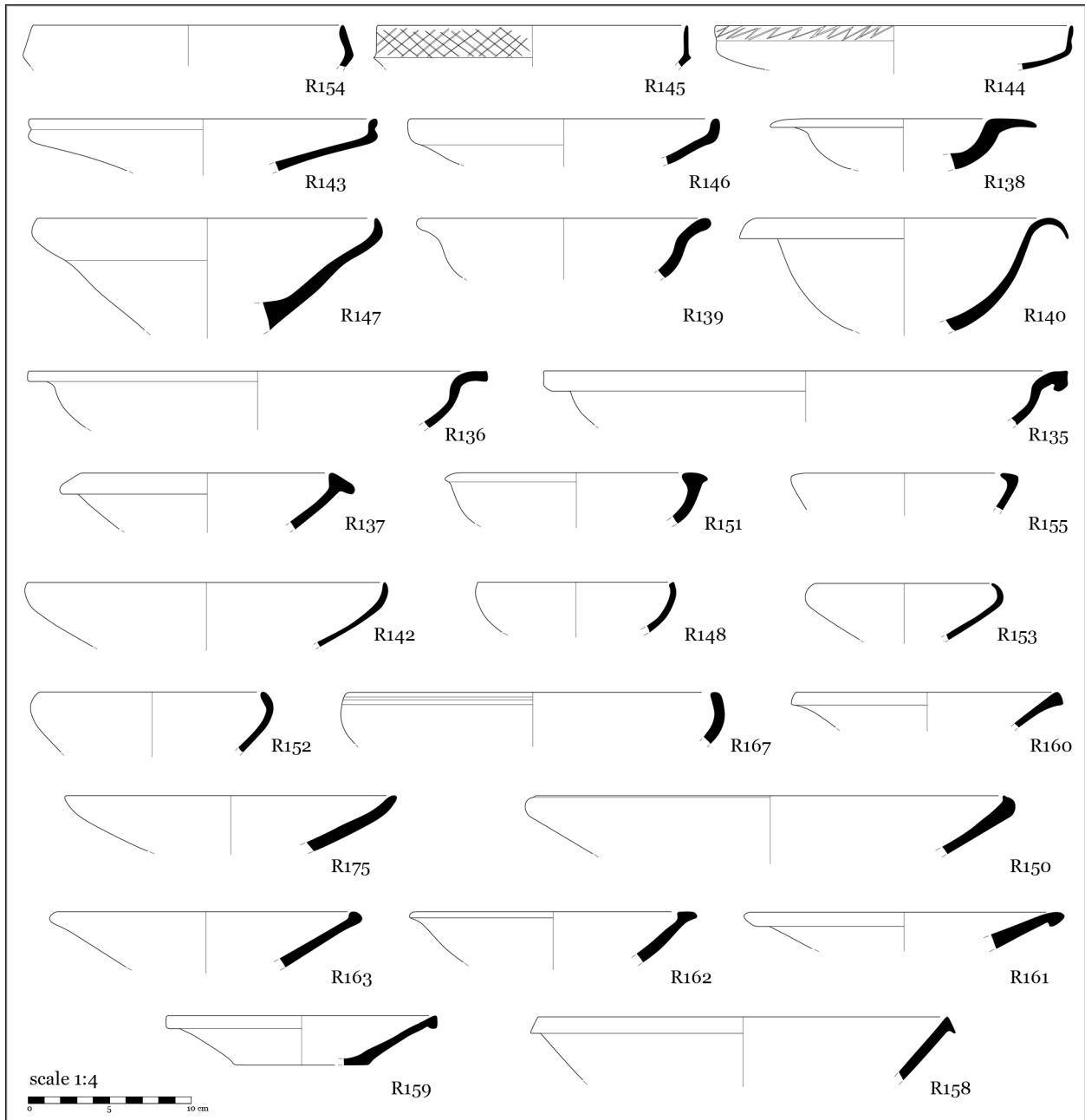

Figure 386: Compendium of Shape Group XIV vessels

*Upper Profile Type 154 (n=37)*

This small shallow bowl type is a thin walled vessel with a curve in the wall from the rim to the body walls (Figures 387-389). It has an incurved rim, with a varied angular curve at the upper rim. It has a rounded lip. There is a single example of a full profile with Lower Profile Type 12.

It has rim diameters between 12 and 30 centimeters. It has been found in Peach Cream fabric (10 sherds), Pink/Buff B fabric (12 sherds), and Pink/Buff A fabric (15 sherds). Undecorated examples are equally as common as those with red or occasionally eggplant colored semi-glossy slip. This is rarely used in conjunction with starburst patterned burnishing on the interior of the vessel.

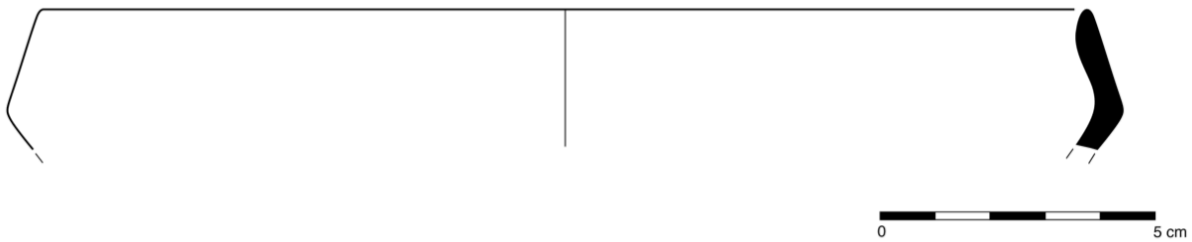

Figure 387: Rim in Peach Cream fabric; BH 2005 UF 37

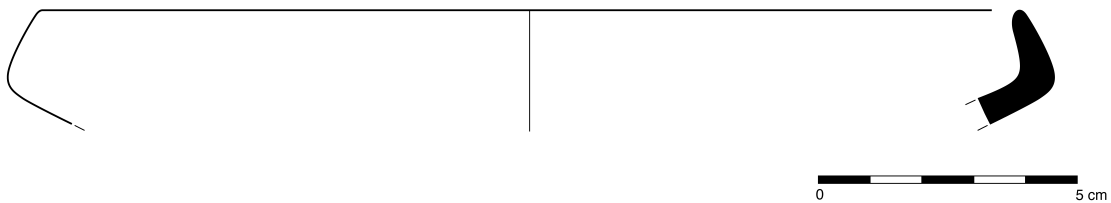

Figure 388: Rim in Pink/Buff B fabric, unslipped; TZ 2008 Ch.6 UF 19

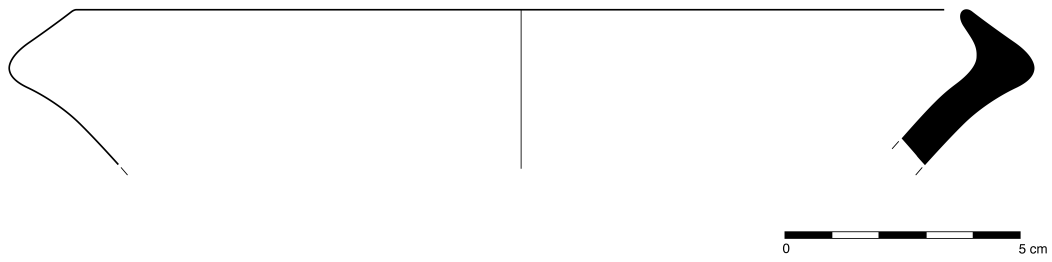

Figure 389: Rim in Peach Cream fabric; TZ 2005 Ch.6 UF 4

*Upper Profile Type 145 (n=8)*

This small shallow bowl type is thin walled with a slight outcropping between the rim and the body walls (Figure 390). It has a thin vertical rim with a plain rounded lip and a slight carination at the angle change that has a fairly sharp edge. Examples have various types of ring feet.

It has rim diameters between 18 and 22 centimeters. It has been found primarily in Pink/Buff A fabric (5 sherds), but there are also examples in Pink/Buff B fabric (3 sherds). Red and eggplant colored semi-glossy slip is ubiquitous, but the red is often slightly browner in color than the usual red slip. This is often used in conjunction with starburst patterned burnishing on the interior surface, or very rarely, the exterior of the lower walls. The exterior of the vertical rim usually has crosshatched burnished lines.

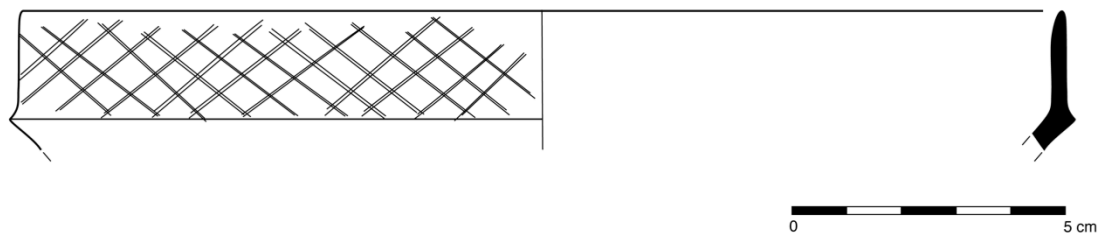

Figure 390: Rim in Pink/Buff B fabric with semi-glossy eggplant colored slip and crosshatched burnished decoration; TZ 2004 Ch.6 décapage

*Upper Profile Type 144 (n=308)*

This small shallow bowl type is a thin walled vessel with a curve in the wall from the rim to the body walls (Figures 391-394). It has a vertical rim with a plain rounded lip and a slight carination at the angle change. Examples have various types of ring feet.

It has rim diameters between 15 and 26 centimeters. It has been found primarily in Pink/Buff A fabric (121 sherds) and Pink/Buff B fabric (185 sherds), but there are occasional examples in Orange fabric (2 sherds). Eggplant colored and more commonly red semi-glossy slips are ubiquitous on all surfaces of the vessel except the underside of the base. Starburst patterned burnishing is usually found on the interior of the vessel and the short vertical rim often has regular or squat crosshatched burnishing or messy vertical burnished stripes on the exterior. The flat exterior space on the vertical rim provides space for burnished decoration; this space is the diagnostic difference between this shape and R143, whose upper rim is too bulbous to decorate.

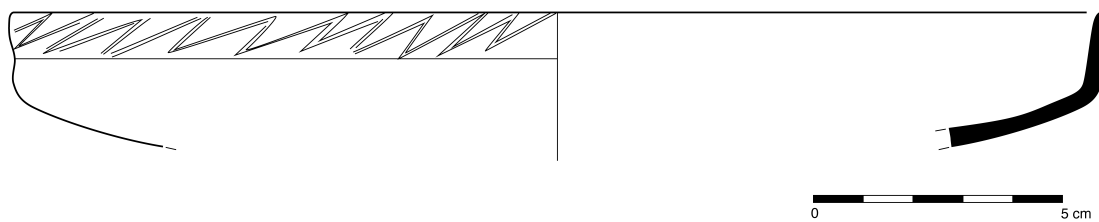

Figure 391: Rim and body in Pink/Buff A fabric with semi-glossy red slip and starburst pattern burnishing on interior, slanted zigzag on exterior rim; TZ 2005 Ch.6 UF 32

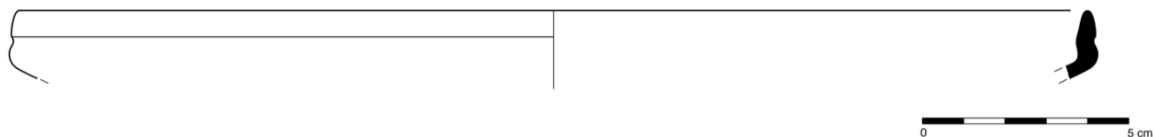

Figure 392: Rim in Pink/Buff A fabric with semi-glossy red slip; TZ 2007 Ch.14 UF 4

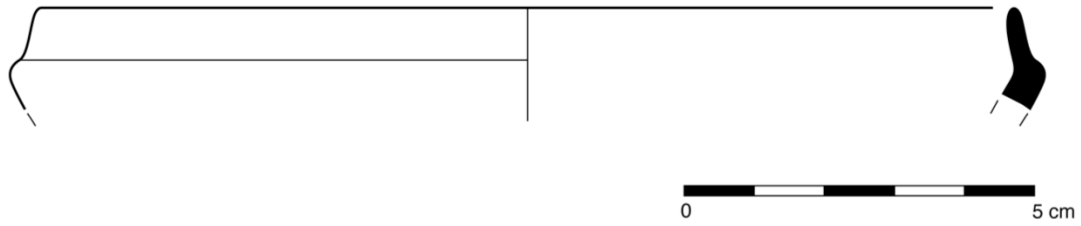

Figure 393: Rim in Pink/Buff A fabric with semi-glossy red slip and squat crosshatched burnished decoration on exterior rim; TZ 2004 Ch.4 Sec.2 UF 4

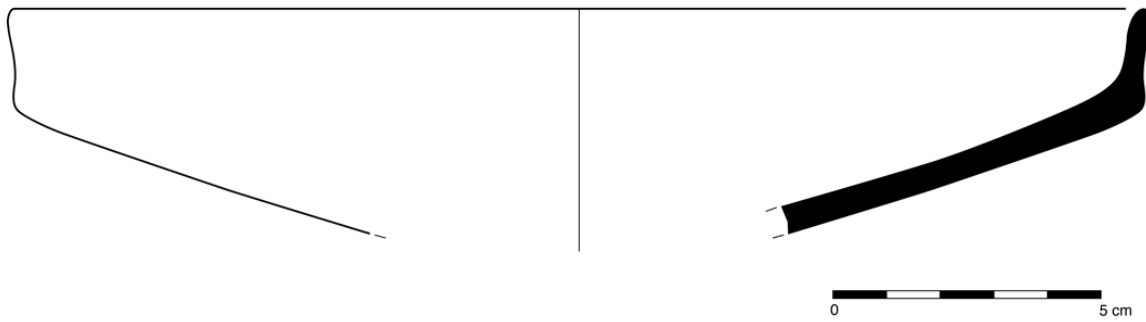

Figure 394: Rim and body in Pink/Buff A with semi-glossy eggplant colored slip; TZ 2008 Ch.6 UF 6

*Upper Profile Type 143 (n=60)*

This small shallow bowl type is a thin walled vessel with a curve in the wall from the rim to the body walls (Figures 395, 396). It has a short, vertical rim with a plain rounded lip, although there is a slight, bulging carination between the rim and the body. Examples with profiles to the base have various types of ring feet.

It has rim diameters between 12 and 25 centimeters. It has been found in Pink/Buff A fabric (24 sherds) and Pink/Buff B fabric (36 sherds). Eggplant colored and more commonly red semi-glossy slip are ubiquitous, often combined with starburst patterned burnishing.

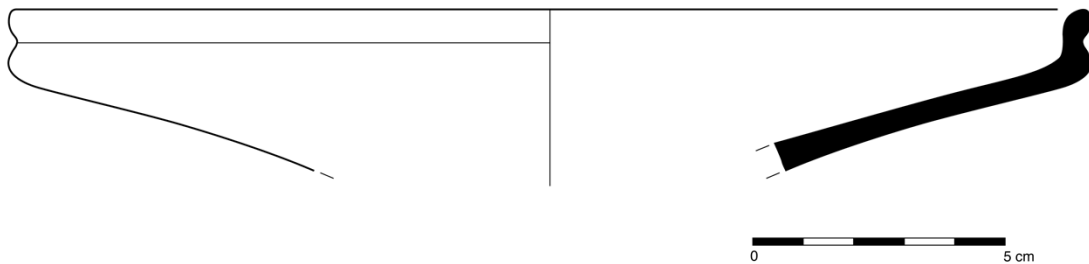

Figure 395: Rim in Pink/Buff B fabric with semi-glossy red slip and starburst patterned burnishing on interior; TZ 2007 Ch.6 UF 8

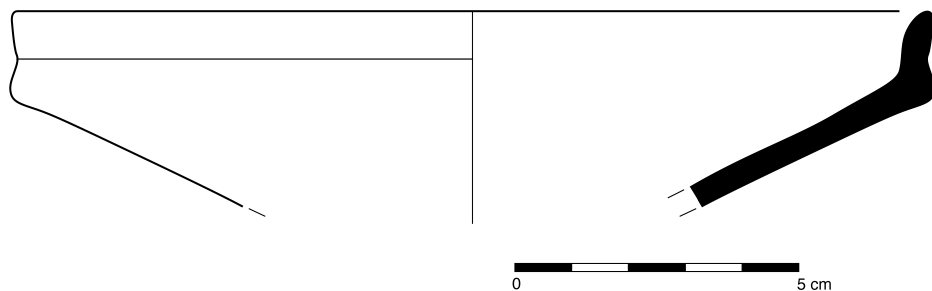

Figure 396: Rim in Pink/Buff B fabric with semi-glossy red slip; TZ 2008 Ch.18 décapage



*Upper Profile Type 146* (n=10)

This small shallow bowl type is a thin walled vessel with a curve in the wall from the rim to the body walls (Figure 397). It has a short, vertical rim with a plain rounded lip. It is similar to Upper Profile Type 143, but does not have a bulge at the join of the rim and body and tends to be a deeper vessel. Examples are not preserved to the base.

It has rim diameters between 15 and 30 centimeters. It has been found primarily in Pink/Buff A fabric (4 sherds) and Pink/Buff B fabric (5 sherds), but there is one example in Peach Cream fabric. Red and eggplant colored semi-glossy slip is common, and there is one example of lustrous orange slip. There is also one example of red semi-glossy slip used in conjunction with burnished radial lines on the interior of the vessel.

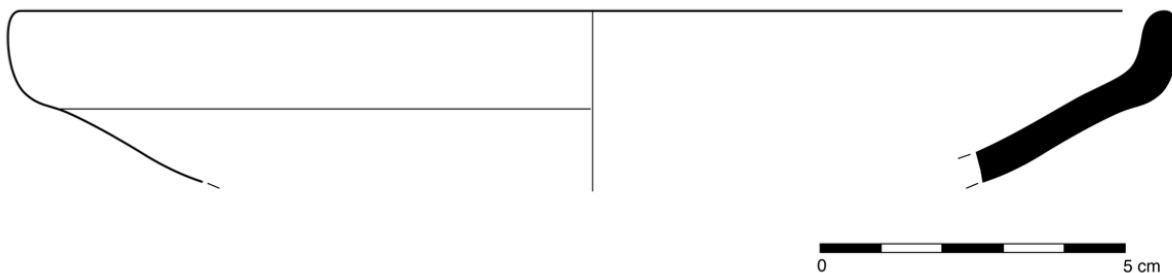

Figure 397: Rim and body in Pink/Buff B fabric with semi-glossy red slip with radial burnished lines; TZ 2004 Ch.4 UF 20

*Upper Profile Type 147 (n=3)*

This small bowl type is a thin walled vessel with a curve in the wall from the rim to the body walls (Figures 398, 399). It has a short or tall, vertical rim with a plain rounded lip. Examples are not preserved to the base, but one example shows thickened lower walls.

It has rim diameters between 18 and 21 centimeters. It has only been found in Peach Cream fabric (3 sherds).

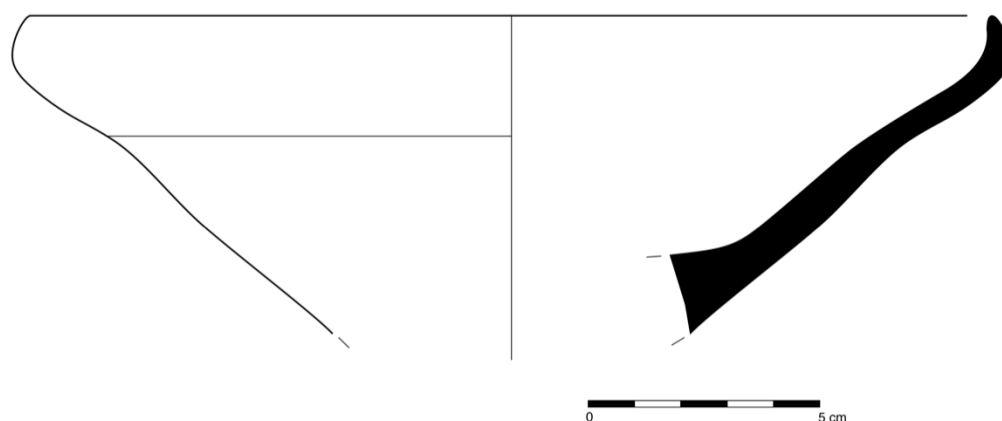

Figure 398: Rim and body in Peach Cream fabric; BH 2005 UF 32

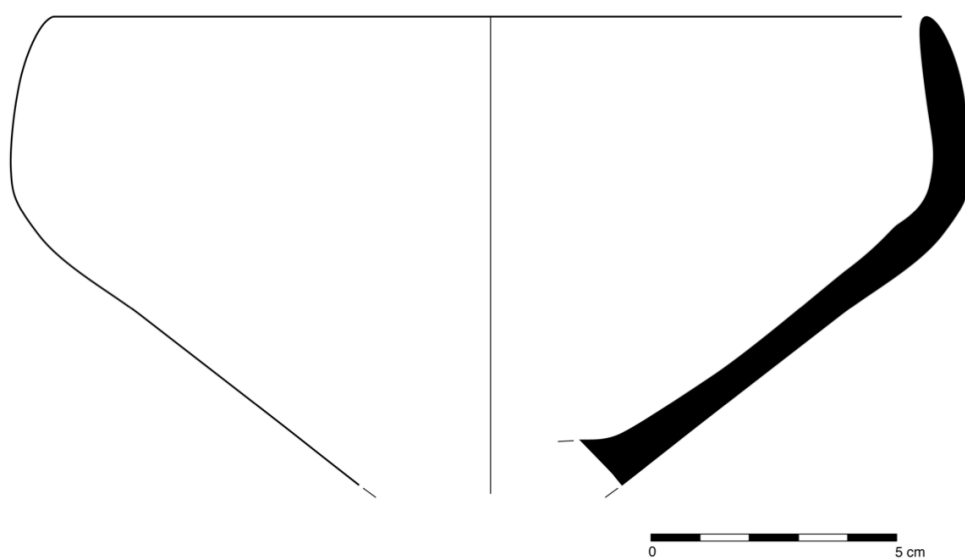

Figure 399: Rim and body in Peach Cream fabric; BH 2005 UF 37

*Upper Profile Type 138 (n=7)*

This small shallow bowl type is a thin walled vessel with curved walls (Figure 400). It has an everted, horizontal, overhanging rim with a slightly rounded top. No examples are preserved to the base.

It has rim diameters between 12 and 18 centimeters. It has been found primarily in Pink/Buff A fabric (6 sherds), but there is a single example in Pink/Buff B fabric. All examples are decorated with red semi-glossy or matte slip.

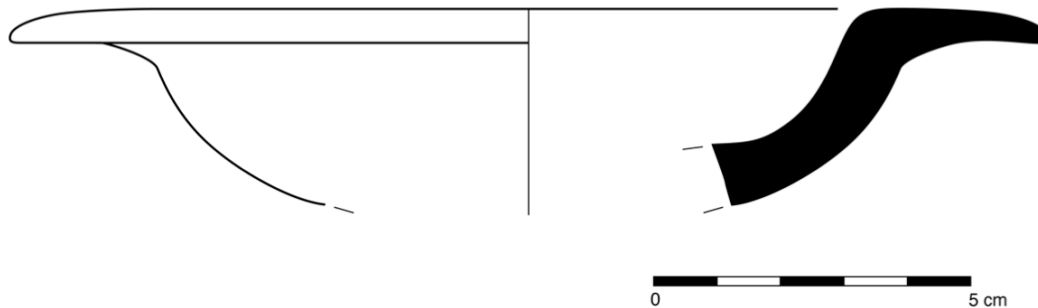

Figure 400: Rim in Pink/Buff A fabric with matte red slip; TZ 2005 Ch.6 UF 55

*Upper Profile Type 140 (n=2)*

This small shallow bowl type is a thin walled vessel with curved walls (Figure 401). It has a delicate, everted, slightly overhanging rim with a plain, rounded lip.

Lower Profile Types are unknown.

It has rim diameters between 13 and 26 centimeters. It has been found in Pink/Buff B fabric (2 sherds). There is one undecorated example and one with eggplant colored semi-glossy slip and incised wavy and straight lines on the upper interior walls of the vessel.

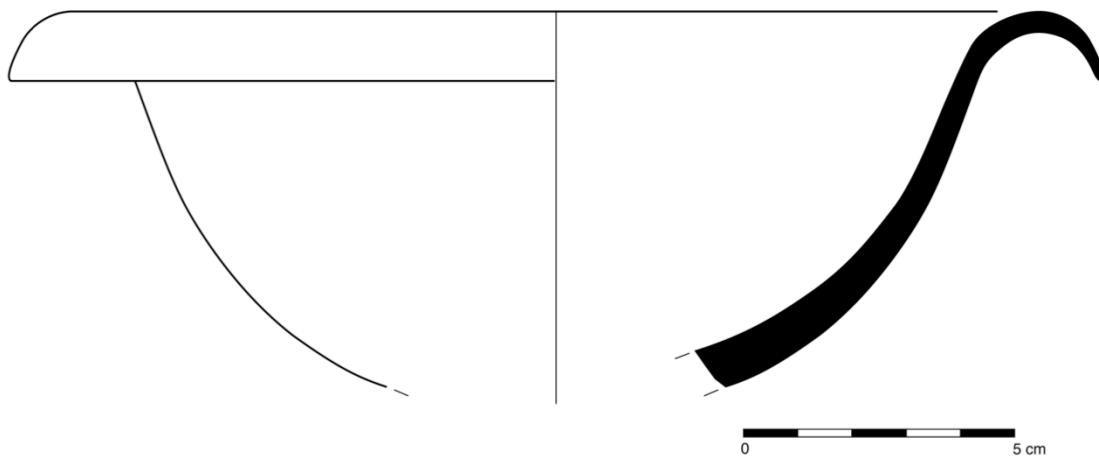

Figure 401: Rim in Pink/Buff B fabric with semi-glossy eggplant colored slip on all surfaces; TZ 2007 Ch.6 UF 8

*Upper Profile Type 139 (n=66)*

This small shallow bowl type is a thin walled vessel with curved walls (Figures 402-404). It has an everted, outward slanting rim with a rounded lip. There is one full profile that shows curved lower walls and Lower Profile Type 12.

It has a wide range of rim diameters, but most are between 20 and 35 centimeters. It has been found primarily in Pink/Buff B fabric (25 sherds), Pink/Buff A fabric (38 sherds), but there are several examples in Gray fabric (3 sherds). The Gray examples have black slip. There are undecorated examples, but more common is red or eggplant colored semi-glossy slip, frequently used with incised wavy and straight lines on the upper interior of the vessel.

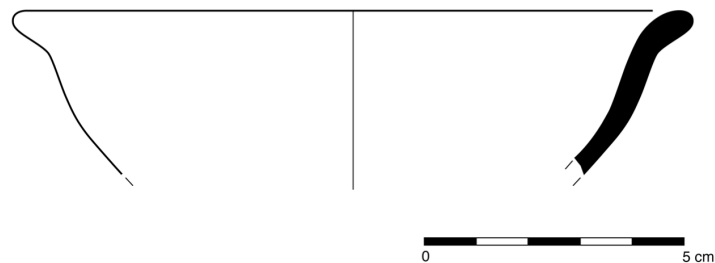

Figure 402: Rim in Pink/Buff B fabric with semi-glossy eggplant colored slip; TZ 2008 Ch.6 UF 28

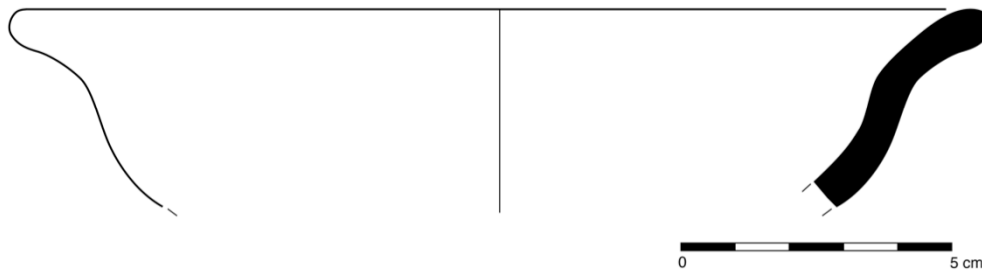

Figure 403: Rim in Gray fabric, unslipped; TZ 2004 Ch.4 Sec.2 UF 5

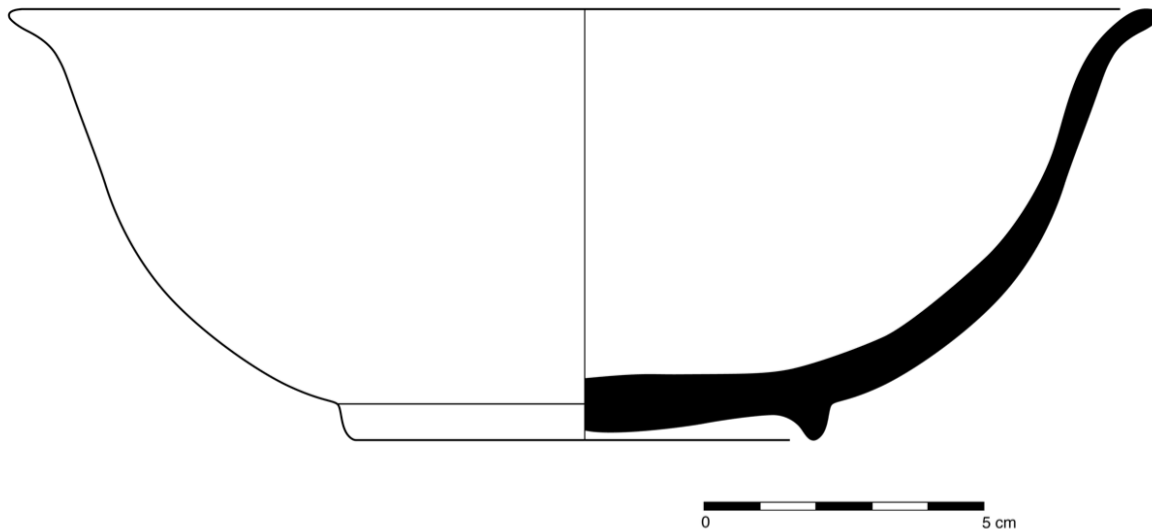

Figure 404: Whole profile with ring base in Pink/Buff B fabric, unslipped; TZ 2008 Ch.18 UF 11

*Upper Profile Type 136 (n=15)*

This small shallow bowl type is a thin walled vessel with curved walls (Figure 405). It has an everted rim with a flattened lip. No examples are preserved to the base.

It has rim diameters between 20 and 35 centimeters. It has been found in Pink/Buff A fabric (10 sherds) and Pink/Buff B fabric (5 sherds). There are occasional undecorated examples, but most have red or eggplant colored semi-glossy slip or red matte slip. This is often used in conjunction with incised decoration of varying complexity. One or two wavy lines in concentric circles on the upper interior are common, as are concentric circles of alternated wavy and straight lines, occasionally with rows of short vertical lines.

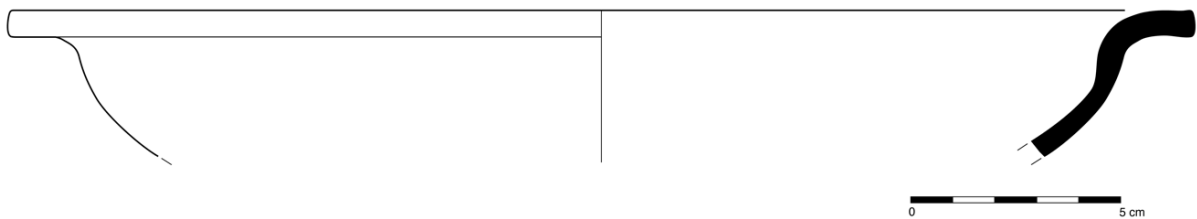

Figure 405: Rim and upper body in Pink/Buff B fabric with matte eggplant colored slip with wavy and straight incised lines on interior of rim; TZ 2008 Ch.6 UF 11

*Upper Profile Type 135 (n=4)*

This small shallow bowl type is a thin walled vessel with curved walls (Figure 406). It has an everted, overhanging rim with curved lip. No examples are preserved to the base.

It has rim diameters between 20 and 30 centimeters. It has been found only in Pink/Buff A fabric (4 sherds). All examples have red matte or semi-glossy slip and this is often used in conjunction with incised, wavy concentric lines on the upper interior of the vessel.



Figure 406: Rim and upper body in Pink/Buff A fabric with matte red slip and wavy incised line on interior of rim; TZ 2005 Ch.6 UF 52



*Upper Profile Type 137 (n=2)*

This small shallow bowl type is a thin walled vessel with curved walls (Figure 407). It has an everted, overhanging rim with a downward slanting lip. No examples are preserved to the base.

It has rim diameters from 28 to 34 centimeters. It has been found in Pink/Buff A fabric (1 sherd) and Pink/Buff B fabric (1 sherd). There is one unslipped example and one with red semi-glossy slip.

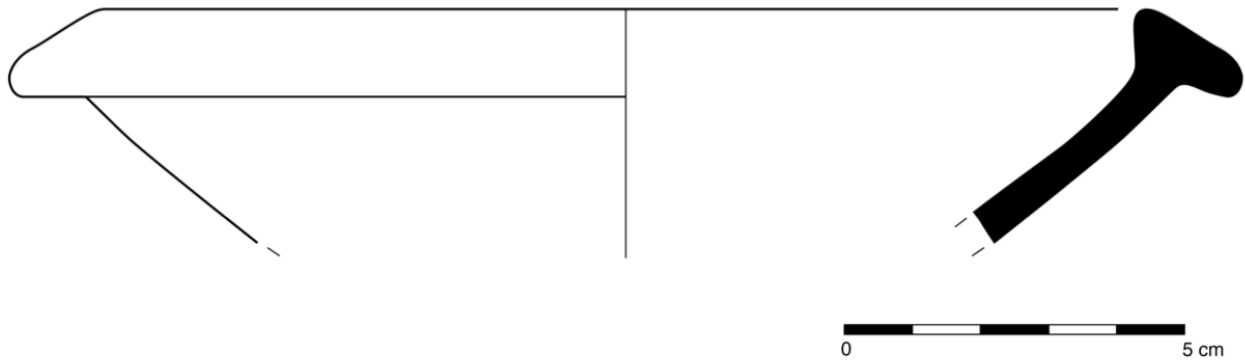

Figure 407: Rim and upper body in Pink/Buff B fabric, unslipped; BH 2005 UF 27

*Upper Profile Type 151 (n=4)*

This small shallow bowl type is a thin walled vessel with a curve in the wall from the rim to the body walls (Figure 408). It has a short, vertical rim with a widened, rounded top. Examples are not preserved to the base.

It has rim diameters between 15 and 30 centimeters. It has been found in Pink/Buff B fabric (3 sherds) and Pink/Buff A fabric (1 sherd). Two examples are unslipped, some with incised grooves in the top of the lip. There is one example each of red and eggplant colored semi-glossy slip.

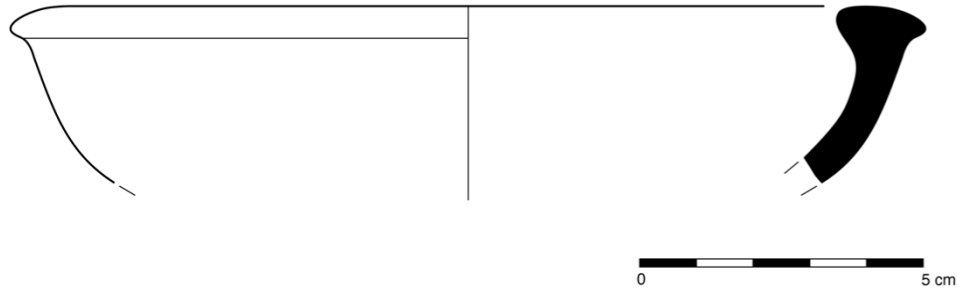

Figure 408: Rim and body in Pink/Buff B fabric, unslipped; TZ 2004 Ch.2 UF 29

*Upper Profile Type 155 (n=10)*

This small shallow bowl type is a thin walled vessel with a curve in the wall from the rim to the body walls (Figures 409, 410). It has an incurved rim, with a thickened curve at the upper rim. It has a rounded lip. There are no examples preserved to the base.

This type has rim diameters between 10 and 20 centimeters. It has been found primarily in Pink/Buff B fabric (6 sherds), but there are rare examples in Pink/Buff A fabric (1 sherd) and Peach Cream fabric (3 sherd). Buff examples are both undecorated or have semi-glossy red slip.

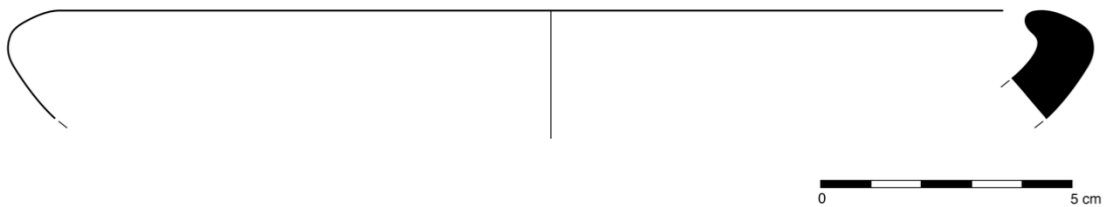

Figure 409: Rim in Pink/Buff B fabric with semi-glossy red slip; TZ 2007 Ch.14 UF 625

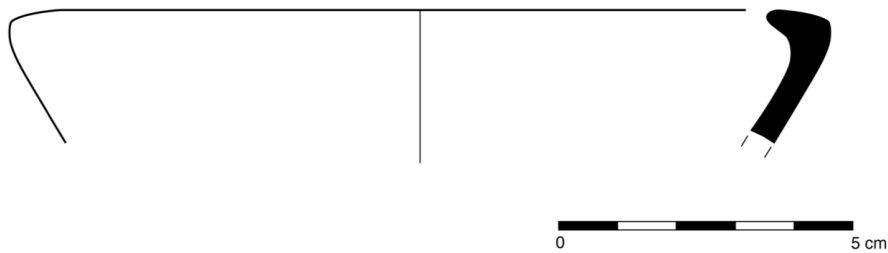

Figure 410: Rim in Pink/Buff A, unslipped; TZ 2005 Ch.6 UF 5

*Upper Profile Type 141 (n=3)*

This small shallow bowl or plate type is a thin walled vessel with slightly curved walls (Figures 411, 412). It has a slightly everted rim that is at a more vertical angle than the body and a rounded lip. No examples are preserved to the base.

This rare type has rim diameters between 20 and 25 centimeters. It has been found in Pink/Buff B fabric (1 sherd) with lustrous red slip and Orange fabric (2 sherds) with lustrous orange slip. It is probably imported.



Figure 411: Rim in Pink/Buff B fabric with lustrous red slip; TZ 2007 Ch.14 UF 195



Figure 412: Rim in Orange fabric with lustrous orange slip; TZ 2004 Ch.4 UF 15

*Upper Profile Type 142 (n=35)*

This small shallow bowl type is a very thin walled vessel with curved walls (Figures 413, 414). It has a slightly curved rim with a distinct, almost vertical slant coming to a point. No examples are preserved to the base.

It has rim diameters mostly between 15 and 25 centimeters. It has been found in Pink/Buff A fabric (18 sherds) and Pink/Buff B fabric (17 sherds). Undecorated examples have been found, but more common is red or eggplant colored semi-glossy slip, often used in conjunction with starburst patterned burnishing on the interior of the vessel or rarely stamps and finger impressions on the exterior walls of the vessel.

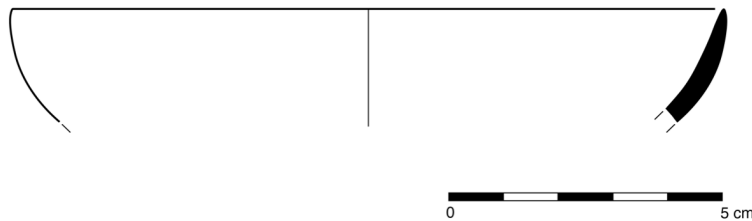

Figure 413: Rim in Pink/Buff B fabric with semi-glossy red slip; TZ 2008 Ch.6 UF 5

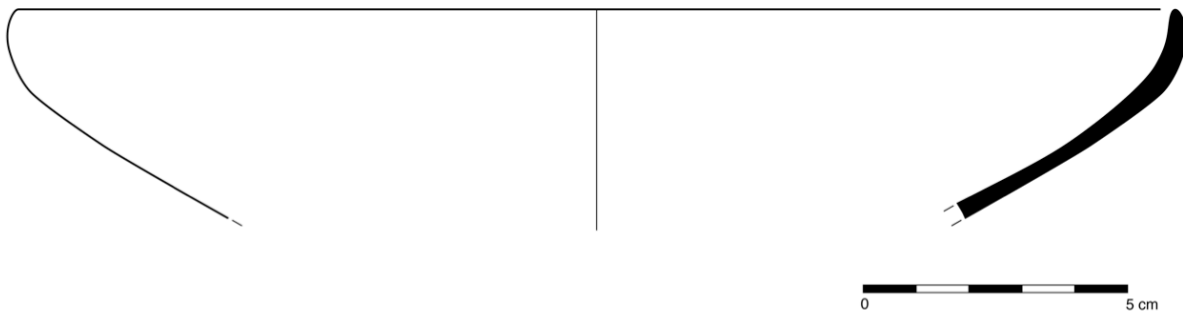

Figure 414: Rim in Pink/Buff A fabric with semi-glossy red slip; TZ 2008 Ch.6 UF 15

*Upper Profile Type 148 (n=24)*

This small shallow bowl type is a thin walled vessel with a curve in the wall from the rim to the body walls (Figures 415-417). It has a vertical rim with a plain slightly squared lip. Examples are not preserved to the base.

This type has rim diameters between 10 and 30 centimeters. It has been found primarily in Pink/Buff B fabric (14 sherds) and Pink/Buff A fabric (7 sherds), but there are also rare examples in Peach Cream fabric (2 sherds) and Gray fabric (1 sherd) with lustrous black slip. There are rare undecorated examples, but most Pink and Buff vessels have red or eggplant colored semi-glossy slip, with rare examples of lustrous red slip.

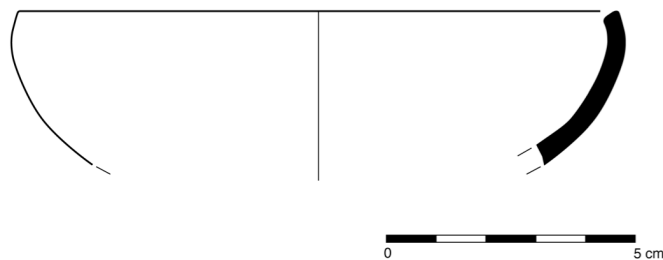

Figure 415: Rim and body in Pink/Buff A fabric with semi-glossy red slip; TZ 2005 Ch.6 UF 10

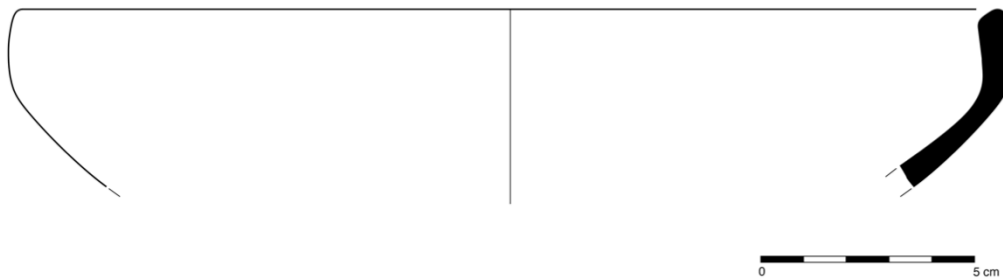

Figure 416: Rim and body in Pink/Buff A fabric with semi-glossy red slip; TZ 2005 Ch.6 UF 32

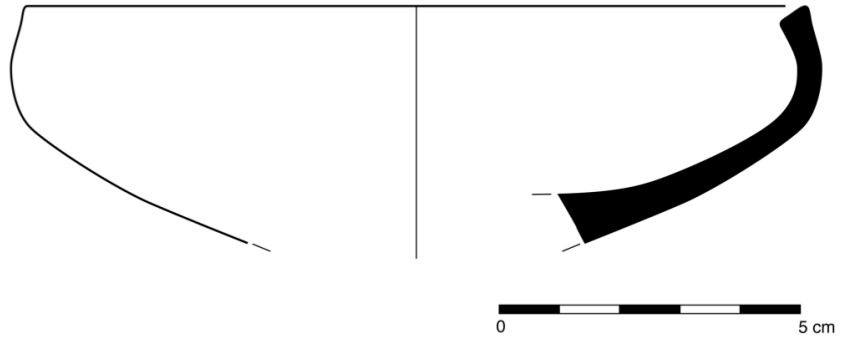

Figure 417: Rim and body in Peach Cream fabric; BH 2005 UF 53

*Upper Profile Type 153 (n=50)*

This small shallow bowl type is a thin walled vessel with a curve in the wall from the rim to the body walls (Figures 418, 419). It has an incurved rim, with a pronounced curve at the upper rim. It has a plain, rounded lip.

It has rim diameters between 7 and 22 centimeters. It is found primarily in Pink/Buff A fabric (21 sherds) and Pink/Buff B fabric (26 sherds), but there are occasional examples in Orange fabric (1 sherd) and Peach Cream fabric (2 sherds). There are rare unslipped examples, but more common is red or eggplant colored semi-glossy slip. This is occasionally used in conjunction with a single shallow incised groove on the exterior of the rim or starburst patterned burnishing on the interior. There is a single example of small impressed squares in the exterior surface.

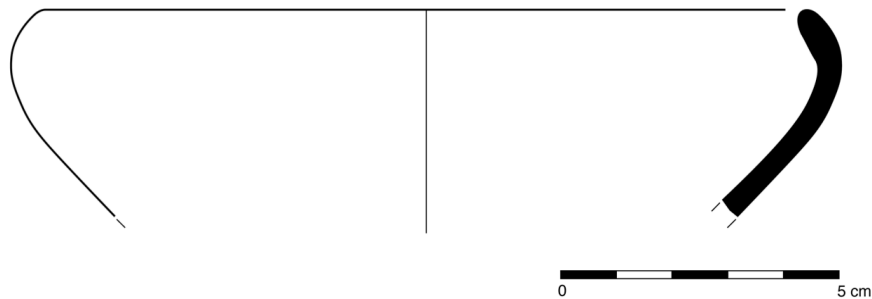

Figure 418: Rim in Pink/Buff B fabric with semi-glossy eggplant slip; TZ 2004 Ch.2 UF 80

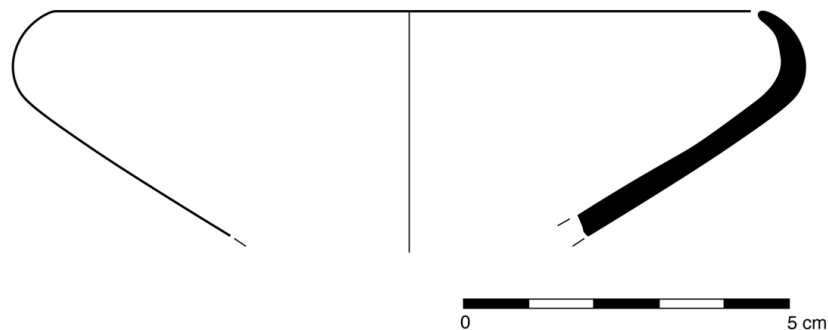

Figure 419: Rim in Pink/Buff B with semi-glossy red to eggplant colored slip; TZ 2004 Ch.4 Sec.2 UF 14



*Upper Profile Type 152 (n=64)*

This small shallow bowl type is a thin walled vessel with a curve in the wall from the rim to the body walls (Figures 420, 421). It has an incurved rim, with only a slight short curve at the upper rim. Examples are not preserved to the base.

It has rim diameters from 13 to 25 centimeters. It has been found primarily in Pink/Buff A fabric (29 sherds) and Pink/Buff B fabric (30 sherds), but there are occasional examples in Peach Cream fabric (1 sherd), Gray fabric with black slip (1 sherd), and Orange fabric (3 sherds). The Orange examples and the Pink/Buff A and B examples usually have eggplant colored or more commonly red semi-glossy slip. This is sometimes used in conjunction with patterned burnishing on the interior and there is an example of black slipped stripes on the interior. There are rare examples of lustrous red slip. There are occasional undecorated examples.

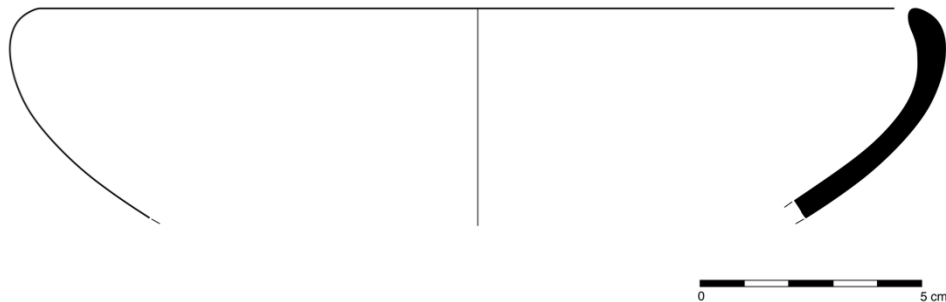

Figure 420: Rim in Pink/Buff A fabric with semi-glossy red slip; BH 2007 UF 317

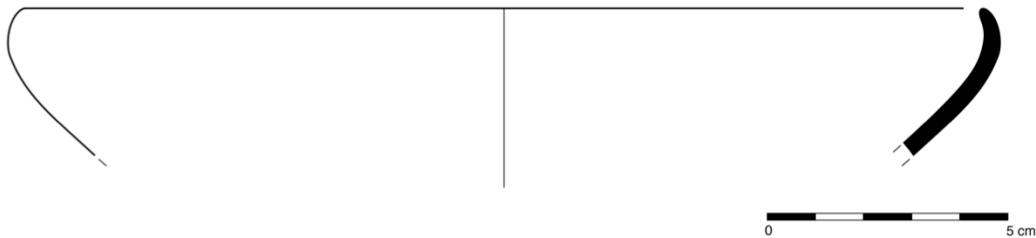

Figure 421: Rim in Pink/Buff B fabric, unslipped; TZ 2004 Ch.4 Sec.2 UF 2

*Upper Profile Type 167 (n=36)*

This shallow bowl type is a thin walled vessel with a curve in the wall from the rim to the body walls (Figures 422-424). It has an incurved rim, with only a slight curve at the upper rim. It tends to have slightly thick walls and frequent grooves on the exterior of the rim. Examples are not preserved to the base.

It has rim diameters between 15 and 35 centimeters. It has been found in Pink/Buff A fabric (18 sherds) and Pink/Buff B fabric (18 sherds). There are undecorated examples. Equally as common are semi-glossy and matte red or eggplant colored slip. Multiple parallel straight and wavy incised lines are common on the upper exterior of the rim on both slipped and unslipped vessels.

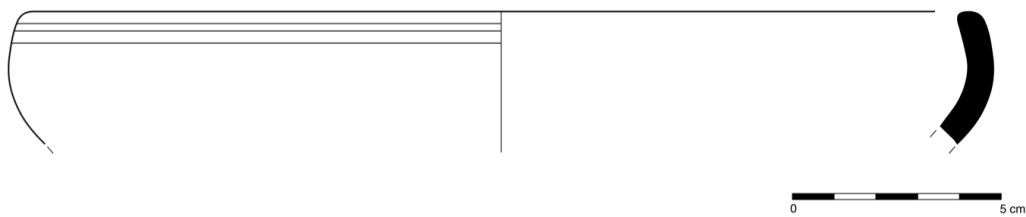

Figure 422: Rim in Pink/Buff A fabric with matte red slip and incised grooves in outer walls; TZ 2004 Ch.4 Sec.2 UF 18

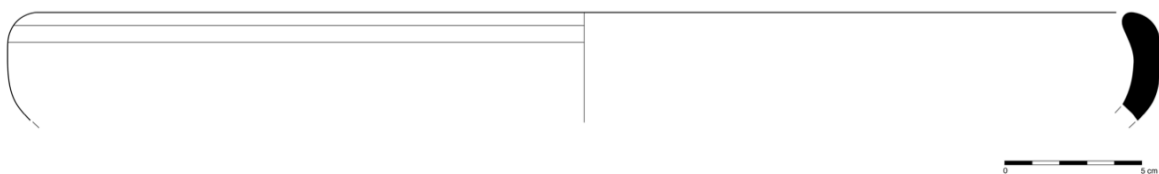

Figure 423: Rim in Pink/Buff B fabric with matte red slip and incised grooves in outer walls; TZ 2005 Ch.6 UF 5

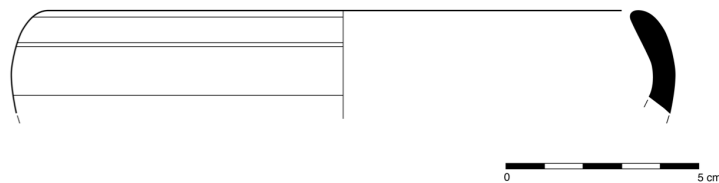

Figure 424: Rim in Pink/Buff A fabric with matte red slip and incised grooves in outer walls; TZ 2008 Ch.18 UF 15

*Upper Profile Type 175 (n=9)*

This small shallow bowl type is a thin walled vessel with outward slanting straight walls (Figure 425). The rim is plain and the lip is rounded. There are no examples preserved to the base.

It has rim diameters between 18 and 20 centimeters. It has been found in Pink/Buff A fabric (3 sherds), Pink/Buff B fabric (2 sherds), and Orange fabric (4 sherds). These are usually decorated with red semi-glossy slip, sometimes used in conjunction with starburst patterned burnishing, and red semi-lustrous slip.

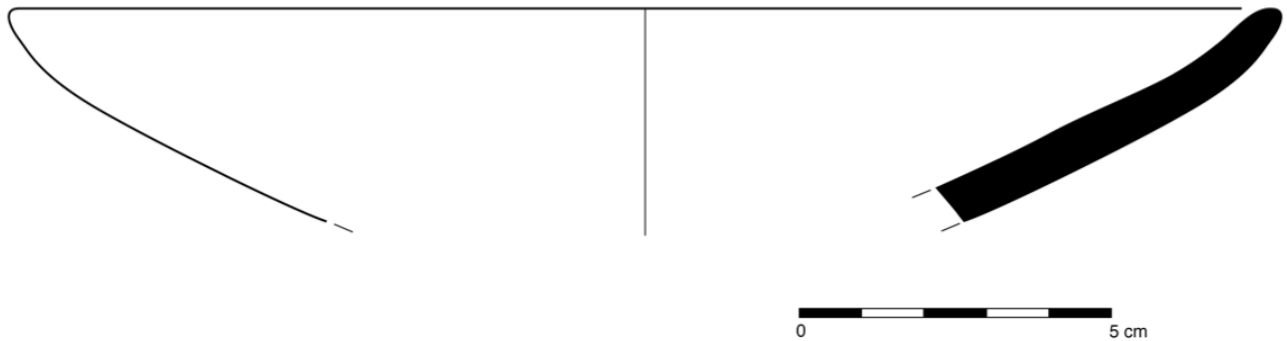

Figure 425: Rim in Pink/Buff A fabric with lustrous red slip; TZ 2008 Ch.6 UF 12

*Upper Profile Type 160 (n=45)*

This small shallow bowl type is a thin walled vessel with outward slanting straight walls (Figures 426-427). The rim has an exterior articulation, triangular in section. The lip is slightly squared. There are several examples preserved to the base, Type 27.

It has rim diameters between 15 and 30 centimeters. It has been found primarily in Pink/Buff A fabric (15 sherds) and Pink/Buff B fabric (27 sherds), but there are occasional examples in Peach Cream fabric (2 sherds) and Orange fabric (1 sherd). Most examples are undecorated, but there are some with red or eggplant colored semi-glossy slip.



Figure 426: Rim in Pink/Buff B fabric, unslipped; TZ 2008 Ch.18 UF 28

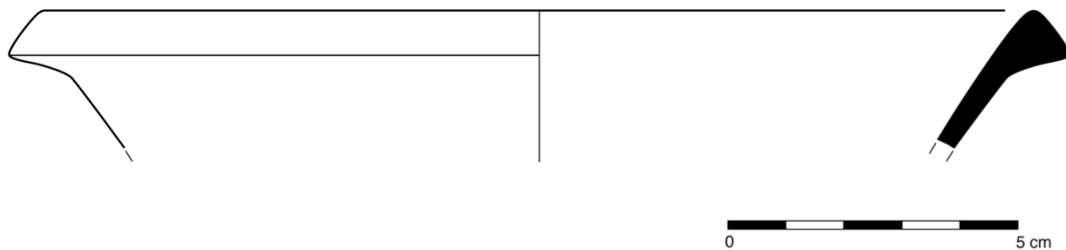

Figure 427: Rim in Pink/Buff A fabric with semi-glossy red slip; TZ 2004 Ch.4 UF 9

*Upper Profile Type 150 (n=5)*

This small shallow bowl type is a thin walled vessel with a slight curve in the wall from the rim to the body walls (Figures 428, 429). It has a short, vertical rim with a pinched lip. Examples are not preserved to the base.

It has rim diameters between 15 and 28 centimeters. It has been found in Pink/Buff A fabric (2 sherds) and Pink/Buff B fabric (3 sherds). Red or eggplant colored semi-glossy slip is on all.



Figure 428: Rim and body in Pink/Buff B fabric with semi-glossy eggplant colored slip; TZ 2008 Ch.18 UF 15

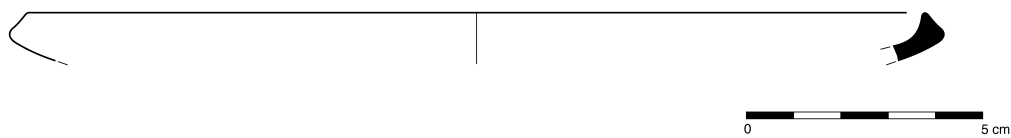

Figure 429: Rim in Pink/Buff A fabric with semi-glossy red slip; TZ 2008 Ch.18 UF 15

*Upper Profile Type 163 (n=46)*

This small shallow bowl type is a thin walled vessel with outward slanting straight walls that curve into a rounded rim (Figure 430). The rim has a rounded interior articulation and the lip is rounded. There are no examples preserved to the base.

It has rim diameters between 15 and 35 centimeters. It has been found in primarily Pink/Buff A fabric (25 sherds) and Pink/Buff B fabric (16 sherds), but there are some examples in Gray fabric (4 sherds) and Orange fabric (1 sherd). Most examples are undecorated, but occasionally Gray examples have black slip and others have semi-glossy red or eggplant colored slip. Given the proportion of these vessels in Gray fabric, far higher than most, it is likely that at least these examples are the rims of fishplates and join with base types 17 and 18.

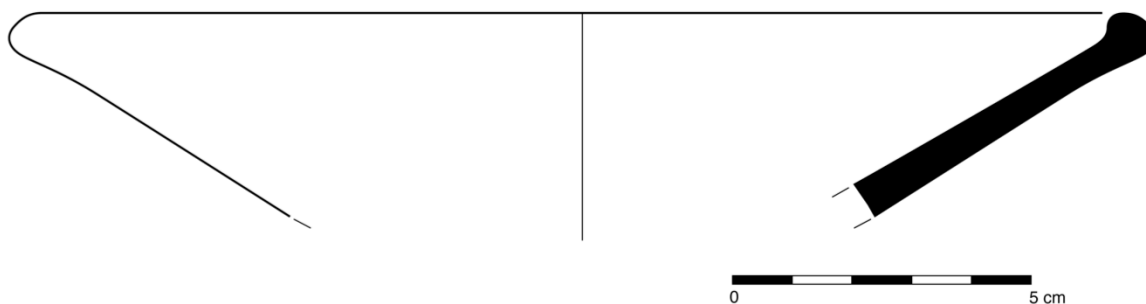

Figure 430: Rim in Gray fabric with black slip; TZ 2008 Ch.18 UF 28

*Upper Profile Type 162 (n=14)*

This small shallow bowl type is a thin walled vessel with outward sloping straight walls (Figures 431, 432). The rim has an angular interior articulation and squared. There are no examples preserved to the base.

It has rim diameters between 8 and 20 centimeters. It has been found in Pink/Buff A fabric (6 sherds) and Pink/Buff B fabric (8 sherds). Most examples are undecorated, but there are some examples with semi-glossy red and eggplant colored slip.



Figure 431: Rim in Pink/Buff A fabric with semi-glossy red slip; TZ 2008 Ch.18 UF 28

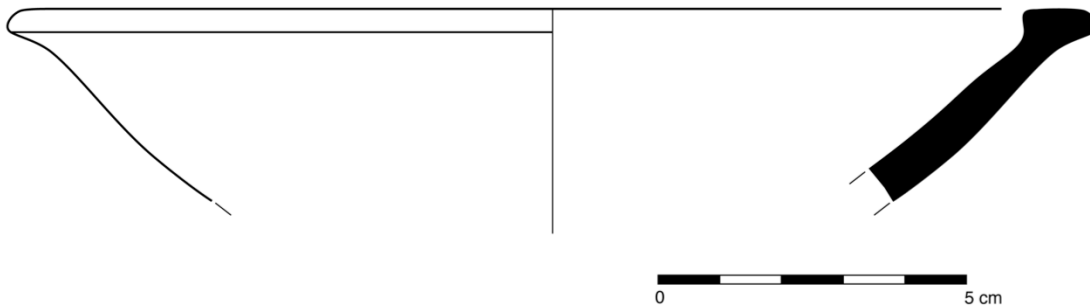

Figure 432: Rim in Pink/Buff A fabric with semi-glossy red slip; TZ 2008 Ch.18 UF 28

*Upper Profile Type 161 (n=3)*

This small shallow bowl type is a thin walled vessel with outward slanting straight walls (Figure 433). The rim has an exterior articulation, a slight partial oval. There are no examples preserved to the base.

This rare type has rim diameters between 18 and 21 centimeters. It has been found in Pink/Buff A fabric (2 sherds) and Orange fabric (1 sherd). No examples are decorated.

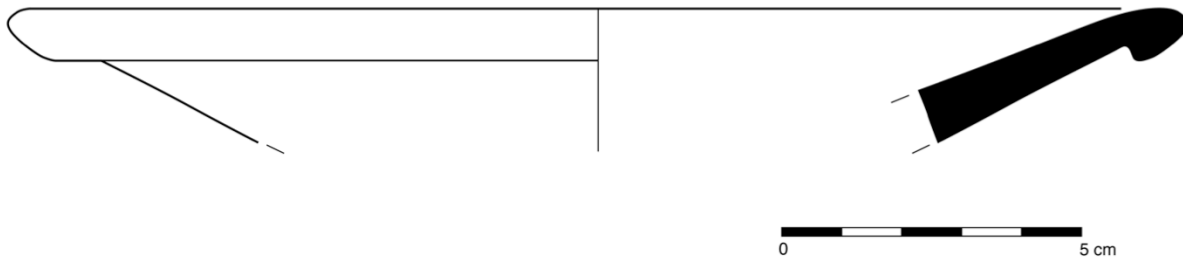

Figure 433: Rim in Pink/Buff A fabric, unslipped; TZ 2008 Ch.18 UF 28



*Upper Profile Type 159 (n=26)*

This small shallow bowl type is a thin walled vessel with outward slanting straight walls (Figures 434-436). The rim has an exterior articulation, a slight, rounded overhang. There is a single example with a full profile, with Lower Profile Type 27.

It has rim diameters between 15 and 20 centimeters. It has been found in Pink/Buff B fabric (13 sherds), Pink/Buff A fabric (7 sherds), Peach Cream fabric (2 sherds), and Gray fabric (4 sherds). The Gray examples have black slip, but there are no other decorated examples. Like Upper Profile Type 163, the rims in Gray fabric might be the upper portions of fishplates and join with base types 17 or 18.

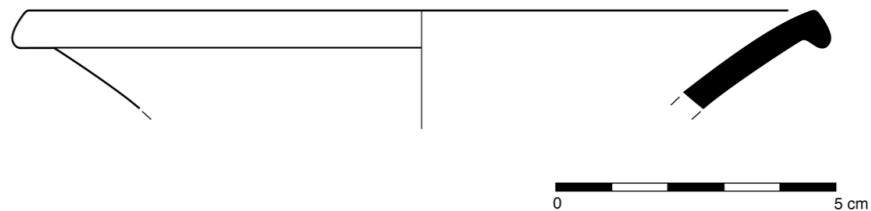

Figure 434: Rim in Gray fabric, unslipped; TZ 2008 Ch.6 UF 28

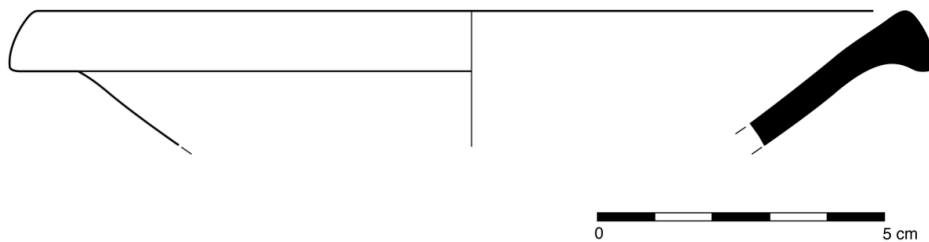

Figure 435: Rim in Pink/Buff B fabric, unslipped; TZ 2008 Ch.6 UF 28

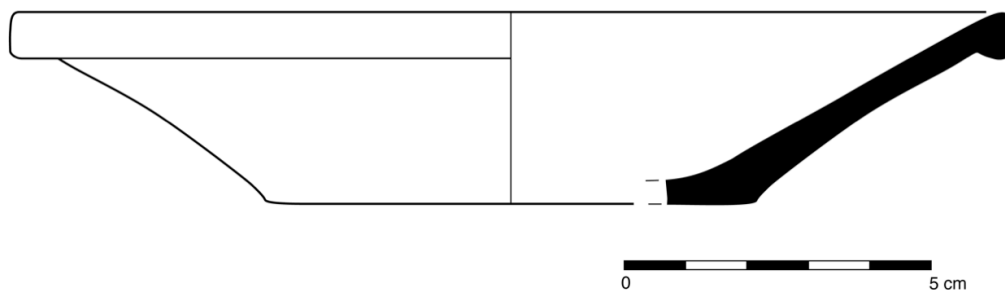

Figure 436: Whole profile in Peach Cream fabric; TZ 2005 Ch.6 UF 45

*Upper Profile Type 158 (n=17)*

This small shallow bowl type is a thin walled vessel with outward slanting straight walls (Figures 437, 438). The rim has an exterior articulation, a slight angular overhang. There are no examples preserved to the base.

It has rim diameters between 15 and 30 centimeters. It has been found in Peach Cream fabric (3 sherds), Pink/Buff B fabric (9 sherds), and Pink/Buff A fabric (5 sherds). Equally common are undecorated examples and semi-glossy red and eggplant colored slip.

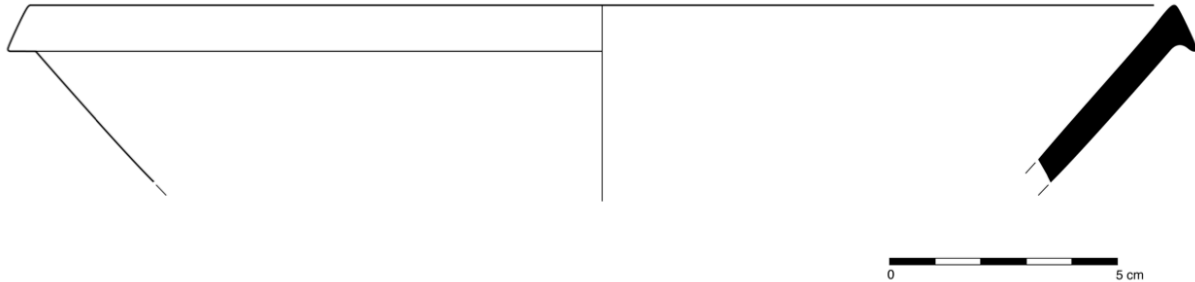

Figure 437: Rim in Pink/Buff B fabric, unslipped; BH 2005 UF 32

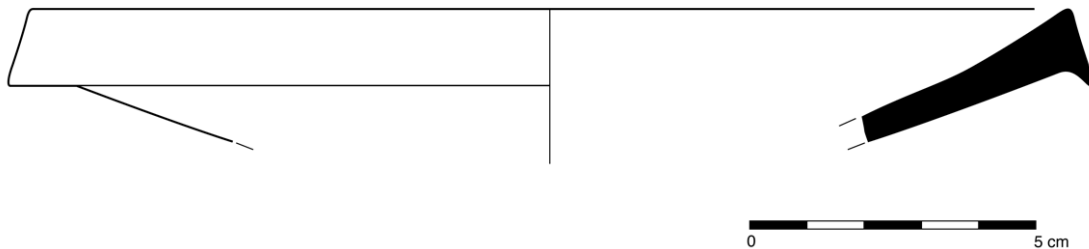

Figure 438: Rim in Pink/Buff B fabric with semi-glossy red slip; TZ 2008 Ch.18 UF 28

## Shape Group XV: Small Hemispherical and Carinated Table Bowls

### Upper Profile Types 149, 156, 157, 164-166, 168

These vessel types usually range in diameter from 15 to 25 centimeters (Figure 439). With fairly hemispherical dimensions, these were probably used for table service, perhaps for soups or liquids. Rims tend to be smooth and round and the carinated varieties show fairly vertical upper walls and slanting lower walls. Bases vary widely from plain to disc to ring bases, though some could have also have pedestal bases, particularly Type 157.

Upper Profile Types 156 and 149 are rare.

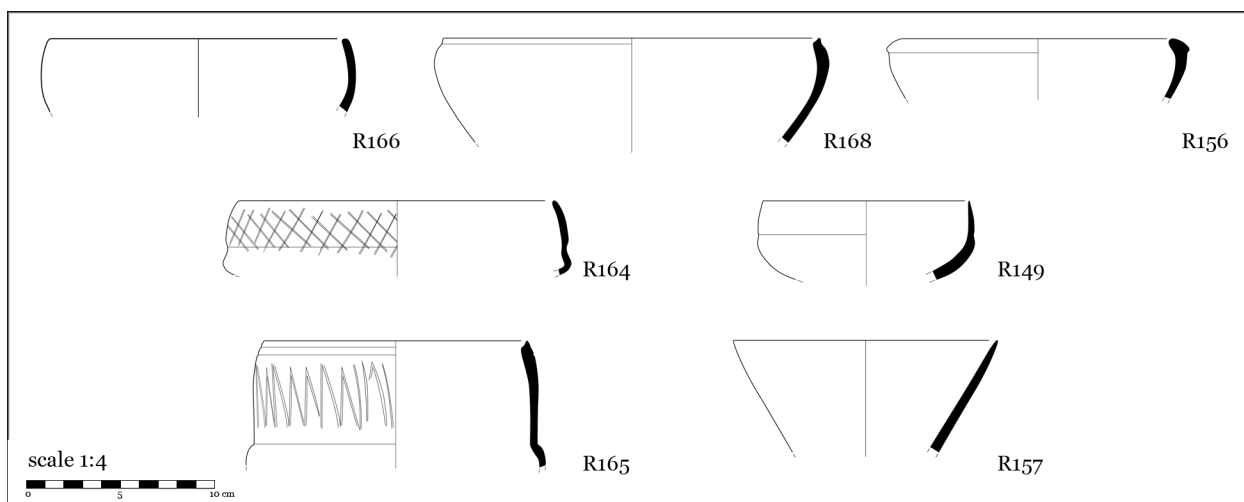

Figure 439: Compendium of Shape Group XV vessels

*Upper Profile Type 166 (n=12)*

This hemispherical shaped bowl type is a thin walled vessel with a curve in the wall from the rim to the body walls (Figures 440, 441). It has an incurved rim, with a continuous curve from the lip to the lower body. The lip is plain and rounded. There is a single example with a full profile and Lower Profile Type 12. There is one example with a single small handle.

It has rim diameters between 15 and 20 centimeters. It has been primarily found in Pink/Buff B fabric (9 sherds), but there are occasional examples in Pink/Buff A fabric (2 sherds) and Gray fabric (1 sherd). There are rare undecorated examples, but most are slipped. The Gray example has black slip, a single Buff example has brown slip, and the rest have eggplant colored or more commonly red semi-glossy slip. There is a single example with an affixed small spout in the upper wall of the vessel, likely a form of baby bottle.

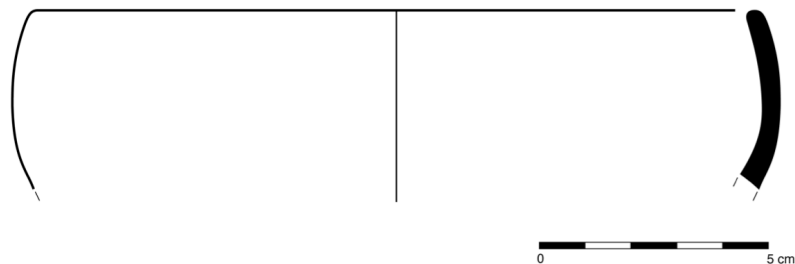

Figure 440: Rim in Gray fabric with black slip; TZ 2005 Ch.6 UF 55

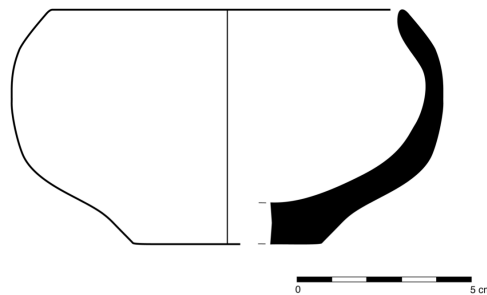

Figure 441: Whole profile in Peach Cream fabric; BH 2005 UF 24

*Upper Profile Type 168 (n=21)*

This hemispherical shaped bowl type is a thin walled vessel with a curve in the wall from the rim to the body walls (Figures 442-444). It has an incurved rim, with only a slight curve at the upper rim. It has a slightly pinched lip. Examples are not preserved to the base.

It has rim diameters between 15 and 30 centimeters. It has been found in Pink/Buff A fabric (5 sherds) and Pink/Buff B fabric (16 sherds). There are occasional undecorated examples, but red or eggplant colored semi-glossy slip is more common. This is sometimes used in conjunction with wavy and straight parallel incised lines in the upper exterior. There is a single example with impressed circles on the exterior and raised circles on the interior—possibly the only example of mold made decoration found on site.

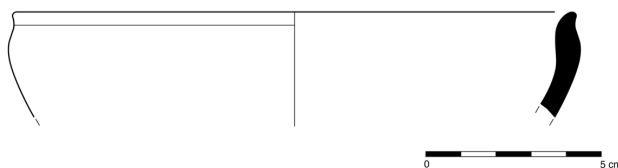

Figure 442: Rim in Pink/Buff B fabric, unslipped; TZ 2005 Ch.6 UF 5

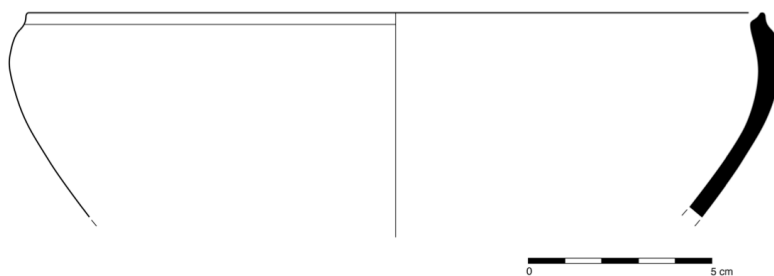

Figure 443: Rim in Pink/Buff B fabric with semi-glossy eggplant colored slip; TZ 2004 Ch.4 Sec.2 UF 17

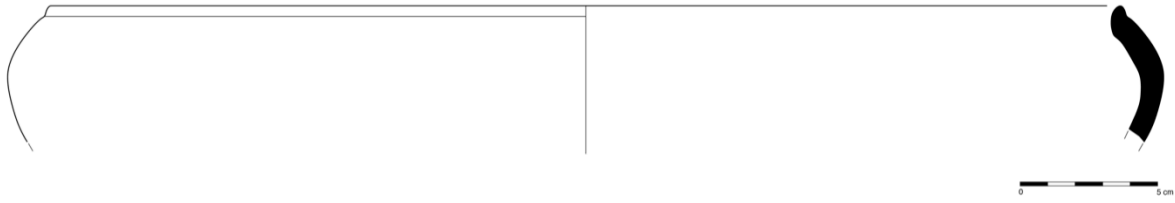

Figure 444: Rim in Pink/Buff A fabric, unslipped; TZ 2004 Ch.4 UF 15

*Upper Profile Type 156 (n=5)*

This small bowl type is a thin walled vessel with a curve in the wall from the rim to the body walls (Figure 445). It has an incurved rim, with a thickened, rounded lip with a slight articulation at the point of curvature. There are no examples preserved to the base.

It has rim diameters between 15 and 34 centimeters. It has been found in Pink/Buff A fabric (3 sherds) and Pink/Buff B fabric (2 sherds). All examples have semi-glossy red slip, often used in conjunction with wavy and straight incised lines on the interior of the rim.

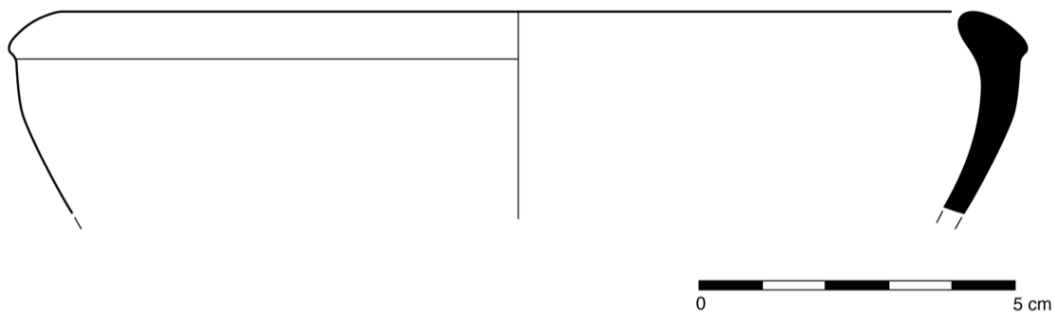

Figure 445: Rim in Pink/Buff A fabric with matte red slip; TZ 2004 Ch.2 UF 73

*Upper Profile Type 164 (n=88)*

This short hemispherical shaped bowl type is a thin walled vessel with fairly vertical upper walls (Figures 446-448). The rim is vertical, plain, and rounded, normally 3-4 centimeters in height. The lip is plain and rounded. There is a slight constriction of the walls below the rim and a slight convex swelling below this, which leads to fairly straight lower walls that lead to a variety of bases.

It has rim diameters between 15 and 25 centimeters. It has been found primarily in Pink/Buff B fabric (72 sherds), but there are occasional examples in Pink/Buff A fabric (16 sherds). All vessels are decorated, almost all with red semi-glossy slip, but there is one example in eggplant colored semi-glossy slip and one with brown slip and black crosshatched lines on the upper exterior of the rim. Most vessels have burnished decoration on the upper exterior of the rim. Most have sloppy vertical burnishing, but almost as common is crosshatched lines.

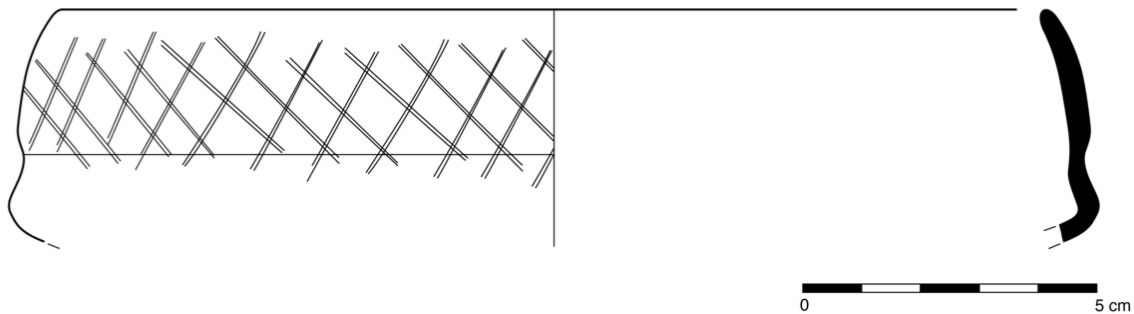

Figure 446: Rim in Pink/Buff B fabric with semi-glossy red slip and crosshatch burnishing on rim; TZ 2005 Ch.6 UF 50



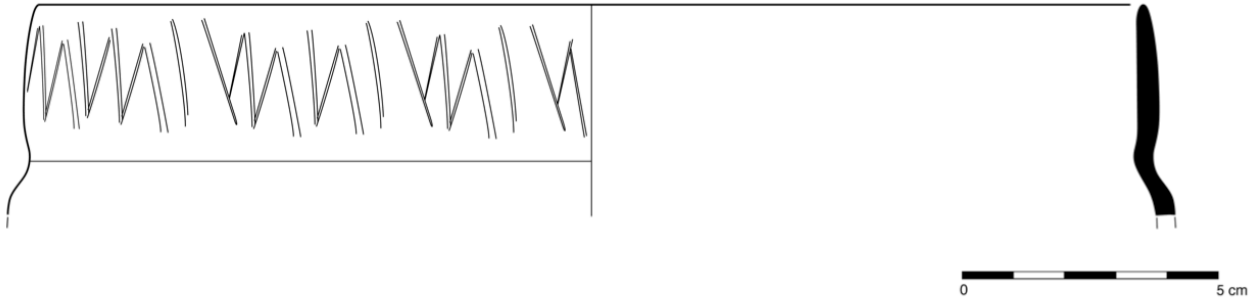

Figure 447: Rim in Pink/Buff B fabric with semi-glossy red slip and vertical burnishing on rim;  
TZ 2008 Ch.18 UF 15

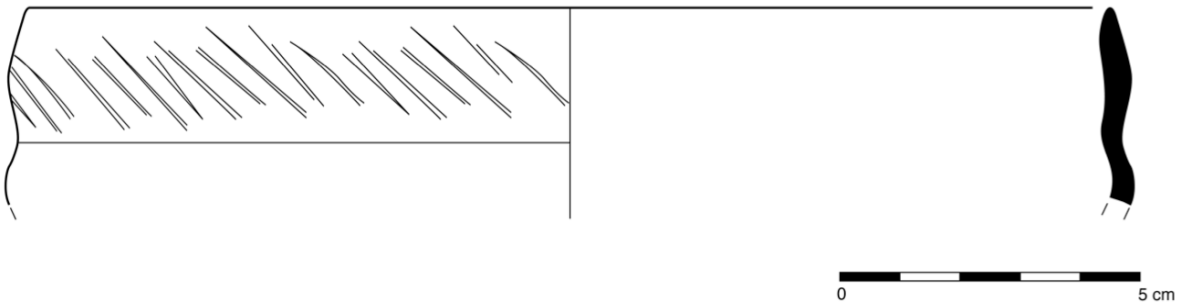

Figure 448: Rim in Pink/Buff B fabric with semi-glossy red slip and diagonal burnishing on rim;  
TZ 2008 Ch.18 UF 15

*Upper Profile Type 165 (n=484)*

This tall hemispherical shaped bowl type is a thin walled vessel with fairly vertical upper walls (Figures 449-453). The rim is vertical and plain, normally 5-6 centimeters in height, and the lip is beveled. There is a slight constriction of the walls below the rim and a slight convex swelling below this, which leads to fairly straight lower walls that lead to a variety of bases.

It has rim diameters between 12 and 20 centimeters. It is found primarily in Pink/Buff A fabric (212 sherds) and Pink/Buff B fabric (254 sherds), but there are occasionally examples in Orange fabric (18 sherds). Almost all vessels have two shallow parallel incised grooves on the upper exterior of the rim; a single example has three grooves. All vessels are slipped, Orange fabric typically has orange semi-glossy slip. All others have eggplant colored or more commonly red semi-glossy slip. The slip is almost ubiquitously used in conjunction with patterned burnishing. Most common is sloppy vertical burnishing on the exterior of the rim, but there are rare examples of crosshatched burnished lines. There is one unburnished example and one example with an affixed plastic decoration, possibly an animal head, at the bottom of the rim exterior.

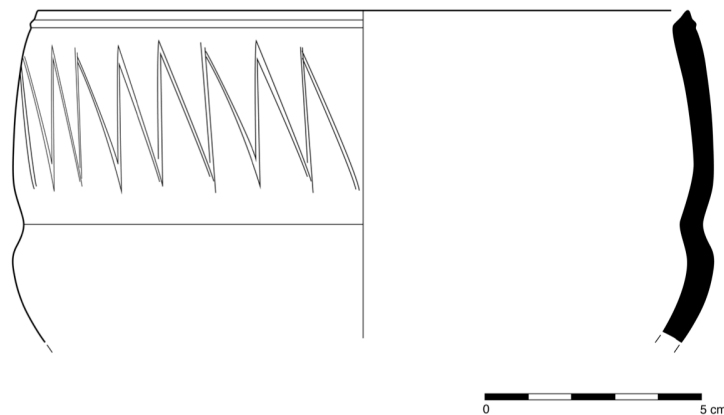

Figure 449: Rim in Pink/Buff A fabric with semi-glossy red slip and vertical burnishing on rim; TZ 2004 Ch.4 UF 11

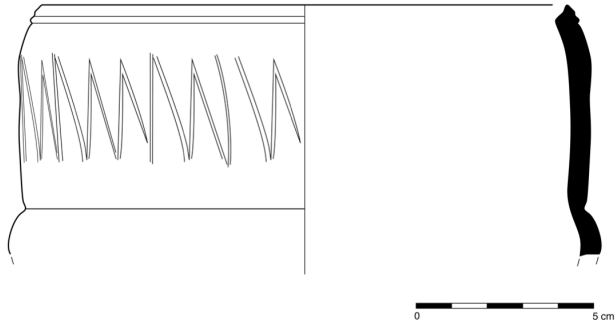

Figure 450: Rim in Pink/Buff B fabric with semi-glossy eggplant colored fabric and vertical burnishing on rim; TZ 2004 Ch.6 décapage

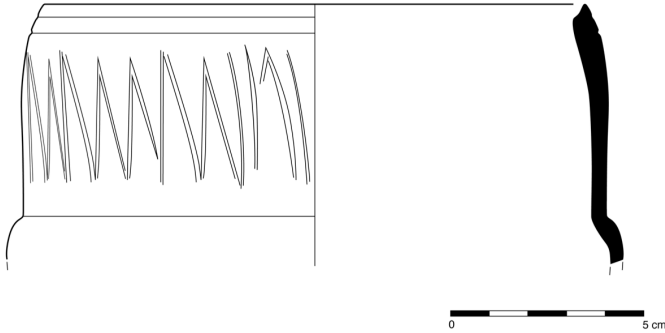

Figure 451: Rim in Orange fabric with semi-glossy red slip and vertical burnishing on exterior of rim; TZ 2005 Ch.6 UF 32

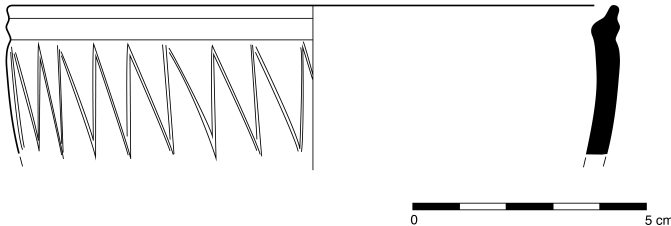

Figure 452: Rim in Pink/Buff B fabric with semi-glossy red slip and vertical burnishing on rim; TZ 2004 Ch.4 UF 9

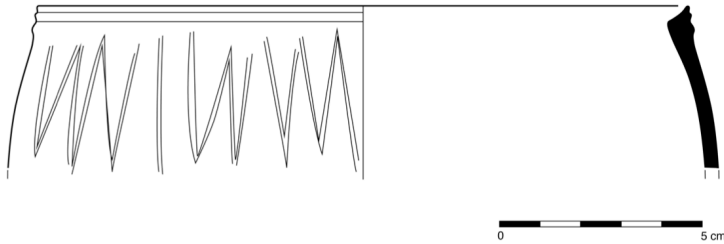

Figure 453: Rim in Pink/Buff B fabric with semi-glossy red slip and vertical burnishing on rim; TZ 2004 Ch.4 UF 9

*Upper Profile Type 149 (n=3)*

This small bowl type is a thin walled vessel with a slight curve in the wall from the rim to the body walls (Figure 454). It has a vertical rim with a pointed lip and a slight articulation on the external wall below the rim. The inner walls have a continuous curve, unlike the Upper Profile Types 143, 144, and 145, which are more plate-like than bowl-like. Examples are not preserved to the base.

It has rim diameters between 11 and 14 centimeters. It has only been found in Pink/Buff B fabric (3 sherds) and all examples have red semi-glossy slip. One example has burnished zigzag stripes on the exterior of the rim.

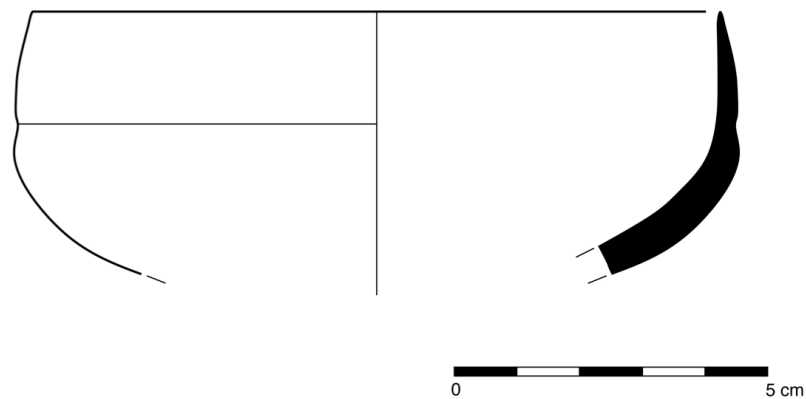

Figure 454: Rim and body in Pink/Buff B fabric with semi-glossy red slip; TZ 2008 Ch.18 UF 15

*Upper Profile Type 157 (n=57)*

This small bowl or cup type is a thin walled vessel with outward slanting straight walls (Figures 455, 456). It has a plain rim with a rounded lip. There are no examples preserved to the base, but the taller examples are likely the upper portions of pedestal goblets.

It has rim diameters between 11 and 32 centimeters. It has been found in Pink/Buff B fabric (22 sherds), Pink/Buff A fabric (30 sherds), Gray fabric (2 sherds), and Peach Cream fabric (3 sherds). Gray examples have black slip, as does a single Buff example. There are undecorated examples, but equally common on Buff and Pink examples is semi-glossy red or eggplant colored slip. There are rare examples of lustrous red slip.

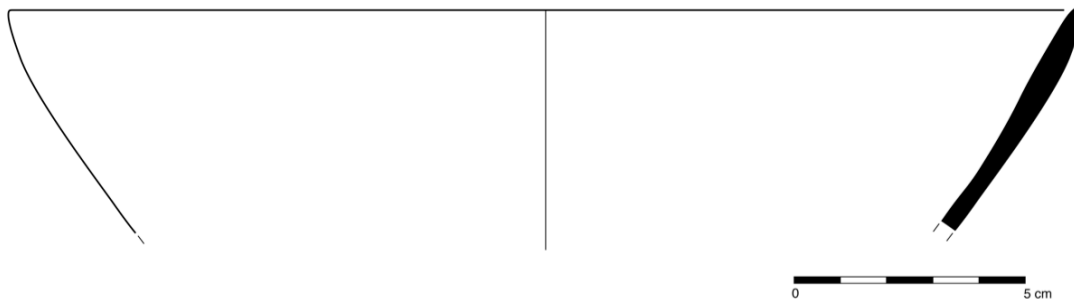

Figure 455: Rim in Pink/Buff B fabric with semi-glossy red slip; TZ 2004 Ch.4 UF 20

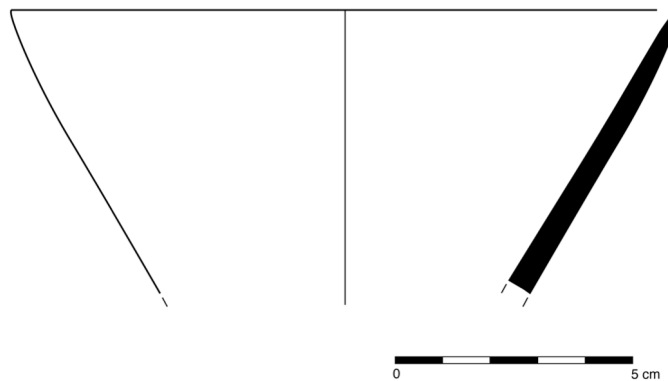

Figure 456: Rim in misfired a Pink/Buff fabric with slightly vitrified black slip; TZ 2005 Ch.6 UF 32

## Shape Group XVI: Straight-walled Drinking and Serving Vessels

### Upper Profile Types 169-174

These vessel types range in diameter from 10 to 25 centimeters and are deeper than they are wide (Figure 457). With relatively vertical walls and fairly plain rims, they were probably used for table service, the smaller varieties for drinking and the larger varieties for serving liquids. Some profiles show inward sloping lower walls, but not all base or lower profile types are known. The exception is forms 169 and 171. Examples of these forms in Peach Cream fabric likely had lower profile forms 4, 5, and 6. Bases of other forms are unknown.

Upper Profile Types 170 and 172 are rare. Upper Profile Type 169 is very common.

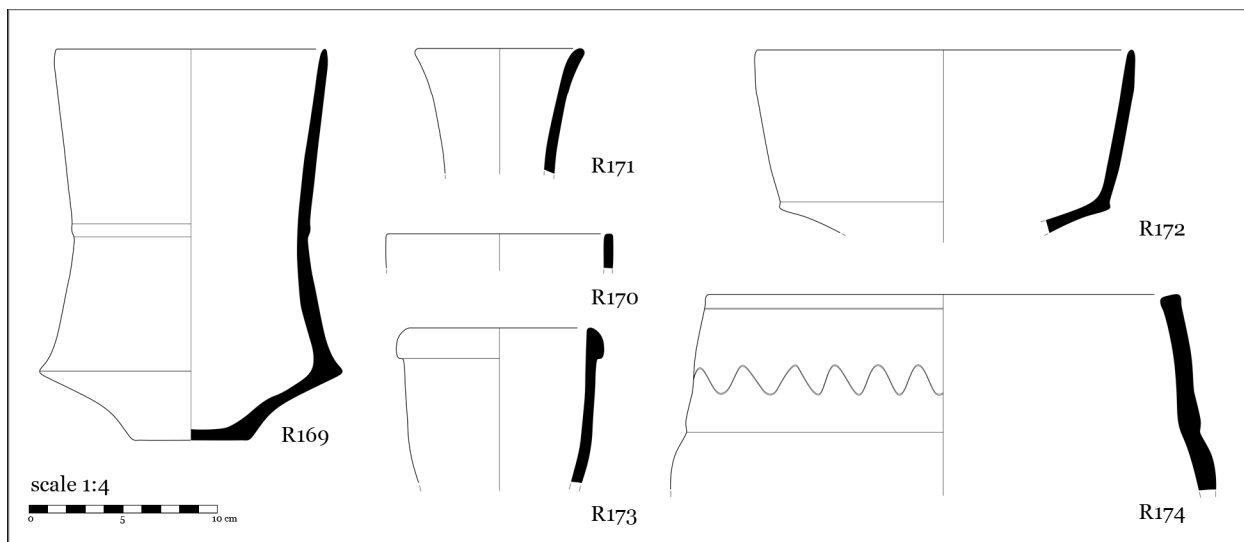

Figure 457: Compendium of Shape Group XVI vessels

*Upper Profile Type 169 (n=177)*

This cylindrically shaped vessel type is thin walled with vertical upper walls (Figures 458-462). This is a fairly deep open vessel with an unarticulated, straight rim. It has a rounded lip and straight walls. Some of the examples have a carination low on the vessel body. Many vessels with this upper profile likely end in lower profile types 4, 5, and 6, but probably not all. Only two whole profiles are preserved, one in an otherwise unknown coarse fabric,<sup>126</sup> another in Peach Cream fabric.

This type has rim diameters between 10 and 25 centimeters. The smaller varieties were probably individual cups, the larger varieties were used for serving. The size range is continuous and does not show bimodal distribution. It has been found primarily in Peach Cream fabric (155 sherds) and it is these vessels that likely end in Lower Profile Types 4, 5, and 6. There are occasional examples in Pink/Buff B fabric (10 sherds), Pink/Buff A fabric (9 sherds), coarse fabric (1 sherd), and Orange fabric (2 sherds), but these fabrics never appear in Lower Profile Types 4, 5, and 6, so they likely have other bases. Of the many examples in Peach Cream fabric, two have traces of matte red slip around the rim. Most vessels are undecorated, but there are several Buff, Pink, and Orange vessels with matte and semi-glossy red slip. There is a single example of a buff colored vessel with an otherwise unattested cream colored slip and crosshatched brown paint.<sup>127</sup>

---

<sup>126</sup> A description of this fabric is found in the Miscellaneous Fabric category earlier in this chapter.

<sup>127</sup> This is the only painted Iron Age vessel I found. It is similar to a Tillya Tepe type, see Lhuillier 2013 Planche 46.2.

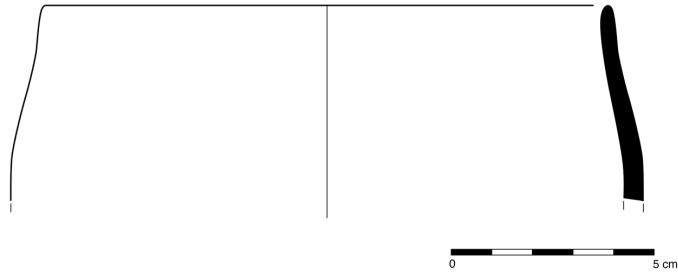

Figure 458: Rim in Orange fabric with matte red slip; BH 2007 UF 300

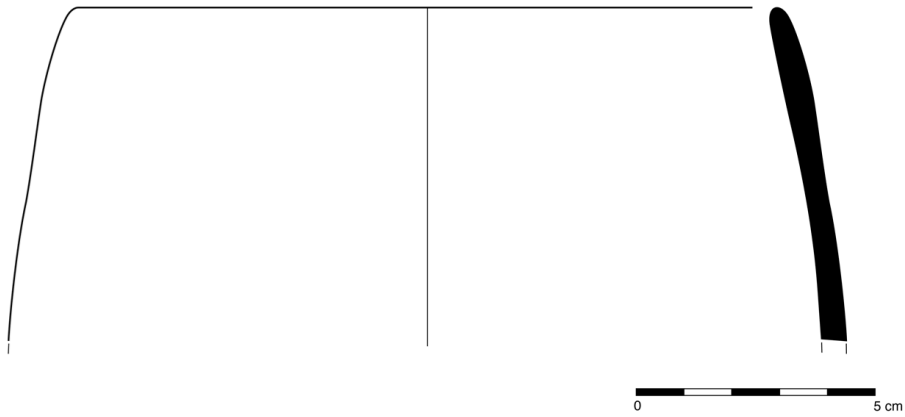

Figure 459: Rim in Pink/Buff B fabric with matte red slip; TZ 2004 Ch.4 UF 13

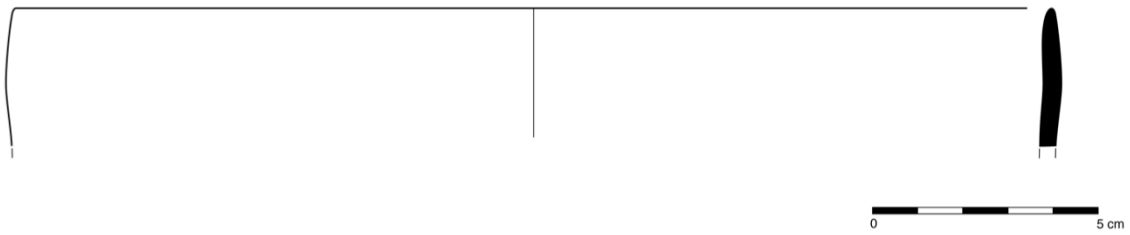

Figure 460: Rim in Pink/Buff B fabric with black and red slip; TZ 2004 Ch.4 UF 20

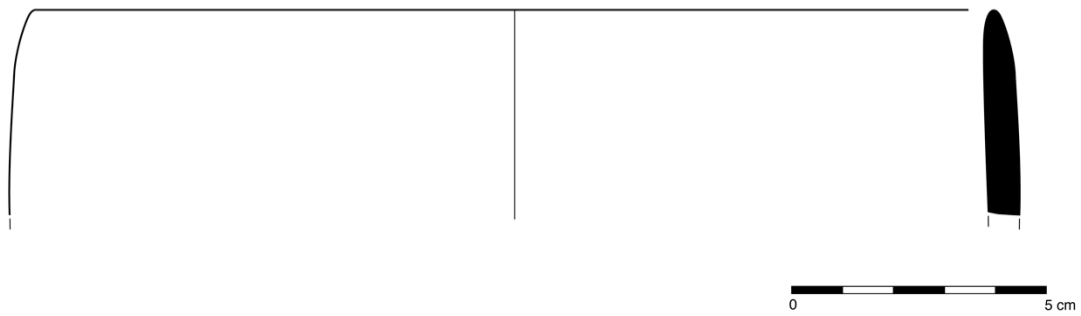
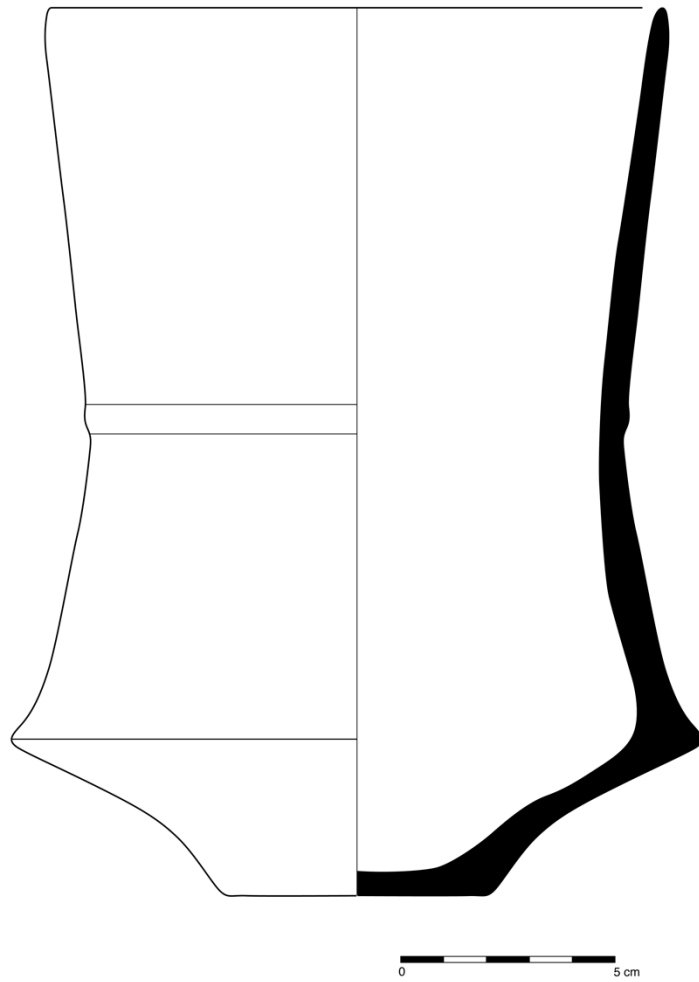

Figure 461: Rim in Peach Cream fabric; TZ 2004 Ch.4 UF 14





le

Figure 462: Whole profile in Peach Cream fabric; BH 2005 UF 33

*Upper Profile Type 170 (n=4)*

This deep bowl type is a thin walled vessel with vertical upper walls (Figures 463-465). It has an unarticulated, straight rim with a squared lip and straight walls. No examples are preserved to the base.

It has rim diameters between 17 and 20 centimeters. It has only been found in Pink/Buff A fabric (4 sherds). All examples have semi-glossy red slip. One has a shallow groove in the top of the lip.

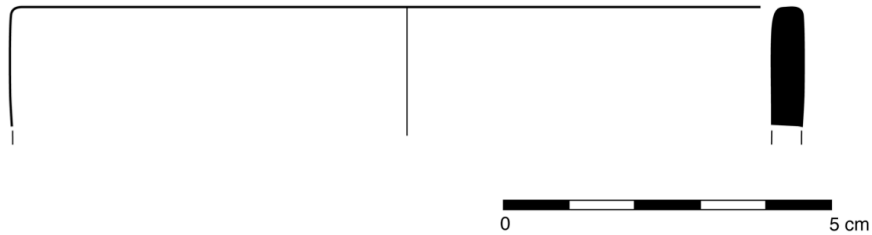

Figure 463: Rim in Pink/Buff A with semi-glossy red slip; TZ 2007 Ch.6 UF 107

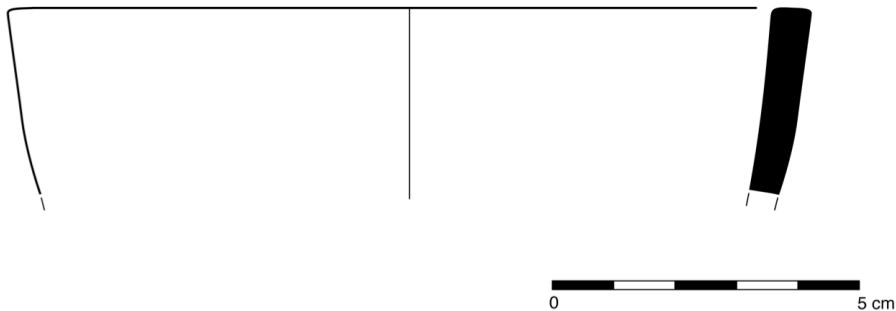

Figure 464: Rim in Pink/Buff A fabric with matte red slip; TZ 2005 Ch.6 UF 5

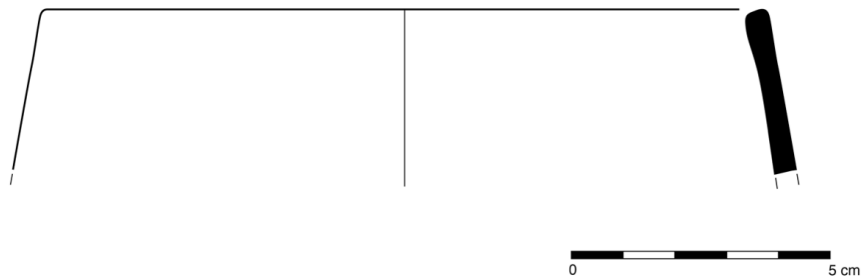

Figure 465: Rim in Pink/Buff B fabric, unslipped; TZ 2005 Ch.6 UF 5

*Upper Profile Type 171 (n=8)*

This tall cup type is a thin walled vessel with fairly vertical upper walls (Figures 466, 467). It has an unarticulated, flaring rim with a rounded lip and straight walls. No examples are preserved to the base, but it is likely that the Peach Cream examples have a carinated base and the Pink/Buff A and Gray examples have a pedestaled or disc base. The upper profiles themselves, however, are almost identical. Further evidence will likely show that the more deeply flared rims are significantly later.

It has rim diameters between 10 and 25 centimeters. It has been found primarily in Peach Cream fabric (3 sherds) and Pink/Buff A fabric (4 sherds), but there is a single example in Gray fabric and a single example in a buff fabric with slightly larger inclusions than other fine fabrics. Most are undecorated, but several Pink examples have matte red slip.

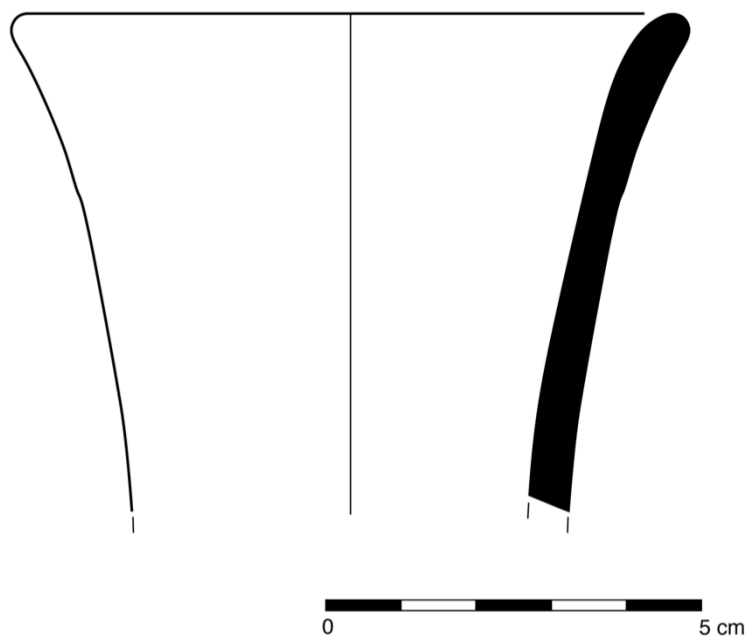

Figure 466: Rim in Peach Cream fabric; BH 2005 UF 26

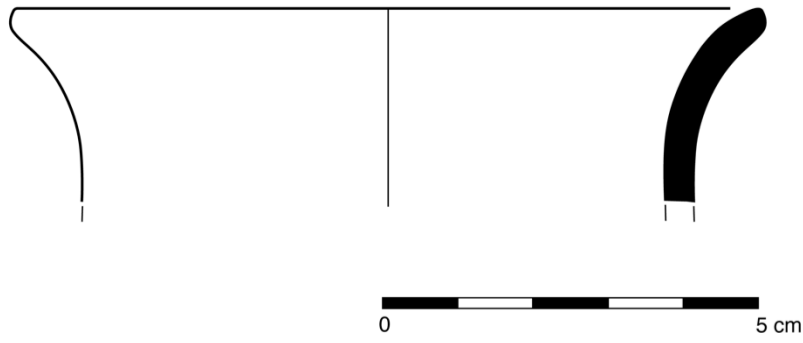

Figure 467: Rim in buff fabric, moderately coarse, unslipped TZ 2005 Ch.6 UF 50

*Upper Profile Type 172 (n=2)*

This deep bowl or cup type is a thin walled vessel with vertical upper walls (Figures 468, 469). It has an unarticulated, straight rim with a rounded lip and straight walls that change angle at the lower body at an obtuse angle. No examples are preserved to the base.

It has rim diameters between 16 and 20 centimeters. It has only been found in Peach Cream fabric (2 sherds).

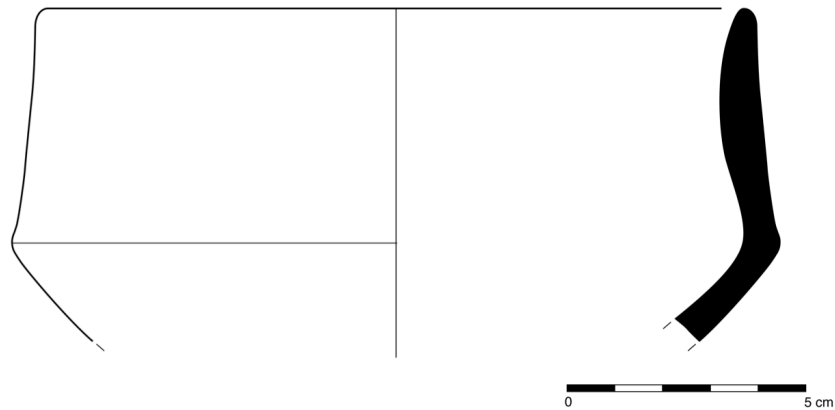

Figure 468: Rim and body in Peach Cream fabric; BH 2007 UF 219

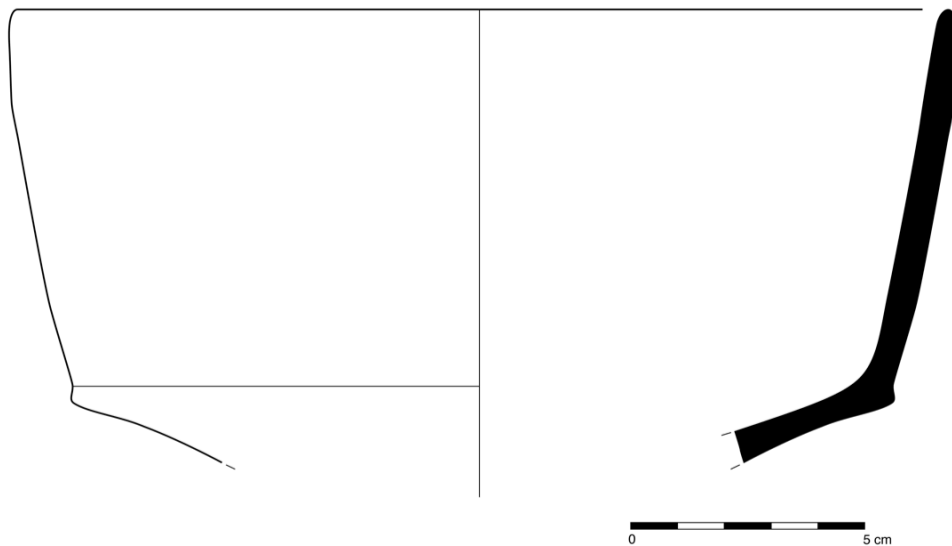

Figure 469: Rim and body in Peach Cream fabric; BH 2007 UF 219

*Upper Profile Type 173 (n=18)*

This deep cup type has a very thick-pedestaled base (Figure 470). With steeply sloping walls, it has a rim with a rounded external articulation and a rounded lip. The lower walls and base form a nearly vertical line. These vessels appear very hastily wheel-made, probably pulled from the same cylinder of clay and quickly cut. They are fairly irregular because of this.

It has rim diameters between 8 and 12 centimeters. It has only been found in Pink/Buff B fabric (18 sherds) and is never decorated.

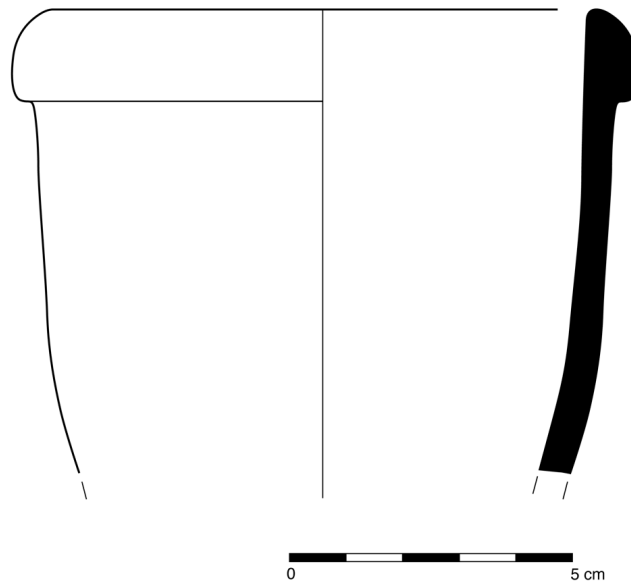

Figure 470: Rim in Pink/Buff B fabric, unslipped; TZ 2004 Ch.6 Fosse Kouchan

*Upper Profile Type 174 (n=19)*

This cylindrically shaped vessel type is thin walled with slightly inverted upper walls (Figure 471). It has an unarticulated rim and a slightly squared lip. There is an outer groove in the upper exterior wall. Lug handles are not uncommon. The vessel shape is unknown; it could have vertical walls to its base or be a more pear shaped jar. No examples are preserved to the base.

It has a wide range of rim diameters, between 15 and 45 centimeters, the smaller probably used for individual drinking vessels, the larger for serving. It has been found in Pink/Buff A fabric (8 sherds) and Pink/Buff B fabric (11 sherds). All examples are slipped with red or eggplant colored semi-glossy slip, often used in conjunction with wavy or straight impressed or incised lines are common along the exterior rim and upper body of the vessel.

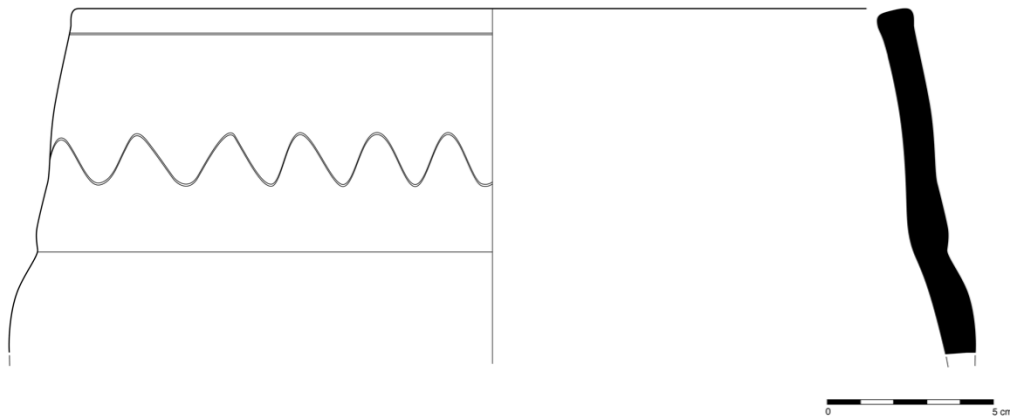

Figure 471: Rim in Pink/Buff A fabric with matte red slip and incised decoration; TZ 2008 Ch.18 UF 15

## **Lower Group Cluster A: Diagnostically Useful Forms**

This cluster consists of twenty-seven lower profile types contained in four groups. The vessels in this cluster are both open and closed and are mostly made of fine fabrics, but there are occasional examples in coarse fabrics.

### *Lower Group Cluster A: Diagnostically Useful Forms*

- *Shape Group I: Closed Small Jars, Lower Profile Types 1-3*
- *Shape Group II: Carinated Straight-walled Vessels, Lower Profile Types 4-6*
- *Shape Group III: Small Shallow and Deep Bowls, Lower Profile Types 7-19, 39-40*
- *Shape Group IV: Pedestaled Drinking and Serving Vessels, Lower Profile Types 20-25*

Group I shapes probably held small amounts of liquid, perhaps oil, wine, or perfume in the smaller varieties. Group II shapes range widely in size, so the smaller varieties were probably individual drinking vessels and the larger varieties were probably used for serving or group dining. Group III shapes were individual dining and drinking vessels. Group IV shapes were individual drinking cups and goblets.



## Shape Group I: Closed Small Jars

### Lower Profile Types 1-3

These vessel types have plain, disc, or low pedestal bases with round or pear shaped bodies (Figure 472). Some have evidence of straight necks, but most examples are not preserved well enough. These types have base diameters that range from 3 to 8 centimeters. These likely held small amounts of liquid. All examples are in fine fabrics and are rarely decorated, but there are occasional examples of stamps or matte red or eggplant colored slip.

Lower Profile Types 1 and 3 are rare.

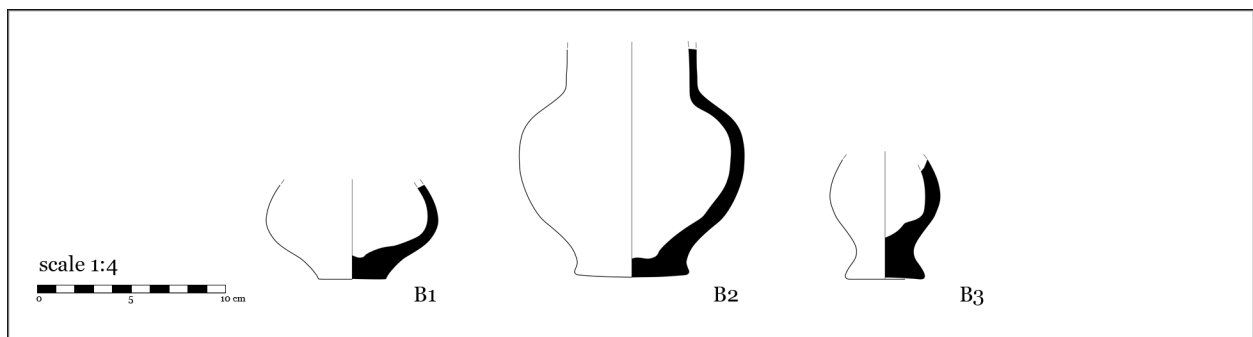

Figure 472: Compendium of Lower Shape Group I vessels

*Lower Profile Type 1 (n=4)* <sup>128</sup>

This jar type is a plain, flat base of a small, closed vessel (Figure 473). The join of the bottom and the vessel walls is angular. The lower walls are relatively straight, then curve into a rounded belly. All examples have body walls at an angle of 15 to 45 degrees from the bottom plane.

It has base diameters from 3 to 5 centimeters. It has been found in Pink/Buff A fabric (1 sherd) and Pink/Buff B fabric (3 sherds). Most examples are unslipped, but there are occasional instances of matte red slip.

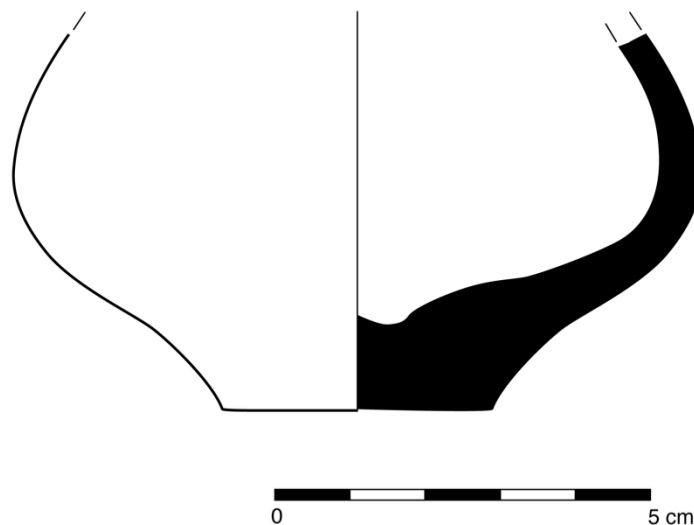

Figure 473: Base, body, and neck in Pink/Buff B fabric, unslipped; TZ 2005 Ch.6 UF 5

<sup>128</sup> Lower Profile Types 1 and 2 describe some of the vessels from Bactra in the National Museum of Afghanistan, but I was unable to analyze them in the scope of this project.

*Lower Profile Type 2 (n=7)*

This is an articulated base of a closed vessel type (Figure 474). It has a low, rounded disc foot. The lower walls are narrow near the base. The walls are rounded and are preserved to a height that shows the inward curve of the shoulder above the belly of the vessel.

Most examples have base diameters around 5-8 centimeters, but there is one miniature example with a 1.8 centimeter diameter. Only this miniature example is decorated, with red semi-glossy slip. All others are undecorated. This shape has only been found in Pink/Buff B fabric (7 sherds).

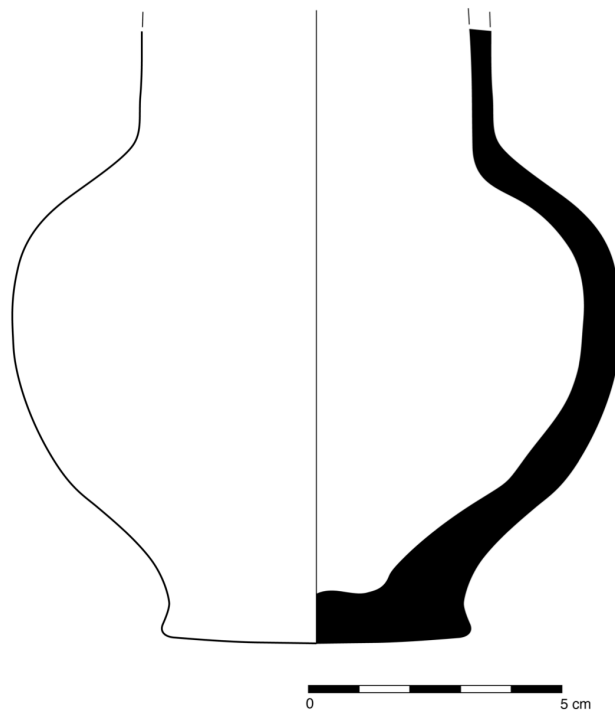

Figure 474: Base, body, and neck in Pink/Buff B fabric, unslipped; TZ 2004 Ch.4 Sec.2 UF 4

*Lower Profile Type 3 (n=3)*

This type is an articulated base of a small closed vessel (Figure 475). It has a disc foot and a short, conical pedestal. The lower walls angle outward on all examples and meet the bottom plane at an angle between 45 and 90 degrees.

It has base diameters between 3 and 5 centimeters. It has been found in Pink/Buff A fabric (1 sherd) and Pink/Buff B fabric (2 sherds). No examples are decorated.

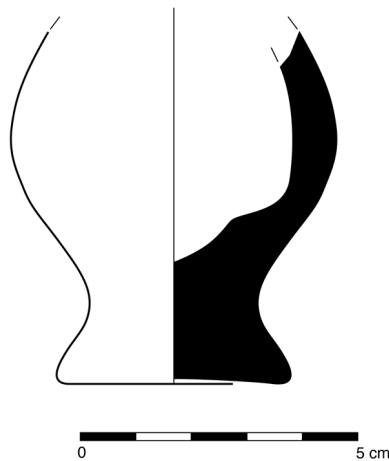

Figure 475: Base and body in Pink/Buff B fabric, unslipped; TZ 2005 Ch.6 UF 53

## Shape Group II: Carinated Straight-walled Vessels

### Lower Profile Types 4-6

These vessel types have straight walls and either a carination on the lower body and a plain base or a flared, plain base (Figure 476). Preserved profiles show straight upper walls and plain rims. These vessels have a wide range in size, from 7 to 25 centimeters in diameter. Some were probably used as individual drinking cups, some were probably used for serving liquids. Most examples are in Peach Cream fabric, one example is in an unidentified moderately coarse fabric.

Lower Profile Type 6 is rare.

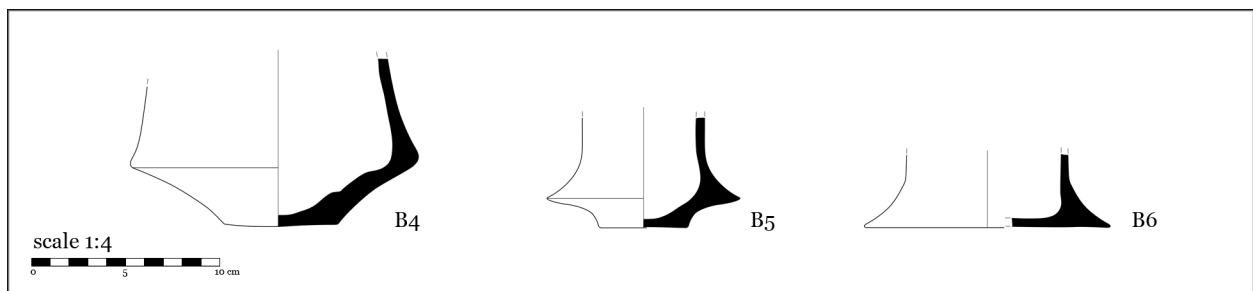

Figure 476: Compendium of Lower Shape Group II vessels

*Lower Profile Type 4 (n=7)*

This type has a plain, flat base (Figure 477). The join of the bottom and the vessel walls is angular. The lower walls are concave. They angle outward before joining a carination on the lower body, changing angle, and becoming vertical. The carination itself is fairly rounded. All examples have body walls at an angle of 15 to 45 degrees from the bottom plane.

It has base diameters between 4 and 8 centimeters. It has only been found in Peach Cream fabric (7 sherds).

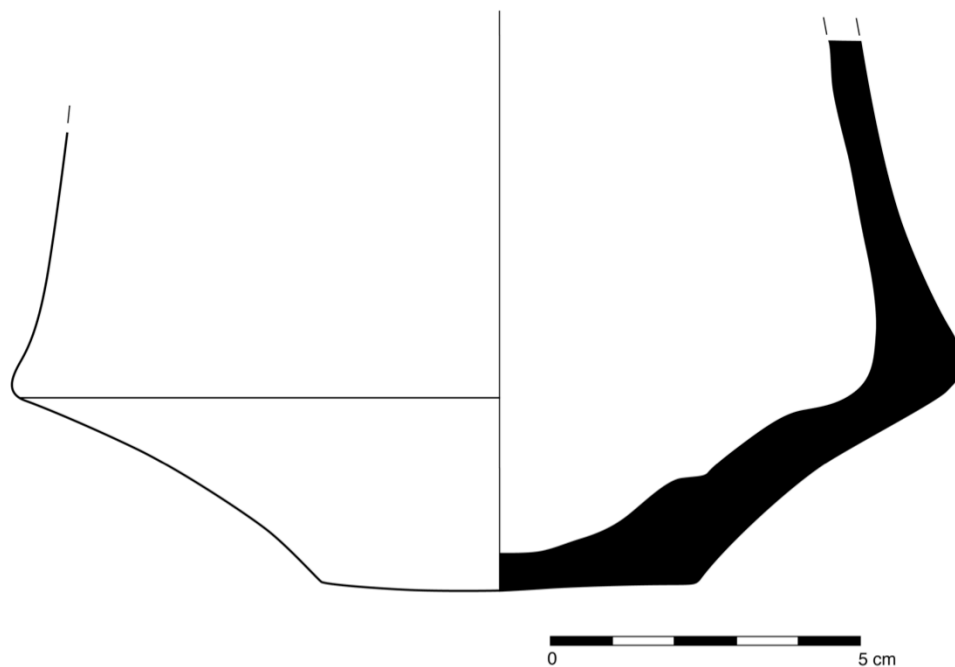

Figure 477: Base in Peach Cream fabric; BH 2005 UF 53

*Lower Profile Type 5 (n=12)*

This type has a plain, flat base (Figures 478, 479). The join of the bottom and the vessel walls is angular. The lower walls are concave. They angle outward before joining a carination on the lower body, changing angle, and becoming vertical. The carination itself is angular with a sharp outcropping. All examples have body walls at an angle of 15 to 45 degrees from the bottom plane.

It has base diameters between 4 and 15 centimeters. It has only been found in Peach Cream fabric (12 sherds).

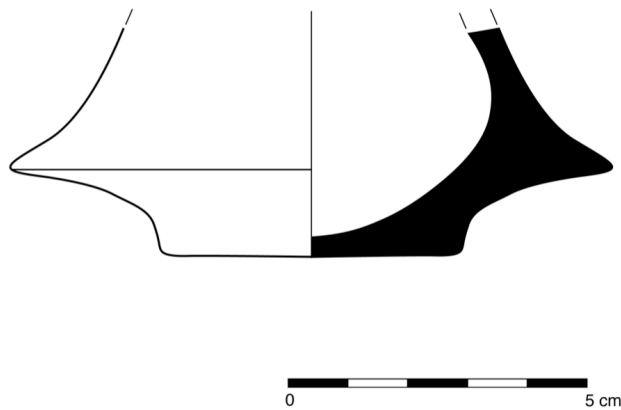

Figure 478: Base in Peach Cream fabric; TZ 2005 Ch.6 UF 56

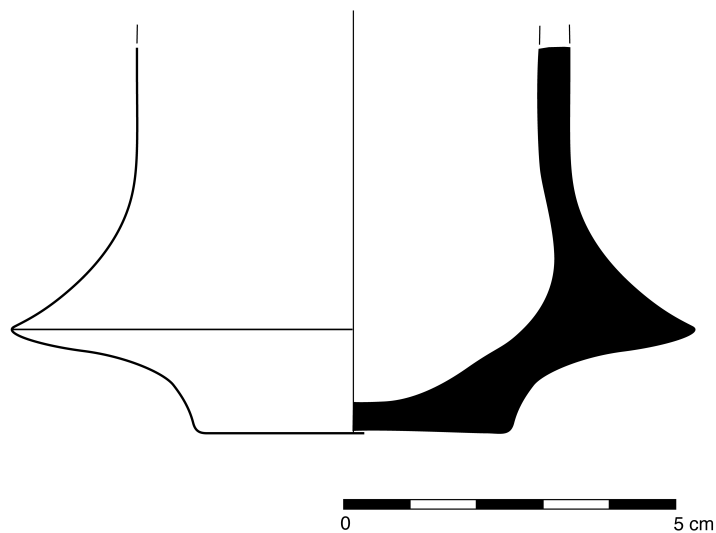

Figure 479: Base in Peach Cream fabric; BH 2005 UF 37

*Lower Profile Type 6 (n=2)*

This type has a flat base that quickly narrows to vertical walls (Figure 480). The shape is similar to Lower Profile Type 5, but instead of a carination at the lower body, the base is the widest portion of the vessel. They angle outward before changing angle and becoming vertical.

It has base diameters between 11 and 15 centimeters. It has only been found in Peach Cream fabric (2 sherds).

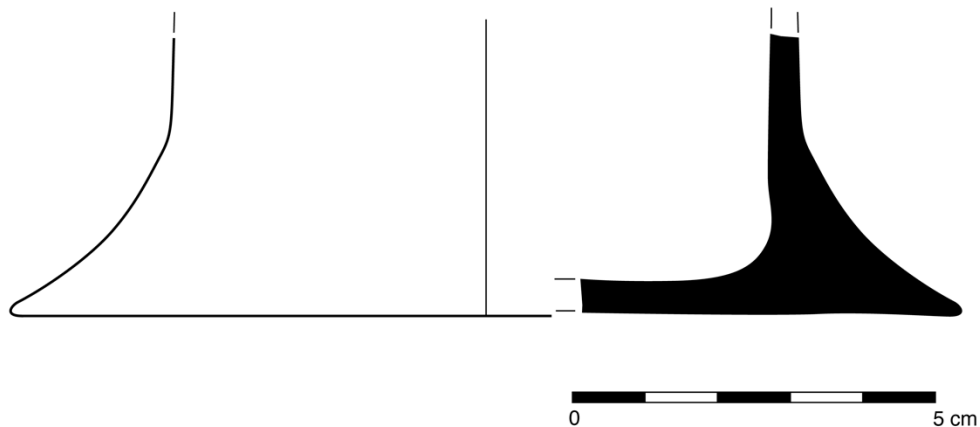

Figure 480: Base in Peach Cream fabric; TZ 2008 Ch.6 UF 19



### Shape Group III: Small Shallow and Hemispherical Bowls and Plates

#### Lower Profile Types 7-19, 39-40

These vessel types have bases that range in size from 3-10 centimeters (Figure 481). With plain, disc, and ring bases, this group of vessels is united by their personal table service functions. With a wide range of shallow, open bodies, there are few whole profiles, so no statistically significant statements can be made about correlation of the rim types associated with any of the bases of this group.

Lower Profile Types 8, 11, and 17 are rare. Lower Profile Type 39 is very common.

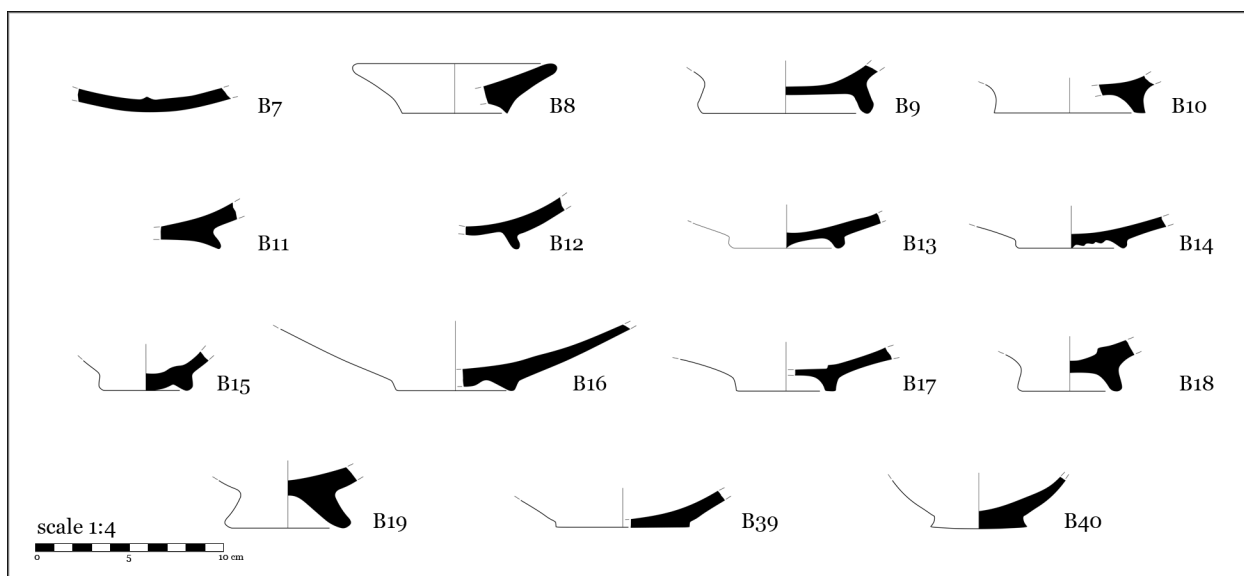

Figure 481: Compendium of Lower Shape Group III vessels

*Lower Profile Type 7 (n=21)*

This type has a plain, entirely convex base (Figures 482-484). The join of the bottom and the walls of the vessel is either poorly defined and rounded or undefined. Identification of this base is usually accomplished by noting wheel marks. It otherwise looks similar to body sherds of globular vessels.

Because of the undefined join of the base and the walls, the diameters of these bases can only be approximated at between 5 and 15cm. It has been found in Peach Cream fabric (9 sherds), Pink/Buff A fabric (4 sherds), Pink/Buff B fabric, (3 sherds) and coarse fabrics (4 sherds). There is a single example in Gray fabric with black slip. Buff and Pink/Buff A examples usually have red matte or semi-glossy slip, sometimes used in conjunction with one or more concentric circles between 3 and 5 centimeters in diameter on the interior of the vessel.

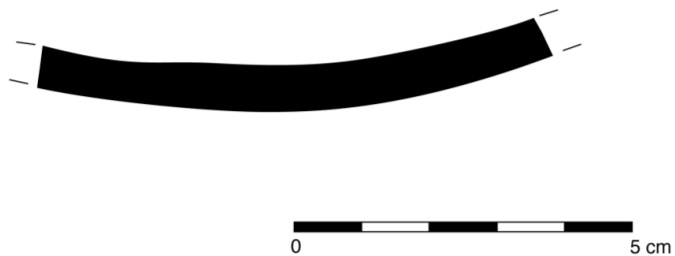

Figure 482: Base in Pink/Buff A fabric with matte red slip; TZ 2005 Ch.6 UF 45

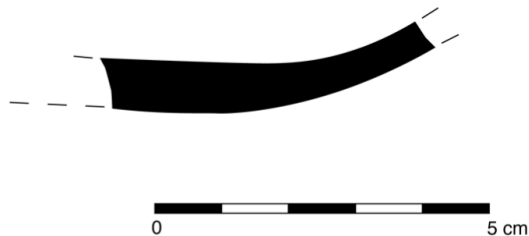

Figure 483: Base in Pink/Buff B fabric with semi-glossy red slip; TZ 2004 Ch.4 Sec.2 UF 5

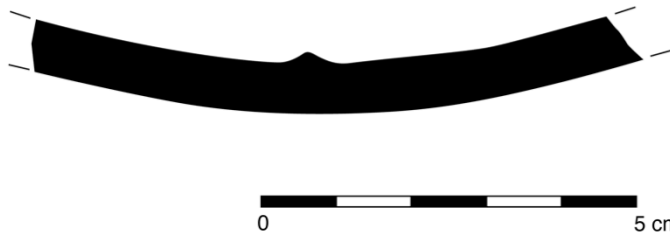

Figure 484: Base in Pink/Buff B fabric with semi-glossy red slip and starburst pattern burnishing on interior; TZ 2004 Ch.4 Sec.2 UF 17

*Lower Profile Type 8 (n=4)*

This type has an articulated base (Figure 485). It has a ring foot, the walls of which are at a vertical angle and the bottom of the ring is pointed. This ring foot is probably a mock ring foot, not made separately and attached. Some examples have complete profiles that create small shallow plates. Others are incomplete, but have much larger diameters.

It has base diameters between 5 and 8 centimeters. It has been found in Pink/Buff A fabric (2 sherds) and Pink/Buff B fabric (2 sherds). All examples have red matte or semi-glossy slip. This is often used in conjunction with starburst patterned burnishing on the interior of the vessel.

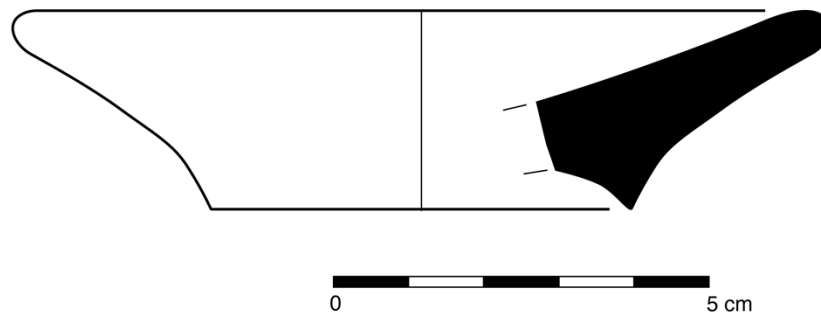

Figure 485: Rim to base in Pink/Buff A fabric with red semi-glossy slip and black hatch marks on interior surface; TZ 2004 Ch.4 Sec.2 UF 8

*Lower Profile Type 9 (n=11)*

This type has an articulated base (Figure 486). It has a ring foot, the walls of which are at a vertical angle. The bottom of the ring is rounded. The raised area within the foot is flat. This ring foot is a mock ring foot, not made separately and attached. On most examples, the lower walls angle outward. They meet the bottom plane at an angle between 0 and 45 degrees. Upper profiles are shallow small bowls and possibly lamps.

It has base diameters between 6 and 13 centimeters. It has been found most commonly in Pink/Buff A fabric (5 sherds), but also appears in Peach Cream fabric (1 sherd), Pink/Buff B fabric (2 sherds), and Gray fabric (3 sherds). Gray examples have black slip and one small, incised circle on the interior of the vessel. Other examples are either undecorated or slipped with semi-glossy red slip. This is often used in conjunction with a central incised circle on the interior of the vessel.

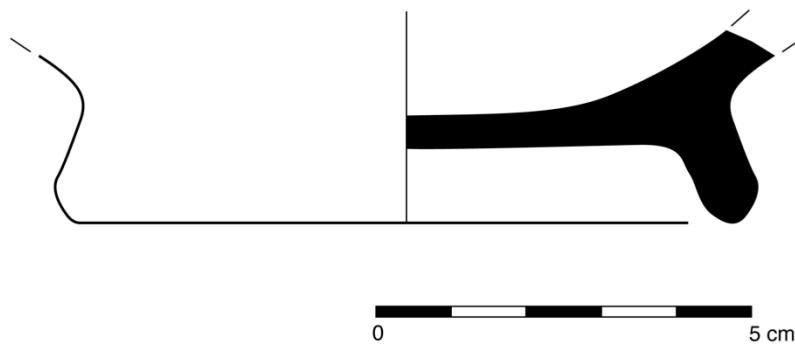

Figure 486: Base in Pink/Buff B fabric with semi-glossy eggplant colored slip; TZ 2004 Ch.4 UF 20

*Lower Profile Type 10 (n=8)*

This type has an articulated base (Figure 487). It has a ring foot, the walls of which are at a vertical angle. The bottom of the ring is squared. The raised area within the foot is flat. This ring foot is a mock ring foot, not made separately and attached. On examples, the lower walls angle outward. They meet the bottom plane at an angle between 0 and 45 degrees. Upper Profile Types are unknown.

It has base diameters between 5 and 8 centimeters. It has been found in Pink/Buff A fabric (5 sherds) and Pink/Buff B fabric (3 sherds). There are undecorated examples, but more common is red semi-glossy red slip. This is often used in conjunction with a central incised circle on the interior of the vessel or starburst patterned burnishing.

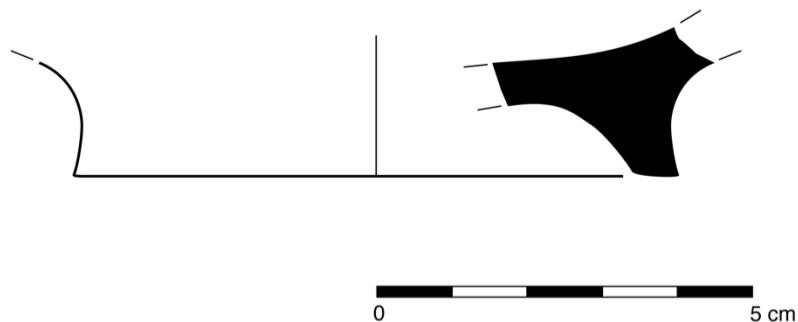

Figure 487: Base in Pink/Buff B fabric with matte red slip and two incised concentric circles; TZ 2004 Ch.4 Sec.2 UF 14

*Lower Profile Type 11 (n=3)*

This type has an articulated base (Figure 488). It has a ring foot, the walls of which are at an outward angle. The bottom of the ring is rounded. The raised area within the foot is concave. This ring foot is a mock ring foot, not made separately and attached. On most examples, the lower walls angle outward. They meet the bottom plane at an angle between 0 and 45 degrees.

It has base diameters between 5 and 7 centimeters. It has been found in Pink/Buff A fabric (1 sherd) and Pink/Buff B fabric (2 sherds). All examples have eggplant colored or red semi-glossy slip. This is used in conjunction with a central incised circle on the interior of the vessel or starburst patterned burnishing.

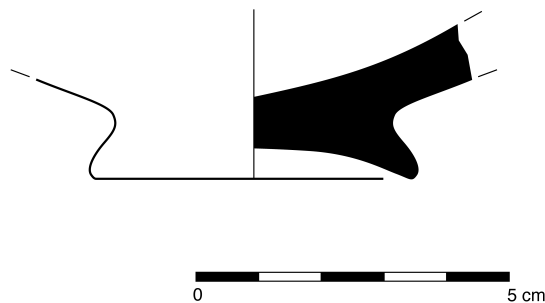

Figure 488: Base in Pink/Buff B fabric with traces of matte eggplant colored slip; TZ 2004 Ch.4 Sec.2 UF 18

*Lower Profile Type 12 (n=76)*

This type has an articulated base (Figure 489). It has a ring foot and does not have a pedestal. The walls of the foot are at an outward angle from the body and the bottom of the ring is rounded. The raised area within the foot is convex, following the contour of the interior of the vessel wall. Some examples have whole profiles with Upper Profile Types 139 and 154.

It has base diameters between 4 and 12 centimeters. It has been found primarily in Pink/Buff B fabric (13 sherds) and Pink/Buff A fabric (58 sherds), but there are occasional examples in Gray fabric (3 sherds), Orange fabric (1 sherd), and an unknown coarse fabric (1 sherd). Unslipped examples have been found, often with central incised circles. Gray examples have lustrous black slip. Other examples occasionally have eggplant colored semi-glossy slip, but more common is red semi-glossy slip. These are often used in conjunction with one or more central incised circles, impressed circles (like a fishplate), or starburst patterned burnishing.

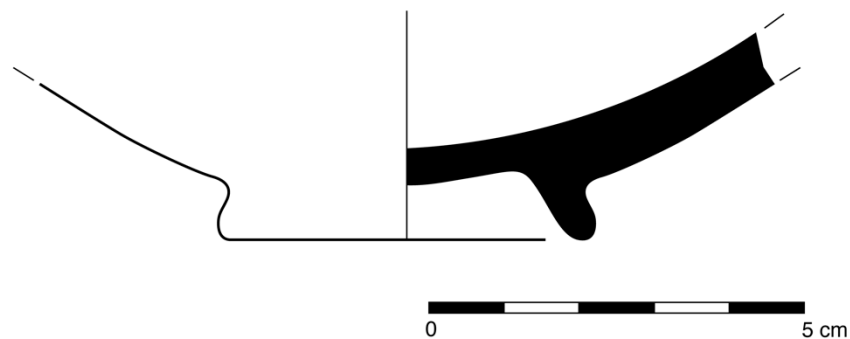

Figure 489: Base in Gray fabric, unslipped; TZ 2008 Ch.6 UF 28



*Lower Profile Type 13 (n=36)*

This type has an articulated base (Figure 490). It has a ring foot, the walls of which are at a vertical angle. The bottom of the ring is rounded. The raised area within the foot is relatively flat with a central pointed nipple. This ring foot is a mock ring foot, not made separately and attached.

It has base diameters between 4 and 10 centimeters. It is found in Pink/Buff B fabric (26 sherds) and Pink/Buff A fabric (10 sherds). There are rare undecorated examples, but red, or less commonly, eggplant colored semi-glossy slip is almost ubiquitous. This is usually used in conjunction with starburst pattern burnishing, but occasionally used with incised central circles.

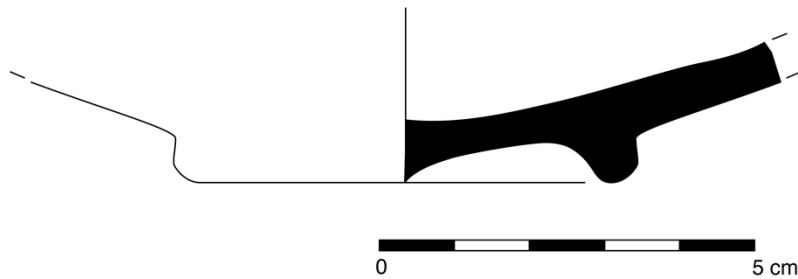

Figure 490: Base in Pink/Buff B fabric with semi-glossy red slip and starburst patterned burnishing on interior; TZ 2004 Ch.6 Fosse Kouchan

*Lower Profile Type 14 (n=5)*

This type has an articulated base (Figure 491). It has a ring foot, the walls of which are at a vertical angle. The bottom of the ring is rounded. The raised area within the foot is relatively flat with a central pointed nipple and spiral grooves/finger marks. This ring foot is a mock ring foot, not made separately and attached.

It has base diameters between 3 and 6 centimeters. It is found in Pink/Buff B fabric (2 sherds) and Pink/Buff A fabric (3 sherds). There are undecorated examples, but red semi-glossy or lustrous slips are common.

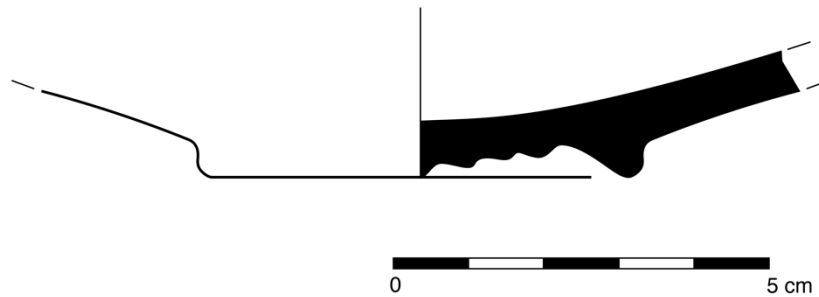

Figure 491: Base in Pink/Buff A fabric with semi-glossy red slip; TZ 2004 Ch.4 Sec.2 UF 9

*Lower Profile Type 15 (n=23)*

This type has an articulated base (Figures 492, 493). It has a ring foot and does not have a pedestal. The walls of the foot are at a vertical angle and the bottom of the ring is rounded. The raised area within the foot is convex in the center, a slight bulge from the body of the vessel, which is usually as low as the actual bottom of the ring foot. This ring foot is a mock ring foot, not made separately and attached.

It has base diameters between 4 and 7 centimeters. It has been found in Pink/Buff A fabric (11 sherds) and Pink/Buff B fabric (12 sherds). There are occasional undecorated examples, but most have eggplant colored or more commonly red semi-glossy slip. This is frequently used with either starburst pattern or vertical stripe burst patterned burnishing.

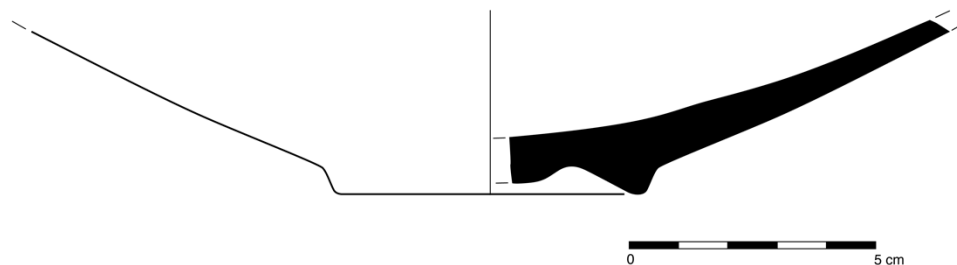

Figure 492: Base in Pink/Buff B, unslipped; TZ 2004 Ch.4 UF 12

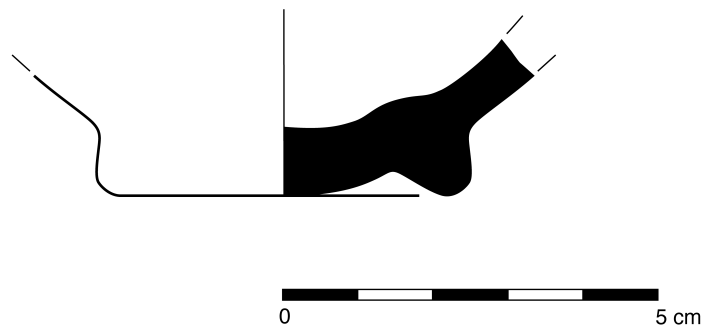

Figure 493: Base in Pink/Buff A fabric with semi-glossy red slip; TZ 2007 Ch.14 UF 4

*Lower Profile Type 16 (n=18)*

This type has an articulated base (Figures 494, 495). It has a ring foot and does not have a pedestal. The walls of the foot are at a vertical angle and the bottom of the ring is rounded. The raised area within the foot is convex in the center, a slight bulge from the body of the vessel that is usually not as low as the bottom of the vessel base. This ring foot is a mock ring foot, not made separately and attached.

It has base diameters between 4 and 6 centimeters. It has been found primarily in Pink/Buff A fabric (7 sherds) and Pink/Buff B fabric (10 sherds), but there is one example in Orange fabric. There are occasional undecorated examples, but most have eggplant colored or more commonly red semi-glossy slip. This is frequently used with starburst patterned burnishing.

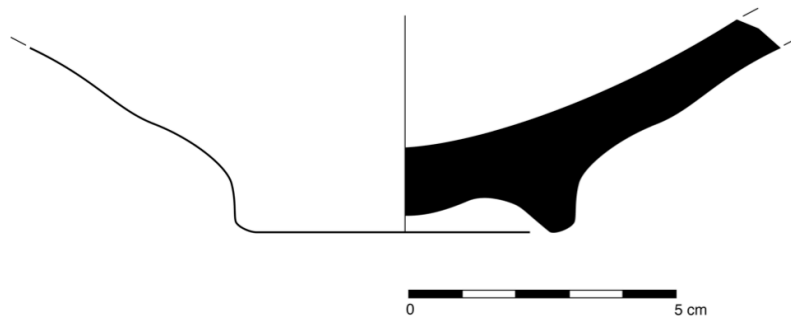

Figure 494: Base in Pink/Buff B fabric, unslipped with two incised concentric circles; TZ 2004 Ch.6 décapage

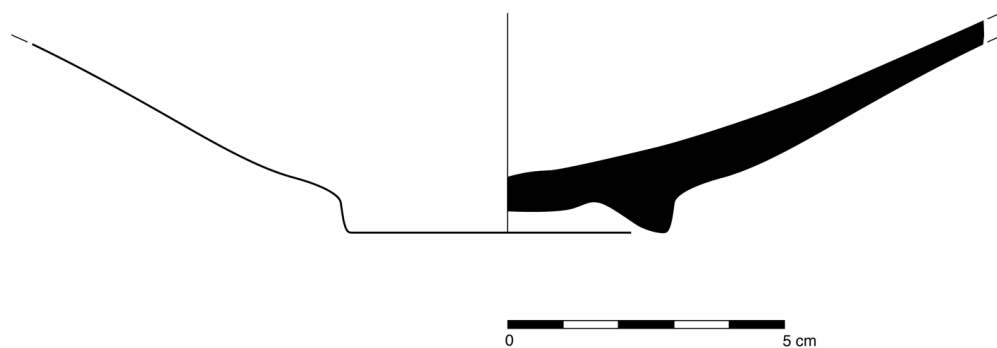

Figure 495: Base in Pink/Buff B fabric with semi-glossy red slip and starburst pattern burnishing; TZ 2005 Ch.6 UF 10

*Lower Profile Type 17 (n=3)*

This type has an articulated base (Figure 496). It has a ring foot and a deep indentation in the central interior that creates a fishplate. The walls of the ring foot are vertical and the bottom is sharply squared.

This rare type has base diameters between 5 and 8 centimeters. It has been found in Pink/Buff A fabric (1 sherd), Pink/Buff B fabric (1 sherd), and Gray fabric (1 sherd). Only the Pink/Buff A example is decorated, with red semi-glossy slip.

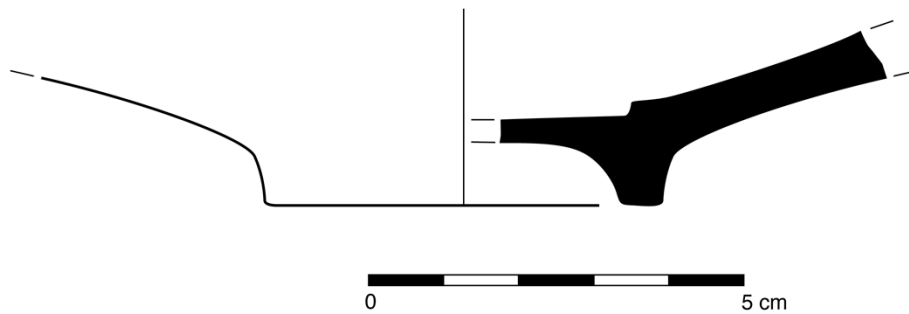

Figure 496: Base in Pink/Buff A fabric with matte red slip; TZ 2005 Ch.6 UF 32

*Lower Profile Type 18 (n=5)*

This type has an articulated base (Figures 497, 498). It has a ring foot and a deep indentation in the central interior that creates a fishplate. The walls of the ring foot are vertical and the bottom is rounded.

This rare type has base diameters between 5 and 8 centimeters. It has been found in primarily in Gray fabric (4 sherds), but there is a single example in Pink/Buff B fabric with red semi-glossy slip. The Gray examples have black slip.

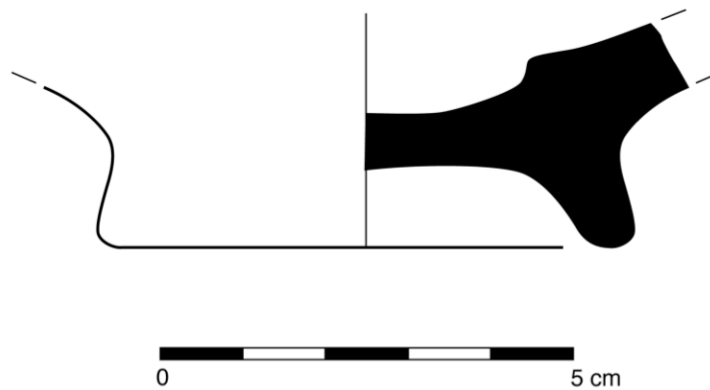

Figure 497: Base in Gray fabric, unslipped; BH 2005 UF 22

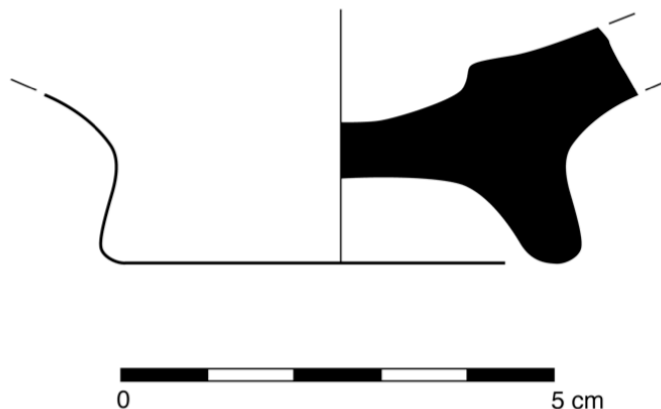

Figure 498: Base in Gray fabric with black slip; TZ 2008 Ch.6 UF 28

*Lower Profile Type 19 (n=80)*

This type has an articulated base (Figures 499-501). It has a ring foot and does not have a pedestal. The walls of the foot are at an outward angle from the body and the bottom of the ring is rounded. The raised area within the foot is deeply concave.

It has base diameters between 4 and 7 centimeters. It has been found primarily in Pink/Buff A fabric (55 sherds) and Pink/Buff B fabric (21 sherds), but there are occasional examples in Gray fabric (4 sherds). Unslipped examples have been found, some with incised circles on the interior of the vessel. Eggplant colored, and more commonly red, semi-glossy slip are very common, usually used in conjunction with one or more incised circles in the center of the vessel. There are rare examples of shallow central impressions.

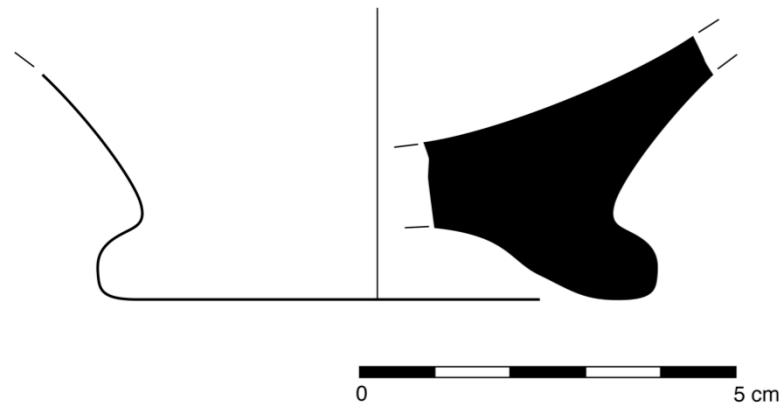

Figure 499: Base in Pink/Buff B fabric with matte red slip and two concentric circles; TZ 2004 Ch.4 Sec.2 UF 18

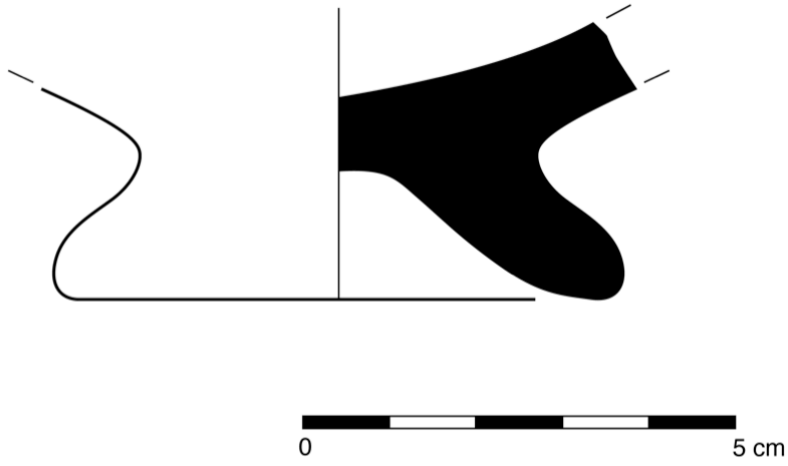

Figure 500: Base in Gray fabric with black slip and two concentric incised circles; TZ 2005 Ch.6 UF 17

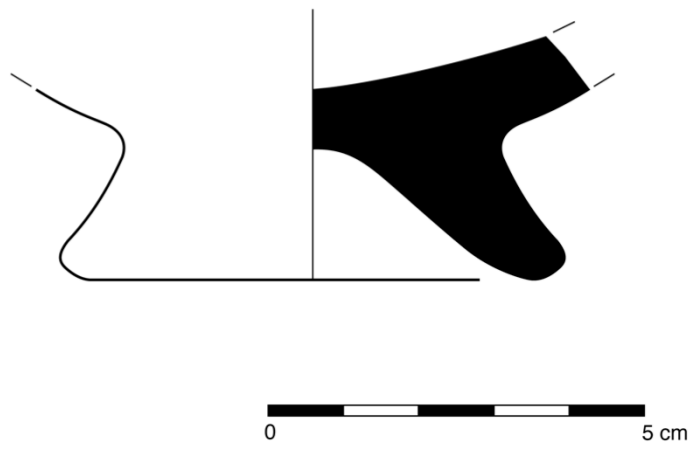

Figure 501: Base in Pink/Buff B fabric with matte red slip; BH 2005 UF 24



*Lower Profile Type 39 (n=95)*

This type has an articulated disc foot (Figures 502, 503). The join of the side of the foot and the bottom of the foot is angular and 90 degrees. The join of the vessel walls and the foot is concave. The lower walls angle outward on all examples and meet the bottom plane at an angle between 0 and 45 degrees.

It has base diameters between 3 and 13 centimeters. It has been found in Pink/Buff A fabric (54 sherds), Pink/Buff B fabric (36 sherds), and occasionally Orange fabric (1 sherd), Peach Cream fabric (2 sherds), and Gray fabric (2 sherds). There are undecorated examples, but red semi-glossy slip is common. This is often used in conjunction with central circular impressions or incised concentric circles on the interior center.

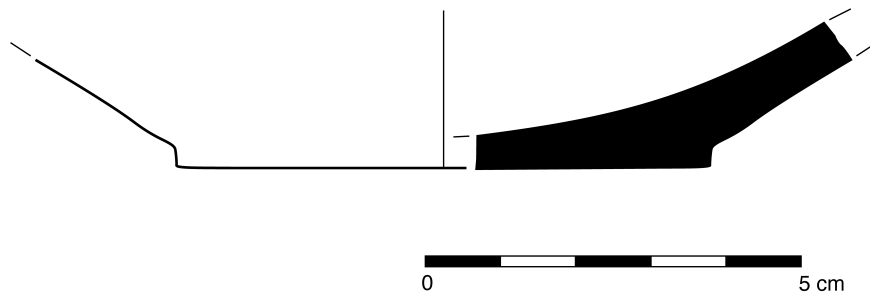

Figure 502: Base in Orange fabric with orange lustrous slip; TZ 2004 Ch.4 UF 15

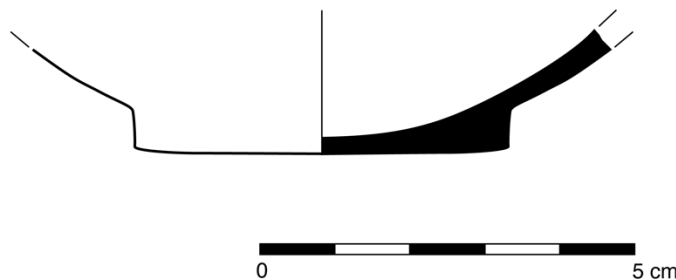

Figure 503: Base in Pink/Buff B fabric with semi-glossy red slip; TZ 2004 Ch.4 UF 11

*Lower Profile Type 40* (n=10)

This type has an articulated disc foot (Figure 504). The join of the side of the foot and the bottom of the foot is angular and  $>90$  degrees, creating a disc with a pointed lower angle. The join of the vessel walls and the foot is concave. The lower walls angle outward on all examples and meet the bottom plane at an angle between 0 and 45 degrees.

It has base diameters between 4 and 6 centimeters. It has been found in Pink/Buff A fabric (4 sherds) and Pink/Buff B fabric (6 sherds). There are undecorated examples, but equally common is semi-glossy red slip, sometimes used in conjunction with starburst patterned burnishing on the interior or vertical burnishing on the exterior.

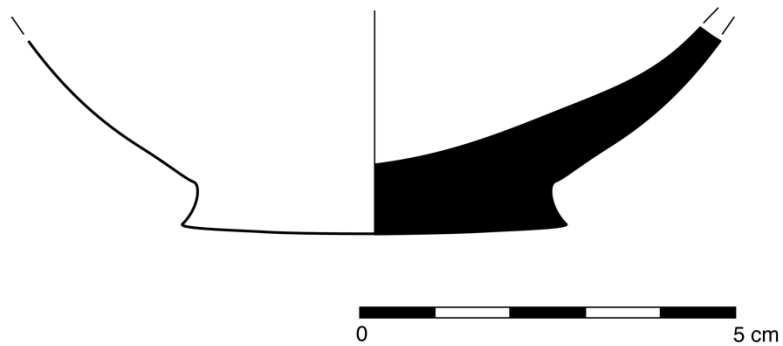

Figure 504: Base in Pink/Buff B fabric, unslipped; TZ 2004 Ch.4 UF 11

## Shape Group IV: Pedestaled Open Drinking Vessels

### Lower Profile Types 20-25

These vessel types have bases that range from 3-8 centimeters in diameter and all have pedestals with plain, disc, and ring profiles (Figure 505). With a wide range of bodies, extant sherds suggest vessels that are taller than they are wide. These are likely personal drinking vessels, mostly decorated, but some varieties tend to be plain and poorly formed.

Lower Profile Type 25 is rare.

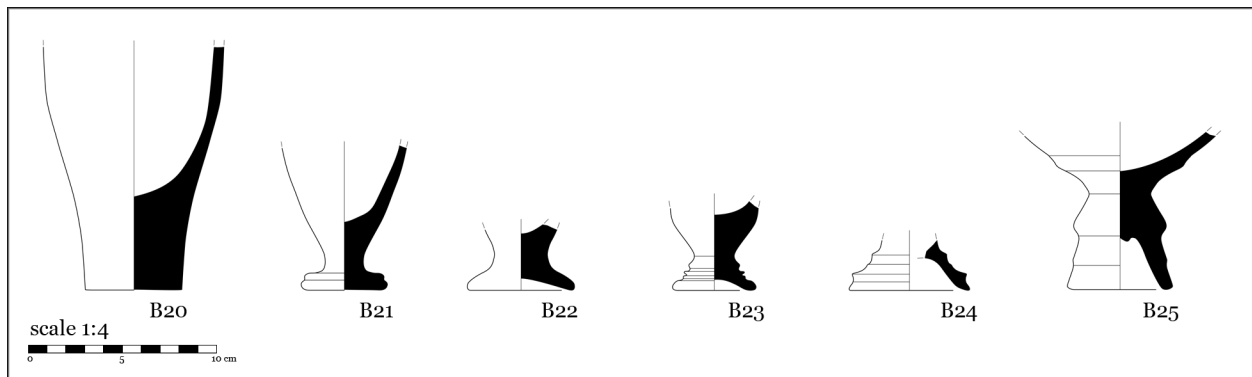

Figure 505: Compendium of Lower Shape Group IV vessels

*Lower Profile Type 20 (n=24)*

This is a drinking vessel type with a very high, thick pedestal base (Figure 506). It has a flat bottom, frequently with sloppy wire or string marks from removal from the wheel, perhaps thrown from the hump. The pedestal is cylindrical, usually at least 5 centimeters high, and leads to a curved cup body with thin curved walls and a slightly inverted rim with a rolled lip. This goes with Upper Profile Type 173.

This type has base diameters between 5 and 7 centimeters. It has only been found in Pink/Buff B fabric (24 sherds) and is entirely undecorated.

It has been found in waster form fused with Upper Profile Type 165, which indicates at least some local production.

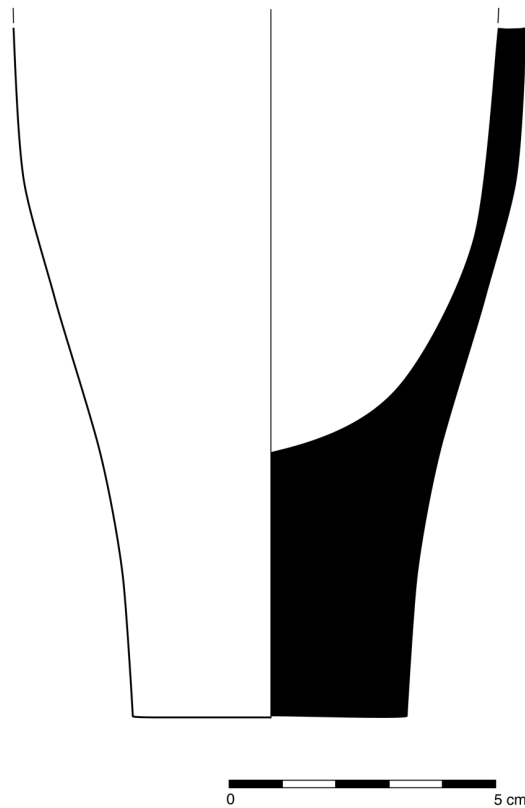

Figure 506: Base in Pink/Buff B fabric, unslipped; TZ 2004 Fosse Kouchan

*Lower Profile Type 21 (n=11)*

This is disc foot type below a rounded, conical pedestal (Figure 507). The lower walls angle outward on all examples and meet the bottom plane at an angle between 45 and 90 degrees. There are no whole profiles, but upper profiles likely make up vertical drinking vessels.

It has base diameters between 3 and 9 centimeters. It is found primarily in Pink/Buff A fabric (7 sherds), but there are rare examples in Pink/Buff B fabric (4 sherds). All Pink/Buff A examples have red matte and semi-glossy slip and tend to have smaller base diameters than Pink/Buff B examples. Pink/Buff B examples have eggplant colored semi-glossy slip or red and black slip.

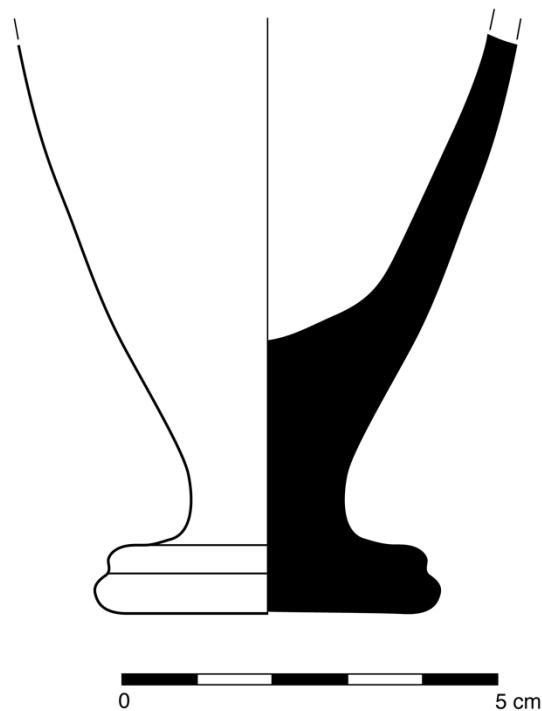

Figure 507: Base in Pink/Buff B fabric with red and black slip; TZ 2004 Ch.4 Sec.2 UF 6

*Lower Profile Type 22 (n=5)*

This is a ring foot type and can have a short pedestal, but does not always (Figures 508, 509). The walls of the foot are at an outward angle from the body and the bottom of the ring is pointed. The raised area within the foot is slightly concave and plain.

It has base diameters between 3 and 6 centimeters. It has been found in Pink/Buff A fabric (1 sherd) and Pink/Buff B fabric (4 sherds). It is not usually decorated, but there are rare examples of semi-glossy red slip on the interior surface.

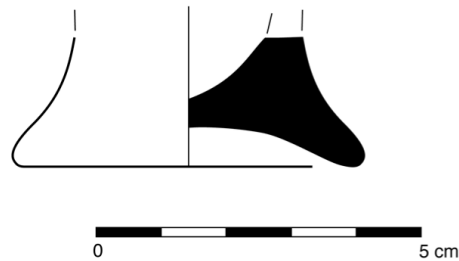

Figure 508: Base in Pink/Buff B fabric with matte red slip on exterior; TZ 2005 Ch.6 UF 4

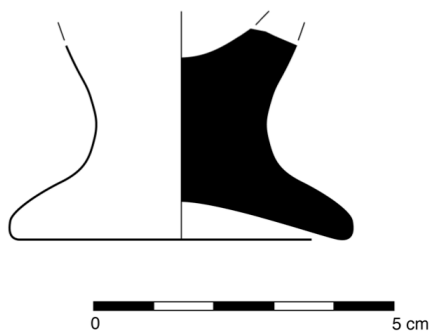

Figure 509: Base in Pink/Buff A, unslipped; TZ 2005 Ch.6 UF 10

*Lower Profile Type 23 (n=10)*

This type has an articulated base (Figure 510). It has a ring foot and a thick pedestal above a slightly concave indentation in the bottom of the vessel. The walls of the ring foot are angled outward from the body. The outer walls of the foot have varying numbers of molded grooved decoration.

It has base diameters between 4 and 7 centimeters. It has been found in Pink/Buff A fabric (6 sherds), Pink/Buff B fabric (2 sherds), and Gray fabric (2 sherds). Undecorated examples have been found, but red or eggplant colored semi-glossy slip is just as common.

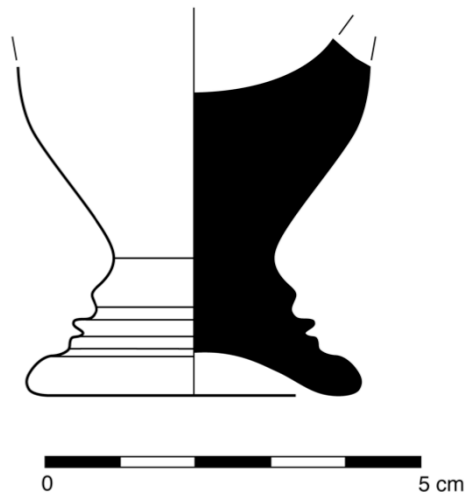

Figure 510: Base in Pink/Buff A fabric with semi-glossy red slip; TZ 2005 Ch.6 UF 10

*Lower Profile Type 24 (n=129)*

This type has a ring foot and a thick pedestal above a deep concave indentation in the bottom of the vessel (Figures 511, 512). The walls of the ring foot are angled outward from the body. The outer walls of the foot have varying numbers of molded grooved decoration.

It usually has base diameters between 3 and 7 centimeters, but there is one example in Gray fabric with a 15 centimeter base diameter. It has been found primarily in Pink/Buff A fabric (79 sherds) and Pink/Buff B fabric (45 sherds), but there are occasional examples in Gray fabric (5 sherds). The Gray examples usually have dark gray slip. There are undecorated examples, but just as common is semi-glossy slip, usually red, but sometimes eggplant colored.

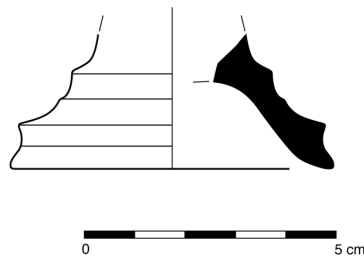

Figure 511: Base in Pink/Buff B fabric with semi-glossy eggplant colored slip; TZ 2008 Ch.18 UF 28

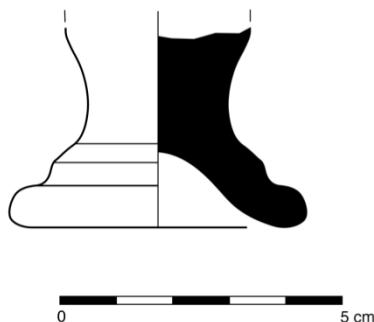

Figure 512: Base in Pink/Buff B fabric with semi-glossy red slip and vertical burnishing; TZ 2005 Ch.6 UF 5



*Lower Profile Type 25 (n=1)*

This type has an articulated base (Figure 513). It has a ring foot and a thick pedestal above a deep indentation in the bottom of the vessel. The walls of the ring foot are close to vertical.

The single example has a base diameter of 5.5 centimeters. It has been found in Pink/Buff B fabric with red semi-glossy slip.

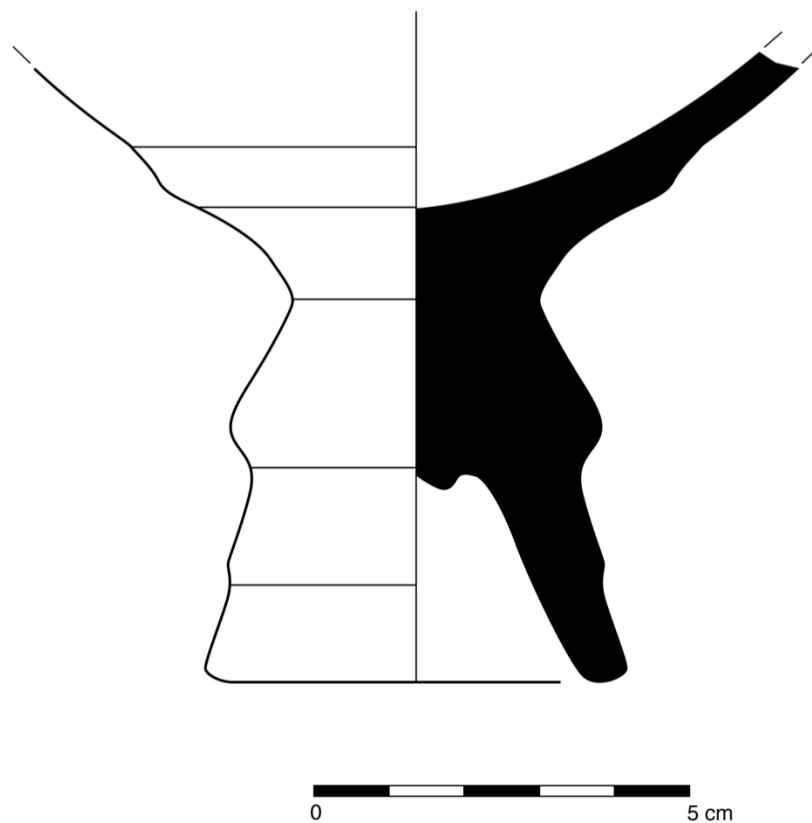

Figure 513: Base in Pink/Buff B fabric with semi-glossy red slip; TZ 2005 Ch.6 UF 53

## **Lower Group Cluster B: Diagnostically Non-useful Forms**

This cluster contains thirteen types in two groups. They are diagnostically not useful in the sense that either all examples of a given type are too poorly preserved to determine the shape of the vessel or that a type is so commonly used across shape groups that alone it offers no useful information. These are found in a great variety of fabrics and range of sizes. Function cannot be determined for these vessels, so they are grouped by morphological distinctions of base formation, either plain or articulated.

### *Lower Cluster Group B: Diagnostically Non-useful Forms*

- *Shape Group V: Plain Bases, Lower Profile Types 26-28*
- *Shape Group VI: Articulated Bases, Lower Profile Types 29-38*

## Shape Group V: Plain Bases

### Lower Profile Types 26-28

This group contains three types of unarticulated, or plain, bases (Figure 514). They are found in both coarse and fine fabrics and can be bases for both open and closed vessels.

Lower Profile Type 27 is very common.

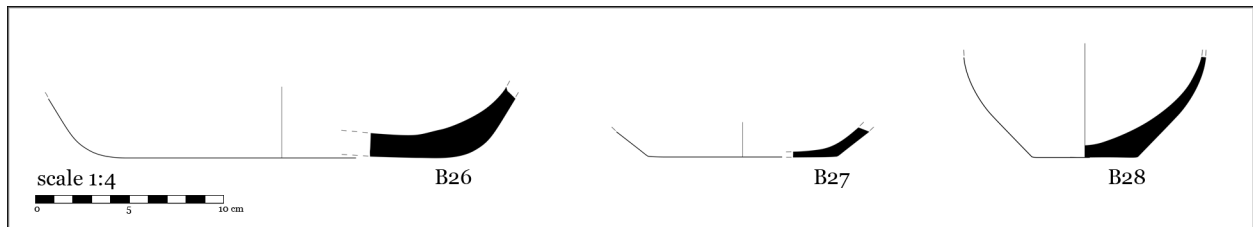

Figure 514: Compendium of Lower Shape Group V vessels

*Lower Profile Type 26 (n=19)*

This type has a plain, flat base (Figure 515). The join of the bottom and the walls of the vessel is defined and rounded.

It has base diameters between 4 and 25 centimeters. It has been found in Pink/Buff A fabric (5 sherds), Pink/Buff B fabric (6 sherds), Peach Cream fabric (1 sherd), and coarse fabrics (7 sherds). There are undecorated examples as well as red semi-glossy slip.

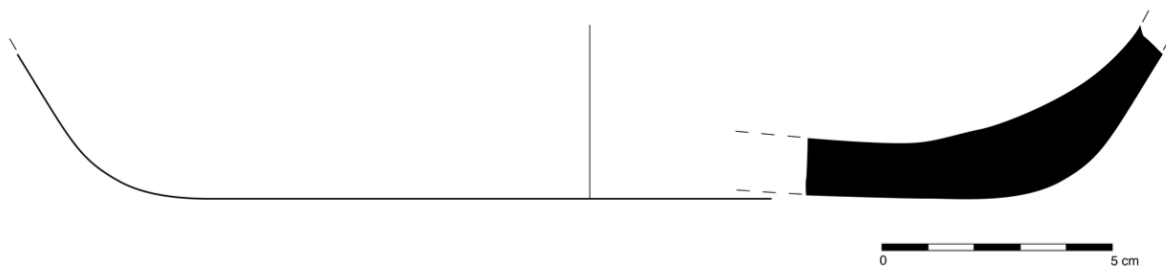

Figure 515: Base in Light Brown fabric; TZ 2004 Ch.4 Sec.2 UF 18

*Lower Profile Type 27 (n=2009)*

This type is a plain, flat base (Figures 516-519). The join of the bottom and the vessel walls is angular. The lower walls are straight, angled outward, and plain.

It has base diameters between 5 and 42 centimeters. This type has been found in Pink/Buff B fabric (828 sherds), Pink/Buff A fabric (791), Peach Cream fabric (88 sherds), and coarse fabrics (302 sherds). One of the most common types, there are unslipped varieties as well as red and eggplant colored matte and semi-glossy slips. Several examples have been found in lustrous red slip.

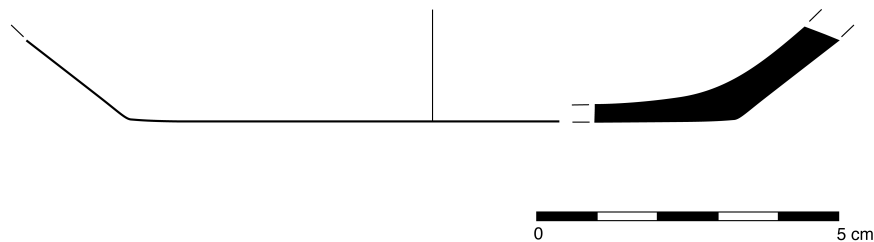

Figure 516: Base in Pink/Buff B fabric with semi-glossy red slip; TZ 2004 Ch.2 UF 9

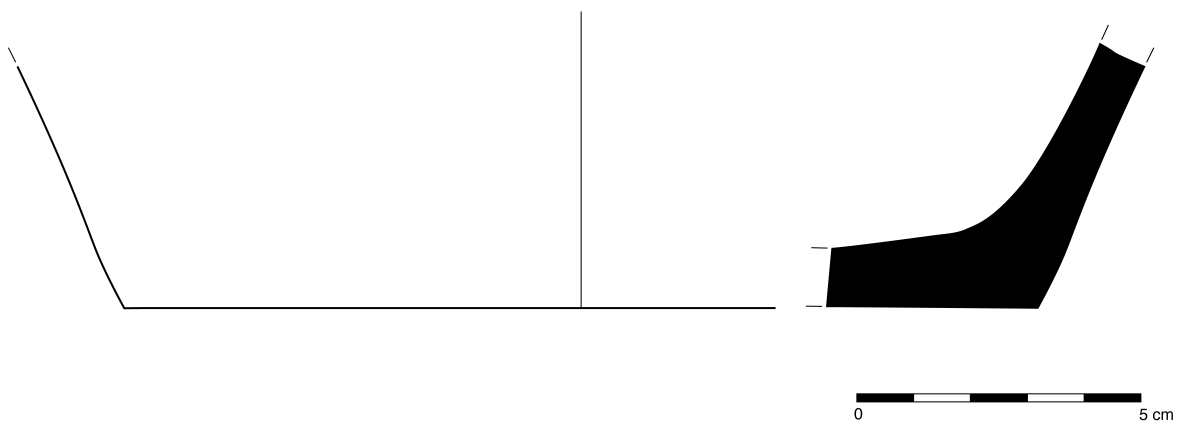

Figure 517: Base in Muddy Jar fabric; TZ 2004 Ch.2 UF 65

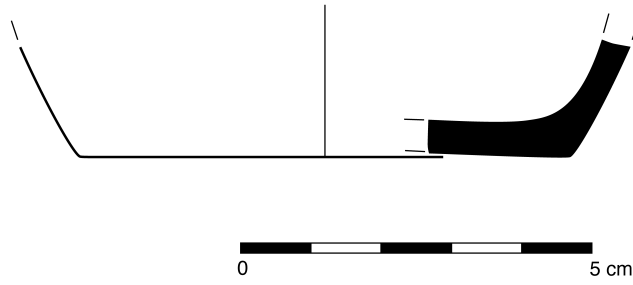

Figure 518: Base in Pink/Buff B fabric with semi-glossy red slip; TZ 2004 Ch.4 Sec.2 UF 17

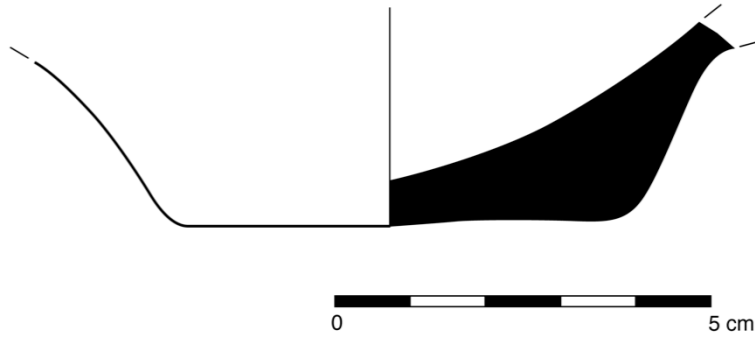

Figure 519: Base in Peach Cream fabric; TZ 2008 Ch.18 UF 27

*Lower Profile Type 28 (n=24)*

This type is a plain, flat base (Figure 520). The join of the bottom and the vessel walls is angular. The lower walls are convex.

It usually has base diameters between 20 and 25 centimeters in coarse examples (23 sherds). The single example in Pink/Buff B fabric has a 5 centimeter base and red semi-glossy slip. No others are decorated.

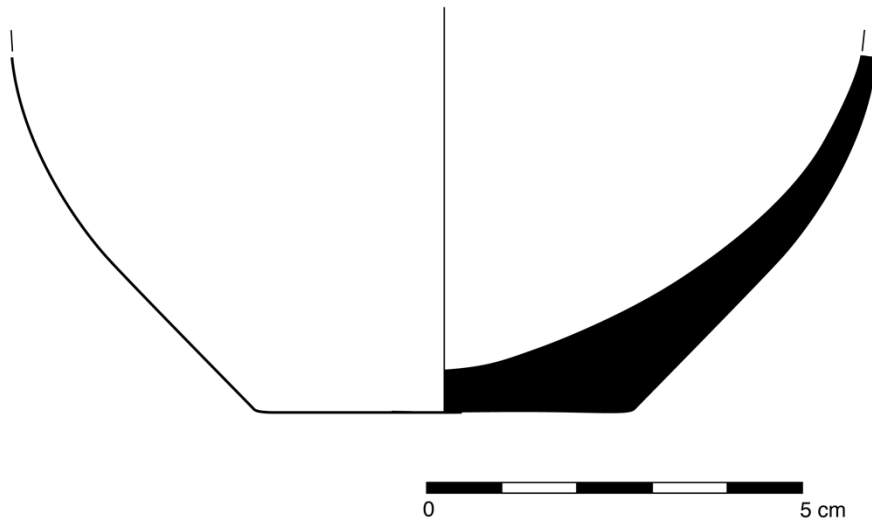

Figure 520: Rim in Pink/Buff B fabric with red semi-glossy slip; TZ 2004 Ch.2 UF 65

## Shape Group VI: Articulated Bases

### Lower Profile Types 29-38

This group contains 10 types of articulated bases (Figure 521). Like the vessels in Group 5, they are found in both coarse and fine fabrics and can be bases for both open and closed vessels.

Lower Profile Type 30 is rare. Lower Profile Types 32 and 34 are very common.

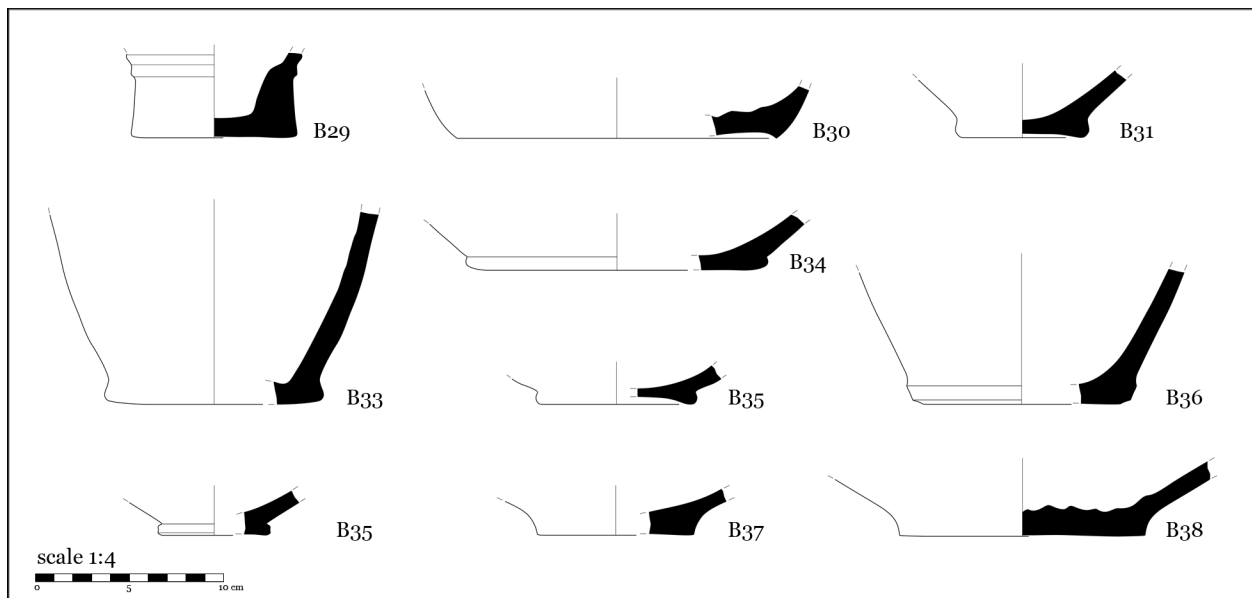

Figure 521: Compendium of Lower Shape Group VI vessels



*Lower Profile Type 29 (n=8)*

This type is a plain, flat base (Figure 522). The join of the bottom and the vessel walls is angular. The lower walls are straight, vertical, and have a ridge on the lower body.

It has base diameters between 8 and 12 centimeters. It has been found in Peach Cream fabric (5 sherds) and Pink/Buff A fabric (3 sherds); there are no decorated examples.

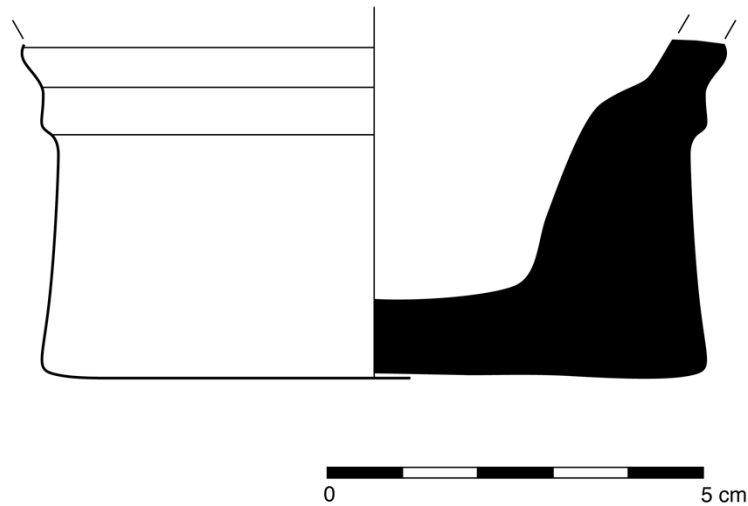

Figure 522: Base in Peach Cream fabric; TZ 2008 Ch.18 UF 1

*Lower Profile Type 30 (n=3)*

This type is a plain, slightly concave base (Figure 523). The join of the bottom and the vessel walls is angular. The lower walls are slightly convex and angle outward. All examples have body walls at an angle of 15 to 45 degrees from the bottom plane.

It has base diameters between 15 and 20 centimeters. It has been found in Pink/Buff B fabric (3 sherds), occasionally with eggplant colored semi-glossy slip.

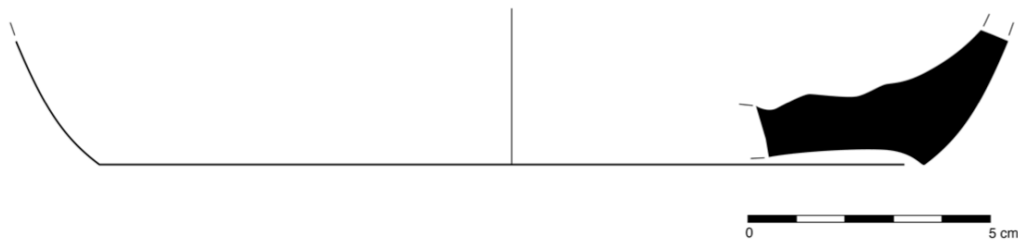

Figure 523: Base in Pink/Buff B fabric, unslipped; TZ 2005 Ch.6 UF 53

*Lower Profile Type 31 (n=44)*

This type is a well-articulated disc foot (Figures 524-526). The join of the side of the foot and the bottom of the foot is rounded. Many upper profile types likely join with this base.

It has base diameters between 5 and 30 centimeters. It has been found primarily in Pink/Buff A fabric (29 sherds) and Pink/Buff B fabric (13 sherds), and rarely coarse fabrics (2 sherds). There are undecorated varieties. Red semi-glossy slip is also common, often used in conjunction with starburst patterned burnishing. There are rarely incised concentric circles on the interior.

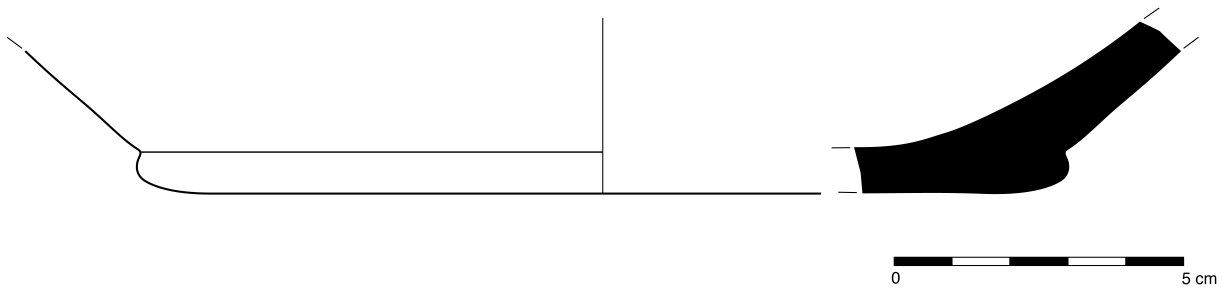

Figure 524: Base in Pink/Buff A fabric with semi-glossy red slip on interior; TZ 2005 Ch.6 UF 3

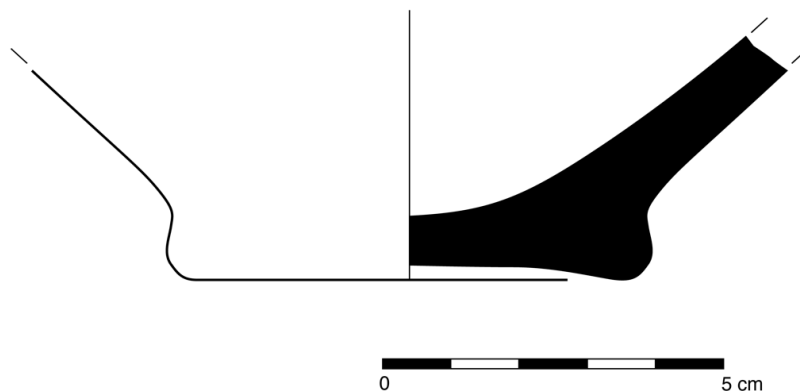

Figure 525: Base in Pink/Buff B fabric, unslipped; TZ 2005 CH.6 UF 53

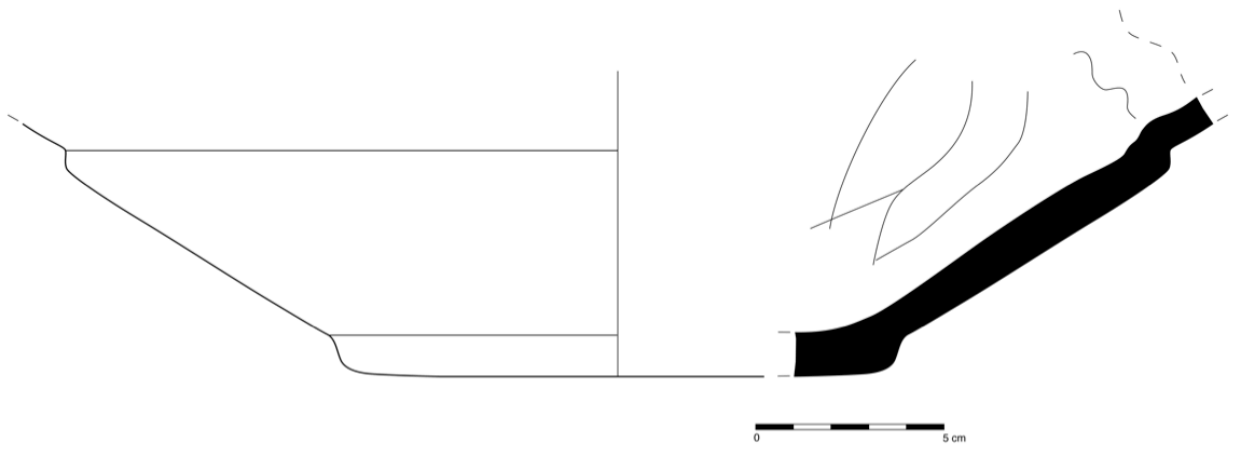

Figure 526: Base and lower walls in Pink/Buff A fabric with semi-glossy red slip and starburst burnishing on interior and incised wavy lines on upper walls; TZ 2004 Ch.2 UF 9

*Lower Profile Type 32 (n=1645)*

One of the most common Lower Profile Types, this type is an articulated disc foot and does not have a pedestal (Figure 527). The join of the side of the foot and the bottom of the foot is rounded. The lower walls angle outward and meet the bottom plane at an angle between 0 and 45 degrees. The lower walls are slightly rounded inward, but they are not definitively open or closed vessels.

It has base diameters between 5 and 45 centimeters. It has been found in primarily in Pink/Buff B fabric (748 sherds), coarse fabrics (36 sherds), and Pink/Buff A fabric (838 sherds), but there are occasional examples in Peach Cream fabric (2 sherds), Orange fabric (20 sherds), and Gray fabric (1 sherd). There are many undecorated examples. Red semi-glossy and matte slip are relatively common, sometimes used in conjunction with incised concentric circles or patterned burnishing.

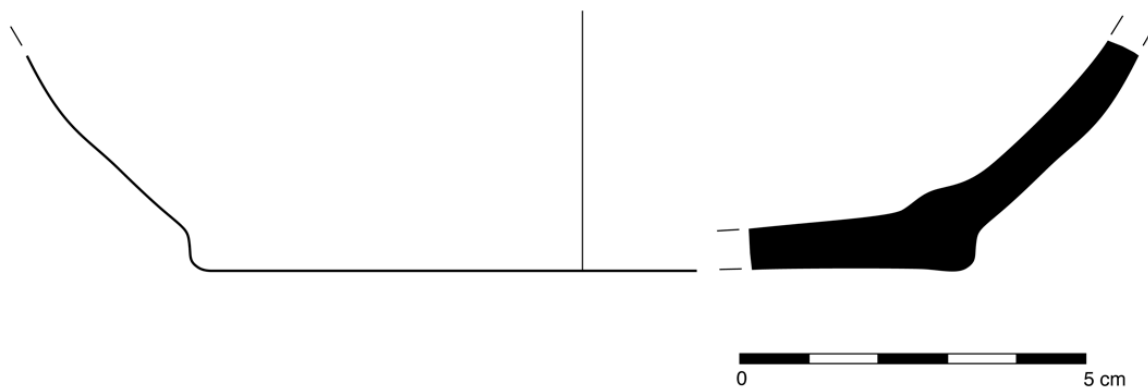

Figure 527: Base in Pink/Buff B fabric with semi-glossy eggplant colored slip on interior; TZ 2004 Ch.2 UF 9

*Lower Profile Type 33* (n=14)

This type has an articulated disc foot and does not have a pedestal (Figure 528). The join of the side of the foot and the bottom of the foot is rounded. The lower walls angle outward and meet the bottom plane at an angle between 45 and 90 degrees. The walls are straight. These are likely closed vessels.

It has base diameters between 3 and 17 centimeters. It has been found in Pink/Buff A (2 sherds) and Pink/Buff B (12 sherds) fabrics. It is often unslipped, but red semi-glossy slip is common, often used in conjunction with vertical burnishing on the exterior of the vessel.

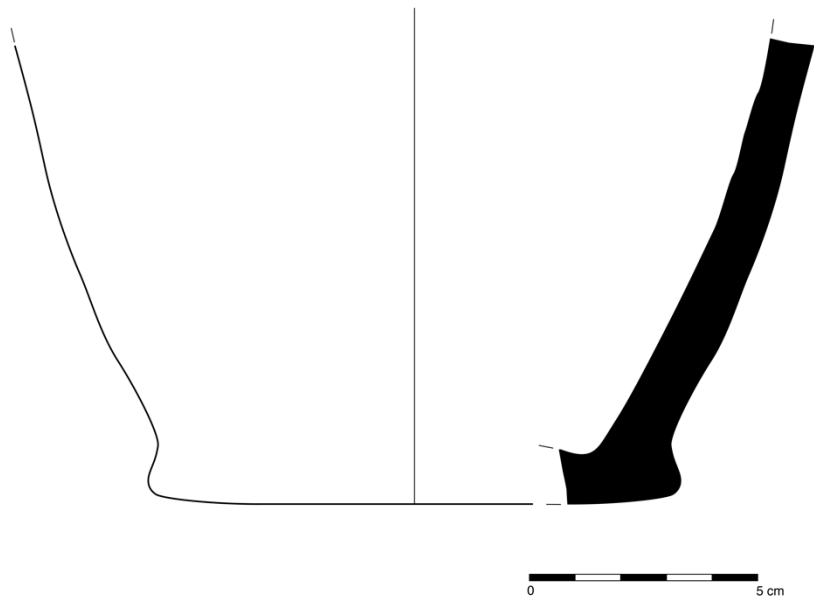

Figure 528: Base in Pink/Buff B fabric, unslipped; TZ 2005 Ch.6 UF 1

*Lower Profile Type 34* (n=150)

This type is an articulated, very low ring foot and does not have a pedestal (Figures 529-531). The walls of the foot are at an outward angle from the body and the bottom of the ring is rounded. The raised area within the foot is slightly concave.

This type has base diameters between 4 and 10 centimeters. It has been found primarily in Pink/Buff B fabric (59 sherds) and Pink/Buff A fabric (86 sherds), but there are occasional examples in Orange fabric (1 sherd) and Gray fabric (4 sherds). There are undecorated varieties. The Gray examples are not painted and often have incised concentric circles on the interior of the vessel. Red and eggplant colored semi-glossy and matte paint is common, frequently used in conjunction with incised concentric circles, between one and three. There is occasional patterned burnishing.

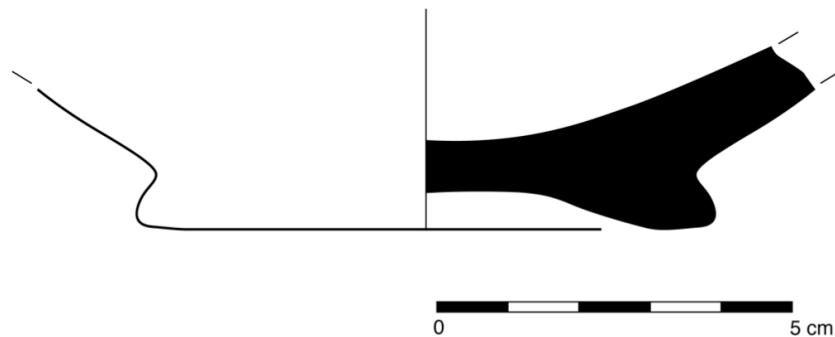

Figure 529: Base in Pink/Buff A fabric with semi-glossy red slip on interior; TZ 2005 Ch.6 UF 107

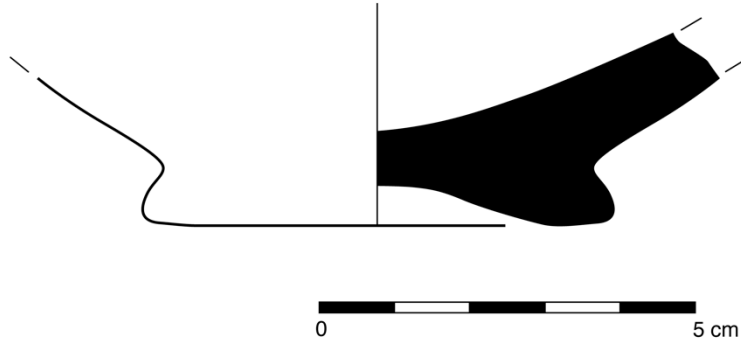

Figure 530: Base in Pink/Buff B fabric with semi-glossy red slip and burnished starburst pattern on interior; TZ 2005 Ch.6 UF 56

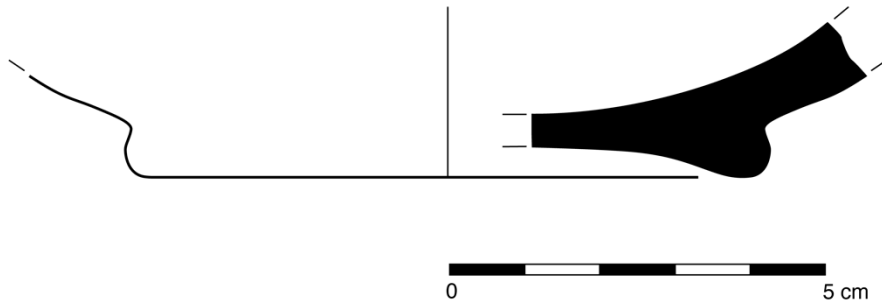

Figure 531: Rim in Pink/Buff B fabric, unslipped with four concentric circles on interior; TZ 2007 Ch.6 UF 12



*Lower Profile Type 35 (n=7)*

This type has a disc foot and does not have a pedestal (Figure 532). The join of the side of the foot and the bottom of the foot is angular. The foot has multiple worked angles at the join of its side and bottom. The lower walls angle outward and meet the bottom plane at an angle between 0 and 45 degrees.

It has base diameters between 4 and 11 centimeters. It has been found in Pink/Buff A fabric (5 sherds) and Pink/Buff B fabric (2 sherd). There are unslipped examples, but red semi-glossy slip is common, sometimes of unusually high quality.

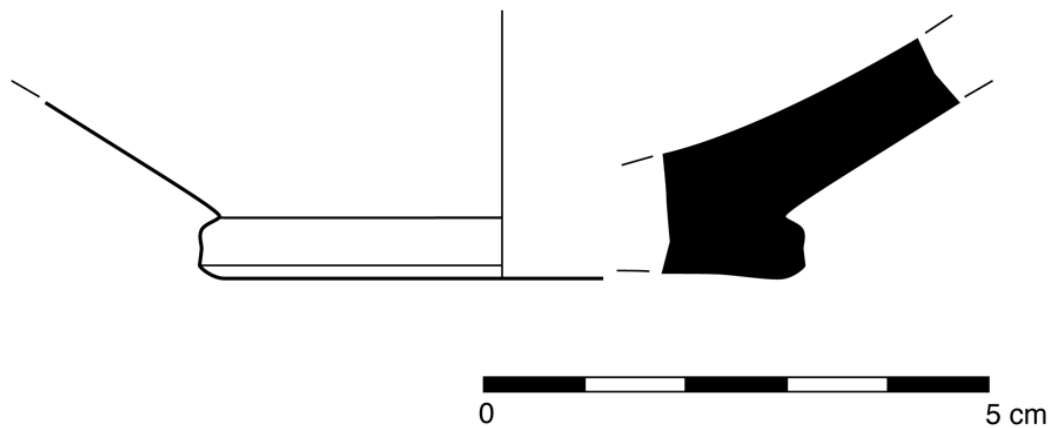

Figure 532: Base in Pink/Buff A fabric with high quality semi-glossy red slip on interior; TZ 2005 Ch.6 UF 1

*Lower Profile Type 36 (n=51)*

This type has a disc foot and does not have a pedestal (Figure 533). The join of the side of the foot and the bottom of the foot is angular. The foot has multiple worked angles at the join of its side and bottom. The lower walls angle outward and meet the bottom plane at an angle between 45 and 90 degrees.

It has base diameters between 10 and 20 centimeters. It has been found primarily in coarse fabrics (46 sherds), but there are occasional examples in Pink/Buff B fabric (5 sherds). Most examples are undecorated, but red semi-glossy slip is sometimes found.

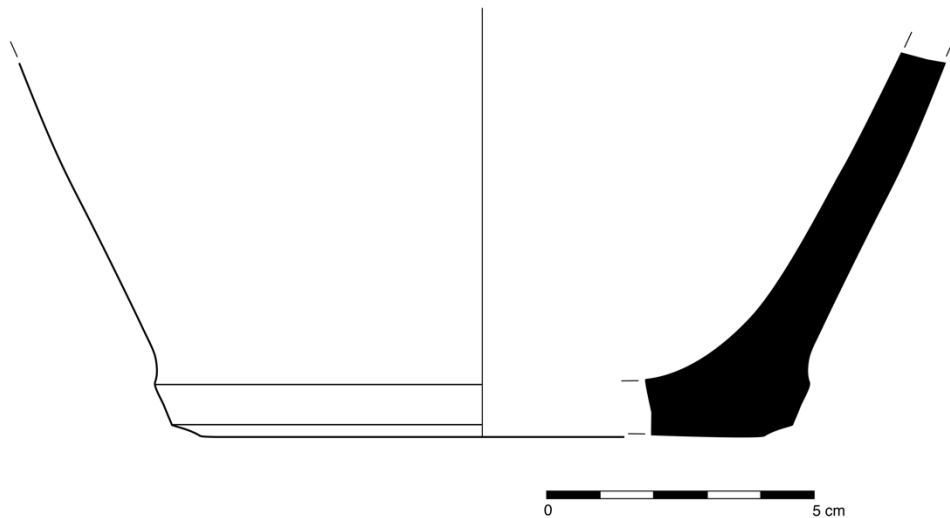

Figure 533: Base in Muddy Jar fabric; TZ 2007 Ch.6 UF 3

*Lower Profile Type 37 (n=14)*

This type has an articulated disc foot (Figure 534). The join of the side of the foot and the bottom of the foot is angular. The join of the vessel walls and the foot is concave. The lower walls angle outward on all examples and meet the bottom plane at an angle between 0 and 45 degrees.

It has base diameters between 4 and 8 centimeters. It has been found primarily in Pink/Buff A fabric (12 sherds), but there are rare examples in Pink/Buff B fabric (2 sherds). Most examples are unslipped, but red semi-glossy slip occurs and there is one example of a circle of red paint surrounded by black slip in the interior of the vessel.

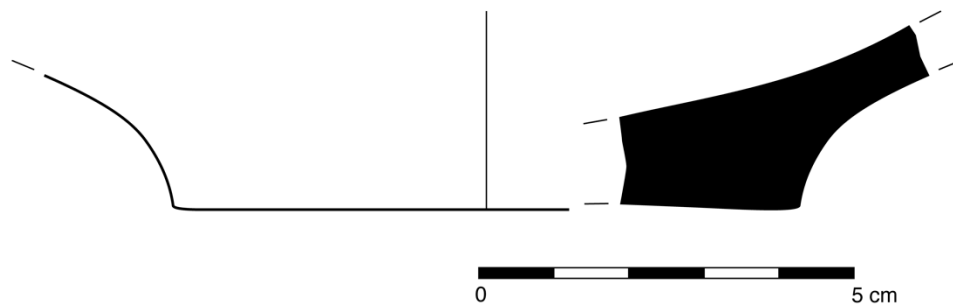

Figure 534: Base in Pink/Buff A fabric, unslipped; TZ 2005 Ch.6 UF 17

*Lower Profile Type 38 (n=2)*

This type has an articulated disc foot (Figure 535). The join of the side of the foot and the bottom of the foot is angular. The join of the vessel walls and the foot is concave. The lower walls angle outward on all examples and meet the bottom plane at an angle between 0 and 45 degrees. The interior walls and floor are wavy, probably from finger grooves while being constructed on a wheel or tournette.

This rare type has base diameters between 10 and 15 centimeters. It has only been found in Pink/Buff A fabric (2 sherds) with red semi-glossy slip.

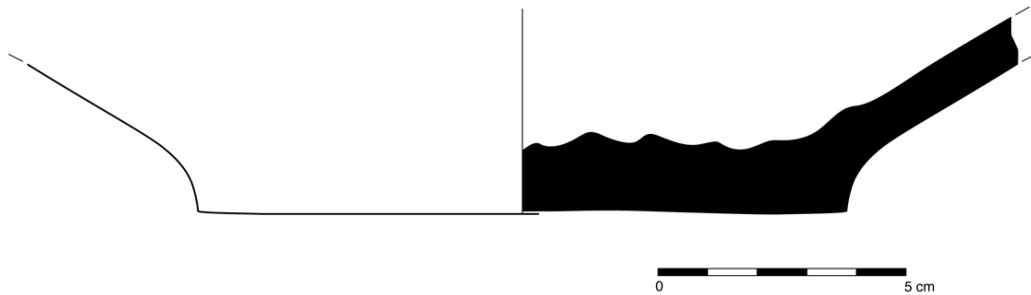

Figure 535: Base in Pink/Buff A fabric with semi-glossy red slip dripped on exterior; TZ 2005 Ch.6 UF 53

## Lids

Only four examples of identifiable lids have been found at Bactra (Figures 536-539). In fine and coarse fabrics, those with definable edges range in diameter from 10 to 12 centimeters, but a broader range is likely. The contextual information is not sufficient to determine with which vessels these lids were used. They all have graspable tops, while the specimen in coarse fabric has a narrow hole running completely through it, perhaps for a rope.

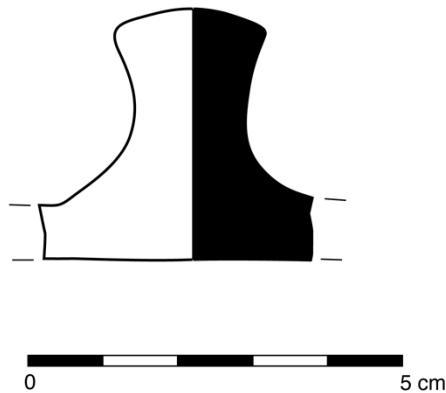

Figure 536: Lid in Pink/Buff A fabric, unslipped; TZ 2005 Ch.6 UF 4

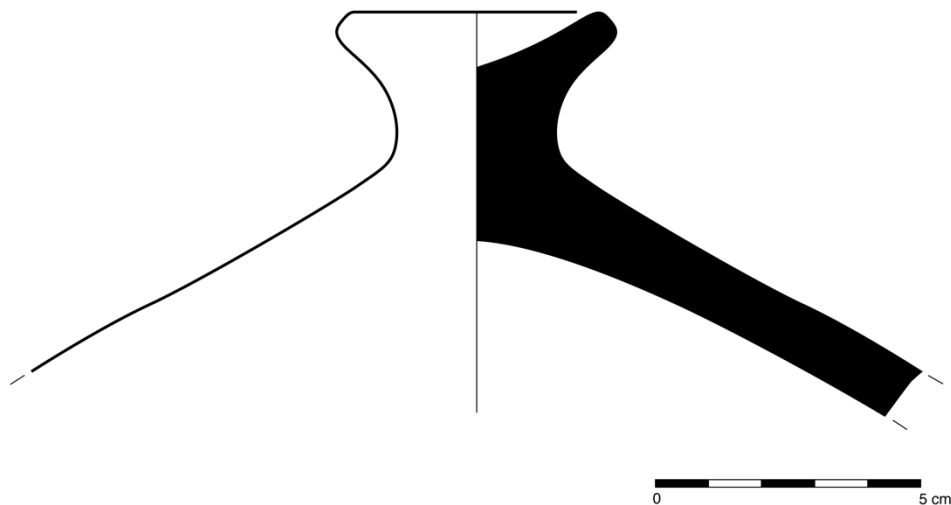

Figure 537: Lid in Peach Cream fabric; BH 2005 UF 16

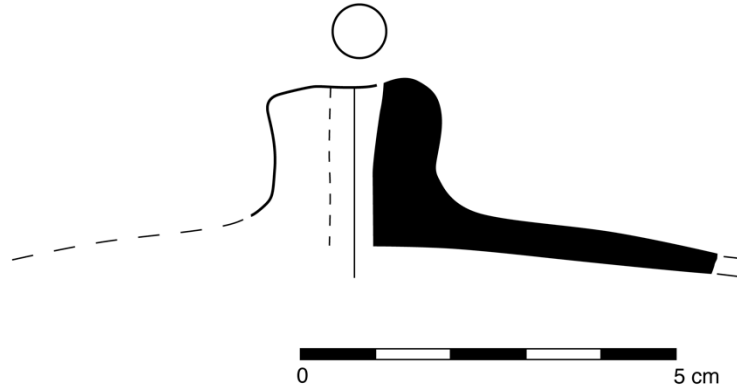

Figure 538: Lid in Muddy Jar fabric; TZ 2005 Ch.6 UF 53

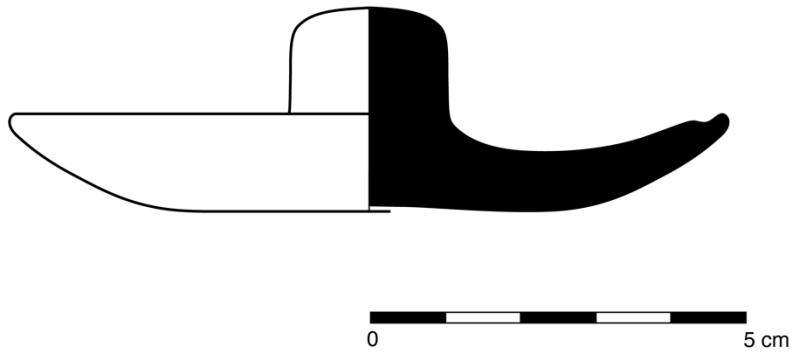

Figure 539: Lid in Pink/Buff A fabric, unslipped; TZ 2005 Ch.6 UF 5

## Handles

A variety of handles types are found on both utilitarian and table vessels (Figures 537-540). Utilitarian vessels tend to have either small loop handles (Figure 542), horse-shoe shaped handles (Figures 540, 541), vestigial attached handles, or large lug handles. Amphorae of all sizes tend to have fairly plain handles that are indented in section (Figure 543). Typically, only the straight portion of the handle is found, but occasionally the hooked section joining with the neck is preserved (1921 examples). The most distinctive handle type seen at Bactra is a rope-shaped handle (79 examples). This appears only on large, straight walled open table vessels (Figures 544, 545, 546). All examples that can be connected with a shape type are on Upper Profile Type 124. The rope handles are the only chronologically diagnostic type and seem to indicate a late Kushano-Sasanid date. There are scalloped-shaped hand holds that tend to be connected to either Upper Profile Type 122 or 123 (Figure 547).



Figure 540: Photo of horseshoe-shaped handle on Upper Profile Type 4 in White Grit Brown fabric with impressed dots and incised lines on shoulder; TZ 2005 Ch. 6 UF 4

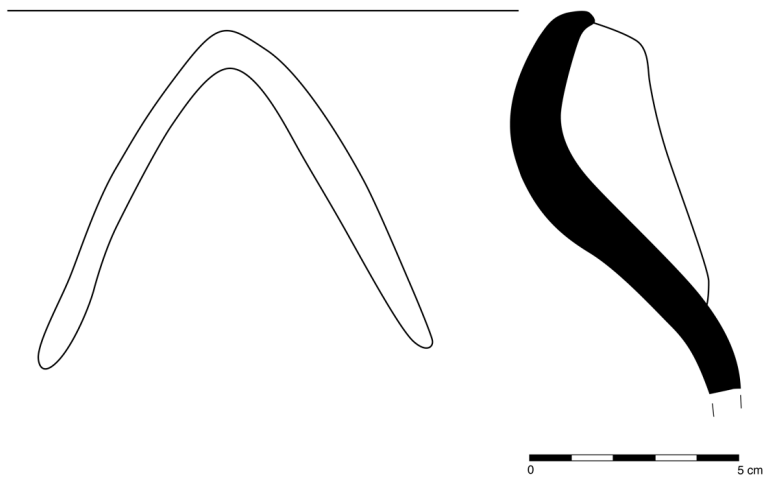

Figure 541: Drawing of horse-shoe-shaped handle; *ibid.*



Figure 542: Photo of loop handle on tureen in Pink/Buff A fabric with matte red slip on rim and upper body; TZ 2005 Ch.6 UF 17



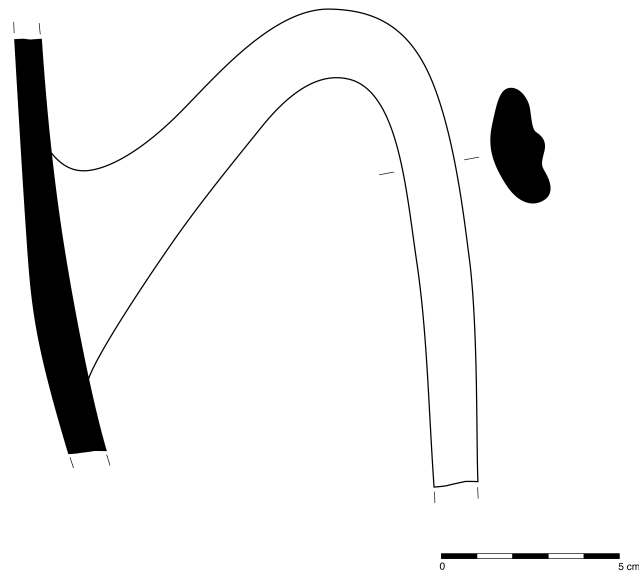

Figure 543: Body sherd with amphora handle in Pink/Buff B fabric with semi-glossy eggplant colored slip; TZ 2005 Ch.6 UF 4



Figure 544: Photo of rope handle and rim of Upper Profile Type 124 in Pink/Buff B fabric with matte eggplant colored slip and incised/combed wavy lines; TZ 2008 Ch.6 UF 15



Figure 545: Photo of rope handle and rim of Upper Profile Type 124 in Pink/Buff B fabric with matte red slip and incised wavy lines; TZ 2008 Ch.6 UF 15

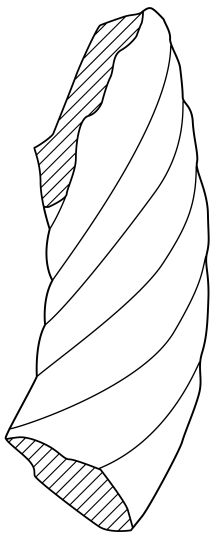

Figure 546: Drawing of typical rope handle



Figure 547: Photo of scalloped hand hold on Upper Profile Type 123 in Pink/Buff B fabric with semi-glossy red slip; TZ 2005 Ch.6 UF 4

## Lamps

All lamps in the pre-Islamic material from Bactra are open shapes. The closed, mold made lamps typical of the Hellenistic period elsewhere, recognizable even in small pieces, are not present in the Bactra corpus. The most common style has slanted walls and an inward folded rim (Figures 548, 549). Where preserved, they show a slightly pinched spout. Less common are lamps with slanted or curved walls and flat lips (Figure 551). Several examples of lamps have straight, plain walls that have iron-shaped bases (Figure 550). Unless a large portion of the lamp is preserved, they are difficult to identify.

Folded and flat-lipped lamps have rim diameters from 5-12 centimeters and base diameters from 3 to 8 centimeters. All examples appear wheel-made. Iron shaped lamps are usually 5-7 centimeters wide and at least 8 centimeters long. When it is possible to determine technique, iron-shaped lamps appear hand-made. All lamp forms have been found in Pink/Buff A and Pink/Buff B fabrics. No examples are decorated.

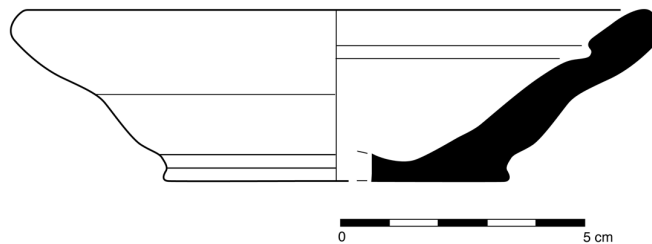

Figure 548: Folded rim lamp

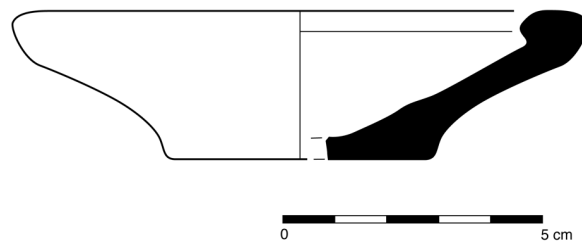

Figure 549: Folded rim lamp

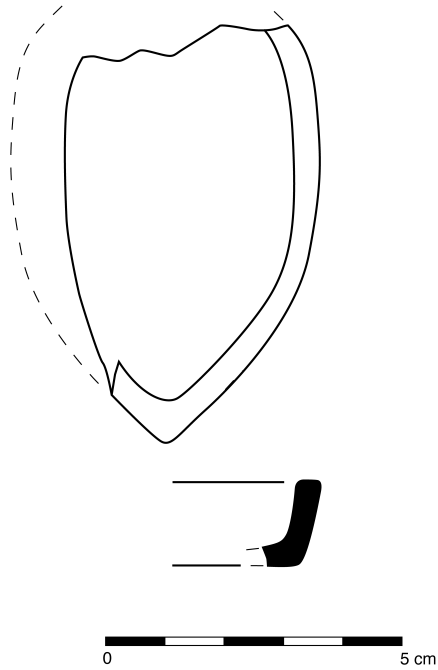

Figure 550: "Iron" shaped lamp

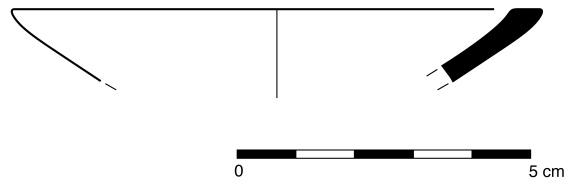

Figure 551: Slant-walled flat lipped lamp

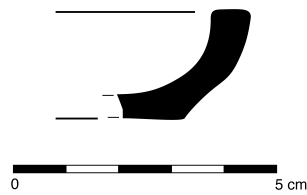

Figure 552: Curved walled lamp with flat lip

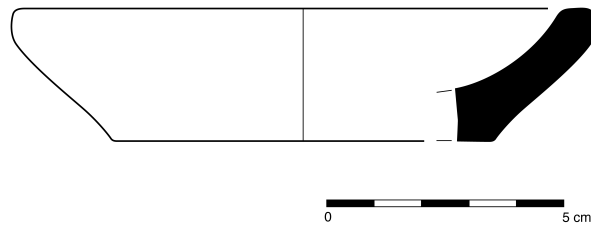

Figure 553: Curved walled lamp with flat lip

## Spouts and Nozzles

Many spouted vessels exist in the Bactra corpus, but unfortunately no spouts are attached to other diagnostic sherds. They are all found in Pink/Buff A and Pink/Buff B fabrics and are often decorated with semi-glossy red and less commonly eggplant colored slip. They range in length from 7 to 25 centimeters and are between 2.5 and 5 centimeters in width (Figure 554). These were likely attached to small table amphorae vessels in such a way that would turn them into pitchers, but no examples are preserved well enough to prove this.

There is a single example of a kendi nozzle at Bactra (Figures 555-557). In Pink/Buff A fabric with matte red slip, this is likely locally made, but is similar to south Indian examples.



Figure 554: Typical slipped spout, 14cm lengthwise



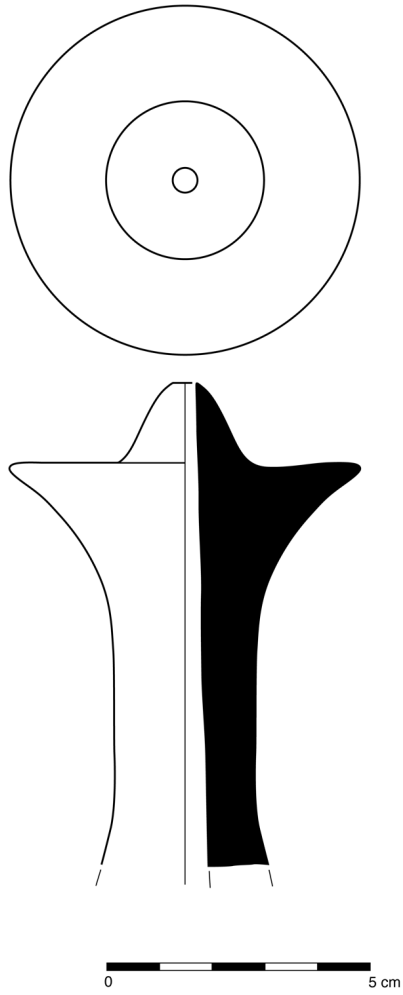

Figure 555: (above left) Kendi profile drawing

Figure 556: (above right) Kendi, photo in profile



Figure 557: (above right) Kendi, photo of broken edge of lower portion of nozzle

## CHAPTER FOUR

### CERAMIC CHRONOLOGY

#### **Introduction**

In this chapter, a ceramic sequence for ancient Bactra is proposed, roughly spanning from the pre-Achaemenid period through the Kushano-Sasanid period. Absolute dates and the historical periods associated with them are offered first in order to provide a rough temporal orientation, established where architectural or external ceramic parallels allowed for reasonable suggestions. Proceeding chronologically, an overview of the evidence used to establish each phase is then presented. This is followed by the relative chronological sequence, which was produced using a combination of qualitative methods as well as rigorously quantitative statistical analysis, as described in Chapter Two.<sup>129</sup> Chapter Five contextualizes this ceramic sequence in the larger world of Central Asia.

The relative ceramic sequence is presented according to six major phases, or horizons, each of which contains three subphases. The sequence of some shape types is more certain than others and this degree of certainty is demonstrated using color-coded charts. I have a greater degree of certainty for the primary phases than the subphases. For instance, although there is a high degree of certainty that small bowl form R165 appears in Phase VI; there is less certitude that it appears in Phase VI-C. In order to

---

<sup>129</sup> The numismatic material at Bactra is problematic. Of the roughly 3500 coins, I can only place 53 in stratified deposits. Most have either not been cleaned, are associated with stratified deposits whose ceramics have been lost, or are not usable because of the mistakes and inconsistencies found in the numismatic report. Overall, given the lack of information about deposit types, they do not resolve any chronological problem.



indicate the level of certainty for the subphases, each shape's type number is indicated by a color with a sliding scale from dark to light. The darker the color, the higher degree of confidence. Certainty was greater for larger numbers of specific vessel types, which allowed for more robust statistical analysis. Three degrees are assigned to each color. The lightest hue indicates little statistical certainty for the particular chronological subphase, although a given assignment to any one phase is in itself most certain.

Moreover, the phasing charts attempt to render the longevity of each shape's use. For those shapes whose fabric and decoration change drastically throughout the period of their production, this information appears in the description of the first subphase to which it is assigned. Some common base forms and utility shapes changed little over the duration of the approximately thousand-year period of my study.

### **Absolute Chronology**

This section proposes a tentative absolute chronology that serves to temporally anchor the relative chronology. The absolute dates cover approximately 600 BCE to 425 CE (Table 13). Each ceramic phase is offered with absolute dates that refer to historical periods. This is followed by an analysis of the evidence that is used to arrive at a specific date and hence the relative certainty of each phase.

<b>Phase I</b>	<b>Phase II</b>	<b>Phase III</b>	<b>Phase IV</b>	<b>Phase V</b>	<b>Phase VI</b>
6 <sup>th</sup> -4 <sup>th</sup> /early 3 <sup>rd</sup> c. BCE	3 <sup>rd</sup> /early 3 <sup>rd</sup> -mid 1st c. BCE	mid 1 <sup>st</sup> c. BCE-mid c. CE 1 <sup>st</sup> c.	mid-1 <sup>st</sup> -2 <sup>nd</sup> c. CE	3 <sup>rd</sup> -early 4 <sup>th</sup> c. CE	early 4 <sup>th</sup> – early 5 <sup>th</sup> c. CE
600-301/276 BCE	300/275-51 BCE	50 BCE – 50 CE	51-200 CE	201-325	326-425
Achaemenid and early Hellenistic	Seleucid, Graeco-Bactrian, and Nomadic	Nomadic Period	Kushan	Kushan and Kushano-Sasanid	Kushano-Sasanid

Table 13: Suggested Absolute Dates of Ceramic Phases

### *Ceramic Phase I: 6<sup>th</sup>-4<sup>th</sup> c. BCE*

In political terms, the absolute dates of this ceramic phase include an unknown length of time in the pre-Achaemenid Iron Age, the period of Achaemenid rule and a quarter- to half-century of Hellenistic rule. The earliest absolute dates of this ceramic phase are far from certain and could be as early as the 7<sup>th</sup> or 8<sup>th</sup> century BCE. Only a handful of identifiably Middle Iron Age sherds has been found at Bactra, and there does not appear to be any residual ceramic material with this sole exception. It is likely that the pottery of this phase, while remarkably homogenous and occurring largely within the temporal parameters of Achaemenid rule, is the product of a local or regional tradition that, although not affected by Achaemenid rule, was disrupted relatively quickly by the Hellenistic conquest.

Circumstantial evidence provides a fairly secure end date for this phase in the late 4<sup>th</sup> century-early 3<sup>rd</sup> century BCE. The Hellenistic conquest seems to have brought about a different dining culture characterized by the sudden appearance of a variety of individual dining vessels. The 4<sup>th</sup>/early 3<sup>rd</sup> century as end date of this phase is arrived at by assuming that the ceramic production would change after a generation or two has passed.<sup>130</sup>

### *Ceramic Phase II: 3<sup>rd</sup>-mid 1<sup>st</sup> c. BCE*

Politically, the absolute dates of this ceramic phase encompass the period from the end of Seleucid rule in Bactria, through the era of the Graeco-Bactrians, to the early

---

<sup>130</sup> The change in ceramic technology to which I allude concerns the firing technique that created Peach Cream fabric and the shaping techniques. The Peach Cream firing method is used to create some of the early Hellenistic shapes, perhaps implying that local potters were catering to new demands using traditional technology. Most of these shapes also appear in the Pink/Buff fabrics in Phase II. The implication is that within the production span of these shapes two distinct firing technologies were in use simultaneously. If we assume that more than half of the examples appearing in Pink/Buff fabric were produced in under a century, then we may estimate that a quarter- to half-century must have elapsed between the introduction of small dining vessels and the loss of Peach Cream fabric.

Nomadic period. Although this ceramic phase includes three politically distinct periods, it is characterized by continuity of ceramic material culture.

It is fairly certain that the ceramic transition from Phase I to Phase II likely occurred around the late 4<sup>th</sup> to early 3<sup>rd</sup> century BCE. The end date of Phase II in the mid first century BCE is based partially on the revised ceramic chronology of Ai Khanoum. Although there is much controversy about the absolute dates for the site's Greek occupation, Ai Khanoum has a Greek ceramic sequence spanning the early 3<sup>rd</sup> to at least the late 2<sup>nd</sup> centuries BCE. A number of problems are associated with the date of the Greek abandonment of the site, as it was still occupied in the first century BCE, although not necessarily by Greeks.<sup>131</sup> Bactra and Ai Khanoum do not share identical assemblages, but there are enough commonalities to suggest a parallel absolute temporal date range for Phase II that encompasses *at least* the entire occupation period of Ai Khanoum.

In this study, I am drawing on the latest proposed dates for the occupation of Ai Khanoum and I am assuming that in the period of Nomadic hegemony, the site's material culture may not have been strongly affected by larger political changes.<sup>132</sup> Thus the end date of Phase II is based partially on the date for the Greek abandonment of Ai

---

<sup>131</sup> There is controversy surrounding the absolute dates of the Greek occupation of Ai Khanoum. For the moment, I simply furnish a rough chronology and will discuss in greater detail the implications of these disagreements in Chapter Five.

<sup>132</sup> For the most recent discussions of Ai Khanoum chronological issues, see: Lerner, Jeffrey D. "Correcting the Early History of Ay Kanom." *Archaeologische Mitteilungen aus Iran und Turan* 35-36, (2003-2004): 373-410; Lerner, Jeffrey D. "Revising the Chronologies of the Hellenistic Colonies of Samarkand-Marakanda (Afrasiab II-III) and Ai Khanoum (Northeastern Afghanistan)." *Anabasis: Studia Classica et Orientalia* 1, (2010): 58-79; Lerner, Jeffrey D. "A Reappraisal of the Economic Inscriptions and Coin Finds from Ai Khanoum." *Anabasis: Studia Classica et Orientalia* 2, (2011): 103-147; Holt, Frank. "When did the Greeks Abandon Ai Khanoum?" *Anabasis: Studia Classica et Orientalia* 3 (2012): 161-172; Lyonnet, Bertille. "Questions on the Date of the Hellenistic Pottery from Central Asia (Ai Khanoum, Marakanda and Koktepe)." *Ancient Civilizations from Scythia to Siberia* 18(1), (2012): 143-173; Lyonnet, Bertille. "La Céramique Hellénistique en Asie Centrale." In *Networks in the Hellenistic World--According to the Pottery in the Eastern Mediterranean and Beyond*, edited by Nina and Christiane Romer-Strehl Fenn, 351-370. Oxford: Archaeopress, 2013.

Khanoum and the continuation of ceramic forms at Bactra. The end date of the mid-1<sup>st</sup> century BCE relies on controversial evidence and might be changed with further evidence.<sup>133</sup>

*Ceramic Phase III: mid-1<sup>st</sup> c. BCE – mid 1<sup>st</sup> c. CE*

Politically, the absolute dates of this ceramic phase encompass part of the period of Nomadic hegemony and the beginning of Kushan hegemony. The beginning date of this period is problematic, because it relies on the controversial dates associated with Ai Khanoum. The end date is equally uncertain. There is a change in pottery characteristics, but it is not possible at this time to correlate it directly to a secure date. A date of the mid-1<sup>st</sup> century CE is suggested because of the introduction of new forms, possibly coinciding with greater trade during the consolidation of Kushan power, but this is admittedly uncertain.

*Ceramic Phase IV: mid-1<sup>st</sup>-2<sup>nd</sup> c. CE*

The absolute dates of this ceramic phase cover the Kushan dynasty and its expansion to the south. The beginning date of this phase is not secure and will undoubtedly change with improved data. The abandonment of Kampyr Tepe on the northern bank of the Oxus River helps establish the tentative end date of Phase IV. Kampyr Tepe contains many sealed deposits and floor deposits that are well dated by numismatic evidence, which indicate that the site was abandoned during or immediately

---

<sup>133</sup> It is important to note that the so-called Greek ceramic period IV of Ai Khanoum contains a number of high quality Hellenistic forms, including moldmade bowls, well decorated kraters, and Hellenistic lamps, none of which have been found at Bactra. The lower quality table vessels at Ai Khanoum do, however, have parallels at Bactra. Some of those high quality forms are the best dated, which is problematic for comparative purposes because they have been found in such low quantities at Bactra. Susan Rotroff has written about the diminishing production of kraters in the Mediterranean during the Hellenistic period and suggested that this trend indicates a change in symposium or drinking customs. Perhaps we should view the well-made sympotic assemblage at Ai Khanoum as a conscious attempt to perform 'traditional' Greek social customs. See Rotroff, S. "The Missing Krater and the Hellenistic Symposium: Drinking in the Age of Alexander the Great," Broadhead Classical Lecture No. 7, University of Canterbury, Christchurch, New Zealand, 1996.

after the reign of Kanishka, in the mid-2<sup>nd</sup> century CE. The ceramic assemblages at Bactra and Kampyr Tepe share enough similarities that the introduction of forms at Bactra that are not present at Kampyr Tepe is compelling evidence for the final date of Phase IV to have coincided with the abandonment of Kampyr Tepe or shortly thereafter.

The end date of this phase is more secure than its beginning, but given the problems of dating the reign of Kanishka as well as local assemblage differences, this date could be down-dated or up-dated by a half-century.<sup>134</sup>

#### *Ceramic Phase V: 3<sup>rd</sup> –early 4<sup>th</sup> c. CE*

The absolute dates of this ceramic phase encompass the end of the Kushan period to the beginning of the Kushano-Sasanid period.

The beginning date of this period is somewhat secure, but the end date, the early 4<sup>th</sup> c. CE, is less so. It is based on the dating of the most characteristic form of this period: the highly standardized vertical rim plate, R144. In a 2013 article Ladislav Stančo proposed a production date of this vessel form in Bactria and Sogdiana from mid-3<sup>rd</sup> to mid-4<sup>th</sup> c. CE, covering approximately a century, and I have adopted this dating for the Bactra chronology.<sup>135</sup> In previous research, proposed dates for this vessel form have ranged widely, from the 1<sup>st</sup> c. BCE to the beginning of the 7<sup>th</sup> c. CE, but Stančo's reassessment of the chronological range using published examples and dates revised with the latest numismatic data is persuasive. Given the great chronological

---

<sup>134</sup> See Cribb, J. "Numismatic evidence for Kushano-Sasanian chronology" *Studia Iranica* 19, pp. 151-193, 1990.

<sup>135</sup> Stančo, L. "Late Antique Fine Ware Dishes with Indented Rim in Bactria. Diffusion or Evolution?" *Parthica* 15, pp. 127-155, 2013. Stančo examined 158 examples of vertical rim plates from 21 sites around Bactria and southern Sogdiana, looking particularly at Jandavlateppa, Zartepa, and Karatepa. He collected numismatic evidence from these sites, including well-dated grave deposits from the Termez area, then used Joe Cribbs' 1990 re-assessment of Kushan and Kushano-Sasanid numismatic dates to "correct" the earlier numismatic dates provided for the vertical rim plate. He also relied on sites that have well-dated abandonments before the 3<sup>rd</sup> century CE, including Kampyr Tepe, whose (published) ceramic assemblages *do not* include the vertical rim plate.

controversies surrounding these vessels, however, the absolute dates remain insecure.

*Ceramic Phase VI: early 4<sup>th</sup> – early 5<sup>th</sup> c. CE*

The proposed absolute dates of this ceramic phase encompass part of the Kushano-Sasanid political era. They are not particularly secure and rely on both the insecure date of the end of production of the vertical rim bowl as well as the end of production of the quintessential form of Phase VI, the carinated hemispherical bowl, R165. Production dates for this form are very insecure and likely overlap to a large degree with R144, so it is possible that Phase VI lasts only to the early or mid- 5<sup>th</sup> century, but it is equally likely that further analysis will push the dates of both of these important forms forward by as much as a century.

**Internal Phasing and Relative Chronology**

The relative chronology presented in this chapter was constructed based entirely on internal data from Bactra. Only after this was established did I attempt to link the Bactra chronology with ceramic parallels from other sites in the region and establish an absolute chronology. I have endeavored to delineate phases that contain assemblages with cohesive characteristics. Because shapes and assemblages need not change at consistent intervals, some phases likely encompass longer spans of time than others. Phase I, for instance, likely lasted far longer than Phase VI. I have had to make some subjective decisions about phasing, particularly in the tripartite sub-phasing, but each decision is based on all available quantitative data. For those shape types with very few examples, I have suggested a sequential position, but stress the uncertainty in the

phasing tables.<sup>136</sup>

The tripartite subphases within each phase cluster shapes most likely to be found together. For instance, any two shapes in a single subphase are more likely to be found with each other than they are with shapes from a different subphase in the same phase. Because of the mathematical reality that there are more examples within a phase than a subphase, the phase distinctions are statistically stronger. With a larger sample size it might be possible to distinguish eighteen phases instead of six. At this time, I can only offer suggestions.

In showing the longevity of a shape's use, inevitable problems with residual material arise. I have attempted to demonstrate the longevity of a shape's production and its use by accounting for statistically probable levels of its residual presence in later deposits. Thus the length of a given shape type is accounted for by its residual material and thereby reflects the duration of its production and use.

Ceramic phases need not directly align with phases of political hegemony, and the relative chronology was determined without dependence on political periods. The absolute chronology provides a temporal framework within which the relative chronology can be contextualized.

---

<sup>136</sup> Dividing each phase into three subphases is somewhat arbitrary and I expect that further study will greatly refine them. For the moment, however, they have the potential to allow greater accuracy in a relative dating scheme than would otherwise be possible.

Phase I

Phase I			Phase II			Phase III			Phase IV			Phase V			Phase VI			Shape
A	B	C	A	B	C	A	B	C	A	B	C	A	B	C	A	B	C	Description
	R169																	small bowl
	R154																	small bowl
	R147																	small bowl
		R172																drinking vessel
		R166																small bowl
		R160																small bowl
R24																		deep bowl
		R31																deep bowl
		R114																platter
	R3																	small jar
	R52																	utility bowl
	R51																	utility bowl
		R53																utility bowl
	R67																	storage jar
	R75																	storage jar
	R54																	neckless jar
	R55																	neckless jar
	R57																	neckless jar
	R58																	hole mouth jar
	R59																	neckless jar
		R60																neckless jar
R62																		thick rim jar
R63																		thick rim jar
R64																		thick rim jar
R65																		thick rim jar
		R61																thick rim jar
	small car.																	body fragment
	medium car.																	body fragment
	large carination																	body fragment
R85																		hole mouth jar
		R17																hole mouth jar
		R5																utility pitcher
	B4																	beaker base
	B5																	beaker base
	B6																	beaker base
	B27																	plain base
	B29																	plain base
		B7																concave base
		B26																plain base

Table 14: Schematic of Phase I

Phase I is characterized by a preponderance of Peach Cream fabric large storage shapes and a dearth of small table vessels (Table 14), a repertoire I call Stack-fired Ware.

The Peach Cream fabric is self-slipped and fired pale buff on the outer surfaces, but



beyond this there is almost no decoration. There are very rare instances of matte red paint on bowls and crude, parallel, incised lines on hole-mouthed jars.

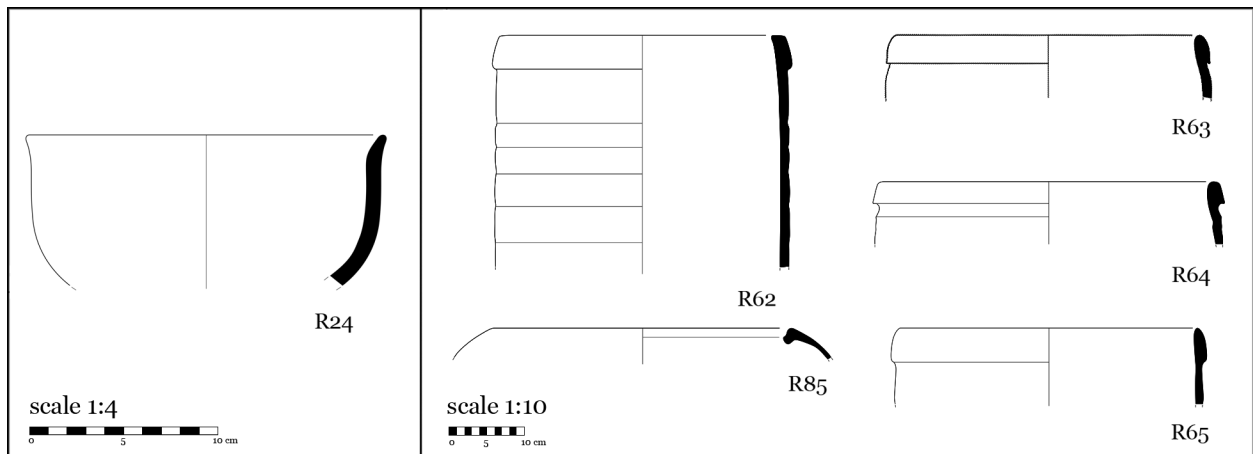

Figure 558: Subphase I-A Shape Types

Subphase I-A contains the shapes that are definitively the earliest vessels in the corpus, most of which are straight-walled, thickened rim storage vessels (Figure 558). These probably have low carinated shoulders like other regional examples, though few full profiles were found at Bactra. The lack of articulated bases suggests they had rounded bottoms that would not appear different than body sherds. Some of these thickened rim jars likely continue into subphase I-B, as does the hole-mouthed storage jar. Only one small table vessel has been associated with this subphase, a simple open bowl, R24, and there are few examples. In this phase all vessels are of Peach Cream fabric, except for the hole-mouthed jar, R85, which is found in coarse fabric.

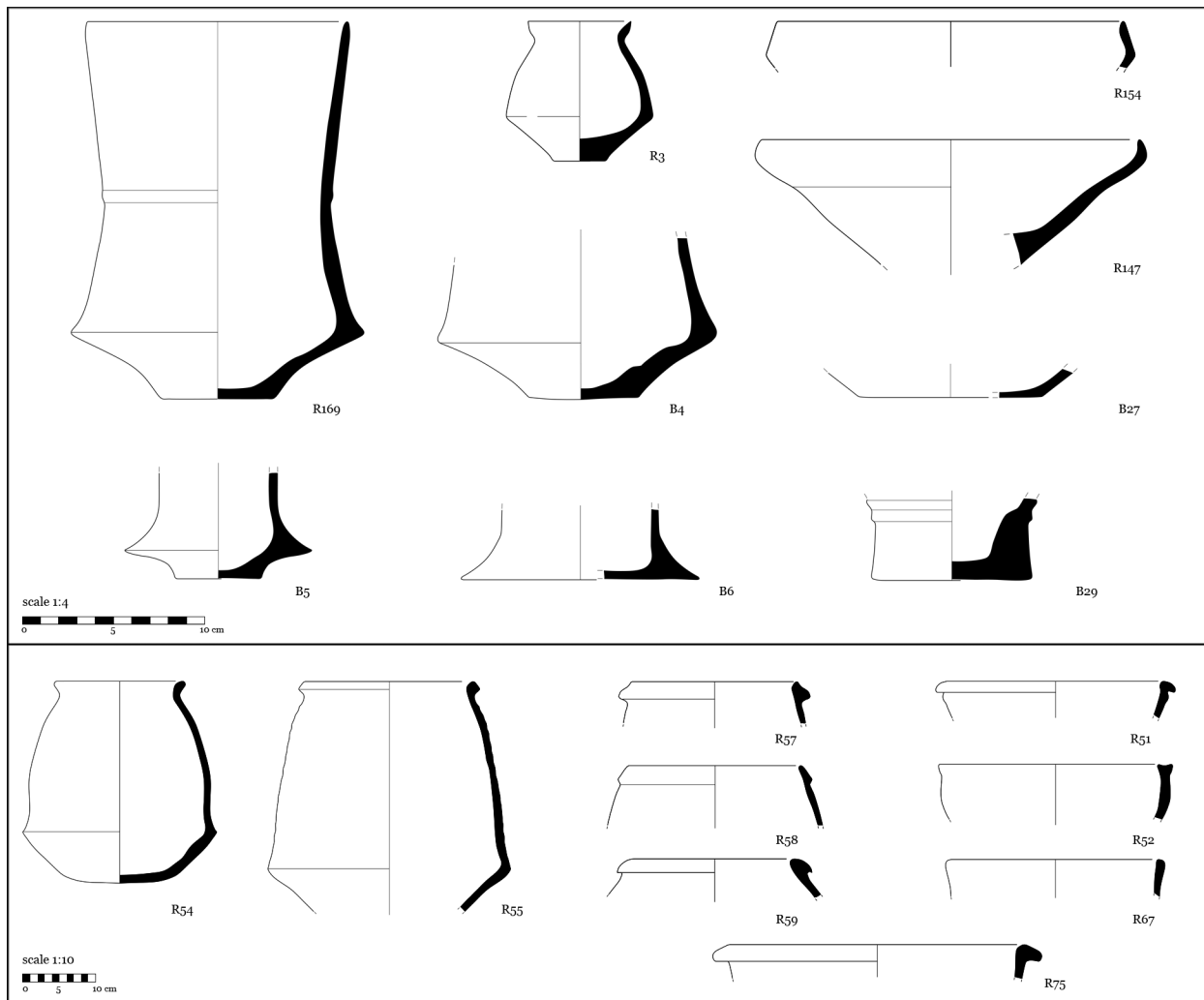

Figure 559: Subphase I-B Shape Types

It is probable that the majority of forms from Subphase I-A continue to be used during subphase I-B and it is possible that some vessels from I-B, particularly the rolled neckless rim jars, R54, occur as early as I-A vessels (Figure 559). Neckless storage jars and large open utility jars and bowls are the most common vessel types. The tall straight-walled, carinated beaker, R169, is the most common table vessel, although there are occasional examples of small open table bowls. The majority of vessels in this subphase are found in Peach Cream fabric, but rolled rim neckless jars begin to be produced in Pink/Buff A fabric as well. The carinated beakers and carinated rolled rim

jars continue to be produced for the remainder of Phase I and drop out of use in Phase II. A plain, unarticulated base, B27, comes into use during this period, likely as a base for the small table vessels. This continues to be the most common base form in this corpus until the simple disc foot begins to be used in Phase II, at which point these two forms comprise the overwhelming majority of bases.

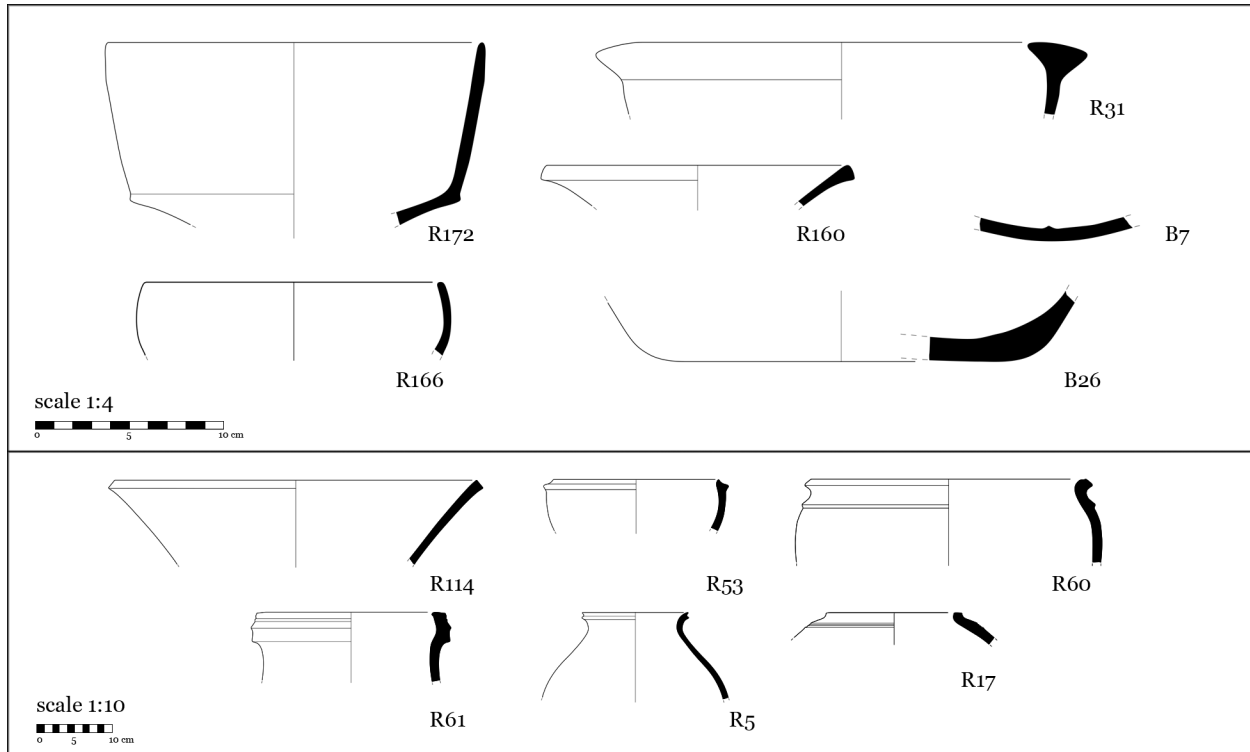

Figure 560: Subphase I-C Shape Types

Subphase I-C is the last phase during which thickened rim storage jars are common (Figure 560). Types R60 and R61 show a tendency towards more flourishes in the profiles, but these are rare. In addition to the carinated beakers, small, slightly carinated table bowls, R172, come into use<sup>137</sup>, as do hemispherical bowls and small

<sup>137</sup> The carinated hemispherical bowl has the most in common with an earlier shape Lyonnet calls “Gobelets à pari à ressaut,” which she claims are a local form of goblet. Although they have been found at sites close to Bactra, none were found at Bactra. A very deep bowl with a high, vertical rim and a slight articulation on the lower exterior of the rim, this is frequently slipped and often has vertical burnishing decoration on the lower, and sometimes upper, outer walls. See Lyonnet 1997 pp. 145-146 and pp. 384, Figure 45 (4).

slanted walled bowls. Along with these changes in small table vessels come some changes in serving vessels, most noticeably the introduction of the large sloping-walled bowl or platter shape that is to predominate decorated serving vessels for centuries. Most storage jars continue to be made in Peach Cream fabric, and many of the small table vessels are as well, but Pink/Buff A becomes more commonly used in most vessel types. Hole-mouthed jars and short-necked jars are usually made in coarse fabrics.

Phase II

Phase I			Phase II			Phase III			Phase IV			Phase V			Phase VI			Shape
A	B	C	A	B	C	A	B	C	A	B	C	A	B	C	A	B	C	Description
	R169																	small bowl
	R154																	small bowl
		R166																small bowl
		R160																small bowl
	R67																	storage jar
	R54																	neckless jar
	R55																	neckless jar
	B27																	plain base
			R107															amphora
			R140															small bowl
			R150															small bowl
			R158															small bowl
			R159															small bowl
			R161															small bowl
			R163															small bowl
			R146															small bowl
				R148														small bowl
				R138														small bowl
				R135														small bowl
				R141														small bowl
					R152													small bowl
					R156													small bowl
					R151													small bowl
					R175													small bowl
			R33															deep bowl
			R34															deep bowl
				R28														deep bowl
				R41														deep bowl
				R35														deep bowl
				R36														deep bowl
					R32													deep bowl
					R40													deep bowl
					R177													deep bowl
			R118															platter
				R117														platter
				R113														platter
					R125													platter
					R131													platter
					R1													small jar
					R2													small jar
			R77															storage jar
					R56													neckless jar
					R76													storage jar
					R72													storage jar
						R69												storage jar
																		short neck jar
																		short neck jar
																		pinch neck jar
																		neckless jar
						R16												hole mouth jar
						R4												utility pitcher
							R12											pinch neck jar
																		ring base
																		ring base
																		ring base
																		plain base
																		plain base
																		disc base
																		disc base
																		fishplate base
																		fishplate base
																		disc base
																		small jar base

Table 15: Schematic of Phase II

Phase II is characterized by the sudden abundance of diverse small table bowls, the relatively rapid decline in production of Stack-fired Ware and the introduction and almost ubiquitous use of Pink/Buff A and Pink/Buff B fabrics, the introduction of red slip, and a greater diversity of coarse fabrics in a variety of short and pinch neck shapes (Table 15). The disc foot appears and becomes ubiquitous.<sup>138</sup> The changes in fabric are rapid and Pink/Buff A and Pink/Buff B continue to dominate ceramic production through at least the end of Phase VI. Overall, the ceramics of this phase appear to signal a major change in dining habits, either due to the appearance of different foods or due to the introduction of different social practices surrounding the consumption of foods.

---

<sup>138</sup> The simple disc foot is among the easiest types of articulated bases to construct on a wheel. Requiring no additional material, the vessel is either turned upside down or left upright and an indented articulation is made with a small tool. As long as enough clay is left at the base of the vessel, this is a simple procedure.

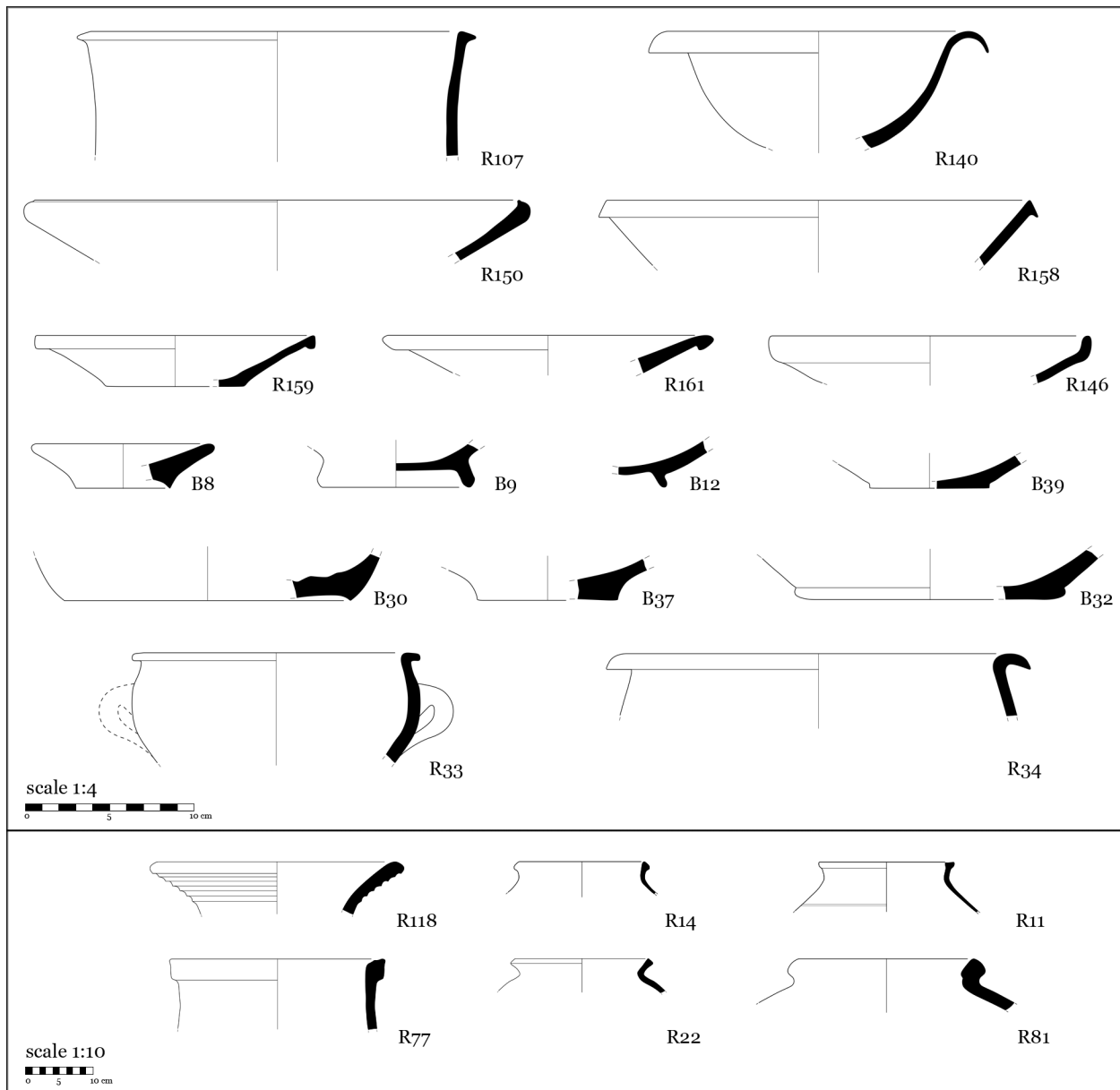

Figure 561: Subphase II-A Shape Types

Subphase II-A contains a fairly large number of small bowl forms (Figure 561). It is likely that with further stratigraphic information a more detailed relative sequence of these bowls could be determined, but given the evidence at hand, they are currently grouped together. Notable in this first series of individual serving bowls is the higher proportion of straight-walled open bowls to curved-walled bowls.

Two types of deep bowls come into use, one with a rolled rim, R33, and another

with an overhanging rim, R44. At this point large sloping-walled platters are not yet common, but there are rare early examples. It is likely that one of the storage vessels from Phase I, R54, continues in Phase II, though with changes to the lower walls and base. Unfortunately, not enough examples with whole profiles exist to determine this conclusively.

During Subphase II-A, Peach Cream fabric starts to drop out of use, and a wider range of coarse fabrics appear in pinched and short neck storage and cooking jars. The hole-mouthed storage jars of Phase I slowly drop out of use throughout Phase II. Due in large part to the introduction of individual dining bowls, there is a much wider range of base forms than is seen earlier. Ring and disc bases of various styles become common, and many of these continue to be produced for many centuries.



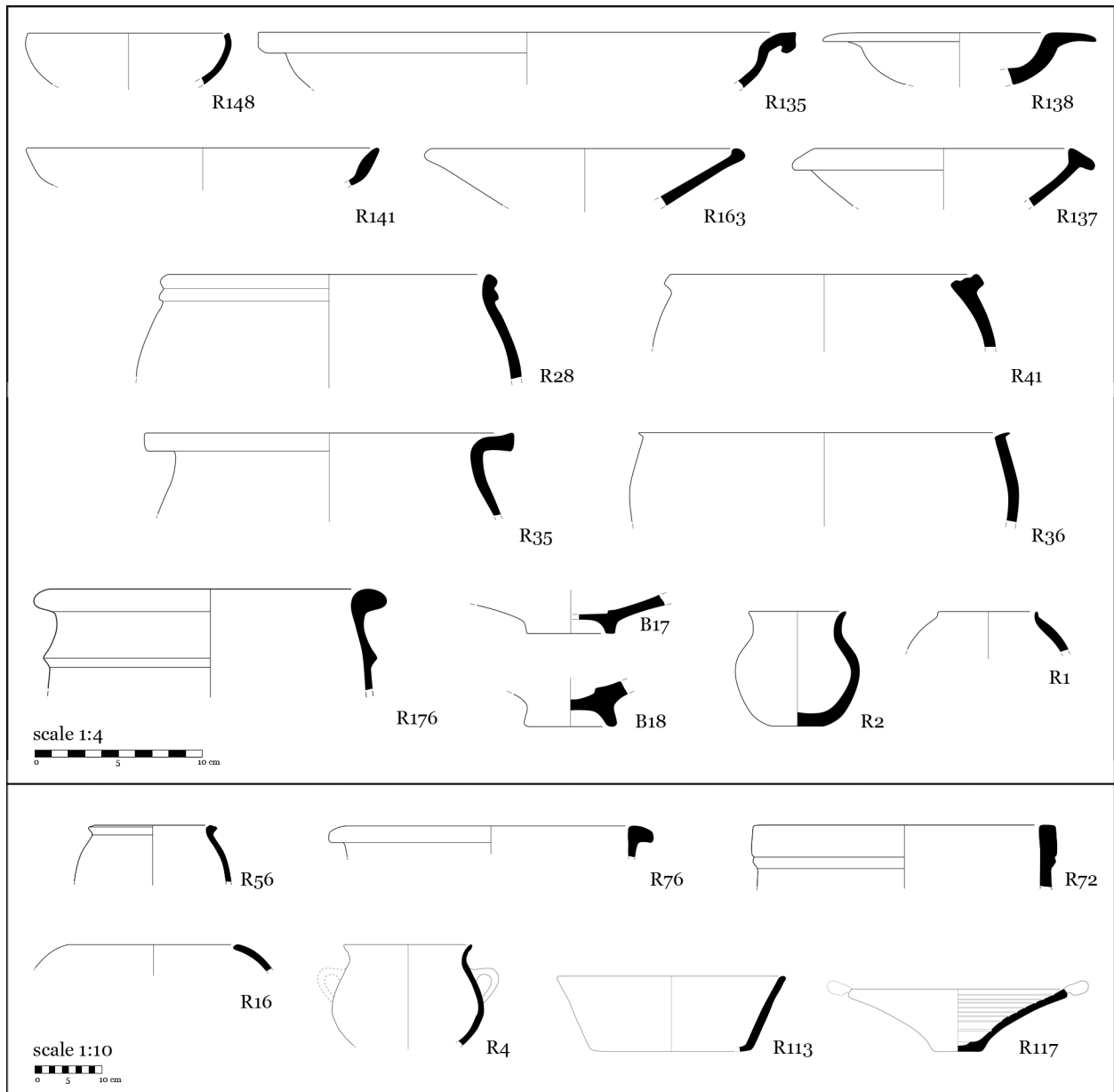

Figure 562: Subphase II-B Shape Types

Phase II-B sees a continuation of most of the small bowl forms of II-A with the addition of several other bowl forms with curved walls (Figure 562). In this subphase, a form that is likely a fishplate comes into use, R163. This form is found in Gray fabric proportionally more often than any other rim form at Bactra, and likely joins with lower forms B17 or B18, which are ring feet with central impressions and are also found mostly in Gray fabric. Although not definitive, Gray fabric at Bactra could be as much a

chronological indicator as the fishplate form itself.

Small curved-walled bowls, including incurved-rim bowls, become more common than straight-walled bowls at this point and continue to be common through Phase VI. One table amphora form in particular, R176, has a very distinct profile and is likely an import, due to its distinctive and unusual ridged upper body. Several deep bowl forms are in use and large, open sloping-walled bowls/platters become more popular. The plainest of these forms, R113, comes into use during this phase, but continues to be produced in a range of fabrics and decorations through Phase VI. This form, in fact, is much more prevalent in later phases and is at peak use in Phases V and VI.

The rolled rim jar form produced in Phase I and Subphase II-A continues to be produced, and another similar form with a slight modification in the lip, R56, appears in Subphase II-B. Large open storage jars with well-articulated rims are common and tend to be thicker-walled and with larger diameters than their predecessors. Some small oil or perfume jars have been found, but the rare examples can only tentatively be placed in this phase.

Subphase II-B sees the complete discontinuation of Peach Cream fabric. The fine fabrics that become ubiquitous are Pink/Buff A and Pink/Buff B, equally common unslipped or with red slip.<sup>139</sup> Both matte and semi-glossy red slips are popular, and simple, incised decorations are seen, though not as frequently as in later phases.

---

<sup>139</sup> The cream colored surfaces of Peach Cream fabric appear as they do largely due to a self-slip and firing technology. So while it is possible that the Pink/Buff fabrics were sourced from the same areas and levigated with similar results as the fabric of Peach Cream fabric (though this is by no means certain), there is a technological or production difference that results in ceramics having a very different appearance.

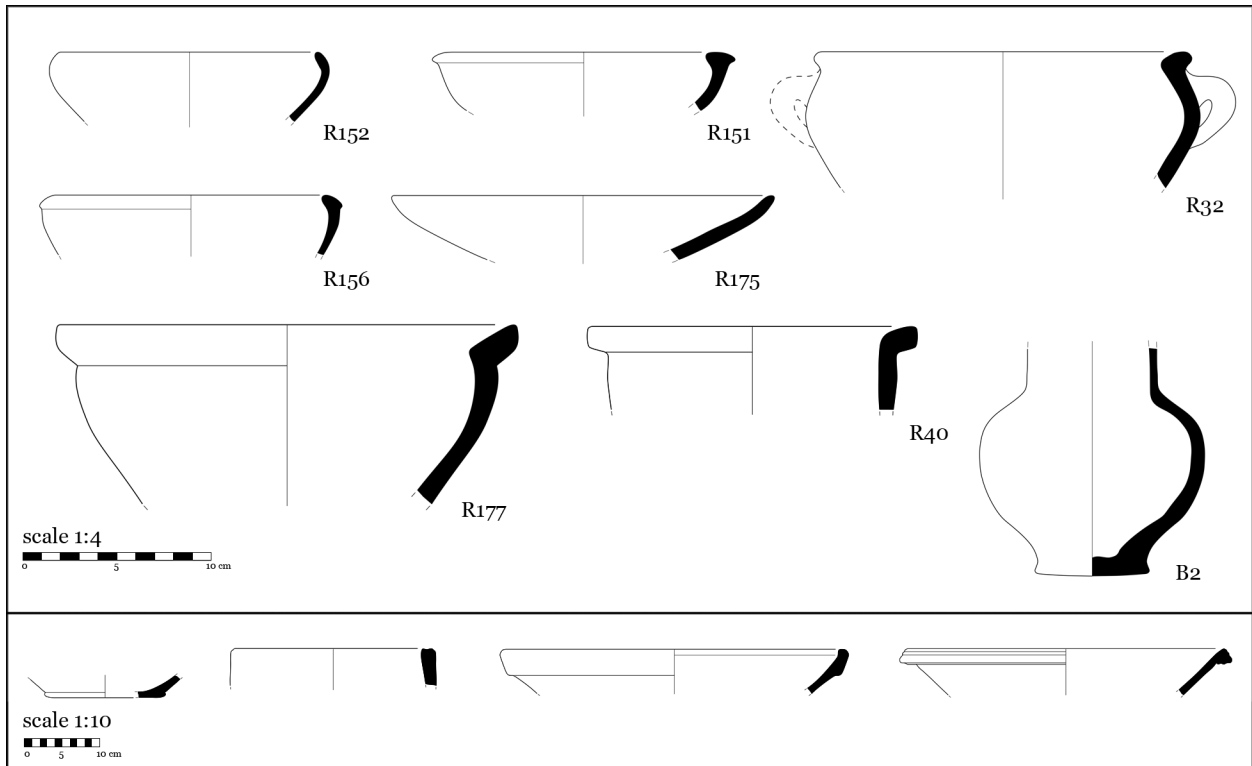

Figure 563: Subphase II-C Shape Types

Subphase II-C sees the growing production of incurved rim bowls of several varieties (Figure 563). It is possible that these forms were introduced earlier, but they are most common in this phase alongside a growing variety of deep bowl forms and large open sloping-walled bowls. These large bowls begin to have carefully articulated rims, some varieties of which are in production for several phases.

Short and pinch neck jars continue, including one with a slight hammerhead rim with fingertip impressions. In this subphase the disc foot becomes predominant and continues to be the most common base type at Bactra for centuries.

Phase III

Phase I			Phase II			Phase III			Phase IV			Phase V			Phase VI			Shape
A	B	C	A	B	C	A	B	C	A	B	C	A	B	C	A	B	C	Description
	B27																	plain base
			R163															small bowl
					R152													small bowl
					R32													deep bowl
				R113														platter
			R11															short neck jar
			R14															short neck jar
			R81															neckless jar
				R4														utility pitcher
					R12													pinch neck jar
			B9															ring base
			B12															ring base
			B39															plain base
			B32															disc base
					B2													small jar base
						R97												amphora
						R99												amphora
						R102												amphora
						R106												amphora
						R90												amphora
						R105												amphora
						R139												small bowl
						R153												small bowl
						R157												small bowl
						R162												small bowl
						R176												amphora
						R170												drinking vessel
						R155												small bowl
						R137												small bowl
						R30												deep bowl
						R37												deep bowl
						R46												deep bowl
						R47												deep bowl
						R42												deep bowl
						R26												platter
						R130												platter
						R122												platter
						R128												platter
						R132												platter
						R66												pan
						R74												storage jar
						R71												storage jar
						R79												storage jar
						R70												storage jar
						R7												straight neck jar
						R6												straight neck jar
						R8												short neck jar
						R9												short neck jar
						R10												pinch neck jar
						R20												neckless jar
						R21												neckless jar
						R83												neckless jar
						R80												hole mouth jar
						B3												small jar base
						B33												disc base
						B36												disc base
						B21												goblet base
						B34												ring base
						B22												goblet base
						B25												goblet base
						B38												disc base

Table 16: Schematic of Phase III

Phase III is characterized by the growing popularity of table amphora forms, the continuation of small curved walled bowls with a growing variety of rim forms, and the introduction of several new shape and decoration elements (Table 16). This phase witnesses the introduction of pedestal-footed goblets, perhaps an innovation from the Indo-Greek territories, or perhaps just quickly adopted in those regions.<sup>140</sup> At this point eggplant colored slip begins to be used alongside red slip, both in matte and semi-glossy styles. Both of these elements continue to grow in popularity and reach their peak in Phase IV. There is a continuing and growing variety of large open sloping-walled bowls as well as storage and cooking jars.

Although this phase falls politically within the Nomadic rule of Bactria, there is no significant break in pottery production quality or style. Unlike Ai Khanoum, there is no evidence that Bactra was abandoned by any sector of its population, and the material culture of the city shows no evidence of economic or political collapse. However, only a small portion of the city has been excavated, so this assessment cannot be taken as certain at this point.

---

<sup>140</sup> This is very uncertain. Lyonnet associates these pedestal feet with the Nomadic period. Lyonnet 1997, p. 165.

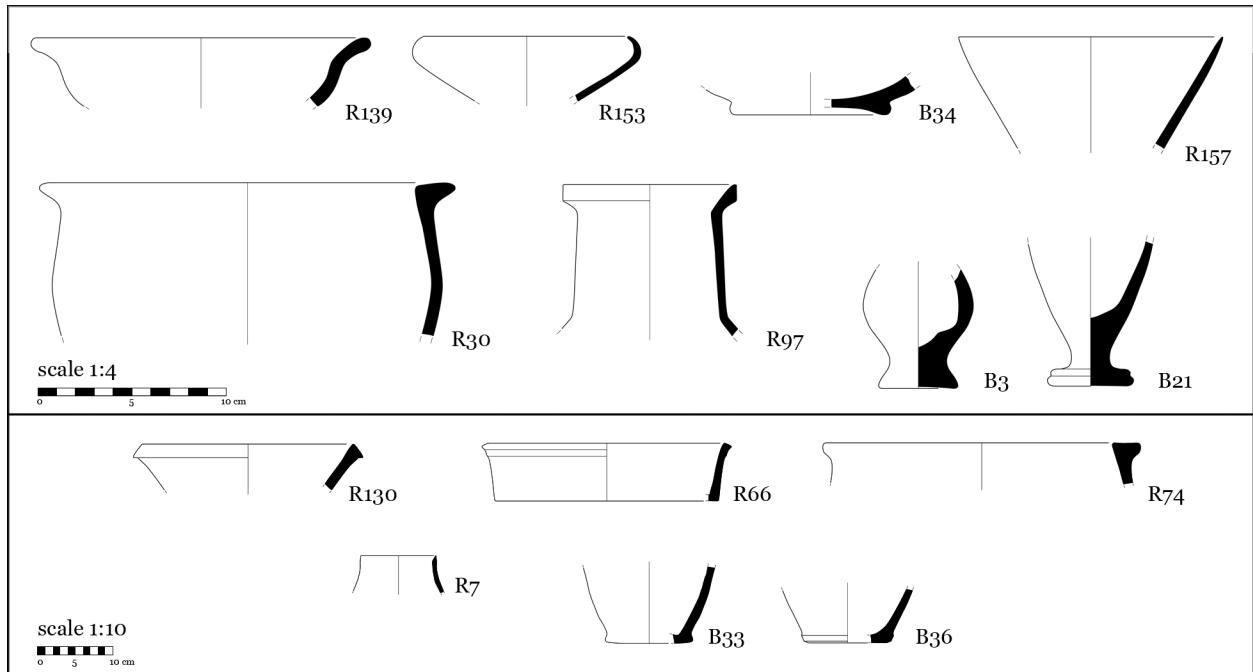

Figure 564: Subphase III-A Shape Types

Subphase III-A sees the continuation of many small bowl and deep bowl forms from Phase II (Figure 564). The greatest distinction is the addition of pedestal-based drinking goblets, a style that becomes more common in Phase IV. These tend to have large, cone-shaped bodies and are often decorated with red slip and occasionally pattern burnishing. There are rare examples in Gray fabric, reflecting a continuation of firing technology from Phase II.<sup>141</sup> It is possible that these represent a change in dining or drinking habits, possibly brought on by greater contact with the Indian subcontinent.

A large open pan comes into use in Phase III, indicating a new cooking method was introduced perhaps for preparing a traditional dish.<sup>142</sup> Several varieties of large open pans were produced in Phases III, IV, and V. It is possible that these pans were far more common than we know, but without full profiles, it is impossible to identify these

<sup>141</sup> Gray pottery does not seem to be produced at Bactra, but the continued use in new shapes indicates it is produced at regional sites from which imported ceramics reached Bactra.

<sup>142</sup> It is possible that some earlier forms of this vessel were not fired at the same temperature and thus did not survive well. Črepna in Roman-period Eastern Europe follow this trend (personal observation at Konjuh, R. Macedonia).

shapes, as their rims look similar to many large open jars.

Many of the storage and cooking shapes common in Phase II continue into subphase III-A. The prevalence of base types 33 and 36, disc bases with upright walls, parallels the growing popularity of table amphorae and pitchers. Some of these have pattern burnishing on their necks and shoulders over red or eggplant colored slip. This style of decoration continues to be popular through Phase VI, with a growing range of patterns and complexity.

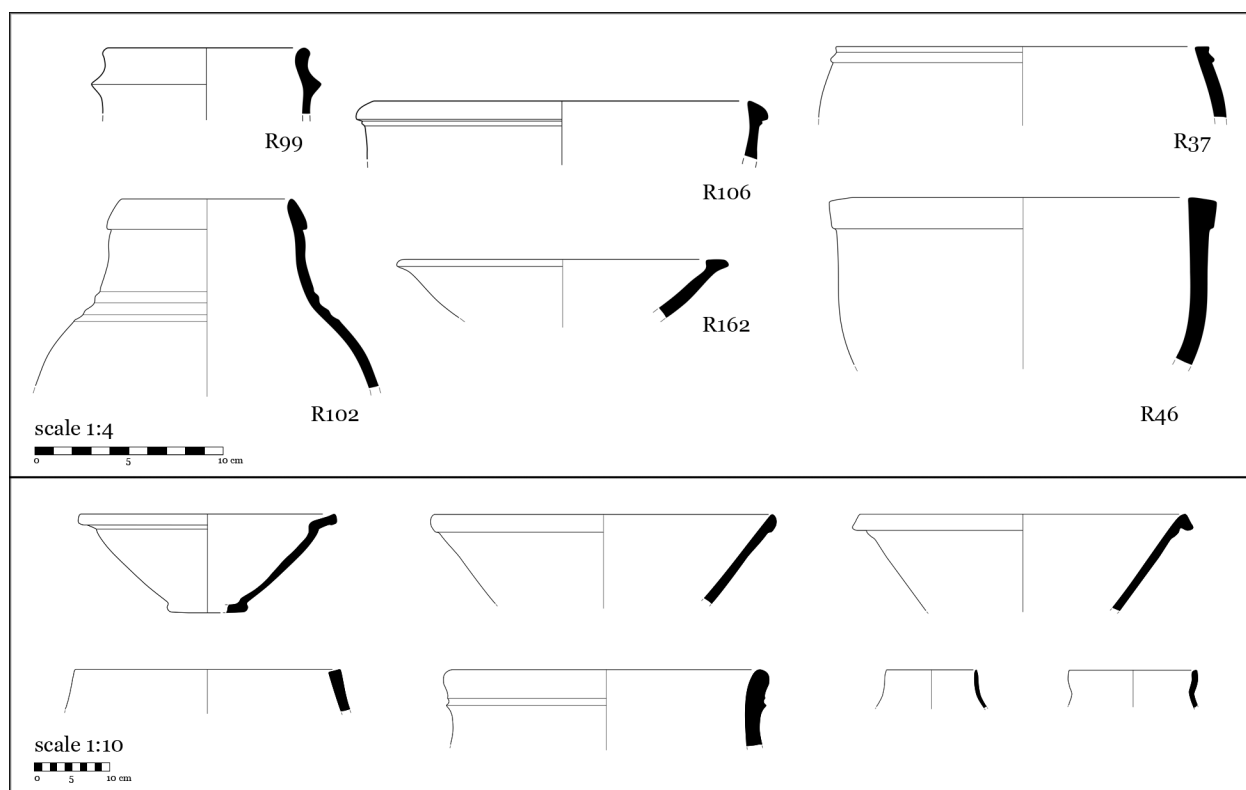

Figure 565: Subphase III-B Shape Types

Subphase III-B contains a growing number of table amphora forms with a variety of rim forms and sizes (Figure 565). Some of these are probably pitchers, while others are wider-mouthed large table amphorae. There are two additional deep bowl forms, though earlier forms probably continue to be produced.

There are three new varieties of large open sloping-walled bowls/platters. One of

these, R122, might be a predecessor of other very common platter forms, R123 and R124, which appear in Phase V and Phase VI respectively. R122 has a fairly distinct separate register as a rim. As this style evolves in Phases IV-VI, the register becomes decorated and contains two, three, or four distinct delineations.

The decoration tendencies of Subphase III-A, pattern burnishing and red and eggplant colored slips, continue to be popular. Incised decoration in the form of parallel straight or wavy lines comes into use, as does stamped decoration. Stamped decoration at Bactra does not have as much variety as is common at other regional sites, particularly Termez and Kampyr Tepe.<sup>143</sup> The leaf stamp is almost ubiquitous, with rarer examples of chevrons, sunbursts, and honeycombs.

---

<sup>143</sup> At Mes Aynak, south of the Hindu Kush, stamps are a primary form of decoration and there are dozens of varieties, many of which seem to imitate coins, especially portraiture or nature scenes (personal analysis). These are wholly absent from the Bactra material. In general, there does seem to be a more developed stamped decoration tradition south of the Hindu Kush than in the Oxus-River area. See: Marquis, Philippe and Engel, Nicolas, eds. *Recent Archaeological Works in Afghanistan: Preliminary Studies on Mes Aynak Excavations and Other Works*. Kabul: Ministry of Information and Culture of the Islamic Republic of Afghanistan, 2013.



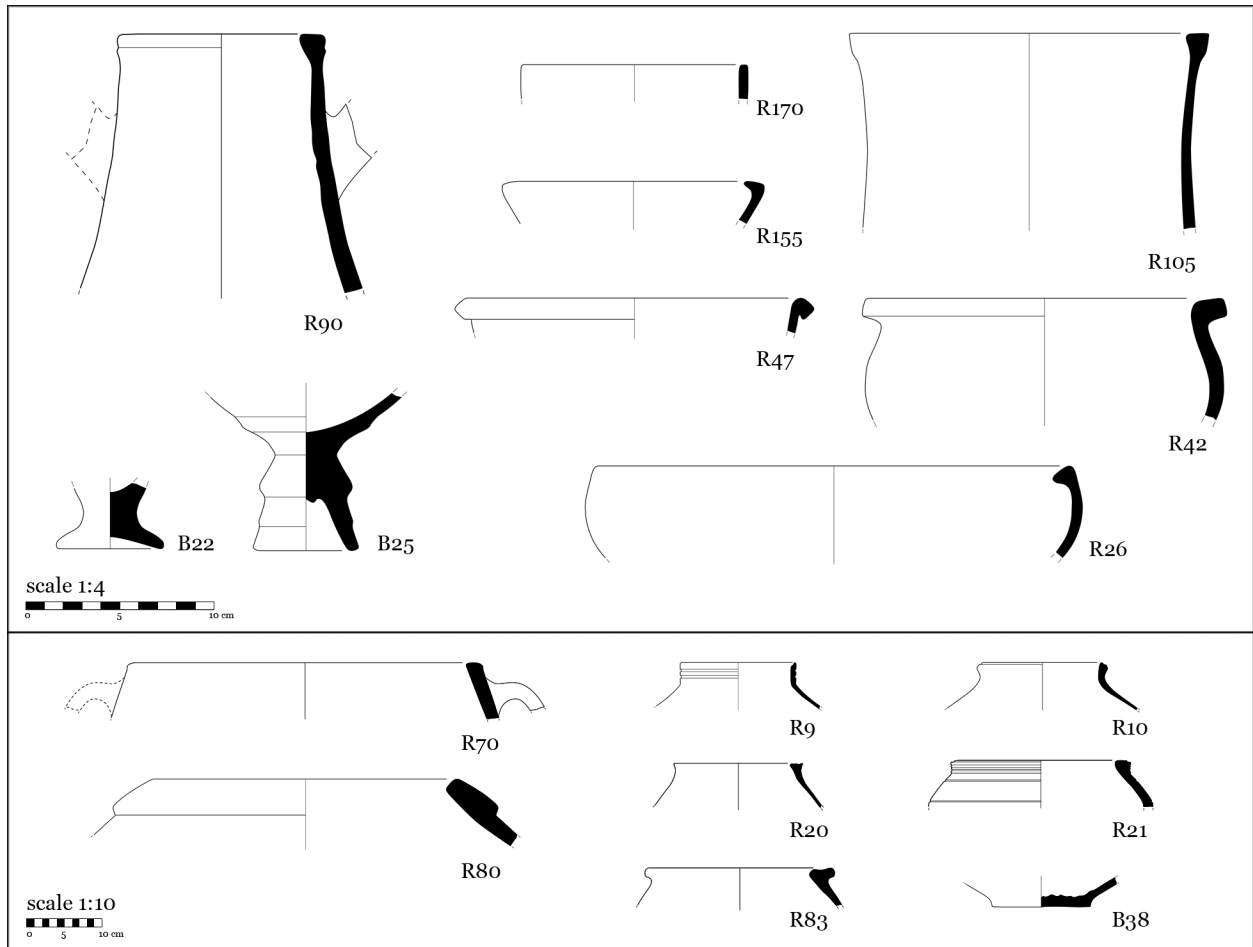

Figure 566: Subphase III-C Shape Types

Phase III-C continues much the same as III-A and III-B, with the addition of several amphora styles, small bowls, and deep bowls (Figure 566). Pedestaled goblets continue to be used, and there are rare examples of high-footed pedestals, B25, likely Indian in origin.<sup>144</sup>

Several additional varieties of short- and pinch neck storage and cooking jars appear. The most distinct utility vessel is a ledge rim jar, R83, which continues to be fairly common through Phase V.

<sup>144</sup> Cf. Marshall, John. *Taxila: an illustrated account of archaeological excavations carried out at Taxila under the orders of the Government of India between the years 1913 and 1934*. Vol. 3, 1951. Plate 125, Nos. 131, 132a, 132b, and 132c. Pedestaled goblets in stone and metal have also been found at Taxila.

Phase IV

Phase I			Phase II			Phase III			Phase IV			Phase V			Phase VI			Shape
A	B	C	A	B	C	A	B	C	A	B	C	A	B	C	A	B	C	Description
	B27																	plain base
				R113														platter
			R11															short neck jar
					R12													pinch neck jar
			B12															ring base
			B32															disc base
					B2													small jar base
							R102											amphora
						R139												small bowl
						R153												small bowl
						R157												small bowl
							R46											deep bowl
						R130												platter
							R122											platter
							R128											platter
							R132											platter
							R79											storage jar
								R70										storage jar
								R10										pinch neck jar
						B36												disc base
						B34												ring base
									R103									amphora
									R110									amphora
									R104									amphora
										R111								amphora
										R112								amphora
											R95							amphora
									R167									small bowl
										R168								small bowl
											R143							small bowl
									R43									deep bowl
										R25								deep bowl
										R27								deep bowl
										R45								deep bowl
										R48								deep bowl
											R39							deep bowl
									R134									platter
										R129								platter
										R116								platter
											R120							platter
									R82									pan
									R78									storage jar
											R49							utility bowl
											R13							short neck jar
											B24							goblet base
											B19							ring base
											B23							goblet base
											B1							small jar base
											B28							plain base
											B31							low ring base
											B15							ring base

Table 17: Schematic of Phase IV

Phase IV sees a continuation of small table bowls, though many slanted-walled small bowls drop out of use (Table 17). The rims of table amphorae become more embellished, as do some platter rims. There is a greater variety of pedestal-footed goblets, many with decorated and grooved feet, and these become quite popular. A very shallow vessel, R143, is introduced, which later evolves into what becomes the most common table vessel in Phase V, R144, the vertical rim plate.

This phase is characterized in large part by the pattern burnishing and incised styles that become very common on table vessels. Eggplant colored slip becomes equally as popular as red slip. On amphorae and pitchers, vertical burnishing on the neck is the most popular decoration. Incised decoration begins to be commonly used on large sloping-walled bowls, a technique that becomes more popular and complex in Phases V and VI.

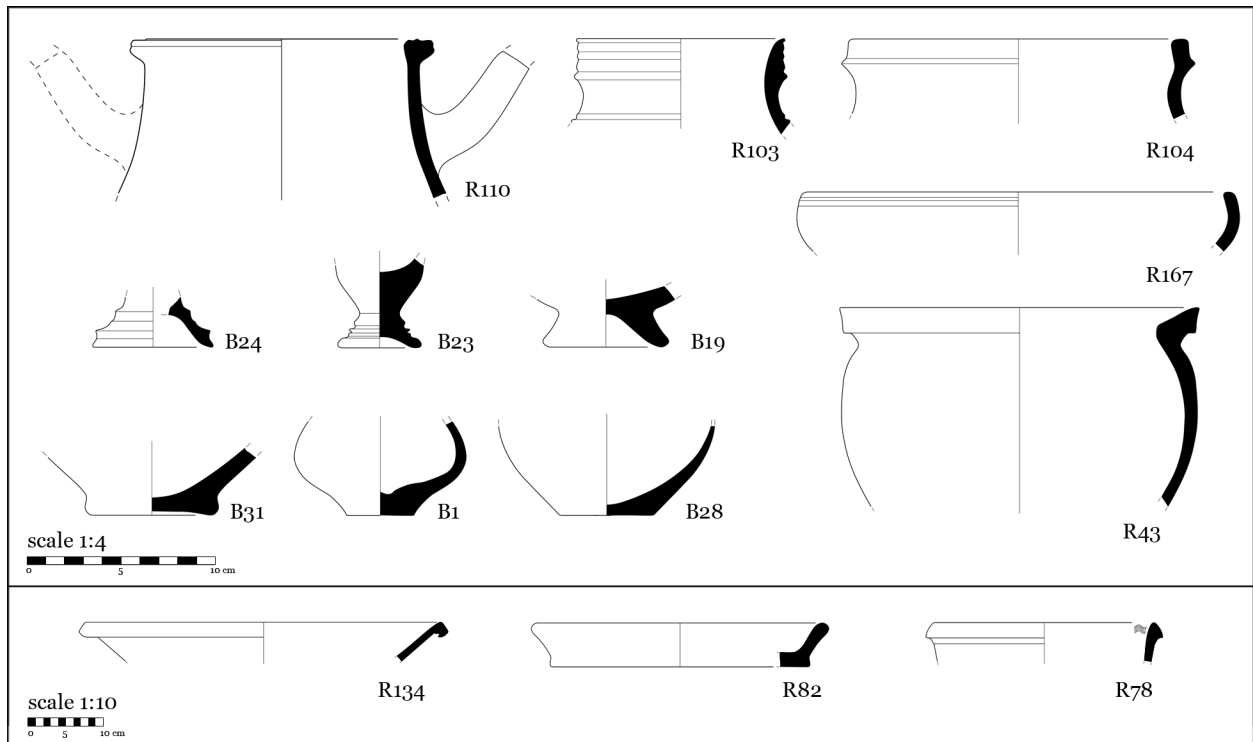

Figure 567: Subphase IV-A Shape Types

Subphase IV-A sees the introduction of several amphorae forms with embellished rims, R103, R104, and R110 (Figure 567). These tend to have red or eggplant colored semi-glossy slip as well as pattern burnishing on the neck and sometimes the shoulders. Eggplant colored slip, although introduced earlier, becomes common in this period. During this subphase two varieties of pedestal feet come into use and remain popular for the remainder of Phase IV. Small incurved rim bowls continue to be used and another variety that typically has incised decoration on the exterior of the rim becomes common. There is a general continuation of the common pinch neck and short necked storage jars and the distinctive ledge rim storage jar continues to be used.

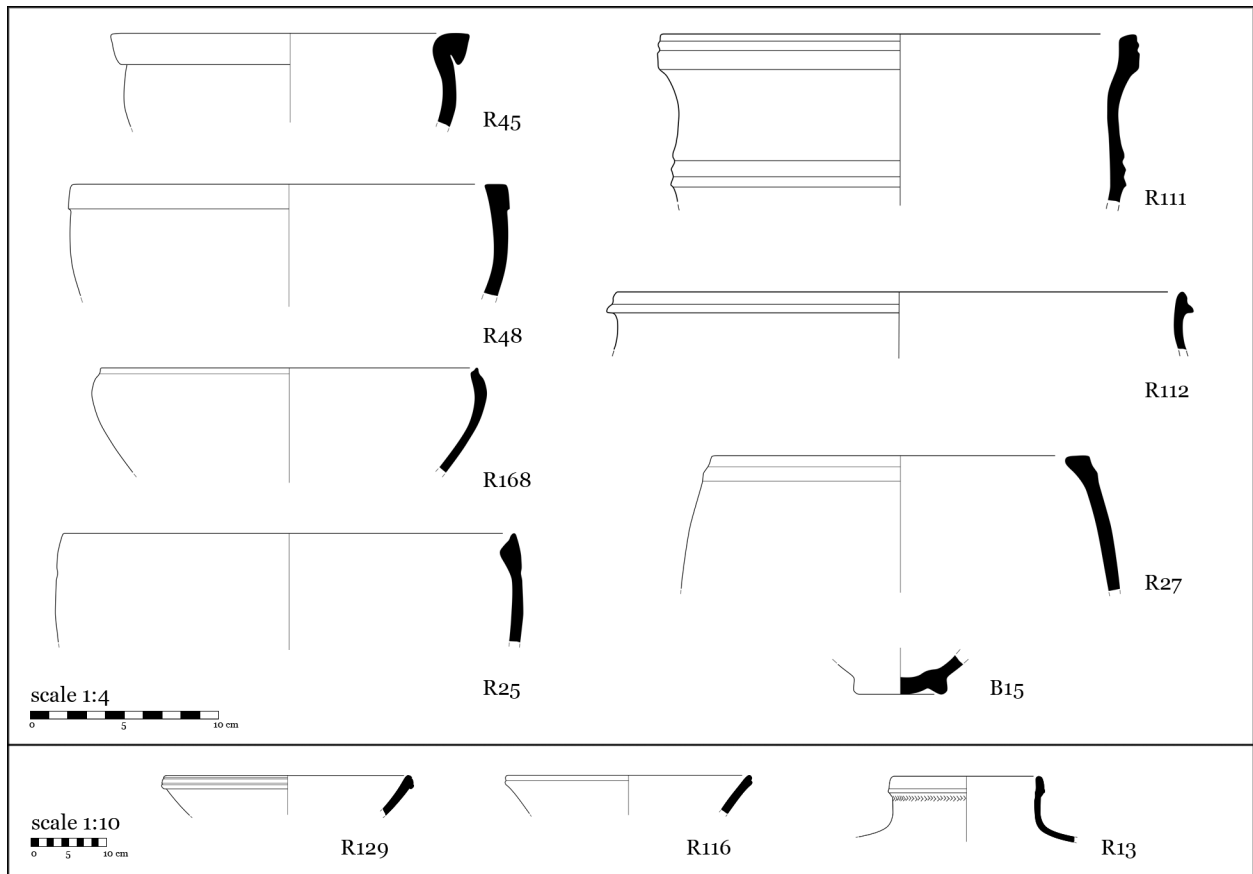

Figure 568: Subphase IV-B Shape Types

This subphase sees the introduction of more amphorae with embellished rims, again typically slipped with red or eggplant colored pattern burnishing, and often with stamped or incised decoration (Figure 568). Several varieties of deep bowls are introduced, all with very similar bodies as earlier deep bowls, almost globular in shape. There are two new varieties of large open sloping-walled bowls/platters, but many of the varieties introduced in earlier phases continue to be used. Red and eggplant colored semi-glossy slip is almost ubiquitous on these platters.

A longer-necked storage pot, usually with indented decoration on the rim, comes into use and continues through Phase VI. The most popular utility vessel, however, continues to be R11.

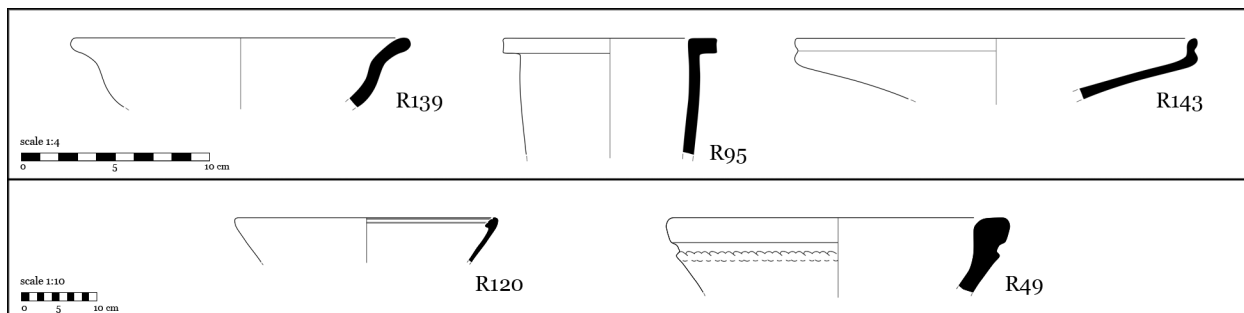

Figure 569: Subphase IV-C Shape Types

Subphase IV-C sees the introduction of what will evolve to be one of the most common shapes in Phases V and VI, R143, a vertical rim plate (Figure 569). The slightly bulbous rim eventually lengthens and becomes thinner, but the general shape of the vessel stays relatively similar. These vessels are almost always decorated with red semi-glossy slip and often have pattern burnishing on the interior surface. This is used in addition to a variety of small bowls introduced earlier. Red slip tends to be more common on small bowls while eggplant colored slip becomes more common on table amphora vessels. A new style of deep bowl is introduced, but overall this vessel category is not as common in this phase as it was earlier.

A large, distinctive, open utility vessel, R49, seems to become popular in this period, but not enough examples were found to definitely date their introduction to this period instead of Subphase IV-B.

Phase V

Phase I			Phase II			Phase III			Phase IV			Phase V			Phase VI			Shape																						
A	B	C	A	B	C	A	B	C	A	B	C	A	B	C	A	B	C	Description																						
	B27																	plain base																						
				R113														platter																						
			R11															short neck jar																						
			B32															disc base																						
						R130												platter																						
							R128											platter																						
								R132										platter																						
									R70									storage jar																						
										R10								pinch neck jar																						
						B34												ring base																						
									R167									small bowl																						
										R143								small bowl																						
											R27							deep bowl																						
												R39						deep bowl																						
													R129					platter																						
														R116				platter																						
															R120			platter																						
																R13		short neck jar																						
																B1		small jar base																						
																	B31	low ring base																						
																		B15	ring base																					
																		R108	amphora																					
																			R93	amphora																				
																				R109	amphora																			
																					R94	amphora																		
																						R96	amphora																	
																							R98	amphora																
																								R101	small bowl															
																									R142	small bowl														
																											R144	small bowl												
																												R145	small bowl											
																													R38	deep bowl										
																													R44	deep bowl										
																														R121	platter									
																															R133	platter								
																																R127	platter							
																																	R115	platter						
																																		R119	platter					
																																		R126	platter					
																																			R123	platter				
																																			R15	pinch neck jar				
																																				R19	neckless jar			
																																					R84	neckless jar		
																																						B40	disc base	
																																							B16	ring base

Table 18: Schematic of Phase V

This phase sees the growing popularity of large open sloping-walled bowls/platters with complex pattern burnished and incised decoration (Table 18). It also sees the rise of a vertical rim plate, R144, with highly standardized production in terms of fabric and slip quality, size, and decoration. This is easily the most common form of this period and provides the advantage of being diagnostic even in body sherds. This high quality, standardized product is a hallmark of this period and continues through Phase VI, albeit with different vessel forms.

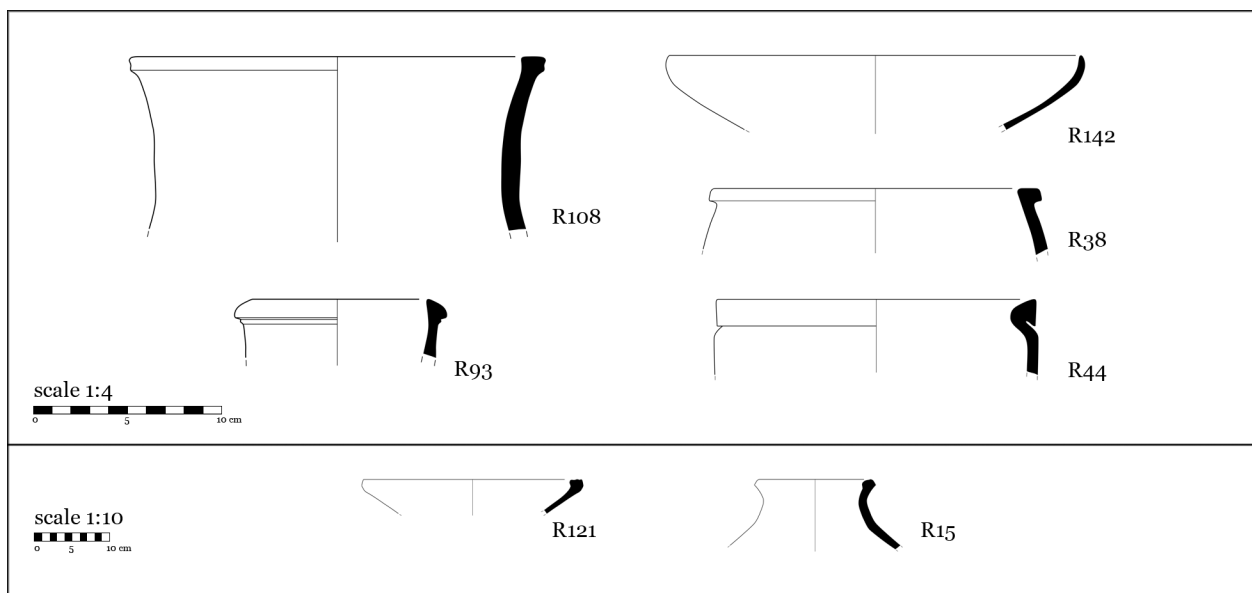

Figure 570: Subphase V-A Shape Types

This subphase sees the modest evolution of some earlier shapes (Figure 570). The rims of several amphora forms are articulated with slight differences from earlier forms, although the general vessel shape and decorations remain the same. A small curved-wall bowl with very thin upper walls becomes popular. This is usually decorated with a very high quality semi-glossy red slip, a quality of slip that is common on the later vertical rim plate and the carinated hemispherical bowl, both very standardized shapes. A wide variety of large sloping walled bowls continues to be produced, with semi-glossy



red slip a more popular decoration than eggplant colored, though both are seen. Combed, parallel, incised lines are often used on these vessels and the decorative elements become more fanciful.

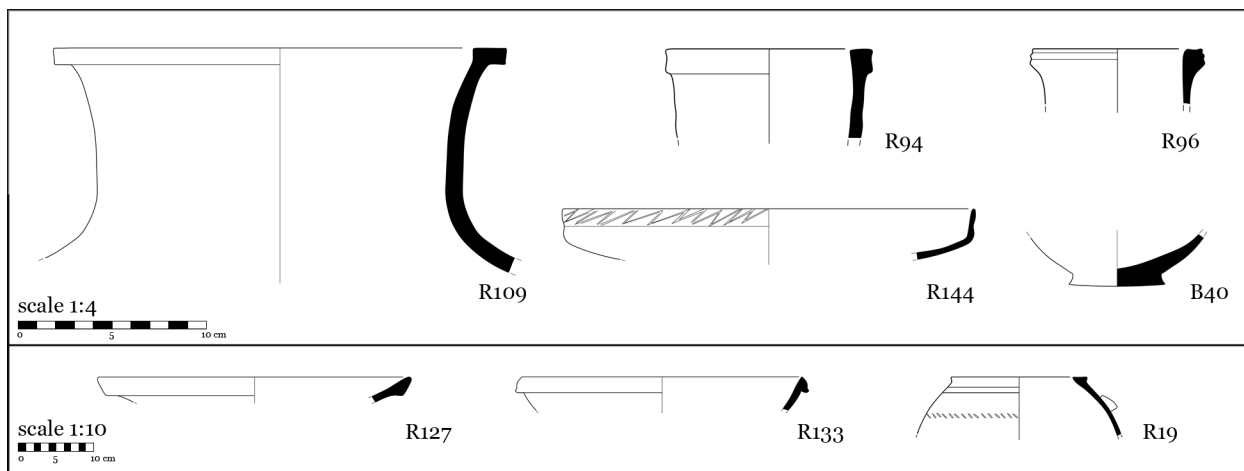

Figure 571: Subphase V-B Shape Types

This subphase sees the introduction of the vertical rim plate, R144, which quickly gains popularity (Figure 571). Many earlier bowl forms drop out of use, and this form becomes ubiquitous in all deposits with evidence of dining vessels. The standardization of the shape, fabric, slip, and burnished decoration suggests well-organized potters' workshops, and the presence of several misfires together with the large quantity of sherds suggests local production. It is likely that potters at other major sites, particularly Termez and Afrasiab, produced variants of these vessels that adhered to the same general elements of design. A slightly different version of this vessel appears in the following subphase and might originate at one of those other production sites.

Large open sloping-walled bowls remain in use, as do many amphora forms. A table assemblage of this phase through the end of Phase VI would likely consist of large and small semi-glossy slipped open vessels, both of communal and individual size, and standing table amphora and pitchers. Almost all of these are red or eggplant colored

with additional burnished, stamped, and incised decoration. Perhaps some tall pedestal-foot goblets were still in use, but these are not as popular as they were in Phase IV.

Utilitarian vessels do not change drastically, but there is the addition of a neckless jar with fairly consistent decoration and vestigial handles. At this point the ledge rim storage vessels seem to drop slowly out of use.

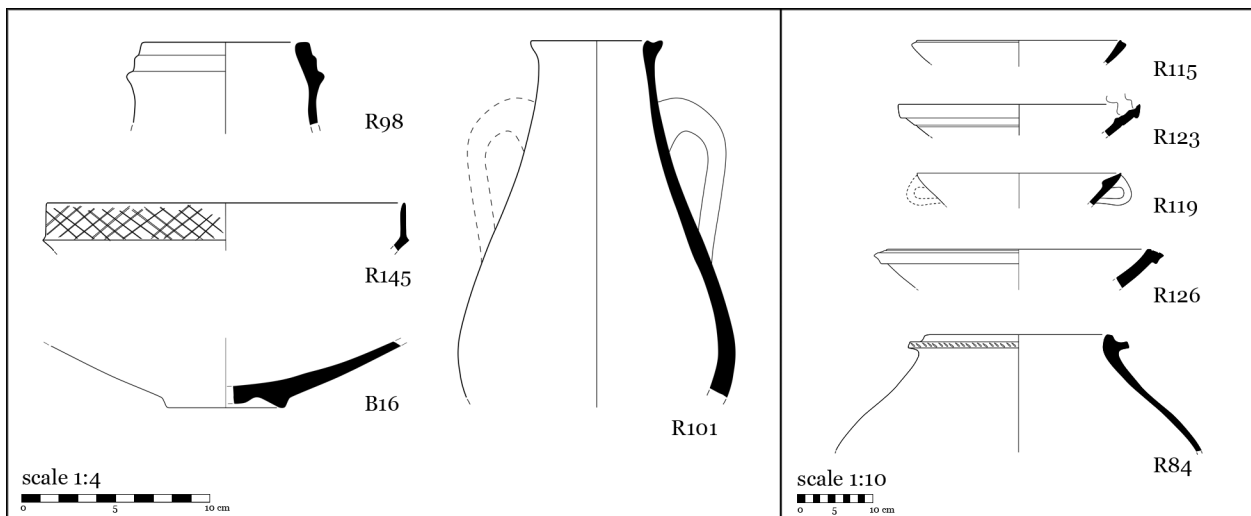

Figure 572: Subphase V-C Shape Types

This subphase sees the continuation of the vertical rim plate, R144, which continues to grow in popularity and remain in use through Phase VI, where it seems to slowly drop out of use (Figure 572). Subphase V-C sees the introduction of a slightly different vertical rim plate, R145, a form that typically has a slightly browner slip, sharper edges, and very prominent burnishing on the exterior of the rim as well as less prominent burnishing on the interior. This form has the same elements as R144, but a different execution that belies a different workshop. Given the smaller number found, this is probably a regional import.

This phase sees the addition of several amphora styles, a shape group that

remains popular from the time of its introduction in Phase II throughout Phase VI and into the Islamic period. A large sloping-walled bowl/platter form with a decorated register becomes popular, R123, and this form is sometimes found with rope shaped handles, a style that becomes more common in Phase VI.

A different style of ledge-rim storage jar comes into use at this time, R84. It has an angular external ledge that is usually decorated with rope-like impressions. These are relatively standardized in size and decoration, but are not particularly common.

Phase VI

Phase I			Phase II			Phase III			Phase IV			Phase V			Phase VI			Shape
A	B	C	A	B	C	A	B	C	A	B	C	A	B	C	A	B	C	Description
	B27																	plain base
				R113														platter
			R11															short neck jar
			B32															disc base
										B15								ring base
												R108						amphora
												R93						amphora
													R94					amphora
													R96					amphora
														R98				amphora
													R144					small bowl
													R133					platter
														R119				platter
														R123				platter
														R19				neckless jar
														R84				neckless jar
														B40				disc base
															B16			ring base
															R86			amphora
															R91			amphora
															R92			amphora
																R100		amphora
																R87		amphora
																R88		amphora
																R89		amphora
															R171			drinking vessel
															R164			small bowl
																R165		small bowl
															R173			drinking vessel
															B20			drinking vessel base
															R174			drinking vessel
																Rope handle		handle
															R124			platter
																R50		utility bowl
																R68		storage jar
																R73		storage jar
															R18			straight neck jar
																R23		pinch neck jar
															B11			ring base
															B10			ring base
															B14			ring base
															B13			ring base

Table 19: Schematic of Phase VI

Phase VI sees the increasing popularity of several important forms, including a carinated hemispherical bowl, R165, that is easily the most popular table form of this

period and is likely related to the earlier vertical rim pattern burnished plate, R144, (Table 19). The large open sloping-walled bowl/platter form R124, which usually has rope shaped handles, becomes very popular. This form has the aforementioned register style upper walls and they become decorated with increasing complexity and diversity.

This phase is characterized by the preponderance of standardized forms, both the continued and declining vertical rim plate, R144, and the carinated hemispherical bowls, R164 and R165. Red and eggplant colored slips continue to be used on table forms, but the standardized forms tend to be largely red slipped.

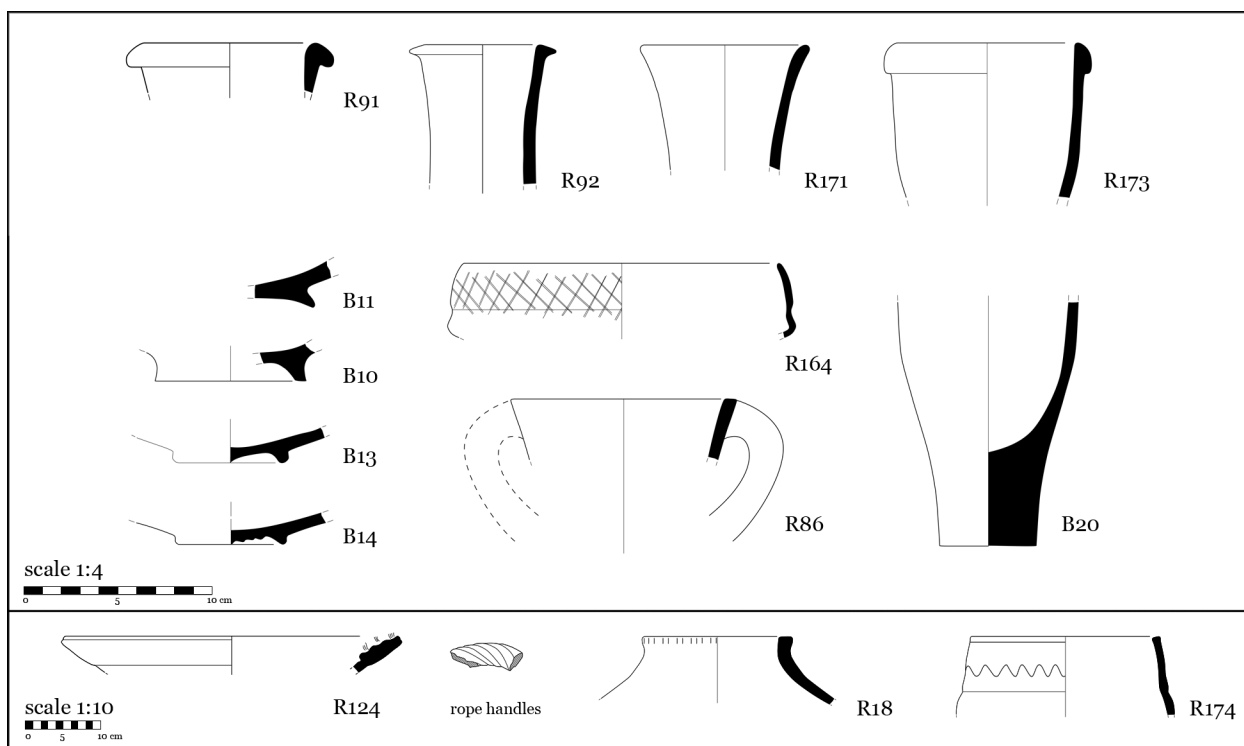

Figure 573: Subphase VI-A Shape Types

This subphase sees the rise of a number of new shape varieties. Amphorae continue to be used, but a new, flared-neck style, R86, comes into use (Figure 573). Usually red slipped, it does not often have the pattern burnished decoration so common on other amphorae, and the rim is entirely unarticulated. Although less common in

general, there are still some tall goblets, and a more flared-mouth version, R171, comes into use. The upper portions of Phase I carinated beakers tend to look very similar to this in shape, but those are always in Peach Cream fabric and have very different lower bodies and bases. A very plain, pedestaled goblet, R173/B20 comes into use.<sup>145</sup> Although designed for individual drinking, it is rather utilitarian in construction and of markedly lower quality than other drinking vessels. In unslipped Pink/Buff B fabric, these are rather sloppily wheel turned and twisted off the wheel with little to no smoothing on the bottom or on the slightly articulated rim.

A short, squat carinated hemispherical bowl, R164, comes into use. Perhaps a sort of intermediary between the vertical rim plate, R144, and the tall carinated hemispherical bowl, R165, this is not as common as either and could have held either liquid or solid foodstuffs. Like R144 and the later R165, these are fairly high quality vessels made with standardized, fine fabric, typically high quality red semi-glossy slip, and consistent pattern burnishing. Providing an interesting window into local production, a waster of R164 fused with R173/B20 was found, two shapes whose quality and production could not seem more different.

Another important addition to the assemblage is the platter form R124, a large sloping walled bowl with a normally highly decorated register and rope shaped handles. These were probably used contemporaneously with R123 and would have provided a decorated border for communally served food in a dining context.

---

<sup>145</sup> Although far from perfect, perhaps an analogous modern shape for this cup style is the red Solo cup: ubiquitous at student parties, easy to produce, relatively large volume, low quality, and disposable.

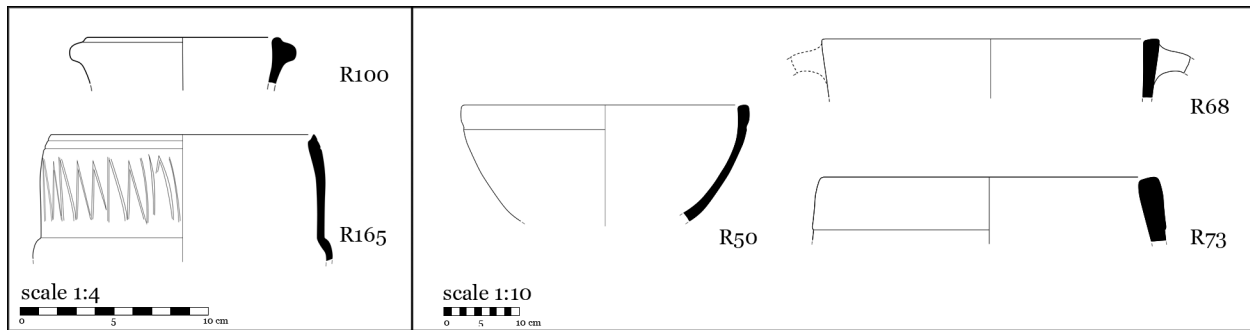

Figure 574: Subphase VI-B Shape Types

This subphase (Figure 574) sees the huge popularity of the carinated hemispherical bowl, R165, whose fabric, slip, and decoration combined with production standardization place it in the same small group of high quality vessels as the vertical rim plate, R144, and the squat carinated bowl, R164 (Figures 571, 573).<sup>146</sup> All of these vessels are used during this phase as well as Subphase V-IC, but R165 is the most common of these. Along with the rise of this shape, many earlier bowl forms seem to drop from popularity. Table amphorae forms are still diverse and well decorated, often with highly articulated rims and pattern burnished necks.

Two large, straight-walled storage vessels come into use, R68 and R73, typically unslipped but with relatively high quality, fine fabric. The utility bowl form R50 is also

<sup>146</sup> The two major standardized shapes in Phases V and VI are R144, the vertical rim plate, and R165, the carinated hemispherical bowl. Statistical analysis places R165 as overlapping both phases, but later than R144 and they share enough similarities of paste, slip, and decorative techniques that production was perhaps in the same workshops, certainly with similar tools and aesthetic sensibilities. If one were to look at these shapes with an eye to shape evolution, however, R165 looks quite similar to an earlier deep bowl with vertical upper walls that was common in the Hellenistic period, perhaps suggesting a date earlier than R144. Although that style of bowl has been detected at many other sites in Bactria and Sogdiana, none have been found at Bactra thus far. Given the tenuous nature of the deposit data at Bactra and the lack of sequence information from other sites of which I am aware, there is significantly more uncertainty with this sequence than is ideal. Unfortunately, these are two of the most important shapes for the Kushan/Kushano-Sasanid periods. I have presented here the most likely sequence, given the statistical analysis of the Bactra corpus. The opposite evolution, of the tall rimmed R165 evolving to R164 and then R144 has been suggested in: Fitzsimmons, T. "Ceramics and Chronology of Dilberdzhin Tepe and Zhiga Tepe (North Afghanistan) *Zinbun: memoirs of the Research Institute for Humanistic Studies, Kyoto University*, Vol.29, pp.33-60, 1995.

typically made from fine fabric. This tendency to produce utility shapes in fine fabrics was more popular in Phase I than in the intermediary phases.

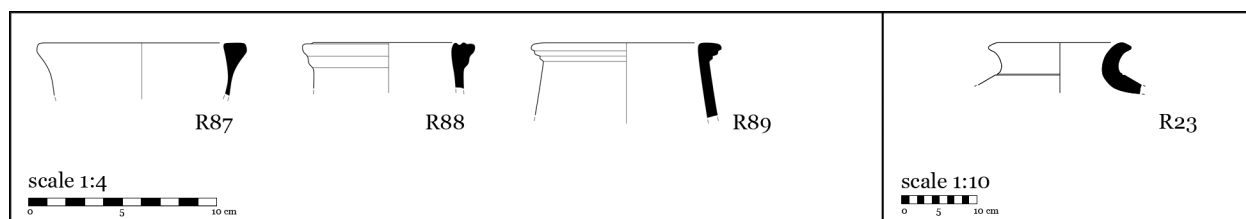

Figure 575: Subphase VI-C Shape Types

This subphase sees the continued, though slightly less common, use of the vertical rim plate and the two carinated bowl forms (Figure 575). Decorated amphorae remain popular and three varieties with well-articulated rims reach their peak popularity at this period. There is also the addition of a very thick-walled, large, pinch neck storage jar that is usually produced with fine clay.

## Conclusions

Organizing the ceramic sequence into phases and examining them chronologically reveals much about the continuity and discontinuity of ceramic forms and assemblages at Bactra, including aspects of firing technology, fabric, function, shape, and decoration.

There is a long-running tradition of wheel-made, self-slipped manufacturing technology in Central Asia, possibly extending back into the Bronze Age. In the Iron Age, likely before the Achaemenid Persian rule and continuing throughout the period of their rule, there is a shape repertoire that I have called Stack-fired Ware, which employs a firing arrangement that creates distinctive surface colors. This repertoire features a small and homogenous group of large storage vessels, beakers, and very rare individual dining vessels.



Sometime not long after the Macedonian conquest, the ceramic industry at Bactra underwent the most dramatic discontinuity of any phase transition, that of Phase I to Phase II. The shapes, functions, fabrics, firing styles, and decorations change suddenly and completely. First, there are new shapes and functions, most importantly a wealth of small dining vessels, then there are new fabrics and firing styles, primarily Pink/Buff fabrics without self-slips or visible evidence of kiln stacking, but also a wide range of coarse fabrics. Shortly thereafter new decorative styles, including slips and incised marks, come into use. All aspects of ceramic production used in Phase I cease, which I believe signals a fundamental change in dining customs, technology, aesthetic taste, and perhaps new pottery workshops.

From Phase II onwards, there is a greater degree of continuity between phases and most differences are in shape and decoration, only occasionally in function and firing technology. Phases III through VI see a growing complexity of pattern burnished decoration, which is overall a very local, Central Asian form of decoration, and there does not seem to be any further direct Mediterranean influence on the ceramic traditions. Pedestaled goblets are introduced in Phase III and continue to grow in popularity through the end of Phase IV. Eggplant colored slip also begins in Phase III, remaining popular through Phase VI. Incised decoration on slipped table vessels is more commonly used in Phase IV, and most small, straight walled bowl forms are discontinued, with the exception of one small plate form, R143. Phase V witnesses the use of increasingly complex incised and pattern burnished decoration on table vessels, as well as standardization in the production of a vertical rim plate form, R144, which likely evolved from the Phase IV plate form R143. Phase VI sees an even greater increase in standardization, with the overwhelming majority of small table vessels being

either the vertical rim plate, R144, or the carinated hemispherical bowl, R165. The consistency of fabric, firing, shape, slip, size, and decoration show an adherence to widespread standards, although the origin and mechanism of those standards are unknown. The Hellenistic era immigrants forever changed the pottery repertoire of Bactra, but beyond the original, functional differences in vessels, the subsequent changes remained true to local variations and trends that sprang not from the Mediterranean world, but from Central Asia. I consider the implications of this assertion further in Chapter Five, where I situate the Bactra ceramics in their larger regional context.