

Experimental validation of Monte Carlo dosimetry for therapeutic beta emitters with radiochromic film in a 3D printed phantom

Benjamin Van¹, Yuni K. Dewaraja¹, Jeremy T. Niedbala¹, Gerrid Rosebush¹, Matthew Kazmierski¹, David Hubers¹, Justin K. Mikell^{2,4*}, Scott J. Wilderman^{3*}

5 ¹ Department of Radiology, Michigan Medicine, Ann Arbor, MI, 48109, USA

²Department of Radiation Oncology, Michigan Medicine, Ann Arbor, MI, 48109, USA

³Department of Nuclear Engineering and Radiologic Sciences, University of Michigan, Ann Arbor, MI, 48109, USA

⁴Department of Radiation Oncology, Washington University in St. Louis, St. Louis, MO, 63110, USA

*Co-senior Authorship

10

Corresponding Author: Yuni K. Dewaraja

Email: yuni@umich.edu

Mail: Yuni Dewaraja, PhD

Professor

15

Division of Nuclear Medicine

Department of Radiology

University of Michigan

1301 Catherine

2276 Med Sci 1/SPC 5610

20

Ann Arbor, MI 48109

Running Title: Therapeutic beta emission dosimetry

25

Abstract

Purpose: Validation of dosimetry software, such as Monte Carlo (MC) radiation transport codes used for patient-specific absorbed dose estimation, is critical prior to their use in clinical decision making.

However, direct experimental validation in the clinic is generally not performed for low/medium-energy
30 beta emitters used in radiopharmaceutical therapy (RPT) due to the challenges of measuring energy deposited by short-range particles. Our objective was to design a practical phantom geometry for radiochromic film (RF) based absorbed dose measurements of beta-emitting radionuclides and perform experiments to directly validate our in-house developed Dose Planning Method (DPM) MC code dedicated to internal dosimetry.

35 **Methods:** The experimental setup was designed for measuring absorbed dose from beta emitters that have a range sufficiently penetrating to $\sim 200\mu\text{m}$ in water as well as to capture any photon contributions to absorbed dose. Assayed ^{177}Lu and ^{90}Y liquid sources, 13 - 450MBq estimated to deliver 0.5-10Gy to the sensitive layer of the RF, were injected into the cavity of two 3D printed half-cylinders that had been sealed with $12.7\mu\text{m}$ or $25.4\mu\text{m}$ thick Kapton Tape. A $3.8\times 6\text{cm}$ strip of GafChromic EBT3 RF was
40 sandwiched between the two taped half-cylinders. After a 2-48hr exposures, films were retrieved and wipe tested for contamination. Absorbed dose to the RF was measured using a commercial triple-channel dosimetry optimization method and a calibration generated via 6MV photon beam. Profiles were analyzed across the central 1cm^2 area of the RF for validation. Eleven experiments were completed with ^{177}Lu and nine with ^{90}Y both in saline and a bone equivalent solution. Depth dose curves were
45 generated for ^{177}Lu and ^{90}Y stacking multiple RF strips between a single filled half-cylinder and an acrylic backing. All experiments were modeled in DPM to generate voxelized MC absorbed dose estimates. We extended our study to benchmark general purpose MC codes MCNP6 and EGSnrc against the experimental results as well.

Results: A total of 20 experiments showed that both the 3D printed phantoms and the final absorbed dose values were reproducible. The agreement between the absorbed dose estimates from the RF measurements and DPM was on average -4.0% (range -10.9% to 3.2%) for all single film ^{177}Lu experiments and was on average -1.0% (range -2.7% to 0.7%) for all single film ^{90}Y experiments. Absorbed depth dose estimates by DPM agreed with RF on average 1.2% (range -8.0% to 15.2%) across all depths for ^{177}Lu and on average 4.0% (range -5.0% to 9.3%) across all depths for ^{90}Y . DPM absorbed dose estimates agreed with estimates from EGSnrc and MCNP across the board, within 4.7% and within 3.4% for ^{177}Lu and ^{90}Y respectively, for all geometries and across all depths. MC showed that absorbed dose to RF from betas was greater than 92% of the total (betas + other radiations) for ^{177}Lu , indicating measurement of dominant beta contribution with our design.

Conclusions: The reproducible results with a RF insert in a simple phantom designed for liquid sources demonstrate that this is a reliable setup for experimentally validating dosimetry algorithms used in therapies with beta-emitting unsealed sources. Absorbed doses estimated with the DPM MC code showed close agreement with RF measurement and with results from two general purpose MC codes, thereby validating the use of this algorithms for clinical RPT dosimetry.

1. Introduction

Nuclear medicine clinics worldwide are seeing an increase in the number of available radiopharmaceutical therapy (RPT) options.^{1,2} In addition to the well-established ^{90}Y microsphere radioembolization (RE) for hepatic malignancies, ^{177}Lu peptide receptor radionuclide therapy (PRRT) for neuroendocrine tumors and ^{177}Lu radioligand therapy for prostate cancer have both been recently approved. Even new applications of ^{131}I , the classical therapy radionuclide used for decades in radioiodine therapy, are emerging.³ Alongside the rise of these new therapeutic applications comes a renewed interest in individualized dosimetry-guided treatment planning. Accurate absorbed dose data is

also required for answering key questions that remain in the field; such as what absorbed dose-response relationships exist, what scale of dosimetry is necessary, and how spatial distribution affects outcomes.⁴

75

RPT, unlike brachytherapy or external beam radiotherapy (EBRT), commonly relies on ligand or antibody uptake in the specific cancer cell, or its close neighbors, in order to deliver a therapeutic dose of radiation. This process is inherently dependent on the cell function and distribution on a microscopic level and absorbed dose may be very non-uniform over even a couple of millimeters. This is in stark contrast to EBRT where the known beam geometry covers a much larger area and any given pulse of radiation can be relatively flat across the beam. Even in brachytherapy the applicators are, relative to the size of a cell, quite large and absorbed dose approximations can be made reliably as the radiation is applied using a fixed geometry. The dependence on a non-uniform, microscopic geometry paired with short-range beta emitters in RPT increases the need to validate the absorbed dose calculation software at very short distances.

85

Experimental absorbed dose validation for radionuclides such as ^{60}Co or ^{137}Cs used in EBRT has been widely achievable with the use of ionization chambers or thermoluminescent dosimeters (TLD),^{5,6} due to the photon component being used for therapy. Radionuclides with less penetrating radiations, such as ^{177}Lu used in radiopharmaceutical therapies, require geometries and methods not commonly available in commercial systems in order to directly measure the beta contribution of the absorbed dose. Low energy betas may lack the penetration distance necessary for ion chamber measurement and the liquid nature of the therapeutic agents makes contamination an additional challenge that must be overcome when using TLD's or similar detectors.

90

In order to directly and reliably measure the beta contribution of absorbed dose a detector must be placed sufficiently close to a liquid source and have a repeatable geometry. Both RF and gel

95

dosimetry can fit this niche need. Gel dosimetry has been shown to be a viable measurement system for beta particles from ^{90}Y brachytherapy seeds⁷ and further investigation may be warranted in future studies. For a much simpler, more accessible, and less-costly measurement, film dosimetry has proven to be a reliable method of acquiring high resolution data one plane at a time. Film dosimetry has a rich history in EBRT measurements with its use in a variety of applications from megavoltage beam commissioning to small field and in-vivo measurements.⁸ Given the thin ($\sim 25\ \mu\text{m}$) active layer, high resolution, and low dependence on absorbed dose-rate and particle energy,⁹ RF can also be easily extended for use in beta measurements relevant to RPT.

The ongoing interest in these low energy beta measurements has prompted other experiments with Tiwari et. al.¹¹ demonstrating the use of RF measurement for ^{90}Y and ^{177}Lu at distances between 1mm and 15mm from the source, although the first 1-2mm of the film was impacted by delamination. Their experimental configuration showed good correlation with GEANT4 Application for Tomographic Emission (GATE)¹² MC at these distances and incorporated direct measurement of the beta, gamma, and bremsstrahlung portions of the deposited dose. The experimental geometries and materials used for their research allowed for effective measurement of absorbed dose from the ^{90}Y beta in all three of the common clinical mediums; soft tissue, lung, and bone, however direct measurement of ^{177}Lu was restricted to only lung equivalent materials due to the significantly shorter maximum beta range, 1.8mm in tissue for ^{177}Lu vs 11mm¹³ in tissue for ^{90}Y . As many of the currently used or experimental beta emitters have low average electron energies (**Error! Reference source not found.**), the majority of their absorbed dose will be deposited in path lengths shorter than 1.5mm, and a different geometry is required for comprehensive absorbed dose validation work in this space.

Villarreal-Barajas et. al.¹⁴ attempted RF measurement of betas at distances as short as $104\ \mu\text{m}$ from a liquid ^{153}Sm source in an acrylic phantom. Their experimental results showed excellent agreement with film measurement with depths between $416\ \mu\text{m}$ and $832\ \mu\text{m}$ having agreement within

120 5%. They noted that films closer than $416\mu\text{m}$ ended up damaged during removal from the phantom, which highlights the complexity involved in both being close to a liquid source and avoiding contamination or other damage when doing so.

The MC method is a valuable tool for radiopharmaceutical therapy dosimetry, especially when voxel-level estimates are of interest. As detailed in a recent publication¹⁵, there are multiple general purpose and specialized MC codes that can be used for dosimetry with explicit radiation transport using the patient's own anatomical and emission images as well as for generating the kernels for dose kernel convolution methods.^{16,17} While direct MC radiation transport is generally accepted as superior to convolution using MC-derived dose kernels it is computationally very demanding and can be associated with long simulation times to obtain good statistics when general purpose codes (e.g. MCNP, EGSnrc, 125 GATE) are used. 130

To overcome this, the specialized MC code Dose Planning Method (DPM)¹⁸ was originally developed at University of Michigan for fast absorbed dose estimation in EBRT. DPM achieves its significant speed-up over conventional MC via special transport mechanics that permits long transport steps across heterogeneous boundaries. The accuracy of DPM at energies and geometries relevant to EBRT has previously been demonstrated by benchmarking against measurements.^{19,20} Since DPM was optimized specifically for absorbed dose computations in voxel geometries, in particular, those derived from CT-scans, it is perfectly suited for patient specific absorbed dose estimation in RPT. Therefore, we previously adapted DPM for RPT applications by sampling decay locations internally within the voxelated geometry.²¹ We have previously demonstrated the use of DPM for efficiently performing direct MC dosimetry in patients undergoing ¹³¹I radioimmunotherapy,^{22,23} radioiodine therapy²⁴, ⁹⁰Y radioembolization²⁵ and very recently ¹⁷⁷Lu-DOTATATE peptide receptor radionuclide therapy²⁶. Thus 140 far, DPM benchmarking for RPT consisted of comparison with estimates from EGS4 and OLINDA.^{21,22} Although some initial measurements with TLDs were performed to experimentally validate the photon

contribution²¹, no experimental validation of the beta component of DPM was undertaken at the time, due to the challenges associated with the short range. To our knowledge, prior experimental studies undertaken by others have also not attempted to directly measure absorbed dose deposition in water equivalent or high-density mediums by beta emitters that have a range as low as that of the betas associated with ¹⁷⁷Lu.

Motivated by the recent surge in interest in RPT dosimetry and the scarcity of experimental measurements relevant to validating dosimetry calculations in RPT, our goal was to design a practical and reproducible experimental setup for measuring the absorbed dose deposited in water/tissue by beta emitting therapy radionuclides. We then use our experimental setup to perform a full (electron + photon components) validation of our in house DPM MC code for ⁹⁰Y and ¹⁷⁷Lu. Secondary benchmarking of Monte Carlo N-Particle version 6.2²⁷ (MCNP6) code as well as the general purpose EGSnrc²⁸ against the experimental results was also performed, as both are widely available/used for RPT dosimetry.

2. Materials and Methods

2.1 Experiments

Two types of measurements were performed with the RF. The first was a measurement of absorbed dose to a single sheet of film (SF) and the second was measurement of radionuclide depth dose (DD) curves using a stack of films. Absorbed doses were measured for ¹⁷⁷Lu (in the form of ¹⁷⁷Lu DOTATATE) and ⁹⁰Y (in the form of ⁹⁰YCl₃) in saline (S) and a bone (B) equivalent solution. Two different thicknesses of tape (used between the film and the radioactive solution) were tested for ¹⁷⁷Lu. The nomenclature used to identify each experiment is indicated in the last column of Table 2.

2.1.1 Phantom Design

The main challenge with experimental measurements that are relevant to RPT dosimetry are the short beta particle ranges and the need to have the radioactive material in liquid form. These considerations were key to our final design of the phantom, which is shown in Figure 1 and Figure 2.

170

The phantom was modeled using computer aided design (CAD) software and 3D printed utilizing a Form 2 printer using stereolithography in a photopolymer resin. Each phantom was designed as a half-cylinder with an open cavity and three top holes used for filling the volume with the radioactive liquid as seen in Figure 1. The phantom cavity size was chosen to provide a smooth absorbed dose distribution across the center 1cm x 1cm area of the film measurement. External dimensions were modeled to fit inside a standard 90mL urine sample container, commonly found at most hospitals, in order to contain inadvertent leakage.

175

After printing, the model was allowed to dry for 24 hours. All excess support structures were manually removed and the front face of the phantom was sanded with a 400 grit diamond plate to improve tape to surface adhesion. A 3.8cm by 6cm length of Kapton tape²⁹ was mounted across the front of the phantom to enclose the cavity. These taped phantoms were used as the core component in all validation procedures and allowed for a wide variety of experiments to be performed (**Error! Reference source not found.**) with consistent reproducibility.

180

Gafchromic EBT3 was cut into 3.8cm x 6.0cm strips using a Full Spectrum Laser Hobby Series 20x12 CO Laser Cutter and a small watermark was cut into the top right corner to provide consistent orientation during post-exposure film scanning. Strips were sandwiched in between two taped half-cylinder phantoms before insertion into the standard specimen container per Figure 2.

185

2.1.2 Activity Measurement and Solution Preparation

190 The ^{177}Lu and ^{90}Y activities used for the different experiments ranged from 13 - 450 MBq. Injected activity levels were selected to minimize both exposure during phantom handling and cost, while providing absorbed dose in the sensitive range for EBT3⁹ in each configuration. Prior to each experiment the necessary exposure time was estimated by scaling the Monte Carlo predicted dose rate for each geometry by a number of decays until the film absorbed dose was within this sensitive range. This total
195 number of decays was combined with the available radionuclide activity to estimate the required exposure time. Activities were measured in a Capintec 15R dose calibrator within a 10cc syringe. The dial setting used was 55 x 10 for ^{90}Y ³⁰ and 48 x 10 for ^{177}Lu . The setting for ^{177}Lu was determined by a dial setting transfer performed in house to match activity readings for a 10cc syringe and for a Schott vial with the NIST recommended setting³¹ of 449 x 10. The activity solutions were combined in a 60cc syringe
200 with either ~30cc of saline or bone equivalent liquid that included ethylenediaminetetraacetate (EDTA) to avoid any potential absorption from heavy metal radionuclides into the walls of the container.

The bone equivalent liquid was prepared by combining deionized water with K_2HPO_4 salt at a ratio of 100g for salt per 67g water, which results in density and linear attenuation coefficient close to that of cranial bone.³² The phosphate-buffered saline mixture was assembled with 1xPBS at 7.3 pH with
205 EDTA added until a concentration of 2.5- μM EDTA³³ was reached. For the bone equivalent solution, the EDTA salt was mixed directly into the solution until a concentration of 2.5- μM was reached.

2.1.3 Measuring Absorbed Dose to Closest Layer using a Single Film

A single strip of 3.8cm by 6.0cm Gafchromic EBT3 film was placed between the two phantom
210 halves and then secured in a standard specimen container. A cross sectional view of each material layer is shown in Figure 2A. Two phantom halves were each enclosed with Kapton tape (12.7 or 25.4 μm) and

filled with radioactive solution. The entire center cavity of each phantom half was filled for a total of ~33cc of fluid, ~16.5ml in each half. The semi-clear nature of the 3D print material allowed for visual confirmation of the solution level in each phantom during filling. Precise solution volumes were
215 calculated from calibrated digital scale measurements of the empty, filled, and residual syringes as well as the empty and full phantoms. Phantoms were shielded and secured in locked facilities for 3-47 hours before the film was removed.

220

2.1.4 Measuring Absorbed Depth Dose using Stacked Films

Measurement of radionuclide absorbed depth dose curves was also completed using a very similar phantom setup, except that only one phantom half was used in this case. The single phantom half was
225 enclosed with 25.4 μ m thick Kapton tape and filled with radioactive solution. The cavity of the single phantom half was filled full, resulting in a total of ~16.5ml of solution. Five (for ^{177}Lu measurements) to ten (for ^{90}Y measurements) 3.8cm by 6.0cm Gafchromic EBT3 films were placed in between the single phantom half and a backscatter stack of water equivalent acrylic and then secured in a standard specimen container. A cross sectional view of the layers are shown in Figure 2B. Phantoms were
230 shielded and secured in locked facilities for 20-48hrs before the stack of films was removed.

2.2 Film Analysis

Post-exposure optical film scanning was done on an EPSON XL10000 flatbed scanner at 200 dpi with all image correction features turned off. All films were centered in the middle 1/4th of the scanner to avoid

235 lateral response artifacts and a glass compression plate was used to prevent deformation of the film
during scanning.

2.2.1 Calibration Films

Calibration films were created on a Varian TrueBeam Linear Accelerator that was calibrated per TG-51
240 standards⁵ using a 6MV photon beam. Ten calibration films were created over a 0-1850cGy range with a
geometric dose sequence at 0, 79.7, 159.5, 319.0, 478.4, 717.7, 877.1, 1116.4, 1594.8, and 1834.0cGy.
Eight additional calibration films were created at the same time as a secondary validation set for
checking the accuracy of the final fits. The average difference between our calibration curve and the
calibration check films in our measured range was 0.1% and the maximum difference for a single film
245 was 2.2%.

The 10 original calibration films were optically scanned and used to fit a continuous calibration curve for
each of the red, blue, and green color channels. Triple-channel dosimetry optimization methods³⁴ were
250 used to help correct the scanned images for all measurements. The reported absorbed dose values were
computed from the triple-channel optimization reported red channel values. The calibration fits were
created in FilmQA Pro³⁵ using their color rational cubic fit shown in equation 1 and Figure 3 where $X(D)$
is the color channel value, A, B, C, E, and F are the cubic fit parameters, and D is the known delivered
dose.

$$255 \quad X(D) = \frac{(A+BD+CD^2+ED^3)}{(D+F)} \quad (1)$$

2.2.2 Experimental Film Analysis

Film analysis was performed using FilmQA Pro software. Each experimental film was optically scanned with both the measurement film and an unexposed film strip from the same sheet of EBT3 in a single session. All experimental film measurements were analyzed using a film calibration from the same film production batch as the experiment. An average over the 1cm x 1cm square at the center of the exposed film area was used to calculate the mean dose to the film.

Compensation for post exposure film darkening,³⁶ often accomplished by using the single scan protocol,³⁷ was instead corrected by closely matching the post-exposure optical scan time between the calibration strips and the experimental measurements as well as using the dose shift single point recalibration provided by Ashland.³⁸ Equation 2 gives the dose shift single point recalibration with $X(D)$ being the RGB value, D as the original dose, and x and a as scaling factors calculated from the differences between the experimental scan's unexposed film and the calibration scan's unexposed film.

$$X(D) = x(a + D) \quad (2)$$

All ^{90}Y experiments were allowed between 145-176 hours for development while ^{177}Lu films were measured between 45-100hrs. Calibration curves were rescanned to match the experimental film development time with no more than a 4% difference in total film development time for the ^{177}Lu and a maximum 11% development time difference for ^{90}Y .

2.3 Monte Carlo Simulations

Simulations of the experiments were performed using our in-house DPM program as well as two general purpose MC codes: MCNP and EGSnrc. A computational phantom for DPM, MCNP, and EGSnrc

was created based on the material and geometry specifications of the 3D printed phantom, the Kapton tape and manufacturers specifications for Gafchromic film. The material compositions were obtained
280 from Compendium of Material Composition Data for Radiation Transport Modeling³⁹, and
RADIOCHROMIC FILM: Role and Applications in Radiation Dosimetry⁹ and are given in appendix Table
A5. As DPM is designed to perform dose transport on voxelized geometries (for example, patient PET/CT
or SPECT/CT images) the phantom design was voxelized. The voxel size was chosen to be 1.25 x 1.25 x
0.0127mm to model the thin film layers while keeping the total calculation time and memory
285 requirements reasonable. No attempt was made to match the simulation voxel size to the flatbed
scanner pixel dimensions as the average over the 1cm² center of the film was well sampled in both
situations and finer MC binning would significantly increase runtimes. This voxelization caused only
<1.2% difference in the film thickness and <5.2% difference in the Kapton tape thickness (appendix
Tables A2 and A3). The voxelization of the phantom also caused all computational phantom material
290 thicknesses to be somewhere between the average physically measured dimensions and the
manufacturers specified thicknesses, therefore we have high confidence in the final model.

The simulated phantom was specified as filled to 3.5cm high, reaching the bottom of the
insertion holes, with water (Figure 1). This filled water volume in the phantom was used to define the
volume containing the radioactive solution with a uniform activity distribution throughout.

295 The beta energy spectra for all simulations were those generated by BetaShape software version
1.0 available from the Laboratoire National Henri Becquerel.⁴⁰ Photon, x-ray, auger electron, and
electron capture spectrums were acquired from NuDat 3.0 via Brookhaven National Laboratory.⁴¹
Simulations for ⁹⁰Y included only the beta energy spectrum and no transport was attempted on any x-
ray, auger, or conversion electron portions of ⁹⁰Y decay due to their minimal contribution to absorbed
300 dose. Simulation for ¹⁷⁷Lu did include modeling of x-rays and monoenergetic electrons. No attempt was
made to model absorbed dose contribution from contaminants that may be present in the radionuclide

solution, such as ^{177m}Lu in ^{177}Lu DOTATATE,⁴² or ^{90}Sr in $^{90}\text{Y-Cl}_3$ ⁴³ depending on the method used to produce the radionuclide.

In the DPM simulations, low energy beta and photon cutoffs were set to 20keV and 4keV
305 respectively and the energy of source betas and/or x-rays born below or reaching the respective cutoffs was deposited locally. To test the validity of this assumption, we started with a much higher beta cutoff (100 keV) and re-ran with lower cutoff values until the difference in absorbed dose-rate values was <0.5%. With the mean free path of ~0.1mm for a 4 keV photon in tissue being less than the minimum distance from the fluid to the active layer of the radiochromic film (~150um) and only ~7% of the total
310 absorbed dose coming from photons, we did not observe meaningful differences when lowering the cutoff under 4 keV. A total of 8 billion decays spread uniformly throughout the solution were simulated, giving an uncertainty of <0.5% in the center 1cm^2 of the first film of each simulation. Run times varied depending on the isotope from 13-90 hours of CPU time on a 2.7GHz Intel Xeon E5-2697v2.

MCNP calculations were defined in the same way as the DPM setup, with a few exceptions.
315 Instead of a uniform voxel distribution the geometry was defined via MCNP's macrobody and universe style definitions. The same beta and photon spectra and electron yields described above for DPM were included for transport in MCNP. Energy cutoffs were matched to the DPM run. MCNP simulations were run for 1 billion histories, due to the much longer run times of a general-purpose MC code, giving an uncertainty of <1.0% in the center of each film. Run times varied depending on the isotope from 880-
320 3690 hours of CPU time on a 3.4GHz AMD Threadripper 1950x. MCNP simulations were run on 16 processors to obtain results in <10 days.

EGSnrc calculations were also defined as close to the DPM setup as possible. Instead of a uniform voxel distribution the geometry was defined via EGSnrc's C++ geometry module. The same beta and photon spectra and electron yields described above for DPM were included for dose transport

325 in EGSnrc. Energy cutoffs and number of histories were matched to the DPM run. This gave an
uncertainty of <0.5% in the center of each film. Run times varied depending on the isotope from 46-562
hours of CPU time on a 3.4GHz AMD Threadripper 1950x.

3. Results

330

A total of 55 films were analyzed over the course of 20 experiments. The first plot in Figure 4 shows all experimental absorbed dose readings vs the DPM predictions across a wide range of dose (41.7-1561.6cGy). The central plot in Figure 4 shows experiment vs MCNP calculations for all experimental configurations and the final plot shows experiment vs EGSnrc.

335

Horizontal and vertical profiles from all MC simulations as well as experimental measurement from our single film geometry, Figure 5, show the design provides a uniform absorbed dose region across the center film planes.

3.1 Single Film Results: Dose to Closest Layer

340

The agreement between measurement and each of the three MC estimated absorbed doses are given in Table 3 for the different single film experiments. The agreement between the absorbed dose estimates from the RF measurements and DPM was on average -4.0% (range -10.9% to 3.2%) for all single film ^{177}Lu experiments and was on average -1.0% (range -2.7% to 0.7%) for all single film ^{90}Y .

345

The contribution from the beta emissions to the total absorbed dose deposited in the single films was calculated with MC, which showed that the primary contribution to the absorbed dose was indeed the beta particles for all configurations. Absorbed dose to the Lu177_{SF,S,25.4} film was 93% from the beta, Lu177_{SF,S,12.7} was 94% and Lu177_{SF,B,25.4} was 90%. The conversion electrons and auger electrons contributed <0.15% of dose to the first layer of the film. The rest of the contribution (7 to 10%) in the ¹⁷⁷Lu experiments is from photons (x-rays and gamma-rays), which are dominated by the emissions at 113 keV and 208 keV.⁴¹ Dose from ⁹⁰Y experiments was considered to be effectively 100% from the betas as no other starting particles were simulated due to their negligible dose contributions. All dose from secondary particles, i.e. Bremsstrahlung, was grouped as part of the starting particle dose estimate in the MC simulation tallies.

3.2 Stacked Film Results: Depth Dose

The agreement between measurement and DPM, EGSnrc, and MCNP estimated absorbed doses are given in

as well as Figures 6 and 7 for the different stacked film experiments. Depth dose estimates by DPM agreed with RF measurement on average 1.2% (range -8.0% to 15.2%) across all depths for ¹⁷⁷Lu and on average 4.0% (range -5.0% to 9.3%) across all depths for ⁹⁰Y. At the deepest measured depth (1.3152mm) the ¹⁷⁷Lu film measurement received only 5.9% of the absorbed dose that the shallowest film (0.2032mm) received.

MC simulations predicted that absorbed dose from betas was 92.8%, 63.5%, 13.2%, 1.6% and 1.2% of the total (betas + others) going from the film closest to the ^{177}Lu solution to the furthest as seen in Figure 8, indicating a large component of the beta dose was measured across our design.

370

The measured absorbed doses for ^{90}Y showed closer agreement to the MC code estimates than the ^{177}Lu across all 10 depths. Absorbed dose to the 10th film (2.7052mm) was 11.4% of the dose to the shallowest (0.2032mm). Due to the longer range of the ^{90}Y beta complete measurement across the entire beta range was not attempted with this phantom geometry.

375

MC calculations done using EGSnrc, MCNP, and DPM agreed with each other across the board, within 4.7% and within 3.4% for ^{177}Lu and ^{90}Y respectively, for all geometries and across all depths.

3.3 Uncertainty Estimation

Overall uncertainty in the measurement was determined by evaluating the level of reproducibility across repeated experiments. Table 2 shows each of the 7 experimental setups along with the number of times each experiment was attempted, with 2-4 repetitions for any given configuration. The coefficient of variation of the absorbed dose rate across all the runs of each setup was between 0.0-4.5% for the ^{177}Lu experiments and 1.0-6.0% for the Y-90 experiments. The coefficient of variation for single films was 0.5-3.0% (Table 3) and for the depth dose measurements 0.0–6.0% (Table 4).

385

Although individual components contributing to the uncertainty in the recorded dose-rates are difficult to measure and uncertainty propagation challenging, some estimates can be made. Use of the Capintec 15R dose calibrator for each of the radionuclide activity measurements provides a high degree

of accuracy. Zimmerman et. al.³⁰ gives ~1-2% uncertainty for a ⁹⁰Y Capintec 15R measurement using a
390 10ml syringe and Denis E. Bergeron and Jeffrey T. Cessna³¹ estimate their dose calibration uncertainty at
~1%. The geometry dependence of the dose calibrator reading was also verified to have a minimal
impact on our activity measurement (Figure A2) and a sensitivity analysis was completed to estimate
potential error in activity measurement across both dose calibrators and dial settings (**Error! Reference
source not found.**A1). The uncertainty in the phantom fluid-volume measurement that also contributes
395 to the uncertainty in the activity is expected to be negligible based on the scale validation data given in
Figure A1.

Variability in experimental geometry for any given experiment was evaluated by repeated
caliper measurements of the 3D printed phantom, Kapton tape, and RF. Agreement between the 3D
print and the CAD design was within ~3% (Table A4), except for wall thickness, which is not expected to
400 impact the overall dose-rate measurement. Variation in Kapton film thickness was 4 – 5% (Table A3) and
RF layer thicknesses was ~1% (Table A2).

Among factors associated with RF measurement/calibration uncertainty are calibration curve
fitting, and post-exposure film darkening. The uncertainty associated with film calibration curve fitting is
estimated as 0.1% on average and up to 2.2 % for any given film (Section 2.2.2). Variations in post-
405 exposure film darkening were evaluated across multiple post-exposure timepoints from 1-400 hours for
a subset of the experiments. Both calibration films and experimental films were rescanned at 8 post-
exposure timepoints and dose to the central 1cm² was measured to quantify the variation in only using a
single recalibration film strip. This rescanning protocol also evaluates overall film analysis repeatability
by including variation in flatbed scanner light/heat levels, film position on the scanner, among other
410 things. A standard deviation of 4.4% was found across the varied post-exposure readout film subset,
giving us high confidence in the repeatability of the film analysis procedures.

Statistical uncertainties associated with the MC simulations were well under 0.5% according to the estimates provided by all three MC codes, with the shorter 1 billion history MCNP runs having the highest uncertainties. Potential uncertainty in the simulations due to parameters such as photon or
415 electron cutoffs, step size, and the voxelization sizes are expected to be larger contributions than statistical uncertainty and are estimated at ~0.5% (Section 2.3)

4 Discussion

Experimental validation of the absorbed dose estimation step is critical for clinical translation of
420 dosimetry guided RPTs. This is however, rarely undertaken due to the challenges of measuring dose deposited in tissue by short range particles such as the betas associated with ^{177}Lu . In this study we design, construct, and test a simple phantom for RF-film based measurement of beta and gamma components of ^{177}Lu and ^{90}Y absorbed doses, which is then used to validate our in-house developed DPM MC dosimetry code. The single film geometry provided for a wide variety of experiments to be
425 performed, allowing for several aspects of the setup to be tested independently without substantial increases in time or experimental complexity. Variations on the transport medium, either saline or bone equivalent fluid, and depth to the film, via Kapton tape thickness, were easily implemented. Further changes to the 3D printed cavity height, depth, or shape for any given radionuclide have not been evaluated yet, but the platform we have developed will allow such evaluation in the future. The depth
430 dose measurements showed the high level of agreement between DPM and experiment in regions both dominated by beta energy deposition and by photon deposition. Figure 6B and Figure 7B show the relative differences between DPM, MCNP, and EGSnrc vs the experiment. When the DPM vs experiment difference increases, the MCNP vs experiment difference and EGSnrc experiment difference also increase, and vice versa. While the magnitude of the difference for each comparison varies, the overall
435 trends match across all three MC simulations.

Dose to film for both measured radionuclides showed excellent agreement with DPM regardless of experimental setup, with an average of -4.0% for all single film ^{177}Lu experiments, 1.2% for depth dose ^{177}Lu , -1.0% for single film ^{90}Y , and 4.0% for depth dose ^{90}Y (Table 3,4). The average difference between measurement and simulation was within the overall measurement uncertainty estimated from the repeats. While four of the five single film experimental geometries showed an average agreement of <2% with DPM, the bone liquid experiment (Lu177_{SF,B,25.4}) was an outlier with a 10.2% difference between measurement and simulation. With both MCNP and EGSnrc also showing relatively large discrepancies compared with experiment, 6.8% and 8.2% respectively, experimental setup variation associated with the challenges of working with the bone liquid is likely the primary factor for this disagreement. Additional investigation using FilmQA Pro revealed larger non-uniformities in the vertical and horizontal film profiles than was seen in other experimental setups. Mixing of the thick bone solution with the ^{177}Lu DOTATATE may have been insufficient during the filling procedure, potentially creating non-uniform distributions within the phantom volume. We did not see mixing issues with the ^{90}Y chloride in bone solution, however the chloride's yellow tint helped verify the solution was uniformly mixed, whereas the DOTATATE was translucent.

When validating Monte Carlo codes, multiple factors such as step size, cut-off energies, material/geometry specifications can contribute to the difference between experiment and simulation. While specifications for the composition of the phantom material, RF and the Kapton tape were available^{32,9}, the composition of the silicone adhesive on the tape was not provided by the vendor and was estimated using the entry for silicone. However, the impact of the adhesive material composition appears to be minimal, because the percent difference between absorbed dose-rates from experiment and simulation were very similar when using a much thinner tape/adhesive combination in the ^{177}Lu experiments (Table A3). Additionally, micrometer measurements of multiple film sheets and measurements within any given sheet of RF shows close manufacturing tolerances within the film itself,

460 measuring within $3\mu\text{m}$ of specification for the film base, active layer, and total thickness (Table A2).
Similar evaluation of the 3D printed phantoms also provided good agreement in every batch of 3D prints
(Table A4).

The radiochromic film energy dependence between the 6MV calibration energy and the
much lower energy betas of ^{177}Lu and ^{90}Y is expected to be minimal as the electron restricted stopping
465 power ratios between EBT3 and water over the 10keV-10MeV range show minimal variation.⁴⁴ A 6MV
photon beam was chosen due to the extensive validation of absorbed dose delivery, and because such
beams should be readily available at other institutions. Other photon energies may be used for
calibration⁸, however use of low energy photon sources (<50 keV) may need alternative procedures or
calibration factors. The dose rate dependence for EBT3 is minimal,⁹ and prior studies with beta-emitting
470 eye plaques have successfully irradiated RF to 30 Gy over 1 week⁴⁵, which is ~ 18 cGy/h compared to the
 ~ 1 -100 cGy/h used in our study.

The use of relatively low activity radionuclide sources resulted in long exposure times (3-48hrs)
for the validation measurements in our study. A portion of the polymerization process that would
typically be considered “post-exposure” is now taking place alongside the experimental polymerization
475 as the absorbed dose slowly builds up over a course of days. As the post-exposure polymerization can
be approximated by logarithmic fits,³⁶ the majority of the additional development happens in the first
24-48 hours. In addition, the rate of change in net optical density is dependent on the initial deposited
dose, with higher doses having significantly higher rates of post-exposure polymerization. This makes
matching calibration curve post-exposure time development to experimental post-exposure time
480 development in RPT applications more complicated than in traditional EBRT film studies. We have
chosen to extend our calibration and experimental scan times to help compensate for any initial changes
in optical densities, but this is an issue that may need further investigation in the future.

Prior work on experimental measurement of short-range beta emitters has shown the viability of using RF as an effective measurement tool for these radionuclides, but lacks the capability to reliably measure at short distances, where a large portion of the dose is deposited for many radionuclides of interest. Tiwari et al.¹¹ was able to measure beta energy deposition above 1mm and Villarreal-Barajas et. al.¹⁴ showed the potential to measure at 0.104mm, but found damage to their first three layers of RF, and recorded their first clean measurement at 0.416mm. It is unclear if the geometry proposed by Villarreal-Barajas et al would be reliable at 0.416mm or at any lower distances as only a single measurement appears to have been attempted. The 3D printed phantom developed for this study has shown the ability to both place the RF within 0.1651mm cleanly and repeatedly.

Future refinements for the phantom would include optimizing the cavity shape/volume for different radionuclides and for depth dose measurements would include using less sensitive film (EBTXD) closer to the source and more sensitive (EBT3) further away. Our work could also be extended to other radionuclides not evaluated in the current study including alpha particle emitters. With thinner Kapton tape and delaminated RF, one can measure the absorbed dose from particles with ranges below 100 microns.

5 Conclusion

The experimental measurements presented in this work validates both electron and photon components of our in-house DPM internal dosimetry code, which we had previously only performed for photons using TLDs. Furthermore, the experimental setup we present can be used in other clinics for validating their internal dosimetry calculations/software. Despite the extensive checks and verifications completed while performing the absorbed dose measurements the overall process is straightforward and able to be completed in any hospital that has access to RF dosimetry equipment. The level of repeatable results using this relatively simple inexpensive design across experiments was encouraging

for future endeavors. The 20 experiments performed in this setup showed that the combination of 3D printing and film measurement can provide a viable base for inexpensive repeatable measurements that could be used for one time validation or continued (annual) quality assurance in almost any clinic. For short range radionuclide that have increased sensitivity to any variation in experimental setup we were able to obtain measurements with low standard deviations.

Validation of DPM showed remarkably good agreement with experimental measurement, for both single and depth dose geometries, between experiment and DPM, with an average difference of <4%. Experiments that did show higher variation from the DPM calculated values also showed high deviation with the two other MC codes, indicating DPM's transport methodology was likely not the source of disagreement. With the consistent repeatability of experimental setup and measurement, the low level of differences between DPM, MCNP, and EGSnrc, and the high level of agreement between MC and experiment, DPM has shown itself to be a reliable dose transport engine for photons and short/medium range betas relevant to RPT.

520 **Acknowledgements**

Our team would like to recognize the contributions from the Michigan Medicine department of Radiation Oncology for their support in providing access to their RF dosimetry tools including linear accelerator time and flatbed scanner. We would also like to thank Steven Kronenberg for his time and expertise in 3D design and printing.

525

Funding

Funding from National Institute of Biomedical Imaging and Bioengineering, Grant/Award Number: R01 EB022075; National Cancer Institute; NIH, Grant/Award Number: R01 CA240706 is acknowledged.

Disclosures

530 The authors have no conflicts to disclose.

References

1. Malcolm J, Falzone N, Lee B, Vallis K. Targeted radionuclide therapy: New advances for improvement of patient management and response. *Cancers*. 2019;11(2):268. doi:10.3390/cancers11020268
- 535 2. St. James S, Bednarz B, Benedict S, et al. Current status of radiopharmaceutical therapy. *International Journal of Radiation Oncology*Biophysics*. 2021;109(4):891-901. doi:10.1016/j.ijrobp.2020.08.035
3. Yu EY, Laidley D, Pouliot F, et al. A multicenter, randomized, controlled phase II study: Efficacy and safety of PSMA-targeted Radioligand Therapy I-131-1095 (1095) plus enzalutamide (ENZA) in 18F-DCFPYL PSMA scan avid, metastatic castration-resistant prostate cancer (mcrpc) patients post-abiraterone (ABI) progression (arrow). *Journal of Clinical Oncology*. 2020;38(6_suppl). doi:10.1200/jco.2020.38.6_suppl.tps260
- 540 4. Stabin MG, Sharkey RM, Siegel JA. Radar commentary: Evolution and current status of dosimetry in nuclear medicine. *Journal of Nuclear Medicine*. 2011;52(7):1156-1161. doi:10.2967/jnumed.111.088666
- 545 5. Almond PR, Biggs PJ, Coursey BM, et al. AAPM's TG-51 protocol for clinical reference dosimetry of high-energy photon and electron beams. *Medical Physics*. 1999;26(9):1847-1870. doi:10.1118/1.598691
6. Rivard MJ, Coursey BM, DeWerd LA, et al. Update of AAPM Task Group No. 43 report: A revised AAPM protocol for brachytherapy dose calculations. *Medical Physics*. 2004;31(3):633-674. doi:10.1118/1.1646040
- 550 7. Massillon-JL G, Minniti R, Mitch MG, Maryanski MJ, Soares CG. The use of gel dosimetry to measure the 3D dose distribution of A90SR/90y intravascular brachytherapy seed. *Physics in Medicine and Biology*. 2009;54(6):1661-1672. doi:10.1088/0031-9155/54/6/017
- 555 8. Niroomand-Rad A, Chiu-Tsao ST, Grams MP, et al. Report of AAPM Task Group 235 radiochromic film dosimetry: An update to TG-55. *Medical Physics*. 2020;47(12):5986-6025. doi:10.1002/mp.14497
9. Das IJ. *Radiochromic Film: Role and Applications in Radiation Dosimetry*. Boca Raton, FL: CRC Press, Taylor & Francis Group; 2018.
- 560 10. Sgouros G, Bolch WE, Chiti A, et al. ICRU report 96, dosimetry-guided radiopharmaceutical therapy. *Journal of the ICRU*. 2022;21(1):1-212. doi:10.1177/14736691211060117
11. Tiwari A, Sunderland J, Graves SA, Strand S, Flynn R. Absorbed dose distributions from Beta-decaying radionuclides: Experimental validation of Monte Carlo Tools for radiopharmaceutical dosimetry. *Medical Physics*. 2020;47(11):5779-5790. doi:10.1002/mp.14463
- 565

12. Jan S, Santin G, Strul D, et al. Gate: A simulation toolkit for PET and SPECT. *Physics in Medicine and Biology*. 2004;49(19):4543-4561. doi:10.1088/0031-9155/49/19/007
13. Kassis AI. Therapeutic radionuclides: Biophysical and Radiobiologic Principles. *Seminars in Nuclear Medicine*. 2008;38(5):358-366. doi:10.1053/j.semnuclmed.2008.05.002
- 570 14. E. Villarreal-Barajas J, Ferro-Flores G, Hernandez-Oviedo O. Experimental validation of Monte Carlo depth-dose calculations using radiochromic dye film dosimetry for a beta-gamma 153Sm radionuclide applied to the treatment of rheumatoid arthritis. *Radiation Protection Dosimetry*. 2002;101(1):439-444. doi:10.1093/oxfordjournals.rpd.a006021
- 575 15. Zaidi H. *Monte Carlo Calculations in Nuclear Medicine*. Second ed. IOP Publishing; 2022.
16. Bolch WE, Bouchet LG, Robertson JS, et al. MIRD pamphlet No. 17: the dosimetry of nonuniform activity distributions--radionuclide S values at the voxel level. Medical Internal Radiation Dose Committee. *J Nucl Med*. 1999;40(1):11S-36S.
- 580 17. Tiwari A, Gravesa SA, Sunderland J. The impact of tissue type and density on dose point kernels for patient-specific voxel-wise dosimetry: A Monte Carlo Investigation. *Radiation Research*. 2020;193(6):531. doi:10.1667/rr15563.1
18. Sempau J, Wilderman SJ, Bielajew AF. DPM, a fast, accurate Monte Carlo code optimized for photon and electron radiotherapy treatment planning dose calculations. *Physics in Medicine and Biology*. 2000;45(8):2263-2291. doi:10.1088/0031-9155/45/8/315
- 585 19. Chetty IJ, Moran JM, McShan DL, Fraass BA, Wilderman SJ, Bielajew AF. Benchmarking of the dose planning method (DPM) Monte Carlo code using electron beams from a racetrack microtron. *Medical Physics*. 2002;29(6):1035-1041. doi:10.1118/1.1481512
20. Chetty IJ, Moran JM, Nurushev TS, et al. Experimental validation of the DPM Monte Carlo code using minimally scattered electron beams in heterogeneous media. *Physics in Medicine and Biology*. 2002;47(11):1837-1851. doi:10.1088/0031-9155/47/11/301
- 590 21. Wilderman SJ, Dewaraja YK. Method for fast CT/SPECT-based 3D Monte Carlo absorbed dose computations in internal emitter therapy. *IEEE Transactions on Nuclear Science*. 2007;54(1):146-151. doi:10.1109/tns.2006.889164
22. Dewaraja YK, Wilderman SJ, Ljungberg M, Koral KF, Zasandy K, Kaminiski MS. Accurate dosimetry in 131I radionuclide therapy using patient-specific, 3-dimensional methods for SPECT reconstruction and absorbed dose calculation. *J Nucl Med*. 2005 May;46(5):840-9.
- 595 23. Dewaraja YK, Schipper MJ, Shen J, et al. Tumor-absorbed dose predicts progression-free survival following 131I-tositumomab radioimmunotherapy. *Journal of Nuclear Medicine*. 2014;55(7):1047-1053. doi:10.2967/jnumed.113.136044
24. Sisson JC, Dewaraja YK, Wizauer EJ, Giordano TJ, Avram AM. Thyroid carcinoma metastasis to skull with infringement of brain: Treatment with Radioiodine. *Thyroid*. 2009;19(3):297-303. doi:10.1089/thy.2008.0426
- 600 25. Dewaraja YK, Devasia T, Kaza RK, et al. Prediction of tumor control in 90Y radioembolization by logit models with PET/CT-based dose metrics. *Journal of Nuclear Medicine*. 2019;61(1):104-111. doi:10.2967/jnumed.119.226472
- 605 26. Dewaraja YK, Miranda DM, Peterson A, et al. A pipeline for automated voxel dosimetry: Application in patients with multi-SPECT/CT imaging following 177Lu peptide receptor radionuclide therapy. *Journal of Nuclear Medicine*. April 2022. doi:10.2967/jnumed.121.263738
- 610 27. Goorley T, James M, Booth T, et al. Initial MCNP6 release Overview. *Nuclear Technology*. 2012;180(3):298-315. doi:10.13182/nt11-135
28. Kawrakow I, Rogers D, Mainegra-Hing E, Tessier F, Townson R, and Walters B. EGSnrc toolkit for Monte Carlo simulation of ionizing radiation transport, doi:10.4224/40001303 [release v2021], 2000.
- 615 29. DuPont Kapton HN polyimide film datasheet. Dupont.com. <https://www.dupont.com/content/dam/dupont/amer/us/en/products/ei-transformation/documents/DEC-Kapton-HN-datasheet.pdf>. Accessed May 25, 2021.

30. Zimmerman BE, Cessna JT, Millican MA. Experimental determination of calibration settings for plastic syringes containing solutions of ^{90}Y using commercial radionuclide calibrators. *Applied Radiation and Isotopes*. 2004;60(2-4):511-517. doi:10.1016/j.apradiso.2003.11.068
- 620 31. Bergeron DE, Cessna JT. An update on ‘dose calibrator’ settings for nuclides used in nuclear medicine. *Nuclear Medicine Communications*. 2018;39(6):500-504. doi:10.1097/mnm.0000000000000833
- 625 32. de Dreuille O, Strijckmans V, Ameida P, Loc'h C, Bendriem B. Bone equivalent liquid solution to assess accuracy of transmission measurements in SPECT and PET. *IEEE Transactions on Nuclear Science*. 1997;44(3):1186-1190. doi:10.1109/23.596985
33. Park M-A, Mahmood A, Zimmerman RE, Limpa-Amara N, Makrigiorgos GM, Moore SC. Adsorption of metallic radionuclides on Plastic Phantom walls. *Medical Physics*. 2008;35(4):1606-1610. doi:10.1118/1.2871191
- 630 34. Micke A, Lewis DF, Yu X. Multichannel Film Dosimetry with nonuniformity correction. *Medical Physics*. 2011;38(5):2523-2534. doi:10.1118/1.3576105
35. Film QA Pro. *FilmQA Pro Users Guide*. www.gafchromic.com/filmqa-software/filmqapro/. Accessed July 16, 2021.
- 635 36. Palmer AL, Bradley D, Nisbet A. Evaluation and implementation of triple-channel Radiochromic Film Dosimetry in Brachytherapy. *Journal of Applied Clinical Medical Physics*. 2014;15(4):280-296. doi:10.1120/jacmp.v15i4.4854
37. Lewis D, Micke A, Yu X, Chan MF. An efficient protocol for radiochromic film dosimetry combining calibration and measurement in a single scan. *Medical Physics*. 2012;39(10):6339-6350. doi:10.1118/1.4754797
- 640 38. Micke A. Gafchromic protocol. GafChromic Protocol Workshops Europe February 2015. http://www.gafchromic.com/documents/Micke_GafChromic_Protocol_Europe_201502%20C.pdf. Accessed January 18, 2022.
39. Detwiler R, McConn R, Grimes T, Upton S, Engel E. Compendium of material composition data for Radiation Transport Modeling. 2021. doi:10.2172/1782721
- 645 40. Mougeot X. Erratum: Reliability of usual assumptions in the calculation OFBANDNSPECTRA [phys. rev. C91, 055504 (2015)]. *Physical Review C*. 2015;92(5). doi:10.1103/physrevc.92.059902
41. National Nuclear Data Center NuDat (Nuclear Structure and Decay Data). NuDat 3. <https://www.nndc.bnl.gov/nudat3/>. Accessed December 18, 2021.
- 650 42. Kock AL. STC-18-042-licensing of lutetium-177. LICENSING OF LUTETIUM-177 (STC-18-042) (2018). <https://www.nrc.gov/docs/ML1815/ML18156A589.pdf>. Accessed August 6, 2021.
- 655 43. Wike JS, Guyer CE, Ramey DW, Phillips BP. Chemistry for commercial scale production of yttrium-90 for Medical Research. *International Journal of Radiation Applications and Instrumentation Part A Applied Radiation and Isotopes*. 1990;41(9):861-865. doi:10.1016/0883-2889(90)90064-n
44. Sutherland JG, Rogers DW. Monte Carlo calculated absorbed-dose energy dependence of EBT and EBT2 film. *Medical Physics*. 2010;37(3):1110-1116. doi:10.1118/1.3301574
- 660 45. Trichter S, Soares CG, Zaider M, DeWynngaert JK, DeWerd LA, Kleiman NJ. 15 years of ^{106}Ru Eye plaque dosimetry at Memorial Sloan-Kettering Cancer Center and Weill Cornell Medical Center using radiochromic film in a solid water phantom. *Biomedical Physics & Engineering Express*. 2018;4(4):045017. doi:10.1088/2057-1976/aab674
- 665

670 **Appendix**

A. Verification of Experimental Parameters

When using experimental measurement to validate MC simulation, it is imperative that physical properties such as material composition, material thicknesses, and injected activities used in the MC model be highly accurate. For this work we carefully verified these parameters as shown below.

675 **A. 1. Activity Verification**

Activity measurements used in this study were taken using a Capintec 15R dose calibrator. For Y-90, the Capintec 15R activity measurements were checked against two other dose calibrators in our pharmacy. A sensitivity analysis was completed to estimate potential error in activity measurement across both dose calibrators and dial settings **Error! Reference source not found.**A1. All activity

680 measurements were taken in a 10cc syringe placed in the center of the dose calibrator holder

A. 2. Activity/Experimental Process Verification

The phantom radionuclide activity was calculated based on the weight of the saline injected into the phantom. These injections ranged between 30-35ml per experiment and was measured on an

685 available digital scale. We performed a calibration for the scale which is shown in Figure A1. Calibration
was completed across the 1-50g range and no major deviations were seen over the measured range.

The syringe used for activity injection into each phantom was also checked to make sure the dose
calibrator activity in the syringe was consistent over the entire range of 0-10ml for ^{177}Lu . Figure A2
690 shows the dose calibrator reading from <0.5ml to >9.5ml and which has good linearity over the whole
range, so no additional calibration curve was applied to the dose calibrator readings.

A. 3. Physical Model Dimension Verification

695 Both Gafchromic EBT3 film and Kapton tape thickness measurements were acquired using a
Mitutoyo 293-344-30 micrometer. Three sets of measurements were taken at different points across 3
reference film cutouts to measure the total thickness and then the film was carefully peeled apart and
each layer was measured individually. Results showed an active layer thickness of 25.1 μm and a base
thickness of 128 μm , very close to the values used in our simulation models, 25.4 μm and 127 μm
700 respectively. These results are presented in Table A2.

Kapton tape thickness was measured at 5 locations across multiple strips of tape and averaged
values are reported in Table A3. The tape is composed of two materials, a layer of Kapton film and a
layer of silicone adhesive. Two tape thicknesses were used in our experiments: a 25.4 μm thick Kapton
tape with a 38.1 μm thick adhesive layer, and a 12.7 μm thick Kapton tape with a 12.7 μm thick adhesive
705 layer. Manual verification of the overall thickness of each tape strip showed close agreement with the
manufacturer's listed thicknesses with \sim 4-5% difference.

The 3D printed phantom was also measured using the same micrometer to verify printing tolerances. Three different phantoms were randomly selected, and four sections of the phantom were measured; the thickness of the top, the radial width, the thickness of the bottom and the side wall thickness. Table A4 shows the results with only the sidewall thickness showing a substantial deviation from the modeled values. This may be due to the interaction between the curvature of the wall and the micrometer's flat sensor face. It is not expected that the wall thickness will substantially affect the results in any way for this experimental design as the overall change in volume is negligible and any displaced fluid is not in near proximity to the film measurement.

A. 4. Simulation Material Compositions

Material compositions and densities for each simulation have been included in this appendix for future reference and/or result reproducibility.

755

Figure Legend Listing – For typesetting use only

Figure 1: 3D CAD cross-sectional and photo views of a phantom half-cylinder (A) alongside entire assembly views of the taped and filled finished product with exploded CAD model (B). Three filling ports with corks for sealing (red objects in (A and B)) were used to facilitate the filling process and reduce back pressure.

760

Figure 2: Cross-sectional view of each material layer at the center of the single film phantom to measure absorbed dose-to-closest-layer phantom (A) and stacked film phantom to measure absorbed depth dose (B). In B, 5 and 10 film layers were used for ^{177}Lu and ^{90}Y , respectively.

765

Figure 3: Rational cubic film calibration curve 150hrs after initial exposure.

Figure 4: Complete experimental absorbed dose comparisons across all doses, measurements, and computation engines. Identity line shown in black.

Figure 5: Vertical and horizontal linear profiles for both evaluated radionuclides. Profiles were obtained from single film experimental geometries with a saline medium. Scanned images of representative exposed films are inset under each horizontal profile.

Figure 6: Depth dose curves for both ^{177}Lu depth dose experiments showing (A) absolute absorbed dose values (B) percentage differences relative to experiment

770

Figure 7: Depth dose curves for three ^{90}Y depth dose experiments showing (A) absolute absorbed dose values and (B) percentage differences relative to experiment

775

Figure 8: Absorbed dose contribution from beta and gamma. Values calculated in DPM for the Lu177_{DD,S,25.4} experimental geometry

Figure A1: Measurement of scale linearity from 1 to 50g using calibrated weights.

Figure A2: Variation in dose calibrator readout for ¹⁷⁷Lu 10cc syringe. Linear response across entire range of radionuclide fill level within syringe.

780

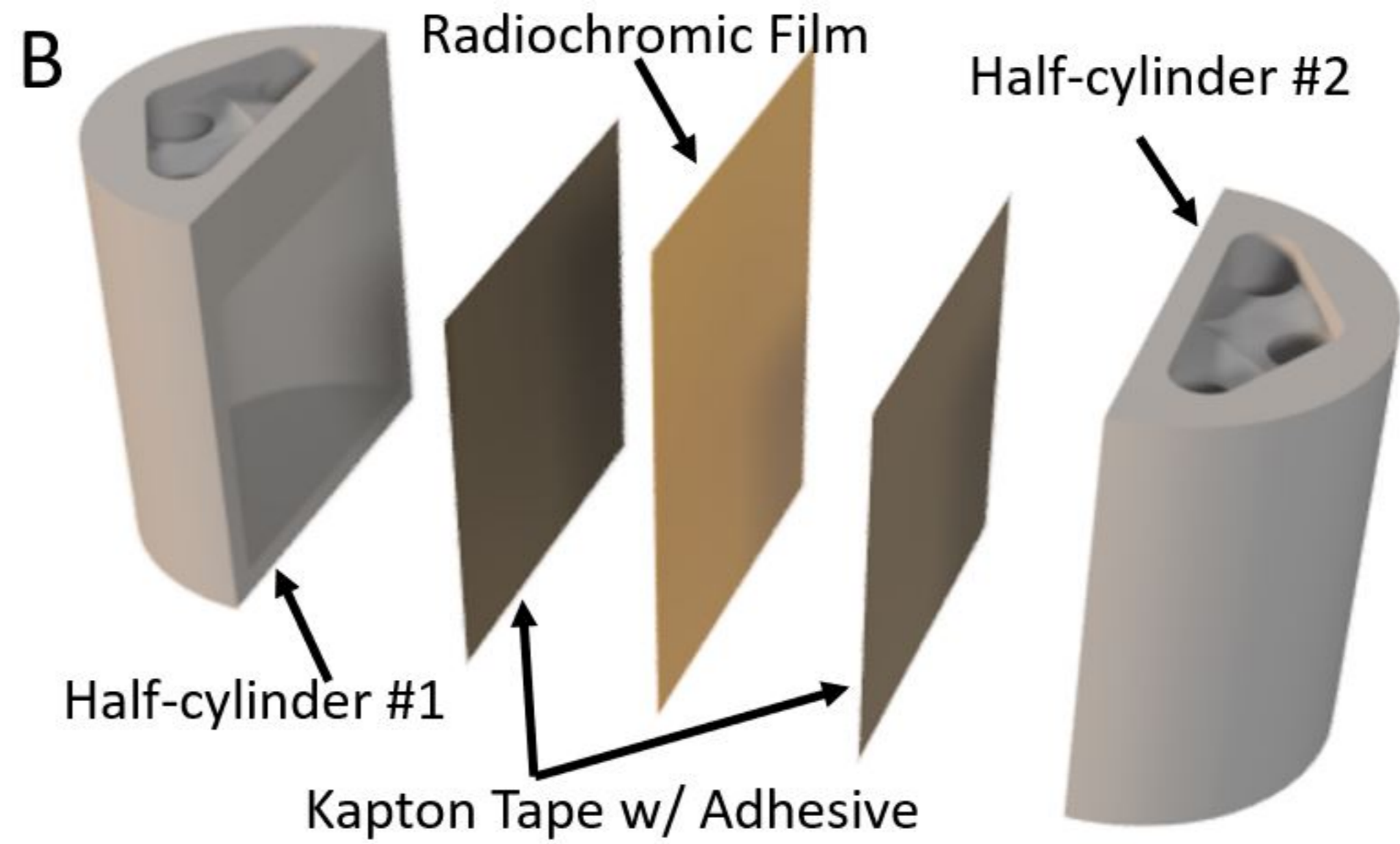
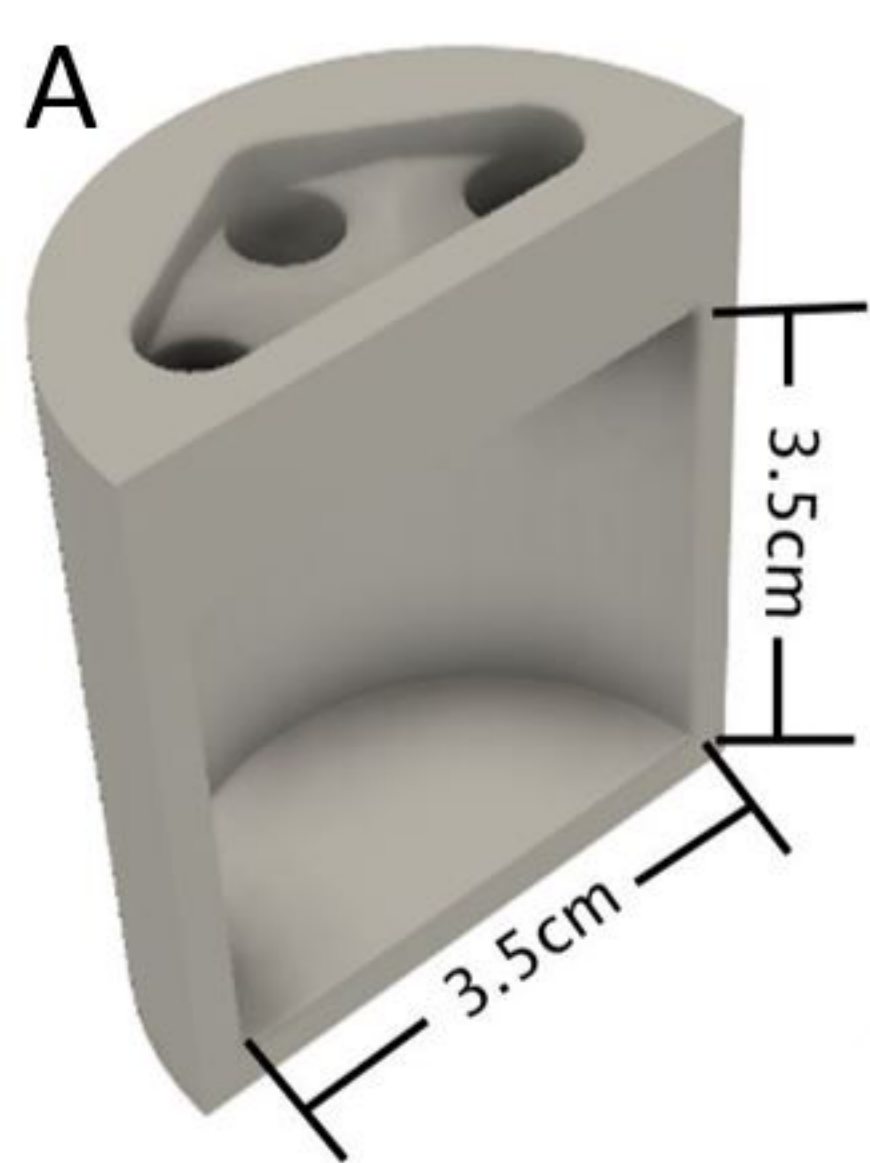

A Single Film

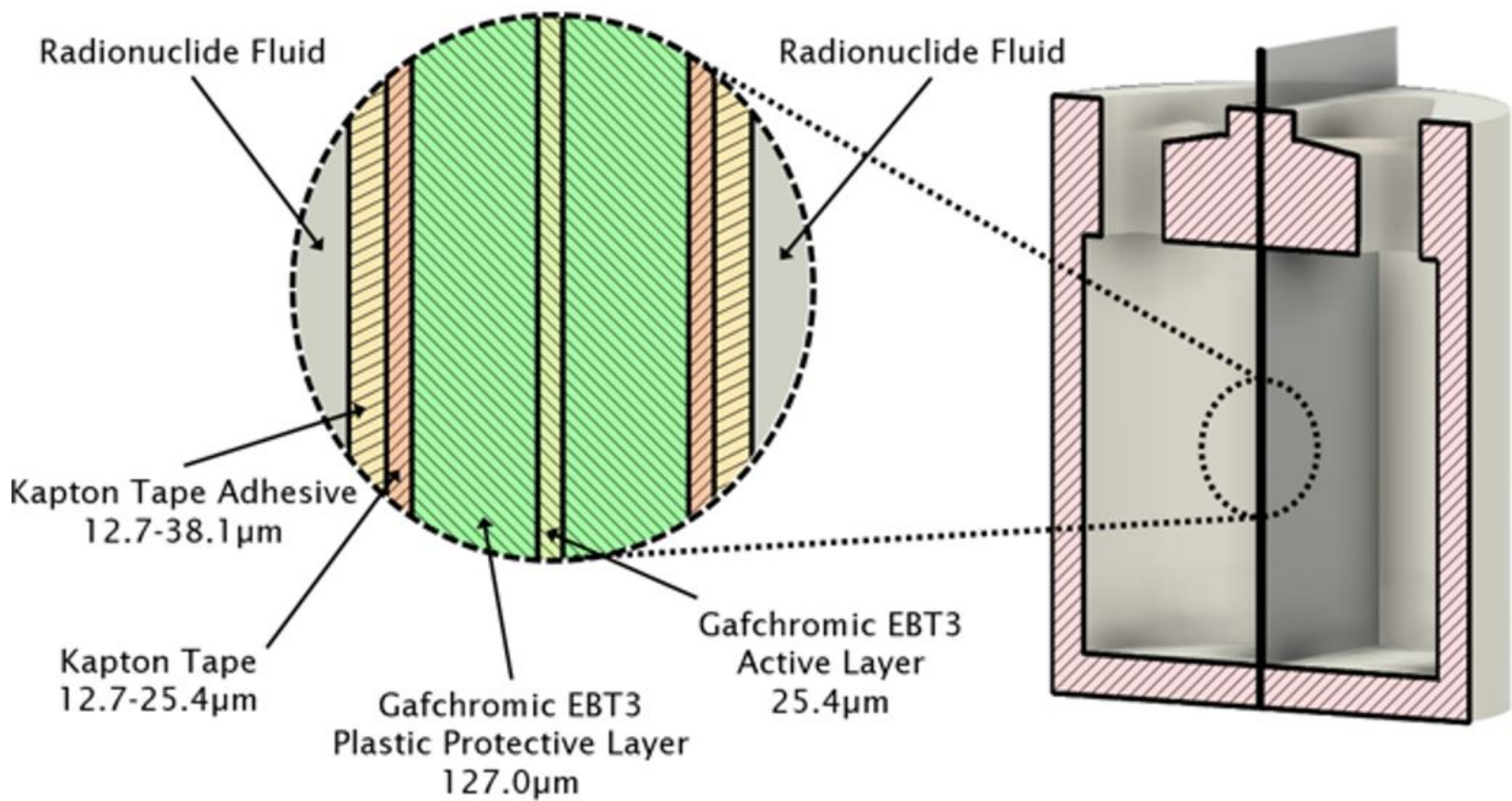

B Depth Dose

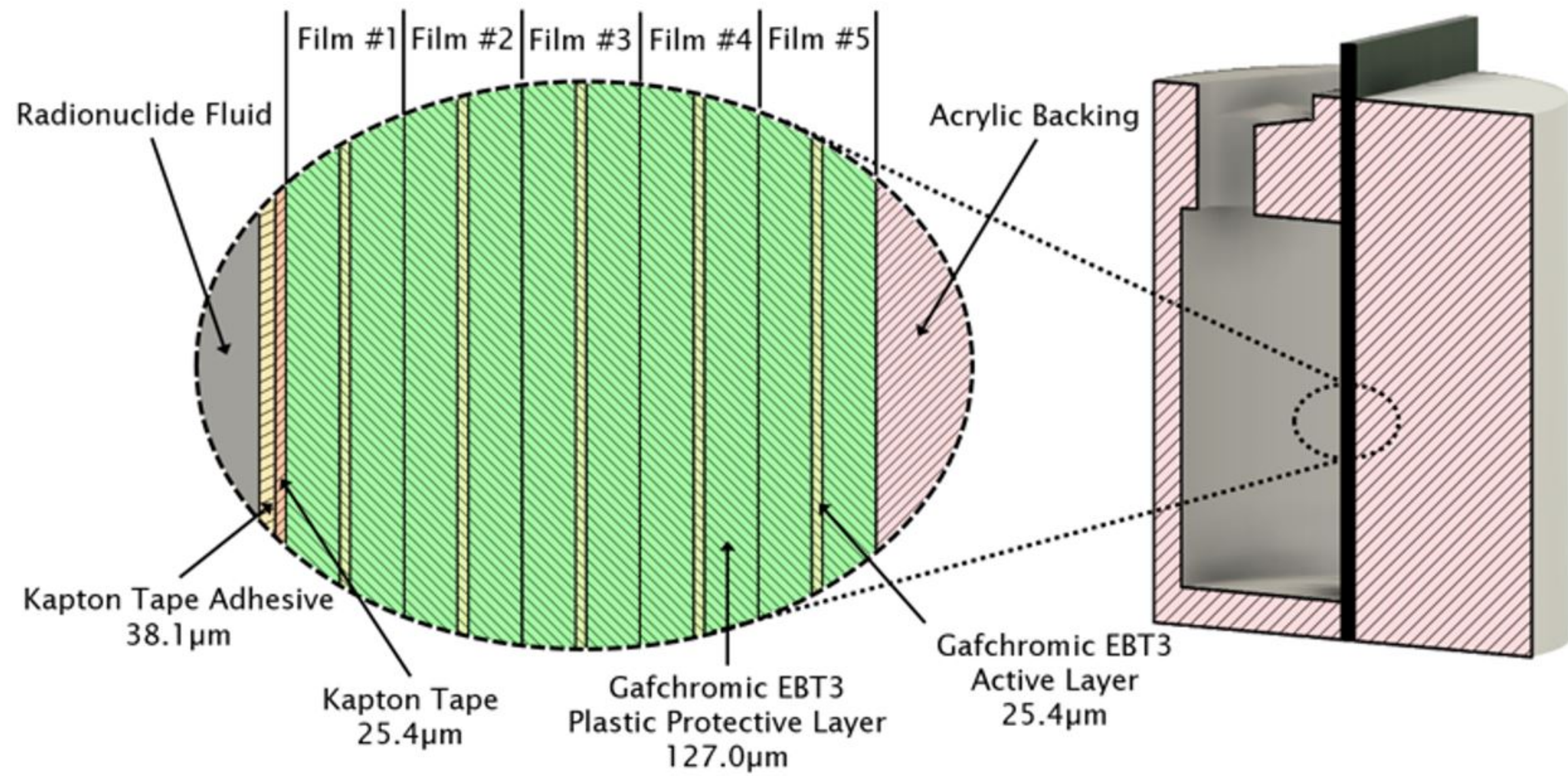

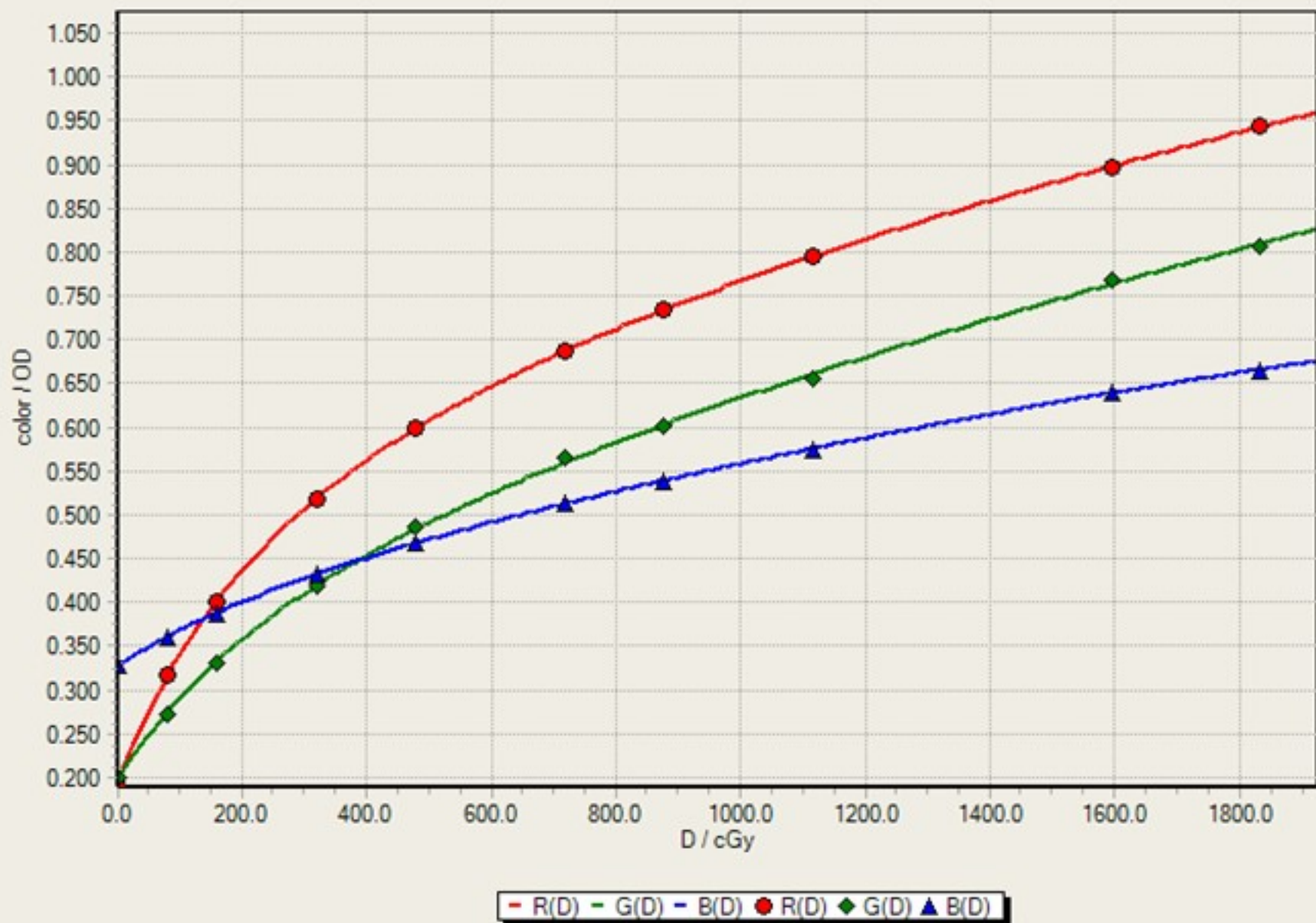

Absorbed Dose Measurements

Experiment vs DPM

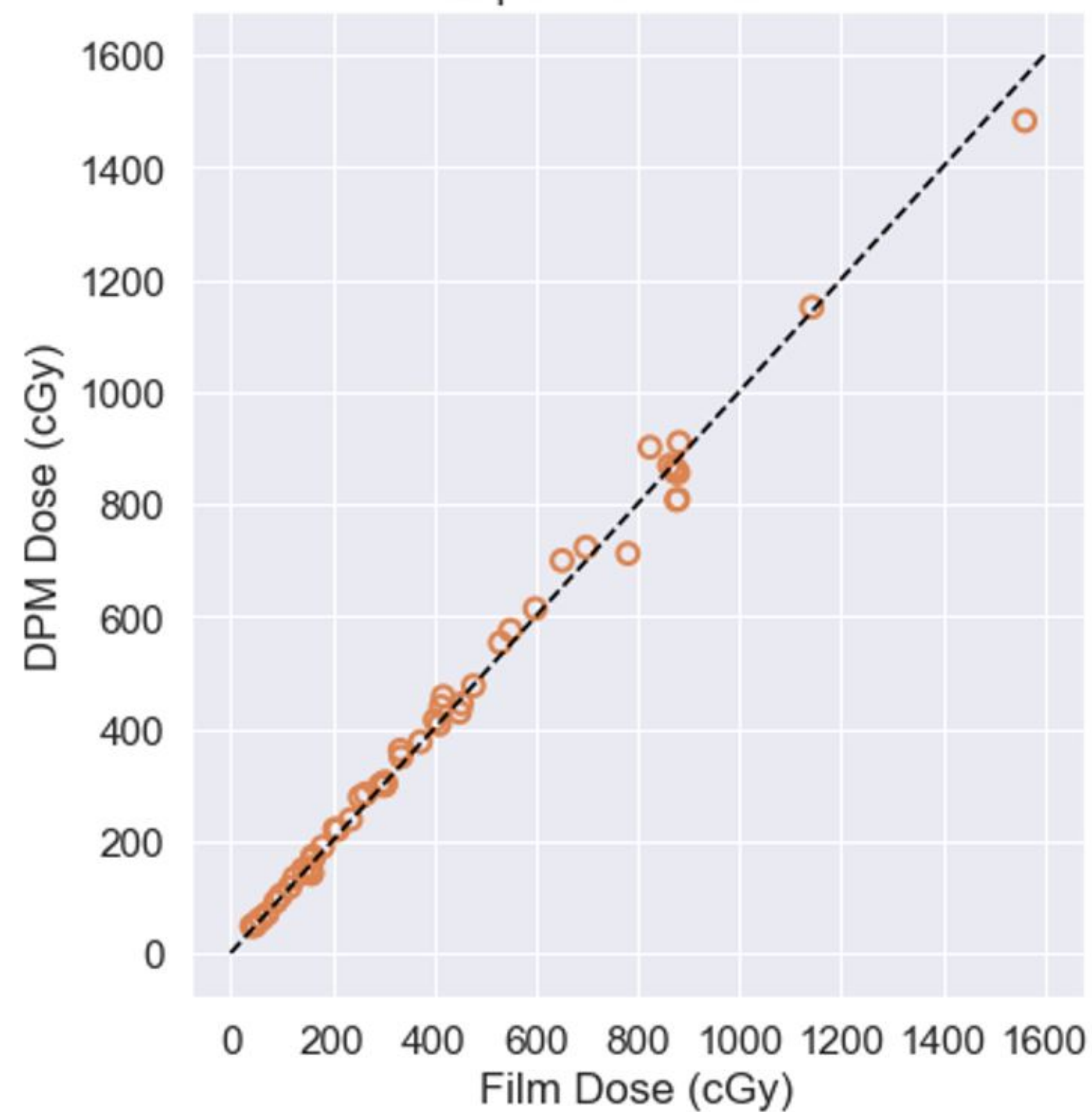

Experiment vs MCNP

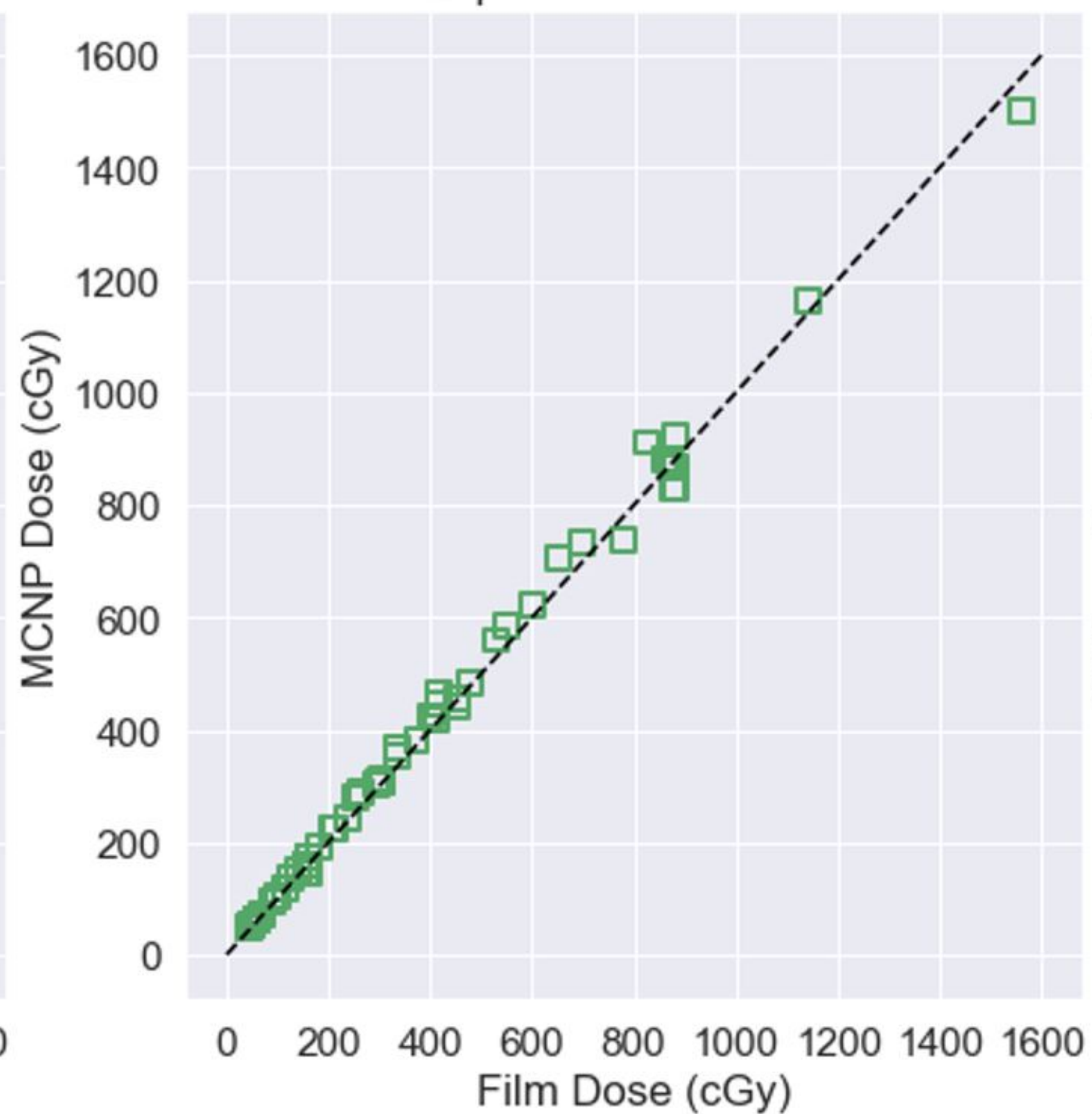

Experiment vs EGSnrc

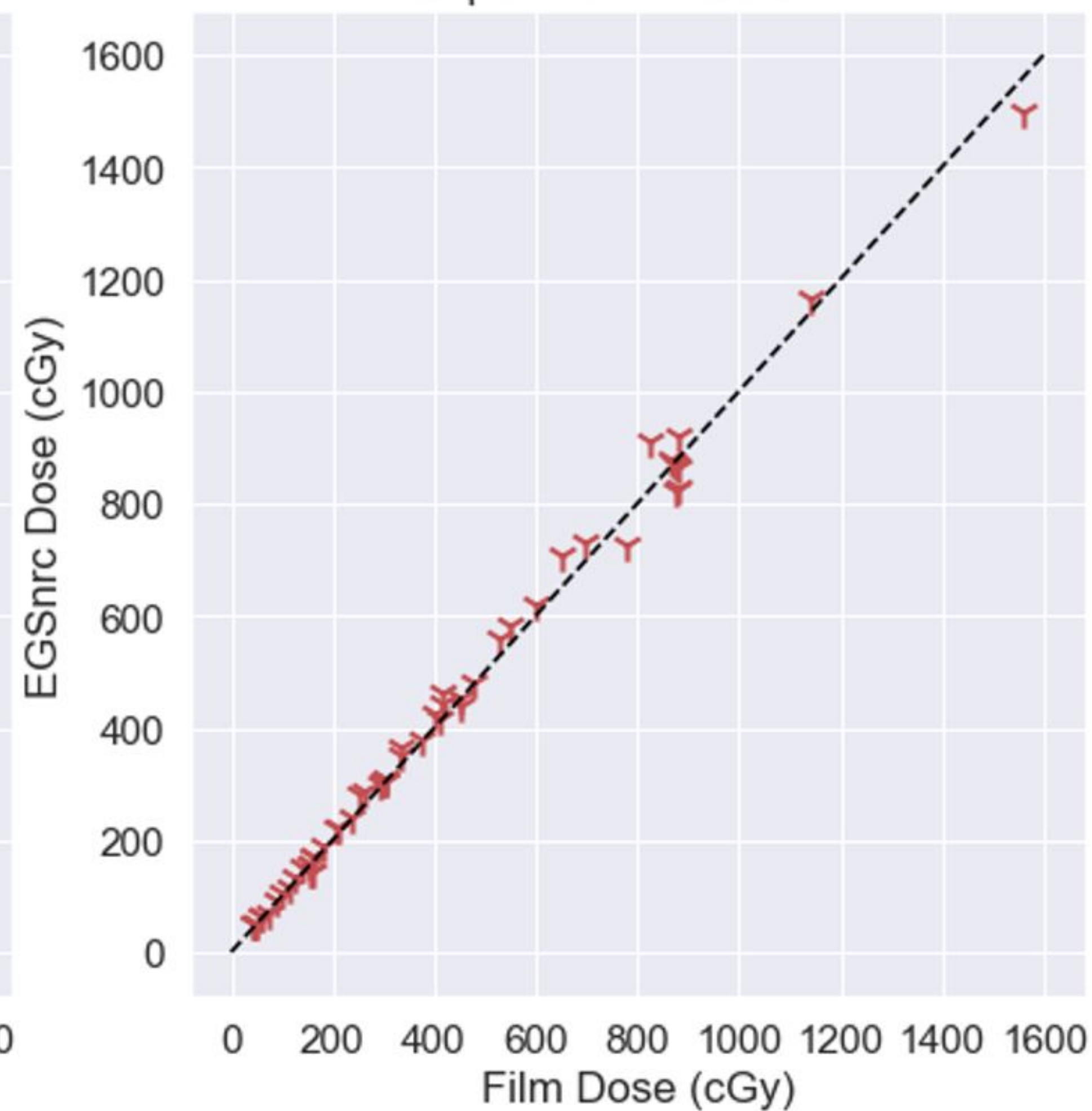

Absorbed Dose Linear Profile Curves

Lu177_{SF, S, 25.4} #3 Vertical Profile

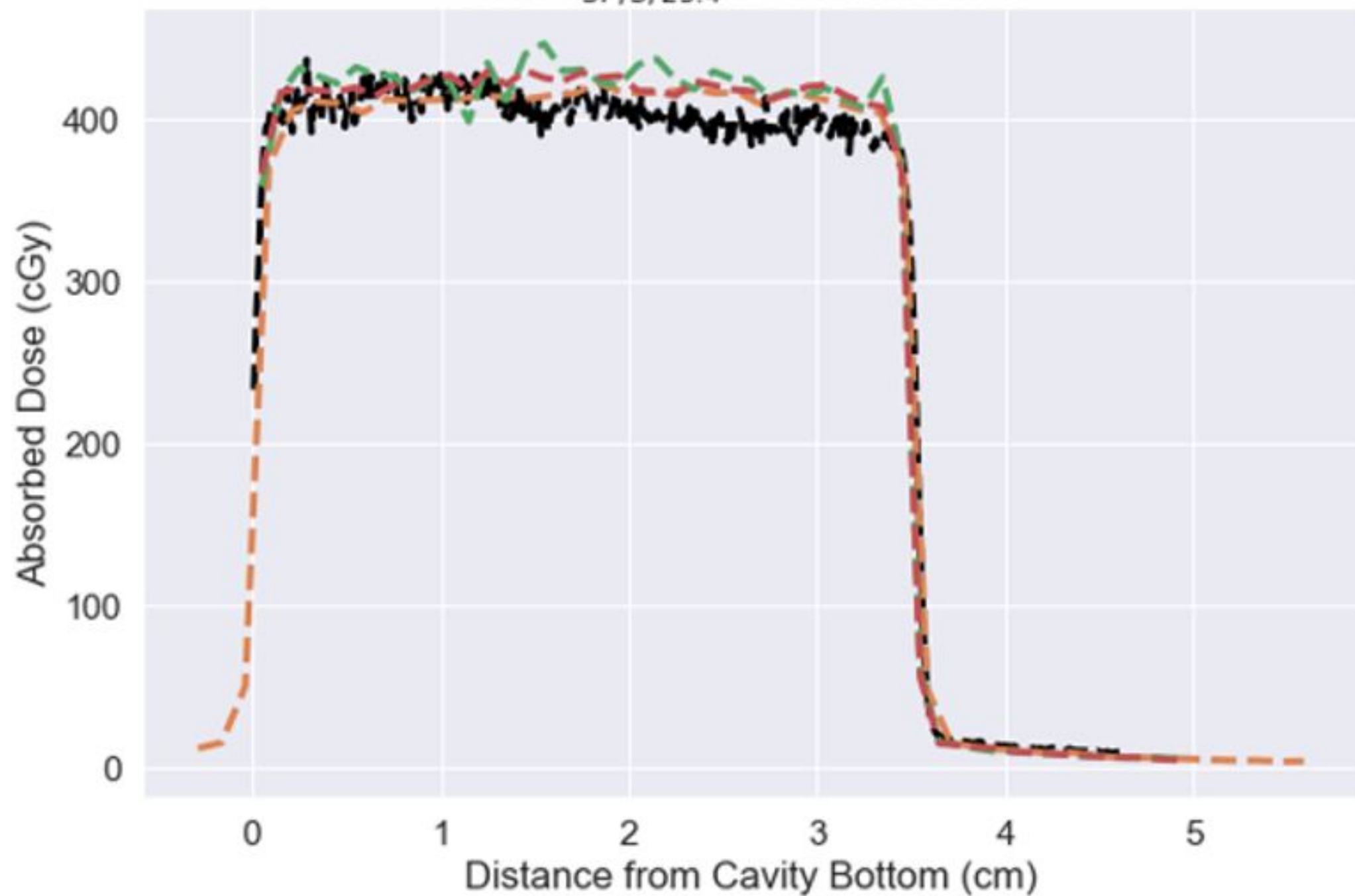

Y90_{SF, S, 25.4} #3 Vertical Profile

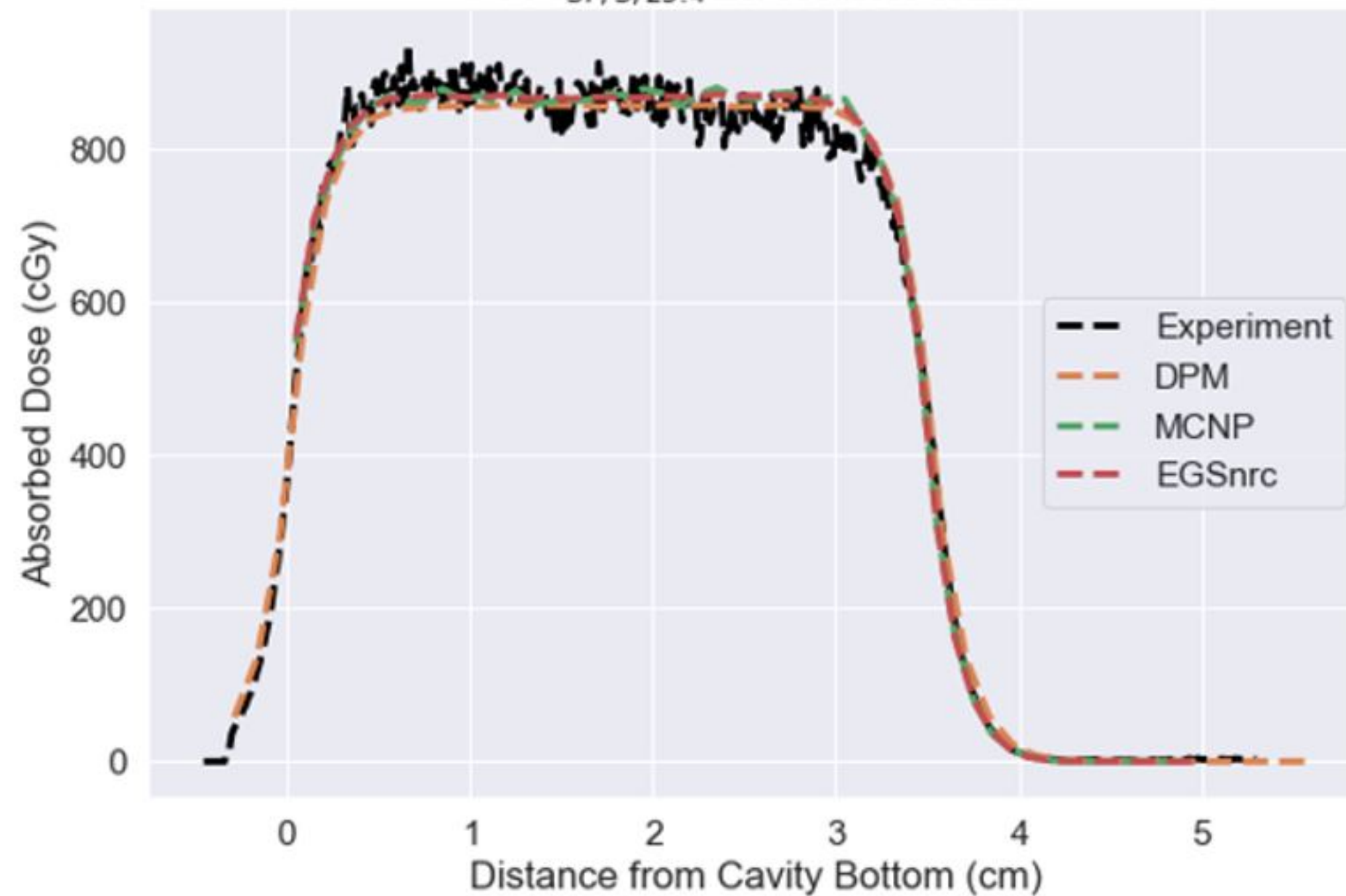

Lu177_{SF, S, 25.4} #3 Horizontal Profile

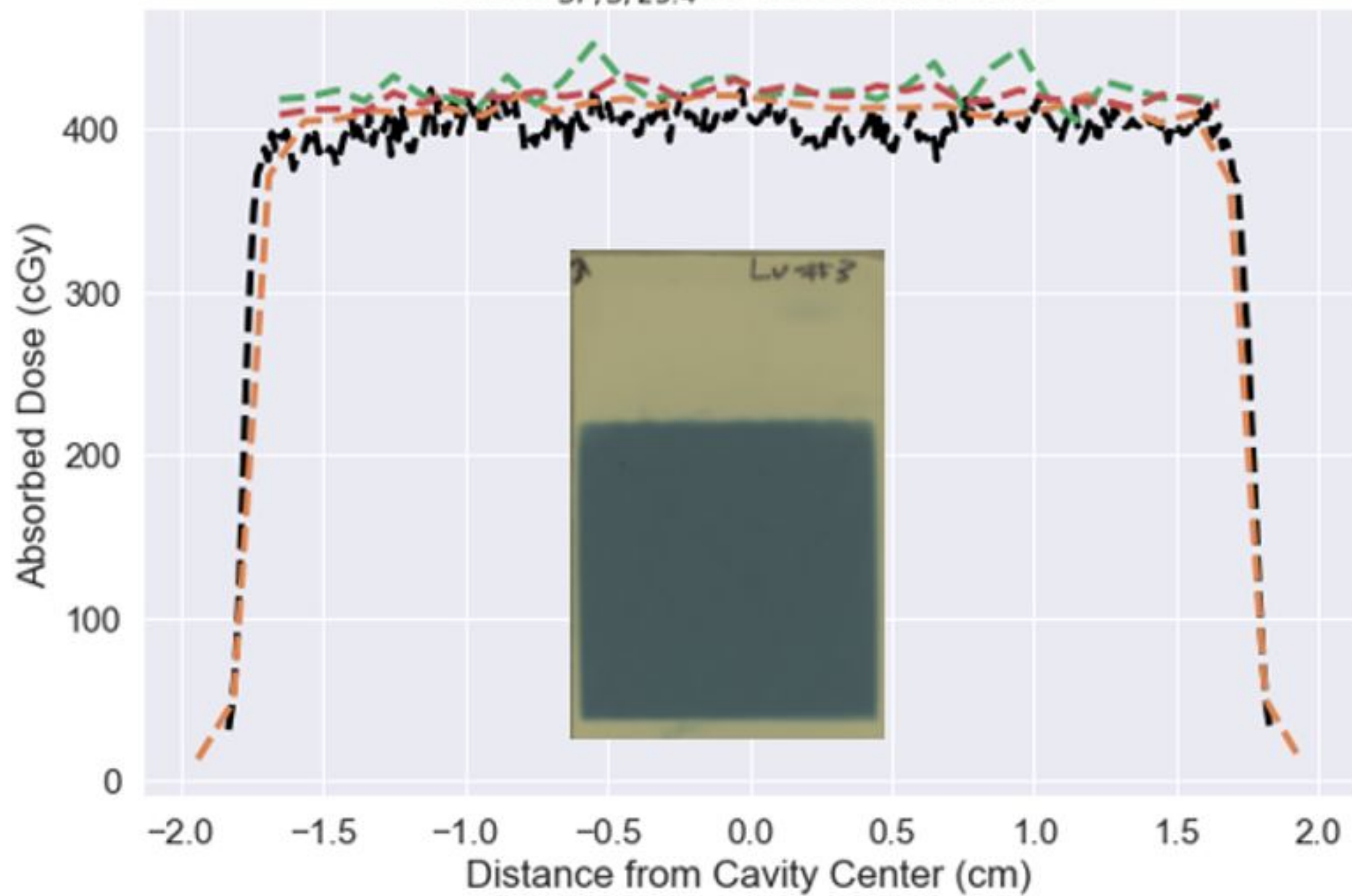

Y90_{SF, S, 25.4} #3 Horizontal Profile

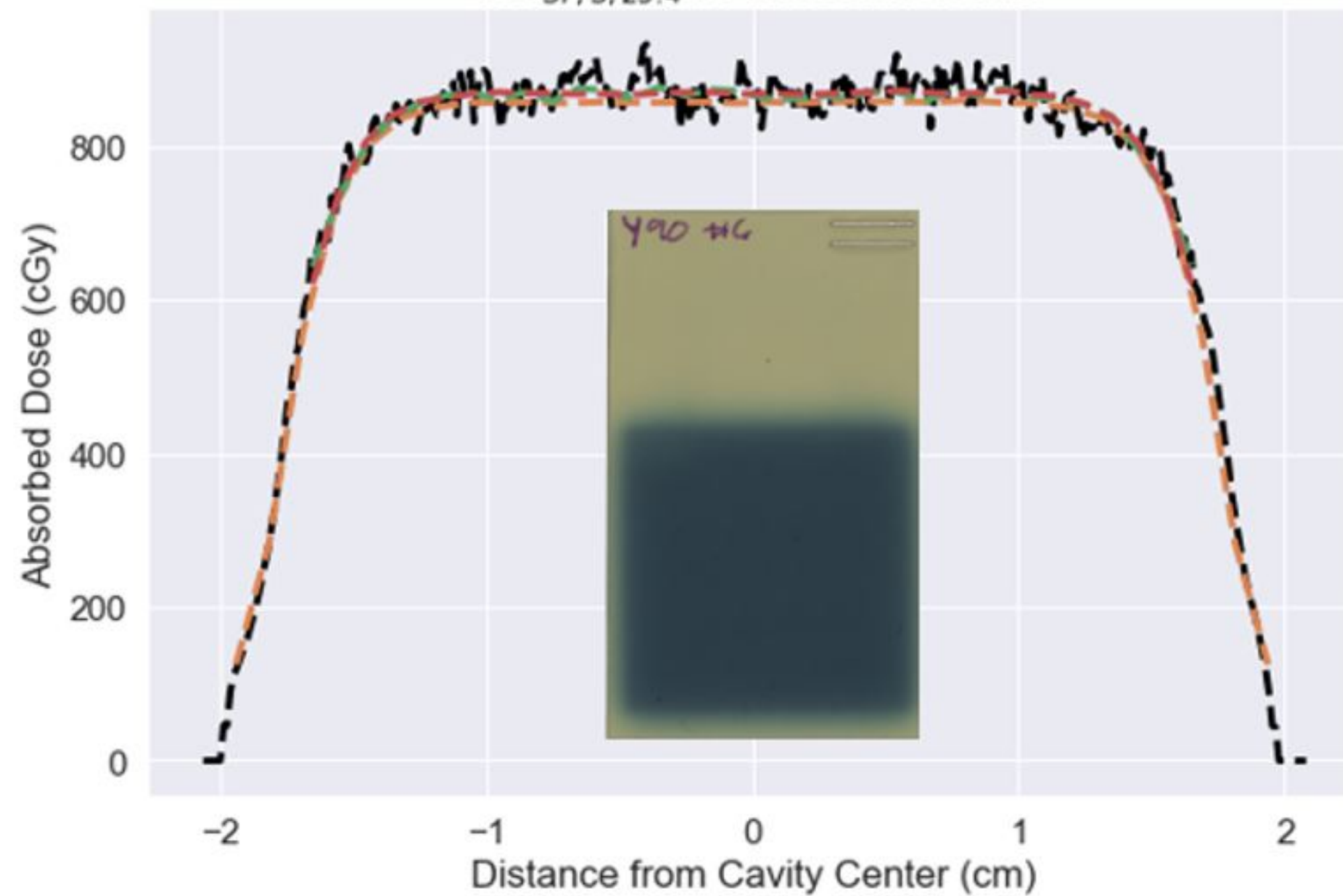

A Lu-177 Depth Dose Curves

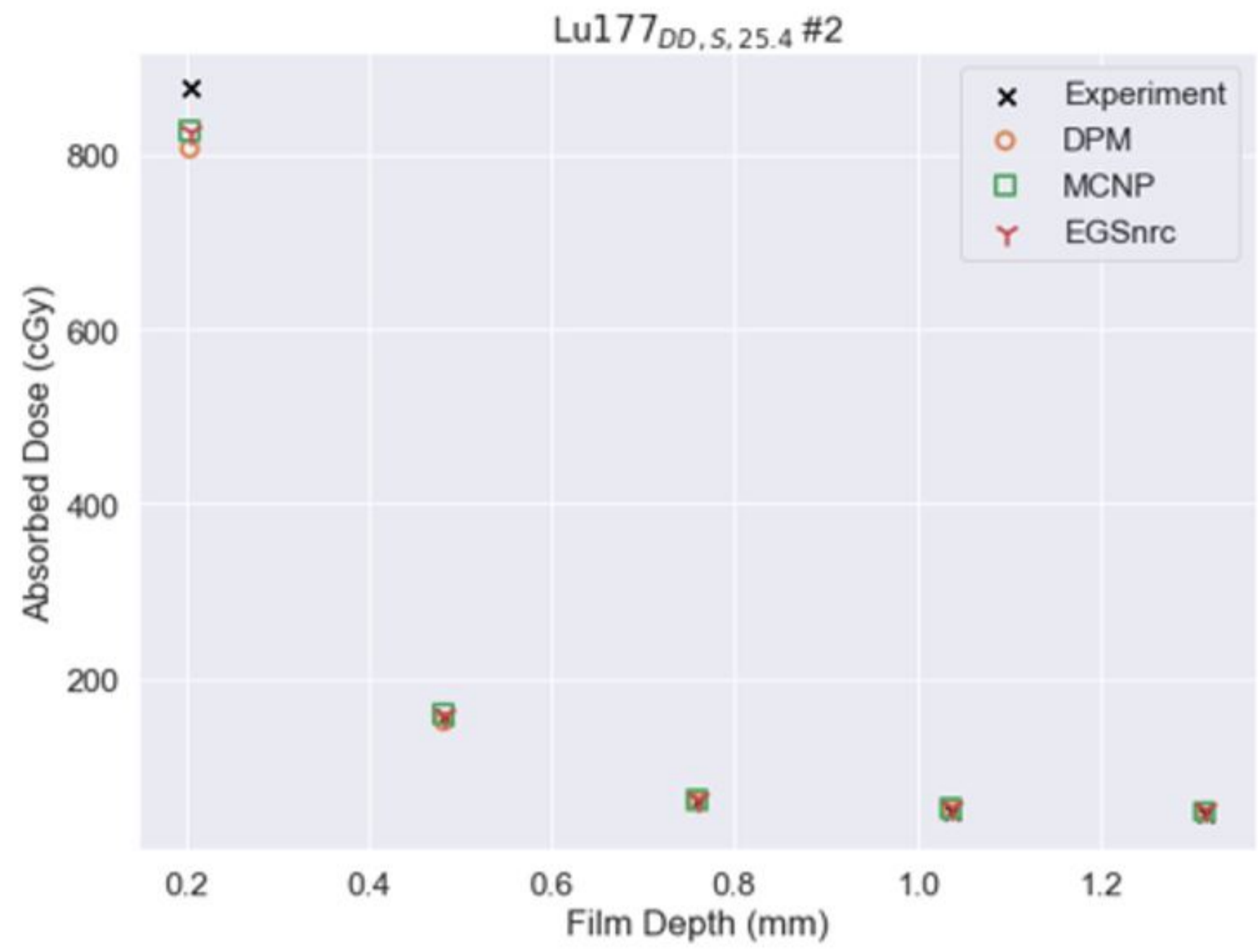
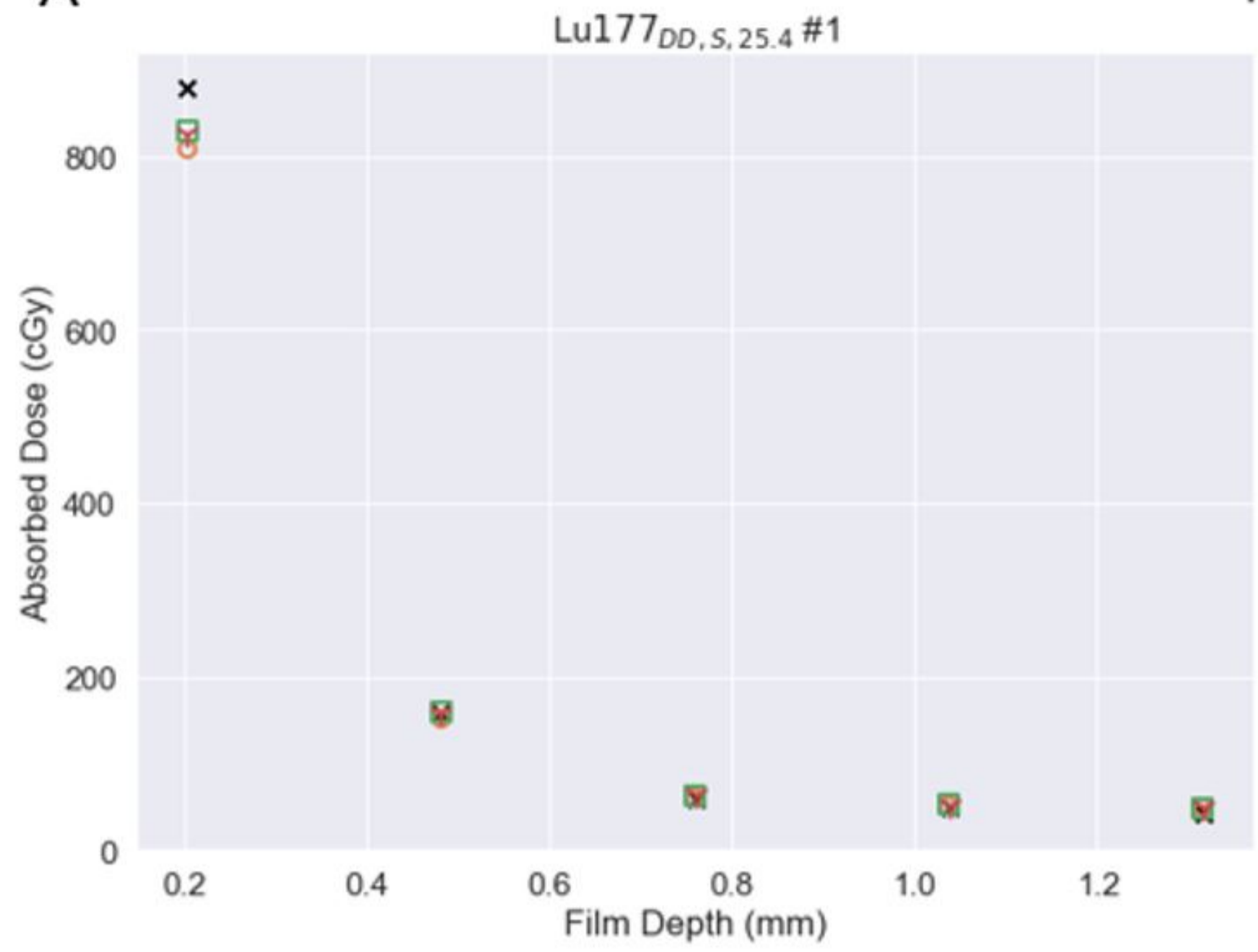

B Lu-177 Depth Dose Curve Differences

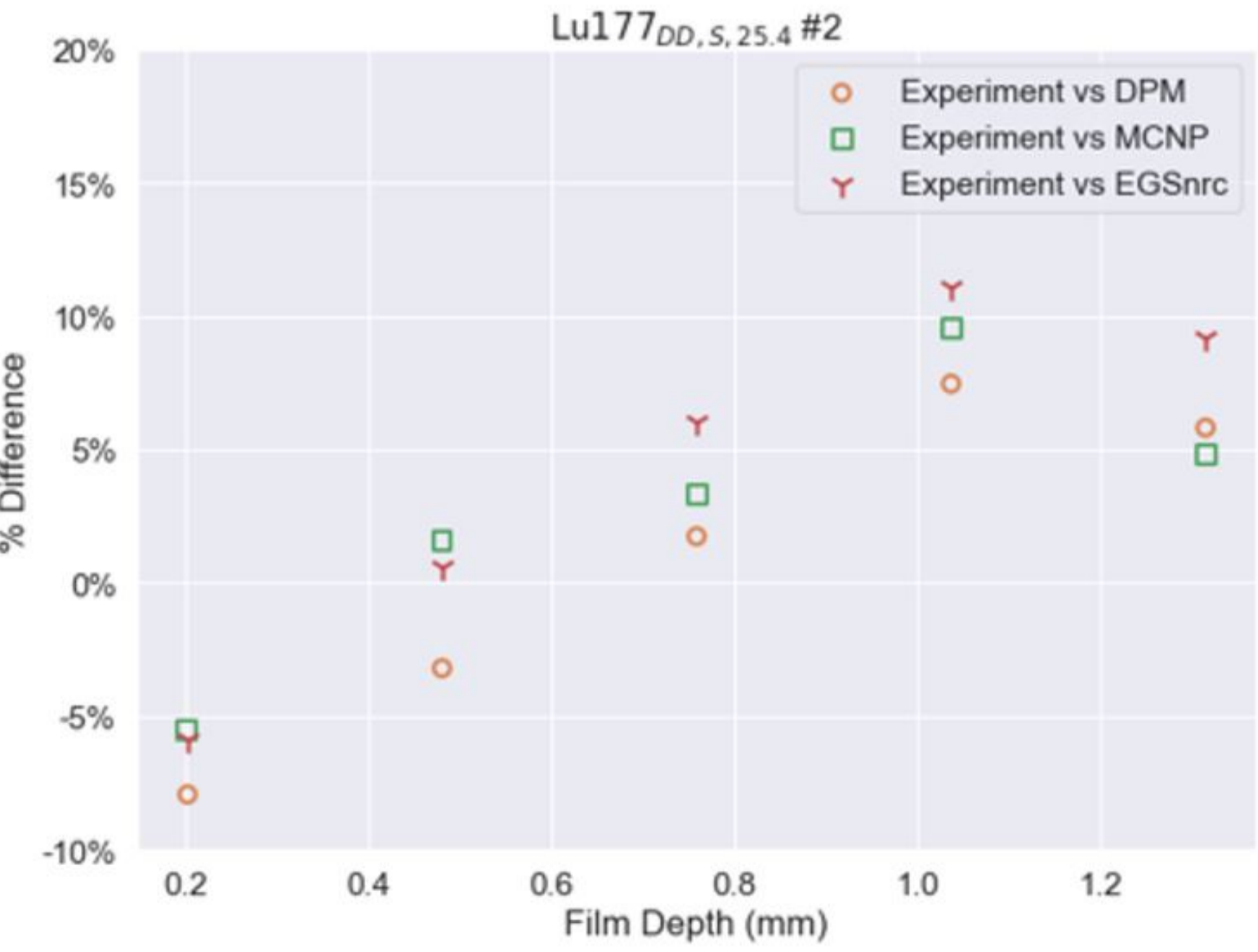
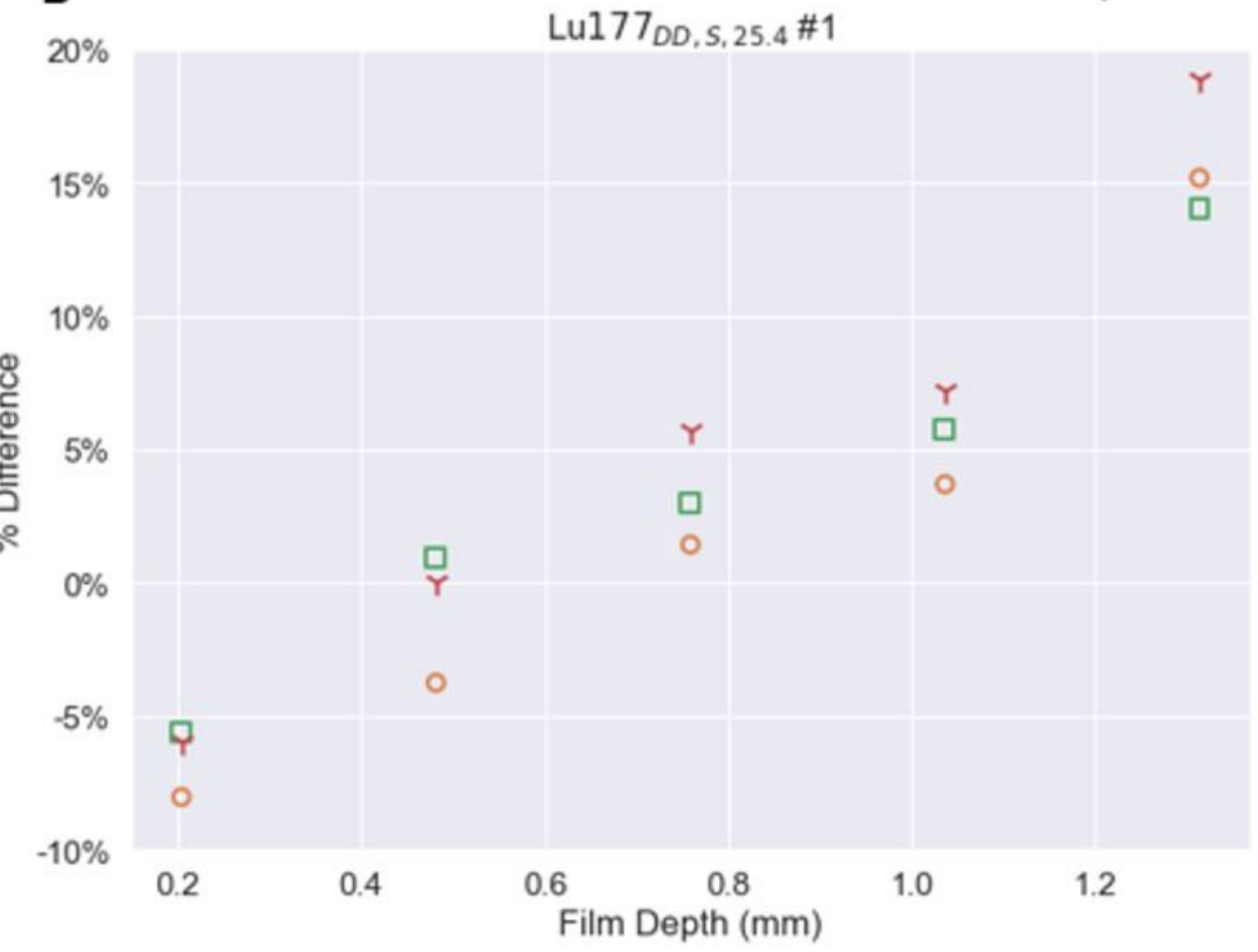

A

Y-90 Depth Dose Curves

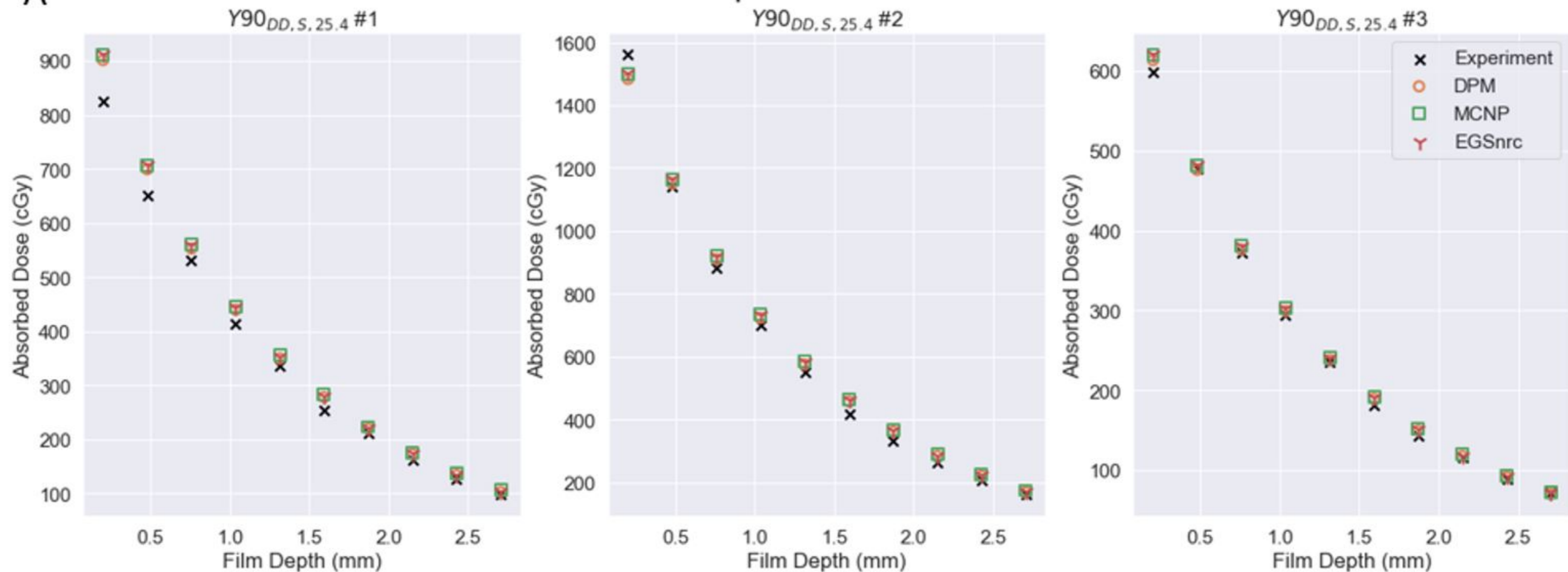

B

Y-90 Depth Dose Curve Differences

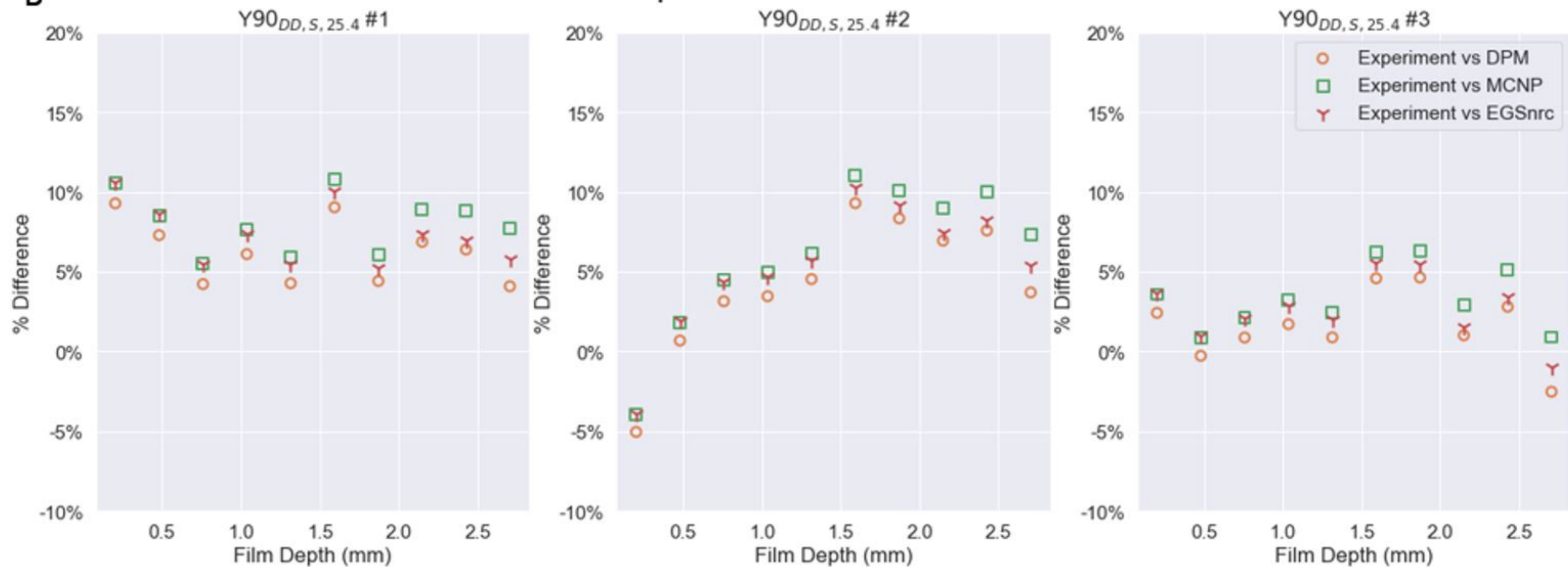

Lu-177 Absorbed Dose Rate Contribution by Emitted Particle Type

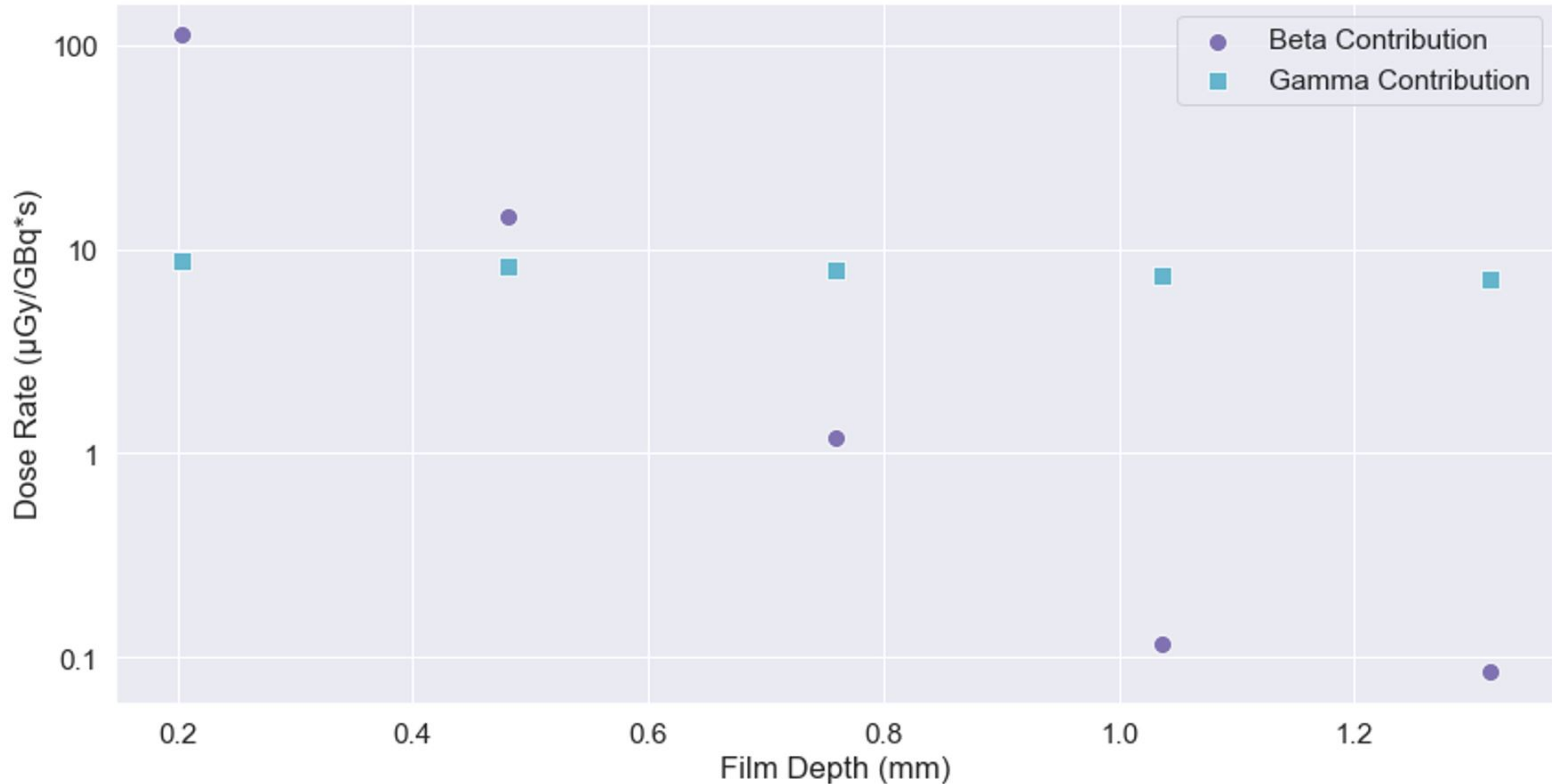

Scale Verification

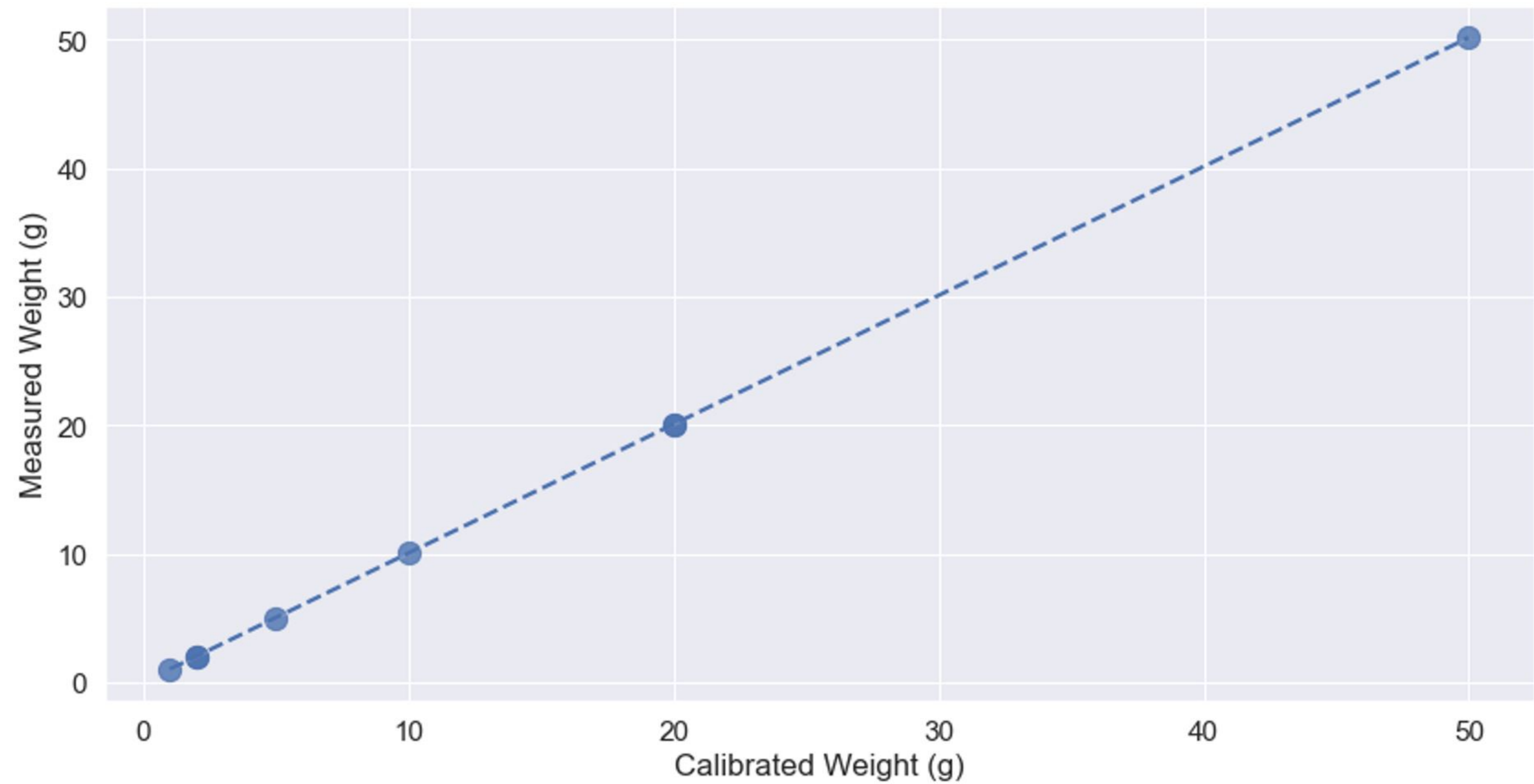

Lu-177 Weight vs Activity

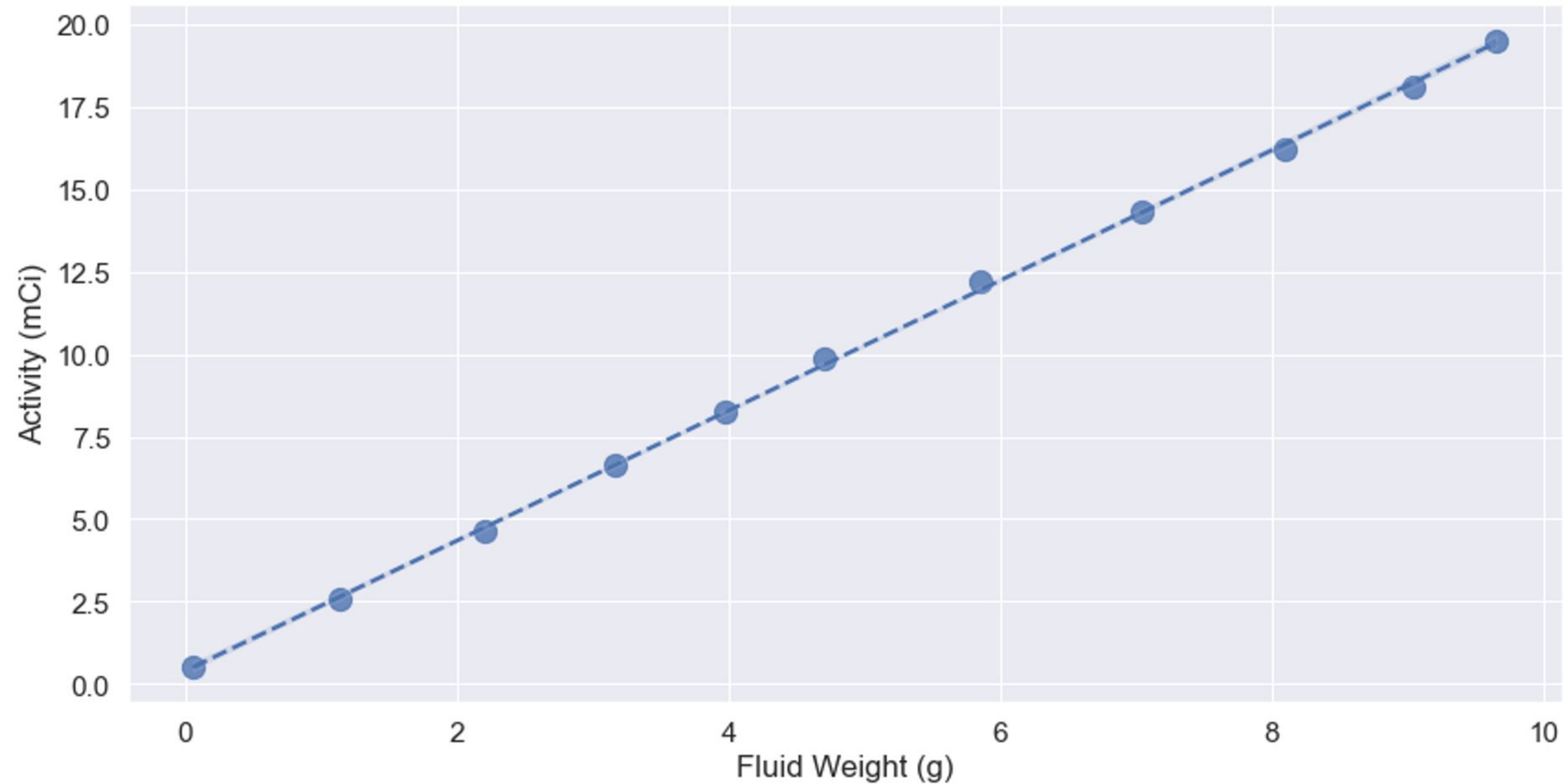

Table 1: Beta emitters of interest in RPT and their physical characteristics¹⁰

Nuclide	Half-life	Mean Beta Energy (keV)	Maximum Beta Energy (keV)	CSDA range for maximum beta energy (mm)
¹⁷⁷ Lu	6.71 d	133	497	1.8
¹²⁴ I	4.18 d	188	610	2.3
¹³¹ I	8.02 d	182	606	2.3
¹⁵³ Sm	46.3 h	225	705	2.8
¹⁸⁶ Re	3.72 d	323	1070	4.4
⁸⁹ Sr	50.5 d	583	1490	7.1
¹⁸⁸ Re	17.0 h	765	2120	10
⁹⁰ Y	2.67 d	934	2280	11

Note: Continuous slowing down approximation (CSDA) range is an approximation of the average distance traveled by a charged particle. The displayed CSDA range only includes the range of the highest energy beta for the radionuclide.

Table 1: Variations in experimental setup parameters

Radionuclide*	Measurement Type	Liquid Solution	Measurement Depth (mm)	Kapton ^{**} Tape Thickness	Repeat Measurements	Experimental Setup Name
¹⁷⁷ Lu	Single Film	Saline	0.2032	25.4µm	4	Lu177 _{SF,S,25.4}
	Single Film	Saline	0.1651	12.7µm	2	Lu177 _{SF,S,12.7}
	Single Film	Liquid bone	0.2032	25.4µm	3	Lu177 _{SF,B,25.4}
	Depth dose	Saline	0.2032–1.3152	25.4µm	2	Lu177 _{DD,S,25.4}
⁹⁰ Y	Single film	Saline	0.2032	25.4µm	4	Y90 _{SF,S,25.4}
	Single Film	Liquid bone	0.2032	25.4µm	2	Y90 _{SF,B,25.4}
	Depth dose	Saline	0.2032-2.7052	25.4µm	3	Y90 _{DD,S,25.4}

*¹⁷⁷Lu DOTATATE [Novartis], ⁹⁰Y Chloride [Eckert & Ziegler]

**Used to seal the solution

Table 1: Average value of differences between absorbed doses from experimental measurement and estimates by DPM, MCNP, and EGSnrc MC codes for the single film setup. The standard deviation in the dose rate is calculated across repeat measurements for each film setup.

Experiment	Repeat measurements	Measurement Depth (mm)	Experiment Dose rate ($\mu\text{Gy}/\text{GBq}\cdot\text{s}$)	DPM vs Experiment (%)	MCNP vs Experiment (%)	EGSnrc vs Experiment (%)
Lu177 _{SF,S,25.4}	4	0.2032	123.1 \pm 4.1	-1.1	1.4	1.1
Lu177 _{SF,S,12.7}	2	0.1651	153.3 \pm 1.2	-0.6	1.7	1.3
Lu177 _{SF,B,25.4}	3	0.2032	96.9 \pm 1.2	-10.2	-6.8	-8.2
Y90 _{SF,S,25.4}	4	0.2032	3495.3 \pm 51.1	-1.2	0.0	0.1
Y90 _{SF,B,25.4}	2	0.2032	2438.9 \pm 26.8	-0.4	1.5	1.1

Table 1: Average value of differences between absorbed doses from experimental measurement and estimated by DPM, MCNP, and EGSnrc MC codes for the depth dose setup. The standard deviation in the dose rate is calculated across repeat measurements for each film depth.

Experiment	Repeat measurements	Depth (mm)	Experiment Dose rate ($\mu\text{Gy}/\text{GBq}\cdot\text{s}$)	DPM vs Experiment (%)	MCNP vs Experiment (%)	EGSnrc vs Experiment (%)
Lu177 _{DD,S,25.4}	2	0.2032	132.1 \pm 0.1	-8.0	-5.6	-5.9
		0.4812	23.6 \pm 0.1	-3.5	1.3	0.3
		0.7592	8.9 \pm 0.0	1.6	3.2	5.9
		1.0372	7.2 \pm 0.2	5.6	7.6	9.1
		1.3152	6.6 \pm 0.4	10.5	9.4	14.0
Y90 _{DD,S,25.4}	3	0.2032	3371.2 \pm 237.6	2.2	3.4	3.5
		0.4812	2601.4 \pm 102.3	2.6	3.7	3.8
		0.7592	2050.9 \pm 34.4	2.7	4.0	4.0
		1.0372	1614.3 \pm 34.2	3.8	5.3	5.0
		1.3152	1290.7 \pm 25.8	3.2	4.8	4.4
		1.5932	983.5 \pm 24.5	7.6	9.4	8.6
		1.8712	791.1 \pm 16.3	5.8	7.5	6.6
		2.1492	626.2 \pm 20.7	4.9	6.9	5.4
		2.4272	483.7 \pm 11.5	5.6	8.0	6.2
2.7052	384.4 \pm 14.3	1.8	5.3	3.4		

Table A1: Sensitivity analysis for Capintec dose calibrators for Y-90 syringe activity measurements

	Dose Calibrator Setting					
	45	48	51	55	59	62
Capintec 15	0.43	0.43	0.42	0.41	0.39	0.38
Capintec 55	0.43	0.419	0.411	0.398	0.388	0.378
Capintec 55	0.413	0.404	0.395	0.383	0.373	0.363

Table A2: Measured variation in EBT3 film layer thicknesses. Values averaged over 3 different films with 3 positions measured for each variable.

	Measured Thickness (μm)	Manufacturer Specification (μm)	DPM Voxelized Thicknesses (μm)	% Difference MC Modeled Thickness vs Measured Thickness
Base	128.0	125.0	127	0.78
Active	25.1	28.0	25.4	1.19
Total	281.8	278.0	279.4	0.85

Table A3: Measured variation in Kapton tape with silicone adhesive. Values averaged over 2 different films with 3 positions measured for each thickness.

	Measured Thickness (μm)	Manufacturer Specification (μm)	DPM Voxelized Thicknesses (μm)	% Difference MC Modeled Thickness vs Measured Thickness
25.4μm Kapton	60.4	63.5	63.5	5.13
12.7μm Kapton	26.4	25.4	25.4	3.79

Table A4: Measured variation in 3D printed phantom thicknesses. Values averaged over 3 different phantoms with 3 positions measured for each variable.

	Measured (mm)	Designed (mm)	% Difference
Radial Depth	20.503	20.358	0.71
Wall Thickness	3.318	3.000	10.61
Top Thickness	11.861	11.500	3.13
Base Thickness	3.969	4.000	0.78

Table A5: Simulation materials and densities

Material	Density (g/cc)	Element	Atomic Fraction
Water	0.998	H	0.333
		O	0.666
Polyester Film Base	1.20	H	0.364
		C	0.455
		O	0.182
Active Film Layer	1.35	H	0.568
		Li	0.006
		C	0.276
		O	0.133
		Al	0.016
Kapton Polyimide Film	1.42	H	0.256
		C	0.564
		N	0.051
		O	0.128
Kapton Adhesive (Rubber, Silicon)	1.02	H	0.597
		C	0.199
		O	0.104
		Si	0.099
Liquid Bone	1.55	H	0.509
		O	0.382
		P	0.036
		K	0.073