

What's In Your Refrigerator?

Shivalika Kohli
Integrative Project

2022-23

James Cogswell
Roland Graf
Kate Rubin



Table of Contents

Artist Statement	4
Introduction	5
Exhibition Documentation	6
Contextual Discussion: Research and Thinking	10
Methodology + Creative Works	19
Reflection	37
Acknowledgements	38
Bibliography	39
Appendix	40

Artist Statement

This installation explores refrigerators as unconventional private spaces that house the curated choices of an individual's food consumption. I focus on refrigerators that belong to some of my closest friends through a series of painted explorations and an interactive artist book.

I have been thinking deeply about the dynamic nature of refrigerators, how we use them, and what they represent. Refrigerators are a place for constant interaction; their contents are constantly changing. We purchase food, arrange it, and then rearrange it daily while consuming and adding to it over time. These processes are intimate and unique and are indicative of an individual's personality and lifestyle – just as the food one consumes is.

Through this project, I have discovered a complexity in the relationships people have with food. But I have also discovered a sense of whimsy when trying to figure out those relationships by looking at other people's refrigerators. My hope is that one leaves this installation feeling curious about the way they look at their own refrigerator and the ones of the people close to them.

Introduction

I have always been drawn to food as a subject matter. Not only because of visual intrigue but also because of how food can be associated with identity and emotions. Very quickly this fascination turned into the starting point of my research for the following semesters.

My strong instinct to find food and identity inseparable, stems from my personal relationship with food. As a young adult, I found myself for the very first time being completely responsible for my own food consumption, from making lists based on what I wanted to eat to grocery shopping to stocking up my fridge and preparing my meals. This gave me the opportunity to truly discover some new things about myself in relation to food: I enjoy cooking food for friends and family. I despise grocery shopping. I love recreating my mom's recipes and things I grew up eating, but also equally love attempting to try new foods. These thoughts helped me get started.

You are what you eat!

Shivalika Kohli

In what ways do our food habits and cultural influence our personalities?



Food as a Grid, 2011
by Mikal Gilmore

Food as a Landscape, 2012
by Sabina Ruzic

Food as a Collage, 2011
by Barbara H. Smith

Food as a Portrait, 2011
by Nando Katal

Food as a Still Life, 2011
by Vela Burke

The first two references I chose have in common an artist using a portrayal of food to express certain emotions/memories. But the second 2 are about rendering (illustration and ceramic) food in warm and welcoming ways that still reflect the artists' personality. The last reference by Vela Burke particularly ignited the urge to merge the human form with food.

As an Artist, my strengths lie in painting(oil and acrylic) and illustration, which I believe will allow me to play with both Physical and Digital media for exploring my proposals.



Scan for IP blog!

Moving, Growing and Adulthood

Shivalika Kohli

How did the process of moving away from home and stepping into adulthood contribute to personal growth for me?



Moving Home, 2011
by Thomas Hirschhorn

Green Cities, 2011
by Barbara Hirschhorn

City Scapes, 2012
by Paul Arden

My Desk, 2012
by Vela Burke

My Desk, 2012
by Vela Burke

For this particular proposal it was a bit challenging to find references. However of the ones I did find there is a running theme of nostalgia. A couple of these references also carry themes of solitude which I personally think is an important feeling to address while talking about the growth that comes from moving away from home and family. I also enjoyed the manner in which media such as pen and ink were used in City Scapes giving it a sense of business, which could also reflect thought.

As an Artist, my strengths lie in painting(oil and acrylic) and illustration, which I believe will allow me to play with both Physical and Digital media for exploring my proposals.



Scan for IP blog!

Summer Assignment Posters with buds of ideas that don't directly translate into my final idea but had significant elements that influenced the work I did through IP.

Exhibition Documentation



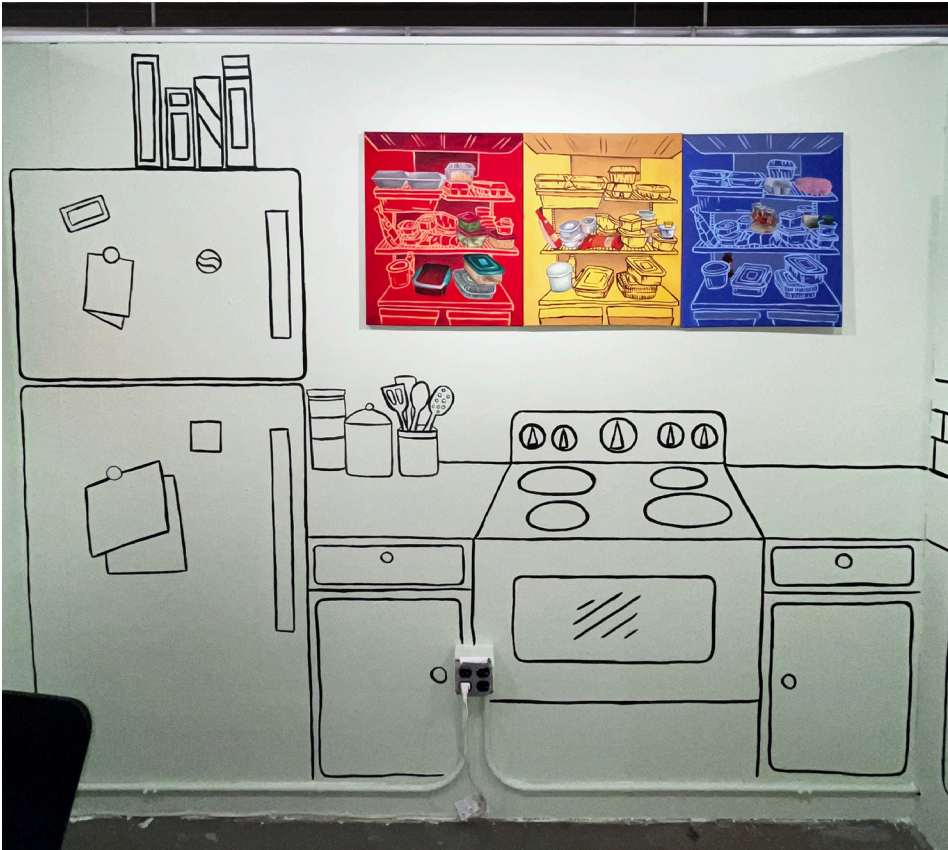

Center Wall: with series 1 of paintings on mural of kitchen set.



Right Wall: with series of wood panel paintings on mural of kitchen set.



Left Wall: with 2 series of paintings and dining table set with interactive artist book on it.

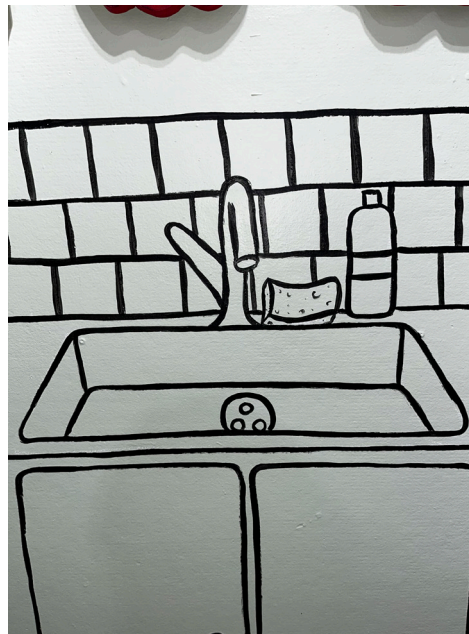

Closeups of wall Mural of kitchen set.

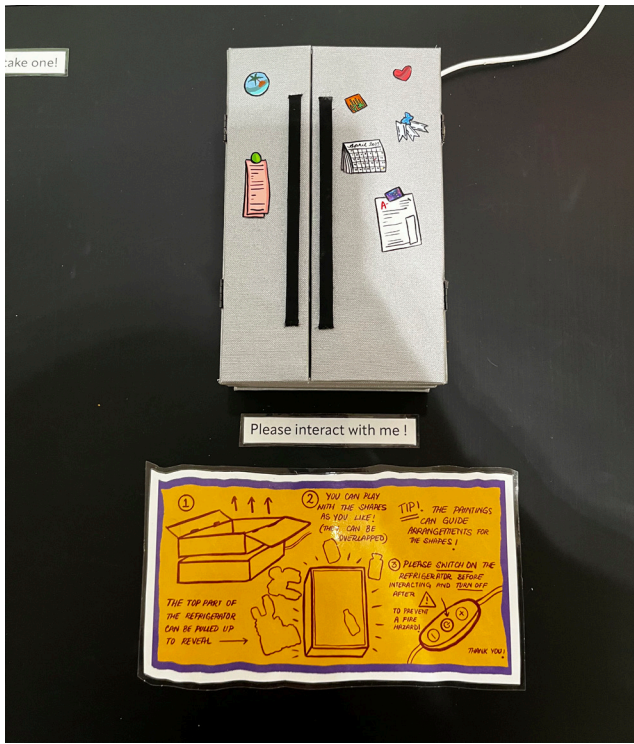

Closeups of Artist Book/ Interactive Refrigerator Piece.



The Makeathon

An 8-hour marathon in making and being creative.

The general goal was to just let making take over and allow you to sort through your thoughts for directions for your project resulting in the adjacent image.

The main thoughts that guided these digital and watercolor explorations were:

- Grocery shopping habits
- Food labels: organic, etc
- Refrigerator Portraits
- Food consumption
- Ingredients



Makeathon work on the wall of my IP studio

The two pieces that stood out to me from the makeathon based on discussion with my peers and Professor can be seen on the right.

1. Watercolor illustration of my partner Erik's Refrigerator
2. Colored stripes of the colors of actual food consumption and not just the packaging.

With these two pieces as a start, a clear direction for research emerged.



Close up of Watercolor illustration of my partner Erik's refrigerator.



Close up of colored stripes of food being consumed in the refrigerator.

Sophie Calle, Chromatic Diet, 2011

My second piece from the makeathon was at its core about the color of the food we consume, which directly related to this photographer's work, which was rooted in color-based categorizations of meals.

"Sophie Calle asked writer and filmmaker Paul Auster to "invent a fictive character which I would attempt to resemble" and served as the model for the character Maria in Auster's novel Leviathan (1992). This mingling of fact and fiction so intrigued Calle that she created the works of art created by the fictional character, which included a series of color-coordinated meals."¹

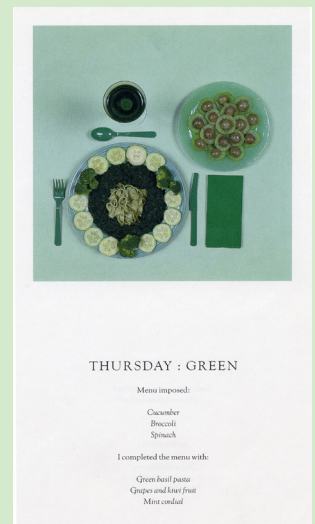
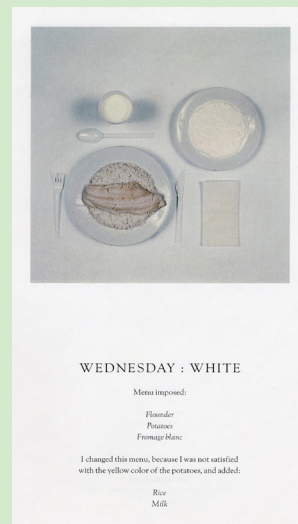
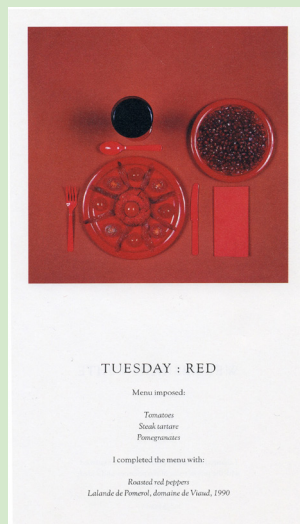
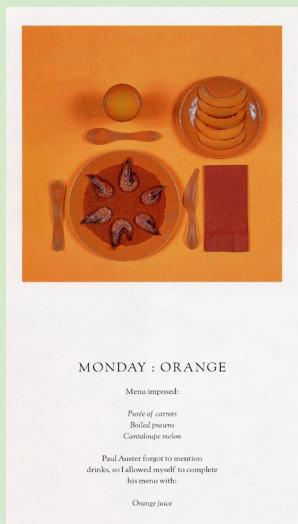

Essential takeaways for me:

- How the color of each of these photographs catered to a unique mood in each of these works.
- It made me think of a way I could integrate color not only as a way of linking it to food but also in the way it could convey other elements of mood and personality.

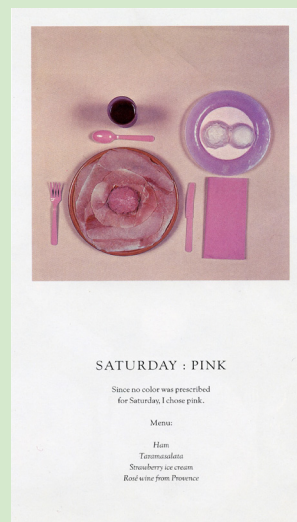
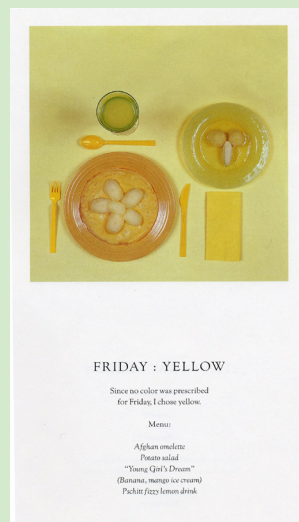

<https://crowincrowndotcom.wordpress.com/2011/02/23/the-chromatic-diet-sophie-calle/>

¹ Calle, Sophie. "The Chromatic Diet." Crown in Crown. February 23, 2011. <https://crowincrowndotcom.wordpress.com/2011/02/23/the-chromatic-diet-sophie-calle/>.

Radha Pandey, Taking Stock, 2012

"Taking Stock explores the amount of consumption that takes place on a daily basis. It catalogs and categorizes all my belongings after one year of moving to Iowa, and lists them according to the materials used in their manufacture."¹

My key takeaway from this piece were:

- The idea of the refrigerator as an inventory.
- Consumption of material, and food as material
- objects

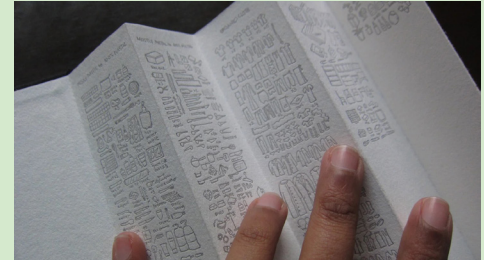

<https://www.radhapandey.com/taking-stock>

¹ Pandey, Radha. "Taking Stock." Radha Pandey. 2012. <https://www.radhapandey.com/taking-stock>.

Interdisciplinary Sources

Contemporary Portraiture:

The Turning of a Blind (Third) Eye, Portraiture and Critical Reflections on Being, by Euripides Altintzoglou

Due to the influence of Michelle Kondrich's piece, I wanted to learn more about contemporary portraiture and its existence without human figures. This led me to *The Turning of a Blind (Third) Eye*, a chapter in this book called "Portraiture and Critical Reflections on Being" which was about the evolution of values around portraiture and its transition from a traditional art practice to a contemporary one. This reading describes how traditional portraiture is rooted in the concept of artistic dualism: the conflict between an artist's "individualization" and the sitter's/patron's "idealization" of the painted portrait.¹ The evolution and development of contemporary portraiture started with a critique of dualism portraits and the suggestion that photography is a solution to resolving that conflict.

Personally, I am not sure I completely agree with that critique but it was important to bear in mind for me as I went on thinking about aspects of modern vs Traditional portraiture in my project. This reading also addresses how traditional portraiture throughout history has been competing on the grounds of their ability to represent their subjects' inner being or character as opposed to rendering objective reality.²

When thinking about these ideas in relation to what I was trying to achieve, my goal became to find a balance between representing the subject matter but also being able to represent an inner quality that is not an objective reality. I also wanted to challenge the idea of the structure of a portrait, and its subject matter.

This source also talks about Allegories and the return of this classical concept in modern-day portraiture practices.³ This piqued my interest in seeing how food items can be viewed as allegories for the values of the people they belong to. And as this project evolved, how refrigerators at large can also be seen as allegories for the personalities and thought processes of their owners.

¹ Altintzoglou, Euripides. 2018. *Portraiture and Critical Reflections on Being*. N.p.: Taylor & Francis Group. 10.4324/9780429507236-5, 118

² (Altintzoglou 2018, 119)

³ (Altintzoglou 2018, 121)

The Relevant Demographic:

Jane Gardner, and PJ Gray. Smart Grocery Shopping/ Shop Smart (Living Skills). Lifeskills in Action.

During the initial stages of my project (before I settled on the Refrigerator as the central object to build my research and creative process around) I was thinking about food consumption from a holistic start-to-finish process; from grocery shopping to cooking.

This is when I came across this lifeskills book on the “art of grocery shopping” for young adults who are in charge of grocery shopping for the first time in their lives. It focussed on efficiency regarding both time and money.¹

Going through this at the time seemed irrelevant to my purpose, however, it made me aware of a specific demographic that this book was targeting. The demographic is young adults in their late teens to early twenties, who for the first time in their lives are responsible for their own food consumption, for the most part, independent of their families.

Until now when thinking about food consumption and grocery shopping and refrigerators, I was thinking about my experience and the experiences of the people around me, who like the demographic of this book are young adults in their early twenties. This also has to do with the fact that my immediate social circle involves college students and recent graduates.

This solidified a demographic and underlined a common experience. Food consumption specifically in young adults.

¹Jane Gardner, and PJ Gray. Smart Grocery Shopping/ Shop Smart (Living Skills). Lifeskills in Action. [N.p.]: Saddleback Educational Publishing, 2016.
<https://search-ebshost-com.proxy.lib.umich.edu/login.aspx?direct=true&db=e700xna&AN=1194453&site=ehost-live&scope=site>.

Anthropological Approach to a Refrigerator:

The Stories Our Refrigerators Tell, by Krystal D'Costa, Scientific American Blog

"The refrigerator gives us a claimable space that serves as a center in our home. In fact, if you were to spend 10 minutes anywhere in someone's home, I'd argue that the refrigerator would probably tell you the most about that person. And people know this: when I asked for refrigerator photos, every single photo came with a story/apology attached. "There's too much stuff on here, I know," "It's not very interesting. I'm sorry," etc. These machines, decorated by representations of ourselves, become deeply intertwined in our lives and offer personal glimpses into our lives."¹

This source comes from the Scientific American blog written by an anthropologist working in digital media. I chose to look at it due to the inherently anthropological nature of my subject matter which was human interaction with an electronic appliance and how that appliance captures a part of our personality. This source affirmed the thoughts I had, about the refrigerator being a dynamic space that houses a curation of decisions around not only food consumption, but aesthetics, organization, the social dynamic of the home, and many other socioeconomic factors."The refrigerator becomes a gallery. It's a ritual space where we track the culture of our household."²

This source underlines that personality manifests itself in our decision-making that takes the form of the display that is the refrigerator. She uses the word "glimpse into our lives"³ which makes me think about all the photographs I have of people's refrigerators over time and how the change and a single photograph cannot fully inform that dynamic shift in its content.

1 D'Costa, Krystal. 2014. "The Stories Our Refrigerators Tell." Scientific American Blog. <https://blogs.scientificamerican.com/anthropology-in-practice/the-stories-our-refrigerators-tell/>

2 (D'Costa 2014)

3 (D'Costa 2014)

Primary Sources

Interviews with Close Friends about their Food Consumption

This primary research source includes interviews about grocery shopping habits with individuals whose refrigerators I am looking into. I was hoping to get a better understanding of their food consumption habits as a whole. Many of the questions that I asked were based on the refrigerator photos I had collected from these individuals.

Participants in the interview are: Hannah Heithoff, Myrka Cardoso-Garcia, Lily Nazarian, Erik Aittama.

Thematic Analysis of Interviews.

	A	B	C	D	E	F	G
3	Employment	Part time Medical Scribe	Part time Lab Assistant	Annual Giving & Stewardship Officer @ Alumni Association UM	Systems Engineer @ Raytheon Technologies	Part time, Program Assistant at Center for South Asian Studies	
4	City	Ann Arbor, MI	Ann Arbor, MI	Ann Arbor, MI	Tucson, AZ	Ann Arbor, MI	
5	Kind of residence	6 person on campus Apartment	On Campus Studio Apartment	Off campus 3 bedroom House	1 Bedroom Apartment	2 Bedroom Apartment, North Campus	
6	Sharing of refrigerator (no of people)	2 refrigerators, 6 people	1, self	1 - 2 (usually lives alone, Grandmother lives here for some parts of the year)	1, self	2 people	
7	Grocery shopping Brands	Trader Joe's, Meijer	Meijer, Aldi, Sam's Club, Target, (CVS, Walgreens)	Kroger, Costco	Fry's (Kroger), Local Indian Grocery Store	Kroger, Local Indian Grocery Store, Target	
8	Online Grocery Shopping Brands	NA	Walmart	NA	NA	Imperfect Foods, Instacart, Wholefoods	
9	Mode of Transportation for Grocery Shopping	Friends/ Roommate's cars	Boyfriend's Car, Bus	Own Car	Own Car	Bus	
10	Frequency of Grocery Shopping	2-3 weeks	once a week	once a week	Once a week	3-4 weeks	
11	Budget	50 - 100\$	15 - 60\$	20 - 50\$	60 - 80\$	60 - 100\$	
12	Lists	no lists are made	Makes lists, Modified by meals planned	Plans a couple of meals, makes the rest based on ingredients available	No lists, usuals repeated	Always makes lists	
13	Meals for weeks Planned	NO, prepares meals with ingredients available	Sometimes meals planned based on cravings	Makes meals based on ingredients palnmed	All meals are planned prior to shopping	Plans a couple of meals, makes the rest based on ingredients available	
14	Staples	tofu, salad ingredients,	eggs, lunch meat, lettuce, avacado, bread	Tomato, Cheese, bread, cranberry juice	Veggies: tomato, onion, potato, etc	Ham, Bread, Pasta, Onion, Tomatoes, Chicken	
15	Pre Packaged meals	Many from Trader Joes	Rarely	Rarely	Never	Never	
16	Eating outside	once a week	Mostly on the weekend	Once a week	On the weekend	often through the weekdays	
17	Items Avoided	Candy, chips, eggs (has phases with cvertain foods)	Carbonated drinks, sugary drinks, organic label foot Sodas, Junk food, Gluten(sometimes)		Frozen foods, junk foods	Sugary drinks, Chips, Cookies/brownies	
18							

Through the process of analyzing the data I gathered, I also compared it in relation to my own personal experience with grocery shopping and food consumption. Much of my analysis hinted towards similar trends and habits based on age group and general demographic.

All the people I interviewed were college students or recent graduates, all in their early twenties. A major insight i had from this process was that while food consumption can be very personal and unique to an individual, there is a commonality in the experience that comes from being in the same demographic and being exposed to similar socioeconomic conditions, such as being a college student, or having your first real job and navigating the current economy.

Full transcripts can be seen in the appendix.

Photographs of Refrigerators:

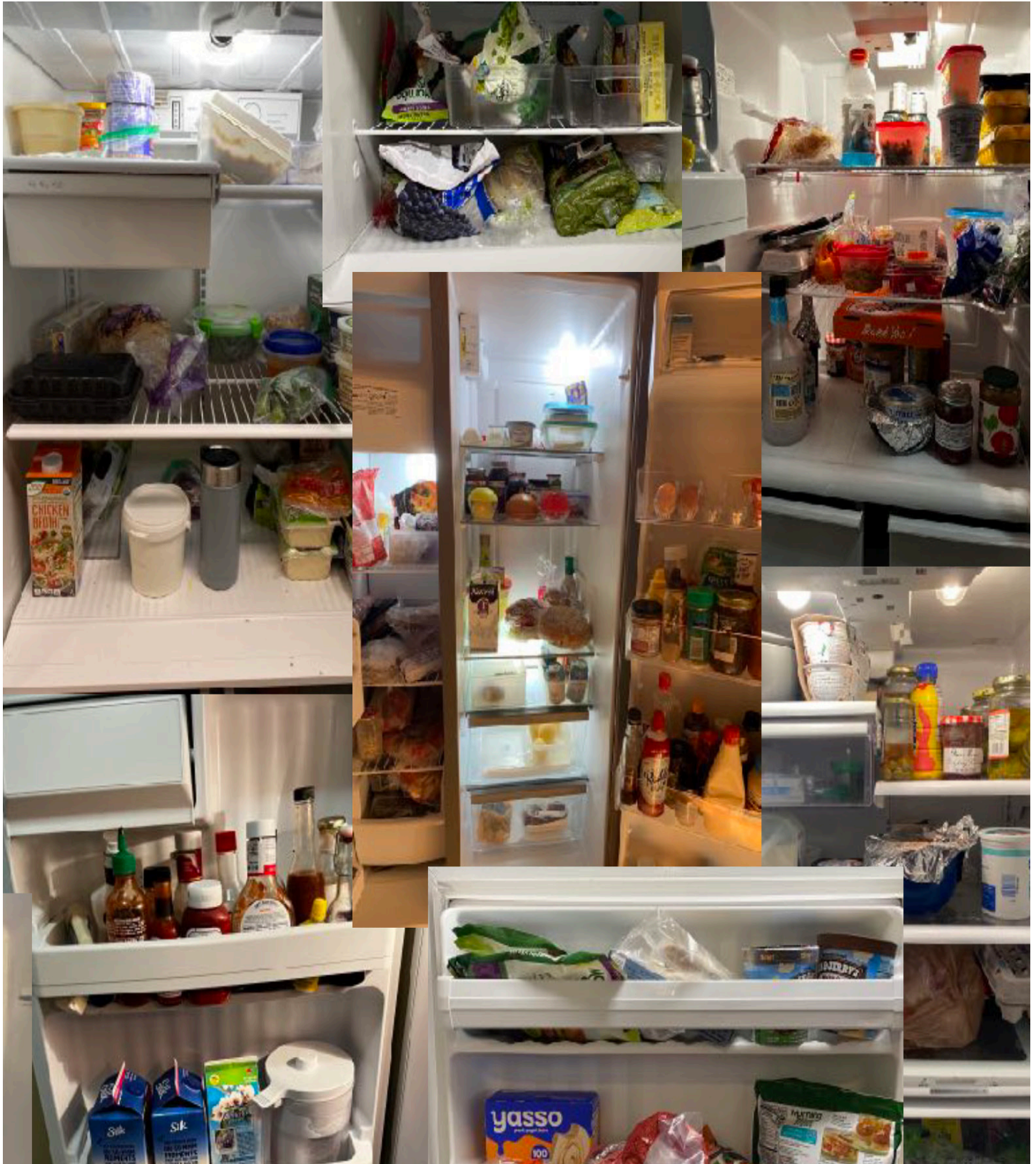

Methodology + Creative Works

The Obsession with the Refrigerator

Initially I was interested in capturing the personalities of my closest friend through a holistic food consumption lens. However when starting to look at the contents of their refrigerators, not only was I visually intrigued, I was also overwhelmed, in a good way. I realised that I had never before truly looked inside these refrigerators to just look at them. It felt like I was seeing a glimpse of them through their refrigerator. And at that point I decided to shift from trying to capture them from a holistic food consumption lens to capturing them through the contents of their refrigerators.

The Venn Diagram of Goals

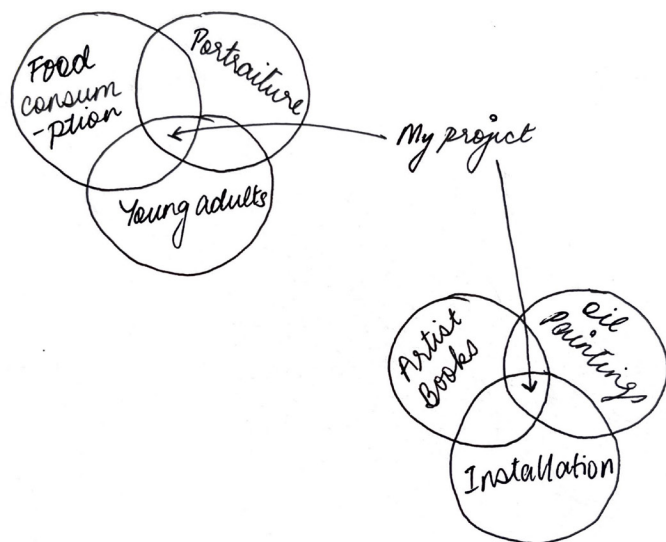

These venn diagrams helped me clarify what my subject matter and what mediums I was most interested in using.

The Still Life Approach: Phase 1 of Painting



As I began my journey in making, I was looking at parts of the refrigerator as well as the whole, and started making thumbnail sketches and getting my feet wet with painting.

My approach was rooted in the traditional manner of starting my compositions from observation. This resulted in the first phase of my work seeming very much like photographic still lifes.

Graphite Sketches of refrigerators from photographs collected.

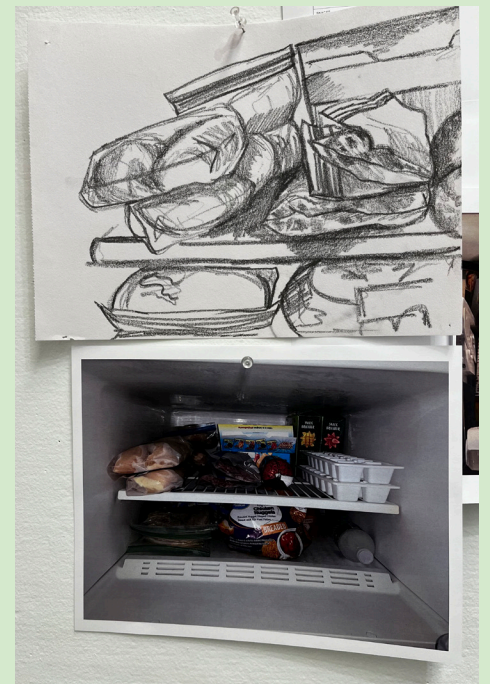



Oil Painting of a miscellaneous shelf in my partner Erik's fridge, with pickle jars, jams and strawberry milk.



Oil Painting of my friend Myrka's freezer with chicken nuggets, frozen meats, tortillas, popsicles and ice.

In this particular composition the physical space of the refrigerator became quite significant, and the painting was not just about the food contents.

I was also experimenting with a shift in style from more realistic to graphic. The need for this change in stemmed from a realisation that my still life approach wasn't quite conveying what I wanted it to.

Honestly this was a point in my IP project where I was genuinely stuck. I really needed to figure out the content of my paintings in a way that would do justice to the excitement and curiosity I had about my subject matter.



Oil painting process of my roommate and my fridge's condiment shelf.

Thinking in Series: Phase 2 of Painting

To help myself out of my creative rut, I decided to take Sequential Images in Painting in the winter semester. I had made it my personal objective to use the structure of this class as an extension of IP to allow myself to discover more about my subject matter through creative explorations in series.

Series 1: Leftovers, Dairy, Misc.

I started out this exploration by looking closely at the photographs of refrigerators and starting out with some digital sketches.

The process of sketching allowed me to distinguish categories of food I was observing within this refrigerator.



Photograph and digital sketch of my friend Hannah's Refrigerator that she shares with one other roommate.

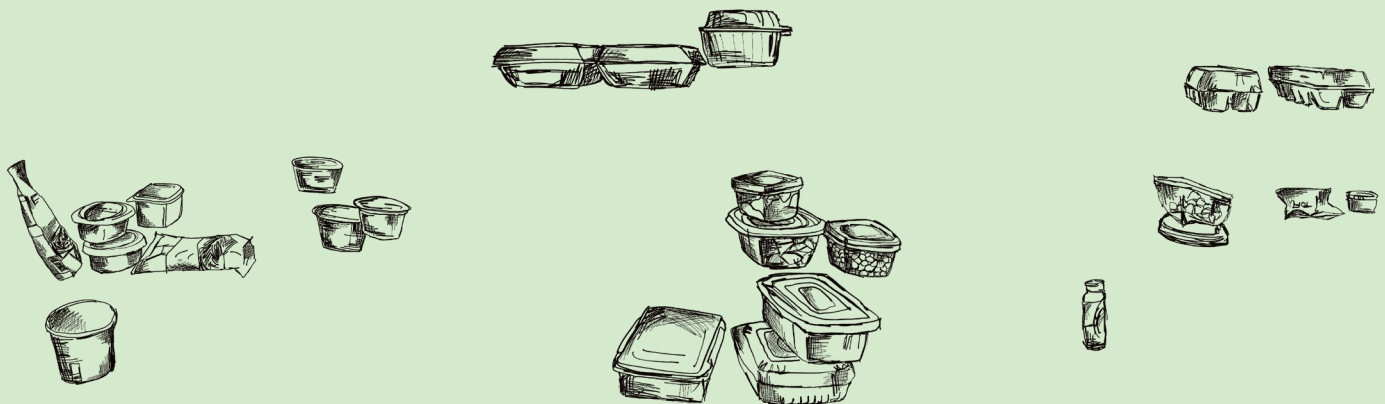

Categories: Dairy, Leftovers, Miscellaneous

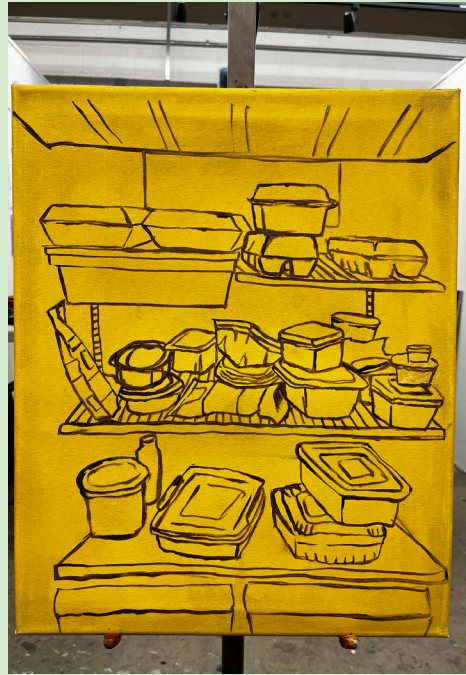

Initial color washes and painted illustrations of sketches.

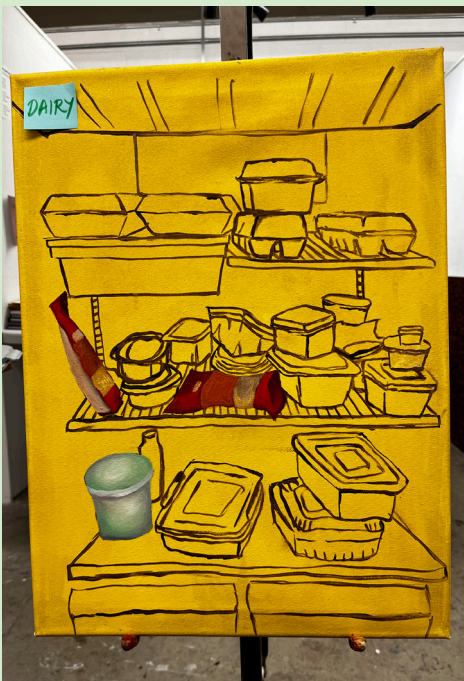

I wanted to use saturated color as a means to capture the mood and essence of the personalities of the people whose refrigerator this is.

Through this series my goal was to get the audience to look closely at these paintings that look the same, but aren't quite the same and to perhaps identify the categories that I had identified prior to making these paintings.



Closeups of line work and juxtaposition of fully rendered objects.



Final Paintings in Exhibition set up and in studio.



Series 2: The Beverage Whimsy



I followed the same methodology as the first series for this series which was a set of 2 paintings.

I found that a sense of whimsy took over the sense of categorization I was looking for when I found a majority of beverages in a close friend's refrigerator.

Which by no means was definitive of the fact that the owner has a majority preference for beverages in her food consumption, but was just a product of circumstance and a recent water bottle case purchase.



This made me think deeply about how dynamic refrigerators are, and no one glimpse in time can give us the whole picture of a person and their food consumption.

These sketches are based on my friend Myrka's Refrigerator.



Juxtaposition of linework and rendered objects.



Final Paintings in studio.

Series 3: Miscellaneous Shelf

The third series followed a similar approach to the first and second. However, my focus shifted from the whole structure of the refrigerator to the miscellaneous shelf. I was intrigued by the manner in which my roommate and I divide our refrigerator, where the first shelf is theirs the second is mine, and the third shelf is where miscellaneous things trickle down.



Based on the Miscellaneous Bottom Shelf of my Refrigerator, where some of it belongs to me and some belongs to my roommate.



After the initial sketching with paint on canvas, I decided to swipe my paintbrush across to create a mild blur effect.



Final images of the paintings in the studio: Displaying cohabitation of the refrigerator.



Closeups of illustrated and fully rendered objects juxtaposed.

Series 4: Color Studies on Wood Panel.

From very early on in the project I was interested in the colors of food consumption. I started collecting color bands based on the photographs of refrigerators that belong to my closest friends. Initially I grouped these colors based on the individual, but started thinking about grouping by categories of common ingredients, which resulted in specific wood panel shapes in the next stage. I was interested in this series becoming a artistic interpretation of data that I collected.

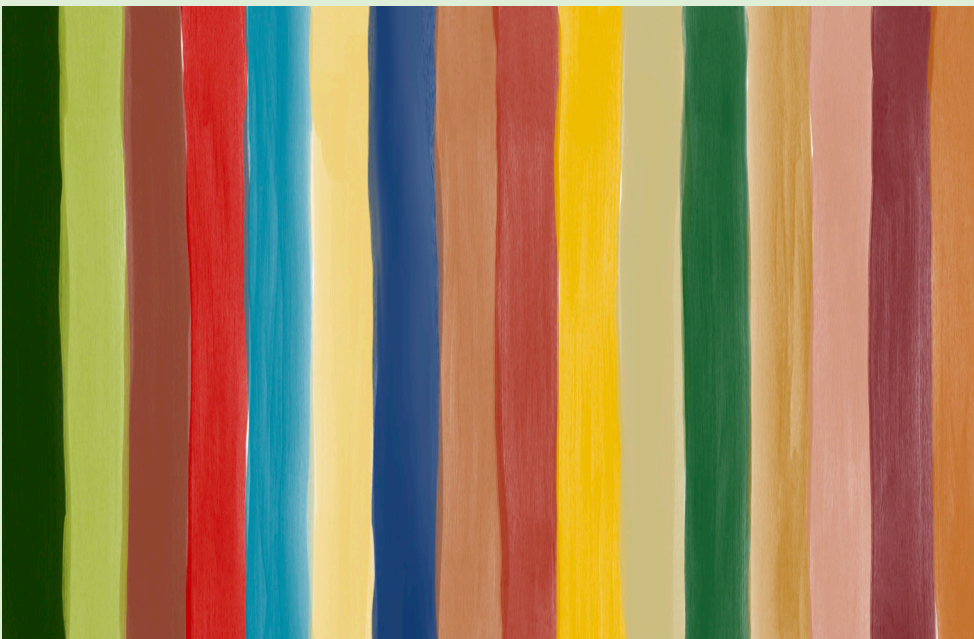

Digital Color swipes.



Digital Color swipes.



Using woodpanel to cut out identifiable shapes of food containers, to categorize the colors further.





In progress pictures: figuring out arrangements on wall



Final Arrangement in exhibition



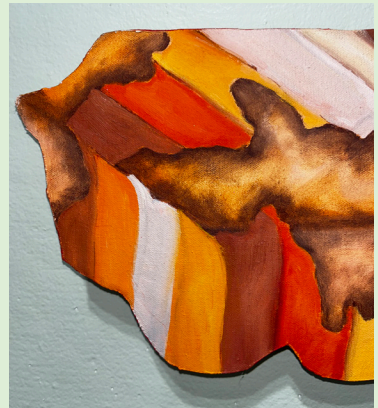
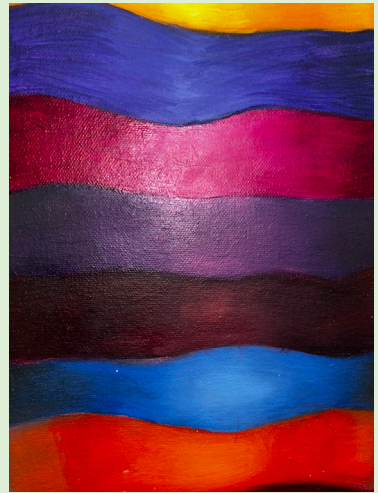

Detailed shots of oil painted color stripes and food details on canvas on wood panel shapes.



The Artist Book

Due to my interest in artist books, I wanted to use my paintings in a unique way to integrate them into an interactive experience. As food is tactile and refrigerators are all about interaction.

I was very interested in seeing how my digital sketches for my paintings would interact with transparency. I started out by experimenting with printing on vellum. However, I soon realized that vellum was too delicate of a material and didn't respond well to saturated color prints. I changed my approach and began to use laser-cut shapes on acrylic, and printed on them using a UV printer.

The use of light in the background served two purposes for me: It enhanced the transparency and was a parallel for the way refrigerators radiate light from within. Hence integrating my own lightbox into my artist book structure became a part of the plan.

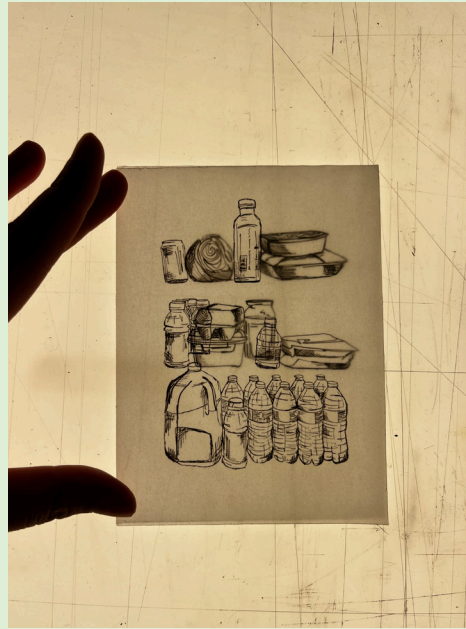

Vellum prints of sketches on a lightbox.

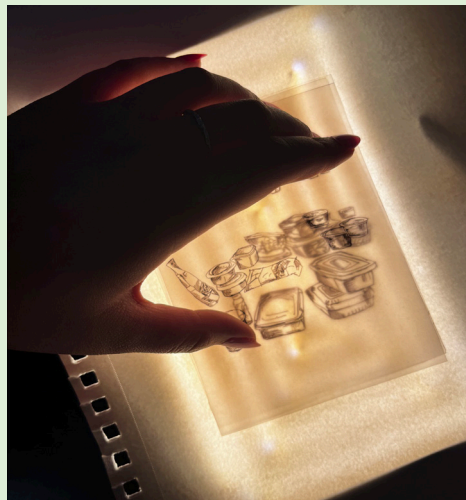
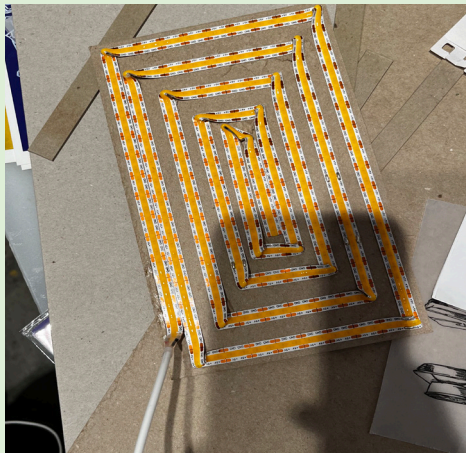

Using LED strips to create light component, and testing for structure of lightbox.



Using laser cutter on acrylic to cut shapes and UV printer to print mini version of woodpanel paintings.

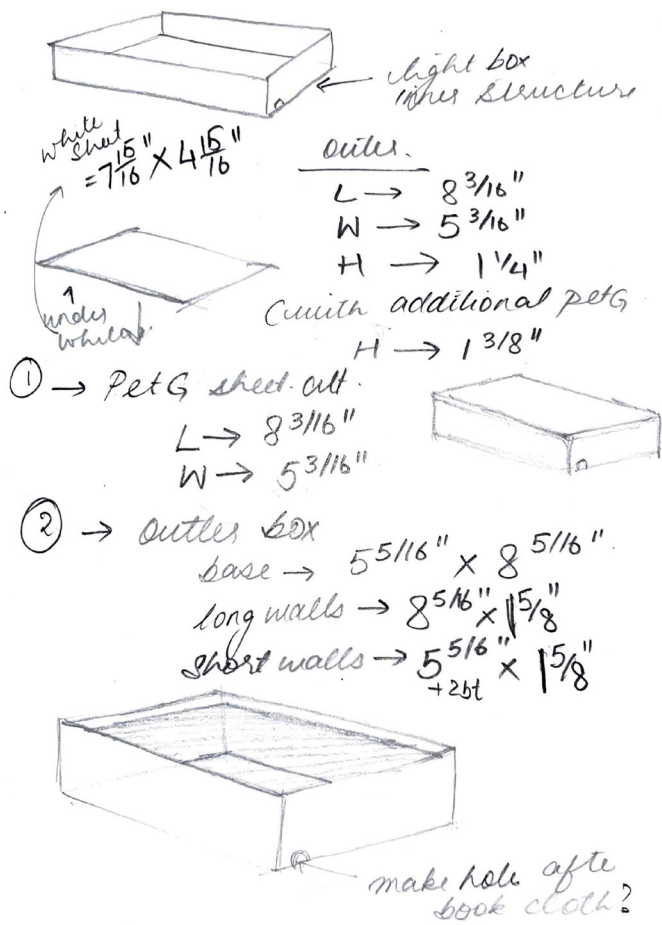

second tray.

outer walls + base = base outer structure

inner lip.
 = PetG sheet - book cloth thickness.

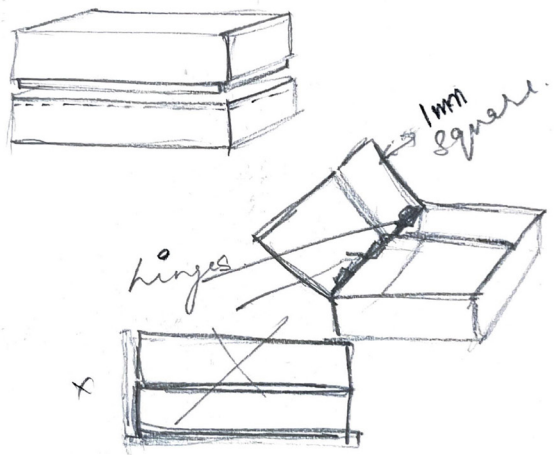

Sketchbook Process for figuring out refrigerator box structure.

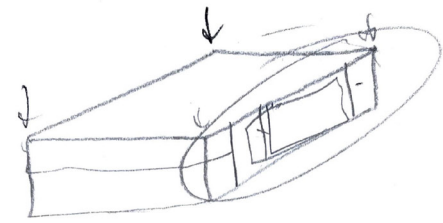
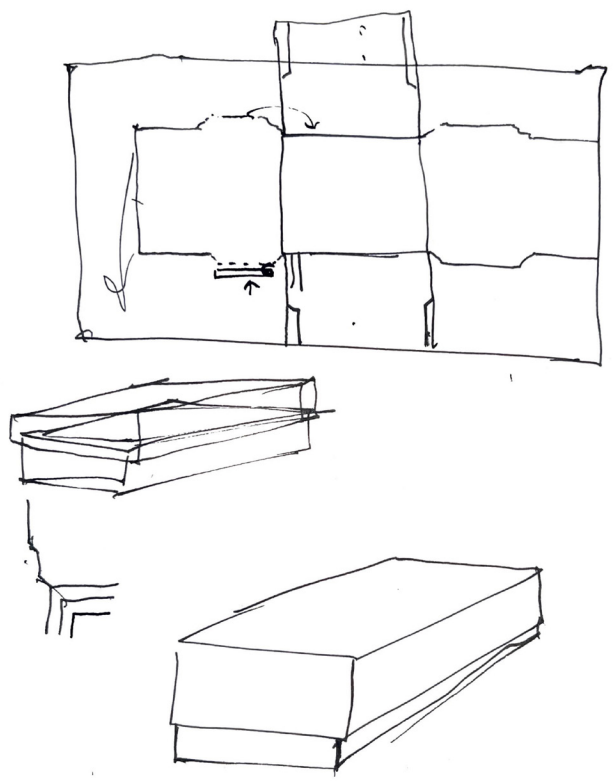

TOP BOX

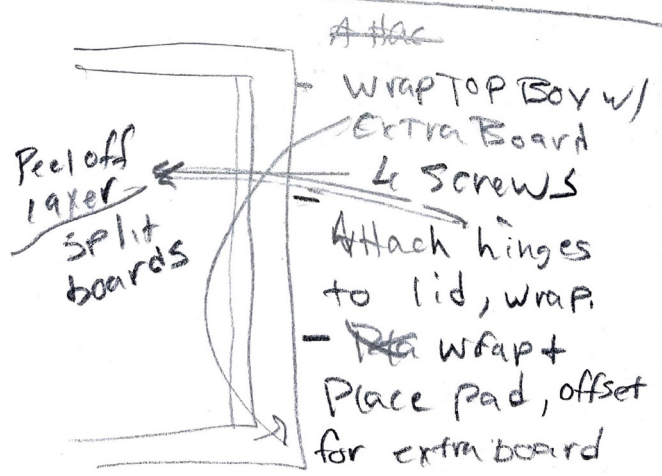



Final Refrigerator Artist Book.

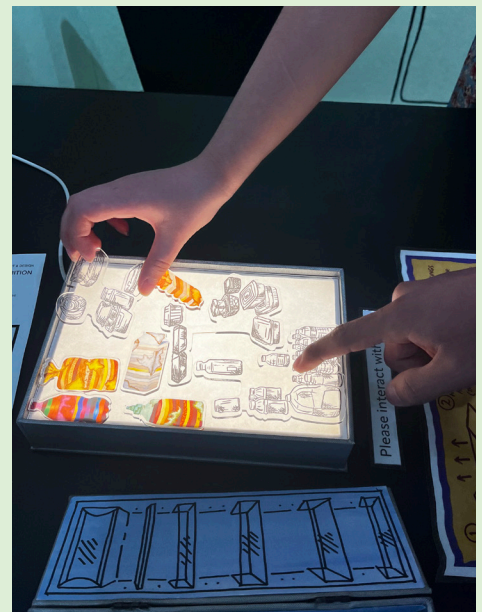
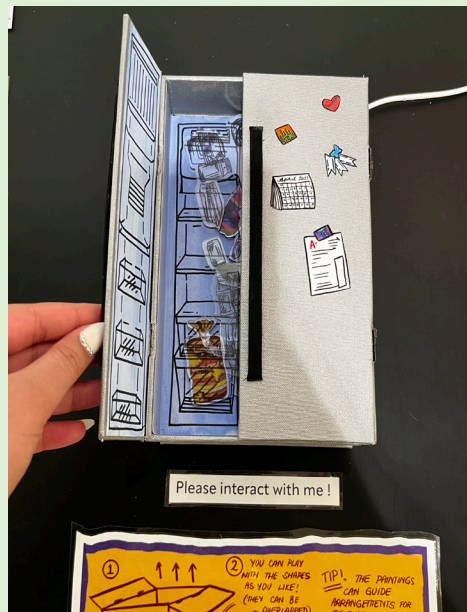
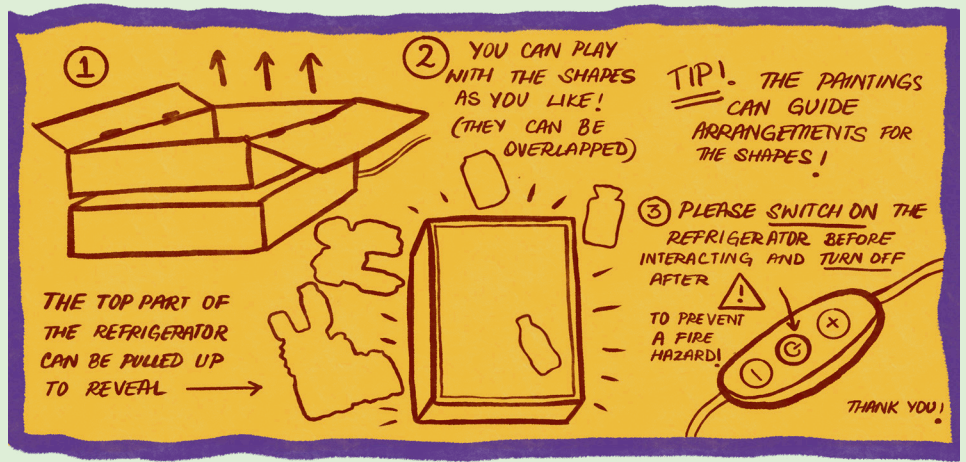

Reflection

Through this process, I found joy in looking at the nuances around a central object: The Refrigerator. I found whimsy in making joyful, colorful paintings that gave me a glimpse into the personalities of my closest friends from the lens of their food consumption. In many ways there was an intimate bond perhaps maybe even a little voyeuristic in constantly looking at all their refrigerators and taking hundreds of photographs of them.

It was mainly a sense of curiosity that sparked this project and my goal through setting up my exhibition was to share my curiosity and leave my audience thinking about the food they consume and the contents of their refrigerators, and those of their loved ones in a whimsical way.



Acknowledgements

People I couldn't have done this without.

Erik Aittama
Hannah Heithoff
Myrka Cardoso-Garcia
Lily Nazarian

Jessie Karlsberger
Nicholos Dowgwillo
Carly Lowe
Kyle Clark
Liz Guilmet

Bibliography

Kondrich, Michelle. "What's In Your Fridge?" Michelle Kondrich Illustration. April 24, 2014. <https://michellekondrich.wordpress.com/2014/04/24/whats-in-your-fridge/>.

Calle, Sophie. "The Chromatic Diet." Crown in Crown. February 23, 2011. <https://crowincrowndot-com.wordpress.com/2011/02/23/the-chromatic-diet-sophie-calle/>.

Pandey, Radha. "Taking Stock." Radha Pandey. 2012. <https://www.radhapandey.com/taking-stock>.

Altintzoglou, Euripides. 2018. *Portraiture and Critical Reflections on Being*. N.p.: Taylor & Francis Group. 10.4324/9780429507236-5., 118

Jane Gardner, and PJ Gray. *Smart Grocery Shopping/ Shop Smart (Living Skills)*. *Lifeskills in Action*. [N.p.]: Saddleback Educational Publishing, 2016. <https://search-ebshost-com.proxy.lib.umich.edu/login.aspx?direct=true&db=e700xna&AN=1194453&site=ehost-live&scope=site>.

D'Costa, Krystal. 2014. "The Stories Our Refrigerators Tell." *Scientific American Blog*. <https://blogs.scientificamerican.com/anthropology-in-practice/the-stories-our-refrigerators-tell/>

Appendix

Interview 1: Hannah Heithoff

Shivalika: Can you tell me your full name, the year of college you're in and where you live?

Hannah: My name is Hannah Heithoff. I am a senior this year and I live in Ann Arbor. Could you specifically tell me what part of Ann Arbor you live in? Like what do you mean like South U yeah I live on the lake near South University with a east quad OK that's awesome so tell me a little bit more about your living situation do you live in a house or an apartment and how many roommates you have I live in an apartment with six total people survive roommates. Five other roommates.

So Hannah, how many people do you share this refrigerator with?

Hannah: So we have two fridges and we split it between three different people each. However I share a fridge with my roommate Gabby. Honestly I don't know who else uses it. I feel like everybody else just uses the other fridge because Gabby and I have the most food.~ OK so that would mean you share this one fridge that we are looking at today with between the two of you yes OK sounds good.

How often do you go grocery shopping?

Hannah: About 2 to 3 weeks.

So where do you mostly buy your groceries from and can you list them all?

Hannah: I usually alternate between Trader Joe's in Meijer there are particular items that each store has that I usually buy a ton of I usually go to both of those like once a month but sometimes I go to target when I need like produce or lettuce or things that like go bad after a week because target is on campus and I could walk but Trader Joe's in Meijer are usually get a ride with somebody to go there.

So in order to get to places like Trader Joe's in Meijer and how do you usually go about transportation?

So do you have friends that I ask that have cars like every once in a while ask them or if my parents come to town like I also get a ride with them and sometimes like when I wanna go with people who don't have cars will either take the bus or will Uber there.

So from the sounds of it it seems like there is not a specific routine but it really depends on I guess your availability and whatever is convenient at the moment. Would you say grocery shopping stresses you out as a student?

Honestly I'm not too concerned too stressed about it I just go based on when I run out of things to eat and then when I do go I usually like find somebody who's willing to go with me I just reach out to like whoever is willing to at the moment and I usually find somebody and worse comes to worse I just go by myself which I haven't had to do yet.

Do your roommates have more modes of transportation you share with them?

Two of my roommates have cars. I've gone once with one of my roommates but the other room and I haven't gone with. A lot of it has to do with scheduling like we just haven't had schedules that match up because like my roommates will go during the week but I usually go on the weekend.

What groceries do you think you always tend to repeat when you're going grocery shopping?

I am a vegetarian so I get a lot of plant-based protein options like tofu and Tempe and then I also get cheese like feta mozzarella pepper jack I get a lot of vegetables I get Romaine lettuce cucumbers tomatoes and stuff like that to make salads and I also like to buy apples because those don't go bad very fast I haven't met my fridge for like a month and they're still good I also buy avocados cause you can add that to a lot of meals and those are my staples can't think of anything else.

Would you describe yourself as an adventurous shopper? yes or no and elaborate on that?

I feel like I'm not super adventurous when it comes to grocery shopping. I know what I like and I buy a lot of them but sometimes if I see something in an aisle and I think it looks good I'll definitely like to grab it but I do know what I want when I go grocery shopping.

When you go about grocery shopping do you tend to make a grocery list?

I never make a list. In the back of my head I always know what I want and I just grab it and I kind of like to not have a list because I keep my options open a little bit when I grocery shop even though I just said I wasn't very adventurous and also I feel like I know like what I want and I always forget to make a list too cause I also like I said before I never know exactly when I'm gonna go grocery shopping next so like if I went like at a regular basis I got a regular day I would have a list but since I never know when I'm gonna go I usually just forget.

Do you buy groceries based on meals that you plan for in the coming weeks or do you just tend to make meals with whatever is there in your fridge I don't even point of time?

I usually make very similar meals I definitely have meals in mind when I go grocery shopping but like I make a lot of the same meals like I make salads every week so I know I'm gonna buy stuff for a salad for example and if I do want to try a new meal I know I'm gonna make it before I go grocery shopping I mean if I'm on the last stretch of food I just go with whatever's in my fridge but for the most part I like know the meals I'm going to make.

How does cost factor into your decision making around grocery shopping?

I don't really look at the price when I buy groceries because I know I don't go grocery shopping a lot so I'm like I know I'm going to spend a lot of money like when I go at once like I spent enough for like a few weeks worth of groceries which is how I rationalize it and also like I buy pretty much the same thing every time I grocery shop so I kind of know the price but the price isn't going to limit me unless it's absolutely ridiculous it's also a new item that I'm not used to like it was a \$10 thing that like I've never tried I'm not gonna be that adventurous but for my staples I'm not gonna let price like different deter me from buying it.

What does a grocery trip usually cost for you on average?

Depending on how much food I have and eat it can range from like \$50-\$100 and also depending on when I went last grocery shopping because sometimes it will only be two weeks in between trips and other times it will be like over a month so it depends on that.

In an ideal sense, given that you have control over all the variables around grocery shopping, what would the most seamless and ideal grocery shopping trip look like for you?

I like that question. Ideally I would have my own car and I would be able to drive whenever I wanted because you are at the moment I rely on other people to drive me and ideally I would be a millionaire and I have to worry about money because even though I don't worry about money now like I still determined to sell from buying stuff sometimes just because of the fact and because when I do grocery shopping I have like five or six like humongous bags because of how little I grocery shop so it would be nice to my own car because when I Uber anger with other people room in the back of the car and I have to carry them up to my apartment another ideal thing I would like is not to have stairs to my apartment so I could go in but otherwise not really anything else comes to mind.

How often do you cook your own food, and eat out?

I try and cook my food every day if not multiple times a day I feel like cooking is kind of a mental health activity that I like to do I always quickly cook like 10 minute meals like nothing like to elaborate like I'll just like hook some frozen razor like cook tofu in the air fryer but like I still like try and cook because also I feel like it's more fresh that way within other times I'll just like meal prep like meals but like usually I'll like assemble a salad at lunch that will be like my version of cooking and then for dinner I'll have like a meal prepped meal so I hope that I do I do feel like I cook a lot more than the average college student I really don't eat out that much I go out probably like once or twice a week just with friends not even by myself but yeah.

Do you tend to buy prepackaged meals or frozen meals?

Not really, but actually I do buy some like Trader Joe's has really nice frozen meals which is one of the reasons why I go there I buy like frozen like parts of the meal but a lot lots I don't buy the whole like frozen meal like for example I'm a buy like a frozen burger patty with then I have to like heat it up and like get the bun and the cheese and stuff like I don't like have the black not like the typical like frozen packaged meal and then like I said a lot of times I like buy like tofu tempeh and stuff and I'll just like cook that and like put it in stuff it's not like it's like a preset meal or anything but every now and then I'll enjoy a nice frozen meal.

What are some groceries you tend to avoid?

I avoid stuff that even though it looks good in the moment I know I'm not gonna eat like them eat like some like candy or snack or something like oh this will be tasty but I'm like I know this is gonna be sitting in my house forever and I know I'm not gonna eat it and like also like some things like something like eggs I don't really eat that much I'm like if I don't feel like I'm gonna eat them I'm not gonna buy them I don't know I just like things I like kind of in the back of my head I know that I'm not gonna like eat or like if I'm at the checkout and I see that my bill is like really high like take some things out I'm like OK oh I'll just limit I'll just like survive without that for a while.

I tend to have phases with certain foods I buy, like I don't really eat eggs a lot now but there definitely was a phase like at the beginning of the school year i would have eggs every morning for breakfast.....

-----Interview 2:
Myrka Cardoso-Garcia

Shivalika: Can you tell me your name, what year you are at UofM and where in Ann Arbor you live?

Myrka: Hi my name is Myrka Cardoso-Garcia I am a senior in the school of Public health. I live on Central campus Near Thompson St and Liberty St in the studio by myself.

How often do you go grocery shopping?

It really depends on when I'm available. I probably go about every two weeks to three weeks. It depends on when my boyfriend can take me grocery shopping.

Tell me more about why you depend on your boyfriend to take you grocery shopping?

It's just easier when he takes me because he has a car. If he doesn't take me then I either have to take the bus or I have to order food online but that is not ideal, there are always additional costs like service fees and shipping delivery fees. If I ever need food immediately I can just go to the target that's about a block away from my house but I prefer to go to a bigger grocery store where I can just get all the food I need.

Which grocery stores do you mostly shop from? Can you list all of them and maybe how often you go to them and for what exactly you prefer to go to each one?

I go to Meijer and Aldi but when I order food I like ordering from Walmart. Aside from that I go to Target, CVS or Walgreens when I need something urgently because those are near my house. When I need something in bulk I order from Sam's Club.

What groceries do you think you always repeat when you go grocery shopping?

I always buy eggs, lunch meat, bread, cheese, lettuce and avocados. I always buy these foods because I make a lot of sandwiches at home because it's an easy meal to make. For cooking bigger meals such as pasta or Mexican dishes those require different ingredients but I don't cook those as often because they take up more time and sometimes I don't have time because of school.

How do you think your ethnicity and cultural background affects your food choices and the groceries you buy and the meals you prepare?

I usually cook a Mexican dish about once a week and I try to plan ahead of what I'm gonna cook so make sure that I have the ingredients when I go grocery shopping, usually that requires a lot of tomato, onion and garlic.

Would you describe yourself as an adventurous shopper yes or no and elaborate on that?

No, because I'm a very picky eater so I like to eat what I've already tried. If I try something new it's usually at a restaurant and then I decide to buy ingredients to make it if I really liked it.

When at a grocery store do you ever just like to walk down an aisle and see something that's attractive and then just pick it up or do you tend to stick to a grocery list and only buy what you have already planned to buy?

Sometimes I do buy items based off the packaging because it looks cute but most of the time I end up buying from my grocery list because my boyfriend takes me grocery shopping and he wants to get out of there fast so I usually just buy what's on the list and then leave but if I have more time I will look around and grab whatever looks good.

Do you make plans about the meals that you prepare for the coming weeks and accordingly make a grocery list or is it just a very specific set in stone grocery list of staples that you buy every single time and then depending on what is available you make your meals. ~ does the meal planning come first or does the grocery list come first?

I usually have the same grocery list every time I go grocery shopping but if I had a craving for saying Mexican dish then I know to add that to my grocery list but I don't really plan ahead of what I'm going to cook I just cook whatever I have available in my fridge or what I'm craving because I usually buy the ingredients for that.

You mentioned that you cook a lot of Mexican dishes and also plan your grocery shopping around that sometimes. Do you tend to find all the ingredients for the Mexican food you wanna cook at the grocery stores that you listed before or do you ever have to make trips to a special grocery store for any of these ingredients?

I find a lot of the ingredients in the grocery stores I go to but for example I never find chorizo unless it's at Walmart or I never find Queso-fresco which is a Mexican cheese at any of the grocery stores I usually bring back from home and my favorite corn tortillas are also from a Mexican store because the corn or tortillas in the grocery store don't taste good to me.

How does cost affect your decision making around grocery shopping?

I tend to buy items that are at a cheaper price so when I buy meat I like for the ones that are on sale or buy store brand items because I'm usually not picky about the quality of the food and I try to have a budget when I go grocery shopping so if I want something that's a little more expensive next time I go grocery shopping I'll avoid buying something.

~Basically in order to fit something in the budget you would take something else out of the conventional staples.

When it comes to online versus in person grocery shopping how do you think cost affects you in that sense?

I usually avoid getting groceries delivered unless I have a discount or if I have a membership that I got for free such as a free trial that delivers the groceries to me at a lower price. If not, I prefer to wait till I can go to the grocery store.

You talk a little bit about the target that is on campus on State Street. Tell me a little bit more about your relationship with this particular store and why it doesn't quite fit into your regular grocery shopping?

I really love that they open the Target really close to Central campus. They often have things that other stores nearby don't such as meat or fruit and vegetables however a lot of the times that I go I don't find the food that I need one time I was trying to buy eggs and they were out of stock so I had to buy six dollar eggs at CVS for a cost I could've paid for at target being two dollars. ~out of stock very often.

In an ideal world say you didn't have any of the restrictions that you currently do, what would an ideal grocery shopping practice look for you in your life?

I would be buying a lot of meat to cook every single day and my favorite fruits which sometimes are available in stores because it's not the season or sometimes they are over priced because again it's not the season. I would also be going once a week so I can get more fresh items and drive myself. I don't like when I have to have food delivered to my apartment because a lot of the times I get some substitutions that I ideally wouldn't have picked but I need them. I also don't like having to depend on my boyfriend having free time to take me grocery shopping so I would go whenever I need to or even get fresh ingredients so I can cook my meals right away because I kind of forget to thaw my meat.

How much of the food that you eat do you prepare yourself and how often do you tend to cook and how much do you I guess eat outside?

I cook meals about three times a week, I usually make more quantities so that I have leftovers for the next day so it's not required every single day to cook. I also make sandwiches a lot which I don't really count as cooking in terms of eating out. I usually only eat once with my friends and then once with my boyfriend even if my boyfriend comes for the whole weekend we like to cook in my

apartment to save money.

How often do you buy prepackaged meals or frozen meals or frozen items?

I try to avoid buying frozen meals because I don't like the taste of them as much. My freezer consists of lots of meat and Popsicles or frozen tortillas and chicken nuggets but apart from that I don't really have any other frozen foods in my freezer.

What would you say is like a very easy go to cheat meal for yourself?

My favorite cheap meal to eat is a (scrambled) egg with a hotdog cut up in it with a tortilla. It's very easy to make and I usually always have the ingredients ~ Kind of like a breakfast burrito.

What are some groceries that you actively avoid when you go grocery shopping for whatever reason and feel free to elaborate?

When I'm in the grocery store I usually avoid organic because I know it's more expensive. I also avoid foods I'm not familiar with because I'm a picky eater. I also avoid the drinks area because I drink a lot of water and I know if I bring juices or pop I won't be drinking as much water as I should be I also avoid the sweet pastry area because I usually don't crave sweet things so if I buy them I know I will just be eating them when I'm stressed or when I want a distraction not necessarily because I want something sweet.

TW IBS: I know that you have irritable bowel syndrome so how does that factor into things that you eat or don't eat and how does that affect I guess you're grocery shopping because I know for me personally does a lot.?

When I got diagnosed with irritable syndrome they told me to avoid a lot of juices and pops because they have ingredients that make you more prone to activating iridal bowel syndrome so I also avoid these items because of that aside from that I avoid yogurt personally and food that is high in my toes because this also affects my digestive-health.

-----Interview 3:

Lily Nazarian

Shivalika: Can you tell me your name and tell me about where you are in life and where in Ann Arbor you live?

Lily: My name is Lily Nazarian. I recently graduated from the University of Michigan and I'm working full-time now and I live in Ann Arbor near stadium and Liberty which is not too far from Central campus...

Tell me a little bit about your cultural background and how that affects your food habits?

I am Armenian because both my parents are from Armenia but I was born in the United States and lived here for eight years of my life before I started traveling and living in China, Russia, Korea and Dubai. Living internationally has affected the types of foods that I eat but I primarily grew up eating Armenian food.

How often do you go grocery shopping?

Because I have a car I find it easy to just get in and go get groceries when I find that I'm missing something so that can happen as early as every two days or so but my bigger grocery shopping trips are once a week, on the weekend because I work full-time so I'm very tired at the end of the day to go grocery shopping during the week.

What grocery stores do you mostly shop from? Can you list all of them and tell me about why you

choose the specific ones and what purposes they serve you?

I mostly shop at Kroger just out of convenience it's about a two minute drive from my house and I've even walked there before to grocery shop I like it because it has what I need and it's not one of the more expensive grocery stores like Whole Foods or Trader Joe's but from time to time I do go to Trader Joe's just because they have some niche items that I like some of those items are Some of those items are frozen aisle foods like the mini ice cream's or the cauliflower frozen pizzas but I really go there on occasion I also have a Costco membership that I recently got I signed up when I had to buy a lot of food in bulk and it was really useful at the time because I had a party and I decided to keep it because Costco isn't too far from where I live it's about 15 minutes and when I go there I do buy some items in bulk like tomatoes I love tomatoes I eat them all the time and it's cheap to buy it there are many salad mixes and cheeses they have lots of cheese that is in bulk and that's a big part of my diet and the meat really nice because Kroger doesn't always have the rail food that I'm looking for when it comes to seafood and meat so if I had to sum it down at Kroger and Costco most of the time.

What groceries do you think you always repeat on your staples when you go grocery shopping?

My staple groceries are tomatoes, some sort of cheese bread, cranberry juice and some array of random fruits and veggies depending on what is available.

Would you describe yourself as an adventurous shopper yes or no and if so elaborate?

I find that question interesting depending on context so to pre-face it I'd say I'm a adventurous eater I like to eat things that are just new to me I've never had before or from a different culture but when it comes to cooking these items I find that I would love to but it's rare because I have to plan how to cook it and learn how to cook it so it doesn't come as often as I would like but when I do plan for an interesting meal or a adventurous meal I'm able to find everything in the grocery stores that I need most the time who's that I go for are typically east Asian food to cook but also another aspect of adventurous shopping is sometimes I'm in a grocery store and I see something and I think I've never had that but the packaging looks cool or that food looks cool so I'm just gonna add it to my card and I feel like that comes from a place of as a kid my parents never really let me just add something to the cart like if I wanted something I have to ask you and explain why I wanna and then they'll buy it if it's not on their list and now that I have my own money it's like OK I'm gonna buy this thing and if it's bad it'll be a waste of my money but at least I got to try it because I want to.

This question is about your grocery shopping process so firstly do you make lists and if so are those lists based on meals that you plan on making in the week to come and because you wanna make these things that these things are on your list or is it more like you go to the grocery store you buy what you want and then you make food accordingly?

When I go grocery shopping it's kind of a bit of both because throughout the week if I realize I don't have a certain food that I know is a staple or I want I'll grab a pen and write on the grocery list that's hanging on my fridge door and before I go grocery transfer that list to my online app on my phone which is called listonic. Once I'm in the grocery store I like to check off what's on my list if everything is available if it's not I look for substitutes and that's what I do for staple items but sometimes I do like to plan out certain meals throughout my week so I'll add those food items to my list as well but kind of going back to the earlier question once I have found everything from my list if I'm still walking around and see a certain interesting food I'll add it anyways cause why not.

How does cost affect your decision-making when it comes to grocery shopping?

I grew up in a house where it was really important to check the cost of the items when we go food shopping but we didn't always do it and then depending on who I was shopping with sometimes so when I would shop with my mom she wouldn't always look at the price but if I'm with my dad he

would and I'd find that would be an important conversation to have when food goes bad and the family is like oh why do we buy food if it goes bad or how is the bill so high for these many things so when I'm shopping I kind of keep that in mind and I do try to look for if a food item is on sale that has an alternative or I make sure to use my Kroger rewards so I get the discount on the food but I do also spend to be spent on for example cheese is an item I will spend more money than I probably should just because I find the quality of that really important to me or I know how some meats and seafoods are more expensive but I'm willing to pay more if it's a meal that I don't often eat so I want it to turn out right so it's a little bit of both.

I guess this is an interesting question which was a hit with the last two interviews: what would your ideal grocery shopping experience look like if there were no factors that were limiting you in any way.

So a perfect grocery shopping scenario for me comes from I guess not a very recent but I've seen the past year problems I've been having with grocery shopping which is fresh produce not necessarily always being regular at where I shop or always there so my utopia experience would be a farmers like it farmers market type of grocery store they have all the greens all the veggies all the fruits available to you that are like the cream of the crop they look amazing their packaging doesn't have to be fancy it's just real raw food that I have available to pick from I just find it hard when I go to Kroger and I'm looking for the only one that's there is the prepackaged one that's eight dollars I don't want that I wanna go rummaging for the perfect bushel and I think that would be a really nice experience to have while grocery shopping I feel very connected with the food and very knowledgeable about what's going into my meals moving forward when I come home and try to cook something rather than you know finding the one last garlic that's slightly brown because I decided to shop on a Friday evening at 8 PM when there's no more groceries left but yeah having that type of access 24 seven. ~ same for meat and seafood , fresh available! Straight from the source

How much of the food that you consume do you yourself prepare and how often in a week do you cook?

So the word Cook to me is a little interesting through it while I live alone so if I am working from home breakfast lunch and dinner will be made by me by and if I am working in office I'll eat breakfast at home bring a packed lunch and then come home and have dinner so that's kind of my schedule and I find that I only really consider myself cooking when it's dinner because I see cooking as you know using fire or warm water or oven and something completely changed and maybe some people might consider making a sandwich cooking which is often time my lunch but I don't really see making a sandwich is cooking so I feel like it's kind of perspective for me .

How often do you eat out in a week?

I would say that I eat out one to two times a week on average and it's never eating out alone. I always eat out with either a group of friends or rarely family but I can be family.

Do you buy prepackaged foods or like frozen foods and how often is that a part of your food consumption?

I would say I buy prepackaged foods not too often the ones that I do buy is maybe a couple Romans four if I expect to have an off day or just randomly will when they want to eat it or a hot pocket if I feel like it but it's never planned by it's just if I walk by it and think oh it would be cool to have some Ramen at home for you know a rainy day but I find for breakfast I like to have granola bars or a pop tart around and I guess I consider i don't really have to do much to it I just take it out of the wrapping and eat it for breakfast with a glass of milk or tea but yeah those would be the more regular ones but a full meal not really.

Kohli 48

What are some groceries or items that you actively avoid when you go grocery shopping?

When I go grocery shopping I avoid like sodas or pop and junk food that I can snack on so that could be chips or you know cake ice cream I don't really count as junk food so I feel like it's a nice dessert to add on so I do buy that it's important for me to make that distinction other than that I find that sometimes I actively look for what food is labeled gluten-free because my boyfriend has to eat gluten-free and I like to think in advance for when he comes to my house it would be nice to have some snacks or food that I can make for him so I I don't know Shirley planet void pasta that has gluten in it and I buy gluten-free pasta so if I ever need it I'll have it on hand or a snack if I see I like to granola bars but one of them is gluten-free and one of them is it I'll just avoid the glutinous one because I like both and it'll be beneficial to people so it's kind of avoiding but not necessarily.

Interview 4: Erik Aittama

shivalika kohli 0:01

Hi. Can you tell me your name? And tell me a little bit about yourself? Like, what is your profession? How old are you? Where do you live?

Erik Aittama 0:18

I'm Erik Aittama. I'm 24. I'm a Systems Engineer at Raytheon technologies. And I live in Tucson, Arizona.

shivalika kohli 0:31

Okay. Tell me a little bit about your cultural background and how food habits in your childhood may or may not have been affected by that.

Erik Aittama 0:43

I guess primarily my cultural background is. I don't want to say just white. ~caucasian

shivalika kohli 1:00

That's totally fine.

The next question is basically about, like, what kind of cultural backgrounds have affected your food habits? And like, any of like, maybe the food habits in your childhood and how they affect your food habits now?

Erik Aittama 1:24

I guess they didn't. I don't know, for some households, some people. Some families have like staple food, or like dishes. And outside of like, some holidays, we didn't really have those sort of staple, or go to dishes. So really,

for me, it's just No, I don't really have much of a cultural sort of household growing up. But Yeah, I was exposed to a lot of different types of foods. So.

So we kind of just, I don't know, we kind of just bounced around all the different types of cuisines and stuff.

shivalika kohli 2:29

How often do you go grocery shopping?

Erik Aittama 2:33

I have a pretty strict grocery schedule. I go once per week. Because usually after during this mainly during the weekend, because I don't like having to deal with going to the grocery store after working overnight hours every day. And the only days where I do go during the week or days after I travel, so but always pretty much once a week. I get everything I need once

shivalika kohli 3:08

what groceries do what grocery stores do you most frequently shop from if there are multiple of them, can you list them all? And tell me about why you choose these and what specific purposes they serve to you.

Erik Aittama 3:23

Well, there's pretty much only two places I go to one I go to primarily Fry's, which is just Kroger on the East Coast. And for me, I go to Indian grocery stores a lot because Indian food has become a big part of my life. Thanks to you.

shivalika kohli 3:44

What groceries Do you think you always repeat? And like Like what are your staples when you go grocery shopping?

Erik Aittama 3:54

Alright, I have you I don't know if like just saying like vegetables was a thing unless you want yeah,

shivalika kohli 4:02

no, that's that's fine. You can just go as specific as vague, whatever.

Erik Aittama 4:07

Well I guess fruits arise I kind of get the same fruit lately I've been getting pomegranates and getting those and bananas and grapes and blueberries. So those are the things I really get. And then onions tomatoes in terms of produce among other things. And then for meats and that I get mainly chicken everything else the beats and then like basic pasta. I get a lot of yogurt. Okay, among other

things, but those are staples.

shivalika kohli 4:52

What do you describe yourself as an adventurous shopper yes or no? And whatever the answer is it elaborate on that?

Erik Aittama 5:01

Adventurous as of now? No, because I kind of get the same things, but desperately want the energy to be adventurous in terms of being?

Unknown Speaker 5:14

Okay. This question is about your grocery shopping process. So do you make a list and then go grocery shopping? Okay, so that's the first part of the question. And the second part of the question is, if you do make lists, are they based on meals that you plan on making in the week? Or is it that you just buy your groceries? Like you're set in stone kind of stuff you want to eat? And then based on what you have you make your meals?

Erik Aittama 5:55

Kohli 50

So I'll answer that first, I pretty much exclusively know what meals I'm gonna make for that the week before I go grocery shopping, when I first started grocery shopping, because I wasn't very good at it. So I was new. And I always forget things. I always made a list because I'd always forget things. And I get mad. But as of late, I don't really have to make grocery lists unless I have unless there's a new recipe that I'm trying to know what to buy for that. But overall, nowadays, I don't really use grocery lists anymore. Okay.

shivalika kohli 6:37

How does cost affect your decision making when it comes to grocery shopping?

Unknown Speaker 6:44

Well unfortunately, the price of groceries in general, has gone up an awful lot in the last year and a half. Even noticeable. I mean, I buy the same things. Fortunately, I'm able to still buy the same things. I don't really let it affect me. I mean, I do think about costs. And I do try to save it when I can. But at the same time, I'm fortunate enough where I don't have to really think about it. But the unfortunate part is I still buy the same things as I used to a year and a half ago and my grocery bills are probably \$20 more. Okay, that goes to things.

Unknown Speaker 7:22

Brings us to the next question seamlessly. What is the usual grocery shopping trip cost for you?

Unknown Speaker 7:31

Oh, yeah, back when I first started, it was probably like \$60 for the week. Now pretty much buying the same things. It's almost pushing 80 Okay. I'm really not buying anything different.

shivalika kohli 7:47

That's that's an interesting observation

Unknown Speaker 7:50

you could probably see in the receipts especially over the last month or so, because just from those receipts I've saved over the last month. I guarantee if you look, you can see prices out there increase.

Unknown Speaker 8:02

Okay. What would your ideal grocery shopping experience look like? Like in an ideal utopian world, if you had control over all the variables and everything else...

Erik Aittama 8:19

one of the thing I really like, and it's very popular in some parts, urban cities or other parts of the world. I do not like the once a week buy everything for a week grocery trip at all. I would prefer to make a few smaller trips throughout the week. As of maybe like once every other day, just pick up things you want to make that day or need. And then that's it. Because it's my opinion that saves waste saves money. It's easier but like, right answer is it's really difficult to get into a car or to stop after work to go into these grocery stores to just do daily shopping. That's they're not set up for that. So for me I would like to do something like that. How she was like that for me

shivalika kohli 9:11

how much of the food that you consume? Do you prepare yourself? And how often in a week do you cook?

Erik Aittama 9:19

I could probably I cook almost every other day then weekends not so I guess Saturday, some Fridays are not so much I take a kind of a break. And then how much I owe pretty much everything. I pretty much prep myself.

Unknown Speaker 9:44

So that means like you pack yourself a lunch everyday?

Unknown Speaker 9:52

Thanks to travel and other things. I've eaten more at work of late, but generally I pretty much rarely ever Have you lunch at work? For example, I always bring my own 99% of the time.

shivalika kohli 10:07

Okay, so I guess you answered it a little bit, but how often do you eat out in a week?

Erik Aittama 10:17

Once or twice,

shivalika kohli 10:19

okay. Do you buy prepackaged foods? Or like frozen foods?

Erik Aittama 10:28

I pretty much never buy frozen frozen foods and prepackaged. Like what do you mean?

Unknown Speaker 10:34

Like I guess stuff that is like, you just heat up?

Erik Aittama 10:41

Yeah, no. Other than like, robbing to have on a day where I don't necessarily feel like cooking. I pretty much don't ever buy stuff.

shivalika kohli 10:52

Okay, what are some grocery items that you actively avoid when you go grocery shopping?

Erik Aittama 11:02

Attribute void I mean, I guess I just answered it. I don't really buy frozen things. Unless it's like berries for smoothies, which I don't even make those books anymore. Because berry frozen berries got so dang expensive. So I don't even I just don't even buy it anymore. Like frozen stuff. I tend to stay away from like other I mean occasionally I buy like, like some junk food but like not much to kind of avoid that as well. Like those are like the main things I avoid trying to think of anything else I actively avoid. Other than those things I don't really settle don't buy

Unknown Speaker 11:51

Yeah, this is the last question. What is your easy go to meal like absolutely low effort when you're like, you don't have a lot at hand but you just want a quick meal out of it

Erik Aittama 12:10

I mean, probably some pasta dish. You can use pasta for anything as long as you have like a tomato base, whether it's tomato sauce or just tomatoes. I mean, really at its core so you need us that's pretty much my always my always my go to unless they could ask is easy. Have you printed every-

Kohli 52

thing and make it easy? All the time the permissions I don't have the energy to cook Michelin star meals. Okay, or the or the cutlery to do so.

shivalika kohli 12:52

Okay, that is the end of our interview. Thank you so much.

Transcribed by <https://otter.ai>