

THE UNIVERSITY OF MICHIGAN
COLLEGE OF ENGINEERING
DEPARTMENT OF ELECTRICAL AND COMPUTER ENGINEERING
Radiation Laboratory

**THE NUMERICAL SOLUTION OF LOW FREQUENCY
SCATTERING PROBLEMS**

By

THOMAS B. A. SENIOR AND DAVID J. AHLGREN

February 1972

Scientific Report No. 12

Contract No. F19628-68-C-0071

Project No. 5635

Task No. 563502

Work Unit No. 56350201

Approved for public release; distribution unlimited.

Contract Monitor: **JOHN K. SCHINDLER**
MICROWAVE PHYSICS LABORATORY



Prepared for:

Air Force Cambridge Research Laboratories
Air Force Systems Command
Laurence G. Hanscom Field
Bedford, Massachusetts 01730

Ann Arbor, Michigan
48105

Qualified requestors may obtain additional copies from the Defense Documentation Center. All others should apply to the National Technical Information Service.

ABSTRACT

The low frequency scattering of electromagnetic and acoustic waves by rotationally symmetric bodies is considered. By concentrating on certain quantities such as the normalised component of the induced electric and magnetic dipole moments, it is shown how the first one or two terms in the far zone scattered fields can be expressed in terms of quantities which are functions only of the geometry of the body. Each of these is the weighted integral of an elementary potential function which can be found by solving an integral equation. A computer program has been written to solve the appropriate equations by the moment method, and for calculating the dipole moments, the electrostatic capacity, and a further quantity related to the capacity. The program is described and related data are presented.

TABLE OF CONTENTS

	ABSTRACT	ii
	ACKNOWLEDGEMENTS	iv
I	INTRODUCTION	1
II	PERFECTLY CONDUCTING BODIES	3
	2.1 Formulation	3
	2.2 Procedure for P_{11}	9
	2.3 Procedure for P_{33} and C	11
	2.4 Procedure for M_{11}	18
	2.5 Procedure for M_{33}	21
	2.6 Disjoint Surfaces	22
III	ACOUSTICALLY SOFT OR HARD BODIES	33
	3.1 General Procedure	33
	3.2 Soft Bodies	35
	3.3 Hard Bodies	40
IV	THE COMPUTATIONAL TASK	52
	4.1 Integral Equations	52
	4.2 The Kernels and Their Singularities	55
	4.3 The Body and Its Volume	62
V	NUMERICAL SOLUTION OF THE INTEGRAL EQUATIONS	69
	5.1 P_{11}/V_0 Computation	69
	5.2 P_{33}/V_0 Computation	73
	5.3 M_{11}/V_0 Computation	75
	5.4 Sampling Rate	78
VI	CONCLUDING REMARKS	81
	REFERENCES	86
	APPENDIX: THE COMPUTER PROGRAM	87

1. INTRODUCTION

When a plane electromagnetic wave is incident on a finite perfectly conducting body, or a plane acoustic wave incident on a finite acoustically soft or hard body, the scattered field in the far zone can be expanded in a power series in the wave number k if k is sufficiently small. The determination of the first few terms in these series requires the solution of certain elementary potential problems. We here consider the potential problems associated with the first (Rayleigh) term in the electromagnetic expansion and the first two terms in each of the acoustic expansions, and show how in the case of a singly connected body of revolution all of these terms can be deduced from the solutions of just five potential problems. If the body is not singly connected, only the axial component of the induced electric dipole moment is affected, and for a body consisting of two separate parts, an expression for the modified component is obtained.

Each potential satisfies a simple integral equation. Computer programs are described for solving the equations by the moment method, and since most of the equations are of first order type, the computational procedures are rather similar to those of Mautz and Harrington (1970). The appropriate elements of the electric and magnetic polarisability tensors (Keller et al, 1972) are then computed, along with the electrostatic capacity and a quantity γ related to this, and these are sufficient to specify the electromagnetic and acoustic scattering for any direction of plane wave incidence and any direction of scattering. For relatively simple geometries, the entire computation takes about 3 seconds on an IBM 360 computer.

In our presentation we first examine (Section 2) the problem of a plane electromagnetic wave of arbitrary polarisation and incidence direction, and

The Numerical Solution of Low Frequency Scattering Problems

By

Thomas B. A. Senior and David J. Ahlgren
The University of Michigan
Radiation Laboratory
2455 Hayward Street
Ann Arbor, Michigan 48105

February 1972

Scientific Report No. 12
Contract F19628-68-C-0071
Project No. 5635
Task No. 563502
Work Unit No. 56350201

Approved for public release; distribution unlimited.

Contract Monitor: John K. Schindler
Microwave Physics Laboratory

Prepared For

Air Force Cambridge Research Laboratories
Air Force Systems Command
Laurence G. Hanscom Field
Bedford, Massachusetts 01730 |

2. PERFECTLY CONDUCTING BODIES

2.1 FORMULATION

Let B be a finite, closed, perfectly conducting body of revolution about the z axis of a rectangular Cartesian coordinate system (x, y, z). In terms of the cylindrical polar coordinates (ρ, ϕ, z) where

$$\rho = \sqrt{x^2 + y^2}, \quad \phi = \arctan \frac{y}{x},$$

the surface will be described by the equation

$$\rho = \rho(z)$$

where ρ can be a multivalued function of z as, for example, in the case of a disk or a re-entrant shape, but is never infinite and is zero outside some interval in z . Let \underline{r} be the radius vector to an arbitrary point in the domain \mathcal{V} exterior to B and let \hat{n} be a unit vector normal to the surface drawn into \mathcal{V} .

A linearly polarised electromagnetic wave is incident with electric and magnetic vectors

$$\underline{E}^i = \hat{a} e^{ik \hat{k} \cdot \underline{r}}$$

$$\underline{H}^i = Y \hat{b} e^{ik \hat{k} \cdot \underline{r}}$$

where \hat{k} , \hat{a} and \hat{b} are mutually perpendicular unit vectors such that $\hat{b} = \hat{k} \wedge \hat{a}$; Y is the intrinsic admittance of the homogeneous isotropic medium (of permittivity ϵ) exterior to B and a time factor $e^{-i\omega t}$ has been suppressed.

For k small but kr large, the resulting scattered field \underline{E}^S , \underline{H}^S can be written as (Kleinman, 1965)

$$\underline{E}^S \sim - \frac{e^{ikr}}{4\pi r} k^2 \left\{ \frac{1}{\epsilon} \hat{r} \wedge (\hat{r} \wedge \underline{p}) + \frac{1}{Y} (\hat{r} \wedge \underline{m}) \right\} \quad (2)$$

$$\underline{H}^S \sim \frac{e^{ikr}}{4\pi r} k^2 \left\{ \frac{Y}{\epsilon} (\hat{r} \wedge \underline{p}) - \hat{r} \wedge (\hat{r} \wedge \underline{m}) \right\}$$

where \underline{p} and \underline{m} are the electric and magnetic dipole moments respectively. As shown by Keller et al (1972),

$$\underline{p} = \epsilon \left\{ P_{11} \hat{a} + (P_{33} - P_{11}) (\hat{a} \cdot \hat{z}) \hat{z} \right\} \quad (3)$$

$$\underline{m} = -Y \left\{ M_{11} \hat{b} + (M_{33} - M_{11}) (\hat{b} \cdot \hat{z}) \hat{z} \right\}$$

where P_{11} , P_{33} , M_{11} and M_{33} are functions only of the geometry of the body.

For a given body, P_{11} , P_{33} , M_{11} and M_{33} are constants whose values are as follows:

$$(i) \quad P_{11} = \iint_B x \frac{\partial}{\partial n} (x - \Phi_1) dS \quad (4)$$

where Φ_1 is such that

$$\begin{aligned} \nabla^2 \Phi_1 &= 0 && \text{in } \mathcal{V} \\ \Phi_1 &= x && \text{on } B \end{aligned} \quad (5)$$

$$\bar{\Phi}_1 = O(r^{-2}) \quad \text{as } r \rightarrow \infty .$$

$$(ii) \quad P_{33} = \iint_B z \frac{\partial}{\partial n} (z - \bar{\Phi}_3) dS \quad (6)$$

where $\bar{\Phi}_3$ is such that

$$\begin{aligned} \nabla^2 \bar{\Phi}_3 &= 0 & \text{in } \mathcal{V} \\ \bar{\Phi}_3 &= z + \gamma & \text{on } B; \end{aligned} \quad (7)$$

γ is a constant chosen to make

$$\iint_B \frac{\partial \bar{\Phi}_3}{\partial n} dS = 0, \quad (8)$$

implying zero total induced charge on B, and ensuring that

$$\bar{\Phi}_3 = O(r^{-2}) \quad \text{as } r \rightarrow \infty .$$

$$(iii) \quad M_{11} = \iint_B \hat{n} \cdot \hat{x} (x - \bar{\Psi}_1) dS \quad (9)$$

where $\bar{\Psi}_1$ is such that

$$\begin{aligned} \nabla^2 \bar{\Psi}_1 &= 0 & \text{in } \mathcal{V} \\ \frac{\partial \bar{\Psi}_1}{\partial n} &= \frac{\partial x}{\partial n} & \text{on } B \end{aligned} \quad (10)$$

$$\begin{aligned} \Psi_1 &= \Phi(r^{-2}) \quad \text{as } r \rightarrow \infty . \\ \text{(iv)} \quad M_{33} &= \iint_B \hat{n} \cdot \hat{z} (z - \Psi_3) \, dS \end{aligned} \quad (11)$$

where Ψ_3 is such that

$$\begin{aligned} \nabla^2 \Psi_3 &= 0 \quad \text{in } \mathcal{V} \\ \frac{\partial \Psi_3}{\partial n} &= \frac{\partial z}{\partial n} \quad \text{on } B \\ \Psi_3 &= O(r^{-2}) \quad \text{as } r \rightarrow \infty . \end{aligned} \quad (12)$$

Although the values assumed by the potential function Ψ_3 on B are quite distinct from those of Ψ_1 , $\frac{\partial \Phi_1}{\partial n}$ and $\frac{\partial \Phi_3}{\partial n}$, nevertheless, as shown by Karp (1956) and Payne (1956),

$$M_{33} = \frac{1}{2} P_{11} . \quad (13)$$

This obviates the need for solving the potential problem (iv) if the only purpose for finding Ψ_3 is to calculate M_{33} .

There is one other electromagnetic quantity of interest and this is the electrostatic capacity C of the body in isolation. If the body is raised to the potential unity, the surface charge density is

$$\rho_s = -\epsilon \frac{\partial \Phi_0}{\partial n} \quad (14)$$

where Φ_0 is an exterior potential function satisfying the boundary condition

$$\Phi_0 = 1 \quad \text{on } B \quad . \quad (15)$$

The electrostatic capacity is then equal to the total charge induced on the surface and is

$$C = -\epsilon \iint_B \frac{\partial \Phi_0}{\partial n} \, dS \quad . \quad (16)$$

Note, however, that if all portions of the surface are not in electrical contact with one another, charge can no longer flow freely over the entire surface, and additional (mutual) capacities can be defined. In particular, such electrical separation has a profound effect on the calculation of P_{33} , and the modifications that result when the surface is disjoint are discussed in Section 2.

The five quantities listed in eqs. (4), (6), (9), (11), and (16) can be computed by solving five separate potential problems of a rather standard nature, and the manner in which this is done is as follows.

Let V be some potential function satisfying $\nabla^2 V = 0$ outside and on B , and let V^s be the regular part of V . V^s is therefore an exterior potential and we can regard

$$V - V^s = V^i \quad (17)$$

as an incident potential. Green's theorem applied to the function V in the region \mathcal{V} then yields

$$V(\underline{r}) = V^i(\underline{r}) + \frac{1}{4\pi} \iint_B \left\{ V(\underline{r}') \frac{\partial}{\partial n'} \left(\frac{1}{R} \right) - \frac{1}{R} \frac{\partial}{\partial n'} V(\underline{r}') \right\} dS \quad (18)$$

where $R = |\underline{r} - \underline{r}'|$.

If the boundary condition on the potential V is

$$V(\underline{r}) = 0 \quad , \quad \underline{r} \text{ on } B, \quad (19)$$

eq. (18) reduces to

$$V(\underline{r}) = V^i(\underline{r}) - \frac{1}{4\pi} \iint_B \frac{1}{R} \frac{\partial}{\partial n'} V(\underline{r}') dS' \quad , \quad (20)$$

and since the integral exists for all \underline{r} including points on B , we can allow \underline{r} to lie on B and apply the boundary condition (19) to obtain

$$V^i(\underline{r}) = \frac{1}{4\pi} \iint_B \frac{1}{R} \frac{\partial}{\partial n'} V(\underline{r}') dS' \quad , \quad (21)$$

which is an integral equation of the first kind for $\frac{\partial V}{\partial n}$.

If, on the other hand, the boundary condition on the potential V is

$$\frac{\partial}{\partial n} V(\underline{r}) = 0 \quad , \quad \underline{r} \text{ on } B, \quad (22)$$

eq. (18) reduces to

$$V(\underline{r}) = V^i(\underline{r}) + \frac{1}{4\pi} \iint_B V(\underline{r}') \frac{\partial}{\partial n'} \left(\frac{1}{R} \right) dS' \quad , \quad (23)$$

and because of the non-integrable singularity of $\frac{\partial}{\partial n'} \left(\frac{1}{R} \right)$ at $\underline{r}' = \underline{r}$, eq. (23) is valid as it stands only if \underline{r} is not on B . To obtain an integral equation for V , we allow \underline{r} to approach a point on B in the direction of the

inward normal, in which case it can be shown that

$$\lim_{\underline{r} \rightarrow B} \iint_B V(\underline{r}') \frac{\partial}{\partial n'} \left(\frac{1}{R} \right) dS' = 2\pi V(\underline{r}) + \overline{\iint}_B V(\underline{r}') \frac{\partial}{\partial n'} \left(\frac{1}{R} \right) dS'$$

where the bar across the integral signs denotes the Cauchy principal value. Hence

$$V(\underline{r}) = 2V^i(\underline{r}) + \frac{1}{2\pi} \overline{\iint}_B V(\underline{r}') \frac{\partial}{\partial n'} \left(\frac{1}{R} \right) dS' \quad (24)$$

for \underline{r} on B , which is an integral equation of the second kind for V .

2.2 PROCEDURE FOR P_{11}

The solution of problem (i) and, hence, the computation of P_{11} is a straightforward application of the integral equation (21).

If

$$V^i = x, \quad V^s = -\Phi_1$$

$$\text{then} \quad V = x - \Phi_1 = V_1 \quad (\text{say}) \quad (25)$$

with $V_1 = 0$ on B . Since $x = \rho \cos \phi$ and the equation of the surface is independent of ϕ , the potential V_1 must everywhere have the same ϕ dependence as V^i , implying

$$V_1(\underline{r}) = V_1(\rho, z) \cos \phi. \quad (26)$$

This is true also of $\frac{\partial V_1}{\partial n}$, and we can therefore write

$$\begin{aligned} \frac{\partial}{\partial n'} V_1(\underline{r}') &= \frac{\partial}{\partial n'} V_1(\rho', z') \cos \phi' \\ &= T_1(s') \cos \phi' \end{aligned} \quad (27)$$

where s' is arc length along a profile of the body. Moreover,

$$R = \left\{ (\rho - \rho')^2 + (z - z')^2 + 2\rho\rho'(1 - \cos \psi) \right\}^{1/2} \quad (28)$$

with

$$\psi = \phi - \phi'$$

and since

$$dS' = \rho' d\phi' ds' ,$$

the integral equation (21) now takes the form

$$\begin{aligned} \rho \cos \phi &= \frac{1}{4\pi} \int_0^{2\pi} \int_0^s T_1(s') \frac{\cos \phi'}{R} \rho' d\phi' ds' \\ &= \frac{1}{4\pi} \int_0^{2\pi} \int_0^s T_1(s') \frac{\cos(\psi - \phi)}{R} \rho' d\psi ds' \\ &= \frac{1}{2\pi} \int_0^s \rho' K_1 T_1(s') ds' \cos \phi \end{aligned}$$

where the kernel is

$$K_1 \equiv K_1(\rho, z; \rho', z') = \int_0^\pi \frac{\cos \psi}{R} d\psi \quad (29)$$

and the integration is along the profile of the body. The integral equation for $T_1(s)$ is therefore

$$\int_0^s \rho' K_1 T_1(s') ds' = 2\pi\rho \quad (30)$$

which can be solved to determine $T_1(s)$. In terms of this quantity

$$\begin{aligned} P_{11} &= \iint_B x \left| \frac{\partial}{\partial n} V(\underline{r}) \right| dS \\ &= \int_0^{2\pi} \int_0^s \rho^2 \cos^2 \phi T_1(s) d\phi ds \end{aligned}$$

which reduces to

$$P_{11} = \pi \int_0^s \rho^2 T_1(s) ds \quad (31)$$

2.3 PROCEDURE FOR P_{33} AND C

The solution of problem (ii), leading to the calculation of P_{33} , involves two successive applications of the integral equation (21).

In the first case we consider an incident potential

$$V^i = V_2^i = z \quad (32)$$

and seek the corresponding total potential V_2 satisfying the boundary condition

$V_2 = 0$ on B . Since V_2^i is everywhere independent of ϕ , it follows that V_2 and $\frac{\partial V_2}{\partial n}$ are likewise ϕ independent. We can therefore write

$$\frac{\partial V_2}{\partial n'} = T_2(s') \quad (33)$$

and the integral equation (21) now becomes

$$\begin{aligned} z &= \frac{1}{4\pi} \int_0^{2\pi} \int_0^s T_2(s') \frac{1}{R} \rho' d\phi' ds' \\ &= \frac{1}{2\pi} \int_0^s \rho' K_0 T_2(s') ds' \end{aligned}$$

where the kernel is

$$K_0 \equiv K_0(\rho, z; \rho', z') = \int_0^\pi \frac{d\psi}{R} \quad (34)$$

The integral equation from which to determine $T_2(s)$ is therefore

$$\int_0^s \rho' K_0 T_2(s') ds' = 2\pi z \quad (35)$$

The second of the two basic problems is that in which the incident potential is

$$V^i = V_3^i = 1 \quad . \quad (36)$$

We again seek the total potential V_3 satisfying the boundary condition $V_3 = 0$ on B , and writing

$$\frac{\partial V_3}{\partial n'} = T_3(s') \quad , \quad (37)$$

the integral equation (21) takes the form

$$\int_0^s \rho' K_0 T_3(s') ds' = 2\pi \quad , \quad (38)$$

from which $T_3(s)$ can be found.

In problem (ii), however,

$$V^i = z + \gamma \quad \text{and} \quad V^s = -\Phi_3 \quad .$$

Thus,

$$V^i = V_2^i + \gamma V_3^i \quad (39)$$

implying

$$V = V_2 + \gamma V_3 \quad , \quad (40)$$

and if we write

$$\frac{\partial V}{\partial n'} = T(s') , \quad (41)$$

then

$$T(s) = T_2(s) + \gamma T_3(s) \quad (42)$$

where $T_2(s)$ and $T_3(s)$ are the solutions of the integral equations (35) and (38) respectively. The constant γ is determined by the condition (8) for zero total induced charge on B , viz.*

$$\iint_B \frac{\partial}{\partial n} (V^i - V) dS = 0 . \quad (43)$$

But

$$\iint_B \frac{\partial V^i}{\partial n} dS = \iint_B \frac{\partial}{\partial n} (z + \gamma) dS = 0 , \quad (44)$$

as can be seen by application of the divergence theorem; moreover

$$\begin{aligned} \iint_B \frac{\partial V}{\partial n} dS &= \int_0^{2\pi} \int_0^s T(s) \rho d\phi dS \\ &= 2\pi \int_0^s \rho T(s) ds \end{aligned}$$

* We are here assuming that the surface is not disjoint.

$$= 2\pi \int_0^s \rho T_2(s) ds + 2\pi \gamma \int_0^s \rho T_3(s) ds$$

and hence, by virtue of eqs. (43) and (44),

$$\gamma = - \frac{\int_0^s \rho T_2(s) ds}{\int_0^s \rho T_3(s) ds} \quad (45)$$

Since $T_2(s)$ and $T_3(s)$ can be found from the integral equations (35) and (38), the constant γ given in eq. (45) now completes the specification of the surface field $T(s)$, and in terms of $T(s)$

$$\begin{aligned} P_{33} &= \iint_B z \frac{\partial}{\partial n} V(\underline{r}) dS \\ &= 2\pi \int_0^s z \rho T(s) ds \end{aligned}$$

Hence

$$P_{33} = 2\pi \int_0^s z \rho T_2(s) ds + 2\pi \gamma \int_0^s z \rho T_3(s) ds \quad (46)$$

A valuable by-product of the above analysis is the electrostatic capacity

C defined in eq. (16). This fact is apparent on recalling that the determination of C requires us to find the exterior potential Φ_0 satisfying the boundary condition (15) on B, and this can be accomplished using the integral equation (21) with

$$V^i = 1, \quad V^s = -\Phi_0$$

so that

$$V = 1 - \Phi_0 \quad (= 0 \text{ on } B).$$

The problem is therefore identical to the second of the two basic ones considered above, and indeed

$$\Phi_0 = 1 - V_3 \tag{47}$$

implying

$$\frac{\partial \Phi_0}{\partial n} = - \frac{\partial V_3}{\partial n} = - T_3(s) \tag{48}$$

where $T_3(s)$ is the solution of the integral equation (38). Hence, when the body is at unit potential, the surface charge density as a function of arc length is

$$\rho_s = \epsilon T_3(s) \tag{49}$$

and the capacity C is

$$C = 2\pi\epsilon \int_0^s \rho T_3(s) ds. \tag{50}$$

We observe that the denominator of the expression (45) for γ is simply

$C/(2\pi\epsilon)$, which ensures that γ can never be infinite.

Some simplification of the preceding results is possible. Since V_2^s and V_3^s are both exterior potentials, Green's theorem can be applied to the region \mathcal{U} exterior to B to yield the reciprocity relation

$$\iint_B V_2^s \frac{\partial V_3^s}{\partial n} dS = \iint_B V_3^s \frac{\partial V_2^s}{\partial n} dS \quad (51)$$

(Van Bladel, 1968). But

$$\frac{\partial V_2^s}{\partial n} = T_2(s) - \hat{n} \cdot \hat{z}$$

and

$$\frac{\partial V_3^s}{\partial n} = T_3(s) ,$$

and from the boundary conditions on V_2 and V_3

$$V_2^s = -z , \quad V_3^s = -1$$

on B . Substituting these into eq. (51), we have

$$\iint_B z T_3(s) dS = \iint_B \left\{ T_2(s) - \hat{n} \cdot \hat{z} \right\} dS$$

which reduces to

$$\int_0^s \rho T_2(s) ds = \int_0^s z \rho T_3(s) ds . \quad (52)$$

With the aid of this result, the constant γ of eq. (45) can be expressed in terms of the surface field $T_3(s)$ alone:

$$\gamma = - \frac{\int_0^s z \rho T_3(s) ds}{\int_0^s \rho T_3(s) ds} \quad (53)$$

i. e.

$$\gamma = - \frac{2\pi\epsilon}{C} \int_0^s z \rho T_3(s) ds \quad , \quad (54)$$

but whilst this reduces from four to three the number of separate surface field integrations involved in the calculation of P_{33} , there is no way to avoid entirely the determination of the surface field $T_2(s)$. Indeed, the simplest expression for P_{33} is

$$P_{33} = 2\pi \int_0^s z \rho T_2(s) ds - \gamma^2 \frac{C}{\epsilon} \quad . \quad (55)$$

2.4 PROCEDURE FOR M_{11}

The solution of problem (iii) leads to the calculation of M_{11} and is a straightforward application of the integral equation (24). If

$$V^i = x \quad \text{and} \quad V^s = -\Psi_1 \quad ,$$

then

$$V = x - \Psi_1 = V_4 \quad (\text{say}) \quad (56)$$

and $\partial V_4 / \partial n = 0$ on B as a consequence of the boundary condition (10).

Since $x = \rho \cos \phi$ and the equation of the surface is independent of ϕ , V_4 must have the same ϕ dependence as V^i , namely, $\cos \phi$. In particular, on the surface

$$V_4(\underline{r}) = V_4(s) \cos \phi \quad (57)$$

which enables us to write eq. (24) as

$$V_4(s) \cos \phi = 2\rho \cos \phi + \frac{1}{2\pi} \int_0^{2\pi} \int_0^s V(s') \cos \phi' \frac{\partial}{\partial n'} \left(\frac{1}{R} \right) \rho' d\phi' ds$$

But

$$\hat{n}' = \cos \alpha' (\hat{x} \cos \phi' + \hat{y} \sin \phi') - \hat{z} \sin \alpha' \quad (58)$$

where

$$\alpha' = \tan^{-1} \frac{\partial \rho'}{\partial z'}, \quad (59)$$

so that

$$\begin{aligned} \frac{\partial}{\partial n'} \left(\frac{1}{R} \right) &= \hat{n}' \cdot \nabla' \left(\frac{1}{R} \right) \\ &= -\frac{1}{R^3} \left\{ \cos \alpha' (\rho' - \rho \cos \psi) - \sin \alpha' (z' - z) \right\} \quad (60) \end{aligned}$$

with $\psi = \phi - \phi'$ as before. Hence

$$\begin{aligned} \int_0^{2\pi} \cos \phi' \frac{\partial}{\partial n'} \left(\frac{1}{R} \right) d\phi' &= \cos \phi \int_0^{2\pi} \cos \psi \frac{\partial}{\partial n'} \left(\frac{1}{R} \right) d\psi \\ &= 2 \cos \phi \left\{ \rho \cos \alpha' \Omega_2 + \left[(z' - z) \sin \alpha' - \rho' \cos \alpha' \right] \Omega_1 \right\} \end{aligned}$$

where

$$\Omega_1 = \Omega_1(\rho, z; \rho', z') = \int_0^{\pi} \frac{\cos \psi}{R^3} d\psi, \quad (61)$$

$$\Omega_2 = \Omega_2(\rho, z; \rho', z') = \int_0^{\pi} \frac{\cos^2 \psi}{R^3} d\psi. \quad (62)$$

The integral equation from which to determine $V_4(s)$ is now

$$V_4(s) = 2\rho + \frac{1}{\pi} \int_0^s V_4(s') \left\{ \rho \cos \alpha' \Omega_2 + \left[(z' - z) \sin \alpha' - \rho' \cos \alpha' \right] \Omega_1 \right\} \rho' ds' \quad (63)$$

and in terms of $V_4(s)$:

$$\begin{aligned} M_{11} &= \iint_B \hat{n} \cdot \hat{x} V_4(\underline{r}) dS \\ &= \int_0^{2\pi} \int_0^s \cos \alpha V_4(s) \cos^2 \phi \rho d\phi ds \end{aligned}$$

i. e.
$$M_{11} = \pi \int_0^s \rho V_4(s) \cos \alpha ds \quad . \quad (64)$$

2.5 PROCEDURE FOR M_{33}

Although it is not necessary to compute M_{33} directly because of the relation (13), the integral equation which the corresponding potential satisfies must be solved if the second term in the low frequency expansion for an acoustically hard body is to be evaluated. It is therefore appropriate to describe the determination of this potential function here.

Once again we have a straightforward application of the integral equation (24). If

$$V^i = z \quad \text{and} \quad V^s = -\Psi_3$$

then

$$V = z - \Psi_3 = V_5 \quad (\text{say}) \quad (65)$$

with $\frac{\partial V_5}{\partial n} = 0$ on B. Since V_5 must be independent of ϕ , eq. (24) implies

$$V_5(s) = 2z + \frac{1}{2\pi} \int_0^{2\pi} \int_0^s V_5(s') \frac{\partial}{\partial n'} \left(\frac{1}{R} \right) \rho' d\phi' ds' \quad .$$

But

$$\int_0^{2\pi} \frac{\partial}{\partial n'} \left(\frac{1}{R} \right) d\phi' = \int_0^{2\pi} \frac{\partial}{\partial n'} \left(\frac{1}{R} \right) d\psi$$

$$= 2 \left\{ \rho \cos \alpha' \Omega_1 + \left[(z' - z) \sin \alpha' - \rho' \cos \alpha' \right] \Omega_0 \right\}$$

where Ω_1 is as defined in eq. (61) and

$$\Omega_0 \equiv \Omega_0(\rho, z; \rho', z') = \int_0^\pi \frac{d\psi}{R^3} . \quad (66)$$

The integral equation from which to determine $V_5(s)$ is therefore

$$V_5(s) = 2z + \frac{1}{\pi} \int_0^s V_5(s') \left\{ \rho \cos \alpha' \Omega_1 + \left[(z' - z) \sin \alpha' - \rho' \cos \alpha' \right] \Omega_0 \right\} \rho' ds' \quad (67)$$

and we note in passing that

$$M_{33} = \iint_B \hat{n} \cdot \hat{z} V_5(s) dS$$

$$= - \int_0^{2\pi} \int_0^s \sin \alpha V_5(s) \rho d\phi ds ,$$

$$\text{i. e.} \quad M_{33} = -2\pi \int_0^s \rho V_5(s) \sin \alpha ds . \quad (68)$$

2.6 DISJOINT SURFACES

So far it has been assumed that all portions of the surface are in electrical contact with one another, and if this requirement is not met, the analysis is no

longer valid. Thus, for example, an application of the above procedures to a body consisting of two separate spheres leads instead to the solution for the two spheres joined by an infinitesimal wire along the axis of symmetry, and though the presence of the wire (producing electrical contact) does not affect the values of M_{11} and P_{11} (and hence M_{33} , by virtue of eq. 13), it does have a profound effect on P_{33} . This is not unnatural since P_{33} is proportional to the longitudinal (z) component of the induced electric dipole moment.

The breakdown in our formulation when B has several distinct parts stems from the imposition of the zero induced charge criterion (8). If charge cannot flow freely between the n parts B_1, B_2, \dots, B_n , eq. (8) must be replaced by the n equations

$$\iint_{B_i} \frac{\partial \Phi_3}{\partial n} dS = 0, \quad i = 1, 2, \dots, n. \quad (69)$$

Since this obviously affects only the potential Φ_3 and leaves the procedure (and results) for P_{11}, M_{11} and M_{33} unchanged, our efforts will be directed at P_{33} alone with the objective of finding an approach which is applicable when B consists of just two electrically isolated portions B_1 and B_2 . So that we may use to the fullest extent the work that we have already done, it is desirable to have this new approach as similar as possible to that appropriate when the two portions are electrically connected.

By analogy with problem (ii) of Section 2.1, the task is to find an exterior potential Φ_3 satisfying the equation $\nabla^2 \Phi_3 = 0$ in the domain \mathcal{V} exterior to B , together with the boundary conditions

$$\Phi_3 = z + \gamma_1 \quad \text{on } B_1 \quad (70)$$

$$\Phi_3 = z + \gamma_2 \quad \text{on } B_2 \quad (71)$$

where the constants γ_1 and γ_2 are such that

$$\iint_{B_1} \frac{\partial \Phi_3}{\partial n} dS = 0, \quad (72)$$

$$\iint_{B_2} \frac{\partial \Phi_3}{\partial n} dS = 0. \quad (73)$$

The quantity P_{33} is then given by eq. (6) as before.

Because the boundary conditions on B_1 and B_2 differ, it is no longer convenient to think in terms of incident and total potentials, with the difference representing the desired exterior potential. Let us therefore consider the basic potential problem in which $\Phi_3^{(1)}$ is an exterior potential satisfying the boundary condition

$$\Phi_3^{(1)} = \begin{cases} 1 & \text{on } B_1 \\ 0 & \text{on } B_2 \end{cases} \quad (74)$$

By application of Green's theorem to the domain \mathcal{V} , we have

$$\begin{aligned} \Phi_3^{(1)}(\underline{r}) &= \frac{1}{4\pi} \iint_B \left\{ \Phi_3^{(1)}(\underline{r}') \frac{\partial}{\partial n'} \left(\frac{1}{R} \right) - \frac{1}{R} \frac{\partial}{\partial n'} \Phi_3^{(1)}(\underline{r}') \right\} dS' \\ &= \frac{1}{4\pi} \iint_{B_1} \frac{\partial}{\partial n'} \left(\frac{1}{R} \right) dS' - \frac{1}{4\pi} \iint_B \frac{1}{R} \frac{\partial}{\partial n'} \Phi_3^{(1)}(\underline{r}') dS' \end{aligned}$$

and the first integral is identically zero since B_1 is itself a closed surface. If, now, \underline{r} is allowed to approach B , application of the boundary condition (74) gives

$$\frac{1}{4\pi} \iint_B \frac{1}{R} \frac{\partial}{\partial n'} \Phi_3^{(1)}(\underline{r}') dS' = \begin{cases} -1 & , \quad \underline{r} \text{ on } B_1 \\ 0 & , \quad \underline{r} \text{ on } B_2 \end{cases} \quad (75)$$

which is an integral equation from which to determine $\frac{\partial \Phi_3^{(1)}}{\partial n'}$. It can be simplified somewhat by observing that $\Phi_3^{(1)}$ and, hence, $\frac{\partial \Phi_3^{(1)}}{\partial n}$ are independent of the azimuthal coordinate ϕ . When the ϕ integration is performed, eq. (75) reduces to

$$\int_0^s \rho' K_0 T_3^{(1)}(s') ds' = \begin{cases} 2\pi & , \quad \underline{r} \text{ on } B_1 \\ 0 & , \quad \underline{r} \text{ on } B_2 \end{cases} \quad (76)$$

c.f. eq. (38), where

$$T_3^{(1)}(s') = - \frac{\partial}{\partial n'} \Phi_3^{(1)}(\underline{r}') \quad (77)$$

and K_0 is the kernel defined in eq. (34). It will be noted that the integration in (76) is over the entire profile of the body $B = B_1 + B_2$.

Similarly, if $\Phi_3^{(2)}$ is an exterior potential function satisfying the boundary condition

$$\Phi_3^{(2)} = \begin{cases} 0 & \text{on } B_1 \\ 1 & \text{on } B_2 \end{cases} , \quad (78)$$

then

$$\int_0^s \rho' K_0 T_3^{(2)}(s') ds' = \begin{cases} 0, & \underline{r} \text{ on } B_1 \\ 2\pi, & \underline{r} \text{ on } B_2 \end{cases} \quad (79)$$

where

$$T_3^{(2)}(s') = - \frac{\partial}{\partial n'} \Phi_3^{(2)}(\underline{r}') . \quad (80)$$

Comparison of eqs. (76) and (79) with (38) shows that

$$T_3^{(1)}(s) + T_3^{(2)}(s) = T_3(s) \quad (81)$$

where $T_3(s)$ is that surface field quantity which is appropriate when B_1 and B_2 are electrically connected. If $T_3(s)$ has already been computed, it is clearly necessary to compute only one of $T_3^{(1)}(s)$ and $T_3^{(2)}(s)$.

Let us now return to the potential problem set forth in eqs. (70) through (73). As regards the boundary conditions (70) and (71), an exterior potential satisfying them is

$$\Phi_3 = z - V_2 + \gamma_1 \Phi_3^{(1)} + \gamma_2 \Phi_3^{(2)} \quad (82)$$

where V_2 is the total potential considered in Section 2.3. Hence

$$\frac{\partial \Phi_3}{\partial n} = \frac{\partial z}{\partial n} - T_2(s) - \gamma_1 T_3^{(1)}(s) - \gamma_2 T_3^{(2)}(s) \quad (83)$$

and since $T_2(s)$ is given as the solution of the integral equation (35), it only remains to specify the constants γ_1 and γ_2 .

From the zero charge condition (72) and using the fact that

$$\iint_{B_1 \text{ or } B_2} \frac{\partial z}{\partial n} dS = 0 ,$$

we have

$$\gamma_1 \int_{(1)} \rho T_3^{(1)}(s) ds + \gamma_2 \int_{(1)} \rho T_3^{(2)}(s) ds = - \int_{(1)} \rho T_2(s) ds \quad (84)$$

where the symbol (1) below the integral signs shows that the integrations are carried out over the profile of the portion B_1 alone. Similarly, from eq. (73),

$$\gamma_1 \int_{(2)} \rho T_3^{(1)}(s) ds + \gamma_2 \int_{(2)} \rho T_3^{(2)}(s) ds = - \int_{(2)} \rho T_2(s) ds \quad (85)$$

where the integrations are over the profile of B_2 alone, and if we now define

$$\left. \begin{aligned} C_{11} &= 2\pi\epsilon \int_{(1)} \rho T_3^{(1)}(s) ds , & C_{12} &= 2\pi\epsilon \int_{(1)} \rho T_3^{(2)}(s) ds , \\ C_{21} &= 2\pi\epsilon \int_{(2)} \rho T_3^{(1)}(s) ds , & C_{22} &= 2\pi\epsilon \int_{(2)} \rho T_3^{(2)}(s) ds , \end{aligned} \right\} \quad (86)$$

eqs. (84) and (85) take on the more compact form

$$\gamma_1 C_{11} + \gamma_2 C_{12} = -2\pi\epsilon \int_{(1)} \rho T_2(s) ds , \quad (87 a)$$

$$\gamma_1 C_{21} + \gamma_2 C_{22} = -2\pi\epsilon \int_{(2)} \rho T_2(s) ds . \quad (87 b)$$

It will be observed that the quantities C_{11} , etc. all have the dimensions of capacity, and by virtue of eqs. (50) and (81),

$$C_{11} + C_{12} + C_{21} + C_{22} = C \quad (88)$$

where C is the capacity when electrical contact is maintained.

Rather than solve the eqs. (87) directly, it is more convenient to first eliminate the surface field quantity $T_2(s)$ from the expressions. That this is possible can be shown by application of reciprocity to the exterior potential functions $z - V_2$, $\Phi_3^{(1)}$ and $\Phi_3^{(2)}$. From the pair $z - V_2$ and $\Phi_3^{(1)}$, we have

$$\iint_B \Phi_3^{(1)} \frac{\partial}{\partial n} (z - V_2) dS = \iint_B (z - V_2) \frac{\partial}{\partial n} \Phi_3^{(1)} dS .$$

Hence

$$\iint_{B_1} T_2(s) dS = \iint_B z T_3^{(1)}(s) dS ,$$

implying

$$\int_{(1)} \rho T_2(s) ds = \int_0^s z \rho T_3^{(1)}(s) ds . \quad (89)$$

Similarly,

$$\int_{(2)} \rho T_2(s) ds = \int_0^s z \rho T_3^{(2)}(s) ds \quad (90)$$

and we note that by addition of the last two equations we recover eq. (52).

Finally, from the function pair $\Phi_3^{(1)}$ and $\Phi_3^{(2)}$,

$$\iint_{B_1} T_3^{(2)}(s) dS = \iint_{B_2} T_3^{(1)}(s) dS ,$$

implying

$$\int_{(1)} \rho T_3^{(2)}(s) ds = \int_{(2)} \rho T_3^{(1)}(s) ds \quad (91)$$

i. e.

$$C_{12} = C_{21} \quad (92)$$

as expected.

Using eqs. (89) and (90), $T_2(s)$ can be eliminated from the eqs. (87) and if we also eliminate $T_3^{(2)}(s)$ using eq. (81), we obtain

$$(\gamma_1 - \gamma_2) C_{11} + \gamma_2 2\pi\epsilon \int_{(1)} \rho T_3(s) ds = -2\pi\epsilon \int_0^s z \rho T_3^{(1)}(s) ds$$

$$(\gamma_1 - \gamma_2) C_{21} + \gamma_2 2\pi\epsilon \int_{(2)} \rho T_3(s) ds = 2\pi\epsilon \int_0^s z \rho T_3^{(1)}(s) ds$$

$$-2\pi\epsilon \int_0^s z \rho T_3(s) ds .$$

These can be solved to give

$$\gamma_1 - \gamma_2 = \frac{1}{\Delta} \left\{ \int_0^s z \rho T_3(s) ds \int_{(1)} \rho T_3(s) ds - \int_0^s z \rho T_3^{(1)}(s) ds \int_0^s \rho T_3(s) ds \right\} \quad (93)$$

$$\gamma_2 = -\frac{1}{\Delta} \left\{ \int_0^s z \rho T_3(s) ds \int_{(1)} \rho T_3^{(1)}(s) ds - \int_0^s z \rho T_3^{(1)}(s) ds \int_0^s \rho T_3^{(1)}(s) ds \right\} \quad (94)$$

where

$$\Delta = \int_0^s \rho T_3(s) ds \int_{(1)} \rho T_3^{(1)}(s) ds - \int_0^s \rho T_3^{(1)}(s) ds \int_{(1)} \rho T_3(s) ds . \quad (95)$$

We can now proceed to the calculation of P_{33} . If we write this quantity as \tilde{P}_{33} to distinguish it from the P_{33} of eq. (55) for B_1 and B_2 in electrical contact, we have, from eqs. (8) and (83),

$$\begin{aligned} \tilde{P}_{33} &= \iint_B z \left\{ T_2(s) + \gamma_1 T_3^{(1)}(s) + \gamma_2 T_3^{(2)}(s) \right\} dS \\ &= 2\pi \int_0^s z \rho \left\{ T_2(s) + \gamma_2 T_3(s) + (\gamma_1 - \gamma_2) T_3^{(1)}(s) \right\} ds . \end{aligned} \quad (96)$$

But

$$P_{33} = 2\pi \int_0^s z\rho \left\{ T_2(s) + \gamma T_3(s) \right\} ds$$

(see eq. 46) where γ is given by eq. (53), and thus

$$\tilde{P}_{33} = P_{33} + 2\pi(\gamma_2 - \gamma) \int_0^s z\rho T_3(s) ds + 2\pi(\gamma_1 - \gamma_2) \int_0^s z\rho T_3^{(1)}(s) ds . \quad (97)$$

Moreover, from eqs. (53), (94) and (95), after some manipulation,

$$\gamma_2 - \gamma = -(\gamma_1 - \gamma_2) \frac{\int_0^s \rho T_3^{(1)}(s) ds}{\int_0^s \rho T_3(s) ds} , \quad (98)$$

which enables us to write eq. (97) as

$$\tilde{P}_{33} = P_{33} + 2\pi(\gamma_1 - \gamma_2) \int_0^s (z + \gamma) \rho T_3^{(1)}(s) ds . \quad (99)$$

The factor $(\gamma_1 - \gamma_2)$ is defined in eq. (93) and invoking yet again the expression (53) for γ together with the identity (91), we have

$$\gamma_1 - \gamma_2 = -\frac{1}{\Delta} \int_0^s \rho T_3(s) ds \left\{ \gamma \int_0^s \rho T_3(s) ds + \int_0^s z\rho T_3^{(1)}(s) ds \right\}$$

$$u = \frac{C}{2\pi\epsilon\Delta} \int_0^s (z + \gamma)\rho T_3^{(1)}(s) ds ,$$

giving

$$\tilde{P}_{33} = P_{33} - \frac{C}{\epsilon\Delta} \left\{ \int_0^s (z + \gamma)\rho T_3^{(1)}(s) ds \right\}^2 \quad (100)$$

where C and Δ are defined in eqs. (50) and (95) respectively.

This is our final expression for \tilde{P}_{33} . Compared to the situation when B_1 and B_2 are electrically connected, the only additional field quantity that must now be found is $T_3^{(1)}(s)$, which is given as the solution of the integral equation (76); and since C/ϵ and Δ are both positive, electrical separation decreases the longitudinal component of the induced electric dipole moment.

3. ACOUSTICALLY SOFT OR HARD BODIES

3.1 GENERAL PROCEDURE

Let B now be a finite, closed acoustically soft or hard body of revolution about the z axis of a Cartesian coordinate system (x, y, z) . It is of no concern whether B is disjoint or not. A plane acoustic wave is incident and its velocity potential U^i is written as

$$U^i = e^{ik \hat{k} \cdot \underline{r}} \quad (101)$$

where \hat{k} is again a unit vector in the direction of propagation. If U^s is the scattered field that is produced, then U^s satisfies

$$(\nabla^2 + k^2) U^s = 0 \quad \text{in } \mathcal{V}, \quad (102)$$

$$r \left(\frac{\partial U^s}{\partial r} - ik U^s \right) \rightarrow 0 \quad \text{as } r \rightarrow \infty, \quad (103)$$

and the boundary condition

$$U^s = -U^i \quad \text{on } B \quad (104)$$

if B is soft, or

$$\frac{\partial U^s}{\partial n} = - \frac{\partial U^i}{\partial n} \quad \text{on } B \quad (105)$$

if B is hard. Eqs. (104) and (105) are equivalent to

* To avoid any possible confusion, we shall henceforth refer to U as a field.

$$U = 0 \quad \text{on } B \quad (106)$$

$$\frac{\partial U}{\partial n} = 0 \quad \text{on } B \quad (107)$$

respectively, where $U = U^i + U^s$ is the total field.

A general expression for $U(\underline{r})$ at an arbitrary point in \mathcal{V} is provided by the Helmholtz representation:

$$U(\underline{r}) = U^i(\underline{r}) + \frac{1}{4\pi} \iint_B \left\{ U(\underline{r}') \frac{\partial}{\partial n'} \left(\frac{e^{ikR}}{R} \right) - \frac{e^{ikR}}{R} \frac{\partial}{\partial n'} U(\underline{r}') \right\} dS' \quad (108)$$

where $R = |\underline{r} - \underline{r}'|$ as before. For sufficiently small k , U^i , U^s and, hence, U can be expanded as power series in ik of the form

$$U^i(\underline{r}) = \sum_{m=0}^{\infty} (ik)^m U_m^i(\underline{r}), \quad (109)$$

and when these are inserted into eq. (108), the coefficients of like powers of ik on both sides of the equation can be set equal to give

$$U_m(\underline{r}) = U_m^i(\underline{r}) + \frac{1}{4\pi} \sum_{\ell=0}^m \frac{1}{(m-\ell)!} \iint_B \left\{ (m-\ell-1) R^{m-\ell-2} \frac{\partial R}{\partial n'} U_\ell(\underline{r}') - R^{m-\ell-1} \frac{\partial}{\partial n'} U_\ell(\underline{r}') \right\} dS' \quad (110)$$

for $m = 0, 1, 2, \dots$ By allowing \underline{r} to lie on B , an integral equation is obtained from which $U_m(\underline{r})$ can be found; and as is seen by substituting

the power series for $U(\underline{r})$ into eq. (102),

$$\begin{aligned} \nabla^2 U_0 &= \nabla^2 U_1 = 0 \\ \nabla^2 U_m &= U_{m-2}, \quad m \geq 2, \end{aligned} \tag{111}$$

showing that $U_0(\underline{r})$ and $U_1(\underline{r})$ are potential functions, but $U_2(\underline{r})$ is not unless $U_0(\underline{r}) \equiv 0$.

In the far zone ($r \rightarrow \infty$) the low frequency expansion of the scattered field deduced from eq. (108) is

$$\begin{aligned} U^S(\underline{r}) \sim \frac{e^{ikr}}{4\pi r} \sum_{m=0}^{\infty} \sum_{\ell=0}^m (-1)^{m-\ell+1} \frac{(ik)^m}{(m-\ell)!} \iint_B (\hat{\mathbf{r}} \cdot \underline{\mathbf{r}}')^{m-\ell} \\ \times \left\{ (\hat{\mathbf{n}}' \cdot \hat{\mathbf{r}}) U_{\ell-1}(\underline{\mathbf{r}}') + \frac{\partial}{\partial n'} U_{\ell}(\underline{\mathbf{r}}') \right\} dS' \end{aligned} \tag{112}$$

(Kleinman, 1965, with the correction of a sign error), provided $U_{-1}(\underline{\mathbf{r}}')$ is taken to be zero. Our objective is to calculate the first few terms in this series.

3.2 SOFT BODIES

We now specialise the above results to the case of a soft rotationally symmetric body illuminated by the plane wave (101), and seek the first two terms in the low frequency expansion of the far zone scattered field. By

invoking the boundary condition

$$U_m(\underline{r}) = 0 \quad \text{on } B, \quad (113)$$

$m = 0, 1, 2, \dots$, we have

$$U^S(\underline{r}) = \frac{e^{ikr}}{4\pi r} (-1) \left\{ \iint_B \frac{\partial}{\partial n'} U_0(\underline{r}') dS' - ik \iint_B \left[(\hat{r} \cdot \underline{r}') \frac{\partial}{\partial n'} U_0(\underline{r}') - \frac{\partial}{\partial n'} U_1(\underline{r}') \right] dS' + O(k^2) \right\}, \quad (114)$$

showing that only the potential functions $U_0(\underline{r})$ and $U_1(\underline{r})$ are required.

From eqs. (101) and (107) it follows that

$$U_0^i(\underline{r}) = 1, \quad U_1^i(\underline{r}) = \hat{k} \cdot \underline{r} \quad (115)$$

and by inserting the boundary condition (113) into (110), the latter becomes

$$U_m^i(\underline{r}) = U_m^i(\underline{r}) - \frac{1}{4\pi} \sum_{\ell=0}^m \frac{1}{(m-\ell)!} \iint_B R^{m-\ell-1} \frac{\partial}{\partial n'} U_\ell(\underline{r}') dS'$$

which, for \underline{r} on B , reduces to

$$U_m^i(\underline{r}) = \frac{1}{4\pi} \sum_{\ell=0}^m \frac{1}{(m-\ell)!} \iint_B R^{m-\ell-1} \frac{\partial}{\partial n'} U_\ell(\underline{r}') dS' \quad (116)$$

When $m = 0$, eq. (116) gives

$$1 = \frac{1}{4\pi} \iint_B \frac{1}{R} \frac{\partial}{\partial n'} U_0(\underline{r}') dS' \quad (117)$$

This is identical to the integral equation satisfied by the potential $V_3(\underline{r})$ of Section 2.3, and hence

$$U_0(\underline{r}) = V_3(\underline{r}) \quad , \quad \frac{\partial}{\partial n} U_0(\underline{r}) = T_3(s) \quad (118)$$

We note that

$$\iint_B \frac{\partial}{\partial n} U_0(\underline{r}) dS = 2\pi \int_0^s \rho T_3(s) ds = \frac{C}{\epsilon} \quad (119)$$

(see eq. 50), where C is the electrostatic capacity.

From eq. (116) with $m = 1$,

$$\hat{k} \cdot \underline{r} - \frac{1}{4\pi} \iint_B \frac{\partial}{\partial n'} U_0(\underline{r}') dS' = \frac{1}{4\pi} \iint_B \frac{1}{R} \frac{\partial}{\partial n'} U_1(\underline{r}') dS' \quad (120)$$

and using eq. (119), the left hand side can be written as

$$(\hat{k} \cdot \hat{x}) \rho \cos \phi + (\hat{k} \cdot \hat{y}) \rho \sin \phi + (\hat{k} \cdot \hat{z}) z - \frac{C}{4\pi\epsilon} \quad .$$

Since the surface of the body is independent of ϕ , it follows that $U_1(\underline{r})$ must have the form

$$U_1(\underline{r}) = \left\{ (\hat{k} \cdot \hat{x}) \cos \phi + (\hat{k} \cdot \hat{y}) \sin \phi \right\} U_1^{(1)}(\underline{r}) + (\hat{k} \cdot \hat{z}) U_1^{(2)}(\underline{r}) - \frac{C}{4\pi\epsilon} U_1^{(3)}(\underline{r}) \quad (121)$$

where the individual $U_1^{(j)}(\underline{r})$, $j = 1, 2, 3$, satisfy

$$\rho = \frac{1}{4\pi} \iint_B \frac{1}{R} \frac{\partial}{\partial n'} U_1^{(1)}(\underline{r}') dS' , \quad (122)$$

$$z = \frac{1}{4\pi} \iint_B \frac{1}{R} \frac{\partial}{\partial n'} U_1^{(2)}(\underline{r}') dS' , \quad (123)$$

$$1 = \frac{1}{4\pi} \iint_B \frac{1}{R} \frac{\partial}{\partial n'} U_1^{(3)}(\underline{r}') dS' . \quad (124)$$

Comparison of eqs. (124) and (117) shows

$$U_1^{(3)}(\underline{r}) = U_0(\underline{r}) = V_3(\underline{r}) , \quad \frac{\partial}{\partial n} U_1^{(3)}(\underline{r}) = T_3(\underline{r}) . \quad (125)$$

Similarly, $U_1^{(1)}(\underline{r}) \cos \phi$ is identical to the potential $V_1(\underline{r})$ of Section 2.2, implying

$$U_1^{(1)}(\underline{r}) = V_1(\rho, z) \quad (126)$$

so that

$$\frac{\partial}{\partial n} U_1^{(1)}(\underline{r}) = T_1(s) , \quad (127)$$

and $U_1^{(2)}(\underline{r})$ is identical to the potential $V_2(\underline{r})$ of Section 2.3, so that

$$\frac{\partial}{\partial n} U_1^{(2)}(\underline{r}) = T_2(s) . \quad (128)$$

It is now a trivial matter to evaluate the right hand side of eq. (114).

The first integral is clearly C/ϵ , and the second can be written as

$$\begin{aligned} & \iint_B \left\{ (\hat{r} \cdot \underline{r}') T_3(s') - \left[\left\{ (\hat{k} \cdot \hat{x}) \cos \theta' + (\hat{k} \cdot \hat{y}) \sin \theta' \right\} T_1(s') \right. \right. \\ & \quad \left. \left. + (\hat{k} \cdot \hat{z}) T_2(s') - \frac{C}{4\pi\epsilon} T_3(s') \right] \right\} ds' \\ & = 2\pi \int_0^s \left\{ \left[(\hat{r} \cdot \hat{z}) z' + \frac{C}{4\pi\epsilon} \right] T_3(s') - (\hat{k} \cdot \hat{z}) T_2(s') \right\} \rho' ds' . \end{aligned}$$

But

$$\int_0^s \rho' T_2(s') ds' = \int_0^s z' \rho' T_3(s') ds' \quad (52)$$

and hence the second integral on the right hand side of (114) is

$$\begin{aligned} & 2\pi \int_0^s \left\{ \frac{C}{4\pi\epsilon} - \gamma (\hat{r} - \hat{k}) \cdot \hat{z} \right\} \rho' T_3(s') ds' \\ & = \frac{C}{\epsilon} \left\{ \frac{C}{4\pi\epsilon} - \gamma (\hat{r} - \hat{k}) \cdot \hat{z} \right\} \end{aligned}$$

where γ is as defined in eqs. (53) and (54).

The low frequency expansion of the far field is therefore

$$U^S(\underline{r}) \sim \frac{e^{ikr}}{4\pi r} \left(-\frac{C}{\epsilon}\right) \left\{ 1 - ik \left[\frac{C}{4\pi\epsilon} - \gamma(\hat{r} - \hat{k}) \cdot \hat{z} \right] + O(k^2) \right\}, \quad (129)$$

showing that a knowledge of C and γ alone is sufficient to specify the first two terms. As demonstrated by Van Bladel (1968), a similar result obtains even for a body which is not rotationally symmetric.

3.3 HARD BODIES

The final case to be considered is that in which B is a hard rotationally symmetric body. The boundary condition on $U_m(\underline{r})$, $m = 0, 1, 2, \dots$, is then

$$\frac{\partial}{\partial n} U_m(\underline{r}) = 0 \quad \text{on } B \quad (130)$$

and when this is inserted into eq. (112), the low frequency expansion of the far zone scattered field becomes

$$U^S(\underline{r}) \sim \frac{e^{ikr}}{4\pi r} (-1) \left\{ ik \iint_B (\hat{n}' \cdot \hat{r}) U_0(\underline{r}') dS' + k^2 \iint_B [(\hat{r} \cdot \underline{r}') U_0(\underline{r}') - U_1(\underline{r}')] (\hat{n}' \cdot \hat{r}) dS' - ik^3 \iint_B \left[\frac{1}{2} (\hat{r} \cdot \underline{r}')^2 U_0(\underline{r}') - (\hat{r} \cdot \underline{r}') U_1(\underline{r}') + U_2(\underline{r}') \right] (\hat{n}' \cdot \hat{r}) dS' + O(k^4) \right\}. \quad (131)$$

As we shall see later, the first term $O(k)$ is identically zero, and we therefore need $U_0(\underline{r})$, $U_1(\underline{r})$ and $U_2(\underline{r})$ to compute two non-zero terms in the expansion.

From eq. (110) and the boundary condition (130), an expression for $U_m(\underline{r})$ at an arbitrary point \underline{r} in \mathcal{V} is

$$U_m^i(\underline{r}) = U_m^i(\underline{r}) + \frac{1}{4\pi} \sum_{\ell=0}^m \frac{1}{(m-\ell)!} \iint_B (1-m+\ell) R^{m-\ell} U_\ell(\underline{r}') \frac{\partial}{\partial n'} \left(\frac{1}{R} \right) dS', \quad (132)$$

and in particular, when $m=0$,

$$U_0(\underline{r}) = U_0^i(\underline{r}) + \frac{1}{4\pi} \iint_B U_0(\underline{r}') \frac{\partial}{\partial n'} \left(\frac{1}{R} \right) dS'. \quad (133)$$

Clearly $U_0^s(\underline{r}) = U_0(\underline{r}) - U_0^i(\underline{r})$ is an exterior potential function

and $\frac{\partial}{\partial n} U_0^s(\underline{r}) = 0$ on B since $\frac{\partial}{\partial n} U_0^i(\underline{r}) = 0$. In addition,

$U_0^s(\underline{r})$ vanishes more rapidly than r^{-1} as $r \rightarrow \infty$ since there is no term

$O(k^0)$ present in the expansion (131), and hence

$$U_0^s(\underline{r}) \equiv 0 \quad (134)$$

implying

$$U_0(\underline{r}) = U_0^i(\underline{r}) = 1. \quad (135)$$

From eq. (132) with $m=1$, we have

$$U_1(\underline{r}) = U_1^i(\underline{r}) + \frac{1}{4\pi} \iint_B U_1(\underline{r}') \frac{\partial}{\partial n'} \left(\frac{1}{R} \right) dS' \quad (136)$$

which can be converted into an integral equation for $U_1(\underline{r})$ by allowing \underline{r} to approach B. Because of the non-integrable singularity of the kernel for \underline{r} on B, it is necessary to apply a limiting process, and if a bar across an integral sign is again used to denote the Cauchy principal value, we obtain

$$U_1(\underline{r}) = 2 U_1^i(\underline{r}) + \frac{1}{2\pi} \overline{\iint}_B U_1(\underline{r}') \frac{\partial}{\partial n'} \left(\frac{1}{R} \right) dS' \quad (137)$$

for \underline{r} on B, where $U_1^i(\underline{r})$ is given by eq. (115). In terms of the cylindrical polar coordinates (ρ, ϕ, z) ,

$$U_1^i(\underline{r}) = \left\{ (\hat{k} \cdot \hat{x}) \cos \phi + (\hat{k} \cdot \hat{y}) \sin \phi \right\} \rho + (\hat{k} \cdot \hat{z}) z$$

and since the surface of the body is independent of ϕ , it follows that $U_1(\underline{r})$ can be split up into three parts each of which has the ϕ dependence of that part of $U_1^i(\underline{r})$ giving rise to it. In particular, on the surface,

$$U_1(\underline{r}) = \left\{ (\hat{k} \cdot \hat{x}) \cos \phi + (\hat{k} \cdot \hat{y}) \sin \phi \right\} V_4(s) + (\hat{k} \cdot \hat{z}) V_5(s) , \quad (138)$$

where $V_4(s)$ and $V_5(s)$ are the potentials introduced in Sections 2.4 and 2.5 respectively and satisfying the integral equations (63) and (67).

For the remaining function $U_2(\underline{r})$ an expression at an arbitrary point \underline{r} in \mathcal{V} is given by eq. (132) with $m=2$ and is

$$U_2(\underline{r}) = U_2^i(\underline{r}) + \frac{1}{4\pi} \overline{\iint}_B U_2(\underline{r}') \frac{\partial}{\partial n'} \left(\frac{1}{R} \right) dS' \quad (139)$$

where (see eqs. 101 and 109)

$$U_2^i(\underline{r}) = \frac{1}{2} (\hat{k} \cdot \underline{r})^2 \quad . \quad (140)$$

An integral equation for $U_2(\underline{r})$ can be obtained by allowing \underline{r} to approach B, but it proves unnecessary to determine $U_2(\underline{r})$ explicitly if the only purpose is to calculate the term $O(k^3)$ in eq. (131).

To see this we first note that since $U_0^S(\underline{r}) \equiv 0$, the eqs. (111) imply

$$\nabla^2 U_2^S = 0 \quad ,$$

showing that U_2^S is a potential function. Moreover, from eq. (139), $U_2^S = U_2 - U_2^i$ is an exterior potential, being of double-layer type, and since

$$\frac{\partial}{\partial n} U_2^i(\underline{r}) = (\hat{k} \cdot \underline{r}) (\hat{k} \cdot \hat{n}) \quad , \quad (141)$$

the boundary condition on $U_2^S(\underline{r})$ is

$$\frac{\partial}{\partial n} U_2^S(\underline{r}) = -(\hat{k} \cdot \underline{r}) (\hat{k} \cdot \hat{n}) \quad (142)$$

for \underline{r} on B. U_2^S clearly depends on the direction of incidence as well as that of the normal to the surface, and in principle nine separate but elementary potential problems must be solved to find U_2^S . In terms of these potentials,

$$U_2^S(\underline{r}) = \sum_{i=1}^3 \sum_{j=1}^3 k_i k_j G_{ij}(\underline{r}) \quad (143)$$

where, for convenience, we have put

$$x = x_1, \quad y = x_2, \quad z = x_3,$$

and the potential functions $G_{ij}(\underline{r})$ are such that

$$\frac{\partial}{\partial n} G_{ij}(\underline{r}) = -(\hat{n} \cdot \hat{x}_i)(\underline{r} \cdot \hat{x}_j), \quad \blacksquare \quad i, j = 1, 2, 3 \quad (144)$$

for \underline{r} on B . In like manner we can write

$$U_1^s(\underline{r}) = \sum_{i=1}^3 k_i F_i(\underline{r}) \quad (145)$$

where the functions $F_i(\underline{r})$ are such that

$$\frac{\partial}{\partial n} F_i(\underline{r}) = -\hat{n} \cdot \hat{x}_i \quad (146)$$

on B , and comparison of (145) with (115) and (138) shows that on the surface

$$\begin{aligned} F_1(\underline{r}) &= \left\{ V_4(s) - \rho \right\} \cos \phi, \\ F_2(\underline{r}) &= \left\{ V_4(s) - \rho \right\} \sin \phi, \\ F_3(\underline{r}) &= V_5(s) - z. \end{aligned} \quad (147)$$

Following Van Bladel (1968) we now apply reciprocity to the exterior potentials $F_\ell(\underline{r})$ and $G_{ij}(\underline{r})$, $\ell, i, j = 1, 2, 3$, in the region \mathcal{V} to get

$$\iint_B G_{ij}(\underline{r}') \frac{\partial}{\partial n'} F_\ell(\underline{r}') dS' = \iint_B F_\ell(\underline{r}') \frac{\partial}{\partial n'} G_{ij}(\underline{r}') dS'$$

which reduces to

$$\iint_B G_{ij}(\underline{r}')(\hat{n}', \hat{x}_l) \cdot dS' = \iint_B F_l(\underline{r}')(\hat{n}', \hat{x}_i)(\underline{r}', \hat{x}_j) dS' \quad (148)$$

when the boundary conditions (144) and (146) are employed. Hence

$$\begin{aligned} \iint_B U_2^s(\underline{r}')(\hat{n}', \hat{x}_l) dS' &= \sum_i \sum_j k_i k_j \iint_B G_{ij}(\underline{r}')(\hat{n}', \hat{x}_l) dS' \\ &= \sum_i \sum_j k_i k_j \iint_B F_l(\underline{r}')(\hat{n}', \hat{x}_i)(\underline{r}', \hat{x}_j) dS' \\ &= \iint_B F_l(\underline{r}')(\hat{k}, \hat{n}')(\hat{k}, \underline{r}') dS' , \end{aligned}$$

implying

$$\iint_B U_2^s(\underline{r}')(\hat{n}', \hat{r}) dS' = \sum_l \iint_B F_l(\underline{r}')(\hat{r}, \hat{x}_l)(\hat{k}, \hat{n}')(\hat{k}, \underline{r}') dS'$$

and

$$\begin{aligned} \iint_B U_2^{\blacksquare}(\underline{r}')(\hat{n}', \hat{r}) dS' &= \sum_l \iint_B F_l(\underline{r}')(\hat{r}, \hat{x}_l)(\hat{k}, \hat{n}')(\hat{k}, \underline{r}') dS' \\ &\quad + \frac{1}{2} \iint_B (\hat{k}, \underline{r}')^2 (\hat{n}', \hat{r}) dS' . \end{aligned} \quad (149)$$

This integral is the only form in which $U_2(\underline{r})$ enters the far field expansion through terms $O(k^3)$, and since the $F_l(\underline{r}')$ are known by virtue of the eqs. (147), the integral can be computed without the explicit determination of $U_2(\underline{r})$ itself.

We are now in a position to evaluate the individual terms shown in eq. (131). Since $U_0(\underline{r}) = 1$, we have

$$\iint_B (\hat{n}' \cdot \hat{r}) U_0(\underline{r}') dS' = 0, \quad (150)$$

verifying that the leading term in the far field expansion is $O(k^2)$, and

$$\begin{aligned} \iint_B (\hat{r} \cdot \underline{r}') U_0(\underline{r}') (\hat{n}' \cdot \hat{r}) dS' &= \hat{r} \cdot \iint_B \hat{n}' (\hat{r} \cdot \underline{r}') dS' \\ &= \hat{r} \cdot \iiint_{V_0} \nabla' (\hat{r} \cdot \underline{r}') d\tau' \\ &= V_0 \end{aligned} \quad (151)$$

where V_0 is the volume of the body. Also, from eq. (138),

$$\begin{aligned} \iint_B U_1(\underline{r}') (\hat{n}' \cdot \hat{r}) dS' &= \hat{r} \cdot \int_0^{2\pi} \int_0^s \left\{ \cos \alpha' \cos \phi' \hat{x} + \cos \alpha' \sin \phi' \hat{y} - \sin \alpha' \hat{z} \right\} \\ &\times \left\{ \left[(\hat{k} \cdot \hat{x}) \cos \phi' + (\hat{k} \cdot \hat{y}) \sin \phi' \right] V_4(s') + (\hat{k} \cdot \hat{z}) V_5(s') \right\} \rho' d\phi' ds' \\ &= \hat{r} \cdot \left\{ \hat{x} (\hat{k} \cdot \hat{x}) + \hat{y} (\hat{k} \cdot \hat{y}) \right\} \pi \int_0^s \rho' V_4(s') \cos \alpha' ds' \end{aligned}$$

$$-(\hat{r} \cdot \hat{z})(\hat{k} \cdot \hat{z}) 2\pi \int_0^s \rho' V_5(s') \sin \alpha' ds'$$

where α' is the angle defined in eq. (59). Hence, from eqs. (64) and (68),

$$\iint_B U_1(\underline{r}') (\hat{n}' \cdot \hat{r}) dS' = \hat{k} \cdot \left\{ \hat{r} M_{11} - \hat{z}(\hat{k} \cdot \hat{z})(M_{11} - M_{33}) \right\} \quad (152)$$

where M_{11} and M_{33} are the elements of the magnetic polarisability tensor discussed in Sections 2.4 and 2.5 respectively. As we have previously noted, for a body of revolution M_{33} is related to P_{11} (see eq. 13).

When the results of eqs. (150) through (152) are substituted into eq. (131), the low frequency expansion of the far zone scattered field is found to be

$$U^S(\underline{r}) \sim \frac{e^{ikr}}{4\pi r} \left\{ k^2 \left[\hat{k} \cdot \left\{ \hat{r} M_{11} - \hat{z}(\hat{k} \cdot \hat{z})(M_{11} - M_{33}) \right\} - V_0 \right] + O(k^3) \right\} \quad (153)$$

where the actual term involving k^3 is

$$ik^3 \iint_B \left[\frac{1}{2} (\hat{r} \cdot \underline{r}')^2 U_0(\underline{r}') - (\hat{r} \cdot \underline{r}') U_1(\underline{r}') + U_2(\underline{r}') \right] (\hat{n}' \cdot \hat{r}) dS' \quad (154)$$

Unfortunately, the evaluation of this is rather a messy task.

Since $U_0(\underline{r}) = 1$ (see eq. 135),

$$\iint_B \frac{1}{2} (\hat{r} \cdot \underline{r}')^2 U_0(\underline{r}') (\hat{n}' \cdot \hat{r}) dS' = \frac{1}{2} \hat{r} \cdot \iint_B \hat{n}' (\hat{r} \cdot \underline{r}')^2 dS' \quad \blacksquare$$

$$\begin{aligned}
&= \frac{1}{2} \hat{\mathbf{r}} \cdot \iiint_{V_0} \nabla \left\{ (\hat{\mathbf{r}} \cdot \underline{\mathbf{r}}')^2 \right\} d\tau' \\
&= \hat{\mathbf{r}} \cdot \iiint_{V_0} \underline{\mathbf{r}}' d\tau' . \quad (155)
\end{aligned}$$

To simplify the treatment of the next two integrals in (154), write

$$\tilde{\mathbf{F}}_\ell(\underline{\mathbf{r}}) = \mathbf{F}_\ell(\underline{\mathbf{r}}) + \underline{\mathbf{r}} \cdot \hat{\mathbf{x}}_\ell \quad (156)$$

so that (see eq. 145)

$$U_1(\underline{\mathbf{r}}) = \sum_\ell k_\ell \tilde{\mathbf{F}}_\ell(\underline{\mathbf{r}}) . \quad (157)$$

Using eq. (149) we then have

$$\begin{aligned}
&\iint_B \left\{ -(\hat{\mathbf{r}} \cdot \underline{\mathbf{r}}') U_1(\underline{\mathbf{r}}') + U_2(\underline{\mathbf{r}}') \right\} (\hat{\mathbf{n}}' \cdot \hat{\mathbf{r}}) dS' \\
&= \sum_\ell \iint_B \tilde{\mathbf{F}}_\ell(\underline{\mathbf{r}}') \left\{ (\hat{\mathbf{r}} \cdot \hat{\mathbf{x}}_\ell)(\hat{\mathbf{k}} \cdot \underline{\mathbf{r}}')(\hat{\mathbf{n}}' \cdot \hat{\mathbf{k}}) - (\hat{\mathbf{k}} \cdot \hat{\mathbf{x}}_\ell)(\hat{\mathbf{r}} \cdot \underline{\mathbf{r}}')(\hat{\mathbf{n}}' \cdot \hat{\mathbf{r}}) \right\} dS' \\
&\quad + \iint_B \left\{ \frac{1}{2}(\hat{\mathbf{k}} \cdot \underline{\mathbf{r}}')(\hat{\mathbf{n}}' \cdot \hat{\mathbf{r}}) - (\hat{\mathbf{r}} \cdot \underline{\mathbf{r}}')(\hat{\mathbf{n}}' \cdot \hat{\mathbf{k}}) \right\} (\hat{\mathbf{k}} \cdot \underline{\mathbf{r}}') dS' . \quad (158)
\end{aligned}$$

But

$$\iint_B \frac{1}{2} (\hat{\mathbf{k}} \cdot \underline{\mathbf{r}}')^2 (\hat{\mathbf{n}}' \cdot \hat{\mathbf{r}}) dS' = (\hat{\mathbf{k}} \cdot \hat{\mathbf{r}}) \hat{\mathbf{k}} \cdot \iiint_{V_0} \underline{\mathbf{r}}' d\tau'$$

and

$$\iint_B (\hat{\mathbf{r}} \cdot \underline{\mathbf{r}}') (\hat{\mathbf{n}}' \cdot \hat{\mathbf{k}}) (\hat{\mathbf{k}} \cdot \underline{\mathbf{r}}') dS' = \left\{ \hat{\mathbf{r}} + (\hat{\mathbf{k}} \cdot \hat{\mathbf{r}}) \hat{\mathbf{k}} \right\} \cdot \iiint_{V_0} \underline{\mathbf{r}}' d\tau'$$

as may be shown by analyses similar to that performed above. Hence

$$\iint_B \left\{ \frac{1}{2} (\hat{\mathbf{k}} \cdot \underline{\mathbf{r}}') (\hat{\mathbf{n}}' \cdot \hat{\mathbf{r}}) - (\hat{\mathbf{r}} \cdot \underline{\mathbf{r}}') (\hat{\mathbf{n}}' \cdot \hat{\mathbf{k}}) \right\} (\hat{\mathbf{k}} \cdot \underline{\mathbf{r}}') dS' = -\hat{\mathbf{r}} \cdot \iiint_{V_0} \underline{\mathbf{r}}' d\tau' \quad (159)$$

which cancels the contribution (155) of the first term in the integrand of (154).

The complete integral (154) is therefore

$$ik^3 \sum_{\ell} \iiint_B \tilde{F}_{\ell}(\underline{\mathbf{r}}') \left\{ (\hat{\mathbf{r}} \cdot \hat{\mathbf{x}}_{\ell}) (\hat{\mathbf{k}} \cdot \underline{\mathbf{r}}') (\hat{\mathbf{n}}' \cdot \hat{\mathbf{k}}) - (\hat{\mathbf{k}} \cdot \hat{\mathbf{x}}_{\ell}) (\hat{\mathbf{r}} \cdot \underline{\mathbf{r}}') (\hat{\mathbf{n}}' \cdot \hat{\mathbf{r}}) \right\} dS' \quad (160)$$

and to simplify this we now invoke the rotational symmetry of the body.

From eqs. (147) and (156) we have

$$\tilde{F}_1(\underline{\mathbf{r}}') = V_4(s') \cos \phi', \quad \tilde{F}_2(\underline{\mathbf{r}}') = V_4(s') \sin \phi', \quad \tilde{F}_3(\underline{\mathbf{r}}') = V_5(s') \quad (161)$$

When these are inserted into (160) and the azimuthal integration performed, the contribution of the first term in the integrand is

$$\pi (\hat{\mathbf{k}} \cdot \hat{\mathbf{z}}) \left\{ \hat{\mathbf{k}} \cdot \hat{\mathbf{r}} - (\hat{\mathbf{k}} \cdot \hat{\mathbf{z}}) (\hat{\mathbf{r}} \cdot \hat{\mathbf{z}}) \right\} \int_0^s \rho (z \cos \alpha - \rho \sin \alpha) V_4(s) ds$$

$$\begin{aligned}
& + \pi (\hat{\mathbf{r}} \cdot \hat{\mathbf{z}}) \left\{ 1 - (\hat{\mathbf{k}} \cdot \hat{\mathbf{z}})^2 \right\} \int_0^s \rho^2 V_5(s) \cos \alpha \, ds \\
& - 2 \pi (\hat{\mathbf{r}} \cdot \hat{\mathbf{z}}) (\hat{\mathbf{k}} \cdot \hat{\mathbf{z}})^2 \int_0^s \rho z V_5(s) \sin \alpha \, ds.
\end{aligned}$$

The contribution of the second term in the integrand of (160) differs only in having $\hat{\mathbf{r}}$ and $\hat{\mathbf{k}}$ interchanged, and when the two are subtracted, the final expression for the term in k^3 in the far field expression (153) is

$$\begin{aligned}
& ik^3 \pi (\hat{\mathbf{k}} - \hat{\mathbf{r}}) \cdot \hat{\mathbf{z}} \left[\left\{ \hat{\mathbf{k}} \cdot \hat{\mathbf{r}} - (\hat{\mathbf{k}} \cdot \hat{\mathbf{z}}) (\hat{\mathbf{r}} \cdot \hat{\mathbf{z}}) \right\} \int_0^s \rho (z \cos \alpha - \rho \sin \alpha) V_4(s) \, ds \right. \\
& - \left\{ 1 + (\hat{\mathbf{k}} \cdot \hat{\mathbf{z}}) (\hat{\mathbf{r}} \cdot \hat{\mathbf{z}}) \right\} \int_0^s \rho^2 V_5(s) \cos \alpha \, ds \\
& \left. - 2 (\hat{\mathbf{k}} \cdot \hat{\mathbf{z}}) (\hat{\mathbf{r}} \cdot \hat{\mathbf{z}}) \int_0^s \rho z V_5(s) \sin \alpha \, ds \right]. \quad (162)
\end{aligned}$$

Although this is only the second non-zero term in the low frequency expansion, it is much more complicated than the second term in the expansion for a soft body. The surface field quantities involved are the same as those associated with M_{11} and M_{33} , but there is now no simple relationship analogous to (13) which enables us to dispense with $V_5(s)$. If the direction of incidence or

observation is parallel to the axis of symmetry, i.e. $\hat{k} = \pm \hat{z}$ or $\hat{r} = \pm \hat{z}$, the integral containing $V_4(s)$ disappears, but there is no comparable situation where the integrals containing $V_5(s)$ are absent except for the special case of forward scatter, $\hat{r} = \hat{k}$, when the entire expression (162) vanishes.

4. THE COMPUTATIONAL TASK

When this study was first undertaken the main objective was to develop an effective program for computing the quantities P_{11} , P_{33} and M_{11} specifying the low frequency scattering behavior of perfectly conducting rotationally symmetric bodies. The realisation that the calculation of P_{33} produces as a by product the electrostatic capacity led us to add this to the list of quantities considered, but it was only later that the question of acoustic scattering came up. Since the first two terms in the low frequency expansion for a soft body are expressible in terms of C/ϵ and γ , and γ is implicit in the P_{33} computation, it was only natural to add this to our list, and for a hard body the first term involves no additional work. But the second term, (162), is another matter. In particular, it requires the explicit calculation of the surface field $V_5(s)$ that had hitherto been avoided by virtue of the relation (13), and even if this were done, the nature of the k^3 term is almost such as to preclude any physical understanding of the data. For these reasons it was decided not to implement the computation of $V_5(s)$ and, hence, to ignore the second term (162) in the hard body expansion. The quantities which we are now left with are all ones which are needed for the electromagnetic problem.

4.1 INTEGRAL EQUATIONS

It is convenient to begin by listing the integral equations which have to be solved and the quantities to be computed from their solutions.

Assuming that the profile $\rho = \rho(z)$ of the finite, closed, rotationally symmetric body has been specified in some manner and its volume V_0 computed as a preliminary step, then:

(i) solve

$$\int_0^s \rho' K_1 T_1(s') ds' = 2\pi\rho \quad (163)$$

where the kernel K_1 is defined in eq. (29); compute

$$\frac{P_{11}}{V_0} = \frac{\pi}{V_0} \int_0^s \rho^2 T_1(s) ds \quad (164)$$

(ii) solve

$$\int_0^s \rho' K_0 T_2(s') ds' = 2\pi z \quad , \quad (165)$$

$$\int_0^s \rho' K_0 T_3(s') ds' = 2\pi \quad , \quad (166)$$

where the kernel K_0 is defined in eq. (34); retain the option to print out $T_3(s)$; compute

$$\frac{C}{\epsilon} = 2\pi \int_0^s \rho T_3(s) ds \quad , \quad (167)$$

$$\gamma = -\frac{\epsilon}{C} 2\pi \int_0^s z\rho T_3(s) ds \quad , \quad (168)$$

$$\frac{P_{33}}{V_0} = \frac{2\pi}{V_0} \int_0^s z \rho T_2(s) ds - \frac{C}{\epsilon} \frac{\gamma^2}{V_0} \quad (169)$$

(iii) if and only if B consists of two separate closed parts B_1 and B_2 ,
solve

$$\int_0^s \rho' K_0 T_3^{(1)}(s') ds' = \begin{cases} 2\pi & \underline{r} \text{ on } B_1 \\ 0 & \underline{r} \text{ on } B_2 \end{cases} ; (170)$$

compute

$$\frac{\delta P_{33}}{V_0} = - \frac{\frac{2\pi}{V_0} \left\{ \int_0^s (z + \gamma) \rho T_3^{(1)}(s) ds \right\}^2}{\int_{(1)} \rho T_3^{(1)}(s) ds - \frac{\epsilon}{C} 2\pi \left\{ \int_{(1)} \rho T_3(s) ds \right\}^2}, \quad (171)$$

where the symbol (1) below the integral sign means that the integration is carried out over the profile of B_1 alone

(iv) solve

$$\begin{aligned} \int_0^s V_4(s') \left\{ \rho \cos \alpha' \Omega_2 + \left[(z' - z) \sin \alpha' - \rho' \cos \alpha' \right] \Omega_1 \right\} \rho' ds' \\ = \pi \left\{ V_4(s) - 2\rho \right\} \end{aligned} \quad (172)$$

where Ω_1 , Ω_2 and α' are defined in eqs. (61), (62) and (59) respectively and the bar across the integral sign denotes the Cauchy principal value; compute

$$\frac{M_{11}}{V_0} = \frac{\pi}{V_0} \int_0^s \rho V_4(s) \cos \alpha' ds \quad . \quad (173)$$

We therefore have four (five) integral equations to be solved, three (four) being of the first kind and one of the second, and five (six) derived quantities to be computed from their solutions: the numbers in parentheses refer to the unusual situation where B is disjoint. Before attempting this task, there are certain features of the equations to be examined.

4.2 THE KERNELS AND THEIR SINGULARITIES

The kernels K_0 and K_1 of the integral equations (163), (165), (166), (170) can be expressed in terms of complete elliptic integrals of the first and second kinds.

From the definition of R given in eq. (28), we have

$$R = \left\{ (\rho + \rho')^2 + (z - z')^2 \right\}^{1/2} (1 - m \sin^2 \theta)^{1/2} \quad (174)$$

where

$$m = \frac{4\rho\rho'}{(\rho + \rho')^2 + (z - z')^2} \quad (175)$$

and

$$\theta = \frac{1}{2} (\pi - \psi) \quad . \quad (176)$$

Hence

$$\frac{1}{R} = \frac{1}{2} \left(\frac{m}{\rho \rho'} \right)^{1/2} (1 - m \sin^2 \theta)^{-1/2} \quad (177)$$

and when this is substituted into the definition (34) for K_0 , we immediately obtain

$$K_0 = \left(\frac{m}{\rho \rho'} \right)^{1/2} K(m) \quad (178)$$

where

$$K(m) = \int_0^{\pi/2} (1 - m \sin^2 \theta)^{-1/2} d\theta \quad (179)$$

is the complete elliptic integral of the first kind (see, for example, Abramowitz and Stegun, 1964, p. 590).

By a trivial manipulation, we also have

$$\frac{\cos \psi}{R} = \left(\frac{2}{m} - 1 \right) \frac{1}{R} - \frac{R}{2 \rho \rho'} \quad (180)$$

implying

$$\left| \frac{\cos \psi}{R} = (m \rho \rho')^{-1/2} \left\{ \left(1 - \frac{m}{2} \right) (1 - m \sin^2 \theta)^{-1/2} - (1 - m \sin^2 \theta)^{1/2} \right\} \right. \quad (181)$$

and hence, from the definition (29) of K_1 ,

$$K_1 = \frac{2}{(m \rho \rho')^{1/2}} \left\{ \left(1 - \frac{m}{2} \right) K(m) - E(m) \right\} \quad (182)$$

where

$$E(m) = \int_0^{\pi/2} (1 - m \sin^2 \theta)^{1/2} d\theta \quad (183)$$

is the complete elliptic integral of the second kind (loc. cit.).

The above representations of K_0 and K_1 are exact. Since ρ, z, ρ', z' are all real with $\rho, \rho' \geq 0$, it can be verified that $0 \leq m \leq 1$. Over this range $E(m)$ is a finite slowly-varying function, having the values $\pi/2$ for $m = 0$ and unity for $m = 1$. A finite polynomial approximation sufficient for computing $E(m)$ with an error of less than 2×10^{-8} is given in Section 17.3.36 of the above reference. Through the first three terms the precise expansion is (Jahnke and Emde, 1945):

$$E(m) = 1 - \frac{1}{4} m_1 + \frac{1}{2} m_1 \Gamma + O(m_1^2, m_1^2 \Gamma) \quad (184)$$

with

$$m_1 = 1 - m, \quad (185)$$

i. e.

$$m_1 = \frac{(\rho - \rho')^2 + (z - z')^2}{(\rho + \rho')^2 + (z - z')^2} \quad (186)$$

and

$$\Gamma = \frac{1}{2} \ln \frac{16}{m_1}. \quad (187)$$

We observe that $m_1 = 0$ if and only if $\rho' = \rho, z' = z$, that is, when the integration and observation points coincide. For an integration point in the immediate vicinity of the observation point,

$$m_1 \approx \left(\frac{s}{2\rho} \right)^2 \quad (188)$$

where s is to a first order the arc length between the points.

The elliptic integral $K(m)$ also has the value $\pi/2$ for $m = 0$ but becomes logarithmically infinite as $m \rightarrow 1$. A finite polynomial approximation sufficient

to compute $K(m)$ with an error of less than 2×10^{-8} is given in Section 17.3.34 of Abramowitz and Stegun (1964), and a precise expansion through the first three terms is (Jahnke and Emde, 1945):

$$K(m) = \Gamma + \frac{1}{2} m_1 \Gamma - \frac{1}{4} m_1^2 + O(m_1^2, m_1^2 \Gamma) . \quad (189)$$

Because of the infinity of $K(m)$ as $m \rightarrow 1$ ($m_1 \rightarrow 0$), K_0 and K_1 are also infinite in this limit, but their behavior in the vicinity of the singularity is easy to determine. Using (184) and (189) we have

$$K_0 = \frac{1}{(\rho \rho')^{1/2}} \left\{ \Gamma + O(m_1, m_1^2 \Gamma) \right\} \quad (190)$$

and

$$K_1 = \frac{1}{(\rho \rho')^{1/2}} \left\{ \Gamma^{-2} + O(m_1, m_1 \Gamma) \right\} , \quad (191)$$

showing that the singularity at $\rho' = \rho$, $z' = z$ is an integrable one in each case. The contributions of the singular (or self) cells to the integrals in eqs. (163), (165), (166), and (170) are therefore finite and can be analytically approximated as follows.

Consider for example the integral equation (165). If the self cell in the sampling procedure is centered on $s = s_n$ (where $\rho = \rho_n$) and is of arc length Δs , then

$$\int_{\text{self}} \rho' K_0 T_2(s') ds' = \int_{s_n - \frac{1}{2} \Delta s}^{s_n + \frac{1}{2} \Delta s} \rho' K_0 T_2(s') ds'$$

$$\approx \rho_n T_2(s_n) \int_{s_n - \frac{1}{2} \Delta s}^{s_n + \frac{1}{2} \Delta s} K_0 ds'$$

$$\approx T_2(s_n) \int_{-\frac{1}{2} \Delta s}^{\frac{1}{2} \Delta s} \left(\ln \left(\frac{8\rho_n}{|s'|} \right) \right) ds'$$

and hence

$$\int_{\text{self}} \rho' K_0 T_2(s') ds' \approx T_2(s_n) \left(\ln \frac{16\rho_n}{\Delta s} + 1 \right) \Delta s . \quad (192)$$

It is desirable to retain the first correction, unity, to the logarithmic term to ensure the necessary accuracy when the sampling is relatively coarse and/or ρ_n is small. For the integral equations (166) and (170) the results differ from the above only in having $T_3(s_n)$ and $T_3^{(1)}(s_n)$ respectively in place of $T_2(s_n)$; and for the integral equation (163):

$$\int_{\text{self}} \rho' K_1 T_1(s') ds' \approx \rho_n T_1(s_n) \int_{s_n - \frac{1}{2} \Delta s}^{s_n + \frac{1}{2} \Delta s} K_1 ds'$$

$$\approx T_1(s_n) \int_{-\frac{1}{2} \Delta s}^{\frac{1}{2} \Delta s} \left(\ln \frac{8\rho_n}{|s'|} - 2 \right) ds' ,$$

giving

$$\int_{\text{self}} \rho' K_1 T_1(s') ds' \approx T_1(s_n) \left(\ln \frac{16\rho_n}{\Delta s} - 1 \right) \Delta s . \quad (193)$$

For the integral equation (172) the computation of the kernel is a more complicated task due partly to the presence of the functions Ω_1 and Ω_2 . However, these also can be expressed in terms of complete elliptic integrals, and the resulting method of computation is much less time consuming than a direct numerical evaluation of the integral expressions for Ω_1 and Ω_2 .

The definition of Ω_1 is given in eq. (61), and using eqs. (177) and (181), the integrand can be written as

$$\frac{\cos \psi}{R^3} = \frac{1}{4m} \left(\frac{m}{\rho\rho'} \right)^{3/2} \left\{ \left(1 - \frac{m}{2}\right) (1 - m \sin^2 \theta)^{-3/2} - (1 - m \sin^2 \theta)^{-1/2} \right\}$$

from which we have

$$\Omega_1 = \frac{1}{2m} \left(\frac{m}{\rho\rho'} \right)^{3/2} \left\{ \left(1 - \frac{m}{2}\right) \int_0^{\pi/2} (1 - m \sin^2 \theta)^{-3/2} d\theta - K(m) \right\}. \quad (194)$$

To evaluate the remaining integral, differentiate the expression (179) for $K(m)$ with respect to m to get

$$K'(m) = \frac{1}{2} \int_0^{\pi/2} \frac{\sin^2 \theta}{(1 - m \sin^2 \theta)^{3/2}} d\theta \quad \blacksquare$$

$$\begin{aligned}
&= \frac{1}{2m} \int_0^{\pi/2} \left\{ \frac{1}{(1-m \sin^2 \theta)^{3/2}} - \frac{1}{(1-m \sin^2 \theta)^{1/2}} \right\} d\theta \\
&= \frac{1}{2m} \int_0^{\pi/2} (1-m \sin^2 \theta)^{-3/2} d\theta - \frac{1}{2m} K(m) .
\end{aligned}$$

Hence

$$\int_0^{\pi/2} (1-m \sin^2 \theta)^{-3/2} d\theta = K(m) + 2mK'(m) \quad (195)$$

and when this is substituted into eq. (194), the result is

$$\Omega_1 = \left(\frac{m}{\rho \rho'} \right)^{3/2} \left\{ \left(1 - \frac{m}{2}\right) K'(m) - \frac{1}{4} K(m) \right\}. \quad (196)$$

The procedure for Ω_2 is similar. From eqs. (177) and (181),

$$\frac{\cos^2 \psi}{R^3} = \frac{1}{2m^2} \left(\frac{m}{\rho \rho'} \right)^{3/2} \left\{ \left(1 - \frac{m}{2}\right)^2 (1-m \sin^2 \theta)^{-3/2} - (2-m)(1-m \sin^2 \theta)^{-1/2} + (1-m \sin^2 \theta)^{1/2} \right\}$$

implying

$$\Omega_2 = \frac{1}{m^2} \left(\frac{m}{\rho \rho'} \right)^{3/2} \left\{ \left(1 - \frac{m}{2}\right)^2 \int_0^{\pi/2} (1-m \sin^2 \theta)^{-3/2} d\theta - (2-m)K(m) + E(m) \right\},$$

and when the expression (195) for the integral is substituted into this, we have

$$\Omega_2 = \frac{1}{m^2} \left(\frac{m}{\rho \rho'} \right)^{3/2} \left\{ 2m \left(1 - \frac{m}{2} \right)^2 K'(m) - \left(1 - \frac{m^2}{4} \right) K(m) + E(m) \right\}. \quad (197)$$

The finite polynomial approximations to $E(m)$ and $K(m)$ were mentioned earlier, and in particular, for the latter,

$$K(m) = (a_0 + a_1 m_1 + \dots + a_4 m_1^4) + (b_0 + b_1 m_1 + \dots + b_4 m_1^4) \ell_n \frac{1}{m_1} + O(m_1^5, m_1^5 \ell_n \frac{1}{m_1}) \quad (198)$$

where values for the coefficients a_i and b_i , $i = 0, \dots, 4$ are given in Section 17.3.34 of Abramowitz and Stegun (1964). Since $d/dm = -d/dm_1$, it follows that

$$K'(m) = \left\{ \frac{b_0}{m_1} + (b_1 - a_1) + (b_2 - 2a_2) m_1 + (b_3 - 3a_3) m_1^2 + (b_4 - 4a_4) m_1^3 \right\} - (b_1 + 2b_2 m_1 + 3b_3 m_1^2 + 4b_4 m_1^3) \ell_n \frac{1}{m_1} + O(m_1^4, m_1^4 \ell_n \frac{1}{m_1}), \quad (199)$$

which can be used to compute $K'(m)$. We note the pole-like behavior of $K'(m)$ when $m_1 = 1 - m = 0$, and this is reflected in the non-integrable singularity of the kernel of eq. (172) at $\rho' = \rho$, $z' = z$.

4.3 THE BODY AND ITS VOLUME

One of the many factors motivating the present study was the need to

compute the low frequency scattering behavior of missile-like targets. These are generally rotationally symmetric bodies (or can be approximated as such to an accuracy which is adequate at low frequencies), and are often made up of several distinct parts, e. g. a cone mated to a cylinder which is terminated in a spherical cap. Although the complete profile of such a body is certainly not an analytic curve, each individual segment has a relatively simple equation whose form can be used to advantage in the numerical process.

It is therefore assumed that the profile is a finite piecewise smooth curve composed of straight line and circular arc segments. For definiteness, the number of segments is limited to 15 or less. At the end points of the profile where it intersects the z axis of rotation of the body, $\rho = 0$ (of course), and the nature of the program is such that segments which are perpendicular to the z axis can be handled, as can a 'disjoint' body having two separate parts provided each portion of the complete profile terminates on the axis.

Every segment contributes to the total volume V_0 which can be found by adding the individual contributions δV_0 . In certain cases, a volume contribution can be negative and subtract from the volume attributable to the other segments. Where this occurs, it must be noted as part of the input specification for the segment in question.

In the following we list the input specifications of circular arc (Types 1 and 2) and linear (Type 3) segments, and give expressions for the corresponding volume contributions (assumed positive). The segments must be described sequentially starting at the intersection of the left hand segment with the axis, and the ordered sequence of segments defines the profile of the body. In some cases it may be desirable to regard a single linear or curved portion of the profile as two or more segments to permit a non-uniform

spacing of the sampling points over the whole.

Type 1 Segment (Circular Arc, Concave Down)

Specification:

$$z_1, z_2$$

$$\rho_1 = \rho(z_1), \rho_2 = \rho(z_2)$$

$$\theta \text{ (degrees), } 0 < \theta \leq 180$$

volume sense

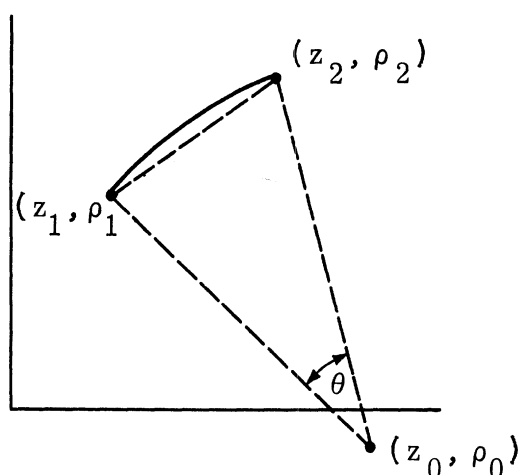

If θ is the angle subtended by the arc at the center of curvature, then the radius a is

$$a = \frac{1}{2 \sin \frac{\theta}{2}} \left\{ (\rho_2 - \rho_1)^2 + (z_2 - z_1)^2 \right\}^{1/2} . \quad (200)$$

Since we permit the specification of re-entrant circular arc segments we do not require $z_2 > z_1$. In order to obtain correct results for both standard ($z_2 > z_1$) and re-entrant segments define the quantity

$$d = \frac{z_2 - z_1}{|z_2 - z_1|} . \quad (201)$$

Then, the coordinates (z_0, ρ_0) of the center curvature are

$$\begin{aligned} z_0 &= \frac{1}{2} \left\{ z_1 + z_2 - d (\rho_1 - \rho_2) \cot \frac{\theta}{2} \right\} \\ \rho_0 &= \frac{1}{2} \left\{ \rho_1 + \rho_2 - d (z_2 - z_1) \cot \frac{\theta}{2} \right\} . \end{aligned} \quad (202)$$

The volume of rotation is given by

$$\delta V_0 = \pi \left| \int_{z_1}^{z_2} \rho^2(z) dz \right| ,$$

and since the equation of the circular arc segment is

$$(\rho - \rho_0)^2 + (z - z_0)^2 = a^2 ,$$

the incremental volume δV_0 is

$$\begin{aligned} \delta V_0 &= \pi \left| (z_2 - z_1) \left\{ \rho_0^2 + a^2 - \frac{1}{3} (u_2^2 + u_1 u_2 + u_1^2) \right\} \right. \\ &\quad \left. + \rho_0 \left\{ u_2 (\rho_2 - \rho_0) - u_1 (\rho_1 - \rho_0) + d a^2 \theta \right\} \right| , \end{aligned} \quad (203)$$

where

$$u_2 = z_2 - z_0$$

$$u_1 = z_1 - z_0 .$$

Type 2 Segment (Circular Arc, Concave Up)

Specification:

same as for Type 1

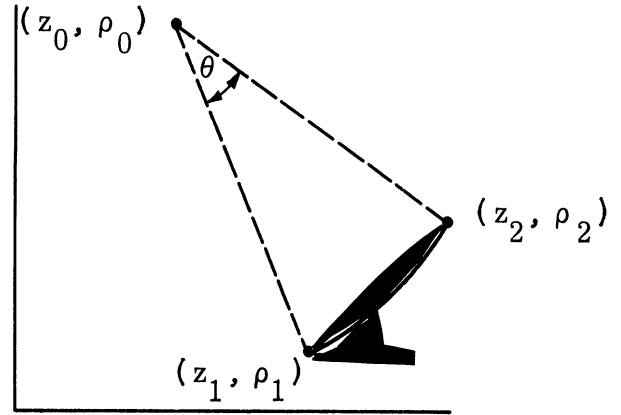

Eq. (200) gives the radius a of the type 2 segment, but the coordinates (z_0, ρ_0) of the center of curvature are now

$$\begin{aligned} z_0 &= \frac{1}{2} \left\{ z_1 + z_2 + d(\rho_1 - \rho_2) \cot \frac{\theta}{2} \right\} \\ \rho_0 &= \frac{1}{2} \left\{ \rho_1 + \rho_2 + d(z_2 - z_1) \cot \frac{\theta}{2} \right\} . \end{aligned} \quad (204)$$

The incremental volume of the type 2 segment is

$$\begin{aligned} \delta V_0 &= \pi \left| (z_2 - z_1) \left\{ \rho_0^2 + a^2 - \frac{1}{3} (u_2^2 + u_1 u_2 + u_1^2) \right\} \right. \\ &\quad \left. - \rho_0 \left\{ u_2 (\rho_2 - \rho_0) - u_1 (\rho_1 - \rho_0) + d a^2 \theta \right\} \right| . \end{aligned} \quad (205)$$

Note that only simple sign changes distinguish (202) from (204) and (203) from (205). Relationships that hold for both type 1 and type 2 segments may be derived by using a constant ξ defined as follows:

$$\xi = \begin{cases} -1 & \text{type 1 segment} \\ 1 & \text{type 2 segment} \end{cases} . \quad (206)$$

The center of curvature (z_0, ρ_0) and the incremental volume δV_0 for circular arc segments of types 1 and 2 are then

$$\begin{aligned} z_0 &= \frac{1}{2} \left\{ z_1 + z_2 + \xi d (\rho_1 - \rho_2) \cot \frac{\theta}{2} \right\} \\ \rho_0 &= \frac{1}{2} \left\{ \rho_1 + \rho_2 + \xi d (z_2 - z_1) \cot \frac{\theta}{2} \right\} \end{aligned} \quad (207)$$

$$\begin{aligned} \delta V_0 &= \pi \left| (z_2 - z_1) \left\{ \rho_0^2 + a^2 - \frac{1}{3} (u_1^2 + u_1 u_2 + u_2^2) \right\} - \xi \rho_0 \left\{ u_2 (\rho_2 - \rho_0) \right. \right. \\ &\quad \left. \left. - u_1 (\rho_1 - \rho_0) + d a^2 \theta \right\} \right| , \end{aligned} \quad (208)$$

where, as before,

$$u_2 = z_2 - z_0$$

$$u_1 = z_1 - z_0 .$$

Type 3 Segment (Linear)

Specification:

$$z_1, \quad z_2$$

$$\rho_1 = \rho(z_1), \quad \rho_2 = \rho(z_2)$$

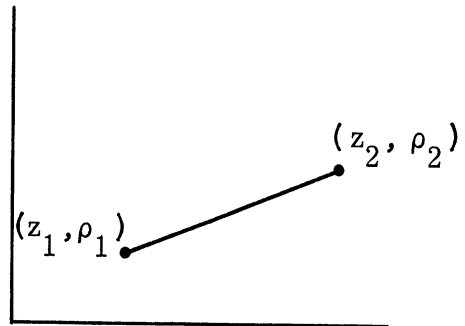

The equation of the segment is clearly

$$\rho = \rho_1 + \frac{\rho_2 - \rho_1}{z_2 - z_1} (z - z_1) \quad (209)$$

and the volume contribution is

$$\delta V_0 = \int_{z_1}^{z_2} \pi \rho^2 dz$$

i. e.

$$\delta V_0 = \frac{\pi}{3} (z_2 - z_1) (\rho_2^2 + \rho_2 \rho_1 + \rho_1^2) \quad (210)$$

which is positive or negative according as $z_2 > z_1$, $z_2 < z_1$, respectively.

5. NUMERICAL SOLUTION OF THE INTEGRAL EQUATIONS

The numerical procedures involved in finding P_{33}/V_0 , M_{11}/V_0 and where appropriate, \tilde{P}_{33}/V_0 are quite similar to those required for P_{11}/V_0 , and it is therefore sufficient to give full details only for P_{11}/V_0 .

5.1 P_{11}/V_0 COMPUTATION

The primary task is the solution of the integral equation (163) for the function $T_1(s)$ and this entails the determination of a sequence of values $T_1^{(i)}$, $i = 1, 2, \dots, N$, approximating $T_1(s)$ at the sampling points $s = s_i$ on the profile $\rho = \rho(z)$. For this purpose the profile is divided into N cells C_i of arc length Δs_i and midpoints s_i corresponding to the coordinates (ρ_i, z_i) . Within each cell we also define the points s_{i-} and s_{i+} where

$$s_{i-} = s_i - \alpha_0 \Delta s_i \tag{211}$$

$$s_{i+} = s_i + \alpha_0 \Delta s_i$$

with the restriction

$$0 \leq \alpha_0 \leq \frac{1}{2}.$$

By assuming that $T_1(s)$ has the constant value $T_1^{(i)}$ over the i th cell,

the integral on the left hand side of (163) can be evaluated as a linear combination of the $T_1^{(i)}$ whose coefficients depend on the position (ρ, z) of the field point, leading to a linear system of N equations in N unknowns, viz.

$$T_1^{(1)} \int_{C_1} \rho' K_1 ds' + T_1^{(2)} \int_{C_2} \rho' K_1 ds' + \dots + T_1^{(N)} \int_{C_N} \rho' K_1 ds' = 2\pi\rho_i$$

$$i = 1, 2, \dots, N. \quad (212)$$

Hence, the system to be solved is

$$A t_1 = b \quad (213)$$

where t_1 is a column vector with elements

$$t_{1i} = T_1^{(i)}, \quad i = 1, 2, \dots, N, \quad (214)$$

A is a square matrix with elements

$$a_{ij} = \int_{C_j} \rho' K_1 ds', \quad i, j = 1, 2, \dots, N, \quad (215)$$

and b is a row vector with elements

$$b_j = 2\pi\rho_j, \quad j = 1, 2, \dots, N. \quad (216)$$

Increasing the complexity of the quadrature technique used to evaluate the integrals \int_{C_j} will generally improve the accuracy but will almost

certainly increase the computational cost. What is therefore desired is the least expensive procedure capable of giving the required accuracy. The two simplest approaches are to integrate first and second order approximations to give ($i \neq j$):

$$a_{ij} = \rho_j K_1(i, j) \Delta s_j \quad (217)$$

$$a_{ij} = \left[w_1(\alpha_0) \left\{ \rho_{j-} K_1(i, j-) + \rho_{j+} K_1(i, j+) \right\} + w_0(\alpha_0) \rho_j K_1(i, j) \right] \Delta s_j \quad (218)$$

respectively, where the subscripts $j-$ and $j+$ correspond to the points s_{j-} and s_{j+} of eqs. (211), and $K_1(i, j)$ is the kernel defined in eq. (29) and evaluated at the points (ρ_i, z_i) , (ρ_j, z_j) . By requiring $\alpha_0 < \frac{1}{2}$, we ensure that the sampling points s_{j-} and s_{j+} do not coincide with the end points of the cell C_j , and thereby avoid any difficulty in the computations of Ω_1 and Ω_2 (see eqs. 196 and 197). When

$$\alpha_0 = \frac{1}{2} \sqrt{\frac{3}{5}}, \quad (219)$$

eq. (218) reduces to the three-point Gaussian formula for which

$$w_0 = \frac{4}{9}, \quad w_1 = \frac{5}{18} \quad (220)$$

With this choice of w_0 and w_1 , the advantages of eq. (218) vis-a-vis eq. (217) were now determined by computing P_{11}/V_0 for a sphere using various values of N . Fig. 1 shows percent accuracy and C. P. U. time versus N for each integration scheme. It is apparent that for a given expenditure of C. P. U. time the Gaussian three-point technique is much more accurate than

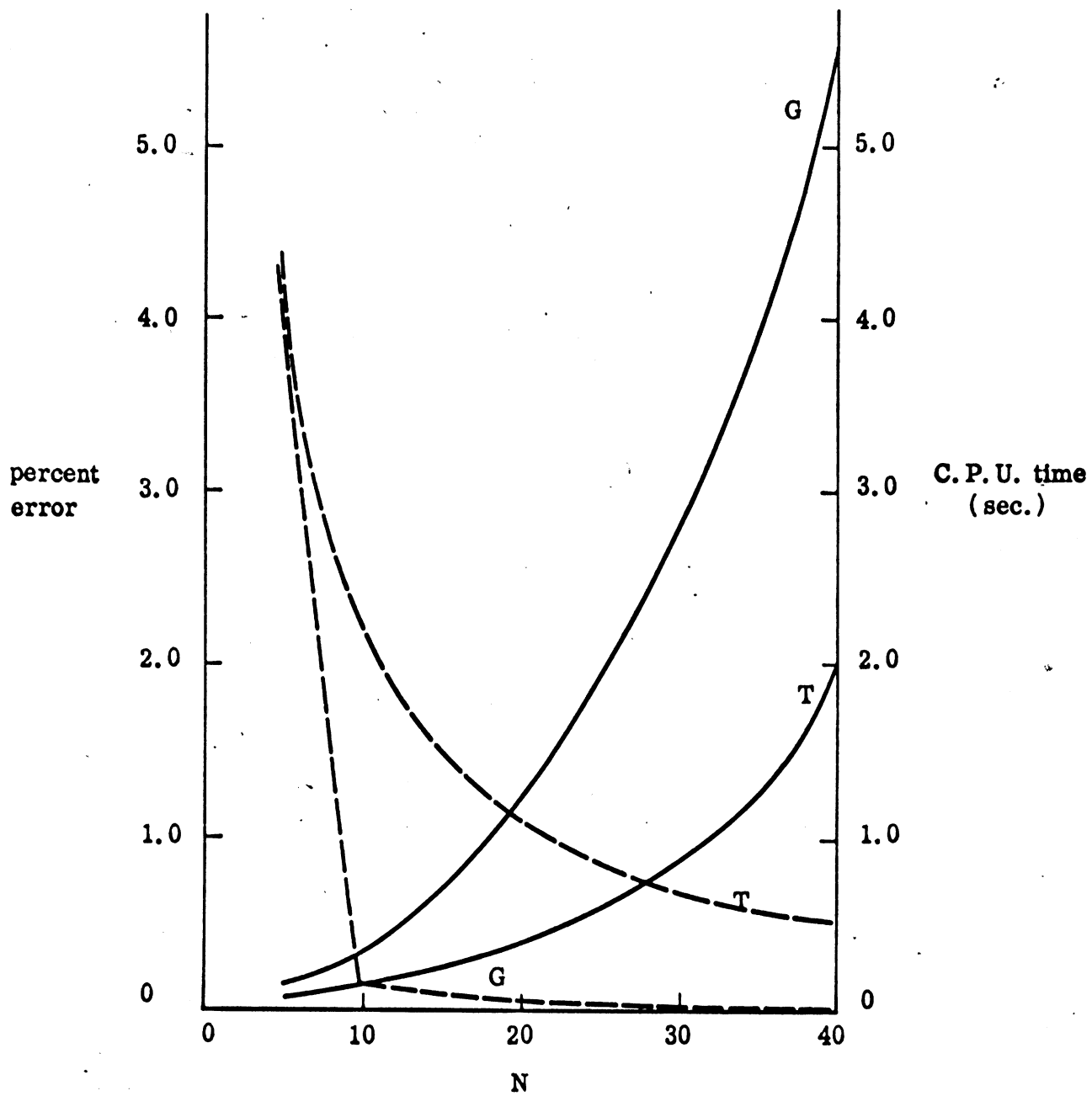

Fig. 1: Percent error and C. P. U. time of P_{11}/V_0 calculation for a sphere: T denotes trapezoidal rule computation and G denotes three-point Gaussian.

the trapezoidal method, though the accuracies of both are severely degraded if N is too small ($N \lesssim 5$). Since the Gaussian scheme with $N = 10$ produces an accuracy of better than 99.8 percent for a sphere, there is no point in going to a more complicated procedure, and the computer program was therefore written using three-point Gaussian quadrature to determine the matrix elements a_{ij} .

In summary, the integral equation (163) is solved by conversion to the matrix system (213) in which

$$a_{ij} = \left[\frac{5}{18} \left\{ \rho_{j-} K_1(i, j-) + \rho_{j+} K_1(i, j+) \right\} + \frac{4}{9} \rho_j K_1(i, j) \right] \Delta s_j$$

$$i, j = 1, 2, \dots, N; i \neq j \quad (221)$$

$$a_{ii} = \left[\ln \left(\frac{16\rho_i}{\Delta s_i} \right) - 1 \right] \Delta s_i, \quad i = 1, 2, \dots, N.$$

Having determined the sampled values $T_1^{(i)} = T_1(s_i)$, P_{11}/V_0 is computed from eq. (164) by integration over each segment of the profile using a second order integration procedure (subroutine INTEG, described in the Appendix).

5.2 P_{33}/V_0 COMPUTATION

The point sampling method of solution of the integral equations (165) and (166) requires us to find the sequences $T_2^{(i)} = T_2(s_i)$ and $T_3^{(i)} = T_3(s_i)$, $i = 1, 2, \dots, N$, from these equations. To determine the $T_2^{(i)}$, choose α_0 , w_0 and w_1 in accordance with (219) and (220) and thence solve the

matrix system $At_2 = b$ where

$$t_{2i} = T_2^{(i)} \quad i = 1, 2, \dots, N \quad (222)$$

$$b_i = 2\pi z_i$$

and

$$a_{ij} = \left[\frac{5}{18} \left\{ \rho_{j-} K_0(i, j-) + \rho_{j+} K_0(i, j+) \right\} + \frac{4}{9} \rho_j K_0(i, j) \right] \Delta s_j$$

$i, j = 1, 2, \dots, N; i \neq j, (223).$

$$a_{ii} = \left[\ln \left(\frac{16\rho_i}{\Delta s_i} \right) + 1 \right] \Delta s_i, \quad i = 1, 2, \dots, N.$$

The $T_3^{(i)}$ are similarly determined by solving the matrix system $At_3 = b$ where the elements a_{ij} are again given by (223), but

$$t_{3i} = T_3^{(i)} \quad i = 1, 2, \dots, N \quad (224)$$

$$b_i = 2\pi.$$

The quantities C/ϵ , γ and P_{33}/V_0 defined in eqs. (167), (168) and (169) respectively are computed using the same second order integration procedure employed in calculating P_{11}/V_0 .

If the body profile consists of two discrete parts, it is also necessary to solve the integral equation (170). The corresponding matrix system is

almost identical to that in (224), and from the sampled values $T_3^{(1)}(s_i)$ and $T_3(s_i)$, $\delta P_{33}/V_0$ (see eq. 171) is computed and, hence, \tilde{P}_{33}/V_0 .

5.3 M_{11}/V_0 COMPUTATION

The basic approach is similar to the above in spite of the more complicated integral equation (172) that must now be solved. The matrix equation for the sampled values $V_4(s_i) = V_4^{(i)}$ is $Av_4 = b$ where

$$v_{4i} = V_4^{(i)} \quad i = 1, 2, \dots, N \quad (225)$$

$$b_i = 2\pi\rho_i$$

and

$$a_{ij} = - \left[\frac{5}{18} \left\{ \rho_{j-} f(i, j-) + \rho_{j+} f(i, j+) \right\} + \frac{4}{9} f(i, j) \right] \Delta s_j \quad i, j = 1, 2, \dots, N; \quad i \neq j, \quad (226)$$

$$a_{ii} = \pi - \int_{s_i - \frac{1}{2} \Delta s_i}^{s_i + \frac{1}{2} \Delta s_i} \rho' f(s') ds' \quad i = 1, 2, \dots, N$$

in which

$$f(i, j) = \left[\rho_i \cos \alpha_j \Omega_2(i, j) + \left\{ (z_j - z_i) \sin \alpha_j - \rho_j \cos \alpha_j \right\} \Omega_1(i, j) \right] \quad i, j = 1, 2, \dots, N; \quad i \neq j. \quad (227)$$

We observe that the computation of each diagonal element of A requires the numerical evaluation of a Cauchy principal value (denoted by the bar across the integral sign in the above expression for a_{ii}). As an approximation to this principal value, we remove from the cell C_i a slice defined by the interval $(s_i - \frac{1}{2} \beta \Delta s_i, s_i + \frac{1}{2} \beta \Delta s_i)$ where β , $0 < \beta \leq 1$, is the fractional exclusion; $\beta = 1$ implies no exclusions, i. e. that the principal value is not taken.

We now have

$$a_{ii} \approx \pi - \int_{s_i - \frac{1}{2} \Delta s_i}^{s_i - \frac{\beta}{2} \Delta s_i} \rho' f(s') ds' - \int_{s_i + \frac{\beta}{2} \Delta s_i}^{s_i + \frac{1}{2} \Delta s_i} \rho' f(s') ds' \quad (228)$$

and these integrals are also computed using three-point Gaussian quadrature.

Defining

$$\begin{aligned} s_{i2} &= s_i - \frac{1}{4} (1+\beta) \Delta s_i \\ s_{i1} &= s_{i2} - \frac{1}{2} \alpha_0 (1-\beta) \Delta s_i \\ s_{i3} &= s_{i2} + \frac{1}{2} \alpha_0 (1-\beta) \Delta s_i \\ s_{i5} &= s_i + \frac{1}{4} (1+\beta) \Delta s_i \\ s_{i4} &= s_{i5} - \frac{1}{2} \alpha_0 (1-\beta) \Delta s_i \\ s_{i6} &= s_{i5} + \frac{1}{2} \alpha_0 (1-\beta) \Delta s_i \end{aligned} \quad (229)$$

we obtain

$$a_{1i} \approx \pi - \frac{1}{2}(1-\beta) \left[\frac{5}{18} \left\{ \rho_{11} f(1,1_1) + \rho_{13} f(1,1_3) + \rho_{14} f(1,1_4) + \rho_{16} f(1,1_6) \right\} + \frac{4}{9} \left\{ \rho_{12} f(1,1_2) + \rho_{15} f(1,1_5) \right\} \right] \Delta s_i \quad (230)$$

Equations (225) through (230) completely describe a system of N linear equations in N unknowns V_{4i} , $i = 1, 2, \dots, N$. Their solution and subsequent integration of the V_{4i} according to eq. (173) yield M_{11}/V_0 .

Experiments were performed to find an appropriate value for the fractional exclusion β . As an example, for a sphere ($M_{11}/V_0 = 1.5$) with $N = 20$, the data in Table 1 were computed. If we exclude the fortuitous (?)

Table 1

β	M_{11}/V_0	percent error
1.0	1.480	-1.33
0.1	1.516	1.07
0.01	1.503	0.18
0.001	1.501	0.08

error zero occurring for β somewhere in the range $0.1 < \beta < 1$, these data indicate that the choice $\beta = 0.001$ is sufficient to keep the error less than 0.1 percent.

5.4 SAMPLING RATE

Increasing the number N of points at which the surface is sampled will generally increase the accuracy of computation, but since the number of matrix elements increases as N^2 and the cost of a linear system solution increases roughly as N^3 , this improvement is obtained at the expense of an increase in computation cost. Unfortunately, there is no rule for specifying the minimum value of N sufficient for a given accuracy, and the information which follows is based only on our experience in using the program.

The results in Fig. 1 and Table 1 show that for a sphere P_{11}/V_0 and M_{11}/V_0 are accurately determined with N as small as 20, and this is also true of P_{33}/V_0 . On the other hand, if the body has a discontinuity in $d\rho/dz$ lying off the axis, it appears necessary to increase N to 50 or more to maintain the same accuracy (error $\lesssim 0.5$ percent) in the P_{11}/V_0 and P_{33}/V_0 computations. This is illustrated by the results in Table 2 for

Table 2

N	N_1	N_2	P_{11}/V_0
11	7	4	2.752
20	15	5	2.801
40	30	10	2.872
70	50	20	2.888

Note: N_1 is the number of sampling points on the generator of the cone (linear segment) and N_2 is the number on the (half) base (circular arc segment).

a rounded cone with half angle 15° . The small but not negligible (0.58 percent) change in P_{11}/V_0 as N increases from 40 to 70 suggests that such large values of N may be essential for bodies such as this for which $T_1(s)$, $T_2(s)$ and $T_3(s)$ have infinities at one or more points on the profile.

For the same rounded cone, the results for M_{11}/V_0 are given in Table 3. Since an increase in N from 17 to 35 produces only an insignifi-

Table 3

N	N_1	N_2	M_{11}/V_0
17	10	7	1.680
35	25	10	1.678

cant change in M_{11}/V_0 , the choice $N = 20$ is now adequate. Observe that the surface field $V_4(s)$ associated with M_{11}/V_0 does not become infinite at a discontinuity in $d\rho/dz$, and this is undoubtedly the reason why in many cases a small value of N now produces the same accuracy as does a much larger value in the P_{11}/V_0 and P_{33}/V_0 computations. No attempt has been made to exploit this finding in the general program.

When treating bodies composed of several segments, a strategy which has proved successful is to divide all segments into cells of approximately equal length. This serves to fix the allocation of any given number N of sampling points among the various segments. Tests so far performed have not conclusively shown the advantages of dividing a single segment into two or more smaller segments so as to effect a non-uniform sampling. It is, however, believed that such a sub-division may, for a given N , improve

accuracy in the P_{11}/V_0 and P_{33}/V_0 computations for bodies like the rounded cone having infinities in the surface field quantities.

6. CONCLUDING REMARKS

We have here considered the low frequency scattering of electromagnetic and acoustic waves by axially symmetric bodies. By concentrating on certain quantities such as the normalised components of the induced electric and magnetic dipole moments, we have shown how it is possible to arrive at rather elegant expressions for the far zone scattered field in terms of quantities which are functions only of the geometry of the body. Each such quantity is expressible as a weighted integral of an elementary potential function which can be found by solving an integral equation.

A computer program has been written to solve these equations by the moment method and to calculate the dipole moments, the electrostatic capacity, and a further parameter γ related to the capacity. Any body can be treated whose profile is made up of straight line and circular arc segments and it is even possible to have two distinct bodies with or without an electrical connection between them. Although no serious attempt has been made to optimise the program, only a few seconds are required to compute all of the above quantities to an accuracy of better than one half percent.

We have already used the program to compute the scattering from a variety of shapes, and it may be helpful to list some of the results obtained so far. Data for a rounded cone consisting of the intersection of a cone of half angle θ with a sphere centered on the apex are given in Table 4. l/w is the length-to-width ratio of the body. For $\theta < 90^\circ$, the values of P_{11}/V_0 and P_{33}/V_0 are quite similar to those previously computed by Senior (1971) using a mode matching method, but since M_{11}/V_0 showed significant discrepancies, this quantity was determined for a variety of θ . Detailed checking has confirmed that the present data are accurate

Table 4: Rounded Cones

θ (deg.)	l/w	V_0	P_{11}/V_0	P_{33}/V_0	M_{11}/V_0	$C_{\rho}/(\epsilon\sqrt{l/w})$
3	9.554	0.002870			1.884	
7.5	3.837	0.01792			1.813	
15	1.932	0.07137	2.865	8.147	1.678	
30	1.000	0.2806	3.664	3.494	1.484	5.406
45	0.7071	0.6134			1.366	
60	0.5774	1.047	4.520	1.931	1.312	6.386
80	0.5321	1.731			1.334	
90	0.5000	2.094	4.428	2.184	1.373	
93	0.5262	2.204	4.368	2.242	1.386	7.428
99.2	0.5799	2.429	4.261	2.372	1.416	7.303
108	0.6545	2.742	4.071	2.553	1.458	7.123
120	0.7500	3.142	3.789	2.769	1.507	6.889
140	0.8830	3.699	3.370	3.006	1.547	6.586
151.7	0.9402	3.938	3.187	3.042	1.540	6.441
180	1.0	4.189	3.0	3.0	1.5	6.283

to three significant figures. When $\theta = 90^\circ$ the body is a hemisphere for which precise values of P_{11}/V_0 and P_{33}/V_0 are available: $P_{11}/V_0 = 4.430\dots$, $P_{33}/V_0 = 2.189\dots$ (Schiffer and Szegő, 1949, p. 152). The corresponding values in Table 4 are within 0.2 per cent of these. For $\theta > 90^\circ$ the cone is a re-entrant one, i.e. a sphere with a conical region removed, and when $\theta = 180^\circ$ the body is a sphere for which exact data are also known.

Results for ogives and symmetrical lenses whose arcs subtend an angle θ at their centers of curvature are shown in Table 5. The transitional shape is a sphere for which $\theta = 180^\circ$.

To illustrate the computations when two bodies are present, Table 6 gives data for two identical spheres separated by a distance ϵd where d is the sphere diameter. When the two spheres are touching ($\epsilon = 0$) it is known that $P_{33}/P_{11} = 8/3$ (Schiffer and Szegő, 1949, p. 154); the ratio deduced from Table 6 is 2.678, which is within 0.4 per cent of the exact value. As ϵ increases, P_{11}/V_0 , M_{11}/V_0 and \tilde{P}_{33}/V_0 rapidly approach the values appropriate to a single sphere in isolation. P_{33}/V_0 , on the other hand, is proportional to the axial component of the induced electric dipole moment for two spheres which are electrically connected by an infinitesimal wire, and with increasing ϵ this increases indefinitely, as expected (Kleinman and Senior, 1972). The same is true of $C/(\epsilon V_0)$. The parameter γ has also been included in Table 6, and since its exact value can be shown to be $-(1 + \epsilon/2)$, the accuracy of computation can be judged.

Table 5: Ogives and Lenses

Shape	$\theta(\text{deg.})$	l/w	V_0	P_{11}/V_0	P_{33}/V_0	M_{11}/V_0	$C/(\epsilon\sqrt{lw})$
ogive	22.8	10.02	0.004146	2.089	49.88	1.943	6.128
	36	6.314	0.01058	2.100	24.15	1.910	5.696
	56	4.011	0.02650	2.189	12.57	1.843	5.451
	88	2.475	0.07148	2.363	6.778	1.739	5.424
	132	1.540	0.1966	2.647	4.136	1.611	5.696
sphere	150	1.303	0.2847	2.775	3.595	1.564	5.880
	180	1	0.5236	3	3	1.5	6.283
	64.4	0.6297	1.212	3.779	2.161	1.368	6.570
	43.6	0.4000	2.586	5.182	1.674	1.252	7.375
	28	0.2493	6.448	7.649	1.390		8.758
lens	17.2	0.1512	17.30	11.88	1.225	1.098	10.759
	11.4	0.09981	39.55	17.49	1.144	1.061	12.982

Table 6: Two Spheres

ϵ	P_{11}/V_0	P_{33}/V_0	\tilde{P}_{33}/V_0	M_{11}/V_0	$C/(\epsilon\sqrt{\ell w})$	γ
0	2.702	7.237	7.237	1.605	6.153	-1.0004
0.005	2.706	7.280	5.021	1.586	6.151	-1.0029
0.01	2.709	7.319	4.800		6.150	-1.0054
0.02	2.715	7.402	4.557	1.607	6.148	-1.0100
0.05	2.732	7.655	4.210	1.592	6.141	-1.0250
0.1	2.759	8.026	3.922	1.579	6.130	-1.0503
0.5	2.891	12.02	3.299	1.528	6.015	-1.2502
1.0	2.950	18.19	3.142	1.511	5.822	-1.5001
5.0	2.994	120.6	3.045	1.500	4.384	-3.5001
10.0	3.002	383.1	3.046	<u>1.501</u>	3.470	-6.0000

REFERENCES

- Abramowitz, M. and I. A. Stegun (Eds.) (1964), Handbook of Mathematical Functions, NBS Appl. Math. Series No. 55.
- Forsythe, G. and C. B. Moler (1967), Computer Solution of Linear Algebraic Systems, Prentice Hall, Englewood Cliffs.
- Jahnke, E. and F. Emde (1945), Tables of Functions, Dover, New York.
- Karp, S. N. (1956), Relation of Electric and Magnetic Dipole Moments (abstract only), Quart. Status Report No. 1, Contract AF 19(604)1717, Institute of Mathematical Sciences, New York University.
- Keller, J. B., R. E. Kleinman and T. B. A. Senior (1972), Dipole Moments in Rayleigh Scattering, J. Inst. Math. and Applics. (to be published).
- Kleinman, R. E. (1965), The Rayleigh Region, Proc. IEEE 53, No. 8, 848-856.
- Kleinman, R. E. and T. B. A. Senior (1972), Rayleigh Scattering Cross Sections (to be published).
- Mautz, J. R. and R. F. Harrington (1970), Computation of Rotationally Symmetric Laplacian Potentials, Proc. IEE (London) 117, 850-852.
- Payne, L. E. (1956), New Isoperimetric Inequalities for Eigenvalues and Other Physical Quantities, Comm. Pure Appl. Math. 9, 531-542.
- Schiffer, M. and G. Szegö (1949), Virtual Mass and Polarization, Trans. Amer. Math. Soc. 67, 130-205.
- Senior, T. B. A. (1971), Low Frequency Scattering by a Finite Cone, Appl. Sci. Res. 23, 459-474.
- Van Bladel, J. (1968), On Low Frequency Scattering by Hard and Soft Bodies, J. Acoust. Soc. Amer. 44, 1069-1073.

APPENDIX: THE COMPUTER PROGRAM

The program computes P_{11}/V_0 , C/ϵ , γ , P_{33}/V_0 , M_{11}/V_0 and, where appropriate, \tilde{P}_{33}/V_0 , and consists of a main program and six subroutines.

A.1 DATA SET

A data set is made up of one control card and a number of segment specification cards, one for each segment (or sub-segment) of the profile. The segment specifications conform to the convention stated in Section 4.3.

Control Card

Columns	Description
1	The number (1 or 2) of bodies.
3-4	Two digit integer (right justified): the number of segments on the first body (the body to the left). When there is only one body, use these columns.
6-7	Same as columns 3-4, but for body to the right.
9	A printing key: 1: print T_3 from P_{33}/V_0 computation. 0 or blank: do not print T_3 .

- 11 A computation key (0, blank or 1)
 1: suppresses computation of P_{11}/V_0 ,
 C/ϵ , γ , P_{33}/V_0 .
- 13 A computation key (0, blank or 1)
 1: suppresses computation of M_{11}/V_0 .
- 21-30 A real number: the fractional exclusion β .
 If these columns are blank, β defaults to
 0.001.

Segment Specification Card

Columns	Description
1-2	Two digit integer (right justified): the number of sampling points or cells on the segment.
4	Segment type key: 1: circular arc, concave down 2: circular arc, concave up 3: linear.
6	Volume sense: + or blank: additive volume - : subtractive volume.
11-20, 21-30	Two real numbers: respectively, the end coordinates z_1 and z_2 of the segment.

31-40, 41-50

Two real numbers: respectively, the end coordinates ρ_1 and ρ_2 of the segment.

51-60

A real number: for circular arcs, the included angle in degrees.

There are the following restrictions:

- (i) the total number of segments must not exceed 15,
 - and (ii) the total number of cells over all segments must not exceed 80.
- The profile is specified in the direction of increasing profile-length, beginning at its left-hand intersection with the z-axis and ending at its right-hand intersection with the z-axis. Re-entrant segments are permitted, allowing $z_1 > z_2$.

A.2 MAIN PROGRAM

The main program reads and prints data and supervises all computations. A rough flow chart showing the interaction of the subroutines is given below

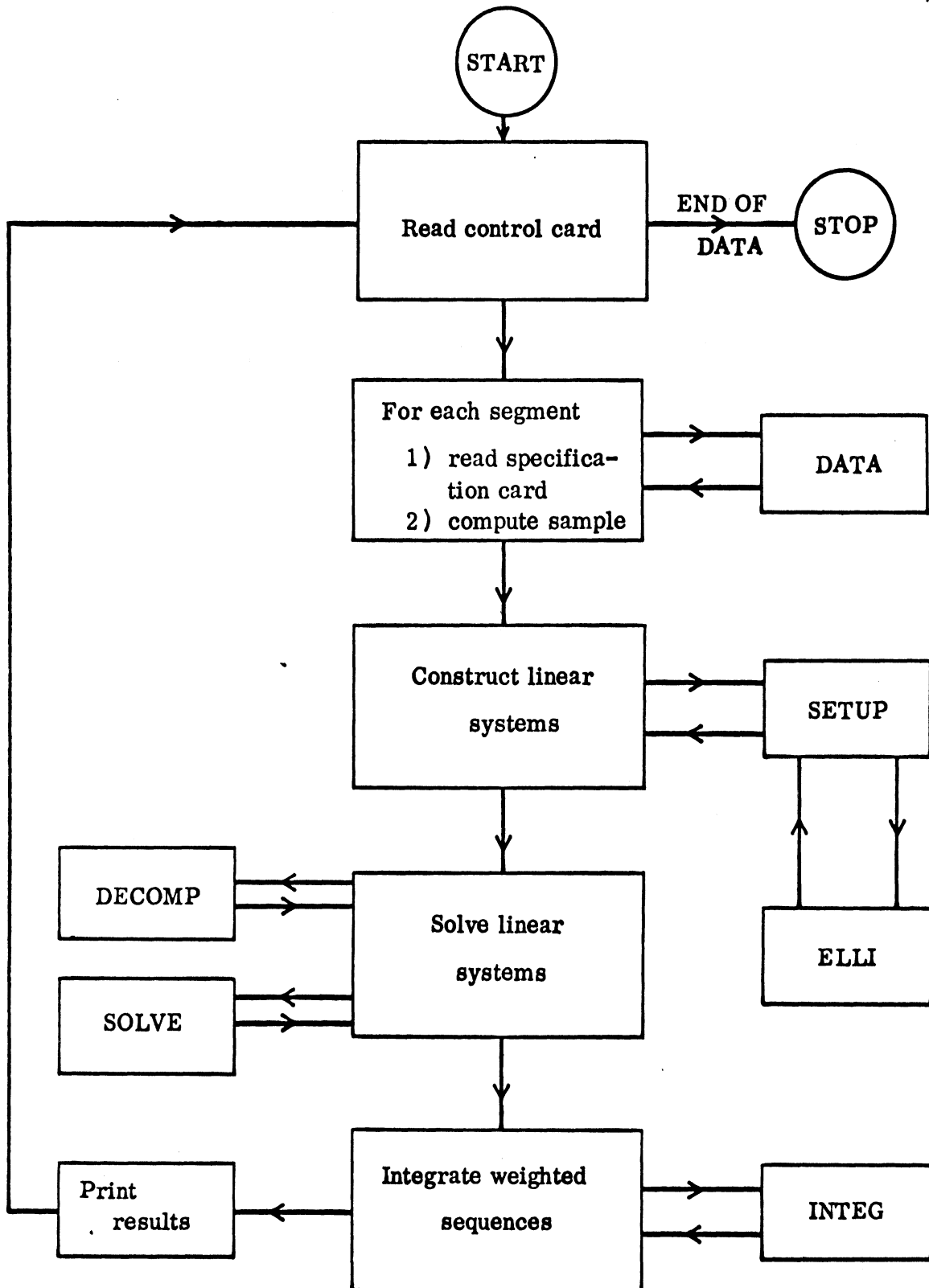

```

REAL AP11(80,80),AP33(80,80),AM11(80,80),X(80),B(80),
6 ZEP(2),RHOEP(2),ST3(6),T3(80),M11,T1(80)
INTEGER NUMPTS(15),PLUS/'+'/,RL/' '/,INDX(2)
COMMON RHO(80,9),Z(80,9),ARC(80),C(80,9),S(80,9)/SUL/IPS(80)
DATA MIN,TWOPI,PI,W0,W1/'-',6.283185,3.141593,.4444444,.2777777/
37 READ(5,34,END=999)NR0D,NS1,NS2,IPRINT,KEYP11,KEYM11,FR
34 FORMAT(I1,1X,2(I2,1X),3(I1,1X),6X,F12.7)
WRITE(6,4)NR0D,NS1
4 FORMAT('1*** BEGINNING OF DATA SET:/'/'0',5X,'BODIES',6X,'=',I2/
5 ' ',5X,'SEGMENTS:/'/' ',5X,'BODY #1',5X,'=',I2)
IF(NR0D .LE. 0 .OR. NR0D .GT. 2) GO TO 990
NSEGS=NS1+NS2
IF(NR0D .EQ. 2) WRITE(6,1)NS2
1 FORMAT(' ',5X,'BODY #2',5X,'=',I2)
IF(NR0D .EQ. 1) GO TO 10
IF(NS1 .LE. 0 .OR. NS2 .LE. 0) GO TO 990
10 IF(NSEGS .LE. 0 .OR. NSEGS .GT. 15) GO TO 990
WRITE(6,352)IPRINT,KEYP11,KEYM11
352 FORMAT(' ',5X,'PRINT KEY',3X,'=',I2/' ',5X,'COMP KEY P''S=',I2/
6 ' ',5X,'COMP KEY M''S=',I2)
IF(FR .LE. 0 .OR. FR .GT. 1.) FR=.001
IF(KEYM11 .EQ. 0) WRITE(6,5)FR
5 FORMAT(' ',5X,'EXCLUSION =',F7.4)
IF(KEYP11 .NE. 0 .AND. KEYM11 .NE. 0) GO TO 990
M=0
NC1=0
V0=0.0
DO 11 I=1,NSEGS
READ(5,12) NUMPTS(I),ITYP,ISIGN,ZEP,RHOEP,THETA
12 FORMAT(I2,1X,I1,1X,A1,4X,5F10.7)
IF(NUMPTS(I) .LE. 0 .OR. ITYP .LE. 0 .OR. ITYP .GT. 3) GO TO 990
IF(ISIGN .EQ. BL) ISIGN=PLUS
WRITE(6,13)I,NUMPTS(I),ITYP,ISIGN,ZEP,RHOEP
13 FORMAT('0SEGMENT #',I2,':/'/' ',5X,'CELLS',7X,'=',I2/' ',5X,
6 'TYPE KEY',4X,'=',I2/' ',5X,'VOLUME SENSE=',A4/' ',5X,
8 'Z-COORDINATE END POINTS =(' ',F12.7,' ',' ',F12.7,')/'/' ',5X,
5 'RHO-COORDINATE END POINTS=(' ',F12.7,' ',' ',F12.7,')')
IF(ITYP .NE. 3) WRITE(6,14) THETA
14 FORMAT(' ',5X,'THETA (DEG) =',F10.5)
IF(KEYM11 .EQ. 1) FR=1.0
N=M
THETA=PI*THETA/180.
M=M+NUMPTS(I)
IF(I .LE. NS1) NC1=NC1+NUMPTS(I)
IF(M .GT. 80) GO TO 990
CALL DATA(ITYP,N,M,ZEP,RHOEP,THETA,FR,VOLINC)
IF(ITYP .NE. 3 .AND. ISIGN .EQ. MIN) VOLINC=-VOLINC
11 V0=V0+VOLINC
WRITE(6,52)V0
52 FORMAT('0COMPUTED RESULTS:/'/' ',5X,'VOLUME',6X,'=',F10.5)

```

```
      DO 2 N=1,M
      INDX(1)=N
      AN=ARC(N)
      TN=RHO(N,8)
      DO 3 L=N,M
      IF(L .EQ. N) GO TO 82
      AL=ARC(L)
      TL=RHO(L,8)
      IF(KEYM11-1)110,109,109
110   AM11(N,L)=0.0
      AM11(L,N)=0.0
      IF(KEYP11-1)111,112,112
111   AP11(N,L)=0.0
      AP11(L,N)=0.0
      AP33(N,L)=0.0
      AP33(L,N)=0.0
112   INDX(2)=L
```



```

      DO 103 J=1,3,2
      JP6=J+6
      DO 104 LL=1,2
      I=3-LL
      I1=INDEX(LL)
      I2=INDEX(I)
      TI2=RHO(I2,JP6)
      CALL SETUP(KEYP11,KEYM11,I1,I2,JP6,API11,API33,AM11,1)
      IF(KEYP11-1)105,106,106
105  AP11(I1,I2)=AP11(I1,I2)+API11*TI2
      AP33(I1,I2)=AP33(I1,I2)+API33*TI2
106  IF(KEYM11-1)107,104,104
107  AM11(I1,I2)=AM11(I1,I2)-AM11*TI2
104  CONTINUE
103  CONTINUE
      CALL SETUP(KEYP11,KEYM11,N,L,8,API11,API33,AM11,1)
      IF(KEYP11-1)108,209,209
108  U=W0*API11
      AP11(N,L)=AL*(W1*AP11(N,L)+U*TL)
      AP11(L,N)=AN*(W1*AP11(L,N)+U*TN)
      U=W0*API33
      AP33(N,L)=AL*(W1*AP33(N,L)+U*TL)
      AP33(L,N)=AN*(W1*AP33(L,N)+U*TN)
209  IF(KEYM11-1)210,3,3
210  AM11(N,L)=AL*(W1*AM11(N,L)-AM11*W0*TL)
      CALL SETUP(1,0,L,N,8,API11,API33,AM11,0)
      AM11(L,N)=AN*(W1*AM11(L,N)-AM11*W0*TN)
      GO TO 3
82  IF(KEYP11-1)83,84,84
83  U=ALOG(16.*TN/AN)
      AP11(N,N)=(U-1.0)*AN
      AP33(N,N)=(U+1.0)*AN
84  IF(KEYM11-1)85,3,3
85  IF(FR .EQ. 1.0) GO TO 3
      DO 86 I=1,6
86  CALL SETUP(1,0,N,N,I,U,U,ST3(I),1)
      U=.5*(1.0-FR)*AN
      AM11(N,N)=PI-U*(W0*(RHO(N,2)*ST3(2)+RHO(N,5)*ST3(5))
3  +W1*(RHO(N,1)*ST3(1)+RHO(N,3)*ST3(3)+RHO(N,4)*ST3(4)+
4  RHO(N,6)*ST3(6)))
3  CONTINUE
2  CONTINUE

```

```

      DO 20 I=1,M
20    R(I)=TWOPI*RHO(I,8)
      IF(KEYP11-1)21,24,24
21    CALL DECOMP(AP11,M)
      CALL SOLVE(AP11,X,B,M)
      DO 22 I=1,M
22    X(I)=RHO(I,8)**2*X(I)
      CALL INTEG(X,NSEGS,NUMPTS,P11)
      P11=P11*PI/VO
24    IF(KEYM11-1)25,28,28
25    CALL DECOMP(AM11,M)
      CALL SOLVE(AM11,X,B,M)
      DO 26 I=1,M
26    X(I)=RHO(I,8)*C(I,8)*X(I)
      CALL INTEG(X,NSEGS,NUMPTS,M11)
      M11=PI*M11/VO
28    IF(KEYP11-1)32,45,45
32    DO 29 I=1,M
29    B(I)=TWOPI*Z(I,8)
      CALL DECOMP(AP33,M)
      CALL SOLVE(AP33,X,B,M)
      DO 134 I=1,M
134   X(I)=Z(I,8)*RHO(I,8)*X(I)
      B(I)=TWOPI
      CALL INTEG(X,NSEGS,NUMPTS,P33)
      CALL SOLVE(AP33,T3,B,M)
      DO 35 I=1,M
35    X(I)=RHO(I,8)*T3(I)
      B(I)=Z(I,8)*X(I)
      CALL INTEG(X,NSEGS,NUMPTS,CAP)
      CAP=TWOPI*CAP
      CALL INTEG(B,NSEGS,NUMPTS,GAM)
      GAM=-TWOPI*GAM/CAP
      P33=(TWOPI*P33-CAP*GAM*GAM)/VO
      IF(NBOD - 1) 39,39,54
54    DO 36 I=1,M
      IF(I-NC1)305,305,306
305   B(I)=TWOPI
      GO TO 36
306   B(I)=0.0
36    CONTINUE

```

```

CALL SOLVE(AP33,T1,B,M)
DO 307 I=1,M
307 X(I)=RHO(I,8)*T1(I)
CALL INTEG(X,NSEGS,NUMPTS,TL)
CALL INTEG(X,NS1,NUMPTS,TN)
DO 308 I=1,M
308 X(I)=Z(I,8)*X(I)
CALL INTEG(X,NSEGS,NUMPTS,U)
DELTAP=-((TWOPI/VO)*(U+GAM*TL)**2/(TN-TWOPI*TL*TL/CAP)
U=P33+DELTAP
39 WRITE(6,40)CAP,GAM,P11,P33
40 FORMAT(' ',5X,'CAPACITANCE =',F10.5/' ',5X,'GAMMA',7X,'=',F10.5/
8 ' ',5X,'P11/V',7X,'=',F10.5/' ',5X,'P33/V',7X,'=',F10.5)
IF(NBOD .EQ. 2)WRITE(6,309)DELTAP,U
309 FORMAT(' ',5X,'DELT P33/V',2X,'=',F10.5/' ',5X,'DISJNT P33/V=',
6 F10.5)
45 IF(KEYM11-1)42,337,337
42 WRITE(6,43)M11
43 FORMAT(' ',5X,'M11/V',7X,'=',F10.5)
337 IF(IPRINT .EQ. 1 .AND. KEYP11 .EQ. 0) WRITE(6,44)
6 (Z(I,8),RHO(I,8),T3(I),I=1,M)
44 FORMAT('0',5X,'Z',10X,'RHO',12X,'T3'/' ',3(F12.6,2X))
GO TO 37
990 WRITE(6,991)
991 FORMAT('0*** ERROR IN DATA')
999 CALL SYSTEM
END

```

A.3 SUBROUTINE DATA (IN, MX, MY, ZEP, RHOEP, THETA, B, VOL)

This subroutine is called once for each segment of the profile. From the input specification for the segment, DATA computes the (z, ρ) coordinates of the necessary sampling points on the profile, the quantities $\cos \alpha$ and $\sin \alpha$ at these points and the incremental volume of the segment.

Arguments :

IN	Type key for segment.
MX	Total number of cells in segments to the left.
MY	MX + (number of cells in this segment).
ZEP	z - coordinate end points of segment: ZEP (1) = z_1 , ZEP (2) = z_2 .
RHOEP	ρ - coordinate end points of segment: RHOEP (1) = ρ_1 , RHOEP (2) = ρ_2 .
THETA	Angle (in radians) subtended by a circular arc at its center.
B	Fractional exclusion, β .
VOL	Incremental volume of segment.

Comments :

Stored in COMMON are the arrays RHO (80, 9), Z (80, 9), ARC (80), C (80, 9) and S (80, 9) which contain the numbers computed by DATA.

For the Ith cell, the subscripts (I, J) correspond to the points s_{ij} of (229) when $1 \leq J \leq 6$. For $J = 7, 8, 9$, the subscripts (I, J) refer to the points s_{i-} , s_i and s_{i+} respectively of (211).

```

SUBROUTINE DATA(IN,MX,MY,ZEP,RHOEP,THETA,B,VOL)
DIMENSION ZEP(2),RHOEP(2)
COMMON RHO(80,9),Z(80,9),ARC(80),C(80,9),S(80,9)
DATA STEP/.3872988/
MXP1=MX+1
EN=FLOAT(MY-MX)
IF(B .NE. 1) SUBSTP=.5*(1.0-B)*STEP
IF(IN-2)1,2,3
1  CC=-1.0
   GO TO 10
2  CC=1.0
10 ST2=SIN(THETA/2.0)
   A=ZEP(2)-ZEP(1)
   RAD=0.5*SQRT((RHOEP(1)-RHOEP(2))**2+A*A)/ST2
   DD=A/ABS(A)
   T=CC*DD*COS(THETA/2.)/ST2
   ZCNT=0.5*(ZEP(1)+ZEP(2)+T*(RHOEP(1)-RHOEP(2)))
   RHOCNT=0.5*(RHOEP(1)+RHOEP(2)+T*A)
   U2=ZEP(2)-ZCNT
   U1=ZEP(1)-ZCNT
   VOL=3.141593*ABS(A*(RHOCNT**2+RAD*RAD-(U2**2+U1*U2+U1**2)/3.0)
3  -CC*RHOCNT*(U2*(RHOEP(2)-RHOCNT)-U1*(RHOEP(1)-RHOCNT) +RAD*RAD
3  *DD*THETA))
   BETA=CC*DD*THETA/EN
   THET1=ATAN2(RHOEP(1)-RHOCNT,ZEP(1)-ZCNT)
   U=ABS(BETA*RAD)
   B3=STEP*BETA
   DO 902 I=MXP1,MY
   PHI=THET1+(I-MX-.5)*BETA
   IF(B .EQ. 1.0) GO TO 1905
   DO 1902 J=1,2
   ANG=PHI+.5*(J-1.5)*BETA*(1.0+B)
   DO 1903 L=1,3
   PSI=ANG+(L-2)*SUBSTP*BETA
   M=L+3*(J-1)
   C(I,M)=-CC*SIN(PSI)
   S(I,M)=CC*COS(PSI)
   Z(I,M)=ZCNT+RAD*CC*S(I,M)
1903 RHO(I,M)=RHOCNT-CC*RAD*C(I,M)
1902 CONTINUE
1905 DO 903 J=7,9
   ANG=PHI+(J-8)*B3
   C(I,J)=-CC*SIN(ANG)
   S(I,J)=CC*COS(ANG)
   Z(I,J)=ZCNT+RAD*CC*S(I,J)
903  RHO(I,J)=RHOCNT-CC*RAD*C(I,J)
902  ARC(I)=U
   RETURN

```

```

3      DX=(ZEP(2)-ZEP(1))/EN
      DY=(RHOEP(2)-RHOEP(1))/EN
      U  =SQRT(DX*DX+DY*DY)
      SI=DY/U
      CI=DX/U
      DO 917 I=MXP1,MY
      PHI=FLOAT(I-MX)-.5
      IF( B .EQ. 1.0) GO TO 1800
      DO 1802 J=1,2
      ANG=PHI+.5*(J-1.5)*(1.0+B)
      DO 1803 L=1,3
      M=L+3*(J-1)
      PSI=ANG+(L-2)*SUBSTP
      Z(I,M)=ZEP(1)+PSI*DX
      RHO(I,M)=RHOEP(1)+PSI*DY
      S(I,M)=SI
1803   C(I,M)=CI
1802   CONTINUE
1800   DO 913 J=7,9
      ANG=PHI+(J-8)*STEP
      Z(I,J)=ZEP(1)+ANG*DX
      RHO(I,J)=RHOEP(1)+ANG*DY
      C(I,J)=CI
913    S(I,J)=SI
917    ARC(I)=U
      VOL=1.047198*(ZEP(2)-ZEP(1))*(RHOEP(1)**2+RHOEP(1)*RHOEP(2)+
8 RHOEP(2)**2)
      RETURN
      END

```

A.4 SUBROUTINE INTEG (V, NSEG, NUMPTS, SUM)

INTEG numerically integrates quadratic interpolating polynomials approximating the data on each segment of the profile. When the profile is composed of several segments, no interpolation is performed across segment boundaries. Hence, the integration is accurate even for disconnected segments, e. g. the circular arcs of two spheres.

Arguments :

V	Real vector of function values, ordered as the cells.
NSEG	Total number of segments in the profile.
NUMPTS	Integer array containing in NUMPTS (I) the number of cells on the Ith segment: $I = 1, \dots, NSEG$.
SUM	Integral of V across the profile.

Comments :

Stored in COMMON are the arc lengths $ARC(I)$, $I = 1, \dots, N$ required to compute the integral.

```

SUBROUTINE INTEG(V,NSEG,NUMPTS,SUM)
COMMON RHO(80,9),Z(80,9),ARC(80),C(80,9),S(80,9)
DIMENSION V(80),NUMPTS(15)
SUM=0.0
JACC=1
DO 3000 I=1,NSEG
T=ARC(JACC)
L=NUMPTS(I)
N=I+JACC-1
SUM=SUM+T*(0.625*(V(JACC)+V(N))-0.125*(V(JACC+1)+V(N-1)))
IF(L/2 .NE. (L+1)/2) GO TO 3001
SUM=SUM+T*(0.666667*V(N-1)-0.08333333*V(N-2)+0.416667*V(N))
3001 LM1=N-1
JL0=JACC+1
DO 3002 J=JL0,LM1,2
3002 SUM=SUM+0.3333333*T*(V(J-1)+4.0*V(J)+V(J+1))
3000 JACC=JACC+L
RETURN
END

```

A.5 SUBROUTINES DECOMP (A, N) AND SOLVE (A, X, B, N)

Used together, DECOMP and SOLVE solve the linear system $AX = B$. DECOMP performs a L-U decomposition of the $N \times N$ matrix A and SOLVE performs back-substitution. These routines are adapted from Forsythe and Moler (1967, pp. 68-69).

```

SUBROUTINE DECOMP(UL,N)
DIMENSION UL(80,80)
COMMON /SOL/IPS(80)
DO 5 I=1,N
5  IPS(I)=I
   NM1=N-1
   DO 16 K=1,NM1
   BIF=0.0
   DO 11 I=K,N
   IP=IPS(I)
   IF(ABS(UL(IP,K)) .LE. BIF) GO TO 11
   BIF=ABS(UL(IP,K))
   IDXPIV=I
11  CONTINUE
   IF(IDXPIV .EQ. K) GO TO 15
   J=IPS(K)
   IPS(K)=IPS(IDXPIV)
   IPS(IDXPIV)=J
15  KP=IPS(K)
   PIVOT=UL(KP,K)
   KP1=K+1
   DO 16 I=KP1,N
   IP=IPS(I)
   EM=-UL(IP,K)/PIVOT
   UL(IP,K)=EM
   DO 16 J=KP1,N
   UL(IP,J)=UL(IP,J)+EM*UL(KP,J)
16  CONTINUE
   RETURN
   END

```

```

SUBROUTINE SOLVE(UL,X,B,N)
DIMENSION UL(80,80),B(80),X(80)
COMMON /SOL/IPS(80)
NP1=N+1
IP=IPS(1)
X(1)=B(IP)
DO 2 I=2,N
IP=IPS(I)
IM1=I-1
SUM=0.
DO 1 J=1,IM1
1 SUM=SUM+UL(IP,J)*X(J)
2 X(I)=B(IP)-SUM
IP=IPS(N)
X(N)=X(N)/UL(IP,N)
DO 4 IBACK=2,N
I=NP1-IBACK
IP=IPS(I)
IP1=I+1
SUM=0.0
DO 3 J=IP1,N
3 SUM=SUM+UL(IP,J)*X(J)
4 X(I)=(X(I)-SUM)/UL(IP,I)
RETURN
END

```

A.6 SUBROUTINE ELLI (M1, K, E, KPR, KEY)

This computes the elliptic integrals $K(m)$ and $E(m)$ and the derivative $K'(m)$ from their power series approximations (see Section 4.2).

Arguments:

M1	Real, the quantity $(1 - m)$.
K	Real, $K(m)$.
E	Real, $E(m)$.
KPR	Real, $K'(m)$.
KEY	Integer: 0 Compute K, E and KPR; 1 Compute K, E but omit KPR.

```

SUBROUTINE ELLI(M1,K,E,KPR,KEY)
REAL M1,K,KPR
T=-ALOG(M1)
K=1.386294+.5*T+M1*(9.666344E-2+.1249859*T+M1*(3.590092E-2
5 +6.880249E-2*T+M1*(3.742564E-2+3.328355E-2*T+M1*(1.451196E-2
5 +4.41787E-3*T))))
E=1.0+M1*(.4432514+.2499837*T+M1*(6.260601E-2+9.20018E-2*T+M1*(
8 4.757384E-2+4.069698E-2*T+M1*(1.736506E-2+5.264496E-3*T))))
IF(KEY .EQ. 1) RETURN
KPR=.5/M1 + 2.83225E-2 - .1249859*T + M1*(-2.999362E-3-.137605*T
6 +M1*(-7.899336E-2 - 9.985066E-2*T + M1*(-5.362998E-2 -
5 1.767148E-2 * T )))
RETURN
END

```

A.7 SUBROUTINE SETUP (KEYP11, KEYM11, I, J, L, API11, API33, AMI11, IJ)

This is essential in computing the linear systems. Specifically SETUP, after calling ELLI, computes the quantities API11 (K_1 of eq. 182), API33 (K_0 of eq. 178), Ω_1 (eq. 196) and Ω_2 (eq. 197). The quantities Ω_1 and Ω_2 are used to compute $f(i, j)$ (AMI11) of eq. (227).

Arguments :

KEYP11	0 when computing API11 and API33, else 1.
KEYM11	0 when computing AMI11, else 1.
I	Subscript of observer (unprimed) cell.
J	Subscript of remote (primed) cell.
L	Index of the point within remote cell for which the kernels are to be computed (see DATA, Comments).
API11, API33 AMI11	Described above
IJ	0: use last value of M1 in kernel computations; 1: compute new M1.

```

SUBROUTINE SETUP(KEYP11,KEYM11,I,J,L,API11,API33,AMI11,IJ)
COMMON RHO(80,9),Z(80,9),ARC(80),C(80,9),S(80,9)
REAL M,M1,K,KPR
ZD=Z(J,L)-Z(I,8)
R=RHO(I,8)
RP=RHO(J,L)
IF(IJ .EQ. 0) GO TO 115
RRP=R*RP
A1=RRP+RRP
A2=R*R+RP*RP+ZD*ZD
M1=(A2-A1)/(A2+A1)
M=1.-M1
CALL ELLI(M1,K,E,KPR,KEYM11)
A0=M/RRP
A1=SQRT(A0)
A2=M+M
A3=2.-M
IF(KEYP11-1)113,114,114
113 API11=A1*(A3*K-E-E)/M
API33=A1*K
114 A1=A1*A0
A3=.5*A3
IF(KEYM11-1)115,116,116
115 A0=C(J,L)
OM1=-A1*(.25*K-A3*KPR)
OM2=A1*(E-A3*((A3+M)*K - A2*A3*KPR))/(M*M)
AMI11=R*A0*OM2+(ZD*S(J,L)-RP*A0)*OM1
116 RETURN
END

```

UNCLASSIFIED

Security Classification

DOCUMENT CONTROL DATA - R & D

(Security classification of title, body of abstract and body of annotation must be entered when the overall report is classified)

1. ORIGINATING ACTIVITY (Corporate author) The University of Michigan Radiation Laboratory 2216 Space Research Bldg., North Campus Ann Arbor, Michigan 48105	2a. REPORT SECURITY CLASSIFICATION UNCLASSIFIED
	2b. GROUP -----

3. REPORT TITLE
THE NUMERICAL SOLUTION OF LOW FREQUENCY SCATTERING PROBLEMS

4. DESCRIPTIVE NOTES (Type of report and inclusive dates)
Scientific Interim

5. AUTHOR(S) (First name, middle initial, last name)
Thomas B. A. Senior
David J. Ahlgren

6. REPORT DATE February 1972	7a. TOTAL NO. OF PAGES 105	7b. NO. OF REFS 12
---------------------------------	-------------------------------	-----------------------

8a. CONTRACT OR GRANT NO. F19628-68-C-0071 b. PROJECT NO. Project, Task, Work Unit Nos. c. 5635-02-01 DoD Element 61102F d. DoD Subelement 681305	9a. ORIGINATOR'S REPORT NUMBER(S) 013630-9-T Scientific Report No. 12
	9b. OTHER REPORT NO(S) (Any other numbers that may be assigned this report) AFCRL-72-0162

10. DISTRIBUTION STATEMENT
A - Approved for public release; distribution unlimited.

11. SUPPLEMENTARY NOTES TECH, OTHER	12. SPONSORING MILITARY ACTIVITY Air Force Cambridge Research Laboratories (LZ) L. G. Hanscom Field Bedford, Massachusetts 01730
--	---

13. ABSTRACT

The low frequency scattering of electromagnetic and acoustic waves by rotationally symmetric bodies is considered. By concentrating on certain quantities such as the normalised component of the induced electric and magnetic dipole moments, it is shown how the first one or two terms in the far zone scattered fields can be expressed in terms of quantities which are functions only of the geometry of the body. Each of these is the weighted integral of an elementary potential function which can be found by solving an integral equation. A computer program has been written to solve the appropriate equations by the moment method, and for calculating the dipole moments, the electrostatic capacity, and a further quantity related to the capacity. The program is described and related data are presented.

14. KEY WORDS	LINK A		LINK B		LINK C	
	ROLE	WT	ROLE	WT	ROLE	WT
Low Frequency Scattering Electromagnetic Acoustic Rotational Symmetry Computer Program Numerical Data						