

UMTRI-84-41

**REVIEW OF ANTHROPOMORPHIC TEST DEVICE INSTRUMENTATION,
DATA PROCESSING, AND CERTIFICATION TEST PROCEDURES**

Rudi H. Arendt and David J. Segal
MGA Research Corporation
Akron, New York

Richard Cheng
Wayne State University
Detroit, Michigan

TASK C FINAL REPORT
December 1984

Prepared under subcontracts to:

The University of Michigan
Transportation Research Institute
Ann Arbor, Michigan 48109

Prime Contract No. DTNH22-83-C-07005,
The Engineering Design, Development, Testing, and Evaluation
of an Advanced Anthropomorphic Test Device

National Highway Traffic Safety Administration
Department of Transportation
Washington, D.C. 20590

This document is disseminated under the sponsorship of the Department of Transportation in the interest of information exchange. The United States Government assumes no liability for the contents or the use thereof.

Technical Report Documentation Page

1. Report No.	2. Government Accession No.	3. Recipient's Catalog No.	
4. Title and Subtitle REVIEW OF ANTHROPOMORPHIC TEST DEVICE INSTRUMENTATION, DATA PROCESSING, AND CERTIFICATION TEST PROCEDURES		5. Report Date December 1984	6. Performing Organization Code
		8. Performing Organization Report No. UMTRI-84-41	
7. Author(s) R. Arendt, D. Segal, and R. Cheng*		10. Work Unit No. (TRAIS)	11. Contract or Grant No. DTNH22-83-C-07005
9. Performing Organization Name and Address The University of Michigan Transportation Research Institute 2901 Baxter Road Ann Arbor, Michigan 48109		13. Type of Report and Period Covered TASK C FINAL REPORT	
		14. Sponsoring Agency Code	
12. Sponsoring Agency Name and Address U.S. Department of Transportation National Highway Traffic Safety Administration Washington, D.C. 20590		15. Supplementary Notes *Work performed under subcontracts to: MGA Research Corporation, Akron, New York Wayne State University, Detroit, Michigan	
16. Abstract This report reviews the state of the art of instrumentation and data processing technology applicable to anthropomorphic test devices (ATDs) as well as the certification test procedures currently in use. Recommendations are also made for hardware and procedures appropriate for the advanced ATD. Further revisions to these recommendations, based on changing technology and AATD requirements, will appear in a subsequent report on Task E of this program.			
17. Key Words Anthropomorphic Test Devices, Instrumentation, Data Processing, Certification		18. Distribution Statement Unlimited	
19. Security Classif. (of this report) None	20. Security Classif. (of this page) None	21. No. of Pages 67	22. Price

PREFACE

This report reviews the state of the art of instrumentation and data processing technology applicable to anthropomorphic test devices (ATDs) as well as the certification test procedures currently in use. Recommendations are also made for hardware and procedures appropriate for the advanced ATD. Further revisions to these recommendations, based on changing technology and AATD requirements, will appear in a subsequent report on Task E of this program.

CONTENTS

PREFACE	v
1. INSTRUMENTATION, R. Cheng	1
Force and Moment	1
Acceleration	2
Pressure	3
Flow Measurement	3
Deformation Measurement	4
Summary	4
2. DATA PROCESSING, R. Arendt	7
Recommendations	8
Review of Data Acquisition and Processing Systems	10
Environmental Specifications	19
Electronic Design Concept	25
Calibration Requirements	30
Test Set Characteristics	32
References	34
3. CERTIFICATION TEST PROCEDURES, D. Segal	35
Recommendations	35
Review of Existing Dummy Certification Procedures	36
Advanced Dummy Certification Testing	43
Appendix: Analysis of Certification Testing Procedures	53
OTHER REPORTS IN THIS SERIES	57

CHAPTER 1

INSTRUMENTATION

R. Cheng
Wayne State University
Detroit, Michigan

State-of-the-art technology was reviewed with regard to the measurement of force, moment, linear and angular acceleration, pressure, and displacement as might be applied to the AATD. Innovative near-term developments were analyzed in this context, and instrument size, weight, power consumption, performance, and compatibility with the planned data acquisition system were considered.

Current transducer technology is adequate for most of the sensors used in today's test dummies. However, as part of the effort to develop a multidirectional dummy that can respond more like a human and to instrument it with sensors that can more accurately yield injury data, some deficiencies do exist.

Rather than discussing the specific measurements required for each body region, a more general approach is taken of analyzing the various types of measurements that are likely to be needed. The standard force, moment, and acceleration measurements will still be required. For the AATD, additional information relating to deformation in the thoracic region is considered important. Either a direct or indirect measurement that correlates with the deformation will be made.

FORCE AND MOMENT

The technology to measure force and moment is well established. The most commonly used transducers are the piezoresistive (PR) and piezoelectric (PE) types. For the AATD program, an important consideration is size, so that the transducers can be housed within a limited space. Another consideration is the dynamic characteristics of the different types of transducers. The transducers currently available for test dummy applications are all of the PR type and are manufactured by either GSE or Denton.

GSE makes a range of instruments, several of which are designed specifically for vehicle safety applications. Denton load cells are primarily designed for vehicle safety test usage. Both companies follow the basic principle of utilizing strain gage signals to measure the changes in deformable beams due to applied loads. Most GSE units are uniaxial, while most Denton load cells are multicomponent. From a packaging standpoint, some of the multicomponent units can readily be adapted for use in the AATD spinal column. The head-neck interface units, designed for the existing Part 572 or Hybrid III ATDs, can readily be accommodated in the AATD.

Since the change in resistance of a strain gage depends on the physical deformation of a structural member, the design requirement in one loading direction determines the characteristics in the transverse direction. The stiffness of the transducer in the axial direction (along the spinal S-I) could be quite high and thus result in a high natural frequency. However, for an AATD designed for multidirectional impact, the transverse

INSTRUMENTATION

natural frequencies of the transducer must be taken into account, especially when several transducers in series along the spine are being contemplated. The effect of the transducer stiffness must be included in the overall AATD design to ensure that the proper responses are obtained. This could be a problem area in that there is very little flexibility to alter the transducer stiffness in the different directions independently. The piezoelectric transducer may have an advantage over the piezoresistive in this respect. Due to the nature of the properties of the quartz sensing elements, the natural frequencies of the PEs are orders of magnitude higher. Most of the PE force and moment transducers are much larger in size, however, than the PRs and therefore cannot be readily incorporated in the AATD design. It is very unlikely that the manufacturers of piezoelectric transducers will develop miniaturized versions of these sensors in the near future.

Another consideration is the quality of transducer response and dynamic performance. Kistler, a manufacturer of PEs, has conducted a study comparing a strain-gage force plate with one of the PE type. This study indicates the type of analysis that could be conducted in making selections for the AATD. The tests included static crosstalk, dynamic crosstalk, and frequency response. Tests were conducted on a strain-gage multi-axis force plate. Very large crosstalk errors (10–30%) were found in some axes at low loads (about 10% of full scale). Frequency response tests showed that, although the natural frequency along the vertical axis was suitably high (400 Hz), the horizontal axes both had lowest natural frequencies around 100 Hz, seriously reducing the usable frequency range of the device. The combination of the above two factors produced dynamic crosstalk deficiencies in which the low frequency resonance of the horizontal axes was affecting the vertical axis results. Based on the test reports and personal discussions with Kistler and others, it can be concluded that Kistler is much more experienced than others in typical transducer dynamic tests directly applicable to the AATD. Only very limited dynamic test data are available from the other manufacturers.

For the AATD, where multidirectional impact is expected, moment measurements could become significant, and frequency response of moment transducers must be considered carefully. In general, moment frequency response is more difficult to obtain than force frequency response. Force and moment sensing in the neck of the AATD will quite certainly be required. Response data for the transducers designed for this application are seriously lacking. It is not adequate to only determine the natural frequency of the mechanical structure of the load cell; it is necessary to have the actual input-output signal ratio. Dynamic crosstalk between the axes must also be investigated further. There has been very limited study of these potential problems with any of the moment transducers thus far. Another consideration prior to contemplating more complete testing of transducers, however, is that the frequency spectra from the available human response data may indicate that the currently specified requirement of SAE J211 Class 1000 is not necessary. The transducer specifications must be based on human response corridors.

ACCELERATION

Linear accelerations in current ATDs have been routinely measured using PR accelerometers, whose frequency bandwidth is appropriate for measuring ATD response. The compatibility of PR units with existing laboratory systems is an important consideration in accelerometer selection. Calibration is accomplished by sending a known signal in and comparing it to the output signal. This "shunt" calibration can be done just prior to testing and thus improves the reliability of the test data obtained.

Calibration values are normally given at a specific frequency. Our response test data show that these units are consistently within their specifications (e.g., $\pm 10\%$), which

is reasonably adequate to meet response corridors. Enough variation exists among individual units, however, that erroneous values may result if linear accelerations are used to determine angular accelerations in a 3-3-3 or 3-2-2-2 configuration. An error-sensitivity analysis based on the data frequency spectrum could be of substantial benefit in determining the proper transducer specifications. The current error analysis work of Gordon Plank at the Transportation Systems Center (TSC) should give considerable insight into the transducer specifications required.

The potential problem related to phase angles of different accelerometers has not been of much concern in ATD usage thus far, because of the use of transducers of the same make within any cluster. For example, Entran units, whose phase angle can vary with the user-specified damping factor, would not be mixed with Endevco units, which have almost zero damping. Data obtained from different model transducers should be handled carefully, however, and may be quite difficult to compare.

Another potential alternative is the somewhat smaller piezoelectric accelerometer, which utilizes the advances in circuitry miniaturization technology to incorporate the charge amplifier along with the sensor. This alleviates many of the problems with the long transmission line usually associated with PEs. Although the manufacturers claim superior high-frequency response to that of the PR units, this feature is probably not important for the AATD application. The biggest disadvantage of the PE accelerometer is that it requires calibration on a shake table. Thus, a shunt calibration just prior to testing is not possible.

Although head injury mechanisms are not completely understood as yet, head angular acceleration will likely be a parameter that needs to be measured. This can be determined by using linear accelerometers spaced a fixed distance apart, such as in the 3-2-2-2 or 3-3-3 configuration. The other alternative is to use an angular accelerometer. Currently only Endevco markets such a transducer, and much testing remains to be performed before it can be considered operational. The practical problems that AATD users will face is whether they will have the capability to readily check the calibration values prior to testing. Calibration problems will surely be compounded in the case of angular accelerometers.

PRESSURE

In the AATD, some injury prediction may be based on pressures within a mechanical analog during impact. One of the thoracic designs under consideration would use fluid-filled compartments connected by one-way orifices to a gas-filled accumulator. The fluid flow from each chamber into the accumulator would be indicated by the resulting gas pressure and would be correlated with the amount of fluid loss from individual compartments during impact. In addition, the fluid pressure in each compartment would be measured to indicate flow rate. In general, pressure measurements during impact have been made without any difficulties, as evidenced by aortic pressure routinely monitored in cadaver tests, in which saline is used to pressurize the vascular system.

FLOW MEASUREMENT

The most versatile and reliable method of measuring fluid flow is probably the measurement of differential pressure across an orifice. This method would allow the orifice size to be varied as needed to obtain the proper response of the system. Direct flow measurements, which are normally obtained by the use of various kinds of positive

INSTRUMENTATION

displacement or mechanical meters, were also investigated. Most of these must be rejected, however, because of the impact environment. Hot-wire anemometers are also unsuitable in this test environment, and propeller or turbine-type rotating meters cannot be used because the bearings are likely to be sensitive to repeated impact conditions. All these flow meters are primarily designed for industrial usage.

Some of the more specialized flow meters, such as those designed for biomedical usage, might be more adaptable to the AATD application. Several types of flow meters have been developed to measure the flow through blood vessels. A range of units are available for the various lumen diameters. The design of these transducers is usually based on Faraday's Law or on the sonic Doppler shift principle. The fluid-conductor magnetic flowmeter uses a field generated by either electromagnetic coils or permanent magnets and a pair of electrodes. The three are orthogonal to each other. As the fluid moves through the magnetic field, an electromotive force proportional to the flow velocity is generated and measured as the potential between the electrodes. The output signal is generally very low, in the range of microvolts. Extreme care in reducing the signal noise must be exercised. This is possible in a controlled medical-care environment but will be difficult under AATD test conditions. Flow measuring devices based on the sonic Doppler shift principle use a transmitter emitting a continuous signal wave into the stream of blood flow and a receiver to detect the delayed version of the original source. The time difference is correlated to the velocity of the flow. In normal blood flow, the cells themselves reflect the signal. For the AATD application, any fluid used would have to have particulates added to it in order to reflect the signal. Maintaining an even distribution of the particulates during impact is quite problematic. For either type of flow sensor, the number of manufacturers is very limited. Magnetic-type meters are made by In Vivo Metric Systems and Biotronex. Sonic units are made by Sonicaid, Medsonic, and Parkes.

DEFORMATION MEASUREMENT

The use of potentiometers and capacitive, inductive, or reluctance displacement transducers for measuring deformation is a well-established technology. In most of the applications, however, the displacement of only a very specific point is measured. In the AATD, information on global thoracic deformation may be of importance. Current ATDs measure only the sternum A-P deformation. For a multidirectional AATD, where the thorax could be made up of fluid-filled compartments, the deformation must be considered in a different context. One such option could be the use of wire-mesh cloth to cover the thorax. Variknit is a stainless steel mesh that is electrically conductive. During impact, the resistivity change of the mesh is varied proportional to the deformation. The problem here is to correlate this change to the location of deformation. This is certainly one option that should be investigated further.

SUMMARY

Force and moment measurements can be made using piezoresistive (PR) or piezoelectric (PE) sensors. PRs have the advantage of being smaller than PEs and can thus be easily incorporated into an AATD design. On the other hand, PEs are more well suited to multidirectional dynamic measurement. Their miniaturization, however, is not likely in the near future.

For linear acceleration, PR accelerometers are routinely used because a shunt calibration can be performed just prior to testing. There is some question, however, whether their frequency response is of sufficient accuracy to allow angular accelerations to

INSTRUMENTATION

be determined using multiple linear-accelerometer arrays. Although linear PE accelerometers are also available, their advantages with regard to pre-test calibration and compatibility with existing systems eliminate them as a choice at this time. Presently, angular accelerometers are not sufficiently developed to be considered for this type of application.

Pressure transducers of various types are available for the different requirements in the AATD. They can be used to indicate impact severity in the compartmented chest being considered. Direct measurement of the flow between compartments can also be made with the various flowmeters developed for medical applications. However, differential pressure measured across an orifice, whose size could be readily varied, would probably be more versatile and reliable.

INSTRUMENTATION

CHAPTER 2

DATA PROCESSING

R. Arendt
MGA Research Corporation
Akron, New York

The objective of the work reported here was to review the data acquisition and processing techniques that are currently used by crash and sled testing facilities to measure anthropomorphic dummy response data during impact testing. Based on the material reviewed and the current and near-term state-of-the-art potential in measurement technology, design specifications for a measurement system that has promise for use with the advanced dummy is detailed.

First, recommendations are given for the measurement system, which include both electrical performance characteristics for the equipment as well as reasonable ranges in environmental exposure within which the test device might be expected to operate.

A review is then presented of instrumentation equipment and processing techniques currently employed at crash and sled testing facilities. Information is given regarding the types of sensor, signal conditioning, recording, and data processing equipment in current usage. In addition, the overall accuracy of current data systems in terms of frequency response, amplitude linearity, time linearity, and HIC measurement accuracy is addressed.

Following this review of current measurement equipment, preliminary performance specifications for the advanced dummy instrumentation are presented, including both electrical and environmental requirements. A preliminary conceptual design is then described for a measurement system that is on-board the dummy. This system includes 40 data channels with future expansion capability to about 60 channels.¹

The calibration requirements for the electronic instrumentation, the primary measurement sensors, and the overall electronics equipment items are discussed in terms of routine data measurement applications as well as to verify traceability to National Bureau of Standards references. Finally, the electronics on-board the dummy are designed to operate as an integral part with an off-board test set. The overall characteristics for this test set along with the fundamental basis for its inclusion in the design are presented.

As a result of this work, there are several follow-on work activities that should be performed to further the development effort for an advanced dummy instrumentation system. These areas relate to the on-dummy instrumentation, the dummy sensors, the environmental performance requirements, and the associated test set.

The major follow-on work related to the dummy on-board instrumentation pertains to the development of detailed design specifications for the system. This work will involve system-packaging designs consistent with available space within the dummy as well as the

¹Subsequent work has upgraded this capability to 72 channels, expandable to 100. See Task E report.

DATA PROCESSING

preparation of detailed circuit schematics. In addition, design variations should be addressed to accommodate specialized accuracy and channel capacity inputs such as may be dictated by a nine-component head accelerometer array or other sensor requirements.

The specific on-dummy processing requirements should be addressed. The time of occurrence and manner in which the pre- and post-test calibration functions will be implemented as well as the required programming flexibility for the on-board microprocessor must be defined. The interface bus between the on-dummy microprocessors and the external test set should also be reviewed and specified.

The calibration procedures for all anticipated dummy sensors should be reviewed and expanded upon. It is also recommended that the specified calibration procedures be verified through actual tests to confirm that the procedures are consistent with available test apparatus.

With regard to the comparison external test set, the detailed performance characteristics for this device must be defined. This would include the overall elements of the test set as well as the computational requirements for the unit. The type of interface bus between the test set and the dummy must be designed along with the type of necessary computer peripheral support equipment.

RECOMMENDATIONS

This section summarizes our recommendations regarding the development of an advanced dummy instrumentation system. The specific recommendations presented below are purposely given in a rather concise manner. Later in the report, the basis for the recommendations is presented in more detail.

1. Based on the projected data channel requirements of from 40 to 60 data channels² on-board the advanced dummy, and based on the present size of state-of-the-art instrumentation, the development of an on-dummy instrumentation system is recommended. This system should be designed to include integral memory but with capability to conveniently expand record times through use of external memory.

The on-dummy instrumentation should be developed as a microprocessor based system to perform on-dummy analysis and control functions as well as to allow transfer of measured data to an external computer based test set. The on-dummy microprocessor would also function to perform self tests of individual data channels under both internal and external control.

2. A microprocessor based external test set should be developed as an integral part of the advanced dummy instrumentation system. The test set should be designed to allow calibration signals to be injected into individual data channels on-board the dummy. The test set would also function to perform analysis of data channel response signals. The response signals may result from injected calibration signals or actual dummy responses generated during dummy certification tests. The test set would allow for rapid turn-around of results to provide pass/fail indications of channel performance immediately after a verification test was performed.

²Subsequent work has upgraded this capability to 72 channels, expandable to 100. See Task E report.

3. The advanced dummy instrumentation should be developed to meet the requirements for data systems as outlined in ISO 6487, *Road Vehicles—Techniques of Measurement in Impact Test—Instrumentation*. In specialized cases, as may apply to the nine component head accelerometer array, increased accuracy may be required. The recommended performance for the advanced dummy instrumentation is summarized in Table 2-1.

4. Procedures should be developed for use in calibrating accelerometers and other sensors. ISO 6487 should serve as a basis for the procedures. At a minimum, the following parameters should be calibrated at six-month intervals.

- Amplitude linearity at a fixed frequency
- Amplitude response versus frequency
- Phase response

5. The advanced dummy instrumentation should be designed to meet specified environmental performance criteria. Recommended criteria and suggested limits are summarized in Table 2-2.

TABLE 2-1

ADVANCED DUMMY INSTRUMENTATION REQUIREMENTS

Amplitude Linearity	2.5%
Amplitude Resolution	12 bits (0.02%)
Time Linearity	1%
Time Synchronization	0.1 ms
Time Zero Offset	0.1 ms
Sample Rate	8000 Hz
Record Time (per channel)	500 ms
Channel Capacity	40 (expandable to 60)*

*Subsequent work has upgraded this capability to 72 channels, expandable to 100. See Task E report.

TABLE 2-2

ENVIRONMENTAL SPECIFICATIONS

Parameter	Design Limits
High Temperature	180°F.
Low Temperature	-10°F.
Temperature Shock	170°F.
Humidity	85%
Acceleration (linear)	10 G
Vibration	1 G RMS Random
Shock	500 G, 0.5 ms (Head) 250 G, 1 ms (Chest, Pelvis)
EMI/RFI	Standard Industrial

DATA PROCESSING

REVIEW OF DATA ACQUISITION AND PROCESSING SYSTEMS

This section presents a review of data acquisition and processing systems currently used by crash and sled testing facilities to measure dynamic test impact data and is based on previous work by Arendt and Miller (1981). In general, it is noted that the current state-of-the-art of instrumentation and data processing equipment used at most crash testing and sled testing facilities reflects electronic technology from the late 1960 time frame. It was during this time that many of the test facilities were first developed, and major instrumentation and data processing systems acquired. These systems remain in use to this day.

A block diagram of the major components of facility data recording and processing equipment is presented in Figure 2-1. As noted in Figure 2-1, sensors are mounted on the object to be tested, and signal conditioning provides a high level signal proportional to the sensor output. Conditioning electronics are employed both on-board the test article or off-board at a ground recording station. In this case, on-board refers to the test automobile or the test sled buck and not the test dummy. In no case was signal conditioning found in use on-board the test dummy.

Signal conditioning electronics are powered by battery supplies or, in the case of off-board systems, AC-line-powered regulators. The output signals are connected to a ground recording station by means of an umbilical cable. For calibration purposes, provisions are also integrated into the measurement system to electrically simulate a known quantity of the physical parameters measured by each data channel.

Data transmission from the test article to the recording station tends to utilize individual data channel transmission (one umbilical wire per data channel) with some systems using FM (frequency multiplexed) techniques. The FM systems combine up to about fourteen (14) data channels into a single channel thereby decreasing umbilical cable size and weight.

Individual data channels or multiplexed channels are typically recorded on magnetic tape recorders in an analog format. A time code signal is also recorded along with the test data to provide a time reference. The test event "time zero" signal is combined with the time code signal for use in data processing and output presentation graphics. The time code signal is also recorded on film data at some facilities.

After the completion of a test, the recorded data is played back, de-multiplexed, if required, and printed out for a "quick look" review of test and equipment performance. The data may also be digitized at this time for subsequent computer processing. The digitizing process includes anti-aliasing filtering, multiplexing, analog to digital conversion, and the generation of magnetic data tapes compatible with the data processing computer.

Once the data are input into a digital computer, data processing may begin. The required output reduction operations are performed on the data including the generation of facility hard copy results for reporting purposes and the production of a raw data tape for submission to the NHTSA crash test data base systems.

Characteristic of many of the data systems in operation today is the use of system components purchased from commercial sources. Commercial manufacturers design their product lines to satisfy a broad spectrum of applications and, consequently, tend to incorporate general features that are often not required for a specific test configuration. Furthermore, commercial systems are packaged for laboratory use and do not normally emphasize miniaturization in their overall design and packaging. Consequently, the

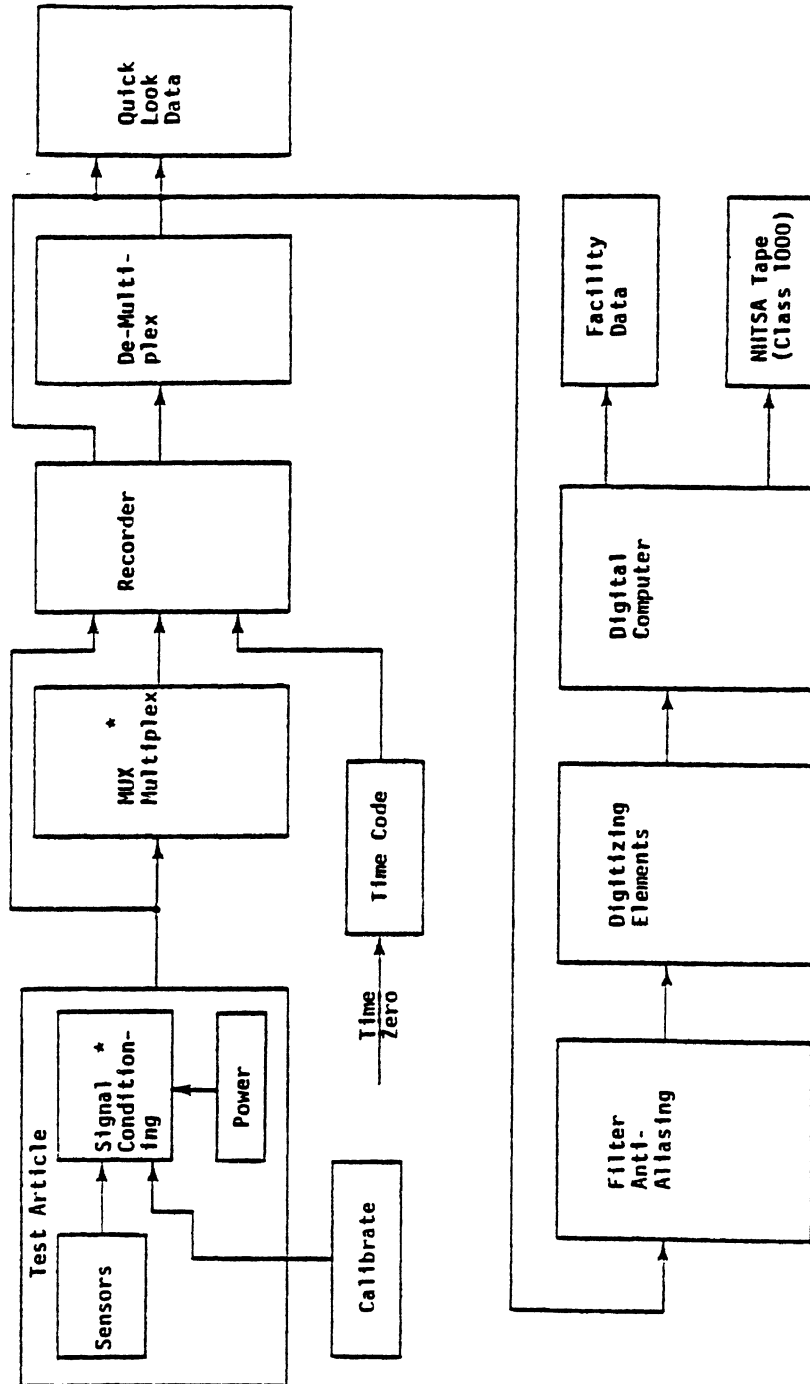

*May be positioned either on-board the test vehicle or sled or off-board at the recording station.

FIGURE 2-1. Typical Elements of Recording and Processing Equipment.

DATA PROCESSING

majority of the data systems in operation today do not reflect even the state-of-the-art technology available for custom designed equipment for the late 1960 time period.

An additional characteristic of many of the present data acquisition and processing systems is the use of existing or modified facility equipment to support a crash or sled testing operation. Often the main data processing computer is the overall company computer, and data processing time must be shared with all company projects. Also, several intermediate data handling steps and equipment items are involved in translating measured test data into a digital form suitable for processing on the main digital computer. These steps involve operator time and include quick-look playback review, data playback for digitizing, filtering, etc. Often these different functions are performed at physically different locations requiring additional effort to transport equipment. As a result, current data handling is often time-consuming and inefficiently performed.

Based on the results obtained from the Test Site Instrumentation Study (Arendt and Miller 1981), it is noted that significant differences in the performance of data acquisition systems occurs across all facilities that were observed. In addition, differences in performance of different data channels at a given facility were also noted. These observed differences in the performance of facility data acquisition systems are thought to have a major bearing on the development of the advanced dummy instrumentation.

If the advanced dummy is designed independent of the electronic instrumentation, facilities will likely continue to use existing signal processing equipment for data acquisition purposes. Consequently, the overall performance achieved with this approach will result in considerable variability between data channels and across different facilities. In all likelihood, the overall performance will not improve significantly beyond that achieved at facilities today. Consequently, NHTSA will be confronted with having developed an advanced test device, but with considerable variability present in measured data resulting from data acquisition system variability, due to the use of non state-of-the-art instrumentation equipment.

Facility data acquisition systems are generally noted to have been designed to conform to the requirements of the Society of Automotive Engineers (SAE) Recommended Practice - SAE J211 JUN80. However, in most cases, tests are not performed to verify the degree to which a given system meets or exceeds the requirements.

From conversations with representatives from European test facilities and automobile manufacturers, it is noted that these organizations are moving to adopt the International Standards Organization (ISO) Standard 6487, *Road Vehicles—Techniques of Measurement in Impact Test—Instrumentation*, to establish the performance requirements for these data acquisition systems. This standard is more encompassing and demanding than the SAE J211 JUN80 standard and should be considered as a guide for an advanced dummy instrumentation system.

The overall performance requirements specified in the SAE and ISO standards are contrasted in Table 2-3. Basically there are three areas where the ISO standard is more stringent than the SAE specifications. These pertain to amplitude and time accuracy specification.

The allowable amplitude linearity error for data systems must be less than 2.5% according to the ISO standard, whereas the SAE standard does not address this parameter. With regard to time accuracy, the ISO standard limits time zero and time synchronization errors to less than ± 0.1 ms, while SAE allows values of ± 1.0 ms. The

TABLE 2-3
ELEMENTS OF SAE J211 AND ISO 6487 STANDARDS

Elements	SAE J211	ISO 6487
Data Amplitude Accuracy (%)		
Static	±6	±6
Dynamic	(+6, -11) @ 100 Hz	(+6, -11) @ 100 Hz
Linearity	Not defined	2.5%
Data Time Accuracy		
Absolute	±1%	±1%
Linearity	±1%	±1%
Time Zero	±0.1 ms	±0.1 ms
Synchronization	±0.1 ms	±0.1 ms
Frequency Response		
Amplitude	(Class 1000)	(Class 1000)
Phase	None	0.1 ms
Data Processing		
Sampling Rate	8,000 Hz	8,000 Hz
Anti Aliasing	Yes	Yes
Amplitude Resolution	8 bits	8 bits
Calibration		
Sensors	Yes	Yes
Data Channel	Yes	Yes

ISO standard also limits phase shift errors to less than ± 0.1 ms, while SAE does not place a limit on phase errors.

Based on the results obtained in Phase 1 of the Test Site Study, some facilities do not appear to meet the current SAE J211 JUN80 performance requirements. Specifically, the required $\pm 6\%$ amplitude accuracy is exceeded as is the 1% time accuracy and the ± 1 -ms time zero error. The current requirement for a minimum sample rate of 8000 samples per second is also not available at some facilities.

During the Test Site Study, test waveforms were developed and recorded at test facilities to measure the frequency response as well as amplitude and time accuracy performance of data channels. Based on the analysis of the recorded waveform, it was possible to establish the performance of data channels.

The results that were obtained for the amplitude linearity performance of data systems is summarized here. The reader should review Arendt and Miller (1981) for a complete description of overall test methods and other results obtained in the Test Site project.

DATA PROCESSING

The amplitude accuracy of data systems was determined by measuring the amplitude for known but different level inputs that ranged from negative to positive full scale for the data channel. As described in the report, a staircase waveform was used to test for amplitude linearity. The Class 1000 results for these tests based on NHTSA processed data are presented in Figure 2-2. The error, in percent of full scale, that was measured across all facilities and at one facility at the respective input amplitudes is presented there. The scatter in the actual data for the facility indicated in Figure 2-2 is thought to be representative of typical facility performance.

In Figure 2-3, amplitude performance data is presented for another facility, again contrasted to the range in performance across all facilities. In this case, the scatter of the individual data points is within a $\pm 1\%$ band. This data is representative of the best achievable performance at current test facilities.

As a further comparison point, the amplitude linearity of a laboratory-based digital data acquisition system at MGA Research was measured. This system employs differential input high quality instrumentation amplifiers in its design. Measured data are digitized and stored on-line in digital memory for subsequent data processing purposes. The measured amplitude accuracy that was obtained for one data channel processed through the MGA data acquisition system is presented in Figure 2-4. As noted in this graph, overall results are excellent. However, two data points at negative full scale amplitudes of 80% and 100% contain errors of about 1%. Consequently, it is thought that an amplitude error band of $\pm 1\%$ is about the best that can be expected for state-of-the-art acquisition systems developed and used for crash testing purposes.

Using an approach similar to that used to measure amplitude linearity, the time linearity of data systems was also evaluated. Presented in Figure 2-5 is a graph that identifies the time linearity performance variation that was observed across all facilities and also at one facility.

Based on a straight line fit to the facility data, the time linearity can be determined based on the slope of the straight line. In addition, the intercept of the straight line at zero time provides a measure of the time zero offset error for the measured data channel. As noted, the identified facility data indicates that time is expanded by about 4 ms in 75 ms. Furthermore, a time zero error of about 1 ms is noted.

Using similar techniques of analyzing recorded calibration signals, overall performance characteristics of data acquisition systems were measured. In addition, crash pulses were also recorded to evaluate the HIC measurement accuracy of data systems. Based on these results, variations in HIC calculations were determined. For identical input crash waveforms, variations of ± 10 percent in HIC values were obtained across many facilities.

Based on the review of facility data acquisition equipment, it is clear that existing facility data acquisition equipment does not reflect state-of-the-art capability. In addition, based on work performed in support of the Test Site Instrumentation Study, significant differences exist in data channel measurement accuracy both across all facilities and also at a given facility. However, it is noted that the variations that were found across all facilities were generally two to three times greater than the variations within a facility.

To achieve the highest level of consistency in measured data in the advanced dummy, identical instrumentation should be utilized for all test devices. This would assure that identical equipment was employed by all facilities. If this is not done, different

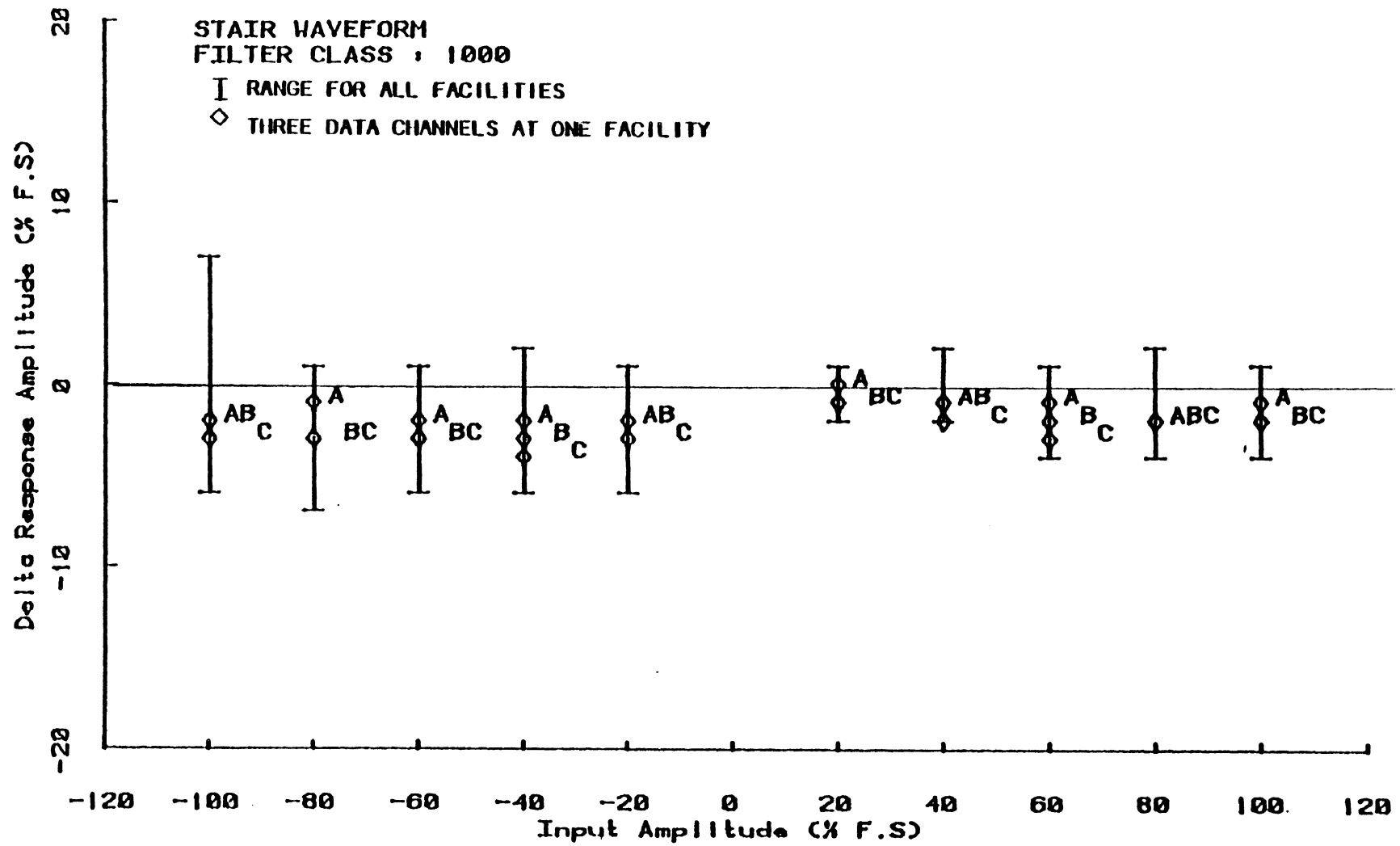

FIGURE 2-2. Facility with Representative Amplitude Error Performance.

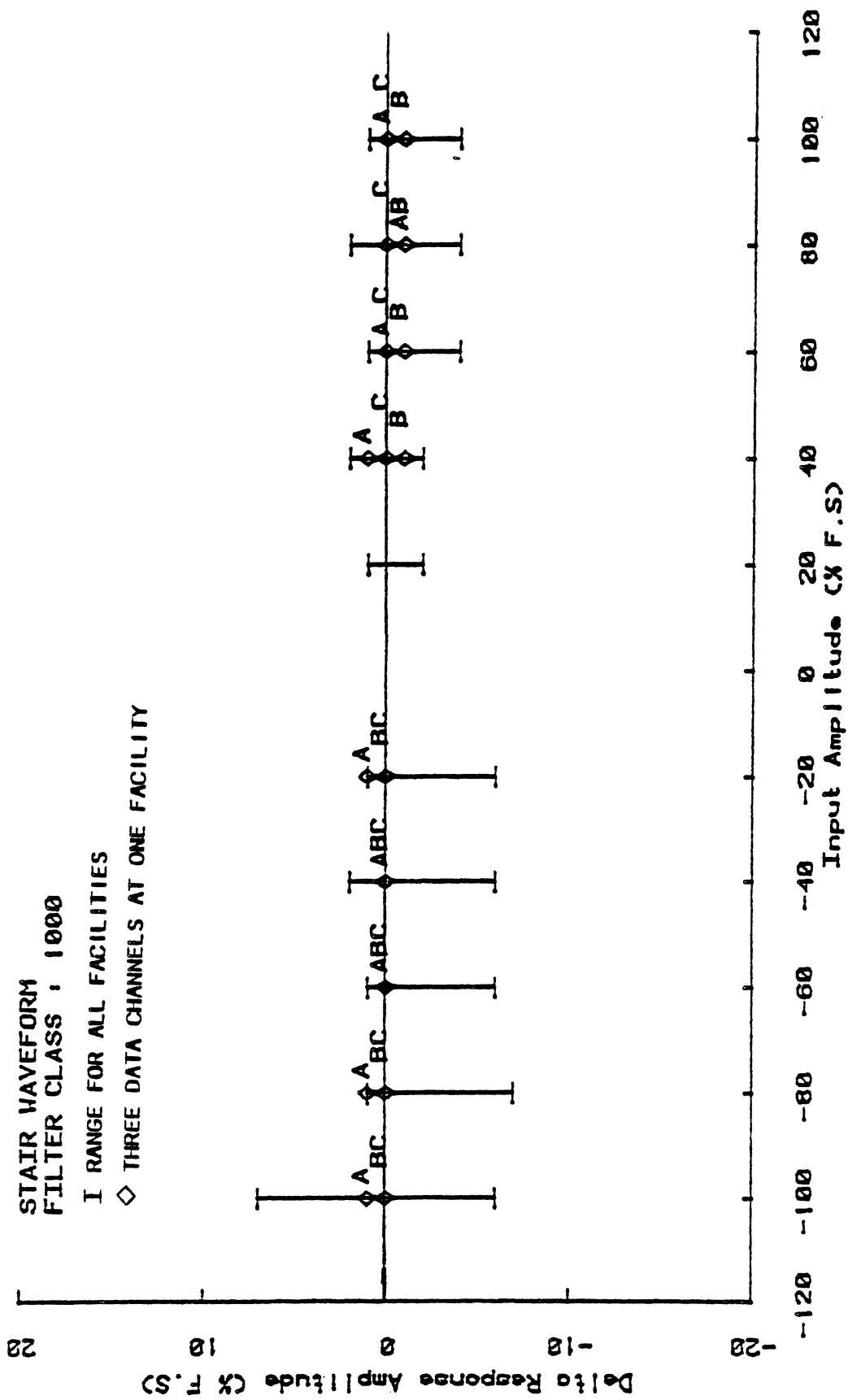

FIGURE 2-3. Facility with Amplitude Errors within about ± 1 Percent.

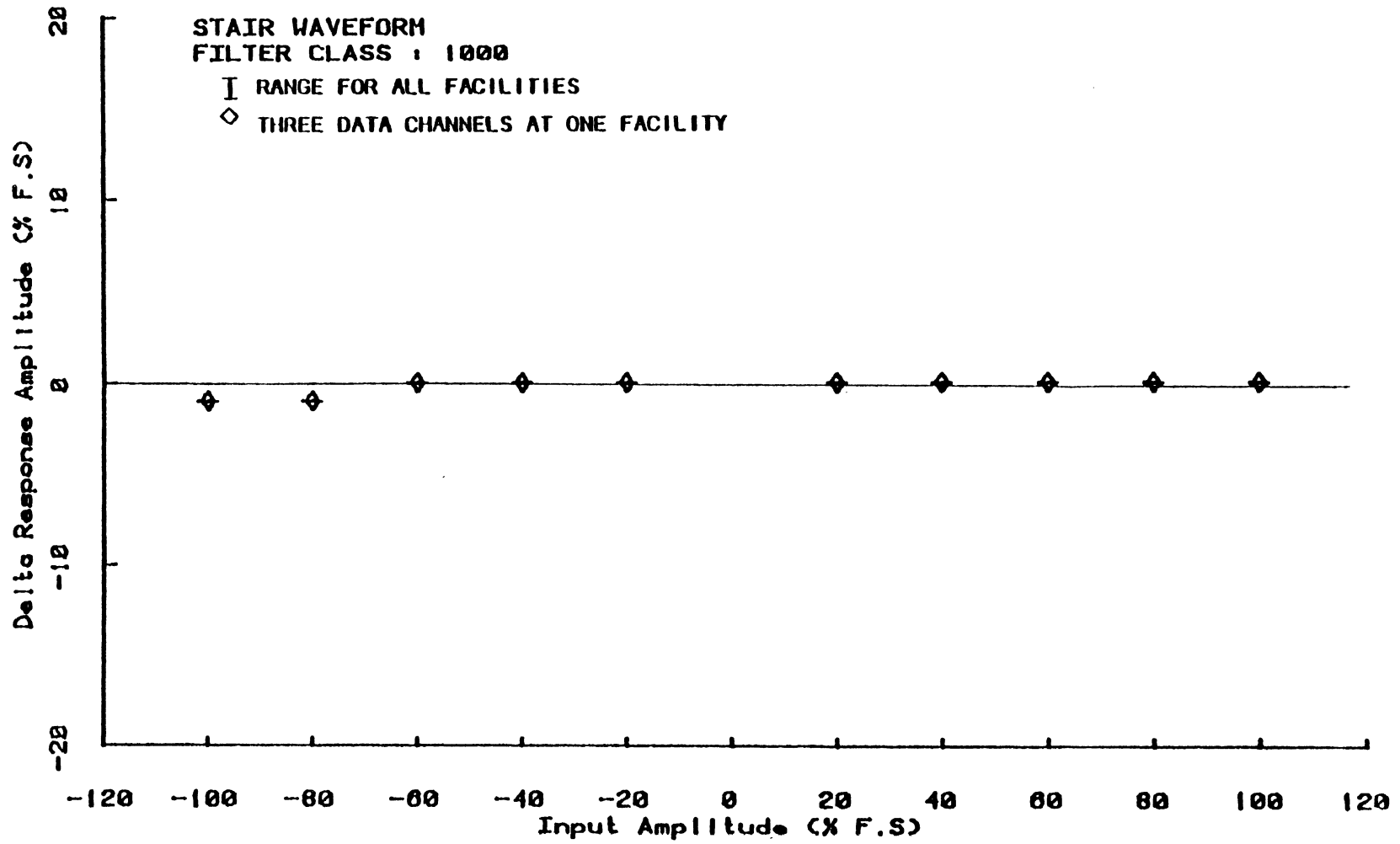

FIGURE 2-4. Amplitude Accuracy Performance for MGA Data Acquisition System.

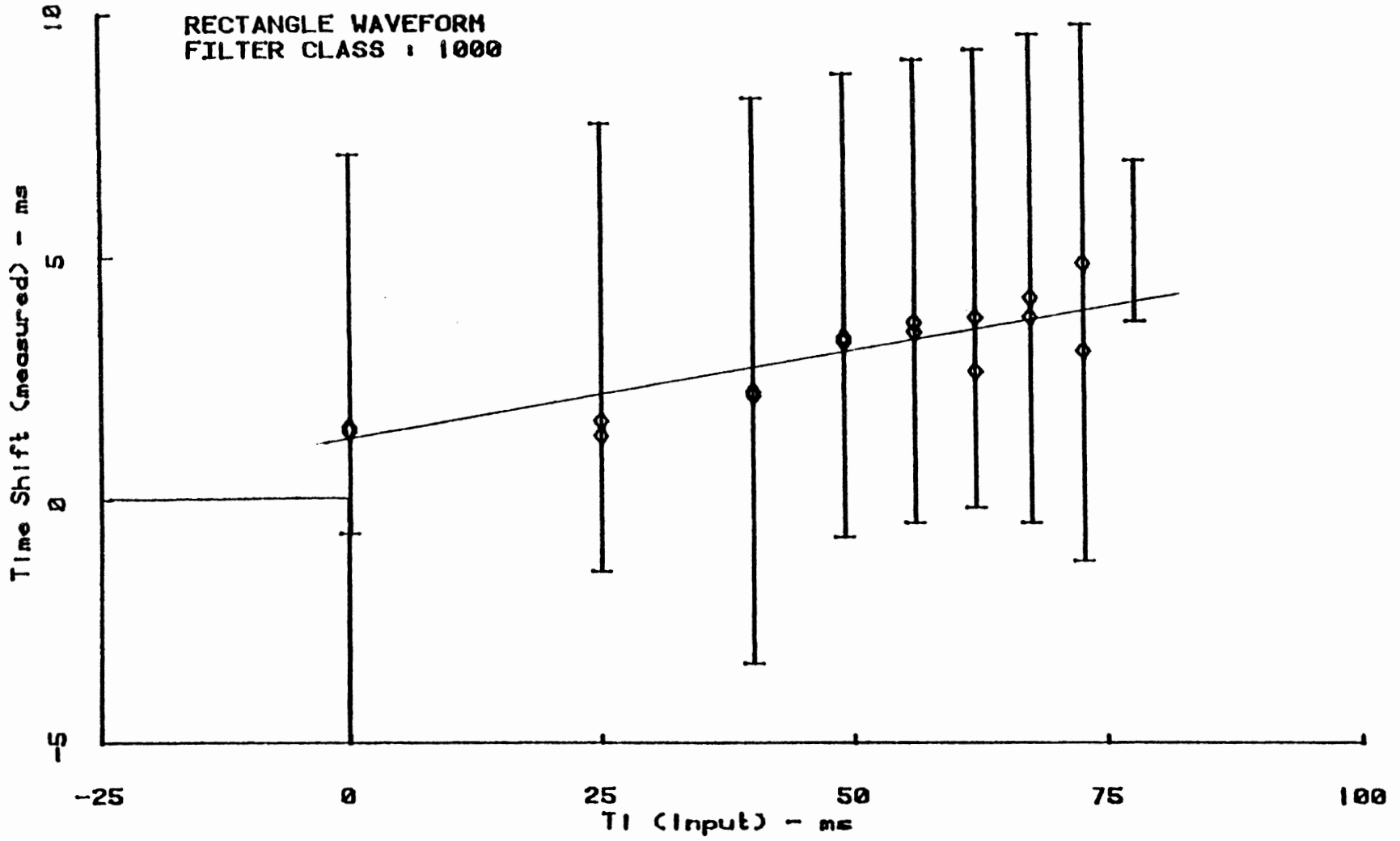

FIGURE 2-5. Representative Facility Time Accuracy Performance.

facilities will tend to use different equipment hardware and software to obtain and process test data, thereby introducing variability in test results.

ENVIRONMENTAL SPECIFICATIONS

This section addresses the overall environmental design criteria that should become an integral part of the performance specifications for the advanced dummy instrumentation. As a guide in developing these specifications, similar criteria applicable to military equipment were reviewed. Specifically, Military Standard 810D, which provides environmental test methods and engineering guidelines for the development of military equipment, was used as a basis for the material presented in this section.

The various test methods that are covered in MIL-STD 810D are summarized in Table 2-4 along with the corresponding test method numbers. Many of the test methods are inappropriate or are judged to be non-applicable to the advanced dummy electronic system. On the other hand, several are directly related and are judged to be essential. The following selected from the listing of Table 2-4 are judged to be applicable to the advanced dummy.

- high temperature
- low temperature
- temperature shock
- humidity
- acceleration
- vibration
- shock
- electro magnetic/electro static

A discussion of each follows.

High Temperature. High temperature tests are performed to determine if system components and materials can be stored and operated under hot climatic conditions without experiencing physical damage or deterioration in performance. High temperatures may temporarily or permanently impair the performance of the test item by changing the physical properties or dimensions of the materials composing it. Examples of some other problems that could occur as a result of high temperature exposure are

- parts binding from different expansion of dissimilar materials;
- lubricants becoming less viscous, joints losing lubrication by outward flow of lubricant;
- materials changing in dimension, either totally or selectively;
- packing, gaskets, seals, bearings, and shafts becoming distorted, binding, and failing, causing mechanical or integrity failures;
- gaskets displaying permanent set;
- closure and sealing strips deteriorating;
- fixed resistance resistors changing in values;
- electronic circuit stability varying with differences in temperature gradients and differential expansion of dissimilar materials.

DATA PROCESSING

TABLE 2-4

MILITARY STANDARD 810D TEST METHODS

Method No.	Method
500.2	Low Pressure (Altitude)
501.2	High Temperature
502.2	Low Temperature
509.2	Temperature Shock
504	(deleted)
505.2	Solar Radiation (Sunshine)
506.2	Rain
507.2	Humidity
508.9	Fungus
509.2	Salt Fog
510.2	Sand and Dust
511.2	Explosive Atmosphere
512.2	Leakage (Immersion)
519.3	Acceleration
514.9	Vibration
515.9	Acoustic Noise
516.9	Shock
517	(deleted)
518	(deleted)
519.9	Gunfire
520.0	Temperature, Humidity, Vibration, Altitude
521.0	Icing/Freezing Rain
522	(to be added later)
529.0	Vibro-Acoustic, Temperature

The primary objectives of the high temperature tests are to determine if:

1. The test article will operate with degradation in, or after storage in, a climate which produces a high temperature;
2. The test article can be operated and handled without affecting its integrity.

Tests are typically performed to verify both operational and storage temperature conditions for the test article.

Electronic circuit components available today are produced in the following three broad usage categories listed below along with their performance temperature limits:

Commercial	150°F
Industrial	180°F
Military	257°F

Based on the design objectives for the advanced dummy, the industrial component category with a hot temperature range to 180°F is recommended. A suggested test cycle is given here:

1. Place test article in temperature chamber.
2. Raise temperature to 120°F and hold for 6 hours.
3. Raise temperature to 154°F within 1 hour and hold for 4 hours.
4. Lower temperature to 120°F within 1 hour.
5. Repeat this cycle two additional times (making a total of three 12-hour cycles).
6. Return to ambient and operate to verify performance.

Low Temperature. Low temperature tests are performed to determine if materials can be stored, manipulated, and operated under pertinent low temperature conditions without experiencing damage or deterioration in performance. Low temperatures have adverse effects on almost all basic materials. As a result, exposure of test items to low temperature may either temporarily or permanently impair the operation of the test item by changing the physical properties of the materials composing it. Therefore, low temperature tests must be considered whenever the test item will be exposed to temperatures below standard ambient. Examples of some problems that could occur as a result of exposure to cold are

- hardening and embrittlement of materials;
- binding of parts from different contraction of dissimilar materials and the different rates of expansion of different parts in response to temperature gradients;
- loss of lubrication and lubricant flow due to increased viscosity;
- changes in electronic components (resistors, capacitors, etc.);
- changes in performance of transformers and electromechanical components;
- stiffening of shock mounts;
- cracking and crazing, embrittlement, changes in impact strength, and reduced strength.

The primary objective of the low temperature test is to determine if the test item can meet the performance specifications after storage and during operation in a cold environment. Based on the following three limits for cold temperature performance of electronic components, the industrial grade is recommended for the advanced dummy.

Commercial	32°F
Industrial	-40°F
Military	-67°F

A recommended test procedure should include both storage and operational tests as per Procedure I and II, respectively, of MIL-STD 810D.

Temperature Shock. Temperature shock tests are performed to determine if materials can withstand sudden changes in the temperature of the surrounding atmosphere without experiencing physical damage or deterioration in performance. As a result of sudden temperature changes, operation of the test item may be affected either temporarily or permanently. Examples of problems that could occur as a result of exposure to sudden changes in temperatures are

- binding or slackening of moving parts;
- separation of constituents;

DATA PROCESSING

- changes in electronic components;
- electronic or mechanical failure due to rapid water or front formation;
- differential contraction or expansion of dissimilar materials;
- deformation or fracture of components;
- cracking of surface coatings;
- leaking of sealed compartments.

The primary objective of the temperature shock test is to determine if the test item can operate correctly after exposure to sudden changes in temperature of the surrounding atmosphere. A recommended test procedure follows:

1. Place items in a high temperature chamber at 160°F and hold for 4 hours.
2. Transfer within 5 minutes to a cold temperature of -10°F and maintain for 4 hours.
3. Repeat this cycle four times for a total exposure of 32 hours.
4. Return to ambient temperature and verify performance.

Humidity. Humidity tests are performed to determine the resistance of materials or systems to the effects of a warm, humid atmosphere. Moisture can cause physical and chemical deterioration of material. Temperature changes and humidity may cause condensation inside of equipment. Typical problems that can result from exposure to a warm, humid environment are

- swelling of materials due to moisture absorption;
- loss of physical strength;
- changes in mechanical properties;
- degradation of electrical and thermal properties in insulating materials;
- electrical shorts due to condensation;
- binding of moving parts due to corrosion or fouling of lubricants;
- oxidation and/or galvanic corrosion of metals;
- loss of plasticity;
- accelerated chemical reactions;
- chemical or electro chemical breakdown of organic surface coatings;
- deterioration of electrical components.

Procedure III of the humidity test in MIL-STD 810D is recommended for advanced dummy equipment. This procedure exposes test items to more extreme temperature and humidity levels than those found in nature but for shorter duration. It is used to reduce the time and cost of testing. This procedure is used to identify potential problem areas, and the test levels are, for all practical purposes, fixed. During a 48 hour exposure, the humidity is maintained above 85% and the temperature varies from 86 to 140°F. Tests are conducted for a total of 15 days.

Acceleration. Acceleration tests are performed to assure that equipment can structurally withstand the G forces that are expected to be induced by acceleration in the service environment and function without degradation during and following exposure to these forces. In this case, acceleration refers to constant acceleration as would result on a spinning table. For the advanced dummy, instrumentation equipment should be designed for steady-state acceleration exposures of about 10 G. However, vibration and shock criteria discussed next are thought to be more significant.

Vibration. Vibration testing is performed to determine the resistance of equipment to vibrational stresses expected in its shipment and application environments. Vibration can cause

- wire chafing,
- loosening of fasteners,
- intermittent electrical contacts,
- touching and shorting of electrical parts,
- seal deformation,
- cracking and rupturing,
- loosening of particles or parts that may become lodged in circuits or mechanisms,
- excessive electrical noise.

Test variations for vibration include

- test apparatus,
- test item configuration,
- on/off state of test item,
- vibration spectrum and intensity,
- axis of exposure.

The exposure profile suggested for the advanced dummy equipment is taken from Category 1 of MIL-STD 810D, which is appropriate for basic transportation environments. All equipment shipped as secure cargo by land, sea, or air will encounter this environment. The test levels are based upon land transport stress levels because these are higher than air or sea stresses.

The recommended exposure is based on random vibration testing methods, and the power spectral density curve for the exposure is presented in Figure 2-6. As can be noted, the spectral density is constant from 10 to 40 Hz and then attenuates at a constant rate to a higher frequency of 500 Hz. The RMS value for the overall exposure is about 1 G. Test duration is based on an exposure of one hour per 1000 miles of travel distance. It is suggested that items be tested for one hour along each of three mutually perpendicular axes.

Shock. Shock tests are performed to assure that material can withstand the relatively infrequent nonrepetitive shocks or transient vibration encountered in handling, transportation, and service environments. Shock tests are also used to measure an item's fragility, so that packaging may be designed to protect it, if necessary, and to test the strength of devices that attach to platforms that can crash.

Mechanical shocks will excite an equipment item to respond at both forced and natural frequencies. This response among other things, can cause

- failures due to increased or decreased friction, or interference between parts;
- changes in dielectric strength, loss of insulation resistance variations in magnetic and electrostatic field strength;
- permanent deformation due to overstress;
- more rapid fatiguing of materials.

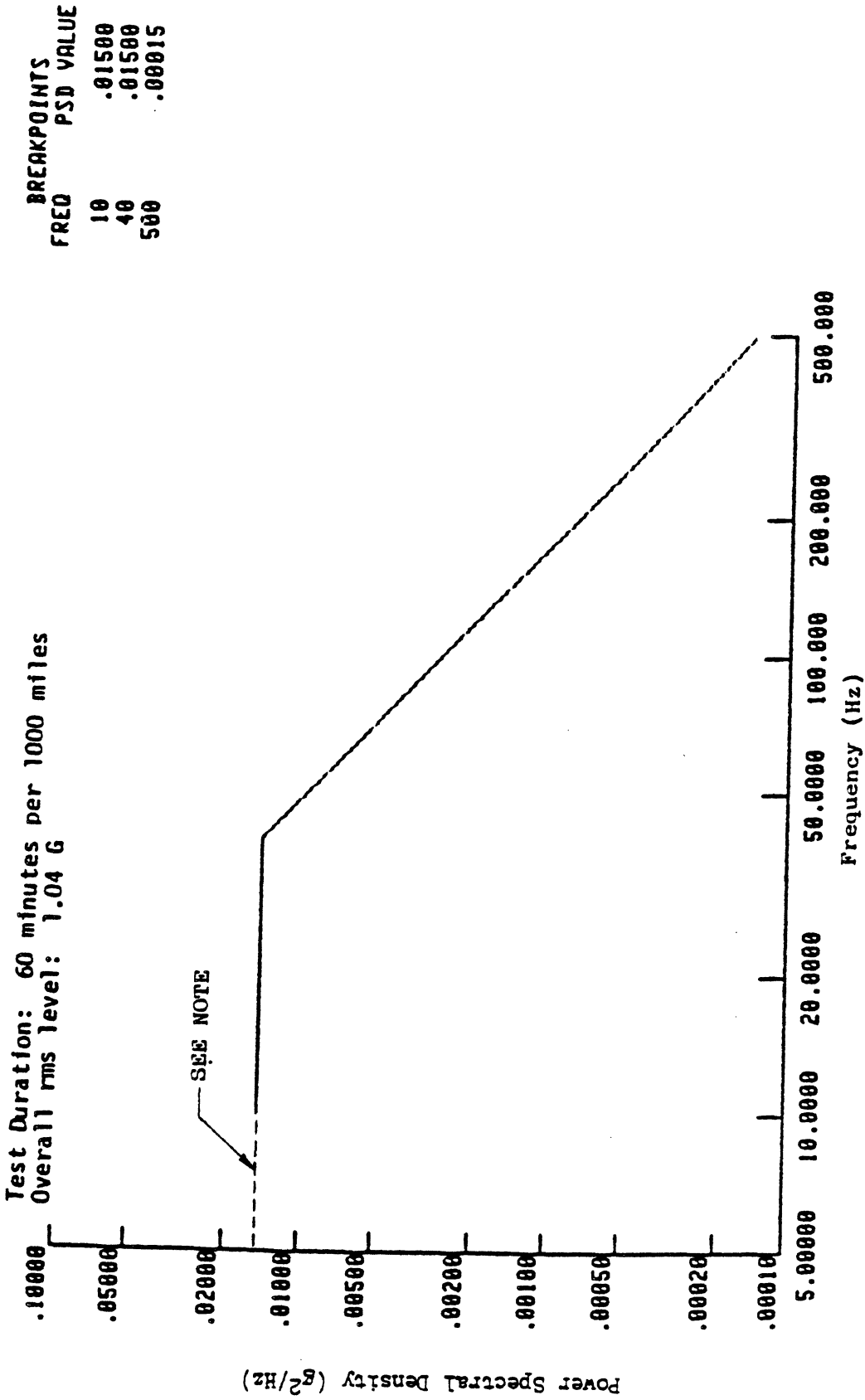

NOTE: If it is known that excitation is expected below 10 Hz, the curve shall be extended and shaped to comply with the available data.

FIGURE 2-6. Recommended Exposure for Random Vibration Testing.

Based on the exposure of different parts of the test dummy, the following amplitudes and time durations are suggested for shock testing purposes.

Head	500 G	0.5 ms
Chest	250 G	1.0 ms
Pelvis	250 G	1.0 ms

Shock pulses should be a half sine waveform, and three pulses should be applied in each direction along three mutually perpendicular axes (a total of 18 shocks per test article).

Electromagnetic/Electrostatic. The sensitivity of equipment to electromagnetic and electrostatic fields must be verified to ensure proper operation. The precise range and level of possible interference fields present during crash tests is currently unknown. It is known, however, that various equipment items and events occur that are known to generate electrical interference.

For example, high speed cameras as well as camera lighting systems are often synchronized to the crash event drawing high amplitude currents that can create magnetic disturbances. Systems on-board the vehicle, such as bags firing, are also known to generate large electro-static fields that can cause data recording errors.

To guard against these interference sources, use of proper shielding and grounding techniques must be employed. In addition, filters may be required on entry and exit cables. Equipment items should also be fully enclosed in a grounded metal container to assure maximum protection from stray disturbance fields.

ELECTRONIC DESIGN CONCEPT

The overall design concept for the advanced dummy instrumentation includes equipment items both internal to the dummy and also external to the dummy. The internal equipment is discussed later in this section but includes sensors and on-dummy processing electronics. Measured sensor data is amplified, filtered, multiplexed, digitized, and stored in digital memory on-board the dummy.

The on-dummy electronics are microprocessor based and can be interfaced to an external test set. The external test set is required to perform necessary calibration tests on dummy data channels in a quick and efficient manner prior to each test. The test set will also function to allow analysis of measured dummy response data during certification testing to be performed consistent with the planned usage of the device. Consequently, the test set will have the capability to inject known signals into data channels, receive measured responses to the injected signals, and analyze the results.

An overall diagram of the full system concept is shown in Figure 2-7. In this concept, the acquisition modules are integrated into the dummy along with a photo-electric sensor. This sensor is used to provide a time zero signal to one of the acquisition modules. This input is activated by a time-zero flash.

The recording of data, however, is controlled independently of the time zero input. Prior to impact, each acquisition module is in a state of continuous recording. The data is not saved until the impact event has begun; that is, when one of the input signals exceeds a threshold level. When this occurs, a predetermined amount of data prior to impact will be stored along with the post-impact data for a total of 0.5 second.

DATA PROCESSING

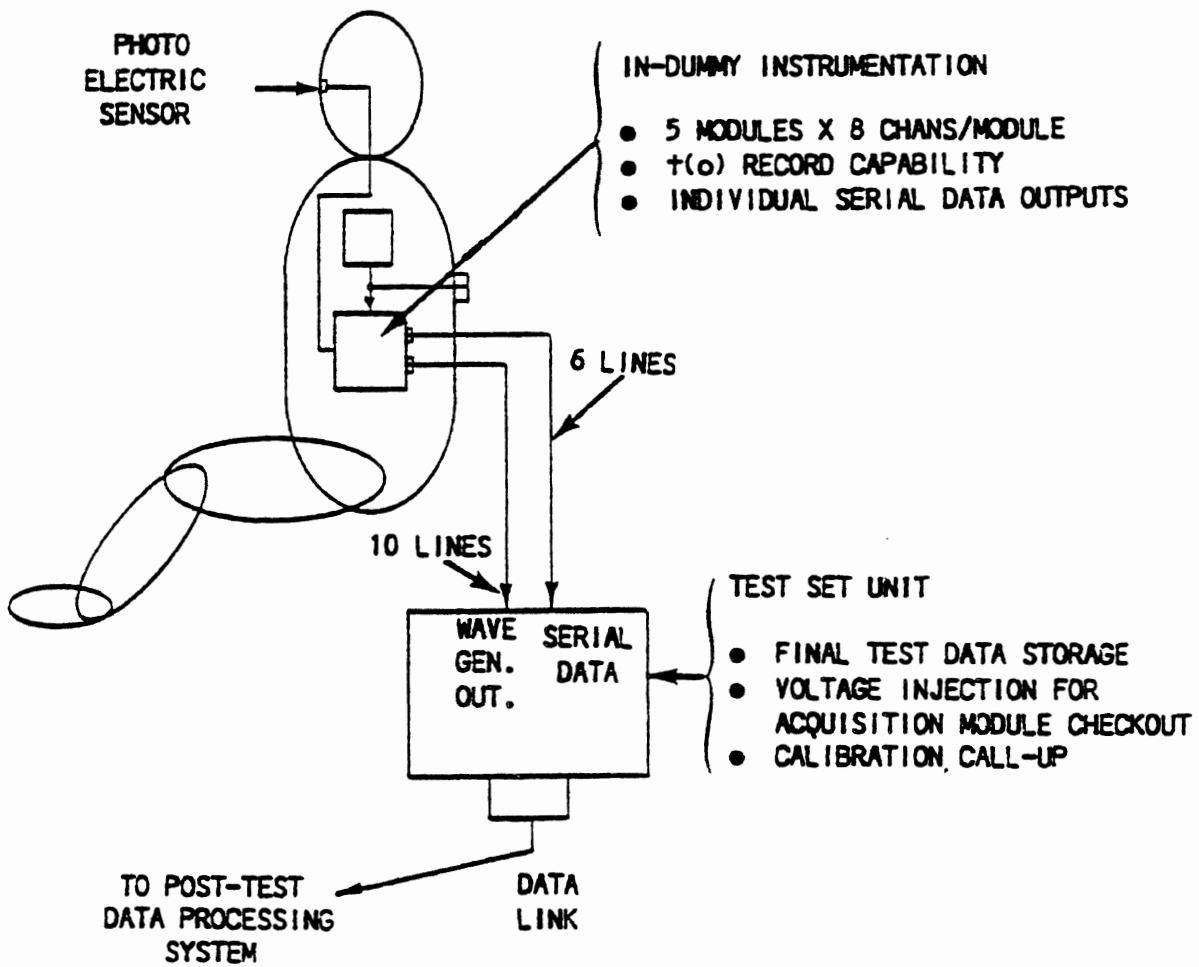

FIGURE 2-7. Full System Concept.

Each acquisition module will record data in one particular location of the dummy, such as the head or the chest. These individual modules will be synchronized in time with respect to each other due to two status lines that interconnect them. When one module senses a threshold level, a status line is activated. This line is then polled by the remaining modules which then begin impact data recording.

Also among the design considerations are that of 40 data channels total but retaining a "patch" capability of up to 60 transducer inputs.³ The input signal conditioners will be designed to work in conjunction with bridge or other voltage generator type transducers.

An external test set is utilized to provide functions that cannot be implemented in the acquisition modules themselves. The test set provides a shunt calibration feature and voltage injection for verifying the dynamic performance of each signal channel. Also included are serial data links to all acquisition modules. This provides a device that accommodates centralized storage of all data recorded during impact.

The acquisition modules include those functional components that are required to acquire and store data during an impact test. The two-card acquisition module consists of an analog circuit card and the CPU card. A functional block diagram of an entire two-card module is shown in Figure 2-8.

The components on the analog board include individual instrumentation amplifiers for each channel. Several amplifier units are currently available that incorporate anti-aliasing filter stages, thus conserving valuable space. A multiplexer stage and a high speed analog-to-digital converter (12 bit A/D) are used to digitize the incoming signals. The diagram shows an 8-channel layout, although expansion beyond this is possible. A single precision regulator supplies the excitation voltage for all transducers interconnected to one module.

The CPU board's function is to collect and temporarily store data and then to transfer that data on command. A high-speed 8-bit microprocessor (CPU) is used to control the flow of the data. Current state-of-the-art microprocessors provide performance levels that are acceptable for 8-channel modules at these sample rates. The microprocessor stores the data in a bank of 64K bytes of on-board dynamic R.A.M. This is adequate storage for 0.5 s of recorded data for eight data channels sampled at the 8000 Hz. These data are transferred out of the dummy on a serial interface bus after the tests. The diagram of Figure 2-9 illustrates an estimate of board sizes for the 8-channel acquisition module. The components shown represent industry standard dimensions for the integrated circuit products.

The data acquisition module described above is based on the use of on-dummy data memory. The on-dummy memory concept is thought to be achievable using currently available circuit components and memory chips. Furthermore, there is good promise to achieve improved memory density within the next year. For example, memory circuits that are currently under development by Texas Instruments and Fujitsu should be available in the latter portion of 1984 and will provide a memory capacity of 256K bits.⁴

³Subsequent work has upgraded this capability to 72 channels, expandable to 100. See Task E report.

⁴These circuits are now available and form the basis for the upgraded channel capability. See Task E report.

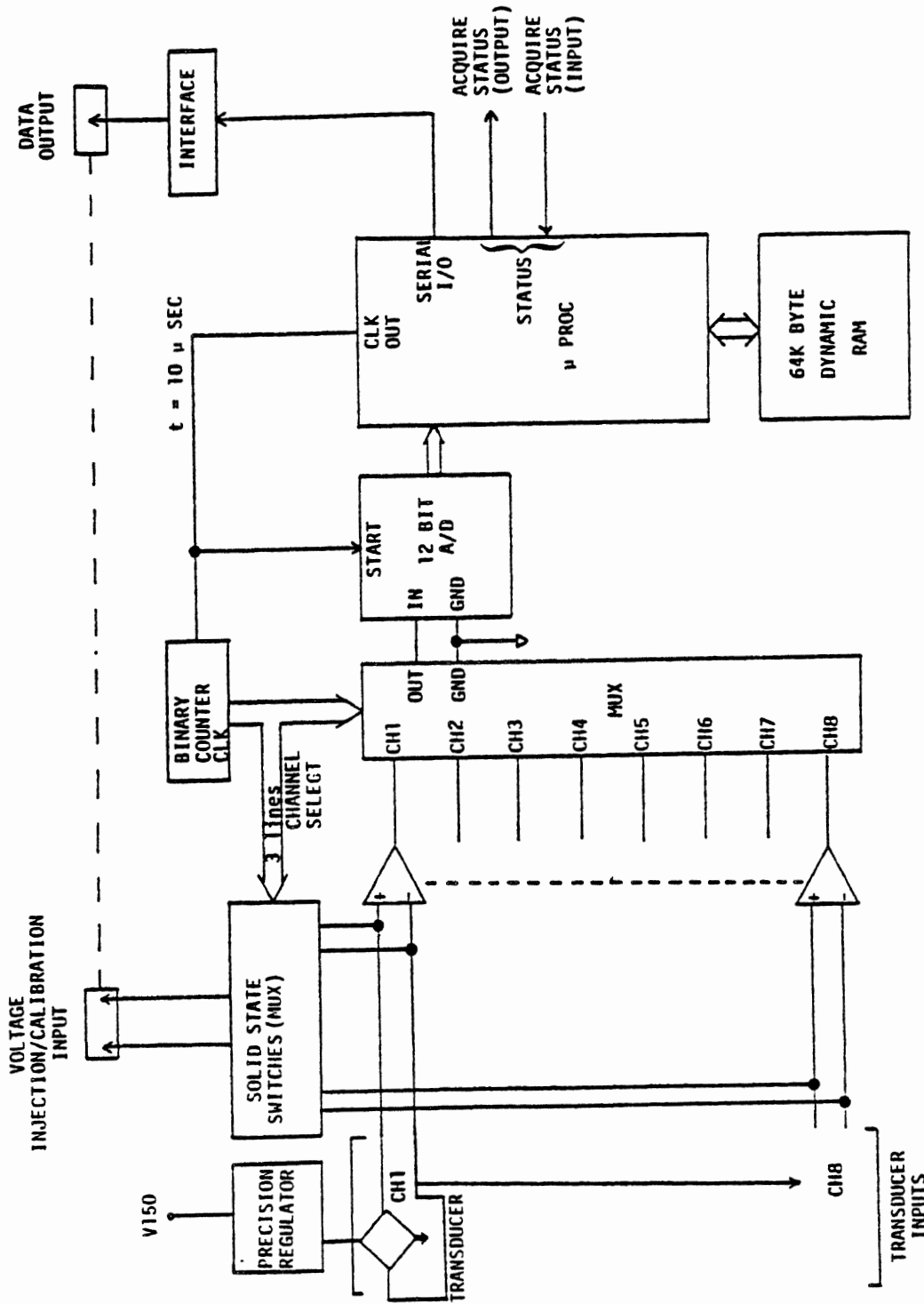

FIGURE 2-8. Data Acquisition Module Block Diagram.

DATA PROCESSING

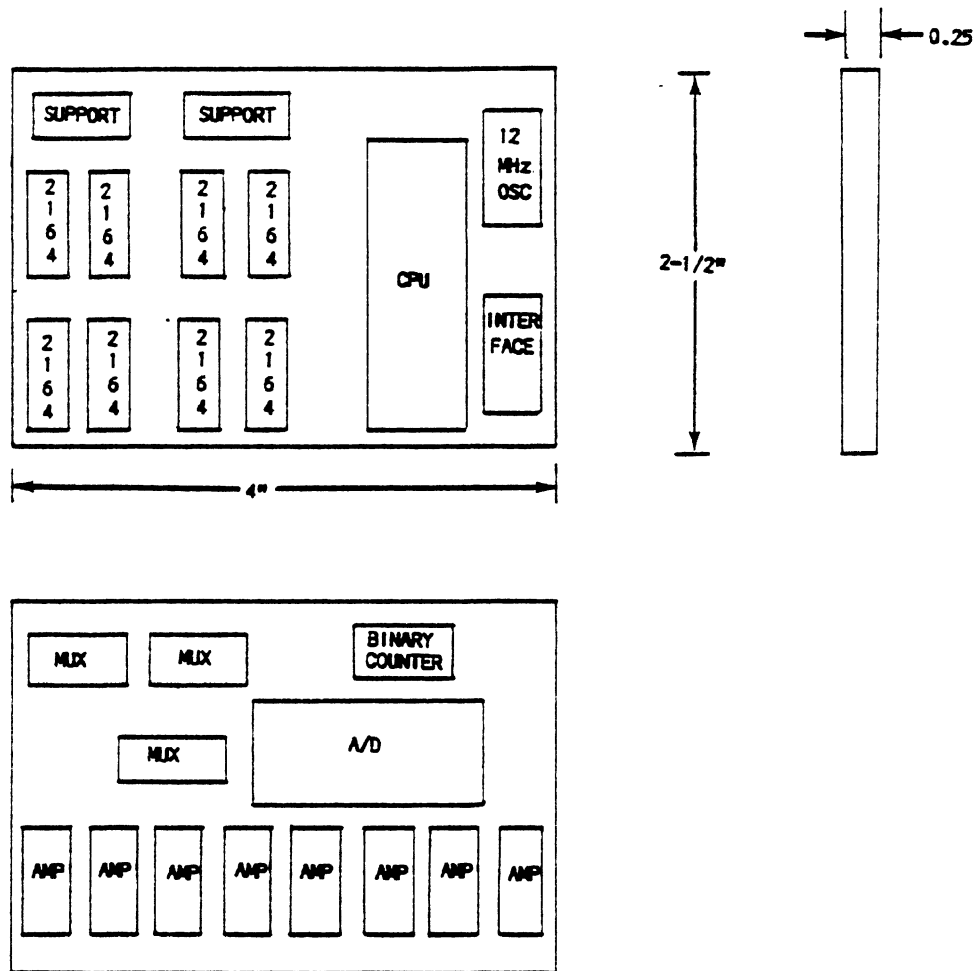

FIGURE 2-9. Estimated Board Size for Eight-Channel Module.

DATA PROCESSING

These chips will be physically similar to the Intel 2164 circuits illustrated in Figure 2-9 for the memory circuit card. The new memory chips will result in memory card sizes that are about one quarter of the size illustrated in Figure 2-9. Conversely, for the same physical size, data storage capacity can be increased by four times. Consequently, the on-dummy memory concept is realistic using currently available memory circuits with good promise for improved storage capacity.

As an alternative to on-dummy data storage, an off-board-the-dummy concept can also be considered. For off-dummy storage, the physical size of the memory elements is less important. In this case, the size (number of wires) of the interconnect cable between the dummy and the memory system is of greater importance. Consequently, a serial data bus should be employed to transfer measured data to an off-dummy memory module.

The off-dummy memory concept allows greater flexibility in memory size but requires more setup effort to install the memory modules during a test. In addition, the reliability of the off-dummy storage concept is judged to be less than that for the on-dummy approach due to the vulnerability of the data interconnect cables. The design concept for an off-dummy memory system has not been developed at this time due to the strong evidence that an on-dummy approach is achievable using currently available technology. It is thought, however, that the design for the off-dummy approach is straightforward and would not result in any major design difficulties.

The appropriateness of an on-dummy data acquisition and storage system is clearly dependent on the proper packaging of the system into the dummy while maintaining biofidelity. It is also important that the system functions reliably during anticipated usage. The former requirement deals with the weight and physical size of the system elements, whereas the latter relates more to the manner in which it is assembled and interconnected. A system packaging design will be developed working in conjunction with the volume envelope space available within the dummy. Consideration will be given to both the total available volume of space as well as the possible reduction in volume that can occur during impact conditions. Currently it is planned to mount the major elements of the data acquisition and processing electronics in the pelvic area of the dummy, with possible overflow into the lumbar spine. The system battery and associated regulators will also be packaged into the pelvic region. System component elements will be interconnected using high quality cables and military grade connectors.

Shock hardening of the system will be assured through appropriate attention to the system design. First, components will be selected that have been shock tested by the manufacturer and are known to function at the anticipated design levels. In those cases where the manufacturer has not tested the item, actual shock tests will be conducted on both a component and assembly basis.

Shock tests will be performed on all system components and sub-assemblies prior to final design. These tests will be performed with the system items powered to verify operational performance as well as basic mechanical integrity.

CALIBRATION REQUIREMENTS

Calibration requirements for the advanced dummy electronic instrumentation fall into two general categories. First, it is recommended that the dummy electronic instrumentation be verified prior to each test. Second, on regular intervals not exceeding six months, the various sensors used in the test device should be calibrated.

The regular data channel verification tests performed prior to each test requires that known waveforms be injected into a data channel, recorded, and then analyzed to determine channel performance. Major channel performance variables that should be evaluated during these routine tests include but are not limited to amplitude linearity, time linearity, frequency response, time zero offset, and time synchronization.

To determine that data channels conform to specified performance levels quickly and efficiently, it will be necessary to analyze recorded waveforms using an external test set. This device is described in more detail in the following section, but, briefly, it contains the waveforms that are injected into data channels and the analysis software used to process recorded data. Consequently, it is possible with this test set to determine immediately if a data channel conforms to specified requirements.

Other tests of channel integrity can also be performed by the test set. For example, it is planned to record data channel zero and to calibrate levels prior to and immediately after each test. Verification of the absolute value of the zero level of a data channel within pre-defined limits indicates that the channel is operational from the sensor to the output of the data channel. Furthermore, agreement between pre- and post-test levels within a few percent indicates that the sensor likely was not damaged during a test.

On a regular basis not exceeding six months, all dummy sensors should be removed and calibrated. NHTSA currently requires compliance test contractors to calibrate measurement and test equipment at six month intervals, according to the procedures outlined in Military Standard MIL-C-45662A, *Calibration System Requirements*. The same procedure should be required for the advanced dummy sensors.

A specific uniform calibration procedure should be developed for each type of sensor used in the advanced dummy. Accelerometers will likely constitute the major sensor used in the dummy and therefore warrant the greatest emphasis. Current practice among the various facilities regarding accelerometer calibration varies considerably.

In our review of facility practice as a part of our Test Site Instrumentation Study, it was noted that both oscillating shaker tables and rotating spin tables are used to generate a controlled acceleration input for accelerometer calibration. Large variations in sensor calibration procedures were also noted among the test facilities. For example, some facilities perform sensor linearity tests as well as frequency response measurements, whereas others perform only single point spin table calibrations.

Accelerometer sensitivity (volts/G) is often determined at different acceleration levels, at different frequencies of excitation, as well as statically, e.g., with a centrifuge. Consequently, one facility may base the sensor calibration on the response to a sinusoidal input acceleration at a peak amplitude of say 50 G and a frequency of 100 Hz, whereas another facility may base the calibration on the response to a steady-state input at 100 G.

To provide increased consistency in the procedures and techniques used to calibrate accelerometers, the following calibration tests⁵ are recommended for accelerometers to be performed at regular time intervals.

- Determine amplitude linearity at a fixed frequency
 - Determine frequency response at a fixed amplitude
 - Determine phase response at a fixed amplitude
 - Determine the sensor calibration factor
-

⁵These test procedures follow the guidelines outlined in ISO 6487.

DATA PROCESSING

The amplitude linearity of an accelerometer should be determined by measuring the sensor output at a frequency of 100 Hz over an input range from zero to $\pm 100\%$ of the channel full scale level. A minimum of five equally spaced values should be used. The amplitude linearity equals the ratio of the sensor output to input at a constant input amplitude between 10% and 100% of the channel full scale. To be acceptable, the measured frequency response curve must fall within the SAE J211 JUN80 frequency response envelope specified for the entire data channel class between the F_L and F_N frequency limits. At frequencies above F_N , the measured frequency response must fall within or be above the defined channel class envelopes.

Sensor phase response equals the phase time (measured in seconds) between the input and output of a sensor at an input amplitude between 10% and 100% of the channel full scale value. In conformance with the requirements outlined in ISO 6487, the maximum allowable phase delay time between the input and the output shall not vary by more than $1/10 F_H$ seconds between $0.03 F_H$ and F_H . This results in a maximum allowable phase delay time of 0.1 ms for Class 1000 data.

The sensor calibration factor equals the average value of the slope of the straight line representing the best fit to the measured amplitude response data. The calibration factor is determined at a frequency of 100 Hz. The calibration factor represents a single number that identifies the relationship between sensor output voltage and the physical variable being measured.

The calibration factor is used to identify the value of a calibration signal in response to a shunt or voltage injection calibration procedure. The value of the calibration level simulated by a shunt or voltage calibration procedure shall be determined to within $\pm 0.1\%$ of channel full scale.

A procedure similar in scope and detail to the above should be developed for all sensors used. It is recognized, however, that frequency response calibration on such sensors as load cells and displacement potentiometers are difficult to perform with commonly available test apparatus.

TEST SET CHARACTERISTICS

The overall characteristics of the microprocessor based test set that would interface with the advanced dummy are briefly described in this section. As indicated previously, the purpose of the test set is to provide state-of-the-art computer support capability for the advanced dummy instrumentation. This will allow calibration waveforms to be injected into the on-dummy data acquisition channel. It would also allow recorded response data to be processed and analyzed by the test set to provide channel performance results quickly on a routine basis.

The test set would also function to process dummy response data generated during certification testing. This would again allow test results in the form of GO/NO-GO and also other acceptance criteria to be produced immediately following a certification test. Consequently, certification tests could be performed efficiently and in conjunction with a powerful data control and analysis support system.

A preliminary block diagram that illustrates the overall characteristics of the computer based test set is presented in Figure 2-10. As noted, the test set is cable connected to the advanced dummy instrumentation by way of a bidirectional high speed

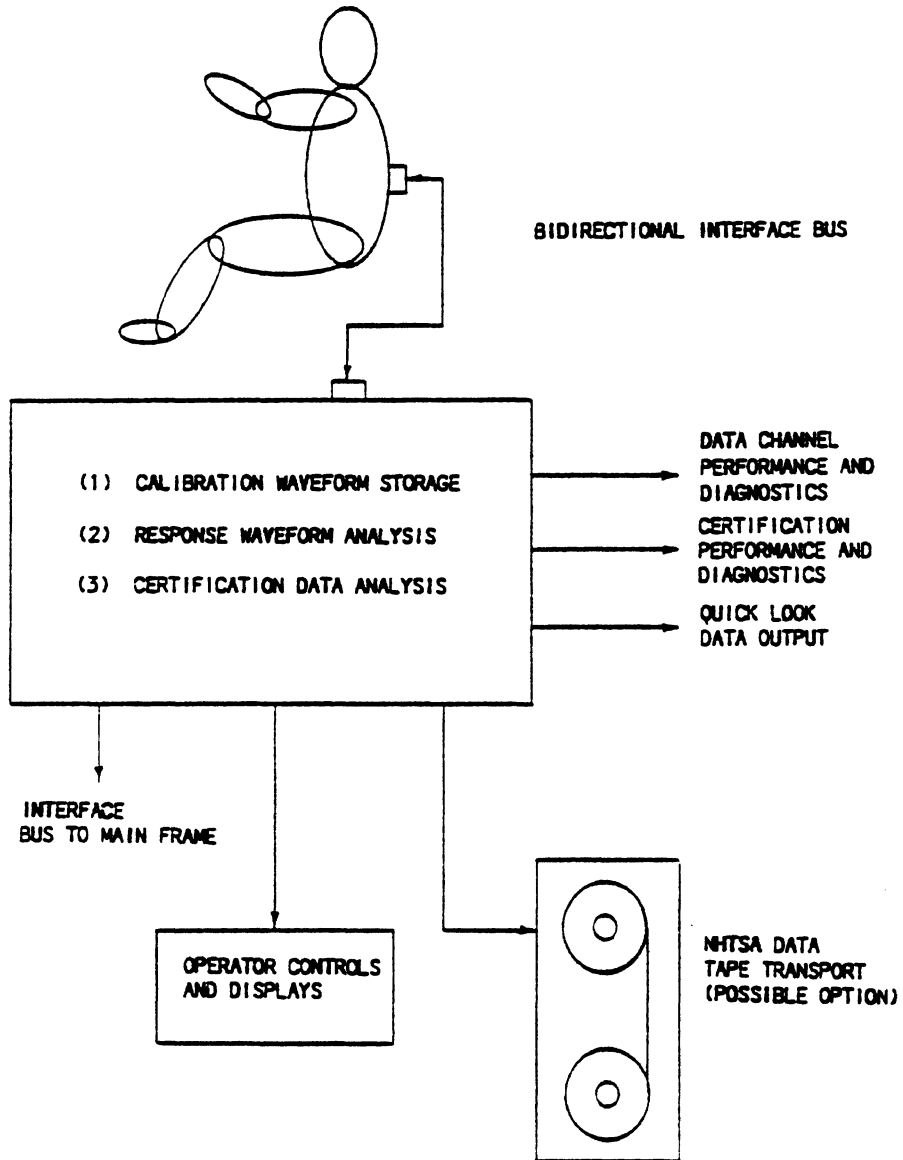

FIGURE 2-10. AATD Test Set.

DATA PROCESSING

computer interface bus. This bus allows information in the form of measured data stored in the on-dummy memory to be transferred to the test set.

In addition, through appropriate logic circuits included in the on-dummy instrumentation, waveforms stored in the test set can be injected into on-dummy data channels. This capability is required to permit data channel calibrations to be performed in a routine manner.

The test set includes an operator control keypad as well as a CRT to display test results to the operator. Data output can also be produced in the form of a printer output and test data time histories. This would allow for quick-look capability of test data and also a means for documentation of system performance using a printer output record.

The test set could also contain a general purpose interface bus to transfer test data to a main frame computer for additional analysis purposes if desired. As an optional feature, the test set could also be designed to produce a properly formatted NHTSA data tape of measured test data.

REFERENCES

- Arendt, R.H.; and Miller, P.M. (1981) *Test site instrumentation study, Volume I*. MGA Report No. G22-V-1. MGA Research Corp., Akron, N.Y.
- ISO 6487. (1980) *Road vehicles—Techniques of measurement in impact tests—Instrumentation*. International Organization for Standardization, Geneva.
- MIL-C-45662A. (1962) Calibration system requirements. U.S. Department of Defense, Washington, D.C.
- MIL-STD-810D. (1983) *Environmental test methods and engineering guidelines*. U.S. Department of Defense, Washington, D.C.
- SAE J211. (1980) *Instrumentation for impact tests*. Society of Automotive Engineers, Warrendale, Pa.

CHAPTER 3

CERTIFICATION TEST PROCEDURES

D. Segal
MGA Research Corporation
Akron, New York

The objectives of this effort were to review test procedures that are currently employed to certify the Part 572 anthropomorphic dummy for use in crash tests and to recommend approaches that appear promising for use with the advanced dummy. These certification tests are intended to ensure that dummy responses to impact stimuli are both repeatable and reproducible. A brief review of Hybrid III dummy certification procedures was also conducted.

The major recommendations resulting from the study are presented first, followed by a review of current Part 572 dummy certification test procedures. Approaches toward certification of the advanced dummy are then discussed. Because certification testing and instrumentation development efforts are closely related in terms of sensor calibration requirements and data channel integrity checks, the overall instrumentation concept is also summarized. Finally, an appendix presents the results of a brief analytical study in which the response discrimination capabilities of a current dummy were evaluated via computer simulation techniques.

RECOMMENDATIONS

A number of recommendations have been developed as a result of the review of current dummy certification test procedures and consideration of alternatives. These are given below.

1. Routine certification testing should be done on a completely assembled advanced anthropomorphic dummy. Test procedures should involve dynamic exposure of the dummy to levels that are consistent with the automobile crash environment. That is, certification testing should mimic the in-use environment to the maximum extent possible. Test procedures and equipment must be developed that will allow efficient and rapid testing.

2. On-dummy instrumentation should be used in certification testing. It is recognized that additional electronic measurements may be necessary as a part of new test procedures; however, where possible, the sensors, instrumentation, etc., that are a part of the dummy should be utilized to provide certification test data. As this instrumentation is part of the dummy, it is reasonable that it should also be checked as a part of the certification process. However, a complete calibration of sensors is not thought to be necessary each time a dummy is certified. Rather, a calibration interval would be defined at which time all instrumentation would undergo calibration according to established procedures. These procedures and intervals are being developed as a part of the instrumentation development effort. During the interim periods, certification testing would involve a check of each data channel via a signal injection and analysis by the test set included as a part of the overall instrumentation concept. Furthermore, any certification test response signals exceeding allowable bounds would indicate a problem, either

CERTIFICATION

mechanical or electrical, with a dummy component. This component would then be looked into in detail. Thus, certification testing is viewed as a check on both mechanical and instrumentation response.

We should also note that a data acquisition and processing system should be a part of the overall certification test equipment. This approach will allow rapid processing of test results to determine whether a response is within acceptable limits immediately after a given test.

3. Performance criteria should include injury measures as well as engineering measures. That is, if Head Injury Criterion (HIC) is used as an injury measure for the head, then a test procedure that results in a comparison of a HIC with established error bounds should be utilized. This approach results in a better knowledge of error limits on the primary dummy outputs than is currently available. It should be noted, however, that measures of response in addition to injury measures may be desirable and even necessary for identification of sources of unacceptable component response.

4. Dummy disassembly and component level testing should be undertaken only if whole body testing indicates a problem in meeting response limits. That is, component level testing should be undertaken as a diagnostic aide in determining a specific mechanical item in need of repair or adjustment.

5. Subsequent activities must be undertaken to develop specific test procedures later in this phase and in subsequent phases of development of the advanced anthropomorphic dummy. These activities include investigations of the following:

- Specific tests and fixturing to be utilized (e.g., pendulum drop, etc.);
- Dummy response acceptability bands;
- Multicomponent discrimination capability (i.e., does a stimulus applied to one component allow determination of the acceptability of a separate component response?);
- Frequency domain and mechanical impedance techniques as applied to performance measures;
- Temperature and humidity response dependency.

REVIEW OF EXISTING DUMMY CERTIFICATION PROCEDURES

In the United States, two principal anthropomorphic test devices are utilized in frontal automotive safety testing and evaluation. These are commonly known as the Part 572 and the Hybrid III dummies. In conjunction with their use for safety evaluation testing, these test devices, or dummies, are required to undergo certification testing to ensure that the measured responses are repeatable and reproducible. These certification procedures are summarized below with emphasis on the Part 572 dummy, because its use is currently specified in Federal Motor Vehicle Safety Standard (FMVSS) 208, Occupant Protection.

Part 572 Dummy. Title 49, Code of Federal Regulations, Part 572, Subpart B describes the 50th percentile male anthropomorphic test device (dummy) to be used for compliance testing of motor vehicles and motor vehicle equipment according to the various FMVSS. Part 572 makes reference to dummy specifications and drawings, and it also contains test procedures and test response criteria for determining whether an individual dummy and its component parts are within certain performance bounds. These specifications, test procedures, and response criteria in turn result in what is hoped to be a

CERTIFICATION

repeatable and reproducible performance of the dummy in an automotive crash environment. The objective of this section is to briefly review the test procedures that are currently in use.

Six individual test procedures are specified for various dummy components along with test response specifications. The head, neck, thorax, lumbar spine, abdomen, and knees are subject to tests as described below.

Head. The head is subjected to a drop test from a height of 10 inches onto a 2-inch-thick steel plate. The initial orientation of the head is specified. The peak resultant head acceleration must be between 210 and 260 G and must be above the 100-G level for between 0.9 and 1.5 ms. The lateral acceleration must not exceed 10 G.

Neck. The neck assembly is also subjected to a dynamic component test. The neck assembly with the head attached is mounted on a pendulum of specified design. The pendulum is released from a height that causes an impact at 23.5 ± 2 f/s. The motion of the pendulum is stopped with a prescribed deceleration. The rotation and chordal displacement of the head are determined as a function of time and must fall within the bounds illustrated in Figure 3-1. The peak resultant head acceleration must not exceed 26 G.

Thorax. Dynamic tests are performed on the thorax at two energy levels. A test probe weighing 51.5 lb is used to impact the thorax at velocities of 14 and 22 f/s. The orientation and positioning of the dummy is specified, and the test probe is guided so that it moves with no significant lateral, vertical, or rotational movement during the impact. Deflection of the sternum relative to the spine is measured by a potentiometer inside the thorax cavity, and impact force is measured by the test probe. Upper limits on sternal deflection of 1.1 and 1.7 inches for the two test speeds are specified as are limits on peak force of 1450 and 2250 lb, respectively. The internal hysteresis for each impact is limited to between 50 and 70 percent.

Lumbar Spine. The lumbar spine is subjected to a quasi-static flexion test. A test fixture is used to secure the pelvis, and femur-friction plungers at each hip socket are adjusted to 240 inch-pounds of torque. A force is applied perpendicular to the thorax instrument cavity at a specified location, and a measurement of force versus angular flexion is made up to 40 degrees of flexion. The acceptance criteria for these measurements is illustrated in Figure 3-2.

Abdomen. The abdomen is tested with a quasi-static compression test. With the assembled thorax, lumbar spine, and pelvic assemblies in a supine position, a rigid cylinder of 6-inch diameter is placed transversely across the abdomen at a specified location. A zero deflection point is established at a 10-pound force level. Subsequent force versus deflection measurements must fall within the bounds indicated in Figure 3-3.

Limbs. Each knee is subjected to a dynamic impact test with a 51.5-lb impactor at a speed of 6.9 f/s. Positioning of the dummy is specified, and force measurements are made on each femur. The maximum force measured must be between 1850 and 2500 lb, with a duration above 1000 lb of not less than 1.7 ms.

Test Conditions and Instrumentation. Test conditions and instrumentation requirements are specified for each of the tests. Generally, test conditions specify the positioning of the dummy or component part with respect to the stimulus, environmental conditions (temperature, etc.), and the settings of adjustable components (e.g., joint torque

CERTIFICATION

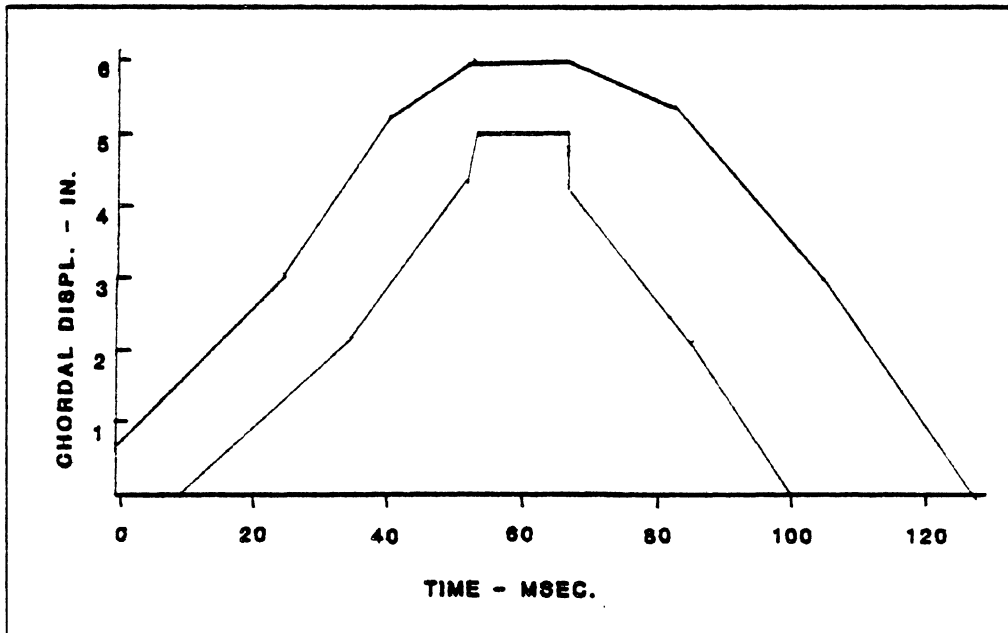
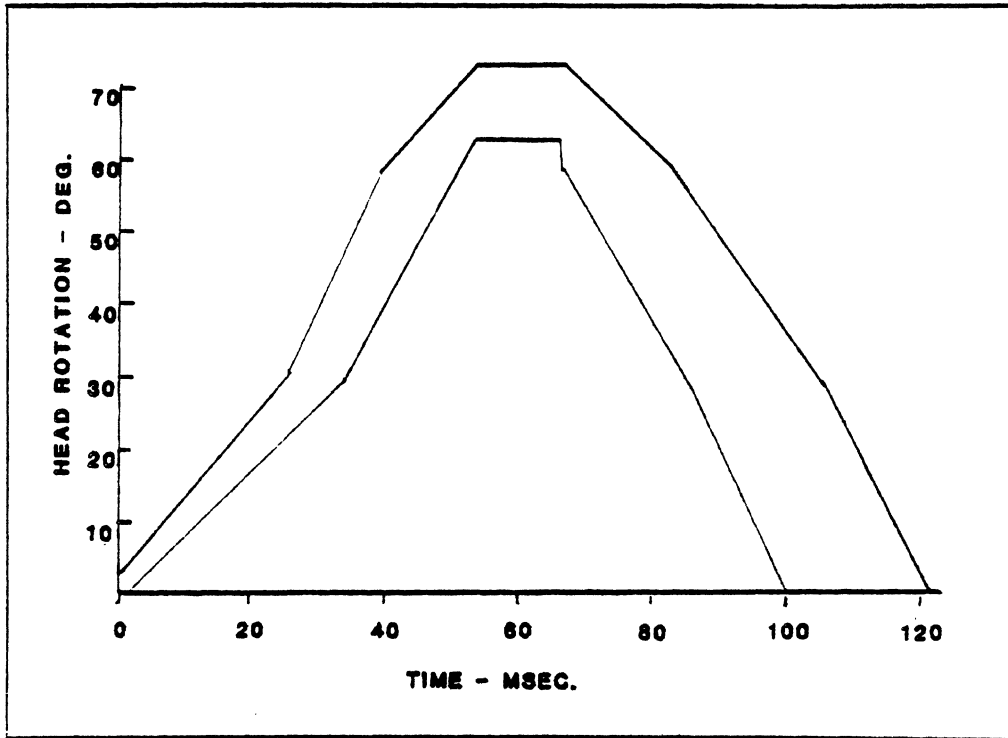

FIGURE 3-1. Head Response Bounds for Neck Component Test.

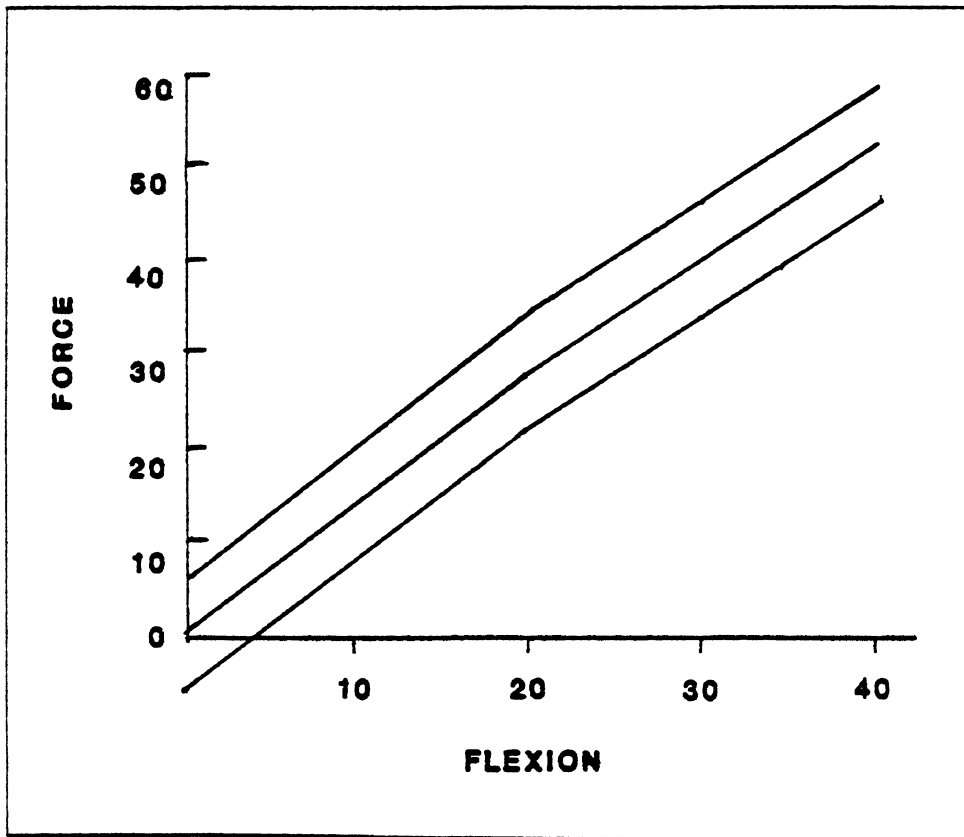

FIGURE 3-2. Lumbar Spine Flexion Measurement Criteria.

CERTIFICATION

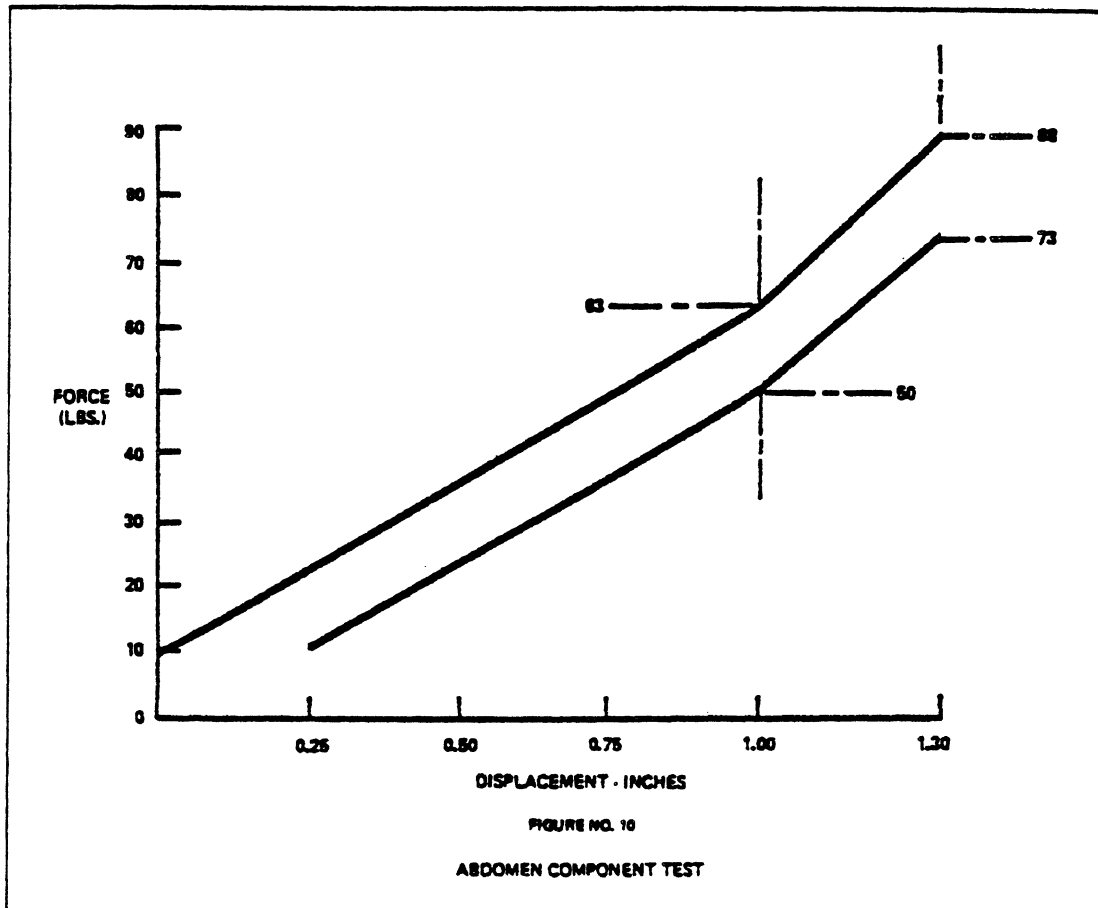

FIGURE 3-3. Abdomen Component Test Measurement Criteria.

CERTIFICATION

settings). Acceleration and force sensing devices used in the procedures are required to conform to SAE Recommended Practice J211 according to the following schedule:

- Head acceleration, Class 1000
- Pendulum acceleration, Class 60
- Thorax acceleration, Class 180
- Thorax compression, Class 180
- Femur force, Class 600

Hybrid III Dummy. The Hybrid III dummy was developed as an improvement on the Part 572 dummy in terms of its biomechanical fidelity. It is based on the Part 572 dummy but includes a number of revised body parts. Because it is not the test device specified by Federal regulation, it is not used as extensively within the automotive safety community. However, recommended dynamic response specifications have been developed for a number of body parts including the head, neck, and knee. These specifications include test procedures that closely follow the corresponding procedures for the Part 572 dummy with some modifications to exposures or response measures as are briefly described below.

Head. As with the Part 572, the Hybrid III dynamic head response is checked with a drop test. In this case, however, the head is dropped from a height of 14.8 inches at a specified orientation, and three tests are required with each having to meet peak acceleration response limits.

Neck. The head-neck assembly is subject to dynamic testing utilizing a pendulum similar to that specified in Part 572. For the Hybrid III, both extension and flexion are subject to test specifications, which include the moment measured about the occipital condyles and head rotation angle. Three separate tests are required to be run on each assembly.

Thorax. As with the Part 572, the Hybrid III thorax response is checked with a pendulum impact test at two energy levels. This test is done on a completely assembled dummy with test setup geometry specified. Response measurements include sternum displacement, thorax load, and hysteresis ratio. As with the previous tests, three repetitions are required.

Knee. Rigid pendulum impacts are conducted on the Hybrid III dummy knees with a test setup specified. Three pendulum weights are used to achieve different energy level inputs at a constant impact velocity. Minimum and maximum force levels are specified for each. Three replicate tests are required for each pendulum.

Discussion of Dummy Certification Procedures. The current procedures used to certify a dummy for use in crash testing are deficient in a number of areas. The level of effort required to complete all tests and data processing and evaluation is on the order of two days with the current Part 572 dummy. This appears to be unnecessarily excessive given the limited number of measurements that are made with this frontal impact dummy. Clearly, more efficient procedures will be necessary if certification of a new multidirectional dummy is to be accomplished at a reasonable effort level.

Equipment requirements for the current test procedures are modest, and equipment items required to conduct the tests are generally well defined. Positioning of a stimulus with respect to the dummy is generally accomplished by the specification of measurements from a reference surface. Better procedures for this positioning could result in improvements from the point of view of both consistency and operational efficiency.

CERTIFICATION

Instrumentation requirements are referenced to the rather loose definition of performance specifications established in SAE Recommended Practice J211. No calibration requirements are explicitly stated for measurement sensors or other items required for data acquisition and processing. While most of the current tests require little post-test data processing, all require that, at a minimum, a test measurement be compared to a reference or response band. No procedures are specified for processing the measured electronic signals into a form suitable for comparison with the standards.

The lack of a standard data acquisition and processing system can have a substantial influence on the reproducibility of test results across different testing laboratories. That is, even if an identical measurement signal is available to different data acquisition and processing systems, a substantial difference in results can still be obtained due to hardware and/or software differences. On a previous project, *Test Site Instrumentation Study*, (Contract No. DTNH22-82-C-070410), MGA identified scatter in data processing results from various automobile crash and sled test facilities on the order of ± 10 percent due only to differences in data acquisition and processing systems. Consequently, the results of certification tests at different laboratories may, in some instances, be very different if this level of difference is typical of dummy certification data systems.

Some test procedures involve disassembly of the dummy into a number of component parts. The component parts are then tested separately in isolation from the rest of the dummy. Note that torso impact tests are performed with the dummy assembled, but no attempt is made to collect data from other components than the one of interest. Hence, in no case is the complete dummy exercised fully with the current procedures.

Current Part-572 procedures set no requirements on test repetition. Presumably a marginal component could be tested until, by random, it meets response requirements. That component would then be considered to be just as acceptable as a component that always passed the test. This deficiency has been corrected in the Hybrid III test procedure recommendations, in that three replicate tests are specified.

Three injury measures are currently specified in FMVSS 208. These are the HIC number based on head resultant acceleration, the upper thorax peak resultant acceleration, and the peak axial femur forces. Maximum limits are placed on each of these measures for compliance crash testing. Certification testing, however, uses only one of these injury measures directly as a means of evaluating dummy performance. That is, femur loads are directly measured and compared to response limits specified. No dynamic acceleration measurements are made in thorax impact tests. Head acceleration is measured in the head drop test, but HIC is not calculated or used as an evaluation criterion.

The performance criteria used in qualifying dummy responses for use in crash testing should, to the extent possible, relate directly to the injury indices upon which an injury interpretation is based. That is, if HIC is used as the primary index of head injury potential, performance criteria should be established using HIC itself rather than, or in addition to, acceleration measurements upon which HIC is based. In this manner, confirmation of the entire system performance, including mechanical response, electronic measurement, and data processing, is made. Further, direct control is provided over the error bounds associated with a given injury measure.

Consider, for example, the performance limits placed on the head acceleration response from the drop test employed with the current Part 572 dummy. Basically, the limits require that, when dropped from a height of 10 inches onto a rigid steel plate, the

peak head acceleration should be between 210 and 260 G with a duration above 100 G of between 0.9 and 1.5 ms. If we assume a simple half-sine acceleration pulse meeting each of these limits, then a HIC can be calculated for each, as is done in Table 3-1.

TABLE 3-1
HIC RANGE FOR HEAD DROP TESTS

Peak Accel	Time Above 100 G	HIC
260 G	0.9 ms	542
260 G	1.5 ms	904
210 G	0.9 ms	350
210 G	1.5 ms	580

As can be seen in this table, a substantial variation in HIC, from 350 to 904, can result from this test, while the head still meets the current acceleration criterion. Thus, it is thought that the criterion for acceptance of a component response should include consideration of the injury measure associated with that component.

In summary, the current dummy certification test procedures are relatively simple and straightforward tests with rather modest equipment requirements. Dynamic tests are based on the use of gravity and thus offer excellent potential for repeatable exposures. Major improvements in the overall test procedures are possible through better specification of response criteria, development of testing procedures that do not require dummy disassembly, and more efficient data acquisition and reduction equipment and procedures.

ADVANCED DUMMY CERTIFICATION TESTING

The overall certification process to be developed for the advanced dummy will involve three principal areas of activity: (1) certification to component specifications; (2) inspection, maintenance and calibration; and (3) biodynamic response certification.

First, overall dummy development will include the development of component specifications for use in the dummy manufacturing process. These components will be specified by reference to drawings, material properties, performance specifications, etc. Dummy manufacturers will be required to certify that their products and components meet each of these specifications prior to sale. Component specifications will also provide the basis for evaluating the condition of a given dummy part, in the event that certification test results indicate a failure to meet selected response criteria. In that case, disassembly of the dummy will be necessary, and comparison of a component with its specifications will indicate the need to adjust or replace the part.

The second area to be addressed is that of inspection, maintenance, and calibration. This should be a regularly scheduled activity for each dummy based on the calibration requirements for its instrumentation. We should note that NHTSA requires a complete calibration of all measurement instruments, traceable to the National Bureau of

CERTIFICATION

Standards, on a six-month interval for its Motor Vehicle Safety Standard Compliance Testing programs. Military specifications also call for either a one-year or a six-month calibration period. In any event, at the interval to be specified, the dummy would be completely disassembled in order to remove sensors for calibration. At this time, a detailed inspection of the mechanical aspects of the dummy and all of its component parts would be performed. Any required maintenance, either regularly scheduled or identified as necessary as a result of this inspection, would also be performed at this time.

Finally, biodynamic response certification, involving dummy exterior inspection and adjustment as well as whole-body stimulus/response testing, would be performed at varying intervals depending on dummy usage.

A flow chart of the entire suggested certification process is presented in Figure 3-4. Discussed below are some specific aspects of certification addressed in this study. Because dummy instrumentation and its calibration is an important element of the overall biodynamic certification of a dummy, an overview of the instrumentation plan is provided first. Then biodynamic certification approaches are discussed, followed by a preliminary assessment of equipment requirements for certification testing.

Instrumentation Design Concept. The proposed instrumentation concept for the advanced dummy involves equipment both internal and external to the dummy. This arrangement is necessary because of the size limitations of on-dummy instrumentation as well as the desire to perform comprehensive data channel integrity verification tests in a route fashion. In addition, the use of an integrated external test set in the overall electronic system design assures efficient and rapid turn-around time for conducting a test and obtaining a readout of the test results. Therefore, the components of the recommended instrumentation include an external test set along with internal data acquisition modules.

An overall diagram of the full system concept, also described in the previous chapter, is shown in Figure 3-5. In this concept, the acquisition modules are integrated into the dummy along with a photo-electric sensor. This sensor is used to provide a time-zero signal to the acquisition system. This input is activated by a time-zero flash. The recording of data, however, is controlled independently of the time-zero input. Prior to impact, each module is in a state of continuous recording. The data is not saved until the impact event has begun; that is, when a trigger signal has been received or one of the input signals exceeds a threshold level. When this occurs, a predetermined amount of data prior to impact will be stored along with the post-impact data for a total of 0.5 second. This approach provides a redundant means of initiating data storage while ensuring that all data are recorded. The amount of data stored prior to time-zero has yet to be finalized. This data may be used as a channel zero level if sufficient data are stored.

Each acquisition module will record data in a particular area of the dummy. For example, localized modules will record head accelerations or chest accelerations. These individual modules will be synchronized in time with respect to each other by way of two status lines that interconnect them. When one module senses a threshold level, a status line is activated. This line is then polled by the remaining modules, which then begin impact data recording.

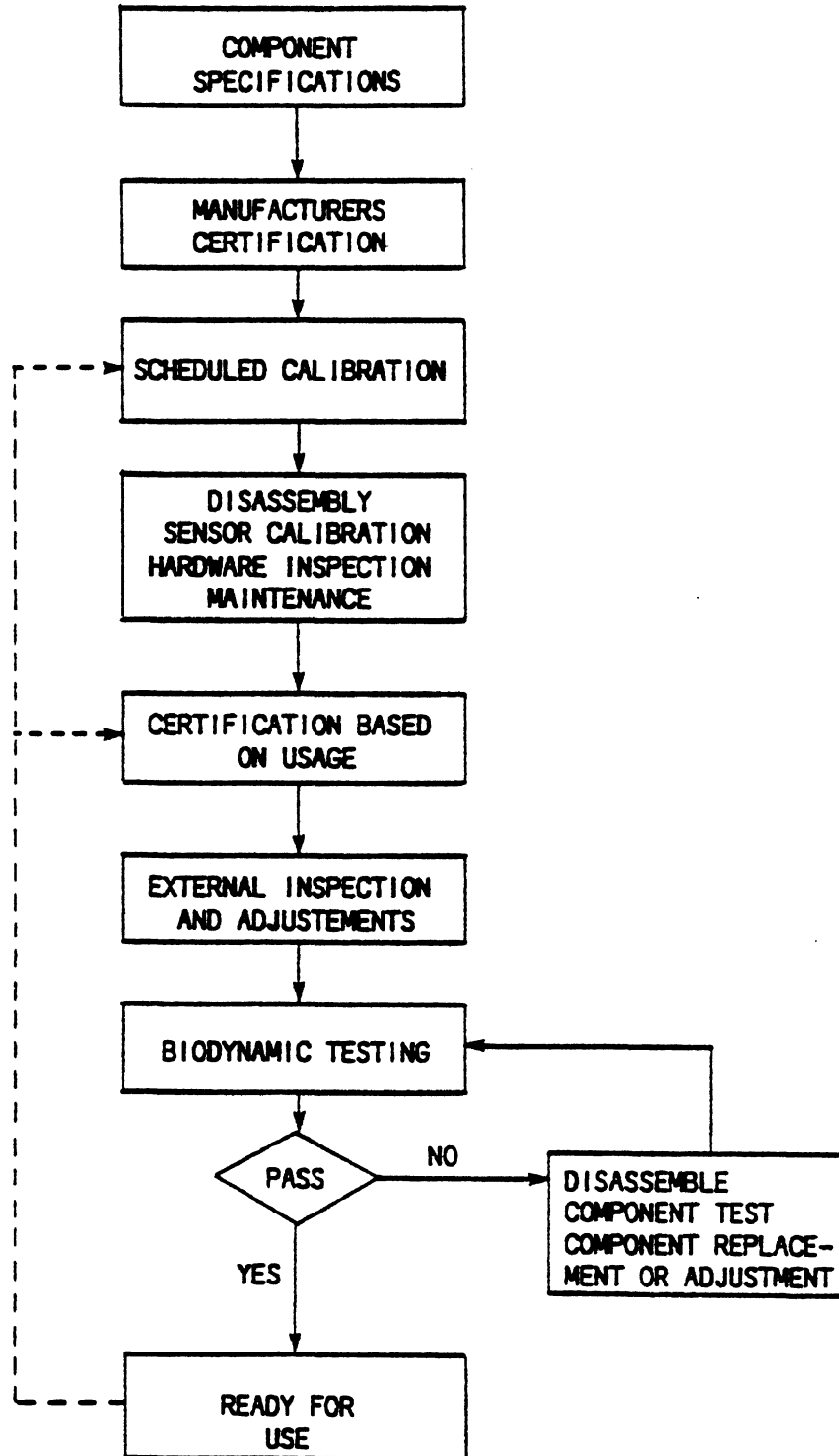

FIGURE 3-4. Advanced Dummy Certification Approach.

CERTIFICATION

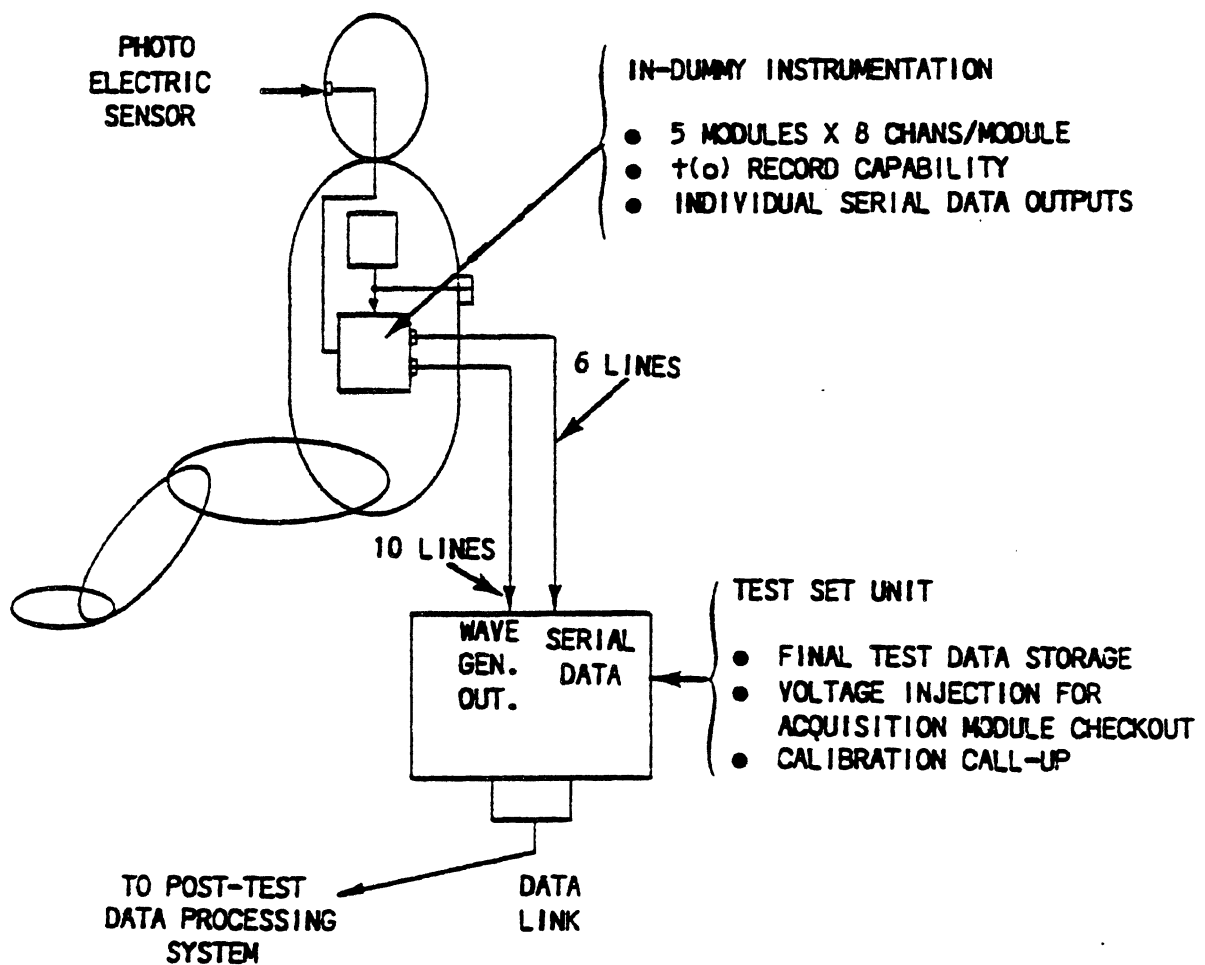

FIGURE 3-5. Full System Concept.

CERTIFICATION

The system is designed to accommodate up to about 40 data channels but provides a "patch" capability for up to 60 transducer inputs⁶. The input signal conditioners will be designed to work in conjunction with bridge or other voltage generator type transducers.

An external test set is utilized to provide functions that cannot be implemented in the acquisition modules themselves. The test set provides a shunt calibration feature and voltage injection for verifying the dynamic performance of each signal channel. Also included are serial data links to all acquisition modules. This allows the test set to accommodate centralized off-dummy data storage of all data recorded during impact.

The acquisition modules include those functional components that are required to acquire and store data during an impact test. The two circuit card acquisition modules consist of an analog circuit card and a CPU card. A functional block diagram of an entire two card module is shown in Figure 3-6.

The components on the analog board include individual instrumentation amplifiers for each channel. Several amplifier units are currently available that incorporate anti-aliasing filter stages, thus conserving valuable space. A multiplexer stage and a high speed analog-to-digital converter (12 bit A/D) are used to digitize the incoming signals. The diagram of Figure 3-6 shows an 8-channel layout, although expansion beyond this is possible. A single precision regulator supplies the excitation voltage for all transducers interconnected to one module.

The CPU board functions to collect and temporarily store data and then to transfer that data on command. A high speed 8-bit microprocessor (CPU) is used to control the flow of the data. Current state-of-the-art microprocessors provide performance levels that are acceptable for 8-channel modules at the required sample rates. The microprocessor stores the data in a bank of 64K bytes of on-board dynamic R.A.M. This is adequate storage for 0.5 s of recorded data at the 8000 Hz digitizing rate for one 8-channel module. These data are transferred out of the dummy on a serial interface bus after the tests.

This design configuration allows the verification of proper operation of all dummy data channels to be performed prior to each test. Although it will be necessary to perform other individual calibrations on the sensors that are used in the dummy, these calibrations will likely be performed at six-month intervals.

Equipment calibration requirements are currently specified by NHTSA for the performance of FMVSS compliance tests. These requirements are specified in Military Standard MIL-C-45662A, which requires that measurement sensors be calibrated to a National Bureau of Standards traceable reference at six-month intervals. It is recommended that a similar concept be adopted for the advanced dummy instrumentation.

Biodynamic Certification. Biodynamic response certification will be undertaken for a given dummy on the basis of usage. That is, certification testing would be required at a specified frequency relative to the crash test exposure. At one extreme, this might be before and after a test; however, experience may prove that less frequent testing is acceptable. This frequency will have to be defined based on test experience later in the development process.

⁶Subsequent work has upgraded this capability to 72 channels, expandable to 100. See Task E report.

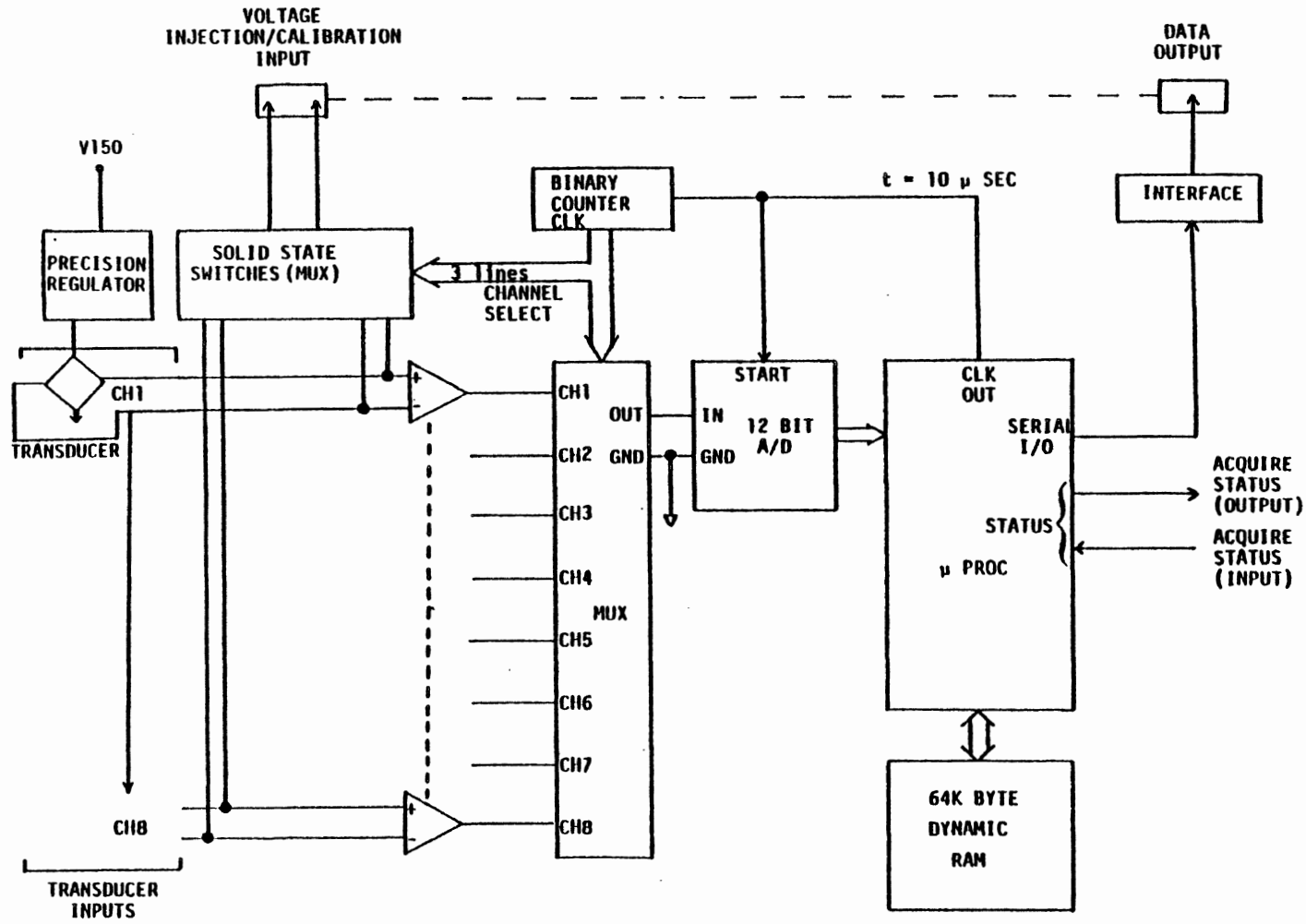

FIGURE 3-6. Data Acquisition Module Block Diagram.

CERTIFICATION

Certification testing will involve two activities: inspection and adjustment, and dynamic whole-body testing.

A general inspection of the dummy would be required prior to dynamic testing. This would include both cosmetic aspects and certain functional aspects of the dummy. Cosmetic inspection would include examination of the outer skin for rips or tears, inspection of zippers or other closures for proper operation and integrity, and external dimensional checks to assure consistency with design specifications.

Certain functional aspects of the dummy would also be checked and/or adjusted at this time. These would likely include range of motion and friction torque measurements and/or joint settings. Special tools and fixtures would be designed and developed along with suitable attachment points on the dummy so that these measurements and adjustments could be made in an efficient manner.

The primary approach to certifying the advanced dummy should involve whole-body testing with no disassembly of the dummy into component parts. This approach is technically feasible; the only questions to be resolved are with regard to the number and types of test stimuli that must be applied to the dummy in order to determine its conformance with response criteria. The means of applying stimuli to the dummy as well as the number, level, and types of stimuli cannot be finalized at this time. Much guidance in this area will come from the biomechanics aspect of the dummy design, particularly in relation to injury measures. That is, important dummy responses to be considered in certification tests are those that relate to injury measures.

Two means of applying stimuli are currently considered as possible alternatives. These are impacting a stationary dummy with a pendulum device, and impacting the dummy positioned on a pendulum into stationary targets. Both of these approaches offer the potential for good repeatability of exposure as controlled by drop height and gravity. A practical limitation on pendulum or drop-test technique, however, is that of contact velocities achievable at reasonable drop heights. For example, a drop height of ten feet yields an impact speed of 17 mph. Consequently, in order to achieve impact velocities in the 25- to 35-mph range, rather substantial drop heights are necessary (21 to 41 feet). Alternately, an exposure to injury consistent with typical automotive crash environments can be achieved at lower impact velocities by using stiffer contact surfaces than are typically encountered in automobiles. The use of rigid impact surfaces has the added advantage of being highly repeatable, while the use of padded surfaces is much less so. The rigid-surface approach is taken, for example, in the current Part 572 head drop test, in which an impact velocity of 5 mph produces a peak head acceleration of about 240 G. This general approach toward achieving design exposure levels (as determined by biomechanical information) appears a reasonable approach to pursue for the advanced dummy.

Evaluation of dummy responses to input stimuli must include consideration of both the ultimate injury measures as well as other engineering measures of response. The example given previously for the current Part 572 head drop test, in which HICs ranging from 350 to 904 can result from acceleration responses that meet established criteria, suggests that, at a minimum, the injury measure ranges associated with allowable dummy responses should be established. This would provide a feel for the range of injury measure variations associated with the dummy variability. It is, however, recognized that engineering response measures should also be considered in evaluating dummy response. This is for two reasons. First, injury measures may change as more and more biomechanical research is available, and, second, engineering measures may be necessary to help associate response failures with specific dummy components.

CERTIFICATION

It is clear that multiple stimuli will be necessary for certifying an advanced dummy. At the high extreme, it might be necessary to subject each dummy component to two or three stimuli from which an injury measure is determined. The potential ability to evaluate two or more component responses from a single stimulus offers the opportunity to reduce the number required. This approach must be further explored, however, to fully evaluate technical feasibility. The analytical study documented in the appendix appears to support the feasibility of this approach, at least for large variations in properties. Additional analytical and experimental study must be undertaken before a firm approach is recommended.

If we consider, for the moment, a dummy composed of the current Part 572 and SID (Side Impact Dummy) representations as being a first guess at what injury measures a new multidirectional dummy might afford, then a series of stimuli can be suggested that would exercise those dummy components considered important in injury determination. A hypothetical matrix of stimuli is provided in Table 3-2, in which seventeen impact stimuli are identified. We are not suggesting that these particular stimuli are appropriate to the new dummy, but we only wish to make a rough approximation of the number of tests that may be necessary.

TABLE 3-2

HYPOTHETICAL IMPACT STIMULUS MATRIX

Impact Stimulus	Direction of Stimulus			
	Front	Rear	Side	Oblique
Head Impact	X	X	X	X
Thorax Impact	X		X	X
Femur Impact	X			X
Pelvis Impact			X	
Neck Bending	X	X	X	X
Lumbar Bending	X		X	X

In addition, the effects of temperature and humidity on response measures must be addressed. While these factors must be considered in the component design stage to minimize response variations, it is also likely that, at least in the early stages of certification test procedure development, experimental investigation and documentation of these effects should be undertaken.

Since multiple instrumentation channel measurements will be made in each individual certification test, it is clear that a great deal of data must be acquired and processed before a dummy can be certified for use in crash tests. In order to accomplish this efficiently, a data acquisition and processing system dedicated to the certification test equipment will be necessary. This system should be an expanded version of the test set that accompanies the dummy and its instrumentation. It would operate on the acquired data channels to provide the operator with immediate feedback as to the component pass/fail status. Thus, if a problem were identified, immediate corrective action could be taken without a delay for post-test data processing. A secondary advantage of such a system is

that all data processing carried out for dummy certification would be accomplished with identical computer systems and software, further enhancing consistency of results among test laboratories. An additional consideration with such a system is that it would easily allow processing of multiple stimuli of the same type to produce a statistically based response evaluation, should this be identified as necessary.

Component Level Testing. It is envisioned that component level testing, that is, testing of individual dummy components in a disassembled state, would not be done as a matter of course in the certification testing. Component level testing would be undertaken only if whole-body test results indicated a failure in meeting response criteria. Then, disassembly and testing of specific components would be necessary to identify causes of failure to meet response criteria and to determine conformance with component design specifications. The specific testing to be undertaken would naturally vary with the individual components in question. These tests would include dimensional measurements, mass and inertia measurements, and mechanical property (e.g., force-deflection) measurements.

Equipment Requirements. Equipment requirements for advanced dummy certification testing cannot be well defined at this point. A major goal, however, will be to make the equipment as simple as possible and consistent with the requirements for efficiency in test operations.

Two major elements are required for biodynamic certification testing: (1) a means of delivering stimuli to the dummy and (2) a means of processing measured responses. Each of these has been mentioned in previous discussions. Additional discussion of preliminary concepts is provided here.

The most attractive methods of providing stimuli to the dummy are pendulum impact and drop tests. Both rely on gravity and drop heights to provide the impact velocity, and thus this test condition can be easily controlled. Practical impact velocities are limited to those achievable with reasonable drop heights, but the use of rigid impact surfaces would result in impact severities at reasonable drop heights that are consistent with the automobile crash environment and also highly repeatable.

Two alternatives for delivering impulsive loadings to dummies that are considered as reasonable approaches for further study are (1) a stationary, fixtured dummy impacted by a bifilar pendulum, and (2) a fixtured dummy mounted on a pendulum impacting fixed targets. The first approach is similar to the thorax and knee impact tests conducted on the current Part 572 dummy for certification purposes. The second approach can be considered to be similar in concept to the Part 572 neck test, except that the whole dummy would be mounted on a pendulum device. In either case, the dummy would be positioned in a rotatable fixture with various components held securely in a prescribed position by means of attachment points built into the dummy and the positioning device. Various impact orientations would be obtained by rotating the entire fixture, while different components would be tested by varying the position of the impactor or targets as well as by changing the way the dummy is attached to allow duplication of appropriate component responses in a controlled manner. However, other impact devices, such as a pneumatic impactor, may offer the advantage in ease of the test setup and impact direction control, and of exposure level control. Various alternatives must be evaluated in the context of an overall preliminary design effort.

The data acquisition and reduction system will be integral to the success of the certification concept. As discussed, multiple impacts with multiple data channel acquisition

CERTIFICATION

will be inherent in the ultimate testing procedures. In order to handle this large amount of data efficiently, automated acquisition and processing will be essential.

The concept that is currently envisioned involves an expansion of the test set concept discussed earlier. That is, the test set, which is used for verifying data channel integrity via a DLR calibration before a test, and which provides an off-board data storage location post-test, would be expanded in function to allow for immediate post-test data processing. A data read-out and display capability would communicate the results of the data processing to the test operator. Such functions could be provided by a desk-top microcomputer coupled to the test set via a data communications link. This concept is noted in the instrumentation system concept presented previously in Figure 3-4. In the context of certification testing, the post-test data processing system would be dedicated to the certification equipment and would provide for all data processing functions necessary.

Summary. A multi-level approach to advanced dummy certification for use in crash testing is recommended. Major elements of the approach include the following:

1. **Manufacturers' Certification**
Ensures that each component meets established component specifications
2. **Inspection, Maintenance and Calibration**
Regularly scheduled intervals
Complete dummy disassembly and inspection
Instrumentation calibration
Scheduled or required maintenance
3. **Biodynamic Certification**
External inspection and adjustment
Dynamic stimuli
Response criteria to include injury measures
Dedicated data acquisition and processing system for immediate response evaluation
4. **Component Testing**
Used only to identify component failure or misadjustment

The general approach to dummy certification testing offers the potential for a rapid qualification of a dummy for use in automotive crash testing, with exposures consistent with the crash test environment and response evaluations based on injury measures as well as engineering measures. The technical feasibility of the overall approach appears to be very good, but further evaluation efforts are required. A combined analytical and experimental effort is recommended to accomplish the following objectives:

1. Quantify response modes and excitation levels needed;
2. Explore the potential for multi-component evaluation from a single stimulus;
3. Explore the potential for frequency response and mechanical impedance techniques as applied to the identification of component degradation;
4. Develop preliminary test procedure recommendations, fixturing requirements, and data processing requirements.

APPENDIX: ANALYSIS OF CERTIFICATION TESTING PROCEDURES

It is, of course, necessary that any test performed to certify a dummy be capable of discriminating acceptable versus non-acceptable response. If a response is found to be unacceptable, a specific component or adjustment requiring attention should ideally be identified by the experimental response.

Current certification procedures use a direct measurement approach for each component, to be tested. That is, a stimulus is applied to a component and the response of that same component is measured. In most cases, this approach involves disassembly of the dummy. Since it is desirable to minimize manual effort in the total certification process, it is of interest to explore the possibilities of testing without disassembly (i.e., whole-body testing) and of multiple component evaluation from a single stimulus. A modest analytical effort was undertaken to begin exploration of these possibilities.

The CAL-3D CVS program was configured to simulate a pendulum impact to the head of a Part 572 dummy in the A-P direction. The baseline condition consisted of the standard dummy inputs, a pendulum weight of 51.5 lb, and an impact speed of 14 fps. Extreme variations were then made in the neck pivot and head pivot bending stiffness characteristics (that is, they were doubled and halved), and both head and chest responses to the same impact conditions were examined. Resultant head and chest accelerations from these three simulated conditions are shown in Figure 3-7. Clearly, the extreme differences in neck torque characteristics result in response differences at both the head and upper torso locations. The response differences in both the head and chest resulting from these rather extreme variations in neck torque characteristics indicated that there was a potential for whole-body testing to discriminate degradation in a component other than that undergoing the direct stimulus.

Additional CAL-3D runs were made to determine what level of change in head-skin force-deflection characteristics would still produce a discernible variation in head and chest accelerations. A pendulum impact to the head was simulated with the head-skin stiffness increased by 10%. The head and chest accelerations resulting from this condition are compared with the baseline curves in Figure 3-8. In both comparison plots, there is a noticeable difference in response.

A second run was then made in which the head-skin force-deflection characteristics were increased by 2.5 percent relative to the baseline run. Results from this second run are compared with the baseline run in Figure 3-9. The response differences are much smaller in this case.

This very limited analytical study has indicated the potential for the whole-body testing approach to be capable of discriminating component differences. Additional effort is required to expand this study to consider other components and to quantify the differences that one might expect to be able to detect.

CERTIFICATION

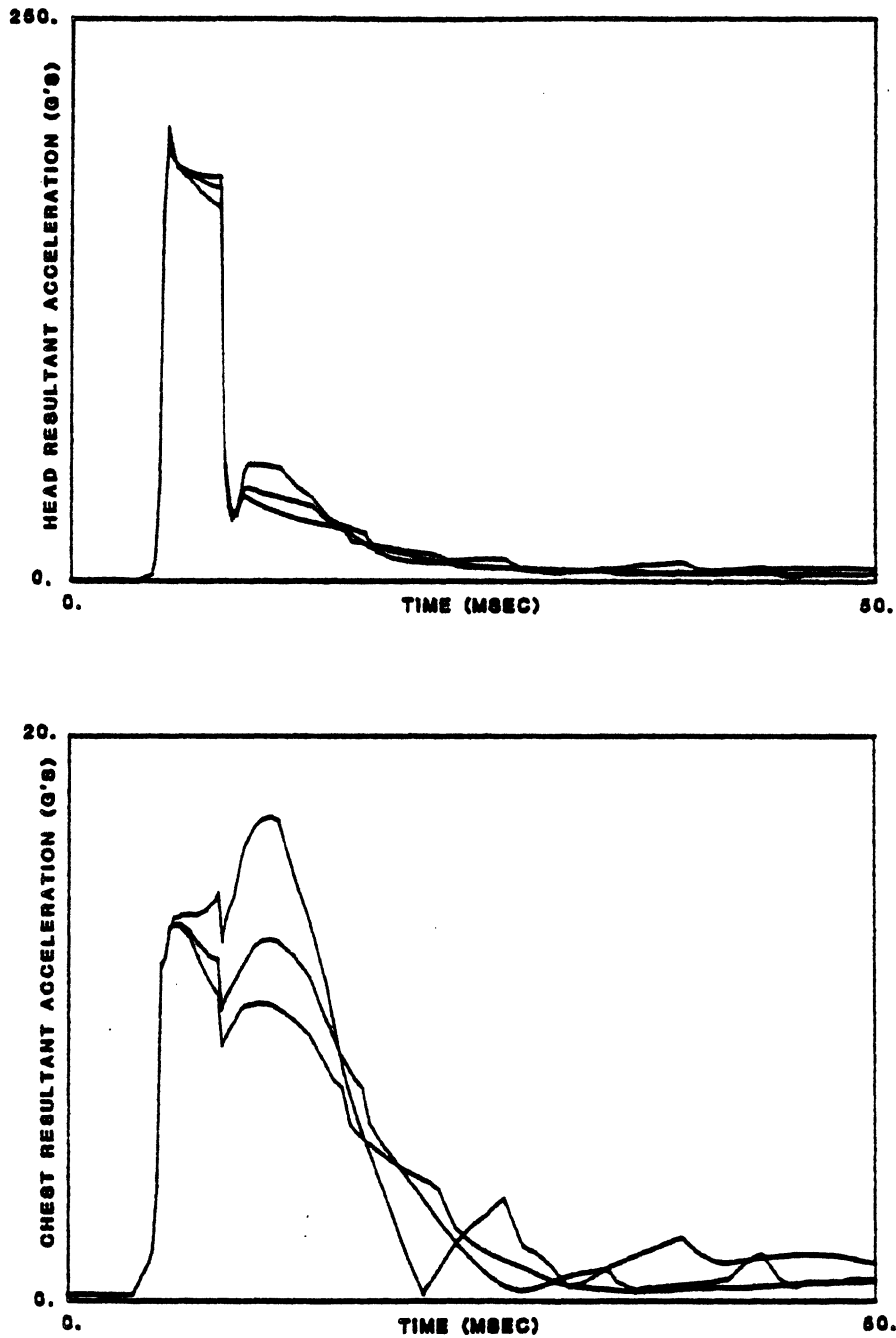
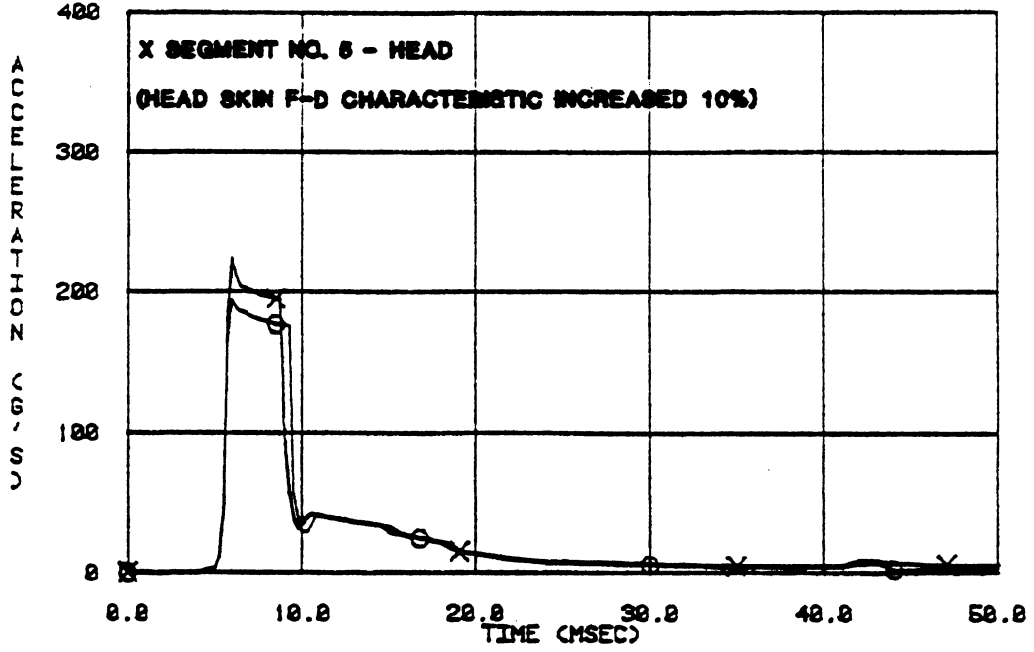

FIGURE 3-7. Comparison of Head and Chest Response for Extreme Variations in Neck Torque.

DUMMY CALIBRATION SIMULATION DUMMY-PART572
 PENDULUM VELOCITY = 14 FPS, WEIGHT = 51.5 LBS
 O SEGMENT NO. 5 - HEAD RES



DUMMY CALIBRATION SIMULATION DUMMY-PART572
 PENDULUM VELOCITY = 14 FPS, WEIGHT = 51.5 LBS
 O SEGMENT NO. 3 - UT RES

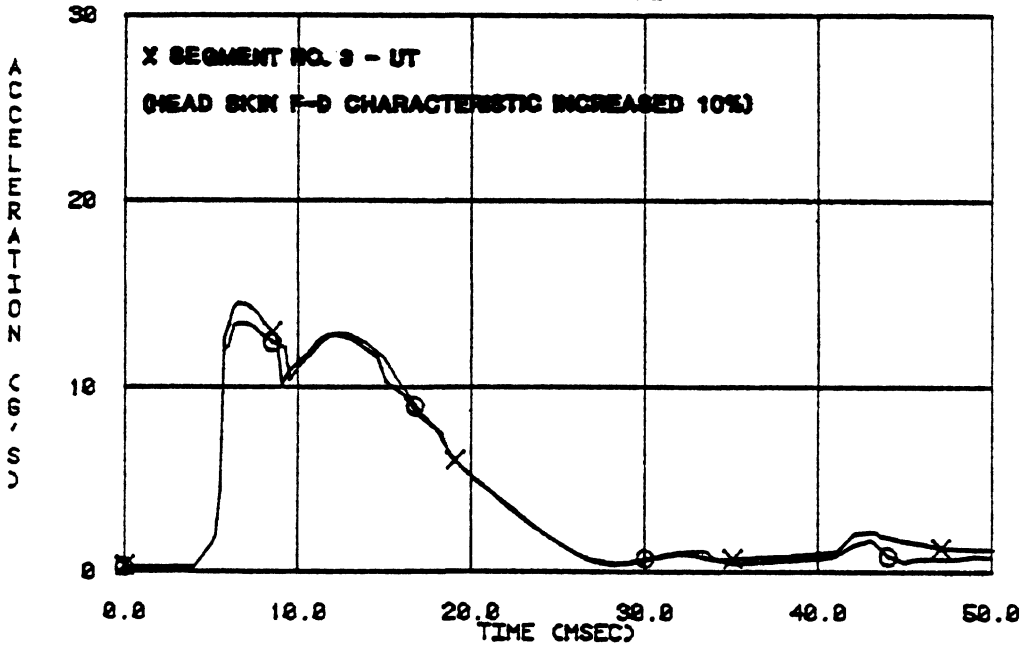

FIGURE 3-8. Comparison of Head and Chest Response for a 10% Change in Head-Skin F-D Characteristic.

CERTIFICATION

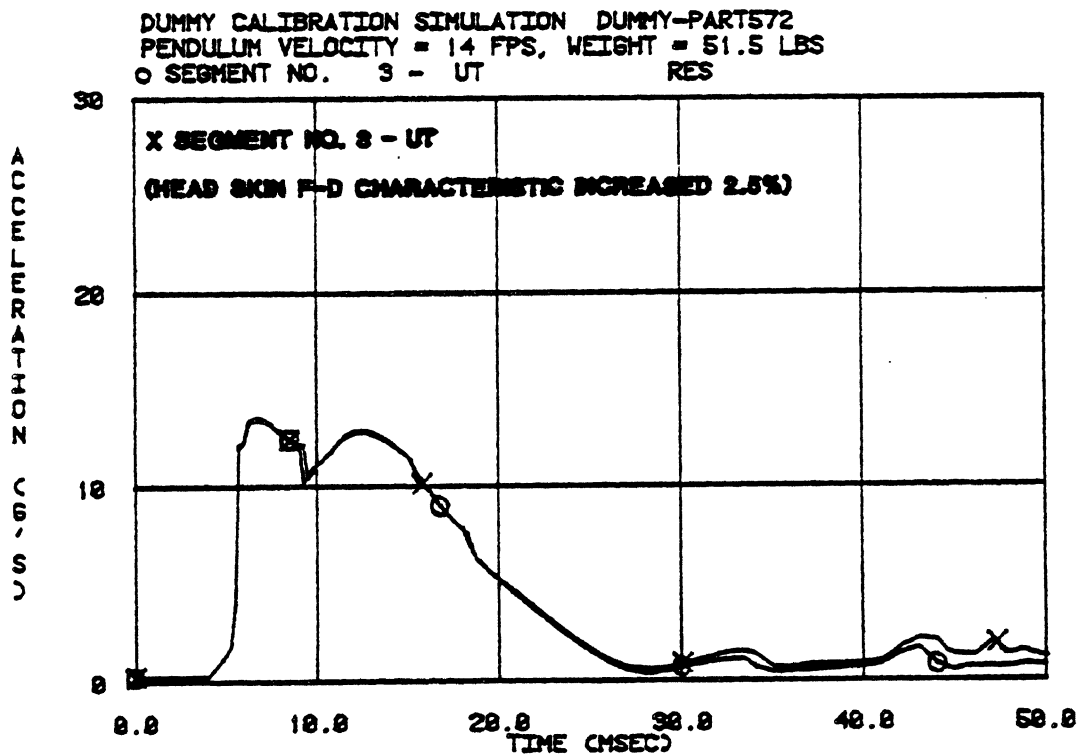
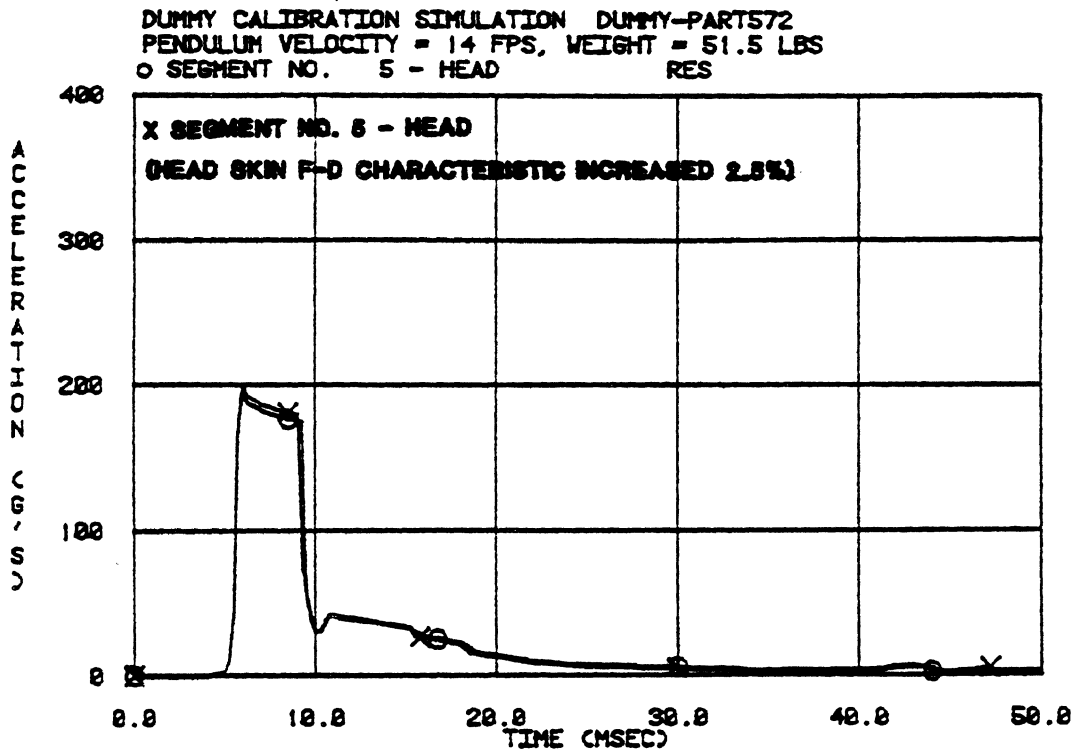

FIGURE 3-9. Comparison of Head and Chest Response for a 2.5% Change in Head-Skin F-D Characteristic.

OTHER REPORTS IN THIS SERIES

OTHER REPORTS

TASK A
INJURY PRIORITY ANALYSIS

Oliver Carsten
James O'Day

PREVIOUS WORK

Overview
The Economic Costs of Injuries
The NHTSA Societal Cost Study
The Harm Model
The Consequences of Injury
The AMA Guides to Permanent Impairment

METHODOLOGY

Overview
Filling in the Gaps in the Chi Data
Translating the Chi Codings into Impairment
Calculating the Present Discount Values
Generating Injury Prioritization from NASS

RESULTS OF THE INJURY PRIORITY ANALYSIS

Overview
The Global Picture
Passenger Car Occupant
Delta V and Clock Direction

COMPARISON OF IPR WITH HARM

CONCLUSIONS

APPENDICES

- A: The Medical Panel Meeting
- B: Development of a Dependent Variable
for NASS/NCSS Data Analysis
- C. Tables at the Occupant Level
- D. NASS Codes for Body Region

REFERENCES

OTHER REPORTS

TASK B

REVIEW OF BIOMECHANICAL IMPACT RESPONSE AND INJURY
IN THE AUTOMOTIVE ENVIRONMENT

John W. Melvin and Kathleen Weber
Editors

HEAD, P. Prasad, J.W. Melvin, D.F. Huelke,

A.I. King, and G.W. Nyquist

Anatomy of the Head

Head Injury from Clinical Experience

Head Impact Response

Head Injury Mechanisms, Tolerance, and Criteria

Summary and Conclusions

References

SPINE, G.W. Nyquist and A.I. King

Anatomy of the Spine

Spinal Injury Mechanisms from Clinical
and Laboratory Experience

Biomechanical Response of the Spine

Spinal Injury Tolerance and Criteria

Summary and Conclusions

References

THORAX, J.W. Melvin, R.L. Hess, and K. Weber

Anatomy of the Thorax

Thoracic Injury from Clinical Experience

Biomechanical Response of the Thorax

Thoracic Injury Mechanisms, Tolerance,
Criteria, and Predictive Models

Summary and Conclusions

References

Appendix: Bibliography of Thoracic Clinical Literature

ABDOMEN, A.I. King

Anatomy of the Abdomen

Abdominal Injuries from Clinical Experience

Abdominal Injury Mechanisms, Tolerance, and Response

Summary and Conclusions

References

Appendix: Bibliography of Clinical Literature
on Belt-Induced Abdominal Injuries

PELVIS, A.I. King

Anatomy of the Pelvis

Pelvic Injuries from Clinical Experience

Pelvic Impact Response and Tolerance to Injury

Summary and Conclusions

References

LOWER EXTREMITIES, G.W. Nyquist and A.I. King

Anatomy of the Lower Extremities

Lower Extremity Injuries from Clinical Experience

Injury Mechanisms of the Lower Extremities
from Laboratory Testing

Injury Tolerance of the Lower Extremities

Mechanical Response of the Lower Extremities

References

OTHER REPORTS

TASK C

**REVIEW OF ANTHROPOMORPHIC TEST DEVICE
INSTRUMENTATION, DATA PROCESSING, AND
CERTIFICATION TEST PROCEDURES**

**Rudi H. Arendt
David J. Segal
Richard Cheng**

INSTRUMENTATION, R. Cheng

Force and Moment
Acceleration
Pressure
Flow Measurement
Deformation Measurement
Summary

DATA PROCESSING, R. Arendt

Recommendations
Review of Data Acquisition and Processing Systems
Environmental Specifications
Electronic Design Concept
Calibration Requirements
Test Set Characteristics
References

CERTIFICATION TEST PROCEDURES, D. Segal

Recommendations
Review of Existing Dummy Certification Procedures
Advanced Dummy Certification Testing
Appendix: Analysis of Certification Testing Procedures

TASK D

REVIEW OF DUMMY DESIGN AND USE

**John W. Melvin
D. Hurley Robbins
Kathleen Weber
Kenneth L. Campbell
Joseph Smrcka**

DUMMY USER SURVEY RESULTS, K. Weber

Introduction
Mechanical Design
Serviceability and Maintenance
Durability
Certification
Repeatability and Reproducibility
Ease of Use
Summary and Conclusions
Appendix A: Affiliation of Survey Respondents
Appendix B: Dummy User Survey Questionnaire

**REVIEW OF DUMMY DESIGN, MANUFACTURING,
AND COST CONSIDERSTIONS, J. Smrcka**

Part 572 Dummy
Hybrid III Dummy
General Issues

REPEATABILITY AND REPRODUCIBILITY, K.L. Campbell

Types and Sources of Error
Statistical Techniques
References

**ANTHROPOMETRIC DATA AND BIOMECHANICAL RESPONSE
SIMULATION FOR AATD DESIGN, D.H. Robbins**

Status of Data Resources and Their
Application to Design Concepts
Biomechanical Response Simulation
Conclusions and Recommendations
References

ATD CRITIQUE, J.W. Melvin

Review of ATDs by Body Region
Overall Effectiveness of Hybrid III and SID
References

OTHER REPORTS

TASK E-F

**AATD SYSTEM TECHNICAL CHARACTERISTICS,
DESIGN CONCEPTS, AND
TRAUMA ASSESSMENT CRITERIA**

**John W. Melvin
Albert I. King
Nabih M. Alem**

BIOMECHANICAL DATA BASE

Development of the Data Base
Using Biomechanical Impact Response Data

TECHNICAL CHARACTERISTICS AND DESIGN CONCEPTS

Anthropometry Overview
Head
Spine
Thorax
Abdomen
Pelvis
Extremities
Data Processing
Certification System

TRAUMA ASSESSMENT CRITERIA

Current Trauma Assessment Criteria Recommendations
Data Analyses to Improve Trauma Assessment Criteria

APPENDIX: A FINITE ELEMENT MODEL OF THE HEAD

REFERENCES