

HIERARCHIES FOR 3-ORBIFOLDS

William D. DUNBAR

Department of Mathematics, University of Michigan, Ann Arbor, MI 48109, USA

Received 11 September 1986

Revised 30 April 1987

We generalize to the category of orbifolds (topological spaces locally modelled on Euclidean space modulo a finite group) some fundamental theorems in the study of 3-manifolds, including the fact that compact \mathbb{P}^2 -irreducible 3-manifolds with nonempty boundary have incompressible surfaces and can be decomposed into balls by repeated cutting along such surfaces.

AMS (MOS) Subj. Class.: 57N10, 57S30 orbifold hierarchy sufficiently large

An orbifold is a kind of generalized manifold, a topological space with local models given by quotients of \mathbb{R}^n by finite groups. In particular, the quotient of a manifold by a properly discontinuous group action naturally inherits the structure of an orbifold. Ever since W. Thurston made use of 3-dimensional orbifolds in his proof of the existence of hyperbolic structures on atoroidal Haken 3-manifolds, it has been a commonplace that a concept or theorem about manifolds can easily be translated into an analogous concept or theorem that holds for orbifolds. This is indeed the case quite often, as with the fundamental group or the Euler characteristic. 'Predictable' definitions of this sort are listed for the reader's convenience in the Glossary, which also explains such jargon as "BALL" and "turnover". Further background on orbifolds may be found in a number of sources, including [14, Chap. 13], [13, § 2], [1], and [3].

However, there are concepts, such as homology groups, which do not translate well. This makes it difficult to generalize the usual proof of the existence of 2-sided, non- ∂ - \parallel , incompressible surfaces in a 3-manifold M , which involves showing that $H_1(M)$ is infinite [7, Theorem 6.6]. We turn therefore to another method for finding incompressible surfaces, due to Stallings, that involves finding a nontrivial action of $\pi_1(M)$ on a (simplicial) tree, constructing an equivariant map from \tilde{M} to the tree, and then looking at the inverse images of midpoints of edges [2, Prop. 2.3.1]. As it turns out, for technical reasons we prefer to use the machinery of [2] rather than to generalize Stallings's method in a straightforward way, so the mode of attack outlined above is obscured in the proof of Theorem 11 that we give.

Since it is not *quite* true that irreducible 3-orbifolds admitting incompressible 2-suborbifolds have hierarchies ending in balls (or quotients of balls), the word “Haken” will not be used in connection with 3-orbifolds, as it would tend to lead to confusion. 3-orbifolds having 2-sided, non- ∂ - \parallel , incompressible 2-suborbifolds will be called *sufficiently large*, and 3-orbifolds which can be decomposed into BALLS by repeated cutting along such suborbifolds will be said to have a (*strong*) *hierarchy*. Sufficiently large 3-orbifolds do have a hierarchy of a weaker sort, which is occasionally useful (as in [15]).

The main result of the paper can be stated as follows (a combination of Theorem 11 and Corollary 17):

Theorem. *Let Q be a smooth, compact, connected, irreducible, abad, orientable 3-orbifold, in which every turnover with $\chi \leq 0$ is boundary-parallel. If Q is sufficiently large, and in particular if ∂Q has a component which is not a turnover, then Q has a strong hierarchy.*

There are numerous examples of 3-orbifolds with nonempty boundary in which every 2-sided, incompressible 2-suborbifold is ∂ - \parallel . They include BALLS, (any turnover with $\chi \geq 0$) $\times [0, 1]$ and the following (singular edges can have any order ≥ 3 , e.g.):

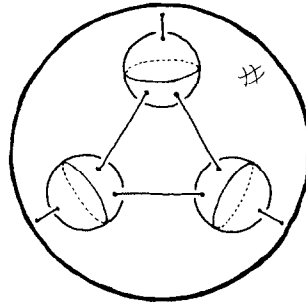

Fig. 1

Doubling this orbifold along one boundary component yields an irreducible, sufficiently large 3-orbifold which does not have a strong hierarchy.

In fact, take any closed 3-orbifold which is not sufficiently large (e.g. a spherical 3-orbifold) and has at least one vertex in its singular set. Remove a regular neighborhood of all vertices, and renumber the orders of all edges so as to ensure that the boundary turnovers have $\chi \leq 0$. The result will be a compact 3-orbifold with nonempty boundary which is not sufficiently large.

When one is trying to decompose an arbitrary 3-orbifold into irreducible pieces by cutting along SPHERES and filling in with BALLS, it is not any more difficult to cut along turnovers with $\chi \leq 0$ (without filling anything in). The above theorem implies that the resulting pieces (sometimes called ‘primitive’) will either have a strong hierarchy or will not be sufficiently large.

Convention. We will generally be concerned only with 3-orbifolds which are smooth, compact, connected, abad, irreducible, and orientable. We will remind the reader of this by referring to them as “3-orbifolds satisfying (*)”. Furthermore, 2-orbifolds will be assumed to be smooth, compact, and connected unless otherwise specified. As a consequence of restricting attention to orientable 3-orbifolds, compressions can only occur along disks and cones, ∂ -compressions only along disks, and annulus-compressions only along annuli. Also, a 2-suborbifold of an orientable 3-orbifold is 2-sided if and only if it is orientable.

We begin with a few introductory propositions of independent interest, which should help to accustom the reader to the terminology. These are followed by the main results: Theorem 11, which gives conditions for the existence of a 2-sided, non- ∂ -||, incompressible 2-suborbifold, and Corollary 17, which gives conditions for the existence of a hierarchy.

Proposition 1. *Let T be a compressible torus in an irreducible, orientable 3-orbifold Q . Then either T bounds a $DISK \times S^1$ in Q or T is contained in a 3-ball in Q .*

Proof. Mimic the manifold proof, e.g. as in [6]. One possible conclusion is that T is contained in a cone $\times [0, 1]$, but upon further inspection, one sees that such a T must bound a solid torus. \square

Proposition 2. *Any turnover S with $\chi(S) \leq 0$, that is a suborbifold of a 2-orbifold, is superincompressible.*

Proof. There can be no compressing DISKS or compressing annuli, since all circles in S bound DISKS. \square

Proposition 3. *Let S be a superincompressible 2-suborbifold (\neq turnover with $\chi \leq 0$) of a 3-orbifold Q satisfying (*). Then S is non- ∂ -||.*

Proof. Suppose that S is ∂ -||; from the definition of superincompressibility, S is orientable and $\chi(S) \leq 0$.

Case 1: ($\partial S \neq \emptyset$). Take a circle in S that doesn't bound a DISK, and use the ∂ -parallelism to extend it to an annulus with the other boundary component in ∂Q . This will be a compressing annulus for S (a contradiction).

Case 2: ($\partial S = \emptyset$). Take an arc in S (∂ -to- ∂) that is not ∂ -||, i.e. does not separate off a disk. The ∂ -parallelism will yield a ∂ -compressing disk for S (a contradiction). \square

Proposition 4. *Let Q be a Seifert-fibered orbifold satisfying (*), with boundary consisting of a union of tori. Let A be a vertical annulus in Q . Suppose that A projects to a non- ∂ -|| arc in the base orbifold of the fibration; then A is 2-sided and superincompressible (hence non- ∂ -|| by Proposition 3).*

Proof. The first property is immediate. A is incompressible since a compression would imply that fibers in some (torus) component of ∂Q bounded DISKS, and hence (by Proposition 1) Q would equal $\text{DISK} \times S^1$, Seifert-fibered by meridional circles, an impossibility. A has no ∂ -compressions since then one could show A to be ∂ - \parallel . A has no compressing annuli since simple closed curves on A either bound disks or are ∂ - \parallel . \square

Proposition 5. *If F is a compact orientable 2-orbifold, and S is a 2-sided incompressible 2-suborbifold of $F \times [0, 1]$, $\emptyset \neq \partial S \subseteq F \times 0$, then S is boundary-parallel.*

Proof. S separates $F \times [0, 1]$ into two pieces A and B , with $F \times 1 \subset \partial B$. The incompressibility of S ensures (via the Equivariant Loop Theorem [11]) that all inverse images of S in the universal covers of $F \times [0, 1]$, A , and B , are universal covers of S . Thus

$$\pi_1^{\text{orb}}(F) \cong \pi_1^{\text{orb}}(F \times [0, 1]) \cong \pi_1^{\text{orb}}(A) *_{\pi_1^{\text{orb}}(S)} \pi_1^{\text{orb}}(B),$$

but since the second factor maps onto, the amalgamated free product is trivial, and $\pi_1^{\text{orb}}(S) \rightarrow \pi_1^{\text{orb}}(A)$ is an isomorphism. Applying the 3-dimensional h -cobordism theorem [7, Theorem 10.2] to a finite cover of A , and using the fact that finite group actions on a product are standard ([4, Theorem 4.1] for the case $\partial F \neq \emptyset$, [10] for the closed case), we conclude that $A \cong S \times [0, 1]$. \square

Proposition 6. *If S is a 2-sided, incompressible, non- ∂ - \parallel 2-suborbifold of an orientable 3-orbifold, then some component of the suborbifold S' obtained from S by either a ∂ -compression or an annulus-compression is both incompressible and non- ∂ - \parallel .*

Proof (∂ -compression along D). We will first show that any component of S' is either incompressible or a ∂ - \parallel DISK. If some component of S' had a compressing DISK E , any intersection of ∂E with $\bar{N}(D)$ can be removed by isotoping the arcs into $S' \cdot \bar{N}(D)$, bordermost first. Any remaining intersections of E with the 3-cell $\bar{N}(D)$ can be eliminated by isotopies to yield a compressing DISK for S , a contradiction.

Furthermore, if some component of S' is a ∂ - \parallel DISK, then S' must have two components and the other component must be incompressible. To see that $S \cap D$ separates S , note that otherwise S would have to be an annulus (or annulus with 1 cone point) which arises as the boundary of a half-BALL with $N(D)$ either removed (the result is compressible) or added (the result is ∂ - \parallel); see Fig. 2. Note that as a consequence, any ∂ - \parallel DISKS in S' must in fact be ∂ - \parallel cones, since D was a ∂ -compressing disk.

To see that S' cannot consist of two ∂ - \parallel cones, note that either the products they cut off would be disjoint, which would make S ∂ - \parallel , or one cone C_1 would be a suborbifold of the product $C_2 \times [0, 1]$ cut off by the other, in which case C_1 would be ∂ - \parallel inside $C_2 \times [0, 1]$ by Proposition 5, and S would be compressible disk-with-two-singular-points; see Fig. 3.



Fig. 2



Fig. 3

Let us say that a component of S' is *parallel outward* if the product it cuts off from Q misses the ∂ -compressing disk D , and is *parallel inward* if the product includes D . If some component is non- ∂ - \parallel , it is incompressible as well by the arguments in previous paragraphs. So suppose that to the contrary that all components of S' are ∂ - \parallel . If S' is connected and parallel outward, then S would be ∂ - \parallel ; if parallel inward, a compressing disk for S could be constructed. If S' has two components S_1 and S_2 , either both are parallel outward (in which case S would be ∂ - \parallel) or by Proposition 5 we may assume that S_1 is parallel inward, to a suborbifold of ∂Q which contains the suborbifold of ∂Q to which S_2 is outwardly parallel. From an arc in S_2 not parallel to a fixed subarc of ∂S_2 (the attaching point for $\bar{N}(D)$), and from the corresponding arc in S_1 , we can construct a compressing disk for S . Note that this procedure works even when S_2 is a ∂ - \parallel cone.

The argument for annulus compressions is similar. \square

Proposition 7. Any orientable BALL satisfies (*) and is not sufficiently large.

Proof. Any orientable BALL B is clearly smooth, compact, and connected. It is abad since it is covered by a ball, and it is irreducible by examination of the three cases: no singular set, singular set an (unknotted) arc, singular set Y-shaped. The first case is handled by the Schönflies theorem. In the second case, we observe that any sphere separates B into two pieces, one of which is topologically a ball and misses the singular set. If B contains a football, then by intersecting it with the topological disk $(\text{arc from cone point to bdy}) \times [0, 1] \subseteq \text{cone} \times [0, 1] = B$, we find

that the football bounds its corresponding BALL (the singular arc in the topological ball bounded by the football is unknotted). Elementary intersection theory shows that B contains no SPHERES with 3 singular points. The third case is handled similarly, using 3 topological disks in B each bounded by 2 edges of the Y plus an arc in ∂B ; see Fig. 4.

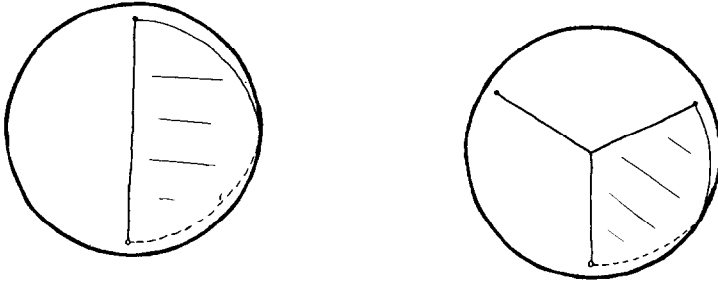

Fig. 4

Suppose that F is a 2-sided, incompressible 2-suborbifold of B . F must be closed, since otherwise some boundary component would bound a DISK in ∂B , which would lead to the conclusion that F was a ∂ -|| DISK (using the irreducibility of B). B cannot be a ball, since $\pi_1(F) \rightarrow \pi_1(B)$ would not inject, for example. B also cannot be a football, since an innermost arc of intersection of F with the topological disk in Fig. 4 would yield a compressing disk D for F ($D \cap F$ bounds a disk with two singular points in F). B cannot be a turnover for similar reasons (in this case D may be a DISK). \square

Proposition 8. *Let M be a compact, connected 3-manifold, and let F_1, \dots, F_n be disjoint, connected 2-sided surfaces in M ; then*

$$\left(\# \text{ of components of } M = \bigcup F_i \right) \geq n - \beta_1(M) + 1.$$

Proposition 9. *Let M be a compact, connected 3-manifold, and let F_1, \dots, F_n be disjoint, connected, 1-sided surfaces in M ; then $n \leq \beta_1(M; \mathbb{Z}_2)$.*

Proof. $\beta_1(M; \mathbb{Z}_2) = \beta_2(M; \mathbb{Z}_2)$, by Poincaré duality and the coefficient theorem. If n were larger than the latter, then some \mathbb{Z}_2 -linear-combination (i.e. some subcollection) of $\{F_1, \dots, F_n\}$ would equal zero in $H_2(M; \mathbb{Z}_2)$, i.e. would bound a compact codimension-0 submanifold in M , contradicting one-sidedness. \square

Theorem 10. *Let Q be a simple 3-orbifold satisfying (*) with singular set $\Sigma \neq \emptyset$. Set $M := Q - N(\Sigma)$; then either*

(A) M has a geometrically finite hyperbolic structure where meridians in ∂M (dual to edges in Σ) correspond to parabolic isometries under the holonomy map $\pi_1(M) \rightarrow PSL(2, \mathbb{C})$, or

(B) M is a Seifert-fibered manifold, and Q is a Seifert-fibered orbifold which has a 2-sided, non- ∂ -||, superincompressible suborbifold S if $\partial Q \neq \emptyset$.

Proof. Let $P \subseteq \partial M$ be a union of tori corresponding to circle components of Σ , plus tori in ∂Q , plus annuli corresponding to arcs in Σ (vertex-to-vertex, vertex-to- ∂Q , ∂Q -to- ∂Q). We will attempt to show that (M, P) is a simple Haken manifold which is ‘pared’ in the sense of [9, p. 58]. If successful, we will be in case (A) by [9, p. 60] and hence be done. If not, we will still be able to satisfy the requirements of case (B).

(1) M is irreducible: If S is a sphere in M , it lies in Q , so it bounds a ball by irreducibility of Q . This ball is disjoint from Σ , so it persists in M .

(2) M is Haken: M is compact, orientable, irreducible, and has non-empty boundary (if necessary, $M = B^3$ can be ruled out by calculating $\chi(\partial M)$).

(3) M is simple: If T is an incompressible torus in M , then as a TORUS in Q , it is either incompressible or compressible. If the former, then T is ∂ - \parallel in Q . Boundary components of Q which are tori (and product neighborhoods thereof) persist in M , so T is ∂ - \parallel in M . If the latter, by Proposition 1, either T bounds $\text{cone} \times S^1$ in Q ($\Rightarrow T$ ∂ - \parallel in M) or T is contained in a 3-ball in Q (contradicting T incompressible in M , since $\mathbb{Z} \times \mathbb{Z} \rightarrow 1 \rightarrow \pi_1(M)$ can’t inject) or T bounds a solid torus in Q (also contradicts incompressibility of T in M).

(4) Components of P are incompressible in M : Consider first the tori in P ; if one is compressible in M , then it must bound a solid torus (torus \subseteq ball is impossible if torus $\subseteq \partial M$), which in turn implies $M = \text{solid torus}$ and $Q = (\text{solid torus}) \cup (\text{solid torus with singular core})$. Q is thus a Seifert-fibered orbifold with empty boundary, and we are in case (B). Consider next the annuli in P ; if one is compressible in M , the compressing disk D , together with the cone which ∂D bounds in Q , forms a bad suborbifold of Q , a contradiction; see Fig. 5.

(5) We now wish to show that every abelian, noncyclic subgroup of $\pi_1(M)$ is conjugate to a subgroup of $\pi_1(P)$. By [5, Corollary 3.3], such a subgroup is finitely generated, and therefore by standard arguments (e.g., [7, Theorem 9.13]), it suffices to consider subgroups isomorphic to $\mathbb{Z} \times \mathbb{Z}$ (other formulations of [9, p. 60], e.g. [16], restrict consideration to $\mathbb{Z} \times \mathbb{Z}$ in the definition of a pared manifold).

Suppose $\mathbb{Z} \times \mathbb{Z} \cong H \subseteq \pi_1(M)$ is not conjugate into $\pi_1(P)$. Construct a map $f: S^1 \times S^1 \rightarrow M$ such that $f_*: \pi_1(S^1 \times S^1) \rightarrow \pi_1(M)$ is injective and $\text{im } f_* = H$ (for some choice of base points). In the language of [8], (M, P) is a Haken manifold pair, and $f: (S^1 \times S^1, \emptyset) \rightarrow (M, P)$ is a nondegenerate map of pairs. By the Torus Theorem [8, VIII.14], either there exists a nondegenerate embedding $g: S^1 \times S^1 \rightarrow M$ or M is a ‘special Seifert-fibered manifold’. The former is impossible since $\text{im } g$ would be an incompressible torus in M that was not ∂ - \parallel , contradicting M simple (note that if T is a torus in ∂M that is not contained in P , then T is a union of annuli in P and annuli in $\partial Q \cdot N(\Sigma)$. Since Q is irreducible, it would have to be $\text{cone} \times [0, 1]$, M would be a solid torus, and H could not exist). If the latter holds, we are in case (B), and we proceed to describe the Q ’s and S ’s. Proposition 4 will generally be used to show that S has the desired properties.

(a) M Seifert-fibered over D^2 with zero or one exceptional fiber: Impossible, for then M would be a solid torus, and H could not exist.

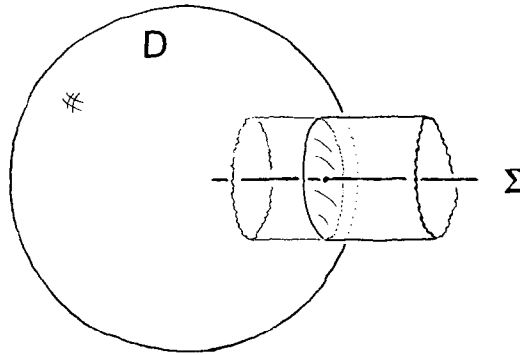

Fig. 5

(b) M Seifert-fibered over D^2 with 2 exceptional fibers: if the fibers are not homotopic to a meridian of $\partial\tilde{N}(\Sigma)$, then the fibering of M extends to a fibering of Q over a 2-orbifold ($\partial Q = \emptyset$). Fiber \cong meridian leads to a contradiction to the irreducibility of Q by examining the football in Q whose intersection with M is a vertical annulus over an arc in D^2 separating the singular fibers.

(c) M Seifert-fibered over an annulus with no exceptional fibers: then M is $T^2 \times I$. If α (and possibly β) represent the meridians of $\partial\tilde{N}(\Sigma)$ in $\pi_1(T^2) \cong \pi_1(T^2 \times 0) \cong \pi_1(T^2 \times 1)$, then fibering $T^2 \times I$ by curves γ not homotopic to α or β will permit extension to a Seifert fibering of Q . Either $\partial Q = \emptyset$ or $Q = \text{cone} \times S^1$; in the latter case, take $S = \text{cone} \times *$.

(d) M Seifert-fibered over an annulus with one exceptional fiber: as in (b), Q is Seifert-fibered unless one of the (1 or 2) meridians of $\partial\tilde{N}(\Sigma)$ is homotopic to a fiber of M , in which case we could construct a vertical annulus in M (see Fig. 6), then a football in Q , and reach a contradiction as in (b). The solid football must be on the side we ‘expect’ because the other side either has a torus boundary component or an $S^1 \subseteq \Sigma$. If $\partial Q \neq \emptyset$, then it either fibers over a disk with one singular point (choose S as in (c)) or over a disk with two singular points (take S to be a vertical annulus over an arc separating the two points).

(e) M is Seifert-fibered over a pair of pants with no exceptional fibers: Q is Seifert-fibered unless one of the (1, 2, or 3) meridians of $\partial\tilde{N}(\Sigma)$ is homotopic to a fiber, in which case we reach a contradiction as before. If $\partial Q \neq \emptyset$, Q will fiber over a disk with zero, one, or two singular points (choose S as in (d)) or over an annulus with zero or one singular point (take $S :=$ vertical annulus over an arc connecting the two boundary components).

(f) M is Seifert-fibered over a Möbius band with no exceptional fibers: then $M = (\text{orientable } I\text{-bundle over Klein bottle})$. Since M has 2 Seifert fiberings, we can find one that extends to Q ($\partial Q = \emptyset$).

(g) All other special Seifert-fibered manifolds have empty boundary. Thus, our supposition that there was a $\mathbb{Z} \times \mathbb{Z}$ in $\pi_1(M)$ not conjugate into $\pi_1(P)$ has led either into case (B) or to contradictions.

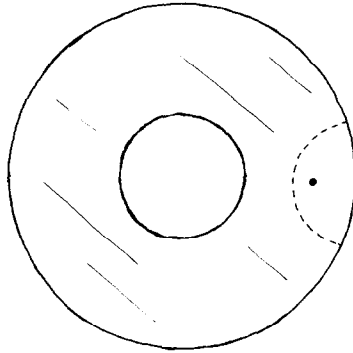

Fig. 6

(6) Finally, we wish to show that if $\phi : (S^1 \times I, S^1 \times \partial I) \rightarrow (M, P)$ injects on π_1 , then ϕ is homotopic as a map of pairs to $\psi : (S^1 \times I, S^1 \times \partial I) \rightarrow (P, P)$. Suppose that ϕ is not homotopic into P ; then ϕ is a nondegenerate map and by the annulus theorem, there is a nondegenerate embedding $\xi : (S^1 \times I, S^1 \times \partial I) \rightarrow (M, P)$ [8, VIII.13]. Set $A := \text{im } \xi$. There are several possibilities:

(a) ∂A lies on distinct tori T_1, T_2 in P : $T := \partial \bar{N}(T_1 \cup A \cup T_2)$, if compressible, bounds a solid torus away from $T_1 \cup T_2$, and we conclude that M fibers over an annulus with ≤ 1 singular point (M is the result of one ‘Dehn filling’ on pants $\times S^1$; fiber \simeq meridian would yield a reducible M). From here, we follow the argument in (5c) and (5d). On the other hand, if T is incompressible, it must be ∂ -|| since M is simple. This implies that $M = \text{pants} \times S^1$ and we follow (5e).

(b) ∂A is contained in a torus T_1 in P : $\bar{N}(T_1 \cup A)$ is either pants $\times S^1$ or the orientable S^1 -bundle over (Möbius band – disk). If the former, M will Seifert-fiber over a disk with 0, 1, or 2 singular points (the first two are impossible, the third is handled as in (5b)), over an annulus with 0 or 1 singular point (cf. (5c) and (5d)), or over pants (cf. (5e)) [6, Lemma 3.7]. If the latter, the conclusion is that $M =$ (orientable I -bundle over Klein bottle) and one proceeds as in (5f).

(c) Both components of ∂A lie on annuli in P (possibly equal): capping off A with cones (in Q) yields either a bad 2-suborbifold (contradicting Q abad) or a football (which gives a homotopy of A into P , contradicting ξ nondegenerate). Here we are using the fact that, by construction, there are no parallel annuli in P .

(d) One component is on a torus T in ∂Q , the other on an annulus: consider $\partial \bar{N}(T \cup A)$, which is a football, once capped off in Q . The solid football that it bounds in Q must be on the side away from T . We conclude that Q is cone $\times S^1$, for which P contains no annuli, a contradiction.

(e) One component is on a torus T in $\partial \bar{N}(\Sigma)$, the other on an annulus: consider $\partial \bar{N}(T \cup A)$, which is a football, once capped off. The solid football that it bounds in Q must be on the side away from T (the side towards T has an $S^1 \subseteq \Sigma$). We conclude that Q is $(\text{cone} \times S^1) \cup_b (\text{cone} \times S^1)$, for which P contains no annuli, a contradiction. \square

Theorem 11. *Let Q be a 3-orbifold satisfying (*) ($\neq \text{BALL}$) such that ∂Q has a component C which is not a turnover; then Q has a 2-sided, non- ∂ - \parallel , superincompressible 2-suborbifold S .*

Proof. If $\Sigma = \emptyset$, then the hypotheses imply that Q is an orientable \mathbb{P}^2 -irreducible 3-manifold not homeomorphic to B^3 and with $\partial Q \neq \emptyset$. A proof in this case is given in [9, p. 57], so we assume in what follows that $\Sigma \neq \emptyset$.

Suppose Q has an incompressible, non- ∂ - \parallel torus T . If there is no compressing annulus for T , then take $S := T$. If there is one (call it A), let B be the annulus component of $\partial \bar{N}(T \cup A)$. If there is no ∂ -compressing disk for B , take $S := B$. If there is one (call it D), it must lie on the same side of T as A (or T would be compressible). We can take $S :=$ disk component of $\partial \bar{N}(B \cup D)$, since T not ∂ - \parallel implies S not ∂ - \parallel ; see Fig. 7.

Suppose Q has an incompressible, non- ∂ - \parallel pillow T with all cone angles equal to π . If there is no compressing annulus for T , then take $S := T$. If there is one (call it A), let B_1, B_2 be the disks with 2 cone points obtained by compressing T along A . If there is no ∂ -compressing disk for B_1 (resp. B_2), let $S := B_1$ (resp. B_2). If both are ∂ -compressible (by disks D_1, D_2), they must all lie on the same side of T as A (or T would be compressible). At least one of the 4 cones obtained by compressing B_1 and B_2 along D_1 and D_2 is not ∂ - \parallel (or else T would be ∂ - \parallel), so take $S :=$ one such cone; see Fig. 8.

Suppose Q has a non- ∂ - \parallel turnover T with $\chi = 0$; then take $S := T$ (Proposition 2). Otherwise Q is simple, and by Theorem 10 we can assume without loss of

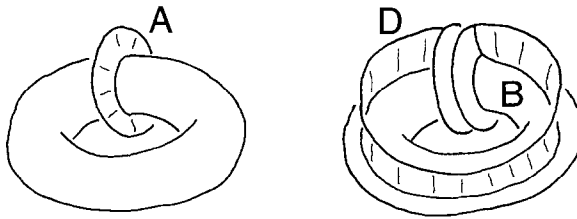

Fig. 7

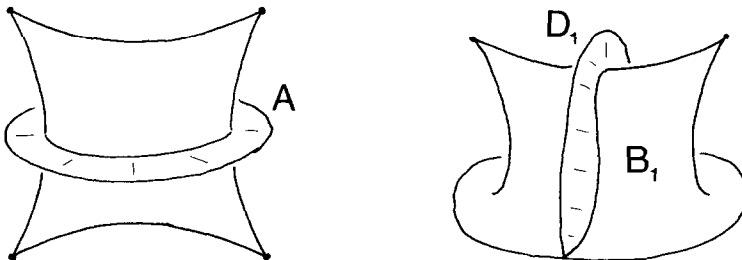

Fig. 8

generality that $M := Q - N(\Sigma)$ has a geometrically finite hyperbolic structure where meridians correspond to parabolic isometries. Our first step will be to find a 2-sided, non- ∂ - \parallel , incompressible 2-suborbifold of M , with all boundary curves parallel to meridians. We will use the methods (and the notation) of [2] to accomplish this.

Let $\Pi := \pi_1(M)$; then

$$\begin{aligned} \dim(X(\Pi)) &\geq -3\chi(M) + T + C = -\frac{3}{2}\chi(\partial M) + T + C \\ &= -\frac{3}{2}(\chi(F) - B - I) + T + C = -\frac{3}{2}\chi(F) + \frac{3}{2}B + \frac{3}{2}I + T + C \end{aligned}$$

where T is the number of tori in ∂Q , C is the number of circle components of Σ , B is the number of ‘boundary’ (univalent) vertices of Σ , I is the number of ‘interior’ (trivalent) vertices of Σ , and F is the underlying surface of ∂Q .

We would like to keep the meridians parabolic, i.e. keep their traces equal to ± 2 . Since the number of meridians is equal to the number of edges of Σ (counting a circle as one edge), and since $3I + B + 2C = 2$ (\neq of edges), we need to put $\frac{3}{2}I + \frac{1}{2}B + C$ conditions on $X(\Pi)$. This leaves a variety $Y(\Pi)$ of dimension $\geq -\frac{3}{2}\chi(F) + B + T$. Looking at ∂Q component by component, we see that the contributions are usually > 0 , except when a component of ∂Q is a turnover ($F = S^2$ and $B = 3$). Under the hypotheses of the theorem, $Y(\Pi)$ is positive-dimensional, hence has an ideal point, and hence there is a splitting of Π such that each meridian is conjugate into a vertex group [2, 2.2.1]. Taking $\mathcal{K} :=$ union of thickened meridians $\subseteq \partial M$, we can find a nonempty system \mathcal{S} of 2-sided, incompressible, non- ∂ - \parallel surfaces in M , whose boundaries miss \mathcal{K} [2, 2.3.1]. Thus we can conclude that $\mathcal{S} \cap (\partial M - \partial Q)$ consists of curves parallel to meridians.

Taking any component of \mathcal{S} , we perform annulus-compressions towards \mathcal{K} and towards ∂Q , and perform ∂ -compressions towards ∂Q , until we can do so no longer (∂ -compressions increase χ , and annulus-compressions increase the number of boundary components while fixing χ , so this process must eventually stop). Some component \bar{S} of the resulting surface is incompressible and non- ∂ - \parallel , (either by Proposition 6, or because we can perform the compressions by isotoping the map—from \tilde{M} to a tree—which generated \mathcal{S}) and can be capped off with cones in Q to form a suborbifold of Q , which we call S . S can immediately be seen to be 2-sided and non- ∂ - \parallel ; it can also be seen that S admits no compressing DISKS (\bar{S} would have a compressing disk or a compressing annulus), no ∂ -compressing disks, and no compressing annuli. \square

Remark. The approach that we will take from here on, with the goal of showing the existence of hierarchies, is modelled on [8, chaps. III and IV].

Theorem 12. *Let Q be a 3-orbifold satisfying (*); then there exists a positive integer $n_0(Q)$ such that if $\mathcal{F} = \{F_1, \dots, F_n\}$ is any collection of pairwise disjoint 2-sided, incompressible, closed 2-suborbifolds in Q , either $n < n_0$ or for some $i \neq j$, F_i is parallel to F_j in Q .*

Remarks. The smallest such number $n_0(Q)$ for fixed Q is called the *closed Haken number* of Q and is denoted $\bar{h}(Q)$; it is one greater than the maximal number of pairwise disjoint and non- \parallel , closed, 2-sided, incompressible 2-suborbifolds which can fit in Q .

There are no major obstructions to generalizing Theorem 12 by replacing “closed” with “compact, ∂ -incompressible”.

Proof of Theorem 12, Step 1. (The special case where Q has incompressible boundary, or no boundary.) Take a triangulation of Q for which the singular set Σ is a subcomplex. After one barycentric subdivision (result =: T , with i -skeleton denoted $T^{(i)}$), we can assume that any 3-simplex in T intersects Σ in one edge, one vertex, or the empty set. Observe that the F_i can be put in general position w.r.t. T by a (small) isotopy; e.g., adjust near Σ first and then on the rest of Q , rel $N(\Sigma)$ (in particular, \mathcal{F} misses $T^{(0)}$). Define the complexity of the intersection to be (α, β) , where $\alpha := \#(T^{(1)} \cap \mathcal{F})$ and $\beta := \sum_{\sigma \in T^{(2)}} (\# \text{ of components of } \sigma \cap \mathcal{F})$, ordered lexicographically. Now isotope \mathcal{F} so as to obtain a collection (still designated \mathcal{F}) of minimal complexity. This collection has the following properties:

Property 1. For all 2-simplices σ of T , $\sigma \cap \mathcal{F}$ contains no closed curves.

Proof (by contradiction). If σ is an interior 2-simplex, and C is an innermost such curve, then using incompressibility of \mathcal{F} and irreducibility of Q , you could isotope \mathcal{F} to reduce β , while α does not increase, contradicting minimal complexity.

Property 2. For all 2-simplices σ of T , $\sigma \cap \mathcal{F}$ contains no arcs that have both boundary points in the same edge.

Proof. Again by contradiction, in cases:

(Edge $\subset \Sigma$) take an innermost such arc, take a regular neighborhood of the disk it cobounds with a piece of the edge, and obtain a circle that bounds a disk in Q . By incompressibility of \mathcal{F} , it must also bound a disk in \mathcal{F} ; it can't do so towards the edge (you have a disk with two singular points), so that component of \mathcal{F} must be a football, which is never incompressible in an irreducible orbifold; contradiction.

(Otherwise) take an innermost such arc and shove it to the other side of the edge; α is decreased by 2 (and β probably is not increased), so contradiction.

Thus, for each 3-simplex $\tau \in T$ and for each component J of $\mathcal{F} \cap \partial\tau$, the (two) components of $\partial\tau - J$ each contain at least one vertex of τ ; for if some component contained no vertex, its intersection with $T^{(1)}$ would be a collection of arcs. A bordermost such arc δ would lead to a contradiction to Property 2.

Property 3. For each 3-simplex $\tau \in T$, every component C of $\mathcal{F} \cap \tau$ is (topologically) a disk.

Proof. If there were components that were not disks, there would be an innermost one (still called C), having a boundary component J that bounds a (topological) disk E in $\partial\tau$ such that all components of $\mathcal{F} \cap \text{int}(E)$ bound disks in \mathcal{F} . After possible slight modification near Σ , J is a circle in \mathcal{F} that bounds a disk in Q , so it must bound a disk in \mathcal{F} ; see Fig. 9. Those two disks and the ball they bound (by irreducibility of Q) give an isotopy of \mathcal{F} that reduces α (and probably β too), either

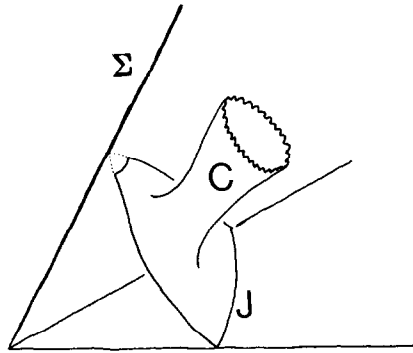

Fig. 9

by eliminating J or eliminating $\partial C - J$. C must be planar since \mathcal{F} is incompressible, so $\partial C - J \neq \emptyset$.

Now take n_0 to be 6 ($\#$ of 3-simplices in T) $+$ $\beta_1(M)$ $+$ $\beta_1(M; \mathbb{Z}_2)$ $+$ ($\#$ of ∂ -components of Q), where M is the 3-manifold that is the underlying topological space for Q . If $n \geq n_0$, then the complement of \mathcal{F} has $\geq n_0 - \beta_1(M) + 1$ components, by Proposition 8. The closures of at least $\beta_1(M; \mathbb{Z}_2) + (\# \partial\text{-comp}) + 1$ of these components look like I -bundles (over a 2-orbifold) in each 3-simplex of T , hence are global I -bundles. Finally, no more than $\beta_1(M; \mathbb{Z}_2)$ of these can be nontrivial globally, by Proposition 9. The rest are products of 2-orbifolds with I , and at least one does not intersect ∂Q . Hence its two boundary components are parallel suborbifolds of Q . This completes Step 1; we pause now to prove two lemmas.

Lemma 13. *Let Q be a 3-orbifold satisfying $(*)$; then there is a finite (possibly empty) collection of pairwise disjoint DISKS $\{D_1, \dots, D_r\}$ such that each component of $Q - \bigcup N(D_i)$ is either a 3-orbifold satisfying $(*)$ with all boundary components incompressible, or a BALL. Any such collection of DISKS is called a complete system of DISKS for Q .*

Proof (induction on $\chi(\partial Q)$). If $\chi(\partial Q) > 0$, then some component of ∂Q is a SPHERE, which implies by irreducibility that Q is a BALL (so an empty collection of DISKS works). If $\chi(\partial Q) \leq 0$, either no boundary components compress (which is fine) or some boundary component compresses along a disk D . Now $\bar{Q} := Q - N(D)$ has $\chi(\partial \bar{Q}) = \chi(\partial Q) + 2\chi(D) > \chi(\partial Q) + 2/N$, where $N :=$ maximum order of an edge in the singular set of Q . \bar{Q} is immediately seen to be compact, abad, irreducible, and orientable. By induction (suppose true for $\chi > -k/N$, prove for $\chi > -(k+1)/N$), \bar{Q} has a collection $\{\bar{D}_1, \dots, \bar{D}_s\}$, and after an isotopy we can assume that they are all disjoint from $D \times 0$ and $D \times 1 \subseteq \partial \bar{Q}$. Take $r := s + 1$ and $\{D_1, \dots, D_r\} := \{D, \bar{D}_1, \dots, \bar{D}_s\}$, using the fact that $\bar{Q} \subseteq Q$. Components of $Q - \bigcup_1^r D_i$ are precisely the components of $\bar{Q} - \bigcup_1^s \bar{D}_j$, so by the induction hypothesis, we are done. \square

Lemma 14. *Let Q be a 3-manifold satisfying (*) and let F be a (possibly disconnected) 2-sided, incompressible, and ∂ -incompressible surface in Q . Then there exists a complete system of DISKS $\Delta = \{D_1, \dots, D_r\}$ for Q , such that $F \cap (\bigcup_{i=1}^r D_i) = \emptyset$.*

Proof. If all components of F are closed, then any complete system of DISKS intersecting F can be isotoped to one whose intersection with F has fewer components, by looking at a component which is innermost in Δ , and using incompressibility of F and irreducibility of Q (note that Lemma 13 was used). This argument can be extended to handle situations where $\partial F \neq \emptyset$ as in [8, III.20, (step 2) and III.22]. This time, any complete system of DISKS can be replaced by another system, whose intersection with F has fewer components; cut-and-paste arguments are used. \square

Proof of Theorem 12, Step 2. (The general case.) If Q is a BALL, $n_0(Q) := 1$ works, by Proposition 7; otherwise, by Lemma 14 there is a complete system of DISKS Δ for Q which is disjoint from \mathcal{F} . Suppose that n , the number of 2-orbifolds in \mathcal{F} , is greater than or equal to $n_0(Q) := \sum n_0(Q_i)$, where $\{Q_1, \dots, Q_k\}$ are the components of Q split open along Δ , and the $n_0(Q_i)$ come from Step 1 (or from Proposition 7). Since $\Delta \cap \mathcal{F} = \emptyset$, each F_i is contained in some component Q_j . There is *some* J , $1 \leq J \leq k$, for which $n_j \geq n_0(Q_j)$, where n_j is the number of components of \mathcal{F} in Q_j , since otherwise we would be able to contradict the hypothesis that $n \geq n_0(Q)$. Focusing on Q_j , we see that $\mathcal{F} \cap Q_j$ consists of at least $n_0(Q_j)$ surfaces, all incompressible in Q_j . Hence 2 of them are parallel in Q_j and thus also parallel in Q . \square

Theorem 15. *Let Q be a 3-orbifold satisfying (*). Suppose that $(Q_1, F_1), \dots, (Q_n, F_n), \dots$ is a partial hierarchy for Q . If for each n , the 2-orbifold F_n is both incompressible and ∂ -incompressible in Q_n , then there exist at most $3\bar{h}(Q)$ integers n for which F_n is not a DISK.*

Proof. Proceed as in [8, IV.7], using Lemma 14 in place of IV.8 and Theorem 12 in place of III.20. \square

Theorem 16. *Any sufficiently large 3-orbifold Q satisfying (*) has a weak hierarchy.*

Proof. The idea is to split along 2-orbifolds that are ∂ -incompressible, and show that the partial hierarchy can't go on forever.

If Q is not sufficiently large when split along a (possibly empty) complete set of DISKS, then we are done. Otherwise, $Q =: Q_1$ contains a 2-sided, incompressible, non- ∂ -|| 2-orbifold which is not a DISK; call it F_1 . By Proposition 6, F_1 may be assumed to be ∂ -incompressible as well. Note that $Q_2 := Q_1 - N(F_1)$ is compact, abad, irreducible, and orientable. If Q_2 is not sufficiently large when split along a complete set of DISKS, then we are done; otherwise, we can find F_2 , not a DISK, and continue. By Theorem 15, this process cannot continue for more than $3\bar{h}(Q)$ steps. \square

Corollary 17. *A sufficiently large 3-orbifold satisfying (*) in which every turnover with $\chi \leq 0$ is ∂ - \parallel has a strong hierarchy.*

Proof. If Q is an orbifold as above, it has a hierarchy ending in pieces Q_1, \dots, Q_n which are not sufficiently large. If some piece, say Q_1 , were not a BALL, ∂Q_1 would consist of turnovers with $\chi \leq 0$ (by Theorem 11), which as suborbifolds of Q must be ∂ - \parallel . This leads one to conclude that $Q = Q_1$ or $Q_1 = \text{turnover} \times [0, 1]$, either of which contradicts the hypotheses. \square

Remark. “Orbifolds which are not sufficiently large when split along a complete set of DISKS” are playing the role of handlebodies. It is not immediately apparent how to classify such orbifolds; even “orbifolds which are BALLS when split along a complete set of DISKS” deserve to be better understood.

Glossary

Abad 3-orbifold Q: Q has no bad 2-suborbifolds (“pseudo-good” has also been used).

Bad n-orbifold Q: there is no manifold M such that Q is the quotient of a properly discontinuous group action on M (equivalently, “no manifold covers Q ” or “the universal cover of Q has nonempty singular set”).

BALL: a 3-orbifold which is diffeomorphic to B^3/Γ , $\Gamma \subset O(3)$ finite (note that there is a 1-1 correspondence between SPHERES and BALLS).

WARNING! At this point, it has not yet been shown that all 3-orbifolds covered by balls are of this form (cf. [12, Thm. 3]).

∂ -compressing disk D for a 2-suborbifold S of a 3-orbifold Q : ∂D is a union of two arcs α and β , $\alpha \subset S$, $\beta \subset \partial Q$, α cobounds no disk in S with $\gamma \subset S \cap \partial Q$ (exactly the same definition as for manifolds).

∂ - \parallel suborbifold S of (codim 1 in) Q : one of the components of $Q - S$ is homeomorphic to $S \times (0, 1]$.

Compressing DISK D for a 2-suborbifold S of a 3-orbifold Q : $D \cap S = \partial D$ is an embedded circle on S which does not bound $D' \cong D$ in S .

Compressing annulus A for a 2-suborbifold S of a 3-orbifold Q : $\partial_0 A \subset S$, $\partial_1 A \subset \partial Q$, $A \cap S = \partial_0 A$, $\partial_0 A$ is not ∂ - \parallel in S , does not bound a DISK in S and is not the boundary of any compressing DISK for S .

Cone: a 2-orbifold (with ∂), topologically a 2-disk, with singular set = 1 cone point.

Cone points: points in the singular set of a 2-orbifold modelled on $\mathbb{R}^2/(\text{rotation by } 2\pi/n)$, for some integer $n > 1$.

DISK: a 2-orbifold which is diffeomorphic to D^2/Γ , $\Gamma \subset O(2)$ finite (equivalent to being covered by a disk). An orientable DISK is either a disk or a cone (but not both).

Euler characteristic χ of an orbifold Q : triangulate Q with the singular set being a subcomplex, and take the usual alternating sum, weighting each piece by $1/(\text{order of finite group})$.

Football: a 2-orbifold, topologically a 2-sphere, with singular set = 2 cone points of equal order.

Hierarchy, partial (Q a compact 3-orbifold): a finite or infinite sequence of pairs $(Q_1, F_1), \dots, (Q_n, F_n), \dots$ where $Q_1 = Q$, F_n is a 2-sided, incompressible, non- ∂ - \parallel 2-suborbifold in Q_n , and Q_{n+1} is the orbifold obtained from Q_n by splitting along F_n (i.e., $Q_{n+1} = Q_n - N(F_n)$).

Hierarchy, strong: a (finite) partial hierarchy where for some n , all components of $Q_n - N(F_n)$ are BALLS.

Hierarchy, weak: a (finite) partial hierarchy where for some n , no component of $Q_n - N(F_n)$ has a 2-sided, incompressible, non- ∂ - \parallel 2-suborbifold.

Incompressible 2-suborbifold S of a 3-orbifold Q : S is a non- ∂ - \parallel DISK or $(\chi(S) \leq 0)$ and S has no compressing DISKS).

Irreducible 3-orbifold: every suborbifold which is a SPHERE bounds the corresponding BALL.

Meridians: simple closed curves on ∂M , bounding cones in Q (where $M = Q - N(\Sigma)$).

$N(\cdot)$, $\bar{N}(\cdot)$: used to denote open and closed regular neighborhoods.

n-orbifold: topological space locally modelled on $\mathbb{R}^2/(\text{finite group})$ (or $\{(x_1, \dots, x_n): x_1 \geq 0\}/(\text{finite group})$ at the boundary).

k-suborbifold of an n-orbifold: locally modelled on $(\mathbb{R}^n, \mathbb{R}^k)/(\text{finite group})$ (with appropriate modification at the boundary).

Order of cone point (resp. singular edge): order of cyclic group Γ of rotations providing the model \mathbb{R}^2/Γ (resp. \mathbb{R}^3/Γ).

Orientable orbifold Q : $Q - (\text{singular set})$ is orientable, and all finite groups act preserving orientation.

Pants or pair of pants: a 2-orbifold (with ∂), topologically a disk-with-two holes with empty singular set.

Pillow: a 2-orbifold, topologically a 2-sphere, with singular set = 4 cone points.

Seifert-fibered 3-orbifold Q : there is a projection $p: Q \rightarrow O$ to a 2-orbifold O , where p restricted to the inverse image of a small open set U/Γ in O is $(U \times S^1)/\Gamma \rightarrow U/\Gamma$, where Γ acts diagonally on $U \times S^1$ ("Q fibers over a 2-orbifold with (generic) fiber S^1 ").

Simple 3-orbifold: an abad, irreducible 3-orbifold in which every 2-sided incompressible TORUS is ∂ - \parallel .

Singular set of an orbifold: points with neighborhoods modelled on $\mathbb{R}^n/(\text{non-trivial group})$.

SPHERE: a 2-orbifold which is diffeomorphic to S^2/Γ , $\Gamma \subset O(3)$ finite (equivalent to being covered by a sphere).

Sufficiently large: a 3-orbifold which has a 2-sided, non- ∂ - \parallel , incompressible 2-suborbifold.

Superincompressible 2-suborbifold S of a 3-orbifold Q : S is a non- ∂ -|| DISK or ($\chi(S) \leq 0$ and S has no compressing DISKS, ∂ -compressing disks or compressing annuli).

TORUS: a 2-orbifold which is diffeomorphic to \mathbb{E}^2/Γ , Γ a crystallographic group (equivalent to being covered by a torus).

Turnover: a 2-orbifold, topologically a 2-sphere, with singular set = 3 cone points.

2-sided suborbifold S of (codim 1 in) Q : $\partial\bar{N}(S)$ is disconnected.

Vertical 2-suborbifold of a Seifert-fibered 3-orbifold: one that is a union of fibers.

Acknowledgement

The author would like to thank M. Culler and W. Jaco for their help, and would like to express his appreciation to the referee for his/her comments. The central ideas in the proof of Theorem 11 are due to W. Thurston, who generously shared them.

References

- [1] F. Bonahon and L. Siebenmann, The classification of Seifert fibred 3-orbifolds, in: Low Dimensional Topology, LMS Lecture Note Series 95 (Cambridge University Press, Cambridge, 1985).
- [2] M. Culler and P. Shalen, Varieties of group representations and splittings of 3-manifolds, *Annals of Math.* 117 (1983) 109–146.
- [3] M.W. Davis and J.W. Morgan, Finite group actions on homotopy 3-spheres, in: *The Smith Conjecture* (Academic Press, New York, 1984).
- [4] A.L. Edmonds and C. Livingston, Group actions on fibered 3-manifolds, *Comm. Math. Helv.* 58 (1983) 529–542.
- [5] B. Evans and W. Jaco, Varieties of groups and 3-manifolds, *Topology* 12 (1973) 83–97.
- [6] A. Hatcher, Torus decomposition, mimeographed notes, UCLA, 1979.
- [7] J. Hempel, 3-Manifolds, *Annals Math Studies* 86 (Princeton University Press, Princeton, 1976).
- [8] W. Jaco, Lectures on 3-manifold topology, CBMS Regional Conference Series 43 (AMS, Providence, 1980).
- [9] J.W. Morgan, On Thurston's uniformization theorem for three-dimensional manifolds, in: *The Smith Conjecture* (Academic Press, New York, 1984).
- [10] W. Meeks and P. Scott, Finite group actions on 3-manifolds, preprint, 1983.
- [11] W. Meeks and S.T. Yau, The equivariant Dehn's lemma and equivariant loop theorem, *Comment. Math. Helv.* 56 (1981) 225–239.
- [12] W. Meeks and S.T. Yau, Group actions on \mathbb{R}^3 , in: *The Smith Conjecture* (Academic Press, New York, 1984).
- [13] P. Scott, The geometries of 3-manifolds, *Bull. London Math. Soc.* 15 (1983) 401–487.
- [14] W. Thurston, The geometry and topology of 3-manifolds, mimeographed notes, Princeton University, 1978.
- [15] W. Thurston, 3-manifolds with symmetry, preprint, Princeton University, 1982.
- [16] W. Thurston, Hyperbolic structures on 3-manifolds I: Deformations of acylindrical manifolds, *Annals Math.* 124 (1986) 203–246.