

RELIABILITY OF CORRODED STEEL GIRDER BRIDGES

Jack R. Kayser and Andrzej S. Nowak

Department of Civil Engineering, University of Michigan, Ann Arbor, MI 48109 (U.S.A.)

(Received May 23, 1988; accepted in revised form February 20, 1989)

Key words: bridges; bearing; girder; flexure; steel; corrosion; reliability; shear.

ABSTRACT

Steel girder bridges corrode due to environmental exposure. The result is a reduction in both the carrying capacity of a bridge and level of certainty concerning what the capacity may be. As a consequence, the level of safety diminishes with corrosion. A damage model is developed which evaluates the reliability of a corroded steel girder bridge over time. This model is used to evaluate the effects of bridge design and environment on safety. A sensitivity analysis is carried out to identify the most important parameters in corroded bridge safety.

INTRODUCTION

Bridges, as well as other structures in nature, deteriorate over time. The main causes of deterioration in bridge superstructures are the repeated live loads (fatigue), and the environment. For steel bridges one of the most dominant forms of deterioration is corrosion. The possible types of bridge corrosion have been studied by Kayser and Nowak [1]. The major effect of corrosion is the loss of metal section resulting in a reduction of structural carrying capacity. There is also an increase in the level of uncertainty about the structural performance, due to inherent randomness in the deterioration process.

Load effect and resistance (load carrying capacity) are random variables. Therefore, it is convenient to measure structural performance in terms of reliability. Models are available to calculate the reliability indices for bridge members [2] and bridge systems [3]. In general, the resistance is not a time-invariant variable. Due to the accumulation of damage (fatigue, corrosion, cracking, permanent deformations) the capacity decreases with time. The rate of deterioration is often nonuniform and difficult to predict.

Deterioration affects various structural parts differently. Deck and deck joint decay do not present a direct threat to bridge safety. They do, however, seriously reduce the serviceability

(smooth ride) of a bridge. In the result, there is also an increased exposure of the superstructure to a corrosive environment. The dynamic loads may also be increased. Fatigue and corrosion of the superstructure may cause a considerable reduction of resistance. Corrosion may not only cause fracture, but also yielding or buckling of members. In particular, three possible changes to a steel girder bridge can be considered; an increase in stress, a change in geometric properties (e.g. decrease of section modulus), and a buildup of corrosion products.

Changes in member stresses and geometric properties are associated with a loss of material. This loss may be on a local or microscopic level, such as pitting; or in a general area, such as surface corrosion. A reduction in the net area of a member will cause an overall increase in member stresses for a given load. If the loss of material is local, as in the case of pitting, small surface discontinuities can create stress risers which may increase the member's sensitivity to fatigue. A consequence of surface corrosion is the reduction in member cross section properties, such as the section modulus or the slenderness ratio. Such properties are critical in a member's ability to resist bending moments or axial forces. Corrosion product buildup may also affect structural performance. Accumulated rust can act as a desiccant, retaining moisture may further promote corrosion. Also, growing "pack rust" can exert a considerable pressure on adjacent elements [4]. Such pressure can cause damage to connections by wedging apart connected elements.

The objective of this paper is to present an approach to quantifying the reduction in safety for deteriorating steel bridges. The discussion will concentrate on the surface corrosion of simple span composite steel bridges. A system reliability model is developed, based on three failure modes of a girder; bending, shear, and bearing. The statistical model of the resistance reduced by corrosion is calculated using sampling methods. To illustrate the approach, the reliability analysis is carried out for two bridges. The calculations are performed for various lifetimes and environmental conditions. A sensitivity analysis is carried out to identify the most important parameters affecting the safety of corroded bridges.

SURFACE CORROSION

The corrosion of metal in outdoor environments has been intensively studied since the 1940's. A large amount of data has been collected on the rate of material loss of metal specimens in different environments. From this data it has been observed that corrosion loss follows an exponential function [5].

$$C = At^B \quad (1)$$

where C represents the average corrosion penetration, in μm , t is number of years, and A and B are the parameters determined from the analysis of experimental data. The parameters A and B are random variables. Therefore, the actual corrosion loss, C , is also a random variable. The values of A and B depend on the environment in which a bridge is located. Albrecht and Naeemi [6] have summarized corrosion test results for various environments.

In this study the environment is classified as either rural, urban, or marine. Average values for A and B are listed in Table 1 for unprotected carbon steel and weathering steel. These values were determined from tests of small metal specimens. In the extrapolation to full-size bridges, some error may occur due to variations in component size, orientation, and local environment.

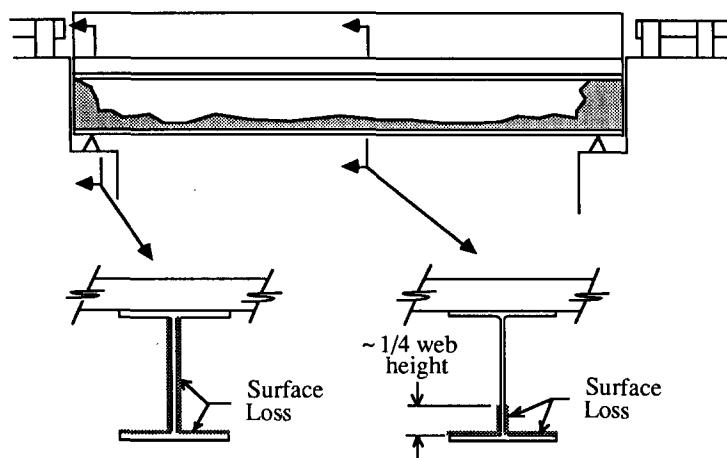

Fig. 1. Typical location of corrosion on a steel girder bridge.

TABLE 1

Average values for corrosion parameters A and B , for carbon and weathering steel

Environment	Carbon steel		Weathering steel	
	A	B	A	B
Rural	34.0	0.65	33.3	0.50
Urban	80.2	0.59	50.7	0.57
Marine	70.6	0.79	40.2	0.56

As more data become available on the corrosion of actual steel bridges, the parameters A and B can be revised.

To determine where corrosion occurs, several field surveys were conducted [7]. From these studies it was observed that corrosion is likely to occur along the top surface of the bottom flange, due to traffic spray accumulation, and over the entire web near the supports, due to deck leakage. These areas of steel bridge corrosion are illustrated in Fig. 1.

STRUCTURAL EFFECTS

Loss of material may affect any one of three modes of resistance in a girder; bending, shear, and bearing. Loss of flange material will cause a reduction in the net area available to resist bending. The moment of inertia will be reduced, causing an increase in deflection. Also, the ultimate bending strength will be reduced, causing a reduction in maximum carrying capacity. In this study a section analysis program was used which calculates bending based on a composite strip method [1]. In the method a section is treated as a collection of composite segments. Each segment has a defined stress-strain relationship. A strain level is set for the top layer and the correct depth to neutral axis is iteratively determined. From this, the bending moment and curvature relationship is developed, providing the initial bending stiffness and ultimate moment capacity of the section.

The loss of web material may influence the resistance modes of shear and bearing. Shear capacity can be calculated based on standard methods developed from plate theory [8]. Bearing capacity, though, will depend on whether a stiffener is installed at the support. If a stiffener is present, column analogy can be applied to an effective width of the web [9]. If no stiffener is present, plate theory can be used, assuming the ultimate capacity of the web in bearing is reached once the panel begins to buckle [8]. The equations used to calculate bending, shear and bearing capacity can be combined with sampling methods to determine the statistics of resistance.

The modeling of resistance is very difficult due to the large variation in experimental observations. From the compilation of corrosion studies it is apparent that the parameters A and B have a large and inconsistent variation. For the behavior of the web panel in buckling, there is an uncertainty in the boundary conditions of the plate. This boundary condition is reflected in the plate coefficient k . An important parameter is the amount of shear load distributed to each girder. In ordinary design, an assumption of simple beam deck behavior is used [10]. This method of distributing loads has proved adequate for new bridges, however it remains uncertain and possibly critical for old bridges. To investigate the effect of variations in shear distribution, a shear factor, SF, is used to represent a linear increase or decrease in the shear load per girder. The four parameters, A , B , k , and SF, are investigated separately in a sensitivity analysis.

BRIDGE RELIABILITY

Bridge load, Q , is a sum of dead load, D , static live load, L , dynamic load, I , environmental loads (wind, earthquake, temperature, etc.), E , and other loads (collision, emergency braking, etc.), S ,

$$Q = D + L + I + E + S \quad (2)$$

The statistical data on load components are summarized in recent studies [11].

The dead load is the sum of the weight of separate bridge components. The weight of these components is considered normally distributed, with the bias ratio (mean-to-nominal) varying from 1.03 for factory-made members (precast girders, and steel girders) to 1.05 for cast-in-place members (slabs, cast-in-place girders). The coefficient of variation varies from 0.04 for factory-made members to 0.08 for cast-in-place members. The asphalt wearing surface has a bias ratio of 1.10 (mean thickness of 75 mm), with a coefficient of variation of 0.25.

Live load was modeled by Ghosn and Moses [12]. In their model the calculation of static and dynamic live load is combined. The load is considered as normally distributed,

$$L + I = amW^*HgiGr \quad (3)$$

where $(L + I)$ is the mean 50-year bending moment in the critical girder due to static and dynamic load, a is a deterministic value depending on truck configuration and span length, m is a random value based on the variation of load effect for a given truck type, W^* is the 95th percentile of weight for the dominant truck type at the bridge site, H is a value related to the probability of closely spaced vehicles on a bridge, g is the girder distribution factor, i is the dynamic amplification factor, and Gr is the future growth factor.

For short to medium span highway bridges, the effects of environmental and accidental loads are not critical. In this study only the dead load and live load will be considered.

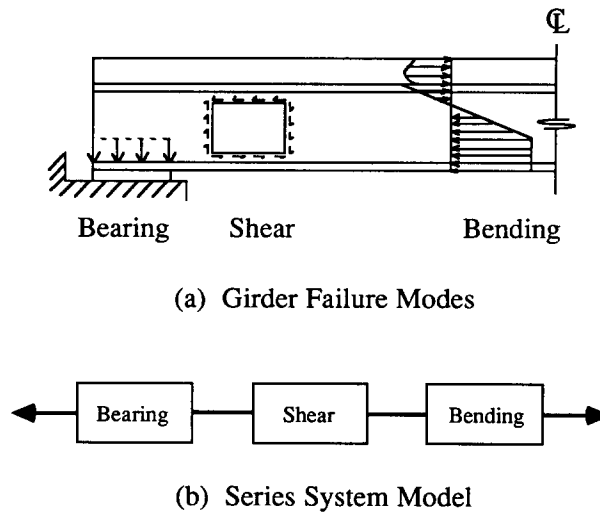

Fig. 2. System model for the bending, shear and bearing failure modes.

Resistance models were developed for each mode (bending, shear, and bearing) separately, Fig. 2(a). Statistics of the random values associated with each mode are summarized by Nowak et al. [11], Table 2.

In order to calculate the statistics of resistance a sampling method developed by Zhou [13] is used. Zhou derived integration formulas for computing the statistical parameters of a function of a random vector. The formula is a numerical procedure using selected weights and points to estimate integrals, in particular calculation of the first few moments. The point and weights are predetermined in the independent standard normal variable space. The sample points in basic variable space are then obtained by various transformations.

TABLE 2

Parameters associated with modes of resistance.

Parameter	Mode of resistance		
	Bending	Shear	Bearing
f_y steel compression	*		*
f_y steel shear		*	*
E steel	*	*	*
f_y steel reinforcement	*		
f_c' reinforcement	*		
Uncorroded web thickness	*		
Uncorroded flange thickness	*		
Corroded web thickness	*	*	*
Corroded flange thickness	*		
Shear plate coefficient		*	*
Poisson's ratio		*	*
Bearing plate coefficient			*

Let g be a function of n random variables, $X = X_1, X_2, \dots, X_n$,

$$g = g(X) = g(X_1, X_2, \dots, X_n) \quad (4)$$

Then, the expected values of g and g^2 can be calculated using sample points $x_i = x_{1i}, x_{2i}, \dots, x_{ni}$, and weights w_i ,

$$E[g(X)] = \sum_{i=1}^m w_i g(x_i) \quad (5)$$

$$E[g^2(X)] = \sum_{i=1}^m w_i g^2(x_i) \quad (6)$$

where m is the number of points considered.

The points, $x_{1i}, x_{2i}, \dots, x_{ni}$, and weights, w_i , were determined by Zhou [13] for various values of m .

The safety margin, g , can be considered as the difference between the resistance, R , and the load, Q . The corresponding limit state function is,

$$g = R - Q \quad (7)$$

Each of the modes of failure is associated with a separate limit state function. Safety can be measured in terms of the reliability index, β [14]. In the simplest form,

$$\beta = (\bar{R} - \bar{Q}) / \sqrt{\sigma_R^2 + \sigma_Q^2} \quad (8)$$

where: \bar{R} , \bar{Q} is the mean of resistance and load, respectively, and σ_R , σ_Q is the standard deviation of resistance and load, respectively.

For each mode of failure, i , the reliability index, β_i , can be calculated, with the corresponding probability of failure, P_i ,

$$P_i = \Phi(-\beta_i) \quad (9)$$

where Φ is the standard normal distribution function.

A bridge can be considered as a system of girders. For each girder, failure may occur in any one of the modes (bending, shear, or bearing). The resulting excessive deflection would make the bridge unserviceable. Therefore, the three modes of resistance can be considered as a series system, Fig. 2(b) [15]. The system probability of failure, P_F , can be estimated using the Ditlevsen bounds [16],

$$P_1 + \sum_{i=2}^3 \max \left[\left(P_i - \sum_{j=1}^{i-1} P_{ij} \right), 0 \right] \leq P_F \leq \sum_{i=1}^3 P_i - \sum_{i=2, j < i}^3 \max P_{ij} \quad (10)$$

where P_{ij} is the joint probability of failure corresponding to modes i and j . The modes can be numbered so as to obtain the narrowest bounds.

The joint probability of failure can be calculated, provided that the reliability and correlation of the modes is known [17,18],

$$P_{ij} = \Phi(-\beta_i)\Phi(-\beta_j) + \int_0^{\rho_{ij}} \phi(-\beta_i, -\beta_j, \rho) d\rho \quad (11)$$

$$\phi(-\beta_i, -\beta_j, \rho) = \frac{1}{2\pi\sqrt{1-\rho^2}} \exp \left(-\frac{1}{2} \frac{\beta_i^2 + \beta_j^2 - 2\rho\beta_i\beta_j}{(1-\rho^2)} \right) \quad (12)$$

where ρ_{ij} is the correlation between modes i and j , and ϕ is the bivariate probability density function.

BRIDGE EVALUATION

The effect of corrosion on reliability is evaluated for two typical simple span steel girder bridges, of length 12 m and 18 m. The bridges were designed using the Load Factor Design approach [10]. Both bridges carry two lanes of traffic, and are supported by five longitudinal girders. The 12 m bridge uses composite W24 \times 76 steel girders, with 75 \times 19 mm bearing stiffeners. The 18 m bridge uses composite W30 \times 116 girders, with 100 \times 19 mm bearing stiffeners. The A36 steel girders are spaced at 2.5 m centers, supporting a 190 mm thick concrete deck. The installation of bearing stiffeners is not required for either of the bridges. In the analysis each bridge is considered with and without bearing stiffeners.

The bridges were examined for the change in their modal and system reliability, while they were exposed to an unprotected marine environment. The load and resistance statistical parameters are assumed as described previously. The shear per girder is calculated by applying the same distribution factor as for the bending moment.

12 m Span

The analysis results of the 12 m span are shown in Fig. 3. For the three-mode series system of the bridge, the reliability coincides with the lowest modal reliability. In this case, the system reliability equals the reliability corresponding to the bearing mode without stiffeners. When stiffeners are installed, the reliability of the system is the same as the reliability corresponding to the shear mode.

The loss of girder material due to corrosion has more effect on the web, than on the flange. This causes a larger percentage decrease in shear and bearing reliability, than in bending reliability. The decrease in unstiffened bearing resistance is severe enough to cause drop in the bridge reliability index to 0, after 25 years of exposure.

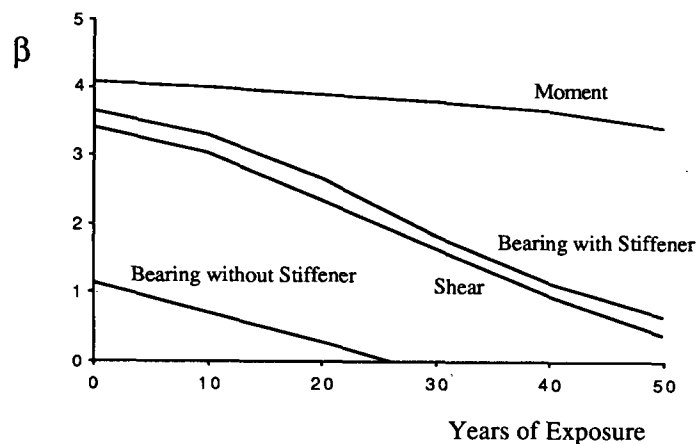

Fig. 3. Reliability versus time for the 12 m bridge.

18 m Span

The results of the 18 m span are shown in Fig. 4. The plot is similar to that used for the 12 m span. As with the shorter bridge, the system reliability is often equal to the lowest modal reliability. The system reliability of the bridge depends on whether web stiffener is present. Without a stiffener, the bearing mode determines the minimum reliability over the entire life of the bridge. If stiffeners are installed, the controlling mode is bending when the bridge is new. However, after approximately 20 years of exposure the bearing mode becomes critical.

The rapid decrease in bearing or shear reliability is dependent on the relative thickness of the web. For the case of the 18 m span a web is 14 mm thick, while a flange is 22 mm. This means that a surface loss of 2 mm on both sides of the web and on the top of the flange, will reduce the web area by 27%, and the flange area by 10%. The web will further be affected by the fact that it acts in compression, subject to buckling, while the flange is in tension.

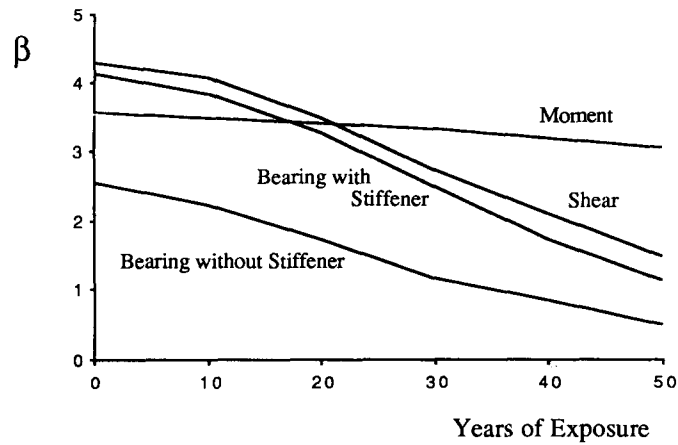

Fig. 4. Reliability versus time for the 18 m bridge.

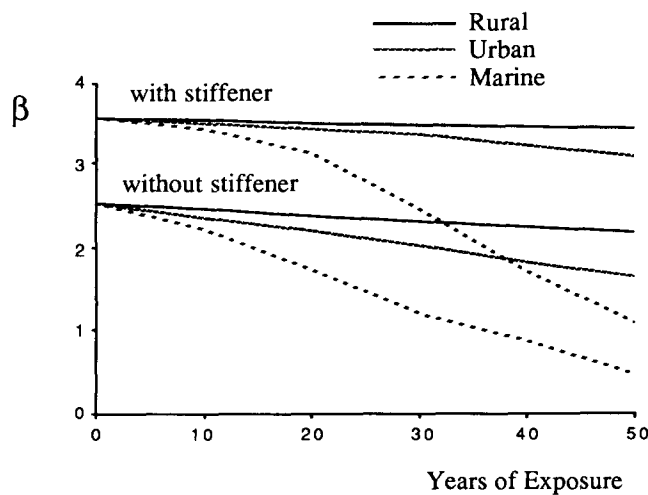

Fig. 5. Reliability versus time for the 18 m span in different environments.

The system reliability was studied for the 18 m span (with and without stiffeners) in three different environments; rural, urban, and marine (Table 1). The results are shown in Fig. 5. There is a visible difference in safety between the stiffened and unstiffened bridges. The stiffeners increased the relative safety during the entire life of the bridge. The reduction in safety over time is dependent on the type of environment. The rural environment was benign, causing a negligible reduction in safety. The urban environment caused a small reduction, approximately 8% for the stiffened bridge, and 20% for the unstiffened bridge. The marine environment caused the greatest reduction in safety, amounting to 70% for the stiffened bridge, and 80% for the unstiffened bridge.

SENSITIVITY STUDY

The parameters in the resistance model involve uncertainty. Some of these parameters were studied in a sensitivity analysis to determine whether their variation will have a significant effect on the 50-year safety of the unstiffened 18 m bridge. The parameters are varied over a range of values which they may possibly assume. The datum values of the parameters are: corrosion coefficient $A = 60.0$, corrosion exponent $B = 0.68$, bearing plate coefficient $k = 1.28$, and shear distribution parameter $SF = 1.0$. The corresponding reliability index is denoted by β_0 .

The results are presented in Fig. 6. The most influential parameter is the corrosion exponent B . This parameter significantly affected the 50-year reliability index in both the positive and negative direction. The parameter which controlled the amount of shear load per girder, SF , was the next most influential parameter. The corrosion coefficient A had a minor linear effect on safety. The bearing plate coefficient k did not influence safety in the positive direction, and only affected safety when reduced by more than 30%.

From this sensitivity it can be seen that the rate of corrosion, as influenced by A and B , has a significant effect on long-term safety. The amount of shear load per girder is also important. Variation of the bearing plate coefficient, in its probable range of occurrence, is not important to the long-term safety of the bridge.

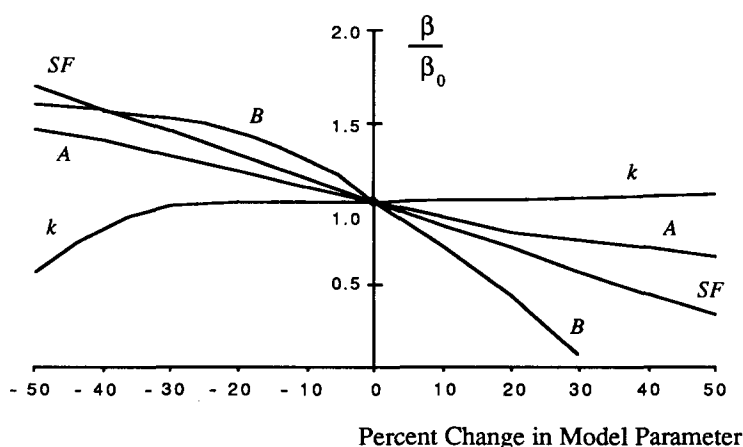

Fig. 6. Sensitivity study of model parameters.

CONCLUSIONS

The safety of corroding steel girder bridges can be evaluated using models based on the probable rate and location of corrosion. These corrosion predictions can be combined with structural analysis methods and estimate methods to determine the statistics of resistance. Reliability methods can then be applied to determine the reliability of a corroded steel bridge over a given length of time.

The developed corrosion model was used to evaluate two typical span steel girder bridges. From this analysis it was shown that safety depends on relative slenderness of girder elements, and whether the elements are in tension or compression. Corrosion loss has a greater effect on compression strength because of the possibility of buckling. The web, being a compression element, is the component most susceptible to corrosion loss. This variation in safety loss from one component to another, or from one mode of resistance to another, means that resistance criterion which governs when a bridge is new may not govern when a bridge becomes corroded.

Using the corrosion model a bridge was studied in three different environments. It was found that a rural environment, with exposure to pure water, negligibly effects a bridge. An urban environment, with automobile and industrial pollutants, moderately environment, with salt from sea water or deicer use, significantly reduces safety over a 50-year life. For shorter span bridges, with no bearing stiffeners, a total loss of safety can occur.

Sensitivity analysis showed that the most important factors in corrosion performance are the parameters used in determining corrosion loss, particularly B , and the factor which determines the amount of shear load per girder, SF . These factors should be the focus of continuing research to improve the corrosion model for bridges.

ACKNOWLEDGEMENTS

This work was partially supported by the National Science Foundation under Grant No. ECE-8413274, with John B. Scalzi as Program Director. The authors are also grateful to the Michigan Department of Transportation for their cooperation, particularly Martin O'Toole and Ron McCrum, and the Washtenaw County Road Commission for allowing access to bridge information.

References

- 1 J.R. Kayser and A.S. Nowak, Evaluation of corroded steel bridges, in: Bridges and Transmission Line Structures, American Society of Civil Engineers, 1987, pp. 35–46.
- 2 A.S. Nowak and N.C. Lind, Practical bridge code calibration, J. Struct. Div. ASCE, 105 (ST12) (December 1979) 2497–2510.
- 3 A.S. Nowak and J.H. Zhou, Reliability models for bridge analysis, Report No. 85-3, University of Michigan, Ann Arbor, MI, March 1985.
- 4 R.L. Brockenbrough, Considerations in the design of bolted joints for weathering steel, AISC Eng. J., 20 (1) (1983) 40–45.
- 5 M.E. Komp, Atmospheric corrosion ratings of weathering steels—Calculations and significance, Mater. Perform., 26 (7) (July 1987) 42–44.

- 6 P. Albrecht and A.H. Naeemi, Performance of weathering steel in bridges, National Cooperative Highway Research Program, Report 272, July 1984.
- 7 J.R. Kayser, The Effects of Corrosion on the Reliability of Steel Girder Bridges, Ph.D. Thesis, Dept. of Civil Eng., University of Michigan, Ann Arbor, MI, 1988.
- 8 B.C. Johnston, Guide to Stability Design Criteria for Metal Structures, Structural Stability Research Council, 3rd edn., Wiley, New York, 1976.
- 9 AISC, Manual of Steel Construction Load and Resistance Factor Design, American Institute of Steel Construction, First Edition, 1986.
- 10 AASHTO, Standard Specification for Highway Bridges, American Association of State Highway and Transportation Officials, Washington, DC, 1983.
- 11 A.S. Nowak, J. Czernecki, J.H. Zhou and J.R. Kayser, Design loads for future bridges, Report No. FHWA/RD-87/069, University of Michigan, Ann Arbor, MI, July 1987.
- 12 M. Ghosn and F. Moses, Reliability calibration of bridge design code, J. Struct. Eng. ASCE, 112 (4) (April 1986) 745-763.
- 13 J-H. Zhou, System Reliability Models for Highway Bridge Analysis, Ph.D. Thesis, Dept. of Civil Eng., University of Michigan, Ann Arbor, MI, 1987.
- 14 C.A. Cornell, A first order reliability theory of structural design, in: Structural Reliability and Codified Design, SM Study No. 3, University of Waterloo, Waterloo, Ont., Canada, 1970.
- 15 T. Tharmabala and A.S. Nowak, Mathematical models for bridge reliability, Can. J. Civ. Eng., 14 (2) (April 1987) 155-162.
- 16 P. Thoft-Christensen and M.J. Baker, Structural Reliability and Its Applications, Springer-Verlag, New York, 1982.
- 17 E.H. Vanmarcke, Matrix formulation of reliability analysis and reliability-based design, Comput. Struct., 3 (1973) 757-770.
- 18 H.O. Madsen, S. Krenk and N.C. Lind, Methods of Structural Safety, Prentice-Hall, Englewood Cliffs, NJ, 1986.