

Equilibrium Hydrogen Transfer between Benzene and C₆ Hydrocarbons over Supported Metal Catalysts

G. PARRAVANO

*From the Department of Chemical and Metallurgical Engineering,
University of Michigan, Ann Arbor, Michigan 48104*

Received April 15, 1969; revised August 15, 1969

A kinetic method is presented for the study of the hydrocarbon-surface interaction taking place during the catalytic conversion of hydrocarbons. The method involves the study of the rate of redistribution of an isotopic tracer between hydrocarbon molecules in thermodynamic equilibrium with the catalyst surface. A general discussion of the approach is given; its potentialities and advantages in studying the individual steps of hydrocarbon reactions are analyzed. These ideas are applied to the study of the rate of hydrogen transfer between cyclohexane and other C₆ hydrocarbons on the one side and benzene on the other over Pt, Pd, Ir, Rh, and Ru supported on Al₂O₃ and SiO₂. The investigation covered the effect on the reaction rate of the ratio of C₆ hydrocarbon to benzene and of metal particle size at 117°C.

With few exceptions the transfer rate increased upon increasing the ratio of cyclohexane to benzene and upon addition of molecular H₂ to the reactants. For the cyclohexane-benzene combination the relative activity among the metals investigated was Pt > Pd > Ir > Ru > Rh. In the range of Pt crystallite size studied (12-2000 Å) the hydrogen surface coverage was influenced by the particle size, but the reaction rate constant per unit of metal surface area was little dependent upon crystallite size. Reactive surface efficiencies were in the range 10⁻⁴ to 10⁻⁷. Experiments on the hydrogen transfer between benzene and other C₆ hydrocarbons produced the following sequence of reaction efficiency: cyclohexene > cyclohexane > methylcyclopentane > n-hexane, 2,3-dimethylbutane. A surface equilibrium reaction and a rate-controlling step consistent with the experimental results are postulated. The nature of the reactive metal surface, particularly the role of the adsorbed hydrogen, is pointed out. The conclusions are analyzed in the framework of the present understanding of metal catalysis.

INTRODUCTION

Hydrogen transfer steps occupy a prominent position in the catalytic conversion of hydrocarbons. Reactions of hydrogenation, hydrogenolysis, hydrocracking, cyclization, ring expansion and contraction include hydrogen-surface and hydrocarbon-surface interactions. The study of the activation and desorption of molecular hydrogen has been vigorously pursued by means of the ortho-para hydrogen conversion and the H₂-D₂ exchange reaction, but no parallel development of research has taken place for the hydrocarbon-surface interaction. The characteristics of this interaction have been inferred from structural and kinetic

studies of the overall conversion. Yet the molecular complexity of hydrocarbons demands a more direct kinetic test of catalytic correlations.

In this communication we present a general approach for studying the hydrogen transfer step between hydrocarbon and surface, and for obtaining directly the transfer rate under conditions close to those employed in the catalytic conversion. The method consists in setting a mixture of the hydrogen acceptor and donor hydrocarbon species in the presence of the catalyst surface and in following the transfer of hydrogen between donor and acceptor by isotopic exchange labeling. If the cor-

rect type of isotopic exchange reaction is employed, the rate of the latter gives immediately the rate of the hydrogen transfer step between hydrocarbon and catalytic surface. A general outline of the method, of its characteristics and of the type of exchange reactions needed, is given. The kinetics of the transfer step is analyzed and the advantages of studying the rate of gas-surface reactions under equilibrium conditions are pointed out. Thermodynamic and kinetic information is derived. To demonstrate the usefulness of the method in hydrocarbon catalysis, we present and discuss experimental results on the hydrogen transfer between benzene (BE) and a few C₆ hydrocarbons: cyclohexane (CHA), cyclohexene (CHE), *n*-hexane (HA), 1,2-dimethylbutane (DMB) and methylcyclopentane (MCP).

The bulk of the experimental work was carried out with the BE-CHA combination. This system has been employed to investigate the effect of the nature of the metal (Pt, Pd, Ru, Rh, Ir) and catalytic support (Al₂O₃, SiO₂) and of the metal dispersion (0.3–10 wt %) on the kinetic and thermodynamic characteristics of the surface step. The studies were carried out in the temperature range 93–400°C and over four orders of magnitude variation of the ratio $p_{\text{C}_6\text{H}_{12}}/p_{\text{C}_6\text{H}_6}$ (0.035 to 250).

GENERALIZED HYDROCARBON INTERCONVERSION

Consider the catalytic reaction:

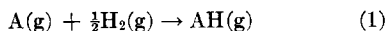

where A, AH represent hydrocarbon molecules. A is a hydrogen acceptor relative to AH. The suffix g refers to the gas phase. It is always possible to describe reaction (1) as the sequence of two gas-surface reactions namely:

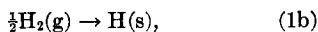

where the suffix s refers to the surface phase. For a complete understanding of reaction (1), the individual rates of reaction steps (1a) and (1b), including the influence of [H(s)] upon these rates, must be known. With this information, it is pos-

sible to calculate the steady state value of [H(s)] and evaluate the net rate of reaction from the rates of reaction steps (1a) and (1b). A convenient method to study the influence of [H(s)] upon the rates of reaction steps (1a) and (1b) is to keep the former constant during a rate experiment by establishing equilibrium conditions between surface and gas phases. This condition dictates the use of a special type of isotopic exchange reaction.

For reaction step (1a), let us consider a mixture of A and AH, containing isotopically labeled species, and let us follow the catalytic redistribution of the tracer, namely:

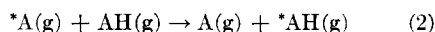

The surface steps of reaction (2) are:



Since reaction step (2a') is the reverse step of reaction (2a), the rates of reaction step (2a) and (2a'), v_a , v'_a , are equal (neglecting kinetic isotope effects), and, consequently, the study of the rate of reaction (2) gives directly the rate v_a (or v'_a). Furthermore, reaction step (2a') is similar to reaction step (1a). Therefore, the study of the rate of the exchange reaction (2) provides a method to obtain the rate of reaction step (1a). In addition, by studying the rate of the former at different ratios $p_{\text{AH}}/p_{\text{A}}$, the influence of [H(s)] on the rate of reaction step (1a) may be brought to light.

The success of the method depends upon the availability of exchange reactions, characterized by the transfer of a single atom (or atomic group), similar to that involved in the gas-surface reaction step under study.

If x is the extent of reaction, the conversion, α , for reaction (2) is given by:

$$\alpha = \frac{x}{x_e} = \frac{p_{^*\text{AH}}}{(p_{^*\text{AH}})_e} = \frac{1 + \beta'}{\beta'} \delta \quad (3)$$

where $\delta = p_{^*\text{AH}}/(p_{^*\text{A}} + p_{^*\text{AH}}) = p_{^*\text{AH}}/(\gamma_{^*\text{AH}})_0$ and $\beta' = p_{\text{AH}}/p_{\text{A}}$. At isotopic equilibrium $\delta_e = 1/(1 + \beta')$. For $\beta' \gg 1$, Eq. (3) gives $\alpha \cong \delta$. In the range of β' values, in which δ increases with β' , α will also increase with increasing β' . For $0 < \beta' \leq 1$,

α is practically controlled by the ratio $(1 + \beta')/\beta'$ and the former increases (sharply) with decreasing β' . Thus, the relation $\alpha = f(\beta')$ should show a minimum.

The derivation of the rate expression for reaction (2) [or (2a) or (2a')] is easily carried out. Consider reaction step (2a'). The rate is given by:

$$\frac{1}{w} \frac{dn_{*AH}}{dt} = k_c p_{*A} - k'_c p_{*AH} \quad (4)$$

where w , n_{*AH} , k_c , k'_c are the catalyst weight, moles of *AH formed and rate coefficients of the forward and backward reaction steps (2a'). Introducing the condition $p_{AH}/p_A = (p_{*AH}/p_{*A})_e$ and since $k'_c(p_{*A})_e = k_c(p_{*AH})_e$. Eq. (4) becomes:

$$\frac{V}{wRT} \frac{d[p_{*AH}/(p_{*AH})_0]}{dt} = k_c(1 - \alpha), \quad (5)$$

where V is the reactor volume. Integration of Eq. (5) (for a flow reactor) and solution for k_c yields:

$$k_c = \frac{\dot{V}}{wRT} \frac{1}{1 + (1/\beta')} \ln \frac{1}{1 - \alpha} \quad (6)$$

where \dot{V} is the total volumetric flow rate at room temperature and atmospheric pressure. Whenever the rate of the catalytic reaction (2) is dependent upon a power of the partial pressure $\neq 1$, the rate coefficient k_c is a function of the partial pressure. This function can be obtained explicitly from Eq. (6) by performing experiments at various β' values.

The rate of reaction step (2a') at equilibrium is given by:

$$(v_a')_e = k_c p_{*A}, \quad (7)$$

$(v_a')_e$ represents the reactive molecular flux established at the catalyst surface during the course of reaction step (2a'). Under similar conditions, the total flux of gas phase collisions experienced by the surface is:

$$\dot{n} = \frac{p_A}{(2\pi mkT)^{1/2}}. \quad (8)$$

The reactive collision efficiency of the surface is then:

$$\gamma = \frac{(v_a')_e}{\dot{n}} = k_c(2\pi mkT)^{1/2}. \quad (9)$$

The study of reaction step (1b) may be carried out in a similar fashion by investigating the influence of p_{H_2} upon the rate of the H_2 - D_2 exchange reaction.

We have applied these considerations to the catalytic hydrogenation of BE and dehydrogenation of CHA:

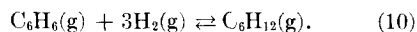

Reaction (10) has been the subject of considerable amount of studies. These, however, were performed on the overall reaction and inferences on the role of the concentration or activity of the adsorbate upon the reaction rate have proven difficult, and opposite physical conditions at the surface have been found to be consistent with the observed results (1).

Let us consider a mixture of BE and CHA in the presence of a catalyst surface. The surface reactions may be represented by:

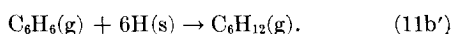
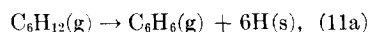

Step (11a) is responsible for the catalytic dehydrogenation, while step (11b'), which is the backward step of (11a), for the catalytic hydrogenation. As written, reaction steps (11a) and (11b') require the transfer of six hydrogen atoms which conceivably participate sequentially to the complete transfer. The kinetic implications of this situation have been argued before (2). The study of the rates of steps (11a) and (11b') at constant surface concentration (or activity) of adsorbed hydrogen, $[H(s)]$, is performed by maintaining a constant partial pressure of BE and CHA in the system and by following the distribution of a carbon tracer between BE and CHA, namely:



where *C is an isotopic carbon atom.

Reaction (11) may be visualized to occur as a sequence of two steps; namely, steps (11a) and (11b)

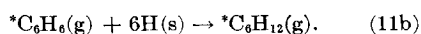

Neglecting kinetic isotope effects, the rate of reaction step (11b) is similar to that of step (11b'). Thus, the study of the rate of

reaction (11) at various ratios $p_{C_6H_{12}}/p_{C_6H_6} = \beta$ may yield important information on the role of $[H(s)]$ on the rates of the transfer steps (11a) and (11b').

There are no direct observations recorded in the literature on reaction (11). Some years ago, in studies from this laboratory, it was found that the exchange reaction:

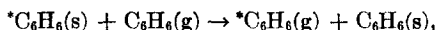

occurred readily on Pt black at temperature $\leq 80^\circ C$ (3). The observation was later confirmed in other laboratories (4). This fact suggested the possibility of occurrence of reaction (11). Indeed in preliminary runs it became evident that reaction (11) may be observed under mild catalytic conditions (5).

To seek a broader perspective of the kinetic method here described, experiments were also performed at a constant set of catalyst conditions but with different hydrogen donor molecules. It was decided to study the rate of ^{14}C redistribution between BE and an isomer of CHA with a C_5 ring (methylcyclopentane, MCP, ring contraction), a straight chain hexane (*n*-hexane, HA, hydrolytic ring fission) and a branched C_6 hydrocarbon (2,3-dimethylbutane, DMB).

The transfer reaction between CHA and cyclohexene (CHE) was also investigated. At the operating conditions employed in the study CHE readily underwent disproportionation. Although the exact stoichiometry of the disproportionation reaction and, particularly, the presence or absence of molecular hydrogen in the products was not investigated, only CHA and BE were detected in the reaction products. Recently, additional kinetic evidence was presented in favor of a disproportionation that include a sequence of dehydrogenation and hydrogenation steps (6) analogous to those here postulated for reaction (11). Thus, CHE disproportionation may be considered to provide adsorbed hydrogen donors whose dehydrogenation reaction entails four H atoms only, the first two dehydrogenation steps of CHA being eliminated. These initial hydrogen abstraction steps in CHA have been often cited as being energetically more difficult than the subsequent

steps. Therefore, it was reasoned that the rate of the redistribution reaction (11) might be expected to increase if CHE instead of CHA were fed with *BE to the reactor.

EXPERIMENTAL METHODS

Materials

Reagent grade hydrocarbons were employed and high purity He gas was used as a carrier. Reagent grade metal salts and $\eta-Al_2O_3$ were used in the preparation of the catalysts. The powdered Al_2O_3 employed had a surface area of 201 m^2/g , a pore volume of 74 cm^3/g , and contained 0.34 wt % of Na. A 24.1-mg portion (0.50 mC) of ^{14}C containing BE was diluted with nonradioactive BE. The stock solution was employed by further dilution as required. Radioactive purity of the *BE was about 99.3%.

Catalyst Preparation and Characterization

Weighted amounts of $Pt(NH_3)_2(NO_2)_2$, $IrCl_3$, $Ru(NO)(NO)_3$, $Pd(NO_3)_3$, $RhCl_3$ were dissolved in distilled water, Al_2O_3 added, and left soaking for several hours. The suspension was then heated at boiling under vigorous stirring and a reducing solution (1% oxalic acid, or 10% formaldehyde) was added. This was sufficient to precipitate all of the metal present. The suspension was washed repeatedly by decantation or dialysis in cellophane bags with distilled H_2O over a period of 2 months. It was then dried overnight under an IR lamp and evacuated at $300^\circ C$, 0.1 torr, for about 2 hr. The fraction between 25 and 30 mesh size was used in the catalytic experiments. X-Ray analysis of the fresh catalysts was carried out by standard X-ray techniques. No other solid phase, except for Al_2O_3 and the metal, was found present. The average particle size of the Pt-containing catalysts was measured with a vertical Phillips diffractometer and a proportional counter employing $Cu-K\alpha$ radiation. The Au was used as a standard, and calculations were performed on the (111) and (311) lines of Pt. The difference in the width at half height, $\beta'' = (B^2 -$

TABLE 1
 CHARACTERIZATION OF Pt CATALYSTS^a

Pt (wt %)	r (Å)	n (g ⁻¹)	A (m ² /g)	D (%)
0.3	50	8.72×10^{16}	27.4	13.7
0.7	130	4.96×10^{15}	10.5	5.25
2.0	315	3.49×10^{14}	4.35	2.18
5.0	1000	1.09×10^{13}	1.37	0.7

^a Average radius of Pt particles, r ; particles of Pt per gram, n ; surface area per gram of Pt, A ; and Pt coverage of Al₂O₃ support in Pt catalysts, D .

$b^2)^{1/2}$, was employed to calculate the average particle diameter $d = K\lambda/(\beta'' \cos \theta)$. In these expressions B , b are the widths at half height of the Au standard and of the Pt sample, respectively, and $K \cong 1$. Assuming a spherical shape for the Pt particles, the number of particles per gram of Pt, n , the Pt surface area per gram of Pt, A , and Pt coverage of the Al₂O₃ support, D , were calculated. The value of D was obtained by assuming a monatomic film of Pt on Al₂O₃. The results of the calculations are summarized in Table 1.

Additional catalysts studied include: Rh on SiO₂ (Cabosil HS5, 300 m²/g) containing 1 and 10 wt % Rh (Esso) (7). The metal surface area of these catalysts, as determined by H₂ and CO adsorption, was 40.8 and 19.6 m²/g, respectively. Assuming spherical particles, these values correspond to particle diameters of 12 and 25 Å. We have also investigated a Pt-Al₂O₃ catalyst (UOP) containing 0.374% Pt on fluorided Al₂O₃ (1/16-in. spheres).

Procedure

The rate of reaction (11) was studied in a flow system (Fig. 1) at a total pressure of 1 atm. Three He streams, controlled by Nupro valves and metered by orifice meters, were led through charcoal traps: one passed through a BE saturator containing a known concentration of *BE, the second through a CHA saturator and the third was merged directly into the previous streams emerging from the saturators. The feed ratio CHA/BE = β was modified by manipulation of the flow rate through the saturators and/or by using known mixtures of BE and CHA in the saturators. The mixed feed was passed into the reactor (10 ml) and through the catalyst bed (1–2 g). The reactor exit was led directly into a sample valve of an inline gas chromatograph. Samples were withdrawn from time to time, fractionated chromatographically and the fractions were collected in U tubes by freezing with liquid N₂. A

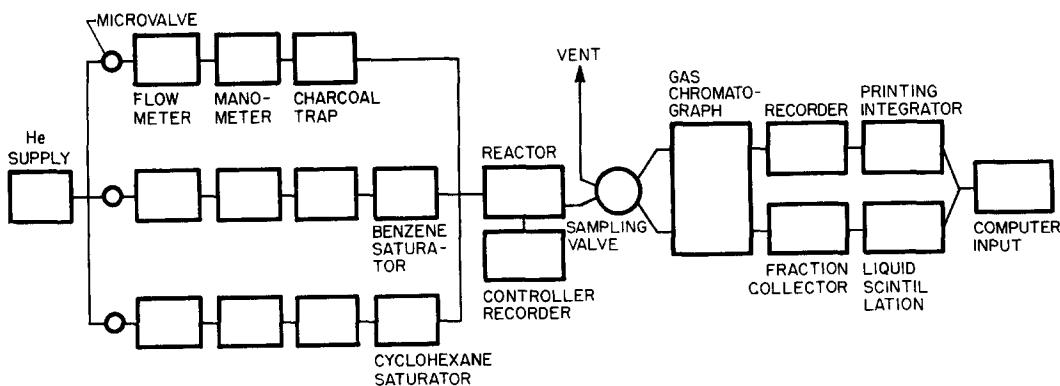

FIG. 1. Experimental setup for the study of the rate of reaction (11).

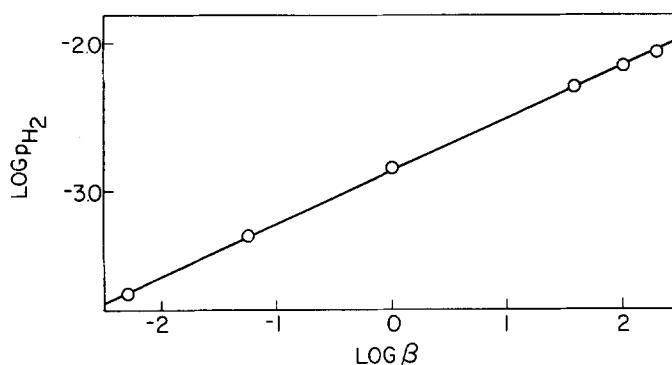

FIG. 2. p_{H_2} from reaction equilibrium (10) as a function of β at 117°C [from data in Ref. (8)], p_{H_2} (atm).

printing integrator, connected to the gas chromatograph, was employed to obtain the peak areas of the BE and CHA fractions. The collected fractions were dissolved in a solution of 5% 1,4-di[2(5-phenyl-oxazolyl)]-benzene in toluene and radioactive analysis on each fraction was carried out by means of liquid scintillation counting techniques. Counting standards were made with ^{14}C -benzoic acid. Radioactive background counts were carried out before each scintillation analysis on samples of similar concentration of BE and CHA. Counting rates were generally in the range of 10^4 cpm for BE (error $<0.2\%$) and of 10^2 cpm for CHA (error $\leq 7\%$). Several counting runs were performed on each sample, and counting times up to 50 min/sample were used. Reaction rate calcula-

tions were carried out on an IBM 360/67 computer with the aid of a program utilizing the inputs from the flow meters, the reactor and room temperatures and pressure and the readouts from the printing integrator and scintillation counter.

Chromatographic analysis showed the absence in the exit stream of products, other than the hydrocarbons fed to the reactor. At the higher temperatures ($\sim 400^\circ C$) small quantities of isomerization products were detected. The establishment of the gas-surface equilibrium under reaction conditions was directly checked at the higher temperatures and values of β with the calculated values of reaction equilibrium (10) (Table 2, Fig. 2). At lower temperatures this check could not be easily carried out because of the low

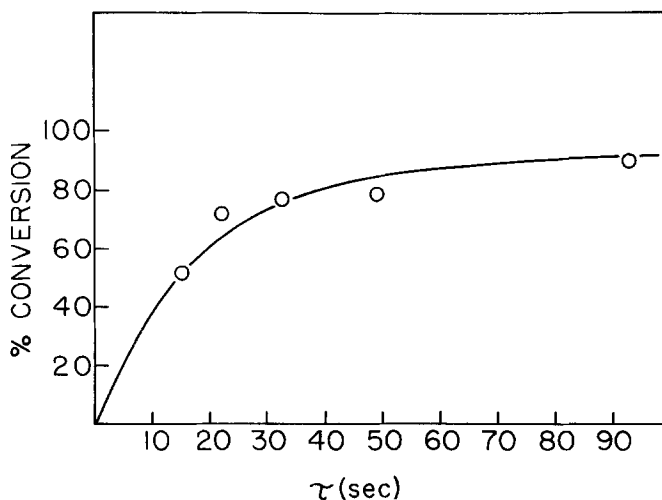

FIG. 3. Influence of contact time, τ , on the conversion, α , for reaction (11) on Pt-Al₂O₃ (UOP), 225°C, $\beta = 0.33$.

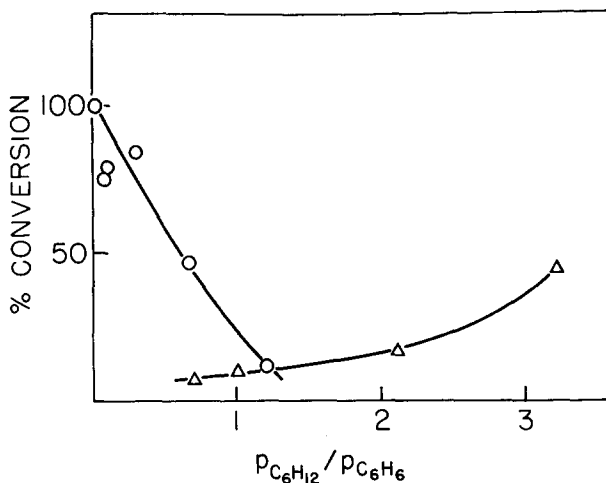

FIG. 4. Influence of β upon the conversion, α , for reaction (11), on Pt-Al₂O₃ (UOP), $\tau = 21$ sec; Δ , 178°C, \circ , 230°C.

TABLE 2
 p_{H_2} FROM REACTION EQUILIBRIUM (10), $\beta = 1$

Temp. (°C)	p_{H_2} (atm)
80	1.3×10^{-4}
117	1.5×10^{-3}
200	6.6×10^{-2}
300	1.54

* Calculated from data in Ref. (8).

values of $(p_{H_2})_e$. The establishment of the equilibrium under these conditions was assumed on the basis of indirect evidence (reversibility and reproducibility of the results).

EXPERIMENTAL RESULTS

Typical results of the influence of contact time, τ , upon α at 225°C and $\beta = 0.33$ are shown in Fig. 3 for the catalyst Pt-Al₂O₃ (UOP). In most of the experiments, $\tau \cong 10$ to 20 seconds. The relation $\alpha = f(\beta)$ at constant τ is shown in Fig. 4 for Pt-Al₂O₃ (UOP) at 178 and 230°C and values of β between about 10^{-1} to 10^2 . These results support the expected influence of δ and $(1 + \beta)/\beta$ upon α . Experiments were also conducted at various flow rates and constant β to ascertain the absence of diffusional limitations. Values of the rate coefficient for reaction (11), k_c , calculated with the aid of Eq. (6) for various metals

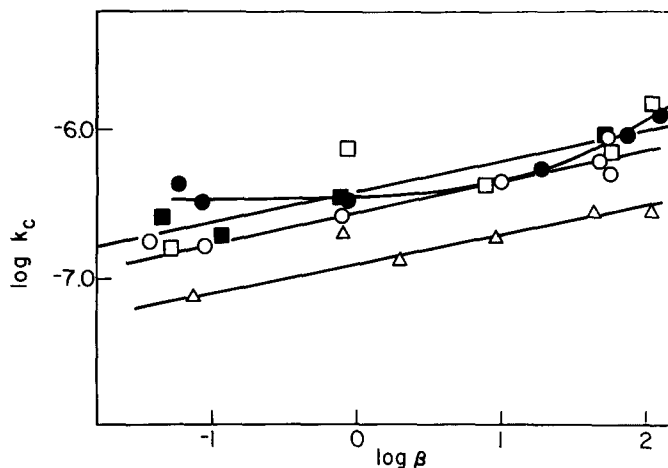

FIG. 5. Influence of β on the rate coefficient for reaction (11), k_c , 117°C, Pt, Δ ; Rh, \circ ; Ru, \square ; Pd, \bullet ; Ir, \blacksquare ; 0.7 wt % metal on Al₂O₃.

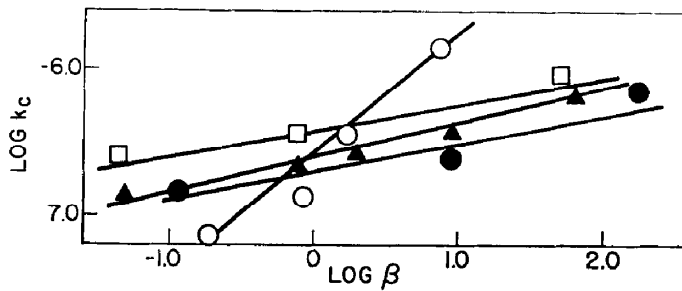

FIG. 6. Influence of the amount of Pt supported on η -Al₂O₃ on the rate coefficient, k_c , for reaction (11), 117°C, ●, 0.3 wt %; □, 0.7 wt %; ▲, 2 wt %, ○, 5 wt %.

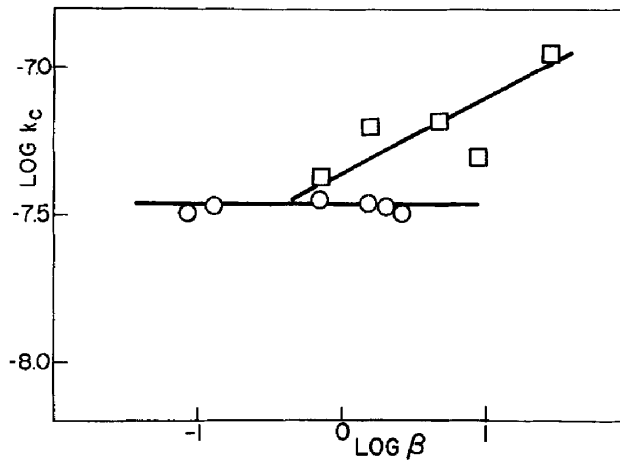

FIG. 7. Influence of β upon the rate coefficient, k_c , for reaction (11) for Rh-SiO₂ catalysts, 230°C, ○, 1 wt % Rh; □, 10 wt % Rh.

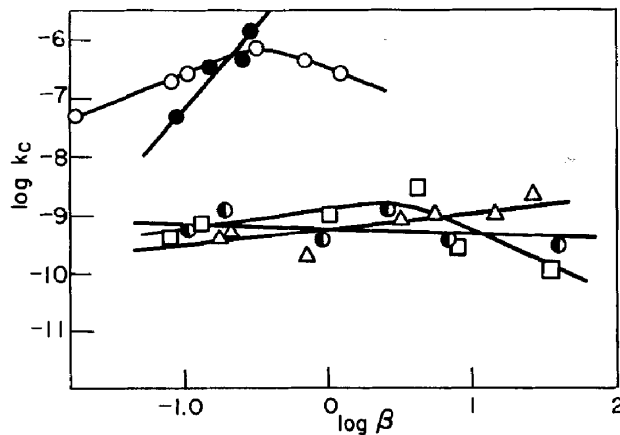

FIG. 8. Influence of the ratio, hydrocarbon/benzene = β , upon the rate of coefficient for the hydrogen transfer reaction: $C_6H_6 + \text{hydrocarbon} \rightarrow C_6H_6^* + \text{hydrocarbon}$; catalyzed by Pt-Al₂O₃ (UOP), ●, cyclohexene, 230°C; ○, cyclohexane, 230°C; □, methylcyclopentane, 300°C; △, 2,3-dimethylbutane ○, n-hexane, 390°C.

TABLE 3
VALUE OF $\partial \ln k_c / \partial \ln \beta = m$ FOR Pt- Al_2O_3
CATALYSTS IN REACTION (11)

Pt (wt %)	Temp. (°C)	m
0.30	117	0.18
0.38 ^a	175	0.90
	230	0.90
0.70	117	0.18
1.00 ^b	117	0.56
2.0	88	0.17
	117	0.24
	150	0.63
5.0	86	0.32
	117	0.68
	150	0.87

^a Fluorided Al_2O_3 .

^b α - Al_2O_3 .

as a function of β at 117°C, are reported in Fig. 5, while Fig. 6 shows the effect of Pt concentration upon k_c and its relation to β . In Fig. 7 the results on the Rh- SiO_2 catalysts at 230°C are presented. In Fig. 8, the results obtained with a feed containing BE and, separately, HA, MCP, DMB, CHE over Pt- Al_2O_3 (UOP) are shown. From the plots of the experimental points of k_c vs. β , the slope m of the straight line through the points was calculated. The values for different experimental conditions are reported in Tables 3, 4, and 5.

Addition of ~5 vol % H_2 to the feed mixture increased the rate of reaction (11)

TABLE 4
VALUE OF $\partial \ln k_c / \partial \ln \beta = m$ FOR REACTION
(11) CATALYZED BY SUPPORTED METALS

Catalyst		Support	Temp. (°C)	m
Metal	wt %			
Ru	0.7	Al_2O_3	117	0.22
Ir	0.7	Al_2O_3	117	0-0.5
Pd	0.7	Al_2O_3	117	0.22
Rh	0.7	Al_2O_3	117	0.22
	1	SiO_2	117	0.46
	1	SiO_2	230	~0
	10	SiO_2	117	0.18
	10	SiO_2	230	0.26

TABLE 5
VALUES OF $\partial \ln k_c / \partial \ln \beta = m$ FOR VARIOUS C_6
HYDROCARBONS IN REACTION (11) ON
Pt- Al_2O_3 (UOP) 0.38 wt % Pt

Hydrocarbon	Temp. (°C)	m	x
Cyclohexene	230	1.95	11.70
	230	0.9 - 0.88	5.4
Methylcyclopentane	393	0.4 - 0.9	2.4
2,3-Dimethylbutane	393	0.27	1.62
<i>n</i> -Hexane	393	-0.09	~0

on Pt catalysts by about one order of magnitude at 93°C.

DISCUSSION

Hydrocarbon-Surface Interaction

The significant experimental results presented in the previous section are: (i) At temperatures $\geq 93^\circ\text{C}$ hydrogen transfer between C_6H_{12} and C_6C_6 , reaction step (11b), occurred at surfaces of Pt, Pd, Ir, Rh, Ru under conditions of or approaching gas-surface equilibrium; (ii) With few exceptions, the rate coefficient, k_c increased with increasing β ; the value of the ratio

$$\frac{\partial \ln k_c}{\partial \ln \beta} = m, \quad (12)$$

was constant for most metals over a wide range of β . It was dependent upon the metal catalyst employed and, for Pt and Rh, metal concentration. In general $0.15 \leq m \leq 1.0$. (iii) On Pt the rate of the transfer step decreased in the following sequence: CHE > CHA > MCP > HA, DMB. (iv) Addition of molecular H_2 increased the rate of reaction (11).

Equation (12) may be rewritten as a Freundlich expression, namely

$$k_c = k_h \beta^m. \quad (13)$$

Equation (13) represents the basis for discussing the experimental results in terms of two key contributions to the catalytic activity of various metals for reaction (11): The thermodynamic, characterized by the exponent m , and the kinetic, represented by the reaction rate constant k_h . In

accordance with the previous discussion the information obtainable from the experimental results on reaction (11) are directly applicable to and can be discussed in relation to the hydrocarbon-surface interaction step (11b) as it takes place during the catalytic conversion of BE.

Let us assume that the adsorption and desorption of hydrogen, through reaction steps (11a) and (11b), involves the formation of a metal-hydrogen surface layer of variable stoichiometry, depending upon the composition of the gas phase. Let us further assume that stoichiometric variations are introduced into the layer through the formation of hydrogen vacancies, V_H . They correspond to surface empty sites, while sites occupied by H(s) are considered similar to interstitial hydrogen. An important feature of the majority of the experimental results (Figs. 5-8) lies in the fact that the slope of the lines through the experimental points is independent of β over a wide range of β (~ 4 orders of magnitude). This implies that the fractional orders in the rate of reaction (11) cannot be interpreted by assuming that the reaction rate is \propto to a hydrogen coverage, given by a classical Langmuir isotherm. Indeed, this conclusion, reached also in studies on the H_2 - D_2 equilibration on Pd and Pt (9a) suggests a thermodynamic treatment for the surface layer formally similar to that employed for bulk compounds. The defect equilibrium of the surface is written as:

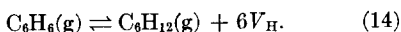

Assuming within the range of values of β explored the validity of the application of the mass action expression to equilibrium (11), and of the relation $[V_H][H(s)] = \text{const}$, one obtains:

$$[H(s)] \propto \frac{1}{[V_H]} \propto \left(\frac{p_{C_6H_{12}}}{p_{C_6H_6}} \right)^{1/6} \quad (15)$$

The rate-determining step for reaction (11b) is written as:

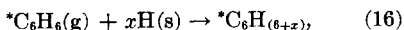

and its rate per unit weight of catalyst:

$$-\frac{dp_{*C_6H_6}}{dt} = k_n p_{*C_6H_6} [H(s)]^x \\ = k_h p_{*C_6H_6} \left(\frac{p_{C_6H_{12}}}{p_{C_6H_6}} \right)^{x/6} = k_c p_{*C_6H_6} \quad (17)$$

where

$$k_c = k_h \beta^{x/6} \quad (18)$$

Comparison between Eqs. (13) and (18) yields

$$x = 6m \quad (19)$$

From Eqs. (18) and (19), values of x and k_h can be calculated.

Depth of Hydrogenation

The x exponent, defined by reaction Eq. (16), is an indication of the amount of the adsorbed hydrogen directly involved in the hydrogenation step. Thus x , by indicating the number of adsorbed hydrogen atoms catalytically added during the rate-controlling step to each hydrocarbon acceptor molecule, defines the depth of the catalytic hydrogenation. It is, then, a valuable means to ascertain whether intermediate unsaturated compounds may be expected to form from the hydrogenation of polyunsaturated hydrocarbons and to determine experimental conditions to optimize their concentration. The value of x may be discussed in terms of three sets of conditions: (a) chemical nature of the metal catalyst, (b) concentration of metal, and (c) temperature. The influence of the metal on the value of x calculated from the values of m reported in Table 4 is shown in Table 6. Table 6

TABLE 6
VALUES OF x FOR VARIOUS METALS (0.7 WT %
ON Al_2O_3) IN REACTION (16), 117°C

Metal	x
Pt	1.10
Pd	1.32
Rh	1.32
Ir	0 to 3.0
Ru	1.32

shows that under similar conditions cycloalkadienes and cycloalkenes are favored in the sequence Pt > Pd, Rh, Ru. The position of Ir in this sequence is critically dependent

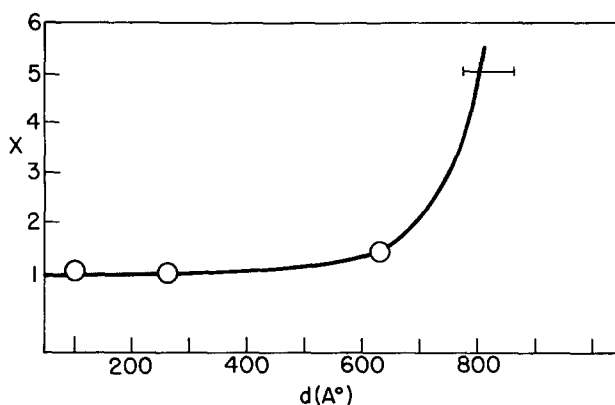

FIG. 9. Effect of particle diameter, d , of Pt-Al₂O₃ catalysts upon x [Eq. (16)], 117°C.

upon the composition of the gas phase. High β 's induce on Ir surfaces a greater ability to hydrogenate in depth in relation to the other metals. The results in Table 6 indicate also the prominent position of Pt in comparison to the other metals. As shown later, x depends upon temperature; thus, the relative position of the metals reported in Table 6, may be modified at higher temperatures.

The influence of the metal concentration upon x may be determined from the results in Table 4. To this purpose the values of x are related to the particle diameter from Table 1 and Fig. 9. For $d \leq \sim 500$ Å there is no appreciable influence of d upon the depth of hydrogenation. For $d \gtrsim 500$ Å there is an increase in the hydrogen content of the reaction complex. This effect may be a result of variations in the heat of adsorption of hydrogen, ΔH , with particle size. If this is the correct interpretation

higher values of x would indicate lower values of ΔH . This is a reasonable expectation. The influence of the temperature on x is summarized in Table 7. As expected, the depth of hydrogenation increases with increasing temperature. Higher concentrations of cycloalkadienes and cycloalkenes are favored by lower temperatures, independently of the metal content of the catalyst. The effect is not noticeable for the catalyst containing fluorided Al₂O₃. In this instance, catalyst acidity may further influence the value of x .

The information of Table 7 may have implications for structural consideration on the adsorption of aromatics. In fact, for $x \leq \sim 2$, it is conceivable that adsorption of the C₆H₆ molecule involved a doublet configuration, while for $x \geq \sim 3$, a flat adsorption mode.

Reaction Efficiency

Values of the reaction rate constant, k_h [Eq. (18)] and of the surface efficiency [Eq. (9)] were computed and are reported in Table 8. Table 8 shows an activity sequence: Pt > Pd > Ir > Ru > Rh. Except for Rh, this sequence follows closely the position of the metals in the period table. In particular, it is in the inverse order of the d character of the corresponding metal orbitals, and of that found for reaction (10) (1). It is noteworthy that collision efficiencies of the same order of magnitude were recently estimated from a study of CHA dehydrogenation by means of field ions spectroscopy (10).

TABLE 7
INFLUENCE OF TEMPERATURE ON x [Eq. (16)]
FOR Pt-Al₂O₃ CATALYSTS

Pt (wt %)	Temp. (°C)	x
0.38 ^a	175	5.4
	230	5.4
2.0	88	1.08
	117	1.45
	150	3.80
5.0	86	1.90
	117	4.10
	150	5.20

^a Fluorided Al₂O₃.

TABLE 8
RATE CONSTANT, k_h , AND REACTION EFFICIENCY,
 γ , FOR REACTION (11) FOR VARIOUS METALS
(0.7 WT % Pt-Al₂O₃, 117°C)

Metals	$k_h \times 10^7$ (moles/g sec)	$\gamma \times 10^6$ ^a
Pt	4.0	9.1
Pd	3.80	8.6
Rh	1.26	2.8
Ir	3.46	7.9
Ru	2.74	6.2

^a Computed assuming a metal surface area of 10 m²/g.

The values of γ are a clear testimony that the occurrence of reaction (11) requires structurally and/or energetically difficult events. Since BE and CHA are relatively large molecules with strict configurational requirements the low efficiency of the surface for reaction (11) is intuitively appreciated, but whether stringent steric conditions and/or inefficient energy transfer are responsible for the low values of γ is unknown. For the purpose of correlating and classifying the activity, of solid surfaces in the performance of elementary reaction steps, taking place during realistic catalytic conditions, the reactive surface efficiency, γ , is a more meaningful quantity than the sticking probability, $s = u/\dot{n}$ where u is the rate of adsorption. Indeed this quantity is generally obtained under conditions far removed from equilibrium, thus making extrapolations to conditions of catalytic interest impossible or, at best, dubious.

The influence of the particle size of the metal upon k_h was investigated on Rh-SiO₂, and Pt-Al₂O₃ catalysts. For this purpose, the values of $k'_h = k_h/A'$, where A' is the metal surface area per unit weight of catalyst (metal + support), were calculated employing the known values of the metal areas of the Rh-SiO₂ and Pt-Al₂O₃ catalysts (Table 1). Despite some scattering, the results indicated little dependence of k'_h upon A .

Since long-range or collective properties of metals are dependent upon particle size for $d \leq 20$ Å, the results may be taken to indicate that the influence of local or short-

range effects was predominant in the hydrocarbon-surface interaction studied. It is, however, surprising that a low efficiency reaction is not kinetically influenced by the particle size of the catalyst down to the 10–20 Å range, where the particle diameter has dimensions of the same order of magnitude as those of the hydrocarbon molecules. This remarkable fact deserves further clarification. It should be recalled also that the particle size distribution of the metal was found in some instances to be a more important catalyst parameter than the average crystallite size, as employed here, and large differences in chemisorptive and catalytic behavior of supported Ni catalysts were related to variations in the particle size distribution (11).

If the rate of the H₂ activation step: H₂(g) → 2H(s) is faster than the rate of reaction step (11b), *BE will be hydrogenated by additions of molecular H₂ to the feed mixture, and the conversion of reaction (11) will be increased, as it was found. This indicates that in the hydrogenation of BE on Pt the slow reaction step at 117°C is (11b').

Influence of Temperature

The Arrhenius plot for the temperature dependence of k_h is shown in Fig. 10 for Pt catalysts containing 2 and 5 wt % of Pt. For both catalysts an activation energy of ~1.5 kcal/mole was computed. Activation energies between 0 and 3 kcal/mole have been reported for the H₂-D₂ exchange reaction on Pt, Ag (12), and Ni films (13). The low value of the activation energy suggests that reaction (11) proceeds primarily through a polyatomic active intermediate with a strictly definite configuration, characterized by low entropy and energy of formation. It is interesting to speculate that this combination of low entropy and energy may be a general characteristic of the transfer reaction of atoms or single atomic groups between large and complex molecules. We already have evidence that the catalytic transfer of CH₂ and CH₃ groups between hydrocarbons has a low activation energy. Although the deeper implications of this ef-

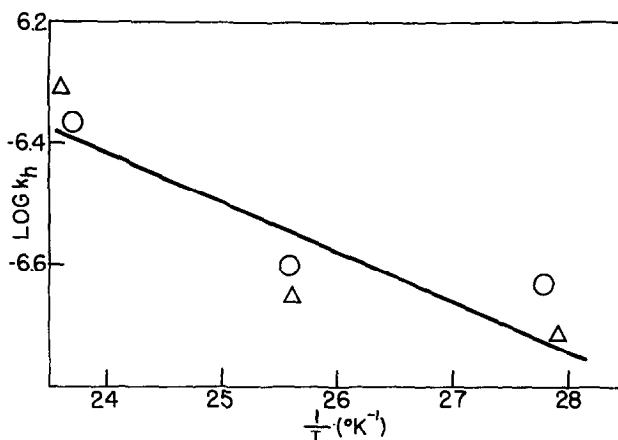

FIG. 10. Arrhenius plots for reaction (11) on Pt-Al₂O₃ catalysts: ○, 2 wt % Pt; △, 52% Pt.

fect are still to be grasped, it is clear that, from a practical point of view, it permits the study of the reaction in question under milder conditions, with the additional advantage to avoid undesirable, side reactions. This gives confidence that other isotopic exchange reactions suitable for the application of the present approach to diverse catalytic transfers are available.

¹⁴C Redistribution between BE and Other C₆ Hydrocarbons

The results of Table 5 show that the value of m decreased in the following sequence: CHE > CHA > MCP > DMB > HA. Since m is related to the surface coverage with H and, consequently, with the heat of H₂ adsorption, it is reasonable to expect that more unsaturated molecular species are more tightly held at the surface with a correspondingly higher fraction of the surface occupied by H. Here the procedure of employing hydrocarbon for hydrogen surface coverage is valid, since the second surface partner, BE, is common for all the other hydrocarbons. For MCP, the results of Fig. 8 show that the exponent m changed at $\beta > \sim 2.5$ to -0.92 . A similar change is also shown by CHA when the Pt-Al₂O₃(UOP) catalyst is employed. The change indicates a drastic modification in the operation of reaction (11), and denotes a reversal in the role of H(s) and V_H in the adsorption of BE [Eq. (16)]. Indeed, it is conceivable that BE is adsorbed by sharing its hydrogens with the surface, in-

stead of by employing surface hydrogen. For this type of adsorption V_H becomes the surface active site. The rate-controlling step is then:

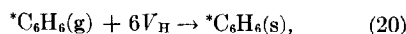

and its rate per unit weight of catalyst:

$$-\frac{dp_{C_6H_6}}{dt} = k_h p_{C_6H_6} [V_H]^6 = k_c p_{C_6H_6}. \quad (21)$$

From Eqs. (15) and (21)

$$k_c = k_h \left(\frac{p_{C_6H_{12}}}{p_{C_6H_6}} \right)^{-1},$$

or $m = -1$. Experimentally $m \cong -0.9$. The agreement is satisfactory, thus supporting the validity of reaction step (20) in the range of higher β 's. It should be remarked that a slight tendency for m to change sign at high β was also detected for Rh-SiO₂ (Fig. 7). It may seem somewhat puzzling that the controlling role of H(s) as surface active centers diminishes as the partial pressure of the hydrogen donor increases. However, the assumption that the hydrogen surface coverage increases continuously with increasing partial pressure of the hydrogen donor may become invalid, and the surface hydrogen coverage, in a certain range of partial pressures of the gas species, may decrease with increasing gas partial pressure of the hydrogen donor. Inversions in surface reactivity for H₂-metal systems have not yet been described but they are known to occur in MeO-O₂ systems (14). Reactivity inver-

TABLE 9
RATE CONSTANTS, k_h AND REACTIVE SURFACE EFFICIENCY, γ , FOR HYDROGEN TRANSFER BETWEEN
 C_6 HYDROCARBONS AND C_6H_6 , Pt- Al_2O_3 (UOP), $\beta = 1$

Hydrocarbon	$T(^{\circ}C)$	k_h^a [molecules/cm ² (metal) sec atm]	γ
Cyclohexene	230	$1.94 \times 10^{14}{}^b$	$8.0 \times 10^{-4}{}^b$
	230	1.94×10^{12}	8.0×10^{-6}
Methylcyclopentane	390	7.7×10^{10}	3.25×10^{-7}
2,3-Dimethylbutane	390	3.4×10^{10}	1.43×10^{-7}
<i>n</i> -Hexane	390	3.4×10^{10}	1.43×10^{-7}

^a Calculated assuming a metal surface area of 10 m²/g (Pt- Al_2O_3 , 1 wt % Pt).

^b Extrapolated values.

sions result from a particular defective structure of the surface layer, that generates asymmetry in the position of the energy levels of the controlling defects. Lacking information on the atomistic details of the H_2 -Me surface layer, it is difficult to speculate further on atomistic interpretations of the inversion effect found for CHA and MCD.

A comparison of the values of the rate constants, k_h , among the hydrocarbons investigated is shown in Table 9. Table 9 shows that the rate of hydrogen transfer is increased when CHA is replaced by CHE. Although the comparison involves for CHE an extrapolation to higher β 's, it is safe to state that at 230°C, $k_{h,CHE}$ is about one to two orders of magnitude larger than $k_{h,CHA}$. This conclusion is consistent with the assumptions that adsorbed CHE may be considered similar to adsorbed CHA, and that the first two, energetically demanding, hydrogen abstraction steps are absent.

CONCLUSION

The present approach attempts to develop a theoretical and experimental framework for the characterization of surface-hydrocarbon interactions, taking place during the catalytic conversion of hydrocarbons. The method permits the differentiation between the thermodynamic and the kinetic contributions to surface reactivity in hydrogen transfer steps.

These steps play a significant role in catalytic reactions between hydrogen donor and acceptor molecules, yet their funda-

mental characteristics are not fully known. The role of the chemical potential of the adsorbate, the surface reactive efficiency, and the relation between these quantities and solid-state catalyst properties are unsettled questions. Over the years a considerable amount of experimental observations have been accumulated to clarify these points. Most of these studies, however, are open to a basic criticism. Indeed, to study the influence of the chemical potential of the adsorbate on the rate of the transfer step, two experimental conditions must be fulfilled, namely: (a) thermodynamic equilibrium between surface and gas phases must be established or closely approached, and (b) experiments should be carried out at various pressures of the gaseous donor acceptor species. With the exception of the investigations on the rate of equilibration of the hydrogen isotopes, most of the former studies were conducted on systems which were not in nor approached a state of thermodynamic equilibrium. Furthermore, the influence of the gas-phase pressure on the reaction rate was determined only in a few of the studies on the H_2 - D_2 equilibration thus preventing theoretical deductions on the thermodynamic aspects of the catalytic reaction.

Experimentally the method here discussed depends upon the study of isotopic reactions, during which hydrogen is transferred among hydrocarbon molecules. The exchange reactions employed are quite different from those underlying studies on the redistribution of hydrogen tracers among various positions occupied by hy-

drogen in complex hydrocarbon molecules. In fact, in the latter studies the same chemical species act as donors and acceptors of hydrogen (exchange reactions), while in the experiments discussed above, hydrogen donors and acceptors are chemically different species (transfer reactions).

Despite the kinetic complexity and low efficiency of the reactions studied, it appears that the method is of rather general application and that isotopic reactions will be discovered to permit the study of surface interactions of interest in other hydrocarbon conversions.

In the application of the method to benzene hydrogenation, as here reported, it was possible to study the influence of the particle size of the catalyst upon the thermodynamics and the kinetics of the hydrocarbon-surface interaction. The analysis showed that for Pt and Rh, the catalyst particle size did not influence the reaction rate constant but it did modify the thermodynamic relationship between hydrogen coverage and gas pressure. Also, the method indicated increased kinetic difficulty when the hydrogen transfer step is accompanied by modification of the molecular backbone of the hydrocarbon. The method provides a useful tool for the development of catalytic correlations between catalyst solid state and molecular structure properties at the level of the individual transfer steps and offers a comprehensive framework for the rational interpretation of catalytic phenomena.

ACKNOWLEDGMENTS

We wish to express our thanks to Dr. J. H. Sinfelt of the Esso Research and Engineering Company for the supply of a sample of the Rh-SiO₂ catalysts and information upon their metal surface area, to Dr. H. S. Bloch of the Universal Oil Products Company for the supply of a sample of the Pt-fluorided Al₂O₃ catalyst, to Dr. G. C. Cohn of Engelhard Inc. for the gift of the noble metal salts employed in the preparation

of the remaining catalysts. Grateful acknowledgment is also made to the donors of the Petroleum Research Fund, administered by the American Chemical Society, for financial support of this research.

REFERENCES

1. AMANO, A., AND PARRAVANO, G., *Advan. Catalysis* **9**, 716 (1957).
2. BALANDIN, A., *Z. Phys. Chem.* **B2**, 289 (1929).
3. BRUNDEGE, J. A., AND PARRAVANO, G., *J. Catalysis* **2**, 380 (1963).
4. TETENYI, P., in "Proceedings of the 3rd International Congress on Catalysis" (W. M. H. Sachtler, G. C. A. Schuit, and P. Zwietering, eds.), p. 1223. Wiley, New York, 1965.
5. PARRAVANO, G., *J. Catalysis* **11**, 269 (1968).
6. SHIMULIS, V. I., AND SAL'DANYA, A. R., *Kinetika i Kataliz* **8**, 125 (1967).
7. YATES, D. J. C., AND SINFELT, J. H., *J. Catalysis* **8**, 348 (1967).
8. ROSSINI, F. D., "Selected Values of Properties of Hydrocarbons," U. S. Govt. Printing Office, Washington, D. C., 1947.
9. (a) SCHOLTEN, J. F., AND KONVALINKA, J. A., *J. Catalysis* **5**, 1 (1966); POLTORAK, O. M., BORONIN, V. S., AND MITROFANOVA, A. N., *Intern. Congr. Catalysis, 4th, Moscow, 1968*, Preprint No. 68; (b) ZHAVORONKOVA, K. N., BORESKOV, G. K., AND NEKIJELOV, V. N., *Kinetika i Kataliz* **8**, 841 (1967); (c) SHOOTER, D., AND FARNSWORTH, H. E., *Phys. Chem. Solids* **21**, 219 (1969); KIPERMAN, S. L., AND DAVYDOVA, I. R., *Kinetika i Kataliz* **2**, 768 (1961); (d) ELEY, D. D., AND NORTON, P. R., *Discussions Faraday Soc.* **41**, 135 (1966).
10. BLOCK, J., *Intern. Congr. Catalysis, 4th, Moscow, 1968*, Preprint No. 2.
11. VAN HERDEVELD, R., AND HARTOG, F., *Intern. Congr. Catalysis, 4th, Moscow, 1968*, Preprint No. 70.
12. AVDEENKO, M. A., BORESKOV, G. K., AND SLIN'KO, M. G., *Probl. Kinet. Catalysis* **9**, 61 (1957).
13. ZHAVORONKA, K. H., BORESKOV, G. K., AND NEKIJELOV, V. N., *Kinetika i Kataliz* **8**, 714 (1967).
14. PARRAVANO, G., *J. Catalysis* **11**, 355 (1968).