

ENGINEERING RESEARCH INSTITUTE
THE UNIVERSITY OF MICHIGAN
ANN ARBOR

Annual Report

November 1, 1955 to October 31, 1956

GAMMA-RAY SPROUT INHIBITION OF POTATOES

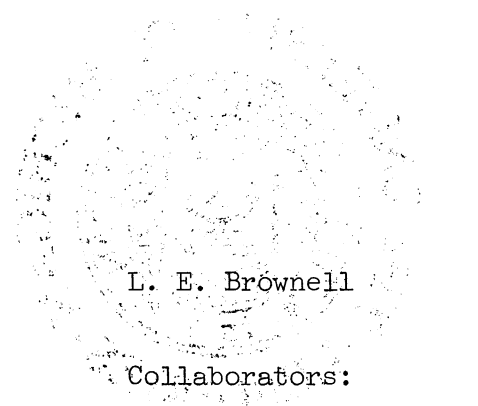

L. E. Brownell

Collaborators:

C. H. Burns	J. V. Nehemias
F. G. Gustafson	R. A. Martens
W. J. Hooker	A. Pendill
D. Isleib	F. Heiligman

Project 2386

QUARTERMASTER ACTIVITIES
DEPARTMENT OF THE ARMY
CONTRACT NO. DA-19-129-qm-349
PROJECT NO. 7-84-01-002

December 1956

10/11

72904111

TABLE OF CONTENTS

	Page
LIST OF TABLES	v
LIST OF FIGURES	vi
SUMMARY	2
I. TECHNICAL OBJECTIVES	4
II. STORAGE PROPERTIES OF IRRADIATED POTATOES	6
A. SPROUT FORMATION	6
B. TEXTURE AND APPEARANCE	7
C. WEIGHT CHANGES	8
D. EFFECTS OF IRRADIATING PORTIONS OF TUBERS	26
E. EFFECT OF SEASON OF IRRADIATION UPON STORAGE PROPERTIES	26
F. EFFECT OF RADIATION DOSE UPON ROTTING QUALITY	28
III. REDUCING SUGAR, SUCROSE, AND STARCH IN IRRADIATED POTATOES	28
A. IRRADIATION AND STORAGE OF POTATOES	30
B. EXPERIMENTAL PROCEDURES IN CARBOHYDRATE DETERMINATIONS	30
C. RESULTS	35
D. DISCUSSION OF RESULTS	36
IV. RESPIRATION STUDIES	45
A. MATERIAL AND METHODS	45
B. RESULTS	51
C. DISCUSSION AND CONCLUSION	56
V. STUDIES ON POTATO "HORMONES"	57
A. INTRODUCTION	57
B. PREPARATION OF SAMPLE	58
C. AVENA TECHNIQUE	61
D. RESULTS OF HORMONE STUDY OF IRRADIATED POTATOES	66
VI. STORAGE OF RING-ROT-INFECTED POTATOES FOLLOWING GAMMA IRRADIATION	68
VII. WOUND HEALING, SUBERIZATION, AND PERIDERM FORMATION	73

TABLE OF CONTENTS (Concl.)

	Page
VIII. ACCEPTABILITY STUDIES	82
A. BACKGROUND	82
B. EXPERIMENTAL	82
C. DISCUSSIONS AND CONCLUSIONS	83
REFERENCES	85

LIST OF TABLES

Table		Page
I	Weight Losses for Irradiated Sebago Potatoes Stored at 45°F	9
II	Weight Losses for Irradiated Russet Rural Potatoes Stored at 45°F	9
III	Accumulative Percentage Weight Loss Since December 7, 1955, for Control and 15-Kilorep Irradiated Potatoes Stored at Various Temperatures	10
IV	Percentage of Original Weight Remaining After Various Storage Times for Russet Rural Potatoes	17
V	Percentage of Original Weight Remaining After Various Storage Times for Sebago Potatoes	18
VI	Numbers and Percentages of Sebago Tubers Remaining Free of Rot After Various Storage Times	21
VII	Numbers and Percentages of Russet Rural Tubers Remaining Free of Rot After Various Storage Times	22
VIII	Carbohydrate Content of Sebago and Russet Rural Variety Potatoes as Affected by Dosage of Gamma Radiation, by Storage Temperature, and by Duration of Storage	37
IX	Carbon Dioxide Production by Whole Potato Tubers	52
X	Oxygen Consumption by Slices of Potato Tubers	55
XI	Oxygen Consumption by Slices of Pontiac Potato Tubers	56
XII	Hormone Activity	68
XIII	Ring-Rot Incidence in Irradiated Sebago Field-Infected Potatoes	69
XIV	Storage-Rot Incidence in Irradiated Sebago Field-Infected Potatoes	69
XV	Effects of Irradiation on Preference in White Potatoes	84

LIST OF FIGURES

Figure		Page
1	Accumulative percentage weight loss vs radiation dose for Sebago variety potatoes stored since December 7, at 45°F.	11
2	Accumulative percentage weight loss vs radiation dose for Russet Rural variety potatoes stored since December 7, at 45°F.	12
3	Accumulative percentage weight loss vs temperature °F for control Sebago potatoes.	14
4	Accumulative percentage weight loss vs temperature °F for 15-kilorep irradiated Sebago potatoes.	14
5	Accumulative percentage weight loss since December 7 vs temperature °F for control Russet Rural potatoes.	15
6	Accumulative percentage weight loss since December 7 vs temperature °F for 15-kilorep irradiated Russet Rural potatoes.	15
7	Percent of original weight lost as a function of radiation dosage (after storage for 196 days at 45°F).	16
8	Percent of original weight of Sebago potatoes remaining as a function of storage time at 45°F.	19
9	Percent of original weight of Russet Rural potatoes remaining as a function of storage time at 45°F.	19
10	Percent of original weight of potatoes remaining as a function of radiation dosage (after 196 days at 45°F).	20
11	Percent of original number of Sebago potatoes remaining free of rot vs storage time for various radiation dosages (stored at 45°F).	23
12	Percent of original number of Russet Rural potatoes remaining free of rot vs storage time for various radiation dosages (stored at 45°F).	23

LIST OF FIGURES (Cont.)

Figure		Page
13	Percent of original number of Russet Rural potatoes, irradiated with 15 kilorep, remaining free of rot vs storage time for various storage temperatures.	24
14	Percent of original number of control Russet Rural potatoes remaining free of rot vs storage time for various storage temperatures.	24
15	Percent of original number of control Sebago potatoes remaining free of rot vs storage time for various storage temperatures.	25
16	Percent of original number of Sebago potatoes, irradiated with 15 kilorep, remaining free of rot vs storage time for various storage temperatures.	25
17	Comparison of typical data for three varieties of potatoes (percentage weight loss vs radiation dose).	27
18	Percent of Russet Rurals remaining free of rot after various periods of storage at 45°F.	29
19	Percent of Sebagos remaining free of rot after various periods of storage at 45°F.	29
20	Effect of radiation dosage on the reducing-sugar, sucrose, and starch content of Russet Rurals stored 8 weeks.	38
21	Effect of radiation dosage on the reducing-sugar, sucrose, and starch content of Sebago potatoes stored 10 weeks.	39
22	Effect of storage temperature on the reducing-sugar, sucrose, and starch content of Russet Rural potatoes stored 8 weeks.	41
23	Effect of storage temperature on the reducing-sugar, sucrose, and starch content of Sebago potatoes stored 10 weeks.	41

LIST OF FIGURES (Cont.)

Figure		Page
24	Effect of dosage of gamma radiation on carbohydrate content of Sebago variety potatoes stored at 45°F for 18 weeks.	42
25	Effect of temperature of storage on carbohydrate content of irradiated Sebago variety potatoes (15,000 rep) stored for 18 weeks.	43
26	Schematic view of gas train currently being used in whole-tuber respiration studies.	47
27	View of original gas train for whole-tuber respiration studies, showing carbon dioxide absorption towers for producing carbon-dioxide-free air.	49
28	View of refrigerator and containers for potatoes used in studies of whole-tuber respiration at 45°F.	49
29	View of the absorption tubes, indicator tubes, and pressure-regulating device in whole-tuber respiration studies.	50
30	Carbon dioxide production by whole tubers (Sebago), presented as percent of control tubers. Radiation dosages given in kilorep.	51
31	Oxygen consumption by potato slices (Sebago), presented as percent of control tubers. Radiation dosages given in kilorep.	54
32	Oxygen consumption by slices (Pontiac), presented as percent of the control tubers. Radiation dosages given in kilorep.	54
33	Chromatograph chamber showing paper hanging from trough of solvent.	60
34	Device for accommodating oat seeds in order to cause sprouting downward.	62
35	Diagram of device for guiding upward the growth of the young oat sprout.	63

LIST OF FIGURES (Concl.)

Figure		Page
36	Photograph of the apparatus used for growing the oat sprouts, showing the sprouts at a stage prior to cutting and applying the agar block containing the extract to be assayed.	63
37	Schematic views of an oat sprout in the process of being cut and manipulated in the Avena hormone assay technique.	64
38	Oat sprouts shown in Fig. 36 after cutting and applying the agar block.	65
39	Shadowgraph of oat sprouts, showing curvature resulting from action of hormone or hormone inhibitor.	65
40	Ring-rot incidence in irradiated field-infected Sebago potatoes stored at 20°C.	70
41	Storage-rot incidence in irradiated field-infected Sebago potatoes stored at 20°C.	71
42	Storage-rot incidence in irradiated field-infected Sebago potatoes stored at 1°C.	72
43	Photomicrograph of Sebago potato-tuber section 48 hours after peeling, showing suberization and periderm formation.	74
44	Photomicrographs of Sebago potato-tuber sections 6 hours after peeling, showing suberization of control only.	76
45	Photomicrographs of Sebago potato-tuber sections 48 hours after peeling, showing suberization of control and treated tubers. Initiation of periderm is evident in control only.	78
46	Photomicrographs of Sebago potato-tuber sections 196 hours after peeling, showing suberization of control and treated tubers. Extensive periderm formation has occurred in controls, none in treated tubers.	80

CONTRACT RESEARCH PROGRESS REPORT

QUARTERMASTER FOOD AND CONTAINER INSTITUTE
FOR THE ARMED FORCES, CHICAGO

Research and Development Division
Office of the Quartermaster General

Fission Products Laboratory Project No. 7-84-01-002
The University of Michigan Contract No. DA19-129-qm-349
Engineering Research Institute File No. S-527
Ann Arbor, Michigan Report No. 9 (Annual)
 Period: 1 November 1955 to
 31 October 1956
 Initiation Date: 20 April 1955

Official Investigator: L. E. Brownell, Supervisor, Fission Products
Laboratory, Professor of Chemical and Nuclear
Engineering, The University of Michigan

Collaborators: C. H. Burns, Biochemist, Fission Products Laboratory
F. G. Gustafson, Professor of Botany, The University of
Michigan
W. J. Hooker, Associate Professor of Plant Pathology,
Michigan State University
D. Isleib, Assistant Professor of Farm Crops, Michigan
State University
J. V. Nehemias, Research Associate, Fission Products
Laboratory
R. A. Martens, Research Assistant, Fission Products
Laboratory
A. Pendill, Analytical Chemist
F. Heiligman, Quartermaster Food and Container Institute

Title of Contract: Gamma-Ray Sprout Inhibition of Potatoes

THIS IS NOT A FINAL REPORT. CONCLUSIONS STATED ARE SUBJECT TO CHANGE ON
THE BASIS OF ADDITIONAL EVIDENCE. THIS INFORMATION IS NOT TO BE REPRINTED
OR PUBLISHED WITHOUT WRITTEN PERMISSION FROM HEADQUARTERS, QM R AND D
COMMAND, NATICK, MASSACHUSETTS.

SUMMARY

Sebago variety potatoes given as little as 5,000 rep show no signs of sprouting, but Russett Rurals given 20,000 rep show occasional evidence of arrested sprout development. Tiny sprouts (1 mm) form but do not proliferate. Nonirradiated potatoes, except those stored at 35°F, show definite sprout development. Most of the potatoes, irradiated and nonirradiated, except those stored at 35°F, show slight softening, usually confined to the skin.

Weight losses during storage for irradiated and control Sebago and Russet Rural variety potatoes have been determined as a function of radiation dose, temperature of storage, and duration of storage. The data for the two varieties and for the Idaho-grown Russet Burbanks studied during the summer of 1955 differ appreciably. In the studies on Russet Rural variety tubers, weight loss for a given storage decreased with increased dosage up to 15,000 to 25,000 rep, whereas the reverse effect was observed with the Sebago variety tubers. Experimental results indicate that this difference is due to characteristics of the varieties rather than the time of irradiation relative to the life cycle of the tuber.

The weight-loss data seem to indicate that the low doses of radiation, which have been found to be sufficient for sprout inhibition, cause less increase in weight loss relative to the control than higher doses. As the higher doses are also observed to promote more rapid spoilage by rotting, the lowest dose which can be demonstrated to inhibit sprouting seems optimum from the point of view of overall storage properties.

A short experiment was performed in which portions of tubers were irradiated. Irradiating the potato, but not the sprout, did not affect subsequent sprout growth. Irradiating the sprout, but not the tuber, stopped growth altogether. Also, tubers irradiated at the bud end only sprouted from other nonirradiated eyes that would normally be inhibited by growth at the bud end.

Reducing-sugar, sucrose, and starch analyses have been made on Sebago and Russet Rural variety potatoes given nine different doses of gamma radiation and stored at five different storage temperatures. Reducing-sugar content of both Sebago and Russet variety potatoes, after approximately eight months of storage, does not rise much above values found shortly after harvest. Low doses of gamma radiation (5 to 25 kilorep) have no effect on this constancy of reducing-sugar levels. Doses of radiation from 50 to 200 kilorep, however, about double the reducing-sugar content over this storage period. In both varieties of potatoes, sucrose contents are markedly elevated by increasing doses of gamma radiation, and most of this increase occurs within eight weeks of irradiation. The sucrose content of Sebago given 5 to 15 kilorep of

radiation does not generally exceed 1%, however, and a curious peak in sucrose content of Russets over the low-range dose (5 to 25 kilorep) is only a transient phenomenon. The starch content of both varieties shows no clear pattern in response to graded doses of gamma radiation, except the general finding that high doses result in a lowered starch content. The effect of storage temperature on the content of all carbohydrates in both varieties is more marked, but there is little effect of irradiation. The lowest storage temperature results in very high reducing-sugar and sucrose contents, usually after two months of storage. The highest storage temperature, 65°F, results only in high sucrose content. Potatoes at the other storage temperatures, irradiated or not, do not have increased reducing-sugar contents. The sucrose content of potatoes held at the elevated temperatures is high in both irradiated and control Sebago and in control Russets, but irradiated Russets stored at 65°F do not show this elevated sucrose level. The starch content of both irradiated and control potatoes of both varieties is lowest when the potatoes are stored at the extremes of storage temperatures, and is highest in potatoes stored at intermediate temperatures.

Studies on rate of carbon dioxide evolution by whole tubers revealed that, compared to controls, the rate is decreased immediately after irradiation, but a few hours thereafter increases to a level roughly one and a half times that of the controls. Oxygen uptake by potato slices also increases as a result of irradiation, but the increase occurs immediately and continues for several weeks after irradiation.

The oxygen consumption decreased during the first week following the initial rise and then increased again, whereas the CO₂ production remained high for several weeks. After several weeks of a high rate of respiration, there was a drop of both CO₂ production and oxygen consumption by those tubers that had received dosages of 5, 15, and 25 kilorep. From the seventh week on, these tubers respired at approximately the same rate as the controls. On the other hand, the tubers that had received dosages of 50, 100, and 200 kilorep respired throughout the experiment at a rate higher than the controls.

Hormone studies on Sebago variety irradiated and control potatoes stored for some time showed such low hormone content that no effect of irradiation could be detected. However, limited data on freshly harvested Pontiac variety (Florida grown) tubers indicate that gamma radiation increases the hormone concentration and decreases inhibitor concentration.

The hormone content of the eyes of nonirradiated Sebago variety potatoes appears to have decreased by about one-fourth over a storage period of two and a half months. Gamma radiation has been found to decrease the content of growth hormone in the eyes of Sebago and Russet variety potatoes, but the magnitude of the effect was not found to be related to the dosage of radiation.

Studies on field-infected Sebago variety potatoes indicate that gamma radiation decreases incidence of ring rot on potatoes stored at 20°C but has no significant effect on the same tubers stored at 1°C. However, other unclassified forms of rot increased at both storage temperatures with increases in radiation dosage.

In studies in suberization and periderm formation, all levels of gamma radiation tested (15,000 to 200,000 rep) were found to inhibit periderm formation completely and to delay but not inhibit suberization. Some irradiated tubers showed scattered divisions of a periderm-like nature, but it seems safe to assume that the treatments preclude any periderm near normal in appearance. In addition, suberization was in general delayed by irradiation although reduced neither in density of deposit nor thickness of cell layer involved if adequate time were allowed subsequent to wounding. Although the relation between the formation of either periderm or suberized layer and incidence of tuber decay has not been carefully studied, it seems logical to suggest that delayed wound healing would be associated with increased decay.

Potatoes (Sebago and Russet Rural varieties), after treatment with ionizing radiation at doses varying from 0 to 200×10^3 rep, were stored at 55° and 72°F (R.H. 85-95%) for acceptance studies. In all lots treated with 15×10^3 rep or more, sprouting was completely inhibited. Abnormal sprouting was noted in the lots with only 5 and 10×10^3 rep. The untreated controls sprouted in a normal manner. Increasing levels of radiation from 0 to 20×10^3 rep appeared to cause a reduction in storage losses as determined by weight losses during storage, decay, and sprouting. Radiation above 25×10^3 rep appeared to cause an increase in storage losses as determined by these factors. Peeling studies, which included an evaluation of peel and trim losses, revealed that the lots treated with 5 and 10×10^3 rep had less loss due to these factors than the untreated controls and the lots treated with higher levels of radiation. Little or no difference in acceptance rating, using the hedonic scale, could be detected between the treated lots and the untreated controls.

I. TECHNICAL OBJECTIVES

Low-dosage gamma irradiation of potatoes has been found to be very successful in preventing sprouting and spoilage of potatoes under storage without the development of undesirable changes. Northern-grown potatoes are available only 8 or 9 months of the year. Because of sprouting followed by rapid deterioration, it usually is not possible to keep potatoes under storage for longer periods. It is believed that desirable types of potatoes can, by irradiation, be made available the year around.

This treatment might be particularly useful in increasing the storage life of any type of potato shipped overseas for the armed services.

More specifically, the general technical objective is described below:

A. A study will be made on the effect of low dosages of gamma radiation (approximately 5,000 to 25,000 rep) on at least one white-skinned and one russet-variety potato with the object of determining the dosage needed to inhibit sprouting when stored at 35°, 40°, 50°, 60°, and 80°F with 85% relative humidity.

B. An investigation will be made, using doses of gamma radiation as high as 200,000 rep on the same types of potatoes as studied in (A) above, to determine the effect of overdose.

C. A study will be made of the effect of three different relative humidities and at two storage temperatures during storage on a white-skinned and a russet-variety potato.

D. An evaluation will be made at no less than four scheduled intervals during the storage of the irradiated potatoes that have been stored. The said evaluation shall include:

1. total starch, sucrose, and reducing-sugar content,
2. sprouting and its inhibition,
3. general appearance and texture,
4. interior fleshy region of peeled and sliced potatoes for decay, black heart, blackening, and other manifestations of enzyme and/or microbial action, and
5. loss in weight, to be determined and subdivided into combined respiration and transpiration loss and loss due to sprouts.

E. As time allows, a limited study will be made on the effects of wound healing, with special emphasis on formation of cork cambium, cellular organization, and structure.

F. A quantitative respiration study will be conducted on at least a white-skinned variety and a selected russet variety of potato.

G. The effect of gamma radiation on the activity of specific enzymes involved in potato respiration will be investigated. This will be aimed at understanding the inhibition of enzyme activity as reflected by changes in starch content, total and reducing-sugar content, and color change, allowing for extended storage life of the potato.

H. A study will be made of the growth hormone and inhibitors in and around the eyes of irradiated and control potatoes to determine whether or not gamma-ray-induced inhibition of potato sprouting is caused by an increase in the quantity of sprout inhibitors.

I. A study will be conducted to determine the incidence of common storage rot in irradiated potatoes. This will include inoculation and storage studies utilizing common potato-rotting bacteria and fungi.

J. Samples of potatoes described under (A) will be made available for acceptance testing by personnel of QM F and CI.

Respiration is one of the fundamental processes of all living organisms. Therefore it was included as one of the processes to be investigated in the study of the influence of gamma irradiation on the sprout inhibition of potatoes.

II. STORAGE PROPERTIES OF IRRADIATED POTATOES

A. SPROUT FORMATION

All nonirradiated Russet Rurals held at 45°F uniformly developed sprouts up to 5 mm in length as of February 3, 1956. About half of the Russets given a 5-kilorep dose of gamma radiation developed sprouts up to 2 mm in length, and the other half showed no signs of sprouting. Russets given radiation doses of 10 and 15 kilorep and stored at 45°F showed very few and very tiny sprouts.

At 20 kilorep, very tiny sprouts having a fresh pale-green color were apparent. Where larger sprouts have formed, their color was brownish green, and larger sprouts had "burned" tips and were dead. This suggests that sprouts started prior to irradiation were arrested by the irradiation, but that sprouts could still occasionally form from eyes that were dormant at the time of irradiation.

No sprout formation whatsoever occurred as of February 3 on any Russet Rural potato given a radiation dose of 25 kilorep or higher.

Russet Rurals given 15 kilorep and stored for 8 weeks at temperatures varying from 35° to 80°F showed a slight increase in sprout formation with increasing temperature. No sprouting occurred at 35°F. The slight sprouting of potatoes stored at 45°F has already been mentioned. At 55°F, tiny live sprouts up to 1 mm long appeared on most potatoes, but sprouts of greater length appeared not to be living. At 65°F, tiny sprouts of 1-2 mm occur uniformly over most of the potatoes; the sprouts are small,

whitish "buds." At 80°F, the extent and appearance of the sprouts were the same as observed with storage at 65°F.

In the case of the Sebago, most but not all of the nonirradiated potatoes held at 45°F had sprouted as of February 3, 1956. However, none of the irradiated potatoes held at 45°F sprouted.

Those potatoes given 15 kilorep and stored at temperatures from 35° to 55°F showed no sprout development after 10 weeks. Those stored at 65°F, however, showed tiny sprouts. Those stored at 80°F showed only a few tiny sprouts. This indicates that 15 kilorep does not destroy the ability of the tubers to begin to sprout.

For the first 8 or 10 weeks after irradiation there appears to be a marked difference between the two varieties of potatoes in the sprout-inhibiting effects of irradiation, with the Russet Rural showing greater resistance. Varietal differences in resistance to the sprout-inhibiting effects of gamma irradiation were also observed with onions.

During the present series of tests with Sebago and Russet Rural varieties of potatoes, post-irradiation sprouting of potatoes has been observed for the first time. It should be stressed, however, that the sprouts were tiny and did not continue to grow. In the case of onions and walnuts, sprouting was actually stimulated by radiation doses up to 50,000 rep but the initial sprouts on the irradiated samples grew only a fraction of an inch, then withered and died; whereas the nonirradiated samples sprouted later but developed normally. This initial limited sprouting of irradiated potatoes was not observed with the Idaho Russet seed potatoes irradiated in May, 1955, nor with the Idaho potatoes irradiated in May, 1953, probably because in each of these cases the tubers were near the end of the normal storage period and already possessed minute sprouts.

B. TEXTURE AND APPEARANCE

1. Sebago.—Most of the Sebago potatoes given radiation doses of 0, 5, and 10 kilorep and held at 45°F for 10 weeks appeared fairly firm and showed no signs of decay, softening, or rot. Potatoes given 15 kilorep exhibited a mottled skin appearance. The skin was soft with slight indentations in the surface. The mottling was apparent at all doses above 15 kilorep. The softness did not increase with higher dosages of radiation and seemed confined to the outside 1/4-1/2-in. layer. The body of the potato was firm.

The Sebago given 15-kilorep doses and stored at 35° and 55°F were firm and of good appearance. The latter, however, show some tendency to green, even though not exposed to light. All the potatoes stored at

65° and 80°F, however, showed varying degrees of softness. This softness did not appear to be due to dehydration.

2. Russets.—The Russets given radiation doses from 0 to 200 kilorep and held at 45°F for two months showed some tendency to soften near the surface, but seemed to have firm interiors. At the higher doses (50 to 200 kilorep) the skins took on a wrinkled appearance and a leathery feel.

Russets stored at 35° and 45°F are fairly firm. A few soft ones were found with storage at 45°F, and most of those stored at 35°F were hard. At 55°F storage, about a fourth of the potatoes had soft, leathery skins. Most of those stored at 65° and 80°F did also, but extensive softness was not as apparent as with the Sebagos stored at higher temperatures.

C. WEIGHT CHANGES

Sebago and Russet potatoes received from Michigan State University were irradiated on or about December 7, 1955, and were immediately placed with appropriate controls in various constant-temperature rooms at The University of Michigan Food Service Building. They were stored in special tared crates to minimize handling. The potatoes were then weighed about twice a month in an effort to gain information about the rate of weight loss and the total amount of weight lost by irradiated and nonirradiated potatoes. After a time it became apparent that potatoes which rotted early would infect sound potatoes if left in the crate. In order to avoid this, rotting potatoes were separated, placed in bags, and kept with the rest of the sample. This was done so that a percentage weight loss of the entire sample could be determined. In addition, the sound potatoes were weighed alone to determine the weight percentage of potatoes that were still usable. The number of potatoes removed was also recorded, and the number percentage of sound potatoes was calculated.

Tables I-III contain total weight-loss data, i.e., with the rotten potatoes included. Table I and Fig. 1 show the weight loss for Sebagos given various doses and stored at 45°F. With increased irradiation, there is an increase in weight loss. In each case, 15 kilorep seems to promote more weight loss than other low doses of radiation, while 10 kilorep seems to promote only slightly more loss than the controls.

Table II and Fig. 2 show the weight loss of Russets treated with various doses of radiation and stored at 45°F. Initially all dosages appear to cause increased weight loss, but after three or four months the lower dosages show less weight loss than the controls. Higher doses, on the other hand, cause weight losses greater than the controls.

The region of 10 kilorep seems to be the most advantageous for

TABLE I. WEIGHT LOSSES FOR IRRADIATED SEBAGO POTATOES STORED AT 45°F
(Rotten potatoes included)

Dose	Time	Percentage Weight Loss in Sebagos Since December 7								
		February 16	March 1	March 19	April 2	April 16	May 11	May 22	June 5	June 21
0		7.3	9.1	10.4	11.4	13.0	14.9	15.8	16.8	18.0
5,000		8.5	10.1	11.4	12.9	14.2	16.1	17.0	17.9	19.2
10,000		8.2	9.8	10.7	12.3	13.5	15.4	16.1	17.3	18.6
15,000		10.6	12.6	14.6	15.7	17.6	20.1	21.1	22.7	24.3
20,000		9.4	10.9	12.5	14.1	15.7	17.9	18.9	20.1	21.3
25,000		10.1	12.0	13.8	14.8	16.4	18.9	20.2	20.8	22.7
50,000		11.4	13.2	15.1	17.0	18.9	22.0	23.3	25.2	27.3
100,000		11.8	14.0	15.9	17.9	19.8	25.8	--	27.4	30.2
200,000		12.5	15.3	17.5	20.0	21.9	26.2	--	31.2	34.7

TABLE II. WEIGHT LOSSES FOR IRRADIATED RUSSET RURAL POTATOES STORED AT 45°F
(Rotten potatoes included)

Dose	Time	Percentage Weight Loss in Russets Since December 7								
		February 16	March 1	March 19	April 2	April 16	May 11	May 22	June 5	June 21
0		3.5	6.0	8.5	9.4	10.8	11.1	12.3	12.9	14.1
5,000		4.7	5.7	6.3	7.3	8.2	10.1	10.7	11.3	12.3
10,000		5.1	6.0	6.7	7.3	8.0	8.6	9.2	9.8	10.5
15,000		6.6	7.2	8.5	9.1	9.7	11.3	11.7	12.3	13.6
20,000		6.3	7.3	7.9	8.6	9.2	10.4	11.1	11.7	12.7
25,000		6.4	7.3	7.6	8.5	9.5	10.4	11.0	11.3	12.6
50,000		5.8	7.3	8.0	8.9	9.9	11.8	12.4	13.4	14.7
100,000		6.3	7.6	8.3	9.5	10.8	12.0	13.3	14.6	15.5
200,000		5.8	7.3	8.3	9.6	11.2	13.4	14.7	16.7	18.5

TABLE III. ACCUMULATIVE PERCENTAGE WEIGHT LOSS SINCE DECEMBER 7, 1955, FOR CONTROL AND 15-
KILOREP IRRADIATED POTATOES STORED AT VARIOUS TEMPERATURES
(Rotten potatoes included)

Variety	Temp	Time		February 2	February 16	March 1	March 19	April 2	April 16	May 11	May 22	June 5	June 21
		Treatment											
Sebago	35°	control	7.2	8.5	9.0	10.3	11.3	12.8	14.0	14.7	16.0	17.2	
		15,000	8.1	10.0	14.4	12.8	13.7	15.6	17.8	18.1	20.0	21.2	
	55°	control	9.1	11.6	13.4	17.2	19.4	24.0	26.6	27.8	29.7	31.6	
		15,000	10.1	12.5	14.4	16.9	19.4	21.9	25.6	26.9	28.1	29.4	
	65°	control	12.5	16.9	21.3	27.5	31.9	37.8	44.4	47.5	50.9	55.0	
		15,000	14.0	17.4	20.2	23.6	27.4	32.2	37.9	40.4	43.5	46.6	
Room	control	16.3	20.4	26.6	--	38.2	discarded	--	--	--	--	--	
	15,000	18.3	22.5	26.9	--	42.5	discarded	--	--	--	--	--	
Russet	35°	control	4.0	4.3	5.0	5.9	6.2	6.5	7.5	7.5	8.7	9.3	
		15,000	3.7	10.3	10.9	11.5	12.1	13.3	14.0	14.3	15.2	15.8	
	55°	control	6.6	8.5	10.3	13.1	15.9	18.1	22.2	24.1	25.9	28.1	
		15,000	7.6	9.3	10.1	12.2	13.5	16.0	16.4	19.8	21.0	21.9	
	65°	control	6.8	10.6	15.0	21.9	27.8	34.4	44.1	49.4	54.1	58.7	
		15,000	9.7	11.9	14.4	17.2	21.5	26.6	33.8	37.5	40.1	45.0	
Room	control	13.0	15.7	21.2	--	36.6	discarded	--	--	--	--	--	
	15,000	10.3	12.4	16.1	--	30.2	discarded	--	--	--	--	--	

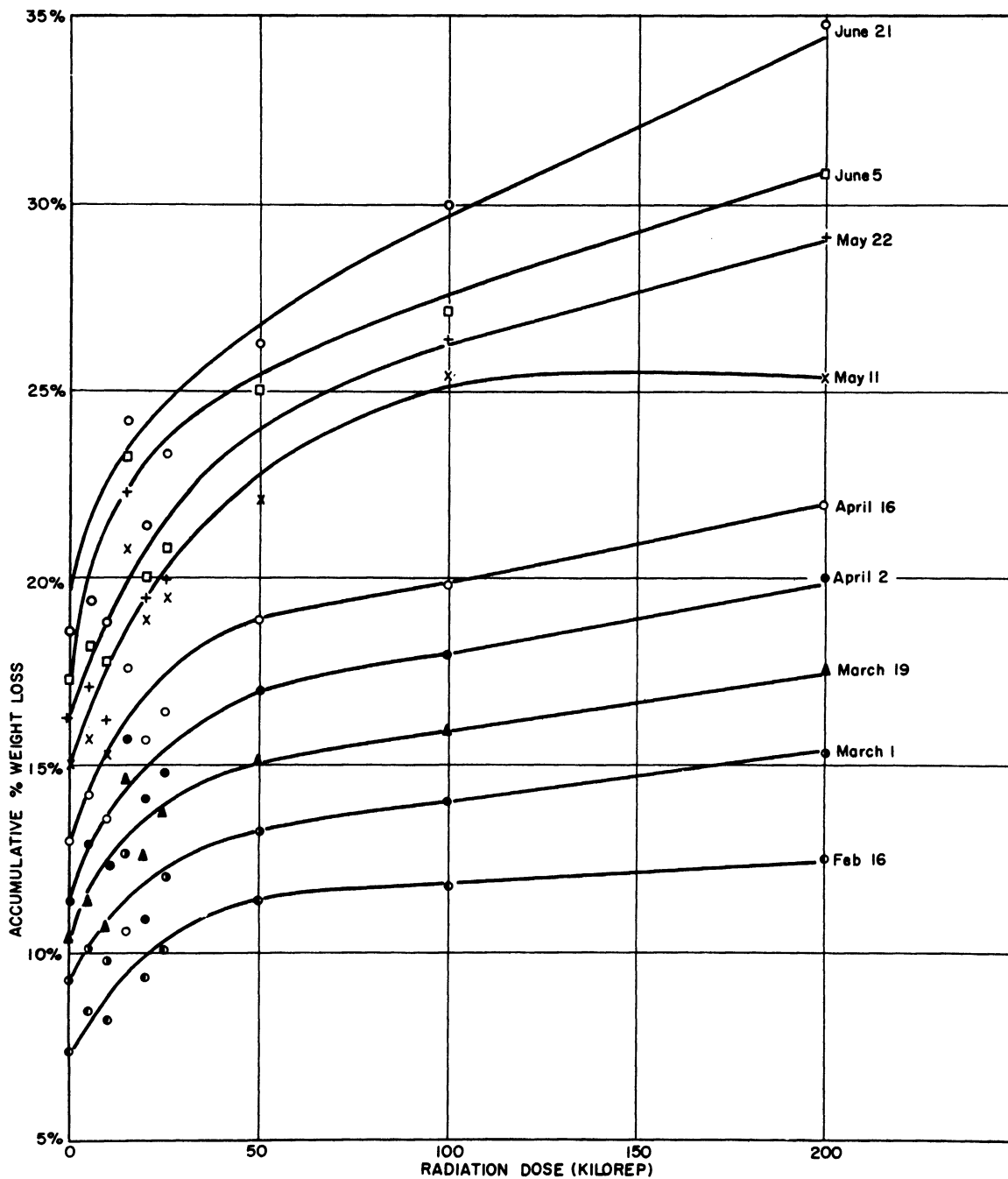

Fig. 1. Accumulative percentage weight loss vs radiation dose for Sebago variety potatoes stored since December 7, at 45°F (rotten potatoes included).

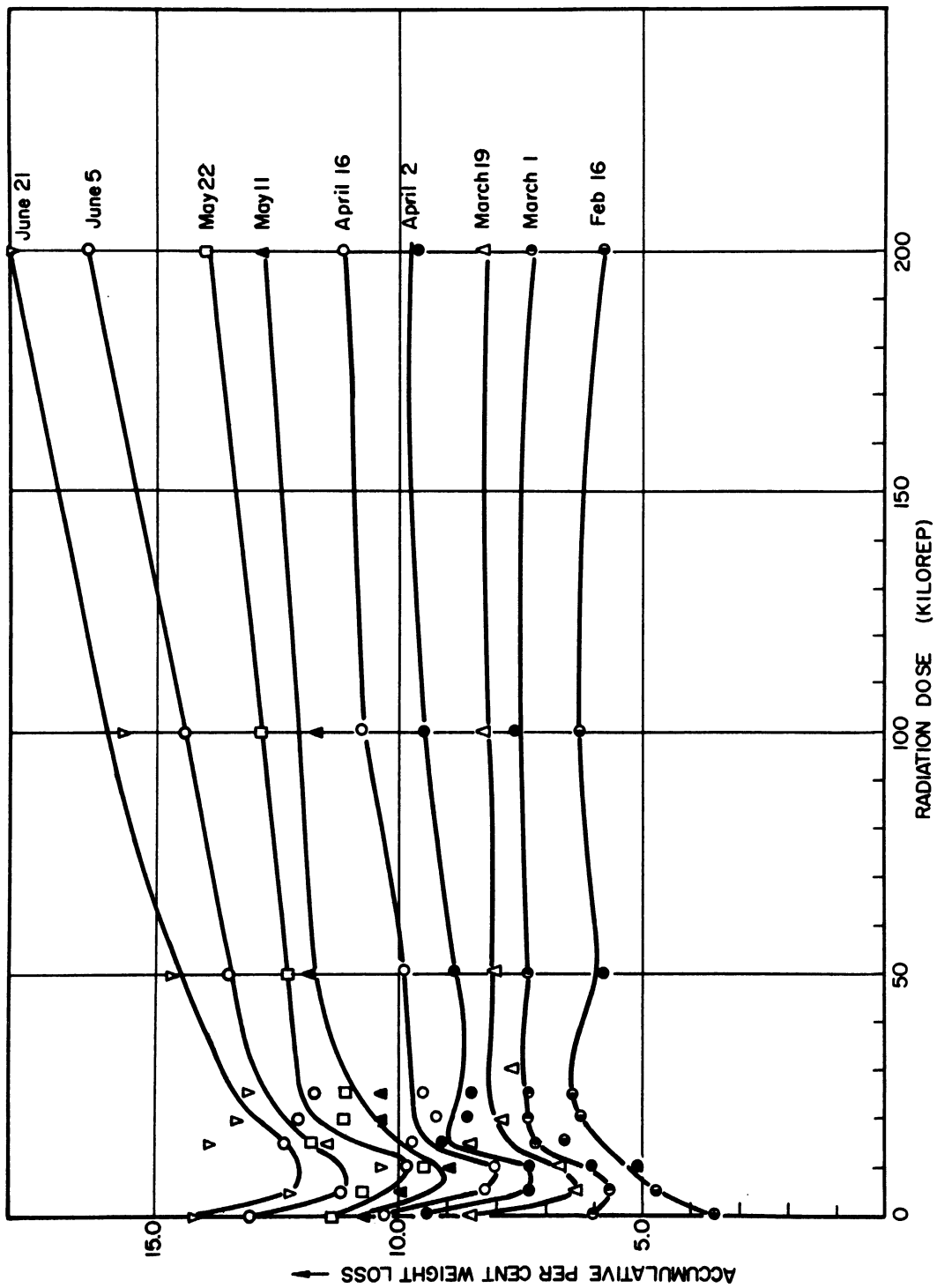

Fig. 2. Accumulative percentage weight loss vs radiation dose for Russet Rural variety potatoes stored since December 7, at 45°F (rotten potatoes included).

decreasing weight loss of this variety of potatoes at this storage temperature. However, 15-kilorep irradiated potatoes show nearly as great a loss as the nonirradiated potatoes, while potatoes irradiated with 20 and 25 kilorep show a somewhat smaller weight loss. This same type of variation with dosage is also indicated in the Sebago potatoes, although in this case all irradiated potatoes lost more weight than the nonirradiated potatoes.

The results discussed above suggest that radiation may act in two different ways. Perhaps the early decrease in weight loss with increase in irradiation is due to action on the cells which slows down metabolism (see respiration). The sudden rise in weight loss, observed at 15 kilorep, may be due to rotting of the tissue. Rotting occurs with increasing frequency at higher doses of radiation. The higher doses appear to cause the potatoes to be more vulnerable to fungi and bacteria. The second apparent dip in the curve may be due to a reduction of the number of surface infective organisms at the time of irradiation.

If these speculations are correct, the peak at 15 kilorep could be a critical point where decreases in water loss no longer occur and killing of infecting organisms is not yet effective, but where vulnerability to infections is beginning to become prominent.

Table III and Figs. 3-6 show the differences between potatoes irradiated with 15 kilorep and control potatoes stored at 35°, 55°, 65°, and 78°F.

In both Russets and Sebagos the irradiated potatoes lose more weight than the controls after storage at 35°F and less than the controls after storage at 65°F. The differences observed at higher temperatures increase with time.

Figure 7 shows the percentage weight loss, from Tables I and II, plotted against radiation dose after 196 days of storage at 45°F. Comparing the Sebagos with the Russets, under these special conditions, suggests that Russets are better potatoes for storage and less subject to weight loss subsequent to irradiation.

Tables IV and V and Figs. 8 and 9 show the weight of usable potatoes remaining as a function of time after the rotting potatoes have been removed. Sebagos treated with doses of radiation less than 20 kilorep retained more than 60% of their original weight 196 days after irradiation. In the case of Russets, retention over the same period is nearly 80%. In both instances the decrease from 102 days to 196 days is slow, as shown by the gentle slope of the curve. In the case of the high doses of radiation, the slope of the curves is steep, due to the removal of rotting potatoes.

All the Sebagos treated with 200,000 rep were lost in the first

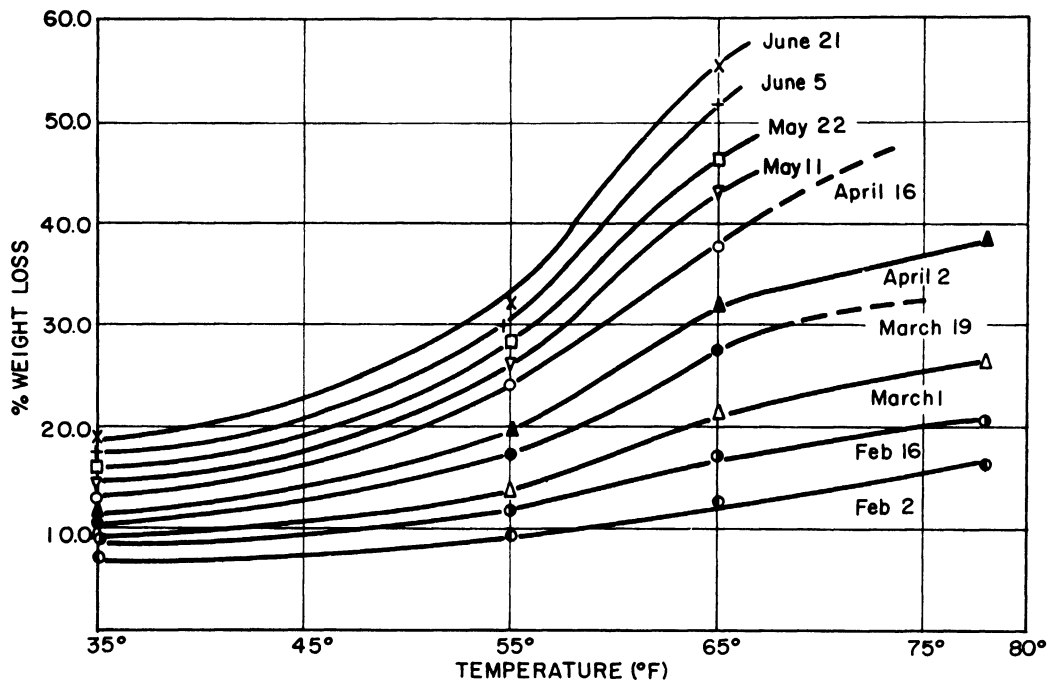

Fig. 3. Accumulative percentage weight loss vs temperature °F for control Sebago potatoes.

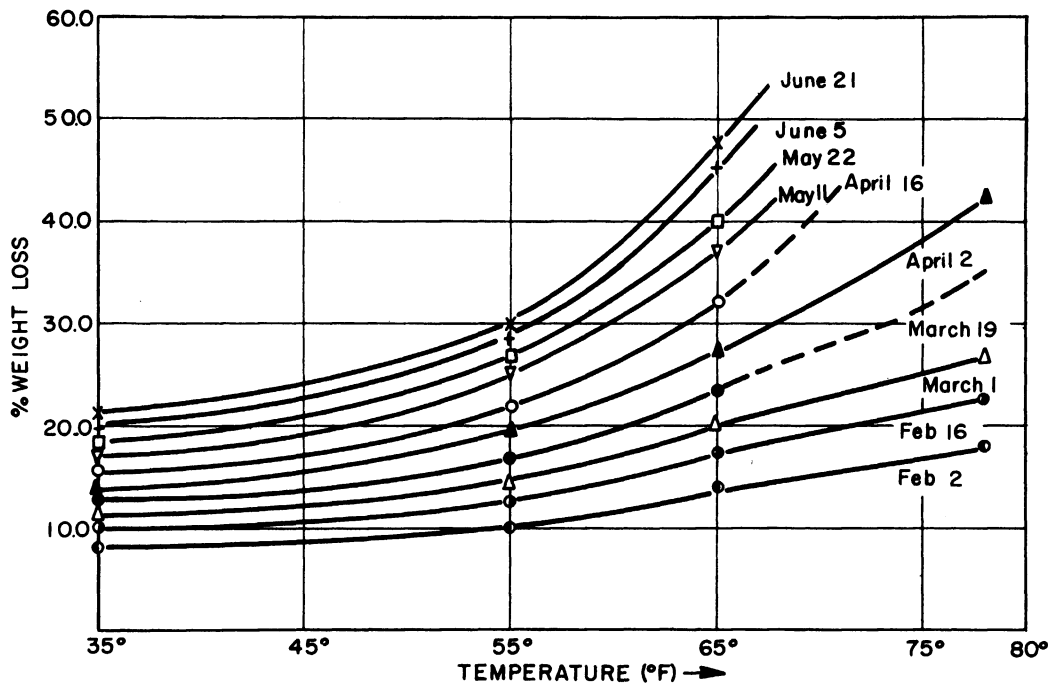

Fig. 4. Accumulative percentage weight loss vs temperature °F for 15-kilorep irradiated Sebago potatoes.

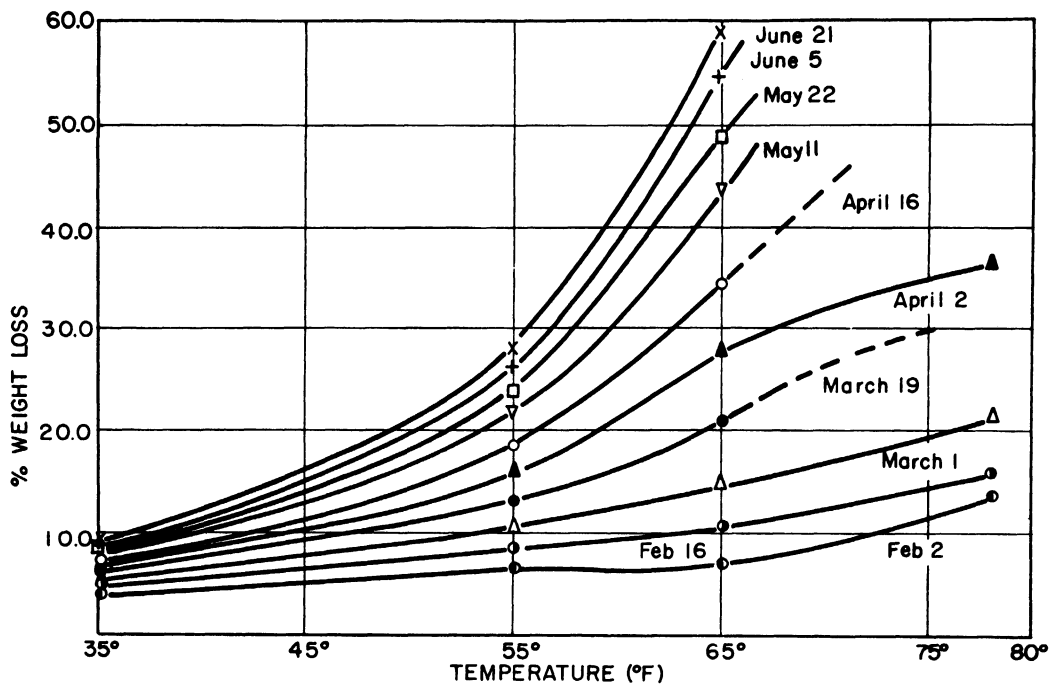

Fig. 5. Accumulative percentage weight loss since December 7 vs temperature °F for control Russet Rural potatoes.

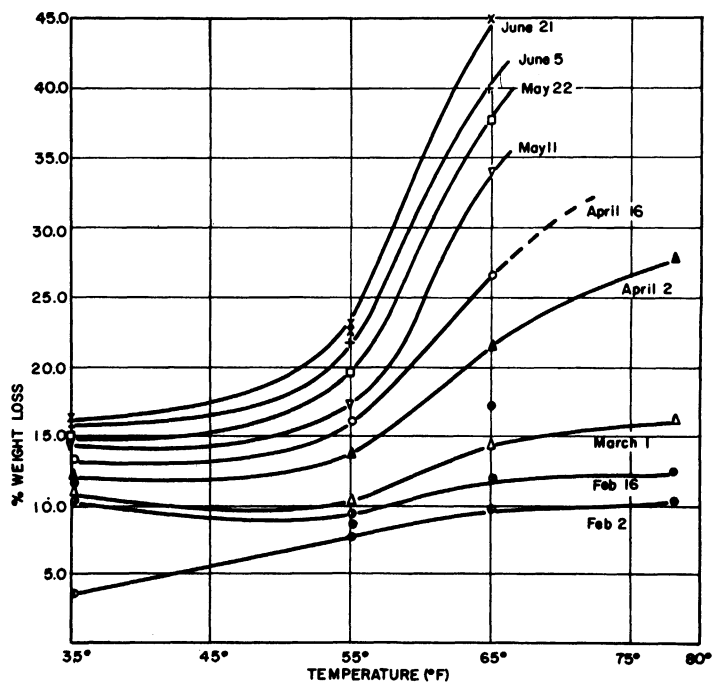

Fig. 6. Accumulative percentage weight loss since December 7 vs temperature °F for 15-kilorep irradiated Russet Rural potatoes.

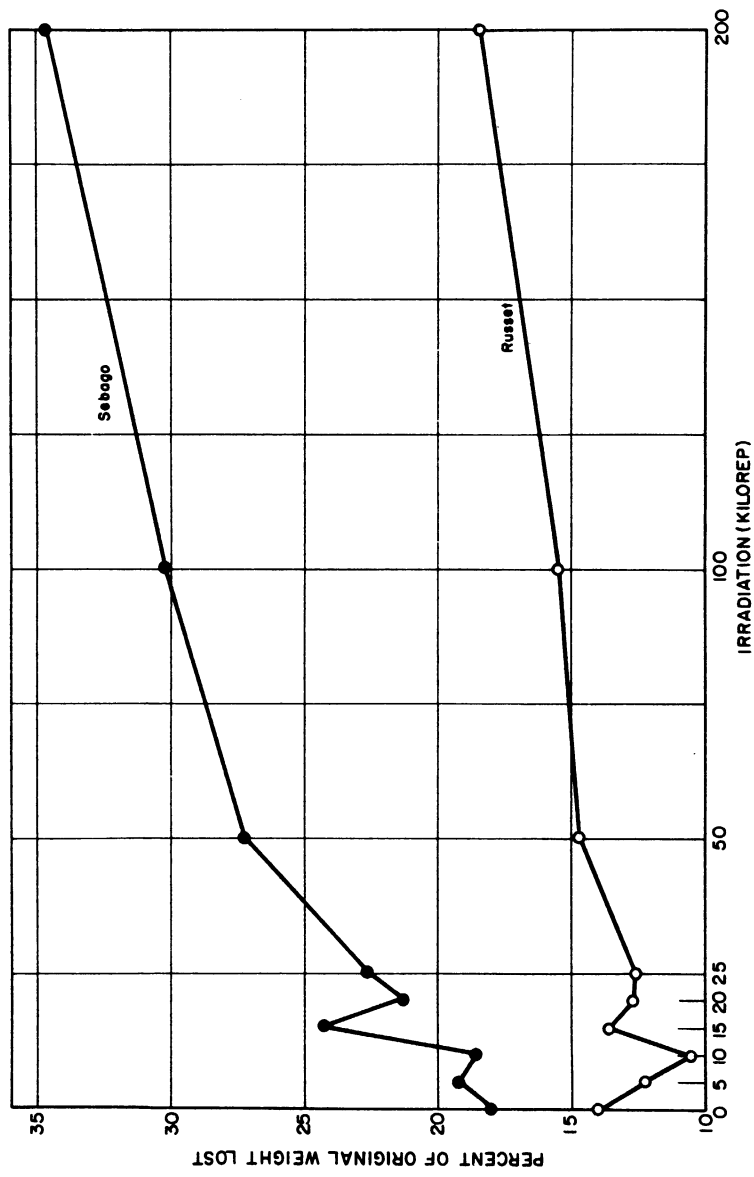

Fig. 7. Percent of original weight lost as a function of radiation dosage (after storage for 196 days at 45°F; rotten potatoes included).

TABLE IV. PERCENTAGE OF ORIGINAL WEIGHT REMAINING AFTER VARIOUS STORAGE TIMES FOR RUSSET RURAL POTATOES (Rotten potatoes included)

Temp	Dose (kilorep)	Time Elapsed Since Irradiation (in days)						
		102	116	130	155	166	180	196
35°	0	94.2%	92.5%	91.7%	89.6%	89.1%	88.5%	87.6%
	15	86.7%	86.1%	84.4%	83.7%	83.2%	83.2%	80.3%
45°	0	91.0%	89.7%	88.8%	87.7%	87.1%	86.5%	84.0%
	5	91.8%	90.7%	89.9%	89.2%	88.5%	87.9%	87.2%
	10	91.5%	90.9%	90.2%	89.5%	88.9%	88.3%	87.6%
	15	90.9%	90.3%	89.4%	87.2%	86.5%	85.9%	82.5%
	20	85.0%	84.5%	83.8%	82.5%	82.5%	81.9%	80.1%
	25	91.4%	88.6%	87.7%	85.8%	85.2%	84.9%	83.9%
	50	80.9%	79.9%	79.4%	76.1%	76.1%	75.5%	74.4%
	100	86.8%	84.1%	75.9%	69.5%	68.9%	68.6%	59.0%
200	73.2%	70.0%	54.1%	35.0%	31.8%	31.8%	19.7%	
55°	0	86.2%	83.4%	81.5%	76.3%	74.7%	72.5%	70.4%
	15	87.9%	86.5%	78.5%	70.7%	70.7%	76.5%	68.4%
65°	0	70.4%	64.9%	55.6%	41.6%	38.4%	35.8%	27.5%
	15	68.2%	64.9%	54.1%	38.8%	37.6%	36.9%	32.2%

TABLE V. PERCENTAGE OF ORIGINAL WEIGHT REMAINING AFTER VARIOUS STORAGE TIMES FOR SEBAGO POTATOES (Rotten potatoes included)

Temp	Dose (kilorep)	Time Elapsed Since Irradiation (in days)						
		102	116	130	155	166	180	196
35°	0	84.0%	82.8%	81.5%	79.6%	79.0%	77.8%	74.1%
	15	78.4%	75.0%	76.3%	74.1%	74.0%	72.5%	52.5%
45°	0	87.7%	84.5%	79.4%	76.9%	75.9%	75.2%	71.6%
	5	84.6%	83.4%	82.1%	80.5%	79.5%	79.4%	74.2%
	10	81.9%	80.2%	76.9%	71.9%	73.9%	73.3%	72.4%
	15	77.4%	74.8%	73.3%	71.1%	70.1%	69.1%	56.8%
	20	76.6%	75.6%	74.4%	69.0%	68.4%	68.1%	66.8%
	25	72.8%	64.8%	64.1%	61.7%	60.9%	60.4%	54.4%
	50	64.1%	61.7%	56.3%	52.9%	52.8%	52.2%	43.4%
	100	63.8%	59.8%	50.4%	35.4%	34.7%	34.4%	22.9%
	200	28.8%	26.8%	13.1%	0.0%	0.0%	0.0%	0.0%
	55°	0	82.8%	79.1%	74.7%	70.8%	69.7%	68.2%
15		80.0%	76.4%	73.6%	64.3%	63.7%	63.1%	60.6%
65°	0	70.7%	65.9%	60.6%	43.8%	41.3%	38.8%	18.8%
	15	64.0%	57.2%	50.6%	38.9%	38.2%	37.2%	20.8%

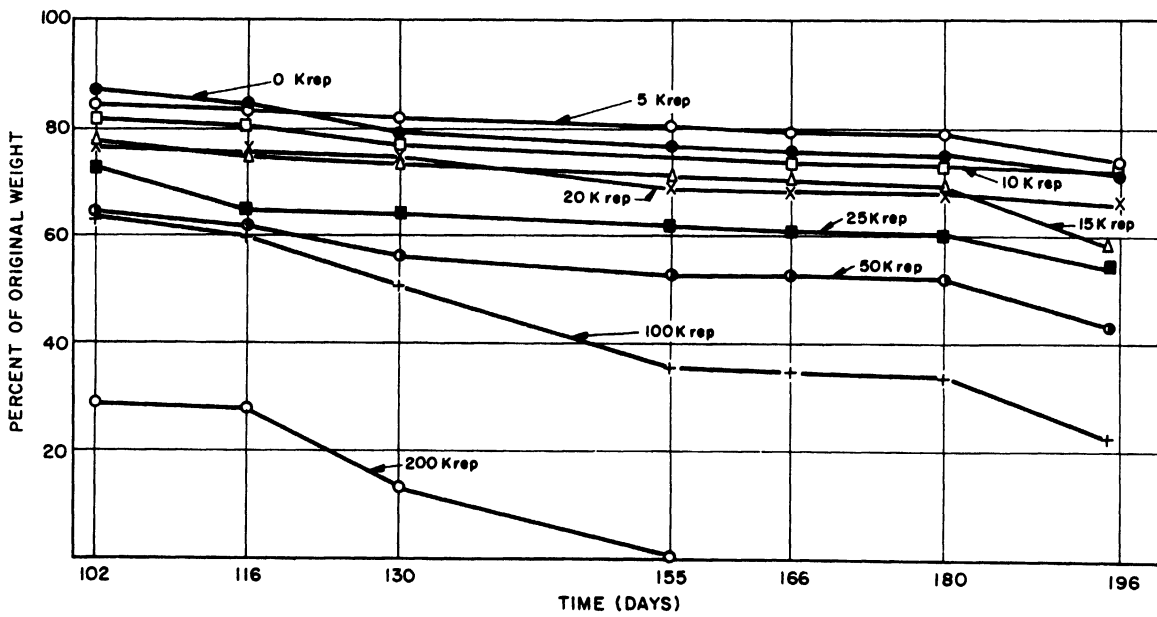

Fig. 8. Percent of original weight of Sebago potatoes remaining as a function of storage time at 45°F (rotten potatoes removed).

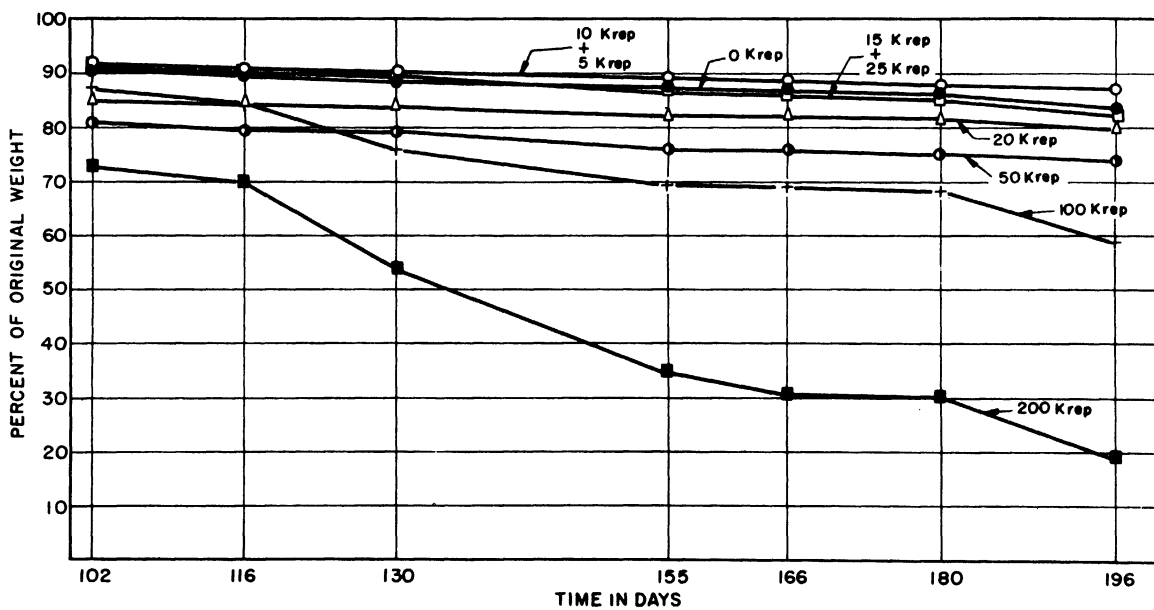

Fig. 9. Percent of original weight of Russet Rural potatoes remaining as a function of storage time at 45°F (rotten potatoes removed). Note: The curve for 10 kilorep is almost identical to the one shown for 5 kilorep.

155 days. This dose resulted in the loss of most of the Russets, but after 196 days 20% were still sound.

Figure 10, which is a plot of weight loss (with the rotten potatoes removed) against radiation dose, shows that a dose of 5 or 10 kilorep decreases the weight lost by Sebago potatoes. This was not shown in earlier observations including the weights of the rotten potatoes (see Fig. 1). The curve of Russet weights shows that treatment of these potatoes also with 5 or 10 kilorep will reduce weight loss. The same conclusion was indicated in Fig. 2.

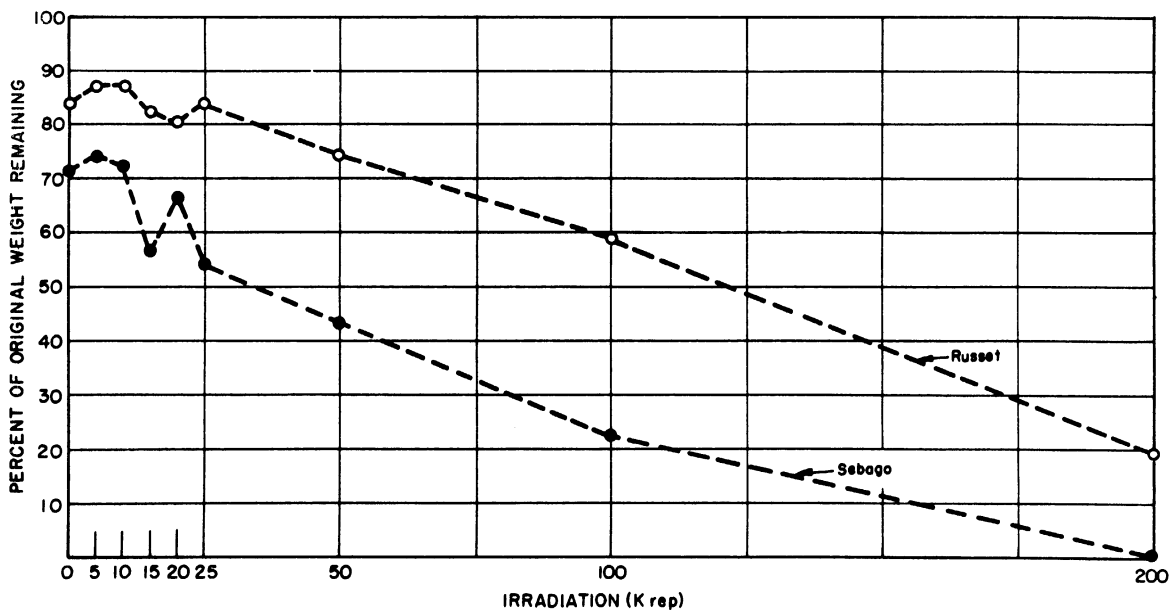

Fig. 10. Percent of original weight of potatoes remaining as a function of radiation dosage (after 196 days at 45°F; rotten potatoes removed).

Since the above curves are affected to a large extent by the removal of rotten potatoes, the percentages of potatoes lost by rotting have been plotted in Figs. 11 and 12 from Tables VI and VII. Figures 11 and 12 with Figs. 8 and 9 compare percent rotten potatoes removed to percent weight loss.

Figures 13 and 14 show the weight losses for Russet Rurals. In no case did the irradiated potatoes rot more slowly than the controls, although the irradiated potatoes stored at 65°F lost less water than the controls, i.e., irradiated potatoes surviving 187 days of storage at 65°F were usable, while the surviving controls were not. (The 65°F room was maintained at an extremely low humidity.)

Figures 15 and 16 show the same data for Sebago potatoes. The

TABLE VI. NUMBERS AND PERCENTAGES OF SEBAGO TUBERS REMAINING FREE OF ROT AFTER VARIOUS STORAGE TIMES

Temp	Treatment	Time	December	March	March	April	May	June
			7	8	26	9	11	12
35°	control		62 (100%)	58 (93.6%)	58 (93.6%)	58 (93.6%)	57 (91.9%)	55 (88.7%)
	15,000		69 (100%)	59 (85.5%)	59 (85.5%)	59 (85.5%)	58 (84.1%)	47 (68.1%)
45°	control		56 (100%)	54 (98.2%)	53 (96.4%)	51 (92.9%)	50 (91.1%)	48 (85.7%)
	5,000		74 (100%)	71 (95.9%)	71 (95.9%)	71 (95.9%)	71 (95.9%)	68 (91.9%)
	10,000		64 (100%)	61 (95.3%)	60 (93.6%)	59 (92.2%)	58 (90.6%)	58 (90.6%)
	15,000		62 (100%)	59 (95.2%)	58 (93.5%)	58 (93.5%)	57 (91.9%)	50 (80.6%)
	20,000		52 (100%)	48 (92.3%)	48 (92.3%)	48 (92.3%)	45 (86.5%)	45 (86.5%)
	25,000		61 (100%)	55 (90.2%)	53 (86.9%)	53 (86.9%)	51 (83.6%)	47 (77.1%)
	50,000		58 (100%)	44 (75.9%)	43 (74.1%)	40 (69.0%)	38 (65.5%)	32 (55.2%)
	100,000		63 (100%)	50 (79.4%)	48 (76.2%)	43 (68.3%)	34 (54.0%)	26 (41.3%)
55°	200,000		51 (100%)	20 (39.2%)	18 (35.3%)	8 (15.7%)	0 (0.0%)	0 (0.0%)
	control		53 (100%)	53 (100%)	52 (98.1%)	50 (94.3%)	50 (94.3%)	50 (94.3%)
65°	15,000		60 (100%)	58 (96.7%)	57 (95.0%)	56 (93.3%)	53 (88.3%)	51 (85.0%)
	control		45 (100%)	43 (95.6%)	43 (95.6%)	43 (95.6%)	33 (73.3%)	16 (33.3%)
Room	15,000		70 (100%)	63 (90.0%)	60 (85.7%)	55 (78.6%)	45 (64.3%)	30 (42.8%)
	control		67 (100%)	58 (86.6%)		49 (73.1%)		
	15,000		57 (100%)	29 (50.9%)		13 (22.8%)		

TABLE VII. NUMBERS AND PERCENTAGES OF RUSSET RURAL TUBERS REMAINING FREE OF ROT AFTER VARIOUS STORAGE TIMES

Temp	Treatment	Time	December	March	March	April	May	June
		7	8	26	9	11	12	
35°	control	95 (100%)	95 (100%)	94 (98.9%)	93 (97.9%)	93 (97.9%)	93 (97.9%)	
	15,000	89 (100%)	88 (98.9%)	88 (98.9%)	88 (98.9%)	87 (97.8%)	86 (96.6%)	
45°	control	79 (100%)	78 (98.7%)	78 (98.7%)	78 (98.7%)	78 (98.7%)	76 (96.2%)	
	5,000	93 (100%)	91 (97.8%)	91 (97.8%)	91 (97.8%)	91 (97.8%)	91 (97.8%)	
	10,000	82 (100%)	81 (98.8%)	81 (98.8%)	81 (98.8%)	81 (98.8%)	81 (98.8%)	
	15,000	69 (100%)	68 (98.6%)	68 (98.6%)	67 (97.1%)	66 (95.7%)	64 (92.8%)	
	20,000	60 (100%)	56 (93.3%)	56 (93.3%)	56 (93.3%)	56 (93.3%)	55 (91.7%)	
	25,000	58 (100%)	57 (98.3%)	56 (96.6%)	56 (96.6%)	55 (94.8%)	55 (94.8%)	
	50,000	86 (100%)	80 (93.0%)	80 (93.0%)	80 (93.0%)	78 (90.7%)	77 (89.5%)	
	100,000	87 (100%)	82 (94.3%)	81 (93.1%)	74 (85.1%)	69 (79.3%)	59 (67.8%)	
55°	control	86 (100%)	69 (80.2%)	67 (77.9%)	54 (62.8%)	38 (44.2%)	20 (23.3%)	
	15,000	67 (100%)	66 (98.5%)	66 (98.5%)	66 (98.5%)	65 (97.0%)	64 (95.5%)	
65°	control	63 (100%)	63 (100%)	63 (100%)	58 (92.1%)	56 (88.9%)	56 (88.9%)	
	15,000	105 (100%)	96 (91.4%)	95 (90.5%)	90 (85.7%)	75 (71.4%)	*	
Room	control	85 (100%)	69 (81.2%)	68 (80.0%)	61 (71.8%)	48 (56.5%)	36 (42.4%)	
	15,000	62 (100%)	41 (66.1%)		31 (50.0%)			
		83 (100%)	53 (63.9%)		30 (36.1%)			

*Potatoes not rotted but in such poor shape as to be unusable, i.e., due to water loss and consumption of carbohydrate in respiration.

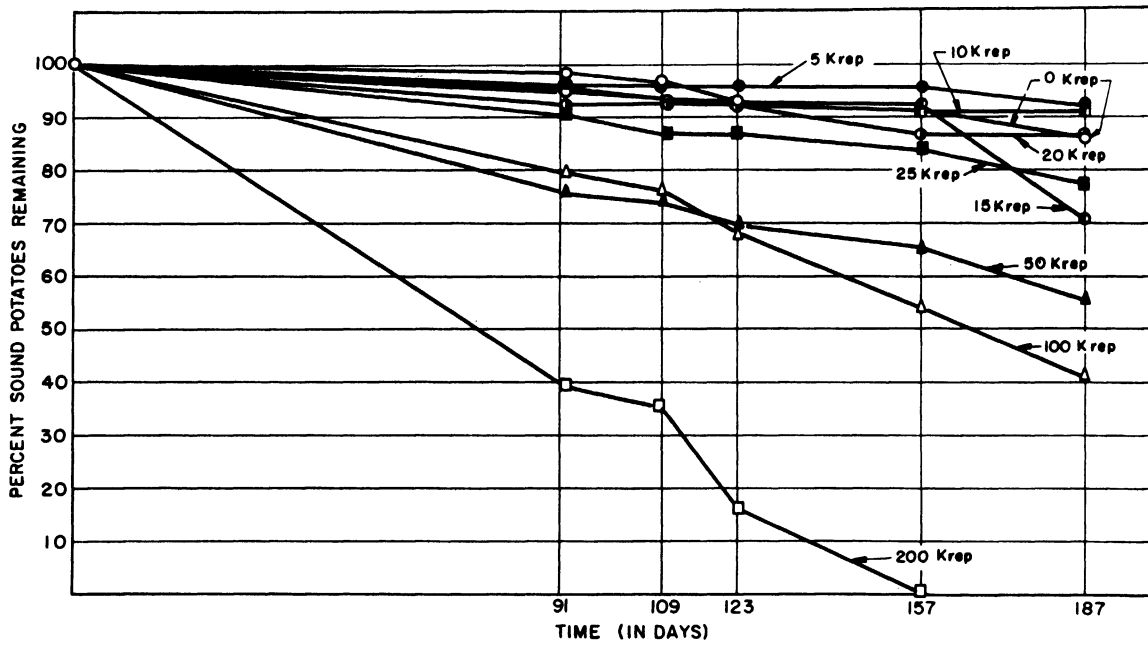

Fig. 11. Percent of original number of Sebago potatoes remaining free of rot vs storage time for various radiation dosages (stored at 45°F).

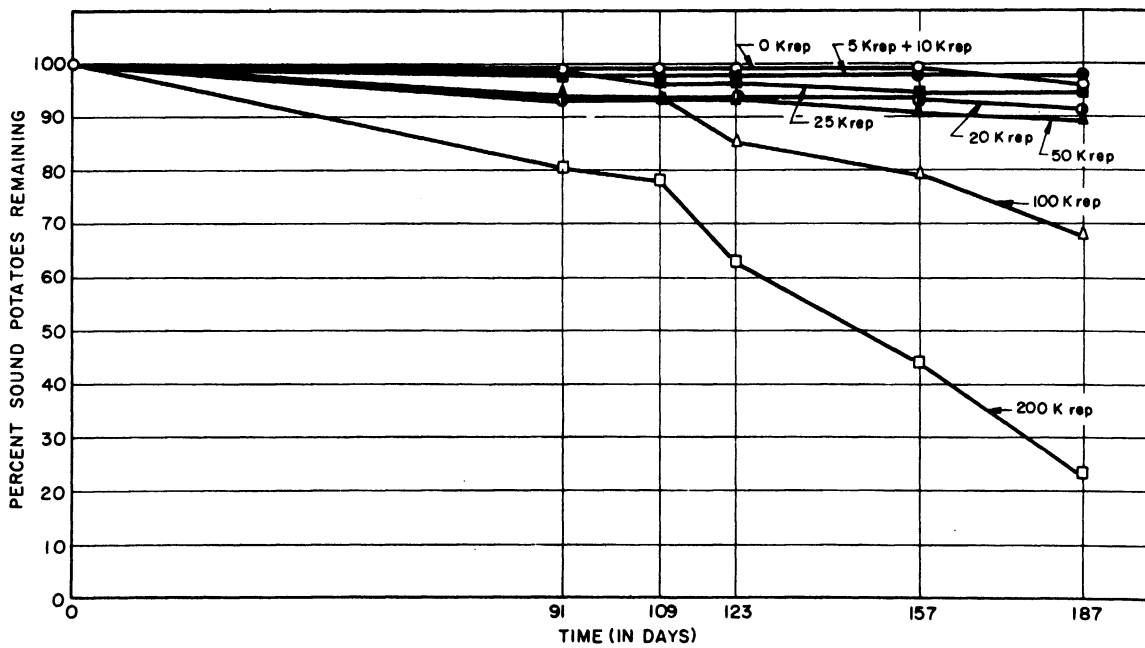

Fig. 12. Percent of original number of Russet Rural potatoes remaining free of rot vs storage time for various radiation dosages (stored at 45°F).

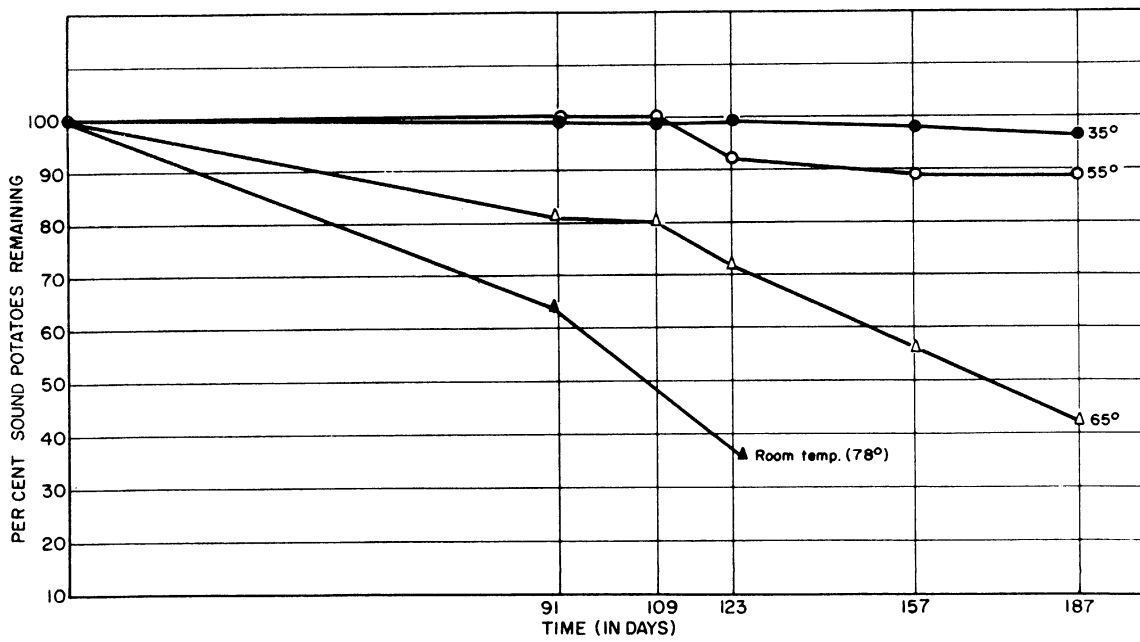

Fig. 13. Percent of original number of Russet Rural potatoes, irradiated with 15 kilorep, remaining free of rot vs storage time for various storage temperatures.

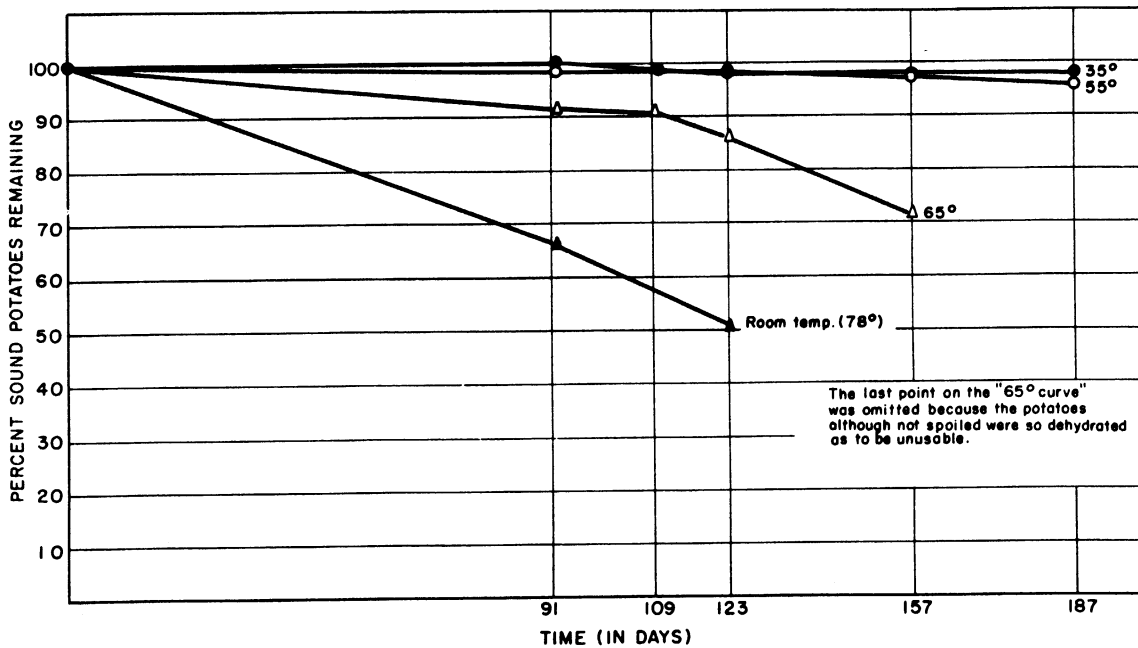

Fig. 14. Percent of original number of control Russet Rural potatoes remaining free of rot vs storage time for various storage temperatures.

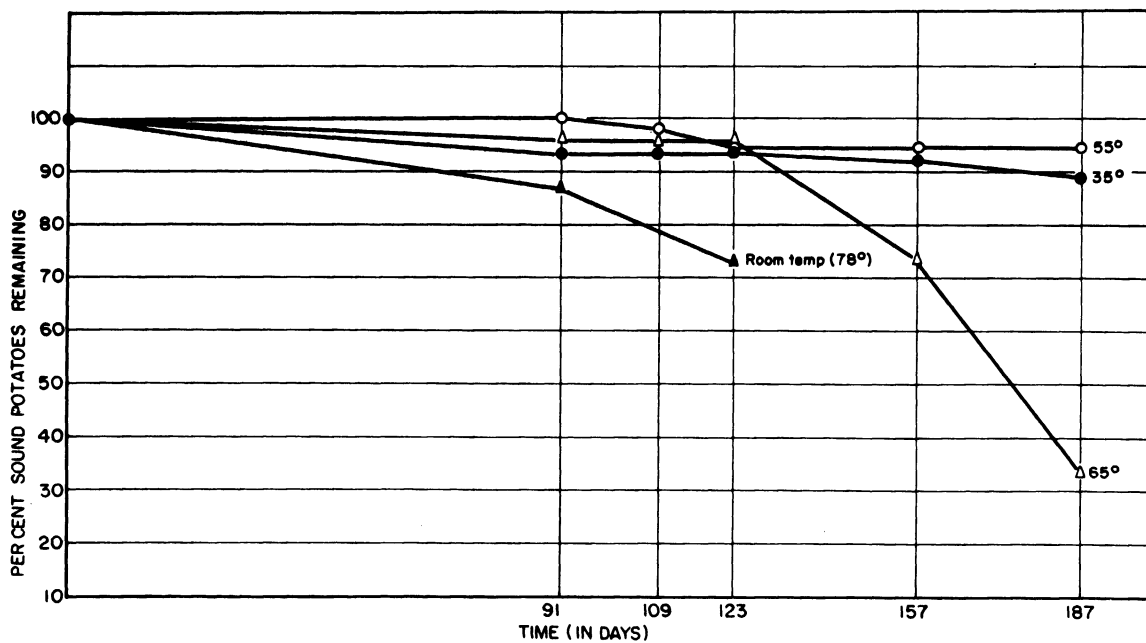

Fig. 15. Percent of original number of control Sebago potatoes remaining free of rot vs storage time for various storage temperatures.

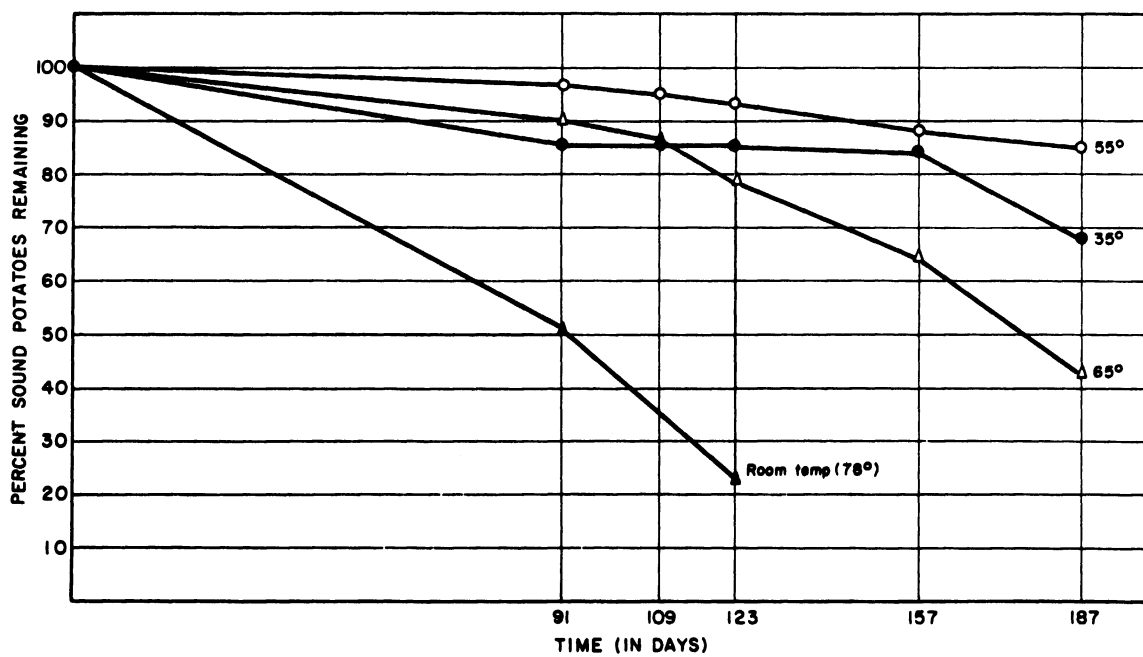

Fig. 16. Percent of original number of Sebago potatoes, irradiated with 15 kilorep, remaining free of rot vs storage time for various storage temperatures.

results are much the same except that the irradiated Sebagoes were preserved longer at 65°F than the controls. This is probably explainable by the dehydration phenomenon noted above.

It would seem, therefore, that a low dose of radiation, perhaps 5 to 10 kilorep, may be optimum in storing potatoes. Dosages of this magnitude stop sprouting and do not cause any increase in weight loss relative to the controls.

Doses of 15 kilorep or more seem inadvisable because of the increase in rotting and general weight loss.

D. EFFECTS OF IRRADIATING PORTIONS OF TUBERS

To seek additional information, potatoes were irradiated with 5 and 10 kilorep as follows. Potatoes which were already sprouted were irradiated with the sprouts shielded. This treatment had no effect on sprout growth, indicating that irradiation does not affect the availability and transport of nutrients in the potato.

Other potatoes already sprouted were irradiated with the tuber shielded and only the sprout receiving radiation. The result was an immediate cessation of growth of the irradiated sprout, with a concurrent commencement of growth in other eyes on the potato. The indication is that the action of radiation on a sprout produces nothing which stops growth in other parts of the organism. Also, radiation apparently halts the production of growth hormone (probably IAA) in the tip of the irradiated sprout, which until this time has maintained apical dominance over the other eyes of the tuber, inhibiting them from sprouting.

Unsprouted tubers were irradiated at the bud end and then placed in a warm, dark place. The eyes of the potato, other than the bud eyes, sprouted. Usually only the bud eyes sprout. This indicates again that the tiny sprouts were stopped in some way, and once again no sprout-inhibiting substance was produced that could move through the tuber to the other eyes and stop their growth.

Probably irradiation disturbs the dividing mechanism or the metabolic systems of the sprout cells. It probably does not affect the metabolic process of the cells of the tubers themselves, which make energy source materials available to the sprouts.

E. EFFECT OF SEASON OF IRRADIATION UPON STORAGE PROPERTIES

Variations in the storage properties of irradiated potatoes between different experiments, primarily observable in weight-loss data,

seem to indicate a possible effect due to the season at which irradiation occurs. Figure 17, taken from Fig. 3 of Progress Report No. 6, indicates these variations. The Sebago and Russets were irradiated in the early winter, the Idaho seed potatoes in the previous spring.

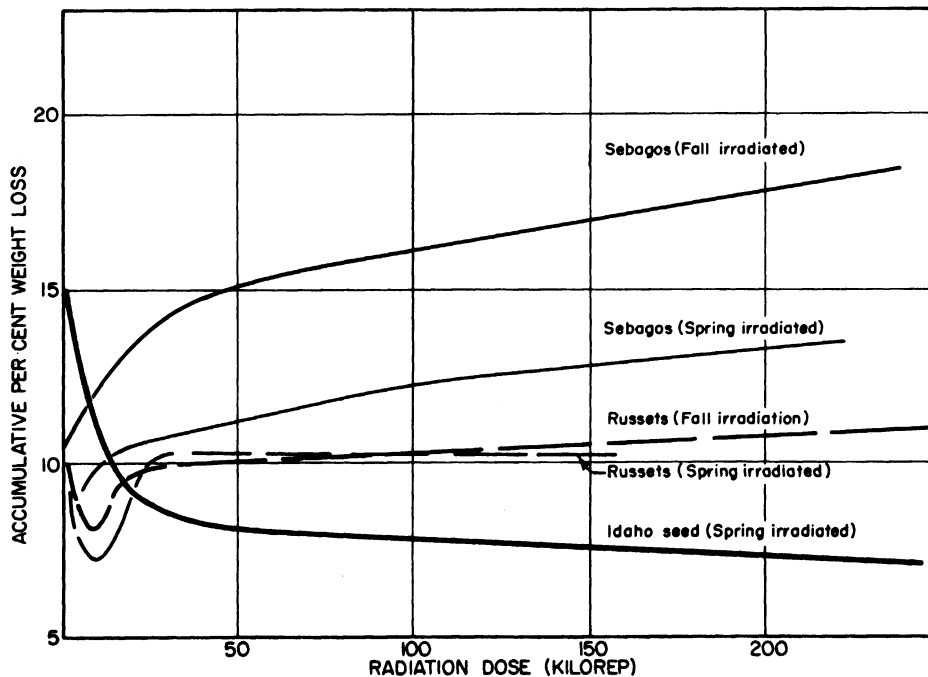

Fig. 17. Comparison of typical data for three varieties of potatoes (percentage weight loss vs radiation dose).

Russet Rural and Sebago potatoes from the same batch used for the experiment illustrated in Fig. 17 were irradiated this spring. These were then used as the basis of a short experiment designed to indicate whether season of irradiation or variety of potato is the important parameter in these differences of storage properties.

The weight-loss data from this short spring irradiation experiment are superimposed on Fig. 17 and seem to indicate that the season of irradiation is not an important contributory parameter in the form of the weight-loss vs dose plot. This would seem to lend strength to the hypothesis, proposed in Progress Report No. 6, of competing radiation-induced and radiation-inhibited processes, whose balance may be shifted between varieties by differences in the physical or chemical nature of the variety under study. Of course, this single, short-term experiment does not establish these hypotheses. Carefully controlled experiments with other parameters held constant, using many different varieties of potatoes, could reveal much about the existence or the nature of these hypothesized interactions.

After the short-term experiment had been in progress for two months, and the corroborating data just discussed had been obtained, the experiment was discontinued. The high rate of spoilage observed in both varieties and the probability that the altered metabolism of the rotting potatoes would tend to invalidate hypotheses based on weight-loss data dictated the termination of the experiment.

F. EFFECT OF RADIATION DOSE UPON ROTTING QUALITY

An appreciable loss by rotting of the Sebagos which had been subjected to 100,000 and 200,000 rep compared to the lower levels of treatment seemed to suggest a possible increase in rotting with dose. The potatoes remaining free of rot, as determined by Mr. Moises Yudelovitch, an agronomist, were utilized then for a second short experiment designed to observe possible variations in rotting rate with dose.

Periodic checks of each potato for any sign of rot gave further indication of dependence of rotting rate on dose. The resulting data are plotted in Figs. 18 and 19.

In both varieties, a marked increase in rotting rate at the higher doses indicates an effect of radiation on the potato, either enzymatic or mechanical, which encourages the growth of rotting organisms. The physiological effect is markedly different between the two species. Rot occurred much more frequently among Sebagos and, when it did occur, usually produced very soft, wet spoilage sites. The predominant rot observed on the Russet Rurals, on the other hand, produced dry, hard spoilage sites.

III. REDUCING SUGAR, SUCROSE, AND STARCH IN IRRADIATED POTATOES

Measurements of reducing sugars and sucrose in irradiated potatoes are needed because the increase in reducing sugars that follows irradiation usually leads to an undesirable product in processed potatoes. These measurements are likewise of importance in fundamental studies since they afford a starting point from which the primary effect of radiation can be explored. Not only do carbohydrates make up the bulk of potato solids, but these are intimately linked with metabolic systems that are probably more vulnerable to radiation effects.

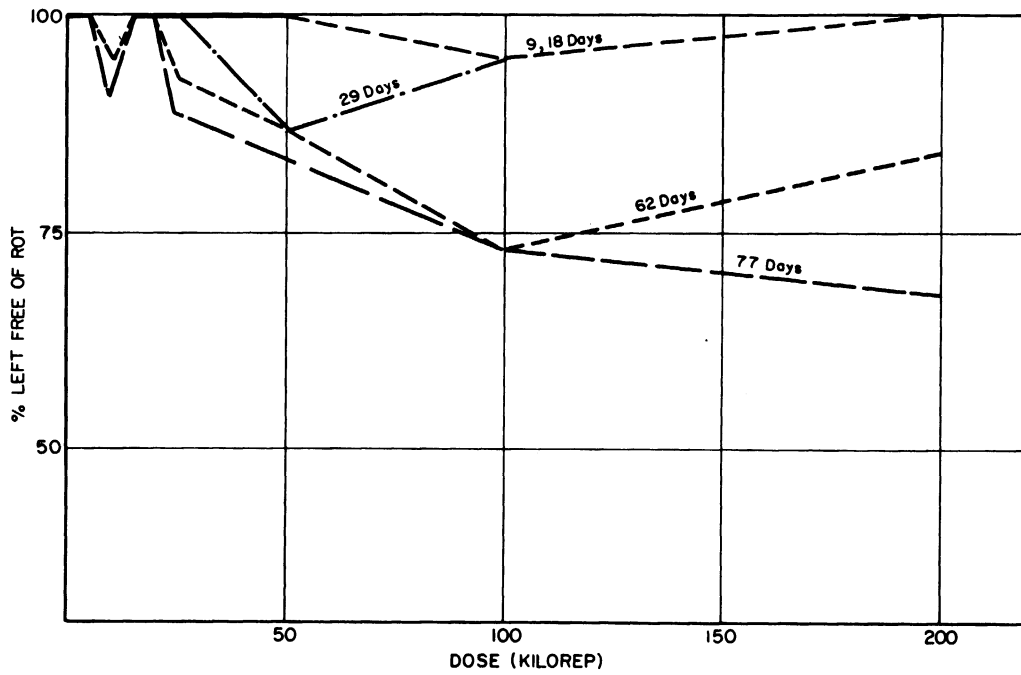

Fig. 18. Percent of Russet Rurals remaining free of rot after various periods of storage at 45°F.

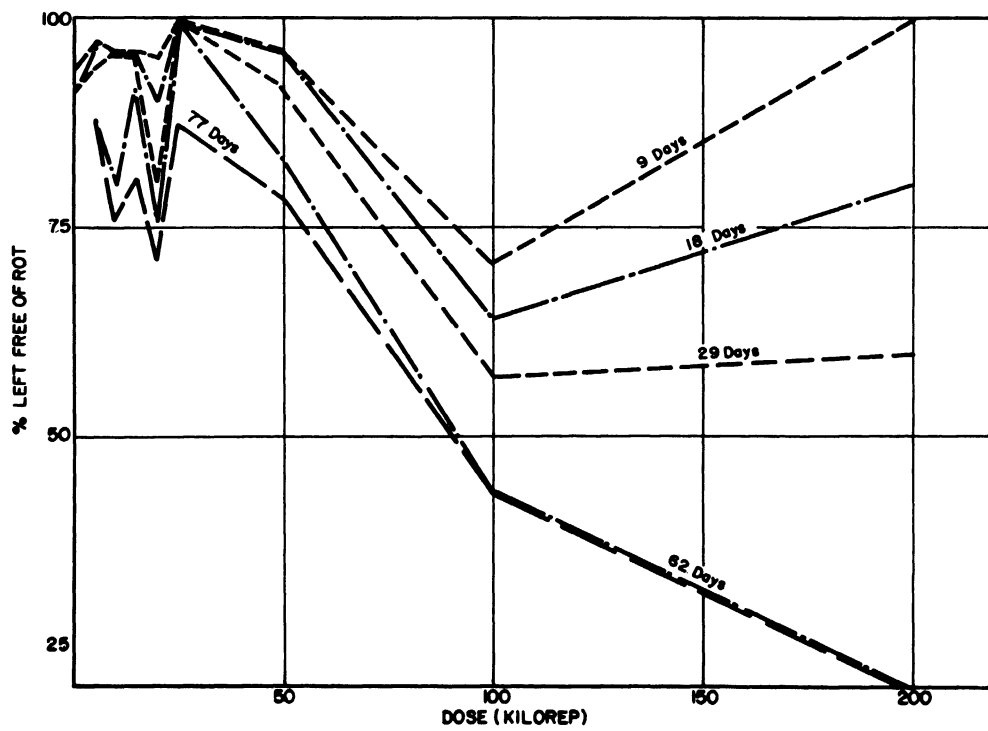

Fig. 19. Percent of Sebagos remaining free of rot after various periods of storage at 45°F.

A. IRRADIATION AND STORAGE OF POTATOES

The Sebago (white skinned) variety potatoes were received from Michigan State University Farm Crops Department on November 1, 1955. They were given the designated dosages of gamma radiation and placed in the 45°F storage room at the Food Service Building during the period November 2-5. Those potatoes being stored at temperatures other than 45°F were transferred to the appropriate storage rooms on November 7. Zero-time determinations of reducing sugar and sucrose were made shortly thereafter. The dose of radiation was applied just prior to the time the determinations were made. The data to be presented for the values for reducing sugar, sucrose, and starch following the first storage period were obtained during the third week in January, 1956. The first storage period was thus ten weeks in duration.

The Russet Rural variety potatoes were received from Michigan State University Farm Crops Department on November 15, 1955. They were held between 35° and 45°F until further treatment. They were irradiated and placed in the 45°F storage room at Food Service during the period November 27 to December 1, 1955. Those potatoes which were to be stored at temperatures other than 45°F were transferred to the appropriate storage rooms on December 7, 1955. Zero-time determinations of reducing sugar and sucrose were made shortly thereafter. The dose of radiation was applied just prior to the time the determinations were made. The data to be presented for the values for reducing sugar, sucrose, and starch following the first storage period were obtained during the last week in January and the first week in February, 1956. The first storage period was thus eight weeks in duration for Russets.

B. EXPERIMENTAL PROCEDURES IN CARBOHYDRATE DETERMINATIONS

Considerable emphasis was placed on methods of analysis for reducing sugar. This program consisted of three steps: first, selection and perfection of a rapid means of determining reducing sugar; second, simplification of previous extraction procedures with a view toward facilitating measurement of other than carbohydrate compounds; and third, investigation of a procedure for proper sampling of a large number of potatoes.

A rapid means of determining reducing sugars is necessary because the inevitable potato-to-potato variation requires determinations on a large number of potatoes receiving any one of the many treatments. It is also indispensable because the reducing-sugar content is believed to be the correlating factor for other biochemical substances. The "official" methods,¹ besides involving exhaustive extractions, involve a tedious gravimetric method, but are available for establishing the usefulness of newer methods.

With regard to the rapid measurement of reducing sugar, four methods were considered: (a) optical methods; (b) a colorimetric method utilizing the reaction of carbohydrates with anthrone;² (c) a chromatographic method involving the separation on Dowex-50 of the borate complexes of the carbohydrate compounds followed by spectrophotometric analysis;³ (d) a direct titration method involving the reduction of ferric to ferrous ion by the reducing sugars and the titration of the ferrous ion formed with ceric ion.⁴

1. Choice of Procedure.—Optical methods are very rapid but may not be sufficiently sensitive. The first optical method investigated for the analysis of sugars in potatoes under investigation was the refractometric method. The refractive indices of sucrose and d-glucose are almost the same for sugar solutions with concentrations below 10%. Consequently, d-glucose and l-fructose, in an aliquot of potato extract, could be determined by use of a refractometer.

A Bausch and Lomb Precision Refractometer, made available by the Department of Chemical Engineering, The University of Michigan, was used for preliminary checks. A solution of sucrose was prepared and divided into two portions. A few drops of invertase were added to one portion and left at room temperatures for several hours. The indices of both portions of sugar solution were taken and compared. It was found that they agreed quite satisfactorily.

The use of this method, however, was hindered by the very low concentration of sugars in potato extract. The refractive index of a solution containing 0.001 gram glucose per liter was the same as that of distilled water, i.e., 0.3° to 27.5°C on the Precision Refractometer.

A second optical method studied involved the establishment of a spectrophotometric calibration for potassium borate solution containing various sugar solutions.³ These sugar solutions are obtained as effluent from a chromatographic column. The column will also be used to separate the various sugars from one another in other methods of analysis. A Cambridge-type spectrophotometer was used in the first spectrophotometer tests. A wavelength of 620 microns was employed, and a blank borate solution was used as the reference solvent. The percent light transmittancy of a 0.01 M borate solution and that of such solution containing 0.01 gram glucose per liter are 100 and 102%, respectively. As these concentrations are what could ordinarily be expected in this analytical method, it was decided that the spectrophotometric readings with this instrument would not be sufficiently accurate.

The anthrone method does not distinguish between reducing and nonreducing sugars and also requires a colorimeter, which is not on hand; however, it may be the most rapid means of estimating total carbohydrate. The chromatographic method makes possible the separation of the two principal

reducing sugars in potatoes, glucose and fructose, as well as sucrose and other compounds, but requires many hours for operation. The ceric sulfate method appeared to satisfy the requirements for the present studies and was chosen for the initial determinations. This method was verified by Williams et al.,⁵ using two other methods; the cuprous oxide gravimetric method of the A. O. A. C. and the Somogyi method, involving the reduction of iodate to iodine by the cuprous oxide formed from the reducing sugars and titration of the iodine with thiosulfate.⁵ These authors found it necessary to use ion-exchange resins in place of lead acetate or carbon as a means of clarifying the extracts for ceric sulfate titrations.

2. Preparation of Extract.—In regard to preparation of extract, there appears to be no study showing the most efficient manner of extracting reducing sugar from the potato solids. The exhaustive alcoholic extraction used by Williams et al.⁵ required the removal of alcohol before non-sugar-reducing substances could be removed by ion-exchange resins. Ideally, the preferred method would consist of a hot-water extraction aided by a mechanical blender without any use of alcohol. The slurry can be filtered and the filtrate passed directly into a cation-resin and an anionic-resin bed in series, as the use of ion-exchange resins to remove non-sugar-reducing compounds was shown by Williams et al. to be superior to the use of lead acetate or carbon for this purpose. Also, the use of ion-exchange resins offers the advantage of isolating all cationic and anionic materials (e.g., sugar phosphates) as a single group.

Individual potatoes vary considerably as to their normal reducing-sugar content and their response to irradiation and storage. Therefore, it is necessary to give a large number of potatoes any one of the desired external treatments and to analyze each potato individually for reducing sugars. To achieve the same result with fewer analyses, the possibility was investigated as to whether or not a small portion of any given potato is reasonably representative of the whole potato, and whether or not such small portions from each potato receiving a given treatment can be combined and analyzed as a single sample. This was done simply by determining reducing-sugar contents on several small portions of each of several potatoes at random.

3. Procedures Adapted in Potato Analysis.—

a. Extraction of Sugar

In the preparation of potatoes for sugar extraction one or more raw potatoes were quickly peeled, keeping the peel as thin as possible. The peeled potatoes were cut into pieces, and 40 g were put into a Waring Blendor with 100 cc of distilled water. After blending for about five minutes, a very fine suspension of potato pulp in water was obtained and no small pieces of potato remained. A sample of 40 g of potato was taken in order to have sufficient volume to operate a large-size blendor. Pre-

liminary studies, using a small blender, gave a less uniform slurry.

b. Clarification

In the clarification of the slurry, an excess of saturated neutral lead acetate solution (4 cc) was added to the solution and blending continued for from 30 seconds to 1 minute. Then the slurry was transferred from the blender to a tared 500-cc Erlenmeyer flask and brought to 400 g net weight with distilled water. After allowing the slurry to stand in the distilled water for 15 minutes, 4 g of disodium orthophosphate were added in order to remove the excess of lead acetate. The mixture was shaken well, allowed to stand for 30 minutes, and then filtered through a 12.5-cm Schleicher and Schuell No. 575 fluted filter paper into two Erlenmeyer flasks, discarding the first few cc. It was not necessary to filter the whole slurry, but just enough for future sugar evaluations.

c. Sugar Evaluation

Very small amounts of the sugar solution, generally from 0.5 to 2 ml, which was a clear, slightly golden liquid, were pipetted into large test tubes. Blanks and titrations of known amounts of glucose were performed at the same time. All solutions were diluted to 5 cc with distilled H₂O, and 5 cc of alkaline solution of ferricyanide were added. These solutions were boiled for exactly 15 minutes in a water bath and cooled for about 5 minutes to room temperature. Five cc of 5 normal H₂SO₄ were then added with six drops of indicator solution (Setopaline). The samples were then titrated with 0.01 normal ceric sulfate solution. The color of the original samples varied from golden to green, the intensity of the color toward green increasing with sugar concentration. In this titration one must be careful, because the change of color from golden green to the orange end-point is very sudden.

Since the quantity of ceric sulfate solution corresponding to a known quantity of glucose solution of known concentration is known, it is possible to determine the amount of sugar in samples and, therefore, the percent of reducing sugar in the whole amount of potatoes.

d. Sucrose

The determination of sucrose is made on the same filtrate of the potato slurry as used for the reducing-sugar determination. The quantity of acetic acid necessary to make 50 ml of solution distinctly acid to methyl red indicator (pH = 4.6) is determined. Then to another 50 ml this quantity of acetic acid and 5 ml of invertase solution (nutritional biochemicals) are added. The flask is filled almost to 100 cc and allowed to stand overnight, preferably at not less than 20°C. It is cooled, neutralized, and made to 100 cc. The percent of reducing sugar is determined using the formula for sucrose as follows:

Percent sucrose = (percent reducing sugar after inversion minus percent reducing sugar before inversion) x 0.95.

e. Starch

The determination for starch is made according to Method 22.4 in the Official and Tentative Methods of Analysis of the Association of Official Agricultural Chemists, seventh edition, p. 358.¹ It is the official direct acid hydrolysis for materials such as raw starch, potatoes, etc. The method is quoted as follows: "Stir weighed sample, representing 2.5-3 g of the dry material, in a beaker with 50 ml of cold H₂O 1 hr. Transfer to filter and wash with 250 ml of cold H₂O. Heat insol. residue 2.5 hrs with 200 ml of H₂O and 20 ml HCl (sp. gr. 1.125) in flask provided with reflux condenser. Cool, and nearly neutralize with NaOH. Complete vol. to 250 ml, filter, and det. dextrose [glucose, or reducing sugar] in aliquot of filtrate. . . . Wt of dextrose obtained x 0.90 equals wt of starch." Dextrose was determined by Method (a), above.

The procedure is modified in that a 1:10 dilution of the 250-ml volume must be made prior to determination by the ceric sulfate method. This dilution is necessary to bring the glucose concentration within range of the ceric sulfate method. The filter paper as well as the insoluble residue is included in the hydrolysis for simplicity in transferring the residue. The acid treatment of the paper does not yield a detectable amount of reducing sugar. An iodine test on the filtrate revealed that no starch was lost from the residue through the filter paper. Ceric sulfate determinations on the filtrate after 10-minute hydrolysis and after prolonged hydrolysis with HCl showed no change, further indicating that nothing other than reducing sugar and sucrose is present in the filtrate to give a test for reducing sugar. Filtration is facilitated by the use of celite as a filter aid and by vacuum.

4. Summary of Analytical Procedure for Reducing-Sugar Determinations Using Ceric Sulfate.--

a. References

Hassid, W. Z. - Ind. Engin. Chem. Anal. Ed., 8:138, 1936.
- Ibid., 9:228, 1937.

b. Procedure

- (1) Pipette a 5-ml sample, containing a maximum of 3.5 mg reducing sugars, into an 8-in. test tube.
- (2) Add 5 ml of alkaline ferricyanide solution.
- (3) Boil in water bath for exactly 15 min (\pm 1 sec).
- (4) Cool to room temperature (approximately 3 min in tap water).
- (5) Add 5 ml of 5N sulfuric acid.
- (6) Add 5 to 7 drops of indicator solution.

(7) Titrate with 0.01N ceric sulfate solution until the green solution changes to a golden-brown color.

c. Standardization

Apply the above procedure to a sample containing a known quantity (approximately 2 mg) of glucose and calculate the number of ml ceric sulfate that corresponds to 1 mg glucose.

d. Reagents

Alkaline ferricyanide solution: Dissolve 8.25 g potassium ferricyanide and 10.60 g sodium carbonate in distilled water and make to volume 1 liter.

Ceric sulfate (stock solution): Dissolve ceric sulfate in 600 ml distilled water to which has been added 60 ml sulfuric acid (conc.) and make to volume 1 liter. Adjust the quantity of ceric sulfate to give a solution 0.25N in ceric sulfate, i.e., oxidation-reduction 132.1 g normality.

Ceric sulfate (0.01N): Dilute stock solution with distilled water (20 ml stock solution plus 25 ml conc. sulfuric acid made to volume 500 ml with distilled water).

Indicator solution: Dissolve 0.1 g of Setopaline-C in 100 ml of water.

Sulfuric acid (5N): Make approximately 140 ml of conc. sulfuric acid to volume 1 liter with distilled water.

Lead acetate: Saturated aqueous solution.

Sodium phosphate: Used in solid form (dibasic, crystalline).

C. RESULTS

Determinations for reducing sugar and sucrose were performed on samples from the nine lots of each variety of potatoes treated to graded doses of radiation and stored at one temperature (45°F) and also on samples from four lots of each variety each treated to two doses of radiation (0 and 15 kilorep) but stored at different temperatures. Each sample consisted of a minimum of four potatoes selected at random from each lot (consisting of 40-50 potatoes initially). Values for reducing sugar, sucrose, and starch corresponding to a single sample were made on the same four or more potatoes. Each potato in the sample was cut up, the pieces pooled, and aliquots taken for (a) reducing sugar and sucrose determination, (b) starch determination, and (c) for dry-weight determination.

These thirty-four analyses were performed at zero time, after 8-10 weeks of storage, after 18-20 weeks of storage, and finally after 30-34 weeks of storage. The determinations of starch content were made on all thirty-four samples except at zero time, so long as the samples had not completely deteriorated. Percent solids were determined for all thirty-four samples at the terminal stage of storage, for all seventeen

Russet Rural samples at the 18-week storage interval, and for random samples at earlier stages for both varieties.

All the values are presented in Table VIII.

D. DISCUSSION OF RESULTS

The effect of radiation dosage on the reducing-sugar and sucrose contents of both Russet Rural and Sebago variety potatoes measured directly after irradiation is negligible. The values for reducing sugar in Sebagos for all doses of radiation have an average of $0.78 \pm .11\%$, with no apparent pattern among the values; for sucrose the average value is $0.19 \pm .08\%$. The corresponding values for Russet Rurals at zero time are $.47 \pm .06\%$ for reducing sugar and $.24 \pm .04\%$ for sucrose, again with no pattern among the values with respect to dose of radiation.

At the end of the first storage period (10 weeks for Sebagos and 8 weeks for Russet Rurals), there is still no apparent effect of dose level of radiation on the reducing-sugar content. The values for reducing sugar in Sebagos for all levels of radiation have an average of $0.98 \pm .08\%$, only very slightly higher than the zero-time values. In Russet Rurals, the average value is $.60 \pm .12\%$, not significantly higher than the zero-time value.

Sucrose levels in both Russets and Sebagos following the first storage interval, however, do show a marked effect of dosage level of radiation. An increase in dose from 0 to 200 kilorep increases the sucrose level in Sebagos from 0.43 to 3.8% and in Russets from 0.28 to 2.98%. These values are shown graphically in Figs. 20 and 21 which also show the values for reducing sugar and starch for the first storage period. In the case of the Sebagos, the curve showing the change in sucrose levels progresses from low to high values with increasing radiation dosage. In the case of the Russets, there appears to be a more marked change in the slope of the curve, producing a "hump" at about 10 kilorep. Except for this change in slope, there is a gradual increase in sucrose content with increase in radiation dosage comparable to that observed for the Sebagos. The change in slope may correspond to a related "dip" in the curve for starch or may simply be experimental deviation.

Values for starch content do not show the constancy or regularity of change with dose of radiation as do the other two carbohydrates. One explanation may be that since starch is a storage compound, only part of the total amount is responsive to metabolic processes. However, in the case of both the Russet and Sebago varieties, it appears that the starch content decreases abruptly with increasing dosage of radiation up to about 10-20 kilorep, then increases gradually to a second maximum, after which it falls gradually with increasing dosage up to 200 kilorep. The decreases may bear

TABLE VIII. CARBOHYDRATE CONTENT OF SEBAGO AND RUSSET RURAL VARIETY POTATOES AS AFFECTED BY DOSAGE OF GAMMA RADIATION, BY STORAGE TEMPERATURE, AND BY DURATION OF STORAGE
(All figures are percent of whole tuber. Storage periods in weeks head each column.)

Dose kilorep	Storage Temp. °F	Reducing Sugar			Sucrose			Starch			Total Carbohydrate			Potato Solids				
		0	10	18	30	0	10	18	30	0	10	18	30	0	10	18	30	
		SEBAGO																
0	45	0.95	0.90	0.86	0.69	0.33	0.43	0.42	0.98	17.1	14.2	14.9	18.4	15.5	16.6	21.7	23.5	22.1
5	45	0.75	1.00	1.05	0.79	0.21	0.78	0.98	0.70	15.5	12.8	13.2	17.3	14.2	14.7	---	---	20.2
10	45	0.92	1.06	0.80	0.93	0.36	1.51	0.85	0.59	13.3	13.9	11.1	15.9	15.6	12.6	18.4	20.5	20.7
15	45	0.89	1.11	1.12	1.03	0.11	1.19	0.60	1.38	15.6	10.6	10.8	17.9	12.3	13.3	---	---	19.0
20	45	0.72	1.00	0.75	1.04	0.17	1.37	---	1.13	12.9	15.2	10.8	15.2	17.1	13.0	---	24.2	18.8
25	45	0.80	0.91	0.97	0.90	0.09	2.08	1.12	1.43	14.9	7.23	14.7	17.9	8.8	17.0	18.7	19.9	21.3
50	45	0.64	0.75	---	1.00	0.24	2.14	0.59	0.84	14.9	---	10.8	17.8	---	12.6	18.1	---	18.2
100	45	0.59	1.10	---	1.15	0.15	2.47	---	2.32	14.9	---	8.4	18.5	---	12.1	19.4	---	20.1
200	45	0.80	0.97	---	---	0.09	3.8	---	---	12.7	---	---	17.5	---	---	17.5	---	---
0	35	0.95*	1.61	2.07	2.48	0.33*	0.75	1.83	5.09	18.1	13.3	13.2	20.5	17.2	20.7	---	---	23.0
0	45	0.95*	0.90	0.86	0.69	0.33*	0.43	0.42	0.98	17.1	14.2	14.9	18.4	15.5	16.6	21.7	---	22.1
0	55	0.95*	0.47	0.30	0.64	0.33*	0.41	0.42	0.66	19.3	13.2	15.3	20.2	13.9	16.6	---	---	24.8
0	65	0.95*	0.28	0.40	0.69	0.33*	0.68	1.10	2.27	17.7	16.5	16.9	18.7	18.0	19.8	---	---	26.4
0	room	0.95*	0.48	---	---	0.33*	0.26	---	---	13.4	---	---	14.1	---	---	---	---	---
15	35	0.89*	2.3	2.73	2.10	0.11*	2.19	0.84	3.72	13.4	13.3	7.8	17.9	16.6	13.6	---	---	19.3
15	45	0.89*	1.11	1.12	1.03	0.11*	1.19	0.60	1.58	15.6	10.6	10.8	17.9	12.3	13.3	---	---	19.0
15	55	0.89*	0.61	0.33	0.60	0.11*	0.24	0.54	0.51	13.7	12.4	---	14.6	13.3	13.1	---	---	19.1
15	65	0.89*	0.26	0.40	0.81	0.11*	1.92	1.67	2.48	11.8	12.9	12.7	14.0	15.0	16.0	---	---	22.9
15	room	0.89*	0.51	---	---	0.11*	0.53	---	---	12.3	---	---	13.3	---	---	---	---	---
RUSSET RURAL VARIETY																		
0	45	0.43	0.50	0.36	0.45	0.19	0.28	0.30	0.77	20.7	14.5	15.5	21.5	18.1	16.7	22.1	26.0	25.1
5	45	0.43	0.64	0.62	0.50	0.23	0.38	0.50	0.63	19.8	18.6	16.9	20.8	19.7	18.1	---	---	23.1
10	45	0.45	0.78	0.37	0.49	0.18	1.3	0.50	0.95	21.4	18.7	15.7	23.5	19.6	17.2	27.3	23.5	23.4
15	45	0.43	0.40	0.45	0.59	0.30	0.81	0.61	0.80	21.4	16.0	16.5	22.6	17.1	17.9	---	21.5	20.7
20	45	0.44	0.75	0.81	0.60	0.27	3.56	1.36	1.61	17.2	16.7	13.6	21.5	18.9	15.8	---	21.3	21.5
25	45	0.52	0.40	0.63	0.57	0.23	0.63	0.27	2.70	16.0	18.4	17.7	17.0	20.0	21.0	21.1	22.3	25.1
50	45	0.37	0.56	0.68	0.77	0.20	1.32	0.81	2.10	17.7	15.0	16.4	19.6	16.5	19.3	22.2	20.5	24.7
100	45	0.68	0.57	0.67	1.53	0.29	3.02	2.43	2.60	18.7	12.5	12.2	22.3	15.6	16.3	29.2	23.8	23.1
200	45	0.44	0.77	0.99	1.00	0.29	2.98	4.28	4.51	16.0	13.2	11.3	19.8	18.5	16.8	---	23.8	21.0
0	35	0.43*	1.71	2.48	1.87	0.19*	0.47	1.19	2.94	13.1	14.8	13.1	15.3	18.5	17.9	---	24.7	22.2
0	45	0.43*	0.50	0.36	0.45	0.19*	0.28	0.30	0.77	20.7	17.5	15.5	21.5	18.1	16.7	22.1	26.0	25.1
0	55	0.43*	0.27	0.37	0.64	0.19*	0.31	0.33	0.62	20.4	16.3	17.9	21.0	17.0	19.2	---	25.1	28.2
0	65	0.43*	0.37	0.57	0.70	0.19*	0.25	2.27	2.86	20.9	17.7	19.4	21.5	18.6	23.0	---	32.8	41.7
0	room	0.43*	0.36	---	---	0.19*	0.46	---	---	22.5	---	---	25.3	---	---	---	---	---
15	35	0.43*	1.25	1.42	1.44	0.30*	2.71	1.90	3.32	13.4	13.9	13.8	17.4	17.2	18.8	---	22.4	21.6
15	45	0.43*	0.40	0.43	0.59	0.30*	0.81	0.60	0.80	21.4	16.0	16.5	22.6	17.1	17.9	---	21.5	20.7
15	55	0.43*	0.43	0.48	0.65	0.30*	0.45	0.30	0.73	20.4	14.3	15.5	21.3	15.1	16.9	---	21.3	22.7
15	65	0.43*	0.55	0.40	0.50	0.30*	0.20	1.00	0.61	20.9	17.1	17.3	21.7	18.5	19.4	---	22.3	26.8
15	room	0.43*	0.37	---	---	0.30*	0.49	---	---	17.1	---	---	18.0	---	---	---	---	---

*Values assumed identical since no storage time elapsed.

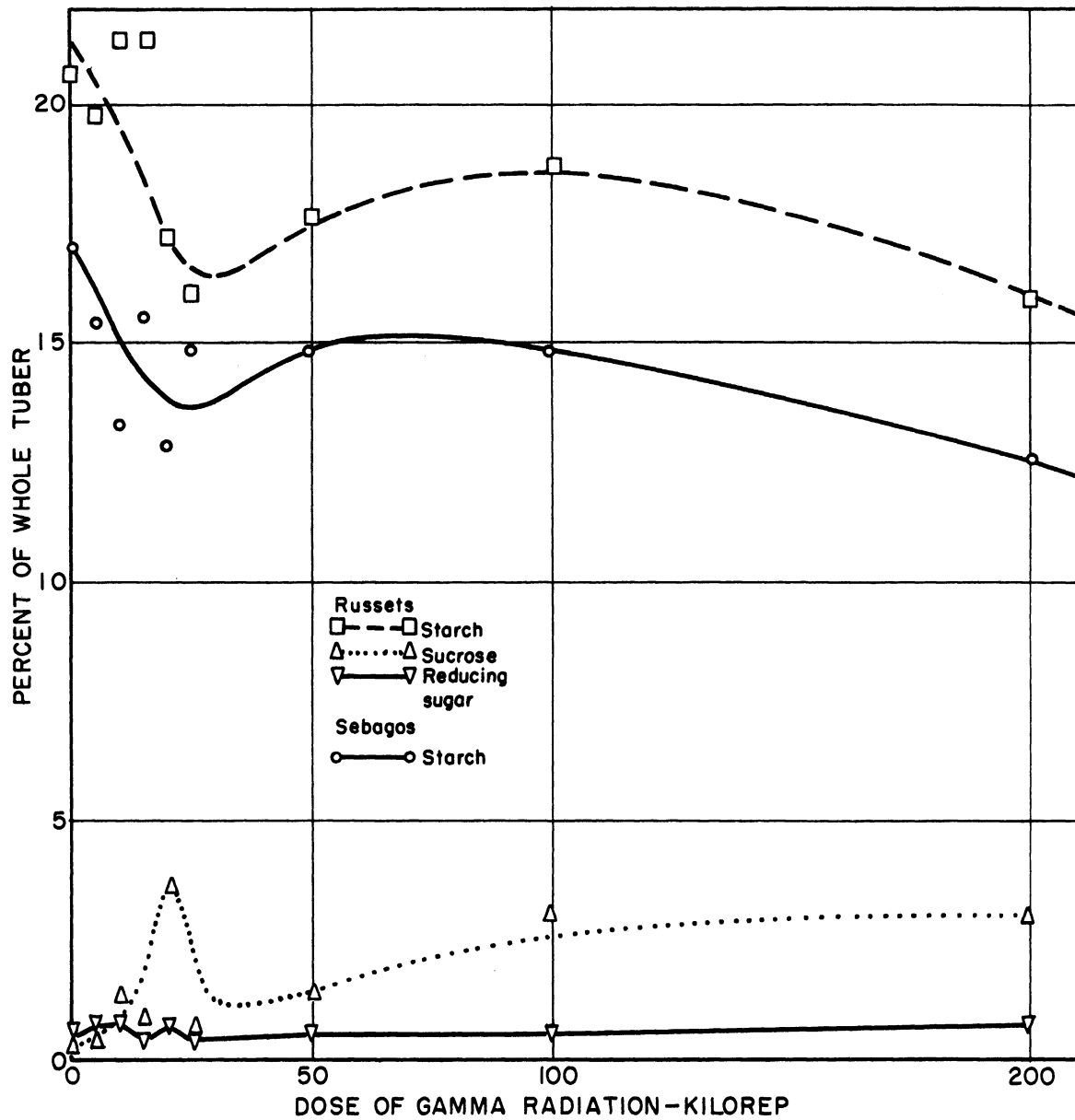

Fig. 20. Effect of radiation dosage on the reducing-sugar, sucrose, and starch content of Russet Rurals stored 8 weeks.

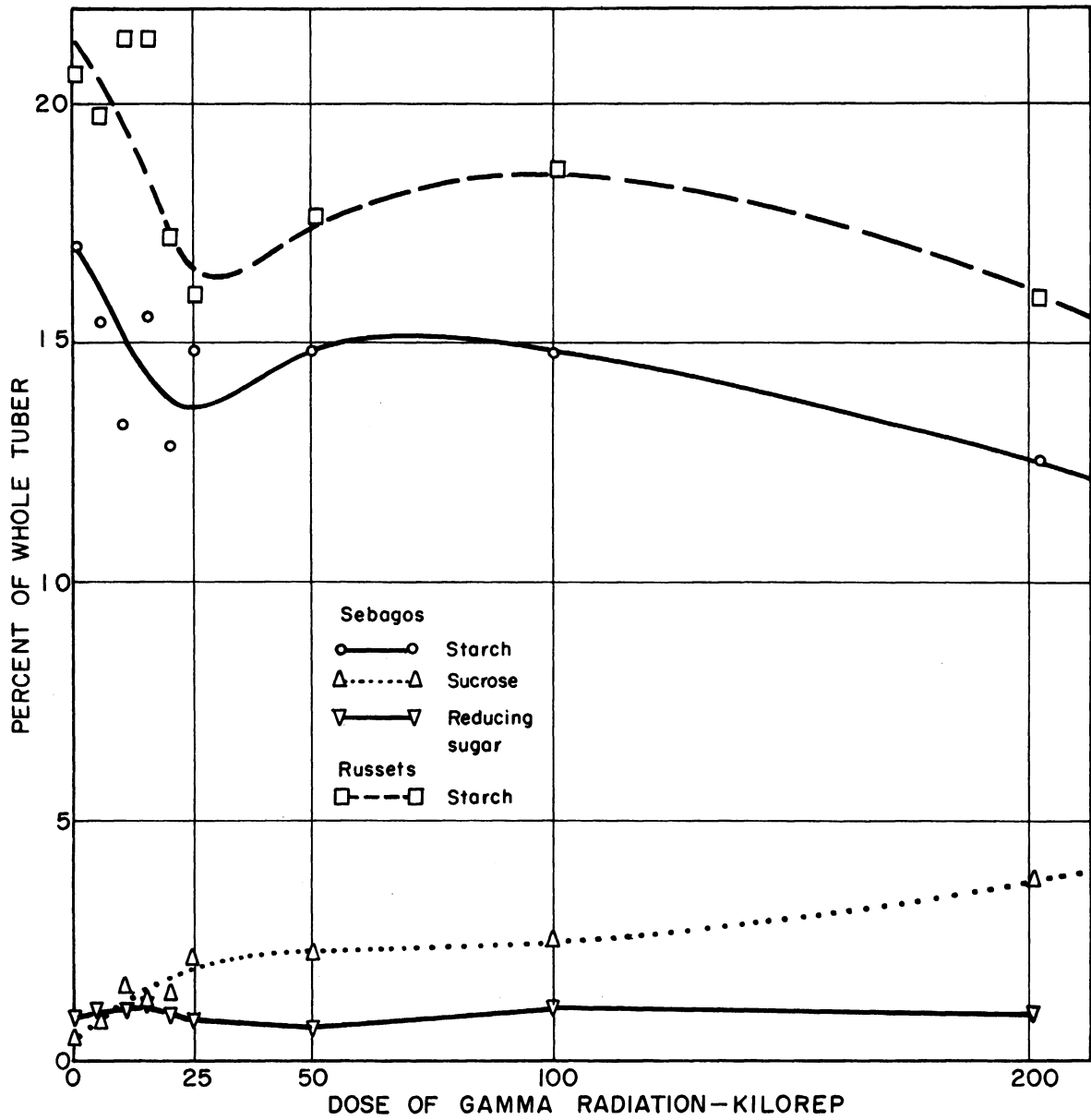

Fig. 21. Effect of radiation dosage on the reducing-sugar, sucrose, and starch content of Sebago potatoes stored 10 weeks.

some relation to the amount of sucrose formed, indicating that irradiation stimulates a conversion of starch to sucrose (or possibly inhibits the conversion of sucrose to starch), this effect being more apparent with the Russets than with the Sebagos.

The effect of temperature of storage for both irradiated (15 kilorep) and nonirradiated potatoes of both varieties for the first storage period is shown graphically in Figs. 22 and 23. For both the Russets and the Sebagos the lowest temperature level results in elevated sucrose and reducing-sugar contents, but all other storage temperatures result in low levels.

The values for starch show a somewhat irregular pattern with respect to storage temperature. The curves drawn through these points suggest that there is probably little effect of storage temperature until room temperature is reached, which results in a lowering of the starch content.

In the third round of carbohydrate analyses, at 18 weeks, of the irradiated Sebago and Russet Rural variety potatoes in storage, the potatoes given 100,000- and 200,000-rep radiation had deteriorated to a point where analyses became fruitless. The deterioration appeared to be due to fungus invasion, but it is not known whether rotting preceded or followed the fungus growth. This is not true of the Russet Rural variety potatoes given the high radiation dosages.

Figure 24 shows graphically the results for the Sebagos. There appears to be no consistent effect of radiation up to 50,000 rep on either sucrose or reducing sugar, but there does appear to be an effect on the total. The sum of the two sugars increases slightly with dosage of radiation up to 25,000 rep and then decreases slightly. When expressed on a dry-weight basis, all doses of radiation appear to increase the sum of reducing sugar and sucrose by an equal amount. Starch values tended to decline from a value of about 14% for the nonirradiated potatoes to values less than 10% for the potatoes given 50,000-rep radiation.

Figure 25 shows the effect of storage temperature on the carbohydrate content of the irradiated (15,000 rep) Sebago potatoes stored for 18 weeks; the values for reducing sugar and sucrose were highest at the lowest temperatures. Reducing sugar decreased from about 2.5% in potatoes stored at 35°F to about 0.33% in potatoes stored at 55°F, with little increase above this at the highest temperature, and showing a slight increase due to irradiation. Values for sucrose did not show the rate of decline with increasing storage temperature and showed the highest value at the highest storage temperature. These high values at 65°F may be associated with rotting, which had proceeded to some degree in these potatoes. Irradiation caused a small increase in sucrose content at all but the lowest temperature, where it effected a decrease in sucrose content.

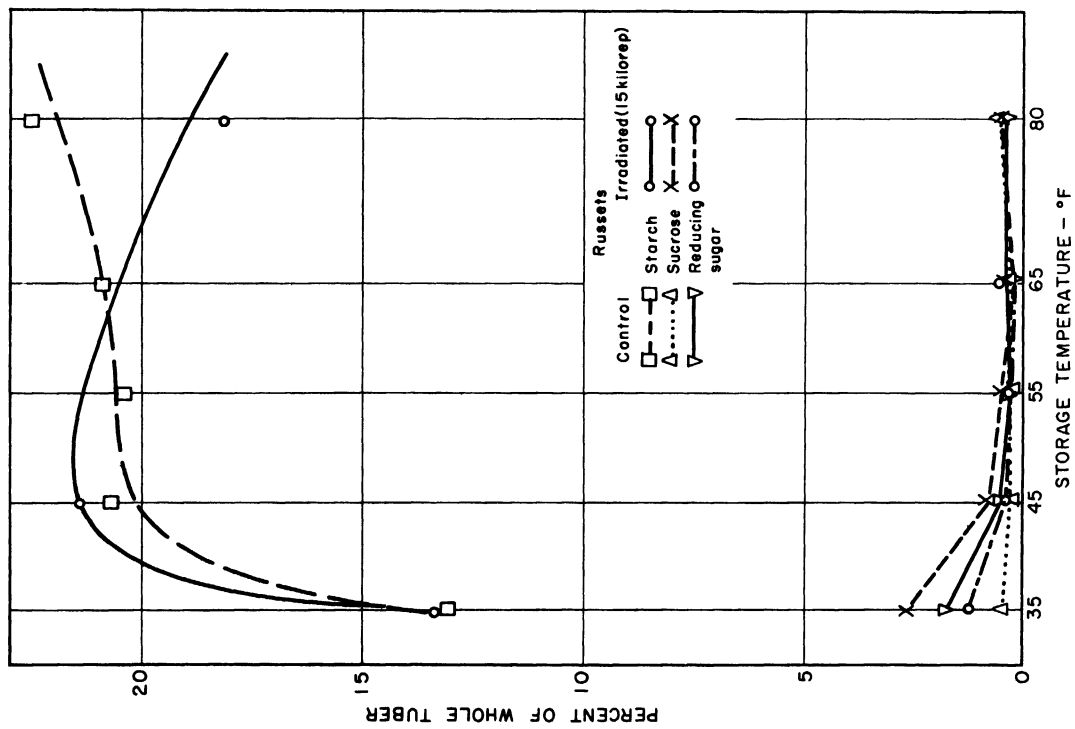

Fig. 22. Effect of storage temperature on the reducing-sugar, sucrose, and starch content of Russet Rural potatoes stored 8 weeks.

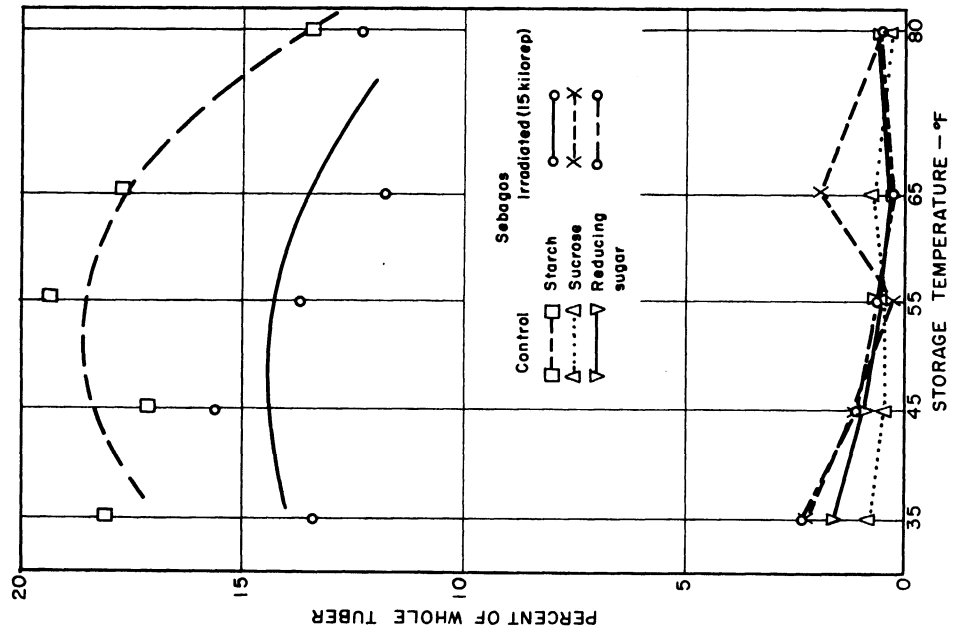

Fig. 23. Effect of storage temperature on the reducing-sugar, sucrose, and starch content of Sebago potatoes stored 10 weeks.

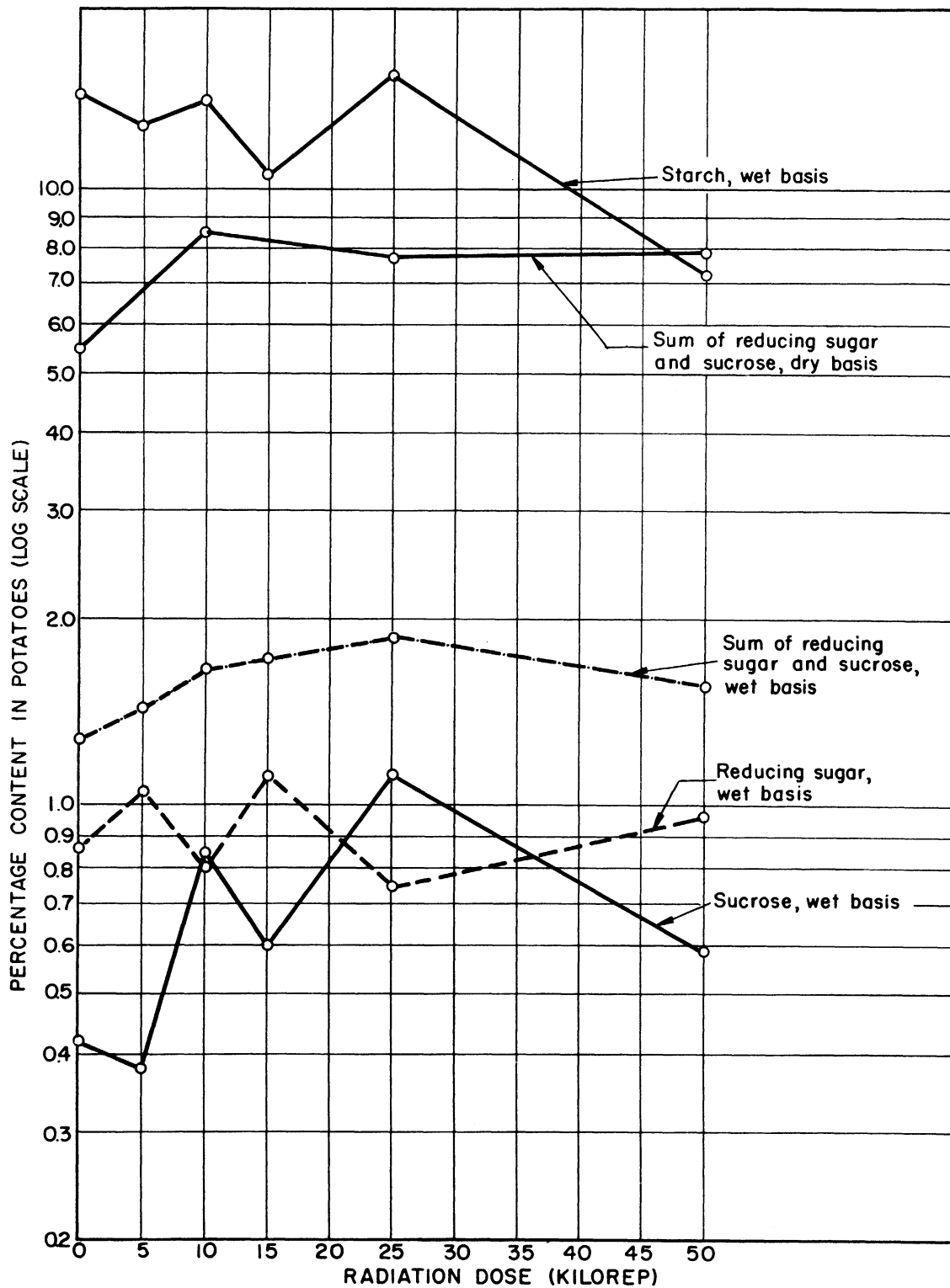

Fig. 24. Effect of dosage of gamma radiation on carbohydrate content of Sebago variety potatoes stored at 45°F for 18 weeks.

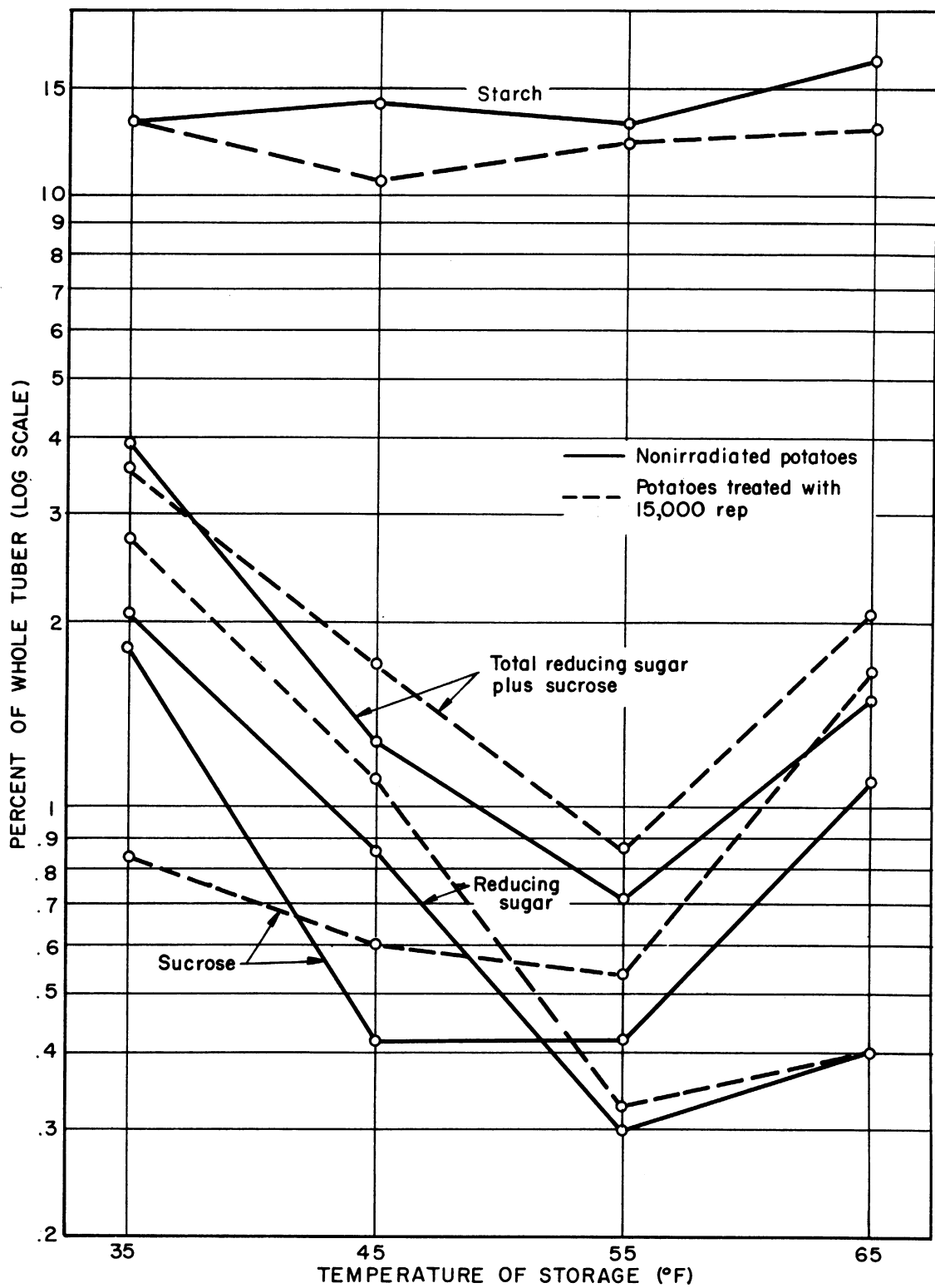

Fig. 25. Effect of temperature of storage on carbohydrate content of irradiated Sebago variety potatoes (15,000 rep) stored for 18 weeks.

The sum of reducing sugar and sucrose showed the highest value at the lowest storage temperature and next to the highest values at the highest storage temperature.

Values for starch showed little consistent effect with temperature of storage, but irradiation appeared to have decreased the starch content in potatoes stored at all but the lowest temperature of storage.

In Russets stored eighteen weeks, reducing sugar still showed no effect of dosage level of radiation. The effect of graded doses of radiation on the sucrose level continued to be a peak at a low dose, in this case, 20 kilorep. The 25- and 50-kilorep doses resulted in values only a little higher than did those below 20 kilorep. The sucrose values at the two highest radiation doses continued to increase by the eighteenth week. The starch content appeared to be low in the nonirradiated potatoes and also in those given 100-200 kilorep, namely 12.5-14.5%. The radiation doses in between resulted in higher values, 15.0-18.7%, with some evidence of lower starch values with higher radiation doses.

Terminal analyses for carbohydrates in this series of potatoes was conducted when the Sebagos had been in storage for thirty weeks and the Russets for thirty-four weeks.

An effect of increasing doses of radiation on the reducing-sugar level became apparent in both varieties after the prolonged storage. From the lowest to the highest doses, there was a gradual increase in reducing sugar, from 0.70 to 1.15% in Sebagos, and from 0.45 to 1.53% in Russets. With regard to temperature, the same observations made at prior stages in storage of these potatoes were made again; high levels of reducing sugar in potatoes stored at 35°F, and low levels of reducing sugar in both varieties, whether irradiated or not, in potatoes stored at the three higher temperatures. All values for the Sebagos in this temperature—reducing-sugar level relationship were about one and a half times higher than the corresponding values in the Russets.

The effect of radiation dose on sucrose levels in Sebagos after thirty weeks of storage at 45°F is similar to that after ten or eighteen weeks, namely, an increase in reducing sugar with increasing radiation dose, the values ranging from less than 1.0% for the low doses to 2.5% for the 100-kilorep dose. The effect of dose on sucrose content in Russets was similar, the values ranging from about 0.7 to 2.6% for the 100-kilorep dose and to 4.5% for the 200-kilorep dose.

The effect of storage temperature on the sucrose content of Sebagos after thirty weeks of storage was to increase considerably the levels in potatoes stored at all temperatures over the levels of eighteen weeks, but there was no consistent difference between control and irradiated potatoes in this respect. In the case of the Russets, values were doubled

from those at eighteen weeks of storage for all storage temperatures except the highest. Nonirradiated potatoes stored at 65°F did not gain much sucrose during the last sixteen-week period of storage, and irradiated potatoes stored at this temperature actually had less sucrose in them than did irradiated potatoes stored at any other temperature.

The effect of radiation dosage on the starch content of both Sebago and Russets when the starch content is based on either wet or dry weight, is to cause a decline with increasing dose of radiation, which is especially apparent at the 100- and 200-kilorep dose levels. Otherwise there is no particular pattern to dose effect. In Sebago there appears to be a decline from 0 to 10 kilorep, then an increase from 10 to 25 kilorep, then a decline at the higher dose levels. This is also true for the values of total carbohydrate when related to the dry basis. Total carbohydrates in Russets, based on dry weight, show no pattern whatsoever as a function of radiation dosage.

The starch content of Sebago and Russets, both control and irradiated, varies in a similar manner with temperature of storage and reflects the high levels of sucrose produced in potatoes stored at the lowest storage temperature (35°F) and at the highest storage temperature (65°F). Starch contents are lowest at these extremes of storage temperature and highest in potatoes stored at the intermediate temperatures.

IV. RESPIRATION STUDIES

A. MATERIAL AND METHODS

Two varieties of potatoes were used, the Sebago and the Pontiac. The former were obtained from Michigan State University in November and stored at 45°F. The latter were obtained from Homestead, Florida,* in the middle of March and have also been stored at 45°F.

The irradiation was performed in the radiation cave of the Fission Products Laboratory, The University of Michigan. The potatoes, in paper bags, were placed in the center well, i.e., within the circle of cobalt rods, and irradiated for various lengths of time to give the desired dosages. The tubers, still in the bags, were returned to the storage room and removed as needed. Before treatment the tubers had been carefully selected for uniformity. Dosages of 5, 15, 25, 50, 100, and 200 kilorep were used.

Both carbon dioxide production and oxygen consumption were measured, but in different experiments and on different tubers.

*We are indebted to Dr. John C. Noonan for these potatoes.

1. Carbon Dioxide Production.—The carbon dioxide production was determined on whole tubers, all of which were used throughout the investigation. On January 11 four lots of Sebago tubers were selected, each lot consisting of 7 or 8 tubers and weighing a total of about one kilo. These potatoes were given the following dosages of gamma radiation: 0, 5, 15, and 25 kilorep. On January 18 four other lots were given dosages of 0, 50, 100, and 200 kilorep. At intervals, for a period of twenty weeks, the CO₂ production of these potatoes has been determined.

The CO₂ was determined by passing it through a Ba(OH)₂ solution, allowing it to react with the latter. The Ba(OH)₂ was placed in long Pettenkofer tubes, through which the air from the respiration jars was drawn slowly, allowing the CO₂ to be completely absorbed.

Figure 26 is a schematic picture of the setup. Laboratory air was slowly drawn through the apparatus by the aid of an aspirator. The air first entered the soda-lime towers (2), where the CO₂ from the air was removed, then through the cooling coil (4) into a bottle (5) containing Ba(OH)₂ to test for the presence of CO₂. The CO₂-free air next passed into the respiration jars (6) containing the potatoes. The cooling coil and the jars were inside a large refrigerator kept at 45°F to maintain the storage temperature. From the respiration jars the air, now containing CO₂ produced by the tubers, was passed into long Pettenkofer glass tubes (7) and through a narrow glass tube shown in detail. This broke the air stream into small bubbles which passed through the Ba(OH)₂ solution, where the CO₂ was absorbed. To be certain that all the CO₂ had been absorbed, a test bottle (8) was placed at the end of each tube. This bottle contained phenolphthalein in a solution of pH 8.5. If all of the CO₂ was not absorbed, the color in the detector tube changed.

For the CO₂ determination the tubers were removed from the storage room and placed in the jars in the refrigerator. This was done early in the morning and CO₂-free air was drawn through the apparatus for two hours to allow equilibrium to be reached. During this time the Pettenkofer tubes contained distilled water. After equilibrium had been reached, two collections each extending over a period of three hours, were made. The Ba(OH)₂ was titrated and calculations made to determine the amount of CO₂ produced. The respiration has been expressed as CO₂ per kilogram of fresh potato tubers.

2. Oxygen Consumption.—The oxygen consumption was determined by the manometric technique in the usual manner. Respiration vessels of approximately 90 ml were used instead of the usual 25-ml vessels, to facilitate the use of a larger amount of plant material. All the determinations were made at 28°C (82°F) because no facilities were available to use the storage temperature of 45°F.

For an experiment three tubers from a lot to be studied were used. Sections 0.8 mm thick and 12 mm in diameter were cut with a microtome

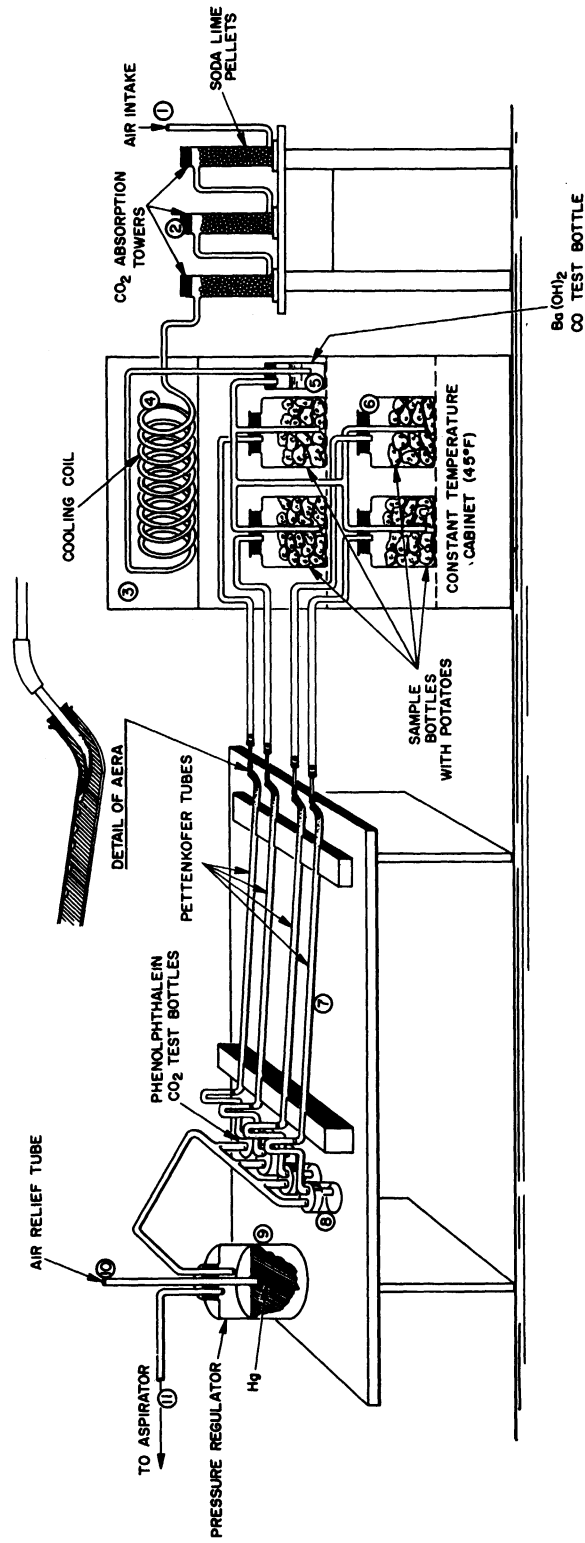

Fig. 26. Schematic view of gas train currently being used in whole-tuber respiration studies.

from cylinders cut around an "eye." Two such cylinders were cut from each tuber, midway between the stem end and the apex. Seven disks were cut from each cylinder in sequence, the first one containing the surface. Each assay (determination) was made in duplicate and 21 disks were used for each assay. In all experiments the disks were used as soon as cut. During the assay they were immersed in 0.01 M phosphate buffer of pH 6.0. A period of 50 minutes was allowed for equilibrium to be reached, and the oxygen consumption then was determined for 3 consecutive periods of 20 minutes each.

Oxygen consumption was determined for both the Sebago and the Pontiac varieties. The Sebagos were selected and irradiated separately from those used for CO₂ production.

3. Respiration of Whole Tubers.—In the studies on the respiration of whole potatoes the output of carbon dioxide was used as the indicator of respiration rate. A stream of carbon-dioxide-free air was drawn through an enclosed chamber containing the tubers and thence drawn through long tubes containing a known volume of barium hydroxide solution (standardized 0.1N). The solution was titrated with 0.1N oxalic acid to determine the amount of Ba(OH)₂ remaining after carbon dioxide absorption. The amount of Ba(OH)₂ lost is equivalent to the amount of CO₂ absorbed.

As shown in Fig. 27, air was drawn by an aspirator through granular soda lime in three 12-in. towers and then was bubbled through a solution of barium hydroxide as an added guarantee of absence of carbon dioxide in the air stream.

Experiments were first run in the last part of November, and in early December, 1955, with the setup shown in Fig. 27. However, this setup was found to be quite unsatisfactory as a result of wide variations in room temperature in the laboratory. As a result of the high temperatures, the potatoes became covered with molds in a few days. The variations in room temperature also caused wide variations in respiration rate so that no valid comparisons could be made.

Toward the end of December, a refrigerator was installed (see Fig. 28) and adapted so that the potatoes could be kept inside at a temperature comparable to the one at which they had been stored (45°F). It was hoped that this procedure would give the approximate rate of respiration that was occurring in the storage rooms held at 45°F.

The barium hydroxide solution was placed inside the refrigerator beside the jars in which the potatoes were kept. Then the CO₂-free air was passed from the Ba(OH)₂ solution into the jars containing the potatoes through a tube which led to the bottom of each jar. The gas was removed from the top of the jar as shown in Fig. 28. This arrangement of tubes was used in an effort to insure complete gas displacement in the jars.

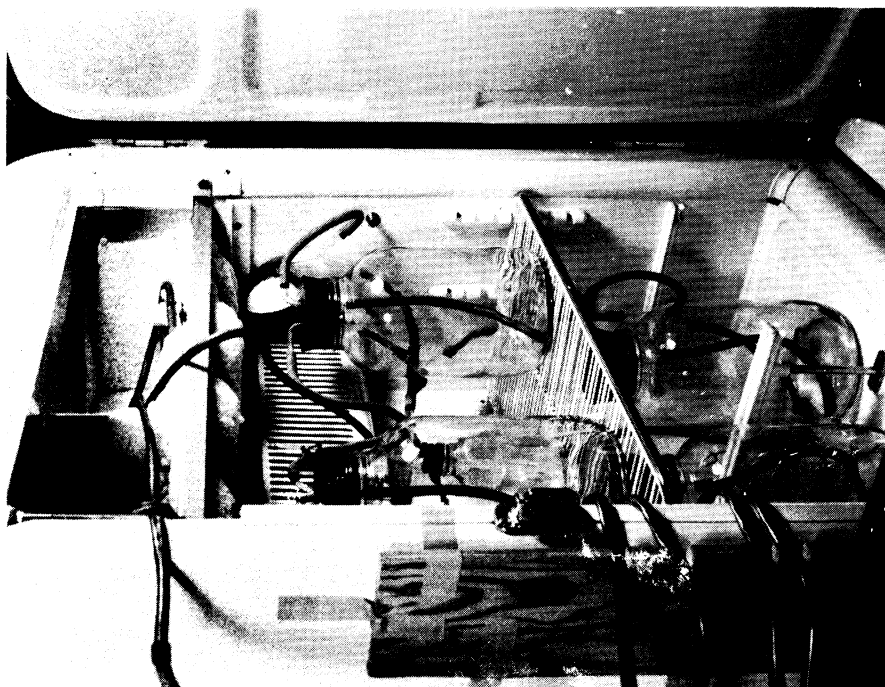

Fig. 28. View of refrigerator and containers for potatoes used in studies of whole-tuber respiration at 45°F.

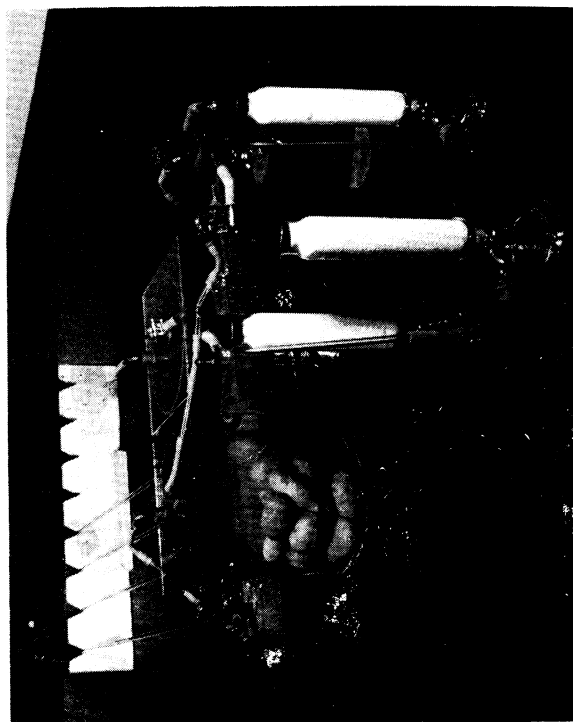

Fig. 27. View of original gas train for whole-tuber respiration studies, showing carbon dioxide absorption towers for producing carbon dioxide-free air.

The gas from the jars was then drawn from the refrigerator by copper tubing and rubber tubing which was connected to the absorption tubes as shown in Fig. 29. The gas enters the absorption tubes via a short piece of glass tubing which has been drawn to a fine tip. This small tip aids in producing small bubbles which expose the gas more effectively than large bubbles to the barium hydroxide.

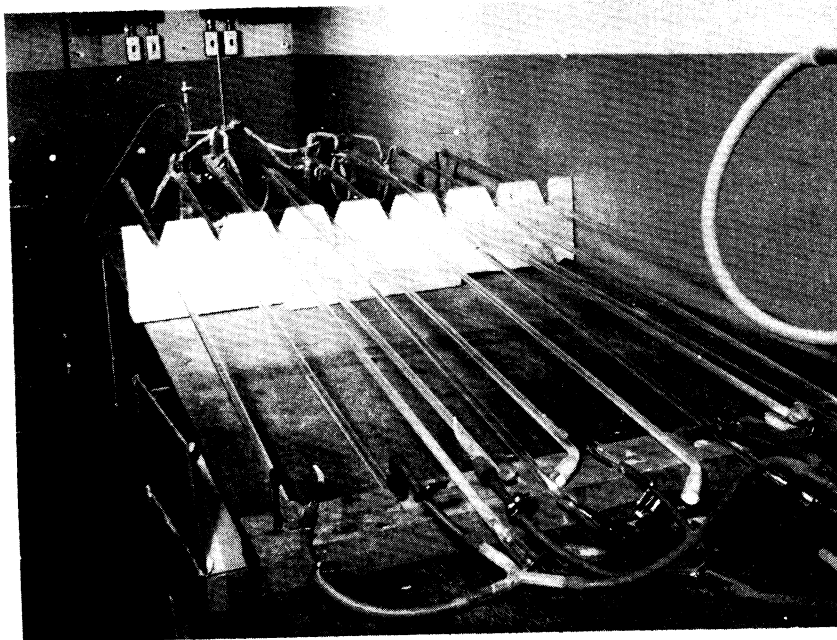

Fig. 29. View of the absorption tubes, indicator tubes, and pressure-regulating device in whole-tuber respiration studies.

The gas flow is regulated so that the rate of flow is rapid without the bubbles becoming too large and merging with one another as they pass through the tubes. The tubes are about 6 ft long and can hold about 100 cc of liquid. In this experiment, however, only 80 ml of the $\text{Ba}(\text{OH})_2$ is added to each tube. The occurrence of foaming necessitates leaving a free space at the top of the tube. The gas emerging from the tube is passed through test tubes containing phenolphthalein in a slightly alkaline solution to test for unabsorbed CO_2 . The gas is drawn from the absorption tubes through a jar of mercury which serves as a vacuum regulator and then to the aspirator.

After the collecting system has run for the desired length of time, the barium hydroxide solution is carefully removed from the tubes. (It can be noted that the carbon dioxide absorbed reacts with barium hydroxide to yield barium carbonate, a white precipitate which is insoluble in this solution.) A 20-ml sample of this solution is placed in an Erlenmeyer flask, and a drop of 0.1% phenolphthalein solution is added, which turns the solution red. Then 0.1 N oxalic acid is added until the solution remains colorless for about 30 seconds.

Oxalic acid is used because it is a weak acid and will not react with BaCO_3 to release CO_2 . Hence, the procedure used is a titration of the Ba(OH)_2 that was not consumed by the CO_2 to produce BaCO_3 . The oxalic acid also forms a white precipitate with the barium hydroxide in this titration, which gives a good background for judging the color change of the phenolphthalein.

Routine followed: on the morning of the day an experiment was to be started the samples of potatoes were brought from the Food Service and irradiated immediately. They were then weighed and the weight recorded at the same temperature as the room in which they had been stored (45°F). Usually seven or eight potatoes were chosen which together weighed just over a kilo. At this time the carbon-dioxide-free air was allowed to flow through the voids between the potatoes. The system was equilibrated by drawing the air through tubes containing distilled water for the first two hours after the potatoes were placed in the refrigerator. After two hours the gas stream was diverted to the absorption tubes containing the Ba(OH)_2 and allowed to run for 2-1/2 to 3 hours. Then the Ba(OH)_2 was collected and titrated.

B. RESULTS

Figure 30 and Table IX give the results for whole tubers. With the exception of the tubers that received 5 kilorep, there was a considerable increase in respiration two days after irradiation. This was followed by a decrease after two or four weeks, and seven weeks after irradiation

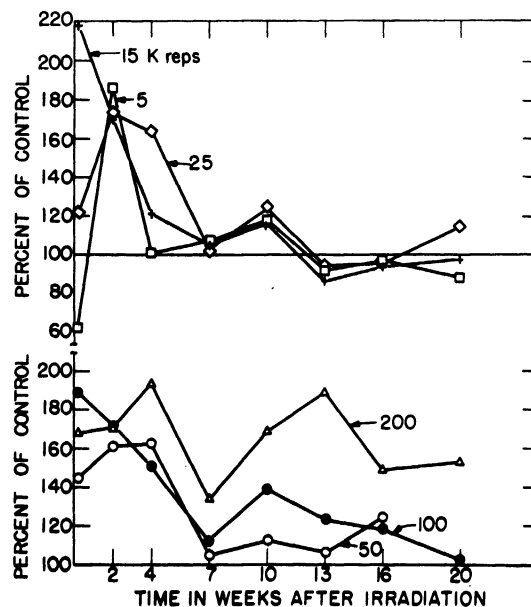

Fig. 30. Carbon dioxide production by whole tubers (Sebago), presented as percent of control tubers. Radiation dosages given in kilorep.

TABLE IX. CARBON DIOXIDE PRODUCTION BY WHOLE POTATO TUBERS. THE UPPER FIGURE IN EACH SQUARE DENOTES MILLIGRAMS OF CO₂ PRODUCED PER KILOGRAM OF FRESH POTATO PER HOUR, AND THE FIGURES WITHIN PARENTHESES THE PERCENT OF THE CONTROL. DOSAGES ARE GIVEN IN KILOREP.

Time After Dosage	Irradiation		2		4		7		10		13		16		20	
	Days	Weeks	Days	Weeks	Days	Weeks	Days	Weeks	Days	Weeks	Days	Weeks	Days	Weeks	Days	Weeks
0	Control	1.40	1.35	1.94	1.48	1.22	1.97	2.06	1.79							
5		0.87 (62%)	2.49 (184%)	1.96 (101%)	1.57 (106%)	1.45 (119%)	1.80 (91%)	2.00 (97%)	1.59 (89%)							
15		3.06 (219%)	2.30 (170%)	2.34 (121%)	1.56 (105%)	1.42 (116%)	1.69 (86%)	1.94 (94%)	1.75 (98%)							
25		1.70 (121%)	2.32 (172%)	2.79 (164%)	1.55 (105%)	1.53 (125%)	1.85 (94%)	1.95 (95%)	2.06 (115%)							
0	Control	2.35	1.84	1.34	1.82	1.94	1.56	1.87	2.05							
50		3.41 (145%)	2.96 (161%)	2.17 (162%)	1.91 (105%)	2.19 (113%)	1.47 (106%)	2.32 (124%)	1.24 (60%)							
100		4.44 (189%)	3.17 (172%)	2.02 (151%)	2.04 (112%)	2.79 (144%)	1.92 (123%)	2.20 (118%)	2.08 (102%)							
200		3.95 (168%)	3.15 (171%)	2.59 (193%)	2.44 (134%)	3.24 (168%)	2.97 (190%)	2.80 (150%)	3.14 (153%)							

the rate was low for all dosages. This low point was followed by an increase, which was dependent on the dosage applied; the tubers receiving a dosage of 5 kilorep increased the least, and those receiving the 200 kilorep, the most. The latter continued to show an even higher rate at the next analyses (13 weeks). By the thirteenth week the CO₂ produced by those tubers receiving dosages of 5, 15, and 25 kilorep was less than that of the controls, and all except those receiving the 200 kilorep were respiring less than at the preceding analysis and then continued to respire less. In general, the observation was made that after the first rise in respiration the rate of respiration coincided with the dosage given. Those given the lowest dosage respired the least and those having received the highest dosage used (200 kilorep) respired the most. There may be slight individual variations but in general this is true.

A few days after the last CO₂ determination was made the potatoes that had been used for the duration of the experiment were examined externally and internally. Both control lots had a few small sprouts, never over 5 mm long, and they were somewhat wilted, but the flesh was white, with no blemishes. None of the irradiated tubers had any sprouts. The 5-, 15-, and 25-kilorep dosages caused internal browning in one tuber in each lot; otherwise they were as good as the controls. Fifty-kilorep irradiation caused more browning and 100 and 200 kilorep caused still more browning.

The oxygen consumption is given in Fig. 31 and Table X for the Sebago, and in Fig. 32 and Table XI for the Pontiac. The day after irradiation there was an increase in oxygen consumption over that in the controls, but by the end of the week there had developed a decrease, except in those that had received the 200-kilorep irradiation. Those receiving the two lowest dosages were actually using less oxygen than the untreated samples. The assay made during the third week indicated a second peak, but from then on there was a decrease in consumption by the tubers having received the lower radiation doses, and the rate varied little from that of the control, though generally it was a little lower. The tubers having received the higher dosage treatment continued to respire at a rate considerably higher than their control.

Three weeks after irradiation controls began to sprout, but only nonsprouting eyes were used. On the fourteenth week tubers having received 25 kilorep were wilted and showed pits caused by fungus infection. However, there were areas not infected, and these were used. The 50-kilorep treatment was causing considerable wilting. All others used were in good condition. By the eighteenth week all treated tubers showed considerable wilting. The 50-kilorep-treated tubers were the poorest and showed black areas in the flesh, but these areas were not used. Twenty-two weeks after irradiation the 5- and 15-kilorep-treated tubers were essentially like the nonirradiated controls, except that they had no sprouts. All were a little wilted.

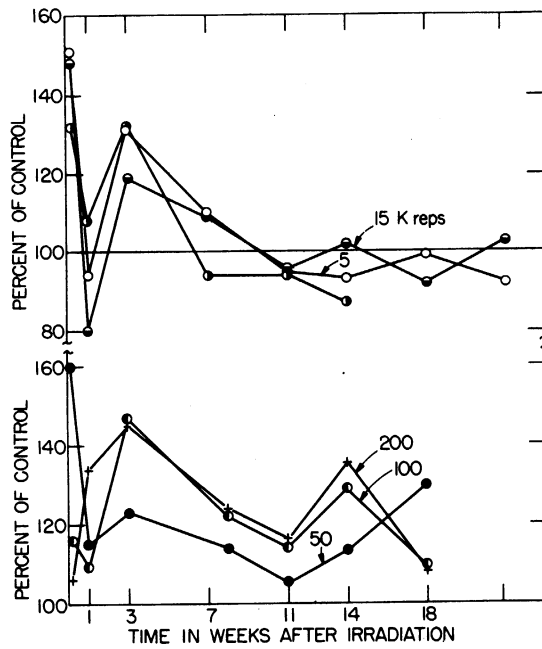

Fig. 31. Oxygen consumption by potato slices (Sebago), presented as percent of the control tubers. Radiation dosages given in kilorep.

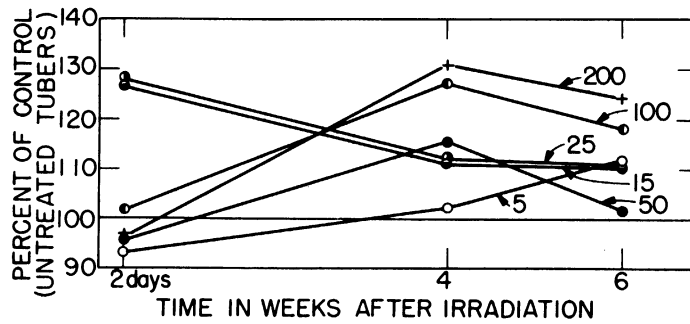

Fig. 32. Oxygen consumption by slices (Pontiac), presented as percent of the control tubers. Radiation dosages given in kilorep.

TABLE X. OXYGEN CONSUMPTION BY SLICES OF POTATO TUBERS. THE UPPER FIGURE IN EACH SQUARE DENOTES MICROLITERS OF OXYGEN CONSUMED PER MILLIGRAM OF DRY WEIGHT PER HOUR, AND THE FIGURES IN PARENTHESES THE PERCENT OF CONTROL. DOSAGES ARE GIVEN IN KILOREP.

Time After Dosage	Irradiation								
	27 Hours	1 Week	3 Weeks	7 Weeks	8 Weeks	11 Weeks	14 Weeks	18 Weeks	22 Weeks
0 Control	.730	.60	.651	.64	.71	.725	.710	.605	
5	1.10 (151%)	.56 (93%)	.851 (131%)	.705 (110%)	.675 (95%)	.675 (93%)	.705 (99%)	.555 (92%)	
15	1.08 (148%)	.48 (80%)	.778 (119%)	.70 (109%)	.68 (96%)	.74 (102%)	.66 (93%)	.62 (102%)	
25	.993 (132%)	.65 (108%)	.858 (132%)	.60 (94%)	.665 (94%)	.625 (86%)			
0 Control	.752	.73	.558	.705	.755	.660	.745		
50	1.204 (160%)	.84 (115%)	.689 (124%)	.805 (114%)	.795 (105%)	.75 (114%)	.965 (130%)		
100	1.124 (116%)	.80 (110%)	.821 (147%)	.86 (122%)	.860 (114%)	.85 (129%)	.815 (109%)		
200	1.029 (106%)	.98 (134%)	.813 (146%)	.875 (124%)	.880 (117%)	.895 (136%)	.80 (107%)		

TABLE XI. OXYGEN CONSUMPTION BY SLICES OF PONTIAC POTATO TUBERS. THE UPPER FIGURES IN EACH SQUARE DENOTE MICROLITERS OF OXYGEN CONSUMED PER MILLIGRAM OF DRY MATERIAL PER HOUR, AND THE FIGURES IN PARENTHESES THE PERCENT OF CONTROL. DOSAGES ARE GIVEN IN KILOREP.

Dosage	Time after Irradiation	2 Days	4 Weeks	6 Weeks
0	Control	0.865	0.840	0.660
5		0.805 (93%)	0.860 (102%)	0.737 (112%)
15		1.095 (127%)	0.930 (111%)	0.728 (110%)
25		1.110 (128%)	0.940 (112%)	0.733 (111%)
0	Control	0.930	0.865	0.781
50		0.885 (95%)	1.000 (116%)	0.791 (101%)
100		0.945 (102%)	1.100 (127%)	0.918 (118%)
200		0.890 (96%)	1.130 (131%)	0.968 (124%)

The variety Pontiac was studied for only 6 weeks. The results are given in Fig. 32 and Table XI. The oxygen consumption on the second day after irradiation shows no relation to the dosage applied, but by the fourth week there was a positive relationship. By the sixth week there was a leveling off, but the tubers having received the 100- and 200-kilorep dosages were still consuming more oxygen than any of the others. As was to be expected there was no sprouting of any of these tubers, and all were in excellent condition.

C. DISCUSSION AND CONCLUSION

The early rise may be associated with a greater utilization of energy, thus using up more ATP and producing more ADP, which could

increase the respiration. The drop in oxygen consumption associated with a high CO₂ production may be due to a temporary aerobic fermentation, which has been frequently mentioned in the literature.⁶ The continued high rate could be associated with a rise in the sugar content, which lasts for several weeks.⁷ When this surplus sugar is used up, those tubers that received the lower dosages could be thought of as going back to their normal rate; no permanent physiological changes had been induced. Those tubers that had received dosages of 50, 100, and 200 kilorep continued to respire at a rate greater than that of the controls. This could be associated with injury as a result of the irradiation. There could be a shift in the path of respiration, whereby phosphorylation might be avoided. Millerd, Bonner, and Biale⁸ have suggested that the increased respiration in ripening avocado fruits is due to an uncoupling of the phosphorylation in respiration.

From this study one can conclude that gamma irradiation of potatoes with dosages of 5-15 kilorep is most likely to prove satisfactory. These dosages inhibit sprouting over a storage period of 22 weeks, produce little or no alteration in the physical appearance of the tubers, and after an early spurt in respiration settle down to a rate very nearly that of the nonirradiated tubers. Higher dosages caused disturbances such as browning, blackening, fungus infection, and an increase in respiration, which continued throughout the investigation.

V. STUDIES ON POTATO "HORMONES"

A. INTRODUCTION

The observation that plants tend to grow toward the source of light is very old. That this phototropic action is related to definite chemical compounds was first clearly indicated in the classical investigations of Boysen-Jensen⁹ on the coleoptile of *Avena*. Naturally occurring chemical compounds possessing the property of being able to regulate plant growth were given the name "hormone." Any compound, either synthetic or naturally occurring, that has this property is termed auxin. A large number of scientific articles have appeared relating to auxins.¹⁰

The effects of x-rays on living matter have been studied since the 1890's. Investigators studied the effects on plant growth in the 1920's; but Skoog,¹¹ in 1935, was probably the first to study the effects on an auxin. Using a high-voltage tube capable of being operated at 900 kilovolts and 3 to 4 milliamperes, Skoog demonstrated the inactivating effect of x-rays on an auxin (indoleacetic acid) as well as on auxin extracts from plants. He showed this inactivation to be the result of an oxidation, on the basis of experiments in air and in nitrogen atmosphere.

In general, if there is no auxin present, there will be no growth, but a supra-optimal concentration of auxin will also prevent growth. Only minimal quantities are required for plant growth, and the application of an excess will retard or stop growth. By the use of chemicals it is possible to prolong artificially the rest period of potato tubers. On the other hand, the normal resting period can also be shortened by using ethylene chlorohydrin. The belief prevails that the content of auxin not only varies in quantity during storage, but that the concentration also varies in the different parts of the potato. Prior to sprouting of the potatoes in the spring an increase in auxin has been observed in the fleshy part of the potato, while later the auxin, or its precursor, increases in the potato peel. The change of the precursors into auxin is generally assumed to be enzymatic in origin. One of the chief precursors may be presumed to be the amino acid tryptophane, because it has been shown that the amount of biosynthesis of auxin in a medium depends on the content of tryptophane in the medium.

One of the objectives of this research project is to increase the storage life of potatoes as a result of gamma irradiation. Gamma irradiation has been shown to slow down or halt the sprouting of the potato. Therefore, a study of the concentration of the growth-regulating substances which control sprouting appears advisable. This study involved a comparison of concentrations of phytohormones in irradiated and nonirradiated potatoes under varying storage conditions. The indole ring which occurs in most phytohormones is believed to be affected by irradiation, which may be a possible explanation of some of the phenomena of sprout inhibition.

The term auxin is specifically defined as: an organic substance which promotes growth along the longitudinal axis, when applied in low concentrations to shoots of plants freed as far as practical from their own inherent growth-promoting substance.

The term phytohormone is defined as: an organic substance produced naturally in plants, controlling growth or other physiological functions at a point other than that of production. It is active in small quantities.

In this research study an extract of the "eyes" and a small amount of surrounding tissue of potatoes was made with freshly distilled ether, which is completely free of hormone-destroying hydrogen peroxide. The various growth-regulating substances were then separated by paper chromatography.

B. PREPARATION OF SAMPLE

1. Extraction.—The sample consists of the eyes of several potatoes, including a small portion of the flesh around each eye. The eyes

at the apical end are not used because they seem quite variable. Care is taken to sample uniform material. About 10 gm of this material is collected and covered with peroxide-free ether. (The ether is rendered peroxide-free by distilling it from a 50-50 mixture of calcium oxide and ferrous sulfate just prior to use.) The ether and eye tissue are kept in the refrigerator (about 40°F) for a period of 20 hours. The ether is then decanted and evaporated to dryness. The residue is taken up in about 0.1 ml of alcohol, and this solution is subjected to paper chromatography.

2. Chromatography.—Chromatography had its origin with the Russian botanist M. Tswett,¹² who was able to separate chlorophyll pigments on adsorption columns. Chromatography is a method of separating similar compounds on the basis of differences in their adsorption coefficients, in the case of adsorption chromatography; or on the basis of differences in their partition coefficients, in the case of partition chromatography. A very high degree of resolution can be achieved. The method is applicable to the minutest amounts of mixtures, and, in fact, works best only when small amounts are involved.

In adsorption chromatography, a solvent is allowed to flow slowly down through a column of finely divided adsorbent. The components of the mixture, layered out at the top of the column, are carried down at different rates, each component appearing as a separate "band" down the length of the column. If a second solvent, immiscible with the moving solvent, is first adsorbed and held stationary on the adsorbent, the components of the mixture are distributed between the two liquid phases. This becomes partition chromatography and is analogous to counter-current distribution.

Where minute amounts of material are involved, as in the case of hormones, or other materials isolated from small amounts of living matter, a sheet of paper is substituted for the cylindrical column of adsorbent. This has the advantage of exposing the entire amount of each component to view and also facilitates the process of recovering each isolated component. The disadvantage is that the paper must be hung in a closed chamber to insure complete equilibration of the liquid phases with the atmosphere. Both adsorption chromatography and partition chromatography can be performed with paper. In the former method, the mobile solvent is allowed to flow down dry paper (in equilibrium with the atmosphere), at the top of which the mixture has been applied as a tiny spot; in the latter, the paper is first dampened or wetted with the other, immiscible, stationary phase. The principles and many of the details of paper chromatography were worked out by Martin¹³ and Synge.¹⁴

3. Chromatography Procedure.—The residue from the ether extraction is dissolved in the minimum amount of absolute alcohol. This solution is drawn into a micropipette and applied to the chromatograph paper in the

smallest spot possible. The paper is cut in vertical strips with a common top edge, and the spot is applied at the top of each separate strip. A view of the chromatograph chamber and the paper inside is shown in Fig. 33. A household hairdryer is used to direct a current of warm air at the paper as the spot is being applied so as to hasten the evaporation of the solvent before it spreads by capillarity and hence spreads the area of the spot. The smaller the spot, the smaller the area of overlap of constituents of the extract in the finished chromatogram. The extracts of potatoes treated in different ways can each be spotted at the head of one of the strips and subjected to the same conditions as the others.

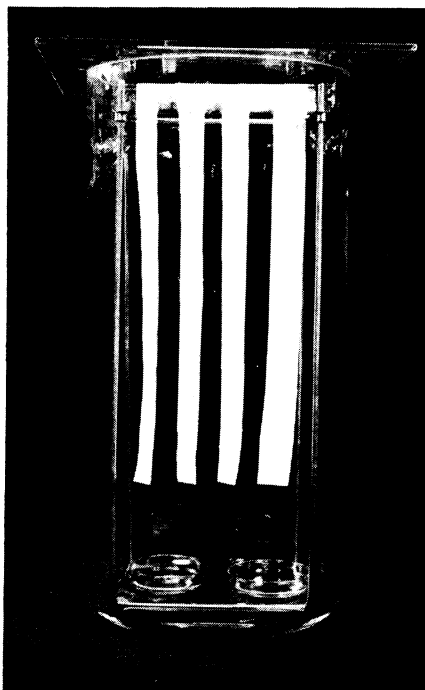

Fig. 33. Chromatograph chamber showing paper hanging from trough of solvent. To obtain complete equilibration of solvent between atmosphere and paper, it is necessary to provide more surface area for solvent than shown here. This is done by placing a layer of solvent in the bottom of the jar and lining the inside of the jar with paper which sits in the solvent.

After drying, the paper is hung from the trough at the top of the chromatograph chamber, shown also in Fig. 33. No solvent is placed in the trough for 24 hours, but solvent is placed in the bottom of the chamber during this period to insure complete equilibration of solvent with the atmosphere and the paper. After 24 hours, a stopper in the top lid is removed and solvent is admitted to the trough. As the solvent front moves down the paper and over the spots, the chroma-

togram begins to form. The solvent is allowed to flow down the paper for about 24 hours. The paper is then removed and allowed to dry.

Since the percent of growth hormone in the tissues is very low, a modified technique similar to that used by other investigators is employed.^{15,16,17} This involves cutting strips of the dried chromatographic paper containing the adsorbed extract into five equal pieces. Each piece is placed in a separate flask and eluted with peroxide-free ether. After 12 hours extraction in the cold, the ether is decanted and the strips rinsed with a small portion of fresh ether. The ether is evaporated to dryness, and the residue analyzed for growth-hormone activity by the standard Avena assay method. Growth activity is then plotted against the R_f , or percent the chemical has traveled with respect to the rate which the solvent has traveled. Peaks of activity may be taken as evidence of the presence of the hormone. These peaks are then correlated with the position of known compounds.

C. AVENA TECHNIQUE

The auxins thus separated were assayed by the Avena (oat) technique. In this procedure 72-hour-old plants which have been grown in the dark at a relative humidity of 85% and at a temperature of 25°-26°C are used. Plants of this age and grown under these conditions are very reactive. This assay procedure was originally developed by Went,¹⁸ but it has been variously modified by other investigators. It may be briefly described as follows:

Procedure for Avena Technique

(1) Seeds of a pure line of Siegeshafer oats are husked and soaked from two to three hours in water.

(2) The soaked seeds are placed on glass strips covered with strips of paper toweling which are then placed in a damp chamber (i.e., a glass refrigerator-type jar, which contains a small amount of water sufficient to cover the bottom of the jar).

In this step the seeds are placed with the embryo side up and overhanging the edge of the glass strips previously mentioned (see Fig. 34). Placing the embryo end of the seed over the edge of the strip permits the roots of the young seedlings to grow straight downward. This root orientation allows the seedlings to secure water when they are placed in the holders at a later stage of the experiment. After this point all work must be done in red light because other wavelengths cause phototropic curvature and a decrease in the sensitivity of the plants. The damp chamber is placed in a weak red light in a room which is held at a temperature of 25°-26°C.

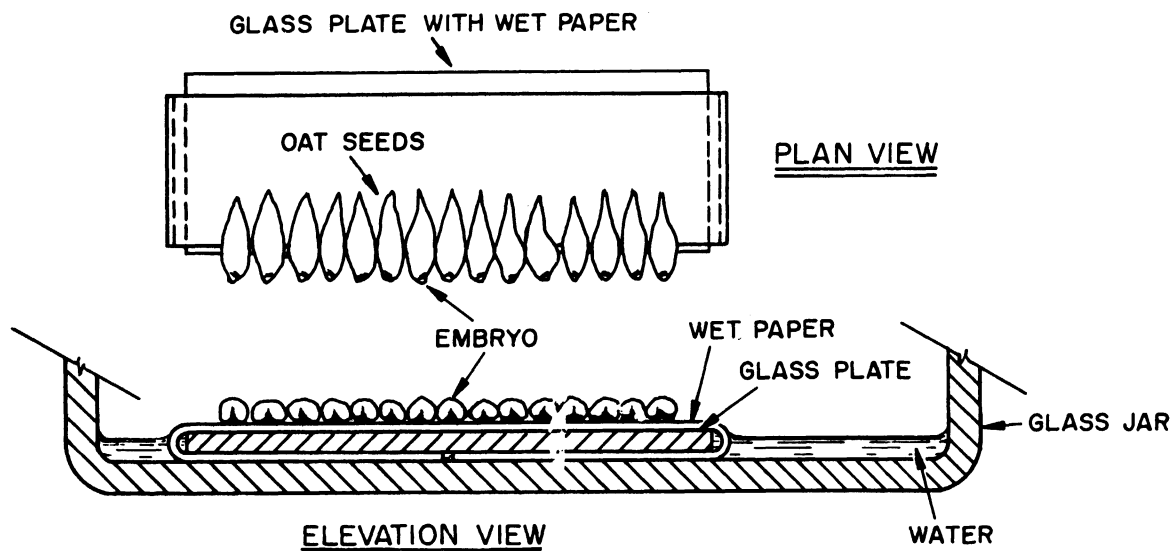

Fig. 34. Device for accommodating oat seeds in order to cause sprouting downward.

(3) Thirty hours later the rooted seedlings are placed in special glass holders. The roots dip into water in a zinc trough coated on the inside with paraffin and the coleoptile (young oat sprout) grows vertically upward through a guide (see Fig. 35). The holders are held in brass clips in rows of twelve (see Fig. 36). The holder can be rotated in the clip and the clip can be moved back and forth so that the seedling can be made to stand strictly perpendicular. The seedlings are allowed to grow in the dark for about 40 more hours at a temperature of 25°-26°C and a relative humidity of 85-90%.

(4) After 40 hours, seedlings that are straight and of the same height are selected and about two millimeters of the tip of the coleoptile is removed with a sharp razor blade (see Fig. 37a and b).

(5) Meanwhile, agar blocks are made by mixing equal quantities of three-percent agar and a standard solution of auxin. These are poured hot into a mold and then allowed to solidify. The large blocks produced in this manner are cut into 12 small blocks, each containing a volume of about 10 mm³. The actual size is not very important because the curvature is dependent on the concentration of auxin in the blocks rather than on the volume.

(6) Three hours after the first decapitation a second decapitation is made (see Fig. 37d and e). In this cut about 1 to 1-1/2 millimeters are removed from the top of the coleoptile. This is performed with a special pair of scissors which cut the coleoptile but not the leaf which

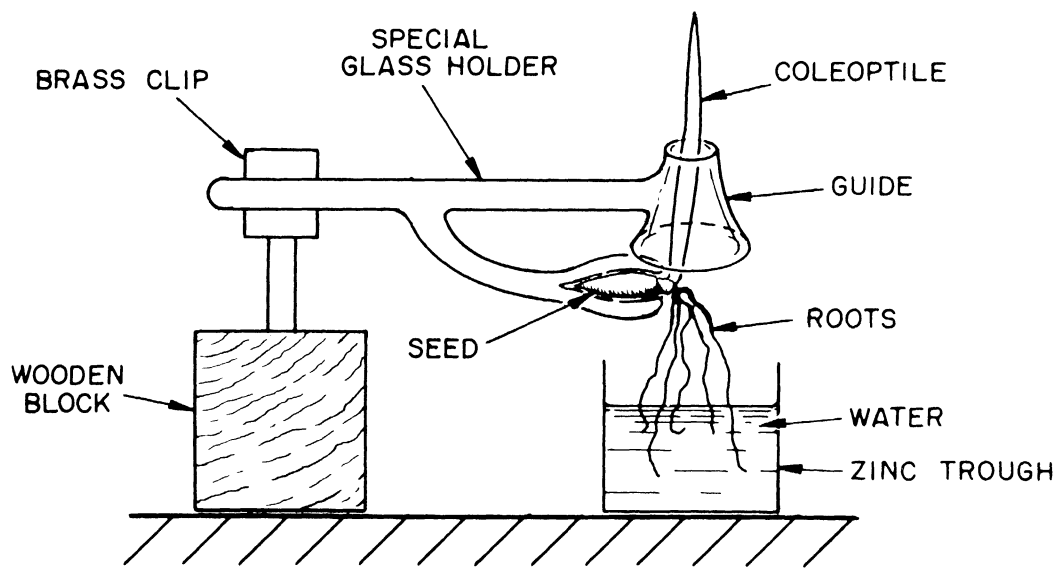

Fig. 35. Diagram of device for guiding upward the growth of the young oat sprout.

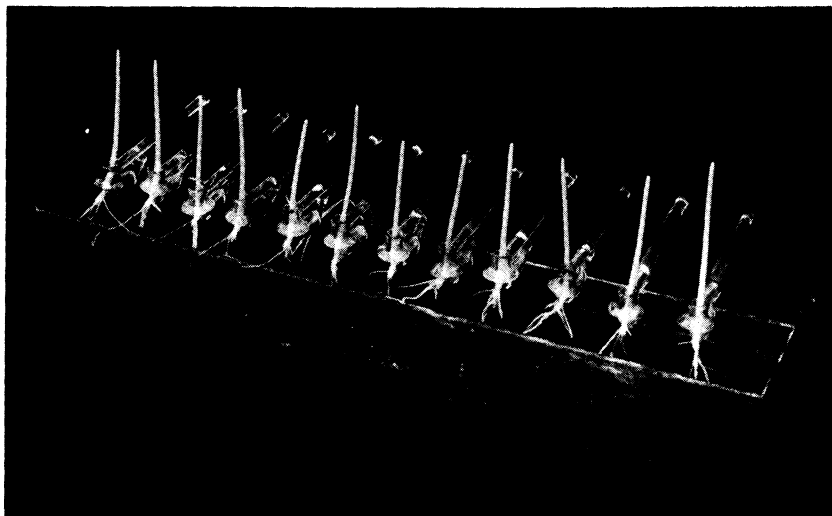

Fig. 36. Photograph of the apparatus used for growing the oat sprouts, showing the sprouts at a stage prior to cutting and applying the agar block containing the extract to be assayed.

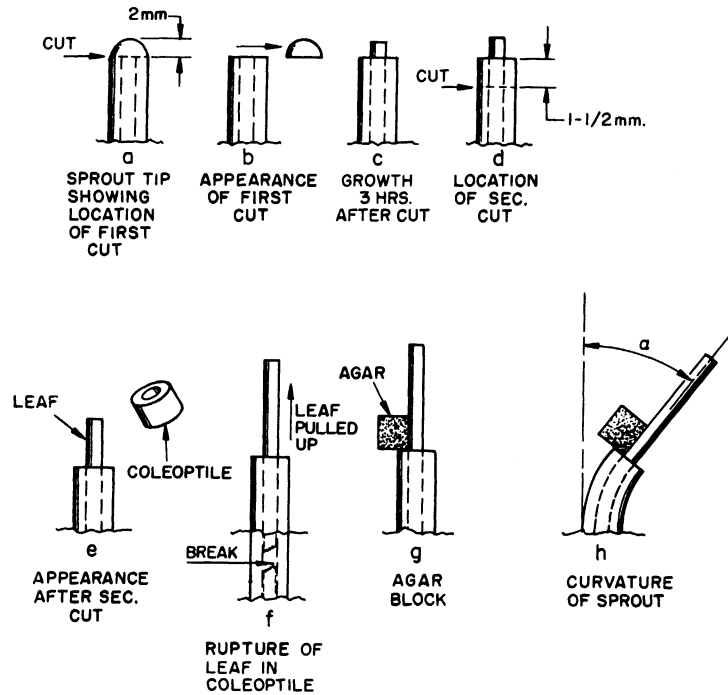

Fig. 37. Schematic views of an oat sprout in the process of being cut and manipulated in the *Avena* hormone assay technique.

it surrounds (see Fig. 37e). The leaf is then pulled upward with forceps until it breaks off deep inside the coleoptile (see Fig. 37f). The leaf is not actually attached to the plant but is only held by the coleoptile and used as a support for the agar block. The purpose of the two decapitations is to remove the region of hormone synthesis and produce a plant low in hormone, which will respond to the added auxins.

(7) Immediately after rupture of the leaf the small agar blocks are placed on the cut end of the coleoptile with one edge against the leaf (see Fig. 37g). The blocks must be placed precisely perpendicular to the plane of the light source to be used in photographing the seedlings, otherwise the full extent of the curvature will not be recorded. Figure 38 shows sprouts with attached agar blocks. The auxin diffuses down into the coleoptile and stimulates growth. Since the agar block is located on one side of the coleoptile, growth is more rapid on one side than the other. This results in curvature away from the agar block.

(8) The plant is allowed to stand thus for ninety minutes and then a shadowgraph is taken as shown in Fig. 39. If left more than ninety minutes, there is a "regeneration of the physiological tip," which produces auxin on both sides of the coleoptile so that the curvature is decreased.

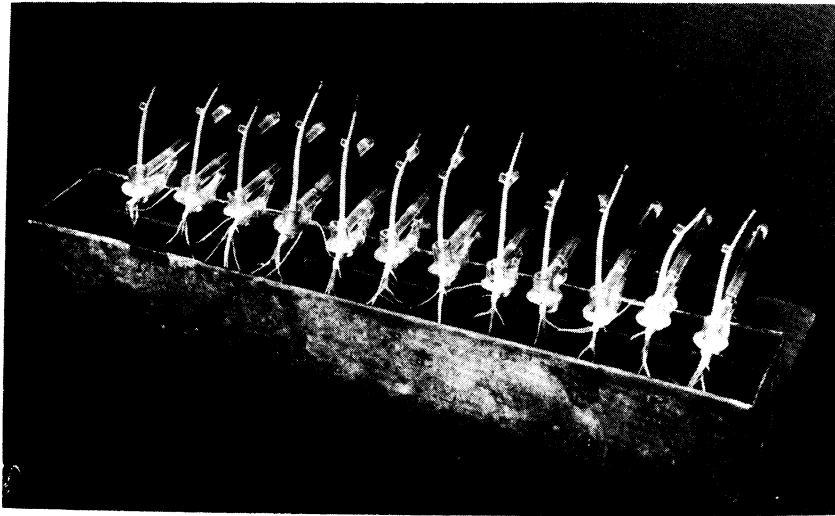

Fig. 38. Oat sprouts shown in Fig. 36 after cutting and applying the agar block.

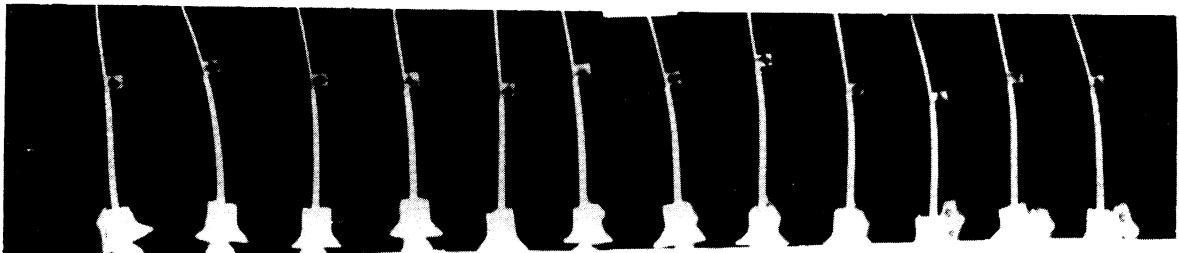

Fig. 39. Shadowgraph of oat sprouts, showing curvature resulting from action of hormone or hormone inhibitor.

The shadowgraph is measured with a special protractor to determine the number of degrees in the angle produced by the curvature (see Fig. 37h).

For a given range of auxin concentrations (e.g., 15-30 micrograms per liter of agar), the curvature is directly proportional to the amount of auxin present. Thus a standard solution can be made and used on one set of oat sprouts while at the same time and under the same conditions an extract is used on another set, and by comparison the amount of auxin extracted from a given amount of plant material can be determined.

D. RESULTS OF HORMONE STUDY OF IRRADIATED POTATOES

Nearly a dozen experiments have been conducted to date. The purpose of the first set of experiments was to test the Avena assay with varying amounts of whole extract (not chromatographed) of the eyes of nonirradiated tubers, using Sebagos for this purpose. The results showed that such extracts had pronounced growth-hormone activity. The purpose of the second set of experiments (also with Sebagos) was to determine if the extract could be resolved by paper chromatography into separate components, and to determine the activity of each. In the early studies, two components were separated, one which moved slowly, by paper chromatography, and one which moved fast. The latter was found to consist of essentially all the growth-promoting activity of the original mixture (positive bending of the oat coleoptile to an approximate angle of 25°). The former, however, appeared to possess slight growth-hormone-inhibiting activity, as shown by a negative bending of the oat coleoptile. The extent of the negative bending was considerably less than 25° , indicating that the hormone inhibition, if any, was considerably weaker than the positive growth-stimulating activity. Furthermore, the subsequent assays showed no evidence at all of the hormone-inhibitor activity in the eyes of nonirradiated as well as irradiated potatoes. This would be consistent with other studies which have shown the amount of growth-hormone inhibitor to decrease with cessation of dormancy.

The purpose of the next set of experiments was to determine the effect of irradiation of the potatoes on the hormone activity of the eye tissue directly after irradiation. Sebagos given 5, 15, 25, and 50 kilorep were used in the first assay. It was found that all doses of irradiation caused a decrease in growth-hormone activity. As mentioned above, there was no hormone-inhibition action in either irradiated or nonirradiated samples. Most of the activity appeared to come from one "spot" on the paper chromatogram, although this region of the chromatogram may contain several components only partially resolved. It was not possible to distinguish differences in the extent by which different doses of radiation caused a decrease in hormone activity with respect to controls. In a

set of experiments with Russet Rurals given 5-, 15-, and 25-kilorep dosages of radiation, similar results were found. Since samples of Sebagos and Russets have not yet been assayed in the same experiment, it is not possible to compare the two varieties.

It has also been noted that throughout the course of these experiments, the amount of growth-hormone activity in the control (nonirradiated) Sebagos, which were used each time an experiment was conducted, has been slowly but steadily decreasing. Whereas the approximate average angle of bending was 25° in the first experiments, it has decreased to 18° in recent experiments (two and a half months later). There are no longer any freshly harvested Sebagos available. Thus, there is no way of determining whether these results were caused by a real change in hormone content or by some unnoticed change in the conditions under which the extract is prepared and assayed. Furthermore, the last two experiments, in which the effect of 100 and 200 kilorep was to be measured, resulted in the nonirradiated potatoes showing no hormone activity whatsoever. This may be due to destruction of the hormones at some point during the preparation of the sample prior to assay. The current experiments are devoted to solving this difficulty.

When the hormone and inhibitor concentrations of the control and irradiated tubers were compared, it was found that the observed differences were of such a small magnitude that they could be the result of errors in technic and not due to any significant difference between irradiated and control tubers. This indicates that the inhibition of sprouting as a result of irradiation is not associated with the hormones and inhibitors found in or just around the eyes in Sebago variety stored potatoes.

In late March a shipment of freshly harvested Pontiac potatoes was received from Homestead, Florida. These potatoes were obtained for the purpose of investigating the hormone and inhibitor concentrations in freshly harvested tubers.

Only three experiments have been run, and the first test was made for the purpose of determining what amounts to use in subsequent experiments. In the other two tests, dosages of 25 and 75 kilorep were given a week before the analyses. Table XII gives the results for the two experiments.

These two experiments would tend to show that irradiation increases the hormone concentrations. In the April 20 experiment there is for the first time evidence of a high concentration of inhibitor. This was found both in the control and the treated tubers so there seems to be no error. In both experiments the treated tubers had less inhibitor.

TABLE XII. HORMONE ACTIVITY

Date	Treatment	Total Hormone Activity in Degrees Curvature of Oat Seedlings	Total Inhibitor Activity in Degrees Curvature of Oat Seedlings
April 13	Control	10.0	1.9
	25-kilorep dosage	17.6	0
April 20	Control	9.2	22.8
	75-kilorep dosage	13.5	16.2

VI. STORAGE OF RING-ROT-INFECTED POTATOES FOLLOWING GAMMA IRRADIATION

Field-infected Sebago potatoes were obtained on December 5 from a grower near Howard City, Michigan. These tubers were uniformly sized, ranging between 1-1/2 and 2 in. They had been graded twice, once over a 2-in. screen with the oversize removed and again over a 1-1/2-in. screen with the undersize removed.

The tubers were gamma irradiated in the Fission Products Laboratory on December 12-13 and were taken to East Lansing on December 19 in a heated truck. They were first examined on December 22, 10 days after treatment, for incidence of ring rot and other storage rots. The results of this and subsequent inspections are given in Tables XIII and XIV, and the data on incidence of ring rot for tubers stored at 20°C are plotted in Fig. 40. No trend was observed in incidence of ring rot in tubers stored at 1°C (see Table XIII); therefore, these data were not plotted. In the inspection, tubers suspected of being rotted were cut and those showing typical ring-rot symptoms were considered to have ring rot. Stain diagnosis was not made. Other rotted tubers lacking ring-rot symptoms were placed in a second grouping classed as "storage rot," as shown in Table XIV, and the data are plotted in Figs. 41 and 42.

It should be pointed out that some of the potatoes infected with ring rot in this lot had been discarded during harvesting operations and in grading operations before shipment. Thus, the amount of ring rot as shown in Table XIII and Fig. 40 does not reflect the total

TABLE XIII. RING-ROT INCIDENCE IN IRRADIATED SEBAGO FIELD-INFECTED POTATOES

Radiation Dose (rep)	20°C										1°C				
	10	30	45	66	80	94	129	10	38	58	72	92	133		
	Days %	Days %	Days %	Days %	Days %	Days %	Days %	Days %	Days %	Days %	Days %	Days %	Days %		
0	2.8	5.0	7.5	8.8	9.4	10.0	13.2	1.6	1.6	1.6	1.6	2.0	4.6		
12,000	2.5	3.9	5.6	6.3	6.3	6.4	7.3	2.6	2.6	2.6	2.6	3.0	4.0		
32,000	1.3	3.2	5.5	6.1	6.1	6.8	8.1	2.4	2.4	2.4	3.1	3.8	4.4		
80,000	1.0	3.7	5.0	5.7	6.4	6.7	7.7	.67	.67	.67	.67	1.0	3.0		
200,000	.34	2.1	3.5	3.8	4.1	4.5	6.9	3.3	3.3	3.9	4.6	4.9	4.9		
500,000	0	0	0	0	0	0	0	4.0	4.0	4.0	4.0	4.0	4.0		

TABLE XIV. STORAGE-ROT INCIDENCE IN IRRADIATED SEBAGO FIELD-INFECTED POTATOES

Radiation Dose (rep)	20°C										1°C				
	10	30	45	66	80	94	129	10	38	58	72	92	133		
	Days %	Days %	Days %	Days %	Days %	Days %	Days %	Days %	Days %	Days %	Days %	Days %	Days %		
0	0	0.6	1.6	2.2	2.5	2.8	5.0	0	1.3	2.0	2.3	3.3	7.9		
12,000	0	1.8	3.5	4.2	4.5	4.9	9.1	0	1.6	2.0	2.0	2.6	6.6		
32,000	0	1.6	6.5	7.7	8.4	9.4	17.7	0	2.7	2.7	3.8	4.8	9.9		
80,000	0	1.7	6.4	8.4	10.7	12.7	22.7	0	1.4	1.4	1.4	3.4	12.5		
200,000	0	6.2	17.6	25.9	30.0	33.1	45.5	0	1.6	2.9	4.6	15.3	52.1		
500,000	2.1	92.0	100.0					0	35.6	56.4	74.8	84.6	96.0		

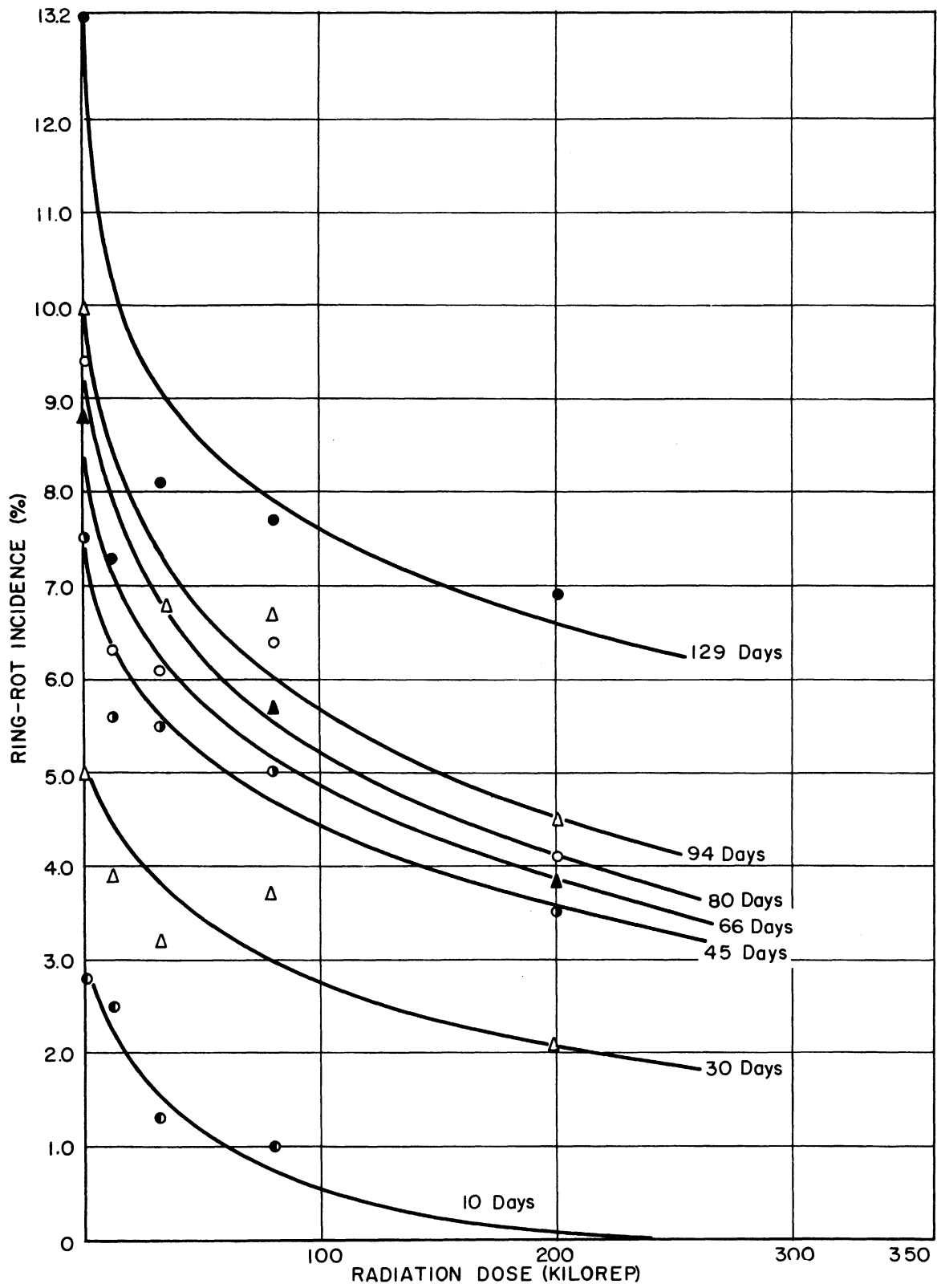

Fig. 40. Ring-rot incidence in irradiated field-infected Sebago potatoes stored at 20°C.

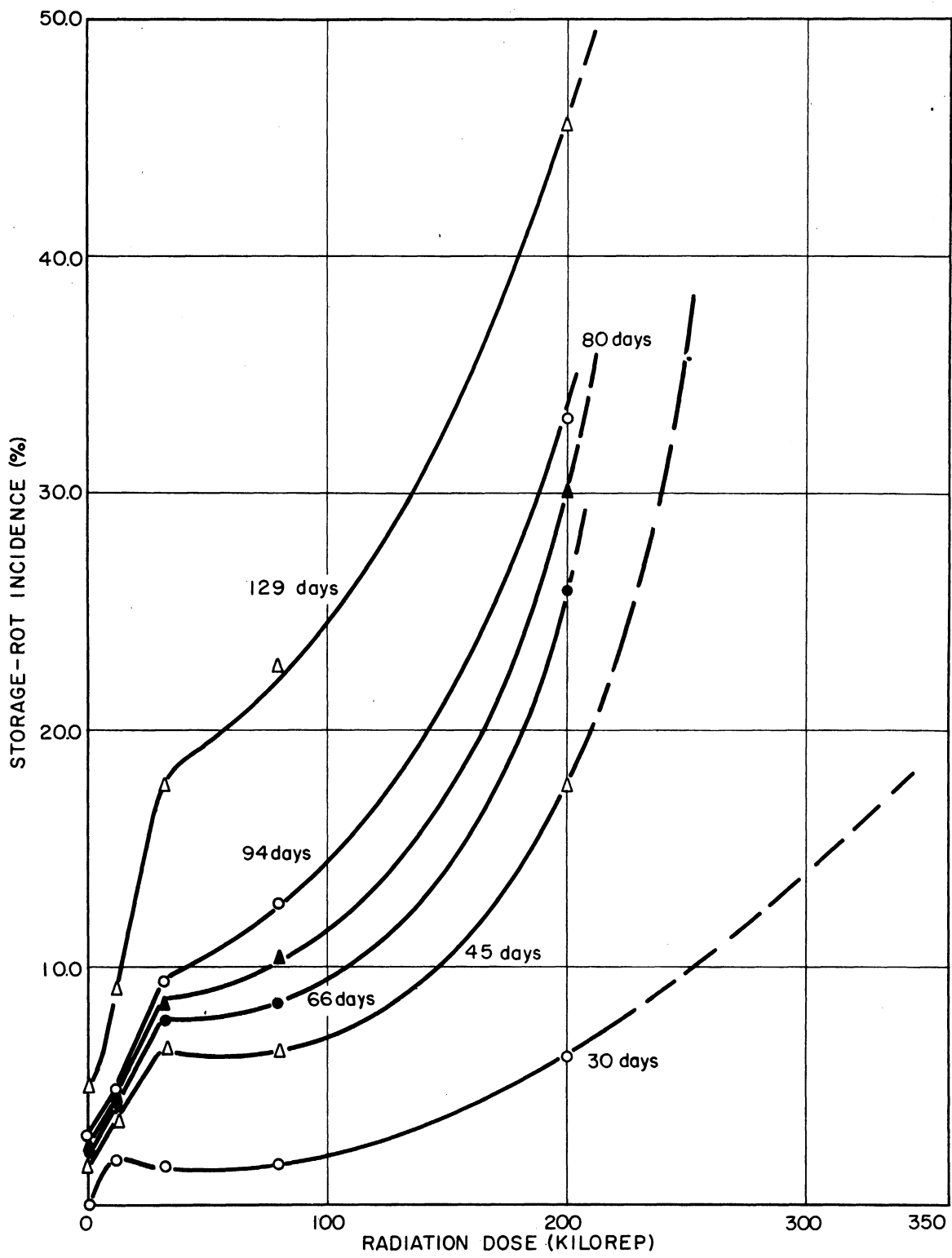

Fig. 41. Storage-rot incidence in irradiated field-infected Sebago potatoes stored at 20°C.

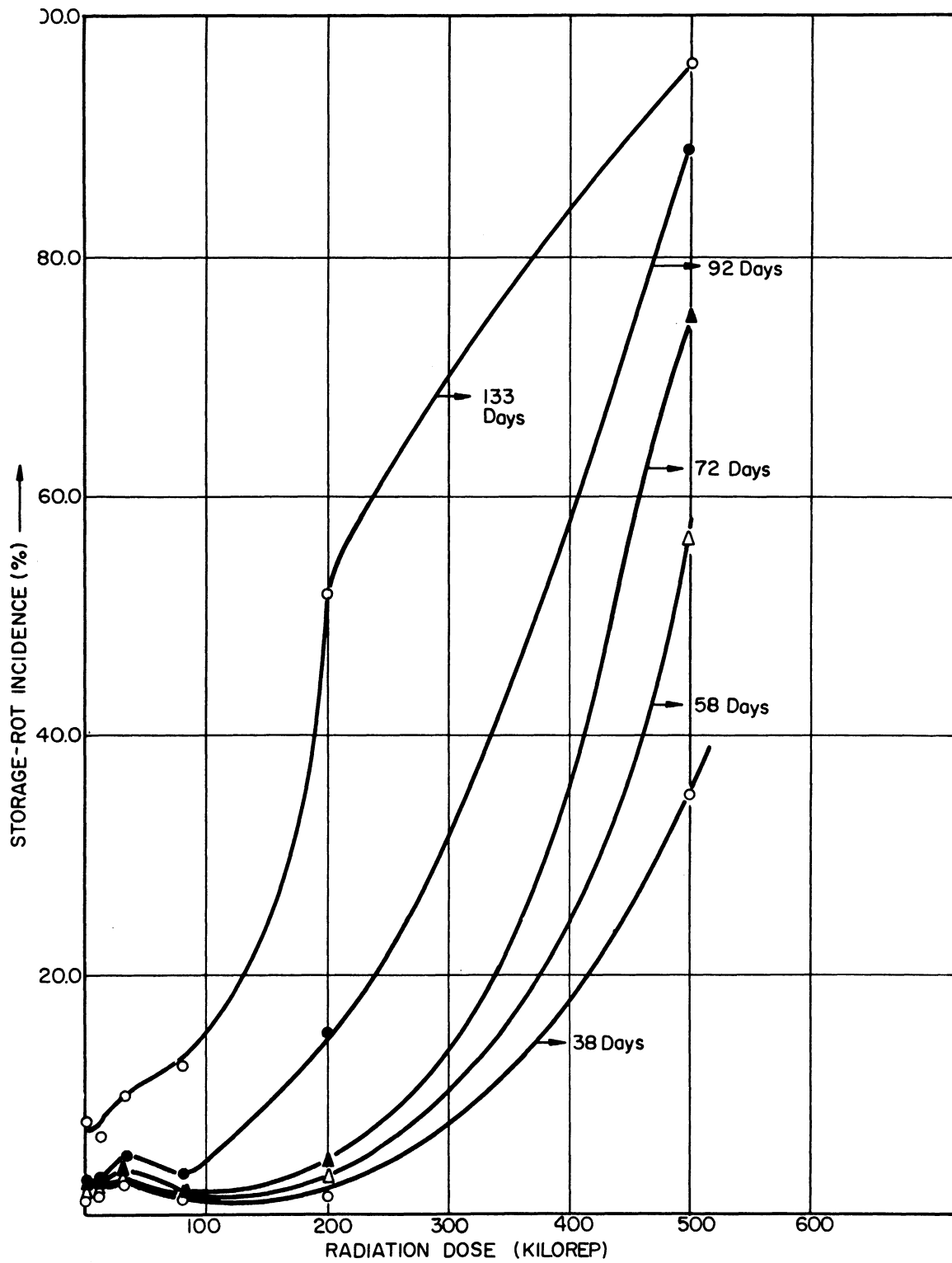

Fig. 42. Storage-rot incidence in irradiated field-infected Sebago potatoes stored at 1°C.

amount of infection in the lot. There was no late blight in the shipment of tubers, which made possible rather accurate diagnosis of the tuber injury.

Tuber injury due to radiation was not evident following 10 days in storage. By the end of 30 days, the majority of tubers receiving 500,000 rep were rotted and a few receiving 200,000 rep had broken down. Positive diagnosis of ring rot in tubers receiving the 500,000-rep treatment could not be made due to inability to identify ring rot following severe radiation injury.

Radiation injury resembled severe freezing injury in many respects. Affected tubers were often somewhat cheesy in consistency, later breaking down into a soft rot. Affected tubers often had a fermented odor, and the general appearance was more suggestive of storage rot of the sweet potato than that of the Irish potato. The alcoholic-type fermentation observed in the tubers receiving the higher dose of gamma radiation is consistent with the sucrose analyses reported previously.

Many tubers held at 20°C were rather badly wilted after 80 days in storage. Nonirradiated controls were so badly sprouted at the 129-day inspection that all tubers were cut for ring-rot evaluation. At 1°C storage there was little wilting after 133 days and tubers had not begun to sprout.

At 20°C storage (Fig. 40) there was some evidence that ring rot was developing somewhat more slowly in the irradiated tubers than in the untreated tubers. The increase in incidence of ring rot at the 129-day period is due in part to the cutting of all the tubers remaining in the sample because of sprouting.

VII. WOUND HEALING, SUBERIZATION, AND PERIDERM FORMATION

Three series of irradiation and wounding treatments have been completed on tubers of three varieties; Sebago, Katahdin, and Russet Rural. In an initial study, suberization and periderm formation following wounding of nonirradiated Sebago tubers were observed. These tubers were peeled uniformly by hand, packed loosely in moist sphagnum moss, and held at 26°C for the two-day period during which observations were made. A one-half-inch cork borer was used to obtain tissue samples which were taken from the median region of the tubers. The cylindrical samples were then trimmed to rectangular shape, fixed in FAA, dehydrated in an ethyl alcohol series, changed to chloroform, infiltrated with and embedded in ordinary paraffin, and cut into sections 10 to 20 microns thick on a rotary microtome. The sections were stained with saffranine and fast green. This procedure was standard for all material prepared for this study.

The preliminary study of untreated Sebago tubers yielded results similar to those described by Artschwager¹⁹ in his classical study of potato histology. Six hours after wounding there is evidence of suberization of the surface layer of cells. This layer increases in depth and in density of suberin deposit until after 48 hours three to four cells from the wounded surface show distinct suberization. Periderm formation is not evident after 36 hours, but after 48 hours distinct periderm involving two to four cells is apparent. Some of these cells appear not to have completed division, but are binucleate with traces of developing wall appearing along a median plane of the parent cell. Figure 43 is a photomicrograph of this stage of periderm formation.

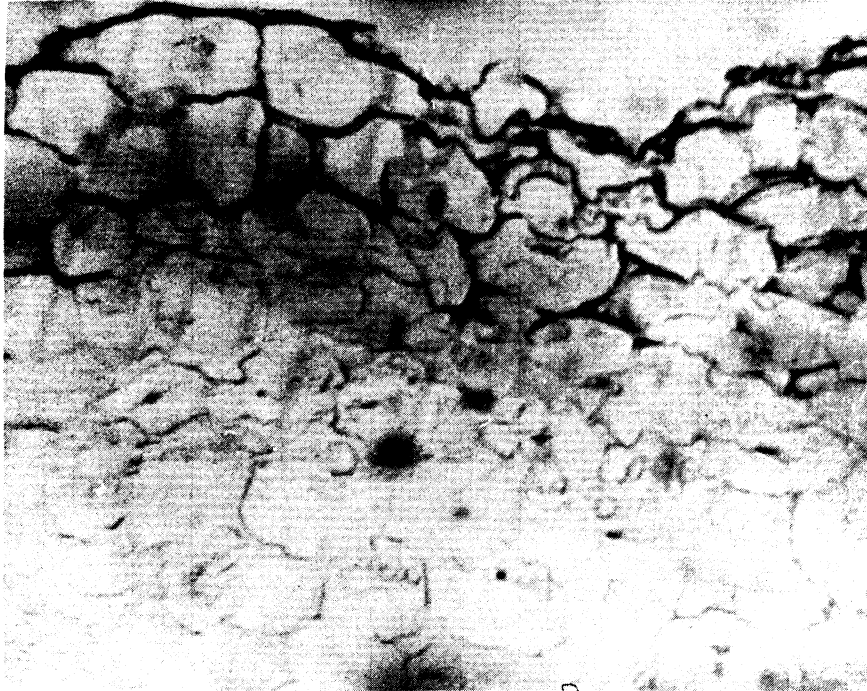

Fig. 43. Photomicrograph of Sebago potato-tuber section 48 hours after peeling, showing suberization and periderm formation. 80X

In the second series of tests, Sebago tubers which were irradiated at 0-, 15-, and 200-kilorep dosages were peeled and sampled as described for the initial study, but the number of sampling intervals was increased to include 0, 6, 12, 24, 48, 96, and 192 hours after wounding. Fifty days had elapsed between irradiation and wounding for this study.

After six hours, only the nonirradiated tubers showed any suberization. Traces of suberization were apparent in treated sections after 36 hours, and at 48 hours there was little to distinguish the suberiza-

tion in treated sections from that in control sections. Periderm formation in controls was not evident at 48 hours, but periderm was well developed after 96 hours. There was no evidence of periderm formation in either of the two treated series even after 196 hours, and it is assumed that cell division was completely inhibited in the treated potatoes, precluding the possibility of periderm formation. Beginning at the 48-hour stage and continuing through 96 and 192 hours, the depth of the layer of suberized cells and the intensity of suberization were essentially the same in both treated and control potatoes. Figures 44, 45, and 46 illustrate the response of tubers at each treatment level and after 6, 48, and 192 hours, respectively, subsequent to wounding.

In the third series of tests, tubers of Sebago, Katahdin, and Russet Rural varieties were irradiated at 0-, 2,500-, 5,000-, 10,000-, and 20,000-rep dosages and were wounded (peeled) within a week after treatment. Three sampling intervals were used, 36, 72, and 192 hours.

Suberization occurred in all tubers with little difference evident among the various treatments and varieties. Periderm formation was prevented at all radiation levels, excepting one sample of Katahdin in which some periderm was apparent at 2500-rep dosage. This series has not been completed and will be supplemented with a second similar series in which a longer interval will have elapsed between irradiation and wounding.

The results of this study so far indicate practically complete inhibition of periderm formation in irradiated, wounded tubers at almost any level of radiation, but certainly complete in the dosage range contemplated for economic sprout inhibition. Suberization may be somewhat reduced in extent, but not markedly so, and the degree of suberin deposition in the cells involved does not differ appreciably between treated potatoes and controls. The roles of suberization and periderm formation are difficult to separate with regard to water loss and resistance of wounded tubers to disease, but gross observation of these samples which were subjected to extreme wounding treatment and decay conditions indicated greater incidence of soft-rot decay among treated tubers than among controls. The delay in suberization as a result of treatment could easily be responsible for early infection of treated tubers by decay organisms and subsequent increased tissue destruction. It seems obvious that irradiated potato tubers would, at least, be more susceptible to decay following injury, and that great care would be necessary to avoid injury after treatment. In the event of injuries incurred by the tubers, suberization would have to be encouraged at the same time that development of rot was delayed. This might be possible by storage at lower temperature (60°-70°F) and lower relative humidity (75-85%) than that most favorable for decay.

Sebago, Katahdin, and Russet Rural tubers irradiated as in Series 3 were held 29 days, then peeled and handled as in Series 3. No

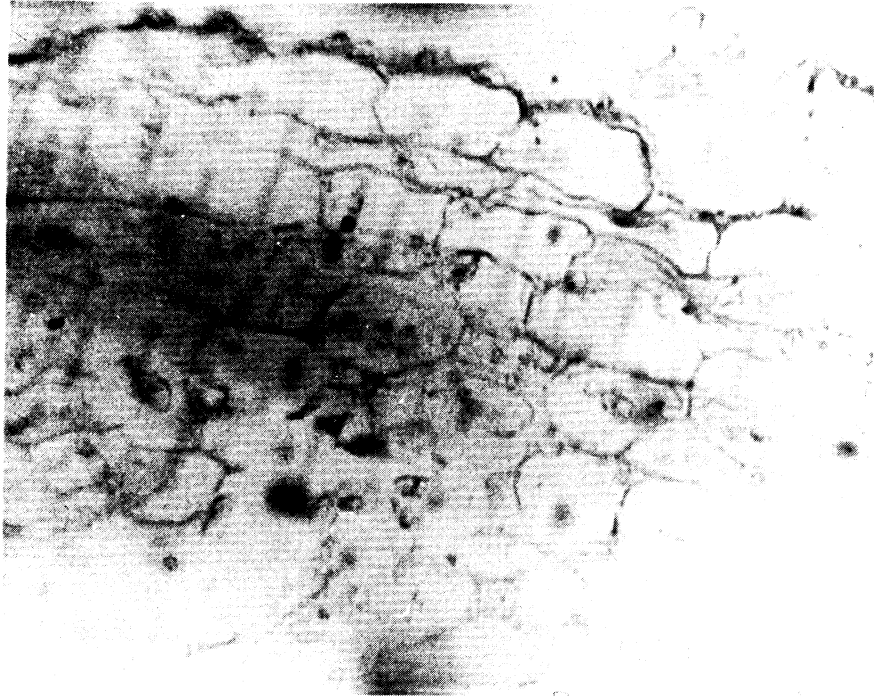

Control

Fig. 44. Photomicrographs of Sebago potato-tuber sections 6 hours after peeling, showing suberization of control only. 80X



15,000-
rep
dosage

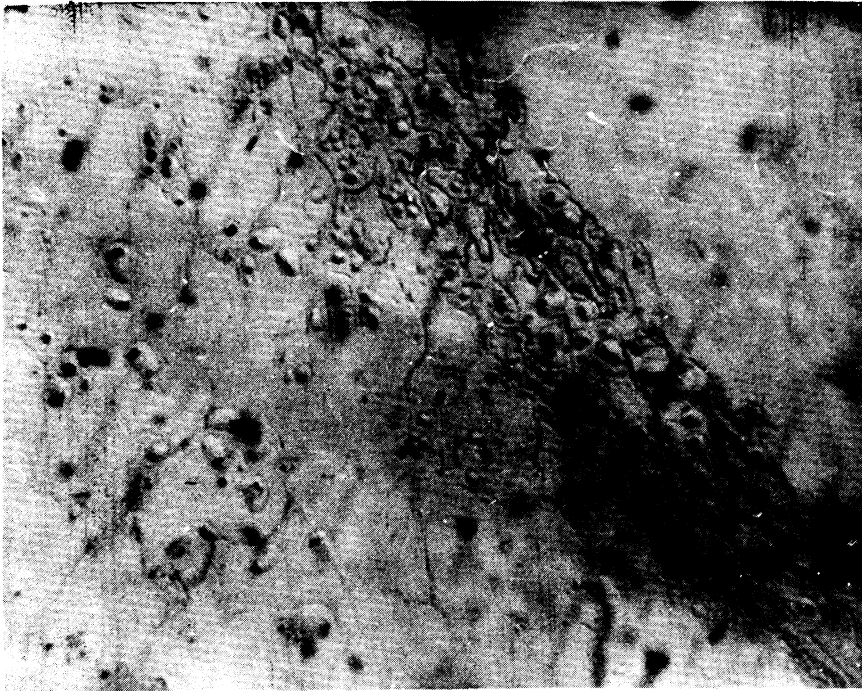

200,000-
rep
dosage

Fig. 44. Concluded.

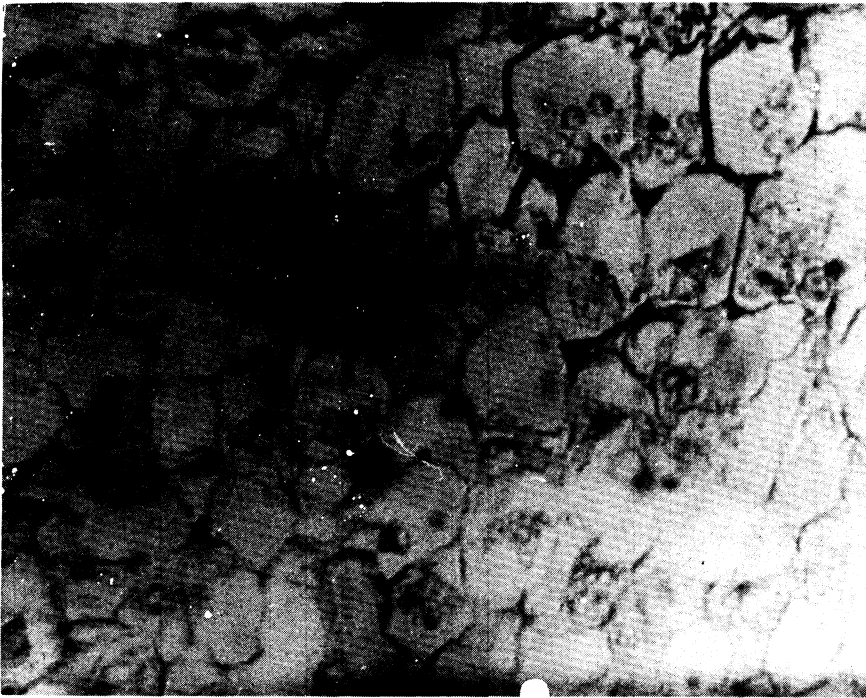

Control

Fig. 45. Photomicrographs of Sebago potato-tuber sections 48 hours after peeling, showing suberization of control and treated tubers. Initiation of periderm is evident in control only. 80X

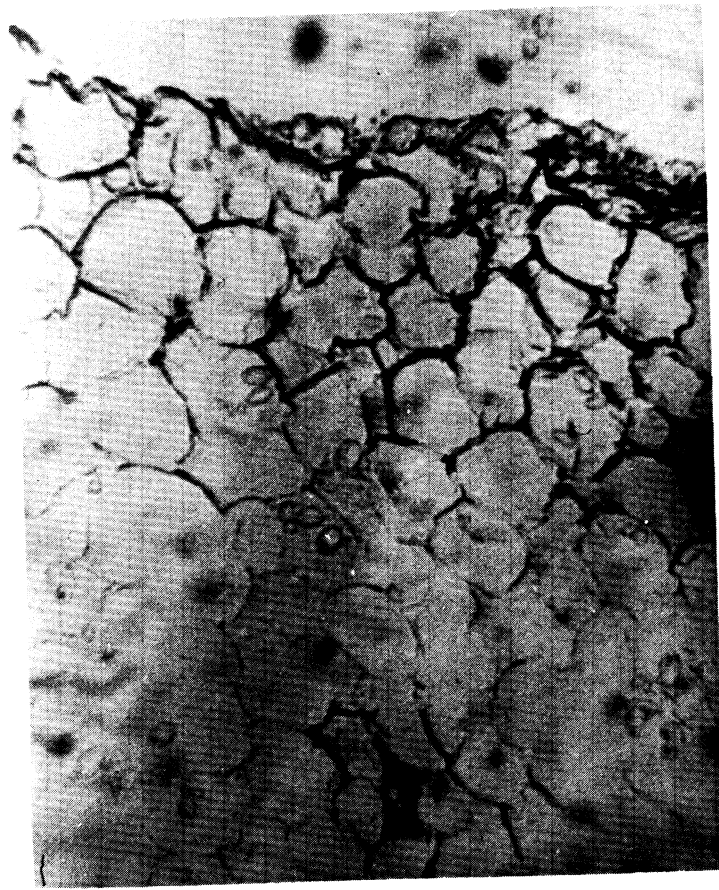

15,000-
rep
dosage



200,000-
rep
dosage

Fig. 45. Concluded.



Fig. 46. Photomicrographs of Sebago potato-tuber sections 196 hours after peeling, showing suberization of control and treated tubers. Extensive periderm formation has occurred in controls, none in treated tubers. 80X

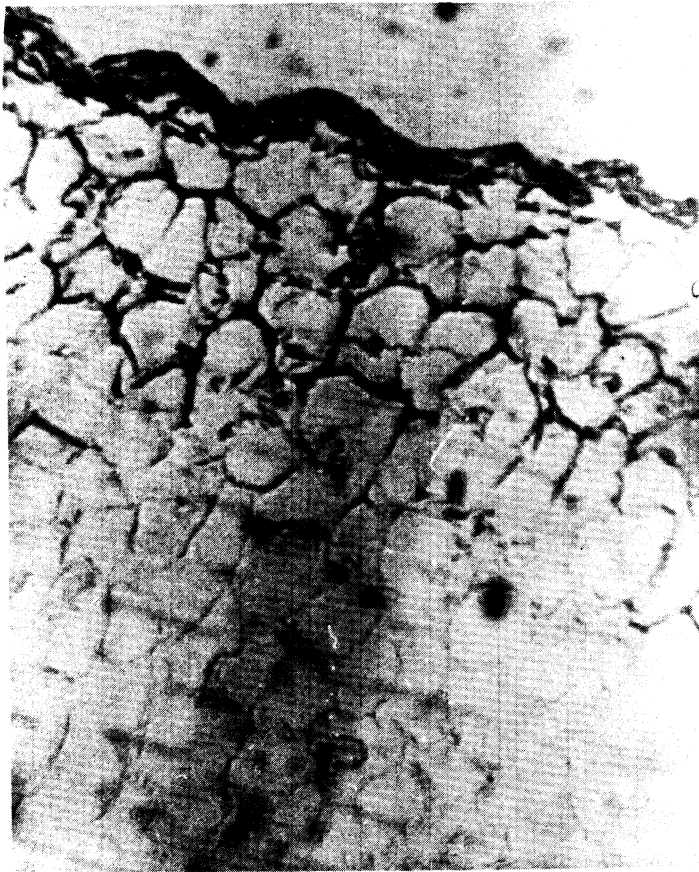

15,000-
rep
douage

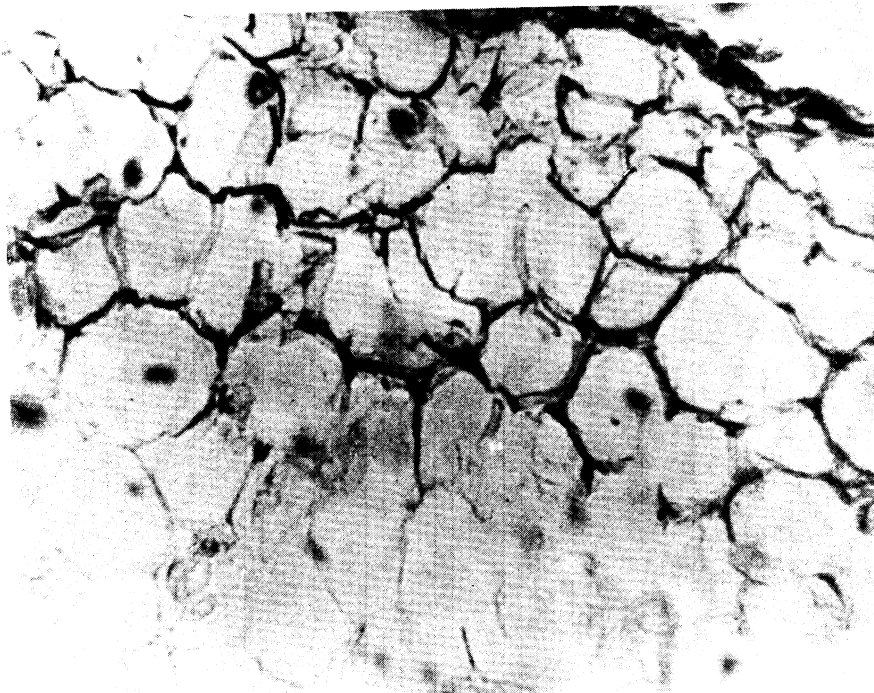

200,000-
rep
douage

Fig. 46. Concluded.

distinct periderm could be distinguished in tubers receiving any level of irradiation. At 10,000 rep there were scattered periderm-like groups of cells, and other treated tubers showed occasional pairs of periderm-like cells. Distinct periderm was evident in controls after 72 hours. Suberization was delayed but not prevented by the irradiation treatments.

Katahdin tubers showed evidence of slightly more frequent periderm-like divisions, but again there was no obvious continuous periderm such as appeared in control tubers. Suberization was delayed slightly less than in Sebago tubers.

Russet Rurals showed fewer of the scattered periderm-like areas than either Sebagos or Katahdins. Those which were observed occurred chiefly in tubers irradiated at 2500 rep, but not at higher dosages. However, suberization was not very distinctly slowed in Russet Rurals, in contrast to the other two varieties.

VIII. ACCEPTABILITY STUDIES

A. BACKGROUND

Previous studies have indicated that radiation doses up to 200×10^3 rep have little or no differential effect on the acceptance of white potatoes. These studies also indicated that doses of 10×10^3 rep and higher reduced peeling and trim losses and had no appreciable effect on the cooking and "mashing" quality.

The present studies were undertaken to confirm these observations and to study the effects of radiation on storage losses.

B. EXPERIMENTAL

For these studies two lots of white potatoes, Sebago and Russet Rural varieties, were procured from the Fission Products Laboratory, The University of Michigan, Ann Arbor, Michigan. These potatoes had been grown by Michigan State University, East Lansing, Michigan, on one of its experimental farms. The potatoes were harvested in October, 1955, delivered to the Fission Products Laboratory on 1 November 1955, and held at 40°F until irradiated. The potatoes were irradiated on 9 to 11 December 1955 at nine dose levels (0, 5, 10, 15, 20, 25, 50, 100, and 200×10^3 rep) using a cobalt 60 source. The potatoes were received by the Quartermaster Food and Container Institute on 3 January 1956. On arrival at QM F and CI there was no observable evidence of sprouting or decay in any of the various lots. However, the potatoes appeared to be

softening and had a slightly shriveled appearance.

On arrival, samples of each lot were studied by the Food Evaluation Section and the Food Acceptance Branch. The balance of each lot was packed in open-mesh potato bags (10-lb size) in weighed aliquots (approximately 4-1/2 lb) and stored at 55° and 72°F (R.H. 85-95%).

After one- and two-month storage periods, aliquots of each treatment were examined for storage losses and then submitted to the two evaluation sections for additional studies.

Effects of Irradiation on Weight Losses, Sprouting, and Decay.— Each aliquot, when withdrawn from storage, was again weighed. The observed decrease in weight represents the combined losses due to the normal respiration and transpiration of the tubers, the respiration and growth of the contaminating microorganisms, and losses due to the growth of sprouts. All sprouts over 1/4 inch long were removed, counted, and weighed. All visible decay was removed and weighed. The remainder was weighed and is expressed as the usable portion before peeling.

Mention should be made that the lots irradiated at the 5-kilorep level had many small sprouts (less than 1/4 inch long); these are not included as sprouting losses and are included in the usable-before-peeling portion.

Effects of Irradiation on Peeling Losses.—The samples, as submitted to the Food Evaluation Section, were studied for peel and trim loss. Weighed portions of each sample were peeled and trimmed, using a hand potato peeler and paring knife.

Effects of Irradiation on Acceptance Rating.—The samples, when submitted to the Food Acceptance Branch, had been previously peeled. After dicing, the samples were cooked in boiling salted water, drained, and buttered. The various samples were rated for preference by the Radiation Testing Panel, using the hedonic rating scale.

C. DISCUSSIONS AND CONCLUSIONS

The results clearly indicate that 15×10^3 rep is ample radiation to prevent potatoes from sprouting while in storage. Weight losses in storage and decay appears to be lowest at 10 to 20×10^3 rep. Irradiation below this level permits sprouting, thus losses due to the growth of sprouts are higher. At high levels (25 to 200×10^3 rep), radiation appears to affect the potatoes in such a way that they are more susceptible to decay. These results appear to be consistent for the two varieties and the two storage temperatures studied.

Irradiation appears to affect peeling and trim losses in a similar manner. Losses due to these factors appear to be lowest at 5 and 10 x 10³ rep. At higher doses, losses are greater and are probably due to increases in decay. Again, both varieties appear to be affected in a similar manner.

The results of acceptance studies (Table XV) confirm previous observations; irradiation doses up to 200 x 10³ rep have little or no effect on preference ratings.

TABLE XV. EFFECTS OF IRRADIATION ON PREFERENCE IN WHITE POTATOES

Hedonic Mean for Main Effects

Temperature vs Time					
Temperature	Time				Average
	Initial	One Month	Two Months		
55°F	6.7	6.7	6.7		6.7
72°F	6.7	6.5	6.5		6.6
Average	6.7	6.6	6.6		6.6

Time vs Irradiation Dose					
Time	Dose x 10 ³ rep				Average
	0	10	20	100	
Initial	6.9	6.8	6.8	6.4	6.7
One Month	6.8	6.8	6.4	6.6	6.7
Two Months	6.8	6.7	6.6	6.3	6.6
Average	6.8	6.8	6.6	6.5	6.7

Temperature vs Variety			
Temperature	Sebago	Russet Rural	Average
55°F	6.6	6.8	6.7
72°F	6.5	6.6	6.6
Average	6.6	6.7	6.6

REFERENCES

1. Official and Tentative Methods of Analyses of the Assn. Off. Agr. Chemists, ed. H. A. Lepper, 7th ed., p. 506 (1950).
2. R. Dreywood, Science, 107, 254 (1948).
3. J. X. Khym and L. T. Zill, J. Am. Chem. Soc., 74, 2090 (1952).
4. W. Z. Hassid, Ind. Eng. Chem., Anal. ed., 8, 136 (1936); ibid., 9, 228 (1937).
5. W. T. Williams et al., J. Assn. Off. Agr. Chemists, Nov. 1949, p. 698.
6. Beevers, H., "2,4-Dinitrophenol and Plant Respiration," Am. J. Bot., 40, 91-96 (1953).
7. Burr, H. K., U.S. Western Regional Res. Laboratory, Albany, Calif., private communication.
8. Millerd, A., Bonner, J., and Biale, J. B., "The Climacteric Rise in Fruit Respiration as Controlled by Phosphorylative Coupling," Plant Physiology, 28, 521-531 (1953).
9. Boysen-Jensen, P., "Über die Leitung des phototropischen Reizes in Avena-keimpflanzen," Ber. Deut. Bot. Ges., 28, 118-120 (1910).
10. Leopold, A. C. Auxins and Plant Growth. Berkeley: Univ. of Calif. Press, 1955.
11. Skoog, F., "Effect of X-Irradiation on Auxin and Plant Growth," J. Cell. and Comp. Physiol., 7, 227-270 (1935).
12. Tswett, M., "Physicalisch-chemische Studien über das Chlorophyll. Die Adsorptionen," Ber. Deut. Bot. Ges., 24, 316-323 (1906).
13. Martin, A. J. P., Ann. N. Y. Acad. Sci., 49, 249 (1948); Biochem. Soc. Symposia, No. 3, Cambridge Univ. Press (1949); Ann. Repts. Progress Chem., 45, 267 (1949).

REFERENCES (Concl.)

14. Synge, R. L. M., Biochem. J., 44, 542 (1949); 48, 429 (1951); 49, 642 (1951).
15. Andus, L. J., and Thresh, R., "A Method of Plant Growth Substance Assay for Use in Paper-Partition Chromatography," Physiologia Plantarum, 6, 451-465 (1953).
16. Bennet-Clark, T. A., Tambiah, M. S., and Kefford, N. P., "Estimation of Plant Growth Substances by Partition Chromatography," Nature, 169, 452-453 (1952).
17. Luckwill, L. G., "Application of Paper Chromatography to the Separation and Identification of Auxins and Growth Inhibitors," Nature, 169, 375 (1952).
18. Went, F. W., and Thimann, K. V. Phytohormones. New York: The Macmillan Co., 1937.
19. Artschwager, E., J. Agr. Res., 35, 995 (1927).

