

UMTRI-87-28

**ENGINEERING ANALYSIS OF
CARGO RESTRAINT ON
COMMERCIAL HIGHWAY TRUCKS**

Final Report

Thomas D. Gillespie, Ph.D.

August 1987

Technical Report Documentation Page

1. Report No.	2. Government Accession No.	3. Recipient's Catalog No.	
4. Title and Subtitle Engineering Analysis of Cargo Restraint on Commercial Highway Trucks		5. Report Date July 1987	6. Performing Organization Code
		8. Performing Organization Report No. UMTRI-87-28	
7. Author(s) Thomas D. Gillespie, Ph.D.		10. Work Unit No. (TRAIS)	11. Contract or Grant No. DTFH61-85-C-00122
9. Performing Organization Name and Address The University of Michigan Transportation Research Institute 2901 Baxter Road, Ann Arbor, Michigan 48109		13. Type of Report and Period Covered Final Report 11/85 - 7/87	
		14. Sponsoring Agency Code	
12. Sponsoring Agency Name and Address Federal Highway Administration U. S. Department of Transportation Washington, D. C. 20590		15. Supplementary Notes	
16. Abstract <p>Securement of cargo on commercial highway trucks is regulated by CFR 49, Part 393, Sections 100 - 106. As a result of a review of these regulations by users and enforcement personnel it was recommended that an engineering analysis of restraint requirements and methods be conducted to develop guidelines for practice more rigorously based on engineering principles.</p> <p>A review of BMCS accident data indicates that loss, spillage, or shift of cargo is a causative factor in approximately one percent of the accidents reported, and an associated event in another six percent of the accidents. It is argued that a set of simplified rules for restraint based on sound engineering principles would help shippers improve restraint practice, and provide enforcement personnel with a much-needed objective reference for enforcement action.</p> <p>The performance requirements for cargo restraint systems are reviewed. Based on truck braking and turning capabilities it is concluded that the cargo securement system must hold to a minimum of 0.75 g in the longitudinal direction and 1.0 g in the lateral direction. A critical cargo weight of 1000 lb is identified as the threshold size at which individual cargo items constitute a serious threat to life in the event of loss, and therefore warrant special restraint.</p> <p>The mechanics of cargo securement by friction, enclosures, blocking, and tiedowns are analyzed to identify the influential variables and their effects. The application of these findings is then demonstrated by the development of a simplified set of rules for securing single items of cargo on flatbed trailers.</p>			
17. Key Words Cargo restraint, cargo securement, motor carrier regulations, tiedowns, cargo shift, cargo spillage		18. Distribution Statement No restrictions.	
19. Security Classif. (of this report) NONE	20. Security Classif. (of this page) NONE	21. No. of Pages 97	22. Price

TABLE OF CONTENTS

<i>Section</i>	<i>Page</i>
1 INTRODUCTION.....	1
1.1 Background.....	1
1.2 Objectives.....	1
1.3 Method.....	2
1.4 Organization of the Report.....	3
1.5 Definitions and Terminology.....	3
2. THE PROBLEM.....	6
2.1 Introduction.....	6
2.2 Accident Data on Shifting or Falling Loads.....	7
2.3 Cause of the Problem.....	7
2.4 Performance Requirements for Load Restraint.....	9
3. ENGINEERING ANALYSIS OF RESTRAINT METHODS.....	23
3.1 Introduction.....	23
3.2 Frictional Coupling.....	23
3.3 Restraint by Enclosures.....	27
3.4 Blocking Restraints.....	37
3.5 Crossover Tiedowns.....	40
3.6 Horizontal Tiedowns.....	58
3.7 Summary of Tiedown Properties.....	62
4. APPLICATIONS.....	66
4.1 Objective.....	66
4.2 Review of Relevant Findings.....	66
4.3 Restraint Rules.....	67
4.4 Discussion.....	79
5. SUMMARY, CONCLUSIONS AND RECOMMENDATIONS.....	81
6. REFERENCES.....	83
APPENDIX A. Engineering Analysis of Tiedowns.....	85

LIST OF FIGURES

<i>Figure</i>	<i>Page</i>
2.1 Effect of CG offset on rollover threshold.....	11
2.2 Example "μ-slip" curve, providing definitions of the peak and slide coefficients of friction	13
2.3a Peak and slide coefficients of friction versus load for bias-ply truck tires at 20 mi/h on dry concrete	14
2.3b Peak and slide coefficients of friction versus load for radial truck tires at 20 mi/h on dry concrete	15
2.4 Envelopes of lateral traction performance on dry concrete.....	18
3.1 Cumulative percent of braking deceleration levels with passenger cars.....	25
3.2 Cumulative percent of lateral acceleration levels with passenger cars on rural roads	26
3.3 Model of load shift in a trailer.....	28
3.4 Forces imposed on the front wall of a trailer during hard braking.....	31
3.5 Pressure distribution on front wall of a trailer during hard braking with (a) small package cargo, and (b) large package cargo	33
3.6 Unrestrained cargo at the rear of a trailer free to slide forward during braking	35
3.7 Dimensions determining the effectiveness of blocking.....	39
3.8 Actions of a tiedown in resisting a shifting load.....	42
3.9 Action of resistance forces on movement of cargo restrained by tiedowns at a shallow angle	47
3.10 Action of resistance forces on movement of cargo restrained by tiedowns at a high angle	48
3.11 Action of tiedown restraints to prevent tipping.....	53
3.12 Restraint forces during rolling movement of round articles.....	56
3.13 Configurations for tiedown restraints in the horizontal plane.....	59
3.14 Analysis of forces in a horizontal tiedown arrangement.....	60
4.1 Classification of cargo articles by shape.....	68
4.2 Alternatives for lateral securement of Type LN articles.....	70
4.3 Alternatives for lateral securement of Type LW articles.....	73
4.4 Alternatives for lateral securement of Type TN articles.....	75
4.5 Alternatives for longitudinal securement of Types LN & LW articles.....	77
A.1 Generic tiedown.....	86
A.2 Free-body diagram of cargo and tiedowns.....	86
A.3 Variables in analysis of lateral movement of cargo.....	88
A.4 Limit cases for lateral movement without tiedown slip.....	88
A.5 Analysis of forces with tiedown slip.....	91
A.6 Normalized tension load changes as a function of lateral displacement.....	93
A.7 Resistance force for cargo slipping under a tiedown.....	93

LIST OF TABLES

<i>Table</i>		<i>Page</i>
1.	Primary Aspect of Accident by Trailer Body Style, ICC Regulated and Tractor Trailer–BMCS 1984	8
2.	Associated Crash Event by Trailer Body Style, ICC Regulated and Tractor Trailer–BMCS 1984	8
3.	Examples of Acceleration Performance Requirements for Cargo Restraint Systems	17
4.	Relationships between Blocking Height and Lateral Acceleration Limits for Coiled Articles	41
5.	Tiedown Preload/Weight Values for Cargo Restraint.....	50
6.	Summary of Crossover Tiedown Functions.....	63
7.	Summary of Horizontal Tiedown Functions.....	64

1. INTRODUCTION

1.1 Background

This document presents a Final Report on the project "Engineering Analysis of CFR 49 Part 393—Cargo Restraint Study." The study was performed by The University of Michigan Transportation Research Institute for the Federal Highway Administration, Motor Carrier Office. The project was initiated in November of 1985 under the title, "Engineering Analysis of CFR 49 Part 393," for the purpose of reviewing all major sections of CFR 49 - Part 393 [1] (References are listed in Section 6), regulating "parts and accessories necessary for safe operation" of motor carriers. The review included a conference with representatives of the various interest groups in the trucking community (vehicle and component manufacturers, driver organizations, fleet operators, and safety and enforcement personnel). The product of that work was the collection of information and comments on the regulations, and those items were submitted to FHWA in October 1986.

A significant outcome of the review of Sections 100 through 106, dealing with Protection Against Shifting or Falling Cargo, was the observation that the regulations relating to cargo restraint were often ambiguous and subject to different interpretations. Comments from the user community (fleets and shippers) and from enforcement personnel reflected a need for more careful analysis of restraint requirements and methods, and documentation to serve as a reference to guide practice in the field.

In addition, it is observed that existing regulations do not necessarily reflect the current knowledge of vehicle dynamics and engineering design. Much of the practice and regulation relating to cargo restraint has been developed from an empirical approach in the past. Knowledge of certain vehicle dynamic characteristics and principles of engineering design used in other contexts are applicable to the problem at hand. These issues provided further motivation for taking a fresh look at rational practice in cargo securement. Thus this study was undertaken. It is largely exploratory in nature, intended to identify where there are needs for improved practices, and where other knowledge provides appropriate guidance. This report is not offered as the "last word" on these topics, but rather as a pilot study to suggest areas of improvement, the methods, and the needs for more rigorous work. The suggestions that come out of this work are likely to be controversial, and should be subjected to review by the user community before any action is contemplated.

1.2 Objectives and Scope

The objectives of the cargo restraint study were to:

- Review cargo restraint requirements imposed by public agencies throughout the world.
- Collect comments on critical cargo restraint design and enforcement issues.
- Analyze and develop a rational criteria for restraint design relating to acceleration levels, safety factors, and restraint methods.
- Demonstrate how the criteria can be applied to an example restraint area.

It should be noted that the study focused on the problems of restraint with general types of cargo. Although there is considerable interest at this time in the problems of safe transport of toxic and hazardous cargoes, there was no particular effort to assess special methods warranted to restrain or contain those types of materials during transport. Similarly, liquid- and dry-bulk products have their own special problems related to shifting and spillage. Liquid-bulk products are most commonly transported in trailer-mounted tanks. Cargo shifting with liquid products is a special problem in the category of "sloshing," and has been treated in other studies.^[2] Spillage of liquid cargoes involves problems of tank integrity related to maintenance, and damageability in accidents. In the transport of dry-bulk products, cargo shifting is not known to be a serious problem. Spillage or loss of cargo is concentrated in the topical areas of covering open loads and damage in accidents. Because of the special nature of the problems with bulk products, these issues were not considered within the scope of the study.

This project is an effort to focus on cargo restraint as an engineering discipline within the commercial transportation industry. It is an effort to identify what engineering principles can be applied, to demonstrate how they may be applied, and to develop a prototype set of guidelines for cargo restraint which illustrates the conclusions that are reached. Confrontation with the issues reveals that the problem is complex, yet only through this process is it possible to develop a framework for reducing the complex problem to a series of simpler problems. It is the expectation that the discourse contained in this report will provide some structure to the issues, and clarify where further work is needed.

1.3 Method

The study was performed primarily as an analytical effort. Cargo restraint regulations were collected from a number of countries and different states within the United States. Trucks were observed in the field to see what methods were being applied in current practice, and a number of on-highway incidents involving shifting cargo were investigated to develop a practical feel for the problems. The dynamics of load forces on motor vehicles were analyzed, in combination with the established literature on truck performance properties, to determine what demands may be placed on a cargo restraint system and what capabilities they must possess to perform reliably.

The mechanics of general types of cargo restraint (blocking, tiedowns, etc.) were analyzed to develop "engineering models" characterizing their performance. The models are an attempt to identify the controlling variables and their relationship to performance in various modes. These were then used to design set of guidelines for restraint methods that will achieve the performance capabilities identified earlier.

It should be noted that no experimental testing was included in the project. Therefore, the findings should be considered preliminary because they lack validation from empirical tests. Areas where the findings suggest restraint methods that differ significantly from current practice should be seen as areas in which either the engineering models are deficient and need improvement, or where current practice may have shortcomings.

1.4 Organization of the Report

This document presents an exposition on the findings from the study. In Section 2 the general nature of the problem is examined with a brief assessment of its severity and a critical look at the general performance levels that are warranted from cargo restraint systems in order to reduce the incidence of accidents related to deficiencies in cargo restraint.

An engineering analysis of restraint methods is contained in Section 3. The analysis examines the mechanisms by which restraining forces are developed via friction, blocking, enclosures, and tiedowns. The analyses show what factors are important to restraint performance, and under what circumstances. It is through an understanding of these mechanisms that restraint systems can be designed by which to achieve the performance levels rationalized above.

Section 4 provides an example of the application of those principles to individual items of cargo carried on commercial vehicles. Finally, an overview of the problem and findings developed here are presented in the final section, Summary and Conclusions.

1.5 Definitions and Terminology

Throughout the text of the report, it will be necessary to use certain terms repeatedly. For clarity in the presentation those terms are defined here as they will be used.

Load restraint (or securement)—Any vehicle component or auxiliary device intended to prevent cargo in a truck from shifting, tipping, falling, or loss. Restraint may be provided by the walls of the vehicle (sideboards, headerboard, etc.), the floor (wheel wells, etc.), tiedowns (cables, chains, straps, bands, etc.), or blocking (timbers, angles, etc.)

Tiedown—Tension members intended to hold a cargo item in place by pulling down or horizontally on the item. A tiedown is the complete tension member (comprised of chains, cables, straps, ropes, or bands in combination with tensioning devices, such as binders or winches) extending from one anchorage point to the other.

Tiedown leg—Section of a tiedown member extending from the anchorage point on the vehicle to the point of contact on the cargo article.

Blocking—Obstructions to movement of an item of cargo in the horizontal direction. Blocking is most commonly fabricated from wooden timbers either fastened to the floor (by nails or bolts) or placed between items of cargo.

Bracing—Blocking or other members emplaced against the sides of a cargo item for the purpose of restricting or preventing tipping.

Working strength—The nominal tensile load limit advisable in routine use of a tiedown member, sometimes given as "working load limit" by chain manufacturers.

Ultimate strength—The tension load at which the tiedown member is expected to break.

Shifting—Any incremental movement of an item of cargo from the position in which it was originally placed on the truck.

Tipping—Any change in vertical orientation or alignment of items of cargo, for example, when stacked items shift sideways, or when tall items rotate in the vertical plane.

Reliability—As used in engineering design, reliability implies confidence that a system will perform its intended function despite uncertainties in the condition of its components or the environment in which it serves. A reliable restraint system is one that will ensure that cargo does not shift or fall from a vehicle during transit.

The infinite variety of products hauled in trucks adds multiple dimensions to the problem of systematic analysis of restraints. It is helpful to categorize the products/shipments into groups that have similar restraint problems. The following categories were identified for purposes of the analysis reported here, although only a few are discussed in any detail.

Coiled products—This category covers rolled materials such as metal or paper which are heavy enough that they constitute a hazard if freed from the vehicle, and large enough that they require special restraint to prevent them from rolling in the course of typical on-highway maneuvers. The current regulations identify metal coils weighing 5000 lb or more as a category of product warranting special regulations.

Cylindrical products—Materials that are predominantly long and cylindrical in form fall into a single category. They are characterized by a length great enough that they must be carried in a longitudinal orientation on the vehicle, and require restraint to prevent them from rolling from the vehicle. Pipes, rods, bar stock, poles, and logs are typical examples. Because of the specialized equipment used for hauling poles and logs, these cargoes are often subject to specific regulations.

Rectangular products—Many products substantially rectangular in form are carried on trucks, such as ingots, billets, plates, square bar stock, and crated or palleted materials. These materials are characterized by random sizes and lengths, but shaped such that they are not likely to roll when unrestrained.

Stationary machinery and equipment—This category encompasses the large, heavy items of machinery and equipment that are irregular in form. Examples are electrical power transformers, machine tools, and stationary generators. Their size and/or unusual shape often require design of specialized restraint systems to reliably secure them during transit.

Rubber-tired vehicles—Automobiles, trucks and construction equipment mounted on rubber tires represent a special category of load. The distinction comes about because of the need to restrain a heavy object which rests on compliant tires, and experiences secondary vibrations during transit. The transport of automobiles is a special case in this category because of the specialized design of auto-transporter vehicles that are used.

Loose products—Many products are carried as loose items on trucks. These include general cargo items packaged in cardboard boxes, barrels or drums, bags, or even unpackaged (cinder blocks and sod). These are typically carried without tiedowns in enclosed trailers, or tied down on an open trailer. When the loose products are stacked and

tied to pallets, the restraint design considerations fall in the category of rectangular products listed previously.

Intermodal containers—Intermodal containers are enclosed containers of standardized sizes designed for intermodal shipments. The cargo restraint provided within the container is typically an unknown factor because the containers are closed and sealed. The restraint issues are proper attachment to the specialized trailers often used for their transport, or restraint on general purpose trailers (normally flatbed trailers) when such are used for transport.

2. THE PROBLEM

2.1 Introduction

Every day millions of trucks proceed about the nation's highways carrying cargo distributed for personal use, or to support the nation's industrial activity. The cargo carried on those trucks varies in size, weight, shape, and density. Different methods are used to restrain the cargo depending on these factors and the experience of the truck operator or shipper. The restraint may be in the simple form of the sideboards on an open-top truck or trailer, or may be much more sophisticated, involving blocking and tiedown constraints on the cargo items. In the great majority of cases, the travel is accomplished without incident. In many cases—only infrequently reported—the cargo moves about in the truck and experiences damage, or a mishap occurs that interrupts the trip due to a problem with cargo shifting or loss. In more serious cases—normally reported—an accident occurs which causes injury, loss of life, or loss of property. In a fraction of the cases, the accident cause is specifically associated with shift or loss of cargo. It is speculated that in many other cases the accident severity is increased by shift or loss of cargo. Incidents of this type include the cases of truck frontal collisions in which cargo breaks loose and impacts the cab of the truck, and accidents in which cargo breaks loose from the truck and is hit by other vehicles.

It is not possible to appraise the total costs in dollars or life of the consequences from shifting or falling cargo on commercial trucks. The costs arise from a number of sources, the main categories being as follows:

- *Death, injury, and property loss in accidents*—This is the one category in which there are consolidated records that allow some measure of the cost involved. Most on-road accidents of any severity are reported in one or more records maintained by state and federal agencies. An assessment of accident experience involving loss, shifting, and spillage of cargo is provided in the next section.

- *Delay or impediment to highway traffic*—Traffic may be slowed or stopped by accidents, debris on the road following loss of cargo, or due to stopped vehicles along the side of the road when a cargo shift has occurred.

- *Damage to cargo*—Damage arising from shifting or falling action is rarely distinguished from that due to the vibrations characteristic of a moving truck. Although effective restraint may in some cases reduce the vibration level (and potential for damage), the specific cause of damage is rarely diagnosed and documented.

- *Damage to highways*—Highway damage may be caused both by accidents and loss of cargo. Accidents may frequently involve damage to roadside appurtenances (guard rails, bridge rails, etc.), signs and lights, and even the road surface itself. Occasions have been recorded in which large objects falling from trucks (e.g., steel coils) have fractured bridge deck sections requiring extensive and costly repair.

- *Recovery of lost or shifted cargo*—Aside from the recovery costs from an accident (police and firemen's time, wrecker/recovery costs, etc.), similar costs may be involved in a loss or shifted cargo incident. Typically, a truck must be stopped along the roadside for correction of the problem. This involves loss of time to the truck and driver, time and attention from law enforcement personnel, and services from cranes or wreckers to reset the load.

2.2 Accident Data on Shifting or Falling Loads

Comprehensive accident reports and statistics are collected by various agencies throughout the country which document the accident experience of trucks. The accidents reported to BMCS^[3] provide the most concentrated information relating to accidents of trucks used in commercial transport. The BMCS file for 1984 was interrogated to identify accidents related in any way to shifting or loss of cargo. An incident of this type can be identified either as a primary aspect of an accident, in which it is reported that cargo shifting or loss was a primary contributor to accident causation, or as an associated accident event, in which case cargo spillage occurred although it did not necessarily contribute to causation.

A summary of accident statistics stratified by primary aspect is given in Table 1. Two categories are of interest here—loss/spillage of cargo and cargo shift. Out of the total of 25,276 reported accidents, these categories represented 230 accidents ($\approx 1\%$). That is to say, in 1% of the reportable accidents, a loss, spillage, or shift of cargo occurred and was seen to play a significant role in the causation or severity of the accident in the judgement of the reporting carrier. Note also that flatbeds are overrepresented in these types of accidents. More than one-half of the accidents due to spillage occurred with flatbed trailers, even though flatbeds are represented in only 14.7% of the total accidents. Alternately, the statistics show that cargo loss, spillage, or shift is a primary aspect of 3.4% of reported accidents with flatbed trailers.

Data on cargo spillage can also be extracted from the "associated crash event" coding of the BMCS reports. Table 2 shows a breakdown of the accident statistics for 1984 including this strata. Of the 25,276 total reported accidents, 1560 ($\approx 6\%$) involved spillage of cargo. Flatbed involvement in accidents with an accompanying spillage of cargo is especially high—spillage rate is three times as high as the overall involvement rate for flatbeds. The "associate crash event" coding indicates that the spillage occurred in association with the accident, but was not identified as significant to causation or severity.

These statistics point out that cargo loss, spillage, or shifting has a measurable impact on accident experience. No matter which statistics one chooses to use, the involvement rates are high enough to warrant review of appropriate countermeasures, especially in the case of cargo hauled on flatbed trailers.

2.3 Cause of the Problem

In part, the explanation of these problems with cargo shifting and loss on the highways is a matter of motivation. Understanding the motivations provides an insight to the problem, and effective means for intervention.

Experience teaches that a majority of the incidents are caused by improper restraint of cargo. Cargo is placed in a van trailer with no restraint whatsoever, especially when the trip length is relatively short. At other times, a restraint is applied, but is ineffective in performing the intended function. One might ask, who has the responsibility for seeing

**Table 1 Primary Aspect of Accident by Trailer Body Style,
ICC Regulated and Tractor Trailer — BMCS 1984**

Trailer Body Style	Accident Type					Totals
	Loss/Spillage of cargo	Cargo Shift	Rollover	Other Non-collision	Collision	
Van	16	23	873	2156	10,230	13,298
col%	12.1	23.5	45.0	57.7	52.8	52.6
Flatbed	73	52	385	452	2,741	3,703
col%	55.3	53.1	19.8	12.1	14.1	14.7
Tank	5	0	201	286	1,460	1,952
col%	3.8	0.0	10.4	7.7	7.5	7.7
Auto	4	1	10	48	816	879
col%	3.0	1.0	0.5	1.3	4.2	3.5
Other	9	6	145	194	981	1,335
col%	6.8	6.1	7.5	5.2	5.1	5.3
Unknown	25	16	326	598	3,144	4,109
col%	<u>18.9</u>	<u>16.3</u>	<u>16.8</u>	<u>16.0</u>	<u>16.2</u>	<u>16.3</u>
TOTALS	132	98	1940	3734	19,372	25,276

**Table 2 Associated Crash Event by Trailer Body Style,
ICC Regulated and Tractor Trailer — BMCS 1984**

Trailer Body Style	Associated Event				Totals
	Hazardous Cargo Spillage	Other Cargo Spillage	Other Event	Not applicable	
Van	37	370	104	12,787	13,298
col%	22.6	26.5	46.0	54.4	52.6
Flatbed	10	619	34	3,040	3,703
col%	6.1	44.3	15.0	12.9	14.7
Tank	89	87	22	1,754	1,952
col%	54.3	6.2	9.7	7.5	7.7
Auto	0	6	11	862	879
col%	0.0	0.4	4.9	3.7	3.5
Other	11	113	12	1,199	1,335
col%	6.7	8.1	5.3	5.1	5.3
Unknown	17	201	43	3,848	4,109
col%	<u>10.4</u>	<u>14.4</u>	<u>19.0</u>	<u>16.4</u>	<u>16.3</u>
TOTALS	164	1,396	226	23,490	25,276

that a load is properly restrained and what are the motivations to ensure that it is done adequately. Current regulations place the responsibility for compliance with Part 393 upon "...every motor carrier, and its officers, agents, drivers, representatives, and employees."^[4] In cases where a driver picks up a load from an independent shipper, the driver becomes the representative of the motor carrier with regard to cargo loading and restraint.

The reasons for vehicles getting on the road without sufficient restraint are three:

1) *Belief that a restraint is not needed in a particular situation*—A truck driver is not inclined to take unreasonable chances in his/her occupation, considering the potential consequences of an accident. The disincentives to restrain a load are the physical effort required, the time involved, and the possible lack of proper gear. Yet, if the driver was convinced that there was significant risk when a load is not tied down, he is likely to make the effort. However, accidents are rare events and those due to improper load restraint are even more rare.

2) *Insufficient knowledge of the proper method of restraint*—Many truck accidents related to shift or loss of cargo involve trucks on which some load restraint is applied, but does not function effectively. Chains or cables may slip or break, blocking may be dislocated, etc. Despite an earnest effort by the shipper or carrier, the unanticipated occurs.

3) *Lack of enforcement*—One of the major incentives for proper load restraint is provided by enforcement personnel. The inconvenience and loss of time on the road when a truck is stopped for inadequate load restraint is a powerful incentive to good practice. The major problem arises from the difficulty in determining when regulations are not met, and defining acceptable action. With the variety of loads and restraint types, enforcement personnel are on the spot when it comes to stopping a truck. The economic consequences to the fleet imply a level of seriousness that demands the enforcement personnel be objective and correct. Comments received from the CVSA staff indicate that this is a major concern.

Although education offers some potential to develop driver incentive to overcome the first cause, it is not a certain cure. Developing a simplified set of guidelines for restraint practices, as is the objective of this work, is a step in the direction of solving the second and third. Designing a reliable restraint system requires application of engineering principles taking into account a number of factors. Inasmuch as, it is not appropriate for every load restraint to be "engineered," there is need for engineering analysis applied to restraint design, but with the results reduced to simple rules of thumb that can be easily utilized by the practitioners. Further, a simplified set of guidelines for load restraint is the tool needed by enforcement personnel to permit objective decisions to be made on enforcement actions. If both shipping practice and enforcement are based on the same guidelines, theoretically the problems for both should be minimized.

2.4 Performance Requirements for Load Restraint

The U.S. regulations^[1] require that cargo be restrained on commercial vehicles so as to prevent cargo movement to any degree that detracts from the safety of operations. The

objective in this section is to apply engineering knowledge of vehicle dynamics to establish the performance requirements that should be met by load restraint systems.

Cargo movement in the course of normal driving is not permissible if it diminishes the ability of the truck to turn or brake in any way. As illustrated in Figure 2.1, lateral movement of the load diminishes the rollover threshold of a truck. In a turn the "D'Alembert force" produced by lateral acceleration produces a roll moment on the vehicle that is opposed by transfer of load from the inside (left) to outside (right) wheels of the vehicle. The detailed mechanics that control the rollover process are somewhat complicated by roll of the chassis on its suspension and tires, nonlinearities of the suspension and other factors.[5] However, relative effects can be examined by considering the simple model shown in the figure. In this simple model, the maximum lateral acceleration that can be sustained with a centered load is:

$$a_{y \max} = \frac{t}{2 h_{cg}} \quad (1)$$

If the load shifts off center by a distance "y" the rollover threshold is reduced to the level given by the equation:

$$a_{y \max} = \frac{t/2 - y}{h_{cg}} \quad (2)$$

Thus the threshold diminishes in proportion to the size of the offset distance, y, relative to the half-track of the wheels, t/2. Rollover is a common outcome in truck accidents[6]. Thus, shifting cargo can be a contributing factor. Similar studies of the cornering with trucks carrying loads of hanging meat have shown that the cargo shift both disturbs the turning process and reduces the rollover threshold.[7] It is well recognized that truck cornering limits are the lowest among highway motor vehicles, typically limiting at 0.3 to 0.4 g due either to instability associated with oversteer or rollover. Allowing cargo movement to disturb that critical process is unwarranted. Experience with truck accidents reveals that rollover on exit ramps is often blamed on a "shift" of the load, even though it is normally impossible to confirm that cause after the accident.

To a lesser degree, shifting cargo can compromise braking performance. Truck brakes are normally sized so that the heavily loaded axles produce approximately the same friction utilization and all axles work equivalently during a stop. While this is impossible to achieve in practice, the driver's task during a severe braking maneuver is to work the brakes to the limit without allowing lockup of an axle that would cause instability. Shifting of the load during braking has the potential to upset the balance the driver is attempting to maintain and disrupt his efforts to achieve optimum performance under the prevailing conditions.

The rationale of the preceding discussion clearly justifies the argument that cargo restraint should be adequate to prevent shifting up to the limits of truck cornering and braking. It has been argued that the ideal restraint system would hold to this limit, and then release the load in order to allow the truck to recover prior to a rollover or other type of accident. That argument is dismissed on the basis that a load released on the highway is a

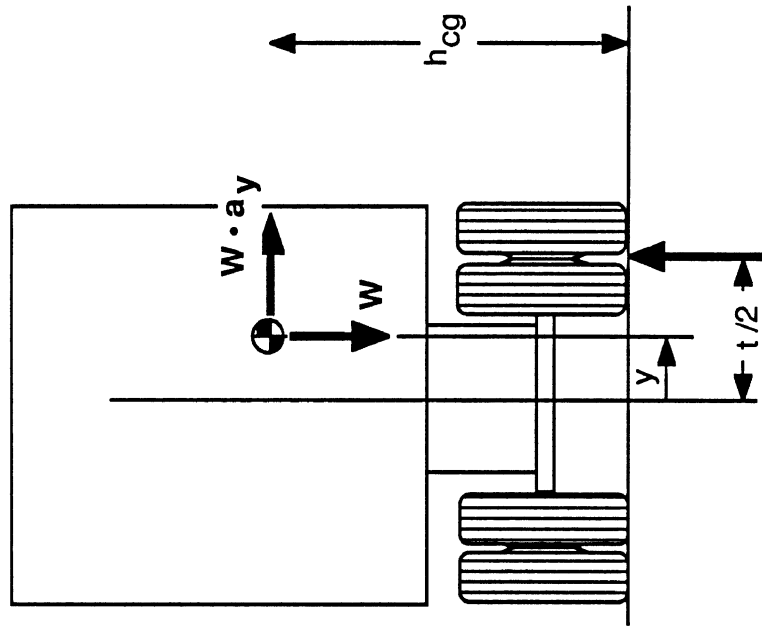

$$a_{y \text{ max}} = \frac{t/2 - y}{h_{cg}}$$

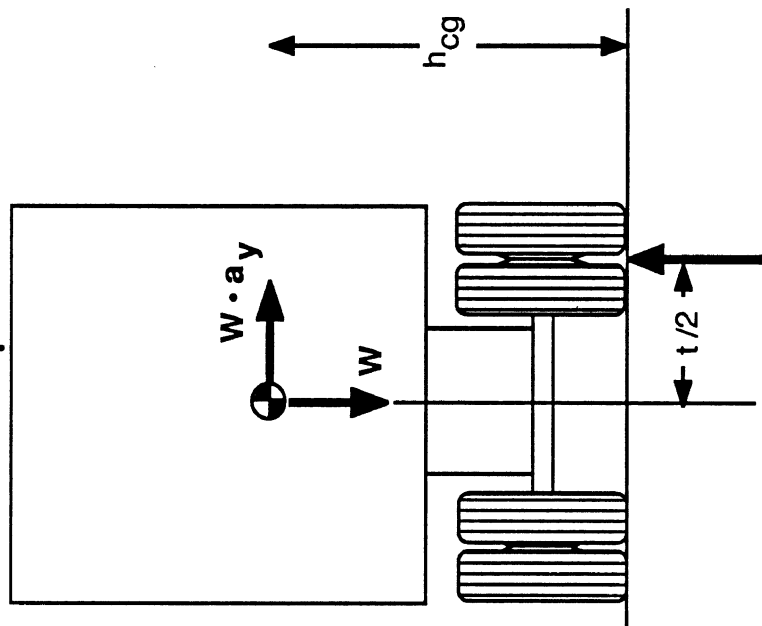

$$a_{y \text{ max}} = \frac{t/2}{h_{cg}}$$

Fig. 2.1 Effect of CG offset on rollover threshold.

hazard to other traffic. There are multiple examples in the accident records of accidents caused to other motor vehicles due to loss of load by a truck.

One might also ask if it is not reasonable to restrain the load such that it is not released from the truck even in the course of an accident, thus minimizing the risk to other vehicles. Defining the limits of force or acceleration in an accident, however, is not an easy task. Acceleration levels measured in collision situations are variable with the collision circumstances and location on the vehicle, and typically range on the order of 10 to 30 g. In a rollover, the magnitude of the force or acceleration upon impact with the ground will further vary with the type of surface contacted. In a frontal collision, the level of force and acceleration will depend on the impacted objects, whether another vehicle or a bridge abutment. Setting limits for the worst case is likely to impose unreasonably difficult restraint requirements on the industry at an economic cost that is not justified.

2.4.1 Longitudinal acceleration requirements—A restraint system should prevent load movement under the limits of longitudinal acceleration, whether it be acceleration from the engine, or deceleration from braking. Acceleration from the engine is transmitted through the transmission and driveline. The maximum acceleration is achieved in the lower (start-up) gears due to the greater mechanical advantage of the engine. An order of magnitude for accelerations can be obtained from the rule of thumb^[8] that a truck engine-driveline combination should be capable of start-up on a 12% grade (equivalent to 0.12 g acceleration). In order to start-up on the grade there must be some excess acceleration capacity. Using a factor of two as an estimate of the excess capability, the acceleration limit in the rearward direction from the engine would be no greater than 0.25 g.

Braking is obviously the more severe case of longitudinal acceleration. Braking deceleration may be limited by the torque output of the brakes or by the frictional coupling to the road. Of the two, the frictional coupling is the more reasonable basis for establishing limits. (While the brake torque may limit decelerations to less than the available coefficient of friction when a vehicle is fully loaded, under partially loaded conditions there is likely to be an excess of brake torque, such that the friction coefficient becomes the limit. Choosing the friction coefficient as the limit is a more conservative, or "worst case" choice.) Studies of truck tire traction properties^[9] have shown that the frictional coupling is a function of the tire, road surface, load, speed, and slip conditions. The longitudinal force (normalized by load) varies with slip as shown in Figure 2.2. Most braking is accomplished along the rising portion of the curve (0 - 20% slip), but is limited by the peak value of coefficient near the 20% slip point. Braking beyond this point results in the wheel going to lockup, and the sliding coefficient of friction prevails.

Figure 2.3 shows typical ranges of peak and slide coefficients of friction measured on dry concrete for radial and bias-ply tires. As evident, peak values in the range of 0.85 and higher are readily achieved under some conditions. This equates to a potential for braking deceleration up to 0.85 g. Actual truck braking performance usually falls below this level because all tires cannot be brought up to the peak traction level simultaneously. In contrast, the slide coefficients are lower in magnitude and more sensitive to speed. Slide coefficients up to 0.75 are frequently seen in such data. The slide coefficient is very significant as a limit because it is easy to realize on a truck when the wheels are locked up in an emergency stop.

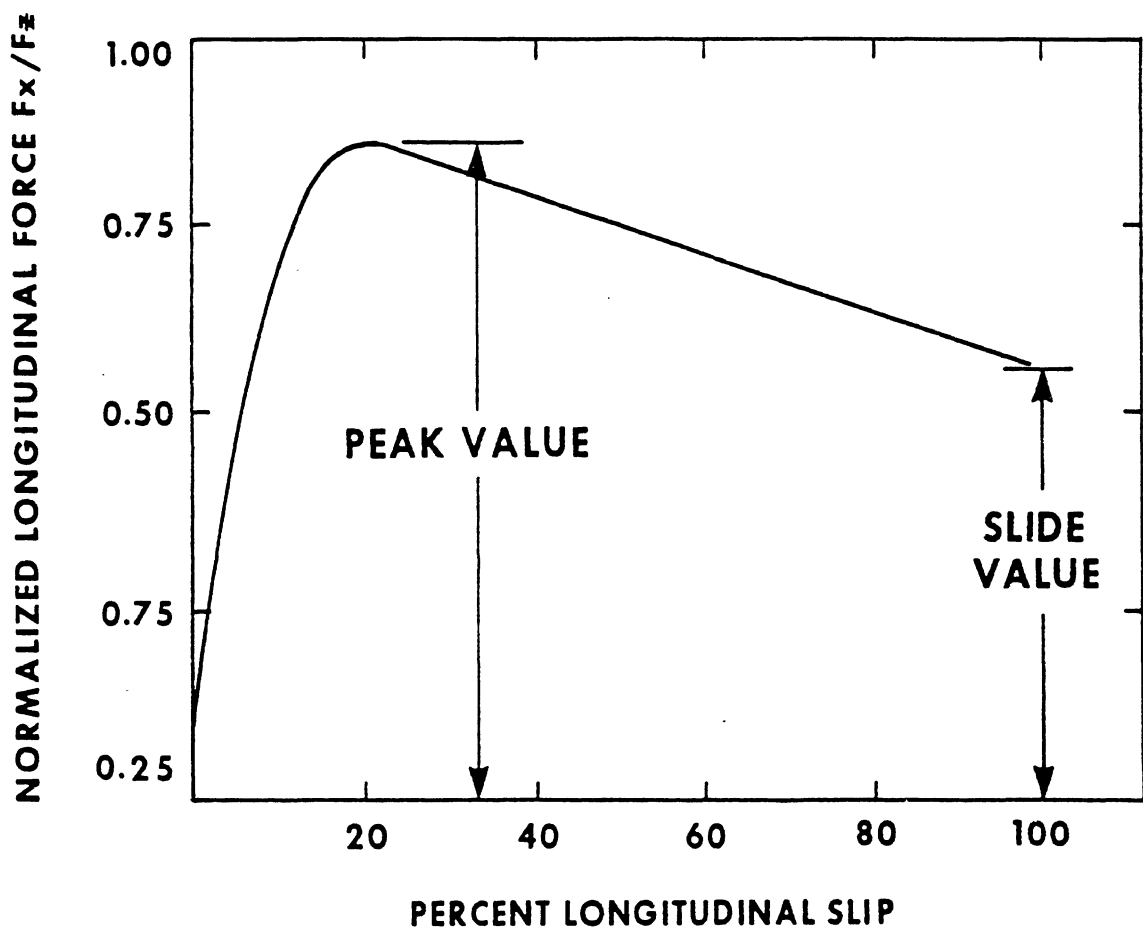

Fig. 2.2 Example " μ -slip" curve, providing definitions of the peak and slide coefficients of friction.

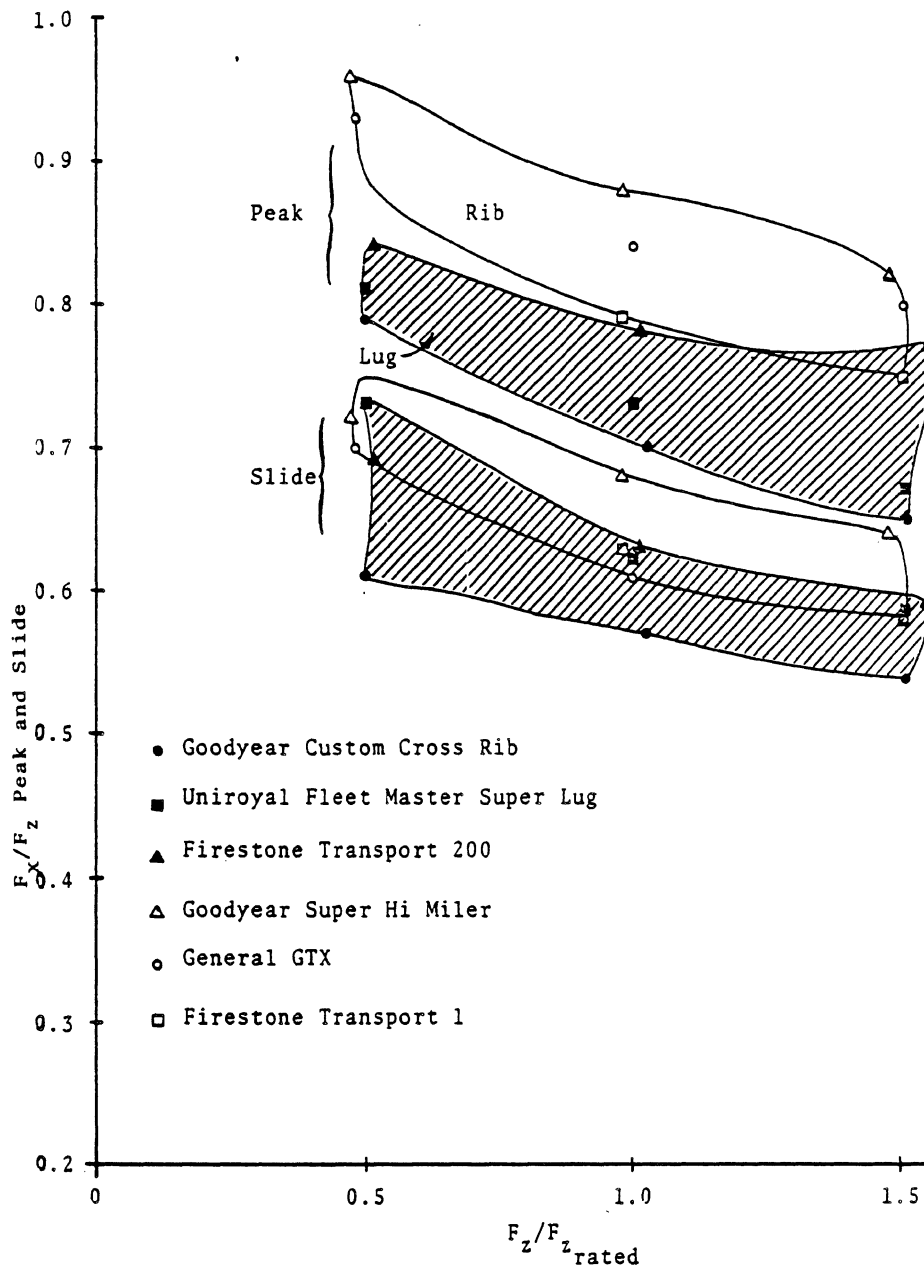

Fig. 2.3a Peak and slide coefficients of friction versus load for bias-ply truck tires at 20 mi/h on dry concrete.

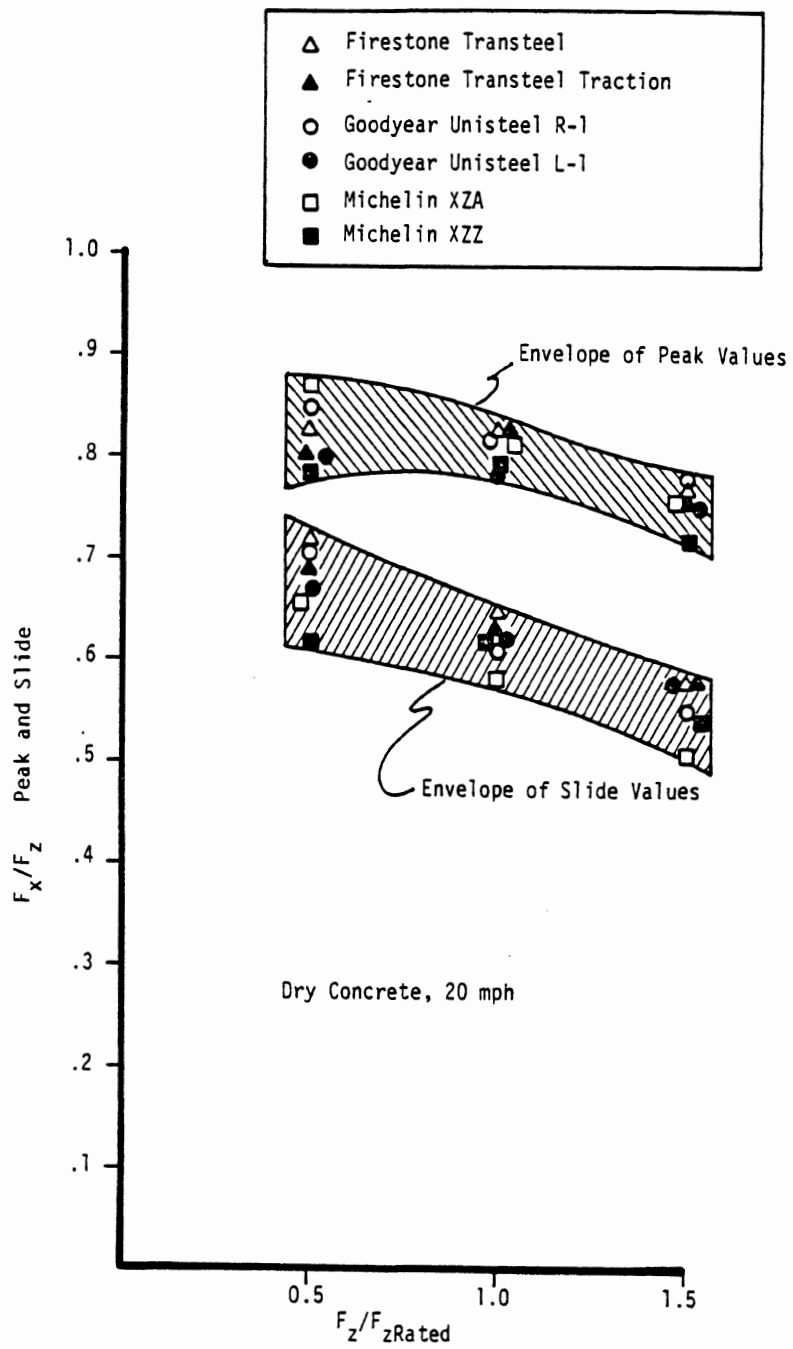

Fig. 2.3b Peak and slide coefficients of friction versus load for radial truck tires at 20 mi/h on dry concrete.

Decelerations close to this limit can be experienced on a truck. In the early days of Federal Motor Vehicle Safety Standard 121^[10] the 245 foot stopping distance requirement at 60 mi/h required an average deceleration of 0.6 g. Because the deceleration is not constant throughout a stop, even higher peak deceleration must occur in order to achieve the average deceleration of 0.6 g. The relaxed standards of today are more typically on the order of 0.45 g deceleration. Nevertheless, these performance requirements do not preclude the sale of trucks that have substantially better performance, especially at lower speeds and in the partially loaded condition. In the early experience of developing trucks to meet FMVSS 121, average decelerations of nearly 0.7 g were achieved in high speed stops on some occasions with peak values that would be even greater. Thus, it must be concluded that trucks have the potential to experience braking decelerations up to 0.75 g, and that cargo restraint systems must be designed with at least this potential in mind. Inasmuch as brake applications may be made in both the forward and backward directions, this limit should be applied to both directions. In the future, improvements in truck tire traction performance and broader usage of anti-lock braking systems (ABS) should be reason for review and revision of this specification.

The acceleration levels recommended here are not unrealistic when compared with regulations from other organizations. Table 3 provides a sampling of the acceleration performance levels required by others.

2.4.2 Lateral acceleration requirements—The lateral acceleration that a truck can sustain may be limited by rollover or skidding. Skidding is the condition where the tires have reached their cornering force limits. Skidding at the front axle represents limit understeer, in which case the vehicle ploughs out. Skidding at the rear axle(s) of a straight truck results in spinout. Skidding on the rear axle(s) of the tractor in a tractor-semitrailer combination produces a jackknife. Skidding of the trailer axle(s) results in trailer swing.

Rollover is a phenomena most commonly experienced on trucks with a high load center (typically with light to medium density products that stack 6 to 8 feet above the bed). In those cases, a considerable amount of engineering study and experiment has shown that the rollover thresholds will be on the order of 0.3 to 0.4 g.^[6] When trucks have very little load, or are loaded with high density materials (e.g., steel plate) the total vehicle CG height is much lower and the rollover threshold is increased accordingly. The maximum rollover threshold is dictated by the lowest CG height (relative to track width) that can be achieved. Less is known of the rollover limits in these cases. For typical trucks with bed heights in the 50 - 55 " range this limit is estimated to be approximately 0.75 g^[11]. The very low trailer styles, such as low-boys and step vans, should be capable of even higher cornering levels without rollover.

In the absence of rollover the cornering (lateral acceleration) limit is determined by tire traction capabilities. Although it is common that trucks may still experience oversteer instability at relatively low lateral acceleration levels, the exact behavior will depend on the load and its distribution among the axles. The "worst case" acceleration limits will occur when the truck is most equally balanced in cornering, and able to perform to the limits of tire traction. Truck tire cornering behavior has been measured experimentally.^[9] Figure 2.4 shows the normalized lateral force performance as a function of slip angle. As slip angle increases, the lateral force approaches a peak value of nearly 0.9. Although the limits

Table 3. Examples of Acceleration Performance Requirements for Cargo Restraint Systems

<u>Organization</u>	<u>Acceleration Level (g)</u>		
	<u>Forward</u>	<u>Rearward</u>	<u>Lateral</u>
Australia ^[23]	1.0	0.5	0.5
Sweden ^[24]	1.0	0.5	0.5
BMCS ^[1]	0.4 - 0.6	----	----
Ontario, Canada ^[25]	0.6	----	----
ANSI ^[26]	2.3	2.3	1.6
United Kingdom ^[27]	2.0	1.0	1.0

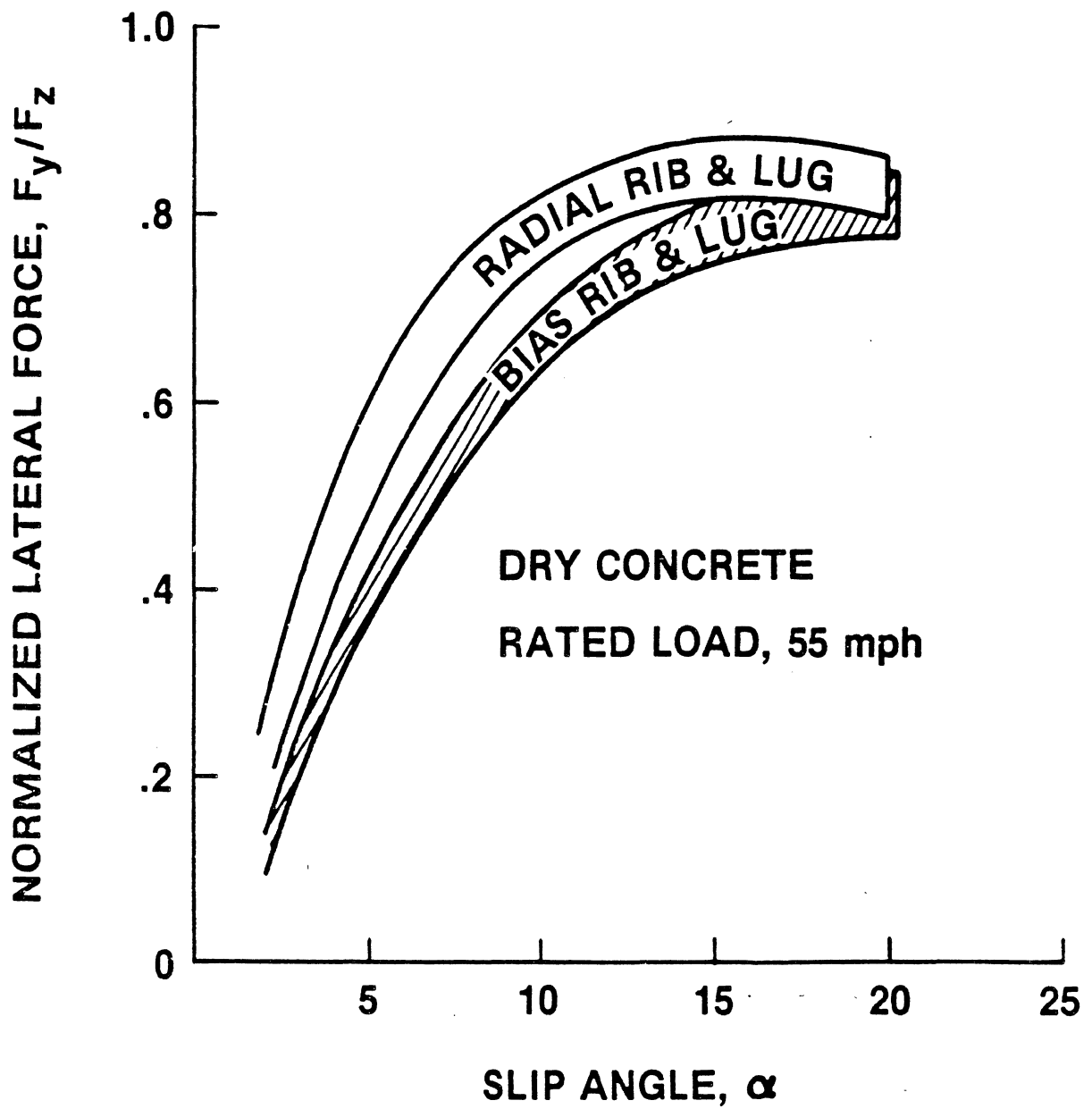

Fig. 2.4 Envelopes of lateral traction performance on dry concrete.

vary with tire type, surface condition, and load, an upper limit of 0.9 coefficient of friction (corresponding to 0.9 g lateral acceleration) captures nearly all conditions on paved surfaces.

Of the two limits—rollover and tire traction—traction is the more reasonable limit to which restraint systems should be designed. The tire traction limit is lower than the levels of lateral acceleration that might actually be developed when a truck slides into a curb or soft earth. However, the upper limits for these situations are unbounded and could impose excessive hardships on the trucking industry if restraint design criteria were inflated to cover these cases. On many trucks this limit will be well above the performance that can be achieved because rollover will dominate. Yet in the general case the carrier does not know the rollover limit on individual vehicles or shipments, and can not be certain that the restraint is reliable to the limits of performance unless the traction limit is assumed. If not designed to this performance limit the operator runs the risk that in an emergency maneuver or loss of control situation the cargo will break loose from the vehicle and involve other vehicles in accidents.

In addition to the lateral acceleration produced in cornering, the truck body rolls toward the outside of the turn. That inclination of the bed adds a gravitational component to the lateral acceleration experienced by the load equivalent to the tangent of the angle. The amount of body roll, of course, varies with the truck and load condition. Experience in truck testing suggests that roll angles on the order of 6 degrees will occur as the truck approaches the cornering or rollover limit. For a 6 degree inclination, the gravitational component is approximately 0.10 g. This adds to the effective lateral acceleration experienced by the load. Considering the 0.9 g contribution from tire traction limits, plus 0.1 g for roll angle, an overall design acceleration level of 1.0 g is obtained.

The lateral acceleration performance requirements from other organizations given in Table 3 are in some cases lower than that suggested here. Lower limits are undoubtedly rationalized by the fact that many trucks experience rollover at relatively low acceleration levels, and chassis roll may not be taken into account as a contributing factor. It is argued here that, because the driver does not know the rollover limits of a truck with an arbitrary load, the performance requirements should be based on the upper limits that may be encountered.

2.4.3 Critical cargo weight—The concerns for adequate cargo restraint must recognize that, as the weight of an individual cargo item increases, proper securement becomes more critical. For example, the special requirements for securement of coiled metal articles^[12] applies to one or more coils which, individually or as a combination banded together, weigh 5000 lbs or more. Elsewhere in the regulations metal articles weighing 2000 or more are required to receive special attention with regard to restraint. The importance of proper restraint of all other cargo types is dependent on the total weight as well. The degree of care taken to ensure reliable securement of large items, however, is not always appropriate for small items. A rationale for selecting the break point of critical cargo weight should be based on the potential hazard to other traffic in the event of cargo loss.

The loss of a major cargo item from a truck presents a hazard to other traffic through the risk of collision with other vehicles, either by falling on top of the car or by landing in the path of travel of a car.

Current federal standards^[13] require that the roof of a passenger car be capable of sustaining a load (slowly applied) equal to 1.5 times with weight of the car with no more than 5 inches of deformation. This does not mean that the critical weight is 1.5 times the weight of the car, because the lost load will be moving and have kinetic and potential energy. The energy (in inch-pounds) absorbed in the federal test procedure (assuming the force is proportional to deformation) is numerically equal to 3.75 times the weight of the car, which is approximately equal to the energy that would be released if a weight equal to that of the car were just placed in contact with the roof and dropped (releasing potential energy as it crushes into the roof). The height to the roof of typical passenger cars is 50" - 55", which closely matches the nominal bed height of most trucks. Thus, the roof-crush standard is just sufficient to ensure that a car could withstand a load of equal weight rolling or sliding off of a truck bed onto its roof. Cars vary in weight. Sub-compacts (which are the smallest vehicles commonly seen on the road) fall in the weight range of 1900 to 2300 lb.

The consequences of hitting a lost load in the lane of travel can be estimated from occupant crash protection requirements. Modern cars are designed with the objective of survival in crashes up to the severity of a 30 mi/h change in velocity (ΔV).^[14] The relationship between the weight of a cargo item and severity of crash is developed by application of conservation of momentum to the non-elastic collision of a car with a cargo. This is expressed by the equation:

$$W_p \cdot \Delta V_p = W_c \cdot \Delta V_c \quad (3)$$

where

- W_p = weight of the passenger car
- ΔV_p = change in velocity of the passenger car
- W_c = weight of the cargo item
- ΔV_c = change in velocity of the cargo item

The critical weight of a cargo item is that value which would produce a ΔV on a passenger car greater than the 30 mi/h survivability limit on impact. That is,

$$W_c \leq W_p \frac{\Delta V_p}{\Delta V_c} \quad (3a)$$

As an example case consider a sub-compact car weighing 1900 lb traveling at 55 mi/h, which impacts a lost load, sitting stationary on the highway, in a non-elastic collision. The load goes from an initial speed of zero to the final speed of 25 mi/h (the initial car speed of 55 mi/h less the 30 mi/h ΔV), and its corresponding ΔV is 25 mi/h. Then:

$$W_c = 1900 \frac{30}{25} = 2280 \text{ lb.} \quad (4)$$

That is, the maximum weight of an item of cargo that could be hit in a survivable accident would be 2280 lb. The critical weight changes if it has some initial velocity in the

direction of the approaching car (if dropped from the side of a truck as the vehicle is passing in the opposite direction). Presuming the worst case of the passenger car and the truck traveling at 55 mi/h when the load is lost, the ΔV for the load will be 80 mi/h (55 mi/h initial speed changing to 25 mi/h in the opposite direction). In that case:

$$W_c = 1900 \frac{30}{80} = 712 \text{ lb.} \quad (5)$$

Thus the critical weight of cargo will vary considerably with the conditions leading up to an impact. The largest critical weight is 1900 lb based on potential for roof crush of the smallest sub-compact, and the smallest is 712 lb based on the worst case scenario of a head-on collision with load falling from an approaching truck. A reasonable compromise is the designation of 1000 lb as the critical weight of an article of cargo for which reliable restraint must be ensured. This is not to say that cargo of any weight falling from a truck is without risk. There are accident reports in the records showing injuries and deaths from loss of cargo items weighing less than 100 lbs. The objective here is to demonstrate that the existing 2000 and 5000 lb limits are larger than appropriate under the most tolerant rationale. Although more restrictive than current regulations, the 1000 lb limit has the advantage that any error favors safety, and provides some allowance for the evolutionary reductions in weight of automobiles in the future. It is difficult to argue that this limit is inappropriate when the rationale for selection has been crash survival. Strong arguments can be made for a much lower critical weight on the basis that any cargo lost from a truck constitutes a safety hazard to other motorists.

2.4.4 Safety factors—In the engineering design of any system that serves a critical function it is routine to compensate for uncertainties in the materials, environment, or design method by application of a factor to the design calculations that will ensure performance under all conditions. In effect, the system is designed to endure a load greater than the expected load, that ratio being known as a safety factor.^[15] Safety factors vary from values of 1.25 to 8 in typical engineering designs, depending on uncertainties in materials and environment, the economic circumstances, and the consequences of failure. In addition, designs are often analyzed to anticipate failure modes and potential consequences so that the severity of the consequences can be diminished or even prevented by design to yield a "fail-safe" condition. The fail-safe philosophy strives to prevent any catastrophic consequences in the event of a failure, to provide redundant members so that if one load-carrying member fails a second member is able to assume the full load, and to ensure that any incremental failure is immediately evident to responsible personnel.

In a situation where the engineering materials are reasonably well known, along with the environment and loading conditions, safety factors on the order of 1.5 to 2.5 are typically recommended^[15]

From engineering experience, a safety factor of no less than 2 is recommended for cargo restraint systems, and the design should include redundant components that will achieve minimum performance levels in the event of failure of any one component.

Further, cargo restraints on commercial trucks should be designed and specified with the same cautions as applied to other systems. Items of a size above the critical weight have the potential to cause serious injury or death to truck drivers or other motorists when

restraint systems fail. To prevent such incidents the design should have sufficient strength to meet the performance requirements despite the variables of use. This can be achieved by over-design of individual restraints or by use of redundant restraint methods. For example, metal coils restrained by two chains and blocking can still retain the load even if one chain fails, thereby preventing an accident until such time as the driver becomes aware of the failure. It is also important that failure of a component will be obvious to the driver either during visual inspections or by other warning methods.

.

3. ENGINEERING ANALYSIS OF RESTRAINT METHODS

3.1 Introduction

In modern trucking, a broad range of products are transported restrained by one of two methods—either fixed to the bed of the truck by various devices (tiedowns, blocking, etc.), or carried in an enclosed vocational body. Adequate restraint for the variety of cargoes hauled requires some flexibility in design and involves choices between numerous restraint methods.

The principles that govern the performance of restraint devices are not especially well-known and documented. Therefore, the engineering principles by which restraint methods function will be examined and explained in this chapter as a resource of general utility to the truck transport community. (Application to example cases is demonstrated in the next chapter.) The explanation of the mechanics involved is a first step toward developing a systematic basis for restraint design, a process which is complicated by the variety of restraint methods, the several directions in which each may function, and how they work in combination. Only through this process is it possible to understand clearly the significance of such factors as preload in a tiedown (which serves different purposes depending on configuration) and the relationships between strength and performance of a tiedown.

3.2 Frictional Coupling

With any restraint method, the frictional coupling between the load and the truck is frequently seen as a restraint element. This is exemplified by the practice of loading loose cargo in vans with no restraint and ample space for the article(s) to shift. The practice is used widely in local delivery operations, and even in long-haul operations. The author has observed the case of a van trailer loaded to its weight capacity with a few heavy drums positioned centrally in the interior. The drums were unrestrained, but expected to remain in place due to friction. The practice is used because it is possible to drive the truck on the highway and with proper care not have the cargo move. With a closed van, enforcement personnel are unlikely to be aware of the practice. Furthermore, until the cargo shifts or falls no regulation has been violated. On close analysis this practice creates unnecessary risk and is unjustified.

The risk comes about from the fact that *friction is insufficient to hold the cargo in place up to the limits of truck performance, thus it invites cargo shift in a critical maneuver*. The friction coefficient between cargo and the floor material is rather unpredictable. In typical engineering handbooks^[16,17] the friction coefficient of metal on wood or of wood on wood is variously reported to be on the order of 0.5 and 0.8 static, and 0.5 sliding. When any contamination is present, such as dirt, gravel, or oil, the coefficient drops drastically to values on the order of 0.03 to 0.1. The static friction coefficient defines the longitudinal or lateral acceleration level that can be sustained before sliding begins. In the previous chapter, evidence has been presented indicating that trucks are capable of acceleration levels much greater than the friction coefficients reported here. In normal driving, high acceleration levels are not required, but in emergency maneuvers they are.

Studies have been made of the braking levels used by drivers of passenger cars.^[18] The results are presented as plots of the probability distribution of braking level as shown in Figure 3.1. The plot shows percent of brake application time (vertical axis) exceeding the braking level value indicated on the horizontal axis. Ninety-nine percent of the time, brake applications involve decelerations less than 0.3 g. Conversely, 1% of the braking time exceeds 0.3 g deceleration, and for 0.05% of the time it exceeds 0.5 g. Although comparable data for truck drivers is not available, it would be expected to be similar in appearance, perhaps with the curve shifted to lower deceleration levels. Even so, the implication is that for some small percentage of brake applications, braking demands will exceed the deceleration levels that can be sustained by the friction coefficient of an unrestrained load and the load will shift.

A similar analysis can be applied to lateral accelerations. Figure 3.2 shows the probability distribution for lateral acceleration experienced by a group of drivers of passenger cars.^[19] For one percent of the distance traveled, they drove at lateral acceleration levels greater than 0.2 g, and for 0.01% of the distance the acceleration exceeded 0.4 g. If data of this type were available for truck drivers, it would be expected that the curves would be similar in form, although the overall acceleration levels might be less. Nevertheless, the curves would show that for some finite percentage of the turning experience with trucks the lateral acceleration level would exceed the static coefficient of friction of an unrestrained load, with the implication that load would shift.

The driving patterns at low levels of lateral acceleration are the normal driving maneuvers. High lateral acceleration levels are not routine practice, but represent those times when (because of misjudgements, traffic conflicts, etc.) the driver is forced to take the vehicle near its limit of control. At these times the driver and the vehicle are being challenged to their limits. Compounding the situation with a shift in the load is simply irrational.

When one considers that driving a vehicle is the task of generating the accelerations by which to flow with the traffic and negotiate turns, it is an unreasonable burden for the driver of an unrestrained load to take on the task of trying to avoid conditions beyond the limits of the friction holding the load in place. It is inevitable with any amount of driving to experience traffic conflicts and other situations where the driver is forced to take the vehicle to a higher limit. In those circumstances the sliding load is bound to add to the risk and consequences of an accident.

The use of friction as a restraint has the further complication that no one can adequately judge the level of friction that will be available on a truck in a driving situation. Because the friction coefficient is so critically dependent on surface conditions of the load and truck bed, no one can reasonably judge its adequacy short of conducting tests under each condition. Friction is an unreliable restraint. Oil and dirt, common contaminants on the bed of a truck, can seriously compromise friction level. Vibrations during transit have the same effect. It is well recognized that vibration overcomes friction and, in fact, vibration is used commercially as a way to reduce friction in loading operations and conveyor systems.^[20] Truck vibration is largely caused by road roughness and with the deteriorating conditions of the national road network^[21], it is more likely than ever to precipitate load-shift incidents and accidents.

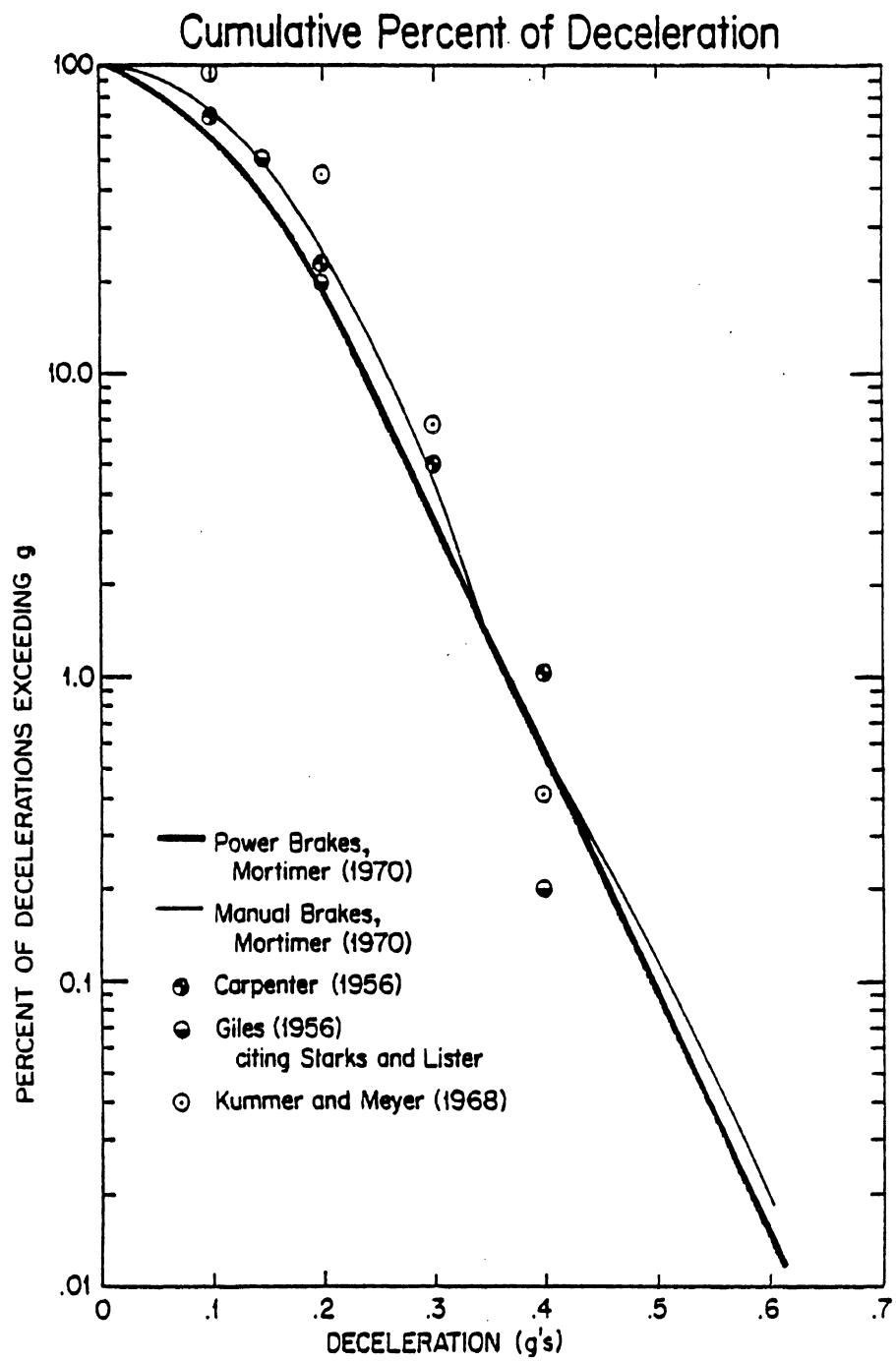

Fig. 3.1 Cumulative percent of braking deceleration levels with passenger cars.

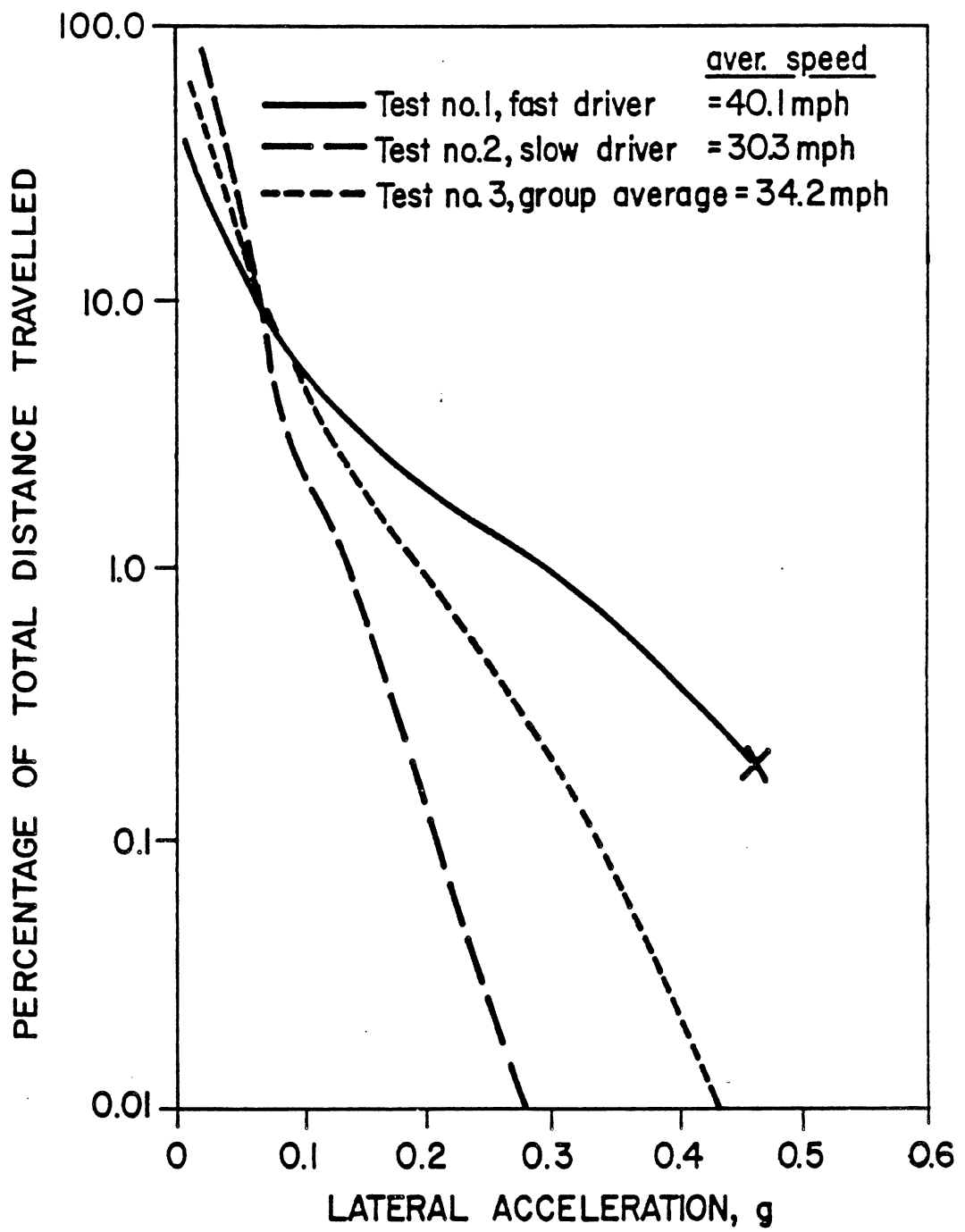

Fig. 3.2 Cumulative percent of lateral acceleration levels with passenger cars on rural roads.

3.3 Restraint by Enclosures

A large percentage of highway shipments are hauled in enclosed trailers (65% of the trailers on the road are vans). In many of these vehicles the primary method of restraint is provided by the walls and ends of the trailer. In other cases the cargo may be restrained within the trailer by tiedown systems. In this latter case, the discussion in the later section on Tiedown Restraints is appropriate.

From an engineering viewpoint, there are two fundamental concerns related to hauling unrestrained cargo in enclosed vehicles. These are:

- 1) Loading methods that prevent the cargo from shifting to the degree that it would compromise vehicle behavior in a critical maneuver
- 2) Sufficient strength in the walls of the trailer to sustain acceleration/deceleration forces or impacts from shifting cargo.

3.3.1 Laterally shifting loads—Any load hauled in a truck experiences some shifting in the course of travel. If it has the freedom to shift laterally, an abrupt shift may occur, for example, during the sustained lateral acceleration while negotiating an exit ramp. The movement of the CG will alter the turning behavior of the truck and may cause loss of control or initiate rollover.

The potential for lateral shift occurs with many load types. As an illustration for purposes of analysis, consider the not-untypical case of pallet-loaded goods placed along the sides of a van trailer as illustrated in Figure 3.3. A "model" of the phenomena of interest assumes that there is a weight and CG location for the base vehicle, and weights and CG locations for two loads placed along the sides of the vehicle. The CG of the base truck will be approximately on center of the vehicle. The CG's for the two loads are approximately at the center of the loads. A free space separates the two loads by the distance L_1 . If there is no blocking in the free space between the loads, the load on the inside may slide to the outside during a turn, with a resultant repositioning of the CG for the total vehicle.

Assuming for simplicity that the two weights are equivalent in magnitude and that their CG's are equidistant from the centerline of the vehicle, then the CG of the total vehicle will be located on the centerline (the ideal for a properly loaded truck). Now assuming the truck makes a lefthand turn, the weight on the inside of the turn (left side) can slide to the right until it makes contact with that against the righthand wall. It can be shown that the lateral translation of the total vehicle CG will be:

$$y_{cg} = W_1 \frac{L_1}{W_{tot}} \quad (6)$$

where

- y_{cg} = lateral translation of the total vehicle CG
- W_1 = weight of the load that is free to move laterally
- L_1 = lateral distance the weight can move
- W_{tot} = total weight of the vehicle and load

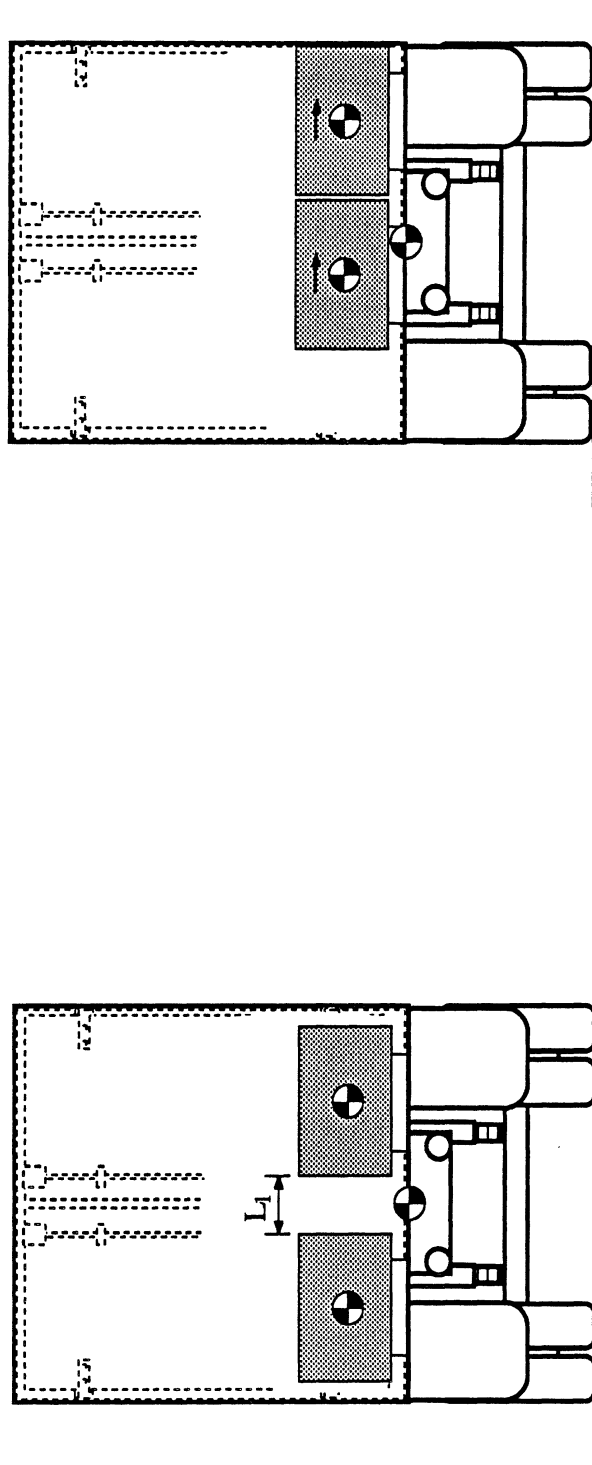

Fig 3.3. Model of load shift in a trailer

It was shown earlier that the rollover threshold of a loaded vehicle is given by:

$$a_{y \max} = \frac{t}{2 h_{cg}} \quad (1)$$

And when the load shifts laterally such that the CG is offset from the centerline by the distance, y_{cg} , the threshold is determined by:

$$a_{y \max} = \frac{t/2 - y_{cg}}{h_{cg}} \quad (2)$$

Substituting Eq. 6 into Eq. 2 and re-arranging produces the expression:

$$a_{y \max} = \frac{t}{2 h_{cg}} \left(1 - \frac{2 L_1}{t} \frac{W_1}{W_{tot}} \right) \quad (7)$$

Thus it is shown that the rollover threshold is reduced from its ideal (Eq. 1) in a factor that is proportional to the nondimensional distance of the shift ($2 L_1/t$), and the proportion of the total vehicle weight that is free to shift (W_1 / W_{tot}). As an illustration of the equation, consider a tractor-semitrailer with a base weight of 30,000 lb, hauling palleted goods weighing 40,000 lb (distributed equally as 20,000 lb for the two weights shown in Figure 3.3). If these were loaded such that there is a 12-inch lateral clearance between the left and right rows of pallets, L_1 will be 12 inches. For a typical truck with dual wheels, the track (between centerlines of the duals) is 72 inches. Thus, the load shift factor would be:

$$\frac{2 L_1}{t} \frac{W_1}{W_{tot}} = \frac{12}{36} \frac{20,000}{70,000} = .095 \quad (8)$$

In other words, the rollover threshold of the vehicle would be reduced by approximately 10% in the course of a turn if the load shifted laterally. In addition, the impact produced as the load collided with the stationary load could disturb the vehicle in roll and yaw behavior.

Although 10% may not sound like an overly large number, its significance needs to be appreciated. A load shift of this nature does not occur on every exit ramp because of the frictional coupling between the load and the floor. Rather it occurs when the vehicle is being pushed harder in a curve due perhaps to a misjudgement of the severity of turn by the driver. Thus it adds to the difficulty of the driver's task, and in many cases precipitates an accident. A "load shift" is frequently reported by drivers as the "cause" of an accident, but without factual basis. For one, it is difficult to prove from post-accident evidence that a load shift occurred prior to the accident, because a shift occurs during the accident and is thus always observed. Secondly, "load shift" is viewed as a way for the driver to transfer blame in an accident that would otherwise be attributed to driver error. Thus, the driver is not viewed as an objective source for this information. Load shifting is a potential contributing factor to any rollover accident of a vehicle with unrestrained loads. Although it might be clear that the accident was not initiated by shifting load (indeed the shift normally occurs as a secondary event), there is always the possibility that the driver might have recovered control without an accident had the load shift not occurred.

As a practical goal, one should always strive to minimize the potential for lateral load shifts. A quick estimate of potential magnitude of a lateral shift problem for a planned load can be obtained by computing the lateral shift factor from Eq. 8. Simply compute the product of the weight of any load component that could shift and the lateral distance in inches that it could move. (In the case of multiple load components that can each move different distances, compute the product of load and distance for each component and take the sum over all components.) Divide that by 36 times the total weight to get the lateral shift factor. Factors on the order of a few percent are probably typical of the best that can be achieved practically, and are likely to be inconsequential to vehicle performance.

3.3.2 Longitudinal shifting loads—Compared to the lateral, a longitudinal load shift has a less direct influence on truck performance. Although longitudinal shift can disturb braking and turning maneuvers, the much greater length dimension of the truck reduces the effect. In addition, it will only occur during braking, which already involves a dynamic load transfer from rear to front axles, so its influence will be less pronounced. A longitudinal shift factor can be computed similar to that for the lateral direction. The longitudinal shift factor would take the form:

$$\text{Longitudinal shift factor} = \frac{2 L_1 W_1}{WB W_{\text{tot}}} \quad (9)$$

where

WB = wheelbase of the truck or trailer

On typical vehicles the dynamic load transfer onto forward axles during a severe brake stop usually amounts to 10% to 20% of the total weight. Thus a longitudinal shift factor of a few percent would be unobservable. Only when the factor gets to the same order of magnitude would its influence on handling or braking be noticeable. A longitudinal shift in the magnitude of 10% to 20% would be a significant event in other regards. Half of the total weight (virtually the entire load) would have to move 1/4 of the length of the vehicle to produce a noticeable effect. Should that happen, other serious events would occur (axles may become overloaded, the impact of the load on the front of the truck or trailer may cause damage, etc.)

3.3.3 Wall Strength—Under circumstances where the front and side walls of the truck or trailer body are the primary restraint for the load, the carrier has responsibility to ensure that they have adequate strength to prevent the load from shifting or falling from the vehicle. Presuming the load is placed in contact with these walls, they must be strong enough to sustain the acceleration forces. In the case where the load is separated from the walls, they must be strong enough to resist the impact forces should the load slide into the wall. Specifying adequate, but not excessive, strength is a difficult task. Engineering models can be formulated to represent the physics at work and provide guidance for design and regulatory actions. Two models are necessary—one to represent the force distribution of an accelerating cargo in contact with the walls, and another to represent the dissipation of impact forces when cargo slides into a wall.

Static loads—Cargo that is emplaced against the wall of a trailer will impose what is essentially a static force on the wall during maneuvering accelerations. Figure 3.4

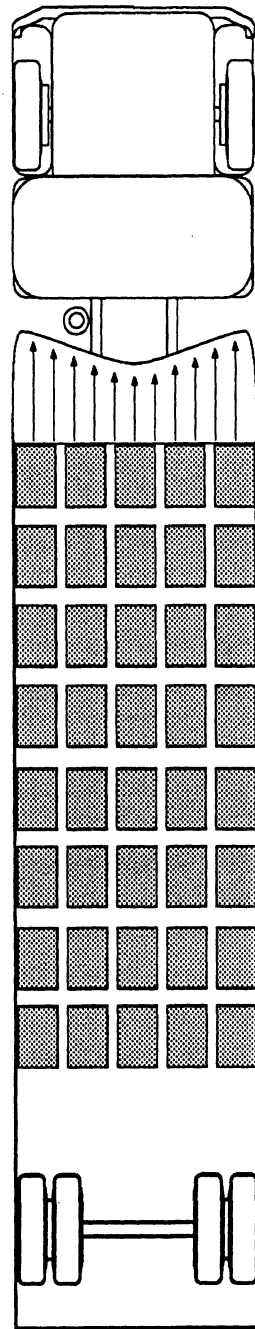

Force on the front wall
due to braking deceleration

Fig. 3.4 Forces imposed on the front wall of a trailer during hard braking.

illustrates those forces in a braking situation. The magnitude and distribution of the forces will depend on the type of load and the operating conditions. The force can be represented as pressure on the wall, varying in intensity as a function of position. The integral of pressure over the affected area is the total force which will equal the weight of the unrestrained cargo times the acceleration (in g's), less the component reacted as friction force against the floor. However, as has been pointed out in a previous section, the friction force is unreliable as a restraint force and can be nullified by simply passing over a road bump. Thus the conservative approach to modeling the physics is to neglect any aid from friction coupling. In that case the force is given by:

$$F_{\text{wall}} = \int P \, dA = W_1 a \tag{10}$$

where

- F_{wall} = Net force on the affected wall of the vehicle
- P = Local pressure from the load (pounds/unit area)
- dA = Increment of area on the affected wall
- A = Area of the wall over which the integration is performed
- W_1 = Weight of the unrestrained cargo
- a = Acceleration (g's)

While this defines the total strength requirement for the wall, the issues of how it is distributed and implications with regard to localized strength are unresolved. For example, a load of bagged or boxed materials will act much like a fluid load, distributing pressure uniformly against the wall. On the other hand, a small heavy item, such as a machine tool, may impose its force in a localized area (idealized as a "point load"). The first implies need for an overall strength requirement for the complete wall assembly, whereas the second case requires strength for penetration resistance. The second case covers such a broad range of possibilities that, in effect, one would be forced to specify wall strength requirements that would restrain the entire load capacity of a truck or trailer within a small area at every position on the wall. This would be both burdensome for the manufacturer (because of the variety of loads that can be hauled on a truck), and for the trucking industry (its weight would reduce capacity to a degree that would be economically unjustifiable). The more rational approach would be to require auxiliary blocking, etc. in a vehicle used to carry such loads to ensure that acceleration loads would be distributed across the affected wall.

In the distributed pressure case, the actual pressure distribution will depend on the type of loading. Small packaged items will tend to exert a uniform pressure distribution, as illustrated in Figure 3.5a, because they are free to move and follow any distortion of the wall arising from the load. When the load consists of larger packages (or pallets), the distribution of pressure may not be as uniform. A rigid, flat-faced package pressing against the wall may tend to develop the highest pressures at its edges as the wall deflects under load. This case is illustrated in Figure 3.5b. The greatest pressures are then developed at the corners of the wall, which typically have the greatest strength because of attachments to the adjacent walls.

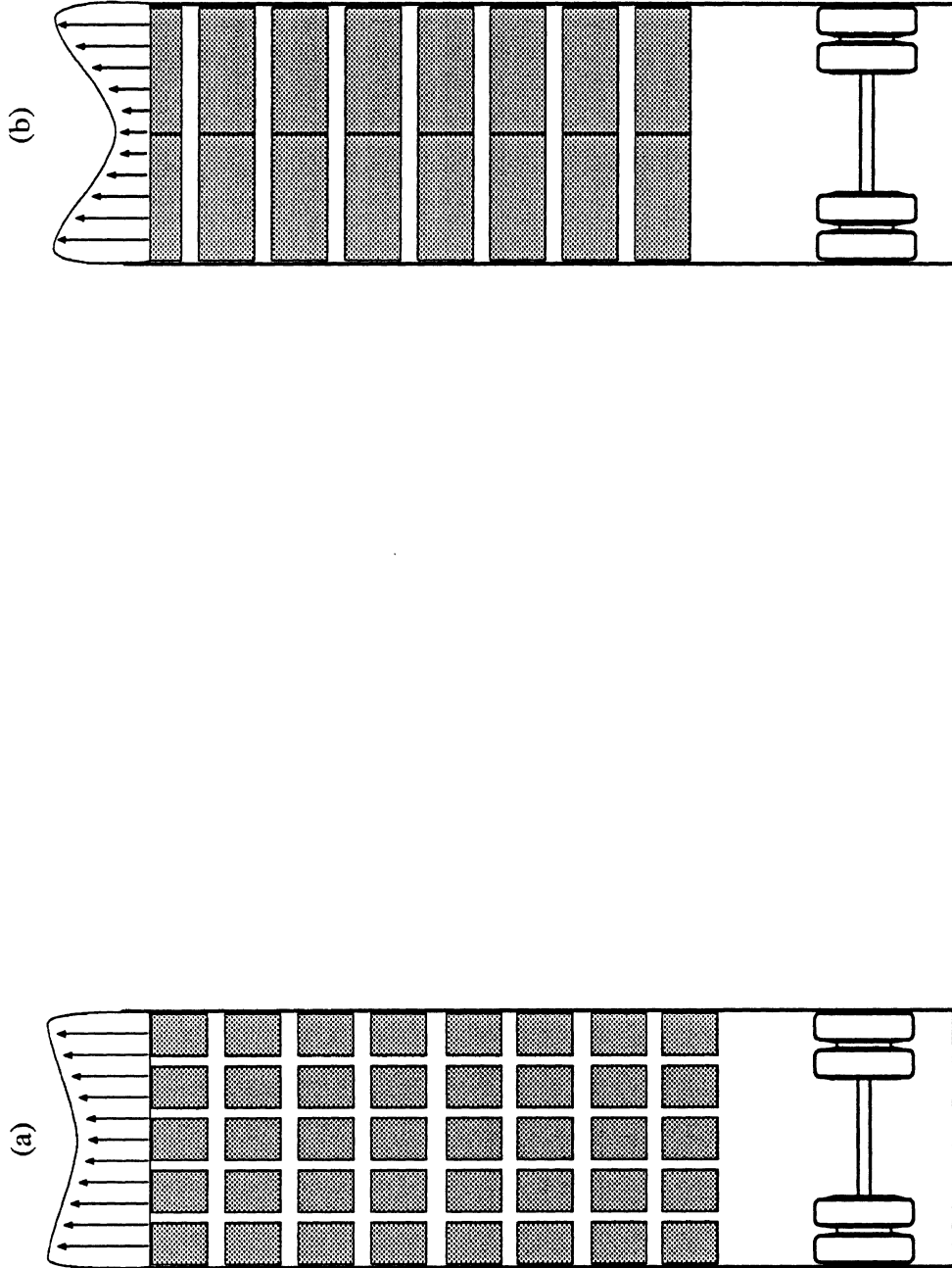

Fig. 3.5 Pressure distribution on front wall of a trailer during hard braking with
(a) small package cargo, and
(b) large package cargo.

Of the two cases, the uniform pressure distribution represents the most critical test as it requires strength throughout the entire wall assembly and defines a reasonable regulatory objective.

Dynamic loads—Unrestrained cargo free to move within a truck will impact the walls during driving maneuvers and impose short-term dynamic loads. The physical phenomenon involved during impact is governed by an energy balance. Consider an unrestrained cargo item of weight W_1 in the rear of a truck body as shown in Figure 3.6. If unrestrained, it would be free to move a distance x in the event of a brake application, should the braking deceleration exceed the static coefficient of friction under the cargo item. In the process it would build up velocity until final impact with the front wall of the truck body. Assuming a constant acceleration, and neglecting friction on the truck floor, the kinetic energy is given by:

$$KE = 0.5 \frac{W_1}{g} V^2 = W_1 x a \quad (11)$$

where

- KE = Kinetic energy
- W_1 = Weight of the unrestrained cargo item
- V = Velocity at impact on the wall
- x = Distance of travel to a restraining wall
- a = Acceleration of the truck

Upon impact with the wall, the force exerted deforms the wall and in the process dissipates the kinetic energy. The energy dissipation process depends on the integral of the resisting force presented by the wall times the deformation. Assuming the resistance force builds up linearly with deformation, the impact energy dissipated is:

$$IE = K_w \frac{d^2}{2} \quad (12)$$

where

- IE = Impact energy dissipated
- K_w = Stiffness of the truck wall
- d = Deformation of the wall

If the kinetic energy of the moving cargo is less than the dissipation capacity of the wall, the cargo item will be stopped and not allowed to escape from the vehicle. The requirement is:

$$K_w \frac{d^2}{2} \geq W_1 x a \quad (13)$$

The implication of this simple analysis is that the trailer walls must be designed to absorb impact energy when used to transport unrestrained cargo, where that energy rating dictates the maximum weight that may be carried unrestrained in accordance with its location relative to the wall and the maneuvering accelerations that are to be endured. The

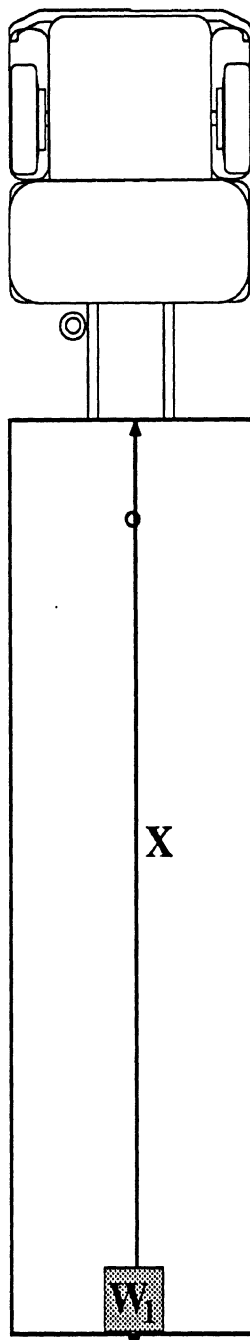

Fig. 3.6 Unrestrained cargo at the rear of a trailer free to slide forward during braking.

energy rating associated with a wall will be dependent on its stiffness and the amount of deformation that can be sustained before structural failure occurs.

To achieve adequate protection from penetration of unrestrained loads in practice, a trailer manufacturer would have to provide an impact energy capacity rating for the walls of the trailer, and the motor carrier would have to apply this rating to individual load circumstances. Given an impact energy rating IE_r , the carrier would need to ensure that for any unrestrained load item, weight and distance from the wall in the forward direction is:

$$W_1 x \leq \frac{IE_r}{0.75} \quad (14a)$$

And in the lateral direction:

$$W_1 \cdot x \leq IE_r \quad (14b)$$

The preceding analyses of the static and dynamic forces of cargo against the walls of a truck both point to the need for rating the walls of a commercial vehicle for their ability to restrain cargo. A translation of these into regulatory requirements would specify the following conditions:

1) Header board strength to sustain a static load equivalent to 75% (0.75 g force equivalent) of the weight capacity of the vehicle, uniformly distributed over the width of the structure. Because loads may vary in height, consideration should be given to requirements to sustain the load over a range of heights (i.e., from 10% to 100% of the overall height). A headerboard impact energy rating, IE_r , based on the stiffness and deformation limits ($K_w \cdot d^2/2$) should be stated. The motor carrier would then be obligated to ensure that for any unrestrained load carried in the vehicle, the magnitude of the unrestrained load and its distance from the headerboard satisfies Eq. 14a.

2) Side wall strength to sustain a static load equal to the cargo-weight capacity of the vehicle (1.0 g force equivalent), uniformly distributed over the length of the structure. Because loads may vary in height, consideration should be given to requirements to sustain the load over a range of heights (i.e., from 10% to 100% of the overall height). A side wall impact energy rating, IE_r , based on the stiffness and deformation limits ($K_w \cdot d^2/2$) should be stated. The motor carrier would then be obligated to ensure that for any unrestrained load carried in the vehicle, the magnitude of the unrestrained load and its distance from the side walls satisfies Eq. 14b.

3) Any load consisting of a large heavy item that will not distribute acceleration forces across the full width of the wall must be blocked so as to cause the forces to be distributed across the full width.

The requirements defined here would impose strength constraints on the walls of trailer (or truck) bodies in proportion to the load they are intended to carry, if the load is otherwise unsecured. Thus trailers would be rated not only for the vertical load capacity, but for their capacity to restrain the load. While these changes might be viewed by some as burdensome because of the need to strengthen the walls of truck bodies and trailers, they are only a rational response to the need to ensure safety on the highway with loads that are otherwise unsecured within the vehicle. Such regulations would provide a forthright statement of

intent and need. If the walls have a payload rating, the carrier has the choice of accepting the cost and weight penalty of providing the necessary cargo restraint protection in that manner. Or he may choose to use vehicles with a wall strength rating less than the payload rating, but with a clear mandate to provide other load restraint means. This approach to regulation would provide a basis for dealing with restraint practices applied to "soft-side" trailers as well. The trailer manufacturers would be required to provide a clear statement of the capability of the soft sides to restrain load, should a carrier choose not to provide other restraint. With a wall load rating for the trailer walls, enforcement personnel should find it easy to determine when a carrier is in violation of good practice.

3.4 Blocking Restraints

One method of cargo restraint often used in combination with enclosures and tiedown restraints is blocking. Blocking refers to supports used to prevent shipments from shifting during transit. Blocking is frequently comprised of timbers (2"x4", or 4"x4") placed on the floor against the load. For routine transport of certain special cargoes, blocking devices fabricated especially for the application may be used. Two functions of blocking devices warrant analysis—preventing the cargo from sliding, and preventing the cargo from tipping or rolling.

3.4.1 Prevention of sliding—Typical cargo items may be blocked in order to prevent the cargo from sliding along the truck bed during periods of hard acceleration. The purpose of the blocking is to supplement the frictional coupling because the frictional coupling is unreliable under the vibration conditions present on a truck. Thus, the blocking hardware should be sized to perform the full function of resisting the sliding action.

Unless supplemented by tiedown restraints (see next section), the blocking hardware should be designed to resist the full weight of the restrained load to the level of 0.75 g in the longitudinal direction and 1.0 g in the lateral. This may be accomplished by emplacing blocking that transmits the sliding load to the sidewalls of the vehicle, or is transmitted into the floor by fastening the blocking to the floor. When blocking is constructed so as to transmit the forces to the sidewalls, the importance of distributing it properly on the walls, per the recommendations of the previous section, should be observed.

When blocking is to be fastened to the floor, spikes and nails are the most commonly used fasteners. The fasteners must thus resist movement by developing shear forces as the blocking is loaded. For this intended function, the nails should be driven through the blocking timber into the wooden floor of the trailers in the perpendicular direction. Information on proper fastening and the shear strength achieved is available from the construction industry. Rules of thumb obtained from the Timber Design Manual^[22] are as follows:

- 1) Nails/spikes should be long enough that at least half of their length extends into the trailer floor (i.e., their length should be twice the thickness of the timber). Thus, 2"x4" lumber should be fastened with 16d bright common nails (3.5" long) or larger, and 4"x4" timbers should be fastened with 8-inch common spikes or larger.

2) Nails/spikes should be spaced no closer to the edge or end of a timber than a distance equal to 1/4 of their length. They should be spaced no closer than one-half of their length.

3) Under the circumstances typical of a truck, the shear strength of the nail or spike for resisting sliding of the load is approximately 100 lb/nail for the 16d nail, and 300 lb/spike for the 8-inch spikes.

4) The timbers must have adequate strength for the load. Assuming a compressive strength of 500 lb per square inch (in the direction of the grain), there should be two square inches of timber in the direction of force for every 1000 lb of load. Further, timbers loaded as a column should be reinforced against buckling at maximum intervals equal to twelve times the minimum cross-sectional dimension (i.e., 2"x4" lumber should be braced about every two feet, and 4"x4" timbers should be braced about every 4 feet).

These rules of thumb are not always practical in application. For example, to secure blocking for a 40,000 lb load, 400 nails (≈ 10 lb) or 133 spikes (≈ 30 lb) would be required. It is doubtful that fastening this securely with nails and spikes would be considered practical by the shipping industry. Yet, this is the conclusion of applying reasonable principles to design of a blocking system secured with nails.

One must conclude from this that blocking against the side walls is clearly a more attractive alternative for loads near the capacity of the trailer, and nailing is only a reasonable choice for lighter loads.

3.4.2 Prevention from tipping—A second function that blocking can serve is to prevent (or brace) loads from tipping. Tipping occurs when cargo with a large height-to-base ratio is exposed to acceleration. Figure 3.7a illustrates the case in point. The forces on the blocking are in the shear direction, and by implication the blocking should be designed to resist shear as described in the previous section. Consider a cargo item that is blocked at its base with a CG height at a distance h above the blocking, and with the CG located at a distance w from the edge of its base in the direction of the applied acceleration. By taking moments about the top edge of the lefthand block, it can be shown that the item will remain in place under accelerating conditions up to the limit of:

$$a_{\max} = \frac{w}{h} \tag{15}$$

So long as the minimum w/h ratio is less than 0.75 in the longitudinal direction, and 1.0 in the lateral direction, the item is not at risk of tipping during any foreseeable maneuver the vehicle will undergo. If not, however, blocking should be placed against the item at a greater height to increase the w/h ratio in whatever direction(s) it is deficient, or tiedowns may be employed to supplement the blocking.

3.4.3 Prevention from rolling—When a cargo item with a substantially round cross section is exposed to acceleration, rolling is a possible response (presuming no other restraint). The mechanics of that situation are illustrated in Figure 3.7b. For most circular items the CG is located near its geometric center at the distance ' r ' above the bed. Presuming blocking is placed against the item contacting it at an angle of ' θ ' from the vertical, the item will not roll up to an acceleration level of:

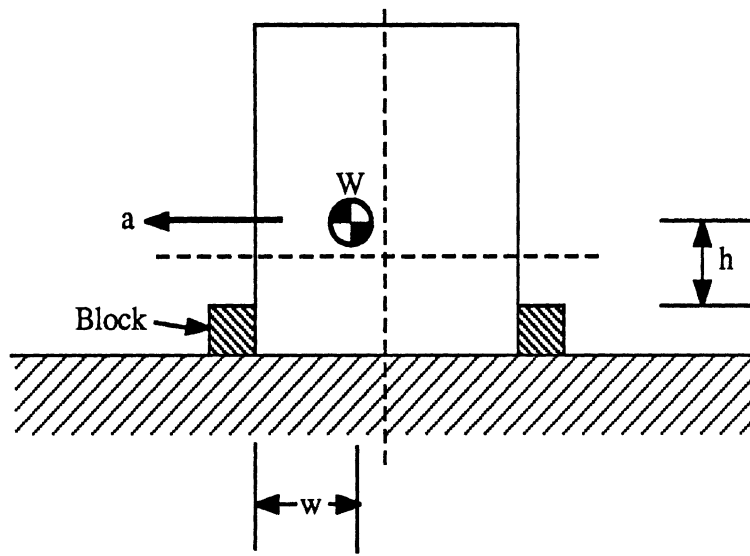

a) Rectangular cargo

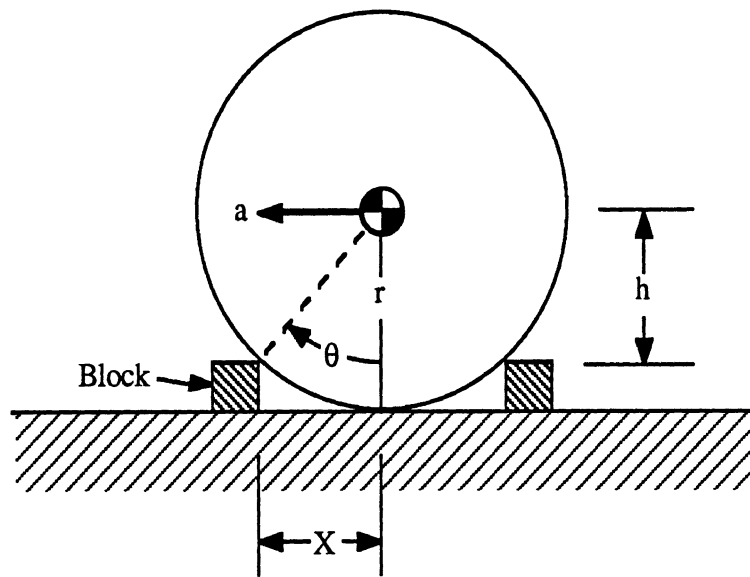

b) Round cargo

Fig. 3.7 Dimensions determining the effectiveness of blocking.

$$a_{\max} = \tan \theta = \frac{X}{h} \quad (16)$$

While this implies a need to apply trigonometric rules for proper use, only a few angles must be known. To achieve adequate resistance from rolling in either the forward or rearward directions (0.75 g) an angle of 37 degrees is required. This implies blocking to a height that is at least 20% of the radius of the item. To prevent rolling to the side (1.0 g) an angle of 45 degrees is required, equivalent to blocking to a height of at least 30% of the radius. As a rule of thumb, blocking to the 30% level is sufficient to prevent rolling in all directions.

It should be noted that blocking to this height is greater than that used in common practice. The 2"x4" and 4"x4" blocking commonly used with large rolls of coiled steel does not meet this requirement. This point warrants special attention, because small blocks position low under the coil. Consequently, the rolling action presses the blocking against the truck bed thereby locking it in place by friction. At the point where the coil lifts onto the blocking, the vertical force on the block equals the coil weight, and the lateral force equals the weight times the lateral acceleration. The blocking will not slide if:

$$a_{\max} = \frac{F_h}{W} \leq \mu_{bb} \quad (16a)$$

where

μ_{bb} = Coefficient of friction between the bed and the block

Some typical values for this relationship are given in Table 4. The coefficient of friction between blocking and the bed will typically be no greater than 0.5. Therefore, unsecured blocking will not function reliably if its height is any more than 10% of the radius of the coil, and the maximum acceleration without rolling will be approximately 0.5 g. Blocking to a level that makes contact higher on the coil as a means to withstand higher accelerations results in the coil imposing loads with a higher component in the lateral (shear) direction and less vertical (clamping) force. Thus, the use of high blocks must provide means to resist the shear forces. The design of the blocking must generally follow the rules to prevent sliding discussed in the preceding section.

3.5 Crossover Tiedowns

In many trucking operations, particularly shipments on open vehicles, the load is restrained by an arrangement of tiedowns. Tiedowns are flexible tension elements (chains, cables, ropes, straps, or bands) that pass over, around, or through the item to hold it securely in place. In its most common form a tiedown is a single tension member that crosses over an article in an essentially symmetric fashion, as illustrated in Figure 3.8a. The tiedown is anchored at the sides of the truck bed with a free span reaching up to the article on either side. The free span sections of the tiedown are referred to as "tiedown legs" in this analysis. A tiedown in this configuration may serve one of more of the following functions:

- 1) To clamp the article down (to resist sliding, tipping, and vertical vibration)

Table 4. Relationships between Blocking Height and Lateral Acceleration Limits for Coiled Articles

Blocking Height*	a_{\max}	Min. μ_{bb} required
0.05 r	0.32	0.32
0.10 r	0.48	0.48
0.15 r	0.62	0.62
0.20 r	0.75	0.75
0.25 r	0.88	0.88
0.30 r	1.02	1.02
0.35 r	1.17	1.17
0.40 r	1.33	1.33
0.45 r	1.52	1.52
0.50 r	1.73	1.73

* Blocking height as a fraction of coil radius

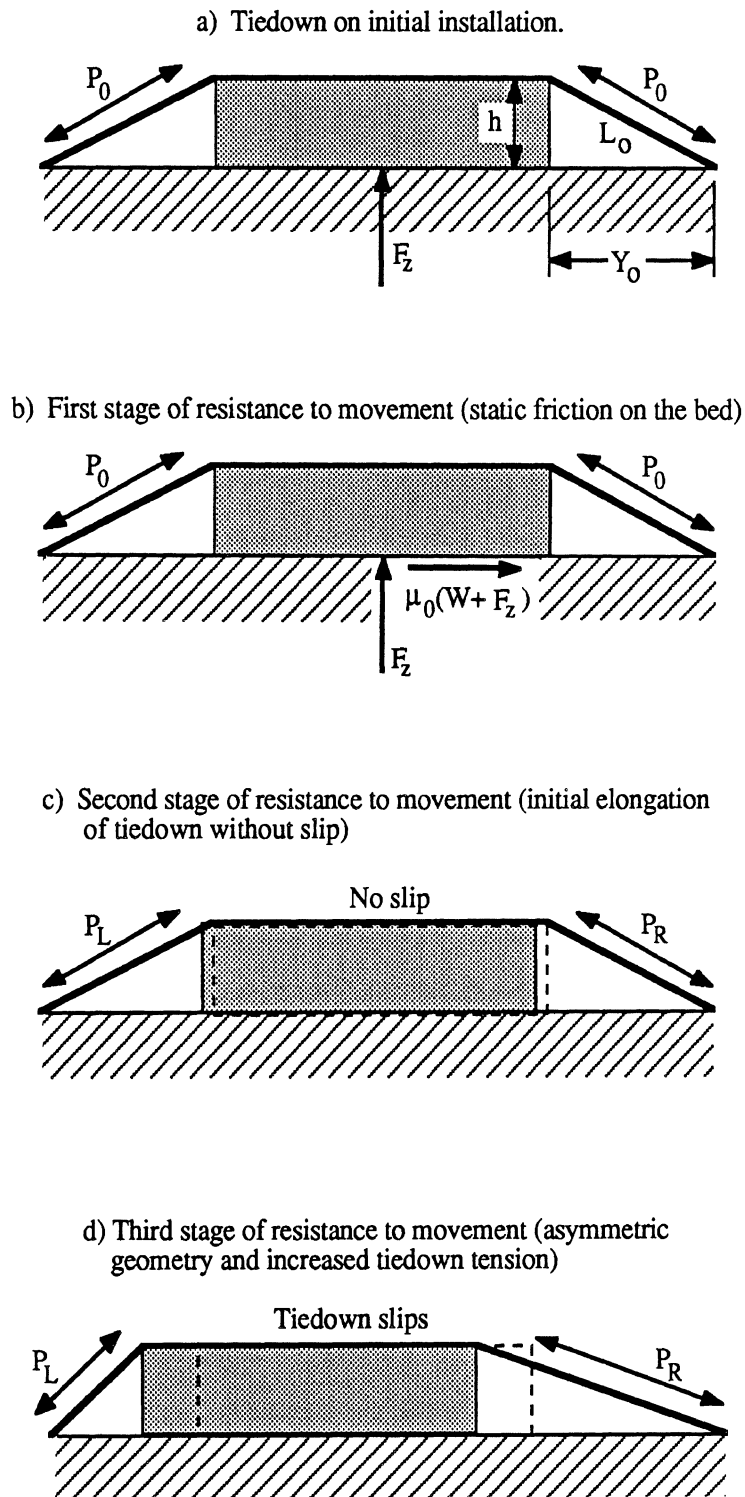

Fig. 3.8 Actions of a tiedown in resisting a shifting load.

- 2) To resist lateral movement of the article.
- 3) To resist longitudinal movement of the article.

3.5.1 Prevention of sliding in the lateral direction—A primary function of a crossover tiedown is to prevent movement of the article in the lateral direction (side-to-side in Fig. 3.8). An initial tension (preload) is produced in the tiedown by anchoring with binders, winches, etc., in order to clamp the article to the truck bed. It is assumed that the preload is nominally equal throughout the tiedown. Given that the legs of the tiedown form an angle β with the horizontal, a simple force balance shows that the vertical load imposed on the article is:

$$F_z = 2 P_o \sin \beta = \frac{2 P_o h}{L_o} \quad (17)$$

where

- F_z = Vertical load imposed on the article by the tiedown
- P_o = Preload force in the tiedown
- β = Angle between the tiedown leg and the horizontal
- h = Height of the article
- L_o = Length of the tiedown leg

Friction on the truck bed—The vertical load imposed by the tiedown is a mechanism that serves as the first stage of resistance to any shift of the cargo from its initial position. The "clamping" force from the tiedown supplements the weight of the article enhancing the frictional "lock" to the surface. The lock resists any horizontal movement of the article up to the limits of force dictated by the static coefficient of friction (see Fig. 3.8b). That limit is:

$$F_h \leq \mu_o (W + F_z) = \mu_o (W + 2 \cdot P_o \cdot \sin \beta) \quad (18)$$

where

- F_h = The maximum horizontal resistance force that can be developed
- μ_o = Static coefficient of friction between the cargo and the bed
- W = Weight of the article

Thus for the tied down load, the horizontal acceleration it can sustain without sliding because of the static friction on the truck bed is:

$$a_{\max} = \frac{F_h}{W} = \mu_o \left(1 + 2 \frac{P_o}{W} \sin \beta\right) \quad (19)$$

The relative improvement that can be achieved by use of the tiedowns is represented in the last term of the above equation. If the article is tall and/or wide, such that the tiedowns are effectively vertical ($\beta = 90^\circ$), the lateral acceleration limit is:

$$a_{\max} \approx \mu_o \left(1 + 2 \frac{P_o}{W}\right) \quad (19a)$$

That is, for a preload equal to the weight of the article, a lateral acceleration equal to three times the static coefficient of friction can be withstood. (This example illustrates the benefit

that derives from the action of tension in both legs of the tiedown. Even though the preload is only equal to the weight, the fact that it acts in both tiedown legs doubles the benefit.) At a more typical tiedown angle of 45° ($\text{Sin } \beta = 0.707$), accelerations up to 2.4 times the coefficient can be sustained.

Finally, when the tiedowns are essentially horizontal—such as when thin steel plates are chained down onto a flatbed—no significant improvement is obtained from preload in the tiedowns because $\text{Sin } \beta = 0$. In that case only the weight of the article acts to generate friction, and:

$$a_{\text{max}} \approx \mu_o \quad (19b)$$

Tiedown elongation without slip—The frictional lock described above resists any initial movement of the article. Even though the tiedown passes over the article, it does not contribute directly to any horizontal force resisting initial movement. A tiedown is compliant whereas the article is assumed to be rigid. In order to resist horizontal movement, a difference in tension between the left and right legs must be created; but the difference in tension does not develop until the article moves. Thus the first stage of resistance to shifting cargo is the friction lock between the cargo and the truck bed. The tiedowns only come into play after the static friction bond has been broken and the article has moved. The tiedowns then act to limit how far the article can slide in response to any sustained horizontal accelerations.

The initial resistance to movement by the tiedown arises from the elongation of the tiedown legs prior to any slipping of the tiedown on the surface of the article (see Fig. 3.8c). In this initial stage the tiedown is locked to the surface of the article by any number of mechanisms, including friction, mechanical interference of chain links on the edge of the article, mechanical connections, etc. At some point, the tiedown member may slip on the article. Thereafter the restraining force is produced by other mechanisms described later.

The initial resistance (before tiedown slip) can be characterized by an effective stiffness in the lateral direction attributable to the tiedown. The mathematical analysis of the mechanics is somewhat laborious and has therefore been deferred to Appendix A. In the analysis it is shown that the effective stiffness of the tiedown restraint upon initial movement is given by the equation:

$$K_{1y} = \frac{2 P_o}{L_o} - \frac{2 (P_o - K)}{L_o} \text{Cos}^2 \beta = \frac{2 P_o}{L_o} - \frac{2 (P_o - K)}{L_o} \left(\frac{Y_o}{L_o} \right)^2 \quad (20)$$

where

- K_{1y} = Effective stiffness in lateral movement
- P_o = Preload (initial tension) in tiedown member
- L_o = Initial length of the tiedown leg (see Fig. 3.8a)
- K = Tiedown stiffness
- Y_o = Lateral distance from tiedown point to the article (see Fig. 3.8a)

The stiffness expressed above represents the rate (force/distance) at which the tiedown builds up force to restrict lateral movement. High stiffness minimizes any lateral shift of a load, whereas low stiffness may permit excessive lateral movement. The performance that

will be obtained from the tiedown is dependent upon the initial preload, P_o , the tiedown properties, K , and the initial geometry as described by Y_o and L_o .

When the tiedown is used to restrain a wide article (nearly as wide as the bed) such that the tiedown leg is nearly vertical, Y_o is zero. Assuming that during the initial movement the side of the article does not contact the tiedown leg, the effective stiffness obtained is:

$$K_{1y} = \frac{2 P_o}{L_o} = \frac{2 P_o}{h} \quad (21)$$

For this case, the stiffness is not dependent on the material properties of the tiedown, except through the magnitude of the initial preload that can be achieved. The stiffness is diminished by the length of the tiedown leg, which in this case equals the height of the article. Thus, the taller the article, the lower the lateral stiffness achieved. (If the article is the full width of the truck bed, it will immediately begin pressing against the tiedown leg secured on that side, and a much higher stiffness will be experienced. Because of the short length of tiedown free to elongate very little movement can occur before the tiedown must slip. Thus for the no-slip case, the stiffness is so high that it does not warrant analysis.)

At the other extreme is the case of a tiedown placed at a very shallow angle across a low load (steel plate, for example). In this case Y_o equals L_o and the stiffness becomes:

$$K_{1y} = 2 \cdot K \quad (22)$$

The stiffness represented by this expression is equivalent to the stiffness of the tiedown leg as it would be measured conventionally. That is, K_{1y} is the same as the stiffness that would be observed in a force-displacement measurement at the end of a section of the tiedown material of length L_o . Because of the shallow angle, however, it must be kept in mind that this stiffness value may apply only up to a minimal level of restraint unless the tiedown member is mechanically secured to the load. Otherwise, the maximum force will be limited by friction, which will be low due to the absence of any significant normal load against the top of the article.

Tiedown resistance with slip—As the horizontal restraining force builds up with lateral movement of the cargo item, the tiedown will eventually slide against the surface of the article, unless it is mechanically attached to the article. The point at which sliding will occur is determined by the effective coefficient of friction between the tiedown and the article, and by the vertical force. The coefficient may be of the classical nature (independent of load, sliding velocity, etc.) or erratic in nature (chains sliding over a sharp edge). Regardless of the form, this limits the buildup of lateral force due to elongation of the tiedown legs running up to the edge of the article. As the tiedown slips, the load equalizes to some extent between the legs on either side of the article. However, the lateral movement stretches the tiedowns (increasing their tension), and produces an asymmetry in the two tiedown legs yielding a net restraint force because of the geometry (see Fig. 3.8d). The mathematical analysis of this case is given in Appendix A, but is too complex to illustrate with simple equations. The analysis shows a buildup of a restraining force with lateral movement because of the horizontal components of the tension force imposed on each edge of the load.

The stiffness of this mechanism is zero at the initial stage of movement. The resistance force only builds up when the load moves far enough to develop asymmetry in the tiedown legs and an increase in tiedown tension. As seen in Appendix A, the rate at which resistance force is developed is a function of the preload, the stiffness of the tiedown element, and the geometry of the load.

The results of this analysis are summarized in the plots of Figures 3.9 and 3.10. Figure 3.9 represents the limit case of a shallow load condition. Because of the low tiedown angle, the initial resistance to movement is due primarily to the weight of the cargo acting on the static coefficient of friction. Should the lateral acceleration exceed this value sliding begins and the resistance immediately drops to the level of the sliding coefficient of friction. The tiedown member immediately begins to stretch, contributing to the resisting force. Because of the straight pull the stiffness is high (the sum of that for both tiedown legs); and if the tiedown is attached to the article, the resistance force continues to grow accordingly (along the dashed line).

If not connected, however, the force quickly exceeds the friction limit and the tiedown slides on the article. At this point the total force is that due to the sliding friction under the article, plus the sliding friction of the tiedown on top of the article. With continued lateral movement the resistance force builds slowly as the angularity of the tiedown legs increases along with the tension.

Figure 3.10 shows the nature of the resistance forces on an article that is restrained with tiedowns at a high angle. Because of the download produced by the tiedown, a much higher acceleration level can be reached within the constraints of the static coefficient of friction. Once sliding occurs, the tiedown develops a resisting force due to stretching of the inside leg. Due to the high angle and relatively long length of the tiedown, its stiffness is much lower than in the previous case. If the tiedown is connected to the article, the resistance force grows continuously until the ultimate strength of the tiedown is reached (following the dashed line). In the absence of a connection, however, at some point the tiedown member will slip on the article with an associated drop in force to the level determined by the sliding coefficient of friction. As the article continues to move sideways, the increasing tiedown tension and asymmetric geometry contribute to a gradual growth in the resisting force.

Figures 3.9 and 3.10 both show the profound benefit obtained from the practice of attaching the tiedown to the article in contrast to simply placing it across the article, depending on friction to develop resistance to movement. The effect is especially significant for loads that are relatively shallow. This effect can be achieved by use of edge protectors which engage the tiedown member as a part of their function.

Preload effects—One of the very important in-use variables affecting the performance of crossover tiedowns is the preload established upon installation. In order to quantify the significance of preload in the performance obtained, it is helpful to express the nominal level of restraint in a general equational form. Inasmuch as the objective is to minimize cargo shift, the primary interest is in the behavior associated with initial movement up to the point where the tiedowns just begin to slide across the article. In the

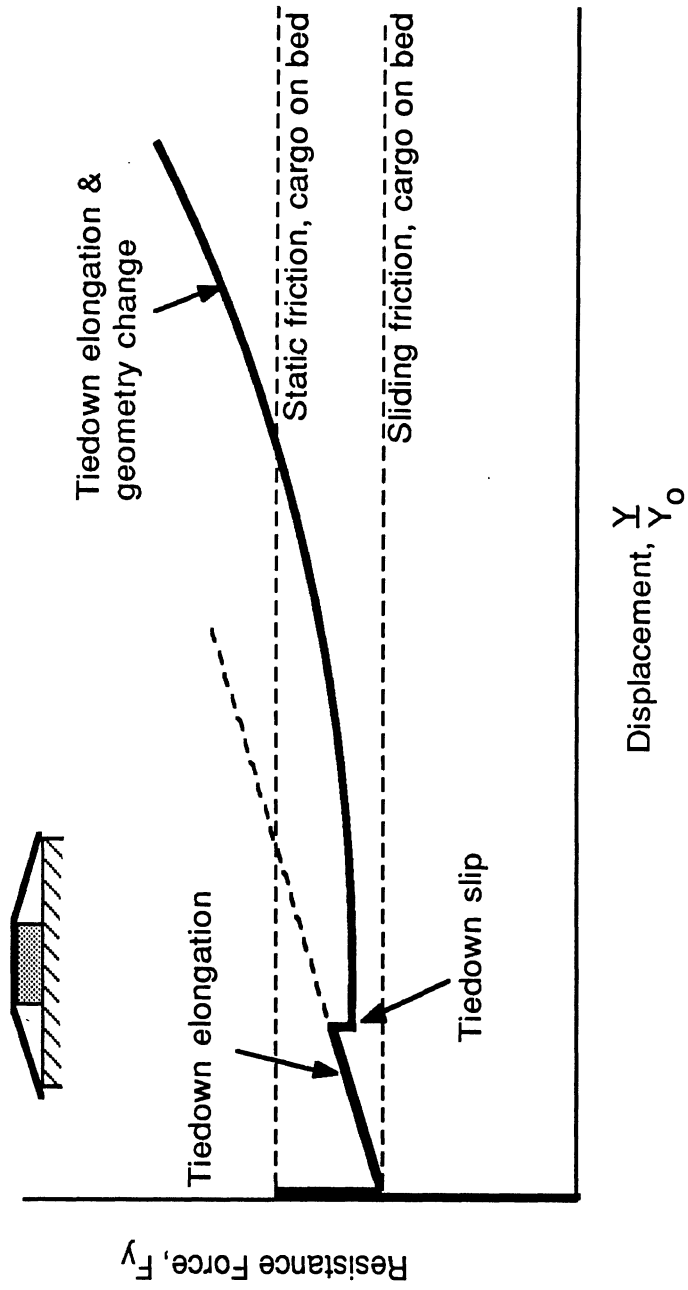

Fig. 3.9 Action of resistance forces on movement of cargo restrained by tiedowns at a shallow angle.

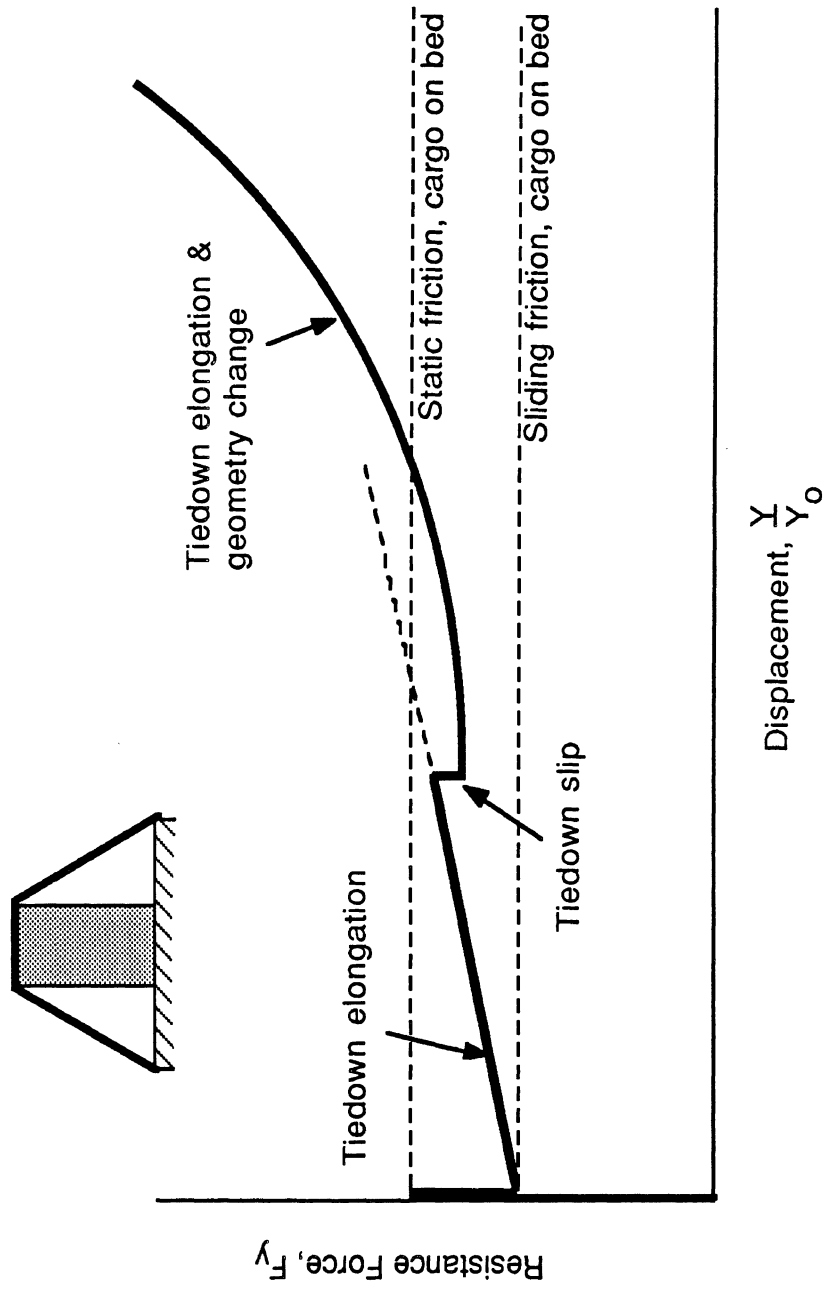

Fig. 3.10 Action of resistance forces on movement of cargo restrained by tiedowns at a high angle.

absence of direct attachment of the tiedowns to the cargo, the restraint depends upon the frictional forces of the bed and tiedowns on the cargo. In the most general form;

$$a_y = \frac{F_y}{W} \leq \mu_{cb} \left(1 + 2 \frac{P_o h}{W L}\right) + \mu_{ct} 2 \frac{P_o h}{W L} \quad (23)$$

where

μ_{cb} = Effective coefficient of friction between cargo and bed

P_o = Aggregate preload of all the crossover tiedown(s)

h = Height of the load

L = Length of a tiedown leg

μ_{ct} = Effective coefficient of friction between cargo and tiedown

Minimum performance is realized when sliding prevails and both μ_{cb} and μ_{ct} equal the sliding coefficient values. To simplify the expression, assume that the coefficient of friction between the cargo and bed is approximately the same as that between the cargo and tiedown, and is denoted by μ . Then;

$$a_y = \mu \left(1 + 4 \frac{P_o h}{W L}\right) \quad (24)$$

The coefficient of friction is variable with the conditions on the truck, therefore the level of restraint will vary as well. Table 5 shows the computed value for the preload (normalized as P_o/W) for various tiedown geometric configurations and several levels of acceleration. The h/L value of 1 for tall loads represents the case where the tiedown legs are essentially vertical. The h/L equal to 0.7 corresponds to tiedown legs that are at 45 degrees; and h/L equal to 0.1 corresponds to tiedowns that are just 6 degrees from the horizontal.

On clean, dry surfaces the effective coefficient of friction may be on the order of 0.5. Thus for articles with h/L values of 0.7 or greater, aggregate preloads on the order the weight of the article can withstand accelerations up to 2 g. (Aggregate preload refers to the total of the preload forces for all tiedowns when more than one is used.) Any contamination on the surface has the potential to reduce the coefficient of friction down to the range of 0.1 to 0.2. Under that condition, that level of preload is just marginal for restraining the load to 0.75 g acceleration. Truck vibration may also reduce the effective frictional level.

For shallow articles, preload has virtually no value in securing the article. Therefore with shallow articles, the tiedown should be attached directly to the cargo item, or blocking should be placed on top of the article to obtain a more advantageous tiedown angle.

Strength requirements—Another important property of a crossover tiedown that must be established is the strength required to endure design acceleration levels. The critical tension load in a tiedown when the cargo item shifts is comprised of its preload plus the component arising from elongation of the resisting leg. While friction of the cargo on the bed of the truck normally aids in limiting movement, an encounter with a road bump is all that is needed to instantaneously break the friction bond, thereby placing the full burden on the tiedowns. Thus for estimating strength requirements, the friction mechanism should be

Table 5. Tiedown Preload/Weight Values for Cargo Restraint to:

a) 0.75 g acceleration

μ	Tall article (h/L = 1)	Intermediate article (h/L = .7)	Shallow article (h/L =.1)
0.1	1.62	2.32	16.2
0.2	0.69	0.98	6.9
0.3	0.38	0.54	3.8
0.5	0.13	0.18	1.3
0.8	0.00	0.00	0.0

b) 1.0 g acceleration

μ	Tall article (h/L = 1)	Intermediate article (h/L = .7)	Shallow article (h/L =.1)
0.1	2.25	3.21	22.5
0.2	1.00	1.43	10.0
0.3	0.58	0.83	5.8
0.5	0.25	0.36	2.5
0.8	0.06	0.09	0.6

c) 1.5 g acceleration

μ	Tall article (h/L = 1)	Intermediate article (h/L = .7)	Shallow article (h/L =.1)
0.1	3.50	5.00	35.0
0.2	1.62	2.32	16.2
0.3	1.00	1.43	10.0
0.5	0.50	0.71	5.0
0.8	0.22	0.31	2.2

d) 2 g acceleration

μ	Tall article (h/L = 1)	Intermediate article (h/L = .7)	Shallow article (h/L =.1)
0.1	4.75	6.75	47.5
0.2	2.25	5.45	22.5
0.3	1.42	2.02	14.2
0.5	0.75	1.07	7.5
0.8	0.38	0.54	3.8

neglected. In equational form, the tension in the more heavily loaded leg of the tiedown may be estimated by:

$$\frac{P_{cr}}{W} = \frac{P_o}{W} + a_y \frac{L}{Y_o} \quad (25)$$

where

P_{cr} = Critical tension load in the tiedown assembly

P_o = Aggregate preload in the tiedown members

W = Weight of the cargo

a_y = Acceleration level

L = Length of the tiedown leg

Y_o = Horizontal distance from tiedown attachment to the edge of the cargo item

That is the tiedown must have strength to absorb the preload, plus the inertial force from the cargo acceleration, adjusted for the geometry (L/Y_o) of the action direction of the tension force. For very shallow loads L/Y_o approaches one and the tiedown load is simply the preload plus the inertial force of the article.

Equation 25 will estimate very high strength requirements for tiedowns used to restrain tall loads. For very tall loads L/Y_o may become quite large (it is infinity for vertical tiedowns), and the equation would imply that infinite strength is required. Presuming a preload nominally equal to the weight, the critical strength of the tiedown assembly would have to be 10 or more times the weight. This, of course, is not realistic. Most tiedown materials are capable of elongation up to about 5% before ultimate failure, which means that the article can slide sideways, stretching the tiedown legs to approximately an 18 degree angle before failure. At that angle the resisting force is 30% of the tiedown tension load. This would suggest that for tall and/or wide loads with a high tiedown angle, the effective L/Y_o value is nominally 3.0 and the appropriate equation would be:

$$\frac{P_{cr}}{W} = \frac{P_o}{W} + a_y f \quad (25a)$$

where

$$f = L/Y_o \text{ for } L/Y_o \leq 3.0 \\ = 3.0 \quad \text{for } L/Y_o \geq 3.0$$

3.5.2 Sliding in the longitudinal direction—On occasion a crossover tiedown may be expected to provide resistance to sliding in the longitudinal direction (perpendicular to the direction in which the tiedowns are aligned, as illustrated in Fig. 3.11b). Unless the tiedown is attached to the article, the restraint must depend on friction of the article against the bed and the tiedowns. Upon initial movement the resistance is due only to friction of the cargo on the bed. As displacement increases the tiedowns deflect in the direction of movement due to frictional coupling to the article. The increasing angle produces a resisting force in proportion to the tension and angle. The two mechanisms are described by the equation:

$$\frac{F_x}{W} = a_x \leq \mu_{cb} \left(1 + 2 \frac{P_o}{W} \frac{h}{L}\right) + 2 \frac{P_o}{W} \frac{h}{L} \frac{X}{L} \quad (26)$$

where

μ_{cb} = Coefficient of friction between the cargo and bed

h = Height of the article

L = Length of the tiedown leg

X = Distance the article slides

A reasonable level of restraint can only be achieved in this manner if the article is relatively high ($h/L \geq 0.7$), the surfaces are clean and dry, and the tiedowns are well preloaded against the article. Across a shallow article ($h/L \approx 0$) the tiedowns will not develop significant vertical force to load the article against the bed (the first term in the equation), or to produce a friction coupling to the article. Thus there is no effective restraint from the tiedowns unless they are connected to the article.

The relationship of tiedown strength to the acceleration levels that can be withstood depends on the ability of the tiedowns to stretch and develop an angle in order to resist movement. Again the help from friction on the bed is discounted for purposes of assessing strength requirements because it can be defeated by vibrations. Due to geometry the resisting force will be the tension times $2 \cdot X/L$ (the factor of 2 is due to the fact that there are two legs in the tiedown resisting movement), which must be equal to the weight times its acceleration. Assuming 5% elongation capability in the tiedowns allows movement to an 18 degree angle, for which $L/X \approx 3$. Then the strength required in the tiedowns is that necessary to accept the preload plus the acceleration forces:

$$\frac{P_{cr}}{W} = \frac{P_o}{W} + 1.5 a_x \quad (27)$$

Therefore, the strength-to-weight ratio for the tiedowns must accommodate the preload plus a factor that is 1.5 times the design acceleration level. (Note: this condition can only be achieved if the coefficient of friction between the tiedown and cargo is at least equal to 0.3, and the tiedown members are prevented from rolling along the top of the article.)

3.5.3 Tipping in the lateral direction—Tiedowns may also provide restraint to prevent tipping of loads that have a tall narrow shape. In the idealized limit case shown in Figure 3.11a, any tendency for the article to tip is opposed by elongation of the tiedown member on the righthand side. Analysis of this case is the same as that from which Eq. 20 is derived (see Appendix A). The effective stiffness expressed by Eq. 20 characterizes the resistance to lateral movement at the top of the load where the tiedown makes contact. Because the restoration force is only generated with lateral displacement, the top of the article will tend to move continuously as the accelerations vary in transit. If the base of the article has sufficient width to provide some stabilizing action, the article will remain motionless up to its tipping point. Only after it begins tipping do the tiedowns develop a resisting moment.

The preload in the system affects the lateral stiffness developed and would hence have an effect on vibration that occurs. More importantly, however, it affects the frictional coupling between the cargo and tiedown that is necessary to keep the article upright. Assuming that the CG is at the middle of the article, and neglecting any lateral shift of the CG, the acceleration levels that can be endured are:

a) End view

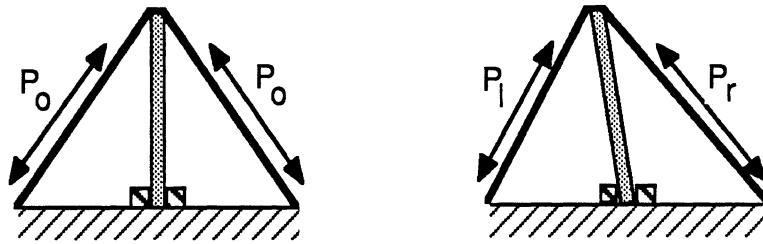

b) Side view

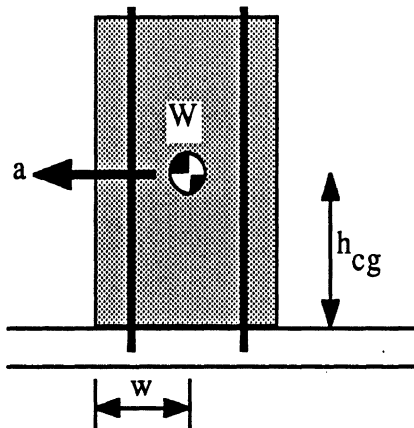

Fig 3.11 Action of tiedown restraints to prevent tipping

$$a_y = \mu_{ct} 2 \frac{P_o h}{W L} \quad (28)$$

where

μ_{ct} = Coefficient of friction between the cargo and tiedown

h = Height of the cargo item

L = Length of the tiedown leg

For tall loads ($h/L \geq 0.7$), a coefficient of friction of 0.5, and a preload equal to the weight of the article, acceleration up to 0.7 g is possible. Preload is necessary to endure high acceleration levels, or to compensate for low friction. If the article cannot withstand high preloads, a direct connection to the article should be provided.

The strength demanded from the tiedown can be determined from an overall moment balance about the pivot point on the truck bed. The tiedown must absorb both the preload tension as well as that arising from the lateral force at the top of the article. The appropriate relationship is:

$$\frac{P_{cr}}{W} = \frac{P_o}{W} + 0.5 a \frac{L}{Y_o} \quad (29)$$

where

Y_o = Horizontal distance from tiedown anchorage to the edge of the cargo item

L = Length of the tiedown leg

For an article to be tall and narrow enough that it is at risk of tipping, L/Y_o must be at least on the order of 3 (an article 10' tall that is 3.3' in from the edge of the bed). Thus the critical strength will be on the order of the preload plus a factor that is 1.5 times the acceleration.

3.5.4 Tipping in the longitudinal direction—Tiedowns in this configuration may also be called upon to resist tipping in the longitudinal direction as shown in Figure 3.11b. Assuming the tiedowns are located equidistant from the CG of the article, they impose a vertical force at the center (through the CG) equal to the vertical components of the preload which provides a moment resisting the action of the acceleration. The relationship is determined by taking moments about the bottom-left corner of the article. Tipping is prevented so long as:

$$a_x = \left(1 + 2 \frac{P_o h}{W L}\right) \frac{w}{h_{cg}} \quad (30)$$

In the event the acceleration exceeds this level, the article will begin to tip thereby increasing the tiedown tension until a balance is reached. Thus there is a tendency for the tiedowns to compensate even when tipping begins.

The strength requirements for the tiedowns depend upon their location along the length of the article. If there were two tiedowns, both located in the middle of the article, they would share the load equally. If, however, they are located at the ends, only one would

absorb the load. With both in the middle, the relationship between tiedown tension and maximum acceleration is:

$$a_x = (1 + 2 \frac{P_{cr} h}{W L}) \frac{w}{h_{cg}} \quad (31)$$

or:

$$\frac{P_{cr}}{W} = 0.5 (a_x \frac{h_{cg}}{w} - 1) \frac{L}{h} \quad (31a)$$

If the tiedowns are located at the ends of the article, the one on the left absorbs none of the moment and that on the right absorbs it all. That is, the one tiedown undergoes no change in tension, while the other goes to twice the tension indicated in Eq. 31a. The tensile strength required of that one tiedown is then:

$$\frac{P_{cr}}{W} = (a_x \frac{h_{cg}}{w} - 1) \frac{L}{h} \quad (31b)$$

3.5.5 Protection from rolling—The accelerations acting on round articles (coiled metal products, etc.) may induce a rolling or sliding actions, or combinations of the two. These may take several forms if the article is not blocked.

1) Rolling on the bed—If there is a good friction coupling of the cargo on the bed, it will attempt to roll under the action of an acceleration. Elongation of one or the other of the tiedown legs opposes the movement up to the limit of the frictional coupling of the tiedown on the article. The effective stiffness given in Eq. 20 applies to this case. Because the tiedown is compliant, on-road accelerations will cause the coil to roll back and forth continuously. Constant motion of the cargo is inadvisable from the standpoint of vehicle control, as well as the potential for the coil and/or tiedown to shift position in the course of travel. The resisting force as a function of movement is illustrated for this case in Figure 3.12a. With no movement it is zero, increasing with displacement according to the stiffness of the tiedowns. At some point, the tiedowns may slip on the article, such that the resisting force from thereon only increases due to tiedown elongation and geometry change. By placing blocking against the article as shown in Figure 3.12b, immediate movement is prevented up to the point where the item attempts to roll over the blocking. The nominal acceleration level required for movement is greater than that derived from the blocking alone (see Eq. 16) because of the additional vertical force produced by the tiedown. The nominal acceleration level for movement is:

a) Restraint without blocking

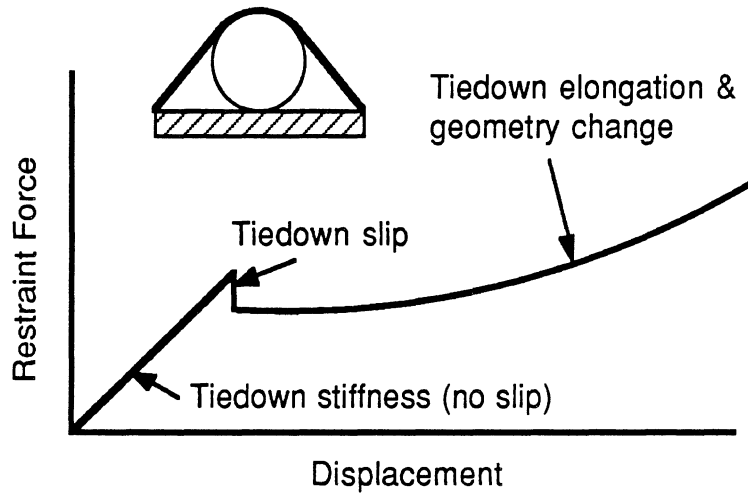

b) Restraint with blocking

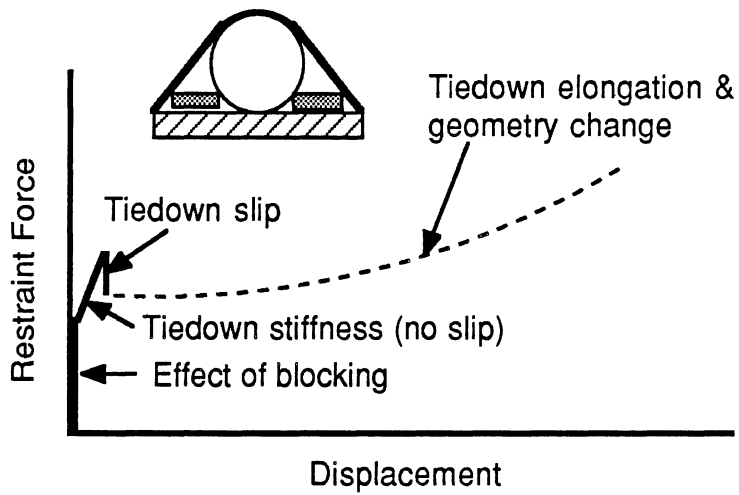

Fig. 3.12 Restraint forces during rolling movement of round articles.

$$a_y = \frac{F_z}{W} \tan \theta = \left(1 + 2 \frac{P_o h_c}{W L}\right) \frac{X}{h} \quad (32)$$

where

a_y = Acceleration level at initial movement

F_z = Total vertical load of the article on the bed (weight plus tiedown forces)

P_o = Tiedown preload

h = Height of the center of the article above the top of the blocking

h_c = Height of the contact point of the tiedown on the article

L = Length of the tiedown leg

X = Lateral distance from the center of the article to point of contact on blocking

Even after movement begins, the initial slope of the resisting force is greater because the tiedowns must stretch more as the article mounts the blocking. Blocking should be considered essential with cargos such as this, both as a means to eliminate the constant movement during transit, and to elevate the acceleration level at which movement occurs as described in Eq. 32 above.

2) Rolling under the tiedown—A round article resting on a slippery truck bed or stacked on other round articles can experience movement with a counter-rotation such that the tiedown does not have to slip on the article. The tiedown thereby only resists the motion by the elongation required (thus increasing its tension), and the asymmetric geometry that results. The resisting force created is then similar to that previously ascribed to tiedowns under the conditions of slippage (that labeled as "tiedown elongation & geometry change" in Figures 3.9 and 3.10). The buildup of resistance force under these circumstances may involve significant movement of the cargo item (depending on geometry). Blocking is an effective means of preventing movement of this type, and therefore insurance against this possibility.

3) Sliding—A round article may shift by slipping on both the bed and the tiedown without substantial rotation. The mechanics are similar to that described for rectangular articles in Section 3.5.1. The resistance force is developed initially as a consequence of friction, then by tiedown elongation and asymmetric geometry as sliding occurs. Blocking is effective in attempting to prevent this type of movement.

For all of the possible ways in which a round load may shift, the combination of tiedowns with blocking provides an effective means of control. Preload in the tiedowns has a strong influence on the effectiveness. As seen in Eq. 32, preload in the tiedown is responsible for a vertical force component adding to the weight in resisting any tendency for the article to roll over the blocking.

The strength requirement for the tiedowns to retain the load under any given acceleration condition is intimately tied to the geometry of the situation (specifically the height of the blocking, the tiedown angle, and the height at which the tiedown contacts the article, etc.). Inasmuch as the maximum resistance occurs at initial movement, strength requirements are dictated by the preload desired. That is, Eq. 32 may be used to estimate the preload and strength required for a given level of acceleration performance, in which case:

$$\frac{P_{cr}}{W} = 0.5 \left(a_y \frac{h}{X} - 1 \right) \frac{L}{h_c} \quad (33)$$

3.6 Horizontal Tiedowns

The analyses thus far have dealt with the case of a tiedown passing over an item of cargo. Tiedowns are often installed in a horizontal orientation (with little or no vertical constraint capability) to restrain cargo from moving either longitudinally and/or laterally. Figure 3.13 illustrates several of the typical configurations used. There are several engineering aspects of the design that warrant attention.

Referring to Figure 3.14, the restraining force in the longitudinal (x-) direction is given by:

$$\frac{F_x}{W} = a_x = 2 \frac{P}{W} \cos \phi = 2 \frac{P}{W} \frac{X_o}{L} \quad (34)$$

One very important parameter in the design is the angle of the tiedown, ϕ . Because the restraining force is the tension multiplied by $\cos \phi$, if ϕ is near 90 degrees, the restraint force approaches zero. That is, the equation simply reflects the obvious notion that if the tiedown does not have sufficient angle, it is possible to generate very large tension forces with very little force in the x direction. In order to maximize the effectiveness of the tiedown in this regard, the angle should be no less than 45 degrees (70% efficient).

3.6.1 Tiedown against an abutment—The ability of the tiedown to prevent any shifting of the cargo depends on the opposing restraint. If the article is positioned so that the tiedown pulls it against an abutment (wall, blocking, etc.) the article will not move in the x-direction (away from the abutment) until the acceleration force is sufficient to overcome the static coefficient of friction against the truck bed plus the preload forces of the tiedown. Neglecting the frictional component, the tiedown will restrain the article without movement up to the acceleration level of:

$$a_x = \frac{F_x}{W} \leq 2 \frac{P_o}{W} \cos \phi = 2 \frac{P_o}{W} \frac{X_o}{L} \quad (35)$$

where

P_o = Preload in the tiedown

X_o = Length of the tiedown in the x-direction (see Fig. 3.14)

L = Length of the tiedown leg

Once the acceleration exceeds the clamping limit of the tiedown, the article moves free from the wall, elongating the tiedown and increasing the tension as necessary to equal the inertial forces. The strength required from the tiedown to resist acceleration at a given design level is derived from Eq. 34 as:

$$\frac{P_{cr}}{W} = 0.5 a_x \frac{L}{X_o} \quad (36)$$

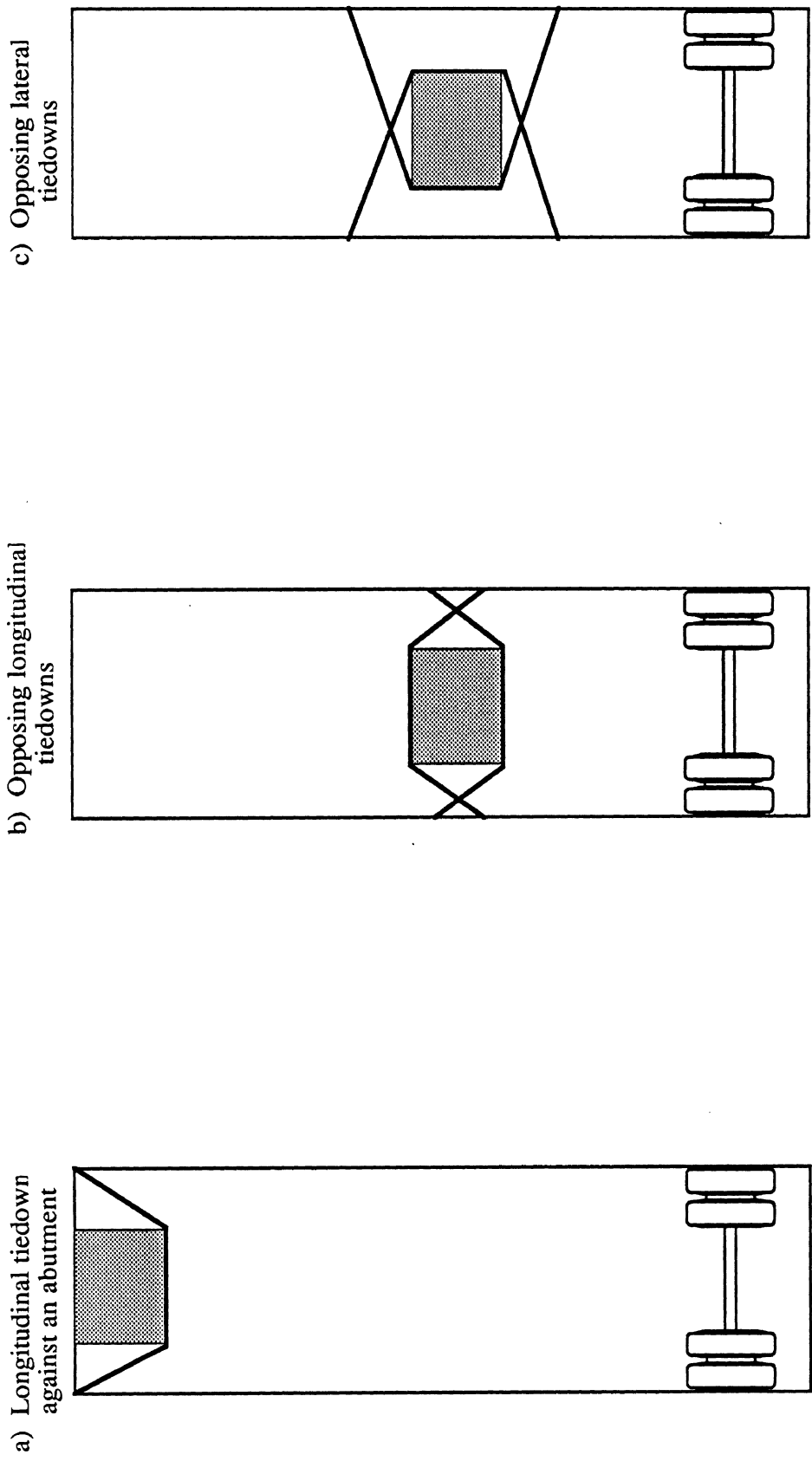

Fig. 3.13 Configurations for tiedown restraints in the horizontal plane.

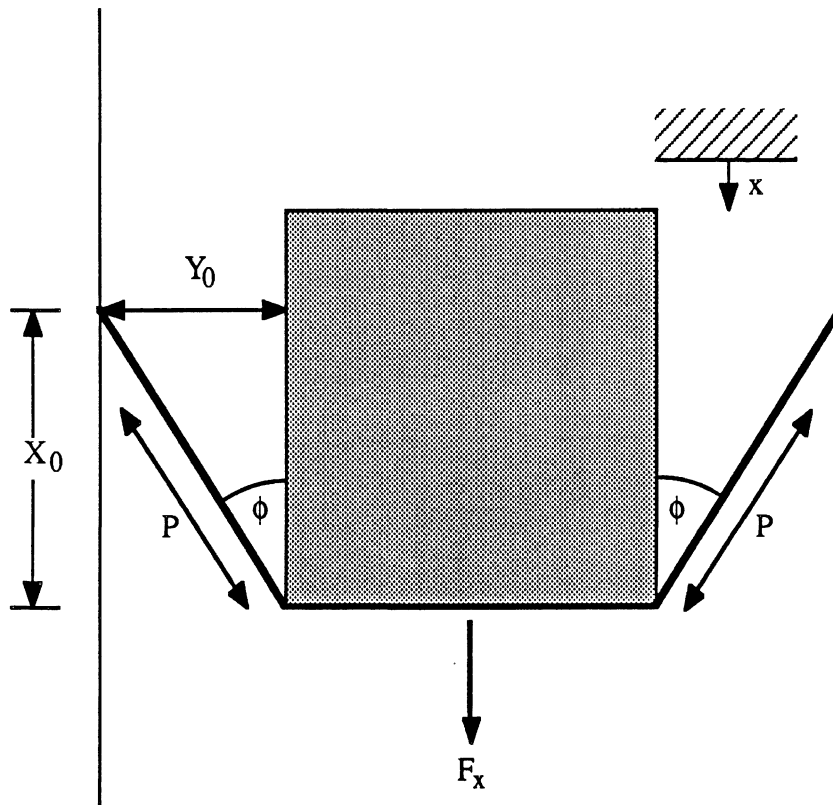

Fig. 3.14 Analysis of forces in a horizontal tiedown arrangement.

The resistance to lateral movement from a tiedown arrangement of this form derives from friction of the article against the abutment and the tiedown itself. This is similar to the crossover tiedown (Eq. 23) except that the weight of the article does not contribute, and the height parameter is replaced by X_o . Therefore the acceleration limit is related to the preload by the equation:

$$a_y = \frac{F_y}{W} \leq \mu_{cb} \left(2 \frac{P_o}{W} \frac{X_o}{L}\right) + \mu_{ct} \left(2 \frac{P_o}{W} \frac{X_o}{L}\right) \quad (37)$$

As with the crossover tiedown case, the strength requirement is given by Eq. 25a.

3.6.2 Side-to-side tiedowns—In the event two horizontal tiedowns are installed side-to-side in an opposing fashion as illustrated in Figs 3.13b, the resistance to movement in the longitudinal direction (the x-direction of Fig. 3.14) derives from friction on the truck bed and elongation of the tiedown in the direction of the acceleration. Some preload in the tiedowns is necessary to ensure they remain positioned properly, but does not enhance the effective stiffness of the restraint. Preload does, however, affect the strength requirements because it adds with the inertial forces to the tension load in the tiedown. That is:

$$\frac{P_{cr}}{W} = \frac{P_o}{W} + 0.5 a_x \frac{L}{X_o} \quad (38)$$

The side-to-side tiedowns also have some capability to resist lateral movement by virtue of their frictional coupling to the article. Preload is important to performance in this direction because it is the source of the normal load determining the friction level. Because there are four tiedown legs, each with a preload tension, the frictional force is enhanced. The acceleration limit at which slip occurs is:

$$a_y = \frac{F_y}{W} \leq \mu_{ct} \left(4 \frac{P_o}{W} \frac{X_o}{L}\right) \quad (39)$$

From the standpoint of strength, only the two tiedown legs on the side opposite to the direction of acceleration develop resisting forces. Their tension load consists of the preload plus the inertial force (corrected for geometry), and the strength equation is:

$$\frac{P_{cr}}{W} = \frac{P_o}{W} + 0.5 a_y \frac{L}{Y_o} \quad (40)$$

As with the derivation of strength requirements for crossover tiedowns leading to Eq. 25a, this equation falls down when Y_o becomes too small (when the article is close to the same width as the truck bed). The ability of the tiedowns to elongate allows the article to slide sideways, creating a more favorable geometry before failure occurs. Based on the rationale used with crossover tiedowns, then the maximum value for the L/Y_o ratio should be limited to three.

3.6.3 Tiedowns to one side—Finally, the tiedowns may be installed at each side of the truck bed, pulling to the side as illustrated in Figure 3.13c. Their function is similar to that of the side-to-side orientation, except that performance in the x and y directions is now switched. That is, the longitudinal acceleration limit at which slip occurs, and the relationship to strength is similar to that of Eqs. 39 and 40. Specifically:

$$a_x = \frac{F_x}{W} \leq \mu_{ct} \left(4 \frac{P_o}{W} \frac{Y_o}{L} \right) \quad (41)$$

and

$$\frac{P_{cr}}{W} = \frac{P_o}{W} = 0.5 a_x \frac{L}{X_o} \quad (42)$$

where

Y_o = Lateral distance from the tiedown anchorage to the point of contact on the article

X_o = Longitudinal distance from the tiedown anchorage to the point of contact on the article

On the basis of previous arguments, the maximum value for the L/X_o ratio in Eq. 42 should be limited to three.

In the lateral direction, the acceleration limit is unaffected by preload, while the strength requirement is similar to that of Eq. 38. That is:

$$\frac{P_{cr}}{W} = \frac{P_o}{W} = 0.5 a_y \frac{L}{Y_o} \quad (43)$$

3.7 Summary of Tiedown Properties

The preceding analysis of the mechanics by which tiedowns function has revealed that there is a complex number of combinations. It is seen that the preload in the tiedown performs an important function for restraint in one direction, but may diminish the capacity for restraint in another. Thus there exist certain compromises in the choices between preload and strength. The complexity of the tiedown function is further compounded by the variables of geometry and the uncertainties of frictional forces. As an aid to comprehension of the complexities, the various modes of tiedown function are summarized in Tables 6 and 7. The first covers the functions of crossover tiedowns, and the second covers horizontal tiedowns. Entries in the preload column of the tables show the relationship between limit acceleration and the preload in the tiedowns. These equations are helpful in showing how preload affects performance in different directions, and the way in which it is influenced by the geometry of the tiedown. The strength column shows the necessary tiedown strength to achieve any given acceleration tolerance in a particular direction.

Many types of tiedown members are in common use, including chains, cables, straps, ropes, and bands. The choice of tiedown type used in a shipping mode and the way in which it is configured may depend on many factors. The analysis here has pointed out certain desirable choices to obtain most effective restraint of cargo. In summary these are:

- *Strength* —The strength of a tiedown member is important because it determines the ultimate forces that can be developed for control of cargo movement.

Table 6 Summary of Crossover Tiedown Functions

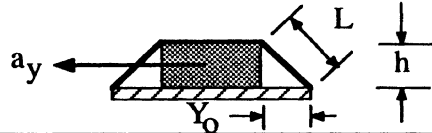
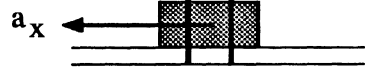
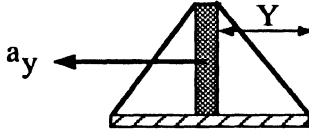
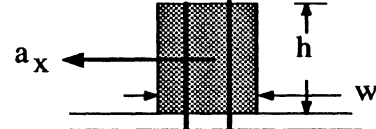
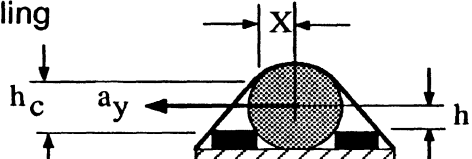
	Preload	Strength
a) Sliding in lateral direction 	$a_y = \mu_{cb} \left(1 + 2 \frac{P_O h}{W L} \right) + \mu_{ct} \left(2 \frac{P_O h}{W L} \right)$	$\frac{P_{cr}}{W} = \frac{P_O}{W} + a \cdot f$ $f = L/Y_0 \text{ for } L/Y_0 \leq 3$ $f = 3 \text{ for } L/Y_0 \geq 3$
b) Sliding in longitudinal direction ($h/L \geq 0.7$) 	$a_x = \mu_{cb} \left(1 + 2 \frac{P_O h}{W L} \right) + 0.6 \frac{P_O}{W}$	$\frac{P_{cr}}{W} = \frac{P_O}{W} + 1.5 \cdot a_x$
c) Tipping in lateral direction 	$a_y = 2 \cdot \mu_{ct} \frac{P_O h}{W L}$	$\frac{P_{cr}}{W} = \frac{P_O}{W} + 0.5 \cdot a_y \cdot \frac{L}{Y_0}$
d) Tipping in longitudinal direction 	$a_x = \left(1 + 2 \frac{P_O h}{W L} \right) \frac{w}{h}$	$\frac{P_{cr}}{W} = \left(a_x \cdot \frac{h}{w} - 1 \right) \frac{L}{h}$
e) Rolling 	$a_y = \left(1 + 2 \frac{P_O h_c}{W L} \right) \frac{X}{L}$	$\frac{P_{cr}}{W} = 0.5 \left(a_y \cdot \frac{h}{X} - 1 \right) \frac{L}{h_c}$

P_O = Aggregate preload of all crossover tiedowns
 P_{cr} = Aggregate ultimate strength of all crossover tiedowns

Table 7 Summary of Horizontal Tiedown Functions

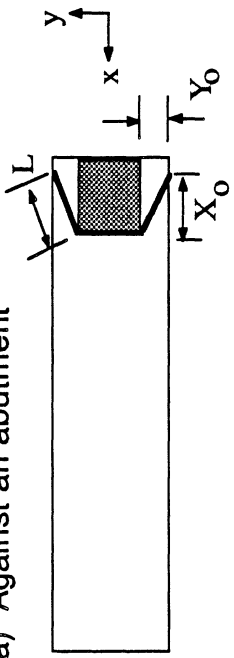
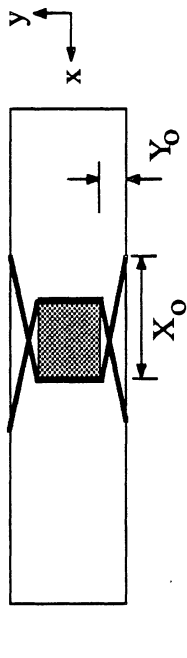
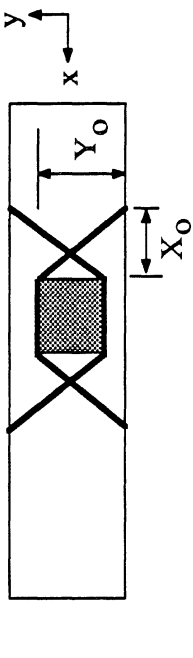
	Preload	Strength
<p>a) Against an abutment</p> 	$a_x = 2 \frac{P_o X_o}{W L}$ $a_y = \mu_{cb} \left(2 \frac{P_o X_o}{W L} + \mu_{ct} \left(2 \frac{P_o X_o}{W L} \right) \right)$	$\frac{P_{cr}}{W} = 0.5 a_x \cdot \frac{L}{X_o}$ $\frac{P_{cr}}{W} = \frac{P_o}{W} + a_y \cdot f$ $f = \frac{L}{Y_o} \text{ for } L/Y_o \leq 3$ $f = 3 \text{ for } L/Y_o \geq 3$
<p>b) Side-to-side, at front and back</p> 	<p>a_x - Not applicable</p> $a_y = \mu_{ct} \cdot 4 \frac{P_o X_o}{W L}$	$\frac{P_{cr}}{W} = \frac{P_o}{W} + 0.5 a_x \cdot \frac{L}{X_o}$ $\frac{P_{cr}}{W} = \frac{P_o}{W} + 0.5 a_y \cdot f$ $f = \frac{L}{Y_o} \text{ for } L/Y_o \leq 3$ $f = 3 \text{ for } L/Y_o \geq 3$
<p>c) Tiedowns to each side</p> 	$a_x = \mu_{ct} \cdot 4 \frac{P_o Y_o}{W L}$ <p>a_y - Not applicable</p>	$\frac{P_{cr}}{W} = \frac{P_o}{W} + 0.5 a_x \cdot f$ $f = \frac{L}{X_o} \text{ for } L/X_o \leq 3$ $f = 3 \text{ for } L/X_o \geq 3$ $\frac{P_{cr}}{W} = \frac{P_o}{W} + 0.5 a_y \cdot \frac{L}{Y_o}$

P_o = Aggregate preload of tiedowns in each direction

P_{cr} = Aggregate ultimate strength of tiedowns in each direction

- *Stiffness*—The analysis has shown that stiffness in the tiedown member is important to minimize any movement when the friction coupling has been broken. A negative aspect of high stiffness is the possibility that the preload will diminish from its initial setting as the load "settles" during the first miles of travel. This is well recognized in the trucking industry and is the basis for driver practices of checking load securement after the first 50 or so miles of travel. From experience, one concludes that the stiffness of chain and cable types of tiedowns is quite adequate for load securement.

- *Frictional qualities*—The frictional qualities of the tiedown material are important in order for the tiedown to resist sliding on the article. Chains can potentially engage the edges of cargo items adding to their ability to restrain cargo. Materials that have a slippery texture are at a disadvantage in their ability to perform as a restraint device.

- *Preload*—Preload in a tiedown member serves several functions. The first and most obvious is that it loads the cargo against the bed of the truck increasing the frictional force resisting movement. Second, with certain configurations preload increases the effective stiffness of the tiedown assembly in resisting load shift once the frictional bond has been overcome. Lastly, preload increases the frictional coupling of the tiedown against the cargo item, adding further to resistance to movement.

- *Angle*—The angle at which a tiedown crosses a cargo article affects its ability to resist cargo shift. A shallow angle is deficient in providing frictional coupling to the cargo item. In those cases a supplementary device should be used to provide some mechanical coupling to the cargo. At a high angle the resistance to movement (effective stiffness) is dependent on preload. In those cases, care should be taken to ensure that maximum preload is achieved.

- *Elongation capability*—While stiffness is important to minimize cargo shifting, the ability for a tiedown to elongate reasonably without failure can be important in certain functional modes. For example, tiedowns passing over a cargo article only react against transverse accelerations after movement has taken place to place them at an angle. The typical requirements for 15% elongation capability in tiedowns is reasonable to ensure that they can function in this way.

4. APPLICATIONS

4.1 Objective

The objective in this chapter is to apply the findings from the engineering analysis to restraint design. The process identifies general rules that should be followed in practice if reliable restraint up to the proposed acceleration levels is to be achieved in common practice. At the same time, it demonstrates the complexity of restraint design because of the variety of cargo shapes and the many alternative ways in which restraints may be applied.

The number of possible cargo items and configurations is too large to address all possibilities, thus the focus will be in single-unit rectangular loads large enough to warrant tiedown. The intent is not to cover every detail of restraint design comparable to that contained in typical regulatory statements. Rather, the discussion will describe the generic design elements for restraint systems that can achieve the desired performance levels. It is suggested that these designs can be used as reference points for critique of current practices.

4.2 Review of Relevant Findings

Certain key findings from the analyses of the previous chapters have particular significance with regard to restraint design. These are repeated here to highlight the areas warranting special consideration in the discussion of restraint design:

1) Flatbed trailers—Loads on flatbed trailers require special attention with regard to restraint because they are overinvolved in accidents in which loss, spillage, or shift of cargo occurs.

2) Acceleration requirements—Based on analysis of truck performance limits restraint systems should be designed to endure accelerations to the limits of:

0.75 g — longitudinal

1.0 g — lateral

3) Critical cargo weight—Items of cargo greater than 1000 lb in weight present serious risk if not properly restrained. Every item of such cargo should receive appropriate attention to ensure that it is restrained.

4) Safety factors—Cargo restraints should be designed with the intent of achieving a minimum safety factor of two. That is, the restraint design should have a theoretical strength of at least twice the expected maximum load. The design should include redundant elements so that failure of any one will not render the load unsecured.

5) Friction—Friction forces should not be included as a part of the intended restraint forces because of their unreliable nature, being defeated by contamination on the truck bed or vibrations during travel.

6) Preload—Preload in a tiedown system is seen as being significant to the performance of tiedowns in a number of functional modes. However, preload is generally an unknown factor in a tiedown system. It is possible for drivers or enforcement personnel

to confirm qualitatively that tiedowns have a preload (are taut); however, with the currently available equipment it is not possible to know the exact amount of tension.

7) Enclosure restraints—Where cargo is hauled in vehicles using the sides and end walls as restraints, those structures should be rated for capacity in preventing shift or loss of cargo.

8) Blocking—Where blocking is used to counteract the acceleration forces acting on an item of cargo, the blocking method should be designed adequately for that purpose. This means that the blocking must either transmit sliding forces to the walls of the vehicle, or transfer them to the floor via nail/spike fasteners.

4.3 Restraint Rules

The application of these findings to securement of articles that are generally rectangular in form suggests some specific rules of practice that are warranted. The discussion here is applicable to items weighing 1000 lb or more (the critical weight). In the systematic analysis of securement in the previous chapter, the objectives were to prevent any significant shift in position of the cargo and to prevent the cargo from tipping. The effectiveness of different restraint methods depends on the geometry of the cargo and the restraint system. Thus, different rules are appropriate for different cargo types, and a rational regulation of cargo securement practices must recognize the different types. For purposes of the discussion the abbreviated classification system described below will be used. For the general problem of design and evaluation of restraint systems a more extensive classification system would be required taking into account the propensity for articles to roll; and the combinations of multiple articles secured by common restraint members.

4.3.1 Cargo classification—There are several key variables in the dimensions of rectangular articles that impact on the type of securement needed and the way in which a securement system will function. With regard to the cargo and its placement on the vehicle, securement practices must take into account the possibility that the cargo can tip or roll. A variable of further significance is the height/width dimensions of the article relative to the dimensions of the truck bed which determine the angle at which crossover tiedowns act upon the article. These variables result in four classifications, illustrated in Figure 4.1 and described as follows:

Type LN—Refers to articles that are low in height-to-width ratio such that they are not at risk of tipping, and narrow in comparison to the width of the truck bed such that the vertical angle of crossover tiedowns is within 45 degrees of the horizontal. The definition of "low" comes about from the concern that the article will not tip when exposed to accelerations of 0.75 g in the longitudinal direction or 1.0 g in the lateral direction. This requires that the CG height be no greater than its distance from any edge of the base. While the CG location is not generally known for cargo items, if uniform density is assumed the CG will be at the geometric center of the article. Thence, low articles can be defined as "any article for which the height is less than the width or length of its base."

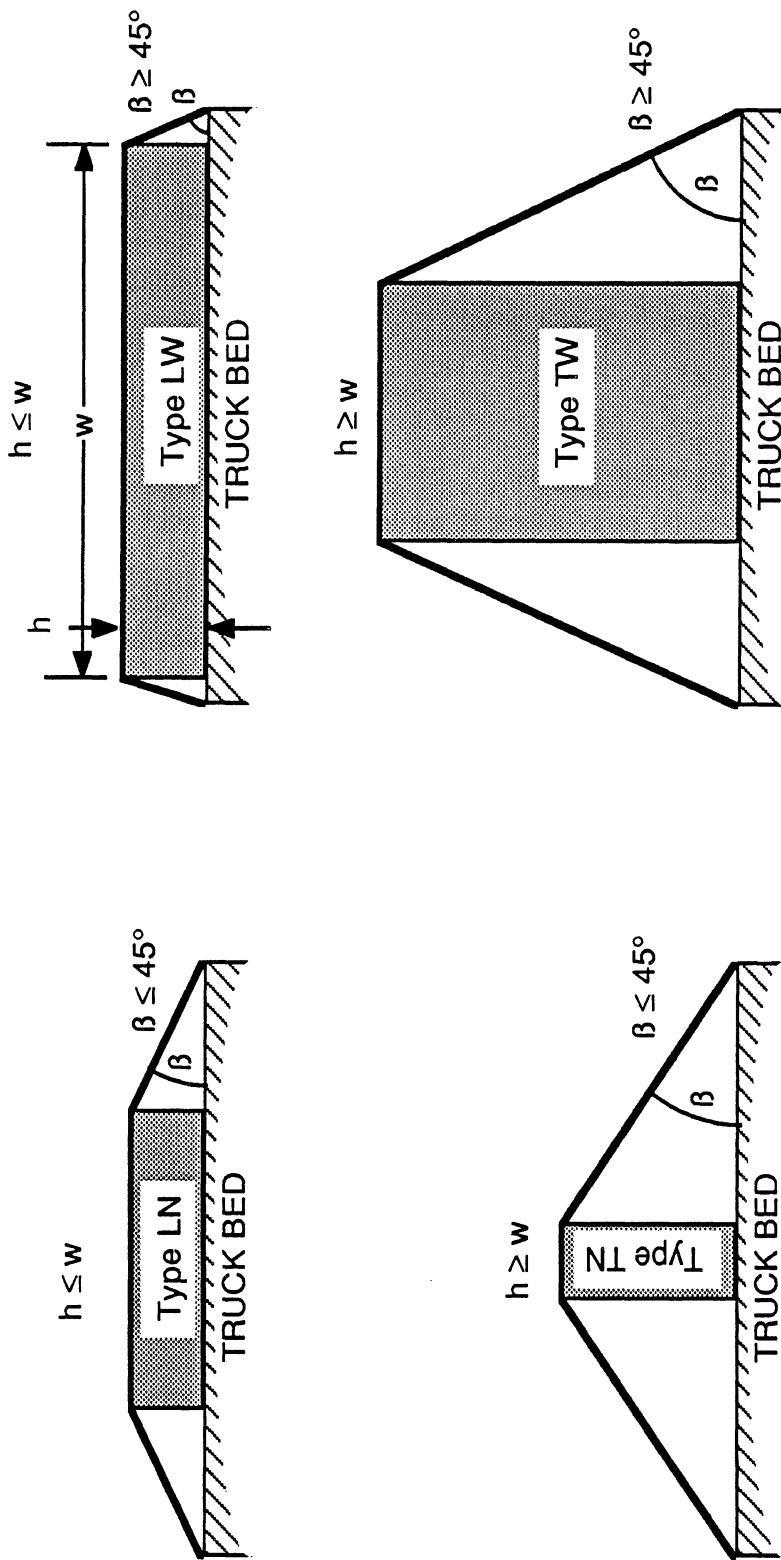

Fig. 4.1 Classification of cargo articles by shape.

Type LW—Refers to articles that are low enough in profile (as defined in the previous paragraph) that they are not at risk of tipping, and wide enough in comparison to the truck bed that crossover tiedowns have a vertical angle greater than 45 degrees.

Type TN—Refers to articles that are tall enough in profile that they are at risk of tipping, and narrow enough in comparison to the truck bed that the vertical angle of the tiedowns is less than 45 degrees. Based on previous arguments "tall" is defined as "any article for which the height is greater than the width or length of its base."

Type TW—Refers to articles that are tall enough in profile (as defined in the previous paragraph) that they are at risk of tipping, and wide enough in comparison to the truck bed that crossover tiedowns have a vertical angle greater than 45 degrees.

4.3.2 Lateral restraint—Cargo on commercial trucks must be restrained adequately to endure lateral accelerations up to 1.0 g without tipping or significant movement. Securement for the cargo should adhere to the following rules:

Type LN articles on an open truck or trailer—*must be secured by any one of the following methods:*

1) *With lateral crossover tiedowns, at least two in number, having an aggregate strength (total for all tiedown members) equal to four times the weight of the article, and with blocking placed in the lateral direction extending from the article to the tiedown connection point on the side of the bed. (See illustration in Figure 4.2a)*

2) *With lateral crossover tiedowns, at least two in number, having an aggregate strength (total for all tiedown members) equal to four times the weight of the article, connected directly to the article via fasteners with strength equal to the strength of the tiedowns. (See illustration in Figure 4.2b)*

The tiedown strength requirement for the above two methods comes from Table 6, Part a. In order to restrain the cargo under limit conditions, the strength must be equal to the preload plus the additional load due to lateral acceleration. With the tiedown devices in common use today, there is no way to know the amount of preload. Lacking that knowledge, it is presumed that it will be on the order of the working strength of the tiedown, but in no case greater than one-half of the ultimate strength (i.e., $P_0 \leq 0.5 P_{cr}$). The acceleration requirement in this direction is 1.0 g, and the L/Y_0 factor is approximately one; these parameters resulting in the strength factor of two. Applying a safety factor of two results in the strength requirement of four times the weight.

A minimum of two tiedowns are specified to ensure that the article is prevented from rotating on the truck bed or slipping at one end, as might occur if only one tiedown were used. The use of multiple crossover tiedowns provides the further advantage of redundancy in the lateral direction.

Because the parameter ratio h/L in the preload equation (Table 6, Part a) may be near zero, it must be assumed that little or no resistance to lateral movement (acceleration) is obtained from preload. The only resistance factor comes from the weight of the article, and that is potentially insufficient to resist sliding at limit performance. The additional restraint against movement is provided by blocking (method 1) or by connecting the tiedowns to the article (method 2). With the blocking

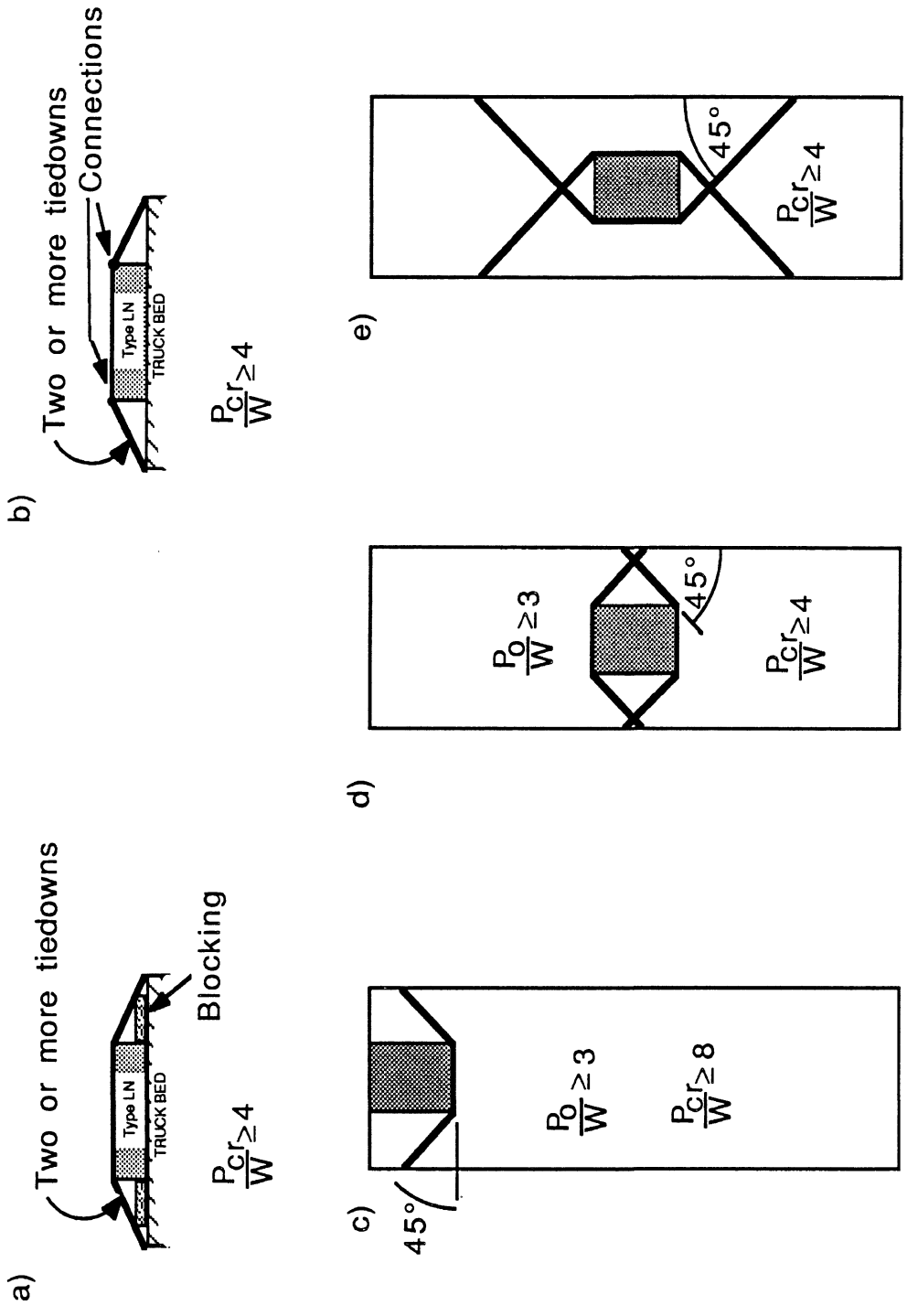

Fig. 4.2 Alternatives for lateral securement of Type LN articles.

positioned against the tiedowns, the tiedowns must still pick up the lateral load; therefore, the presence of blocking does not diminish the strength requirements for the tiedowns.

3) *Secured against an abutment by side-to-side horizontal tiedowns having an aggregate strength equal to eight times the weight, with the legs anchored at a 45 (± 15) degree horizontal angle to the longitudinal axis of the vehicle, and with a preload equal to three times the weight. (See illustration in Figure 4.2c)*

The securement follows the model given in Table 7, Part a. In order to restrain the cargo under limit conditions, the strength must be equal to the preload plus the additional load due to lateral acceleration. Again it is presumed that the preload will be on the order of the working strength of the tiedown, but in no case greater than one-half of the ultimate strength (i.e., $P_o \leq 0.5 P_{cr}$). The L/Y_o factor will vary with angle, but at a minimum angle of 30 degrees (allowing for the 15 degree tolerance) has a maximum value of two. Using these parameters in the strength equation for the lateral direction results in the strength requirement of eight times the load with a safety factor of two. For the preload calculations using the equation for the lateral direction, coefficients of friction of 0.3 have been assumed, and the worst case angle of 60 degrees (allowing for the 15 degree tolerance) is applied.

This type of restraint is not adequate for articles that have a length dimension much greater than the width. Under those circumstances, it may be possible for the end of the article against the abutment to move laterally. Therefore, this method should be limited to use with articles that have a length dimension no greater than their width.

4) *Secured by side-to-side horizontal tiedowns at the front and back of the article having an aggregate strength of four times the weight, with the legs anchored at a 45 (± 15) degree horizontal angle to the longitudinal axis of the vehicle, and with a preload equal to three times the weight. (See illustration in Figure 4.2d)*

The securement method follows the model given in Table 7, Part b. The same parameter values as used in the previous paragraphs are used for calculation of the preload and strength requirements.

5) *Secured by horizontal tiedowns to each side having an aggregate strength of four times the weight, and with the legs anchored at a horizontal angle no less than 45 degrees from the longitudinal axis of the vehicle. (See illustration in Figure 4.2e)*

The securement method follows the model given in Table 7, Part c. There is no preload requirement for securement. Nevertheless, a preload is necessary to keep the tiedowns in place, thus a value equal to one-half of the ultimate strength has been assumed for the strength calculation. All other parameters are the same as assumed above. The minimum angle is specified to ensure that the tiedown members are substantially oriented toward the side of the vehicle as necessary to provide lateral restraint.

Type LW articles on an open truck or trailer—*must be secured by any one of the following methods:*

1) *With lateral crossover tiedowns, at least two in number, having an aggregate strength (total for all tiedown members) equal to twelve times the weight of the article, and with blocking placed in the lateral direction extending from the article to the tiedown connection point on the side of the bed. (See illustration in Figure 4.3a)*

The strength requirement comes about from Table 6, Part a. Tiedown strength must be equal to the preload plus the forces due to lateral acceleration. Preload is unknown, therefore it is presumed to be no greater than one-half of the ultimate strength. The acceleration requirement in this direction is 2.0 g (1.0 g times a safety factor of two). The L/Y_o parameter can be any value up to three. Using these parameters the strength factor of twelve is obtained. Although large, a strength of this magnitude is required because of the disadvantageous angle of the tiedowns when resisting lateral movement.

A minimum of two tiedowns are specified to ensure that the article is prevented from rotating on the truck bed or slipping at one end, as might occur if only one tiedown were used. The use of multiple crossover tiedowns provides the further advantage of redundancy in the lateral direction.

The blocking is required to ensure against lateral movement, although it does not diminish the strength requirements of the tiedowns.

2) *Secured against an abutment by side-to-side horizontal tiedowns having an aggregate strength equal to eight times the weight, with the legs anchored at a 45 (± 15) degree horizontal angle to the longitudinal axis of the vehicle, and with a preload equal to three times the weight. (See illustration in Figure 4.3b)*

Same rationale as for Type LN article.

3) *Secured by side-to-side horizontal tiedowns at the front and back of the article having an aggregate strength of four times the weight, with the legs anchored at a 45 (± 15) degree horizontal angle to the longitudinal axis of the vehicle, and with a preload equal to three times the weight. (See illustration in Figure 4.3c)*

Same rationale as for Type LN article.

4) *Secured by horizontal tiedowns to each side having an aggregate strength of four times the weight, and with the legs anchored at a horizontal angle no less than 45 degrees from the longitudinal axis of the vehicle. (See illustration in Figure 4.3d)*

Same rationale as for Type LN article.

Type LN & LW articles on an enclosed truck or trailer—may be secured in the manner as prescribed above for transport on open vehicles; or, they may be secured only with lateral blocking if the sidewalls are rated with strength adequate for the load.

This requirement recognizes that if cargo is transported in an enclosed vehicle with walls having strength adequate to resist the lateral accelerations, the crossover tiedowns are not needed. The lateral acceleration forces are transmitted to the walls of the enclosure by the blocking, thereby providing the needed securement.

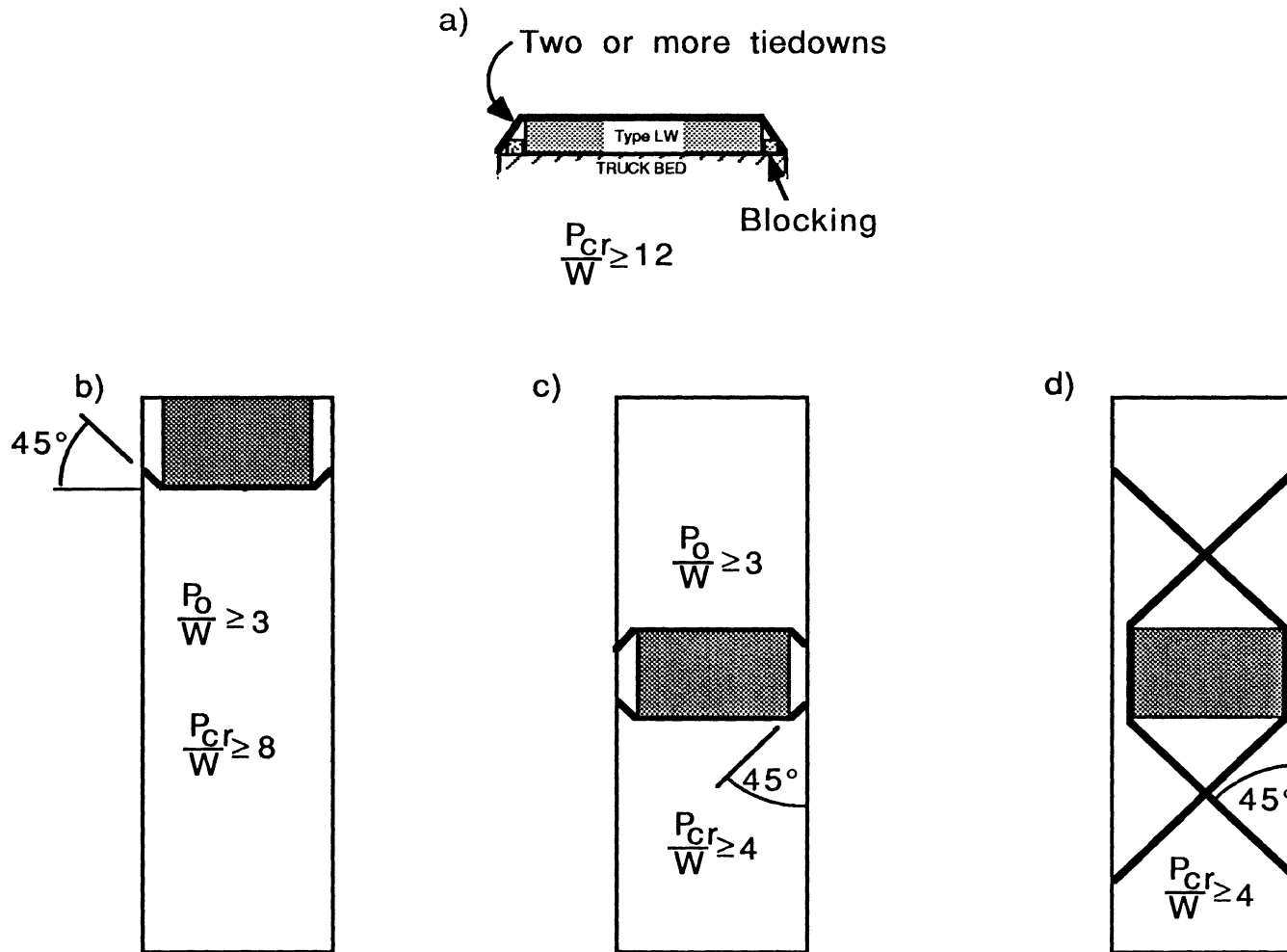

Fig. 4.3 Alternatives for lateral securement of Type LW articles.

Type TN articles—*must be secured to prevent sliding by lateral crossover tiedowns, at least two in number, having an aggregate strength equal to four times the weight of the article; and secured to prevent tipping by either of the following methods:*

a) With blocking placed in the lateral direction extending from the article to the tiedown connection point on the side of the bed and extending to the height of the mid-point of the article (See illustration in Figure 4.4a), or

b) With blocking placed in the lateral direction extending from the article to the tiedown connection point on the side of the bed and by connecting the tiedowns directly to the article via fasteners with strength equal to three times the weight of the article. (See illustration in Figure 4.4b)

The tiedown requirements to prevent sliding are analagous to those for Type LN articles because of the low vertical angle of the tiedowns (less than 45 degrees). The strength requirement is determined from the equation in Table 6, Part a, using the same rationale as explained for the Type LN articles.

Tipping may be prevented by installing blocking against the sides of the article to brace it. In that case, the blocking must extend up the sides to be within close proximity of the center of gravity. In general, blocking up to the mid-point of the article is sufficient (method a). Alternately, tipping can be prevented by connecting the tiedowns directly to the article (method b).

Type TW articles—*must be secured against tipping by either method a or b below, and against sliding by any one of the methods c through f below:*

a) With lateral crossover tiedowns, at least two in number, having an aggregate preload (total for all tiedown members) equal to five times the weight of the article, and with blocking placed in the lateral direction extending from the article to the tiedown connection point on the side of the bed.

b) With blocking placed in the lateral direction extending from the article to the tiedown connection point on the side of the bed and extending to the height of the mid-point of the article.

Tipping may be prevented (method a) by the frictional coupling of the tiedowns at the point where they pass over the article in accordance with the method shown in Table 6, Part c. The preload must be sufficient to provide the necessary frictional force. Assuming a coefficient of friction of 0.3 and that the h/L value is no greater than 0.7 (equivalent to 45 degrees) results in the preload requirement of five times the weight. The strength requirement (based on the concern for tipping) is on the order of six times the weight and will necessarily be met by tiedowns with the required preload.

Tipping may also be prevented by installing blocking against the sides of the article to brace it. In that case, the blocking must extend up the sides to be within close proximity of the center of gravity. In general, blocking up to the mid-point of the article is sufficient (method b).

c) With lateral crossover tiedowns, at least two in number, having an aggregate strength (total for all tiedown members) equal to twelve times the weight of the article, and

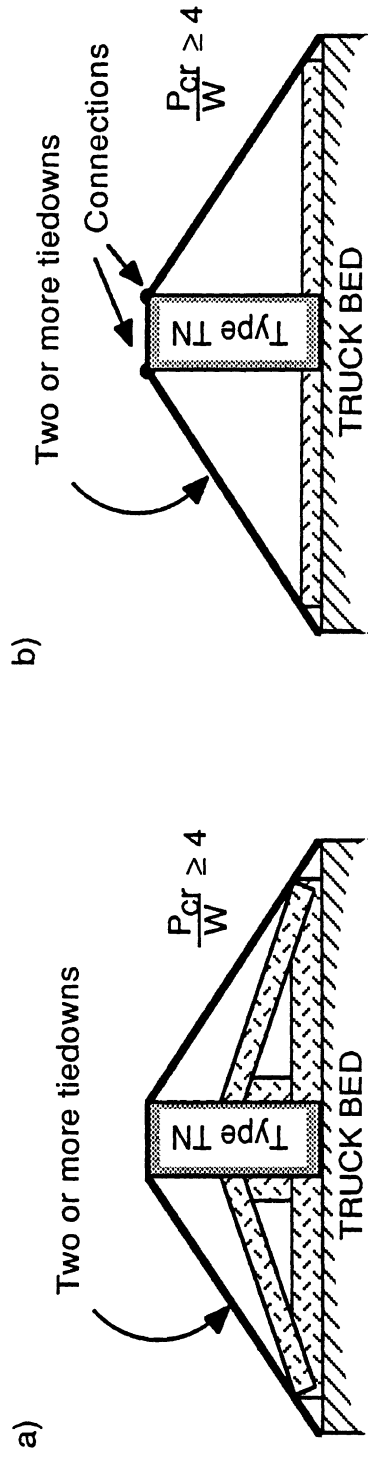

Fig. 4.4 Alternatives for lateral securement of Type TN articles.

with blocking placed in the lateral direction extending from the article to the tiedown connection point on the side of the bed. (Same as the illustration provided in Figure 4.3a)

The strength requirement comes about from Table 6, Part a. Tiedown strength must be equal to the preload plus the forces due to lateral acceleration. Preload is unknown, therefore it is presumed to be no greater than one-half of the ultimate strength. The acceleration requirement in this direction is 2.0 g (1.0 g times a safety factor of two). The L/Y_0 parameter can be any value up to three. Using these parameters the strength factor of twelve is obtained. Although large, a strength of this magnitude is required because of the disadvantageous angle of the tiedowns in resisting lateral movement.

A minimum of two tiedowns are specified to ensure that the article is prevented from rotating on the truck bed or slipping at one end, as might occur if only one tiedown were used. The use of multiple crossover tiedowns provides the further advantage of redundancy in the lateral direction.

The blocking is required to ensure against lateral movement, although it does not diminish the strength requirements of the tiedowns.

d) Secured against an abutment by side-to-side horizontal tiedowns having an aggregate strength equal to eight times the weight, with the legs anchored at a 45 (± 15) degree horizontal angle to the longitudinal axis of the vehicle, and with a preload equal to three times the weight. (Same as the illustration provided in Figure 4.3b)

Same rationale as for Type LN article.

e) Secured by side-to-side horizontal tiedowns at the front and back of the article having an aggregate strength of four times the weight, with the legs anchored at a 45 ($+ 15$) degree horizontal angle to the longitudinal axis of the vehicle, and with a preload equal to three times the weight. (Same as the illustration provided in Figure 4.3c)

Same rationale as for Type LN article.

f) Secured by horizontal tiedowns to each side having an aggregate strength of four times the weight, and with the legs anchored at a horizontal angle no less than 45 degrees from the longitudinal axis of the vehicle. (Same as the illustration provided in Figure 4.3d)

Same rationale as for Type LN article.

4.3.2 Longitudinal restraint—Cargo on commercial trucks must be restrained adequately to endure longitudinal accelerations up to 0.75 g without tipping or significant movement. Securement for the cargo should adhere to the following rules:

Type LN & LW articles on an open truck or trailer—*must be secured by any one of the following methods:*

1) Secured against an abutment by side-to-side horizontal tiedowns having an aggregate preload equal to 1.5 times the weight of the article, and with the legs anchored at a 45 (± 15) degree horizontal angle to the longitudinal axis of the vehicle. (See illustration in Figure 4.5a)

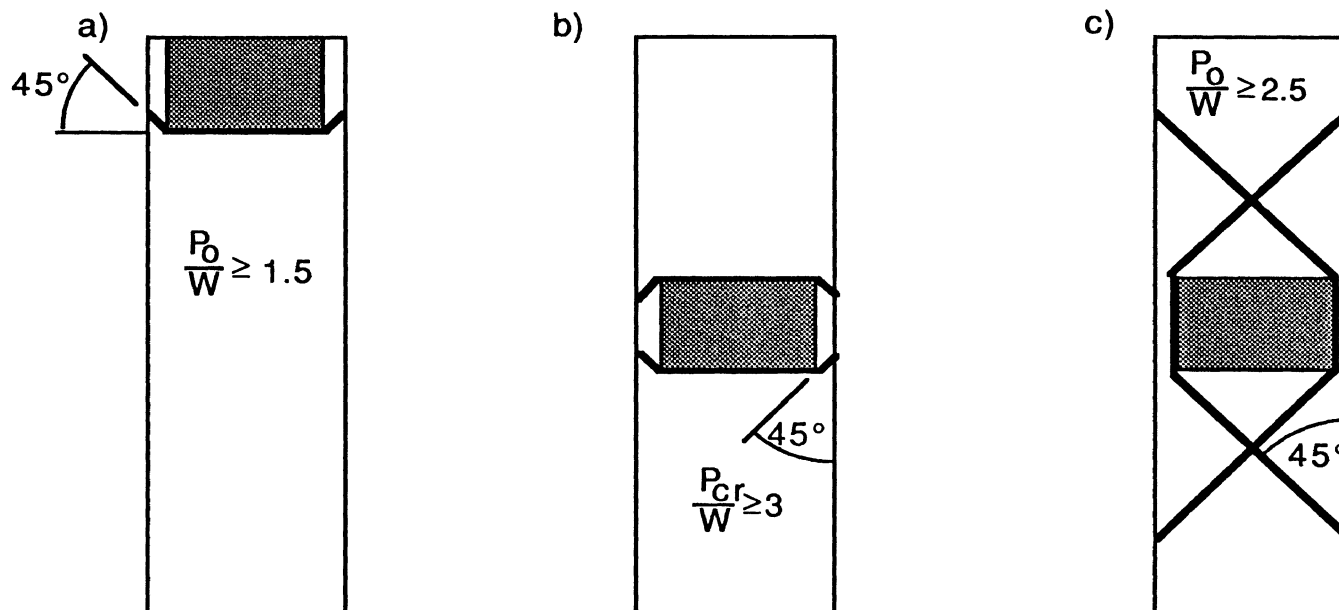

Fig. 4.5 Alternatives for longitudinal securement of Types LN & LW articles.

The securement method follows the model given in Table 7, Part a. The worst case angle for preload calculations in this configuration is 60 degrees (45 plus the tolerance of 15) which yields an X_0/L value of 0.5. To achieve restraint to a level of 1.5 g (0.75 g with a safety factor of 2) requires preload of 1.5 times the weight of the article.

For strength calculations, the largest L/X_0 value occurs at an angle of 30 degrees (45 minus the tolerance of 15) and has the value of two. The strength required is therefore 1.5 times the weight, which is not critical because it is assured by the preload specification.

2) *Secured by side-to-side horizontal tiedowns at the front and back of the article having an aggregate strength of three times the weight, and with the legs anchored at a horizontal angle no greater than 45 degrees to the longitudinal axis of the vehicle. (See illustration in Figure 4.5b)*

The securement method follows the model given in Table 7, Part b. Preload is not important to the longitudinal restraint function except as necessary to keep the tiedowns in place. The strength requirement, however, does depend on the preload level. Presuming the preload is no greater than one-half the ultimate strength, and that L/X_0 cannot exceed two, the strength requirement of three is obtained.

3) *Secured by horizontal tiedowns to each side having an aggregate preload equal to 2.5 times the weight, and with the legs anchored at a 45 (± 15) degree horizontal angle to the longitudinal axis of the vehicle. (See illustration in Figure 4.5c)*

The securement method follows the model given in Table 7, Part c. The preload requirement dominates that of strength. The worst-case angle for preload calculations in this configuration is 60 degrees (45 plus the tolerance of 15) which yields an X_0/L value of 0.5. To achieve restraint to a level of 1.5 g (0.75 g with a safety factor of 2), assuming a friction coefficient of 0.3, requires preload of 2.5 times the weight of the article. The strength calculations yield a factor of three times the weight, which will necessarily be met with tiedowns at the prescribed preload condition.

Type LN & LW articles on an enclosed truck or trailer—*may be secured in the manner as prescribed above for transport in open vehicles; or they may be secured only with longitudinal blocking if the end walls are rated with strength adequate for the load.*

This requirement recognizes that if cargo is transported in an enclosed vehicle with end walls having strength adequate to resist the longitudinal accelerations, blocking against those walls is sufficient.

Type TN & TW articles—*must be secured to prevent sliding in the longitudinal direction by any of the methods a through e below, and secured against tipping by either of the methods f or g below.*

a) *Secured against an abutment by side-to-side horizontal tiedowns having an aggregate preload equal to 1.5 times the weight of the article, and with the legs anchored at a 45 (± 15) degree horizontal angle to the longitudinal axis of the vehicle. (Same as illustration provided in Figure 4.5a)*

b) *Secured by side-to-side horizontal tiedowns at the front and back of the article having an aggregate strength of three times the weight, and with the legs anchored at a*

horizontal angle no greater than 45 degrees to the longitudinal axis of the vehicle. (Same as illustration provided in Figure 4.5b)

c) Secured by horizontal tiedowns to each side having an aggregate preload equal to 2.5 times the weight, and with the legs anchored at a 45 (± 15) degree horizontal angle to the longitudinal axis of the vehicle. (Same as illustration provided in Figure 4.5c)

d) Secured by longitudinal blocking against end walls of strength rated for the load at 1.5 g.

e) Secured by lateral crossover tiedowns, at least two in number, having an aggregate strength equal to five times the weight of the article, and an aggregate preload equal to two times the weight of the article.

Securement by the crossover tiedowns follows the method shown in Table 6, Part b. The strength requirements are based on the assumption of a preload no greater than one-half of the ultimate strength of the tiedowns. Thence, to withstand an acceleration of 1.5 g, a strength close to five times the weight is required. The preload requirement is less obvious because of its dependence on the coefficient of friction and on the h/L ratio. A coefficient of 0.3 is assumed. The h/L value may vary from nearly zero to one depending on the geometry of the situation. Assuming the worst case of zero results in a preload requirement of twice the weight of the article.

f) Secured against tipping in the longitudinal direction by lateral crossover tiedowns, at least two in number, having an aggregate strength of four times the weight, and an aggregate preload equal to two times the weight.

Securement against tipping by the crossover tiedowns follows the method shown in Table 6, Part d. The values for preload and strength depend on the relative magnitudes of the height, h, the longitudinal width, w, and the length of the tiedown legs, L. It is assumed that a reasonable maximum value for h/w that would be used in practice is no greater than two. Similarly, the maximum practical value for L/h is two (equivalent to tiedown legs at a 30 degree vertical angle and a maximum article height of two feet). Applied to the strength equation, these parameters result in the requirement for strength equal to at least four times the weight; and in the preload equation they result in the requirement for preload equal to twice the weight.

g) Secured against tipping by blocking in the longitudinal direction to the height of the mid-point of the article.

Tipping may be prevented by installing blocking against the ends of the article within close proximity to the center of gravity. In general, blocking up to the mid-point of the article is sufficient.

4.4 Discussion

It is clear from the above exposition that a rationally designed restraint system involves consideration of a broad range of factors impacting on performance, which makes a systematic treatment quite complicated. Geometry of tiedowns plays an important and variable role influencing the effectiveness of preload in restraining an article and the

ultimate strength that must be required of a tiedown system. Variations in the height and width dimensions of articles have profound influences on how they should be restrained, and the effectiveness of crossover tiedowns. Likewise, variations in the way horizontal tiedowns are installed have a strong influence on the restraint performance that will be achieved in a particular direction. With this level of complexity it is hard to expect a truck driver to assimilate so much information into the daily decisions made "on the spot" as each new shipment is loaded onto a truck.

To some extent these rules can be simplified to make them more understandable, but usually with some penalty because of the need to over-specify a restraint requirement in order to be safe in the most extreme cases. Cargoes hauled in enclosed vehicles can be covered by a rather simple rule—*Always block the article in all directions against sliding or tipping*. Simplified rules applicable to cargo hauled on flatbed trucks and trailers are more complex, but may follow the examples listed below:

1) *Every cargo article must be secured to prevent movement of more than a few inches in any direction under the most extreme conditions.*

2) *Crossover tiedowns used to provide lateral restraint of low-profile articles (ones for which the vertical angle of the tiedown leg is less than 45 degrees) should have an aggregate strength of four times the weight, and blocking should be installed in the space between the article and the anchorage point of the tiedowns.*

3) *Crossover tiedowns are not reliable in providing lateral restraint to high-profile articles (ones that yield a tiedown that is essentially vertical in orientation) because of the dependence upon friction.*

4) *Crossover tiedowns are only effective for longitudinal restraint of high-profile articles (ones for which the vertical angle of the tiedown leg is greater than 45 degrees). The tiedowns must be preloaded to at least twice the weight, and should be secured so that they cannot roll or slide longitudinally along the article.*

5) *Whenever possible, crossover tiedowns should be fastened to an article (or to edge protectors when used) to increase their effectiveness in preventing the article from sliding or tipping.*

6) *Horizontal tiedowns should be installed with the legs at 45 degree angles, and preloaded up to three times the weight of the article.*

7) *Articles that are at risk of tipping (height greater than width) should be braced with blocking up to the mid-point of the article.*

While these rules of thumb simplify comprehension of cargo securement they do impose high demands on the restraint systems. It is likely that the preload and strength requirements, being several multiples of the weight, are departures from current practice. To some extent the severity could be diminished if a less stringent safety factor was adopted (i.e., they could be cut in half if the safety factor was reduced to one); however, it is not justified in normal engineering practice. Rather, the contrast with current regulations and practice should be viewed as reason to question both the validity of the analytical methods used here and the sufficiency of current practices. With regard to the analytical methods, the strength and preload requirements are heavily influenced by the classification

5. SUMMARY, CONCLUSIONS, AND RECOMMENDATIONS

This project has provided the unusual opportunity to take a look at the problems in securement of loads on commercial highway vehicles from the engineering perspective. Though the study is only of a preliminary nature, the outcome provides a preview of the areas where improved practice is warranted and the methods that can be applied to the issues.

The examination of the general performance levels to which cargo restraints should function successfully leads to the conclusion that restraints should be designed for higher performance than generally required in current regulations. The basis for this conclusion derives from the argument that restraint systems are employed to prevent shift or loss of cargo during that fraction of a percent of the driving experience when emergency situations arise. They are not needed for the low-level maneuvers that prevail during the majority of driving. If their primary function is required during emergency situations, then they should perform appropriately up to the limits of truck braking and turning response. Permitting restraints that function to anything less than the truck maneuvering limits may reduce, but will not eliminate, accidents caused by cargo shift or loss.

From the review of truck maneuvering limits, new acceleration performance requirements for cargo securement were formulated. Those of most significance are:

- Designation of 1000 lb as the critical cargo weight requiring special attention to ensure proper restraint during transit.
- Restraint design to sustain lateral acceleration levels up to 1 g without failure.
- Restraint design to sustain longitudinal accelerations to 0.75 g without failure.
- Need to rate the restraint strength of vocational body enclosures when used to haul cargo that is otherwise unrestrained.

The mechanical analysis of restraint function has shown that proper design of a restraint system is complicated by the variables of each situation. The variables are associated with:

- Multiple functions of a restraint system—prevention of sliding, tipping and rolling in the lateral and longitudinal directions.
- Multiple types of restraints—blocking/bracing, crossover tiedowns, horizontal tiedowns, and enclosures.
- Multiple configurations of cargo items—ranges of weight, length, height, and width.

Considering only tiedown restraints it is seen that preload, strength, installation angles, stiffness, and location of the tiedowns are important variables affecting performance. Different factors predominate in the different functional roles with every configuration of a cargo article. Thus, it is difficult to reduce tiedown design to simple rules of thumb applicable to all load types. In effect, different rules are required for each load type, and the extent to which they can be simplified depends on the degree to which over-specification will be accepted in return for reduced number of cargo classifications.

The changes in practice that would be required if these suggestions were incorporated into regulations are not trivial. The theoretical basis for the suggestions is not so rigorous as to justify changes without further consideration; but the fact that this engineering

analysis points out a need for performance improvements is one of the most important conclusions. The recommended approach to further work is as follows:

1) Engineering study of cargo restraint—The analysis has demonstrated the need for more systematic engineering design of cargo securement methods. There is little known about certain properties found to be critical to performance (coefficients of friction, tiedown stiffness, etc.), especially in the everyday environment of the truck transport business. A more extensive engineering study involving substantial experimental work is warranted in order to validate the models of how restraints function, and to establish appropriate values for the parameters that are critical to restraint function. Only through such work is it possible to "design" a restraint system that will function reliably in every case, and only with that capability is it possible to optimize the restraint methods used in practice.

2) Cargo classifications—The many variables related to cargo type affect the ability to achieve reliable restraint. High-profile articles depend on different mechanisms for restraint than low-profile articles. Soft or compliant items respond differently to tiedowns than rigid items. Rubber-tired vehicles are notoriously difficult to restrain reliably. Thus to achieve reliable restraint of all cargo, it is necessary to develop a systematic method of classifying cargoes in accordance to their response to restraints. This need should be addressed in conjunction with the findings from the engineering study suggested above.

3) Application—A need is evident for means to get the available knowledge on cargo restraint into the proper segments of the trucking community. This means getting information into the hands of motor carriers, their agents, enforcement personnel, etc. on proper methods for restraint. The regulations can become the handbook of practice if they can be simplified via the actions suggested above. They also provide motivation for improvements in equipment (trailer sidewall ratings, strength markings on chains, tiedown preload indicators, etc.) by demanding those ratings for optimal use of equipment.

6. REFERENCES

1. 49 CFR, Part 393, "Parts and Accessories Necessary for Safe Operation."
2. R. D. Ervin, "Liquid Cargo Shifting and the Stability of Cargo Tank Trucks." Final Report, Contract No. DTFH61-83-C-00160, The University of Michigan Transportation Research Institute, September 1985.
3. Accident data files for the year 1984 recorded on Form MCS 50-T.
4. 49 CFR, Part 393.1, (a), "Scope of the Rules for Part 393."
5. R. D. Ervin, "The Influence of Size and Weight Variables on the Roll Stability of Heavy-Duty Trucks." SAE Paper No. 831163, August 1983.
6. R. D. Ervin, et al., "Future Configuration of Tank Vehicles Hauling Flammable Liquids in Michigan." The University of Michigan Highway Safety Research Institute, Report No. UM-HSRI-80-73, December 1980.
7. C. C. MacAdam, et al, "The Dynamic Behavior of a Refrigerated Semitrailer with a Hanging Meat Load." The University of Michigan Transportation Research Institute, Technical Memorandum , December 1979.
8. D. A. Klokkenga, "Selecting Powertrain Components for Heavy Duty Trucks." SAE Paper No. 760830, 1976.
9. *Noise and Traction Characteristics of Bias-Ply and Radial Tires for Heavy Duty Trucks.* G. R. Thurman and W. A. Leasure, Eds., U. S. Department of Transportation, Report No. DOT-TST-78-2, October 1977.
10. 49 CFR 571.121, "Air Brake Systems."
11. T. D. Gillespie and R. D. Ervin, "Comparative Study of Vehicle Roll Stability." The University of Michigan Transportation Research Institute, Report No. UMTRI-83-25, May 1983.
12. 49 CFR, Part 393.100 (c) (3), "General Rules for Protection Against Shifting or Falling Cargoes."
13. 49 CFR, Part 571.216, "Roof Crush Resistance - Passenger Cars."
14. 49 CFR Part 571.208, "Occupant Crash Protection."
15. Juvinall, R. C. *Fundamentals of Machine Component Design.* John Wiley & Sons, New York, 1983, Section 6.12
16. *Handbook of Tables for Applied Engineering Science.* R. E. Bolz and G. L. Tuve, Eds., The Chemical Rubber Co., Cleveland, Ohio, 1970
17. *Mechanical Engineers' Handbook.* T. Baumeister, Ed., Sixth Edition, McGraw-Hill Book Co. New York
18. R. D. Ervin and C. B. Winkler, "Estimation of the Probability of Wheel Lockup." Presented at IAVSD Congress on Vehicle Design and Components, Geneva, March 3-5, 1986
19. W. E. Meyer and M. O. Schrock, "Tire Friction, A State-of-the-Art Review." Automotive Safety Research Program Report S-34, The Pennsylvania State University, April 1969.
20. *Vibrating Feeders.* Sales Brochure, Vibra Screw, Inc., 755 Union Blvd., Totowa, N.J., 1980.

21. "America's Highways: Accelerating the Search for Innovation." Transportation Research Board Special Report 202, 1984
22. *Timber Design Manual*. Laminated Timber Institute of Canada, PO Box 2698 Station D, Ottawa, Canada K1P 5W7 (April 1972).
23. *Truck Loading Code: Recommended Code of Practice for the Safety of Loads on Road Vehicles*. Australian Government Publishing Service, 1981, 99 pp.
24. *Securing Goods on Semi-Trailer—Guidelines for Securing Goods Conveyed in Combined Modes of Transport*. Swedish Transport Research Commission, Report No. 1986:6 E, 1986, 50 pp.
25. *Guide to Security of Loads*. Ontario Ministry of Transportation and Communications
26. "Draft American National Standard Design Basis for Resistance to Shock and Vibration of Radioactive Material Packages Greater than One Ton in Truck Transport." American National Standards Institute, Inc., May 1980.
27. *Atomic Energy Code of Practice 1006—Securing Radioactive Materials Packages in Conveyances*. Standards Section, Engineering Directorate, UKAEA (Northern Division, Risley, Warrington, UK, August 1979.

APPENDIX A

Engineering Analysis of Tiedowns

A tiedown is defined as a flexible tension member passing over or around an article of cargo. The analysis presented here is concerned with the crossover tiedown as illustrated in Figure A.1, although the results may be applied to other configurations, as well. The article of cargo is assumed to be placed in a central position on a truck and the tiedown is positioned across the item in a symmetric manner. An initial tension, called the "preload," is established in the tiedown by anchoring it with binders, winches, or other means to draw it tight. It is assumed that upon initial placement, the preload force is constant throughout the tiedown. The two elements of the tiedown reaching from the edge of the cargo item to the anchorage point on the bed are denoted as the tiedown "legs." The legs form an angle β with the plane of the bed.

At each edge where the tiedown legs turn downward, there exists a tensile force equal to the preload, P_o . The static forces on the article can be analyzed by taking a free-body diagram cutting through the tiedown legs at this point as illustrated in Figure A.2. The tension forces can be resolved into components that are horizontal and vertical. The horizontal components on opposing sides of the free-body are equal in magnitude and opposite in direction; therefore, they cancel. The two vertical components are in the same direction and therefore impose a vertical load on the article of a magnitude:

$$F_z = 2 P_o \sin \beta = 2 P_o \frac{h}{L_o} \quad (A.1)$$

where

- F_z = Total vertical load imposed on the article of cargo by the tiedown
- P_o = Initial preload force in the tiedown
- β = Angle between the tiedown legs and the horizontal
- h = Height of the article
- L_o = Length of the tiedown leg

This load, in combination with the weight of the article, serves to clamp it to the bed of the truck and increase the static friction between the article and the bed. Thus, it helps to keep the article from moving when exposed to cornering or braking accelerations. The acceleration limit that can be sustained without movement is:

$$a_{\max} = \frac{F_h}{W} = \mu_o \left(1 + \frac{2 P_o}{W} \sin \beta \right) \quad (A.2)$$

where

- μ_o = Static coefficient of friction between the cargo and the bed
- W = Weight of the article



Fig. A.1 Generic tiedown

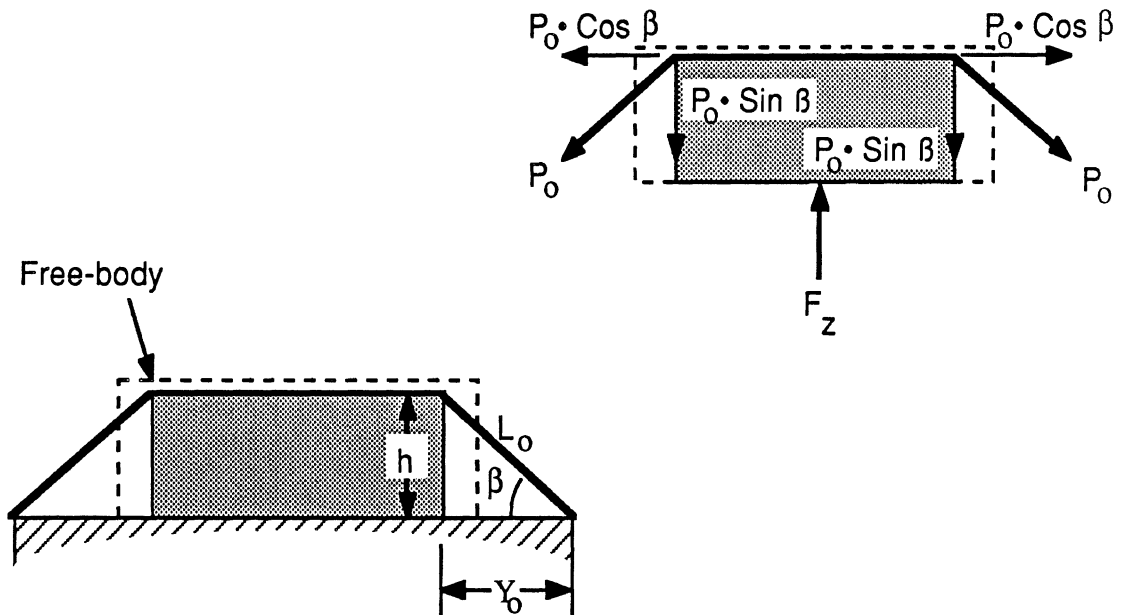

Fig. A.2 Free-body diagram of cargo and tiedowns

Lateral movement without tiedown slip—Should the acceleration exceed the limit of the above equation, the "inertial" force on the article will break its static friction bond with the bed, and the article will begin to slide sideways on the vehicle. Upon initial movement the tiedown has a uniform preload throughout its length, but thereafter the tension in one leg increases as elongation occurs, while that in the opposite leg diminishes from its preload value. The horizontal force component on either side of the free-body diagram of Figure A.2 will be:

$$F_h = P \cos \beta = P \frac{Y_o}{L_o} \quad (A.3)$$

where

P = The tension force in the leg of the tiedown
 Y_o = Initial position of the article

Upon initial movement the friction of the tiedown on the article will keep it fixed to the edge of the article and cause it to stretch. The tension force, P, will be equal to the preload plus any change due to elongation of the tiedown leg. The tiedown is elastic, therefore from Hooke's Law:

$$P = P_o + K \cdot \Delta L \quad (A.4)$$

where

K = Stiffness of the tiedown leg
 ΔL = Change in length of the tiedown leg

With lateral movement from its initial position, Y_o to $(Y_o + Y)$ as shown in Figure A.3, the change in length on the righthand leg is:

$$\Delta L = L - L_o = \sqrt{(Y_o + Y)^2 + h^2} - \sqrt{Y_o^2 + h^2} \quad (A.5)$$

In addition, $\cos \beta$ will always be equivalent to $(Y_o + Y)/L$. Therefore, with substitutions from Eqs. A.4 and A.5, Equation A.3 can be rewritten as:

$$F_{hr} = \left\{ P_o + K\sqrt{(Y_o + Y)^2 + h^2} - K\sqrt{Y_o^2 + h^2} \right\} \frac{Y_o + Y}{\sqrt{(Y_o + Y)^2 + h^2}} \quad (A.6)$$

This is the general expression for the horizontal force component arising from the increase in tension of the righthand leg of the tiedown. On the lefthand leg, the tension decreases in a similar fashion. That is:

$$\Delta L = L - L_o = \sqrt{(Y_o - Y)^2 + h^2} - \sqrt{Y_o^2 + h^2} \quad (A.7)$$

and

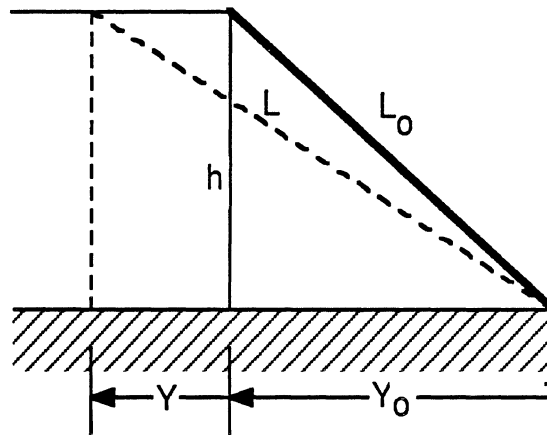

Fig. A.3 Variables in analysis of lateral movement of cargo

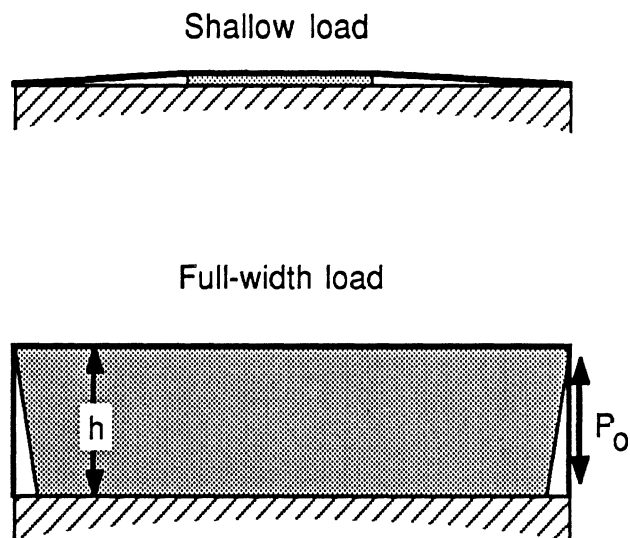

Fig. A.4 Limit cases for lateral movement without tiedown slip

$$F_{hl} = \left\{ P_o + K\sqrt{(Y_o - Y)^2 + h^2} - K\sqrt{Y_o^2 + h^2} \right\} \frac{Y_o - Y}{\sqrt{(Y_o - Y)^2 + h^2}} \quad (A.8)$$

Therefore, as the article slides to the left, a horizontal force to the right is created by tiedown elongation. The force is given by the expression:

$$F_h = F_{hr} - F_{hl}$$

$$F_h = \left\{ P_o + K\sqrt{(Y_o + Y)^2 + h^2} - K\sqrt{Y_o^2 + h^2} \right\} \frac{Y_o + Y}{\sqrt{(Y_o + Y)^2 + h^2}} - \left\{ P_o + K\sqrt{(Y_o - Y)^2 + h^2} - K\sqrt{Y_o^2 + h^2} \right\} \frac{Y_o - Y}{\sqrt{(Y_o - Y)^2 + h^2}} \quad (A.9)$$

While this equation is quite cumbersome, it provides an exact expression for the way in which a horizontal resisting force is developed as the article of cargo slides laterally under the tiedown without slippage of the tiedown. (The sliding friction force of the article on the truck bed adds to this resisting force). The significance of the equation can be seen more readily by examining the rate at which resistance force grows with displacement, obtained by taking the derivative of Eq. A.9 at the point where $Y = 0$. Differentiation yields:

$$\frac{\partial F_h}{\partial Y} \Big|_{Y=0} = K_{1y} = \frac{2 P_o}{L_o} - \frac{2 (P_o - K)}{L_o} \cos^2 \beta = \frac{2 P_o}{L_o} - \frac{2 (P_o - K)}{L_o} \left(\frac{Y_o}{L_o} \right)^2 \quad (A.10)$$

A high rate is desirable to ensure that the restraining force on the article arising from this mechanism develops as immediately as possible. There are two limit cases of this equation as illustrated in Figure A.4. When the article of cargo is the same width as the bed of the truck, Y_o equals 0. Equation A.9 then reduces to:

$$F_h = 2 \left\{ P_o + K\sqrt{Y^2 + h^2} - K h \right\} \frac{Y}{\sqrt{Y^2 + h^2}} \quad (A.11)$$

Upon initial movement (while Y is effectively zero) the rate of change of force with lateral displacement is obtained from Eq. A.10 as:

$$\frac{\partial F_h}{\partial Y} \Big|_{Y=0} = K_{1y} = \frac{2 P_o}{L_o} = \frac{2 P_o}{h} \quad (A.12)$$

That is, the rate of change of force as the article begins to slide is proportional to the preload in the tiedown, and inversely proportional to the height of the article (or the length of the tiedown leg). In this analysis the possibility that the bottom edge of the article will contact the tiedown upon sideways movement has been neglected. Articles that have an overhang as shown in the figure, or which are somewhat narrower than the bed, will be controlled by this equation. If the article is the full width of the bed, it will make immediate contact with the tiedown at its bottom edge. Thence the effective stiffness will be the stiffness of that short section of tiedown, because it must elongate in the direction of movement.

The second case of interest is an article that is *shallow* in depth, such that the tiedown extends out at nearly a horizontal angle from the anchorage point on the truck bed to the article. In that case $h = 0$ and $Y_0 = L_0$, and Eq. A.9 reduces to:

$$F_h = 2 \cdot K \cdot Y \quad (\text{A.13})$$

The associated stiffness for this case is simply:

$$\frac{\partial F_h}{\partial Y} = 2 K \quad (\text{A.14})$$

This equation says that the restoring force is determined by the stiffness of the tiedown member multiplied by two because both legs act together in resisting lateral movement. The stiffer the tiedown member, the more effective it is at reducing lateral movement during this phase of action.

In either case it is helpful to consider the overall tension developed in the more heavily loaded righthand leg of the tiedown as a basis for establishing a strength requirement for the tiedown. The tension force is given by:

$$P = P_0 + K \sqrt{(Y_0 + Y)^2 + h^2} - K \sqrt{Y_0^2 + h^2} \quad (\text{A.15})$$

The tensile force in the tiedown consists of the initial preload value (first term in the above equation) plus the superimposed force due to stretching (the second and third terms). Initial preload in a tiedown is essential for it to function (providing vertical clamping force on the article). As long as there is no movement, the load in the tiedown is unchanged and theoretically it could be preloaded to its ultimate strength with no penalty. However, once movement begins the resisting force provided by the mechanism described above increases the load in the tiedown member. Hence, if failure is to be avoided, the preload must be less than the ultimate strength by a margin sufficient to allow for the additional load developed upon movement.

Lateral movement with tiedown slip—The mechanics described above act to resist lateral movement so long as the tiedown does not slip on the article. If the tiedown is not fastened to the article in any way, slip is only prevented by frictional coupling. Once the horizontal force reaches the limit of the vertical force times the static coefficient of friction, slip will occur. Thereafter, any movement must stretch the tiedown because of the asymmetry in the geometry of the tiedown crossing over the article. (The tiedown is shortest when the load is on center and must increase in length as the article moves off center. Of course, additional resisting forces are contributed by friction of the article sliding on the bed and friction of the article sliding under the tiedown.)

The analysis of the mechanics can be performed using the method shown in Figure A.5. The total horizontal resistance force that is generated is:

$$F_h = P \frac{Y_0 + Y}{L_r} - P \frac{Y_0 - Y}{L_l} \quad (\text{A.16})$$

where

$$P = P_0 + K (L_l + L_r - 2 L_0) = P_0 + \Delta P \quad (\text{A.16a})$$

Initial position

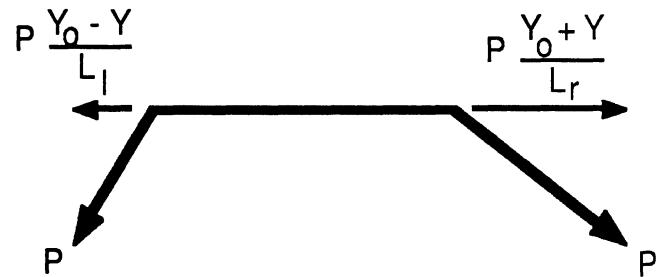
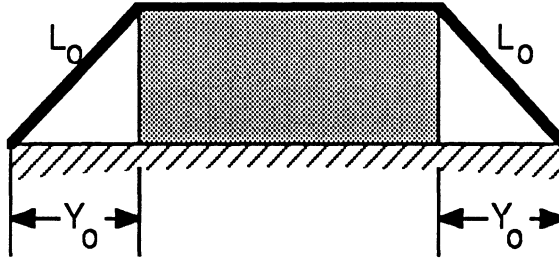

After slipping

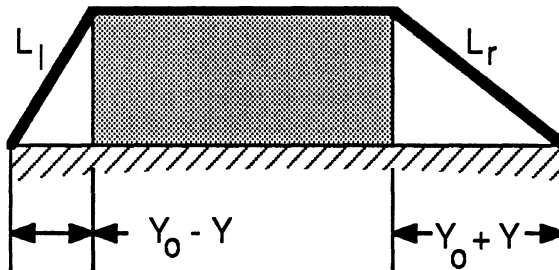

Fig. A.5 Analysis of forces with tiedown slip

$$L_r = \sqrt{(Y_o + Y)^2 + h^2} \quad (\text{A.16b})$$

$$L_l = \sqrt{(Y_o - Y)^2 + h^2} \quad (\text{A.16c})$$

$$L_o = \sqrt{Y_o^2 + h^2} \quad (\text{A.16d})$$

The combination of these terms into a single equation relating the horizontal force to Y results in an expression that is too complex to comprehend readily; therefore it will not be shown. The mechanics at work can be better understood by separately considering what happens to the tension force and the effect of the geometry.

The tension force is given in Eq. A.16a. The force consists of the preload plus an increment due to elongation as the article moves sideways. The incremental force, ΔP , is a function of the stiffness of the tiedown member, K, the initial length of the legs, L_o , and the length of the legs (L_l and L_r) at an arbitrary lateral position of the article. (In this case the stiffness, K, is that for the entire tiedown member, not just one leg.) With proper substitutions, it can be shown that:

$$\Delta P = K \cdot Y_o \cdot f(Y/Y_o, h/Y_o) \quad (\text{A.17})$$

where

$$f() = \sqrt{\left(1 + \frac{Y}{Y_o}\right)^2 + \left(\frac{h}{Y_o}\right)^2} + \sqrt{\left(1 - \frac{Y}{Y_o}\right)^2 + \left(\frac{h}{Y_o}\right)^2} - 2\sqrt{1 + \left(\frac{h}{Y_o}\right)^2} \quad (\text{A.17a})$$

The algebraic expression of Eq. A.17a simply describes how the change in length of the tiedown (normalized by Y_o) is dependent on the normalized lateral displacement, Y/Y_o , and the initial geometry, h/Y_o . A plot of the function is shown in Figure A.6. At $Y = 0$ the function starts out with a value of zero, increasing as Y goes positive (or negative). The rate of change of tension with displacement is the slope and is always zero at the initial point of movement. Thus, some displacement must occur before the system begins to react.

The interaction of the tension with the geometry of the system is expressed in Eq. A.16. The total behavior is shown in the plot of Figure A.7. As seen from Eq. A.16, the resistance force is dependent on the preload, the stiffness of the tiedown, and the geometry. For this example, it is assumed that a box 20" high x 56" wide is involved (the 56" dimension translating into $Y_o = 20$ " when loaded on a truck bed 96" wide). Further, it is assumed that $K \cdot Y_o$ is ten times the preload. The resistance force due to this mechanism is zero when the load is on center and grows at an ever increasing rate with the lateral displacement. By the time the normalized displacement approaches 0.5 ($Y = 10$ ") the force is on the order of the preload in magnitude. Beyond this point the forces become so large in relation to the preload that they are probably not meaningful to consider.

Of course, different curves would be obtained with each different set of parameters considered. Although not presented here, behavior of a similar nature would be expected with each. As the height of the article (normalized by Y_o) is diminished, the curves become more shallow and the system is less effective in preventing lateral shift. Similarly when the article is quite tall, the effectiveness is also diminished.

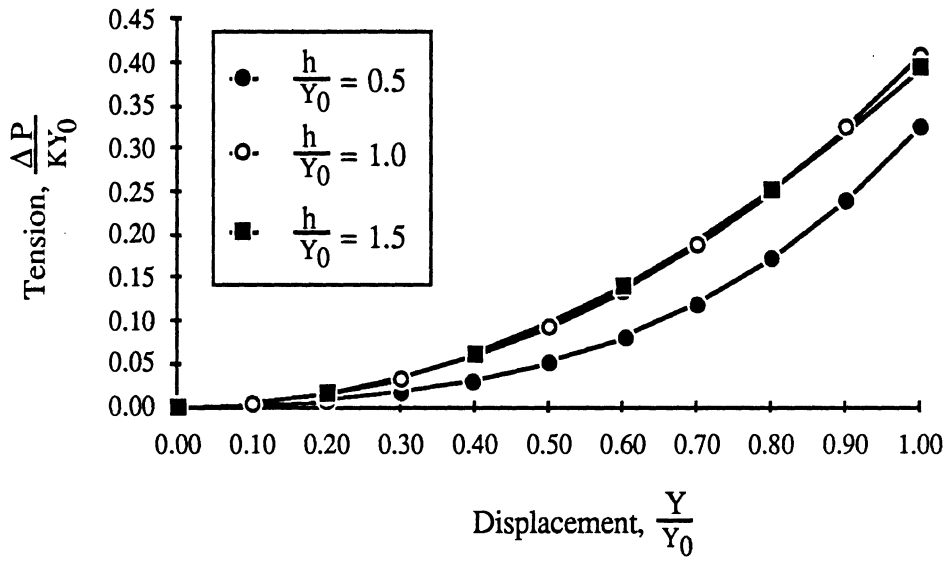

Fig. A.6 Normalized tension load changes as a function of lateral displacement.

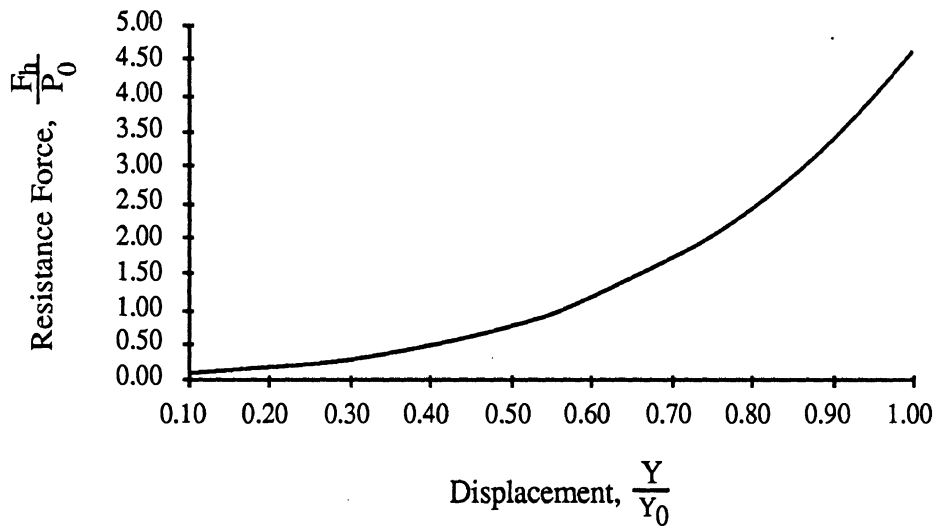

Fig. A.7. Resistance force for cargo slipping under a tiedown

