

ENGINEERING RESEARCH INSTITUTE
UNIVERSITY OF MICHIGAN
ANN ARBOR

A METHOD FOR THE DETERMINATION
OF THE CRITICAL ANGLE OF REFLECTION OF SOUND
FROM THE BOTTOM OF THE OCEAN

R. R. GOODMAN

Project M936

OFFICE OF NAVAL RESEARCH, U. S. NAVY DEPARTMENT
N6onr-23221, ONR PROJECT NO. NR 261 008

August, 1954

Engle

0

UMR

1670

A METHOD FOR THE DETERMINATION
OF THE CRITICAL ANGLE OF REFLECTION OF SOUND
FROM THE BOTTOM OF THE OCEAN

INTRODUCTION

In the past many sound transmission experiments were made in the ocean using sound pulses on the order of 0.2 seconds long. For transmission runs made in shallow water (i.e. 100 fathoms or less) it is possible not only to obtain information concerning the attenuation of the sound with increasing range but also to observe the relationship between the length of the received pulse and range. It is shown in this report that this relationship gives additional information concerning the critical angle of reflection of sound from the bottom, and therefore, the velocity of sound in the bottom. A simple derivation is made which predicts the pulse length as a function of range, water depth and the critical angle for total reflection of the sound from the bottom. The critical angles for two transmission runs made by UCDWR in 1945 using frequencies

of 200 and 600 cps are obtained and a discussion of the method is presented.

DERIVATION OF RELATIONSHIP BETWEEN RANGE,
WATER DEPTH AND CRITICAL ANGLE

The model used for the transmission run experiment is shown in Fig. 1. Several assumptions are made to simplify the derivation. These are:

1. Both the source and the receiver are omnidirectional.
2. The medium is isovelocity water.
3. Reflection is specular from both top and bottom and the surfaces are parallel to one another.

4. There is total reflection from the top surface but from the bottom surface there is a loss due to transmission into the bottom which has the following reflection coefficient*, $\mu(\theta)$:

$$\begin{array}{ll} \text{for } \theta < \theta_c & \mu(\theta) \leq A \\ \text{for } \theta > \theta_c & \mu(\theta) = 1 \end{array}$$

where $A < 1$ and θ is the angle between the direction of the sound rays and the normal to the bottom surface (see Fig. 1).

* The $\mu(\theta)$ given here is an approximation of the reflection coefficients calculated by J.M. Ide, R.F. Post and W.J. Fry, The Propagation of Underwater Sound at Low Frequencies as a Function of the Acoustic Properties of the Bottom. NRL Rept. No. S 2113, pp. 58, 115. (Unclassified)

5. Both the source and the receiver are close enough to the top surface to be considered at the surface (i.e. the depths of source and receiver are very small compared to the depth of the water.

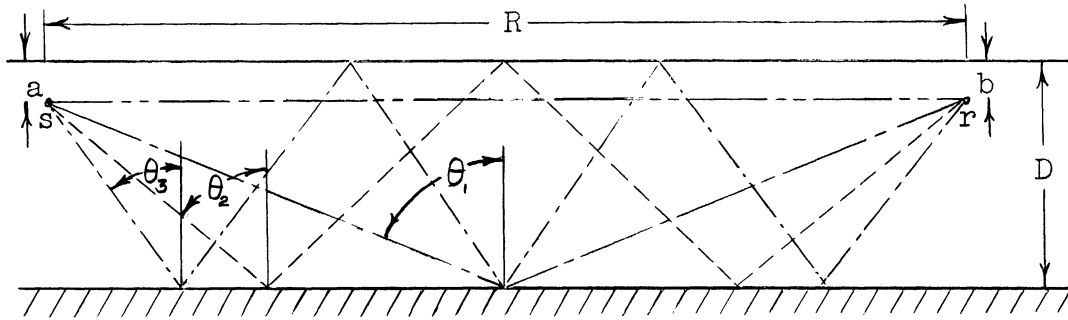

- is direct signal,
- is first bottom reflected signal,
- is second bottom reflected signal,
- is third bottom reflected signal.

Fig. 1. Model for sound propagation in shallow water. s and r designate the positions of the source and receiver respectively.

The difference in the path length of a signal that has been reflected n times from the bottom and the path length of the direct signal is seen to be

$$\Delta r_n = \sqrt{R^2 + (2nD)^2} - R \tag{1}$$

where R is the distance between the source and the receiver and D is the depth of the water. The sound pulse that is reflected n times will therefore arrive a short time later than the direct signal. If the difference between the two arrival times is designated as Δt_n , then

$$\Delta t_n = \frac{\Delta r_n}{c} = \frac{R}{c} \left\{ \sqrt{1 + \left(\frac{2nD}{R}\right)^2} - 1 \right\} \tag{2}$$

where c is the velocity of sound in the water. The range dependence of the time difference Δt_n for various values of n are shown in Fig. 2.

The angle of incidence of the n 'th reflected ray upon the bottom is

$$\theta_n = \cotan^{-1}\left(\frac{2nD}{R}\right) \quad (3)$$

If $\theta_n < \theta_c$ then the contribution of the n 'th ray to the signal will not be observed since this signal will be attenuated by at least A^n due to the reflection coefficient that is assumed. This quantity becomes negligible for large values of n . This implies that the Δt_n is only observed for the highest value of n such that $\theta_n > \theta_c$ when n is large. As the range increases more modes of reflection are possible since θ_n increases monotonically with the range for all values of n .

Ideally this means that at some range R , θ_n reaches the value θ_c and then the n 'th reflected signal contributes to the total pulse making it longer in time. It can, therefore be expected that the signal would increase incrementally in time, with the range interval between the jumps constant for the entire range. Figure 3 shows the pulse length dependence on the range for various assumed values of θ_c . By superposing Fig. 3 on Fig. 2 it is easy to see how the curves on Fig. 3 were obtained.

For a sound transmission run whose oceanographic conditions approximate those used in the derivation above, it is possible to find experimentally the critical angle

of the bottom reflected sound by plotting the observed time difference Δt as a function of range. The choice of the theoretical curve in Fig. 3 which best fits the data determines the value of the critical angle.

EXPERIMENTAL RESULTS

As an example of the method described above, 0.6 kc and 0.2 kc sound transmission runs were analyzed. These runs were made by UCDWR off the coast of California on May 20, 1945, and were chosen because the oceanographic data show them to have a shallow (40 fathom), flat, mud bottom and a negative water temperature gradient.

The UCDWR data have a sound signal and a radio signal recorded on each run. The radio signal is the same length as the transmitted sound signal, hence it is assumed to be the same length as the direct signal. Thus Δt can be measured by subtracting the length of the radio signal from the observed sound pulse. An ideal record of the sound pulse is shown in Fig. 4.

Measurements of Δt were made for records in which the range varied from 200 yards to 12,000 yards. These measurements are plotted in Fig. 3. The theoretical curves which give best fit to the maximum experimental values of Δt can be seen to lie between 72° and 78° for the 0.6 kc

run and between 72° and 75° for the 0.2 kc run. These limits of the critical angle give ratios for the velocity of sound in the mud bottom to the velocity in water of 1.05 to 1.02. These values are in fair agreement with measurements made elsewhere.¹

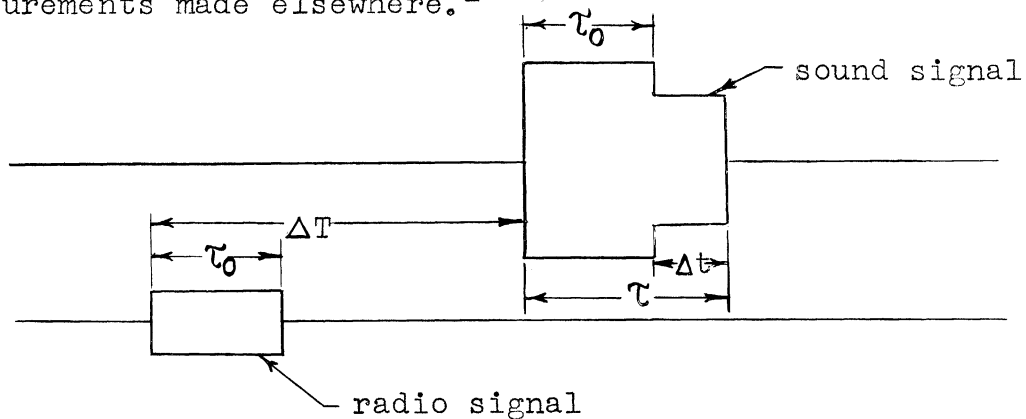

Fig. 4. An idealized picture of the sound and radio signals. τ_0 is the length of the radio signal (and the direct signal). τ is the length of the observed sound signal. $\tau - \tau_0 = \Delta t$. $\Delta T \times c$, where c is the velocity of sound in the water, is equal to the range R .

DISCUSSION

The above method for finding the critical angle is straightforward; however there are some difficulties which are only evident when actual analysis is attempted. The first of these difficulties arises from the fact that the attenuation per reflection may be small, thus making

1. J.A. Oliver and C.L. Drake, Bull. of Geol. Soc. of Am. 62, 1287, (Nov. 1951)

difficult the distinction between a signal whose angle of incidence on the bottom is less than the critical angle θ_c and one whose angle is greater than θ_c . However the attenuation after several reflections becomes large, so at longer ranges, where the only signals with an angle of incidence less than θ_c are those undergoing many bottom reflections, the distinction between $\theta_n > \theta_c$ and $\theta_n < \theta_c$ is no longer difficult. Another difficulty, and perhaps the greatest is caused by interference phenomenon, both in the combined signal and in the separate contributions to the signal. Since the source and receiver are both located below the top surface by a distance which is usually greater than or equal to the wavelength, interference is present for the direct signal as well as the reflected components. Constructive interference clearly presents no problem, but destructive interference frequently makes a component of the signal so small that it is not observed in measuring Δt . This clearly leads to a value of θ_c which is greater than the actual critical angle. However this error is a periodic one, and if a theoretical curve that lies above most experimental points is chosen, the value of θ_c will be fairly accurate.

Since the thermal structure in the ocean is at best an approximation to an isovelocity medium an error is introduced in using the model set forth here. However if care is taken to limit the experimental runs used to those

having negative velocity gradients whose ray patterns are similar to those of isovelocity media, the error is small and the results could be corrected if desired by taking into account the change in the angle of incidence on the bottom due to the thermal pattern. Velocity gradients other than those which are negative or isovelocity give complicated ray patterns and are not approximated by the isovelocity case.

In the presence of a negative velocity gradient the direct signal usually disappears at ranges close to 1000 yards due to the downward refraction of the sound rays. This, however, presents a small error, as the time difference between the direct signal and the first reflected signal is already very small at a range of 1000 yards (see Fig. 2).

It must be noted that the bottom surface must be very flat for the above approach to be valid. It can be shown that a slope of α degrees in the bottom will change the angle of incidence on the bottom $2n\alpha$ degrees after being reflected from the bottom n times, the sign of the change depending on whether the propagation is up or down the slope. So a limit must be placed on the permissible slope of the bottom if the present model is to be applicable; this limit is given by

$$2n\alpha \ll \theta_n \quad .$$

SUMMARY

A method of measuring the critical angle of bottom reflection by observing the range dependence of the length of a pulsed signal is found. Measurements are made on data for a mud bottom with 0.2 and 0.6 kc sound signals which give values from 72° to 78° as the critical angle of incidence. These values of the critical angle give a velocity of sound in the mud bottom around 1.02 and 1.05 times the velocity of sound in water.

2-8-54

(UNCLASSIFIED)

Distribution List for Technical Reports
University of Michigan
Contract N6onr-232(21), NR 385-203

Chief of Naval Research
Acoustics Branch (Code 411)
Washington 25, D.C. (2 copies)

Chief of Naval Research
Undersea Warfare Branch (Code 466)
Washington 25, D.C. (1 copy)

Director,
Naval Research Laboratory
Technical Information Officer
Washington 25, D.C. (6 copies)

Commanding Officer
Office of Naval Research
Branch Office
1030 E. Green Street
Pasadena 1, Calif. (1 copy)

Commanding Officer
Office of Naval Research
Branch Office, 10th Floor
The John Crerar Library Bldg.
86 E. Randolph St.
Chicago 1, Ill. (1 copy)

Commanding Officer
Office of Naval Research
Branch Office
346 Broadway
New York 13, N.Y. (1 copy)

Commanding Officer
Office of Naval Research
Branch Office
1000 Geary Street
San Francisco, Calif. (1 copy)

Commanding Officer
Office of Naval Research
Navy No. 100, Fleet Post Office
New York, New York (1 copy)

Office of Technical Services
Department of Commerce
Washington, D.C. (1 copy)

Armed Services Technical
Information Agency
Document Service Center
Knott Building
Dayton 2, Ohio (5 copies)

Director,
Naval Ordnance Laboratory
White Oak, Md.
Attn: Sound Division (1 copy)

Commanding Officer and Director
U.S. Navy Underwater Sound
Laboratory
Fort Trumbull, New London,
Conn. (1 copy)

Commanding Officer and Director
U.S. Navy Electronics Laboratory
San Diego 52, Calif. (1 copy)

Commander,
Naval Air Development Center
Johnsville, Pa. (1 copy)

Chief,
Bureau of Ships (Code 847)
Navy Department
Washington 25, D. C. (1 copy)

Superintendent,
U.S. Navy Postgraduate School
Physics Department
Monterey, Calif.
Attn: Prof. L.E. Kinsler
(1 copy)

Harvard University
Acoustics Laboratory
Division of Applied Science
Cambridge 38, Mass. (1 copy)

Catholic University of
America
Department of Physics
Washington 17, D.C. (1 copy)

Distribution List (cont'd)

Brown University
Department of Physics
Providence 12, Rhode Island (1 copy)

Massachusetts Institute of Technology
Acoustics Laboratory
Cambridge 39, Mass. (1 copy)

Director,
Marine Physical Laboratory
University of California
U.S. Navy Electronics Laboratory
San Diego 52, Calif. (1 copy)

Hudson Laboratories
Columbia University
145 Palisades St.
Dobbs Ferry, N.Y. (1 copy)

Lamont Geological Laboratory
Columbia University
Torre Cliffs
Palisades, N.Y. (1 copy)

Woods Hole Oceanographic Institution
Woods Hole, Mass.
Attn: Mr. Vine (1 copy)

U.S. Undersea Warfare Committee
Navy Department
Washington 25, D.C.

UNIVERSITY OF MICHIGAN



3 9015 03127 2845