

SOLUTION OF PARTIAL DIFFERENTIAL EQUATIONS
BY DIFFERENCE METHODS
USING THE ELECTRONIC DIFFERENTIAL ANALYZER

by

V. S. Haneman, Jr.

Research Engineer, Engineering Research Institute
University of Michigan

R. M. Howe

Assistant Professor of Aeronautical Engineering
University of Michigan

Department of Aeronautical Engineering
Engineering Research Institute
University of Michigan

PREFACE

The purpose of this report is to summarize the results of an investigation into the suitability of an electronic differential analyzer for solving linear differential difference equations. These equations arise when a partial differential equation is converted to a system of ordinary differential equations by replacing one or more of the partial derivatives by finite differences.

The report includes both a theoretical analysis of the accuracies attainable using the difference method and actual examples of solutions of specific problems by the electronic differential analyzer. Three general types of partial differential equations are included; the heat equation, the wave equation, and the vibrating beam equation.

No attempt is made to discuss in a detailed manner the theory of operation of the electronic differential analyzer, nor are the actual circuits of the d-c amplifiers and power supplies given here. For this information the reader is referred to other reports.^{1,3}

The actual computer solutions were carried out on the electronic differential analyzer of the Department of Aeronautical Engineering. As a result of the promise shown by the difference method discussed in this report, construction of an 80-amplifier analyzer has begun. Complete details of this new computer will be presented in a later report.

TABLE OF CONTENTS

<u>Chapter</u>	<u>Title</u>	<u>Page</u>
1	INTRODUCTION	1
	1.1 Usual Differential Analyzer Technique for Solving Partial Differential Equations	1
	1.2 Replacement of Partial Derivatives by Finite Differences	1
2	PRINCIPLES OF OPERATION OF THE ELECTRONIC DIFFERENTIAL ANALYZER	4
	2.1 Introduction to Operational Amplifiers	4
	2.2 Solution of an Ordinary Differential Equation with Constant Coefficients	7
	2.3 Solution of Two Simultaneous Ordinary Differential Equations	12
3	SOLUTION OF THE HEAT EQUATION	16
	3.1 Equation to be Solved	16
	3.2 Derivation of the Difference Equations	17
	3.3 Imposing Boundary Conditions	18
	3.4 Imposing Initial Conditions	20
	3.5 Complete Differential Difference Equations for a Given Set of Boundary Conditions	20
	3.6 Theoretical Solutions of the Difference Equations for Heat Flow	23
	3.7 Computer Solution for One-Dimensional Heat Flow	32
	3.8 Computer Solution for Two-Dimensional Heat Flow	36
	3.9 Summary of Investigation of the Use of Difference Techniques for the Heat Equation	41
4	SOLUTION OF THE WAVE EQUATION	43
	4.1 Equation to be Solved	43
	4.2 The Wave Equation for the Stretched String	44
	4.3 Derivation of the Difference Equation for the Stretched String	45
	4.5 Solution of the String Equation by Separation of Variables	46
	4.6 Difference Equation Solution of the Stretched String	49
	4.7 Summary of Investigation of Difference Techniques Applied to the Wave Equation	50
5	VIBRATING BEAMS	52
	5.1 Equation to be Solved	52
	5.2 Derivation of the Difference Equation for the Vibrating Beam	53

<u>Chapter</u>	<u>Title</u>	<u>Page</u>
5 (cont'd)		
5.3	Representation of Boundary Conditions in the Difference Equations	54
5.4	Computer Circuit for Solving the Cantilever Beam by Difference Techniques	55
5.5	Theoretical Solution of the Difference Equation for Vibrating Beams	57
5.6	Computer Solution for a 5-Cell Cantilever Beam	67
5.7	Accuracy Requirements for the Difference Technique	72
5.8	Summary of Difference Technique for Vibrating Beams	74

41

Drift

Van 416

50

55

72

CHAPTER 1

INTRODUCTION

1.1 Usual Differential Analyzer Technique for Solving Partial Differential Equations

The electronic differential analyzer is limited to the solution of ordinary differential equations. When one desires to solve a linear partial differential equation on the analyzer, it is necessary to separate variables and hence convert the partial differential equation to ordinary differential equations of the eigenvalue type. One must then find, usually by trial and error techniques, the normal modes, from which the complete solution to the original problem can be built up.

The above method of separating variables and obtaining a series type of solution can be carried out fairly efficiently on an electronic differential analyzer.^{1,2,3} Certainly, for most problems the analyzer is much faster than any hand methods. But for the engineer who is interested in getting numerical answers to specific problems, even the analyzer approach might seem somewhat tedious. It therefore would be highly advantageous to be able to solve the partial differential equations directly. This can be done by replacing some of the partial derivatives by finite differences in order to convert the original partial differential equation into a system of ordinary differential equations. In the next section we shall show how this is done.

1.2 Replacement of Partial Derivatives by Finite Differences

Assume we are interested in solving a partial differential equation in which the dependent variable $y(x,t)$ is a function of both a distance variable x and a time variable t . Instead of measuring the variable y at all distances x , let us measure y only at certain stations along x ; thus, let y_1 be the value of y at the first x station, y_2 be the value of y at the second x station, y_n be the value of y at the n th x station. Further, let the distance between stations be a constant Δx .

Now clearly a good approximation to $\left. \frac{\partial y}{\partial x} \right|_{\frac{1}{2}}$ (i.e., the partial derivative of y with respect to x at the $\frac{1}{2}$ station) is given by the difference

$$\left. \frac{\partial y}{\partial x} \right|_{1/2} = \frac{y_1 - y_0}{\Delta x} . \quad (1-1)$$

In fact the limit of equation (1-1) as $\Delta x \rightarrow 0$ is just the definition of the partial derivative at that point. Writing (1-1) in more general terms

$$\left. \frac{\partial y}{\partial x} \right|_{n-1/2} = \frac{y_n - y_{n-1}}{\Delta x} . \quad (1-2)$$

In the same way

$$\left. \frac{\partial^2 y}{\partial x^2} \right|_n = \frac{1}{\Delta x} \left\{ \left. \frac{\partial y}{\partial x} \right|_{n+1/2} - \left. \frac{\partial y}{\partial x} \right|_{n-1/2} \right\} \quad (1-3)$$

or from equation (2-2)

$$\left. \frac{\partial^2 y}{\partial x^2} \right|_n = \frac{y_{n+1} - 2y_n + y_{n-1}}{(\Delta x)^2} . \quad (1-4)$$

Similarly

$$\left. \frac{\partial^3 y}{\partial x^3} \right|_{n-1/2} = \frac{y_{n+1} - 3y_n + 3y_{n-1} + y_{n-2}}{(\Delta x)^3} \quad (1-5)$$

and

$$\left. \frac{\partial^4 y}{\partial x^4} \right|_n = \frac{y_{n+2} - 4y_{n+1} + 6y_n - 4y_{n-1} + y_{n-2}}{(\Delta x)^4} . \quad (1-6)$$

Thus we have converted partial derivatives with respect to x into algebraic differences. The only differentiation needed now is with respect to the time variable t , so that we are left with a system of ordinary differential equations involving dependent variables $y_0(t), y_1(t), \dots, y_n(t), \dots$

Before considering how a specific partial differential equation is transformed into differential difference equations or how boundary conditions are imposed, we will review the principles of operation of the electronic differential analyzer. The reader familiar with such a computer may choose to omit the following chapter and go immediately to Chapter 3 (Solution of the Heat Equation).

CHAPTER 2

PRINCIPLES OF OPERATION OF THE ELECTRONIC DIFFERENTIAL ANALYZER

2.1 Introduction to Operational Amplifiers

The basic component of the electronic differential analyzer is the operational amplifier, which is shown schematically in Figure 2-1. It consists of a d-c voltage amplifier of high gain, an input impedance Z_i , and a feedback impedance Z_f .

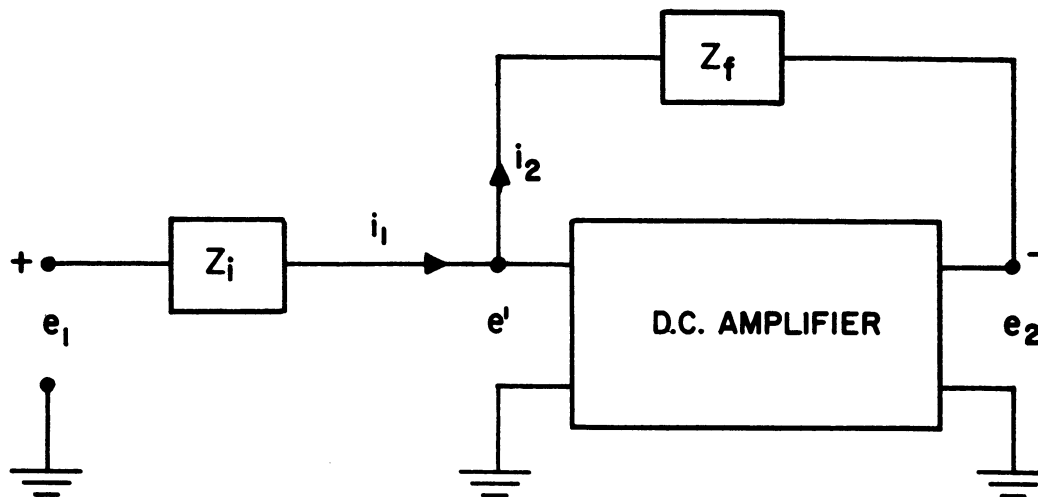

Figure 2-1. Operational Amplifier.

If we neglect the current into the d-c amplifier itself (i.e., neglect the current to the grid of the input tube), it follows that $i_1 = i_2$. Let us also neglect the voltage input e' to the d-c amplifier in comparison with the output voltage e_2 or the input voltage e_1 to the operational amplifier. We then have

$$i_1 = i_2$$

or

$$\frac{e_1}{Z_i} = - \frac{e_2}{Z_f}$$

from which

$$e_2 = - \frac{Z_f}{Z_i} e_1 \quad (2-1)$$

which is the fundamental equation governing the behavior of the operational amplifier. In general, Z_f/Z_i is made the order of magnitude of unity. We shall now consider the scheme by which the operational amplifier can be used to perform three different functions.

(a) Multiplication by a constant.

If we wish to multiply a certain voltage e_1 by a constant factor k , we need only make $Z_f/Z_i = k$. From equation (2-1), then, the output voltage e_2 of the operational amplifier will be given by

$$e_2 = - k e_1 \quad (2-2)$$

Thus the required multiplication by a constant has been achieved, except for a reversal of sign. For example, if we wish k to be 10, we may let $Z_i = 1$ megohm resistance, $Z_f = 10$ megohms resistance. If we also desire the sign of e_2 to be the same as e_1 , we must feed e_2 through an additional operational amplifier with $Z_i = Z_f = 1$ megohm. This second operational amplifier merely acts as a sign changer by multiplying any voltage by -1 .

(b) Addition.

In order to add a number of voltages, say e_a , e_b , and e_c , the arrangement shown in Figure 2-2 is used. Here $i_a + i_b + i_c = i_2$, and if we neglect e' as small compared with e_2 , we have

$$\frac{e_a}{Z_a} + \frac{e_b}{Z_b} + \frac{e_c}{Z_c} = - \frac{e_2}{Z_f}$$

or

$$e_2 = - \left[\frac{Z_f}{Z_a} e_a + \frac{Z_f}{Z_b} e_b + \frac{Z_f}{Z_c} e_c \right]. \quad (2-3)$$

Thus the output voltage e_2 is the sum of the three input voltages, each multiplied respectively by a constant $-Z_f/Z_n$ ($n = a, b, \text{ or } c$). The operational amplifier can, of course, be used in general to sum any number of input voltages.

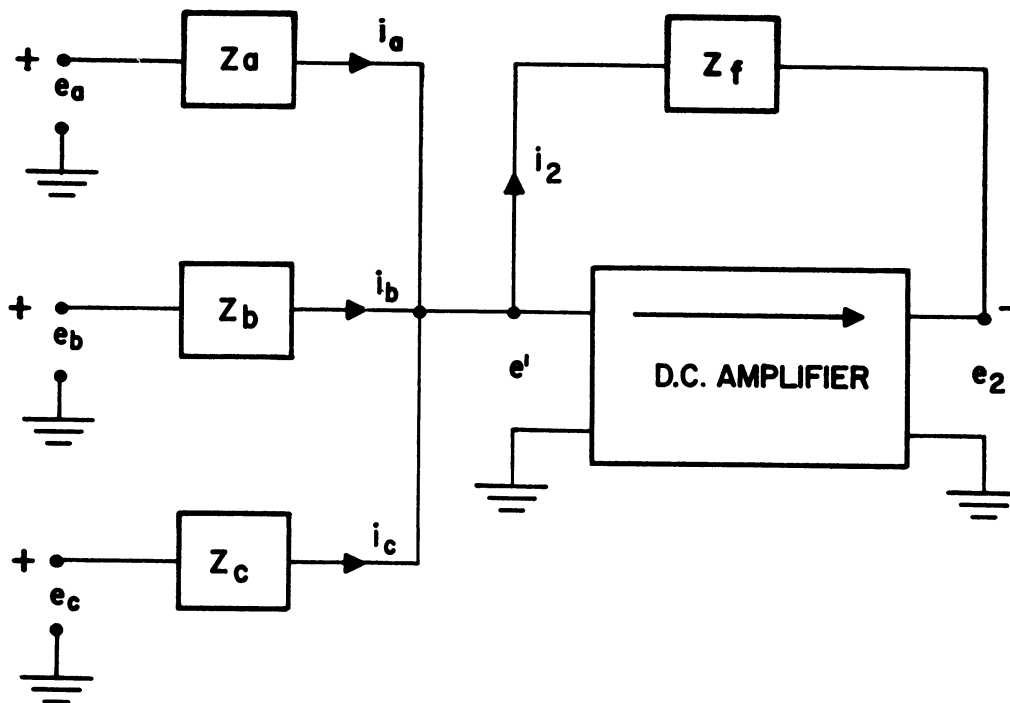

Figure 2-2. Operational Amplifier Used for Summation.

(c) Integration.

If we make the input impedance Z_i a resistor and the feedback impedance Z_f a capacitor, then the operational amplifier serves as an integrator. Referring to Figure 2-3, we see that if we neglect e' and let $i_1 = i_2$ as before, we have

$$e_2 = - \int \frac{i_1 dt}{C} \quad \text{and} \quad i_1 = \frac{e_1}{R},$$

from which

$$e_2 = -\frac{1}{RC} \int e_1 dt . \quad (2-4)$$

The output voltage e_2 is then the integral with respect to time of the input voltage e_1 (multiplied by a constant factor $-1/RC$).

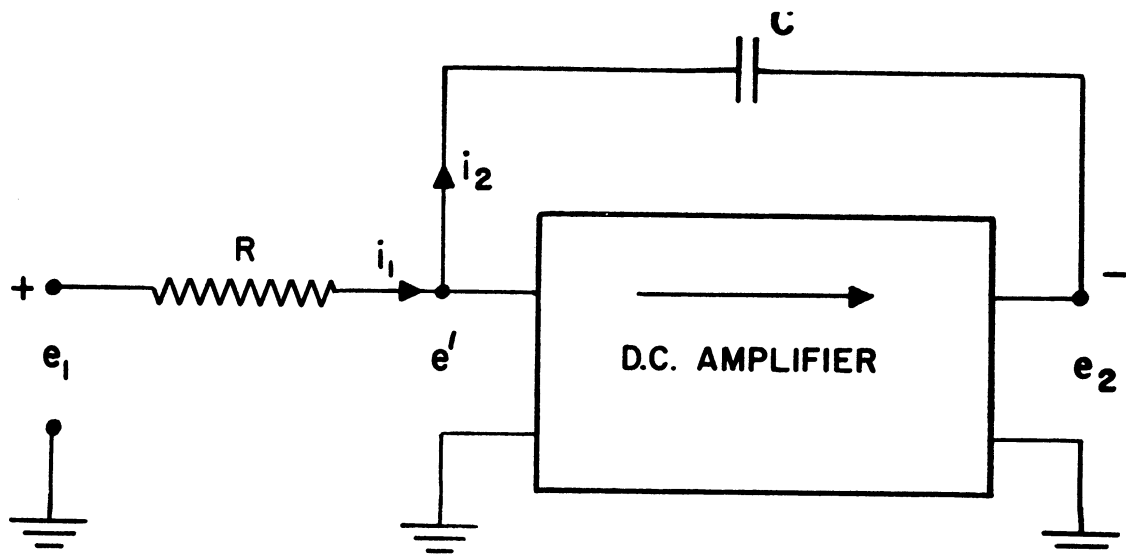

Figure 2-3. Operational Amplifier as an Integrater.

2.2 Solution of an Ordinary Differential Equation with Constant Coefficients

In order to demonstrate how operational amplifiers performing the above three functions can be combined to solve ordinary linear differential equations, we will now set up the amplifier circuits required to solve the following differential equation:

$$a_2 \frac{d^2 y}{dt^2} + a_1 \frac{dy}{dt} + a_0 y = f(t) \quad (2-5)$$

subject to the initial conditions

$$y(0) = V_1 \quad \text{and} \quad \frac{dy}{dt}(0) = V_2 . \quad (2-6)$$

The constants a_2 , a_1 , and a_0 are assumed positive. Since the electronic differential analyzer integrates with respect to time, the independent variable t in equation (2-5) will be time. The dependent variable y is represented by voltage.

The computer circuit for solving equation (2-5) subject to initial conditions (2-6) is shown schematically in Figure 2-4. If we assume that the output of amplifier A_2 is $a_2\ddot{y}$, then this voltage is multiplied by $-1/a_2$ and integrated once in passing through amplifier A_3 , the output of which is therefore $-\dot{y}$. This voltage is in turn multiplied by -1 and integrated once to give y as the output of A_4 . In order to obtain $+a_1\dot{y}$ instead of $-\dot{y}$, it is necessary to pass $-\dot{y}$ through summing amplifier A_1 . At the same time $f(t)$ is fed into A_1 , so that the output of A_1 is $+a_1\dot{y} - f(t)$. This output is then added to a_0y in amplifier A_2 , which finally has as its output $-a_1\dot{y} - a_0y + f(t)$. But we originally assumed the output of A_2 to be $a_2\ddot{y}$. Hence

$$a_2\ddot{y} = -a_1\dot{y} - a_0y + f(t),$$

which is just the equation which we wish to solve.

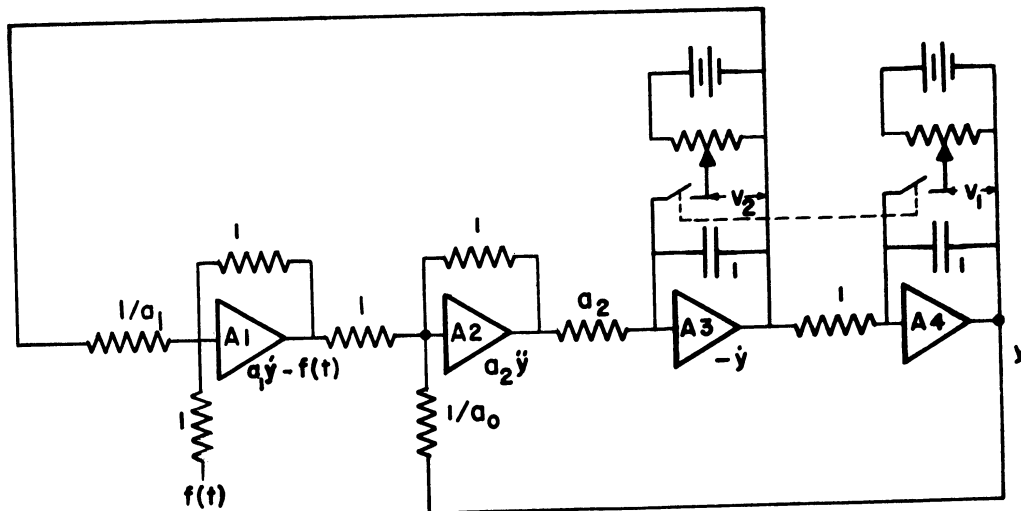

ALL RESISTOR UNITS ARE MEGOHMS
ALL CAPACITORS ARE 1MFD.
GROUND CONNECTIONS ARE OMITTED FOR CLARITY

Figure 2-4. Computer Circuit for Solving

$$a_2\ddot{y} + a_1\dot{y} + a_0y = f(t).$$

The initial conditions (2-6) are imposed as voltages across the integrating condensers of A_3 and A_4 in Figure 2-4. When the two switches holding the initial voltages across the condensers are opened simultaneously, the solution of the problem begins, i.e., the time variation in voltage output of A_4 represents $y(t)$.

The mechanical analogy to equation (2-5) is the mass-spring-damper arrangement shown in Figure 2-5. The type of transient response of such a system depends upon the damping ratio ξ , which is defined as

$$\xi = \frac{a_1}{2\sqrt{a_0 a_2}} \quad (2-7)$$

For $\xi < 1$ the transient response is oscillatory (underdamped), and for $\xi > 1$ the transient response is exponential (overdamped).

In order to have a specific problem for the computer, let us examine the response of our second-order system to a step-function input force. For simplicity, assume $a_0 = a_2 = 1$. Then $\xi = a_1/2$ and we can vary ξ merely by changing a_1 . Also, let us assume that initially $y(0) = \dot{y}(0) = 0$.

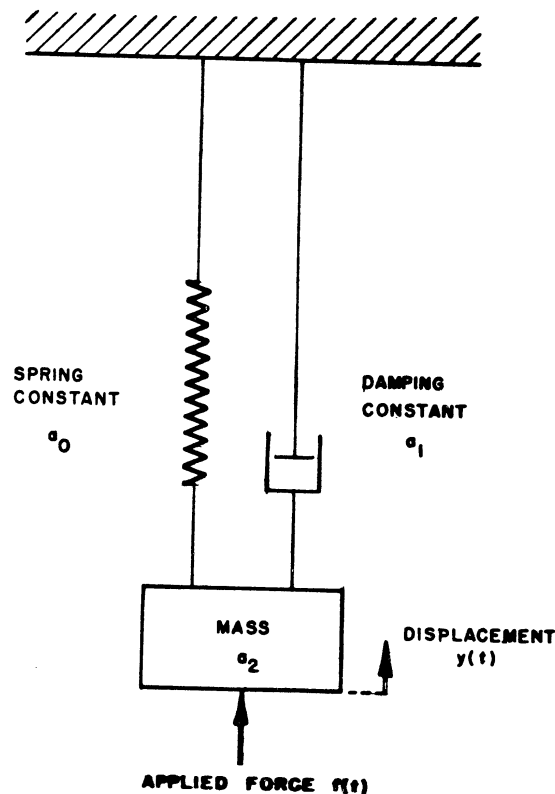

Figure 2-5. One-Degree-of-Freedom Mass, Spring, Damper System.

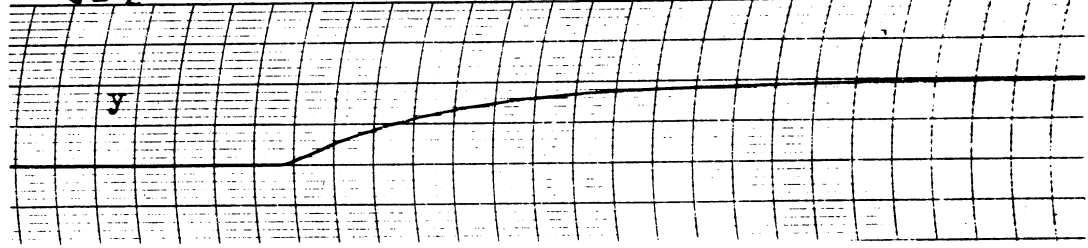
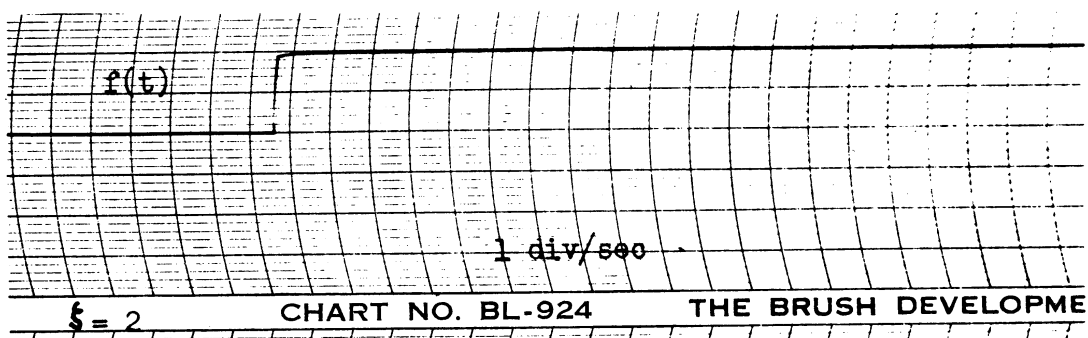
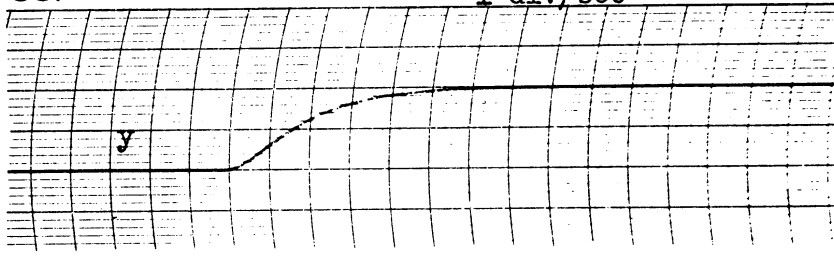
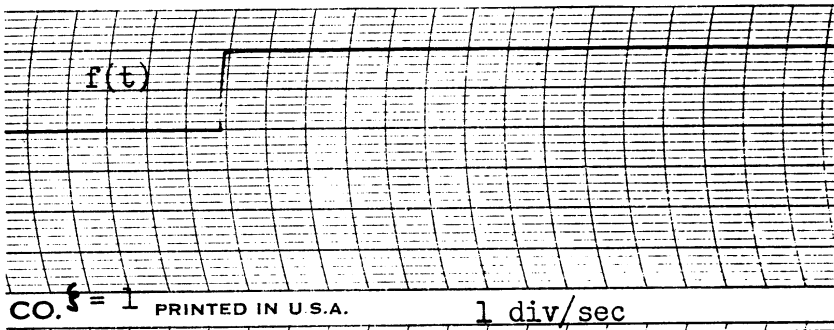
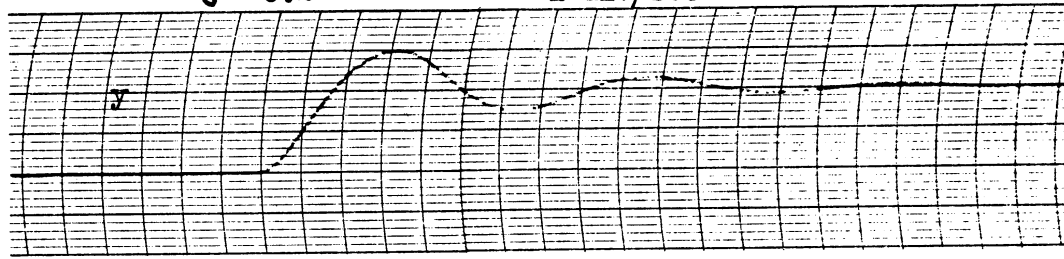
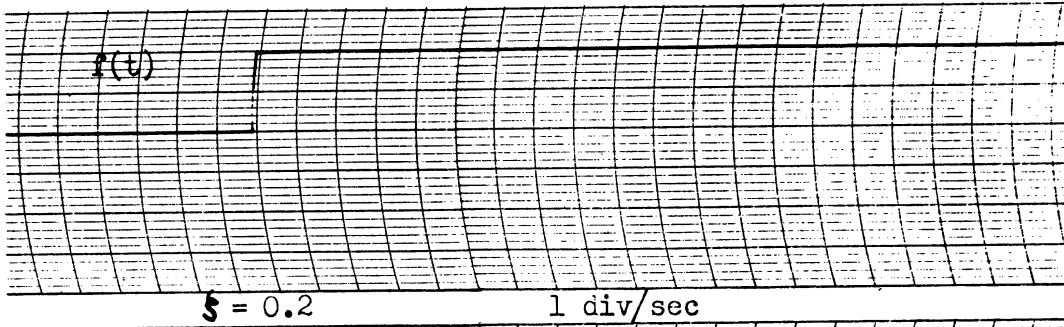

Figure 2-6. Step-Function Response of Second-Order System.

The computer response to a step-voltage input at $t = 0$ for $\zeta = 0.2$, $\zeta = 1$, and $\zeta = 2$ is shown in Figure 2-6. The input and output voltages $y(t)$ were recorded on a Brush, Model BL-202, two-channel magnetic oscillograph.

In Figure 2-7 the response to a step-function input is shown when $\zeta = 0$. The result is undamped simple harmonic motion of period 2π seconds. One can obtain some measure of the inherent accuracy of the electronic differential analyzer by observing that it takes many hundreds of cycles before this sinusoidal oscillation has decreased to half-amplitude.

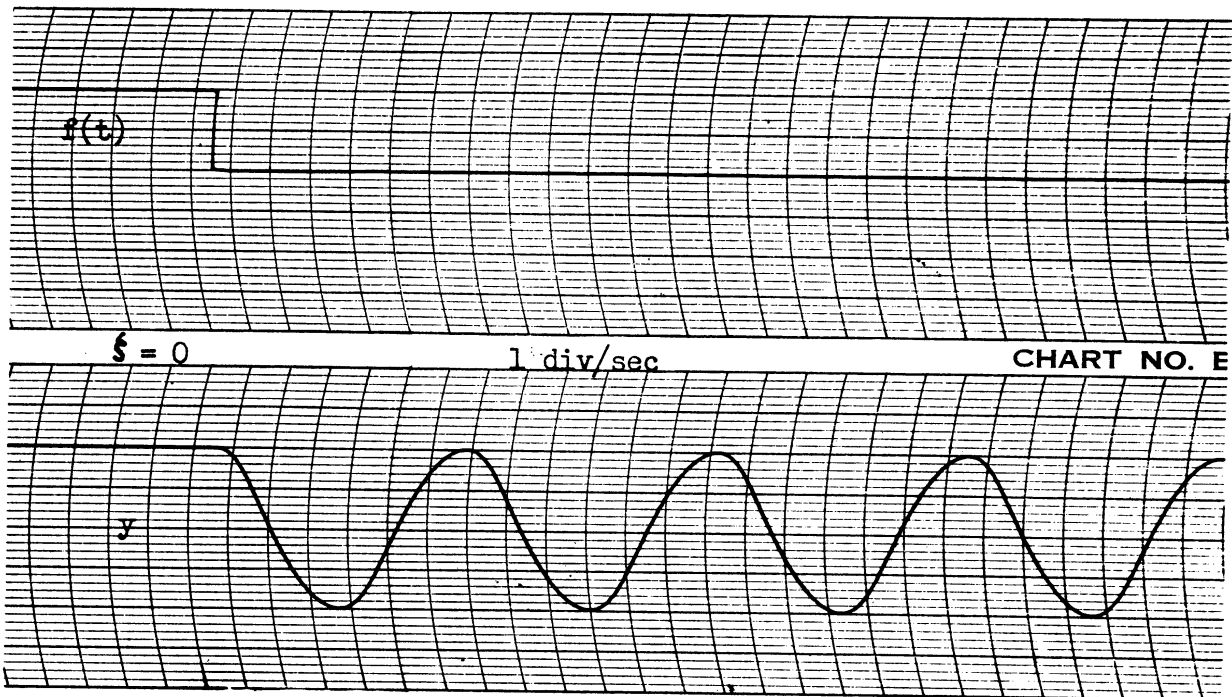

Figure 2-7. Second-Order System with Zero Damping .

2.3 Solution of Two Simultaneous Ordinary Differential Equations

Consider the two-degree-of-freedom system shown in Figure 2-8. The two masses m_1 and m_2 are supported by springs having constants k_1 and k_2 , and are coupled by a spring with constant k_3 . If the masses are constrained to vertical motion, then in terms of the deflections y_1 and y_2 we find the following equations of motion:

$$m_1 \ddot{y}_1 + (k_1 + k_3)y_1 - k_3 y_2 = 0$$

and

$$m_2 \ddot{y}_2 + (k_2 + k_3)y_2 - k_3 y_1 = 0.$$

(2-8)

The computer circuit for solving these equations is shown in Figure 2-9. The analysis of the circuit is exactly the same as the analysis described for Figure 2-4. The upper bank of amplifiers in Figure 2-8 represents the first equation of (2-8), the lower bank the second of (2-8). Cross-connections between the two banks are made as necessary to satisfy equation (2-8).

For simplicity, assume $m_1 = m_2 = 1$, $k_1 = k_2 = 1$. Let us make k_3 somewhat less, say 0.2. For initial conditions we will set $\dot{y}_1(0) = \dot{y}_2 = 0$ (i.e., no initial velocity for the masses).

As a first example we let the masses start with equal displacement, so that $y_1(0) = y_2(0) = V$. The response of the masses for these initial conditions is shown in Figure 2-10. Evidently the masses perform simple harmonic oscillation in phase with each other, so that the coupling spring is never compressed or expanded. The period of oscillation of each of the masses is therefore the natural period of the single mass-spring system without coupling, namely 2π seconds. This is evident in Figure 2-10.

For a second example, let the masses start with equal but opposite displacement, so that $y_1(0) = -y_2(0) = V$. The response for these initial conditions is shown in Figure 2-11, and now the masses oscillate 180 degrees out of phase and with a shorter period (actually $2\pi/\sqrt{1.4}$ seconds).

In the above two examples we have found the two normal modes of vibration of our two-degree-of-freedom system. Any other motion which the two masses can exhibit must consist of a superposition of these two normal modes. For example, if we start one mass with finite displacement and the other mass with zero displacement, so that $y_1(0) = V$, $y_2(0) = 0$, we get the response

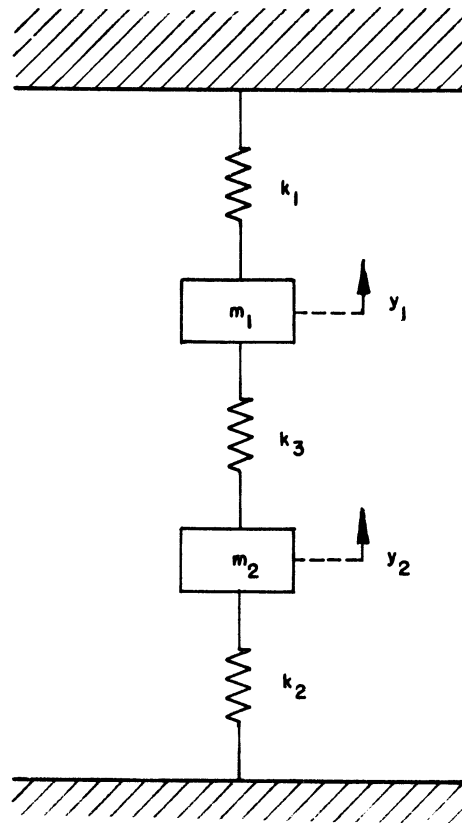

Figure 2-8. Two-Degree-of-Freedom System with Spring Coupling.

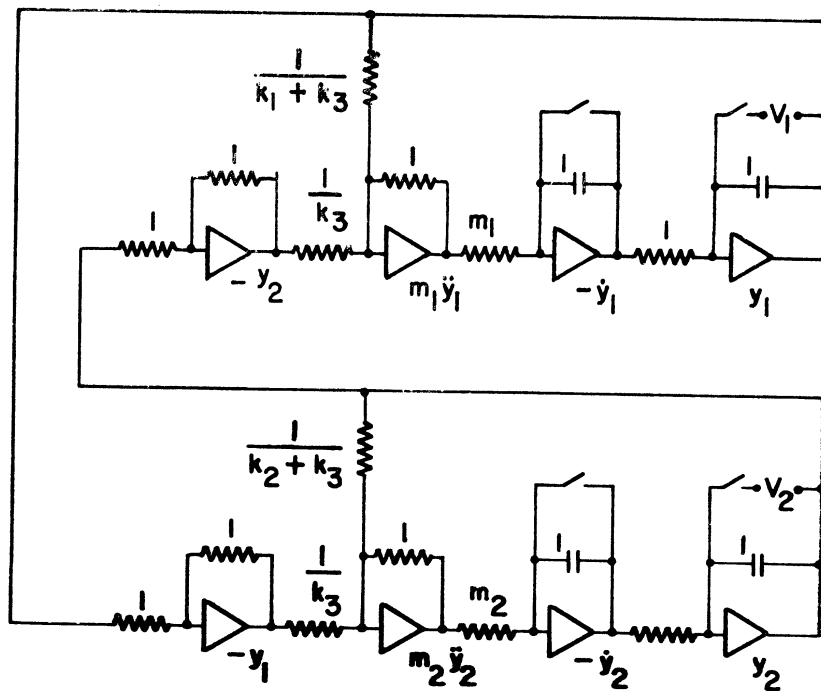

Figure 2-9. Computer for Solving the Simultaneous Differential Equations of Equation (2-8).

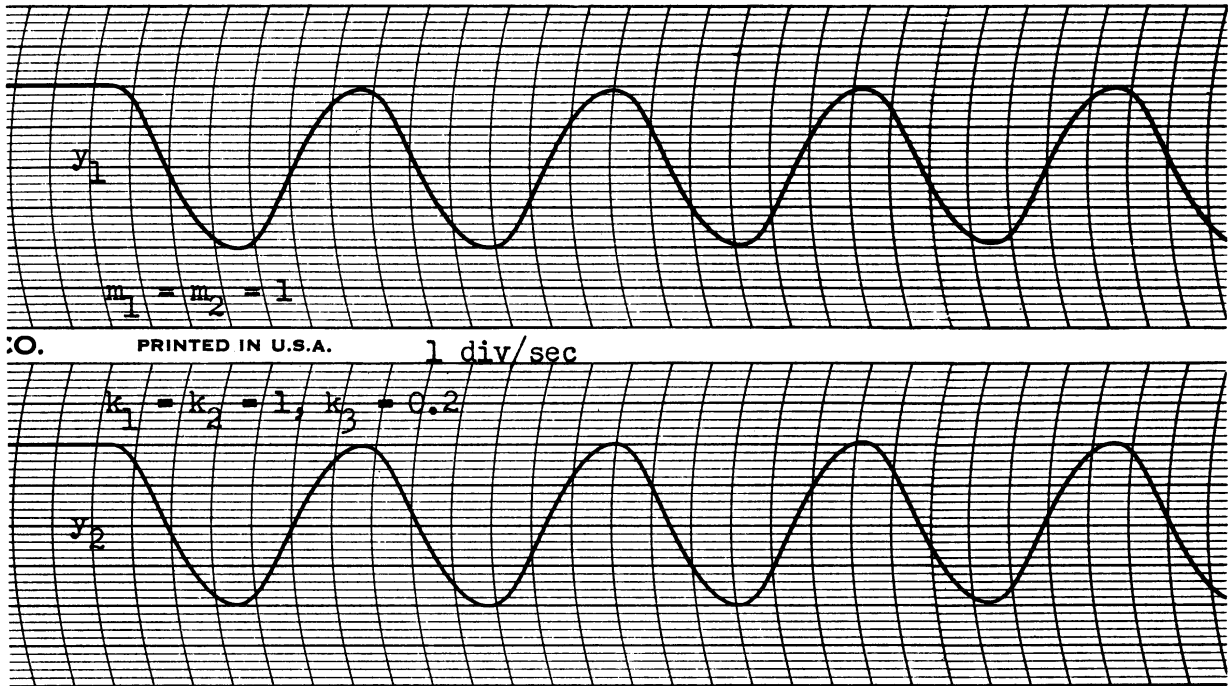

Figure 2-10. Coupled System, Masses Started with Same Deflection.

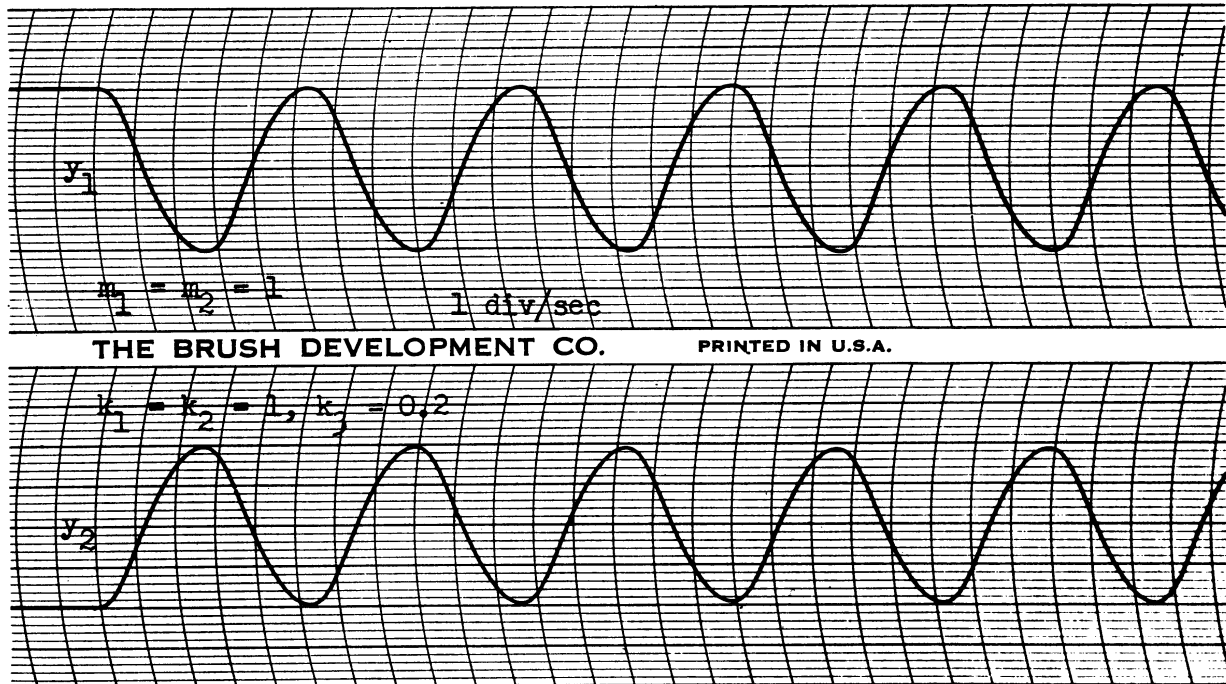

Figure 2-11. Coupled System, Masses Started with Opposite Deflection.

shown in Figure 2-12. Evidently, the masses are exchanging energy back and forth through the coupling spring. The frequency of energy exchange is just the beat frequency of the two normal modes.

It is obvious that an arbitrary forcing function could be added to the two masses in Figure 2-8 along with damping. Such effects can readily be incorporated into the computer circuit exactly as done in Figure 2-4.

This simple example of a two-degree-of-freedom system illustrates the way in which the differential analyzer can be used to solve simultaneous ordinary differential equations and hence differential difference equations. We now turn to a consideration of a simple partial differential equation, namely, the heat equation, which will be solved by the difference technique.

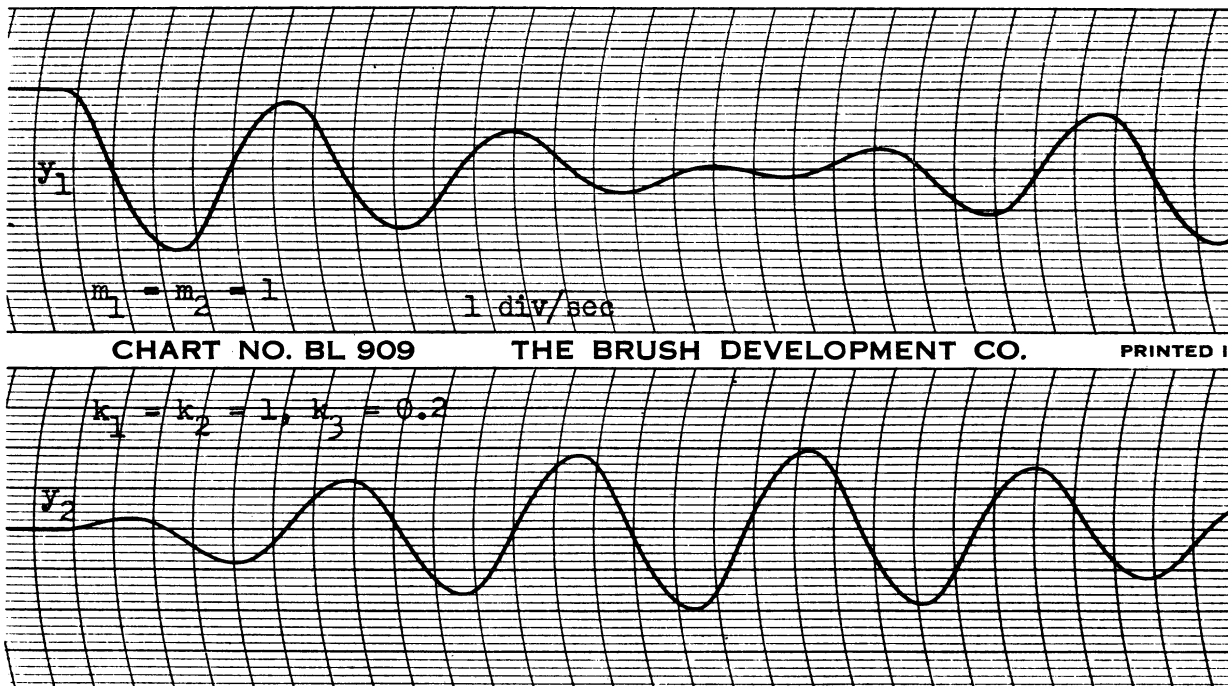

Figure 2-12. Coupled System, One Mass Started with Zero Deflection.

CHAPTER 3

SOLUTION OF THE HEAT EQUATION

3.1 Equation to be Solved

As a first example of a partial differential equation, it seemed advisable to select the equation of heat flow through a continuous medium, since it involves second order spacial derivatives and only first order time derivatives. The basic heat equation is given by

$$c\delta \frac{\partial u}{\partial t} = \nabla \cdot K \nabla u + f \quad (3-1)$$

where

u = temperature and is a function of the spacial coordinates and time

K = thermal conductivity, in general a function of the spacial coordinates,

C = specific heat, a function of spacial coordinates,

δ = density, also a function of spacial coordinates,

t = time,

f = rate of heat supplied by sources in the medium, a function of spacial coordinates and time.

The left-hand side of equation (3-1) represents the rate at which heat is stored in a unit volume due to the heat capacity of the medium. The right-hand side represents the rate at which the unit volume receives heat, first due to heat conduction into the volume from the neighboring medium (the $\nabla \cdot K \nabla u$ term) and second due to the heat flow into the volume from sources within the volume itself (the f term). Written in terms of Cartesian coordinates x , y and z , equation (3-1) becomes

$$c\delta \frac{\partial u}{\partial t} = \frac{\partial}{\partial x} (K \frac{\partial u}{\partial x}) + \frac{\partial}{\partial y} (K \frac{\partial u}{\partial y}) + \frac{\partial}{\partial z} (K \frac{\partial u}{\partial z}) + f \quad (3-2)$$

The actual heat flow or flux due to conduction normal to any unit surface is given by $-K \nabla u$ (component of ∇u normal to the surface). Thus the heat flux F_x across a unit surface normal to the x direction is given by

$$F_x = -K \frac{\partial u}{\partial x}. \quad (3-3)$$

In a given heat flow problem it is necessary to stipulate spacial boundary conditions either on the temperature u or the heat flow $-K \nabla u$, as well as the initial temperature distribution throughout the medium.

3.2 Derivation of the Difference Equations

For simplicity in illustrating the application of difference techniques, let us assume for the time being that spacial variations in the temperature u are confined to the x direction. Equation (3-2) then becomes

$$C(x) \frac{\partial u(x,t)}{\partial t} = \frac{\partial}{\partial x} \left[K(x) \frac{\partial u(x,t)}{\partial x} \right] + f(x,t), \quad (3-4)$$

where we have let

$$C(x) = c(x) \delta(x). \quad (3-5)$$

For example, this could represent the temperature distribution in a medium between two infinite slabs, as shown in Figure 3-1.

Following the technique discussed in Section 1.2, we will consider only values of u at certain equally spaced stations along the x coordinate axis. Thus $u(x,t)$ is replaced by $u_1(t)$, $u_2(t)$, ..., etc. If Δx is the distance between stations, we can write for the heat flux $F_{n-\frac{1}{2}}$ at the $n-\frac{1}{2}$ station

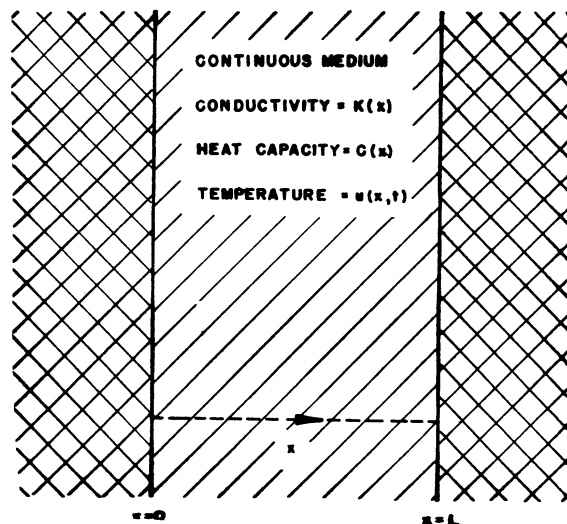

Figure 3-1. Temperature Distribution Between Two Infinite Slabs.

$$F_{n-\frac{1}{2}} = -K \left. \frac{\partial u}{\partial x} \right|_{n-\frac{1}{2}} = -\frac{K_{n-\frac{1}{2}}}{\Delta x} (u_n - u_{n-1}) \quad (3-6)$$

In the same way, $\frac{\partial}{\partial x} (K \frac{\partial u}{\partial x})$ at the nth station becomes

$$\left. \frac{\partial}{\partial x} (K \frac{\partial u}{\partial x}) \right|_n = \frac{K \left. \frac{\partial u}{\partial x} \right|_{n+\frac{1}{2}} - K \left. \frac{\partial u}{\partial x} \right|_{n-\frac{1}{2}}}{\Delta x}$$

or

$$\left. \frac{\partial}{\partial x} (K \frac{\partial u}{\partial x}) \right|_n = \frac{\frac{K_{n+\frac{1}{2}}}{\Delta x} (u_{n+1} - u_n) - \frac{K_{n-\frac{1}{2}}}{\Delta x} (u_n - u_{n-1})}{\Delta x} \quad (3-7)$$

From equations (3-4) and (3-7) we can now write the equation of heat-flow balance at the nth station. Thus

$$C_n \frac{du_n}{dt} = \frac{K_{n+\frac{1}{2}}}{(\Delta x)^2} (u_{n+1} - u_n) - \frac{K_{n-\frac{1}{2}}}{(\Delta x)^2} (u_n - u_{n-1}) + f_n \quad (3-8)$$

where C_n is the heat capacity at the nth station and f_n is the rate of heat supplied by a heat source at the nth station. (f_n will in general be a function of time). Note that du_n/dt is now a total derivative and not a partial derivative, since by definition x remains fixed while we take du_n/dt .

Equation (3-8) will be iterated for different values of n until the boundaries in x are reached, at which point it is necessary to impose boundary conditions.

3.3 Imposing Boundary Conditions

(a) Conditions on the temperature.

Suppose that one of the boundary conditions specifies the temperature at $x = 0$ (i.e., at the zero station). Then we have

$$u_0 = \text{constant}$$

and hence

$$F_{\frac{1}{2}} = -\frac{K_{\frac{1}{2}}}{\Delta x} [u_1(t) - u_0] \quad (3-9)$$

Our difference equation for the first station is now

$$C_1 \frac{du_1(t)}{dt} = \frac{K_{3/2}}{(\Delta x)^2} [u_2(t) - u_1(t)] - \frac{K_{1/2}}{(\Delta x)^2} [u_1(t) - u_0] + f_1(t). \quad (3-10)$$

The equation for the second station proceeds as in equation (3-8) for $n = 2$. All we have done in imposing the boundary condition, then, is to fix $u_0(t)$ at a constant value of u_0 .

If the temperature is specified at $x = L$ (i.e., at the N th station, where $N = L/\Delta x$), then for $u_N(t)$ we substitute $u_N = \text{constant}$, the desired temperature.

(b) Conditions on the heat flow.

Often a condition is placed on the rate of heat flowing past a boundary, either that this flow be zero (as for an insulating boundary) or a constant. Suppose we let

$$F_{1/2} = \text{constant}.$$

Then the equation for the first station is

$$C_1 \frac{du_1(t)}{dt} = - \frac{F_{3/2}(t) - F_{1/2}}{\Delta x} + f_1(t) \quad (3-11)$$

or

$$C_1 \frac{du_1(t)}{dt} = \frac{K_{3/2}}{(\Delta x)^2} [u_2(t) - u_1(t)] + \frac{F_{1/2}}{\Delta x} + f_1(t). \quad (3-12)$$

The equations for u_2, u_3, \dots are the same as usual. If we desire $F_{N+1/2} = \text{constant}$ as a boundary condition, then the equation for the N th station becomes

$$C_N \frac{du_N(t)}{dt} = - \frac{F_{N+1/2}}{\Delta x} - \frac{K_{N-1/2}}{(\Delta x)^2} [u_N(t) - u_{N-1}(t)] + f_N(t). \quad (3-13)$$

The process of setting in boundary conditions is evidently quite straightforward. Notice, however, that when we denote temperature at integral

stations, the boundary occurs at an integral station when temperature at the boundary is specified, whereas the boundary occurs at a half-integral station when the heat flow at the boundary is specified.

3.4 Imposing Initial Conditions

In addition to specifying boundary conditions in this type of heat problem, it is necessary to specify the initial temperature distribution in our medium. Thus we have

$$\begin{aligned} u_1(0) &= U_1 \\ u_2(0) &= U_2 \\ u_3(0) &= U_3 \\ &\vdots \\ &\vdots \\ u_N(0) &= U_N \end{aligned} \tag{3-14}$$

These initial conditions must then be imposed on the electronic differential analyzer, similar to the way in which initial conditions are applied in Figure 2-4.

3.5 Complete Differential Difference Equations for a Given Set of Boundary Conditions

For purposes of illustration, let us assume that the boundary conditions of our conducting slab in Figure 3-1 are that at $x = 0$ the temperature remains fixed at u_0 , and at $x = L = \Delta x(N + \frac{1}{2})$ the heat flow is zero. The space between $x = 0$ and $x = L$ is therefore broken into N cells, and from equations (3-8), (3-10), and (3-13) we have for our complete set of differential difference equations

$$C_1 \frac{du_1}{dt} = \frac{K_{3/2}}{(\Delta x)^2} (u_2 - u_1) - \frac{K_{1/2}}{(\Delta x)^2} (u_1 - u_0) + f_1$$

$$C_2 \frac{du_2}{dt} = \frac{K_{5/2}}{(\Delta x)^2} (u_3 - u_2) - \frac{K_{3/2}}{(\Delta x)^2} (u_2 - u_1) + f_2$$

$$\begin{array}{cccc} \cdot & \cdot & \cdot & \cdot \\ \cdot & \cdot & \cdot & \cdot \end{array}$$

$$C_n \frac{du_n}{dt} = \frac{K_{n+\frac{1}{2}}}{(\Delta x)^2} (u_{n+1} - u_n) - \frac{K_{n-\frac{1}{2}}}{(\Delta x)^2} (u_n - u_{n-1}) + f_n$$

(3-15)

$$C_{N-1} \frac{du_{N-1}}{dt} = \frac{K_{N-\frac{1}{2}}}{(\Delta x)^2} (u_N - u_{N-1}) - \frac{K_{N-3/2}}{(\Delta x)^2} (u_{N-1} - u_{N-2}) + f_{N-1}$$

$$C_N \frac{du_N}{dt} = - \frac{K_{N-\frac{1}{2}}}{(\Delta x)^2} (u_n - u_{n-1}) + f_N \cdot$$

The initial conditions specify the temperature for each station at $t = 0$ [see equation (3-14)]. A schematic diagram showing all the locations relative to the conducting slab is shown in Figure 3-2 for $N = 10$.

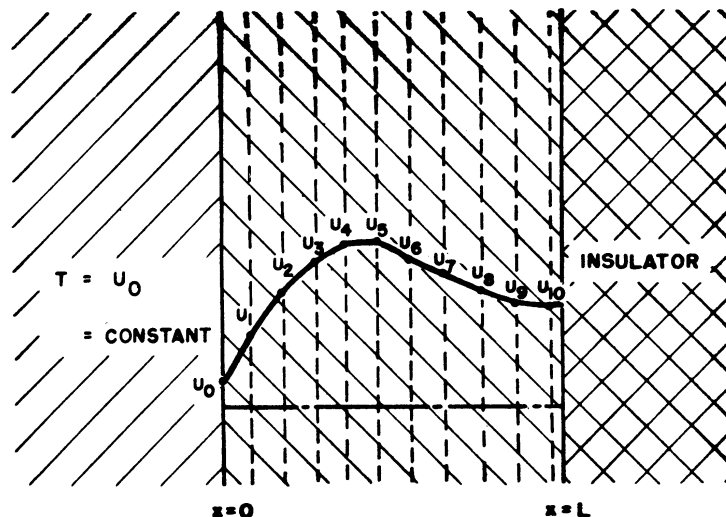

Figure 3-2. Station Arrangement for $N = 10$.

In Figure 3-3 the computer arrangement for solving equations (3-15) is shown. Note that the outputs of each successive row of amplifiers are

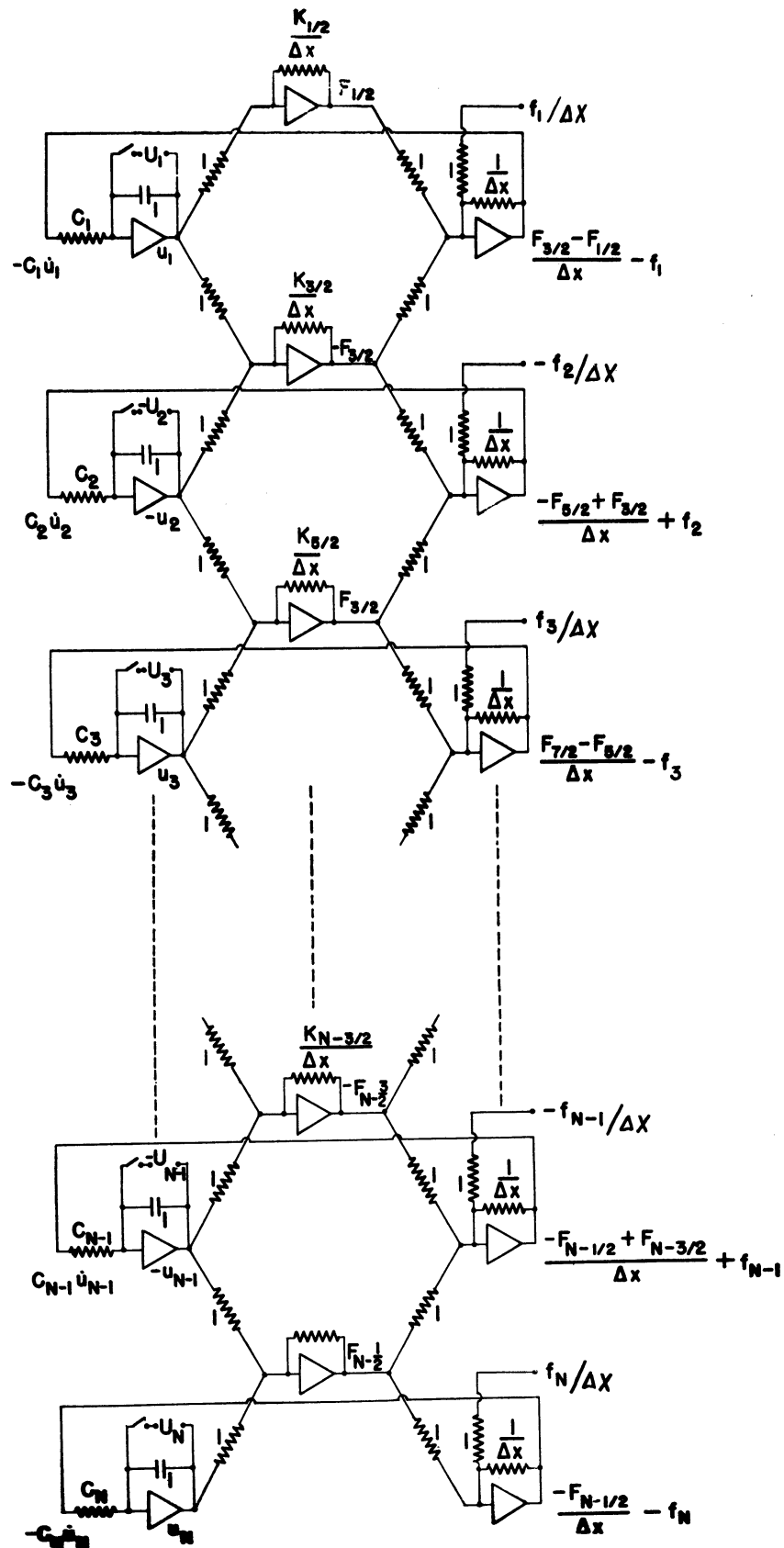

Figure 3-3. Computer Circuit for Solving the General Heat Equation with Temperature = 0 at $x = 0$ and Heat Flux = 0 at $x = L = (N+1/2)\Delta x$.

reversed. This allows the necessary differences to be taken without sign-reversing amplifiers. Note also that the heat flow or flux F is available at any half-station as a dependent variable. Thus one can observe directly as a function of time the temperature u and heat flux F across the slab.

It is possible to reduce the number of amplifiers shown in Figure 3-3 from three to one per station. The exact way in which this is done is explained in Section 3.7. In many ways, however, the circuit of Figure 3-3 is simpler despite the increased number of amplifiers. To change the conductivity K or heat capacity C at any station, one need only vary the appropriate resistor. Initial temperature distribution across the slab is changed by setting the U_1, U_2, \dots, U_N voltages to the desired values. The heat sources through the slab are represented by the voltages f_1, f_2, \dots, f_N which may be varied as a function of time in any desired manner.

Before actually solving a particular heat problem with the differential analyzer, it might be well for us to make some calculations of the accuracies we can expect when using the difference technique.

3.6 Theoretical Solutions of the Difference Equations for Heat Flow

(a) Preliminary solution by separation of variables.

In order to evaluate the accuracy of the difference technique, it is worthwhile first to solve the partial differential equations of heat flow by separating variables. For simplicity we will solve the problem of the temperature distribution between two infinite slabs held at a temperature of zero (Figure 3-4). Assume that the medium has constant conductivity K and constant specific heat capacity c . Also assume no heat sources within the medium. Then from equation (3-4)

$$\frac{c\delta}{K} \frac{\partial u}{\partial t} = \frac{\partial^2 u}{\partial x^2}. \quad (3-16)$$

The boundary conditions are

$$u(0,t) = u(L,t) = 0. \quad (3-17)$$

Let us assume as a simple initial condition that the temperature in the medium is everywhere constant at $t = 0$. Thus

$$u(x,0) = U = \text{constant}. \quad (3-18)$$

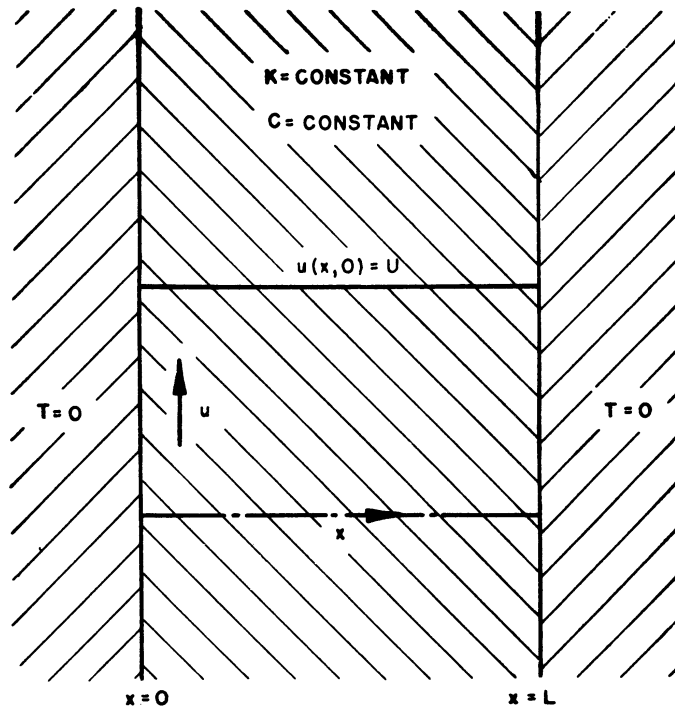

Figure 3-4. Temperature Problem Solved by Separation of Variables.

To solve this problem by separation of variables we let

$$u(x,t) = X(x)T(t). \quad (3-19)$$

Substituting (3-19) in equation (3-16) we find that

$$\frac{X''(x)}{X(x)} = \frac{c\delta}{K} \frac{T'(t)}{T(t)}. \quad (3-20)$$

For equation (3-23) to hold for all values of x and t , it necessarily follows that both sides of the equation equal a constant, say $-\alpha^2$. Thus

$$\frac{X''}{X} = \frac{c\delta}{K} \frac{T'}{T} = -\alpha^2 \quad (3-21)$$

from which we obtain the following two equations:

$$X''(x) + \alpha^2 X(x) = 0 \quad (3-22)$$

and

$$T'(t) - \frac{K}{c\delta} \alpha^2 T(t) = 0.$$

The general solution to equation (3-24) is

$$X(x) = A \cos \alpha x + B \sin \alpha x \quad (3-23)$$

while the solution to equation (3-25) is

$$T(t) = D e^{-\frac{K}{c\delta} \alpha^2 t} \quad (3-24)$$

The boundary conditions (3-17) can be satisfied only if $X(0) = X(L) = 0$. Reference to equation (3-23) shows that this is true when $A = 0$ and when α has discrete values α_n given by

$$\alpha_n = \frac{n\pi}{L}, \quad n = 1, 2, 3. \quad (3-25)$$

These values α_n are known as eigenvalues, and the resulting functions

$$X_n(x) = B_n \sin \frac{n\pi x}{L} \quad (3-26)$$

are known as eigen functions or normal modes. They are orthogonal, since

$$\begin{aligned} \int_0^L X_n(x) X_m(x) dx &= 0 \quad n \neq m \\ &= \frac{L}{2} \quad n = m. \end{aligned} \quad (3-27)$$

From equation (3-19), (3-24), and (3-26) we see that the complete solution to our heat problems can be written as

$$u(x,t) = \sum_{n=1}^{\infty} B_n \sin \frac{n\pi x}{L} e^{-\frac{K}{c\delta} \left(\frac{n\pi}{L}\right)^2 t} \quad (3-28)$$

To evaluate the B_n constants we must apply the initial condition (3-18). Thus

$$u(0,t) = U = \sum_{n=1}^{\infty} B_n \sin \frac{n\pi x}{L} . \quad (3-29)$$

Multiplying both sides of equation (3-29) by $\sin \frac{m\pi x}{L}$ and integrating between 0 and L we have

$$\int_0^L U \sin \frac{m\pi x}{L} dx = \sum_{n=1}^{\infty} B_n \int_0^L \sin \frac{m\pi x}{L} \sin \frac{n\pi x}{L} dx .$$

From the orthogonality relation (3-27) it is evident that the right side of the above equation vanishes except when $m = n$, so that

$$\int_0^L U \sin \frac{m\pi x}{L} dx = B_n \frac{L}{2}$$

from which

$$B_n = \frac{4U}{n\pi} \quad n \text{ odd} \quad (3-30)$$

$$= 0 \quad n \text{ even} .$$

The final solution can now be written in the series form

$$u(x,t) = \frac{4U}{\pi} \sum_{j=1}^{\infty} \frac{1}{2j-1} \sin \frac{(2j-1)\pi x}{L} e^{-\frac{K}{c\delta} \frac{(2j-1)^2 \pi^2}{L^2} t} . \quad (3-31)$$

This solution actually represents an infinite number of sinusoidal temperature distributions across the medium from $x = 0$ to $x = L$. At $t = 0$ the sine waves all add up to give the initial flat temperature distribution. For $t > 0$

the sine waves decay exponentially at different rates, with the decay rate faster for those sine waves having more nodes and loops. The resulting temperature distribution at various times is plotted in Figure 3-5, where a dimensionless time variable \mathcal{T} has been used. \mathcal{T} is defined as

$$\mathcal{T} = \frac{K}{c\delta L^2} t . \quad (3-32)$$

Thus Figure 3-5 is independent of the physical constants of the problem.

We will now proceed to calculate the α_n 's for a differential difference equation representation of the heat equations. If these α_n 's agree well with the values $\alpha_n = n\pi/L$ from the solution above, and if the equivalent normal modes X_n show good agreement with sine waves, then we can expect accurate results using the difference technique.

(b) Solution of the difference equation for N cells.

When the space between $x = 0$ and $x = L$ in Figure 3-4 is broken up into N cells so that there are N + 1 temperature stations, the general difference equation is given by (3-8). At station 1 and station N-1 the difference equation is obtained from equation (3-8) by setting u_0 and u_N equal to zero respectively. In the problem under consideration the conductivity K and specific heat capacity C are constant. By proper choice of our distance variable x we can make $\Delta x = 1$, so that $L = N\Delta x = N$. By proper choice of our time variable t we can make $C/K = 1$ so that for $f = 0$ equation (3-8) becomes for the ith cell.

$$\dot{u}_i = u_{i+1} - 2u_i + u_{i-1} . \quad (3-33)$$

For N cells and for boundary conditions $u_0 = u_N = 0$, we have

$$\dot{u}_1 = u_2 - 2u_1$$

$$\dot{u}_2 = u_3 - 2u_2 + u_1$$

.

.

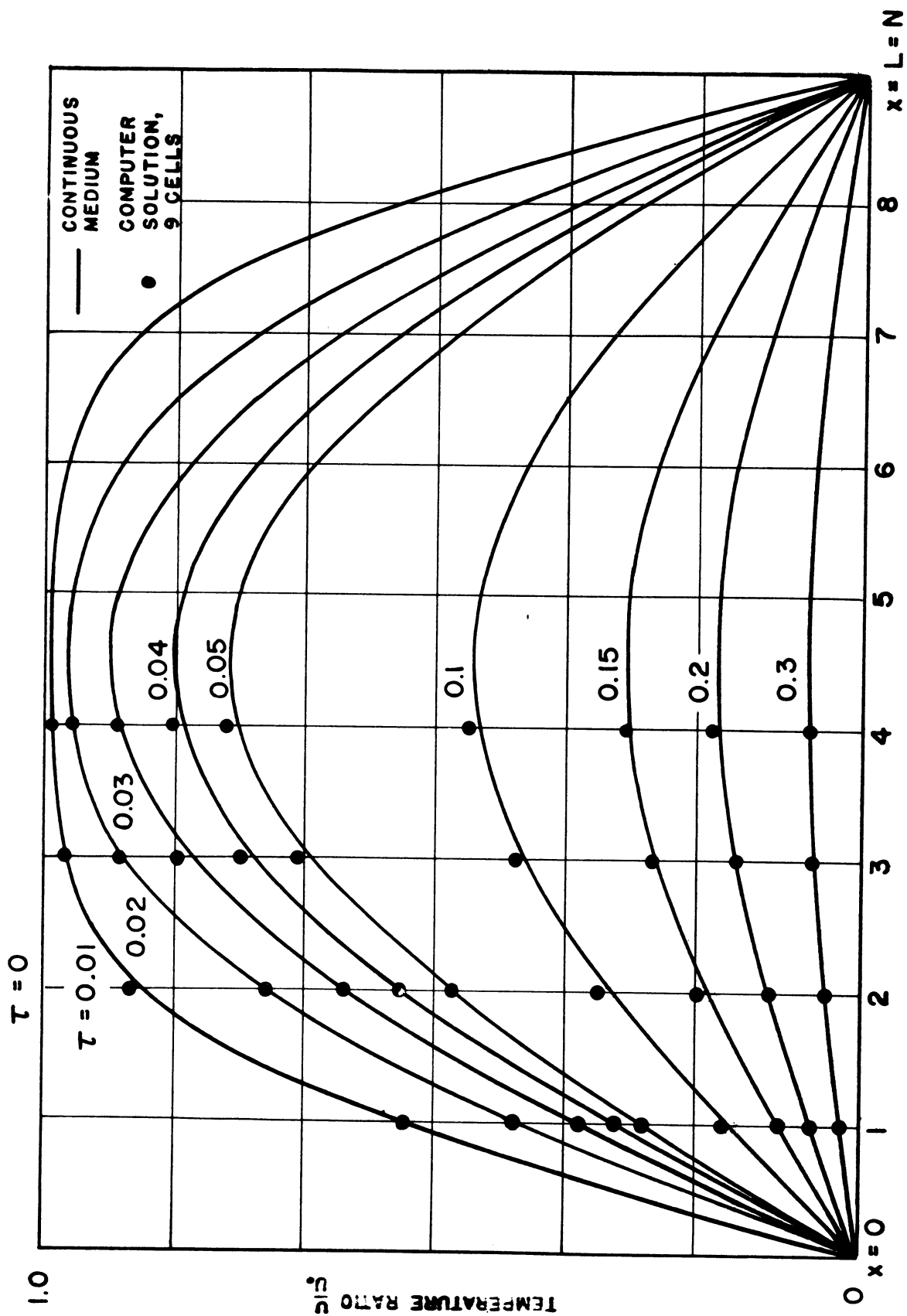

Figure 3-5. Temperature Distribution as a Function of Time.

$$\begin{array}{cccc} \cdot & \cdot & \cdot & \cdot \\ \cdot & \cdot & \cdot & \cdot \end{array} \quad (3-34)$$

$$\dot{u}_{N-2} = u_{N-1} - 2u_{N-2} + u_{N-3}$$

$$\dot{u}_{N-1} = -2u_{N-1} + u_{N-2}$$

To solve for the normal modes we assume that the i th temperature u_i varies with time as $a_i e^{-\lambda t}$, where a_i is a constant. If this is true, then equations (3-34) become

$$(-\lambda + 2)a_1 - a_2 = 0$$

$$-a_1 + (-\lambda + 2)a_2 - a_3 = 0$$

$$\begin{array}{ccc} \cdot & \cdot & \cdot \\ \cdot & \cdot & \cdot \end{array}$$

$$-a_{N-1} + (-\lambda + 2)a_{N-2} - a_{N-3} = 0$$

$$(-\lambda + 2)a_{N-1} - a_{N-2} = 0$$

The only nontrivial solution of equations (3-35) is obtained when the determinant of the coefficient vanishes. Thus

$$\begin{vmatrix} (\lambda - 2) & 1 & 0 & \cdot & \cdot & \cdot & \cdot & \cdot \\ 1 & (\lambda - 2) & 1 & 0 & \cdot & \cdot & \cdot & \cdot \\ \cdot & 1 & (\lambda - 2) & 1 & 0 & \cdot & \cdot & \cdot \\ \cdot & \cdot & \cdot & \cdot & \cdot & \cdot & \cdot & \cdot \\ \cdot & \cdot & \cdot & \cdot & \cdot & \cdot & \cdot & \cdot \\ \cdot & \cdot & \cdot & \cdot & \cdot & \cdot & \cdot & \cdot \\ \cdot & \cdot & \cdot & \cdot & 1 & (\lambda - 2) & 1 & \cdot \\ \cdot & \cdot & \cdot & \cdot & \cdot & 1 & (\lambda - 2) & 1 \\ \cdot & \cdot & \cdot & \cdot & \cdot & \cdot & 1 & (\lambda - 2) \end{vmatrix} = 0$$

This determinant, when expanded, becomes a polynomial in λ of order $N-1$. The polynomial will have $N-1$ positive roots λ_n which are the eigenvalues for our N cell system, corresponding to the eigenvalues α_n^2 of the continuous system [see equation (3-25)]. To solve this determinant for a specific N is very tedious, and to solve it in general would be next to impossible. The roots λ_n can be found much more easily by the following procedure:

Assume that the spacial mode shape for the difference equations is the same as for the continuous equation, i.e., sinusoidal. If this is true, then for the temperature u_i at the i th station we have

$$u_i = a \sin \frac{n\pi i}{N} e^{-\lambda_n t} \quad (3-36)$$

From simple trigonometry it follows that

$$u_{i+1} + u_{i-1} = 2a \sin \frac{n\pi i}{N} \cos \frac{n\pi}{N} \quad (3-37)$$

From equations (3-33) we have for the i th station

$$(2 - \lambda_n) \sin \frac{n\pi i}{N} e^{-\lambda_n t} = 2 \sin \frac{n\pi i}{N} \cos \frac{n\pi}{N} e^{-\lambda_n t}$$

from which

$$\lambda_n = 2(1 - \cos \frac{n\pi}{N}) \quad (3-38)$$

By substituting equation (3-36) into the first and last of equations (3-34) it is easy to show that the boundary conditions are satisfied. Thus, our assumed solution (3-36) is the exact solution, where the eigenvalues λ_n are given by (3-38). Expanding equation (3-38) in a power series, we have

$$\lambda_n = \left(\frac{n\pi}{N}\right)^2 \left[1 - \frac{1}{12} \left(\frac{n\pi}{N}\right)^2 + \dots\right] \quad (3-39)$$

In the limit of infinitely many cells N equation (3-39) reduces to equation (3-25) for α_n^2 , since here $L = N\Delta x = N$ (We assumed earlier that $\Delta x = 1$).

The equivalent of the decay constant α_n^2 is λ_n . In Figure 3-6 the percentage deviation in α_n^2 due to the difference method as a function of the number of cells N is shown. Note that the lower modes (lower values of n) require fewer cells to give accurate decay constants.

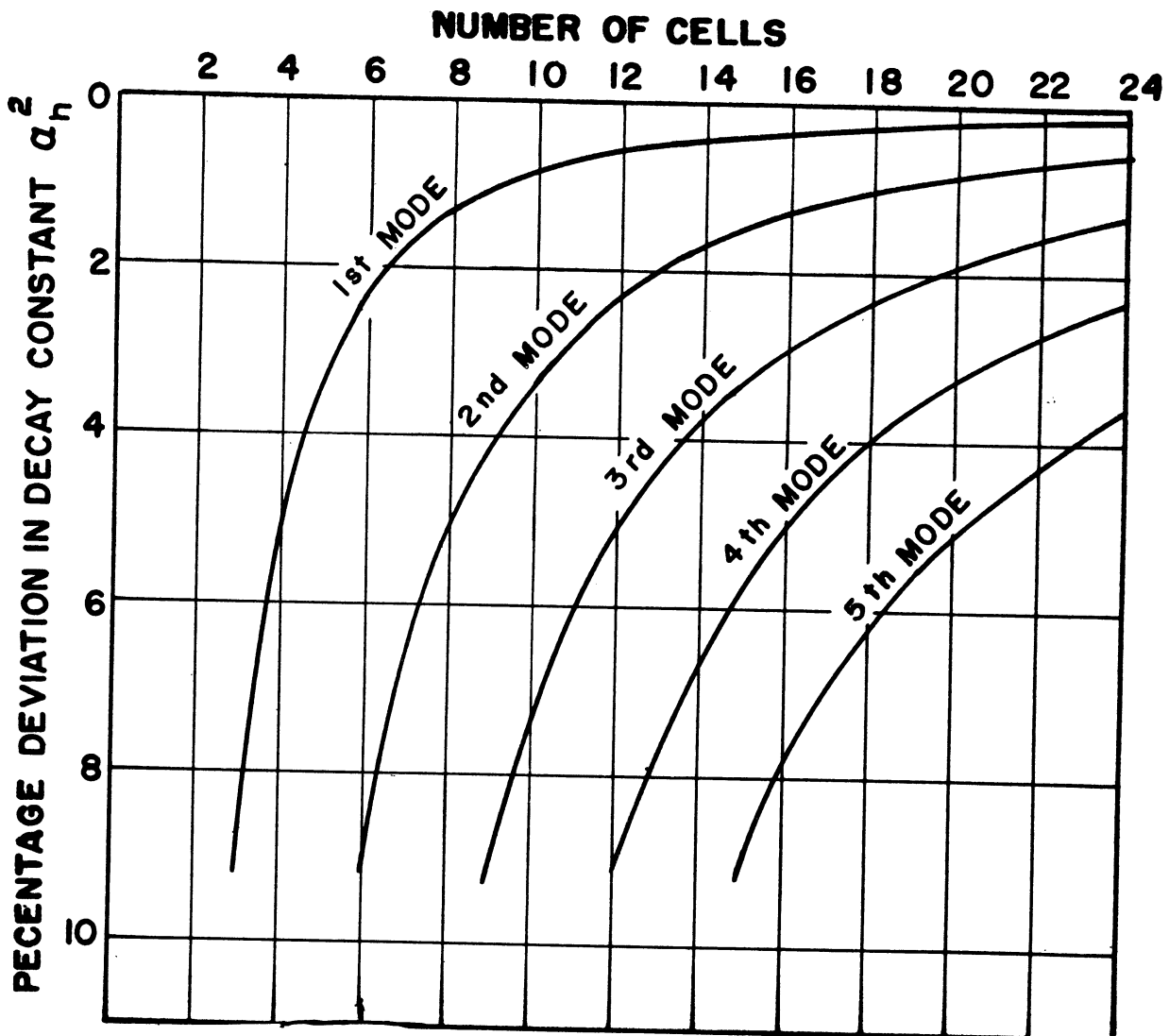

Figure 3-6. Percentage Deviation in the Decay Constant α_n^2 as a Function of the Number of Cells.

To summarize, we see that when the spacial derivatives of the heat equation are replaced by finite difference, the resulting normal mode shapes agree exactly, whereas the decay constants (eigenvalues) for each mode are somewhat smaller. This means that the higher modes will decay somewhat slower when the differential difference equation approximation is used. The error is bigger for higher modes, but fortunately the higher modes are generally much less important.

3.7 Computer Solution for One-Dimensional Heat Flow

We now proceed to the computer solution of the one-dimensional heat flow problem considered in the last section, namely the temperature distribution between two infinite slabs a distance L apart and with boundaries held at zero temperature (See Figure 3-4). We can select the distance variable so that $\Delta x = 1$ and hence $L = N\Delta x = N$, where N is the number of cells. After proper choice of the units of time t so that $K/c\delta = 1$, the basic heat equation becomes from (3-16)

$$\frac{\partial u}{\partial t} = \frac{\partial^2 u}{\partial x^2} \quad (3-40)$$

which in terms of a difference equation is

$$\frac{du_n}{dt} = u_{n+1} - 2u_n + u_{n-1} \quad (3-41)$$

For the problem in Section 3.6 the initial temperature distribution was a constant U . Thus, we have the initial conditions

$$u_n(0) = U = \text{constant} \quad (3-42)$$

Boundary conditions are

$$u_0 = u_N = 0 \quad (3-43)$$

Let us solve this heat problem with the differential analyzer for 9 cells. From equations (3-41) and (3-43) the difference equations become

$$\begin{aligned}
 \dot{u}_1 &= u_2 - 2u_1 \\
 \dot{u}_2 &= u_3 - 2u_2 + u_1 \\
 \dot{u}_3 &= u_4 - 2u_3 + u_2 \\
 \cdot & \quad \cdot \quad \cdot \quad \cdot \\
 \cdot & \quad \cdot \quad \cdot \quad \cdot \\
 \cdot & \quad \cdot \quad \cdot \quad \cdot \\
 \dot{u}_6 &= u_7 - 2u_6 + u_5 \\
 \dot{u}_7 &= u_8 - 2u_7 + u_6 \\
 \dot{u}_8 &= -2u_8 + u_7
 \end{aligned} \tag{3-44}$$

where du_n/dt has been abbreviated as \dot{u}_n . Equation (3-44) is subject to the initial condition (3-42). The computer circuit used to solve equation (3-44) is shown in Figure (3-7). Note that only one amplifier per cell is needed.

The results of the computer solutions are shown in Figure 3-8, where temperature at stations 1, 2, 3, and 4 appears as a function of time. Since our initial temperature distribution is symmetrical about the station 4-1/2, as are our boundary conditions, the temperature distribution remains symmetrical as a function of time. Thus

$$u_4 = u_5, \quad u_3 = u_6, \quad u_2 = u_7, \quad \text{and} \quad u_1 = u_8.$$

In order to compare the computer results with the solution shown in Figure 3-5 for a continuous medium, we must convert our computer time units to the dimensionless units of Figure 3-5. Remembering that we chose computer time units so that $K/c\delta = 1$, we have from equation (3-32)

$$\tau = \frac{1}{L^2} t$$

or since $L = N\Delta x$ where $\Delta x = 1$,

$$\tau = \frac{1}{N^2} t. \tag{3-45}$$

INITIAL CONDITION CIRCUITS
OMITTED FOR CLARITY

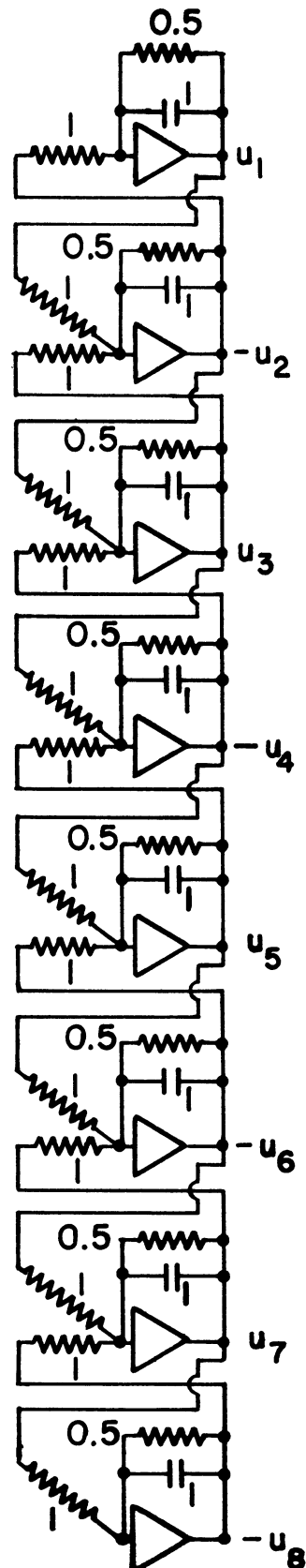
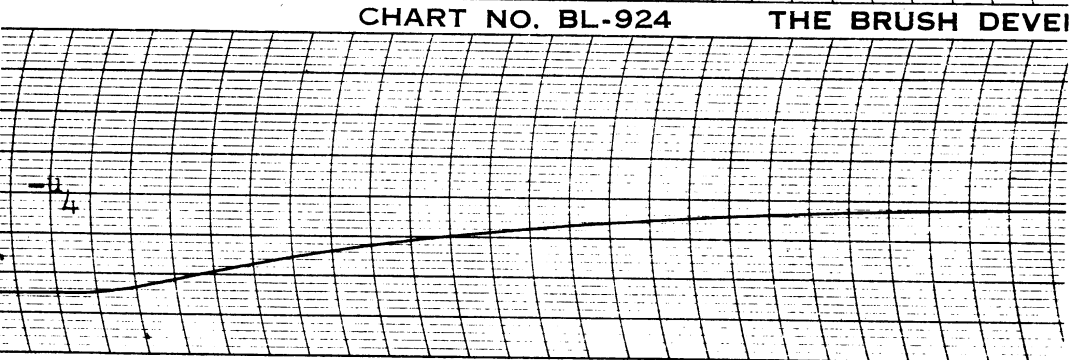
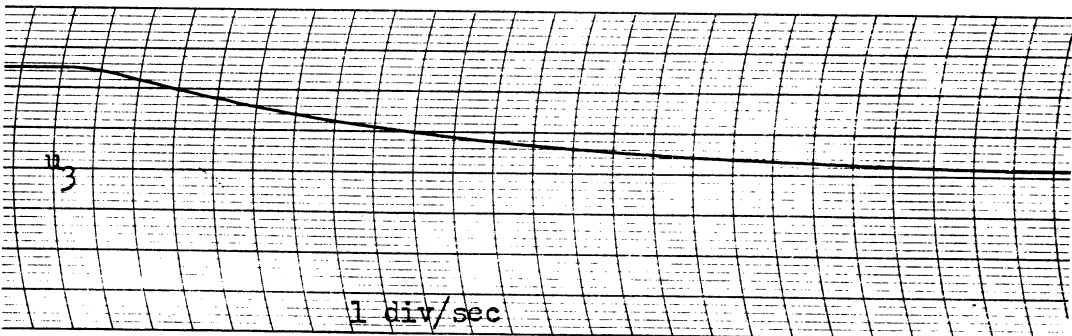
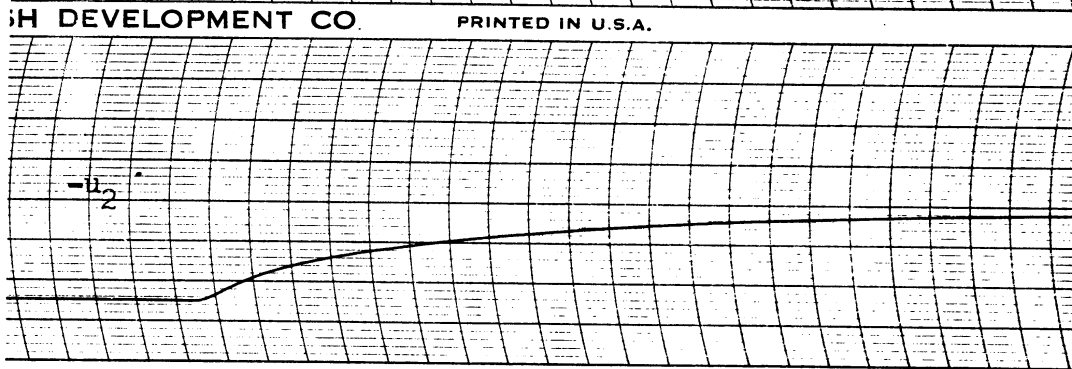
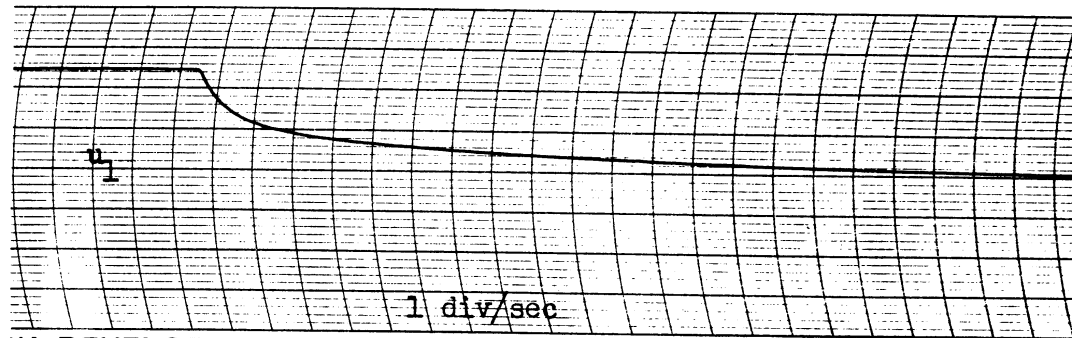

Figure 3-7. Computer Circuit for Solving 9-Cell Heat Problem .



SH DEVELOPMENT CO. PRINTED IN U.S.A.

CHART NO. BL-924 THE BRUSH DEVELOPMENT CO.

Figure 3-8. Computer Solution for 9-Cell Heat Problem.

Thus for our 9-cell problem we divide computer time t in Figure 3-8 by 81 to obtain the dimensionless time \mathcal{T} of Figure 3-5. In this way points from the computer solution are compared in Figure 3-5 with the theoretical solution for a continuous medium. The correlation is evidently quite good, as we could have predicted from our theoretical work in Section 3.6.

It has already been pointed out that the temperature distribution is symmetrical for this problem. Therefore, the heat flow will be zero at station 4-1/2, and the appropriate boundary condition can be established there. If this is done, it is only necessary to solve the problem half-way across the distance between the slabs, the solution for the other half being symmetrical. In this case our difference equations become

$$\begin{aligned}\dot{u}_1 &= u_2 - 2u_1 \\ \dot{u}_2 &= u_3 - 2u_2 + u_1 \\ \dot{u}_3 &= u_4 - 2u_3 + u_2 \\ \dot{u}_4 &= -u_4 + u_3\end{aligned}\tag{3-46}$$

subject again to initial conditions (3-42). The four-amplifier circuit required to solve equation (3-46) is shown in Figure (3-9).

In the same way, if the initial temperature distribution in our homogeneous medium had been antisymmetrical with respect to station 4-1/2, we could have treated the problem for N cells by setting $u_0 = u_{N/2} = 0$ and solving the $N/2$ -cell problem. Here we must obviously have an even number of cells to begin with, whereas in the symmetrical case we needed an odd number of cells.

It is evident that by considering symmetry effects the number of amplifiers needed may often be cut in half. Furthermore, any arbitrary initial temperature distribution can always be split into a symmetrical and antisymmetrical form. The solution for each of these initial distributions can then be found, and since the equations are linear, the final solution is the sum of the two solutions. Of course this procedure will only work when the conductivity K and the specific heat capacity $c\delta$ for the medium are

INITIAL CONDITION CIRCUITS
OMITTED FOR CLARITY

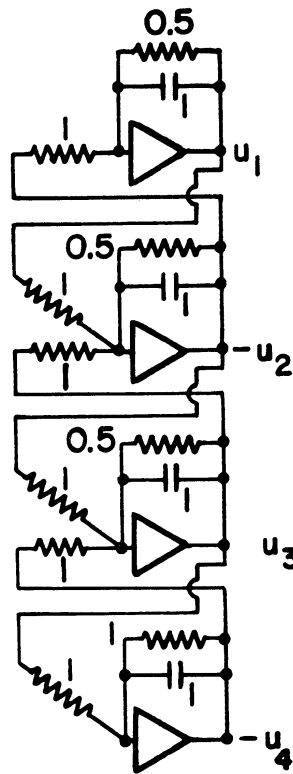

Figure 3-9. Computer Circuit for Solving 9-Cell Symmetrical Heat Problem .

constant (as in our problem) or symmetrical about the center of the medium. Also, the boundary conditions must be symmetrical.

3.8 Computer Solution for Two-Dimensional Heat Flow

It was felt that it would be interesting to solve at least one second order space problem using the difference technique. Because only one amplifier per cell is required, the heat equation was selected as the simplest two-dimensional problem for the electronic differential analyzer. Consider the homogeneous medium of rectangular cross section shown in Figure 3-10. Let the temperature u be a function of x and y and independent of the height z . The walls are held at zero temperature and separated by X and Y respectively. We can select the units of time so that $k/c\delta = 1$. Thus, the heat equation becomes

$$\frac{\partial u}{\partial t} = \frac{\partial^2 u}{\partial x^2} + \frac{\partial^2 u}{\partial y^2} . \quad (3-47)$$

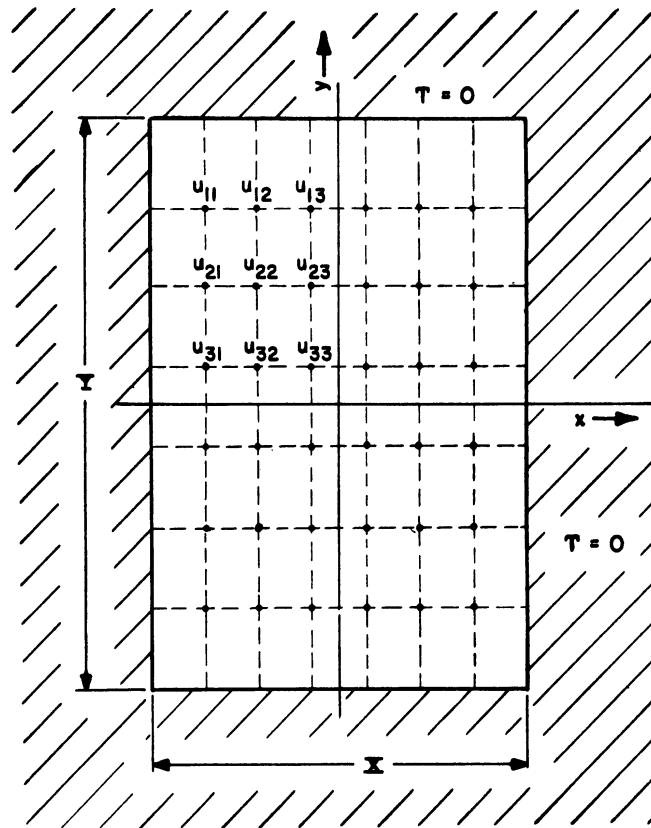

Figure 3-10. Two-Dimensional Problem in Heat Flow.

with boundary conditions

$$u(-X/2, y, t) = u(X/2, y, t) = u(x, -Y/2, t) = u(x, Y/2, t) = 0.$$

The division of the medium into cells and the numbering system for the cells is shown in Figure 3-10. By selecting the units in x and y properly we can make $\Delta x = \Delta y = 1$. Thus for an $N \times N$ cell division $X = Y = N$.

Since the initial distribution is symmetrical with respect to the x and y axes, we can solve the problem in one quadrant (See Figure 3-10), subject to the new boundary conditions

$$u(-\frac{X}{2}, y, t) = u(x, \frac{Y}{2}, t) = 0 \quad (3-49)$$

$$\frac{\partial u}{\partial x}(0, y, t) = \frac{\partial u}{\partial x}(x, 0, t) = 0. \quad (3-50)$$

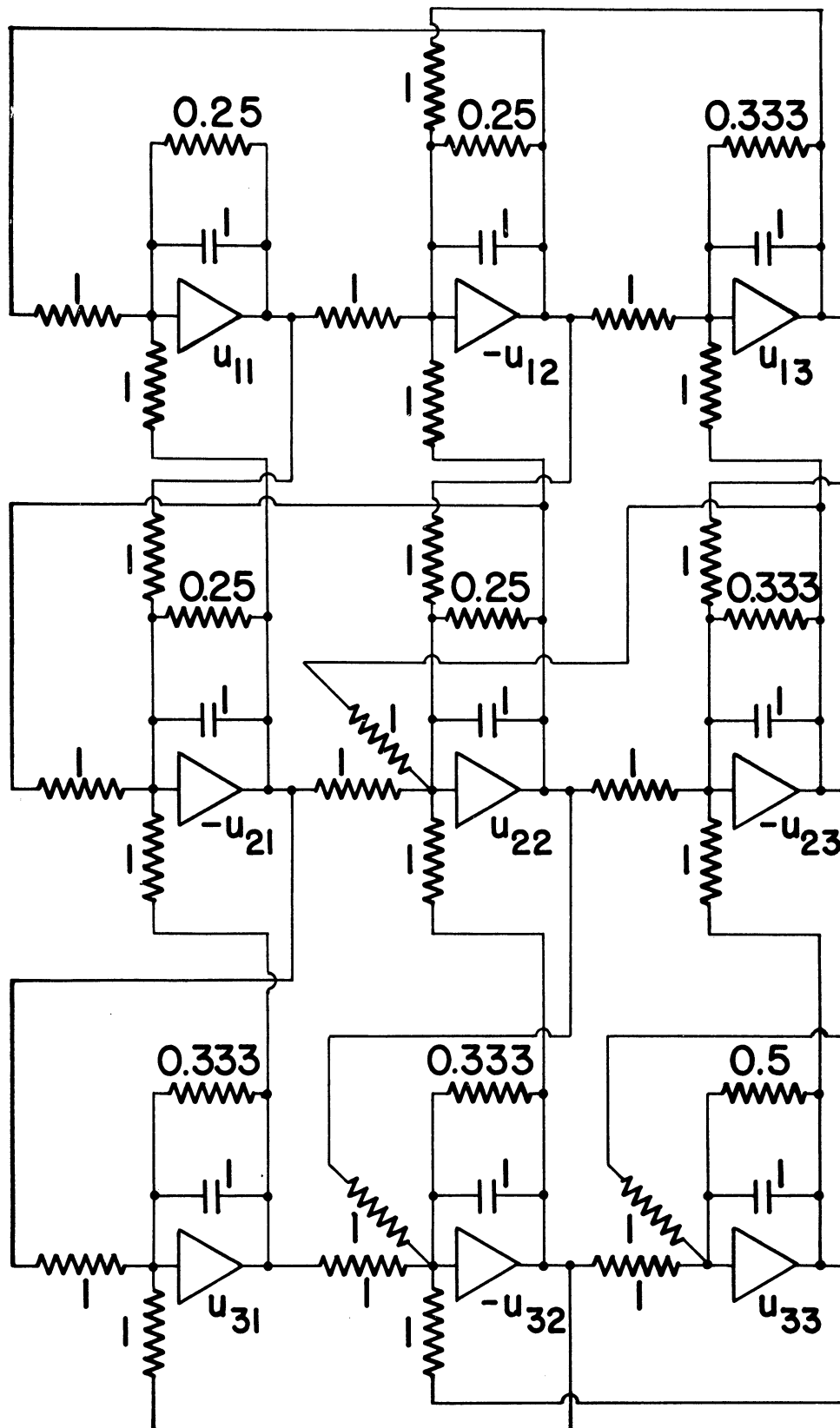

Figure 3-11. Computer Circuit for Two-Dimensional Heat Problem .

The difference equation for the temperature $u_{n,m}$ becomes

$$\frac{du_{n,m}}{dt} = u_{n+1,m} - 2u_{n,m} + u_{n-1,m} + u_{n,m+1} - 2u_{n,m} + u_{n,m-1}$$

or

$$\frac{du_{n,m}}{dt} = u_{n+1,m} - u_{n-1,m} - 4u_{n,m} + u_{n,m+1} + u_{n,m-1} \quad (3-51)$$

Let us consider the 7-cell by 7-cell system shown in Figure 3-10. The boundary conditions of equation (3-45) are imposed by setting

$$u_{01} = u_{02} = u_{03} = u_{10} = u_{20} = u_{30} = 0,$$

and the boundary conditions of equation (3-50) are imposed by setting

$$u_{13} = u_{14}, \quad u_{23} = u_{24}, \quad u_{33} = u_{34}, \quad u_{31} = u_{41}, \quad u_{32} = u_{42}, \quad u_{33} = u_{43}.$$

The complete set of 9 difference equations representing the upper left-band quadrant of Figure 3-10 then reduces to

$$\begin{aligned} \dot{u}_{11} &= u_{21} - 4u_{11} + u_{12} \\ \dot{u}_{12} &= u_{22} - 4u_{12} + u_{11} + u_{13} \\ \dot{u}_{13} &= u_{23} - 3u_{13} + u_{12} \\ \dot{u}_{21} &= u_{31} - 4u_{21} + u_{11} + u_{22} \\ \dot{u}_{22} &= u_{32} + u_{12} - 4u_{22} + u_{23} + u_{21} \\ \dot{u}_{23} &= u_{33} + u_{13} - 3u_{23} + u_{22} \\ \dot{u}_{31} &= u_{21} - 3u_{31} + u_{32} \\ \dot{u}_{32} &= u_{22} - 3u_{32} + u_{33} + u_{31} \\ \dot{u}_{33} &= u_{32} - 2u_{33} + u_{23}. \end{aligned} \quad (3-52)$$

As in the case of the one-dimensional heat flow treated in the previous sections, we solve the problem for an initial temperature which is everywhere constant. Thus, the initial condition becomes

$$u_{n,m} = U = \text{constant}.$$

The computer circuit used to solve the set of difference equations (3-52) is shown in Figure 3-11. Computer solutions for temperature u_{11} , u_{12} , u_{13} , and u_{33} as a function of time are shown in Figure 3-12. By symmetry $u_{12} = u_{21}$, and $u_{13} = u_{31}$.

The resulting temperature agrees closely with the theoretical distribution calculated for a continuous medium.

3.9 Summary of Investigation of the Use of Difference Techniques for the Heat Equation

We have shown that it is both simple and straightforward to solve the heat equation with the electronic differential analyzer by replacing spacial derivatives with finite differences. Normal mode shapes show exact agreement with those calculated by separation of variables for the simple problems considered. Decay constants corresponding to the various modes also show good agreement but tend to be somewhat lower than the values calculated by separation of variables, particularly for higher modes or if fewer cells are used. For most engineering problems the order of eight to sixteen cells per spacial dimension should be completely adequate (see Figure 3-5).

Only one operational amplifier is needed per cell, although in some problems it may be more convenient to use three amplifiers per cell. The problem is completely stable, and the final outputs of the computer are temperature and heat flow as a function of spacial coordinates and time.

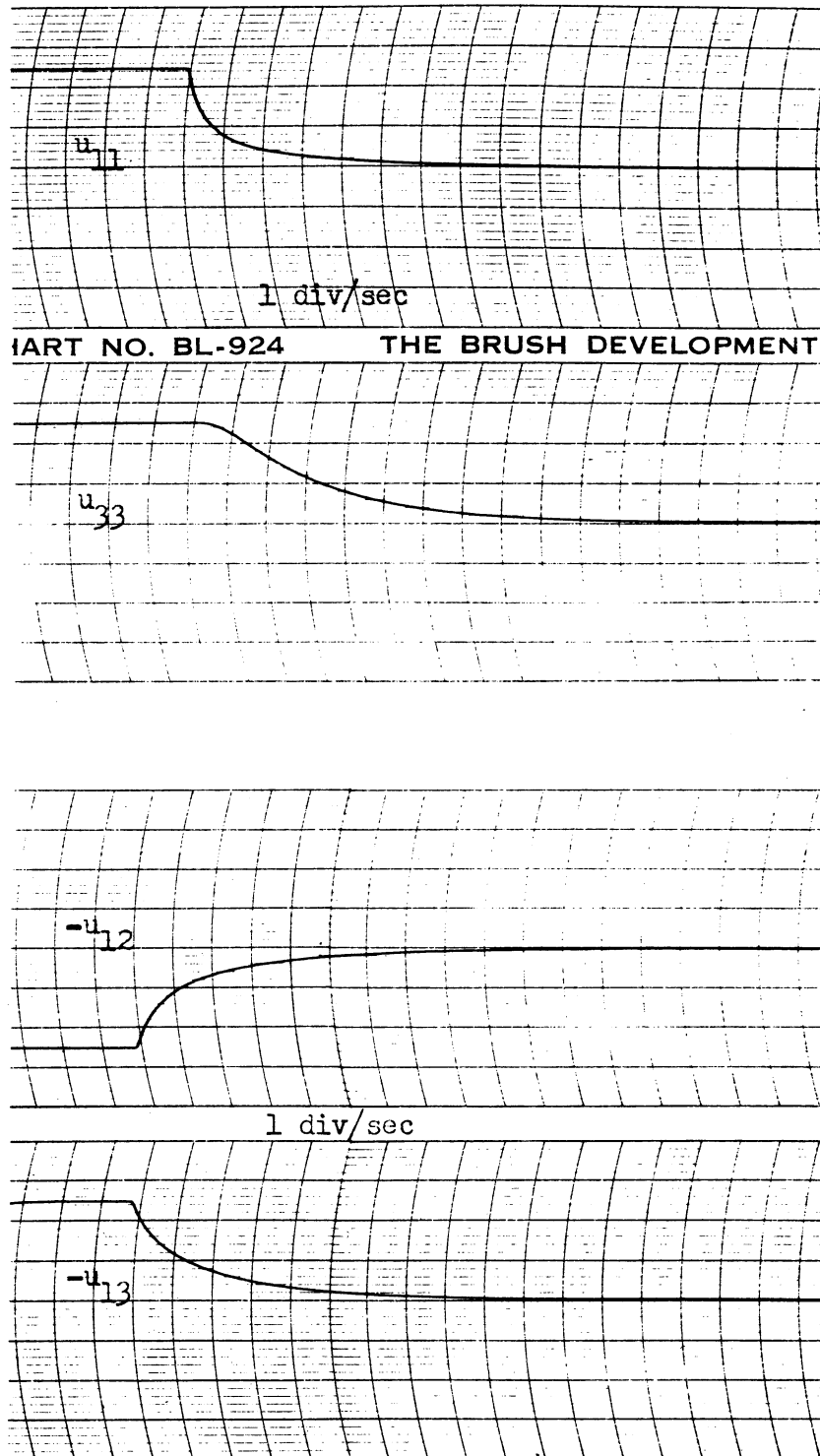

Figure 3-12. Computer Solution for Two-Dimensional Heat Problem.

CHAPTER 4

SOLUTION OF THE WAVE EQUATION

4.1 Equation to be Solved

One of the most important partial differential equations met in physics or engineering is the wave equation. If we let ϕ represent the magnitude of a disturbance in any medium in which wave propagation can take place, then we can write the wave equation as

$$\nabla^2 \phi = \frac{1}{v^2} \frac{\partial^2 \phi}{\partial t^2} \quad (4-1)$$

or in terms of Cartesian coordinates x , y , and z

$$\frac{\partial^2 \phi}{\partial x^2} + \frac{\partial^2 \phi}{\partial y^2} + \frac{\partial^2 \phi}{\partial z^2} = \frac{1}{v^2} \frac{\partial^2 \phi}{\partial t^2} \quad (4-2)$$

Here v is the wave velocity in the medium and t is the time variable. Equation (4-1) or (4-2) must of course be subject to spacial boundary conditions and initial time conditions.

The spacial derivatives of the wave equation have exactly the same form as the heat equation, but the time derivative is second order instead of first order. The difference techniques for converting the partial differential equation to a system of ordinary differential equations in time are also practically identical. Because of this similarity it was decided in this report not to solve any problems involving the application of the electronic differential analyzer to the wave equation, but rather to limit the discussion to a theoretical one showing what the analyzer should be able to do.

In order to have a specific problem involving the wave equation to use as an example, the classical problem of the vibrating string will be treated.

4.2 The Wave Equation for the Stretched String

Consider the string shown in Figure (4-1). Let the string be fastened at $x = 0$ and $x = L$, and assume that the transverse displacement of the string is $\phi(x,t)$. If $T(x)$ is the longitudinal tension in the string at

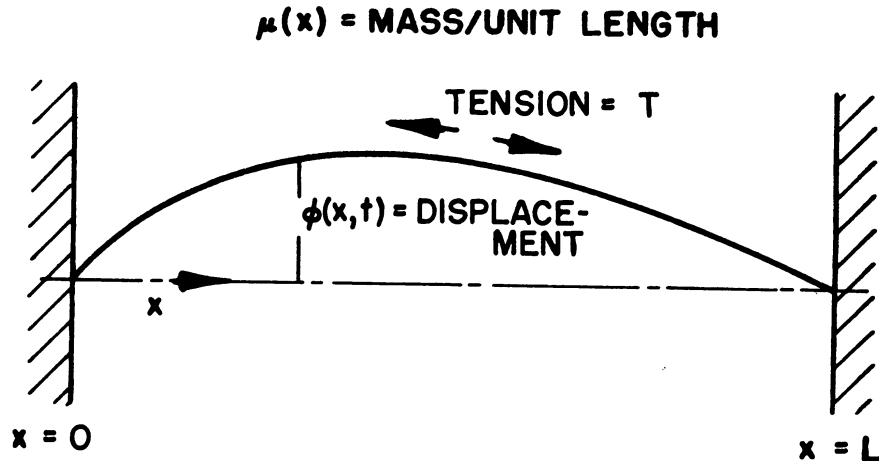

Figure 4-1. Stretched String .

any distance x , and $\mu(x)$ is the mass per unit length of the string at any x , then the equation of motion for the string becomes

$$\frac{\partial}{\partial x} \left(T \frac{\partial \phi}{\partial x} \right) = \mu \frac{\partial^2 \phi}{\partial t^2} \quad (4-3)$$

with boundary conditions

$$\phi(0,t) = \phi(L,t) = 0. \quad (4-4)$$

The left side of equation (4-3) represents the transverse force on a unit length of the string due to the curvature in the transverse displacement; the right-hand side represents the inertial force on a unit length of the string.

If the tension T in the string is a constant independent of x , then equation (4-3) can be written

$$\frac{\partial^2 \phi}{\partial x^2} = \frac{\mu(x)}{T} \frac{\partial^2 \phi}{\partial t^2} \quad (4-5)$$

which is seen to be the wave equation (4-2) in one space dimension. Thus, the velocity of wave propagation in the string will be given by

$$v = \sqrt{\frac{T}{\mu}} \quad (4-6)$$

and in general may be a function of x . When the wave velocity is a function of spacial coordinates, equation (4-5) is much more difficult to solve by separation of variables, and hence it is of considerable interest to have a direct method of solution by means of a computer.

The initial conditions for our string problem can be written in general as

$$\phi(x,0) = f(x) \quad (4-7)$$

$$\frac{\partial \phi}{\partial t}(x,0) = g(x).$$

4.3 Derivation of the Difference Equation for the Stretched String

We now proceed to break the string up into N cells a distance Δx apart. The difference equation for ϕ_n , the displacement at the n th station, is given by

$$\frac{(\Delta x)^2}{v_n^2} \frac{d^2 \phi_n}{dt^2} = \phi_{n+1} - 2\phi_n + \phi_{n-1}. \quad (4-8)$$

Here $v_n = \sqrt{T/\mu_n}$, where v_n is the wave velocity at the n th station and μ_n is the mass per unit length at the n th station. The boundary conditions given in equation (4-4) are imposed by letting $\phi_0 = \phi_N = 0$. The complete set of difference equations then becomes

$$\frac{(\Delta x)^2}{v_1^2} \ddot{\phi}_1 = \phi_2 - 2\phi_1$$

$$\frac{(\Delta x)^2}{v_2^2} \ddot{\phi}_2 = \phi_3 - 2\phi_2 + \phi_1$$

$$\frac{(\Delta x)^2}{v_3^2} \ddot{\phi}_3 = \phi_4 - 2\phi_3 + \phi_2$$

$$\begin{array}{cccc} \cdot & \cdot & \cdot & \cdot \\ \cdot & \cdot & \cdot & \cdot \\ \cdot & \cdot & \cdot & \cdot \end{array}$$

(4-9)

$$\frac{(\Delta x)^2}{(v_{N-3})^2} \ddot{\phi}_{N-3} = \phi_{N-2} - 2\phi_{N-3} + \phi_{N-4}$$

$$\frac{(\Delta x)^2}{(v_{N-2})^2} \ddot{\phi}_{N-2} = \phi_{N-1} - 2\phi_{N-2} + \phi_{N-3}$$

$$\frac{(\Delta x)^2}{(v_{N-1})^2} \ddot{\phi}_{N-1} = -2\phi_{N-1} + \phi_{N-2}$$

The equations are subject to initial conditions $\phi_1(0), \phi_2(0), \dots, \phi_{N-1}(0)$ and $\dot{\phi}_1(0), \dot{\phi}_2(0), \dots, \dot{\phi}_{N-1}(0)$.

For some types of problems involving the wave equation, $\partial\phi/\partial x$ may be specified at the boundary instead of ϕ . In this case the boundary occurs half-way between two stations, and the boundary condition is imposed by equating the ϕ 's on either side of the boundary (See Section 3.3).

4.4 Computer Circuit for Solving the Stretched String

Although the set of difference equations (4-9) was derived for the stretched string of Figure 4-1, it clearly represents the wave equation (4-1) in general when the propagation is in one direction. The electronic differential analyzer circuit for solving equation (4-9) is shown in Figure 4-2.

4.5 Solution of the String Equation by Separation of Variables

Once again it will prove instructive to solve for the normal modes of vibration of our stretched string by separating time and space variables. By comparing the normal mode shapes and frequencies obtained by this method with those gotten from the difference equations, we can evaluate critically the accuracy of the difference method as a function of the number of cells.

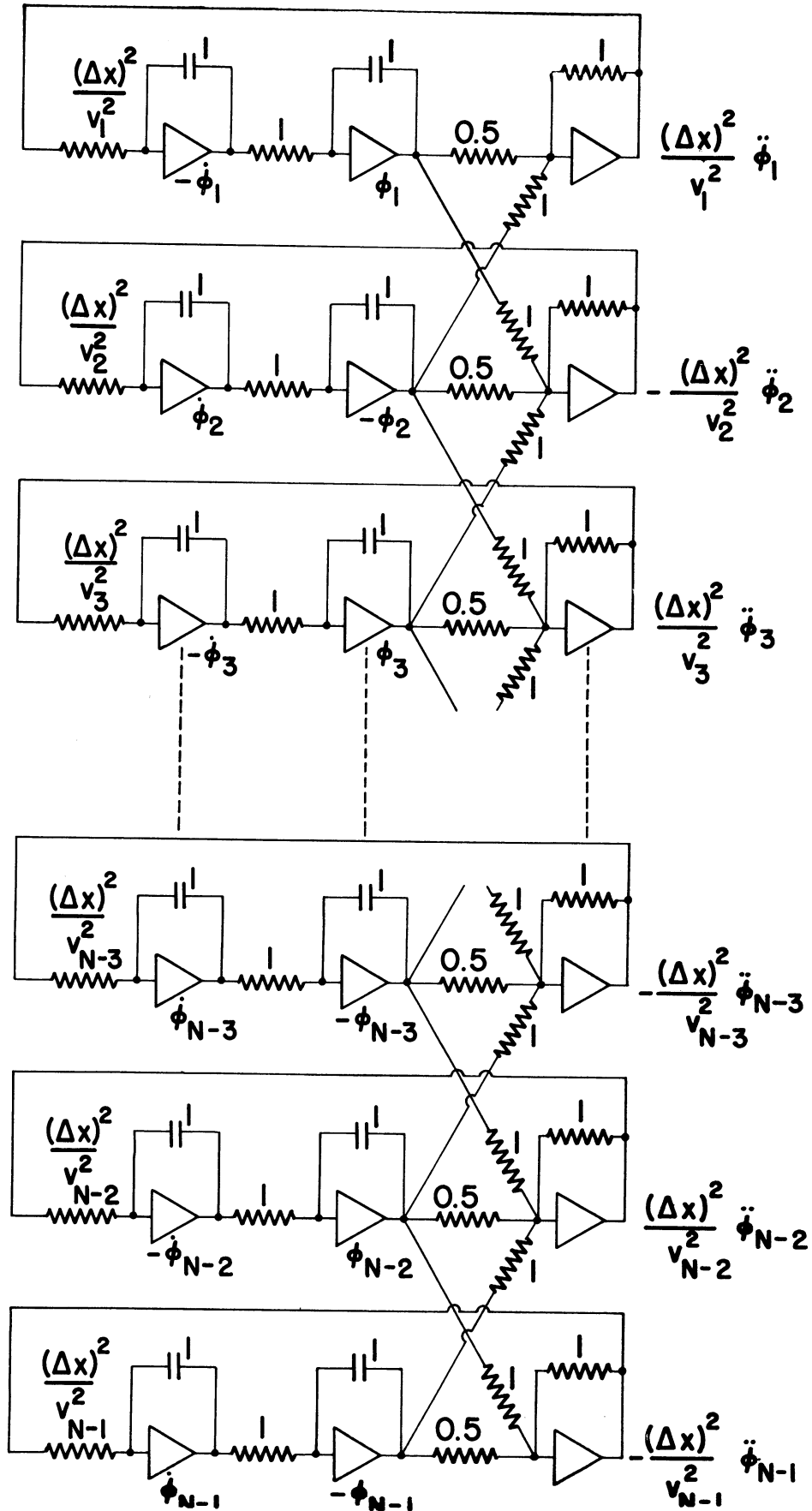

Figure 4-2. Computer Circuit for Solving the Wave Equation.

As in Section 3.6a, we begin by assuming that

$$\phi(x,t) = X(x) Y(t). \quad (4-10)$$

Although it is not a necessary simplification, we make the further assumption that the string is uniform, i.e., $\mu = \text{constant}$. The wave equation (4-5) then becomes

$$\frac{\mu}{T} \frac{Y''}{Y} = \frac{X''}{X} = -\alpha^2 = \text{constant} \quad (4-11)$$

from which

$$X''(x) + \alpha^2 X(x) = 0 \quad (4-12)$$

and

$$Y''(t) + \frac{T}{\mu} \alpha^2 Y(t) = 0. \quad (4-13)$$

The general solution to the second of these equations is

$$Y(t) = A \cos \sqrt{\frac{T}{\mu}} \alpha t + B \sin \sqrt{\frac{T}{\mu}} \alpha t. \quad (4-14)$$

The boundary conditions of equation (4-4) can be met only if $X(0) = X(L) = 0$. The latter condition limits solutions of equation (4-12) to the following:

$$X(x) = \sin \alpha_n x \quad (4-15)$$

where

$$\alpha_n = \frac{n\pi}{L}, \quad n = 1, 2, 3, \dots \quad (4-16)$$

The general solution to the problem is then

$$\phi(x,t) = \sum_{n=1}^{\infty} (A_n \cos \omega_n t + B_n \sin \omega_n t) \sin \frac{n\pi x}{L} \quad (4-17)$$

where the normal-mode frequency of oscillation ω_n is given by

$$\omega_n = \frac{n\pi}{L} \sqrt{\frac{T}{\mu}}, \quad n = 1, 2, 3, \dots \quad (4-18)$$

The constants $A_1, A_2, \dots, B_1, B_2, \dots$ are evaluated from the initial conditions (4-7) by the method used in Section 3.6a.

Thus, the normal modes are sinusoidal in shape and the frequency of the n th mode is n times the frequency of the fundamental, which is $(\pi/L)\sqrt{T/\mu}$.

We will now solve for the normal modes of the difference equation and compare them with the true normal modes given above.

4.6 Difference Equation Solution of the Stretched String

We have already derived the difference equations obtained when the string is divided into N cells [see equation (4-9)]. If our string is uniform so that $v = \sqrt{T/\mu} = \text{constant}$, then we can always select our units of time and distance so that $\Delta x = 1$ and $v = 1$. The length L of the string then becomes $L = N\Delta x = N$, and we have from equation (4-8) for the i th cell

$$\ddot{\phi}_i = \phi_{i+1} - 2\phi_i + \phi_{i-1}. \quad (4-19)$$

Let us assume that the normal modes of vibration of the difference equations have the same shape as those for the continuous string. Then for the n th mode

$$u_i = a \sin \frac{n\pi i}{N} \sin \lambda_n t \quad (4-20)$$

and

$$u_{i\pm 1} = a \left(\sin \frac{n\pi i}{N} \cos \frac{n\pi}{N} \pm \cos \frac{n\pi i}{N} \sin \frac{n\pi}{N} \right) \sin \lambda_n t. \quad (4-21)$$

Substituting equations (4-20) and (4-21) into (4-19) we have

$$\lambda_n^2 = 2(1 - \cos \frac{n\pi}{N}) \quad (4-22)$$

as the expression for the normal-mode frequency λ_n . From equation (4-20) it is apparent that $u_0 = u_N = 0$, so that our boundary conditions are met.

Equation (4-22) can be expanded in a power series giving

$$\lambda_n^2 = \left(\frac{n\pi}{N}\right)^2 \left[1 - \frac{1}{12} \left(\frac{n\pi}{N}\right)^2 + \dots \right]. \quad (4-23)$$

In the limit of infinitely large N the λ_n above approaches the ω_n given in equation (4-18), since here $L = N$ and $\sqrt{T/\rho} = 1$. For a finite N the normal-mode frequencies from the difference equations are evidently lower than those for the continuous string. A plot of this frequency deviation as a function of the number of cells for the first seven modes is shown in Figure 4-3.

4.7 Summary of Investigation of Difference Techniques Applied to the Wave Equation

The equation of the stretched string has been solved both by separation of variables and by replacing spacial derivatives with finite differences. Comparison of the normal-mode shapes in both cases shows exact agreement. Comparison of normal-mode frequencies shows the difference equation frequencies are somewhat lower than the true frequencies, particularly for higher modes or if fewer cells are used (see Figure 4-3). Since the string equation is the wave equation, the above remarks apply to the solution of the wave equation in general by difference techniques.

Thus far we have considered partial differential equations with boundary conditions occurring a finite distance apart. It seems evident that our difference techniques as used here are limited to this type of equation. Thus, it would not seem possible to solve problems in semi-infinite or infinite media unless one can let the time variable in the computer represent the spacial variable which goes to infinity.

It should be straightforward to solve problems having spacial coordinate systems other than Cartesian, e.g., cylindrical, spherical, etc. For the appropriate geometries this would undoubtedly require many less cells to realize a desirable accuracy.

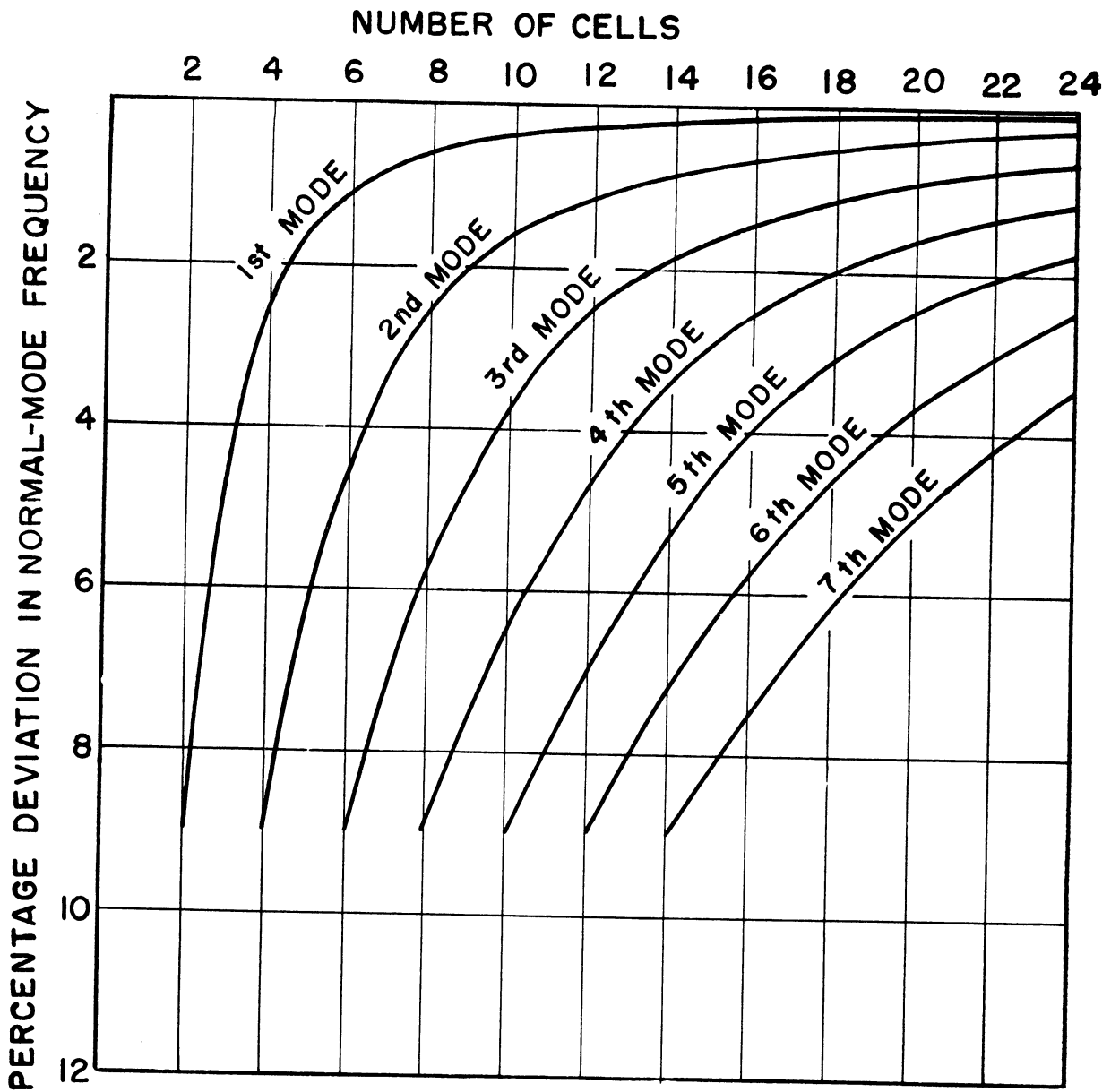

Figure 4-3. Comparison of Normal-mode Frequencies of the Difference Equations and the Continuous String.

CHAPTER 5

VIBRATING BEAMS

5.1 Equation to be Solved

It would seem of particular engineering interest to investigate the usefulness of the difference technique in solving the problem of flexural vibration of beams. Work of this type has been done on the Caltech analogue computer.⁴ In this chapter we will investigate the theoretical possibilities of the difference technique and present the results of solutions by the electronic differential analyzer at the University of Michigan.

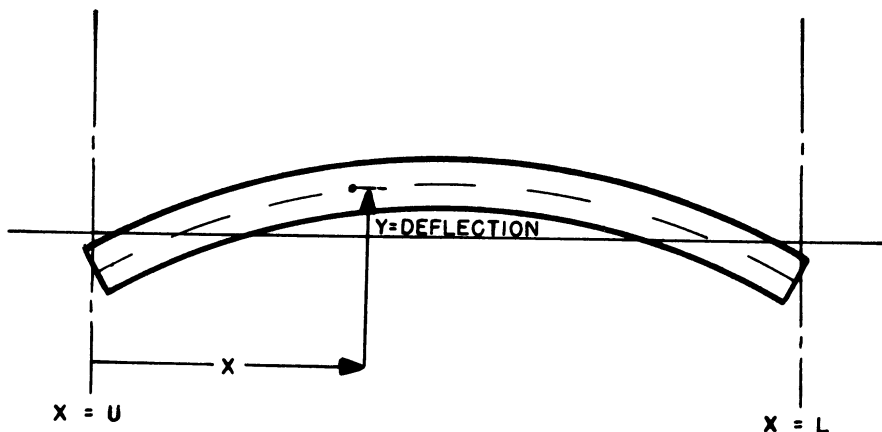

Figure 5-1. Vibrating Beam.

Consider the vibrating beam shown in Figure 5-1. If we limit ourselves to the transverse deflection shown and assume that the flexural planes remain parallel, then for small deflections the equation of motion is given by

$$\rho(x) \frac{\partial^2 y(x,t)}{\partial t^2} + \frac{\partial^2}{\partial x^2} \left[EI(x) \frac{\partial^2 y(x,t)}{\partial x^2} \right] = 0 \quad (5-1)$$

where

x = horizontal distance from the left end of the beam

t = time

$y(x,t)$ = transverse deflection of the beam at any instant

$\rho(x)$ = mass per unit length of beam, at x .

$I(x)$ = area moment of inertia, at x
 $E(x)$ = modulus of elasticity, at x
 $EI(x)$ = flexural rigidity at x .

In the derivation of equation (5-1) the effects of rotary inertia and deflection due to transverse shear are neglected. This is valid when cross-sectional dimensions are small compared with the length. We observe that the bending moment $M(x,t)$ is given by

$$M(x,t) = EI(x) \frac{\partial^2 y(x,t)}{\partial x^2} \quad (5-2)$$

whereas the shear is given by

$$V(x,t) = \frac{\partial}{\partial x} M(x,t). \quad (5-3)$$

Equation (5-1) is of course subject to both boundary and initial conditions. The boundary conditions depend on the type of end conditions. Various end fastenings and the appropriate boundary condition at the end are summarized in the following table:

Boundary Conditions

<u>End of Beam</u>	<u>Boundary Conditions</u>
Free	$M = 0, \quad V = 0$
Hinged	$y = 0, \quad M = 0$
Built-in	$y = 0, \quad \frac{\partial y}{\partial x} = 0$

The two types of beams of most general engineering interest are the free-free beam (both ends free) and the cantilever beam (one end built-in, the other free). We will also consider the hinged-hinged beam because it is the easiest to analyze theoretically and will give us a good idea of how the other beams will behave when difference techniques are used.

5.2 Derivation of the Difference Equation for the Vibrating Beam

Once again we will convert the partial differential equation (5-1) for the vibrating beam into a set of ordinary differential equation by using the difference technique. Thus, distance along the beam is broken into N seg-

ments of width Δx ; the displacement y_n at the n th station will then be a function of time only. Following the method of Section 1.2, we have from (5-1) as the equation of motion of the n th cell

$$(\Delta x)^2 \rho_n \frac{d^2 y_n}{dt^2} + M_{n+1} - 2M_n + M_{n-1} = 0 \quad (5-4)$$

where

$$M_i = \frac{EI_i}{(\Delta x)^2} (y_{i+1} - 2y_i + y_{i-1}). \quad (5-5)$$

We also note that

$$V_{n-1/2} = \frac{M_n - M_{n-1}}{\Delta x} \quad (5-6)$$

and

$$\left. \frac{\partial y}{\partial x} \right|_{n-1/2} = \frac{y_n - y_{n-1}}{\Delta x}. \quad (5-7)$$

Before writing down the complete set of difference equations for N cells, it is necessary to consider the boundary conditions.

5.3 Representation of Boundary Conditions in the Difference Equations

Assume we have an N cell beam and wish to impose the boundary conditions associated with a particular end fastening, e.g., a free end at the right-hand extremity of the beam. This means that both the shear V and bending movement M must vanish at the beam end. Let us assume, then, that the end occurs at $N+1/2$ and that $V_{N+1/2} = 0$. From equation (5-6) this implies that $M_N = M_{N+1} = 0$. But from equation (5-4) this means that

$$(\Delta x)^2 \rho_N \frac{d^2 y_N}{dt^2} + M_{N-1} = 0$$

$$(\Delta x)^2 \rho_{N-1} \frac{d^2 y_{N-1}}{dt^2} - 2M_{N-1} + M_{N-2} = 0.$$

The remainder of the equations are similar to equation (5-4) until the left-hand boundary is reached, at which point the difference equations again depend on the type of end fastening.

Following the same line of reasoning as above, one obtains the following set of conditions for the difference equations for various end fastenings of an N cell beam:

<u>End</u>	<u>Where End Occurs</u>	<u>Condition</u>
Free	$N+1/2$	$M_N = M_{N+1} = 0$
Hinged	N	$M_N = y_N = 0$
Built-In	$N+1/2$	$y_N = y_{N+1} = 0$

The actual way in which these conditions modify the difference equations is best seen by considering a specific type beam, as in the next section.

5.4 Computer Circuit for Solving the Cantilever Beam by Difference Techniques

Since it involves both a free end and a built-in end, the cantilever beam shown in Figure 5-2 seems the best choice for a specific example. The

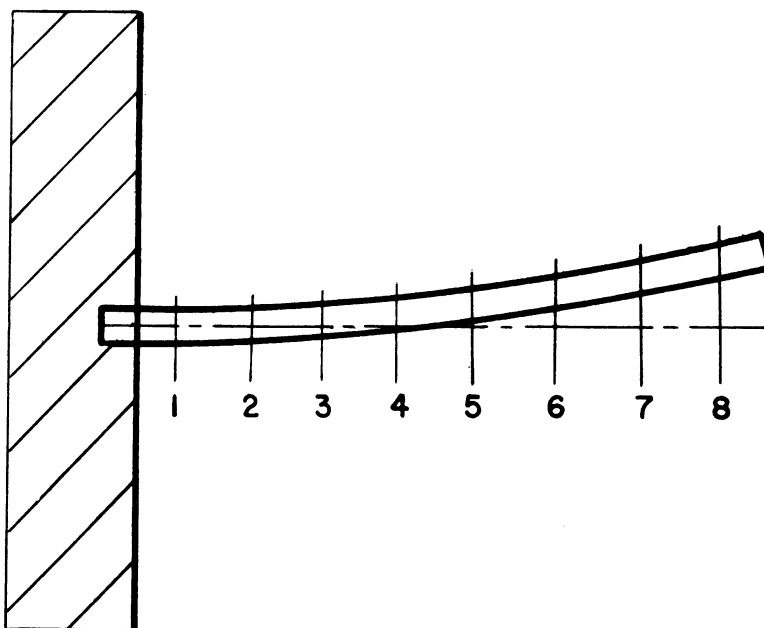

Figure 5-2. Cantilever Beam.

left-hand end of this beam occurs at station $l/2$, while the right-hand end occurs at station $N+1/2$. From equations (5-4), (5-5), and (5-7) along with the boundary conditions of Section 5.3 we obtain the following set of difference equations:

$$(\Delta x)^2 \rho_2 \frac{d^2 y_2}{dt^2} + M_3 - 2M_2 + M_1 = 0$$

$$(\Delta x)^2 \rho_3 \frac{d^2 y_3}{dt^2} + M_4 - 2M_3 + M_2 = 0$$

$$\begin{array}{ccccccc} \cdot & \cdot & \cdot & \cdot & \cdot & & \\ \cdot & \cdot & \cdot & \cdot & \cdot & & \\ \cdot & \cdot & \cdot & \cdot & \cdot & & \end{array}$$

(5-8)

$$(\Delta x)^2 \rho_{N-2} \frac{d^2 y_{N-2}}{dt^2} + M_{N-1} - 2M_{N-2} + M_{N-3} = 0$$

$$(\Delta x)^2 \rho_{N-1} \frac{d^2 y_{N-1}}{dt^2} - 2M_{N-1} + M_{N-2} = 0$$

$$(\Delta x)^2 \rho_N \frac{d^2 y_N}{dt^2} + M_{N-1} = 0$$

where

$$M_1 = \frac{EI_1}{(\Delta x)^2} y_2$$

$$M_2 = \frac{EI_2}{(\Delta x)^2} (y_3 - 2y_2)$$

$$M_3 = \frac{EI_3}{(\Delta x)^2} (y_4 - 2y_3 + y_2)$$

$$M_4 = \frac{EI}{(\Delta x)^2} (y_5 - 2y_4 + y_3)$$

$$\begin{array}{c} \cdot \\ \cdot \\ \cdot \end{array} \quad \begin{array}{c} \cdot \\ \cdot \\ \cdot \end{array}$$

(5-9)

$$M_{N-2} = \frac{EI}{(\Delta x)^2} (y_{N-1} - 2y_{N-2} + y_{N-3})$$

$$M_{N-1} = \frac{EI}{(\Delta x)^2} (y_N - 2y_{N-1} + y_{N-2})$$

Notice that even though the left-hand end of the beam occurs at station $l/2$, the displacement y_1 at station 1 is held fixed at zero.

The computer circuit for solving equations (5-8) and (5-9) is shown in Figure 5-3. Initial conditions on y_n and \dot{y}_n must of course be specified in an actual problem.

5.5 Theoretical Solution of the Difference Equations for Vibrating Beams

(a) Hinged-hinged beam.

In order to check the accuracy of the difference method for beams, we will now solve for the normal modes of vibration of a hinged-hinged beam by separation of variables. The resulting mode shapes and frequencies will then be compared with the difference equation solution of the normal modes for a hinged-hinged beam. From equations (5-1) we have for a uniform beam

$$\frac{\rho}{EI} \frac{\partial^2 y}{\partial t^2} + \frac{\partial^4 y}{\partial x^4} = 0 \quad (5-9)$$

with end conditions

$$y(0,t) = y(L,t) = \frac{\partial^2 y}{\partial x^2}(0,t) = \frac{\partial^2 y}{\partial x^2}(L,t) = 0 \quad (5-10)$$

We separate variables by assuming that

$$y(x,t) = X(x) T(t) \quad (5-11)$$

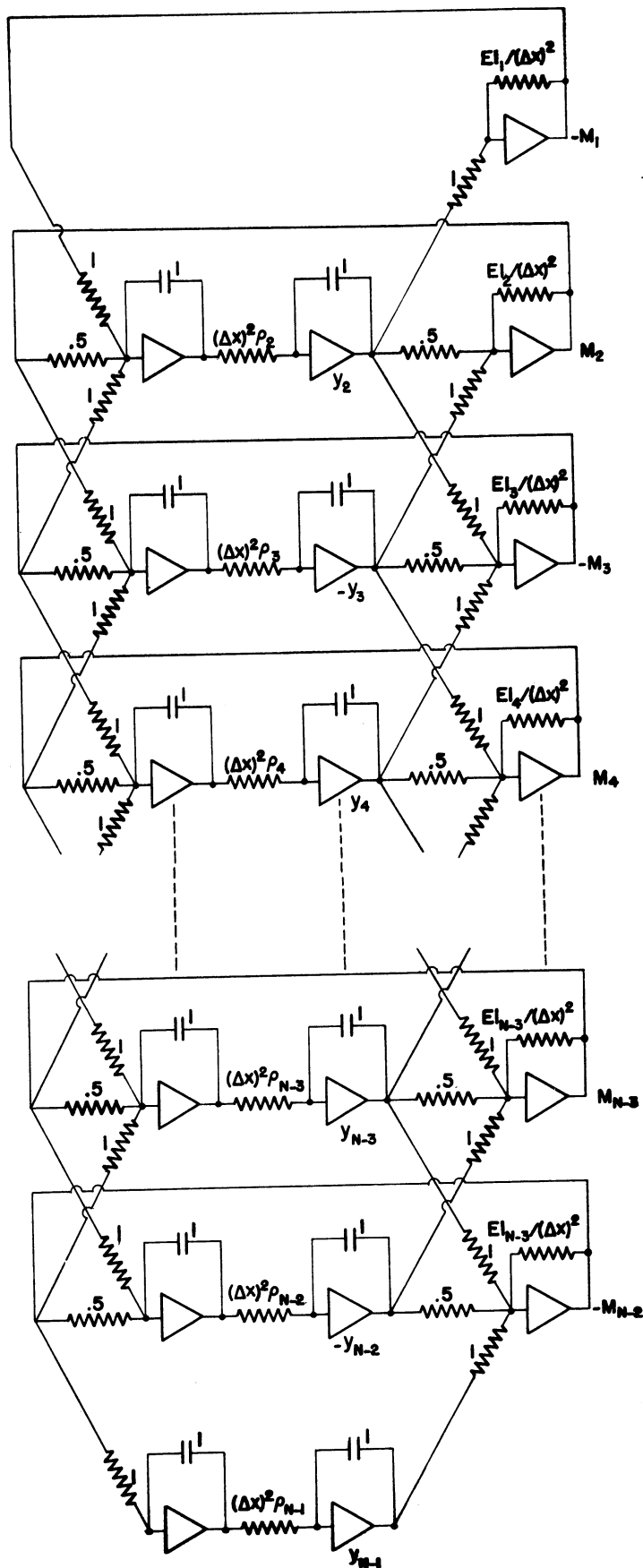

Figure 5-3. Computer Circuit for Solving the Cantilever Beam by the Difference Method.

Substituting equation (5-11) into (5-9), we have

$$\frac{\rho}{EI} \frac{T''}{T} = \frac{X^{IV}}{X} = -\alpha^2 = \text{constant} \quad (5-12)$$

from which

$$T'' + \alpha^2 \frac{EI}{\rho} T = 0 \quad (5-13)$$

and

$$X^{IV} + \alpha^2 X = 0 \quad (5-14)$$

The solution to the first of these equations is

$$T(t) = A \cos \alpha \sqrt{\frac{EI}{\rho}} t + B \sin \alpha \sqrt{\frac{EI}{\rho}} t. \quad (5-15)$$

The only way the boundary condition (5-10) can be met is if $X(0) = X(L) = X''(0) = X''(L) = 0$. Hence, equation (5-14) has the solution

$$X(x) = \sin \sqrt{\alpha} x = \sin \frac{n\pi x}{L}, \quad n = 1, 2, 3, \dots \quad (5-16)$$

from which α can have only discrete values α_n given by

$$\alpha_n = \left(\frac{n\pi}{L}\right)^2, \quad n = 1, 2, 3, \dots \quad (5-17)$$

Thus, from equations (5-15) and (5-17) the normal mode frequencies ω_n are

$$\omega_n = n^2 \pi^2 \sqrt{\frac{EI}{\rho L^4}}. \quad (5-18)$$

The shape of the modes is seen from equation (5-16) to be sinesoidal.

Let us now proceed to solve for the normal modes of the uniform hinged-hinged beam when the spacial derivatives are replaced by finite differences. If we select our unit of x so that $\Delta x = 1$ and hence $L = N \Delta x = N$, the equation of motion for the i th cell becomes from (5-4) and (5-5)

$$\frac{\rho}{EI} \frac{d^2 y_i}{dt^2} + y_{i+2} - 4y_{i+1} + 6y_i - 4y_{i-1} + y_{i-2} = 0. \quad (5-19)$$

We now assume that the normal modes of vibration of the difference equation are the same as those for the continuous beam, namely, sinesoidal. Then for the nth mode

$$y_i = a \sin \frac{n\pi i}{N} \sin \lambda_n t \quad (5-20)$$

where λ_n is the normal mode frequency for the nth mode. It is evident that this solution satisfies the boundary conditions that $y_0 = M_0 = 0$ and $y_N = M_N = 0$. Substituting equation (5-20) into (5-19) we find that

$$\lambda_n^2 = \frac{2EI}{\rho} \left[3 - 4 \cos \frac{n\pi}{N} + \cos \frac{2n\pi}{N} \right] \quad (5-21)$$

is the expression for λ_n . After expanding the cosine functions of (5-21) in a power series, it follows that

$$\lambda_n^2 = \frac{EI}{\rho N^4} (n\pi)^4 \left[1 - \frac{1}{6} \left(\frac{n\pi}{N} \right)^2 + \dots \right]. \quad (5-22)$$

Since here $N = L$, comparison of equation (5-22) with equation (5-18) shows that as the number of cells N becomes very large, the normal-mode frequency λ_n approaches the value ω_n for the continuous beam. For finite N the difference equation frequency λ_n is somewhat lower than the true frequency ω_n . A plot of the percentage deviation in normal-mode frequency versus the number of cells is shown in Figure 5-4 for the first five modes.

(b) Free-free beam.

One can solve for the normal modes of vibration of a uniform free-free beam by separating variables, just as we did for the hinged-hinged beam. However, in order to find the normal-mode frequencies ω_n it is necessary to solve for the roots of a transcendental equation.⁵ If we define a dimensionless frequency parameter β_n as

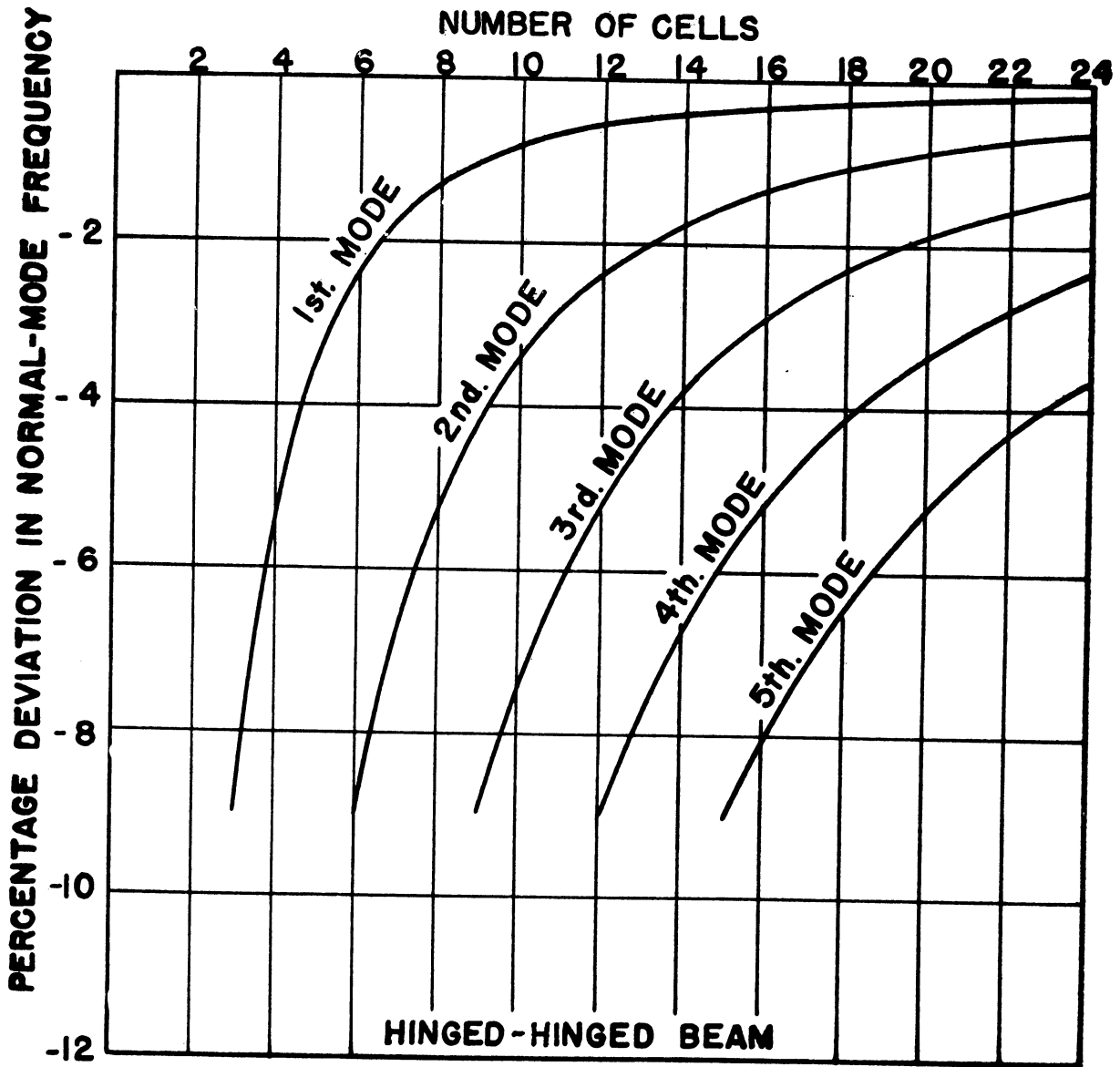

Figure 5-4. Frequency Deviation for a Hinged-Hinged Beam.

$$\beta_n = \frac{\omega_n}{\sqrt{\frac{EI}{\rho L^4}}} \quad (5-23)$$

then the values of β_n for the first five modes of a free-free beam are:

1	2	3	4	5
22.4	61.6	121.0	199.8	298.6

It is not so straightforward to solve for the normal modes of the difference equation representation of the uniform, free-free beam. If we choose our units of x so that $\Delta x = 1$ and our units of time so that $\frac{\rho}{EI} = 1$, then from equations (5-4) and (5-5) we have for the i th cell

$$\ddot{y}_i + y_{i+2} - 4y_{i+1} + 6y_i - 4y_{i-1} + y_{i-2} = 0. \quad (5-24)$$

After we apply the boundary conditions we are left with a set of N ordinary differential equations. Contrary to the case of the hinged-hinged beam, it is not easy to solve for the normal modes here in general. Rather, we have to choose a particular number of cells N , write down the specific difference equations, and solve for the normal modes by a direct but tedious process.

Suppose, for example, we decide to solve for the normal modes for 8 cells. If we choose the ends of the beam at the $1/2$ station and $8-1/2$ station, then from equation (5-24) and the boundary conditions in Section 5.7 for a free-free beam we have the following set of equations:

$$\begin{aligned} \ddot{y}_1 + y_1 - 2y_2 + y_3 &= 0 \\ \ddot{y}_2 - 2y_1 + 5y_2 - 4y_3 + y_4 &= 0 \\ \ddot{y}_3 + y_1 - 4y_2 + 6y_3 - 4y_4 + y_5 &= 0 \\ \ddot{y}_4 + y_2 - 4y_3 + 6y_4 - 4y_5 + y_6 &= 0 \\ \ddot{y}_5 + y_3 - 4y_4 + 6y_5 - 4y_6 + y_7 &= 0 \end{aligned} \quad (5-25)$$

$$\ddot{y}_6 + y_4 - 4y_5 + 6y_6 - 4y_7 + y_8 = 0$$

$$\ddot{y}_7 + y_5 - 4y_6 + 5y_7 - 2y_8 = 0$$

$$\ddot{y}_8 + y_6 - 2y_7 + y_8 = 0$$

In order to solve for the normal modes of vibration we assume that at the i th station, y_i varies with time as $\sin \lambda t$, where λ is the frequency of the oscillation. Making this substitution in equations (5-25) gives us

$$\begin{aligned} (1 - \lambda^2)y_1 - 2y_2 + y_3 &= 0 \\ -2y_1 + (5 - \lambda^2)y_2 - 4y_3 + y_4 &= 0 \\ y_1 - 4y_2 + (6 - \lambda^2)y_3 - 4y_4 + y_5 &= 0 \\ y_2 - 4y_3 + (6 - \lambda^2)y_4 - 4y_5 + y_6 &= 0 \\ y_3 - 4y_4 + (6 - \lambda^2)y_5 - 4y_6 + y_7 &= 0 \\ y_4 - 4y_5 + (6 - \lambda^2)y_6 - 4y_7 + y_8 &= 0 \\ y_5 - 4y_6 + (5 - \lambda^2)y_7 - 2y_8 &= 0 \\ y_6 - 2y_7 + (1 - \lambda^2)y_8 &= 0 \end{aligned} \quad (5-26)$$

The only nontrivial solution of these 8 simultaneous algebraic equations is the one for which the determinant of the coefficients vanishes; i.e., we have to eliminate the y 's and find an equation in λ . When the tedious algebra is carried out, one is left with the following equation in λ^2 :

$$-336 + 3312\lambda^2 - 5140\lambda^4 + 2432\lambda^6 - 456\lambda^8 + 36\lambda^{10} - \lambda^{12} = 0. \quad (5-27)$$

The roots of the polynomial then represent the normal-mode frequencies. The first three values of λ_n obtained from equation (5-27) are

$$\lambda_1 = 0.352, \lambda_2 = 0.940, \lambda_3 = 1.74 .$$

From equation (5-23) we must evidently multiply λ_n by 64 to obtain β_n for the 8 cell free-free beam, since now $L = N = 8$, and $EI/\rho = 1$. A summary of the dimensionless normal-mode frequencies β_n for the continuous beam and the cellular beam is shown below.

Free-Free Beam

<u>Mode</u>	<u>(continuous beam)</u>	<u>(8 cells)</u>	<u>% deviation</u>
1	22.37	22.55	+ 0.8
2	61.7	60.1	- 2.5
3	121.0	111.3	- 8.0

Comparison of these results with those for the hinged-hinged beam with 8 cells (see Figure 5-4) indicate that the difference method gives somewhat more accurate frequencies for the normal modes of a free-free beam.

In order to solve for the mode shapes, it is necessary to substitute the roots λ_n back into equations (5-26). In Figure 5-5 a comparison of the 8-cell mode shapes with the mode shapes for the continuous beam is made.

(c) Cantilever beam.

When the space and time variables are separated in the equation for a cantilever beam and the normal-mode frequencies are determined, the following values of the dimensionless frequency parameter β_n defined in equation (5-23) are obtained:⁵

1	2	3	4	5
3.516	22.03	61.7	121.0	199.8

If the units are selected so that $\Delta x = 1$ and $\rho/EI = 1$, equation (5-24) represents the difference equation for y_i when the cantilever beam is broken into cells. Again let us consider 8 cells. When the boundary conditions outlined in Section 5.3 are applied (left end built in, right end free) the following set of seven simultaneous difference equations result:

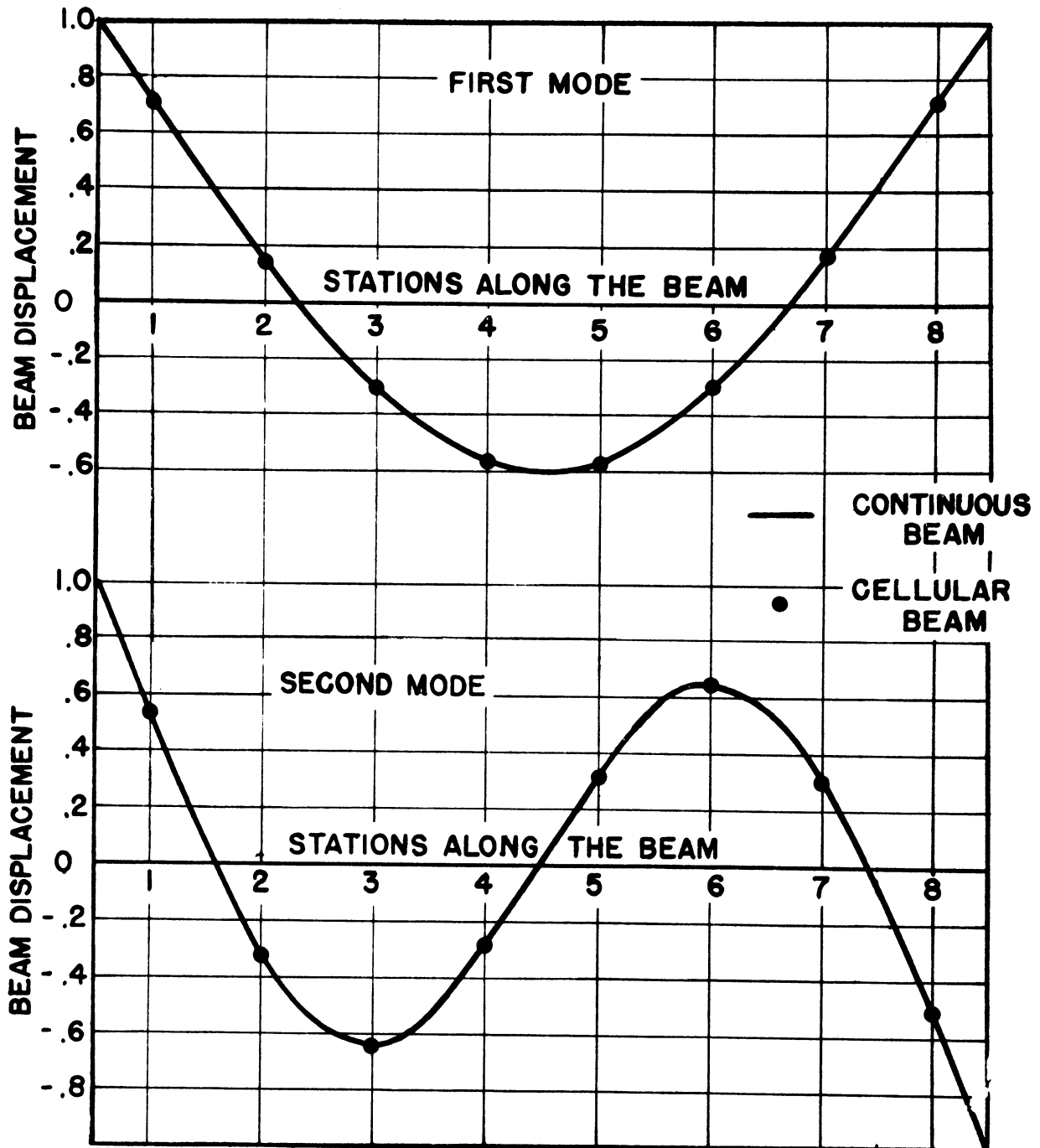

Figure 5-5. Comparison of Mode shapes for 8-Cell Free-Free and Continuous Beam.

$$\begin{aligned}
 y_2 + 6y_2 - 4y_3 + y_4 &= 0 \\
 y_3 - 4y_2 + 6y_3 - 4y_4 + y_5 &= 0 \\
 y_4 + y_2 - 4y_3 + 6y_4 - 4y_5 + y_6 &= 0 \\
 y_5 + y_3 - 4y_4 + 6y_5 - 4y_6 + y_7 &= 0 \\
 y_6 + y_4 - 4y_5 + 6y_6 - 4y_7 + y_8 &= 0 \\
 y_7 + y_5 - 4y_6 + 5y_7 - 2y_8 &= 0 \\
 y_8 + y_6 - 2y_7 + y_8 &= 0
 \end{aligned}
 \tag{5-28}$$

As before, we assume y_i varies with time as $\sin \lambda t$. Equations (5-28) are then reduced to 7 simultaneous algebraic equations. Eliminating the y 's gives us

$$1 - 336\lambda^2 + 3312\lambda^4 - 5140\lambda^6 + 2432\lambda^8 - 456\lambda^{10} + 36\lambda^{12} - \lambda^{14} = 0.$$

(5-39)

The roots of the above polynomial in λ^2 are the normal mode frequencies. The first four values of λ_n obtained from equation (5-29) are

$$\lambda_1 = 0.0554, \lambda_2 = 0.347, \lambda_3 = 0.940, \lambda_4 = 1.77.$$

For our 8-cell cantilever beam $\Delta x = 1$ and $L = N = 8$. Also, $EI/\rho = 1$ and hence the dimensionless normal-mode frequency β_n of equation (5-23) is obtained by multiplying λ by 64. In the following table β_n for the 8-cell beam is compared with β_n for the continuous beam.

Mode	Cantilever Beam		% deviation
	(continuous beam)	(8 cells)	
1	3.516	3.545	+ 0.8
2	22.03	22.2	+ 0.8
3	61.7	60.1	- 2.5
4	121.0	111.3	- 8.0

Evidently an 8-cell uniform cantilever beam (actually requiring only 22 operational amplifiers) gives tolerable normal-mode frequencies for the first four modes. For many engineering problems this would be entirely adequate. Difference-equation representation of a nonuniform cantilever beam would presumably give the same order of accuracy.

The mode shapes are calculated in the same manner used for the free-free beam. In Figure 5-6 these mode shapes are compared with those for the continuous beam. Agreement seems to be entirely satisfactory.

5.6 Computer Solution for a 5-Cell Cantilever Beam

By choosing our units of x so that $\Delta x = 1$ and our units of time so that $\rho/EI = 1$, then from equations (5-4) and (5-5) the equation for the i th cell becomes

$$\ddot{y}_i + y_{i+2} - 4y_{i+1} + 6y_i - 4y_{i-1} + y_{i-2} = 0. \quad (5-24)$$

For the 5-cell beam under consideration here let us assume that the clamped end occurs at the $1/2$ station and the free end at the $5-1/2$ station. Then after applying the boundary conditions as in Section 5.5c we are left with four differential difference equations:

$$\begin{aligned} \ddot{y}_2 + 6y_2 - 4y_3 + y_4 &= 0 \\ \ddot{y}_3 - 4y_2 + 6y_3 - 4y_4 + y_5 &= 0 \\ \ddot{y}_4 + y_2 - 4y_3 + 5y_4 - 2y_5 &= 0 \\ \ddot{y}_5 + y_3 - 2y_4 + y_5 &= 0 \end{aligned} \quad (5-30)$$

We note that the length of our beam is $L = N \Delta x = 5$ for 5 cells. From equation (5-23) and the table for β_n in Section 5c the period of the fundamental mode for an N cell cantilever beam is

$$T_n = \frac{2\pi}{\lambda_n} = \frac{2\pi L^2}{\beta_n \sqrt{\frac{EI}{\rho}}} = \frac{2\pi N^2}{\beta_n} \quad (5-31)$$

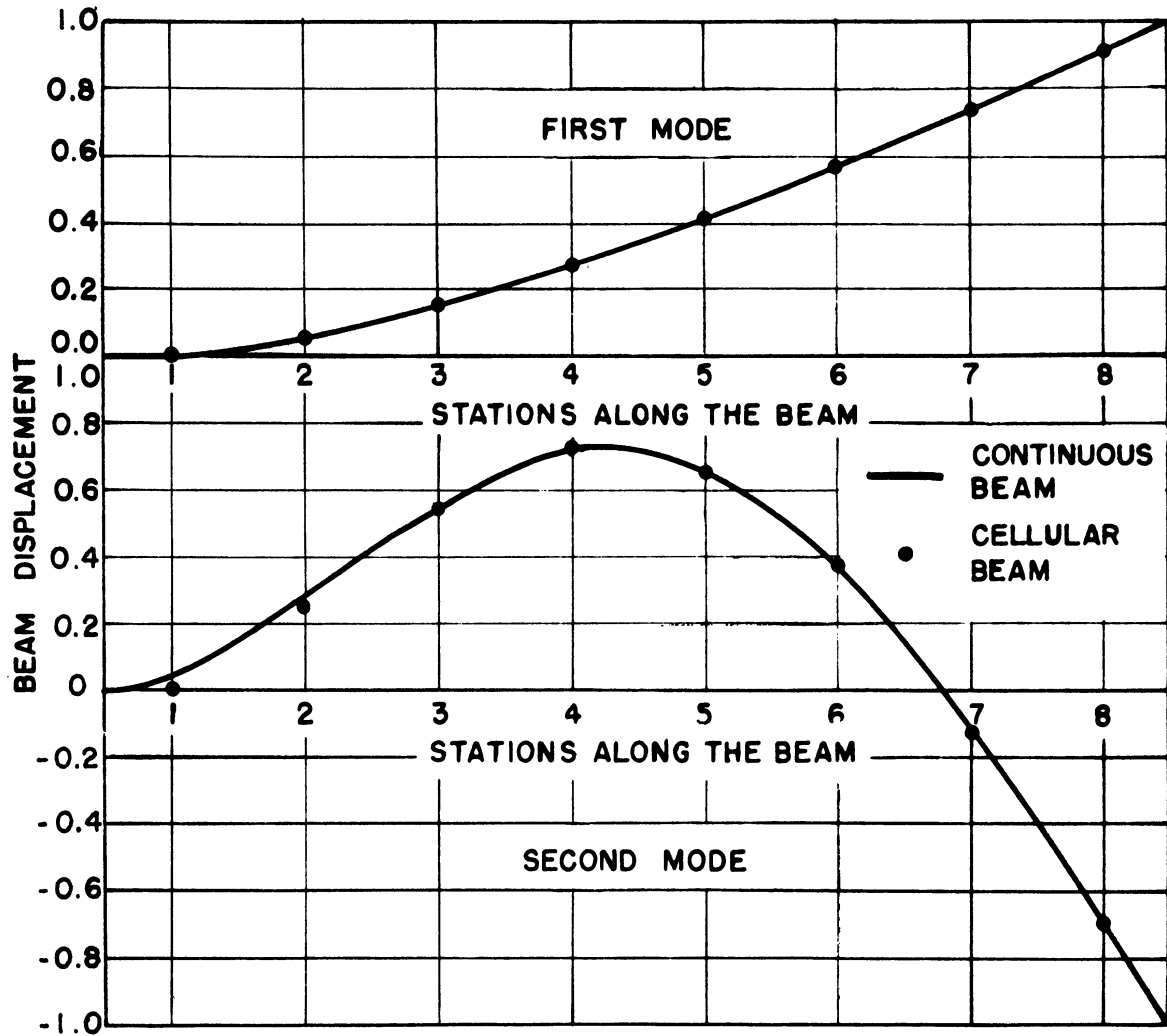

Figure 5-6. Comparison of Mode Shapes for 8-Cell Cantilever Beam and Continuous Beam.

since $EI/\rho = 1$ for our beam. Thus, when $N = 5$ we find that $T_1 = 44.7$ seconds, which is somewhat inconvenient for the electronic differential analyzer. In order to shorten the normal-mode periods by a factor of five the input resistor to each of the integrating amplifiers is reduced by a factor of five. Then one unit of computer time actually is the equivalent of 0.2 seconds. The computer circuit for the 5-cell cantilever beam is shown in Figure 5.7.

It was decided to examine the response of the beam to a step force applied at station 3, i.e., at the middle of the beam. In order to do this, a voltage $V(t)$ was summed with the various feedbacks of station 3 (see Figure 5-7). A constant voltage was first applied and resistors were inserted across several of the integrating condensers to damp out the resulting beam oscillations. The damping resistors were then removed and finally the constant voltage input was released. This corresponds to suddenly removing a force at station 3. The resulting computer response at each of the four stations is shown in Figure 5-8. Note that the second harmonic is clearly visible at stations 2 and 3. Higher harmonics (There are four in all) are visible in Figure 5-9, where the acceleration \ddot{y}_2 (near the clamped end of the beam) is shown as a function of time.

From Figure 5-8 the periods of the fundamental and second harmonic are 8.90 and 1.42 seconds, corresponding to 44.5 and 7.1 units of computer time. From equation (5-31) the value of β_n for $n = 1$ and $n = 2$ can be calculated. In the following table these values of β_1 and β_2 are compared with those for a continuous cantilever beam and those calculated for a 5-cell beam using the method of Section 5.5c.

Mode	(continuous beam)	(computer, 5 cells)	(theoretical, 5 cells)
1	3.516	3.54	3.59
2	22.03	22.1	22.3

The theoretical values of β for a 5-cell cantilever beam were calculated by assuming y_1 varies in time as $\sin \lambda t$. Equations (5-30) then become algebraic and are satisfied only for those values of λ satisfying the equation

$$1 - 50\lambda^2 + 75\lambda^4 - 18\lambda^6 + \lambda^8 = 0 \quad (5-32)$$

By multiplying the roots of this polynomial by $N^2 = 25$ as in Section 5.5c, one obtains the values of frequency parameter β .

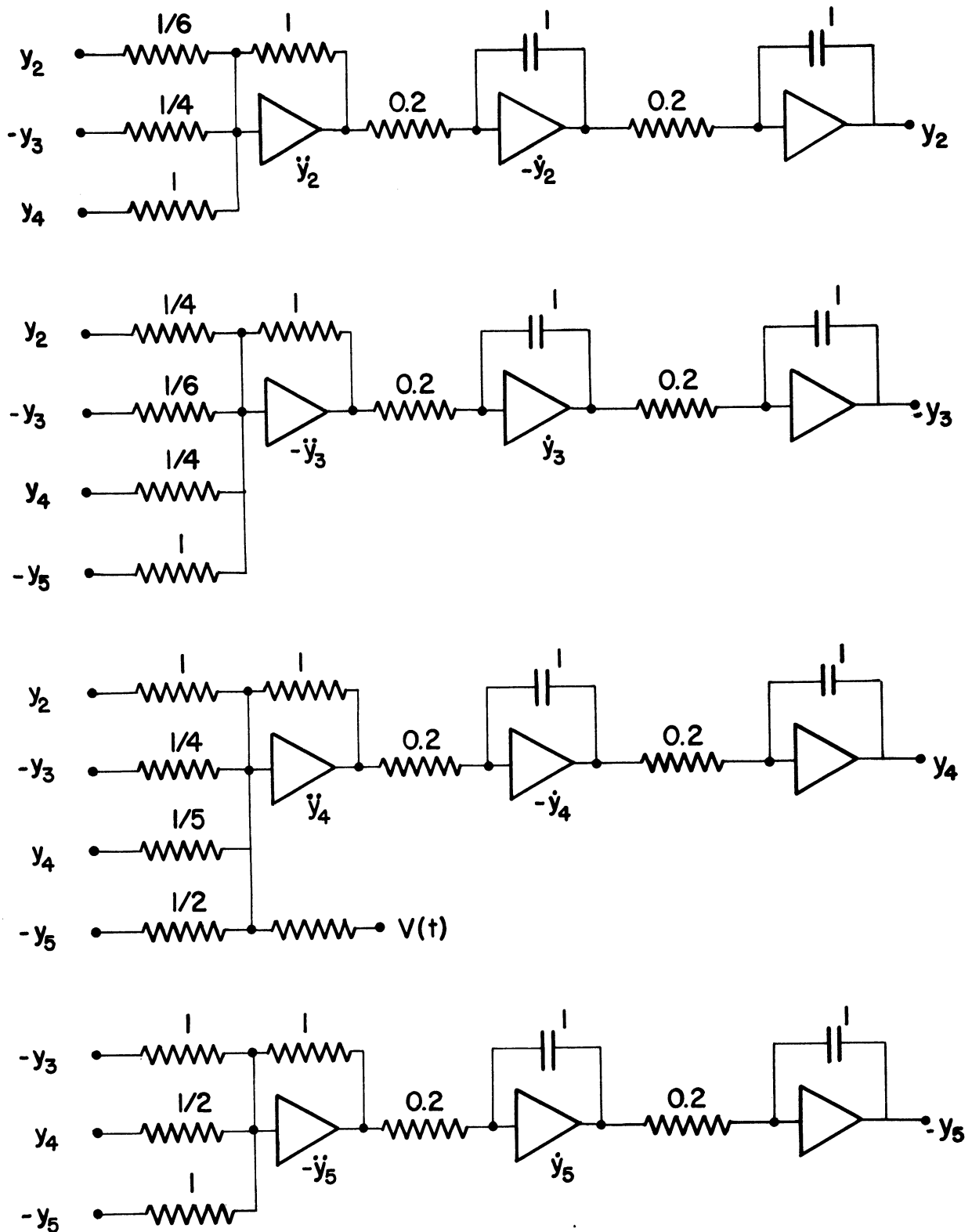

FEEDBACK CONNECTIONS OMITTED FOR CLARITY

Figure 5-7. Computer Circuit for 5-Cell Cantilever Beam.

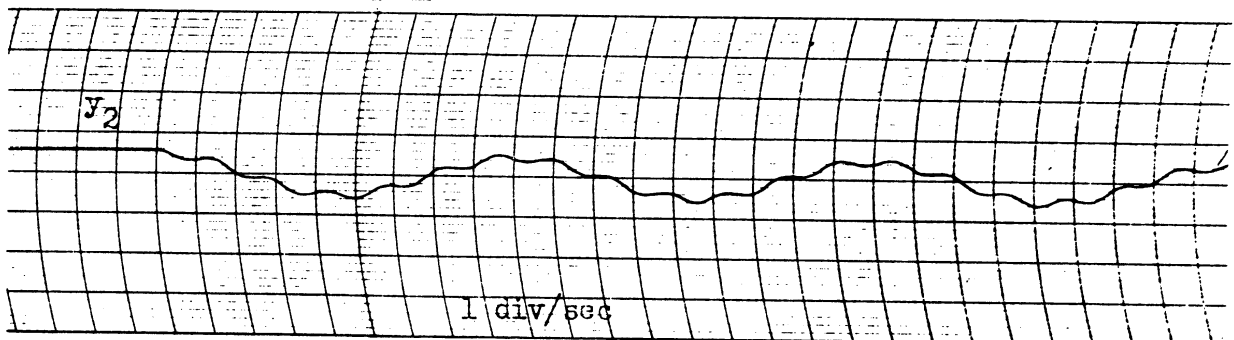

CHART NO. BL

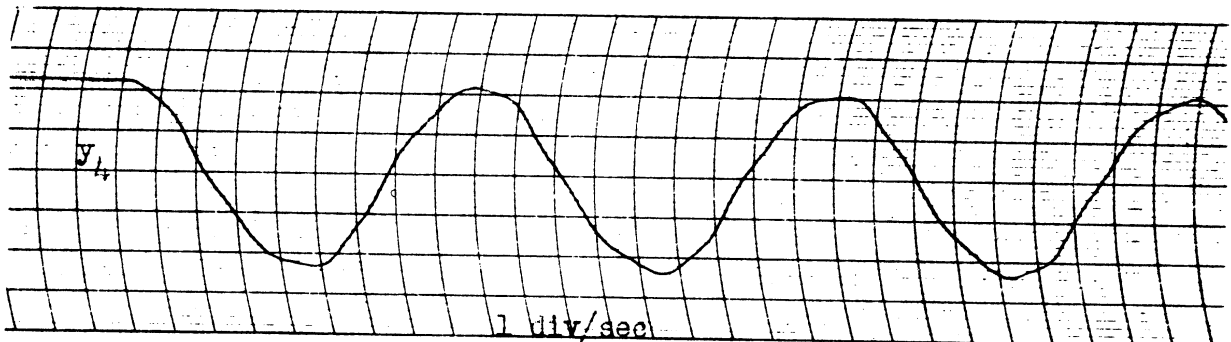
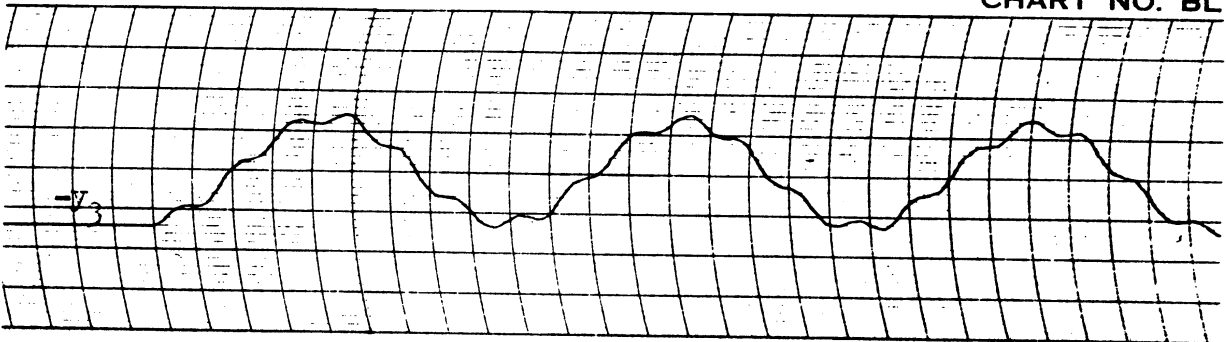

CHART NO. BL-924

THE BRUSH DEVELOPMENT C

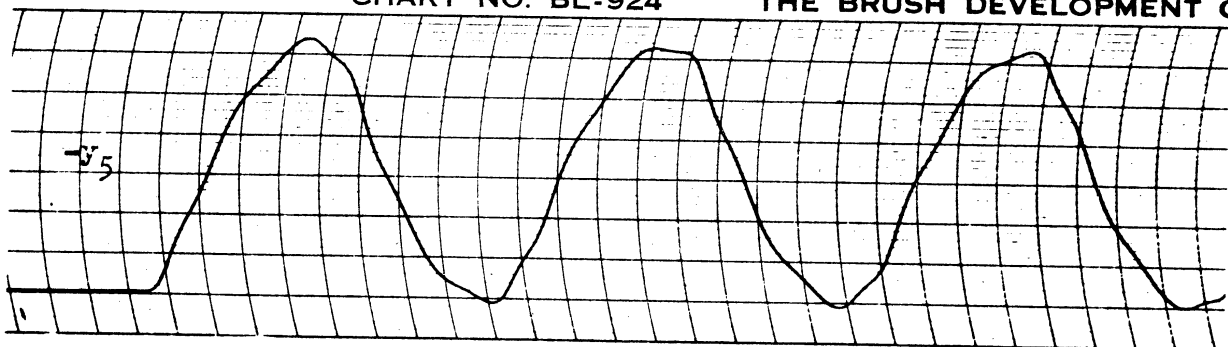

Figure 5-8. Computer Solution for 5-Cell Cantilever Beam.

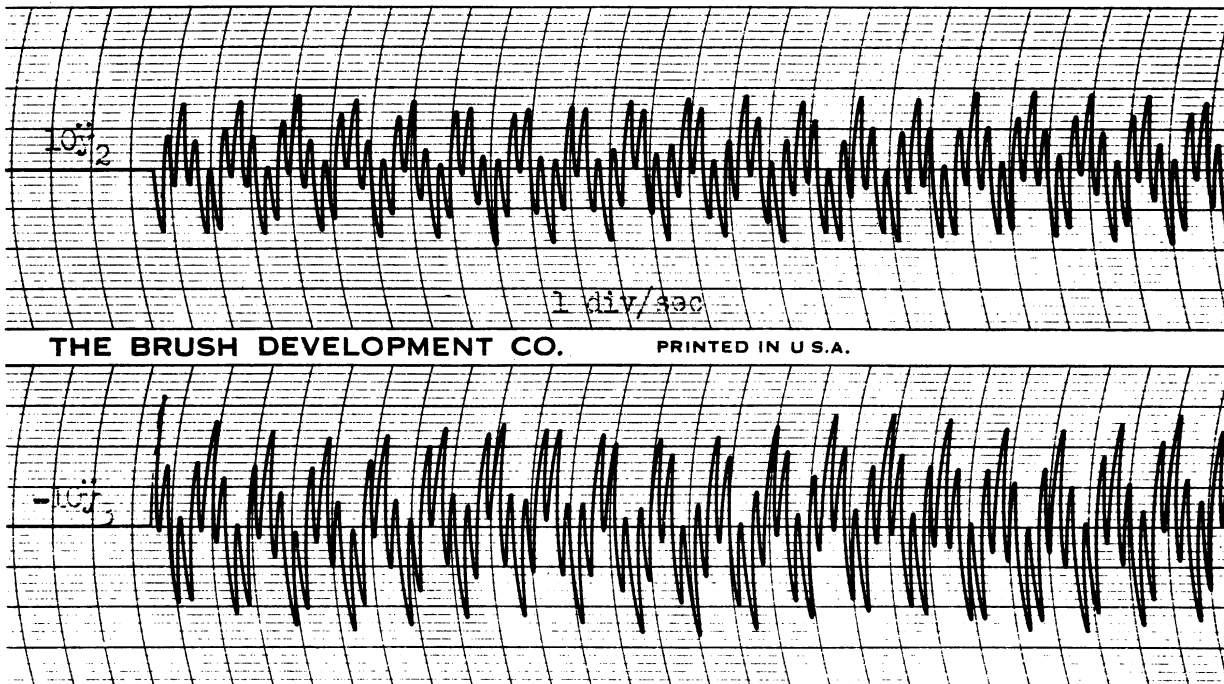

Figure 5-9. Acceleration along the 5-Cell Cantilever Beam
Following a Step Input Force.

It should be remarked that the input resistors to each summing amplifier were matched to 0.1 percent. This is necessary to assure that accurate differences are obtained. This point is analyzed in the next section.

5.7 Accuracy Requirements for the Difference Technique

(a) Component accuracy.

One of the fundamental difficulties encountered when continuous derivatives are replaced by finite differences is that the smaller the interval used, the more accuracy is required in taking the difference. This is particularly true when the order of the derivative is high, such as fourth order.

In the case of the vibrating beam, it is evident that the greater the number of cells for any half-wave length of a normal mode, the smaller the differences become and the more critical the accuracy requirements become for the summing resistors. For example, consider the 5-cell cantilever beam of

the previous section. Suppose all the summing resistors in Figure 5-7 are perfectly accurate except the y_3 input resistor to the bottom bank of amplifiers. Let us assume that it is 1 percent high, i.e., 1.01 instead of 1 megohm. Then, the difference equations are exactly the same as those given in (5-30) except that the last equation is now

$$\ddot{y}_5 + 1.01y_3 - 2y_4 + y_5 = 0 .$$

The characteristic polynomial for this perturbed system is

$$1.11 - 49.87\lambda^2 + 74.99\lambda^4 - 18\lambda^6 + \lambda^8 = 0 \quad (5-33)$$

compared with

$$1 - 50\lambda^2 + 75\lambda^4 - 18\lambda^6 + \lambda^8 = 0 \quad (5-32)$$

for the unperturbed system. The value of β_1 obtained from the first root of equation (5-33) is 3.79, which is 5.6 percent higher than the value of 3.59 calculated for the unperturbed system.

Thus, a 1 percent error in 1 of the 14 summing resistors of Figure 5-7 results in a 5.6 percent error in the frequency of the fundamental mode. The error in the higher modes will be very much less, of course.

This simple example is graphic demonstration of the necessity in maintaining high accuracy in the summing resistors. The main requirement is that the relative values of any set of input resistors to one amplifier be accurate. The absolute values are relatively unimportant. Also, the tolerance in the resistors representing EI and ρ in Figure 5-3 is not critical.

For the summing resistors requiring high tolerance it is planned to use wire-wound resistors matched to the order of 0.01 percent.

(b) Effect of small voltage transients.

The deflection of a beam due to an applied force is proportional to the fourth power of the length of the beam. The deflection of the beam at any point is represented by a voltage output of the electronic differential analyzer, while an applied force is equivalent to a voltage input to a summing amplifier in Figure 5-7. This latter voltage may be deliberately introduced through an input resistor or may be inadvertently introduced through a sudden shift in the balance of a summing amplifier. As a result, transient oscilla-

tions in the whole computer circuit can be caused by fluctuations in power supply voltage. The sensitivity of the network to small voltage inputs will increase as the fourth power of the number of cells.

Thus, it becomes important to have an extremely well regulated power supply.³ Drift stabilized amplifiers would not help a transient condition but would serve to maintain the static deflections to a high degree of accuracy.

5.8. Summary of Difference Technique for Vibrating Beams

The vibrating-beam equation has been solved with the difference method both theoretically and with the electronic differential analyzer. Results show that normal-mode shapes and frequencies exhibit good agreement with continuous beams providing 3 or more cells per half-wave length of the normal mode are used.

If a large number of cells is used, it is necessary to realize extreme precision in the summing resistors in order to be able to take small differences accurately. Also, a large number of cells means that transient voltages, such as might be introduced by power supply fluctuations, must be held to a minimum.

Cantilever and hinged-hinged beams have a fixed equilibrium position relative to their surroundings and hence are stable on the electronic differential analyzer. Free-free beams are not supported, however, and will tend to be unstable, since any small voltage unbalance will cause them to rotate and translate as well as vibrate.

Damping can easily be included in the beam equation by placing the appropriate resistors across integrating condensers. Any variable force as a function of time can be introduced at any point or points along the beam. The final computer response gives directly the bending moment and displacement as a function of time and distance along the beam.

This same difference method can be used to solve beams with both torsional and lateral bending.⁴ In this case the torsional equation is similar to the wave equation treated in Chapter 4. The proper cross-coupling resistors then tie the two systems together.

BIBLIOGRAPHY

1. Hagelbarger, Howe, and Howe, Investigation of the Utility of an Electronic Analog Computer in Engineering Problems, External Memorandum UMM-28 (April 1, 1949), University of Michigan Engineering Research Institute, AF Con. W33-038-ac-14222 (Project MX-794).
2. Howe, Carl E., Further Application of the Electronic Differential Analyzer to the Oscillation of Beams, External Memorandum UMM-47 (June 1, 1950), University of Michigan Engineering Research Institute, AF Con. W33-038-ac-14222 (Project MX-794).
3. Howe, Howe, and Rauch, Application of the Electronic Differential Analyzer to the Oscillation of Beams, Including Shear and Rotary Inertia, External Memorandum UMM-67 (January 1951), University of Michigan Engineering Research Institute.
4. McCann and MacNeal, Beam-Vibration Analysis with the Electric-Analog Computer, Journal of Applied Mechanics, Vol. 17, No. 1, March, 1950.
5. Timoshenko, S.P., Vibration Problems in Engineering, D. Van Nostrand.

