

THE UNIVERSITY OF MICHIGAN
COLLEGE OF ENGINEERING
Department of Naval Architecture and Marine Engineering

RESEARCH IN RESISTANCE AND PROPULSION

Part II. Streamline Calculations for Singularities Distributed
on the Longitudinal Centerplane

Tetsuo Takahei
Finn C. Michelsen
Hun Chol Kim
Nils Salvesen

Project Director: R. B. Couch

ORA Project 04542

under contract with:

MARITIME ADMINISTRATION
U. S. DEPARTMENT OF COMMERCE
CONTRACT NO. MA-2564, TASK 1
WASHINGTON, D.C.

administered through:

OFFICE OF RESEARCH ADMINISTRATION ANN ARBOR

February 1963

TABLE OF CONTENTS

	<u>Page</u>
ABSTRACT.....	iii
INTRODUCTION.....	1
A. The Velocity Potential and Velocity Components due to a given Singularity Distribution.....	6
i) Triangular Draftwise Distribution.....	12
ii) Parabolic Draftwise Distribution.....	12
B. An Approximate Singularity Distribution for Series-60 Water Lines.....	17
BIBLIOGRAPHY.....	20
APPENDIX I Computer Program for the Determination of Streamlines Due to a Prescribed Singularity Distribution on the Center Plane.....	21
A. Cosine Hull.....	33
B. Polynomial Hull.....	41
APPENDIX II Hull Forms Obtained from Stream Line Traces.....	45
APPENDIX III Effects of Depths of Singularity Distributions on Traced Hulls (Series-60, Polynomial Distribution)..	59

ABSTRACT

A computer program was written for the problem of determining the hull form produced by a given singularity distribution defined on the longitudinal center plane.

The program is based on the Runge-Kutta fourth order method in solving the differential equations of the stream lines. Results indicate the number of subdivisions required to meet a specified degree of accuracy. The program admits rather general forms of the singularity distribution functions.

A computer program was also written for the purpose of determining the two-dimensional singularity distribution for a given shape of the waterline. Applied to a Series-60 set of lines the three-dimensional effect of truncation has been investigated and found to be substantial.

Introduction

The linear wave-resistance theory, developed by Michell⁽¹⁾ and Havelock,⁽²⁾ has until recently found very little direct application in the design of ships. Although it was demonstrated many years ago by Wigley⁽³⁾ and Weinblum⁽⁴⁾ among others that the theory would accurately predict the effect on the wave-resistance of small changes in ship form, and also the location of humps and hollows of the wave-resistance curve, it was soon realized that it would not predict the magnitude of the resistance with sufficient accuracy. Introduction of corrections for viscous effects were helpful but not sufficient, mainly because they did not remove the limitations imposed on the theory by the linearized boundary conditions.

The boundaries of concern are the free surface of the sea and the surface of the ship. In regard to the free surface the effect of linearization is probably not too great since it can be shown⁽⁵⁾ that the linear velocity potential is exact to within a second order term. The hull surface is a different matter, however. When Michell formulated his wave-resistance theory in 1898 he made the assumption that approximate conditions on the hull surface were to be satisfied on the longitudinal plane of symmetry of the ship. The theory proposed was therefore exact only for a ship of zero beam. For geosim ship forms of finite beam it predicted the wave-resistance to be proportional to the square of the beam.

When Havelock introduced the concept of representing ship forms by means of a distribution of singularities over the hull surface he did, at least in principle, provide us with an integral expression for the

velocity potential that would, for a given form, satisfy the hull boundary conditions exactly. The evaluation of these integrals, being defined on a rather complex surface, were impractical, if not impossible to solve. By locating the singularities on the longitudinal plane of symmetry and assuming that the strength of the source distribution was proportional to the product of the velocity of the ship and the slope of the hull surface with respect to the direction of motion, Havelock arrived at an expression that was shown to be identical to that of Michell. It appeared therefore, that he had not, in reality, been able to remove any of the limitations of the linearized boundary conditions.

For many years one very important feature of Havelock's expression for the velocity potential seems to have been overlooked until Inui⁽⁶⁾ discussed and made full use of it in much of his extremely important work on wave-resistance. Fully realizing that a source distribution on the center plane did not represent a form as assumed by Havelock, he proceeded to trace the closing streamlines for a given distribution assuming the free surface to be rigid. This assumption can be shown to be not too serious.

The resulting hull forms differed considerably from those of Havelock's theory, especially in regard to the bottom configuration. The waterlines near the free surface were also appreciably different in particular towards the ends. It is important to recognize that the hull forms produced from the streamline traces satisfy the hull boundary conditions to a high order of approximation.

The relationship between singularity distribution and hull form is one to one, i.e. for a given distribution there exists a unique closing

stream surface. In the past it has been customary to determine the singularity distribution from the hull form, whereas, in tracing the streamlines, we are determining the hull form from a given singularity distribution. We shall therefore refer the latter procedure as the inverse method.

The problem of determining the source distribution on the center plane for a given hull form, that would satisfy the hull boundary conditions to the same order of approximation as that obtained by the inverse method, is extremely difficult. It may indeed be impossible to solve because of the beam draft ratios normally used for conventional ship forms. The conditions to be met are further complicated by the presence of flat bottoms. Since the part of the hull close to the free surface gives rise to the greater portion of the wave-making resistance there is general belief, however, that the boundary conditions being violated near the bottom of a ship is not too serious. Experimental results^(7,8) have verified that this is indeed so. It has been brought to our attention that Dr. Pien of D.T.M.B. is currently working on a method by which he is locating the singularity distribution on four vertical planes forming a rhombus in the plane view. In this way he is apparently able to represent more conventional forms. The publication of his results is expected to bring to light a great many important findings. Other avenues of approach may also be available. Inui has, for instance, proposed an additional line sink source distribution along the keel line.

Although, as stated above, the inverse method cannot be expected to represent conventional ship forms when applied to a center plane

distribution of singularities, it does provide us with an accurate tool by which we can investigate many wave-making resistance phenomena. Theoretical calculations coupled with experimental results will also make it possible to investigate effects of viscosity and eddies in a rational manner. This must be kept in mind when considering the great amount of work going into the study of hull forms far removed from those of final interest, namely ship form of more conventional dimensions.

In the world only very few forms have so far been traced. Most of these are shown in the Appendix II. There are two good reasons for this. Firstly, the numerical work of the streamline calculations are lengthy and very involved. Only the very high speed, large computers can bring the cost of calculations down to a reasonable figure. Until the University of Michigan started to trace streamlines using an IBM 7090 digital computer, similar work had, as far as we know, previously been performed on much smaller computers only in Germany and Japan. To emphasize the importance of high speed computers it should be pointed out that the determination of the streamlines for the so-called cosine hull form took two hours in Japan, whereas the same calculations can be performed in three minutes on the IBM 7090. In addition to reducing the required computing time a greater accuracy of results has also been obtained. Figure 1 shows the maximum beam of traced hull form as a function of the number of station used in the calculations. On the basis of this figure we are now using 100 stations (for $L/2$) for our stream line calculations. The details of the computer program is given in the Appendix I.

Secondly, at present, the calculation of the wave-making resistance from the linear theory is complex even for simple singularity

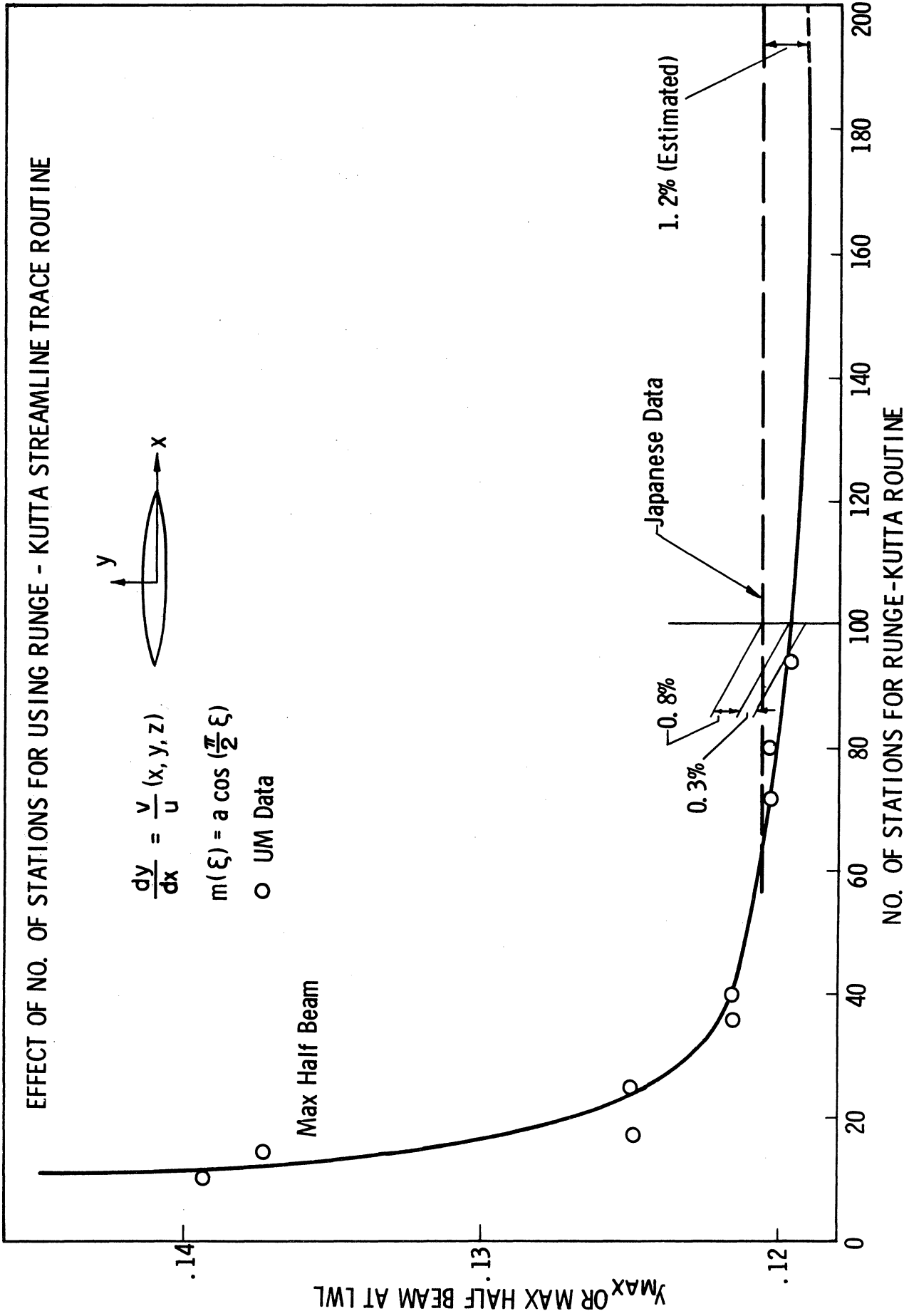

Figure 1

distributions. Much work is being done on the simplifications of these calculations and we hope results will be forthcoming soon. In the meantime fundamental research on the simple hull forms should be continued. The fact that such research is extremely fruitful is readily shown by the experimentally verified concept of wave interference effects of large bulbs. In developing the waveless hull form from theory Inui has lead the way to a new approach to the study of ship resistance characteristics. The horse has been put before the carriage so that theoretical predictions are made before they are experimentally verified, thus making it possible to perform hull form studies in a rational manner.

In the following sections we are reporting on research dealing with the determination of streamlines of hull forms for simple singularity distributions on the center plane completed at the U of M to date. Much of this is still only in the form of equations which remains to be computed. The computer program has been run for the cosine hull forms, however, and is checked against results of calculations made in Japan. The existing program will admit very general singularity distributions and additional forms will be determined as they become part of our overall study of wave-making resistance characteristic of ship hulls.

A. The Velocity Potential and Velocity Components due to a given Singularity Distribution.

For a given hull form the linear wave-resistance theory assumes that the hull can be represented by a distribution of singularities.

This distribution can be divided into three parts.

- (i) A distribution of sources in the plane of symmetry of the ship of strength given by the slope of the hull surface.

- (ii) An image system, with respect to the static free surface, of source distribution as given by (i).
- (iii) A distribution of singularities distributed above the free-surface to satisfy the free-surface conditions.

The systems (i) and (iii) combined represent the double model of the given hull form moving in an infinite fluid region.

The assumption of the linear theory that the source strength at a point in the plane of symmetry of the ship is given by the slope of hull form at that point is only exact in the limit as the beam approaches zero.

For a hypothetical wall sided model of infinite draft the problem of determining the closed stream lines of the source distribution representing the hull, neglecting the free surface effects, is reduced to a two-dimensional case. It can be solved either by the method of conformal mapping or by solving a first degree integral equation.⁽⁶⁾ In the case of finite draft, i.e., a three dimensional hull form, the direct problem of obtaining the singularity distribution which represents a given hull form becomes extremely difficult even if the free surface effects are neglected. Its solution involves integral equations of the second order.

No simple method of correcting for the finite beam exists. In an attempt to satisfy the hull boundary conditions exactly, Inui⁽⁶⁾ and Eggers⁽⁹⁾ considered therefore the inverse problem, namely, the determination of the hull form produced by a given singularity distribution.

The complete inverse problem, which includes the contribution from the singularity system (iii), becomes a very difficult one to solve.

The secondary effect of system (iii) is relatively small at small Froude numbers, however, and only the singularity distribution representing a double model moving at constant speed in an infinite fluid needs to be considered.

Let the singularity distribution to be of the simple form

$$m(\xi, \zeta) = f_1(\xi) \cdot f_2(\zeta) \quad (1)$$

where $m(\xi, \zeta)$ is the strength of a distributed source (flow per unit area per unit time) divided by the ship's speed V . Because a double model has to be considered, the region of source distribution is given by

$$-1 \leq \xi \leq 1, \quad -t \leq \zeta \leq t \quad (2)$$

where

$$\xi = \frac{x'}{L}, \quad \zeta = \frac{z'}{2L},$$

the length of the ship being equal to $2L$ and the draft of the ship at bow and stern, $T_F = tL/2$.

Since it is required that the hull form be closed, the total source strength must be equal to zero, thus

$$\int_{-t}^t \int_{-1}^1 m(\xi, \zeta) d\xi d\zeta = 0$$

Due to symmetry with respect to the L.W.L. it follows that

$$m(\xi, -\zeta) = m(\xi, \zeta)$$

For fore-and-aft symmetry,

$$m(\xi, \zeta) = -m(\xi, \zeta)$$

For a source distribution of this type, the location of stagnation points at bow and stern ξ_f and ξ_a become:

$$\xi_f = 1 + \epsilon$$

$$\xi_a = -1 - \epsilon$$

Ship length is in reality $2 + 2\epsilon$, but ϵ is normally small and is neglected. Drafts at bow and stern becomes $t + \epsilon'$ by similar analogy, but ϵ' can also be neglected.

The velocity potential due to a source distribution $m(\xi, \zeta)$ in a uniform flow is

$$\phi(x, y, z) = - \frac{1}{4\pi} \int_{-t}^t \int_{-1}^1 \frac{m(\xi, \zeta) d\xi d\zeta}{\sqrt{(x - \xi)^2 + y^2 + (z - \zeta)^2}} - x$$

and by definition the velocity components become

$$m = + \frac{\partial \phi}{\partial x} = + \frac{1}{4\pi} \int_{-t}^{+t} \int_{-1}^1 \frac{m(\xi, \zeta) (x - \xi)}{R^3} d\xi d\zeta + 1$$

$$v = + \frac{\partial \phi}{\partial y} = \frac{1}{4\pi} \int_{-t}^{+t} \int_{-1}^1 \frac{m(\xi, \zeta) y}{R^3} d\xi d\zeta$$

$$w = + \frac{\partial \phi}{\partial z} = \frac{1}{4\pi} \int_{-t}^{+t} \int_{-1}^1 \frac{m(\xi, \zeta) (z - \zeta)}{R^3} d\xi d\zeta$$

where $R^2 = (x - \xi)^2 + y^2 + (z - \zeta)^2$

The velocity components can be substituted into the differential equation for the streamlines given by

$$\frac{dx}{u} = \frac{dy}{v} = \frac{dz}{w}$$

and a stream line may thus be obtained by means of successive integration using the Runge-Kutta method. Four or five suitably chosen streamlines will normally define a hull form with sufficient accuracy. As for the initial values of the integral, $u(1 + \epsilon, 0, 0) = 0$ gives the stagnation point at the bow. The value of ϵ is determined by equating u to zero. It is preferable to start at $x = 1$, and since the flow around the bow is essentially two-dimensional the initial value of y may be determined from the two-dimensional case as outlined later. The initial value of z is optional within the depth of the singularity distribution. Actually the streamlines converge closely toward the midship and a slight error in the starting value of y makes little difference in the tracing of the streamlines.

When the singularity distribution is uniform draftwise,

$$f_2(\xi) = 1 \quad (-t \leq \xi \leq t)$$

the velocity components become

$$\begin{aligned} -4\pi u &= 4\pi - \int_{-t}^t \int_{-1}^1 \frac{f_1(\xi) (x - \xi) d\xi d\zeta}{R^3} \\ &= \int_{-1}^1 \frac{f_1(\xi) (x - \xi)}{(x - \xi)^2 + y^2} \left(\frac{z - t}{r_t} - \frac{z + t}{r_{-t}} \right) d\xi \\ -4\pi v &= - \int_{-t}^t \int_{-1}^1 \frac{f_1(\xi) y d\xi d\zeta}{R^3} \end{aligned}$$

$$\begin{aligned}
 &= + \int_{-1}^1 \frac{f_1(\xi) y}{(x - \xi)^2 + y^2} \left[\frac{z - t}{r_t} - \frac{z + t}{r_{-t}} \right] d\xi \quad (4) \\
 - 4\pi w &= - \int_{-t}^t \int_{-1}^1 \frac{f_1(\xi) (z - \zeta) d\xi d\zeta}{R^3} \\
 &= - \int_{-1}^1 f_1(\xi) \left(\frac{1}{r_t} - \frac{1}{r_{-t}} \right) d\xi
 \end{aligned}$$

where

$$\begin{aligned}
 r_t &= [(x - \xi)^2 + y^2 + (z - t)^2]^{1/2} \\
 r_{-t} &= [(x - \xi)^2 + y^2 + (z + t)^2]^{1/2}
 \end{aligned}$$

For two dimensional flow, the streamline is given by

$$y = \frac{1}{2\pi} \int_{-1}^1 f_1(\xi) \tan^{-1} \left(\frac{y}{x - \xi} \right) d\xi \quad (5)$$

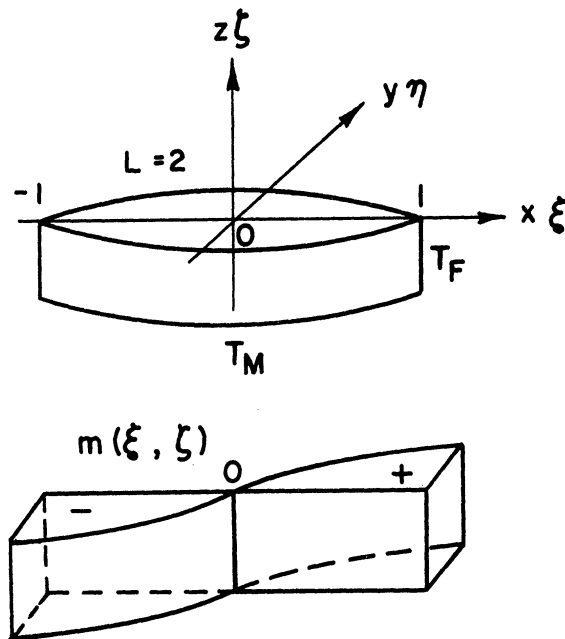

Figure 2. Uniform draftwise distribution.

For non-uniform draftwise rectangular source distribution the velocity components for two special cases become

i. Triangular draftwise distribution

$$m(\xi, \zeta) = m_1(\xi) \cdot m_2(\zeta)$$

$$\text{where } m_2(\zeta) = 1 - \left| \frac{\zeta}{t} \right|$$

$$\begin{aligned} u &= -1 + \frac{1}{4\pi t} \int_{-1}^{+1} m_1(\xi) \frac{(x - \xi)}{r^2} (r_t + r_{-t} - 2r_0) d\xi \\ v &= \frac{1}{4\pi t} \int_{-1}^{+1} m_1(\xi) \frac{y}{r^2} (r_t + r_{-t} - 2r_0) d\xi \\ w &= \frac{1}{4\pi t} \int_{-1}^{+1} m_1(\xi) \log_e \frac{(z + r_0)^2}{(z - t + r_t)(z + t + r_{-t})} d\xi \end{aligned} \quad (6)$$

$$\begin{aligned} \text{where } r_0^2 &= (x - \xi)^2 + y^2 + z^2 \\ r^2 &= (x - \xi)^2 + y^2 \\ r_t^2 &= (x - \xi)^2 + y^2 \end{aligned}$$

ii. Parabolic draftwise distribution

$$m(\xi, \zeta) = m_1(\xi) \cdot m_2(\zeta)$$

$$\text{where } m_2(\zeta) = 1 - \left(\frac{\zeta}{t} \right)^2$$

$$\begin{aligned} u &= -1 + \frac{1}{4\pi t^2} \int_{-1}^{+1} m_1(\xi) \frac{x - \xi}{r^2} \cdot [(z + t) \cdot r_t - (z - t)r_{-t}] d\xi \\ &+ \frac{1}{4\pi t^2} \int_{-1}^{+1} m_1(\xi) (x - \xi) \log_e \frac{z - t + r_t}{z + t + r_{-t}} d\xi \\ v &= \frac{1}{4\pi t^2} \int_{-1}^{+1} m_1(\xi) \frac{y}{r^2} [(z + t) \cdot r_t - (z - t) r_{-t}] d\xi \end{aligned} \quad (7)$$

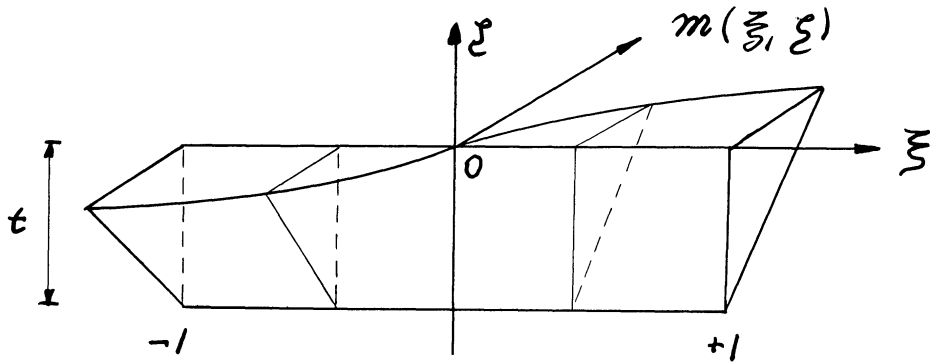

Figure 3. Triangular draftwise source distribution.

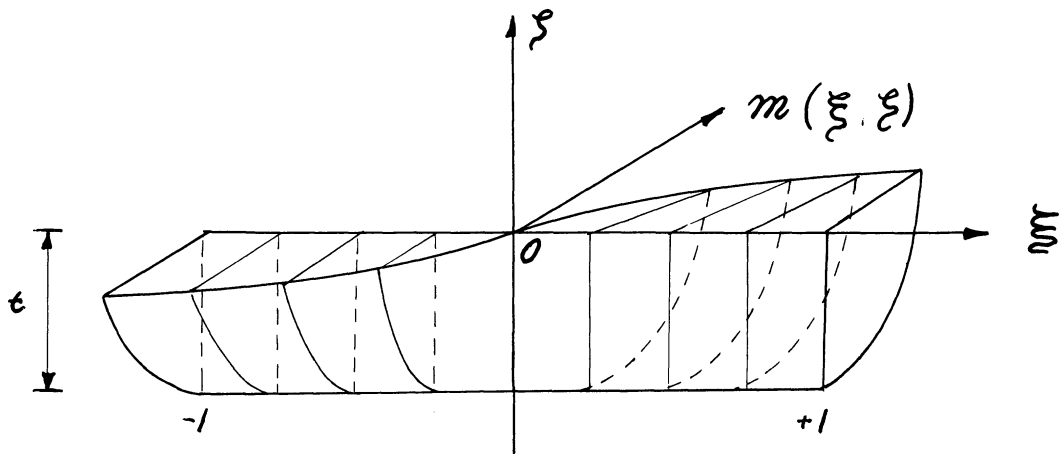

Figure 4. Parabolic draftwise source distribution.

$$+ \frac{1}{4\pi t^2} \int_{-1}^{+1} m_1(\xi) y \log_e \frac{z - t + r_t}{z + t + r_{-t}} d\xi$$

$$w = \frac{1}{4\pi t^2} \int_{-1}^{+1} 2 m_1(\xi) (r_t - r_{-t} + z \log \frac{z + t + r_{-t}}{z - t + r_t}) d\xi$$

In an attempt to reduce the draft of the mathematical hull forms amidships it was decided to investigate the effect of a variation of depth of singularity distribution over the length of the hull. The distribution was again assumed to be of the simple form

$$m(\xi, \zeta) = f_1(\xi) \cdot f_2(\xi)$$

with

$$f_1(\xi) = a_1 |\xi| + a_2 \xi^2 + a_3 \xi^2 |\xi| + a_4 \xi^4 + a_5 \xi^4 |\xi| \quad (8)$$

and

$$f_2(\xi) = 1 - \left(\frac{\xi}{h}\right)^2$$

By definition

$$m(\xi, \zeta) = 0 \quad |\xi| > 1$$

$$= 0 \quad |\zeta| > t(\xi)$$

In general h will also be a function of ξ . For source distribution given in general by Equation 8, the velocity component can be expressed in the following form.

$$u = -1 + \frac{1}{4\pi} \int_{-1}^1 \frac{1}{h^2} m_1(\xi) (x - \xi) \log \frac{z - t(\xi) + r_t}{z + t(\xi) + r_{-t}} d\xi$$

$$+ \frac{1}{4\pi} \int_{-1}^{+1} \frac{1}{h^2} m_1(\xi) (x - \xi) \left[\frac{(z^2 - h^2)(z - t)}{r^2 r_t} \right.$$

$$\left. + \frac{z + t}{r_t} - \frac{(z^2 - h^2)(z + t)}{r^2 r_{-t}} - \frac{(z - t)}{r_{-t}} \right] d\xi$$

$$v = -1 + \frac{1}{4\pi} \int_{-1}^1 \frac{1}{h^2} m_1(\xi) y \log \frac{z - t + r_t}{z + t + r_{-t}} d\xi$$

$$+ \frac{1}{4\pi} \int_{-1}^{+1} \frac{1}{h^2} m_1(\xi) y \left[\frac{z^2 - h^2(z - t)}{r^2 r_t} \right.$$

$$\left. + \frac{z + t}{r_t} - \frac{(z^2 - h^2)(z + t)}{r^2 r_{-t}} - \frac{z - t}{r_{-t}} \right] d\xi$$

$$w = \frac{1}{4\pi} \int_{-1}^{+1} \frac{2}{h^2} m_1(\xi) [r_t - r_{-t} + z \log \frac{z + t + r_{-t}}{z - t + r_{-t}}] d\xi$$

$$+ \frac{1}{4\pi} \int_{-1}^{+1} m_1(\xi) \left[1 - \left(\frac{t}{h}\right)^2 \right] \left[\frac{1}{r_t} - \frac{1}{r_{-t}} \right] d\xi$$

(9)

Three special cases of singularity distribution are as follows:

i) $h = \infty$

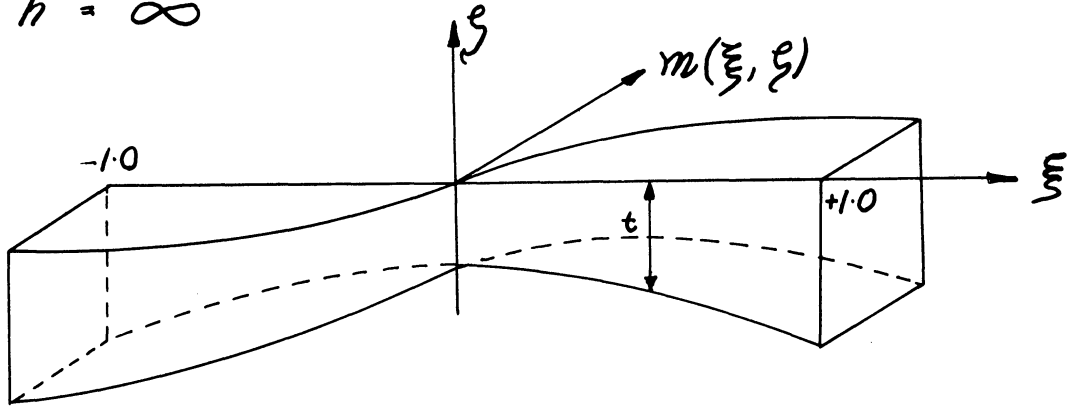

Figure 5

ii) $h = t$

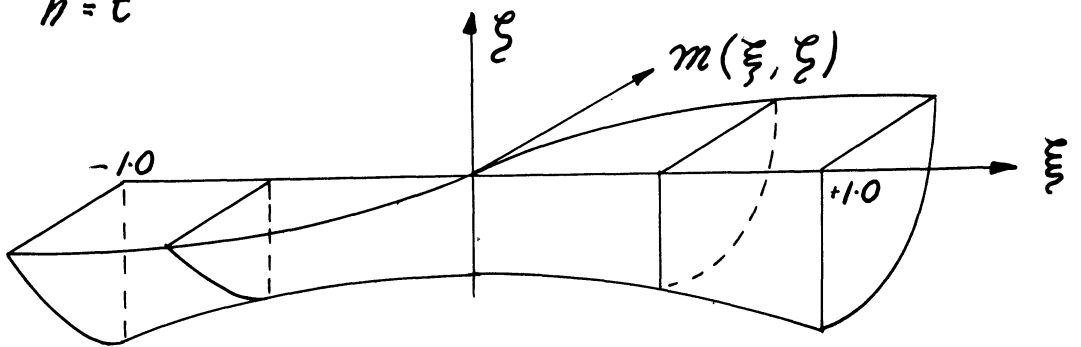

Figure 6

iii) $h = \text{CONSTANT}$.

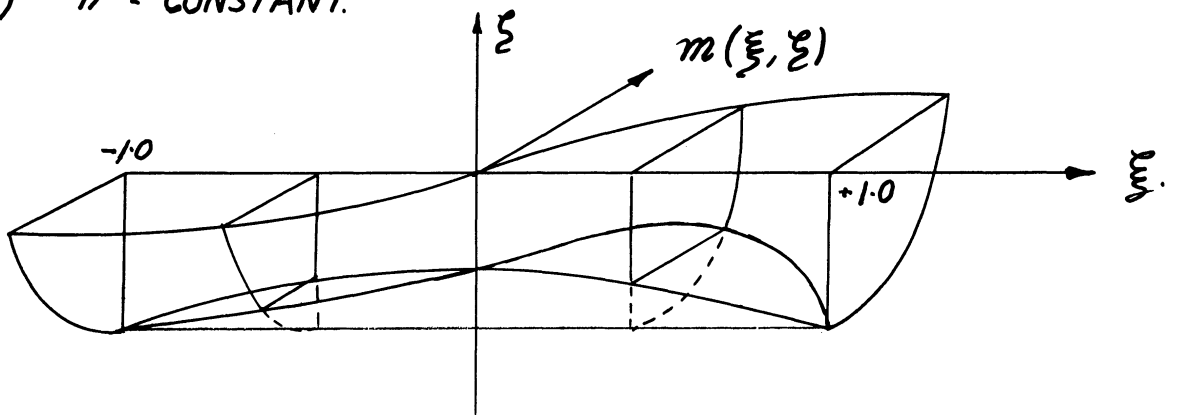

Figure 7

A computer program for the determination of streamlines due to a singularity distribution as given by Equations (8) has been completed. Trial runs of the program did not produce usable streamline traces, however, since too small initial values lead to difficulties caused by the logarithmic singularity of the integrands of Equations (9). Results will become available as this work is being continued.

Singularity distributions other than those mentioned above will also be tried. The purpose of the complete streamline study is twofold:

1. To provide a rational basis on which to investigate effects of hull form changes and the effect of large appendages such as bulbs.
2. To determine singularity distributions which represent hull forms of conventional proportions.

The development of singularity distributions must be closely related to our ability to evaluate the wave-resistance from theory. It is for this reason impractical at present to consider distributions that are not defined in a rectangular region on the centerline plane. An additional limitation is introduced when it is assumed that the distribution function $m(\xi, \zeta)$ is given by Equation (1). This assumption puts a very serious restriction on the admissible form of $m(\xi, \zeta)$. A distribution as shown in Figure 8, which may produce a flat bottomed hull cannot be represented by the simple relationship of Equation (1). Because of progress being made at the University of Michigan on the problem of wave-resistance evaluation from theory,⁽¹⁰⁾ we hope that we shall be able to consider the distribution, as shown in Figure 8, in the near future.

B. An Approximate Singularity Distribution for Series-60 Water Lines.

From the discussion above it is clear that with the restrictions imposed by Equation (1), it is impossible to find a particular distribution

function that will produce streamlines which correspond closely to a particular set of Series-60 lines. To arrive at an estimate of the size and

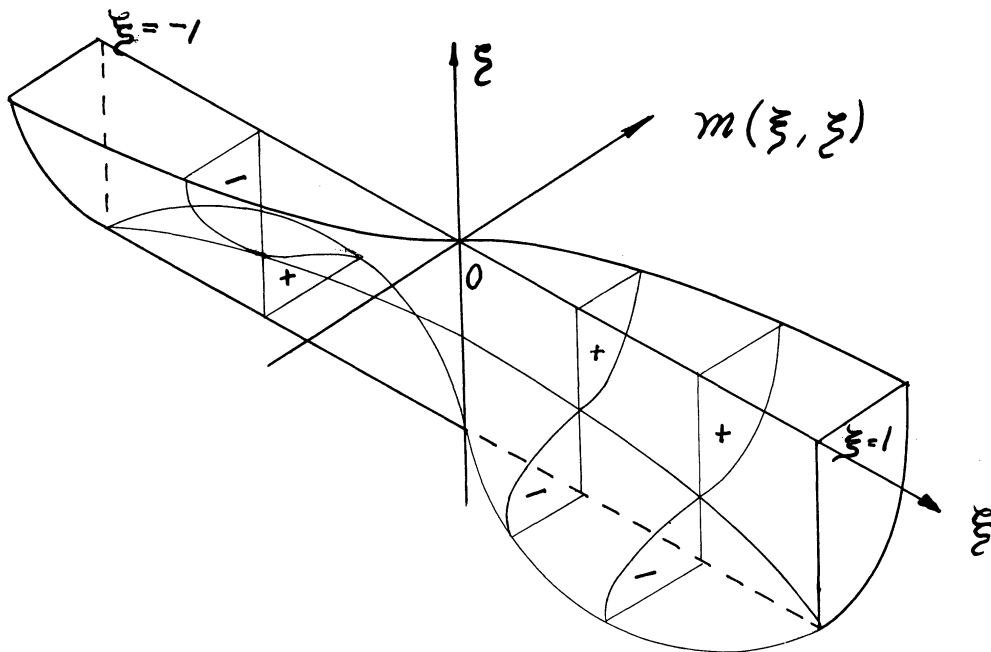

Figure 8

location of optimum bow bulbs, however, it is important to know which distribution function might possibly produce a L.W.L approximately equal to that of the Series-60 hull form. It was therefore decided to try to obtain the best possible fit to the load waterlines of a Series-60 set of lines of block coefficient $C_B = .60$ using a fifth degree polynomial for $f_1(\xi)$ of Equation (1). Appendix IV shows a computer program written for this purpose. Inui⁽⁶⁾ has tabulated the integral of the velocity components for the two-dimensional case. Inui only considered symmetric distribution functions. It was believed sufficient to do so also for the Series-60 lines, the reason being that the shape of the fore-body would be of primary importance as far as bow bulbs were concerned. In regard to the draft-wise distribution of singularities only the uniform case, with the distribution terminated at various depths, have been evaluated

at the University of Michigan to date.

As the depth of singularity distribution is decreased, so is, as a result, the beam of the L.W.L. If the L.W.L shape is to be preserved, the strength of the singularities of the two-dimensional case for that waterline configuration must therefore be increased as the depth of singularity distribution is reduced to a finite dimension. Based on results published by Inui⁽⁶⁾ this increase in strength was estimated to be approximately equal to 20 per cent at the midship for the case of the Series-60 lines. Calculations revealed that this amount was not large enough. A number of depths of singularity distributions were then run on the computer to determine the relationship between depth and L.W.L. beam. The results are shown in Appendix III.

It is noted that the variation of maximum beam with respect to depth of singularity distribution is rather large. This leads us to believe that early investigations⁽²⁾ of the effect of draft on the wave-making resistance resulted in erroneous conclusions. Such investigations were based on the Michell approximation of the hull boundary conditions and significant variations in beam could therefore not be avoided, as shown by the results of streamline calculations published in this report.

It is also observed that the draft amidships is approximately twice that at the fore-foot. Since we do not as yet have a program which will produce a flat bottom streamlines it was of interest to determine experimentally the effect on wave-making resistance of removing of the major portion of the hull form below the depth of the singularity distribution. In general it can be said that the changes in the wave-making resistance were found to be small. Details of results will be presented in a separate report.⁽⁸⁾

BIBLIOGRAPHY

1. J. H. Michell, "The Wave Resistance of a Ship," Philosophical Magazine, Vol 45, (1898), pp. 106-122.
2. T. H. Havelock, "The Calculation of Wave Resistance," Proceedings of the Royal Society, London, England. Series A, Vol. 144, p. 514, 1934.
3. W. C. S. Wigley, "Ship Wave Resistance - A Comparison of Mathematical Theory with Experimental Results," Transactions of the Institution of Naval Architects, vol 68 pp. 124-137, (1926)
4. G. P. Weinblum, "Untersuchungen über den Wellenwiderstand Velliger Schiffefomen," Jahrbuck Schiffbau Gesellschaft, vol 35 pp. 164-192, (1934).
5. H. Lamb, Hydrodynamics, Sixth Edition, Dover Publications, N. Y., p. 417.
6. T. Inui, "A New Theory of Wave-Making Resistance Based on the Exact Conditions if the Surface of Ships," JSNA Japan vol 93, 1953.
7. T. Inui "Wave-Resistance of Ships," Transactions of Society of Naval Architects and Marine Engineering, New York, 1962.
8. Resistance Characteristics of Mathematical Hull Forms. University of Michigan ORA Report (To be Published)
9. K. Eggers and W. Wetterling, "Über die Ermittlung der Schiffsähnlichen Umströmungskörper vargegebe Quell-Senken-Derteilungen mit Hilfe elektronischer Rechenmaschinen," Schiffstechnik Bd. 4 (1957), Hift 24.
10. F. C. Michelsen, Wave Resistance Solution of Michell's Integral for Polynomial Ship Forms, Microfilms, Inc. Ann Arbor, Michigan, 1960. (Thesis)
11. P. Thomsen and K. Eggers, "Zur Berechnung von Umströmungskörpern zu Ouell - Lenken - Verseilungen" Schiffsticknik Bd. 7 -1960-Hift 38.
12. T. Takahei, "Calculations of Ship Hull Terms With Electronic Digital Computers" The University of Michigan, Department of Naval Architecture and Marine Engineering.

APPENDIX I

COMPUTER PROGRAM FOR THE DETERMINATION OF STREAMLINES DUE TO A PRESCRIBED SINGULARITY DISTRIBUTION ON THE CENTER PLANE

The program is written for the IBM 7090 digital computer in the language of MAD (Michigan Algorithm Decoder). It traces the streamlines, defined by the system of differential equations

$$\frac{dx}{u(x,y,z)} = \frac{dy}{v(x,y,z)} = \frac{dz}{w(x,y,z)},$$

by means of the Runge-Kutta fourth order method.

As mentioned in Section A of this report the starting point selected in tracing a particular streamline is taken at $x = 1.0$. The starting value of z is arbitrary as long as it is less or equal to the draft at the fore foot plus some small quantity ϵ' . To insure that the traced streamline belong to the hull surface or is located in the region slightly outside the hull surface the starting value of y is estimated under the assumption that the flow near the bow is not very much different as that described by the two-dimensional case. For two dimensional flow the streamline is given by Equation (5) i.e.

$$y(x) = \frac{1}{2\pi} \int_{-1}^1 f_1(\xi) \tan^{-1} \frac{y(x)}{x - \xi} d\xi$$

The y coordinate at $x = 1$ can be evaluated approximately by assuming that $f_1(\xi) = f_1(1) = c$; $0 < x < 1$ Thus

$$\frac{2\pi}{c} y(1) = \int_0^1 \cot^{-1} \frac{1 - \xi}{y} d\xi = \int_0^1 \cot^{-1} \frac{\xi}{y} d\xi$$

$$= \tan^{-1} y + \frac{y}{2} \log \left(1 + \frac{1}{y^2} \right)$$

For $y \ll 1$ it follows that

$$\left(\frac{2\pi}{c} - 1 \right)^2 \approx \log \left(\frac{1}{y^2} \right)$$

from which

$$y(1) \approx e^{-\left(\frac{2\pi}{c} - 1 \right)}$$

As a starting value of y we therefore use

$$y(1) \geq e^{-\left(\frac{2\pi}{c} - 1 \right)}$$

normally $y(1) = 10^{-6}$ to 10^{-4} .

It is not too serious if the initial value of y is slightly too large since the streamlines will converge toward amidships. On the other hand a too small initial value of y will lead to great difficulties, probably because the streamline is then inside the hull surface and therefore turns sharply normal to the center plane. Such a sharp turn can be described with the aid of the Runge-Kutta method only if a large number of subdivisions are being used. Whether the initial value of y actually used in the computations is satisfactory can most readily be judged from a plot of the velocity components such as shown in Figure I-1.

Runge-Kutta step size must also be given. Approximately 100 stations along the half-length of the hull seem to be satisfactory as explained earlier. In the present program, the Runge-Kutta step size is automatically refined until a predetermined accuracy is obtained.

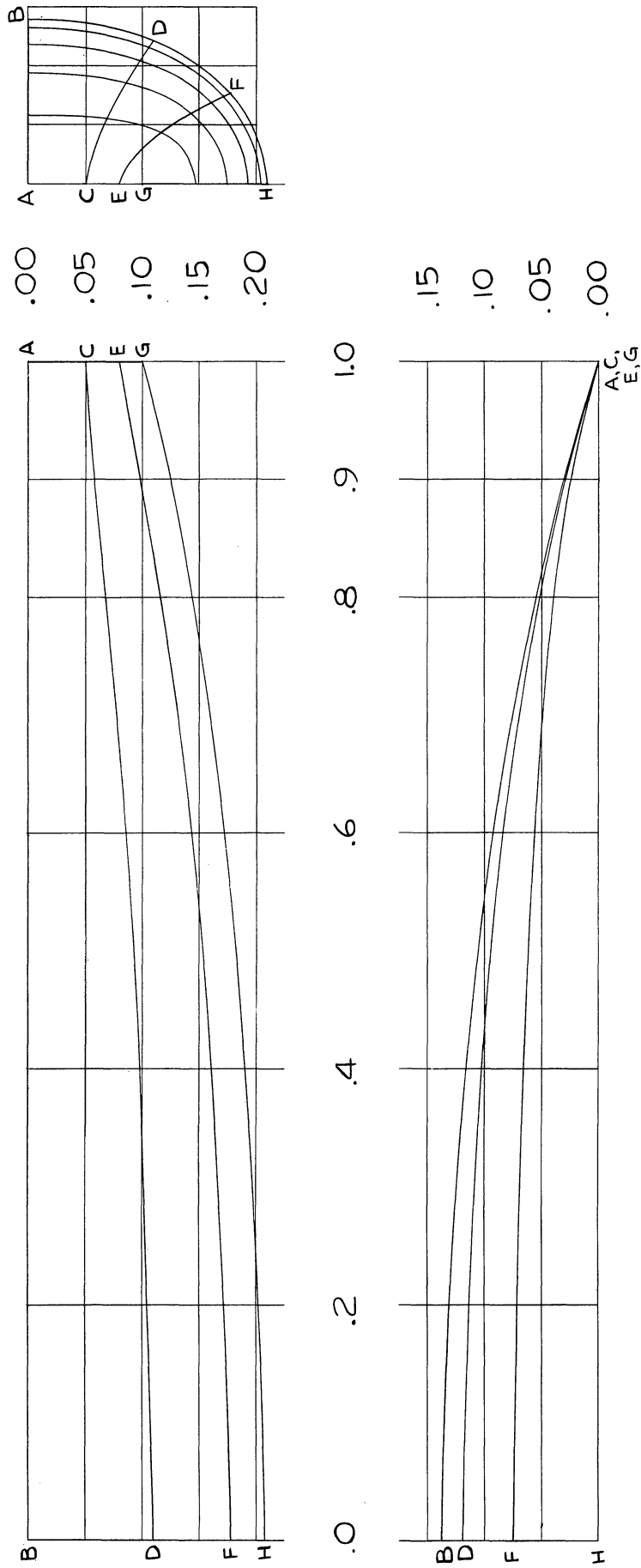

(a) Traced streamlines on cosine hull C-201.

Figure I-1

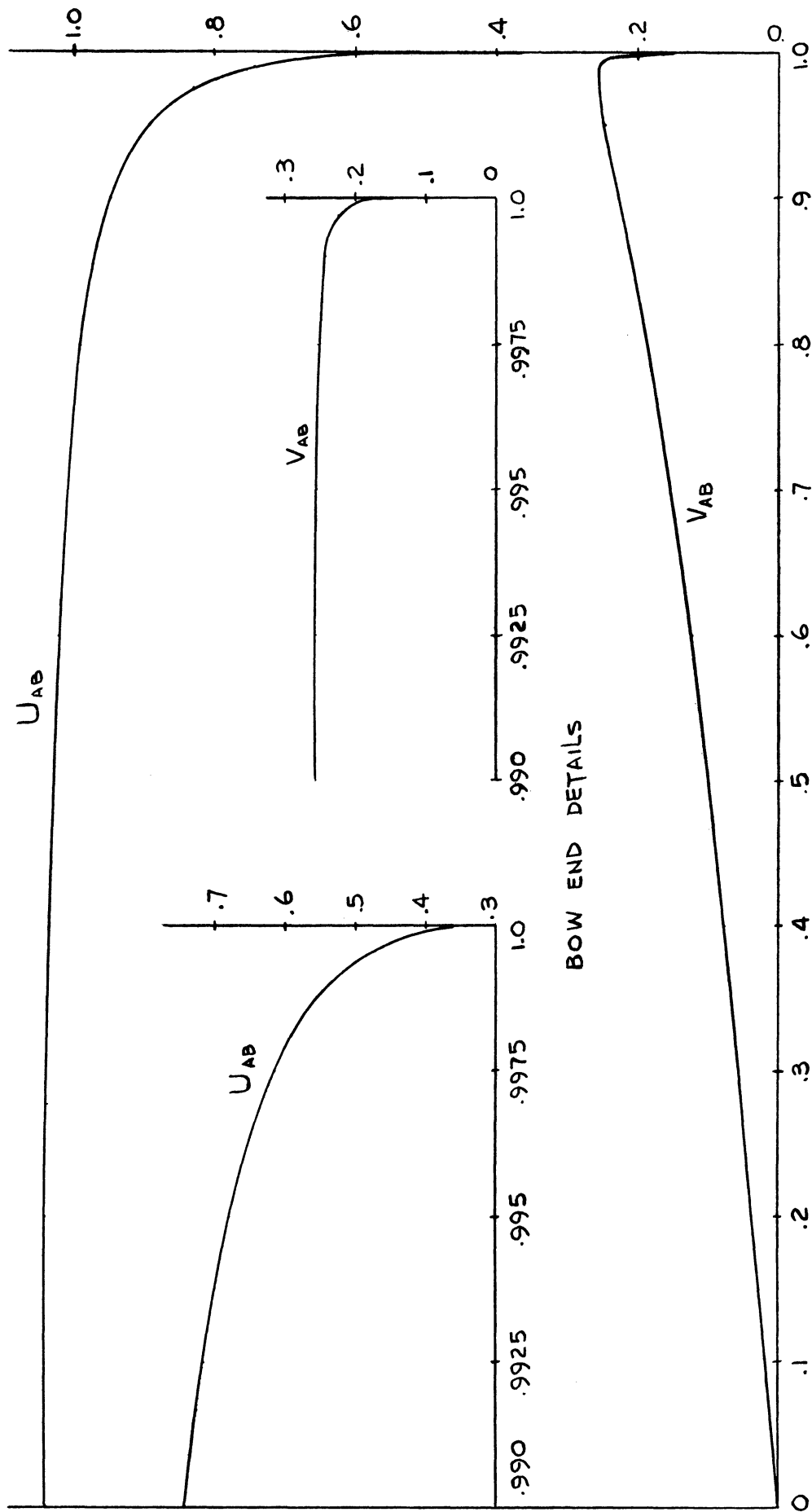

(b) Velocity components, streamline AB.

Figure I-1 (Continued)

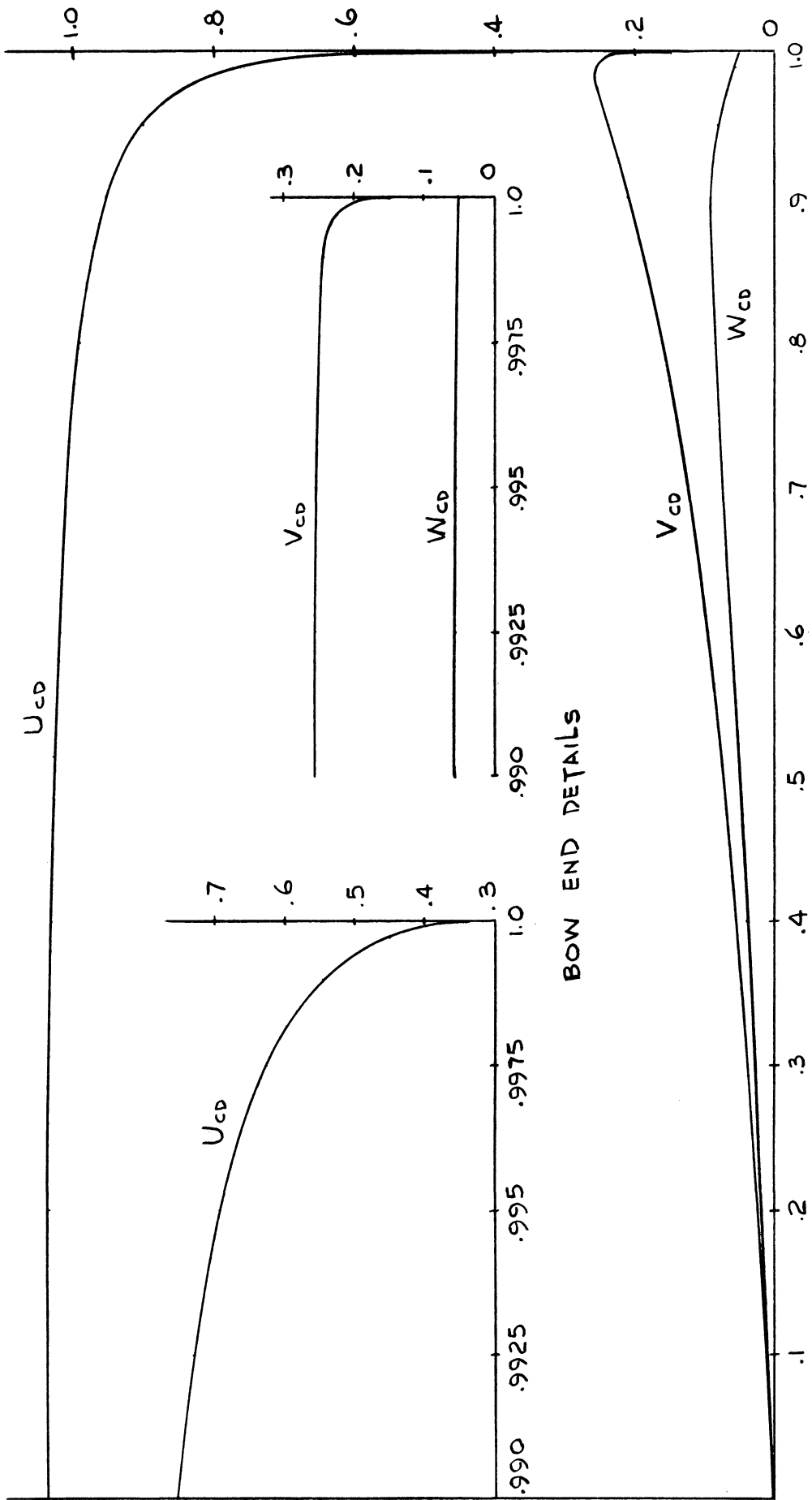

(c) Velocity components, streamline CD.

Figure I-1 (Continued)

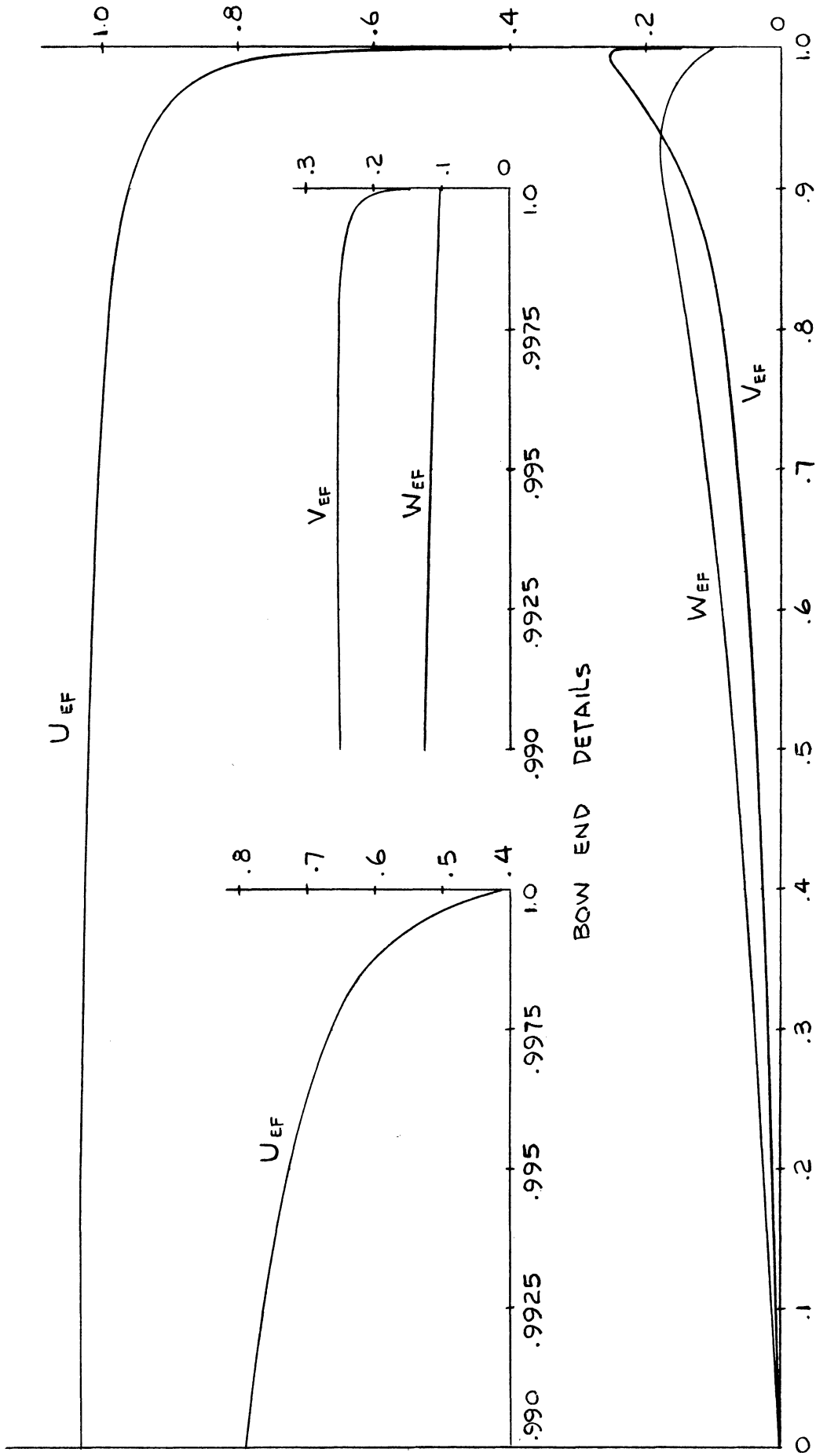

(d) Velocity components, streamline EF.

Figure I-1 (Continued)

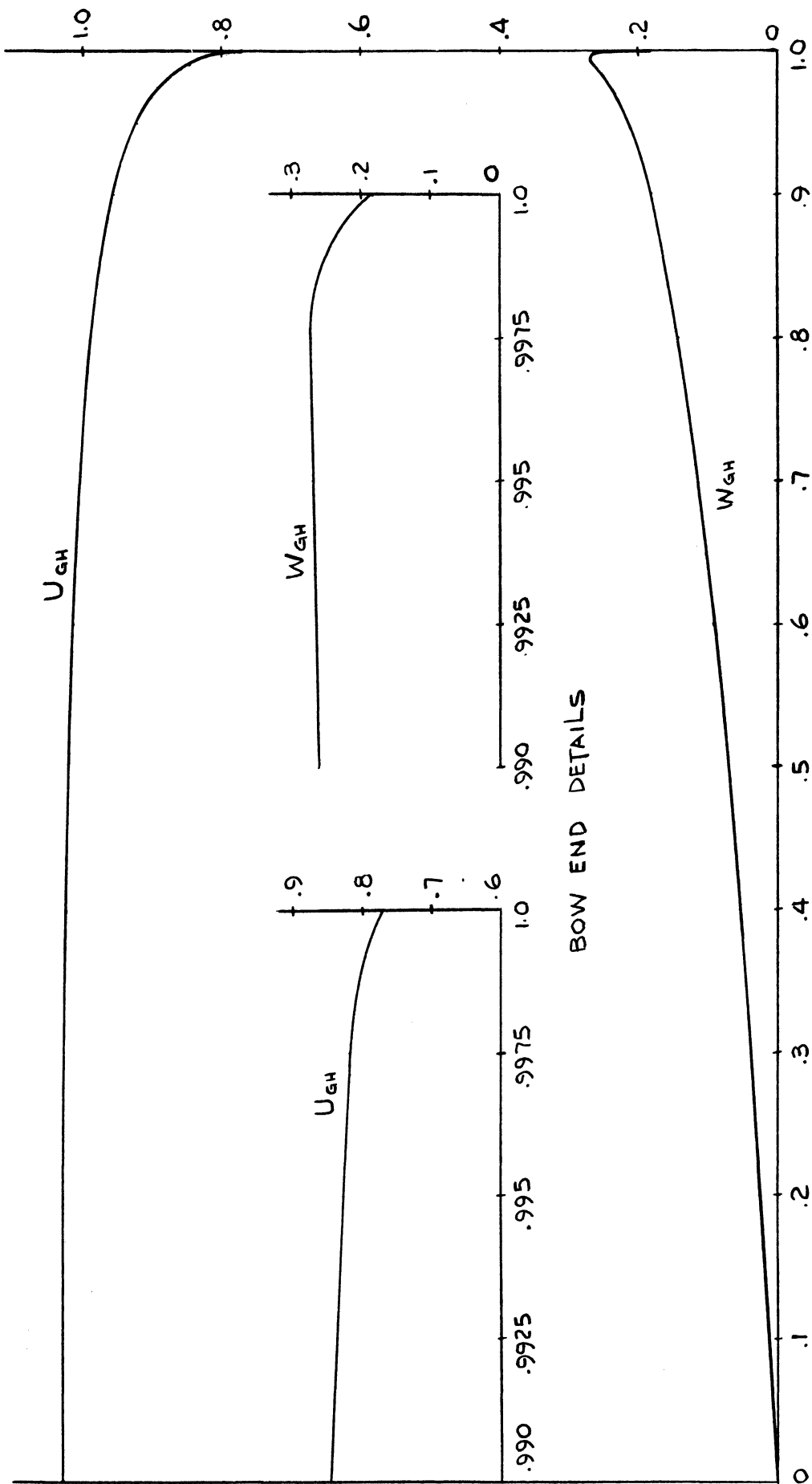

(e) Velocity components, streamline GH.

Figure I-1 (Concluded)

Since calculations have been restricted to source distributions which are symmetric with respect to midships only the streamline traces of the fore-body have had to be determined.

In the following the computational procedure is given in more detail for the case of a singularity distribution described by

$$m_1(\xi) = a_1 \cos(\alpha \xi); m_2(\xi) = 1$$

The depth of distribution is given as

$$t = t_0 - b_1 \cos(\alpha \xi)$$

Input Data

- (1) Initial values of x, y and z (starting point)
- (2) a_1 and α in source $a_1 \cos(\alpha \xi)$
- (3) t_0 and b_1 in bottom truncation $t = t_0 - b_1 \cos(\alpha \xi)$
- (4) Maximum number of print out line
- (5) Accuracy of y i.e. 10^{-5}
- (6) Stations in x , i.e., $x_0 - - - - x_n$ and n

At the station x_n along the hull, following substations are set up.

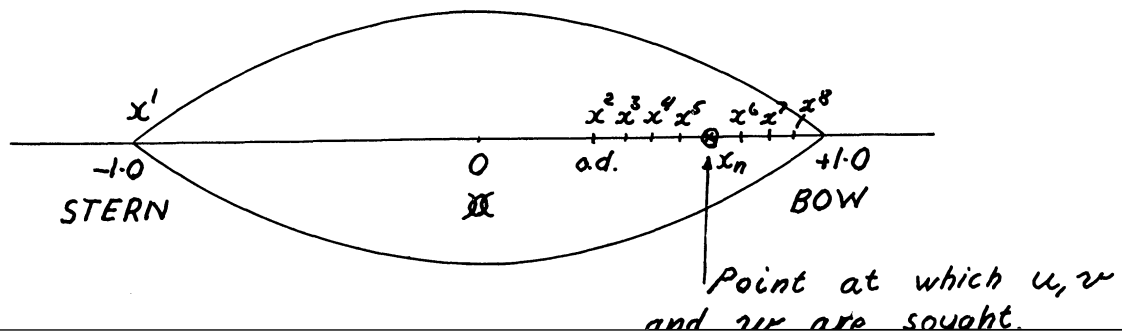

$$\begin{aligned}
 x^1 &= -1.0 \\
 x^2 &= 0.4 && \text{where } y_0 = y(1) \\
 x^3 &= x_n - \sqrt{y_0} \\
 x^4 &= x_n - 4y_0 \\
 x^5 &= x_n - 2y_0 \\
 x^6 &= x_n + 2y_0 \\
 x^7 &= x_n + 4y_0 \\
 x^8 &= x_n + \sqrt{y_0}
 \end{aligned}$$

In order to obtain a good accuracy of computed values of velocity components the region $0 \leq x \leq 1$ is divided into two subregions, thus for $x_n \leq .95$,

$$\begin{aligned}
 u &= -1.0 - [DU.(x^1, x^3) + DU.(x^3, x^5) + DU.(x^5, x_n) \\
 &\quad + DU.(x_n, x^6) + DU.(x^6, x^8) + DU.(x^8, x^9)] \\
 v &= - [DV.(x^1, x^3) + DV.(x^3, x^5) + DV.(x^5, x^6) + DV.(x^6, x^8) \\
 &\quad + DV.(x^8, x^9)] \\
 w &= - [DW.(x^1, x^3) + DW.(x^3, x^5) + DW.(x^5, x^6) + DW.(x^6, x^8) \\
 &\quad + DW.(x^8, x^9)]
 \end{aligned}$$

whereas for $x_n > .95$

$$\begin{aligned}
 u &= -u' -1.0 - [DU.(x^1, x^2) + DU.(x^2, x^3) + DU.(x^3, x^5) \\
 &\quad + DU.(x^5, x_n)]
 \end{aligned}$$

$$v = -v' - [DV.(x^1, x^2) + DV.(x^2, x^3) + DV.(x^3, x^4) + DV.(x^4, x_n)]$$

$$w = -w' - [DV.(x^1, x^2) + DW.(x^2, x^3) + DW.(x^3, x^4) + DW.(x^4, x_n)]$$

where

$$u' = DU.(x_n, x^6) + DU.(x^6, x^8) + DU.(x^8, x^9)$$

$$v' = DV.(x_n, x^7) + DV.(x^7, x^8) + DV.(x^8, x^9)$$

$$w' = DW.(x_n, x^7) + DW.(x^7, x^8) + DW.(x^8, x^9)$$

for $|x_n - 1.0| > 10^{-6}$

$$u' = v' = w' = 0 \quad \text{for} \quad |x_n - 1.0| \leq 10^{-6}$$

The functions $DU(A,B)$ are treated as internal functions in the computer program. They are defined as follows:

$$DU.(A,B) = (B - A) \sum_{i=1}^9 I_i \frac{a_1}{8\pi} \sin(\alpha \xi_i) \left[\frac{(x - \xi_i)}{R_i} \left(\frac{z - t}{R_{-t_i}} - \frac{z + t}{R_{+t_i}} \right) \right]$$

$$DV.(A,B) = (B - A) \sum_{i=1}^9 I_i \frac{a_1}{8\pi} \sin(\alpha \xi_i) \left[\frac{y}{R_i} \left(\frac{z - t}{R_{-t_i}} - \frac{z + t}{R_{+t_i}} \right) \right]$$

$$DW.(A,B) = (B - A) \sum_{i=1}^9 I_i \frac{a_1}{8\pi} \sin(\alpha \xi_i) \left[\frac{1}{R_{-t_i}} - \frac{1}{R_{+t_i}} \right]$$

where I_i = Gauss weight functions at the proper stations see

Table I-I $i = 1, 2, \dots, 9$

a_1 = Amplitude of source strength

α = phase parameter $\alpha = \frac{\pi}{2}$ for c-101 and c-201

ξ_i = stations for Gauss integral formula. See Table I-I.

x, y, z = coordinate at which velocity is sought

$t = t_0 - b_1 \cos(\alpha \xi_i)$: depth of singularity distribution
with bottom trunkated $b_1 \cos(\alpha \xi_i)$

b_1 = amplitude of bottom trunkation in source distribution

$b_1 = 0$ for c-101 and c-201

$$R_i = \frac{1}{[(x - \xi_i)^2 + y^2]^{1/2}}$$

$$R_{-t_i} = \frac{1}{[(x - \xi_i)^2 + y^2 + (z - t)^2]^{1/2}}$$

$$R_{tt_i} = \frac{1}{[(x - \xi_i)^2 + y^2 + (z + t)^2]^{1/2}}$$

The velocity components u, v and w are calculated at station x_n . By Runge-Kutta method, values of y and z at station x_{n+1} and at an intermediate station $\frac{1}{2}(x_n - x_{n+1})$ are calculated and compared.
If

$$|y, z(x_{n+1}) - y, z_{\frac{1}{2}}(x_n - x_{n+1})| \leq \quad ,$$

Values of x, y and z and $u, v,$ and w at x_{n+1} are printed out.

If $|y, z(x_{n+1}) - y, z_{\frac{1}{2}}(x_n - x_{n+1})| > \quad ,$

y and z at $\frac{1}{4}(x_n - x_{n+1})$ are calculated and the process is repeated until the absolute values of difference in y and z are smaller than a preset value ξ , designated "YERR" in the program.

Print-out includes x,y,z,u,v,w, and the absolute value of differences in y or z (whichever is larger) when the above limiting condition is satisfied.

The computer programs for the cosine and the polynomial hull forms are shown below, printed in the MAD language. Print out for the L.W.L of the cosine hull form has also been included. It is noted that coordinates are given only for $x \leq .9$. The reason for this is that for the particular run recorded here the initial value of y was that obtained at $x = .9$ from a separate calculation.

It should be emphasized that the stream line program can be used to trace any streamline in the fluid region outside the hull and also for the determination of velocity components. The magnitude of the potential wake can therefore be readily evaluated.

TABLE I-I
STATIONS AND WEIGHT FUNCTIONS FOR GAUSS
INTEGRAL FORMULA (When A is at -1.0 and B is at +1.0)

i	A	9	8	7	6	5	4	3	2	1	B
Station	-1.0	-.96816	-.83603	-.61337	-.32425		.32425	.61337	.8337	.96816	+1.0
Weight Functions		.08127	.18065	.26061	.31235	.33024	.31235	.26061	.18065	.08127	

...003003.....003003.....003003.....003003.....003003.....003003.....003003.....003003.....003003.....003003.....

JOB NO. 003003 UNIVERSITY OF MICHIGAN EXECUTIVE SYSTEM (MODEL GV212) TUESDAY, NOVEMBER 27, 1962 8 16 32.8 PM

TAKAHEI SALVESEN GREENE S160F 002 002 070 04542

A. Cosine Hull Yerr = 10⁻⁵

N = 36 automatically changed to N = 94 (two separate runs).

See the last page for "Yerr."

..003003.....003003.....003003.....003003.....003003.....003003.....003003.....003003.....003003.....003003.....

MAD (16 APR 1962 VERSION) PROGRAM LISTING

MARITIME TASK 1 PROJECT NR. 04542

CALCULATION OF SHIP HULL FORM MATHEMATICALLY PRODUCED BY THE GIVEN SINGULARITY DISTRIBUTION

TAKAHEI

COSINE SHIP RUNGE-KUTTA STEP SIZE IS AUTOMATICALLY REFINED

DIMENSION E(13), F(2), H(9), I(9), O(2), X(9999), Y(2) INTEGER CO, CO MAX, K, L, M, N, NI STATEMENT LABEL D

INTERNAL FUNCTION (A, B) ENTRY TO DU.

D = BETA TRANSFER TO ALPHA ENTRY TO DV. D = GAMMA TRANSFER TO ALPHA ENTRY TO DW. D = DELTA C = 0.

ALPHA

THROUGH EPSILN, FOR M = 1, 1, M.G.9 XI = ((1.+H(10-M)) * B + (1.-H(10-M)) * A) * .5 XI1 = XI * ALFA XI2 = X - XI XI3 = X12 * X12 + Y(1) * Y(1) G = TNAUT - B1 * COS.(XI1) ZGM = Y(2) - G ZGP = Y(2) + G F1 = A1 * SIN.(XI1) * 397887357E-10 R INVS = I(M) / SQRT.(XI3 + ZGM * ZGM) RPRIMI = I(M) / SQRT.(XI3 + ZGP * ZGP) DIFF 1 = R INVS * ZGM - RPRIMI * ZGP DIFF 2 = R INVS - RPRIMI IIGRND = F1 * DIFF 1 / XI3

BETA

C = C + IIGRND * XI2 TRANSFER TO EPSILN C = C + IIGRND * Y(1)

GAMMA

TRANSFER TO EPSILN C = C + DIFF2 * F1

DELTA

CONTINUE FUNCTION RETURN C * (B - A) END OF FUNCTION

EXECUTE SETKD. (2, Y(1), F(1), 0, X, STEP)

H(1) = .96816024 H(2) = .83603111 H(3) = .61337143 H(4) = .32425342 H(5) = .0 I(1) = .08127439

*001 *002 *003

*004 *005 *006 *007 *008 *009 *010 *011 *012 *013 *014 *015 *016 *017 *018 *019 *020 *021 *022 *023 *024 *025 *026 *027 *028 *029 *030 *031 *032 *033 *034 *035 *036

*037 *038 *039 *040 *041 *042 *043

```

*044
*045
*046
*047
*048
*049
*050
*051
*052
*053
*054
*055
*056
*057
*058
*059
*060
*061
*062
*063
*064
*065
*066
*067
*068
*069
*070
*071
*072
*073
*074
*075
*076
*077
*078
*079
*080
*081
*082
*083
*084
*085
*086
*087
*088
*089
*090
*091
*092
*093
*094
*095
*096
*097
*098

I(2) = .18064316
I(3) = .26061770
I(4) = .31234708
I(5) = .33023936
THROUGH ZETA, FOR L = 6, 1, L.G./9
H(L) = -H(10 - L)
I(L) = I(10 - L)
READ FORMAT TITLER, E...E(13)
READ FORMAT G, X, Y(1), Y(2)
READ DATA AI, TNAUT, BI, ALFA, N, CO MAX, Y CRIT
READ FORMAT R, X(1)...X(N)
WHENEVER ALFA .E. Y, ALFA = 1.5707963
PRINT FORMAT TITLER, E...E(13)
PRINT COMMENT $4 INPUT VALUES READ WERE$
PRINT RESULTS AI, TNAUT, BI, N, ALFA, CO MAX, Y CRIT,
1 X...X(N)
PRINT COMMENT $1$
WHENEVER N.G./28, TRANSFER TO THETA
PRINT COMMENT $4$
PRINT FORMAT S, X, Y(1), Y(2)
CO = 1
CO MAX = 4 * CO MAX
K = 0
N1 = N + 1
X(N1) = X
X1 = -1.
X2 = .4
X9 = -X1
THROUGH MU, FOR L = 0, 1, L.G./N1
X3 = X - SQR(X1)
X4 = X - 4 * Y(1)
X5 = X - 2 * Y(1)
X6 = X + 2 * Y(1)
X7 = X + 4 * Y(1)
X8 = X * 2. - X3
WHENEVER X.LE..95
U = DU.(X1, X3) + DU.(X3, X5) + DU.(X5, X) + DU.(X, X6)
+ DU.(X6, X8) + DU.(X8, X9)
1 V = DV.(X1, X3) + DV.(X3, X5) + DV.(X5, X6) + DV.(X6, X8)
+ DV.(X8, X9)
1 W = DW.(X1, X3) + DW.(X3, X5) + DW.(X5, X6) + DW.(X6, X8)
+ DW.(X8, X9)
1 OTHERWISE
U = DU.(X1, X2) + DU.(X2, X3) + DU.(X3, X5) + DU.(X5, X)
V = DV.(X1, X2) + DV.(X2, X3) + DV.(X3, X4) + DV.(X4, X)
W = DW.(X1, X2) + DW.(X2, X3) + DW.(X3, X4) + DW.(X4, X)
WHENEVER .ABS.(X-1.) .G. 1E-6
U = U + DU.(X, X6) + DU.(X6, X8) + DU.(X8, X9)
V = V + DV.(X, X7) + DV.(X7, X8) + DV.(X8, X9)
W = W + DW.(X, X7) + DW.(X7, X8) + DW.(X8, X9)
END OF CONDITIONAL
END OF CONDITIONAL
U = -1. - U
V = -V
WHENEVER CO .GE. CO MAX
1 PRINT RESULTS CO, L, Y1, K, U0, X0, Y0, Z0, U, X, Y(1),
Y(2), P
TRANSFER TO ETA
OR WHENEVER K .E. 0

```



```

WHENEVER L.NE.0
PRINT FORMAT T, X, Y(1), Y(2), U, V, W, Y1
WHENEVER L.E.N1
PRINT COMMENT $-
1 Y OBTAINED AT EACH STEP BY RECALCULATION WITH TWICE AS FIN
2E A STEP SIZE AS IS INDICATED.$
TRANSFER TO ETA
END OF CONDITIONAL
OTHERWISE
PRINT FORMAT T1, X, Y(1), Y(2), U, V, W
END OF CONDITIONAL
STEP = X(L + 1) - X
UO = U
VO = V
WO = W
XO = X
YO = Y(1)
ZO = Y(2)
OR WHENEVER K.E.1
L = L - 2
Y1 = Y(1)
STEP = STEP * .5
U = UO
V = VO
W = WO
X = XO
Y(1) = YO
Y(2) = ZO
OR WHENEVER K.E.2
P = Y(1)
END OF CONDITIONAL
F = RKDEQ.(O)
F(1) = V / U
F(2) = W / U
TRANSFER TO KAPPA
OR WHENEVER K.E.2
Y1 = .ABS.(Y1 - Y(1))
WHENEVER Y1.G. Y CRIT
K = 1
L = L - 1
Y1 = P
TRANSFER TO IOTA
END OF CONDITIONAL
K = -1
LAMBDA
THROUGH LAMBDA, FOR L = 1, 1, X(L).L.X+STEP .OR. L.G.N1
L = L - 2
CO = CO + 1
K = K + 1
VECTOR VALUES Q = $F10,2E20*$
VECTOR VALUES R = $8F10*$
VECTOR VALUES S = $S17,91HCALCULATION OF SHIP HULL FORM MATHE
MATICALLY PRODUCED BY THE GIVEN SINGULARITY DISTRIBUTION//S91
2,7HTAKAHEI//S7,89HCOORDINATES OF POINTS ON STREAMLINES AND
3CORRESPONDING VALUES OF FLOW VELOCITY COMPONENTS//S7,28HINI
4TIAL VALUES OF STREAMLINES10,4HX =F8.4,S7,4HY =F11.8,S7,4HZ
5 =F11.8//S16,1HX15,1HYS16,1HZS20,1HVS16,1HKS14,5HY
6ERR//*

```

```

*099
*100
*101
*102
*102
*103
*104
*105
*106
*107
*108
*109
*110
*111
*112
*113
*114
*115
*116
*117
*118
*119
*120
*121
*122
*123
*124
*125
*126
*127
*128
*129
*130
*131
*132
*133
*134
*135
*136
*137
*138
*139
*140
*141
*142
*143
*144
*145
*146
*147
*148
*149
*149
*149
*149
*149
*149
*149

```

VECTOR VALUES T = \$F20.7,2E19.9,4E17.4*\$
VECTOR VALUES T1 = \$F20.7,2E19.9,3E17.4*\$
VECTOR VALUES TITL = \$I11/I1H813C6,C2*\$
VECTOR VALUES TITLER = \$I13C6,C2*\$
END OF PROGRAM

*150
*151
*152
*153
*154

INPUT VALUES READ WERE

36

N =

B1 = .000000,

TNAUT = .100000,

A1 = .600000,

36

YCRIT = 10.000000E-06

COMAX = 999,

ALFA = 1.570796,

X(0)...X(36)

9.000000E-01	8.750000E-01	8.500000E-01	8.250000E-01	8.000000E-01	7.750000E-01	7.500000E-01	7.250000E-01
7.000000E-01	6.750000E-01	6.500000E-01	6.250000E-01	6.000000E-01	5.750000E-01	5.500000E-01	5.250000E-01
5.000000E-01	4.750000E-01	4.500000E-01	4.250000E-01	4.000000E-01	3.750000E-01	3.500000E-01	3.250000E-01
3.000000E-01	2.750000E-01	2.500000E-01	2.250000E-01	2.000000E-01	1.750000E-01	1.500000E-01	1.250000E-01
10.000000E-02	7.500000E-02	5.000000E-02	2.500000E-02	.000000E-02	.000000E-02	.000000E-02	.000000E-02

36

CALCULATION OF SHIP HULL FORM MATHEMATICALLY PRODUCED BY THE GIVEN SINGULARITY DISTRIBUTION
TAKAHEI

COORDINATES OF POINTS ON STREAMLINES AND CORRESPONDING VALUES OF FLOW VELOCITY COMPONENTS

INITIAL VALUES OF STREAMLINE									
X	Y	Z	U	V	W	Y ERR			
.9000000	.302499995E-01	.000000000E 00	-.9478E 00	.2280E 00	.0000E 00	.6657E-05			
.8937500	.317477487E-01	-.000000000E 00	-.9521E 00	.2256E 00	.0000E 00	.5106E-05			
.8890625	.328551732E-01	-.000000000E 00	-.9552E 00	.2238E 00	.0000E 00	.2803E-05			
.8820312	.344954669E-01	-.000000000E 00	-.9593E 00	.2210E 00	.0000E 00	.6185E-05			
.8750000	.361087136E-01	-.000000000E 00	-.9632E 00	.2183E 00	.0000E 00	.4643E-05			
.8687500	.375200383E-01	-.000000000E 00	-.9664E 00	.2159E 00	.0000E 00	.6024E-05			
.8640625	.385643363E-01	-.000000000E 00	-.9686E 00	.2141E 00	.0000E 00	.6185E-05			
.8570312	.401120633E-01	-.000000000E 00	-.9718E 00	.2114E 00	.0000E 00	.6024E-05			
.8500000	.41635377E-01	-.000000000E 00	-.9747E 00	.2087E 00	.0000E 00	.4643E-05			
.8437500	.429688714E-01	-.000000000E 00	-.9771E 00	.2063E 00	.0000E 00	.6185E-05			
.8390624	.439560652E-01	-.000000000E 00	-.9789E 00	.2046E 00	.0000E 00	.6024E-05			
.8320312	.454197541E-01	-.000000000E 00	-.9814E 00	.2019E 00	.0000E 00	.4643E-05			
.8250000	.468610749E-01	-.000000000E 00	-.9837E 00	.1993E 00	.0000E 00	.6185E-05			
.8187500	.481233522E-01	-.000000000E 00	-.9857E 00	.1971E 00	.0000E 00	.6024E-05			
.8093750	.499882452E-01	-.000000000E 00	-.9884E 00	.1937E 00	.0000E 00	.4643E-05			
.8000000	.518159851E-01	-.000000000E 00	-.9910E 00	.1903E 00	.0000E 00	.6185E-05			
.7937500	.530123644E-01	-.000000000E 00	-.9926E 00	.1881E 00	.0000E 00	.6024E-05			
.7843750	.547804318E-01	-.000000000E 00	-.9949E 00	.1849E 00	.0000E 00	.4643E-05			
.7750000	.565138973E-01	-.000000000E 00	-.9971E 00	.1817E 00	.0000E 00	.6185E-05			
.7687500	.576489002E-01	-.000000000E 00	-.9984E 00	.1796E 00	.0000E 00	.6024E-05			
.7593750	.593266137E-01	-.000000000E 00	-.1000E 01	.1764E 00	.0000E 00	.4643E-05			
.7500000	.609719075E-01	-.000000000E 00	-.1002E 01	.1733E 00	.0000E 00	.6185E-05			
.7437500	.620493919E-01	-.000000000E 00	-.1003E 01	.1713E 00	.0000E 00	.6024E-05			
.7343750	.636423044E-01	-.000000000E 00	-.1005E 01	.1683E 00	.0000E 00	.4643E-05			
.7250000	.652046822E-01	-.000000000E 00	-.1007E 01	.1654E 00	.0000E 00	.6185E-05			
.7187500	.662279859E-01	-.000000000E 00	-.1008E 01	.1634E 00	.0000E 00	.6024E-05			
.7093750	.677409098E-01	-.000000000E 00	-.1009E 01	.1605E 00	.0000E 00	.4643E-05			
.7000000	.692249425E-01	-.000000000E 00	-.1011E 01	.1577E 00	.0000E 00	.6185E-05			
.6937500	.701969720E-01	-.000000000E 00	-.1012E 01	.1558E 00	.0000E 00	.6024E-05			
.6843750	.716341108E-01	-.000000000E 00	-.1013E 01	.1530E 00	.0000E 00	.4643E-05			
.6750000	.730437942E-01	-.000000000E 00	-.1014E 01	.1503E 00	.0000E 00	.6185E-05			
.6687500	.739670992E-01	-.000000000E 00	-.1015E 01	.1485E 00	.0000E 00	.6024E-05			
.6593750	.753321417E-01	-.000000000E 00	-.1016E 01	.1458E 00	.0000E 00	.4643E-05			
.6500000	.766709991E-01	-.000000000E 00	-.1017E 01	.1432E 00	.0000E 00	.6185E-05			
.6437500	.775478229E-01	-.000000000E 00	-.1018E 01	.1414E 00	.0000E 00	.6024E-05			
.6343750	.788440168E-01	-.000000000E 00	-.1019E 01	.1389E 00	.0000E 00	.4643E-05			
.6250000	.801151417E-01	-.000000000E 00	-.1020E 01	.1363E 00	.0000E 00	.6185E-05			
.6187500	.809474669E-01	-.000000000E 00	-.1021E 01	.1346E 00	.0000E 00	.6024E-05			
.6093750	.821776830E-01	-.000000000E 00	-.1022E 01	.1321E 00	.0000E 00	.4643E-05			
.6000000	.833838239E-01	-.000000000E 00	-.1023E 01	.1296E 00	.0000E 00	.6185E-05			
.5937500	.841734067E-01	-.000000000E 00	-.1023E 01	.1280E 00	.0000E 00	.6024E-05			
.5843750	.853401899E-01	-.000000000E 00	-.1024E 01	.1256E 00	.0000E 00	.4643E-05			
.5750000	.864837766E-01	-.000000000E 00	-.1025E 01	.1232E 00	.0000E 00	.6185E-05			
.5687500	.872321732E-01	-.000000000E 00	-.1026E 01	.1216E 00	.0000E 00	.6024E-05			

.5593750	.883377872E-01	-.1026E 01	.1192E 00	.0000E 00	.5638E-05
.5500000	.894209862E-01	-.1027E 01	.1169E 00	.0300E 00	.5570E-05
.5375000	.908332989E-01	-.1028E 01	.1138E 00	.0300E 00	.9779E-05
.5250000	.922068030E-01	-.1029E 01	.1107E 00	.0300E 00	.9629E-05
.5125000	.935420811E-01	-.1030E 01	.1077E 00	.0000E 00	.9487E-05
.5000000	.948396817E-01	-.1031E 01	.1047E 00	.0000E 00	.9354E-05
.4875000	.961001284E-01	-.1032E 01	.1018E 00	.0000E 00	.9226E-05
.4750000	.973239064E-01	-.1033E 01	.9886E-01	.0000E 00	.9109E-05
.4625000	.985114865E-01	-.1034E 01	.9597E-01	.0000E 00	.8996E-05
.4500000	.996633068E-01	-.1034E 01	.9311E-01	.0000E 00	.8899E-05
.4375000	.100779779E 00	-.1035E 01	.9028E-01	.0000E 00	.8787E-05
.4250000	.101861313E 00	-.1036E 01	.8747E-01	.0000E 00	.8691E-05
.4125000	.102908261E 00	-.1036E 01	.8468E-01	.0000E 00	.8601E-05
.4000000	.103920989E 00	-.1037E 01	.8191E-01	.0000E 00	.8514E-05
.3875000	.104899831E 00	-.1038E 01	.7917E-01	.0000E 00	.8435E-05
.3750000	.105845101E 00	-.1038E 01	.7645E-01	.0000E 00	.8358E-05
.3625000	.106757089E 00	-.1039E 01	.7374E-01	.0000E 00	.8283E-05
.3500000	.107636067E 00	-.1039E 01	.7105E-01	.0000E 00	.8214E-05
.3375000	.108482368E 00	-.1040E 01	.6838E-01	.0000E 00	.8149E-05
.3250000	.109296173E 00	-.1041E 01	.6573E-01	.0000E 00	.8088E-05
.3125000	.110077739E 00	-.1041E 01	.6309E-01	.0000E 00	.8031E-05
.3000000	.110827304E 00	-.1041E 01	.6046E-01	.0000E 00	.7974E-05
.2875000	.111545071E 00	-.1042E 01	.5785E-01	.0000E 00	.7926E-05
.2750000	.112231240E 00	-.1042E 01	.5525E-01	.0000E 00	.7875E-05
.2625000	.112886004E 00	-.1043E 01	.5267E-01	.0000E 00	.7831E-05
.2500000	.113509543E 00	-.1043E 01	.5009E-01	.0000E 00	.7786E-05
.2375000	.114102021E 00	-.1043E 01	.4752E-01	.0000E 00	.7747E-05
.2250000	.114663593E 00	-.1044E 01	.4497E-01	.0000E 00	.7709E-05
.2125000	.115194410E 00	-.1044E 01	.4242E-01	.0000E 00	.7674E-05
.2000000	.115694605E 00	-.1044E 01	.3988E-01	.0000E 00	.7642E-05
.1875000	.116164304E 00	-.1045E 01	.3735E-01	.0000E 00	.7607E-05
.1750000	.116603635E 00	-.1045E 01	.3483E-01	.0000E 00	.7579E-05
.1625000	.117012694E 00	-.1045E 01	.3231E-01	.0000E 00	.7556E-05
.1500000	.117391601E 00	-.1045E 01	.2980E-01	.0000E 00	.7532E-05
.1375000	.117740430E 00	-.1046E 01	.2730E-01	.0000E 00	.7506E-05
.1250000	.118059285E 00	-.1046E 01	.2480E-01	.0000E 00	.7487E-05
.1125000	.118348241E 00	-.1046E 01	.2231E-01	.0000E 00	.7459E-05
.1000000	.118607357E 00	-.1046E 01	.1982E-01	.0000E 00	.7451E-05
.0875000	.118836701E 00	-.1046E 01	.1733E-01	.0000E 00	.7437E-05
.0750000	.119036339E 00	-.1046E 01	.1485E-01	.0000E 00	.7424E-05
.0625000	.119206309E 00	-.1047E 01	.1237E-01	.0000E 00	.7412E-05
.0500000	.119346656E 00	-.1047E 01	.9893E-02	.0000E 00	.7400E-05
.0375000	.119457416E 00	-.1047E 01	.7418E-02	.0000E 00	.7395E-05
.0250000	.119538613E 00	-.1047E 01	.4944E-02	.0000E 00	.7388E-05
.0125000	.119590275E 00	-.1047E 01	.2472E-02	.0000E 00	.7384E-05
-.0000000	.119612403E 00	-.1047E 01	-.1164E-09	-.0000E 00	.7382E-05

Y ERR IS THE IMPROVEMENT IN Y OBTAINED AT EACH STEP BY RECALCULATION WITH TWICE AS FINE A STEP SIZE AS IS INDICATED.

..003886.....003886.....003886.....003886.....003886.....003886.....003886.....003886.....003886.....003886.....

JOB NO. 003886 UNIVERSITY OF MICHIGAN EXECUTIVE SYSTEM (MODEL OV302) THURSDAY, DECEMBER 13, 1962 7 08 30.8 PM
KIN - GREENE S000F 001 020 160 DRA04542

..003886.....003886.....003886.....003886.....003886.....003886.....003886.....003886.....003886.....003886.....

B. Polynomial Hull

MAD (16 APR 1962 VERSION) PROGRAM LISTING

MARITIME TASK 1 PROJECT NR. 04542
 CALCULATION OF SHIP HULL FORM MATHEMATICALLY
 PRODUCED BY THE GIVEN SINGULARITY DISTRIBUTION

POLYNOMIAL SHIP

DIMENSION F(2),H(9),I(9),K(13),O(2),P(4),X(999),Y(2),Z(1)
 EQUIVALENCE (RTM, XI), (RTP, XII)
 BOOLEAN H IS T
 INTEGER J, L, M, N
 STATEMENT LABEL D

INTERNAL FUNCTION (A, B)
 ENTRY TO DU.

D = GAMMA
 TRANSFER TO ALPHA
 ENTRY TO DV.
 D = DELTA
 TRANSFER TO ALPHA
 ENTRY TO DW.

ALPHA

EXECUTE ZERO.(C, F1)
 THROUGH ZETA, FOR M = 1, 1, M.G.9
 XI = ((J.+H(10-M)) * B + (1.-H(10-M)) * A) * .5
 XII = .ABS. XI

BETA

THROUGH BETA, FOR J = 0, 1, J.G.4
 F1 = (F1 + P(J)) * XII
 WHENEVER XI.L.0., F1 = -F1
 F1 = E * F1 * I(M)
 XI2 = X - XI
 XI3 = XI2 * XI2 + Y(1) * Y(1)
 G = TNAUT + B1 * XI * XI
 ZGM = Y(2) - G
 ZGP = Y(2) + G
 RTM = SQRT.(XI3 + ZGM * ZGM)
 RTP = SQRT.(XI3 + ZGP * ZGP)
 F2 = ELOG.(ZGM + RTM) / (ZGP + RTP))
 WHENEVER H IS T

F1 = F1 / (G * G)
 ITRND = F1*(F2+(ZGP*RTM-ZGM*RTP)/XI3)

OTHERWISE

H1 = H1 * H1
 F1 = F1 / H1
 ZH2M = Y(2) * Y(2) - H1
 ITRND = F1*(F2-((ZGP*RTM-ZGM*RTP)*ZH2M+(ZGM*RTM-ZGP*RTP)*
 XI3)/((RTM*RTP*XI3)))

1

END OF CONDITIONAL
 TRANSFER TO D
 C = C + ITRND * XI2
 TRANSFER TO ZETA
 C = C + ITRND * Y(1)
 TRANSFER TO ZETA

GAMMA

DELTA

*001
 *002
 *003
 *004
 *005
 *006
 *007
 *008
 *009
 *010
 *011
 *012
 *013
 *014
 *015
 *016
 *017
 *018
 *019
 *020
 *021
 *022
 *023
 *024
 *025
 *026
 *027
 *028
 *029
 *030
 *031
 *032
 *033
 *034
 *035
 *036
 *037
 *038
 *039
 *040
 *041
 *042
 *043
 *044

```

EPSILN      C = C + FI * (RTM - RTP - F2 * Y(2))
            WHENEVER H IS T, C = C + FI*(HI-G*G)*(RTP-RTM)/(I2.*RTP*RTM)
ZETA        CONTINUE
            FUNCTION RETURN C * (B - A)
            END OF FUNCTION

            *045
            *046
            *047
            *048
            *049

            *050
            *051
            *052
            *053
            *054
            *055
            *056
            *057
            *058
            *059
            *060
            *061
            *062
            *063
            *064
            *065
            *066
            *067
            *068
            *069
            *070
            *071
            *072
            *073
            *074
            *075
            *076
            *077
            *078
            *079
            *080
            *081
            *082
            *083
            *084
            *085
            *086
            *087
            *088
            *089
            *090
            *091
            *092
            *093
            *094
            *094
            *095
            *095
            *096
            *096
            *097
            *098
            *099
            *100

EXECUTE SETRKD. (Z, Y(1), F(1), O, X, STEP)
H(1) = .96816024
H(2) = .83603111
H(3) = .61337143
H(4) = .32425342
H(5) = .0
I(1) = .08127439
I(2) = .18064816
I(3) = .26061070
I(4) = .31234708
I(5) = .33023936
THROUGH ETA, FOR L = 6, 1, L.G.9
H(L) = -H(I0 - L)
I(L) = I(I0 - L)
READ FORMAT R, P...P(4)
READ DATA N
READ FORMAT R, X(1)...X(N)
E = 1. / (8. * 3.1415927)
X1 = -1.
X2 = .4
X9 = -X1
READ FORMAT TITLER, K...K(I13)
READ DATA TNAUT,B1,HI
READ FORMAT Q, X, Y(1), Y(2)
PRINT FORMAT TITLER, K...K(I13)
Y = Y(1)
Z = Y(2)
PRINT COMMENT $4 INPUT VALUES READ WERE$
PRINT COMMENT $4$
PRINT RESULTS TNAUT,B1,HI,N,P...P(4),X...X(N),X,Y,Z
H IS T = .ABS.(HI - TNAUT) .L. 1E-5
PRINT COMMENT $1$
WHENEVER N.G.28, TRANSFER TO IOTA
PRINT COMMENT $4$
PRINT FORMAT S, X, Y(1), Y(2)
THROUGH LAMBDA, FOR L = 0, 1, L.G.N
X = X(L)
X3 = X - SQRT.(Y(1), MU)
X4 = X - 4 * Y(1)
X5 = X - 2 * Y(1)
X6 = X + 2 * Y(1)
X7 = X + 4 * Y(1)
X8 = X * 2. - X3
WHENEVER X .LE. .95
    U = DU.(X1, X3) + DU.(X3, X5) + DU.(X5, X) + DU.(X, X6)
    + DU.(X6, X8) + DU.(X8, X9)
    V = DV.(X1, X3) + DV.(X3, X5) + DV.(X5, X6) + DV.(X6, X8)
    + DV.(X8, X9)
    W = DW.(X1, X3) + DW.(X3, X5) + DW.(X5, X6) + DW.(X6, X8)
    + DW.(X8, X9)
1 OTHERWISE
    U = DU.(X1, X2) + DU.(X2, X3) + DU.(X3, X5) + DU.(X5, X)
    V = DV.(X1, X2) + DV.(X2, X3) + DV.(X3, X4) + DV.(X4, X)
    W = DW.(X1, X2) + DW.(X2, X3) + DW.(X3, X4) + DW.(X4, X)

```



```

*101 WHENEVER .ABS.(X-1.) .G. 1E-6
*102 U = U + DU.(X, X6) + DV.(X6, X8) + DU.(X8, X9)
*103 V = V + DV.(X, X7) + DV.(X7, X8) + DV.(X8, X9)
*104 W = W + DW.(X, X7) + DW.(X7, X8) + DW.(X8, X9)
*105
*106 END OF CONDITIONAL
*107
*108 U = -1. - U
*109 V = -V
*110 W = 2. * W
*111 PRINT FORMAT T, X, Y(1), Y(2), U, V, W
*112 WHENEVER L.E.N, TRANSFER TO THETA
*113 STEP = X(I + 1) - X
*114 F = RKDEQ.(0)
*115 WHENEVER F.E.I.
*116 F(1) = V / U
*117 F(2) = W / U
*118 TRANSFER TO KAPPA
*119
*120 END OF CONDITIONAL
*121 CONTINUE
*122 PRINT COMMENT $4 ARGUMENT OF SQUARE ROOT FUNCTION IS NEGATI
1VE*$
PRINT RESULTS X, Y, Z, L, STEP, Y(1), Y(2), F, U, V, W
TRANSFER TO THETA

VECTOR VALUES Q = $F10,2E20*$
VECTOR VALUES R = $8F10*$
VECTOR VALUES S = $S17,91HCALCULATION OF SHIP HULL FORM MATHE
2,7HTAKAHEI///S7,89HCOORDINATES OF POINTS ON STREAMLINES AND
3CORRESPONDING VALUES OF FLOW VELOCITY COMPONENTS///S7,28HINI
4TIAL VALUES OF STREAMLINES10,4HX =F8.4,S7,4HY =F11.8,S7,4HZ
5 =F11.8///S16,1HXS18,1HYS18,1HS22,1HUS18,1HVS18,1HW//*$
VECTOR VALUES T = $F19.4,S2,2E19.4,S4,3E19.4*$
VECTOR VALUES TITLE = $1H1/1H813C6,C2*$
VECTOR VALUES TITLER = $13C6,C2*$

END OF PROGRAM

```

KAPPA

LAMBDA
MU

APPENDIX II

HULL FORMS OBTAINED FROM STREAM LINE TRACES

Very few hull forms have so far been obtained from the traces of streamlines for given singularity distributions. For convenience we have included the particulars of forms produced elsewhere in Table II-1, and in Figures II-1(a) through II-1(i).

It is noted that all hull forms have a singularity distribution of the separable type, i.e.

$$m(\xi, \zeta) = m_1(\xi) \cdot m_2(\zeta)$$

Except for hull G-4-V, where $m_2(\xi)$ is a linear function of ξ . All hulls have a uniform distribution of singularities with respect to depth i.e.

$$m_2(\xi) = 1$$

The depth of the singularity distribution is the same as the draft at the F.P. The function $m_1(\xi)$ is shown as a chain line in each figure.

TABLE II - I
LIST OF STREAMLINE HULL

Source Distribution $m(\xi, \zeta) = m_1(\xi) \cdot m_2(\zeta)U$										
Model	Lengthwise $m(\xi)$	Draftwise $m_2(\xi)$	B/L	Tf/L	T/L	$m_1(\xi = 1)$	$m_1(\xi = 1)$	$m_1(\xi = 1)$	Figure	Remarks
S-101	0.4 ξ	Constant $t = 0.1$	0.0748	0.050	0.0806	0.4	0.4	0.4	II - (a)	Ref. (6)
S-102	0.4 ξ	" $t = 0.2$	0.0839	0.100	0.1356	0.4	0.4	0.4	II - (b)	
S-201	0.8 ξ	" $t = 0.1$	0.1229	0.050	0.0979	0.8	0.8	0.8	II - (c)	
S-202	0.8 ξ	" $t = 0.2$	0.1454	0.100	0.1562	0.8	0.8	0.8	II - (d)	
#G-1	0.8 ξ	" $t = 0.2$	0.1454	0.100	0.1562	0.8	0.8	0.8	II - (d)	Ref. (9)
#G-2	$1.170\xi - 0.780\xi^2$	" $t = 0.1$				0.39	-0.39	-0.39	II - (e)	
#G-3	$1.952\xi(1 - \xi^2)$	" $t = 0.1$				0	-3.904	-3.904	II - (f)	
G-4-V	0.8 ξ	$1-5 \xi $, $t = 0.2$				0.8	0.8	0.8	II - (g)	Ref. (11)
C-101	$0.4 \sin \frac{\pi}{2} \xi$	Constant $t = 0.1$	0.0904	0.050	0.0859	0.4	0.4	0	II - (h)	Ref. (12)
C-201	$0.6 \sin \frac{\pi}{2} \xi$	" $t = 0.1$	0.1208	0.050	0.0984	0.6	0.6	0	II - (i)	

U = undisturbed flow velocity

$$1 \geq \xi \geq -1 \quad t \geq \xi \geq -t,$$

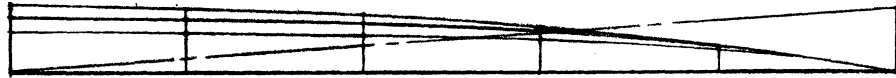
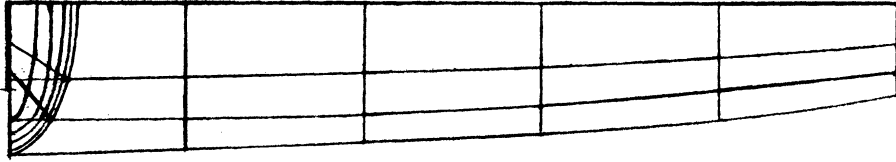

(a) S-101

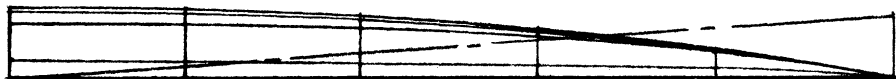
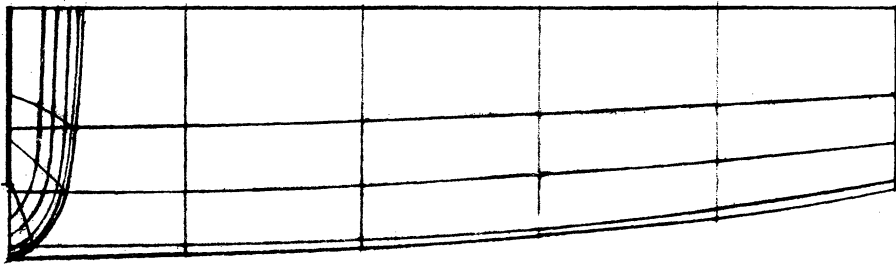

(b) S-102

Figure II-1

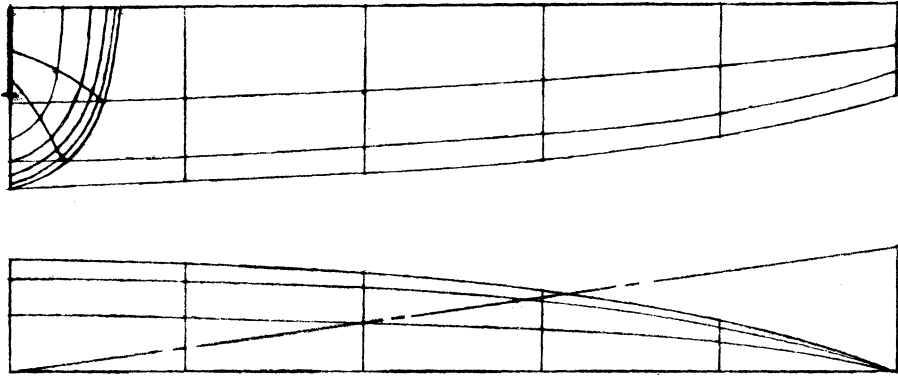

(c) S-201

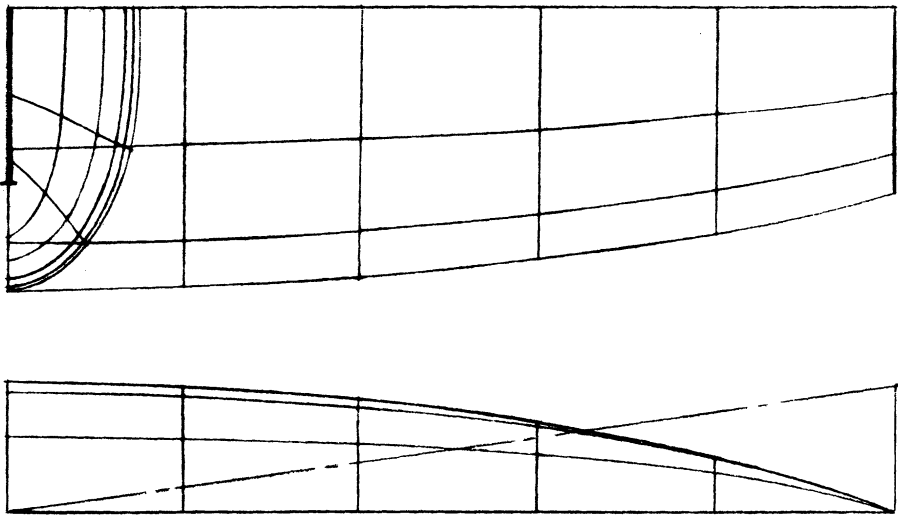

(d) S-202

Figure II-1 (Continued)

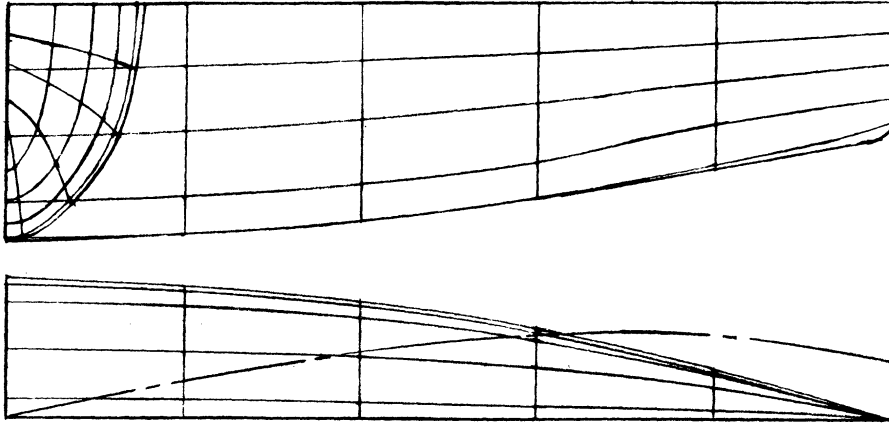

(e) G-2

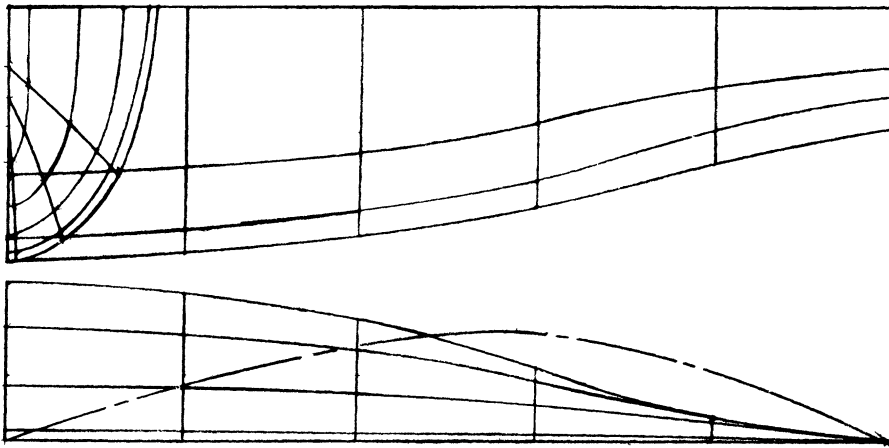

(f) G-3

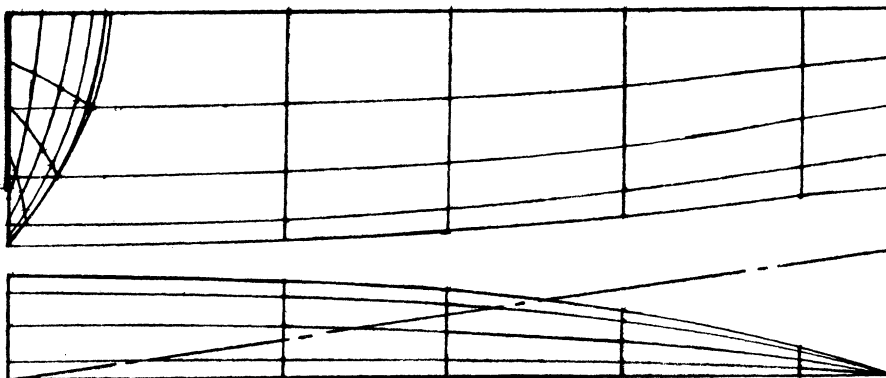

(g) G-4-V

Figure II-1 (Continued)

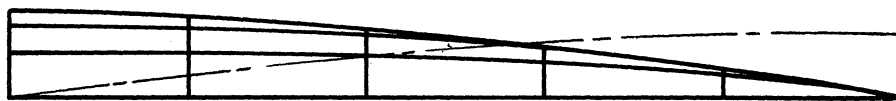
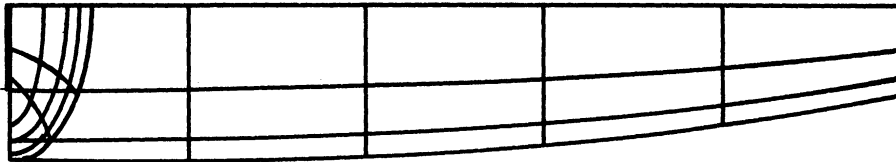

$B/L=0.090$ $T_F/L=0.050$ $T_M/L=0.0859$

(h) C-101

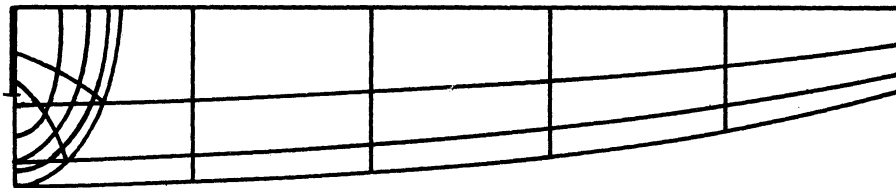

$B/L=0.121$ $T_F/L=0.050$ $T_M/L=0.0984$

(i) C-201

Figure II-1 (Concluded)

APPENDIX III

EFFECT OF DEPTHS OF SINGULARITY DISTRIBUTIONS ON TRACED HULLS (SERIES-60, POLYNOMIAL DISTRIBUTION)

To investigate the effect of the depth of source distribution on the hull lines, the following six hulls' streamlines (four streamlines each) were traced. The result indicates that the hulls obtained by the uniformly distributed sources at the centerplane have maximum draft approximately twice the depth of the distribution. Therefore, if the bottom has to be cut off for the draft consideration, it is recommended that the effect of this extremely large cut off be first investigated.

Fig. III - 1 shows the source distribution used above.

Table III - 1 shows the depth of singularity distribution and starting points for Models A-1-1~6. Four streamlines are traced for each hull.

Fig. III - 2 shows the body plans of the hulls, A-1-1, A-1-2, A-1-5, A-1-6 and Series-60.

Fig. III - 3 shows the load waterlines. The changes in load waterlines due to the changes in source distribution is the maximum at the midship and they taper off parabolically toward the tip. All waterlines appear to have similar shapes.

Fig. III - 4 shows the keel lines. Again all keel lines appear to have the same shapes and the changes in shapes due to those in depth of distribution may for all practical purposes be neglected.

Fig. III - 5 cross-plots of Fig. III - 2. Note that the changes amidship are the greatest. This graph may be used for estimating the three-dimensional effect from two-dimensional case and vice versa.

Fig. III - 6 is cross-plots of Fig. III - 3. This may be used to estimate the maximum draft for the changes of source distribution.

TABLE III - I

LIST OF MODELS

Source Distribution: $m(\xi) = 9.88 |\xi|^2 - 17.58 |\xi|^3 + 5.96 |\xi|^4 + 1.98 |\xi|^5$

Hull No.	Depth of Source Distribution	Initial Values of Streamlines				
		X	Y	z		t ₀
UM. Hull	t ₀			2/3 t ₀	5/6 t ₀	t ₀
A - 1 - 1	.0775	1.0	1.69 x 10 ⁻⁴	.05167	.06458	.07751
A - 1 - 2	.1067	1.0	"	.07113	.08892	.10671
A - 1 - 3	.070	1.0	"	.04667	.05833	.07001
A - 1 - 4	.060	1.0	"	.04000	.05000	.06001
A - 1 - 5	.050	1.0	"	.03333	.04166	.05001
A - 1 - 6	1.000	1.0	"	.6667	.83333	1.0001

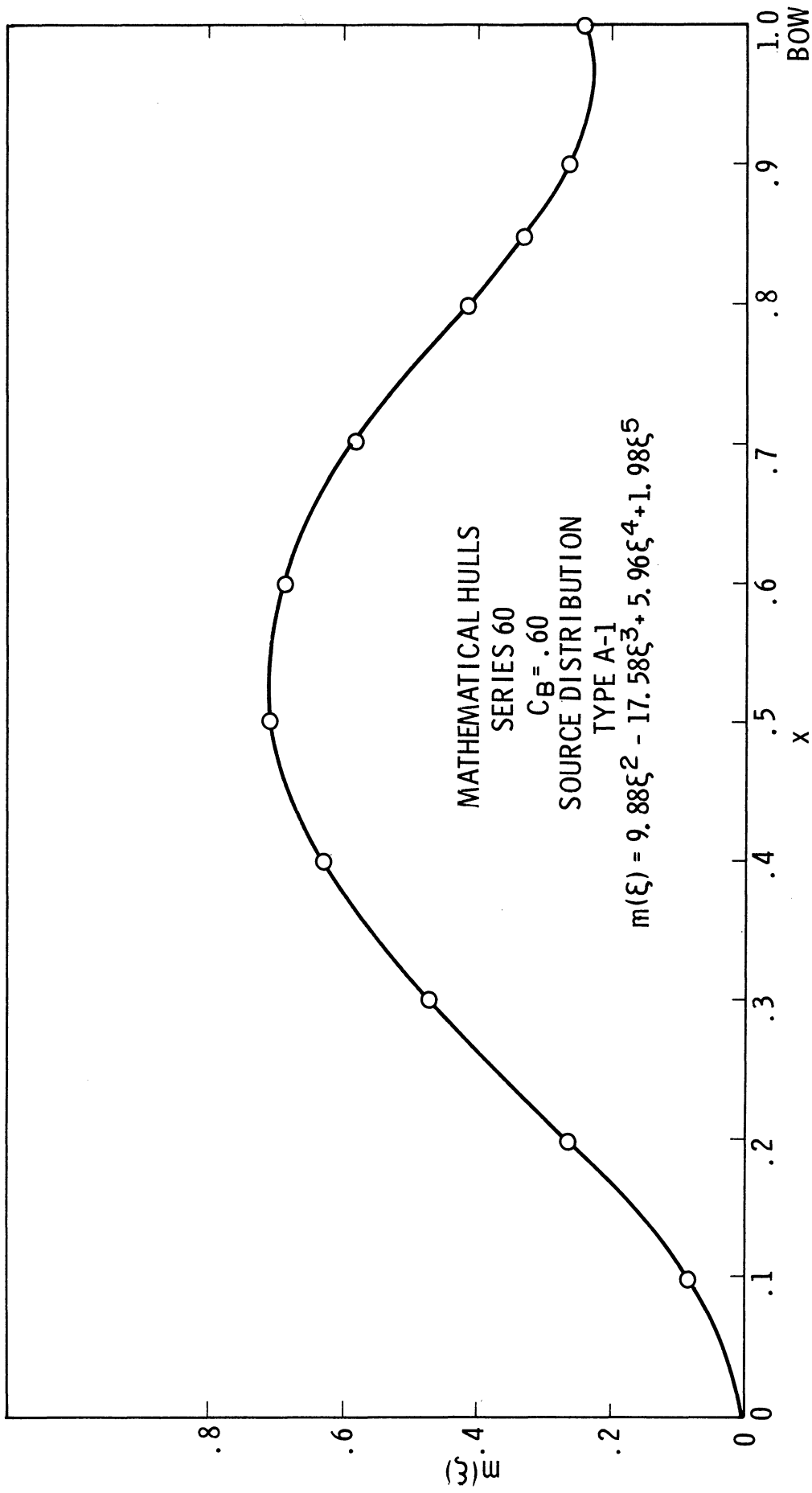

Figure III-1

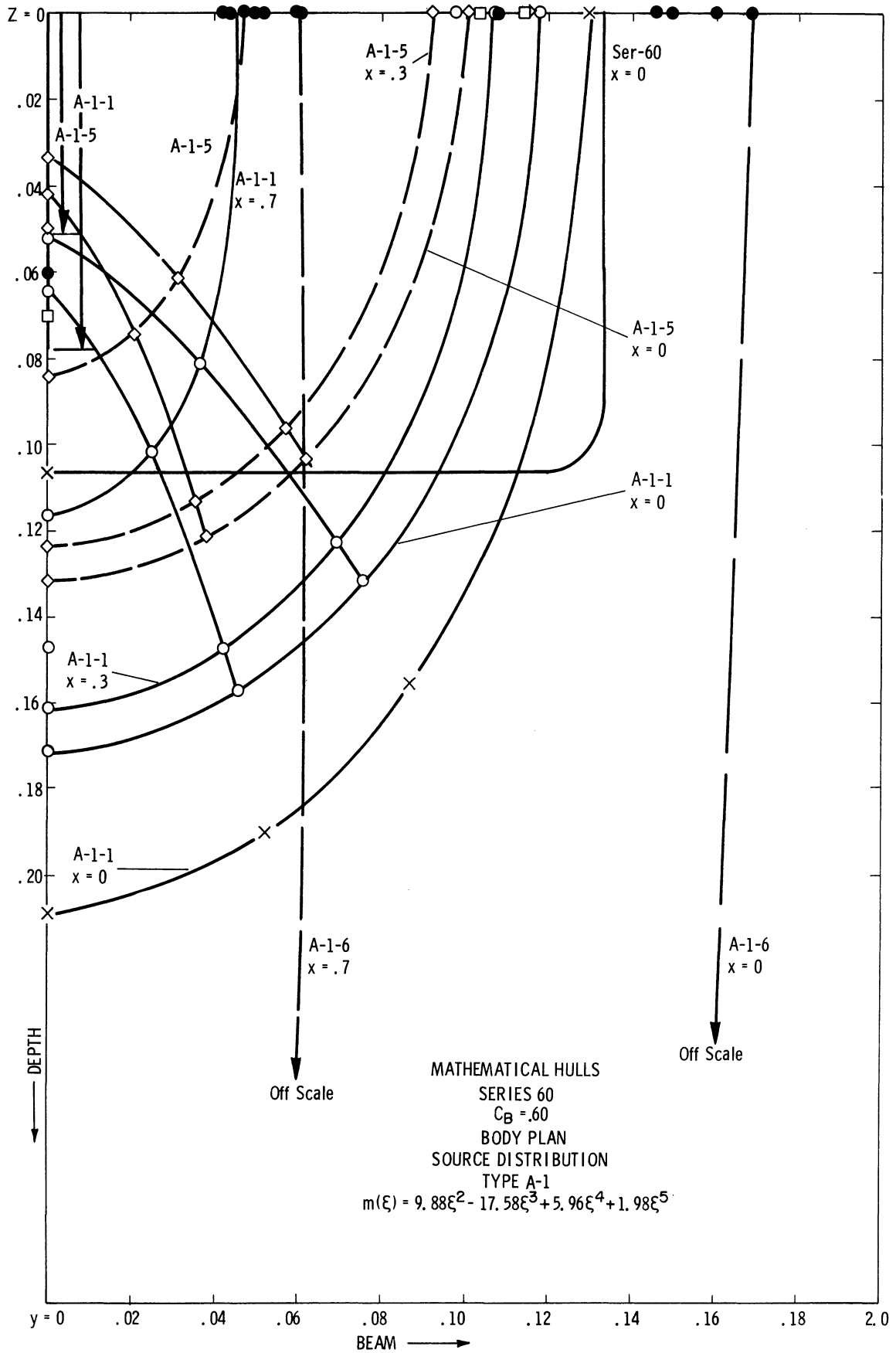
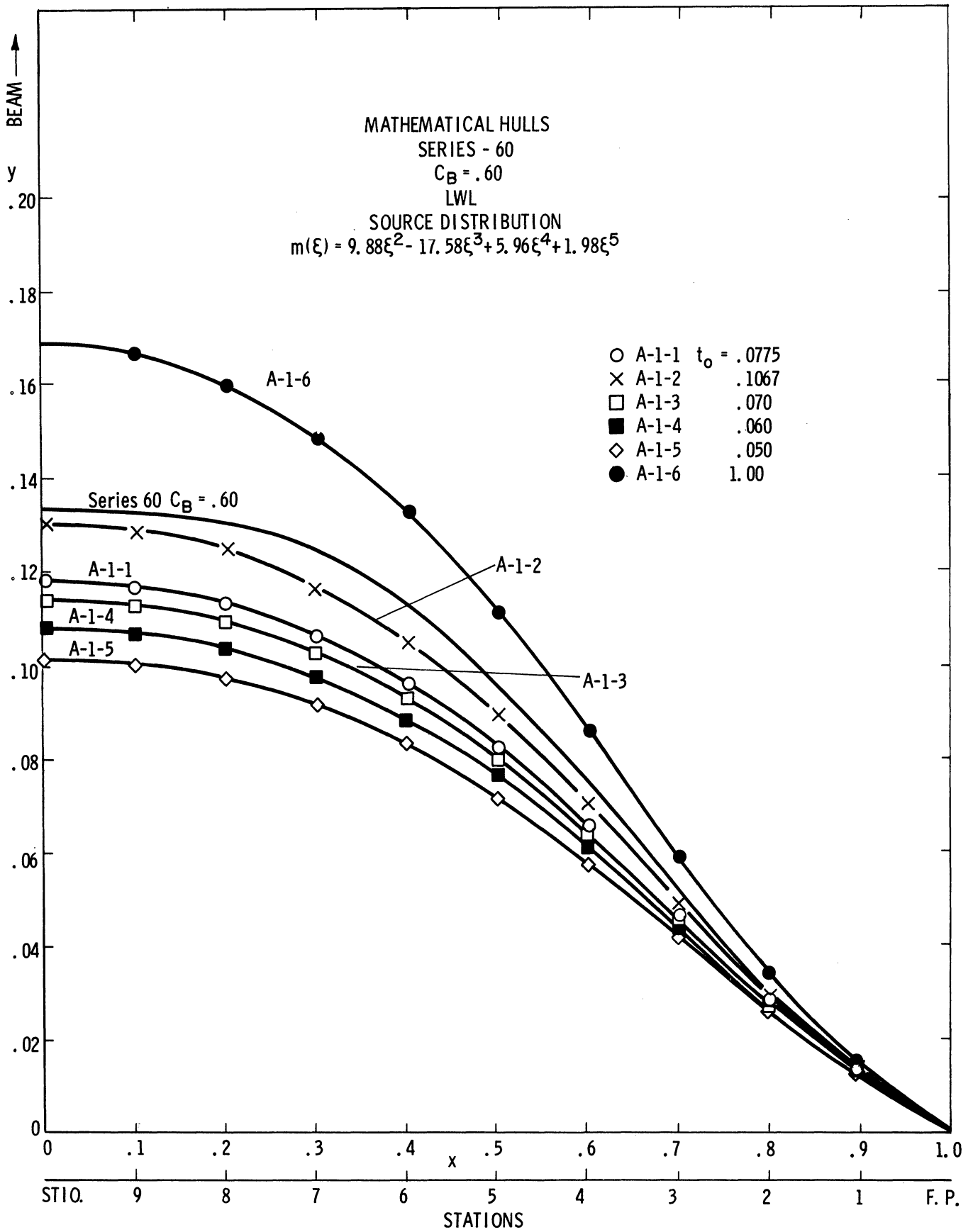

Figure III-2



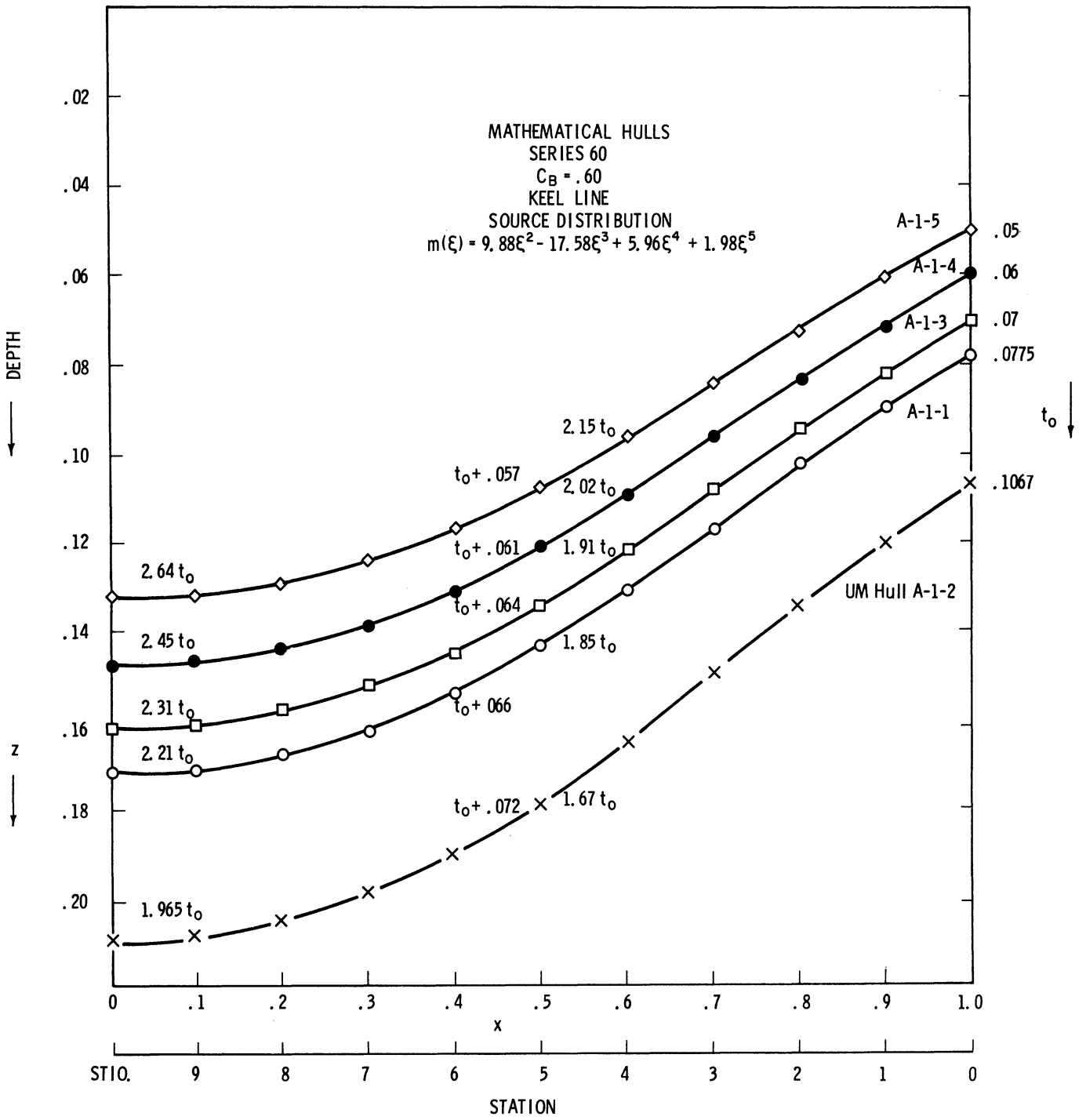

Figure III-4

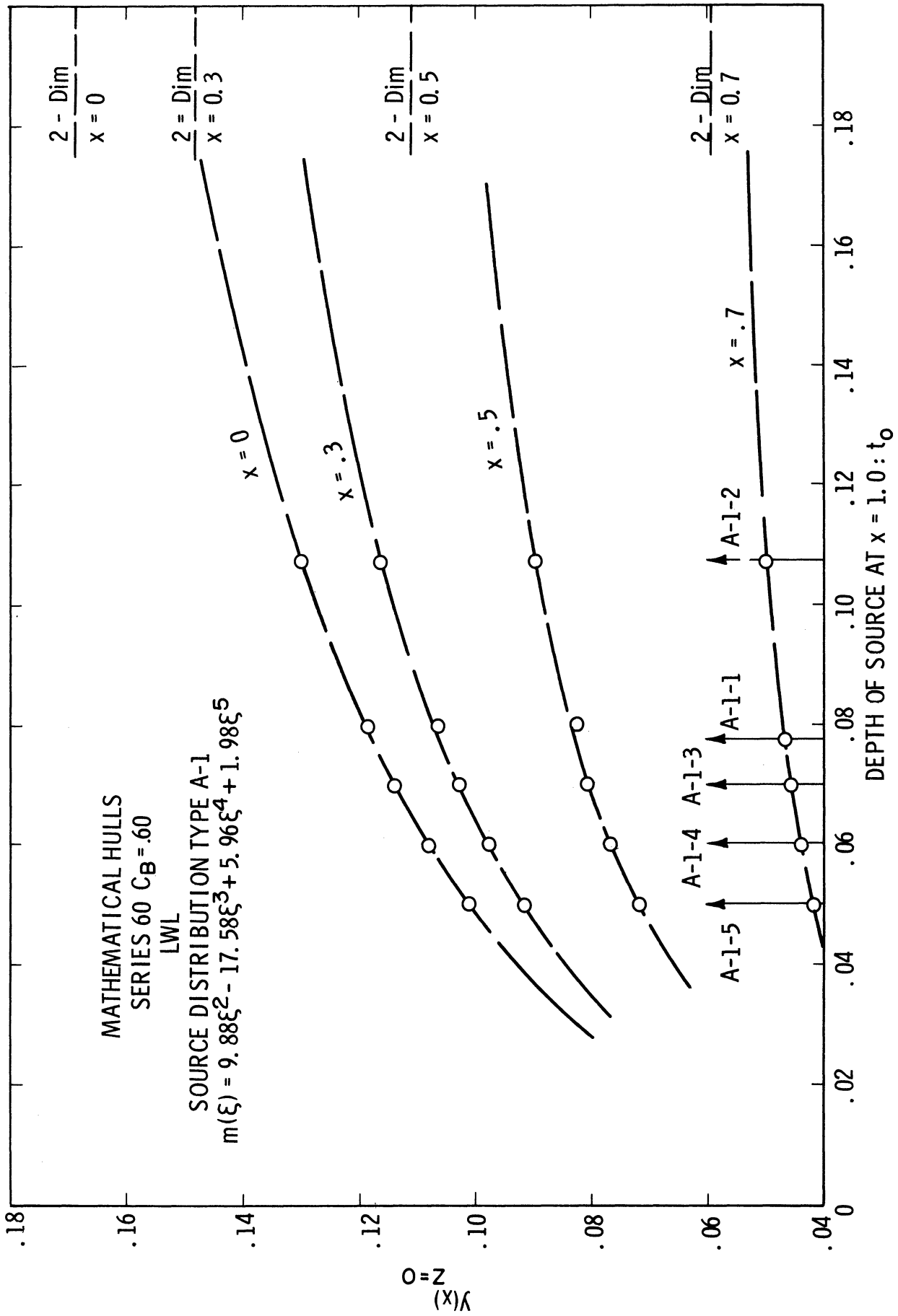

Figure III-5

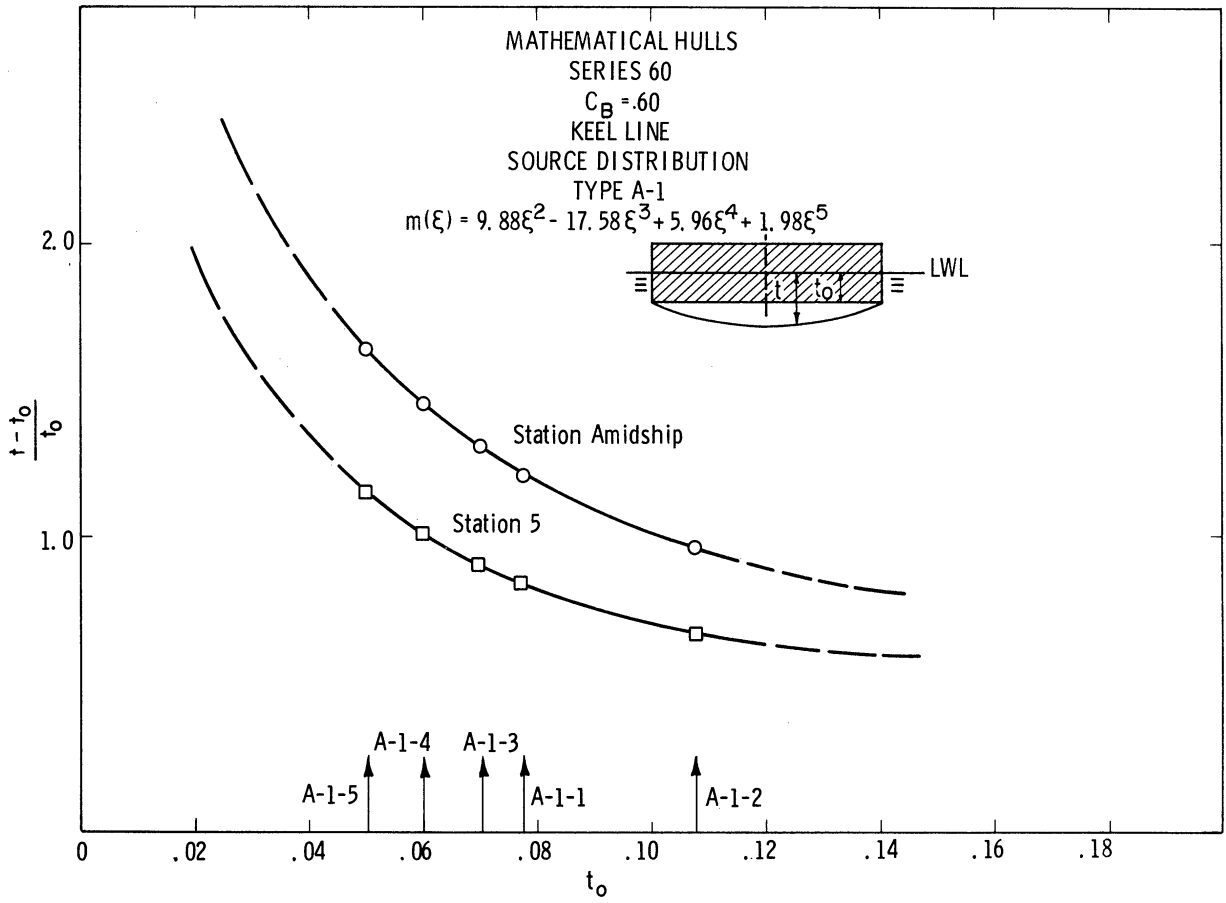

Figure III-6

APPENDIX IV

COMPUTER PROGRAM FOR FINDING THE SOURCE DISTRIBUTION FOR A GIVEN LOAD WATERLINE SHAPE FOR TWO-DIMENSIONAL CASE

The method of finding a general source distribution representing a given hull form is not yet available. For a two-dimensional case, however, the integral equation can be reduced to a set of simultaneous equations, which can be readily solved.

Assume a two-dimensional source distribution at the longitudinal centerplane in power series form:

$$m(\xi) = V \sum_{n=0}^N a_n \xi^n, \quad 0 \leq \xi \leq 1 \quad (IV-1)$$

$$m(\xi) = V \sum_{n=0}^N (-1)^{n+1} a_n \xi^n, \quad -1 \leq \xi \leq 0$$

where

a_n = coefficients to be determined

$m(\xi)$ = source strength

V = uniform velocity

N = number of terms in polynomials.

The coordinate systems is defined as in Figure IV - 1. The stream function for the singularity distribution defined by Equations (IV - 1) can be written as of those due to the individual terms as:

$$\psi(x,y) = \sum_{n=1}^N \psi_n(x,y)$$

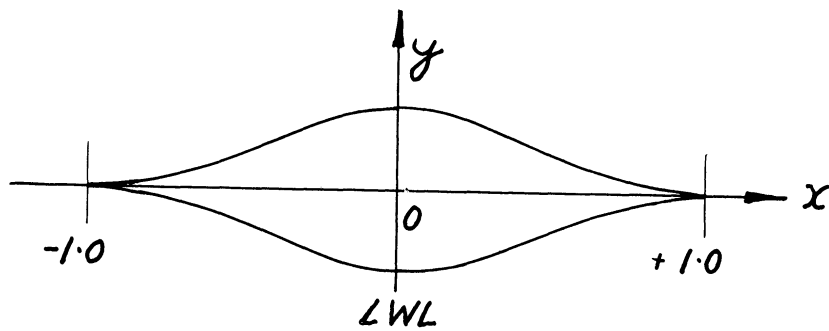
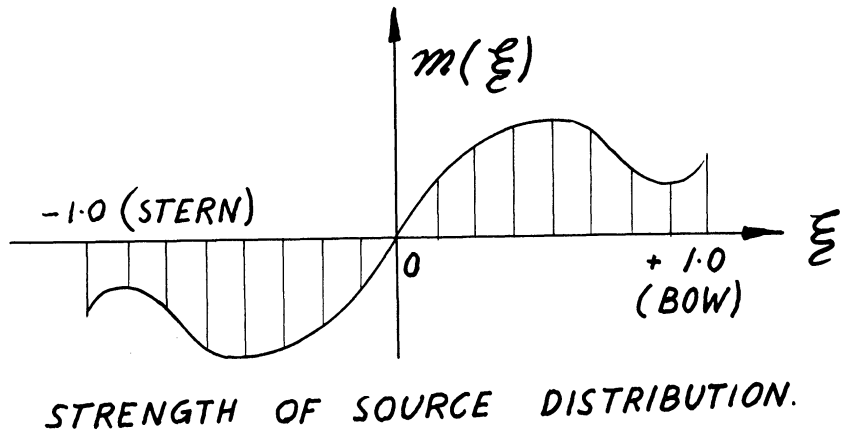

Figure IV-1

where

$$\psi_n = -\frac{Va_n}{2\pi} \int_{-1}^1 \theta(x,y;\xi) \xi^n d\xi \text{ for } n = \text{odd}$$

$$\psi_n = -\frac{Va_n}{2\pi} \left[\int_0^1 \theta(x,y;\xi) \xi^n d\xi \right. \tag{IV-2}$$

$$\left. - \int_{-1}^0 \theta(x,y;\xi) \xi^n d\xi \right] \text{ for } n = \text{even}$$

with θ defined as shown in Figure IV-2.

From the condition that the dividing streamline at the centerline forms on the hull surface, it follows that

$$\frac{1}{2\pi} \int_{-1.0}^{1.0} m(\xi) \theta(x,y;\xi) d\xi - V y(x) = 0 \tag{IV-3}$$

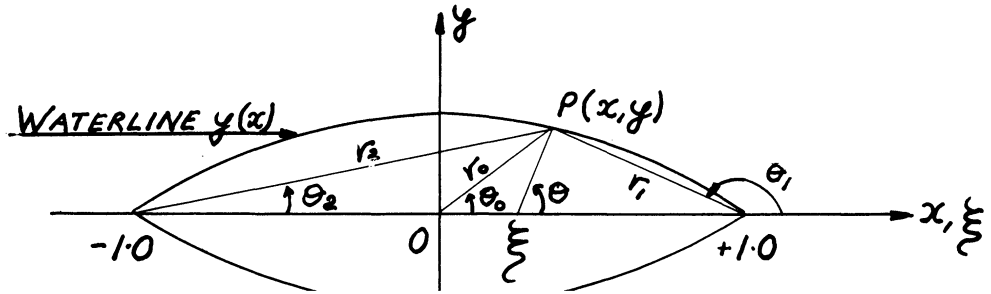

$$I_1 = (\theta_1 - \theta_2) - (x^2 - y^2) (\theta_1 - \theta_2) - 2y [1 + x (\ln r_1 - \ln r_2)]$$

$$I_2 = (\theta_1 - \theta_2) - x(x^2 - 3y^2) (\theta_1 + \theta_2 - 2\theta_0) \\ - y [1 + (3x^2 - y^2) (\ln r_1 + \ln r_2 - z \ln r_0)]$$

$$I_3 = (\theta_1 - \theta_2) - (x^4 - 6x^2y^2 + y^4) (\theta_1 - \theta_2) \\ - 2y[1/3 + (3x^2 - y^2) + 2x(x^2 - y^2) (\ln r_1 - \ln r_2)]$$

$$I_4 = (\theta_1 - \theta_2) - x(x^4 - 10x^2y^2 + 5y^4) (\theta_1 + \theta_2 - 2\theta_0) \\ - y[1/2 + (3x^2 - y^2) + (5x^4 - 10x^2y^2 + y^4) \\ (\ln r_1 + \ln r_2 - 2 \ln r_0)]$$

$$I_5 = (\theta_1 - \theta_2) - (x^2 - y^2) (x^4 - 14x^2y^2 + y^4) (\theta_1 - \theta_2) \\ - 2y[1/5 + \frac{3x^2 - y^2}{3} + (5x^4 - 10x^2y^2 + y^4) \\ + x(3x^4 - 10x^2y^2 + 3y^4) (\ln r_1 - \ln r_2)]$$

with

$$\theta_0 = \tan^{-1} \frac{y}{x} \text{ [rad]}$$

$$\theta_1 = \tan^{-1} \frac{y}{x - 1}$$

$$\theta_2 = \tan^{-1} \frac{y}{x + 1}$$

$$r_0 = \sqrt{x^2 + y^2}$$

$$r_1 = \sqrt{y^2 + (x - 1)^2}$$

$$r_2 = \sqrt{y^2 + (x + 1)^2}$$

For $x = x_0, x_1, \dots, x_n$, the corresponding values of y_n are

known from the LWL, and a_n are found by solving n simultaneous equations.

The desired solution is found by substituting a_n into Equation (1).

The computer program is written for $n = 5$. It solves for a_n in

$$[I] [C] = [Y] \text{ and}$$

$$A_n = C_n 2\pi (n + 1)$$

and punches out A_n .

```

KIM
KIM
$COMPILE MAD, EXECUTE, DUMP, PRINT OBJECT
R WATERLINE CALCULATION 2-DIMENSIONAL
R TAKAHEI KIM
R
DIMENSION I(100,DIM),V1(10),V2(10),V3(10),V4(10),X(9),Y(9),
ICU(20)
VECTOR VALUES DIM = 2,1,5
INTEGER N,J
READ DATA A, X(1),,X(5),
VECTOR VALUES A = $8F10.5*$
READ DATA A, Y(1),,Y(5),
PRINT FORMAT B, X(1),,X(5)
PRINT COMMENT $4$
PRINT FORMAT B, Y(1),,Y(5)
VECTOR VALUES B = $S12,ZE10.5*$
THROUGH ALPHA, FOR J=1,1,J,G.5
X = X(J),
Y = Y(J)
WHENEVER X.E.0.0
TH0 = 3.1416/2.0
OTHERWISE
TH0 = ATAN.(Y/X)
END OF CONDITIONAL
TH1 = ATAN.(Y/(X-1))
IH2 = ATAN.(Y/(X+1))
R1 = ((Y*Y)+((X-1)*P.2)).P.0.5
R2 = ((Y*Y)+((X+1)*P.2)).P.0.5
R0 = ((Y*Y)+(X*X)).P.0.5
B = (IH1-IH2)
D = (ELOG.(R1)-ELOG.(R2))
F = (IH1+IH2-(2*IH0))
E = (ELOG.(R1)+ELOG.(R2)-(2*ELOG.(R0)))
G = (X*X*Y)
L = ((X*X)-(Y*Y))
M = (3*X*X)-(Y*Y)
I(1,J) = B-(L*B)-(2*Y*(1+(X*D)))
I(2,J) = B-(X*X)-((X*X)-(3*Y*Y))*E)-(Y*(1+(M*E)))
I(3,J) = B-((X.P.4-(6*G)+Y.P.4)*B)-(2*Y*(1/3+M+(2*X*L*D)))
I(4,J) = B-(X*(X.P.4-(10*G)+(5*Y.P.4)*E)-(Y*(1/2+M)
1+((5*X.P.4)-(10*G)+Y.P.4)*F))
I(5,J) = B-(L*(X.P.4-(14*G)+Y.P.4)*B)-(2*Y*(1/5+(M/3)
1+((5*X.P.4)-(10*G)*Y.P.4)+(X*(13*X.P.4)
2-(10*G)+(3*Y.P.4)*D)))
THROUGH BETA, FOR N=1,1,N,G.5
C=GJRT.(5,6,1,CO)
WHENEVER C=1,CO(N)=CO*2.*3.1416*(N+1)
WHENEVER C=-1, PRINT COMMENT $ DETERMINANT EQUALS ZERO $
PRINT RESULTS X,CO(N)
TRANSFER TO START
END OF PROGRAM
$DATA
0.0
0.2
0.192
0.168
0.4
0.128
0.6
0.8
0.072

```

ORA04542
ORA04542

001 010 000
001 010 000

S293F
S293F

54 12 46

