

UMTRI-87-23

**THE PERFORMANCE  
OF TRUCKS  
BRAKING ON ICE**

**Final Report**

**Robert D. Ervin  
Yoram Guy  
Luis Balderas**

**August 1987**



1. Report No.	2. Government Accession No.	3. Recipient's Catalog No.	
4. Title and Subtitle <b>THE PERFORMANCE OF TRUCKS BRAKING ON ICE</b>		5. Report Date <b>June 1987</b>	6. Performing Organization Code
		8. Performing Organization Report No. <b>UMTRI-87-23</b>	
7. Author(s) <b>Robert D. Ervin, Yoram Guy, Luis Balderas</b>		10. Work Unit No. (TRAI5)	11. Contract or Grant No. <b>DTNH22-85-D-07259</b>
9. Performing Organization Name and Address <b>The University of Michigan Transportation Research Institute 2901 Baxter Road, Ann Arbor, Michigan 48109</b>		13. Type of Report and Period Covered <b>Final 2/25/87 - 6/15/87</b>	
		14. Sponsoring Agency Code	
12. Sponsoring Agency Name and Address <b>National Highway Traffic Safety Administration U.S. Department of Transportation Washington, D.C. 20590</b>		15. Supplementary Notes	
16. Abstract <p>The study addressed the braking performance of heavy-duty trucks operating on ice with and without chains installed at various axle positions. The research method included full-scale vehicle tests, measurements of the traction properties of truck tires with and without chains, and computerized analysis of vehicle braking performance. Friction utilization diagrams are appended, showing the axle-by-axle friction demands associated with braking on ice with various configurations of brake systems. The results also include a rare set of data showing the traction properties of truck tires operating under differing ice conditions with two varieties of chains installed.</p> <p>Primarily, the study was intended to determine whether the use of front brakes might degrade braking performance when stopping on ice with chains installed at the rear wheels of a truck or tractor. Existing data showing example brake system properties for U.S. vehicles were used in order to project "typical" and "extreme" levels of front-biased distribution of brake forces. The results show that few vehicles will have the level of front-bias needed for front-wheel lockup to constitute the performance limit on ice.</p>			
17. Key Words <b>ice, braking performance, chains, trucks, tires, front brakes</b>		18. Distribution Statement <b>UNLIMITED</b>	
19. Security Classif. (of this report) <b>NONE</b>	20. Security Classif. (of this page) <b>NONE</b>	21. No. of Pages <b>199</b>	22. Price



## Executive Summary

The purpose of this study was to collect experimental data and conduct analyses showing the braking performance characteristics of air-braked, heavy-duty trucks operating on ice. The study was prompted by two factors, namely,

- recent federal action requiring front brakes on all heavy vehicles employed in interstate transportation, and
- concern by some truckers that front brakes may pose a hazard when trucks are operated on ice with chains installed on the drive wheels. Such concerns pertain mainly to mountain driving situations in which certain states require chains to be used on icy roadways.

The study was designed to provide (a) test results showing the stopping behavior of vehicles, (b) measurements of the traction properties of truck tires braking on ice with and without chains, and (c) a general analysis which would address the trucking fleet, at large. The original plans for a rather extensive vehicle testing program were curtailed, however, due to unseasonably warm weather at the northern Michigan test site. Tire traction measurements were conducted at an alternate site in the northern extremes of Canada in order to obtain suitable ice conditions for testing with a mobile dynamometer device. The analytical effort was then expanded in order to cover the broad range of brake systems, vehicle loadings, and tire/chain installations of interest.

This study has succeeded in defining the performance issues which are faced during the braking of heavy-duty trucks on ice. The "bottom line" question which these results address is the following:

**"For cases in which trucks must operate on ice with chains installed on drive axles, what is the extent of the problem posed by the requirement for operational front brakes?"**

The simple answer to the question, and the primary finding of the study is,

**"Very little, since it appears that few vehicles would degrade in performance under these conditions, and most would improve, with the use of front brakes."**



The more substantive answer to this question must consider the distribution of brake system properties across the population and the vehicle loadings that prevail, with a concern for balancing the findings over the entire spectrum of road surfaces upon which trucks operate from day to day. In attempting to address trucks at large, existing data were used to show the variations in brake systems of contemporary trucks and trailers. These data are crucial for distinguishing between "common" and "rare" behavior among trucks in the U.S. fleet. The analysis combining these data with tire and chain traction measurements was focussed upon the conditions causing front wheels to lock first when braking on ice. The "first-to-lock" criterion is pertinent since it identifies the axle which is most "overbraked," thus causing performance to suffer. Although one should not assume that front-first lockup constitutes a "worst-case" among the differing modes of loss-of-control, it does serve the purposes of this study as a useful indicator of the condition in which front brakes are a "problem."

The following conclusions serve to flesh out the simple finding expressed above and to place the potential for front-first lockup in perspective.

- The only brake systems that cause front wheels to lock first on ice are those incorporating the highest-output front brakes which are believed to be in use. Such brake systems are referred to here as the "most front-biased" in their distribution of brake forces across axles. Vehicles exhibiting this extent of front-bias are thought to be possible, but uncommon in the U.S. population.

- Front wheels were not the first to lock on ice when automatic limiting valves were employed in conjunction with the most front-biased distributions of foundation brakes. Recognizing that the overwhelming majority of heavy vehicles in the U.S. incorporate a limiting valve, this result suggests that the actual prevalence of trucks in the U.S. which are, in fact, able to lock front wheels first on ice is quite low.

*(Please note, however, that this observation does not amount to an endorsement of limiting valves, per se. The authors note that most air-braked trucks in this country are so under-braked at the front axle that limiting valves are of no value whatsoever, regardless of the surface or loading conditions and, in fact, cause braking performance to be degraded.)*

- In no cases were front wheels seen to lock first on ice when the vehicle was empty.
- Concern for front-lockup on ice represents only a small portion of the total requirements for truck brake performance. Although this study has found conditions





Existing data shows  
combination vehicles  
in this range

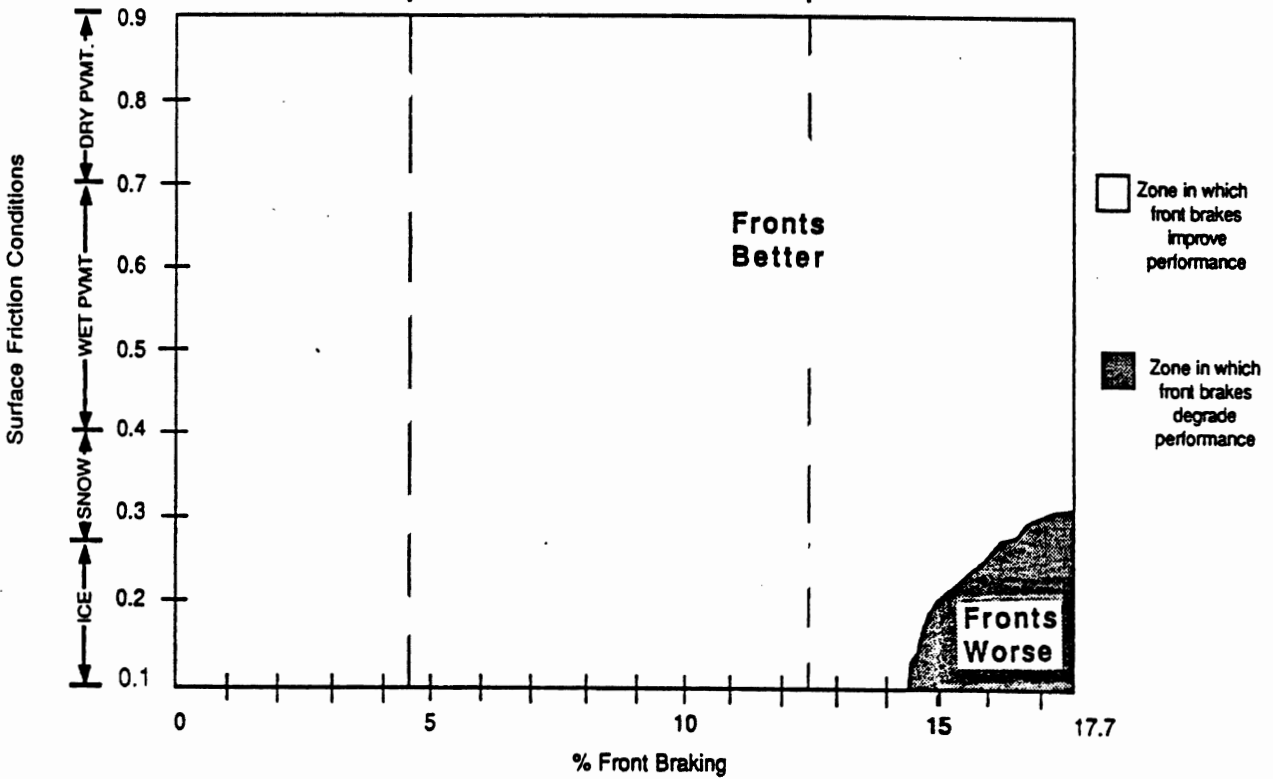

The conceptualized spectrum of brake system bias  
levels and road friction conditions



in which front brakes can degrade performance on ice, this result must be put into perspective given the great range of brake system characteristics and the differing road conditions under which trucks operate. The figure below illustrates the portion of the conceptualized spectrum of vehicles and roadways in which front brakes would degrade performance. Conversely, it illustrates the major set of situations in which front brakes have improved the braking performance of U.S. trucks. Not only is the lower right portion of the figure small in area relative to the rest, there is also good reason to believe that braking systems achieving these extreme levels of front-bias are not in common use in this country. Also, the figure is for the worst (fully loaded) case although front brakes improve performance even further under all lighter loading conditions.

Such perspective is especially important in formulating policy on truck braking performance because it has been so well established that the general problem in the U.S. is one of *deficient* rather than excessive front braking levels. Thus, in the view of the authors, the issue should not be left at the question "should front brakes be hooked up?", but rather, "how much further should we go in assuring that front brakes are strong enough to achieve good brake balance?" To this end, efforts have been underway, with government and industry cooperation, that point toward a rationalization of brake balance on trucks.

- The study also showed that the use of chains on all tractor axles, including the steering axle, provides for high braking levels when a substantial level of front braking is available. At the same time, for more typical brake systems, the trailer is sufficiently overbraked that no arrangement of chains on the tractor will help to reduce trailer wheel lockup, which poses a threat to other motorists. Again, the problem is one of balanced brake force distributions.

The research findings clearly indicate, within the constraints of existing data, that front-first lockup on ice is not a risk factor for the typical heavy-duty vehicle in this country. In the light of this finding, we confirm that the use of front brakes will improve braking performance under virtually all road conditions, including ice.

For vehicles that must travel extended distances on ice-covered roadways, it is recommended that the installation of chains at all wheel positions be considered—including trailer positions. It is worthy to note that installation of chains on one pair of dual wheels on a semitrailer offers promise as a simple, effective, means of resisting trailer swing instabilities on ice. Especially when dense traffic places heavy vehicles in the proximity of passenger cars while operating on ice, the argument for using chains to assure control over both the tractor and the trailer(s) is compelling.



Finally, the study also indicated that chain designs could be improved by reducing the spacing between the strands of chain which lie across the tire tread. A reduction in this spacing would assure high traction performance when wheels are locked on lightly-loaded axles.



## TABLE OF CONTENTS

<i>Section</i>	<i>Page</i>
1.0 Introduction.....	1
2.0 Research Method .....	3
2.1 Full-Scale Vehicle Tests .....	3
2.2 Tire/Chain Traction Measurements .....	7
2.3 Analysis of Braking Performance .....	15
3.0 Results .....	22
3.1 Results of Vehicle Stopping Tests .....	22
3.2 Results of Tire/Chain Traction Measurements .....	26
3.3 Results of Braking Performance Analyses .....	47
4.0 Conclusions and Recommendations .....	67





## **Acknowledgements**

We wish to acknowledge the efforts of a number of persons and organizations who facilitated the conduct of this study. Vehicle testing was made possible through the loan of a tractor from the Rockwell International Corporation. A semitrailer was provided for testing by the Vehicle Research and Test Center (VRTC) of the National Highway Traffic Safety Administration. Tire chains were provided by the Peerless Chain Company. Vehicle tests were conducted with the able assistance of the staff of the Keewenau Research Center of Michigan Technological University. Ice-traction tests were performed with the kind assistance of the staff of Saskatchewan Transportation, the transportation agency of that province. The test driver who performed vehicle and tire traction tests was Mr. Donald Foster. Collection of traction data was performed by Mr. Michael Campbell. Logistical support was provided by Mr. Thomas Dixon. Gracious assistance was received from Mr. Richard Radlinski of VRTC relative to the interpretation and use of his data on truck brake systems. The kind cooperation of the FHWA technical manager, Mr. William Snow is also gratefully acknowledged.



## 1.0 Introduction

This document constitutes the final report on a research study funded by the Office of Motor Carrier Standards of the Federal Highway Administration. The project was administered through the assistance of the National Highway Traffic Safety Administration. The work has been conducted by The University of Michigan Transportation Research Institute, with use of the facilities of the Michigan Technological University and the Saskatchewan Transportation Department.

The purpose of the study was to collect experimental data and conduct analyses showing the braking performance characteristics of air-braked, heavy-duty trucks operating on ice with tire chains installed. The study was prompted by two factors, namely,

- recent federal action to require front brakes on all heavy vehicles employed in interstate transportation, and
- concern by some parties in the trucking community that front brakes may pose a hazard when vehicles are operated on ice with chains installed on the drive wheels of a truck tractor. Such concerns have focussed primarily on the mountain driving scenario in which certain states require chains to be used when snow and ice cover the roadway in winter.

The study was designed to provide (a) direct experimental evidence of the stopping behavior of vehicles, (b) experimental measurement of the traction properties of truck tires braking on ice with and without chains, and (c) generalized analyses which address the broader issues. The original plans for a rather extensive vehicle testing program were curtailed, however, due to unseasonably warm weather at the northern Michigan test site in February, 1987. Tests of tire traction performance were relocated to a site in northern Canada in order to secure suitable ice conditions for measurements using a mobile dynamometer device. Subsequent analyses employed a computerized evaluation of braking performance for various conditions of vehicle loading, brake system properties, and tire and chain installations.

The results speak to the issues of the maximum deceleration capability of vehicles under selected ice conditions as well as the tendency to lock wheels at the various axle positions under differing combinations of vehicle and tire/chain properties. Particular focus is put upon the likelihood of locking the wheels on the front axle. Also, the prospect that the driver will be able to modulate the brake pedal application in order to avoid front-wheel lockup is examined. Particular attention is given to front lockup in response to the concerns which prompted the study rather than due to any established convention that front lockup is more hazardous than other wheel-lock conditions. Indeed, the authors subscribe to the general position that a brake application which results in lockup of all wheels on *any*

axle (or on both axles of any tandem set) portends an imminent loss-of-control. Thus, front lockup is, in the broad sense, simply one of the modes by which control may be lost during braking.

In addition to addressing the general issue of braking hazards associated with ice conditions and the use of tire chains, the authors have elected to expand upon the traction data which were obtained in the study. That is, since no other data of this type are known to have appeared in the public literature, these measurements are seen as having value, by themselves, for other researchers. Accordingly, the traction data are presented in somewhat greater detail than is otherwise warranted simply for treating the braking performance of overall vehicles.

The report is organized in three primary sections and two appendices as follows:

Section 2.0 The Research Method (addressing all the matters of test conditions, equipment, procedures and the analytical methods used to study braking performance in detail)

Section 3.0 Results (presenting the results of vehicle tests, traction measurements and analyses, together with discussion of the mechanisms which explain behavior and permit generalization)

Section 4.0 Conclusions and Recommendations (summarizing the findings and the alternative actions that can be taken)

Appendix A Traction Data (presenting the detailed time history responses obtained with the mobile dynamometer test device, as well as the numerical measures of traction limits which were derived from the direct force measurements)

Appendix B Diagrams of Braking Performance (presenting friction utilization and deceleration diagrams as a function of air pressure at the treadle valve)

Appendix C Formulation of the Braking Performance Model (presenting the underlying equations upon which the analytical model is based)

## 2.0 Research Method

The research method comprised three distinct tasks, namely, (1) the measurement of vehicle stopping performance, (2) the measurement of tire/chain traction limits, and (3) analysis of vehicle braking performance. In this section, the equipment, procedures, and analytical models used in conducting these tasks are described.

### 2.1 Full-Scale Vehicle Tests

It was originally planned that one fully-loaded and one empty tractor-semitrailer would be operated on an ice facility with various tire and chain installations so as to provide direct illustration of vehicle braking performance. On the day before testing was to begin, March 8, 1987, a record temperature of 70° Fahrenheit (21° C) was reached at the test site in Houghton, Michigan, thus damaging the prepared rink facility. Weather in the subsequent weeks was sufficiently moderate that testing could only be done with the empty vehicle and then only during one or two hours at dawn, while the rink was suitably frozen. Accordingly, the vehicle testing phase of the program assumed a relatively modest scope. The analytical portions of the study were expanded to compensate for this change in scope. Because of the high variability of brake system characteristics found in heavy-duty trucks and trailers, however, the authors' conviction is that the overall study has produced more substantive findings as a consequence of this restructuring of the project.

#### *2.1.1 Test Site*

Vehicle tests were conducted at the ice rink facility of the Keewenau Research Center (KRC) of Michigan Technological University in Houghton, Michigan. This northernmost test site in Michigan was selected because of the availability of a groomed, 15-acre (61,000 m<sup>2</sup>), ice rink which is maintained through the winter primarily for testing military vehicles. The facility comprised an approximate 18-inch (45-cm) base of ice which is resurfaced and groomed by means of a grader, watering truck, and power broom.

At the time tests were conducted, the ice surface was somewhat irregular due to the severe thawing period which preceded testing. Although nighttime temperature approached zero Fahrenheit (- 18 deg C), the rink contained a trapped layer of water beneath the refrozen ice cap such that a fully-loaded tractor-semitrailer could not be supported. Tests were conducted with the empty trailer under ice conditions in which the surface was dry and ambient temperatures were between 16 and 27 deg F (-9 to -3 deg C).

### *2.1.2 Test Equipment*

The vehicle used in stopping tests on the KRC rink was a 5-axle tractor-semitrailer combination comprised of a Ford CL-9000 6X4 tractor and a Kentucky Trailers, 2-axle, 45-ft (13.7 m) van semitrailer. The vehicle was equipped with a fifth-wheel-type speed/distance measuring package which displayed the initial speed and the stopping distance following actuation of the stoplight circuit. This vehicle was tested both as a combination and with the tractor, alone, in the bobtail configuration. Tire pressures were adjusted to 100 psi (cold).

Tire chains were installed at the tractor drive axles and steering axle in selected tests. Two types of chains were included in the tests, namely,

- Peerless "Highway Service Twist Link" Chain, shown in Figure 1 and referred to here as "single" chain
- Peerless "Wedge-Bar" Chain, shown in Figure 2 and referred to here as "reinforced" chain

In order to achieve the condition of trailer-wheel lockup without suffering the disruption of a large articulation due to "trailer swing," a set of chains was installed on the right-rear duals of the trailer tandem, and the brakes at that wheel position were disconnected. Accordingly, when full braking was applied, the other trailer wheels would achieve lockup while the chain-equipped trailer tires kept rolling, maintaining the directional stability of the trailer. The approximate 0.006 g reduction in deceleration capability due to the non-braked pair of trailer tires thus had a uniform effect on the measured deceleration performance in all test runs.

In addition to the tractor-semitrailer test vehicle, another bobtail tractor was employed to conduct locked-wheel stopping tests, with bare tires, as a crude check of the ice-friction condition.

### *2.1.3 Test Procedure*

Because of the brief period in which a suitable ice condition prevailed, only locked-wheel stopping tests were conducted. The vehicle was braked from an initial straight-line trajectory, with rapid full-treadle application of the brakes. With each stop, the vehicle was maneuvered onto a "clean" portion of the ice rink in which chains had not been previously employed. Initial vehicle speed in all tests was 15 mph (24 km/h). The test matrix covered the conditions shown in Table 1.



Figure 1 Peerless "Single" Chain



Figure 2 Peerless "Reinforced" Chain

**Table 1. Matrix of Stopping Tests**

<u>Tire/Chain Installations</u>	<u>Empty Semi</u>	<u>Bobtail</u>
No Chains	X	X
Single Chain, Axles 2,3	X	X
Single Chain, Axles 1,2,3	X	X
Reinforced Chain, Axles 2,3	X	
Reinforced Chain, Axles 1,2,3	X	



## 2.2 Tire/Chain Traction Measurements

Measurements of the braking traction properties of truck tires on ice, with and without tire chains installed, were made using a specialized dynamometer on a frozen lake. The results were used to define frictional limits under these wintertime driving conditions so that the braking performance of truck combinations could be analyzed.

### 2.2.1 Test Site

The tire traction measurements were made at Lake Wollaston, Saskatchewan. This site was selected because of the need to access a suitable ice surface late in the winter. Because the site was located 600 miles (960 km) north of any paved roads, it was necessary to employ a heavy-hauler service in order to transport the instrumented dynamometer over the rough gravel access route (see Figure 3). The lake, itself, shown in Figure 4, provided a very smooth ice surface and is so large that it enabled virtually steady-state collection of repeated lockup sequences without turning the dynamometer around. Thus, all tests were conducted on "virgin ice." The ice thickness was approximately 53 inches (135 cm).

Three segments of tests under significantly-differing frictional conditions were made possible through variations in ambient conditions and by grooming the ice surface. The three surface conditions are defined as follows:

- 1) A crusted-ice condition at approximately 18° F (-8° C), in which a very thin (approx. 1/8 in (0.3 cm)) layer of crusted snow lay on top of an otherwise-smooth ice surface. This condition is shown in the photo of Figure 5.

- 2) A bare ice condition for which ambient temperatures ranged from 12° to 29° F (-11° to -2° C) and which was achieved by sweeping the snow crust from the lake using a power broom. This condition is shown in the photo of Figure 6. Note that the test tire (which is located on the centerline of the mobile dynamometer) was always run in the smooth, undisturbed, portion of the path.

- 3) A bare ice condition whose temperature was right at or slightly above freezing. Depending upon cloud cover, the solar radiation produced a wet surface condition which prevailed only for the testing of both samples of tires without chains. Tests conducted with chains immediately following the wet-surface condition were at the same nominal ambient temperature, but without the solar radiation, such that the ice surface was nominally dry.

As a side issue, it was understood that the operation of heavy-duty truck equipment on frozen lakes can be hazardous relative to the risk of falling through the ice. Since the Saskatchewan government monitors and regulates the use of northern lakes as wintertime truck routes, the research team prevailed upon the expertise of the Province's



Figure 3 Mobile Dynamometer on hauler for trip to Lake Wollaston



Figure 4 Site of traction tests, Lake Wollaston, Saskatchewan

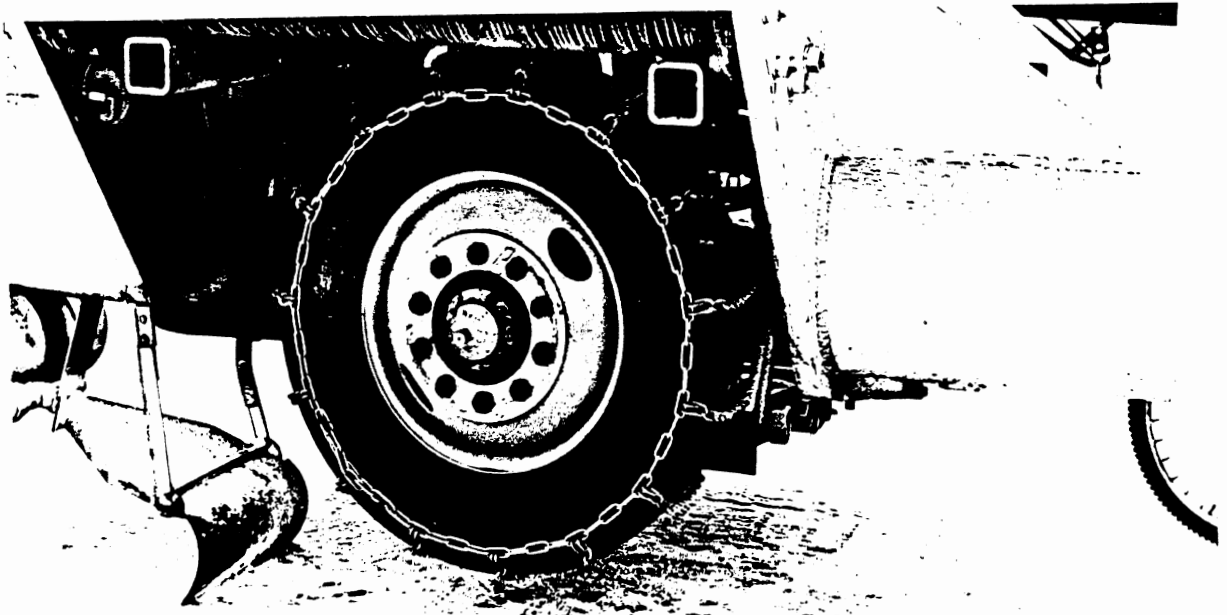

Figure 5 Crusted-ice condition (note the nominal 1/8-inch depth of crust as evidenced by penetration of the reinforced chain links.)



Figure 6 Bare ice test condition (test tire was operated only on the undisturbed ice path)

Transportation Department to get advice on safe operations. The department provided an expert in lake road operations to work with the test crew. Particular constraints on the test practice included limiting the maximum speed to 25 mph (40 km/h) in order to avoid an ice wave effect that produces cracking and also a speed constraint of 10 mph (16 km/h) when approaching within 1 mile of the shoreline, to avoid a reflective wave phenomenon that can threaten break-through near the shore.

### *2.2.2 Test Equipment*

Shown in Figure 7 is the UMTRI Mobile Traction Dynamometer. This tractor-semitrailer combination weighs 64,000 lbs (29 m-tons) and is equipped for measuring the braking force, vertical load, and spin velocity of a heavy-duty truck tire while the vehicle proceeds at a steady speed. The test tire is mounted on the centerline of the semitrailer unit and is supported by a parallel-arm suspension. The test wheel is loaded by means of an air spring which is inflated to achieve the desired vertical load condition. Vertical load and shear force responses of the tire during the brake application sequence are measured by means of a strain-gauge load cell which is mounted serially between the wheel spindle and the suspension assembly. The load cell is initially calibrated in the laboratory using a computer-driven data-collection system. Engineering measurements of tire forces are within 1% of the values predicted by the linearized calibration constants. The instantaneous spin velocity of the test wheel is transduced by means of a tachometer. The test wheel is braked using a conventional air-actuated friction brake, supplemented by valving which controls the rate of torque application.

The traction test variables are measured continuously during the brake application cycle and are recorded on a digital magnetic tape. The data-collection system is controlled by an on-board computer which performs electrical calibration and zero adjustment functions prior to each group of tests. The data gathered on digital tape are reviewed on a run-by-run basis in the field by displaying selected slip cycles on the computer monitor. This review procedure is performed periodically to assure the proper functioning of instrumentation and to assure suitable adjustment of the brake air supply valves.

The tire traction measurements were conducted using two tire specimens and two specimens of chain, as follows:

#### *Tires...*

- Michelin XZA 11 R 22.5 (rib-tread highway tire)
- Goodyear G159 295/75 R 22.5 (rib-tread, low-profile, highway tire)

#### *Chains...*

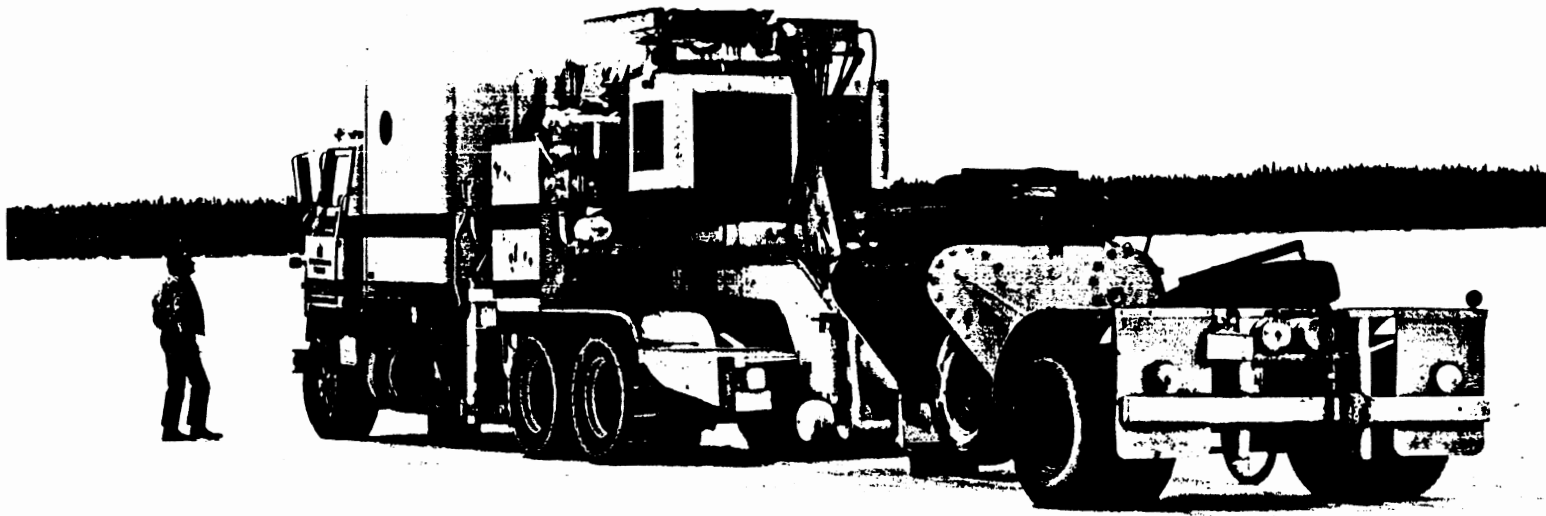

Figure 7 UMTRI Mobile Truck Tire Dynamometer (note central location of test wheel on trailer)

- the same Peerless "Highway Service Twist Link" Chain which was shown previously in Figure 1 and is referred to in the traction test matrix as "single chain"
- the same Peerless "Wedge-Bar" Chain which was shown previously in Figure 2 and is referred to in the traction test matrix as "reinforced chain"

### *2.2.3 Test Procedure*

The test tires and chains were in a new condition prior to testing. Test tires were inflated to a value of 100 psi (689 kPa) and chains were installed per manufacturer's recommended practice relative to tensioning.

The mobile dynamometer was operated in a straight line, tracking a path that positioned the centerline-mounted test tire over the desired portion of the ice surface. Tests were conducted at constant speeds of 10 and 25 mph (16 and 40 km/h). Throughout the brake application, the speed of the test vehicle was maintained constant within approximately 5% of the nominal target value. Wheel load was established through regulation of the pressure delivered to an air spring such that single tire loads of 2,000, 4,000, and 6,000 lbs (0.9, 1.8, and 2.7 m-tons) were achieved.

In each cell of the test matrix (i.e., with fixed load and speed values), the test tire was subjected to six repeats of a brake application which resulted in wheel lockup. The air pressure level delivered to the brake actuator in each cycle was modulated so that an approximate 1-to-2 second ramp of increasing torque was developed prior to achieving the lockup condition in each case. The tire was then maintained in the locked condition for 2 to 3 seconds.

### *2.2.4 Matrix of Tire/Chain Traction Measurements*

Shown in Table 2 is the matrix of conditions which were covered in the course of tire and chain traction tests. In this table, the abbreviations "G" and "M" represent the respective Goodyear and Michelin tire specimens while the abbreviations "SC" and "RC" represent the respective single- and reinforced-style of chain. The combined installations of a given tire with a given chain are designated by the combined code (for example, the Goodyear tire fitted with the Single Chain would be "GSC").

The matrix shows that the crusted ice condition is represented by tests with the Goodyear tire without chains and also with the single-style chain. Because the solar loading needed for obtaining a distinctly wet-surface condition prevailed only briefly during

Speed (mph)	Load (lb)	Ice Condition									
		Ice with Crust		Bare Ice				Wet Ice		Wet/Dry Ice	
		G	GSC	G	M	MSC	MRC	M	G	GSC	GRC
10	2,000	X	X	X	X	X	X			X	X
	4,000	X	X	X	X	X	X			X	X
	6,000	X	X	X	X	X	X			X	X
25	2,000	X	X	X	X	X	X	X	X	X	X
	4,000	X	X	X	X	X	X	X	X	X	X
	6,000	X	X	X	X	X	X	X	X	X	X

**Table 2. Matrix of Tire and Chain Traction Measurements**

testing, the tests of the Michelin and Goodyear specimens on wet ice were confined to the 25 mph (40 km/h) speed condition, only.

### *2.2.5 Data Analysis Procedure*

The traction test data were reduced to time histories of force and wheel velocity using a computerized process. Because the nature of the locked-wheel data with chains installed was so unlike that produced by tires, alone, prepared algorithms for determining peak and slide traction data were discarded in favor of a manual-interactive method. This method provided for filtering the primary oscillatory component from the raw data and for ready determination of peak values of the normalized longitudinal force,  $\mu_p$ , defined by the ratio,  $F_{xp}/F_z$ , (where  $F_{xp}$  is the peak value of the longitudinal, or braking force produced by the tire and  $F_z$  is the normal load on the tire). In dealing with the locked-wheel condition, the longitudinal force data were averaged over a period of one second following the occurrence of lockup in order to evaluate a normalized locked wheel value,  $\mu_s$ , defined by the corresponding ratio,  $F_{xs}/F_z$ .

The above numeric measures from each of the six repeated lockup cycles in each test group were then averaged together in establishing the final value to be cited for a given speed and load condition.



## 2.3 Analysis of Braking Performance

The traction test data were employed in a computerized analysis of the braking performance of tractor-semitrailers on ice. The analysis was confined to the study of tractor-semitrailers in order to contain the scope of effort, recognizing also that the five-axle tractor-semitrailer combination is the principal long-haul configuration used in the U.S. Also, the shorter-wheelbase tractors typically used with doubles tend to place a higher proportion of the dynamic load onto the steering axle such that lockup of front tires on typical doubles combinations should be somewhat less likely than with tractor-semitrailers.

The analytic effort in this study focussed upon the effectiveness with which the vehicle utilizes the available friction conditions to maximize deceleration during controlled braking in a straight line. With an interest only in "controlled braking," computations were not performed to show the likely *outcome* when vehicle control is lost due to wheel lockup at the steering axle or any set of tandem axles. Such demonstrations were seen as unnecessary since there is a great deal of literature [e.g., 1,2,3,4,] which suggests that:

1) A total loss of steering control accompanies *lockup of the tractor steering axle*. The result of such a breakdown in control is that the vehicle proceeds in a straight-line trajectory. If the vehicle is being operated in a curve at the time front lockup is experienced, the vehicle will depart from the curved lane along a tangent—either exiting the roadway or crossing into an adjacent lane.

2) So-called "tractor jackknife" results from *lockup of all tractor drive wheels*. The jackknife response constitutes a generally very rapid rotation of the tractor about the fifth wheel coupling, with the tractor cab finally impacting the semitrailer. Path control is completely lost under such circumstances.

3) So-called "trailer swing" results from *lockup of all wheels on a semitrailer*. The trailer swing response involves an angular acceleration of the trailer about the fifth wheel coupling, with the trailer sweeping a very wide path as the vehicle continues to proceed forward. Such an articulation causes the trailer rear extremity to intrude rather quickly beyond the road edge or into adjacent lanes occupied by other traffic.

While all three of these modes of control-loss threaten other motorists, it would appear that truck drivers are especially concerned with the anomalies which immediately disturb the tractor. That is, both a loss of steering control and the occurrence of jackknife appear to be central concerns of the truck-driving community. Correspondingly, the issue which has been posed relative to trucks equipped with front brakes has been a focussed concern for conditions causing front lockup. In order to treat this issue, the analytical portion of this

study has concentrated upon the front lockup aspects of braking on ice with and without chains installed. It should not be construed, however, that this focus reflects a conviction by the authors that front lockup is a "worst outcome." Rather our view is that all three modes of control loss cited above present imminent peril. While modes (1) and (2) may more immediately threaten the truck driver, mode (3) is highly perilous to other motorists.

The analysis of the braking performance of tractor-semitrailers on ice required that a suitable computational model be adapted to the problem and that representative data be employed so that the computations addressed real-world vehicles and component characteristics, to the maximum extent possible. In this section, the elements of this overall analysis are discussed.

### *2.3.1 The Analytical Model*

A quasi-static analysis program, implemented on a microcomputer, was employed to compute the brake forces and wheel loads prevailing at each axle of the vehicle as well as the vehicle's deceleration as a function of brake pressure at the treadle valve. Appendix C presents the underlying equations and formulation of the model [5]. The model does not treat pitch/bounce dynamics, but rather deals with the static weight transfer effects of steady deceleration. It also represents the transfer of load between axle pairs in a tandem set due to kinematic coupling mechanisms. Brake torque inputs at each axle position are represented in the model by means of a threshold, or "pushout" pressure, beyond which a torque response develops, and either a linear or nonlinear function by which brake torque rises with actuation pressure.

Although the model was originally designed to represent the same frictional limits at each axle position, it was also possible, with minimal loss in accuracy, to represent the large frictional differences associated with the presence and absence of chains at various axles.

The primary output of the model is a determination of the friction (or adhesion) utilization,  $\mu_{ji}$ , on each axle, as defined below,

$$\mu_{ji} = F_{Bji} / F_{Zji}$$

where  $F_{Bji}$  is the total longitudinal force due to braking at the  $j$ th axle of the  $i$ th vehicle unit, and

$F_{Zji}$  is the total load borne on this axle.

Recognizing that the friction utilization variable constitutes a "friction demand" level, the upper bound on  $\mu_{ji}$  at any axle position is equal to the corresponding value of the tire

traction limit,  $\mu_p$ , which was defined in the earlier discussion of tire and chain traction. Firstly, the model is operated assuming constant frictional limits at all axles. Next, the friction utilization levels are inspected relative to the traction limits which prevail, given the assumed tire and chain installations. The first axle to lock up, say axle  $m$  on unit  $n$ , is then identified and its brake force function is modified such that  $F_{Bmn}$  peaks at a value equal to  $(\mu_{pmn})(F_{Zm})_l$  and then immediately falls down to a value equal to  $(\mu_{smn})(F_{Zmn})_l$ , where the respective  $p$  and  $s$  subscripts represent peak and slide traction limits and  $(F_{Zmn})_l$  denotes the vertical load prevailing at the point of lockup.

The response of the vehicle is examined in successive stages of the analysis until a *critical lockup* point is reached, at which either (a) the steering axle locks up, (b) both tractor tandem axles lock, or (c) both trailer axles lock. The order of axle lockup is then apparent and the deceleration level achieved prior to a critical lockup can be viewed as the maximum controllable performance level of the vehicle.

A small error is introduced by the above-described simplification when some axle locks prior to a "critical lockup" as defined in (a), (b), or (c). That is, the method allows for the lockup of one axle in a tandem set prior to achieving the limit performance condition. The locked-wheel state is represented by a *constant* level of brake force, as in  $F_{Bmn} = (\mu_{smn})(F_{Zmn})_l$ , above, where  $(F_{Zmn})_l$  is a constant. Thus, this approach does not allow the locked-wheel frictional force to continue to follow changes in vertical load such as occurs due to load transfer with continuing increase in braking level. Since the "critical lockup" generally occurs at only a modestly higher level of braking than an initial non-critical lockup, however, the magnitude of this error is negligible.

### 2.3.2 Vehicles and Brake Systems Represented

The analysis considered empty and loaded cases for a five-axle tractor-semitrailer configuration. The empty vehicle, having a gross weight of approximately 29,325 lbs (13.3 m-tons), incorporated tractor and semitrailer units that represent popular vehicle types used in the U.S. Vehicle geometric and weight distribution parameters were drawn from reference [6]. The loaded vehicle incorporated the same tractor and semitrailer, with a gross weight of 78,000 lbs (35.5 m-tons) and an axle load distribution of 10,000 lbs front, 34,000 lbs tractor tandem, and 34,000 lbs trailer tandem (4.5 m-tons front, 15.5 m-tons tractor tandem, 15.5 m-tons trailer tandem). The selection of a gross weight slightly under 80,000 lbs (36.4 m-tons) was to represent a high-weight, legal, loading scheme which results in a quite rear-biased distribution of axle loads on the tractor. (Note that a full legal limit of 80,000 lbs (36.4 m-tons) requires placing 12,000 lbs (5.9 m-tons) on the steering axle, with 34,000 lbs (15.5 m-tons) on the drive-axle tandem.) The indicated distribution of loads is seen as a common means of achieving a heavily-loaded, rear-biased

case, recognizing the preference of many truck drivers to position the fifth wheel such that no more than 10,000 lbs (4.5 m-tons) is carried on the steering axle, whenever possible. The input data defining the empty and loaded vehicle cases is included in Appendix B.

Brake system parameters were determined from data reported in References [7,8,9]. This study reported in References [7] and [8], conducted by the Vehicle Research and Test Center (VRTC) of the National Highway Traffic Safety Administration, measured the properties of 15 vehicle combinations supplied by trucking fleets, and is seen as the most complete set of data available for describing contemporary vehicles in U.S. service. The testing program had been commissioned by the Truck Trailer Brake Research Group in support of an effort to develop a recommended practice through the Society of Automotive Engineers. The vehicles included nine tractor semitrailers and six sets of doubles. All vehicles were late model units (when tested in November, 1985). Brakes were fully adjusted prior to testing. A procedure was employed for determining the relationship between braking force at each axle and applied pressure in the control line. In the current study, these VRTC data were converted to "torque gain" (TG) values, in units of in-lbs of torque on an axle per psi of control line pressure. Also, the threshold, or "pushout pressures" (PP), defining the value of control line pressure beyond which wheel torque begins, were measured in the VRTC study and employed in the analytical work here. It should be noted that pushout pressures were reported by VRTC in a fashion which includes half of the hysteresis component of the pushout response [see Reference 8].

It is recognized that the VRTC data do not represent a statistical sample of vehicles. Further, it is clear that the fully-adjusted status of the brakes and the relatively new condition of most of the vehicles suggests "better than average" brake function. Nevertheless, given that the focus of the present study was on torque *distribution* characteristics at the low braking levels associated with stopping on ice, it is believed that these data provide a quite reasonable picture of the issues faced by the larger trucking fleet.

The VRTC data were used in two ways, namely, (1) to provide a basis for defining a baseline, or typical set of brake system properties, and (2) to enable definition of forward-biased brake distributions in terms of both torque gains and pushout pressures. In addition, an automatic limiting valve cited in an earlier VRTC publication [9] was represented in conjunction with selected brake parameters.

Shown in Table 3 are three sets of brake system parameters that were employed in the analytical study. The selected values were derived from VRTC data that showed the following ranges:

- Front Axle, TG from 725 to 1245 in-lb/psi (11.6 to 19.8 N-m/kPa)  
PP from 5.3 to 15 psi (36.5 to 103.4 kPa)

- Drive Axle, TG from 1789 to 3147 in-lb/psi (28.5 to 50.2 N-m/kPa)  
PP from 4.7 to 8.8 psi (32.4 to 60.6 kPa)
- Trailer Axle, TG from 1359 to 3564 in-lb/psi ( 21.7 to 56.8 N-m/kPa)  
PP from 3.9 to 7.0 psi (26.9 to 48.2 kPa)

**Table 3. Properties of Simulated Brake Systems**

<u>Case</u>	<u>Description</u>	<u>Front Axle</u>		<u>Drive Tandem</u>		<u>Trailer Tandem</u>	
		<u>TG*</u>	<u>PP**</u>	<u>TG</u>	<u>PP</u>	<u>TG</u>	<u>PP</u>
1	Baseline	950	9.4	2450	6.1	2450	4.9
2	Fwd-biased TG's	1250	9.4	1790	6.1	1360	4.9
3	Fwd-bias TG's & PP's	1250	5.3	1790	8.8	1360	7.0

\* (TG values expressed in units of in-lbs/psi)

\*\* (PP values expressed in units of psi)

The baseline case, No. 1, represents a more-or-less typical layout as derives from average values of pushout pressure measurements and median values of torque gains from VRTC data. All of the data on both 6X4 and 4X2 tractors were used in determining tractor properties and all but the dolly-axle data were used in determining trailer properties.

Case No. 2 represents one form of forward-biased distribution in which the highest front brake torque gain (rounded off to 1,250 in-lb/psi (19.9 N-m/kPa)) was combined with the lowest values of gain for drive and trailer axle brakes (viz., 1,790 in-lb/psi (28.5 N-m/kPa) at the drive axles and 1,360 in-lb/psi (21.7 N-m/kPa) at the trailer axle). The baseline values of pushout pressure were maintained for this case.

Case No. 3 combines a most forward-biasing of pushout pressures with the forward-biased brake torque gains of Case No. 2. In this case, the front brakes "come on" at the lowest pressure level relative to brakes on aft axles and they generate torque at a high level of gain, while brakes on aft axles "come on" slower and generate torque at the lowest gain values found in the VRTC test fleet for the respective axles in question.

An automatic limiting valve was also represented in certain simulated cases. This valve, described in Reference [9] exhibits a three-stage effect, namely, (1) the nominal torque gain of the front brake is reduced by 50% for control line pressures from 0 to 40 psi (275 kPa), (2) front torque gain rises linearly from 50% to 100% of its full value from 40

to 60 psi (275 to 413 kPa), and (3) the full level of front torque gain is delivered at all pressures above 60 psi (413 kPa).

As will become very clear in considering the conclusions of the study, the crucial questions involve statistical representativeness of the various brake properties employed for study. While it is clearly possible that a vehicle such as in Case 3 can exist, for example, it is not known how likely such cases are. Further, we do not know the level of confidence with which we could assume that "most" vehicles behave in a manner similar to the baseline case, No.1. Nevertheless, it is the authors' belief that the employed brake properties are reasonable, if not demonstrably representative from the viewpoint of population statistics.

### *2.3.3 Matrix of Analyses*

Shown in Table 4 is the matrix of braking performance analyses. The matrix shows cases covering differing tire and chain installations for both the empty and loaded vehicle configurations. Brake system properties were varied over a set of conditions that utilized the three cases defined in the preceding section. In addition, these sets of brake properties were combined with representations of the automatic limiting valve, ALV, and one case having no front brakes, NFB. Thus, for example, the case labelled in Table 4 as (1)/ALV represents the baseline brake system with a front limiting valve installed to reduce front brake pressure as defined above. Similarly, the case labelled (1)/NFB employs all of the baseline system properties except that the front brakes are considered to be disconnected.

The tire and chain designations represent a portion of the traction data that was seen as imposing the more demanding ice condition. That is, upon inspecting the tire traction data presented in Section 3.2.2, it was apparent that the "wet ice" condition resulted in the lowest traction limits for tires operating without chains. Similarly, it was noted that the traction performance of tires with chains maintained high levels under the condition which closely approximated the wet-ice surface. Since the focus of the study was to be upon the condition that might promote front-wheel lockup with chains installed on tractor drive axles only, it was determined that all simulated cases would be confined to this portion of the traction data.

The matrix provides for three primary illustrations, namely, (1) the influence of various tire and chain installations on the performance of a vehicle with a "baseline" brake system, (2) the same influence on a "most-forward-biased" brake system, and (3) the influence of variations in brake system properties on the performance of a vehicle having standard-type chains installed on the tractor drive axles. Additional observations are also afforded from this matrix of computations, and are discussed in Section 3.3.

Brake Systems	Tire/Chain Installations						
	Vehicle Empty		Vehicle Loaded				
	G	GSC23	G	GSC23	GSC123	G12C 23	GRC123
[1]	X	X	X	X	X	X	X
[1]/ALV				X			
[1]/NFB				X			
[2]			X	X			
[2]/ALV			X	X			
[3]	X	X	X	X	X	X	X
[3]/ALV			X	X		X	

**Table 4. Matrix of Braking Performance Analyses**

## 3.0 Results

In this section, the experimental and analytical results of the study are presented. The results of the very limited program of vehicle braking tests on ice are presented first, illustrating the locked-wheel braking levels obtainable from vehicles with and without chains installed. These data are useful primarily for confirming the nominal findings of the traction measurements conducted on a mobile dynamometer.

The tire and chain traction measurements are presented in some detail, recognizing the general lack of such data in the published literature. As was stated, only a portion of these data were employed directly in the analysis of braking performance. The results of the analytic work are discussed at greater length since the findings of the study hinge primarily upon this analysis.

### 3.1 Results of Vehicle Stopping Tests

Shown in Figure 8 are values of average deceleration, in g's, obtained with a bobtail tractor that was operated without chains as a crude means of assessing the surface friction level at the KRC test site in northern Michigan. The vehicle was braked with full treadle application from a speed of 15 mph (24 km/h) to obtain these data. Inadvertently, a front-axle antilock system with which the vehicle was equipped was left in the active mode during these friction-check tests. Accordingly, the indicated deceleration levels reveal a peculiar blend of both locked-wheel and peak friction levels. The four values shown at the left were obtained through periodic stops with the bobtail friction-check vehicle. The four data points at the right were obtained in a back-to-back set of repeat runs made at the conclusion of the tests. The data basically illustrate the substantial level of variability in the surface friction condition.

Shown in Figure 9 are average decelerations measured with the Ford CL-9000 tractor in a bobtail configuration. The data clearly indicate the major benefit due to chains. Note, especially, the large jump in deceleration level achieved in the right group of data, when chains are installed on the steering axle ("standard chains on axles 1,2, and 3"). Clearly, with half or more of the static weight bearing on the steering axle, the bobtail tractor benefits greatly from the enhancement of traction level at the front.

Shown in Figure 10 are deceleration results for the unloaded tractor-semitrailer with the full matrix of differing chain installations. Again, the benefit of chain usage is clear. The authors tend to question the results for the case of standard chains on axles 2 and 3, however, since the increment in deceleration above that of the "no chains" case seems too large. Recognizing the spatially nonhomogeneous condition of the KRC ice rink at the time



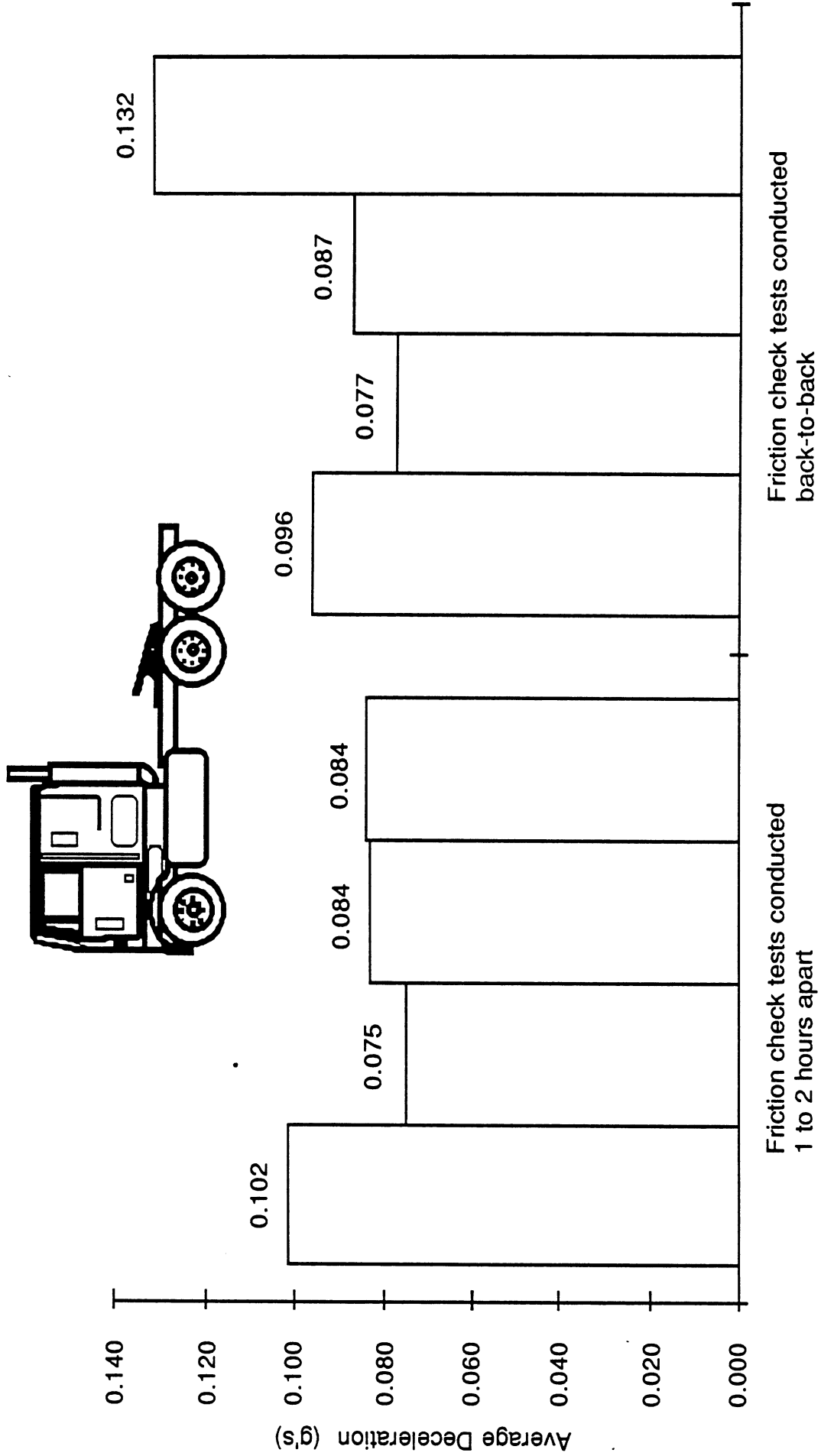

Figure 8 Friction Checks using reference bobtail tractor w/o chains

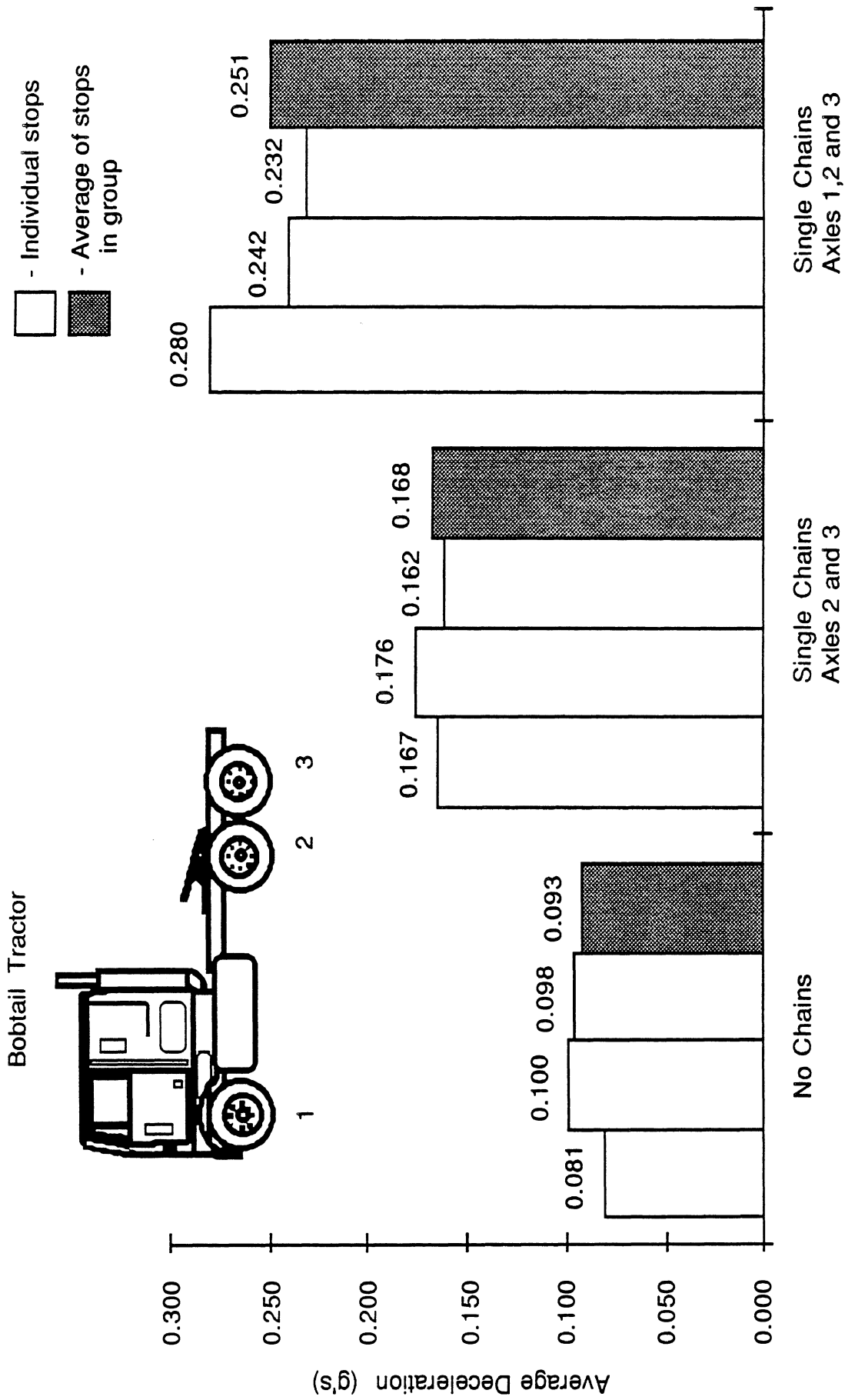

Figure 9 Deceleration Measurements using bobtail Ford CL-9000 tractor with and without chains

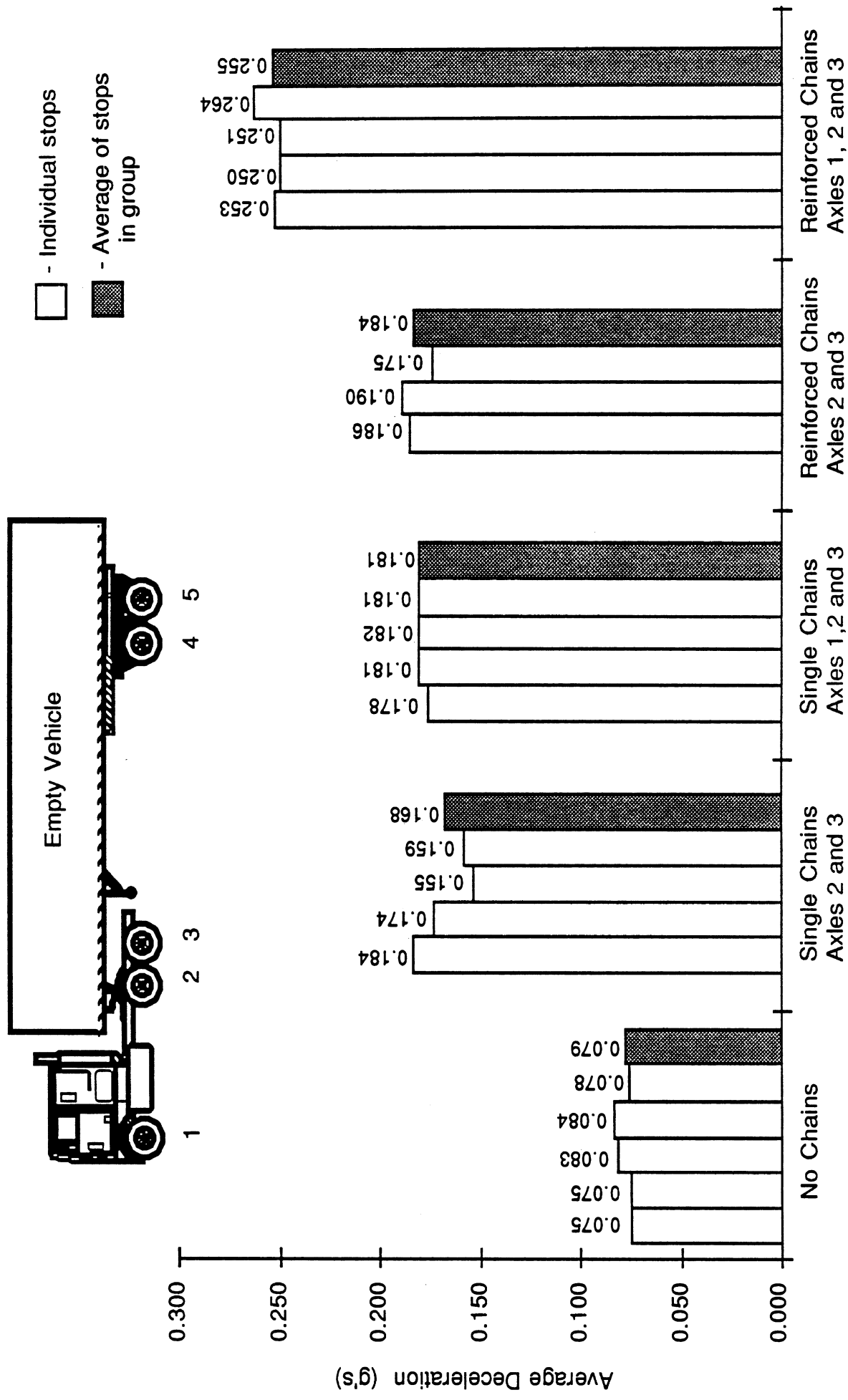

Figure 10 Deceleration Measurements on empty tractor semitrailer with and without chains

of these tests, our inclination is to suspect that some locally rougher ice surface was being used in that group of runs such that the deceleration levels were higher. Note that the vehicle's stopping path in each run was located on the rink such that prior stopping paths in which chains had been used were avoided.

Of special note in Figure 10 is the elevated performance level achieved with the "reinforced" chain. These results give nominal confirmation to the traction data presented in the next section.

## 3.2 Results of Tire/Chain Traction Measurements

The results of the traction measurements will be presented in two stages. Firstly, the detailed nature of the traction response will be discussed, with attention to the peculiar nature of the raw longitudinal force developed with chains installed. Secondly, the reduced data comprising peak and slide values of normalized braking force are presented, showing the sensitivities of response to variations in speed, load, ice condition, and the particular tire and chain elements tested.

### 3.2.1 Discussion of Traction Force Histories

Shown in Figure 11 is an example set of time histories which were processed from the digital recordings on the mobile dynamometer. A complete set of such time histories is presented in Appendix A. The figure illustrates the instantaneous wheel spin velocity and longitudinal force signals developed during six repeat lockup cycles for the case of:

- Goodyear tire without chains
- Bare ice condition at 14 deg F (-10 deg C)
- test speed = 25 mph (40 km/h)
- tire load = 6000 lbs (2.7 m-tons)

The basic nature of the lockup cycle, as shown, is such that the wheel spin rate drops fairly rapidly to zero while the longitudinal force signal rises to a pronounced peak and falls down when wheel lockup is attained. This is a classical response characteristic which is exhibited by all tires (without chains) on slippery surfaces. In virtually all of the data gathered in this test exercise, the slide traction levels were less than half of the peak values for tires without chains. Further, the peak and slide traction levels for tires without chains were reasonably repeatable from one cycle to the next, typically varying on the order of +/- 15% over a group of six lockup cycles.

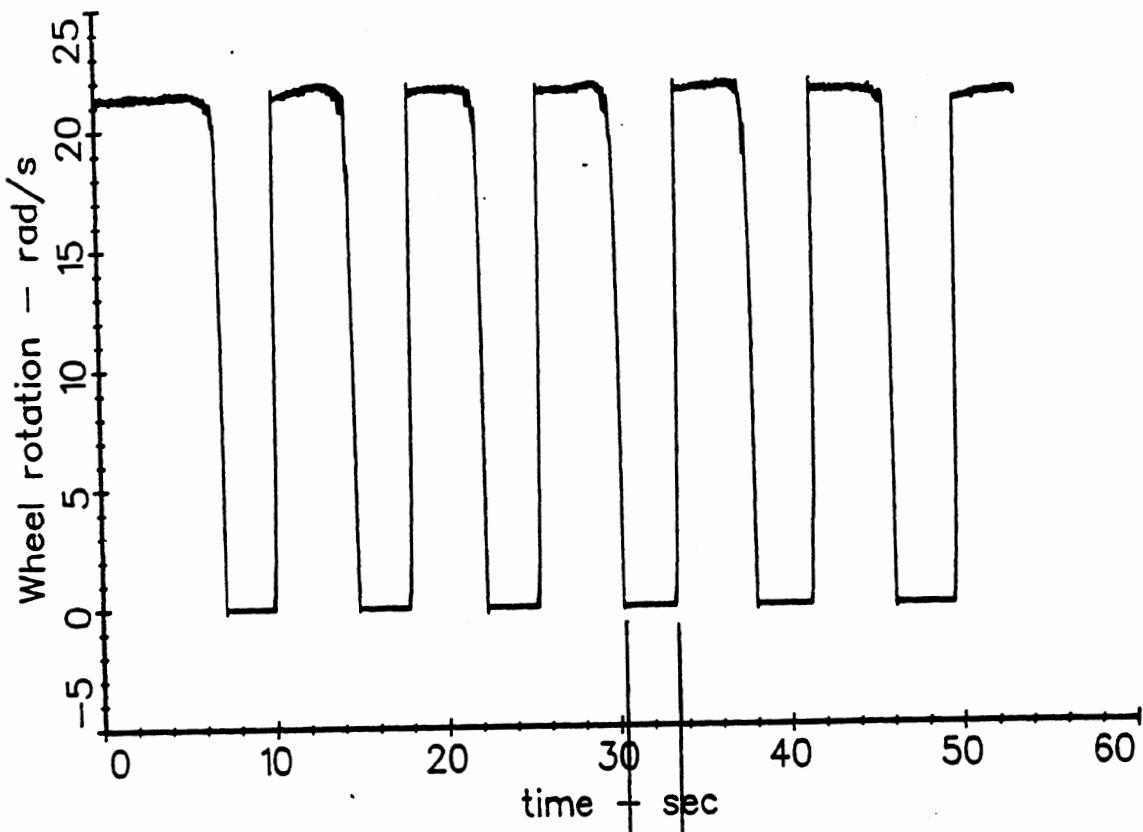

04/02/87 10:39:01 GD YR 295/75R22.5 NO CHA 6000 AT 25MPH

LOCKED WHEEL

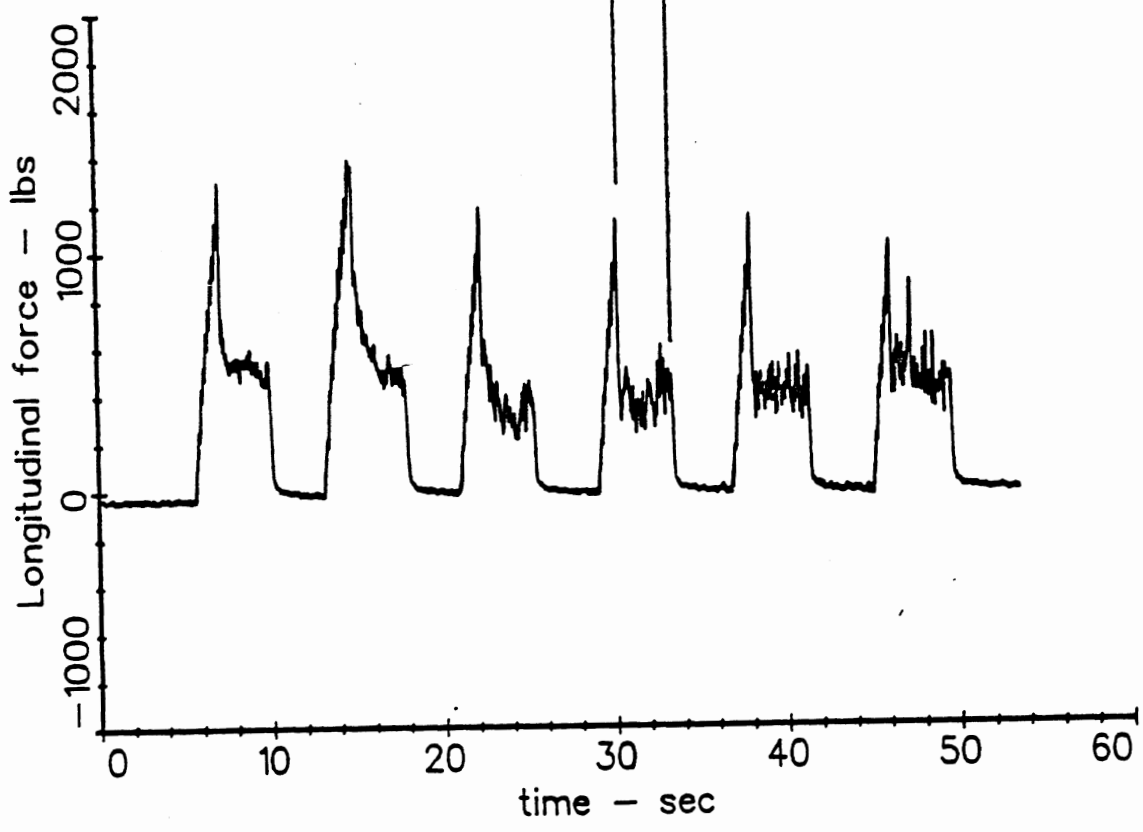

Figure 11 Slip Cycles, Goodyear tire without chains, at 6000 lbs load

By way of contrast with the data taken without chains, Figure 12 shows data from a set of six lockup cycles at 10 mph (16 km/h) and a tire load of 2000 lbs (0.9 m-tons), with the single-style chain mounted on the Goodyear tire and operating on bare ice. Although the initial peak values of longitudinal force are repeatable within +/- 10%, the traction response in the locked wheel condition is wildly variant from run to run. Most notably, there are cases in which the traction value in the locked-wheel condition is substantially in excess of that prevailing at the "initial peak." The apparent explanation for the dramatic variance in the locked-wheel value with chains installed derives from the probability that one or more chain strands will lay across the contact patch when the wheel has locked. This probability is, in turn, determined by the ratio of the spacing between chain strands to the contact length of the tire at a given load (where "contact length" refers to the length of the contacted interface between the tire and the surface).

It is reasonable to hypothesize that the developed braking forces rise when multiple chain strands lie in the contact zone. It is also reasonable to suggest that traction force is enhanced when a minimum portion of the contact patch is supported on the undisturbed, smooth, ice surface rather than on the roughened surface which trails behind a chain strand. Further, it would appear that the penetration of the chain into the ice, and thus the potential for generating large shear forces, depends upon the chain strand being positioned rather within the leading and trailing edges of the contact patch so that a substantial portion of the tire load is supported by the chain. Given the circumferential spacing between strands of the selected chains and the contact lengths prevailing under the examined tire loads, it is apparent that the probability of achieving a high level of locked-wheel brake force goes up considerably at the higher loads producing longer contact lengths. The length dimensions in question are approximately as follows:

Spacing between chain strands = 7.5 inches (19 cm)

Contact Length of tire at load of 2000 lbs (0.9 m-tons) = 8 inches (20 cm)

Contact Length of tire at load of 4000 lbs (1.8 m-tons) = 10 inches (25 cm)

Contact Length of tire at load of 6000 lbs (2.7 m-tons) = 11.5 inches (29 cm)

Shown in Figure 13 are variations in the locked-wheel traction value, normalized to the average for a given load. That is, these data express the ratio,  $\mu_s / \mu_{s(\text{average})}$ , for twelve repeat cycles at each of the three indicated loads. The much larger variation seen in the locked-wheel response of the tire at a lighter load reveals the higher probability that (a) the chain strand will fail to land well within the contact zone or (b) the single strand that is well within this zone will be located rather toward the rear of the patch (such that most of the tire load is supported on smooth ice). At loads of 4,000 and 6,000 lbs (1.8 and 2.7 m-tons),

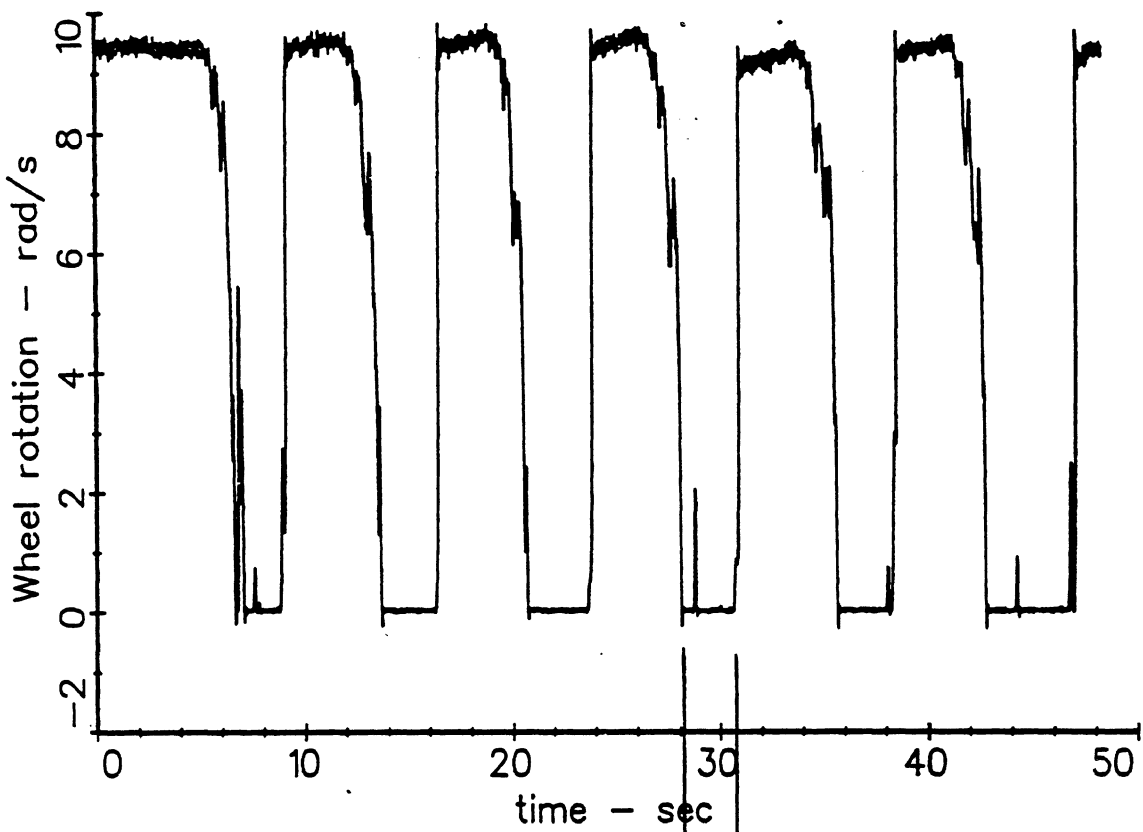

04/02/87 14:41:37 GD YR 295/75R22.5 SINGLE 2000 AT  
10MPH

← LOCKED WHEEL

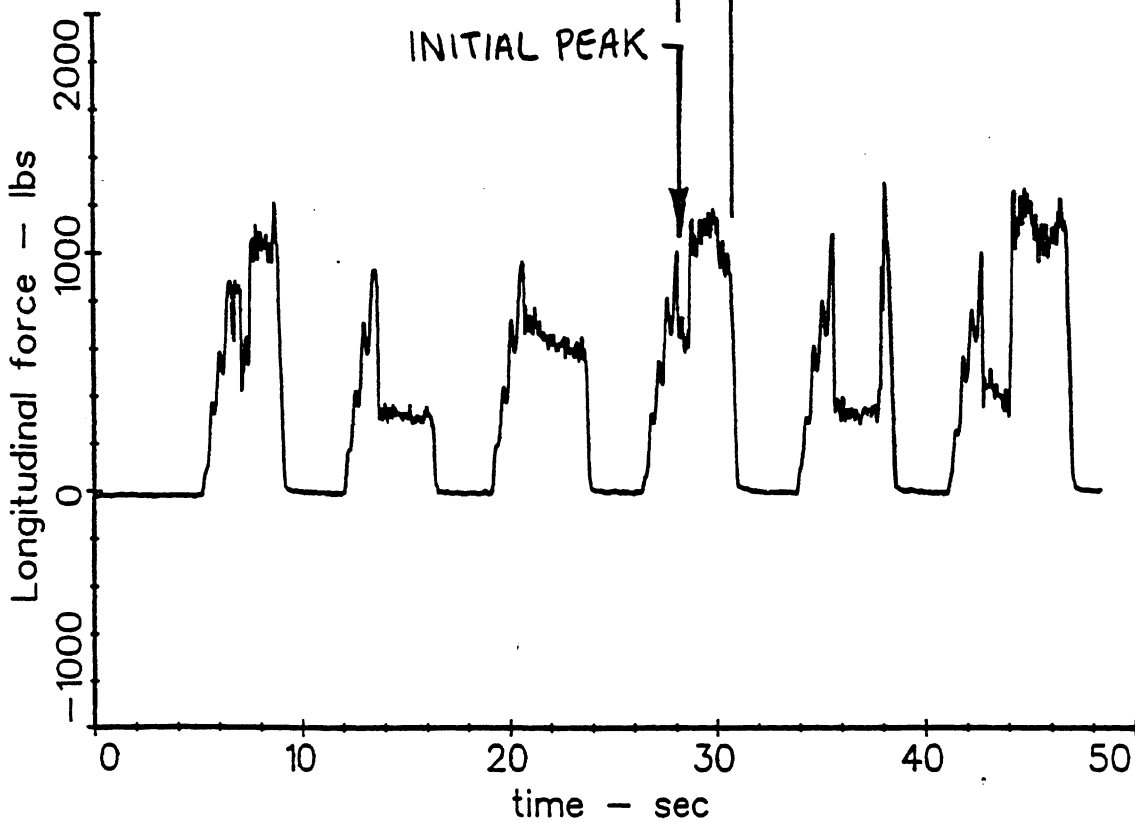

Figure 12 Slip Cycles, Goodyear tire with chains, at 2000 lbs load

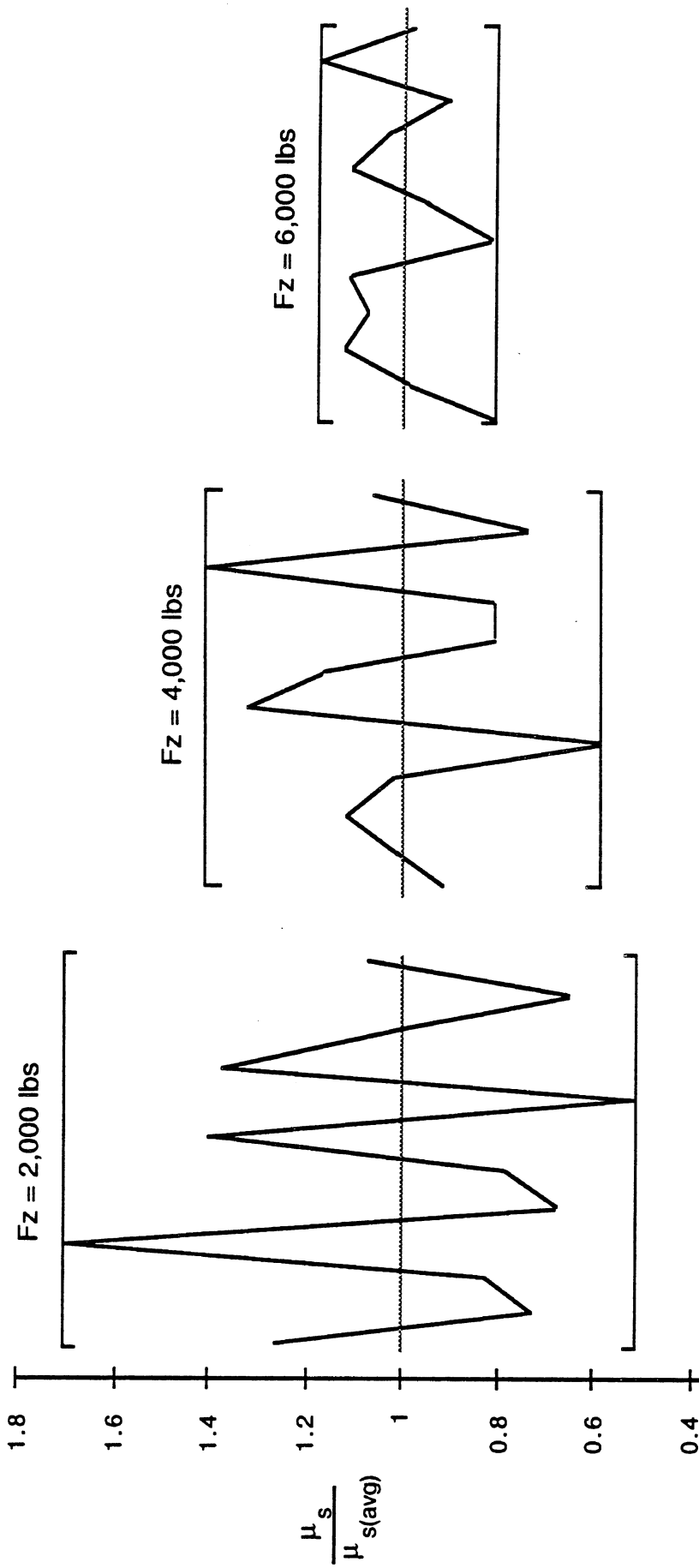

Figure 13 Variance in  $\mu_s / \mu_{s(\text{average})}$  at three test loads, when conducting repeated lockup cycles with single-style chains



the probability of high locked-wheel traction levels is increased because it is certain that at least one chain strand will lie at least 1.25 or 2 inches (3 or 5 cm), respectively, within the extremes of the contact length.

Accordingly, although locked-wheel traction data have been reduced in this study by an averaging scheme for the sake of simplifying the analytical problem, it should be recognized that the probabilistic issue prevails, especially at light loads that result in contact lengths which approach the spacing of the chain strand placement.

### *3.2.2 Trends in Peak and Slide Traction Performance*

Shown in Table 5 are the peak and slide traction numerics measured over the full set of tires, chains, and ice conditions. Each value in the table represents the average of six repeat cycles, examples of which were shown in the earlier discussion. The data shown in matrices #8, 9, and 10 were used in constructing traction limits in the analytical portion of this study. In order to illustrate the trends in the overall group of traction data, however, the tabular data will be presented in the following groups of cross-plots:

- comparisons showing the performance of each tire and each chain type over the set of differing ice conditions, at a speed of 25 mph (40 km/h)
- comparison of the traction levels achieved with and without chains, on each individual ice surface, for a test speed of 25 mph (40 km/h)
- illustration of the influence of test velocity on the traction performance of tires, alone, and each chain type, at a tire load of 4000 lbs (1.8 m-tons)

Shown in Figures 14 through 17 are illustrations of the peak and slide traction values, as a function of tire load, for individual tires and chain types on each of the available ice surfaces. Figure 14 shows that the "crusted" ice condition produced much higher values of both the peak and slide traction performance than were seen on the "bare" or "wet" ice conditions. In general, we see the peak traction level falling off with increasing load, while the locked-wheel values are relatively independent of load. The absolute values of  $\mu_s$  illustrated for "bare" and "wet" ice, ranging from 0.063 to 0.099 are just above a 0.05 to 0.07 range of measurements of the locked-wheel deceleration of several trucks reported for a smooth, prepared, ice surface [10]. Also, these results are quite comparable to the locked-wheel decelerations presented earlier in Figures 9 and 10, for a bobtail tractor and a tractor-semitrailer combination braking with no chains installed.

Clearly, very large reductions in traction level accompany the transition from peak to slide. Such large reductions constitute part of the basis for desiring antilock control systems that succeed in maintaining the traction response near its peak.

Figure 15 shows the traction performance of the Michelin tire on the two ice surfaces for which data are available. Interestingly, the traction data do not significantly distinguish

Load (lb)	TIRE	CHAIN	ICE	TEMP (°F)
	Goodyear	No Chains	With Crust	17.6
	10 mph		25 mph	
	$\mu_{pk}$	$\mu_s$	$\mu_{pk}$	$\mu_s$
2,000	0.2693	0.1347	0.3546	0.1483
4,000	0.2732	0.1236	0.3163	0.1426
6,000	0.2512	0.1131	0.2974	0.1336

Matrix #1

Load (lb)	TIRE	CHAIN	ICE	TEMP (°F)
	Goodyear	Single Chains	With Crust	17.6
	10 mph		25 mph	
	$\mu_{pk}$	$\mu_s$	$\mu_{pk}$	$\mu_s$
2,000	0.4903	0.2954	0.5766	0.2625
4,000	0.4072	0.1995	0.4733	0.2500
6,000	0.3909	0.2364	0.4273	0.2558

Matrix #2

Load (lb)	TIRE	CHAIN	ICE	TEMP (°F)
	Goodyear	No Chains	Bare	12.2
	10 mph		25 mph	
	$\mu_{pk}$	$\mu_s$	$\mu_{pk}$	$\mu_s$
2,000	0.2090	0.0966	0.2663	0.0970
4,000	0.1898	0.0822	0.2000	0.0746
6,000	0.1956	0.0990	0.1905	0.0768

Matrix #3

Load (lb)	TIRE	CHAIN	ICE	TEMP (°F)
	Michelin	No Chains	Bare	14.0
	10 mph		25 mph	
	$\mu_{pk}$	$\mu_s$	$\mu_{pk}$	$\mu_s$
2,000	0.1853	0.0948	0.2811	0.0990
4,000	0.1904	0.0968	0.2009	0.0825
6,000	0.1732	0.0897	0.2078	0.0808

Matrix #4

Load (lb)	TIRE	CHAIN	ICE	TEMP (°F)
	Michelin	Single Chains	Bare	14.0
	10 mph		25 mph	
	$\mu_{pk}$	$\mu_s$	$\mu_{pk}$	$\mu_s$
2,000	0.4419	0.2726	0.4867	0.3022
4,000	0.3839	0.3044	0.4422	0.2855
6,000	0.3617	0.2640	0.4050	0.2884

Matrix #5

Load (lb)	TIRE	CHAIN	ICE	TEMP (°F)
	Michelin	Reinf. Chains	Bare	28.4
	10 mph		25 mph	
	$\mu_{pk}$	$\mu_s$	$\mu_{pk}$	$\mu_s$
2,000	0.5478	0.4099	0.5688	0.4304
4,000	0.4816	0.4327	0.5180	0.4197
6,000	0.4484	0.3847	0.4594	0.3980

Matrix #6

**Table 5. Peak ( $\mu_{pk}$ ) and slide ( $\mu_s$ ) traction values for tires tested with and without chains on the mobile dynamometer**

Load (lb)	TIRE	CHAIN	ICE	TEMP (°F)
	Michelin	No Chains	Wet	32.0
	10 mph		25 mph	
	$\mu_{pk}$	$\mu_s$	$\mu_{pk}$	$\mu_s$
2,000	-	-	0.2509	0.0926
4,000	-	-	0.1880	0.0677
6,000	-	-	0.1963	0.0705

Matrix #7

Load (lb)	TIRE	CHAIN	ICE	TEMP (°F)
	Goodyear	No Chains	Wet	32.0
	10 mph		25 mph	
	$\mu_{pk}$	$\mu_s$	$\mu_{pk}$	$\mu_s$
2,000	-	-	0.2606	0.0805
4,000	-	-	0.1881	0.0665
6,000	-	-	0.1661	0.0628

Matrix #8

Load (lb)	TIRE	CHAIN	ICE	TEMP (°F)
	Goodyear	Single Chains	Wet/Dry	32.0
	10 mph		25 mph	
	$\mu_{pk}$	$\mu_s$	$\mu_{pk}$	$\mu_s$
2,000	0.4536	0.2826	0.4904	0.3485
4,000	0.3944	0.2576	0.3980	0.2698
6,000	0.3491	0.2952	0.3813	0.2893

Matrix #9

Load (lb)	TIRE	CHAIN	ICE	TEMP (°F)
	Goodyear	Reinf. Chains	Wet/Dry	32.0
	10 mph		25 mph	
	$\mu_{pk}$	$\mu_s$	$\mu_{pk}$	$\mu_s$
2,000	0.5962	0.5290	0.6095	0.5046
4,000	0.5113	0.4557	0.5497	0.5103
6,000	0.4667	0.3921	0.4796	0.3691

Matrix #10

**Table 5 (continued) Peak ( $\mu_{pk}$ ) and slide ( $\mu_s$ ) traction values for tires tested with and without chains on the mobile dynamometer**

Traction limits,  $\mu_{pk}$  and  $\mu_s$

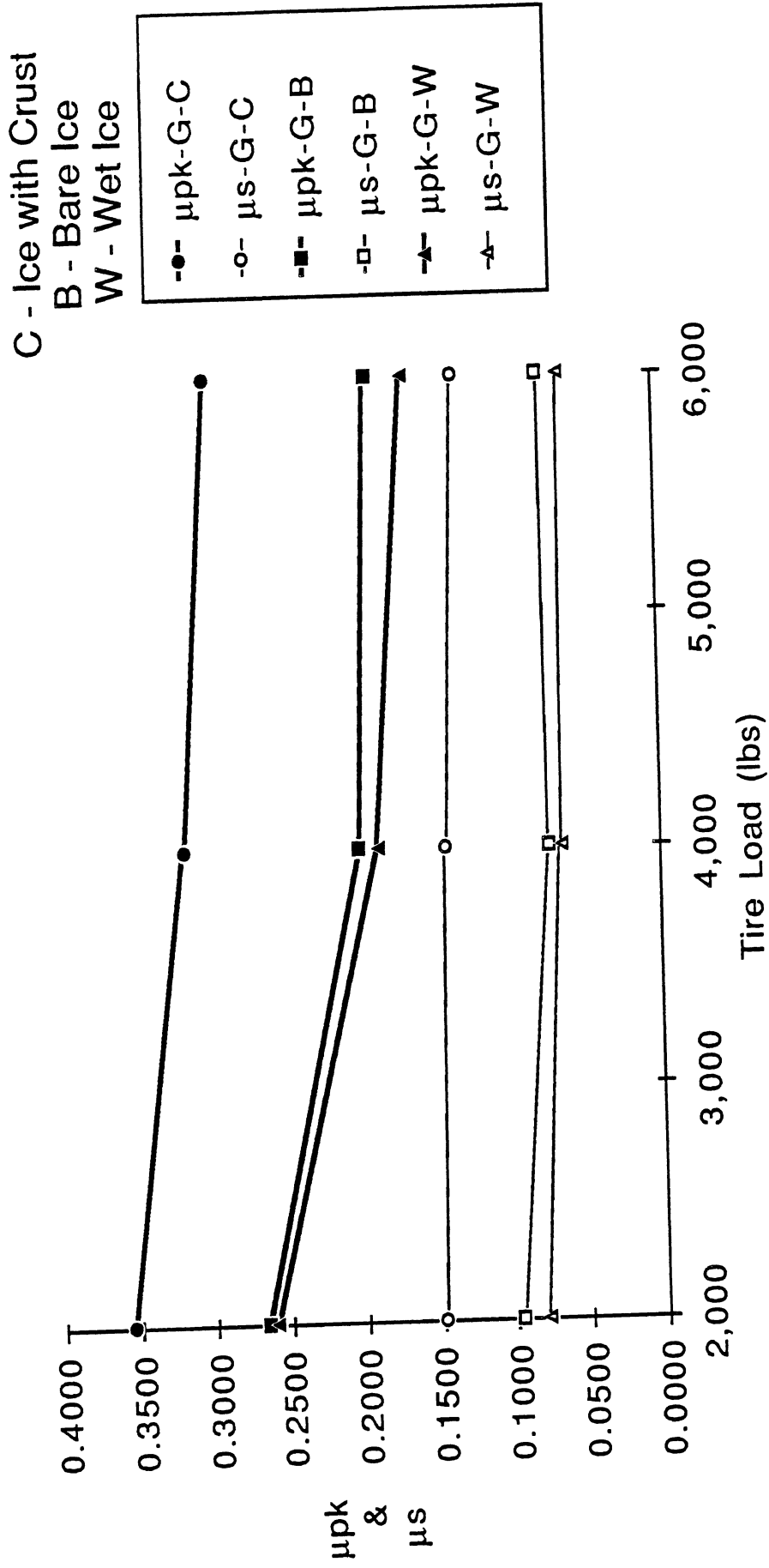

Figure 14 Goodyear tire with no chains under three different ice conditions

Traction limits,  $\mu_{pk}$  and  $\mu_s$

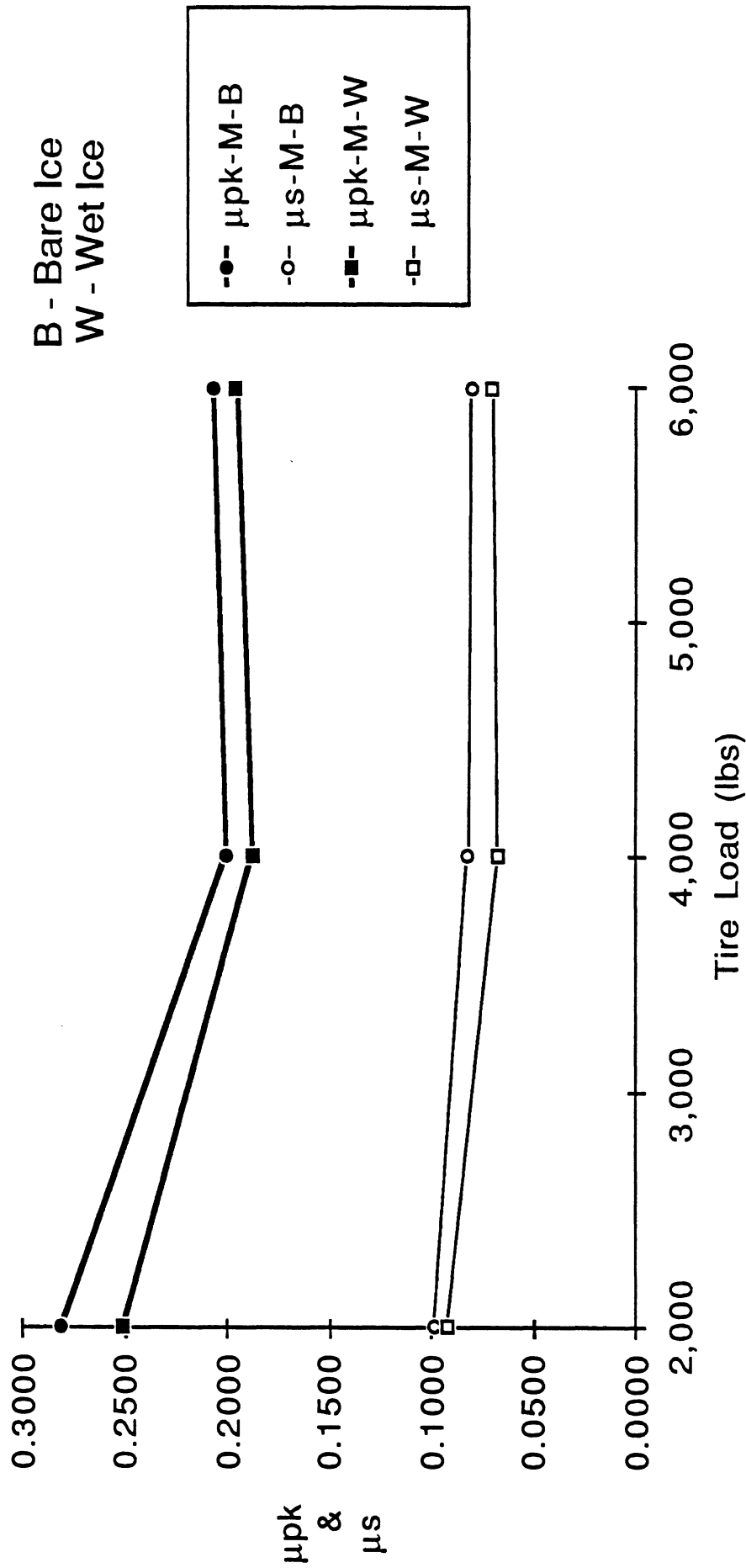

Figure 15 Michelin tires with no chains under two different ice conditions

Traction limits,  $\mu_{pk}$  and  $\mu_s$

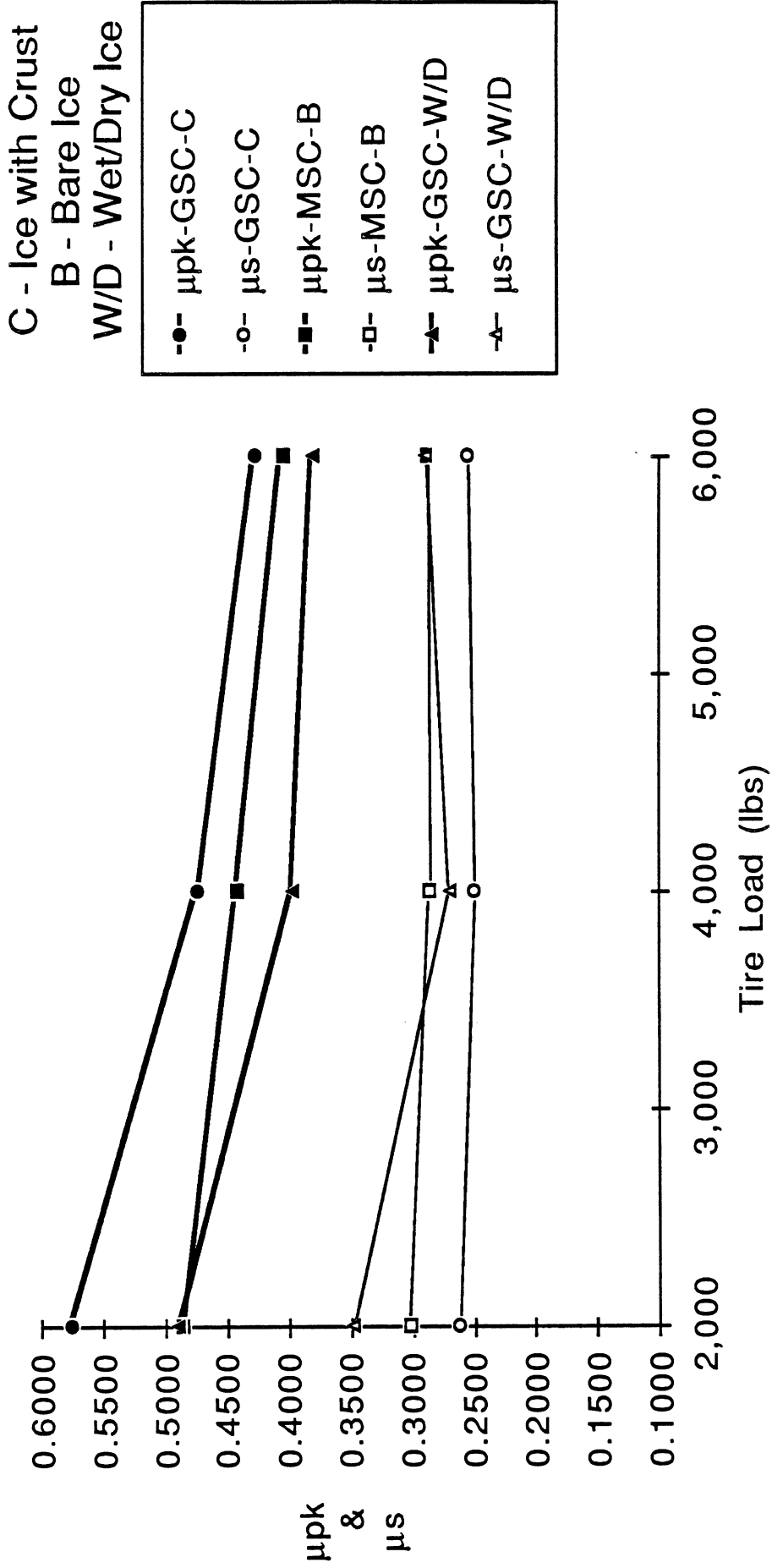

Figure 16 Tires with single chains under three different ice conditions

Traction limits,  $\mu_{pk}$  and  $\mu_s$

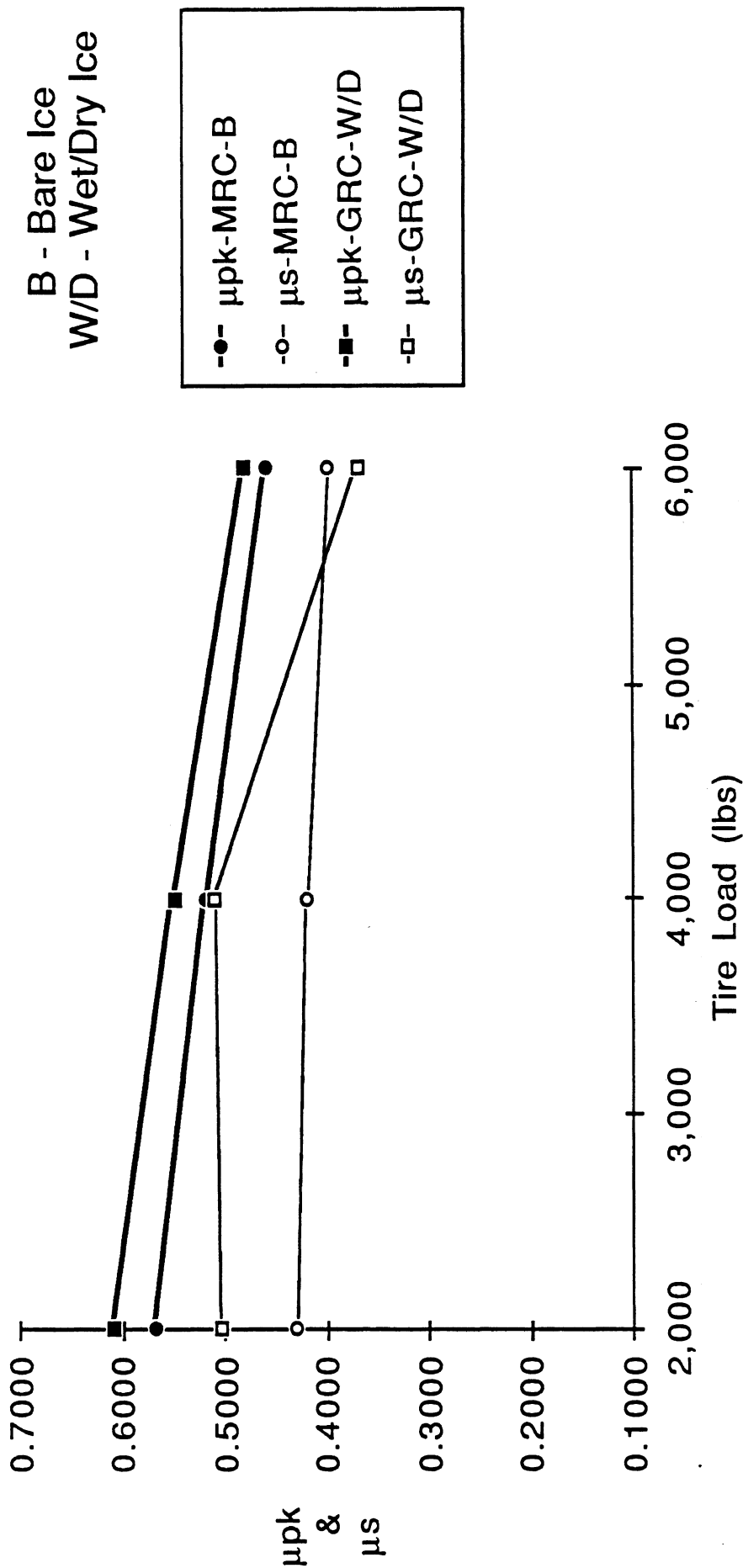

Figure 17 Tires with reinforced chains under two similar ice conditions

between the wet and dry surface conditions, as has prior data showing the traction qualities of car tires on ice [11].

The data in Figures 16 and 17 show that the variations in surface conditions examined here do not strongly affect the performance achieved by chains. Presumably, this is due to the fact that the ice thickness was so great that the temperature, and thus mechanical properties, of the bulk ice remained rather constant throughout the two-day period over which data were collected. On the other hand, there is reason to expect that substantial differences in chain performance would be observed under varying ice temperatures. For example, technical literature on the physics of ice [12, 13] indicates that the shear and tensile strength of ice will rise by 50% or more as ice temperature reduces from 32 to 14 deg F (0 to -10 deg C). If one hypothesizes that the performance of tires operating with chains on rather high-strength ice is dominated by the ice-shear mechanics of the chain engagement, then it would follow that surface conditions are secondary, while ice strength, per se, is primary.

It is assumed that the decline in peak traction values with load, in Figures 16 and 17, is simply indicative of the fact that the depth of chain penetration, and thus the shear area of ice which is engaged, tends to saturate with load. In a similar vein, it is notable that the locked-wheel performance of the reinforced chain is so much superior to that of the single-style chain. Measuring the total height of the chain links in each case indicates a value of 5/8 inch (1.6 cm) for the single chain and 7/8 inch (2.2 cm) for the reinforced chain. Recognizing that a loaded chain link will be depressed somewhat into the tread rubber, the additional 1/4 inch (0.6 cm) depth of the reinforced chain is substantial, indeed, and seems the likely explanation for the greater effectiveness of this style of link when operating on thick ice. Of course, for highway conditions having only a thin ice cover, the performances distinctions related to depth of engagement are moot.

Figures 18, 19, and 20 provide comparisons between tires with and without chains on each of the three respective surface conditions. In Figure 18, the traction values seen with the Goodyear tire without chains on the crusted snow surface are relatively high, such that the improvement due to the single-style chain is on the order of only 50 to 60%, in peak values, and 60 to 70% in slide values.

On the more slippery "bare" ice surface depicted in the data of Figure 19, the chains afford an improvement of 110 to 150% in peak traction and from 200 to more than 400% in slide traction. Clearly, the reinforced-style chain is of greater benefit under this ice condition, with a great advantage over the single chain in the locked-wheel mode.

On the "wet" and similar "wet/dry" surface depicted in the data of Figure 20, the advantage of chains over tires without chains is somewhat more pronounced, as the traction capability of the tires without chains further diminishes. It is worth noting here, as well as



Traction limits,  $\mu$ pk and  $\mu$ s

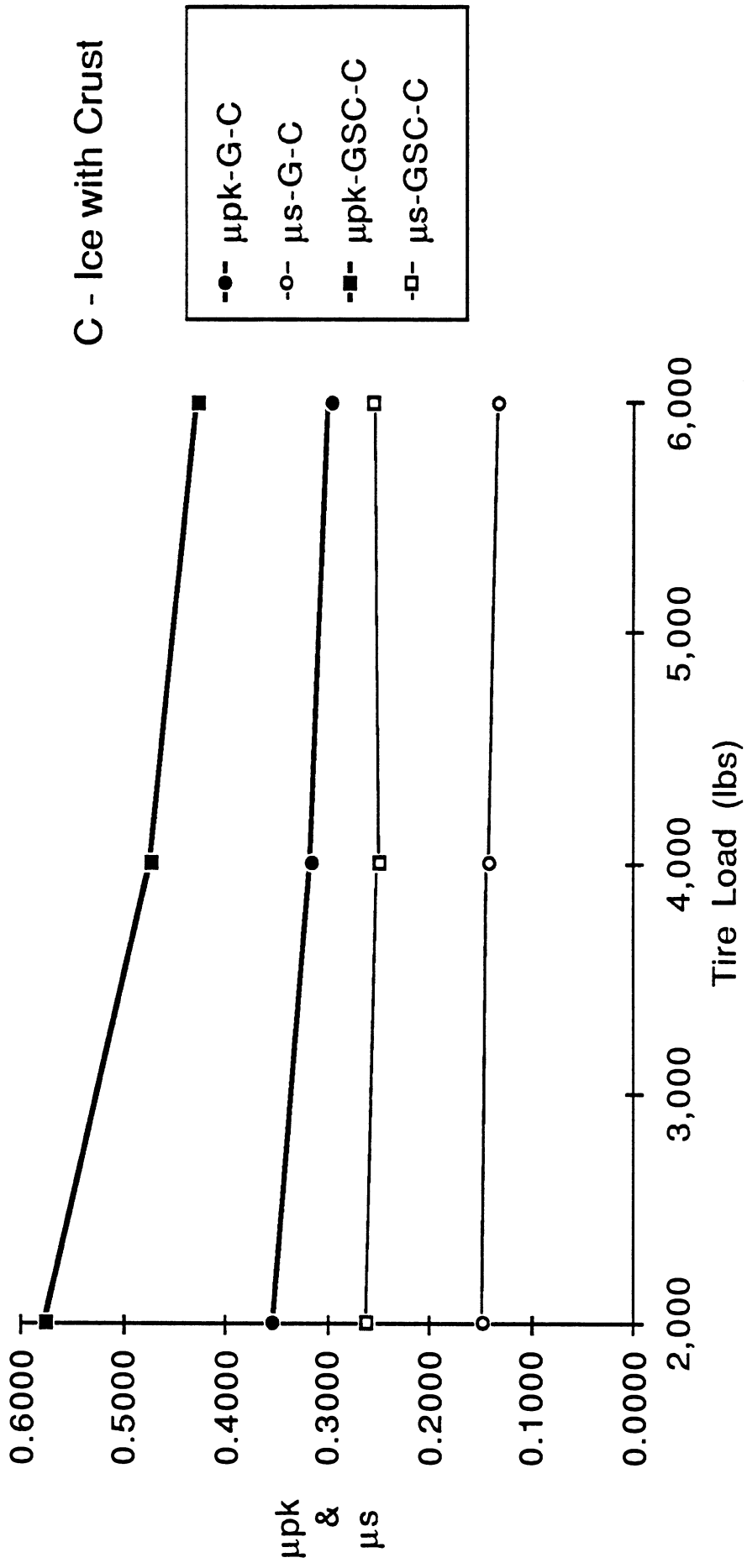

Figure 18 Goodyear tire with and without chains on crusted ice

Traction limits,  $\mu_{pk}$  and  $\mu_s$

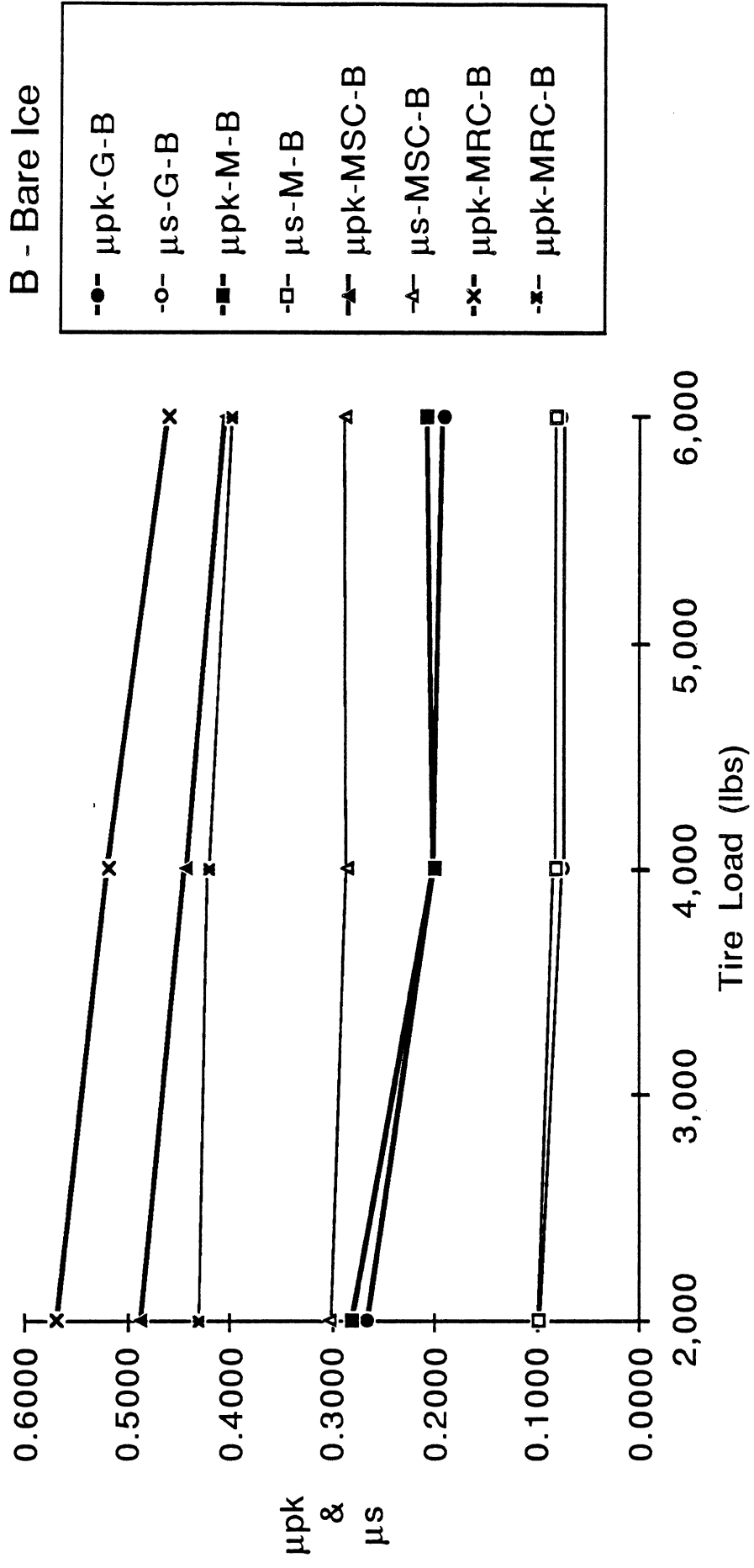

Figure 19 Tires with and without chains on bare ice

Traction limits,  $\mu_{pk}$  and  $\mu_s$

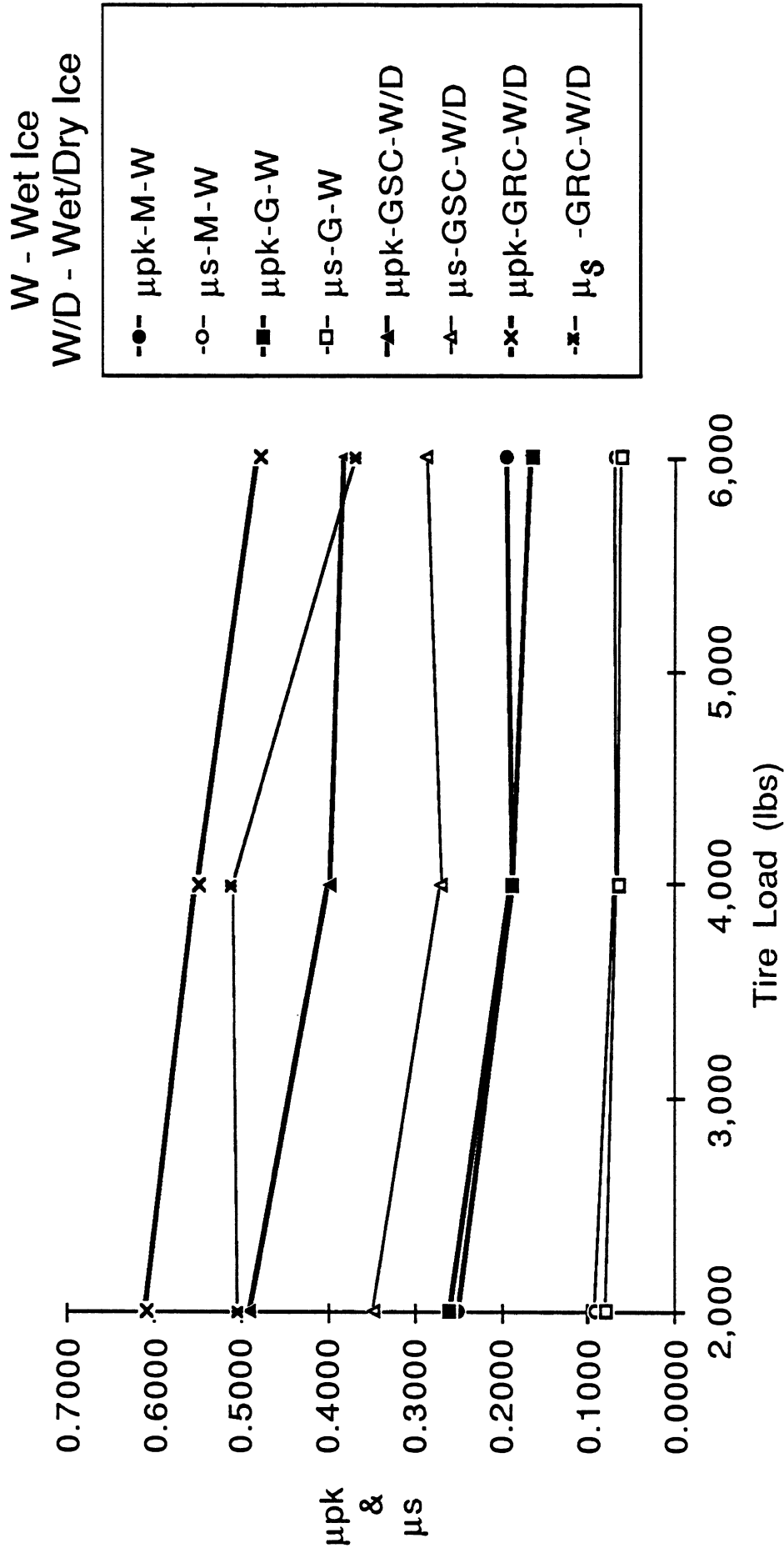

Figure 20 Tires with and without chains on similar wet and wet/dry ice conditions

on Figure 19, that almost no distinction in either peak or slide traction levels is discernible between the Goodyear and Michelin tire specimens operating without chains.

The influence of test velocity on the traction performance of tires with and without chains is shown in Figures 21 through 23. The data show a number of cases in which the peak traction values rise substantially (on the order of 10%) over the modest 15 mph (20.7 km/h) range of speeds. The Goodyear tire without chains operating on crusted ice, plus most of the cases with chains installed show a positive velocity sensitivity, while the sensitivities seen in the slide traction data are quite mixed.

As a final note, the photo in Figure 24 shows the approximate 0.5 inch-deep (1.3 cm) trough which was scoured out by a locked wheel with chains installed. It was observed that the depth of the trough varied notably over the range of loads examined here, but no data were taken to assist in later efforts to validate models of chain behavior (should anyone be so inclined).

Traction limits,  $\mu_{pk}$  and  $\mu_s$ , at 4000 lbs

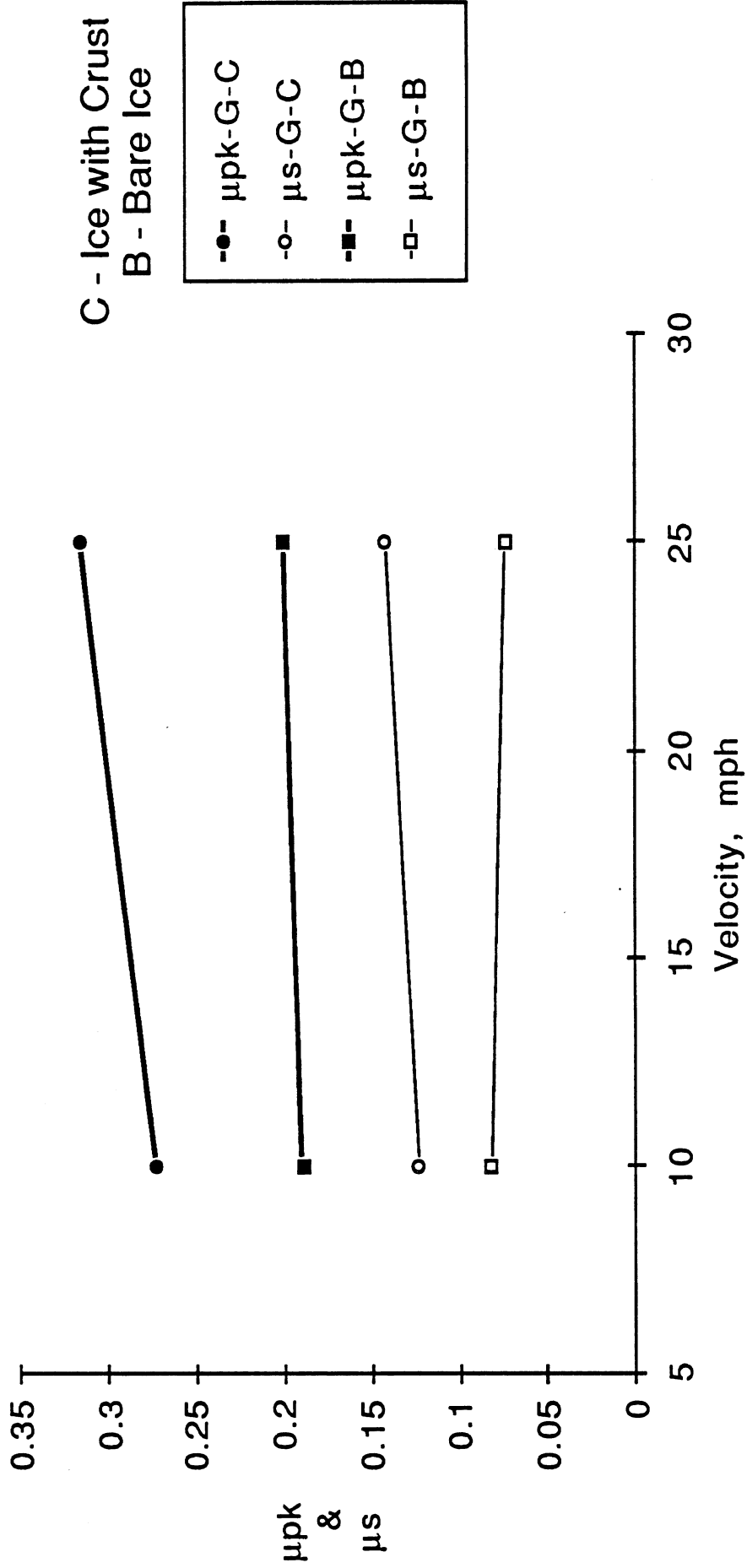

Figure 21 The influence of test velocity on traction without chains

Traction limits,  $\mu_{pk}$  and  $\mu_s$ , at 4000 lbs

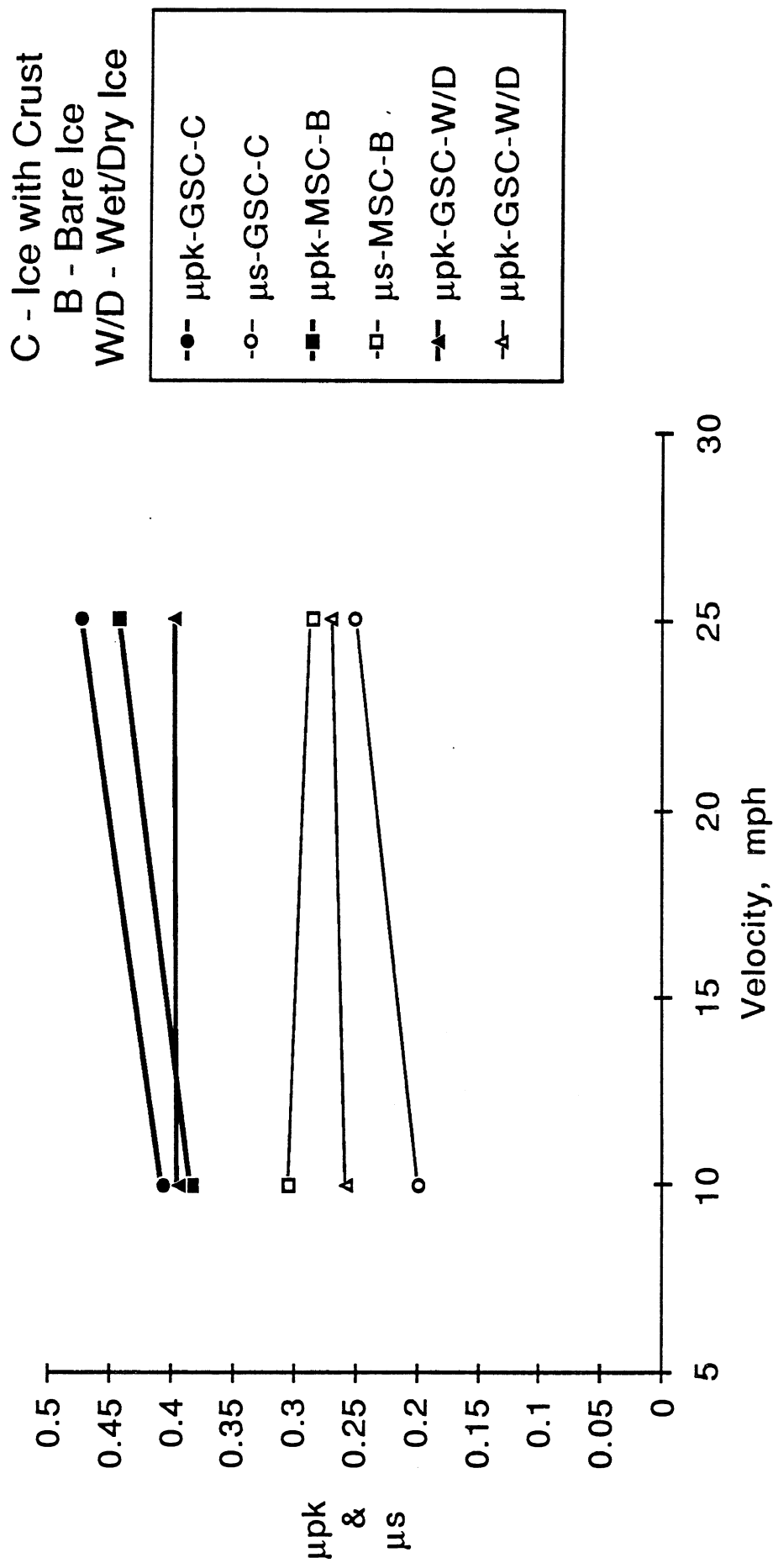

Figure 22 The influence of test velocity on traction with single-style chains installed

Traction limits,  $\mu_{pk}$  and  $\mu_s$ , at 4000 lbs

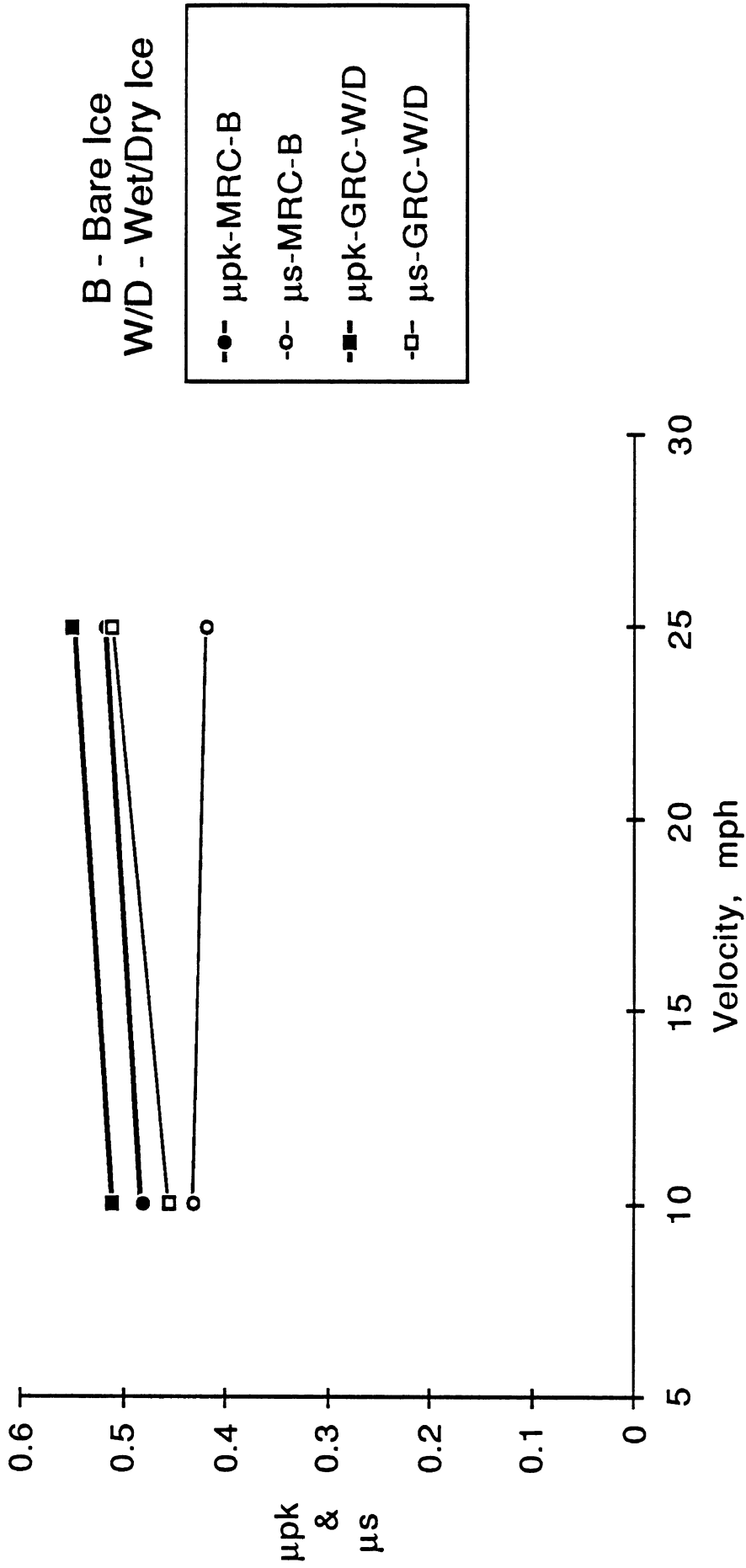

Figure 23 The influence of test velocity on traction with reinforced-style chains installed



Figure 24 Trough in ice produced by locked wheel with chains installed



### 3.3 Results of Braking Performance Analyses

In this section, the results of the braking performance analyses will be presented, with a focus upon the tendency for front-wheel lockup while stopping tractor-semitrailer combinations on ice. The presentation begins with an illustration of the basic format of so-called "friction utilization" diagrams in which all of the results were produced. The use of these diagrams for identifying the order in which the differing axles will lock up is discussed and a concept is presented for quantifying the proximity of front-axle lockup to the critical control limits of the vehicle. An overview of the analytic results provides insight into the influence of the variations in tire/chain installation as well as brake system characteristics on the braking performance.

#### *3.3.1 Friction Utilization Diagrams*

Shown in Figure 25 is a friction utilization diagram for the empty tractor-semitrailer, with a baseline configuration of brake system. This diagram illustrates, on the vertical axis, the level of friction between tire and road which is being demanded at each axle position as the brake control line pressure, on the horizontal axis, is increased. That is, as the brake pedal is depressed to yield a given level of pressure in the brake control line, each axle experiences a certain level of brake torque which, in turn, calls for a certain level of longitudinal force to be developed by the tire if the wheel is to keep rolling. When this demanded level of longitudinal force is divided by the prevailing axle load, given all of the load transfer processes that accompany braking, a value of frictional demand is obtained. When the friction demanded at any axle exceeds the capability of the tire/road interface, wheel lockup occurs and vehicle controllability may be threatened.

The figure traces the friction demanded at each of the five axles of the vehicle. In this example, we note that non-zero pushout pressures cause friction utilization curves to intersect the horizontal axis at those pressure values which have been set for each axle. Beyond the pushout threshold, friction utilization levels rise at a rate determined by the corresponding torque gain and load transfer function at each axle. We see in the figure that the rear trailer axle, No. 5, demands the highest friction levels over the entire indicated range, and the steering axle, No. 1, demands the lowest.

In order to identify the sequence of wheel lockup, it is necessary to determine the friction potential of the tire/road surface at each axle. In the classical implementation of the friction utilization diagram, one assumes that all axles enjoy the same frictional limit such that a line is simply drawn across the diagram at the elevation of the defined friction condition. For example, if we were considering a uniform wet-road condition at, say, a simple tire/road frictional limit of 0.6, we would look at the intersections of the 0.6 friction utilization line with the curves representing the demand at each axle and note that the order

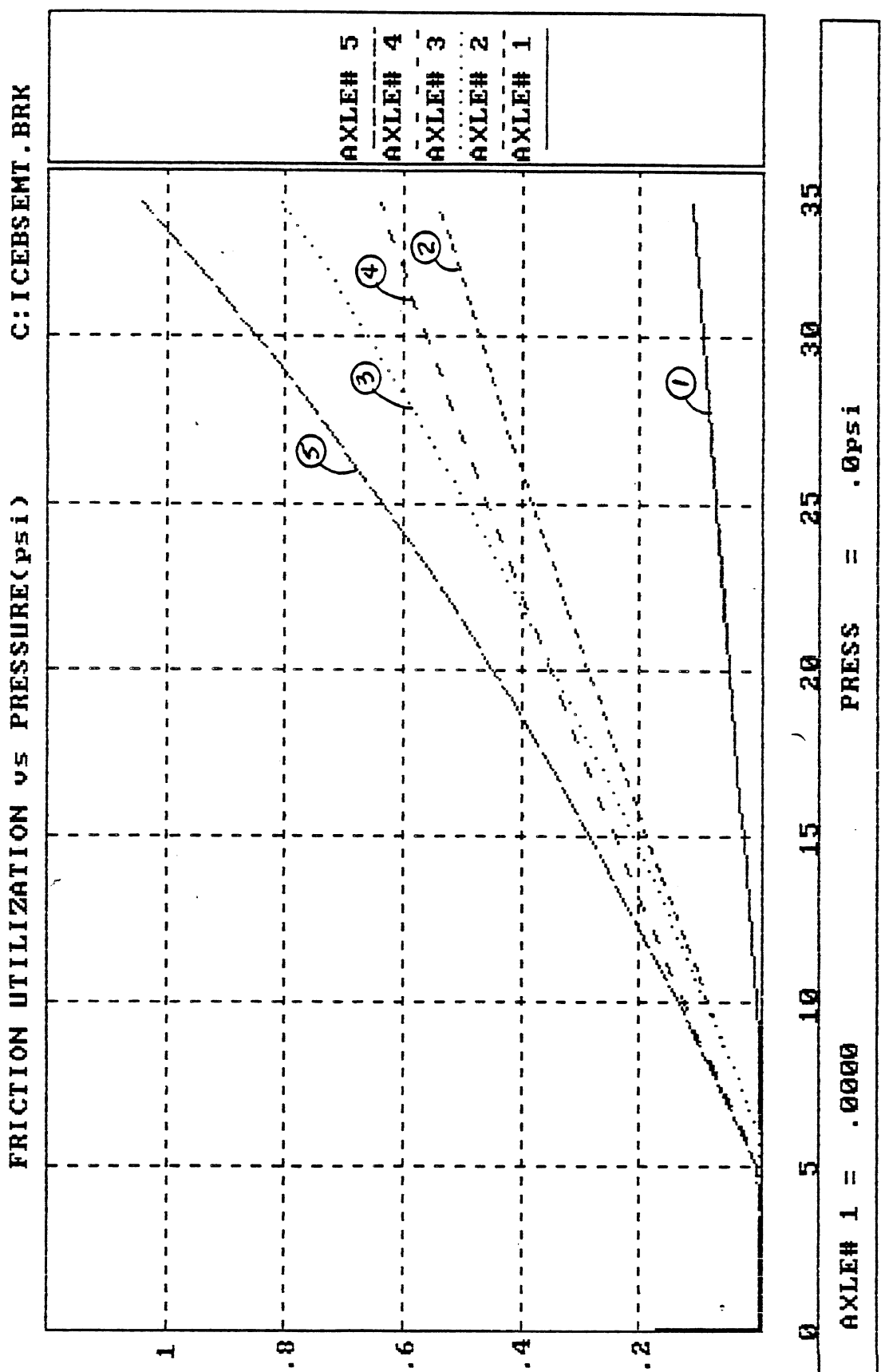

Figure 25 Friction Utilization diagram for baseline empty case

of axle lockup would be 5,3,4,2,1. Recognizing that vehicle control would be lost with lockup of both axles on the trailer tandem, the control limit of the vehicle would be reached at a control line pressure of 32 psi (220 kPa), at which the No. 4 axle achieves lockup.

Considering, now, the case of the above empty vehicle braking without chains on the wet ice surface characterized in this study, we must inspect for lockup at the friction levels applicable to each axle. Employing the tire traction data corresponding to the axle loads computed by the model, one finds that axle No. 5 will reach its peak traction condition of 0.30 at a control line pressure of 16 psi (110 kPa), whereupon the wheels on this axle will lock. Since the locked-wheel traction limit for tires operating without chains on this surface at the prevailing axle load is 0.08, the brake force developed at axle No. 5 will drop precipitously following lockup. This outcome is illustrated in Figure 26, showing the friction demand of axle No. 5 dropping from 0.30 to 0.08.

With this reduced brake force output implemented in the braking model, the other friction utilization curves are altered slightly relative to the baseline case with no wheels locked. Figure 26 shows a "cross-hair" marker at the location of the next wheel lockup that will occur. Namely, axle No. 4 will lock at a friction utilization level of 0.30, thus establishing the control limit for the vehicle at a control line pressure of 18 psi (124 kPa). Going now to a plot of the deceleration response of the vehicle, as a function of control line pressure, Figure 27, we see that the deceleration level at a line pressure of 18 psi (124 kPa) is 0.176 g's.

For cases in which certain axles are equipped with chains while other are not, one simply inspects each friction utilization curve relative to the peak traction limits which correspond to the installed wheel hardware. Axle lockups are traced through one-at-a-time until a critical lockup condition is satisfied. Upon reaching axle lockups that are not, themselves, presenting a control-critical condition, the slide traction values are invoked and the computation extended until a critical condition is reached.

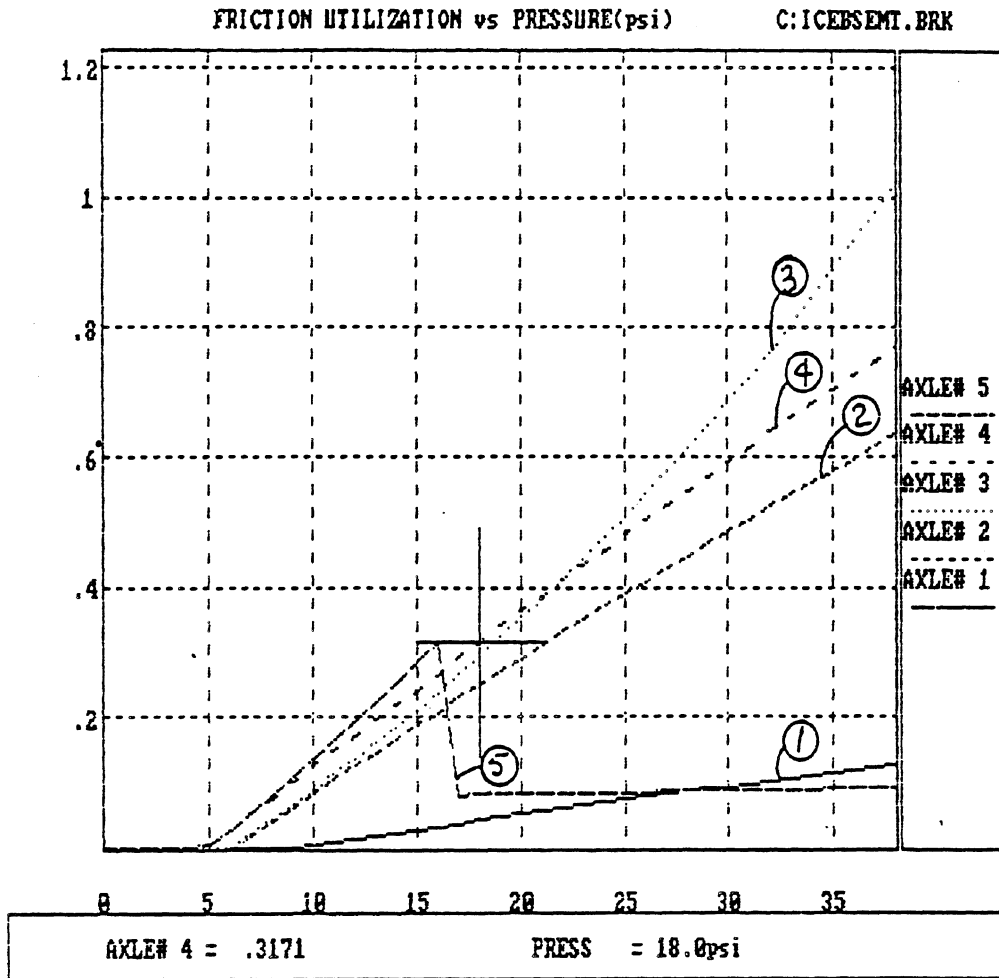

Figure 26 Friction Utilization diagram for baseline empty case with axle No. 5 locked

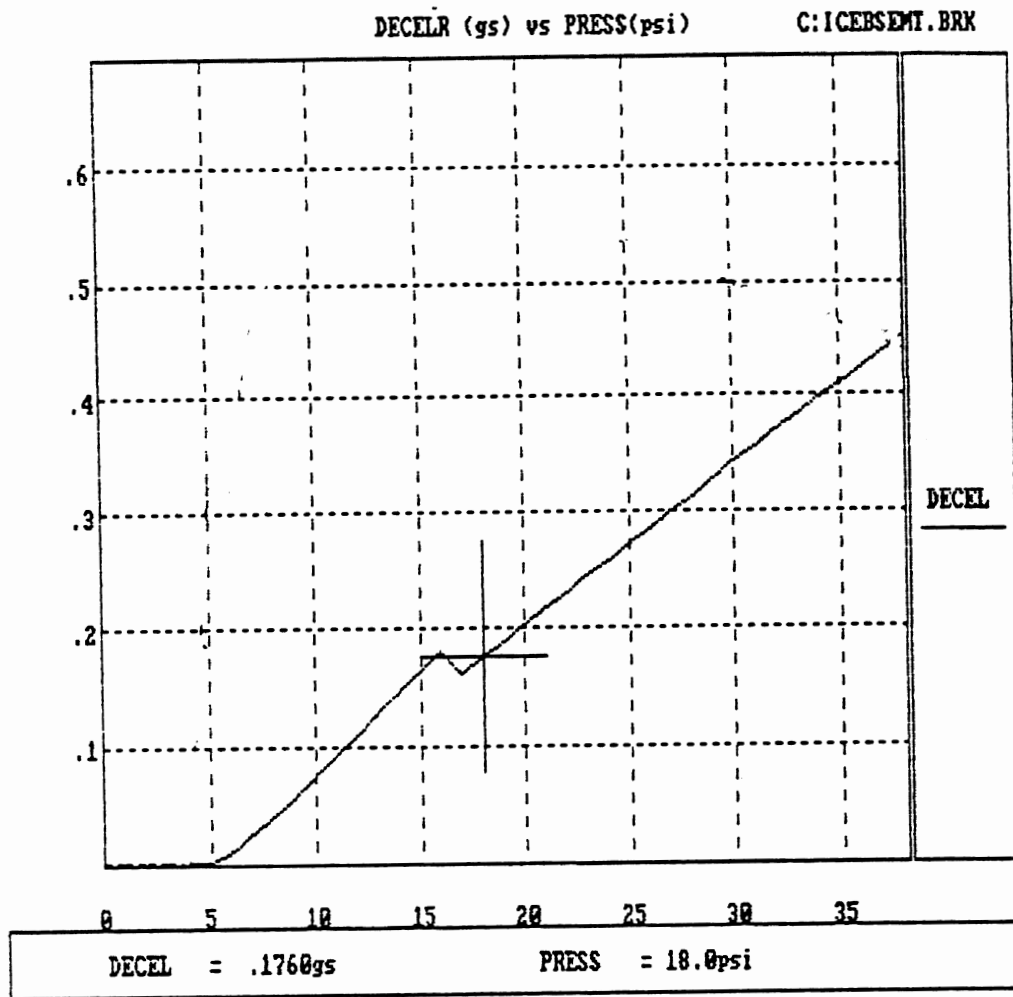

Figure 27 Deceleration Diagram for baseline empty case, with axle No. 5 locked

### 3.3.2 The Concept of Front-Lockup Pressure Margin

In order to highlight the implications of the results for the likelihood of locking the front wheels while braking on ice, a "front-lockup pressure margin" was defined. That is, a measure of braking performance was conceived which quantifies the proximity of the brake application that produces front lockup to the brake applications that cause either of the other two "critical" lockup possibilities, viz., lockup of the tandem axle pair on either the tractor or the trailer. The measure, abbreviated as PM, is simply defined as the difference in control line pressures needed to achieve the critical lockup conditions, relative to the point of lockup of the front axle, viz.,

$$PM_{2,3} = (P_L)_1 - (P_L)_{2,3} \quad \text{and,}$$

$$PM_{4,5} = (P_L)_1 - (P_L)_{4,5}$$

where,  $PM_{2,3}$  is the margin between the pressure,  $(P_L)_1$ , needed to reach lockup of the steering axle and the pressure,  $(P_L)_{2,3}$ , needed to lock up the tractor drive axles

$PM_{4,5}$  is the margin between the pressure,  $(P_L)_1$ , needed to reach lockup of the steering axle and the pressure,  $(P_L)_{4,5}$ , needed to lock both trailer axles

The PM measures are illustrated on the friction utilization diagram of Figure 28. This diagram shows a case in which a loaded vehicle, outfitted with single-style chains on both tractor drive axles, locks up trailer axles No. 5 and No. 4 at control line pressures of 52 and 57 psi (358 and 392 kPa), respectively. The cross-hair cursor is placed on the front-axle curve at 63 psi (434 kPa), corresponding to the point of lockup of the front wheels, given the tire loading and associated traction limits. Also illustrated are the points of impending lockup of the chain-equipped drive axles: 76 psi (523 kPa) for axle No. 3 and 90 psi (620 kPa) for axle No. 2. Accordingly,  $PM_{4,5} = (63 - 57) = (+6)$  psi (+41 kPa) and

FRICION UTILIZATION vs PRESSURE (psi) C: ICEL5LOK.BRK

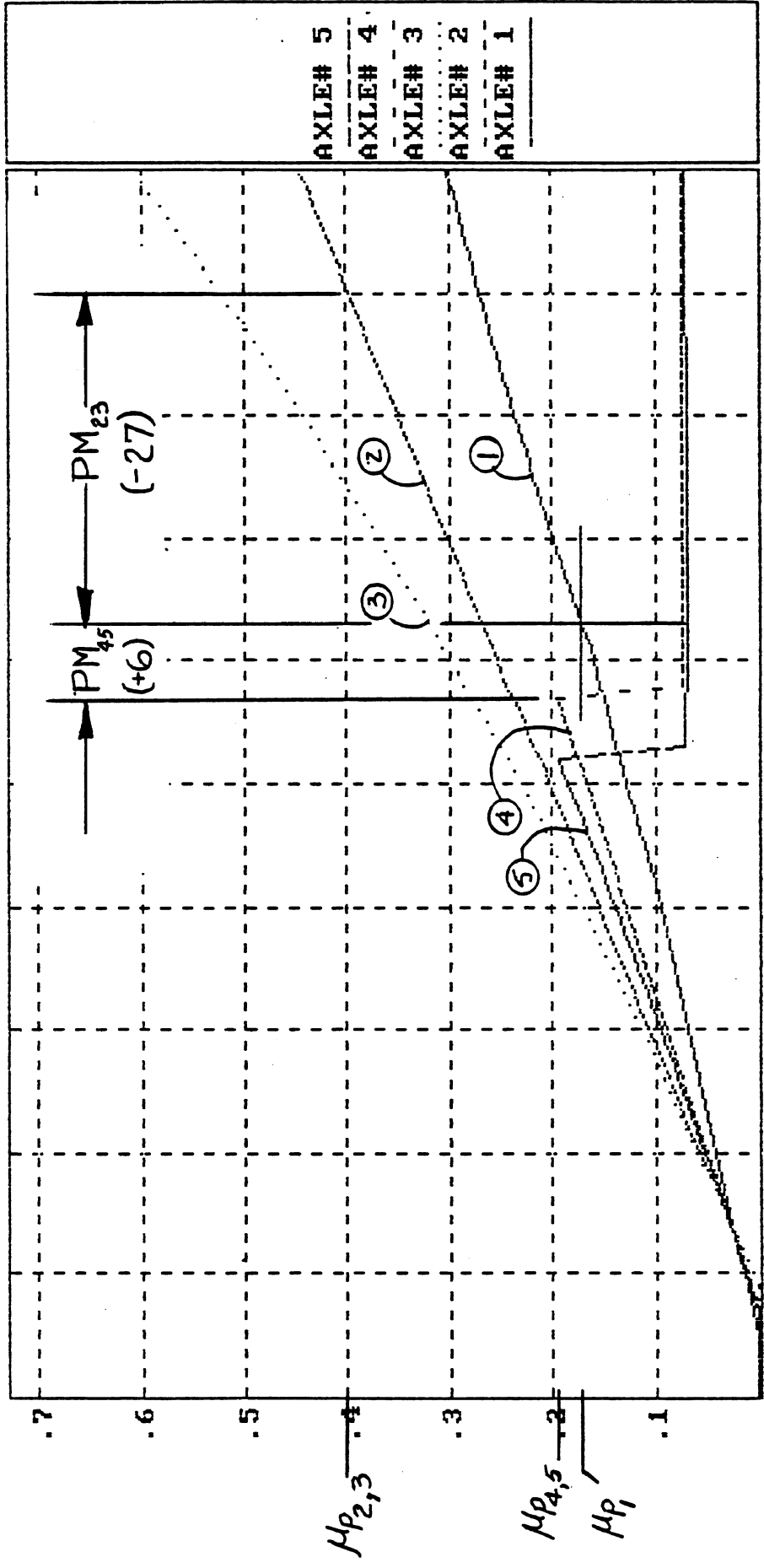

Figure 28 Illustration of the Pressure Margin concept, with example representing a loaded vehicle with chains on axles 2 & 3.

$PM_{2,3} = (63 - 90) = (-27)$  psi (-186 kPa). Basic observations which can be guided by this measure are as follows:

- *If at least one of the two pressure margins is positive (+), front axle lockup does not determine the control-limit condition for the vehicle.*
- *Conversely, if both pressure margins are negative (-), front-lockup is occurring first*
- *Very small values of pressure margin, either positive or negative, probably suggest distinctions in lockup sequence which have no practical consequence to vehicle control*
- *The larger the value of a positive (+) pressure margin, the more unlikely it is that front lockup will accompany the lockup of the indicated tandem axle set.*
- *The larger of two positive (+) pressure margin values identifies the critical tandem whose lockup is defining a control limit.*

In the presentation of results, to follow, the pressure margin values,  $PM_{2,3}$  and  $PM_{4,5}$ , are employed as a characterization of the proximity of front lockup to the control-limit condition.

### 3.3.3 An Overview of Results

In Section 2.3.3, a matrix of analyses was introduced, showing the combined cases of brake system properties and tire/chain installations which were considered under empty and loaded vehicle configurations. For each combination of vehicle loading, brake system, and tire/chain installation, a friction utilization diagram was produced. These diagrams, as well as the deceleration vs. brake pressure plots, are presented in Appendix B. Quantitative measures of performance covering the overall matrix of variations are summarized in Table 6.

The table presents results showing the lockup sequence, pressure margins,  $PM_{2,3}$  and  $PM_{4,5}$ , and the maximum deceleration achieved before reaching a critical lockup condition. The table employs the shorthand designations for brake system properties and tire/chain installations which are fully defined in Section 2.3.3. One approach toward scanning the results is to identify all those cases in which axle No. 1 was the first to achieve lockup; that is, cases in which the "lockup sequence" entry begins with a "1." The cases which satisfy this criterion are Nos. 14, 15, 18, and 20. Closer scrutiny also shows that case No.11 indicates the lockup of axle 1 as critical because it precedes the lockup of either tandem pair. Together, these cases represent brake systems whose torque gains and pushout pressures are quite forward-biased, with and without chains installed at the drive axle positions. Accordingly, although the study was premised upon a concern for premature front lockup when chains were installed at the drive axle positions, it is apparent from case



Table 6. Summary of Quantitative Results

<u>Case No.</u>	<u>Vehicle Loading</u>	<u>Brake System</u>	<u>Tires/ Chains</u>	<u>Lockup Sequence</u>	<u>Pressure Margin, psi</u>		<u>Maximum Decel. g's</u>
					<u>PM<sub>2,3</sub></u>	<u>PM<sub>4,5</sub></u>	
1	Empty	(1)	All G	54321	+28	+32	.176
2	Empty	(1)	G,SC-2,3	54321	+22	+32	.176
3	Empty	(3)	All G	35241	+7	+5	.220
4	Empty	(3)	G,SC-2,3	54312	-7	+7	.230
5	Loaded	(1)	All G	53421	+25	+24	.148
6	Loaded	(1)/NFB	G,SC-2,3	5432-	Fronts Don't Lock		.140
7	Loaded	(1)/ALV	G,SC-2,3	54321	+17	+54	.147
8	Loaded	(1)	G,SC-2,3	54312	-10	+24	.154
9	Loaded	(1)	G,RC-2,3	54132	-34	+24	.154
10	Loaded	(1)	G,SC-1,2,3	5432-	Fronts Don't Lock		.154
11	Loaded	(2)	All G	31254	-3	-13	.143
12	Loaded	(2)/ALV	All G	32541	+18	+10	.141
13	Loaded	(2)/ALV	G,SC-2,3	54132	-24	+11	.187
14	Loaded	(2)	G,SC-2,3	15432	-50	-11	.174
15	Loaded	(3)	All G	13254	-8	-18	.144
16	Loaded	(3)/ALV	All G	32541	+13	+4	.145
17	Loaded	(3)/ALV	G,SC-2,3	54132	-27	+6	.188
18	Loaded	(3)	G,SC-2,3	15432	-58	-19	.144
19	Loaded	(3)/ALV	G,RC-2,3	5413-	-39	+2	.196
20	Loaded	(3)	G,RC-2,3	154--	-62	-19	.144
21	Loaded	(3)	G,SC-1,2,3	54321	+7	+34	.213
22	Loaded	(3)	G,RC-1,2,3	543--	Fronts Don't Lock		.213

Abbrev: Brake systems: (1) Baseline torque gains (TG) and pushout pressures (PP)

(2) Fwd-biased TG, baseline PP

(3) Fwd-biased TG and PP

NFB "No Front Brakes"

ALV "Automatic Limiting Valve"

Tires/chains

G Goodyear tire w/no chains

SC Single-style chains (on axles 1, 2, or 3)

RC Reinforced-style chains (on axles 1, 2, or 3)

No.'s 11 and 15 that front lockup can occur first on ice without any chains installed, if the brake system is as forward-biased as the VRTC data showed to be possible.

Shown in Figure 29, for example, is the friction utilization diagram for case No. 15, with forward-biased torque gains and pushout pressures. The friction utilization curve for the front axle lies above those of the other axles up to a friction level of 0.21 at which point it crosses the curve for axle No. 3. The front axle locks on ice, in this case, at a pressure level of 38 psi (262 kPa), indicated by the cursor. It is useful to also note that the front-axle curve crosses over that of axle No. 2 at a friction level of 0.3, thus precluding the possibility that fronts would lock first on any wet or dry pavements (except under high-speed hydroplaning conditions).

When chains are installed at the drive axles in case Nos. 14, 18, and 20, the negative pressure margins,  $PM_{2,3}$ , are made much more negative than those seen without chains. On the other hand, when we go one step further and install chains on the steering axle, as well, (see case Nos. 10, 21, and 22) front lockup either occurs last in the sequence or becomes unachievable within the maximum deliverable brake pressure.

In order to better reveal the various sensitivities present in these data, the following sections will discuss individual issues in terms of cross-plots of pressure margins and decelerations.

#### *3.3.4 The Influence of Brake System Properties on Performance.*

Shown in Figure 30 is a chart of pressure margin and maximum deceleration values for the loaded tractor-semitrailer having single-style chains installed at the tractor drive wheels. Differing sets of brake system properties are represented over the group of seven cases shown in the chart. The cases have been arranged in descending order of pressure margin results, from left-to-right. Clearly, the results become ordered simply by the increasing level of forward bias in torques delivered to the front wheels. That is, at the far left, the most positive (+) levels of pressure margin are exhibited by the vehicle having no front braking. At the far right, negative (-) pressure margins are exhibited by the vehicle having the highest front torque gains and the smallest front pushout pressure level (brake configuration No. 3). We see that positive (+) values of pressure margin are exhibited for all cases on the chart except the two at the right side of the figure. In these two cases, front-wheel lockup constitutes the critical limit on performance. In all cases, the pressure margin associated with tractor drive axles,  $PM_{2,3}$  is more negative (-) than the corresponding measure relating to trailer axles,  $PM_{4,5}$ , as a result of the particular brake torque and wheel load distributions which were considered here.

The deceleration data associated with each set of brake system properties is shown below the pressure margin results. We see that the maximum controllable deceleration

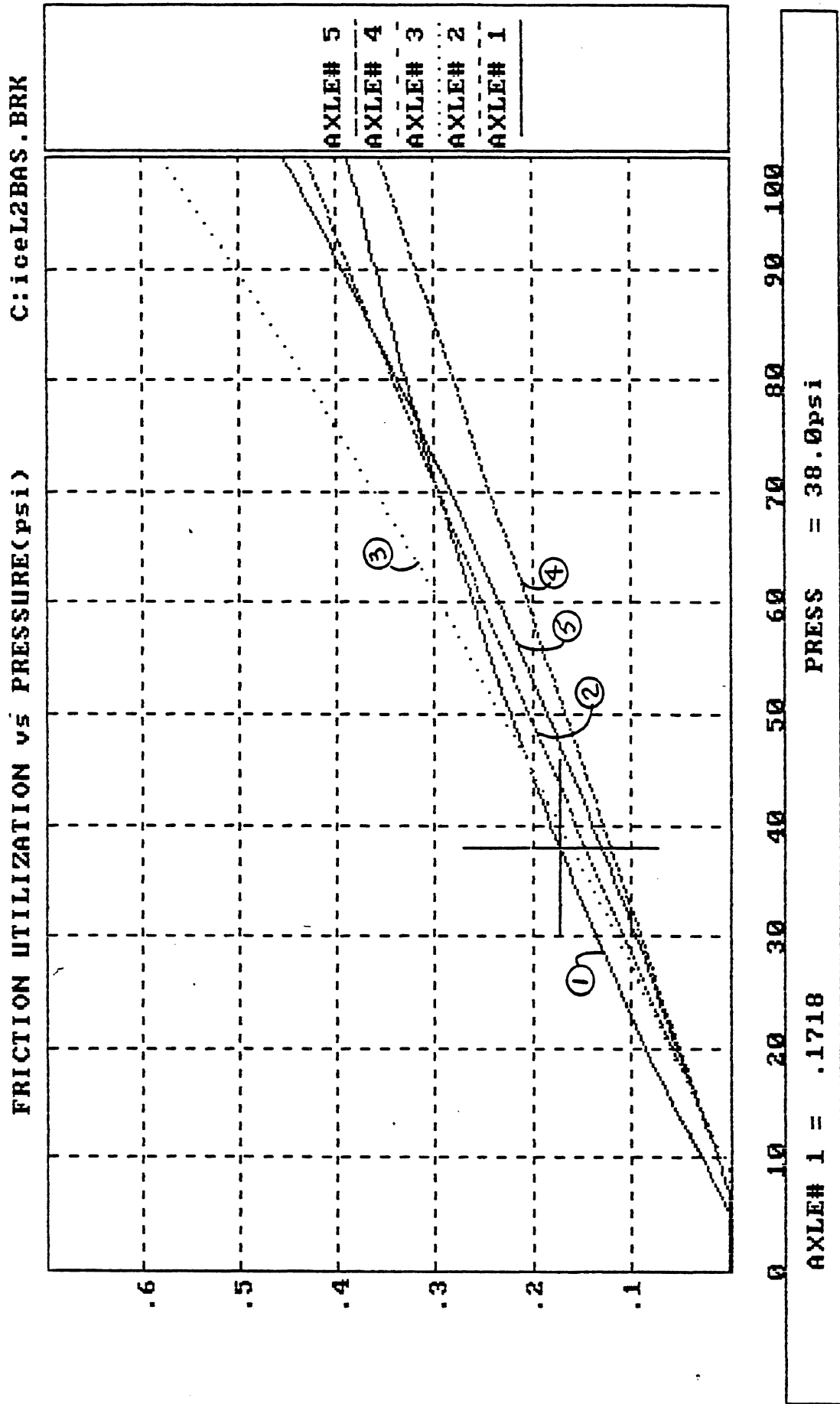

Figure 29 Friction Utilization Diagram for case of loaded vehicle with brake system case (3)

Brake Systems (See Table 6)

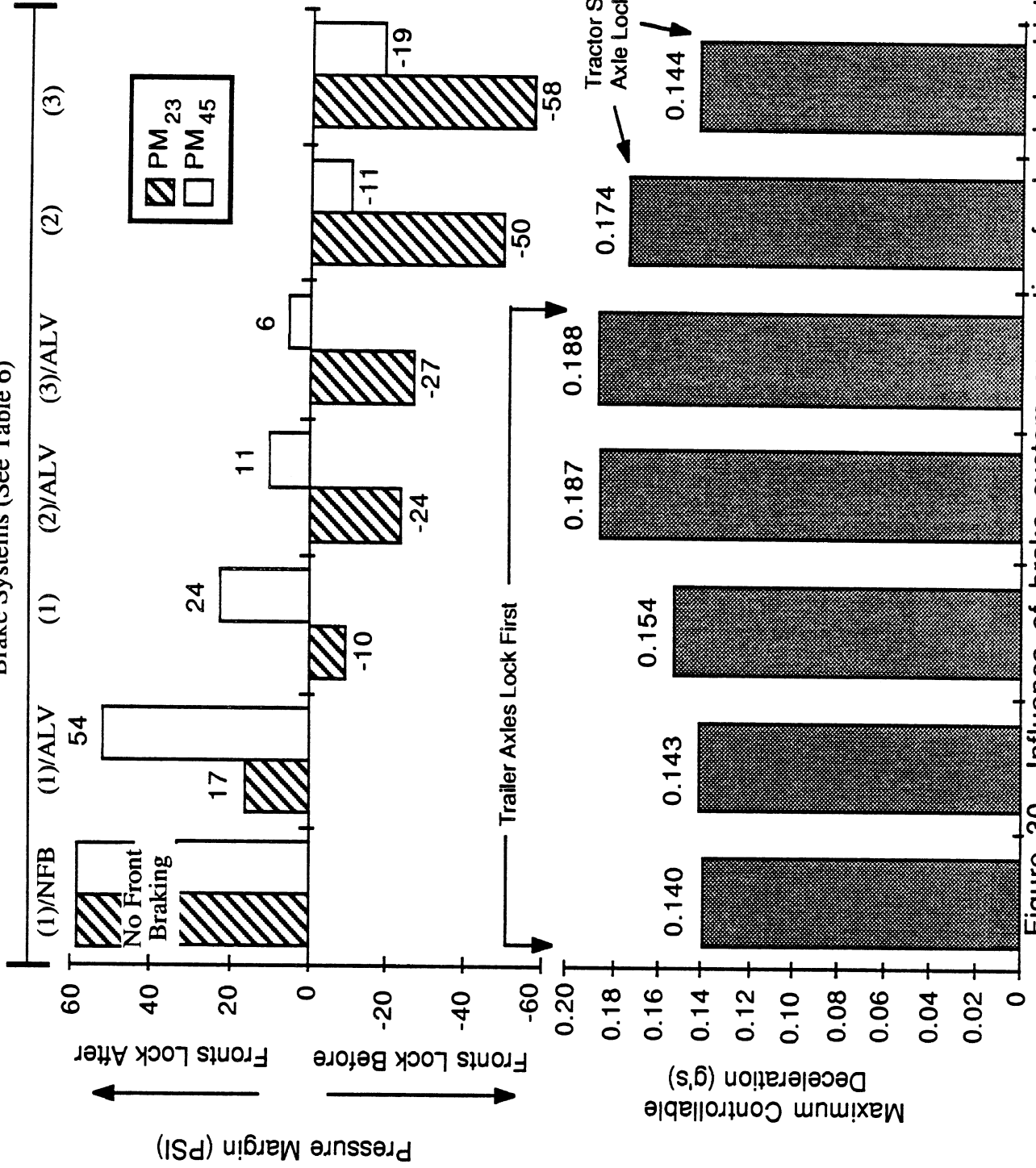

Figure 30 Influence of brake system properties for loaded vehicles with single chains installed at axles 2 and 3.

increases as brake torque distribution becomes more forward-biased, but reaches a maximum value in the case labelled, "(3)/ALV," and then declines. The chart indicates that those cases left of this nominal peak performance were limited by trailer-wheel lockup while the two cases at the right became limited by front-wheel lockup. Clearly, in the case labelled, "(3)/ALV," the matching of brake torques to axle loads attained the closest approach to ideal distribution as was considered in this group of cases.

### 3.3.5 The Influence of Tire\Chain Installation on Performance

Shown in Figure 31 are pressure margin and deceleration values illustrating the influence of various tire and chain installations on the performance of the empty and loaded vehicles for the case of the *baseline* set of brake system properties. This chart illustrates both the "bare-tire" case, labelled "G" for the Goodyear tire specimen, and differing cases of single (SC) and reinforced (RC) chain installed at axles 1, 2, or 3, as indicated. The results show that the vehicle does not become front-axle limited in any of these cases involving the baseline distribution of torque gains and pushout pressures. Indeed, in all cases, the trailer axles will both be locked at least 24 psi in advance of the pressure level needed to lock the front wheels. When chains are installed at all tractor axle positions, (viz., GSC123 and GRC123), the high level of the front tire friction capability renders front-axle lockup impossible, given the prevailing level of front torque gain.

The deceleration results show that, although the empty vehicle is able to achieve somewhat higher levels of braking performance than the loaded case, both loading configurations show no sensitivity of deceleration level to chain installations. The reason for this insensitivity is that the trailer axles determine the critical lockup outcome in each case. That is, the deceleration level needed to attain trailer-axle lockup is unaffected by the friction condition prevailing on tractor axles. Moreover, for tractor-semitrailers having common brake torque distributions that cause trailer axles to lock first on ice, the presence or absence of chains on the tractor will not affect the maximum controllable deceleration levels that can be obtained.

Shown in Figure 32 are results illustrating the influence of differing tire and chain installations on tractor semitrailers equipped with the *most forward-biased distribution* of brake torque gains and pushout pressures. The pressure margin data clearly illustrate that:

- 1) the empty vehicle is rather well balanced in torque distribution both with and without chains, insofar as both the  $PM_{2,3}$  and  $PM_{4,5}$  measures are near zero
- 2) front lockup can constitute the factor which limits the braking performance of the loaded vehicle on ice both with and without chains installed
- 3) rather strong levels of front bias exist when chains are installed on the drive axles, alone

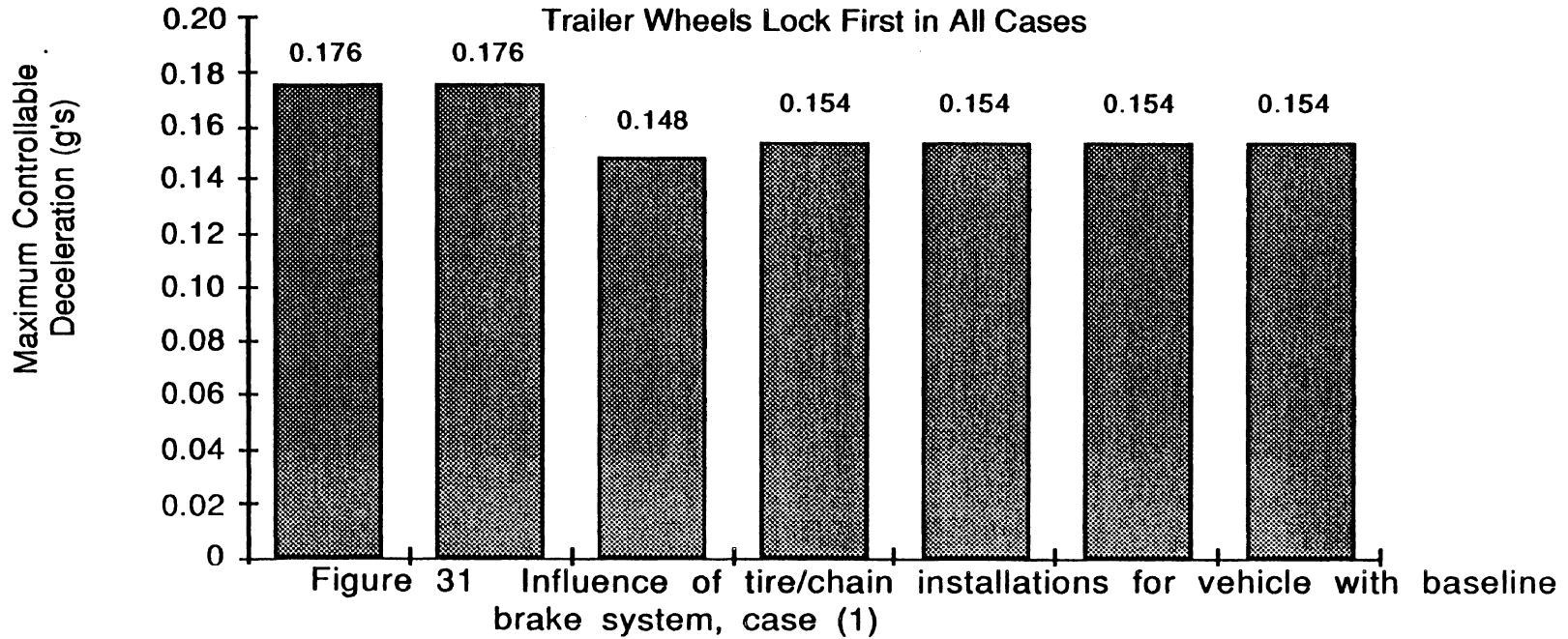
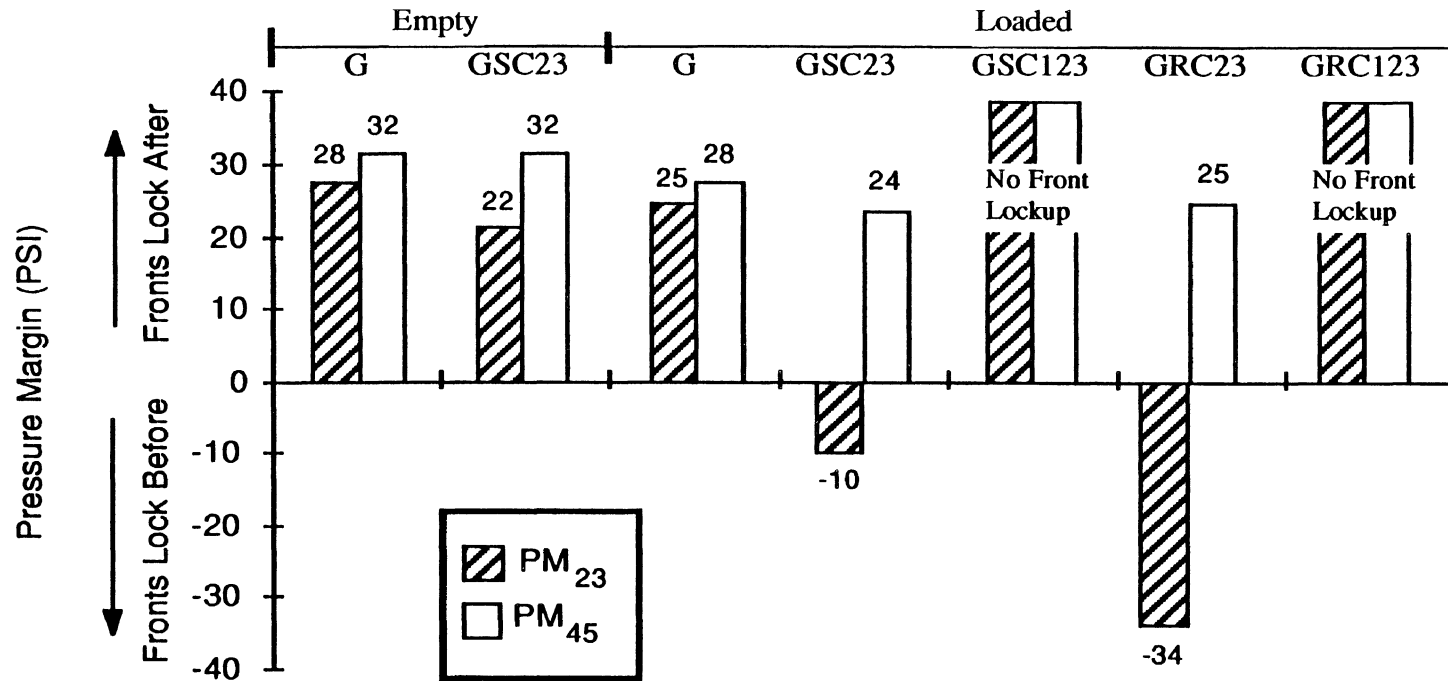

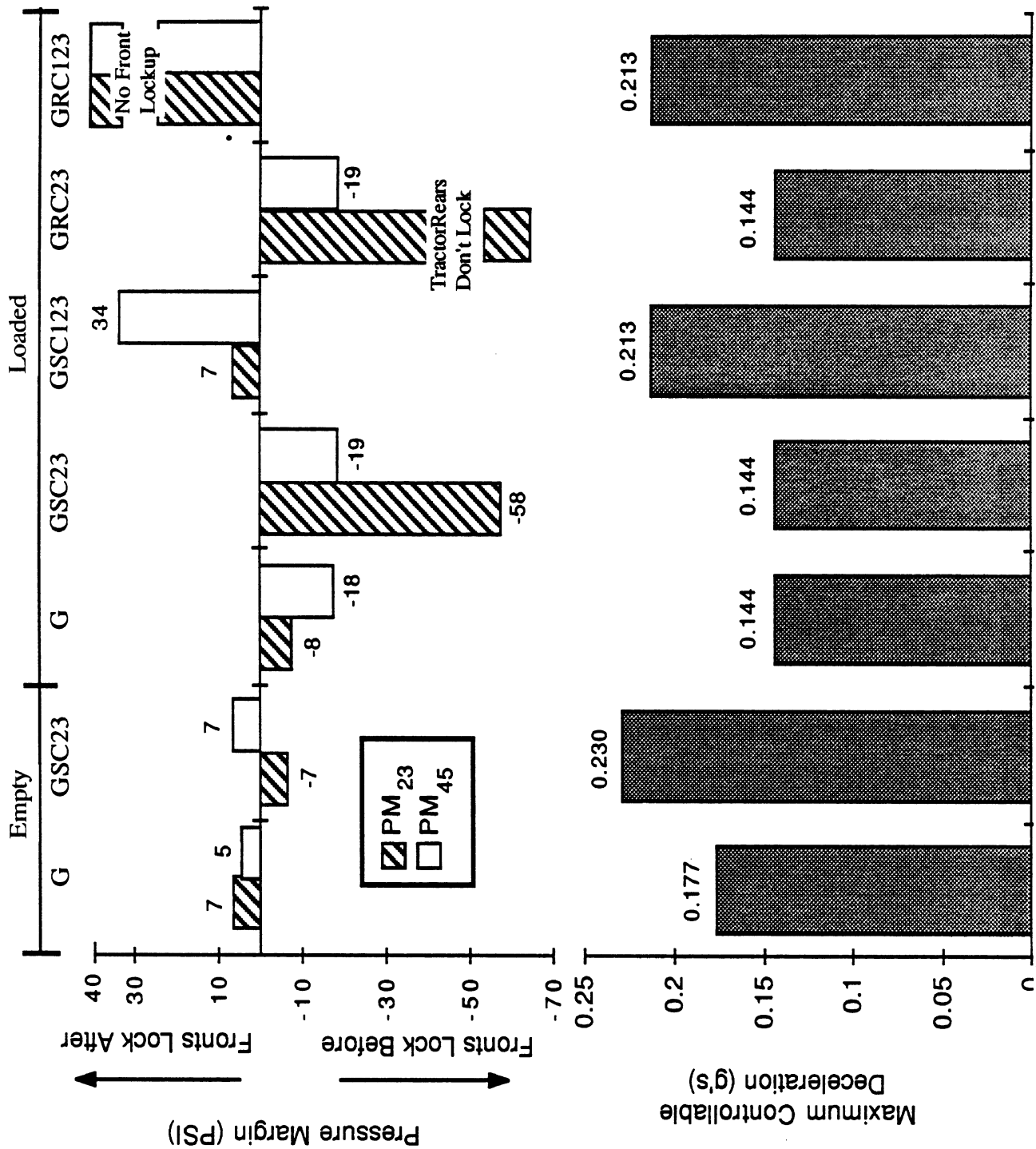

Figure 32 Influence of tire/chain installation for vehicle with forward-biased TG and PP brake properties, case (3)

4) front bias is eliminated by employing chains at all tractor axles.

It is apparent from the deceleration data that the rather good distribution of brake torques on the empty vehicle serve to enable a relatively high level of braking capability. As indicated in the friction utilization plot of Figure 33, the empty vehicle exhibits rather closely-matched utilization curves on all four axles aft of the steering axle. Without chains installed, this vehicle experiences lockup at axles 3 and 5 before reaching the critical lockup of axle 2, at 28 psi (193 kPa). It is interesting to note that since the tires on axles 3 and 5 have dropped to their slide traction values by the time that the critical lockup condition is reached, the deceleration level prevailing at the critical 28 psi (193 kPa) level has dropped to 0.18 g's from the previous peak of 0.22. Accordingly, the maximum value of 0.22 g is reported in the deceleration results.

In the loaded state, the steering axle locks early, thus limiting the deceleration level to a relatively low value—unless chains are installed at all tractor axles, thereby placing the steering axle last in the lockup sequence and causing a major increase in deceleration capability.

### *3.3.6 The Influence of an Automatic Limiting Valve on Performance*

Shown in Figure 34 is a chart illustrating the influence of the automatic limiting valve, ALV, on the pressure margin and deceleration results for the loaded tractor-semitrailer. The chart covers vehicle cases, with and without chains installed, for each of the three nominal arrangements of brake system properties. From left-to-right, the results are arranged according to brake systems (1), (2) and (3) corresponding respectively to brake properties described as baseline, forward-biased torques, and forward-biased torques and pushout pressures. We see the obvious result that the presence of the automatic limiting valve produces positive (+) shifts in the pressure margins in every case but that in which the tractor drive axles fail to reach lockup at all. For the cases shown, the ALV yields a 22 to 27 psi (152 to 186 kPa) increase in the pressure margin results.

By way of example, Figure 35 shows the friction utilization diagrams for the cases of brake system No. 2 (forward-biased torques) and single chains on axles 2 and 3, with and without limiting valve installed. We see without the ALV that the front axle reaches lockup first, at a control line pressure of 43 psi (296 kPa), and a friction level of 0.17. With the ALV installed, the friction utilization curve for the front axle is substantially reduced in slope and reaches its friction limit at a pressure of 66 psi (455 kPa). As a consequence of the higher total brake force development at the critical lockup point, the ALV yields a modest improvement in the deceleration level.

The reader should note, however, that the general use of automatic limiting valves in air-braked trucks in the U.S. typically *reduces* deceleration capability on all pavements



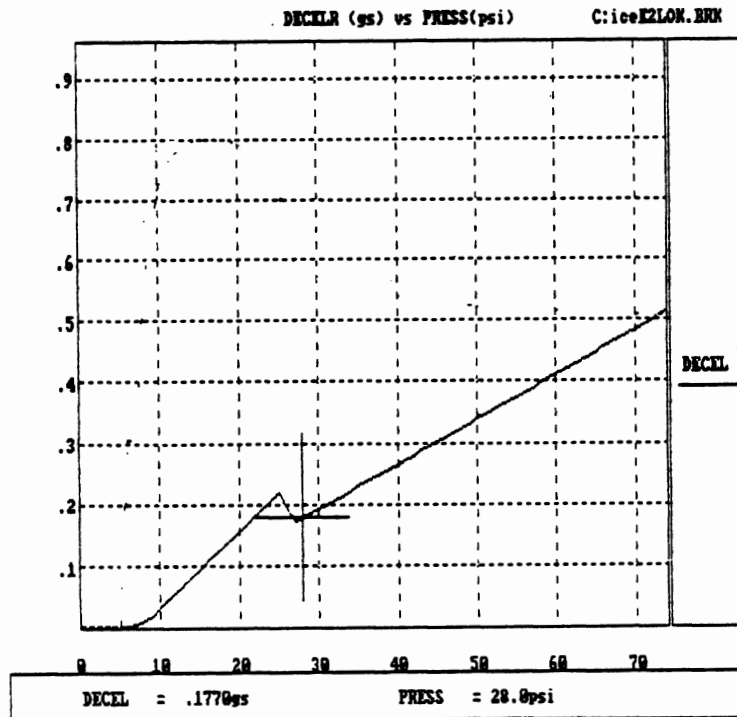
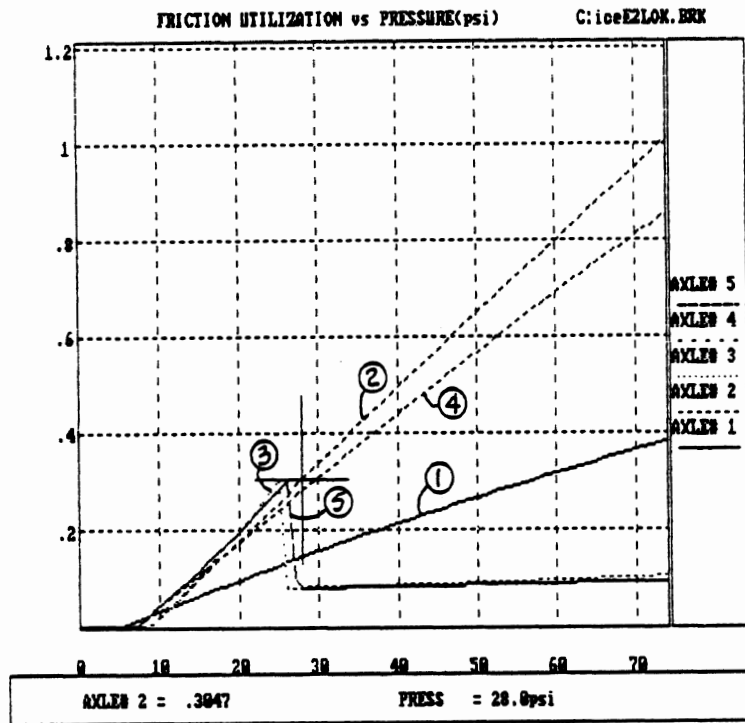

Figure 33 Friction Utilization and Deceleration diagrams for empty vehicle with brake system, case (3)

Influence of Automatic Limiting Valve (ALV) on Front Lockup Pressure Margin for Differing Sets of Brake Properties, for the Loaded Vehicle

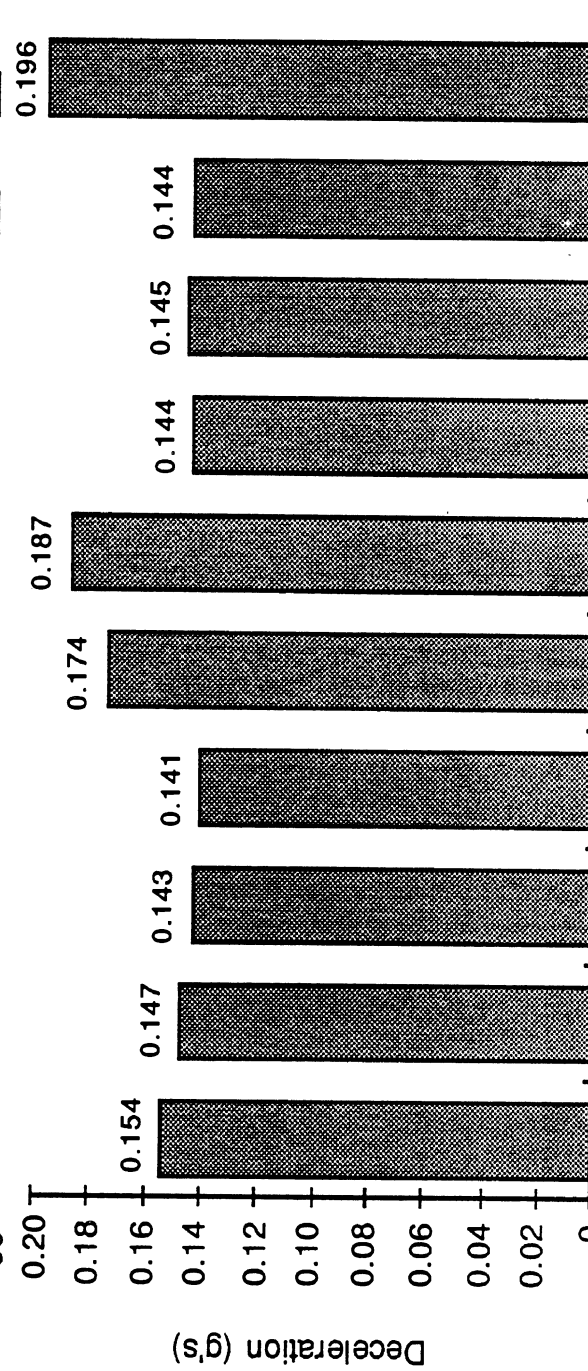
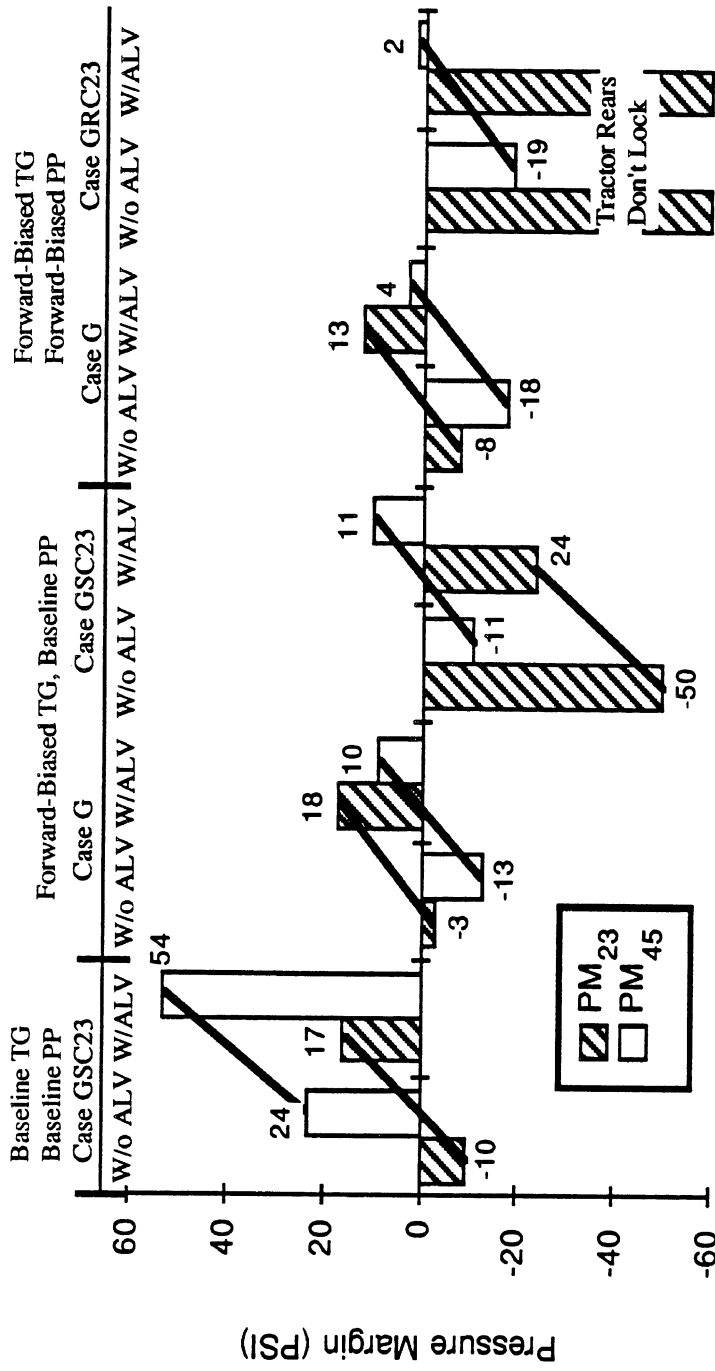
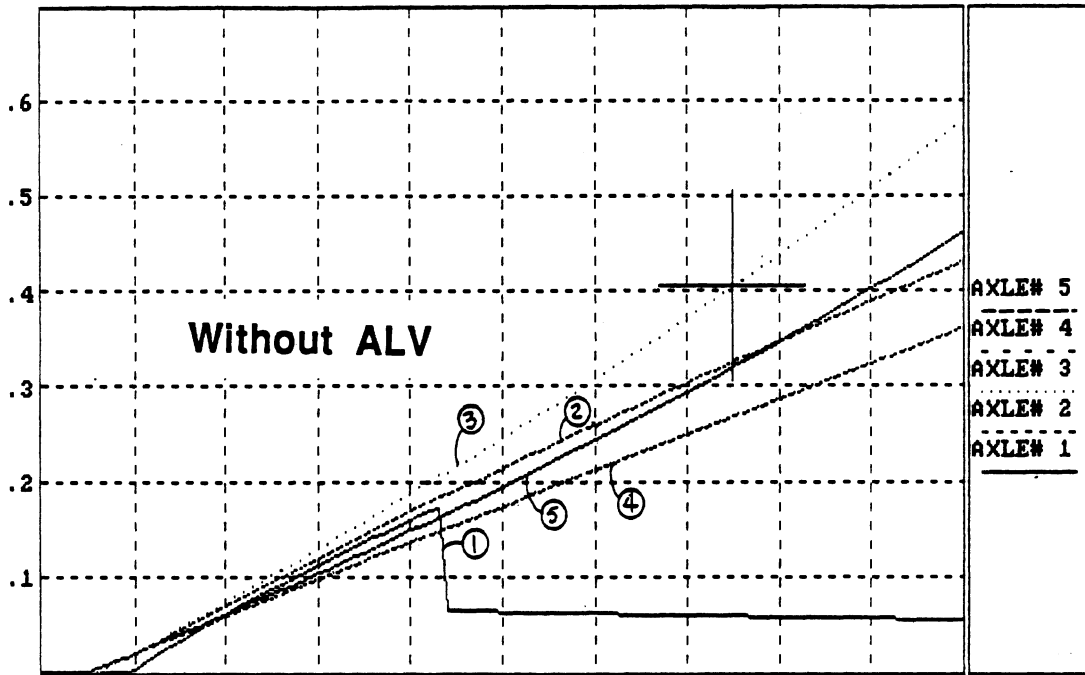

Figure 34 Influence of Automatic Limiting Valve (ALV) for differing sets of brake properties, with the loaded vehicle

FRICION UTILIZATION vs PRESSURE(psi)

C:ICEL2BPP.BRK



FRICION UTILIZATION vs PRESSURE(psi)

C:ICEL4LOK.BRK

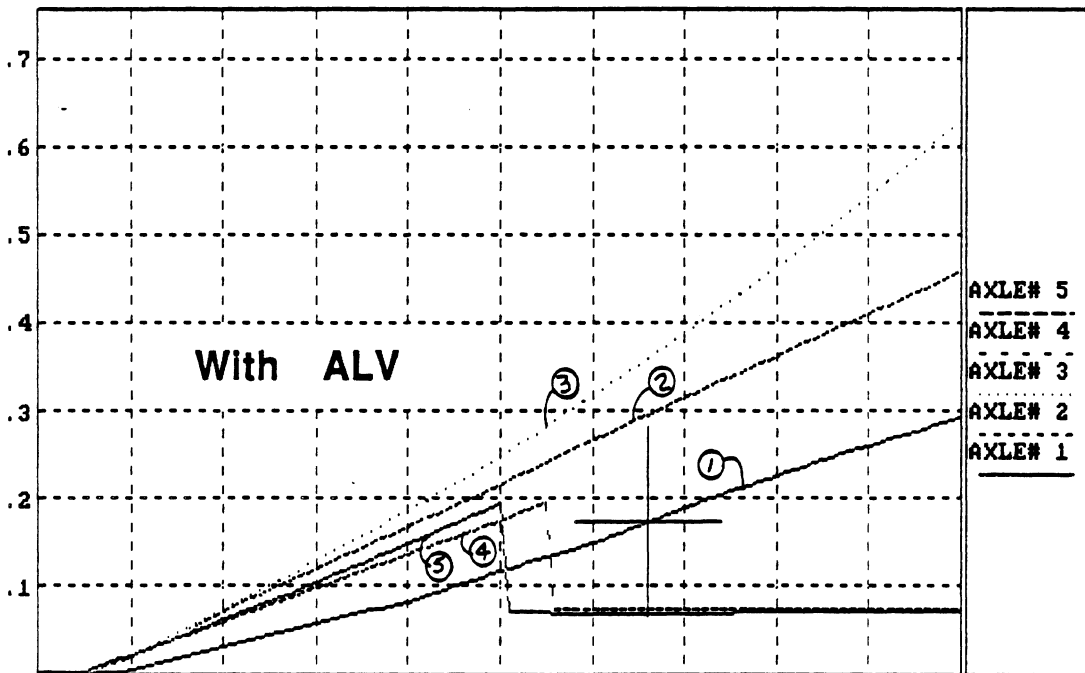

0 10 20 30 40 50 60 70 80 90 100

AXLE# 1 = .1723

PRESS = 66.0psi

Figure 35 Comparison of Friction Utilization Diagrams for brake system case (2), with and without ALV installed

having friction levels above that of ice [e.g.,10]. Thus, the authors caution that one should not assume that ALV's are generally beneficial to the braking performance of trucks, given the current state of practice. As for the case of stopping on ice, the use of the limiting valve can either improve or degrade the maximum deceleration capability depending upon the torque distributions which are assumed to prevail without the valve.

## 4.0 Conclusions and Recommendations

This study has produced experimental data and analytical results which document the conditions which are faced by air-braked, heavy-duty trucks while stopping on ice. While the vehicle test results, traction data, and analytical findings all help to characterize these conditions, the issue that remains for discussion is the "bottom line" question, namely,

**"For cases in which trucks must operate on ice with chains installed on drive axles, what is the extent of the problem posed by the requirement for operational front brakes?"**

The simple answer to the question, and the primary finding of the study is,

**"Very little, since it appears that few vehicles would degrade in performance under these conditions, and most would improve, with the use of front brakes."**

The more substantive answer to this question must consider the distribution of brake system properties across the population and the vehicle loadings that prevail, with a concern for balancing the findings, given the entire spectrum of road surfaces upon which trucks operate from day to day. To address these factors, certain generalized conclusions can be stated in terms of the conditions which cause front wheels to be the first to lock when braking on ice. The "first-to-lock" criterion is pertinent insofar as it identifies the portion of the brake system which is "overbraked" relative to wheel loading, and is thus causing the controllable operating range to be limited. The authors do not, however, consider front-first lockup to constitute a "worst-case" mode of control loss during braking. Rather, front lockup is simply one of the three possible modes that will inevitably limit the control of tractor-semitrailers stopping without antilock systems (the other two modes entailing lockup of either the drive axles or trailer axles).

### 4.1 Conclusions

The following conclusions can be drawn from this study and from the state of knowledge advanced by the Vehicle Research and Test Center of the National Highway Traffic Safety Administration:

- 1) The only sets of brake system properties that result in front wheels locking first on ice are those which yield the most forward-biased distributions of brake force

which are expected to occur. Vehicles exhibiting the extent of front-bias needed to produce this outcome are thought to be possible, but uncommon in the U.S. population.

In addition, front wheels were no longer the first to lock on ice when automatic limiting valves were employed in conjunction with the most front-biased distributions of foundation brakes. Recognizing that the overwhelming majority of heavy vehicles in the U.S. incorporate a limiting valve, this result suggests that the actual prevalence of trucks in the U.S. which are, in fact, able to lock front wheels first on ice is quite low, indeed.

*(Please note, however, that this observation does not amount to an endorsement of limiting valves, per se. The authors note that most air-braked trucks in this country are so under-braked at the front axle that limiting valves are of no value whatsoever, regardless of the surface or loading conditions and, in fact, cause braking performance to be degraded.)*

- 2) In no cases were front wheels seen to lock first on ice when the vehicle was empty. Even with the most front-biased distribution of brake properties, front lockup followed some other critical wheel-lock condition when empty.
- 3) Insofar as this study has focussed on the issue of front lockup on ice, it must be recognized that we have dealt only with a small portion of the total requirements for truck brake performance. More specifically, the study took up a conservative analysis of the front-lockup problem by concentrating on (1) the lowest friction conditions which occur on the roadway, (2) the most-front-biased braking systems for which data are available, (3) the most disadvantageous loading conditions, and (4) the most severe bias in tire traction potential, through placement of chains on drive axles and bare tires on the steering axle.

By way of elaboration on the matter of perspective, for example, Figure 36 shows a conceptualized spectrum of vehicles and roadways as pertains to braking performance. On the vertical axis the surface friction level is plotted, with indication of the nominal ranges typically found under dry, wet, snowy, and icy road conditions. On the horizontal axis, the %-front braking level is represented, ranging from 0% to the maximum value that was represented in this study. At the top of the diagram, the portion of the range that was observed in the test fleet of vehicles reported by Radlinski [7,8] is indicated, with a simple histogram showing the distribution of vehicles in that fleet by %-front braking level. Vehicles landing far to the right of the mean of the VRTC fleet are assumed to be increasingly improbable. The highest level of %-front braking shown on the figure was obtained in this study

only by "mixing and matching" components in order to obtain the greatest degree of forward-bias which is possible using existing data.

The diagram illustrates the portion of this overall road-friction/vehicle space in which front lockup may be problematic. Conversely, front brakes serve to *improve* performance over the larger portion of the chart. The point of the diagram is obviously that the front-lockup issue must be balanced with the recognition that (a) icy roadways represent only one small, and statistically infrequent, portion of the road conditions that must be dealt with, (b) there is good reason to believe that there are rather few trucks having brake systems which are biased sufficiently forward to experience front-first lockup on ice and, (c) the figure is for the worst (fully loaded) case although front brakes improve performance even further under all lighter loading conditions. Such perspective is especially important in formulating policy on truck braking performance because it is so well established [7,8,9,10] that the general problem is one of *deficient* front braking levels, rather than excessive front braking.

- 4) The study also showed, however, that the use of chains on all tractor axles provides for high braking levels in those front-biased cases that might otherwise be of concern. At the same time, for more typical brake systems, the trailer is sufficiently overbraked that no arrangement of chain installations at the tractor will help to alter the tendency for trailer wheel lockup, with its threat of a trailer swing instability.

Thinking beyond the braking context, chains at all tractor axle positions would undoubtedly yield big improvements in directional control on ice in response to steering, alone. Informal communications with truckers in western Canada indicate that such practices are common for truck operations on mountain routes which are snow-laden.

Also, the practice of employing chains at least on one dual-wheel set on a semitrailer offers promise as a means of resisting trailer instability when braking on ice. Some confirmation of this observation is warranted, however, before it might be recommended as a trucking practice.

As a final concluding item, data collected in this study indicate that the locked-wheel traction performance achieved in the light-load condition with chains on ice would be improved if the circumferential spacing between chain strands was reduced. (The authors estimate that a spacing of 4 - 5 inches (10-13 cm) would substantially improve performance under these conditions.)

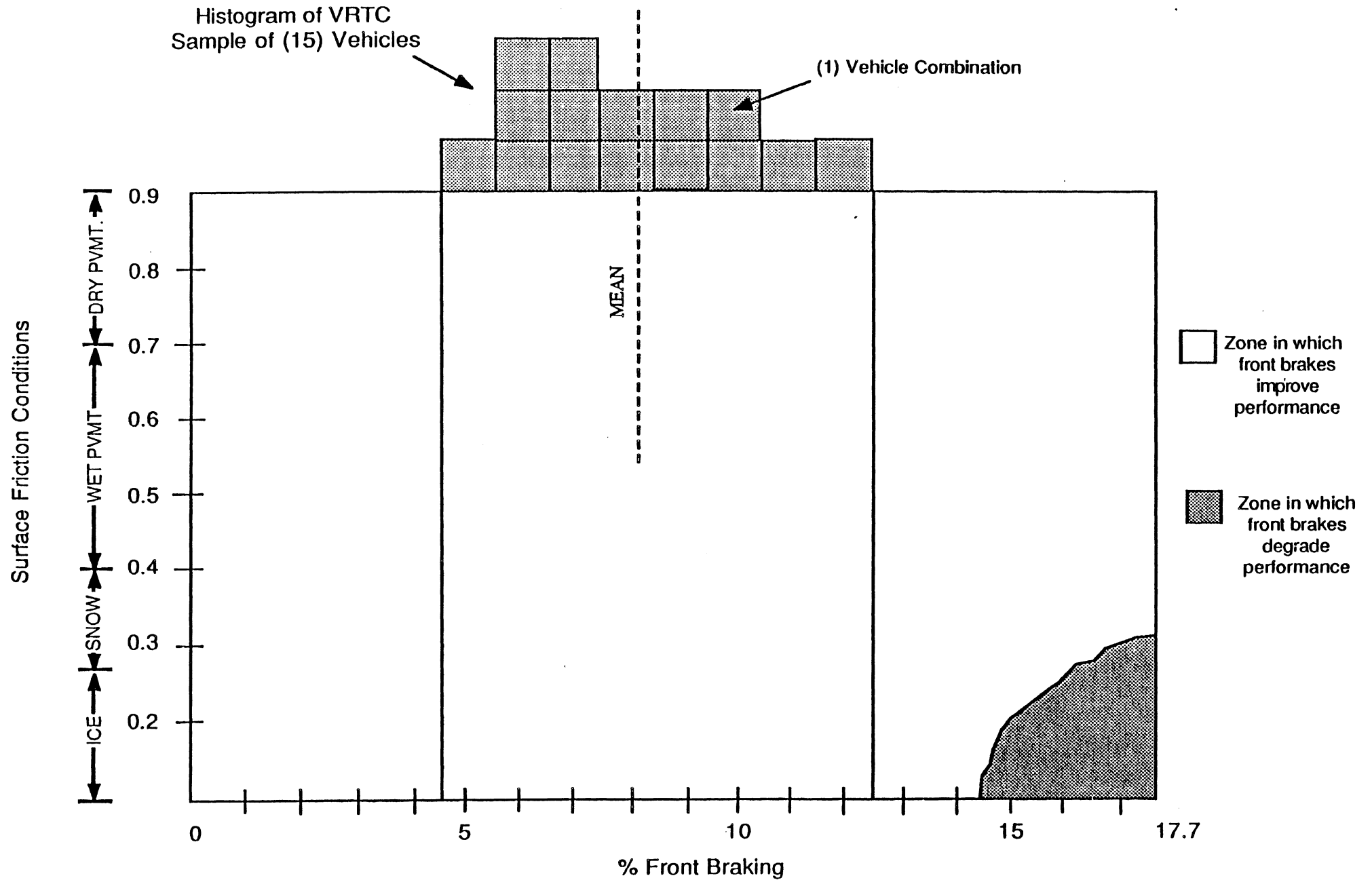

Figure 36 Illustration of the conceptualized spectrum of brake system  
 performance levels and road friction conditions



## 4.2 Recommendations

The research findings clearly indicate, within the constraints of existing data, that front-first lockup on ice is not a risk factor for the typical heavy-duty vehicle in this country. In the light of this finding, it is suggested that the policy of requiring front brakes to be operative will render improvements in braking performance over virtually the whole spectrum of road conditions, generally including ice, as well.

For vehicles that must travel extended distances on ice-covered roadways, it is recommended that the installation of chains at all wheel positions be considered—including trailer positions. Especially when dense traffic places heavy vehicles in the proximity of passenger cars while operating on ice, the argument for dramatically improving controllability in behalf of the safety of other motorists, given the high aggressivity of trucks, is compelling. If such practices are to be commercially practicable, however, we should encourage innovation in the development of traction aids that are easier to apply than conventional tire chains.

In order to attain more consistently-improved performance with truck braking systems, it is recommended that variances in brake torque gains and pushout pressure characteristics be dramatically reduced, perhaps through regulation of both new equipment and aftermarket components. The major observation that can be made by anyone studying the distribution of braking on combination vehicles is that the range of possible properties is truly remarkable! From the viewpoint of an engineering system, the performance of truck and trailer braking hardware is more random than deterministic. Thus, we find that the statistical aspects of the problem are equally as tough and as important, in the present state of practice, as the issues of mechanics.

When the properties of truck brake systems do become more regularized and more uniform, it is clear that rather high levels of front-brake force will be broadly beneficial. When relatively high front braking is achieved, the avoidance of premature lockup on icy roadways can definitely benefit from local shaping of the friction utilization function, such as through front-limiting valves. Thus, when front braking level is high, the limiting valve concept contributes to improved performance, although it is recognized that their popular use in U.S. trucks at present is largely unwarranted and simply serves to degrade braking capability on all surfaces.

Finally, the authors recognize that the ultimate means of assuring a high level of braking efficiency under all loading and roadway conditions is by means of effective antilock control systems. The development and implementation of such hardware in heavy vehicles in this country should be encouraged by all parties concerned with truck safety.

## REFERENCES

1. Hales, F.D. "Lateral Stability Problems of Simply Articulated Vehicles." Intern. Union of Theoretical Mech. Symposium, 1965, pp. 17-34.
2. Mikulcik, E.C. "The Dynamics of Tractor-Semitrailer Vehicles: The Jackknifing Problem." Ph.D. Thesis, Cornell University, June 1968.
3. Leucht, P.M. "The Directional Dynamics of the Commercial Tractor-Semitrailer Vehicle During Braking." 1970 Intern. Auto. Safety Conf. Compendium, SAE Paper No. 700371, May 1970.
4. Ervin, R.D. and Segel, L. "Contrasts in the Dynamic Properties Influencing the Pre-Crash Safety of Cars and Heavy Trucks." Proceedings of 24th Conf. of Amer. Assoc. for Auto. Med., Morton Grove, Ill., 1980, pp. 273-286.
5. Fancher, P.S. and Mathew, A. "A Vehicle Dynamics Handbook for Single-Unit and Articulated Heavy Trucks." Final Rept., Contract No. DTNH22-83-C-07187, Transp. Res. Inst., Univ. of Mich., Rept. No. UMTRI-86-37, May 1987.
6. Fancher, P.S., et al. "A Factbook of the Mechanical Properties of the Components for Single-Unit and Articulated Heavy Trucks." Final Rept. Phase I, Contract No. DTNH22-83-C-07187, Transp. Res. Inst., Univ. of Mich., Rept. No. UMTRI-86-12, December 1986.
7. Detailed data on braking force vs. line pressure delivered to the Truck Trailer Brake Research Group (TTBRG) following tests on 15 vehicles by the Vehicle Research and Test Center of the National Highway Traffic Safety Administration, 1986.
8. Radlinski, R.W. and Flick, M.A. "Tractor and Trailer Brake System Compatibility." SAE Paper No. 861942, November 1986.
9. Radlinski, R.W. and Flick, M.A. "A Demonstration of the Safety Benefits of Front Brakes on Heavy Trucks." Final Rept., National Highway Traffic Safety Admin., Rept. No. DOT HS 807 061, December 1986.
10. Radlinski, R.W. and Williams, S.F. "NHTSA Heavy Duty Vehicle Brake Research Program Report No. 1 -- Stopping Capability of Air Braked Vehicles Volume 1 -- Technical Report." National Highway Traffic Safety Admin., Rept. No. DOT HS 806 738, April 1985.
11. Harned, J.L., Johnston, L.E., and Scharpf, G. "Measurement of Tire Brake Force Characteristics as Related to Wheel Slip (Antilock) Control System Design." SAE Paper No. 690214, January 1969.
12. Hobbs, P.V. *Ice Physics*. Clarendon Press, Oxford, 1974.
13. *Physics of Ice*. R. Nikolaus, B. Bullemer, H. Engelhardt, Eds. Proceedings of the Intern. Symp. on Physics of Ice, Munich Germany, September 1968.

## Appendix A

### Traction Data from Repeated Slip Cycles

This appendix contains plots of the wheel spin and longitudinal force variables measured during repeated slip cycles with the mobile dynamometer. The sheets indicate the tire, chain installation, vertical load (in lbs) and the test speed (in mph). The following table serves as an index to the test runs which address the indicated conditions of the ice surface, and the tire/chain installation.

<u>Run No's</u>	<u>Conditions</u>
2,3,4,7,8,9	Crusted ice, Goodyear, No Ch., 18 deg F
25-28, 31-33	Crusted ice, Goodyear, Single Ch., 18 deg F
38-40, 43-46	Bare ice, Goodyear, No Ch., 12 deg F
49-51, 54-56	Bare ice, Michelin, No Ch., 14 deg F
59-61, 64-66	Bare ice, Michelin, Single Ch., 14 deg F
69-71, 74-76	Bare ice, Michelin, Reinforced Ch., 28 deg F
79, 80, 81	Wet ice, Michelin, No Ch., 32 deg F
84, 85, 86	Wet ice, Goodyear, No Ch., 32 deg F
89-91, 93-95	Wet/Dry ice, Goodyear, Single Ch., 32 deg F
98-100, 103-105	Wet/Dry ice, Goodyear, Reinf. Ch., 32 deg F

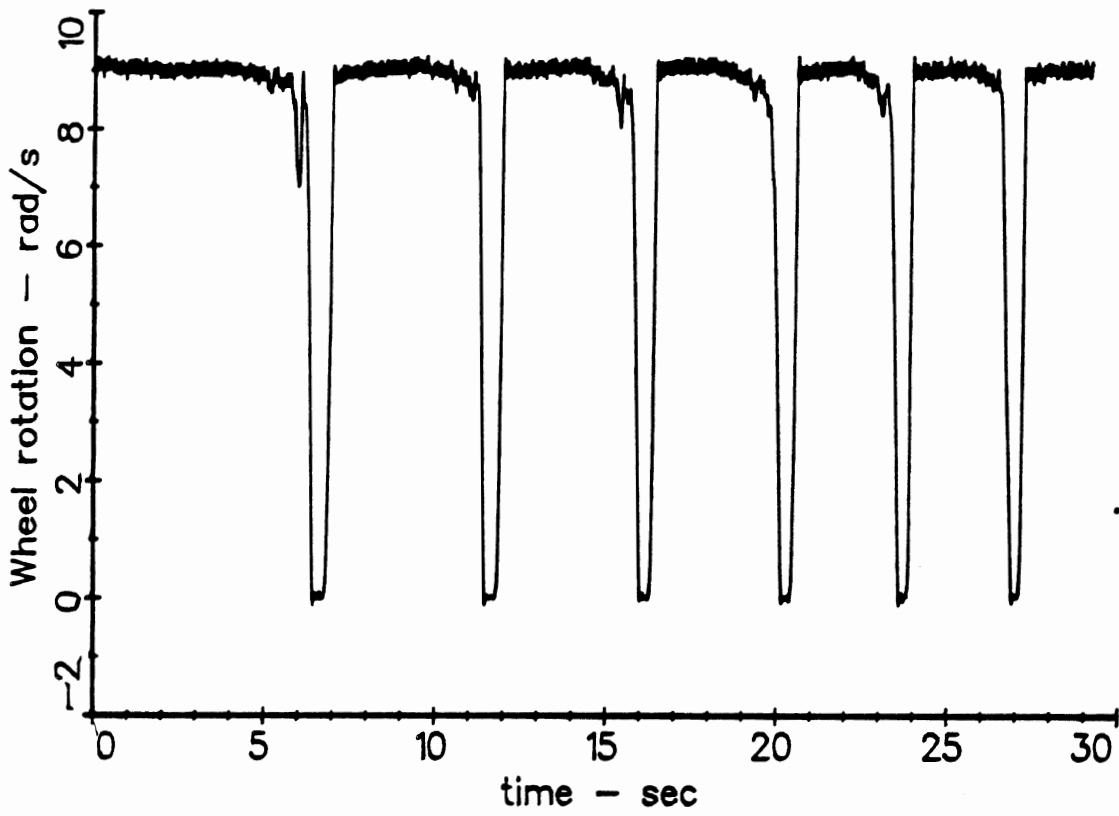

04/01/87 12:46:17 GD YR 295/75R22.5 NO CHA 2000 AT  
10MPH

2

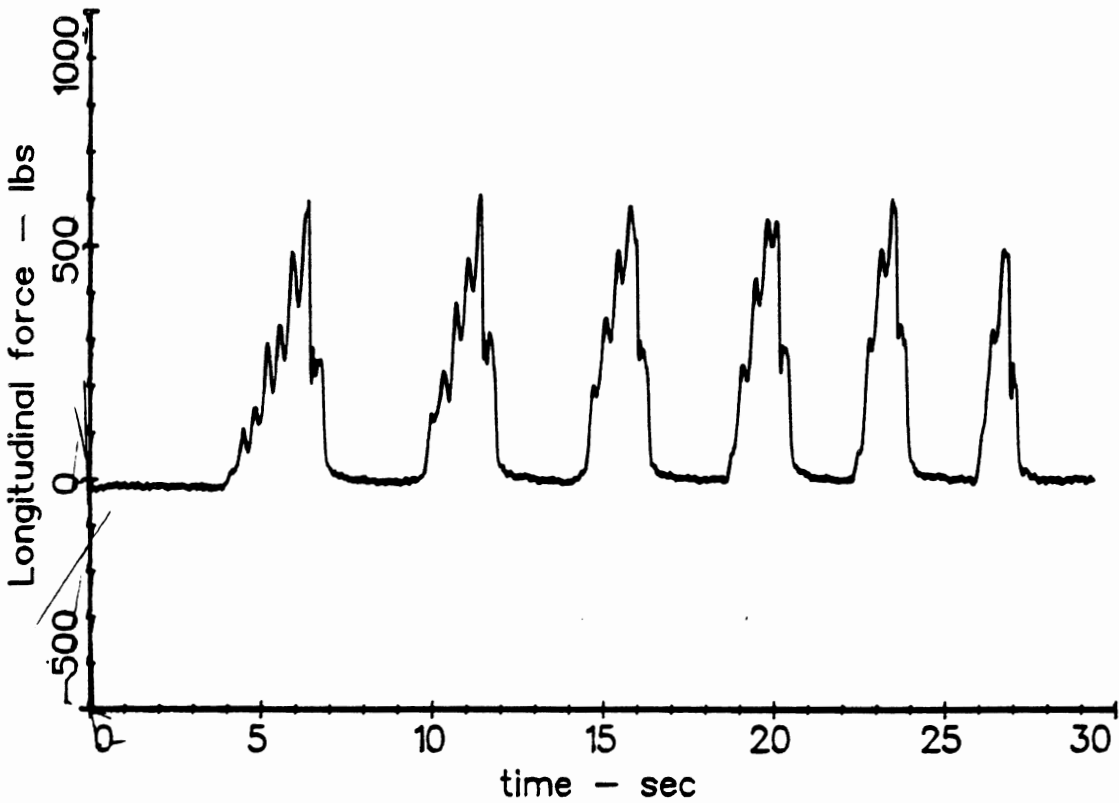

04/01/87 12:46:17 GD YR 295/75R22.5 NO-CHA-2000 AT  
10MPH<sub>74</sub>

Run2

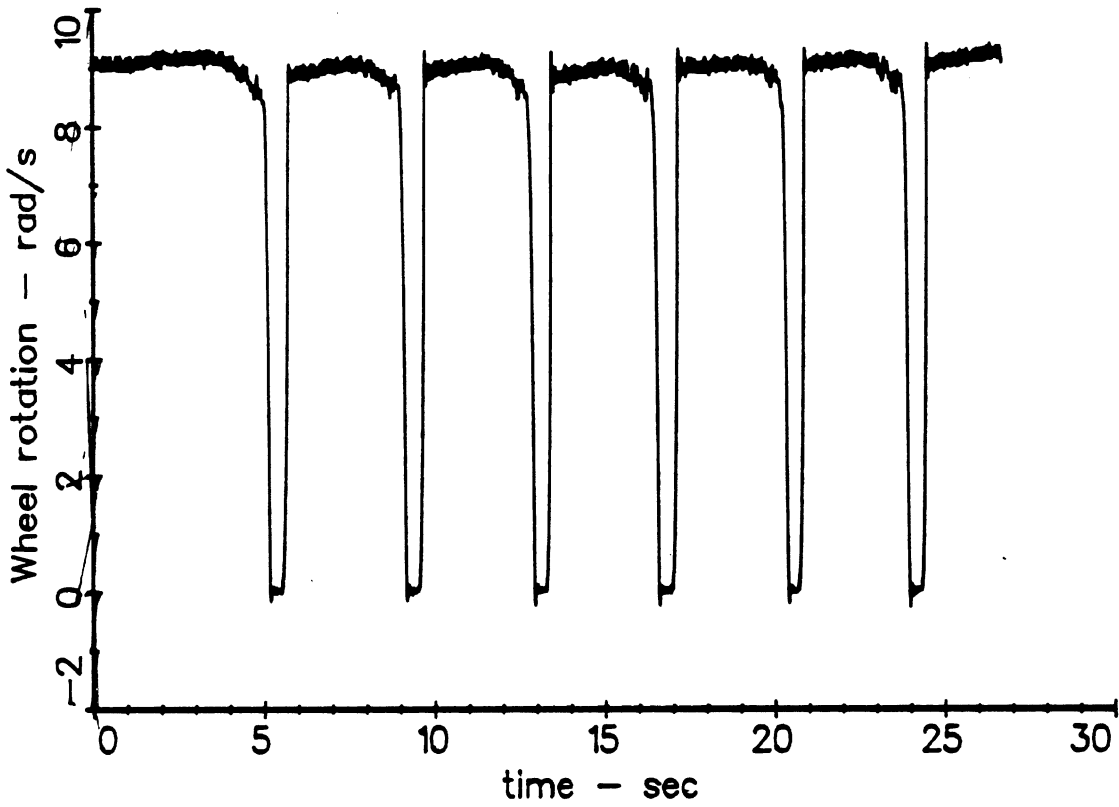

04/01/87 12:48:19 GD\_YR 295/75R22.5 NO CHA 4000 AT  
10MPH

3

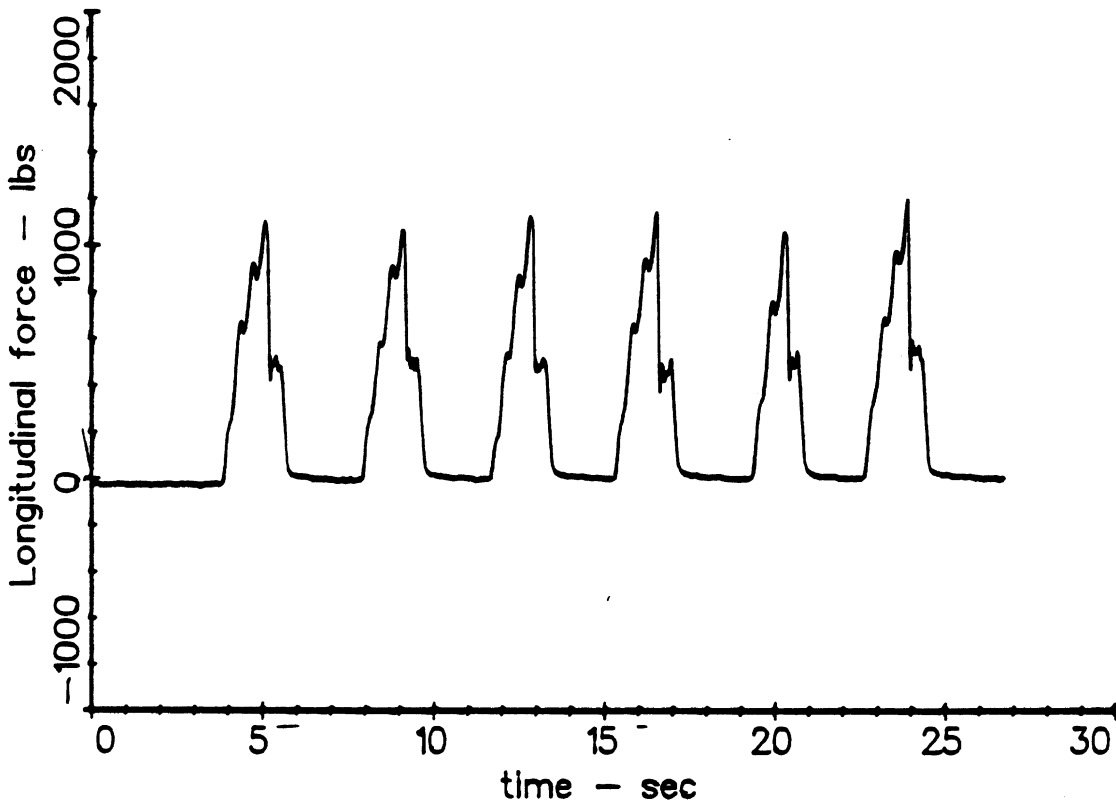

04/01/87 12:48:19 GD YR 295/75R22.5 NO CHA-4000 AT  
10MPH<sub>75</sub>

RUN3

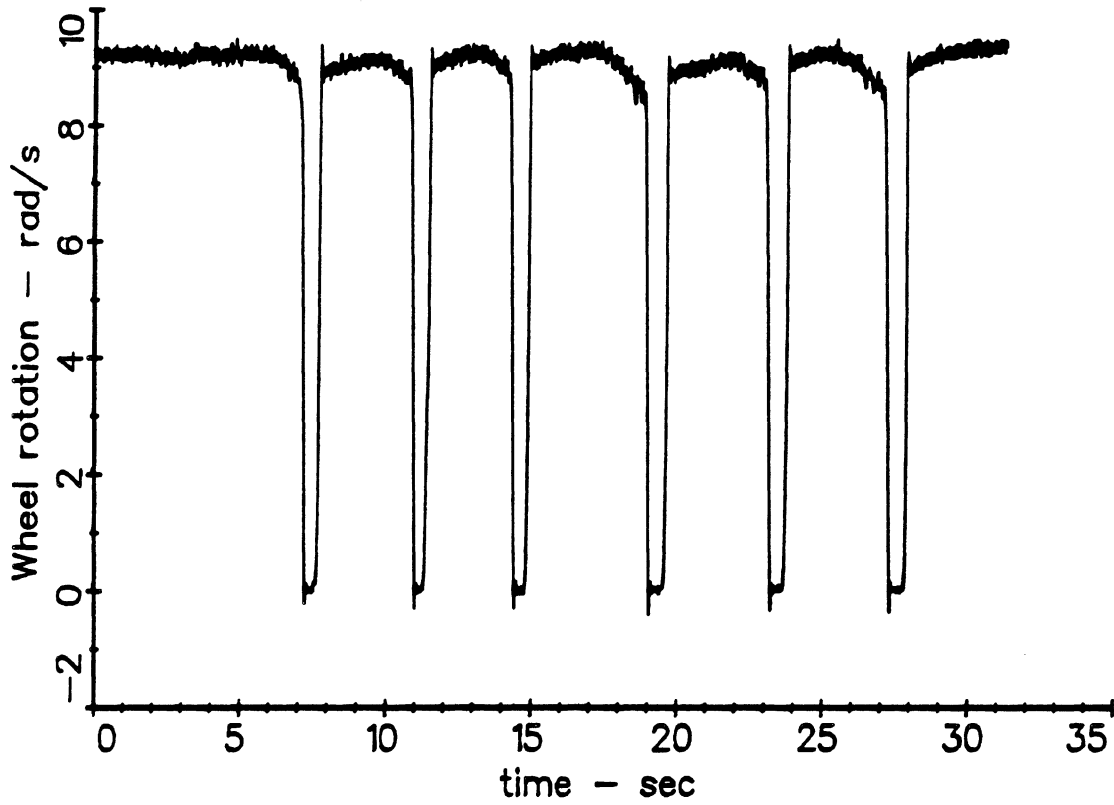

04/01/87 12:55:51 GD YR 295/75R22.5 NO CHA 6000 AT  
10MPH

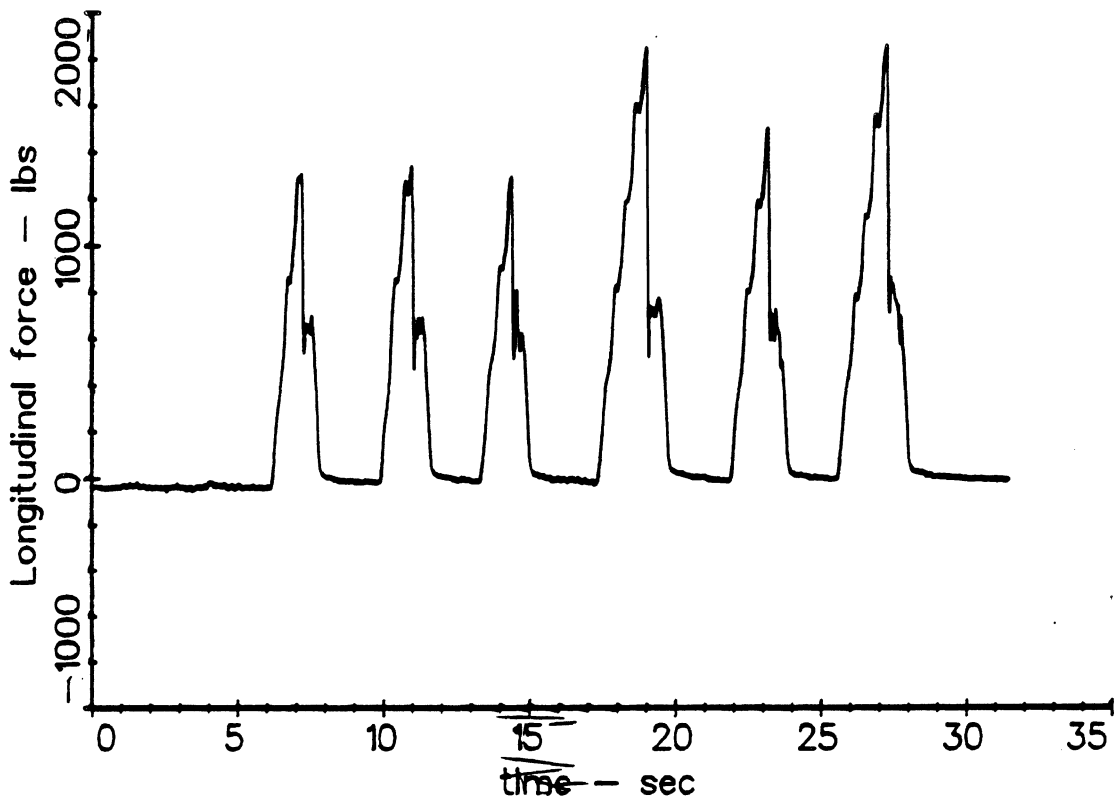

4

04/01/87 12:55:51 GD YR 295/75R22.5 NO CHA 6000 AT  
10MPH

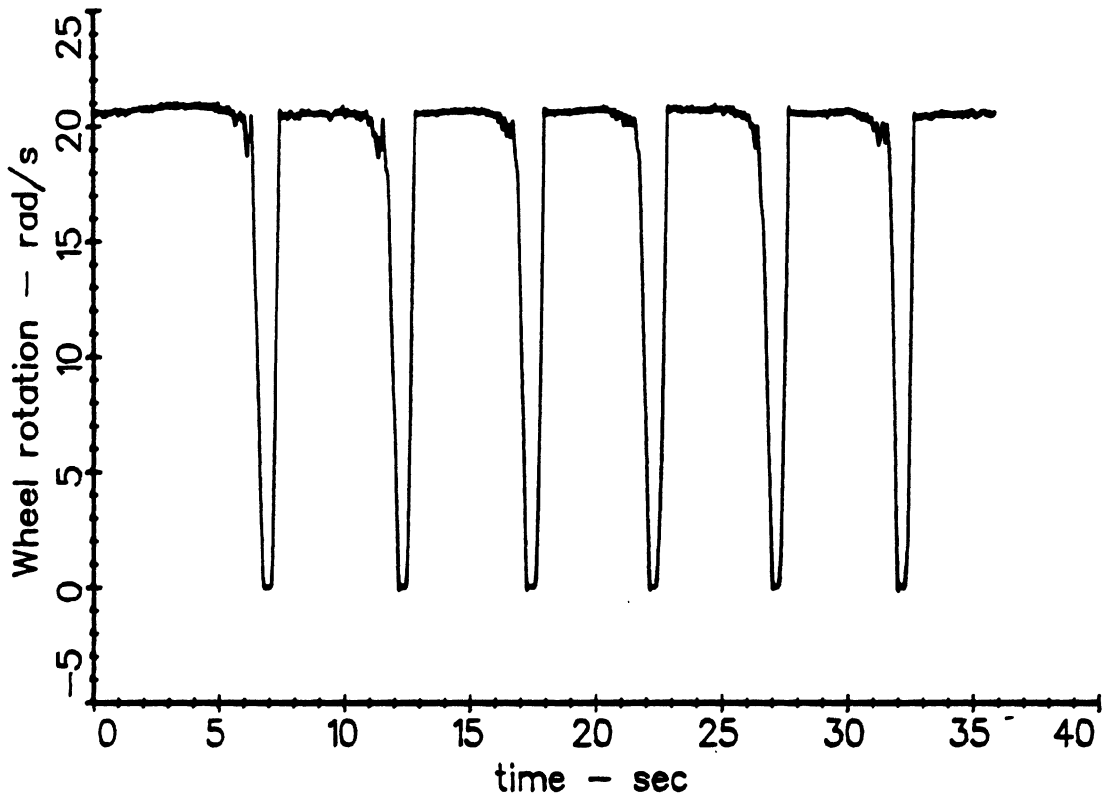

04/01/87 13:02:03 GD YR 295/75R22.5 NO CHA 2000 AT  
25MPH

7

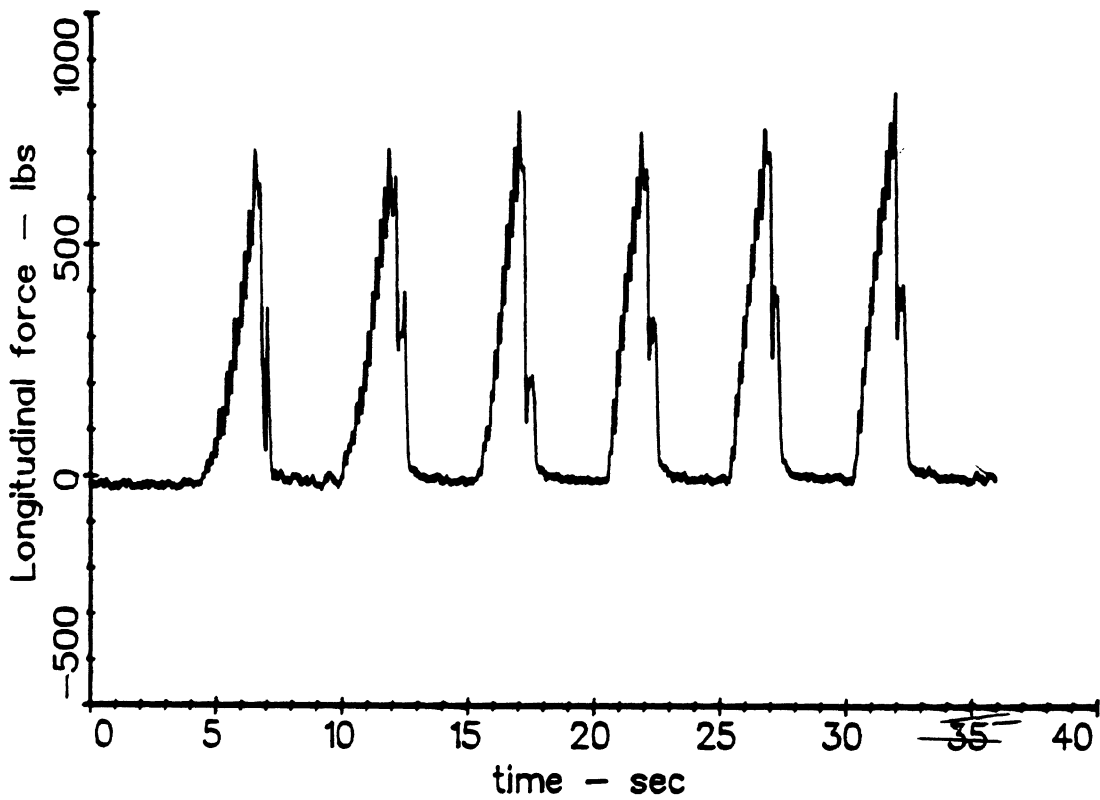

04/01/87 13:02:03 GD\_YR 295/75R22.5 NO CHA ~~2000 AT~~  
25MPH

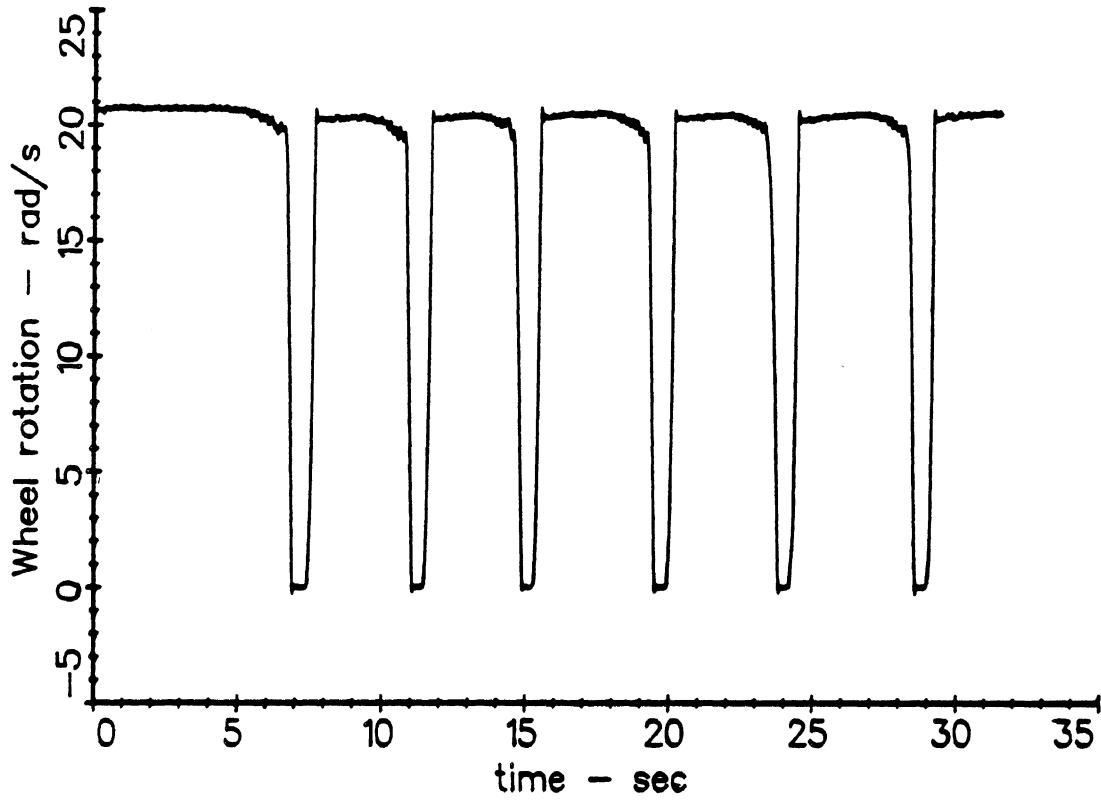

04/01/87 13:03:50 GD YR 295/75R22.5 NO CHA 4000-AT  
25MPH

8

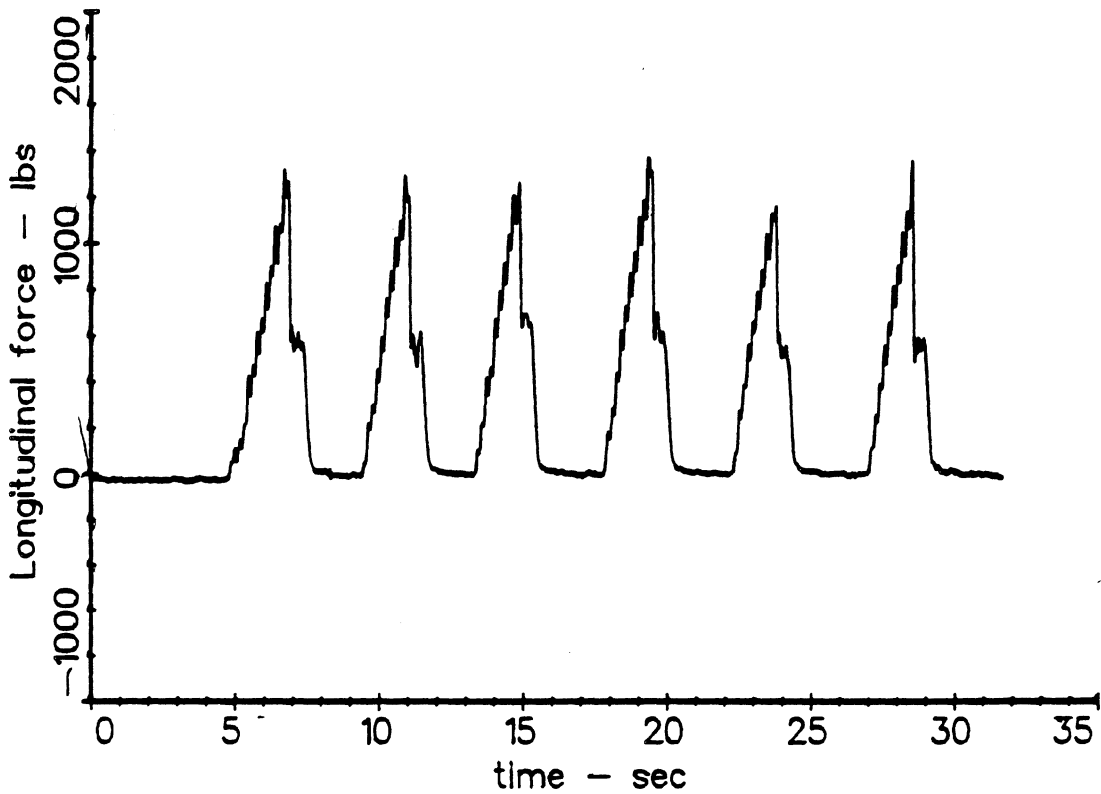

04/01/87 13:03:50 GD YR 295/75R22.5 NO CHA 4000-AT  
25MPH



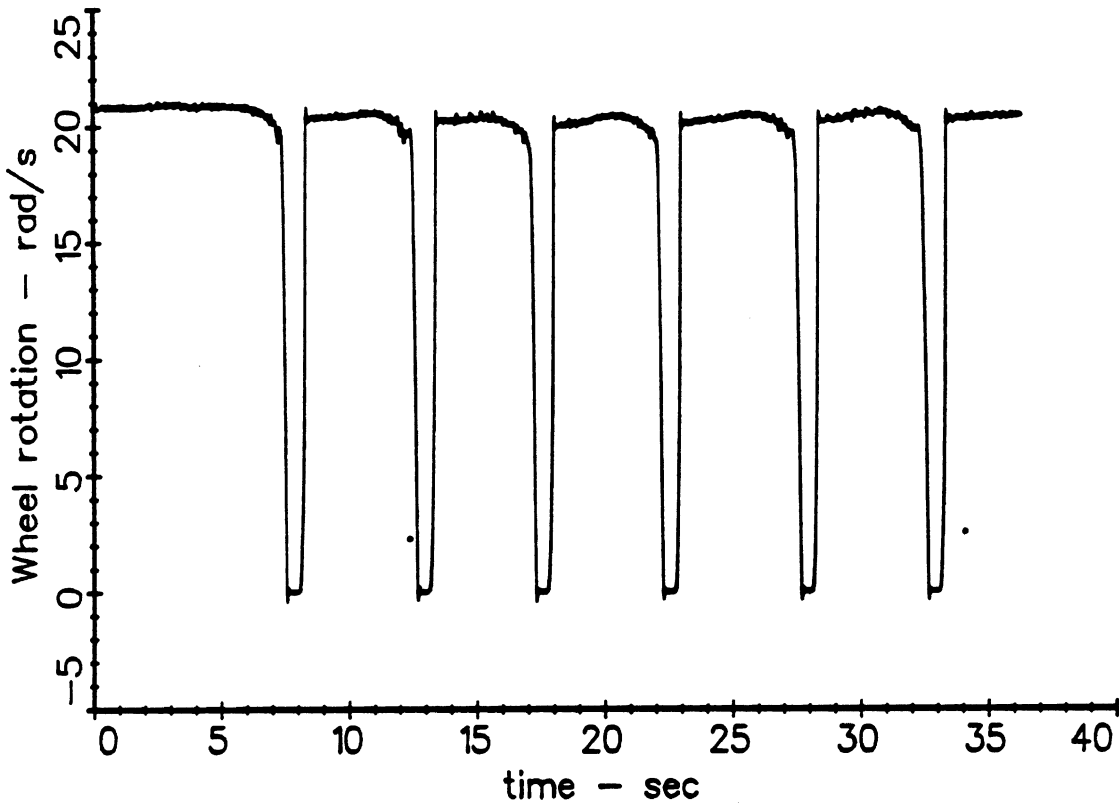

04/01/87 13:06:18 GD YR 295/75R22.5 NO CHA 6000 AT  
25MPH

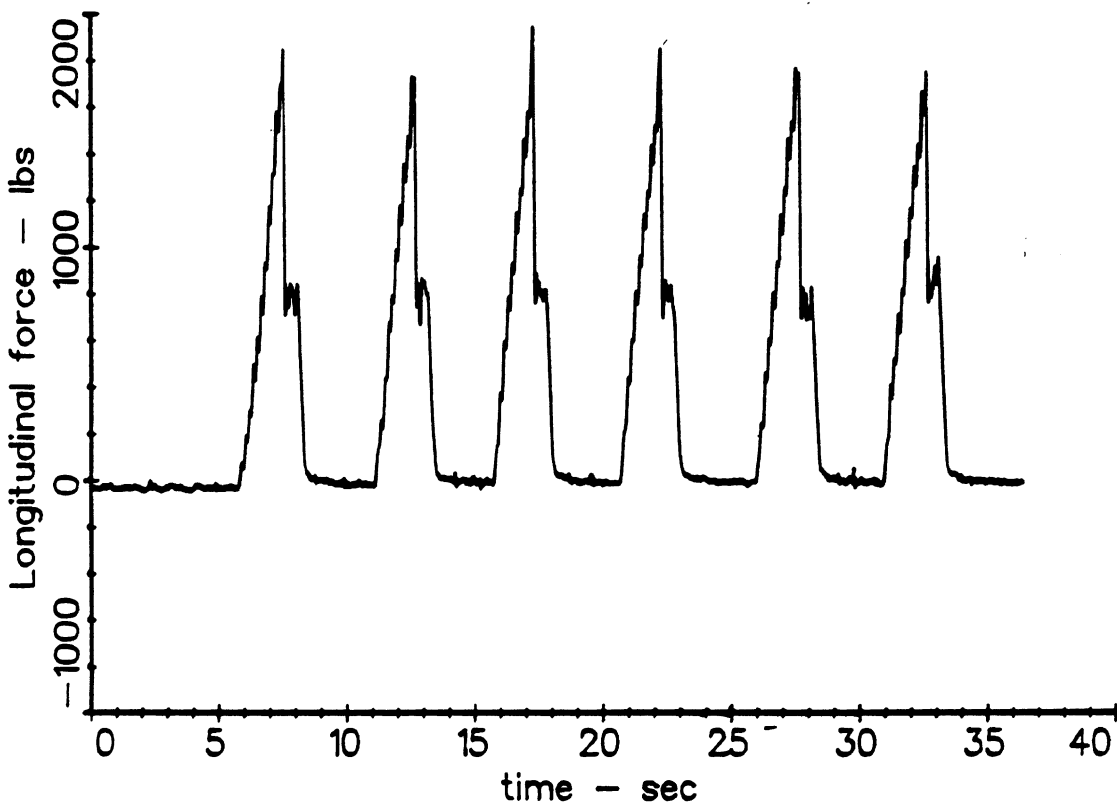

(9)

04/01/87 13:06:18 GD\_YR 295/75R22.5 NO-CHA 6000 AT  
25MPH

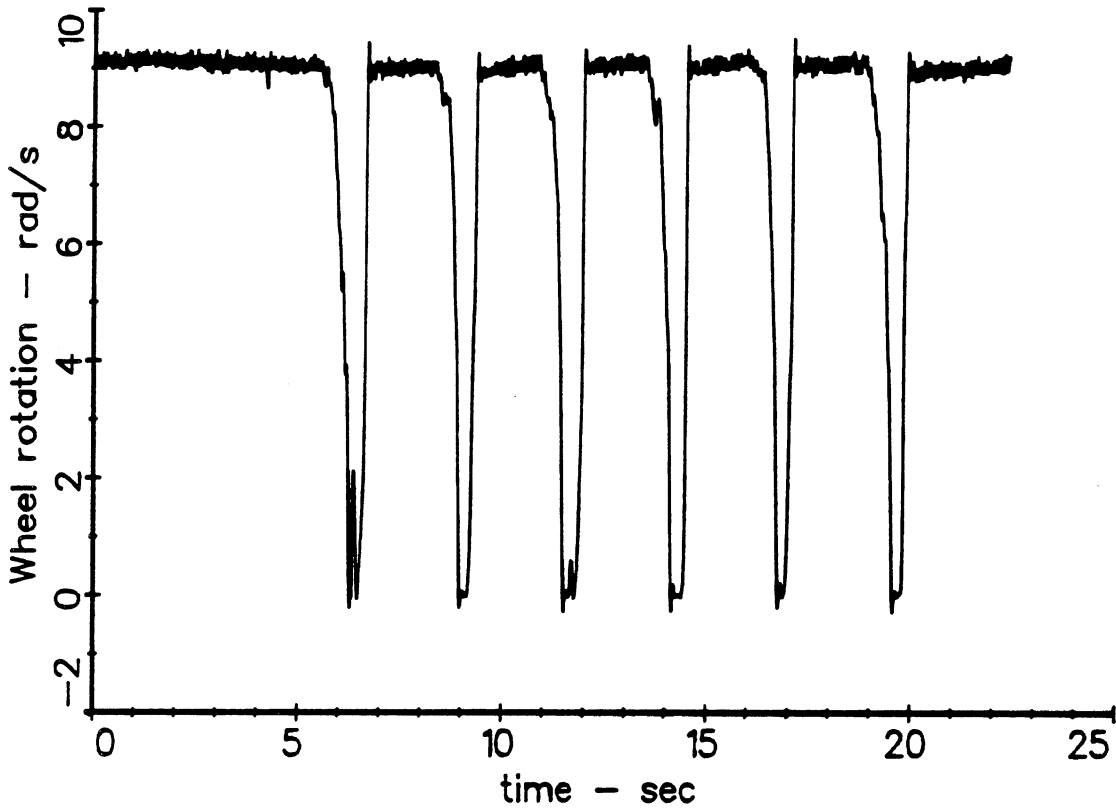

04/01/87 14:27:43 GD YR 295/75R22.5 SINGLE 2000 AT 10

25

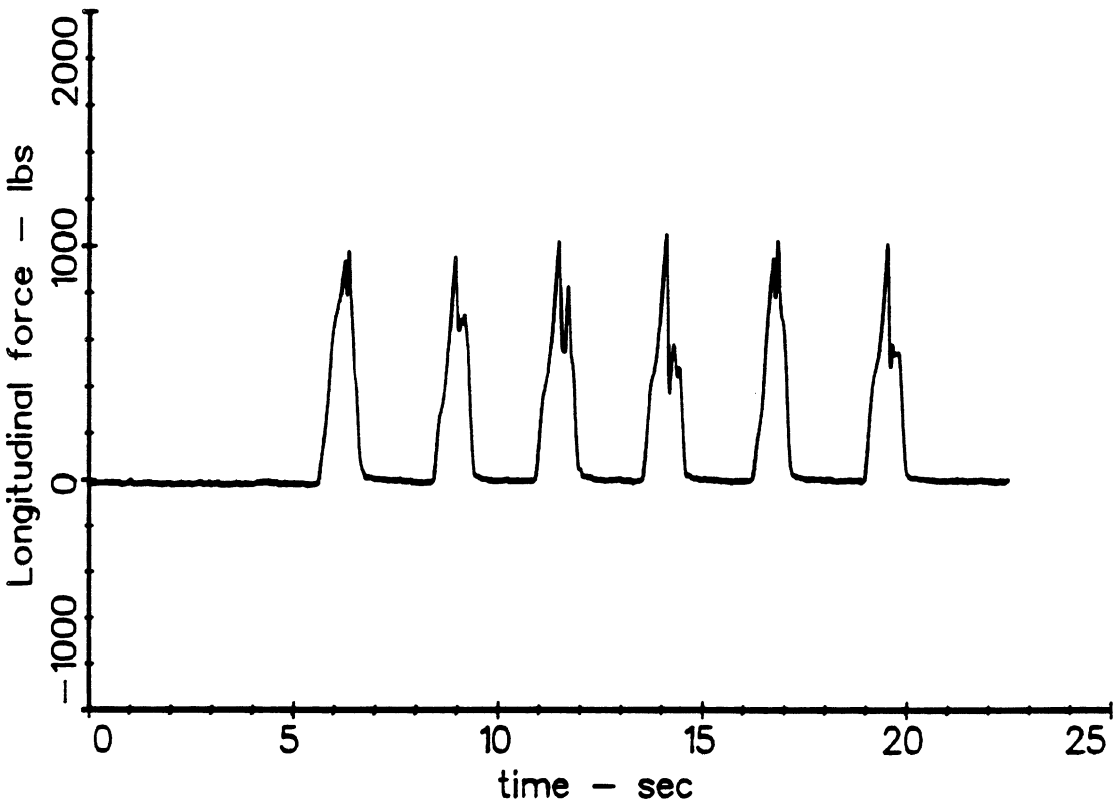

04/01/87 14:27:43 GD YR 295/75R22.5 SINGLE 2000 AT 10

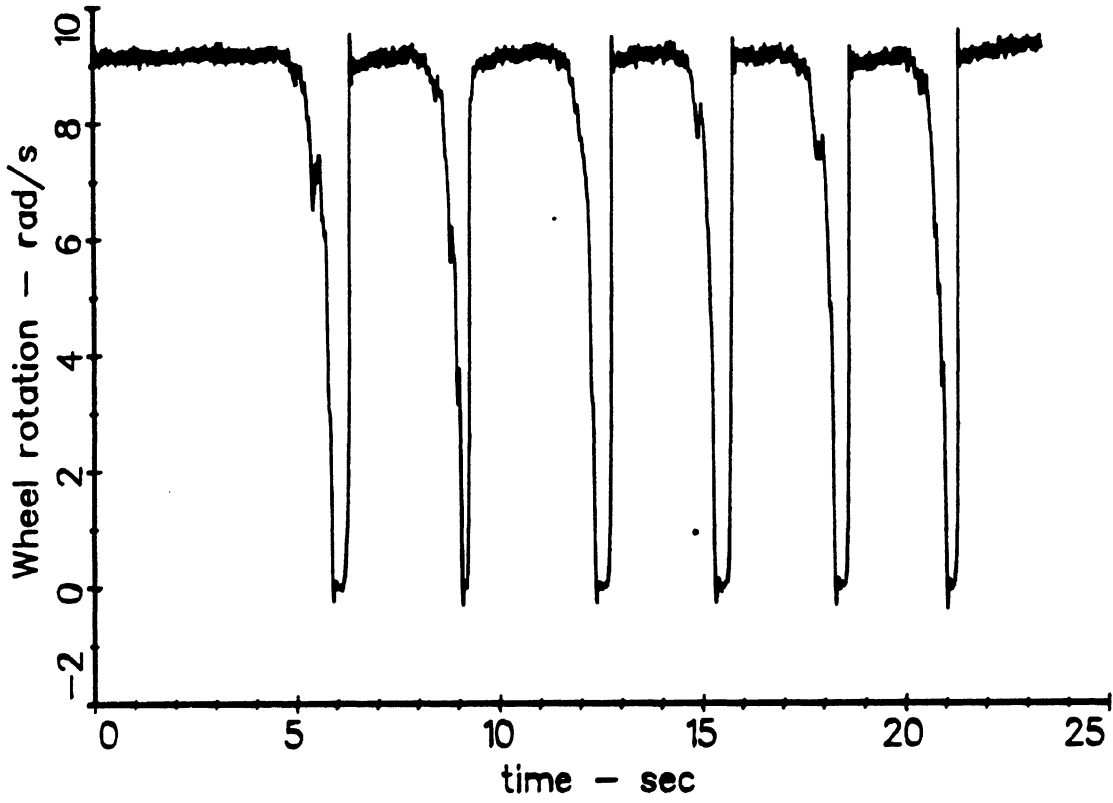

04/01/87 14:29:38 GD YR 295/75R22.5 SINGLE 4000 AT 10 MPH

26

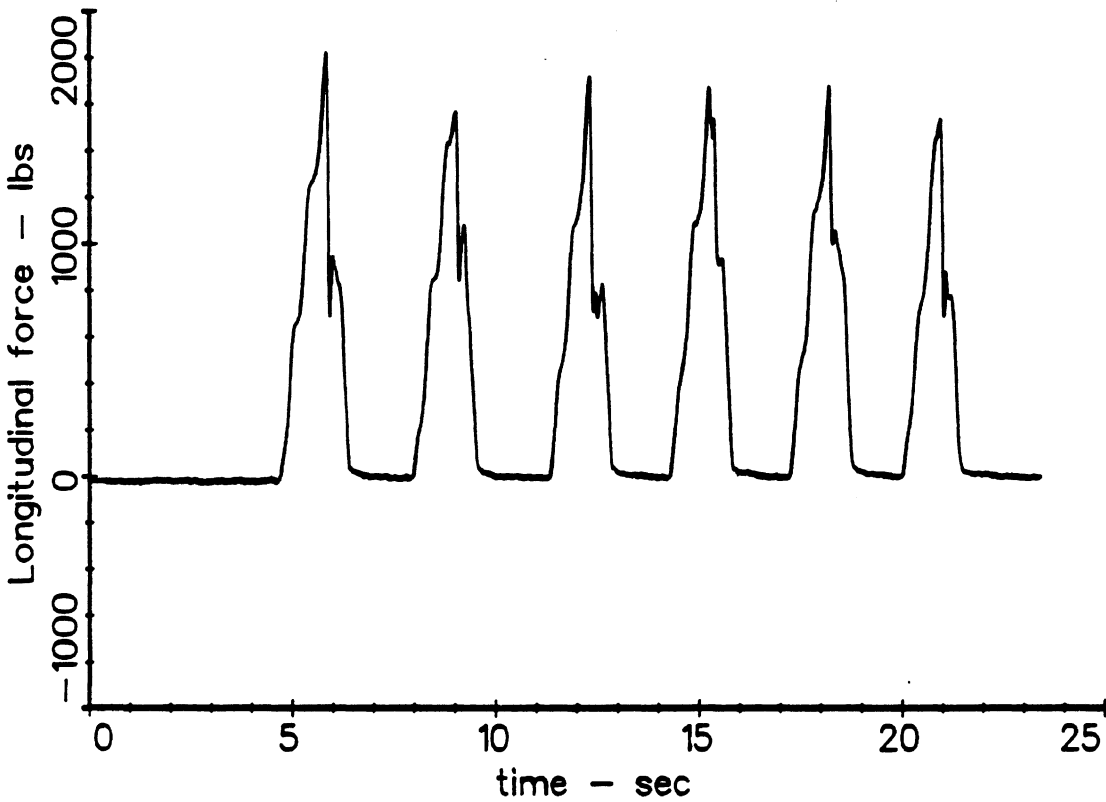

04/01/87 14:29:38 GD YR 295/75R22.5 SINGLE 4000 AT 10 MPH

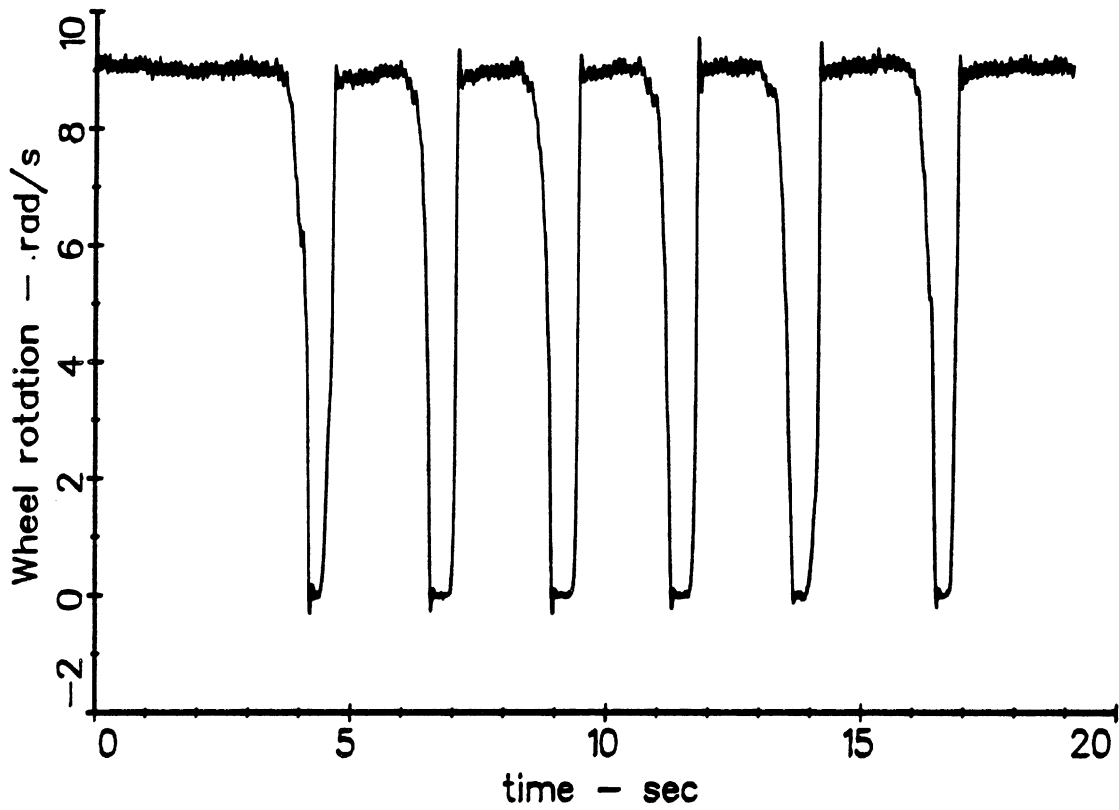

04/01/87 14:31:03 GD YR 295/75R22.5 SINGLE 4000 AT  
10MPH

27

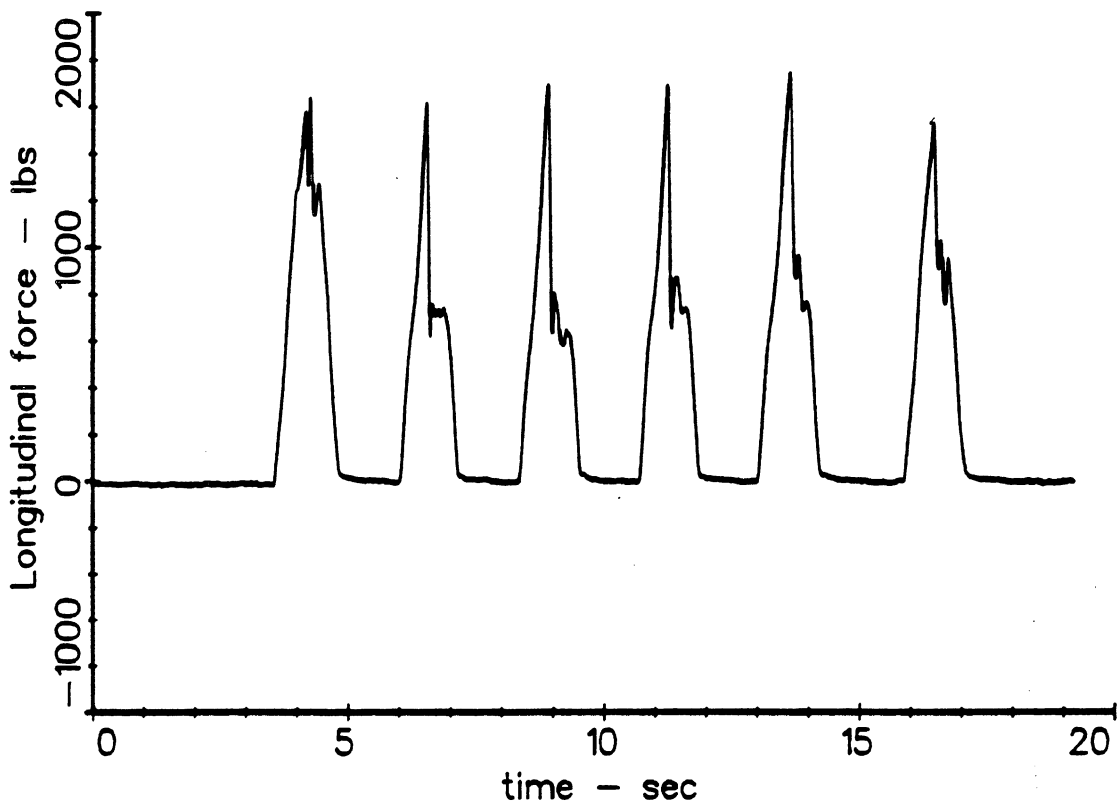

04/01/87 14:31:03 GD YR 295/75R22.5 SINGLE 4000 AT  
10MPH

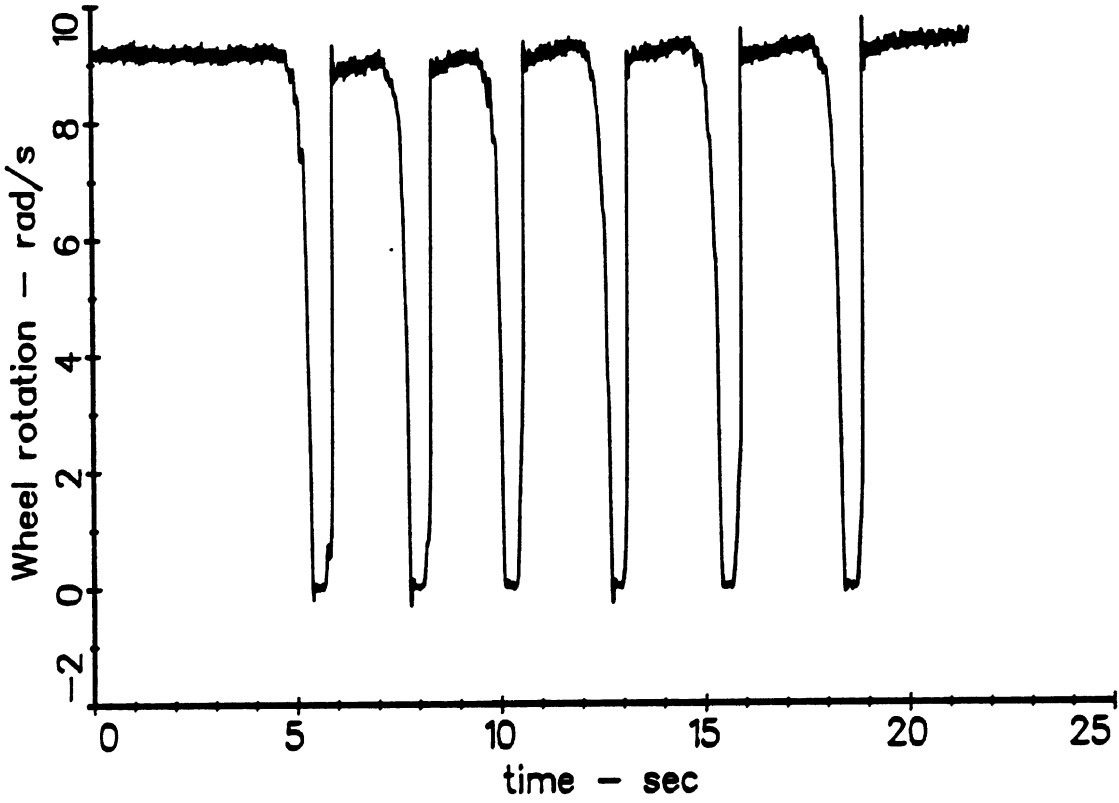

04/01/87 14:33:08 GD YR 295/75R22.5 SINGLE 6000 AT  
10MPH

28

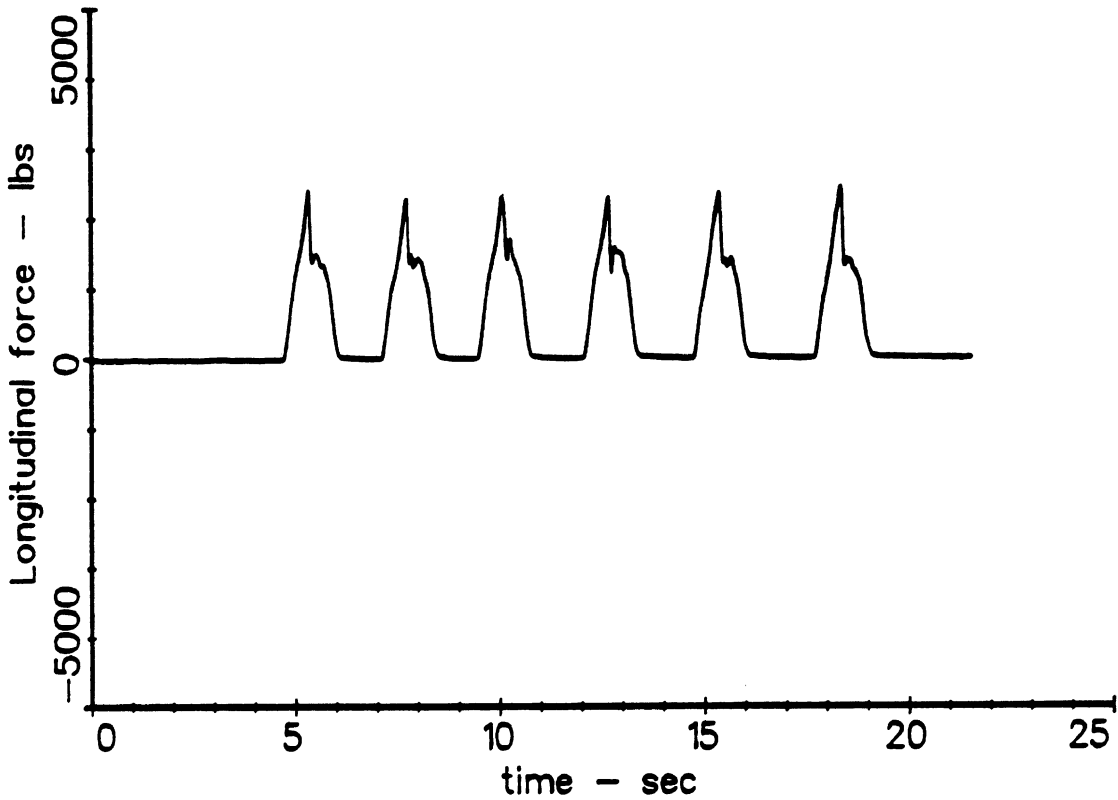

04/01/87 14:33:08 GD YR 295/75R22.5 SINGLE 6000 AT  
10MPH

RUN 28

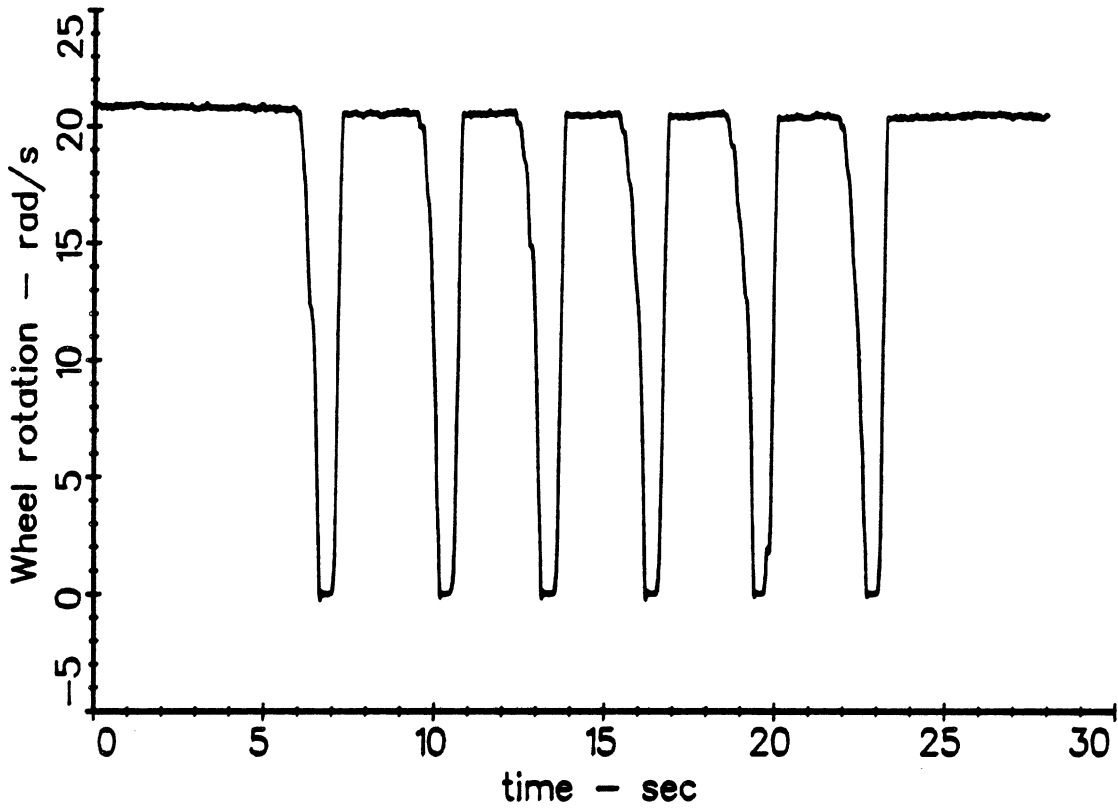

04/01/87 14:44:36 GD YR 295/75R22.5 SINGLE 2000 AT  
25MPH

31

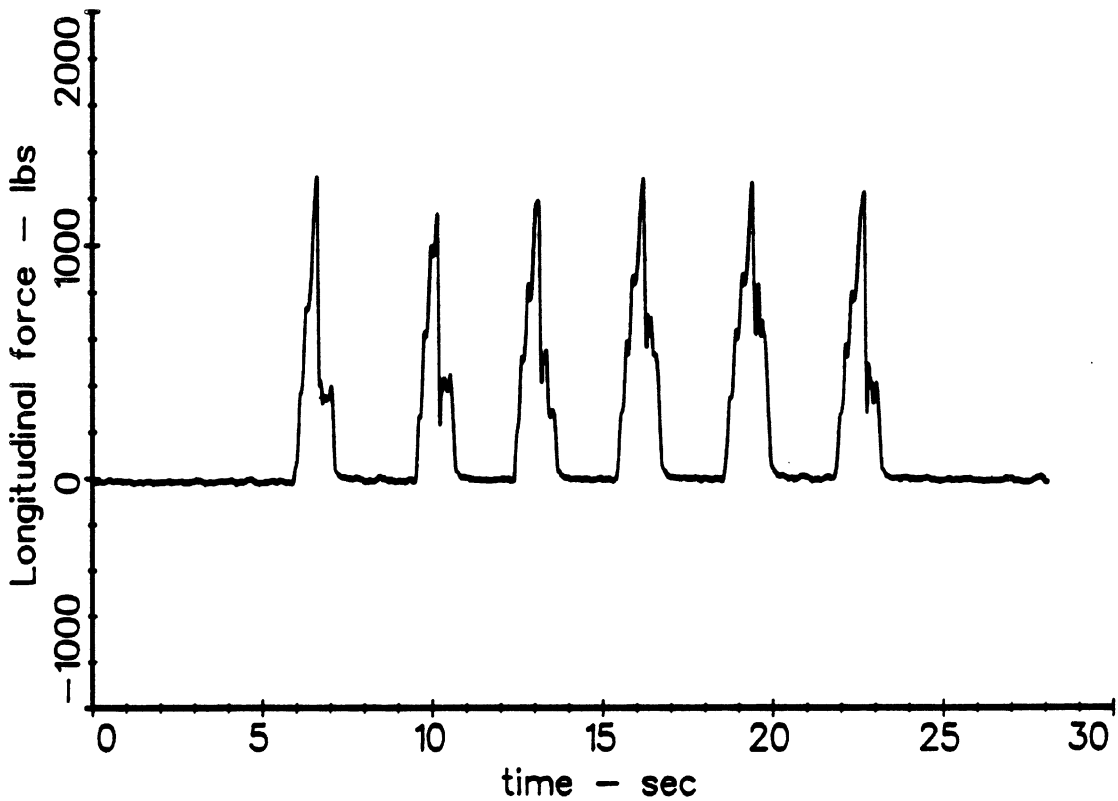

04/01/87 14:44:36 GD YR 295/75R22.5 SINGLE 2000 AT  
25MPH

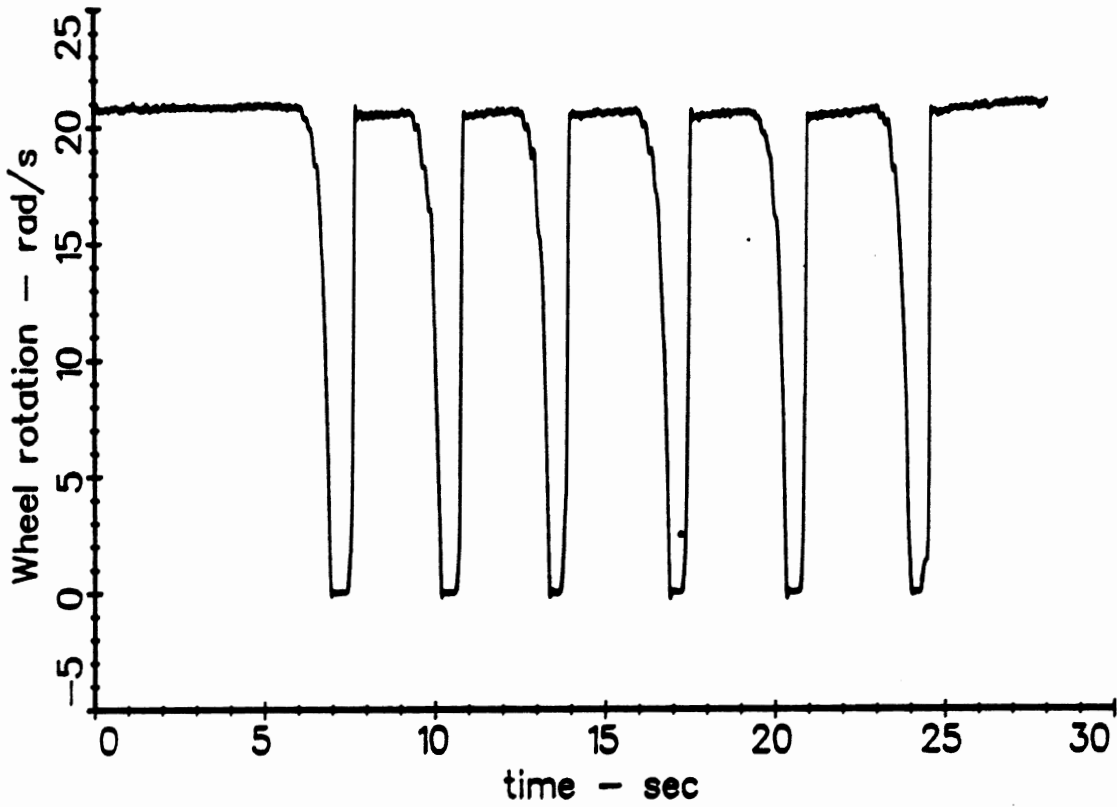

04/01/87 14:46:40 GD YR 295/75R22.5 SINGLE 4000 AT 25MPH

32

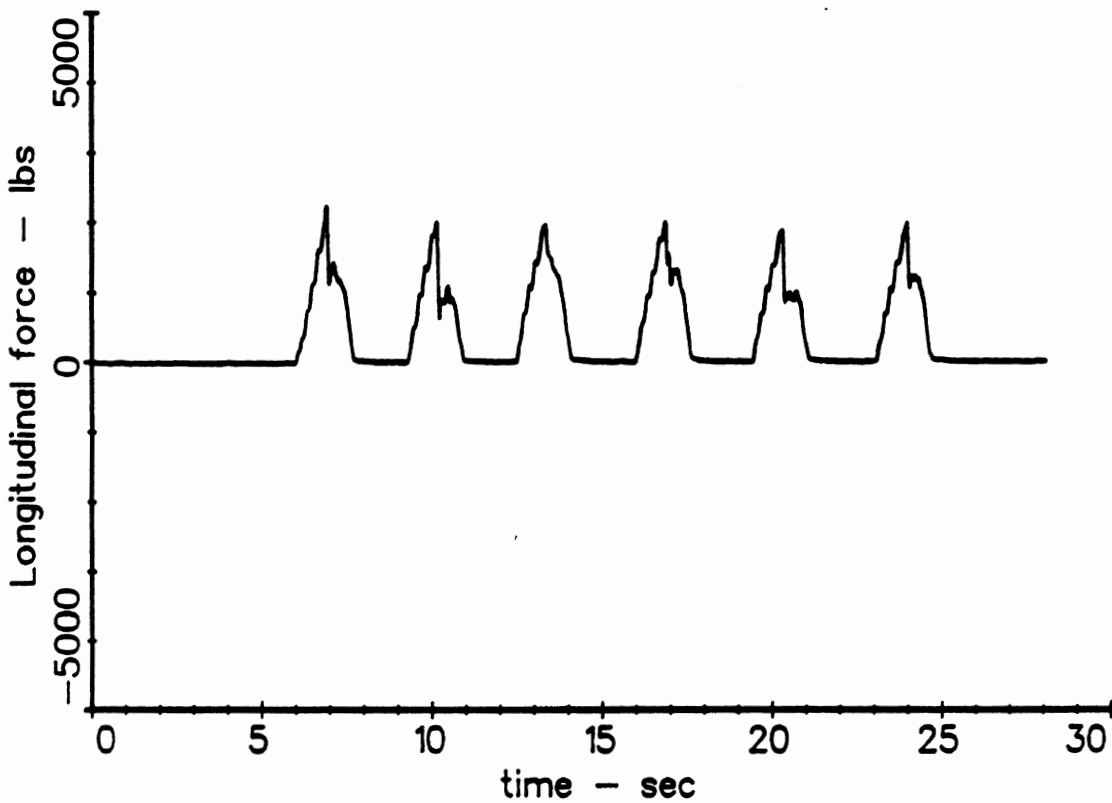

04/01/87 14:46:40 GD YR 295/75R22.5 SINGLE 4000 AT 25MPH

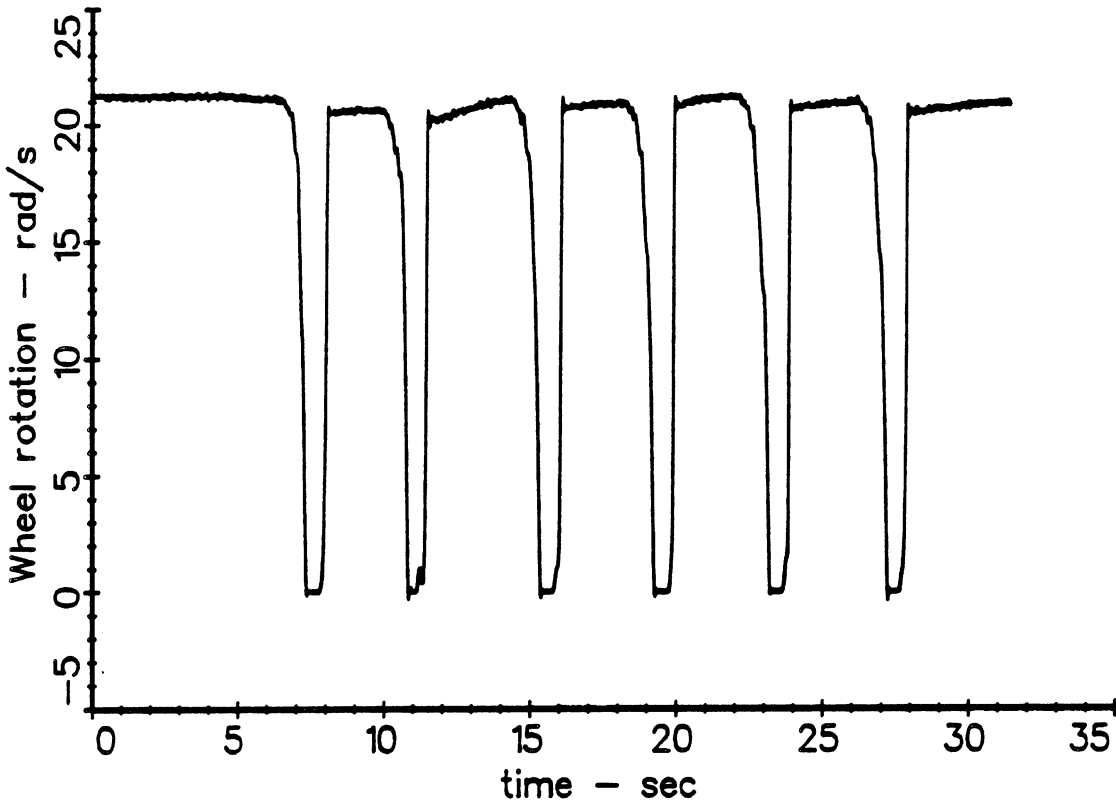

04/01/87 14:48:34 GD YR 295/75R22.5 SINGLE 6000 AT  
25MPH

33

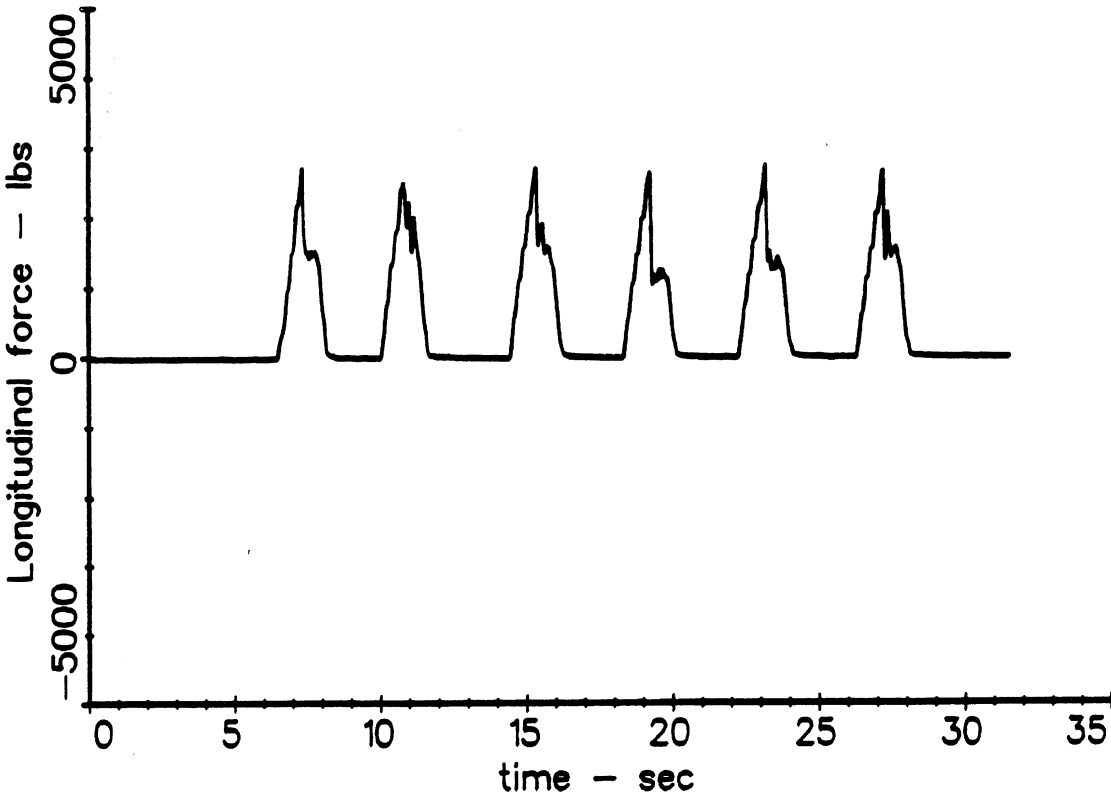

04/01/87 14:48:34 GD YR 295/75R22.5 SINGLE 6000 AT  
25MPH

RUN 33



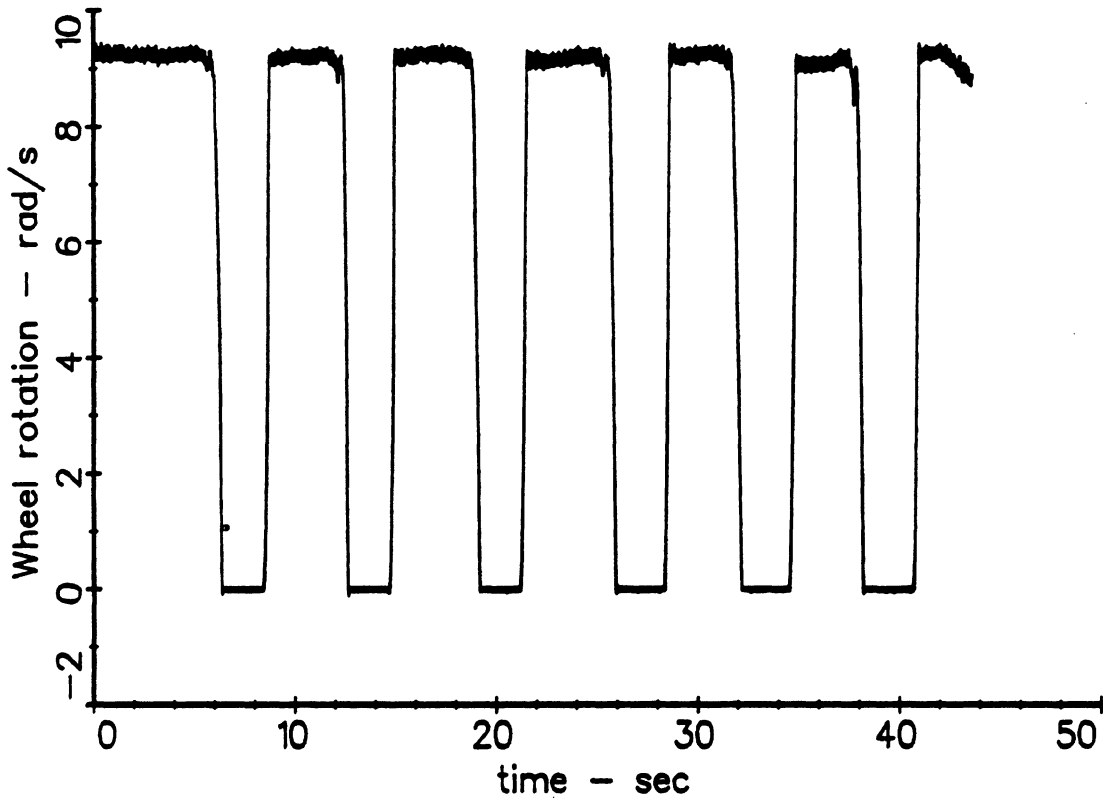

04/02/87 10:12:35 GD YR 295/75R22.5 NO CHA 2000 AT  
10MPH

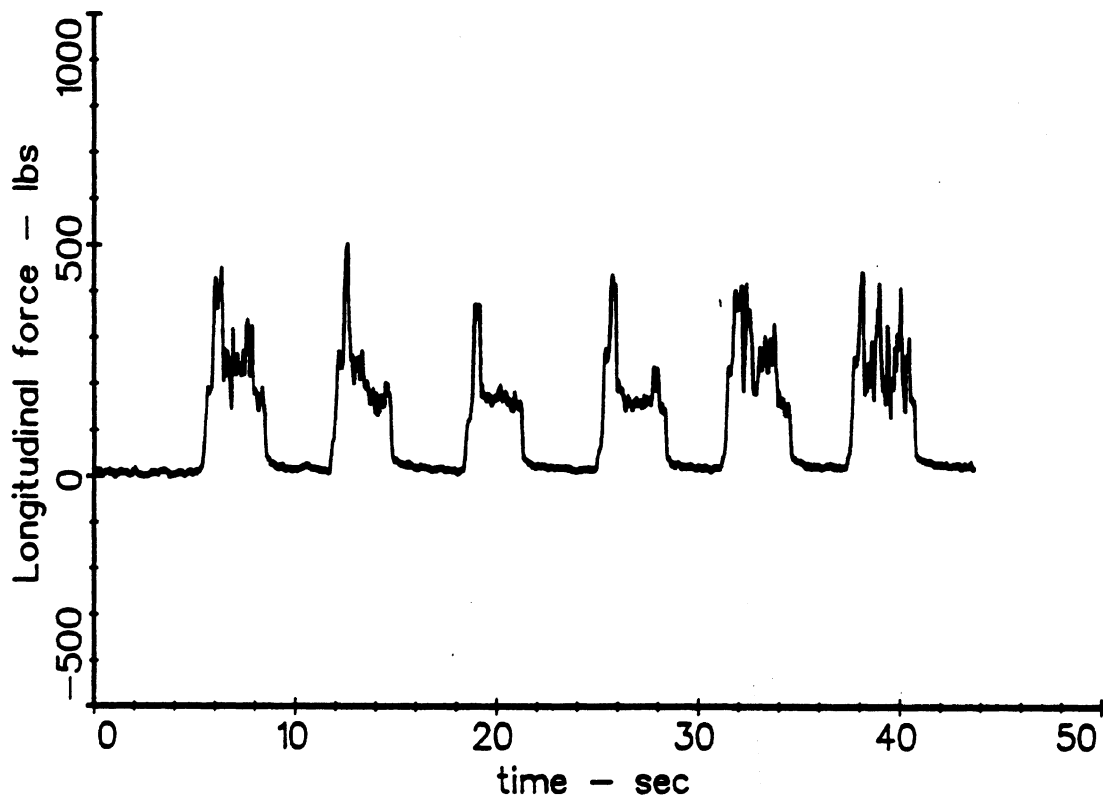

38

04/02/87 10:12:35 GD YR 295/75R22.5 NO CHA 2000 AT  
10MPH

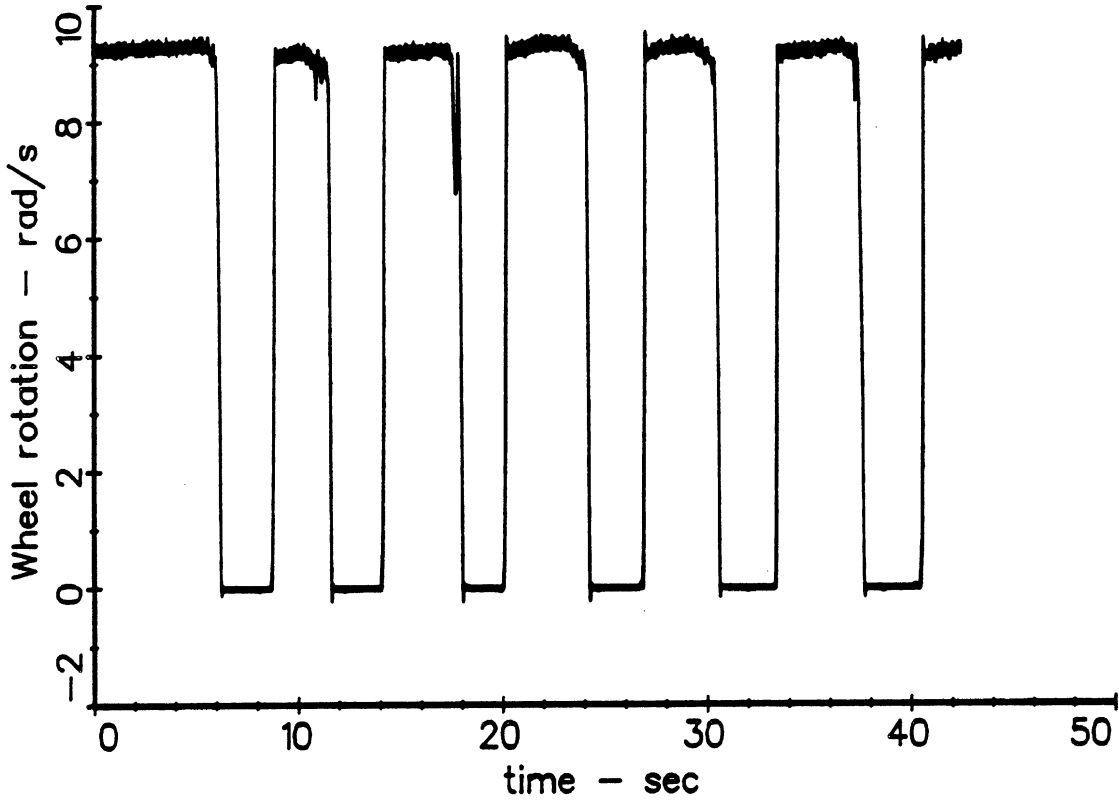

04/02/87 10:17:34 GD YR 295/75R22.5 NO CHA 4000 AT 10MPH

39

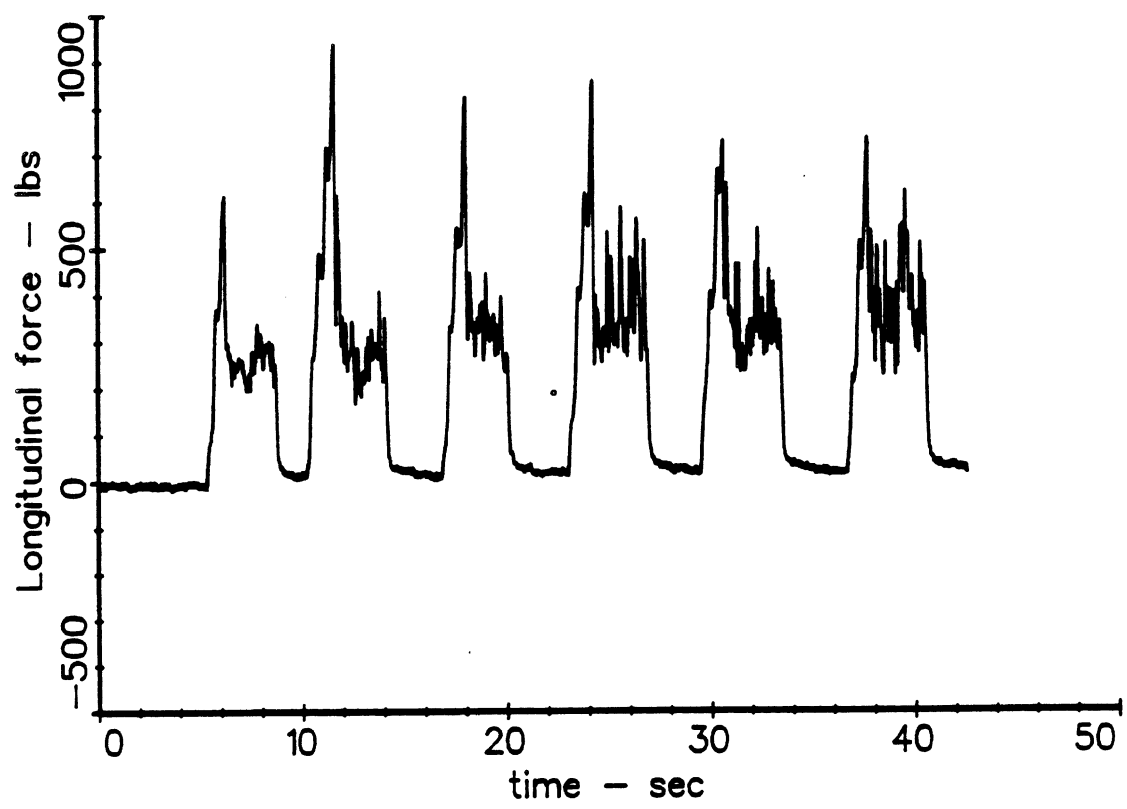

04/02/87 10:17:34 GD YR 295/75R22.5 NO CHA 4000 AT 10MPH

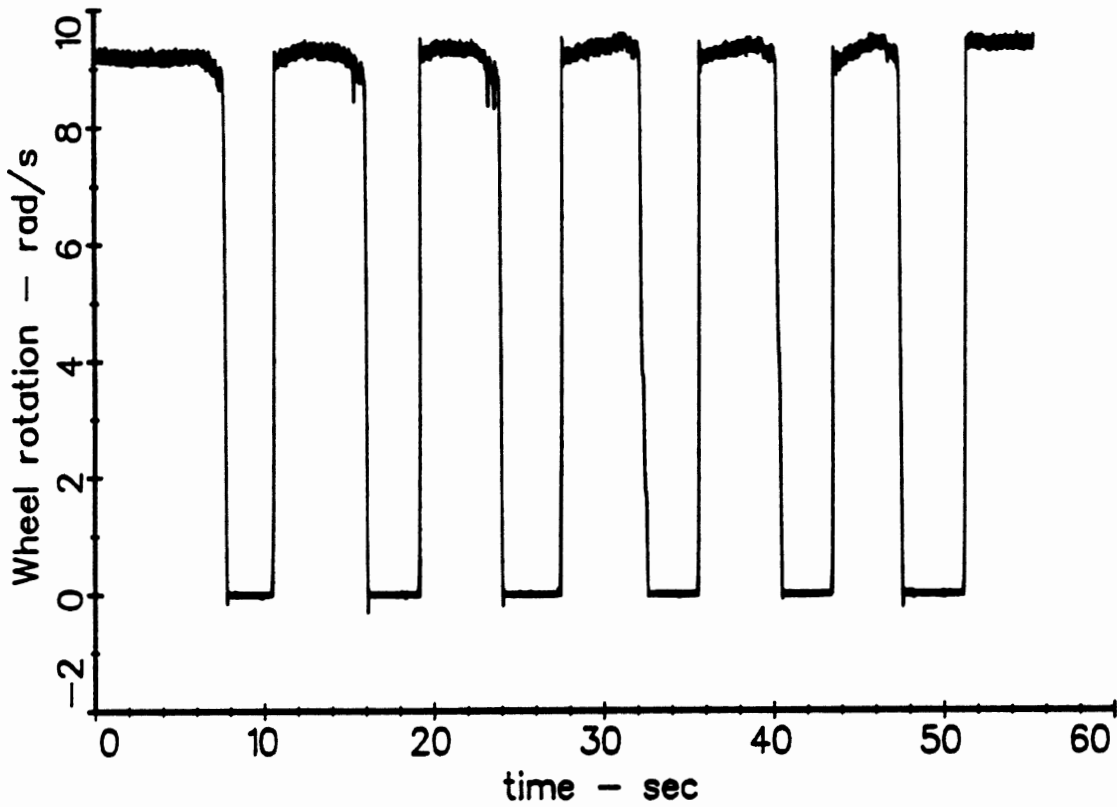

04/02/87 10:21:16 GD YR 295/75R22.5 NO CHA 6000 AT  
10MPH

40

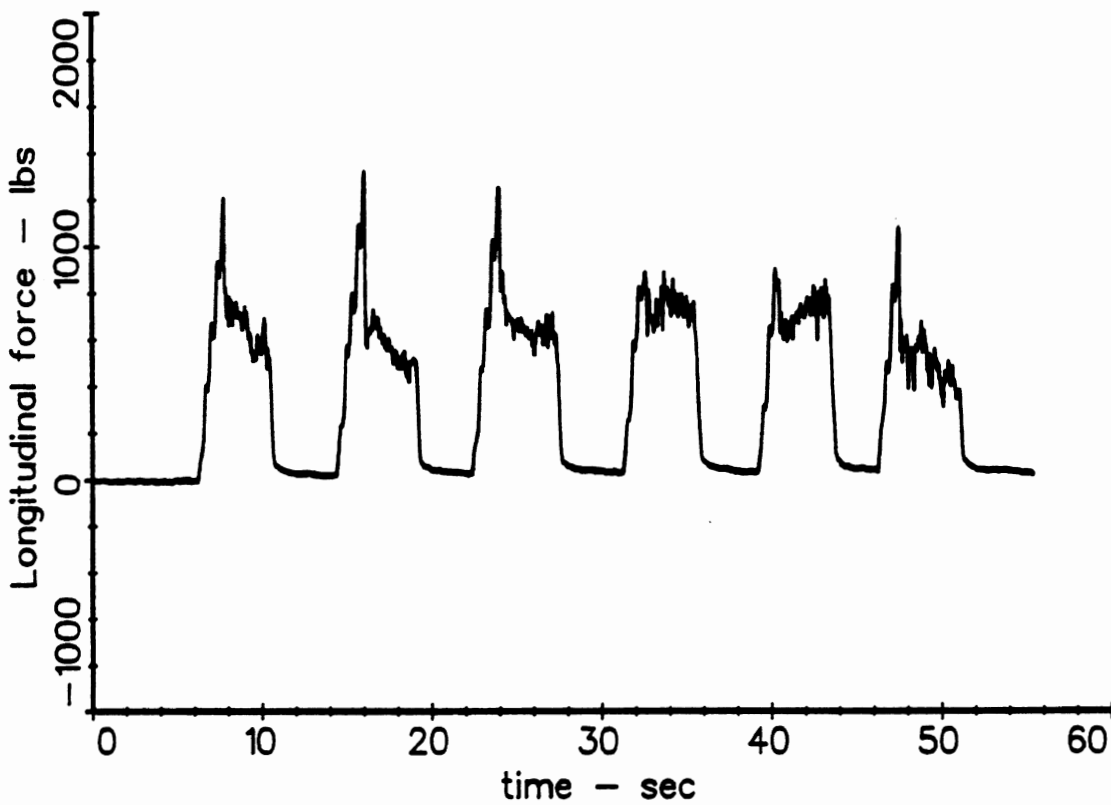

04/02/87 10:21:16 GD YR 295/75R22.5 NO CHA 6000 AT  
10MPH

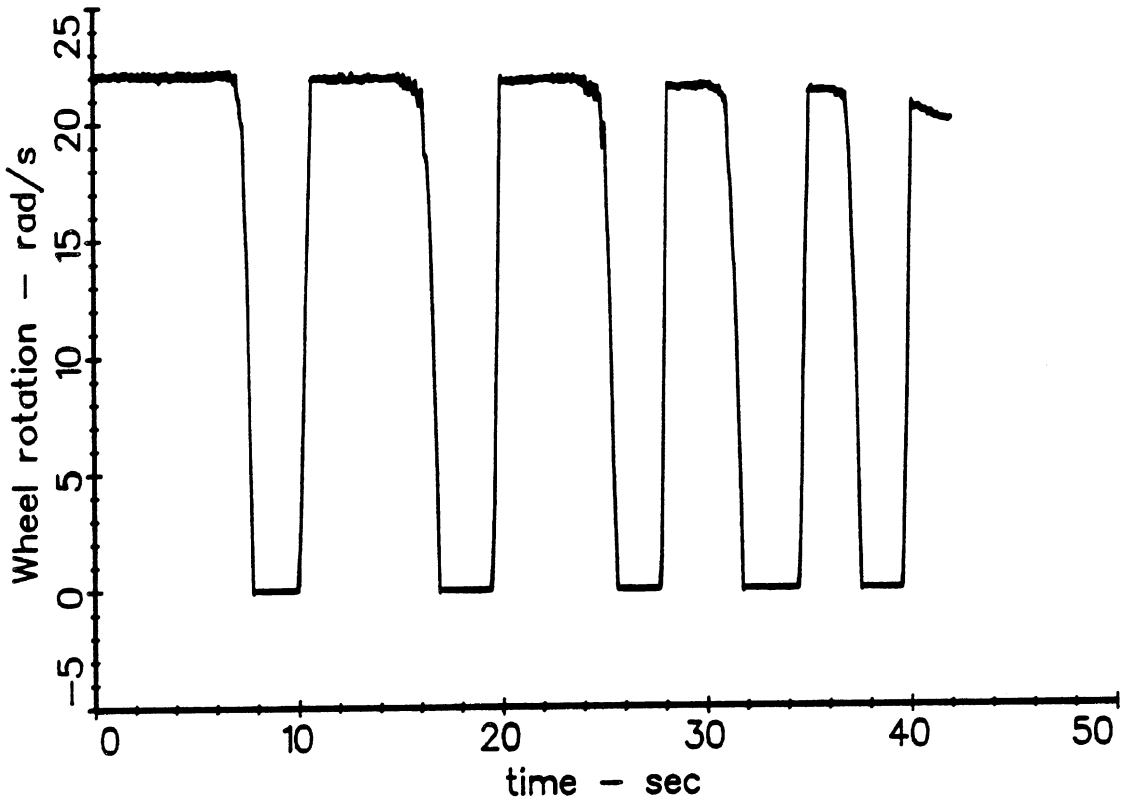

04/02/87 10:29:38 GD YR 295/75R22.5 NO CHA 2000 AT 25

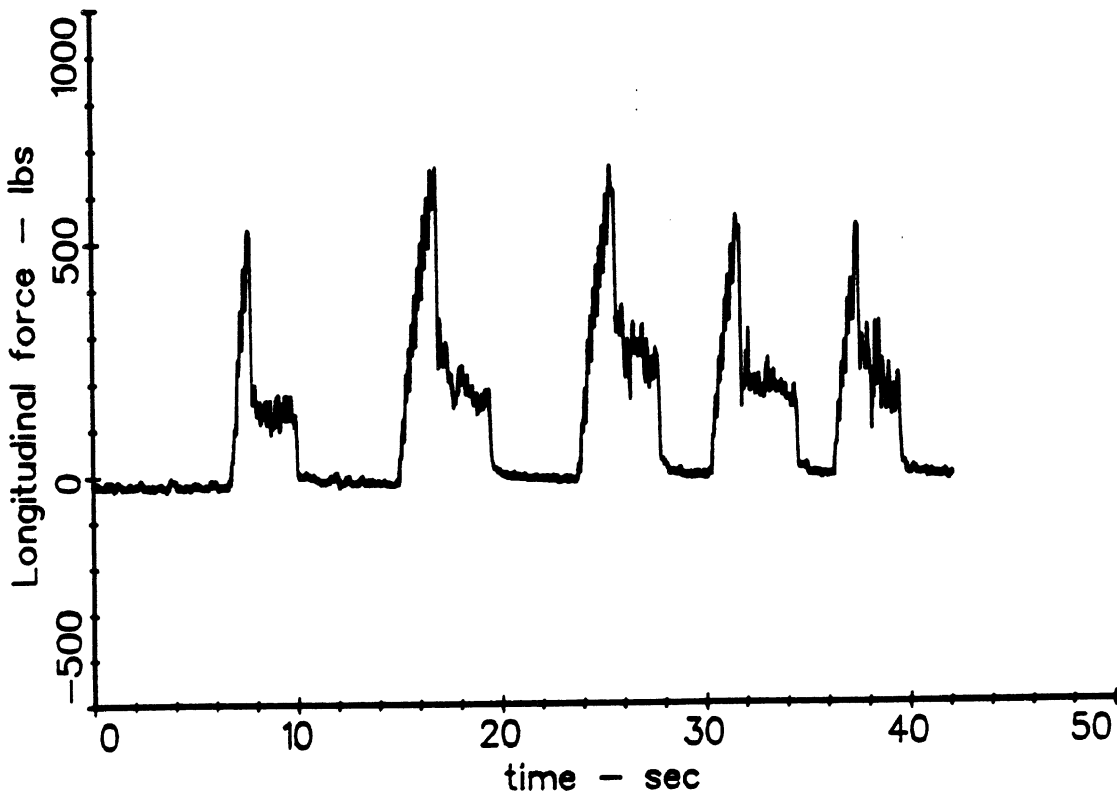

43

04/02/87 10:29:38 GD YR 295/75R22.5 NO CHA 2000 AT 25

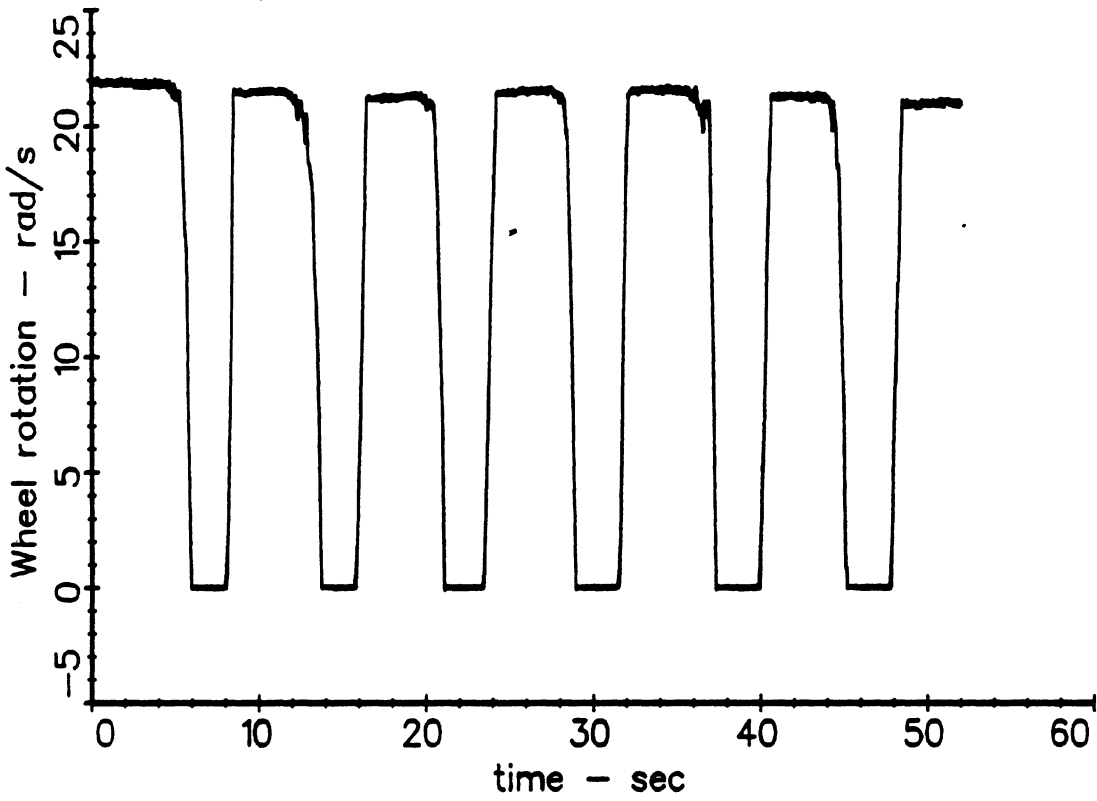

04/02/87 10:32:05 GD YR 295/75R22.5 NO CHA 2000 AT  
25MPH

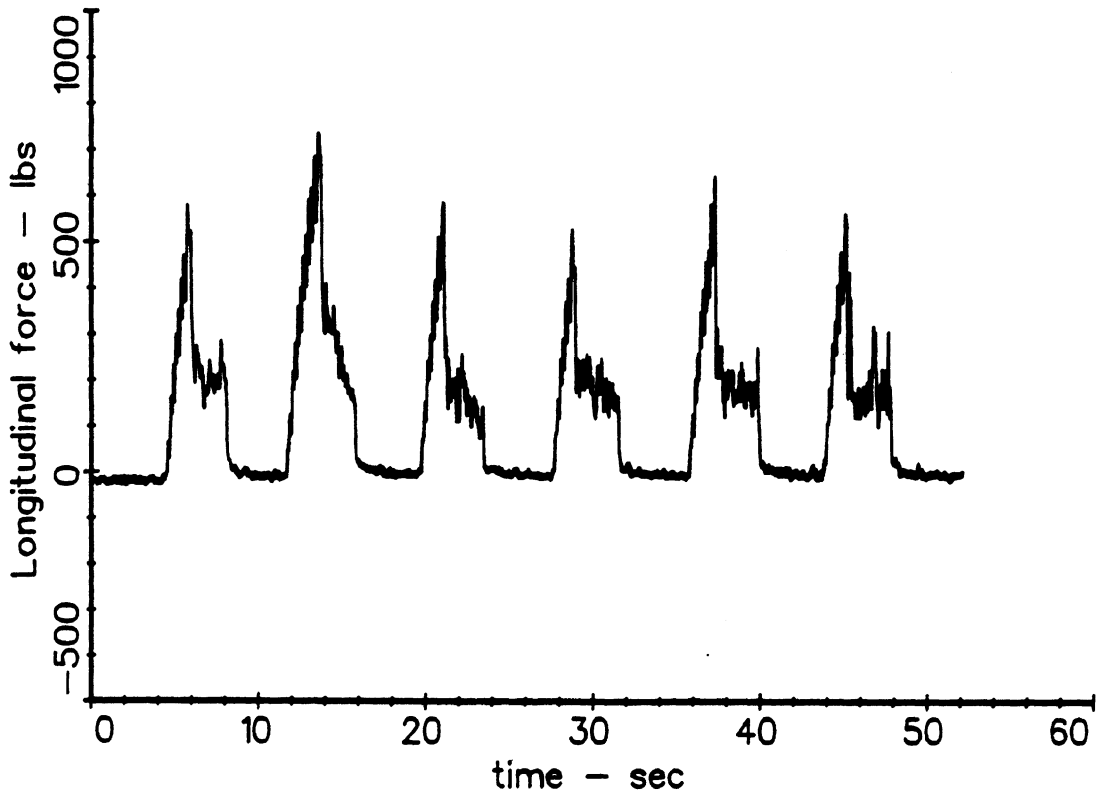

04/02/87 10:32:05 GD YR 295/75R22.5 NO CHA 2000 AT  
25MPH

44

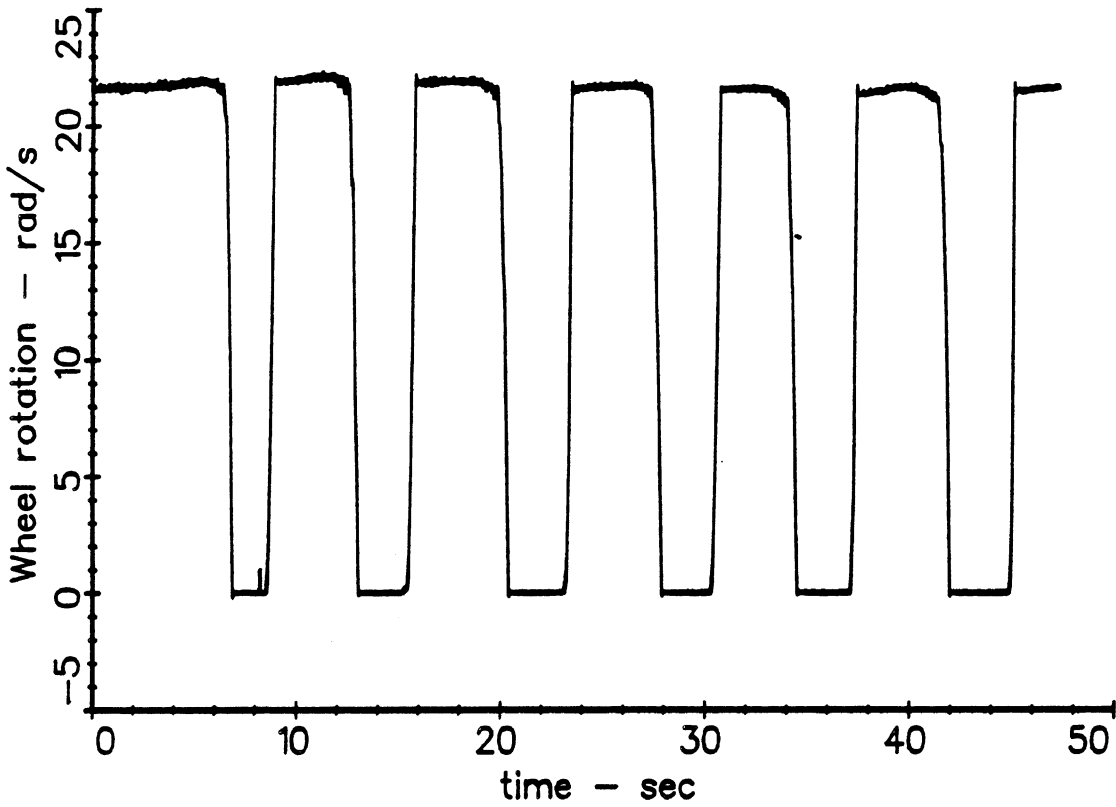

04/02/87 10:35:49 GD YR 295/75R22.5 NO CHA 4000 AT  
25MPH

45

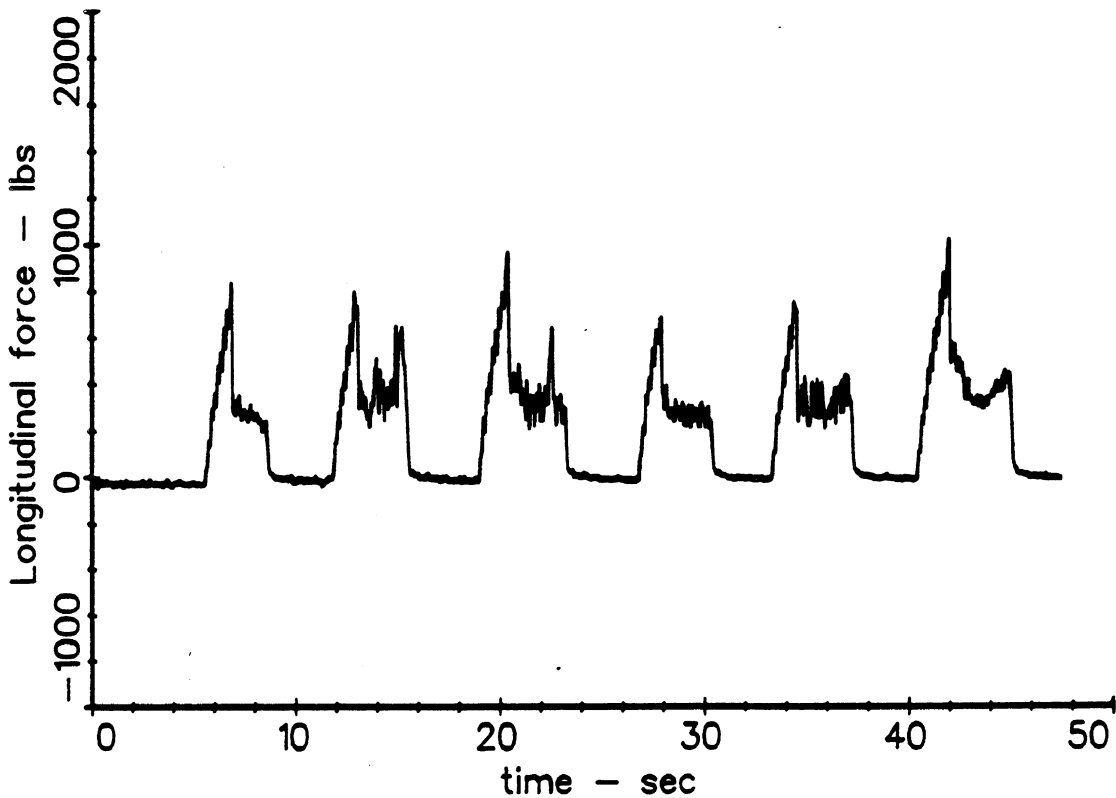

04/02/87 10:35:49 GD YR 295/75R22.5 NO CHA 4000 AT  
25MPH

RUN 45

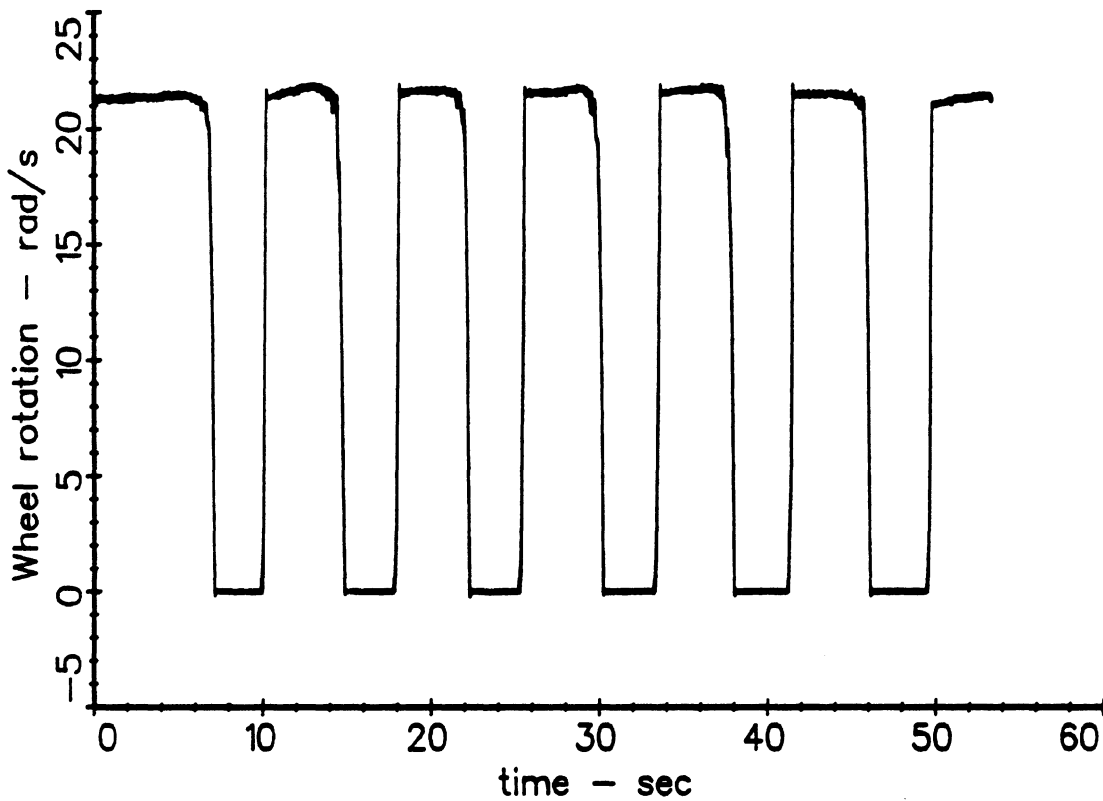

04/02/87 10:39:01 GD YR 295/75R22.5 NO CHA 6000 AT  
25MPH

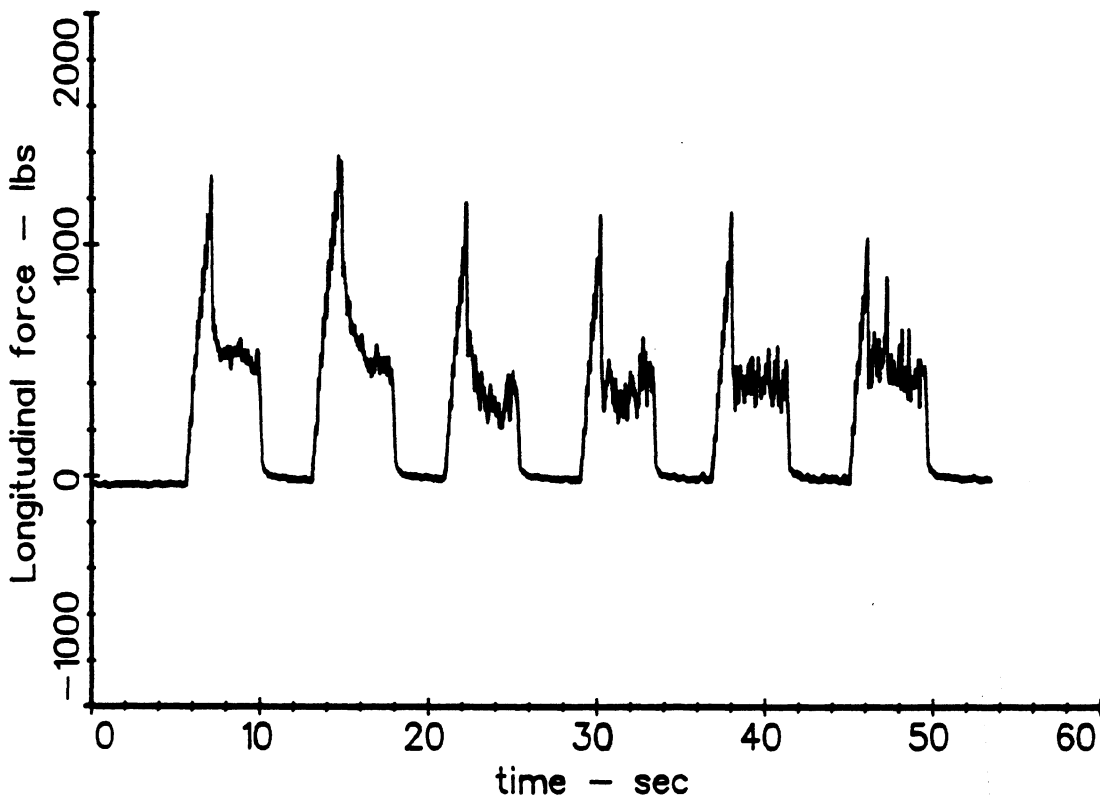

46

04/02/87 10:39:01 GD YR 295/75R22.5 NO CHA 6000 AT  
25MPH

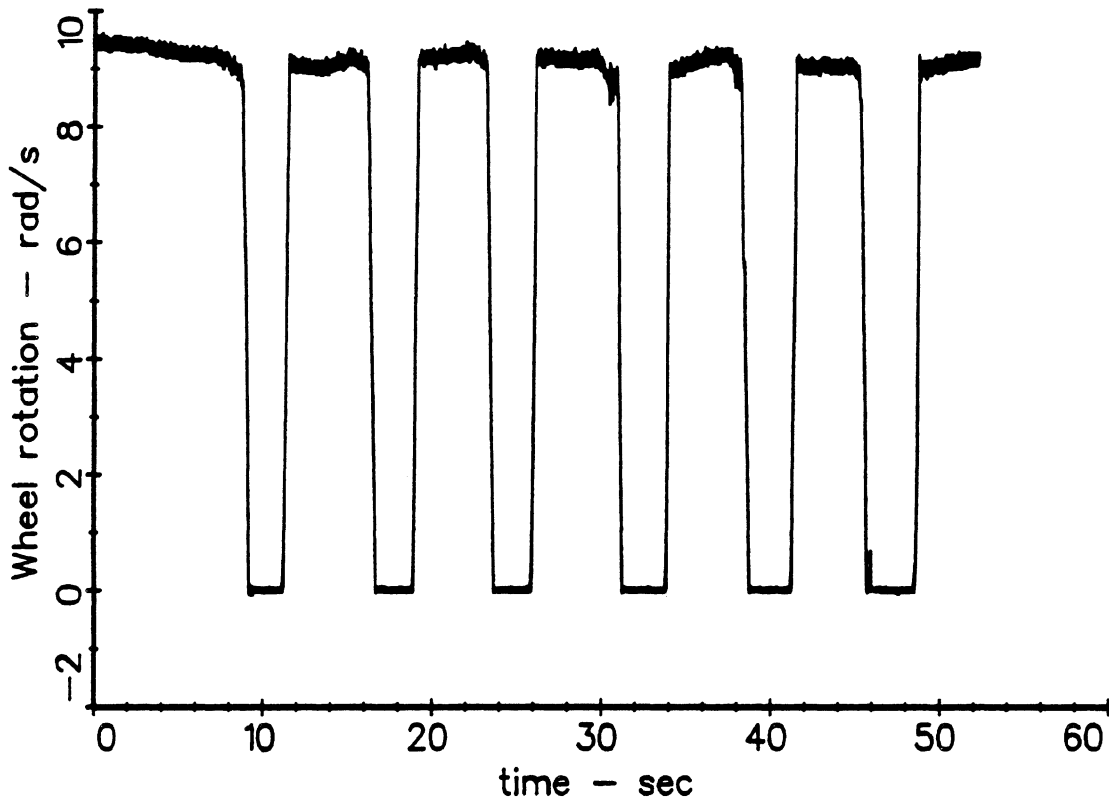

04/02/87 11:05:27 MICH 11R22.5 NO CHAINS 2000 AT  
10MPH

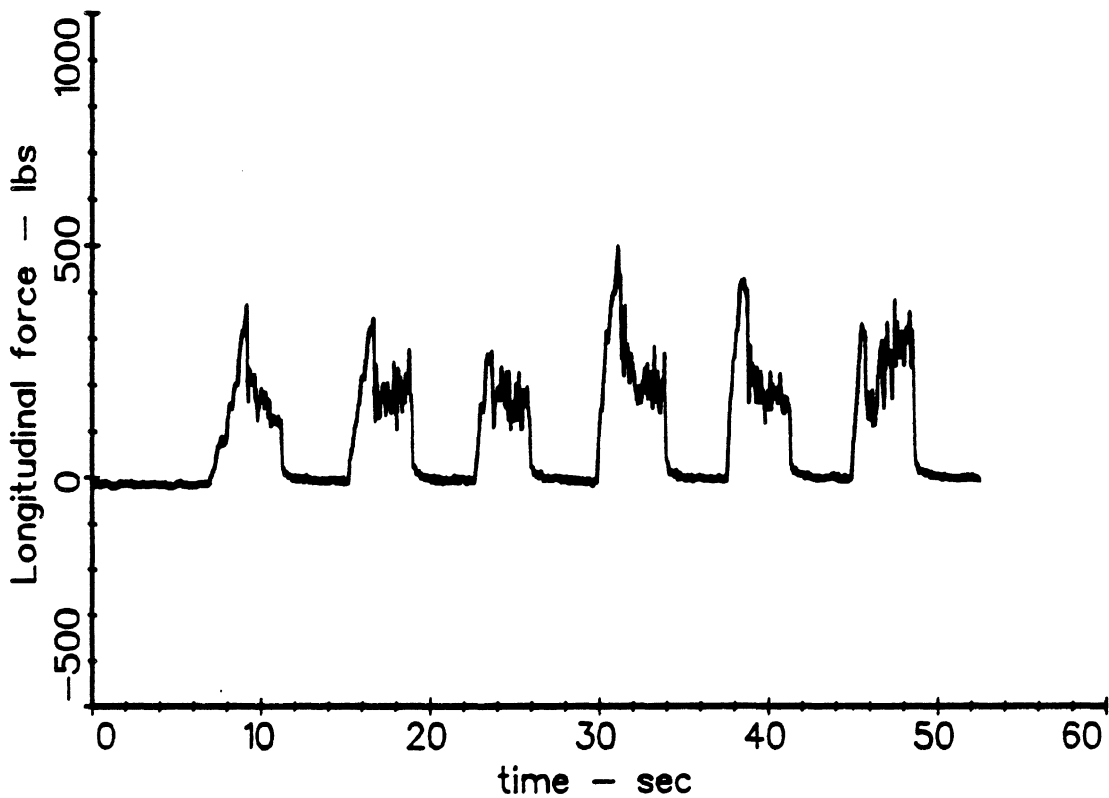

49

04/02/87 11:05:27 MICH 11R22.5 NO CHAINS 2000 AT  
10MPH



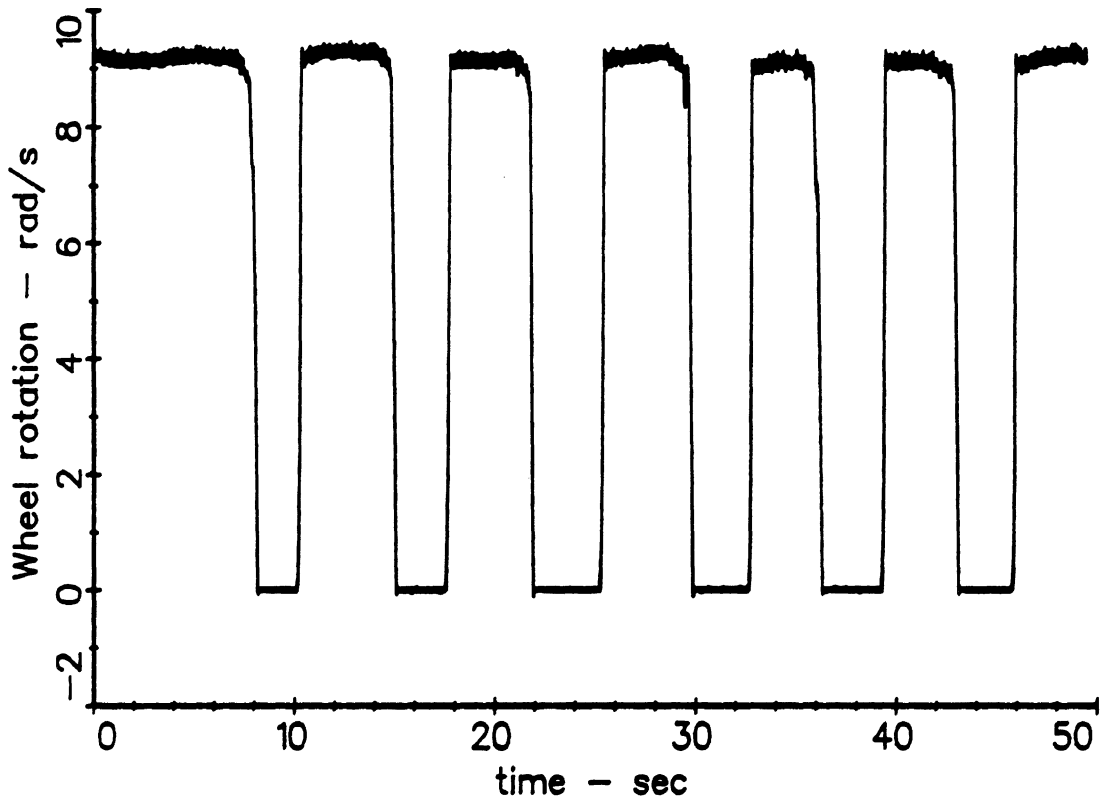

04/02/87 11:07:43 MICH 11R22.5 NO CHAINS 4000 AT  
10MPH

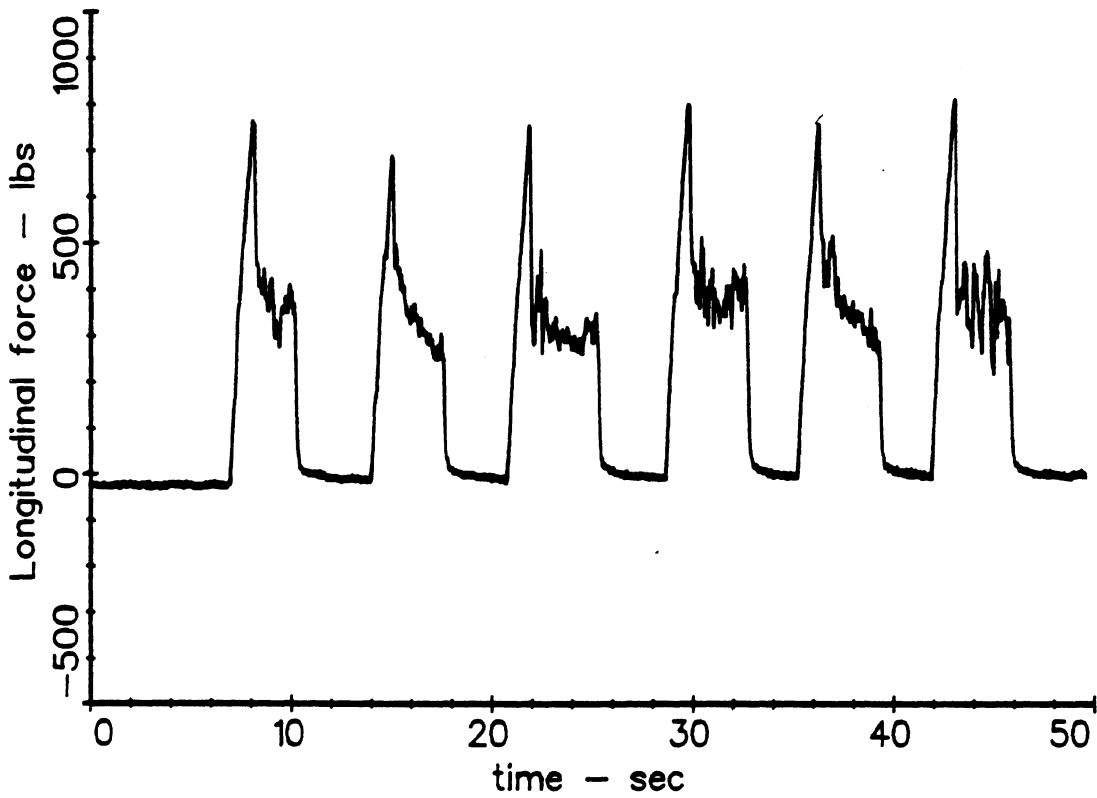

50

04/02/87 11:07:43 MICH 11R22.5 NO CHAINS 4000 AT  
10MPH

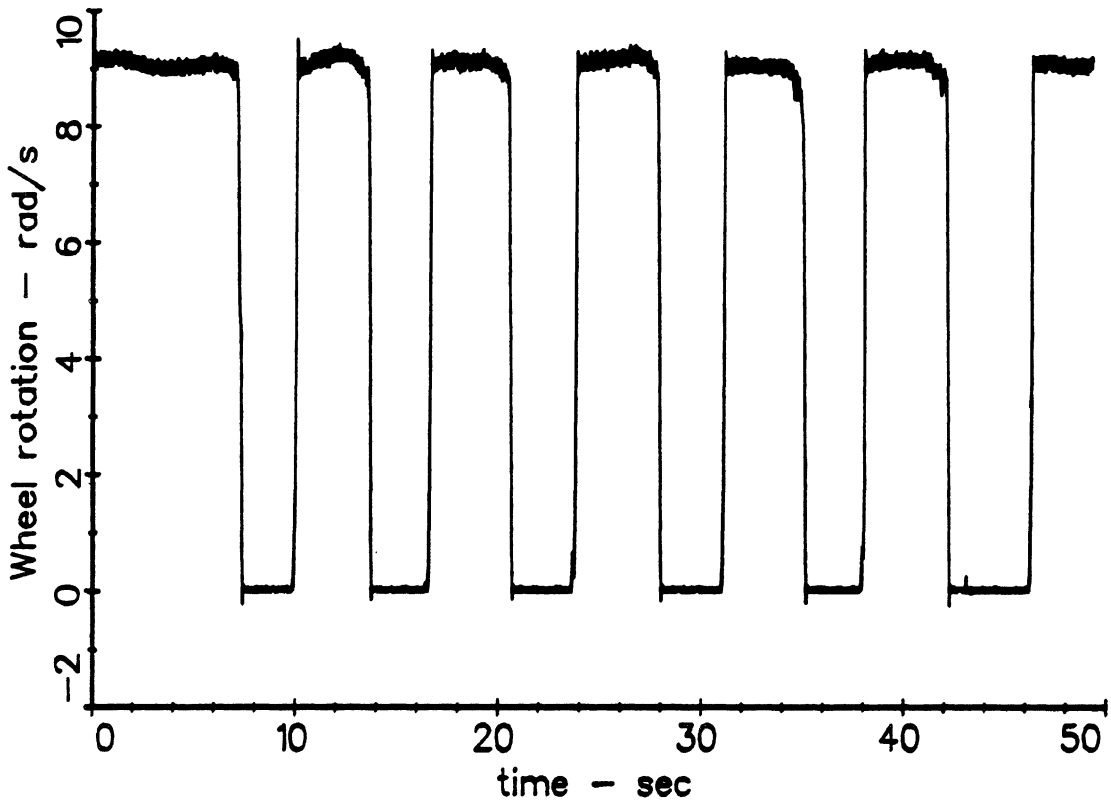

04/02/87 11:11:07 MICH 11R22.5 NO CHAINS 6000 AT 10MPH

SI

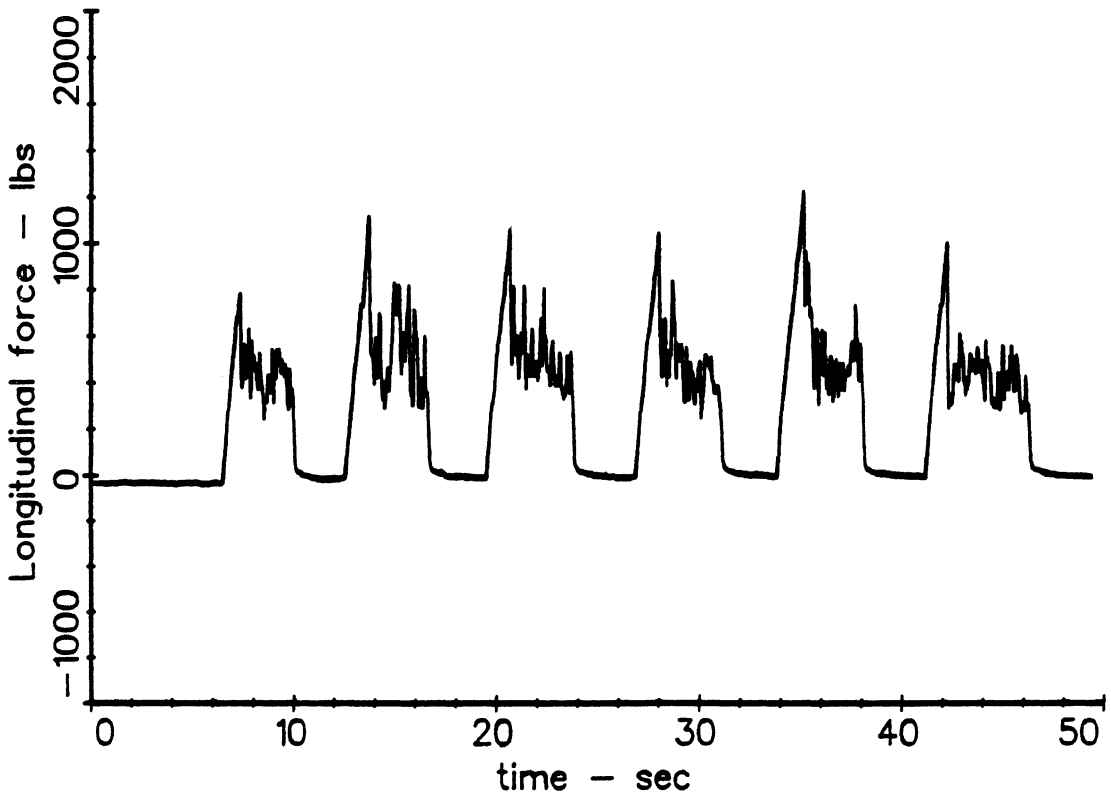

04/02/87 11:11:07 MICH 11R22.5 NO CHAINS 6000 AT 10MPH

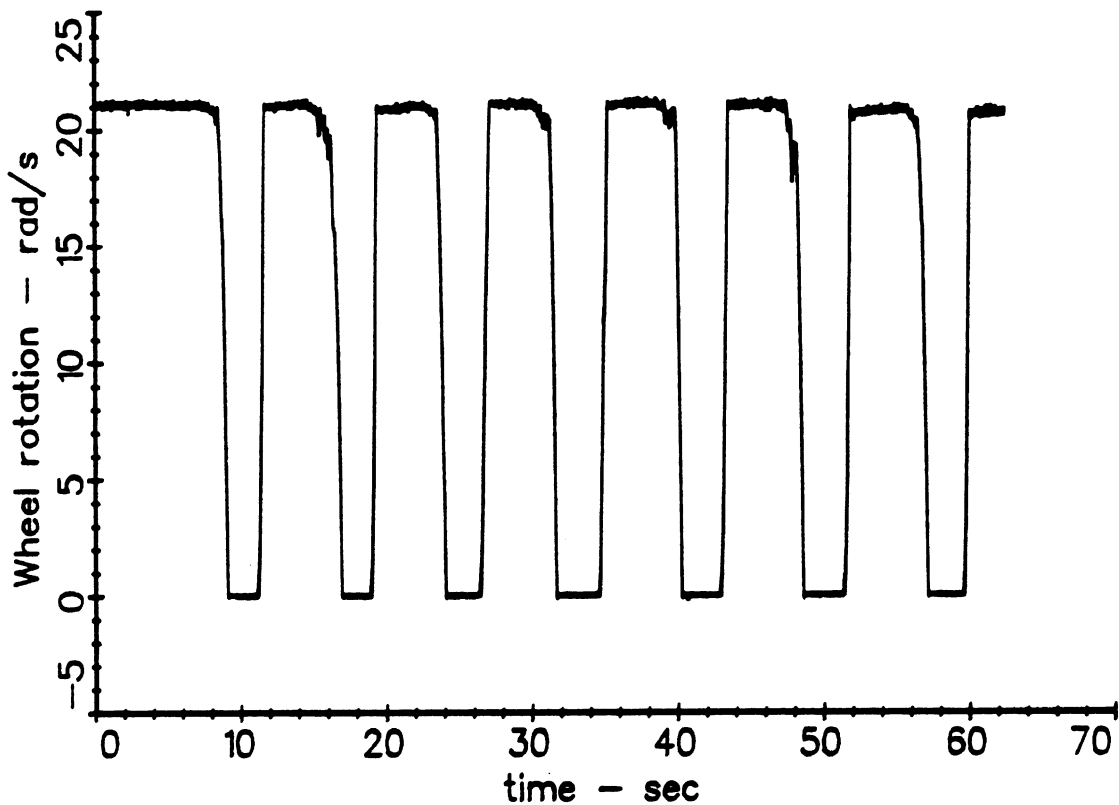

04/02/87 11:21:53 MICH 11R22.5 NO CHAINS 2000 AT  
25MPH

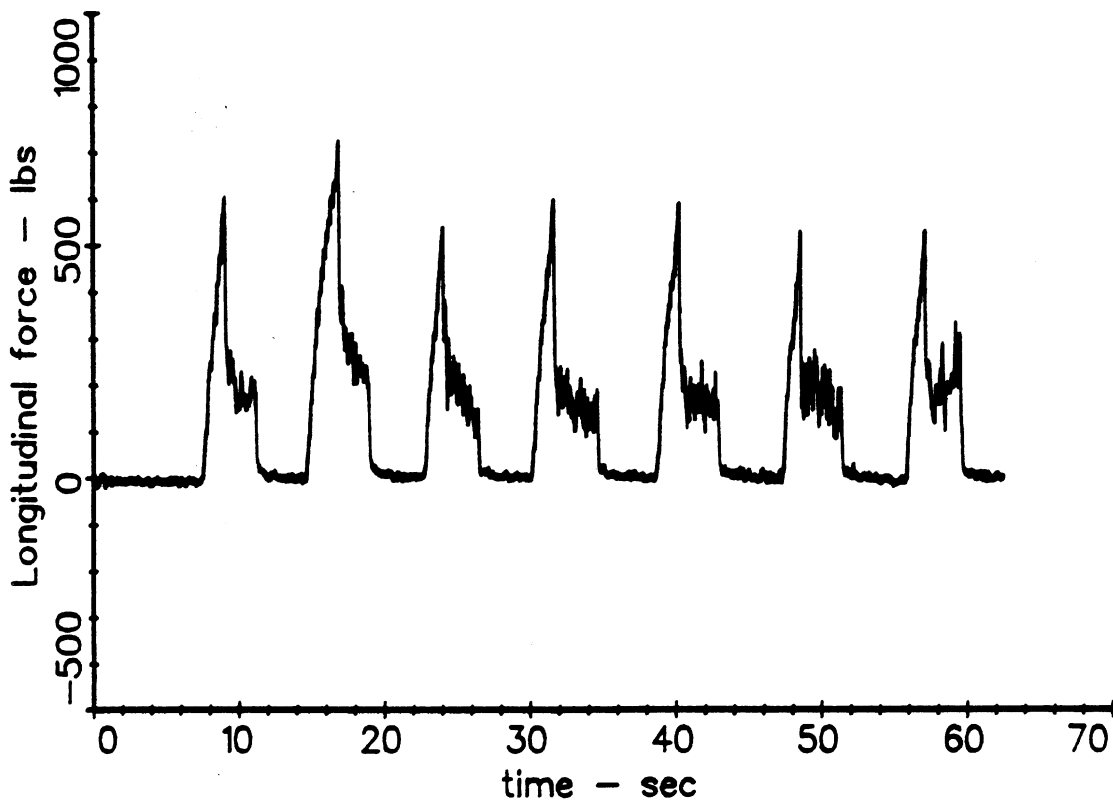

54

04/02/87 11:21:53 MICH 11R22.5 NO CHAINS 2000 AT  
25MPH

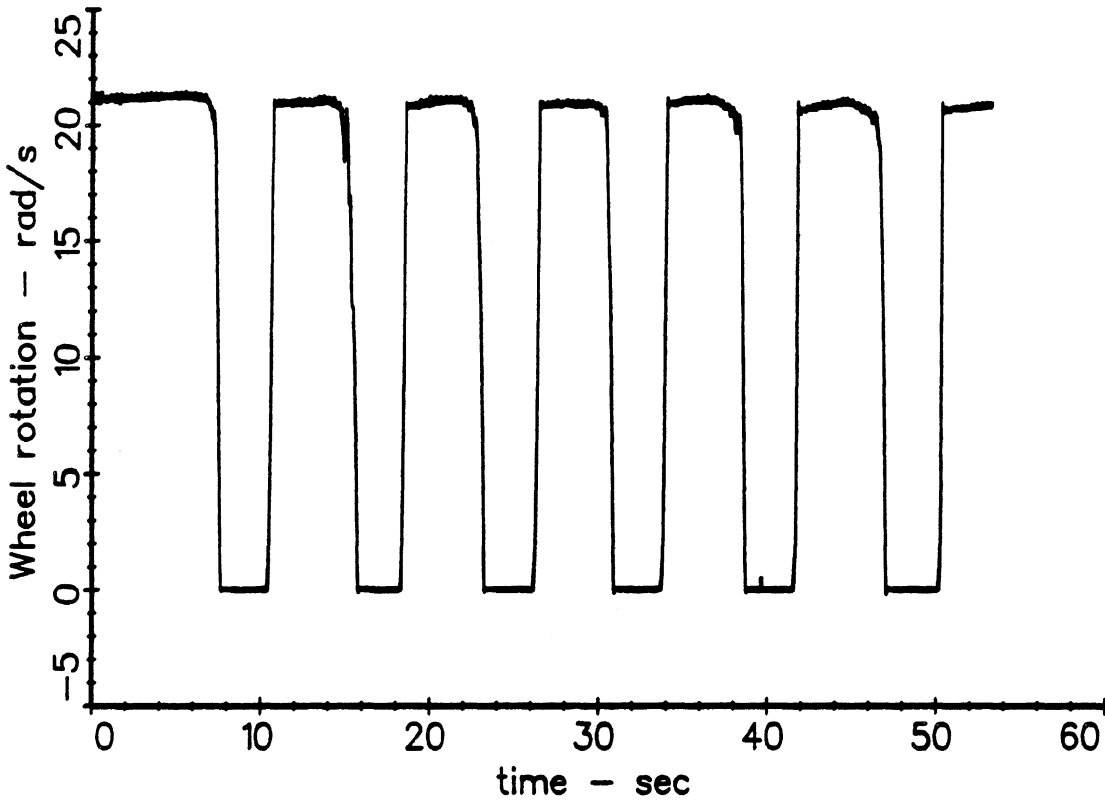

04/02/87 11:25:10 MICH 11R22.5 NO CHAINS 4000 AT  
25MPH

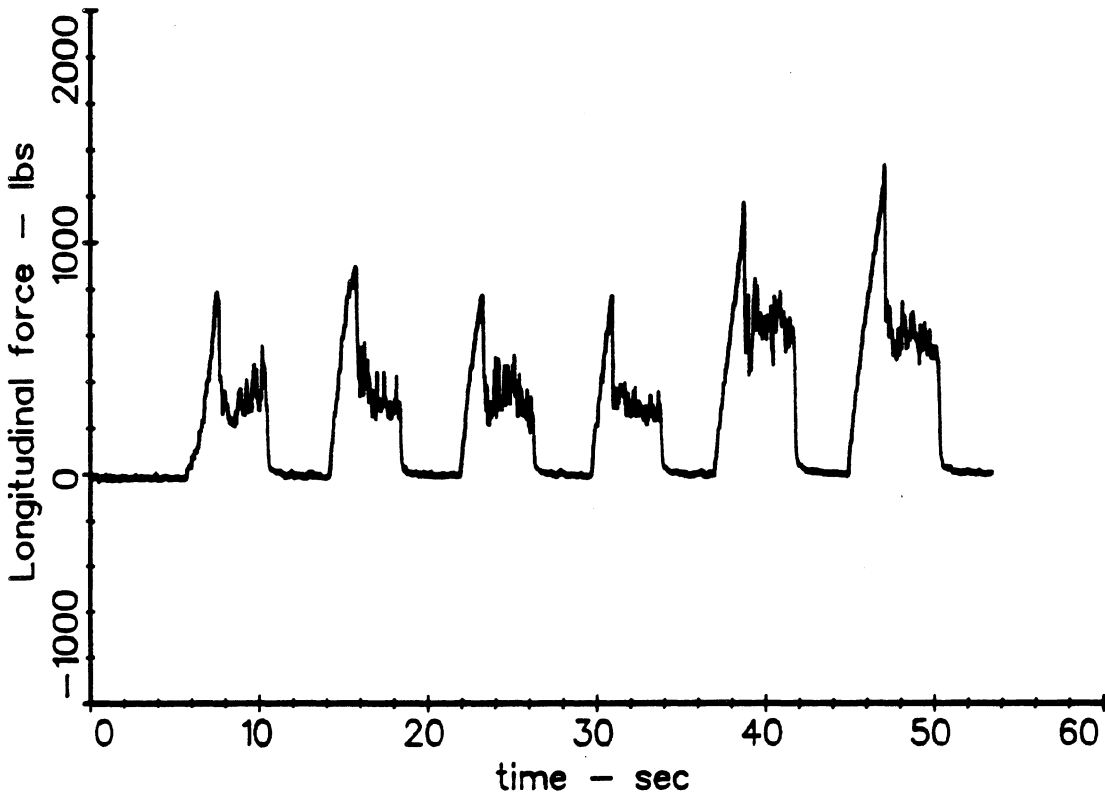

55

04/02/87 11:25:10 MICH 11R22.5 NO CHAINS 4000 AT  
25MPH

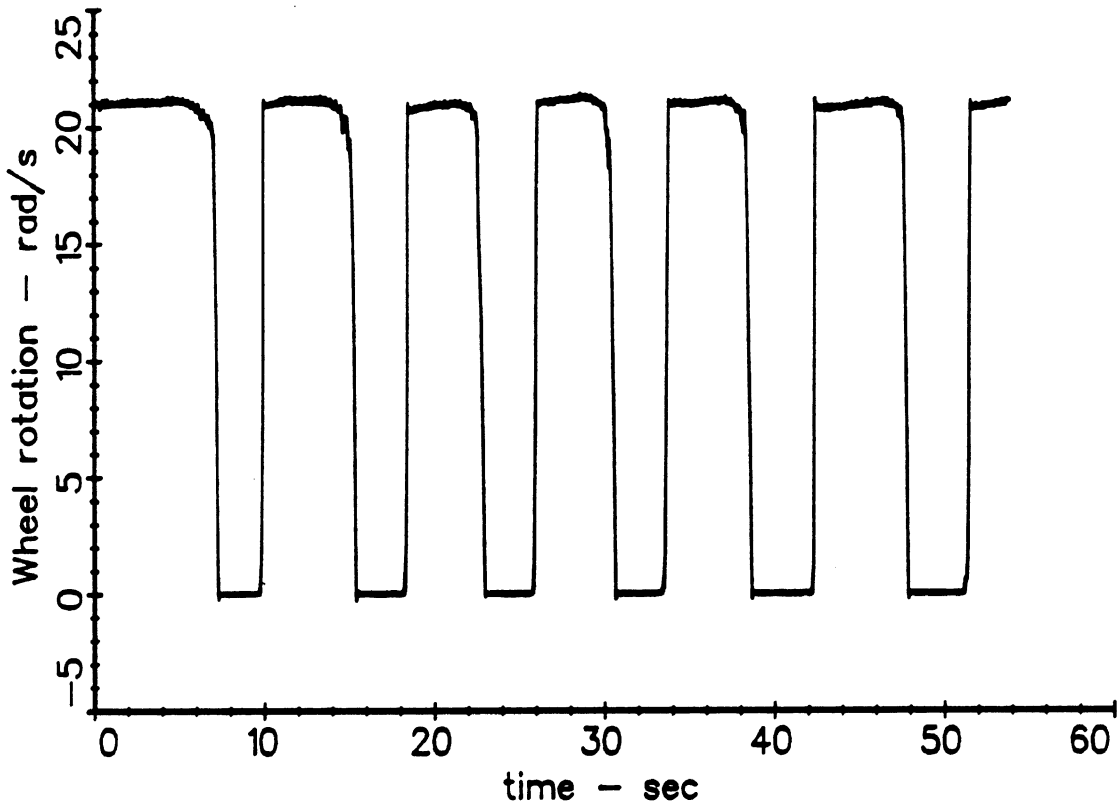

04/02/87 11:28:32 MICH 11R22.5 NO CHAINS 6000 AT  
25MPH

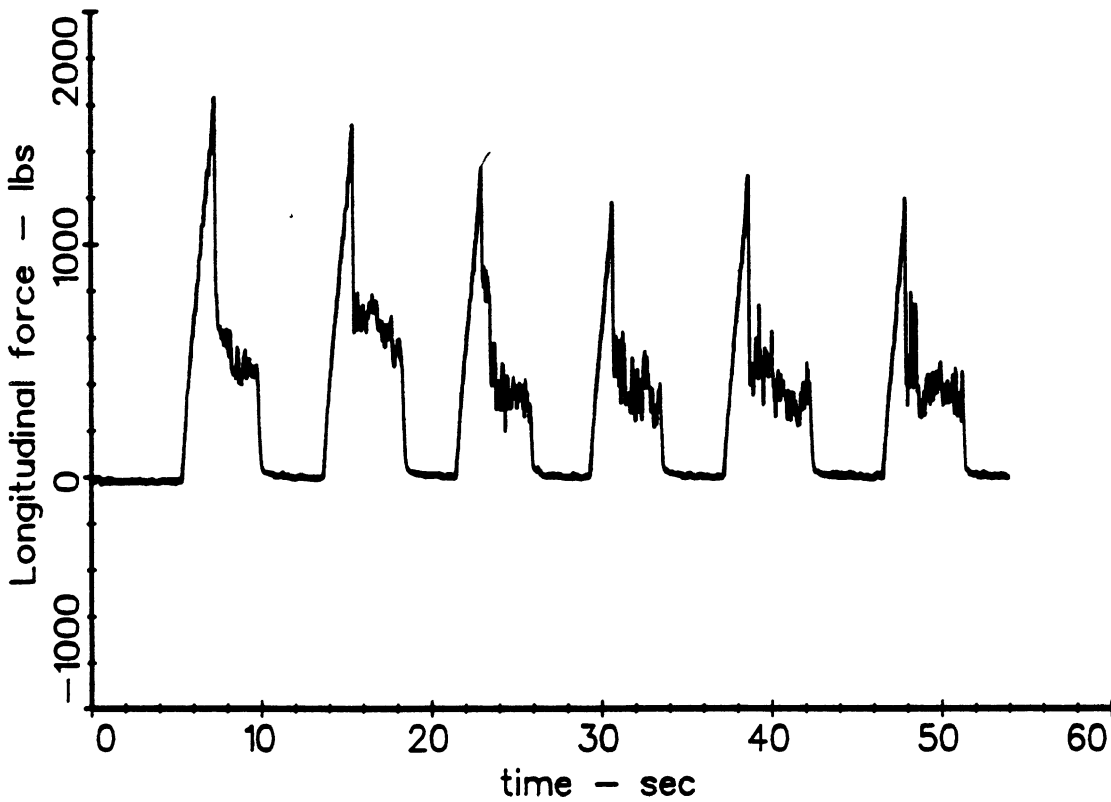

56

04/02/87 11:28:32 MICH 11R22.5 NO CHAINS 6000 AT  
25MPH

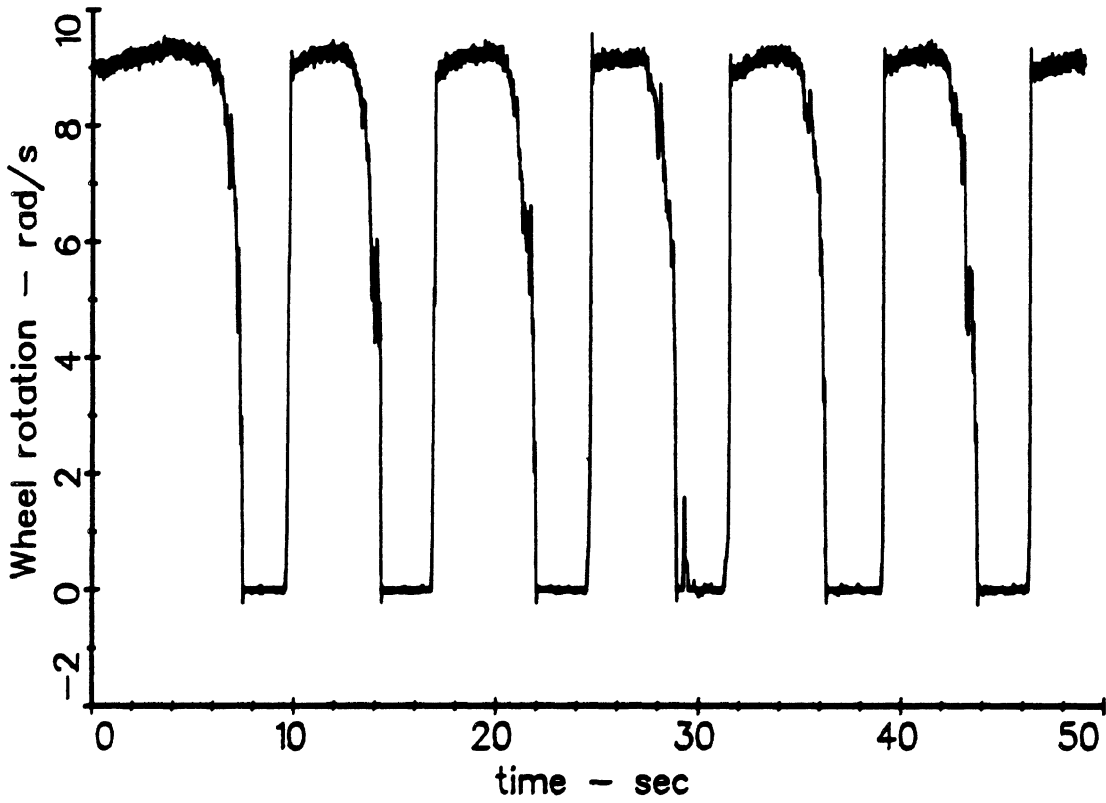

04/02/87 11:49:18 MICH 11R22.5 SINGLE 2000 AT 10MPH

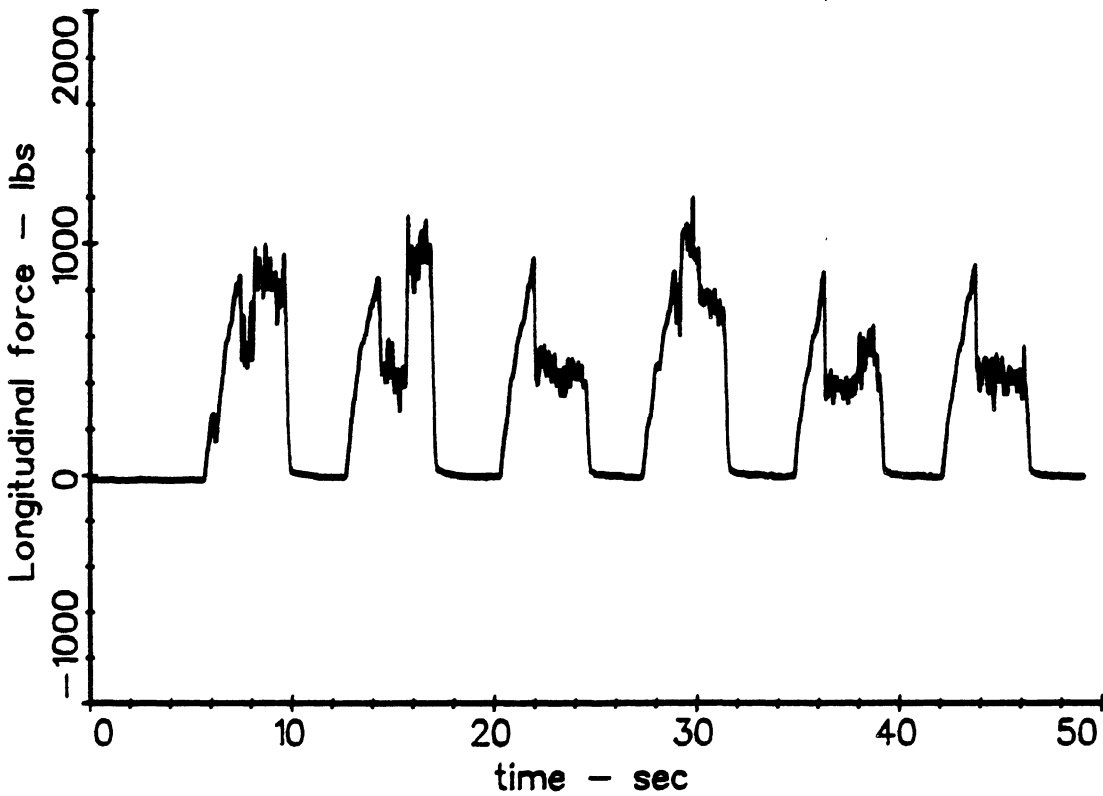

04/02/87 11:49:18 MICH 11R22.5 SINGLE 2000 AT 10MPH

59

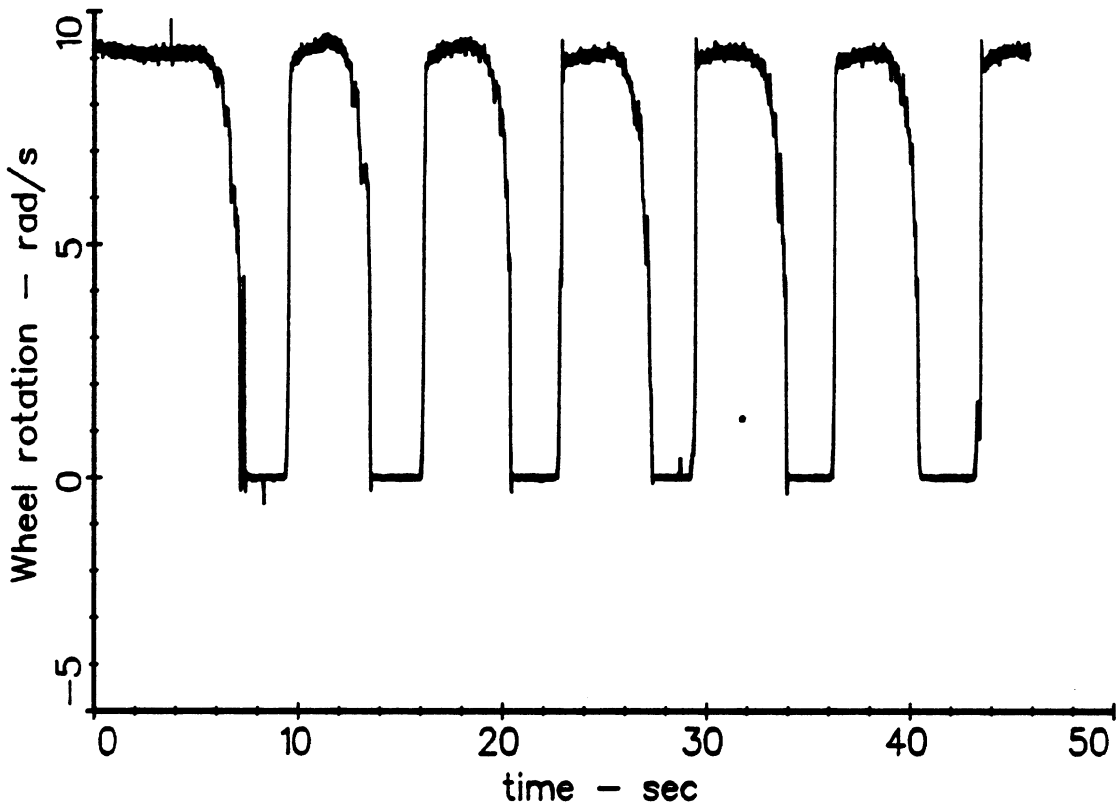

04/02/87 11:52:39 MICH 11R22.5 SINGLE 4000 AT 10MPH

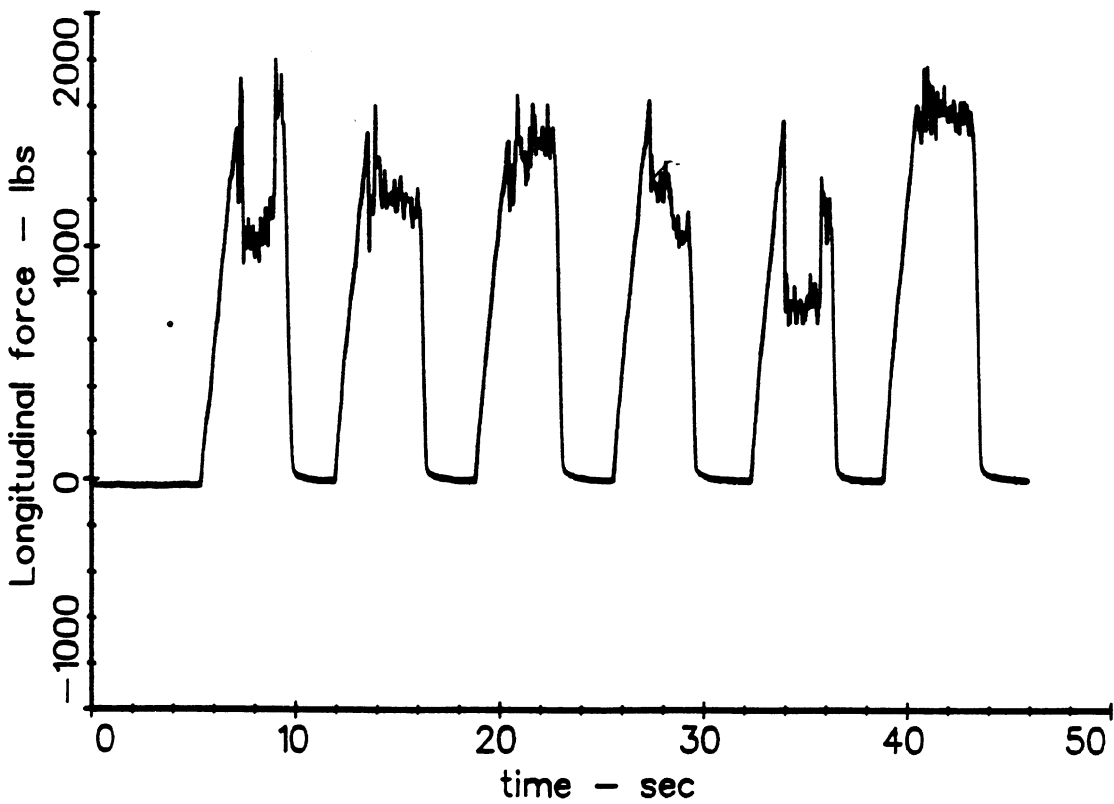

04/02/87 11:52:39 MICH 11R22.5 SINGLE 4000 AT 10MPH

60

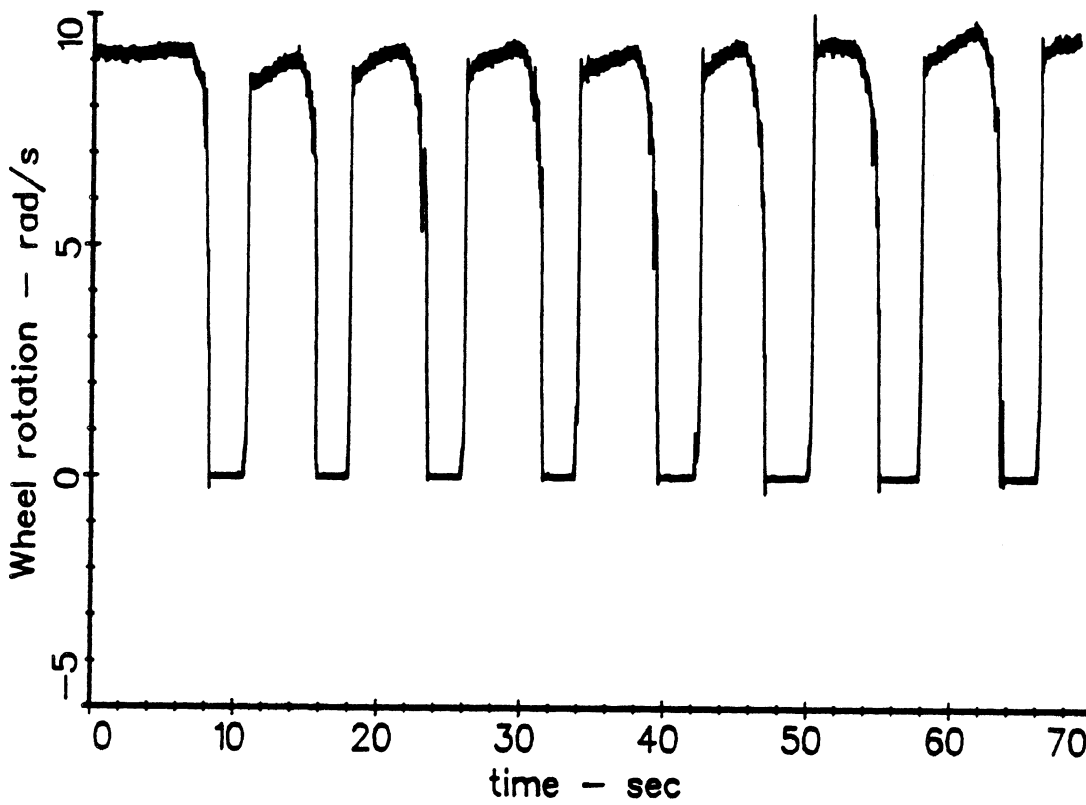

04/02/87 11:57:37 MICH 11R22.5 SINGLE 6000 AT 10MPH

61

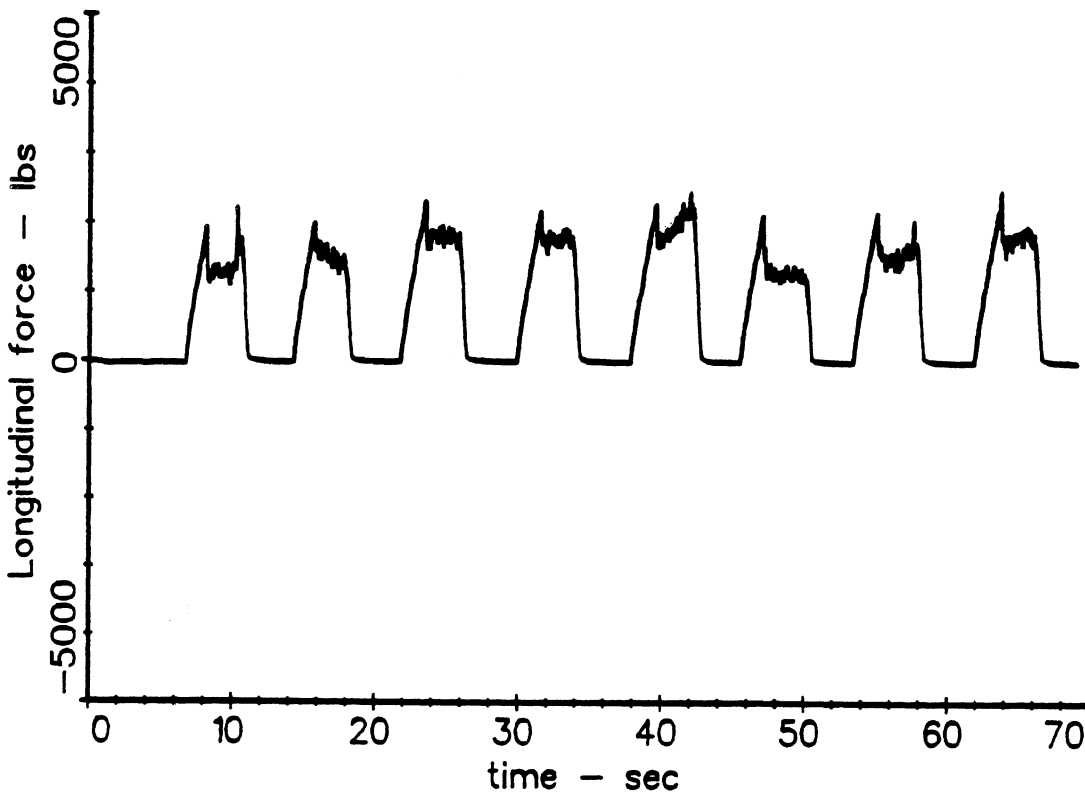

04/02/87 11:57:37 MICH 11R22.5 SINGLE 6000 AT 10MPH



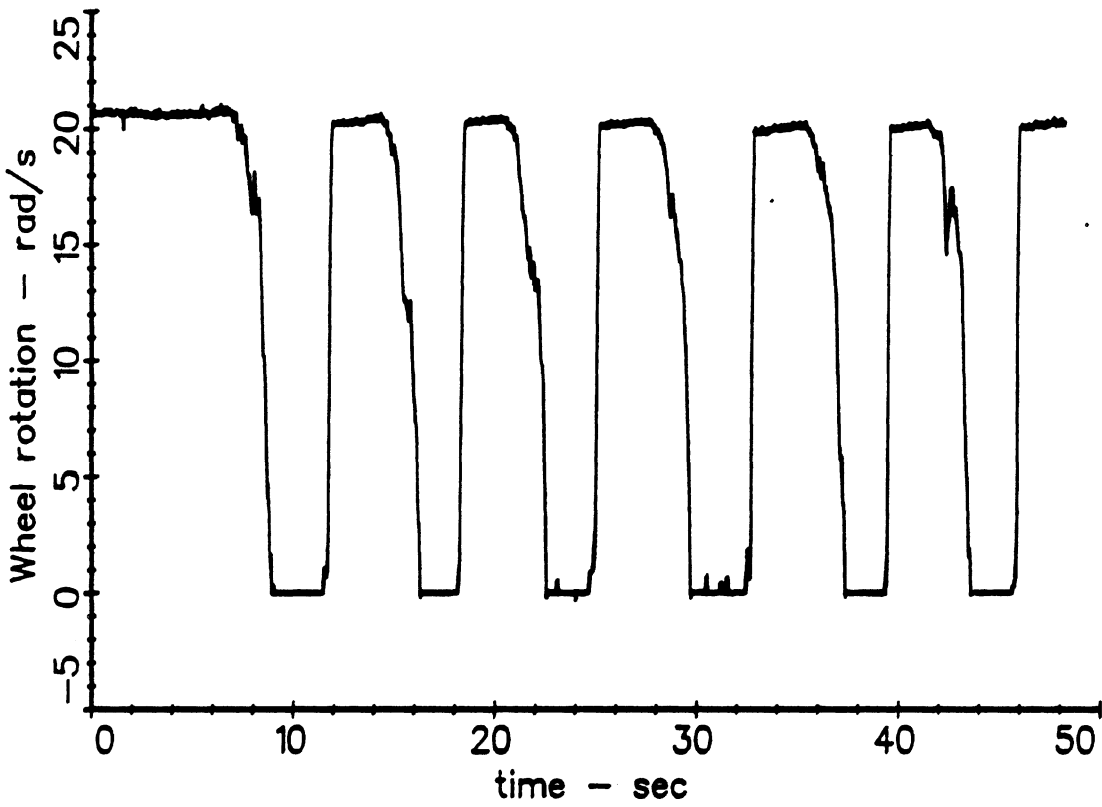

04/02/87 13:03:00 MICH 11R22.5 SINGLE 2000 AT  
25MPH

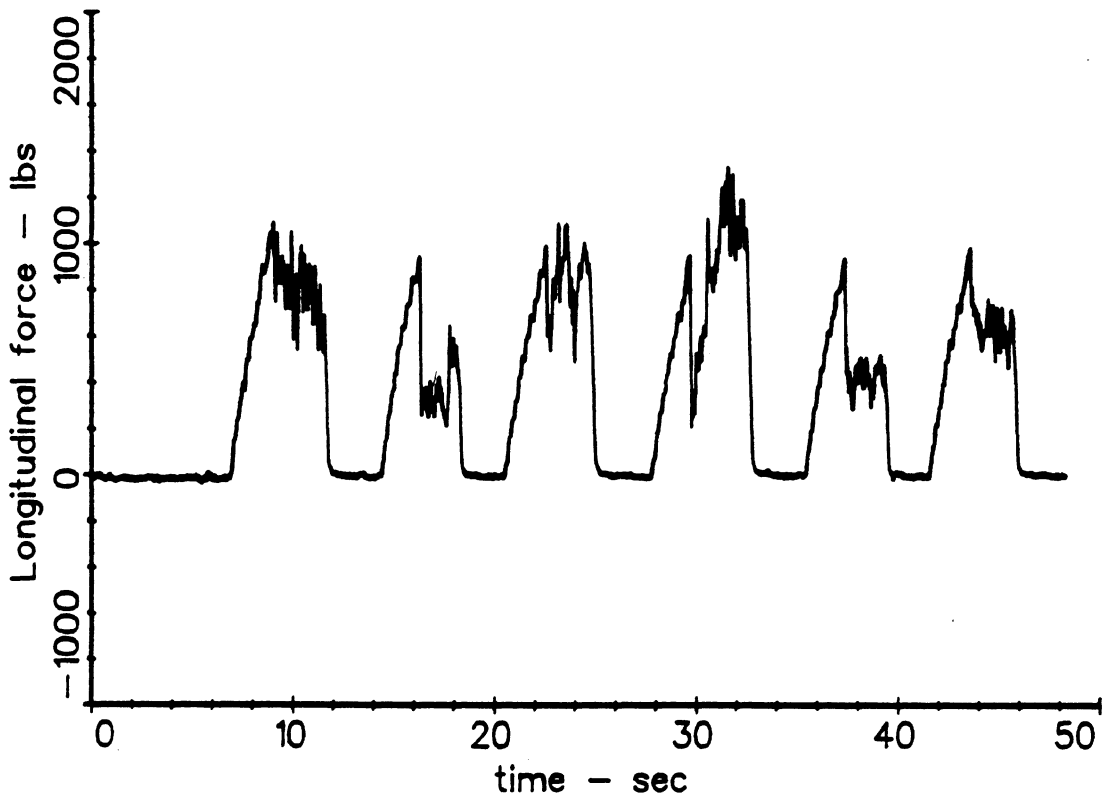

64

04/02/87 13:03:00 MICH 11R22.5 SINGLE 2000 AT  
25MPH

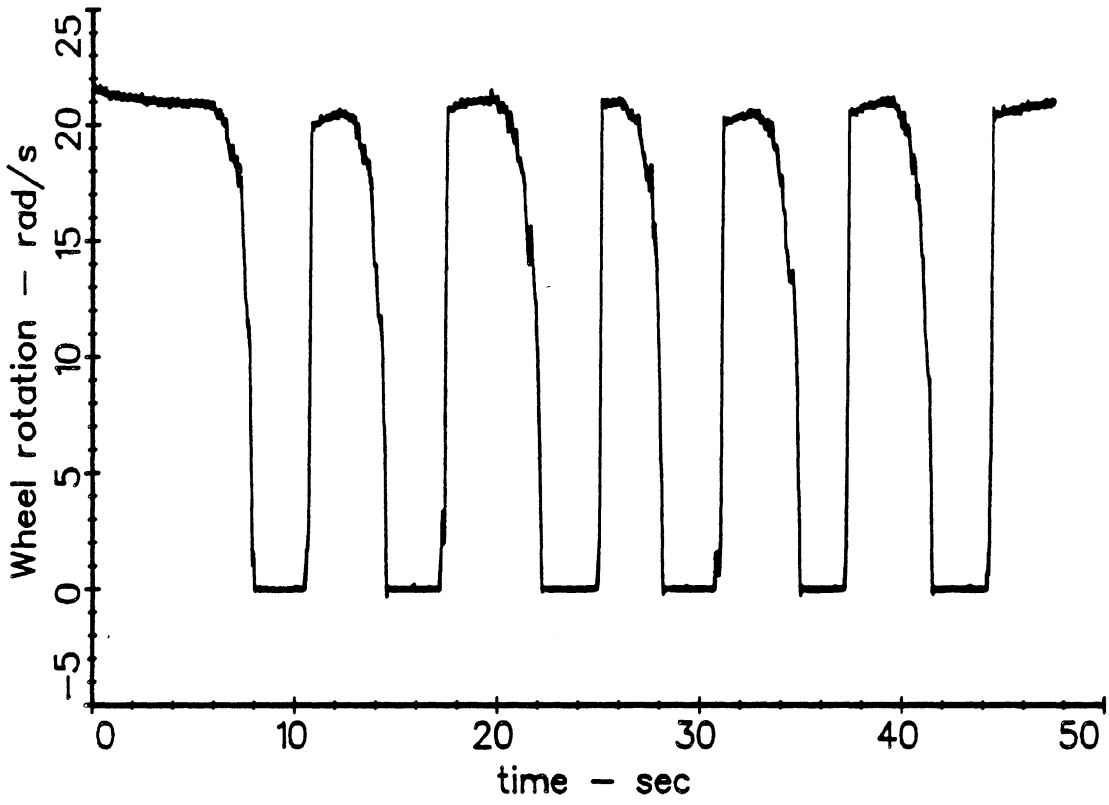

04/02/87 13:06:14 MICH 11R22.5 SINGLE 4000 AT  
25MPH

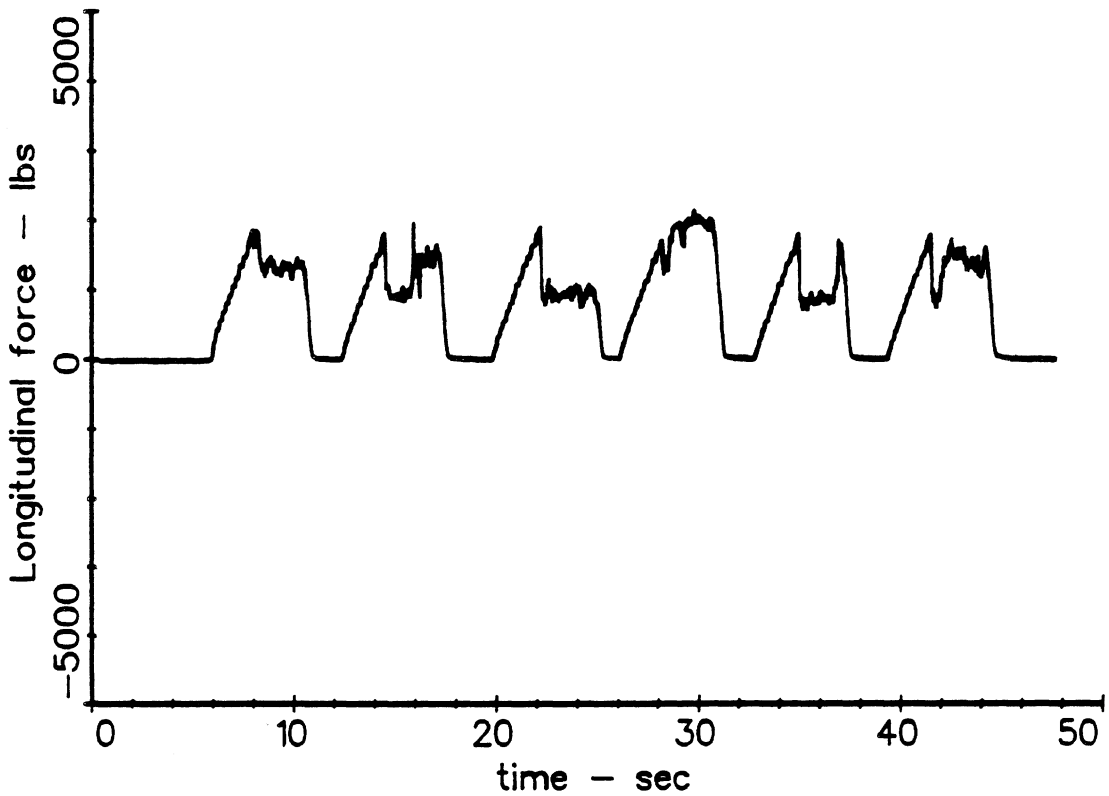

65

04/02/87 13:06:14 MICH 11R22.5 SINGLE 4000 AT  
25MPH

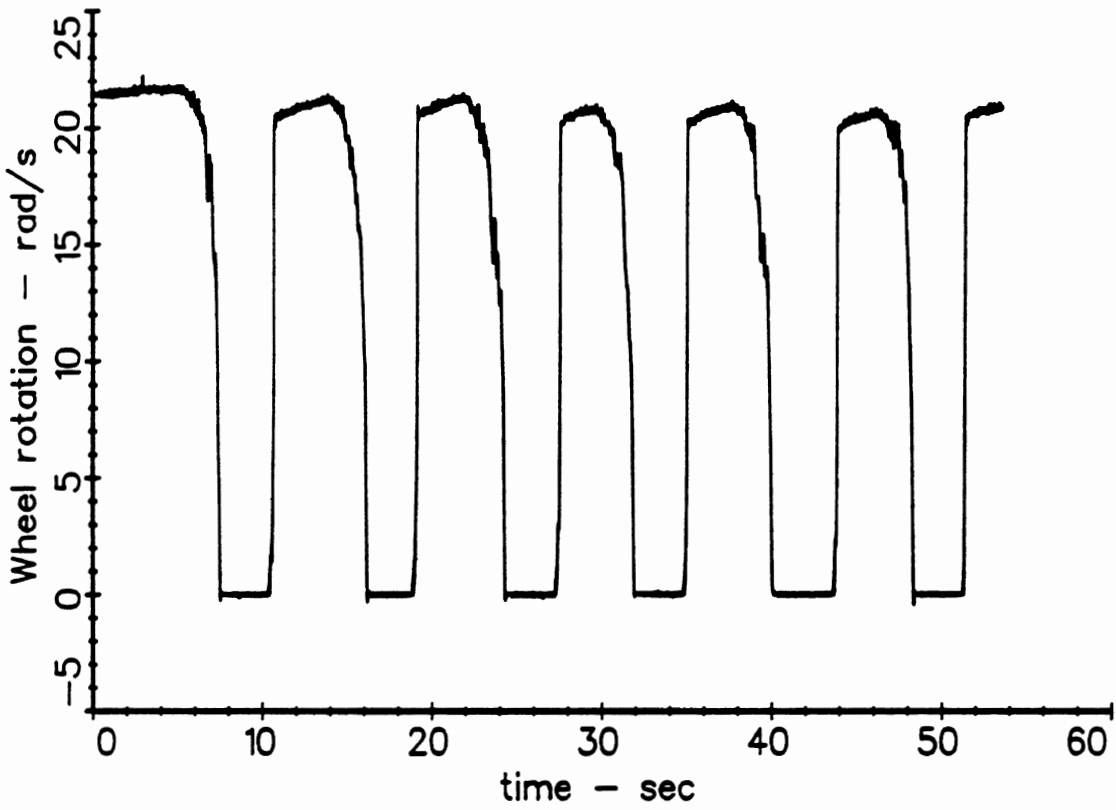

04/02/87 13:10:35 MICH 11R22.5 SINGLE 6000 AT  
25MPH

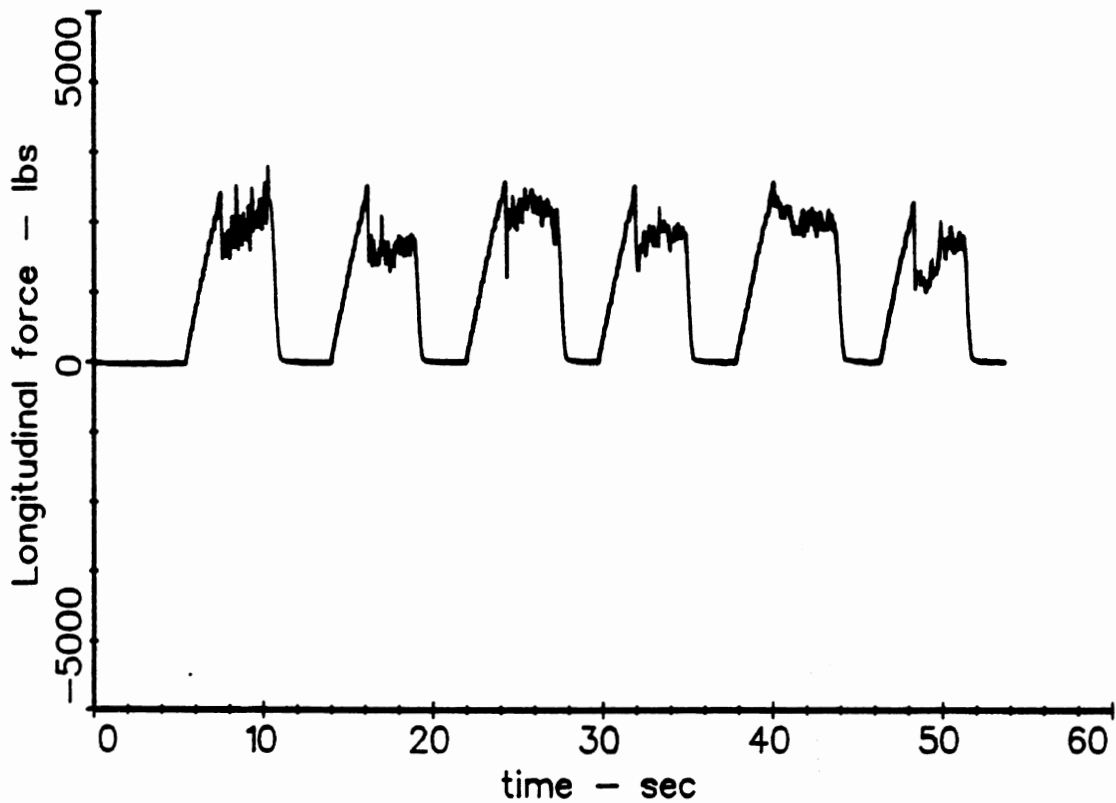

66

04/02/87 13:10:35 MICH 11R22.5 SINGLE 6000 AT  
25MPH

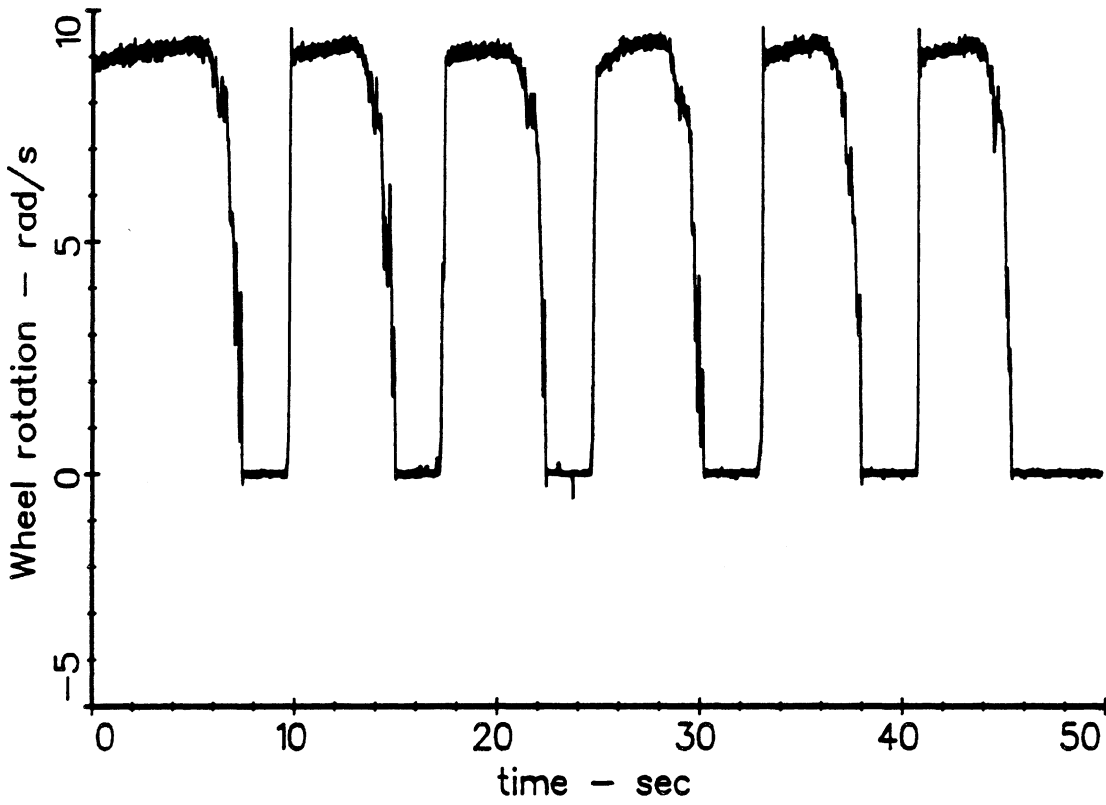

04/02/87 13:22:18 MICH 11R22.5 REINFCD 2000 AT  
10MPH

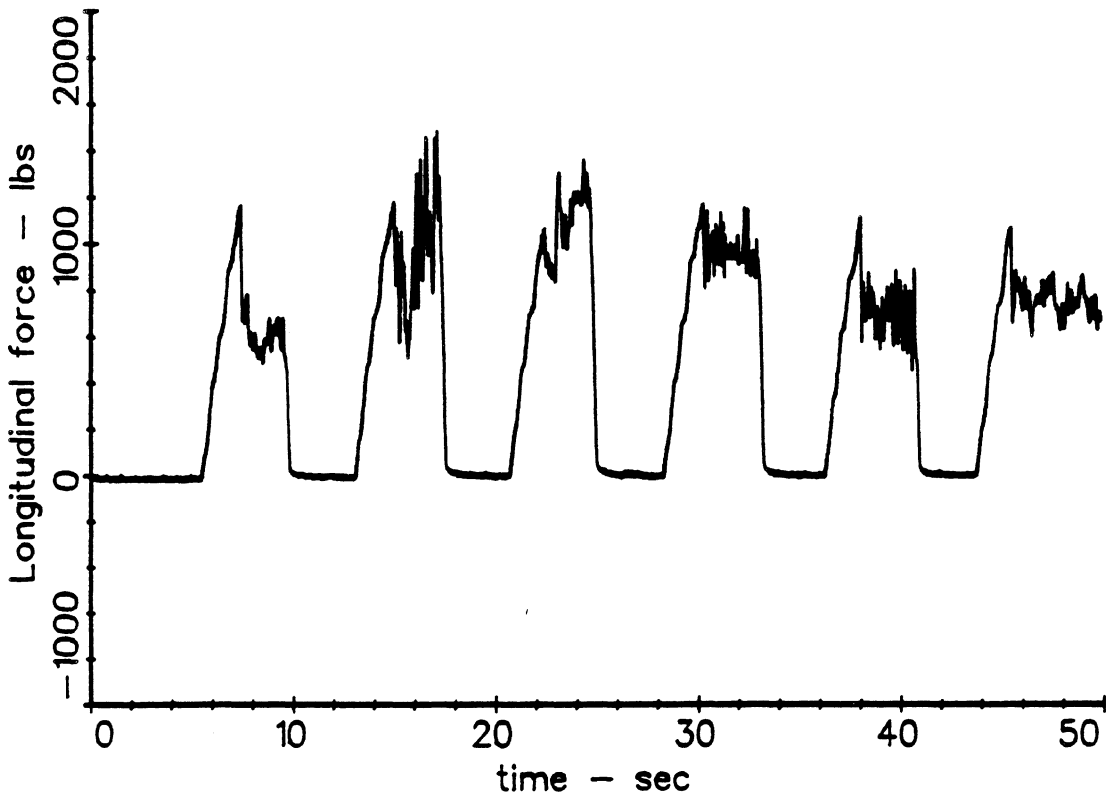

69

04/02/87 13:22:18 MICH 11R22.5 REINFCD 2000 AT  
10MPH

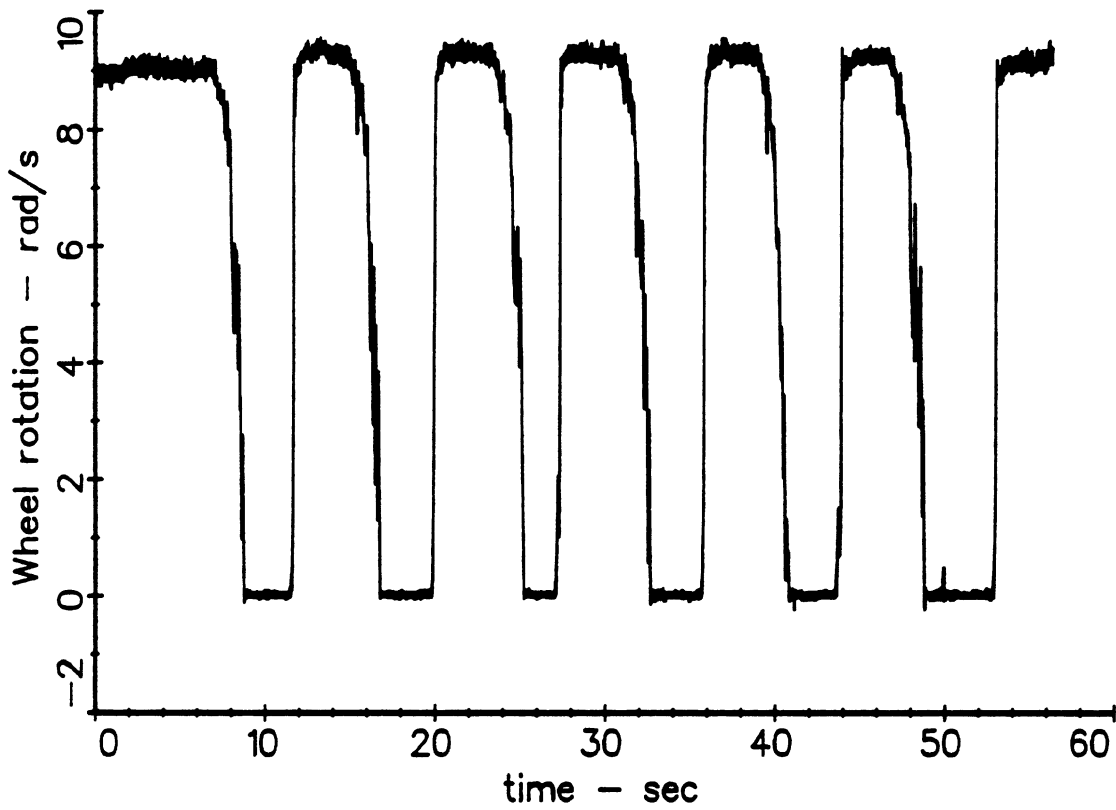

04/02/87 13:28:56 MICH 11R22.5 REINFCD 4000 AT  
10MPH

70

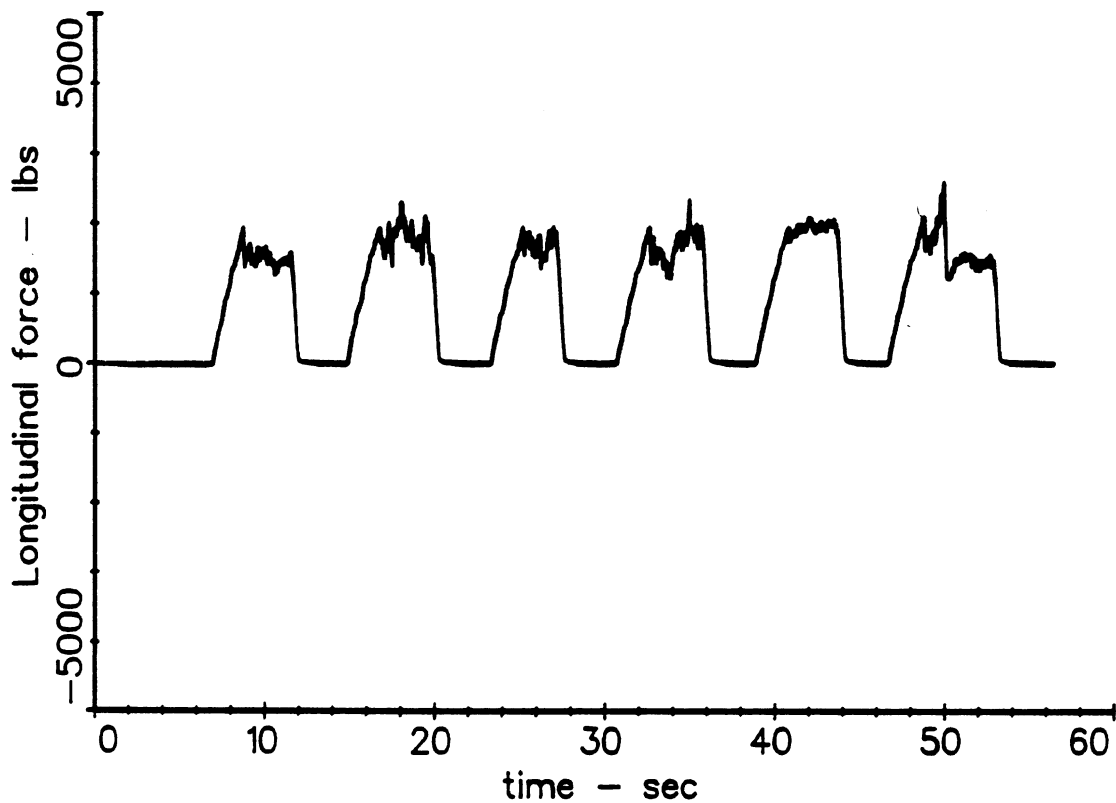

04/02/87 13:28:56 MICH 11R22.5 REINFCD 4000 AT  
10MPH

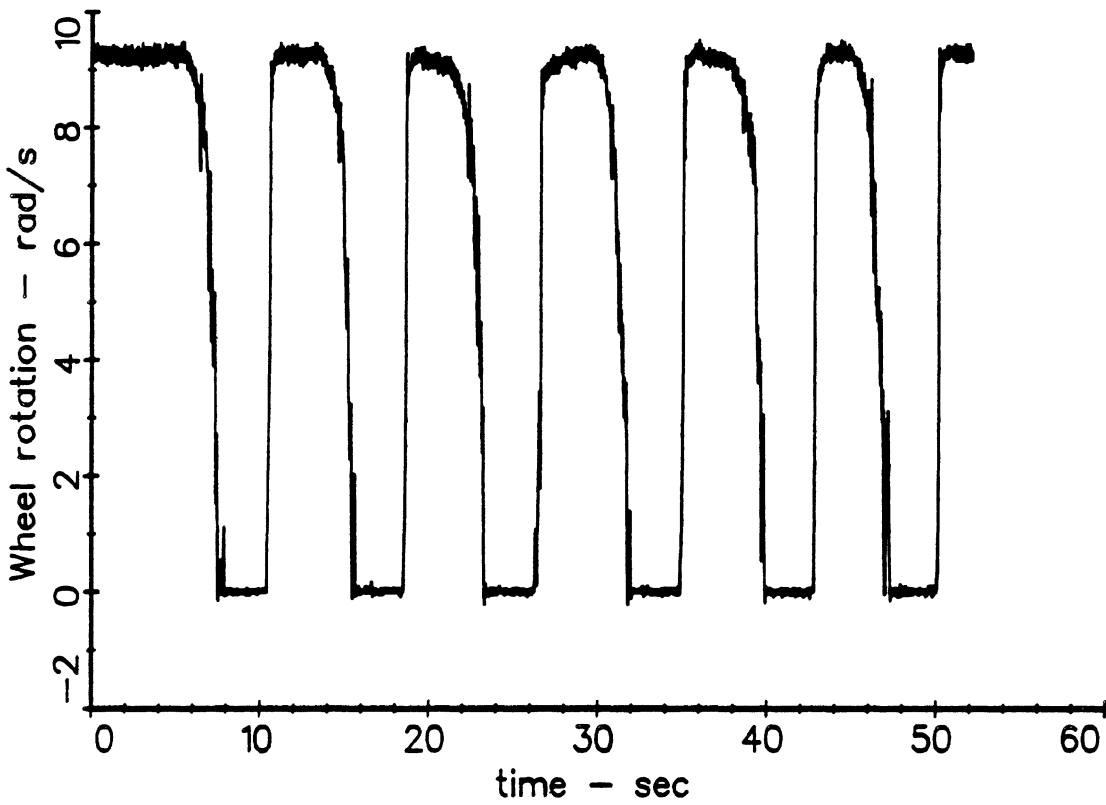

04/02/87 13:34:11 MICH 11R22.5 REINFC D 6000 AT 10MPH

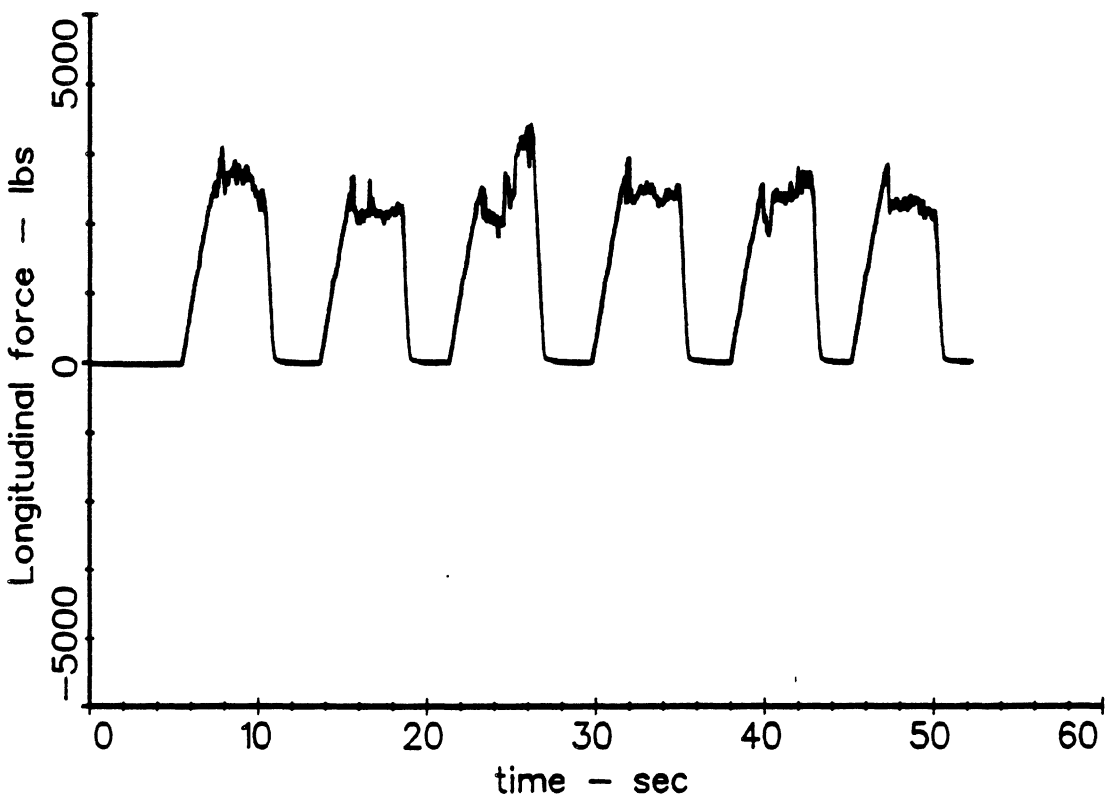

04/02/87 13:34:11 MICH 11R22.5 REINFC D 6000 AT 10MPH

71

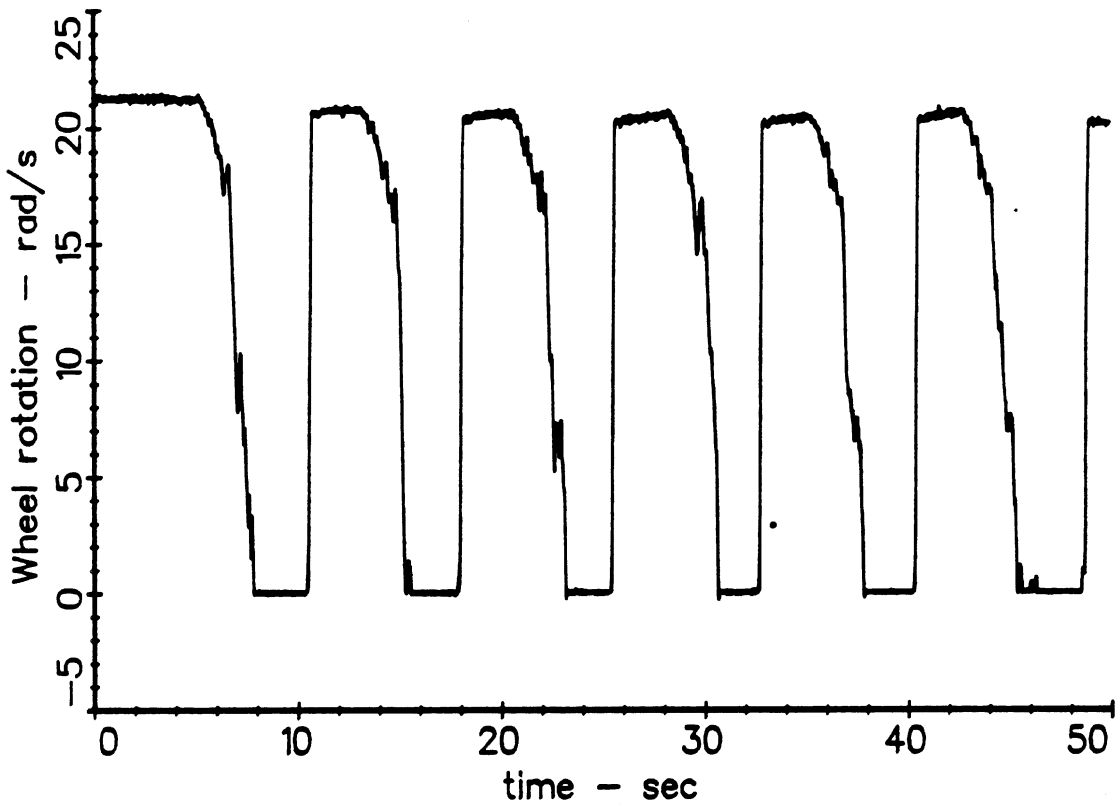

04/02/87 13:40:26 MICH 11R22.5 REINFCD 2000 AT  
25MPH

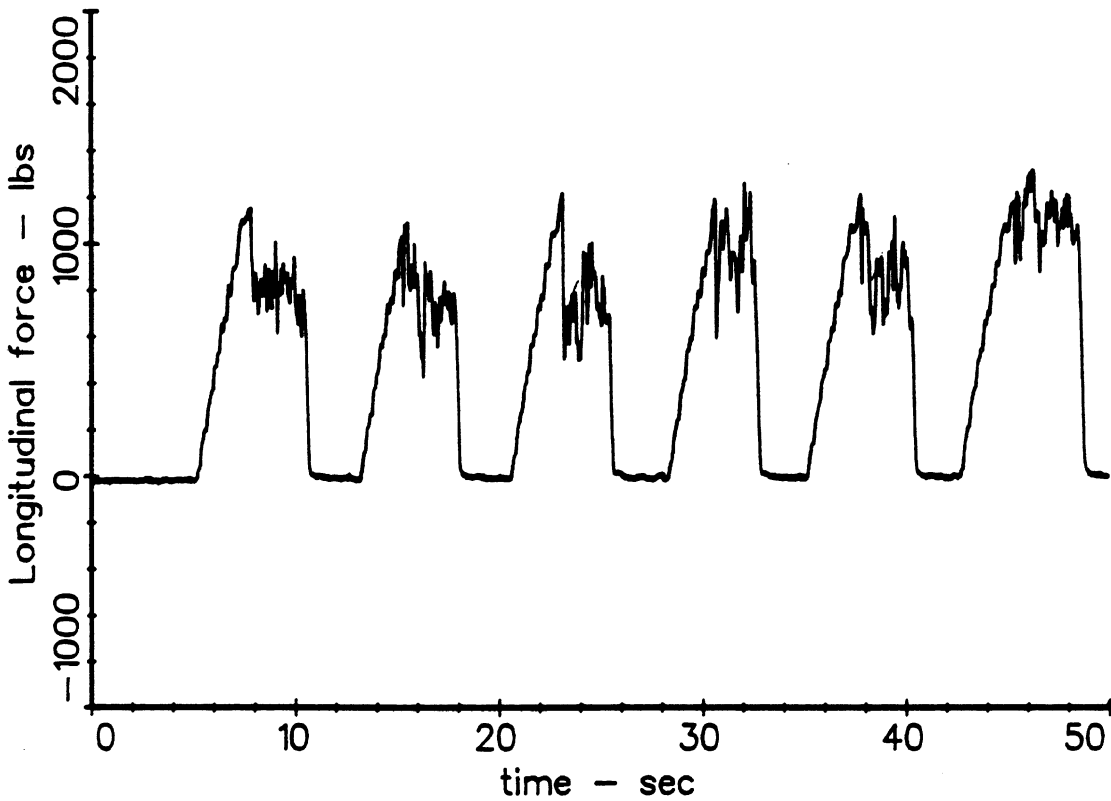

74

04/02/87 13:40:26 MICH 11R22.5 REINFCD 2000 AT  
25MPH

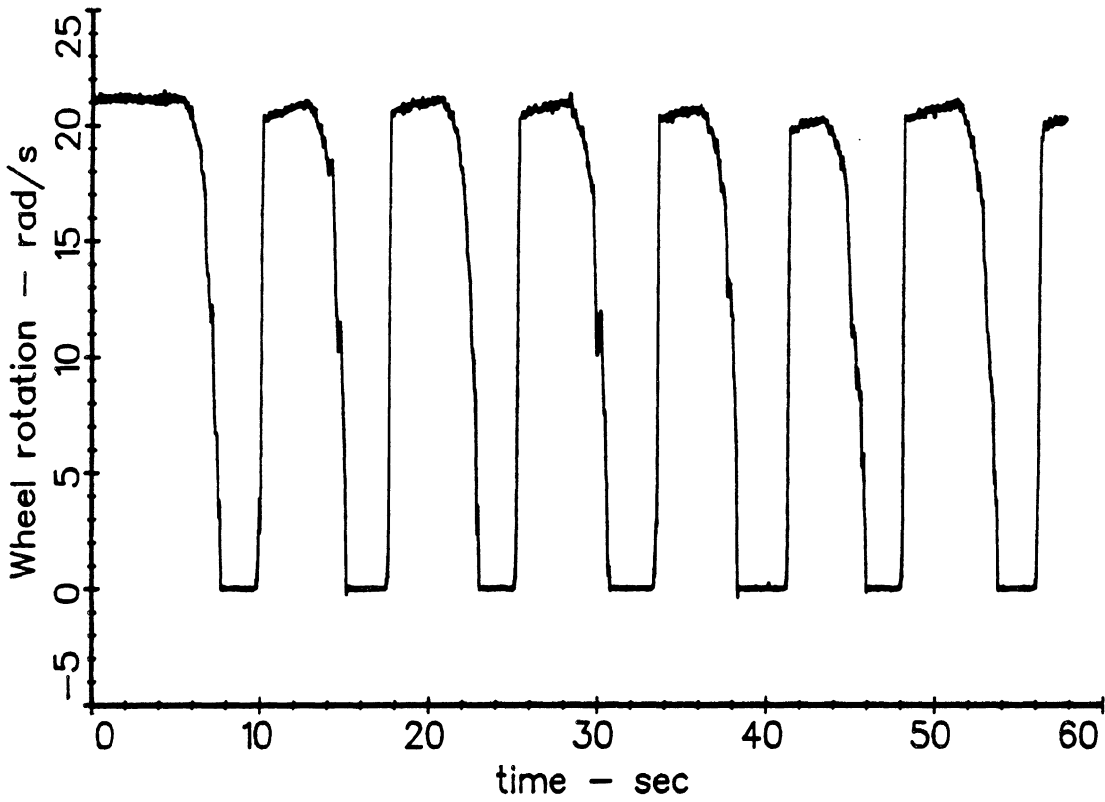

04/02/87 13:43:35 MICH 11R22.5 REINFCD 4000 AT  
25MPH

75

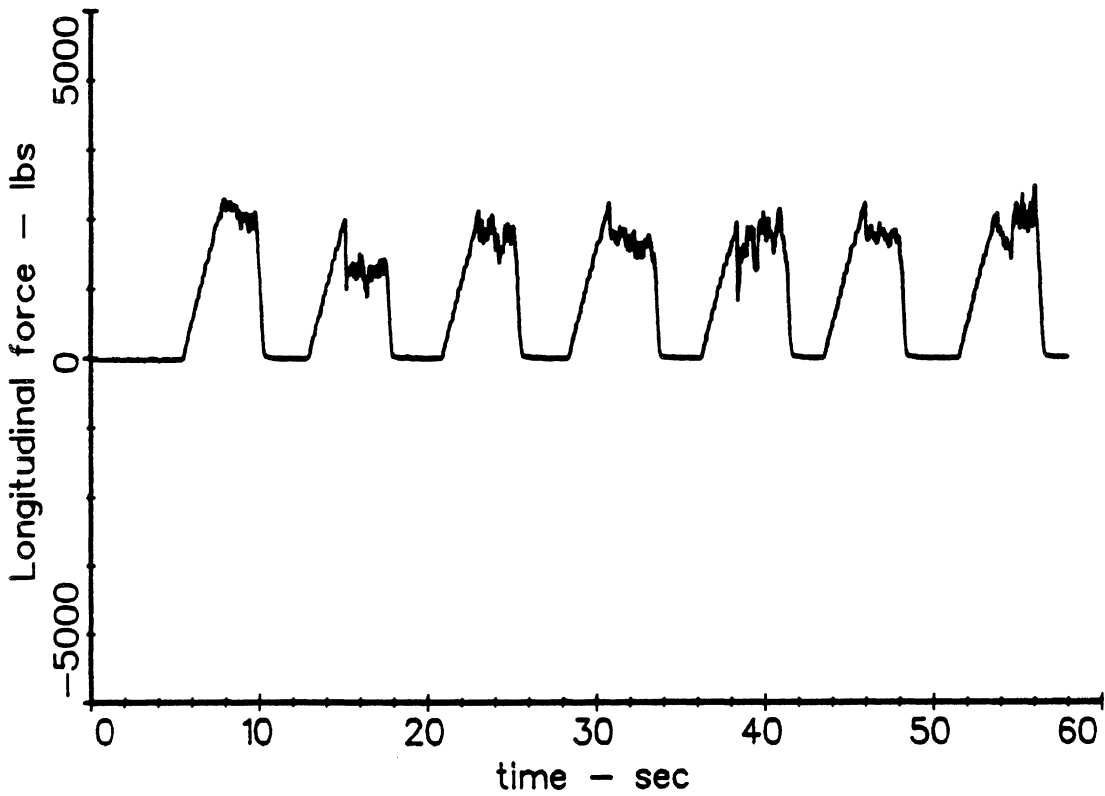

04/02/87 13:43:35 MICH 11R22.5 REINFCD 4000 AT  
25MPH



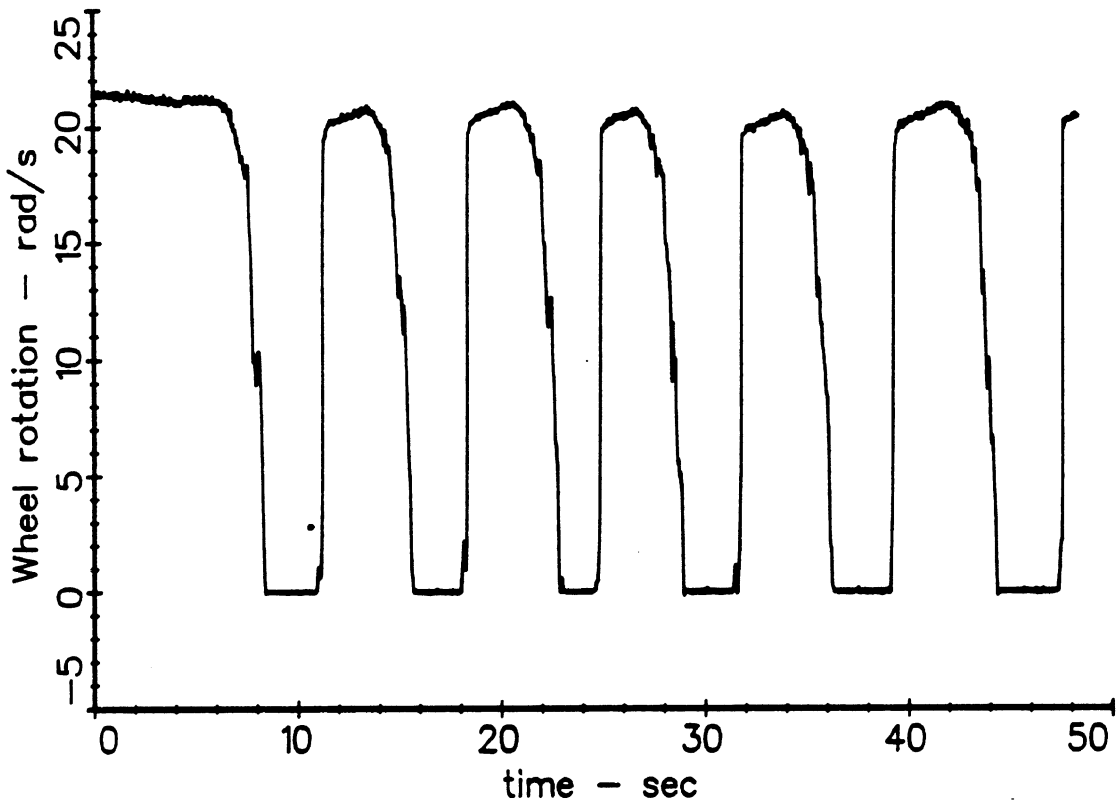

04/02/87 13:50:14 MICH 11R22.5 REINFCD 6000 AT  
25MPH

76

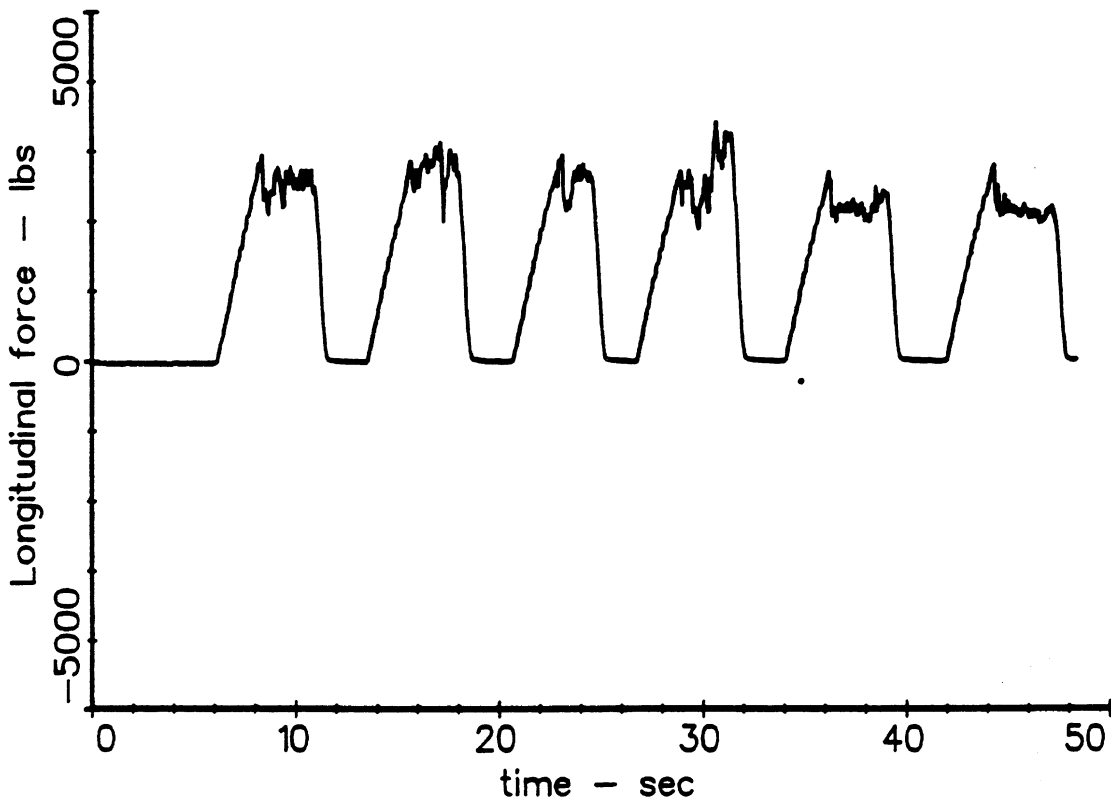

04/02/87 13:50:14 MICH 11R22.5 REINFCD 6000 AT  
25MPH

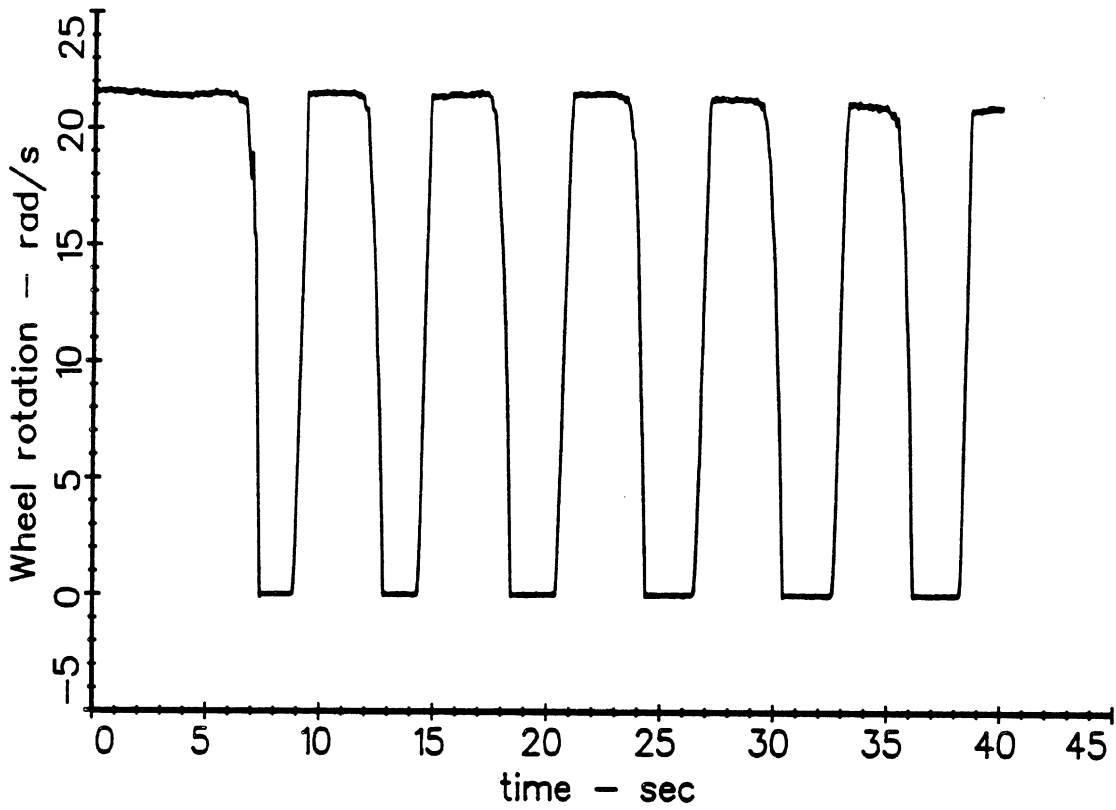

04/02/87 14:00:02 MICH 11R22.5 NO CHAINS 2000 AT  
25MPH

79

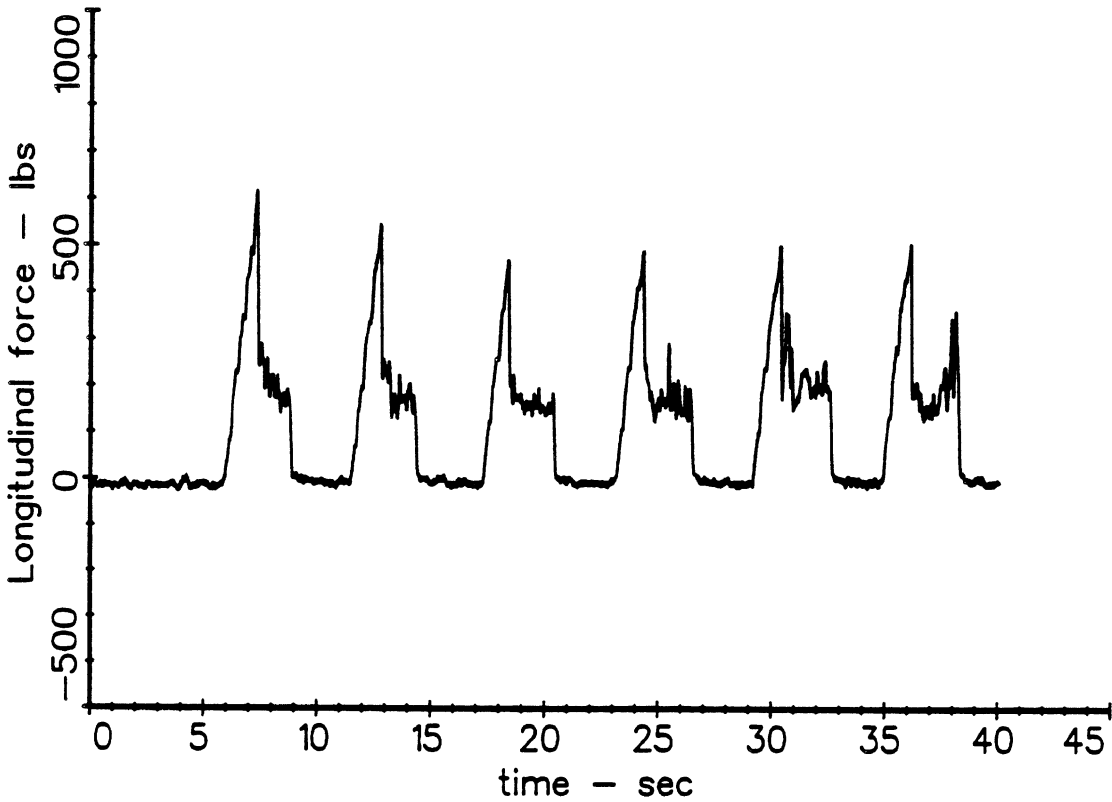

04/02/87 14:00:02 MICH 11R22.5 NO CHAINS 2000 AT  
25MPH

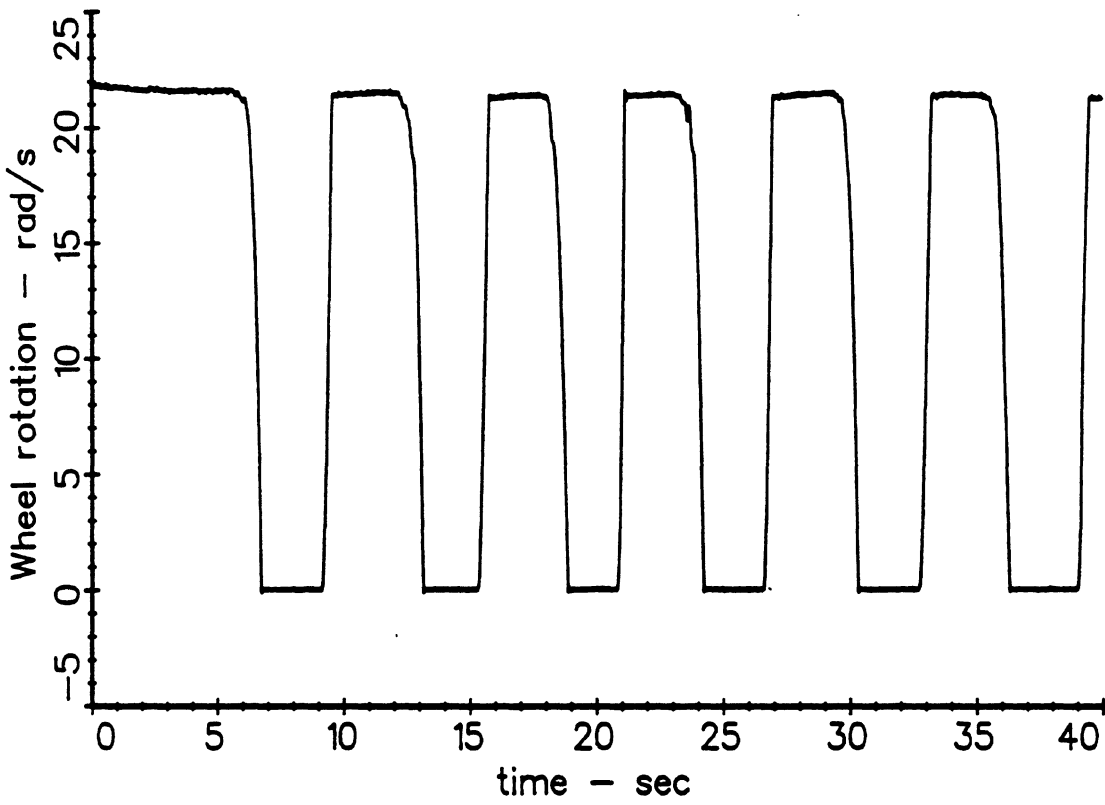

04/02/87 14:02:55 MICH 11R22.5 NO CHAINS 4000 AT  
25MPH

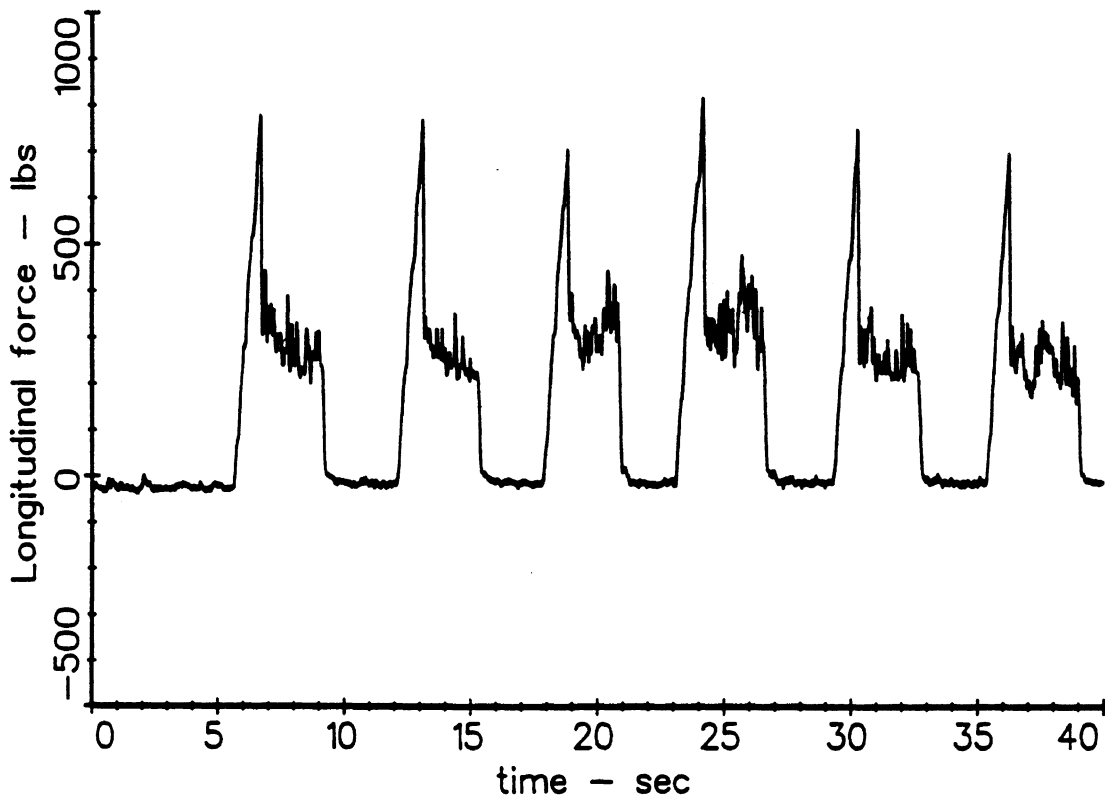

04/02/87 14:02:55 MICH 11R22.5 NO CHAINS 4000 AT  
25MPH

80

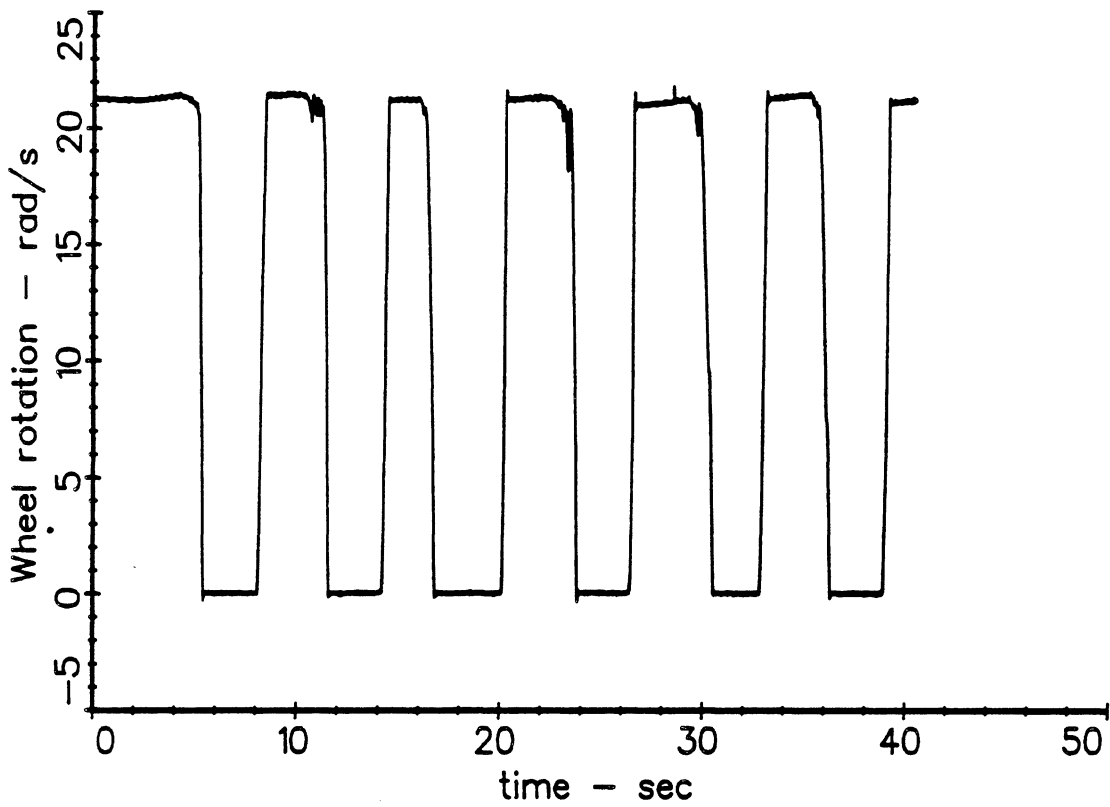

04/02/87 14:05:27 MICH 11R22.5 NO CHAINS 6000 AT  
25MPH

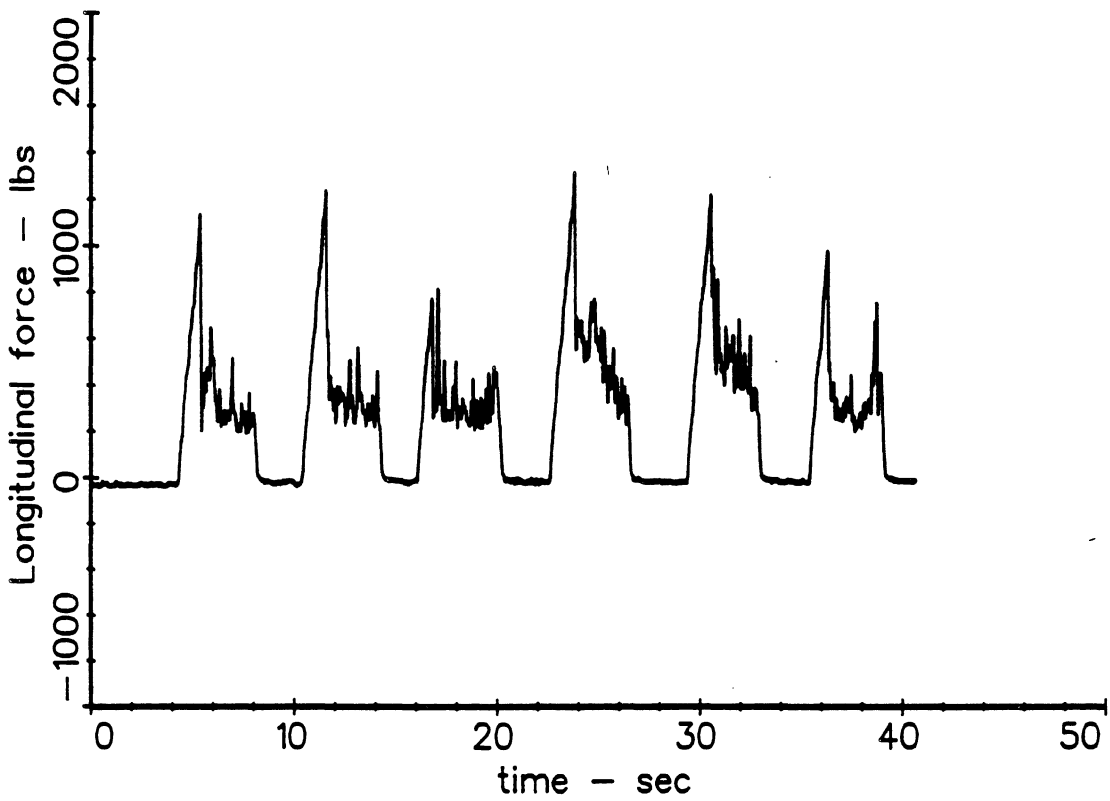

81

04/02/87 14:05:27 MICH 11R22.5 NO CHAINS 6000 AT  
25MPH

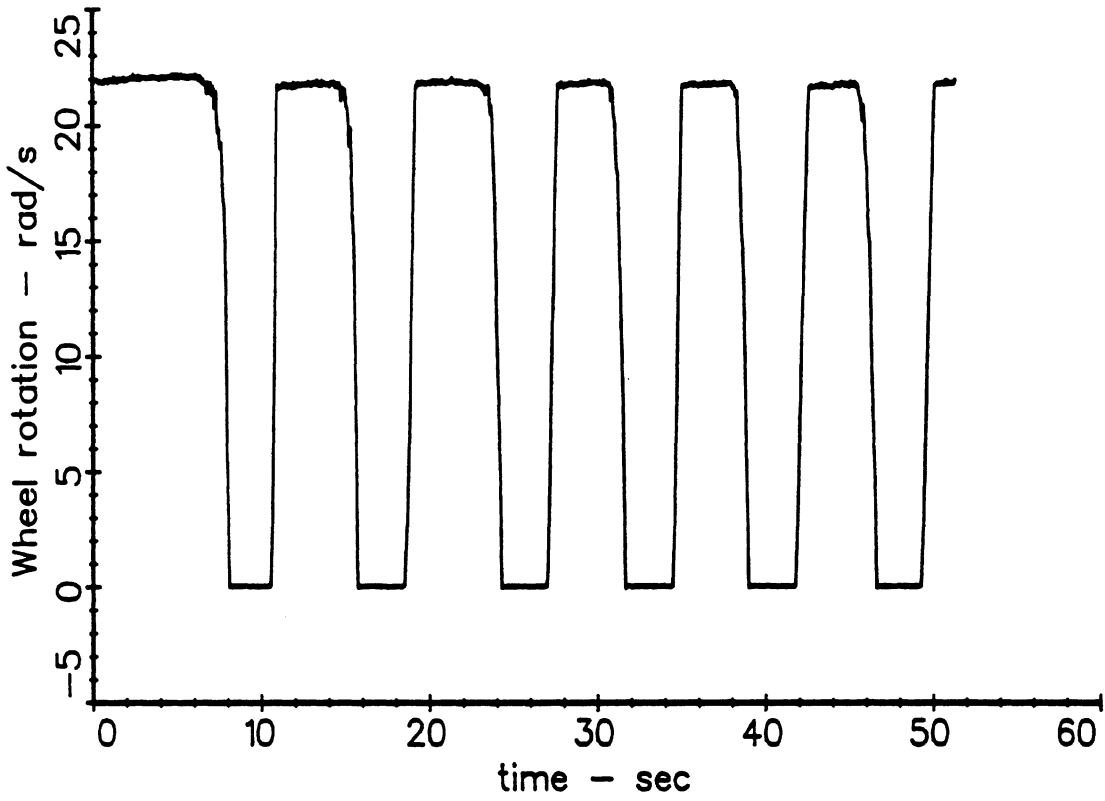

04/02/87 14:22:21 GD YR 295/75R22.5 NO CHA 2000 AT  
25MPH

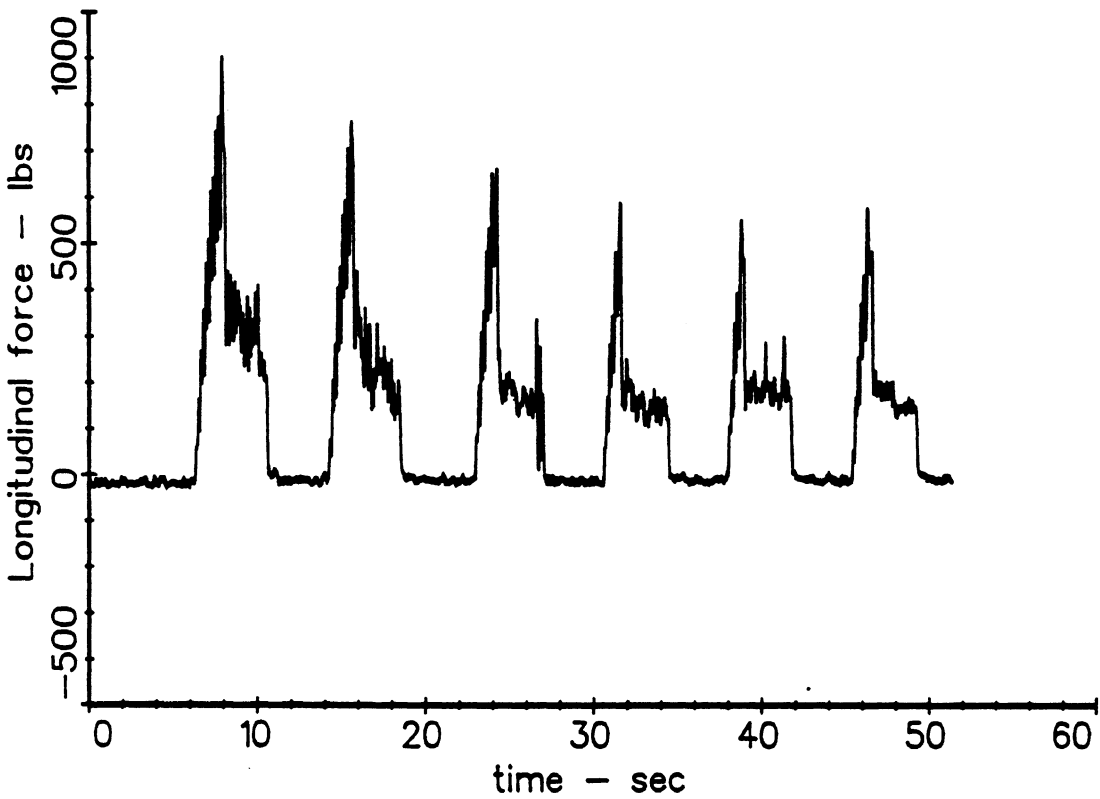

84

04/02/87 14:22:21 GD YR 295/75R22.5 NO CHA 2000 AT  
25MPH

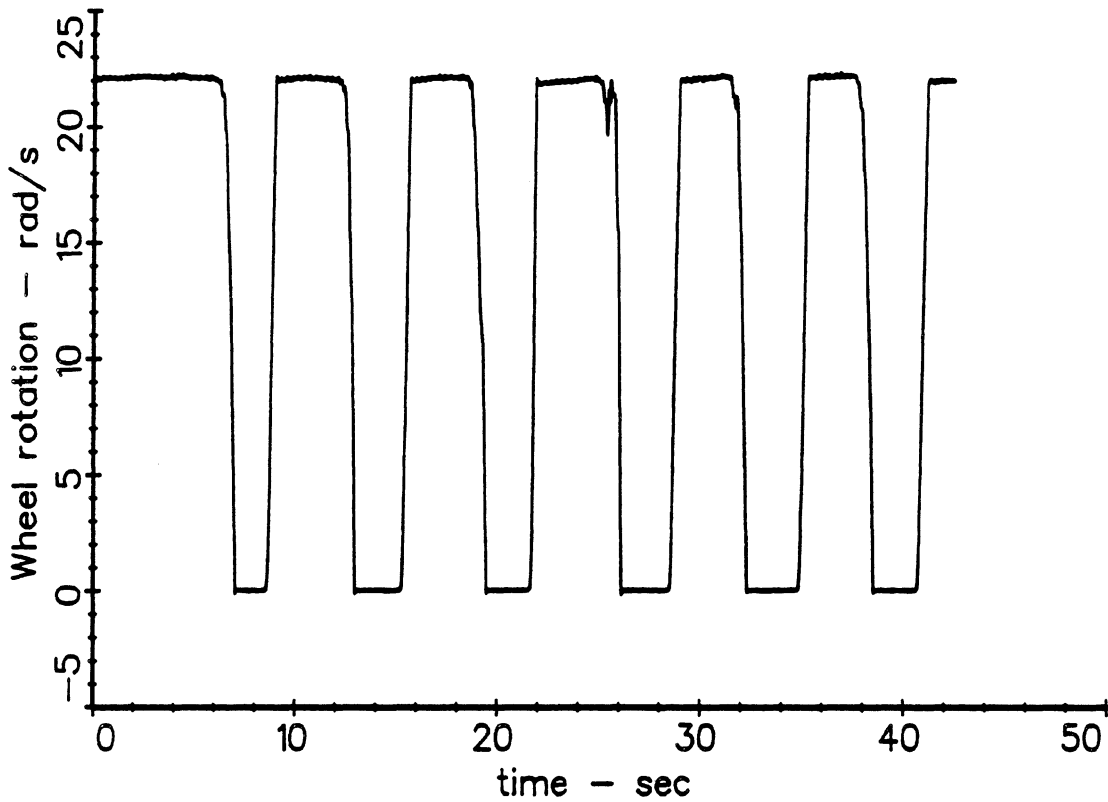

04/02/87 14:24:16 GD YR 295/75R22.5 NO CHA 4000 AT  
25MPH

85

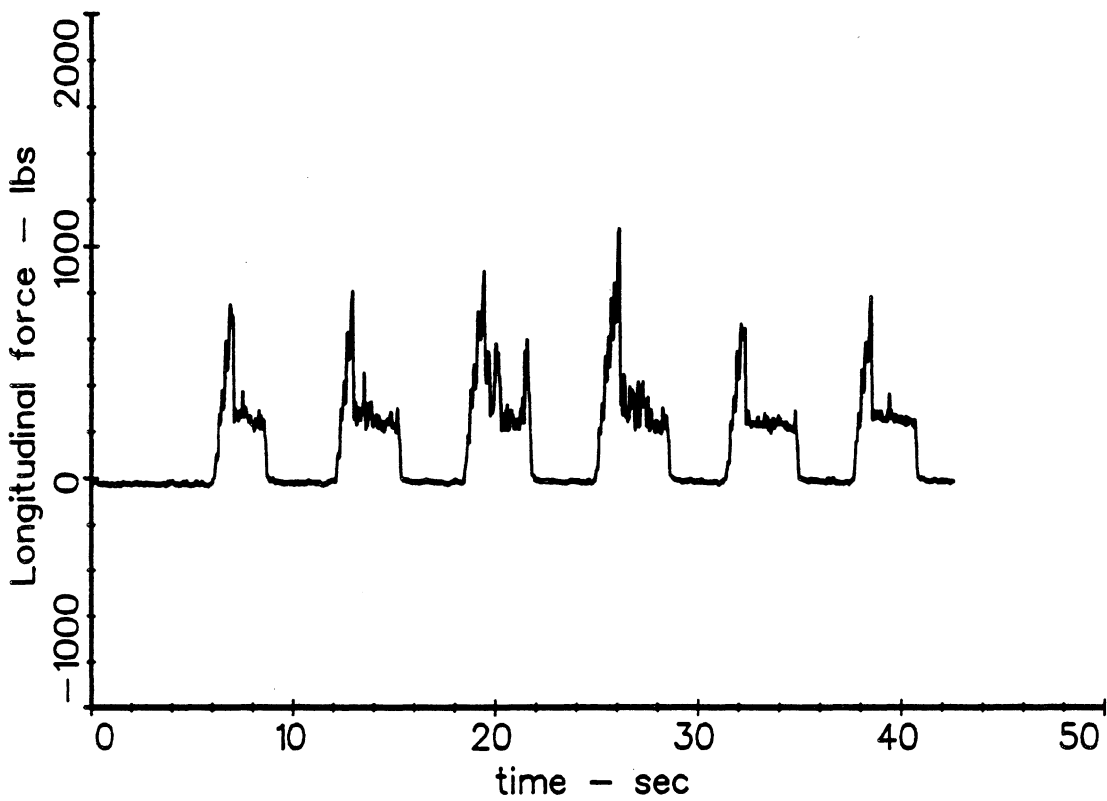

04/02/87 14:24:16 GD YR 295/75R22.5 NO CHA 4000 AT  
25MPH

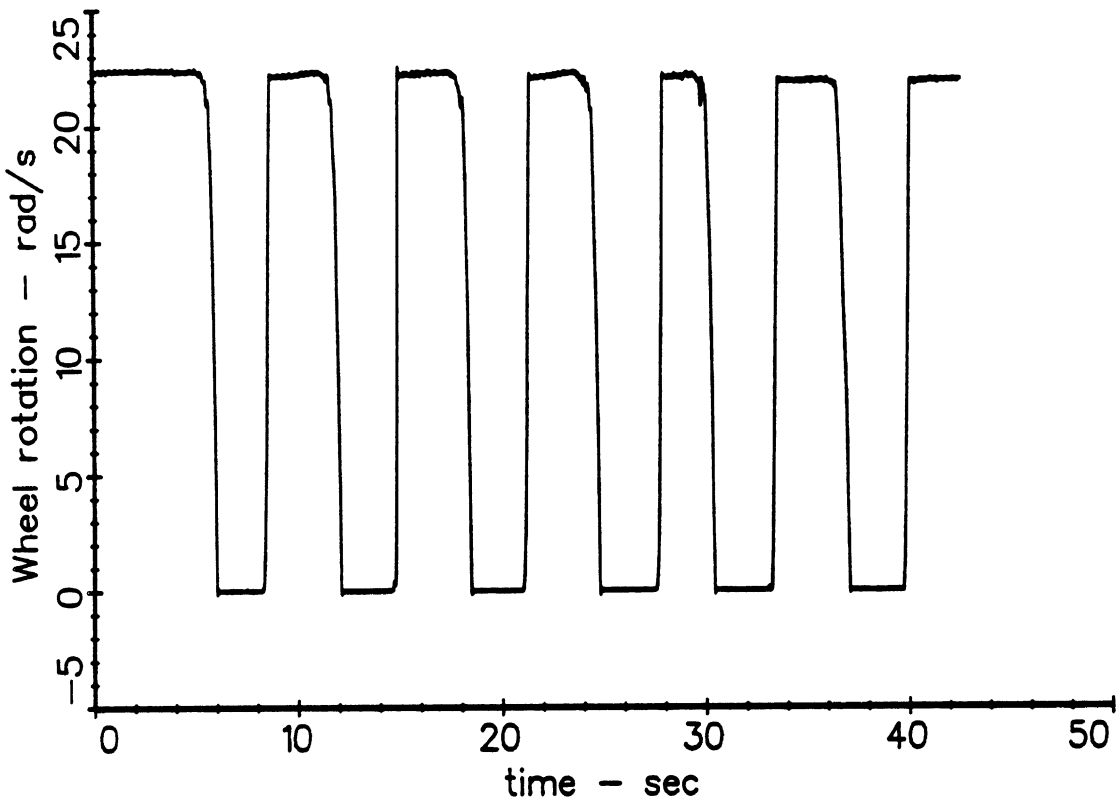

04/02/87 14:26:50 GD YR 295/75R22.5 NO CHA 6000 AT  
25MPH

86

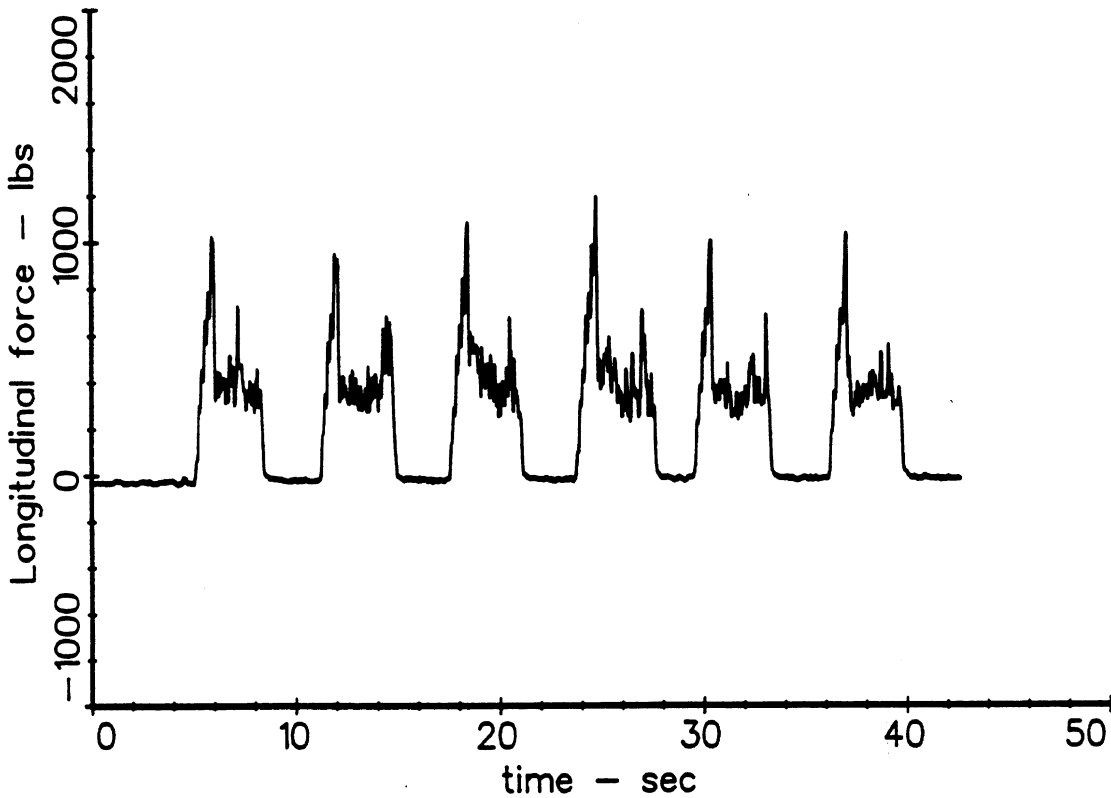

04/02/87 14:26:50 GD YR 295/75R22.5 NO CHA 6000 AT  
25MPH

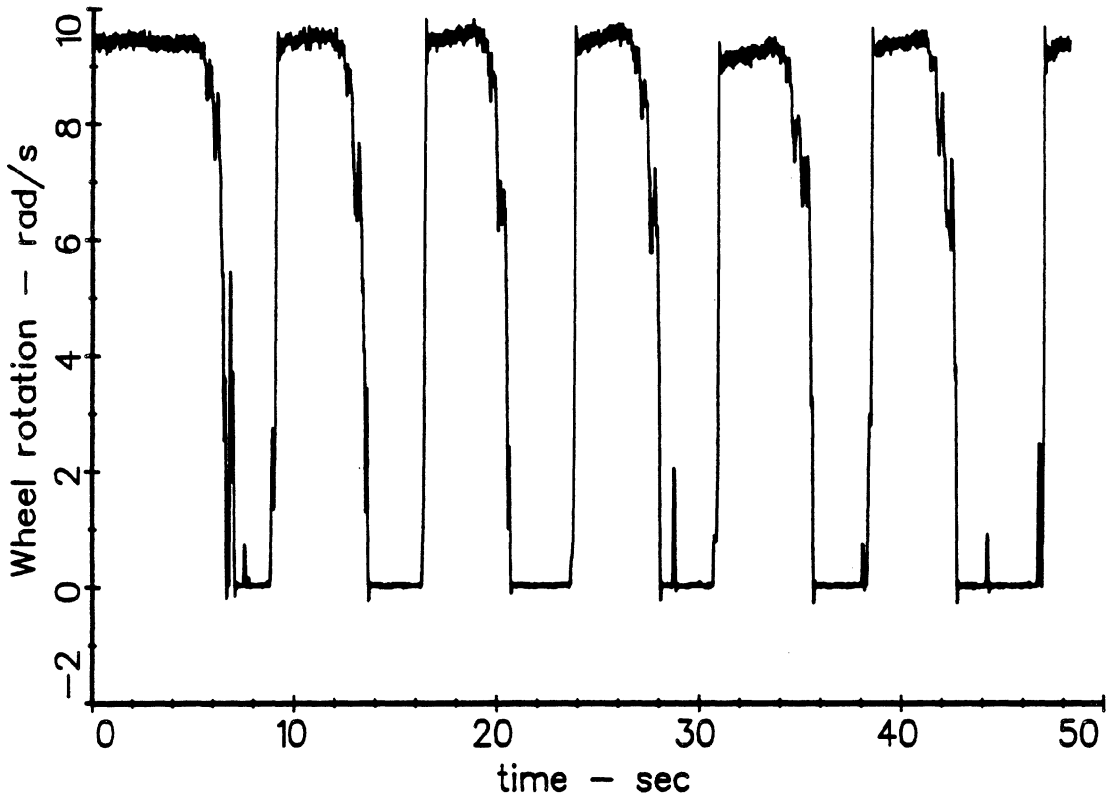

04/02/87 14:41:37 GD YR 295/75R22.5 SINGLE 2000 AT  
10MPH

89

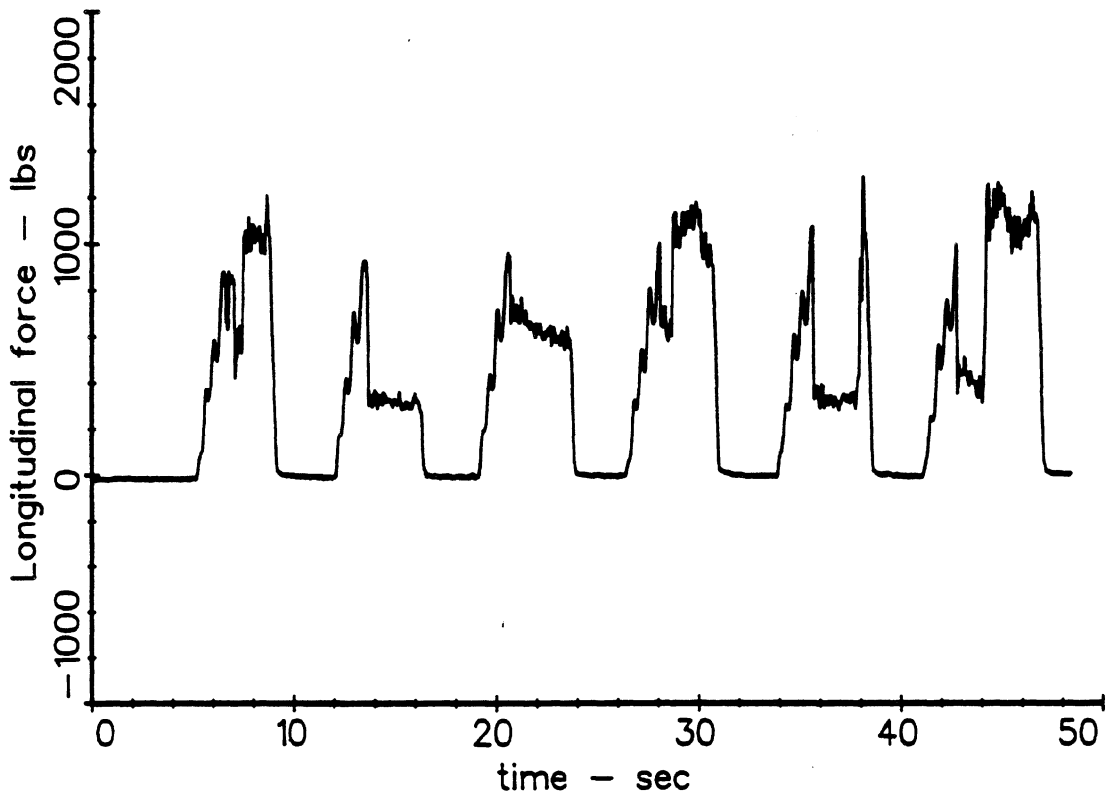

04/02/87 14:41:37 GD YR 295/75R22.5 SINGLE 2000 AT  
10MPH

RUN 09



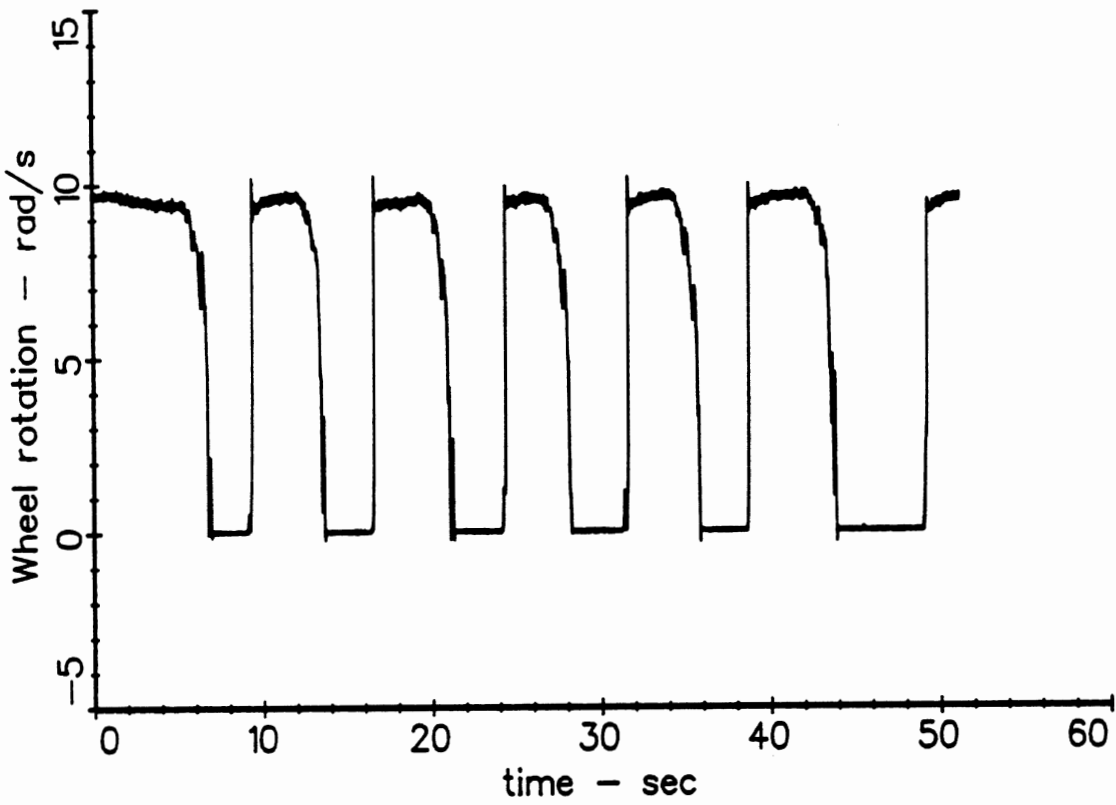

04/02/87 14:43:44 GD YR 295/75R22.5 SINGLE 4000 AT  
10MPH

90

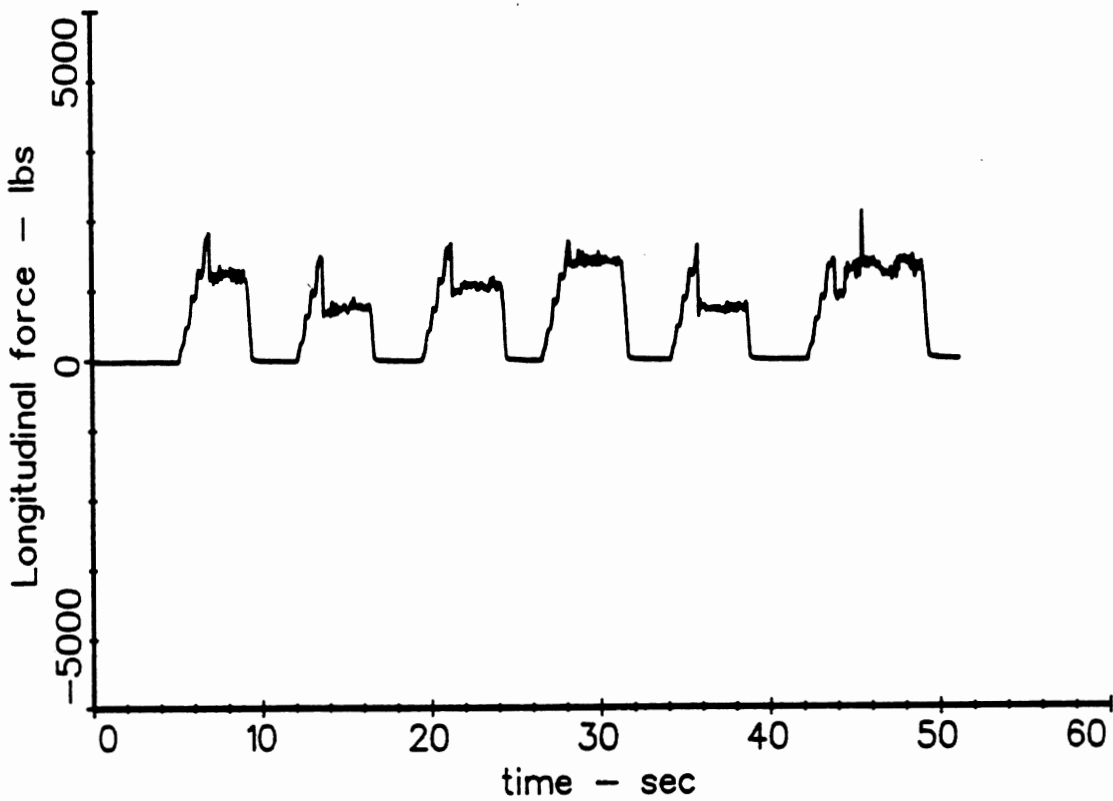

04/02/87 14:43:44 GD YR 295/75R22.5 SINGLE 4000 AT  
10MPH

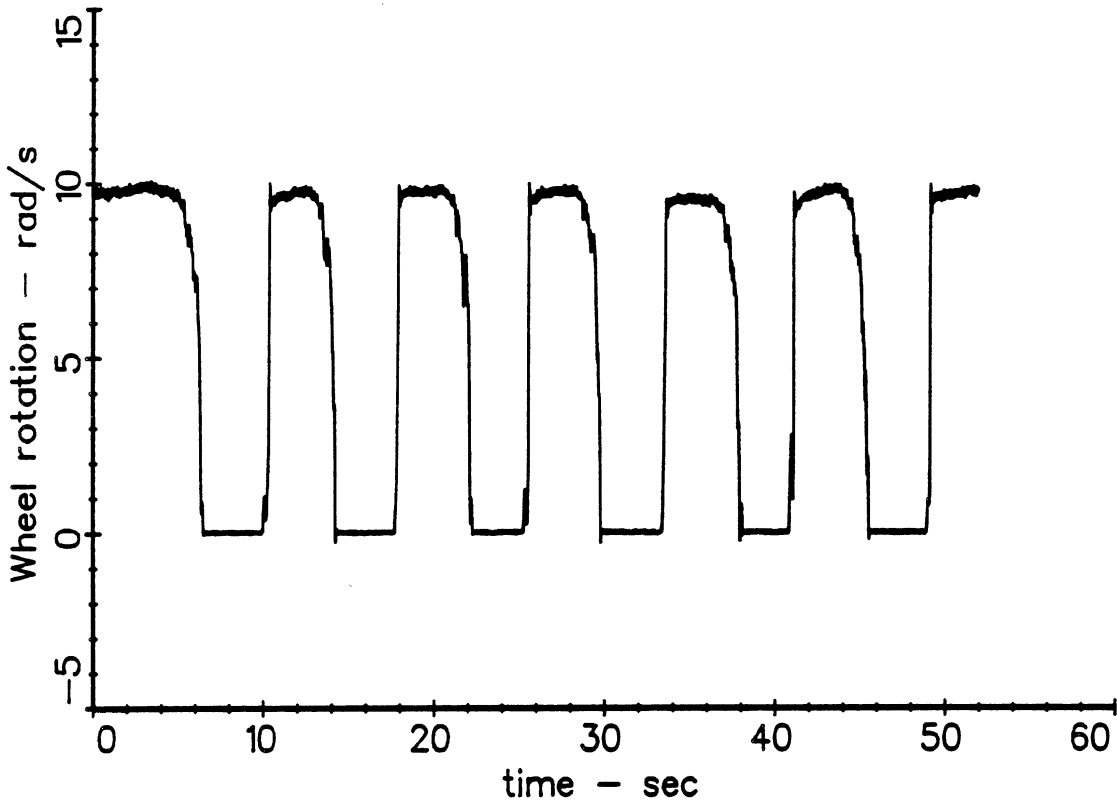

04/02/87 14:45:54 GD YR 295/75R22.5 SINGLE 6000 AT 10MPH

91

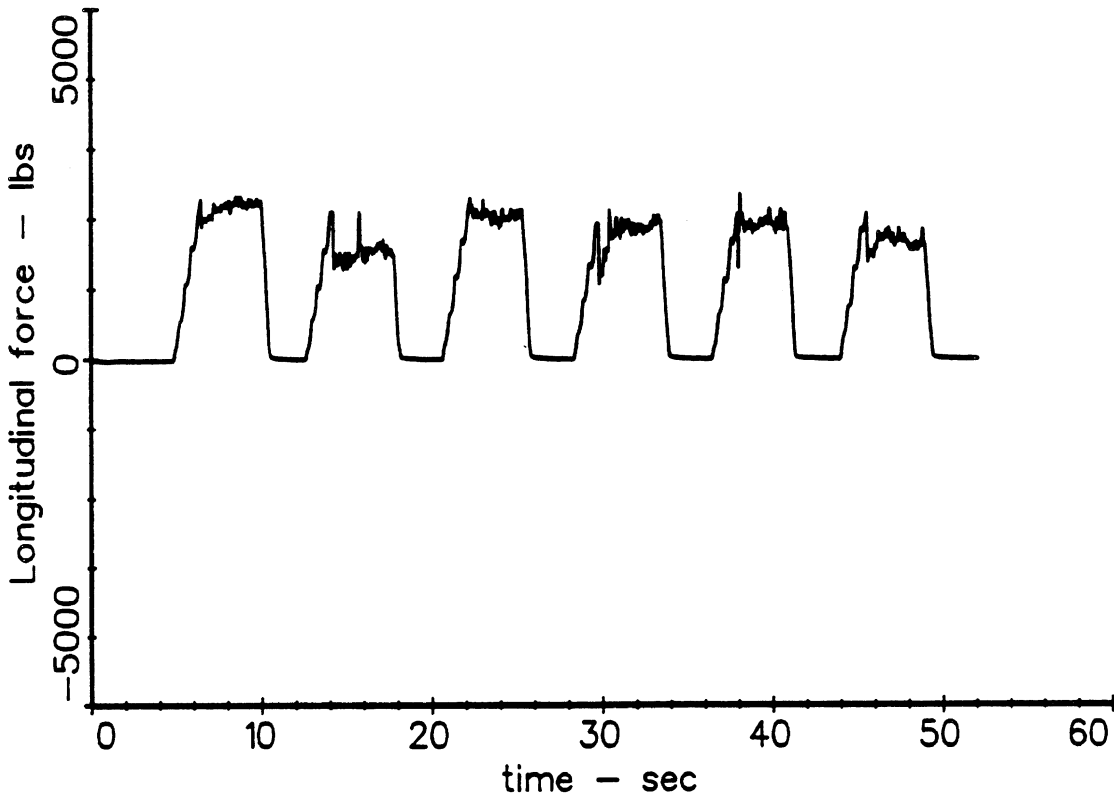

04/02/87 14:45:54 GD YR 295/75R22.5 SINGLE 6000 AT 10MPH

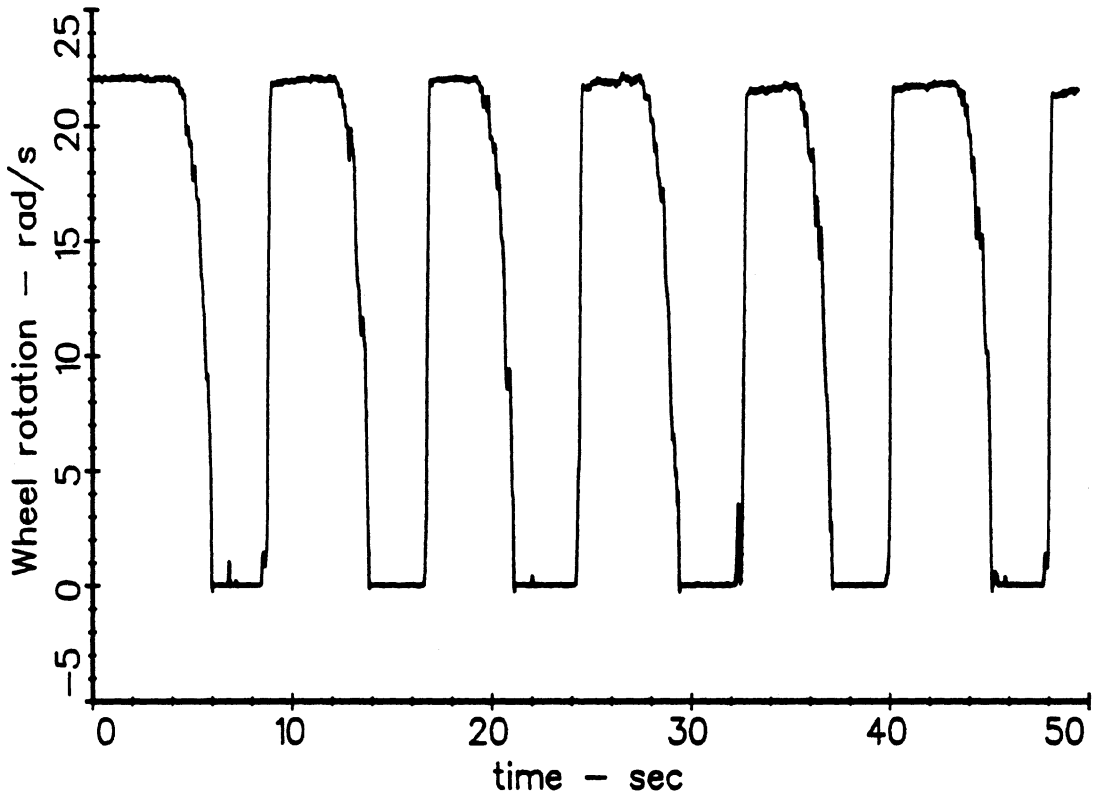

04/02/87 14:50:39 GD YR 295/75R22.5 SINGLE 2000 AT  
25MPH

93

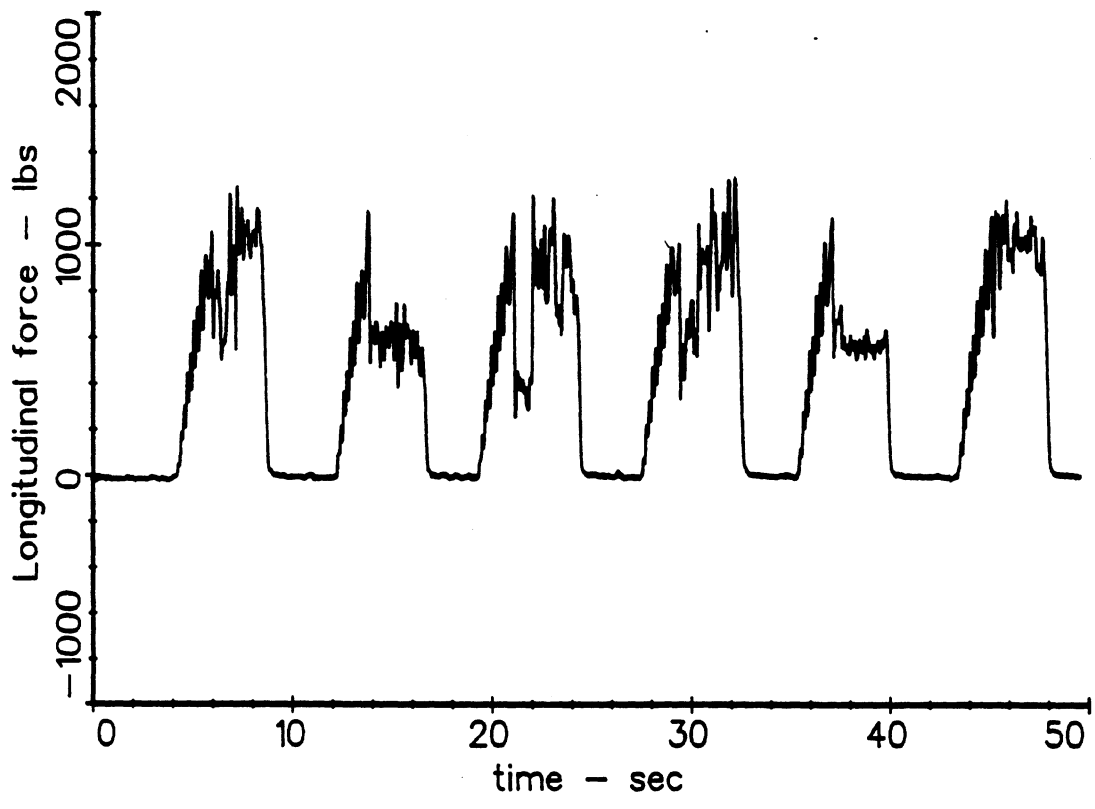

04/02/87 14:50:39 GD YR 295/75R22.5 SINGLE 2000 AT  
25MPH

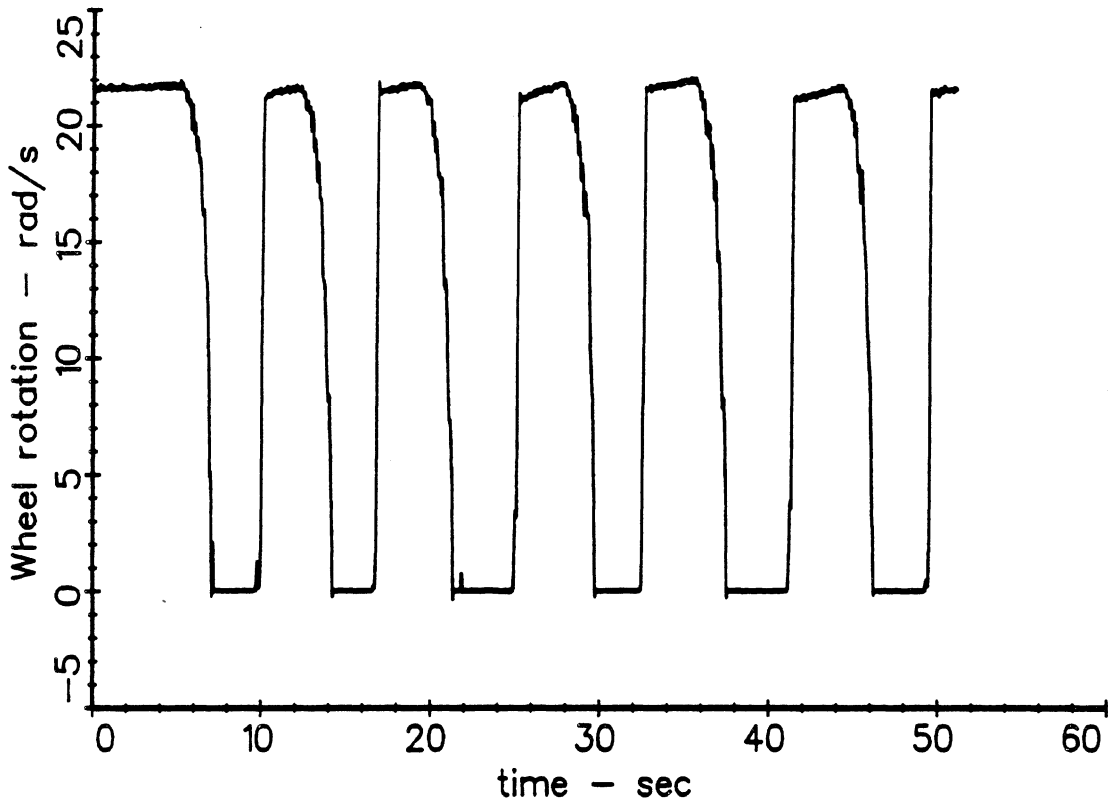

04/02/87 14:53:00 GD YR 295/75R22.5 SINGLE 4000 AT  
25MPH

94

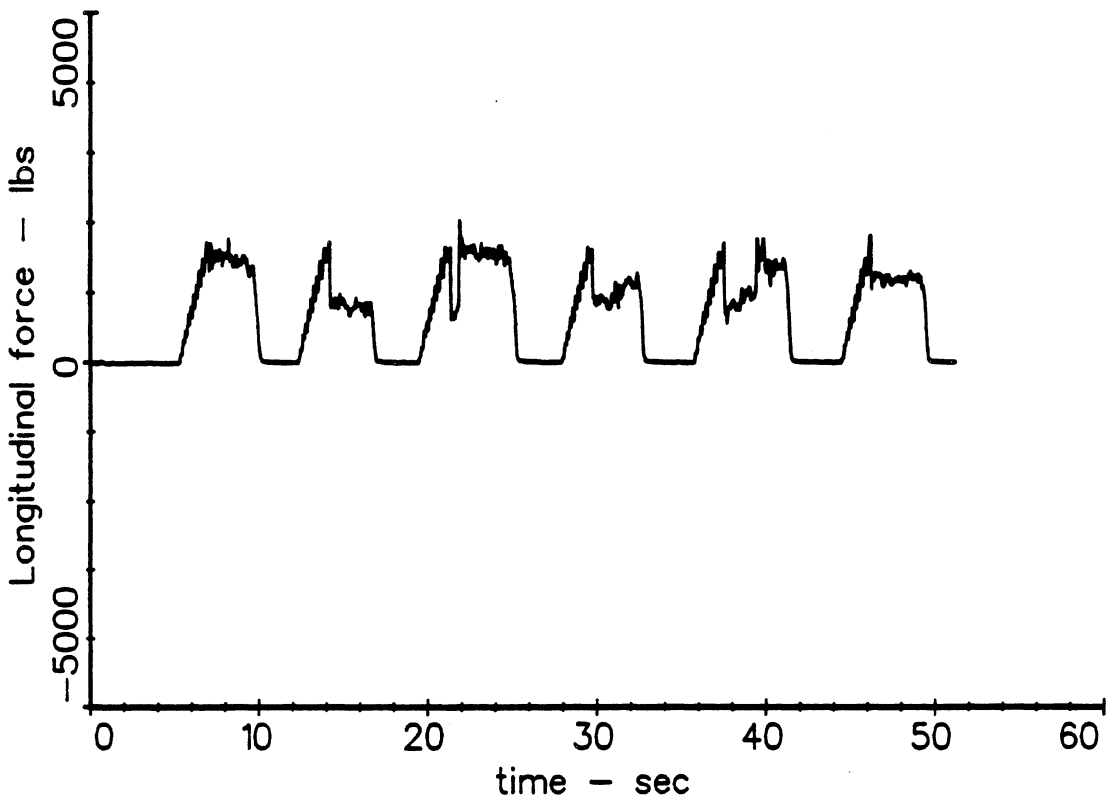

04/02/87 14:53:00 GD YR 295/75R22.5 SINGLE 4000 AT  
25MPH

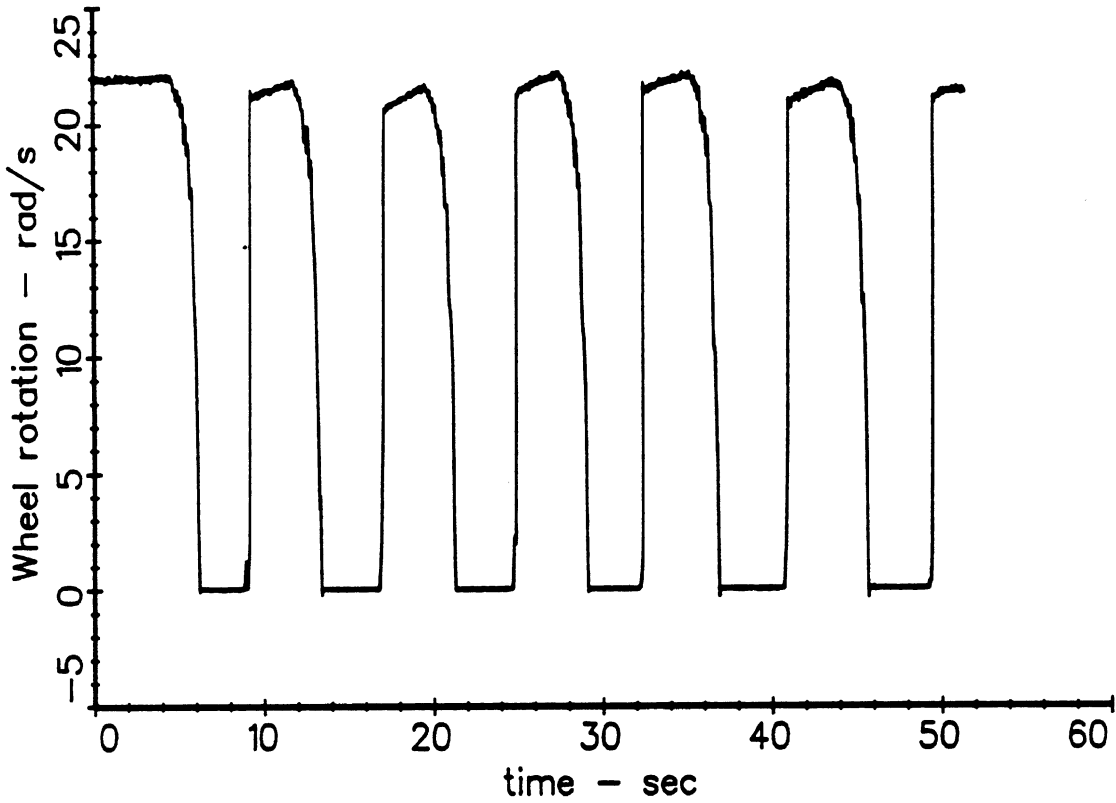

04/02/87 14:57:19 GD YR 295/75R22.5 SINGLE 6000 AT 25MPH

95

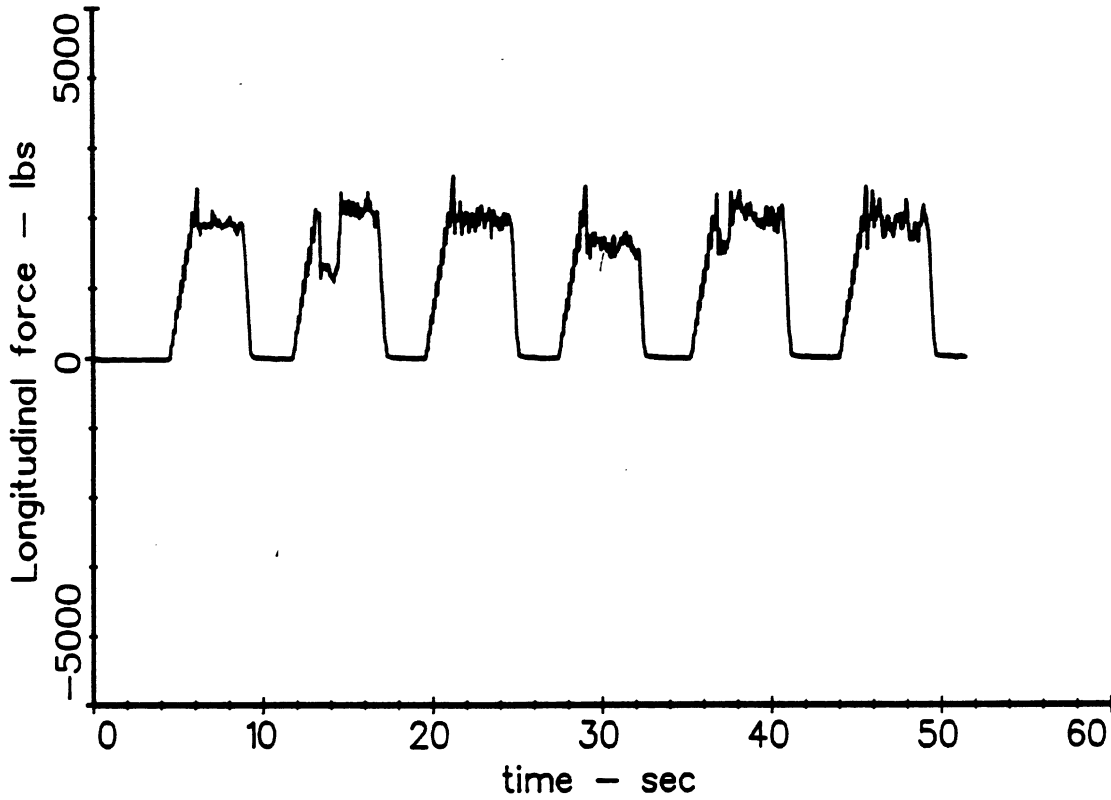

04/02/87 14:57:19 GD YR 295/75R22.5 SINGLE 6000 AT 25MPH

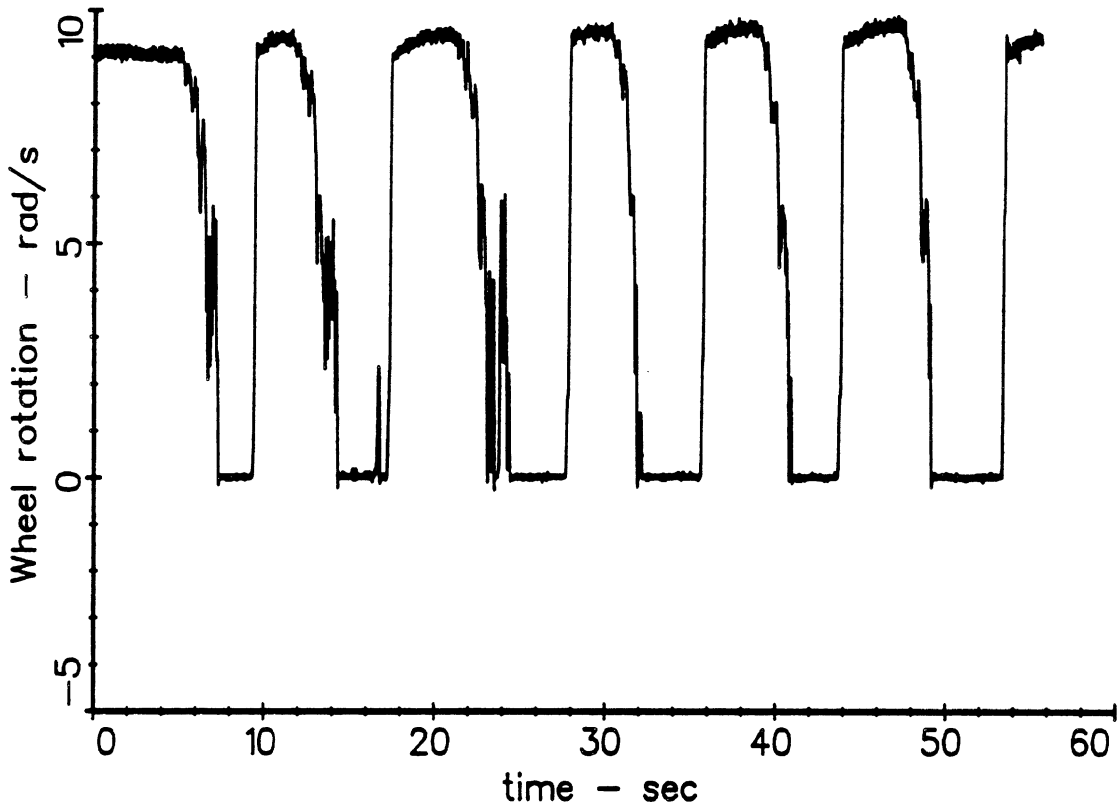

04/02/87 15:13:13 GD YR 295/75R22.5 REINFC 2000 AT  
10MPH

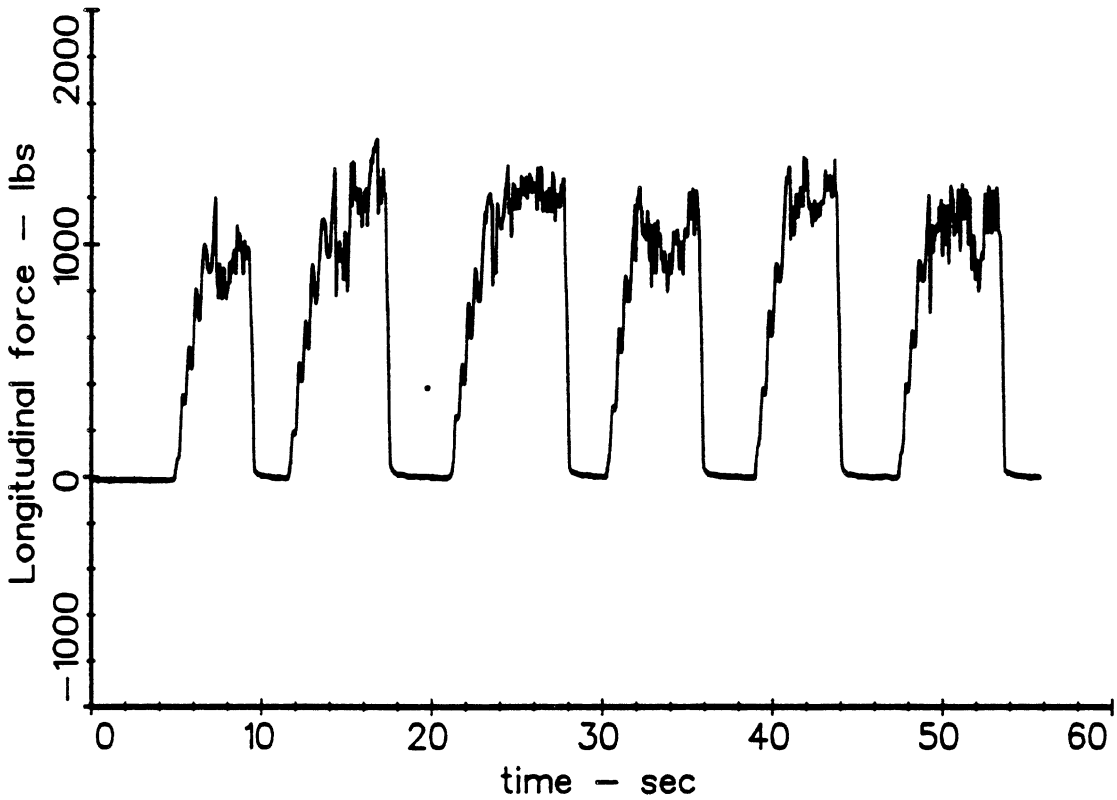

98

04/02/87 15:13:13 GD YR 295/75R22.5 REINFC 2000 AT  
10MPH

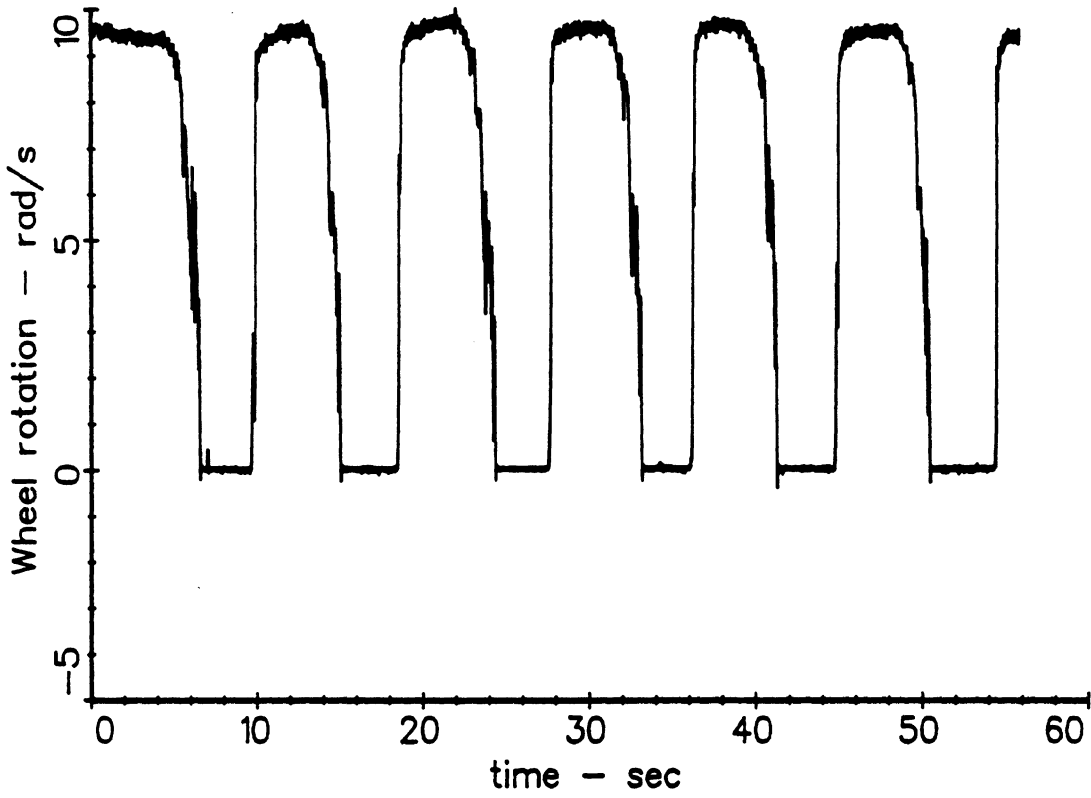

04/02/87 15:15:25 GD YR 295/75R22.5 REINFC 4000 AT  
10MPH

99

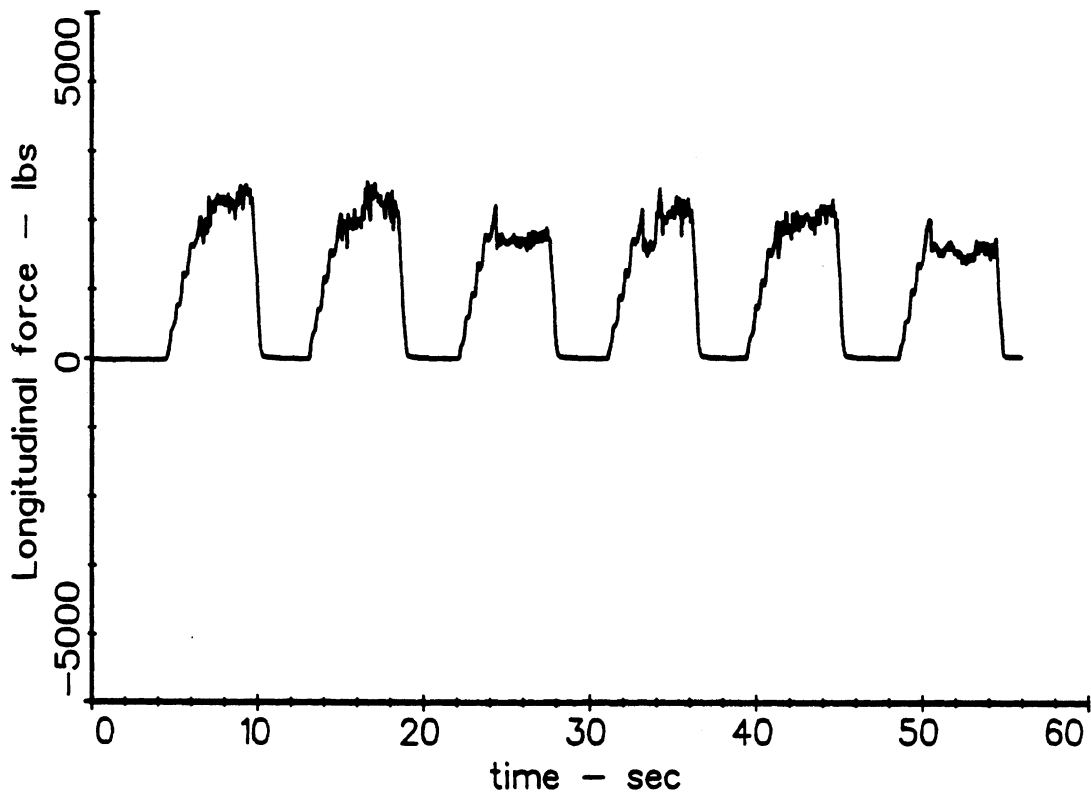

04/02/87 15:15:25 GD YR 295/75R22.5 REINFC 4000 AT  
10MPH

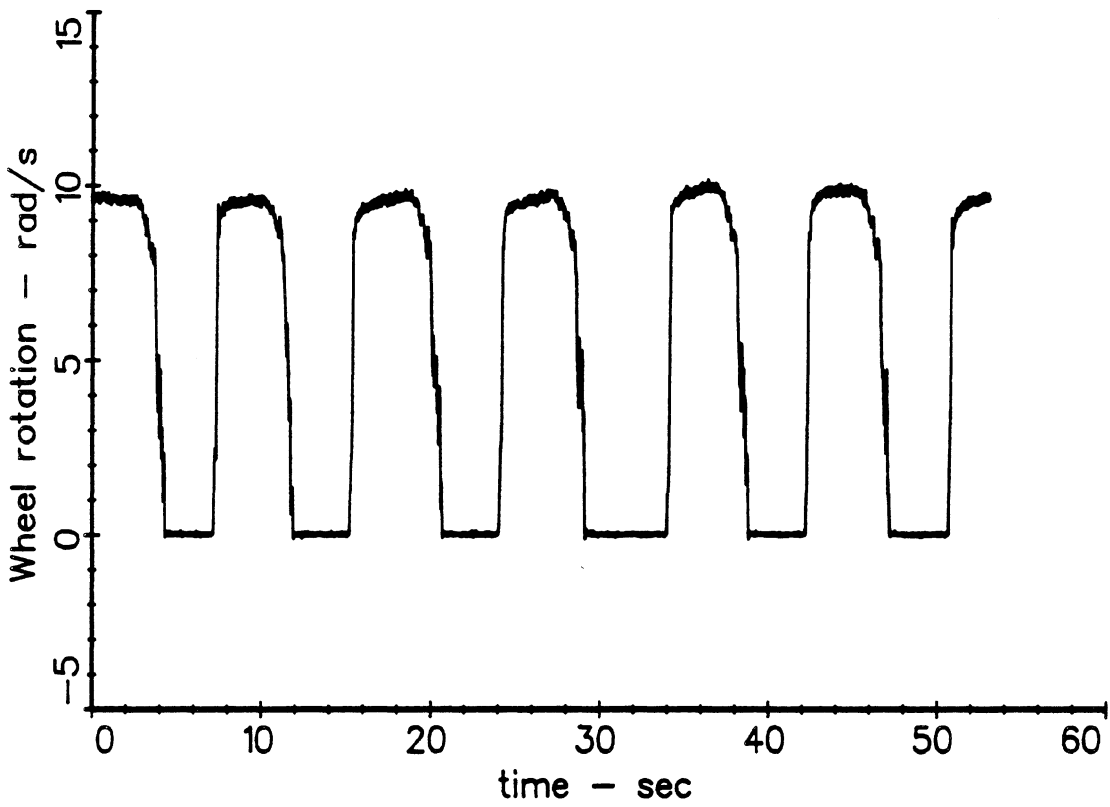

04/02/87 15:17:34 GD YR 295/75R22.5 REINFC 6000 AT  
10MPH

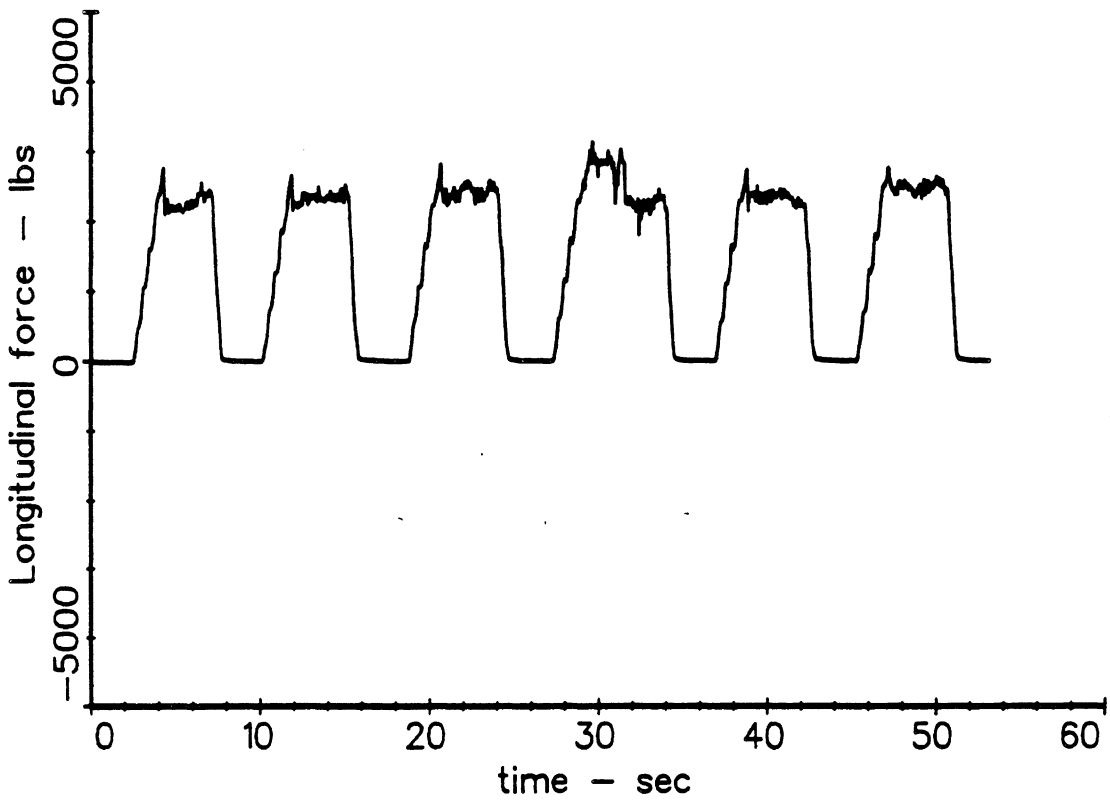

04/02/87 15:17:34 GD YR 295/75R22.5 REINFC 6000 AT  
10MPH



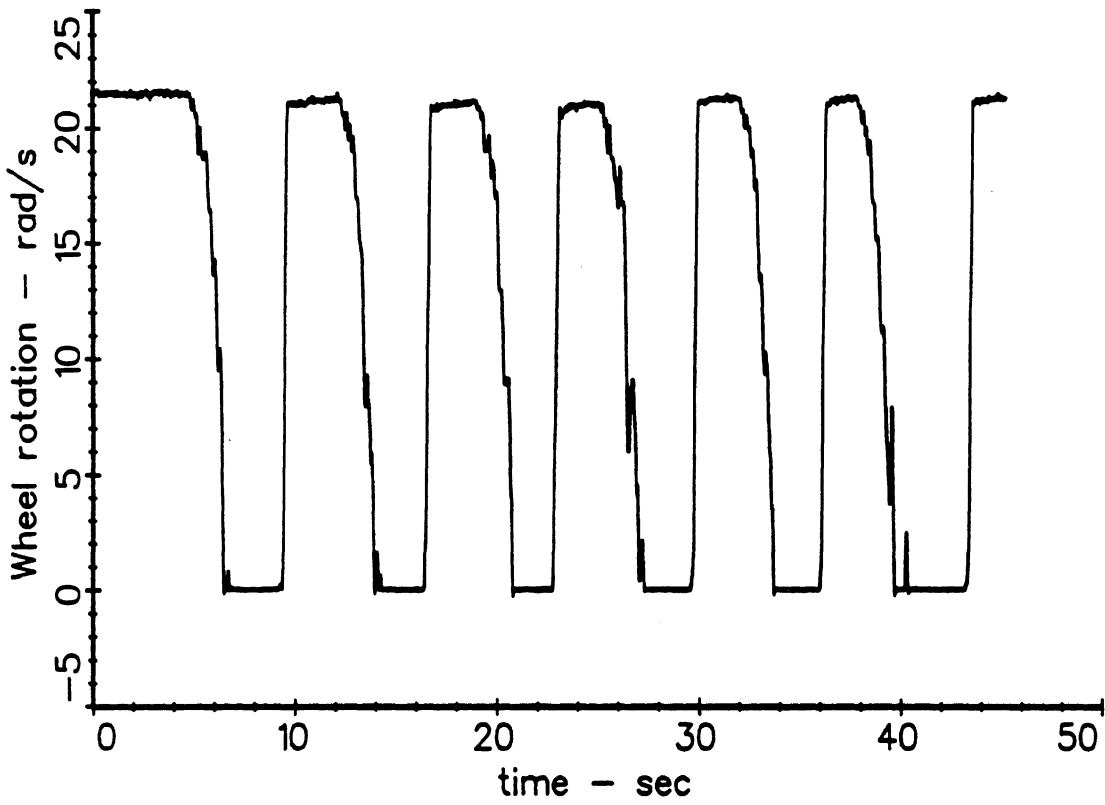

04/02/87 15:23:38 GD YR 295/75R22.5 REINFC 2000 AT  
25MPH

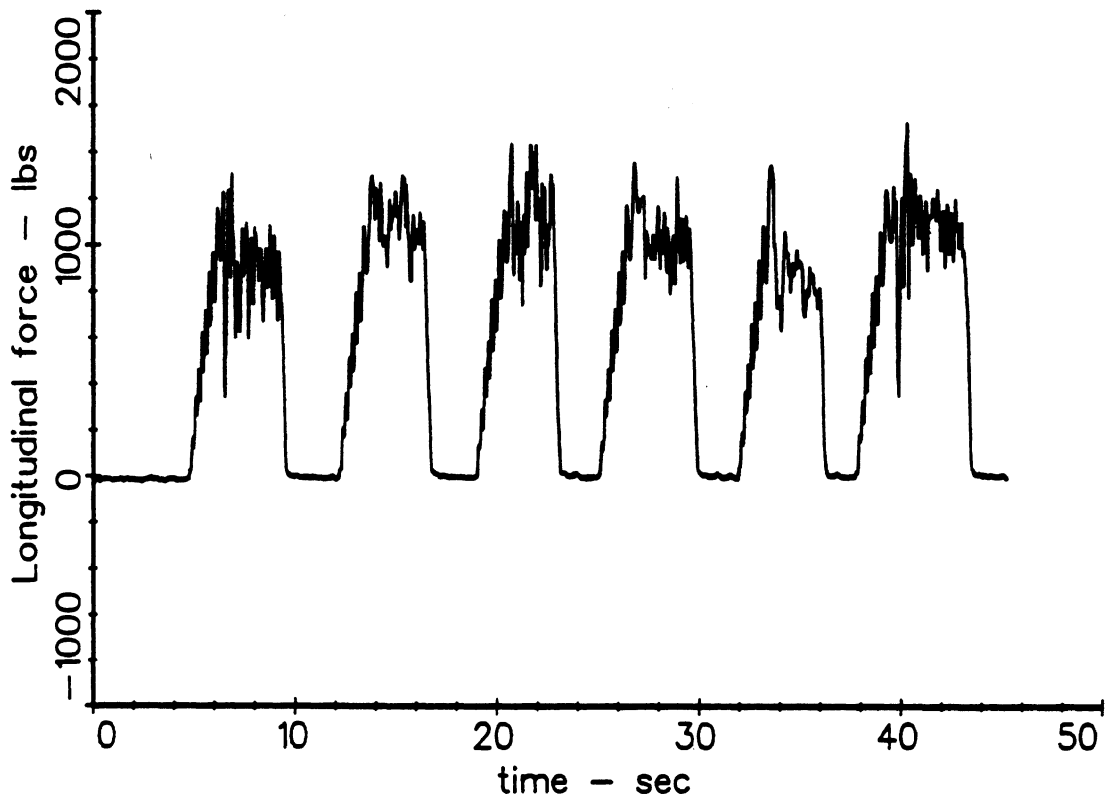

103

04/02/87 15:23:38 GD YR 295/75R22.5 REINFC 2000 AT  
25MPH

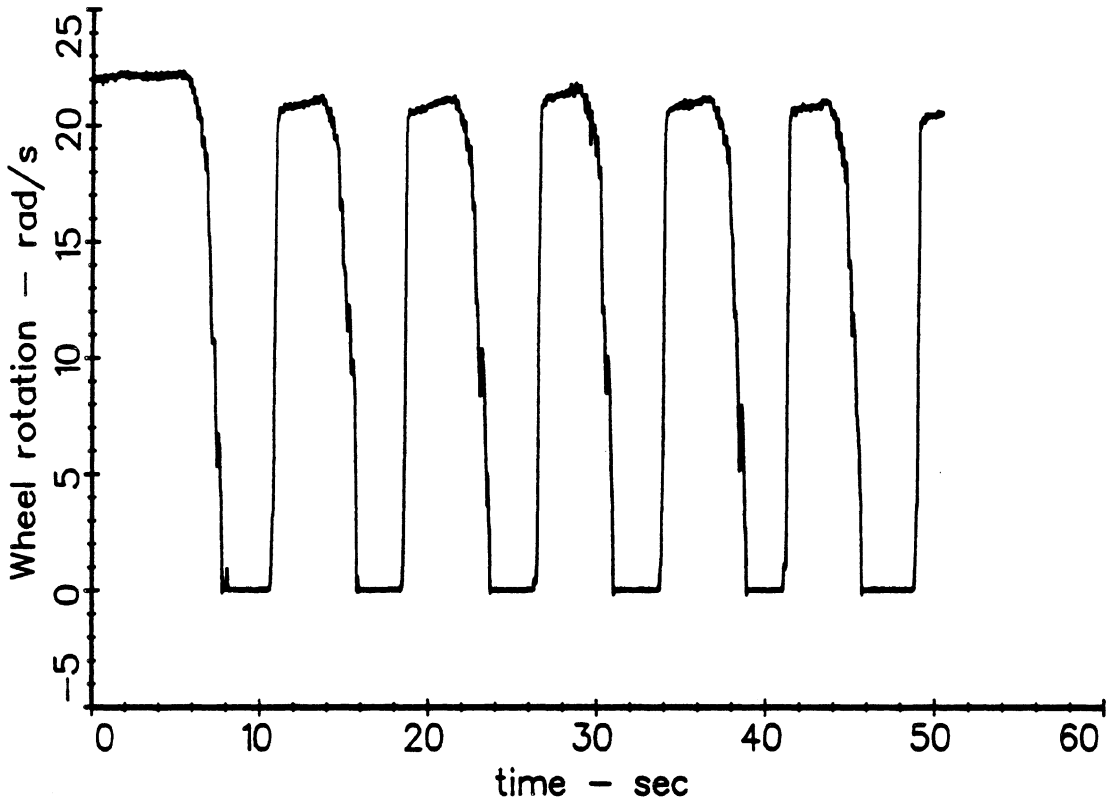

04/02/87 15:26:02 GD YR 295/75R22.5 REINFC 4000 AT  
25MPH

104

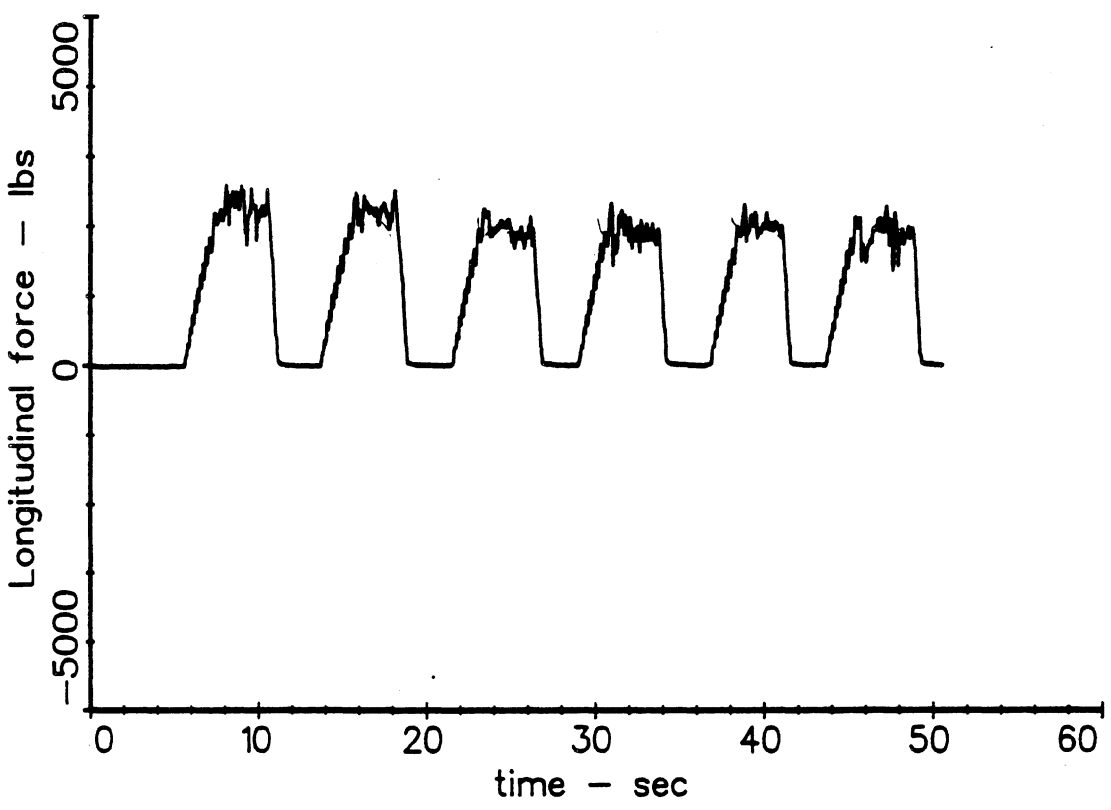

04/02/87 15:26:02 GD YR 295/75R22.5 REINFC 4000 AT  
25MPH

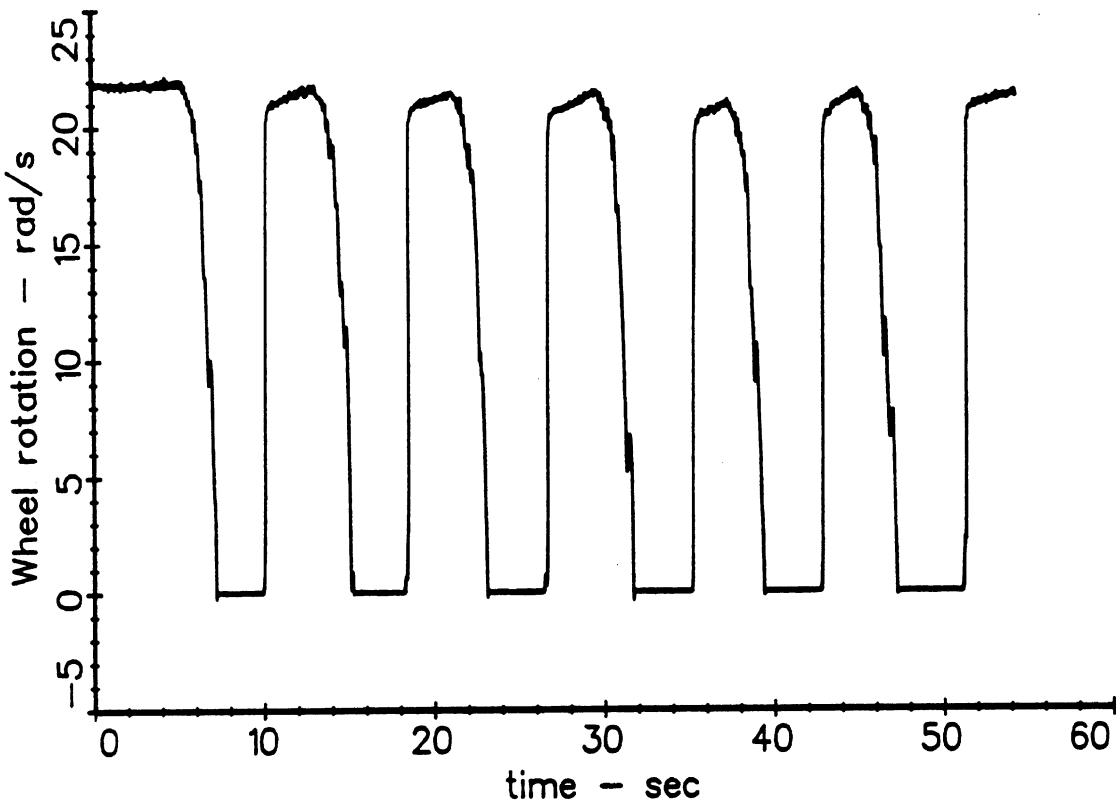

04/02/87 15:29:01 GD YR 295/75R22.5 REINFC 6000 AT  
25MPH

105

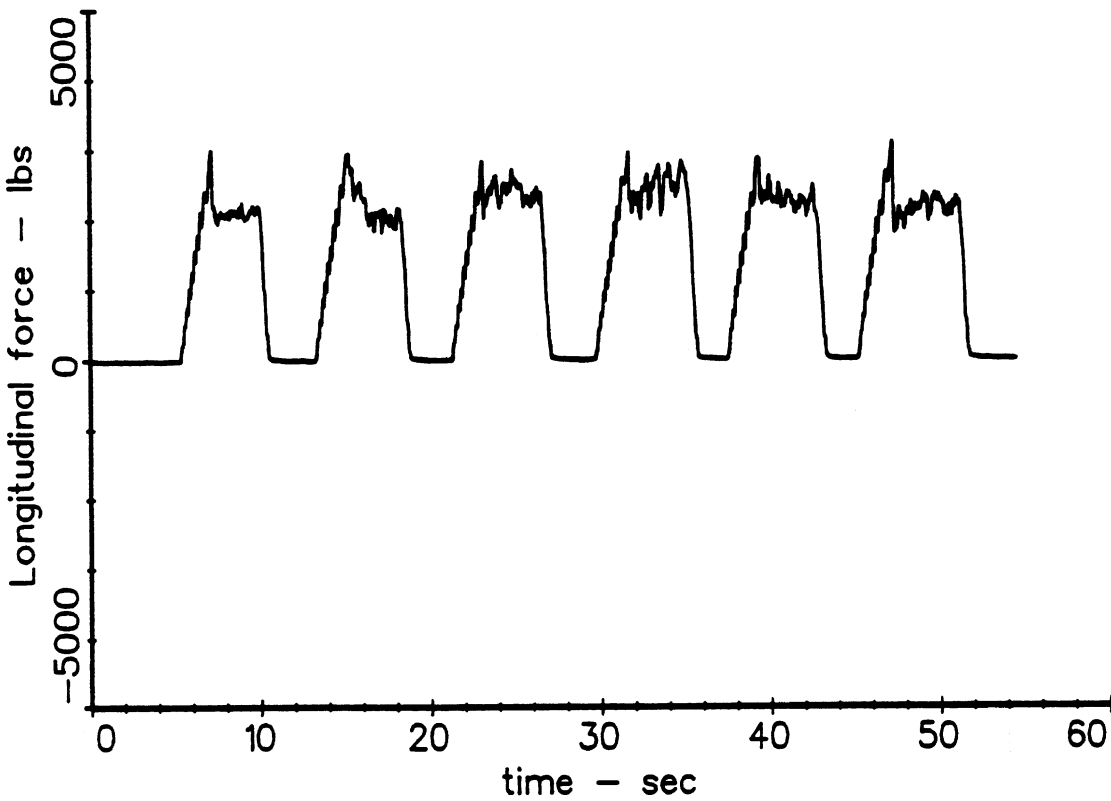

04/02/87 15:29:01 GD YR 295/75R22.5 REINFC 6000 AT  
25MPH

## Appendix B

### Plotted Results from Braking Performance Analyses

This appendix contains plots of the friction utilization and deceleration results obtained through computerized analysis of tractor semitrailers braking on ice. The plots cover the 22 cases which were presented in the technical report under Table 6, which is reproduced on the next page. The table identifies by case number the loading condition, brake system properties, and tire and chain installations which characterized each analyzed case. The sets of brake system torque gains and pushout pressure levels are defined in the technical discussion, Table 3 in Section 2.3.2. The nominal results from each run are then quantified in the table according to the lockup sequence, pressure margin values, and maximum deceleration achieved prior to the "critical lockup".

Some of the friction adhesion utilization diagrams contain illustrations of lockup at additional axles occurring at control line pressures which are beyond the level needed to obtain the "critical lockup" point. Such illustrations (for example, see case 10) are included simply to show the contrast in friction levels at which tires with and without chains achieve lockup.

As a supplement to the 22 cases, the appendix also presents the parametric data describing the analyzed 5-axle tractor semitrailer in its loaded and empty condition. The "echo" of input data for each of these cases is also accompanied by friction utilization and deceleration diagrams showing the general behavior obtained in each case, without considering lockup such as is regularly addressed in the 22 cases of braking on ice.

STRAIGHT LINE BRAKING MODEL

FILE NAME: C:\ICEBSLOD.BRK

Baseline Loaded

Date: 6-5-1987

Time: 13:39:26

---

Information for Unit # 1

General Information

Total Weight = 15500.00 Lbs  
Wheelbase = 153.000 inches  
Distance of Rear Articulation from Front Suspension = 148.50 inches  
Rear Articulation Height = 43.00 inches  
Total C.G. Height = 32.00 inches

Suspension # 1 (Single)

Suspension Load = 10000.0 Lbs  
Axle # 1  
Radius of a Tire = 20.50 inches  
Pushout Pressure = 9.40 PSI  
Brake Key (1=Linear, 2=Non-linear) = 1  
Brake Gain = 950.00 in-lb/psi

Suspension # 2 (Tandem)

Suspension Load = 34000.0 Lbs  
Tandem Axle Separation = 52.00 inches  
Dynamic Load Transfer Coefficient (between -1 & 1) = .1500  
Axle # 1  
Radius of a Tire = 20.50 inches  
Pushout Pressure = 6.10 PSI  
Brake Key (1=Linear, 2=Non-linear) = 1  
Brake Gain = 2450.00 in-lb/psi  
Axle # 2  
Radius of a Tire = 20.50 inches  
Pushout Pressure = 6.10 PSI  
Brake Key (1=Linear, 2=Non-linear) = 1  
Brake Gain = 2450.00 in-lb/psi

---

Information for Unit # 2

General Information

Total Weight = 62500.00 Lbs  
Wheelbase = 486.000 inches  
Distance of Rear Articulation from Forward Articulation = 486.00 inches  
Rear Articulation Height = 40.00 inches  
Total C.G. Height = 82.00 inches  
Unit Key (1 - Independent Unit, Dolly or Semi) = 1  
(2 - Full Trailer - Fixed Dolly)

Suspension # 1 (Tandem)

Suspension Load = 34000.0 Lbs

Tandem Axle Separation = 50.00 inches  
Dynamic Load Transfer Coefficient (between -1 & 1) = .1500  
    Axle # 1  
Radius of a Tire = 20.50 inches  
Pushout Pressure = 4.90 PSI  
Brake Key (1=Linear, 2=Non-linear) = 1  
Brake Gain = 2450.00 in-lb/psi  
    Axle # 2  
Radius of a Tire = 20.50 inches  
Pushout Pressure = 4.90 PSI  
Brake Key (1=Linear, 2=Non-linear) = 1  
Brake Gain = 2450.00 in-lb/psi

FRICION UTILIZATION vs PRESSURE(psi) C: ICEBSLOD BRK

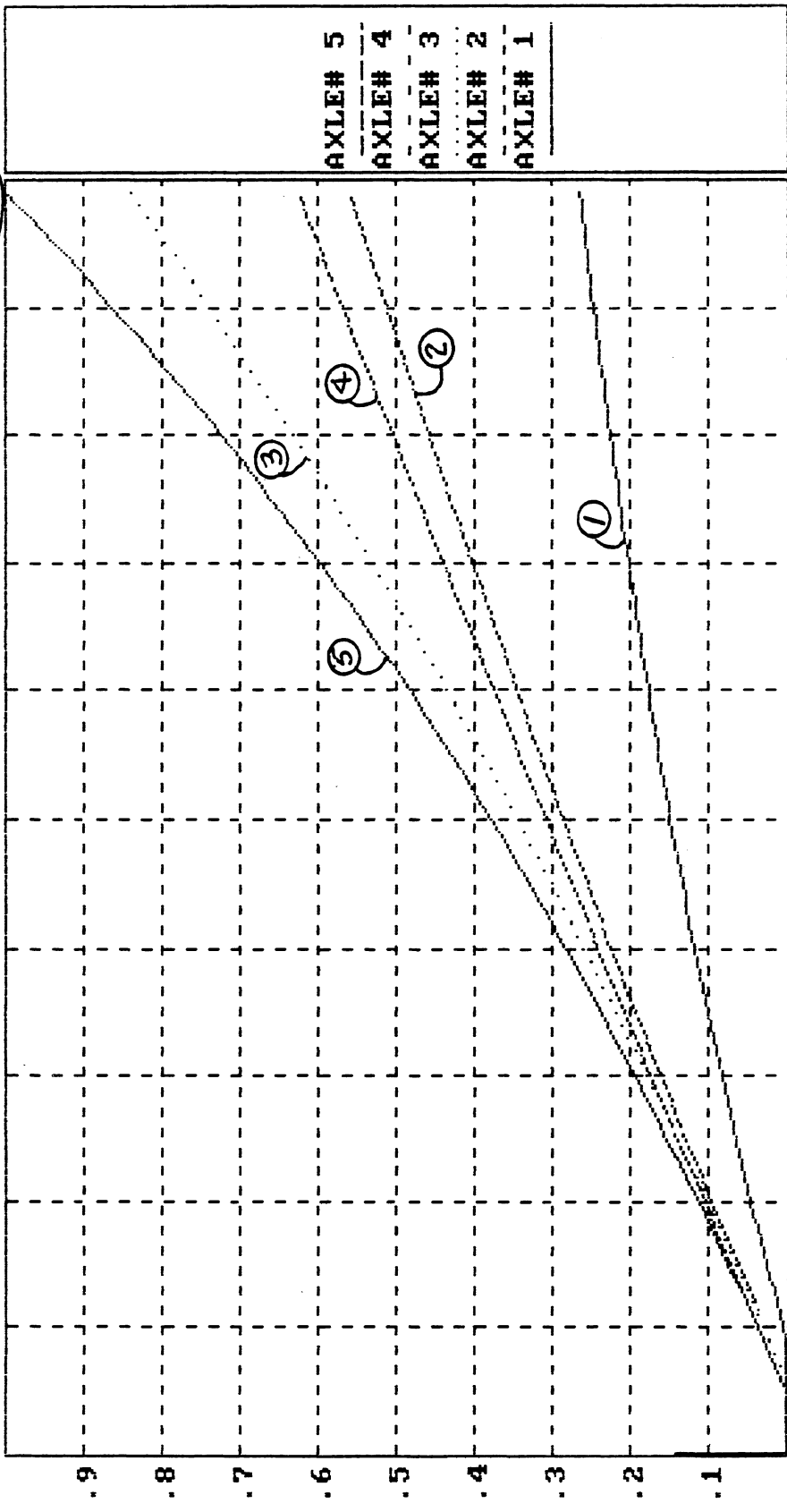

AXLE# 1 = .0000 PRESS = .0psi

BRKING EFFCY & DECELR (gs) vs PRESS (psi) C: ICEBSLOD, BRK

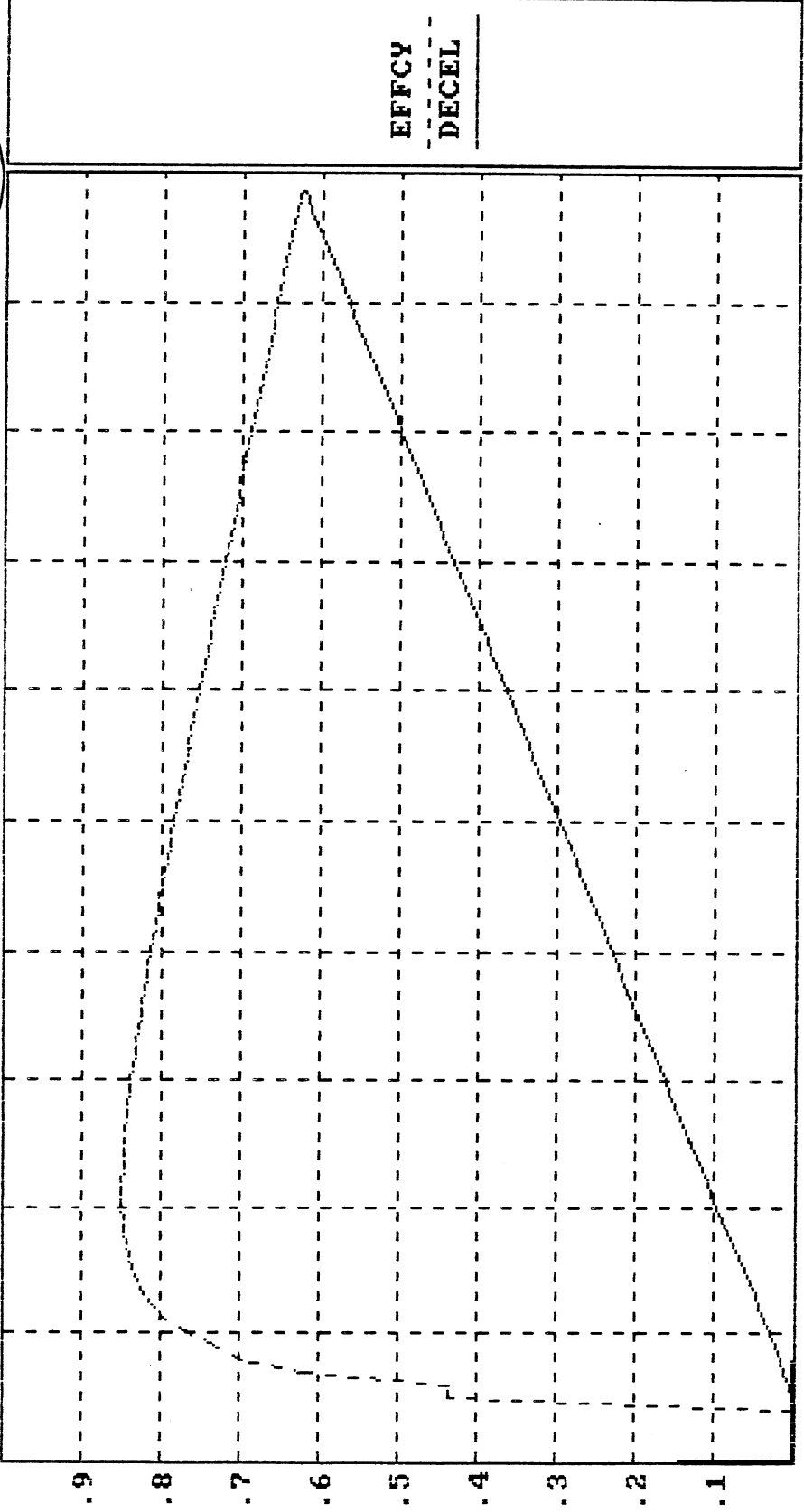

DECEL = .0000gs PRESS = .0psi



STRAIGHT LINE BRAKING MODEL

FILE NAME: C:\ICEBSEMT.BRK

Baseline - Empty

Date: 6- 5-1987

Time: 13:41:12

---

Information for Unit # 1

General Information

Total Weight = 15500.00 Lbs  
Wheelbase = 153.000 inches  
Distance of Rear Articulation from Front Suspension = 153.00 inches  
Rear Articulation Height = 43.00 inches  
Total C.G. Height = 32.00 inches

Suspension # 1 (Single)

Suspension Load = 8960.0 Lbs  
Axle # 1  
Radius of a Tire = 20.50 inches  
Pushout Pressure = 9.40 PSI  
Brake Key (1=Linear, 2=Non-linear) = 1  
Brake Gain = 950.00 in-lb/psi

Suspension # 2 (Tandem)

Suspension Load = 10840.0 Lbs  
Tandem Axle Separation = 52.00 inches  
Dynamic Load Transfer Coefficient (between -1 & 1) = .1500

Axle # 1

Radius of a Tire = 20.50 inches  
Pushout Pressure = 6.10 PSI  
Brake Key (1=Linear, 2=Non-linear) = 1  
Brake Gain = 2450.00 in-lb/psi

Axle # 2

Radius of a Tire = 20.50 inches  
Pushout Pressure = 6.10 PSI  
Brake Key (1=Linear, 2=Non-linear) = 1  
Brake Gain = 2450.00 in-lb/psi

---

Information for Unit # 2

General Information

Total Weight = 13825.00 Lbs  
Wheelbase = 486.000 inches  
Distance of Rear Articulation from Forward Articulation = 504.00 inches  
Rear Articulation Height = 40.00 inches  
Total C.G. Height = 60.00 inches  
Unit Key (1 - Independent Unit, Dolly or Semi) = 1  
(2 - Full Trailer - Fixed Dolly)

Suspension # 1 (Tandem)

Suspension Load = 9525.0 Lbs  
Tandem Axle Separation = 50.00 inches  
Dynamic Load Transfer Coefficient (between -1 & 1) = .1500  
    Axle # 1  
Radius of a Tire = 20.50 inches  
Pushout Pressure = 4.90 PSI  
Brake Key (1=Linear, 2=Non-linear) = 1  
Brake Gain = 2450.00 in-lb/psi  
    Axle # 2  
Radius of a Tire = 20.50 inches  
Pushout Pressure = 4.90 PSI  
Brake Key (1=Linear, 2=Non-linear) = 1  
Brake Gain = 2450.00 in-lb/psi

C: ICEBSEMT BRK

FRICION UTILIZATION vs PRESSURE (psi)

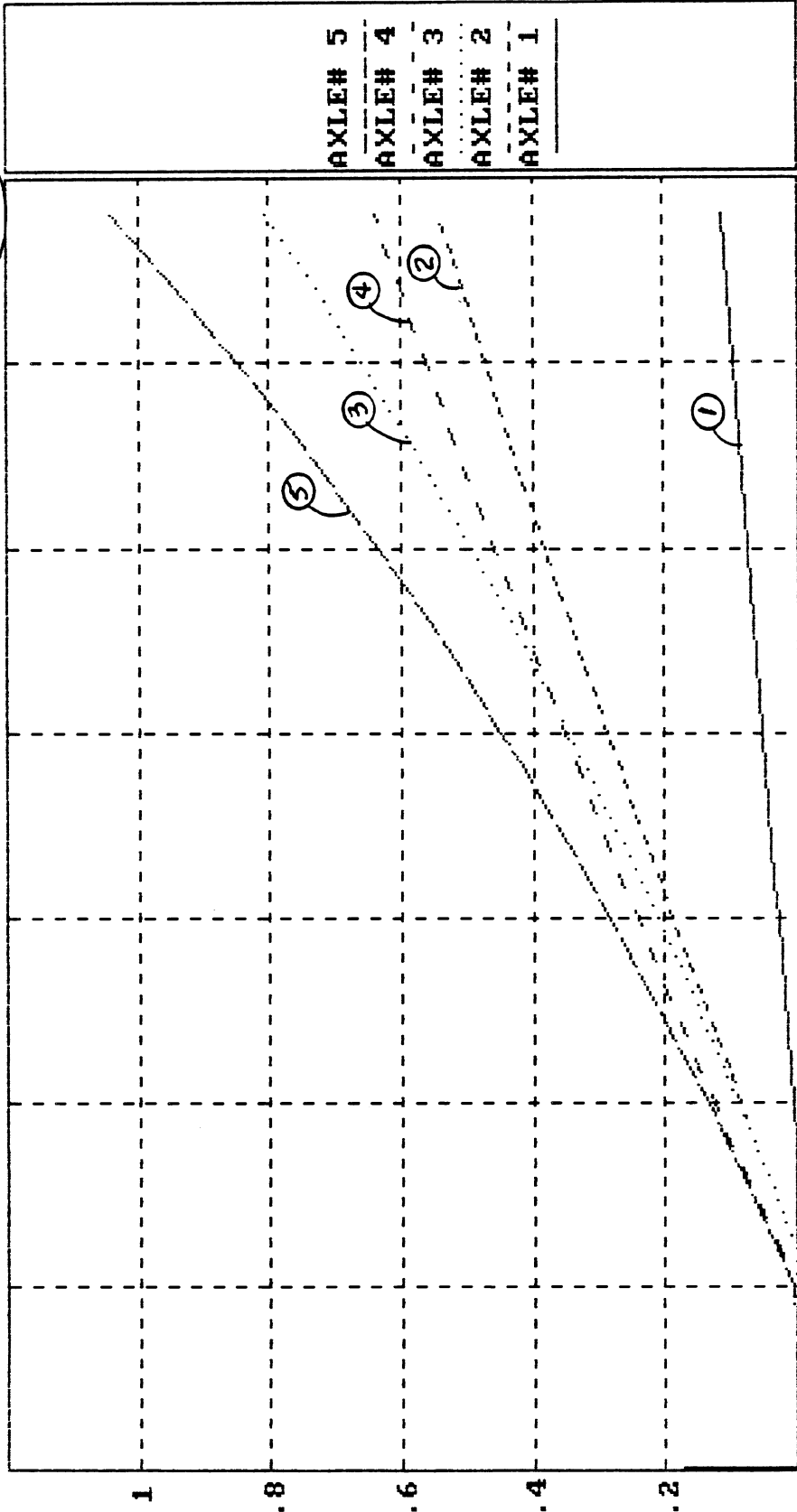

AXLE# 5  
AXLE# 4  
AXLE# 3  
AXLE# 2  
AXLE# 1

0 5 10 15 20 25 30 35

AXLE# 1 = .0000 PRESS = .0psi

C: ICEBSEMT BRK

BRKING EFFCY & DECELR (gs) vs PRESS (psi)

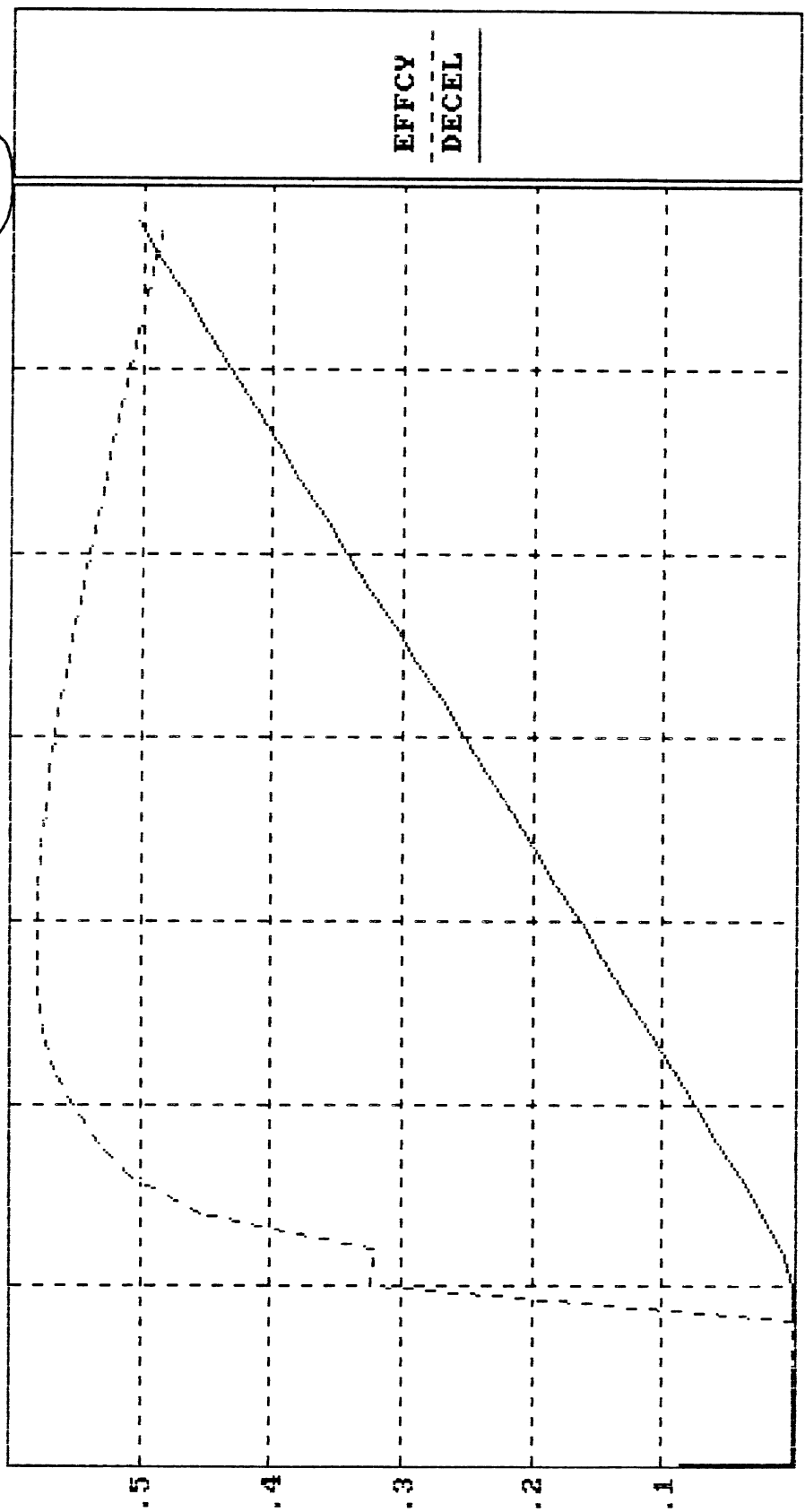

DECEL = .0000gs      PRESS = .0psi

FRICION UTILIZATION vs PRESSURE(psi)

C:ICESEMT.BRK

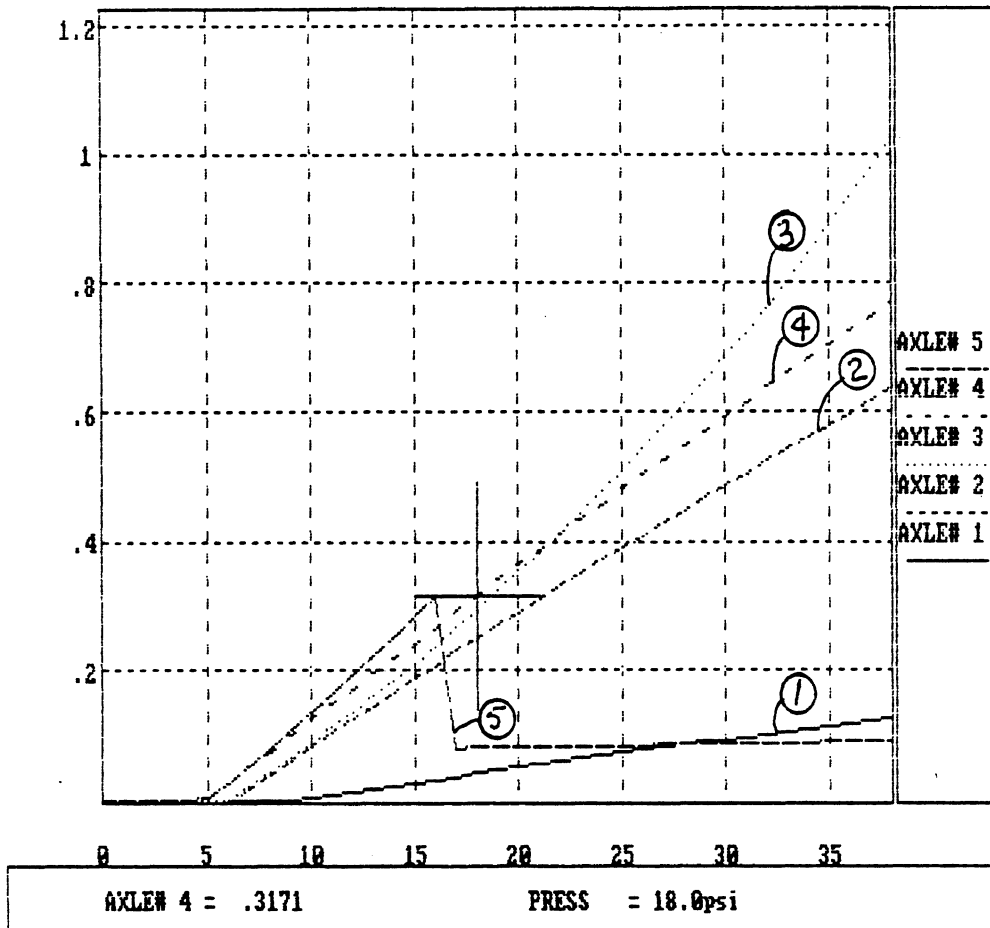

Case 1

BRKING EFFCY & DECELR (gs) vs PRESS(psi)

C:ICEBSEMT.BRK

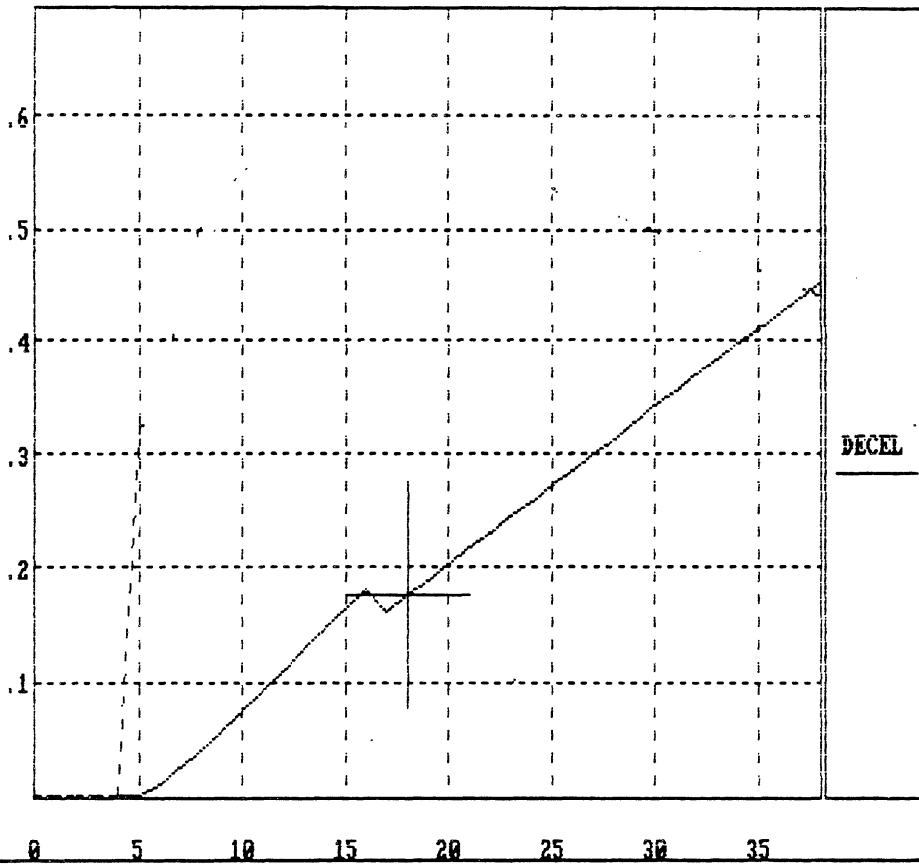

DECEL = .1760gs      PRESS = 18.0psi

Case 1

FRICION UTILIZATION vs PRESSURE(psi)

C:ICESEMT.BRK

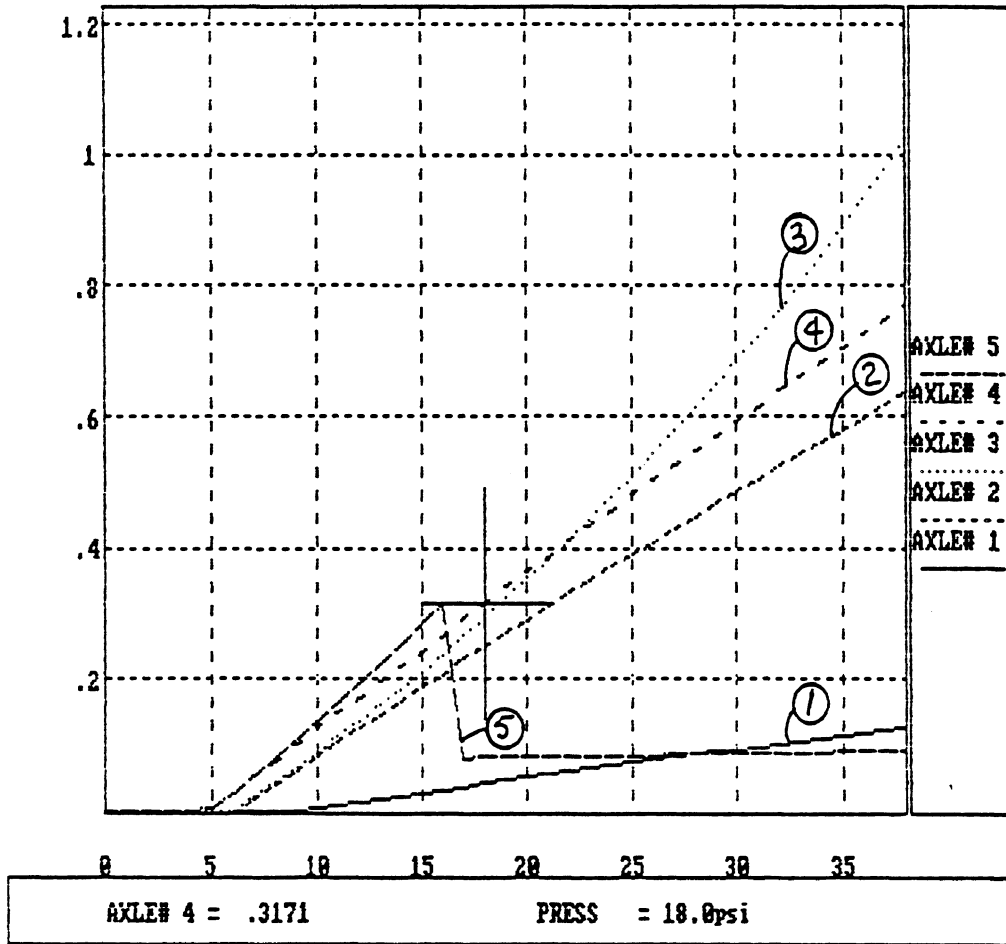

Case 2

BRKING EFFCY & DECEL (gs) vs PRESS(psi)

C:ICEBSEMT.BRK

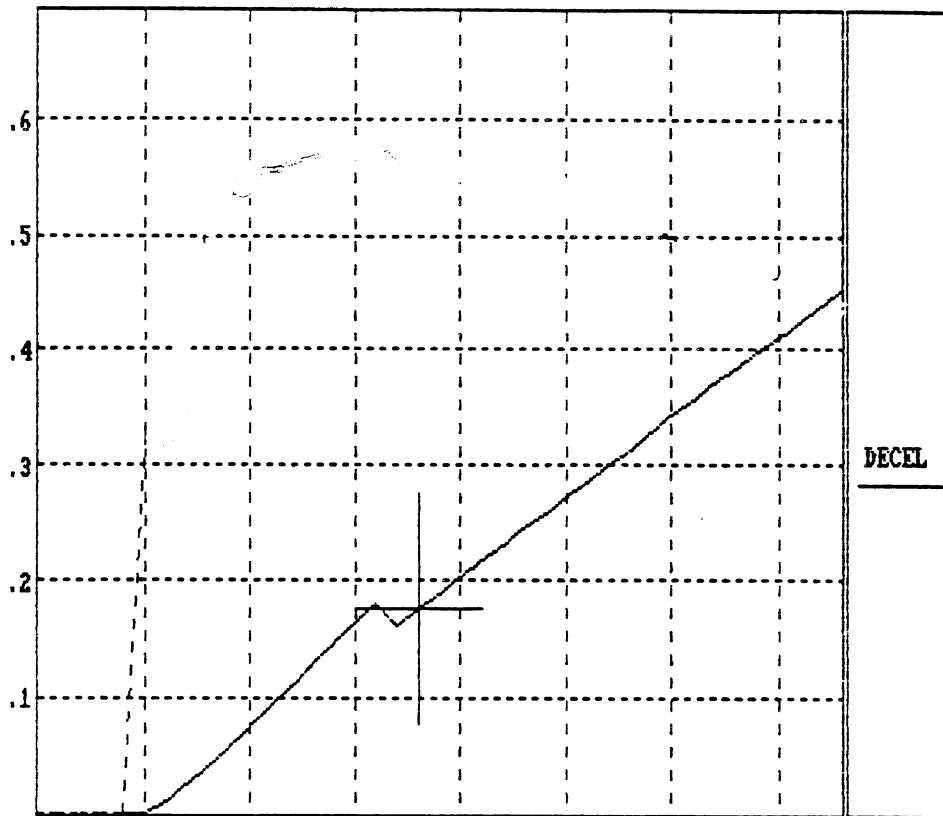

0 5 10 15 20 25 30 35

DECEL = .1760gs

PRESS = 18.0psi

Case 2



FRICION UTILIZATION vs PRESSURE(psi)

C:iceE2LOK.BRK

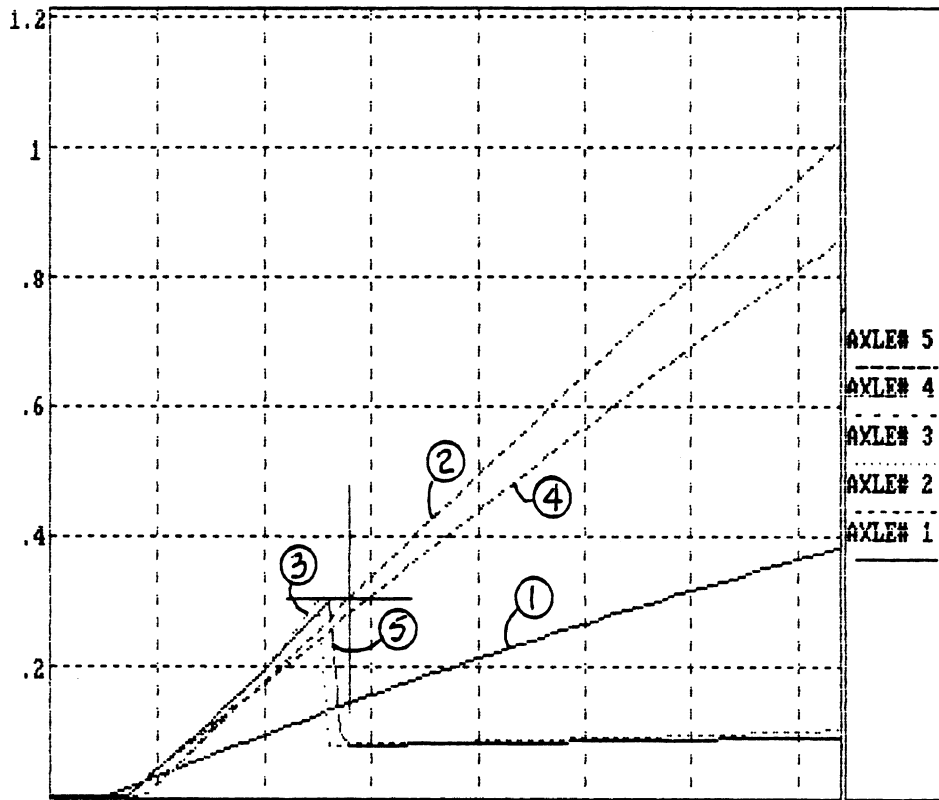

AXLE# 2 = .3047                      PRESS = 28.0psi

Case 3

DECEL (gs) vs PRESS(psi)

C:\iceE2L0K.BRK

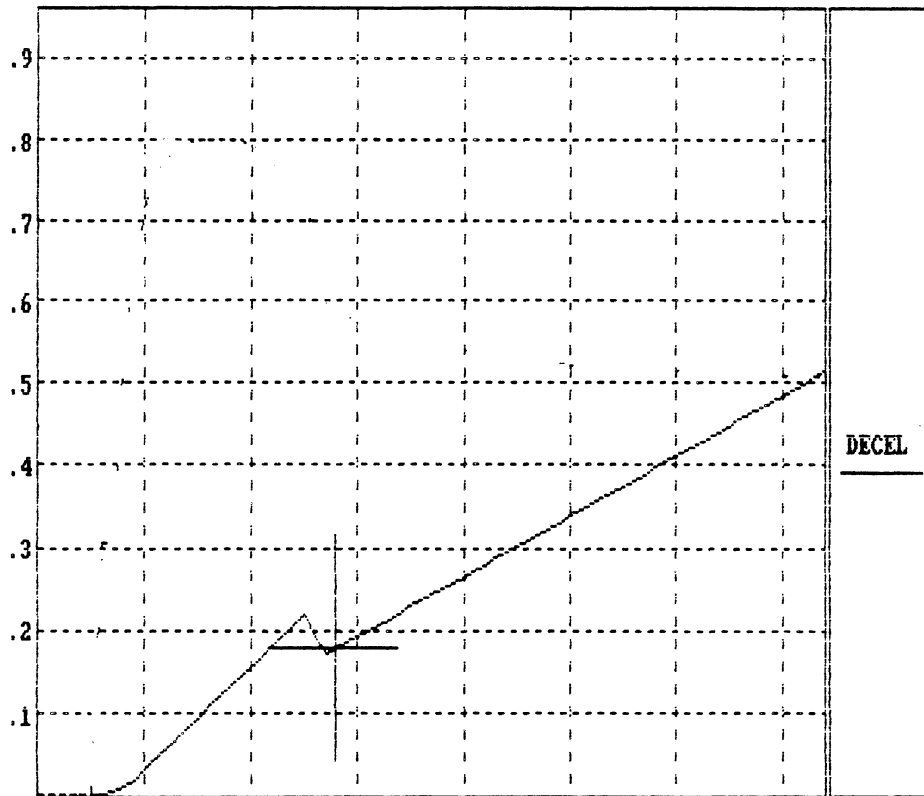

0 10 20 30 40 50 60 70

DECEL = .1770gs

PRESS = 28.0psi

Case 3

FRICION UTILIZATION vs PRESSURE(psi) C:\ice5LOK.BRK

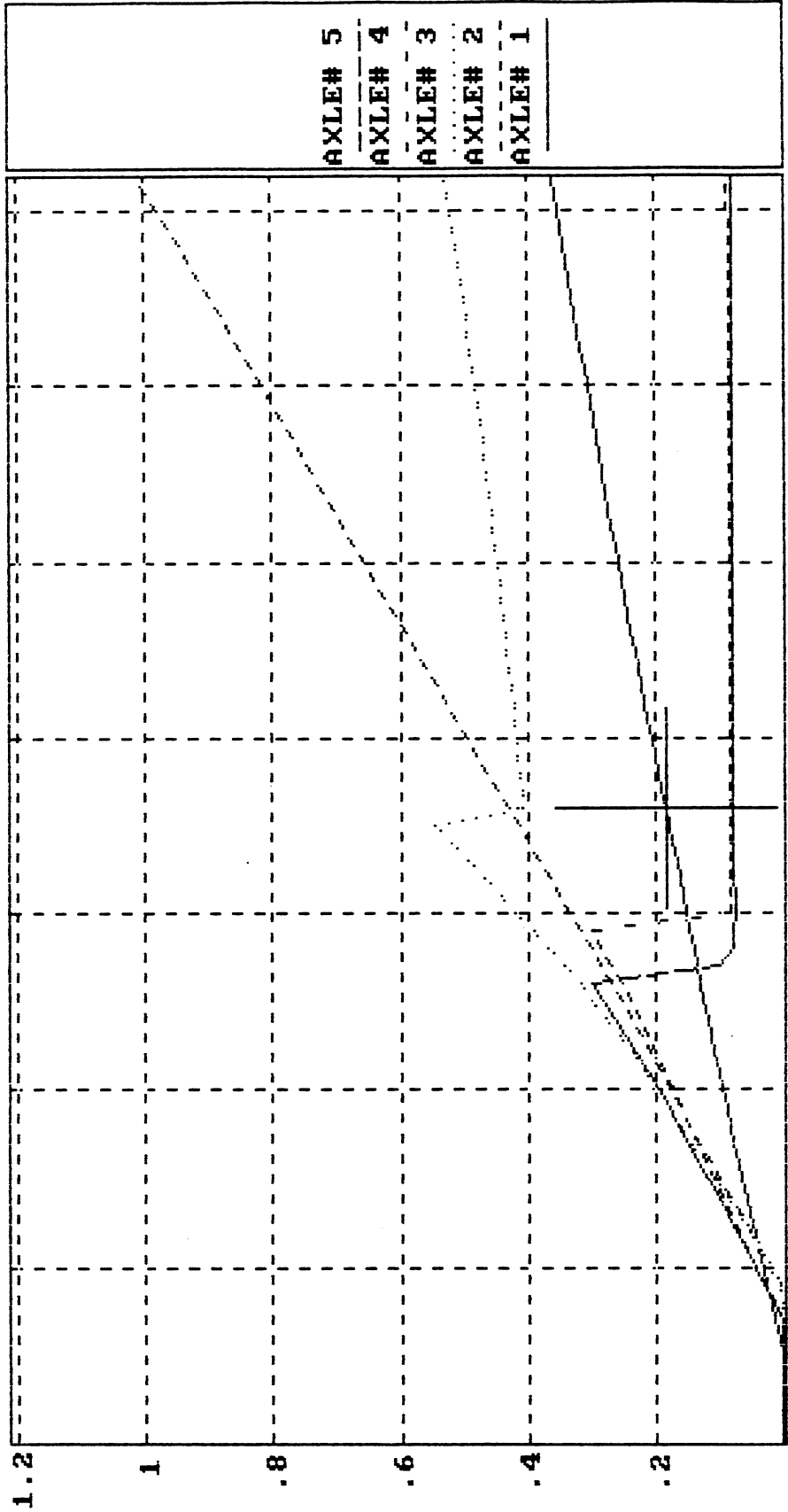

0 10 20 30 40 50 60 70

AXLE# 1 = .1840 PRESS = 36.0psi

Case 4

BRAKING EFFCY & DECELR (gs) vs PRESS(psi)

C:\iceE5LOK.BRK

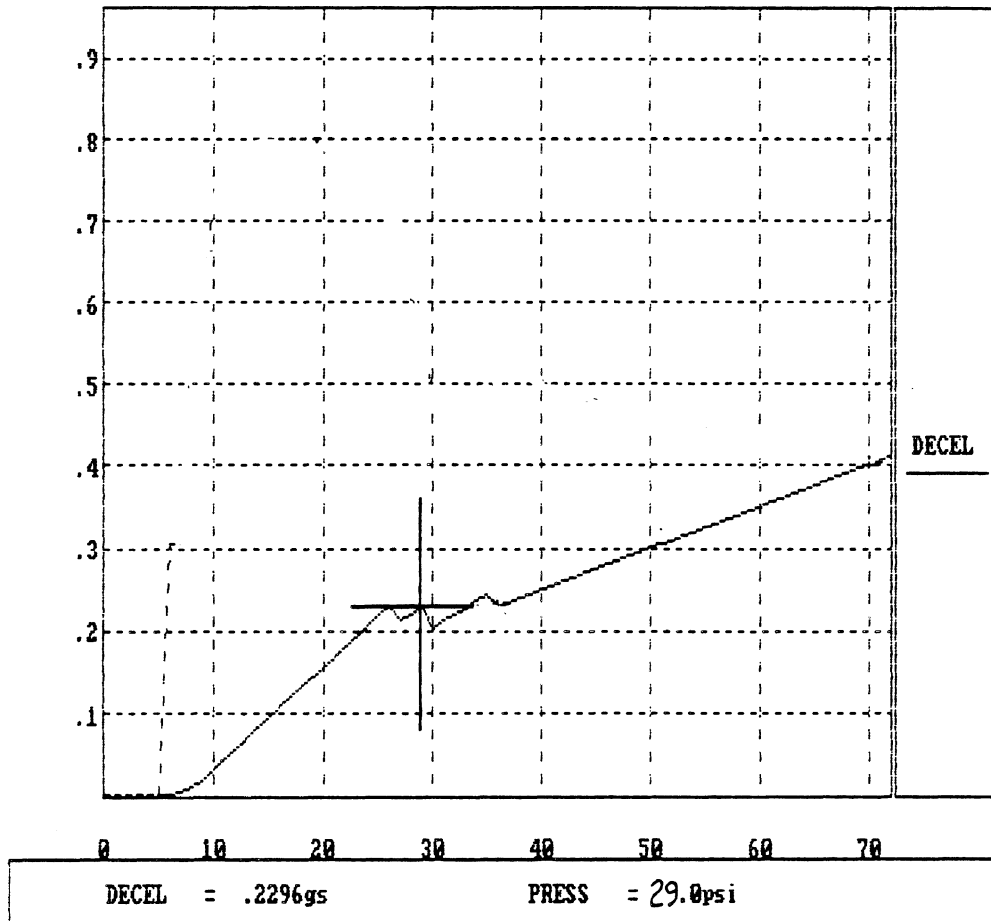

Case 4

FRICION UTILIZATION vs PRESSURE(psi) C:ICEBSLOD.BRK

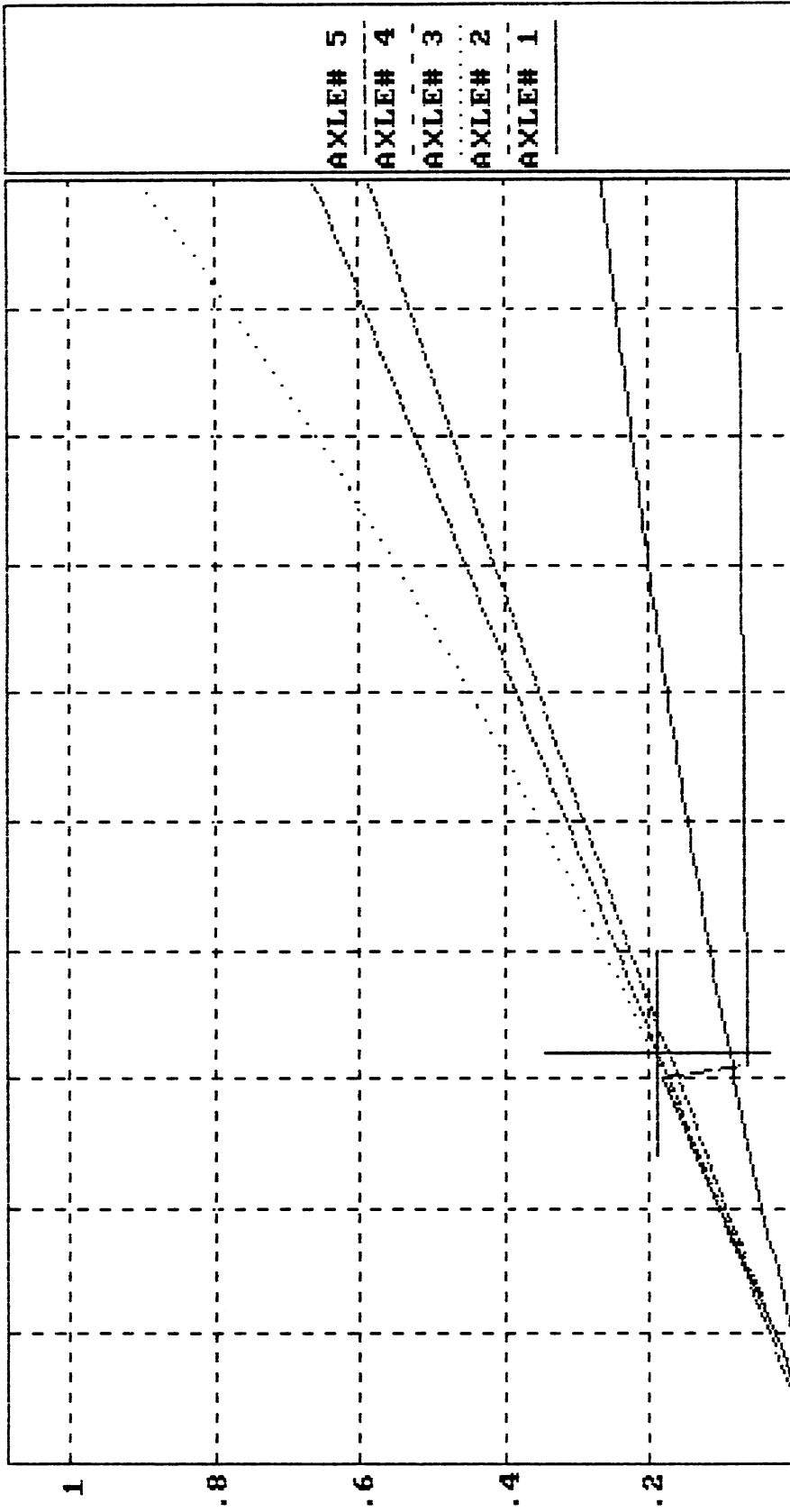

AXLE# 4 = .1892 PRESS = 32.0psi

Case 5

BRKING EFFCY & DECELR (gs) vs PRESS(psi)

C:ICEBSLOD.BRK

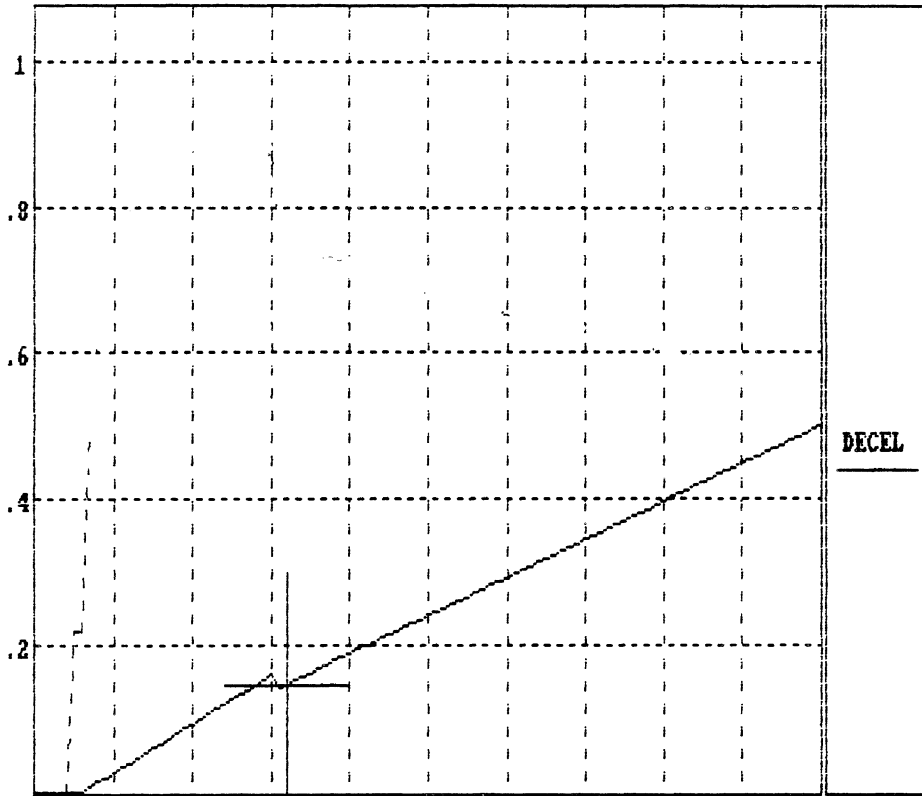

0 10 20 30 40 50 60 70 80 90 100

DECEL = .1478gs

PRESS = 32.0psi

Case 5

FRICION UTILIZATION vs PRESSURE(psi)

C:ICE13BSC.BRK

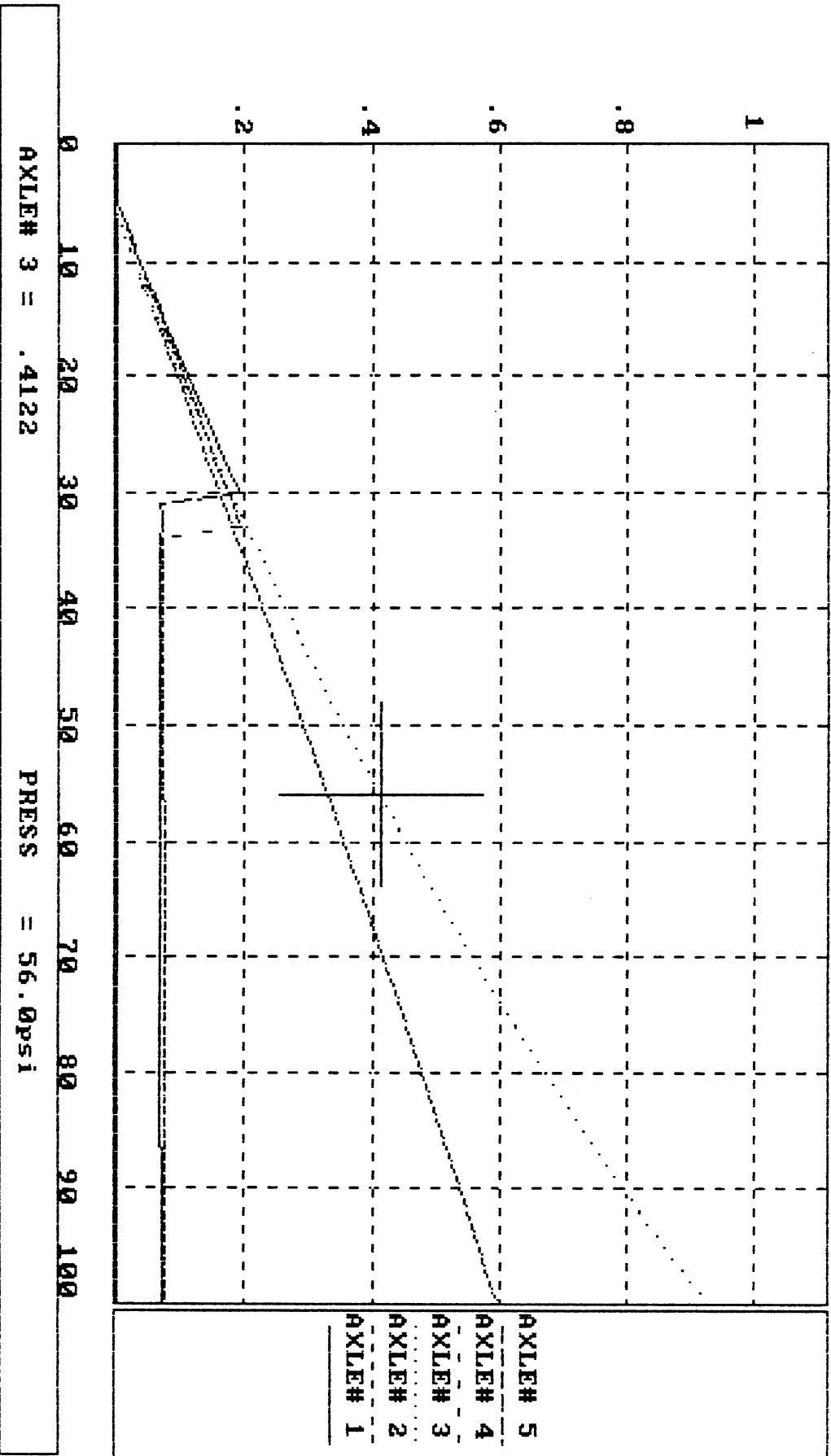

AXLE# 3 = .4122 PRESS = 56.0psi

Case 6

BRAKING EFFCY & DECELR (gs) vs PRESS(psi)

C:ICEL3BSC.BRK

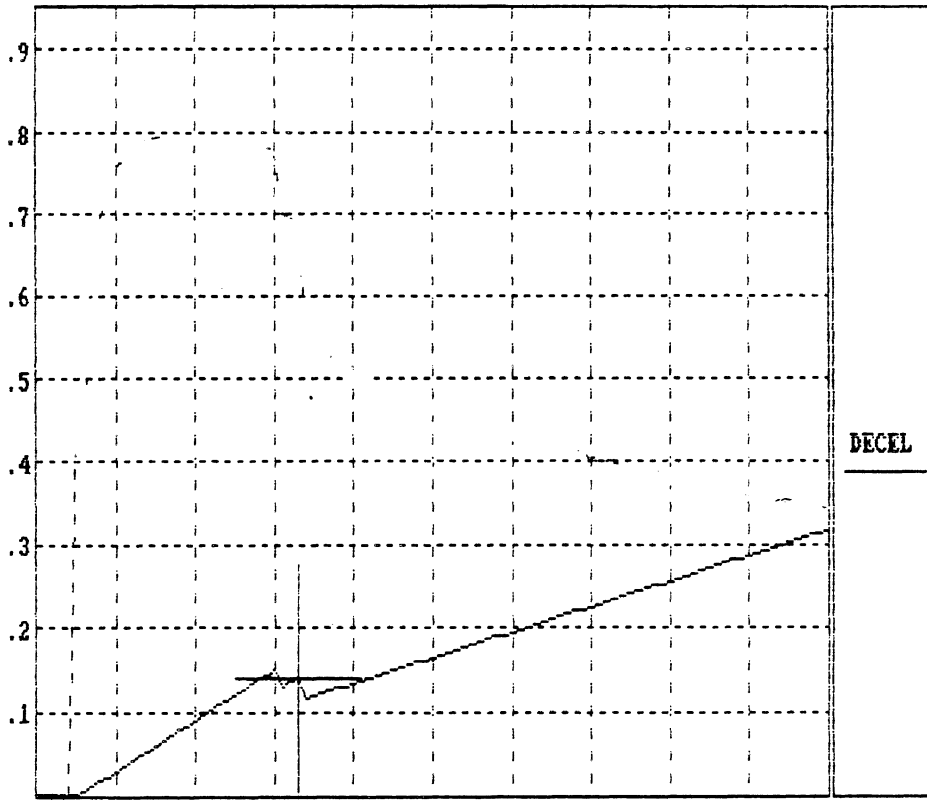

0 10 20 30 40 50 60 70 80 90 100

DECEL = .1397gs

PRESS = 33.0psi

Case 6



C: ICEL3BSC. BRK

FRICION UTILIZATION vs PRESSURE(psi)

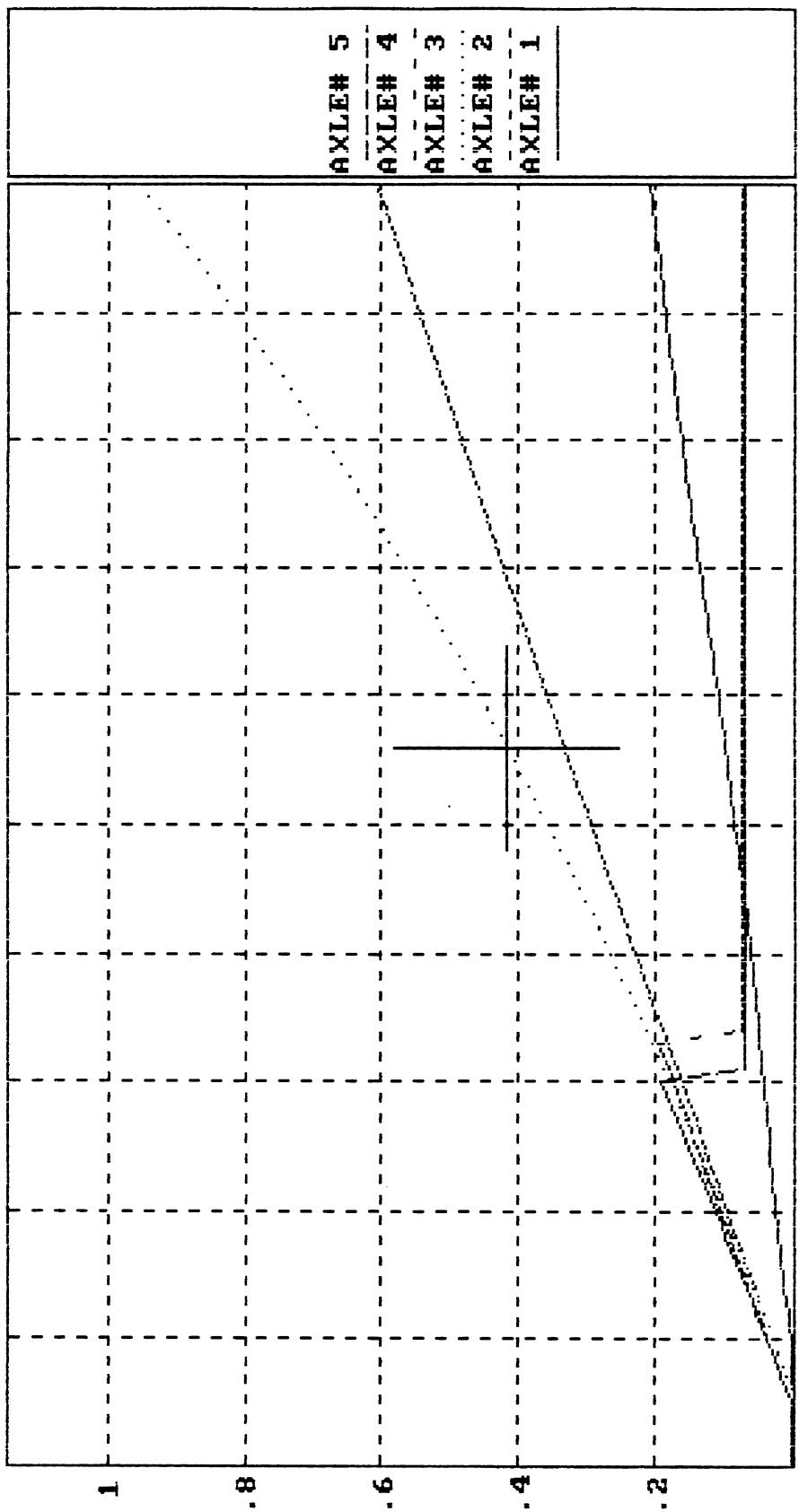

0 10 20 30 40 50 60 70 80 90 100

AXLE# 3 = .4159

PRESS = 56.0psi

Case 7

BRKING EFFCY & DECELR (gs) vs PRESS(psi)

C:ICEL3BSC.BRK

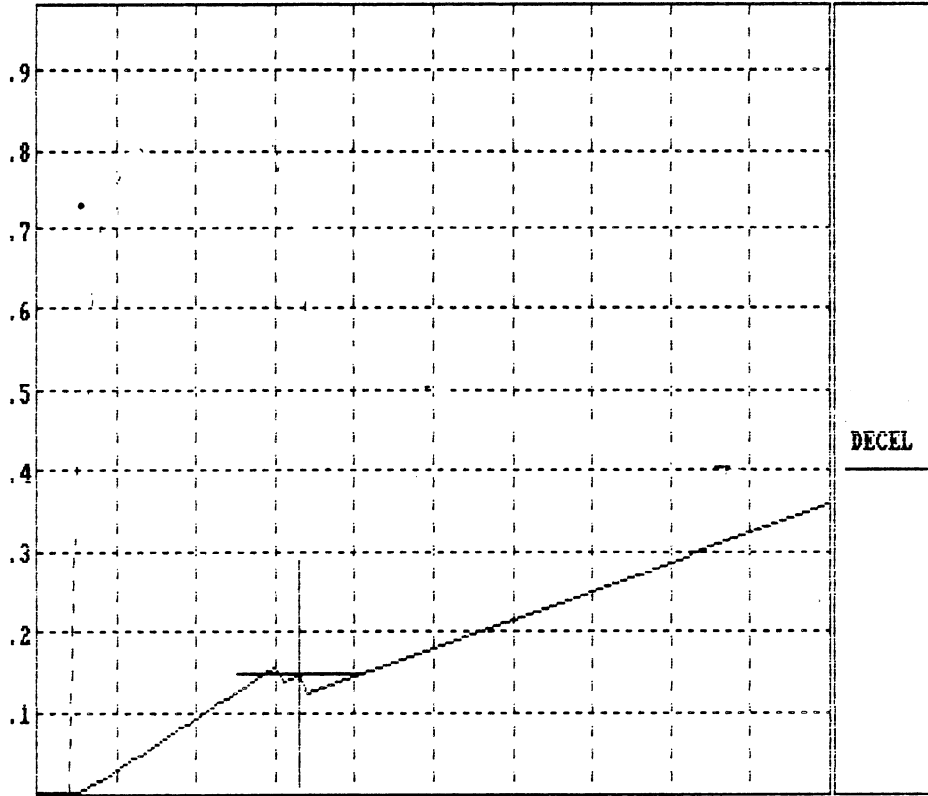

DECEL = .1467gs	PRESS = 33.0psi
-----------------	-----------------

Case 7

FRICION UTILIZATION vs PRESSURE(psi) C:ICEL3BSC.BRK

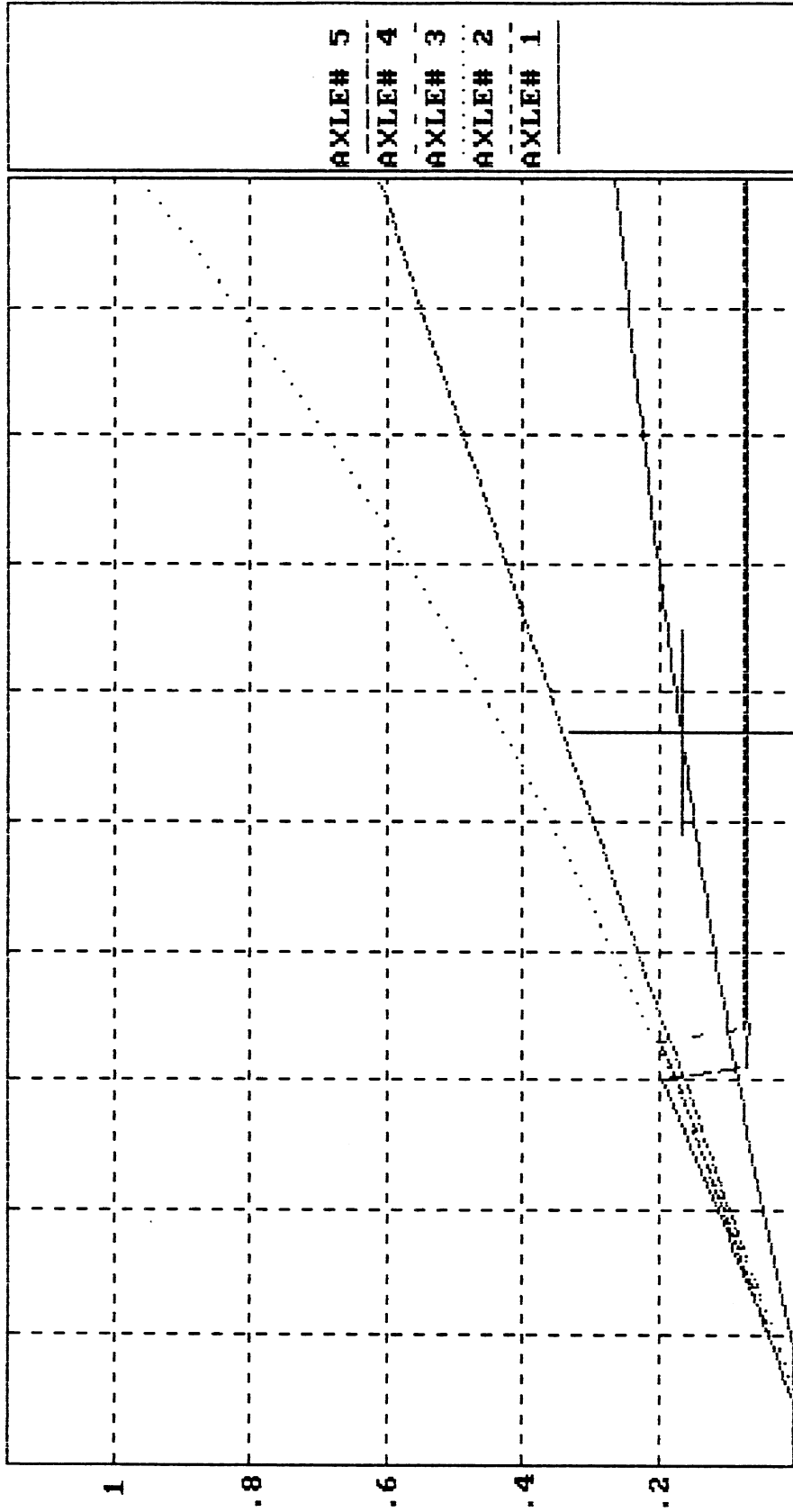

AXLE# 1 = .1669 PRESS = 57.0psi

Case 8

BRAKING EFFCY & DECELR (gs) vs PRESS(psi)

C:ICEL3BSC.BRK

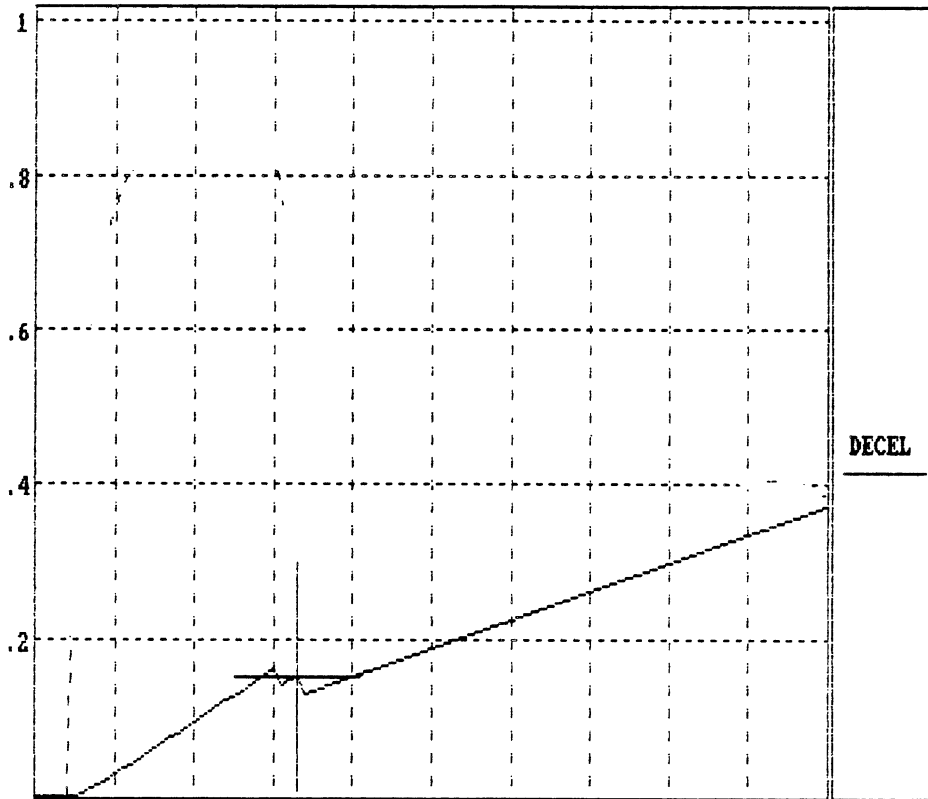

DECEL = .1537gs	PRESS = 33.0psi
-----------------	-----------------

Case 8

C:ICEL3BSC.BRK

FRICION UTILIZATION vs PRESSURE(psi)

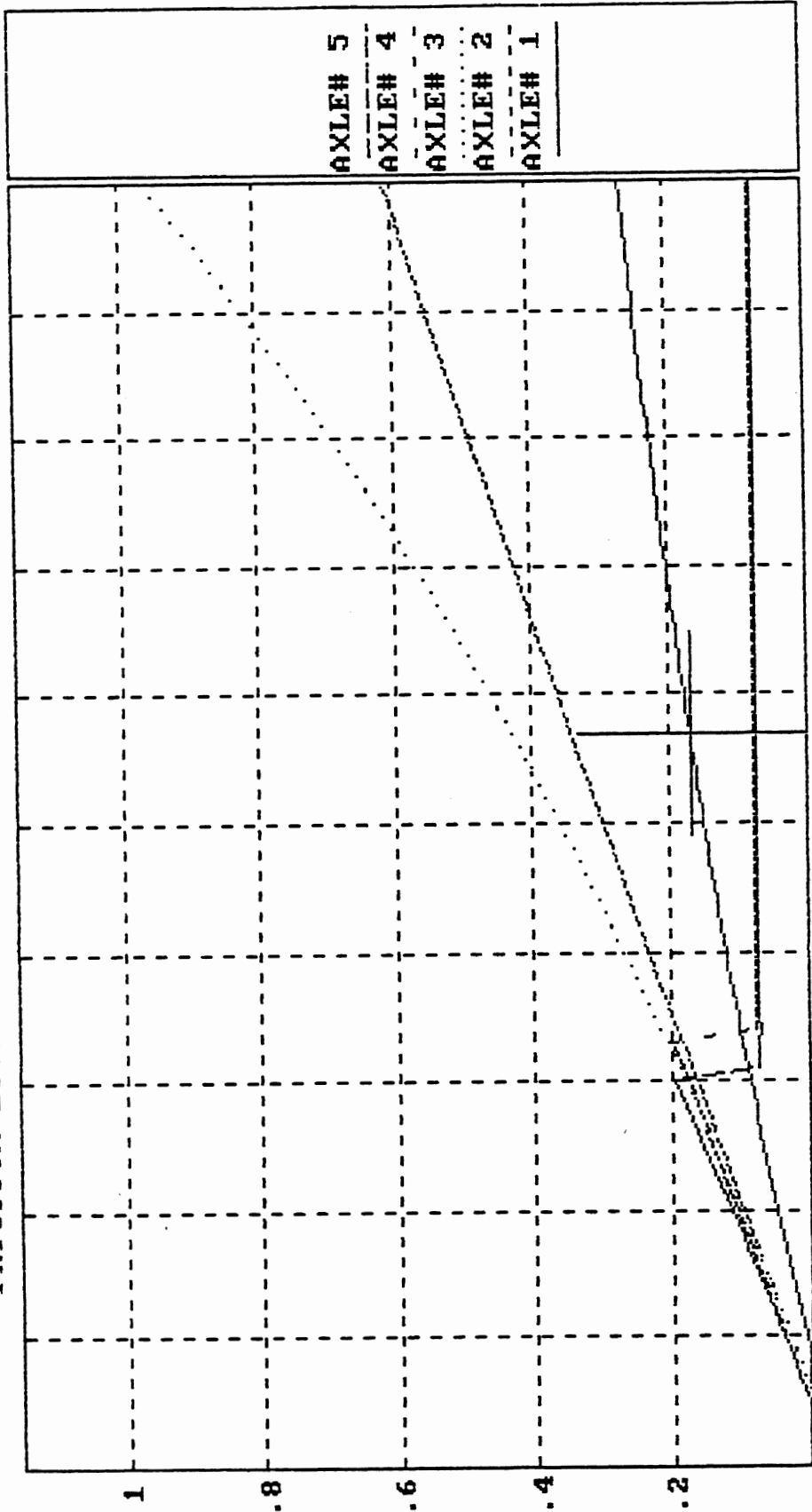

AXLE# 1 = .1669

PRESS = 57.0psi

Case 9

BRAKING EFFCY & DECELR (gs) vs PRESS(psi)

C:ICEL3BSC.BRK

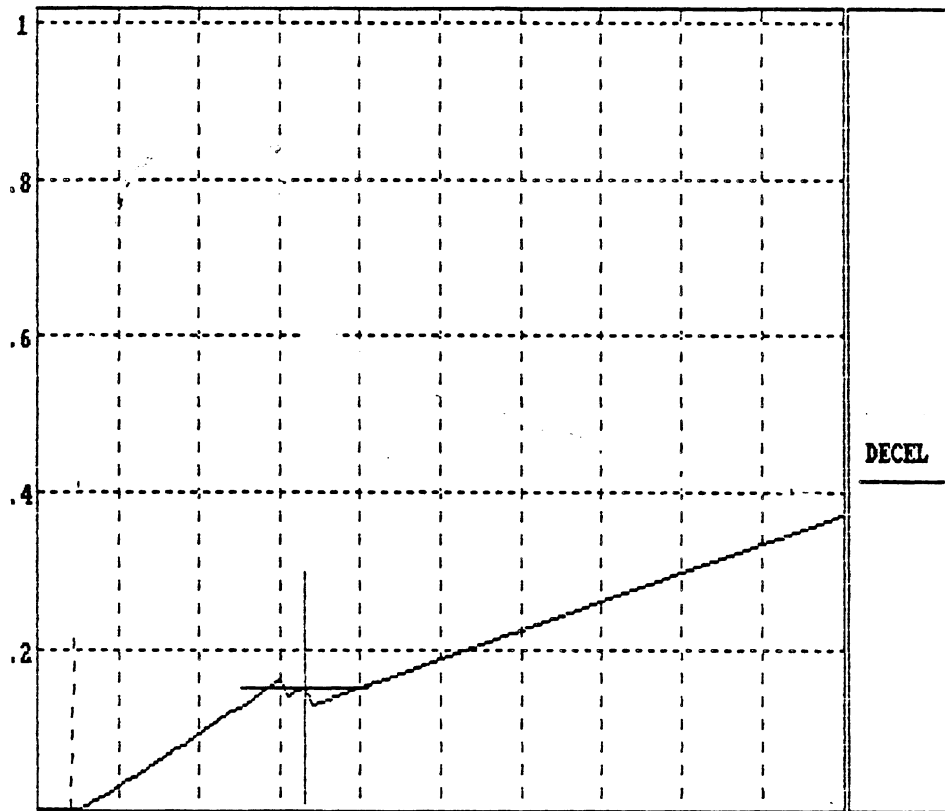

DECEL = .1537gs                      PRESS = 33.0psi

Case 9

FRICION UTILIZATION vs PRESSURE(psi). C:ICEL3BSC.BRK

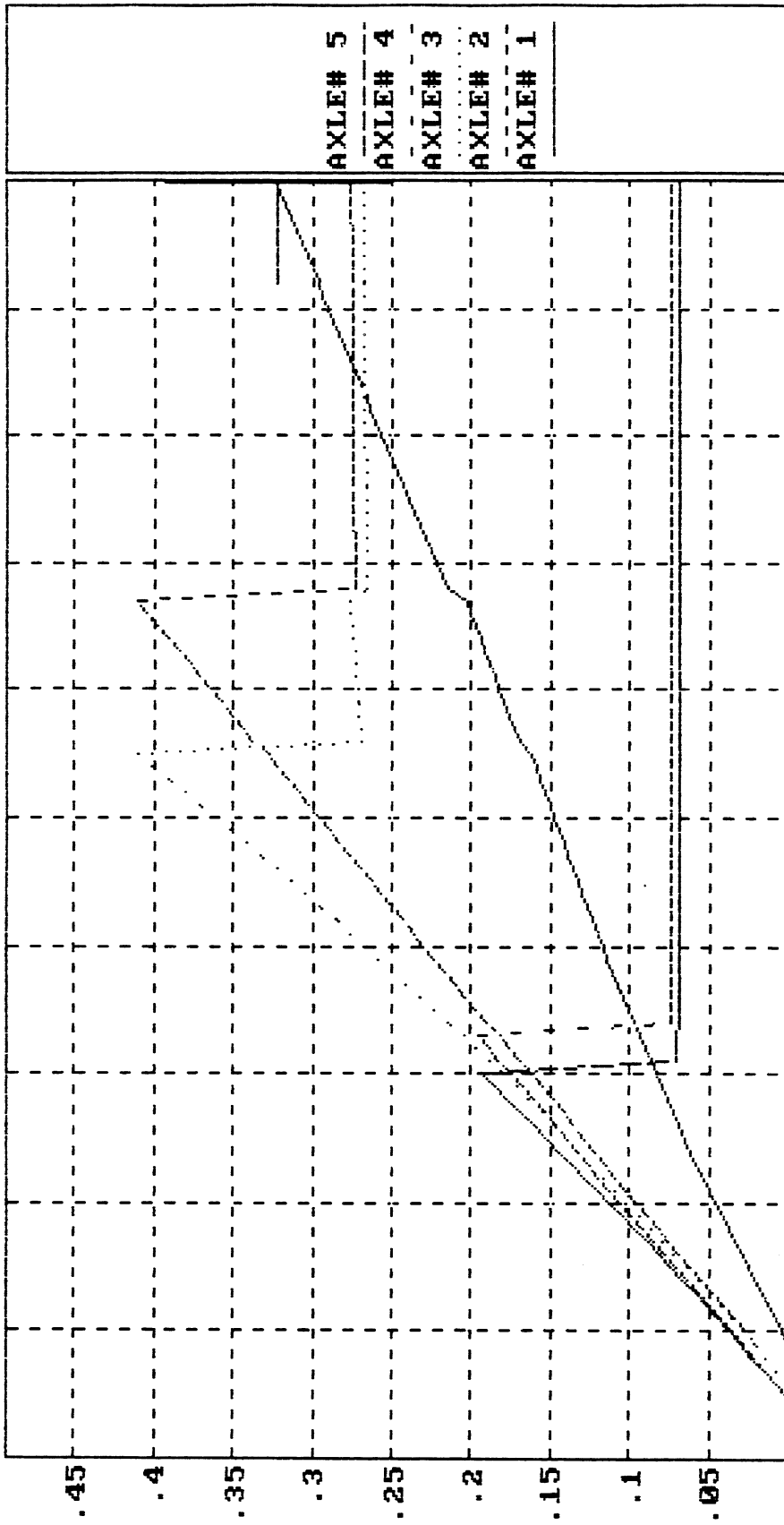

0 10 20 30 40 50 60 70 80 90 100

AXLE# 1 = .3227 PRESS = 100.0psi

Case 10

BRAKING EFFCY & DECELR (gs) vs PRESS(psi)

C:ICEL3BSC.BRK

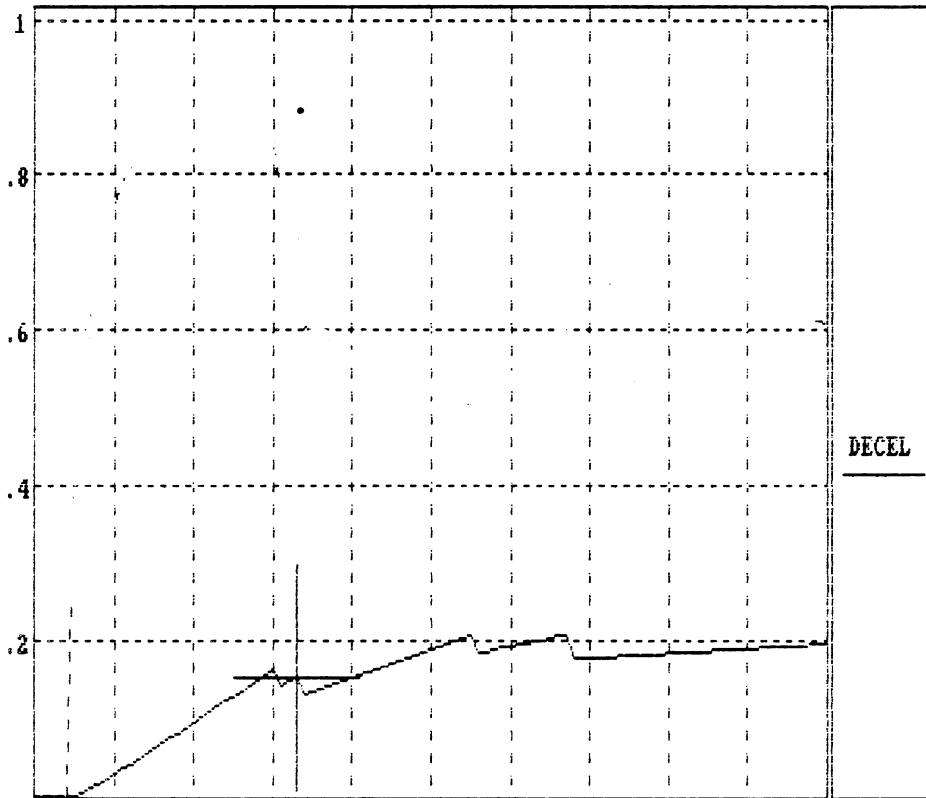

0 10 20 30 40 50 60 70 80 90 100

DECEL = .1539gs

PRESS = 33.0psi

Case 10



FRICION UTILIZATION vs PRESSURE(psi) C:iceL2BAS.BRK

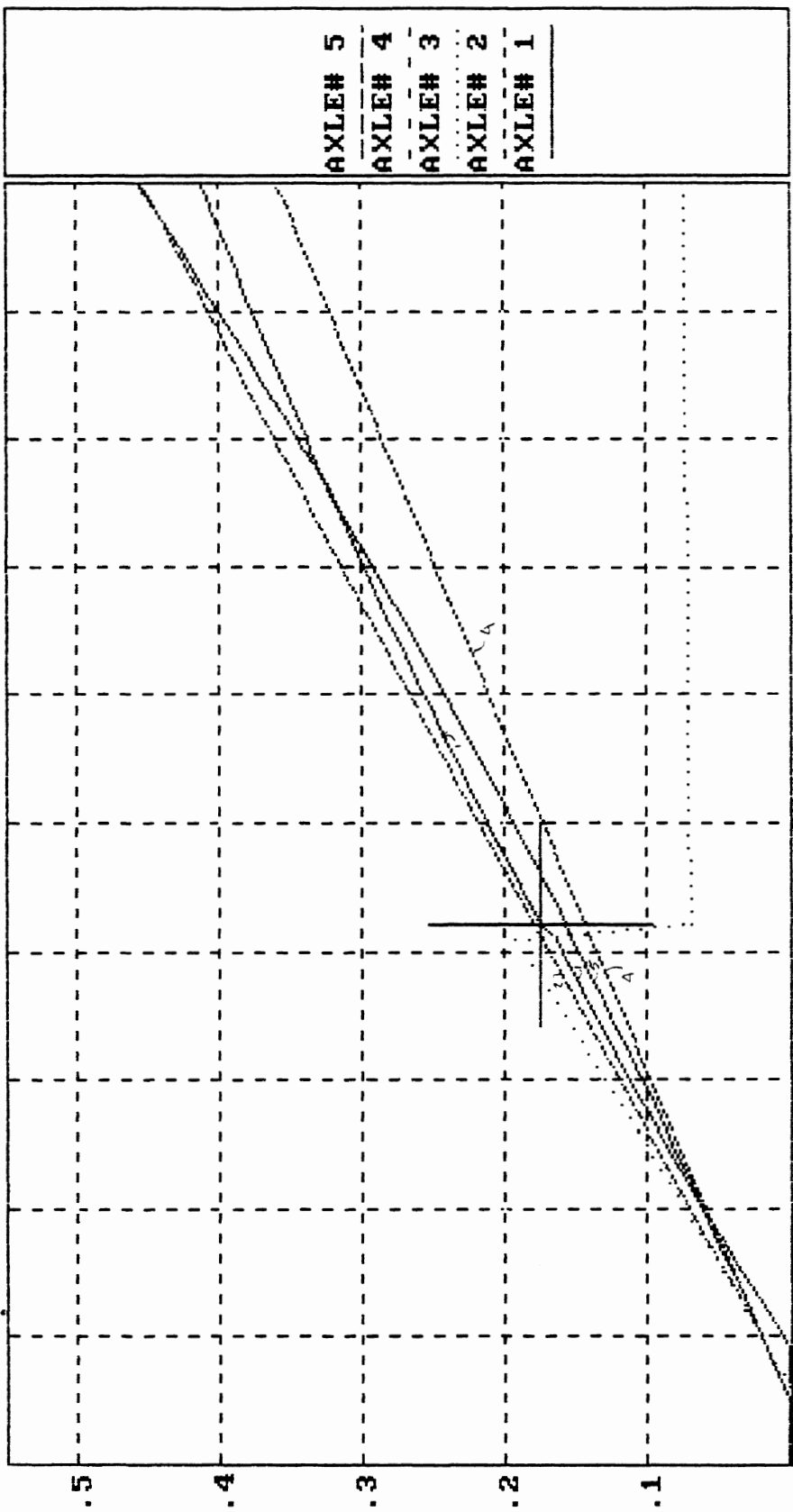

AXLE# 1 = .1742 PRESS = 42.0psi

Case 11

BRKING EFFCY & DECELR (gs) vs PRESS(psi)

C:\iceL2BAS.BRK

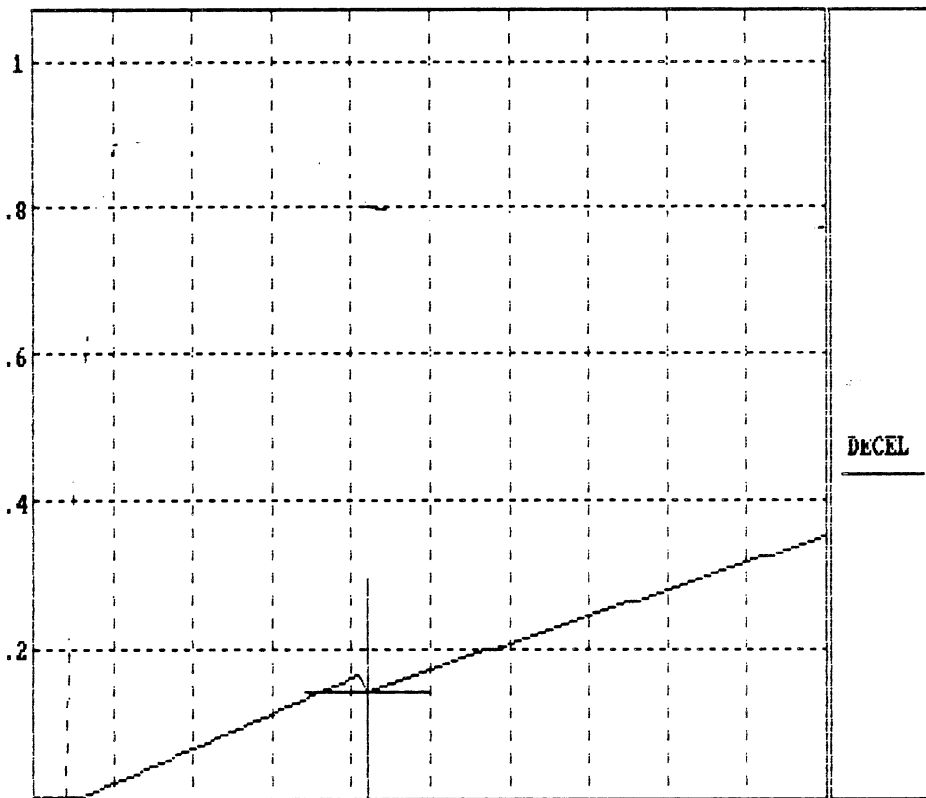

0	10	20	30	40	50	60	70	80	90	100
DECEL = .1432gs					PRESS = 42.0psi					

Case 11

FRICION UTILIZATION vs PRESSURE(psi) C: ICEL4LOK.BRK

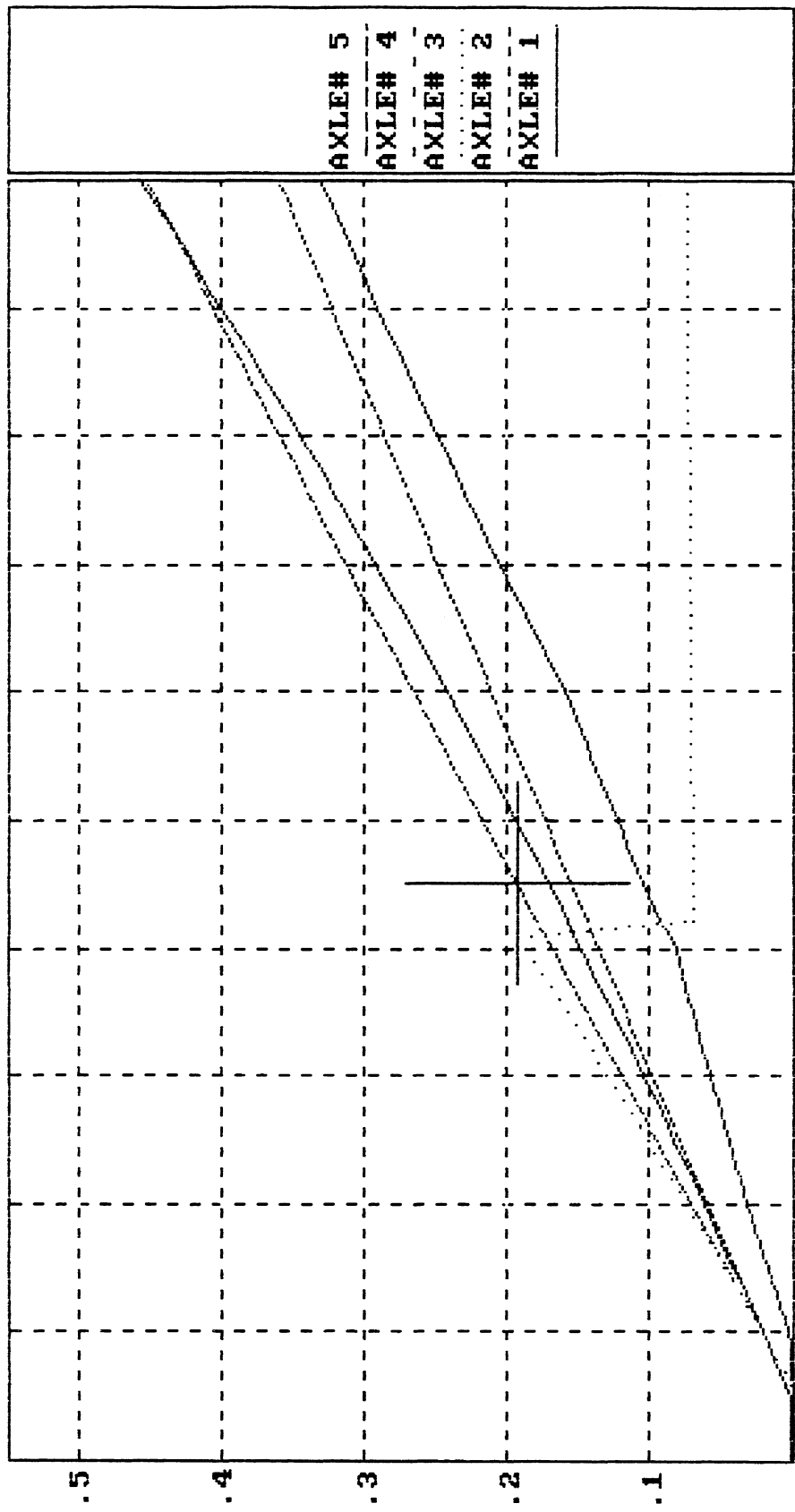

AXLE# 2 = .1929 PRESS = 45.0psi

Case 12

BRKING EFFCY & DECELR (gs) vs PRESS(psi)

C:ICELALOK.BRK

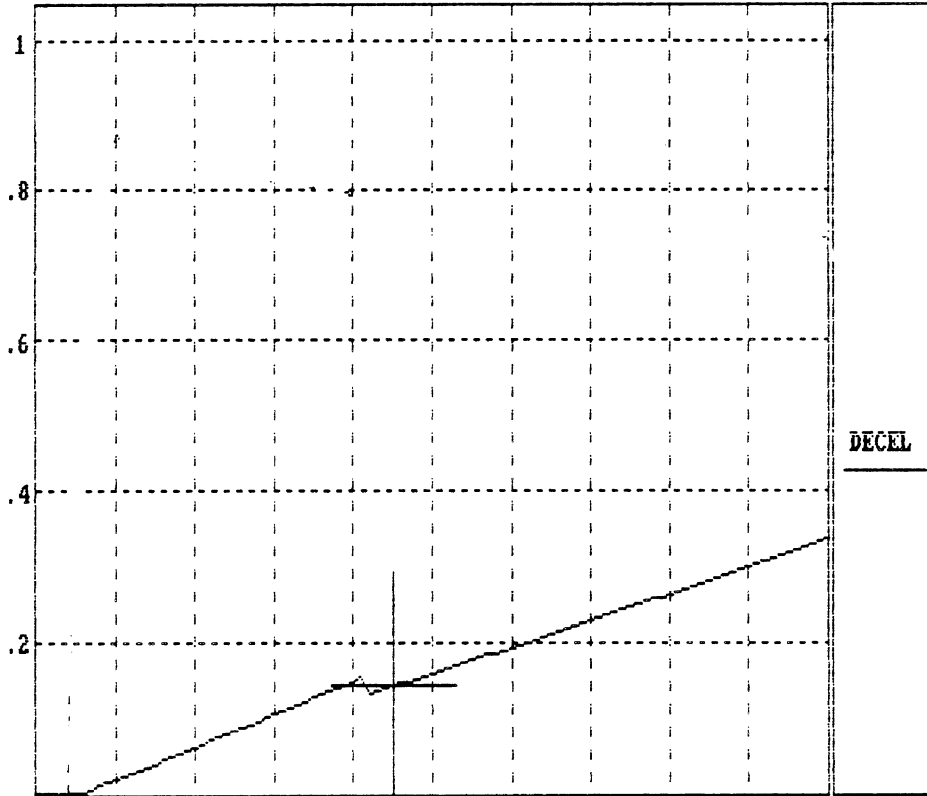

DECEL = .1410gs                      PRESS = 45.0psi

Case 12

FRICION UTILIZATION vs PRESSURE(psi) C:ICEL4LOK.BRK

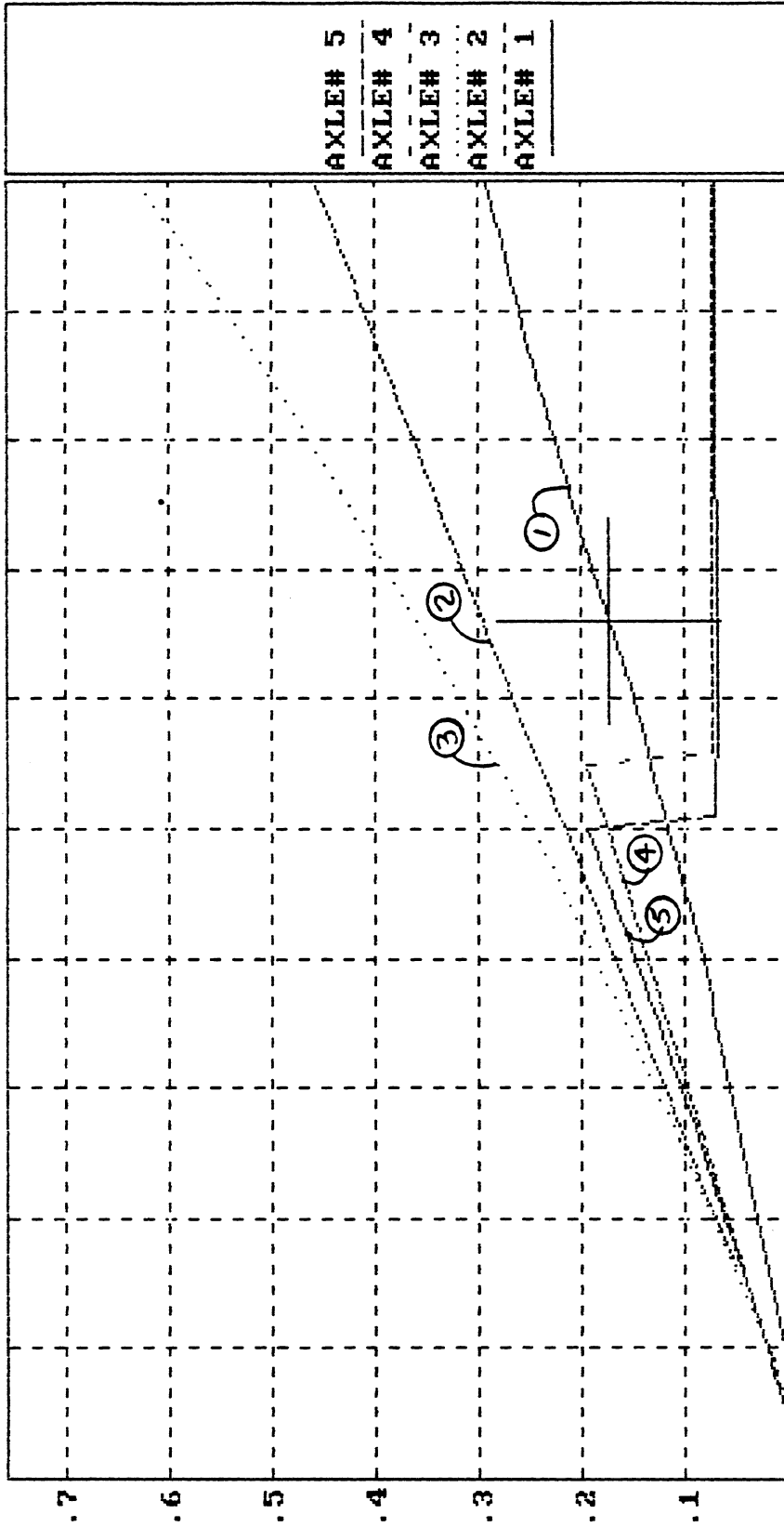

0 10 20 30 40 50 60 70 80 90 100

AXLE# 1 = .1723 PRESS = 66.0psi

Case 13

BRAKING EFFCY & DECELR (gs) vs PRESS(psi)

C:ICEL4LOK.BRK

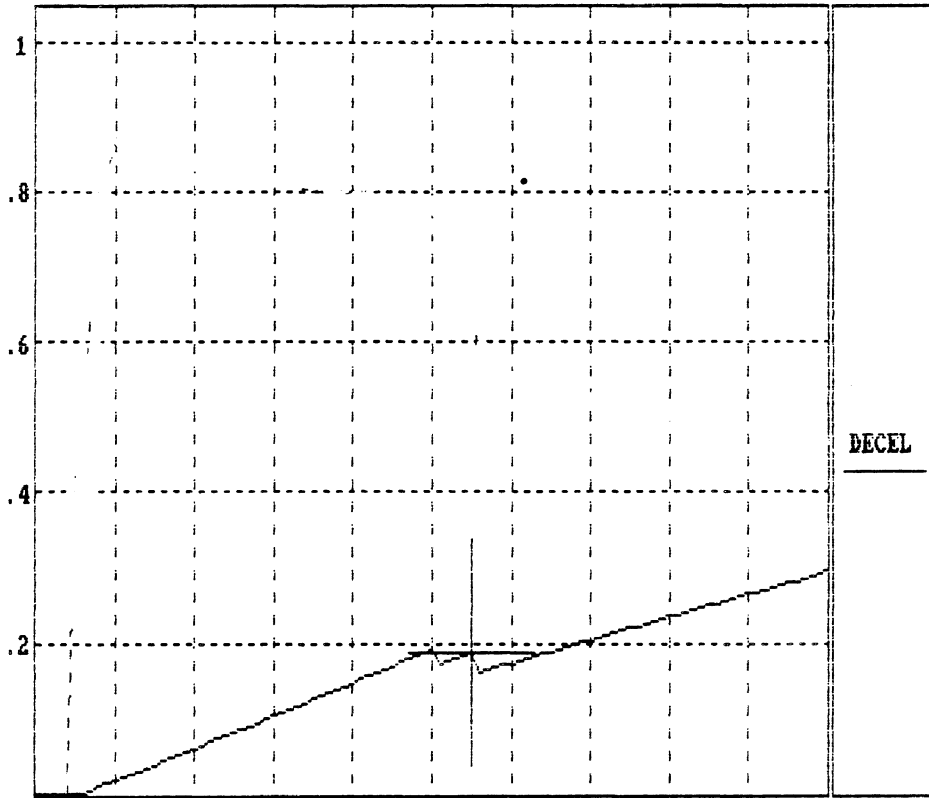

0 10 20 30 40 50 60 70 80 90 100

DECEL = .1870gs

PRESS = 55.0psi

Case 13

C: ICEL2BPP.BRK

FRICION UTILIZATION vs PRESSURE (psi)

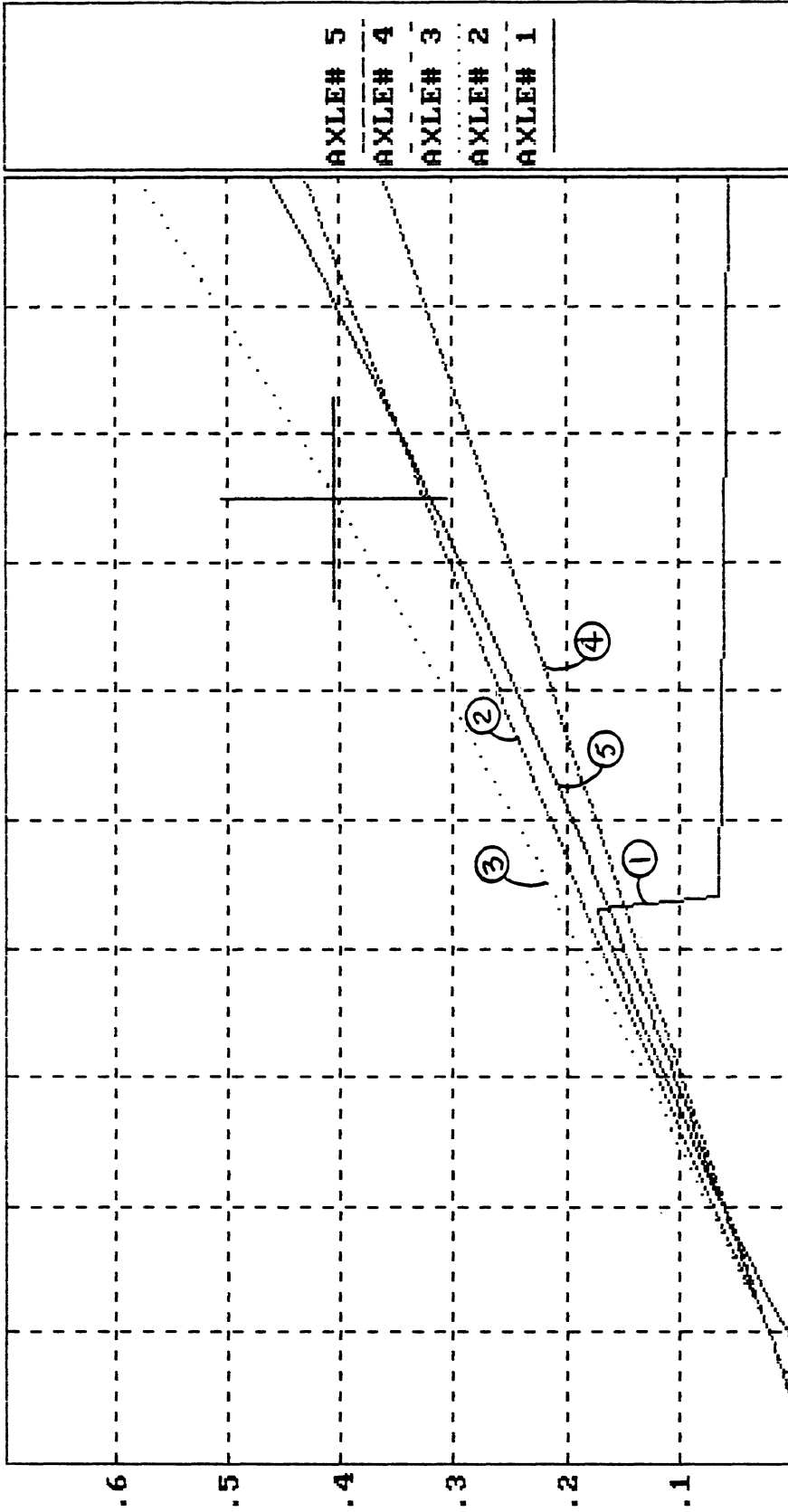

0 10 20 30 40 50 60 70 80 90 100

AXLE# 3 = .4042

PRESS = 75.0psi

Case 14

BRKING EFFCY & DECELR (gs) vs PRESS(psi)

C:\ICEL2BPP.BRK

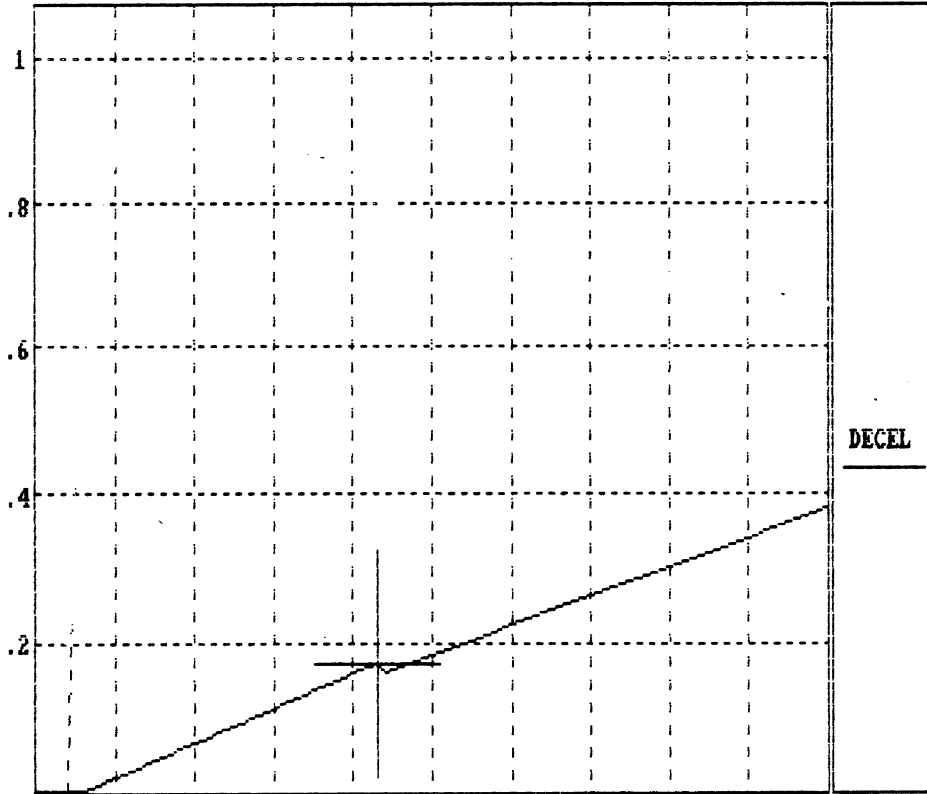

0 10 20 30 40 50 60 70 80 90 100

DECEL = .1737gs

PRESS = 43.0psi

Case 14



FRICION UTILIZATION vs PRESSURE(psi) C:iceL2BAS.BRK

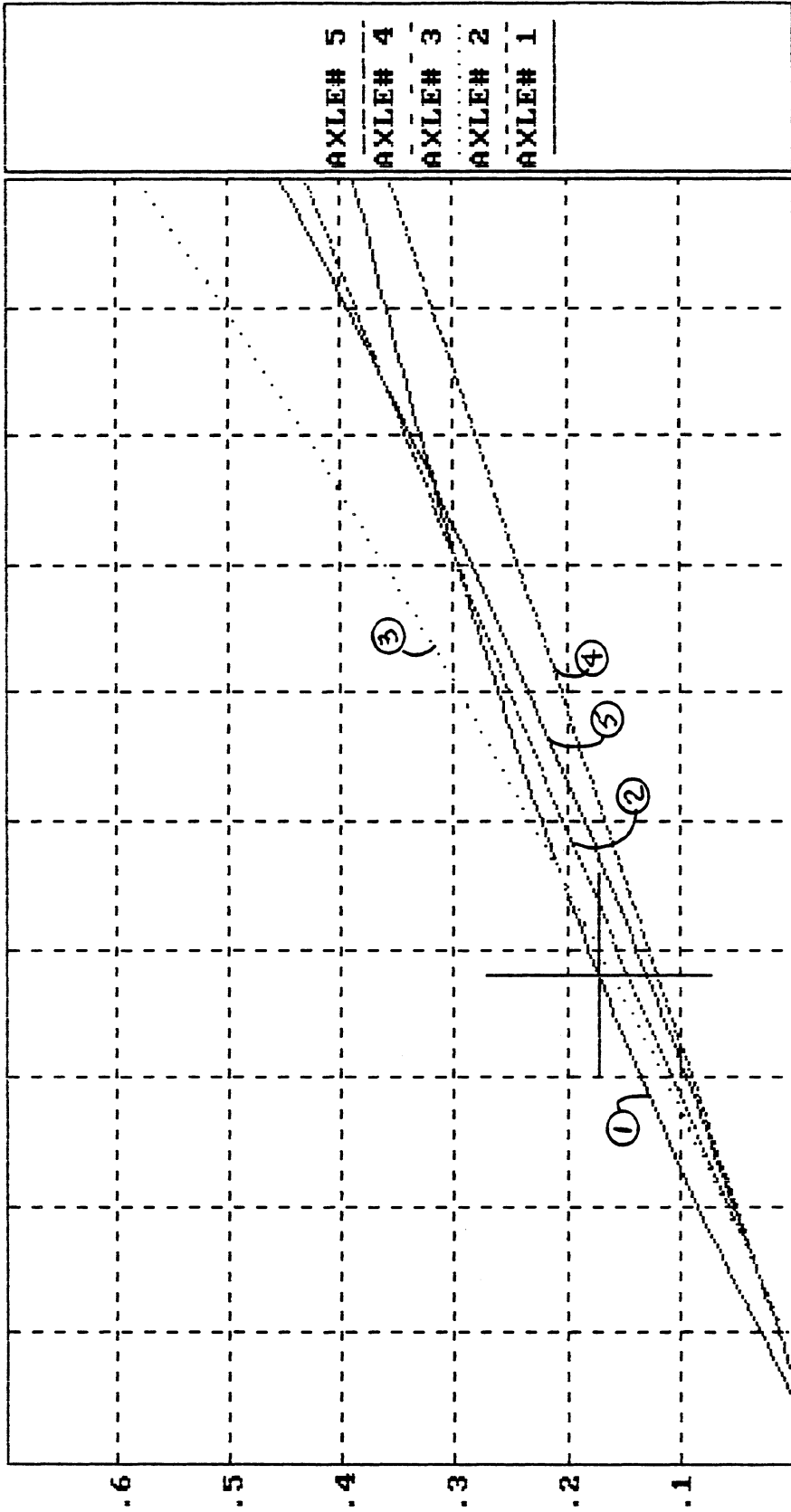

AXLE# 1 = .1718 PRESS = 38.0psi

Case 15

BRKING EFFCY & DECELR (gs) vs PRESS(psi)

C:\iceL2BAS.BRK

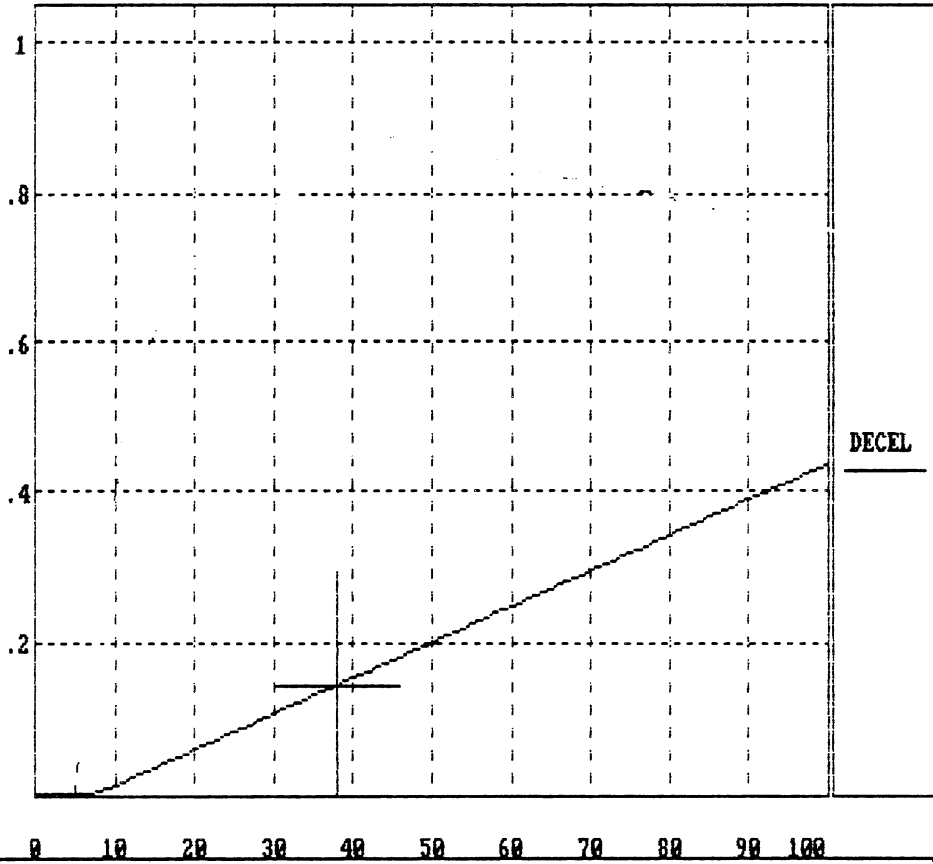

DECEL = .1437gs                      PRESS = 38.0psi

Case 15

FRICION UTILIZATION vs PRESSURE(psi) C:ICEL2BPP.BRK

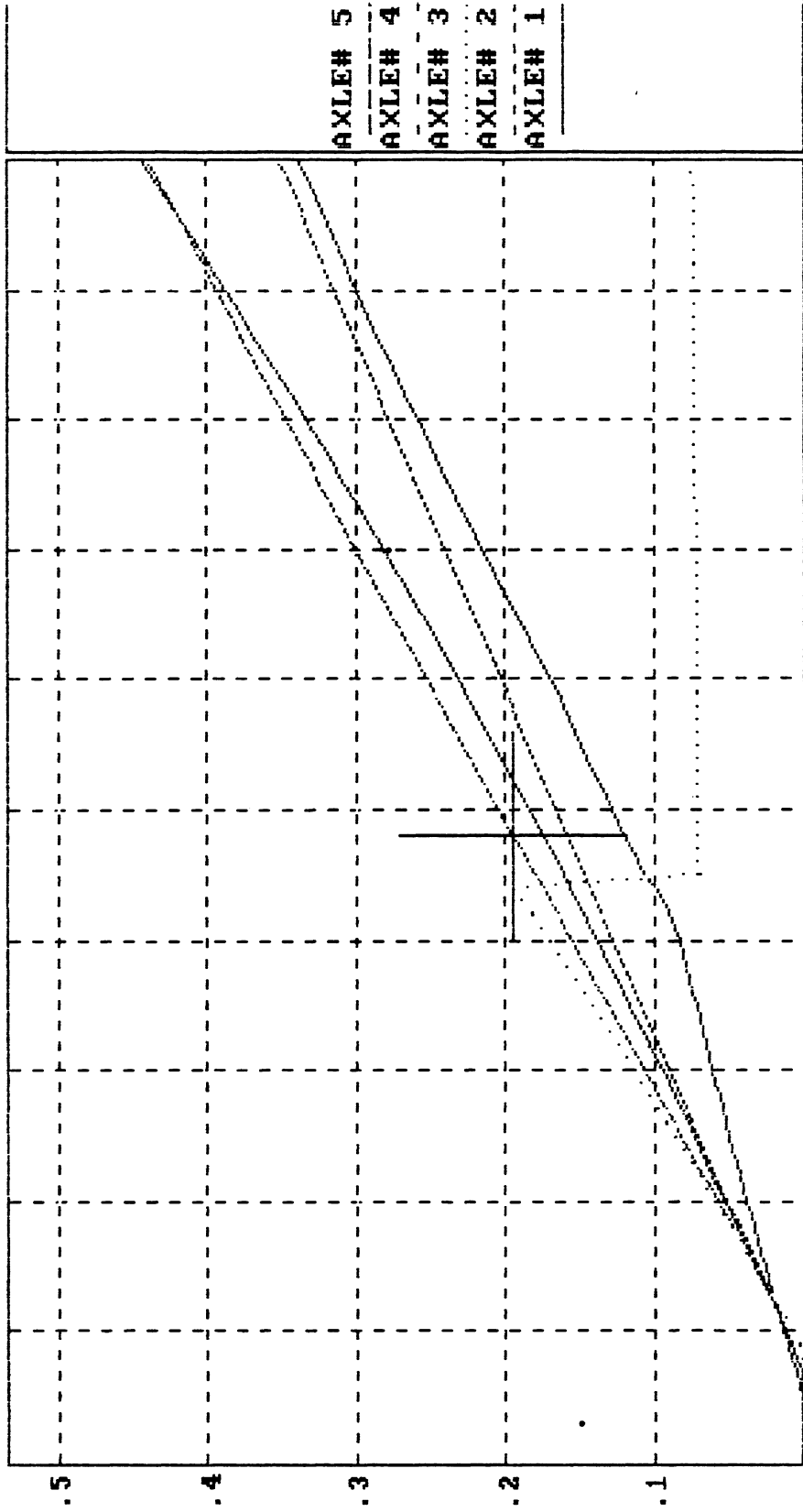

AXLE# 2 = .1945 PRESS = 48.0psi

Case 16

BRKING EFFCY & DECELR (gs) vs PRESS(psi)

C:ICEL2BPP.BRK

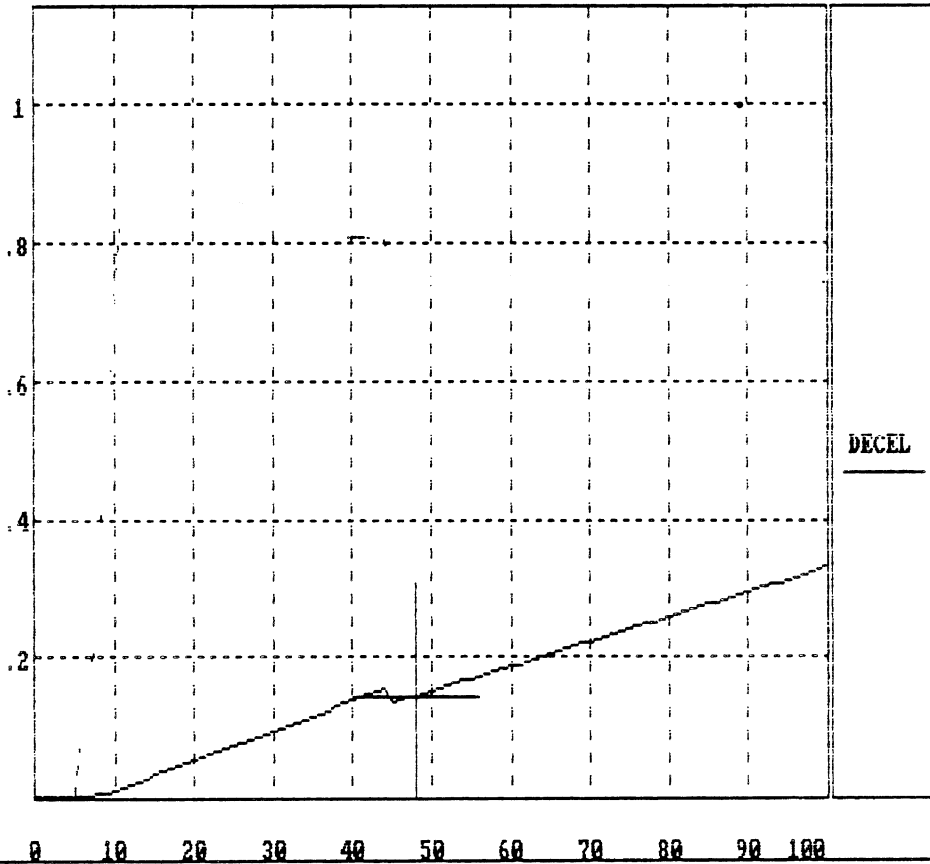

DECEL = .1454gs

PRESS = 48.0psi

Case 16

C: ICEL5LOK.BRK

FRICION UTILIZATION vs PRESSURE (psi)

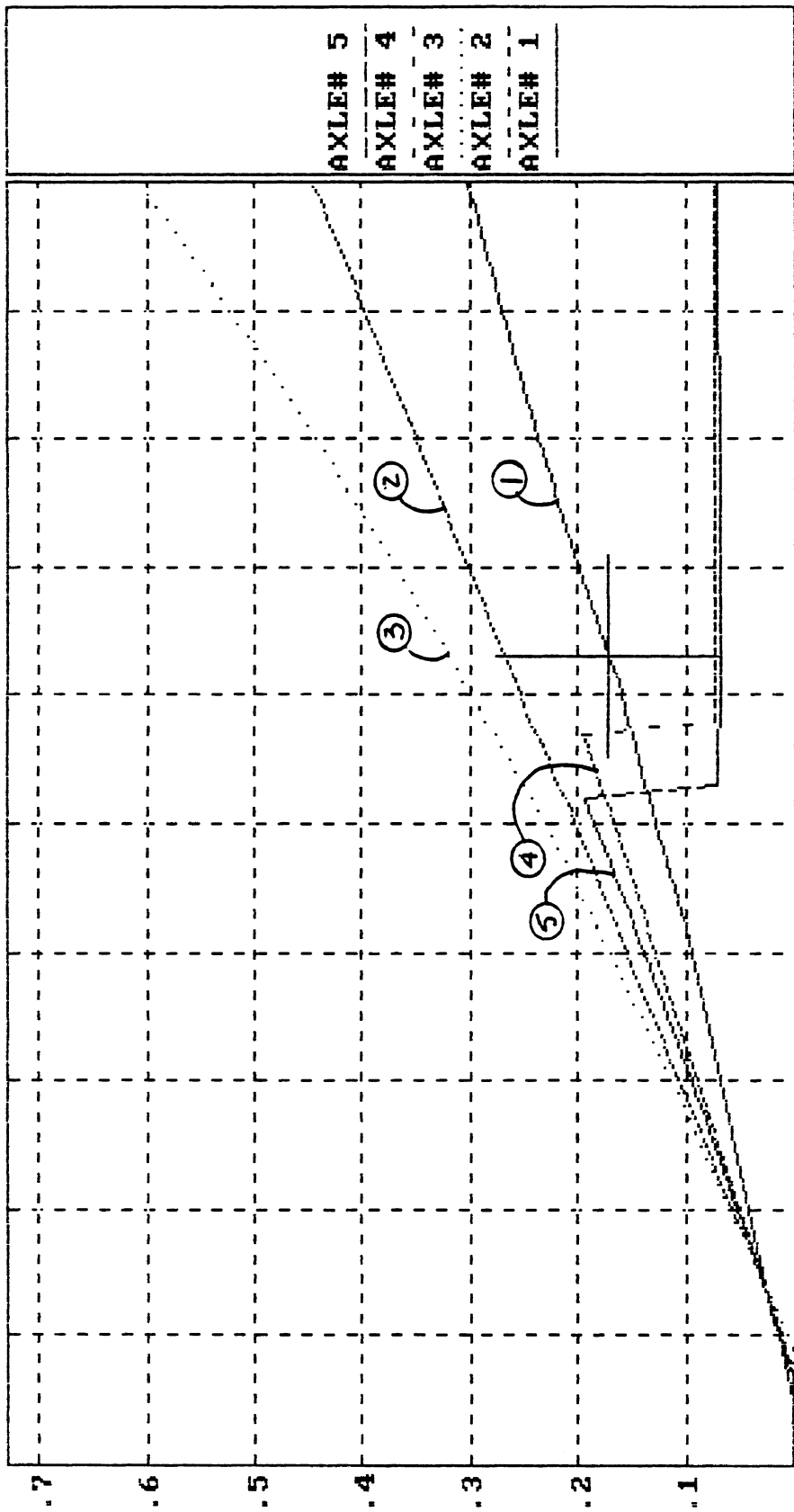

AXLE# 1 = .1709 PRESS = 63.0psi

Case 17

BRAKING EFFCY & DECELR (gs) vs PRESS(psi)

C:ICEL5LOK.BRK

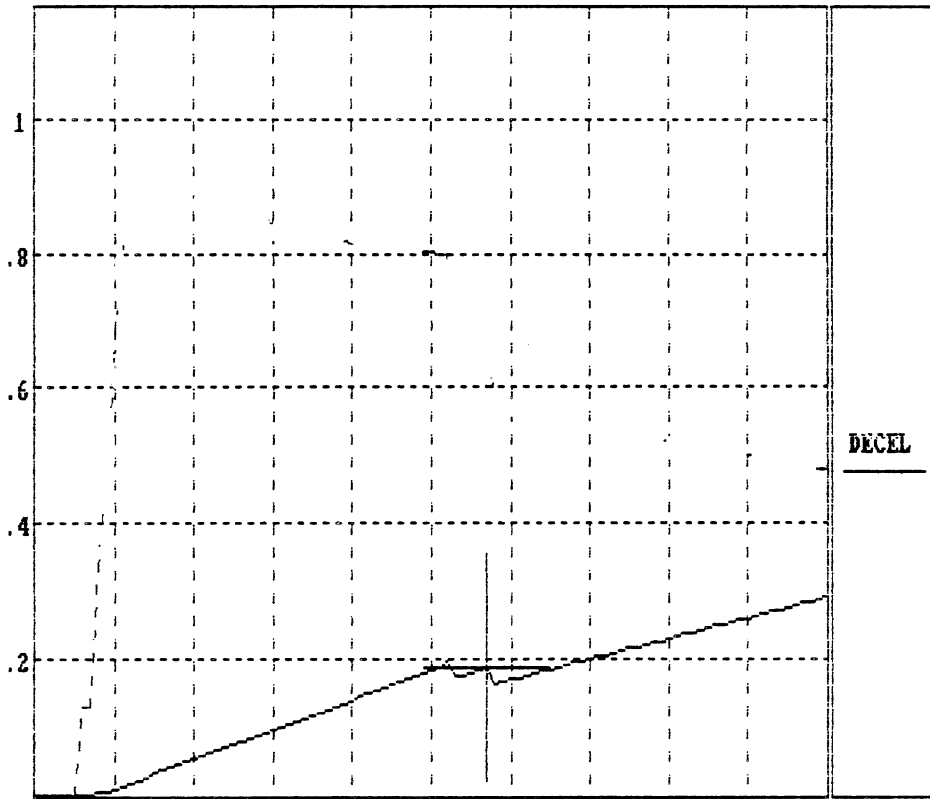

0 10 20 30 40 50 60 70 80 90 100  
DECEL = .188gs PRESS = 57.0psi

Case 17

FRICION UTILIZATION vs PRESSURE(psi) C:iceL4LOK.BRK

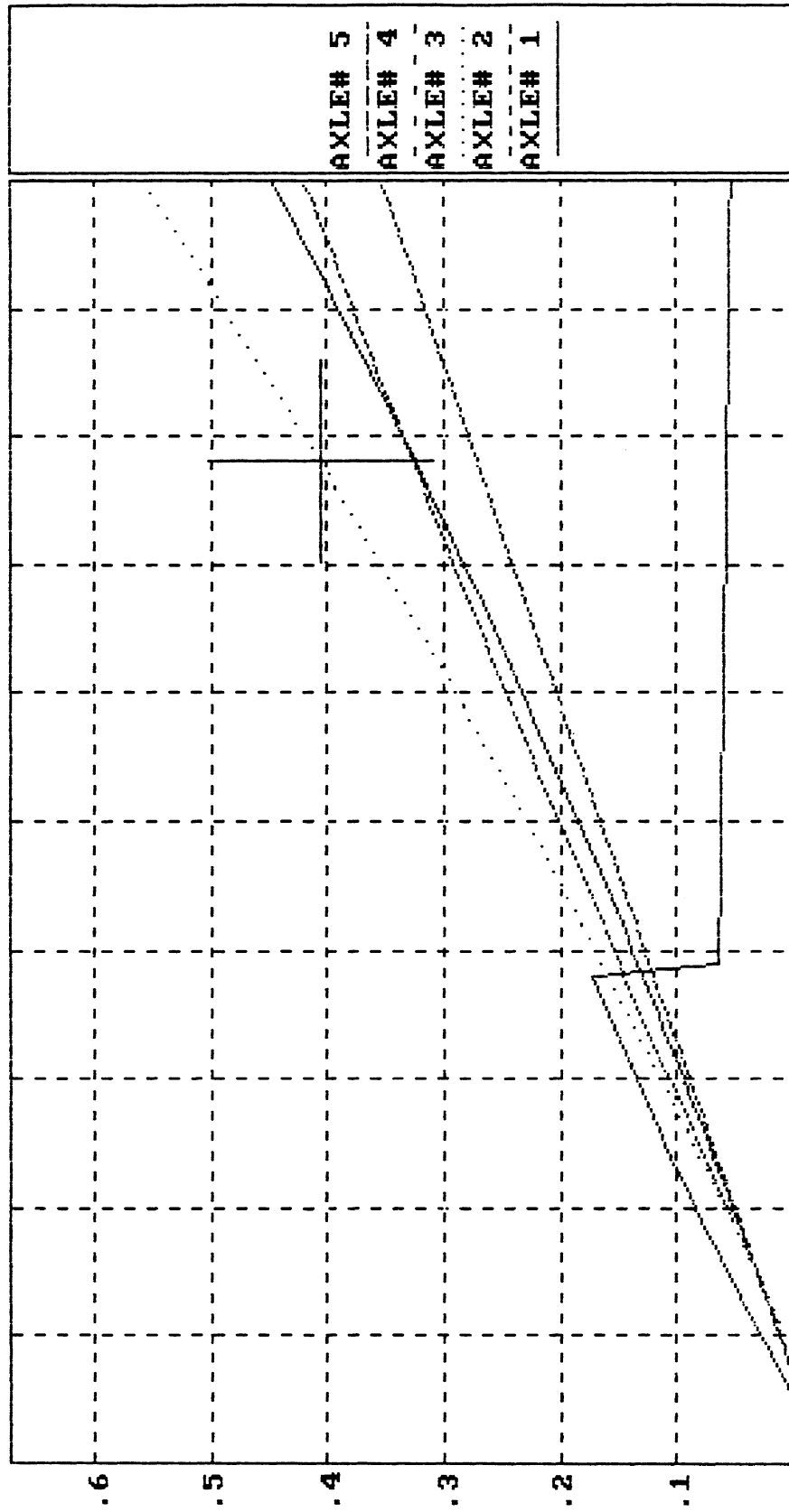

0 10 20 30 40 50 60 70 80 90 100

AXLE# 3 = .4060

PRESS = 78.0psi

Case 18

BRAKING EFFCY & DECELR (gs) vs PRESS(psi)

C:\iceL4LOK.BRK

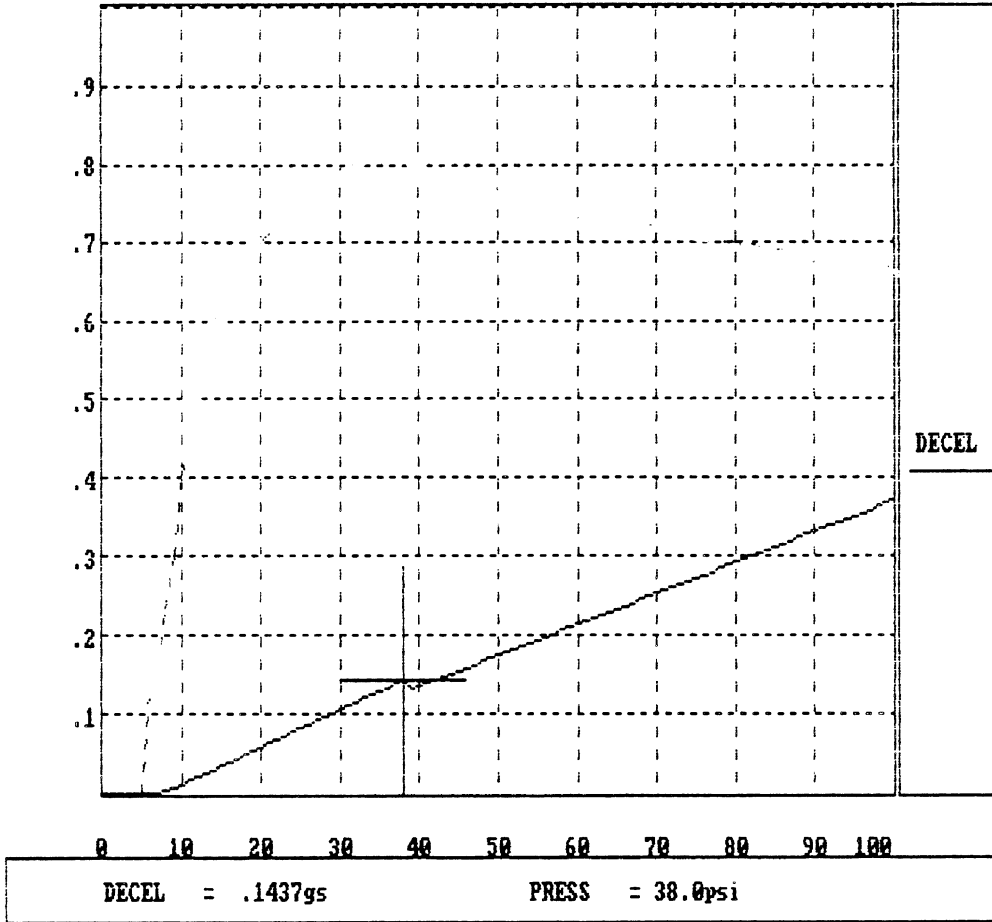

Case 18



FRICION UTILIZATION vs PRESSURE(psi) C:iceL6LOK.BRK

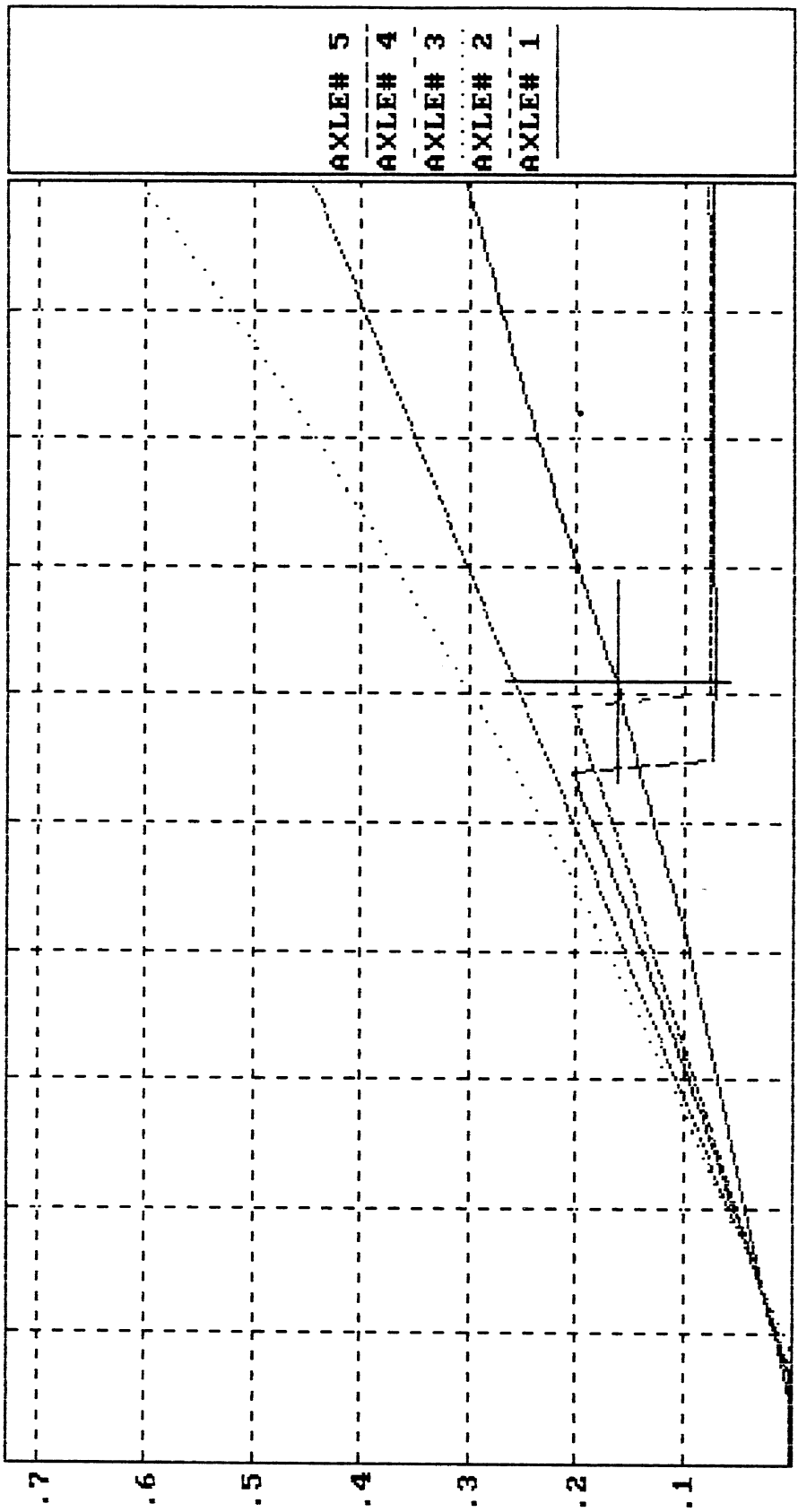

0 10 20 30 40 50 60 70 80 90 100

AXLE# 1 = .1626

PRESS = 61.0psi

Case 19

BRKING EFFCY & DECELR (gs) vs PRESS(psi)

C:ICEL6LOK.BRK

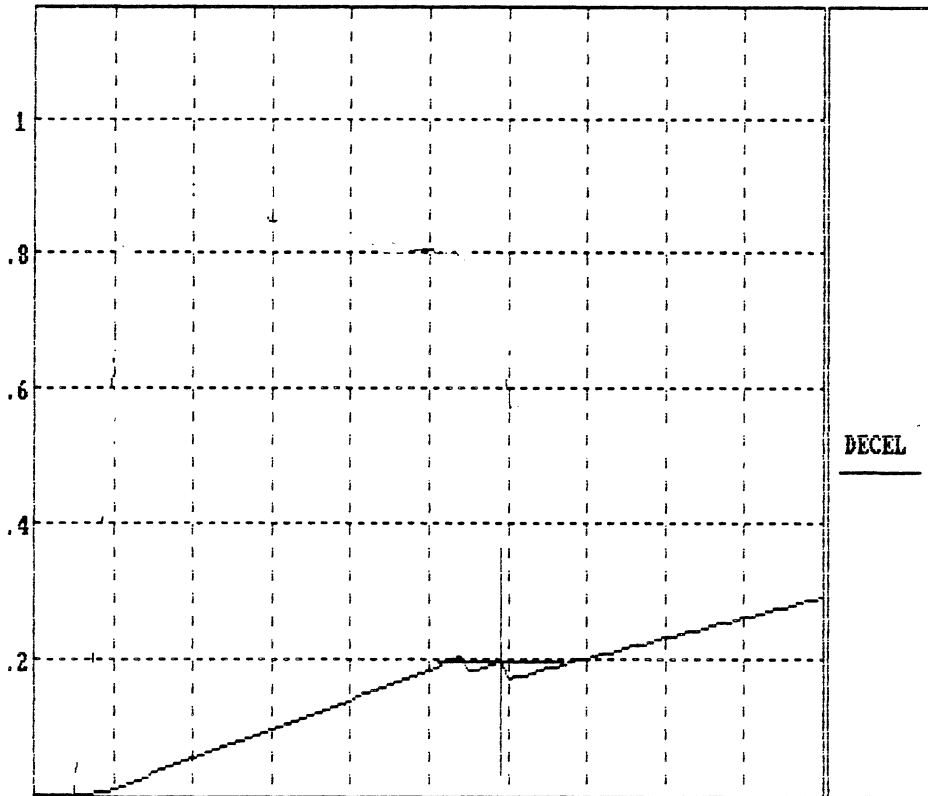

DECEL = .1961gs                      PRESS = 59.0psi

Case 19

BRKING EFFCY & DECELR (gs) vs PRESS(psi)

C:\iceL4LOK.BRK

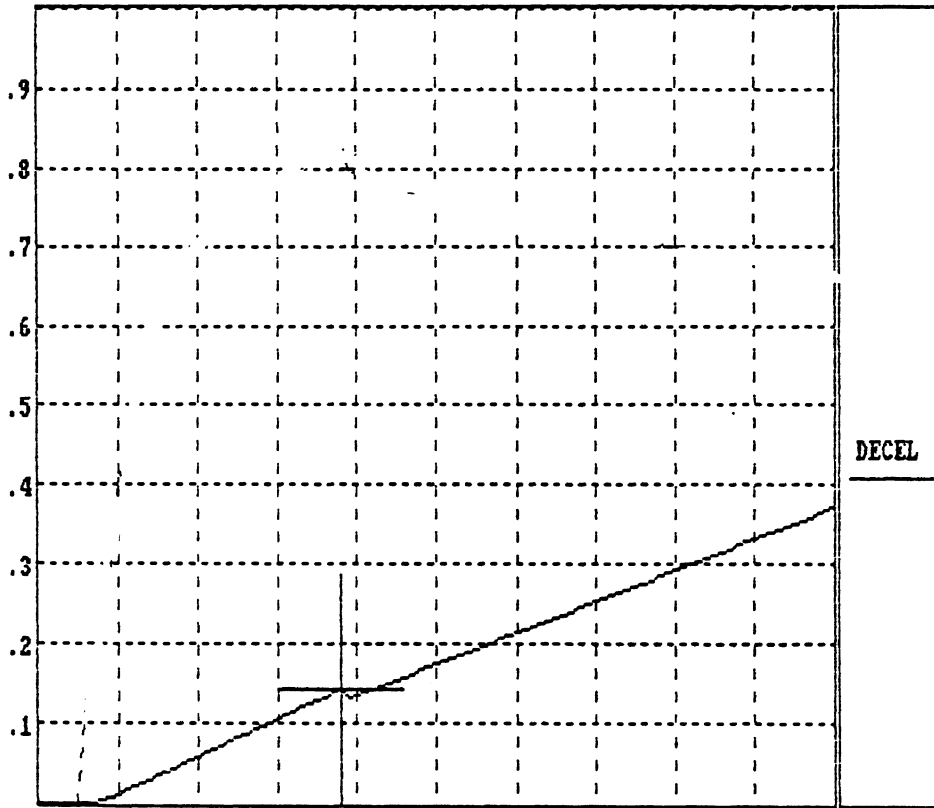

0 10 20 30 40 50 60 70 80 90 100  
DECEL = .1437gs PRESS = 38.0psi

Case 20

C:\iceL4LOK.BRK

FRICION UTILIZATION vs PRESSURE(psi)

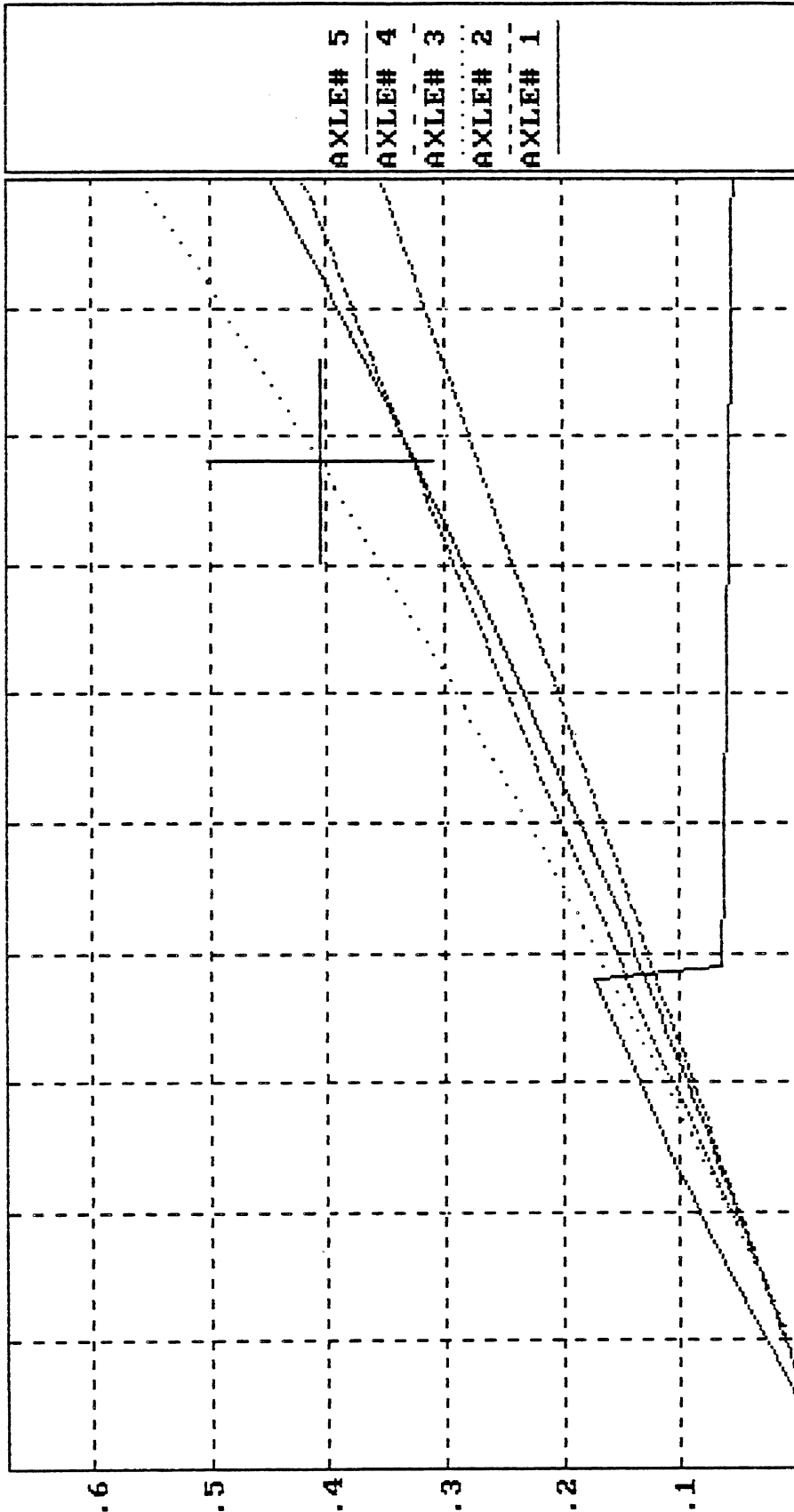

0 10 20 30 40 50 60 70 80 90 100

AXLE# 3 = .4060 PRESS = 78.0psi

AXLE# 3 = .4060

Case 20

BRKING EFFCY & DECELR (gs) vs PRESS(psi)

C:ICEL6LOK.BRK

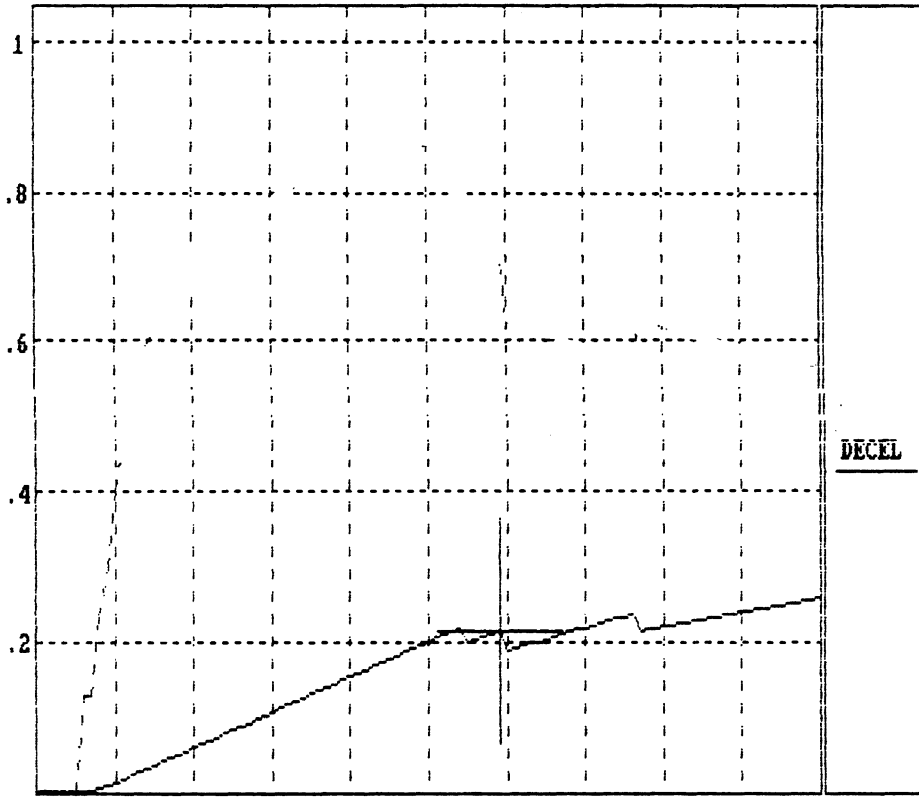

DECEL

0 10 20 30 40 50 60 70 80 90 100

DECEL = .2133gs

PRESS = 59.0psi

Case 21

C:iceL5LOK.BRK

FRICION UTILIZATION vs PRESSURE(psi)

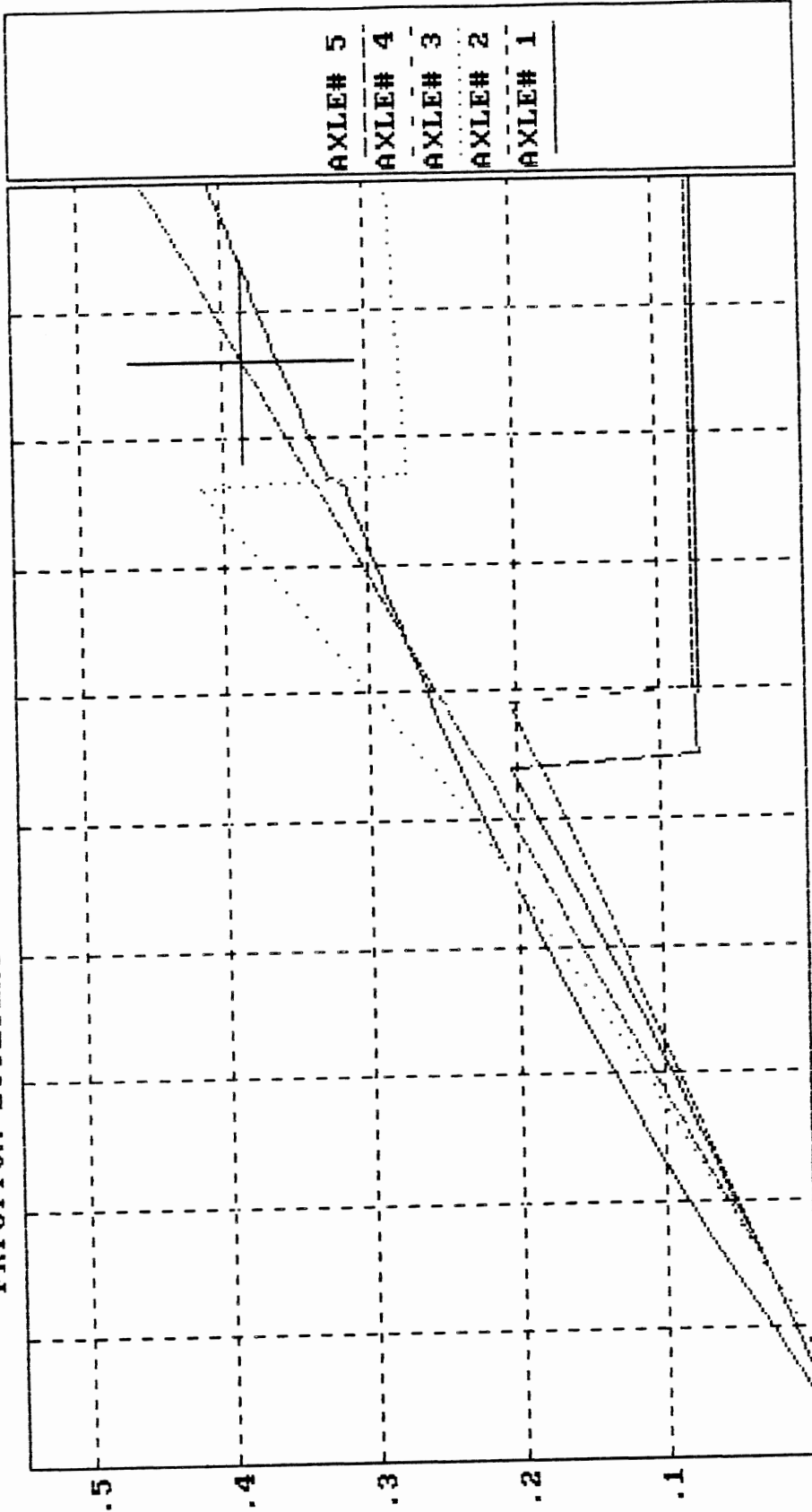

AXLE# 2 = .3861

PRESS = 86.0psi

Case 21

FRICION UTILIZATION vs PRESSURE(psi) C:ICEL6LOK.BRK

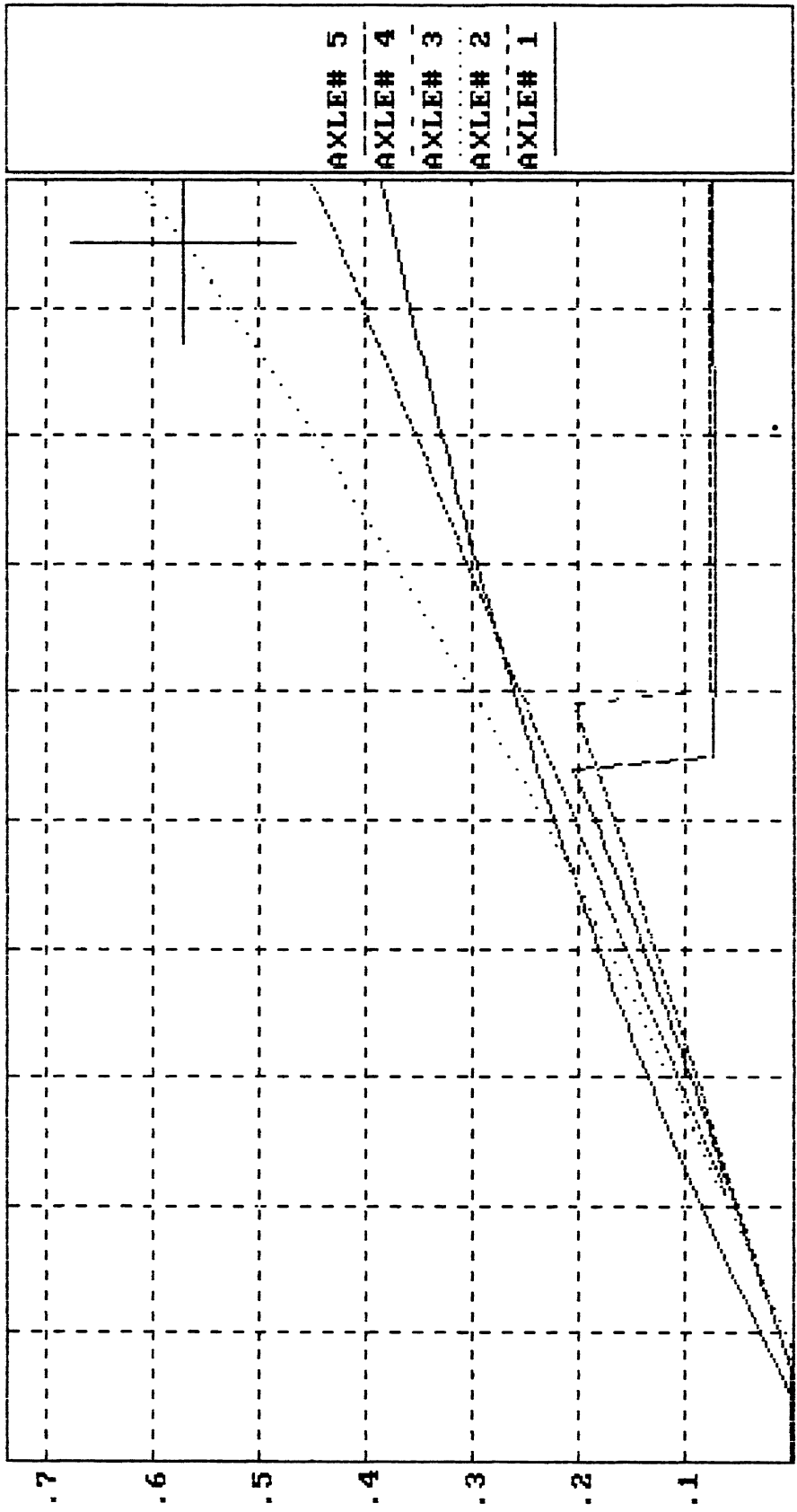

AXLE# 3 = .5699 PRESS = 95.0psi

Case 22

BRKING EFFCY & DECELR (gs) vs PRESS(psi)

C:ICEL6L0K.BRK

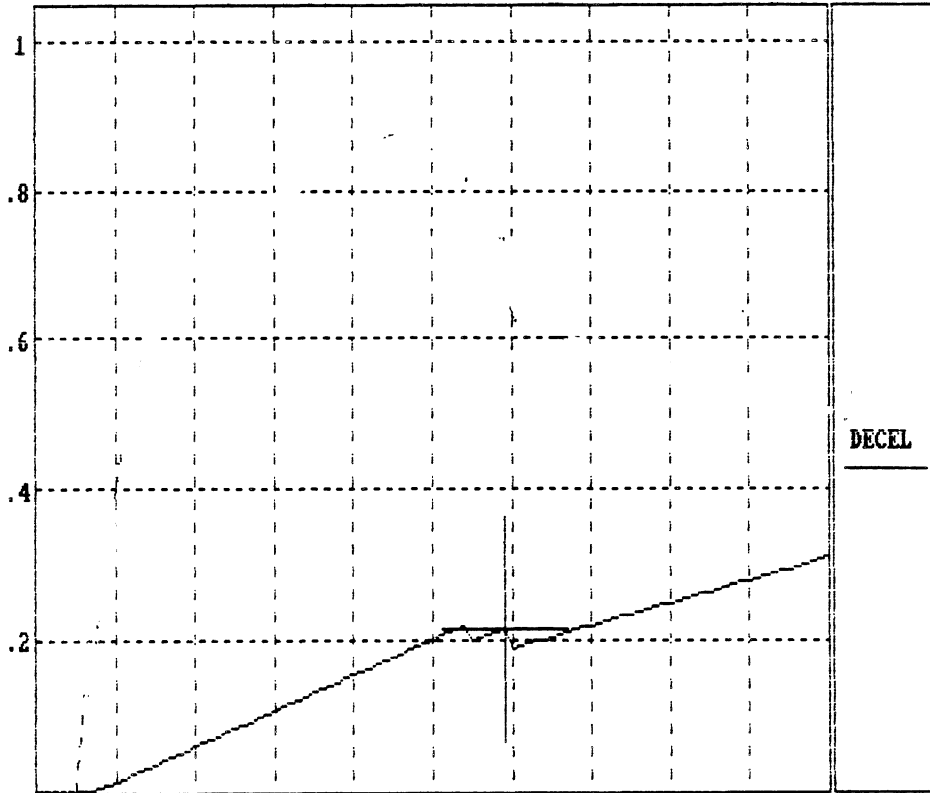

0 10 20 30 40 50 60 70 80 90 100

DECEL = .2133gs

PRESS = 59.0psi

Case 22



## **Appendix C**

### **Formulation of Model used in Braking Performance Analyses**

This appendix contains a writeup of the mathematical formulation of the braking model used to generalize the performance subjects addressed in this study.

## 4.2 BRAKING

4.2.1 Nomenclature and list of symbols used. In the following model the subscript "i" corresponds to a unit number, while "j" refers to the j'th axle on the i'th unit. In some cases the subscript "k" is used to distinguish between different suspensions on a unit. For example, in the case of a full trailer with a fixed dolly, the rear axles would be a part of suspension 2.

Due to the difference in the manner that fixed and converter dollies transfer vertical and horizontal loads, full trailers with fixed dollies are analyzed as composite units.

$W_i$	Total weight (lb)
$a$	Longitudinal deceleration of the vehicle combination (g's)
$h_i$	Total (sprung+unsprung) mass c.g. height (in)
$x_{Fi}$	Longitudinal distance between <u>total</u> c.g. position and forward articulation point (in)
$h_{Fi}$	Height (measured from ground) of the forward articulation point (in)
$F_{xFi}$	Longitudinal force at the forward articulation point (lb)
$F_{zFi}$	Vertical force at the forward articulation point (lb)
$x_{Ri}$	Longitudinal distance between <u>total</u> c.g. position and rear articulation point (in)
$h_{Ri}$	Height (measured from ground) of the rear articulation point (in)
$F_{xRi}$	Longitudinal force at the rear articulation point (lb)
$F_{zRi}$	Vertical force at the rear articulation point (lb)
$x_{ki}$	Longitudinal distance between <u>total</u> c.g. position and suspension "k" (in)
$P_{ki}$	Dynamic load shift parameter - for tandem axle suspensions only
$M_{ki}$	Moment due to dynamic load transfer - for tandem axle suspensions only (in.lb)
$xts_{ki}$	Tandem spread on the k'th suspension (for single axle suspensions $xts_{ki} = 0$ )
$F_{zji}$	Axle load (lb)
$F_{Bji}$	Braking level at an axle (lb)

4.2.2 The Braking Model. This model determines braking performance assuming that the vehicle is making a constant deceleration stop. In addition to the vehicle parameters, the level of braking,  $F_{Bji}$ , is required as an input.

The response to the applied braking forces is described in terms of the longitudinal deceleration,  $a$ , and the vertical loads,  $F_{zji}$ , carried by each axle. For each level of braking input, the "minimum" value of friction needed to avoid wheel lockup is determined. Under the assumptions of the analysis, the wheels on the axle with the largest ratio of  $F_{Bji}$  to  $F_{zji}$  will lock up first. That is, the maximum ratio of  $F_{Bji}/F_{zji}$  represents the friction coefficient,  $\mu_{ji}$ , required to perform a wheels-unlocked stop at the calculated level of deceleration,  $a$ .

The method used to represent inter-axle load transfer depends upon a special parameter,  $P_{ki}$ , that is used to describe the load transfer between the two axles in a tandem pair. This parameter not only describes the amount of load transfer, but also the pitch moment reacted by the sprung mass.

The first step in the calculation is to determine the longitudinal deceleration of the total vehicle. The deceleration of the vehicle combination is given by equation (10)

$$a = \{\sum_i \sum_j F_{Bji}\} / \{\sum_i W_i\} \dots\dots\dots(10)$$

Then, starting with the last unit in the train, longitudinal, pitch, and vertical equations are solved for each unit.

Most vehicle combinations can be broken down into distinct units, which can be further sub-divided into three categories.

1. Towing units
2. Semitrailers and Converter dollies, and
3. Full trailers with fixed dollies.

Note: A full trailer with a converter dolly can be further subdivided into two units, which can then be described by the equations in category 2.

4.2.2.1 Towing Units. By default, the towing unit is the first unit ( $i = 1$ ) in the train. Referring to the geometric layouts and free body diagrams of the two towing units shown in Figure 4.3, the equations of motion are determined as follows.

The horizontal force balance equation is given by,

$$F_{xR1} + [W_1 * a] - F_{B31} - F_{B21} - F_{B11} = 0 \dots\dots\dots (11)$$

If a suspension load is defined as  $F_{Ski}$ , then,

$$F_{S11} = F_{z11} \dots\dots\dots (12)$$

$$F_{S21} = F_{z21} + F_{z31} \dots\dots\dots (13)$$

Summing the moments about a point in the ground, vertically below the front axle, the moment balance equation can be written as,

$$\{F_{S21} * [x_{11} + x_{21}]\} - M_{21} + [F_{xR1} * h_{R1}] - [F_{zR1} * (x_{R1} + x_{11})] + [W_1 * a * h_1] - [W_1 * x_{11}] = 0 \dots\dots\dots (14)$$

Where,

$$M_{21} = P_{21} * [F_{B31} + F_{B21}] * x_{ts21} \dots\dots\dots (15)$$

The axle loads  $F_{z21}$  and  $F_{z31}$  are given by,

$$F_{z21} = [F_{S21}/2] + [M_{21}/x_{ts21}] \dots\dots\dots (16)$$

$$F_{z31} = [F_{S21}/2] - [M_{21}/x_{ts21}] \dots\dots\dots (17)$$

Note: Equations (15) - (17) apply to suspensions with tandem axles.

The vertical force balance equation is given by,

$$F_{zR1} + W_1 - F_{S11} - F_{S21} = 0 \dots\dots\dots (18)$$

Note: For the last unit in the train,  $F_{zRi} = F_{xRi} = 0$

4.2.2.2 Semitrailers and Converter dollies. In the braking model the semitrailer and the converter dolly are modeled as identical units. The equations of motion can be developed based on the geometric layout and free body diagrams of Figure 4.4.

The horizontal force balance equation is given by,

$$F_{xRi} + [W_i * a] - F_{xFi} - F_{B2i} - F_{B1i} = 0 \dots\dots\dots (19)$$

If a suspension load is defined as  $F_{Ski}$ , then,

$$F_{S1i} = F_{z1i} + F_{z2i} \dots\dots\dots (20)$$

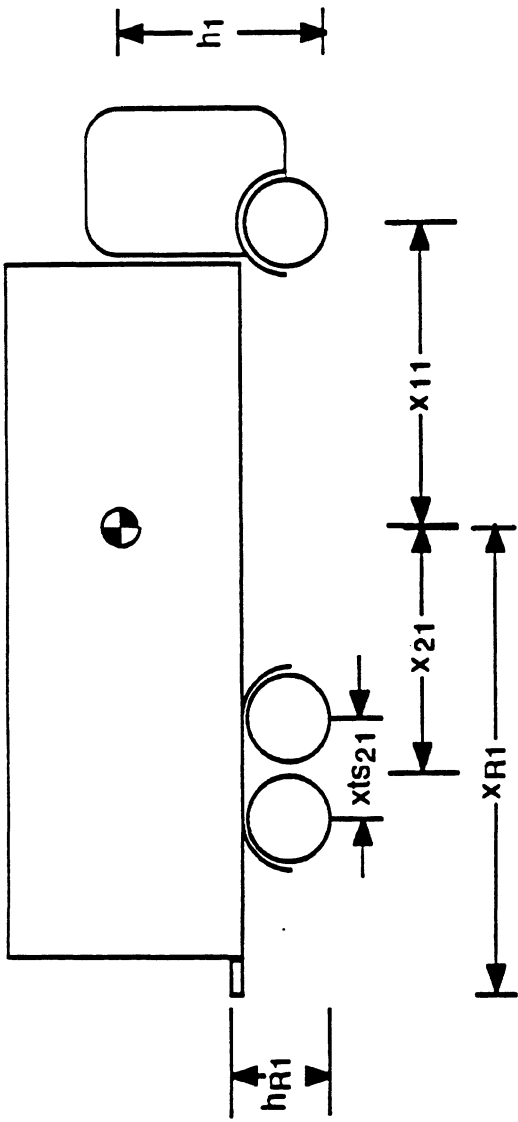

Geometric Layout of a Truck

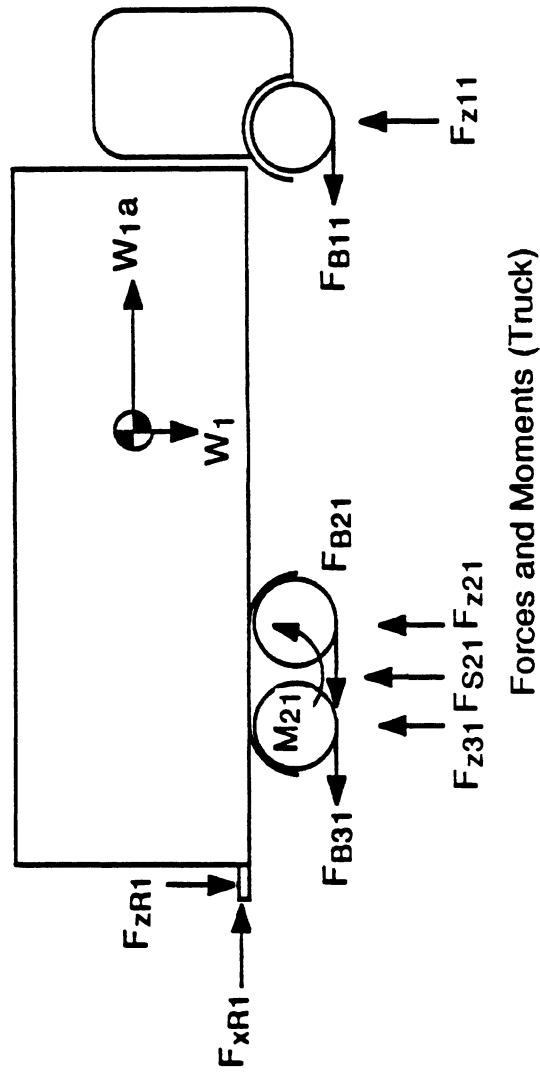

Forces and Moments (Truck)

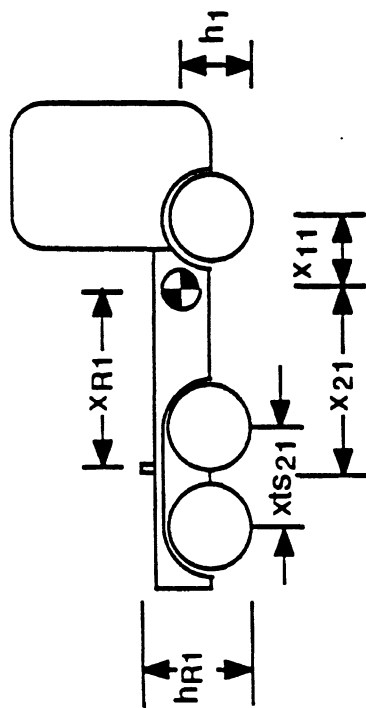

Geometric Layout of a Tractor

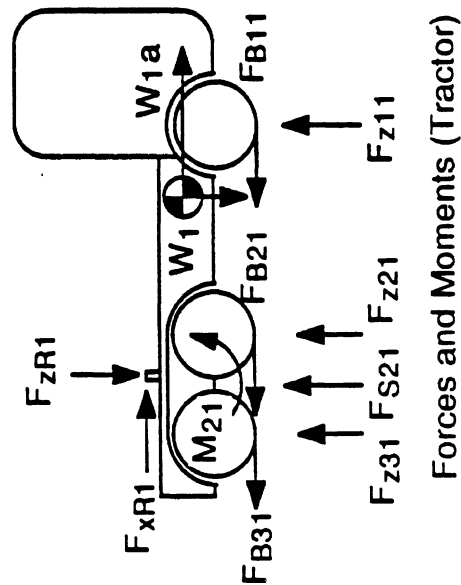

Forces and Moments (Tractor)

Figure 4.3. Geometric Layouts and Free-body diagrams of towing units



Geometric Layout of a Semitrailer

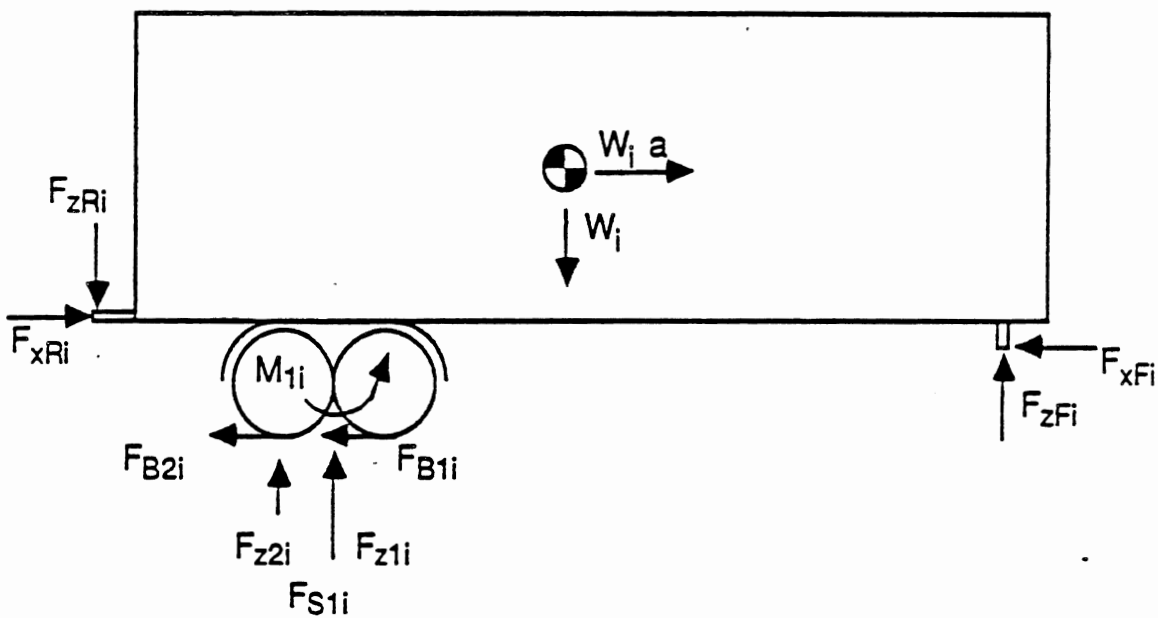

Forces and Moments (Semitrailer)

Figure 4.4. Geometric Layouts and Free-body diagrams of a semitrailer

Summing the moments about the forward articulation point, the moment balance equation can be written as,

$$\{F_{S1i} * [x_{1i} + x_{Fi}]\} - M_{1i} + [F_{xR1} * (h_{Ri} - h_{Fi})] - [F_{zRi} * (x_{Ri} + x_{Fi})] + [W_i * a * (h_i - h_{Fi})] - [W_i * x_{Fi}] + [(F_{B2i} + F_{B1i}) * h_{Fi}] = 0 \dots \dots \dots (21)$$

Where,

$$M_{1i} = P_{1i} * [F_{B2i} + F_{B1i}] * x_{ts1i} \dots \dots \dots (22)$$

The axle loads  $F_{z1i}$  and  $F_{z2i}$  are given by,

$$F_{z1i} = [F_{S1i}/2] + [M_{1i}/x_{ts1i}] \dots \dots \dots (23)$$

$$F_{z2i} = [F_{S1i}/2] - [M_{1i}/x_{ts1i}] \dots \dots \dots (24)$$

Note: Equations (22) - (24) apply to suspensions with tandem axles.

The vertical force balance equation is given by,

$$F_{zRi} + W_i - F_{S1i} - F_{zFi} = 0 \dots \dots \dots (25)$$

Note: For the last unit in the train,  $F_{zRi} = F_{xRi} = 0$

**4.2.2.3 Full trailers with Fixed dollies.** The fixed dolly differs in its basic design from a converter dolly.

1. The drawbar of a fixed dolly is hinged, and cannot transfer any of its pitching motion to the preceding unit in the train - the moment is therefore reacted out at the axles.
2. Fixed dollies normally use turntables instead of fifth wheels, which in turn, introduce an extra pitch moment into the equations of motion.

Due to the reasons listed above, the two unit trailer/fixed dolly combination is more easily modeled as a single unit. The free body diagram of such a full trailer is shown in Figure 4.5.

The horizontal force balance equation is given by,

$$F_{xRi} + [W_i * a] - F_{xFi} - F_{B4i} - F_{B3i} - F_{B2i} - F_{B1i} = 0 \dots \dots \dots (26)$$

If a suspension load is defined as  $F_{Sk_i}$ , then,

$$F_{S1i} = F_{z1i} + F_{z2i} \dots \dots \dots (27)$$

$$F_{S2i} = F_{z3i} + F_{z4i} \dots \dots \dots (28)$$

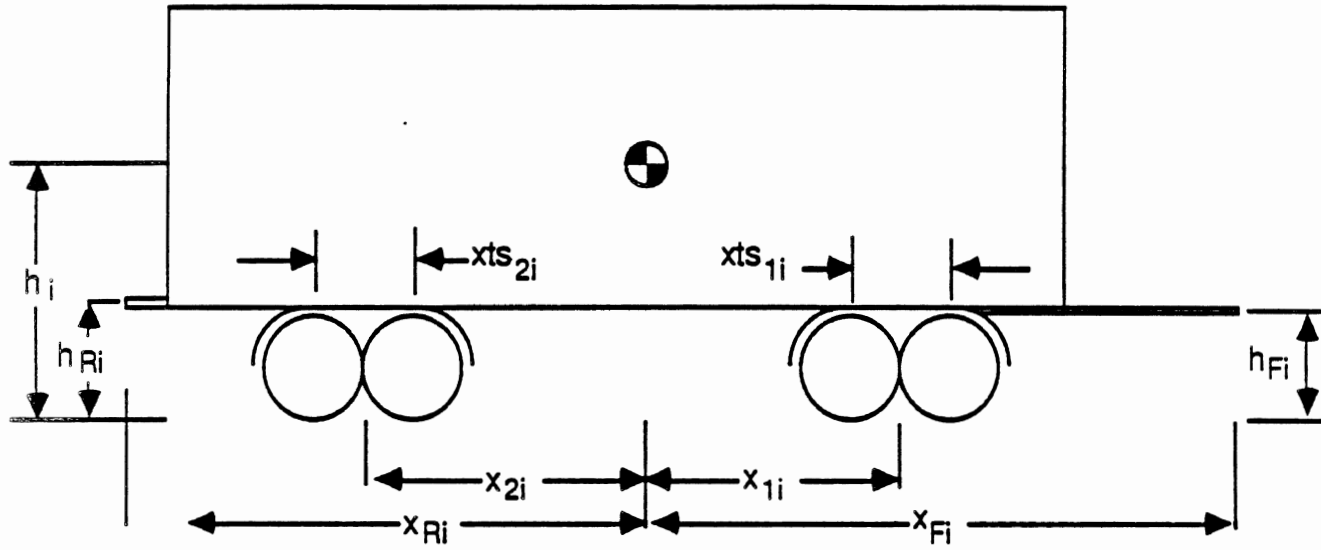

Geometric Layout of a Full trailer and Fixed dolly

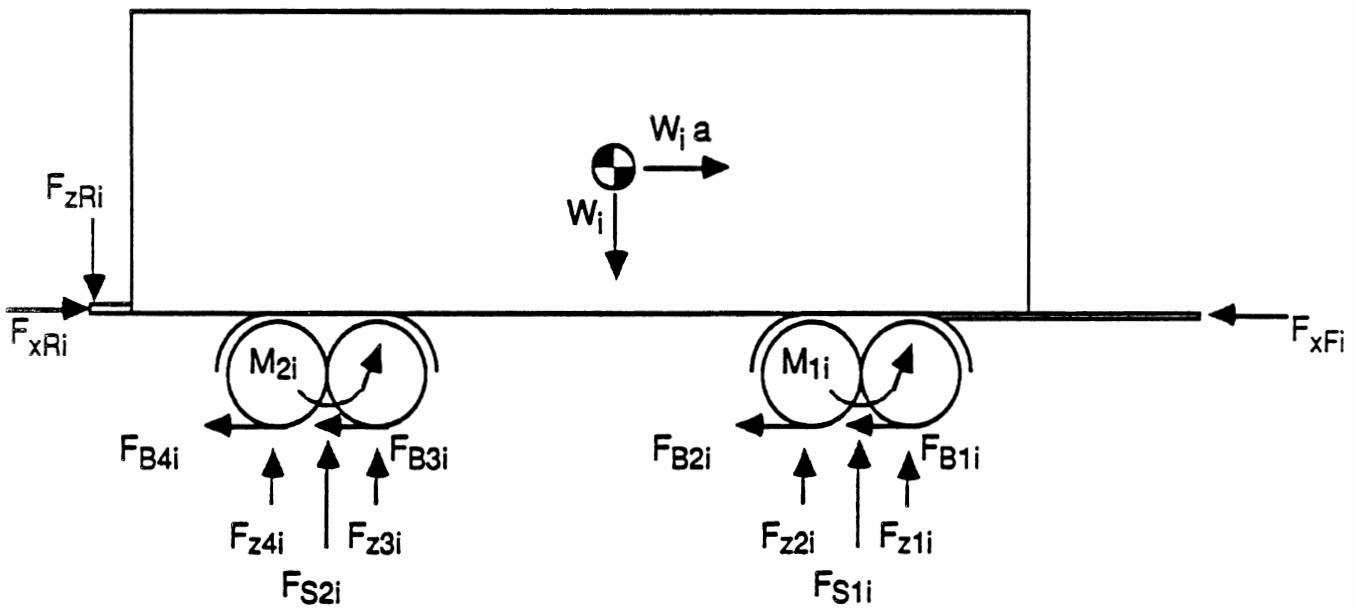

Forces and Moments (Full trailer and Fixed dolly)

Figure 4.5. Geometric Layouts and Free-body diagrams of a full trailer and fixed dolly



Summing the moments about a point in the ground, vertically below the front suspension, the moment balance equation can be written as,

$$\{F_{S2i} * [x_{1i} + x_{2i}]\} - M_{2i} - M_{1i} + [F_{xR1} * h_{Ri}] + [W_i * a * h_i] - [W_i * x_{1i}] - [F_{zRi} * (x_{Ri} + x_{1i})] = 0 \dots\dots\dots(29)$$

Where,

$$M_{1i} = P_{1i} * [F_{B2i} + F_{B1i}] * x_{ts1i} \dots\dots\dots(30)$$

$$M_{2i} = P_{2i} * [F_{B3i} + F_{B4i}] * x_{ts2i} \dots\dots\dots(31)$$

The axle loads are given by,

$$F_{z1i} = [F_{S1i}/2] + [M_{1i}/x_{ts1i}] \dots\dots\dots(32)$$

$$F_{z2i} = [F_{S1i}/2] - [M_{1i}/x_{ts1i}] \dots\dots\dots(33)$$

$$F_{z3i} = [F_{S2i}/2] + [M_{2i}/x_{ts2i}] \dots\dots\dots(34)$$

$$F_{z4i} = [F_{S2i}/2] - [M_{2i}/x_{ts2i}] \dots\dots\dots(35)$$

Note: Equations (30) - (35) apply to suspensions with tandem axles.

The vertical force balance equation is given by,

$$F_{zRi} + W_i - F_{S1i} - F_{S2i} = 0 \dots\dots\dots(36)$$

Note: For the last unit in the train,  $F_{zRi} = F_{xRi} = 0$

4.2.2.4 Friction utilizations and Braking efficiency. At each level of braking, the friction utilization at each axle is given by,

$$\mu_{ji} = F_{Bji}/F_{zji} \dots\dots\dots(37)$$

and, the "Braking Efficiency" is given by,

$$\text{Braking Efficiency} = a/\text{Max}(\mu_{ji}) \dots\dots\dots(38)$$

where,  $\text{Max}(\mu_{ji})$  is the maximum friction utilization at an axle, at a given level of braking.

