

I. DEVELOPING METHODS FOR THE ANALYSIS OF CHEMISTRY STUDENTS'  
INSCRIPTIONS, II. EXPLORING THE REGIOSELECTIVITY OF 1,3-DIPOLAR  
CYCLOADDITIONS OF MÜNCHNONES, III. STEREOCHEMICAL  
INVESTIGATIONS OF C-H ACTIVATION REACTIONS INVOLVING  
GERMYLENE AND STANNYLENE/ARYL IODIDE REAGENTS

by

Alan L. Kiste

A dissertation submitted in partial fulfillment  
of the requirements for the degree of  
Doctor of Philosophy  
(Education and Chemistry)  
in The University of Michigan  
2009

Doctoral Committee:

Professor Brian P. Coppola, Co-Chair  
Professor Joseph S. Krajcik, Co-Chair  
Professor Jay Lemke  
Professor Mark M. Banaszak Holl



*'When I use a word, Humpty Dumpty said in a rather scornful tone, it means just what I choose it to mean — neither more nor less.'*

*'The question is,' said Alice, 'whether you can make words mean so many different things.'*

*'The question is,' said Humpty Dumpty, 'which is to be master — that's all.'*

*Lewis Carroll, Through the Looking Glass. Illustration by John Tenniel*

© Alan L. Kiste

---

All rights reserved

2009

To my husband.

## ACKNOWLEDGEMENTS

My deepest thanks to:

Ahleah Rohr for the contribution of the  $[\text{C}_2\text{H}_4(\text{SiMe}_3)_4\text{C}_2]\text{SnI}(\text{C}_5\text{OH}_7)$ , Ajdin Kavara for the contribution of the  $[\text{C}_2\text{H}_4(\text{SiMe}_3)_4\text{C}_2]\text{Sn}$ , and Randon Walker for the contribution of the  $[(\text{Me}_3\text{Si})_2\text{CH}]_2\text{Ge}$  used in my research, and to them and the rest of the Banaszak-Holl group for their helpful advice.

Eric Chanowski, Ian Gifford, James Haskins,, Jake (Justin) P. Lomont, and Milad Sharifpour from the Coppola group were not only a great help with all aspects of my work but who were also great company in the lab.

Dustin Bringley, Corey Miller, Beth Percha, Alex Poniatowski, Nicole Tuttle, Sara Uhler, Andrew Weiss, and Semyon Zarkhin, Structured Study Group leaders who allowed me to impose on them and their classes in order to collect data.

Brian Spolarich for creation of the Filemaker database and Comparitor software that made thematic analysis possible.

Dr. Jeffrey Kampf and Dr. Nathan Ockwig who performed the X-Ray spectroscopy and to Dr. Chris Kojiro who provided useful advice on using chiral NMR shift reagents.

Helen Olson for careful proofreading of the text.

Professor Eric Rabkin for being at the right place at the right time.

The US Department of Education GAANN Fellowship, the National Science Foundation (Chemsense), University of Michigan Rackham Graduate School (travel grants), The University of Michigan College of Engineering (technology grant), and The University of Michigan Department of Chemistry for funding my work.

My committee members, Professor Jay Lemke, Professor Mark Banaszak-Holl, and Professor William Pearson who provided excellent advice and encouragement. To my co-advisors Professor Brian Coppola and Professor Joseph Krajcik who first suggested the idea of a combined degree and understood what it meant. Particularly to Professor Coppola who has consistently and continually demonstrated the difference between a mentor and a boss.

After many (many) years in school, college, and at the University, I have been fortunate to have many excellent teachers. In particular I want to acknowledge Mrs. Dorothy Arnold (Hallpark Elementary) and Mrs. Patricia Pregitzer (Belding High School). Mrs. Arnold spent hours preparing science lessons just for me – to keep me busy enough to leave her other students alone, I suspect -- but also and more importantly, to keep me interested. Mrs. Pregitzer taught botany, genetics, and AP biology for two years, an hour and half before the school day started, in addition to her regular teaching load, and got thirty sleepy high school students to take those classes, through her inspiration and dedication. Mrs. Arnold inspired my love for science and Mrs. Pregitzer helped it grow, both inspired my love for teaching.

To my friends, who quickly learned never to ask, “When will you be done?”, who were polite enough to appear interested in my research, and who encouraged me the whole way.

To my family, especially my parents Stanley and Ruth Kiste, without whom, obviously, none of this would be possible. They were my first teachers and they are the best.

And finally to my husband, Brian, for everything.

## PREFACE

A good researcher must look for the holes that exist in our understanding of any subject area. In addition, a good researcher must understand the appropriate methods to use to find answers to fill those holes in our understanding. In chemistry, those methods will obviously often involve bench chemistry methods. However, as long as professional chemists are responsible for training up the next generation of professional chemists, there will also be a need for deep understanding in the areas of student learning, pedagogy, the design of educational materials and curricula, and assessment. Chemists should not cede the examination of these questions to educational researchers who have their own priorities. Instead, chemists should continue to take responsibility for asking the questions about chemistry instruction that correspond to the current needs of the field.

The work contained in this dissertation is the result of the first Student Initiated Combined Degree in Chemistry and Education at The University of Michigan. The purpose of such interdisciplinary programs of study is to provide an opportunity to pursue advanced work that combines state-of-the-art research experiences in two (or more) fields. In this particular case, it was my goal to develop expertise in chemistry that would naturally allow greater insight into questions that educational research can answer for the field. That is, rather than develop only an understanding of educational research, asking the questions about chemistry instruction that may be of interest only to educational



researchers, I wanted to develop an understanding of chemistry that would naturally raise questions about how we teach and assess our students. At the same time, I wished to develop an understanding of educational research philosophy and techniques that could support quality high-level research designed to answer such questions.

At the heart of our work as chemists is the communication of our results, not only with our colleagues, but also with our students. Naturally, chemists understand the nature of the communicating chemistry results better than anyone else. Thus, it should be chemists who examine questions about how we communicate with each other and with our students, the next generation of chemists, in order to further the field as a whole. Thus in this work, I have attempted to expand our abilities to examine our discourse by asking questions that chemist would ask, while applying the most appropriate research methods in order to find answers to those questions.

## TABLE OF CONTENTS

<b>DEDICATION</b> .....	<b>ii</b>
<b>ACKNOWLEDGEMENTS</b> .....	<b>ii</b>
<b>PREFACE</b> .....	<b>vi</b>
<b>LIST OF FIGURES</b> .....	<b>xi</b>
<b>LIST OF SCHEMES</b> .....	<b>xiv</b>
<b>LIST OF TABLES</b> .....	<b>xvi</b>
<b>LIST OF APPENDICES</b> .....	<b>xvii</b>
<b>ABSTRACT</b> .....	<b>xix</b>
<b>PART ONE</b> .....	<b>1</b>
<b>CHAPTER 1: INTRODUCTION</b> .....	<b>1</b>
<b>CHAPTER 2: REPRESENTATIONS AND INSCRIPTIONS</b> .....	<b>4</b>
INSCRIPTIONS IN CHEMISTRY .....	6
CHEMISTRY STUDENTS AND THEIR INSCRIPTIONS .....	12
SUMMARY .....	14
<b>CHAPTER 3: PREVIOUS RESEARCH ON STUDENTS' USE OF INSCRIPTIONS</b> .....	<b>15</b>
SUMMARY .....	20
<b>CHAPTER 4: DESIGNING A NEW METHOD OF ANALYSIS: THEORETICAL FRAMEWORK</b> .....	<b>21</b>
INSCRIPTIONS AND REPRESENTATIONS AS LEARNING TOOLS .....	21
THE SOCIAL USE OF REPRESENTATIONS AND INSCRIPTIONS MEANS THAT COMPARISON IS IMPORTANT .....	22
TYPES OF MEANING CONVEYED BY REPRESENTATIONS AND INSCRIPTIONS .....	23
THE SPECIALIZED NATURE OF CHEMISTRY REPRESENTATIONS AND INSCRIPTIONS .....	27
PREVIOUS RESEARCH INFORMS THE NEED FOR NEW ANALYSIS METHODS .....	31
SUMMARY .....	32
<b>CHAPTER 5: SUMMARY OF DATA AND METHODS</b> .....	<b>33</b>
<b>CHAPTER 6: PROTOCOLS FOR ANALYSIS</b> .....	<b>34</b>
FEATURES ANALYSIS .....	34
<i>What is a feature?</i> .....	34
<i>Goal of Features Analysis</i> .....	39
<i>Features Analysis — Step 1: Recording Features</i> .....	40
<i>Features Analysis — Step 2: Comparing Features</i> .....	44
THEMATIC ANALYSIS .....	45
<i>What is a theme?</i> .....	45
<i>Goals of thematic analysis</i> .....	46
<i>Thematic Analysis – Step 1: Transcription of pictorial elements</i> .....	57

<i>Thematic Analysis – Step 1: Transcription of pictorial elements</i> .....	57
<i>Thematic Analysis – Step 2: Translation into Canonical Chemical Themes</i> .....	61
<i>Thematic Analysis – Step 3: Coding the Translations</i> .....	70
<i>Thematic Analysis – Step 4: Creating Thematic Maps</i> .....	72
<i>Thematic Analysis – Step 5: Comparisons of Thematic Maps</i> .....	75
SUMMARY .....	77
<b>CHAPTER 7: CALIBRATION OF THE THEMATIC ANALYSIS METHOD</b> .....	<b>79</b>
SUMMARY .....	86
<b>CHAPTER 8: APPLICATION OF THE ANALYSIS METHODS: TESTING VALIDITY</b> .....	<b>87</b>
<b>CHAPTER 9: RESULTS</b> .....	<b>99</b>
FEATURES ANALYSIS .....	99
THEMATIC ANALYSIS .....	104
<b>CHAPTER 10: ANALYZING TEXTBOOK AND STUDENT INSCRIPTIONS – IMPLICATIONS AND APPLICATIONS</b> .....	<b>128</b>
ANALYSIS OF TEXTBOOK INSCRIPTIONS .....	129
ANALYSIS OF STUDENT INSCRIPTIONS .....	134
<i>Features Analysis</i> .....	137
<i>Thematic Analysis</i> .....	139
<i>General Observations</i> .....	143
IMPLICATIONS .....	146
<i>Improving Research in Chemistry Education</i> .....	146
<i>Improving Educational Research on Representations</i> .....	147
<i>Improving Textbook Design</i> .....	148
<i>Improving Discourse Analysis Research</i> .....	149
APPLICATIONS .....	151
CONCLUSION .....	152
<b>PART TWO</b> .....	<b>154</b>
<b>CHAPTER 11: EXPLORING THE REGIOSELECTIVITY OF 1,3-DIPOLAR CYCLOADDITIONS OF MÜNCHNONES</b> .....	<b>154</b>
INTRODUCTION .....	154
SYNTHESIS OF MÜNCHNONES .....	155
REGIOSELECTIVITY WITH ACETYLENIC DIPOLAROPHILES .....	157
REGIOSELECTIVITY WITH OLEFINIC DIPOLAROPHILES .....	169
<i>Specific Examples Involving Münchnones Reacting with Olefinic Dipolarophiles</i> .....	175
CURRENT WORK .....	179
<i>Tethered Münchnones</i> .....	179
FUTURE WORK .....	189
EXPERIMENTAL .....	190
<i>Materials</i> .....	190
<i>Techniques</i> .....	191
<b>CHAPTER 12: STEREOCHEMICAL INVESTIGATIONS OF C-H ACTIVATION REACTIONS INVOLVING GERMYLENE AND STANNYLENE/ARYL IODIDE REAGENTS</b> .....	<b>196</b>
INTRODUCTION .....	196
<i>Induction</i> .....	197
<i>Retention/Inversion/Scrambling</i> .....	200
CONCLUSIONS .....	206
EXPERIMENTAL .....	208
<i>Materials</i> .....	208

<i>Techniques</i> .....	208
<b>APPENDIX A: PICTORIAL INSCRIPTIONS, AND VERBAL TRANSCRIPTIONS AND TRANSLATIONS</b> .....	<b>218</b>
<b>APPENDIX B: THEMATIC MAPS</b> .....	<b>261</b>
CHEMSENSE GROUP PICTORIAL THEMATIC MAPS.....	262
TRADITIONAL GROUP PICTORIAL THEMATIC MAPS .....	267
ADVANCED GROUP PICTORIAL THEMATIC MAPS .....	272
EGE (1999) PICTORIAL THEMATIC MAP.....	275
CHEMSENSE GROUP VERBAL THEMATIC MAPS .....	276
TRADITIONAL GROUP VERBAL THEMATIC MAP .....	281
ADVANCED GROUP VERBAL THEMATIC MAPS.....	286
EGE (1999) VERBAL THEMATIC MAP.....	290
TEXTBOOK THEMATIC MAPS.....	291
<b>APPENDIX C: DATABASE AND COMPARITOR DESCRIPTION</b> .....	<b>297</b>
DESCRIPTION OF DATABASE AND COMPARITOR TOOL .....	298
FILEMAKER DEVELOPER DATABASE DESIGN REPORT .....	300
“COMPARATOR” DATA ANALYSIS PROGRAM .....	316
<b>APPENDIX D: IRB APPROVAL</b> .....	<b>323</b>
<b>APPENDIX E: SPECTRA</b> .....	<b>325</b>
<b>REFERENCES: PART ONE</b> .....	<b>397</b>
<b>REFERENCES: PART TWO</b> .....	<b>408</b>

## LIST OF FIGURES

Figure 1. Examples of student work. ....	1
Figure 2. Representations and inscriptions. (Note: Though a molecular model itself is a representation and not an inscription, the picture of a molecular model is both an inscription and a representation.) .....	6
Figure 3. A question about the thermal decomposition of cyclopropane. ....	7
Figure 4. Equation 1 from Bartolin (2006). ....	9
Figure 5. Figure 1 from Bartolin, J. M. et. al. (2006) “Tin-Mediated CH Activation and Cross-Coupling in a Single Flask.” <i>Organometallics</i> 25 4738-4740. ....	12
Figure 6. Figure 1 from Nakhleh, M. B. and R. C. Mitchell (1993). ....	16
Figure 7. The eChem “Analyze” screen, Figure 3 from Wu, Krajick, and Soloway (2001). ....	19
Figure 8. Even salt shakers can illustrate orientational meaning. ....	25
Figure 9. Scheme 1 from Nicolaou, K. C., J.-J. Liu, et al. (1995) showing the formation of key intermediates of Ring A of taxol. ....	27
Figure 10. Hoffmann’s language analogy. ....	28
Figure 11. Sample of student work #1. ....	36
Figure 12. Sample of student work #2. ....	37
Figure 13. Quiz. ....	41
Figure 14. Student A’s answer to the quiz question. ....	42
Figure 15. Student B’s answer to the quiz question. ....	43
Figure 16. Sample of a thematic map. ....	46
Figure 17. Some of the themes that accompany the word “instrument”. (photo copyright 2009, Joe Gordon. Used with permission.) .....	48
Figure 18. A simple thematic pattern. ....	50
Figure 19. An elaborated thematic pattern. ....	51
Figure 20. Excerpt of student work. ....	52
Figure 21. An excerpt of a thematic pattern for Figure 15. ....	53
Figure 22. Ethanol. ....	54
Figure 23. Student A’s verbal answer. ....	65
Figure 24. Student B’s verbal answer. ....	69
Figure 25. Thematic map created from Student A’s pictorial inscription. ....	73
Figure 26. Thematic map created from Student B’s pictorial inscription. ....	74
Figure 27. Three hypothetical thematic maps showing different connectivity between the same four themes. ....	77
Figure 28. Bimolecular nucleophilic substitution mechanism from Bruice (1998). ....	81
Figure 29. Bimolecular nucleophilic substitution mechanism from Fox and Whitesell (2004). ....	81
Figure 30. Bimolecular nucleophilic substitution mechanism from McMurray (1992). ..	83

Figure 31. ChemSense Studio. (1) The discussion thread area, (2) The main work space showing a University of Michigan student's assignment, (3) A peer review of the assignment, (4) An information window, (5) Building tools.....	90
Figure 32. Verbal portion of the pretest.....	91
Figure 33. Pictorial portion of the pretest.....	92
Figure 34. Verbal portion of the Week 5 Quiz.....	93
Figure 35. Pictorial portion of the Week 5 Quiz.....	94
Figure 36. Verbal portion of the Week 8 Quiz.....	94
Figure 37. Pictorial portion of the Week 8 Quiz.....	95
Figure 38. Representative student work example B from the pictorial pretest.....	100
Figure 39. Representative student work example B from the pictorial pretest.....	100
Figure 40. Verbal portion of the Week 8 Quiz.....	104
Figure 41. Pictorial portion of the Week 8 Quiz.....	105
Figure 42. Four student inscriptions answering the Week 8 Quiz question, along with the thematic analysis calculation of their similarity.....	107
Figure 43. Similarity measures for the thematic maps created from the pictorial inscriptions of each student group. The Advanced group similarity is significantly higher ( $p=0.001$ ) than the other two student groups.....	111
Figure 44. Similarities of thematic maps created from the pictorial inscriptions of all three student groups and their textbook. Numbers in parenthesis indicate standard deviations.....	112
Figure 45. Similarities of thematic maps created from the verbal inscriptions of all three student groups and their textbook. Numbers in parentheses indicate standard deviations.....	115
Figure 46. Thematic map created from both the verbal and visual portions of the Week 8 Quiz question. Themes coded in black were present in both the verbal and pictorial portions, themes in red were displayed visually only, themes in blue were displayed verbally only.....	116
Figure 47. Four student inscriptions from the Week 8 Quiz question, along with the thematic analysis calculation of their similarity.....	119
Figure 48. Comparisons between the pictorial and verbal thematic maps constructed from the inscriptions of all 3 student groups and the textbook. Numbers in parentheses indicate standard deviations, an asterisk denotes statistical significance ( $p<0.001$ ). .....	122
Figure 49. Examples of student work.....	128
Figure 50. Figures from textbooks. A: Bruice, P. Y. (1998). <i>Organic Chemistry</i> (2nd ed.). Upper Saddle River, NJ: Simon & Schuster., B: Fox, M. A., & Whitesell, J. K. (2004). <i>Organic Chemistry</i> (3rd ed.). Sudbury, MA: Jones and Bartlett., C: Wade, L. G. (2006). <i>Organic Chemistry</i> (6th ed.). Upper Saddle River, NJ: Pearson Education, Inc.....	130
Figure 51. Figures from textbooks. A: Bruice, P. Y. (1998). <i>Organic Chemistry</i> (2nd ed.). Upper Saddle River, NJ: Simon & Schuster., B: Fox, M. A., & Whitesell, J. K. (2004). <i>Organic Chemistry</i> (3rd ed.). Sudbury, MA: Jones and Bartlett., C: Wade, L. G. (2006). <i>Organic Chemistry</i> (6th ed.). Upper Saddle River, NJ: Pearson Education, Inc. Numbers indicate similarity results.....	132
Figure 52. Proposed asymmetrical transition state for monosubstituted münchnones... 158	158

Figure 53. Dipolar interactions in 1,3-dipolar cycloadditions. ....	159
Figure 54. C-4 tethers. ....	167
Figure 55. C-2 and C-4 tethers.....	167
Figure 56. Comparison of the nucleophilicities of amino acids and other nucleophiles. From Figure 7 in Brotzel, F.; Mayr, H. <i>Org. Biomol. Chem.</i> 2007, 5, 3814-3820.	183
Figure 57. Cycloadduct of 1,3 imidazolium-4-olate with methyl (E)- $\beta$ -(toluene-sulfonyl)acrylate .....	188
Figure 58. Potential prochiral substrates.....	198
Figure 59. Europium(III) tris[3-(heptafluoropropylhydroxymethylene)- <i>d</i> -camphorate], (Eu(hfc) <sub>3</sub> ). ....	202
Figure 60. Graph of the change in the <sup>1</sup> H NMR shift values for a 0.235 M racemic solution of 2-methoxybutane with increasing concentration of Eu(hfc) <sub>3</sub> . Numbers 1 and 2 correspond to the two enantiomers present. ....	203
Figure 61. Computational structure of [(Me <sub>3</sub> Si) <sub>2</sub> CH] <sub>2</sub> GeI[CH <sub>3</sub> OCH(CH <sub>3</sub> )(CH <sub>2</sub> CH <sub>3</sub> )] showing steric crowding of the oxygen atom. ....	204
Figure 62. [C <sub>2</sub> H <sub>4</sub> (SiMe <sub>3</sub> ) <sub>4</sub> C <sub>2</sub> ]SnI(C <sub>5</sub> OH <sub>7</sub> ) .....	205
Figure 63. Expansion of the TMS region of the <sup>1</sup> H NMR of a 0.15M solution of [C <sub>2</sub> H <sub>4</sub> (SiMe <sub>3</sub> ) <sub>4</sub> C <sub>2</sub> ]SnI(C <sub>5</sub> OH <sub>7</sub> ) at increasing concentrations of Eu(hfc) <sub>3</sub> in d <sup>6</sup> -benzene. ....	205
Figure 64. Graph of the change in the <sup>1</sup> H NMR shift values for a 0.15M solution of [C <sub>2</sub> H <sub>4</sub> (SiMe <sub>3</sub> ) <sub>4</sub> C <sub>2</sub> ]SnI(C <sub>5</sub> OH <sub>7</sub> ) at increasing concentrations of Eu(hfc) <sub>3</sub> in d <sup>6</sup> -benzene. The letters A and B refer to the two enantiomers present.....	206
Figure 65. Schema for the FileMaker database. ....	299

## LIST OF SCHEMES

Scheme 1. 1,3-Dipoles and the 1,3-dipolar cycloaddition. ....	155
Scheme 2. Münchnone formation. ....	156
Scheme 3. Catalytic synthesis of münchnones. ....	156
Scheme 4. Mechanism of münchnone synthesis. ....	157
Scheme 5. Reactions of substituted münchnones with acetylenic dipolarophiles. ....	164
Scheme 6. Tethered münchnone reactions with acetylenic dipolarophiles. ....	166
Scheme 7. Reactions of N-(2-thiazolinyl) secondary amino acid derivatives with methyl propiolate. ....	168
Scheme 8. Formation of N-(2-thiazolinyl)proline. ....	169
Scheme 9. Reactions of diethylmethylamine N-oxide with styrene. ....	170
Scheme 10. Resonance forms of diazomethane and conjugated olefins. ....	172
Scheme 11. Reaction of nitrile amines with deuterovinyl phenyl sulfone. ....	174
Scheme 12. Reactions of münchnones with nitro olefins. ....	179
Scheme 13. Reactions of substituted münchnones with acetylenic dipolarophiles with the inclusion of a regiocontrol element at R <sub>1</sub> . ....	180
Scheme 14. Attempts to synthesize N-thiazolinyl secondary amino acids. ....	181
Scheme 15. Synthesis of 4,5-dihydro-N-methyl-2-thiazolamine. ....	184
Scheme 16. Attempts to form N-thiazolinyl secondary amino acids from 4,5-dihydro-N-methyl-2-thiazolamine. ....	185
Scheme 17. Formation of $\alpha$ -amidoalkyl sulfones. ....	185
Scheme 18. Formation of tertiary amides from reactions of N-methyl or N-phenyl amides and alkyl or aryl aldehydes in the presence of benzotriazole. ....	186
Scheme 19. Synthesis of $\alpha$ -(dialkylamino) esters from ethyl glyoxylate with a primary aromatic or secondary aliphatic amine in the presence of benzotriazole. ....	186
Scheme 20. Formation of a bicyclic product from thiazolamine, ethyl glyoxylate, using benzotriazole in toluene. ....	187
Scheme 21. Comparison of the formation of a pyrrole derivative from propiolate vs. (E)- $\beta$ -(toluenesulfonyl)acrylate. ....	189
Scheme 22. Possible formation N-thiazolinyl secondary amino acids from 4,5-dihydro-N-methyl-2-thiazolamine and methyl chloroglyoxylate. ....	190
Scheme 23. Formation of amino acid analogues. ....	190
Scheme 24. C-H activations of hydrocarbons and ethers. ....	196
Scheme 25. Activations of allylic C-H bonds using Sn[C <sub>2</sub> (SiMe <sub>3</sub> ) <sub>4</sub> C <sub>2</sub> H <sub>4</sub> ]. From Scheme 1, Kavara, A.; Cousineau, K. D.; Rohr, A. D.; Kampf, J. W.; Holl, M. M. B. <i>Organometallics</i> 2008, 27, 1041-1043. ....	197
Scheme 26. Reaction of Sn[C <sub>2</sub> (SiMe <sub>3</sub> ) <sub>4</sub> C <sub>2</sub> H <sub>4</sub> ] with cyclohexane and phenyl iodide or mesityl iodide. ....	198



Scheme 27. Proposed 5-member transition state for C-H activation of cyclohexene using (R)-2-iodo- $\alpha$ -methylbenzyl trimethylsilylether as a chiral auxiliary. ....	199
Scheme 28. Reaction of $\text{Sn}[\text{C}_2(\text{SiMe}_3)_4\text{C}_2\text{H}_4]$ with cyclohexene and ((R)-2-iodo- $\alpha$ -methylbenzyl trimethylsilylether. ....	200
Scheme 29. Proposed reaction between $[\text{C}_2\text{H}_4(\text{SiMe}_3)_4\text{C}_2]\text{Sn}$ and (S)-2-butyl trimethylsilyl ether or (S)-2-methoxybutane and phenyl iodide.....	200
Scheme 30. Reaction of $[(\text{Me}_3\text{Si})_2\text{CH}]_2\text{Ge}$ with (S)-2-methoxybutane and phenyl iodide. ....	201

## LIST OF TABLES

Table 1. Summary of data sources and their use. ....	33
Table 2. Features of quiz shown in Figure 13.....	41
Table 3. Features of Student A's inscription, Figure 14.....	42
Table 4. Features of Student B's inscription from Figure 15. ....	43
Table 5. Verbal transcription of Figure 14.....	58
Table 6. Verbal translation of Figure 14.....	62
Table 7. Transcription and Translation of Student B's pictorial inscription. ....	67
Table 8. Themes coded from verbal translations. ....	70
Table 9. Examples of theme-relationship-theme triads. ....	72
Table 10. Average similarity and numbers of links and themes for textbook reaction mechanisms. Numbers in parenthesis are standard deviations. ....	80
Table 11. Comparison of various versions of S <sub>N</sub> 2 and S <sub>N</sub> 1 inscriptions based on McMurry (1992). ....	86
Table 12. Summary of data collected. ....	97
Table 13. A summary of the analyses performed on the selected data.....	98
Table 14. Examples of verbal and pictorial features for Question #1. ....	102
Table 15. Results of the pretest features analysis. ....	103
Table 16. A summary of the chemical concepts illustrated by the examples shown in Figure 42. ....	109
Table 17. Chemical concepts expressed by student examples from Figure 47. ....	120
Table 18. Average number of links and used in the thematic maps. ....	125
Table 19. Average percent similarity between student maps and combined expert maps, and the average percentage of theme-link-theme triads shared between student maps and the combined expert map. Numbers in parentheses are standard deviations..	127
Table 20. Summary of findings. ....	137
Table 21. Summary of data sources, results, and major conclusions. ....	144
Table 22. Summary of mono- and disubstituted münchnone reactions methyl propiolate, ethyl propiolate, benzoyl acetylene, and phenyl acetylene.....	160
Table 23. Summary of mono- and disubstituted münchnone reactions with disubstituted dipolarophiles.....	163
Table 24. Reactions of electronically divergent arylthio-substituted münchnones with methyl propiolate. ....	165
Table 25. Reactions of regioisomeric pairs of münchnones with methyl propiolate.....	166
Table 26. Reactions of N-(2-pyrrolinyl)-N-methylalanine and N-(2-pyrrolinyl)-sarcosine with dimethyl acetylenedicarboxylate (DMAD) or methyl propiolate.....	168
Table 27. Reactions of cyclic nitrones with unsymmetrical olefins. ....	170
Table 28. Reactions of diazomethane with vinyl sulfones. ....	171

Table 29. Reactions of nitrile amines with olefinic sulfones.....	172
Table 30. Reactions of nitrile oxides with olefinic sulfones.....	174
Table 31. Reactions of pyrazolidinium ylides with disubstituted vinyl sulfones. ....	175
Table 32. Reactions of münchnones with trifluoromethylated olefins. ....	176
Table 33. Reactions of münchnones with trifluoromethylated olefins. ....	176
Table 34. Reactions of münchnones with trifluoromethylated olefins. ....	177
Table 35. Reactions of münchnones with disubstituted olefins.....	177
Table 36. Reactions of münchnones with nitro olefins.....	179
Table 37. Shift values for a 0.235M racemic solution of 2-methoxybutane at increasing concentrations of Eu(hfc) <sub>3</sub> in d <sup>6</sup> -benzene. Shifts are listed for the two enantiomers 1 and 2, for the resolution of one of the methylene protons and the protons from C1 and C4. Numbers in parentheses are integrations. ....	213
Table 38. Shift values for a 0.183 M solution of (S)-2-methoxybutane at increasing concentrations of Eu(hfc) <sub>3</sub> in d <sup>6</sup> -benzene. Compared to the racemic case, no resolution of enantiomers 1 and 2 is seen. Numbers in parentheses are integrations. ....	213
Table 39. Shift values for a 0.183 M solution of (S)-2-methoxybutane and 0.248 M racemic solution of 2-methoxybutane at increasing concentrations of Eu(hfc) <sub>3</sub> in d <sup>6</sup> -benzene. Compared to (S)-2-methoxybutane. Numbers in parenthesis are integrations.....	214
Table 40. Shift values for 0.147 M solution of [(Me <sub>3</sub> Si) <sub>2</sub> CH] <sub>2</sub> GeI[CH <sub>3</sub> OCH(CH <sub>3</sub> )(CH <sub>2</sub> CH <sub>3</sub> )] made from racemic solution of 2-methoxybutane at increasing concentrations of Eu(hfc) <sub>3</sub> in d <sup>6</sup> -benzene. Compared to [(Me <sub>3</sub> Si) <sub>2</sub> CH] <sub>2</sub> GeI[CH <sub>3</sub> OCH(CH <sub>3</sub> )(CH <sub>2</sub> CH <sub>3</sub> )] alone. Numbers in parenthesis are integrations. Assignments for 3 highest concentrations are tentative due to extreme broadening of all peaks. ....	215
Table 41. Shift values for 0.15M solution of [C <sub>2</sub> H <sub>4</sub> (SiMe <sub>3</sub> ) <sub>4</sub> C <sub>2</sub> ]SnI(C <sub>5</sub> OH <sub>7</sub> ) at increasing concentrations of Eu(hfc) <sub>3</sub> in d <sup>6</sup> -benzene. Compared to [C <sub>2</sub> H <sub>4</sub> (SiMe <sub>3</sub> ) <sub>4</sub> C <sub>2</sub> ]SnI(C <sub>5</sub> OH <sub>7</sub> ) alone. Numbers in parenthesis are integrations. ...	217
Table 42. Database definition and structure. ....	300
Table 43. Students - 6 fields .....	301
Table 44. Themes - 2 Fields.....	303
Table 45. Relations - 4 Fields .....	304
Table 46. ThemeInstances - 6 Fields .....	305
Table 47. Work - 6 Fields .....	307
Table 48. WorkInstances - 6 Fields .....	310
Table 49. Relationships: Table Occurrences .....	312
Table 50. Relationship: <i>Work=WorkInstances</i> .....	312
Table 51. Relationship: <i>Students=WorkInstances</i> .....	313
Table 52. Relationship: <i>WorkInstances=ThemeInstances</i> .....	313
Table 53. Relationship: <i>Themes=ThemeInstances</i> .....	314
Table 54. Relationship: <i>Relations=ThemeInstances</i> .....	315

## LIST OF APPENDICES

APPENDIX A: PICTORIAL INSCRIPTIONS, AND VERBAL TRANSCRIPTIONS AND TRANSLATIONS .....	218
APPENDIX B: THEMATIC MAPS .....	261
APPENDIX C: DESCRIPTION OF DATABASE AND COMPARITOR TOOL .....	297
APPENDIX D: IRB APPROVAL .....	323
APPENDIX E: SPECTRA .....	325

## ABSTRACT

I. Analyzing and comparing student-generated inscriptions in chemistry is crucial to gaining insight into students' understanding about chemistry concepts. Thus, we developed two methods of analyzing student-generated inscriptions: features analysis and thematic analysis. We have also demonstrated how these methods are able to discern differences between both how students inscribe their understandings and the content of those inscriptions, regardless of 1) how those inscriptions were created (ie. computer vs. pencil-and-paper), 2) the nature of the inscriptions (verbal vs. pictorial), and 3) the expertise of the students. The ability to analyze inscriptions regardless of the medium allows the examination of multiple inscriptions in educational research applications as well as in the design and development of educational materials. Also, inscriptions can be compared across contexts, allowing the comparison of student-generated inscriptions derived from various educational interventions. Finally, the ability to compare inscriptions regardless of the level of expertise allows novice/expert comparisons as well as longitudinal comparison over time.

II. Predicting the regiochemistry of 1,3-dipolar cycloadditions of münchnones and acetylenic dipolarophiles is difficult based on frontier molecular orbital theory (FMO) alone. We have proposed that, in addition to FMO considerations, steric factors influencing the non-covalent interactions between reactive centers in the transition state also influence the regioselectivity of these reactions. We have developed a scheme to use

a tether-based regiocontrol strategy to synthesize 2,4-disubstituted pyrroles using N-(2-thiazolinyl) secondary amino acid derivatives. Attempts to synthesize these amino acid derivatives have been, so far, unsuccessful.

III. To provide additional information about the mechanism of C-H activation reactions of stannylenes and germylenes, and to demonstrate the utility of these reactions, we explored inducing stereochemistry at the C-H activation site as well as determining the corresponding stereoselectivity. Attempts at induction produced a racemic mixture of products. Products from C-H activation reactions of chiral 2-methoxybutane could not be analyzed with a chiral NMR shift reagent, Europium(III) tris[3-(heptafluoropropylhydroxymethylene)-*d*-camphorate],  $(\text{Eu}(\text{hfc})_3)$ . However, NMR studies of the substrate revealed no scrambling of the stereocenter of chiral substrates occurs during the reaction. In addition,  $\text{Eu}(\text{hfc})_3$  was shown effective for determining the %ee of these reactions for products with sterically unencumbered oxygen atoms.

## PART ONE

### CHAPTER 1: INTRODUCTION

Figure 1. Examples of student work.

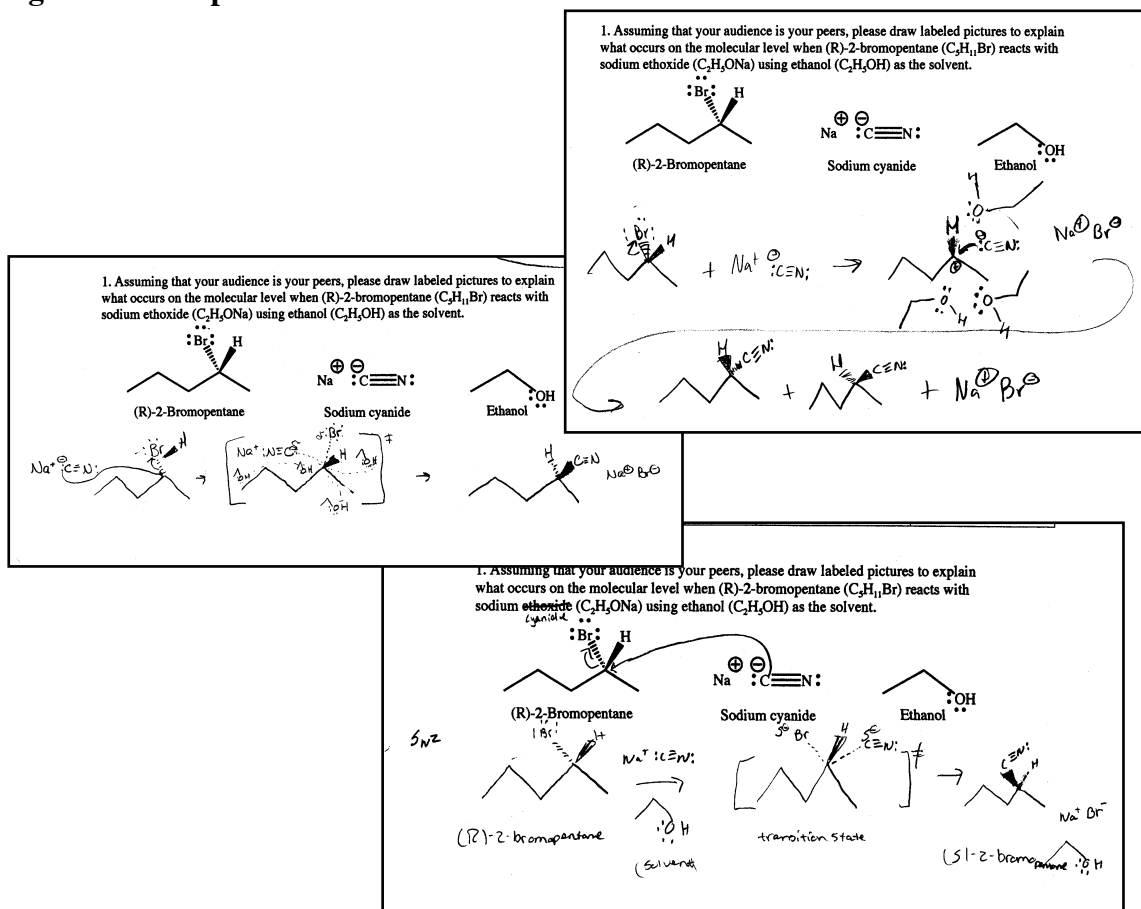


Figure 1 contains three examples of answers to a quiz question given to first-year college chemistry students. How similar are the answers? How similar are they to an external standard such as an expert's answer to the question or the answer key for the quiz? On what basis would such a comparison be made? Are they similar based on the

pictorial forms that the students used to create their answers, or are they similar based on the implied chemistry content of the answers? What constitutes a high degree of similarity, or what levels of similarity might we expect for a question such as this? And why should we care?

Imagine that, instead of comparing student work between peers, we were interested in comparing student work to expert work as a method of assessment. Now the importance of questions regarding similarity becomes more obvious. The pictures above may be correct or they may be incorrect. They may be entirely correct or only partially correct. However, again the same questions arise: correct form or correct content? How similar might we expect them to be? And what would we expect an examination of the similarity between novice and expert pictures to tell us about what researchers and instructors are generally interested in: student understanding?

We care about these drawings because these are exactly the sorts of drawings students use to answer test questions. Such drawings are how students explain their understandings to each other and to the instructor, and such drawings are the basis on which instructors assess student understanding. Instructors make those assessments by asking the question, “How similar is this student’s drawing to the right answer?” If we could make such an assessment explicit, by revealing the concepts underlying the drawing, we could more systematically uncover the mistakes and misconceptions that students have about course material. We could more easily see any disconnects between what the instructors believe they are teaching and what the students learn from the instruction. In addition, researchers would have a tool that would allow them to link the



changes in student drawings to changes in student understanding that may occur during the course of a study.

In this work I will describe how I have developed methods that will allow instructors and researchers to more thoroughly describe and compare student drawings.

The two research questions I will answer in this work are:

1. Can methods of discourse analysis be created, or current methods be modified to analyze the underlying meaning of students' chemistry drawings?
2. What evidence for the validity of these methods can be gathered by applying them to expert and student drawings, and to the comparison between student drawings?

I will begin by defining some terms and explaining why drawings are important in science in general and in student work in particular, especially in the teaching and learning of chemistry. Then I will summarize previous work on analyzing student drawings and the shortcomings of the methods used in that work, which will lead to a set of design requirements for a new method. I will explain the theoretical foundations for the creation of these new methods, paying particular attention to the interaction of students' drawings and students' conceptions, and the types of information contained in chemistry drawings. I will describe in detail the data on which these methods were tested, describe how I calibrated the methods, and then apply these new methods to some examples of student work in order to determine the validity of the approach. Ultimately this work results in two new methods of analyzing student drawings that overcome the shortcomings of previous research methods, and which are based on a theoretical foundation describing the interaction between student drawings and student concepts, and which allow us to answer the two research questions posed above.

## CHAPTER 2: REPRESENTATIONS AND INSCRIPTIONS

Researchers have been studying students' uses of representations in science courses in general, and chemistry classes specifically for decades (Ben-Zvi, Eylon, & Silberstein, 1986, 1987; Cheng, 1999; D. L. Gabel, Samuel, & Hunn, 1987; Garnett, Hackling, & Oliver, 1996; Hoffmann & Laszlo, 1991; Kelly & Crawford, 1996; R. Kozma, 2001; R. Kozma, Chin, Russell, & Marx, 2000; R. B. Kozma & Russell, 1997; Large, Beheshti, Breleux, & Renaud, 1994; Lemke, 1998c; Noh & Scharmann, 1997; W.-M. Roth & McGinn, 1998; Wolff-Michael Roth, Pozzer-Ardenghi, & Han, 2005; Wu, Krajcik, & Soloway, 2001). The representations examined in these studies range from simple pencil and paper drawings to complex computer animations. However, in spite of the extensive work of these and other researchers, there has been a lack of clarity regarding the terms used in this area of research, particularly the terms "representation" and "inscription." In fact, in the previous chapter, I opted for using the more general term "drawing" to avoid confusion. In this chapter I will explain what I mean by the terms "representation" and "inscription" and I will explain in more detail why I am interested in developing methods to analyze student drawings.

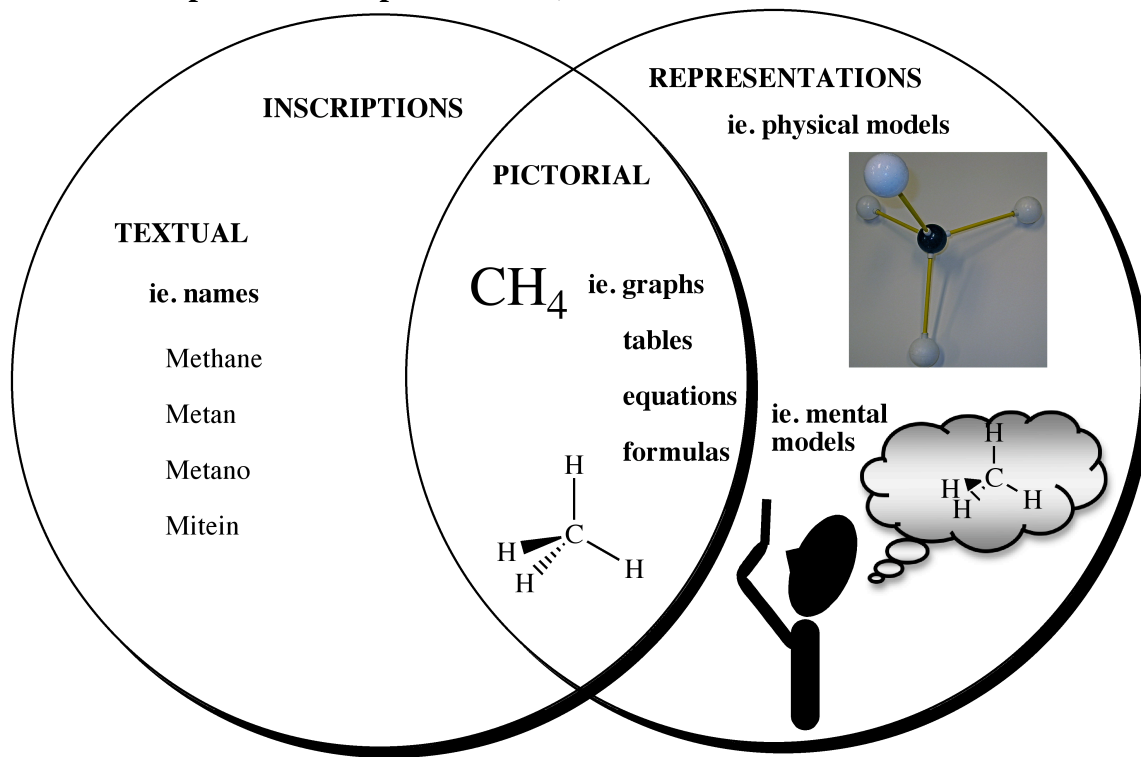
For example, some researchers use the term representation rather than inscription to refer to any depiction of chemistry phenomena — microscopic, macroscopic, or symbolic (D. Gabel, 1998). Other researchers (W.-M. Roth & McGinn, 1998) may use the term inscription in one publication to mean those artifacts that exist in material form,

as opposed to representations which are purely mental constructs, but in subsequent work the word inscription is used to distinguish maps, charts and graphs from text (Wolff-Michael Roth et al., 2005). Or researchers may use representation exclusively in one article (Wu et al., 2001), but use the word inscription in another for the same sorts of depictions (Wu & Krajcik, 2006).

These inconsistencies demonstrate the need for a simple differentiation between the words inscription and representation (Figure 2). In this work, I will define “representation” to mean any sign, symbol, or object that depicts some important surface feature or features of another object, phenomenon, or concept. This definition would include a drawing of a molecule, the elemental symbols used in chemical formulas, graphs, tables, photographs, or physical models. This definition would not include words, which do not illustrate the features of an object. A rose, by any other name, would still smell as sweet and a cat is still a cat, regardless of whether one calls it a “cat” in English, a “gato” in Spanish, or a “chat” in French. In addition, representations may be physically realized or purely mental.

I will use the term “inscription” to refer to anything that can be marked, cut, or engraved whether with a chisel on stone, or displayed on a computer screen. This would include words as well as drawings, graphs, tables, equations, and photographs, but would not include physical models such as a toy car or a wire model of a section of DNA. Thus, pictorial inscriptions, that is a drawing that can actually be inscribed, which carry some feature of the signified object can also be considered representations. For example, a pencil-and-paper drawing of methane, which can carry the three dimensional tetrahedral feature of the molecule methane is both an inscription and a representation.

**Figure 2. Representations and inscriptions.** (Note: Though a molecular model itself is a representation and not an inscription, the picture of a molecular model is both an inscription and a representation.)



## INSCRIPTIONS IN CHEMISTRY

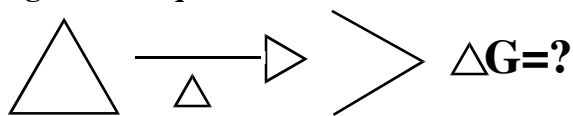
The importance of various types of inscriptions for the presentation of scientific ideas cannot be overemphasized and many authors have examined the wide variety of types and uses of inscriptions by practicing scientists. For example, Latour argues that one of the primary duties of scientists is to turn data and experimental activities into verbal and pictorial summaries (B. Latour & Woolgar, 1986). One of the most basic examples of the creation of these verbal and pictorial summaries is the laboratory notebook. They write,

“After several further excursions into the bench space, it strikes our observer that its members are compulsive and almost manic writers. Every bench has a large leatherbound book in which members

meticulously record what they have just done against a certain code number.” (p. 48)

Inscriptions have no meaning outside the context in which they are created and discussed (W.-M. Roth & McGinn, 1998). For example, consider Figure 3. Here we see four different uses of a triangle. To the untrained eye, each may seem like just another triangle. However, among chemists, a drawing of a triangle may be a representation of the structure of cyclopropane, it may be a shorthand symbol for heat added to a reaction, it may represent the Greek capital letter delta indicating change, or it may be an arrowhead showing how reactants lead to products. Without the context, it is not possible to know which of those meanings is implied.

**Figure 3. A question about the thermal decomposition of cyclopropane.**



Latour (1990) summarizes the important advantages of working with inscriptions: they are mobile, immutable, and flat; the scale can be easily modified; they are easily reproduced; they are easily recombined; they are superimposable; they can be made part of a written text; and they merge with geometry. All of these are advantages that working with actual scientific phenomena lack. An inscription of a chemical reaction can be written down, transmitted from scientist to scientist, combined with other data such as analytical spectra, and published. A flask containing a reaction mixture is generally not mobile, it may be difficult to reproduce the reaction, and is certainly difficult to do so on a large enough scale to use to communicate with other scientists.

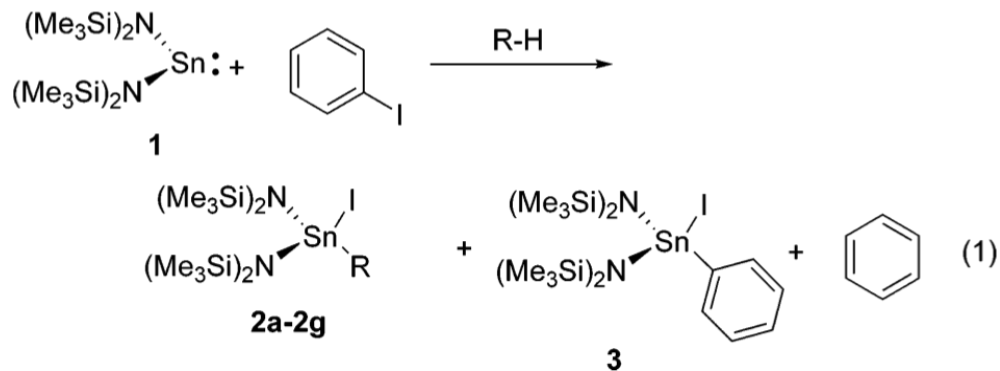
An important feature of pictorial or verbal inscriptions of scientific phenomena is not only their explanatory power, but also their communicative power. That is, for

scientists, the use of inscriptions is inherently social. Scientists must communicate in order for the practice of science to advance (Kovac, 2001). This communication occurs not only within scientific articles, but also in the day-to-day discussion between scientists working in laboratories (Bowen, Roth, & McGinn, 1999; Hoffmann, 1995; R. Kozma, 2001; R. Kozma et al., 2000; B. Latour & Woolgar, 1986; Woolgar, 1990). According to Woolgar (1990), the use of inscriptions to communicate and explain scientific ideas is not limited to an examination of the surface features of the inscription itself. Instead, scientists use the surface features, the underlying meaning, and how a particular inscription fits with other inscriptions to decide on its correctness and utility (W.-M. Roth, Bowen, & McGinn, 1999).

Thus, the inscriptional choices that scientists make are crucial because they can code for different meanings. In drawing a picture of the structure of a particular compound, a chemist may decide to foreground an important functional group by writing in the usually omitted atomic symbols, while backgrounding other, less important, parts of the molecule by not writing in the atomic symbols (Hoffmann & Laszlo, 1991); or whole parts of the molecule, not related to the matter at hand, may be abbreviated. For example, in Figure 4 Bartolin (2006) foregrounds the important tin atom in the stannylene reagent, the carbon-iodine bond, the alkyl-hydrogen bond (R-H), while backgrounding the parts of these molecules not directly related to the bond changes that take place in the reaction, the C-H bonds on the aryl ring for example, or the methyl groups bonded to the silicon atom. Researchers have illustrated the importance of the choices that people make when they use (or fail to use) particular conventions in creating inscriptions, whether in the journals

of professional physicists or in middle school mathematics classes (Cobb, 2002; Forman & Ansell, 2002; Lemke, 1998c).

**Figure 4. Equation 1 from Bartolin (2006).**



The choices that chemists make in how they represent their work, which atoms to foreground or which atoms to background or omit entirely, generally follow typical conventions such as those described by Grossman (2003). These conventions generally reduce confusion and lead to drawings that are (more or less) canonical in nature. In fact, one of the purposes of Grossman's book, The Art of Writing Reasonable Organic Reaction Mechanisms, is to make these conventions explicit for organic chemistry students. Some of these conventions include:

- A) Drawing all hydrogen atoms and heteroatoms near the reactive centers.
- B) Drawing heavy or bold bonds to indicate bonds pointing out of the plane of the paper
- C) Drawing hashed bonds to indicate bonds pointing into the plane of the paper
- D) Drawing wavy lines to indicate a mixture of stereoisomers
- E) Drawing plain lines when the stereochemistry is unknown or unimportant.

While these conventions are generally followed in formal communication and publication, some or all may be ignored in informal discourse when the molecular

structure is understood (or assumed to be understood) by the drawer and the viewer. As Grossman notes, “A particular author may use a dialect that is different from the standard.” However, it is generally assumed that pictures following these conventions will be well understood universally by the community of chemistry experts and so canonical drawings serve as a useful standard against which to compare student drawings. However, we might expect that, as students begin to learn the art of creating and using chemistry representations, their attempts may not always follow these conventions. So it is useful, if we are to get beyond the simple assessment of “correct” and “incorrect,” to develop assessment methods that allow the examination of non-canonical representations.

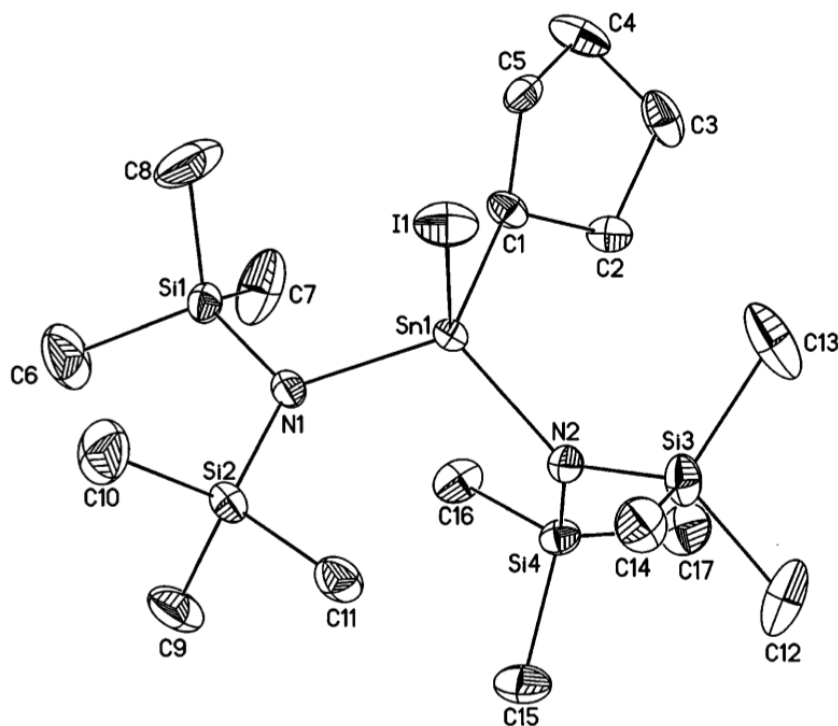
Chemistry, perhaps more than the other sciences, examines phenomena that cannot be seen or experienced directly: atomic and molecular structure and reactivity (Ben-Zvi, Eylon, & Silberstein, 1988; R. Kozma et al., 2000). It was thus important that chemists develop a systematic means of communicating these invisible phenomena early in the development of the field (Hoffmann, 1988). Today, chemists continue to use a variety of forms to illustrate their conceptions of how the invisible world works, including: molecular formulas, structural models, mathematical equations, and graphs. Chemists have also developed ways to combine these forms in different ways to suit their purposes and, in Lemke’s words, “multiply the meaning” of the inscription (1998c).

Lemke (1998) observes that the content of these pictures, diagrams, and schemes is often not, and/or cannot be, recapitulated in the text of the articles. Thus it is important that we understand, not only the words, but also the visuals in these articles. And, it is also important to be able to examine students’ abilities to create and use pictorial



inscriptions if we are to understand the meaning they are making. For example, a study by Lemke (1998c) demonstrates the importance of visuals in scientific publications. According to a preliminary survey of 20 articles from *Physical Review Letters*, the authors included an average of 1.2 graphics per page. A survey of 31 technical reports from *Science* showed an average of 6 graphics per article. In addition to these surveys, the study also notes the interesting case of one 7-page research report in which a diagram used 90% of one page. In another report, nearly 50% of the 2.5 pages were taken up with a set of graphs and a table. These visuals are not simply a supplement to understanding the ideas that the writers are trying to communicate; they are crucial to that understanding. For example, in another figure from Bartolin (2006), (Figure 5) we see a depiction of a structure obtained from X-Ray diffraction. Here we are given a view of the molecule with scale-appropriate bond distances and angles — the overall relationship in space of each atom to every other atom in the molecule. To reproduce this picture in words would not only be unnecessarily verbose, but the difficulties with which language handles precise spatial orientation in space would render the verbal description more open to interpretation by the reader, possibly resulting in mistakes in understanding. So, in the same way that scientists carefully examine the pictorial inscriptions of their peers for communication and understanding of complex ideas, it is crucial to carefully examine the pictorial inscriptions made and used by students in order to appreciate their understandings.

**Figure 5. Figure 1 from Bartolin, J. M. et. al. (2006) “Tin-Mediated CH Activation and Cross-Coupling in a Single Flask.” *Organometallics* 25 4738-4740.**



## CHEMISTRY STUDENTS AND THEIR INSCRIPTIONS

As students are initiated into the practice of chemistry, they must produce and use inscriptions to explore and explain the chemical phenomena they are studying just as practicing chemists do, (Cheng, 1999; Goodwin, 1994). Not only do scientists use multiple types of inscriptions to communicate, but also they also teach, test, and grade students based on the students' ability to generate inscriptions which are correct according to the norms of a particular community of practice. Previous studies have examined the difficulties students have with learning chemistry concepts (D. L. Gabel, 1993; D. L. Gabel et al., 1987; Keig & Rubba, 1993; R. B. Kozma & Russell, 1997; Nakhleh & Mitchell, 1993; Wu et al., 2001). First, students must acquire a massive new vocabulary. For example, an examination of a typical high school or college chemistry

textbook shows that new vocabulary is introduced at the rate of ten to twenty new words per chapter (see for example: Wilbraham, Staley, Matta, & Waterman, 2002; Zumdahl & Zumdahl, 2003). At this rate, students are exposed to almost 300 new words in just one chemistry class. However, Project 2061 has called for trimming down the expansive and overburdened technical vocabulary taught to students (American Association for the Advancement of Science, 1999).

In addition to acquiring this new vocabulary, students must also learn a variety of new inscriptional forms used in their classes and textbooks. Many students have difficulty relating these inscriptional forms to the macroscopic and nanoscopic phenomena they are studying and relating different types of inscriptions of phenomena such as verbal texts and pictures to each other (Ben-Zvi et al., 1988; Wu et al., 2001). Students in introductory classes must not only acquire these inscriptional forms, but also acquire the skills to understand the inscriptions being used to explain those concepts. Thus, learning chemistry is not like a second language, a common comparison made by authors and instructors (Dicks, Skonieczny, Lautens, & Kutas, 2004; Markow, 1988; Shawe), but more like learning one's first language, where understanding both the symbol and the referent are being done at the same time. Students cannot simply translate the phrase "nucleophilic substitution" into "English" because they have no existing concept of nucleophilic substitution in the first place.

Lemke (1998b) has examined the significant demands placed on students learning science in introductory classes. Students in these classes are exposed to a barrage of various types of inscriptions, which often receive little explanation, at an incredible pace.

So then, students are learning not only new chemistry content in their classes, but at the same time the lexicon and inscriptions used to describe that content.

If inscriptions are important in the work of practicing chemists who are training the next generation of practicing chemists, then assessing students' production and use of inscriptions will also be important. Such an analysis may provide us with valuable clues to understanding how, when, and why students use particular inscriptions correctly or incorrectly; may provide us with a way to examine the development of students' inscriptional abilities; and may provide a stronger link between our analysis of students' inscriptions of chemical phenomena and students' understandings of chemical phenomena. We therefore need a method, or methods, to assess students' inscriptions, in the same way that we have methods to assess their content knowledge.

## SUMMARY

Students and teachers use representations and inscriptions to communicate chemical concepts. Thus, we need to define what inscriptions and representations are and how they are used so that we can analyze them in order to assess student understandings.

### **CHAPTER 3: PREVIOUS RESEARCH ON STUDENTS' USE OF INSCRIPTIONS**

Over the past decade, many researchers have been examining student inscriptions and representations in chemistry. The research that has been produced can be roughly divided into two categories: research examining the production and manipulation of representations, what Kozma calls “representational competence” (see for example: Michalchik et al., 2008; Russell & Kozma, 2005) and research examining the interaction between student representations and their conceptions (see for example: Wu & Krajcik, 2006; Wu et al., 2001). I will be concerned with the latter and the sorts of methods used to examine student representations and how those methods relate to understanding student conceptions.

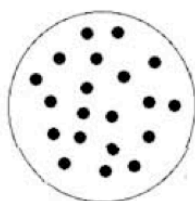
In chemistry, many studies have attempted to test students' conceptual understanding of stoichiometry and gas laws. The goal of these studies was to examine the relationship between students' algorithmic problem solving abilities and their conceptual understanding (Nakhleh & Mitchell, 1993; Nurrenbern & Pickering, 1987; Sawrey, 1990). The methods used in these studies involved administering simple multiple-choice pre- and post-tests in which the answers are supplied in the form of inscriptions rather than numerical answers or equations (Figure 6). These analysis methods suffer from several shortcomings. First, if researchers are interested in students' conceptions of chemical phenomena, then a more valid approach would involve soliciting

student answers rather than providing answers for the students in the form of a multiple choice test. These methods assume that student interpretations of the representations in the answers provided are the same as the expert interpretations of those representations. However no evidence was provided to demonstrate that was the case. The second problem with these methods is that they are not able to reveal the underlying structure of students' concepts nor their beliefs about how various concepts are interrelated.

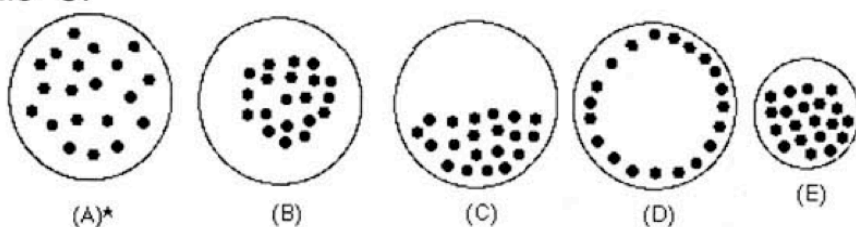
**Figure 6. Figure 1 from Nakhleh, M. B. and R. C. Mitchell (1993).**

**Problem I.**

The following diagram represents a cross-sectional area of a rigid sealed steel tank filled with hydrogen gas at 20 °C and 3 atm pressure. The dots represent the distribution of all the hydrogen molecules in the tank.



Which of the following diagrams illustrate the most probable distribution of molecules of hydrogen gas in the sealed steel tank if the temperature is lowered to  $-5\text{ }^{\circ}\text{C}$ ? The boiling point of hydrogen is  $-252.8\text{ }^{\circ}\text{C}$ .



*Correct answer: (A)*

Other studies have examined the relationship between representations and student conceptions in the context of comparing traditional representation making (e.g. molecular model kits vs. computerized molecular modeling). An illustrative example of such studies by Barnea and Dori (1999) involved two groups of students in similar lessons on

molecular structure: an experimental group that used a computerized modeling program and a control group that used traditional molecular modeling kits. Both groups responded to a pre- and post-test on structure and bonding consisting of six multiple-choice questions and two open-ended questions. The students also completed a questionnaire regarding modeling in general, and a spatial ability test. The authors conclude that the students in the experimental group outperformed the control group students in all three tests. As with the previous studies discussed, a significant weakness in the design of this study is the lack of opportunity for students to express their own chemistry conceptions in the course of the testing. Again, in order to examine the relationship between representations and concepts, a method is needed that can analyze student-generated representations and that can reveal information about the relationship between those representations and student conceptions.

Some researchers have used qualitative methods for evaluating the relationships between students' representations and their chemical conceptions. For example, in the course of examining a chemistry modeling and simulation program, Stieff and Wilensky (2003) interviewed students on their prior understandings of chemical equilibrium before and while using the computer modeling program. These interviews provided evidence of students' shifting conceptions before and after using the modeling program because the interviewer was able to ask the students questions about their reasoning while they completed the tasks. These qualitative research methods improve upon the previous methods discussed in that students are providing not only their own answers to questions, but also detailed explanations which can be mined for information regarding the interaction between the representations they produce and their understandings of

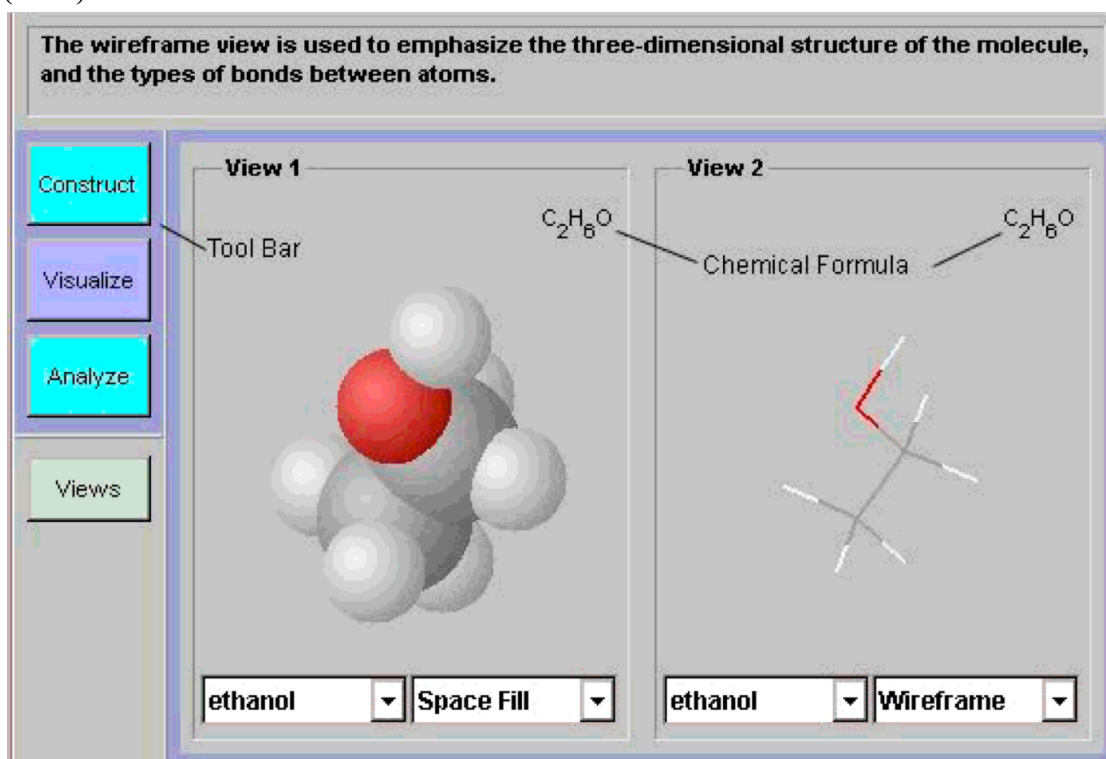
chemical equilibrium. Unfortunately, though interview methods can provide a wealth of detailed information for researchers, the interviews themselves, as well as the detailed transcription and analysis work can be extremely time consuming, and are usually not practical for use in situations other than research studies. For example, an instructor attempting to find out his/her students' conceptual understanding based on test questions in a typical classroom is unlikely to have the time or resources to conduct extensive interviews of more than a few students in his/her class. Consequently, for the classroom instructor, it would be useful to have a method of analyzing the relationships between student representations and their conceptions that could be more broadly applied with less effort and resources than interview methods.

Some researchers have combined several methods in order to more fully explore the connections between students' understanding and students' use of representations. For example, Wu, Krajick, and Soloway (2001) collected curriculum materials, video recordings, field notes, pre- and post-tests, student-generated artifacts and interviews in order to examine the development of student understandings using a computer visualization tool called eChem (Figure 7). In particular, the interview transcripts were coded according to a rubric which designated students' underlying understandings of concepts as accurate, partial, or not understood on tasks such as making translations between chemical and structural formulas and predicting a molecule's polarity based on its structure. The methods employed in this study allowed students the opportunity to provide their own answers and explanations within the constraints of the eChem software; they allowed in-depth examination of the link between concepts and representations; and they go beyond simple right/wrong analyses of representations to



provide a finer grain analysis of student concepts. However, these methods, which again rely heavily on interview transcription and analysis, are likely too involved for the average classroom instructor to use on a regular or semi-regular basis to inform their teaching, and they rely heavily on students creating and using canonical representational forms.

**Figure 7. The eChem “Analyze” screen, Figure 3 from Wu, Krajick, and Soloway (2001).**



Given this overview of the sorts of analyses typically used to examine student concepts and the accompanying representations, we can discern some guidelines for designing a new method of analyzing student representations. In order to overcome the shortcomings of previous research methods, new analytical methods should ideally:

- A. Be able to analyze student-generated inscriptions.
- B. Be able to analyze various types of inscriptions.

- C. Allow the comparison of different types of inscriptions, different styles (e.g. verbal vs. pictorial) as well as those from different individuals with varying levels of expertise.
- D. Provide a fine-grain analysis that goes beyond categorical evaluations of correct and incorrect.
- E. Reveal the underlying structure of the concepts that the inscriptions are designed to illustrate.

## SUMMARY

The examination of the weaknesses in previous approaches to research analyzing student representations leads to design requirements for new methods of analysis.

## **CHAPTER 4: DESIGNING A NEW METHOD OF ANALYSIS: THEORETICAL FRAMEWORK**

### **INSCRIPTIONS AND REPRESENTATIONS AS LEARNING TOOLS**

In order to create or adapt a method to analyze student inscriptions, one must assume those inscriptions are important for examining student understanding. We have already seen how important representations are for the work of practicing scientists. In addition, students construct their chemical understanding through the use of the tools made available to them, including the inscriptional systems they see their instructors use, and perhaps those they create on their own (Von Glaserfeld, 1998). Their use (and misuse) of these inscriptions (R. B. Kozma & Russell, 1997; Krajcik, 1991) in communication with their instructors and their peers is not simply the transmission of a particular concept, but is instead a meaning-making activity itself (R. Kozma et al., 2000). This activity simultaneously affects both the students' understandings and their inscriptions of that understanding (Palincsar & Brown, 1984; Scardamalia & Bereiter, 1991).

In order to examine students' representations, the students must have the opportunity to create their own representations and any method of analysis must be based on analyzing student-generated representations. There is evidence that pre-made visualizations are not as effective in supporting learning as student-generated visualizations (Gobert & Clement, 1999; Morrison & Tversky, 2001). Without the

opportunity to create their own inscriptions, students are not truly learning the skills and inscriptional abilities of chemists. They also do not have the ability to create new types of inscriptions that may be more suitable for their purposes. With pre-made visualizations, students do not need to make choices about which types of inscriptions might be most appropriate to use in a given situation in order to display or explain their ideas — another important skill.

In addition, many researchers have discussed the importance of open discussion and social discourse as a way for students to create meaning and as a way for instructors to assess student understanding for learning in general (Brown, Collins, & Duguid, 1989; Coleman, 1998; Pea, 1993; Pellegrino, Chudowski, & Glasser, 2001) and chemistry specifically (Coppola, 1998, 2001a; Eubanks, 1997). In this view, students' inscriptional choices in a free response environment can be a valuable tool to assist in the assessment of student understanding. In contrast to multiple-choice assessments, free-response assessments can allow instructors to examine not only what students choose to represent, but also how they represent their understandings.

#### THE SOCIAL USE OF REPRESENTATIONS AND INSCRIPTIONS MEANS THAT COMPARISON IS IMPORTANT

If representations and inscriptions are used to open discussion and social discourse as a way to assess student understandings, then it follows that there must be some standard against which those understandings are assessed. Researchers examining a new intervention may ask whether or not student understanding has improved. Classroom instructors assessing student understandings at the end of a semester also ask whether or not student understanding has improved. In order to answer such a question

we must first define what is meant by “improve.” By what standard is such a comparison to be made?

Because there is a community of practice – chemistry experts – that has developed several complex systems of inscription, it is to the standards of this community that we can compare student inscriptions (Hoffmann & Laszlo, 1991). Thus we predict that, as students develop more expert-like facility with the creation and deployment of inscriptions, they are also developing more expert-like chemical understanding of the meanings of these inscriptions.

It is not enough to simply say that student inscriptions differ from expert inscriptions. In order to make comparisons between expert and novice inscriptions, some method of analysis must be adapted or developed in order to move beyond the simple comparison of the surface features of the inscriptions and beyond a simple dichotomy of correct and incorrect. In addition, since the use of inscriptions and representation is a social discourse between learners, it would be useful to make comparisons between various student representations. That is, examining the details of how a particular student’s inscriptions differs from other students, as well as how they differ from an expert’s inscriptions, may provide important information about student understandings.

#### TYPES OF MEANING CONVEYED BY REPRESENTATIONS AND INSCRIPTIONS

Any use of language provides meaning in two ways: what is said or written, and how it is said or written. The first type of language meaning — what is said or written — is described by Lemke (1998a) as presentational meaning. Presentational meaning is the dimension of language that describes a state of affairs. Although Lemke is discussing the dimensions of verbal (language) meaning, and chemistry inscriptions are not always

verbal and not truly a language, this presentational meaning can also be found in chemistry inscriptions. For example, in the context of a chemical equation, the presentational meaning is the description of what reagents are reacting to form a particular product or products, in a particular solvent, at a certain temperature.

In addition to the presentational meaning of language, another dimension of language is the orientational meaning (Lemke, 1998a). This is the meaning contained in how language is used. The orientational aspect of a verbal text describes the social stance of the speaker in relationship to the reader such as whether the writer is being ironic, humorous, formal, hesitant, or amusing. For example, consider the two salt shakers in Figure 8. Both have markings that convey the contents. In the first, the holes that dispense the salt are arranged in the letter “S.” In the second, the chemical formula for salt,  $\text{NaCl}$ , is given. Both provide the same presentational meaning, ie. “This is salt, not pepper.” However, while the first one assumes that the diner understands that “S” stands for salt and “P” stands for pepper, the second assumes that the diner knows the chemical formula for salt is  $\text{NaCl}$ . In the context of chemical inscriptions, a complex meaning like irony is not possible, but thoughtful chemists probably do indicate their orientation toward the subject matter and their audience based on the types of inscriptions they choose. A chemist may, for instance, simply write, “sodium hydroxide reacts with hydrochloric acid to produce water and salt,” if she assumes that the words themselves will have some type of meaning to the reader. However, if she wishes to illustrate the acid/base nature of the reaction, she may write the chemical equation instead, assuming that the reader understands atomic symbols and their use in writing chemical formulas. Thus, the orientational meaning conveyed in chemical inscriptions is a type of

pedagogical content knowledge in which a particular type of inscription is used to convey a particular type of meaning (Shulman, 1986).

**Figure 8. Even salt shakers can illustrate orientational meaning.**

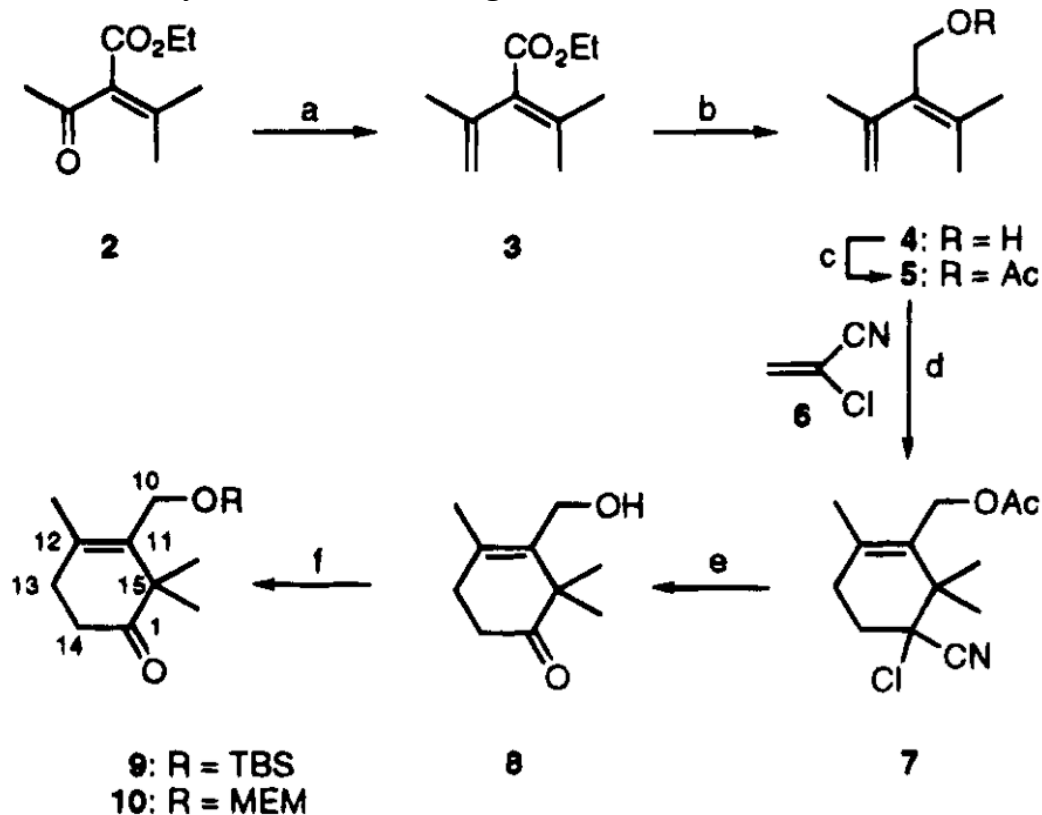


The third type of meaning conveyed by language according to Lemke (1998a) is organizational meaning. This is the meaning conveyed by the broader organization of speech or text such as the particular genre to which it belongs or the rhetorical structures used. For example, though one sentence by itself likely cannot convey much organizational meaning, a group of them can be arranged in such a way as to form the structure of argument. In the same way, chemical structures can be arranged in such a way as to form the structure of an argument, or more precisely the argument for how a particular compound can be synthesized based on chemical precedent. A scheme showing the complex natural synthesis of taxol, for example, can show the reasoning behind a particular approach, in this case the method of convergent synthesis. It can also

make connections to unstated assumptions. In the total synthesis of taxol, for example, the Nicolaou research group (1995) utilized different methods than those employed by other research groups to form the same compound. A piece of this total synthesis, the formation of Ring A of the molecule, is shown in Figure 9. To a chemist, this inscription depicts one way of creating one portion of the molecule. More than that, it implicitly reveals the overall organization of the entire synthesis. Nicolaou and coworkers did not attempt to synthesize the molecule in a serial fashion, one step after another. Instead, he synthesized the four different ring systems simultaneously; then connected them. This scheme also implicitly refers to research from the past, for example, the Diels-Alder reaction shown at arrow “d”. The authors are making an argument that essentially states, “If you accept that there are precedents for the sort of chemistry we’ve shown at arrow ‘a’, and arrow ‘b’, and arrow ‘c’, and arrow ‘d’, and ‘e’, and ‘f’, then we think we can make the final product, starting with the reagent shown at the beginning.” Organization is important here. One cannot get to “d” without starting earlier. And even meta-organization is important, because without the work of Diels and Alder decades earlier, reaction “d” would have no precedent.



Figure 9. Scheme 1 from Nicolaou, K. C., J.-J. Liu, et al. (1995) showing the formation of key intermediates of Ring A of taxol.

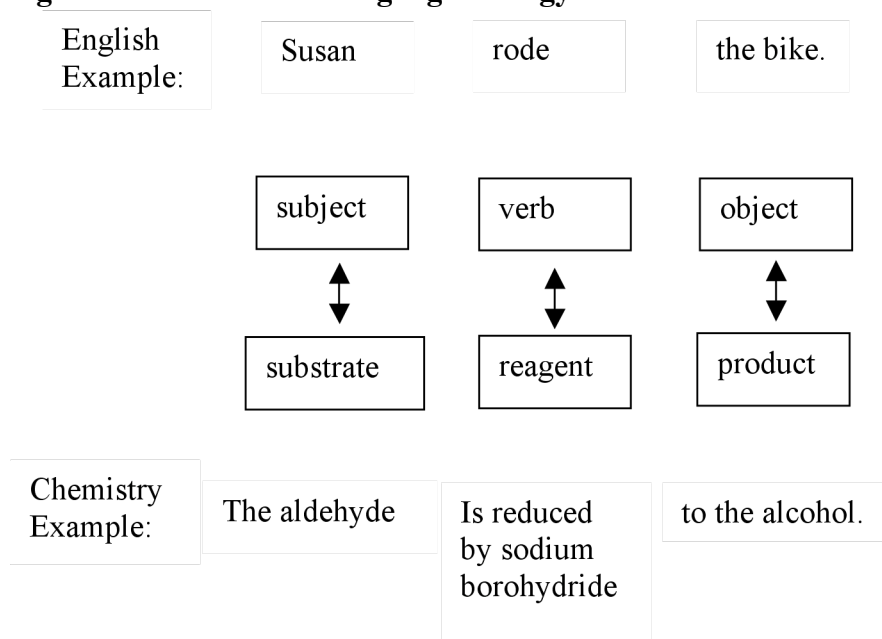


## THE SPECIALIZED NATURE OF CHEMISTRY REPRESENTATIONS AND INSCRIPTIONS

Also informing the design of a method for analyzing students' chemistry inscriptions is our understanding of how chemical inscriptions are used: chemical inscriptions are not a language. The distinction between a language and the forms of chemical inscriptions is an important one because it should guide the ways in which chemical inscriptions can be analyzed. A picture of a ball-and-stick model of water, shown to an expert chemist may conjure many facts, images, and ideas about water: its boiling and melting points, its geometry, its reactivity, its intermolecular interactions with similar and different molecules, for example. In the same way the word cat may conjure

many facts, images, and ideas about cats in the minds of people who have had experience with cats. In this way, chemical inscriptions are similar to words in the ways that they represent objects or actions. Furthermore, Hoffmann (1991) suggests that there is a parallel between chemical equations and sentences, with reactants serving as the subjects and verbs, and products serving as the objects of a simple declarative sentence (see Figure 10).

**Figure 10. Hoffmann's language analogy.**



However well this analogy seems to fit, it is severely limited by the restricted ways in which chemical inscriptions can be used. Though one may be able to create a chemical equation that is an analogy of a declarative sentence using chemical equations, one cannot create a question. Nor can one express complex meanings such as irony, simile, or metaphor with chemical inscriptions (Godman & Payne, 1981; Hoff-Ginsberg, 1997).

So, even though chemical inscriptions do not constitute a language, they do convey some of the same meanings that language conveys and it is useful to categorize these meanings in the same ways that the meanings of language are categorized.

## BREAKING A CONCEPT INTO PIECES: FEATURES AND THEMES

If we are going to develop a method for examining student conceptions utilizing their inscriptions and representations, then it follows that we need to understand the nature of the relationship between concepts and the inscriptions and representations that students use to illustrate and talk about those concepts.

In general, the notion of a concept has been defined in two different ways in the literature. In the first definition, concepts are defined as mental models or frameworks used to explain phenomena. Because in this view concepts are purely mental constructs, they are themselves generally invisible to examination except through examining the language used to describe them (Givry & Roth, 2006). In this view, while language is used to talk about concepts, language itself does not influence the composition of those concepts. These notions have led to a large body of work examining students' conceptions (Nakhleh & Mitchell, 1993; Nurrenbern & Pickering, 1987), conceptual change, and particularly student misconceptions (see for example: diSessa, 1993; Hatano, 2002).

The second definition describes concepts not as an invisible mental model, but as the sum of the various types of discourse used to describe phenomena. In this view (Cobb, 2002; Gee, 2004; Givry & Roth, 2006; Lemke, 1998b), concepts are not invisible mental constructs only referred to by language and other semiotic constructs but are instead the entire framework of multiple semiotic meaning-making practices, the entire collection of representations and inscriptions used to describe an object or phenomenon. This understanding of the nature of concepts is advantageous because it theorizes that the structure of students' talk, representations, inscriptions and any other discourse strategies

does not simply mirror or represent a portion the invisible framework in their minds, but is instead a direct component of that framework. Thus the analysis of representations and inscriptions is really an analysis of various pieces or individual units of a conceptual framework students use to explain a substance or phenomenon.

To illustrate this point, let's consider the concept "water." Ask a child about water and you may find out that it is a wet, clear stuff that is good to drink and bathe in. The child might use words like "wet," "clear," or "drink" to describe water and may draw a picture of a blue lake or pond with waves. If one could establish, through extensive questioning, the sum total of all of the child's talk, gestures, and pictures about water one would have a picture of the child's concept of water itself. Ask a chemist about water and he or she may use those same words as well as others such as "polar" and "liquid." The chemist might draw a picture of the bent geometry of the molecule, illustrating the molecular formula complete with bonds and lone-pair electrons. Taken together, all of these words and pictures represent parts of the whole concept of water, whether it is a child's concept or a chemist's concept. Each word or symbol or representation can be examined for the individual meaning contained within it and whether or not that meaning conforms to commonly held understandings about water. However, we can learn about the concepts held by the child and the chemist not only from the meanings of the words used to illustrate their conceptions (presentational meaning), but also which specific semiotic forms they use to represent those concepts (orientational meaning). A chemist drawing a ball-and-stick model of water not only tells us the chemical formula for water and how the atoms are arranged, but the use of a ball-and-stick model itself tells us that

this person has had at least some scientific training and that he or she supposes that we as the viewer do too.

So then, understanding that any single representation is itself only one part of the whole concept, and that representations carry both presentational and orientation meaning suggests that an analysis of representations can provide not only more detailed information about the pieces of a concept being represented, but also greater detail than a simple evaluation of “correct” or “incorrect.”

#### PREVIOUS RESEARCH INFORMS THE NEED FOR NEW ANALYSIS METHODS

Not only does previous work on the nature of students’ use of representations, an examination of the nature of chemistry representations themselves, and an understanding of the relationship between concepts and representations inform the design of new methods of analysis, but the shortcomings of previous research in the analysis of student representations can also be used as a set of requirements for creating new methods that would reduce or eliminate some of those shortcomings. Researchers may have various goals for analyzing student representations, but if the goal is to examine the link between student representations and student understandings, then any method created should adhere to at least these six design requirements:

- A. The method should be able to analyze student-generated inscriptions.
- B. The method should be able to analyze various types of inscriptions.
- C. The method should allow the comparison of different types of inscriptions, different styles (e.g. verbal vs. pictorial) as well as those from different individuals with varying levels of expertise.

- D. The method should provide a fine-grain analysis that goes beyond categorical evaluations of correct and incorrect.
- E. The method should reveal the underlying structure of the concepts that the inscriptions are designed to illustrate.

## SUMMARY

As with practicing scientists, the use of inscriptions by students is a social meaning-making activity. In order to assess the meaning being made students, analysis should focus on students' own inscriptions since these are illustrations of portions of their conceptual understanding. In addition, this meaning-making is done in the context of social activities with other students and with experts, so comparison between them can provide valuable information about student conceptions. Though these inscriptions and do not constitute a language themselves, they do convey much of the same type of meaning as a language and thus some of the same methods of analysis may be adapted for analyzing them. These ideas regarding the nature and use of inscriptions as well as their relationship to concepts, in addition to the weaknesses in previous analytical approaches should all inform the design of new analytical methods.

## CHAPTER 5: SUMMARY OF DATA AND METHODS

As I turn to an explanation of the methods I have developed to analyze student representations, it is useful to summarize the methods themselves, as well as the data used to calibrate the method, before putting these methods to use and examining the results of the analyses.

Chapter 6 will describe the methods as well as outline the procedures for applying the methods themselves. I have illustrated each step of the methods through their application to actual examples from student work. Chapter 7 will describe a calibration of the methods using expert inscriptions taken from organic chemistry textbooks. Chapter 8 will show the application of the developed and calibrated methods to a sample of student work in order to test the validity of the methods. The data itself and the collection methods used in each of these steps will be described in detail in the corresponding chapter, but is also summarized in Table 1.

**Table 1. Summary of data sources and their use.**

Chapter	Data Source	Use
6	Student work	Illustrating the steps of the method used
7	Textbook inscriptions	Calibrating the methods
8	Student work (same work used as examples in Chapter 6)	Application of the methods in order to test validity

## CHAPTER 6: PROTOCOLS FOR ANALYSIS

Based on the design requirements outlined in Chapter 4, we need methods that can not only tell us what types of inscriptions students are making, but also how they are using those inscriptions to convey meaning. Below, I will describe these two methods: features analysis, which will provide information about the types of inscriptions, and thematic analysis, which will provide information about how students are using the inscriptions.

### FEATURES ANALYSIS

*What is a feature?*

A feature is a verbal description of a particular symbolic form or image used to communicate an idea. A features analysis of an inscription is simply an inventory of the various symbolic forms or images used to display a concept or set of concepts. This method provides information about the types of inscriptional forms that have been used to convey meaning, regardless of that meaning or its correct or incorrect use. So then, features analysis is a method that can be used to examine the orientational meaning contained in a chemical inscription. The analysis tells us only how ideas are presented, it tells us nothing about what is actually said. In the context of this work, it is a survey of the types of chemical symbols used by students to illustrate their answers to a quiz question. The use of chemical symbols instead of words to describe a chemical reaction

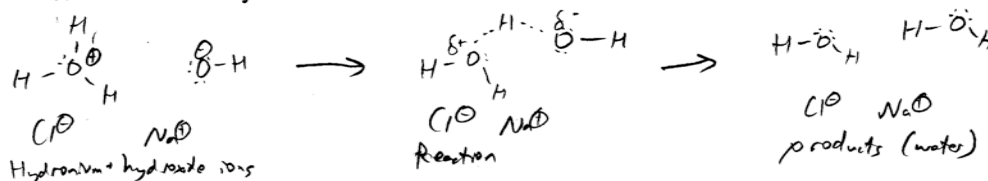


is a feature of a students' work that can be examined (Figure 11). In the absence of any other information, the fact that a student uses chemical symbols to describe a chemical reaction may not be interesting or noteworthy. However, if a student uses only symbols to answer a verbal test, the comparison of the symbols contained in the student's answer with the words used in the test question may yield important information about the student's understanding. Additionally, comparing one student's use of chemical formulas with another student's use of ball-and-stick figures to answer the same question may reveal additional information about both student's understandings, and the types of decisions students make to communicate their ideas. Perhaps these particular inscriptional choices make no difference to the final answer, or perhaps the students are trying to convey different meanings. It is in the comparison that the importance is revealed. This analysis could be performed across instructional contexts, for example, to provide assessment information about the efficacy of a particular educational intervention. My task is to develop a method that allows these different types and levels of comparisons.

Consider the following example. A student is asked the following question: "Please describe, with labeled pictures, the sequence of events that occur on the molecular level when 10 milliliters of a 5 Molar solution of hydrochloric acid in water is mixed with 5 milliliters of a 5 molar solution of sodium hydroxide in water." An example of student work is shown in Figure 11.

### Figure 11. Sample of student work #1

b. 10 milliliters of a 5 Molar solution of hydrochloric acid in water is mixed with 5 milliliters of a 5 Molar solution of sodium hydroxide in water.



In this example, we notice several features of how the student has answered the question.

The student has:

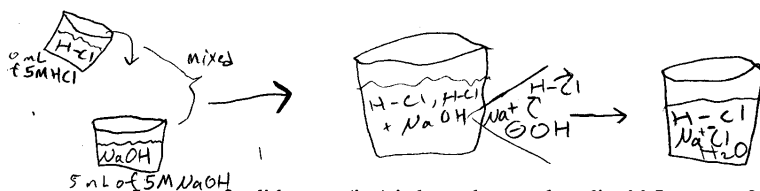
- created an inscription of a nanoscale process
- used atomic symbols
- represented hydronium cations using a structural diagram
- represented hydroxide anions using a structural diagram
- labeled hydronium cations
- labeled hydroxide anions
- used formal charges
- drawn the reaction as a proton transfer
- shown a transition state using dotted lines for partial bonds
- included partial charges
- included nonbonding electrons.
- labeled the reaction
- used arrows to show sequence
- shown sodium ions as charged atomic symbols
- shown that sodium ions do not participate
- shown chloride ions as charged atomic symbols
- shown that chloride ions do not participate

- drawn water as using a structural diagram
- labeled water
- labeled the products
- used single ionic or molecular species to represent the whole solution

Using this list, we can compare the student's answer to the features used in the question itself. Notice, for example, that no atomic symbols were used in the question, nor were the words "hydronium," or "ions," yet the student's answer includes these features. In addition, the problem includes ideas such as quantity and concentration, which the student does not represent. Compare this with another student's answer to the same question, shown in Figure 12.

**Figure 12. Sample of student work #2.**

b. 10 milliliters of a 5 Molar solution of hydrochloric acid in water is mixed with 5 milliliters of a 5 Molar solution of sodium hydroxide in water.



In contrast to the first student, this student's answer contains the following features:

- mixed inscriptions of macroscopic and nanoscale processes
- the reaction represented as the contents of 2 containers being mixed together
- container of acid is labeled with the quantity and concentration
- container of base is labeled with the quantity and concentration
- milliliters is abbreviated mL
- containers are not drawn to scale according to quantity
- mixing is labeled
- mixing is indicated with an arrow

- used atomic symbols
- hydroxide represented as OH
- used formal charges
- sodium ions shown as charged atomic symbols
- sodium ions do not participate
- chloride ions shown as charged atomic symbols
- curved arrows used to show movement of electrons
- water is represented as H<sub>2</sub>O
- excess reactant is shown as H-Cl

A features analysis is then performed on student chemical inscriptions by counting the number of pictorial and verbal inscriptional forms used by the students themselves. The method of coding is based on Glaser's (1992) grounded theory in which the categories of features that are created to code the data arise from the data itself, rather than attempting to fit student inscriptional types into a predetermined coding scheme. Such a scheme allows for coding incorrect or unconventional methods of inscription, which might be missed by creating a group of predetermined categories. As the coding continues, additional categories of features are added as necessary. Thus the entire set of features is not complete until the entire data set has been coded.

Once the features are coded and tabulated, the frequencies of the various categories can be calculated and compared between students, across instructional contexts, media (paper vs. computer), and between experts and novices. Student features can be compared with the initial test questions. Note that although the previous examples illustrated how this method can be used with pictorial data, a features analysis can be

conducted on verbal data as well. For example, some students may refer to hydrochloric acid as “the acid” and sodium hydroxide as “the base,” while others may use chemical formulas such as HCl and NaOH. Again, these verbal features can be coded, tabulated and compared in the same way as the pictorial features.

A comparison of the features coded from Figure 11 and Figure 12 show that only a few of them are shared between the students’ inscriptions. Comparing the work of two students may not be enough to give us any insight into the answers produced, and it does not establish the importance and validity of the method of analysis. However, when the features of many students’ answers are compared, trends may be observed. And, if features analysis is used in multiple contexts and in combination with other modes of assessment, we can begin to constitute the validity of the method (Gee, 1999).

#### *Goal of Features Analysis*

The goal of features analysis is to examine the meaning of student inscriptions provided by the types of diagrams they use. This orientational meaning of the inscription transmits the viewpoint of the writer and his or her relationship to the reader. For example, chemists writing in a journal article will make different decisions about the inscriptions they use than they might if they were writing on a chalkboard for a class of high school students. Writing a journal article, these writers assume a common knowledge of a particular type of inscriptional symbolism, which transmits the notion, “I’m an expert in the field and I assume the reader is as well.” Because writers often have many choices of possible types of symbols to use, the particular symbols they choose can provide us with information about their understanding, which is separate and complimentary to the information we can obtain through thematic analysis about what is

actually being stated. It is possible that a student's inscriptional choices may be informed by ideas about the best way to indicate a particular meaning, or they may simply be the most convenient or familiar method of conveying an idea. Regardless of why the writer made a particular choice, a features analysis provides information about how the meaning is conveyed, and also allows for comparisons between students and between students and experts. The variety or scarcity of types of symbolic forms in student work may provide us with information about which forms they are most comfortable with, or which forms they find more efficient. We can compare these choices with the choices made by experts to examine any similarities and differences between the two groups. These comparisons could be performed across instructional contexts, for example, to provide information about the efficacy of a particular educational intervention.

There are 2 steps in conducting a features analysis:

- 1) recording the features, and
- 2) comparing the number of features contained in different inscriptions.

#### *Features Analysis — Step 1: Recording Features*

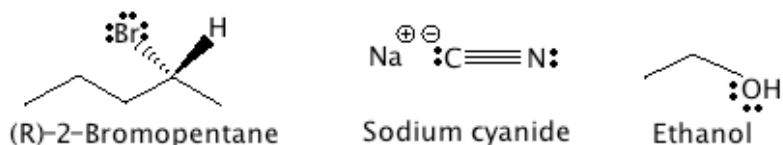
In order to explain the protocol for features analysis, we will consider a quiz question (Figure 13) and two examples of student answers to the question (Figure 14 and Figure 15).

These inscriptions were created by students to answer to the quiz question given during the eighth week of an honors first-year organic class. The students were both first-year chemistry students at a large Midwestern research university. Student A (Figure 14) answered the quiz question using ChemSense (SRI International, 2001) and Student B (Figure 15) answered the question using traditional pen-and-paper means. A strength

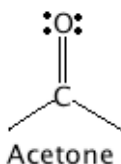
of these analysis methods is that the method of the production of the student work is largely irrelevant to the methods of analysis.

**Figure 13. Quiz**

1. Assuming that your audience is your peers, please draw labeled pictures to explain what occurs on the molecular level when (R)-2-bromopentane ( $C_5H_{11}Br$ ) reacts with sodium cyanide (NaCN) using ethanol as the solvent.



2. Explain why the  $S_N2$  products of the reaction in #1 are formed faster if the solvent is switched to acetone.



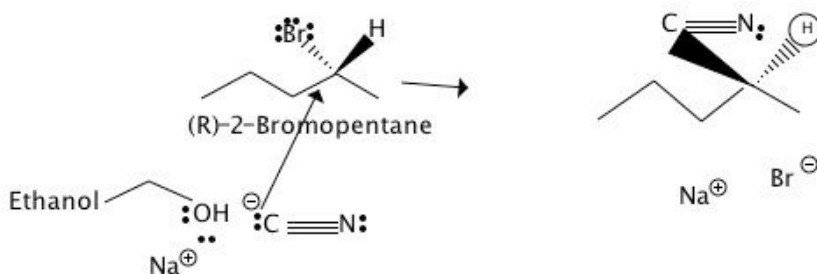
The question contains several features, which are listed in Table 2. As we examine the student answers to this question, it will be useful to refer back to the original question and the features included in it.

**Table 2. Features of quiz shown in Figure 13.**

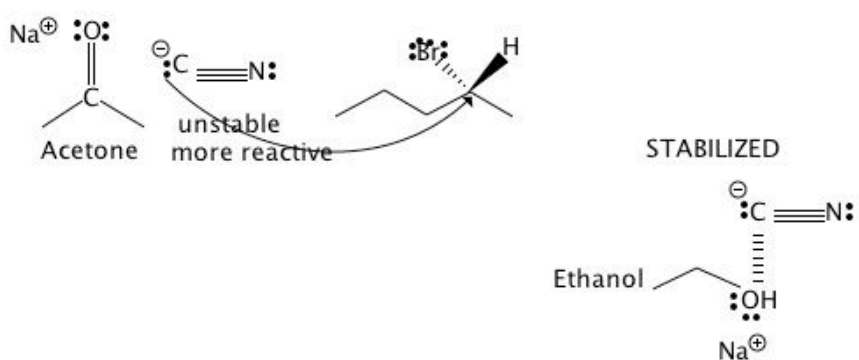
- |  |
|--|
| <ul style="list-style-type: none"><li>• used atomic symbols</li><li>• labeled (R)-2-Bromopentane</li><li>• labeled Sodium cyanide</li><li>• labeled Ethanol</li><li>• labeled Acetone</li><li>• used structural diagrams</li><li>• used dashes and wedges to represent stereochemistry</li><li>• represented ethanol using</li><li>• used formal charges</li><li>• included nonbonding electrons.</li><li>• showed sodium ions as charged atomic symbols</li></ul> |
|--|

**Figure 14. Student A's answer to the quiz question.**

1. Assuming that your audience is your peers, please draw labeled pictures to explain what occurs on the molecular level when (R)-2-bromopentane ( $C_5H_{11}Br$ ) reacts with sodium cyanide (NaCN) using ethanol as the solvent.



2. Explain why the  $S_N2$  products of the reaction in #1 are formed faster if the solvent is switched to acetone.



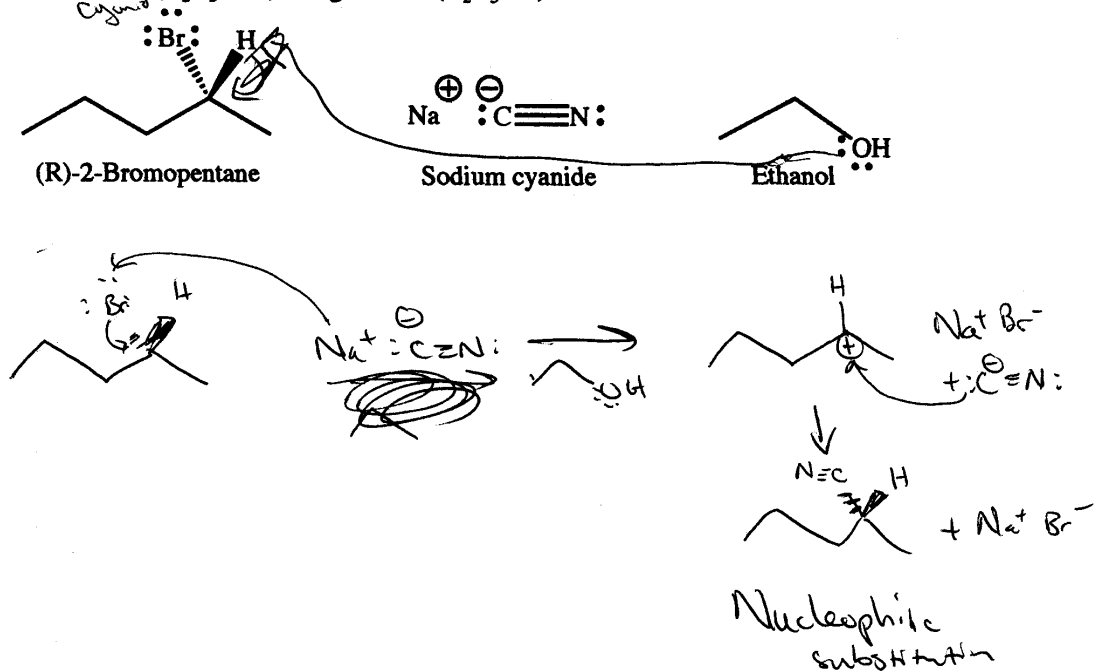
**Table 3. Features of Student A's inscription, Figure 14.**

- used atomic symbols
- labeled (R)-2-Bromopentane
- labeled Ethanol
- labeled Acetone
- used structural diagrams
- used dashes and wedges to represent stereochemistry
- copied structural diagrams from quiz question
- used curved arrow notation to show electron movement
- used formal charges
- included nonbonding electrons.
- showed sodium ions as charged atomic symbols
- showed bromine ions as charged atomic symbols
- wrote "unstable more reactive" near CN next to acetone
- wrote "stabilized" near CN next to ethanol
- used dashed lines between drawings to show intermolecular interactions

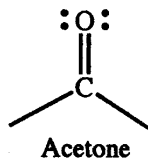


Figure 15. Student B's answer to the quiz question.

1. Assuming that your audience is your peers, please draw labeled pictures to explain what occurs on the molecular level when (R)-2-bromopentane ( $C_5H_{11}Br$ ) reacts with sodium ethoxide ( $C_2H_5ONa$ ) using ethanol ( $C_2H_5OH$ ) as the solvent.



2. Explain why the  $S_N2$  products of the reaction in #1 are formed faster if the solvent is switched to acetone.



Acetone is more likely to take off the hydrogen in the  $CH_3$  location since it stabilizes itself through resonance. By taking the H off ~~near~~ quicker, the cation is formed and the reaction proceeds.

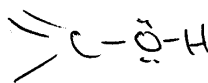


Table 4. Features of Student B's inscription from Figure 15.

- used atomic symbols
- used structural diagrams
- used dashes and wedges to represent stereochemistry
- copied structural diagrams from quiz question
- used curved arrow notation to show electron movement
- used formal charges

- included nonbonding electrons.
- showed sodium ions as charged atomic symbols
- showed bromine ions as charged atomic symbols
- wrote “unstable more reactive” near CN next to acetone
- wrote “stabilized” near CN next to ethanol
- used dashed lines between drawings to show intermolecular interactions

An examination of the features recorded for these examples demonstrates that each is a verbal description of a type of symbolism. That is, we do not describe in detail each symbol used. Noting, for example, that students used structural diagrams in their drawings is enough to provide adequate information about the features contained in the inscription. Thus the list of features is an inventory of types, not an inventory of instances of symbol use. In addition, the features are recorded based on their chemical meaning. That is, we do not record “a line was drawn from left to right in the middle of the paper next to the letters Br” but instead we record “a bond is drawn to a Br atom.” The point of features analysis is to examine the different sorts of symbols and structures students use to convey their chemistry meaning.

#### *Features Analysis — Step 2: Comparing Features*

The features analysis of a single student inscription can be as simple as counting the number of features, which provides information about the complexity of the inscription. We can also examine the types of symbols that a particular student uses in a particular context.

More interesting, however, are comparisons between students and between student inscriptions and expert inscriptions. For these comparisons, the features are recorded in a Microsoft Excel spreadsheet. Using this spreadsheet and simple statistical calculations, we can determine the average number of features used to answer a particular

question, examine any differences between students using different inscriptional methods, compare student groups who have received different educational interventions, and compare the average number of features used by students with the average number of features used by experts. We can also examine the similarities between the types of features used by students and those used by experts.

## THEMATIC ANALYSIS

### *What is a theme?*

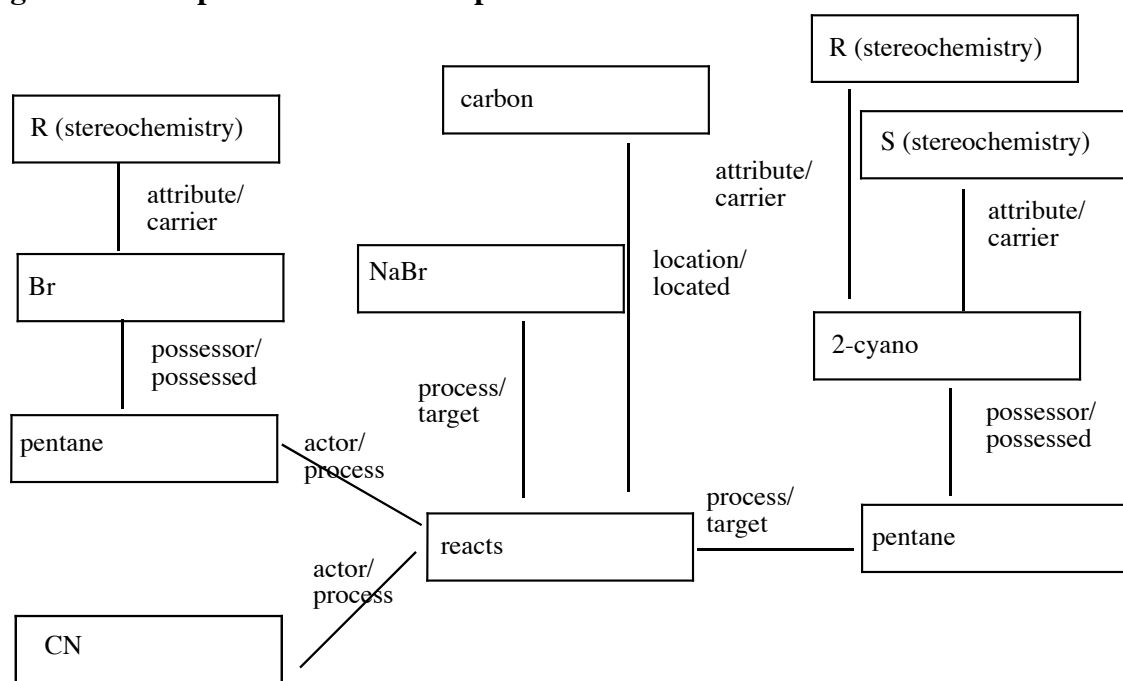
A theme is a semantic item that has particular meaning in a particular field. The theme is not specifically related to a specific word, but can usually be expressed using many different words or pictorial representations. For example, the phrases “bimolecular nucleophilic substitution” and “S<sub>N</sub>2 reaction” both describe the same theme. Recording the themes contained in a student verbal or pictorial inscription is the first stage of our analysis.

After the themes have been recorded, we examine the relationships between themes as indicated by the student inscription. Themes generally relate to other themes in conventional ways within scientific discourse. These relationships create thematic formations, which are common across texts of the same genre. Though the theme indicated by the word “orbital” in chemistry may share some parts of a thematic formation with the theme indicated by the word “orbital” in astronomy, it is the context into which these themes are placed that indicates the difference in meanings between the themes in the two different fields of study. The themes themselves only have meaning

within the relationships they form with other themes in a specific text (Lemke, 1983; 1990.)

The thematic formations contained in an inscription can be mapped visually in a thematic map. These maps are meta-representations that can be compared and contrasted between students and experts. An example of such a map is shown in Figure 16. This is the basis of the thematic analysis method.

**Figure 16. Sample of a thematic map.**



### *Goals of thematic analysis*

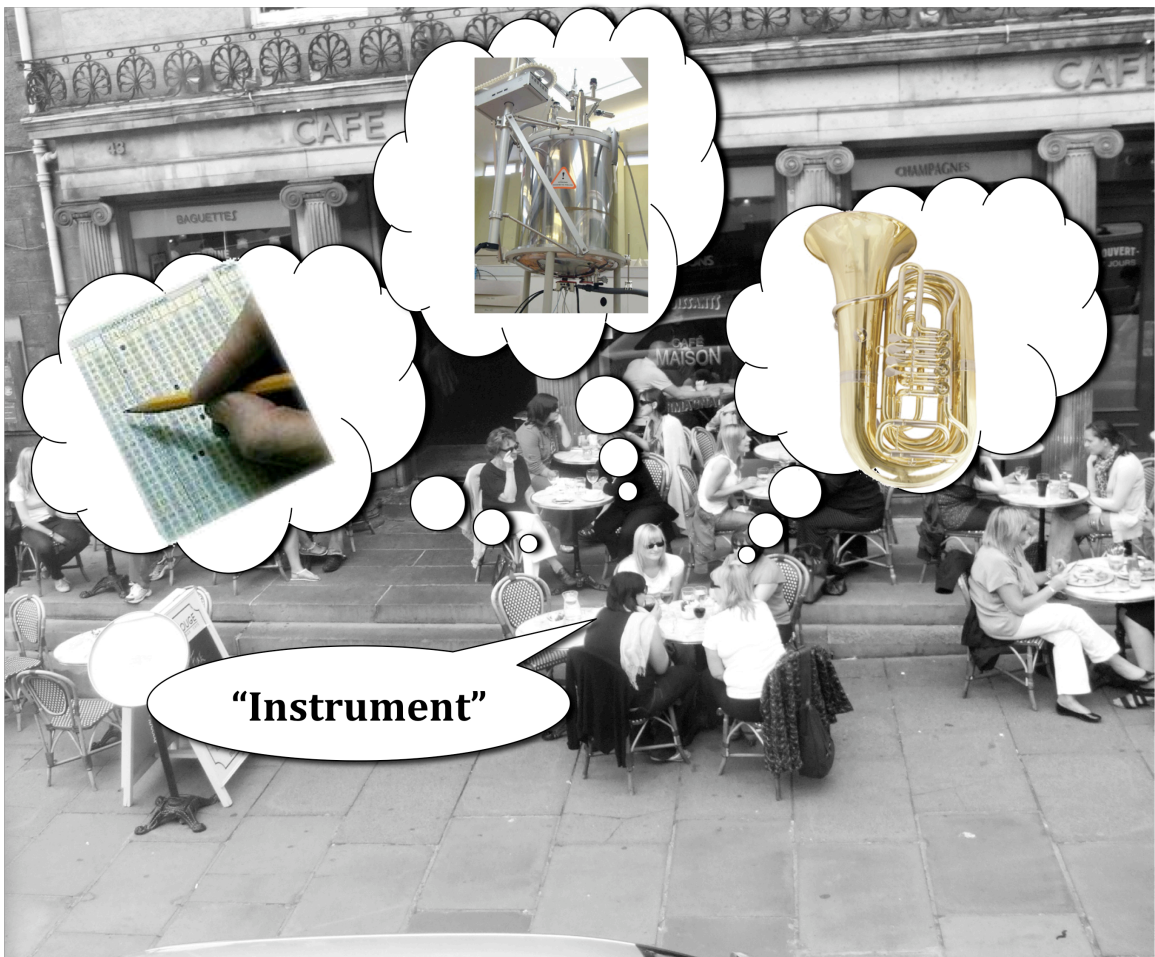
Whereas features analysis provides information about how students are conveying their understandings, thematic analysis provides us with information about what those understandings are without regard to how they are symbolized. Because particular thematic formations are canonical within the discourse of a particular field, we can examine students' formations in an effort to analyze the similarity of their formations to those of the field. Such analyses can serve as an assessment of student understanding

that goes far beyond simple standards of correct and incorrect answers. More than simply evaluating deficiencies in a particular content area, we can examine any missing or extraneous thematic formations present in students' discourses as compared to those of experts. We can examine the discourses of students who have experienced different educational interventions. We can also examine experts' verbal and pictorial discourse and learn valuable information about the similarities and differences between those discourses, learning which information may be best conveyed verbally and which information may be best conveyed pictorially.

By way of explaining the difference between features analysis and thematic analysis, imagine a group of college students chatting at a café (Figure 17). One student, Jean, mentions an interesting new instrument that he learned about in class that day. His friend, Cosette, a psychology major immediately thinks of a psychological test when she hears the word instrument and in her mind pictures people sitting at desks filling out answers to questions. Jean's friend Javert is a music major and immediately thinks of a tuba, the instrument he plays. In the same moment, Jean's friend Fantine, a Chemistry major, pictures an nuclear magnetic resonance instrument. All of these people are thinking about a particular, and different kind of, instrument. As they continue to talk, they will eventually figure out what kind of instrument Jean originally meant. However, that understanding will only develop as they examine the themes that make up the concept "instrument" for each of them. For example, words like "music," "notes," "brass," and "bass" would be closely associated with Javert's instrument. Words like "proton," "spectra," "triplet," and "shielding" would be associated with Fantine's instrument. Each of these words is a theme, a recurring term that has particular meaning

in a particular field. Each of these themes is related to the other themes in specific ways for that field of knowledge. Only in talking, using these themes and the relationships between them, will Jean and his friends work out what is meant by “instrument.” That is the basis of thematic analysis, examining the existence of, and relationships between, semantic units — whether it is a word, a picture, an arrow, or atomic symbols — in a particular text.

**Figure 17. Some of the themes that accompany the word “instrument”. (photo copyright 2009, Joe Gordon. Used with permission.)**



Where features analysis provides information about orientational meaning, thematic analysis provides information about presentational meaning. In the example above, if we were to ask the students to draw pictures about what they meant by the word

“instrument,” the examination of the specific types of drawings they create would be features analysis. And examination of how they relate the meanings of each of the drawings together would be thematic analysis. Though it was originally developed for the analysis of verbal texts (Lemke, 1983, 1990, 1998a), thematic analysis can be modified for pictorial inscriptions including chemical inscriptions. Verbally, thematic analysis examines the words used and the semantic relationships between words, regardless of the forms used to express them. This particular pattern of words and relationships is a thematic pattern, a network of semantic relationships between and among the commonly expressed and discussed ideas of a particular subject (Lemke, 1990). As I described in Chapter 4, even though chemical inscriptions are not a language, they do carry many of the same types of meaning as verbal texts. Thus, the adaptation of thematic analysis for visual representations can provide us with similar information regarding a student’s conceptions as an analysis of a verbal description. The novel adaptation of these techniques to visual representations is not meant to replace the analysis of verbal texts, but supplement it.

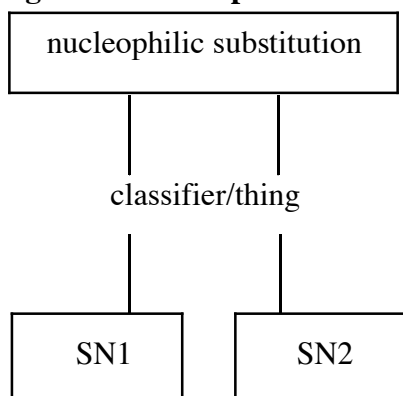
The method of thematic analysis consists of five steps:

- 1) transcription of pictorial elements into verbal descriptions,
- 2) translation of verbal descriptions into canonical chemical themes,
- 3) coding the translations,
- 4) creating thematic maps, and
- 5) comparing thematic maps.

Taken together, these five steps ultimately allow the identification of important themes and their relationships in a particular inscription. For example, a verbal theme that is

communicated in introductory organic chemistry classes is “nucleophilic substitution.” This “phrase” is a theme because it describes a particular concept common across lectures, textbooks, and assessments regardless of which organic chemistry classroom one might visit. The theme of “nucleophilic substitution” is related to two other themes, “S<sub>N</sub>2” and “S<sub>N</sub>1.” These themes are types of nucleophilic substitutions and within any organic chemistry class would always be related to the theme of nucleophilic substitution in the same way, as classes of substitution reactions. These relationships then form a very simple thematic pattern shown schematically in Figure 18. The particular words involved are not important; it is the pattern that students are taught. So, instead of using the abbreviation “S<sub>N</sub>2,” an instructor may say “bimolecular nucleophilic substitution.” The specific phrase used is not important because it is the thematic pattern that carries the presentational meaning.

**Figure 18. A simple thematic pattern.**

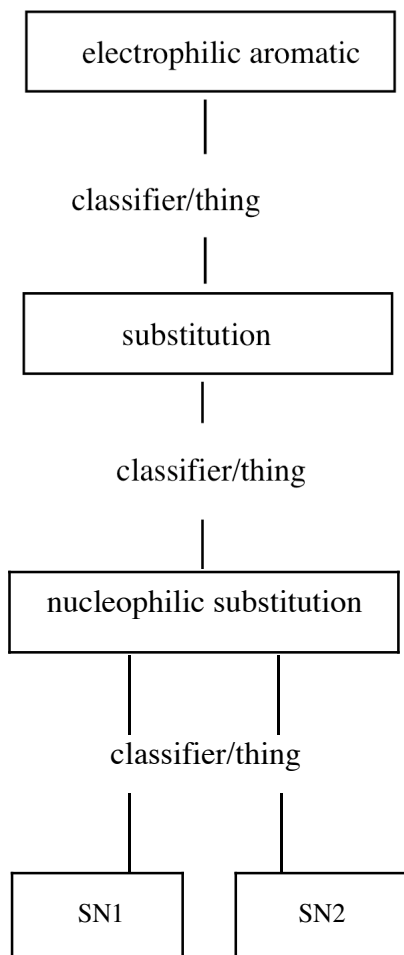


As the students progress in their studies, they will learn about another kind of substitution, the electrophilic aromatic substitution. The thematic pattern will be further elaborated as shown in Figure 19. As the class continues, the instructor and textbook will further complicate the pattern with more themes and more relationships as together they reconstruct the patterns of organic chemistry.



As with the features used by students, one thematic pattern is not especially interesting. However, in comparing the thematic patterns of one student with others, comparing the thematic patterns of the students with the teacher, or with the textbook, may provide important and interesting insights into how these patterns are constructed.

**Figure 19. An elaborated thematic pattern.**



As described above, thematic analysis was developed for use in examining verbal texts. However, thematic analysis can be used to examine the inscriptions used in chemistry and the relationships between these inscriptions. Though I am using the same categories of semantic relationships described by Lemke (1990), which were developed for words and phrases, these relations also serve as useful descriptors of the relationships

between pictorial symbols. For example, students were asked to answer the following question: “Assuming that your audience is your peers, please draw labeled pictures to explain what occurs on the molecular level when (R)-2-bromopentane ( $C_5H_{11}Br$ ) reacts with sodium cyanide ( $NaCN$ ) using ethanol ( $C_2H_5OH$ ) as the solvent.” A small excerpt of one student’s answer is shown in Figure 20.

**Figure 20. Excerpt of student work.**

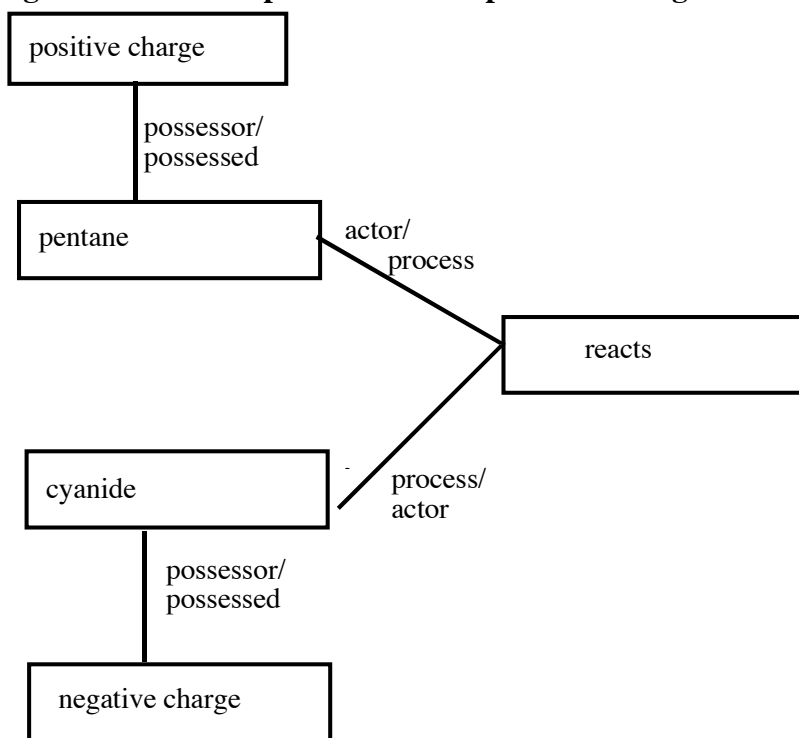


In examining this and several other students’ answers, I saw that the structure of pentane repeats. Also the pentane often was illustrated with a positive charge. Cyanide ions were also illustrated and are often shown with negative charges. Almost all students used arrows to illustrate the change in connectivity or formal bonding convention, a common method of illustrating reactions in the field of organic chemistry. Pictorially these items (pentane, charges, arrows showing reactions, and cyanide) are themes that are used repeatedly in students’ answers to this particular question and students illustrated a small number of relationships between these themes. A thematic pattern for the excerpt of student work in Figure 20 is shown schematically in Figure 21.

Notice that in thematic analysis, we are not concerned with how the pentane molecule is drawn. That information is captured by the features analysis but is not important to the thematic analysis because it does not affect the presentational meaning represented. A structural picture can be drawn of pentane, omitting the carbon and hydrogen atoms, as shown in Figure 20, or the student could write in all of the atom labels. Regardless, the theme represented is still “pentane.” The student may or may not

be following “Grossman’s Rule” (2003) to label all of the hydrogen atoms around the reactive center. The decision to follow or not follow this rule provides us information about the pedagogical decisions that the learner is making as they portray information to someone they presume to be an expert (ie. the instructor reading the quiz.) The information provided may be as simple as “I didn’t know I was supposed to follow the rule about showing hydrogen atoms near the reaction center” but it is important to recognize that these representational choices are themselves important carriers of meaning that are open to analysis. Thus the importance of features analysis is that it can be used to analyze orientational meaning.

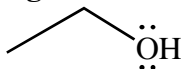
**Figure 21. An excerpt of a thematic pattern for Figure 15.**



In this simple example, it should be obvious that a translation from the pictorial to the verbal was performed between the picture of pentane and the word “pentane.” The method for creating the verbal translations involved creating a verbal transcription of the

pictorial image. In this transcription, I sought to describe the pictorial image, eliminating as much chemical interpretation as possible. This transcription served as a cohesive link between the student's pictorial inscription and the verbal interpretation. One way to perform such a translation would be a detailed description of the drawing itself. For example, a verbal translation of a pictorial inscription of the molecule ethanol (see Figure 22) might be, "a line is drawn from left to right at approximately 30° from horizontal. A second line is drawn at a downward angle of -30° from horizontal, which connects to the upper right end of the first line. At the end of the second line are the letters OH. Two pairs of dots are drawn above and below the O." Such a detailed description would not be useful for thematic analysis because it is the thematic patterns, the network of relationships among the themes, that I am interested in describing; not the ways in which those themes are illustrated. Thus in the transcriptions, standard images of molecules were referred to by their standard names (i.e. "ethanol", Figure 22).

**Figure 22. Ethanol.**



Once the transcription was complete, a translation of the verbal transcription of the pictorial image was created in a second column, parallel to the transcription. This translation allowed us to examine the student's use of inscriptions both from the pictorial text and the verbal transcription. The student's answer to the verbal quiz was also described in this column where it is important or illustrative to do so. The students' pictorial texts, the transcriptions and translations of those images, and the students' verbal texts are included in Appendix A at the end of this paper.

Because my intent is to develop an accurate method of analysis, it is important to have a way to check the accuracy of the verbal translation of the student's inscription. One way to perform such a check is to collect verbal data as well as pictorial data. The verbal data can then be used as a check on the accuracy of the verbal transcriptions created from the pictorial data. Because the students also produced strictly verbal answers to the quiz questions, these verbal answers were used to provide additional evidence that the interpretation of their pictorial text was accurate. For example, one student drew an ethanolic hydroxy group near separated sodium and cyanide ions. This could be interpreted as a picture of an interaction between the ethanol and the ions. The verbal text confirms this interpretation.

A thematic map (Lemke, 1990) was then constructed from the pictorial inscription, the verbal transcription and the verbal translation. All three were used to construct the thematic map in an effort to accurately portray the student's intent. An effort was made to be as conservative as possible in drawing the thematic maps of students' pictorial inscriptions. For example, if the student used or modified drawings originally produced in the quiz question in any way, they are included in the thematic map created for the student's inscription. If the student did not use or modify drawings in their answer, they are not included in the thematic diagram of the student. Simply displaying the original quiz question drawings was not seen to be significant to understanding the student's inscriptions. In addition, if the meaning or interpretation of a student's inscription was unclear, that thematic pattern was not included in the map, unless the student's verbal answer unambiguously clarified the interpretation. A second thematic map was also constructed directly from the student's verbal answers. Any

verbal information contained in the students' pictorial answers was included on the verbal thematic map.

Once thematic maps were created, a small number of maps could simply be compared for similarity or difference by visual inspection. However, once the number of maps exceeded 3 or 4, such a visual comparison was difficult. Instead, computer software was used to examine the similarities between maps. A database and computer program called Comparitor (details in Appendix C) was used to perform the calculation of similarity between networks. Similarity is calculated as a percentage of the number of links shared by two networks compared to the total number of links not shared. Thematic maps can thus be input into a program such as this and compared. There are advantages and disadvantages to the quantitative comparison of these maps. While the Comparitor program can provide similarity data for a large number of maps, the individual differences between the maps is lost. So the large-scale comparisons are useful for large amounts of data or to quickly find important differences among several maps, and then a more detailed comparison of individual maps can be performed to discover the detailed differences if desired.

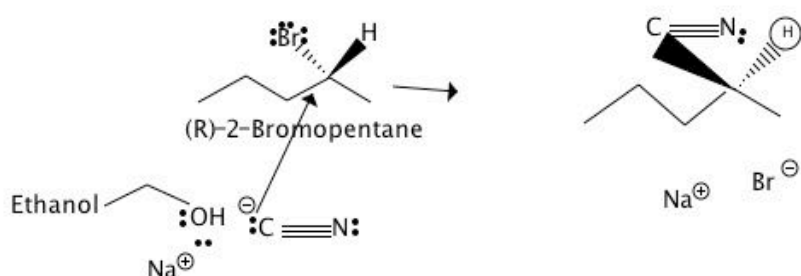
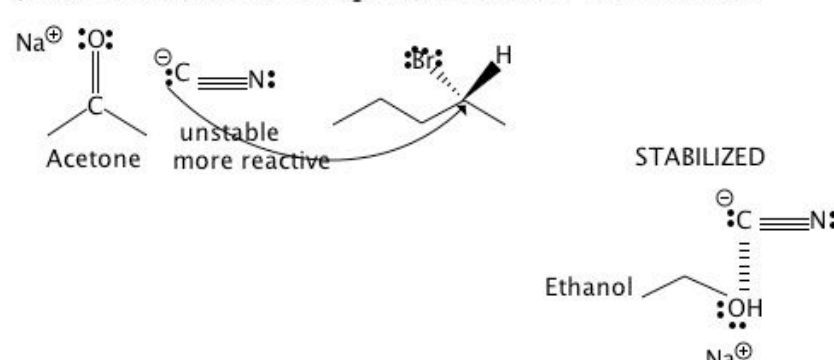
To summarize this procedure, there are five steps in conducting a thematic analysis of a pictorial inscription:

1. transcription of pictorial elements into verbal descriptions,
2. translation of verbal descriptions into canonical chemical themes,
3. coding the translations,
4. creating thematic maps, and
5. comparing thematic maps.

*Thematic Analysis – Step 1: Transcription of pictorial elements*

The thematic analysis of students' pictorial inscriptions in chemistry begins with a translation from pictures to words. Our thematic maps show the thematic formations that are symbolized by words. Themes could instead be symbolized using pictures. However, any computer analysis of similarity would be significantly more difficult using pictures. In addition, Lemke's work on thematic analysis (Lemke, 1983, 1990) was originally developed for verbal data. Thus themes are symbolized as words rather than pictures. The first step in the analysis involves creating a verbal transcription that describes the student-generated picture. In this transcription, the picture is described as clearly as possible while removing as much content — in this case chemistry content — as possible. The transcription of Figure 14 is shown in Table 5.

**Table 5. Verbal transcription of Figure 14.**

<p>1. Assuming that your audience is your peers, please draw labeled pictures to explain what occurs on the molecular level when (R)-2-bromopentane (<math>C_5H_{11}Br</math>) reacts with sodium cyanide (NaCN) using ethanol as the solvent.</p>  <p>2. Explain why the <math>S_N2</math> products of the reaction in #1 are formed faster if the solvent is switched to acetone.</p> 	
<b>Verbal Transcription</b>	<b>Translation/Interpretation</b>
<p>The verbal portion of the first question is shown at the top of the text.</p>	
<p>Beneath the text is a labeled molecular drawing of (R)-2-bromopentane. To the right is a rightward facing arrow. To the right of the arrow is a molecular drawing of (S)-2-cyanopentane. Beneath the (S)-2-cyanopentane is Na with a plus sign slightly above and to the right, and Br with a minus sign slightly above and to the right.</p>	
<p>Below the (R)-2-bromopentane is drawn a labeled molecular drawing of ethanol. To the right of the ethanol drawing is a</p>	



<p>picture of cyanide with a minus sign slightly above and to the left of the C. There is an arrow pointing from the electron dots on the C toward the 2<sup>nd</sup> carbon of pentane. Below the O of ethanol is drawn an Na with a plus sign slightly above and to the right.</p>	
<p>The text of the second question is shown in the approximate middle of the text.</p>	
<p>Below the text of the second question is a labeled molecular drawing of acetone. To the left of the O of acetone is Na with a plus sign slightly above and to the right. To the right of the acetone drawing is a picture of the cyanide with a minus sign slightly above and to the left of the C. To the right of the cyanide is a molecular drawing of (R)-2-bromopentane.</p>	
<p>There is an arrow drawn from the dots on C of cyanide toward the 2<sup>nd</sup> carbon on the (R)-2-bromopentane.</p>	
<p>The words “unstable more reactive” are written underneath the cyanide.</p>	
<p>In the lower right corner of the text is a labeled molecular picture of ethanol. Above the ethanol O is a drawing of cyanide with a minus sign slightly above and to the right of the C. There is a dashed line between the C of the cyanide and the O of ethanol. Below the O is an Na with a plus sign</p>	

slightly above and to the right of the Na. Above these drawings is the word “Stabilized”.	
---	--

The transcription shown in Table 5 demonstrates the conventions used. For example, most chemistry content is eliminated from the transcription in order to accurately describe the picture. However, in some situations it is not practical to do so, as we discussed with the ethanol example earlier (Figure 22). Such finely detailed descriptions are not useful for our purposes because they do not add anything to our understanding of the student’s inscription, particularly how the inscription is used to answer the question. Instead, it serves our purposes to use common chemical terminology in those cases. This convention assumes that a student would understand that the drawing of ethanol, for example, is indeed a picture of ethanol. Such an assumption may not be appropriate for every situation. However, in this particular case, the quiz was given eight weeks into the semester after the students had received several lessons on simple nomenclature. Also, ethanol was drawn and labeled in the quiz question itself. Finally, the theme “ethanol” is defined by the properties of ethanol and how it acts and reacts with other molecules. If the student uses the pictorial symbol for ethanol in ways other than conventional understandings of how ethanol behaves, it will not matter how we verbally transcribe “ethanol” because those differences in the relationship between the “ethanol” theme and other themes will become evident in the thematic map.

In other parts of the transcription, we are more specific about what is drawn. For example, we transcribe a portion of the second question as, “Above the ethanol O is a

drawing of cyanide with a minus sign slightly above and to the right of the C. There is a dashed line between the C of the cyanide and the O of ethanol. Below the O is an Na with a plus sign slightly above and to the right of the Na. Above these drawings is the word 'Stabilized'." We include this level of detail in the transcription because there are no conventions for how intermolecular interactions are drawn, nor are any guides given in the quiz question about how students should illustrate intermolecular interactions.

*Thematic Analysis – Step 2: Translation into Canonical Chemical Themes*

After the verbal transcription is created, the information is translated back into a chemical understanding of the pictures drawn. This translation is based primarily on the verbal transcription but also relies on the pictorial diagram. The extra step of creating a verbal transcription from which the translation is based provides an opportunity to insure that the readers are not inferring more information into the drawing than is actually shown by the student. The verbal translation of the transcription shown in Table 5 is shown in Table 6.

**Table 6. Verbal translation of Figure 14.**

<p>1. Assuming that your audience is your peers, please draw labeled pictures to explain what occurs on the molecular level when (R)-2-bromopentane (<math>C_5H_{11}Br</math>) reacts with sodium cyanide (NaCN) using ethanol as the solvent.</p>	
<p>2. Explain why the <math>S_N2</math> products of the reaction in #1 are formed faster if the solvent is switched to acetone.</p>	
<b>Verbal Transcription</b>	<b>Translation/Interpretation</b>
<p>The verbal portion of the first question is shown at the top of the text.</p>	
<p>Beneath the text is a labeled molecular drawing of (R)-2-bromopentane. To the right is a rightward facing arrow. To the right of the arrow is a molecular drawing of (S)-2-cyanopentane. Beneath the (S)-2-cyanopentane is Na with a plus sign slightly above and to the right, and Br with a minus sign slightly above and to the right.</p>	<p>The student shows an <math>S_N2</math> reaction. The student draws the products of the reaction with inversion of configuration.</p>
<p>Below the (R)-2-bromopentane is drawn a labeled molecular drawing of ethanol. To the right of the ethanol drawing is a</p>	<p>Given the drawing in the lower right of the text, the student appears to be drawing the interaction between the solvent, ethanol, the cyanide anion, and the sodium cation.</p>

<p>picture of cyanide with a minus sign slightly above and to the left of the C. There is an arrow pointing from the electron dots on the C toward the 2<sup>nd</sup> carbon of pentane. Below the O of ethanol is drawn an Na with a plus sign slightly above and to the right.</p>	
<p>The text of the second question is shown in the approximate middle of the text.</p>	
<p>Below the text of the second question is a labeled molecular drawing of acetone. To the left of the O of acetone is Na with a plus sign slightly above and to the right. To the right of the acetone drawing is a picture of the cyanide with a minus sign slightly above and to the left of the C. To the right of the cyanide is a molecular drawing of (R)-2-bromopentane.</p>	<p>The student appears to be drawing the interaction between acetone, the cyanide anion, and the sodium cation. This picture mirrors the drawings of the ethanol interaction above and below.</p>
<p>There is an arrow drawn from the dots on C of cyanide toward the 2<sup>nd</sup> carbon on the (R)-2-bromopentane.</p>	<p>The student redraws the S<sub>N</sub>2 reaction in an attempt to explain the interaction between the solvent and the reaction mechanism.</p>
<p>The words “unstable more reactive” are written underneath the cyanide.</p>	<p>These words attempt to explain how the interaction drawn above influences the mechanism of the S<sub>N</sub>2 reaction.</p>
<p>In the lower right corner of the text is a labeled molecular picture of ethanol. Above the ethanol O is a drawing of cyanide with a minus sign slightly above and to the right of the C. There is a dashed line between the C of the cyanide and the O of ethanol. Below the O is an Na with a plus sign</p>	<p>This picture appears to be a drawing the interaction between ethanol, the cyanide anion, and the sodium cation. The word “stabilized” attempts to explain how this interaction does not favor the S<sub>N</sub>2 reaction, though the mechanism of the reaction is not shown.</p>

slightly above and to the right of the Na. Above these drawings is the word “Stabilized”.	
---	--

The verbal translation created from the verbal transcription along with the student’s pictorial inscription is further checked by examining a verbal answer to the quiz question provided by the student. Figure 23 shows the student’s verbal answer to the same quiz question. Our purpose here is not to examine the student work for consistency between the pictorial and verbal inscriptions. It serves only to provide a check on the interpretation of the drawing.

**Figure 23. Student A's verbal answer.**

1. Assuming that your audience is your peers, please describe, using words only, the sequence of events that occurs on the molecular level when (R)-2-bromopentane ( $C_5H_{11}Br$ ) reacts with sodium cyanide (NaCN) using ethanol ( $C_2H_5OH$ ) as the solvent.

The sodium ~~ions~~ and cyanide separate into ~~a~~ their separate ions which are stabilized by the ethanol solvent. The cyano group attaches to the carbon ~~stereocenter~~ center on the side opposite of the bromide. The Bromine then leaves the carbon.

2. Explain why the  $S_N2$  products of the reaction in #1 are formed faster if the solvent is switched to acetone ( $C_3H_6O$ ).

In acetone ~~the~~ products are stabilized more by the cyano group because there is ~~a~~ less solvation with the hydrogen bonding. The cyano group is more reactive in acetone because it is not stabilized by hydrogen bonding as it is in ethanol. The more reactive cyano group interacts with the ~~more~~ bromopentane faster.

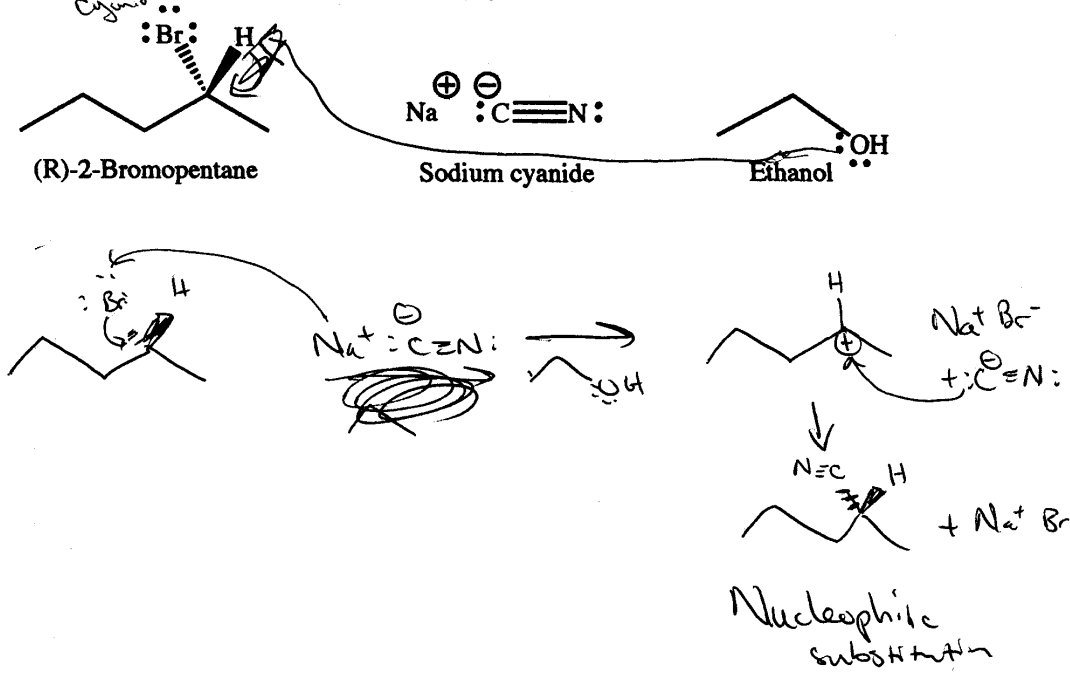
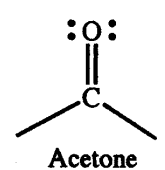
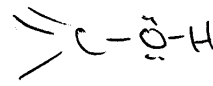
There are three scenarios we may encounter while comparing the students' verbal answers with their pictorial inscriptions. The first scenario is that these two answers may agree and contain the same information. The second scenario is that they contain different information but do not disagree. The third possibility is that they contain different information that disagrees. For example, Student A has drawn stereochemical changes and describes these changes in the verbal answer. We can also imagine an answer in which the student shows stereochemical changes in the pictorial inscription,

but does not discuss those changes verbally. That is, the student does not verbally state that inversion of configuration takes place, nor does the student provide stereochemical labeling of the products in their verbal answer. It is also possible that a student could show inversion of stereochemistry in the pictorial inscription, and either specifically mention retention of configuration in their verbal answer, and/or label the product as the (R) stereoisomer. If there is a conflict between what is drawn and what is written, these conflicts will be evident in the comparison of thematic diagrams created later. We make no attempt to resolve those conflicts, but instead we preserve them so that we may learn something about the interaction between students' pictorial inscriptions and their verbal inscriptions. Even though we are aware that the overlap in meaning between the pictorial and verbal answers may not be complete, this step is another important check on the interpretation of the student's pictorial inscription.

In a second example, Student B's pictorial answer was created using typical pen-and-paper methods and is shown again in Table 7. The procedure is the same for these inscriptions: first create a verbal transcription, and then create a verbal translation of that transcription (Table 7.)



Table 7. Transcription and Translation of Student B's pictorial inscription.

<p>1. Assuming that your audience is your peers, please draw labeled pictures to explain what occurs on the molecular level when (R)-2-bromopentane (<math>C_5H_{11}Br</math>) reacts with sodium ethoxide (<math>C_2H_5ONa</math>) using ethanol (<math>C_2H_5OH</math>) as the solvent.</p>  <p>(R)-2-Bromopentane      Sodium cyanide      Ethanol</p> <p>Nucleophilic substitution</p>	
<p>2. Explain why the <math>S_N2</math> products of the reaction in #1 are formed faster if the solvent is switched to acetone.</p>  <p>Acetone</p> <p>Acetone is more likely to take off the hydrogen in the CBrH location since it stabilizes itself through resonance. By taking the H off <del>more</del> quicker, the cation is formed and the reaction proceeds.</p> 	
<p><b>Verbal Transcription</b></p>	<p><b>Translation/Interpretation</b></p>
<p>The student has altered the drawings given in the quiz question, and provided other drawings in the space below. The student has drawn an arrow from the lone pair of electrons on ethanol to the area of the hydrogen on (R)-2-</p>	<p>Given the way that the arrow is drawn, it isn't possible to discern the student's intent with the first arrow.</p>

bromopentane. However, the student has crossed out the arrowhead end of the arrow.	
In the space below the quiz, the student has redrawn (R)-2-bromopentane and sodium cyanide, including the appropriate charges. An arrow is drawn from the Na of sodium cyanide pointing toward the Br. Another arrow is drawn from the Br to C#2.	The student appears to be showing a reaction between the sodium and the bromide, but does not properly account for electrons.
To the right of the cyanide is drawn a right-pointing arrow, underneath which is a drawing of ethanol. To the right of this arrow is a pentane molecule which is missing the Br, has a + at C#2, and the H is connected with a line rather than a wedge. To the right of the pentane picture and above the CN is drawn NaBr with the appropriate charges.	The student has drawn a carbocation at C#2, and shown NaBr, apparently as a product.
The student redraws the cyanide ion with an arrow pointing toward the + on C#2	The student is showing a reaction between the negatively charged CN and the positively charged C#2.
The student draws an arrow downward from the carbocation pointing toward a picture of (R)-2-cyanopentane. NaBr with charges is drawn to the right of the pentane molecule, a "+" is placed between them. Below these pictures is a label: "Nucleophilic substitution"	The student shows retention of configuration.

Again, the translation is checked against the student's verbal answer, which is shown in

Figure 24.

**Figure 24. Student B's verbal answer.**

The Br is the leaving group of the (R)-2-bromopentane. In the reaction, the Br<sup>-</sup> will be removed and the carbocation will be formed. The :C≡N: group (cyano) will attach to stabilize the carbocation. Therefore, the Br has been replaced by the cyano group, a nucleophilic substitution reaction. The products are (R)-2-cyanopentane and sodium bromide, although S-2-cyanopentane could also exist.

2. Explain why the S<sub>N</sub><sup>2</sup> products of the reaction in #1 are formed faster if the solvent is switched to acetone (C<sub>3</sub>H<sub>6</sub>O).

The acetone more readily deprotonates the C<sub>5</sub>H<sub>11</sub>Br to form a carbocation. This increase, caused since acetone is more basic than C<sub>2</sub>H<sub>5</sub>OH, causes the reaction to proceed at a faster rate. If the carbocation is formed faster, the entire reaction proceeds faster.

In Student B's pictorial inscription (Table 7) we notice that Student B redrew the molecular diagram of (R)-2-bromopentane. Compare this to the work of Student A (Table 6) who cut-and-pasted the original figure from the quiz question and included it in the answer. Some students who used pen-and-paper techniques also did not redraw the molecular diagrams. Instead, they used the pictures already contained in the quiz question and elaborated on those pictures with their own arrows and molecular structures. Differences such as these are captured in the features analysis of the students' work. However, they are only pertinent to the thematic analysis if the use of these diagrams differs in how the themes are presented and/or how they relate to other themes. These differences illustrate the importance of using both a features analysis, which examines how students create their answers, and a thematic analysis, which examines what themes

and relationships are contained in the students' answers, in order to fully examine student work.

*Thematic Analysis – Step 3: Coding the Translations*

Once the verbal translations are created, they are searched and coded for recurring themes. Because themes can be represented by several different possible words or phrases, the coding of themes requires several iterations in order to properly aggregate the synonymous words used in a text, or throughout the texts that have been collected for analysis. For example, the list of themes produced from ten students' answers to the quiz is shown in Table 8.

**Table 8. Themes coded from verbal translations.**

2-amyne [sic] pentane
atom
bond
Br
carbon
charge
CN
compound
configuration
donates
double
electrons
electrophile
enantiomer
ethanol
forms
H
HCN
heterolytic cleavage
inversion
ionic/ion
Leaves/Leaving group/detaches
molecules
Na
NaBr
NaCN

Negatively/Negative  
nucleophile  
opposite side  
partial  
pentane  
pentene  
polar  
positively/Positive  
product  
R (stereochemistry)  
S (stereochemistry)  
reaction  
reacts/attaches/attacks  
replace  
separate  
simultaneously  
S<sub>N</sub>1/Unimolecular Nucleophilic Substitution  
S<sub>N</sub>2/Bimolecular Nucleophilic Substitution  
solvent  
stabilize  
taking  
transition state

Some of these themes are expressly shown by the students' pictorial inscriptions, such as the pictures of (R)-2-bromopentane, or cyanide ions. Others themes must be interpreted from the inscription and from the canonical ways that chemists use certain symbols. An example of such a theme is the "reacts/attaches/attacks" theme. Typically this theme was pictorially expressed by the curved-arrow convention used by organic chemists. The distinction between this theme and the "replace" theme is subtle. The "replace" theme was used when one group replaced another, for instance the replacement of the bromine atom by the cyanide groups, but when no curved arrow notation was provided by the student.

### *Thematic Analysis – Step 4: Creating Thematic Maps*

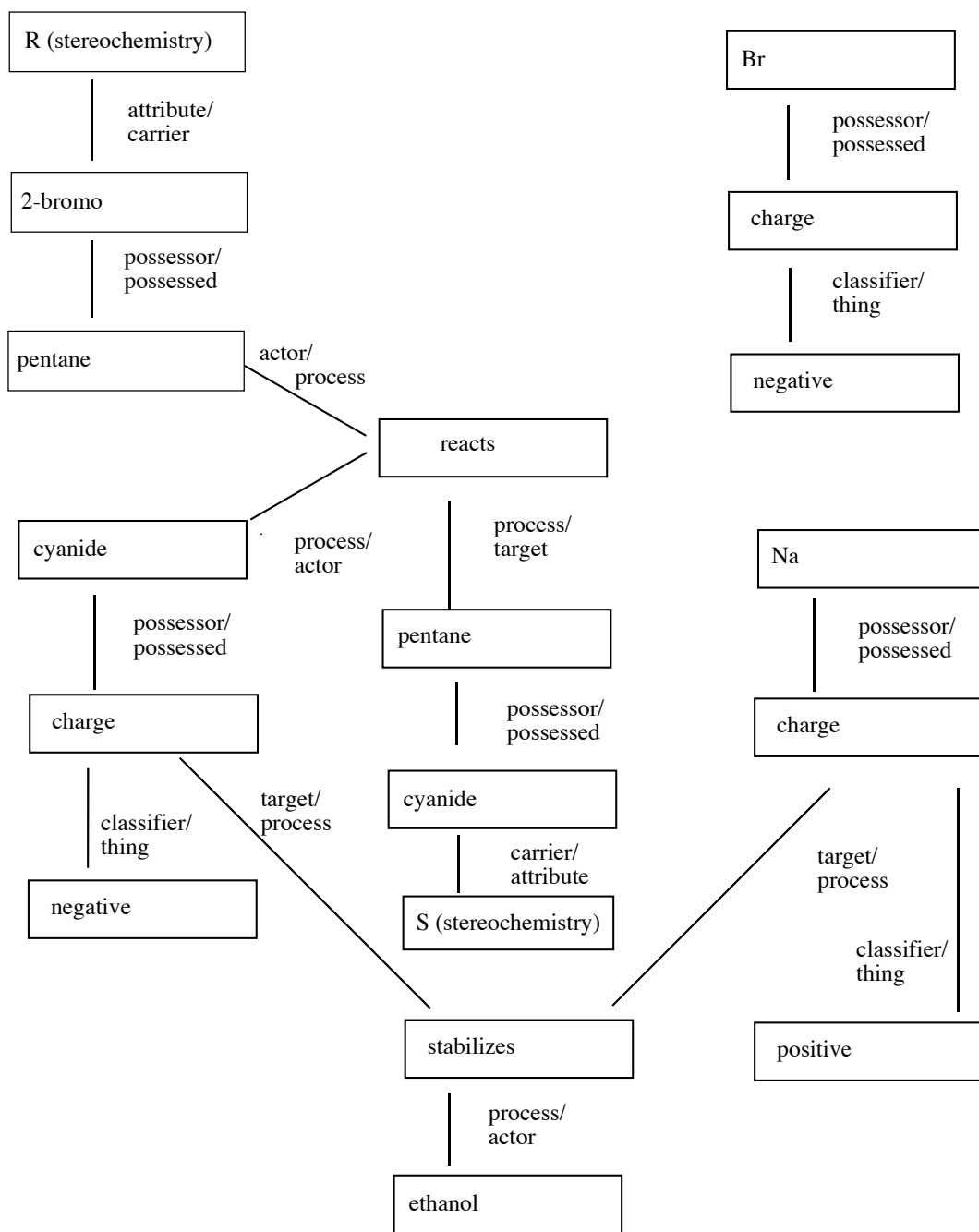
Once a comprehensive list of themes has been created, we examine the verbal translation as well as the original pictorial inscription for the relationships between themes, using a standard set of semantic relationships identified by Lemke (1990). This analysis results in a set of theme-relationship-theme triads. For example in Student A’s work (Figure 14 and Table 6), we see that the sodium atom, symbolized “Na,” is positively charged. The symbol “Na” could, hypothetically, be shown as uncharged, or with a negative charge. Charge itself then can be categorized as either negative or positive. Thus, the sodium atom with a positive charge is not a single thematic entity, but is instead a collection of themes connected by a set of relationships to charge and the type of charge. So, from just this portion of the pictorial inscription we have the set of triads shown in Table 9.

**Table 9. Examples of theme-relationship-theme triads.**

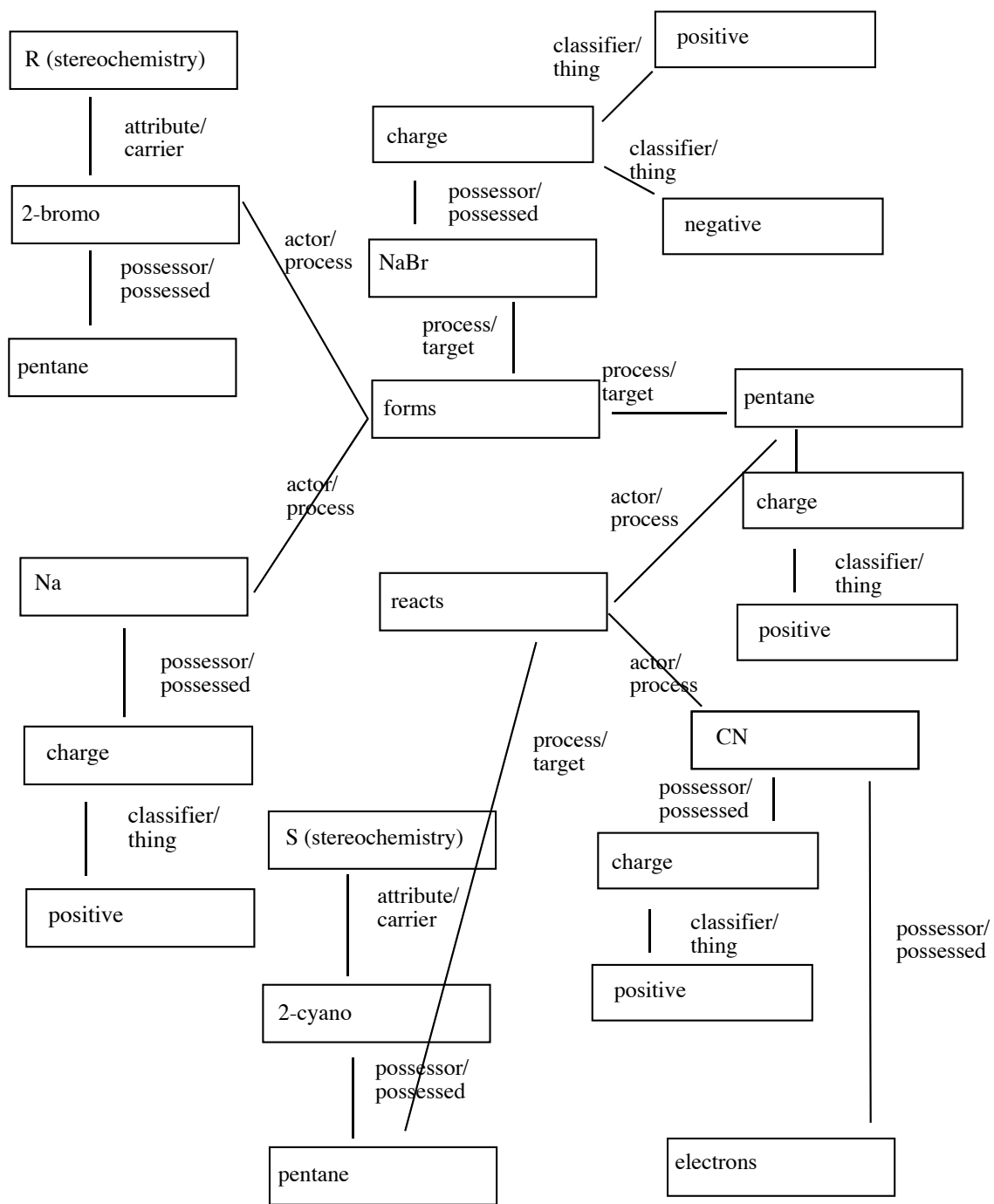
<b>Theme</b>	<b>Relationship</b>	<b>Theme</b>
Sodium	Possessor/possessed	Charge
Charge	Classifier/thing	Charge

As we build up a list of these triads, we can imagine a network structure of all of the themes and their relationships to each other. Such a structure is useful for examining the thematic structure of the student’s text. We refer to these structures as thematic maps, which are meta-representations of the student’s original inscription. For example, when all of the theme-relationship-theme triads we have coded for Student A’s pictorial inscription are shown together, we obtain the map shown in Figure 25 and the thematic map produced from Student B’s pictorial inscription is shown in Figure 26.

**Figure 25. Thematic map created from Student A's pictorial inscription.**



**Figure 26. Thematic map created from Student B's pictorial inscription.**





*Thematic Analysis – Step 5: Comparisons of Thematic Maps*

The thematic maps allow detailed comparisons between student inscriptions. When we compare the thematic maps produced for both students' pictorial inscriptions, we see that there are significant differences in the ways that Student B structured his/her answer. The most obvious difference between these two maps is the significantly higher complexity of Figure 26, which contains many more themes and relationships linking the themes. As we examine detailed differences between the maps, the involvement of the positively charged sodium ion stands out immediately, as does the formation of a positively charged pentane compound. In addition, the formation of sodium bromide is depicted. None of these themes are present in the thematic map created for Student A's work.

However, the real advantage in creating these maps comes not from comparing them two at a time. This is a relatively simple matter for a small number of maps but becomes increasingly complex as the number of maps increases. So the advantage in creating these maps is that, unlike the original inscriptions themselves, they can be compared automatically using computer database software (Schvaneveldt, 1990). The computer analyzes the similarity between two maps based on the following formula:

$$\text{Similarity} = \frac{\# \text{ theme triads in common}}{\# \text{ theme triads total} - \text{ theme triads in common}}$$

in which "theme triad" indicates the theme-relationship-theme triads discussed earlier.

Using this equation, we can calculate the similarity between any two maps. (Appendix C contains a detailed description of the database and computer program used to perform these calculations.) We can also calculate the average similarity of a group of

maps by comparing each of them with the other maps, taken two at a time and averaging each of the resulting similarity values to get an aggregate similarity value for the group.

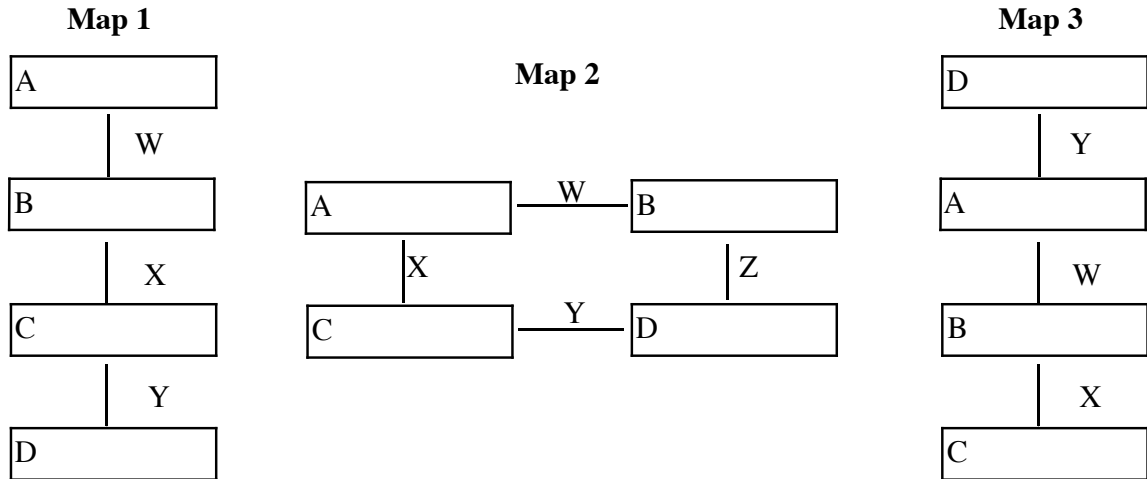
In addition to the calculation of similarity, another measure can also be useful for describing and comparing thematic maps — the complexity. Examining the complexity of a map is a simple matter of looking at the number of themes represented in the map and the total number of links created between those themes.

For example, if we were to compare two hypothetical thematic maps 1 and 2 shown in Figure 27, we would see that they share two triads (AWB and CYD), but they do not share 3 triads (BXC, BZD, AXC). So, their similarity is 40%. However we can also see that the structure of these maps is different and the similarity value does not give us an indication of that difference. However, examining the number of themes and links tells us something more about these maps. In this case, map 1 contains four themes and three links while Map 2 contains 4 links. Thus Map 2 is slightly more complex than Map 1. Obviously, because of the simplicity of these examples, that small difference is negligible, but in larger maps it can provide an important tool for comparison.

The hypothetical maps shown in Figure 27 also provide us with another reason that the complexity measure is useful. We see that rearranging one theme from map 1 to map 3 yields a similarity of 50%. However, we can imagine that for two very large maps, rearranging one theme would not so drastically lower the similarity between them. So, for small maps, small changes can yield larger differences in the percentage of similarity than with large maps. If two maps seem to be highly dissimilar, it may be because they do not share the same themes and relationships, or perhaps they share several themes and relationships but are relatively simple maps. Thus, examining the

complexity of thematic maps can reveal additional information about the similarity results.

**Figure 27. Three hypothetical thematic maps showing different connectivity between the same four themes.**



## SUMMARY

A feature is a verbal description of a particular symbolic form or image used to communicate an idea, and a features analysis is the inventory of all the various symbolic forms or images used to display a concept or set of concepts. The goal of a features analysis is to provide the orientational meaning of students' representations. The process consists of two steps: recording the features used and comparing the features used either between students, or between students and experts.

A theme is a single semantic item that has a particular meaning in a particular field. A thematic analysis is the examination of the themes contained and the relationships between themes that are illustrated in representations. The goal of this analysis is to provide information about thematic frameworks used by students or experts. The analysis consists of five steps: transcription of pictorial elements into verbal

descriptions, translation of verbal descriptions into canonical chemical themes, coding the translations, creating thematic maps, and comparing thematic maps.

## CHAPTER 7: CALIBRATION OF THE THEMATIC ANALYSIS METHOD

While analyzing the similarity of student maps, it would be helpful to have some sense of similarity as a scale. That is, what percentage of similarity might we expect between “highly similar” maps? Or, what percentage of similarity might we expect between “highly dissimilar” maps? Thus, we need the ability to calibrate our methods of thematic analysis.

One mark of experts’ discourse is that they tend to use highly similar thematic constructions to discuss particular topics (Lemke, 1998c, 1999). Therefore, textbooks provide an excellent resource for analyzing highly similar pictorial inscriptions in order to calibrate our methods. A random group of 16 recent editions of these textbooks was examined, from which eight were used in the calibration procedure (Bruice, 1998; Fox & Whitesell, 2004; Hornback, 1998; McMurry, 1992; Smith, 2006; Solomons & Fryhle, 2004; Vollhardt & Schore, 2003; Wade, 2006). These eight textbooks were chosen because they presented organic mechanisms in boxes separate from the verbal text. This organization made the drawings easier to analyze because they depended less on words and discussion in the text for explanation. Four common organic reaction mechanisms were chosen because they were contained in each of the textbooks: radical halogenation, bimolecular nucleophilic substitution, halogen addition to a double bond, and electrophilic aromatic substitution. The standard thematic analysis protocol described

above was used to analyze and compare each of the four mechanisms in each of the textbooks.

The summary of the similarity and complexity data for these comparisons is shown in Table 10.

**Table 10. Average similarity and numbers of links and themes for textbook reaction mechanisms. Numbers in parenthesis are standard deviations.**

Reaction type	Average Similarity	Avg. # of links	Avg. # of themes
Radical halogenation	62% (26)	20	15
Bimolecular nucleophilic substitution	19% (13)	18	16
Addition	45% (26)	16	14
Electrophilic aromatic substitution	50% (18)	22	19

This similarity data shows the utility of the method. Though simply glancing at the surface features of the pictorial inscriptions themselves might yield a false sense of the similarity of the inscriptions, the analysis method reveals underlying differences. The data show that the similarities between expert inscriptions for bimolecular nucleophilic substitution are considerably lower than for the other mechanisms. The lesser degree of similarity between these drawings is due to the fact that the authors included more variety in these mechanisms, such as the inclusion of stereochemical features, transition states and intermediates, than in the other mechanisms. For example, Figure 28 shows the pictorial inscription of a bimolecular nucleophilic substitution reaction from Bruice (1998) and the same mechanism as depicted in Figure 29 from Fox and Whitesell (2004). The verbal transcriptions and translations for these two figures are shown in Appendix A. The thematic maps created for the two figures are shown in Appendix B.

Figure 28. Bimolecular nucleophilic substitution mechanism from Bruice (1998).

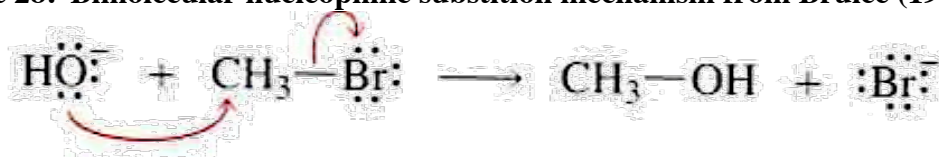
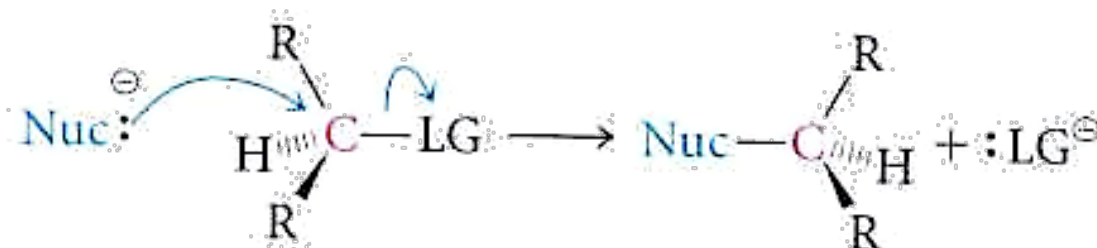


Figure 29. Bimolecular nucleophilic substitution mechanism from Fox and Whitesell (2004).

$\text{S}_{\text{N}}2$  Reaction (for example, LG = Cl, Br, I)



Superficially these two mechanisms look quite similar, however, using thematic analysis methods, their similarity is calculated to be only 8%. The reason for the lack of similarity is that the thematic analysis methods are highly sensitive to the nature of the themes used to generate the thematic maps. In Figure 28 we see that the author used specific ions and compounds in order to demonstrate the mechanism. However, in Figure 29 we see that the authors instead use representations of a generalized nucleophiles and compounds in their inscription. The inclusion of tetrahedral geometry in Figure 29 but not in Figure 28 further decreases the similarity of these two inscriptions. The authors of these texts might assume that they are showing essentially the same reaction. However, reading the first, a learner might assume that only hydroxide anions are capable of working in these reactions. In the second, a reader might assume that “Nuc” and “LG” are elements somewhere on the Periodic Table. Thematic analysis takes these differences into account because the theme “nucleophile” is not the same as the theme “hydroxide anion.” Thus a

difference that might be glossed over by an expert reader can be easily detected using thematic analysis.

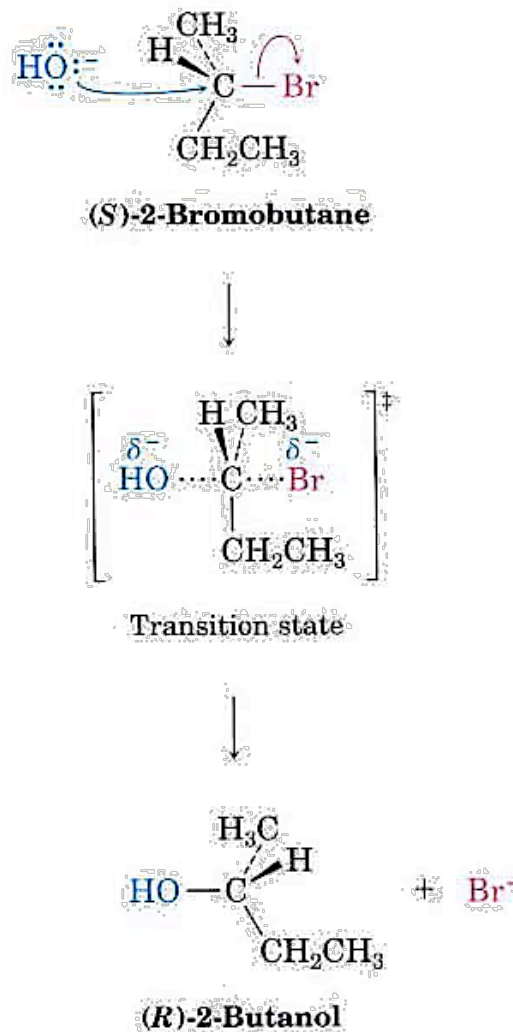
Examining the data for the average number of links and themes also provides some confirmation of the validity of the method. We would predict, for example, that those mechanisms that involve multiple steps would have more themes and links than bimolecular nucleophilic substitution. This is true for two of the multi-step mechanisms but not for the addition mechanisms. However, the addition mechanisms analyzed often did not include stereochemical features, thus decreasing the number of themes and links in the resulting thematic maps as compared with the maps created for bimolecular nucleophilic substitution.



**Figure 30.** Bimolecular nucleophilic substitution mechanism from McMurray (1992).

The nucleophile  $^-OH$  uses its lone-pair electrons to attack the alkyl halide carbon  $180^\circ$  away from the departing halogen. This leads to a transition state with a partially formed C–OH bond and a partially broken C–Br bond.

The stereochemistry at carbon is inverted as the C–OH bond forms fully and the bromide ion departs with the electron pair from the former C–Br bond.



**Figure 11.3** The mechanism of the  $S_N2$  reaction. The reaction takes place in a single step when the incoming nucleophile approaches from a direction  $180^\circ$  away from the departing halide ion. The stereochemistry at carbon is inverted from  $S$  in the starting material to  $R$  in the product.

We can get an appreciation for how these differences affect the similarity measure by making changes in one map and examining the calculated similarities. For example, we chose the inscription of a bimolecular nucleophilic substitution mechanism shown in Figure 30 from McMurry (1992). The verbal translation and transcription of this figure is

shown in Appendix A and the thematic map created for this figure is shown in Appendix B. This is an excellent example because the author uses specific molecules as the nucleophile and electrophile in the reaction. In addition, unlike most of the other authors, McMurry includes a transition state structure and stereochemical information in the mechanism. I modified this inscription to produce four complimentary inscriptions: a bimolecular nucleophilic substitution mechanism with a transition state (the original), the same mechanism without the transition state structure, the same mechanism drawn as if it were a unimolecular nucleophilic substitution in two steps with an intermediate but no transition states, and as a unimolecular nucleophilic substitution mechanism with an intermediate but without the transition states. These inscriptions were analyzed in the usual manner to create thematic maps and those maps were then compared using our similarity measures. The inscriptions, verbal translations and transcriptions are shown in Appendix A and the thematic maps are shown in Appendix B. The results are shown in Table 11. Comparing each map with itself would yield a similarity of 100%, so any reduction in similarity will be due only to the changes we made to the original inscription. The original inscription contained a transition state drawing, so we would expect that removing the transition state drawing from the inscription would decrease the similarity. From the results, we see that removing the transition state drawing from the original inscription yields a similarity of 76%. The original drawing contains a transition state drawing, but no intermediate. So, adding a drawing of an intermediate and removing the transition state should result in even less similarity. From the data, we see that changing the mechanism to a unimolecular-type inscription without a transition state further decreases the similarity to 56%. Addition of transition state structures to that

unimolecular-type inscription with intermediates increases the similarity back to the level we see in the first comparison. We must remember that these comparisons are artificial and are useful only for determining the effect that each change made to the original inscription has on the overall similarity.

We can also compare an actual  $S_N1$  mechanism from the same author with the  $S_N2$  and the  $S_N1$ -like mechanisms we created. The results, also shown in Table 11, follow precisely the predictions we would make for these comparisons. The mechanism used did not contain any transition state drawings. We see a greater similarity between this mechanism and the  $S_N2$  mechanism that did not contain a transition state than with the original drawing that did. We also see greater similarities between the authentic  $S_N1$  mechanism and the two  $S_N1$ -like drawings, the similarity being greater for the drawing that did not include a transition state, as we would expect. Some of the decreased similarity is due to the fact that the actual  $S_N1$  mechanism involved different chemical species, but we can see that the similarity measure does an excellent job of differentiating between the two mechanism types and also differentiates between mechanisms that do or do not contain drawings of transition states and intermediates. Again, these similarity measures must be examined in light of the complexity measures, since the addition of transition state and intermediate drawings increases the complexity of the maps. Thus differences in individual thematic triads are a smaller percentage of the entire map.

**Table 11. Comparison of various versions of S<sub>N</sub>2 and S<sub>N</sub>1 inscriptions based on McMurry (1992).**

	S <sub>N</sub> 2 w/ T-S	S <sub>N</sub> 2 w/o T-S	S <sub>N</sub> 1-like w/ intermediate w/o T-S	S <sub>N</sub> 1-like w/ intermediate w/ T-S	S <sub>N</sub> 1 w/ intermediate
S <sub>N</sub> 2 w/ T-S	100%	76%	56%	77%	9%
S <sub>N</sub> 2 w/o T-S		100%	69%	58%	10%
S <sub>N</sub> 1 w/ intermediate w/o T-S			100%	72%	22%
S <sub>N</sub> 1 w/ intermediate w/ T-S				100%	15%

This analysis demonstrates that the calculated similarity for what should be “highly similar” expert inscriptions will depend a great deal on the amount of detail depicted in the inscriptions, just as predicted. Though the results are variable, we see that a high degree of predicted similarity between expert inscriptions may result in only an approximately 50% calculated similarity for more complicated maps. Thus, our analysis of the similarity of student inscriptions must be guided by the understanding that even a 50% similarity may indicate a high degree of similarity between experts.

## SUMMARY

Because experts, particularly those writing chemistry textbooks, are primarily concerned with using clear and unambiguous canonical inscriptions in order to teach a concept, they should provide a good basis for what constitutes similarity between organic chemistry inscriptions. The application of thematic analysis methods indicates that even a similarity of 50% constitutes a high degree of similarity between expert representations that would be predicted to be highly similar.

## CHAPTER 8: APPLICATION OF THE ANALYSIS METHODS: TESTING

### VALIDITY

In order to evaluate the effectiveness and validity of the methods of features analysis and thematic analysis, I collected student inscriptions from university students in a first semester organic chemistry course. Using these methods to analyze actual student inscriptions allows us to determine whether our design goals are met, namely, we should:

- A) Be able to analyze student-generated inscriptions.
- B) Be able to analyze various types of inscriptions.
- C) Allow the comparison of different types of inscriptions, different styles (e.g. verbal vs. pictorial) as well as those from different individuals with varying levels of expertise.
- D) Provide a fine-grain analysis that goes beyond categorical evaluations of correct and incorrect.
- E) Reveal the underlying structure of the concepts that the inscriptions are designed to illustrate.

In this study I am not interested in evaluating the effectiveness of any particular educational intervention, instead I am taking advantage of particular interventions already in place in order to evaluate the effectiveness of these methods of analysis. I tested the methods on both student-generated pen-and-pencil inscription as well as inscriptions

students created using a computer tool. This will test whether or not we can compare different types of student-generated representations. In addition, I will show that features analysis and thematic analysis will reveal, through a detailed analysis of the inscriptions the underlying structure of the concepts students are conveying. Finally, the use of actual student work will show how these analysis methods can be used both by instructors and researchers to assess student work.

## SAMPLE

The sample consisted of 153 students. Of those, 91 students (59%) were first-year, 56 students (37%) were second-year, and 6 (4%) students were third-year. They were registered in an honors section of an introductory organic chemistry class at a large, Midwestern, research university during the fall semester of 2002. This is a self-selected group of students, participating in this section for honors credit. Non-honors students may also participate in these honors sections if they wish. The majority (97.3%) of these students had previously taken one semester of college chemistry or less. In addition to 3 hourly lectures, one 4-hour laboratory, and one 1-hour recitation section, these students participated in a 2-hour Structured Study Group (SSG) session led by an advanced undergraduate (Coppola, 2001b; Coppola, Daniels, & Pontrello, 2001). The SSG sessions are designed to engage the students with assignments, which deepen and broaden the students' learning of the related course topics. The students then participate in structured peer group critiques of each other's work, facilitated by the advanced undergraduate leader. In the fall of 2002, there were eight SSG groups, and students assigned themselves to a particular group. At the time students register, instructors have not been chosen for any particular time period, so there is little reason for students to sign

up for one group over another other than scheduling, or the desire to take the class with a friend.

Of the eight SSG groups, four were assigned to the ChemSense group and four were assigned to the Traditional group. Students were not aware of the ChemSense or Traditional condition before signing up for the groups. The Traditional groups used pencil-and-paper methods to answer their assignments while the ChemSense groups were provided with 15 networked laptops with a software application called ChemSense Studio (SRI International, 2001) on them to answer some of their assignments and quizzes. ChemSense Studio, a program that supports the creation, sharing, viewing, and editing of text, images, graphs, drawings, and animations of chemical processes, was already being evaluated in the context of its use in SSG groups, so having two groups allowed simple comparisons to be made.

In addition to these students, three additional students who are advanced undergraduates were recruited. All three of these students participated in the SSG groups during their first year of college, and all three of them used ChemSense in their SSG groups. These students had 5 or 6 classes (including laboratory classes) after taking this introductory organic class.

## CHEMSENSE STUDIO

ChemSense Studio (screen capture Figure 31) is an online discussion environment that allows the inscription of chemical concepts using text, HTML, pictures, graphs, molecular structures, and animations (McGinn & Roth, 1999; SRI International, 2001). Developed in collaboration with SRI International and The University of Michigan, the environment is currently being studied for both high school and college student use. The

environment is designed to allow students to explain physical phenomena using any of the various types inscriptions available: text, graphs, HTML, chemical structures, and animations. The discussion environment allows them to share explanations with others, using a variety of inscriptions (Bell & Linn, 2000). In addition, they can comment on others' inscriptions using either verbal or pictorial forms. In addition to these tools, ChemSense allows students to use probeware to import data, which can then be further elaborated by linking to nanoscopic structural inscriptions and verbal descriptions. The ChemSense drawing tools allow students to draw several types of chemical inscriptions such as chemical formulas, structural formulas, ball-and-stick models as either static images or animations.

**Figure 31. ChemSense Studio. (1) The discussion thread area, (2) The main work space showing a University of Michigan student's assignment, (3) A peer review of the assignment, (4) An information window, (5) Building tools.**

The screenshot displays the ChemSense Studio application window. On the left, a 'Discussion Thread' sidebar (1) lists various users and assignments. The main workspace (2) shows three chemical structures labeled Mol 4, Mol 3, and Mol 6, with the title 'Stereocenters with R configuration'. A 'Peer Review' window (3) is open over Mol 4, containing a text review and a 'Build On' button. An information window (4) is open for 'Peer Review -- Liz Gillett', showing creator and modification details. A 'Build' menu (5) is also visible, offering options like Text, HTML, Graph, Image, Drawing, and Animation.



## DATA COLLECTION

The SSG groups serve as a useful means of data collection because, in order to develop, refine, and assess the methods of features and thematic analysis, it is beneficial to collect a large amount of data. In addition, to examine the generalizability of the analysis methods, the data should address several topics in chemistry and should be collected from students using multiple tools for inscription. I collected pictorial data in order to test the methods of analysis, but also verbal data to provide an accuracy check on the pictorial-to-verbal transcriptions described earlier. The students in all sections were given a pretest, two quizzes, and a posttest, which had no bearing on their class grades.

### *Pretest*

In addition to biographical information about the students' prior experiences in chemistry classes, the verbal portion of the pretest consisted of three questions shown in Figure 32.

#### **Figure 32. Verbal portion of the pretest.**

For the following situations, please describe, in your own words, the sequence of events that occur on the molecular level when: (feel free to use the back of this sheet)

- a. 10 milliliters of a 5 Molar solution of hydrochloric acid in water is mixed with 5 milliliters of a 5 Molar solution of sodium hydroxide in water.
- b. 5 grams of solid water (ice) is heated to produce liquid 5 grams of liquid water, which is then heated to produce 5 grams of gaseous water (steam).
- c. 2 liters of ethyl alcohol are mixed with 2 liters of water. (note: this is simply mixing, there is no chemical reaction between water and ethyl alcohol)

These questions were designed to elicit information about how students would represent simple chemical structures or formulas, chemical reactions, phase changes, and mixing, as well as information about how they would represent concentration, and dynamic processes. The pretest was answered by all students in a computer survey environment,

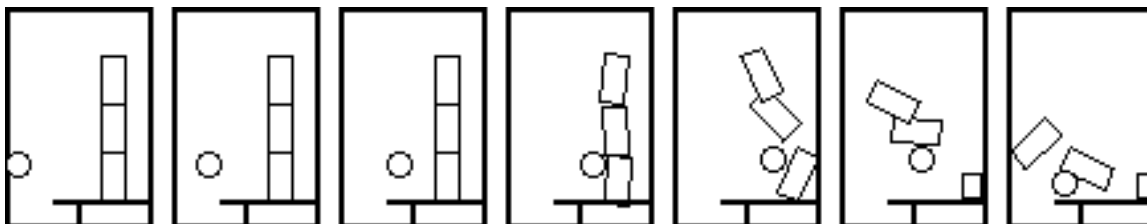
which was being used for other research purposes. The students answered these questions by typing out their answers. The data was then downloaded and saved for analysis. Because the survey was no longer available, the advanced students wrote out their answers by hand.

The pictorial portion of the pretest contained an identical set of questions matched to those asked in the verbal portion and is shown in Figure 33.

**Figure 33. Pictorial portion of the pretest.**

For the following situations, please describe, with labeled pictures, the sequence of events that occur on the molecular level. (**Feel free to use the back of this sheet** - note, the first one has been completed for you)

A storyboard is a series of snapshots, capturing the relative positions of objects in motion. For example, the storyboard for a ball knocking over three stacked cans might look like this:



Sometimes the pictures speak for themselves, other times they need captions, or annotations, in order to make sense. For example, I might want to say that the first image represents a stack of three empty soup cans stacked on each other while sitting on a tabletop. In from the left hand side comes a piece a balled-up play-dough tossed by your younger brother. In the next three images, the play-dough gets closer and closer to the stack of cans until it finally hits the top of the lowest can and disrupts the stack. The forward momentum of the ball is halted by the collision, and the top two cans topple down on top of the ball.

- a. 10 milliliters of a 5 Molar solution of hydrochloric acid in water is mixed with 5 milliliters of a 5 Molar solution of sodium hydroxide in water.
- b. 5 grams of solid water (ice) is heated to produce liquid 5 grams of liquid water, which is then heated to produce 5 grams of gaseous water (steam).
- c. 2 liters of ethyl alcohol are mixed with 2 liters of water. (note: this is simply mixing, there is no chemical reaction between water and ethyl alcohol)

In order to assist students in producing inscriptions of dynamic phenomena, the idea of storyboards was presented. Otherwise the questions asked were identical. All students answered these pictorial pretest questions using traditional pencil-and-paper methods. This work was collected for analysis.

### *Week 5 Quiz*

The first quiz was given to all students in the fifth week of the semester. The verbal portion of the quiz is shown in Figure 34.

#### **Figure 34. Verbal portion of the Week 5 Quiz.**

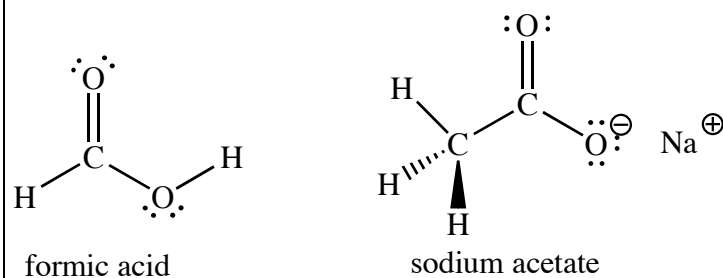
Assuming your audience is your peers, please describe, using words only, what occurs on the molecular level when 6 molecules of formic acid ( $\text{HCOOH}$ ,  $\text{pK}_a = 4$ ) mix with 6 molecules of sodium acetate to form sodium formate and acetic acid ( $\text{CH}_3\text{COOH}$ ,  $\text{pK}_a = 5$ ).

Again, this question was designed to examine how students would represent a simple chemical reaction that includes the idea of dynamic equilibrium. The formulas of both the reactants and the products of the chemical reaction were given in an attempt to separate students' inscriptional abilities from their ability remember the structures and/or predict the products of the reaction. All students answered the verbal portion of the quiz using pencil-and-paper methods. Their work was collected for analysis.

The pictorial portion of the Week 5 Quiz contained the same question, but asked students to answer using labeled pictures and is shown in Figure 35.

**Figure 35. Pictorial portion of the Week 5 Quiz.**

Assuming your audience is your peers, please describe, using labeled pictures, what occurs on the molecular level when 6 molecules of formic acid ( $pK_a = 4$ ) mix with 6 molecules of sodium acetate to form sodium formate and acetic acid ( $pK_a = 5$ ).



In addition, the pictorial portion contained structural drawings of formic acid and sodium acetate but did not contain the chemical formulas of the reactants or products. Students in the Traditional group used pencil-and-paper to answer the pictorial quiz questions. Students in the ChemSense and the Advanced group answered the question using ChemSense Studio. This work was downloaded and saved for analysis.

*Week 8 Quiz*

The verbal portion of the Week 8 Quiz is shown in Figure 36.

**Figure 36. Verbal portion of the Week 8 Quiz.**

1. Assuming that your audience is your peers, please describe, using words only, the sequence of events that occurs on the molecular level when (R)-2-bromopentane ( $C_5H_{11}Br$ ) reacts with sodium cyanide ( $NaCN$ ) using ethanol ( $C_2H_5OH$ ) as the solvent.
2. Explain why the  $S_N2$  products of the reaction in #1 are formed faster if the solvent is switched to acetone ( $C_3H_6O$ ).

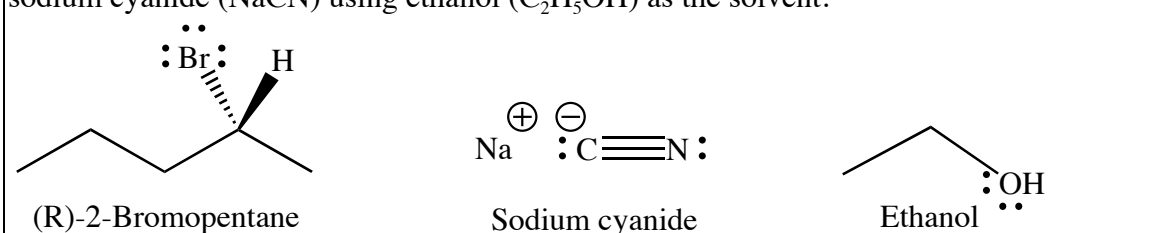
This quiz was designed to elicit inscriptions that included ideas of solvation, stereochemistry, geometry, and the dynamic nature of chemical reactions. Again, chemical formulas were given in order to increase the likelihood that students' answers were less influenced by their ability to use nomenclature rules to decide on the structures of compounds. However, the formulas of the products were not given in order to elicit a

greater variety of correct and incorrect answers. All students answered these questions using pen-and-paper methods and their quizzes were collected for analysis.

The pictorial portion of the quiz (Figure 37) again contained the same question, worded slightly differently to elicit labeled pictures and included structural diagrams of the reactants and the solvents. However, this time I did not include pictures or formulas of the products because I was interested in seeing a greater variety of correct and incorrect structures produced by the students.

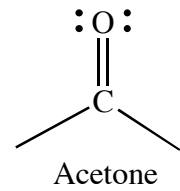
**Figure 37. Pictorial portion of the Week 8 Quiz.**

1. Assuming that your audience is your peers, please draw labeled pictures to explain what occurs on the molecular level when (R)-2-bromopentane ( $C_5H_{11}Br$ ) reacts with sodium cyanide ( $NaCN$ ) using ethanol ( $C_2H_5OH$ ) as the solvent.

The figure shows three chemical structures. On the left is (R)-2-bromopentane, a five-carbon chain with a bromine atom on the second carbon, shown with a wedge bond to the right and a dashed bond to the left. In the middle is sodium cyanide, consisting of a sodium cation (Na+) and a cyanide anion (C≡N-). On the right is ethanol, a two-carbon chain with a hydroxyl group (-OH) on the second carbon, shown with a wedge bond to the right and a dashed bond to the left.

(R)-2-Bromopentane                      Sodium cyanide                      Ethanol

2. Explain why the  $S_N2$  products of the reaction in #1 are formed faster if the solvent is switched to acetone.

The figure shows the chemical structure of acetone, which is a central carbon atom double-bonded to an oxygen atom and single-bonded to two other carbon atoms.

Acetone

The Traditional group answered the quiz using pencil and paper methods and the quizzes were collected for analysis. The ChemSense group and the Advanced Group answered the quiz using ChemSense Studio and their answers were downloaded and saved for analysis.

### *Posttest*

The posttest consisted of the same questions as the pretest and included both the verbal and pictorial portion. However, the additional information about storyboards was not presented in the posttest. All students answered the posttest using paper-and-pencil methods. However, some of the ChemSense sections were not given a posttest because of a difficulty in scheduling. There was no reason for the Advanced students to complete a posttest as the pretest and two quizzes were given over the same one hour time frame. Table 12 presents a summary of the all the data collected.

Of the data collected, features analysis was performed for all students' inscriptions for both the verbal and pictorial pretest. From the results of this features analysis, students were randomly chosen from those who used an average number of features on the pictorial pretest. Five were randomly chosen from the ChemSense group, five from the Traditional group, and all of the Advanced students were chosen. The week 8 quiz inscriptions, both verbal and pictorial, from those thirteen students were chosen to analyze using thematic analysis. A summary which data was analyzed using the two methods is shown in Table 13.

**Table 12. Summary of data collected.**

	<b>Traditional (n=82)</b>	<b>ChemSense (n=70)</b>	<b>Advanced (n=3)</b>
<b>Pictorial</b> <b>Verbal</b>	<b>Pretest</b> paper & pencil computer survey	<b>Pretest</b> paper & pencil computer survey	<b>Pretest</b> paper & pencil paper & pencil
<b>Pictorial</b> <b>Verbal</b>	<b>Quiz Week 5</b> paper & pencil paper & pencil	<b>Quiz Week 5</b> ChemSense paper & pencil	<b>Quiz Week 5</b> ChemSense paper & pencil
<b>Pictorial</b> <b>Verbal</b>	<b>Quiz Week 8</b> paper & pencil paper & pencil	<b>Quiz Week 8</b> ChemSense paper & pencil	<b>Quiz Week 8</b> ChemSense paper & pencil
<b>Pictorial</b> <b>Verbal</b>	<b>Posttest</b> paper & pencil paper & pencil	<b>Posttest</b> paper & pencil paper & pencil	

**Table 13. A summary of the analyses performed on the selected data.**

<b>Data</b>	<b>Analysis performed</b>	<b>Performed on</b>
<ul style="list-style-type: none"> <li>• Pictorial pretest</li> <li>• Verbal pretest</li> </ul>	Features analysis	All student data
<ul style="list-style-type: none"> <li>• Verbal Quiz Week 8 quiz question</li> <li>• Pictorial Quiz Week 8 quiz question</li> <li>• Verbal Quiz Week 8 student inscriptions</li> <li>• Pictorial Quiz Week 8 student inscriptions</li> <li>• Verbal textbook inscription of a comparable reaction</li> <li>• Pictorial textbook inscription of a comparable reaction</li> </ul>	Thematic analysis	<ul style="list-style-type: none"> <li>• Verbal Quiz Week 8 quiz question</li> <li>• Pictorial Quiz Week 8 quiz question</li> <li>• Verbal Quiz Week 8 student inscriptions for               <ol style="list-style-type: none"> <li>1) 5 randomly chosen ChemSense students with an average number of features based on the features analysis results from the pictorial pretest,</li> <li>2) 5 randomly chosen Traditional students with an average number of features based on the features analysis results from the pictorial pretest,</li> <li>3) 3 Advanced students</li> </ol> </li> <li>• Pictorial Quiz Week 8 student inscriptions for the same 5 ChemSense, 5 Traditional and 3 Advanced students described above</li> <li>• Verbal textbook inscription of a comparable reaction</li> <li>• Pictorial textbook inscription of a comparable reaction</li> </ul>

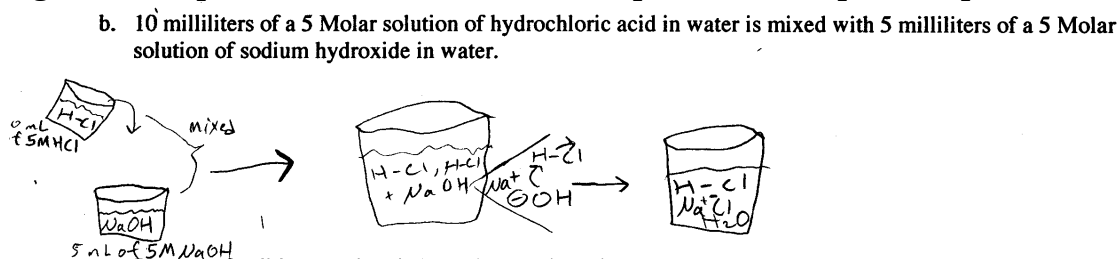


## CHAPTER 9: RESULTS

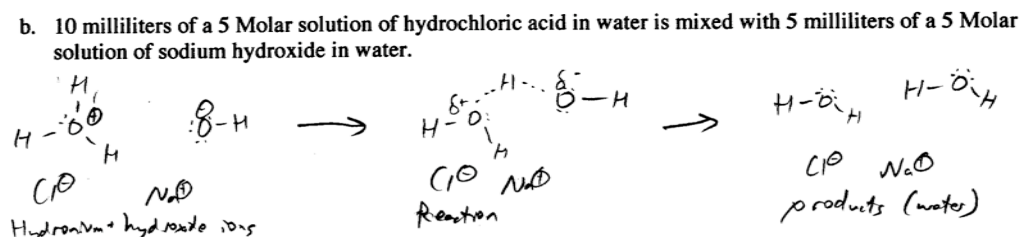
### FEATURES ANALYSIS

All student pretests were analyzed using a features analysis. The feature categories were developed using the student pretests as a guide. A feature was added to this list even if only one student used it once. Table 14 contains a list of some of the feature categories used to code the data. All features used by each student were tallied and comparisons were made between the Traditional group, the ChemSense Group and the Advanced group. It is important to emphasize again that these comparisons are not made in order to evaluate the SSG environment or the ChemSense Studio software. Instead, I make these comparisons to evaluate the method of features analysis. Any similarities or differences between the groups should be due to the medium used to answer the questions or the experience level of the student. The question is not whether there are similarities or differences, but whether or not the method can detect similarities and differences and whether they are rationally explainable based on the differences between the groups.

**Figure 38. Representative student work example B from the pictorial pretest.**



**Figure 39. Representative student work example B from the pictorial pretest.**



Consider the examples of student work shown in Figure 38 and Figure 39. The differences in the features used should be obvious. One student clearly illustrates macroscopic mixing of two solutions, yet at the same time overlays those images with inscriptions illustrating the molecular scale. The other student shows no macroscopic image at all, but does use features like lines to show solvation and labels to show products. As I discussed in the introduction, many chemistry students have difficulty relating the nanoscopic world of chemistry with the macroscopic world of their experience. A features analysis examining the use of both nanoscopic-level depictions or macroscopic-level depictions, or the codeployment of both can quickly and easily allow comparisons between students in order to answer either instructional questions or research questions. Features analysis can also provide an inventory of the sorts of inscriptions students use more frequently and those they use less frequently. For example, while 135 out of 167 students (81%) used some sort of representation of the

nanoscopic level, only 11 students (6.5%) used some sort of representation that illustrated an attraction between ions in solution, such as the dotted lines and partial polarity indications we see in Figure 39.

One could form several hypotheses about why students who used nanoscopic-level representations on their pretest did not use features that illustrate polarity in solution. Perhaps these sorts of features were unfamiliar. Or perhaps the students are making a particular decision about what aspects of the mixing in solution to show and what not to show. The benefit of the features analysis is that it quickly and easily points out these differences for further investigation for instructors or researchers. If an instructor were teaching about the polarity of solutions or a researcher were examining student understandings of the polarity of solutions, a features analysis can give a fine-grained analysis of the sorts of inscriptional forms students do and do not use consistently. Again, this analysis does not tell us whether they are using these forms correctly but only if they use them and how often, and whether students in different classes, or being exposed to different educational interventions use them equally. If one aspect of expertise is knowing when it is most appropriate to use a particular representational form (Lemke, 1998c, 1999), then a features analysis could also be used to compare expert and student inscriptions to examine how expert-like the students' facility is with certain inscriptional forms.

**Table 14. Examples of verbal and pictorial features for Question #1.**

•Verbal Features

- Mention of specific type of reaction (i.e. acid/base).
- Identification of acid and base (i.e. NaOH is the base).
- Discussion of electron exchange amongst atoms.
- Importance of limiting reagent.
- Give exact amount of each molecule.
- Declaration of specific product.
- Use of periodic table abbreviations (i.e. NaOH).
- General use of scientific terms to answer the question.

•Pictorial Features

- Used an inscription to show a macroscale process.
- Used an inscription to show a nanoscale process.
- Showed labeled containers.
- Represented reaction as contents of 2 containers being mixed.
- “neutralization” label used.
- Represented hydrochloric acid as “HCl”.
- Represented sodium hydroxide as “NaOH”.
- Represented hydroxide ion as “OH<sup>-</sup>”.
- Represented water as “H<sub>2</sub>O”.
- Represented hydronium ion as H<sub>3</sub>O<sup>+</sup>
- Labeled volumes of solutions.

The results of the features analysis of the pretests are shown in Table 15. The features analysis demonstrates that there are no differences between the Traditional group and the ChemSense group based on the average number of features used to answer the pretest questions for either the verbal or the pictorial portions of the pretest. There is also no significant difference between the average number of features used by the Advanced group and the two other groups on two of the questions. However one question, the mixing question, did show a statistically significant difference between the Advanced group and the other groups, for both the verbal and the pictorial pretests at the  $p=0.05$  level. In addition, there was a statistically significant difference ( $p<0.001$ ) for both the Traditional group and the ChemSense group in the number of features they used for the

acid/base and phase change questions (avg = 15) than the number of features they used for the mixing question (avg = 8) for the pictorial pretest. There was no significant difference in the number of features the Advanced group used for the mixing question vs. the other two questions on the pictorial pretest.

The statistics calculations performed on the features analysis data only provide for comparisons of the average numbers of features used by the students. The calculations do not compare the student groups based on the actual features used by them. So, the features analysis provides a measure of the complexity of the pictorial and verbal forms contained in the students' answers, but not a direct measure of the similarity.

**Table 15. Results of the pretest features analysis.**

	<b>Traditional (T)</b>	<b>ChemSense (C)</b>	<b>Advanced (A)</b>	<b>p A-T</b>	<b>p A-C</b>	<b>p C-T</b>
<b>Pictorial</b>						
Acid/Base (n=65)	avg=15; sd=5 (range=0-24)	avg=16; sd=5 (range=0-30)	avg=15; sd=5 (range=10-20)	0.93	0.81	0.4
Phase Change (n=55)	avg=14; sd=4 (range=3-24)	avg=14; sd=4 (range=5-23)	avg=17; sd=2 (range=16-20)	0.09	0.10	0.8
Mixing (n=49)	avg=8; sd=4 (range=0-15)	avg=8; sd=3 (range=2-14)	avg=12; sd=2 (range=11-14)	0.04	0.04	0.7
<b>Verbal</b>						
Acid/Base (n=8)	avg=4; sd=2 (range=0-7)	avg=4; sd=1 (range=1-7)	avg=4; sd=0 (range=4-4)	0.21	0.20	0.0
Phase Change (n=4)	avg=2; sd=1 (range=0-3)	avg=2; sd=1 (range=0-3)	avg=2; sd=1 (range=1-2)	0.72	0.68	0.8
Mixing (n=7)	avg=2; sd=1 (range=0-4)	avg=2; sd=1 (range=0-4)	avg=1.0; sd=0 (range=1-1)	0.0	0.0	0.5

In order to provide greater consistency in coding, all of the verbal answers were coded by one researcher, while another coded all of the pictorial answers. After a period of training, interrater reliability was checked by randomly selecting a sample of 10% of the verbal and pictorial portions of the pretests. The verbal portions were then recoded by the person who initially coded the pictorial portions and *vice versa*. Because the “Phase Change” question contained only four verbal features, any discrepancy between the raters greatly lowered the agreement between them. However, the interrater

reliability on the verbal coding was 75% for that question. For the “Acid/Base” question, which had the highest number of verbal features, the reliability was 80%. For the pictorial portions of the pretest, which had many more features, the overall reliability was 92%.

## THEMATIC ANALYSIS

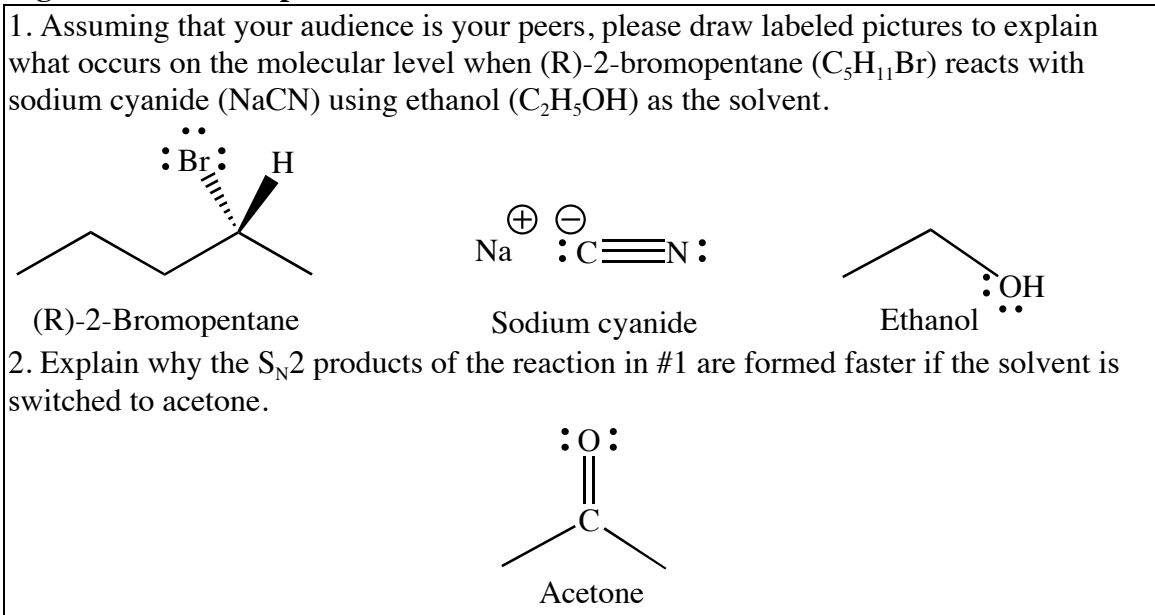
In order to develop and refine a method of pictorial thematic analysis of the students’ work I focused on the second quiz. This quiz came at the eighth week of the semester, after students had considerable practice in using ChemSense Studio and after they had eight weeks of practice in chemistry nomenclature and drawing conventions. Because of these factors, it was assumed that students’ inscriptions would be more canonical, and therefore would make the development of a method of analysis simpler. Once the method is developed and refined, I will apply it to the earlier quiz, the pre- and posttests.

The second quiz, given in Week 8, is shown in Figure 40 and Figure 41. Question number two of the quiz asked students to represent the interactions between the solvent and the reacting species. Because the majority of students either did not finish the second part of the quiz and/or did not answer it correctly, I will initially focus only on the first part of the quiz in order to more easily examine the validity of the analysis methods.

### **Figure 40. Verbal portion of the Week 8 Quiz.**

1. Assuming that your audience is your peers, please describe, using words only, the sequence of events that occurs on the molecular level when (R)-2-bromopentane ( $C_5H_{11}Br$ ) reacts with sodium cyanide ( $NaCN$ ) using ethanol ( $C_2H_5OH$ ) as the solvent.
2. Explain why the  $S_N2$  products of the reaction in #1 are formed faster if the solvent is switched to acetone ( $C_3H_6O$ ).

**Figure 41. Pictorial portion of the Week 8 Quiz.**



All student work for the second quiz was collected from the Traditional, ChemSense, and Advanced groups. Work created on paper was scanned into JPG files, while ChemSense work was captured as JPG files from the server. These files were then copied into Microsoft Word documents. The resulting images are slightly larger than the originals in order to see detail, but are otherwise unaltered. Verbal transcriptions, which eliminate as much chemistry interpretation as possible and simply describe the student's inscription, were created for the pictorial answers. Using the pictorial inscription and these verbal transcriptions, a verbal translation was then made which is an interpretation of the students' answer. Thematic maps were created for the students' pictorial inscriptions using their inscriptions and the verbal transcriptions and translations. Maps were also created directly from their verbal answers to the quiz question. The inscriptions, translation and transcriptions are shown in Appendix A. Appendix B contains the thematic maps created from the students' inscriptions.

The entire process was repeated for 13 students' responses, five from the Traditional group, five from the ChemSense group, and the three from the Advanced group for both the pictorial and verbal quizzes. The Traditional and ChemSense students were randomly chosen from all of the students who used an average number of features in their pretest according to the features analysis data.

In addition to these thematic analyses, a thematic analysis was also performed on pictorial and verbal inscriptions in the textbook used by the students (Ege, 1999) and thematic maps were created. A section of text was selected from the chapter summary that addressed the same topics addressed in the Week 8 Quiz. Though this summary addressed the same topics, it did not use specific chemical examples used in the quiz question. A textbook pictorial summary was also analyzed using the same methods outlined above. Though this pictorial summary was more specific than the verbal summary, it did not use the same specific examples as the Week 8 Quiz.



Figure 42. Four student inscriptions answering the Week 8 Quiz question, along with the thematic analysis calculation of their similarity.

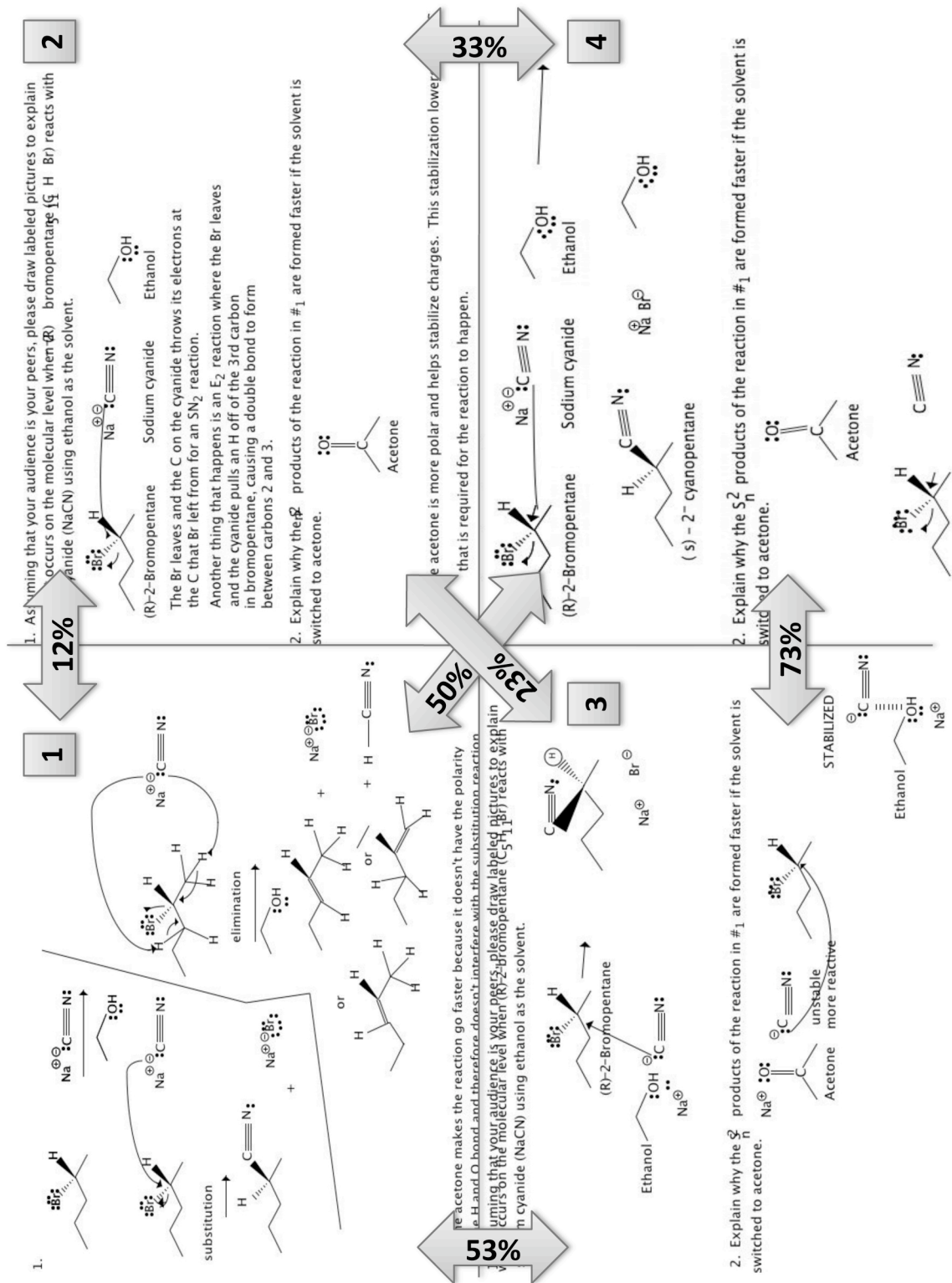


Figure 42 shows four examples of student work and the similarity comparisons produced from the thematic maps derived from these inscriptions. Before we begin a more detailed examination of the results of thematic analysis, I would like to demonstrate how the results of thematic analysis make reasonable chemical sense. If we imagine ourselves as a chemistry expert conducting a detailed visual examination of the chemical concepts illustrated by each student's answer, we will see that this inspection corroborates the similarity measures found through thematic analysis. For instance, all of the examples describe either in pictures or words the formation of a substitution product. However, only Examples 1, 3, and 4 also illustrate pictorially or verbally that the product is chiral. Examples 1, 3, and 4 show that the stereochemistry of the product is a result of the inversion of the stereocenter. Only examples 1, 3, and 4 show that sodium bromide is formed in this reaction. In addition, the verbal description in Example 2 describes the bromine atom leaving first, then the nucleophilic attack in an  $S_N1$  fashion, while the picture illustrates the attack and loss happening simultaneously in an  $S_N2$  fashion. Example 1 shows only an  $S_N2$  reaction with the nucleophilic attack and loss of the leaving group happening simultaneously. Example 3 does have a curved arrow that shows loss of the bromine atom. Example 4 shows too many electrons around the oxygen atom. Only Examples 1 and 3 show eight electrons on the bromine anion. Based on this inspection, a chemistry instructor would assume that Examples, 1, 3, and 4 are more similar to each other than to Example 2. This is the same result found by thematic analysis.

In spite of these differences, Example 1 and Example 2 both describe products from an elimination reaction, Example 1 does so pictorially and Example 2 does so

verbally. We would predict, taking into account the differences between these two examples, that Example 1 would be more similar to Example 2 than Example 2 is similar to Example 3, which does not illustrate an elimination reaction. That is the same result found by thematic analysis. Also, Example 3 illustrates solvation of the ions in sodium cyanide by the solvent, an aspect of the reaction that no other example illustrates. That difference, along with the fact that Example 4 does not show the proper Lewis structure for a bromine anion, indicates why Example 1 and Example 4 are more similar than any of the others are to each other. Table 16 shows a summary of the chemical concepts illustrated in each of these examples found through an expert visual inspection.

**Table 16. A summary of the chemical concepts illustrated by the examples shown in Figure 42.**

<b>1</b>	<b>2</b>
Substitution product Stereochemistry Inversion of configuration Carbon on CN as the nucleophile Br loss NaBr 8 electrons on the bromine anion Elimination product Regiochemistry HCN	Substitution product  Carbon on CN as the nucleophile  Elimination product  $S_N1$ -like description
<b>3</b>	<b>4</b>
Substitution product Stereochemistry Inversion of configuration Carbon on CN as the nucleophile  NaBr 8 electrons on the bromine anion  Solvation	Substitution product Stereochemistry Inversion of configuration Carbon on CN as the nucleophile Br Loss NaBr  Too many electrons around oxygen

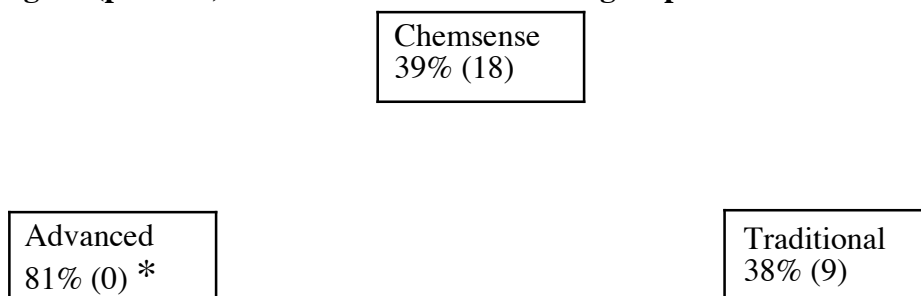
So then, thematic analysis provides information similar to what we might get from a thorough inspection of the student inscriptions by a chemistry expert.

Now that we have a general understanding of the use of thematic analysis to reveal the content of student inscriptions, we will begin to examine the usefulness of thematic analysis when the technique is applied to the data we collected.

In order to demonstrate that thematic analysis can systematically analyze and compare pictorial inscriptions, a thematic analysis was done on the Week 8 Quiz inscriptions produced by the five ChemSense students, the five Traditional students, the three Advanced students, and a pictorial inscription in their textbook that illustrated a comparable  $S_N2$  reaction. The data from the similarity analysis of the pictorial thematic maps is presented in Figure 43. For the ChemSense students, the overall similarity for the thematic maps prepared from their inscriptions was 39% (s. dev = 18). For the Traditional students, the similarity between their maps is 38% (s. dev = 9). For the Advanced students, the similarity is 81% (s. dev = 0), which is statistically significantly higher ( $p=0.001$ ) than the similarity results for the other two student groups. We have already seen in Figure 42 how a thorough examination of individual student inscriptions by a chemistry expert validates the findings of thematic analysis results for the same inscriptions. These results from thematic analysis demonstrate not only that we can systematically analyze and compare pictorial inscriptions within similar student groups but that we can compare those similarities in order to see potential differences between students. In this case, the Advanced student inscriptions are more similar to each other than the ChemSense student inscriptions are similar to each other, or the Traditional

student inscriptions are similar to each other. I am not attempting to explain why we see those differences in similarity between the Advanced students and the novice student inscriptions. Instead, I am pointing out that the differences are real and that the method makes them obvious. A chemistry expert, performing a detailed visual inspection of these inscriptions, might also come to the conclusion that the Advanced students' three inscriptions are more similar than the other two student groups inscriptions. However, a quantitative number describing the similarity allows us to quickly and easily focus on differences between students that might indicate the need for further study.

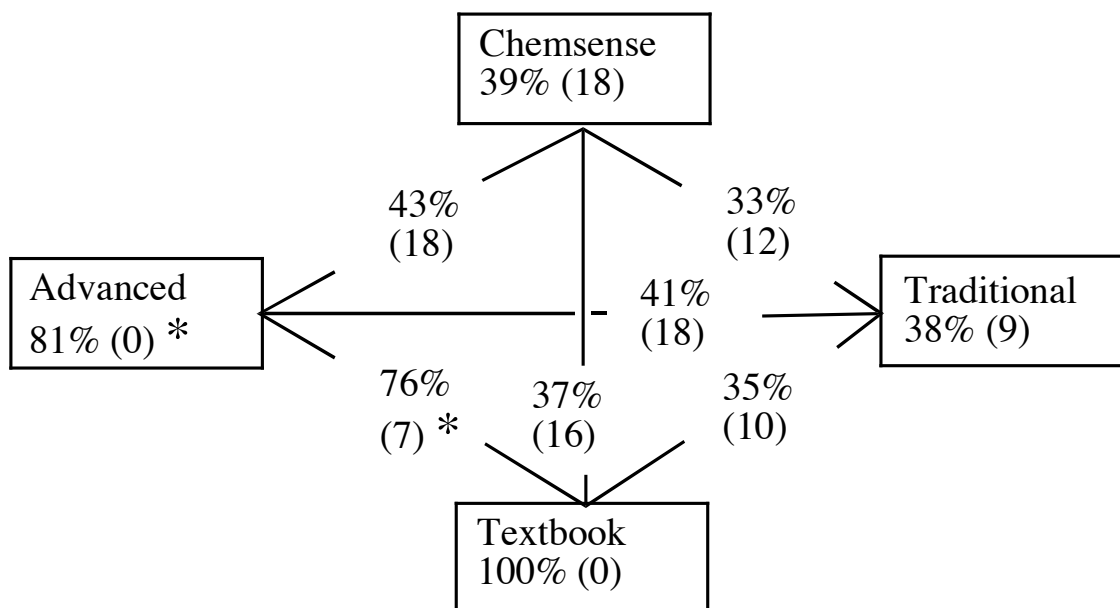
**Figure 43. Similarity measures for the thematic maps created from the pictorial inscriptions of each student group. The Advanced group similarity is significantly higher ( $p=0.001$ ) than the other two student groups.**



We can make two types of comparisons of similarity. As I have just shown we can examine and compare the similarity of the maps created for each member of a particular group with the other members of that group, yielding an internal similarity of that group. However, one of the goals of creating this method is to allow the comparison of inscriptions from individuals with varying levels of expertise. In order to demonstrate the usefulness of thematic analysis for comparing inscriptions from advanced and novice students, we can compare the thematic maps created for the Advanced group with the thematic maps created for the ChemSense group. Both groups used ChemSense to

produce their inscriptions, so the only difference between the groups should be their level of expertise. The results show that the maps from both groups are 43% similar (st. dev. = 18) (Figure 43). We will return to this number in a moment for some insight into what the result can tell us.

**Figure 44. Similarities of thematic maps created from the pictorial inscriptions of all three student groups and their textbook. Numbers in parenthesis indicate standard deviations.**



Another goal of thematic analysis is to provide a method that allows the comparison of inscriptions created using different media. In the case of the Advanced group and the ChemSense group, both groups produced inscriptions using the ChemSense software. However, the students in the Traditional group produced their inscriptions using pencil and paper. Because the Comparitor program is simply comparing themes and relationships in a database, the medium in which the original inscription was created makes no difference in the similarity comparison. Thus we can easily compare the maps created from the ChemSense students' inscriptions with the

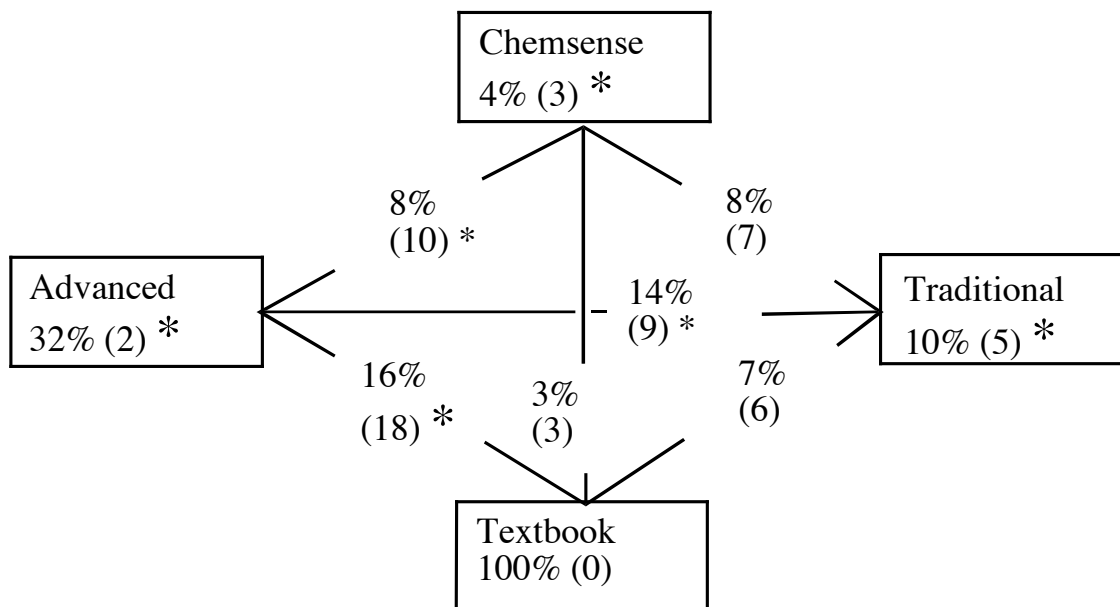
maps created from the Traditional students' inscriptions. In this case, they are 33% (st. dev. = 12) similar. We can make similar comparisons between the Advanced students' maps and the Traditional students' maps (41% similar, st. dev. = 18). Those results are shown in Figure 44.

Returning to the similarity between the Advanced students' maps and the ChemSense students' maps (43% similar, st. dev. = 18) and comparing that to the similarity between the Advanced students' maps and the Traditional students maps (41% similar, st. dev. = 18), and the similarity between the ChemSense students' maps and the Traditional students maps (33% similar, st. dev. = 12), we see that none of the differences in similarity measurements (41% vs. 43% vs. 33%) are statistically significant. One could propose several hypotheses for why there is not a statistically significant difference between the groups, in spite of their differences in experience and in spite of the difference in the medium with which they produced their inscriptions. However, I am not attempting to make such an argument. Instead these results demonstrate that one can compare thematic maps quickly and easily in spite of such differences. If a researcher wanted to do a detailed study on the role of student experience on their inscriptions, these are the sorts of measurements one would need. If a researcher wanted to do a detailed study on the role of a particular educational intervention such as ChemSense on student inscriptions, these are the sorts of measurements that one would need as well. If questions about experience or questions about the changes that result from educational interventions are the sorts of questions researchers are interested in, and we have seen that they are, then thematic analysis can provide another valuable tool for answering those questions.

If we wish to push the method further and attempt to evaluate inscriptions across multiple levels of expertise, we can compare student inscriptions with a pictorial inscription of a comparable reaction from the textbook they used in the course. We see that the Advanced group's pictorial thematic map has a statistically significant ( $p < 0.01$ ) higher degree of similarity with the textbook (76%) than either the ChemSense group (37%) or the Traditional group (35%). However differences in similarity that we see when comparing the ChemSense group with the textbook (37%) and the Traditional group with the textbook (35%) are not statistically significant. One would not want to make a conclusion about the level of expertise that the Advanced students have compared to the novice students based only on the similarity of their inscriptions with one picture in the textbook. What these comparisons show, however, is that student-generated inscriptions can be compared regardless of the level of expertise, regardless of the method of production (e.g. computer vs. pencil-and-paper) and that they can be compared with expert inscriptions as well to yield similarity numbers that make real chemical sense and that could be used to inform research about student inscriptions.

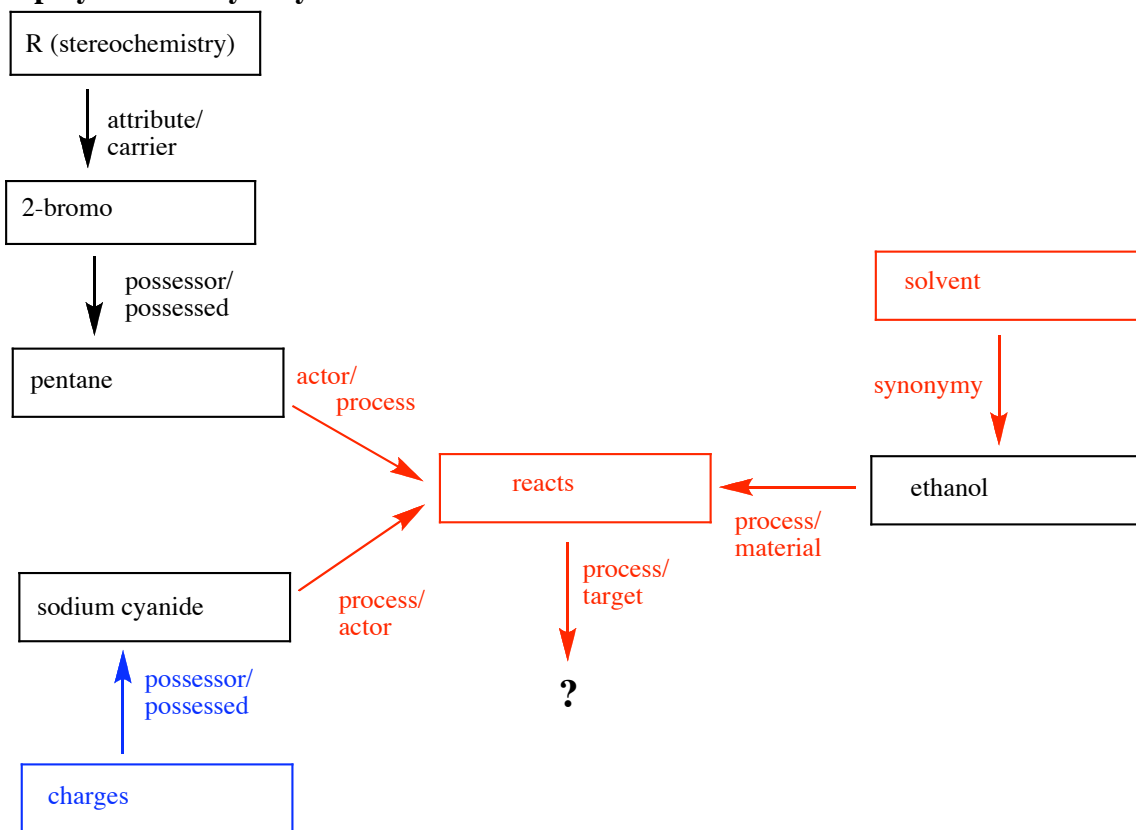


**Figure 45. Similarities of thematic maps created from the verbal inscriptions of all three student groups and their textbook. Numbers in parentheses indicate standard deviations.**



Another expert inscription that we can analyze is the quiz question itself. By comparing the thematic map created from the quiz question with maps created from student answers, we may find important differences from the themes that the question asks about, and the themes students address in their answers. If the quiz contains themes that the students do not use in their answers, it may indicate a misunderstanding on the part of the student, or perhaps a poorly-worded question. The thematic map created for the quiz question is a combined map illustrating the themes represented in both the pictorial and the verbal quiz questions. The map is only partially complete because the question does not contain all of the themes that would be contained in the answer. Because it is only partially complete, a similarity measurement would obviously be low. However, some general comments can be made about how student maps differ from the thematic map created from the quiz question (Figure 46).

**Figure 46. Thematic map created from both the verbal and visual portions of the Week 8 Quiz question. Themes coded in black were present in both the verbal and pictorial portions, themes in red were displayed visually only, themes in blue were displayed verbally only.**



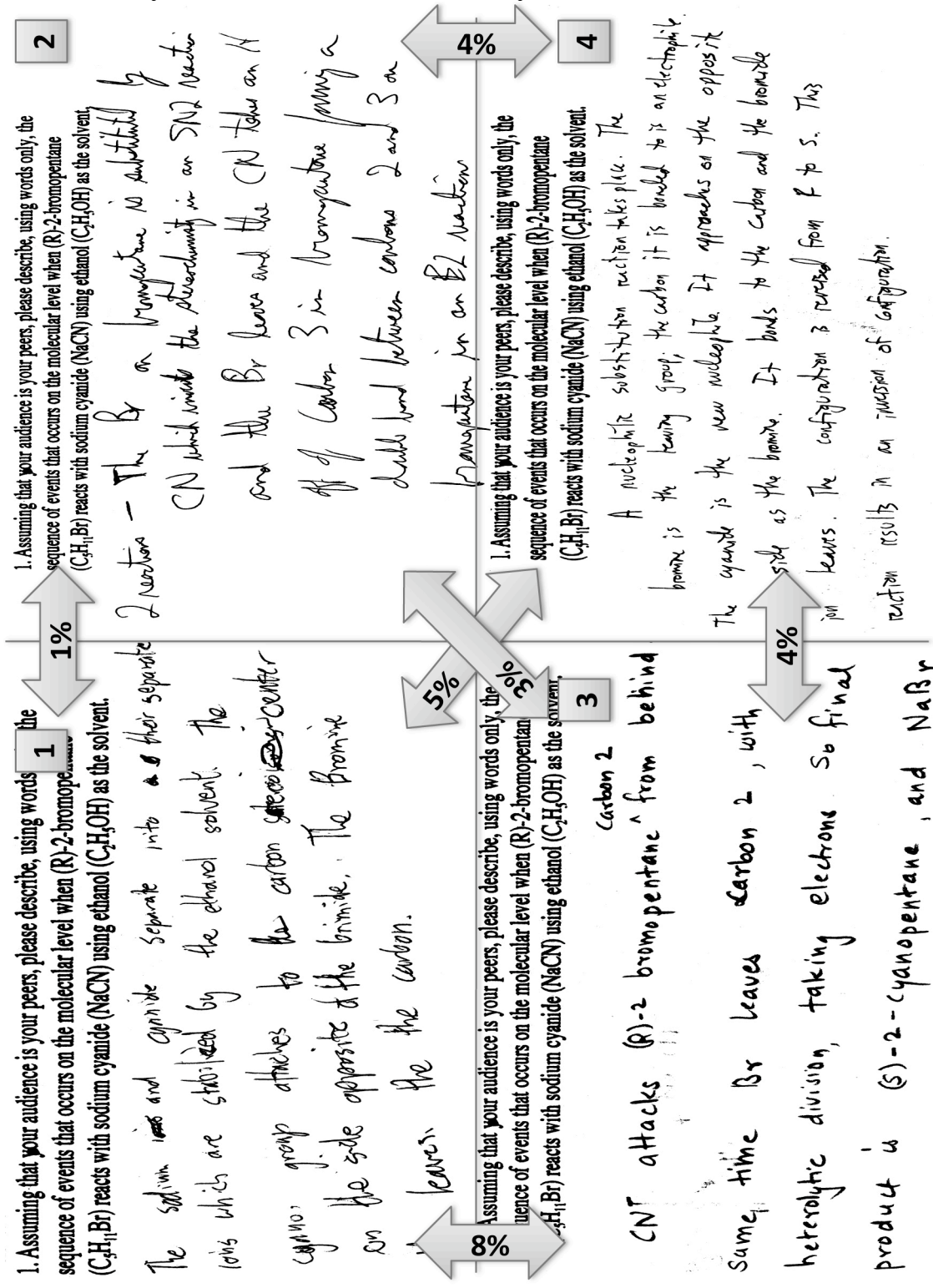
One of the first things that is obvious from examining the thematic map created from the quiz question is that not all of the information displayed pictorially in the quiz was also written verbally. An example is that, although the solvent was drawn and named, the concept of solvation was not mentioned. The question only asks students to describe what happens between the reactants “using ethanol as a solvent.” As we saw in the representative student examples in Figure 42, few students illustrated solvation in their answers. One could develop several hypotheses for why this was the case. However, for our purposes, it indicates that even a rough comparison of thematic maps that does not include the similarity comparison can be useful for finding potential disconnects between student concepts and assessment items.

Another goal for creating the thematic analysis method is that it should be able to analyze not only pictorial inscriptions but other types of inscriptions such as verbal inscriptions as well. Therefore, thematic maps were created for students' verbal inscriptions for the same Week 8 Quiz question. The maps were then compared in the same way that the maps made from the pictorial inscriptions were compared. An examination of the similarity results shown in Figure 45 shows that the similarities within groups' thematic maps of the students in the ChemSense group are 4% (st. dev. = 3), compared with a similarity of 10% (st. dev. = 5) for the maps of the students in the Traditional group and 32% (st. dev. = 2) similarity for the maps of the students in the Advanced group. All of these differences are statistically significant ( $p < 0.001$ ). Remember that, for the thematic maps created for the pictorial inscriptions, only the maps from the Advance group were statistically more similar than the other two groups. We could hypothesize why the verbal inscriptions are more dissimilar than the pictorial inscriptions, but my aim is only to see if I can use the method to see the difference. The method alerts us to a difference that we might be interested in exploring further if we were conducting a study examining the relationship between verbal and pictorial inscriptions.

Examining the between-group comparisons shows that the similarities between the thematic maps created for the Traditional group and the Advanced group (14%) are more similar than the maps created for the ChemSense group and the Advanced group (8%), which is significant at the  $p = 0.05$  level. In addition, comparisons between the student groups and the textbook show a greater similarity for the Advanced group (16%) than the ChemSense group (3%) and the Traditional group (7%). Of these, the only

difference that is statistically significant ( $p < 0.05$ ) is the difference between the Traditional/text comparison and the ChemSense/text comparison. So, as with the pictorial inscriptions, we can compare verbal inscriptions across levels of expertise and regardless of whether the inscription was typed on a computer or written down on paper.

Figure 47. Four student inscriptions from the Week 8 Quiz question, along with the thematic analysis calculation of their similarity.



Let us examine these similarity numbers as a chemistry expert would to see if they make rational chemical sense as the similarity numbers for the pictorial inscriptions did. Four representative examples are shown in Figure 47. A cursory examination might imply that there would seem to be a greater level of similarity between these answers than the results from thematic analysis indicate but a detailed examination shows differently. If we consider that, to a chemist, a “Br” shown without a charge on it is different than a “Br” shown with a charge; if we consider that a “bromine” is different than a “bromide,” that a “CN” is different than a “CN;,” that neither Example 2 nor Example 4 describe a substitution reaction that involves the simultaneous attack of the nucleophile and loss of the leaving group, that Example 1 describes an E2 elimination reaction while Example 2 describes solvation, that two students mention inversion but the other two do not, that only one student has indicated the presence of sodium bromide as a product, that only two students indicate that the cyanide anion approaches the electrophilic carbon from the side opposite the leaving group; if we consider all these differences and the others that are apparent, we should not be surprised that the similarity between the thematic maps created from these student verbal inscriptions is lower than the similarities between the pictorial examples shown in Figure 42. A list of the chemical concepts described in these inscriptions is shown in Table 17.

**Table 17. Chemical concepts expressed by student examples from Figure 47.**

1	2
Na & CN separate Solvation CN as nucleophile (no charge) Br leaves (no charge) Not simultaneous	Substitution  Br leaves (no charge)  Inversion E2 reaction

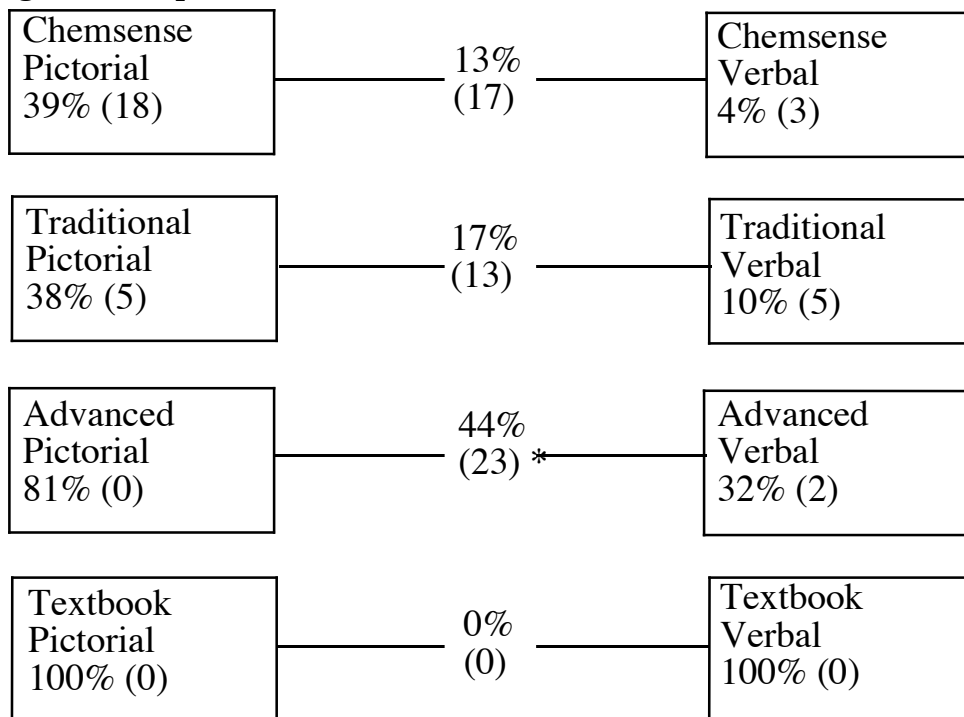
CN from opposite side	
<p style="text-align: center;"><b>3</b></p> <p>Br leaves (no charge)</p> <p>Bimolecular reaction  CN- as nucleophile (charged)  Product is described  Stereochemistry  NaBr  CN from opposite side</p>	<p style="text-align: center;"><b>4</b></p> <p>Inversion</p> <p>CN- as nucleophile</p> <p>CN- from opposite side  Br leaves (charge) "Bromide"  C is electrophile</p>

Again, we could hypothesize many reasons why students' pictorial inscriptions are more similar than their verbal inscriptions. But the point here is to see that, even without thematic analysis, a careful examination of the chemistry content of these verbal inscriptions does show their similarity to be low, and lower than the similarity of the pictorial inscriptions.

What can all these similarity results tell us about the scale of similarity? What constitutes a high degree of similarity? The thematic analysis of the textbook inscriptions from Chapter 7 was designed to calibrate the method but we saw that similarities for expert inscriptions can vary from 19% to 62%, depending on the concepts that the authors meant to convey (e.g. showing transition states or not, showing stereochemistry or not, using specific chemical compounds vs. generalized chemical structures). Instead,

the best calibration of this method is the similarity between the thematic maps created from the Advanced students' pictorial inscriptions, which was 80%. This was a group of students with similar expertise, working on the same problem, using the same medium to provide their answer. So then, while we would not predict 100% similarity between a group of students' inscriptions, 80% seems completely rational given the conditions.

**Figure 48. Comparisons between the pictorial and verbal thematic maps constructed from the inscriptions of all 3 student groups and the textbook. Numbers in parentheses indicate standard deviations, an asterisk denotes statistical significance ( $p < 0.001$ ).**



Thus far I have shown that thematic analysis can allow the analysis and comparison of inscriptions created by both students and experts regardless of the medium with which the inscriptions are created, and that these comparisons make rational chemical sense. Another goal of this method is to be able to compare different types of inscriptions, pictorial vs. verbal. Figure 48 shows the comparisons between each group's pictorial thematic map and their verbal thematic maps. Again, the numbers in the boxes



indicate the within-group similarity of the maps created for the student inscriptions, and the numbers between the boxes indicate the similarities of the maps created for the verbal data with the maps created for the pictorial data. Overall, we see low similarities between the verbal thematic maps and the pictorial thematic maps for all the groups and the textbook. That is, students are not using the same themes in the same ways verbally that they are using pictorially. We see that the ChemSense and Traditional groups show a very low similarity between the themes expressed verbally and those themes that were expressed pictorially (13% and 17%, respectively), though this difference is not significant.

The Advanced group shows a much higher similarity between the maps created for their verbal and pictorial data (43%) than either of the other two groups, a difference that is statistically significant ( $p < 0.001$ ). Once again, our purpose is not to explain these differences, but demonstrate the usefulness of the thematic analysis method to discern significant differences between student inscriptions regardless of student expertise or how they are inscribed, and to make reasonable comparisons between student inscriptions and expert inscriptions.

An interesting result of the comparison between the thematic map created from the textbook pictorial inscription and the thematic map created from the textbook verbal inscription is that there is no similarity between the two. Again, we can easily explain why this makes sense: 1) the pictorial thematic map was created from a specific reaction scheme while the verbal thematic map was created from a general chapter summary, and 2) often, one of the marks of experts in a field is that they use words and pictures differently to express different themes (Lemke, 1998c, 1999).

These comparisons between verbal and pictorial inscriptions demonstrate the usefulness of thematic analysis not only to compare one pictorial inscription with another but also to compare verbal inscriptions with pictorial inscriptions and to do so for inscriptions created by novice students, advanced students, and experts.

Not only is the ability to make these comparisons important, but the results show interesting patterns that further indicate the utility of these methods. We know, for example, that the within-group comparison of the thematic maps created for the Advanced group's pictorial inscriptions is more similar ( $p=0.001$ ) than within-group comparisons for either of the other two student groups. We also know that the within-group comparison of the thematic maps created for the Advanced group's verbal inscriptions is more similar than the within-group comparisons of the other two groups ( $p<0.001$ ). Finally, we know that the comparison between the thematic maps created for the Advanced group's verbal and pictorial inscriptions is more similar than those comparisons for the other two groups ( $p<0.001$ ). These results demonstrate a clear difference between the thematic maps derived from work by Advanced students and thematic maps derived from work by novice students. Not only have we satisfied our design requirements of being able to compare student created inscriptions, using different types of representations (pen-and-paper pictorial, computer pictorial, and verbal) but we are also able to discern differences between the work from novice students and advanced students.

An examination of the average numbers of links contained in the groups' maps, in addition to the similarities between the maps, may tell us something about the complexity of the maps. This data is shown in Table 18. Only one thematic map was created for the

textbook pictorial inscriptions and one for the verbal inscriptions, so no average is possible. The only statistically significant difference is between the number of links and themes contained in the Traditional group's pictorial thematic map and the number of links and themes contained in the Advanced group's pictorial thematic map ( $p < 0.05$ ). We see from these comparisons that the students' verbal thematic maps contained more links and more themes than their pictorial thematic maps. Possible reasons for the larger number of links and themes contained in students' verbal answers is that perhaps students are more able to give detailed answers verbally than pictorially due to greater familiarity with verbal forms than with pictorial forms they have only been learning for a few weeks, or perhaps the pictorial forms are more restricted than verbal forms in their possible use, or perhaps students feel more reason to draw correctly than write correctly when answering a quiz question. Any of these possibilities constitute a possible research question that can be answered through various research methods, but it is thematic analysis that points to the sorts of differences that a researcher would be interested in exploring further. In this way thematic analysis could be used as a type of triage on student data, revealing interesting differences for further study.

**Table 18. Average number of links and used in the thematic maps.**

	<b>Pictorial Thematic Maps</b>		<b>Verbal Thematic Maps</b>	
	Avg. # links	Avg. # themes	Avg. # links	Avg. # themes
<b>ChemSense Group</b>	11	11	14	13
<b>Traditional Group</b>	16	13	19	17
<b>Advanced Group</b>	10	9	14	11
<b>Textbook (Ege, 1999)</b>	12	11	8	10

Finally, we can compare the student pictorial thematic maps with a combined map created from the union of all of the  $S_N2$  textbook thematic maps that were created for

calibrating the method. We can also make the same comparison for the student groups' verbal thematic maps. The results for this comparison are shown in Table 19. If we simply compare the similarity of the thematic maps created from the students' answers with the combined textbook maps, we see that the average similarity for each group is quite low for both their pictorial and verbal thematic maps. This low similarity is not surprising because we are comparing first year college students' understandings of  $S_N2$  reactions with those of eight experts. We might expect a slightly higher similarity between the Advanced group's maps and the textbook maps. However, as we see in Table 18, the Advanced group included slightly fewer links and themes in their maps than did the other groups. Though this difference was not statistically significant, with such a small sample size, it may still be a reason for not seeing a higher similarity in that case. However, we also see that in each case the similarity of the pictorial thematic maps is higher than the verbal thematic maps, even though students generally provided more links and themes in their verbal inscriptions than in their pictorial inscriptions. These differences are significant only for the Traditional group ( $p=0.01$ ) and do not quite reach statistical significance for the ChemSense group ( $p=0.06$ ) or the Advanced group ( $p=0.06$ ) though the trend of lower similarity for the verbal thematic maps is still not surprising. As discussed in the introduction, the experts may provide different or additional information verbally that is not recapitulated in their pictorial inscriptions.

Because we would predict a low similarity between maps created for novices and experts, particularly for very early novices, a more useful analysis is the average percentage of the students' theme-link-theme triads that appear in experts' thematic maps. While the similarity between the maps may be low because the expert thematic

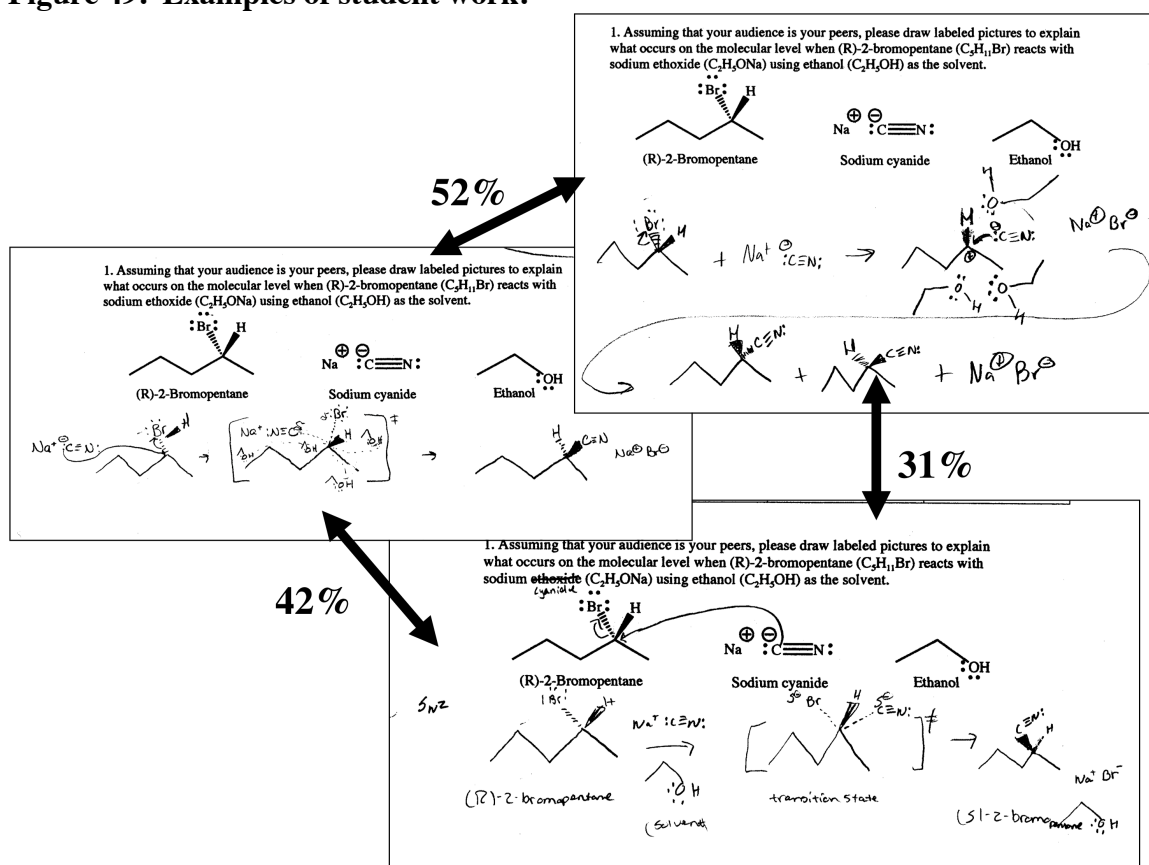
maps are so extensive, the average percent of shared triads gives us information about what percentage of the students' maps are correct with respect to the combined expert map. In these cases, we see that a larger proportion of the Advanced group's pictorial and verbal thematic maps are contained within the combined expert thematic map. All of the differences in the pictorial thematic maps are statistically significant ( $p=0.05$ ). For the verbal thematic maps, all but the difference between the Traditional and ChemSense maps are significant ( $p=0.05$ ). The verbal thematic map comparisons show that a smaller percent of the students' verbal thematic maps were contained in the expert pictorial thematic maps. Again, this result is expected because we predict that experts will make particular pedagogical choices about what information to display pictorially and what to display verbally. Again, for the theme-link-theme triads, thematic analysis is able to discern differences between the pictorial and verbal representations of Advanced students and novice students. The examination of such differences could be used to examine the longitudinal development of students' conceptions over time. Thematic analysis makes these differences obvious and points the way toward further avenues of research.

**Table 19. Average percent similarity between student maps and combined expert maps, and the average percentage of theme-link-theme triads shared between student maps and the combined expert map. Numbers in parentheses are standard deviations.**

	Avg. % Similarity		Avg. % shared theme-link-theme triads	
	Pictorial Maps	Verbal Maps	Pictorial Maps	Verbal Maps
<b>ChemSense Group</b>	6. % (1)	3% (3)	46% (13)	33% (12)
<b>Traditional Group</b>	10% (3)	5% (2)	64% (11)	26% (12)
<b>Advanced Group</b>	10% (0)	7% (1)	90% (0)	52% (13)

CHAPTER 10: ANALYZING TEXTBOOK AND STUDENT INSCRIPTIONS –  
 IMPLICATIONS AND APPLICATIONS

Figure 49. Examples of student work.



I began this research by showing three examples of answers to a quiz question given to first-year college chemistry students asking the question, how similar are the answers? Using thematic analysis we see the answer to this question in Figure 49.

The initial questions driving this research were:

- A) Can methods of discourse analysis be created, or current methods be modified to analyze the presentational and orientational meanings of students' chemistry inscriptions?
- B) What evidence for the validity of these methods can be gathered by applying these methods to expert and student inscriptions, and the comparison of those inscriptions?

In this work I have developed novel methods for analyzing student chemistry inscriptions, including pictorial inscriptions. While a features analysis of inscriptions provides information related to the orientational meaning of inscriptions, thematic analysis provides information on the presentational meaning of students' chemistry inscriptions. I have calibrated these methods using expert inscriptions as a standard and examined the validity of the methods using comparisons of student work based on predictions from the literature. Taken together, these methods provide information that is directly indicative of students' chemistry conceptions and examine the underlying structure of those concepts.

#### ANALYSIS OF TEXTBOOK INSCRIPTIONS

My analysis of the textbook data provided the opportunity to examine the validity of these methods as well as obtain qualitative calibration for our similarity analyses. By examining these inscriptions created by experts, we predicted that we would find a high degree of similarity between the inscriptions because one of the marks of experts' discourse is that they tend to use highly similar thematic constructions to discuss particular topics (Lemke, 1998c, 1999). We also predicted that experts' representations

would be particularly similar in introductory textbooks, so as to provide a common foundation of inscriptional choices when presenting new material to novice students.

**Figure 50. Figures from textbooks. A: Bruice, P. Y. (1998). *Organic Chemistry* (2nd ed.). Upper Saddle River, NJ: Simon & Schuster., B: Fox, M. A., & Whitesell, J. K. (2004). *Organic Chemistry* (3rd ed.). Sudbury, MA: Jones and Bartlett., C: Wade, L. G. (2006). *Organic Chemistry* (6th ed.). Upper Saddle River, NJ: Pearson Education, Inc.**

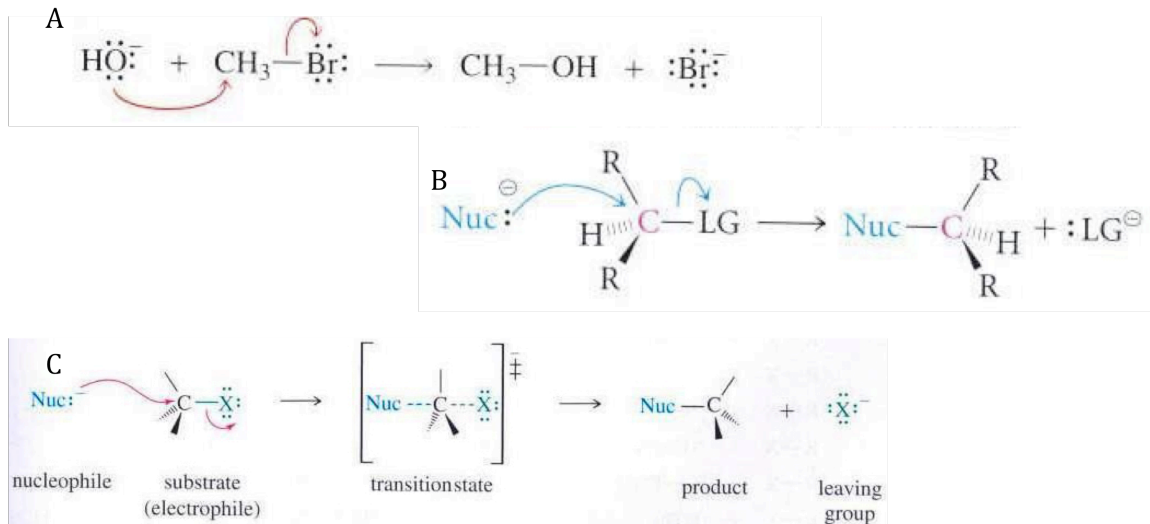
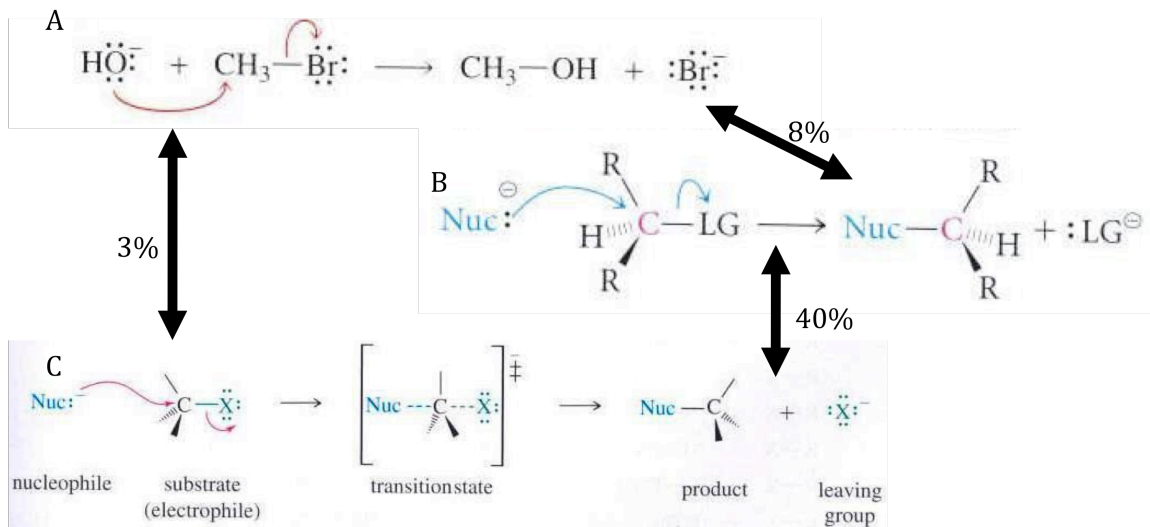


Figure 50 shows three textbook inscriptions of an  $S_N2$  reaction. Upon cursory inspection, these inscriptions look quite similar, and based on the surface features alone – they all depict an  $S_N2$  reaction – we might predict that they are highly similar. Upon closer inspection we would see that Example A does not show three-dimensional structure while the other two do, so we would predict a slightly smaller similarity between A and B/C. Example B and C do show three-dimensional structure, and C shows a transition state structure. So, while B and C are more similar to each other than A, we would predict B and C would be somewhat less than 100% similar because of the presence of the transition state structure in C. In fact, though the similarity measures do follow those general trends, the actual similarities are much smaller than an expert would predict given this cursory examination of these examples.



The results of the similarity analysis for these three examples are shown in Figure 51. As we can see from these results, the similarity of Example A to the other examples is very low, less than 10%. A more detailed examination shows why this is the case. Not only does Example A not show the three-dimensional structure of the electrophile, but because of this choice, it cannot illustrate the inversion of configuration that occurs during the reaction. In fact, given the placement of the Br on the right side of the bromomethane in the reagents, and the OH on the right side of the methanol product, it almost seems designed to be misunderstood by students that inversion does not take place. In addition, Example A uses specific atomic species as the nucleophile and the leaving group. In Example B, the three-dimensional structure of the electrophile is shown with a general leaving group (specified LG), and a general nucleophile (specified Nuc), while in Example C, the electrophile is shown as an X (generally interpreted to be a generalized halogen atom.) Example C also does not show any groups bonded to the carbon atom, instead showing only bonds with nothing bonded. The inclusion of the transition state structure lowers the similarity of Example C with Example B even more, as do the labels applied to the structures.

**Figure 51. Figures from textbooks. A: Bruice, P. Y. (1998). *Organic Chemistry* (2nd ed.). Upper Saddle River, NJ: Simon & Schuster., B: Fox, M. A., & Whitesell, J. K. (2004). *Organic Chemistry* (3rd ed.). Sudbury, MA: Jones and Bartlett., C: Wade, L. G. (2006). *Organic Chemistry* (6th ed.). Upper Saddle River, NJ: Pearson Education, Inc. Numbers indicate similarity results.**



In addition, because these inscriptions contained standard, canonical pictures of chemical themes, we predicted that any changes in the inscriptions themselves should yield predictable changes in the similarity of the thematic maps created for the inscriptions, which we have shown to be the case. The analysis of all the textbook inscriptions yielded similarity results that ranged from 19% to 62% (Table 10). Upon further inspection it became obvious that our hypothesis about the use of textbook inscriptions as a standard for expert inscriptions was faulty. Though generally experts may use highly similar thematic constructions to discuss particular topics (Lemke, 1998c, 1999), these analysis methods are sensitive enough to notice differences within specific examples, showing the limits of that hypothesis.

The use of thematic analysis reveals any differences between what the author intends to convey and what they are actually conveying in the inscriptions they use in their textbooks. The similarity analysis results reveal the important differences between

these textbook inscriptions that appear subjectively similar and therefore these analyses of textbook inscriptions can reveal the interesting pedagogical decisions made by textbook authors. That is, an expert may believe they depicting material in a particular way, because those experts already understand the themes and their connections to other themes. However those connections are not made by novices, who tend to focus only on the surface features of an inscription (Ainsworth, 2006; Chi, Feltovich, & Glaser, 1981; R. Glaser & Chi, 1988; R. Kozma & Russell, 2005; R. B. Kozma & Russell, 1997; Larkin, 1983; Woolgar, 1990). So, our prediction that expert inscriptions in textbooks would be highly similar was incorrect because we did not take into account the particular pedagogical decisions that the authors were making, or may have been unintentionally making. Thematic analysis makes these decisions – or at least the differences in inscriptions due to those decisions – explicit.

A better calibration of the method of thematic analysis can be found in the examination of the pictorial inscriptions from the Advanced group of students. Like the textbook authors, these students shared similar expertise and used the same methods of inscription. Thus we would predict their inscriptions would be highly similar for the same reasons we predicted that the textbook authors' inscriptions would be highly similar. However, in contrast to the textbook authors who were creating inscriptions with different pedagogical purposes in mind, these students were all in the same situation of being students answering exactly the same quiz question. The fact that their inscriptions were more similar than the textbook authors' inscriptions demonstrates that the pedagogical decisions made by students in answering a quiz question provides a constraint on their inscriptions in a way that makes those inscriptions more similar.

Another constraint was the quiz question itself, which asked students to assume an audience of their peers in answering the question. Comparing the results of the similarity analysis of the Advanced students' inscriptions with that of the textbook authors not only demonstrates what constitutes a high degree of similarity, but also demonstrates how pedagogical decisions affect the inscriptions produced.

The analysis of the textbook data led us to reevaluate our initial assumptions about the similarity of expert inscriptions by demonstrating that these methods are particularly sensitive to small differences between inscriptions. Thus, even inscriptions that to experts may, on the surface, appear highly similar yield calculated similarities from 19% to 60% (Table 10). These analyses also demonstrated the importance of comparing not only the similarity of the themes and relationships shown in the inscription, but also the complexity of the thematic maps created for the inscriptions. Together, the similarity comparisons and complexity comparisons provide an excellent method of analyzing chemistry inscriptions.

## ANALYSIS OF STUDENT INSCRIPTIONS

The purpose of comparing features used by students on their pretests and comparing the thematic maps is not to demonstrate the efficacy of the ChemSense Studio as an intervention in the SSG groups. In fact, only the drawing tools in the software's palette that mimic pencil-and-paper were used here and none of the other functions so as to provide a level ground for comparisons. Instead of learning gains from the use of the software, which would be a completely different study, we were interested in examining these comparisons to see if they are consistent with our expectations of similarities and differences based on two predictions: 1) subjects with the same level of expertise who use

the same medium to produce inscriptions should produce inscriptions that are more similar than students who use different media to produce inscriptions, and 2) subjects with different levels of expertise who use the same medium to produce inscriptions should produce inscriptions that are less similar than subjects with the same level of expertise.

The first prediction, that the medium should affect the inscriptions produced by subjects with the same level of expertise is based on situative theory (Brown et al., 1989; Greeno, 1998; Lave & Wenger, 1991; Resnick, 1988; W.-M. Roth & McGinn, 1998) which states that the constraints and affordances of particular physical and representational systems will shape the activities and/or thinking that can be performed when using those systems. Some of the constraints and affordances of the ChemSense program (R. Kozma, 2001; Schank & Kozma, 2002) are different than the constraints and affordances of working with pencil-and-paper, such as the ability to choose atoms directly from a periodic table palette, or the ability to create animations. However, other affordances and constraints are the same. For example, there is no scaffolding integrated into ChemSense that limits students to drawing only correct or canonical structures. Just as with pencil-and-paper, students can draw molecules that include carbon atoms with five bonds, they can place too many electrons around an atom, or forget to include formal charges. So we would predict to see some differences between inscriptions created with ChemSense and representations created using pencil-and-paper, only if the particular constraints and affordances of the two media are sufficiently different enough to limit or alter the ability of students to interact with their inscriptions in different ways (Stieff, Bateman Jr., & Uttal, 2005).

The second prediction is that, all other things being equal, the level of expertise should influence the inscriptions generated by the subjects. A great deal of research has described the differences and similarities between novice and expert representations, as well as the development of novice's representational abilities over time (see for example: Ainsworth, 2006; Chi et al., 1981; R. Glaser & Chi, 1988; R. Kozma & Russell, 2005; R. B. Kozma & Russell, 1997; Larkin, 1983; Woolgar, 1990). According to this body of research, novices typically rely on the surface features of representations. As expertise increases the use of representations and the codeployment of multiple representations increases as does the translation between different representations. However, experts' representations can still be constrained by the particular task they are given (Ainsworth, 2006; Dunbar, 1997; R. Kozma, 2001).

Given these predictions, there are three cases we should consider when examining these comparisons for support of the validity of the methods:

- 1) The features analysis and thematic analysis methods provide evidence of differences between groups which are consistent with the predictions based on differences in the media used to produce the answers, and differences in expertise. This case provides warrant for the validity of the methods.
- 2) The methods provide no evidence of any differences in comparisons where we would predict them, or demonstrated differences where we would not predict them. This case provides warrants against the validity of the method.
- 3) The methods provide no evidence of any differences in comparisons where we do not predict any differences. This case provides no warrants for or against the validity of the method.

## Features Analysis

**Table 20. Summary of findings.**

<b>Summary of Findings from Features Analysis</b>	<b>Ramifications</b>
<ul style="list-style-type: none"><li>• Statistically significant differences found in the average number of features used by student groups on the mixing question of the pretest</li><li>• Individual features are used more or less frequently by students</li><li>• Student pictorial inscriptions showed fewer features than their verbal inscriptions</li></ul>	<ul style="list-style-type: none"><li>• Students' use of features can be easily compared</li><li>• Students' choices of which features they use and which they do not use can be easily discovered and used as a basis for further analysis</li></ul>

For the features analysis of the pretest, we see a difference in the average numbers of features used on the mixing question of the pretest between the Advanced group and other student groups. Because all groups used the same media to produce their answers, we would predict no difference in the average number of features due to the medium used, however we would predict a difference based on student expertise. The results of the features analysis shows no difference between the Advanced group and the Traditional and ChemSense groups on two questions, but we see statistically significant differences on the mixing question. A possible explanation for these results is that some of the questions asked were not complicated enough to demonstrate a difference between the groups on the other questions and in fact what we are seeing in the data is a ceiling effect for those questions. Other researchers have found similar ceiling effects. For example, Levy et. al. (2004) examined secondary and undergraduate students' use of a computer program called Connected Chemistry, which uses multiple representations to link macroscopic phenomena with nanoscopic explanations. In this particular study on particle behavior in gases, the researchers found that increased scaffolding of activities led to no significant increase in student achievement on a transfer task, a result which

they attribute to a ceiling effect. In another study, Kaberman and Dori (2009) also found a ceiling effect for high achieving secondary students who were using a computerized molecular modeling program to assist students in making translations between molecular formula, 2D and 3D molecular models. While lower achieving students net gain scores on pre- and post-tests were statistically significant, no significant gains were seen for high achieving students. Given the SSG students in my study are a self-selected group of students, participating in this section for honors credit, it is possible that I am seeing the same ceiling effect in these results.

However, the mixing question may have been complex enough to demonstrate the predicted differences between student groups based on differences in expertise. Evidence that this was the case can be seen in the differences between the average numbers of features the novice students used in their answers to the pictorial pretest on the Acid/Base and Phase Change questions (avg = 15 features) compared with the average number of features they used to answer the mixing question on the same pretest (avg = 8 features.) This difference was statistically significant for the novice students, but there was no significant corresponding difference for the Advanced group of students.

An interesting result of the features analysis is that students' pictorial answers showed fewer forms than their verbal answers (Table 15). Because the pretest was given during first week of their first college class in chemistry, this result could be because they may not have not acquired the conventions for producing pictorial inscriptions of chemical phenomena. Or this could be due to their choosing more canonical methods of representation. Additional analysis would be required to distinguish between these two alternative hypotheses.



## *Thematic Analysis*

<b>Summary of Findings from Thematic Analysis</b>	<b>Ramifications</b>
<ul style="list-style-type: none"><li>• Student created inscriptions can be analyzed</li><li>• Inscriptions can be compared regardless of how they are produced (computer vs. pencil-and-paper)</li><li>• Inscriptions can be compared regardless of type (verbal vs. pictorial)</li><li>• Comparisons can reveal differences between novice students and advanced students</li></ul>	<ul style="list-style-type: none"><li>• Instructors and researchers do not need to rely on premade visualizations in order to analyze student conceptions</li><li>• Instructors and researchers can compare student inscriptions across a variety of contexts in order to look for differences between students at one point in time, or to look for differences over time</li><li>• Instructors and researchers can compare and contrast multiple types of inscriptions (e.g. verbal vs. pictorial) in order to provide a deeper understanding of student conceptions</li></ul>

As we examine the thematic analysis results, we predict, for example, that the thematic maps developed for both the verbal and pictorial answers of the Advanced group would show a greater similarity to each other than the maps of the students in the Traditional or the ChemSense groups because the students in the Advanced group have had a greater opportunity to develop the canonical thematic patterns that chemists use to discuss reactions such as those shown in the Week 8 Quiz (R. Kozma & Russell, 2005; R. B. Kozma & Russell, 1997). In fact, we see that both the Advanced group's verbal and pictorial thematic maps show greater intra-group similarity than the other two groups. So, not only can these methods be used to compare student inscriptions within groups but they can discern differences between inscriptions between advanced and novice students. The ability to discern these differences in expertise between different students also allows us to examine differences in expertise for the same student that appear over time as his or her expertise increases.

We might also predict that the Advanced group and the ChemSense group pictorial thematic maps may show greater similarity than either a ChemSense/Traditional comparison or an Advanced/Traditional comparison because both the Advanced Group and the ChemSense group used ChemSense Studio to produce their answers. Though thematic analysis examines the themes that are presented, not how they are presented, the ChemSense Studio program may somehow influence which themes students present. However this prediction would only be correct if the constraints and affordances of the software are different enough from the constraints and affordances of pencil-and-paper inscription techniques used by the Traditional group so that students are able to or unable to produce inscriptions that are different in the themes inscribed, not just in the features used (R. Kozma & Russell, 2005; R. B. Kozma & Russell, 1997). However, these quiz questions were purposely designed so that students did not use any of the advanced features of the ChemSense tool, such as the animation studio, graphing tool, or the discussion features in order to produce their inscriptions. Instead they only used tools that allowed them to draw lines, type atomic symbols, place dots to symbolize electrons, and draw arrows, activities that are not different than the activities one can do with pencil and paper. The results comparing the inscriptions from students using ChemSense with those who did not use ChemSense show no statistically significant difference based on the medium used to produce the inscriptions, which is what we predicted based on our design of the quiz questions themselves.

The data for the average number of links in the pictorial and verbal thematic maps show that all groups and the textbook had a larger number of thematic links in their verbal data than in the pictorial data. There are two interpretations of these results: 1) if

the average number of links is a measure of the complexity of the maps, then the higher number of links in the verbal maps may indicate students' greater facility with words compared with chemistry symbols, or 2) perhaps the results indicate that chemistry symbols are more restrictive in the kinds of meanings they can portray and thus fewer themes were represented pictorially.

#### *Comparison of Students' Pictorial Answers with the Quiz Question*

The thematic maps created for the students' pictorial inscriptions compared with the thematic map created for the quiz question shows several similarities. For example, all of the students' thematic diagrams show pentane and cyanide reacting, which the quiz question also shows pictorially. The question itself placed restrictions on the students' answers as it was necessary to express the same themes included in the quiz question in order to answer it. In addition, in examining ChemSense students' pictorial texts, we see that they often simply cut-and-pasted the molecular drawings shown in the quiz itself in order to answer the question, which also restricted their answers.

One major difference between the themes expressed by the quiz question and those expressed by the students involves the solvent, ethanol. The portion of the quiz question involving the solvent was asked verbally, but not recapitulated pictorially. In addition, the verb "using" is more ambiguous than the verb used to describe the relationship between (R)-2-bromopentane and sodium cyanide — "reacts." Only one student pictorially showed an interaction of the solvent with the reactants in some way that could be interpreted as solvation. It is unlikely that students did not recognize that the solvent is important in this reaction since the second question of the quiz specifically notes that the solvent affects the reaction kinetics. So, either the students did not have an

adequate way to represent solvation and/or there were not sufficient verbal or pictorial cues within the question to indicate the theme being requested (i.e. solvation). If the latter is the case, it indicates that this method of thematic analysis offers a useful way to evaluate the potential effectiveness of assessment items. Instructors can utilize thematic analysis to analyze their assessment items to insure that the themes contained in the items are indeed the themes that they wish to assess.

#### *Comparison of Students' Pictorial Answers to Each Other*

Examining the students' individual pictorial thematic maps shows differences between students' answers. For example, although all of the students correctly realized that the cyanide carbon is the reacting species with its lone-pair of electrons and negative charge, three students chose to represent the accompanying sodium cation and two did not. The sodium cation in this situation is referred to as a "spectator ion," that is, it does not directly participate in the reaction. Those two students may be representing this idea by not representing the sodium cation. Only one student attempted to represent the interaction between the solvent, ethanol, and the ions of sodium cyanide. One student pictorially represented an elimination reaction. Four students represented the inversion of stereochemistry that can take place. The fifth student did not represent the products pictorially at all. All of these differences include themes not included in the question itself. So, in general, the places where students' answers differ thematically from each other are also the places that their answers differ thematically from the question. The method of thematic analysis, then, offers a useful way of determining differences between students' pictorial texts that do not rely strictly on the surface features of the inscriptions they create.

### *Comparison of Students' Verbal Answers with the Quiz Question*

Though initially the thematic diagrams constructed for the student's verbal inscriptions look quite different, they actually contain many of the same themes. In general, the bromine leaves, the carbon is attacked, and bonds are formed. Again, however, only one student wrote about the action of ethanol as a solvent. One could argue that the theme of solvation is implied by the use of the term "solvent" in the quiz question. However, a novice may only have a superficial concept of the term solvent as "a liquid that the reaction occurs in," rather than the more expert concept of "a medium that dissolves reactants and products, allows the diffusion of reacting species, and may stabilize certain transition states." Again, the themes expressed in the quiz question likely affected the students' answers. This finding shows that the classroom instructor or the educational researcher can use thematic analysis to design assessment items that are closely aligned with the concepts they intend to assess.

### *General Observations*

Based on the results from both the features analysis and the thematic analysis, we see that the Advanced group of students show statistically significant similarities ( $p < 0.01$ ) to experts, as opposed to the other students. We can say that the Advanced students really are experts when it comes to this material. Based on both the thematic analysis, the Advanced students are found to be similar to experts, while the other students are not.

So, I have developed new methods of analysis which allow us to look at the forms students are using to convey their understandings (features analysis) and how students are using these forms to express the thematic relationships of chemistry (thematic analysis).

These methods provide researchers and others interested in student inscriptions information about those inscriptions that lies below the surface. We have seen that, comparing students, comparing verbal vs. pictorial inscriptions, and comparing different inscriptional media, provides evidence for the validity of the methods of features analysis and thematic analysis. The results and major findings of this work are summarized in Table 21.

**Table 21. Summary of data sources, results, and major conclusions.**

	<b>Data</b>	<b>Result</b>	<b>Conclusions</b>
Chapter 7: Calibration	Expert textbook inscriptions	Even inscriptions that on the surface appear highly similar may yield calculated similarities around 60%.	The methods are particularly sensitive to small differences between inscriptions.
Chapter 8: Application and Validity Testing	<ul style="list-style-type: none"> <li>• ChemSense/ Traditional inscriptions on pre-, posttest data and quizzes</li> <li>• Advanced student inscriptions on pretest and quiz data</li> </ul>	<ul style="list-style-type: none"> <li>• Some significant difference in the number of features used between ChemSense, Traditional, or Advanced groups on some questions</li> <li>• All students' pictorial inscriptions show fewer features than their verbal inscriptions.</li> <li>• No significant difference between ChemSense and Traditional thematic maps, but there is a significant difference between the Advanced group's maps and the other two groups' maps.</li> <li>• The advanced group's maps are more similar to the textbook map than those of the other two groups.</li> <li>• Maps created from verbal data show lower</li> </ul>	<ul style="list-style-type: none"> <li>• Questions asked may not have been complicated enough to see differences between groups.</li> <li>• Questions asked may not have been complicated enough to require more pictorial features.</li> <li>• The Advanced group is more "expert-like" than the other groups.</li> <li>• Questions asked may not have been complicated enough to see differences based on the method of inscription production (traditional vs. ChemSense). Or</li> </ul>

		<p>similarities.</p> <ul style="list-style-type: none"> <li>• Based on thematic analysis, there are low similarities between students' verbal inscriptions and their pictorial inscriptions for the ChemSense and Traditional groups, but not for the Advanced group.</li> <li>• Students verbal inscriptions are somewhat more complex than their pictorial inscriptions.</li> <li>• The thematic maps created for the Advanced group's inscriptions are more similar to a combined textbook thematic map than the other groups' maps when comparing theme-link-theme traids rather than overall similarity.</li> </ul>	<p>the affordances built into ChemSense may not be needed by college students.</p> <ul style="list-style-type: none"> <li>• The inclusion (or lack) of inscriptional forms in student answers corresponding to items in the quiz question may indicate the effectiveness of the question itself.</li> <li>• Similarities and differences between student work and student and expert comparisons demonstrate the validity of these methods.</li> </ul>
--	--	--	--

This work has resulted in the creation of methods for analyzing student representations that meets the design challenges initially laid out. That is, these novel methods for analyzing student inscriptions, particularly (but not limited to) pictorial inscriptions should:

- A. Be able to analyze student-generated inscriptions.
- B. Be able to analyze various types of inscriptions.
- C. Allow the comparison of different types of inscriptions, different styles (e.g. verbal vs. pictorial), as well as those from different individuals with varying levels of expertise.

- D. Provide a fine-grain analysis that goes beyond categorical evaluations of correct and incorrect.
- E. Reveal the underlying structure of the concepts that the inscriptions are designed to illustrate.

## IMPLICATIONS

### *Improving Research in Chemistry Education*

There are several areas of current research that could benefit from the use of the analysis methods I have developed. For example, in Chapter 3 I described the work of researchers who have attempted to compare students' understanding of stoichiometry and gas laws with their ability to solve algorithmic problems on these topics (Nakhleh & Mitchell, 1993; Nurrenbern & Pickering, 1987; Pickering, 1990; Sawrey, 1990). In these examples, students were given traditional algorithmic problems on stoichiometry and gas laws in addition to a conceptual problem that required no algorithmic strategies to solve. These conceptual problems were presented as pictorial multiple-choice questions, while the traditional problems were presented as verbal multiple-choice questions. One criticism of this work is that all of the examples of conceptual problems presented were in graphical form (Beall & Prescott, 1994). While the work with pictorial conceptual problems demonstrated that students gave significantly ( $p < 0.05$ ) more correct answers on traditional questions than the pictorial conceptual questions, Beall suggests that his students showed essentially no difference in their abilities to answer traditional questions vs. verbal conceptual questions. Part of the debate regarding the discrepancy of these results is that the definition of what constitutes a conceptual question was not well



described. Another difficulty with this work, noted by Beall, is that there was no way to insure that each of the corresponding questions was of the same difficulty. A third difficulty not mentioned by any of the researchers is that no effort was made to analyze the conceptual content of the questions, other than matching questions according to general topic (eg. Stoichiometry, Charles' Law, Boyle's law, etc.) Not only is this an interesting research question, but given that the American Chemical Society publishes standardized tests in both traditional and conceptual versions, some effort should be made to insure that the concepts tested are the same across the two styles of tests. Features analysis and thematic analysis can be used to assist in the creation of questions that differ in the features used, but are similar in the themes presented so that a more thorough comparison can be obtained and to insure that test items (whether in research studies, or ACS standardized exams) test for the understanding of the same concepts. In addition, the pictorial inscriptions used in the aforementioned research were not student-generated. Thematic analysis can provide a way to examine students' conceptual understanding derived from student-generated inscriptions, making a much stronger link between their performance on conceptual exercises to the nature of their conceptual understanding.

#### *Improving Educational Research on Representations*

The work of Ainsworth (2003) provides another example of research that could benefit from the use of features and thematic analysis. In one study, Ainsworth and colleagues examined how the format of material (verbal or pictorial) influenced students' self-explanations. Of the twenty subjects, ten received material on the human circulatory system in text and ten received the material in diagrams. The students presented with pictorial information generated significantly more self-explanations than the students

presented with textual information only. In constructing the verbal and visual materials, the authors state,

“Piloting ensured that the information presented in the text was inferable from the diagrams. However, it is impossible to claim that the text and diagrams are informationally equivalent.”

Thematic analysis of both sets of materials can provide a way to measure the similarity between the verbal and pictorial materials. In this example, multiple pictorial diagrams could have been presented and features analysis could be used to describe the similarity and differences between the diagrams, while thematic analysis could be used to insure the similarity of the content of the inscriptions, whether verbal or pictorial.

### *Improving Textbook Design*

Much research has shown that learners have a difficult time coordinating information from multiple types of inscriptions (see for example: Ainsworth, 2006; R. Kozma, 2001; R. B. Kozma & Russell, 1997) so having methods that authors can use to elucidate how information is being presented to the readers could assist in making this coordination more explicit. In addition to providing a useful method for analyzing research data, features analysis and thematic analysis can also assist textbook authors in the use of verbal and pictorial inscriptions to explain information to students. Using these methods would allow authors to analyze and compare the information presented verbally compared to information presented pictorially to insure coordination of the content of these inscriptions.

### *Improving Discourse Analysis Research*

In the area of discourse analysis, much work has been done on the multimodal communication, particularly in trying to sort out the different meanings being conveyed through different modes. For example, Kress (2001) describes a case study from a Year 8 science classroom in London about the human circulatory system. He examines in detail the various modes used in one particular lesson, including the teacher's verbal explanation, the pictorial images provided on the whiteboard and in the textbook, and the teacher's gestures and other actions. He also describes the different meaning-making activities performed within each mode. While Kress provides a general explanation of the types of information presented verbally, pictorially, and gesturally, and how those modes interact, a thematic analysis could also be performed on the detailed transcription of the verbal text, the pictorial symbols used, and though this has not been tested, perhaps even on a transcription of the gestural components of the lesson. Not only could we create a thematic map for the information presented via each modality, but an overall map could be created to examine the connections made, or more importantly for the students, not made during the presentation.

While we are only beginning to understand the implications of multimodality in discourse, including classroom discourse, technology has moved ahead to provide additional ways of providing linked information: hypermedia. Hypermedia such as web pages, blogs, Wikipedia, and Flash© animations can provide text, sound, pictures, and animations, that allow the viewer to interact with this information in ways that a static text cannot. The viewer can examine links between texts, or between text and pictures and animations. The viewer may be able to examine one object or phenomenon at

various levels of detail, while linking aspects of that object to a textual explanation. While a typical classroom lesson may use multiple modalities in similar ways, the links between the modalities are more or less linear in time, while on a web page, the viewer has control over the order in which links are explored (Lemke, 2002). In his study examining the hypermodal meanings provided by a web page from the Goddard Space Flight Center, Lemke (2002) examines the various types of meaning (presentational, orientational, organizational) that are made explicitly or implicitly by the words, pictures, and diagrams on the site and the relationships between them. In addition to this analysis, thematic maps could be created that illustrate the themes and relationships between themes presented in each modality. Using the methods created in this thesis, thematic maps can be created and linked to all the other maps created for each modality in much the same way that a hypertext link is created on a web page. This would have the effect of producing a thematic analysis of the entire site showing how meaning is distributed throughout the various web pages. Being able to examine the thematic content across media in this way would not only allow a greater level of detail for researchers' examinations of such texts, allowing them to compare and contrast the material provided in each modality. In addition, such an analysis would also provide authors of such texts, including educational resources, with the means to examine the themes presented and the links between them, allowing them to make explicit pedagogical decisions how the material is expressed and which modalities are most efficient for presenting the information. These analyses can also be used by authors to test their own assumptions about how they believe they are presenting the material in a single modality, or between multiple modalities. Hypertextual links may be more or less implicit or explicit and

these sorts of thematic analyses could be used to insure that the most important links are as explicit as possible.

At the same time, features analysis can be used to examine the complexity of each of the modalities. Web page authors and designers of hypertext educational resources can use features analysis to examine the complexity of verbal and visual forms to insure that the most important information is explicitly foregrounded for the reader, while at the same time creating new hyperlinks between more complicated forms and additional explanations for readers or learners who need them.

These examples provide a summary of just a few of the possible applications of features analysis and thematic analysis in several different research communities: the chemistry education research community, the science education research community in general, the discourse analysis research community, and the community of authors of scientific texts and hypertexts.

## APPLICATIONS

Given the utility and sensitivity of these analysis methods – particularly the ability to compare student-generated inscriptions, their ability to detect differences between students of varying levels of expertise, and their ability to compare student-generated inscriptions from various media – they are perfectly suited for use in examining several important research questions.

First, because these methods reveal similarities and differences between student-generated representations across levels of expertise, these methods will be useful in examining the development of chemistry student representations as students progress from undergraduates to graduate students. Such research could provide information

about the development of students' use of inscriptions of various kinds, and which inscriptions are particularly useful or problematic in the development of their students' conceptual understanding.

Second, because these methods can be used to examine student-generated inscriptions from various media, they would be useful for examining educational interventions, for example, the examination of whether or not the advanced features of tools like eChem, ChemSense (and their offspring) are useful for fostering students' abilities to represent chemical concepts.

Third, as we have seen, students have difficulty relating chemistry inscriptions with chemistry concepts (Ben-Zvi et al., 1987). One reason for this difficulty may be that instructors regularly rely on the same sorts of inscriptions to teach chemistry concepts that expert chemists use to communicate those concepts. Perhaps some types of inscriptions are more useful for teaching novice learners than the inscriptions that expert chemists use to communicate with each other. Features analysis and thematic analysis could be used to develop and examine types of inscriptions that carry similar thematic content, but that are perhaps less abstract than canonical representations used by experts.

## CONCLUSION

Features analysis and thematic analysis applied to chemistry students' pictorial inscriptions are useful methods of analysis because they provide a level of detail that can call attention to similarities and differences within the inscriptions of students, across levels of expertise, regardless of the medium used to produce the inscriptions, and regardless of the type of inscription (pictorial vs. verbal). These methods allow researchers to examine student work beyond the surface analysis of "right or wrong"

answers to questions. The methods developed herein can be used to compare student inscriptions in order to examine the usefulness of instructional technology, the utility of instructional interventions to improve students' use and understanding of inscriptional systems, and the development of students' inscriptional abilities. The significant depth of these analysis methods, beyond the simple surface features of the inscriptions, allows such questions to be explored. This depth of analysis has important implications both for chemistry instruction and chemical education research as a method of assessment of students' work and a method of assessment of educational interventions.

## PART TWO

### CHAPTER 11: EXPLORING THE REGIOSELECTIVITY OF 1,3-DIPOLAR CYCLOADDITIONS OF MÜNCHNONES

#### INTRODUCTION

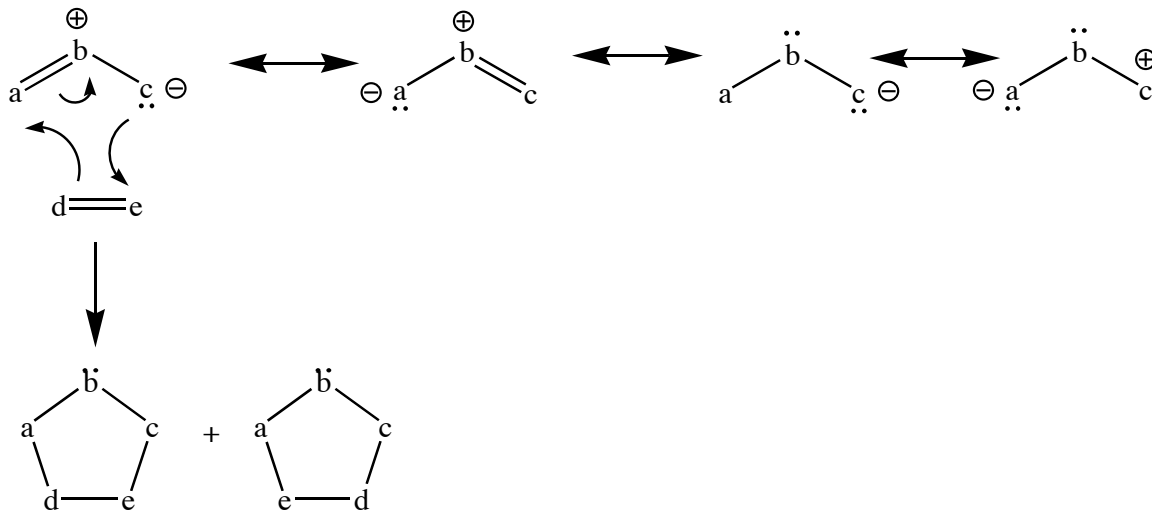
The synthetic utility of cycloaddition reactions is well known. Among the most important are the class of reactions known as 1,3 dipolar cycloadditions. Initial research in the 1960s by Huisgen and coworkers (for a review, see Huisgen, R. In *1,3-Dipolar Cycloaddition Chemistry*; Padwa, A., Ed.; John Wiley & Sons: New York, 1984; Vol. 1, p 1-176) demonstrated the importance of this class of reactions. Continued interest in these cycloadditions (for a more recent review, see: *Synthetic Applications of 1,3-Dipolar Cycloaddition Chemistry Toward Heterocycles and Natural Products*; Padwa, A.; Pearson, W. H., Eds.; John Wiley & Sons: New York, 2002; Vol. 59) is a result of its ability to form important heterocyclic structures that can include several stereocenters in one reaction.

The 1,3-dipolar cycloaddition reaction is characterized by two reacting species, the 1,3-dipole and the dipolarophile, which react to form 5-membered rings. A 1,3-dipole is a covalent, zwitterionic compound with four electrons in three  $\pi$  orbitals (Scheme 1). As is implied by the structures shown in Scheme 1, the two termini of the compound can be both nucleophilic and electrophilic. Because of this dual nature,



reactions between unsymmetrical dipoles and unsymmetrical dipolarophiles result in two regioisomeric compounds.

**Scheme 1. 1,3-Dipoles and the 1,3-dipolar cycloaddition.**



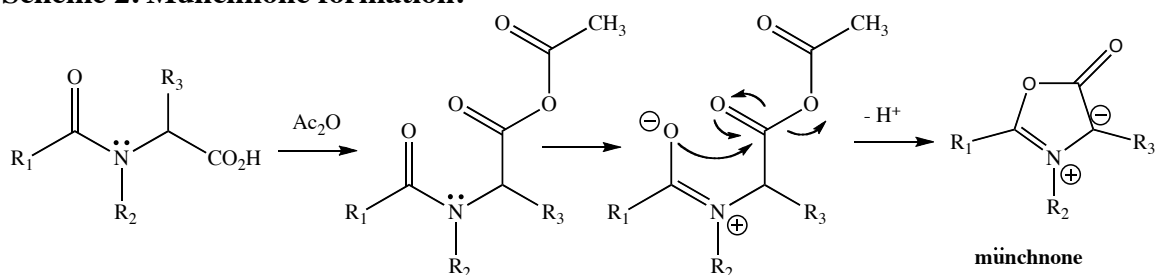
Among the various types of 1,3 dipoles, one group that has received significant attention are the 1,3-oxazolium-5-olates (münchnones). Cycloadditions of münchnones have been used to produce several interesting natural products and medicinal compounds. Recent examples include: an improved synthesis of N-3,4-diphenyl-5-(4-fluorophenyl)-2-isopropyl-1H-3-pyrrolecarboxamide, an intermediate in the synthesis of atorvastatin (Lipitor®, Sortis®);<sup>1</sup> FPL 64176, a calcium channel activator;<sup>2</sup> antifungal compounds;<sup>3</sup> and others. We are interested in examining and exploiting the regioselectivity of the 1,3-dipolar cycloadditions of some münchnones to produce interesting pyrrole-containing compounds.

## SYNTHESIS OF MÜNCHNONES

Münchnones can be prepared from cheap and easily available amino acid precursors; they yield synthetically interesting pyrrole products; and the simple synthetic methods are amenable to industrial applications. Traditionally, they are prepared from

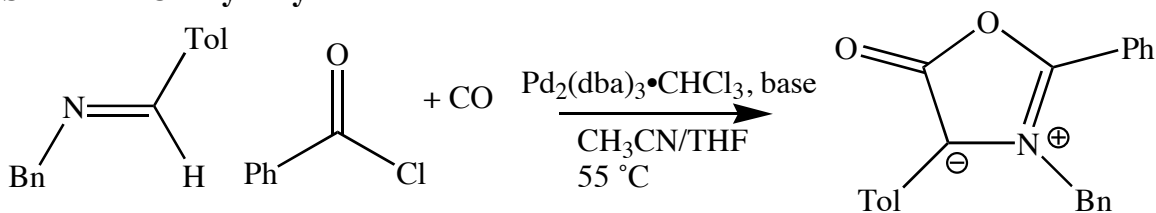
the cyclodehydration of acyl amino acids in the presence of acetic anhydride (Scheme 2). The münchnones, once formed, are highly reactive and are not typically isolated.<sup>4</sup> Other methods that have been developed to form münchnones include: dehydrations using dicyclohexylcarbodiimide (DCC)<sup>5</sup> or N-ethyl-N'-dimethylaminopropylcarbodiimide (EDC);<sup>6</sup> dehydrations in the presence of acetic anhydride and perchloric acid to give the protonated münchnone salt, which can be isolated and then deprotonated to form the münchnone<sup>7,8</sup>; and reactions of oxazoles with acid chlorides.<sup>9</sup>

**Scheme 2. Münchnone formation.**



One of the newest methods of synthesizing münchnones involves a four-component, palladium-catalyzed coupling.<sup>10</sup> In this method, an imine, an acid chloride, and carbon monoxide are coupled yielding a variety of münchnones, many in synthetically useful yields. Scheme 3 illustrates a typical reaction.

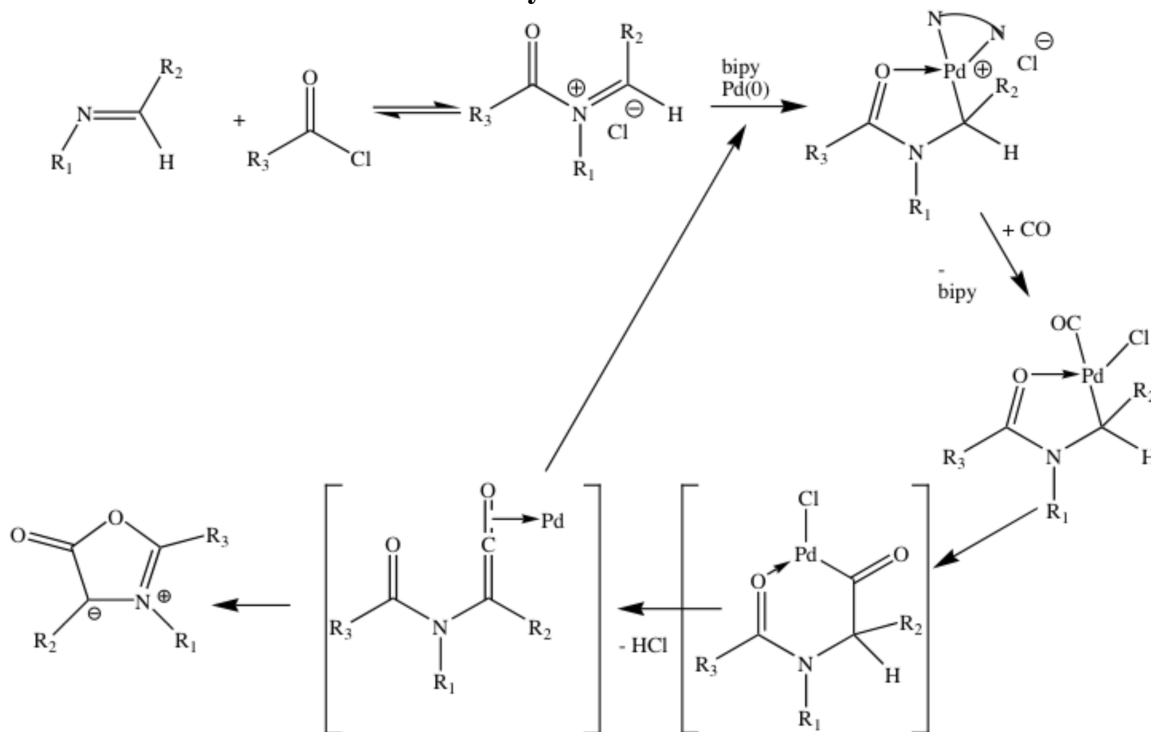
**Scheme 3. Catalytic synthesis of münchnones.**



Initial attempts with these reactions produced lower yields. However, pretreatment of the palladium catalyst with the imine and acid chloride increased yields to 83%. The conditions are tolerant to aryl-halide, ether, ester, and thioether

functionalities and both alkyl and aryl acid chlorides can be used. The proposed mechanism for these reactions is shown in Scheme 4.

**Scheme 4. Mechanism of münchnone synthesis.**



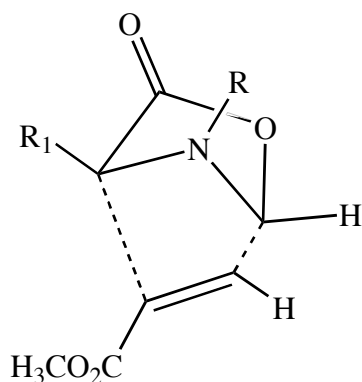
Arndtsen has extended this work by including a variety of alkynes in the one pot synthetic method described above.<sup>11</sup> The result is a variety of pyrroles synthesized from imines, acid chlorides and di-, mono- and unsubstituted alkynes in synthetically useful yields (63-95%), containing a range of ester, indole, halide, thioether, aryl, heteroaryl, and alkyl substituents.

**REGIOSELECTIVITY WITH ACETYLENIC DIPOLAROPHILES**

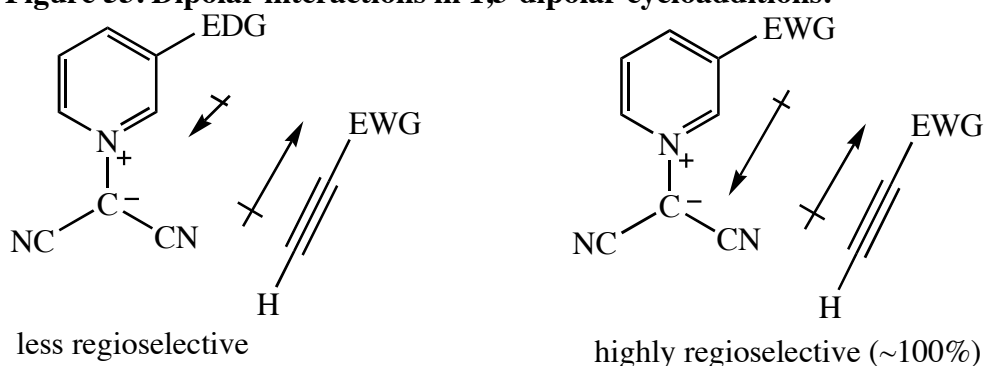
Table 22 summarizes the literature reports where one of the münchnone's termini is substituted by a hydrogen atom ("monosubstituted münchnone"). Examining these results as well as our own (described later), we have proposed<sup>12</sup> that the distribution of isomers can be predicted by an unsymmetrical transition state in which the less

encumbered end of the dipole bonds to the less encumbered end of the dipolarophile (Figure 52). The sole exception, entry 10, might be explained by the presence of the trifluoromethyl substituent altering the electronic character of the ring enough to make FMO considerations dominant. An alternative and untested explanation might also be a dipole-dipole repulsion between the trifluoromethyl group and the ester group of the propiolate that steers the regioselectivity towards the alternative orientation. Other researchers have used such dipole-dipole interactions, for example, to rationalize the regiochemical control of reactions between pyridinium dicyanomethylides with acetylenic dipolarophiles (Figure 53) for reactions in which regiocontrol cannot be explained by FMO factors.<sup>13</sup>

**Figure 52. Proposed asymmetrical transition state for monosubstituted münchnones.**



**Figure 53. Dipolar interactions in 1,3-dipolar cycloadditions.**



Disubstituted münchnones simply seem to form the least crowded regioisomer predicted from a more symmetrical transition state structure. The reported outcomes from reactions of münchnones with phenylacetylene (entries 24-39) do not follow any general trend, so our model may be limited to acetylenes with electron-withdrawing substituents.

The pattern seen for monosubstituted münchnones reacting with methyl propiolate is also seen for disubstituted acetylenic dipolarophiles (Table 23). Again, the product that is formed is consistent with the asymmetrical transition state model shown in Figure 52. For disubstituted münchnones reacting with disubstituted acetylenic dipolarophiles, we see that the reactions are highly regioselective. However, the regioselectivity seems to be completely uninfluenced by the groups at  $R_1$  and  $R_2$ . For example, when similar groups are exchanged at  $R_1$  and  $R_2$  (Table 23, entries 4 & 5, 6 & 7, 8 & 9, and 10 & 11), the product distributions do not change.

**Table 22. Summary of mono- and disubstituted münchnone reactions methyl propiolate, ethyl propiolate, benzoyl acetylene, and phenyl acetylene.**

Group	entry	Substitution				% Regioisomer		
		Monosubstituted münchnones, with methyl propiolate	1	R = CH <sub>3</sub>	R <sub>1</sub> = (CH <sub>3</sub> ) <sub>2</sub> CH	R <sub>2</sub> = H	R <sub>3</sub> = CO <sub>2</sub> CH <sub>3</sub>	
	2	R = CH <sub>3</sub>	R <sub>1</sub> = H	R <sub>2</sub> = (CH <sub>3</sub> ) <sub>2</sub> CH	R <sub>3</sub> = CO <sub>2</sub> CH <sub>3</sub>	25	75	Ref. <sup>12</sup>
	3	R = CH <sub>3</sub>	R <sub>1</sub> = (CH <sub>3</sub> ) <sub>3</sub> C	R <sub>2</sub> = H	R <sub>3</sub> = CO <sub>2</sub> CH <sub>3</sub>	67	33	Ref. <sup>12</sup>
	4	R = CH <sub>3</sub>	R <sub>1</sub> = PhCH <sub>2</sub>	R <sub>2</sub> = H	R <sub>3</sub> = CO <sub>2</sub> CH <sub>3</sub>	83	17	Ref. <sup>12</sup>
	5	R = CH <sub>3</sub>	R <sub>1</sub> = H	R <sub>2</sub> = PhCH <sub>2</sub>	R <sub>3</sub> = CO <sub>2</sub> CH <sub>3</sub>	16	84	Ref. <sup>12</sup>
	6	R = CH <sub>3</sub> CH <sub>2</sub>	R <sub>1</sub> = CH <sub>3</sub>	R <sub>2</sub> = H	R <sub>3</sub> = CO <sub>2</sub> CH <sub>3</sub>	84	16	Ref. <sup>14</sup>
	7	R = CH <sub>3</sub> CH <sub>2</sub>	R <sub>1</sub> = H	R <sub>2</sub> = CH <sub>3</sub>	R <sub>3</sub> = CO <sub>2</sub> CH <sub>3</sub>	25	75	Ref. <sup>15</sup>
	8	R = CH <sub>3</sub> CH <sub>2</sub>	R <sub>1</sub> = Ph	R <sub>2</sub> = H	R <sub>3</sub> = CO <sub>2</sub> CH <sub>3</sub>	86	14	Ref. <sup>14</sup>
	9	R = CH <sub>3</sub> CH <sub>2</sub>	R <sub>1</sub> = H	R <sub>2</sub> = Ph	R <sub>3</sub> = CO <sub>2</sub> CH <sub>3</sub>	25	75	Ref. <sup>14</sup>
	10	R = Ph	R <sub>1</sub> = H	R <sub>2</sub> = CF <sub>3</sub>	R <sub>3</sub> = CO <sub>2</sub> CH <sub>3</sub>	90	10	Ref. <sup>16</sup>

Disubstituted münchnones, with methyl propiolate	11	R = CH <sub>3</sub>	R <sub>1</sub> = (CH <sub>3</sub> ) <sub>2</sub> CH	R <sub>2</sub> = CH <sub>3</sub>	R <sub>3</sub> = CO <sub>2</sub> CH <sub>3</sub>	23	77	Ref. <sup>12</sup>
	12	R = CH <sub>3</sub>	R <sub>1</sub> = CH <sub>3</sub>	R <sub>2</sub> = (CH <sub>3</sub> ) <sub>2</sub> CH	R <sub>3</sub> = CO <sub>2</sub> CH <sub>3</sub>	67	33	Ref. <sup>12</sup>
	13	R = CH <sub>3</sub>	R <sub>1</sub> = CH <sub>3</sub>	R <sub>2</sub> = CH <sub>3</sub> CH <sub>2</sub>	R <sub>3</sub> = CO <sub>2</sub> CH <sub>3</sub>	55	45	Ref. <sup>12</sup>
	14	R = CH <sub>3</sub>	R <sub>1</sub> = Ph	R <sub>2</sub> = CH <sub>3</sub>	R <sub>3</sub> = CO <sub>2</sub> CH <sub>3</sub>	48	52	Ref. <sup>15</sup>
	15	R = CH <sub>3</sub>	R <sub>1</sub> = CH <sub>3</sub>	R <sub>2</sub> = Ph	R <sub>3</sub> = CO <sub>2</sub> CH <sub>3</sub>	65	35	Ref. <sup>15</sup>
	16	R = CH <sub>3</sub> CH <sub>2</sub>	R <sub>1</sub> = Ph	R <sub>2</sub> = 4-NO <sub>2</sub> Ph	R <sub>3</sub> = CO <sub>2</sub> CH <sub>3</sub>	50	50	Ref. <sup>15</sup>
	17	R = CH <sub>3</sub> CH <sub>2</sub>	R <sub>1</sub> = CH <sub>3</sub>	R <sub>2</sub> = Ph	R <sub>3</sub> = CO <sub>2</sub> CH <sub>3</sub>	57	43	Ref. <sup>14</sup>
	18	R = CH <sub>3</sub> CH <sub>2</sub>	R <sub>1</sub> = Ph	R <sub>2</sub> = CH <sub>3</sub>	R <sub>3</sub> = CO <sub>2</sub> CH <sub>3</sub>	38	62	Ref. <sup>14</sup>
	19	R = CH <sub>3</sub> CH <sub>2</sub>	R <sub>1</sub> = PhCH <sub>2</sub>	R <sub>2</sub> = CH <sub>3</sub>	R <sub>3</sub> = CO <sub>2</sub> CH <sub>3</sub>	45	55	Ref. <sup>16</sup>
	20	R = Ph	R <sub>1</sub> = CH <sub>3</sub>	R <sub>2</sub> = Ph	R <sub>3</sub> = CO <sub>2</sub> CH <sub>3</sub>	65	35	Ref. <sup>15</sup>
	21	R = Ph	R <sub>1</sub> = Ph	R <sub>2</sub> = CH <sub>3</sub>	R <sub>3</sub> = CO <sub>2</sub> CH <sub>3</sub>	35	65	Ref. <sup>15</sup>
Mono- and disubstituted münchnones, with ethyl propiolate	22	R = CH <sub>3</sub>	R <sub>1</sub> = Ph	R <sub>2</sub> = H	R <sub>3</sub> = CO <sub>2</sub> Et	75	25	Ref. <sup>14</sup>
	23	R = CH <sub>3</sub>	R <sub>1</sub> = H	R <sub>2</sub> = Ph	R <sub>3</sub> = CO <sub>2</sub> Et	14	86	Ref. <sup>14</sup>
	24	R = CH <sub>3</sub>	R <sub>1</sub> = CH <sub>3</sub>	R <sub>2</sub> = H	R <sub>3</sub> = CO <sub>2</sub> Et	84	16	Ref. <sup>14</sup>
	25	R = CH <sub>3</sub>	R <sub>1</sub> = H	R <sub>2</sub> = CH <sub>3</sub>	R <sub>3</sub> = CO <sub>2</sub> Et	25	75	Ref. <sup>14</sup>
	26	R = CH <sub>3</sub>	R <sub>1</sub> = Ph	R <sub>2</sub> = CH <sub>3</sub>	R <sub>3</sub> = CO <sub>2</sub> Et	38	62	Ref. <sup>14</sup>
	27	R = CH <sub>3</sub>	R <sub>1</sub> = CH <sub>3</sub>	R <sub>2</sub> = Ph	R <sub>3</sub> = CO <sub>2</sub> Et	43	57	Ref. <sup>14</sup>
Mono- and Disubstituted münchnones, with	28	R = CH <sub>3</sub>	R <sub>1</sub> = Ph	R <sub>2</sub> = H	R <sub>3</sub> = CPh	75	25	Ref. <sup>14</sup>
	29	R = CH <sub>3</sub>	R <sub>1</sub> = H	R <sub>2</sub> = Ph	R <sub>3</sub> = CPh	0	100	Ref. <sup>14</sup>
	30	R = CH <sub>3</sub>	R <sub>1</sub> = CH <sub>3</sub>	R <sub>2</sub> = H	R <sub>3</sub> = CPh	80	20	Ref. <sup>14</sup>

benzoyl acetylene	31	R = CH <sub>3</sub>	R <sub>1</sub> = H	R <sub>2</sub> = CH <sub>3</sub>	R <sub>3</sub> = COPh	0	100	Ref. <sup>14</sup>
	32	R = CH <sub>3</sub>	R <sub>1</sub> = Ph	R <sub>2</sub> = CH <sub>3</sub>	R <sub>3</sub> = COPh	2	98	Ref. <sup>14</sup>
	33	R = CH <sub>3</sub>	R <sub>1</sub> = CH <sub>3</sub>	R <sub>2</sub> = Ph	R <sub>3</sub> = COPh	18	82	Ref. <sup>14</sup>
Monosubstituted münchnones, with phenylacetylene	34	R = CH <sub>3</sub>	R <sub>1</sub> = Ph	R <sub>2</sub> = H	R <sub>3</sub> = Ph	100	0	Ref. <sup>14</sup>
	35	R = CH <sub>3</sub>	R <sub>1</sub> = CH <sub>3</sub>	R <sub>2</sub> = H	R <sub>3</sub> = Ph	100	0	Ref. <sup>14</sup>
	36	R = CH <sub>3</sub>	R <sub>1</sub> = Ph	R <sub>2</sub> = CH <sub>3</sub>	R <sub>3</sub> = Ph	98	2	Ref. <sup>14</sup>
	37	R = CH <sub>3</sub>	R <sub>1</sub> = CH <sub>3</sub>	R <sub>2</sub> = Ph	R <sub>3</sub> = Ph	99	1	Ref. <sup>14</sup>
	38	R = Bn	R <sub>1</sub> = Ph	R <sub>2</sub> = CH <sub>3</sub>	R <sub>3</sub> = Ph	>98	<2	Ref. <sup>12</sup>
	39	R = Bn	R <sub>1</sub> = CH <sub>3</sub>	R <sub>2</sub> = CH <sub>3</sub>	R <sub>3</sub> = Ph	100	0	Ref. <sup>17</sup>

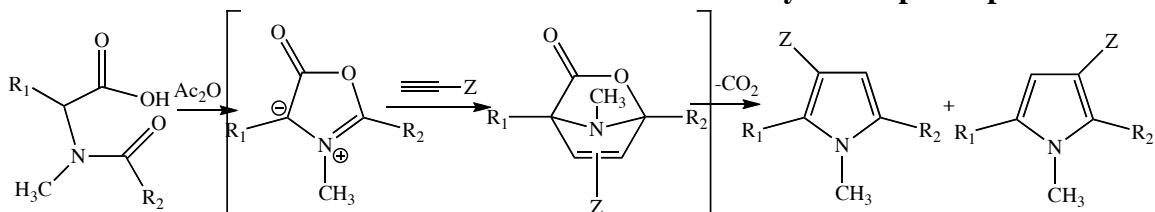


**Table 23. Summary of mono- and disubstituted münchnone reactions with disubstituted dipolarophiles.**

entry	Substitution					% Regioisomer		
1	R = CH <sub>3</sub>	R <sub>1</sub> = PhS	R <sub>2</sub> = H	R <sub>3</sub> = CO <sub>2</sub> CH <sub>3</sub>	R <sub>4</sub> = H	57	43	Ref. <sup>12</sup>
2	R = CH <sub>3</sub>	R <sub>1</sub> = PhS	R <sub>2</sub> = H	R <sub>3</sub> = CO <sub>2</sub> CH <sub>3</sub>	R <sub>4</sub> = CH <sub>3</sub>	25	75	Ref. <sup>12</sup>
3	R = CH <sub>3</sub>	R <sub>1</sub> = PhS	R <sub>2</sub> = H	R <sub>3</sub> = CO <sub>2</sub> CH <sub>3</sub>	R <sub>4</sub> = Ph	67	33	Ref. <sup>12</sup>
4	R = CH <sub>3</sub>	R <sub>1</sub> = Ph	R <sub>2</sub> = CH <sub>3</sub>	R <sub>3</sub> = CO <sub>2</sub> CH <sub>3</sub>	R <sub>4</sub> = Ph	95	5	Ref. <sup>15</sup>
5	R = CH <sub>3</sub>	R <sub>1</sub> = CH <sub>3</sub>	R <sub>2</sub> = Ph	R <sub>3</sub> = CO <sub>2</sub> CH <sub>3</sub>	R <sub>4</sub> = Ph	95	5	Ref. <sup>15</sup>
6	R = CH <sub>3</sub>	R <sub>1</sub> = Ph	R <sub>2</sub> = 4-MeO-Ph	R <sub>3</sub> = CO <sub>2</sub> CH <sub>3</sub>	R <sub>4</sub> = Ph	100	0	Ref. <sup>15</sup>
7	R = CH <sub>3</sub>	R <sub>1</sub> = 4-Me-Ph	R <sub>2</sub> = Ph	R <sub>3</sub> = CO <sub>2</sub> CH <sub>3</sub>	R <sub>4</sub> = Ph	100	0	Ref. <sup>15</sup>
8	R = CH <sub>3</sub>	R <sub>1</sub> = Ph	R <sub>2</sub> = 4-NO <sub>2</sub> -Ph	R <sub>3</sub> = CO <sub>2</sub> CH <sub>3</sub>	R <sub>4</sub> = Ph	100	0	Ref. <sup>15</sup>
9	R = CH <sub>3</sub>	R <sub>1</sub> = 3-NO <sub>2</sub> Ph	R <sub>2</sub> = Ph	R <sub>3</sub> = CO <sub>2</sub> CH <sub>3</sub>	R <sub>4</sub> = Ph	100	0	Ref. <sup>15</sup>
10	R = Ph	R <sub>1</sub> = Ph	R <sub>2</sub> = CH <sub>3</sub>	R <sub>3</sub> = CO <sub>2</sub> CH <sub>3</sub>	R <sub>4</sub> = Ph	90	10	Ref. <sup>15</sup>
11	R = Ph	R <sub>1</sub> = CH <sub>3</sub>	R <sub>2</sub> = Ph	R <sub>3</sub> = CO <sub>2</sub> CH <sub>3</sub>	R <sub>4</sub> = Ph	90	10	Ref. <sup>15</sup>

We have been studying the factors that influence the regioselectivity of 1,3 dipolar cycloadditions of substituted münchnones with acetylenic dipolarophiles to yield pyrrole regioisomers (Scheme 5).

**Scheme 5. Reactions of substituted münchnones with acetylenic dipolarophiles.**



When simple (i.e., R<sub>1</sub>, R<sub>2</sub> = H, alkyl) asymmetrically substituted münchnones undergo cycloaddition with methyl propiolate, there is a consistent trend to produce the 3-pyrrolecarboxylate in a 3-to-4:1 ratio.<sup>18-22</sup> Frontier molecular orbital (FMO) electronic distribution substituent effects are generally the primary factor used to explain the regioselectivity of these reactions.<sup>18-22</sup> However, there are exceptions. Our group prepared a series of electronically divergent arylthio-substituted münchnones whose ratio of cycloaddition products were inconsistent with predictions based on FMO considerations, even though these same substituents were previously used successfully to direct the regioselectivity of Diels-Alder cycloaddition reactions.<sup>23,24</sup> As shown in Table 24, the results of these experiments show essentially no difference in regioselectivity regardless of the arylthio substituent used, although the selectivity is in the direction predicted from FMO control.<sup>18-22</sup> Interestingly, the benzyl substituted compound (“Ar” = “PhCH<sub>2</sub>”) shows the same regioselectivity as the four arylthio groups, which is also inconsistent with the more pronounced electronic effect that the arylthio groups are generally predicted to have relative to an alkyl group.

**Table 24. Reactions of electronically divergent arylthio-substituted münchnones with methyl propiolate.**

<b>1a</b> <sup>12</sup>	Ar = PhCH <sub>2</sub> -	83	17
<b>1b</b> <sup>12</sup>	Ar = <i>p</i> -CH <sub>3</sub> OPhS-	80	20
<b>1c</b> <sup>12</sup>	Ar = PhS-	82	18
<b>1d</b> <sup>12</sup>	Ar = <i>m</i> -CF <sub>3</sub> PhS-	84	16
<b>1e</b> <sup>12</sup>	Ar = <i>p</i> -NO <sub>2</sub> PhS-	84	16

\* N-Formyl- $\alpha$ -arylthioamino acids were prepared according to the general method of amidoalkylation of thiols described in: Zoller, U.; Ben-Ishai, D. *Tetrahedron* **1975**, *31*, 863-866.

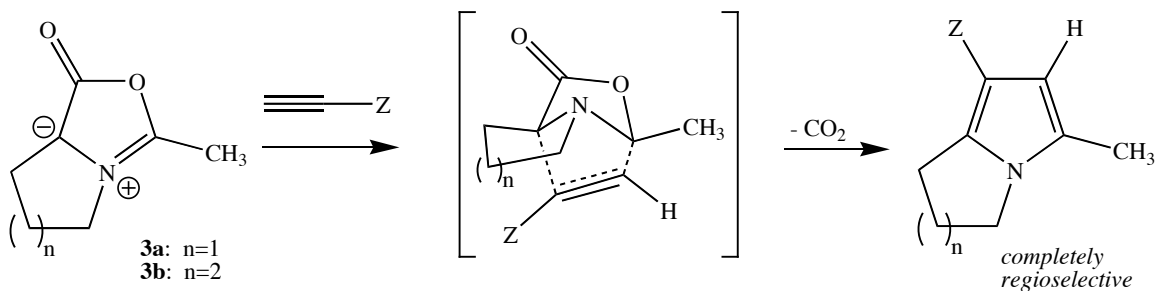
Previously, our group has prepared a series of regioisomeric pairs in order to establish the regiochemical contribution of the asymmetrical mesoionic heterocycle. The results from entries **2a** and **2b** (Table 25) show that there is likely little contribution to the regioselectivity of these reactions by the mesoionic heterocycle. In order to test this conclusion, a pair of regioisometric dipoles differing only in the position of <sup>13</sup>C labeled substituents was prepared. The results from these experiments (entries **2c**, **2d**, **2e**; Table 25) show that there is little regioselective bias that can be assigned to the mesoionic heterocycle. These results provide further evidence that the distribution of isomers can be predicted by an unsymmetrical transition state in which the less-encumbered end of the dipole bonds to the less-encumbered end of the dipolarophile (Figure 52).

**Table 25. Reactions of regioisomeric pairs of münchnones with methyl propiolate.**

<b>2a</b> <sup>12</sup>	R <sub>1</sub> = PhCH <sub>2</sub> , R <sub>2</sub> = H <sup>25</sup>	83	17
<b>2b</b> <sup>12</sup>	R <sub>1</sub> = H, R <sub>2</sub> = PhCH <sub>2</sub> <sup>26</sup>	16	84
<b>2c</b> <sup>12</sup>	R <sub>1</sub> = CH <sub>3</sub> , R <sub>2</sub> = <sup>13</sup> CH <sub>3</sub>	55	45
<b>2d</b> <sup>12</sup>	R <sub>1</sub> = <sup>13</sup> CH <sub>3</sub> , R <sub>2</sub> = CH <sub>3</sub>	53	47
<b>2e</b> <sup>12</sup>	R <sub>1</sub> = CH <sub>3</sub> , R <sub>2</sub> = CH <sub>3</sub>	same compound	

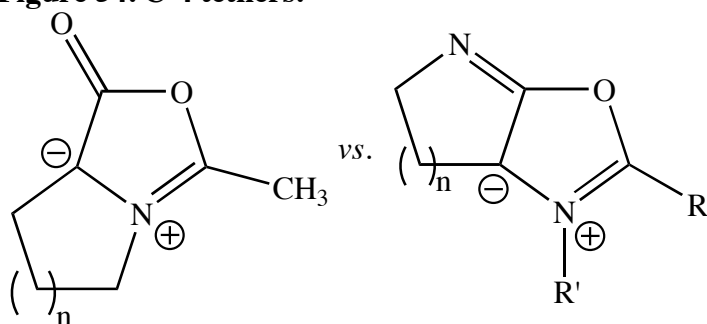
Comparing entries **2d** and **2e** with Pizzorno's work<sup>27,28</sup> (Scheme 6) provides further evidence for our unsymmetrical transition state. We have proposed that the difference in regioselectivity demonstrated by this comparison is due to the increased ability of the unconstrained terminus to achieve a pyramidal shape of C-2 centers in **3a** and **3b** in the transition state, which allows a greater degree of bond formation with the  $\beta$ -carbon of the dipolarophile.

**Scheme 6. Tethered münchnone reactions with acetylenic dipolarophiles.**

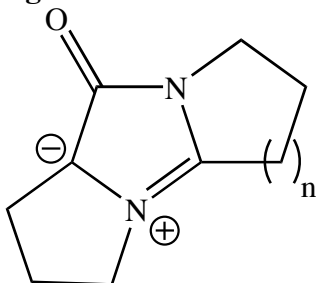


We conceived of three methods for tethering substituents. Situations such as **3a** and **3b** involve tethering a substituent from C-4 center to the mesoionic nucleus. We can also envision compounds in which the carbonyl oxygen atom is replaced with a nitrogen atom, and the C-4 substituent is fused at C-5 creating an imidate (Figure 54). Previous work from our laboratory<sup>29</sup> has examined the use of doubly tethered compounds with substituents at C-2 and C-4 (Figure 55).

**Figure 54. C-4 tethers.**



**Figure 55. C-2 and C-4 tethers.**



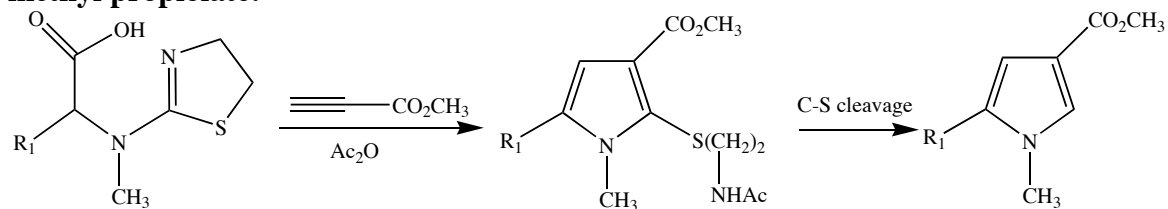
The results of the cycloaddition of N-(2-pyrrolynyl)-N-methylalanine and N-(2-pyrrolynyl)-sarcosine [0.5-0.6 M in Ac<sub>2</sub>O or Ac<sub>2</sub>O/toluene; 65-75 °C, 2-4 hr; stoichiometric to a 3-fold excess of dimethyl acetylenedicarboxylate (DMAD) or methyl propiolate; 0.01 mL triethyl amine or Hünig's base] are shown in Table 26.<sup>29</sup> These cycloadditions proceeded in good yields with high regioselectivity. Again, the regioselectivity conforms to our hypothesis that the center with the untethered substituent will preferentially combine with the β-carbon of the dipolarophile.

**Table 26. Reactions of N-(2-pyrrolinyl)-N-methylalanine and N-(2-pyrrolinyl)-sarcosine with dimethyl acetylenedicarboxylate (DMAD) or methyl propiolate.**

<b>4a</b>	$R_1 = \text{CH}_3,$ $R_2 = \text{CO}_2\text{CH}_3$	74% yield
<b>4b</b>	$R_1 = \text{CH}_3,$ $R_2 = \text{H}$	71% yield
<b>4c</b>	$R_1 = \text{Ac}$ $R_2 = \text{CO}_2\text{CH}_3$	50% yield

Following these results, our group attempted to prepare a series of 2,4-disubstituted pyrroles from N-(2-thiazolanyl) secondary amino acid derivatives via the scheme shown in Scheme 7. We believed that such cycloadditions would also demonstrate high regioselectivity, analogous to those shown by the N-(2-pyrrolinyl) derivatives. Hydrogenolysis of the carbon-sulfur bond would then yield a pyrrole representing the opposite regioselectivity from that observed from the analogous münchnones.

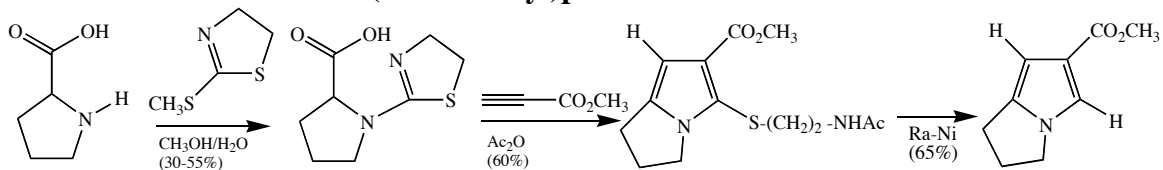
**Scheme 7. Reactions of N-(2-thiazolanyl) secondary amino acid derivatives with methyl propiolate.**



The first attempt<sup>29</sup> involved creating N-(2-thiazolanyl)proline by reacting proline with 2-(methylthio)thiazoline in methanol/water at room temperature. The N-(2-thiazolanyl)proline was then reacted under standard cycloaddition conditions with methyl

propiolate to produce the pyrrole product. Hydrogenolysis of the cycloadduct over Raney-nickel gave the final pyrrole product. (Scheme 8)

**Scheme 8. Formation of N-(2-thiazolanyl)proline.**

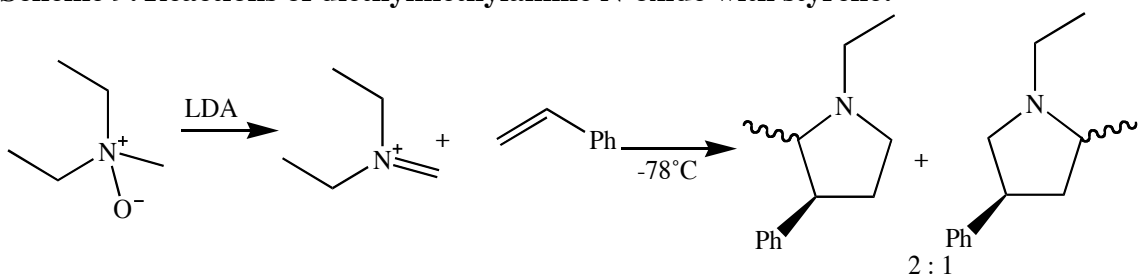


Additional reactions were attempted with derivatives of other N-methylamino acids. However, using sarcosine to prepare the N-(2-thiazolanyl)sarcosine resulted in only about 5% conversion, spectroscopically, and less was isolated. Reactions with N-methylalanine provided only a trace of the thiazolanyl compound spectroscopically and none was isolated. Reactions with N-methylvaline, N-methylleucine, N-methylisoleucine, and N-methylphenylalanine were also unsuccessful, yielding only unreacted starting materials.<sup>29</sup>

**REGIOSELECTIVITY WITH OLEFINIC DIPOLAROPHILES**

Another aspect of our work is examining the regioselectivity of 1,3-dipolar cycloadditions involving münchnones and olefinic dipolarophiles. Unsymmetrical olefins have been used as dipolarophiles in cycloadditions with various dipoles. For example, Chastanet and Roussi<sup>30</sup> used styrene as the dipolarophile in an addition to diethylmethylamine N-oxide (Scheme 9). In this case, the product distribution can be predicted either by FMO predictions, or by proposing an asymmetrical transition state similar to the one we have proposed for reactions of münchnones with acetylenic dipolarophiles.

**Scheme 9. Reactions of diethylmethylamine N-oxide with styrene.**



Ali, et. al.<sup>31</sup> examined the regioselectivity of the reactions of unsymmetrical olefins to cyclic nitrones. (Table 27) Reactions with electron-rich mono- and disubstituted olefins as dipolarophiles are regiospecific with the substituted terminus of the alkene bonding with the oxygen terminus of the nitronium. Electron-poor olefinic dipolarophiles can show a mixture of regioisomers, or reversal of this regiospecificity. These results are consistent with FMO theory.

**Table 27. Reactions of cyclic nitrones with unsymmetrical olefins.**


Nitronium		Substitution		% Regioisomer	
1	R <sub>1</sub> = Ph	R <sub>2</sub> = CO <sub>2</sub> CH <sub>3</sub>	92	8	
2			87	13	
1	R <sub>1</sub> = CH <sub>3</sub>	R <sub>1</sub> = CO <sub>2</sub> CH <sub>3</sub>	93	7	
2			90	10	
1	R <sub>1</sub> = CH <sub>2</sub> OH	R <sub>1</sub> = CO <sub>2</sub> CH <sub>3</sub>	85	15	
2			77	23	
1	R <sub>1</sub> = CO <sub>2</sub> CH <sub>3</sub>	R <sub>2</sub> = CO <sub>2</sub> CH <sub>3</sub>	45	55	



2		60	40
1	$R_1 = \text{CO}_2\text{CH}_3$	$R_2 = \text{CO}_2\text{CH}_3$	83
2	( <i>cis</i> )		84

Reactions using  $\alpha,\beta$  unsaturated sulfones with diazomethane have shown that the vinyl sulfones can be used to form pyrazolines.<sup>32</sup> The results are shown in Table 28.

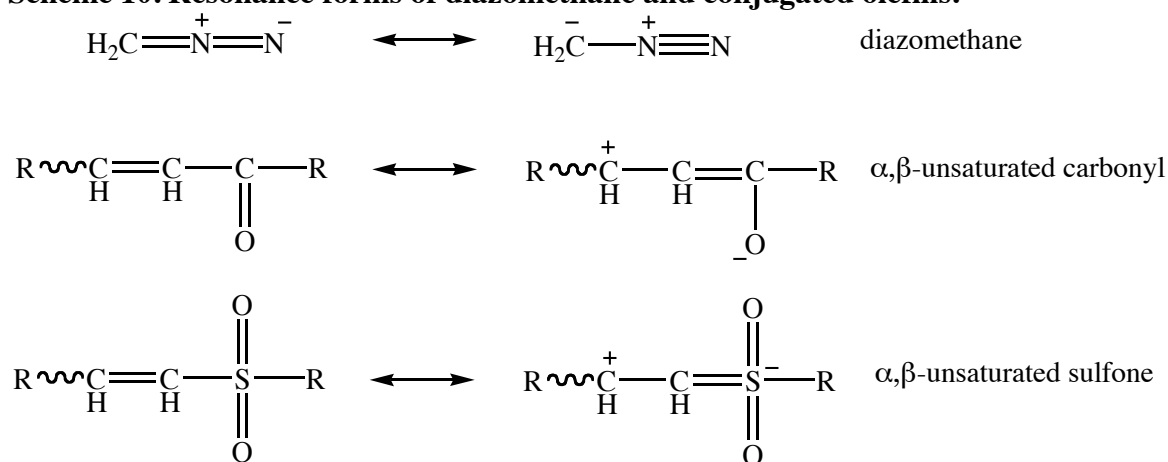
**Table 28. Reactions of diazomethane with vinyl sulfones.**

				
entry	Substitution		% Regioisomer	
1	R = H	$R_1 = \text{Ph}$	100	0
2	<i>trans</i> R = CH <sub>3</sub>	$R_1 = \text{Ph}$	100	0
3	<i>trans</i> R = CH <sub>3</sub>	$R_1 = \text{Ph}$	100	0
4	<i>cis</i> R = Ph	$R_1 = n\text{-C}_4\text{H}_9$	30	70
5	<i>trans</i> R = Ph	$R_1 = \text{CH}_3$	29	71
6	<i>cis</i> R = Ph	$R_1 = \text{CH}_3$	30	70
7	<i>cis</i> R = Ph	$R_1 = \text{Ph}$	25	75

These results were important because, to that time, only the formation of the 3-substituted sulfone regioisomer had been reported for reactions between diazomethane and conjugated olefins. The product distribution is dependent on the nature of R. When R is an alkyl group, only 3-substituted products are formed. When the R group is aromatic, 4-substituted groups are formed preferentially. In addition, the stereochemistry of the sulfone does not appear to alter the product distribution (entries 5 and 6). By examining the resonance form of diazomethane (Scheme 10), we can conclude that the carbon atom is the most nucleophilic atom in the molecule. Resonance forms of conjugated olefins

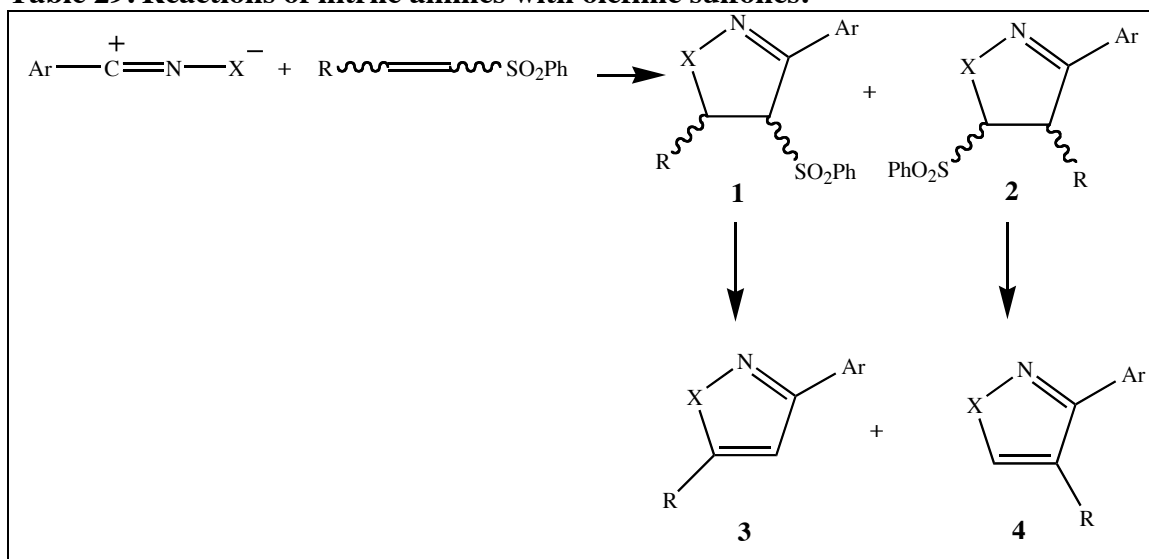
such as an  $\alpha,\beta$ -unsaturated carbonyl show that the  $\beta$  carbon is the most electrophilic atom. The product distribution is therefore determined by the charge densities of these atoms. For  $\alpha,\beta$ -unsaturated sulfone groups, however, the resonance effects are less significant due to the unfavorable d-orbital involvement of the sulfur in the resonance form. Therefore, the reaction is more sensitive to changes elsewhere in the molecule, such as the R substituent.

**Scheme 10. Resonance forms of diazomethane and conjugated olefins.**



Nitrile amines have also been cycloadded to olefinic sulfones.<sup>33</sup> Table 29 shows the results of these experiments.

**Table 29. Reactions of nitrile amines with olefinic sulfones.**

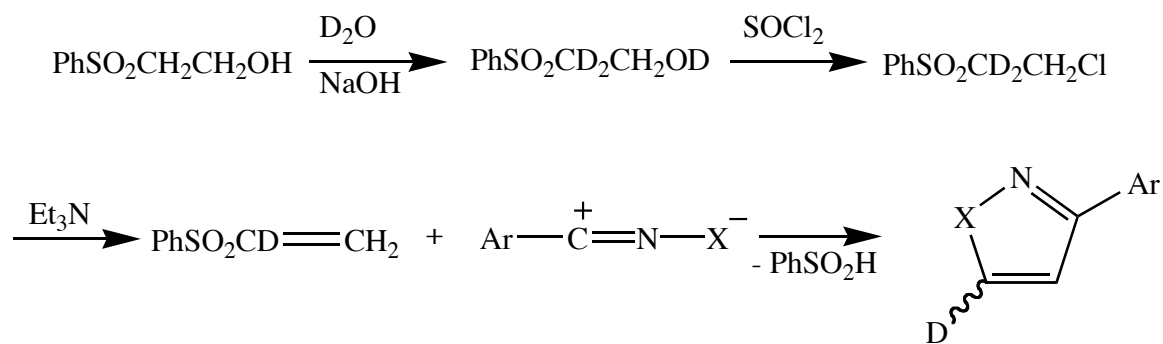


entry	Substitution			Products and Ratio
1	Ar = Ph	X = NPh	R = H	<b>3 &amp; 4 same cmpd</b>
2	Ar = Ph	X = NPh	R = CH <sub>3</sub>	<b>3 : 4 (65:35)</b>
3	Ar = Ph	X = NPh	R = Ph	<b>1 : 4 (90:10)</b>
4 <sup>17</sup>	Ar = Ph	X = NPh	R = COPh	<b>1 : 4 (95:5)</b>
5	Ar = 3,5-Cl, 2,4,6-Me	X = O	R = H	<b>1 : 2 (9:91)</b>
6	Ar = 3,5-Cl, 2,4,6-Me	X = O	R = CH <sub>3</sub>	<b>1 : 2 (90:10)</b>
7	Ar = 3,5-Cl, 2,4,6-Me	X = O	R = Ph	<b>1 : 2 (60:40)</b>
8	Ar = 3,5-Cl, 2,4,6-Me	X = O	R = COPh	<b>1 : 2 (75:25)</b>

Dalla Croce, et. al. explain the results for entries 1-4 via dipole HOMO control, and the results for entries 5-8 dipole LUMO and dipolarophile HOMO interactions.

Shimizu, et. al.<sup>34</sup> reexamined Dalla Croce's work by using 1-deuteriovinyl phenyl sulfone (Scheme 11) in order to unambiguously assign the regiochemistry of the formation of entry 1 in Table 29. For this compound, when R = H, only the final pyrazoline product is isolated and the product is identical regardless of whether compound 1 or 2 were initially formed. Dalla Croce and coworkers labeled their product 3. However, Shimizu's work demonstrates that, in fact, the final pyrazoline product is the result of the initial formation of compound 2, the 5-(phenylsulfonyl)-2-pyrazoline.

**Scheme 11. Reaction of nitrile amines with deuteriovinyl phenyl sulfone.**



Nitrile oxides have been cycloadded to (E)- and (Z)- olefinic sulfones.<sup>35</sup> In the cases reported, the results (Table 30) show these additions to be quite stereoselective for the 5-substituted phenylsulfonyl product. Again, the results are consistent with FMO theory.

**Table 30. Reactions of nitrile oxides with olefinic sulfones.**

entry	Substitution			% Regioisomer		
1	Ar = Ph	E	R = SO <sub>2</sub> Ph	84	16	
2	Ar = Ph	E	R = SO <sub>2</sub> CH <sub>3</sub>	71	29	
3	Ar = mesityl	E	R = SO <sub>2</sub> Ph	62	38	
4	Ar = mesityl	E	R = SO <sub>2</sub> CH <sub>3</sub>	43	57	
5	Ar = Ph	Z	R = SO <sub>2</sub> <i>n</i> Bu	79	21	
6	Ar = Ph	Z	R = SO <sub>2</sub> CH <sub>3</sub>	78	22	
7	Ar = mesityl	Z	R = SO <sub>2</sub> <i>n</i> Bu	95	5	
8	Ar = mesityl	Z	R = SO <sub>2</sub> CH <sub>3</sub>	98	2	

Work with an important relationship to ours is that of Jungheim, et. al.<sup>36</sup> In their report, they examined cycloadditions of pyrazolidinium ylides with vinyl sulfones. The important link to our work is that the vinyl sulfones they used were disubstituted. The reactions were highly regioselective and resulted in good yields. The results are shown in Table 31. The authors did not explain the observation of the regioselectivity of E vs. Z isomers. However, the difference in these compounds is not electronic; it is steric.

**Table 31. Reactions of pyrazolidinium ylides with disubstituted vinyl sulfones.**

entry	Substitution			% Regioisomer	
1	(E)	W = CO <sub>2</sub> CH <sub>3</sub>	R = allyl	97	3
2	(E)	W = COCH <sub>3</sub>	R = allyl	98	2
3	(E)	W = COCH <sub>3</sub>	R = <i>t</i> -butyl	98	2
4	(Z)	W = COCH <sub>3</sub>	R = <i>t</i> -butyl	5	95
5	(E)	W = COCO <sub>2</sub> Et	R = allyl	100	0
6	(E)	W = CN	R = <i>t</i> -butyl	100	0
7	(E)+(Z) 3:2	W = CN	R = <i>t</i> -butyl	86	14
8	(E)	W = H	R = allyl	100	0

#### *Specific Examples Involving Münchnones Reacting with Olefinic Dipolarophiles*

In studying the biological activity of  $\beta$ -trifluoromethyl-substituted pyrroles, Eguchi, et. al. examined the cycloaddition of münchnones to trifluoromethylated olefins.<sup>37</sup> Their results demonstrated were consistent with those of Dalla Croce<sup>14</sup> in finding that the regioselectivity was dependent on the substituent at C(2) or C(4) and that

the regioselectivity of these reactions was explained by HOMO(dipole)-LUMO(dipolarophile) control. However, the larger steric hindrance involved for the phenone (Table 32: entries 1, 2, 3; Table 33: entries 1, 2; and Table 34: entries 1, 2) versus the crotonate (Table 32: entries 4, 5, 6; Table 33: entries 3, 4; and Table 34: entry 3) increases the regioselectivity of these reactions by destabilizing the less favored transition states.

**Table 32. Reactions of münchnones with trifluoromethylated olefins.**

entry	Substitution			% Regioisomer	
1	R = Ph	R <sub>1</sub> = CH <sub>3</sub>	R <sub>2</sub> = Ph	100	0
2	R = CH <sub>3</sub>	R <sub>1</sub> = Ph	R <sub>2</sub> = Ph	100	0
3	R = Ph	R <sub>1</sub> = Ph	R <sub>2</sub> = Ph	100	0
4	R = Ph	R <sub>1</sub> = CH <sub>3</sub>	R <sub>2</sub> = OC <sub>4</sub> H <sub>9</sub>	100	0
5	R = CH <sub>3</sub>	R <sub>1</sub> = Ph	R <sub>2</sub> = OC <sub>4</sub> H <sub>9</sub>	100	0
6	R = Ph	R <sub>1</sub> = Ph	R <sub>2</sub> = OC <sub>4</sub> H <sub>9</sub>	100	0

**Table 33. Reactions of münchnones with trifluoromethylated olefins.**

entry	Substitution		% Regioisomer	
1	R <sub>1</sub> = Ph	R <sub>2</sub> = Ph	72	28
2	R <sub>1</sub> = CH <sub>3</sub>	R <sub>2</sub> = Ph	82	18

3	$R_1 = \text{Ph}$	$R_2 = \text{OC}_4\text{H}_9$	58	42
4	$R_1 = \text{CH}_3$	$R_2 = \text{OC}_4\text{H}_9$	56	44

**Table 34. Reactions of münchnones with trifluoromethylated olefins.**

entry	Substitution			% Regioisomer	
1	$R_1 = \text{Ph}$	$R_2 = \text{Ph}$		100	0
2	$R_1 = \text{CH}_3$	$R_2 = \text{Ph}$		76	24
3	$R_1 = \text{Ph}$	$R_2 = \text{OC}_4\text{H}_9$		68	32

Texier and coworkers studied an extensive series of alkene additions to münchnones.<sup>38</sup> Their results are shown in Table 35.

**Table 35. Reactions of münchnones with disubstituted olefins.**

entry	Substitution					% Regioisomer	
1	$R = \text{CH}_3$	$R_1 = \text{Ph}$	$R_2 = \text{CH}_3$	$R_3 = \text{Ph}$	$Y = \text{CO}_2\text{Me}$	0	100
2	$R = \text{CH}_3$	$R_1 = \text{CH}_3$	$R_2 = \text{Ph}$	$R_3 = \text{Ph}$	$Y = \text{CO}_2\text{Me}$	100	0
3	$R = \text{Ph}$	$R_1 = \text{Ph}$	$R_2 = \text{CH}_3$	$R_3 = \text{Ph}$	$Y = \text{CO}_2\text{Me}$	0	100
4	$R = \text{Ph}$	$R_1 = \text{CH}_3$	$R_2 = \text{Ph}$	$R_3 = \text{Ph}$	$Y = \text{CO}_2\text{Me}$	100	0
5	$R = \text{CH}_3$	$R_1 = \text{Ph}$	$R_2 = p\text{-MeOPh}$	$R_3 = \text{Ph}$	$Y = \text{CO}_2\text{Me}$	35	65

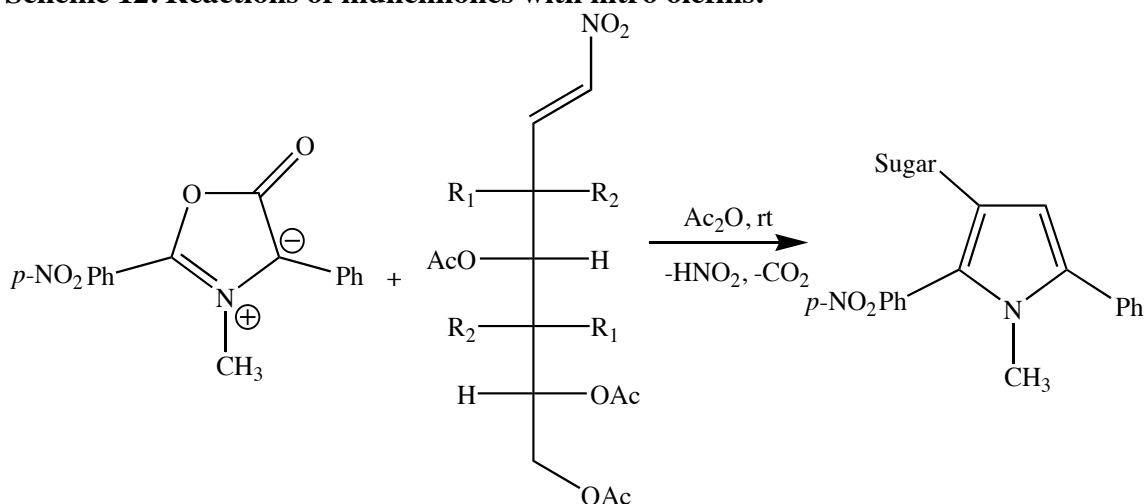
6	R = CH <sub>3</sub>	R <sub>1</sub> = <i>p</i> -MeOPh	R <sub>2</sub> = Ph	R <sub>3</sub> = Ph	Y = CO <sub>2</sub> Me	0	100
7	R = CH <sub>3</sub>	R <sub>1</sub> = Ph	R <sub>2</sub> = <i>p</i> -NO <sub>2</sub> Ph	R <sub>3</sub> = Ph	Y = CO <sub>2</sub> Me	0	100
8	R = CH <sub>3</sub>	R <sub>1</sub> = Ph	R <sub>2</sub> = CH <sub>3</sub>	R <sub>3</sub> = Ph	Y = CN	0	100
9	R = CH <sub>3</sub>	R <sub>1</sub> = CH <sub>3</sub>	R <sub>2</sub> = Ph	R <sub>3</sub> = Ph	Y = CN	60	40
10	R = Ph	R <sub>1</sub> = Ph	R <sub>2</sub> = CH <sub>3</sub>	R <sub>3</sub> = Ph	Y = CN	0	100
11	R = Ph	R <sub>1</sub> = CH <sub>3</sub>	R <sub>2</sub> = Ph	R <sub>3</sub> = Ph	Y = CN	65	35
12	R = CH <sub>3</sub>	R <sub>1</sub> = Ph	R <sub>2</sub> = <i>p</i> -MeOPh	R <sub>3</sub> = Ph	Y = CN	50	50
13	R = CH <sub>3</sub>	R <sub>1</sub> = <i>p</i> -MeOPh	R <sub>2</sub> = Ph	R <sub>3</sub> = Ph	Y = CN	0	100

Entries 1-4 are remarkably regioselective and the regioisomer formed can be predicted by using our asymmetrical transition state model applied to olefinic dipolarophiles. Entries 5 and 6 probably combine the formation of an unsymmetrical transition state and FMO effects. Entries 8-13 show that the unsymmetrical transition state model alone is not sufficient to predict the regioselectivity of these reactions. Both electronic and steric effects are at work here. As the authors state, “the influence of steric factors on the regioselectivity of the reaction is *a priori* difficult to predict.”

Jimenez<sup>39,40</sup> (Scheme 12) and Gribble<sup>41</sup> (Table 36) have used nitro olefins as dipolarophiles in cycloadditions to münchnones. The nitro group has the advantage of being a good electron-withdrawing group as well as a good leaving group, such as nitrous acid. These reactions, though highly regioselective, result in products opposite of those predicted by FMO theory.



**Scheme 12. Reactions of münchnones with nitro olefins.**



**Table 36. Reactions of münchnones with nitro olefins.**

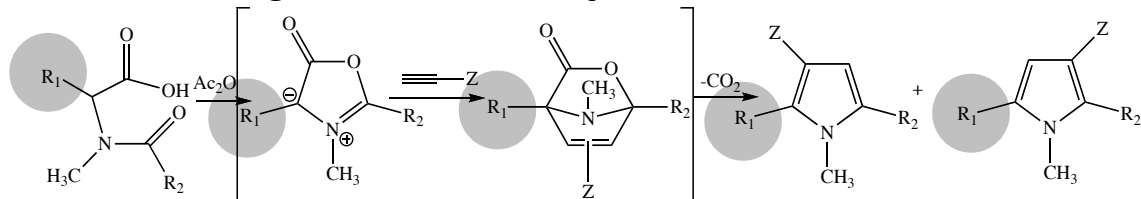
entry		Substitution		% Regioisomer	
1		R <sub>1</sub> = Ph	R <sub>2</sub> = Me	90	10
2		R <sub>1</sub> = Me	R <sub>2</sub> = Ph	85	15

**CURRENT WORK**

*Tethered Münchnones*

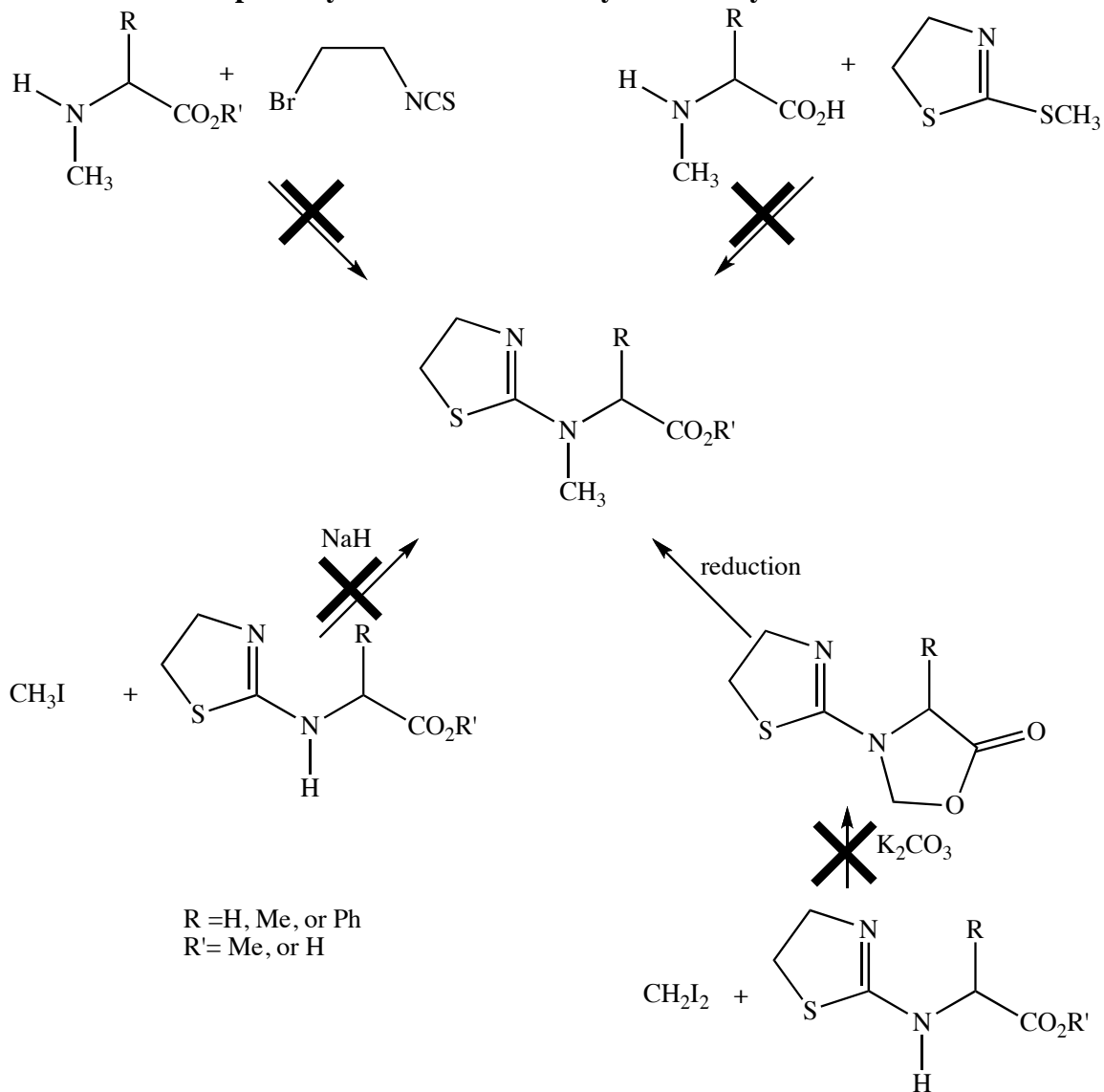
My research questions are: 1) Can 2,4 disubstituted pyrroles of the type shown in Scheme 13 be prepared in a regiocontrolled fashion based the predictions from our hypothesis of an asymmetrical transition state? and 2) Can the synthetic utility of such a scheme be shown by preparing interesting pyrrole target molecules via these methods?

**Scheme 13. Reactions of substituted münchnones with acetylenic dipolarophiles with the inclusion of a regiocontrol element at R<sub>1</sub>.**



To answer these questions, my work has been focused on efforts to synthesize N-thiazolanyl secondary amino acids. Previously, members of our laboratory attempted to introduce the thiazolanyl group on various N-methyl amino acids through condensations between N-methyl amino acids (or their esters) and 2-haloethyl isothiocyanates, reactions of sarcosine with 2-(methylthio)-2-thiazoline in alcohol/water and basic solutions. When these methods were unsuccessful, attempts were made to N-methylate N-thiazolanyl amino acids via various methods of formation and subsequent reduction of oxizolidinones from N-thiazolanyl amino acids and their esters, and also via nucleophilic substitutions with methyl iodide (Scheme 14). All of these methods were unsuccessful.

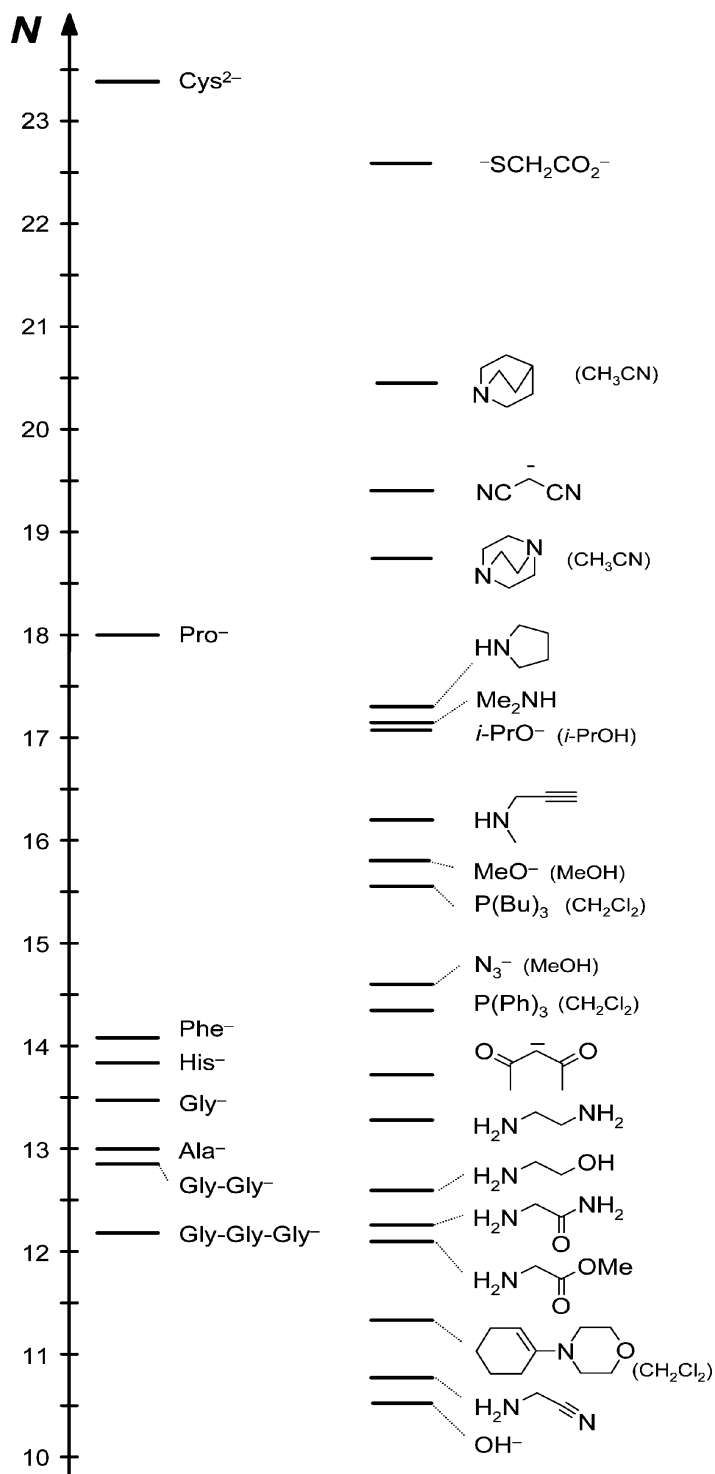
**Scheme 14. Attempts to synthesize N-thiazolanyl secondary amino acids.**



While either N-thiazolanyl or N-methyl amino acids can be synthesized from primary amino acids, the nucleophilicity of secondary amino acids appears to be too low to form N-thiazolanyl secondary amino acids. However, we have been able to prepare N-thiazolanyl proline in good yields, demonstrating the increased nucleophilicity of proline vs. other secondary amino acids. By comparison, while N-thiazolanyl proline can be

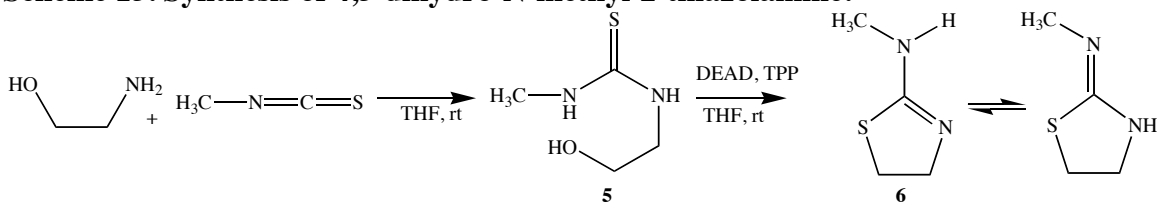
synthesized in good yields, only small amounts of N-thiazolanyl sarcosine (~5%) were formed, and for N-methylalanine, the product could only be observed spectroscopically.<sup>29</sup> Recent work by Brotzel<sup>42</sup> in which the nucleophilicities of various amino acids are compared based on the kinetics of their reaction with benzhydrylium ions confirms our experiences attempting to synthesize N-thiazolanyl secondary amino acids. Figure 56, from their paper, clearly shows the increased nucleophilicity of proline, even compared to primary amino acids.

Figure 56. Comparison of the nucleophilicities of amino acids and other nucleophiles. From Figure 7 in Brotzel, F.; Mayr, H. *Org. Biomol. Chem.* 2007, 5, 3814-3820.



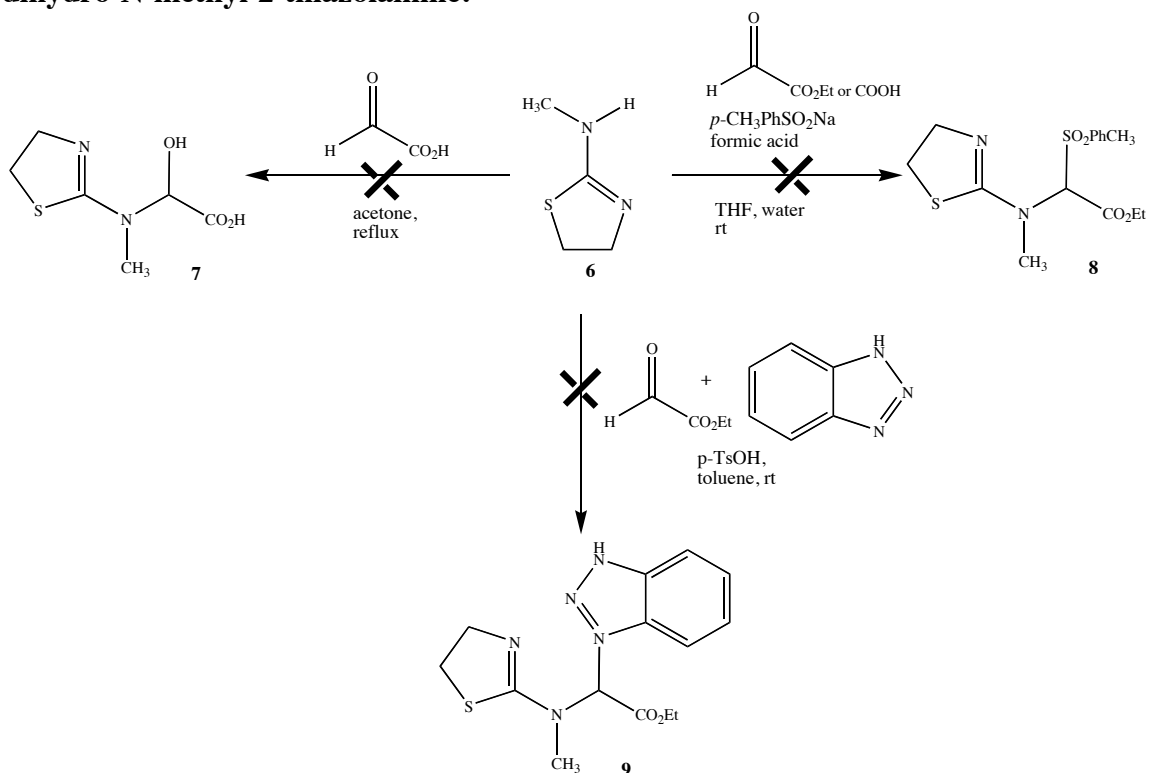
Given these previous difficulties, my approach to synthesize the N-thiazolinyl secondary amino acids starts with 4,5-dihydro-N-methyl-2-thiazolamine, which is synthesized by condensing ethanolamine with methyl isothiocyanate following a standard literature procedure.<sup>43</sup> The resulting thiourea is then cyclized under standard Mitsunobu conditions to form the thiazolamine (Scheme 15).<sup>44</sup>

**Scheme 15. Synthesis of 4,5-dihydro-N-methyl-2-thiazolamine.**

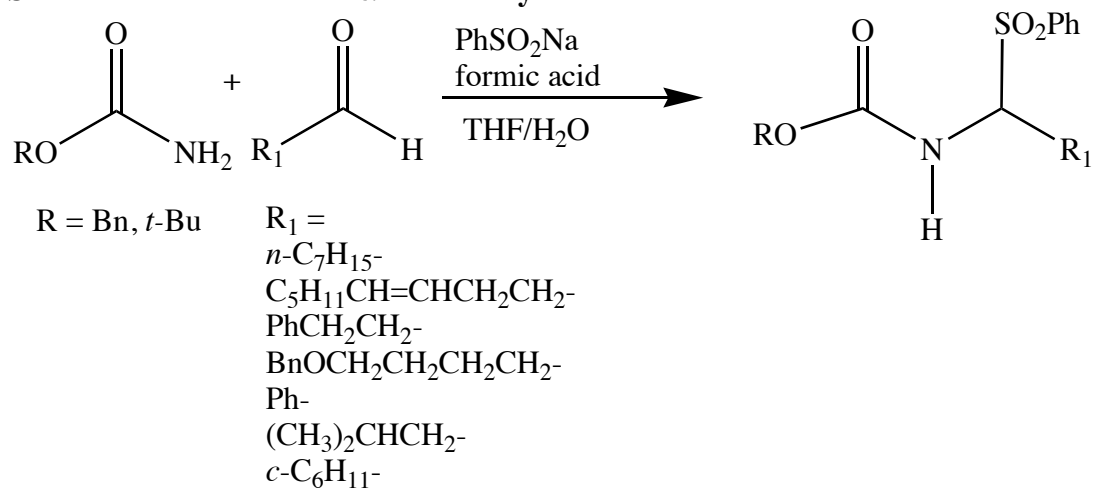


My attempts at forming the N-thiazolinyl secondary amino acids from 4,5-dihydro-N-methyl-2-thiazolamine are shown in Equation 9. Amidoalkylations with glyoxylic acid and 4,5-dihydro-N-methyl-2-thiazolamine in acetone (Scheme 16, compound 6 to 7), which we have used to make other amino acid derivatives,<sup>12</sup> were unsuccessful. These reactions were also carried out in the presence of sodium *p*-toluenesulfinate, and formic acid to form the  $\alpha$ -amidoalkyl sulfone (Scheme 16, compound 6 to 8). In the literature procedures (Scheme 17)<sup>45</sup>, these reactions gave good (70-90%) yields when *t*-butyl or benzyl carbamates were used with aldehydes containing alkyl, phenyl, ether, or alkene groups. However, our attempts using 4,5-dihydro-N-methyl-2-thiazolamine and either glyoxylic acid or ethylglyoxylate did not succeed in forming products.

**Scheme 16. Attempts to form N-thiazolanyl secondary amino acids from 4,5-dihydro-N-methyl-2-thiazolamine.**

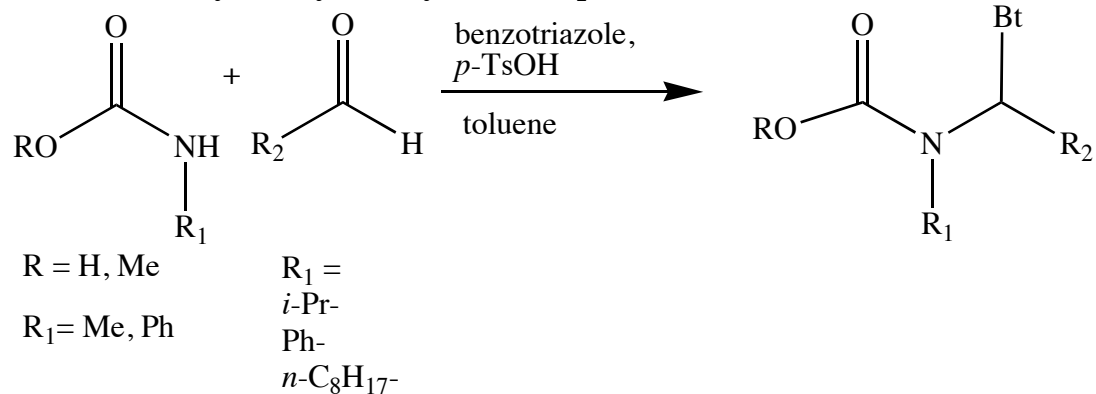


**Scheme 17. Formation of  $\alpha$ -amidoalkyl sulfones.**



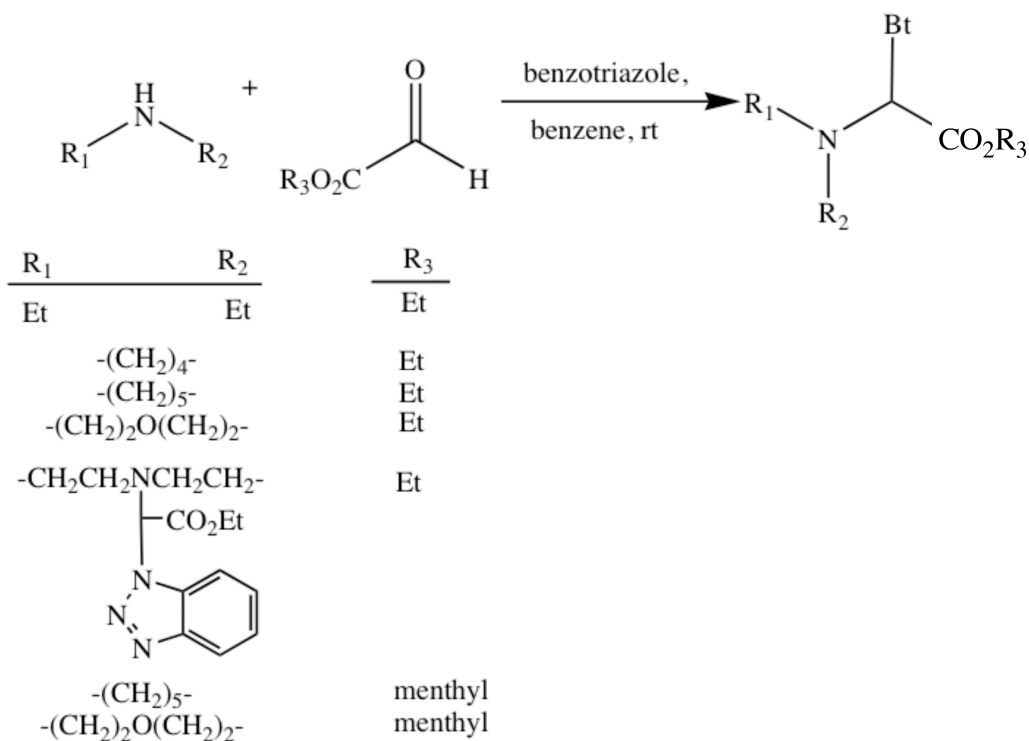
Katritzky reports the synthesis of tertiary amides using N-methyl or N-phenyl amides and simple alkyl or aryl aldehydes (Scheme 18) in the presence of benzotriazole.<sup>46</sup>

**Scheme 18. Formation of tertiary amides from reactions of N-methyl or N-phenyl amides and alkyl or aryl aldehydes in the presence of benzotriazole.**



In addition, Katritzky reports<sup>47</sup> that the synthesis of  $\alpha$ -(dialkylamino) esters can be performed by condensing ethyl glyoxylate with a primary aromatic or secondary aliphatic amine and benzotriazole as shown in Scheme 19.

**Scheme 19. Synthesis of  $\alpha$ -(dialkylamino) esters from ethyl glyoxylate with a primary aromatic or secondary aliphatic amine in the presence of benzotriazole.**

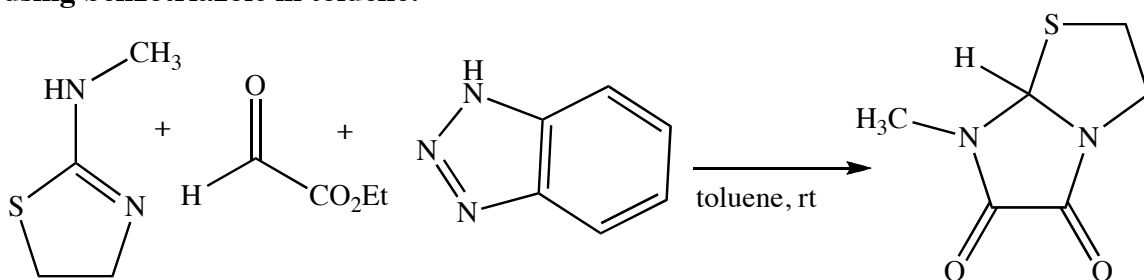


Given these precedents, I attempted reactions with the thiazolamine and ethyl glyoxylate using benzotriazole in toluene. However, they did not result in the predicted



benzotriazole derivative **9** (Scheme 16, compound 6 to 9) regardless of alterations in solvent, reaction temperature, and reaction times. Instead of producing the expected product, a bicyclic compound (**10**) was produced as shown in Scheme 20. The structure of the product was verified by  $^1\text{H}$  and  $^{13}\text{C}$  NMR spectra, a  $^{13}\text{C}$  DEPT experiment, mass and IR spectra, as well as X-RAY diffraction. This product was not formed if benzotriazole was not present. However *p*-TsOH was not necessary for product formation and reaction mixtures with less than one equivalent of benzotriazole showed less conversion.

**Scheme 20. Formation of a bicyclic product from thiazolamine, ethyl glyoxylate, using benzotriazole in toluene.**



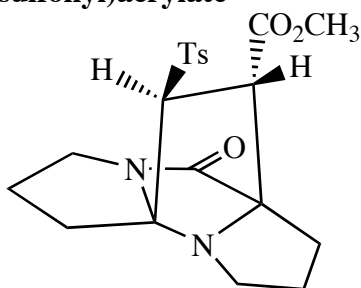
#### *Regiochemistry of Cycloadditions involving Olefinic Sulfoxes as Dipolarophiles*

The difficulty in extrapolating general trends regarding the regioselectivity of 1,3 dipolar cycloadditions with asymmetrically substituted olefinic dipolarophiles is illustrated by the brief review of work described above. Few coherent series exist in which only one substituent is modified at a time. Table 22, for example, is work culled from four different references. It is difficult to make conclusions from these reports because the influence of the structures of R, R<sub>1</sub>, R<sub>2</sub>, and R<sub>3</sub> is not examined systematically. So then, we propose to examine a systematic series of münchnones using examples already reported in the literature and their cycloaddition reactions, with a complementary series of sulfonylacrylates.

Our laboratory is interested in examining the regioselectivity of 1,3 dipolar cycloadditions of münchnones with (E)<sup>36</sup> and (Z)- $\beta$ -(toluenesulfonyl)acrylate<sup>48</sup>, and  $\alpha$ -(toluenesulfonyl)-acrylate.<sup>49</sup> Olefinic compounds such as this are attractive as dipolarophiles due to their synthetic utility. While acetylenic compounds produce only pyrrole ring systems when they react with münchnones, olefinic compounds can produce a wide variety of other ring systems and, optionally, give pyrroles if elimination after cycloaddition allows them to be acetylene equivalents.

We have some experience with using olefinic sulfone compounds as dipolarophiles. We have reported that the synthesis of the cycloadduct (Figure 57) of a mesoionic 1,3 imidazolium-4-olate with methyl (E)- $\beta$ -(toluenesulfonyl)acrylate is completely stereoselective, regioselective, and apparently stereospecific.<sup>50</sup>

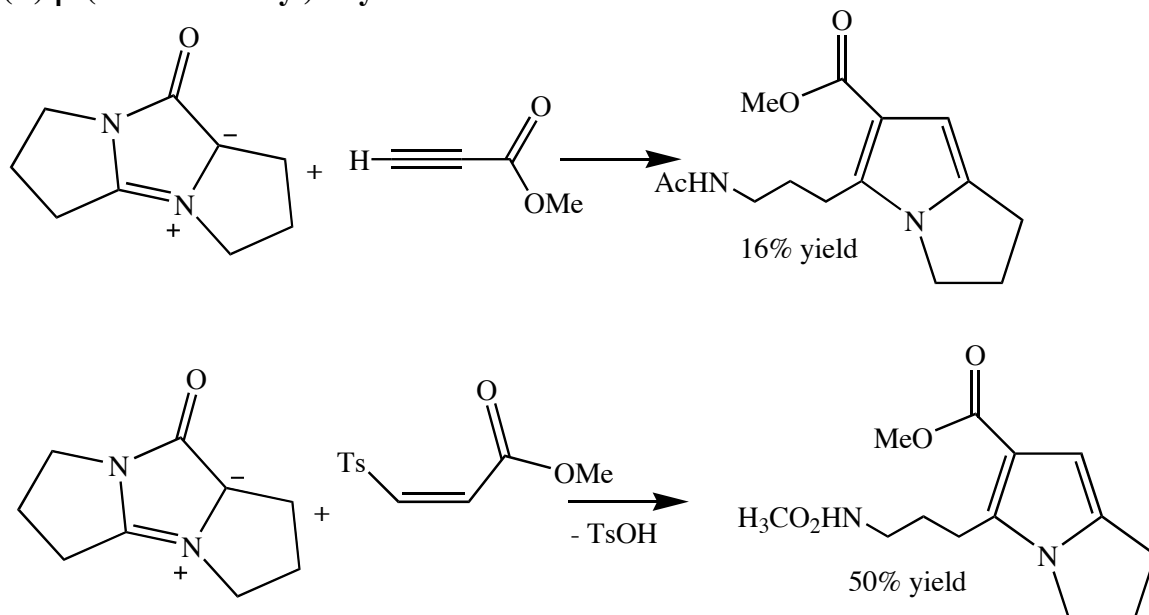
**Figure 57. Cycloadduct of 1,3 imidazolium-4-olate with methyl (E)- $\beta$ -(toluenesulfonyl)acrylate**



An important result of this research is that the cycloadduct shown in Figure 57 was isolated and stable enough for the structure to be solved via X-Ray analysis. It may then be possible to do additional chemistry on this compound in which we have introduced four stereocenters. We demonstrated the use of this dipolarophile as an acetylene equivalent by eliminating the sulfonic group (NaOMe/MeOH) to give a good yield of a pyrrole derivative that was not easily accessible using propiolate (Scheme 21).

We also demonstrated that the reactions involving the (E)-diastereomer were much faster than the (Z)-compound.

**Scheme 21. Comparison of the formation of a pyrrole derivative from propiolate vs. (E)- $\beta$ -(toluenesulfonyl)acrylate.**

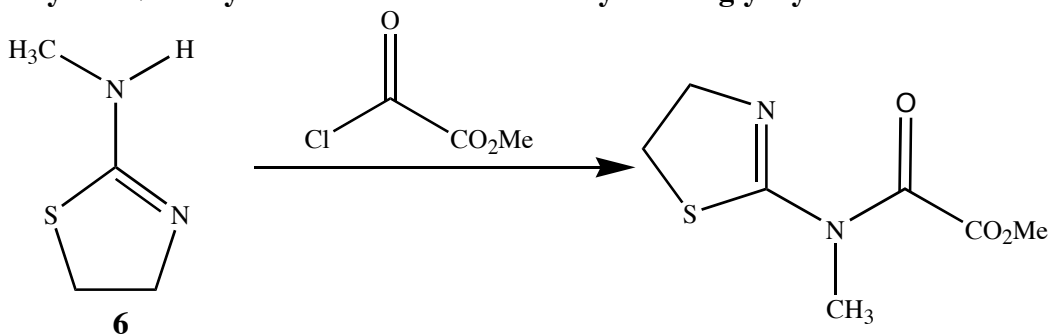


My attempts at cycloaddition reactions with various N-formyl-N-methylaminoacids and  $\alpha$ -(toluenesulfonyl)acrylate under standard reaction conditions did not result in the desired products.

#### FUTURE WORK

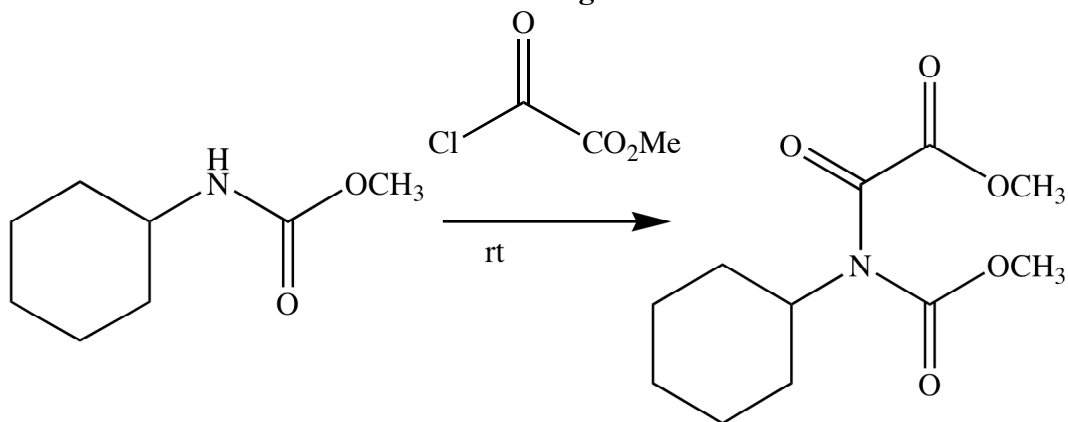
Though previous efforts of synthesizing N-thiazolanyl secondary amino acids from 4,5-dihydro-N-methyl-2-thiazolamine were unsuccessful, a possible alternative approach involves the condensation of 4,5-dihydro-N-methyl-2-thiazolamine with methyl chloroglyoxylate, as shown in Scheme 22. Reactions involving alkyl lithium reagents, for example, would allow me to create amino acid analogs to leucine, valine, and alanine.

**Scheme 22. Possible formation N-thiazolanyl secondary amino acids from 4,5-dihydro-N-methyl-2-thiazolamine and methyl chloroglyoxylate.**



Such reactions have been carried out by Richter and coworkers on carbamates (Scheme 23).<sup>51</sup>

**Scheme 23. Formation of amino acid analogues.**



## EXPERIMENTAL

### *Materials*

Benzotriazole (97%), diethylazodicarboxylate, ethanol (95%), ethanolamine (99+%), formic acid (95-97%), methyl isocyanate (97%), and *p*-toluenesulfonic acid monohydrate (97%), sodium *p*-toluenesulfinate (97%), triphenyl phosphate (99%) were used as received from Aldrich. Dichloromethane was used as received by Burdick and Jackson. Hydrogen peroxide was used as received from Fisher Scientific. N-Methylalanine was

used as received from Sigma. Sodium hydride (60% dispersion in oil, Aldrich) was washed twice with dry pentanes before use. Tetrahydrofuran (THF) was dried by distillation from purple sodium benzophenone ketyl under N<sub>2</sub> or purified using a PureSolv System (columns containing activated alumina and copper). Reagent grade acetic anhydride was dried by distillation from calcium carbide under N<sub>2</sub>. Reagent grade acetonitrile was dried by distillation from calcium hydride under N<sub>2</sub>. All other reagents and solvents were commercially available and were used as received.

### *Techniques*

All reactions were performed under an N<sub>2</sub> atmosphere. <sup>1</sup>H and <sup>13</sup>C NMR spectra were acquired on a Mercury 300 MHz instrument (300.0732 and 75.4534 MHz respectively) or INOVA 400 MHz instrument (399.9650 and 100.5713 MHz respectively), or Varian 400 MHz instrument (399.5409 and 100.4641 MHz respectively). <sup>1</sup>H and <sup>13</sup>C were referenced according to residual proton and solvent carbons, respectively. Mass Spectra were acquired on a VG (Micromass) 70-250-S Magnetic sector mass spectrometer. IR spectra were acquired on a Perkin Elmer Spectrum BX.

**Methyl-2-(*p*-toluenesulfonyl) propionate.** Methyl-2-bromopropionate (19.52 g, 0.1168 mol) and *p*-toluenesulfinic acid, sodium salt (25.18 g, 0.1413 mol) were refluxed in ethanol (80 mL) for 23 h. The solution was allowed to cool to room temperature and the sodium bromide precipitate was filtered off. Solvent was removed via rotary evaporation and the remaining residue was dissolved in diethyl ether. Any remaining sodium bromide was filtered off again. Diethyl ether was removed via rotary evaporation yielding 26.01 g (92%) of white crystals. Mp and <sup>1</sup>H NMR matched literature values.<sup>49</sup> Mp: 52-53 °C. <sup>1</sup>H NMR (CDCl<sub>3</sub>, 300 MHz): 7.78 (d, 2H, ArH), 7.37 (d, 2H, ArH), 4.08

(q, 1H, CH<sub>3</sub>CHSO<sub>2</sub>), 3.68 (s, 3H, CO<sub>2</sub>CH<sub>3</sub>), 2.45 (s, 3H, ArCH<sub>3</sub>), 1.57 (d, 3H, CHCH<sub>3</sub>).

MS (EI) Calculated for C<sub>11</sub>H<sub>14</sub>O<sub>4</sub>S: 242.0613, observed: 242.0609.

**Methyl-2-(phenylseleno)-2-(*p*-toluenesulfonyl) propionate.** A solution of methyl-2-(*p*-toluenesulfonyl) propionate (1.96 g, 0.0081 mol) in 5 mL THF was added dropwise over 30 min to a stirred solution of sodium hydride (0.25 g, 0.0102 mol) in 12 mL THF at -20 °C. The solution was stirred for 2 h. Phenylselenyl bromide (2.34 g, 0.0099 mol) in 8 mL THF was then added dropwise over 15 min. The solution was allowed to warm to room temperature and was stirred for an additional 16 h. A saturated solution of NH<sub>4</sub>Cl (10 mL) was added to the solution. THF was removed via rotary evaporation. The residue was extracted 3 times with diethyl ether (50 mL each). The organic layers were combined, washed with brine, and dried over MgSO<sub>4</sub>. The solvent was removed yielding a tan solid that was triturated in hexane to purify yielding 3.21 g (99.7%) white solid. Mp and <sup>1</sup>H NMR matched literature values.<sup>49</sup> Mp: 100-103 °C. <sup>1</sup>H NMR (CDCl<sub>3</sub>, 300 Mhz): 7.82 (d, 2H, ArH), 7.71 (d, 2H, ArH), 7.32 (m, 5H, ArH), 3.64 (s, 3H, CO<sub>2</sub>CH<sub>3</sub>), 2.46 (s, 3H, ArCH<sub>3</sub>), 1.63 (s, 3H, CHCH<sub>3</sub>). MS (EI) calculated for C<sub>17</sub>H<sub>19</sub>O<sub>4</sub>SeSNa: 420.9989, observed: 420.9996.

**Methyl-2-(*p*-toluenesulfonyl)acrylate.** A solution of methyl-2-(phenylseleno)-2-(*p*-toluenesulfonyl) propionate (7.97 g, 0.0200 mol) in 40 mL CH<sub>2</sub>Cl<sub>2</sub> was stirred at 0 °C. Hydrogen peroxide (30%, 9.26 g, 0.0816 mol) in 18 mL water was added all at once to the stirring solution which was then allowed to warm to room temperature after 2 h. Saturated NaHCO<sub>3</sub> in CH<sub>2</sub>Cl<sub>2</sub> (20 mL) was then added. The organic layer was separated and dried over Na<sub>2</sub>SO<sub>4</sub>. The solvent was removed via rotary evaporation yielding 4.32 g (90%) of tan solid, which was used without further purification. This solid was stable at

room temperature for over 30 days. Mp and  $^1\text{H}$  NMR matched literature values.<sup>49</sup> Mp: 75-77 °C.  $^1\text{H}$  NMR ( $\text{CDCl}_3$ , 300 Mhz): 7.85 (d, 2H, ArH), 7.34 (d, 2H, ArH), 7.12 (s, 1H, alkene), 6.98 (s, 1H, alkene), 3.74 (s, 3H,  $\text{CO}_2\text{CH}_3$ ), 2.44 (s, 3H,  $\text{ArCH}_3$ ). MS (EI) calculated for  $\text{C}_{11}\text{H}_{12}\text{O}_4\text{S}$ : 240.0456, observed: 240.0457.

**N-formyl-N-methylalanine.** Acetic anhydride (10.0 mL, 0.106 mol) was added dropwise over 5 minutes to a solution of N-methylalanine (1.534 g, 0.01487 mol) in 95-97% formic acid (21 mL, 0.5566 mol) and was stirred at 0 °C. The solution was allowed to warm to room temperature after the addition was complete and stirred an additional 3 h. The solvent was removed *in vacuo* to yield 1.89 g (97%) of clear, colorless oil.  $^1\text{H}$  NMR matched literature values.<sup>52</sup>  $^1\text{H}$  NMR ( $\text{CDCl}_3$ , 300 Mhz): Rotamer A: 8.18 ppm (s, 1H, CHO), 5.05 (q, 1H,  $\text{CHCH}_3$ ), 3.00 (s, 3H,  $\text{NCH}_3$ ), 1.54 (d, 3H,  $\text{CHCH}_3$ ); Rotamer B: 8.13 (s, 1H, CHO), 4.31 (q, 1H,  $\text{CHCH}_3$ ), 2.89 (s, 3H,  $\text{NCH}_3$ ), (d, 3H,  $\text{CHCH}_3$ ). MS (electrospray) calculated for  $\text{C}_5\text{H}_9\text{NO}_3$ : 131.13166, observed: 131.0578.

**N-(2-hydroxyethyl)-N'-methylthiourea**<sup>43</sup>. Ethanolamine (4.13 g, 0.0686 mol) was added to a stirring solution of methyl isothiocyanate (4.70 mL, 0.0687 mmol) in 68 mL THF at room temperature. The solution was stirred for 16 h after which the solvent was removed via rotary evaporation. The resulting greenish solid was triturated in and washed with 250 mL diethyl ether, yielding 8.60 g (93.5%) of white solid which was used without further purification.  $^1\text{H}$  NMR ( $\text{CDCl}_3$ , 300 Mhz): 6.8-6.2 (br s, 2H, both NH), 3.84 (t, 2H,  $\text{CH}_2\text{OH}$ ), 3.68 (br m, 3H,  $\text{NHCH}_2$ , and OH), 3.02 (m, 3H,  $\text{CH}_3\text{NH}$ ); mp 72-74 °C, lit.<sup>53</sup> mp 73 °C; exact mass calculated for  $\text{C}_4\text{H}_{10}\text{N}_2\text{OS}$ : 134.0514; found: 134.0510.

**4,5-Dihydro-N-methyl-2-thiazolamine.** A solution of diethylazodicarboxylate (13.26 g, 76.14 mmol) in 100 mL THF was added dropwise over 45 min to a stirring solution of N-

(2-hydroxyethyl)-N<sup>1</sup>-methylthiourea (**5**, 6.98 g, 52.01 mmol) and triphenylphosphine (20.5629 g, 78.40 mmol) in 700 mL THF at room temperature. After 1 h, the solution was treated with 105 mL of an 0.5028 M ethanolic HCl solution, freshly prepared by mixing acetyl chloride in absolute ethanol. The solution became cloudy immediately, was cooled to 0 °C, and stirred 18 h. The resulting white powder was filtered, yielding 6.2811 g (79%) of the hydrochloride salt. The salt was then dissolved in 50 mL THF and treated with 102 mL of a 4 M NaOH solution, which was extracted three times with 75 mL (200 mL total) chloroform. The organic layers were combined, dried over MgSO<sub>4</sub>, filtered, and the solvent was removed via rotary evaporation. A white powder (4.3181 g, 71%) was obtained and used without further purification. <sup>1</sup>H NMR (CDCl<sub>3</sub>, 300 MHz): 4.02 (t, 2H, methylene), 3.90 (br s, 1H, NH), 3.34 (t, 2H, methylene), 2.94 (s, 3H, NCH<sub>3</sub>); mp 88-90 °C, lit.<sup>54</sup> mp 88.5-90 °C; exact mass calculated for C<sub>4</sub>H<sub>8</sub>N<sub>2</sub>S: 116.0408; found: 116.0406.

**C<sub>6</sub>H<sub>8</sub>N<sub>2</sub>O<sub>2</sub>S**. In a 100 mL round-bottom flask was placed 4.3979 g (0.03692 mol) benzotriazole in 30 mL of toluene. To the stirring solution was added 7.5592 g (0.03702 mol) of ethylglyoxylate as a 50% solution in toluene and 3.8937 (0.03551 mol) 4,5-dihydro-N-methyl-2-thiazolamine in 30 mL toluene. The reaction was stirred at room temperature for 22 hrs. Solvent was removed in vacuo, whereupon white crystals formed overnight. The product mixture was purified on 3 cm × 20 cm SiO<sub>2</sub> column using ethyl acetate as the eluant. The product was recrystallized from ethyl acetate to yield 4.48 g (77.7% yield) white crystals. <sup>1</sup>H NMR (CDCl<sub>3</sub>) δ 6.20 (s, 1H, CH), 4.562 (m, 1H, methylene), 3.408 (m, 1H, methylene), 3.262 (m, 2H, methylene), 3.135 (s, 3H, NCH<sub>3</sub>); <sup>13</sup>C 161.5 (C=O), 157.5 (C=O), 79.27 (CH), 46.08 (NCH<sub>2</sub>), 33.17 (SCH<sub>2</sub>), 29.06 (NCH<sub>3</sub>);



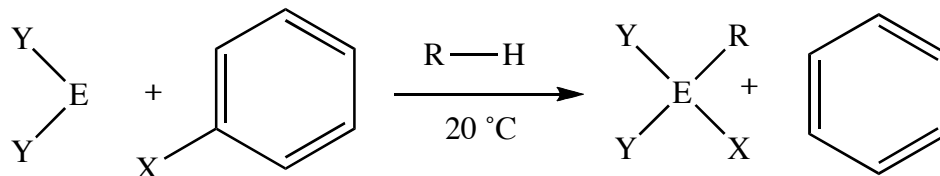
$^{13}\text{C}$  DEPT 79.27 (C with 1H), 46.08 (C with 2H), 33.17 (C with 2H), 29.06 (C with 3H); IR(KBr)  $\text{cm}^{-1}$   $\nu$  3424, 2988, 2959, 2863, 1738, 1402; MS EI (with  $\text{Na}^+$  added)  $m/z$ : actual (with  $\text{Na}^+$ ) 195.1, predicted 195.02044;  $2m/z$  (with  $\text{Na}^+$ ) actual 367.0505, predicted 367.0511. X-Ray data was obtained from crystals grown from THF at 23 °C.

**CHAPTER 12: STEREOCHEMICAL INVESTIGATIONS OF C-H  
ACTIVATION REACTIONS INVOLVING GERMYLENE AND  
STANNYLENE/ARYL IODIDE REAGENTS**

INTRODUCTION

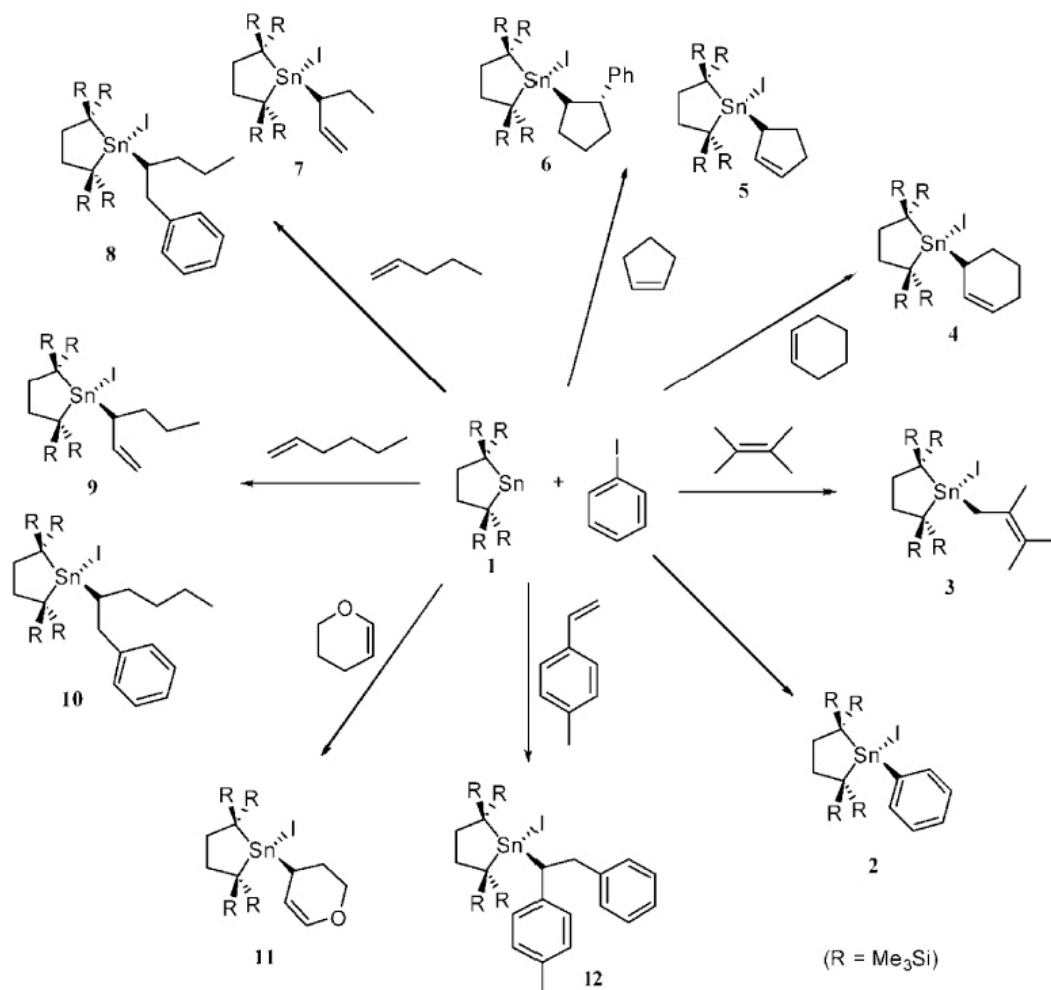
Our laboratory has been investigating the C-H activations of hydrocarbons and ethers under mild conditions using  $EY_2/PhX$  reagents ( $E = Ge, Sn$ ;  $Y = N(SiMe_3)_2, CH(SiMe_3)_2$ ;  $X = I, Br$ ) (Scheme 24).<sup>55,56</sup> Recently we reported the use of the stannylene developed by Kira<sup>57</sup>,  $Sn[C_2(SiMe_3)_4C_2H_4]$  for the activation of allylic C-H bonds in good yields under mild conditions (Scheme 25).<sup>58</sup> In order to explore and expand the utility of these reagents for synthesis, we have begun examining whether chirality can be induced in achiral substrates utilizing chiral aryl iodides as chiral auxiliaries. We are also examining the stereochemistry of these reactions using pro-chiral and chiral substrates.

**Scheme 24. C-H activations of hydrocarbons and ethers.**



$E = Ge, Sn$ ;  $Y = N(SiMe_3)_2, CH(SiMe_3)_2$ ;  $X = I, Br$

**Scheme 25. Activations of allylic C-H bonds using  $\text{Sn}[\text{C}_2(\text{SiMe}_3)_4\text{C}_2\text{H}_4]$ . From Scheme 1, Kavara, A.; Cousineau, K. D.; Rohr, A. D.; Kampf, J. W.; Holl, M. M. B. *Organometallics* 2008, 27, 1041-1043.**

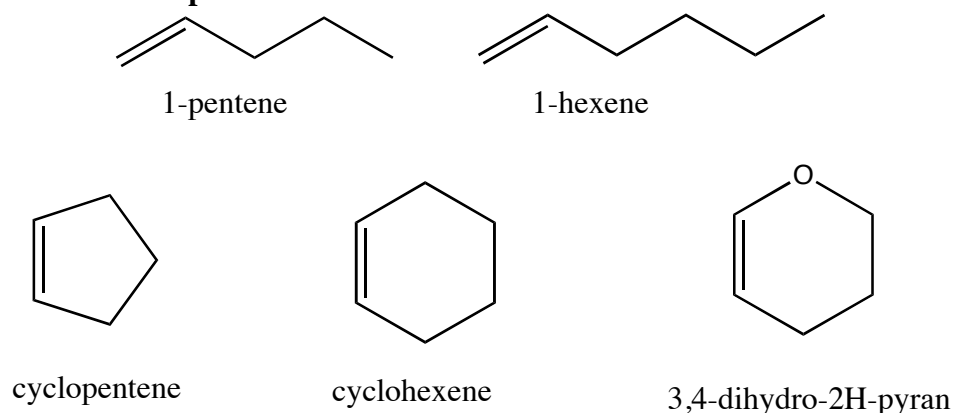


### Induction

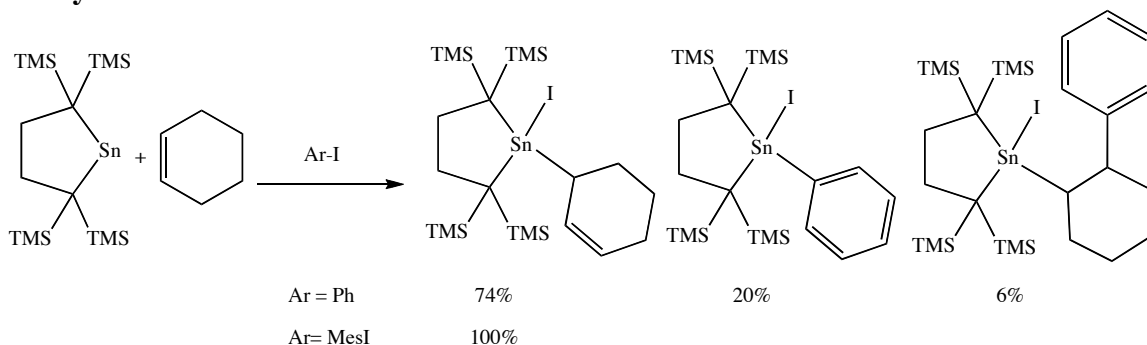
For the attempted induction experiments, 1-pentene, 1-hexene, cyclopentene, cyclohexene, and 3,4-dihydro-2H-pyran were initially considered as possible prochiral substrates for study (Figure 58). Based on our earlier experiences C-H activating these compounds,<sup>58</sup> 1-pentene, 1-hexene, and cyclopentene were rejected as suitable substrates because of the high yield of both C-H activation products and double-bond addition products. Though previous work with 3,4-dihydro-2H-pyran demonstrated a high ratio of

allylic C-H activation to double-bond addition products, we were concerned about the possible presence of small amounts of C-H activation at the prochiral 3 position, which could make analysis of the optical activity of the allylic C-H activation product difficult. Thus, cyclohexene was chosen as the substrate because our previous work showed it produced a high ratio of the desired C-H activation products to the oxidative addition and double-bond addition products when using mesityl iodide as the aryl iodide (Scheme 26), and because, unlike the 3,4-dihydro-2H-pyran case, only one product can be produced. In addition, the products resulting from reaction with cyclohexene are stable to column chromatography, allowing easy separation of the C-H activation product from any oxidative addition and double-bond addition products formed.

**Figure 58. Potential prochiral substrates.**

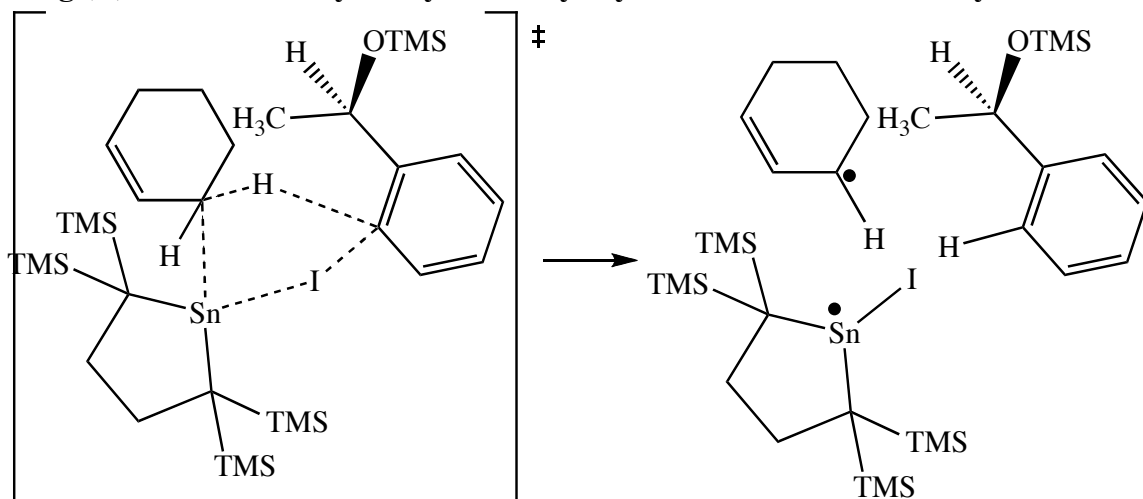


**Scheme 26. Reaction of  $\text{Sn}[\text{C}_2(\text{SiMe}_3)_4\text{C}_2\text{H}_4]$  with cyclohexene and phenyl iodide or mesityl iodide.**

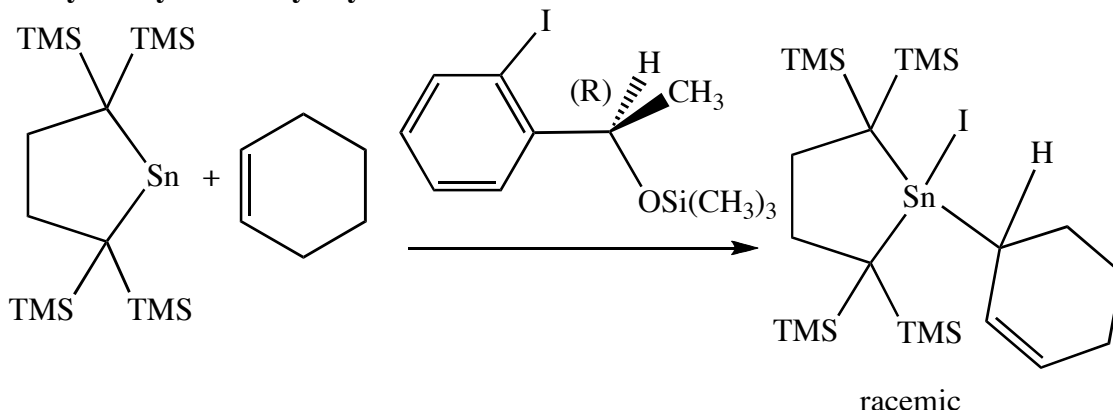


Previous results with iodomesitylene<sup>58</sup> demonstrated that substitution ortho to the iodine atom on the aryl halide influences the course of these C-H activation reactions. Therefore I decided to examine the use of an ortho chiral group on the aryl halide to attempt induction of chirality at the C-H activation site. Our proposed 5-member transition state for these reactions is shown in Scheme 27, indicating a possible relationship of the ortho chiral group to the allylic carbon on cyclohexene. I chose (R)-2-iodo- $\alpha$ -methylbenzyl trimethylsilylether as a chiral auxiliary in this reaction because of the tolerance of the stannylene reagents to TMS groups, the steric bulk of which may lead to greater success at inducing chirality in the C-H activation product. In addition, it is easily synthesized from commercially available R-(+)-2-bromo- $\alpha$ -methylbenzyl alcohol and any aryl iodide remaining after the C-H activation reaction has completed can be removed easily via column chromatography. Using the chiral (R)-2-iodo- $\alpha$ -methylbenzyl trimethylsilylether as the aryl halide in the reaction with cyclopentene and  $\text{Sn}[\text{C}_2(\text{SiMe}_3)_4\text{C}_2\text{H}_4]$  reaction yielded only racemic  $[\text{C}_2\text{H}_4(\text{SiMe}_3)_4\text{C}_2]\text{SnI}(\text{C}_6\text{H}_9)$ , based on polarimetry (Scheme 28).

**Scheme 27. Proposed 5-member transition state for C-H activation of cyclohexene using (R)-2-iodo- $\alpha$ -methylbenzyl trimethylsilylether as a chiral auxiliary.**



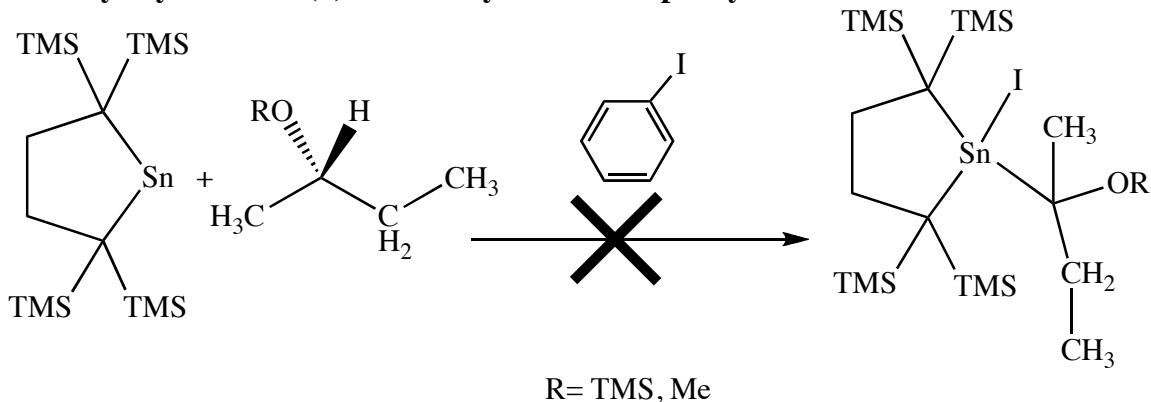
**Scheme 28. Reaction of  $\text{Sn}[\text{C}_2(\text{SiMe}_3)_4\text{C}_2\text{H}_4]$  with cyclohexene and ((R)-2-iodo- $\alpha$ -methylbenzyl trimethylsilylether.**



*Retention/Inversion/Scrambling*

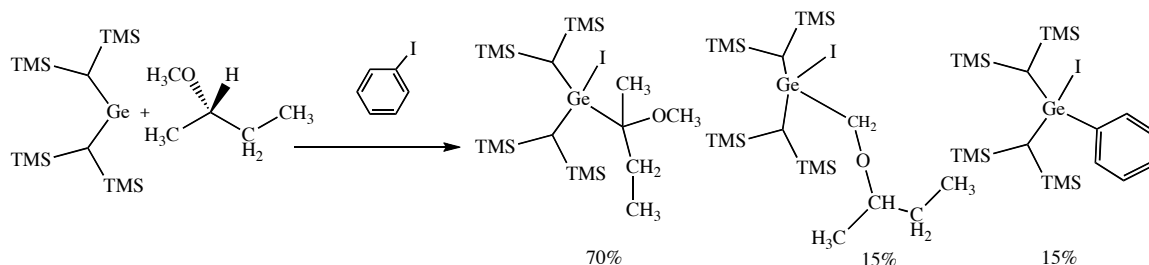
Additional information about the lifetimes of the proposed radical intermediates of these reactions can be obtained by examining C-H activation reactions on chiral compounds. In order to examine the resulting stereochemistry of these C-H activation reactions when employing a chiral substrate, (S)-2-butyl trimethylsilyl ether was initially chosen as a chiral substrate for reaction with the stannylene. However, attempts at C-H activations on (S)-2-butyl trimethylsilyl ether with the stannylene were unsuccessful as were attempts using (S)-2-methoxybutane as a substrate (Scheme 29).

**Scheme 29. Proposed reaction between  $[\text{C}_2\text{H}_4(\text{SiMe}_3)_4\text{C}_2]\text{Sn}$  and (S)-2-butyl trimethylsilyl ether or (S)-2-methoxybutane and phenyl iodide.**



However, C-H activation using  $[(\text{Me}_3\text{Si})_2\text{CH}]_2\text{Ge}$  with (S)-2-methoxybutane was successful in producing the expected product with C-H activation occurring at C-2 (70% conversion by  $^1\text{H}$  NMR (Scheme 30).  $^1\text{H}$  NMR also shows the presence of the oxidative addition product (15%), as well as peaks at  $\delta$  3.86 which may be the result of diastereomeric protons resulting from the C-H activation at the methoxy carbon (15%). Owing to the possible presence of two chiral C-H activation products and the difficulty in separating these two regioisomers, polarimetry would not be successful in determining whether or not the desired C-H activation product was chiral. Instead,  $^1\text{H}$  NMR using the chiral shift reagent Europium(III) tris[3-(heptafluoropropylhydroxymethylene)-*d*-camphorate], ( $\text{Eu}(\text{hfc})_3$ ) was utilized (Figure 59).<sup>59</sup>

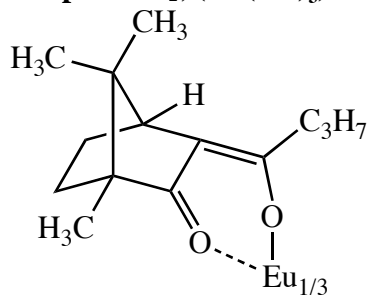
**Scheme 30. Reaction of  $[(\text{Me}_3\text{Si})_2\text{CH}]_2\text{Ge}$  with (S)-2-methoxybutane and phenyl iodide.**



In order to determine the optical purity of the (S)-2-methoxybutane, to model the behavior of the  $\text{Eu}(\text{hfc})_3$ , and to determine whether or not any racemization of the solvent was occurring during the reaction with  $[(\text{Me}_3\text{Si})_2\text{CH}]_2\text{Ge}$ ,  $^1\text{H}$  NMR studies were performed with the chiral shift reagent,  $\text{Eu}(\text{hfc})_3$ . First, a 0.235 M solution of racemic 2-methoxybutane in  $d^6$ -benzene was examined at various concentrations of  $\text{Eu}(\text{hfc})_3$  to determine whether there would be resolution of the enantiomers. The results are shown in Figure 60. By comparison, similar studies with the (S)-2-methoxybutane, which had

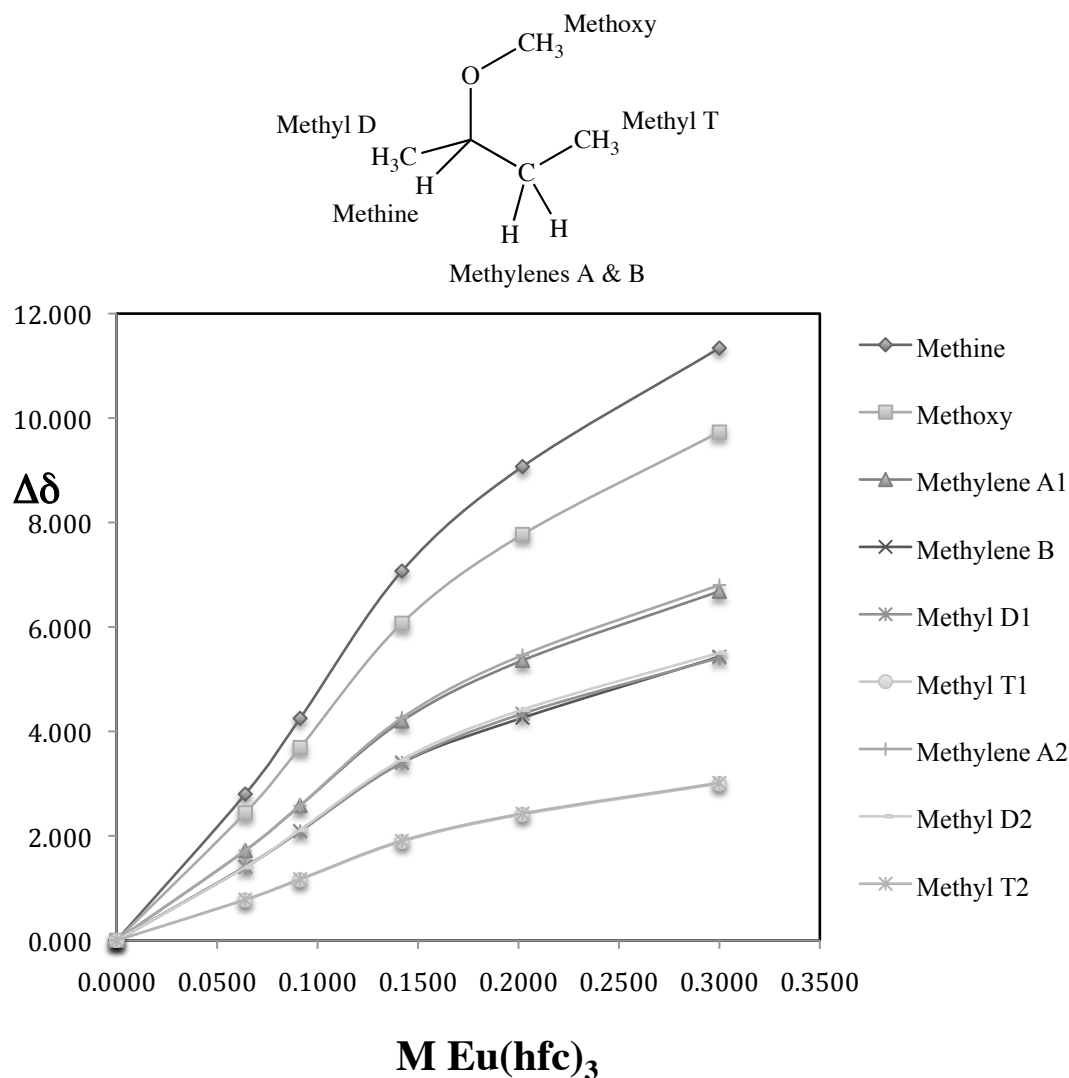
been used and recycled for several C-H activation reactions with  $[(\text{Me}_3\text{Si})_2\text{CH}]_2\text{Ge}$  showed only one enantiomer present.

**Figure 59.** Europium(III) tris[3-(heptafluoropropylhydroxymethylene)-*d*-camphorate],  $(\text{Eu}(\text{hfc})_3)$ .





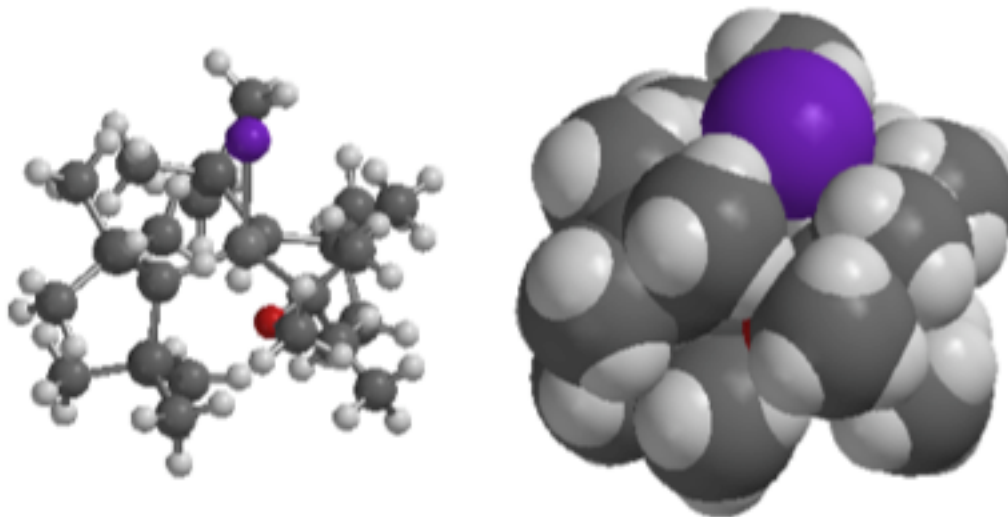
**Figure 60.** Graph of the change in the  $^1\text{H}$  NMR shift values for a 0.235 M racemic solution of 2-methoxybutane with increasing concentration of  $\text{Eu}(\text{hfc})_3$ . Numbers 1 and 2 correspond to the two enantiomers present.



Similar studies were carried out with the resulting C-H activation product,  $[(\text{Me}_3\text{Si})_2\text{CH}]_2\text{GeI}[\text{CH}_3\text{OCH}(\text{CH}_3)(\text{CH}_2\text{CH}_3)]$  and  $\text{Eu}(\text{hfc})_3$ . The  $^1\text{H}$  NMR of these solutions showed negligible shifting of protons from the product and no obvious resolution of enantiomers. Modeling of the product,  $[(\text{Me}_3\text{Si})_2\text{CH}]_2\text{GeI}[\text{CH}_3\text{OCH}(\text{CH}_3)(\text{CH}_2\text{CH}_3)]$ , showed that the Lewis basic oxygen atom

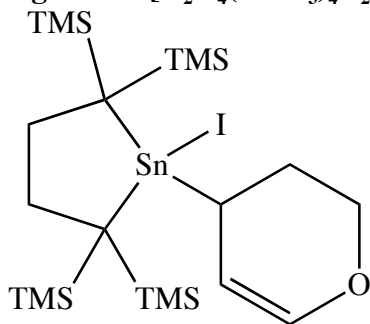
of the 2-methoxybutyl moiety is probably too sterically hindered to associate with the  $\text{Eu}(\text{hfc})_3$  (Figure 61).

**Figure 61. Computational structure of  $[(\text{Me}_3\text{Si})_2\text{CH}]_2\text{GeI}[\text{CH}_3\text{OCH}(\text{CH}_3)(\text{CH}_2\text{CH}_3)]$  showing steric crowding of the oxygen atom.**

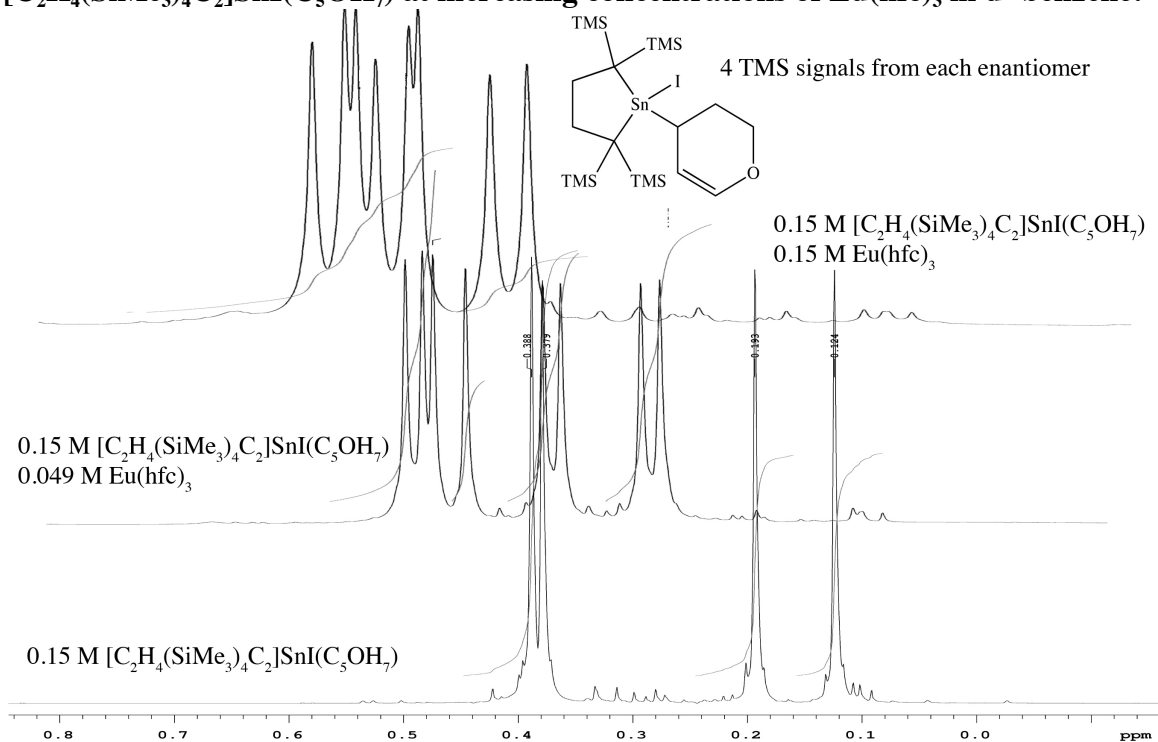


To examine the feasibility of using  $\text{Eu}(\text{hfc})_3$  to determine the %ee of other C-H activation reactions,  $^1\text{H}$  NMR studies were carried out using  $[\text{C}_2\text{H}_4(\text{SiMe}_3)_4\text{C}_2]\text{SnI}(\text{C}_5\text{OH}_7)$  (Figure 62).<sup>58</sup> In this case, I assumed that the oxygen on the pyran ring would be available to interact with the  $\text{Eu}(\text{hfc})_3$ . Excellent resolution of the two enantiomers was observed, particularly for the protons in the TMS region of the  $^1\text{H}$  NMR spectrum (Figure 63). Figure 64 shows the change in the  $^1\text{H}$  NMR shift values ( $\Delta\delta$ ) for a 0.15M solution of  $[\text{C}_2\text{H}_4(\text{SiMe}_3)_4\text{C}_2]\text{SnI}(\text{C}_5\text{OH}_7)$  at increasing concentrations of  $\text{Eu}(\text{hfc})_3$  in  $d^6$ -benzene.

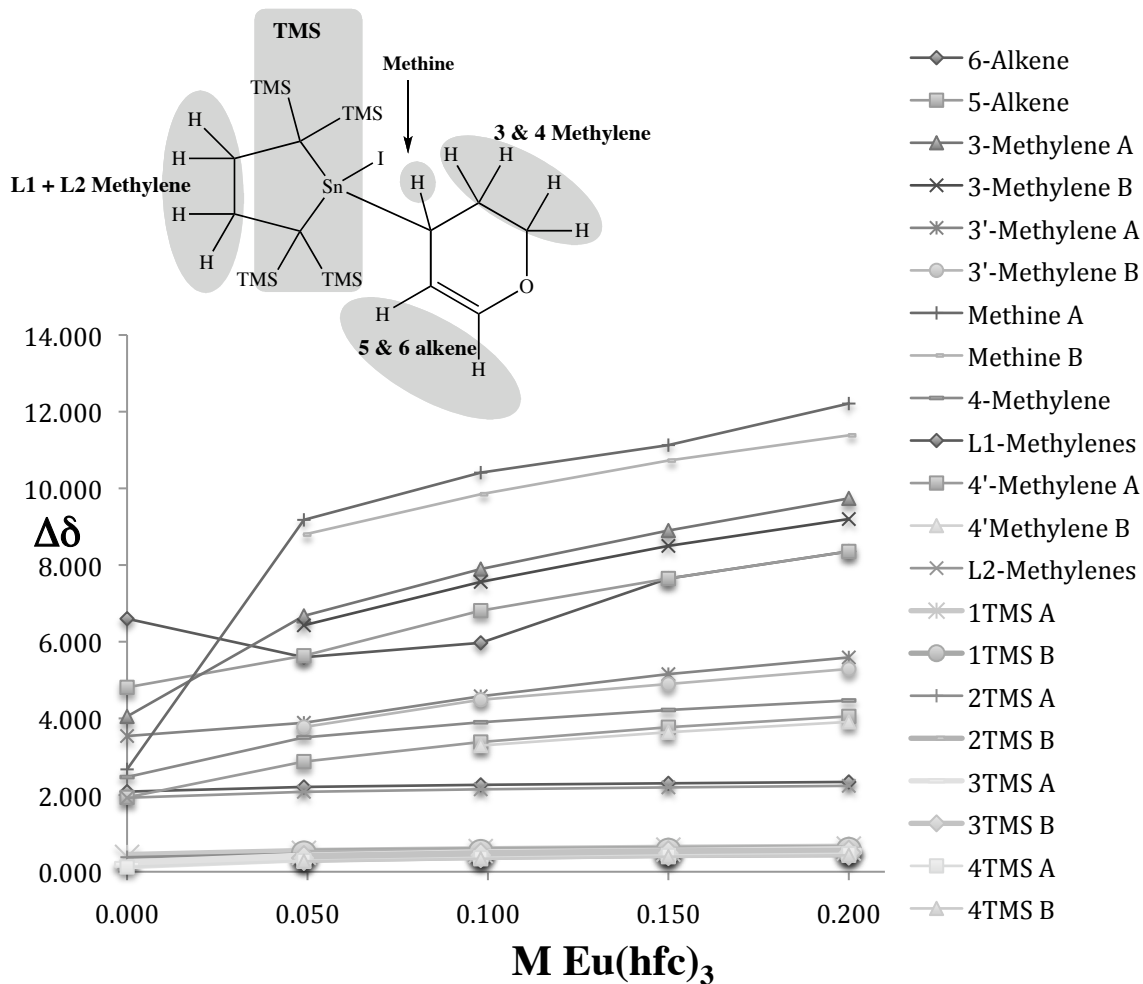
**Figure 62.**  $[\text{C}_2\text{H}_4(\text{SiMe}_3)_4\text{C}_2]\text{SnI}(\text{C}_5\text{OH}_7)$



**Figure 63.** Expansion of the TMS region of the  $^1\text{H}$  NMR of a 0.15M solution of  $[\text{C}_2\text{H}_4(\text{SiMe}_3)_4\text{C}_2]\text{SnI}(\text{C}_5\text{OH}_7)$  at increasing concentrations of  $\text{Eu}(\text{hfc})_3$  in  $\text{d}^6$ -benzene.



**Figure 64.** Graph of the change in the  $^1\text{H}$  NMR shift values for a 0.15M solution of  $[\text{C}_2\text{H}_4(\text{SiMe}_3)_4\text{C}_2]\text{SnI}(\text{C}_5\text{OH}_7)$  at increasing concentrations of  $\text{Eu}(\text{hfc})_3$  in  $d^6$ -benzene. The letters A and B refer to the two enantiomers present.



## CONCLUSIONS

The results of the attempted chiral induction using (R)-2-iodo- $\alpha$ -methylbenzyl trimethylsilylether provide useful information regarding the mechanism of these C-H activation reactions, demonstrating that either 1) the lifetime of the resulting allyl radical (Scheme 27) is long enough to allow subsequent attack by the stannyl radical from either face, or 2) the orientation of the ortho chiral group on the aryl halide is not close enough or not sterically bulky enough to force induction.

In addition, my experiments examining the %ee of the (S)-2-methoxybutane demonstrated that there is no racemization of the solvent during the reaction with  $[(\text{Me}_3\text{Si})_2\text{CH}]_2\text{Ge}$ . This sample of solvent was used and recycled several times for use during several reactions with  $[(\text{Me}_3\text{Si})_2\text{CH}]_2\text{Ge}$ , yet no evidence of the R enantiomer was found in the  $^1\text{H}$  NMR when  $\text{Eu}(\text{hfc})_3$  was added in spite of the fact that, based on the experiments with the racemic solution of (S)-2-methoxybutane, we were at appropriate concentrations of substrate and  $\text{Eu}(\text{hfc})_3$  to see the R enantiomer had it been present. Thus, racemization of the solvent is excluded from the mechanism of these reactions.

Though the attempt to use  $\text{Eu}(\text{hfc})_3$  to determine the %ee of the  $[(\text{Me}_3\text{Si})_2\text{CH}]_2\text{GeI}[\text{CH}_3\text{OCH}(\text{CH}_3)(\text{CH}_2\text{CH}_3)]$  product was unsuccessful, this chiral shift reagent can be used on products of C-H activation reactions that have a Lewis basic atom such as the oxygen of the pyran ring of  $[\text{C}_2\text{H}_4(\text{SiMe}_3)_4\text{C}_2]\text{SnI}(\text{C}_5\text{OH}_7)$ , which is not so sterically crowded that it makes association with the  $\text{Eu}(\text{hfc})_3$  impossible. In addition, there was no evidence that the presence of  $\text{Eu}(\text{hfc})_3$  degraded the product, and the resolution of enantiomers in the  $^1\text{H}$  NMR spectrum, particularly in the TMS region, should make determining the stereochemistry of these reactions on similar substrates simple.

## EXPERIMENTAL

### *Materials*

(R)-(+)-2-bromo- $\alpha$ -methylbenzyl alcohol (98%), N-N'-dimethylethylene diamine (99%), 1,1,1,3,3,3-hexamethyldisilazane (98%), chlorotrimethylsilane (99%), Europium(III) tris[3-(heptafluoropropylhydroxymethylene)-*d*-camphorate] (puriss) were used as received from Aldrich. KI was used as received from Baker. CuI was purified prior to use by dissolving in water with KI then diluting the solution until a white CuI precipitate was formed, which was filtered and dried in vacuo. Cyclohexene was distilled from purple sodium benzophenone ketyl. Sn[C<sub>2</sub>(SiMe<sub>3</sub>)<sub>4</sub>C<sub>2</sub>H<sub>4</sub>],<sup>60</sup> [(Me<sub>3</sub>Si)<sub>2</sub>CH]<sub>2</sub>Ge,<sup>61</sup> and [C<sub>2</sub>H<sub>4</sub>(SiMe<sub>3</sub>)<sub>4</sub>C<sub>2</sub>][SnI(C<sub>5</sub>OH<sub>7</sub>)]<sup>58</sup> were synthesized according to literature procedures. Phenyl iodide was purchased from Aldrich Chemicals and degassed. Solvents were dried over purple sodium benzophenone ketyl. All other reagents and solvents were used as received.

### *Techniques*

Manipulations involving Sn[C<sub>2</sub>(SiMe<sub>3</sub>)<sub>4</sub>C<sub>2</sub>H<sub>4</sub>], [(Me<sub>3</sub>Si)<sub>2</sub>CH]<sub>2</sub>Ge, and [C<sub>2</sub>H<sub>4</sub>(SiMe<sub>3</sub>)<sub>4</sub>C<sub>2</sub>][SnI(C<sub>5</sub>OH<sub>7</sub>)] were performed using air-free techniques. All glassware was oven dried for at least 3 hours before use. <sup>1</sup>H and <sup>13</sup>C NMR spectra were acquired on a Mercury 300 MHz instrument (300.0732 and 75.4534 MHz respectively) or INOVA 400 MHz instrument (399.9650 and 100.5713 MHz respectively), or Varian 400 Mhz instrument (399.5409 and 100.4641 MHz respectively). <sup>1</sup>H and <sup>13</sup>C were referenced according to residual solvent proton and <sup>13</sup>C carbons, respectively. Mass Spectra were acquired on a VG (Micromass) 70-250-S Magnetic sector mass spectrometer. IR spectra were acquired

on a Perkin Elmer Spectrum BX. Specific rotations were measured at 589 nm in dry hexane using a Jasco DIP-370 digital polarimeter.

**(R)-2-iodo- $\alpha$ -methylbenzyl alcohol.** A 1-neck 50 mL round bottom flask was charged with 0.3410 g CuI (2.455 mmol, 0.1 eq.) and 12.2503 g KI (73.7957 mmol, 3 eq.). 0.52 mL N-N'-dimethylethylenediamine (4.8 mmol, 0.2 eq.) was added all at once followed by 4.9267 g (R)-(+)-2-bromo- $\alpha$ -methylbenzyl alcohol (24.502 mmol, 1 eq.), 18 mL xylenes, and 1 mL diglyme. The flask was flushed with N<sub>2</sub> and sealed with a Teflon needle valve. The mixture was stirred at 140 °C under N<sub>2</sub>. After 48 h, the reaction was cooled to room temperature, treated with 10 mL aq NH<sub>4</sub>OH and 50 mL water. The resulting blue solution was extracted 3 times with 75 mL each CH<sub>2</sub>Cl<sub>2</sub>. The organic extracts were combined, dried over MgSO<sub>4</sub>, filtered, and the solvent was removed via rotary evaporation to yield 4.2308 g (69.6%) of white solid, which was used without further purification. <sup>1</sup>H NMR CDCl<sub>3</sub>  $\delta$ : 7.80 (d, 1H Ar-H), 7.56 (d, 1H, Ar-H), 7.36 (t, 1H, Ar-H), 6.57 (t, 1H, Ar-H), 5.06 (q, 1H, C-H), 1.48 (d, 3H, -CH<sub>3</sub>); <sup>13</sup>C NMR CDCl<sub>3</sub>  $\delta$  132.82 (aryl carbon), 128.93 (aryl carbon), 128.02 (aryl carbon), 126.84 (aryl carbon), 69.34 (benzylic carbon), 23.76 (methyl); IR (KBr) cm<sup>-1</sup>  $\nu$  3214, 2966, 1567, 1467, 1096, 756; (MS EI *m/z*: actual 247.9707, predicted 247.9698).

**(R)-2-iodo- $\alpha$ -methylbenzyl trimethylsilylether.** A 25 mL round bottom flask was charged with 2.6764 g (0.01790 mol) of (R)-2-iodo- $\alpha$ -methylbenzyl alcohol in 9 mL toluene. 3.4 mL (0.016, 1.5 eq.) 1,1,1,3,3,3-hexamethyldisilazane was added dropwise over 5 min, followed by 3 drops chlorotrimethylsilane. The reaction was stirred at reflux. After 21 h, the reaction was cooled to room temperature and the solvent was removed via rotary evaporation. The product was distilled under vacuum (0.5 torr) at 55 °C, filtered

through a 2 cm × 2 cm plug of silica gel using 20% ethyl acetate in hexanes to elute. The solvent was removed via rotary evaporation to yield 2.8246 g (82%) clear oil. The oil was dried over MgSO<sub>4</sub> under N<sub>2</sub> for 72 h and redistilled prior to use. <sup>1</sup>H NMR CDCl<sub>3</sub> δ 7.77 (d, 1H, Ar-H), 7.57 (d, 1H, Ar-H), 7.37 (t, 1H, Ar-H), 6.95 (t, 1H, Ar-H), 5.01 (q, 1H, C-H), 1.39 (d, 3H, CH<sub>3</sub>), 0.083 (s, 9 HSiCH<sub>3</sub>); <sup>13</sup>C NMR CDCl<sub>3</sub> δ 148.48 (aryl carbon), 138.87 (aryl carbon), 128.69 (aryl carbon), 128.48 (aryl carbon), 127.17 (aryl carbon), 96.41 (aryl carbon), 74.35 (C-O), 25.61 (CH<sub>3</sub>), 0.05 (3 Si-CH<sub>3</sub>); IR(film) cm<sup>-1</sup> ν 3451, 2956, 1564, 1435, 1250; MS EI *m/z*: actual 320.0083, predicted 320.0093.

**[C<sub>2</sub>H<sub>4</sub>(SiMe<sub>3</sub>)<sub>4</sub>C<sub>2</sub>]SnI(C<sub>6</sub>H<sub>9</sub>).** A 1-neck 50 ml flask was charged with 0.229 g (R)-(+)-2-iodo- $\alpha$ -methylbenzyl trimethylsilylether (0.715 mmol, 1.1 eq). Cyclohexene was added to the flask (28.002 g), which was then capped with a rubber septum and stirred for 5 min. In a separate 1-neck 50 mL flask, a red solution of [C<sub>2</sub>H<sub>4</sub>(SiMe<sub>3</sub>)<sub>4</sub>C<sub>2</sub>]Sn (303 mg, 0.654 mmol) in 28.002 g of cyclohexene was prepared. The stannylene solution was added to the (R)-(+)-2-iodo- $\alpha$ -methylbenzyl trimethylsilylether over 5 min. The solution was allowed to stir for 24 hours to insure completion of reaction, yielding a cloudy white solution. The volatiles were removed in vacuo at 55 °C for 6 hr. The product was purified using flash chromatography on 150 mm × 20 mm silica gel column using hexanes w/ 1% triethylamine. The product-containing fractions were combined and the solvent was removed via rotary evaporation. The resulting white powder was recrystallized from pentane at -78 °C. 67.6 mg (21.8%) <sup>1</sup>H matched literature values.<sup>58</sup> <sup>1</sup>H NMR (CDCl<sub>3</sub>) δ 5.84 (s, 1H, Sn-CH-CH=CH), 5.68 (s, 1H, Sn-CH-CH=CH), 2.78 (m, 1H, Sn-CH), 2.20 (m, 1H, Sn-CH-CH=CH-CH<sub>2</sub>), 2.08 (m, 1H, Sn-CH-CH=CH-CH<sub>2</sub>), 2.08 (m, 2H, Sn-CH-CH<sub>2</sub>), 1.92 (m, 2H, Sn-CH-CH<sub>2</sub>), 1.53 (m, 1H, Sn-C(SiMe<sub>3</sub>)<sub>2</sub>-



$CH_2$ ), 1.22 (m, 1H, Sn-C(SiMe<sub>3</sub>)<sub>2</sub>-CH<sub>2</sub>), 0.22 (s, 18H, Si(CH<sub>3</sub>)<sub>3</sub>), 0.15 (s, 9H, Si(CH<sub>3</sub>)<sub>3</sub>), 0.12 (s, 9H, Si(CH<sub>3</sub>)<sub>3</sub>). <sup>13</sup>C (CDCl<sub>3</sub>) δ 129.75 (Sn-CH-C=C), 127.63 (Sn-CH-C=C), 40.18 (Sn-CH), 34.76 (Sn-CH-CH=CH-CH<sub>2</sub>), 27.083 (Sn-C(Si(CH<sub>3</sub>)<sub>2</sub>), 24.57 (Sn-C(Si(CH<sub>3</sub>)<sub>2</sub>), 22.81 (Sn-C-CH<sub>2</sub>), 21.00 (Sn-C-CH<sub>2</sub>), 4.00 (Si(CH<sub>3</sub>)<sub>3</sub>), 3.94 (Si(CH<sub>3</sub>)<sub>3</sub>), 3.82 (Si(CH<sub>3</sub>)<sub>3</sub>), 3.76 (Si(CH<sub>3</sub>)<sub>3</sub>). Specific rotation (hexane solution)  $[\alpha] = -0.003^\circ \pm 0.002$ .

Colorless needles were grown from a hexane solution at 23 °C. A crystal of dimensions 0.27 × 0.15 × 0.15 mm was mounted on a Bruker SMART APEX CCD-based X-ray diffractometer equipped with a low temperature device and fine focus Mo-target X-ray tube ( $\lambda = 0.71073$  Å) operated at 1500 W power (50 kV, 30 mA). The X-ray intensities were measured at 85(1) K; the detector was placed at a distance 5.055 cm from the crystal. A total of 5190 frames were collected with a scan width of 0.5° in  $\omega$  and  $\phi$  with an exposure time of 10 s/frame. The integration of the data yielded a total of 13609 reflections to a maximum  $2\theta$  value of 56.72° of which 7483 were independent and 7310 were greater than  $2\sigma(I)$ . The final cell constants were based on the xyz centroids of 9584 reflections above  $10\sigma(I)$ . Analysis of the data showed negligible decay during data collection; the data were processed with SADABS and corrected for absorption. The structure was solved and refined with the Bruker SHELXTL (version 6.12) software package, using the space group P2(1)/c with Z = 4 for the formula C<sub>22</sub>H<sub>49</sub>Si<sub>4</sub>SnI. All non-hydrogen atoms were refined anisotropically with the hydrogen atoms placed in idealized positions. Full matrix least-squares refinement based on  $F^2$  converged at R1 = 0.0282 and wR2 = 0.0655 [based on  $I > 2\sigma(I)$ ], R1 = 0.0290 and wR2 = 0.0658 for all data.

**(S)-2-Methoxybutane.**<sup>62</sup> A 500 mL round bottom flask was charged with 63.90 g (1.139 mol, 4 eq) powdered KOH in 200 mL DMSO. 20.02 g (0.2701 mol) (S)-2-butanol was added all at once followed by 77.64 (0.5471 mol, 2 eq) methyl iodide added dropwise over 1.5 hrs. The reaction was stirred at room temperature for an additional 26 hrs. 100 mL DIW was added and the organic layer was separated and dried over MgSO<sub>4</sub>, then distilled at 58-60 °C at 1 atm to yield 16.99 g (71.27% yield). The product was distilled from purple sodium benzophenone ketyl prior to use in C-H activation reactions. <sup>1</sup>H NMR (d<sup>6</sup>-benzene) δ 3.123 (s, 3H, -OCH<sub>3</sub>), 3.01 (m, 1H, methine H), 1.50 (m, 1H, methylene H), 1.41 (m, 1H, methylene H), 1.06 (d, 3H, -CHCH<sub>3</sub>), 0.88 (pseudo t, 3H, -CH<sub>2</sub>CH<sub>3</sub>); <sup>13</sup>C (d<sup>6</sup>-benzene) δ 77.92 (CH), 55.72 (-OCH<sub>3</sub>), 29.34 (CH<sub>2</sub>), 18.69 (-CH<sub>3</sub>), 9.78 (-CH<sub>2</sub>CH<sub>3</sub>); IR(film) cm<sup>-1</sup> ν 2971, 2930, 2878, 2891, 1464, 1372, 1089, MS EI *m/z*: actual 88.0888, predicted 88.0888; Specific rotation (hexane solution) [α] = -17.539° ± 0.002.

Chiral shift reagent studies to determine %ee: To a 0.235 M solution of racemic 2-methoxybutane (synthesized as above, but with racemic 2-butanol, [α]=0.003°± 0.002) in d<sup>6</sup> benzene was added Europium(III) tris[3-(heptafluoropropylhydroxymethylene)-*d*-camphorate] in increments corresponding to a 0.064 M, 0.0913 M, 0.142 M, 0.202 M, and 0.300 M solution. <sup>1</sup>H NMR were taken after each addition and compared to the <sup>1</sup>H NMR of the racemic 2-methoxybutane alone. The results are shown in Table 37.

**Table 37. Shift values for a 0.235M racemic solution of 2-methoxybutane at increasing concentrations of Eu(hfc)<sub>3</sub> in d<sup>6</sup>-benzene. Shifts are listed for the two enantiomers 1 and 2, for the resolution of one of the methylene protons and the protons from C1 and C4. Numbers in parentheses are integrations.**

CSR M	$\delta$								
	CH (1H)	OCH <sub>3</sub> (3H)	CH <sub>2</sub> A1 (1H)	CH <sub>2</sub> A2 (1H)	CH <sub>2</sub> B (1H)	CH <sub>3</sub> d1 (3H)	CH <sub>3</sub> d2 (3H)	CH <sub>3</sub> t1 (3H)	CH <sub>3</sub> t2 (3H)
0.000	3.030	3.130	1.500		1.330	1.000		0.880	
0.0640	5.830	5.570	3.220		2.740	2.400	2.400	1.653	1.660
0.0913	7.280	6.820	4.080		3.420	3.090	3.115	2.040	2.052
0.142	10.100	9.200	5.700	5.760	4.730	4.404	4.461	2.771	2.787
0.202	12.100	10.900	6.859	6.960	5.590	5.340	5.416	3.290	3.308
0.300	14.370	12.857	8.182	8.302	6.760	6.409	6.505	3.879	3.896

To a 0.183 M solution of (S)-2-methoxybutane in d<sup>6</sup> benzene was added Europium(III) tris[3-(heptafluoropropylhydroxymethylene)-*d*-camphorate] in increments corresponding to a 0.0152 M, 0.212 M, 0.300 M, solution. <sup>1</sup>H NMR were taken after each addition and compared to the <sup>1</sup>H NMR of the (S)-2-methoxybutane alone. The results are shown in Table 38.

**Table 38. Shift values for a 0.183 M solution of (S)-2-methoxybutane at increasing concentrations of Eu(hfc)<sub>3</sub> in d<sup>6</sup>-benzene. Compared to the racemic case, no resolution of enantiomers 1 and 2 is seen. Numbers in parentheses are integrations.**

CSR M	$\delta$								
	CH (1H)	OCH <sub>3</sub> (3H)	CH <sub>2</sub> A1 (1H)	CH <sub>2</sub> A2 (1H)	CH <sub>2</sub> B (1H)	CH <sub>3</sub> d1 (3H)	CH <sub>3</sub> d2 (3H)	CH <sub>3</sub> t1 (3H)	CH <sub>3</sub> t2 (3H)
0.000	3.010	3.123	1.500		1.410	1.060		0.880	
0.152	10.800	9.600	6.16		?*	4.793		2.960	
0.212	13.200	11.798	7.500		6.200	5.927		3.566	
0.300	15.400	13.656	8.800		***	6.973		4.129	
* obscured by Eu(hfc) <sub>3</sub> peak									
** obscured by proteo-benzene peak									

To a 0.183 M solution of (S)-2-methoxybutane in  $d^6$  benzene was added 15.3 mg racemic 2-methoxybutane (0.248 M) and Europium(III) tris[3-(heptafluoropropylhydroxymethylene)-*d*-camphorate] in increments corresponding to a 0.212 M and 0.300 M, solution.  $^1\text{H}$  NMR were taken after each addition of  $\text{Eu}(\text{hfc})_3$  and compared to the  $^1\text{H}$  NMR of the (S)-2-methoxybutane alone. The results are shown in Table 39. The ratio of protons  $\text{CH}_3\text{d1}$  to  $\text{CH}_3\text{d2}$  is 1.6:1, which is close to the ratio of S to R isomers in the solution (1.7).

**Table 39. Shift values for a 0.183 M solution of (S)-2-methoxybutane and 0.248 M racemic solution of 2-methoxybutane at increasing concentrations of  $\text{Eu}(\text{hfc})_3$  in  $d^6$ -benzene. Compared to (S)-2-methoxybutane. Numbers in parenthesis are integrations.**

CSR M	$\delta$								
	CH (1H)	OCH <sub>3</sub> (3H)	CH <sub>2</sub> A1 (1H)	CH <sub>2</sub> A2 (1H)	CH <sub>2</sub> B (1H)	CH <sub>3</sub> d1 (3H)	CH <sub>3</sub> d2 (3H)	CH <sub>3</sub> t1 (3H)	CH <sub>3</sub> t2 (3H)
0.000	3.010	3.123	1.500		1.410	1.060		0.880	
0.212	8.400	7.732	?*		4.000	3.665	3.622	2.355	2.340
0.300	10.00	9.214	5.763		?*	4.511	4.449	2.817	2.802
* obscured by $\text{Eu}(\text{hfc})_3$ peak									

$[(\text{Me}_3\text{Si})_2\text{CH}]_2\text{GeI}[\text{CH}_3\text{OCH}(\text{CH}_3)(\text{CH}_2\text{CH}_3)]$ .<sup>63</sup> In a drybox, a 20 mL round bottom flask was charged with 30 mg (0.077 mmol)  $[(\text{Me}_3\text{Si})_2\text{CH}]_2\text{Ge}$ , 10 mL (S)-2-methoxybutane, and 9  $\mu\text{L}$  PhI (0.080 mmol) and capped with a needle valve. The bright yellow solution was stirred at rt for 17 hrs by which time it had become colorless. Volatiles were removed in vacuo leaving a white solid.  $^1\text{H}$  NMR showed 70% conversion to desired product, 15% oxidative addition (based on  $^1\text{H}$  NMR peak at  $\delta$  7.95), and 15% possible activation at the methoxy carbon (based on apparent diastereotopic  $^1\text{H}$  NMR peaks at  $\delta$  3.82).  $^1\text{H}$  NMR ( $d^6$ -benzene)  $\delta$  2.963 (s, 3H,  $-\text{OCH}_3$ ), 2.141 (m, 1H,

CH<sub>2</sub>), 2.00 (m, 1H, CH<sub>2</sub>), 1.44 (s, 3H, Ge-CH-CH<sub>3</sub>), 0.943 (pseudo-t, 3H, CH<sub>2</sub>CH<sub>3</sub>), 0.720 (s, 1H, Ge-CH(TMS)<sub>2</sub>), 0.671 (s, 1H, Ge-CH(TMS)<sub>2</sub>), 0.430 (s, 9H, TMS), 0.420 (s, 9H, TMS), 0.323 (s, 18H, TMS).

Chiral shift reagent studies to determine %ee: To a 0.147 M solution of [(Me<sub>3</sub>Si)<sub>2</sub>CH]<sub>2</sub>GeI[CH<sub>3</sub>OCH(CH<sub>3</sub>)(CH<sub>2</sub>CH<sub>3</sub>)] (synthesized as above, but with racemic 2-methoxybutane) in d<sup>6</sup>-benzene was added Europium(III) tris[3-(heptafluoropropylhydroxymethylene)-*d*-camphorate] in increments corresponding to a 0.152 M, 0.251 M, 0.279 M, and 0.300 M solution. <sup>1</sup>H NMR were taken after each addition and compared to the <sup>1</sup>H NMR of the product alone. The results are shown in Table 40.

**Table 40. Shift values for 0.147 M solution of [(Me<sub>3</sub>Si)<sub>2</sub>CH]<sub>2</sub>GeI[CH<sub>3</sub>OCH(CH<sub>3</sub>)(CH<sub>2</sub>CH<sub>3</sub>)] made from racemic solution of 2-methoxybutane at increasing concentrations of Eu(hfc)<sub>3</sub> in d<sup>6</sup>-benzene. Compared to [(Me<sub>3</sub>Si)<sub>2</sub>CH]<sub>2</sub>GeI[CH<sub>3</sub>OCH(CH<sub>3</sub>)(CH<sub>2</sub>CH<sub>3</sub>)] alone. Numbers in parenthesis are integrations. Assignments for 3 highest concentrations are tentative due to extreme broadening of all peaks.**

CSR M	δ									
	OCH <sub>3</sub> (3H)	CH <sub>2</sub> A (1H)	CH <sub>2</sub> B (1H)	CH <sub>3</sub> s (3H)	CH <sub>3</sub> p-t (3H)	CH A (1H)	CH B (1H)	TMS (9H)	TMS (9H)	2 TMS (18H)
0.000	2.963	2.141	2.000	1.440	0.93	0.720	0.671	0.430	0.420	0.323
0.152	2.916	2.130	2.000	1.398	0.899	0.670	0.621	0.378	0.356	0.318
0.251	2.910	?		1.381	0.891	?	?	0.374		0.314
0.279	2.906	?		1.389	?	?	?	0.373		0.259
0.359	2.889	?		1.365	?	?	?		?	

Studies to determine feasibility of using chiral shift reagents to determine %ee of C-H activation reactions: To a 0.15M solution of previously synthesized [C<sub>2</sub>H<sub>4</sub>(SiMe<sub>3</sub>)<sub>4</sub>C<sub>2</sub>][SnI(C<sub>5</sub>OH<sub>7</sub>)<sup>58</sup>] in d<sup>6</sup>-benzene was added Europium(III) tris[3-(heptafluoropropylhydroxymethylene)-*d*-camphorate] in increments corresponding to a 0.049 M, 0.098 M, 0.15 M, and 0.20 M solution. <sup>1</sup>H NMR were taken after each addition

and compared to the  $^1\text{H}$  NMR of the  $[\text{C}_2\text{H}_4(\text{SiMe}_3)_4\text{C}_2]\text{SnI}(\text{C}_5\text{OH}_7)$  alone. The results are shown in Table 41.

**Table 41. Shift values for 0.15M solution of [C<sub>2</sub>H<sub>4</sub>(SiMe<sub>3</sub>)<sub>4</sub>C<sub>2</sub>]SnI(C<sub>5</sub>OH<sub>7</sub>) at increasing concentrations of Eu(hfc)<sub>3</sub> in d<sup>6</sup>-benzene. Compared to [C<sub>2</sub>H<sub>4</sub>(SiMe<sub>3</sub>)<sub>4</sub>C<sub>2</sub>]SnI(C<sub>5</sub>OH<sub>7</sub>) alone. Numbers in parenthesis are integrations.**

CSR M	δ												
	6- Alkene (1H)	5- Alkene (1H)	3-CH <sub>2</sub> A (1H)	3- CH <sub>2</sub> B (1H)	3'- CH <sub>2</sub> A (1H)	3'- CH <sub>2</sub> B (1H)	CH A (1H)	CH B (1H)	4- CH <sub>2</sub> (2H)	L1- CH <sub>2</sub> (2H)	4'- CH <sub>2</sub> A (1H)	4' CH <sub>2</sub> B (1H)	L2- CH <sub>2</sub> (2H)
0.000	6.600	4.810	4.050		3.540		2.670		2.470	2.090	1.940		1.930
0.049	5.595	5.634	6.674	6.429	3.885	3.775	9.178	8.794	3.503	2.212	2.873		2.085
0.098	5.971	6.810	7.895	7.560	4.578	4.486	10.410	9.847	3.899	2.267	3.384	3.292	2.150
0.15	7.648	7.649	8.900	8.499	5.155	4.897	11.128	10.725	4.219	2.307	3.770	3.639	2.200
0.20	8.355	8.355	9.738	9.200	5.590	5.289	12.212	11.383	4.468	2.343	4.053	3.909	2.241

217

δ							
1TMS A (9H)	1TMS B (9H)	2TMS A (9H)	2TMS B (9H)	3TMS A (9H)	3TMS B (9H)	4TMS A (9H)	4TMS B (9H)
0.388		0.379		0.193		0.124	
0.493	0.478	0.469	0.441	0.373	0.358	0.288	0.272
0.539	0.517	0.508	0.466	0.456	0.433	0.363	0.338
0.577	0.549	0.539	0.522	0.494	0.485	0.424	0.392
0.604	0.572	0.572	0.562	0.538	0.499	0.468	0.430