

Unless otherwise noted, the content of this course material is licensed under a Creative Commons Attribution - Non-Commercial - Share Alike 3.0 License.
<http://creativecommons.org/licenses/by-nc-sa/3.0/>

Copyright © 2009, Paul Conway.

You assume all responsibility for use and potential liability associated with any use of the material. Material contains copyrighted content, used in accordance with U.S. law. Copyright holders of content included in this material should contact open.michigan@umich.edu with any questions, corrections, or clarifications regarding the use of content. The Regents of the University of Michigan do not license the use of third party content posted to this site unless such a license is specifically granted in connection with particular content. Users of content are responsible for their compliance with applicable law. Mention of specific products in this material solely represents the opinion of the speaker and does not represent an endorsement by the University of Michigan. For more information about how to cite these materials visit <http://michigan.educommons.net/about/terms-of-use>.

Any medical information in this material is intended to inform and educate and is not a tool for self-diagnosis or a replacement for medical evaluation, advice, diagnosis or treatment by a healthcare professional. You should speak to your physician or make an appointment to be seen if you have questions or concerns about this information or your medical condition. Viewer discretion is advised: Material may contain medical images that may be disturbing to some viewers.

SI 640 Digital Libraries and Archives

Week 1 – Definitions and History

Themes for this week

1 Themes

- Introductions
- What is a digital library?
- Course requirements
- Archive and library?

“The term ‘digital library’ is relatively new.”

Borgman, 2000.

What are digital libraries?

1 Themes

2 Definition

3 History

4 International

“...organizations that provide the resources...collections that are readily and economically available...” *Don Waters (1998)*

“... the term ‘digital library’ may even be an oxymoron.”

Douglas Greenberg (1998)

“...a collaborator within the academy, yet retains its distinct identity”

Wendy Lougee (2002)

“...a ‘tenth library’ for the University of California”

“...provides a community of users with coherent access to a large, organized repository...”

Cliff Lynch (1995)

“... digitized and organized collection, ‘full-form online material,’ link to audience...”

Michael Lesk (1997)

What are digital libraries?

1 Themes

2 Definition

3 History

4 International

“...the web is not a library.”

Jose-Marie Griffiths (1998)

“... services, architecture, enabling technologies,
users and content”

Christine Borgman (1992)

“...an environment to bring together collections, services, and
people in support of the full life cycle of creation,
dissemination, use, and preservation of data, information
and knowledge”

Paul Duguid (1997)

“a national digital library” *Library of Congress*

DLF Definition

1 Themes

2 Definition

3 History

4 International

Digital libraries are organizations that provide the resources, including the specialized staff, to select, structure, offer intellectual access to, interpret, distribute, preserve the integrity of, and ensure the persistence over time of collections of digital works so that they are readily and economically available for use by a defined community or set of communities.

*Donald J. Waters, What Are Digital Libraries? CLIR Issues
(July/Aug 1998)*

Borgman on digital libraries

1 Themes

2 Definition

3 History

4 International

Image of Christine
Borgman removed

Research and practice: different worlds

- “Digital libraries are a set of electronic resources and associated technical capabilities...
 - Focuses on the technical system
- “Digital libraries are constructed by and for a community of users...”
 - Focuses on process and service

Pre-history

1 Themes

2 Definition

3 History

4 International

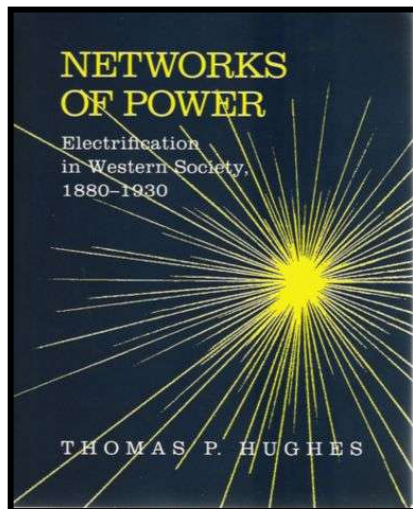

- Networks and mainframes
- Moore's law
- Collaborative work: Doug Engelbart
- Business-government-academic

Thomas Hughes, *Networks of power: electrification of western society, 1880-1930*. Johns Hopkins, 1983.

SI's own history as an educational program is tied up in the evolution of the pre-history of digital libraries.

History – scanning and storage

1 Themes

2 Definition

3 History

4 International

- Xerox PARC 1978 – first scanner
- IBM – storage and workflow
- BellCore – image and text



Building on existing infrastructures, the search for new markets for emerging technologies focused on digital content in “business practices.”

History – govt./business early adoption

1 Themes

2 Definition

3 History

4 International

- Business efficiency – paperless office
- Govt. effectiveness – paperless govt.
- National Archives and Library of Congress – early experimenters
 - ODISS
 - Federal guidelines
 - American Memory pilot

History – university library experiments

1 Themes

2 Definition

3 History

4 International

- Michigan and Cornell, 1989
- LaGuardia Eight
- Digital Library Federation
- National leadership; little funding

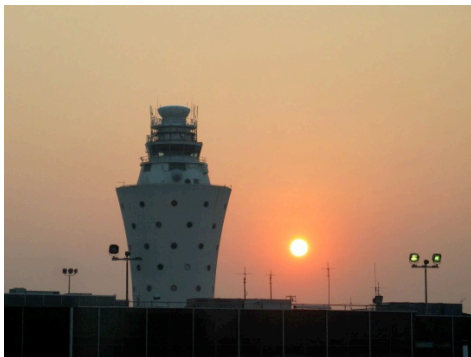

Research libraries have a long and distinguished history of technology experimentation and adoption.
[CLR, CPA, CLIR]

BY: Geoff Stearns

<http://creativecommons.org/licenses/by/2.0>

History – university research efforts

1 Themes

2 Definition

3 History

4 International

- Fox and computer scientists
- NSF DLI1
- NSF DLI2
- Patents and trademarks as an issue



Image of Digital Libraries Initiative website header removed

DLI1: <http://www.dli2.nsf.gov/dlione/>

DLI2: <http://www.dli2.nsf.gov/>

Back to Borgman

1 Themes

2 Definition

3 History

4 International

Separate worlds, separate agendas

- Research vs. practice
- Databases vs. services
- Revolutionary vs. evolutionary
- Distributed vs. institutional

Borgman, p. 48. “Digital libraries are an extension, enhancement, and integration of” ... systems and institutions.

Lorcan Dempsey on a decade

1 Themes

2 Definition

3 History

4 International

- Discovery to delivery
- Create to curate
- Connect, advise, collaborate
- Hybrid library [from publishing, learning and teaching, access to resources TO integration and preservation of...]
- ..resources: legacy, transition, new, future

Dempsey, 2006. <http://www.ariadne.ac.uk/issue46/dempsey/>

Rusbridge, 1998. <http://www.dlib.org/dlib/july98/rusbridge/07rusbridge.html>

European efforts and beyond

1 Themes

2 Definition

3 History

4 International

■ Metadata modeling for the pooling of resources

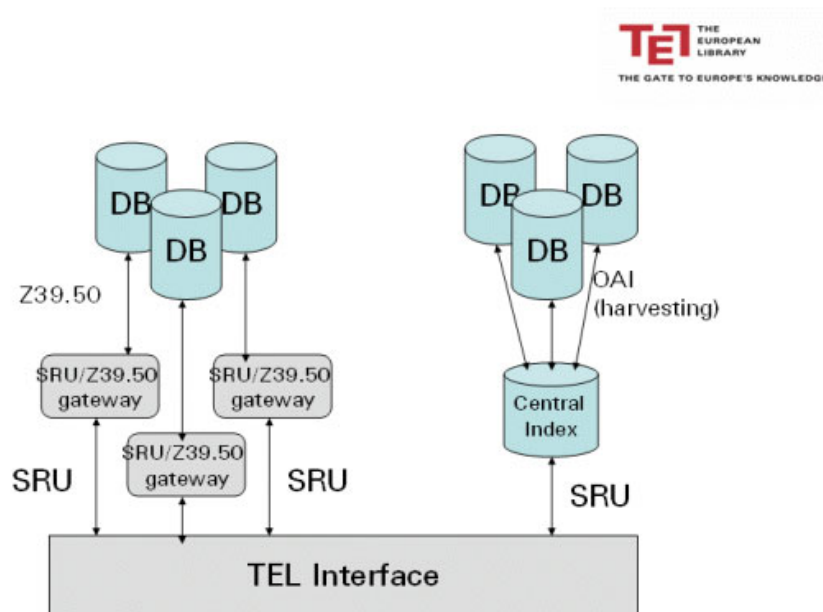

TEL: <http://www.theeuropeanlibrary.org/portal/index.html>

Resources for Further Study

- Journals

- See list in CTools

- Organizations

- DLF <http://www.diglib.org/>
- JISC <http://www.jisc.ac.uk/>
- DELOS <http://www.delos.info/>

- Portals

- ACM <http://www.acm.org/>
- PADI <http://www.nla.gov.au/padi/>

- Conferences

- JCDL <http://www.jcdl.org/>
- ECDL <http://www.ecdl2007.org/index.php>
- ICADL <http://www.icadl.org/>

Thank you!

Paul Conway

Associate Professor

School of Information

University of Michigan

www.si.umich.edu