

Unless otherwise noted, the content of this course material is licensed under a Creative Commons Creative Commons Attribution - Non-Commercial - Share Alike 3.0 License.

<http://creativecommons.org/licenses/by-nc-sa/3.0/>

Copyright © 2009, Paul Conway.

You assume all responsibility for use and potential liability associated with any use of the material. Material contains copyrighted content, used in accordance with U.S. law. Copyright holders of content included in this material should contact [open.michigan@umich.edu](mailto:open.michigan@umich.edu) with any questions, corrections, or clarifications regarding the use of content. The Regents of the University of Michigan do not license the use of third party content posted to this site unless such a license is specifically granted in connection with particular content. Users of content are responsible for their compliance with applicable law. Mention of specific products in this material solely represents the opinion of the speaker and does not represent an endorsement by the University of Michigan. For more information about how to cite these materials visit <http://michigan.educommons.net/about/terms-of-use>.

Any medical information in this material is intended to inform and educate and is not a tool for self-diagnosis or a replacement for medical evaluation, advice, diagnosis or treatment by a healthcare professional. You should speak to your physician or make an appointment to be seen if you have questions or concerns about this information or your medical condition. Viewer discretion is advised: Material may contain medical images that may be disturbing to some viewers.

# SI 640 Digital Libraries and Archives

Week 12 – Sustaining Digital Libraries

# Themes of this presentation

---

## Themes

- to sustain
- Critical ideas
- Looking forward

*“I was told that if a million monkeys sat at a million typewriters, they would eventually write all the works of Shakespeare.”*

# to sustain

---

## **to sustain**

Critical ideas

Looking forward

- To support the efforts, conduct, or cause of...
- To uphold the validity or rightfulness of..
- To keep from failing or giving away
- To cause to continue in a certain state
- To keep going, keep up
- To provide for the life or bodily needs of
- To provide for the upkeep

• Wheatley, 2004.

# Repositories and Preservation

---

## to sustain

Critical ideas

Looking forward

## ■ Preservation functions

- Unique, persistent identification
- Ingest
- Representation systems (registries and networks)
- Technology watch
- Rendering
- Modular structure
- Recording change

# DLF Definition

to sustain

**Critical ideas**

Looking forward

***Digital libraries are organizations that provide the resources, including the specialized staff, to select, structure, offer intellectual access to, interpret, distribute, preserve the integrity of, and ensure the persistence over time of collections of digital works so that they are readily and economically available for use by a defined community or set of communities.***

*Donald J. Waters, What Are Digital Libraries? CLIR Issues (July/Aug 1998)*

# Borgman on digital libraries

---

to sustain

## Critical ideas

Looking forward

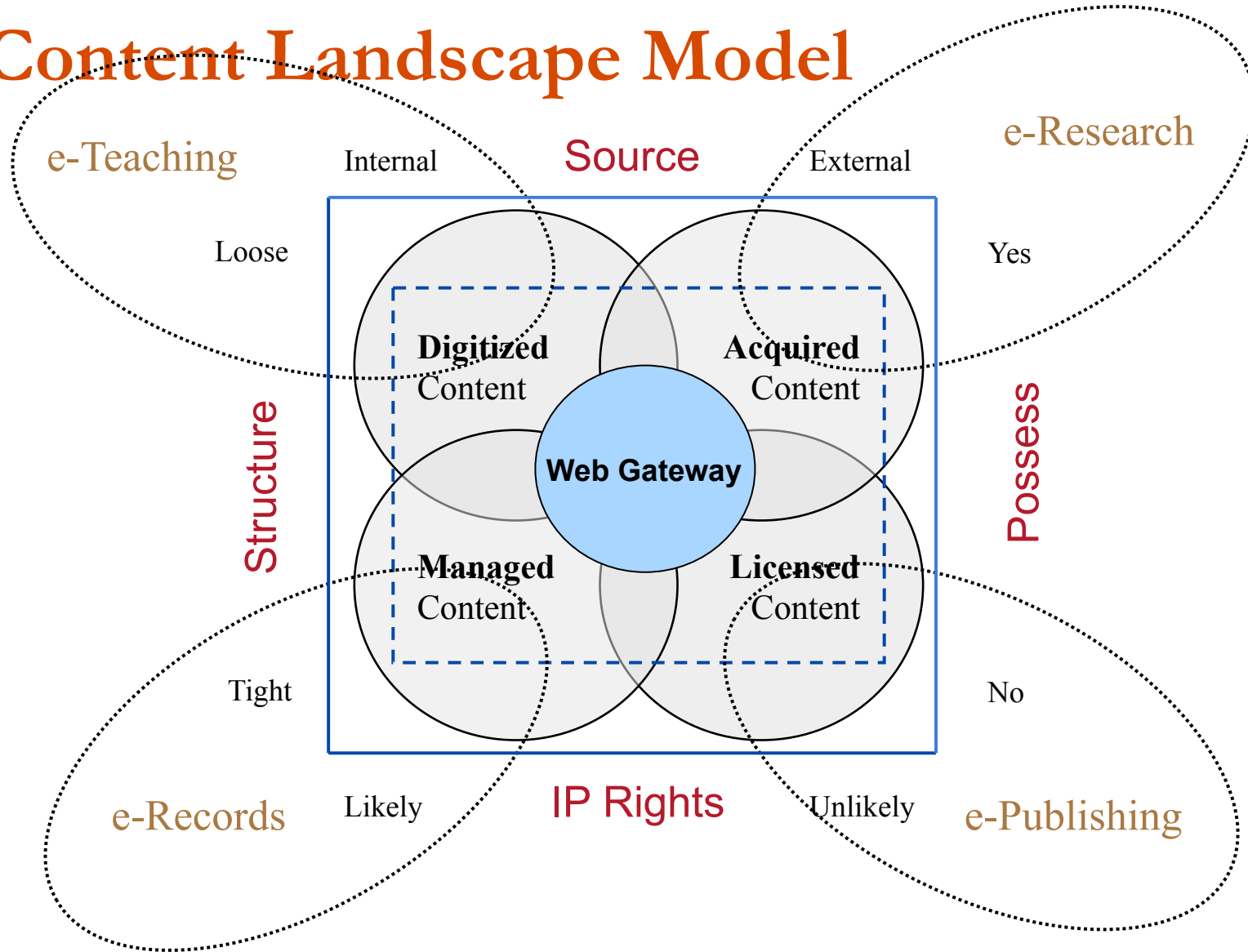

Image of Christine  
Borgman removed

## Research and practice: different worlds

- “Digital libraries are a set of electronic resources and associated technical capabilities...
  - Focuses on the technical system
- “Digital libraries are constructed by and for a community of users...”
  - Focuses on process and service

# Content Landscape Model





# Federated Archives

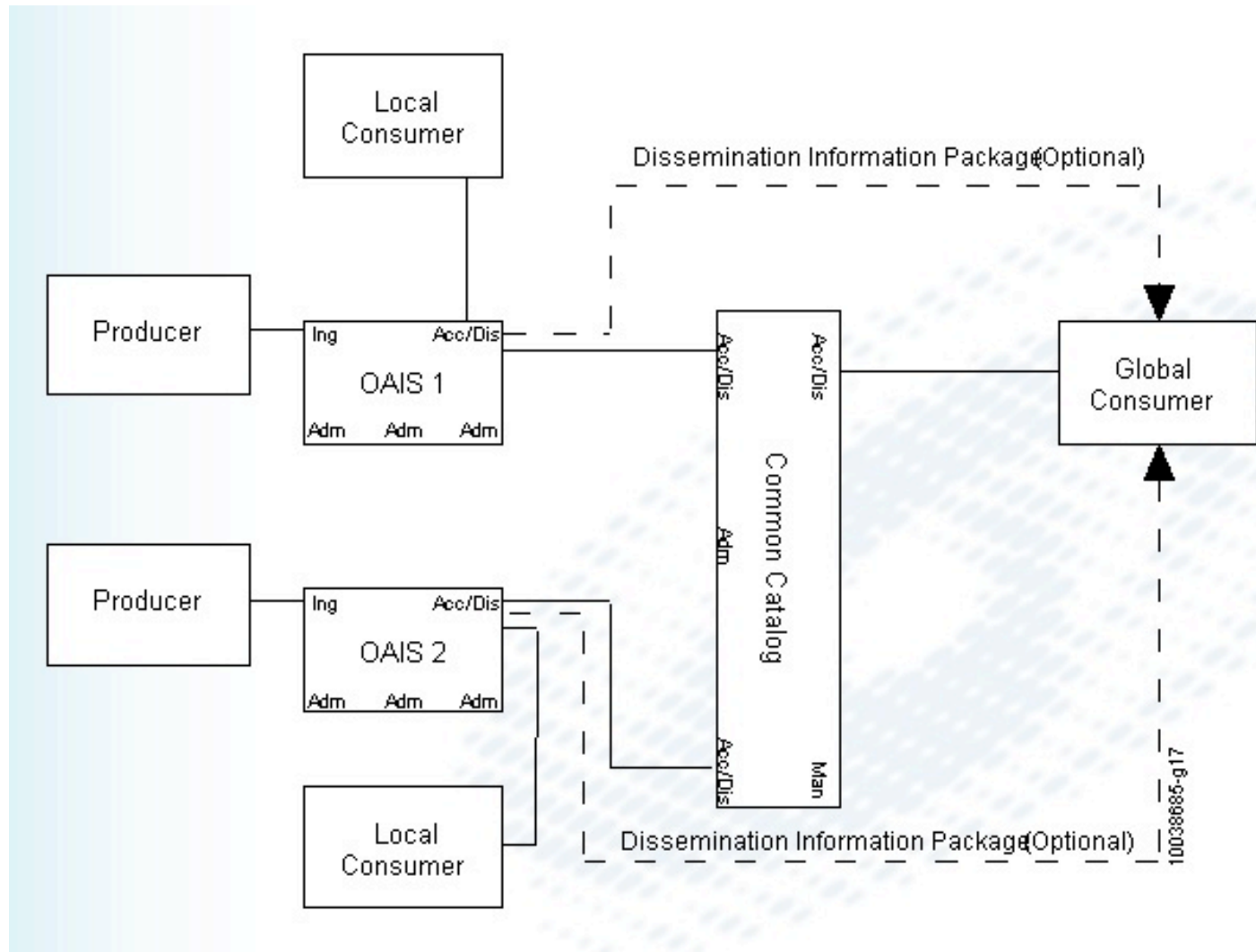

# What is a digital library anymore, anyway?

---

to sustain

## Critical ideas

Looking forward

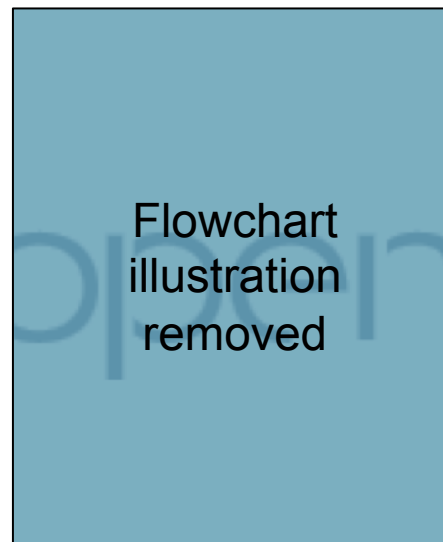

# Information Network Overlay

---

to sustain

## **Critical ideas**

Looking forward

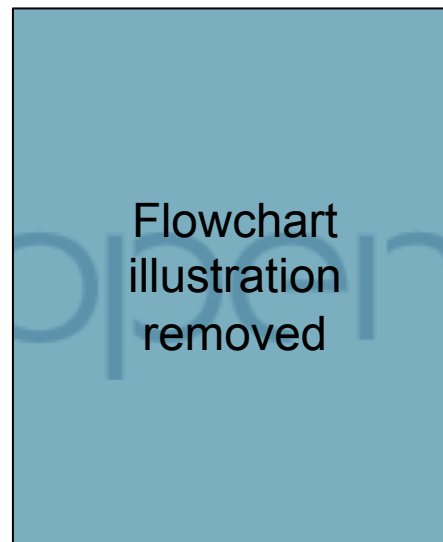

• Flecker, DLib Magazine.

# Harvard library digital architecture

to sustain

**Critical ideas**

Looking forward

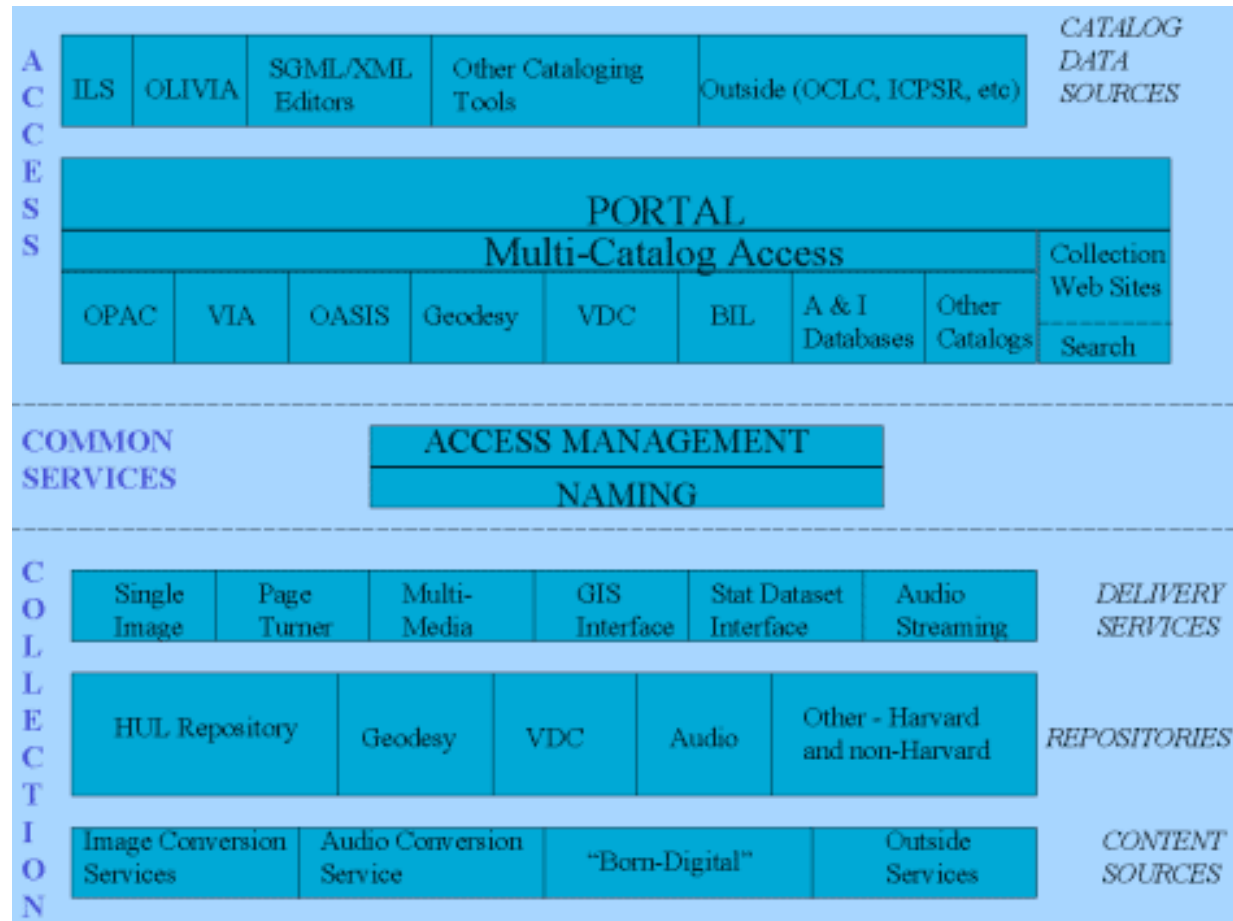

# Where do we go from here?

---

to sustain

Critical ideas

**Looking forward**

- Cyberinfrastructure
- Research
- Large scale deployment
- Digital preservation
- “Other issues”
  - Personal information management
  - HCI
  - Lifelong learning
  - Collaboratories

# Where do we go from here?

---

to sustain

Critical ideas

**Looking forward**

- Perhaps the overarching theme here ... is connecting and integrating digital libraries with broader individual, group and societal activities, and doing this across meaningful time horizons ... digital libraries ... as an integral and permanent part of the ... information environment.

# Thank you!

---

**Paul Conway**

*Associate Professor*

School of Information

University of Michigan

[www.si.umich.edu](http://www.si.umich.edu)