

DEPARTMENT OF CHEMISTRY
UNIVERSITY OF MICHIGAN
Ann Arbor, Michigan

PROGRESS REPORT 8

November 1958 - October 1959

- ACTIVATION ANALYSIS
- NUCLEAR CHEMICAL RESEARCH
- RADIOCHEMICAL SEPARATIONS

Edited by

R. S. Maddock

and

W. W. Meinke, (Project Director)

November 1, 1959

Supported by

Department of Chemistry

Michigan-Memorial Phoenix Project

Project No. 7 Contract No. AT(11-1)-70
U. S. Atomic Energy Commission

The following is a report of the work completed on Project No. 7, Contract No. AT(11-1)-70 during the year of November 1, 1958 to October 31, 1959.

Previous progress reports are listed below:

Progress Report 1	November 1952
Progress Report 2	November 1953
Progress Report 3	November 1954
Progress Report 4 (AECU-3116)	November 1955
Progress Report 5 (AECU-3375)	November 1956
Progress Report 6 (AECU-3641)	November 1957
Progress Report 7 (AECU-3887)	November 1958

TABLE OF CONTENTS

	PAGE
I FACILITIES	1
Michigan Reactor and Pneumatic Tube System	1
Thermal Neutron Fluxes and Cadmium Ratios in Pneumatic Tubes	4
Fast Neutron Measurements in the Pneumatic Tubes	5
Investigation of Trace Polyethylene Contaminants	6
Determination of Neutron Attenuation by Rat Tissue	7
"Bunny Rabbit" System	8
Typical Run Utilizing Pneumatic Systems	13
Neutron Generator	17
Chemistry Building	21
Problems of Air Conditioning	21
II INSTRUMENTATION	24
100-Channel Pulse Height Analyzer	24
Auxiliary Circuits	26
Additional Detectors	28
Three-inch Scintillation Crystal Detector	28
III NUCLEAR CHEMISTRY	30
Absolute (d, alpha) Reaction Cross Sections and Excitation Functions	30
Nuclear Data Analysis: Application of Digital Computers	31
A Search for the Isotope Ir ¹⁹⁶	32
Isomerism of Platinum-199	32
Preliminary Report on Study of Some Short-Lived Fission Product Gases	33

TABLE OF CONTENTS (cont'd)

	PAGE
Search for Some Short-Lived Isomeric Transitions	37
Isomerism of Silver-108	37
New Determination of the Branching Ratio of 2.4-min Silver-108	39
Search for Rhodium-109 (Half-Life 1 hr) in Fission Products	40
IV RADIOCHEMICAL SEPARATIONS	41
Subcommittee on Radiochemistry Program.	41
Pamphlet on "Source Material for Radiochemistry".	41
Radiochemistry Monographs	42
Availability of Cyclotron Service Irradiation Time.	43
Radiochemical Separations of Cadmium.	44
Application of Vacuum Distillation of Metals to Radiochemical Separations.	44
Radiochemical Separations by Amalgam Exchange . . .	46
Experimental.	47
Conclusion.	51
Expressing the Degree of Separation Obtained in a Radiochemical Separation	53
V ACTIVATION ANALYSIS	58
Review Articles and Data Correlation Summaries. . .	58
Review Articles in Activation Analysis.	58
Review of Fundamental Developments in Nucleonics.	58
Activation Analysis for Trace Constituents in Meteorites.	59
Determination of Vanadium in Petroleum Process Streams	59
Determination of Vanadium in Petroleum Catalyst . .	60
Activation Analysis of Niobium.	63

TABLE OF CONTENTS (cont'd)

	PAGE
Activation Analysis of Gold in Marine Organisms.	68
Preliminary Experiments.	68
Analytical Procedure	69
Flux Monitor	70
Calibration Curve.	70
Results Obtained	71
Notes.	71
Activation Analysis of Rhenium in Marine Organisms	72
Analytical Procedure	72
Flux Monitor and Calibration Curve	73
Results Obtained	74
Notes.	75
Activation Analysis of Molybdenum in Marine Organisms.	77
Analytical Procedure	78
Flux Monitor and Calibration Curve	80
Results Obtained and Notes	81
Activation Analysis of Tungsten in Marine Organisms.	82
Analytical Procedure	83
Flux Monitor and Calibration Curve	84
Results Obtained	84
Notes.	85
Activation Analysis of Cobalt in Aluminum-Cobalt Foil	86
Analytical Procedure	86
Calibration and Flux Monitor	87
Results Obtained and Notes	88

TABLE OF CONTENTS (cont'd)

	PAGE
Activation Analysis for Trace Elements in Marine Organisms	88
Activation Analysis of Trace Cobalt, Vanadium and Copper in Tissue.	89
Preliminary Investigations of (n, α), (n,p), and (n, γ) as Competing Reactions in Activation Analysis of Biological Tissue	91
Preliminary Investigations of the Activation Analysis of Trace Selenium in Tissue Using Se ^{77m} , Se ^{79m} , and Se ^{81m}	94
Preliminary Investigations on (n,2n) Reactions for Activation Analysis of Carbon, Nitrogen and Oxygen.	96
Introduction.	96
Procedure	97
Results	97
Discussion.	99
Preliminary Experiments for Activation Analysis of Thallium	100
Radiochemical Analysis of Long-Lived Activity in a High Specific Activity Gold Sample	101
VI APPLICATIONS OF TRACERS TO ANALYSIS	102
Use of Radioactive Tracers to Determine Solubility Products	102
VII SEPARATION PROCEDURES	103
Vanadium (Brownlee)	103
Vanadium (Kaiser)	104
Cobalt (Kaiser)	105
Copper (Kaiser)	106
Niobium (Brownlee).	107
Technetium (Fukai).	108
Tungsten (Fukai).	110

TABLE OF CONTENTS (cont'd)

	PAGE
Rhenium (Fukai)	111
Gold (Fukai).	112
Thallium (Kim).	113
VIII PERSONNEL, PUBLICATIONS, TALKS, MEETINGS.	114
Personnel Listing	114
Papers and Reports Published.	115
Talks	117
Committee Meetings.	120
IX ACKNOWLEDGEMENTS.	121
X LIST OF REFERENCES.	122

LIST OF FIGURES

FIGURE NO.	PAGE
1. Quick opening polyethylene rabbit.	2
2. Thermal neutron flux in pneumatic tube no. 2 of Ford Nuclear Reactor operating at a power level of 1000 kw \pm 10%.	5
3. Neutron attenuation experiment, top view of rabbit	7
4. Neutron attenuation experiment, side view of rabbit	7
5. Gamma detector for 100-channel analyzer set up in hot lab next to hood	9
6. Spectra taken with 1-1/2"x2" crystal in hot lab and with 3"x3" crystal in 100-channel analyzer room.	10
7. "Bunny" rabbit pneumatic tube layout.	11
8. Layout of 3"x3" detector setup	12
9. Pictures 1 through 10 show a typical activation analysis run utilizing the pneumatic tube systems	14
10. Two views of the neutron generator	19
11. Floor plan of Phoenix Laboratory showing proposed housing for neutron generator	20
12. Radioisotope laboratory in Chemistry Building.	22
13. Counting room adjacent to radioisotope laboratory in Chemistry Building	22
14. 100-channel analyzer readout	25
15. Block diagram of auxiliary circuits used with the 100-channel pulse height analyzer.	27
16. 3"x3" NaI(Tl) crystal setup in 40"x40" cave showing beta paddle in place	29
17. Sample preparation for determination of krypton.	34
18. Sample preparation for determination of xenon.	35
19. Gamma-ray spectrum of Ag ^{110m} produced in 1951, 1954 and 1957.	38

LIST OF FIGURES (cont'd)

FIGURE NO.	PAGE
20. Gamma spectra of cracking catalyst.	61
21. Calibration curve for vanadium in cracking catalyst	63
22. Decay scheme for Nb ^{94m}	64
23. Gamma spectra of niobium in Rutile.	65
24. K X-ray spectrum of niobium taken with X-ray proportional detector	66
25. Calibration curve for gold (biological ash).	70
26. Calibration curve for rhenium (biological ash).	74
27. Spectrum of 63.5 kev gamma peak of Re ^{188m} . .	75
28. Decay curves of Re ^{188m}	76
29. Gamma spectra of Mo ¹⁰¹ and Tc ¹⁰¹ after 10 minute irradiation	78
30. Growth and decay of Tc ¹⁰¹ peak.	79
31. Calibration curve for molybdenum (biological ash).	80
32. Gamma spectra of tungsten after 6.3 hours irradiation	83
33. Calibration curve for tungsten (biological ash).	85
34. Calibration curve for cobalt.	87
35. Side view of cadmium-lined rabbit	93
36. Calibration curve for carbon, nitrogen and oxygen.	99

LIST OF TABLES

TABLE NO.	PAGE
I Dose Rates from Rabbits.	3
II Fast Flux Data for Pneumatic Tubes at 1000 Kw.	6
III Preliminary Results from Rare Gas Experiment .	36
IV Decay Data for Silver-108.	39
V Exchange of an Element with its Amalgam. . . .	49
VI Cd ^{115m} Exchange with Cadmium Amalgam in 0.5 M NaNO ₃ Solution for Various Times of Stirring	50
VII Tl ²⁰⁴ Exchange with Concentration of the Thallium Amalgam for Two Minutes Stirring. .	50
VIII Interference of Noble Metals and Mercury . . .	51
IX Methods of Expressing the Degree of Separation that can be Obtained in a Radiochemical Separation	54
X Change in the Decontamination Factor with the Initial Concentration of the Contaminant . .	56
XI Vanadium in Cracking Catalyst.	62
XII Approximate Experimental Sensitivities and Mode of Chemical Separation for Six Trace Elements in Marine Biological Ashes.	90
XIII Activities for Competing Reactions	92

I FACILITIES

A. Michigan Reactor and Pneumatic Tube System

The Ford Nuclear Reactor has operated routinely at a power of 1 megawatt (flux of $\sim 10^{13}$ n cm⁻² sec⁻¹) for the past year on an average of three to four 8-hour days a week, with two weeks off during the month of September for annual maintenance. Of the total number of operating hours our Nuclear Chemistry Group used 2450 hours of running time obtaining 1090 irradiations. (Sometimes several people were irradiating at the same time.) 1056 of these irradiations were short irradiations made at the core utilizing the pneumatic tube system and 34 irradiations were beam port or "in pool" irradiations. The short irradiations are discussed in more detail in the section on activation analysis. The "in pool" irradiations included the production of long-lived tracers such as Fe⁵⁹, Cd¹¹⁵, In¹¹⁴ and Sn¹¹⁷.

Recently an article has been published in Nucleonics (1) describing the current status of our facilities.

The pneumatic tube system (2,3) has been in full operation almost continuously during the year. Occasional problems have arisen when a rabbit has gotten stuck, or when a press-fit rabbit has come apart. These problems, however, represent only a few tenths of one per cent of our total number of irradiations. Similarly we have had some trouble with relays in the control system for the pneumatic tubes, and we have asked the supplier to recheck and overhaul the system in October. This system of four pneumatic tubes, however, has been used continuously for over 2 years and has held up very well under this hard use.

The material for the rabbits (3) used in this pneumatic system was changed because the nylon originally used became quite brittle and cracked after a number of hours irradiation at full power. The new design shown in Fig. 1 includes the use of polyethylene instead

QUICK OPENING POLYETHYLENE RABBIT

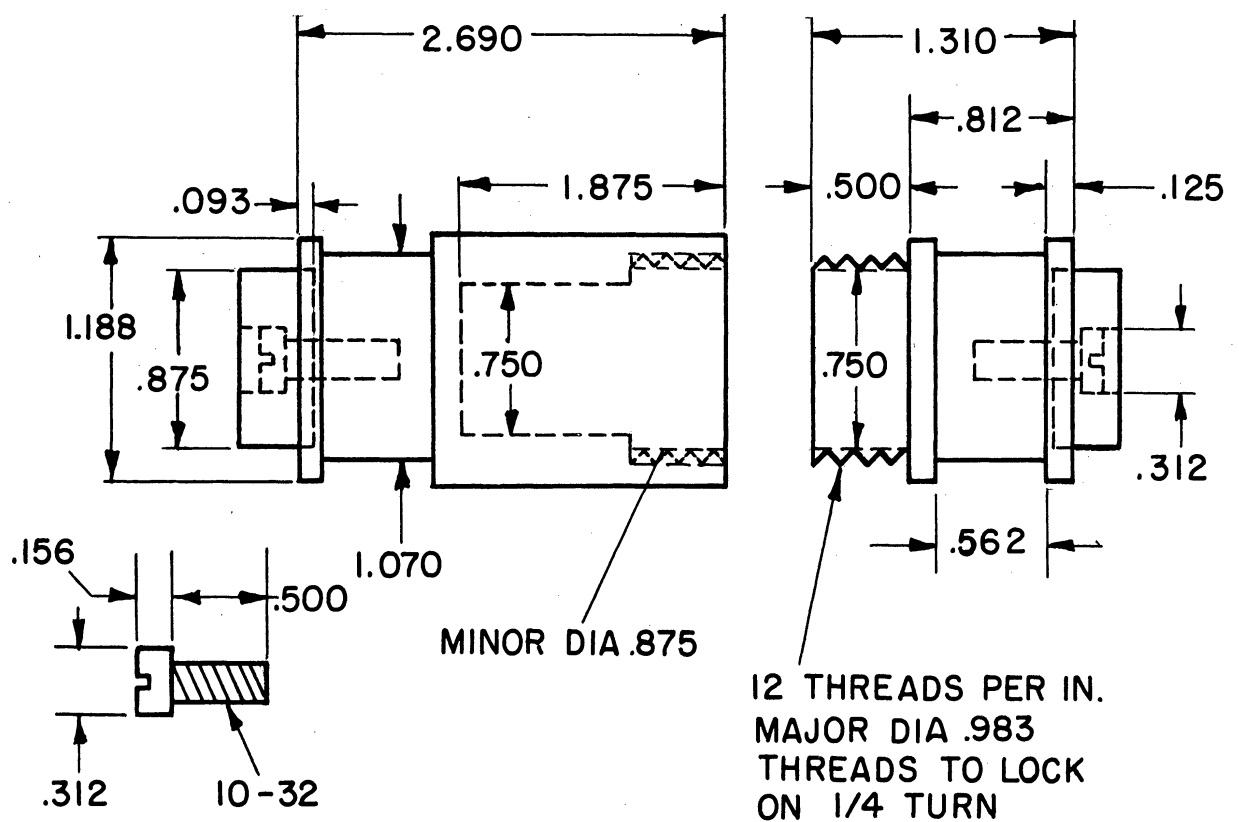

Figure 1. Quick opening polyethylene rabbit.

of nylon and a quarter turn twist lock instead of the press-fit cap described previously (3). It has been found that polyethylene will last at least 2-3 times longer than the nylon and the quarter turn cap can be opened just as fast as the press-fit caps.

Although the original reason for choosing nylon was because of its very low background after radiation, the dosage rates from a polyethylene rabbit are not much greater as shown for pneumatic tube No. 2 in Table I. (1) These values are still small enough

Table I. Dose Rates from Rabbits.

Irradiation time	Surface dose rates* (mr/hr)	
	Polyethylene	Nylon
15 sec	35	30
1 min	140	100
2.5 min	260	200
5 min	310	250

*Measurements were made 3 sec after irradiation at 1 Mw.

that dosage to the hands is negligible during the few seconds it takes to open a rabbit. Finger film badges are always worn to record the dosage received during a set of runs.

To assure a reproducible placement of a sample in the rabbit, a small hollow cylinder of polyethylene is now used to hold the sample in the center of the rabbit.

The possibility of replacing the felt bumper and gasket of the rabbits with plastic is being investigated since two to three times more radioactivity is induced in the felt than in the polyethylene. It is hoped that a suitable plastic can be found to replace the felt and thus considerably reduce the total activity.

1. Thermal Neutron Fluxes and Cadmium Ratios in Pneumatic Tubes

During the past year a record has been kept of the thermal neutron flux at full power in Tube No. 2 (see Fig. 3, ref. 3) with occasional checks of Tube No. 1 and Tube No. 3. The average thermal neutron flux values for the tubes are

Tube No. 1	1.76×10^{12}	n cm ⁻² sec ⁻¹
Tube No. 2	1.24×10^{12}	" "
Tube No. 3	0.92×10^{12}	" "

The average Cd ratio for Tube No. 2 was 14.7 and for Tube No. 3 was 14.8. One mil gold foil covered with 20 mil Cd foil was used for the Cd ratio measurements.

Figure 2 is a plot of the day to day flux measurements taken in Tube No. 2 at 1000 kw. The precision of individual points should be better than 3% based on known errors in foil weighing, positioning in the rabbit, and counting the sample. The measurements were made using 1 mil gold foils weighing $\ll 1.5$ mg to give counting rates within the useful range of the scintillation well counter.

The calculated thermal neutron flux was based on a cross section (2200 m/s) of 98 for Au¹⁹⁷. Since the purpose of the flux monitoring program has been to detect variations in the available flux, no corrections for self shielding and flux

depression of the sample have been made. The configuration of the fuel rods in the reactor core is changed only for special experimental runs and remains the same for the full power operation used in our work. The power level of the reactor at full power is given as $1000 \text{ kw} \pm 10\%$. (H.W. Nass, D.G. Kaiser, R. Fukai)

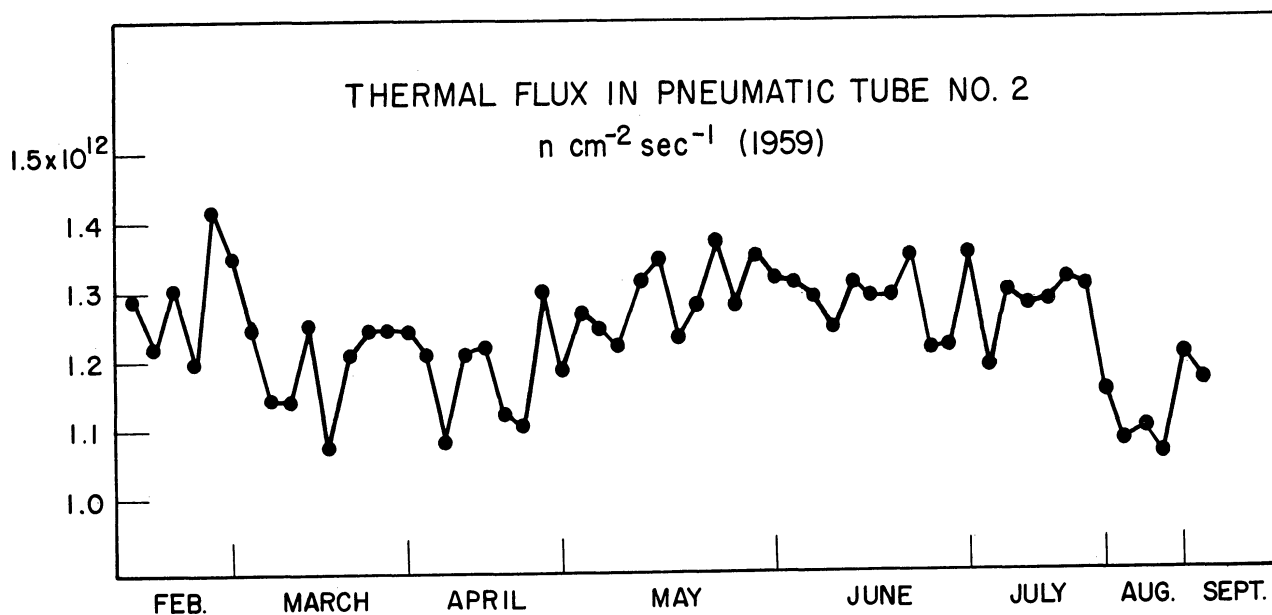

Figure 2. Thermal neutron flux in pneumatic tube no. 2 of Ford Nuclear Reactor operating at a power level of $1000 \text{ kw} \pm 10\%$. The precision of measurement of individual points should be better than 3%.

2. Fast Neutron Measurements in the Pneumatic Tubes

Values for the fast flux in the pneumatic tubes have been redetermined at 1000 kw which is now the regular operating power level of the reactor. Fast flux data is needed to estimate the extent reactions such as the (n,p) and (n, α) can interfere with the (n, γ) reaction during activation analysis.

The $\text{Al}^{27}(\text{n,p})\text{Mg}^{27}$, $\text{Mg}^{24}(\text{n,p})\text{Na}^{24}$ and $\text{Al}^{27}(\text{n},\alpha)\text{Na}^{24}$ reactions were used for the measurements in the same manner as those made at 100 kw (3). Chemical separations were not made. Samples were counted on the 3"x3" NaI(Tl) crystal and suitable corrections for geometry, counting efficiency, decay scheme and peak-to-total ratio were used in order to obtain the disintegration rates of Na^{24} and of the 840 kev γ -ray of Mg^{27} . The absolute disintegration rate of the latter was obtained by subtracting the 1.04 Mev photo-peak of Mg^{27} out of the spectrum, using the 1.11 Mev Zn^{65} photo-peak as a standard. The relative abundance of the 840 kev photo-peak of Mg^{27} was taken as 68%. (J. Brownlee)

Table II. Fast Flux Data for Pneumatic Tubes at 1000 Kw.

Tube	Ratio	$\text{Al}^{27}(\text{n,p})\text{Mg}^{27}$ $E_n \geq 5.3 \text{ Mev}$	$\text{Mg}^{24}(\text{n,p})\text{Na}^{24}$ $E_n \geq 6.3 \text{ Mev}$	$\text{Al}^{27}(\text{n},\alpha)\text{Na}^{24}$ $E_n \geq 8.6 \text{ Mev}$
1	0.84	8.00×10^9	4.03×10^9	1.05×10^9
2	0.74	7.04×10^9 *	3.55×10^9 **	9.25×10^8 *
3	0.50	$4.76 \pm 0.26 \times 10^9$	$2.40 \pm 0.25 \times 10^9$	$6.25 \pm 0.25 \times 10^8$
4	1.00	9.52×10^9	4.80×10^9	1.25×10^9

Error is "standard deviation". * 4 samples. ** 6 samples.

3. Investigation of Trace Polyethylene Contaminants

The use of polyethylene tubing for sample containers was found to be both convenient and readily adaptable to the rapid procedures employed in this laboratory. Because some samples were studied without a chemical separation or removal from these containers, it was necessary to check the polyethylene for trace contaminants. Intramedic Polyethylene Tubing* was irradiated for ten minutes at one Megawatt and allowed to decay for one

* Intramedic Polyethylene Tubing (Medical Formulation PHF - PE410); Clay-Adams, Inc., New York, N.Y.

minute. Gamma spectral determinations showed the presence of sodium, chlorine, and aluminum. Sodium and chlorine were sufficiently long-lived so as to offer few difficulties, however, aluminum introduced an error in qualitative and quantitative fluorine determinations. A quantitative determination showed that the aluminum concentration was in the order of $\sim 2 \times 10^{-7}$ g/g of polyethylene. (D. Kaiser)

4. Determination of Neutron Attenuation by Rat Tissue

Some of the biological samples studied during the course of our investigation weighed between five and ten grams. Although these samples were composed primarily of carbon, hydrogen, oxygen, nitrogen, sulfur, and phosphorus, considerable quantities of sodium, chlorine, manganese, and copper, in addition to the trace elements, were also present. A study of neutron attenuation by biological tissue, specifically, rat liver tissue, was undertaken to determine its magnitude.

An empty rabbit with gold foils around the exterior was irradiated for one minute at one megawatt. The gold foils were sealed in polyethylene film and scotch-taped in position so that one foil was at each 45 degree increment (Fig. 3).

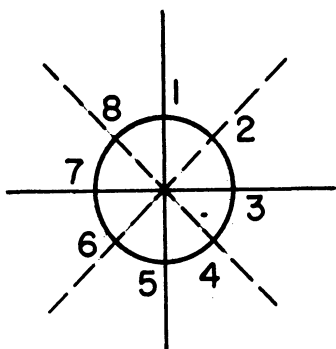

Figure 3. Neutron attenuation experiment, top view of rabbit.

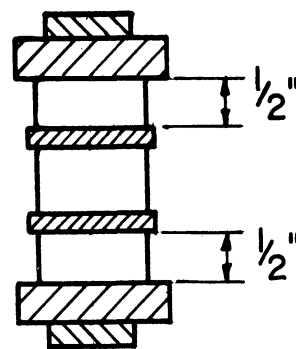

Figure 4. Neutron attenuation experiment, side view of rabbit.

Two separate rows of foils were placed around the rabbit one-half inch in from either felt washer (Fig. 4). Thus the rabbit was monitored both cross-sectionally and longitudinally.

The same rabbit was then irradiated with a liver sample (~ five grams) inside and a new set of gold foils around the exterior. The foil activities were compared within each determination and between each determination. The data within each determination indicated that the cross-sectional neutron flux was decreased by 40% while the longitudinal irradiation varied by 10%. Between each determination, the variation was on the order of 2 - 3%. This would indicate that either the biological sample reduced the neutron flux by 3% or the neutron flux itself varied between the two determinations.

Since all of the foils monitoring the rabbit plus liver sample were this low in activity, it was concluded that the variation was due to neutron flux. (D. Kaiser)

B. "Bunny Rabbit" System

The temporary detector (3) for the 100-channel analyzer set up in the hot laboratory to eliminate the 90-foot run down the hall from lab to counting room proved unsatisfactory for measuring short half-lived radioisotopes. The detector, a 1-1/2" x 2" NaI(Tl) crystal shielded with 4" of lead (Fig. 5) was set up on the floor of the hot laboratory next to the hood and pneumatic tube station No. 2. With this equipment it was possible to begin spectral measurements within a few seconds after the end of irradiation. However, the sensitivity attainable with this detector was poor due to the low gamma ray



Figure 5. Gamma detector for 100-channel analyzer set up in hot lab next to hood.

counting efficiency and the high background of radiation present in the hot lab. Figure 6 shows spectra taken with the small crystal in the lab and with the 3" x 3" crystal in the analyzer room (after the "bunny" system was installed). The high cost of duplicating the 3" x 3" crystal set up in the laboratory and the generally higher background in this location encouraged us to try to find other solutions to our rapid measurement problems.

This was finally solved with the installation of a small pneumatic tube system, the "bunny" rabbit system, which can send a counting sample from the lab to the analyzer room for counting with the 3" x 3" crystal and then return it to the hot lab. The bunny tubes are made of 1/2 inch i.d. aluminum pipe that is used in aircraft fuel lines and is readily available. Straight runs are made of hard pipe and bends of soft material. In the system (Fig. 7) the tubing runs along the east wall of the first floor of the Phoenix Building from above the hood housing Tube No. 2, to the analyzer room, circles the 3" x 3"

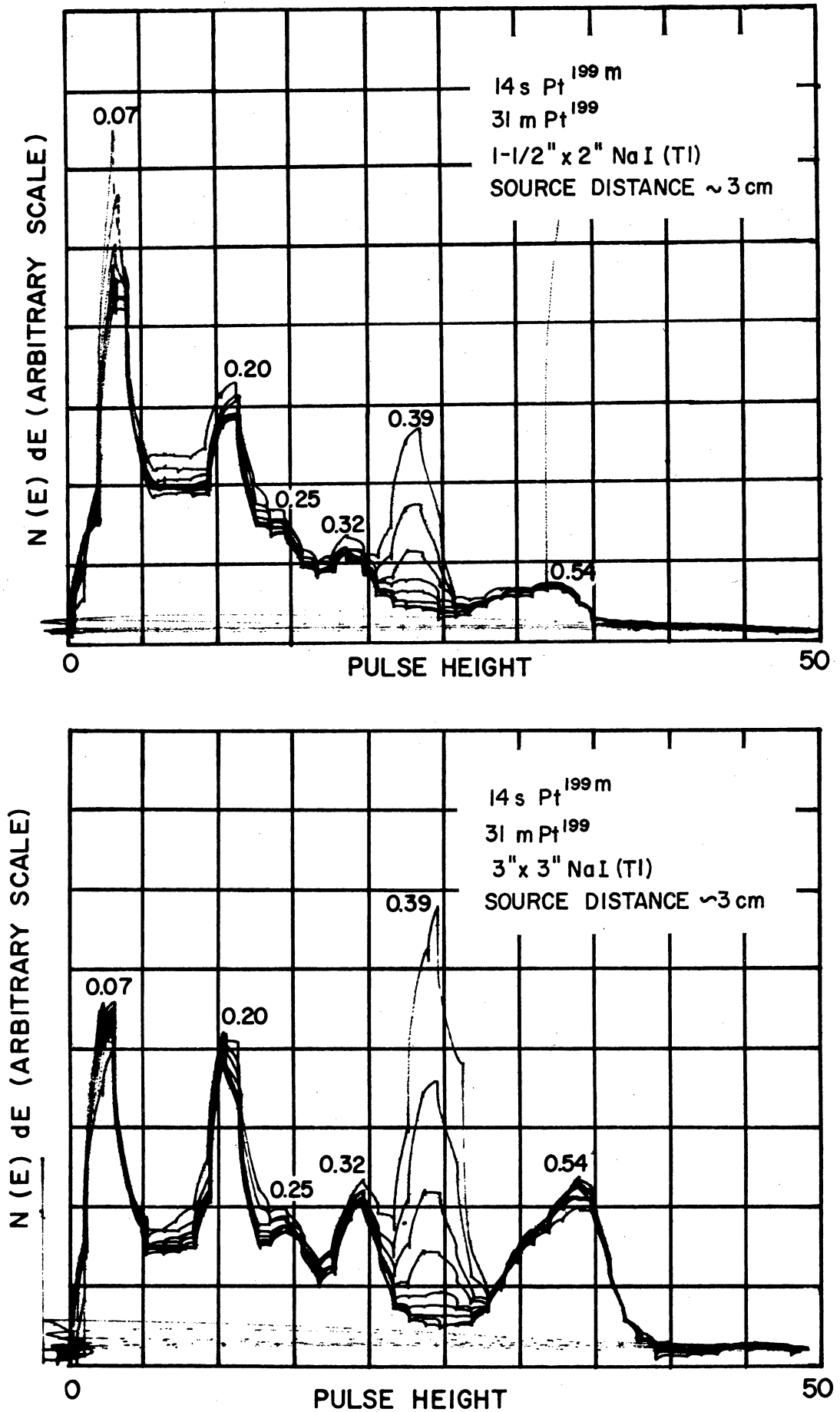
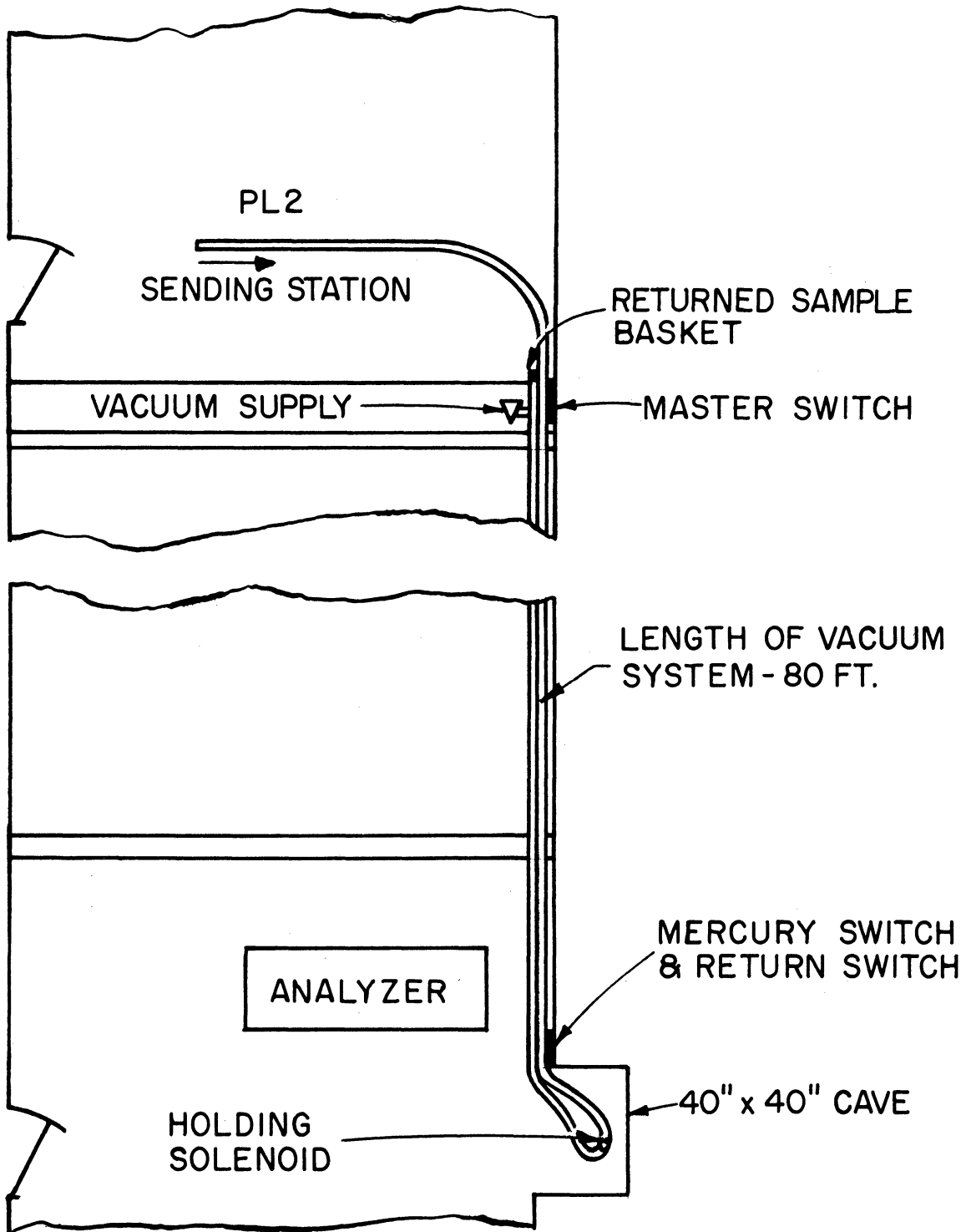

Figure 6. Spectra taken with 1-1/2"x2" crystal in hot lab and with 3"x3" crystal in 100-channel analyzer room.



MATERIAL: 12-FOOT LENGTHS—ALUMINUM TYPE 20-24 T3,
 ID 0.590", OD 0.625"
 BENDS—ALUMINUM TYPE 50
 COUPLINGS—ALUMINUM TYPE 20-24 T3, 3/4"
 SEALING COMPOUND, GLYPTAL 1201, RED

Figure 7. "Bunny" rabbit pneumatic tube layout.

crystal inside the 40" x 40" cave as shown in Fig. 8, and returns to the hot lab. The "send" switch is located at the hood station while the "return" switch is in the analyzer room. The system is completely enclosed and powered by a vacuum cleaner motor drawing $\sim 6"$ of negative pressure.

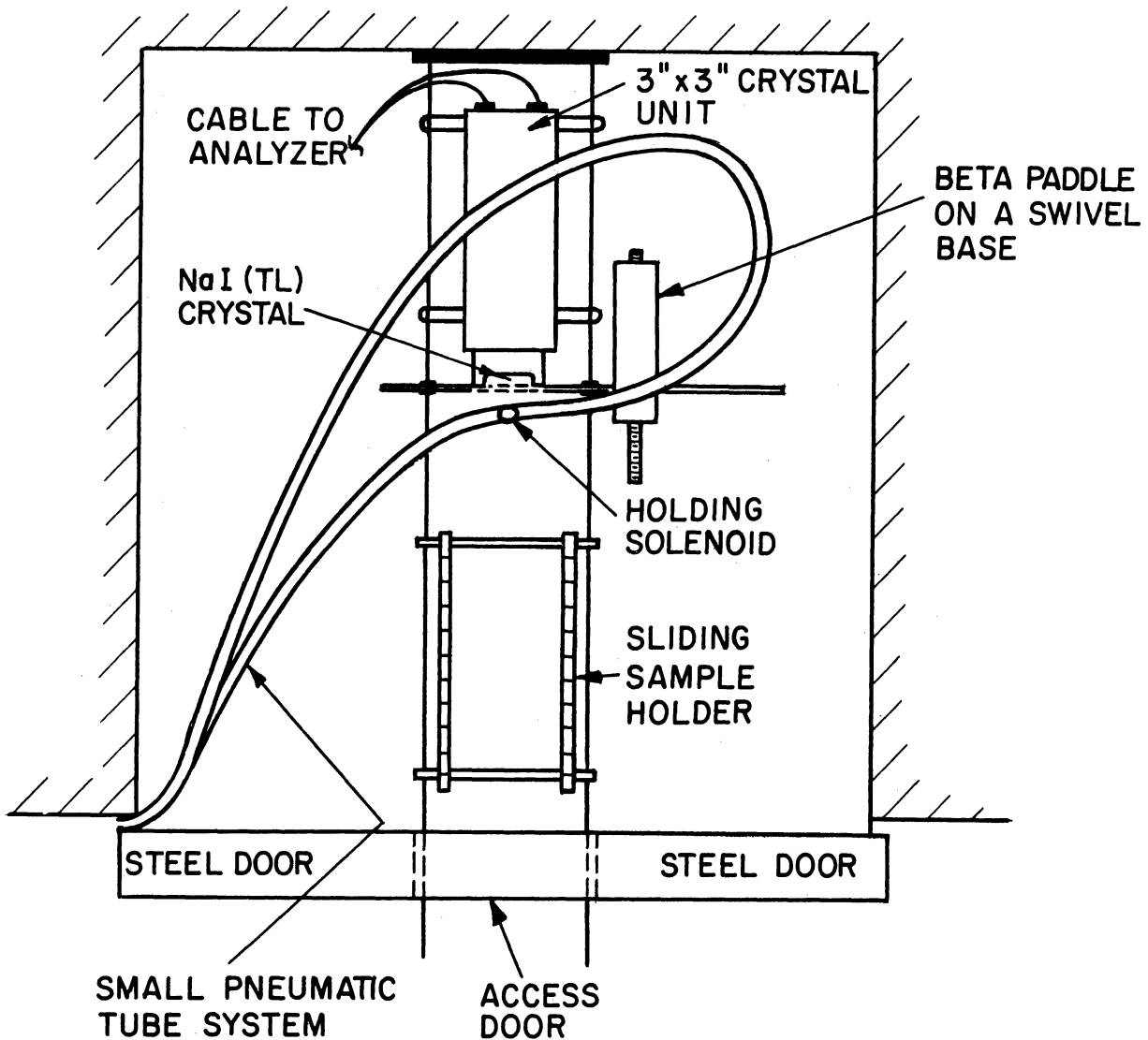

Figure 8. Layout of 3"x3" detector setup (looking down from above).

The samples, which are packaged in small polyethylene test tubes, are stopped in front of the crystal by a forked plunger operated by a solenoid. When the sample is stopped by the plunger, there is a

pressure change on the vacuum side of the sample, which operates a mercury switch shutting off the vacuum and starting the analyzer through the auto-start circuit. (This is described in section II on Instrumentation.) The master control unit for the vacuum system is located in the hot lab. The vacuum system can be run continuously when desired.

The time lapse for a sample from the reactor core to the analyzer is ~ 15 seconds---three seconds from the core to the hood, ~ 10 seconds for transfer to a non-active container and 2 seconds to analyzer room and start of measurement. The auto-start circuit allows one man to do a complete experiment on very short-lived materials without assistance by controlling the analyzer from the laboratory.

(R. Shideler, H. Nass)

C. Typical Run Utilizing Pneumatic Systems

The potentialities of, and the techniques required for, the facilities we have built up here can probably best be appreciated through a series of pictures illustrating one particular run involving a short-lived radioisotope. These pictures are presented in Fig. 9.

It should be emphasized once more that at a flux of $\sim 10^{12}$ n cm⁻² sec⁻¹, available at these pneumatic tube positions, we have found it safe to catch the hot rabbit from a few minute irradiation in our hands and open it manually. This entire procedure takes only 2-3 seconds and finger badge records indicate a minimal exposure is received during this time. For reactors with pneumatic tubes operating at much higher fluxes these dosage considerations would have to be rechecked.

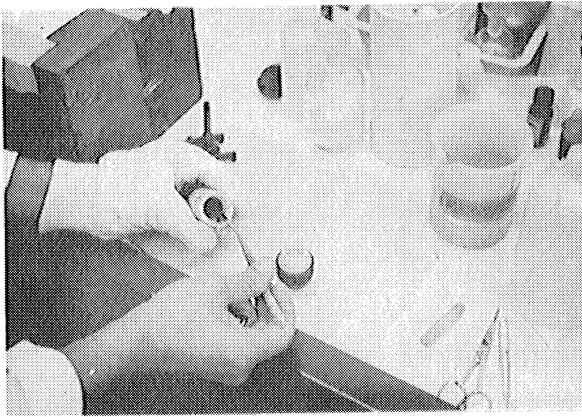

1

Sample is packaged in polyethylene and put in a "rabbit."



2

The "rabbit" is placed in the pneumatic tube system which carries it into the reactor.



3

The sample is held in the field of radiation for a pre-determined time.

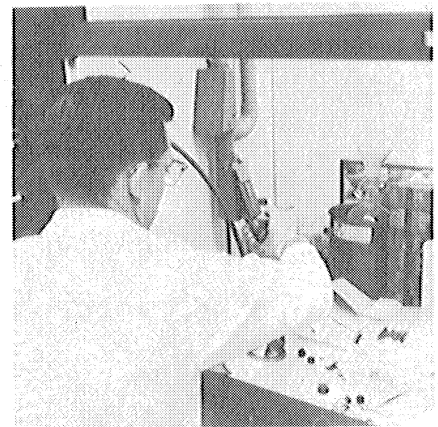

4

Sample is returned to the laboratory.

Figure 9. Pictures 1 through 10 show a typical activation analysis run utilizing the pneumatic tube systems.

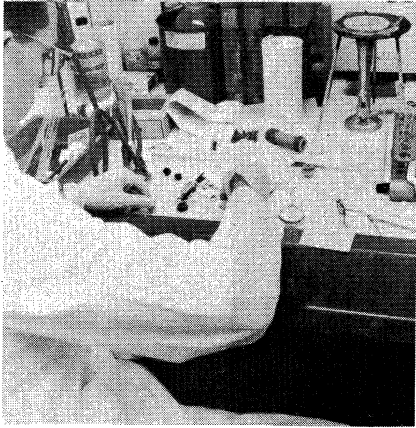

5

Sample is transferred to inactive container. Often a chemical separation is also necessary.

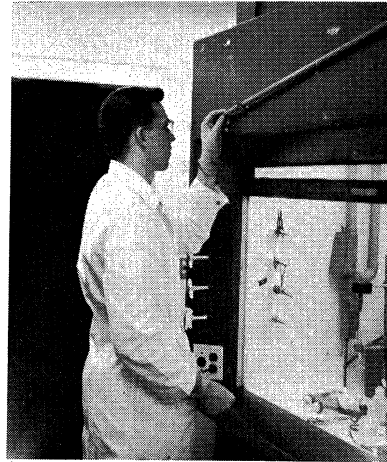

6

The sample is loaded into the pneumatic tube system.

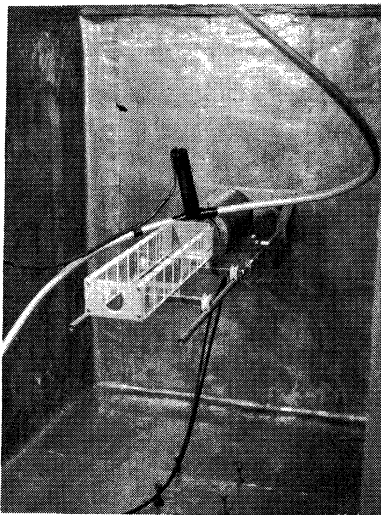

7

It stops in position in the cave which houses the gamma-ray detector.



8

The dual 100-channel analyzer is automatically turned on.

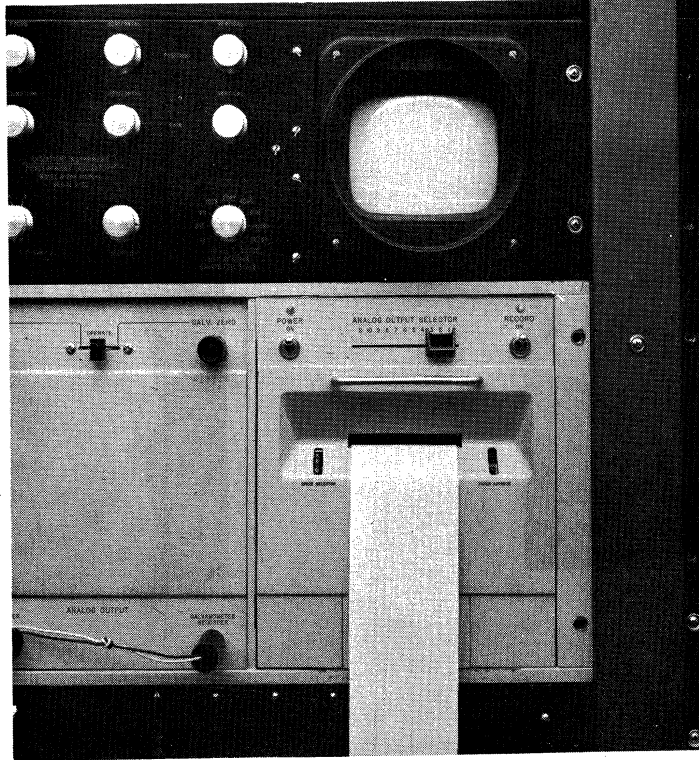

9

The spectra is observed on the scope.
The counts per channel are printed
out on tape.

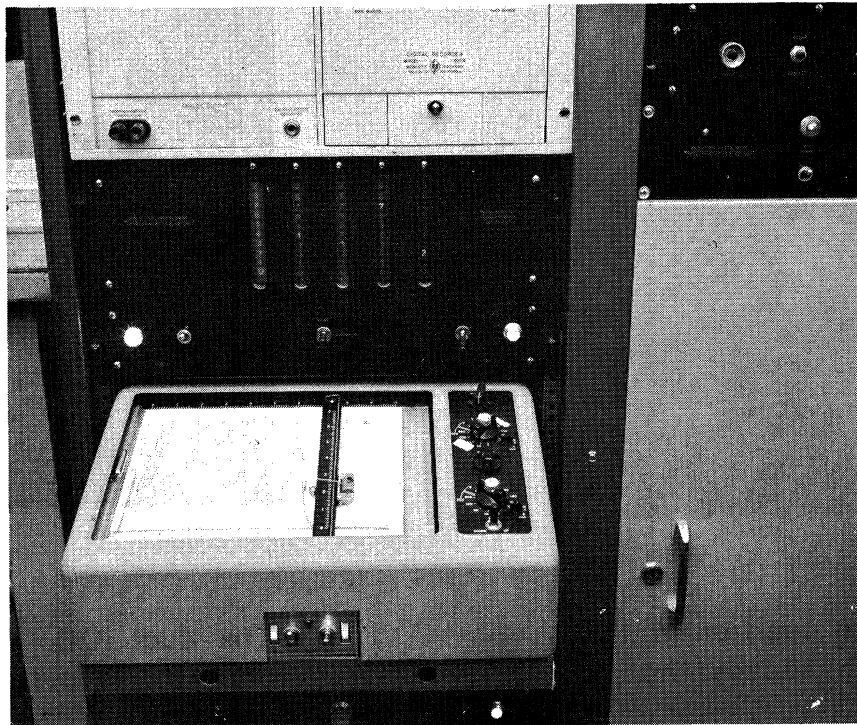

10

And the spectra is automatically plotted
on a linear X-Y recorder.

D. Neutron Generator

For a number of years our research group has been interested in exploring the applications of activation analysis to different systems. Starting in 1952 we began experiments with portable radium-beryllium sources, we extended these later to antimony-beryllium sources, and finally have been working for a year and a half with our Michigan reactor. As we have explored the potentialities of this method it has become very apparent that activation analysis will not be adopted for routine analytical work industrially until some source of neutrons is available which gives neutron fluxes of 10^8 - 10^9 n cm⁻² sec⁻¹ and is considerably less expensive than the \$100,000 required (a year or two ago) for a small reactor or a Van de Graaf generator operating with a zirconium-tritium target. (See page 689, ref. 4 for examples of these sources.)

Several companies are at the present time exploring the feasibility of producing neutron generators approximating these requirements using Cockroft-Walton as well as Van de Graaf generators with zirconium-tritium targets. Although fluxes now available are only 10^7 - 10^8 it would appear that within the next year or two it will be possible to obtain a neutron generator for about \$20,000 that would have a flux of 10^9 n cm⁻² sec⁻¹ of thermal neutrons and could be set up in one corner of a large laboratory. Thus the tools for activation analysis would become comparable in price and space requirements to other large analytical instruments such as the emission spectrograph and the mass spectrograph.

One of the major problems of obtaining high fluxes with these generators lies in the zirconium-tritium target. The life time of

this target is at best only a few hundred hours and thus the generators will be useful primarily for analyses involving short half-lived radioisotopes. Since our group has had considerable experience working with short half-lives with the Michigan reactor we felt we could apply our experience to an evaluation of a neutron generator for activation analysis. If a flux of 10^9 could be obtained eventually, this would be only 1/1000 of the reactor flux we have been working with and would still permit determination of 1 microgram amounts of vanadium in oil samples, etc.

Consequently we have had correspondence with several companies developing these neutron generators and have arranged with Dr. Norman A. Bostrom, president of Texas Nuclear Corporation* to evaluate their Model 100-1H Neutron Generator as a possible source of neutrons for activation analysis. A generator similar to that pictured in Fig. 10 is being delivered in early October to the University of Michigan.

This generator will be set up in the south east corner of the accelerator room of the Phoenix Building in a position indicated by the sketch of Fig. 11. The generator itself will be inside the shielding while the control console will be outside. It is planned to explore the potentialities of this machine both for thermal and fast neutron activation analysis. Sensitivities for different elements will be determined, as well as different operating parameters such as the amount of shielding (and thus the amount of space) required, optimum thermalized flux obtainable, etc. Two additional small

*Texas Nuclear Corporation, P. O. Box 9267, Allandale Station,
Austin 17, Texas.

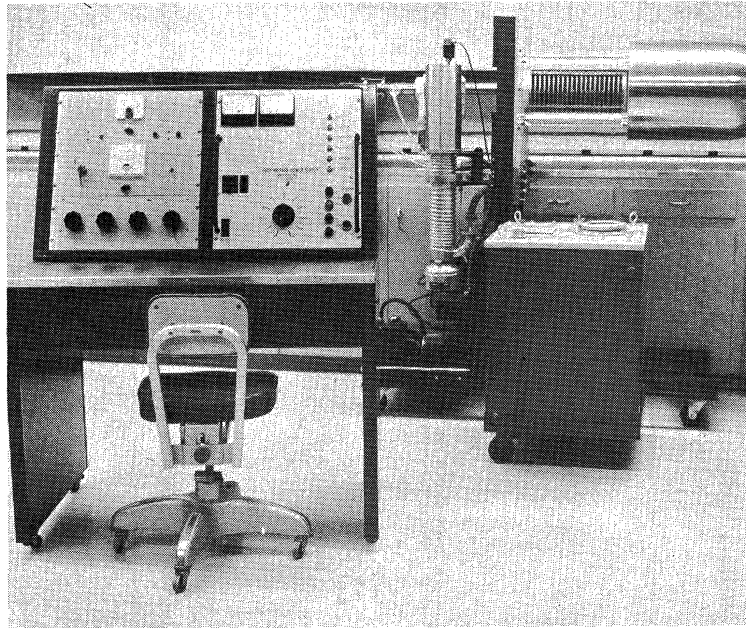
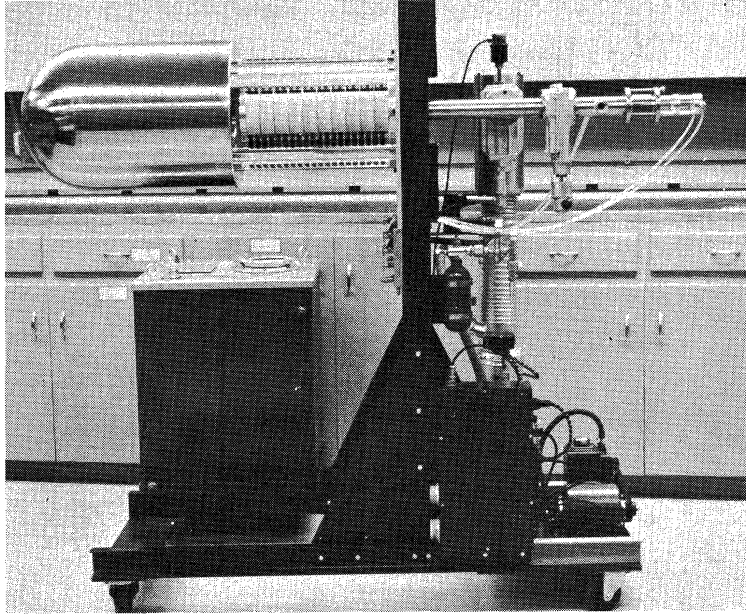
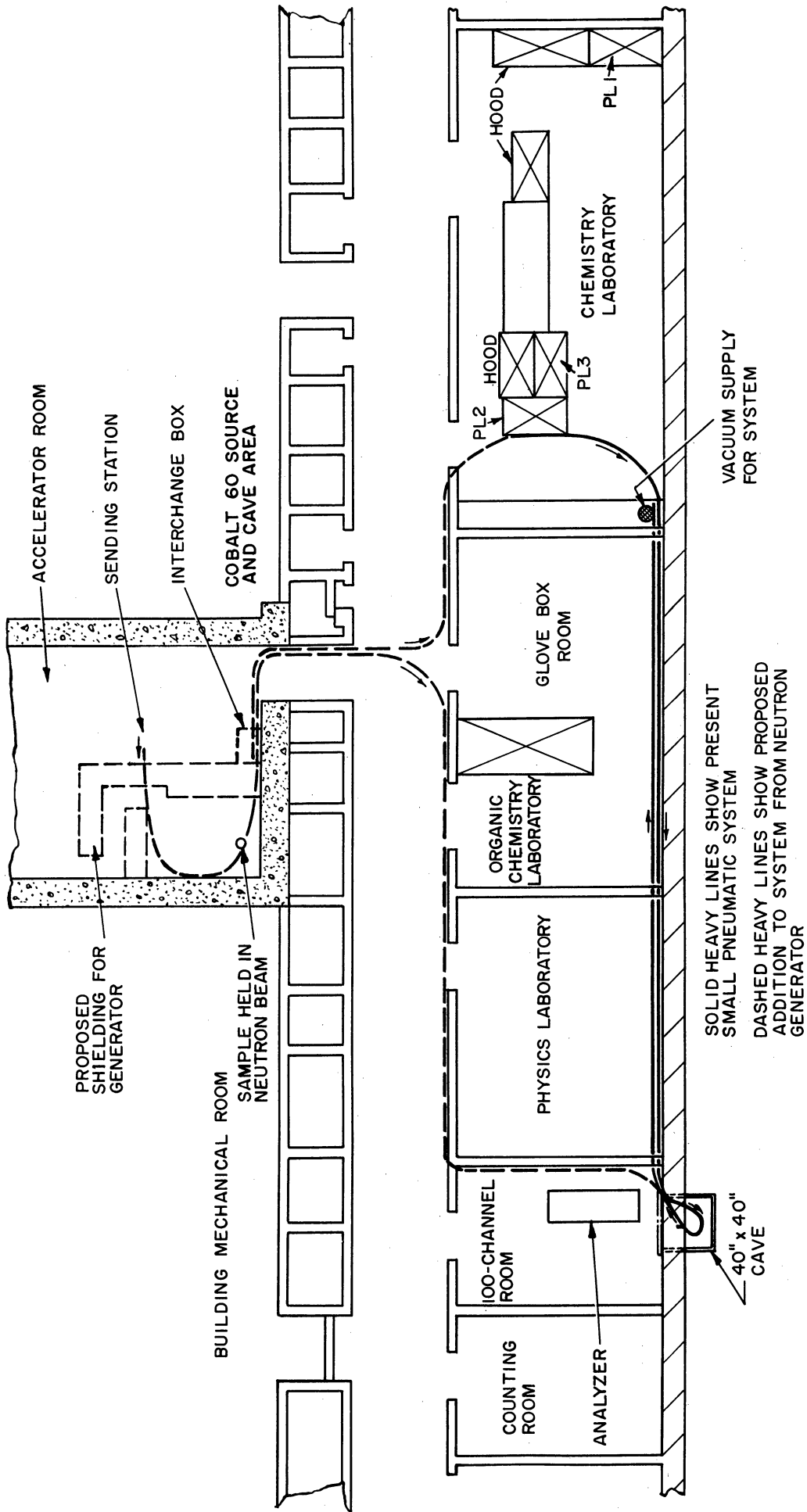

Figure 10. Two views of the neutron generator.



FIRST LEVEL FLOOR PLAN PHOENIX LABORATORY

Figure 11. Floor plan of Phoenix Laboratory showing proposed housing for neutron generator.

pneumatic ("bunny") systems will be set up to take samples from the generator to the hot lab for chemical processing or to the 3" x 3" gamma detector. Thus our facilities will permit meaningful comparisons between analyses done on the reactor and those done with the generator. (W. W. Meinke, R. Shideler)

E. Chemistry Building

Remodeling of the teaching laboratory in the Chemistry Building was completed in late fall of 1958 and gives us a first class radio-isotope laboratory (Fig. 12). It is used for research two-thirds of the time while for one semester a year it is used for the Nuclear Chemical Techniques course. The counting room (Fig. 13) attached to this laboratory is used primarily for the course since the specialized counting room described previously (ref. 3, figs. 6, 7) is air conditioned and humidity controlled to minimize day to day variation in electronic performance.

F. Problems of Air Conditioning

About 2 years ago orders were placed to air condition the 100-channel analyzer room in the Phoenix Laboratory and the counting room in the Chemistry Building. These orders were to include not only temperature control to 70°F but also humidity control to 50 ± 2%. In each case it took 4-6 months for the system to be designed and installed, but workmen have been back on an average of once every month or two ever since to repair or revise the system. For some reason, whether because of initial poor planning, faulty equipment



Figure 12. Radioisotope laboratory in Chemistry Building.

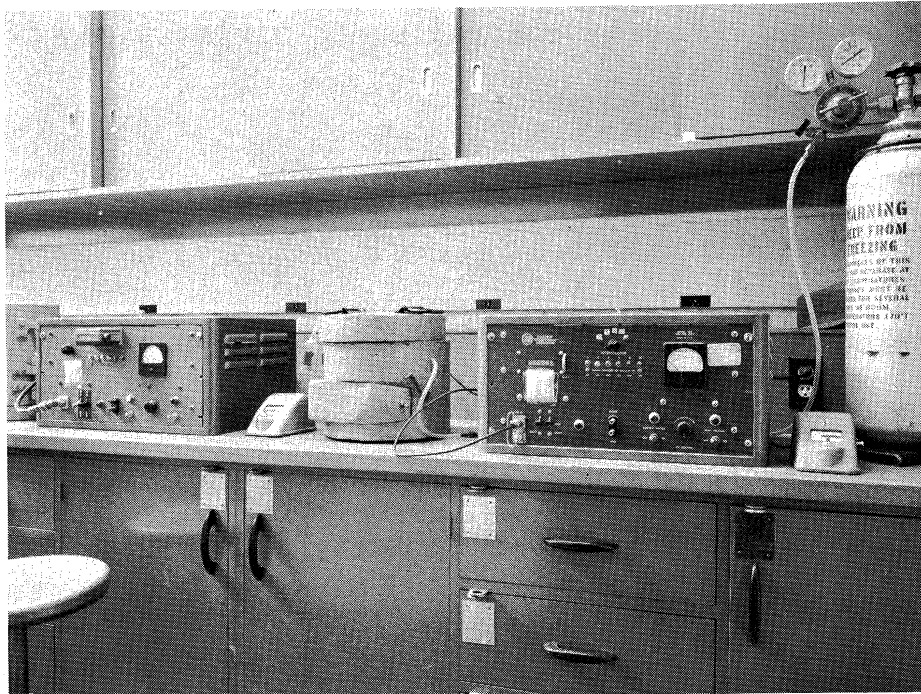

Figure 13. Counting room adjacent to radioisotope laboratory in Chemistry Building.

obtained from General Electric and Frigidaire, or inexperienced installation by Michigan personnel, neither facility has given satisfactory performance for longer than 1 or 2 months at a time.

We try to maintain the temperature at 70° and the humidity at 50%. We have found that temperatures of 85° and above cause the 100-channel analyzer to operate erratically and a 95° and above room temperature (meaning the temperature inside the analyzer is about 110°) causes it to break down completely. High humidity, 65% and above, causes the memories of the analyzer to store erroneously or not at all.

We have had similar problems with scalers used with a scintillation well counter. At times when the air conditioning was inoperative all equipment had to be shut down completely. Some instruments recover from the temperature spurts after a few days while others require considerable electronics repair time and replacement of parts before they will again operate satisfactorily.

The purpose of mentioning our experiences here is twofold. One is to emphasize the necessity for temperature and humidity control for counting rooms. The other is a warning of the troubles that can be encountered in trying to obtain this control with existing equipment on the market. (W. W. Meinke)

II INSTRUMENTATION

A. 100-Channel Pulse Height Analyzer

During the past year the 100-channel analyzer room has remained essentially in the same arrangement as before (Fig. 4; ref. 3).

The 100-channel analyzer (3) has been in almost constant use to measure many different types of samples and radiations in many different problems. The analyzer has been used in excess of 1660 hours during the year while with preventive maintenance and rapid repair, both memories have been out of commission* only ~ 32 hours while in addition A unit individually was down ~ 15 hours and B unit ~ 32 hours.

Data can be obtained from the analyzer by looking at the scope. In addition, spectra can be recorded by printing out of values in each channel and the spectra can be plotted out directly as in Fig. 14.

During the year the normal amount of tube and diode failures were encountered and repaired with little loss of time. There were, however, several major failures which accounted for most of the down time.

The B unit had a memory failure in March which was traced to a bad magnetic core frame connection in the 2⁵ position. The spare frame was connected in with minimum delay but the actual replacement of the bad frame took ~ 30 man hours.

The printing unit, Hewlett-Packard Model 560A, caused much trouble by misprinting either erroneous numbers or no numbers at all.

*Down time is counted only when analyzer is inoperative and one of the group needs to use it.

The difficulty was traced to a misalignment of the commutator discs. These discs are held in place by four soldered bus bars and had been inserted at an angle allowing the print wheels to miss their locking positions. It was the incorrect spacing of the discs on the bus bars that caused the difficulty. The repair is rather touchy and time consuming, so a second print unit was obtained to eliminate long down time. (The print wheels control the autograph recorder as well as the tape printer. Thus if the printer goes out the only means of using the analyzer is by looking at the scope.)

Other time consuming repairs involved the converter unit and the Mosely autograph which has been installed on a sliding tray below the printer assembly, Figure 14b. (H. Nass, R. Shideler)

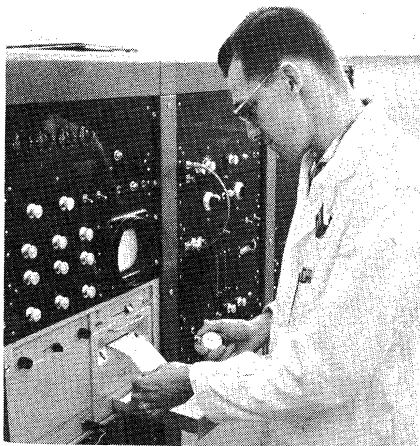

a

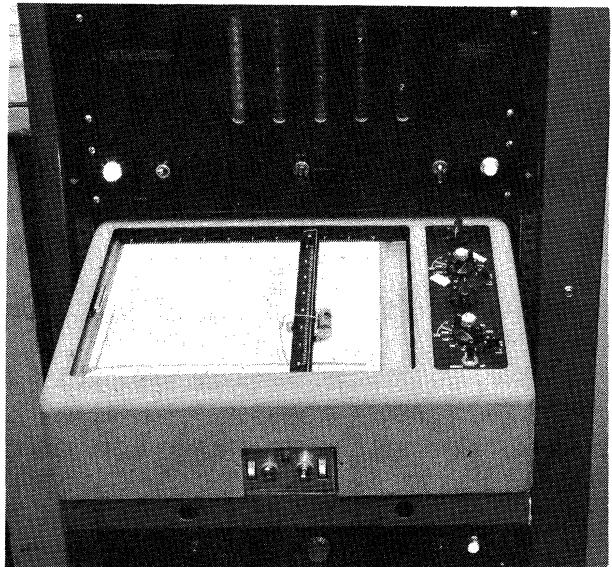

b

Figure 14. 100-channel analyzer readout. a and b.

B. Auxiliary Circuits

Several new auxiliary circuits for the analyzer have greatly increased the versatility of the instrument.

The most important circuits added to the analyzer were installed in a small chassis just below the high voltage supply. The unit contains a Hoogenboon summing circuit with a coincidence signal inverting circuit and an alternator electronic switch.

The Hoogenboon summing circuit as described in Nuclear Instruments (5) is used to gate either the coincidence or anticoincidence circuits. The signal inverting circuit is necessary in order for the analyzer to operate in anticoincidence, when by replacing a negative pulse with a positive pulse the delayed coincidence circuit operates as an anticoincidence gate (Fig. 15).

It was suggested that it might prove useful if we could take alternating beta and gamma spectra. By using the control lines in the analyzer and a relay this was accomplished. It is now possible for "A memory" to store information from one crystal and "B memory" to store information from another crystal.

Two eight position ceramic switches were installed, a) to control the high voltage for an auxiliary crystal (crystals other than 3" x 3" crystal) in six steps and off, and b) to select the signal input to the analyzer. A three position switch was installed to control the signal inverting pulse and the alternating input circuit.

By combining these circuits into one chassis in the analyzer different types of spectra may be taken rapidly by merely turning a switch.

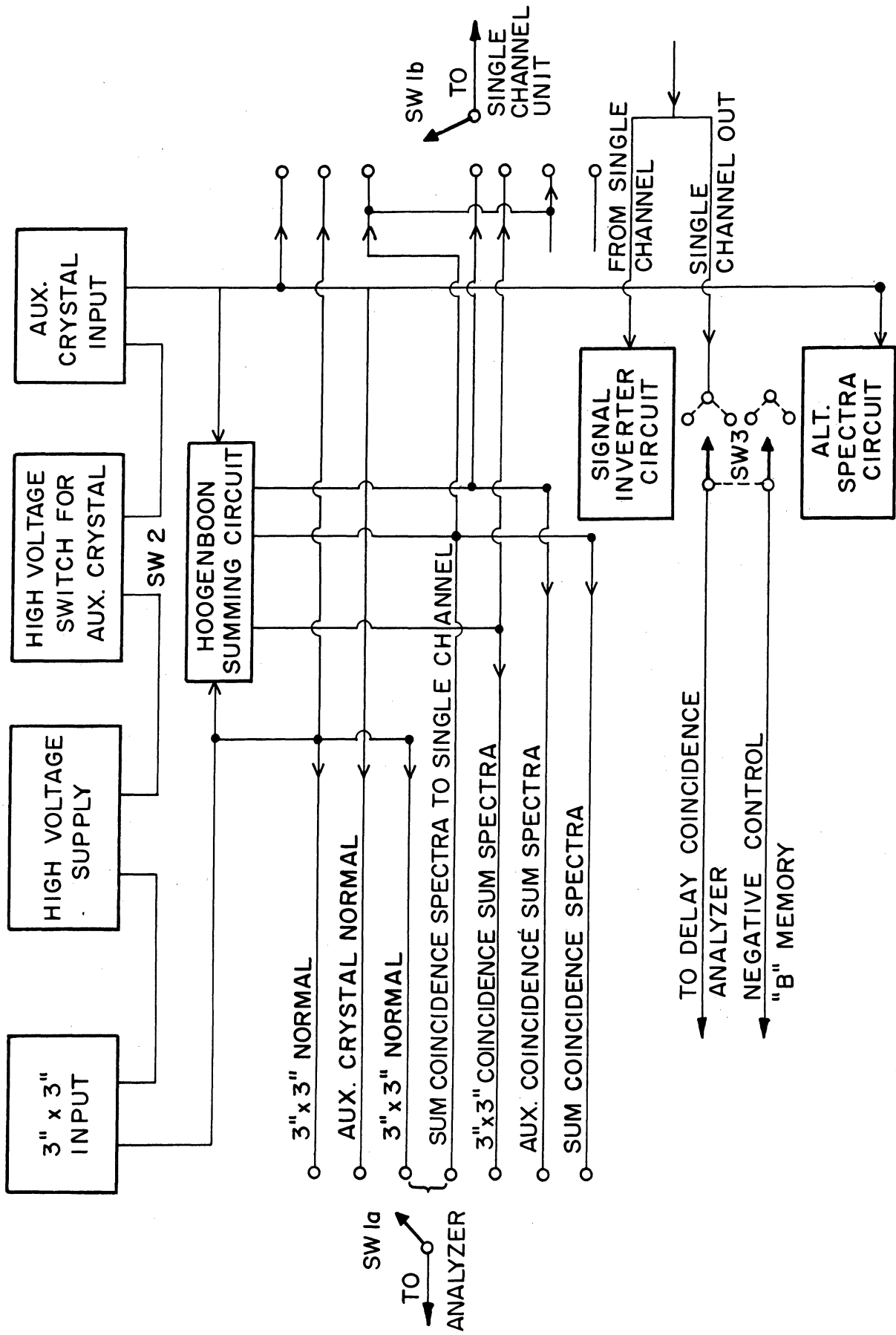

Figure 15. Block diagram of auxiliary circuits used with the 100-channel pulse height analyzer.

Another circuit incorporated in the analyzer is a holding circuit which allows the analyzer to be placed in the auto-recycle mode and held there until manually released or released by the "bunny" system described earlier. This hold circuit consists of two relays, two Grayhill switches, and a mercury switch. When the system is put in readiness the relay circuits lock closed and "A memory" is kept from storing while B unit remains quiescent. At this time the analyzer is set for autoprint operation (both A and B units). This circuit allows the experimenter to set up completely the analyzer before starting his experiment and thus he does not have to switch manually each individual unit into operation as before. When the sample reaches the proper position in the "bunny" rabbit system the mercury switch closes and the analyzer will automatically start to store and print out spectra. (R. Shideler, H. Nass)

C. Additional Detectors

In addition to the 3" x 3" crystal previously described (3) there are three other 2" photo tube-preamp units which can be used with different crystals for coincidence and anticoincidence work. All preamps are interchangeable and may be used independently or in conjunction with the 3" x 3" detector.

D. Three-inch Scintillation Crystal Detector

The 3" x 3" crystal unit housed in the 40" x 40" cave is now permanently mounted on a track such that the unit can be slid forward for repairs or locked into one position. The graduated sample holder

slides in and out of the cave on nylon rollers. The holder is stopped by blocks on the track in front of the 3" x 3" crystal giving reproducible geometry. Mounted to one side of the crystal is a 2" phototube unit with a plastic phosphor elongated crystal which is used for removal of bremsstrahlung in gamma spectra. The arrangement as shown in Figure 16 is very satisfactory and little change in the cave arrangement is contemplated.

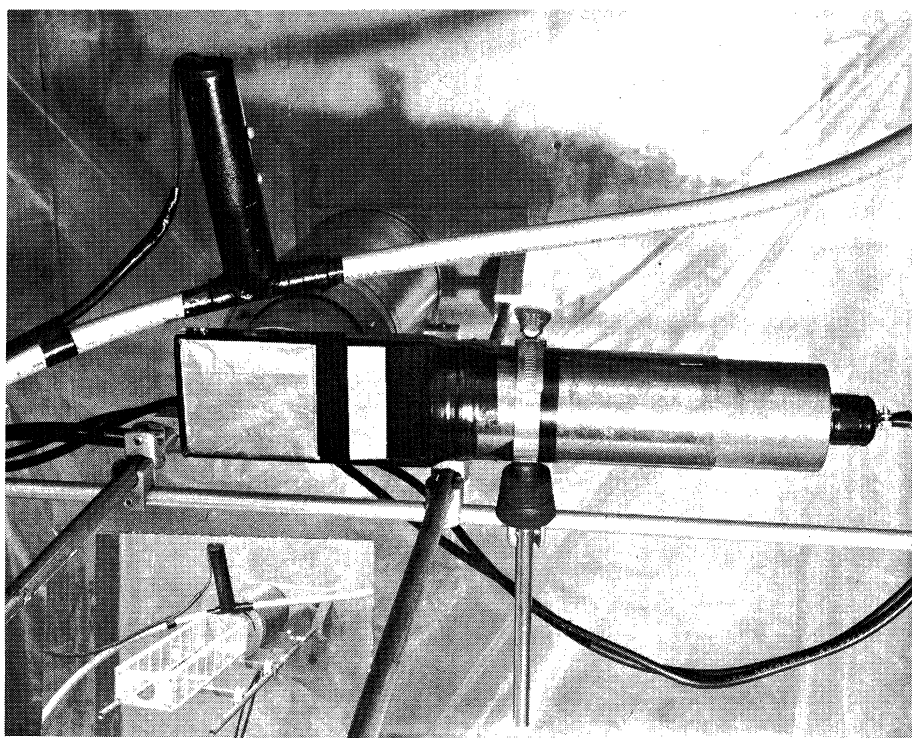

Figure 16. 3"x3" NaI(Tl) crystal setup in 40"x40" cave showing beta paddle in place. Insert shows sample holder in counting position.

III NUCLEAR CHEMISTRY

Again during the past year the emphasis for our work has been on the Michigan reactor and only one cyclotron bombardment was obtained---to produce long-lived vanadium tracer for yield determinations in activation analysis. No cross section measurements have been made although some of the techniques and equipment have been used in reactor flux measurements.

Since the auxiliary facilities for the reactor permit rapid transfer of samples from reactor core to hood to counter (as described in Section I) the decay schemes of a number of radioisotopes with short half-lives have been studied.

A. Absolute (d, alpha) Reaction Cross Sections and Excitation Functions

Hall's work (6) has finally been published in the Journal of Inorganic and Nuclear Chemistry (7) as an article entitled "Determination of (d, α) Reaction Cross Sections". The following is an abstract of this article.

"Absolute cross sections were determined for several (d, alpha) reactions. Thin targets were bombarded by a beam of 7.8-Mev deuterons which were collected in a Faraday cup and measured by a current integrator. Product nuclei were separated chemically from extraneous activities. Absolute disintegration rates were determined by 4 pi beta counting. Cross section values and estimated standard deviations are reported for formation of the following nuclei: Na²², Na²⁴, P³², Sc⁴⁶, 68-min Ag¹⁰⁴, Ag¹¹², and Ag¹¹¹."

Anders' manuscript on some later work is still in rough draft form preliminary to submission to the Physical Review. (K. L. Hall, O. U. Anders)

B. Nuclear Data Analysis: Application of Digital Computers

This work has been summarized in a paper entitled "Method for the Analysis of Multicomponent Exponential Decay Curves" recently published in the Journal of Chemical Physics (8). The following abstract accompanied this paper.

"A frequently encountered problem in many branches of science involves the resolution of experimental data into a sum of independent exponential curves of the form

$$f(t) = \sum_{i=1}^n N_i e^{-\lambda_i t}$$

in order to estimate the physically significant parameters N_i and λ_i . Such problems arise, for example, in the analysis of multicomponent radioactive decay curves, and in the study of the dielectric properties of certain compounds. This paper is concerned with the numerical evaluation of a mathematical approach to the problem. The approach is based on the inversion of the Laplace integral equation by a method of Fourier transforms. The results of the analysis appear in the form of a frequency spectrum. Each true peak in the spectrum indicates a component, the abscissa value at the center of the peak is the decay constant λ_i , while the height of the peak is directly proportional to N_i/λ_i . Results obtained on an IBM 650

computer indicate that the method may possess certain advantages over previous methods of analysis."

(D. G. Gardner, J. C. Gardner, W. W. Meinke)

C. A Search for the Isotope Ir¹⁹⁶

The work on iridium isotopes mentioned previously (2) has finally been published in the Physical Review (9). An abstract follows.

The isotope Ir¹⁹⁶ has been reported to have a half-life of ~ 9 days and to emit β^- particles with a maximum energy of about 0.08 Mev. Using deuteron-bombarded enriched isotopes of platinum, it is shown that the previous mass assignment was incorrect. It is suggested that the ~ 9-day activity found in deuteron bombardments of natural platinum is due to Ir¹⁸⁹ and Ir¹⁹⁰ produced by the (d,n) reaction on osmium impurities. An experimental upper limit of 5 hours for the Ir¹⁹⁶ half-life can be set by these experiments. Rough cross sections for the (d, α) reaction on Pt¹⁹⁴ and Pt¹⁹⁶ are given for several deuteron energies from 9.6 to 20.4 Mev.

(D G. Gardner, W. W. Meinke)

D. Isomerism of Platinum-199

The short-lived platinum activities (~ 16.1 and 31 seconds) reported in the last progress report (3) were studied further. The apparent 31 second activity was shown to be due to the presence of small amounts of silver and rhodium impurities. Small gamma peaks

from the low yield gamma rays at 630 kev and 550 kev, of silver and rhodium, respectively, were found to be present to some extent in all of our pure platinum samples. Careful half-life resolution with good statistical counts also showed the correct half-lives for these contaminating activities.

A sample of platinum enriched to 56.3% in Pt^{198} was procured from the Isotope Sales Division of Oak Ridge, for the study of the shorter-lived gamma activity observed. This activity was shown to be an unreported isomer of platinum-199. The results of this study on Pt^{199m} have been presented in detail in a paper published in the July 1, 1959 issue of the Physical Review (10). The abstract of this paper follows.

"An isomeric state of platinum-199 has been produced by thermal-neutron irradiation of normal and enriched platinum samples. The isomer decays with a half-life of 14.1 ± 0.3 seconds by the emission of γ rays of 32 ± 2 and 393 ± 2 kev energy. The thermal-neutron activation cross section of Pt^{198} for the formation of the isomer is 0.028 ± 0.003 barn. Tentative level assignments are made, consistent with systematics and shell theory."

(M. A. Wahlgren, W. W. Meinke)

E. Preliminary Report on Study of Some Short-Lived Fission Product Gases

Using the pneumatic tube irradiation facility, a miniature charcoal adsorption system described below, and the "auto-start" bunny system with the one-hundred channel analyzer, it has been

possible to study the gamma spectra of 33-second Kr^{90} , 41-second Xe^{139} , and some of the longer-lived fission product rare gases.

For the rapid separation of Kr samples, a sample containing uranyl nitrate, and Norite (charcoal) is prepared in a piece of 1/4" i.d. polyethylene tubing sealed on both ends by warming and crimping shut. This system is sketched in figure 17. The Kleenex

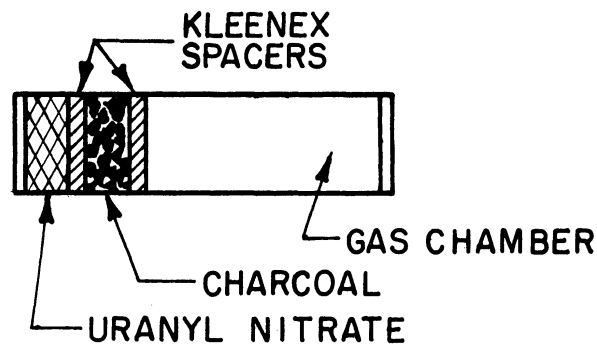

Figure 17. Sample preparation for determination of krypton.

pads are used as spacers to contain the source material and the charcoal filter. (The Norite adsorbs Xe but Kr diffuses through in the gas chamber.) The sample is irradiated for 5-20 seconds, removed from the rabbit and a gas sample of ~ 2 cc taken from the gas chamber with a syringe and hypodermic needle. The gas sample is transferred to a second piece of tubing sealed under partial vacuum. This tubing is then placed in the polyethylene bunny which is sealed with a tight fitting polyethylene plug and sent to the detector.

For Xe samples the Norite is placed in a piece of tubing connecting the needle to the syringe as in figure 18. After

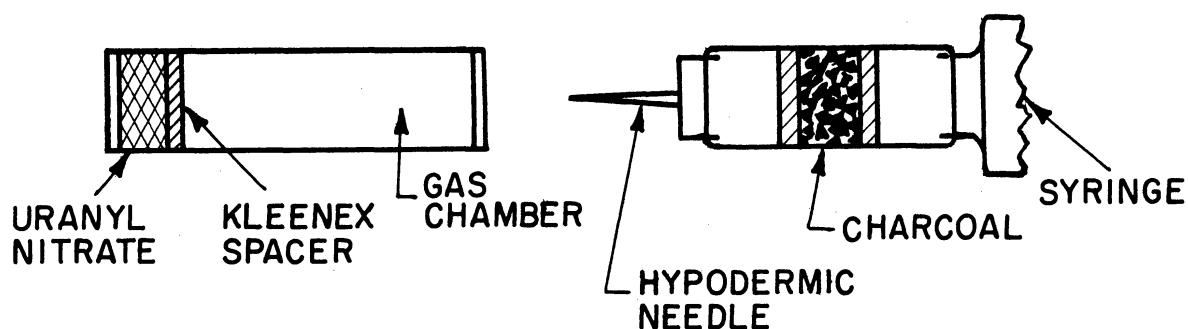

Figure 18. Sample preparation for determination of xenon.

irradiation of the sample and drawing a gas sample, the tubing is placed in the bunny and sent to the counter. In this case the Kr passes through the filter into the syringe and is discarded.

For some samples, the gas was allowed to decay for two half-lives, the residual gas removed by purging with a hot air stream, and the short-lived daughter activities observed.

The time required for handling, separation and transport to the counter for regular gas samples is 20-30 seconds. Operating the analyzer at 30 second recycle it is possible to follow the decay of the two short-lived gases and the growth of the daughters for several cycles. The decay of the daughter activities is then followed on a longer recycle period.

The gamma spectra of the daughters of the Kr samples contained the Rb^{90} and Rb^{89} gamma rays reported by other workers. The purity of the Xe samples was established by separating 17-minute Xe^{138} and following the growth and decay of 32-minute Cs^{138} .

The preliminary results are summarized in the following table.

Table III. Preliminary Results from Rare Gas Experiment.

Isotope	Half-Life	Major Gamma Rays (kev)
Kr ⁹⁰	33 sec	240, 550, 1130, 1530
Kr ⁸⁹	~3 min	complex, 210, 450, 600, others
Rb ^{91m}	1.7 min	100
Xe ¹³⁹	41 sec	90, 150, 190, 270, 380, 520
Xe ¹³⁸	17 min	200, 420, (550), 1760, 2010 (220-1760 γ - γ coinc)
Xe ¹³⁷	~3.8 min	no gamma rays observed
Cs ¹⁴⁰	66 sec	590

The gamma-ray energies quoted are approximate due to the high counting rates, and will be established more accurately in future runs. It may be possible to estimate gamma-ray abundances from the calculated disintegration rate where a daughter activity with a well characterized decay scheme is observed. An attempt will be made to establish coincidences by changing the geometry and observing sum coincidence peaks.

Uranyl nitrate has been used as source material although the emanation of rare gases from this compound is not as complete or rapid as from certain organic salts.

It is of interest to note that the gamma spectrum of gross short-lived fission products shows several of the same gamma peaks as observed in the short-lived gases. From fission yield and half-life considerations these may well be due to Kr⁹⁰ and Xe¹³⁹. (M. Wahlgren)

F. Search for Some Short-Lived Isomeric Transitions

No unreported isomeric transitions of half-life greater than 3 seconds were detected in the gamma spectra of palladium, mercury, rhenium, barium, and of a number of 99.9% pure rare earths obtained from the Lindsay Chemical Company. The rare earths irradiated consisted of samples of La, Ce, Pr, Sm, Eu, Gd, Tb, Ho, Er, Tm, Yb, and Lu. When other longer-lived isotopes of these elements were also formed in the irradiation this limit of 3 seconds is predicated on a cross section within about 2 orders of magnitude of the long-lived material. If its cross section is lower the "background" activity would be so high that the half-life limits would be much poorer. (M. Wahlgren)

G. Isomerism of Silver-108

A long-lived isomer of Ag^{108} has been detected in old $\text{Ag}^{110\text{m}}$ samples. The oldest available sample, produced in 1951 contains an amount of $\text{Ag}^{108\text{m}}$ considerably greater than the 0.05% $\text{Ag}^{110\text{m}}$ (270 day) activity remaining after 8 years of decay. The gamma-ray spectrum of this activity, as well as those of similar samples produced in 1954 and 1957, is given in Fig. 19.

The chemical assignment was confirmed by processing an aliquot of the 1951 activity through a very thorough chemical purification for silver. The mass assignment is based on the identity of the beta ray and of one of the gamma rays observed in this activity and in 2.4-minute Ag^{108} , and is consistent with systematics of neighboring nuclei, e.g. Rh, Ag, In. The half-life has been estimated from the relative amounts of $\text{Ag}^{108\text{m}}$ and $\text{Ag}^{110\text{m}}$ in the several samples,

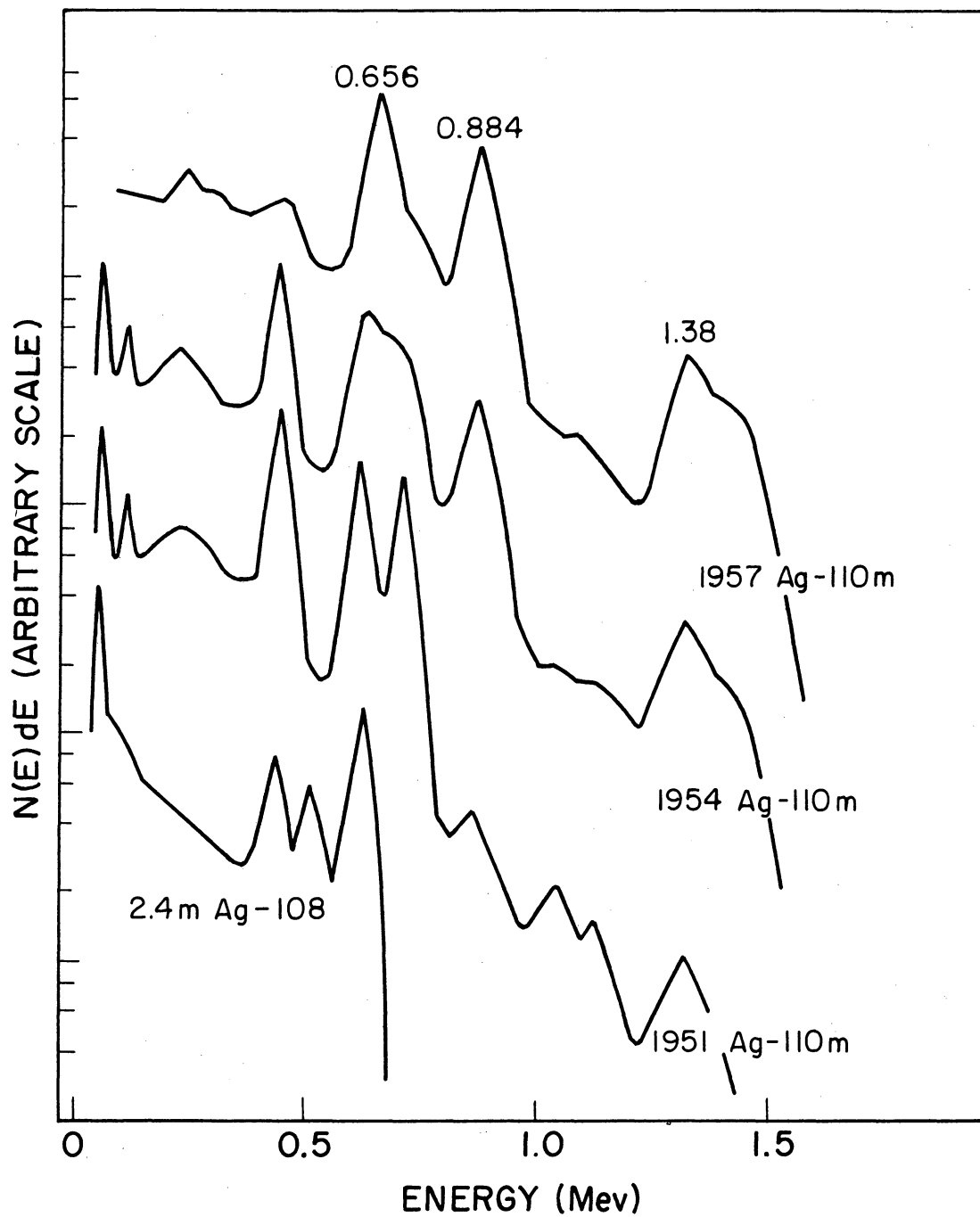

Figure 19. Gamma-ray spectrum of $\text{Ag}^{110\text{m}}$ produced in 1951, 1954 and 1957.

but the uncertainty in the half-life of $\text{Ag}^{110\text{m}}$ and in the amount of initial activity preclude any precise half-life value for $\text{Ag}^{108\text{m}}$ at this time.

The specific activity of the available sample was too low to obtain highly resolved conversion line spectra to uniquely establish the isomeric transition, but from gamma spectra and from coincidence runs, a consistent decay scheme has been proposed.

This work has been summarized in a paper submitted to the Physical Review. The following abstract accompanied this paper.

"A long-lived isomer of Ag^{108} has been detected in old $\text{Ag}^{110\text{m}}$ samples. The isomer decays with a half-life $\gg 5$ years. Gamma- and beta-ray spectrometer data show that 90% of the disintegrations proceed by electron capture followed by a cascade of three gamma rays of 616, 722, and 434 keV energy, while 10% go by isomeric transition to Ag^{108} . New values are given for the branching ratios of 2.4-minute Ag^{108} ." (M. Wahlgren, W. W. Meinke)

H. New Determination of the Branching Ratios of 2.4-min Silver-108

The decay scheme of silver-108 as given by Strominger, Hollander and Seaborg (11) was checked in this laboratory. The results are summarized in the table following.

Table IV. Decay Data for Silver-108.

Radiation	Isotope Table Value	New Value
1.77 Mev	97%	1.65 Mev 93.8%
0.63	1%	0.632 Mev 1.90%
1.78	0.15%	1.83 Mev 0.36%
0.427	0.06%	0.434 Mev 0.18%
0.61	0.2%	0.615 Mev 0.42%

The beta counter was calibrated for this experiment with a P^{32} sample standardized on the 4π counters. The gamma peaks were resolved using the efficiency curves of Lazar (12). The new values indicate a factor of 2 error in the beta calibration of the previous experiment. It should be noted that the calibration error is quantitative only and does not affect the validity of the original spin and parity assignments. These data will be included in the article on Ag^{108m} . (M. Wahlgren)

I. Search for Rhodium-109 (Half-Life <1 hr) in Fission Products

A rapid and specific chemical separation for rhodium was made in six minutes from a uranium solution irradiated in the reactor for one minute. No beta or gamma activity other than that of 24-minute rhodium-107 was detected. An upper limit of one hour had been previously established by Seiler (13) for the half-life of rhodium-109. From the new data it is concluded that any rhodium-109 formed in fission must be of half-life less than one minute or of fission yield considerably less than the 0.03% reported for the next member of the fission chain, palladium-109. The chemical separation was essentially that used by Schindewolf and Wahlgren in the activation analysis of meteorites for rhodium (14). (M. Wahlgren)

IV RADIOCHEMICAL SEPARATIONS

This area has received considerable attention experimentally during the year. DeVoe has completed his work on cadmium as well as on the exploration of radiochemical separations by vacuum distillation. In addition he has developed a new type of separation using amalgam exchange which promises to be very useful in the future for rapid work.

Considerable of the director's time has been taken up as Chairman of the Subcommittee on Radiochemistry of the Committee on Nuclear Science of the National Research Council, a job he assumed in the Fall of 1958. Since then this Subcommittee has had three meetings and has concerned itself with problems ranging from availability of cyclotron-produced isotopes and cyclotron irradiation time to radiochemically pure reagents and stockpiling of contamination-free material. One of the major undertakings of this Subcommittee is coordinating a series of monographs on the radiochemistry of the elements.

A. Subcommittee on Radiochemistry Program

1. Pamphlet on "Source Material for Radiochemistry" (15)

The following statements appear in the foreward to this pamphlet.

"The field of radiochemistry has no journal or other publication outlet to call its own. Some abbreviated material is published in analytical or nuclear journals but seldom is a detailed radiochemical

separation procedure or an elaborate counting technique given full play in the regular literature. Often different groups record their procedures in documents which are circulated within the framework of the Atomic Energy Commission. Most of these documents are also available for sale but many times the "outsider" is not aware of the report or of its availability.

This compilation then is an attempt to list current source material of interest to the radiochemist. It has been compiled from lists submitted by each member of the Subcommittee on Radiochemistry. Emphasis has been placed on documents and reports of a review nature which have proven useful to members of this Subcommittee. No attempt however has been made to include standard analytical reference works which of course are indispensable in planning new procedures."

This compilation consists of a listing of about 60 items. Author, title, a short description of content and a statement as to availability is included for each item. The list will probably be revised during the spring of 1960 and reissued. Copies are available free of charge from the Division of Physical Sciences, National Research Council, 2101 Constitution Avenue, Washington 25, D.C. (W. W. Meinke)

2. Radiochemistry Monographs

The Subcommittee is coordinating the preparation and

issuance of a series of monographs on the radiochemistry of the elements. Individual reports are being prepared on one or several related elements and include a discussion of the features of the chemistry of the element of particular interest to the radiochemist, comments on the problems of getting a sample into solution, and a discussion of preparation and counting techniques. The report concludes with an outline of several detailed radiochemical procedures with which the author is familiar and also a collection of other procedures from the published report literature.

Authors are working on reports for many of the elements now. About 10 of the reports will be completed by November and another 10 or 15 by early 1960. It is planned to issue these monographs as a series although final arrangements are not yet quite complete. Up to date information regarding the publication and availability of these reports can be obtained by writing the Division of Physical Sciences, National Research Council, 2101 Constitution Ave., Washington 25, D.C. (W. W. Meinke)

3. Availability of Cyclotron Service Irradiation Time

A questionnaire was circulated to all cyclotron installations by the Subcommittee requesting information such as location, particles and energies available, whether the cyclotron would often or rarely be available for work of outside groups, the number of hours of such availability, whether the target must be brought in in person to the facility or whether it could be mailed in and returned, and a statement as to the responsible individual to whom a person should write regarding scheduling

policies and tentative pricing information.

A summary of the information obtained in this questionnaire is available from the undersigned. (W. W. Meinke)

B. Radiochemical Separations of Cadmium

The study of the radiochemical separation of cadmium described in the last progress report (3) has been published in the August 1959 issue of Analytical Chemistry (16). The abstract of this article is as follows:

"Radiochemical separations of cadmium by solvent extraction with dithizone in basic media, by ion exchange in hydrochloric acid solution, and by two precipitation methods, one with an organic precipitant and the other with a complex inorganic precipitant, have been developed, allowing a maximum time of separation of 30 minutes per method. These methods have also been critically evaluated for yield and contamination using 18 typical tracers."

(J. R. DeVoe, W. W. Meinke)

C. Application of Vacuum Distillation of Metals to Radiochemical Separations

The following is an abstract of a paper presented in the Symposium on Radiochemical Analysis of the Analytical Chemistry Division of the American Chemical Society at Atlantic City in September, 1959.

"An exploratory investigation has been made to determine the feasibility of effecting radiochemical

separations by distillation of the elemental state.

A vacuum was used to reduce oxide formation and to allow better control of the vapor stream.

The distillation apparatus consists of a small chamber which is evacuated through a liquid nitrogen cold trap by a Welch Duo-Vac pump. An equilibrium pressure of 6×10^{-4} mm Hg can be achieved in 5 minutes. The sample to be distilled is inserted into a cylindrical furnace made by drilling a hole about 6 mm in diameter axially into a carbon rod. The rod is heated externally by means of an induction heater. A heated Vycor deflector directs the vapor to a liquid-nitrogen-cooled, cold finger around which is wrapped a thin film of teflon. The distillate is collected on the teflon which is then removed for counting in either a Geiger or scintillation-well counter.

Systems investigated include the separation of mercury by chemical reduction on a copper foil and subsequent distillation. Yields of about 70% and decontamination factors of 10^3 - 10^4 were obtained in tests with traces of 20 typical elements. Electrolysis of cadmium onto copper foil (or into a mercury cathode with subsequent volatilization of the macro mercury) followed by distillation proved satisfactory if 1 mg of cadmium carrier was used.

A study of the efficiency of separation by vacuum distillation of Cd for various molar ratios of the metal pairs Cd-Zn and Cd-Ag has shown that entrainment of contaminants is an important limitation of the method.

A very useful application of this technique is the separation of relatively volatile carrier-free daughters from macro amounts of non-volatile parent such as $\text{In}^{113\text{m}}$ from irradiated tin, $\text{Ag}^{109\text{m}}$ from irradiated palladium, and Au^{199} from irradiated platinum. For these and for other substances of similar relative volatility, vacuum metal distillation can provide a rapid method for preparing very thin high specific activity counting sources."

The equipment used for these experiments was described in the previous progress report (3). (J. R. DeVoe)

D. Radiochemical Separations by Amalgam Exchange

A new very selective radiochemical separation procedure has been developed by the use of amalgam exchange. The separation of the radioisotope takes place by virtue of the rapid exchange which is known to occur between an element in the form of a dilute amalgam and its ions in solutions. If there are many more inactive atoms of the element in the amalgam than there are of its radioisotope in solution, the amalgam exchange will result in almost all of the activity being present in the amalgam. This amalgam exchange has been found in several cases to be exceedingly rapid (17), therefore the method is useful for the separation of short-lived isotopes. This method is somewhat similar to the silver isotopic exchange method developed by Sunderman (18, 19) but appears to be much more widely applicable.

The selectivity occurs by virtue of the fact that the ions of another contaminating element in solution will not exchange with the

desired element in the amalgam. Because there is little mutual interaction between the phases the degree of separation is exceptionally high.

A number of kinetic studies on this amalgam exchange have been made. The exchange rates of thallium, cadmium, lead, zinc, copper, bismuth, sodium, potassium and cesium have been measured by Randles and Somerton (20). Other work on the detailed mechanisms of individual metal amalgam exchanges by these authors is also available (21,22,23). Ershler, (24), has also studied the amalgam exchange. One of the few references that outlines the preparations of various amalgams is given in Booth's book (25).

1. Experimental

Cadmium, zinc, lead, thallium, gallium, tin and indium amalgams can be prepared by direct contact of the metal which is free of oxidation products, with mercury. This contact is usually made under dilute acid, preferably perchloric acid which usually forms soluble salts. Solution is completed with gentle heating. The amalgams can be stored under 1-2 M HClO_4 to keep air from the surface of the amalgam and to dissolve any oxidation products that may form from the dilute acid solution. The concentrations of all amalgams are expressed in percent by weight.

Strontium amalgam was prepared in two ways: by agitating an aqueous strontium solution with sodium amalgam the strontium is reduced by the sodium amalgam and the precipitated strontium then dissolves in the mercury. Mercury cathode electrolysis of a non-aqueous solution of a strontium salt in absolute ethyl

alcohol is also effective.

An attempt to prepare antimony amalgam and niobium amalgam was made by heating the mercury and the metal together, to 2000°C under pressure. Because of inadequate design of the apparatus the methods were unsuccessful.

The following procedure is used for the measurement of the amount of tracer exchange with the amalgam.

1. Add tracer (negligible volume) of the element to be exchanged to a 50 ml pyrex centrifuge cone and dilute with 2 ml of the electrolyte; stir thoroughly.
2. Take a 100 λ aliquot of this solution and count.
3. Put 1/2 to 1 gm of a 2% (by weight) amalgam (of the desired element) into the solution.
4. Stir vigorously for 5 minutes. Count a 100 λ aliquot of this solution.
5. Correcting for the aliquot removed in step 2, calculate the percent activity which was removed from the solution.

The results of the amalgam exchange in the electrolyte which gives the greatest exchange, are listed in Table V. The results of a more detailed study of the effect of time of stirring on the exchange is given in Table VI. The effect of increasing concentration of thallium amalgam on the exchange is given in Table VII.

Since mercury reduces ions of the noble metals, Au, Pt, Pd, and Ag, and since mercury metal will exchange with its own ions in solution, the interference effect of these elements was studied. The solution was stirred with 10 gms of mercury

Table V. Exchange of an Element with its Amalgam.

Element and Amount of Isotope	Solution	Exchange %
Bi ²¹² (C.F.)	5 <u>M</u> HCl	49
Cd ^{115m} (24 μ g)	0.5 <u>M</u> NaClO ₄	94
	0.5 <u>M</u> Na ₂ C ₂ O ₄	"
	0.5 <u>M</u> NaNO ₃	"
	5 <u>M</u> HClO ₄	"
Ga ⁷² (1 mg)	0.5 <u>M</u> NaNO ₃	none
	sat'd NaCl	"
	2 <u>M</u> HClO ₄	"
	2 <u>M</u> HNO ₃	"
In ¹¹⁴ (1 mg)	5 <u>M</u> HCl	50
Pb ²¹² (C.F.)	0.5 <u>M</u> HNO ₃	90
Sn ¹¹³ (1 mg)	0.5 <u>M</u> NaNO ₃	none
	sat'd NaCl	none
Sr ⁹⁰ (C.F.)	0.5 <u>M</u> NaNO ₃	50-60
Tl ²⁰⁴ (21 μ g)	0.5 <u>M</u> NaNO ₃ *	85
Zn ⁶⁵ (40 μ g)	0.5 <u>M</u> NaNO ₃	90

*This value is taken at two minutes stirring.

Table VI. $\text{Cd}^{115\text{m}}$ Exchange with Cadmium Amalgam in 0.5 M NaNO_3 Solution for Various Times of Stirring.

Time	c/m	Exchange (%)
for 1 min.	6680	29.0
2	4980	47.0
3	3510	63.6
4	1990	79.0
5	1500	93
10	--	90
20	--	90

Table VII. Tl^{204} Exchange with Concentration of the Thallium Amalgam for Two Minutes Stirring.

Conc. of Amalgam (%)	Exchange (%)
2	52
3	90
4	92
5	92
10	95-96

(instead of amalgam) in 0.5 M NaNO₃ for five minutes. The results are shown in Table VIII.

Table VIII. Interference of Noble Metals and Mercury.

Element (Amt)	"Exchange" (%)
Au ¹⁹⁸ (3.5 μ g)	99.8
Pt ¹⁹⁷ (20 μ g)	96-99
Pd ¹⁰⁹ (20 μ g)	99.2-99.8
Ag ^{110m} (3.2 μ g)	97-98.5
Hg ²⁰³ (125 μ g)	99.0-99.2

2. Conclusion

The amalgam exchange of the elements Cd, Tl, Zn, Pb, Bi, Sr, In, and Sn has been demonstrated. The effect on the exchange of most common electrolytes which do not precipitate the element is small.

Since this work was intended to determine the number of elements which exchanged, little was done with any particular element. Work that was done indicated that very interesting studies could be carried out on the exchange process. The elements with two oxidation states such as thallium indicated unusual behavior by not exchanging upon prolonged stirring, but when stirred for a few minutes the exchange is very high. Increased concentration of the amalgam seemed to increase the exchange, a fact which invites investigation into the mechanism of this effect.

An effort will be made to prepare amalgams of the rare earths and transition metals to investigate their exchange properties.

Since mercury itself acts as a reducing agent for the noble metals and since mercury will rapidly exchange with its own ions in solution, the best procedure for a general separation would be to scavenge these elements from the solution by agitating it with pure mercury. Then the separation of the desired radioisotope may be carried out with the appropriate amalgam exchange.

There are several problems involved with this method of separation. Several of these amalgams are known to be reducing agents which have nearly the reducing power of the pure metal of which the amalgam is made. This is a potential source of contamination. One might resolve this difficulty with the use of a selective scavenge step similar to the mercury reduction that is described above. In this case one would scavenge with an amalgam made with a metal just below the desired one in the electromotive series.

At the end of the separation the activity is in the amalgam. If the major activity is from β particles the mercury would act as an absorber and cause serious self absorption errors. If the activity is from γ ray emission the error is less and may not be great enough to prevent use of a correction factor. In any case it may be possible to selectively strip the element from the mercury either by an acid wash or by electrolytic stripping, and thereby reclaim the pure activity with carrier.

It is our intention to explore these problems in connection

with the detailed study of radiochemical separations by amalgam exchange of the metals mentioned above, and of others if the exchange can be demonstrated. (J. DeVoe, C. Kim)

E. Expressing the Degree of Separation Obtained in a Radiochemical Separation

At the present time there has been no consistent method for reporting the degree of separation obtained from a radiochemical separation. In fact there has been little attempt to define the various terms which have been used. This is probably due to the fact that most of the terms seem self explanatory at first glance. However, it appears that improperly defined terms have resulted in misinterpretation of separation data. The various possible methods of expressing the efficiency of a radiochemical separation are listed in Table VIII. These definitions in Table VIII have been made with the intention of paralleling as closely as possible the meaning intended in previous reports. (18,26,27) The percent yield is also listed in Table IX. Expression 5 is not referenced in the literature, but represents another possible expression using the same variables as in 1 and 2.

It is difficult to adequately express the degree of separation of a radiochemical separation. The most logical approach to solving this problem would be to note the applications of most radiochemical separations as described in Chapter 1 of reference 28. The amount of activity of the contaminant which is measured with the desired activity is the most important consideration. Therefore, the efficiency of the separation should be expressed as a percent contamination. Usually the method of reporting the data should be as general as

Table IX. Methods of Expressing the Degree of Separation that can be Obtained in a Radiochemical Separation.

1. DECONTAMINATION FACTOR	A_1'/A_1
2. PERCENT CONTAMINANT CARRIED	$(A_1/A_1')100$
3. PERCENT YIELD	$(A_0/A_0')100$
4. PERCENT CONTAMINATION	$(A_1/A_0)100$
5. PERCENT DECONTAMINATION	$(1 - A_1/A_1')100$

A_1' activity (c/m) of contaminant present initially

A_1 activity (c/m) of contaminant present with desired constituent after separation

A_0' activity (c/m) of desired constituent initially

A_0 activity (c/m) of desired constituent after separation

possible. In each case the activity will be counted with some type of counter (scintillation, Geiger-Muller, or proportional counter). Referring to Table VIII it can be seen that the A_1 and A_0 refer to two entirely different radioactive nuclides which would ordinarily have different counting efficiencies for the emitted radiation when using any given type of counter. Therefore, this method of reporting data is not very general, and the percent contamination changes with the type of counter used because the counting efficiency of a given nuclide would be different for each type of counter.

If the data are reported as a decontamination factor, percent decontamination, or percent carried (all involving the same variables) the difficulty involving changes in counting efficiency, and counter are removed because the same nuclide is measured before and after the separation. There are, however, two additional difficulties which arise. The decontamination factor will not "a priori" to actual experimentation indicate whether the radiochemical separation will be good enough to remove the contaminants to a level below the sensitivity of the counting instrument which will be used, or to a level below which no interference results. This is not a serious difficulty because the decontamination factor still gives a general indication of the degree of the separation which may be obtained. In a given experiment it may be necessary to repeat the separation procedure to get the total desired degree of separation.

The second difficulty is more serious because it affects the generality of the data. The decontamination factor is often dependent upon the concentrations of the contaminant of a given ^{specific} activity. In the specific case of a separation by precipitation, however, the usual procedure is to add 10 mg. of inactive carrier of the desired activity, and as long as the precipitant is in excess, the decontamination factor is constant over a wide range of concentrations of the contaminants.

In the case of a separation where contamination occurs as a result of surface adsorption for example, the decontamination factor is largely dependent on the concentrations of both contaminant and the desired constituent. Suppose that the contaminating effect is surface adsorption of the form indicated by the Freundlich isotherm $Y = KC^{1/n}$ where Y = mass of contaminant adsorbed per unit mass of adsorbent,

C = concentration of contaminant in the medium in which the absorber exists, and n, K = empirical constants. The decontamination factor per unit mass of absorbent per unit volume of the medium is expressed as $D.F. = \frac{C}{Y} = \frac{Y^n}{K^{n+1} C^{1/n}}$. From this it is clear that if $n > 0$ the decontamination factor is dependent on both the concentration of desired constituent and the contaminant. An example of this general effect can be found in a copper foil experiment where copper is used to reduce trace amounts of mercury onto the solid copper metal foil. The procedure involves the reduction of 16 μgm of mercuric ion onto the copper in the presence of possibly contaminating ions which are labeled with its radioactive isotope. The degree of separation of mercury from different concentrations of contaminants is listed in Table X. Since neither barium, lanthanum or indium will be reduced by copper the contamination which is observed is due to some other factor, such as surface absorption. These data clearly show the dependency of the decontamination factor on the concentration of the

Table X. Change in the Decontamination Factor with the Initial Concentration of the Contaminant.

Contaminant	Activity of Cont. added	Amount of Contam.	Activity on Copper c/m	Decont. Factor
Ba-La ¹⁴⁰	1.9×10^6	C.F.	5,700	3×10^2
Ba-La ¹⁴⁰	1.9×10^9	C.F.	8,000	2.6×10^5
In ¹¹⁴	4.8×10^6	4.6 g	48	10^5
In ¹¹⁴	4.4×10^8	0.5 mg	19	2×10^7

contaminant. These data represent only a few examples of the effect.

It is necessary therefore to indicate the quantities of both the desired constituent and the contaminants when effects of this kind are expected. This difficulty is not particularly restrictive because the direction of the effect can often be predicted. In the case of surface adsorption which follows relations similar to the Freundlich isotherm one can predict that at higher concentrations of the contaminant the decontamination factor increases. This indicates an even better separation.

Ideally, to unambiguously express the degree of a separation, recourse must be taken to discussing inactive atoms on a mole fraction basis or mole percent contamination. For a radiochemical separation this is not general for reasons discussed before.

For radiochemical separations the most general method of expressing the degree of the separation is with the decontamination factor or its associated percent contaminant carried, indicating the quantities (gram moles) concerned when the mechanism of the separation as explained above indicates that this is necessary. (J. DeVoe)

V ACTIVATION ANALYSIS

With the reactor operating continuously at 1 megawatt during the past year and with the pneumatic tube facilities and specialized instrumentation described earlier in full operation we had unparalleled facilities for studying the application of activation analysis to many types of systems. In many cases these studies emphasized the use of short-lived radioisotopes in the analysis.

A. Review Articles and Data Correlation Summaries

1. Review Articles in Activation Analysis

An article presenting 3 sensitivity graphs computed on the basis of a thermal neutron flux of 10^{12} n cm⁻² sec⁻¹ and irradiation times of 6 minutes, 600 minutes (10 hours) and 1000 hours was published in the May 1959 issue of Analytical Chemistry (29). The article by Fouarge on Chemical Analysis by Activation with Neutrons was published in the February, 1959 issue of Industrie Chimique Belge (30).

The article entitled "Trace Analysis of Marine Organisms: A Comparison of Activation Analysis and Conventional Methods" by R. Fukai and W. W. Meinke is appearing in the October 1959 issue of Limnology and Oceanography (31).

2. Review of Fundamental Developments in Nucleonics

Considerable effort has been expended in reviewing the literature of the past 2 years for the new biannual review. It will extend from late 1957 until late 1959 without overlapping

the previous review (4). The deadline for submission of the manuscript to Analytical Chemistry is December 1, 1959. It will appear in the Review Supplement to the April, 1960 issue of that journal. Indications are that there will be more than 1000 references included, with Russian literature occupying a more prominent position than previously. (W. W. Meinke)

B. Activation Analysis for Trace Constituents in Meteorites

Articles on the rhodium, silver and indium (14) as well as the selenium and tellurium (32) content of chondritic meteorites have been submitted to Geochimica et Cosmochimica Acta. The first one will be published in a fall issue. The content of these articles was reviewed in the last progress report (3).

(U. Schindewolf, M. Wahlgren)

C. Determination of Vanadium in Petroleum Process Streams

As was reported previously (3), a method has been developed for the non-destructive determination of vanadium in petroleum process streams by neutron activation and gamma scintillation spectrometry. This work was performed at a time when the Ford Nuclear Reactor at the University of Michigan was operating at a power level of 100 kw, producing a thermal neutron flux in the pneumatic tubes of the order of 10^{11} n cm⁻² sec⁻¹.

The sensitivity for this determination has since been redetermined with the reactor operating routinely at a power level of 1000 kw, producing a pneumatic tube thermal neutron flux of the order of

10^{12} n cm⁻² sec⁻¹, and has been found to be increased by a factor of 10.0 ± 0.1 over the sensitivity as determined at 100 kw. This ten-fold increase in sensitivity has, however, given rise to a certain amount of interference due to a sodium-24 photopeak in some of the samples which was not apparent in these samples when irradiated at 100 kw. By suitable "cooling" times, however, this interference can be corrected for, and amounts of vanadium as low as 2.5×10^{-9} grams in approximately 150 milligrams of an oil sample can be determined without chemical separation.

This method has been presented before the April, 1958 meeting of the American Chemical Society, and is being prepared for submission in the near future to Analytical Chemistry. (J. Brownlee, W. W. Meinke)

D. Determination of Vanadium in Petroleum Catalyst

Inasmuch as low concentrations of certain elements, including vanadium, tend to reduce the activity of a petroleum cracking catalyst, there is a pronounced interest on the part of petroleum refiners in the amount of these elements deposited on the catalyst. We have thus extended our work on oil samples to include these solid catalysts.

The catalyst samples (kindly furnished by O. I. Milner of Socony-Mobil Oil Company) have a silicon dioxide - aluminum oxide base and may also contain small amounts of chromium, iron, titanium and zirconium oxides. The gamma spectrum of a representative sample (Fig. 20) shows a very large aluminum photopeak, in addition to smaller vanadium and silicon photopeaks superimposed on the Al²⁸ Compton scatter distribution. Because of the presence of relatively large amounts of aluminum, a chemical separation of the vanadium

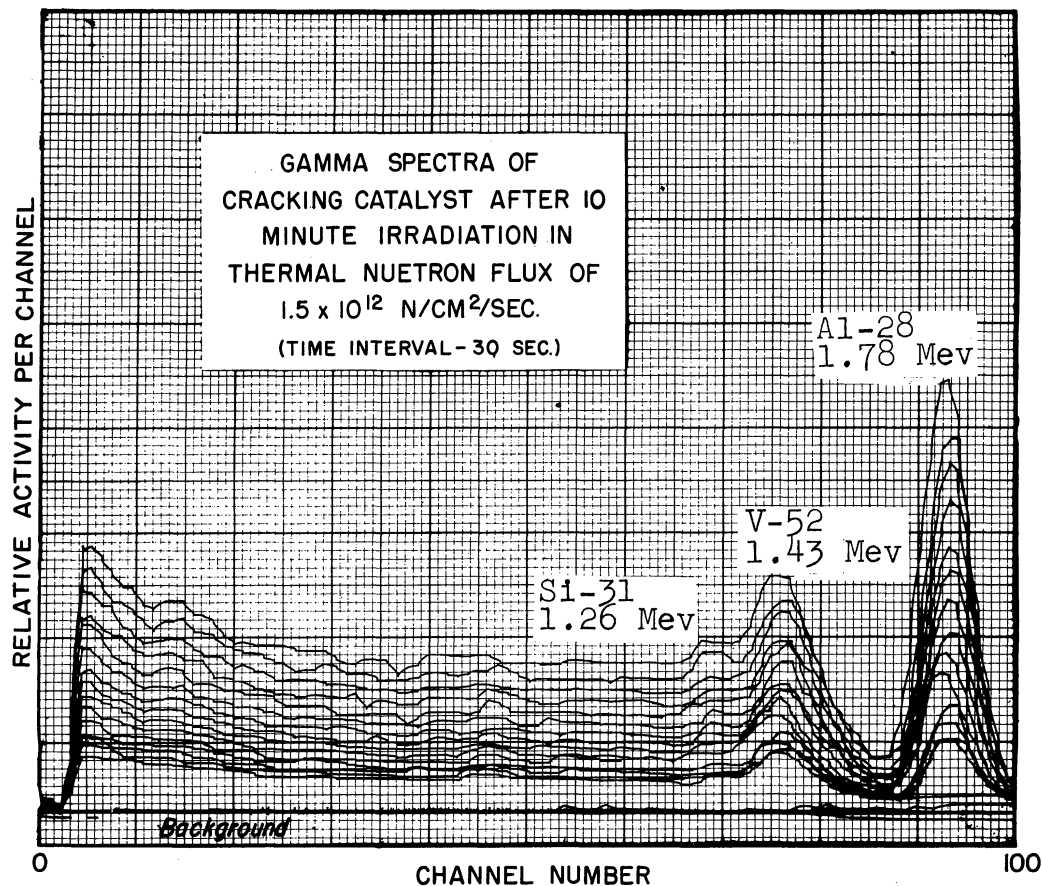

Figure 20. Gamma spectra of cracking catalyst.

was deemed necessary for any reasonably accurate determination. The major problem in such a separation lies in the complete removal of aluminum, inasmuch as the other materials present in the catalyst give rise to gamma photopeaks of energies lower than that of vanadium, and hence would not interfere with a vanadium determination.

Samples of catalyst used for the vanadium determination were treated in the following manner: Forty to one hundred milligrams of finely ground catalyst is weighed into a gelatine capsule and irradiated in a pneumatic tube for ten minutes. The irradiated capsule is then fused in 3-3.5 grams of sodium peroxide containing a known amount of V^{48} activity, cooled rapidly by repeatedly dipping the bottom of the crucible into cold water, and the melt dissolved in 100-ml of a solution containing aluminum and vanadium carriers,

hydrochloric acid and 3 percent hydrogen peroxide. Aluminum is removed by precipitation with 8-hydroxquinoline in acetic acid and filtration through a medium glass frit. The filtrate is acidified, and vanadium extracted into chloroform with cupferron. The chloroform layer is analyzed on the 100-channel analyzer, counting being started exactly ten minutes after removal of the sample from the reactor. (A more detailed description of this radiochemical procedure is given in the section on Separation Procedures.) Successive spectra were recorded every minute for several minutes. In these spectra, V^{52} had the most prominent photopeak, with no photopeaks appearing having gamma energies higher than that of vanadium. The V^{48} tracer provided data on the chemical recovery of vanadium.

The activity found under this photopeak, after being corrected for background radiation, variations in flux, and chemical recovery of vanadium, is related to the amount of vanadium present in the sample as shown in Figure 21. Typical analysis of samples are given in Table XI.

Table XI. Vanadium in Cracking Catalyst

Sample Number	No. of Determinations	ppm V	% Std Dev
1	3	9.66	± 33.5
2	5	24.10	± 5.77

(J. Brownlee)

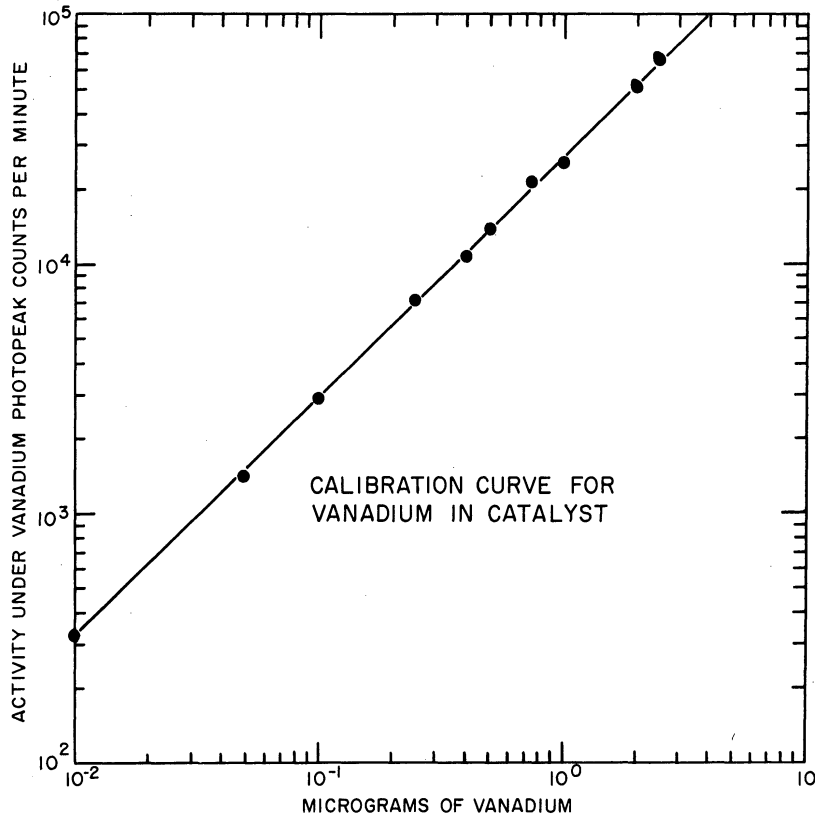

Figure 21. Calibration curve for vanadium in cracking catalyst.

E. Activation Analysis of Niobium

There is some apparent interest at the present time in analysis for trace amounts of niobium in geological materials. Methods in common use today for niobium determinations do not appear to be capable of the high sensitivity found for many elements in the method of analysis by activation. In view of this high sensitivity, an attempt has been initiated to determine niobium by means of the activity induced on neutron bombardment, that of the 4.2-minute Nb^{94m} isomer.

A solution of niobium carrier in dilute hydrofluoric acid was irradiated for fifteen minutes in the pneumatic tube, and its spectrum recorded. On comparing the observed photopeak with the barium K

X-ray (32 kev), it was found that the peak did not have an energy of 42 kev, as might be expected from its decay scheme (Fig. 22), but

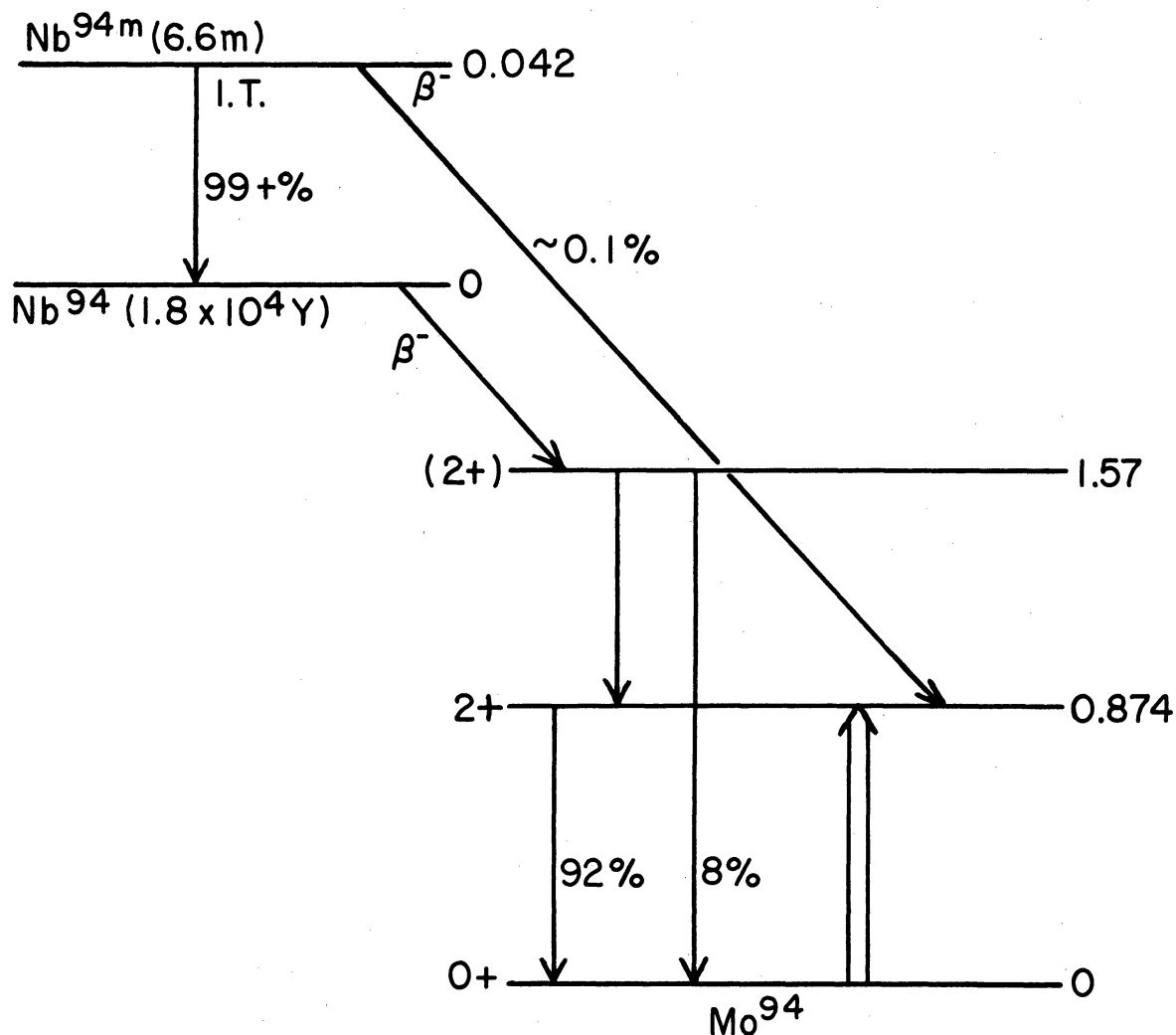

DECAY SCHEME OF $\text{Nb}^{94\text{m}}$

Figure 22. Decay scheme for $\text{Nb}^{94\text{m}}$.

had instead an energy of 16.8 ± 0.7 kev (Fig. 23). Several determinations of the half-life of this peak were made, the average value of which was found to be 6.5 ± 0.2 minutes. Irradiation of two different niobium compounds confirmed that the photopeak recorded was that of niobium having a 6.6 minute half-life. It is known (11) that the

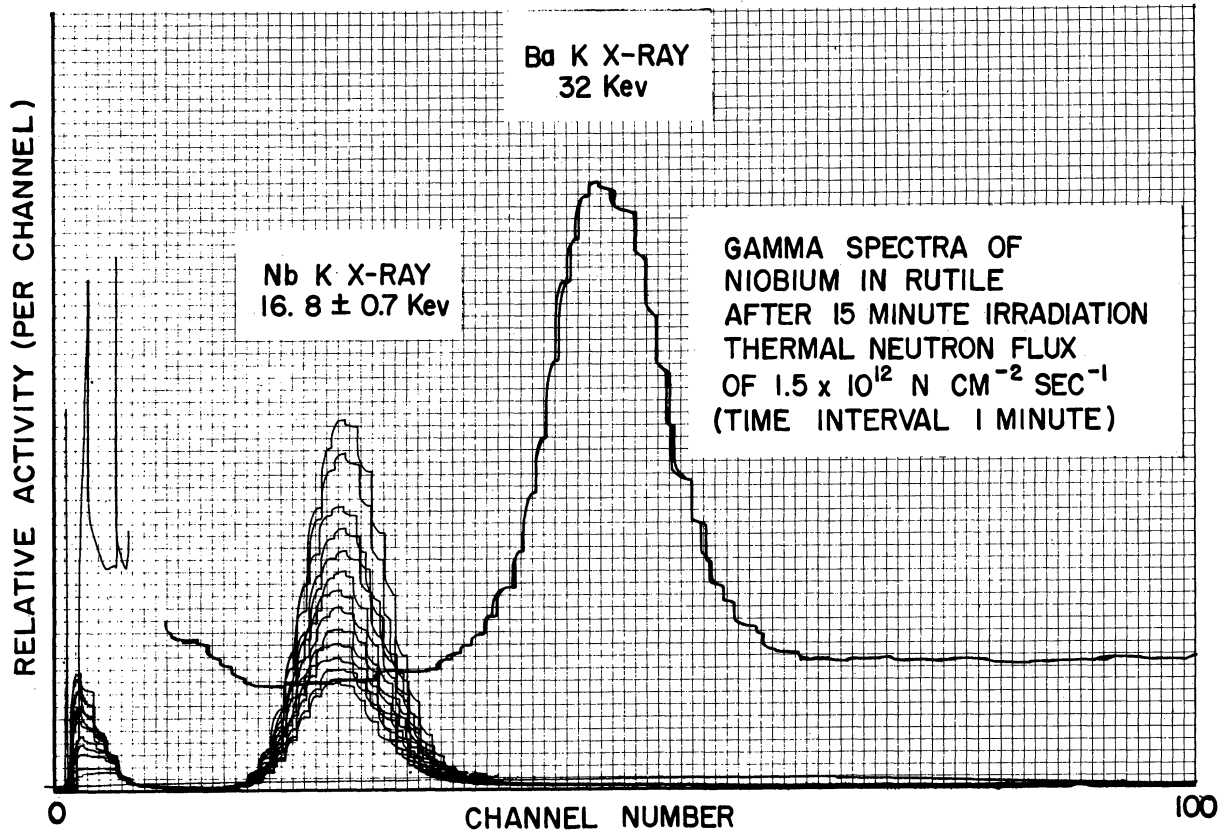

Figure 23. Gamma spectra of niobium in Rutile.

conversion coefficient of Nb^{94m} is large; as a result of the above investigation, it is postulated that the conversion coefficient is so large that the 42-keV gamma from isomeric transition is almost completely converted to an electron and an X-ray.

The niobium X-ray was observed by means of a 3" x 3" NaI(Tl) crystal, but the presence of the X-ray suggested use of an X-ray proportional counter as a detecting medium. Thus a sample of irradiated niobium carrier solution was analyzed by means of a krypton-filled X-ray proportional counter (33), whose output was fed into the 100-channel analyzer. A double peak was observed (Fig. 24), which had the proper half-life, but which did not lend itself to quantitative determinations. In all subsequent work, the 3" x 3"

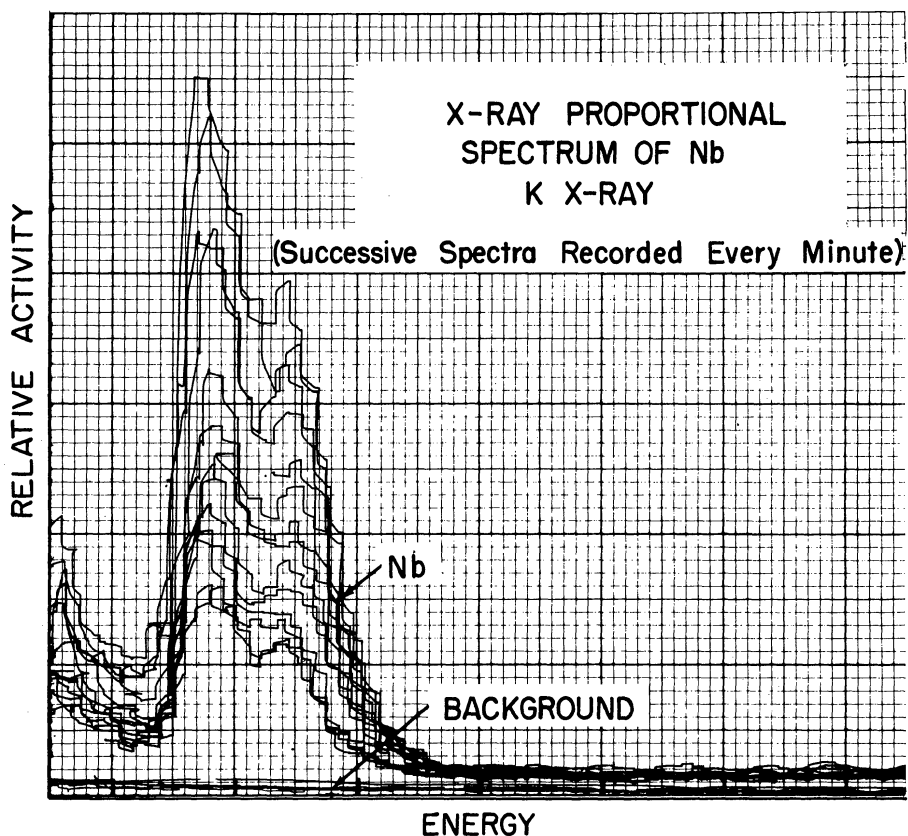

Figure 24. K X-ray spectrum of niobium taken with X-ray proportional detector.

NaI(Tl) crystal was used, with a slightly higher than normal voltage (ca. 1150 volts) applied to the photomultiplier tube.

The chemical separation of niobium has proven to be somewhat of a problem. Most niobium separations involve precipitation of niobium as the hydrated oxide, $\text{Nb}_2\text{O}_5 \cdot \text{XH}_2\text{O}$, or of the tannate complex, or by solvent extraction. The precipitation reactions lead to precipitates which are too finely divided to allow rapid filtration, while the solvent extraction procedures did not appear to give adequate separations in a short time. A method of separating radio-zirconium and niobium from fission products by adsorption on silica gel and filter aids was found (34), and seemed to offer some possibility

for a clean separation of niobium. It was found that 75 percent of Nb⁹⁵ tracer could be adsorbed onto 0.5 gram of commercial silica gel by boiling a mixture of nitric acid, Nb⁹⁵ tracer and silica gel for one minute and filtering. In view of the lack of other suitable methods this method has been adopted, and is under development.

A finely ground sample of rutile, which is primarily titanium dioxide, with small amounts of niobium and vanadium oxides, is activated in the pneumatic tube for fifteen minutes. The irradiated sample, enclosed in a gelatine capsule is then fused with 3-4 grams of sodium peroxide, the melt cooled rapidly, and dissolved in dilute nitric acid. The solution is filtered to remove any undissolved material. Concentrated nitric acid is added to the filtrate, followed by 0.5 gram of silica gel, and boiled for one minute. The solution is filtered through a medium stainless steel filter funnel, the silica gel dried with acetone, and analyzed with the 100-channel analyzer. Chemical recovery was 30-35 percent, determined by means of Nb⁹⁵. A more detailed outline of the procedure is given in the later section on Separation Procedures.

Analysis of the spectra showed a large amount of titanium contamination to be present on the silica gel. It appears, however, that this contamination offers no serious interference to the niobium determination since the niobium X-ray photopeak is so far below that of titanium. Preliminary results show that niobium in amounts as low as 10^{-2} micrograms can be determined following this ten minute separation. (J. Brownlee)

F. Activation Analysis of Gold in Marine Organisms

In the present work the activation analysis of gold in marine biological ashes has been studied by using a simple chemical procedure and γ -spectrometry.

1. Preliminary Experiments

In order to work out the procedure for the radiochemical separation of gold, the following preliminary experiments were carried out by using Au^{198} tracer.

a) Extraction of gold from aqua regia solution with ethyl acetate.

Condition: 30 ml of aqua regia solution of Au (including ~10 mg Au carrier)
30 ml of ethyl acetate

1 min. shaking	Au extracted	99%
3 min. shaking	Au extracted	98%

b) Back-extraction of gold from ethyl acetate layer with ammonium hydroxide.

Condition: ~30 ml of ethyl acetate layer (including extracted Au)
1:4 NH_4OH 25 ml

1 min. shaking	Au back-extracted	96%
2 min. shaking	Au back-extracted	97%

c) Precipitation of Au-metal from 1 M HCl solution by reduction with SO_2 gas

~30 ml of 1 M HCl solution of Au

5 min. bubbling (SO_2 gas)	Au recovered	95.7%
10 min. bubbling (SO_2 gas)	Au recovered	98.1%
15 min. bubbling (SO_2 gas)	Au recovered	99.2%
20 min. bubbling (SO_2 gas)	Au recovered	99.2%

On the basis of these data, the procedures for gold-separation have been arranged (cf. sheets for Chemical Separations).

2. Analytical Procedure

About 500 mg of biological ash were sealed in polyethylene tubing, each of which was covered by 5 mil Al-foil for protection in case the plastic tubing disintegrated in the "in pool" irradiation. The standards were made by pipetting a known volume (10 λ -30 λ) of gold standard solution on to a small piece of filter paper of good quality (15 mm diameter) and by evaporating to dryness. Each filter paper was sealed in plastic and protected in a way similar to the samples. The amount of Au in standards ranged from 7×10^{-9} g to 2.4×10^{-7} g.

All of the samples and standards (6 samples and 6 standards) were placed in the same polyethylene bottle with Pb-metal as a weight. The bottle was placed in contact with the surface of the reactor-core in the reactor pool and irradiated for 14.1 hours.

After the irradiation the samples were quite radioactive (possibly ~ 2.5 r/hr for the whole bottle). Then the samples were allowed to stand for about 5 days to eliminate extra-activities. After the cooling period the chemical separation of gold by extraction with ethyl acetate followed by precipitation with SO₂ gas was carried out as outlined in the section for Chemical Separations.

The separated gold was counted for 5 - 10 minutes on the 0 - 1.0 Mev range of the 100-channel analyzer with the 3" x 3" crystal. The photopeak of the 0.41 Mev γ -ray of Au¹⁹⁸ was used in the analysis.

3. Flux Monitor

Five to 10 mg of Al-Co foils containing 0.356% Co were attached to both sides of each container of samples and standards. After the induced activity of Al died out, the long-lived Co^{60} was counted directly with the 100-channel analyzer. From the counting data obtained the averaged neutron flux for each sample and standard was calculated. In the computation the contribution of Co^{60m} activity to Co^{60} activity was considered.

On an average, the thermal neutron flux of $2.5 \times 10^{12} \text{ n cm}^{-2} \text{ sec}^{-1}$ was obtained for these "in pool" irradiations.

4. Calibration Curve

The calibration curve given in Fig. 25 was constructed on

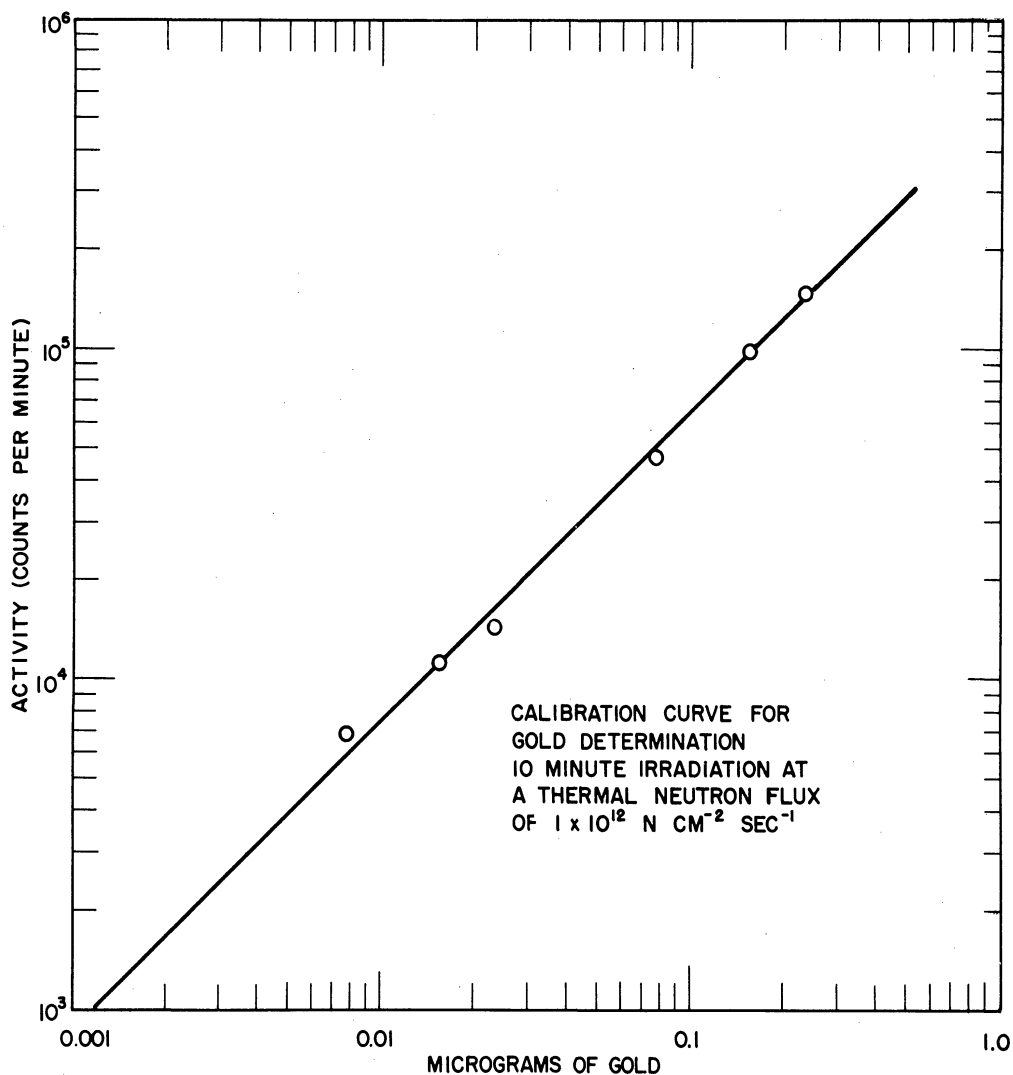

Figure 25. Calibration curve for gold (biological ash).

the basis of the data obtained for the standards after processing through a similar chemical procedure to that used for the samples. Activities plotted in the figure were those normalized to 10 hours irradiation at a neutron flux of $1 \times 10^{12} \text{ n cm}^{-2} \text{ sec}^{-1}$ with corrections for decay and chemical yield.

5. Results Obtained

Sample	Sample Wt. used mg.	Au ppm in Ash
<u>Ulva</u> sp. (seaweed) Collected at Enoshima, Sagami Bay in May, 1956	493.5	0.093
<u>Ulva</u> sp. (seaweed) Collected at Urayasu, Tokyo Bay in May, 1956	496.8	0.015
Mackerel (meat)	495.5	0.003
Clam (meat)	503.2	0.079
Shrimp (meat)	500.1	0.005

6. Notes

In the course of standardization more activity was obtained for the known amount of gold in the standards than was expected. This might possibly be explained by the resonance effects of fast neutrons in the formation of Au^{198} . The lower limit of quantitative determination at the normalized condition stated above (10 hours irradiation at the neutron flux of $1 \times 10^{12} \text{ n cm}^{-2} \text{ sec}^{-1}$) has been estimated to be around $5 \times 10^{-10} \text{ g}$ of Au present (including chemical separation) when the cooling period for one half-life is taken into consideration.

The probable error of the whole analytical procedure near the lower limit of determination may be $\sim \pm 50\%$. The error

of the analyses performed for the samples here may be $\pm 30\%$ or less. (R. Fukai)

G. Activation Analysis of Rhenium in Marine Organisms

In the present work the activation analysis of rhenium has been studied by using solvent extraction of rhenium with tetraphenyl arsonium chloride and chloroform followed by γ -spectrometry.

Rhenium has the following two stable isotopes:

Re^{185} - Abundance: 37.07%; Act. cross section: 100 ± 20 barns

Re^{187} - Abundance: 62.93%; Act. cross section: 75 ± 15 barns

By neutron capture of these stable isotopes, three radioactive isotopes which are suitable for the activation analysis should be produced. These are:

Re^{186} - Half-life: 88.9 hours; Main γ -ray: 0.137 Mev (22%)

Re^{188} - Half-life: 16.7 hours; Main γ -ray: 0.155 Mev (20%)

Re^{188m} - Half-life: ~ 20 min.; Main γ -ray: 0.0635 Mev

In the present work, the γ -ray peak of Re^{186} was used for γ -spectrometry. At the same time, the possibility of utilizing Re^{188m} for activation analysis has also been considered.

1. Analytical Procedure

About 500 mg of biological ash were placed into high purity aluminum tubing (~ 8 mm diameter, 5 mils wall thickness) and both ends of the tubing were squeezed tightly by a laboratory press (1000 lb/inch^2). The filter paper standards were prepared in a way similar to that for gold. The amount of Re in standards ranged from 1×10^{-9} to 6×10^{-8} g.

All of the samples and standards (5 samples and 6 standards) were placed in an aluminum can having wall thickness of 1/2 inch. The can was inserted into the first row of elements in the reactor-core and allowed to stand for 11.5 hours for the irradiation. The samples were cooled for 6 days before the chemical procedure was carried out. Samples were opened in a lead-shielded box. At the time of opening the sample, doses of 100-500 mr/h for β -ray and ~ 3 mr/h for γ -ray were observed for each sample.

After carrying out a chemical separation based on extraction with tetraphenylarsonium chloride as outlined in the section for Chemical Separations, the separated rhenium was counted for 5-10 min on the 0-0.5 Mev range of the 100-channel analyzer with the 3" x 3" γ crystal. The photopeak of the 0.137 Mev γ -ray of Re^{188} was used in the analysis.

2. Flux Monitor and Calibration Curve

About 5 mg foils of Al-Co were used as flux monitors. Each foil was sealed in a clean polyethylene envelope and inserted with the ash-samples and standards. After the irradiation, the activity of Co^{60} was counted and the flux was computed in a way similar to the case of Au-analysis. On an average, a thermal neutron flux of $3.5 \times 10^{12} \text{ n cm}^{-2} \text{ sec}^{-1}$ was obtained.

From the counting data for standards and the data of flux monitoring the normalized activities for 10 hours irradiation at the neutron flux of $1 \times 10^{12} \text{ n cm}^{-2} \text{ sec}^{-1}$ were computed and plotted versus rhenium content as given in Fig. 26.

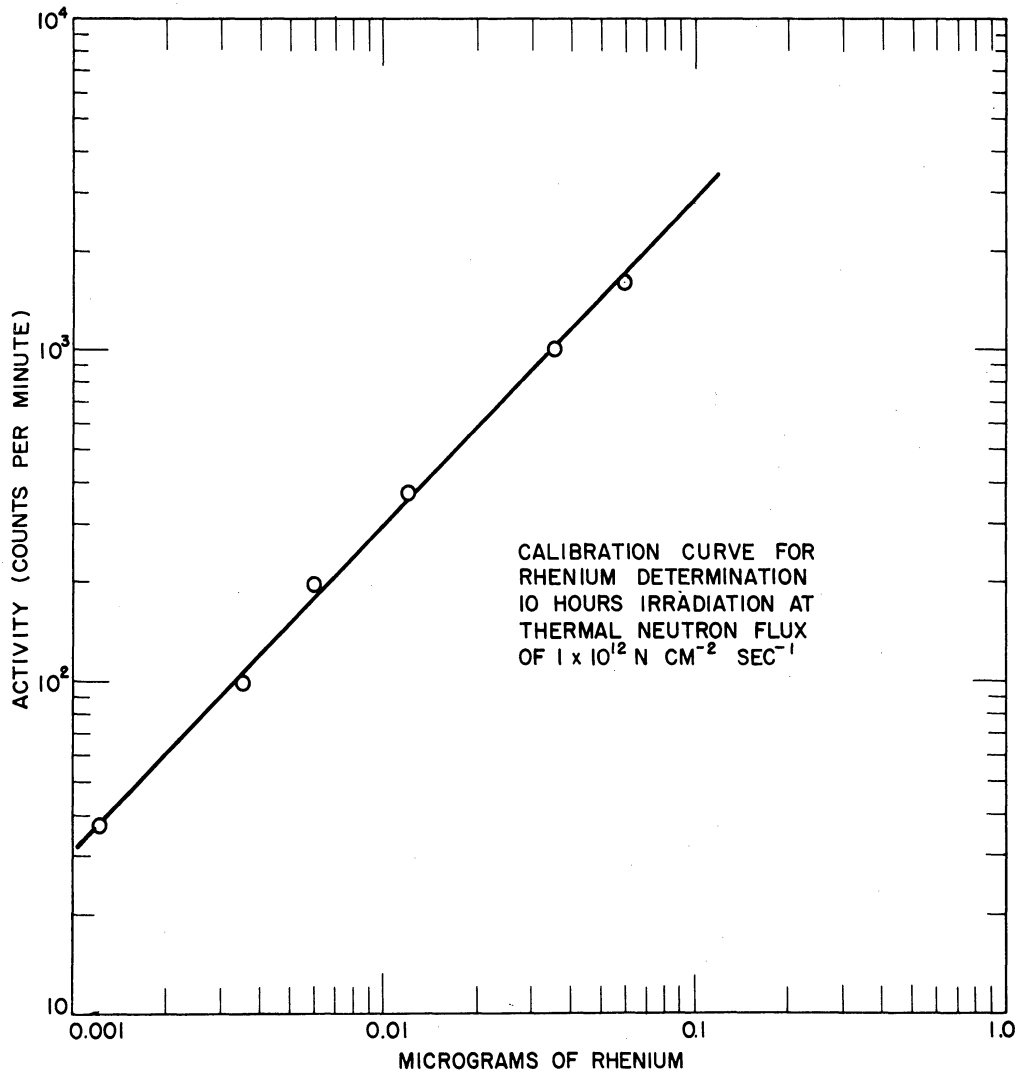

Figure 26. Calibration curve for rhenium (biological ash).

3. Results Obtained

In the spectra of three samples out of five the rhenium-peak in question was found. Results obtained are summarized as follows:

Sample	Sample Wt. used mg.	Re ppm in Ash
<u>Ulva</u> sp. (seaweed) Collected at Enoshima, Sagami Bay in May, 1956	496.5	0.073
<u>Ulva</u> sp. (seaweed) Collected at Urayasu, Tokyo Bay in May, 1956	497.1	0.046
Mackerel (meat)	503.9	< 0.008
Clam (meat)	497.7	0.064
Shrimp (meat)	498.9	< 0.005

4. Notes

From the calibration curve the lower limit of quantitative determination at the normalized condition (10 hours irradiation at the neutron flux of $1 \times 10^{12} \text{ n cm}^{-2} \text{ sec}^{-1}$) has been estimated to be 1×10^{-9} g of Re present (including chemical separation) after the cooling period of one half-life.

On the other hand, the possibility of applying the short-lived rhenium isotope ($\text{Re}^{188\text{m}}$) to the activation analysis seems to be promising. Figs. 27 and 28 show the γ -peak of .0635 Mev of $\text{Re}^{188\text{m}}$ and the decay of this isotope respectively. A half-life of 20.6 minutes has been obtained for $\text{Re}^{188\text{m}}$ in these experiments.

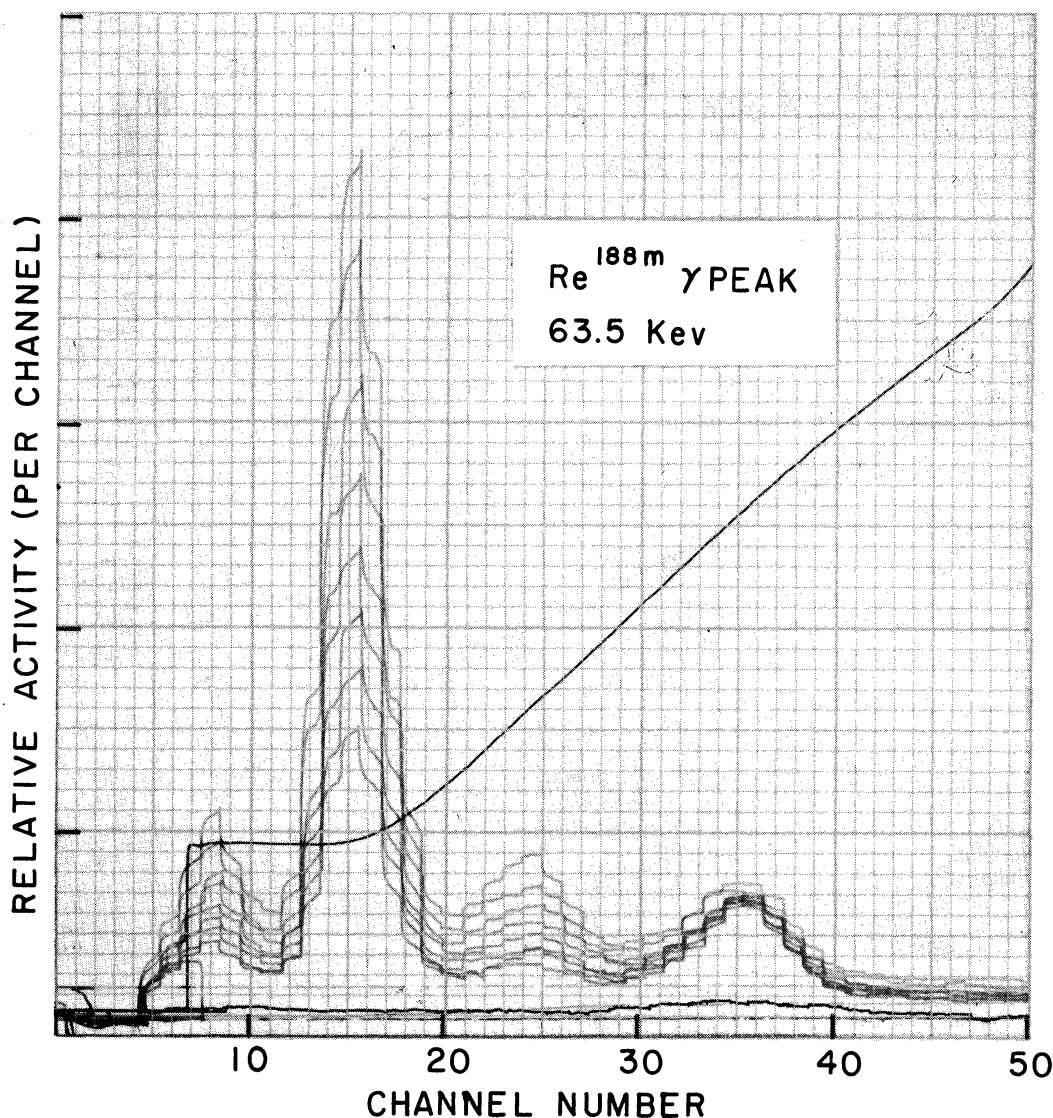

Figure 27. Spectrum of 63.5 keV gamma peak of $\text{Re}^{188\text{m}}$.

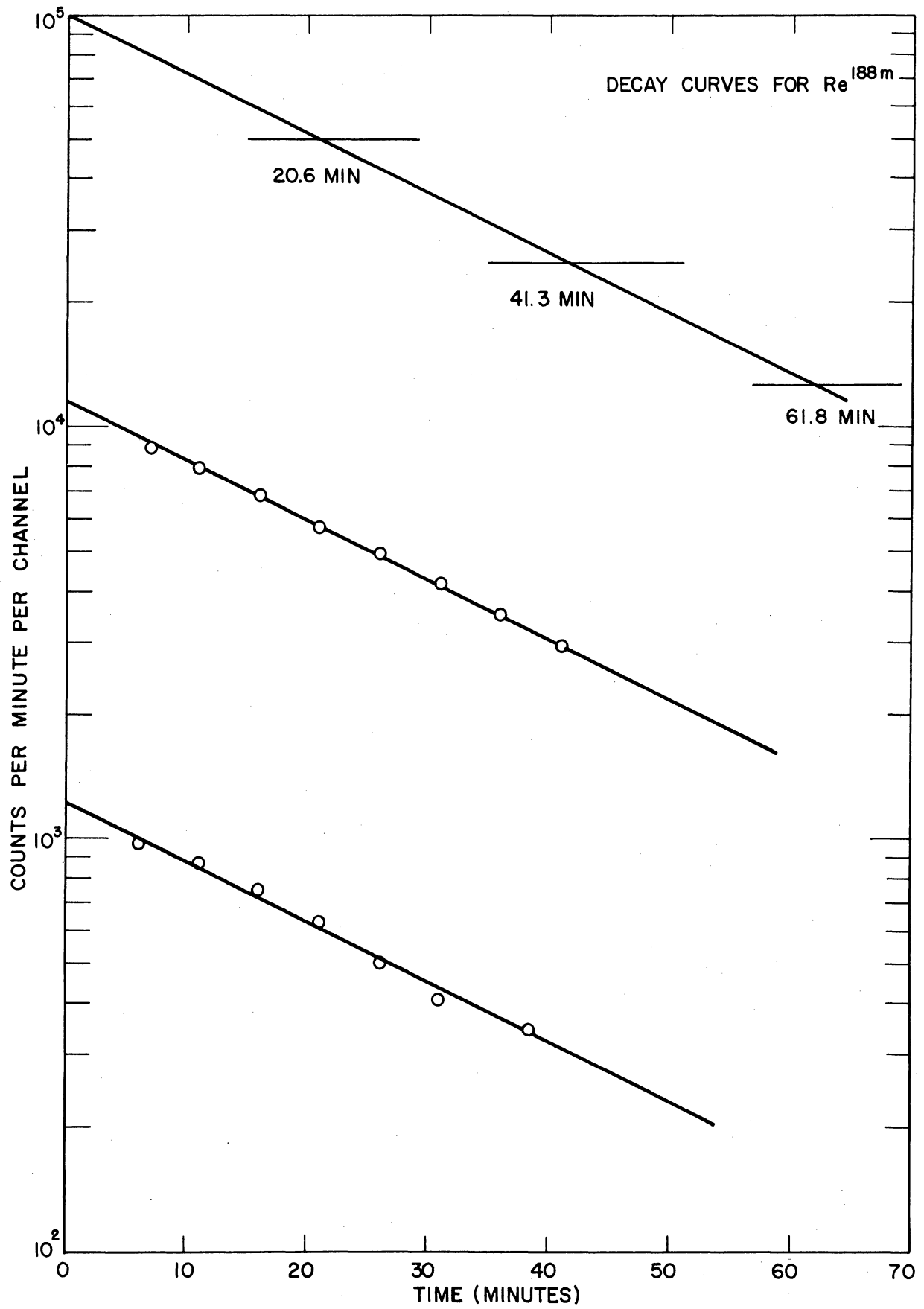

Figure 28. Decay curves of $\text{Re}^{188\text{m}}$.

This value does not agree with the value of 18.7 minutes and 22 minutes which have been reported. At any rate, since the utilization of the short-lived rhenium isotope for the activation analysis should decrease the formation of the extra-activities in the samples, the chemical separation procedures may be carried out much more easily than when using the long-lived isotope. The lower limit of quantitative determination at the normalized conditions (10 min irradiation at the neutron flux of 1×10^{12} n cm⁻² sec⁻¹) should be around 1×10^{-8} g of rhenium present.

The probable error for the activation analysis of rhenium by using the long-lived isotope (Re¹⁸⁶) around the lower limit of determination stated above (1×10^{-9} g Re) is estimated to be around $\pm 35\%$.

The errors included in the present analyses may be estimated to be less than $\pm 25\%$ except for the negative results. (R. Fukai)

H. Activation Analysis of Molybdenum in Marine Organisms

The activation analysis of molybdenum by means of γ -spectrometry has been accomplished by using Tc¹⁰¹ activity. This procedure has been based on the following nuclear reaction:

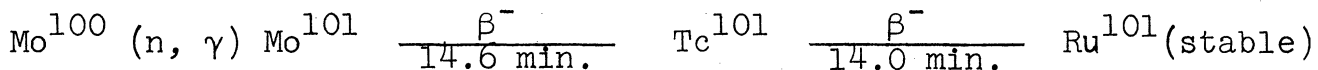

(Abundance: 9.62%, Cross Section 0.5 barns)

By separating Tc¹⁰¹ from other isotopes and by counting the Tc¹⁰¹ activity, the amount of molybdenum originally present could be estimated. For the chemical separation of technetium a method similar to the separation for rhenium can be used. The chemical

separation of technetium by using tetraphenyl arsonium chloride as a complexing agent seems more specific than any separation procedure for molybdenum. In addition to this, it is not necessary to dissolve the sample rapidly since the Tc-activity grows until 15 min. after the irradiation.

Fig. 29 shows an example of an irradiated Mo spectra in which both Mo and Tc peaks appear side by side. Fig. 30 illustrates the decay of the Mo¹⁰¹ peak and the growth and decay of the Tc¹⁰¹ peak appearing in the previous figure.

1. Analytical Procedure

Between 200 and 250 mg of biological ash were sealed in polyethylene tubing and irradiated for 15 minutes in pneumatic tube No. 3 using the quick-opening rabbit. Immediately after

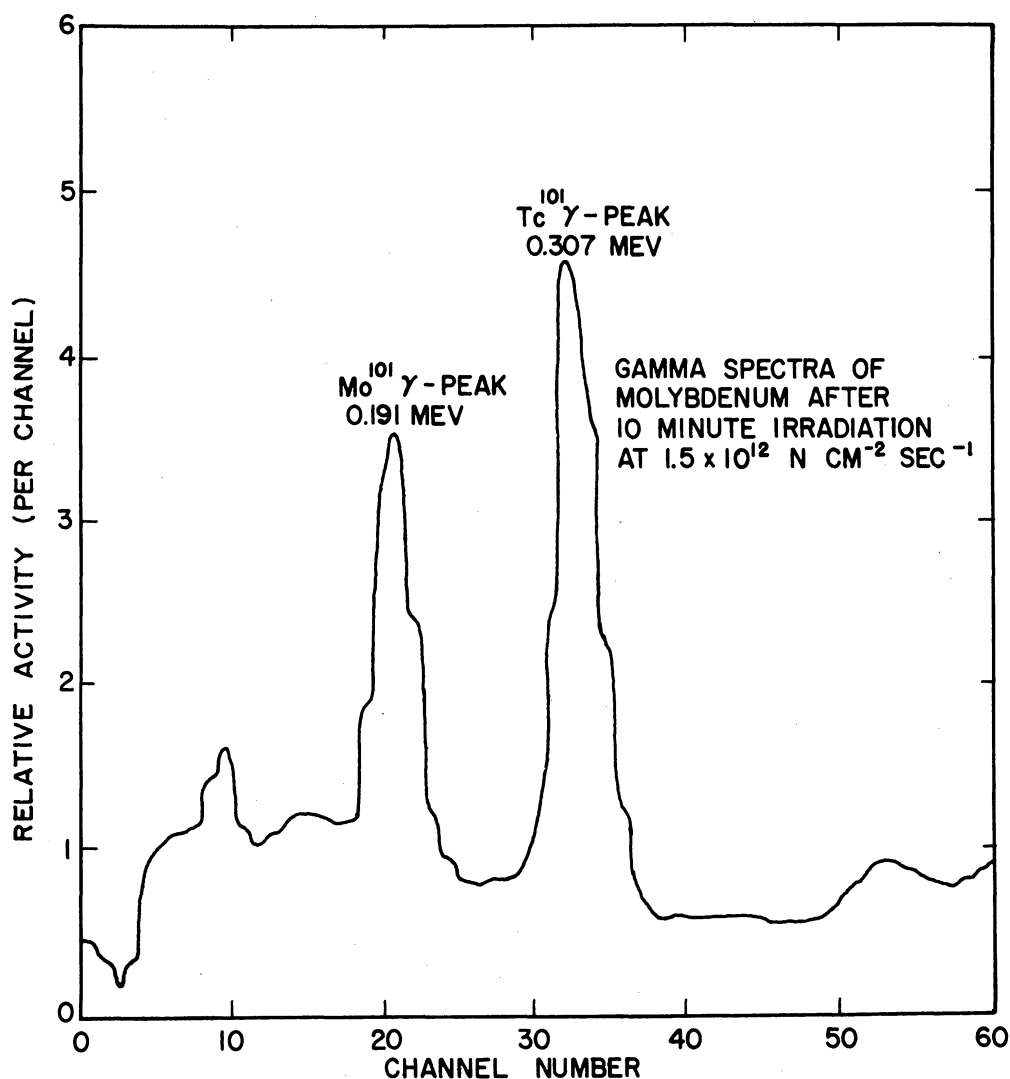

Figure 29. Gamma spectra of Mo¹⁰¹ and Tc¹⁰¹ after 10 minute irradiation.

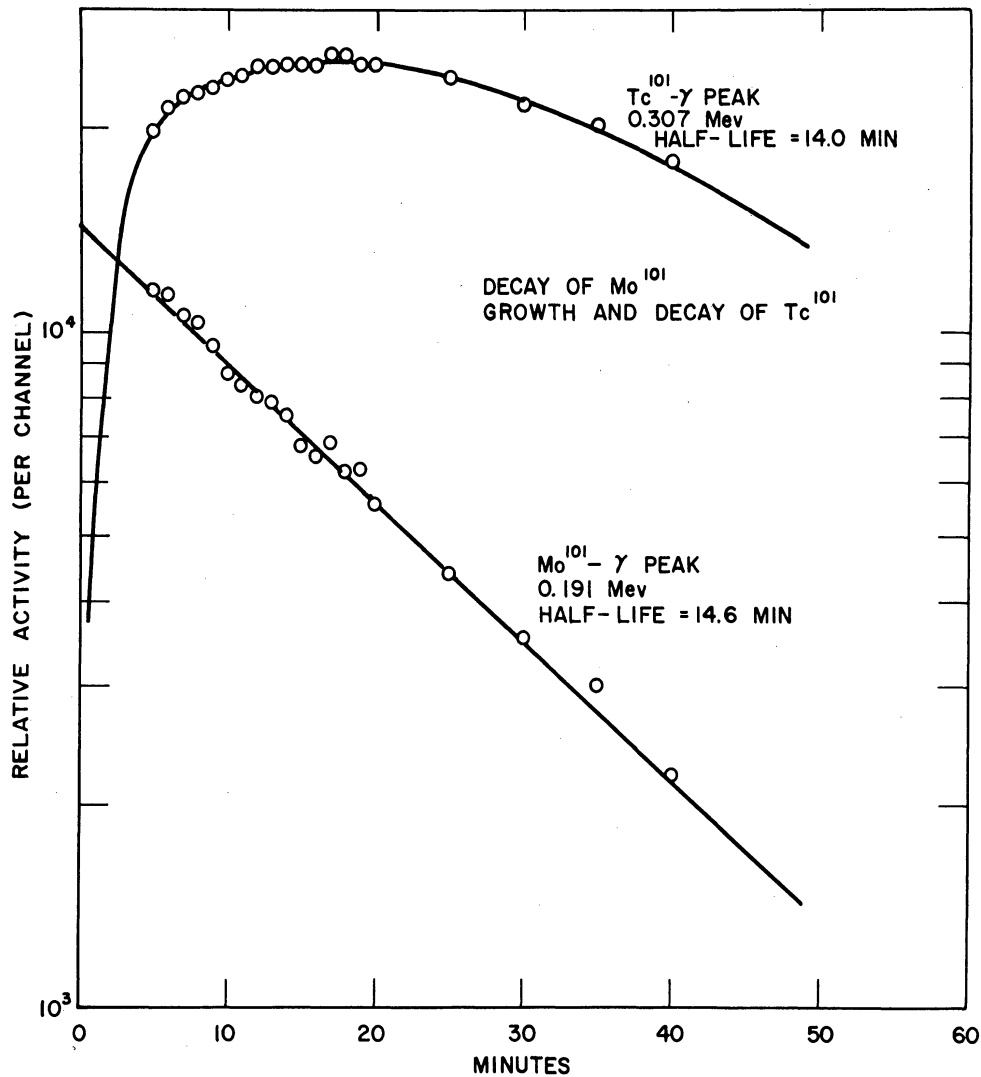

Figure 30. Growth and decay of Tc^{101} peak.

the irradiation the samples were dissolved in oxidizing medium and allowed to stand for 15 minutes for the growth of Tc^{101} . After maximum growth was attained the tetraphenyl arsonium chloride separation outlined in the section on Chemical Separations was made. The separated Tc^{101} activity was counted in the 100-channel γ -analyzer with 3" x 3" crystal. The decay of the Tc^{101} peak (0.307 Mev.) was followed for 10 minutes by recycling the count every 1 minute. The counts obtained for every 1 minute were plotted versus time on semi-logarithmic graphs and the activity at 15 minutes from the end of the irradiation was estimated by extrapolating back the straight line to the time in question. By comparing this activity with those obtained

for standards processed under identical conditions the molybdenum content of samples was estimated.

2. Flux Monitor and Calibration Curve

Gold foils were used as the flux monitor. For 13 irradiations in 3 days the average flux of $9.4 \times 10^{11} \text{ n cm}^{-2} \text{ sec}^{-1}$ was obtained.

The calibration curve for molybdenum determinations shown in Fig. 31 was constructed on the basis of the counting data

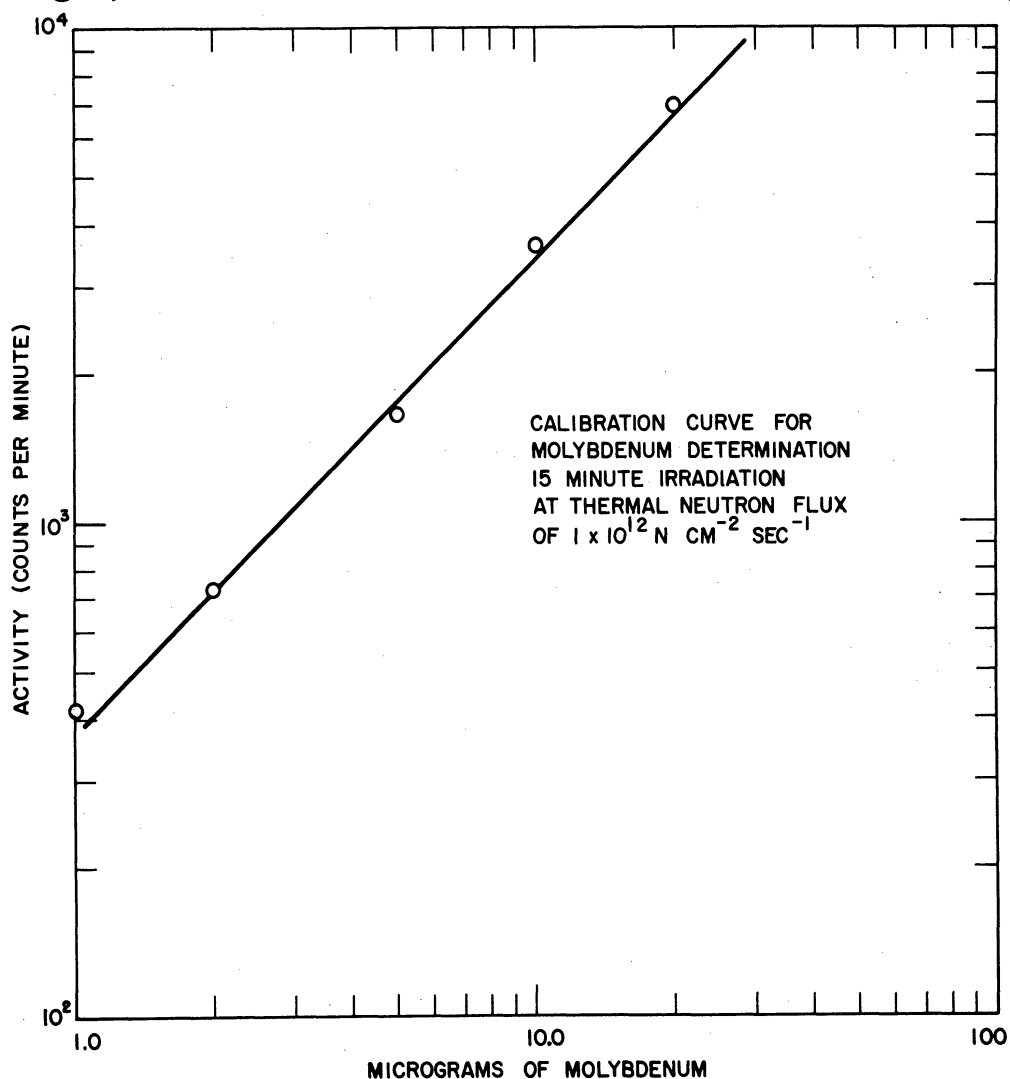

Figure 31. Calibration curve for molybdenum (biological ash).

for standards and the data of flux monitoring. The activity plotted in the figure was normalized for 15 minutes irradiation at a neutron flux of $1 \times 10^{12} \text{ n cm}^{-2} \text{ sec}^{-1}$ and 15 minute growth.

3. Results Obtained and Notes

Three samples of seaweed were analyzed. Among these molybdenum was only determined for one sample. This fact suggests that the sensitivity of the method used was not sufficient to determine the minute quantity of molybdenum present in marine organisms. The results obtained were summarized as follows:

Sample	Sample Wt. used mg.	Mo ppm in Ash
<u>Ulva</u> sp. (seaweed) Collected at Enoshima, Sagami Bay in May, 1956	254.9	Not detected
<u>Ulva</u> sp. (seaweed) Collected at Urayasu, Tokyo Bay in May, 1956	250.4	Not detected
<u>Porphyra</u> sp. (seaweed) Collected at Chiba, Tokyo Bay in Jan., 1957.	198.5	16.6

These data suggest that there is a tendency to find high molybdenum content in seaweed having high vanadium content.

The lower limit of quantitative determination at the normalized condition (15 minutes irradiation at the neutron flux of $1 \times 10^{12} \text{ n cm}^{-2} \text{ sec}^{-1}$) should be around 5×10^{-7} g of molybdenum present (including chemical separation).

The sensitivity may be increased by using the long-lived isotope of molybdenum (67-hour Mo^{99} from Mo^{98} : abundance 23.75%, cross section 0.4 barns), but not too much.

The probable error expected for the analysis in the vicinity of the lower limit of determination may be around $\pm 35\%$.

(R. Fukai)

I. Activation Analysis of Tungsten in Marine Organisms

The activation analysis of tungsten has been studied by using solvent extraction of tungsten and γ -spectrometry. Tungsten has many stable isotopes shown below.

	Abundance	Act. cross section
W^{180}	0.135%	60 ± 60 barns
W^{182}	26.4 %	19 ± 2 barns
W^{183}	14.4 %	11 ± 1 barns
W^{184}	30.6 %	20 ± 0.3 barns
W^{186}	28.4 %	34 ± 3 barns

However, among these only one isotope seems to be suitable for activation analysis. W^{186} has a fairly large abundance and a good activation cross section, so that it should be easy to utilize the W^{187} .

This isotope has a half-life of 24 hours and a decay scheme illustrated below.

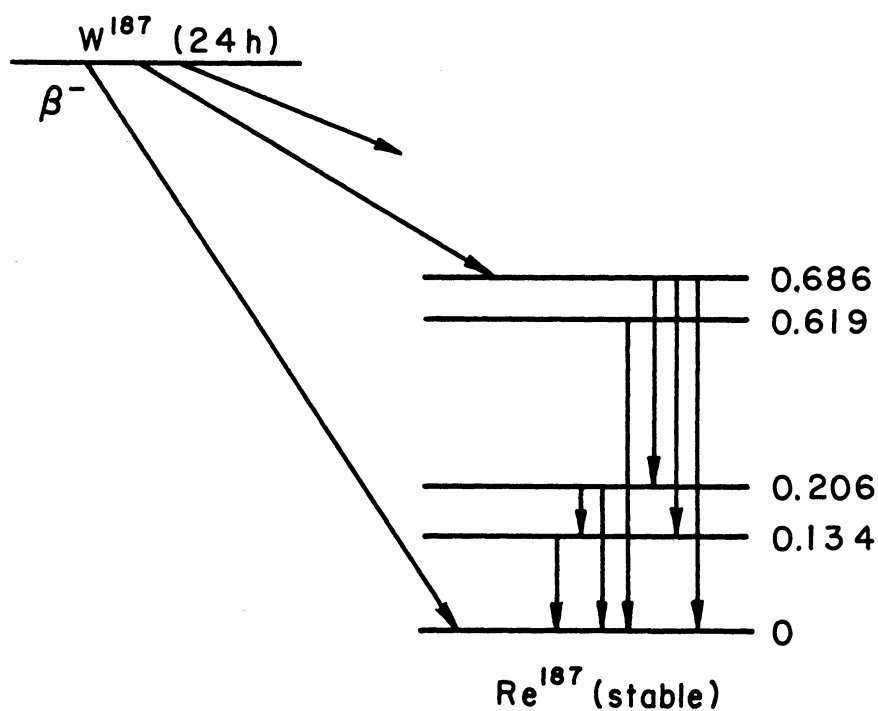

All of these 7 γ -rays were observed in a spectrum taken for irradiated tungsten. An example of spectra in the 0 - 1.0 Mev range is given in Fig. 32.

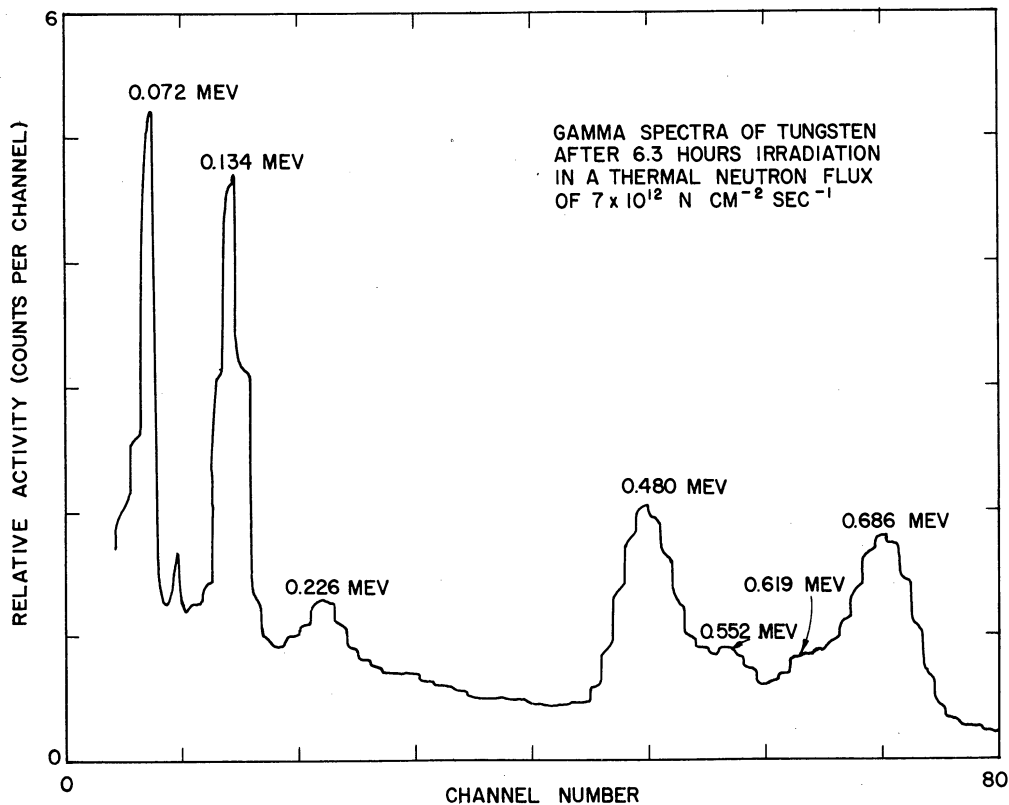

Figure 32. Gamma spectra of tungsten after 6.3 hours irradiation.

For the determination of tungsten by γ -spectrometry the γ -ray of 0.072 Mev was mainly used.

1. Analytical Procedure

About 500 mg of biological ash were sealed in polyethylene tubing. The filter paper standards were prepared in a way similar to that of gold. The amount of tungsten in the standards ranged from 5×10^{-8} g to 1×10^{-6} g.

Five samples and five standards were placed together in an aluminum can in a manner similar to that used in the irradiation of rhenium samples. Then the samples and standards were irradiated for 6.3 hours in the first row of the reactor core.

After the cooling period of 48 hours the chemical separation of tungsten was carried out using a thiocyanate-ethyl acetate extraction as outlined in the section on Chemical separations. Separated tungsten was counted for 5 minutes in the 100-channel γ -analyzer by using the 0-0.25 Mev range. The photopeak of the 0.072 Mev γ -ray of W^{187} was used in the analysis.

2. Flux Monitor and Calibration Curve

The flux monitoring was done in a manner similar to that of the rhenium determination. An average flux of 1.52×10^{12} n cm^{-2} sec^{-1} was obtained.

From the counting data for standards and the data of flux monitoring the normalized activities for 10 hours irradiation at the neutron flux of 1×10^{12} n cm^{-2} sec^{-1} were computed and plotted versus tungsten content as given in Fig. 33.

3. Results Obtained

Among the five spectra obtained for samples, characteristic γ -peaks for tungsten were found in three of these. Results obtained are summarized as follows:

Sample	Sample Wt. used mg.	W ppm in Ash
<u>Ulva</u> sp. (seaweed) Collected at Enoshima, Sagami Bay in May, 1956	497.3	0.13

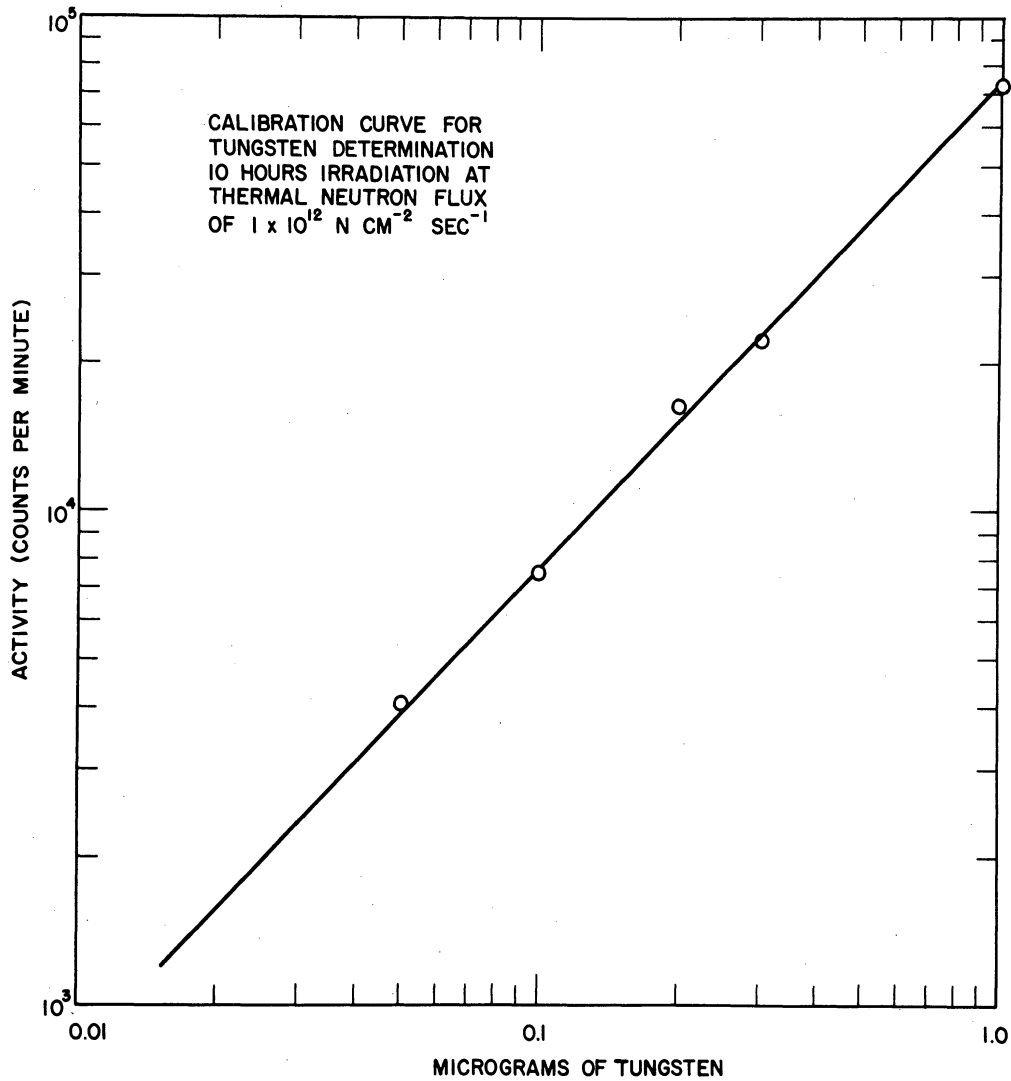

Figure 33. Calibration curve for tungsten (biological ash).

Sample	Sample Wt. used mg.	W ppm in Ash
Ulva sp. (seaweed) Collected at Urayasu, Tokyo Bay in May, 1956	497.7	0.18
Mackerel (meat)	502.5	< 0.014
Clam (meat)	504.6	0.46
Shrimp (meat)	505.0	< 0.005

4. Notes

From the calibration curve the lower limit of quantitative determination at the normalized condition (10 hours irradiation

at the neutron flux of $1 \times 10^{12} \text{ n cm}^{-2} \text{ sec}^{-1}$) should be around $5 \times 10^{-9} \text{ g}$ of tungsten after the cooling period of one half-life (including chemical separation).

A probable error between ± 40 and $\pm 50\%$ may be expected for the values obtained around the lower limit of determination. In the present determinations the errors may be within $\pm 20\%$ except for negative results. (R. Fukai)

J. Activation Analysis of Cobalt in Aluminum-Cobalt Foil

For the long period irradiations (> 3 hours) aluminum-cobalt foil has usually been used as a flux monitor. In the computations of neutron flux from the activities induced in aluminum-cobalt foil, it is essential to know the cobalt content of the foil.

In the present work the activation analysis of cobalt in aluminum-cobalt foil has been carried out by γ -spectrometry without chemistry, in order to obtain basic data for the flux monitor.

1. Analytical Procedure

Three pieces of aluminum-cobalt foil having weights ranging from 1.3 to 1.9 mg were irradiated for about 2 minutes in pneumatic tube No. 3. After the irradiation the samples were cooled for 30 minutes to eliminate the induced activity of aluminum (2.3 minute half-life), and the activity of foil samples was counted directly by the 100-channel γ -analyzer with $3'' \times 3''$ crystal. The decay of the $\text{Co}^{60\text{m}}$ peak (0.059 Mev, 10.5 minute half-life) was followed for 10 minutes by recycling the count every 1 minute. The counts obtained for every 1 minute were plotted versus time on semi-logarithmic graphs and the initial activity of each sample was estimated by extrapolating back the straight line to zero time.

2. Calibration and Flux Monitor

Standard solutions of cobalt were prepared by dissolving $\text{Co}(\text{NO}_3)_2 \cdot 6\text{H}_2\text{O}$ in water. The standards of cobalt were made by pipetting off the known volume (10-30 λ) of cobalt standard solutions onto the small filter paper of good quality (15 mm diameter) and by evaporating off the solution. The range of cobalt content of standards was from 1×10^{-7} g to 1×10^{-6} g cobalt. The standards were irradiated in a way similar to the samples, while the counting was started from 2 minutes after the irradiation. From the data obtained for standards the calibration curve given in Fig. 34 was drawn. Activities plotted in the figure were the estimated initial activities normalized for 2 minute irradiation at the neutron flux of 1×10^{12} n $\text{cm}^{-2}\text{sec}^{-1}$.

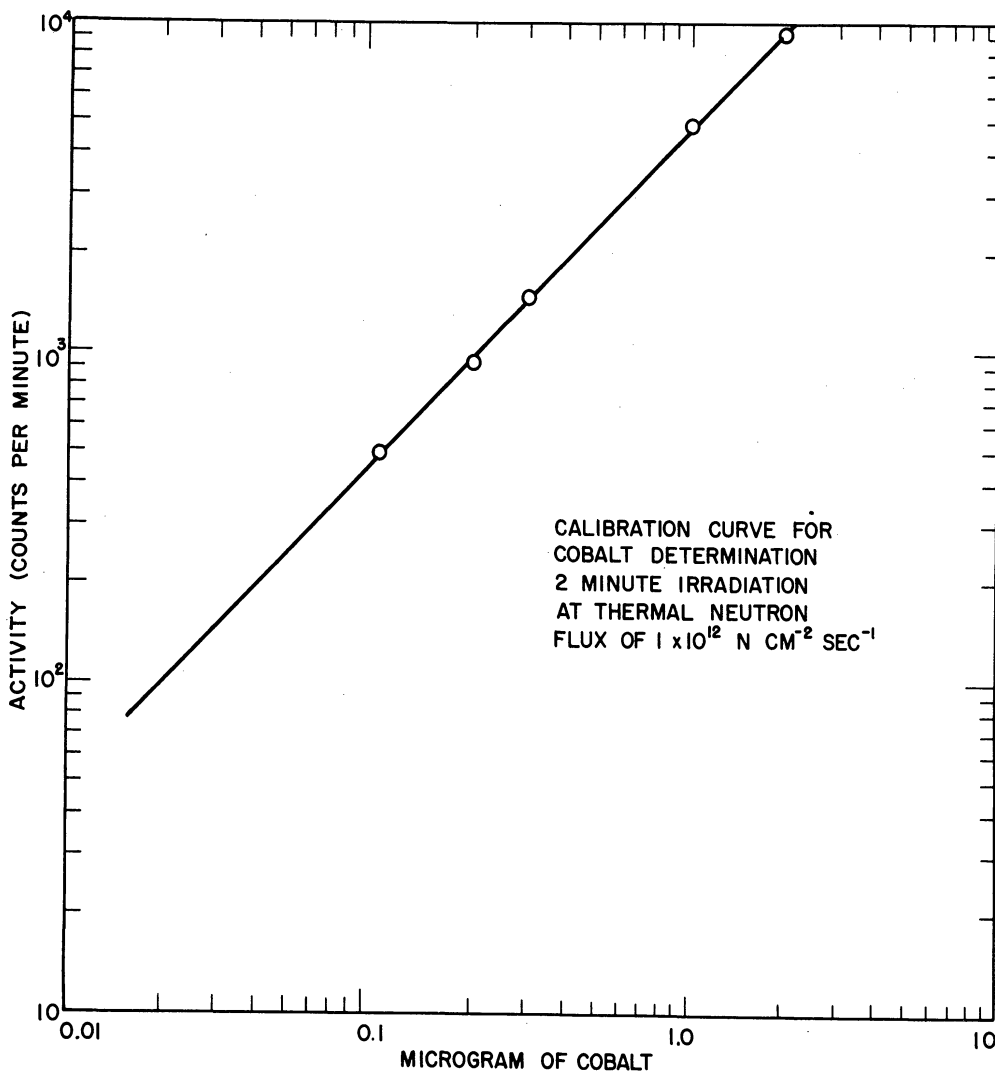

Figure 34. Calibration curve for cobalt.

For monitoring the neutron flux about 1 mg of gold¹⁹⁷-foil was attached to each sample. On an average, a flux of 7.5×10^{11} n cm⁻² sec⁻¹ was obtained for irradiations.

3. Results Obtained and Notes

Results obtained:

Material: Al-Co foil (2 mils thickness)

Sample Wt. (mg)	Irradiation Time (min)	Neutron Flux (n cm ⁻² sec ⁻¹)	Normalized Activity for 2 min irrad. at 1×10^{12} n cm ⁻² sec ⁻¹	Co-Content	
				Co μ g	Co%
1.6	2.5	4.98×10^{11}	26,987	5.7	0.356
1.9	2.0	4.99×10^{11}	32,064	6.8	0.358
1.3	1.0	5.50×10^{11}	21,816	4.6	0.354
				Av. 0.356	

Three values obtained for the same material in slightly different conditions of irradiations showed good agreement with each other.

However, since these values were obtained without considering the effect of self-shielding by foil itself, the actual value may be 5% higher than these values. The effect of self-shielding was evaluated by comparison of the activities obtained for normal standards with those obtained for the standards covered by Al foil during irradiation. (R. Fukai)

K. Activation Analysis for Trace Elements in Marine Organisms

The work summarized previously (3) for vanadium and arsenic has been expanded to include determinations of molybdenum, tungsten,

rhenium and gold as described above.

Analyses were made on samples of ignited marine organisms representative of seaweeds, mollusks (without shell), crustaceans (without carapace), fishes (soft parts) and sea water.

Table XII summarizes the approximate sensitivities obtained for these different elements and lists information pertinent to the chemical separations. The sensitivities listed are probably good to within a factor of 2 and are given only as an indication of the approximate limitations of the specific methods used. This is not to imply that higher sensitivities are not possible with additional improvements in the methods.

This work on the six elements is being summarized in a manuscript which will be submitted soon for publication. (R. Fukai)

L. Activation Analysis of Trace Cobalt, Vanadium and Copper in Tissue

There is considerable interest in analysis for trace elements in tissue. Often standard techniques lack the sensitivity possible with activation analysis or, where they are as sensitive, are plagued with large "blank corrections" for traces of the unknown added during the procedure. Thus it has seemed worthwhile to explore the application of activation analysis to typical tissues (rat liver and kidney) utilizing the short-lived Co^{60m} (10.5-minute), V^{52} (3.7-minute) and Cu^{66} (5.1-minute).

Tissue samples were air dried at room temperature for 24 hours, then placed in envelopes prepared from 4 mil thick polyethylene film which were closed by heat sealing. These sealed samples were then irradiated in the rabbit system along with suitable monitoring foils.

Table XII. Approximate Experimental Sensitivities and Mode of Chemical Separation for Six Trace Elements in Marine Biological Ashes.

	Vanadium	Arsenic	Molybdenum	Tungsten	Rhenium	Gold
Experimental Sensitivity (g)* (Flux: 1×10^{12} $n \text{ cm}^{-2} \text{ sec}^{-1}$)	2×10^{-9} ** (10 min.irrad)	5×10^{-8} (10 h.irrad)	5×10^{-7} (15 min.irrad)	5×10^{-9} (10 h.irrad)	1×10^{-9} (10 h.irrad)	5×10^{-10} (10 h.irrad)
Mode of Chemical Separation	Cupferron-chloroform	Co-ppt with phospho-molybdate	$(\text{C}_6\text{H}_5)_4\text{AsCl}$ -chloroform	thiocyanate-ethyl acetate	$(\text{C}_6\text{H}_5)_4\text{AsCl}$ -chloroform	Ethyl Acetate Extraction
Chemical yield	90%	~60%	60%	30%	70%	80%
Time required for the separation	~ 4 min.	30 min.	30 min.***	40 min.	30 min.	30 min.

*The computation of sensitivity includes the cooling period of one half-life for long-lived isotopes of arsenic, tungsten, rhenium and gold, and the correction for the chemical yield.

**This value was estimated on the basis of counting with a γ -scintillation well counter.

***The time includes the waiting period of 15 minutes.

The irradiated samples were then fused with sodium peroxide in a nickel crucible and the melt then subjected to a rapid radiochemical separation. For cobalt this consisted of an 8-hydroxyquinoline extraction and then precipitation of cobalt as the oxide with Na_2O_2 . The vanadium was separated with a cupferron extraction. The copper was also separated by a cupferron extraction cycle and then precipitated as the sulfide. Details of these procedures can be found in the final section of this report on separation procedures. The radiochemical procedures for cobalt can be completed in 15 minutes, for vanadium in 5 minutes and for copper in 8 minutes.

A description of the work on the $\text{Co}^{60\text{m}}$ will appear in an early issue of *Talanta*; manuscripts describing experiments on the other two elements are being prepared. Experimental sensitivities obtainable for these elements appear to be about 5×10^{-8} grams of cobalt, 3×10^{-9} grams of vanadium and 3×10^{-7} grams of copper at a flux of 10^{12} n cm^{-2} sec^{-1} . (D. Kaiser)

M. Preliminary Investigations of (n, α), (n,p), and (n, γ) as Competing Reactions in Activation Analysis of Biological Tissue

The possibility of (n, α) and (n,p) reactions interfering with (n, γ) activation analyses was considered for $\text{Co}^{60\text{m}}$, Cu^{66} , and V^{52} . If the yields from these reactions were appreciable, the quantitative results of (n, γ) procedures would be higher than expected. Prior to any experiments, rough calculations were made to determine the expected activity from each of the reactions. Assuming the starting materials were present in one gram amounts and the available neutron fluxes for (n, γ), (n,p), and (n, α) reactions were 1×10^{12} , 3.5×10^8 , and 7.1×10^7 , respectively as reported previously for our

reactor (3), the following activities would be expected (Table XIII).

Table XIII. Activities for Competing Reactions.

<u>Reactions</u>	<u>Calculated Activities (d/m)</u>
1. Co^{60m}	
${}_{27}\text{Co}^{59}(n,\gamma){}_{27}\text{Co}^{60m}$	9.60×10^{12}
${}_{28}\text{Ni}^{60}(n,p){}_{27}\text{Co}^{60m}$	1.14×10^7
${}_{29}\text{Cu}^{63}(n,\alpha){}_{27}\text{Co}^{60m}$	2.40×10^4
2. Cu^{66}	
${}_{29}\text{Cu}^{65}(n,\gamma){}_{29}\text{Cu}^{66}$	1.86×10^{11}
${}_{30}\text{Zn}^{66}(n,p){}_{29}\text{Cu}^{66}$	2.64×10^6
${}_{31}\text{Ga}^{69}(n,\alpha){}_{29}\text{Cu}^{66}$	1.14×10^6
3. V^{52}	
${}_{23}\text{V}^{51}(n,\gamma){}_{23}\text{V}^{52}$	2.70×10^{12}
${}_{24}\text{Cr}^{52}(n,p){}_{23}\text{V}^{52}$	1.32×10^7
${}_{25}\text{Mn}^{55}(n,\alpha){}_{23}\text{V}^{52}$	2.04×10^6

Considering the reactions in order, the natural nickel content of rat kidneys is too low to offer any complications by an (n,p) reaction. Copper would be expected to offer the most interference to the ${}_{27}\text{Co}^{59}(n,\gamma){}_{27}\text{Co}^{60m}$ reaction in biological tissue. For the (n, α) reaction to interfere, however, copper would have to be present in relatively larger quantities than naturally occurs in rat kidneys.

This reaction was checked by irradiating 500 micrograms of copper nitrate in a cadmium-lined rabbit (see Figure 35). The sample was irradiated for 30 minutes at one megawatt and allowed to decay for 15 minutes prior to a gamma spectral analysis. Without a chemical

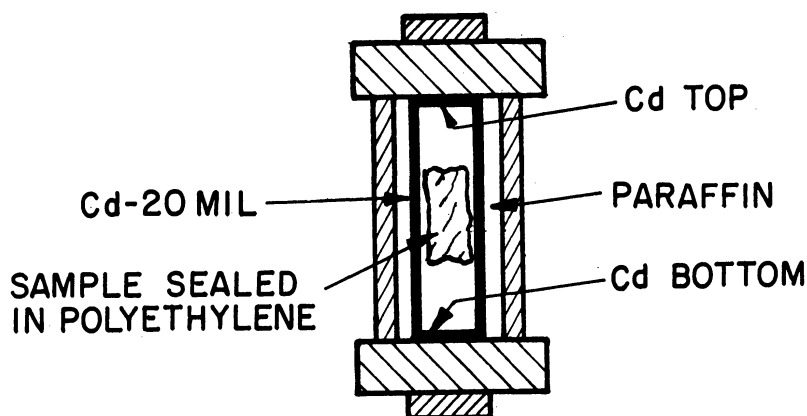

Figure 35. Side view of cadmium-lined rabbit.

separation, no Co^{60m} could be observed.

An (n,p) reaction on Zn^{66} could offer interference to the ${}_{29}\text{Cu}^{65}(n,\gamma){}_{29}\text{Cu}^{66}$ reaction. Naturally occurring zinc is present in amounts that would cause less than 1% variation in quantitative Cu^{66} results. Gallium also would not be expected to interfere because of low abundance.

As a check on the competing reactions in the vanadium analysis, samples of chromium nitrate (~ 500 micrograms) and manganese dioxide (~ 500 micrograms) were irradiated in the previously described cadmium-lined rabbit (Figure 35). Following a ten-minute irradiation and five-minute decay, the gamma spectra exhibited a small V^{52} peak (1.4 Mev). This V^{52} peak was observable without a chemical separation. Excessive amounts of chromium and manganese thus could offer difficulties in the trace analysis of vanadium. However, the quantities which occur in normal rat livers present no problems.

These experiments show that when analyzing for trace constituents competing reactions can present problems in quantitative determinations. Generally these reactions are in low yield because of the

relatively few fast neutrons present compared to thermal neutrons. However, when the interfering elements are present in quantities greater than 10^5 times that of the trace elements, the (n,p) and (n, α) reactions should be thoroughly investigated. (D. Kaiser)

N. Preliminary Investigations of the Activation Analysis of Trace Selenium in Tissue Using Se^{77m} , Se^{79m} , and Se^{81m}

During the course of investigations conducted on selenous acid, rat liver tissue was irradiated to determine the presence and concentration of naturally occurring selenium. Rothstein (35) noted that "administered selenium is distributed in all soft tissues, but is especially high in the liver and kidneys." Because of the unique equipment available in this laboratory for work with short half-lives it was decided to analyze for the 17-second isomer of selenium, i.e., Se^{77m} . The samples could be irradiated for short periods of time (~ 30 seconds), removed from the reactor, rapidly relayed to the counting area by an auxiliary "rabbit" system (15-17 seconds), and identified both qualitatively and quantitatively with the 100-channel analyzer.

First, varying concentrations of selenous acid were irradiated and the rapid transfer procedure perfected. The 0.160 Mev gamma ray was observed to decay with a half-life of 16-17 seconds. This procedure was performed without a chemical separation. A liver sample was then irradiated in an identical manner and similar results were observed. A quantitative determination established that selenium was present in the order of 7×10^{-7} gms/gm of fresh liver tissue.

Isolation of selenium from this tissue via a chemical separation was considered the next step for confirmation. The procedure described

by Schindewolf (3) was applied to the rat livers in an attempt to isolate the 3.9-minute $\text{Se}^{79\text{m}}$. According to the gamma-ray spectrum, however, Mn^{56} was the primary activity obtained.

A second procedure was then developed as follows:

1. Irradiate sample 10 min. at 1 megawatt.
2. Fuse sample in 10 gms Na_2O_2 containing 20 mg selenium carrier.
3. Cool and dissolve melt in 50 ml water.
4. Add 50 ml conc. HCl and heat solution to boiling.
5. Bubble in SO_2 gas and pass through filter chimney.
6. Wash elemental selenium precipitate with water.
7. Dissolve selenium in hot 3 N HCl and place in separatory funnel.
8. Add 10 ml 10% sodium potassium tartrate solution and adjust pH to a value between 7.5 and 12.5.
9. Shake for 30 sec. with 10 ml 1% 8-hydroxyquinoline in CHCl_3 .
10. Discard CHCl_3 layer and acidify aqueous layer with 10 ml conc. HCl.
11. Precipitate elemental selenium with SO_2 gas and pass through filter chimney.
12. Determine activity with 100-channel analyzer.

This procedure required twenty minutes for completion and gave a yield of only 30% (based on recovery of Se^{75}) but spectral analysis of a processed rat liver sample showed that only small amounts of Mn^{56} contamination came along. Since this 20 minute procedure was quite long for the 4-minute $\text{Se}^{79\text{m}}$, the separation was applied to 57-minute $\text{Se}^{81\text{m}}$.

Following a one-hour irradiation and thirty-minute decay, calculations indicated that (1) no detectable activity would be expected from Se^{79} , $\text{Se}^{83\text{m}}$, or $\text{Se}^{77\text{m}}$, (2) detectable amounts of activity would be found in Se^{75} , $\text{Se}^{79\text{m}}$, and Se^{83} , (3) moderate

activity would be obtained from Se^{81m} , and (4) the activity from Se^{81} would be of little value in gamma scintillation spectrometry. The procedure described for Se^{79m} was applied to Se^{81m} with negative results. No attempts were made to analyze for Se^{81} .

It was concluded that trace selenium was present in rat liver tissue but that the chemical separations utilized in this brief preliminary study were: (1) not too specific in this biological system, (2) the chemical yields were not too satisfactory, and (3) the processing time was too long.

0. Preliminary Investigations on (n,2n) Reactions for Activation Analysis of Carbon, Nitrogen and Oxygen

1. Introduction

This study was initiated to investigate the possibilities of using (n,2n) reactions to analyze for carbon, nitrogen and oxygen in biological systems. The familiar (n, γ) reactions can not be readily applied to these elements because of low isotopic abundances, low thermal cross sections, or half-life considerations. For example, carbon activation by an (n, γ) reaction would produce carbon-14. The low isotopic abundance (1.11%), low thermal cross section (0.9 mb), and long half-life (~5,600 y) cause this reaction to be of very low yield. Similar considerations would seem to place nitrogen, and oxygen in the same situation, but, by utilizing the "bunny rabbit" system and the 100-channel analyzer, it was possible to determine nitrogen-16 and oxygen-19. With half-lives of 7.4 seconds and 29 seconds, respectively, little if any time could be allowed for a semi-quantitative chemical separation prior to counting.

The abundances of carbon-12, nitrogen-14 and oxygen-16 are greater than 98%. The half-lives of the (n,2n) products range between two and twenty minutes so that sufficient time could be allotted for a possible chemical separation. Although the fast neutron flux in the Ford Nuclear Reactor pneumatic tubes was low, some indication of the procedure's value could be obtained. It was the purpose of this preliminary study to investigate the possibilities of (n,2n) activation and determine the lower levels of sensitivity without chemical separations.

2. Procedure

The samples for analysis were sealed in polyethylene tubing and then enclosed in a cadmium envelope (2 layers of 10 mil cadmium metal). Samples prepared in this manner were placed in polyethylene rabbits and irradiated in the pneumatic tube system of the Ford Nuclear Reactor. Following a suitable irradiation time, the samples were removed from the reactor and aliquots of the material taken for analysis. Two samples were prepared, one for gamma spectral analysis and the other for half-life determination by proportional counting. The decay curves were resolved and activity versus weight graphs prepared.

3. Results

a. Carbon. This experiment was conducted with analytical reagent benzene as the source of carbon. The samples were irradiated for 10 minutes at 1 Megawatt and allowed to decay for two minutes prior to counting. The ${}^6\text{C}^{12}(n,2n){}^6\text{C}^{11}$ reaction produces a 20.5-minute 0.96 Mev positron-emitting isotope. Aliquots of the irradiated material were pipetted onto filter paper and scotch-taped to cardboard counting

cards. A 0-4 Mev gamma spectral determination, performed with the 100-channel analyzer, yielded the expected 0.511 Mev annihilation radiation peak. By integrating the area under this peak, a quantitative determination for ${}^6\text{C}^{11}$ was obtained. A graph of activity versus concentration of carbon was prepared (Figure 36) from these data. Accepting 100 counts per minute per peak area as the lower limit of detection, 8×10^{-3} gms of carbon may be determined. Decay of the samples was also followed by proportional counting as a cross-check on half-life.

b. Nitrogen. Basically this procedure was the same as for carbon. Nitrogen-13, a 1.2 Mev positron-emitting isotope with a 10-minute half-life, may be produced by the ${}^7\text{N}^{14}(n,2n){}^7\text{N}^{13}$ reaction. Samples of ammonium thiocyanate, sealed in polyethylene, were irradiated for five minutes at 1 Megawatt and allowed to decay for two minutes prior to counting. The decay curves were resolved into their components and the amount of nitrogen determined. Again, two samples were prepared, one for the 100-channel analyzer and the other for proportional counting. A plot of activity versus nitrogen concentration (Figure 36) showed the lower level of sensitivity to be on the order of 1×10^{-3} gms.

c. Oxygen. An (n,2n) reaction on oxygen-16 produces 1.7 Mev positron-emitting oxygen-15 with a 2.1 minute half-life. For this investigation, analytical hydrogen peroxide (35% aq. solution) was irradiated for two minutes at 1 Megawatt. A one-minute delay was allowed for sample preparation, before proportional counting and gamma spectral

determinations were made. According to the plot of activity versus oxygen concentration (Figure 36), the lower level of sensitivity is 1×10^{-1} gms.

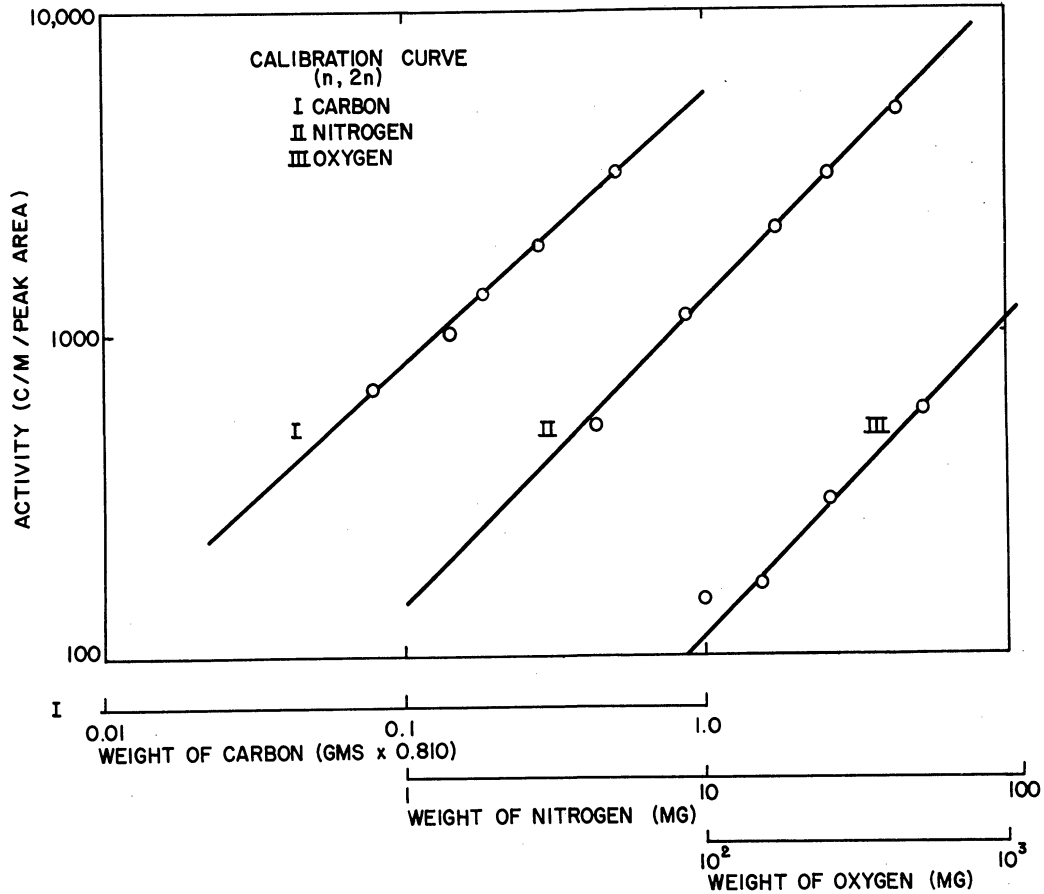

Figure 36. Calibration curve for carbon, nitrogen and oxygen.

4. Discussion

The above procedures for carbon, nitrogen, and oxygen did not require any chemical separation, however, in the case of oxygen, a question arises concerning contamination. The quantitative values obtained would be a composite of the oxygen in hydrogen peroxide as well as the water diluent. Attempting to determine carbon, nitrogen, or oxygen by the 0.511 Mev

annihilation peak in a gamma spectrum is not too promising. Carbon determinations in samples containing only carbon and hydrogen are feasible but when nitrogen or oxygen are present, careful extrapolation is required for resolution of the decay curves. This was evident in the nitrogen analysis of ammonium thiocyanate. The background and carbon component could be extrapolated safely only if the decay was followed for several hours. If a sample contained carbon, nitrogen, and oxygen, the 0.511 Mev annihilation peak would be a composite of all three isotopes (i.e., carbon-11, nitrogen-13, and oxygen-15). They could still be separated by decay curve resolution but the value of gamma scintillation spectrometry, namely qualitative and quantitative results, would be reduced considerably.

(D. Kaiser)

P. Preliminary Experiments for Activation Analysis of Thallium

Procedures are being developed for the activation analysis of thallium in botanical samples and meteorite samples using the short-lived isotope Tl^{206} (4.2-minute half-life).

A rapid radiochemical procedure has been developed utilizing an ether extraction and an iodide precipitation which permits separation of the thallium in about 9 minutes with a yield of 80-85%. This procedure is described in detail in the section on separations.

Since this isotope is a pure beta emitter there are special problems in connection with its assay. Limits of sensitivity and interferences from contaminants are being studied for this determination at the present time.

(C. K. Kim)

Q. Radiochemical Analysis of Long-Lived Activity in a High Specific Activity Gold Sample

After several months storage a sample, consisting of gold evaporated onto an aluminum backing strip, which had been irradiated in the high flux position of the MTR for many days, was found to contain a high level of residual activity.

To identify the radioisotopes present, the gold was mechanically removed from the backing strip and treated separately. The gold was found to contain an appreciable amount of $\text{Ag}^{110\text{m}}$ and a trace of Zn^{65} . The Zn^{65} was identified from the gamma spectra after chemical removal of the silver activity as the chloride.

The aluminum strip was dissolved in conc. HCl and the solution passed over a Dowex 2 ion exchange column. The activity remaining on the column was found to be a mixture of Co^{60} and Zn^{65} by washing the column with 1 N HCl to remove the cobalt. The initial eluate was found to contain an activity with chemistry similar to lanthanum which was probably 13-year Eu^{152} , and another activity identified from its gamma spectrum as Mn^{54} . (M. Wahlgren)

VI APPLICATIONS OF TRACERS TO ANALYSIS

Much of the overall program of this project is involved in the application of tracers to analysis. Most of the problems can be categorized into the previous sections on Radiochemical Separations or Activation Analysis. One problem explored during the past year does not fall in either category, however, and will be described here.

A. Use of Radioactive Tracers to Determine Solubility Products

In the tracer literature one of the most widely quoted examples of the use of tracers in analysis is in the determination of solubility products. Yet a perusal of the literature indicates that this method has been restricted primarily to work with silver chloride. We felt that it would be useful to explore and evaluate the techniques required, the accuracy obtainable, and the limitations inherent in applying this method in general to the determination of solubility products.

To this end $\text{Co}(\text{IO}_3)_2$, AgCl , and TlI were used. Experimental methods have been devised and studies made of the limitations of the method. A paper is being prepared which will report the experimental values obtained and discuss the advantages and disadvantages of this method over other techniques. (G. Ter Haar)

VII SEPARATION PROCEDURES

CHEMICAL SEPARATIONS

Element separated: Vanadium Procedure by: J. Brownlee
 Target material: Cracking catalyst Time for sep'n: 10 min.
 Type of bbd: Neutron (in pneumatic tube) Equipment required: Normal
 10 min at reactor power
 level of 1000 kw
 Yield: Variable (up to 70%)
 Degree of purification: Sufficient for gamma spectroscopy
 Advantages: Complete removal of aluminum; rapid separation

Procedure:

- (1) Fuse 40-100 mg sample (finely ground) and gelatine container with 3-3.5 gm sodium peroxide for two minutes. Cool rapidly (known activity of V-48 present as tracer).
- (2) Dissolve melt in solution containing 16.7 ml conc. HCl, 3 ml aluminum carrier, 0.5 ml vanadium (+5) carrier, and 15 ml 3% hydrogen peroxide.

Caution!! SAFETY WINDOW MUST BE DOWN!!

- (3) Add 30-ml of 10% soln of 8-hydroxyquinoline in 1:4 acetic acid, plus ~60 ml conc. NH_4OH (pH 9-10).
- (4) Filter aluminum precipitate through 120 mm medium glass filter frit.
- (5) Acidify filtrate with HCl. Cool in ice bath or by adding chipped ice directly to filtrate.
- (6) Transfer filtrate to 250 ml separatory funnel containing 5 ml chloroform previously equilibrated with 1-2 N HCl.
- (7) Add 6-ml 6% aqueous cupferron; extract for one minute. Allow layers to separate for 30-60 seconds.
- (8) Transfer chloroform layer to counting tube; analyze gamma activity on 100-channel analyzer, starting at 10.0-minutes after removal of sample from the reactor.

Chemical yield: Determine with V-48 tracer

CHEMICAL SEPARATIONS

Element separated: Copper Procedure by: Kaiser
Target material: Biological tissue Time for sep'n: 8 min.
Type of bbd: Neutron (in pneumatic tube) Equipment required: Standard
5 min. at reactor power
level of 1 Megawatt

Yield: 80%

Degree of purification: Enough for γ -spectroscopy

Advantages: Rapid separation

Procedure:

- (1) Irradiate sample for 5 min. at 1 Megawatt.
- (2) Fuse in 10 Gms. Na_2O_2 containing 10 mg. Cu carrier neutralized with 3 pellets NaOH.
- (3) Cool nickel crucible in 600 ml. H_2O .
- (4) Dissolve melt in 50 ml. water and add 30 ml. conc. HCl (CAUTION!!)
- (5) Cool solution with 50-70 ml. liquid nitrogen.
- (6) Add to 150 ml. separatory funnel containing 5 ml. of equilibrated CCl_4 (1.2 N HCl).
- (7) Add 10 ml. 6% aqueous Cupferron solution and extract for 1 min.
- (8) Back extract Cupferron layer with 10 ml. conc. NH_4OH .
- (9) Precipitate Cu with H_2S .
- (10) Collect precipitate with filter chimney.
- (11) Determine activity with 100-channel analyzer.

Remarks:

Chemical yield: Iodometry.

CHEMICAL SEPARATIONS

Element separated: Technetium
(daughter of molybdenum) Procedure by: Fukai

Target material: Biological ash Time for sep'n: 30 min.
(including waiting period
of ~15 min.)

Type of bbd: Neutron (in pneumatic tube)
15 min. at reactor power Equipment required: Standard
level of 100 kw

Yield: 60%

Degree of purification: Good for γ -spectrometry

Advantages: Simple

Procedure:

- (1) Digest the irradiated ash in 3 ml of hot 12 M NaOH and add 10 ml of HCl. (CAUTION!!)
- (2) Add 5 mg of Re-carrier and 5 ml of saturated Br₂-water. Allow to stand for ~15 min. while keeping the solution warm.
- (3) Expel Br₂ by boiling without too much bubbling.
- (4) Put a watch glass on the beaker as a cover and add 7 g. of NaHCO₃ crystals nimbly without losing the contents of the beaker. (CAUTION!!)
- (5) Dilute the solution to 30 ml. by adding water and adjust pH ~8 with a few drops of 4 M NaOH solution.
- (6) Transfer the solution to a separatory funnel, add 2 ml of 1% tetraphenyl arsonium chloride solution (TPAC) and agitate for 1 min.
- (7) Add 20 ml of CHCl₃ and shake vigorously for 2 min.
- (8) Separate organic layer and add 20 ml of 1 M HCl. Boil off CHCl₃ on hot plate (~3 min.).
- (9) Add 2 ml of Br₂-water to make sure of the oxidation of Re. Heat and expel Br₂.
- (10) Add further 2 ml of tetraphenyl arsonium chloride solution while hot.
- (11) Cool the solution with liquid-nitrogen and filter immediately.
- (12) Wash with 3 ml of ice-cold water twice and mount for counting.

Chemical yield: Determine indirectly for known amount of irradiated molybdenum.

Note: By using Br_2 -water in acid medium there is a possibility to lose some part of technetium.

CHEMICAL SEPARATIONS

Element separated: Tungsten

Procedure by: Fukai

Target material: Biological ash

Time for sep'n: 30-40 min.

Type of bbd: Neutron (pool irradi.)
~6 h at reactor power level
of 100 kw

Equipment required: Standard

Yield: 30%

Degree of purification: Good for γ -spectrometry

Advantages: Simple and clean separation

Procedure:

- (1) Digest the irradiated ash in 5 ml of hot 12 M NaOH with 10 mg of W-carrier.
- (2) Add 10 ml of conc. HCl. (CAUTION!!) Dilute the solution to 30 ml making ~2 M HCl solution.
- (3) Add 0.2 gm of solid $\text{SnCl}_2 \cdot 2\text{H}_2\text{O}$ and 0.5 g of solid NH_4SCN and heat for ~5 min. to form bright green complex.
- (4) Transfer the solution to a separatory funnel, extract twice with 30 ml of ethyl acetate.
- (5) Evaporate the organic layer in a 350 ml beaker to dryness on a hot plate.
- (6) Take up the residue with 10 ml of 6 M HCl and add 5 drops of 30% H_2O_2 and 0.5 ml of conc. HNO_3 .
- (7) Evaporate down almost to dryness.
- (8) Add 10 ml. of 6 M HCl and stir vigorously.
- (9) Filter the precipitate, wash twice with 3 ml. of 6 M HCl and mount for counting.

Chemical Yield: Weigh as tungstic oxide, WO_3 .

CHEMICAL SEPARATIONS

Element separated: Rhenium

Procedure by: Fukai

Target material: Biological ash

Time of sep'n: 30 min.

Type of bbd: Neutron (pool irradiation)
~12 h at reactor power level
of 1000 kw

Equipment required:
Standard

Yield: 70%

Degree of purification: Sufficient for γ -spectrometry

Advantages: Simple

Procedure:

- (1) Put the irradiated ash into a mixture of 10 ml of conc. HCl and 5 ml of saturated Br₂-water, to which 5 mg of Re-carrier has already been added. Dissolve the ash by heating.
- (2) Expel Br₂ by boiling without too much bubbling.
- (3) Put a watch glass on the beaker as a cover and add 7 g. of NaHCO₃ crystal nimbly without losing the contents of the beaker.
(CAUTION!!)
- (4) Dilute the solution to 30 ml. by adding water and adjust pH ~8 with a few drops of 4 M NaOH solution.
- (5) Transfer the solution to a separatory funnel, add 2 ml of 1% tetraphenyl arsonium chloride solution (TPAC) and agitate for 1 min.
- (6) Add 20 ml of CHCl₃ and shake vigorously for 2 min.
- (7) Separate organic layer and add 20 ml of 1 M HCl. Boil off CHCl₃ on hot plate (~3 min.).
- (8) Add 2 ml of Br₂-water to make sure the oxidation of Re. Heat and expel Br₂.
- (9) Add further 2 ml of tetraphenyl arsonium chloride solution while hot.
- (10) Cool the solution with liquid nitrogen and allow to stand for 15 min.
- (11) Filter the precipitate and wash with 3 ml of ice-cold water twice and mount for counting.

Chemical yield: Weigh as tetraphenyl arsonium perrhenate, (C₆H₅)₄AsReO₄.

Note: By using Br₂-water in acid medium there is a possibility of losing some of the rhenium.

CHEMICAL SEPARATIONS

Element separated: Thallium

Procedure by: Chong Kuk Kim

Target material: Plant material (leaf)

Time for sep'n: 9 min.

Type of bbd: Neutron, 10 min., 1 MW.

Equipment required: Standard

Yield: 83%

Degree of purification: Good

Advantages: Rapid separation and easy to run

Procedure:

- (1) Dry sample in oven at 120°C and powder it.
- (2) Dissolve the irradiated sample in 2 ml of conc. HNO₃ by heating on a hot plate. When nearly evaporated to dryness add another 1 ml conc. HNO₃, 1 ml of 75% HClO₄ and heat to dryness. (CAUTION-- Use HClO₄ only after HNO₃ treatment!!)
- (3) Add 10 ml of 1 N HBr, 1 ml Tl-carrier (10 mg/ml) and Br₂ water dropwise to oxidize Tl⁺¹ to Tl⁺³. Be sure any TlBr precipitate present is dissolved by the Br₂-water. Keep solution cool, below 32°C.
- (4) Transfer the solution to a separatory funnel containing 15 ml of isopropyl ether, shake vigorously and draw off organic phase. Repeat once more with 15 ml more of isopropyl ether.
- (5) Combine organic fractions and heat on a hot plate until all ether is evaporated.
- (6) Add 10 ml of 0.8 N H₂SO₄. Reduce with SO₂ gas in a beaker surrounded with crushed ice.
- (7) Add 1 N KI in slight excess to precipitate TlI. Digest and filter onto 1" filter paper disc.
- (8) Mount for counting.

Note: Long-lived Tl²⁰⁴ can be used to determine chemical yield.

VIII PERSONNEL, PUBLICATIONS, TALKS, MEETINGS

A. Personnel ListingProject Director Meinke, W. W.Post Doctoral Fukai, R. (1) (Exchange student from Tokyo, Japan)Kaiser, D. (1) (Michigan Memorial Phoenix Project
No. 151)Exchange Students Kim, C. (Korea)

Das, S. (India)

Graduate Students Brownlee, J. *

DeVoe, J. *

Ter Haar, G. *** (1)

Wahlgren, M. *

Weiss, G. *

Undergraduate Students Sargent, M. ** (1)

Sheperd, E. *** (1)

Carlson, J. *** (1)

Fry, E. **

Staff Assistant Maddock, R. S.Typing Blackburn, J. ** (1)

Schwing, J. **

Coleman, F. *

Electronics Shideler, R. W. ** (Full time beginning August 1, 1959)

Nass, H.

* Half time

** Hourly

*** Hourly summer only

(1) Terminated

B. Papers and Reports Published

1. Beta-Ray Spectroscopy Using a Hollow Plastic Scintillator.
D. G. Gardner and W. W. Meinke. Intern. J. of Appl.
Radiation and Isotopes 3, 232 (1958). 8 pages, 12 figs.
2. Activation Analysis; Radiometric Analysis; Assay of
Radioisotopes. W. Wayne Meinke. Encyclopedia of Science
and Technology. McGraw-Hill. (In press).
3. TTA Extraction Curves. E. Sheperd and W. W. Meinke. U. S.
Atomic Energy Commission Report AECU-3879 (October 1958).
3 pages, 1 fig.
4. Radiochemical Separations of Indium. W. W. Meinke, I. B.
Ackermann and D. N. Sunderman. Anal. Chem. 31, 40 (1959).
4 pages, 2 figs.
5. Determination of (d, α) Reaction Cross Sections. K. Lynn Hall
and W. Wayne Meinke. J. Inorg. Nucl. Chem. 9, 193 (1959).
7 pages.
6. Sensitivity Charts for Neutron Activation Analysis. W. Wayne
Meinke. Anal. Chem. 31, 792 (1959). 4 pages, 3 figs.
7. Trace Analysis of Marine Organisms: A Comparison of
Activation Analysis and Conventional Methods. Rinnosuke
Fukai and W. Wayne Meinke. Limnology and Oceanography.
(In press, October 1959).
8. L'Analyse Chimique Par Activation Aux Neutrons. Jacques
Fouarge. L'Industrie Chimique Belge 24, No. 2, 143 (1959).
12 pages.

9. Method for the Analysis of Multicomponent Exponential Decay Curves. Donald G. Gardner, Jeanne C. Gardner, George Laush and W. Wayne Meinke. *Journal of Chemical Physics*. (In press, October 1959).
10. Search for the Isotope Ir¹⁹⁶. Donald G. Gardner and W. Wayne Meinke. *Phys. Rev.* 114, 822 (1959). 3 pages.
11. Pneumatic Tubes Speed Activation Analysis. W. Wayne Meinke. *Nucleonics* 17, No. 9, 86 (1959). 4 pages, 7 figs.
12. Isomeric State of Pt^{199m}. Morris A. Wahlgren and W. Wayne Meinke. *Phys. Rev.* 115, 191 (1959). 3 pages, 3 figs.
13. Radiochemical Separations of Cadmium. James R. DeVoe and W. Wayne Meinke. *Anal. Chem.* 31, 1428 (1959). 4 pages.
14. Activation Analysis of Some Trace Elements in Marine Biological Ashes. R. Fukai and W. W. Meinke. *Nature*. (In press).
15. The Rhodium, Silver, and Indium Content of Some Chondritic Meteorites. U. Schindewolf and M. Wahlgren. *Geochim. et Cosmochim. Acta*. (In press).
16. Activation Analysis of Trace Cobalt in Tissue Using 10.5-Minute Cobalt-60m. David G. Kaiser and W. Wayne Meinke. *Talanta*. (In press).
17. Source Material for Radiochemistry, Nuclear Science Series Report No. 27, Subcommittee on Radiochemistry, National Research Council, Washington 25, D. C. 23 pages.
18. Tellurium-Selenium Content in Meteorites. U. Schindewolf. *Geochim. et Cosmochim. Acta*. (Submitted).
19. Nucleonics in Analysis--ASTM Bulletin. (In press).
20. Isomerism of Ag¹⁰⁸. M. A. Wahlgren and W. W. Meinke. *Phys. Rev.* (Submitted).

C. Talks

1. J. L. Brownlee, Jr., "Interaction of Beta-Radiation With Matter", U. of M. Chemistry Department Seminar, Ann Arbor, November 12, 1958.
2. W. W. Meinke, "The Nuclear Reactor: Activation Analysis and Other Applications", Symposium on the Contribution of Selected Physical Methods to the Solution of Structural and Analytical Problems, Indiana Section of American Chemical Society, Indianapolis, December 6, 1958.
3. W. W. Meinke, "Activation Analysis Using Short-Lived Activities", Nuclear Chemistry Seminar, University of Chicago, February 18, 1959.
4. W. W. Meinke, "Nucleonics in Analysis", The Pittsburgh Conference on Analytical Chemistry and Applied Spectroscopy, Pittsburgh, March 2, 1959.
5. W. W. Meinke (with J. L. Brownlee, Jr.), "Determination of Vanadium in Petroleum Process Streams by Neutron Activation and Gamma Scintillation Spectrometry", Analytical Division, American Chemical Society, Boston, April 8, 1959.
6. W. W. Meinke, "Nucleonics in Analytical Chemistry", Analytical Group, Western New York Section, American Chemical Society, Niagara Falls, New York, April 14, 1959.
7. W. W. Meinke, "Trace Element Analysis as Applied to Meteorites", Astronomy Colloquium, University of Michigan, Ann Arbor, April 24, 1959.
8. J. R. DeVoe, "Radiochemical Separations", U. of M. Chemistry Department Colloquium, Ann Arbor, May 21, 1959.

9. W. W. Meinke, "Rapid Activation Analysis With a University Research Reactor", Symposium on Radioactivation Analysis sponsored by the International Atomic Energy Agency Joint Commission on Applied Radioactivity. Vienna, Austria, June 1-3, 1959.
10. W. W. Meinke, Eight lectures on basic radioactivity and nuclear physics presented before the AEC-NSF Summer Institute of Radiobiology, Ann Arbor, Michigan, June 23-29, 1959.
11. W. W. Meinke, "Nucleonics in Analysis". Also Chairman of Full Day Symposium on Radioisotopes in Metals Analysis and Testing, American Society for Testing Materials, Atlantic City, New Jersey, June 22, 1959.
12. W. W. Meinke, "Nucleonics", Five Lectures in National Science Foundation Summer Conference for College Teachers, Recent Advances in Analytical Chemistry, Carleton College, Northfield, Minnesota, June 30-July 3, 1959.
13. J. R. DeVoe (with W. W. Meinke), "The Application of Vacuum Distillation of Metals to Radiochemical Separations", Symposium on Radiochemical Analysis, American Chemical Society, Atlantic City, New Jersey, September 18, 1959.
14. W. W. Meinke, "Utilization of Short-Lived Radioisotopes in Activation Analysis", Third Industrial Nuclear Technology Conference, Chicago, Illinois, September 22, 1959.
15. W. W. Meinke, "Activation Analysis for Trace Elements", Midwestern Section, Society of Nuclear Medicine, Ann Arbor, Michigan, October 11, 1959.

16. W. W. Meinke, "Application of Radioactivity to Analytical Chemistry", Nuclear Reactor Symposium, Washington State University, Pullman, Washington, October 19, 1959.
17. W. W. Meinke, "Activation Analysis With the Ford Nuclear Reactor of the University of Michigan", Seventh Detroit Anachem Conference, Association of Analytical Chemists, Detroit, October 26, 1959.

D. Committee Meetings

1. W. W. Meinke, Committee on Nuclear Science, National Research Council, National Academy of Sciences Building, Washington, D. C., November 7, 1958.
2. W. W. Meinke, Subcommittee on Radiochemistry, Committee on Nuclear Science, National Research Council, Ann Arbor, Michigan, December 8, 1959.
3. W. W. Meinke, Subcommittee on Radiochemistry, Committee on Nuclear Science, National Research Council, Washington, D. C., May 2, 1959.
4. W. W. Meinke, N2 Sectional Committee on General and Administrative Standards, American Standards Association (American Chemical Society representative), New York City, October 6, 1959.
5. W. W. Meinke, Subcommittee on Radiochemistry, Committee on Nuclear Science, National Research Council, Berkeley, California, October 9, 1959.

IX ACKNOWLEDGEMENTS

We greatly appreciate the kind cooperation of Professor H. J. Gomberg, A. H. Emmons, C. W. Ricker and the staff of the Michigan Memorial Phoenix Project in arranging for laboratory space and reactor irradiations for this research. Part of this work was supported by Phoenix Projects Nos. 95, 121 and 151.

The help of the Isotopes Division of the Oak Ridge National Laboratory in supplying a number of radioisotopes for this work is acknowledged.

X LIST OF REFERENCES

1. Meinke, W. W., *Nucleonics* 17, No. 9, 86 (1959).
2. Meinke, W. W., "Progress Report No. 6", U. S. AEC Project No. 7, Contract No. AT(11-1)-70; AECU-3641 (November 1, 1957).
3. Meinke, W. W., "Progress Report No. 7", U. S. AEC Project No. 7, Contract No. AT(11-1)-70; AECU-3887 (November 1, 1958).
4. Meinke, W. W., *Anal. Chem.* 28, 686 (1958).
5. Hoogenboon, A. M., *Nuclear Instruments* 3, 57 (1958).
6. Hall, K. L., "Determination of (d, α) Reaction Cross Sections", Doctoral Thesis, Department of Chemistry, University of Michigan. U. S. Atomic Energy Commission Unclassified Report AECU-3126. (September 1955).
7. Hall, K. L. and Meinke, W. W., *J. Inorg. Nucl. Chem.* 9, 193 (1959).
8. Gardner, D. G., Gardner, J. C., Laush, G. and Meinke, W. W., "Method for the Analysis of Multicomponent Exponential Decay Curves", *J. Chem. Phys.* (October 1959).
9. Gardner, D. G. and Meinke, W. W., *Phys. Rev.* 114, 822 (1959).
10. Wahlgren, M. A. and Meinke, W. W., *Phys. Rev.* 115, 191 (1959).
11. Strominger, D., Hollander, J. M. and Seaborg, G. T., *Revs. Mod. Phys.* 30, 683 (1958).
12. Lazar, N. H., *IRE Trans. Nuclear Sci.* NS-5, 138 (1958).
13. Coryell, C. D. and Sugarman, N., "Radiochemical Studies. Fission Products", National Nuclear Energy Series IV, Vol. 9, McGraw-Hill, New York, 1951, p. 860.
14. Schindewolf, U. and Wahlgren, M., "The Rhodium, Silver, and Indium Content of Some Chondritic Meteorites", *Geochim. et Cosmochim. Acta.* (In press).

15. Source Material for Radiochemistry, Nuclear Science Series Report No. 27, National Research Council, Washington, D. C., March 1959.
16. DeVoe, J. R. and Meinke, W. W., Anal. Chem. 31, 1428 (1959).
17. Fronaeus, S., Ostman, C. O., Acta Chem. Scand. 8, 961 (1954).
18. Sunderman, D. N. and Meinke, W. W., Anal. Chem. 29, 1578 (1957).
19. Meinke, W. W., "Progress Report No. 4", U. S. AEC Project No. 7, Contract No. AT(11-1)-70; AECU-3116 (November 1, 1955).
20. Randles, J. E. B., Somerton, K. W., Trans. Faraday Soc. 48, 951 (1952).
21. Randles, J. E. B. and Somerton, K. W., Ibid 48, 828 (1952).
22. Randles, J. E. B., Trans. Faraday Soc. 48, 828 (1952).
23. Fronaeus, S., Acta Chem. Scand. 7, 764-73 (1953). (English) 8, 412 (1954).
24. Ershler, B. V., J. Phys. Chem. U.S.S.R. 22, 683 (1948).
25. Booth, J., Andrieth, A., Boiler, J. C., "Inorganic Synthesis", McGraw-Hill Co., New York (1939).
26. Meinke, W. W., Ackermann, I. B. and Sunderman, D. N., Anal. Chem. 31, 40 (1959).
27. Rodden, C. J., "Analytical Chemistry of the Manhattan Project", National Nuclear Energy Series, Vol. I. McGraw-Hill Co. (1950) p. 396.
28. DeVoe, J. R., "Radiochemical Separations of Cadmium and Application of Vacuum Distillation of Metals to Radiochemical Separations", Doctoral Thesis, Department of Chemistry, University of Michigan, November 1959.
29. Meinke, W. W., Anal. Chem. 31, 792 (1959).
30. Fouarge, J., l'Industrie Chimique Belge 24, No. 2, 143 (1959).

31. Fukai, R., and Meinke, W. W., "Analysis of Trace Elements in Marine Organisms. A Comparison of Activation Analysis and Conventional Methods", *Limnology and Oceanography*. (In press).
32. Schindewolf, U., "Tellurium-Selenium Content in Meteorites", (Submitted to *Geochim. et Cosmochim. Acta*).
33. Anders, O. U., U. S. Atomic Energy Commission, Rept. AECU-3513, April 1957.
34. Roake, W. E., U. S. Atomic Energy Commission, Rept. AECD-3201 (Declassified, January 1951).
35. Rothstein, A., U. S. Atomic Energy Commission, Rept. UR-262 (June 5, 1953).

