

THE UNIVERSITY OF MICHIGAN
INDUSTRY PROGRAM OF THE COLLEGE OF ENGINEERING

A Survey of Automotive Suspension

Michel Moret
Graduate Student
University of Michigan

Charles Lipson
Professor of Mechanical Engineering
University of Michigan

October, 1958

IP-325

TABLE OF CONTENTS

	<u>Page</u>
LIST OF FIGURES.....	iii
INTRODUCTION.....	1
Purpose.....	1
Theory of Spring Suspension.....	2
Comfort.....	13
The Two Types of Suspension.....	14
Suspension Linkage.....	20
METAL SPRINGS.....	27
Leaf Springs.....	27
Coil Springs.....	45
Torsion Bar.....	57
Bibliography on Torsion Bars.....	67
AIR AND OIL-AIR SUSPENSIONS.....	69
Air Suspension.....	69
Oil-Air Suspension.....	86
Bibliography on Air Suspension.....	89
RUBBER SPRINGS.....	91
Principle.....	91
Discussion.....	93
Bibliography on Rubber Springs.....	99
LIQUID SPRINGS.....	101
Principle.....	101
Design (Figure L1).....	101
Discussion.....	103
Conclusion.....	103
Bibliography on Liquid Springs.....	105
CONCLUSION.....	107

LIST OF FIGURES

<u>Figure</u>		<u>Page</u>
1.	Mass-Elastic System of the Suspension.....	3
2.	One-Degree of Freedom.....	3
3.	Free Vibrations.....	5
4.	Damping.....	8
5.	Transmissibility.....	11
6.	Comfort Curves (SAE Riding Comfort Committee).....	15
7.	Independent and Non-Independent Suspensions.....	16
8.	Rigid Axle.....	18
9.	Swing Axle.....	18
10.	Torque Tube.....	22
11.	Silentbloc (A).....	24
	Ball Joint (B).....	24
12.	Double-Acting Hydraulic Telescopic Shock-Absorber.....	24
S1.	Leaf Spring.....	28
S2.	Two Leaf Springs for the Same Load and Deflection.....	28
S3.	Leaf Sections.....	30
S4.	Improvement of Leaf Ends.....	30
S5.	Active Length of Spring.....	30
S6.	Spring Shackles.....	32
S7.	Shackle Angles vs. Deflection.....	32
S8.	Necessity of Shackles.....	33
S9.	Linkages with End Blocks.....	35
S10.	Two-Axle Suspension.....	35
S11.	Tandem Axles.....	36

LIST OF FIGURES (CONT'D)

<u>Figure</u>		<u>Page</u>
S12.	Fiat 600 Front Suspension.....	36
S13.	Studebaker Rear Suspension.....	38
S14.	Jaguar Rear Suspension.....	38
S15.	"Windup" or Torque Reaction on Spring Deflection.....	38
S16.	Load-Deflection Curves.....	41
S17.	Gregoire Variable-Rate Suspension (Daimler 6 CVG Bus)	42
C1.	Transmission of the Load Through the Coil Spring.....	46
C2.	Front Suspension.....	46
C3.	Peugeot 403 Rear Suspension.....	48
C4.	Mercedes Single Joint Swing Axle with Low Pivot.....	48
C4bis	Crossed Swing Axles.....	48
C5	DeDion Axle.....	50
C6.	Diagram of MacPherson Suspension.....	52
C6bis	Nash Sliding Pillar Suspension.....	52
C7.	Gregoire Variable Rate Suspension.....	54
C8.	Double Spring Rate Suspension.....	54
C9.	Spanger Suspension for Dual Axles.....	54
C10.	Pegazo Truck Suspension.....	56
C11.	Diagram of Citroën 2CV Suspension.....	56
T1.	Torsion Bar.....	59
T2.	Multiple Torsion Bars (Volkswagen Front Suspension)..	59
T3.	Deflection of a Torsion Bar Spring.....	59
T4.	Longitudinal Torsion Bars - Wolseley - GB.....	60
T5.	Volkswagen Rear Torsion Bar.....	60

LIST OF FIGURES (CONT'D)

<u>Figure</u>		<u>Page</u>
T6.	Flat Torsion Bar.....	62
T7.	Packard Suspension.....	62
T8.	Example of Torsion Bar Characteristics (Bristol-GB)..	65
A1.	Ideal Load-Deflection Curve.....	72
A2.	Car Air Spring.....	72
A3.	Bus Air Spring. (Firestone).....	72
A4.	Mack Bus Airglide.....	74
A5.	Natural Frequency vs. Reservoir Volume.....	74
A6.	Pneuride Suspension.....	74
A7.	General Tire Cells.....	76
A8.	Truck Linkage Used.....	76
A9.	Natural Frequency vs. Reservoir Volume.....	78
A10.	Pontiac Air Spring. (Front).....	78
A11.	Height Control System - (1958 GM Cars).....	79
A12.	Cadillac Air Spring (Rear).....	79
A13.	Ford Air Spring.....	81
A14.	Relationships in Air Suspension.....	81
A15.	Load-Deflection Characteristics.....	83
A16.	Piston Shapes and Rate Characteristics.....	83
A17.	Load-Deflection Characteristics.....	83
D1.	DS19 Suspension.....	87
R1.	Rubber in Shear.....	92
R2.	Torsilastic Suspension.....	92
R3.	Scottish Device.....	92

LIST OF FIGURES (CONT'D)

<u>Figure</u>		<u>Page</u>
R4.	Neidhart Device - Characteristic Curve.....	94
R5.	Metalastic Front Suspension.....	95
L1.	Liquid Spring.....	102
L2.	Load-Deflection Curve.....	102

INTRODUCTION

Purpose

The suspension of a vehicle is that part of the running gear which is interposed between frame and axle housing. Its purpose is to insulate the compartment of the vehicle including its passengers and cargo from the external shocks and vibrations. This purpose can be summed up in one word--comfort--which is the yardstick of today. Comfort applies not only to passengers (unfavorable sensations) and cargo (avoiding damage) but also comfort for the vehicle itself (excessive stresses).

Hence, a suspension must provide:

1. Maximum comfort (reduction of vibration and noise),
2. Minimum stresses (minimizing external loads),

and at the same time maintain good road handling and stability characteristics. In other words, a suspension must provide a "good ride".

Analysis of vehicle suspension is extremely complicated since we have to define what comfort and comfort limitations are, and also to study the vibrational system which includes the different moving parts of the vehicle.

To have an idea of this problem, we will make many simplifying assumptions and consider only the most fundamental engineering aspects of the suspension system. Although the approach is very restrictive, the results obtained are valid and are of much engineering utility.

Comfort for passengers as well as for materials means softness irrespective of the roughness of the road within given limitations. The softness of a motion involves such aspects as amplitudes, accelerations, and frequencies, as well as their variations.

The only system which is able to filter vibrations, and this is another way to define the purpose of a suspension, is called a spring. A spring must insulate a vibrating mass from a "comfortable" mass. Hence, we should first locate all those parts which should be insulated from the vibrating mass in the vehicle.

Theory of Spring Suspension

A vehicle can be divided into three systems:

1. The Sprung Mass

The sprung mass is that mass which is called the comfortable mass and includes the body containing the passengers and cargo.

2. The Unsprung Mass

The unsprung mass is the vibrating mass which consists of the frame which supports the sprung mass, while at the same time is in direct contact with the road.

3. The Spring

The spring is that part which connects the sprung and unsprung masses into one unit. Therefore, the spring is a part of a suspension system.

Primary Vibrations - Simple Mass-Spring Systems

Because the springs which separate the sprung mass from the unsprung mass (and, therefore, from the road), have flexibility in transmitting motions, each mass may have motions of translation, rotation, or both, along the three principal axes. The transverse and longitudinal flexibilities are of small magnitude and could be neglected on the first approximation. Carrying this argument one step further we may say that

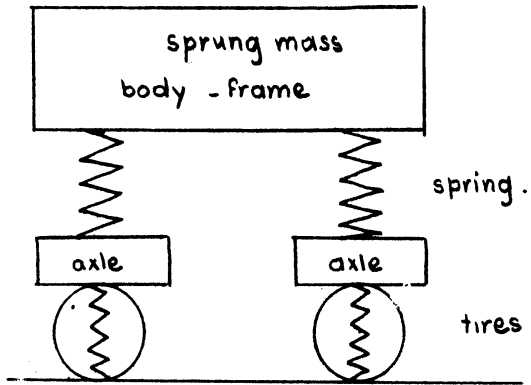

Figure 1.

Mass-Elastic System of the Suspension.

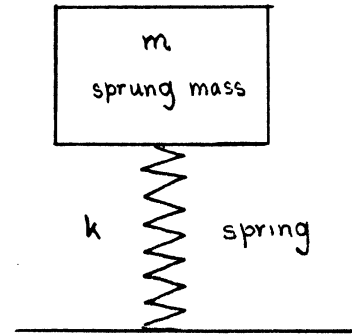

Figure 2.

One-Degree of Freedom.

tires could also be neglected since they have a much greater stiffness in the vertical direction than the springs between axles and frame.

In light of the above, we may consider only the straight up-and-down motion (or vibration), which is the most pronounced one, for the sprung mass, while axles and tires are, for all engineering purposes, at a steady state.

Free Vibrational Motion

If we consider the sprung mass mass m (weight) excited through the spring by a momentary single displacement of the "steady" platform (bump on the road), we will have a force exerted on the mass such that:

$$F = m \frac{d^2x}{dt^2} .$$

But we know also, that the force exerted by the spring equals $F = kx$

where: k is the spring constant and has the dimension of lb/in,

and x is the displacement expressed in inches.

Therefore, by substitution we get

$$m \frac{d^2x}{dt^2} = kx$$

which is the differential equation of motion for the mass.

The solution for this differential equation could be expressed as: $x = a \cos \omega_0 t$ (see curve in Figure 3)

where a is the amplitude of the mass vibration from its equilibrium position, i.e., $t = 0$.

Now, if

$$x = a \cos \omega_0 t ,$$

$$\frac{dx}{dt} = -a\omega \sin \omega_0 t ,$$

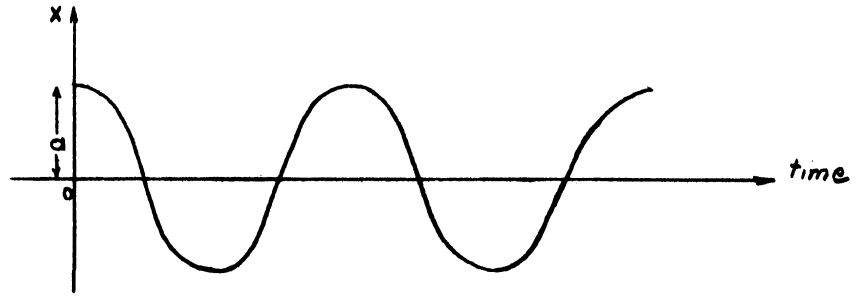

Figure 3. Free Vibrations

and

$$\frac{d^2x}{dt^2} = -a\omega^2 \cos \omega_0 t$$

If $t = 0$, $\cos \omega_0 t = 1$

and, therefore,

$$x = a$$

$$\frac{d^2x}{dt^2} = -a\omega^2$$

Substituting in the differential equation of motion we get:

$$-ma\omega^2 = ka$$

or

$$\omega = \sqrt{\frac{k}{m}}$$

Also for steady state condition the following will be true:

$$mg = -kx$$

$$\text{or } -k = \frac{mg}{x}$$

Substitution for k in the above equation will yield

$$\omega = \sqrt{\frac{g}{x}} = \sqrt{\frac{k}{m}}$$

where ω is expressed in radians per second and g in inches per second squared following

$$f_0 = \frac{1}{2\pi} \sqrt{\frac{k}{m}} = \frac{1}{2\pi} \sqrt{\frac{g}{x}}$$

where f is expressed in cycles per second.

This frequency, which is at the steady state condition, is called the natural frequency; values of f_0 will range between 1 and 1.7 c.p.s.

Damped Vibrational Motion

Observations made on Figure 3, which is the free vibration curve, indicate the necessity of damping for this kind of motion. Damping is provided by viscous friction whose acting force is proportional to the velocity of the displacement,

$$F = c \cdot \frac{dx}{dt}$$

where c is the damping coefficient. The equation of motion then becomes:

$$m \cdot \frac{d^2x}{dt^2} + c \cdot \frac{dx}{dt} + kx = 0 \quad .$$

The solution for this differential equation of motion is:

$$x = a e^{\frac{-ct}{2m}} \left(\cos \omega t + \frac{c}{2m\omega} \sin \omega t \right) \quad .$$

Following the same procedure as for the undamped vibration we reach the following:

$$\omega = \sqrt{\frac{k}{m} - \frac{c^2}{4m^2}}$$

and

$$f = \frac{1}{2\pi} \sqrt{\frac{k}{m} - \frac{c^2}{4m^2}} \quad .$$

It will be obvious from the above that f_0 will be minimum when

$$\frac{k}{m} \approx \frac{c^2}{4m^2} \quad .$$

Curves in Figure 4 illustrate both light and strong damping motions.

The transition between oscillatory damping and strong damping is called the critical damping.

Conclusion of This Analysis

Damping is provided by a "shock-absorber" included in the suspension system.

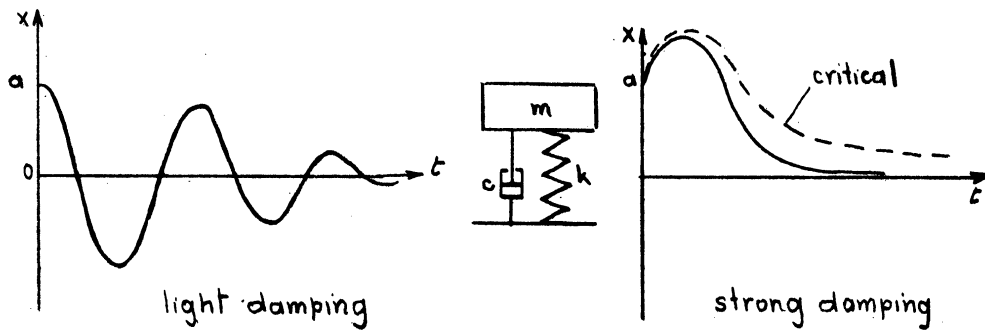

Figure 4.

Damping.

The natural frequency is a function of the spring rate, the sprung mass, and the damping coefficient. The critical damping represents the ideal case since it avoids useless oscillations.

Secondary Vibrations

In the previous analysis we have assumed that the axles, wheels and tires were at a steady state. However, in fact, they form a resilient medium which is disturbed by the road surface unevenness. Secondary vibrations are the direct result of wheel disturbances, transmitted through the suspension system. In any suspension system these disturbances are many and complicated. Indeed, the suspension unit has six degrees of freedom: three translatory motions and three rotational motions. These motions are: parallel hop, fore and aft shift and sideshake (for vertical longitudinal and transverse motions) and yaw, roll and pitch (for rotation about vertical longitudinal and transverse axes).

At this point we may realize that the problem must be simplified; unfortunately, the frequencies of all six motions often lie quite close together and as a result these motions are coupled to each other. The parallel hop is strongly coupled to the fore and aft shift as well as to the pitch by the elastic forces in the suspension system, while the frame is coupled to the side shake and yaw motions. For simplicity let us consider only the vertical motion of the unsprung masses called wheel-hop.

What should be the suspension characteristics to filter such vibrations? In this case the vehicle could be expressed diagrammatically consisting of the following components:

spring mass (m)

spring (k)

shock absorber (c)

and disturbing mass (wheels and axles) which creates a disturbing force F (vibrating under road bump excitation) with frequency f.

The equation of motion is written by balancing the following forces:
transmitted force to body = disturbing force + inertial force

or

$$kx + c \frac{dx}{dt} = F - m \frac{d^2x}{dt^2} .$$

The solution of this equation could be split into two parts:

1. The transient motion similar to the damped vibration motion previously studied.

$$x_1 = a e^{-\frac{ct}{2m}} \left(\cos \omega t + \frac{c}{2m} \sin \omega t \right)$$

2. A motion x_2 which lasts as long as the disturbing force does, and whose equation depends on the force variation.

Conclusion

The purpose of this suspension system is to reduce as much as possible the transmitted force with respect to the disturbing force. Therefore one characteristic of a suspension system will be: the coefficient of transmissibility which is equal to the ratio of the

$$\frac{\text{transmitted force}}{\text{disturbing force}} = \frac{\text{spring force} + \text{damping force}}{\text{exciting force}} .$$

which in turn equals

$$\frac{kx + c \frac{dx}{dt}}{F}$$

The curve in Figure 5 shows the variation of this transmissibility T as a function of the ratio $\frac{f}{f_0}$ where $\frac{f}{f_0} = \frac{\text{exciting frequency}}{\text{natural frequency}} .$

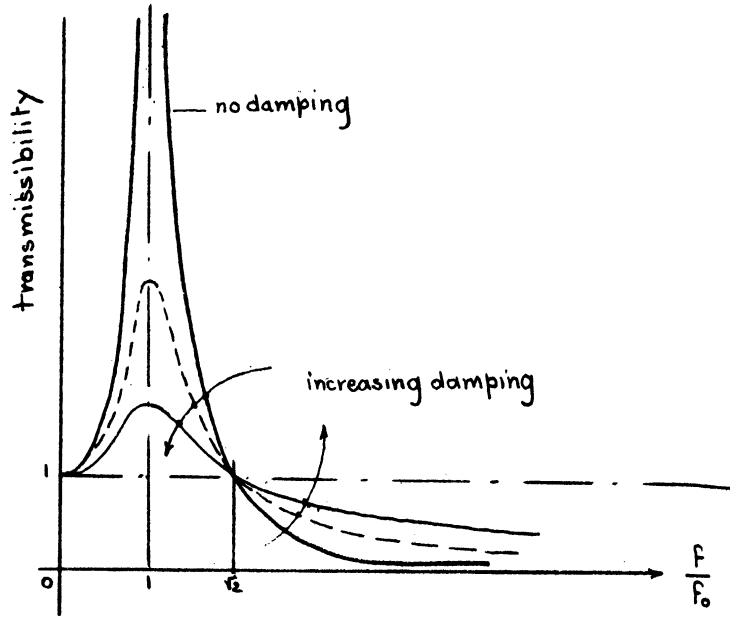

Figure 5.

Transmissibility.

From the curve we may see that the transmissibility is maximum at

$$\frac{f}{f_0} = 1 \text{ (resonance)}$$

The curves show also that in order to keep the transmissibility at a low value, the ratio $\frac{f}{f_0}$ must be greater than $\sqrt{2}$. To increase $\frac{f}{f_0}$ we have to

increase f which in turn means that the mass of the unsprung mass should be decreased since f is a function of $\frac{k}{m}$. Actually the range of f_0 is

is about 1 cps. So, for a wheel-hop of 3cps a very good isolation is provided when $\frac{f}{f_0} = 3$. In summary: increasing $\frac{f}{f_0}$ means decreasing the unsprung mass with respect to the sprung mass.

On the other hand, increase in the sprung mass (load) decreases its own frequency f_0 and lessens the effect of damping. So to keep the damping effect constant (since engineers have not yet found a variable damping shock absorber) the spring rate must be increased, hence the research in variable-rate in the suspension system.

Frequency Range of Vibrations

Primary vibrations (wave) 0-5 cps (body motion)

Secondary vibrations (shake) 5-20 cps (road disturbances)

20-100 cps (harshness)

100+ cps (noise)

A suspension system must provide a high frequency filter, since low frequency (primary) vibrations are damped by shock absorbers.

Suspension Requirements

This analysis shows that: Vibrations and shocks should be filtered as much as possible by the spring and at the same time should provide maximum stability both on a straight and on a curved road.

This last item leads us to consider the behavior of a vehicle on the road in connection with its suspension (but, in fact other factors are involved in this road behavior).

Comfort

Comfort is the primary consideration in the design of a suspension system. Also, as a rule, what is good for the passengers is good for the vehicle and cargo. The problem is then to determine how the passengers react to the vibration.

Effects of Displacement and Its Derivatives

To what quality of motion is the human body most sensitive? This is not the amplitude of the motion, since the body of the vehicle, as well as everything which is contained inside, is moving in the same direction. The velocity or first derivative of the displacement is of little significance in itself, since even the aviator does not feel his own speed of flying as long as the speed is constant. Acceleration, which is the second derivative of the displacement, is not uncomfortable within given limits since acceleration means force, and the human body can bear a steady force considerably without great discomfort.

Actually, experiments and theory show that the human body is most sensitive to the third derivative of the displacement, i.e., the rate of change of its acceleration, that is what we call jerk.

$$\frac{d^3x}{dt^3}$$

According to the simple equation relative to Figure 3,

$$\frac{d^3x}{dt^3} = a\omega^3 \sin \omega t .$$

So to minimize jerk it is necessary to keep the frequency of vibration low. However, the frequency is not the only criterion of comfort. Experiment shows that the displacement is involved in connection with the frequency. Considerable research on the human body yields enough data for the drawing of "comfort curves" which show the maximum frequency allowable with respect to the displacement.

Comfort Curves

Figure 6 shows a mean comfort, or amplitude vs. frequency, characteristic curve. The greater the frequency, the smaller the allowable displacement amplitude.

Engineers and physiologists have introduced the following equation:

$$\text{nuisance} = \text{amplitude} \times \text{frequency}$$

which must be kept under a maximum which is defined by the curve. The comfort curve shows that the maximum "jerk" criterion is within the allowable limits located in the low frequency region, whereas at high frequencies, maximum velocity is the determining factor.

The curves also show that the limit of comfort is 60-80 cps regardless of the amplitude.

The Two Types of Suspension Systems

The two types of suspension systems are the front and the rear. In each of these parts the wheels may be sprung separately or together. This is the difference between independent and non-independent suspensions. Figure 7 shows the basic difference.

The non-independent suspension consists of a rigid axle whereas the independent type lacks this rigidity. One system is non-independent

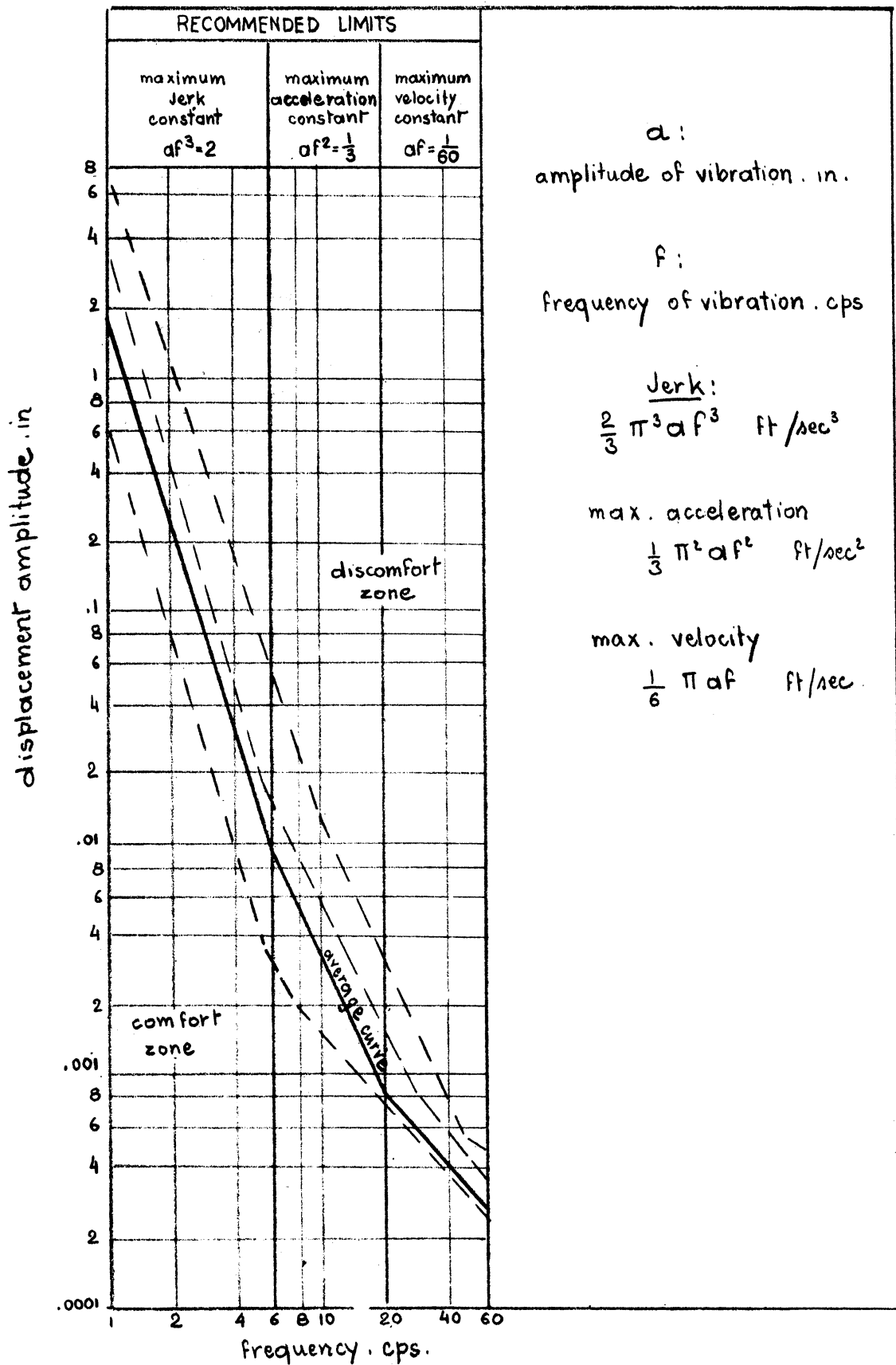
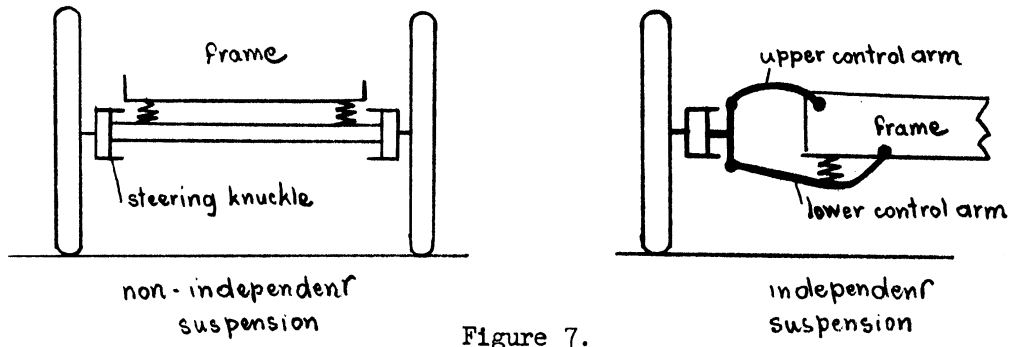

Figure 6. Comfort Curves (SAE Riding Comfort Committee).



Independent and Non-Independent Suspensions.

in the sense that vertical forces acting on one wheel are transmitted to the other wheel and hence tend to rotate the axle about a longitudinal axis. Today, independent front end suspension has replaced the non-independent type on all passenger cars. In heavy-duty vehicles, both types are still used.

In the case of the rear end suspension, independent suspension means independent driving axles. Although this solution is possible (e.g. Mercedes 300 SL De Dion rear axle), it is expensive, except in rear engine vehicles where rear axles are independent by construction.

However, independent suspension is an improvement over the other type. The advantages of independent suspensions are as follows:

1. The unsprung mass is reduced; this is confirmed mainly because of the following reasons: first, each wheel functions only with one suspension unit without interference from the other, and second, the axle is no longer an unsprung mass but becomes part of the frame. Figure 8 shows schematically the action of the rigid axle of a rear suspension with one-sided resilience, which means when a wheel is excited to vibrate separately, (a) shows the equal deflection of both wheels, (b) shows the alternate deflection and (c) the coupled vibration behavior. For a swing axle (independent rear suspension) the sequence is represented in Figure 9, which shows that with unequal deflection of the rear wheels the rigid axle transmits a part of the vibration from the excited wheel directly to the other wheel.

2. Lateral motion of wheels is constrained within definite paths by rigid control rods. This avoids excessively stiff springs in order to keep this lateral rigidity.

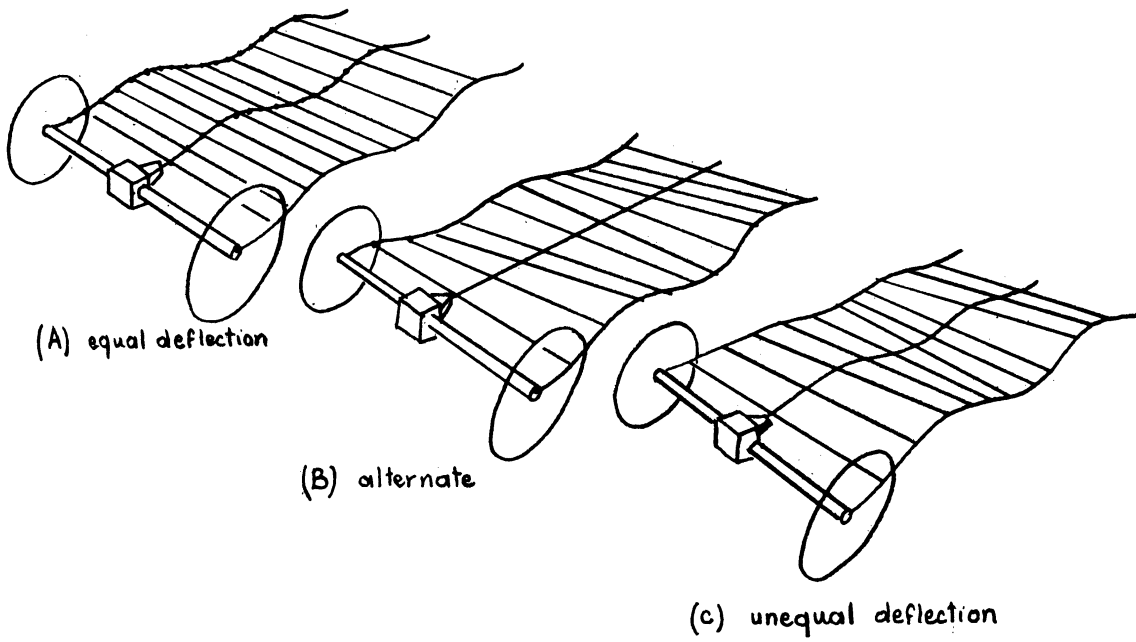

Figure 8. Rigid Axle.

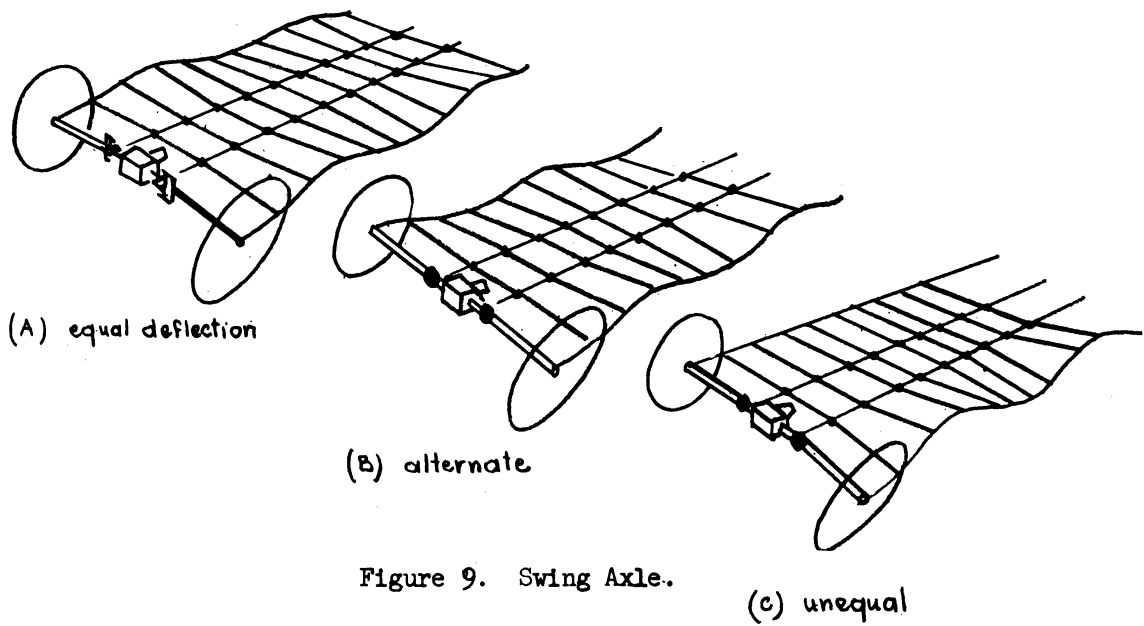

Figure 9. Swing Axle.

3. Shimmy is greatly reduced by independent suspension. Shimmy is caused by a gyroscopic effect on the wheel. This rotating wheel forms a gyroscope, and when its plane of rotation is changed by road irregularities, the wheel will recess. This means that the wheel plane tends to rotate about a vertical axis. This linkage reacts to prevent such a rotation; rapid back and forth oscillation of the wheel occurs and forms the so-called shimmy. Independent suspension minimizes this effect by keeping the wheel plane parallel to itself for any displacement of the wheel. This effect is impossible to achieve with non-independent suspension.

4. At this point another design consideration comes into the picture. As the wheel deflects, tread changes. This means a lateral motion of the wheel. Such sliding of tires is known as tire scrubbing and must be avoided. For this reason independent suspension systems are designed with upper control arm about one-half as long as the lower control arm in order to reduce tire scrubbing. Thus, design of the independent suspension must involve a compromise between shimmy and tire scrubbing. This type of design permits a very large spring deflection and the result is a smoother ride.

5. Knee action - Either wheel can pass over an obstacle without disturbing the path of the other wheel or throwing the car sideways. Thus a so-called "flat ride" is possible on undulating roads. It permits the design of an accurate steering mechanism, since the paths of the wheels relative to the car, are invariable.

Conclusion

We saw most of the advantages of such an independent suspension. This is why most of the cars of today are equipped with an independent

front suspension. Passenger cars which are equipped with rear suspension are still non-independent since this solution is too expensive and is allowed only in some sport cars (Mercedes). In heavy-duty vehicles front independent suspension is sometimes, but not always, used since requirements for "good ride" are less rigorous.

Suspension Linkage

Since suspension involves an elastic medium, appropriate linkages must be provided to control and localize this medium with respect to the body.

What qualities should a suspension linkage possess? It must transmit useful forces (braking, driving forces), and eliminate as much as possible bad reactions without preventing the suspension from acting. In other words it must control the relative motion between body and wheels. Thus a linkage will transmit: driving force, braking force, and cornering force; while avoiding pitching, and rolling forces.

These forces are longitudinal and transverse, but not vertical, since it is the role of the suspension to deal with vertical forces.

Longitudinal forces are transmitted through:

1. Lever, control, torque or trailing arm or torque rod.
See Figure S9, C11, T, T2, A6, A8, A12, A13, R1, R3.
2. Leaf springs, if any, because of their longitudinal rigidity. See Figure S8, S13.
3. Hotchkiss Drive or torque tube drive for rear non-independent systems. Figure S8.

The Hotchkiss drive, Figure S8, absorbs the driving and braking force reactions and allows the use of two universal joints in the drive line. The other solution, the torque tube drive, consists of a hollow

tube which surrounds the drive line and is attached at one end to the rear axle and at the other end to the gear box through a semi-hemispherical joint to permit vertical movement of the rear axle (Figure 10). Only one universal joint is used. The advantage of the torque tube is that it relieves the springs of the function of absorbing driving and braking force. See Figure S8, C3.

All these devices are essentially for the rear suspension.

The front suspension has adopted what is called the wishbone linkage which reacts to both longitudinal and transverse forces. Figure C2, C8, C10, T7, A10, A12, R5.

It consists of two controls, the upper and lower control arms, moving in a transverse vertical plane. They are rigidly supported in this plane and keep the wheel axis in its proper direction. Other advantages have been previously mentioned: constant tread and reduced shimmy (see above independent suspension).

In some European cars (Pengest 403) the upper control arm is formed by the shock absorber arm and the lower control arm with one-half of the transverse leaf spring. See Figure S12, Fiat 600.

The advantage of a leaf spring is its lateral stiffness. Transverse forces are transmitted through leaf springs and through anti-sway bars (Figure C3) which keep the rear axle in the body center. This kind of bar is mostly used with non-rigid springs (coils). Details of these different types of linkage will be seen through this topic.

Since linkage means relation between moving and non-moving parts, the problem is then to ensure joints with maximum rigidity and minimum vibrations and noise transmissibility. This is performed by rubber bushings and ball joints.

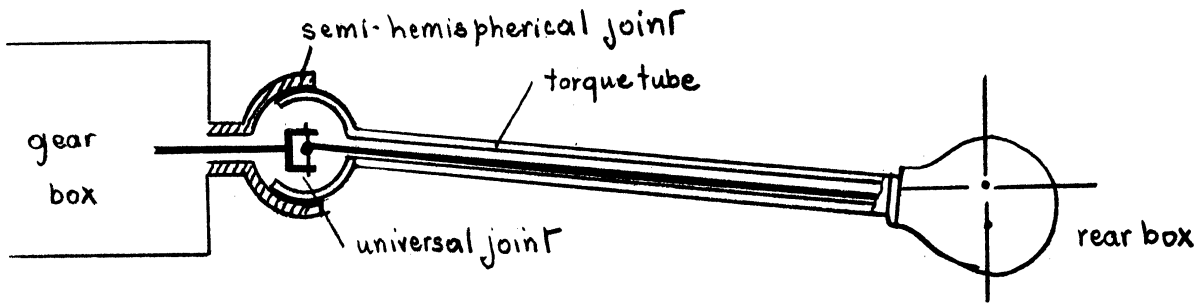

Figure 10. Torque Tube.

A rubber bushing is similar to a rubber bearing. Its main advantage is elasticity with good noise insulation. Figure S14, A13 show different rubber bushings. The most commonly used one is the Silentibloc, Figure 11. The Silentibloc consists of two concentric tubes. Rubber is vulcanized between them. The inner tube is connected to one part of the link and the outer tube to the other part. Rubber can also be used for suspension (according to the same principle as the Silentibloc) in the form of bumpers which limit maximum deflection of suspension.

Ball Joints - Figure 11B

This is a joint used in steering systems which allows displacement in almost any direction. Generally it connects track rods with idler levers, where it has to accommodate large angular deflections, Figure A10. Its advantages are noise and vibration insulation, and there is no requirement for lubrication and maintenance since no wear is caused. The disadvantages are that it cannot be used where drastic rigidity is required and deterioration by oil is in effect.

Stabilizer or Anti-Roll Bar

This is a torsion bar used generally in front and sometimes at the rear suspension (Packard - Figure T7). The ends of this bar are attached to the power suspension arms on the two front wheels through rubber bushings and the middle of the bar is attached to the frame in the same manner. When both front springs deflect evenly the bar has no effect and turns in its frame bearings. But when one spring alone deflects, movement of that wheel control arm relative to the frame twists the bar and causes some of the load to be transferred to the opposite spring. Thus the opposite spring is also deflected. We see that any rolling effect due to

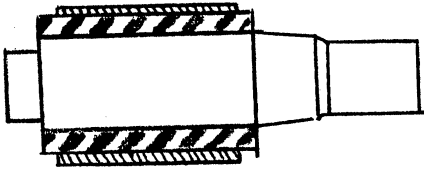

Figure 11. Silentbloc
(A)

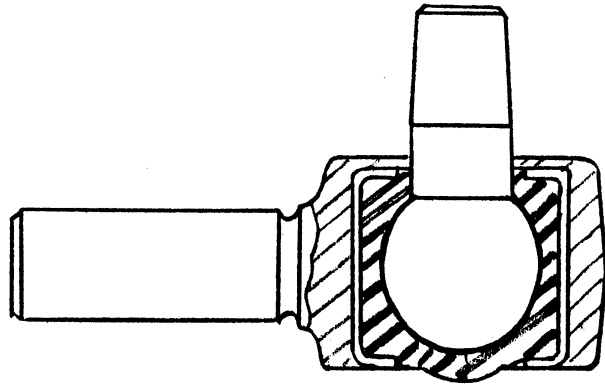

Figure 11. Ball Joint.
(B).

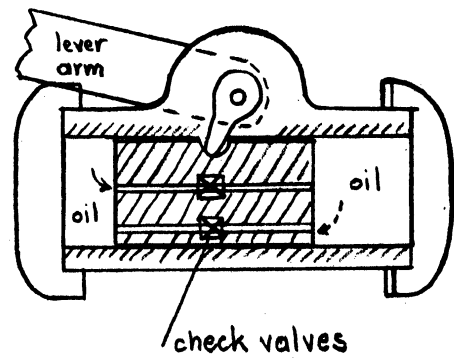
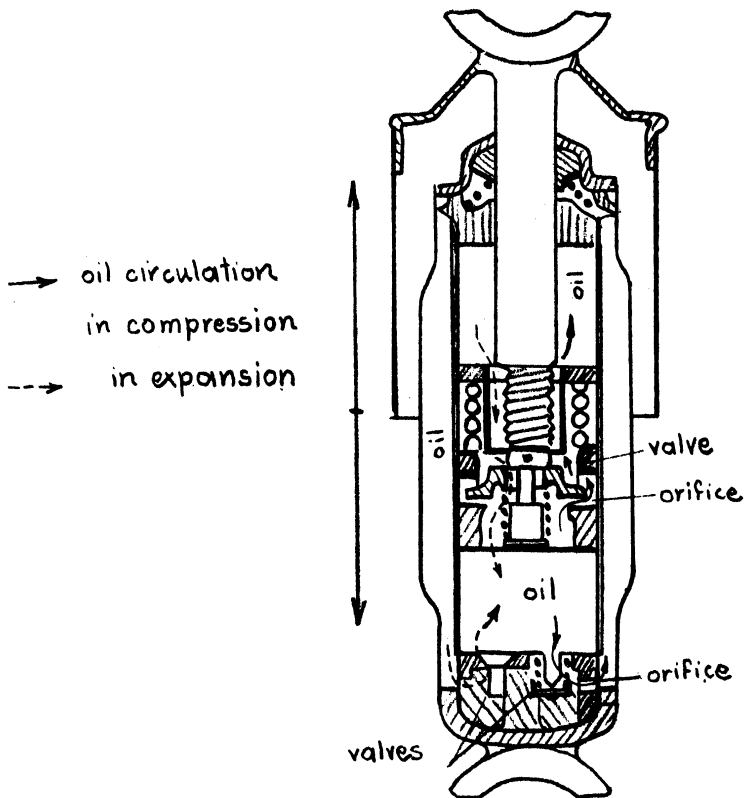

Figure 12. Double-Acting Hydraulic Telescopic Shock-Absorber.

wheel deflection or vehicle cornering is damped by this torsion bar.

Shock Absorber - Figure 12

We have seen the necessity of damping spring oscillations. This damping effect is provided through the shock absorber. The first shock absorber built was of a single-acting type. That means that they only acted when the spring was expanding. At the present time, most of the shock absorbers are double-acting and act both in spring expansion and compression.

There are two kinds of damping. The friction damping which provides a constant friction force. This principle was used in the first shock absorber. However, frequent adjustments were required to compensate for wear. In spite of the fact that this type of constant damping force is not the solution, these types of shock absorbers are still used sometimes in racer cars as well as in railroad trucks. Viscous damping or damping proportional to the velocity is the only one which provides correct damping. The "viscous" shock absorber is the only modern type today.

The requirements of a shock absorber are as follows: It should stiffen up the suspension against roll. A minimum of resistance should be offered at the first inch or two of deflection in order to allow the spring to operate and then progressively stiffen the deflection movement.

This seems to imply that the shock absorber needs to be progressively sensitive to accelerations. When small obstacles such as a ripple surface and cat's-eyes are encountered, these should be absorbed more readily at lower acceleration than at higher ones.

METAL SPRINGS

Leaf Springs

The leaf spring was the most popular spring until 1940. Now it is being replaced more and more by other devices in the suspension system of passenger cars.

Principle

The leaf spring absorbs energy by bending. Theoretically it is a beam of uniform stress, built with leaves which are in such proportions as to unify the stress throughout the length of the spring. Leaf spring softness depends on length, width, and number of leaves.

General Characteristics

The energy stored by bending is less than the energy stored by other types of springs. Hence a leaf spring is always heavier. Its longitudinal and transverse stiffness allow it to be used as an attaching linkage or structural member. Maximum permissible leaf thickness for a given deflection is proportional to the square of the spring length. Therefore, a too short spring can be a non-satisfactory spring even through the requirements for normal load, deflection, and stress would be fulfilled.

Figure S2 shows two different springs computed for the same load. In general it is desirable to choose the length so that the number of leaves will be between 6 and 14. Springs with fewer than 6 leaves will be heavier. While on the other hand springs with more than 14 leaves require more manufacturing; but they could be used for heavy loads.

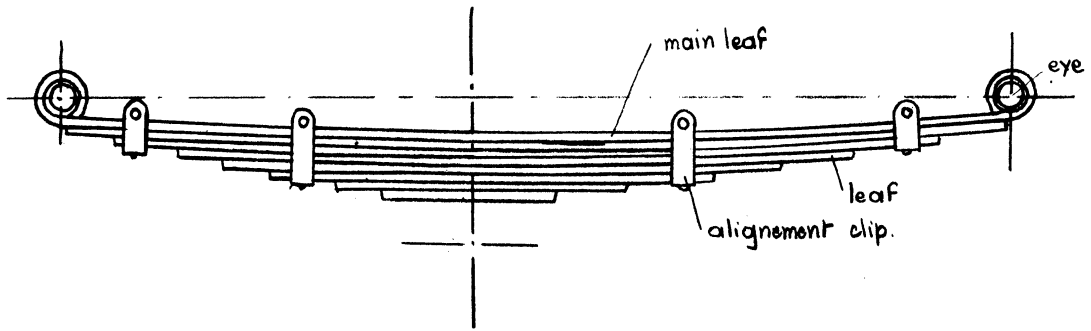
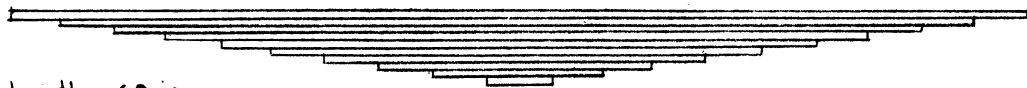
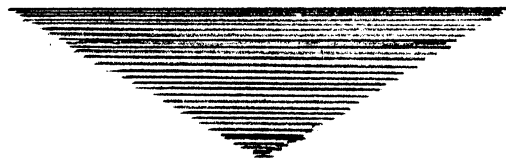

Figure S1. Leaf Spring.



length 60 in
width 3
thickness .4



length 30
width 3
thickness .1

Figure S2. Two Leaf Springs for the Same Load and Deflection.

When subject to pitch torque, spring stress is inversely proportional to the length, and the pitch stiffness is proportional to the square of the length. This fact indicates that a spring should be long enough, as shown on Figure S15. Linkage geometry must fit that of the spring so that stresses do not cause failure.

Fatigue failures start on the tension side of the spring. Special sections as shown on Figure S3 have been developed to avoid this kind of a failure. Springs made of such sections are 5% to 10% lighter with equal fatigue life.

Leaf ends must be so designed that the concentration of inter-leaf pressure is avoided, as shown on Figure S4. Some manufacturers put plastic pads between leaf ends in order to avoid "digging in".

Geometry - A uniformly stressed spring must have a true circular arc shape at all loads. Most springs approximate this theoretical solution. The shapes of the springs of today are either cantilever or semi-elliptic spring.

Linkage

The method of mounting the spring can produce definite handling characteristics in the automobile. In addition, it can also produce a change in spring rate.

The spring installation may consist of either two or one shackle end blocks. These devices were introduced so that the spring length could be varied.

If end blocks are used, the active length of the spring may decrease as it deflects and as a result the rate will increase as shown on Figure S5.

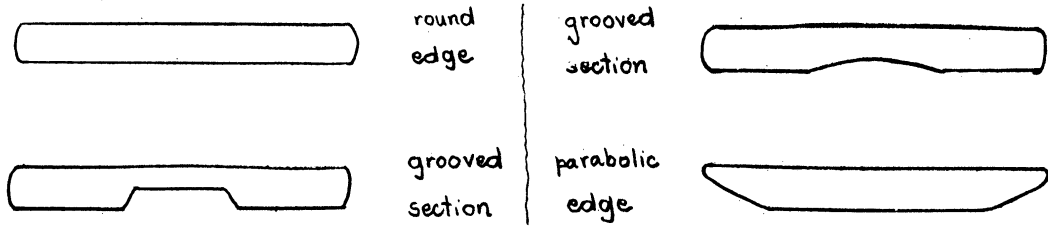

Figure S3. Leaf Sections.

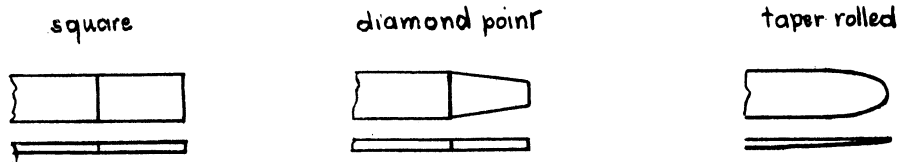

Figure S4. Improvement of Leaf Ends.



Figure S5.

Active Length of Spring.

If shackles are used, two effects will result: 1) As the load increases the distance between the spring eyes increases, causing change in the angular position of the shackle, thus, a change in frame height. 2) The spring action will be changed since shackle angle has a direct effect on it. This direct effect is caused by a component of force along the line connecting the centers of the spring eyes at all times except when the shackle is perpendicular to the line of eye centers. Figure S6 shows how various types of spring shackles subject the main leaf to either tension or compression.

When the shackle subjects the main leaf to tension, the applied load rate and the frequency increases while in the case of compression the load rate and the frequency decreases. The shackle effect is more pronounced with shorter shackles than with longer ones. The shackle length is usually between 5% and 10% of the total spring length.

Shackle angles increase when the spring is deflected from the flat position and this might cause the shackle to swing over from a compression position into a tension position (as the case might be in a rebound, for instance). Thus it is necessary to provide a rebound stop.

If either two shackles or end blocks are used, the spring may be loaded only by vertical forces. Driving and braking forces are transmitted through a torque tube drive or a Hotchkiss drive as shown on Figure S8.

In case one shackle is used, longitudinal load could be carried through the fixed eye. However, as shown in Figure S8, a slip joint in the propeller shaft is required to account for the deflection.

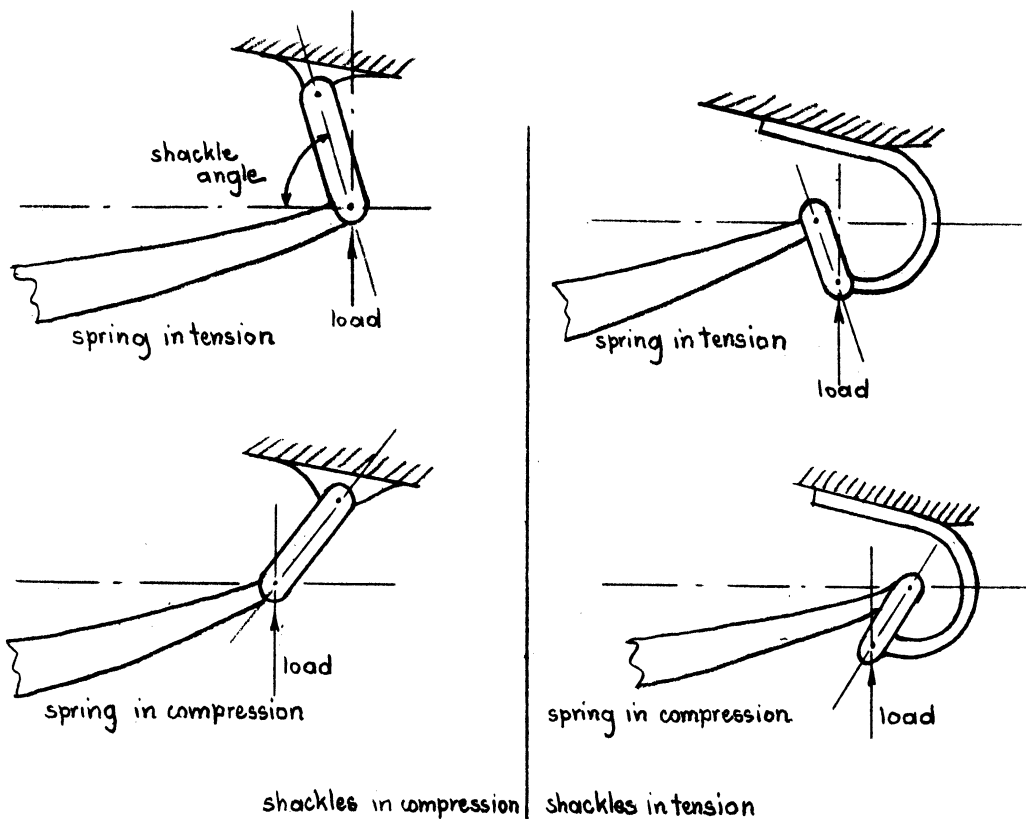

Figure S6.

Spring Shackles.

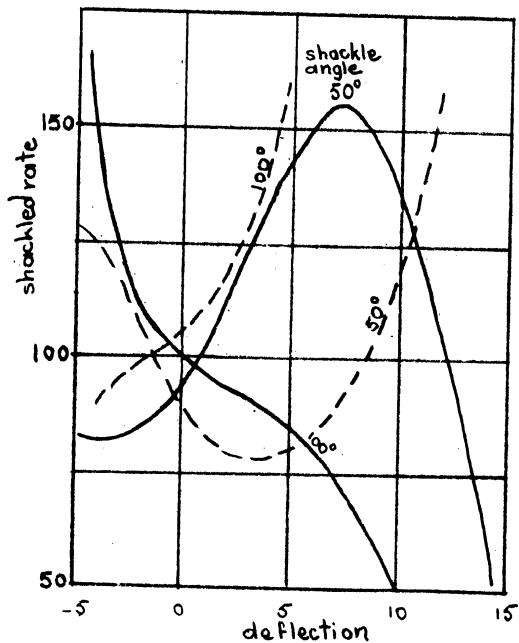
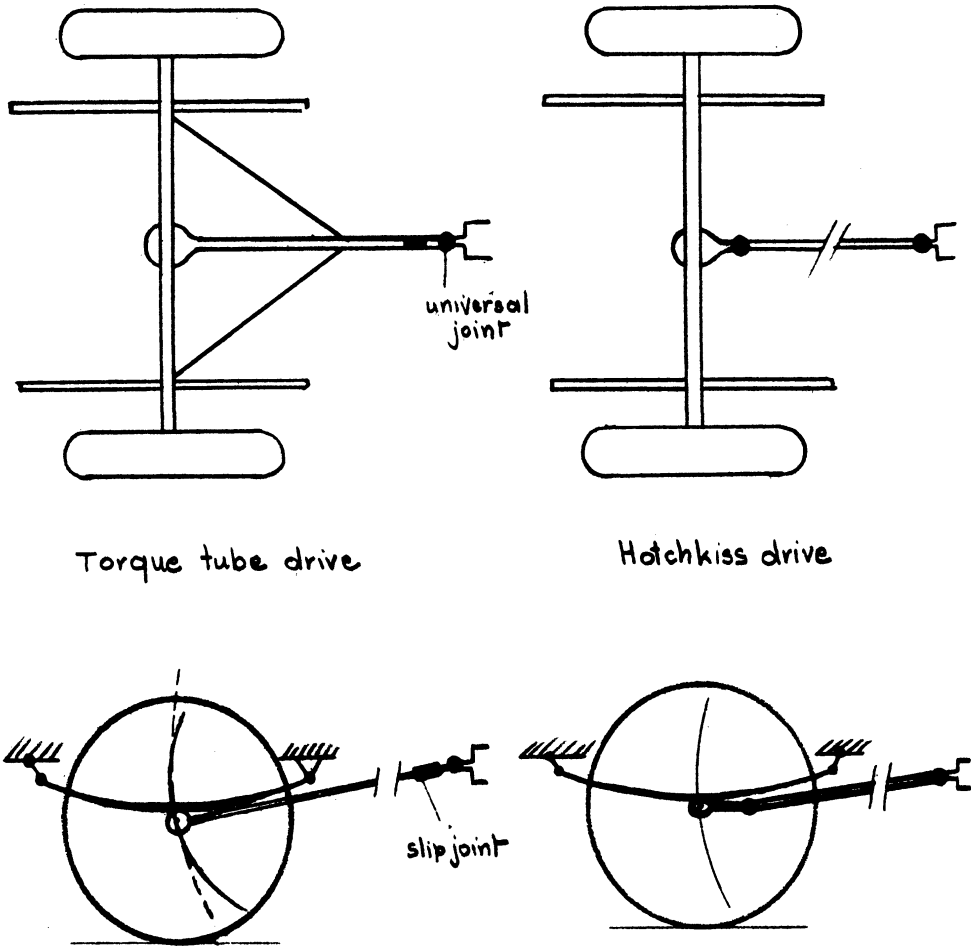

Figure S7. Curves Show in Function of Shackle Angle - Geometric Deflection (in % of Spring Length) vs. Shackled Rate (in % of Nominal Rate) for a Symmetrical Spring - with One Compression Shackle (Full Lines) - with One Tension Shackle (Dotted Lines).



Torque tube drive

Hotchkiss drive

Figure S8. Necessity of Shackles.

Special Linkages

Special linkages are used in heavy-duty vehicles and trailers. Figure S9 shows two types of linkages with rods to transmit braking and driving forces when end blocks are used. Figure S10 shows a leaf spring installed in heavy-duty two-axle suspension. There is a great load concentration at one end of the supporting structure. Figure S11 shows a kind of equalizing suspension between double axle.

Some Particularly Interesting Leaf Spring Suspensions

If we look at Figure S11, we have an illustration of a suspension which depends upon the relationship of spring lengths for uniform load balance. Although theoretically this gear might operate quite smoothly, actually, because of the inherent geometry of the construction, shock transfer would be quite high. Braking reactions would be balanced out, but brake and hop reactions would be noticeable if equipped with towing mechanism as shown in Figure S10. This results in one axle carrying considerably higher load than the other one during braking.

Passenger Car Suspension System

Leaf springs are still used in rear suspension of most American cars which are built with frame and allow such a device.

European cars are built mostly with frameless bodies which forbids the use of leaf springs at the rear. But front transverse leaf springs are used in some cars (Pengest, Simca in France, Fiat in Italy).

Figure S12 shows a front transverse leaf spring suspension. Such a device performs the duties of: The front axle, sway bar, wheel suspension system and spring, all in one. In the Fiat 600 (Italy) the spring

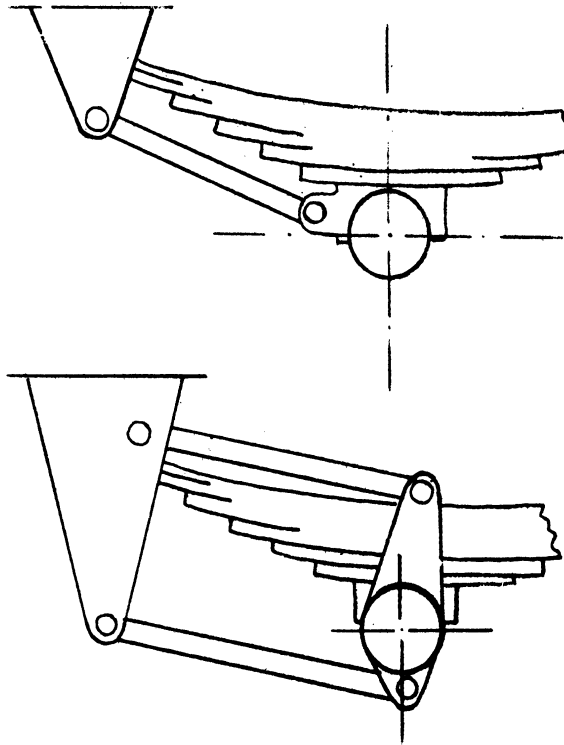

Figure S9. Linkages with End Blocks.

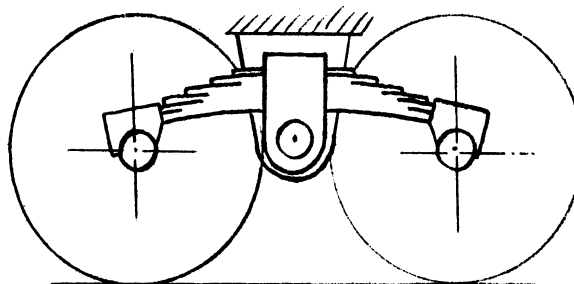

Figure 10. Two-Axle Suspension.

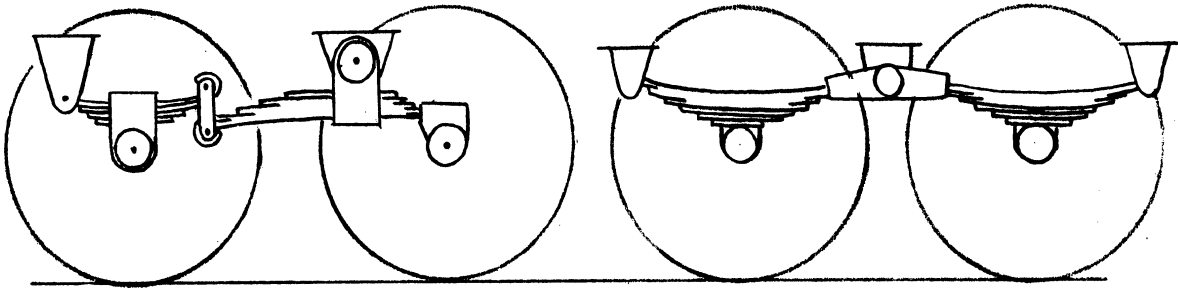

Figure S11. Tandem Axles.

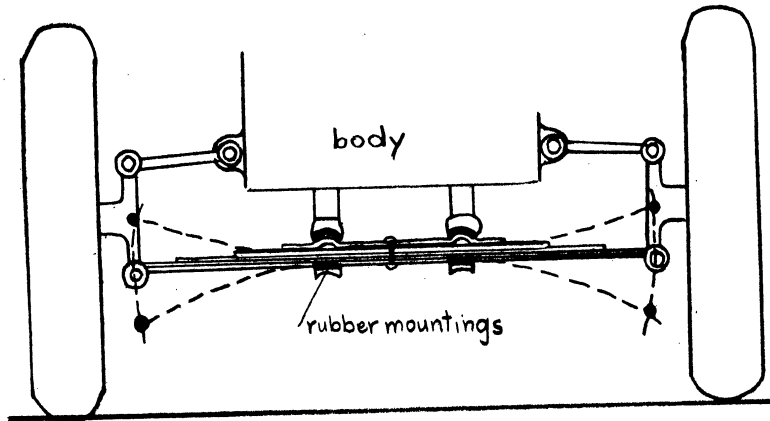

Figure S12. Fiat 600 Front Suspension.

is divided into three distinct parts by two rubber mountings. The vertical components of end motion are independent of each other. The horizontal components are independent of each other but transmissible from one wheel to the other. The transverse stiffness of a leaf spring allows it to perform the duty of a parallelogram rod (at least for light cars); while for heavy duty vehicles a complete wishbone linkage must be added to a transverse spring (See Figure C10). Studebaker (1958) installed an offset spring in the rear suspension to reduce universal joint travel. Spring mountings were moved toward the rear of the frame. The front spring section was shorter than the rear section. This increases the rigidity and reduces rod effect (Figure S13).

Jaguar (2.4 liter) has a special setting for its rear leaf springs as shown in Figure S14. Only one end of the spring is directly in contact with the axle. The center spring pivot which locates the spring sideways and longitudinally, allows a limited fore and aft movement and transmits upward and downward loads from rear axle to the front attachment point, where a rubber pad fitted on an inclined frame member transfers the load from this part of the spring to the chassis.

The Spring Perch Company, Lackawanna, N. Y. have come up with a three leaf "broad-beam" spring which can be manufactured at considerably low cost and at the same time possesses identical or even better features than the usual spring with about 8 leaves.

This kind of a spring has a width of 3 inches (conventional eight-leaf springs are 2 inches in width). (It is understood at this point that only the width could be varied with capacity.) This spring is said to have 15% more fatigue life, to be 25% lighter and its greater weight

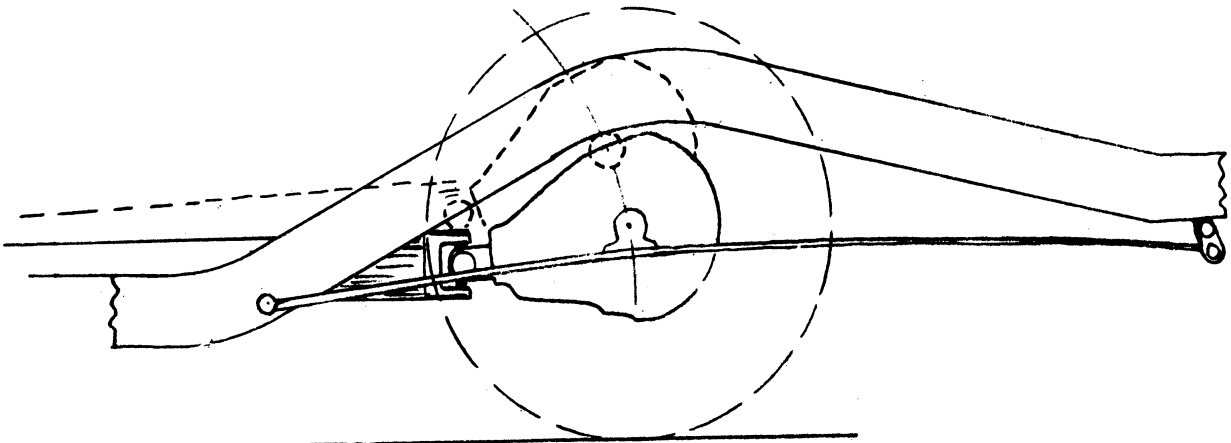

Figure S13. Studebaker Rear Suspension.

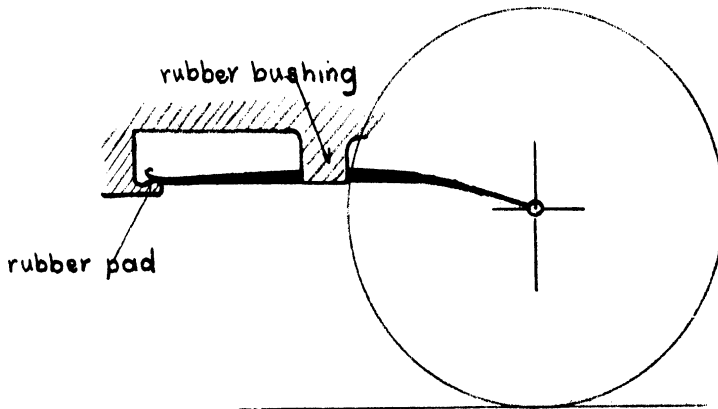

Figure S14 Jaguar Rear Suspension

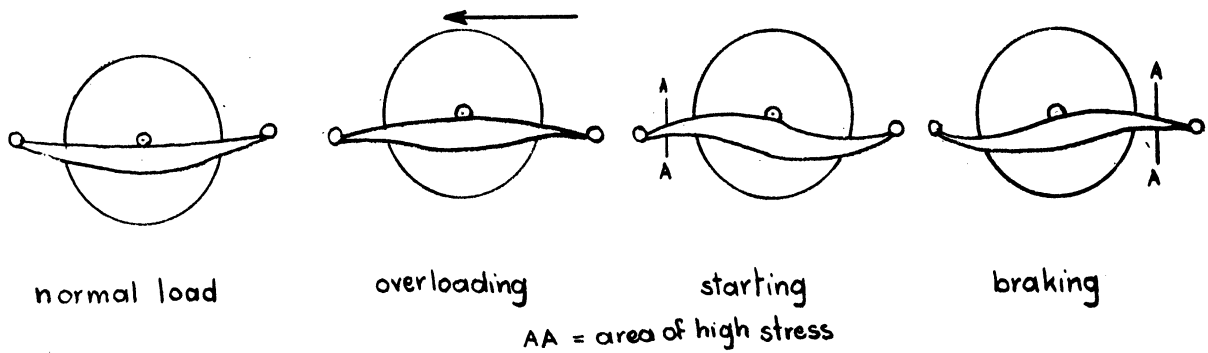

Figure S15. "Windup" or Torque Reaction on Spring Deflection.

provides a greater transverse rigidity while the pitching resistance remains the same. The leaves are separated by a lubricating wax liner to avoid squeaks and other noises.

It is interesting to note that one leaf spring with variable width has been tried but it was found to have too much stress.

Variable-Rate Spring Suspension

1. A kind of a variable rate spring suspension system may be obtained with end block linkage (Figure S5).

2. A shackle arrangement is shown in Figure S6. This arrangement provides a pretty good variable spring rate which is used today in some of the modern passenger cars. The rate of a spring installed with shackle depends on the: nominal rate of the spring, the position of the shackle, the length of the shackle, the chamber of the spring and the load. It will be worth the effort to note that the last three factors are usually overlooked.

Figure S11 provides a typical curve which indicates the effect of shackle angles on spring rates. For example, with a compression shackle, the rate can vary from 90% to 195% of the nominal rate at different chamber positions; whereas with a tension shackle, the rate can be varied from 63% to 225%.

While these possibilities are available and applied in the case of passenger cars without extra cost, it isn't the case in the truck suspension system where springs are still too short, too narrow and too stiff (good riding condition would require too much material and room for the ideal spring). So, other devices have been found for heavy duty vehicles.

3. Progressive spring (Figure S16). In this design the helper section immediately under the main section comes into contact gradually under increasing load.

4. Two-stage spring (Figure S16). Here the helper is placed above the main section and reaches friction pads on the frame when loaded. Corresponding curves show the variation of the spring rate when the load increases.

5. Gregoire's system (Figure S17). With this system, when the vehicle passes from empty height to bounce height, the main spring carries a load proportional to its rate and the correction system (2 coils in tension) starts from a very little load to more and more load until the suspension reaches the bounce position.

Discussion

We have seen all that is involved in the calculation of a leaf spring, and many examples in its utilization. General characteristics of leaf springs lead to the fact that its dimensions should be generous for good up and downward flexibility. Careful considerations have to be given to many other factors: such as weight, number of leaves, rate and load carrying capacity, fatigue life rate, leaf ends, geometry, pitching resistance linkages and shackle angle possibilities, to give variable rate under changing loads.

In conclusion of this topic we may list the advantages and disadvantages of leaf springs.

Advantages

The leaf spring is the one form which is a complete unit by itself in that it can serve both as a radius rod as well as a torque arm

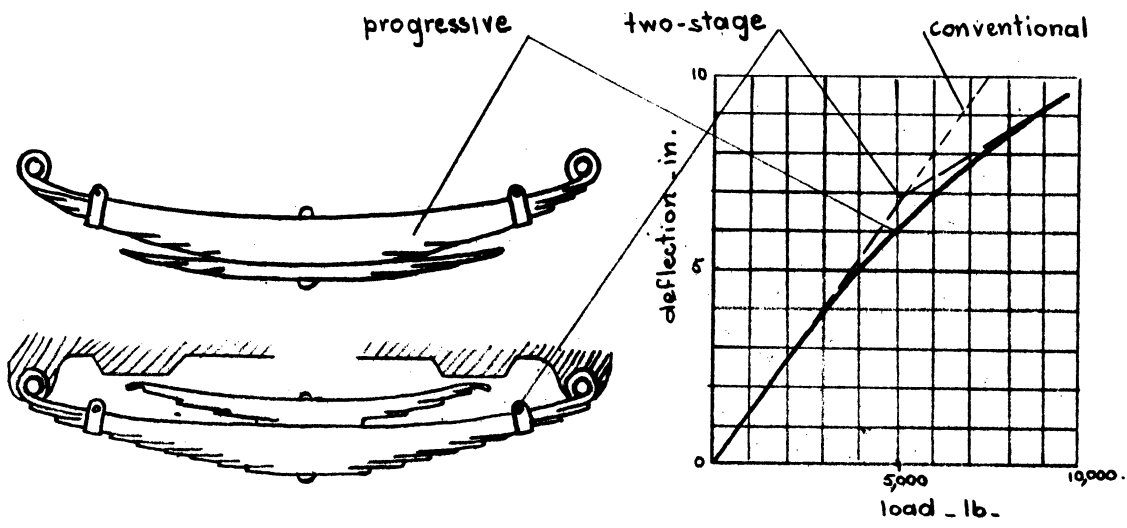

Figure S16. Load-Deflection Curves.

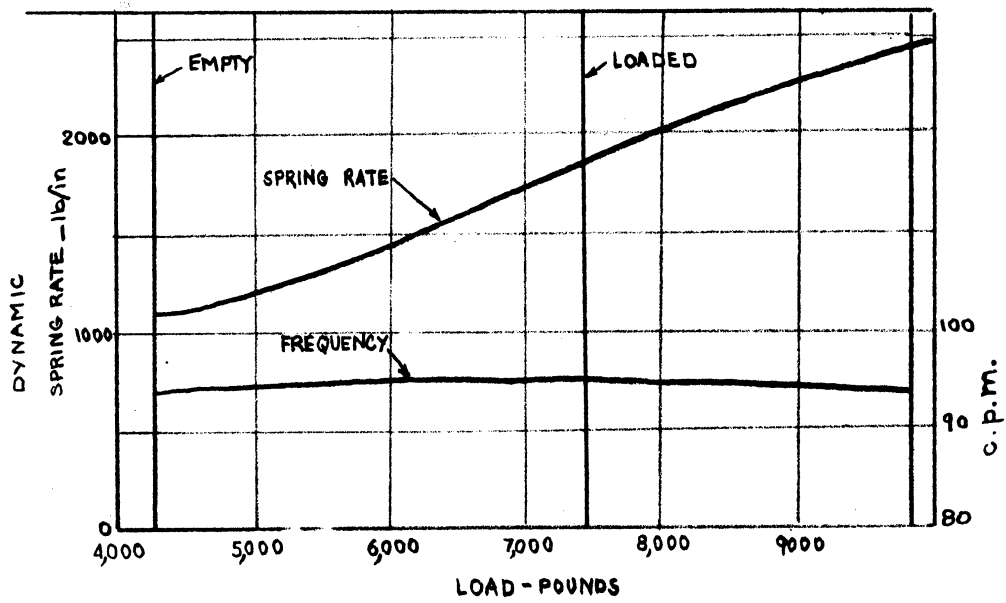
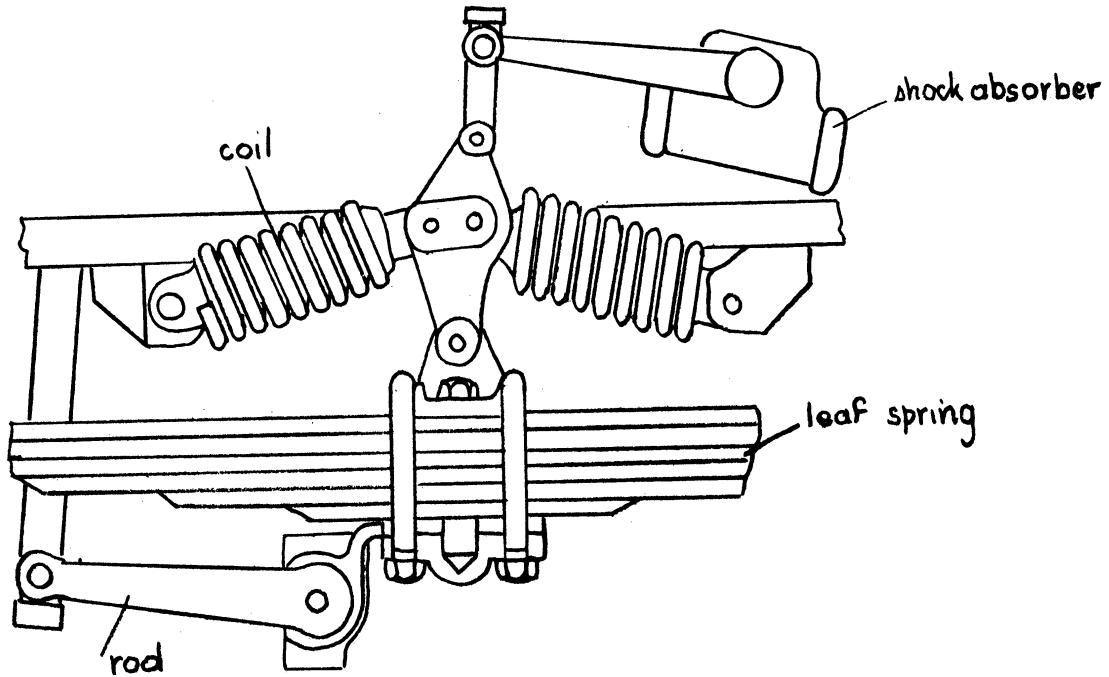

Figure S17. Gregoire Variable-Rate Suspension (Daimler 6 CVG Bus)

without additional weight or parts. This effect is due to its lateral stiffeners which enable it to transmit driving and braking reactions to the frame. Moreover, it has a little sidewise elasticity (mostly long spring), which is distinctly beneficial in elastically cushioning side impact forces especially on rough roads.

Leaf spring is the only spring which possesses some inherent damping characteristics. However, this feature which was an advantage a few years ago is not anymore, primarily because this damping was due to friction, and secondly, because perfectly capable shock absorbers are available on the market. A spring with a variable rate can be obtained by shackle arrangement, even though the spring itself has a constant rate characteristic. Anyhow, other efficient variable rate features have been sought (see above) especially for heavy-duty vehicles where restrictions are more important.

Disadvantages

Careful calculations must be made on the spring characteristics. For a given allowable stress of the material and given amount of energy to be dissipated the required spring volume and thus weight is predetermined. Careful manufacturing is required to avoid surface tension. Leaves must be shot-peened to increase life. The finest steel is required to have minimum decarburization and surface irregularities. It must be heat-treated. The Hotchkiss drive or torque drive is only possible in leaf springs. Rear leaf suspension is not permissible with frameless bodies because it requires strong linkage to the frame.

Excessive starting friction gives a momentary spring rate many times the normal value. This high starting friction will be particularly detrimental to the riding qualities on comparatively smooth roads. This fact explains why manufacturers have tried to reduce the number of leaves in passenger car suspension.

Leaf ends may cause "digging in". Therefore, soft-tapered leaves are necessary (or plastic pads). Without these refinements, springs cannot respond instantly to the road shocks. This explains why shock absorbers are not effective as long as blunt end springs are used.

Leaf springs must be long in order to provide soft ride under given loads. The required length is not permissible in truck suspensions. This fact explains why variable rate suspension devices have been sought for improvement. Since energy is absorbed by bending, the amount of energy absorbed per pound of weight is relatively low compared with other kinds of springs as we shall see below. This fact results in relatively heavier spring leaves. To reduce weight, The General Motors Corp. have used leaves with groovecuts in the compression side as shown in Figure S3. Likewise, we have already seen other attempts to reduce the weight (Spring Perch Co.).

Friction between the leaves make the spring noisy (squeaks) and lubrication is advisable.

Conclusion

Leaf springs are still used in heavy-duty vehicle suspension, where simplicity of mounting and strength are more desirable than comfort and road handling.

However, in passenger cars, leaf springs are used in the rear suspension for framed automobiles and in front suspensions as transverse springs.

Coil Springs

The coil or helical spring is not a new idea in automobiles (1900). But it became popular by 1934 when the so-called knee-action front spring suspension was introduced as well as when frameless bodies, prohibiting leaf springs, appeared. The torque effect of front-wheel brakes made stiff springs desirable because it was necessary to prevent excessive rotation of the front axle when the brakes were applied. Otherwise, the interference, to correct steering geometry, could be very serious.

In the knee-action suspension, flexibilities at the wheel were tripled. This, coupled with the revolutionary shift in the weight distribution of the car towards the front end, resulted in the comfortable "horizontal ride" that is required today.

Principle

Figure C1 shows how the load is transmitted through the coil spring to the wheel. The coil spring absorbs energy mostly by torsion. However, there is practically no inherent damping as in the case of the leaf spring. Hence a larger shock absorber must be used. Also, since this type of spring cannot be used to transmit driving and braking forces, torque rods or torque tubes are required, thus further reducing the weight advantage.

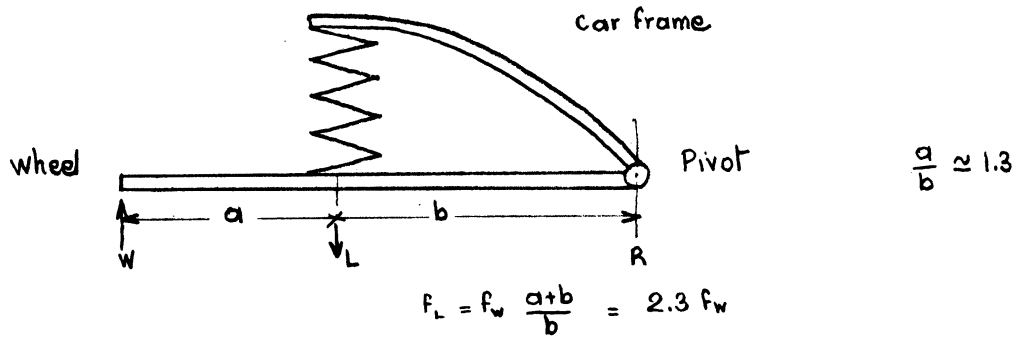

Figure C1

Transmission of the Load Through the Coil Spring.

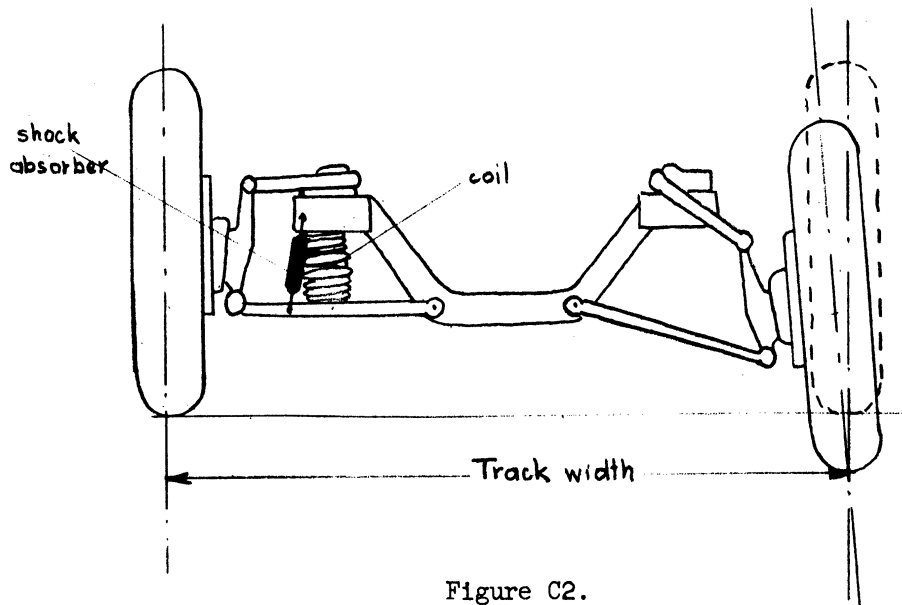

Figure C2.

Front Suspension.

Linkage

Figure C2 shows the coil spring front suspension system as most commonly used today, in spite of the tendency to replace it by torsion bars.

The cushioning is secured by the coil spring alone, so that upper and lower control arms are necessary to link the front end of the car with the wheel and furthermore to secure control, and to guide the wheels' motion in bounce and rebound.

The geometric layout of the suspension must be such that: when the wheels go into bounce or rebound, the track width will always remain constant, thus preventing tire scuff, as shown in Figure C2. The roll axis is raised to a line which is as close as possible to the center of gravity, thus increasing stability. However, the actual layout of the suspension is a compromise between these two conflicting conditions.

In the case of the rear suspension, coil springs could be used with solid axle and torque tube drive as in the case of Peugeot 403 (France) -- see Figure C3.

Another device is the Mercedes swing rear axle (Germany), whose description is given below. But generally, rear coil springs are used with De Dion axle or on rear engine cars (Renault Dauphine).

Some Particularly Interesting Coil Spring Suspensions

1. German Mercedes swing rear axle - Figure C4. This design results in a softer suspension characteristic whenever only one of the rear wheels is affected by shocks due to uneven roads. Another advantage is that, while in a rigid axle, the entire rear axle must move as one unit so that sufficient space is provided, the swing axle requires less space for its deflection due to the fact that the rear axle case is secured on the frame and no additional space is required for the cardan shaft and gear case. Figure C4 shows a crossed swing axle which provides little change in camber and track.

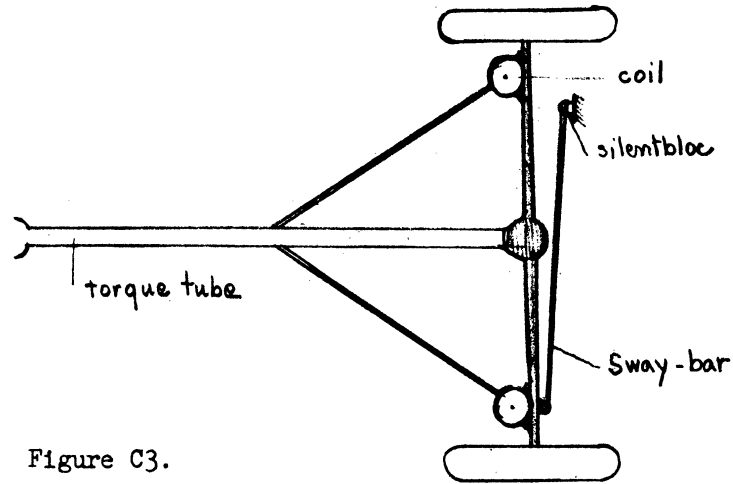

Figure C3.

Peugeot 403 Rear Suspension.

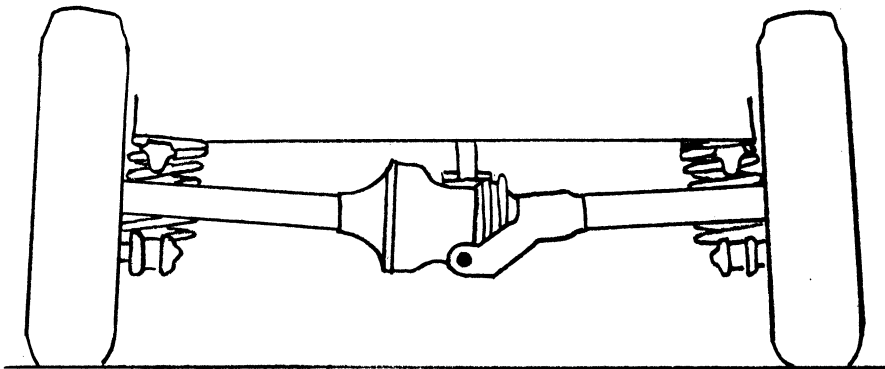

Figure C4

Mercedes single joint swing axle with low pivot

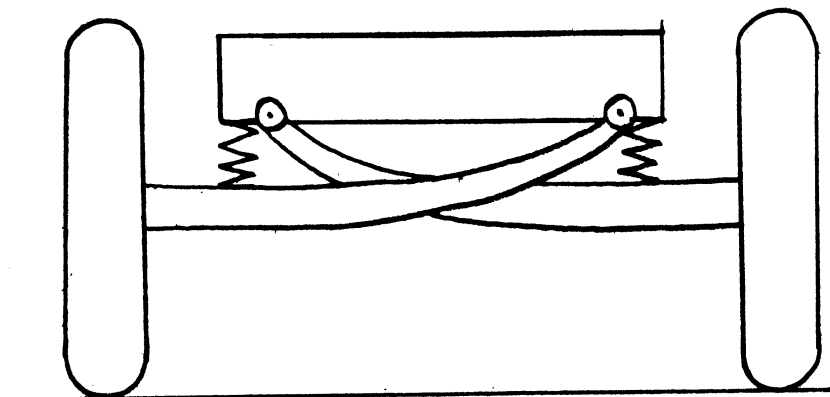

Figure C4bis. Crossed Swing Axles.

2. Comparisons between rigid axle, De Dion axle, and swing axle;

a) Rigid Axle

Assembly conditions

Space must be provided for the movement of the whole axle; the result is loss in trunk space.

Lowering the center of gravity is only possible to a limited extent.

Riding behavior

Unsprung masses are comparatively large, could be reduced; however, not without difficulty.

Comparatively hard ride, since it is necessary to keep the inclination of the car as small as possible.

Bad understeering characteristics in curves because the equal deflection remains constant relative to the other types of axles.

Comparatively large but still tolerable inclination of the sprung mass.

Manufacturing in large scale production

Simple manufacturing and assembling processes.

b) De Dion Axle

Assembly conditions

Similar to the case of rigid axle, however, less loss of trunk space. The gear unit is fixed on the frame.

Riding behavior

Good handling stability (better than with rigid axle).

Unsprung masses could be reduced as compared to the rigid axle, since the gear unit does not swing.

Good lateral guidance.

The ride could be kept soft, without increasing the inclination of the sprung mass.

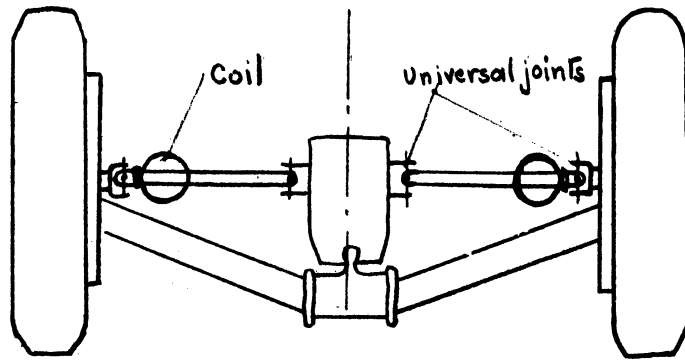

Figure C5
De Dion axle

By selecting the right axle kinematics it is possible to adjust the over- or understeering. The above results in more favorable conditions than the rigid axle even though the camber does not change.

Noise through gearbox.

Manufacturing in large scale production

The construction is more complicated because of the use of four universal joints.

c) Swing Axle

Assembly conditions

Necessary space for the swinging of the arms can be kept comparatively small.

The trunk space can be better utilized.

Lowering of the center of gravity is possible.

Riding behavior

Slight oversteering in curves is noticed only at high speeds.

Reduction of unsprung masses provides a softer ride.

The passengers are well isolated from road shocks and vibration.

The inclination of unsprung mass is less than that with the rigid axle.

Manufacturing in large scale production

The construction is more complicated than both the rigid or the De Dion axles.

Moreover, assembly cost is higher. Therefore, this type is limited to expensive cars only.

3. MacPherson Suspension - Figure C6. This type is used in British Fords (Zephyr - Zodiac) for front and rear suspensions and in French Simca model Vedette (front suspension).

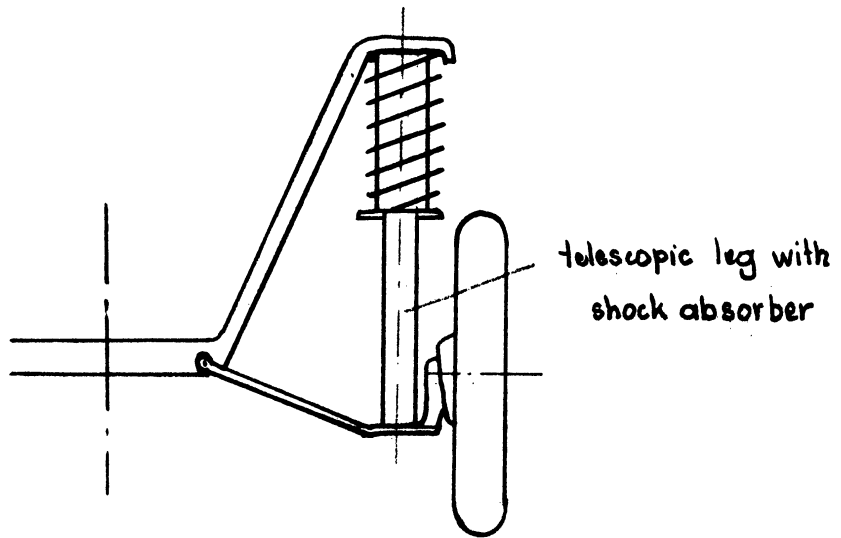

Diagram of MacPherson suspension
Figure C6

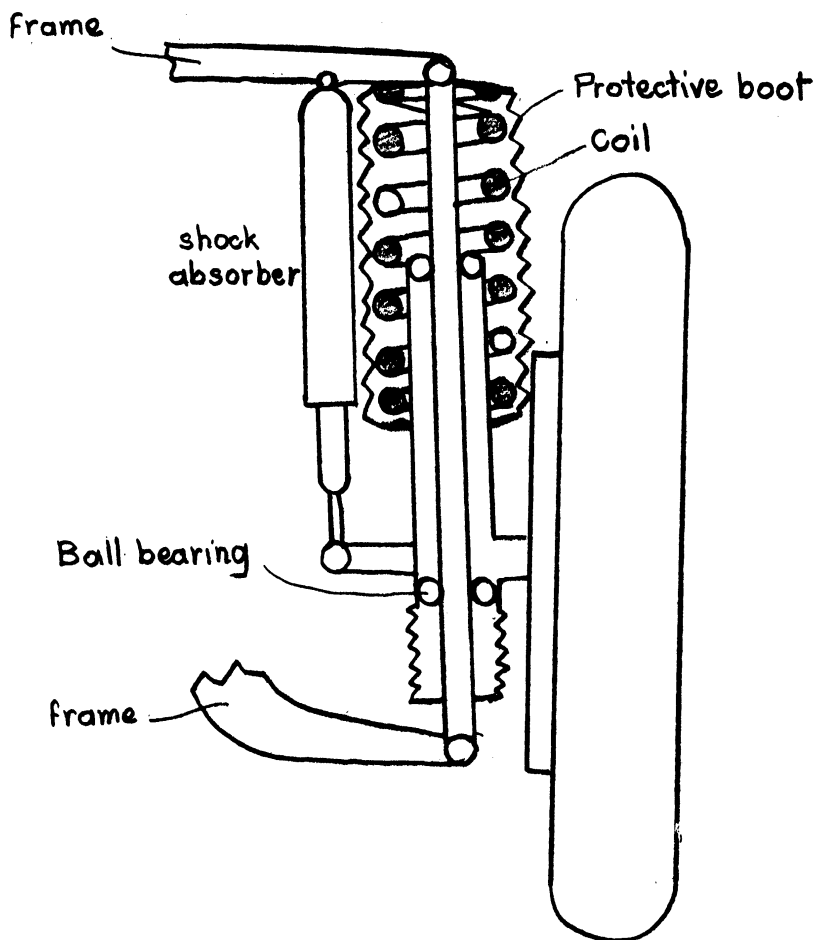

Figure C6bis. Nash Sliding Pillar Suspension.

This type consists of a telescopic shock absorber surrounded by a coil spring. Its upper end is free to rotate in a thrust bearing which is anchored in rubber to a cup bolted to the reinforced fender apron in the upper part of the body. Thereby larger springs could be used. The 1942 Nash suspension (Figure C6) is another example of such a suspension.

4. Variable-Rate Suspension - Gregoire System - Figure C7. The present vertical coil spring was replaced by a lighter spring which was mounted in an inverted V light-alloy member. The two extremities of the V receive supplementary coil springs attached at the other end to the supporting arm. Increase of the oscillation period is only 3% for a loaded passenger car. Hence, the advantage is additional comfort under all loads with better road-handling characteristics.

5. Figure C8 shows another double spring rate coil suspension. It has been determined by extensive laboratory experiments that it is desirable in a coil suspension to provide a resilient spring series, so that one portion of the travel will be free and undamped while the other portion will be damped by the action of a hydraulic shock absorber.

Small deflections or wheel travel are encountered by the resistance of the lower softer coil spring, while larger amplitude in deflections are absorbed both by the upper spring and shock absorber.

Notice that the Studebaker uses a variable rate coil spring, which becomes stiffer when the deflection increases.

6. Truck coil spring suspension - Coils have been adopted in passenger cars because of their greater softness. Therefore, their interest in trucks is less apparent. However, coils have been used, and here are some examples:

Spanger Dual Conversion - uses two coils per dual front or rear axle - Figure C9.

Pegazo Suspension (Spain) - Figure C10. In order to provide additional load capacity for coil springs suspension in trucks,

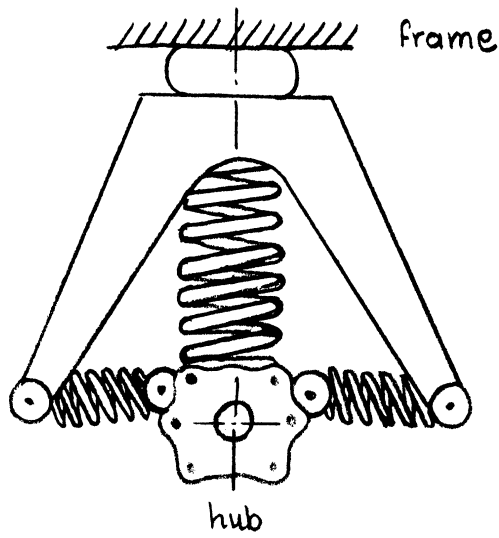

Gregoire variable rate suspension.
Figure C7.

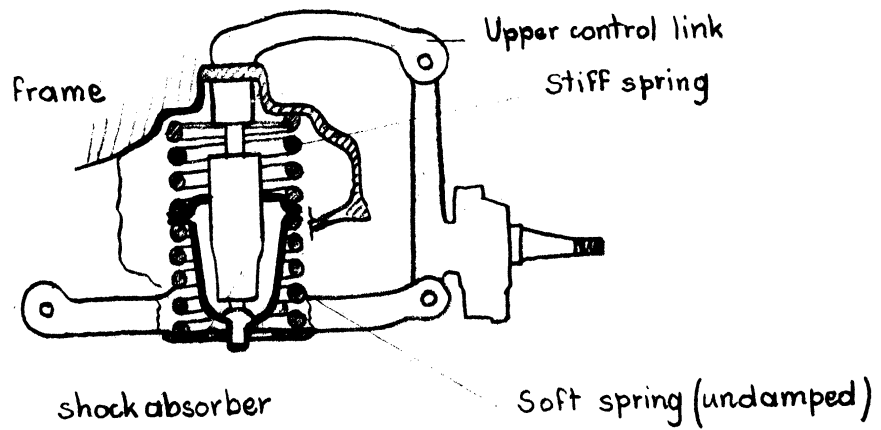

Figure C8.
Double Spring Rate Suspension.

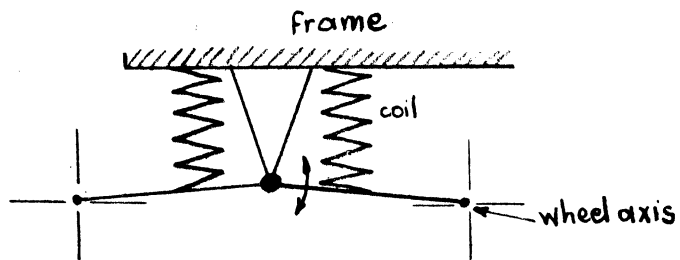

Figure C9.
Spanger Suspension for Dual Axles.

the conventional coil springs were supplemented by a semi-elliptic spring. When the lower control arm deflection reaches a certain magnitude, the yoke roller can contract the transverse spring ends, which results in an immediate increase in the suspension spring rate.

7. Equalizing coil suspension of the French Citroen 2CV - Figure

C11. This is an interesting device using coil springs, and has two generally outstanding features:

- a) Coil spring suspension is indirectly applied on the wheels.
- b) This is an equalizing suspension.

The front and rear wheels are carried by bell-crank levers pivoted on the frame. Pendant ends of these levers are connected to the suspension springs. There are two spring assemblies, one on each longitudinal side of the chassis and each is common to a front and a rear wheel suspension lever.

Figure C11 shows the diagrammatic spring arrangement. Tension rods (1) - connected to the pendant levers, (2) transmit the forces through their dished ends, (3) to the coil springs, (4) which are loaded in compression. To insure stability, additional elements are used, in the form of auxiliary springs (5) which are inserted between the ends of the housing and guides and (6) which are mounted on the frame.

This type of suspension has a low stiffness value so far as pitching is concerned. Thus, if the front wheel moves upward relative to the frame, while the rear one moves downwards, the spring (4) does not oppose the motion which is damped only by friction through the dished ends (3). This makes it possible to reduce both the pitching frequency and the angular acceleration. However, this low angular stiffness also reduces the resistance to angular displacement when the car is accelerated or braked.

Notice that no shock absorbers are used except the damping caused by the dished ends (friction) and also little damping through friction shock absorbers, mounted on axis 7 (not shown).

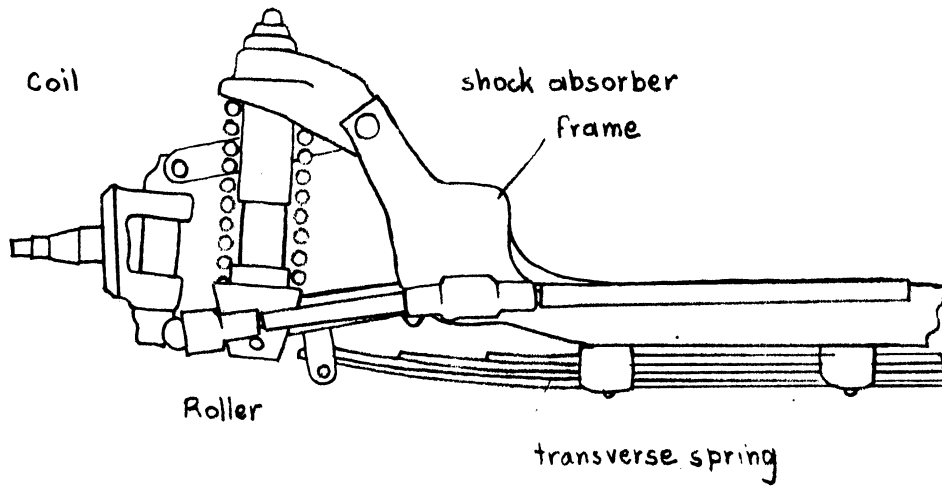

Figure C10. Pegazo Truck Suspension.

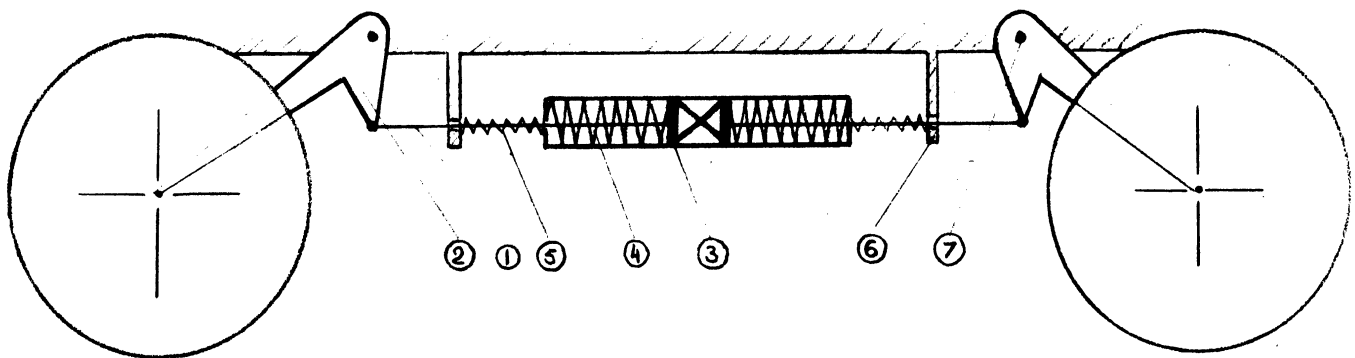

Figure C11. Diagram of Cotroën 2CV Suspension.

Conclusion

Most American cars have coil spring front suspensions. While most European cars have coil springs both in front and rear suspension. The main reason for the latter is that the coil spring provides a softer suspension with less room. At the present time the torsion bar competes with the coil spring. Nevertheless, the coil spring is still used owing to its greater simplicity. Hence, we can name the main advantages which are:

- 1) Simplicity
- 2) Great softness under small room. This last advantage is magnified by the fact that a telescopic shock absorber can be put inside the coil.
- 3) For a given rate, coil springs require half as much metal as the leaf spring type.
- 4) Noise can be filtered through the coil by mounting it in a rubber cup insulating the coil from the frame (English Rover car).

Disadvantages

- 1) Coils have no inherent damping; all the damping must be provided through shock absorbers.
- 2) The spring rate is constant whatever the deflection.
- 3) It is necessary to have lever arms to overcome driving and braking forces.
- 4) Precision products are made of carefully rolled alloys steel, which is usually centerless ground (to insure constant diameter and uniform flexibility as well as decarburization and surface smoothness). The cost could be reduced only through large scale production.

Torsion Bar

Principle

This type of suspension was and still is very prominent in Europe since it was first introduced, for mass production, by Citroen (F) in 1934.

It appeared in U.S. passenger cars on 1955 (Packard), but was used beforehand in truck suspensions (late thirties).

The torsion bar, as its name implies, absorbs energy in torsion. It consists of a special steel rod fixed at one end to the frame and at the other end to the control arm. See Figures T1 and T2.

This type of spring has two outstanding characteristics: a) for the same spring rate, it requires less weight than either the leaf or the coil spring. Appropriate linkage can provide a changing spring rate. b) the greater the angle through which the bar is twisted by a shock force such as P (Figure T3), the shorter the lever arm and the less is the applied torque.

Linkage

Since both torsion bar and coil springs are designed to receive only the cushioning of the vehicle, other devices must be incorporated to provide the linkage between frame and axle. The linkage design for the torsion bar is the same as for the coil spring and therefore, we will not repeat here what was said above about the coil spring suspension.

Classification

- a) A torsion bar may be:
 - (1) longitudinal (Figure T4), i.e., parallel to the vehicle axis (Wolseley, G.B., Packard).
 - (2) transverse (Figure T5), i.e., perpendicular to the vehicle axis (G. B. cars)
- b) One element of suspension for an individual wheel may consist of:
 - (1) one bar only (the most common use)
 - (2) several bars in parallel (Panhard - F; Volkswagen - Germany)
- c) Torsion bar shapes can be:
 - (1) round (the most common)
 - (2) square (Volkswagen front suspension)
- d) Flat or laminated - Salter Co., G. B. (not yet used).

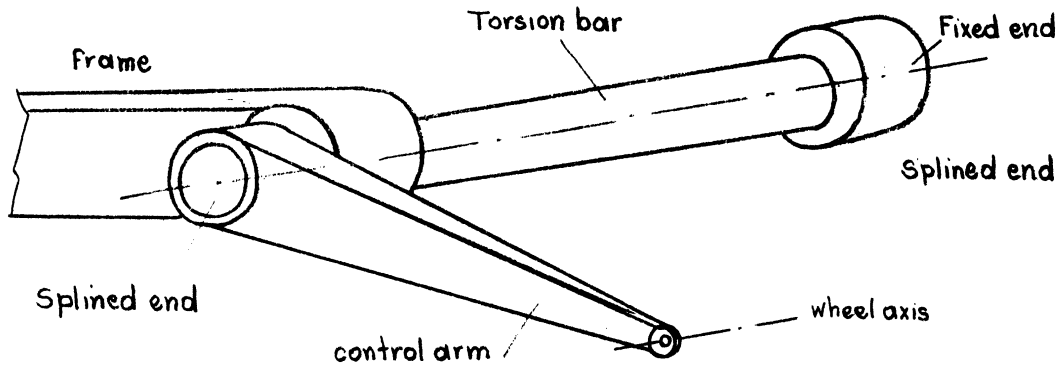

Figure T1. Torsion Bar.

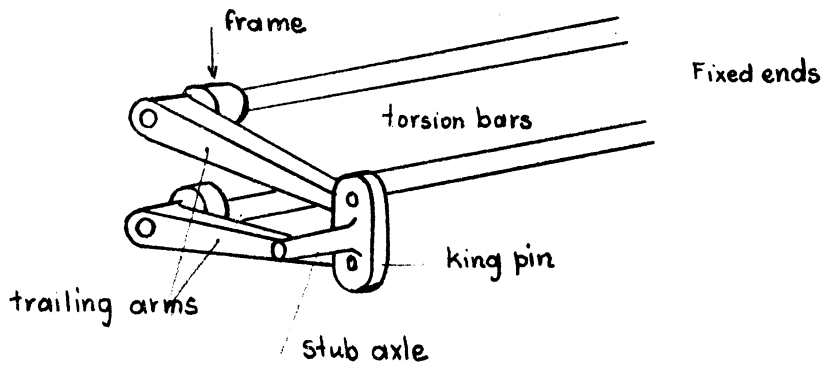

Figure T2. Multiple Torsion Bars (Volkswagen Front Suspension).

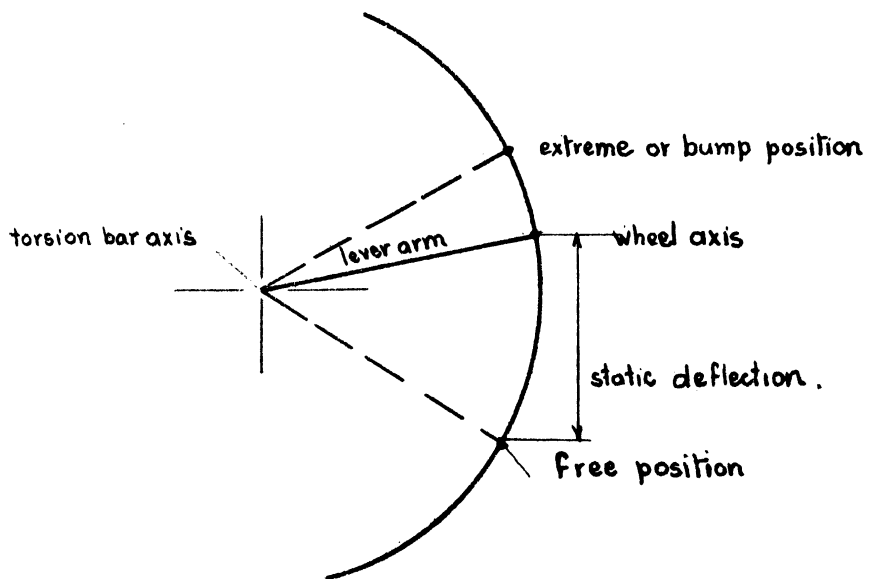

Figure T3.

Deflection of a Torsion Bar Spring.

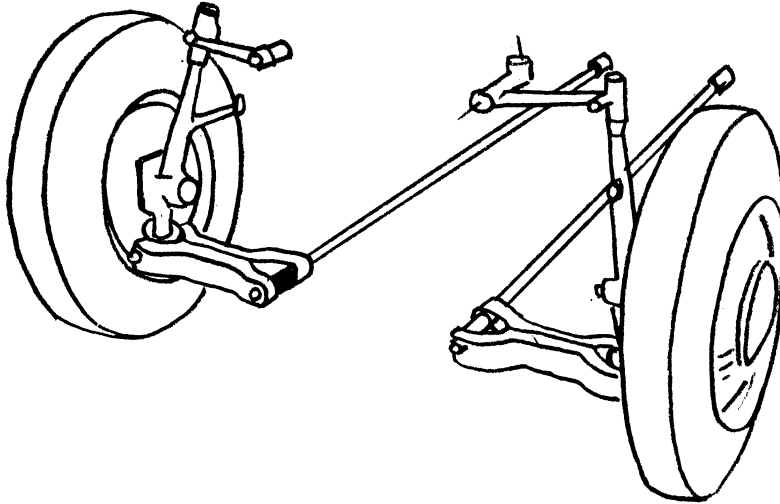

Figure T4. Longitudinal Torsion Bars - Wolseley - GB.

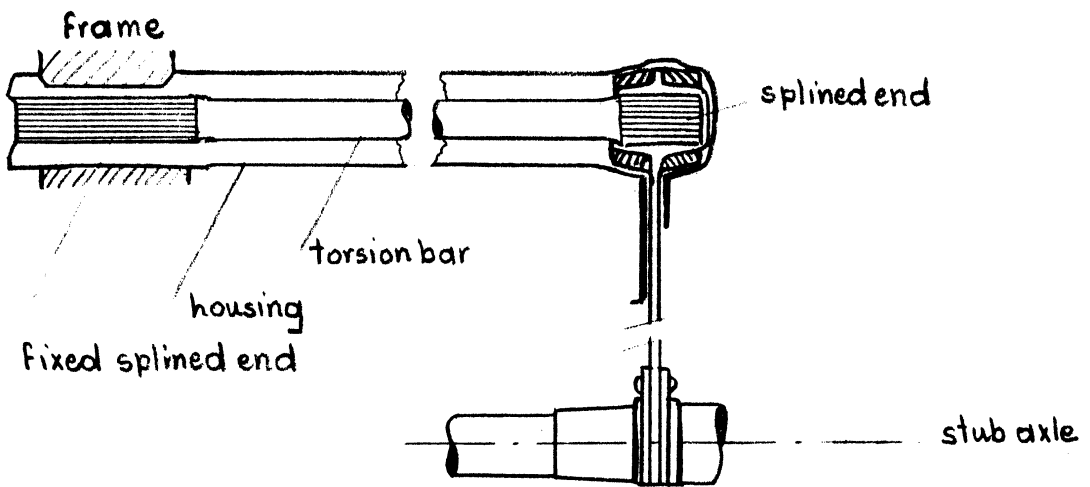

Figure T5. Volkswagen Rear Torsion Bar.

The flat torsion bar is used only in England by Salter Company. The ratio of width/thickness is about 5. This type requires more width but less length than the round bar, and variable spring rate is permissible owing to the S-shape torque twist.

Figure T6 shows the minimum rate that occurs when the spring is flat. This classification shows us the absence of uniformity in design, and all the possibilities available to the designer.

Some Particularly Interesting Examples

For example, let us study the most common use of torsion bars in United States passenger cars:

Packard Torsion Level Suspension - Figure T7.

Design. Packard's new torsion-level suspension combines a torsion bar suspension system with an automatic leveling adjustor. This system is unique in that the torsion bars connect both the front and rear wheels. The automatic levelizer compensates for uneven distribution of loads in the car and keeps it level and stable at all times. Short torsion bars (1) connect the rear wheels to the frame. The adjusting mechanism (2) attached to these bars keeps the car level regardless of the condition of the road. The lower levers bear upon the lower frames of the front suspension through struts. The rear axle is held laterally by the stabilizer and fore and aft against rotation by torque arms (4).

Operation. When, for instance, the front wheel hits a bump, the wheel rises, twisting the torsion bar (5) by front suspension linkage, causing an increase in the upward load at the torsion bar lever bracket attached to the front channel of the frame. The increase in twist in the bar causes the loading of the lever at the rear end of the bar to increase, thereby increasing the push of the rear wheel on the ground. The end result is the lifting of the car without excessive pitch.

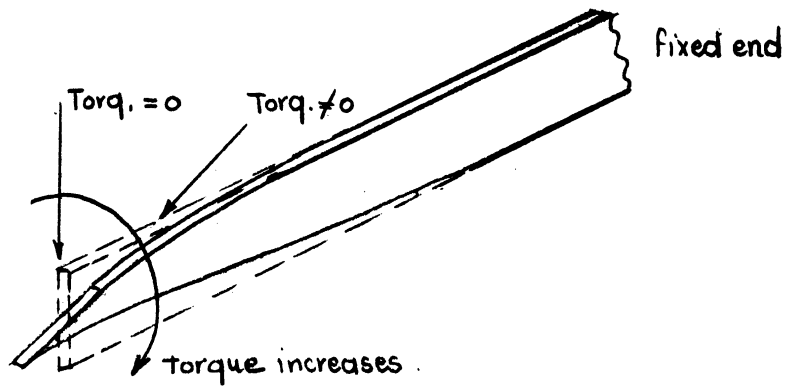

Figure T6. Flat Torsion Bar.

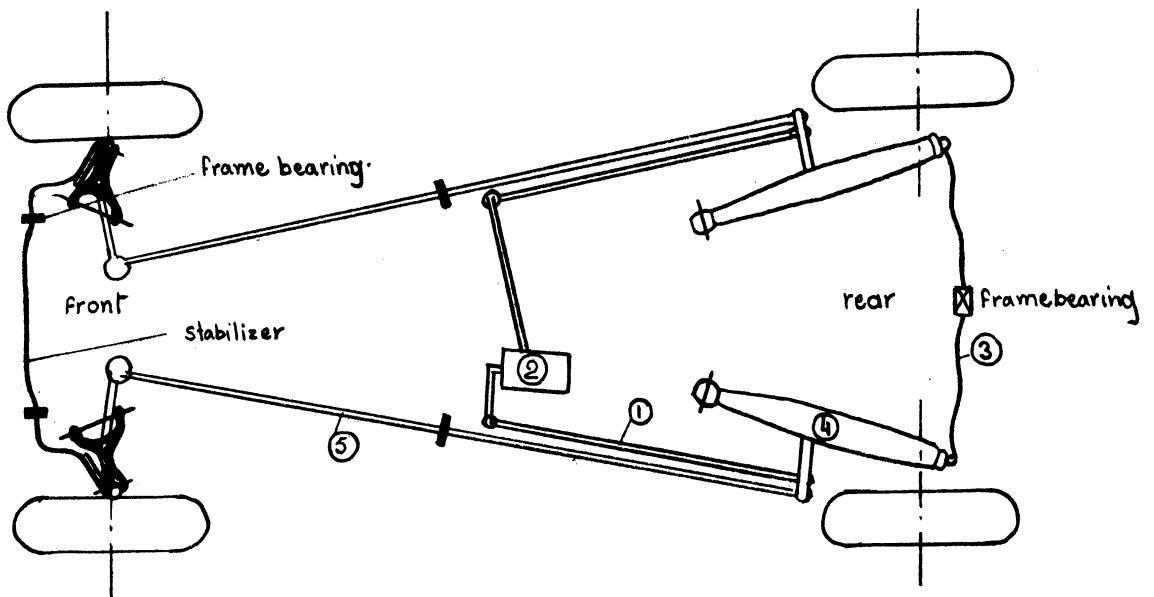

Figure T7. Packard Suspension.

The compensating mechanism. The two short rear bars (1) when twisted, actuate an electric motor (2) through gear reduction and linkage. In so doing the motor winds the bars (1) in either direction in order to raise or lower the car depending on the direction of the load applied.

Advantages. Packard Company feels that the torsion level suspension has the following advantages:

- 1) Flat ride - owing to the long torsion bars
- 2) Level ride - owing to the compensating mechanism
- 3) Softer ride - owing to the low spring rate of long torsion bars.
- 4) Less dive on stopping - no rear end squat.

Chrysler uses the short torsion bar both in the front and end suspensions.

Many European Car Manufacturers Use Torsion Bars at the Rear.

In England:

Bristol and Frazer-Nash - with torsion bars at rear
Jowett - in front and rear
Vauxhall, Jaguar, Lea Francis, Morris, Riley, Armstrong
Siddelay - in front only.

In France:

1934-1955 Citroen - in front and rear (longitudinal
and transverse bars)
Panhard - in rear only (transverse multi-torsion bars)
Salmson - in front only

In Germany:

Volkswagen - in front and rear (Figure T5)
Mercedes

Discussion

The use of torsion bars requires wishbone suspension arm anchorage in the front and torque arm in the rear; at least in the passenger car field.

Torsion bar suspension has been used on trucks. Such heavy-duty vehicles were equipped with dual or tandem rear axles.

In the military field, the torsion bars have proved singularly successful for the suspension of tanks and similar equipment, which operated

over rough terrain and required very large wheel movements. Thus, long torsion bars mounted on the vehicle allow for high flexibility with adequate strength.

Advantages

1. A torsion bar can absorb more energy per pound than any other spring. This is due to its efficient, uniformly-stressed shape.
2. Length could be reduced by using bundles of bars as in the case of Volkswagen (front) or Panhard (rear).
3. Variable spring rate with load and wider range of flexibility with varying load. We notice the increase of the spring rate with the load as sought by engineers. (See curve-load deflection Figure T8).
4. High degree of freedom for the designer in the layout of the chassis, because of its simplicity, compactness and absence of special machining.
5. No external lubrication.
6. Allows leveling device because it is relatively easy to rotate the anchorage of the bar in the frame.
7. Lower noise level by use of rubber bushing in linkage.
8. Indefinite life without sag.
9. Soft ride due to low spring rate of torsion bars. Hence better handling.

Disadvantages

1. Like coil springs, torsion bar springing is extremely responsive to road shocks, and damping through shock absorbers is required.
2. Manufacturing is highly specialized. The steel must be centerless ground, to eliminate decarburization and surface defects.
3. Anchorage to the frame must be given special attention. Bars are usually splined and stress concentration could occur; resulting in fatigue failure of the rod. Special heat-treatment is required for minimum warping.

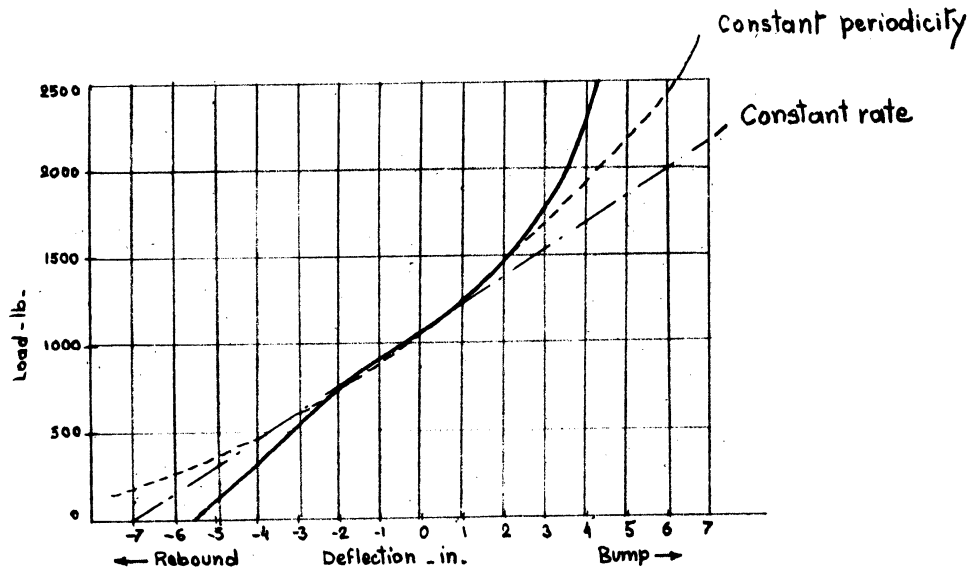

Figure T8. Example of Torsion Bar Characteristics. (Bristol-GB.)

As in the case of coil springs, the function of the torsion bar is none other than springing the load. So that they cannot function without lever systems or other mechanisms (torque rods, lever arms). Therefore, it is quite unfair to compare cost and weight without counting these auxiliary mechanisms. Cost can be reduced only through large-scale production.

Conclusion

Torsion bar suspension is a very attractive solution. At the present time, it is used mostly for military purposes (tanks), where price is not such an important factor.

BIBLIOGRAPHY ON TORSION BARS

1. Hendrickson, N. E., and Fahnestock, M., "Comparing Fundamentals of Spring Suspension," SAE Journal, October, 1949, Vol. 3, No. 4, pp. 571.
2. "Manual on Design and Application of Leaf Springs," SAE Publication.
3. Hendrickson, N. E., and Fahnestock, M., "Comparing Fundamentals of Spring Suspensions," SAE Quarterly Transactions, October, 1949, Vol. 3, No. 4, pp. 571-579.
4. Persner, J. M., "Equalizing Types of Suspension," Automobile Engineer, January, 1957, pp. 10.
5. Bateson, N. E., "Problems in Commercial Vehicle Suspension and Their Elimination by Torsion Bars," SAE Transaction, October, 1947, Vol. 1, No. 4, pp. 549-556. (Discussion pp. 556-558.)
6. Bradley, W. F., "Torsion Bar Suspension," Automotive Industries, February 1, 1950, Part I, pp. 38-43.
7. McFarland, F. R., "The New Packard Torsion Level Suspension," SAE Preprint No. 537, presented at the SAE Golden Anniversary Summer Meeting, Atlantic City, N. J., June 12-17, 1955.
8. Colby, J. M., "Torsion Bar Suspension," SAE Quarterly Trans., Vol. 2, April, 1948.
9. Colby, J. M., "Revolutionary Developments in Wheeled Military Vehicles," SAE Quarterly Transactions, Vol. 3, April, 1949.

AIR AND OIL-AIR SUSPENSIONS

Air Suspension

Introduction

Ride improvement in automobiles has been sought for continually by engineers through the use of different types of springs; the most common being steel springs, such as leaf, torsion bar, or coils.

The preceding chapter has pointed out the different shortcomings that engineers have to meet. They are:

1. Constant rate - the characteristic of metal springs is that the spring rate remains more or less constant for different amounts of load applied. However, an ideal spring is one whose rate increases with load, in order to prevent or at least to soften "striking through". Many auxiliary devices have been found to provide a variable-rate suspension (Gregoire's system, shackle arrangement).

2. Variable frequency - frequency of the suspension increases with load, and therefore, the ride is not constant. In other words, the ride will be soft at full load, while it will be rough at light loads. This effect is more noticeable in heavy-duty vehicles and buses where the load undergoes a great change. This difficulty was overcome through different auxiliary devices (double stage suspension).

3. Friction damping - friction damping was seen to be a disadvantage in leaf springs, since it causes the suspension to behave in a rough manner at light loads. However, this difficulty has been partially overcome.

4. Variable platform height - variable platform height is one of the major disadvantages. This requires large clearance between wheels and frame. To compensate for this, automatic leveling control devices have been

designed, but not without complications and additional cost.

5. Fatigue life - economy of material and high operating stress ranges limit the life of the spring. However, improvements have been made in steel spring metallurgy.

6. Noise transmission - since the steel has the highest transmissibility factor, axle, wheel, brake, and tire noises are transmitted through the suspension.

These limitations recognized by engineers became more and more objectionable in a world where comfort is an important criterion. Thus, the search for a better suspension was diverted into the air suspension field. Since this type of a suspension is going to follow, we will ask ourselves at this point what the criteria of good suspension are, and the answer to this will be:

1. The spring must be reasonable in cost and size. The latter is particularly important to keep in step with the trend of low car design in the future.

2. It must have a long life.

3. It must be adaptable to any type of suspension.

4. It should allow for change in stroke length without altering other features.

5. It should have the desired spring rate characteristics to provide good ride, comfort and handling.

The most important mechanical feature of a spring is its spring rate characteristic since this is directly involved in comfort and ride qualities. Studies of this particular feature were conducted under the assumption of ideal load deflection curve (Figure A1). Analyzing this figure, we realize that the spring should have a high spring rate at the end in order to reduce "striking rough" (DC) and at the same time, have a gradual transition

portion between high and low rate. It is also desirable to seek a considerable reduction in load on rebound (AE). Air suspension gives most of these features (low constant rate near the static deflection, and increasing rate in compression and rebound).

Principle

The simplest air spring consists of two principal devices:

1. Passenger car device - Figure A2

Air can which contains a volume of air

A diaphragm which is basically a rolling seal

Piston and skirt - together they define the boundaries within which the diaphragm rolls.

As the axle moves up and down, the bellows flex, causing change in volume with a resulting increase or decrease in air pressure. This constitutes the elastic medium which absorbs the shock of the bump.

2. Heavy-duty vehicle device - Figure A3

Suspension consists only of bellows which contain the air. These bellows are connected with air reservoir under pressure.

The necessity of air pressure control requires the use of an air feeding system which basically consists of:

Air compressor - to keep the supply of compressed air

Air tank - to store a reserve of air under high pressure

Control valves - to admit or exhaust air from the spring and ensure the required pressure.

Air suspension has been used for a long time in buses and trucks. However, only this year (1958) this type appeared in passenger cars also.

Let us examine different devices used in suspension in order to have some idea of how such an air spring is built and what its operating characteristics are.

Heavy-duty Vehicle Suspension. Air suspension has been used in buses for many years (i.e., General Motors Corporation).

Air spring. Every heavy-duty suspension has the same principle. However, the design differs in detail only due to different manufacturers.

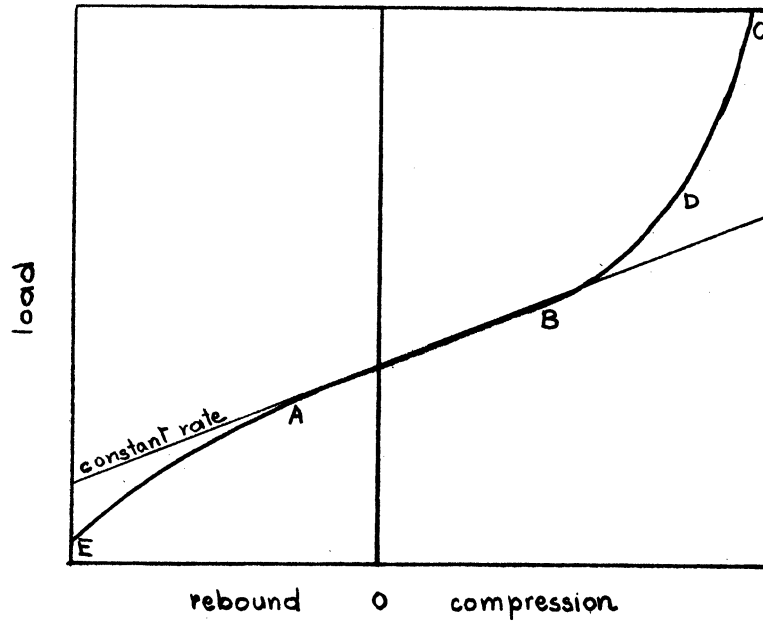

Figure A1. Ideal Load-Deflection Curve.

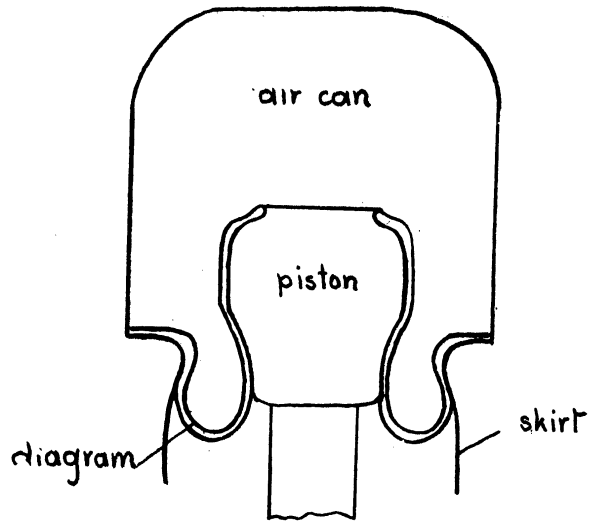

Figure A2. Car Air Spring.

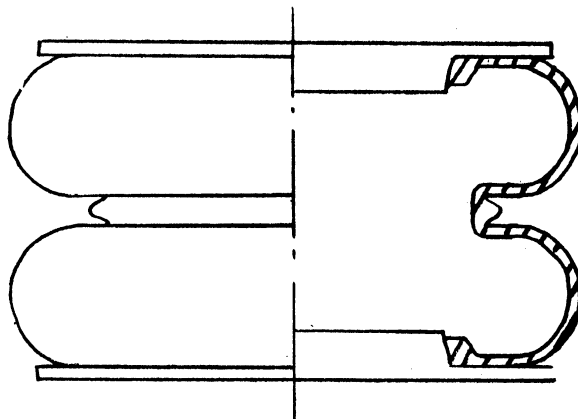

Figure A3. Bus Air Spring. (Firestone)

In other words, the design will consist of bellows in variable shapes and numbers. Figure A4 shows the Mack Bus Airglide suspension with four bellows per wheel mounted on ends of rigid truss formed-beams which are secured to the axle the same way as the conventional leaf springs are.

The General Tire and Rubber Company, which builds the Mack Airglide, also provides a spring consisting of two individual cells with interconnecting passageways. (Figure A7). These cells are joined and bound to upper and lower metal channels in a curing process. Passageways between the spring and the lower beam offer sufficient resistance to produce about one-half of the necessary damping. Notice that the load is distributed over a greater length. The Dunlop Rubber Company (G.B.) has developed the Pneuside air suspension (Figure A6) similar to that above. The same sort of thing has also been developed by the Clark Equipment Company (U.S.). General Motors Corporation has used air suspension for buses in the past and also uses it in trucks at the present time.

Air reservoir. Generally, all these suspensions use air reservoirs in connection with bellows, in order to increase the air volume involved in the suspension and ensure a relative softness and low natural frequency. This natural frequency as shown in Figure A5 is a function of the ratio between the bellows volume and the total volume. If bellows were used without air reservoirs, the natural frequency will range at values that are too high. This air reservoir can be a separate tank, or a part of the frame which is hollow for the purpose of containing air under pressure (General Motors Corporation).

Automatic suspension control. Figure A6 shows a basic system together with its linkage assembly. When load on body increases, the arm rises and the valve is operated to admit more air to the system. This

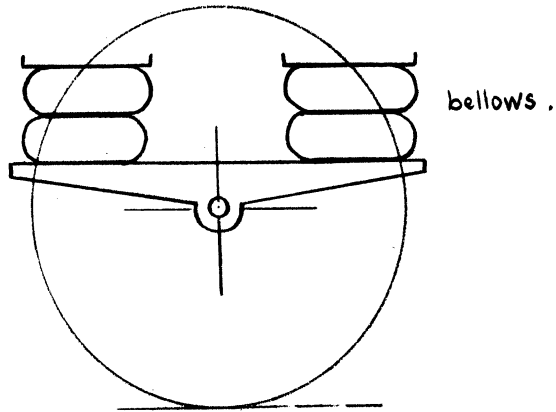

Figure A4. Mack Bus Airglide

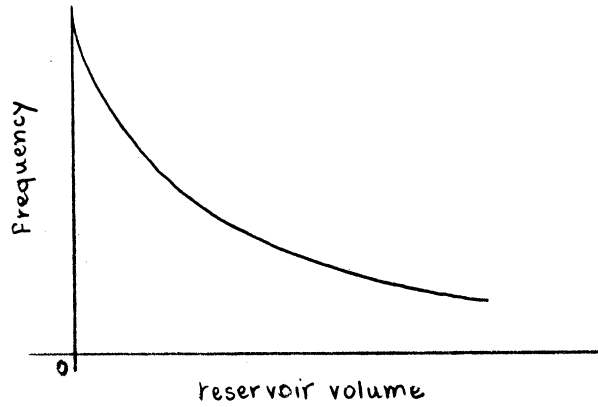

Figure A5

Natural Frequency vs. Reservoir Volume.

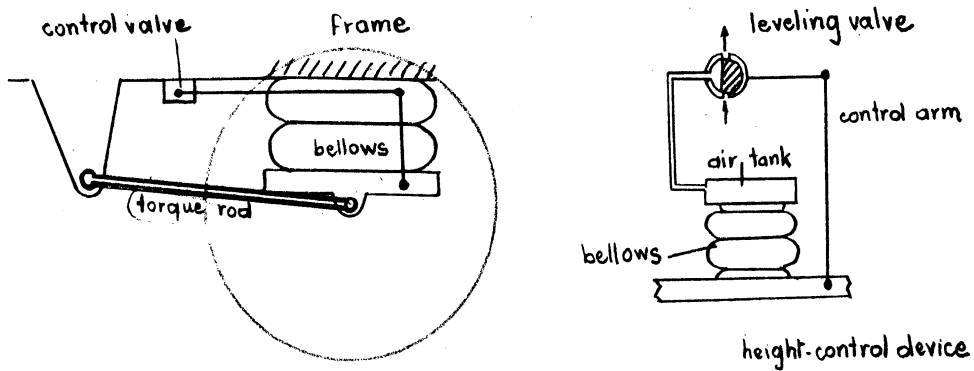

Figure. A6. Pneuride Suspension.

pressure build-up returns the body to its original height. The end result of this automatic suspension control is two-fold; one, the body is always maintained at a fixed position relative to the axles, regardless of the load; second, the deflection rate of the system remains directly proportional to the load, thus causing the frequency to remain constant and the same soft ride, regardless of the load.

Another important function with regard to valve design is that it never admits or exhausts air except when the load is changed, since it pays no attention to normal movements of the axle which occur when the car is moving over a rough road. This function is accomplished by means of a hydraulic damping device mounted on the valve. Failure of any part of the suspension system will not cause a loss of vehicle control, since if a failure would occur, the frame will rest on heavy rubber blocks and all linkage relationships would be maintained.

Control of axle position - linkage. Since air springs are only able to support load in compression, appropriate linkage must be provided to overcome sway, driving and braking forces. In other words, any lateral or longitudinal movement, any twisting of the axle about its own axis, any turning out of the verticle plane, is to be avoided.

Axle positioning is done by a system of torque rods and bars which are equipped with rubber bushings to absorb shock and road noise while eliminating lubrication requirements.

Rods are mounted in fore and aft direction as shown in Figure A6. Lateral bars keep the body centered over the axle while sway bars prevent rolling about the longitudinal axis. Figure A8 shows another linkage used in trucks.

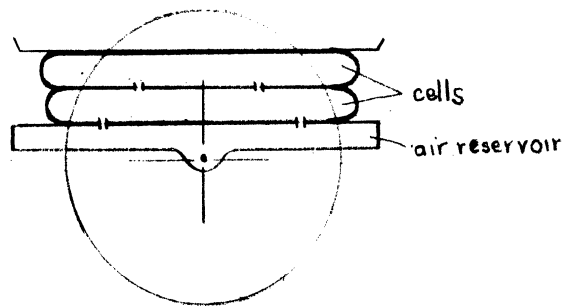

Figure A7. General Tire Cells.

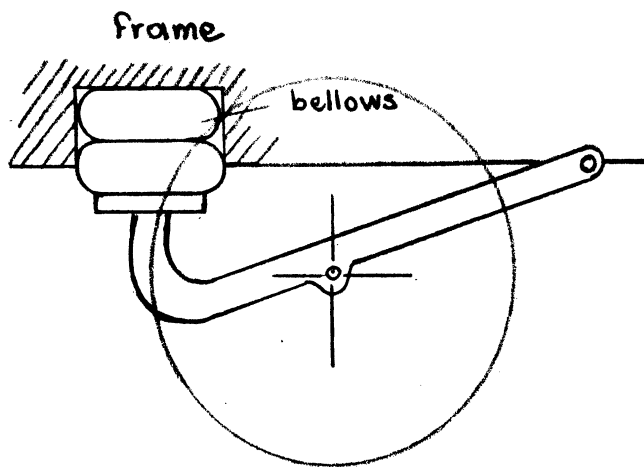

Figure A8

Truck Linkage Used.

Damping. Since all friction is eliminated, damping is absorbed only by shock absorbers. However, notice at this point the partial self-damping of general tire cells (Figure A7) as explained above.

Passenger Car Air Suspension. The basic air spring in passenger cars is not formed by bellows, but rather with piston, skirt, and diaphragm. This device provides a more acceptable ride since its natural frequency is lower as shown in Figure A9.

Let us examine the most common air suspensions available today.

1958 General Motors air suspensions (Pontiac, Cadillac Eldorado Brougham). Figure A10 illustrates the spring and Figure A11 shows the installation. Air is compressed by the air pump and stored in the high pressure tank connected to a pressure regulator valve. This valve outlet leads to the front height control valve on one side and to both rear height control valves on the other side. These valves are connected to the springs, and their exhaust line runs back to the pressure regulator valve. In turn, the pressure regulator valve leads to a junction block which exhausts the air to the compressor and/or the compressor intake. This junction block is located in the carburetor air cleaner which functions both as a silencer and air cleaner for the system. Only three height-control valves are employed (three points determine a plane). All valves are mounted solidly on the frame. At the front, the valve is connected to the roll bar and at the rear they are connected to the power control arms.

1958 Ford air suspension (Edsel). The control system is about the same as General Motors' and differs only in details. For example, it has two speeds. It provides fast leveling when the doors are opened and load changes are likely to occur, and slow leveling when the car moves with doors closed. It also has three leveling valves (two in the front, one at the rear).

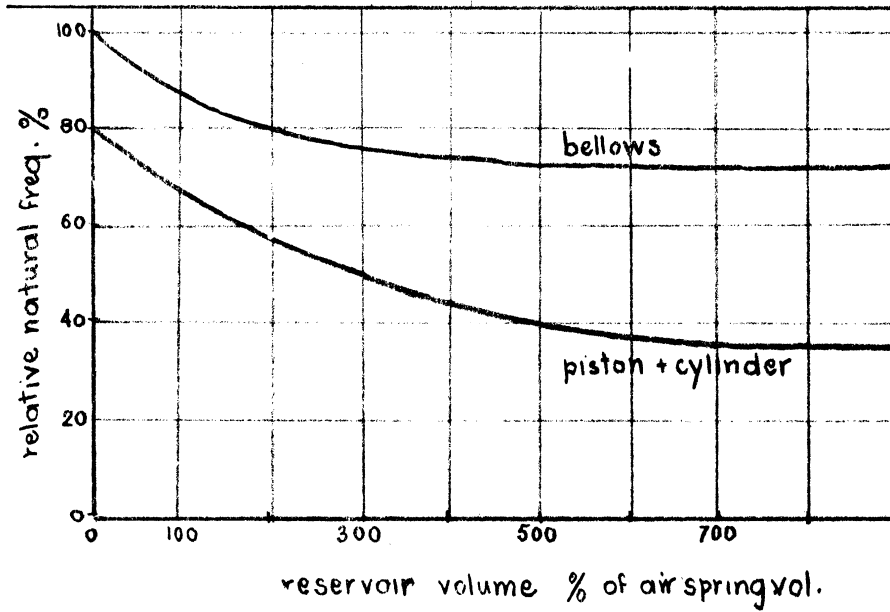

Figure A9

Natural Frequency vs. Reservoir Volume.

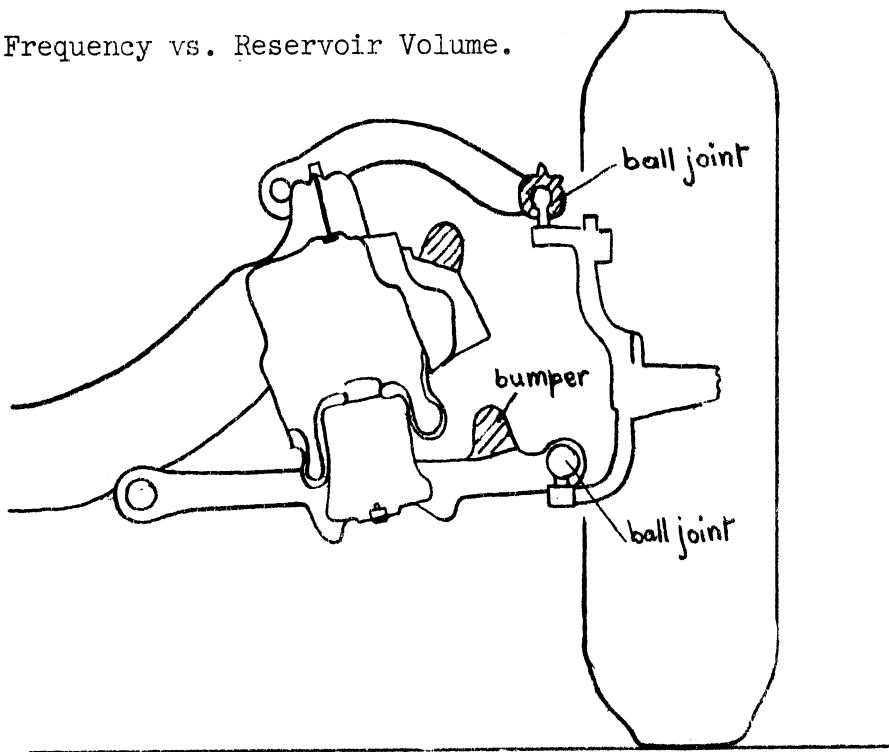

Figure A10. Pontiac Air Spring. (Front)

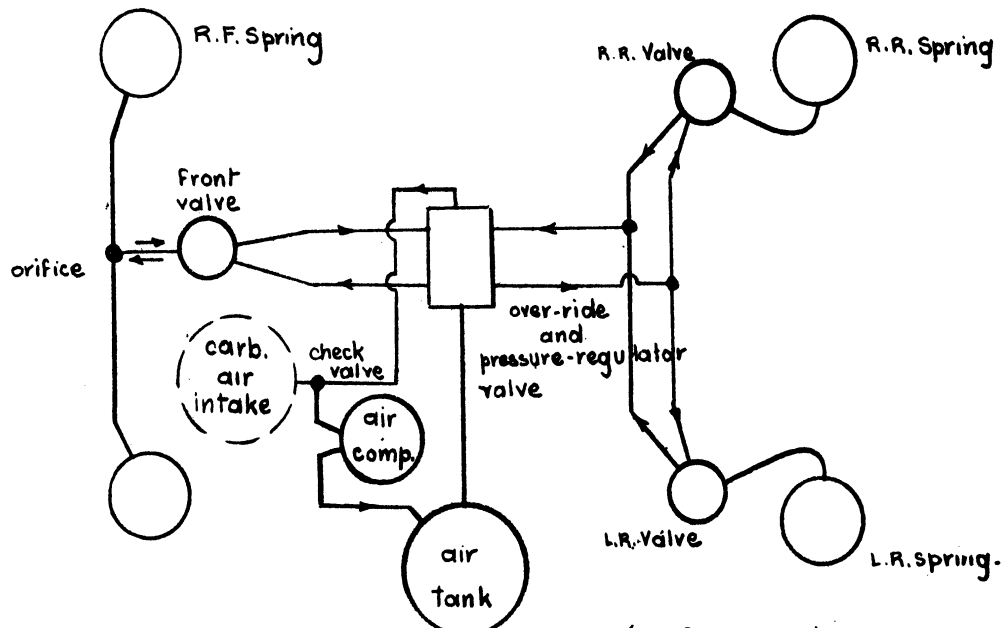

Figure A11. Height Control System - (1958 GM Cars).

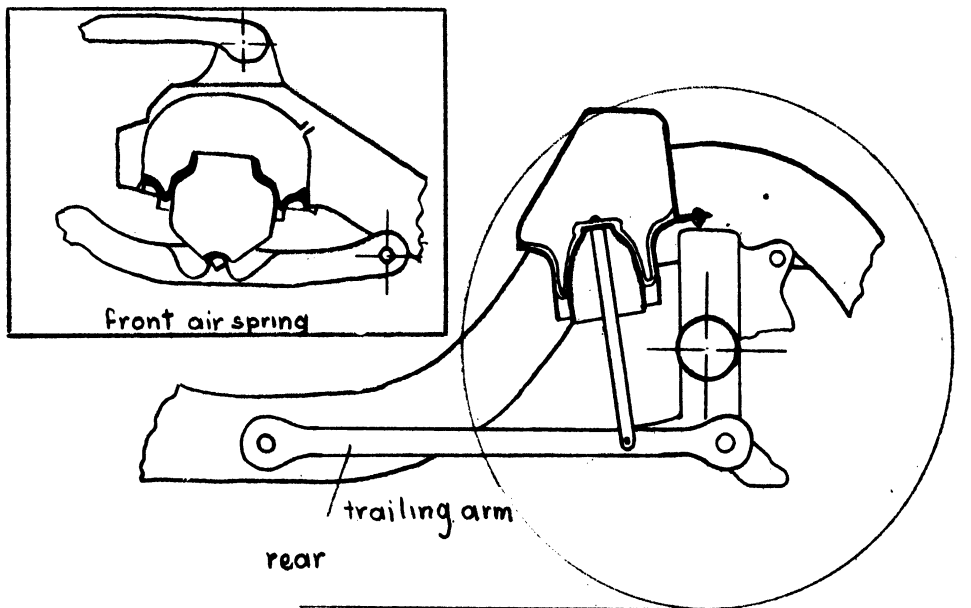

Figure A12. Cadillac Air Spring (Rear)

Figure A13 shows the Ford air spring and its utilization in the rear suspension.

Linkage. In adopting air springs, it was possible to use conventional front linkage used with metal springs. That is, upper and lower control arms. At the rear, modifications were significant. A trailing arm with rubber bushing as mounted in the fore and aft direction. (Figure A12). Lateral stability is provided by a track bar which keeps the body centered over the axle.

Theoretical Consideration of Air Suspension

The examination of truck and car suspensions indicates that both are being served by the same principle and consist of the following arrangement:

Piston, skirt and diaphragm for passenger cars

Bellows and air reservoir (whose number, shape, and location vary) for heavy-duty vehicles.

Control valve system whose first duty is to establish proper pressure in the air springs. Then it provides a self-leveling control to keep the frame height constant. Finally, it may also provide a shock absorber anti-roll effect (Figure A7).

In studying an air suspension, engineers must concern themselves with suspension factors:

Load, deflection, effective area (function of piston and cylinder shape), volume, natural frequency, spring rate and reservoir size (if any).

Figure A14 gives an idea of the relationships between these different values for a bellow spring.

Rough calculations of an air spring are as follows:

Load carried $F =$ air pressure $P \times$ effective area A or

$$F = P \times A$$

$P =$ absolute pressure

$P_0 =$ atmospheric pressure 14.7 psia

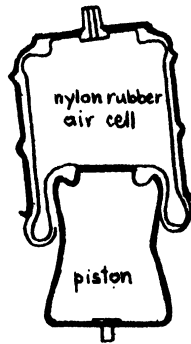
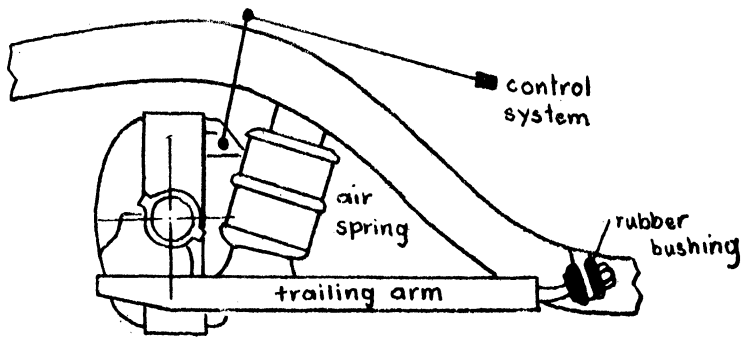

Figure A13. Ford Air Spring.

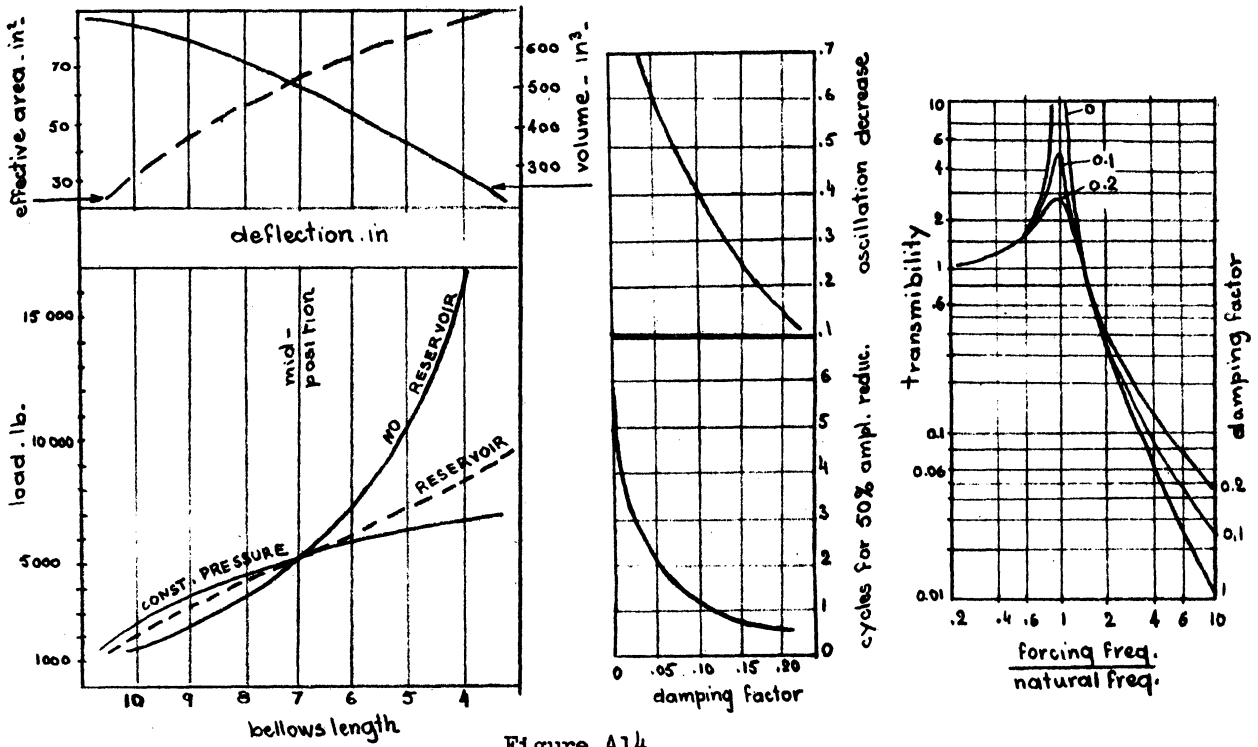

Figure A14.

Relationships in Air Suspension.

Compression law: $P \times V^n = P_0 V_0^n$ where $n = 1.4$ if adiabatic
 $n = 1$ if isothermic

$$\text{Hence } F = \left(\frac{P_0 V_0^n}{V^n} - 14.7 \right) A$$

$$\text{Spring rate } \frac{DF}{dx} = R = \left(\frac{P_0 V_0^n}{V^n} - 14.7 \right) \frac{DA}{dx} - \frac{n \cdot P_0 V_0^n A^2}{V^{n+1}}$$

This last formula shows that:

Since $n = 1$ for isothermic compression and $n = 1.4$ for adiabatic compression, the spring will have two different load-deflection characteristics that form the limits between which the spring will operate. (Figure A15).

The spring rate R depends on

- the load F
- the pressure P
- the effective area A
- the volume of the spring V
- and also on the rate of change of the effective area with the deflection

This explains why we have seen different piston shapes - Figure A16 shows different characteristics obtained with different piston shapes. Furthermore, this explains why air reservoirs are necessary, as shown in Figure A5, especially for heavy-duty vehicles because it is important to keep the natural frequency acceptable and at the same time avoid roughness. Hence, this explains how deflection may be kept constant under varying static loads by varying air pressure. (Figure A17).

Conclusion

Let us examine the advantages and disadvantages of air suspension.

Advantages

1. Air suspension brings a real improvement in comfort. It provides a soft ride when the vehicle is empty and a moderate firm ride when it is loaded. This is due to the characteristics of air springs which can approach the ideal characteristics, which are as follows:

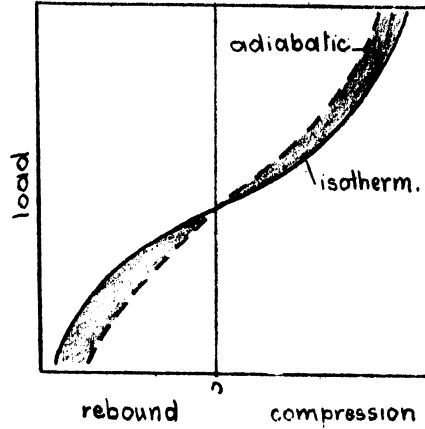
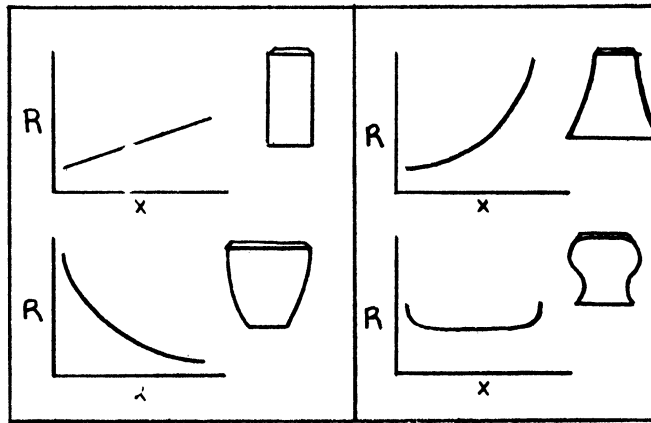

Figure A15.

Load-Deflection Characteristics.



Possible rate characteristics with different piston shape

Figure A16.

Piston Shapes and Rate Characteristics.

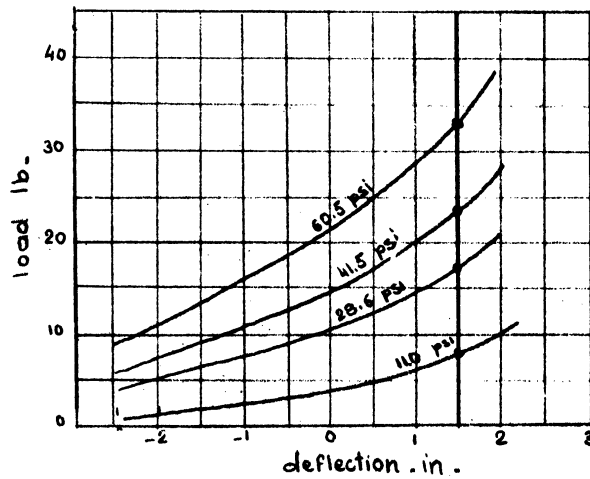

Figure A17.

Load-Deflection Characteristics.

- a) constant spring rate near the static deflection
- b) variable rate - increasing spring rate in compression or rebound (Figure A1).

2. The more the air is compressed, the more its resistance gives rise to the possibility of changing the load-deflection characteristic curve by changing the air pressure. This feature leads to the following other advantages.

3. This type of suspension features great reduction in high frequency vibrations and good sensibility for even the slightest vibration. Hence, there is no stiffness.

4. The noise level is very low because of the large resistance to transmission through air (spring) and rubber (linkage).

5. Constant height of the vehicle is maintained at full load or no load. This function is taken care of by the fully automatic height-control valves which simply call for air until the load is carried at the normal spring height. This permits limited clearance over the axle and thus permits an increase in the interior loading space.

6. There is no appreciable wear in any part of the system. No lubrication is required since there is no metal-to-metal friction, even in the linkage since it is equipped with rubber bushings. Thus, maintenance is lowered.

7. Air has no limited life. This is due to the fact that springs operate at very low flexible stresses so that their life is much improved over metal springs.

8. The linkage is no more complicated than that of other springs.

Disadvantages. The first disadvantage which comes to mind is the complicated device which could increase the cost and wipe out any advantages. Moreover, difficulties have been encountered in preventing leakage.

Even though partial damping could be provided by the air circulation (Figure A7), shock absorbers usually provide full damping and therefore are always necessary.

Air suspension is believed to be the future solution in suspension, especially for heavy-duty vehicles. This is because of its highly superior springing characteristics. Nevertheless, there are some people who do not recognize some of the advantages of its use in trucks, and say:

"Considering the advantage of variable rate as a means of avoiding 'strike through', the benefits will be on the whole considerably less where constant level is maintained. Indeed this advantage can be found in regular suspension with constant-level device and adequate bumpers. The air spring which is wider than the leaf spring will probably necessitate sacrificing some of the width available between wheels."

However, these examples of criticism do not seem very strong and the economical conditions of the air suspension system will probably lead to the replacement of leaf spring suspension for heavy-duty vehicles.

In fact, if some failures have been recorded, it was due to the lack of experience and the relative youth of air suspension. In conclusion, it can be said that much may be expected in future design along this line.

Air suspension for cars seems to be tomorrow's solution, since it is conceivable that the ultimate in design will be a power suspension of some type. With gas turbines or free piston engines, excess power will be available for more power accessories, thus permitting the use of such a suspension.

A suspension of this type will require a sensing device and a very fast follow-up arrangement which will maintain wheel contact on the road and keep the vehicle at constant level with very soft ride under any load.

Oil-Air Suspension

This type of suspension possesses very interesting characteristics. At the present time, it is used only in one model of passenger car, the Citroen D19 (France). All other applications are for dream cars (Firebird II) or in some military vehicles.

Principles

The air spring is actually a rubber ball in which nitrogen has been sealed under pressure. This is enclosed in a metal sphere which forms the upper end of what looks like a direct-acting shock absorber. Thus the spring and damper are in one compact unit.

The damping function is secured by oil. A suspension unit consists of a cylinder containing oil under pressure and air spring (Figure D1). Independent wheels are mounted on trailing arms which are pivoted and interconnected by a transverse bar between two front or rear wheels. Normal bump loads are taken by the trailing arm which actuates the piston in the cylinder. The oil is forced through a double-acting restrictor valve against the rubber diaphragm of the air spring. The restrictor valve functions as a shock-absorber.

A second torsion bar connected at each end to the anti-roll bar operates a height corrector valve for constant leveling, whenever the car load is changed. This type of arrangement increases or decreases the oil pressure in the cylinders thus maintaining the car at constant height.

Advantages

Very soft ride, due to the low-frequency, critically damped system (which prevents damped oscillations).

Automatically controlled variable-rate system.

Damping device within the suspension unit.

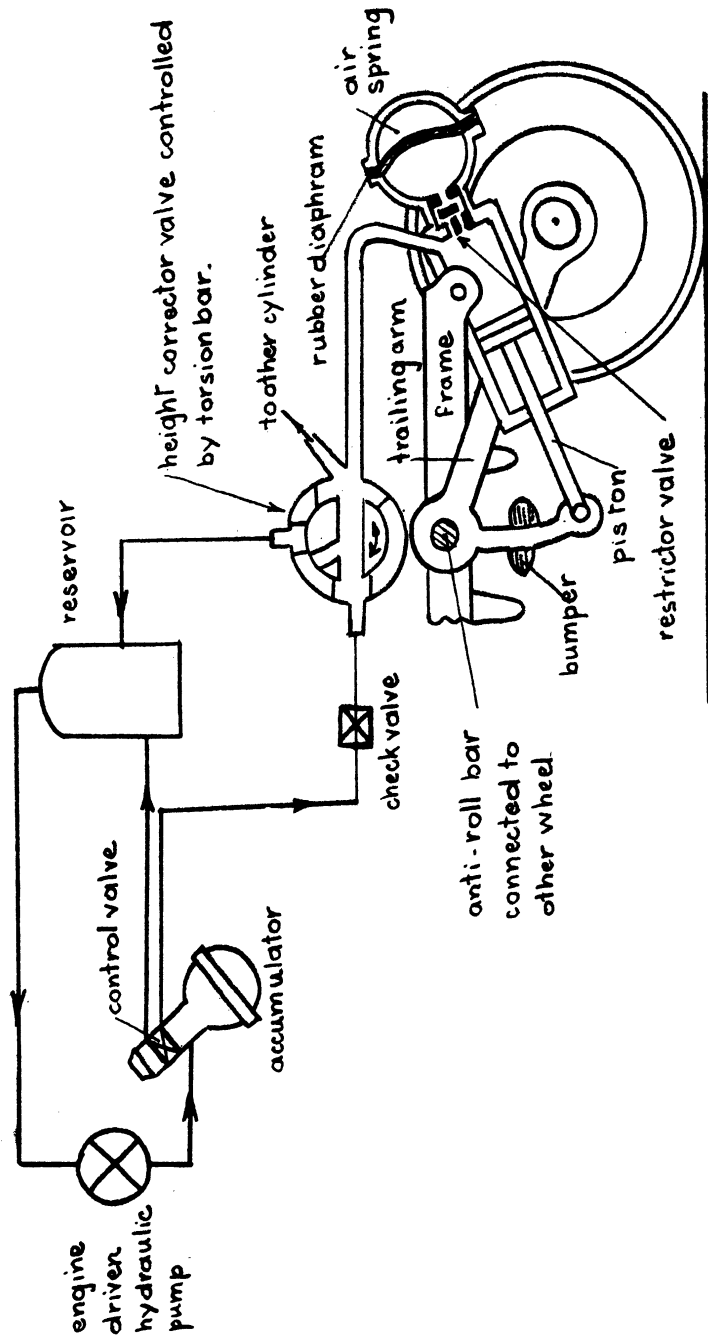

Figure D1. DSL9 Suspension.

Automatic self-leveling control.

No maintenance.

Disadvantages

Complexity (very long plumbing - numerous control devices).

High precision manufacturing.

BIBLIOGRAPHY ON AIR SUSPENSION

1. Fox, H. E. and LaBelle, D. J., "Motor Coach Suspensions," SAE preprint No. 170, presented to the SAE National Transportation Meeting, Chicago, Illinois, November 2-4, 1953.
2. Slemmous, C. O., "Air-Spring Suspensions Find Life Begins at 50," SAE Journal, July, 1954, p. 40.
3. Deist, H. H., "Air Springs," Machine Design, February 6, 1958, p. 141.
4. Brown, Roy W., "Air Spring - Tomorrow's Ride," SAE Journal, Vol. 38, No. 4, April, 1936, pp. 126-132.
5. Hirtreiter, A. B., "A Resume of Bus Suspensions," SAE preprint No. 847, presented at the SAE National Transportation Meeting, New York, October 10-12, 1956.
6. Aldikacti, H., Anderson, E. W., and Harrison, R. D., "Riding on Air," presented at the Junior Panel Meeting, Detroit Section, SAE, November 25, 1957.
7. O'Shea, C. F., "The Ford Approach to Air Suspension," SAE preprint No. 9C, presented at the SAE Annual Meeting, Detroit, Michigan, January 13-17, 1958.
8. Perkins, R. W., "Oldsmobile New-Matic Ride," SAE preprint No. 9E, presented at the SAE Annual Meeting, Detroit, Michigan, January 13-17, 1958.

RUBBER SPRINGS

In automotive industries, rubber is used on a large scale for vibration insulation (Silentbloc-Ball points-Cushions) as well as for noise reduction.

It was for its resilient properties that engineers accepted rubber for suspension purposes. However, it has not been adopted extensively.

Principle

Rubber can be used in two ways: one, in shear (Silentbloc); two, in compression (extension).

Utilization of Rubber in Shear

Figure R1 illustrates this principle: the lever arm suspension is resisted by shearing stresses applied on the rubber which is vulcanized, on the inside, to the arm axle and, on the outside, to the tube which is anchored to the frame. This system has been used for suspension in buses and it is known as the Torsilastic system. (Figure R2 - England). The rear axle, for example, is moving through the shackles and a pair of crank arms. The shackle arrangement reduces side sway and wheel tramp. The axle is located longitudinally and transversely. In the front suspension, the system is the same. But, since the spring acts only as a load carrying member, the path of the wheel must be controlled by the geometry of the linkage.

Note: The spring rate increases with deflection. But with vehicles subject to a wide variation in load (buses), it is desirable to provide additional resilient resistance within the spring suspension. This additional resistance should not alter the frequency of the suspension which in turn will vary the riding condition. Hence, a constant level device permits the reduction of spring rate at will, and thus provides a softer ride.

This self-leveling device could be shown diagrammatically as one cylinder with two pistons and a lever arm connected to each one of them. Both pistons are in the same cylinder and oil is supplied automatically through a valve actuated by a linkage so that as the pressure rises, when the bus is loaded, the spring rate is increased through the piston action. To avoid cycling due to action on the road, each valve is damped hydraulically.

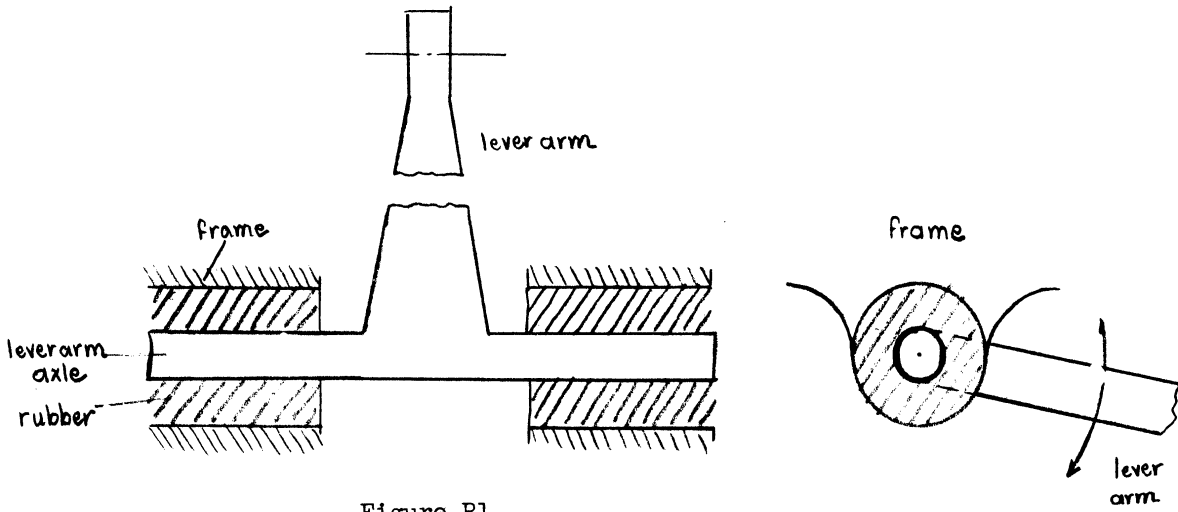

Figure R1.
Rubber in Shear.

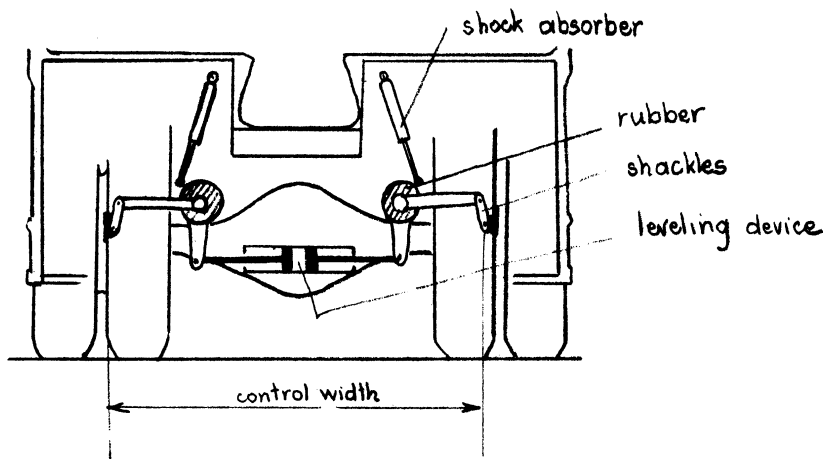

Figure R2. Torsilastic Suspension.

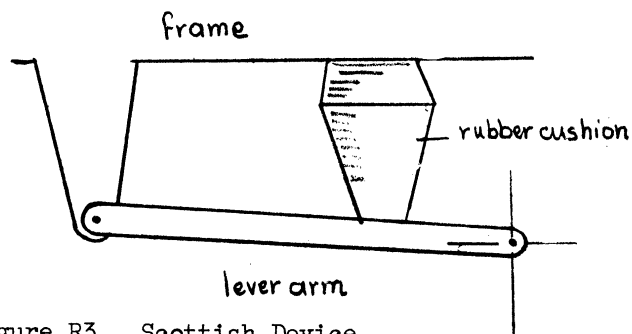

Figure R3. Scottish Device.

Figure R5 shows the Metalastick system (6B) used in front independent suspension. The spring acts only as a load carrying member while the path of the wheel is controlled by the geometry of the linkage. The curve shows how the spring rate is increased with deflection which is obtained by the use of rubber in combined compression and shear.

Utilization of Rubber in Compression

Figure R3 shows the most obvious device resulting from such utilization. It consists of a simple trailing arm suspension on both front and rear, with double conical compression type rubber springs. Notice that this shape allows a variable spring-rate. The General Tire and Rubber Company provides a system of suspension which is now used by Neidhart trailers (2-ton capacity).

Figure R4 shows clearly the compression role of rubber in the torsion arm device. Springs consist of rubber elements placed without any bond in longitudinal spaces between lever arm axle and fixed member. The fixed member crossed the trailer frame without requiring special construction. Note on the characteristic curve the increase of the spring rate with the load.

Discussion

The above mentioned devices show the relative simplicity of this type of suspension. However, the material specifications and the control require experience in rubber technology.

Necessity of damping - with rubber-spring suspensions, it is agreed that the average coefficient of damping should be at least one-third of the critical damping. Therefore, rubber should only be used with a supplementary damper capable of supplying one-half or one-third of the damping of the actual suspension. Hence a shock absorber is necessary.

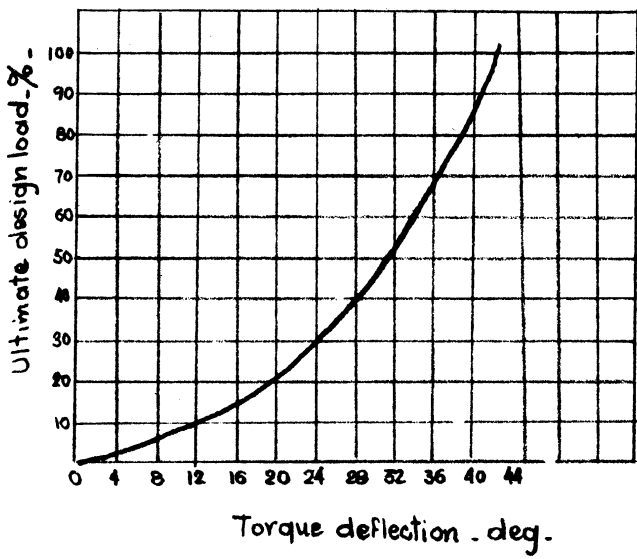
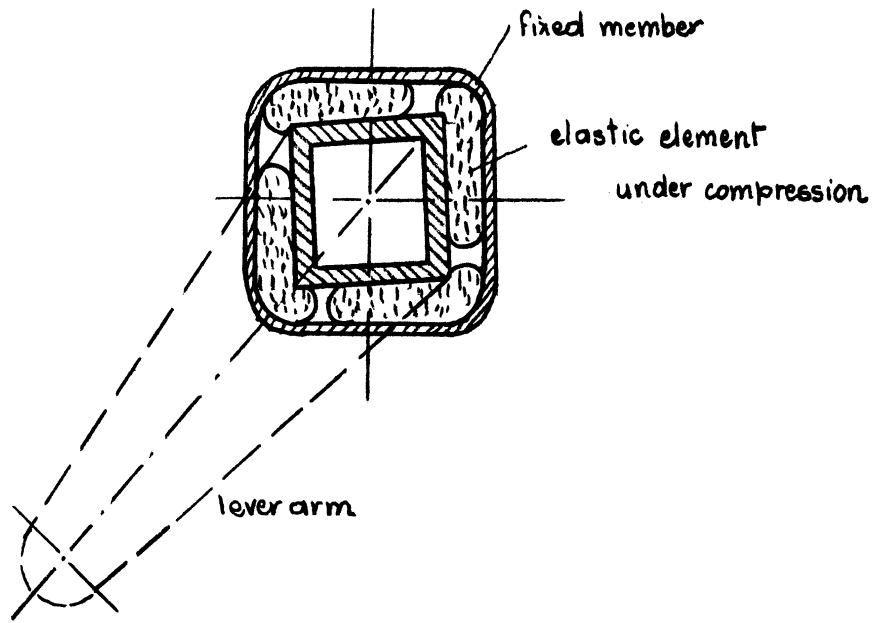

Figure R4. Neidhart Device - Characteristic Curve.

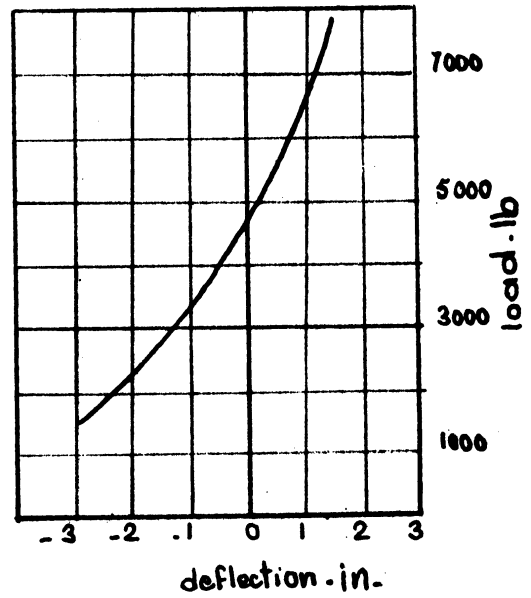
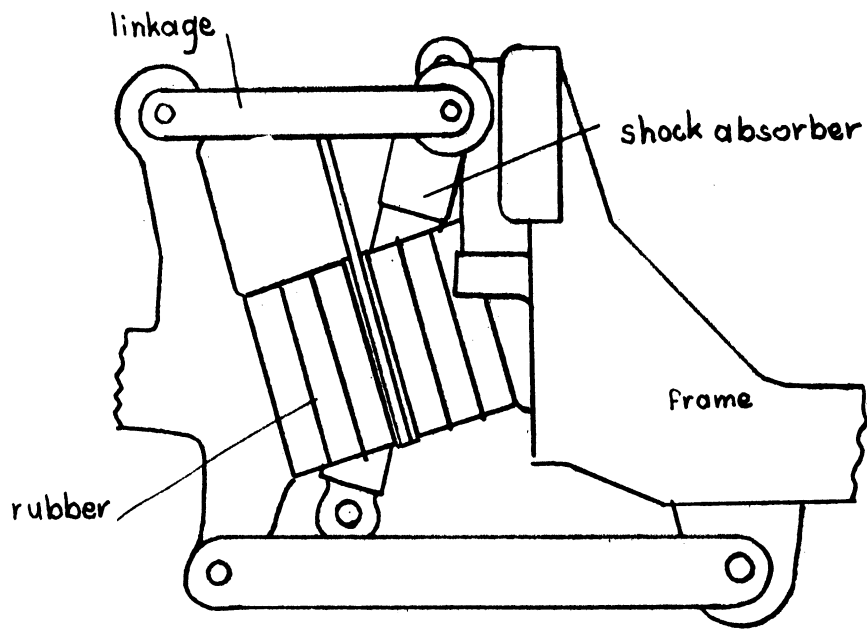

Figure R5. Metalastic Front Suspension.

Effect of temperature - the rubber cannot withstand a temperature below 70°F or above 200°F. These are ambient temperature conditions. But momentary peak temperatures have little effect on rubber parts.

Chemical deterioration - in spite of the fact that progress has been made in this field, rubber still remains susceptible more or less to deterioration by oils.

Fatigue - fatigue is caused by compression and shear which accentuates oxidization. Here, too, progress has been made after some difficulties were reported with creep which required more frequent linkage adjustments.

Advantages

The compact structure requires no lubrication.

The lever arm system permitted by the use of rubber increases vehicle stability

The rubber stops noisy vibrations through the suspension.

There is a reduction in maintenance and replacement.

The cost is relatively low due to the relative simplicity.

Disadvantages

Due to the Joule effect, changes in temperature will cause as much as 50% variation in height, in vehicles suspended with rubber springs. (Hence the use of self-leveling devices in buses and trucks).

There is an inherent tendency of rubber to cold flow under load.

Temperature influences this system.

There is the influence of chemical instability or deterioration mainly by oils.

There is no inherent damping, therefore an efficient shock absorber is necessary.

Note: The rubber spring system requires the use of independently sprung rear wheels. Particularly in the passenger car field there has been quite a reluctance to make such a radical change. For these reasons, the development of rubber suspension systems has been limited primarily to use in buses, although recently there has been some activity in the military, trailer, truck, and railway fields.

BIBLIOGRAPHY ON RUBBER SPRINGS

1. Krotz, A. S., Austin, R. C., Lindblom, L. C., "Rubber Suspensions, Car Design Emerges Using Torsion Springs," SAE Journal, November, 1946, p. 34.
2. Krotz, A. S., Houser, R. E., Kramer, J. H., "An Advanced Bus Suspension Design," Automotive Industries, Vol. 3, July 15, 1954, pp. 38-40.
3. Moulton, A. E., and Turner, P. W., "Rubber Springs for Vehicle Suspension," paper presented at the general meeting of the Automobile Division of the Institution of Mechanical Engineers, London, December 11, 1956.
4. Krotz, A. S., Houser, R. E., and Kramer, J. H., "Self Leveling Torsilastic Suspension," SAE preprint No. 451, presented at the SAE Golden Anniversary Annual Meeting, Detroit, Michigan, January 10-14, 1955.

LIQUID SPRINGS IN VEHICLE SUSPENSIONS

Principle

This type of suspension uses the compressibility of fluids under high pressure which provides the resilient action that makes the liquid spring work. Some suitable new fluids are compressible by as much as 12% under 20,000 psi. Actually, liquid springs are considered to be still in the experimental stage as far as application is concerned. This is because of the following reasons:

1. Difficulties in designing high-pressure chambers
2. Difficulties in sealing liquid at 20,000 psi (actual range of pressure necessary to a resilient property)
3. Difficulties in mass production.
4. Choice of liquid.

Design (Figure 11)

The liquid is sealed in a chamber which must withstand pressure between 1,000 and 20,000 psi. Hence the stress level of this chamber must be high (Rockwell 40) and any failure in it would be explosive.

The liquids used must be chosen with extreme care, for only a few liquids, such as silicone and fluococarbons have compressibilities high enough to do the job (12% at 20,000 psi; such a pressure will carry 10,000 lbs at the end of a 11/16 in. rod).

It is due to the higher operating pressure and the enclosure of liquid in one continuous volume that the liquid spring occupies about one-third the space of a comparable steel coil spring. The spring forces could be varied by changing the volume of the compression chamber (adjuster).

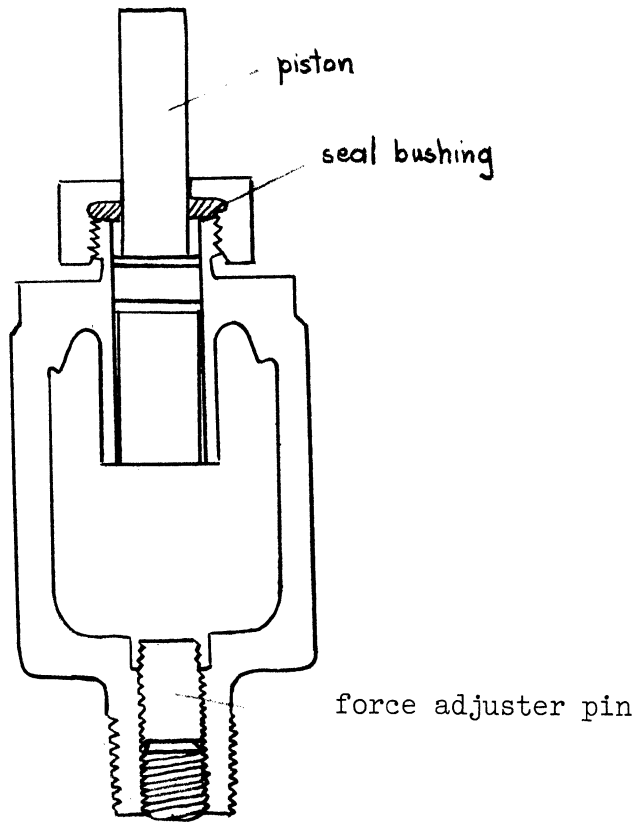

Figure 11.
Liquid Spring.

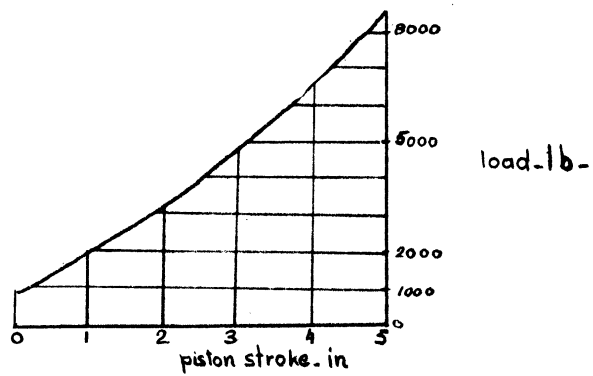

Figure 12. Load-Deflection Curve.

Discussion

Advantages

1. Liquid springs are particularly useful for high-force, short-stroke applications (Figure 12). Also, they are characterized by a high spring rate (application in trucks) and the possibility of a great deal of variation.

2. The volume occupied by the liquid spring is about one-third the space of a comparable steel coil spring.

3. The possibility exists for a combined shock absorber using the flowing property of the liquid itself.

4. This spring has a high natural frequency (through valves supplying damping effect).

5. It permits a greater pay load with more springing.

Disadvantages

1. Special steel is required for chambers with thick walls and the steel must also be free of defects.

2. Heavy-duty perforating equipment and machine tools are required.

3. There are design problems in sealing.

Nevertheless, these difficulties are not insurmountable.

Conclusion

The liquid spring presents some interesting features. However, the problems of manufacturing seem serious enough to prevent any serious development as yet.

Another difficulty seems to arise when personnel involved must be convinced that extraordinary quality control must be maintained. This could affect the cost in such a way as to prohibit mass production.

Note: It may be possible to obtain considerable damping through dissipating energy by the liquid itself. This phenomenon can be explained as follows: Certain liquids are polymorphic, which means, that when heavily compressed, at certain critical pressure and temperature, they contract rather suddenly and change from a liquid into a solid or grease. This sudden contraction releases heat and the re-conversion to a liquid occurs gradually as heat is recovered. Consequently, such a liquid worked at its point of polymorphic change, may supply by itself a powerful damping action.

BIBLIOGRAPHY ON LIQUID SPRINGS

1. Bridgman, P. W., "The Compression of 39 Substances to 100,000 K.G./cm²," Proceedings of American Academy of Arts and Sciences, Vol. 76-3, pp. 55-70.
_____ "The Compression of 177 Substances to 40,000 K.G./cm²," Proceedings of American Academy of Arts and Sciences, Vol. 76-3, pp. 55-70.
_____ "The Linear Compression of Various Single Crystals to 30,000 K.G./cm²," Proceedings of American Academy of Arts and Sciences, Vol. 76-4, pp. 89-99.
_____ "Viscosities to 30,000 K.G./cm²," Proceedings of American Academy of Arts and Sciences, Vol. 77-4, pp. 117-128.
_____ "Further Rough Compression to 40,000 K.G./cm², Especially Certain Liquids," Proceedings of American Academy of Arts and Sciences, Vol. 77-4, pp. 129-145.
2. "Liquid Springing for Automobiles," Automotive and Aviation Industries, June 1, 1947, pp. 47 and 56.
3. Taylor, P. H., "Liquid Springs in Vehicle Suspensions," SAE preprint No. 452, presented at the SAE Golden Anniversary Annual Meeting, Detroit, Michigan, January 10-14, 1955.

CONCLUSION

We have reviewed, in this paper, many kinds of suspensions along with their respective advantages and disadvantages. The fact that engineers are still debating on the advantages and disadvantages of these different suspension systems indicates that no one individual solution far exceeds any of the others.

Nevertheless, we can refer to the criteria of an ideal suspension and draw our own conclusions, thus defining what the characteristics of an ideal suspension should be:

Physical characteristics should be:

1. Variable spring rate increasing with the load (ideal curve Figure A1).
2. Low frequency to filter vibration irrespective of the load.
3. Critical damping to avoid oscillations and hence vibrations.
4. Constant level and equalization between front and rear suspensions.

Commercial characteristics should be:

5. Easy manufacturing - hence low cost.
6. No maintenance and long durability.

In each system we have found a device to obtain an acceptable variable rate suspension. However, low frequency is more easily obtained with air suspension, and critical damping is readily provided by the oil-air suspension. In these last solutions, however, the cost seems prohibitive. Everyone knows he has to pay extra to obtain an air suspension in American cars. However, because of the relative youth of such a suspension, we can expect many improvements in the future.

So, in conclusion, we may say that air suspension, being the only one to meet all the above requirements, should be the future solution. However, other systems of suspension will still have a great deal of usage before being abandoned.

