

Cycle-specific replication of chromosomal and F-plasmid origins

Stephen Cooper ^{a,*}, Jay D. Keasling ^b

^a Department of Microbiology and Immunology, University of Michigan Medical School, Ann Arbor, MI 48109-0620, USA

^b Department of Chemical Engineering, University of California, Berkeley, CA 94720-1462, USA

Received 1 April 1998; revised 15 April 1998; accepted 15 April 1998

Abstract

There have been various proposals for the pattern of F-plasmid replication during the division cycle. Here we show that the recent studies of Gordon et al. (Cell 90, 1113–1121, 1997) on the duplication and segregation of green fluorescent protein (GFP) labeled replication origins of the *Escherichia coli* chromosome and the F plasmid during the division cycle support the proposal that the F plasmid replicates with a cell-cycle-specific (artiocyclic) pattern. © 1998 Published by Elsevier Science B.V. All rights reserved.

Keywords: F plasmid; *Escherichia coli*; Chromosome replication; Origin of replication; Green fluorescent protein; Division cycle

1. Introduction

The study of the pattern of F-plasmid replication during the division cycle has a long history. Early studies using membrane-elution analysis and an enzyme assay [1] indicated that the F plasmid replicated in a cell-cycle-specific manner. This conclusion was strongly supported by the studies of Keasling et al. [2] who used direct radioactive measurements to show that the F plasmid replicated in a cell-cycle-specific manner. More important, Keasling et al. showed that the replication control of the F plasmid during the division cycle was similar to that governing chromosome replication during the division cycle. Specifically, Keasling et al. [2] proposed that, like the chromosome, replication of the F plasmid

was initiated when a certain amount of cell mass per origin was present. However, the amount of cell mass per origin at initiation was not the same for the chromosome and the plasmid. The proposal of cycle-specific plasmid replication has been supported by the data of Koppes [3] and Finkelstein and Helmstetter [4]. A simulation of F-plasmid and chromosome replication during the cell cycle supports the proposal that the F plasmid replicates in a cycle-specific manner [5].

More recently, Helmstetter et al. [6] proposed that the F plasmid replicates with a cell-cycle-independent pattern; i.e., F-plasmid replication occurs randomly throughout the division cycle. Many distinctions can be made between the studies of Keasling et al. [2] and those of Helmstetter et al. [6]. For example, Keasling et al. studied the large, single-copy, native F plasmid, whereas Helmstetter et al. studied a mini-F derivative that appears to be present at an extremely high-copy number. This difference may ac-

* Corresponding author. Tel.: +1 (313) 764-4215; Fax: +1 (313) 764-3562; E-mail: cooper@umich.edu

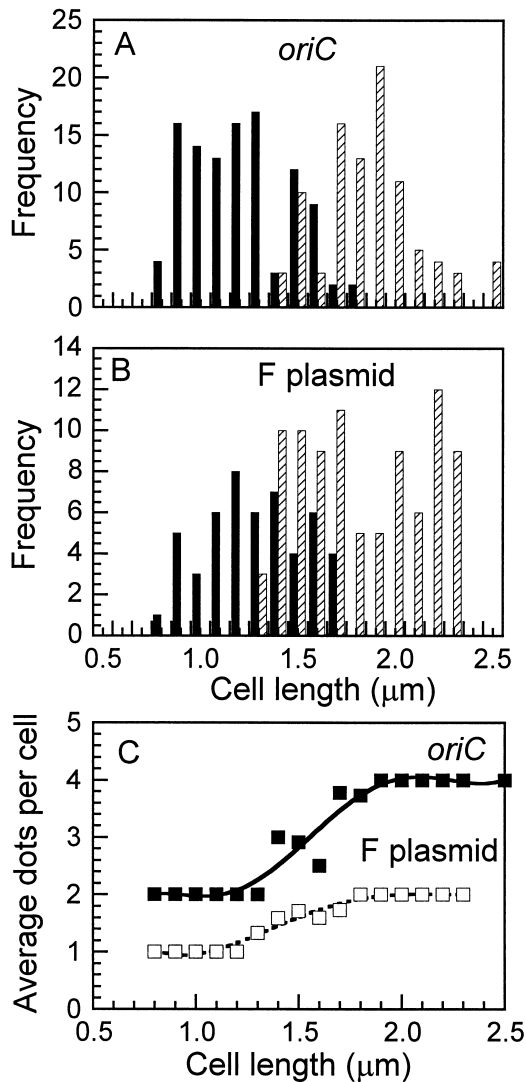

Fig. 1. F plasmid and chromosome duplication during the cell cycle. The segregation data of Gordon et al. (their Figs. 2A and 4B) were scanned and replotted. In A the number of cells with either two or four *oriC* dots are plotted as a function of cell size (filled bars, two dots; striped bars, four dots). It can be seen that in the mid-range of cell sizes (1.3–1.7 microns) there is a doubling of the number of origins measured by the doubling in the number of dots. In B the dots for the F-plasmid origin are plotted (filled bars, one dot; striped bars, two dots). Between sizes 1.4 and 1.8 microns there is a doubling in the number of F plasmids. These results indicate that the timing of replication of the chromosome is similar to timing of replication of the F plasmid. In C the average number of dots per cell for the plasmid (open squares) and the chromosome (filled squares) are plotted for a better comparison. The lines are drawn as the best fit to the data using a standard spline fit.

count for the discrepant results. The high-copy number could lead to an obliteration of the cycle-specific replication pattern that can be observed with the native, large, low-copy F plasmid.

Here we show that the data of Gordon et al. [7] strongly support the cell-cycle-specific pattern of F-plasmid replication.

2. F-plasmid replication during the division cycle

Gordon et al. [7] labeled the origins of the chromosome and the F plasmid with green fluorescent protein (GFP) and measured the number of origin 'dots' present in cells as a function of cell size. We have taken their data and determined the frequency of dots as a function of cell size. The results are plotted as the frequency of cells of a certain size containing either two or four chromosome origin dots (Fig. 1A), or containing one or two F-plasmid dots (Fig. 1B). It can be seen that the F-plasmid dots and the chromosomal origin dots replicate with a very similar cell-cycle synchrony. In the case of labeled *oriC*, the number of dots doubles approximately midway between birth and division. Similarly, the number of dots corresponding to the F plasmid doubles around the middle of the division cycle (i.e. around the mid-size of the cells). This similarity can be seen by plotting the average number of dots per cell for each cell length (Fig. 1C). The congruence of the duplication patterns of *oriC* and the F plasmid is clear.

These studies lend extremely strong support to the proposal of Keasling et al. [2] that the F plasmid replicates in a cell-cycle-specific manner. First, it is generally accepted that replication of the chromosome is cell-cycle specific [8]. Second, the results of Gordon et al. [7] show that replication of the chromosome origin (and terminus) is cell-cycle specific. Third, as shown here, the results of Gordon et al. [7] indicate that F-plasmid replication (i.e. dot doubling) has a degree of synchrony similar to that of the chromosome origin and terminus. During the division cycle, the F plasmid replicates over as narrow a period as the chromosome. Additionally, the best way to ensure that the number of F plasmids doubles prior to cell-cycle-specific segregation would be to have cell-cycle-specific replication. Random

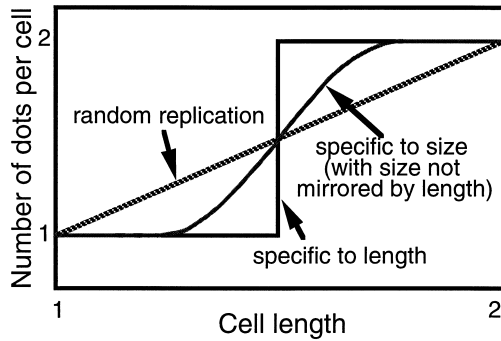

Fig. 2. Expected patterns of F-plasmid dot content for different models of replication. If cell length was the sole determinant of when an F plasmid replicated, then one would observe a sharp increase in the number of plots per cell at a particular length (experimental variation not considered). A random or uniform pattern of replication, where replication could occur at all cell lengths, would give a continuous linear increase in plasmid dot content. However, if mass were an important determinant of the timing of F-plasmid replication then one would observe significant variation in the cell length at which replication occurred due to variation in the width of cells in culture.

replication of the F plasmid would lead to a large fraction of cells that had not replicated the plasmid prior to division.

The variability in the cell length at which replication was observed to occur may be due to the metric by which replication timing was measured (e.g. cell length). If cell length were the main determinant of plasmid replication timing, a sharp increase in the number of dots would be expected at one cell length and not at any other (Fig. 2). In contrast, random or uniform replication throughout the cell cycle would result in a continuous increase in the number of dots with cell length. However, if cell mass were the determining factor for F-plasmid replication, then one would expect significant variation in the observed cell length at which replication occurred. Variations in the widths of cells in a culture would lead to observed variations in the cell length at which replication occurred, even if all cells in the culture initiated replication at exactly the same mass.

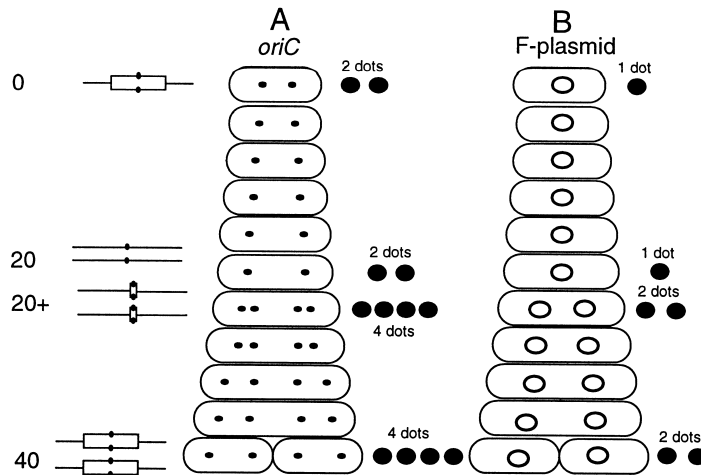

Fig. 3. Chromosomal and plasmid replication patterns for a cell with a 40-min doubling time ($C+D=1.5 \times$ interdivision time). A: Stick figures are drawn to illustrate the presence of a half-replicated chromosome in the newborn cell, giving rise to two completely replicated chromosomes in the middle of the division cycle. Initiation of the next round of replication is coincident with termination of the current round of replication, leading to a doubling of the number of origins. Replication proceeds until there are two chromosomes at the end of the division cycle, each half-replicated and each containing two origins. Next to the stick figures of the chromosomes is a series of cells representing cell sizes during the division cycle. Dots indicate the positions of the chromosome origins in the cells. A representation of how the chromosome origins would appear using the techniques of Gordon et al. [6] is shown at the right of A. B: The F-plasmid replication pattern is illustrated with a simple circle indicating the plasmid. One plasmid replicates to two plasmids in the middle of the division cycle, thus one dot gives rise to two dots in the middle of the division cycle. The ratio of the chromosome origins to F plasmids is 2.

3. Models for chromosome and plasmid replication during the division cycle

We now describe a model for chromosome and plasmid replication to explain the relative number of F-plasmid and chromosomal origins and the replication pattern of these origins during the division cycle.

The data of Gordon et al. [7] indicate that chromosome replication and termination occur somewhere near the middle of the cell cycle. Their studies were performed at 20°C, which would extend both the doubling time and the time necessary to replicate the chromosome compared to growth at 37°C. The replication pattern (specifically mid-cycle initiation of chromosome replication) is physiologically similar to that of *E. coli* B/r growing at 37°C with a C period of 40 min, a D period of 20 min, and a doubling time of either of 40 min (Fig. 3A) or 24 min (Fig. 4A) [2]. In both the 40-min and 24-min replication patterns, initiation of chromosomal replication occurs in the middle of the division cycle (i.e. either 1.5 or 2.5 generations before a specific cell

division). Both patterns, therefore, yield synchronous chromosome replication around the middle of the division cycle [2,6]. For a replication pattern equivalent to that of a 40-min doubling time at 37°C (Fig. 3A), the cell has two chromosomal origins in a newborn cell; the number doubles to four origins around the middle of the division cycle. For a replication pattern equivalent to that of a 24-min doubling time at 37°C (Fig. 4A), the cell has four chromosomal origins in a newborn cell and the number doubles to eight origins around the middle of the division cycle. If the second case were correct, we propose that the origins are grouped in pairs, and that two origins are equal to one dot.

We propose that a mechanism similar to that used by the cell to time chromosome replication within the division cycle is used to time F-plasmid replication. For a cell with a 40-min doubling time, a single F plasmid replicates near the middle of the division cycle (Fig. 3B), giving rise to the two dots observed by Gordon et al. [7]. For a cell with a 24-min doubling time, two F plasmids replicate near the middle of the division cycle (Fig. 4B). In the second case, the

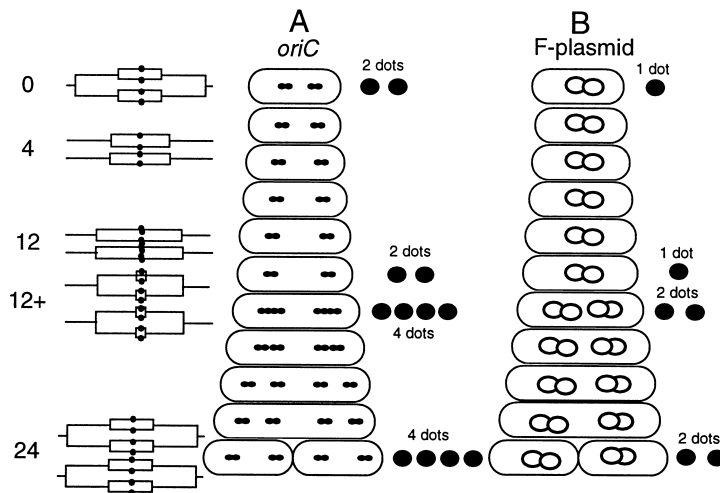

Fig. 4. Chromosomal and plasmid replication patterns for a 24-min doubling time ($C+D=2.5 \times$ interdivision time). The interpretation of the chromosome replication pattern is shown to the left of A. A newborn cell contains one multi-forked chromosome with four origins. As replication proceeds, termination occurs 4 min into the division cycle, initiation occurs at mid-cycle, with the 12+ figure illustrating the eight origins expected shortly after initiation occurs. At 24 min after birth, at the end of the division cycle, there are twice as many chromosomes as in the newborn cell. The interpretation of these chromosomal patterns in terms of origins is given in the middle part of A where the origins are grouped so that the four origins in the newborn cell give two dots. In the middle of the division cycle the eight origins produce four dots. B: The F-plasmid replication pattern is illustrated with a simple circle indicating the plasmid. Two plasmids in the newborn cell give one dot; two dots are present when four plasmids are produced. The ratio of the chromosome origins to F plasmids is 2.

two plasmid origins are grouped in pairs as are the chromosomal origins. In both cases there are twice as many F-plasmid origins as chromosomal origins. The models proposed here fit the important data of Gordon et al. [6] that the ratio of chromosomal origins to F-plasmid origins is two.

4. Distinguishing models

It is unusual to propose two such different patterns for chromosome and plasmid replication. The simple case is where the cells of Gordon et al. are similar to cells growing with a 40-min doubling time at 37°C. The main argument against this proposal is that the patterns of replication are temperature independent and depend primarily on the growth medium [8,9]. Since Gordon et al. grew their cells in rich LB broth, one would not expect growth with C+D equal to 1.5 times the interdivision time.

Rather, one might expect the more complex case in which cells have a replication pattern similar to *E. coli* B/r cells growing with a 24-min doubling time at 37°C. Such cells, with a C+D time equal to 2.5 times the interdivision time, have a more complicated replication pattern (Fig. 3B). Due to the increased number of origins for the 24-min doubling time, the origins are grouped in pairs in order to be consistent with the data of Gordon et al. [7]. Because of peculiarities of strains, differences in temperature of growth, and other variables, we cannot distinguish

Fig. 5. Relationship of initiation of chromosome and plasmid replication during the division cycle at various growth rates. In A, cell mass and chromosome and plasmid replication times are diagrammed for five different growth rates. The saw-tooth lines indicate the cell mass during growth and division. The filled circles indicate the initiation of chromosome replication. This occurs in the middle of the division cycle (60 min prior to a division) in cells with a 40- or 24-min interdivision time (i.e. 1.5 or 2.5 division cycles prior to a division). At the other growth rates (60-, 30-, and 20-min interdivision times), initiation of chromosome replication occurs around the time of cell division. The plasmid replicates one half generation after the chromosome initiates replication and at a cell mass that is 40% larger than for the chromosome [8]. This is illustrated by the filled squares in A. The stippled squares indicate plasmid replication one full generation after initiation of chromosome replication, at twice the cell size per origin as the chromosome. This is 1.5 generations prior to a division in cells with a 24-min interdivision time, and 0.5 generations prior to a division in cells with a 40-min interdivision time. In B the times of plasmid replication and initiation of chromosome replication are plotted as a function of the growth rate. The parallel lines for the plasmid and the chromosome (filled squares and circles) are the basis for the proposal that the rules governing initiation of chromosome and plasmid replication are similar. The positions of the stippled squares indicate plasmid replication one generation after initiation of chromosome replication. The data of Keasling et al. [8] and Finkelstein and Helmstetter [5] are consistent with plasmid replication between one half and one full generation after initiation of chromosome replication. The range of the data are indicated by the shaded trapezoidal area.

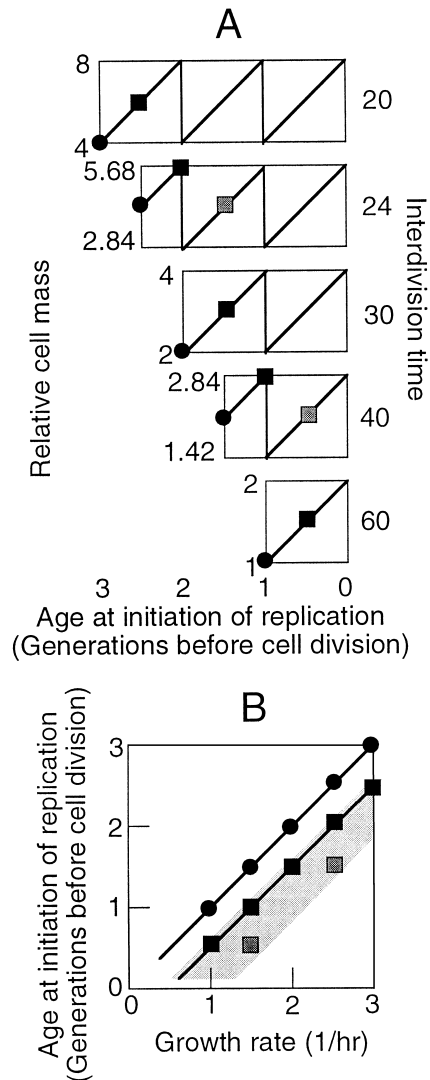

between the proposals in Figs. 3 and 4; therefore we present both cases for completeness.

One way to distinguish between the 40-min doubling time pattern (Fig. 3) and the 24-min doubling time pattern (Fig. 4) is to measure the amount of DNA per cell. Cells with a pattern corresponding to a 40-min doubling time have 2.04 genome equivalents per cell, whereas cells with a pattern corresponding to a 24-min doubling time have 3.35 genome equivalents per cell [8,10].

5. Model for the timing of plasmid replication

Keasling et al. [2,11] proposed that the F plasmid and P1 prophage replicated when the mass per plasmid origin reached a critical value (the initiation mass). This mechanism would be analogous to that proposed for the chromosomal origin [8,12]. It was originally proposed that F-plasmid replication occurred one half generation after chromosome replication (at an initiation mass 40% greater than that of the chromosome) [2]. We now point out that F-plasmid replication a full generation after chromosome replication (at an initiation mass twice that of the chromosome) is consistent with the experimental data (Fig. 5). This can be seen in Fig. 6 of Keasling et al. [2], which summarizes the results of Keasling et al. [2] and those of Finkelstein and Helmstetter [4].

6. Terminology of replication pattern

We propose that replication over a narrow portion of the division cycle be termed artiocyclic (from the Latin *artus* for narrow). Plasmids that replicate over the entire division cycle would be called latiocyclic (from the Latin *latius* for broad). Given this terminology, we propose that the F plasmid, the P1 plasmid, the chromosome, and the minichromosome [13] have artiocyclic replication patterns and the plasmid

pBR322 (replicating randomly throughout the division cycle) exhibits latiocyclic replication.

References

- [1] Cooper, S. (1972) Relationship of F⁺lac replication and chromosome replication. *Proc. Natl. Acad. Sci. USA* 69, 2706–2710.
- [2] Keasling, J.D., Palsson, B.O. and Cooper, S. (1991) Cell-cycle-specific F plasmid replication: Regulation by cell size control of initiation. *J. Bacteriol.* 173, 2673–2680.
- [3] Koppes, L.J.H. (1992) Nonrandom F plasmid replication in *Escherichia coli* K-12. *J. Bacteriol.* 174, 2121–2123.
- [4] Finkelstein, M. and Helmstetter, C.E. (1977) Cell cycle analysis of F⁺lac replication in *Escherichia coli* B/r. *J. Bacteriol.* 132, 884–895.
- [5] Kuo, H. and Keasling, J.D. (1996) A Monte Carlo simulation of F plasmid replication during the bacterial division cycle. *Biotechnol. Bioeng.* 52, 633–647.
- [6] Helmstetter, C.E., Thornton, M., Zhou, P., Bogan, J.A., Leonard, A. and Grimwade, J.E. (1997) Replication and segregation of a mini-F plasmid during the division cycle of *Escherichia coli*. *J. Bacteriol.* 179, 1393–1399.
- [7] Gordon, G.S., Sitnikov, D., Webb, C.D., Teleman, A., Straight, A., Losick, R., Murray, A.W. and Wright, A. (1997) Chromosome and low copy plasmid segregation in *E. coli*: Visual evidence for distinct mechanisms. *Cell* 90, 1113–1121.
- [8] Cooper, S. (1991) Bacterial Growth and Division: Biochemistry and Regulation of Prokaryotic and Eukaryotic Division Cycles. Academic Press, San Diego, CA.
- [9] Schaechter, M., Maaløe, O. and Kjeldgaard, N.O. (1958) Dependency on medium and temperature of cell size and chemical composition during balanced growth of *Salmonella typhimurium*. *J. Gen. Microbiol.* 19, 592–606.
- [10] Cooper, S. and Helmstetter, C.E. (1968) Chromosome replication and the division cycle of *Escherichia coli* B/r. *J. Mol. Biol.* 31, 519–540.
- [11] Keasling, J.D., Palsson, B.O. and Cooper, S. (1991) Replication of prophage P1 is cell-cycle-specific. *J. Bacteriol.* 173, 4457–4462.
- [12] Donachie, W.D. (1968) Relationship between cell size and time of initiation of DNA replication. *Nature (Lond.)* 205, 1084–1086.
- [13] Leonard, A.C. and Helmstetter, C.E. (1986) Cell-cycle-specific replication of *Escherichia coli* minichromosomes. *Proc. Natl. Acad. Sci. USA* 83, 5101–5105.