

THE UNIVERSITY OF MICHIGAN  
INDUSTRY PROGRAM OF THE COLLEGE OF ENGINEERING

THE DETERMINATION OF THE ELECTRON DENSITY  
PERTURBATIONS RESULTING FROM  
THE MIXING OF TWO DIFFERENT PLASMAS

F. V. Schultz

November, 1962

IP-593

TABLE OF CONTENTS

	<u>Page</u>
STATEMENT OF THE PROBLEM.....	1
BOUNDARY CONDITIONS.....	7
CALCULATION OF ELECTRON DENSITY PERTURBATIONS.....	9
CONCLUSIONS.....	22
ACKNOWLEDGEMENTS.....	23
APPENDIX A - DETERMINATION OF BOUNDARY CONDITIONS AT INTERFACE.....	24
APPENDIX B - EVALUATION OF CONTOUR INTEGRAL.....	32
REFERENCES.....	53

I  
STATEMENT OF THE PROBLEM

The problem under consideration is that of determining the mixing of two plasmas, originally of different densities. It is assumed that, for  $t(\text{time}) < 0$ , the half-space  $z < 0$  (Region 1) is filled with a plasma having electron and ion densities each equal to  $n_{10}$  particles per cubic meter, and the half-space  $z > 0$  (Region 2) is filled with a plasma having electron and ion densities each equal to  $n_{20}$  particles per cubic meter. Here  $n_{10}$  and  $n_{20}$  are constants, independent of  $x$ ,  $y$ ,  $z$ , and  $t$ . For  $t \geq 0$  the two plasmas are allowed to mix and the problem is to determine how the perturbations in electron densities,  $n_{11}$  in Region 1 and  $n_{21}$  in Region 2, vary with  $t$  and  $z$ . The time interval considered is assumed to be short enough that the ion densities in the two regions remain essentially unchanged. Other assumptions are these:

- (a) The mean free path is assumed to be very large so that collisions can be neglected.
- (b) The initial electron temperatures ( $T_0$ ) are equal in the two regions.
- (c) The perturbations in electron densities,  $n_{11}$  and  $n_{21}$ , the  $z$ -directed electron streaming velocities,  $u_1$  and  $u_2$ , and the induced electric field intensities,  $E_1$  and  $E_2$ , are small enough that second-order, and higher, products of these

terms can be neglected. This is also assumed to be true of the derivatives of these quantities.

- (d) There are no externally impressed electric, magnetic, or gravitational fields.
- (e) The plasmas obey the perfect gas law. The electron gas pressure is, rather arbitrarily but necessarily, assumed to be a scalar given by  $p = nkT$ .
- (f) The various physical quantities vary only with  $z$  and  $t$ , there being no variations in the  $x$  and  $y$  directions.
- (g) Pressure changes occur adiabatically, so that, for the electrons,

$$\nabla p = \vec{k} \frac{\partial p}{\partial z} = \vec{k} \gamma kT \frac{\partial n}{\partial z} ,$$

where  $\gamma$  is the ratio of specific heats and  $\vec{k}$  is a unit vector in the  $z$ -direction.

Our working equations for the electrons, then, are these, written in two dimensions,  $z$  and  $t$ . MKS units are used.

$$m n \frac{\partial u}{\partial t} + \gamma kT \frac{\partial n}{\partial z} + n e E = 0 \quad (\text{momentum equation}) \quad (1)$$

$$\frac{\partial n}{\partial t} + \frac{\partial}{\partial z} (n u) = 0 \quad (\text{continuity equation}) \quad (2)$$

$$\frac{\partial E}{\partial z} = \frac{e}{\epsilon_0} (n_0 - n) \quad (\text{Poisson equation}) \quad (3)$$

$$p = n k T \quad (\text{equation of state}) \quad (4)$$

There are five unknowns,  $p$ ,  $u$ ,  $n$ ,  $T$  and  $E$ , in these four equations, plus the equation under (g), above. Here:

$m$  = mass of electron

$n$  = number density of electrons

$n_0$  = number density of ions

$p$  = pressure of electron gas

$e = 1.602 \times 10^{-19}$  coulomb

$E$  = electric field intensity (z-directed)

$u$  = z-directed streaming velocity of electrons

$\epsilon_0 = 8.854 \times 10^{-12}$ , permittivity of free space

$k = 1.380 \times 10^{-23}$  joule per degree K

$T$  = temperature in degrees, Kelvin.

Now assume that, in Region 1, for  $t > 0$ , the electron density can be written

$$n_1 = n_{10} + n_{11}(z, t),$$

where

$$n_{11} \ll n_{10}$$

and  $n_{10}$  is a constant. Similarly for Region 2:

$$n_2 = n_{20} + n_{21}(z, t).$$

Also, in the same way,

$$p_1 = p_{10} + p_{11},$$

$$p_2 = p_{20} + p_{21}.$$

The unchanging ion densities are  $n_{10}$  and  $n_{20}$  in the two regions.

Making use of the assumptions mentioned above, one obtains the following forms of the four basic equations for Region 1, with a similar set for Region 2:

$$m n_{10} \frac{\partial u_1}{\partial t} + \gamma k T_o \frac{\partial n_{11}}{\partial z} + n_{10} e E_1 = 0, \quad (1a)$$

$$\frac{\partial n_{11}}{\partial t} + n_{10} \frac{\partial u_1}{\partial z} = 0, \quad (2a)$$

$$\frac{\partial E_1}{\partial z} = - \frac{e}{\epsilon_o} n_{11}, \quad (3a)$$

$$p_{11} = n_{10} k T_{11} + n_{11} k T_{10}. \quad (4a)$$

To obtain a single partial differential equation in  $n_{11}$  alone, one may differentiate (1a) with respect to  $z$ , differentiate (2a) with respect to  $t$ , and use this differentiated form of (2a), and (3a), in (1a). There results:

$$\frac{\partial^2 n_{11}}{\partial t^2} - \frac{\gamma k T_o}{m} \frac{\partial^2 n_{11}}{\partial z^2} + \omega_{p1}^2 n_{11} = 0, \quad (5)$$

where

$$\omega_{p1}^2 = \frac{e^2 n_{10}}{m \epsilon_0} \quad (6)$$

is the electron plasma angular frequency squared in Region 1.

In order to solve (5) for  $n_{11}(z, t)$  one may take the Laplace transform, obtaining

$$s^2 N_{11}(z, s) - s n_{11}(z, +0) - \left. \frac{\partial n_{11}}{\partial t} \right|_{t=+0} - \frac{\gamma k T_0}{m} \frac{\partial^2 N_{11}}{\partial z^2} + \omega_{p1}^2 N_{11}(z, s) = 0. \quad (7)$$

Here  $N_{11}(z, s)$  is the Laplace transform of  $n_{11}(z, t)$ . We are assuming that both  $n_{11}(z, +0)$  and  $\left. \frac{\partial n_{11}}{\partial t} \right|_{t=+0}$  are zero so (7) reduces to

$$c^2 \frac{\partial^2 N_{11}}{\partial z^2} - (s^2 + \omega_{p1}^2) N_{11} = 0, \quad (8)$$

where

$$c = \sqrt{\gamma k T_0 / m} \quad (9)$$

is the adiabatic acoustic velocity in the electron gas.

The solution of (8) is

$$N_{11}(z, s) = F_1(s) e^{-\frac{z}{c} \sqrt{s^2 + \omega_{p1}^2}} + F_2(s) e^{\frac{z}{c} \sqrt{s^2 + \omega_{p1}^2}}, \quad (10)$$

where  $F_1(s)$  and  $F_2(s)$  are undetermined functions of  $s$ , only. By a completely similar process the following equation is obtained for Region 2:

$$N_{21}(z, s) = F_3(s) e^{-\frac{z}{c} \sqrt{s^2 + \omega_p^2}} + F_4(s) e^{\frac{z}{c} \sqrt{s^2 + \omega_p^2}}. \quad (11)$$

In order to take the inverse Laplace transforms of (10) and (11) for obtaining  $n_{11}(z, t)$  and  $n_{21}(z, t)$ , one must find the undetermined functions  $F_1(s), \dots, F_4(s)$ . This is done by applying boundary conditions.



## II BOUNDARY CONDITIONS

Boundary conditions on  $n_{11}(z, t)$  and  $n_{21}(z, t)$  must be satisfied at  $z = 0$  and at  $z = \pm \infty$ . These last conditions are:

$$\lim_{z \rightarrow \infty} n_{21}(z, t) = 0, \quad (12)$$

$$\lim_{z \rightarrow -\infty} n_{11}(z, t) = 0. \quad (13)$$

The boundary conditions at the interface ( $z = 0$ ) are obtained by using the conservation equations for mass, momentum, and energy, together with the following assumptions:

- (a) Viscous effects disappear because of the uniform unidirectional drift motion of the particles.
- (b) Second, and higher, order terms are neglected.
- (c) Heat conduction is negligible, because of the very low density of the gas.

The resultant boundary conditions at  $z = 0$ , then, can be shown to be these:

$$T_1 = T_2 \quad (14)$$

$$u_1 = u_2 \quad (15)$$

$$n_1 = n_2 \quad (16)$$

From (16) one obtains (for  $z = 0$ )

$$n_{21} = n_{11} + (n_{10} - n_{20}), \quad (17)$$

which shows that our results will be valid only for values of  $(n_{10} - n_{20})$  of the same order of magnitude as  $n_{11}$  and  $n_{21}$ .

### III

#### CALCULATION OF ELECTRON DENSITY PERTURBATIONS

We are now in a position to apply the boundary conditions listed above and thus to determine  $F_1(s)$ , ...  $F_4(s)$  of (10) and (11). It is necessary to use also the conservation of momentum equation, and (12) and (13), in the process. When this is done the following relations are obtained:

$$F_1(s) = 0 \tag{18}$$

$$F_2(s) = \frac{(n_{20} - n_{10}) \sqrt{s^2 + \omega_{p2}^2}}{s \left[ \frac{n_{20}}{n_{10}} \sqrt{s^2 + \omega_{p1}^2} + \sqrt{s^2 + \omega_{p2}^2} \right]}, \tag{19}$$

$$F_3(s) = F_2(s) + (n_{10} - n_{20}) \frac{1}{s}, \tag{20}$$

$$F_4(s) = 0. \tag{21}$$

We may now determine  $n_{11}(z, t)$  and  $n_{21}(z, t)$  by using the results of the last paragraph and then taking the inverse Laplace transforms of (10) and (11). We obtain

$$n_{11}(z, t) = \frac{1}{2\pi i} \lim_{\beta \rightarrow \infty} \int_{\gamma - i\beta}^{\gamma + i\beta} N_{11}(z, s) e^{st} ds, \tag{22}$$

and a similar equation for  $n_{21}(z, t)$ .

By using the expression for  $F_2(s)$  given in (19), we obtain

$$n_{11}(z, t) = \frac{n_{20} - n_{10}}{2\pi i} \lim_{\beta \rightarrow \infty} \int_{\gamma - i\beta}^{\gamma + i\beta} \frac{e^{\frac{z}{c} \sqrt{s^2 + \omega_{p1}^2}} e^{st}}{s \left[ \frac{n_{20}}{n_{10}} \sqrt{s^2 + \omega_{p1}^2} + \sqrt{s^2 + \omega_{p2}^2} \right]} ds. \quad (23)$$

An examination of the integrand of this integral shows that there is a simple pole at the origin, branch points at  $\pm i \omega_{p1}$  and  $\pm i \omega_{p2}$ , and only these. Branch cuts can be chosen as shown in Figure 1. It turns out that the Riemann surface of the integrand has four sheets. On the branch cuts between  $i \omega_{p1}$  and  $i \omega_{p2}$ , and between  $-i \omega_{p1}$  and  $-i \omega_{p2}$ , the first and second sheets are connected and the third and fourth sheets are connected. Between  $i \omega_{p2}$  and  $-i \omega_{p2}$  the first and third sheets are connected and the second and fourth sheets are connected.

One may, as is customary, alter the path of integration of (23), as is indicated in Figure 1, in order to facilitate the integration process. In choosing the alternate path we must make sure that, in traversing this path, we remain on the same Riemann surface as is used for Path 1 from  $\gamma - i\beta$  to  $\gamma + i\beta$ , and either that no poles are enclosed between the two paths, or that the values of the residues at the poles are properly taken into account.

In order to make a proper choice of alternate path, let us rewrite (23) as follows:

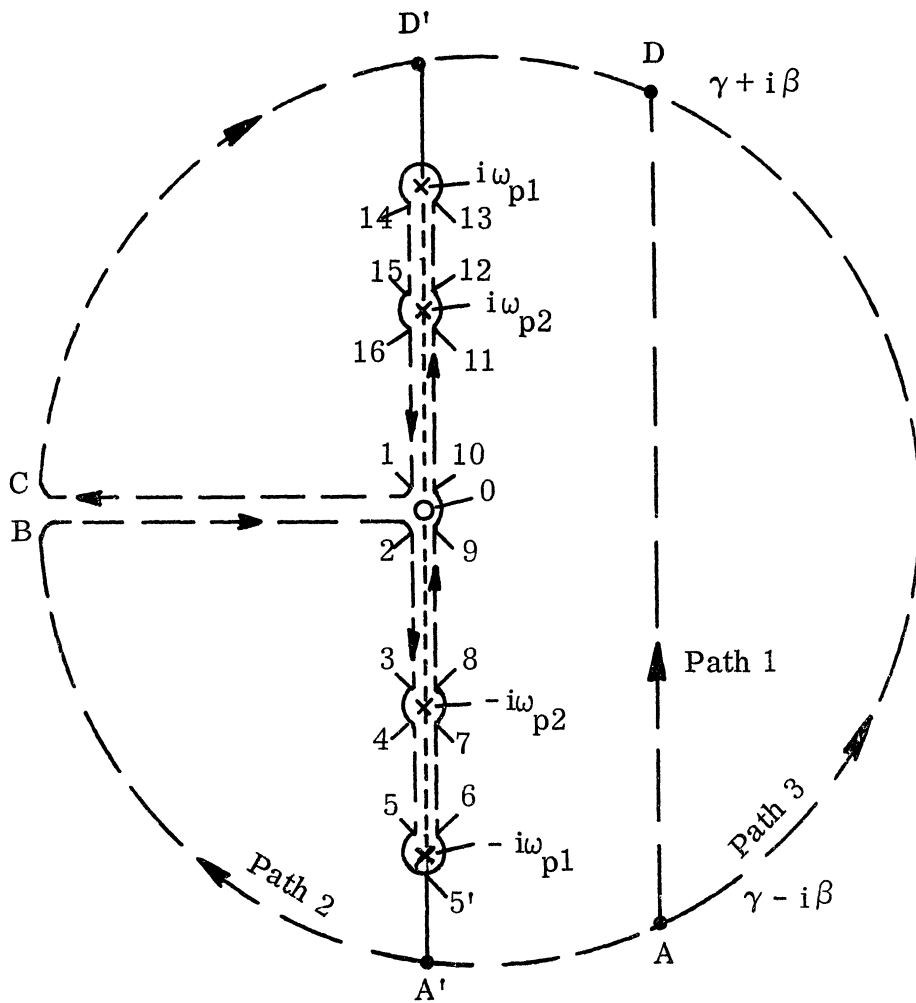

- × Branch Points
- Simple Pole
- Branch Cut
- Paths of Integration

FIGURE 1: S-PLANE FOR INTEGRAND OF EQUATION (23)

$$n_{11}(z, t) = \frac{n_{20} - n_{10}}{2\pi i} \lim_{\beta \rightarrow \infty} \int_{\gamma - i\beta}^{\gamma + i\beta} \frac{e^{s(t + \frac{z}{c}) \sqrt{1 + \frac{\omega_{p1}^2}{s^2}}} \sqrt{s^2 + \omega_{p2}^2} ds}{s \left[ \frac{n_{20}}{n_{10}} \sqrt{s^2 + \omega_{p1}^2} + \sqrt{s^2 + \omega_{p2}^2} \right]}, \quad (24)$$

remembering that  $z < 0$ . If we assume that  $(t + \frac{z}{c}) < 0$ , which means that

$$t < |z|/c \quad (25)$$

for the real part of  $s$  very large, we see that

$$\lim_{\text{Re } s \rightarrow \infty} n_{11}(z, t) = 0. \quad (26)$$

Consequently, since no singular points of the integrand are located on Paths 1 or 3, or within the region bounded by these two paths, we see that

$$\lim_{\beta \rightarrow \infty} \left( \int_{\text{Path 1}} - \int_{\text{Path 3}} \right) = \lim_{\beta \rightarrow \infty} \int_{\text{Path 1}} = 0. \quad (27)$$

Therefore,

$$n_{11}(z, t) = 0 \text{ for } t < |z|/c. \quad (28)$$

For the case when  $(t + \frac{z}{c}) > 0$ , or

$$t > |z|/c, \quad (29)$$

we have devised Path 2 of Figure 1, since in this case the integrand becomes infinite on Path 3, as  $\text{Re } s \rightarrow \infty$ . Path 2 has been so chosen that one remains on one sheet by crossing no branch cuts. Also, no poles or other singularities are

enclosed between Path 1 and Path 2 . Therefore, the value of the integral as determined along Path 2 is equal to the value determined by following Path 1.

In order to carry out the integration it was found necessary to make some simplifying approximations in the integrand, which limit the validity of the results to values of z less than about 1.5 Debye lengths. Then for

$$|z| < 1.5 \text{ Debye lengths, } t > |z|/c$$

the following approximate result was obtained:

$$n_{11}(z, t) = (n_{20} - n_{10}) \left[ \frac{\omega_{p2} \left( \cosh \frac{z}{c} \omega_{p1} \right)}{n_{20} \omega_{p1} + \omega_{p2}} + \frac{\omega_{p1}}{\pi} \frac{z}{c} \text{Si}(\omega_{p2} t) \right. \\ \left. - \frac{1}{2\pi \omega_{p1} t^2} \frac{z}{c} \sin \omega_{p2} t + \frac{\omega_{p2}}{2\pi \omega_{p1} t} \frac{z}{c} \cos \omega_{p2} t \right. \\ \left. + \frac{16 n_{20} \sqrt{\omega_{p1} \omega_{p2}}}{\pi \omega_{p2}^2 (n_{20} - n_{10}) (\omega_{p1} + \omega_{p2})} \left\{ \frac{1}{t^2} (\cos \omega_{p1} t + \cos \omega_{p2} t) \right. \right. \\ \left. \left. + \frac{2}{\omega_{p2} - \omega_{p1}} \frac{1}{t^3} (\sin \omega_{p1} t - \sin \omega_{p2} t) \right\} \right]$$

(Eqn. continued on next page)

$$\begin{aligned}
& - \frac{4 n_{10} \omega_{p1}}{\pi \omega_{p2}^2 (n_{20} - n_{10})(\omega_{p1} + \omega_{p2})} \frac{z}{c} \left\{ \left( \frac{A_1}{t^5} + \frac{B_1}{t^3} + \frac{C_1}{t} \right) \cos \omega_{p1} t \right. \\
& + \left( \frac{A_2}{t^5} + \frac{B_2}{t^3} + \frac{C_2}{t} \right) \cos \omega_{p2} t + \left( \frac{D_1}{t^4} + \frac{E_1}{t^2} \right) \sin \omega_{p1} t \\
& \left. + \left( \frac{D_2}{t^4} + \frac{E_2}{t^2} \right) \sin \omega_{p2} t \right\} \Bigg]. \tag{30}
\end{aligned}$$

Here  $A_1, B_1, \dots, E_2$  are functions of  $\omega_{p1}$  and  $\omega_{p2}$ .

It is obvious that the first four terms in the expression for  $n_{11}(z, t)$ , given by (30) go to zero as  $(n_{20} - n_{10}) \rightarrow 0$ , as they must. The remaining terms in this expression also go to zero as  $(n_{20} - n_{10}) \rightarrow 0$ , since they arise from evaluating integrals between the limits of  $\omega_{p2}$  and  $\omega_{p1}$ , and these limits are equal for  $n_{20} = n_{10}$ .

The expression for  $n_{11}(z, t)$  given by (30) was obtained by assuming that  $n_{10} > n_{20}$ . In order to complete the analysis it is necessary to either compute the perturbation  $n_{21}(z, t)$  in Region 2 for  $n_{10} > n_{20}$  or to recalculate  $n_{11}$  for  $n_{10} < n_{20}$ . The latter procedure was followed and the following result obtained (for  $n_{10} < n_{20}$ ):



$$\begin{aligned}
n_{11}(z, t) = & (n_{20} - n_{10}) \left[ \frac{\omega_{p2} \cosh\left(\frac{z}{c} \omega_{p1}\right)}{\frac{n_{20}}{n_{10}} \omega_{p1} + \omega_{p2}} + \frac{\omega_{p1}}{\pi} \frac{z}{c} \text{Si}(\omega_{p1} t) \right. \\
& - \frac{1}{2\pi \omega_{p1} t^2} \frac{z}{c} \sin(\omega_{p1} t) + \frac{1}{2\pi t} \frac{z}{c} \cos(\omega_{p1} t) \\
& + \frac{16 n_{20} \sqrt{\omega_{p1} \omega_{p2}}}{\pi \omega_{p2}^2 (n_{20} - n_{10})(\omega_{p1} + \omega_{p2})} \left\{ \frac{1}{t^2} (\cos \omega_{p1} t + \cos \omega_{p2} t) \right. \\
& \left. + \frac{2}{t^3 (\omega_{p2} - \omega_{p1})} (\sin \omega_{p1} t - \sin \omega_{p2} t) \right\} \\
& - \frac{4 n_{20} \omega_{p1}}{\pi \omega_{p2}^2 (n_{20} - n_{10})(\omega_{p1} + \omega_{p2})} \frac{z}{c} \left\{ \left( \frac{A'_1}{t^5} + \frac{B'_1}{t^3} + \frac{C'_1}{t} \right) \cos \omega_{p2} t \right. \\
& + \left( \frac{A'_2}{t^5} + \frac{B'_2}{t^3} + \frac{C'_2}{t} \right) \cos \omega_{p1} t + \left( \frac{D'_1}{t^4} + \frac{E'_1}{t^2} \right) \sin \omega_{p2} t \\
& \left. + \left( \frac{D'_2}{t^4} + \frac{E'_2}{t^2} \right) \sin \omega_{p1} t \right\} \left. \right]. \tag{31}
\end{aligned}$$

Here  $A'_1, B'_1, \dots, E'_2$  are functions of  $\omega_{p1}$  and  $\omega_{p2}$ .

It is now in order to investigate the physical significance of the two different expressions for  $n_{11}(z, t)$ : equation (30) for  $n_{10} > n_{20}$  and equation (31) for  $n_{10} < n_{20}$ . This is done only for the case of  $n_{10} > n_{20}$ .

It will be remembered that  $n_{11}(z, t) = 0$  for  $|z|/c > t$ . This means, of course, that the electron density perturbation  $n_{11}$  has a front which is propagating in the direction of decreasing  $z$  with a velocity  $c$ , the adiabatic acoustic velocity in the electron gas. This is characteristic of weak discontinuities, as discussed in Section 93 of [1]. We are, of course, dealing with a weak discontinuity since the linearization of the original partial differential equation, (1), is valid only for  $n_{11}/n_{10} \cong (n_{10} - n_{20})/n_{10} \leq 0.1$ . Another restriction on the solutions is that  $z$  must not exceed about 1.5 Debye lengths.

The following are the values of  $A_1, \dots, E_2$  which appear in (30):

$$A_1 = -24a / \omega_{p1}^2$$

$$B_1 = 2a \left( 5 - \frac{\omega_{p2}^2}{\omega_{p1}^2} \right) + 4b$$

$$C_1 = 0$$

$$D_1 = -\frac{24a + 6b}{\omega_{p1}}$$

$$E_1 = \left( \frac{2a + b}{\omega_{p1}} \right) (\omega_{p1}^2 - \omega_{p2}^2)$$

$$A_2 = 24a/\omega_{p1}^2$$

$$B_2 = - \left( 10a \frac{\omega_{p2}^2}{\omega_{p1}^2} + 6b \frac{\omega_{p2}}{\omega_{p1}} + 2c \right)$$

$$C_2 = 0$$

$$D_2 = \frac{1}{\omega_{p1}} \left( 24a \frac{\omega_{p2}}{\omega_{p1}} + 6b \right)$$

$$E_2 = -2\omega_{p1} \left[ a \left( \frac{\omega_{p2}}{\omega_{p1}} \right)^3 + b \left( \frac{\omega_{p2}}{\omega_{p1}} \right)^2 + c \left( \frac{\omega_{p2}}{\omega_{p1}} \right) \right]$$

Here

$$a = -90.1$$

$$b = 169.5$$

$$c = -79.3$$

$$a + b + c = 0 \text{ (exactly),}$$

these being numerics arising in a curve-fitting procedure used as an approximation in evaluating the integral of (23).

If we now consider the following numerical values:

$$n_{10} = 10^{12} \text{ particles per cubic meter,}$$

$$n_{20} = 0.9 \times 10^{12} \text{ particles per cubic meter,}$$

$$T_o = 1000 \text{ degrees, Kelvin,}$$

we find that

$$\begin{aligned}
h &= 2.18 \times 10^{-3} \text{ meter , (Debye length)} \\
c &= 1.590 \times 10^5 \text{ meters per second, (adiabatic acoustic velocity of} \\
&\quad \text{the electron gas)} \\
f_1 &= 8.98 \text{ megacycles per second, (plasma frequency of Region 1)} \\
f_2 &= 8.52 \text{ megacycles per second, (plasma frequency of Region 2)} \\
\omega_{p1} &= 5.64 \times 10^7 \text{ radians per second} = 2\pi f_1, \\
\omega_{p2} &= 5.35 \times 10^7 \text{ radians per second} = 2\pi f_2, \\
\omega_{p2}/\omega_{p1} &= 0.9486, \\
(\omega_{p2}/\omega_{p1})^2 &= 0.900.
\end{aligned}$$

If these values are used in (30), there results, after collecting terms:

$$\begin{aligned}
\frac{n_{11}(z, t)}{n_{10} - n_{20}} &= -0.512 \cosh 355z - 113 z \text{ Si}(5.35 \times 10^7 t) \\
&+ \left[ 5.03 \times 10^{-13} \frac{z}{t^2} + 5.52 \times 10^{-21} \frac{1}{t^3} + 2.62 \times 10^{-25} \frac{z}{t^4} \right] \sin(5.35 \times 10^7 t) \\
&+ \left[ -0.949 \times 10^{-6} \frac{z}{t} + 0.802 \times 10^{-14} \frac{1}{t^2} - 1.003 \times 10^{-19} \frac{z}{t^3} \right. \\
&+ \left. 9.74 \times 10^{-33} \frac{z}{t^5} \right] \cos(5.35 \times 10^7 t) + \left[ 8.65 \times 10^{-13} \frac{z}{t^2} - 5.52 \times 10^{-21} \frac{1}{t^3} \right. \\
&- \left. 2.91 \times 10^{-25} \frac{z}{t^4} \right] \sin(5.64 \times 10^7 t) + \left[ 0.802 \times 10^{-14} \frac{1}{t^2} + 8.60 \times 10^{-19} \frac{z}{t^3} \right. \\
&- \left. 9.74 \times 10^{-33} \frac{z}{t^5} \right] \cos(5.64 \times 10^7 t). \tag{32}
\end{aligned}$$

If one now attempts to use this expression to determine numerically the values of  $n_{11}$  on the wavefront progressing in the direction of decreasing  $z$ , it is found that, because of the very small values of  $t$  involved, it is very difficult to obtain accurate results. Consequently the integral of (23) was re-evaluated under the assumption that  $t$  was small enough to allow us to replace  $\sin rt$  by  $rt$ , and  $\cos rt$  by unity. The resulting required integration is straightforward (after making other simplifying assumptions as before) and the final result is (for  $n_{10} > n_{20}$  and very small  $t$ ):

$$\begin{aligned}
\frac{n_{11}(z, t)}{(n_{10} - n_{20})} = & - \frac{\omega_{p2} \left( \cosh \frac{z}{c} \omega_{p1} \right)}{n_{10} \omega_{p1} + \omega_{p2}} - \frac{\omega_{p1} \omega_{p2}}{\pi} \frac{z}{c} t \left[ 1 - \frac{1}{6} \frac{\omega_{p2}^2}{\omega_{p1}^2} \right] \\
& + \frac{16}{3\pi} \frac{n_{20}}{(n_{10} - n_{20})} \frac{\sqrt{\omega_{p1} \omega_{p2}}}{(\omega_{p1} + \omega_{p2})} \frac{\omega_{p1}^2}{\omega_{p2}^2} \left( 1 - \frac{\omega_{p2}}{\omega_{p1}} \right)^2 \\
& - \left[ \frac{4}{\pi} \frac{n_{10}}{(n_{10} - n_{20})} \frac{\omega_{p1}}{(\omega_{p1} + \omega_{p2})} \frac{\omega_{p1}^2}{\omega_{p2}^2} \frac{z}{c} t \right] \\
& \cdot \left\{ \omega_{p1}^2 \left[ \frac{a}{6} \left( 1 - \frac{\omega_{p2}^6}{\omega_{p1}^6} \right) + \frac{b}{5} \left( 1 - \frac{\omega_{p2}^5}{\omega_{p1}^5} \right) + \frac{c}{4} \left( 1 - \frac{\omega_{p2}^4}{\omega_{p1}^4} \right) \right] \right. \\
& \left. - \omega_{p2}^2 \left[ \frac{a}{4} \left( 1 - \frac{\omega_{p2}^4}{\omega_{p1}^4} \right) + \frac{b}{3} \left( 1 - \frac{\omega_{p2}^3}{\omega_{p1}^3} \right) + \frac{c}{2} \left( 1 - \frac{\omega_{p2}^2}{\omega_{p1}^2} \right) \right] \right\} . \quad (33)
\end{aligned}$$

If we now use (33) to calculate  $n_{11}/(n_{10} - n_{20})$ , as a function of  $z$  for  $t = |z|/c$ , we get information concerning the amplitude of the wavefront of the electron density perturbation as it moves in the direction of decreasing  $z$ . The results are as follows:

TABLE I

$z$ (mm)	$n_{11}/(n_{10} - n_{20})$
0.0	-0.510
-0.1	-0.510
-0.2	-0.560
-0.3	-0.643
-0.4	-0.759
-0.5	-0.908
-0.6	-1.091
-0.7	-1.306
-0.8	-1.555
-0.9	-1.837
-1.0	-2.153

Another result of physical interest is the variation of  $n_{11}/(n_{10} - n_{20})$  as a function of  $z$  for values of  $t$  large enough that the oscillatory terms of the electron density perturbation have essentially damped out, but  $t$  small enough that the ions have not yet started to move.

This result is easily calculated by using only the first two terms of (32) and one obtains the following values:

TABLE II

$z$ (mm)	$n_{11}/(n_{10}-n_{20})$
0.0	-0.512
-0.1	-0.494
-0.2	-0.477
-0.3	-0.461
-0.4	-0.445
-0.5	-0.431
-0.6	-0.418
-0.7	-0.404
-0.8	-0.391
-0.9	-0.379
-1.0	-0.368
-1.2	-0.347
-1.4	-0.328
-1.6	-0.313
-1.8	-0.301
-2.0	-0.293

It also is of interest to obtain an indication of the rapidity with which the electron density oscillations, as shown by (32), damp out. The  $t^{-1}$  term will damp out the most slowly. Our results are valid only out to  $|z| \cong 2$  millimeters and it takes the perturbation about  $10^{-8}$  second to reach this distance. Consequently, at the end of  $10^{-7}$  second this  $t^{-1}$  term will damp out to about 10 percent of its original value. Since the frequency of oscillation is about 8.52 megacycles, only a cycle, or so, of this oscillation would occur. The  $\text{Si}(5.35 \times 10^7 t)$  term is also a damped oscillating term, and a plot of it shows that several cycles of this exist.

It is considered unnecessary to make a detailed analysis of the behavior of  $n_{21}$  since the equation for it is very similar to that for  $n_{11}$ , so very similar phenomena will occur.

## IV

### CONCLUSIONS

From (32), and Tables I and II, one can conclude that as  $t$  increases from  $t = 0$  the following phenomena occur:

1. Immediately the electron density at  $z = 0$  assumes a value approximately midway between  $n_{10}$  and  $n_{20}$ .
2. A rarefaction wave of electron density moves in the direction of decreasing  $z$ , with a velocity  $c$  and with an increasing amplitude.
3. At each point of the medium, after the passage of the rarefaction wave, the electron density oscillates at two different frequencies, one corresponding to  $\omega_{p1}$  and the other to  $\omega_{p2}$ . These are damped oscillations consisting of only a few cycles.
4. After the oscillations die out the electron density varies smoothly from a value of about  $0.5 (n_{10} - n_{20})$  at  $z = 0$  to a value of  $n_{10}$  for large negative values of  $z$ .



V

ACKNOWLEDGEMENTS

The writer wishes to acknowledge the helpfulness of discussions with several members of the staff of the Radiation Laboratory, particularly Dr. R. J. Leite and Dr. R. K. Ritt, and with Dr. R. A. Holmes of Purdue University.

## APPENDIX A

### DETERMINATION OF BOUNDARY CONDITIONS AT INTERFACE

The boundary conditions at the interface,  $z = 0$ , are determined by first using the applicable form of the momentum equation,

$$\frac{\partial u_i}{\partial t} = - \sum_k u_k \frac{\partial u_i}{\partial x_k} - \frac{1}{n} \sum_k \frac{\partial}{\partial x_k} (n \overline{V_i V_k}) + \frac{q}{m} E_i, \quad (\text{A-1})$$

where  $V_i$  and  $V_k$  are components of the peculiar, or thermal, velocity of a particle, and  $q$  is its charge, plus the continuity equation,

$$\frac{\partial \rho}{\partial t} = - \sum_k \frac{\partial (\rho u_k)}{\partial x_k}, \quad (\text{A-2})$$

where  $\rho = mn$ , the mass density of the fluid. To obtain useful results from (A-1) and (A-2), one uses these equations in connection with the equation

$$\frac{\partial}{\partial t} (\rho u_i) = \rho \frac{\partial u_i}{\partial t} + u_i \frac{\partial \rho}{\partial t}. \quad (\text{A-3})$$

By substituting (A-1) and (A-2) for the right-hand terms of (A-3) we find that

$$\begin{aligned} \frac{\partial}{\partial t} (\rho u_i) = & - \rho \sum_k u_k \frac{\partial u_i}{\partial x_k} - \frac{\rho}{n} \sum_k \frac{\partial}{\partial x_k} (n \overline{V_i V_k}) \\ & + \frac{q \rho}{m} E_i - u_i \sum_k \frac{\partial (\rho u_k)}{\partial x_k}. \end{aligned} \quad (\text{A-4})$$

In our case of uniform unidirectional drift motion of the particles, viscous

effects disappear, with the result that

$$\overline{V_i V_k} = \delta_{ik} \overline{V_i V_k}, \quad (\text{A-5})$$

where  $\delta_{ik}$  is the Kronecker delta. Then

$$\sum_k \frac{\partial}{\partial x_k} (n \overline{V_i V_k}) = \frac{\partial}{\partial x_i} (n \overline{V_i^2}) = \frac{1}{m} \frac{\partial p}{\partial x_i} = \frac{1}{m} \delta_{ik} \frac{\partial p}{\partial x_k}. \quad (\text{A-6})$$

By using this result in (A-4) we obtain

$$\frac{\partial}{\partial t} (\rho u_i) = \sum_k \left[ -\rho u_k \frac{\partial u_i}{\partial x_k} - u_i \frac{\partial (\rho u_k)}{\partial x_k} - \delta_{ik} \frac{\partial p}{\partial x_k} \right] + q n E_i. \quad (\text{A-7})$$

Equation (A-7) can be made more compact and its physical significance made more evident by using this result:

$$\frac{\partial}{\partial x_k} (\rho u_i u_k) = \rho u_k \frac{\partial u_i}{\partial x_k} + u_i \frac{\partial (\rho u_k)}{\partial x_k}.$$

Then (A-7) becomes

$$\frac{\partial}{\partial t} (\rho u_i) = - \sum_k \frac{\partial}{\partial x_k} (\rho u_i u_k + \delta_{ik} p) + q n E_i. \quad (\text{A-8})$$

To get (A-8) into its final useful form, one expresses the electric volume force in terms of the Maxwell stress tensor, by pages 95-97 of [2]:

$$q n E_i = \sum_k \frac{\partial T_{ik}}{\partial x_k}. \quad (\text{A-9})$$

In our case, the Maxwell stress tensor is

$$T_{ik} = \epsilon_0 \left[ E_i E_k - \frac{1}{2} \delta_{ik} E^2 \right], \quad (\text{A-10})$$

since we are dealing with a plasma in otherwise empty space, with a constant electric permittivity  $\epsilon_0$ .

By using (A-9) and (A-10) in (A-8) we obtain

$$\frac{\partial}{\partial t} (\rho u_i) = \sum_k \frac{\partial}{\partial x_k} \left[ -\delta_{ik} p - \rho u_i u_k + \epsilon_0 E_i E_k - \delta_{ik} \frac{E^2}{2} \right]. \quad (\text{A-11})$$

By pages 12-15 of [1], we can write

$$\frac{\partial}{\partial t} (\rho u_i) = - \sum_k \frac{\partial \Pi_{ik}}{\partial x_k},$$

where  $\Pi_{ik}$  is the momentum flux density tensor, given in our case by

$$\Pi_{ik} = \delta_{ik} p + \rho u_i u_k - \epsilon_0 E_i E_k + \delta_{ik} \frac{1}{2} E^2. \quad (\text{A-12})$$

Now  $\sum_k \Pi_{ik} n_k$  is the flux of the  $i^{\text{th}}$  component of momentum through a unit surface area having the unit vector  $\vec{n}$  along its outward normal. The flux of each component of momentum must be continuous at an interface between a

Region 1 and a Region 2, so

$$\sum_k (\Pi_{ik})_1 n_k = \sum_k (\Pi_{ik})_2 n_k, \quad i = 1, 2, 3. \quad (\text{A-13})$$

At the interface  $z = 0$ , we have  $k = 3$  in (A-13) with the following three resulting scalar equations for  $i = 1, 2, 3$ , respectively.

$$\rho_1 u_{1x} u_{1z} - \epsilon_o E_{1x} E_{1z} = \rho_2 u_{2x} u_{2z} - \epsilon_o E_{2x} E_{2z} \quad (\text{A-14})$$

$$\rho_1 u_{1y} u_{1z} - \epsilon_o E_{1y} E_{1z} = \rho_2 u_{2y} u_{2z} - \epsilon_o E_{2y} E_{2z} \quad (\text{A-15})$$

$$p_1 + \rho_1 u_{1z}^2 - \epsilon_o E_{1z}^2 + \frac{1}{2} E_1^2 = p_2 + \rho_2 u_{2z}^2 - \epsilon_o E_{2z}^2 + \frac{1}{2} E_2^2. \quad (\text{A-16})$$

Because our regions are unbounded and homogeneous in the  $x$  and  $y$  directions, the  $x$  and  $y$  components of  $\vec{u}$  and  $\vec{E}$  are zero in both Region 1 and Region 2. Also, we know that  $E_{1z} = E_{2z}$ . Therefore, only (A-16) gives a useful result:

$$p_1 + \rho_1 u_{1z}^2 = p_2 + \rho_2 u_{2z}^2,$$

or

$$(p_{10} + p_{11}) + (\rho_{10} + \rho_{11}) u_{1z}^2 = (p_{20} + p_{21}) + (\rho_{20} + \rho_{21}) u_{2z}^2.$$

Dropping terms of second, and higher, order gives

$$p_1 = p_{10} + p_{11} = p_2 = p_{20} + p_{21}. \quad (\text{A-17})$$

A second boundary condition at  $z = 0$  is given by the fact that the normal flux of electrons must be continuous at the surface  $z = 0$ . That is,

$$u_1 n_1 = u_2 n_2. \quad (\text{A-18})$$

We obtain a third boundary condition here by recognizing that the normal component of energy flux must be continuous at this plane interface between the two regions. By sections 51 and 53 of [3] we have for the conservation of energy, in our case,

$$\frac{\partial}{\partial t} \left( \frac{1}{2} \rho u^2 + \rho \epsilon + \frac{1}{2} \epsilon_0 E^2 + \frac{1}{2} \mu_0 H^2 \right) = -\nabla \cdot \left[ \rho \vec{u} \left( \frac{1}{2} u^2 + w \right) - \vec{u} \cdot \overleftrightarrow{\sigma}' - \mathcal{K} \nabla T + \vec{E} \times \vec{H} \right] \equiv -\nabla \cdot \vec{q}. \quad (\text{A-19})$$

Here :

$\epsilon$  = internal energy per unit mass,

$w$  = enthalpy per unit mass =  $\epsilon + p/\rho$ ,

$\overleftrightarrow{\sigma}'$  = viscosity stress tensor,

$\mathcal{K}$  = thermal conductivity.

As mentioned previously, viscous effects do not enter in our case, so the term  $\vec{u} \cdot \overleftrightarrow{\sigma}'$  in (A-19) is dropped. Also, we are assuming very long mean free paths so collisions can be neglected, allowing us to drop the heat conduction term  $\mathcal{K} \nabla T$ . Because we are dealing with longitudinal oscillations, there is no magnetic field and the Poynting vector term disappears.

By Section 85 of [1] we have for the enthalpy per unit mass of a perfect gas:

$$w = \frac{\gamma p V}{\gamma - 1} = \frac{\gamma}{\gamma - 1} \frac{p}{\rho} = \epsilon + \frac{p}{\rho}, \quad (\text{A-20})$$

whence

$$\epsilon = \frac{1}{\gamma-1} \frac{p}{\rho} . \quad (\text{A-21})$$

Now if these expressions are used in (A-19), together with the results of the last paragraph above, we obtain

$$m n_1 u_1 \left( \frac{1}{2} u_1^2 + \frac{\gamma}{\gamma-1} \frac{p_1}{m n_1} \right) = m n_2 u_2 \left( \frac{1}{2} u_2^2 + \frac{\gamma}{\gamma-1} \frac{p_2}{m n_2} \right) . \quad (\text{A-22})$$

By using the facts that

$$p_1 = p_2$$

and

$$u_1 n_1 = u_2 n_2 ,$$

given by (A-17) and (A-18), respectively, (A-22) above becomes

$$\frac{1}{2} u_1^2 + \frac{\gamma}{\gamma-1} \frac{p_1}{m n_1} = \frac{1}{2} u_2^2 + \frac{\gamma}{\gamma-1} \frac{p_1}{m n_2} . \quad (\text{A-23})$$

By dropping the second-order terms,  $\frac{1}{2} u_1^2$  and  $\frac{1}{2} u_2^2$ , in (A-23), we obtain

$$n_1 = n_2 . \quad (\text{for } z = 0) \quad (\text{A-24})$$

By using (A-24) in (A-17) and (A-18), we get

$$T_1 = T_2, \quad (z = 0) \quad (\text{A-25})$$

$$u_1 = u_2, \quad (z = 0). \quad (\text{A-26})$$

From (A-24) we have

$$n_{10} + n_{11} = n_{20} + n_{21}$$

$$n_{21} = n_{11} + (n_{10} - n_{20}), \quad (z = 0) \quad (\text{A-27})$$

This equation tells us that our results will be valid only for values of  $(n_{10} - n_{20})$  of the same order of magnitude as  $n_{11}$  and  $n_{21}$ .

Taking the Laplace transform of (A-27) gives

$$N_{21}(0, s) = N_{11}(0, s) + \frac{n_{10} - n_{20}}{s}. \quad (\text{A-28})$$

A second relation involving  $N_{11}(0, s)$  and  $N_{21}(0, s)$  can be obtained by taking the Laplace transform of (1a), obtaining

$$m n_{10} \left[ s U_1(z, s) - u_1(z, 0) \right] + \gamma k T_o \frac{\partial N_{11}(z, s)}{\partial z} + n_{10} e \mathcal{E}_1(z, s) = 0, \quad (\text{A-29})$$

where  $U_1(z, s)$  and  $\mathcal{E}_1(z, s)$  are the transforms of  $u_1(z, t)$  and  $E_1(z, t)$ , respectively. One of our initial conditions is that

$$u_1(z, 0) = u_2(z, 0) = 0.$$

Consequently (A-29) can be rewritten

$$U_1(z, s) = -\frac{e}{ms} \mathcal{E}_1(z, s) - \frac{\gamma k T_{10}}{m n_{10} s} \frac{\partial N_{11}(z, s)}{\partial z}, \quad (\text{A-30})$$



with a similar equation for  $U_2(z, s)$ . Because of (A-25) and (A-26), we get from (A-30):

$$\frac{\partial N_{21}(0, s)}{\partial z} = \frac{n_{20}}{n_{10}} \frac{\partial N_{11}(0, s)}{\partial z}, \quad (\text{A-31})$$

where we have made use of the fact that

$$E_1(0, t) = E_2(0, t).$$

We can now use (12), (13), (A-28), and (A-31) to determine  $F_1(s)$ , ...  $F_4(s)$  in (10) and (11). From (13),

$$\lim_{z \rightarrow -\infty} N_{11}(z, s) = 0. \quad (\text{A-32})$$

Now  $F_1(s)$  and  $F_2(s)$  are not functions of  $z$ , so (A-32), in conjunction with (10), shows that it is necessary that  $F_1(s) = 0$ . Similarly, it can be shown that  $F_4(s) = 0$ . Lastly, we can determine  $F_2(s)$  and  $F_3(s)$  by using (A-28) and (A-31). This is routine algebra and the results are:

$$F_2(s) = \frac{(n_{20} - n_{10}) \sqrt{s^2 + \omega_{p2}^2}}{s \left[ \frac{n_{20}}{n_{10}} \sqrt{s^2 + \omega_{p1}^2} + \sqrt{s^2 + \omega_{p2}^2} \right]}, \quad (\text{A-33})$$

$$F_3(s) = F_2(s) + \frac{n_{10} - n_{20}}{s}. \quad (\text{A-34})$$

## APPENDIX B

### EVALUATION OF CONTOUR INTEGRAL

In order to evaluate the integral in (23) we use Path 2 of Figure 1 and rewrite

the integral thus

$$n_{11}(z, t) = \frac{n_{20} - n_{10}}{2\pi i} \lim_{\beta \rightarrow \infty} \int_{\text{Path 2}} \frac{\sqrt{\rho_{21} \rho_{22}} e^{\frac{i}{2}(\phi_{21} + \phi_{22})} e^{\frac{z}{c} \sqrt{\rho_{11} \rho_{12}}} e^{\frac{i}{2}(\phi_{11} + \phi_{12})} e^{re^{i\phi} t} d(re^{i\phi})}{(re^{i\phi}) \left[ \frac{n_{20}}{n_{10}} \sqrt{\rho_{11} \rho_{12}} e^{\frac{i}{2}(\phi_{11} + \phi_{12})} + \sqrt{\rho_{21} \rho_{22}} e^{\frac{i}{2}(\phi_{21} + \phi_{22})} \right]} \quad (\text{B-1})$$

where

$$\begin{aligned} s - i\omega_{p1} &= \rho_{11} e^{i\phi_{11}}, \\ s - i\omega_{p2} &= \rho_{21} e^{i\phi_{21}}, \\ s + i\omega_{p1} &= \rho_{12} e^{i\phi_{12}}, \\ s + i\omega_{p2} &= \rho_{22} e^{i\phi_{22}}, \\ s &= re^{i\phi}, \end{aligned}$$

and  $-\pi/2 < \phi_{mn} < (3/2)\pi$ .

It is to be noted that  $\gamma > 0$ , but  $\gamma$  can be a small quantity. Figure B-1 illustrates the geometry.

The value of the contour integral evaluated on Path 2 is, of course, equal to the sum of the integrals evaluated along the various separate paths which make up Path 2, as shown in Figure 1. We now evaluate our integral along the various separate paths.

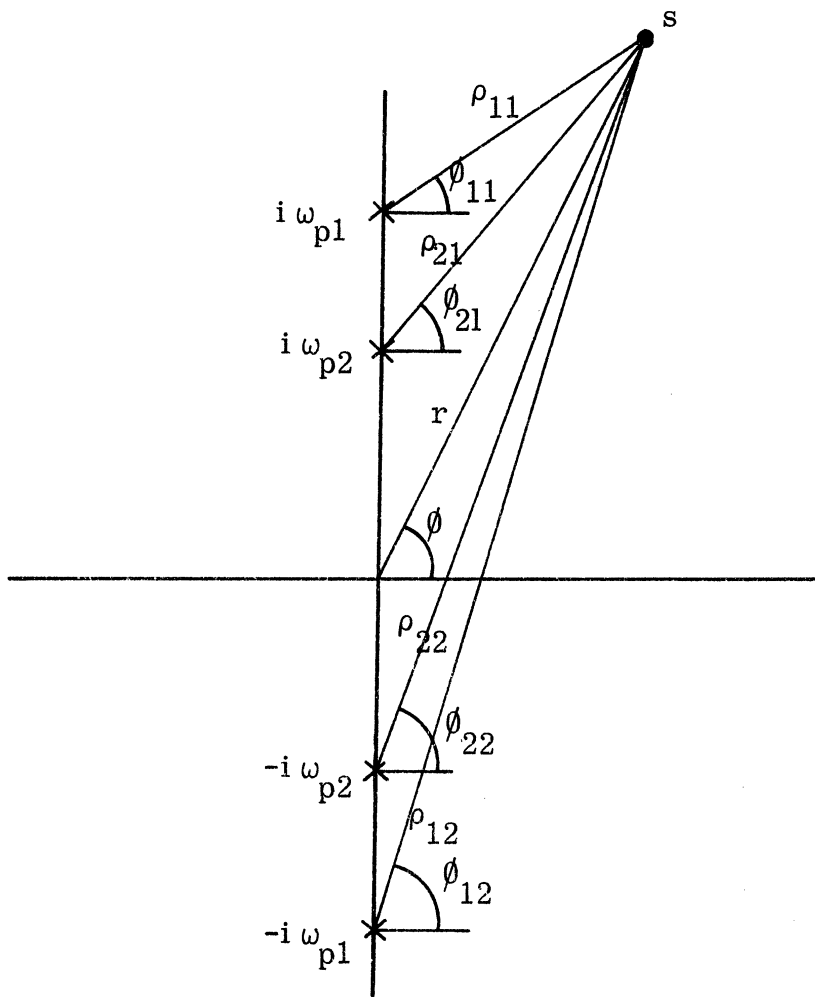

FIGURE B-1: POLAR REPRESENTATION OF  $s \pm i\omega_p$

First, we note that our integrand is analytic along the negative axis of reals, so the integrals along paths B-O and O-C are equal in magnitude and opposite in sign. Also, then, the integrals from 1 to 2, and from A' to D' can be evaluated along continuous paths between these points.

Next, let us consider circular arc A-A' . On this path  $r = r_0$  and  $r_0 \rightarrow \infty$ ,  $\rho_{mn} \rightarrow \infty$ ,  $\phi \rightarrow -\pi/2$ , and  $\phi_{mn} \rightarrow -\pi/2$  as  $\beta \rightarrow \infty$ . Then

$$\lim_{\beta \rightarrow \infty} I_{A-A'} \equiv \lim_{\substack{\beta \rightarrow \infty \\ \phi_0 \rightarrow -\pi/2}} \int_{\phi=\phi_0}^{-\pi/2} \frac{\sqrt{\rho_{21}\rho_{22}} e^{\frac{i}{2}(\phi_{21}+\phi_{22})} e^{\frac{z}{c}\sqrt{\rho_{11}\rho_{12}}} e^{\frac{i}{2}(\phi_{11}+\phi_{12})} e^{tr_0} e^{i\phi}}{\left[ \frac{n_{20}}{n_{10}} \sqrt{\rho_{11}\rho_{12}} e^{\frac{i}{2}(\phi_{11}+\phi_{12})} + \sqrt{\rho_{21}\rho_{22}} e^{\frac{i}{2}(\phi_{21}+\phi_{22})} \right]} d\phi, \quad (B-2)$$

$$\lim_{\beta \rightarrow \infty} I_{A-A'} = \frac{i}{(n_{20}/n_{10})+1} \lim_{\substack{\beta \rightarrow \infty \\ \phi_0 \rightarrow -\pi/2}} \int_{\phi=\phi_0}^{-\pi/2} e^{t\gamma+it\beta} d\phi = 0 .$$

Similarly,

$$\lim_{\beta \rightarrow \infty} I_{D'-D} = 0 \quad (B-3)$$

First, we note that our integrand is analytic along the negative axis of reals, so the integrals along paths B-O and O-C are equal in magnitude and opposite in sign. Also, then, the integrals from 1 to 2, and from A' to D' can be evaluated along continuous paths between these points.

Next, let us consider circular arc A-A'. On this path  $r = r_0$  and  $r_0 \rightarrow \infty$ ,  $\rho_{mn} \rightarrow \infty$ ,  $\phi \rightarrow -\pi/2$ , and  $\phi_{mn} \rightarrow -\pi/2$  as  $\beta \rightarrow \infty$ . Then

$$\lim_{\beta \rightarrow \infty} I_{A-A'} \equiv \lim_{\substack{\beta \rightarrow \infty \\ \phi_0 \rightarrow -\pi/2}} \int_{\phi=\phi_0}^{-\pi/2} \frac{\sqrt{\rho_{21}\rho_{22}} e^{\frac{i}{2}(\phi_{21}+\phi_{22})} e^{\frac{z}{c}\sqrt{\rho_{11}\rho_{12}}} e^{\frac{i}{2}(\phi_{11}+\phi_{12})} e^{t\gamma} e^{i\phi}}{\left[ \frac{n_{20}}{n_{10}} \sqrt{\rho_{11}\rho_{12}} e^{\frac{i}{2}(\phi_{11}+\phi_{12})} + \sqrt{\rho_{21}\rho_{22}} e^{\frac{i}{2}(\phi_{21}+\phi_{22})} \right]} d\phi, \quad (B-2)$$

$$\lim_{\beta \rightarrow \infty} I_{A-A'} = \frac{i}{(n_{20}/n_{10})+1} \lim_{\substack{\beta \rightarrow \infty \\ \phi_0 \rightarrow -\pi/2}} \int_{\phi=\phi_0}^{-\pi/2} e^{t\gamma+it\beta} d\phi = 0.$$

Similarly,

$$\lim_{\beta \rightarrow \infty} I_{D'-D} = 0 \quad (B-3)$$

On the circular arc, A' - D', we use the form of the integral given by

(24), remembering that  $(t + \frac{z}{c}) > 0$ . In the second and third quadrants  $(\text{Re } s) < 0$ , and as  $\beta \rightarrow \infty$ ,  $(\text{Re } s) \rightarrow -\infty$ , so

$$\lim_{\beta \rightarrow \infty} I_{A'-D'} = 0 \quad . \quad (\text{B-4})$$

We next consider the integrals over the paths 1-2 and 9-10. Here  $r = r_0$ , a constant during the integration, and

$$\lim_{r_0 \rightarrow 0} \left\{ \begin{array}{l} \rho_{11} = \omega_{p1} \\ \rho_{21} = \omega_{p2} \\ \rho_{22} = \omega_{p2} \\ \rho_{12} = \omega_{p1} \end{array} \right.$$

On the path 1-2:

$$\lim_{r_0 \rightarrow 0} \left\{ \begin{array}{l} \phi_{11} = \frac{3}{2} \pi \\ \phi_{21} = \frac{3}{2} \pi \\ \phi_{22} = \frac{1}{2} \pi \\ \phi_{12} = \frac{1}{2} \pi \end{array} \right.$$

For the path 9-10,

$$\lim_{r_0 \rightarrow 0} \left\{ \begin{array}{l} \phi_{11} = -\frac{1}{2} \pi \\ \phi_{21} = -\frac{1}{2} \pi \\ \phi_{22} = \frac{1}{2} \pi \\ \phi_{12} = \frac{1}{2} \pi \end{array} \right.$$

Then

$$I_{1-2} = \lim_{\substack{r_o \rightarrow 0 \\ \epsilon \rightarrow 0}} \int_{\phi = \frac{\pi}{2} + \epsilon}^{\frac{3}{2}\pi - \epsilon} \frac{i\omega_{p2} e^{-\frac{z}{c}\omega_{p1}} e^{r_o t} e^{i\phi} d\phi}{\left[ \frac{n_{20}}{n_{10}} \omega_{p1} + \omega_{p2} \right]}, \quad (\text{B-5})$$

$$I_{1-2} = \frac{i\omega_{p2} e^{-\frac{z}{c}\omega_{p1}}}{\frac{n_{20}}{n_{10}} \omega_{p1} + \omega_{p2}} \lim_{\substack{r_o \rightarrow 0 \\ \epsilon \rightarrow 0}} \int_{\phi = \frac{\pi}{2} + \epsilon}^{\frac{3}{2}\pi - \epsilon} e^{r_o t} e^{i\phi} d\phi, \quad (\text{B-6})$$

$$I_{1-2} = \frac{\pi i \omega_{p2} e^{-\frac{z}{c}\omega_{p1}}}{\frac{n_{20}}{n_{10}} \omega_{p1} + \omega_{p2}}.$$

For the path 9-10,

$$I_{9-10} = \lim_{\substack{r_o \rightarrow 0 \\ \epsilon \rightarrow 0}} \int_{\phi = -\frac{\pi}{2} + \epsilon}^{\frac{\pi}{2} - \epsilon} \frac{i\omega_{p2} e^{\frac{z}{c}\omega_{p1}} e^{r_o t} e^{i\phi} d\phi}{\left[ \frac{n_{20}}{n_{10}} \omega_{p1} + \omega_{p2} \right]}, \quad (\text{B-7})$$

$$I_{9-10} = \frac{i\omega_{p2} e^{\frac{z}{c}\omega_{p1}}}{\frac{n_{20}}{n_{10}} \omega_{p1} + \omega_{p2}} \lim_{\substack{r_o \rightarrow 0 \\ \epsilon \rightarrow 0}} \int_{\phi = -\frac{\pi}{2} + \epsilon}^{\frac{\pi}{2} - \epsilon} e^{r_o t} e^{i\phi} d\phi,$$

$$I_{9-10} = \frac{i \pi \omega_{p2} e^{\frac{z}{c} \omega_{p1}}}{\frac{n_{20}}{n_{10}} \omega_{p1} + \omega_{p2}}, \quad (B-8)$$

$$I_1 = I_{1-2} + I_{9-10} = \frac{2\pi i \omega_{p2} \cosh \frac{z}{c} \omega_{p1}}{\frac{n_{20}}{n_{10}} \omega_{p1} + \omega_{p2}}, \quad (B-9)$$

for  $t > |z|/c$ .

For the circular path 3-4 we let  $\rho_{22} \rightarrow 0$  and  $\frac{\pi}{2} + \epsilon \leq \phi_{22} \leq \frac{3}{2} \pi - \epsilon$ , and

then let  $\epsilon \rightarrow 0$ . On this path as  $\rho_{22} \rightarrow 0$ :

$$\rho_{11} = \omega_{p1} + \omega_{p2} \quad \phi_{11} = \frac{3}{2} \pi$$

$$\rho_{21} = 2 \omega_{p2} \quad \phi_{21} = \frac{3}{2} \pi$$

$$\rho_{12} = \omega_{p1} - \omega_{p2} \quad \phi_{12} = \frac{1}{2} \pi$$

$$s = -i \omega_{p2} + \rho_{22} e^{i \phi_{22}}$$

$$ds = i \rho_{22} e^{i \phi_{22}} d\phi_{22}$$

Then

$$\lim_{\rho_{22} \rightarrow 0} I_{3-4} = \lim_{\substack{\rho_{22} \rightarrow 0 \\ \epsilon \rightarrow 0}} \int_{\frac{\pi}{2} + \epsilon}^{\frac{3}{2} \pi - \epsilon} \frac{\sqrt{2\omega_{p2}\rho_{22}} e^{\frac{i}{2}(\frac{3}{2}\pi + \phi_{22})} e^{-\frac{z}{c} \sqrt{\omega_{p1}^2 - \omega_{p2}^2}} (-i\omega_{p2} + \rho_{22} e^{i\phi_{22}})^t i \rho_{22} e^{i\phi_{22}} d\phi_{22}}{(-i\omega_{p2} + \rho_{22} e^{i\phi_{22}}) \left[ \frac{-n_{20}}{n_{10}} \sqrt{\omega_{p1}^2 - \omega_{p2}^2} + \sqrt{2\omega_{p2}\rho_{22}} e^{\frac{i}{2}(\frac{3}{2}\pi + \phi_{22})} \right]} \quad (B-10)$$



$$\lim_{\rho_{22} \rightarrow 0} I_{3-4} = 0 . \quad (\text{B-11})$$

Similarly,

$$\lim_{\rho_{22} \rightarrow 0} I_{7-8} = 0 , \quad (\text{B-12})$$

$$\lim_{\rho_{21} \rightarrow 0} I_{11-12} = 0 , \quad (\text{B-13})$$

$$\lim_{\rho_{21} \rightarrow 0} I_{15-16} = 0 . \quad (\text{B-14})$$

On the path 5-5', we let  $\rho_{12} \rightarrow 0$  and  $\frac{\pi}{2} + \epsilon \leq \phi_{12} \leq \frac{3}{2} \pi$ . Here, as  $\rho_{12} \rightarrow 0$ :

$$\rho_{11} = 2 \omega_{p1} \quad \phi_{11} = \frac{3}{2} \pi$$

$$\rho_{21} = \omega_{p2} + \omega_{p1} \quad \phi_{21} = \frac{3}{2} \pi$$

$$\rho_{22} = \omega_{p1} - \omega_{p2} \quad \phi_{22} = \frac{3}{2} \pi$$

$$s = -i \omega_{p1} + \rho_{12} e^{i\phi_{12}}$$

$$ds = i \rho_{12} e^{i\phi_{12}} d\phi_{12}.$$

Then we obtain

$$\lim_{\rho_{12} \rightarrow 0} I_{5-5'} = \lim_{\substack{\rho_{12} \rightarrow 0 \\ \epsilon \rightarrow 0}} \int_{\frac{\pi}{2} + \epsilon}^{\frac{3}{2}\pi} \frac{\sqrt{\omega_{p1}^2 - \omega_{p2}^2} e^{\frac{z}{c} \sqrt{2\omega_{p1}\rho_{12}}} e^{\frac{i}{2}(\frac{3}{2}\pi + \phi_{12})} (-i\omega_{p1} + \rho_{12} e^{i\phi_{12}})^t \rho_{12} e^{i\phi_{12}}}{(-i\omega_{p1} + \rho_{12} e^{i\phi_{12}}) \left[ \frac{n_{20}}{n_{10}} \sqrt{2\omega_{p1}\rho_{12}} e^{\frac{i}{2}(\frac{3}{2}\pi + \phi_{12})} - i \sqrt{\omega_{p1}^2 - \omega_{p2}^2} \right]} d\phi_{12}, \quad (\text{B-15})$$

$$\lim_{\rho_{12} \rightarrow 0} I_{5-5'} = 0. \quad (\text{B-16})$$

Similarly

$$\lim_{\rho_{12} \rightarrow 0} I_{5'-6} = 0, \quad (\text{B-17})$$

$$\lim_{\rho_{11} \rightarrow 0} I_{13-14} = 0. \quad (\text{B-18})$$

We now consider the following four integrals as a group, since they combine well.

$$I_{16-1} = \int_{r=\omega_{p2}}^0 \frac{\sqrt{\omega_{p2}^2 - r^2} e^{-\frac{z}{c} \sqrt{\omega_{p1}^2 - r^2}} e^{irt} dr}{r \left[ \frac{n_{20}}{n_{10}} \sqrt{\omega_{p1}^2 - r^2} + \sqrt{\omega_{p2}^2 - r^2} \right]} \quad (\text{B-19})$$

$$I_{2-3} = \int_{r=0}^{\omega_{p2}} \frac{\sqrt{\omega_{p2}^2 - r^2} e^{-\frac{z}{c}\sqrt{\omega_{p1}^2 - r^2}} e^{-irt} dr}{r \left[ \frac{n_{20}}{n_{10}} \sqrt{\omega_{p1}^2 - r^2} + \sqrt{\omega_{p2}^2 - r^2} \right]} \quad (\text{B-20})$$

$$I_{8-9} = \int_{r=\omega_{p2}}^0 \frac{\sqrt{\omega_{p2}^2 - r^2} e^{\frac{z}{c}\sqrt{\omega_{p1}^2 - r^2}} e^{-irt} dr}{r \left[ \frac{n_{20}}{n_{10}} \sqrt{\omega_{p1}^2 - r^2} + \sqrt{\omega_{p2}^2 - r^2} \right]} \quad (\text{B-21})$$

$$I_{10-11} = \int_{r=0}^{\omega_{p2}} \frac{\sqrt{\omega_{p2}^2 - r^2} e^{\frac{z}{c}\sqrt{\omega_{p1}^2 - r^2}} e^{irt} dr}{r \left[ \frac{n_{20}}{n_{10}} \sqrt{\omega_{p1}^2 - r^2} + \sqrt{\omega_{p2}^2 - r^2} \right]} \quad (\text{B-22})$$

Combining these four integrals gives

$$I_2 \equiv I_{16-1} + I_{2-3} + I_{8-9} + I_{10-11}, \quad (\text{B-23})$$

$$I_2 = 4i \int_{r=0}^{\omega_{p2}} \frac{\sqrt{\omega_{p2}^2 - r^2} (\sinh \frac{z}{c} \sqrt{\omega_{p1}^2 - r^2}) (\sin rt) dr}{r \left[ \frac{n_{20}}{n_{10}} \sqrt{\omega_{p1}^2 - r^2} + \sqrt{\omega_{p2}^2 - r^2} \right]} . \quad (\text{B-24})$$

We can simplify this integral by considering the first term in the denominator:

$$\frac{n_{20}}{n_{10}} \sqrt{\omega_{p1}^2 - r^2} = \sqrt{\frac{n_{20}}{n_{10}}} \sqrt{\omega_{p2}^2 - \frac{n_{20}}{n_{10}} r^2} .$$

Following (17), we noted that our results will be valid only for  $(n_{10} - n_{20})$  of the same order of magnitude as  $n_{11}$  and  $n_{21}$ , and we have restricted our work to the case of

$$n_{11} \ll n_{10} \text{ and } n_{21} \ll n_{20} .$$

Therefore we must restrict  $n_{20}/n_{10}$  as follows:

$$n_{20}/n_{10} \cong 0.9,$$

$$\sqrt{n_{20}/n_{10}} \cong 0.95,$$

and we can say that

$$\sqrt{\frac{n_{20}}{n_{10}}} \sqrt{\omega_{p2}^2 - \frac{n_{20}}{n_{10}} r^2} \cong \sqrt{\omega_{p2}^2 - r^2} .$$

Then we can write

$$I_2 \cong 2i \int_{r=0}^{\omega_{p2}} \frac{\left( \sinh \frac{z}{c} \sqrt{\omega_{p1}^2 - r^2} \right) (\sin rt) \, dr}{r} . \quad (\text{B-25})$$

This integral still is untractable so we must look for further simplifications.

Now

$$\sinh x = x + \frac{x^3}{3!} + \frac{x^5}{5!} + \dots . \quad (\text{B-26})$$

We can use only the first term with fair accuracy if

$$x \gg 10 \frac{x^3}{3!}$$

or if

$$x \leq 0.774 \quad . \quad (B-27)$$

$\text{Sinh } \frac{z}{c} \sqrt{\omega_{p1}^2 - r^2}$  has its maximum value,  $\text{sinh } \frac{z}{c} \omega_{p1}$ , when  $r = 0$ . Therefore, to represent  $\text{sinh } \frac{z}{c} \omega_{p1}$  by only the first term in the corresponding series we must satisfy the relation

$$\frac{z}{c} \omega_{p1} \leq 0.774.$$

By using the numerical values for  $\omega_{p1}$  and  $c$ , which are given just before equation (32), we find that our approximation for  $\text{sinh } \frac{z}{c} \omega_{p1}$  will be valid for

$$z \leq 3 \text{ millimeters}, \quad (B-28)$$

which is of the order of a Debye length. We then assume that

$$\text{sinh } \frac{z}{c} \sqrt{\omega_{p1}^2 - r^2} \cong \frac{z}{c} \sqrt{\omega_{p1}^2 - r^2}. \quad (B-29)$$

Our last simplifying assumption is this,

$$\frac{z}{c} \sqrt{\omega_{p1}^2 - r^2} \cong \frac{z}{c} \omega_{p1} \left( 1 - \frac{1}{2} \frac{r^2}{\omega_{p1}^2} \right). \quad (B-30)$$

In our integral of (B-25) the upper limit on  $r$  is  $\omega_{p2} = 0.948 \omega_{p1}$ . For this value of  $r$  we have:

$$\sqrt{1 - (r^2/\omega_{p1}^2)} = \sqrt{1 - (\omega_{p2}^2/\omega_{p1}^2)} = 0.316,$$

$$\left( 1 - \frac{1}{2} \frac{r^2}{\omega_{p1}^2} \right) = 0.550.$$

Our approximation (B-30) is thus seen to be only fair at this limit, however, it is much better for smaller values of  $r$ .

By using the above-discussed approximation in (B-25) we get

$$I_2 \cong 2i \frac{z}{c} \omega_{p1} \int_{rt=0}^{\omega_{p2}t} \frac{\sin(rt)}{(rt)} d(rt) - i \frac{z}{c} \frac{1}{\omega_{p1}t^2} \int_{rt=0}^{\omega_{p2}t} (rt)\sin(rt)d(rt), \quad (\text{B-31})$$

$$I_2 \cong 2i \frac{z}{c} \omega_{p1} \text{Si}(\omega_{p2}t) - i \frac{z}{c} \frac{1}{\omega_{p1}t^2} \sin(\omega_{p2}t) + i \frac{z}{c} \frac{\omega_{p2}}{\omega_{p1}t} \cos(\omega_{p2}t), \quad (t \neq 0) . \quad (\text{B-32})$$

Here

$$\text{Si}(\omega_{p2}t) = \int_0^{\omega_{p2}t} \frac{\sin x}{x} dx . \quad (\text{B-33})$$

In order to obtain some idea of the validity of (B-32), we have numerically evaluated  $I_2/2i$ , as given by (B-25), for the following values of the various parameters:

$$\begin{aligned} z &= 1.0 \text{ millimeter,} \\ c &= 2 \times 10^5 \text{ meters per second} \\ \omega_{p1} &= 5 \times 10^7 \text{ radians per second,} \\ \omega_{p2} &= 4.74 \times 10^7 \text{ radians per second,} \end{aligned}$$

and for  $\omega_{p2}t$  taking the values 0.5, 1.0, 1.5, ..., 20.0 radians. Then  $I_2/2i$  was calculated by using (B-32). The results of the two different calculations are shown

in Figure B-2. The numerical integration of  $I_2$  was carried out by using Simpson's rule, with the number of subdivisions increased at  $\omega_{p2}t = 5, 10,$  and  $15$ . This accounts for the jumps on the curve of  $y_1$  at these points.

Our last integral to evaluate is

$$I_3 \equiv I_{4-5} + I_{6-7} + I_{12-13} + I_{14-15} \quad , \quad (B-34)$$

where

$$I_{4-5} = \int_{r=\omega_{p2}}^{\omega_{p1}} \frac{i \sqrt{r^2 - \omega_{p2}^2} e^{-\frac{z}{c} \sqrt{\omega_{p1}^2 - r^2}} e^{-irt} dr}{r \left[ \frac{n_{20}}{n_{10}} \sqrt{\omega_{p1}^2 - r^2} + i \sqrt{r^2 - \omega_{p2}^2} \right]} \quad , \quad (B-35)$$

$$I_{6-7} = \int_{r=\omega_{p1}}^{\omega_{p2}} \frac{i \sqrt{r^2 - \omega_{p2}^2} e^{\frac{z}{c} \sqrt{\omega_{p1}^2 - r^2}} e^{-irt} dr}{r \left[ -\frac{n_{20}}{n_{10}} \sqrt{\omega_{p1}^2 - r^2} + i \sqrt{r^2 - \omega_{p2}^2} \right]} \quad , \quad (B-36)$$

$$I_{12-13} = \int_{r=\omega_{p2}}^{\omega_{p1}} \frac{i \sqrt{r^2 - \omega_{p2}^2} e^{\frac{z}{c} \sqrt{\omega_{p1}^2 - r^2}} e^{irt} dr}{r \left[ \frac{n_{20}}{n_{10}} \sqrt{\omega_{p1}^2 - r^2} + i \sqrt{r^2 - \omega_{p2}^2} \right]} \quad , \quad (B-37)$$

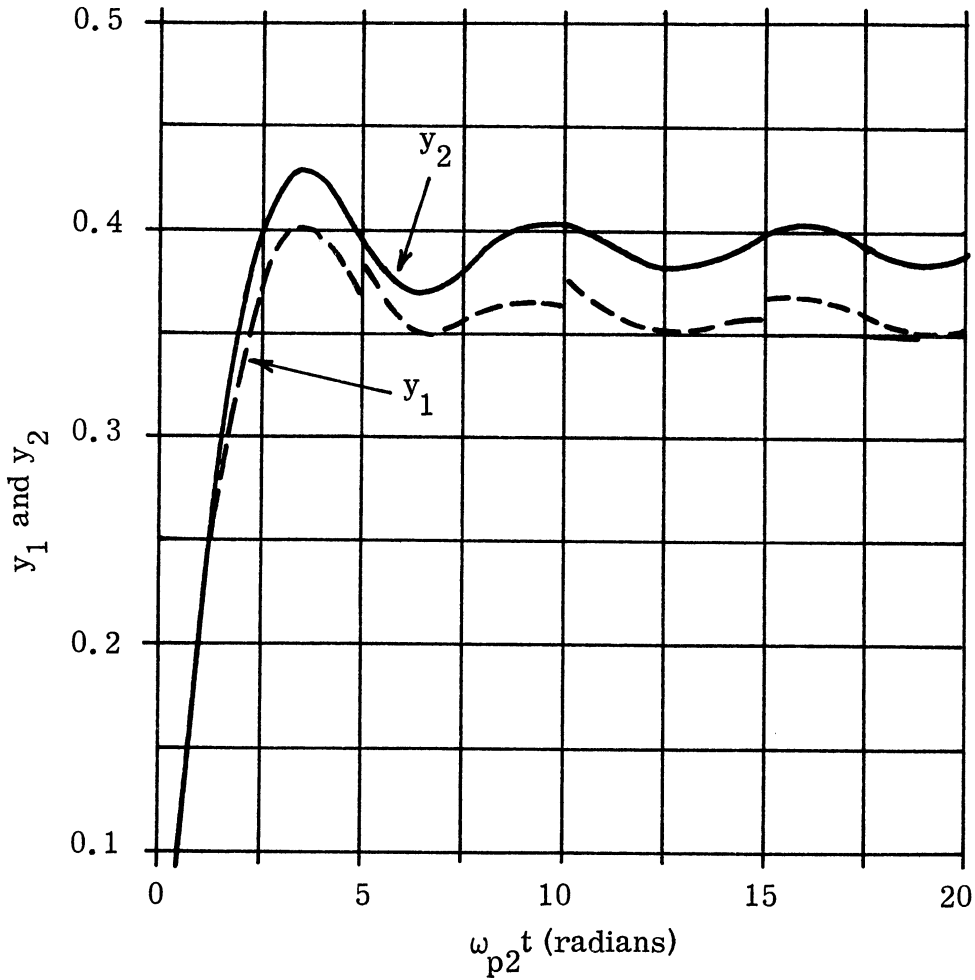

FIGURE B-2: PLOTS OF  $y_1 = \int_{rt=0}^{\omega_{p2}t} \frac{(\sinh \frac{z}{c} \sqrt{\omega_{p1}^2 - r^2})(\sin rt) d(rt)}{(rt)}$

AND 
$$y_2 = \frac{z}{c} \omega_{p1} \text{Si}(\omega_{p2}t) - \frac{1}{2\omega_{p1}t^2} \frac{z}{c} \sin(\omega_{p2}t) + \frac{\omega_{p2}}{2\omega_{p1}t} \frac{z}{c} \cos(\omega_{p2}t),$$

FOR  $z = 10^{-3}, \quad c = 2 \times 10^5, \quad \omega_{p1} = 5 \times 10^7, \quad \omega_{p2} = 4.74 \times 10^7.$



$$I_{14-15} = \int_{r=\omega_{p1}}^{\omega_{p2}} \frac{i \sqrt{r^2 - \omega_{p2}^2} e^{-\frac{z}{c} \sqrt{\omega_{p1}^2 - r^2}} e^{irt} dr}{r \left[ -\frac{n_{20}}{n_{10}} \sqrt{\omega_{p1}^2 - r^2} + i \sqrt{r^2 - \omega_{p2}^2} \right]} . \quad (\text{B-38})$$

After considerable algebraic manipulation, we find that

$$I_3 = \frac{4i n_{20}}{n_{10} - n_{20}} \int_{r=\omega_{p2}}^{\omega_{p1}} \frac{\sqrt{(r^2 - \omega_{p2}^2)(\omega_{p1}^2 - r^2)} (\cosh \frac{z}{c} \sqrt{\omega_{p1}^2 - r^2}) (\cos rt) dr}{r \left[ \left( \frac{n_{10} + n_{20}}{n_{10}} \right) r^2 - \omega_{p2}^2 \right]} + \frac{4i n_{10}}{n_{10} - n_{20}} \int_{r=\omega_{p2}}^{\omega_{p1}} \frac{(r^2 - \omega_{p2}^2) (\sinh \frac{z}{c} \sqrt{\omega_{p1}^2 - r^2}) (\sin rt) dr}{r \left[ \left( \frac{n_{10} + n_{20}}{n_{10}} \right) r^2 - \omega_{p2}^2 \right]} . \quad (\text{B-39})$$

In order to handle these integrals we make use of the fact that our range of integration is very small, since  $\omega_{p2} = 0.948 \omega_{p1}$ .

First, we consider the denominator of the two integrals.  $1/r$  is nearly constant throughout the range of integration, so we replace it by its value at the midpoint of the integration range:

$$\frac{1}{r} \rightarrow \frac{1}{(\omega_{p1} + \omega_{p2}) / 2} = \frac{2}{\omega_{p1} + \omega_{p2}} . \quad (\text{B-40})$$

Next we consider the other factor in the denominator, at the end points of the range of integration

$$r = \omega_{p2}: \left( \frac{n_{10} + n_{20}}{n_{10}} \right) r^2 - \omega_{p2}^2 = \frac{n_{20}}{n_{10}} \omega_{p2}^2 .$$

$$r = \omega_{p1}: \left( \frac{n_{10} + n_{20}}{n_{10}} \right) r^2 - \omega_{p2}^2 = \frac{n_{10}}{n_{20}} \omega_{p2}^2 .$$

Since  $n_{20} = 0.9 n_{10}$ , the above factor is very close to  $\omega_{p2}^2$  throughout the range of integration, and will be taken equal to  $\omega_{p2}^2$ .

The first of the integrals in (B-39) can then be written:

$$I_3' \approx \frac{4i n_{20}}{n_{10} - n_{20}} \frac{2}{\omega_{p1} + \omega_{p2}} \frac{1}{\omega_{p2}^2} \int_{r = \omega_{p2}}^{\omega_{p1}} \sqrt{(r^2 - \omega_{p2}^2)(\omega_{p1}^2 - r^2)} \left( \cosh \frac{z}{c} \sqrt{\omega_{p1}^2 - r^2} \right) (\cos rt) dr . \quad (B-41)$$

In order to handle this integral one must resort to further simplifications.

The cosh term will be equal to unity at the upper limit of integration and equal to  $\left( \cosh \frac{z}{c} \sqrt{\omega_{p1}^2 - \omega_{p2}^2} \right)$  at the lower limit. At this lower limit, the cosh term will be equal to 1.1 if

$$\frac{z}{c} \sqrt{\omega_{p1}^2 - \omega_{p2}^2} = 0.445 . \quad (B-42)$$

By using the previously listed numerical values of  $c$ ,  $\omega_{p1}$ , and  $\omega_{p2}$ , one finds that the relation of (B-42) will be satisfied if  $z = 5.56$  millimeters. Therefore, one is justified in replacing  $\cosh \frac{z}{c} \sqrt{\omega_{p1}^2 - r^2}$  by unity, if  $z \leq 5.56$  millimeters.

Last, we consider the factor  $\sqrt{(r^2 - \omega_{p2}^2)(\omega_{p1}^2 - r^2)}$  in the integrand of

(B-41). To handle this radical we do the following:

$$\sqrt{r^2 - \omega_{p2}^2} = \sqrt{r - \omega_{p2}} \sqrt{r + \omega_{p2}} \cong \sqrt{2 \omega_{p2}} \sqrt{r - \omega_{p2}},$$

$$\sqrt{\omega_{p1}^2 - r^2} = \sqrt{\omega_{p1} - r} \sqrt{\omega_{p1} + r} \cong \sqrt{2 \omega_{p1}} \sqrt{\omega_{p1} - r},$$

so

$$\sqrt{(r^2 - \omega_{p2}^2)(\omega_{p1}^2 - r^2)} \cong 2 \sqrt{\omega_{p1} \omega_{p2}} \sqrt{(r - \omega_{p2})(\omega_{p1} - r)}. \quad (\text{B-43})$$

Now the function  $\sqrt{(r - \omega_{p2})(\omega_{p1} - r)}$  is zero at each limit of integration, has a maximum at  $r = (\omega_{p1} + \omega_{p2})/2$ , and is symmetrical about this maximum. We replace the radical by a parabola which passes through these three points. The parabolic function is

$$y = - \left( \frac{2}{\omega_{p1} - \omega_{p2}} \right) \left( r - \frac{\omega_{p1} + \omega_{p2}}{2} \right)^2 + \left( \frac{\omega_{p1} - \omega_{p2}}{2} \right). \quad (\text{B-44})$$

To check the validity of this substitution, a normalized numerical check was carried out to compare

$$y_1 = \sqrt{(r-1)(1.0548 - r)}$$

with

$$y_2 = -36.5 (r-1.0274)^2 + 0.0274$$

as  $r$  varies from 1.00 to 1.0274. The results are shown below:

$r$	$y_1$	$y_2$
1.000	0.0000	0.0000
1.005	0.0158	0.0091
1.010	0.0212	0.0163
1.015	0.0244	0.0218
1.020	0.0264	0.0254
1.025	0.0273	0.0272
1.0274	0.0274	0.0274

These values of  $y_1$  and  $y_2$  check quite well. One feels fairly well justified, then, in replacing the radical by (B-44). We finally arrive at

$$I'_3 = \frac{8i n_{20}}{\omega_{p2}^2 (n_{10} - n_{20})(\omega_{p1} + \omega_{p2})} 2\sqrt{\omega_{p1}\omega_{p2}} \int_{r=\omega_{p2}}^{\omega_{p1}} \left[ -\left(\frac{2}{\omega_{p1} - \omega_{p2}}\right) \left(r - \frac{\omega_{p1} + \omega_{p2}}{2}\right)^2 + \left(\frac{\omega_{p1} - \omega_{p2}}{2}\right)^2 \right] \cdot \cos rt \, dr \quad (B-45)$$

The integration is straightforward now, and we obtain

$$I'_3 = \frac{32i n_{20} \sqrt{\omega_{p1}\omega_{p2}}}{\omega_{p2}^2 (n_{10} - n_{20})(\omega_{p1} + \omega_{p2})} \left[ -\frac{1}{t^2} (\cos \omega_{p1} t + \cos \omega_{p2} t) + \frac{2}{t^3 (\omega_{p1} - \omega_{p2})} (\sin \omega_{p1} t - \sin \omega_{p2} t) \right] \quad (B-46)$$

It is to be noted that  $I'_3 = 0$  if  $\omega_{p2} = \omega_{p1}$ .

By using the simplifications discussed between (B-39) and (B-41), we can write the second integral of (B-39) thus:

$$I''_3 \cong \frac{4i n_{10}}{n_{10} - n_{20}} \frac{2}{\omega_{p1} + \omega_{p2}} \frac{1}{\omega_{p2}^2} \int_{r=\omega_{p2}}^{\omega_{p1}} (r^2 - \omega_{p2}^2) \left( \sinh \frac{z}{c} \sqrt{\omega_{p1}^2 - r^2} \right) (\sin rt) dr. \quad (\text{B-47})$$

By using the same reasoning as was used in obtaining (B-29), we find that, in the integrand of (B-47), we can use this approximation,

$$\sinh \frac{z}{c} \sqrt{\omega_{p1}^2 - r^2} \cong \frac{z}{c} \sqrt{\omega_{p1}^2 - r^2},$$

if  $z$  is not greater than one centimeter.

With this simplification the integral still is intractable because of the factor  $\sqrt{\omega_{p1}^2 - r^2} = \omega_{p1} \sqrt{1 - (r/\omega_{p1})^2}$ . The series approximation of (B-30) is not satisfactory here, because, throughout the range of integration in this case,  $r/\omega_{p1}$  is close to unity. Because of this, the radical was approximated by the following polynomial:

$$\sqrt{1 - (r/\omega_{p1})^2} = a(r/\omega_{p1})^2 + b(r/\omega_{p1}) + c, \quad (\text{B-48})$$

where the constants of the polynomial were determined by matching the two functions near the end points and center point of the range of  $(r/\omega_{p1})$ . Following are the values of  $a$ ,  $b$ , and  $c$  for our particular range of values of  $r/\omega_{p1}$ :

$$a = -90.13$$

$$b = 169.46$$

$$c = -79.32$$

The goodness of the fit of the parabola for these values of a, b and c is shown by the following table:

$r/\omega_{p1}$	$\sqrt{1 - (r/\omega_{p1})^2}$	$a(r/\omega_{p1})^2 + b(r/\omega_{p1}) + c$
0.95	0.3122	0.3150
0.96	0.2800	0.2881
0.97	0.2431	0.2431
0.98	0.1990	0.1801
0.99	0.1411	0.0991
1.00	0.0000	0.0000

With these simplifications, the integral of (B-47) becomes:

$$I_3'' \cong \frac{8 i n_{10} \omega_{p1}}{\omega_{p2}^2 (n_{10} - n_{20})(\omega_{p1} + \omega_{p2})} \frac{z}{c}$$

$$\cdot \int_{r = \omega_{p2}}^{\omega_{p1}} (r^2 - \omega_{p2}^2) \left[ a(r/\omega_{p1})^2 + b(r/\omega_{p1}) + c \right] (\sin rt) dr .$$

(B-49)

This integration is straightforward, giving

$$\begin{aligned}
I_3'' \cong & \left[ \frac{8 i n_{10} \omega_{p1}}{\omega_{p2}^2 (n_{10} - n_{20}) (\omega_{p1} + \omega_{p2})} \frac{z}{c} \right] \left\{ \frac{a}{\omega_{p1}^2} \left[ \frac{1}{t} (\omega_{p2}^4 \cos \omega_{p2} t - \omega_{p1}^4 \cos \omega_{p1} t) - \frac{4}{t^2} (\omega_{p2}^3 \sin \omega_{p2} t \right. \right. \\
& - \omega_{p1}^3 \sin \omega_{p1} t) - \frac{12}{t^3} (\omega_{p2}^2 \cos \omega_{p2} t - \omega_{p1}^2 \cos \omega_{p1} t) + \frac{24}{t^4} (\omega_{p2} \sin \omega_{p2} t - \omega_{p1} \sin \omega_{p1} t) \\
& \left. \left. + \frac{24}{t^5} (\cos \omega_{p2} t - \cos \omega_{p1} t) \right] + \frac{b}{\omega_{p1}} \left[ \frac{1}{t} (\omega_{p2}^3 \cos \omega_{p2} t - \omega_{p1}^3 \cos \omega_{p1} t) \right. \right. \\
& \left. \left. - \frac{3}{t^2} (\omega_{p2}^2 \sin \omega_{p2} t - \omega_{p1}^2 \sin \omega_{p1} t) - \frac{6}{t^3} (\omega_{p2} \cos \omega_{p2} t - \omega_{p1} \cos \omega_{p1} t) + \frac{6}{t^4} (\sin \omega_{p2} t - \sin \omega_{p1} t) \right] \right. \\
& \left. + (c-a) \frac{\omega_{p2}^2}{\omega_{p1}^2} \left[ \frac{1}{t} (\omega_{p2}^2 \cos \omega_{p2} t - \omega_{p1}^2 \cos \omega_{p1} t) - \frac{2}{t^2} (\omega_{p2} \sin \omega_{p2} t - \omega_{p1} \sin \omega_{p1} t) \right. \right. \\
& \left. \left. - \frac{2}{t^3} (\cos \omega_{p2} t - \cos \omega_{p1} t) \right] - b \frac{\omega_{p2}^2}{\omega_{p1}} \left[ \frac{1}{t} (\omega_{p2} \cos \omega_{p2} t - \omega_{p1} \cos \omega_{p1} t) - \right. \right. \\
& \left. \left. - \frac{1}{t^2} (\sin \omega_{p2} t - \sin \omega_{p1} t) \right] - c \omega_{p2}^2 \left[ \frac{1}{t} (\cos \omega_{p2} t - \cos \omega_{p1} t) \right] \right\} . \quad (B-50)
\end{aligned}$$

## REFERENCES

1. Landau, L. D. , and E. M. Lifshitz, Fluid Mechanics, Addison-Wesley, 1959.
2. Panofsky, W. K. H. , and M. Phillips, Classical Electricity and Magnetism, Addison-Wesley, 1955.
3. Landau, L. D. and E. M. Lifshitz, Electrodynamics of Continuous Media, Addison-Wesley, 1960.