

BUILDING A SUSTAINABLE COMMUNITY IN AFRICA  
MPALA WILDLIFE FOUNDATION

By

Melissa Antokal  
Caitlin Ryan  
Nagapooja Seeba  
Ajay Varadharajan

A project submitted  
in partial fulfillment of the requirements  
for the degree of  
Master of Science  
(Natural Resources and Environment)  
at the University of Michigan  
April 2011

Faculty Advisors:

Professor Don Scavia

Professor Andrew Hoffman

Dr. Abigail R. Mechtenberg (Assistant Research Scientist, Applied Physics, University of Michigan)

Professor Steven Wright



## Executive summary

For this Masters Project, our team evaluated both the water and energy supply and demand at the Mpala Wildlife Foundation and Conservancy (Mpala) in Laikipia, Kenya from a systems perspective. Mpala operates and manages a 48,000 acre wildlife conservancy, working ranch (“the Ranch”), research center (“the Centre” or “MRC”), and a variety of community health and outreach programs in Laikipia, Kenya. Its objectives include preserving biodiversity of the region, supporting the natural migration of native species, providing research and learning opportunities for students, as well as sharing their findings regionally and internationally to contribute to the fields of science and sustainability.

The purpose of this study for Mpala was to make recommendations to develop energy and water systems that are economically and environmentally sound, and can be maintained and functional for long into the future. We evaluated each system’s current state and examined potential solutions to the inefficiencies and shortfalls. The energy group evaluated the potential to reduce the Mpala’s dependence on fossil fuels, while the water group evaluated expanding rainwater catchment as a way to insure adequate water supply and reduce the Centre’s and Centre Village’s reliance on the non-replenishing aquifer and the intermittent river on site.

### *Water*

The water portion of this study proposes a method of capturing and storing a safety stock of water for human consumption during seasonal rains and wet years to provide water during seasonal dry periods and drought years. The Mpala Ranch headquarters (“the Ranch”) was recently equipped with a land weir to supply all of the drinking water to the people that reside at the Ranch employee residences (“the Ranch Village”). Therefore, our team examined a solution for all of those residing and visiting the Centre (“the Centre Village” and “the Centre”). We demonstrate that the current rainwater catchment system at the Centre requires only additions and improvements to provide the current population of the Centre and the Centre Village essential water needs. We also make recommendations for expansion in the future. Our group recommends improving the catchment and filtration systems on the building roofs currently equipped to catch rain water, and expanding the current storage capacity with either underground storage or above ground storage.

We began our study by evaluating current water systems. First we examined the borehole water system. We calculated that Mpala was drawing approximately 30-35 cubic meters of water from the borehole well each day. However, the measured draw at both the Centre and the Ranch added up, on average to a little over half that amount. Despite some expected measurement error on the part of the meters installed, we determined that it was likely the transport system of underground piping was experiencing leaks. The distance of transport (under miles of terrain) was a contributing factor of this inefficiency. At the Centre and the Ranch, the water was used for washrooms for the visitor's quarters as well as for drinking. In order to drink the borehole water, it first had to be put through an expensive filtering system called Reverse Osmosis.

Next we looked at their use of river water, which is drawn from the Ewaso Ngiro (river). This river began to run dry in 2009, the first time in known history. It has since run dry for a period of months each year. This could be due to the more severe droughts the region has been experiencing, but likely, it is from increased abstraction from upstream agriculture. The presence of this agriculture is also a concern for the quality of river water, as unsafe levels of nitrates may be found as a product of run-off from the agricultural land. This water has not been tested.

The final source of water evaluated was the rainwater storage. The Centre has extensive storage tanks at many of the buildings at the Centre, and a few small tanks at the Centre Village. This is a great source of local water; however, the system is not being fully utilized. Our team witnessed water being poorly covered and invested with insects and debris. We also witnessed several birds on the rooftops, leaving dangerous waste that flowed into the tanks during a rain. In addition to these system issues, we also witnessed water running off the roofs and not being captured. This is unmet potential.

After evaluating the sources of water, we looked into ways in which the Centre and the Ranch can reduce their water use levels. We recommended installing low flow fixtures in all of the washroom and shower facilities. This provided a water savings of 14% of the total consumption at the Centre. Since the visitors were the only people that used these facilities, and they made up only 25% of the total population at the Centre and Centre Village, the reduction in washroom consumption was reduced by half, but the overall impact was much smaller. The next system we looked at improving for water use reduction was grey water. Grey water is water that is recycled or reused from such uses as hand washing, bathing and cooking. Grey water can be used to irrigate landscape plants, flush toilets, and, also in the case at Mpala, supply a biogas

plant. This type of system, considering maximum capacity at the Centre, could provide these uses with 888 liters of water per day.

The final suggestion made for reducing water use is to educate. By communicating the value of water conservancy with a campaign of signage and training, as well as regular education of the employees, their families and the visitors, water use can be reduced through behavior change.

After recommending ways to reduce demand, our team looked at the best method of increasing supply. We identified rooftop rainwater collection as our focus for this study. We began by looking at historical rain data from 1999-2009. We identified levels of rain during the driest years, as well as levels of rain during those years with high rainfall. We also became familiar with the distinct seasonality of the rains at Mpala and the region.

The next step was to look at total cumulative demand, and potential cumulative supply based on different levels of rainfall and varying percentages of available rooftop. There is 4255m<sup>3</sup> of roof area when considering all of the built structures at both the Centre and the Centre Village. We assumed current population at the Centre Village, maximum occupancy at the Centre, and unlimited storage (we calculated cumulative run-off with the assumption we had no storage constraints and could capture all of the runoff). What we found was that in a wet year, there was enough water to provide essential water needs (eight liters/person/day) for all of the people at the Centre and Centre Village, and much to spare for a dry year. However, in a dry year, even when the maximum rooftops were used, there was not enough supply to meet demand or provide for a dry year. In addition, we were asked by Mpala management to consider future population growth. When modeling that variable, there simply would not be enough water to supply this area of Mpala.

Once we completed that evaluation, we determined that we would design a rainwater catchment system that could provide the current population and make recommended additions for the future expected growth. We looked at their current rainwater catchment system. Currently, they have 1973m<sup>2</sup> of rooftop area equipped with metal roofs, gutters systems and some form of water storage, sizes varying by building. We calculated, that in a wet year, characterized by heavy and above average rainfall, using only the rooftop area equipped to capture rain, the Centre was missing or not catching a volume as high as 444m<sup>3</sup> or 444,000 liters in a year. This takes into consideration daily draw of the essential water needs of the current population, just over 1000 liters per day. This volume missed was a function of insufficient

storage for the current catchment systems. Therefore, we identified which buildings were missing the greatest amount of rainfall, sized the supplemental storage and determined where and how much additional storage needed to be built.

Once that was complete, we turned our attention to their current catchment systems. A rainwater harvesting (RWH) system is comprised of six general components: a catchment area or surface, such as a roof; gutters or pipes as a conveyance system from the catchment area to the storage tank; a roof washer, to filter major contaminants; a storage container; a method for distributing the water from the tank; and a process of purification, if the water is intended for human consumption (Kinkade-Levario, 2007). We described each component of this RWH system and recommended specific products, providing costs as well.

Once the RWH system was recommended, we evaluated two types of storage – the above ground system of tanks, an expansion of what currently exists at Mpala, and an underground storage tank. Increasing storage capacity from the current 187,000 liters to over 600,000 liters will have a much larger footprint. The underground, centralized tanks will require less space, less capital investment (~\$20,000US) and more than adequate water for the Centre and Village; however, it is less secure, as contamination can destroy the entire supply. The belowground option also leaves potential above ground space for future additional above ground storage, as well as tie-in of new buildings. The above ground option can be phased in, making less of an upfront financial impact (which is estimated at a total of more than \$50,000US), and spreading the risk of contamination out, so that if one tank loses its supply from contamination, the remainder is still secure. We leave it to the Mpala management to make a choice that best suits their immediate priorities.

### *Energy-Water Nexus*

Our team briefly looked at two areas where renewable energy can be used to supply water for Mpala. We looked at a solar pump located at the borehole well and a solar thermal water heating system to provide hot showers for the visitors to the Centre. The solar pump needs to have specifications that allow it to pump 2.5 cubic meters per hour and at a great vertical height because the aquifer head is currently 70 meters below ground and declining. The reduced borehole water use, a result of a grey water system and low flow fixtures at the Centre, comes to about 25-28 m<sup>3</sup> per day. Therefore a pump with the above specifications is required. However, the upfront cost (anywhere from \$2,000 to \$6,000) (Alibaba.com, 2011) is likely to

have a payback period of less than two years up to six years due to costs savings accomplished by eliminating the need for the diesel-powered pump, as \$1,200 per year is saved from diesel use reductions.

The solar thermal water heating system has an upfront capital investment of approximately \$15,000US. These systems, 220 liter tanks with 2.3m<sup>2</sup> solar arrays would be placed on the rooftops of the buildings that provide hot showers to both the visitors and the Centre Director's home. There is not money saved on diesel use reduction in this case, as the current system contains solar flat plate collectors (many in disrepair) and wood-burning stoves. What is saved is the health and environmental hazard of burning wood from the surrounding land to fuel the current heaters.

### *Energy*

The energy portion of this report evaluated several options for Mpala's electricity system now and in the future in an attempt to find sensible solutions that will provide inexpensive and long lasting power to Mpala. The Research Centre management hopes to provide the current visitor capacity with reliable and adequate energy service, as well as scale the system up to provide a larger number of guests in the future. Thus Mpala, with its new system should be able to support the entire additional load. For this reason, in all our analyses, we considered double the current power load at Mpala. The following is an outline of the approach we took to solve the issues at Mpala, and the steps we took to complete our analysis.

The existing system at Mpala is an off-grid power system that is powered primarily by diesel generators and includes a small portion of solar PV and hydro-power. The Mpala Research Centre (MRC) itself meets its load with solar PV, two diesel generators and batteries, whereas the Ranch uses hydro power from a turbine, back-up generators and very little solar PV.

There are many issues with the current system. In general, the power supply is intermittent and not sufficient to meet the entire load. The population at the Centre and the Ranch is expected to increase in the next few years due to the growing popularity of the Research Centre and Conservancy, The system is not well monitored and thus there are large amount of inefficiencies.

At MRC, the generators consume diesel to power the entire area. This is especially problematic due to the growing prices of diesel. The batteries are also not managed to the optimal efficiency, and therefore have to be replaced from time to time.

At the Ranch, the turbine is not consistently in working condition and will have to be replaced. Also, in recent years the Ewaso Ngiro river to which the turbine is fixed has been running dry for almost half the year.

Our initial approach was to track down all the inefficiencies in the current system and as a first step we performed a thorough energy audit of the Ranch and Centre during our stay in Mpala. The results of the energy audit showed us the most energy consuming buildings and the most problematic areas in the system. Once the problem areas were spotted, we took a two pronged approach to solve the issues at Mpala, namely

- Reduce power load - make the current system more efficient.
- Renewable sources – use more renewable sources to meet the new, more efficient system with less power load.

Our first approach was to analyze the consumption of energy by the existing lighting throughout the Centre. We evaluated different products available and found that LED light bulbs provided the most economic and energy efficient solution over time.

For our second approach, we analyzed all of the renewable sources available at Mpala and picked only the ones that are most useful for Mpala's electricity system. Among wind, hydro, solar and biogas, we concluded that everything except wind has great potential for the system at Mpala.

The next step was to use these sources to meet the newly reduced load. To do this, we used a simulation software program namely HOMER to compare the various systems that could be made for Mpala with the renewable sources available at Mpala.

HOMER stands for Hybrid Optimization of Electric Renewables and is a tool provided by National Renewable Energy Labs, Department of Energy of the United States. It is an excellent tool that can be used to analyze, simulate and optimize various combinations of off-grid hybrid renewable energy systems and is used all over the world.

The scenarios explored and analyzed using HOMER could be broadly divided into those that use transmission lines, and those that are independent of transmission lines. With transmission lines, the scenarios explored include different hybrid systems which utilize several forms of renewable energy sources, as well as some diesel, that provide security and options for Mpala.

While at first glance, the use of transmission lines appears to provide more stability and security to the system, we will show how this might not be the case for Mpala. Due to the



extensive existence of wildlife at Mpala, which presents a risk to both the equipment and the animals, using underground transmission is the only viable option. However, using an underground transmission system can prove to be 5-10 times more expensive and more difficult to lay and maintain.

According to the Kenya Electricity Transmission Board, underground transmission lines also last only for half as long as compared to regular transmission lines. For Mpala, we estimate that these lines will have to be replaced at least eight times if laid underground over a period of 100 years. For our analysis however, we assumed that these lines will not be replaced and will last for all 100 years. Despite this assumption, the upfront costs and operational costs are high for a transmission system.

The cost for transmission was calculated using a \$20,000 cost/km and the actual distance was found using UTM coordinates. We analyzed a total of six scenarios for both overhead and underground transmission. They are

- All in one – uses all renewable sources and some diesel
- Only Solar PV
- Solar PV and backup generators
- Only Hydropower
- Hydropower and backup generators
- Only Biogas

Each of these scenarios was then compared to the existing system at Mpala. The results for each of these scenarios are indicated with error bars to account for the above stated assumption that transmission lines will not last for all 100 years without replacement.

We next moved on to analyzing systems that do not use transmission. The most obvious sources for these being solar and biogas energy. The HOMER results for Solar and Biogas showed that Biogas is the cheaper option due to which a more detailed study of the Biogas system was performed.

The biogas scenario was designed such that it will use a separate system for MRC and a separate system for the Ranch. Each of these systems will contain a biogas digester to process the dung to biogas and a generator to produce electricity from biogas. The dung is obtained from the 'bomas' at Mpala, the place where cattle are housed at night. This system will require the use of trucks to carry the dung from the boma to the MRC and Ranch generator sites.

Due to Mpala's more than 2,000 heads of cattle and six bomas, there is a large potential for biogas. From our analysis, we found that using just one boma could power the entire MRC and Ranch. A complete 'use phase analysis' was performed to estimate the total carbon dioxide emissions reduced in the process of using biogas as fuel. The major savings were from the elimination of diesel at MRC and from the diversion of dung from undergoing anaerobic digestion. Anaerobic digestion of dung will produce methane which according to the IPCC fourth assessment report, has a Global Warming Potential that is 25 times that of carbon dioxide when evaluated over a period of 100 years (Forster et al., 2007).

Using biogas without transmission could provide very cheap electricity and the upfront costs (which are also low) could be recovered within 1.5 years due to cheap operating costs. In the process, it will also have a total emissions savings that are as high as 15,400 kg/year.

If Mpala decides to power the villages also with biogas, these emission savings will greatly increase and thus Mpala could look into potential funding using the Clean Development Mechanism, but Mpala would need to create a development mechanism similar to what we discuss in our Behavior and Education section. However, CDM was outside the scope of our analysis and only briefly mentioned here.

Our team will also discuss the costs and benefits of each of these systems and show how using scenarios that do not use transmission or considering other ways of energy storage can prove to be cheaper and more reliable for Mpala.

The system, the existing or the new one, cannot function to its best ability if it is not understood by the people operating the system and by those who are benefiting from it. Education is thus a very important component of the new system to come. Education could be in the form of training local personnel to work the systems and teaching the people using the system to run their own. We have touched upon these options briefly and taken examples of some previous good work that we thought would be suitable for Mpala.

This masters project group hopes this work can be used to improve the systems at Mpala, but also be considered as potential energy and water systems in surrounding communities in the region. Our goal was to propose the most feasible and affordable methods to provide self-sustaining, long-lasting resource systems in Kenya.

## Acknowledgements

This Master's Project owes its deep gratitude to a number of people and organizations. Our advisors – Don Scavia, Andy Hoffman, Abigail Mechtenberg, and Steven Wright – have helped us along every step of the way. From the development of our project proposal to the final calculations, their support, guidance, and recommendations have been invaluable to our group.

Travelling to Mpala for data collection would have been impossible without financial support from the Graham Environmental Sustainability Institute, the International Institute Experiential Learning Fund, and the SNRE Master's Project Research Grant.

The information that we received from personnel at Mpala, including Dr. Margaret Kinnaird, Mike Littlewood, Mburu Tuni, Joseph Leting, and George Aike, was vital to our analyses and the formation of our recommendations. The management at Mpala was very supportive of our study and very generous with their time during our stay and our subsequent research of their challenges. We are also indebted to the staff and visiting researchers at Mpala, all of whom provided helpful insight into the workings and challenges of water and energy systems at Mpala.

Additionally, there are some people not directly a part of this project that have helped us immensely. We would like to thank Professor Arun Agrawal for joining us during our field observations of the bomas and discussing with us the potential for biogas at Mpala. Walker DePuy, Colin Donihue, and Kayla Yurco took some time from their thesis research to provide us with information on Mpala prior to our summer trip. Chelsea Ransom helped with information gathering at Mpala during a winter 2010 trip to Mpala, as well as inspiring the team to investigate biogas and providing background research on the topic.

We are proud to have been able to play a role in establishing and strengthening the long-term relationship between the Mpala Research Centre and Conservancy and the University of Michigan.

**Contents**

Executive summary ..... iii

Acknowledgements ..... xi

List of Tables and Images..... xviii

Abbreviations ..... xxi

List of conversions .....xxii

Introduction ..... 1

Purpose of this report..... 3

    Sustainability ..... 5

        Social sustainability..... 6

        Economic sustainability ..... 7

        Environmental sustainability..... 8

Water ..... 10

    Existing conditions..... 11

        River water ..... 11

        Borehole water ..... 13

        Rainwater ..... 14

    Trends and perceived future challenges..... 16

        Population growth ..... 16

        Rainfall/climate change ..... 18

Energy ..... 20

    Existing System..... 20

        Centre ..... 20

        Ranch House..... 25

        Clifford’s House ..... 26

        Villages ..... 26

    Trends and perceived future challenges..... 26

        Diesel prices ..... 27

        Population and demand per capita ..... 28

        Climate change ..... 28

Methodology..... 30

Water.....	30
Population estimates.....	30
Daily usage .....	30
Borehole supply estimates.....	31
Roof area.....	31
Roof area collection calculations .....	32
Rainfall calculations.....	32
Accumulation graphs.....	32
Water collection scenarios.....	36
Hot water system sizing.....	39
Solar pump sizing .....	40
<b>Energy.....</b>	<b>41</b>
<b>Collection of data .....</b>	<b>41</b>
<b>Processing raw data for HOMER.....</b>	<b>43</b>
<b>Introduction to HOMER.....</b>	<b>46</b>
<b>Definition of all scenarios .....</b>	<b>48</b>
<b>Employing underground transmission costs.....</b>	<b>49</b>
<b>Biogas-powered scenarios .....</b>	<b>49</b>
Options for the future .....	55
Water.....	55
Rainwater catchment systems .....	55
Future considerations.....	61
Filtration systems .....	61
Costs .....	73
Alternative and additional water harvesting .....	81
Financial benefits of altering the current water system.....	82
Behavior and education.....	83
Conclusion and Recommendations.....	85
Water-energy nexus .....	87
Energy.....	91
Energy efficiency .....	91
Potential renewable sources.....	92

Behavior and Education.....	98
Results for Energy Analysis .....	102
Energy Audit Results.....	103
Baseline scenario.....	104
Baseline scenario results.....	105
Optimizing the energy audit .....	106
Proposed Systems .....	108
System Topology .....	108
Existing System.....	109
Scenario analysis results.....	111
Comparison of different scenarios .....	115
Metrics .....	115
Overhead transmission scenarios.....	116
Underground transmission scenarios.....	117
Comparison of overhead and underground scenarios .....	118
Scenarios without Transmission.....	119
Comparing scenarios with and without transmission lines .....	120
Biogas system design.....	122
Life cycle analysis of ‘biogas only’ scenario .....	123
Lifecycle Costing .....	124
Recommendations .....	125
Energy .....	125
To the Mpala Conservancy.....	125
To Future Masters Projects.....	127
Literature Cited .....	129
Appendix W-1: Borehole meter Readings at Main (primary), Ranch & Centre borehole (secondary) (August – December 2010) .....	134
Appendix W-2: Current buildings – roof size and water storage capabilities at MRC .....	138
Appendix W-3: Accumulation graphs.....	139
Appendix W-3a. Accumulated roof runoff and water demand under average rain conditions ....	139
Appendix W-3b. Accumulated roof runoff and water demand under low rain conditions.....	146
Appendix W-3c. Accumulated roof runoff and water demand under high rain conditions .....	152

Appendix W-4: Water collection scenarios .....	158
Appendix W-4a. All MRC Village houses, only villagers drink.....	160
Appendix W-4b. All MRC roofs, only visitors drink .....	161
Appendix W-4c. All MRC roofs, everyone drinks .....	162
Appendix W-4e. All MRC roofs, everyone drinks, two additional tanks .....	164
Appendix W-4f. All MRC roofs, everyone drinks, three extra tanks .....	165
Appendix W-4g. All MRC roofs, everyone drinks, four extra tanks.....	166
Appendix W-4i. Library, everyone drinks .....	168
Appendix W-4j. Library, projected population .....	169
Appendix W-4k. Admin block, current population.....	170
Appendix W-4l. Admin block, projected population .....	171
Appendix W-4m. McCormack lab, current population .....	172
Appendix W-4n. McCormack lab, projected population .....	173
Appendix W-4o. NSF lab, current population .....	174
Appendix W-4p. NSF lab, projected population .....	175
Appendix W-4q. Mess hall, current population .....	176
Appendix W-4r. Mess hall, projected population .....	177
Appendix W-4s. Small kitchen, current population .....	178
Appendix W-4t. Small kitchen, projected population .....	179
Appendix W-4u. Director’s house, current population .....	180
Appendix W-4v. Director’s house, projected population.....	181
Appendix W-4w. GIS house, current population .....	182
Appendix W-4x. GIS house, projected population .....	183
Appendix W-4y. Klee house, current population .....	184
Appendix W-4z. Klee house, projected population.....	185
Appendix W-4aa. Admin house, current population .....	186
Appendix W-4bb. Admin house, projected population.....	187
Appendix W-4cc. Jenga house, current population .....	188
Appendix W-4dd. Jenga house, projected population .....	189
Appendix W-4ee. Store 15, current population.....	190
Appendix W-4ff. Store 15, projected population.....	191
Appendix W-5: Hot water needs and solar thermal hot water sizing and costs .....	192

Appendix W-6: Rainfall data .....	193
W-6a. 2001 rainfall at MRC .....	193
W-6b. 2009-2010 MRC rainfall vs. long-term average .....	193
W-6c. Total rainfall at MRC by year .....	194
Appendix W-7: Costs for building water tanks (above and belowground).....	195
Appendix E-1: Equipment lists .....	196
Appendix E-1a. Administration office load description .....	196
Appendix E-1b. McCormack lab load description .....	196
Appendix E-1c. Library load description .....	196
Appendix E-1d. NSF lab load description .....	196
Appendix E-2: Current PV installations and other power systems at Mpala.....	197
Appendix E-2a. PV array and other power systems for the Administration office. ....	197
Appendix E-2b. PV array and other power systems for McCormack laboratory. ....	197
Appendix E-2c. PV array and other power systems for the Library.....	197
Appendix E-2d. PV array and other power systems for NSF laboratory.....	197
Appendix E-3: Data sampling duration, frequency, and sources .....	198
Appendix E-4 – HOMER SCENARIOS.....	199
Appendix E-4a – Existing System.....	199
Appendix E-4b Scenario: Case of “All in One” hybrid system for the Mpala conservancy .....	203
Appendix E-4c Scenario: With transmission - Only solar for the Mpala conservancy (with batteries and no generator).....	207
Appendix E-4d Scenario: With transmission – Hydro and backup generators for the Mpala conservancy .....	211
Appendix E-4e Scenario: With transmission – Only hydro for the Mpala conservancy .....	215
Appendix E-4f Scenario: With transmission – Solar with backup generators for the Mpala conservancy with transmission .....	219
Appendix E-4g Scenario: With transmission – Only Biogas for Mpala conservancy .....	223
Appendix E-4h Scenario: No transmission – Only solar .....	227
Appendix E-4i Scenario: No transmission – Biogas only.....	231
Appendix E-5 – Lifecycle Analysis – Biogas with No Transmission.....	235
Appendix E-6: Biogas Generating Set Technical Parameters and Costs .....	237
Appendix E-7: Lighting replacement analysis .....	240



Appendix E-8: HOMER Results - Overhead transmission scenarios.....	242
Appendix E-9: HOMER Results – Underground transmission scenarios .....	243
Appendix E-10: HOMER Results - No transmission scenarios .....	244
Appendix E-11: HOMER Results - Cost benefit analysis: Overhead transmission scenarios .....	245
Appendix E-12: HOMER Results – Cost benefit analysis: Underground transmission scenarios.....	246
Appendix E-13: HOMER Results – Cost benefit analysis: Overhead vs Underground transmission scenarios.....	247
Appendix E-14: HOMER Results - Cost benefit analysis: Overhead transmission scenarios .....	248
Appendix E-15: HOMER Results - Cost benefit analysis: No transmission scenarios.....	249
Appendix E -16: Initial Analysis Report.....	250

## List of Tables and Images

All Appendices, Tables and Images that are referenced in the General portion of this report are prefixed with a “G,” in the Water portion with a “W” and in the Energy Portion with an “E.”

### Water

#### Tables

Table W-t 1: Summary of population estimates for Mpala Research Centre and Ranch.....	17
Table W-t 2: Population predictions based on different initial populations, with most likely scenario highlighted.....	17
Table W-t 3: Water collection scenario considering all rooftops at MRC and current total population at Centre and Village (See Appendix W-4).....	58
Table W-t 4: Volume of rainwater missed or not captured during a wet year due to current storage sizes available for catchment (See Appendices W-4i – W-4ff).....	59
Table W-t 5: Washroom fixtures, Standard and Low-Flow rates, costs and sources.....	75
Table W-t 6: Calculated water use per person per bednight in washroom facilities using current and low-flow fixtures broken down by fixture.....	77
Table W-t 7: Calculated per person total washroom water use per bednight including both visitors and on-site employees using current versus low-flow fixtures.....	77
Table W-t 8: Calculated annual washroom water use using current and reduced from low flow fixtures.....	78
Table W-t 9: Borehole pumping reductions.....	82

#### Images

Image W-i 1: Water supply at Mpala.....	10
Image W-i 3: Accumulated run-off (m <sup>3</sup> ) from entire roof area and essential water required (m <sup>3</sup> ) for current population.....	35
Image W-i 4: Accumulated run-off (m <sup>3</sup> ) from current roof area converted to capture water and essential water required (m <sup>3</sup> ) for projected future population.....	35
Image W-i 5: Comparison of current storage capacity and roof catchment serving current and projected total MRC population.....	55
Image W-i 6: Accumulated water run-off in a wet year (m <sup>3</sup> ) from current converted roof area versus accumulated demand (m <sup>3</sup> ) by current population.....	57
Image W-i 7: Accumulated water run-off in a drought year (m <sup>3</sup> ) from current converted roof area versus accumulated demand (m <sup>3</sup> ) by current population.....	57
Image W-i 8: Mess Hall roof, showing degradation as a result of animal activity.....	63
Image W-i 9: birds’ nests on NSF lab gutters. Photograph taken by Melissa Antokal, 7 August 2010.....	64
Image W-i 10: Administration Building during a rainstorm, showing lost run-off due to insufficient conveyance. Photograph by Ajay Varadharajan, 28 December 2010.....	65
Image W-i 11: Mosquito larvae and other contaminants in small tank by kitchen. Photograph by Melissa Antokal, 7 August 2010.....	67
Image W-i 12: plumbing set-up for small water tank by kitchen. Photograph by Melissa Antokal, 7 August 2010.....	68
Image W-i 13: Toilet Lid Sink.....	80
Image W-i 14: Solar thermal water heating system.....	88
Image W-i 15: Grundfos solar pump sizing chart.....	90

## Energy

### Tables

Table E-t 1: Diesel generator costs.....	22
Table E-t 2: Emissions factors of diesel generator .....	22
Table E-t 3: Diesel gen-set specifications .....	22
Table E-t 4: PV panel cost .....	23
Table E-t 5: Turbine specifications .....	24
Table E-t 6: Convertor costs (Oloo, 2010) .....	25
<b>Table E-t 7: Buildings metered, with average and peak power consumption .....</b>	<b>42</b>
<b>Table E-t 8: Sample load data collected for a dormitory at MRC. ....</b>	<b>44</b>
Table E-t 9: Watts used by inefficient lights. ....	92
Table E-t 10: Outputs from HOMER for the individual and combined existing energy systems .....	105
Table E-t 11: Lifetimes of the two lighting options .....	106
Table E-t 12: Cost-benefit and Cost of electricity comparison – Overhead transmission case .....	117
Table E-t 13: Cost-benefit and Cost of electricity comparison – Underground transmission case ...	118
Table E-t 14: Cost-benefit and Cost of electricity comparison – No transmission case .....	120
Table E-t 15: Upfront costs of biogas system .....	124

### Images

Image E-i 1: Kenyan pump price for diesel fuel, in \$US.....	27
<b>Image E-i 2: Analog electricity meter (Centre) connected to one of the buildings at Mpala .....</b>	<b>42</b>
Image E-i 3: Block diagram of inputs and outputs to HOMER analysis used in this report.....	46
<b>Image E-i 4: HOMER model of current system installed at the Mpala Centre .....</b>	<b>47</b>
<b>Image E-i 5: HOMER model of current system installed at the Ranch.....</b>	<b>47</b>
<b>Image E-i 6: HOMER model of the new system design.....</b>	<b>48</b>
<b>Image E-i 7: Diagram of life cycle system boundary.....</b>	<b>53</b>
Image E-i 8: Annual Solar Irradiation Data in Laikipia, Kenya.....	93
Image E-i 9: Clearness Index in Laikipia, Kenya.....	93
Image E-i 10: Average flow of Ewaso-Ngiro in a year .....	95
Image E-i 11: Schematic of a biogas energy system .....	96
Image E-i 12: Polyethylene biogas digester as sold by manufacturer (Liu, 2011) .....	97
Image E-i 13: Wind resource for Laikipia, Kenya .....	98
Image E-i 14: Bicycle generator being used to charge a battery (Muhuro, 2010). ....	101
Image E-i 15: Basic block diagram of the HOMER software used in this analysis.....	103
Image E-i 16: Energy Consumption of Mpala Research Centre’s buildings.....	104
Image E-i 17: Emissions analysis of lighting over time .....	107
Image E-i 18: Net present cost analysis of lighting over time .....	107
Image E-i 19: Off-grid hybrid energy system (Weldemariam, 2010) .....	109
Image E-i 20: Existing energy systems at the Mpala Research Centre and the Ranch headquarters	111
Image E-i 21: Scenarios modeled for two cases: Overhead and underground transmission lines....	112
Image E-i 22: Scenarios modeled for two cases: Overhead and underground transmission lines....	113
Image E-i 23: Scenarios modeled for two cases: Overhead and underground transmission lines....	113
Image E-i 24: Scenarios modeled considering no transmission lines, each for the Research Centre and Ranch separately. ....	114

Image E-i 25: Arrows show all proposed optimal scenario combinations compared (A to H) with each other .....	115
Image E-i 26: Evaluating different hybrid systems – Metric: Cost of electricity (\$/kWh) – UG vs OH .....	118
Image E-i 27: Evaluating different hybrid systems – Metric: COE (\$/kWh) for no transmission case	120
Image E-i 28: Comparison of transmission with no transmission case – Metric: Net present costs (\$)	121
Image E-i 29: Comparison of transmission with no transmission case – Metric: Cost of electricity (\$/kWh).....	122
Image E-i 30: Results from Sima Pro lifecycle analysis .....	123
Image E-i 31: Emissions reductions .....	124

## Abbreviations

AC	Alternating current
BTU	British thermal unit
CDM	Clean Development Mechanism
CER	Certified emission reduction
CETRAD	Center for training and integrated research in ASAL development
DC	Direct current
EPA	Environmental Protection Agency
gpf	gallons per flush
gpm	gallons per minute
HDPE	High-density polyethylene
HOMER	Hybrid Optimization Model for Electric Renewables
HQ	Headquarters
km	kilometers
Ksh	Kenyan Shilling
$(KT)_m$	Monthly mean daily clearness index
kW	kilowatt
kWh	kilowatt hours
kWh/m <sup>2</sup> /day	kilowatt hours per square meter per day
l	liters
lcd	liter per capita per day
LED	Light-emitting diode
m <sup>2</sup> or m <sup>2</sup>	Square Meters
m <sup>3</sup> or m <sup>3</sup>	Cubic Meters
m	meters
MHP	Micro-hydro powerhouse
mm	millimeters
MRC	Mpala Research Centre
MRL	Mpala Ranch, Ltd.
MWh	megawatt hours
ppm	parts per million
PV	Photovoltaic
PVC	Polyvinyl chloride
RO	Reverse osmosis
RWH	Rainwater harvesting [system]
\$USD	U.S. Dollar
UV	Ultraviolet, refers to wavelength of light

## List of conversions

1 m<sup>3</sup> = 1000 liters

1 liter = .001 m<sup>3</sup>

1 mm rain \* 1 m<sup>2</sup> roof = 1 liter

1 bednight = one person staying for one night

1 kWh = 3412 BTU

1 \$US = 83.76 Ksh (Rate as of 5 April 2011)

1 Ksh = \$0.0119 US

1 micron = 1.0 \* 10<sup>-6</sup> meters

1 gallon = 3.785 liters

## Introduction

Mpala Wildlife Foundation (“Mpala”) operates and manages a 48,000 acre wildlife conservancy, working ranch (“the Ranch”), research center (“the Centre”), and a variety of community health and outreach programs in Laikipia, Kenya. Its objectives include preserving biodiversity of the region, supporting the natural migration of native species, providing research and learning opportunities for students, as well as sharing their findings regionally and internationally to contribute to the fields of science and sustainability.

The conservancy has many facets. A majority of the land is open grazing land for cattle. To use the land’s resources without interfering with the migration patterns of native species, the rangeland has not been fenced in. The cattle are herded into portable, mobile, and secure areas at night, but roam the conservancy during the day. Another portion of the land is used for the Research Centre and visiting scholar residences for studying the local ecosystem and its biological components. One objective of the Centre is to research, understand, and contribute to the health and sustainability of the local ecosystem. Mpala is located in a semi-arid savanna, and many of the research efforts aim to understand and support the balance of human and nonhuman needs in such a region to serve as a model to other arid savanna regions, ensure the health and sustainability of the balance in this region, and "define key ecosystem components and processes that will be the target of explicit management plans and policies."

In addition to ecosystem services and study, Mpala is the headquarters to several outreach programs. These programs include a mobile medical clinic that sends two nurses out to local communities with limited access to medical care, an educational arm that supports educating young people by building schools and providing resources needed for education, a cottage industry that includes training single mothers how to make fiber mats for sale and how to keep bees for the production of honey, and community projects which supports local neighboring communities in their own conservation and preservation efforts for the region.

Our Master’s Project Group at the University of Michigan was invited to contribute to the Centre’s mission by creating a plan that reduces impact on the local environment, benefits local communities, and creates more sustainable operations.

This project will support the Research Centre and Ranch headquarters in approaching two of their main objectives: support programs aimed at the ecological stabilization of natural resources in the area, and provide a model for similar centers elsewhere. With these in mind,

this project will allow the Centre to be a model for other communities in similar regions. By reducing the impact of human presence on the local environment, and utilizing resources that are available to Mpala on-site (for energy and water needs), the benefits will be twofold. One is the aforementioned fulfillment of Mpala's objectives, and the other is the benefit of reducing costs, which is an aim of all businesses and non-profit organizations alike.

Our group visited Mpala in August of 2010 to collect data and learn about their current water and energy systems. We were able to identify areas of great success and certain system improvements that could be made. We have taken a systems approach to analyzing their energy and water challenges and made recommendations that we hope will help them self-sustain into the future.



## Purpose of this report

The motivation behind this study is threefold. The first is to create a sustainable community that will serve as an example to others in the region to follow. The second is to minimize hardship and potential health issues related to increasing energy prices and a reduced water supply for the Mpala Conservancy and its inhabitants. The third is to propose energy and water systems that will provide the visitors and employees at the Mpala Ranch and Research Centre with necessary resources in a manner which is cost effective and self-sustaining, without having to rely heavily on resources outside of the property.

Mpala Wildlife Foundation is an operating foundation that funds and runs a world-class Research Centre, a 48,000 acre wildlife conservancy, and a variety of community health and outreach programs in Laikipia, Kenya (African Conservation Foundation, 2011). This report looks at the Research Centre and Ranch House properties on the conservancy.

The Mpala Conservancy serves as a model of community participation, conservation, research and livelihood in Africa. Mpala is an American-owned property in North Central Kenya. It is a member of the Laikipia Wildlife Forum, “a broad-based conservation organisation dedicated to preserving and managing wildlife populations and wilderness habitats in Kenya’s Laikipia region. The Forum is committed to improving the lives of people in the area through supporting and generating livelihoods, while securing dependable, sustained access to essential natural resources” (Laikipia Wildlife Forum, 2011). More specifically, those involved have agreed to keep their ranches and properties fence-free, to serve as an avenue for migration and conservancy for Africa’s native wildlife. Therefore, this consortium of land owners serves as an example to other regions of how to value the natural processes of the land and its inhabitants, while supporting the livelihoods of the people the land supports.

The Mpala Wildlife Foundation, in other words, values community and the environment, as they believe doing so will enable the sustainability of their presence and success on the land. It then comes as no surprise that they hope to operate in such a way that reflects these values. One way to do so is to harness renewable and nonpolluting sources of energy to provide power at Mpala Ranch and Research Centre. Being on the equator, having access to several thousand pounds per day of animal waste, and having access to a local river allow Mpala to use such resources. This report will explore solar power potential, the possibility of using biogas as a fuel source, and consider partial power supply from the Ewaso Ngiro river flow. In addition to the

energy component, a sustainable framework for collecting essential drinking water will reflect the values of this community. Therefore, creating a rainwater collection system will minimize the conservancy's reliance on river and borehole water, which will more directly affect their future water security, as well as that of their neighbors. A large part of the process of becoming a model of sustainability in Africa begins with providing necessary resources to Mpala in a lasting and least impactful way. This report explores methods to do so.

The second reason for the study is to prevent future hardships for Mpala. Just two years ago, the conservancy was so desperate for fresh drinking water, due to a long drought, that they had to request assistance from the local County Council to provide them with supplemental water for their employees and their families. Their situation had become so dire, that they lost several head of cattle (approximately 10% of their stock), and those using the river water were put at risk for bacterial infections and illnesses caused by the reduced flow and increased concentration of harmful biologicals in the water. Since there is no guarantee of future aide from the local government or any way of knowing the extent to which drought can return, and since Mpala hopes to grow in size and population in the near future, a healthy supply of drinking water must be a priority. In fact, sufficient drinking water and a sufficient safety stock of water will be needed to ensure the security and health of the Mpala Conservancy and its inhabitants.

The third reason for this study is to explore ways to help the Mpala Wildlife Foundation run the Ranch and Research Centre more economically. Currently, a majority of the power provided on the property is from diesel generators. There is a portion provided by the hydraulic turbine located at the Ranch headquarters, which provides, at times, all of the energy needed at the Ranch for the office, guest house and Ranch Village. Unfortunately, because the Ewaso Ngiro, the local river, has been running below normal levels and even ran dry during months of the year, a system that is solely run on hydro power will not be adequate. When the river runs at full flow, more power is created than is needed at the Ranch. There is currently no system in place to store this excess energy, and is therefore lost. As a result, in its current state, the Ranch uses a diesel generator as a back-up source. Future studies may consider exploring fuel cell or battery systems to store the excess energy. Mpala Research Centre and Ranch spend approximately 515,000 Kenyan Shillings or \$6,800 USD per month and up to 6million Kenyan Shillings or \$81,500 USD per year on diesel.<sup>1</sup> Therefore, this study explores an investment in a

---

<sup>1</sup> Figures taken from Mpala's 2009 fuel stock record and conversion rate from Google Finance average 2009 conversion rate of Kenyan Shillings to U.S. dollars.

renewable energy infrastructure that includes more sufficient storage systems at Mpala and could, in the short and long run, save the Foundation money. Diesel pumps are also used to bring water up from the borehole and the river. Therefore, relying mostly on locally collected rainwater throughout the site may be more ideal than spending the money to maintain the pipeline and pumps, as well as that spent on the fuel to run the system.

It is clear that the Mpala Wildlife Foundation values the natural beauty, native fauna, and ecological balance of the land they occupy. They rely on this balance to maintain their future prosperity on the land. They also appear to be aware of the impact their presence has and can have on the natural environment. The research performed there is a testament to the contribution it has made to the global scientific community, but also to its neighboring communities. Therefore, this report hopes to play a part in the sustainability of this community for future prosperity, to ensure its success and to support its values in community.

## Sustainability

One of the greatest challenges facing our society is to determine how to balance burgeoning human activity with the processes and resources of the natural world in a way that will sustain the health and well being of our planet in the longer term. With surging populations and rapid economic development across the globe, we are beginning to see limits to the ability of the earth to handle the demands we place upon it.

Sustainable development, although a widely used phrase and idea, has many different meanings and therefore provokes many different responses. In broad terms, the concept of sustainable development is an attempt to address growing concerns about a range of environmental issues with socio-economic issues (Hopwood, Mellor, O'Brien, 2005). Sustainable development has the potential to address fundamental challenges for humanity, now and into the future. Some of the fundamental challenges of humanity today are:

- Climate change
- Energy security
- Water scarcity and quality
- Loss of biodiversity
- Population growth
- Local repairability

The most popular definition of sustainability as defined by the Brundtland Commission in 1987 is to meet the needs of the present without compromising the ability of future generations to meet their own needs.

Webster's definition for sustainability is:

- to support, hold, or bear up from below
- to supply with food, drink, and other necessities of life
- to provide for by furnishing means or funds
- to uphold as valid, just or correct

Oxford's definition for sustainability:

- to maintain at the proper level or standard
- to cause to continue in a certain state

Therefore, this essentially provides us with two important inferences:

- a) Sustainability means use of resources at a rate lesser than that at which they regenerate themselves (or)
- b) Sustainability is consumption at a rate that doesn't deplete the resource base for future generations' use.

The triple bottom line made up of "social, economic and environmental"; i.e. the "people, planet, profit" was coined by Shell for Sustainability. Sustainable design of technology systems is achieved when economically viable designs are created that significantly reduce important environmental and societal concerns relative to other available options. Image 1 summarizes this idea.

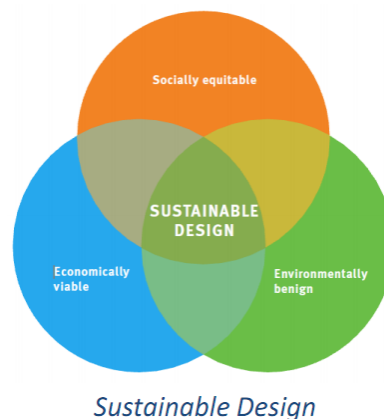

**Image 1: Components of a sustainable design (Daly, 2003)**

## Social sustainability

Social sustainability means maintaining social capital. Social capital is investments and services that create the basic framework for society. It lowers the cost of working together and

facilitates cooperation: trust lowers transaction costs. Only systematic community participation and strong civil society, including government can achieve this. Cohesion of community for mutual benefit, connectedness among groups of people, reciprocity, tolerance, compassion, patience, forbearance, fellowship, love, commonly accepted standards of honesty, discipline and ethics. Commonly shared rules, laws, and information (libraries, film, and diskettes) promote social sustainability.

Shared values constitute the part of social capital least subject to rigorous measurement, but essential for social sustainability. Social capital is undercapitalized; hence the high levels of violence and mistrust.

Social (sometimes called moral) capital requires maintenance and replenishment by shared values and equal rights, and by community, religious and cultural interactions. Without such care it depreciates as surely as does physical capital. The creation and maintenance of social capital, as needed for social sustainability, is not yet adequately recognized. Western-style capitalism can weaken social capital to the extent it promotes competition and individualism over cooperation and community. Violence is a massive social cost incurred in some societies because of inadequate investment in social capital. Violence and social breakdown can be the most severe constraint to sustainability.

### **Economic sustainability**

Economic capital should be maintained. The widely accepted definition of economic sustainability is maintenance of capital, or keeping capital intact. Thus Hicks's definition of income—the amount one can consume during a period and still be as well off at the end of the period—can define economic sustainability, as it devolves on consuming value-added (interest), rather than capital. Economic and manufactured capital is substitutable. There is much overcapitalization of manufactured capital, such as too many fishing boats and sawmills chasing declining fish stocks and forests.

Historically, economics has rarely been concerned with natural capital (e.g., intact forests, healthy air). To the traditional economic criteria of allocation and efficiency must now be added a third, that of scale (Daly, Herman E., 2003). The scale criterion would constrain throughput growth—the flow of material and energy (natural capital) from environmental sources to sinks.

Economics values things in monetary terms, and has major problems valuing natural capital, intangible, intergenerational, and especially common access resources, such as air. Because people and irreversibles are at stake, economic policy needs to use anticipation and the

precautionary principle routinely, and should err on the side of caution in the face of uncertainty and risk.

### Environmental sustainability

Although environmental sustainability is needed by humans and originated because of social concerns, it seeks to improve human welfare by protecting natural capital. As contrasted with economic capital, natural capital consists of water, land, air, minerals and ecosystem services; hence much is converted to manufactured or economic capital. Environment includes the sources of raw materials used for human needs, and ensuring that sink capacities recycling human wastes are not exceeded, to prevent harm to humans.

Humanity must learn to live within the limitations of the biophysical environment. Environmental sustainability means natural capital must be maintained, both as a provider of inputs (sources), and as a sink for wastes. This means holding the scale of the human economic subsystem (the population and consumption, at any given level of technology) to within the biophysical limits of the overall ecosystem on which it depends. Environmental sustainability needs sustainable consumption by a stable population.

On the sink side, this translates into holding waste emissions within the assimilative capacity of the environment without impairing it. On the source side, harvest rates of renewables must be kept within regeneration rates. Technology can promote or demote environmental sustainability. Non-renewables cannot be made sustainable, but quasi-environmental sustainability can be approached for non-renewables by holding their depletion rates equal to the rate at which renewable substitutes are created. There are no substitutes for most environmental services, and there is much irreversibility if they are damaged (Goodland, 2002).

Healthy ecosystems provide vital goods and services to humans and other organisms. There are two major ways of reducing negative human impact and enhancing ecosystem services and the first of these is environmental management. This direct approach is based largely on information gained from earth science, environmental science and conservation biology. However, this is management at the end of a long series of indirect causal factors that are initiated by human consumption, so a second approach is through demand management of human resource use.

Management of human consumption of resources is an indirect approach based largely on information gained from economics. Herman Daly has suggested three broad criteria for ecological sustainability: renewable resources should provide a sustainable yield (the rate of

harvest should not exceed the rate of regeneration); for non-renewable resources there should be equivalent development of renewable substitutes; waste generation should not exceed the assimilative capacity of the environment (Daly, 1990).

Water

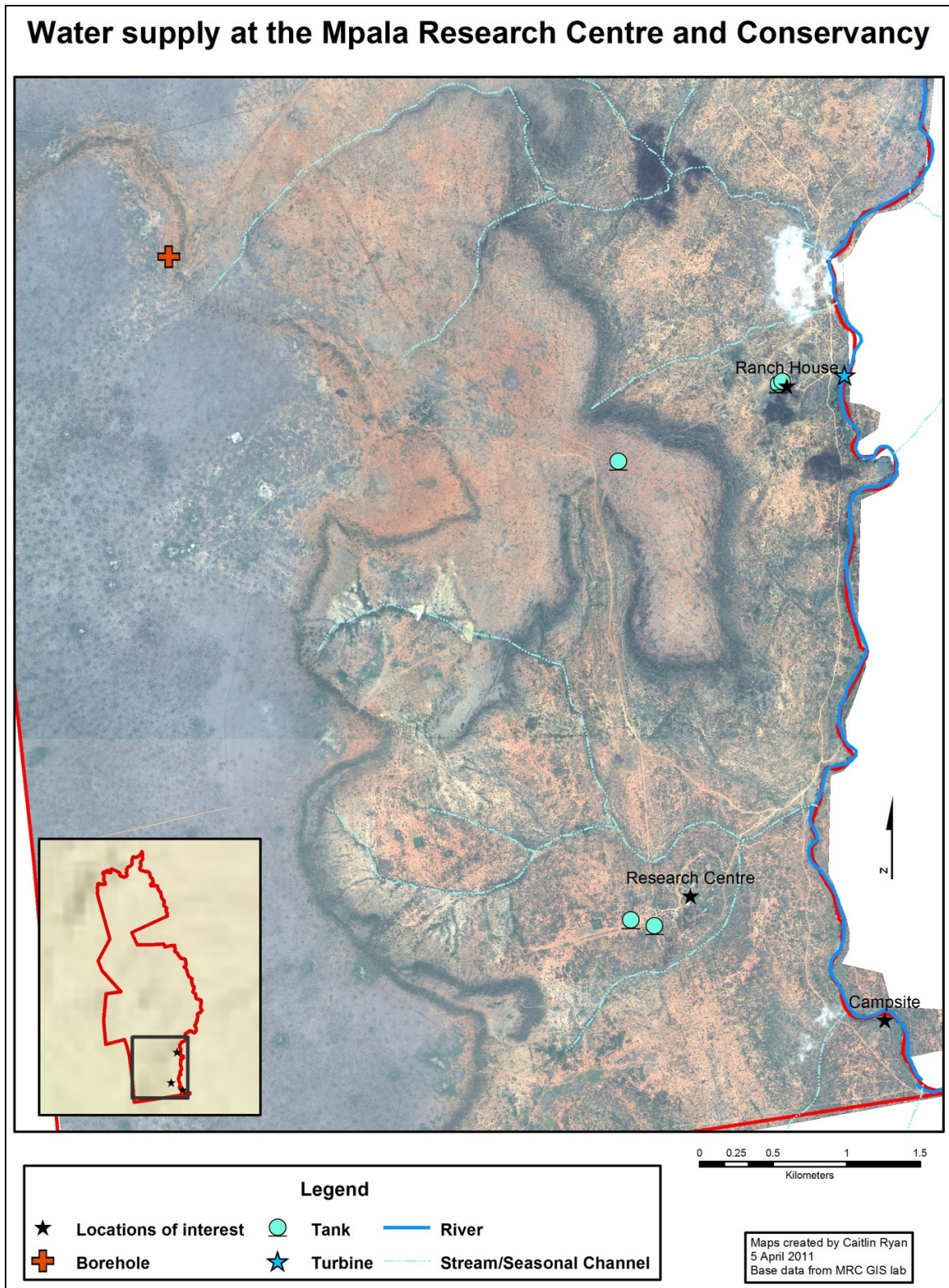

Image W-i 1: Water supply at Mpala



## Existing conditions

There are three main sources of water at Mpala – river, rainwater storage, and borehole. The first two are dependent upon current weather and rainfall. The latter is an ancient and finite supply, with its imperfections and challenges, but whose supply is not dependent upon the current weather conditions. The challenge that Mpala faces is to identify which source, or combination of sources, is ideal to supply water for their daily needs and to minimize water stress during times of drought.

Image W-i 1 (previous page) shows the locations of important aspects of Mpala's water supply, including the central borehole, the turbine location, which pumps water from the Ewaso Ngiro, and storage tanks at the Mpala Ranch and Mpala Research Centre complexes.

### River water

There is a river that runs along the east side and one along the west side of the Mpala property, the Ewaso Ngiro and the Ewaso Narok. Mpala uses its river water for consumption and hydro power from the Ewaso Ngiro. Currently, Mpala pumps water from the Ewaso Ngiro from two separate places. One location pumps water to the staff village at the Centre using a diesel-fueled pump. The other river water is pumped from the Ranch area to the Ranch staff Village at the Ranch and to tanks for the cattle throughout the property, using either the hydroelectric pump powered by the river, or a diesel-fueled pump. The river water is used for consumption by the staff and their families. The cattle use the river water when the reservoirs that have been dug for them throughout the property run dry. They are also used for the spray races, where the cattle are treated for ticks and other insect infestations. According to the pump manager, Masiyoi, the tank at the Centre Village holds 1000 liters and is filled approximately every three days.

The river water is a preferred source by the staff and their families. This is due to cultural and historical ties to the river, but also preferred qualities. They like the taste, and the pH of the water is adequate for creating good lather and clean rinsing in the washing of clothes and house cleaning. With the alternatives currently available, it is difficult to convince the local inhabitants to override this preference. There has been recent and increased use by the Village inhabitants of some borehole and rainwater.

### *Challenges with river water*

The challenges with the river water are supply, quality and energy use. The river, for the first time in living memory, ran dry for a number of months in 2009 and has periodically since that time. It also is seasonal, and therefore, even if it does not run dry, it can run low during the dry seasons (mainly January through March). It is for this reason that it is not a substantial or consistent source of water for consumption and other uses.

The quality is also a concern. The river water is partially contributed to by rain and run-off from the surrounding lands. With commercial horticulture increasing upstream, there is a concern of pesticides and fertilizers running off the land and into the rivers. This could greatly affect the safety of the water for humans and animals. This water has not yet been tested for these compounds, such as nitrates. In addition to anthropogenic contaminants, natural occurrences of bacteria are present in river water. When the river runs high, the bacteria concentration is less of a concern. But if Mpala is providing river water to the staff villages while the river is running low, the concentration of bacteria present in the water has in the past led to diarrhea and other digestive illnesses.

Another pressing concern about using the river water is the extraction and transportation methods. While it would be undesirable to ask the villagers to travel down to the river and carry their water home, maintaining the current method is expensive and polluting. Using diesel pumps is not economically preferable or sustainable. Therefore, if pumping water across any distance is required for this property, a more sustainable, less polluting and renewable form of energy should be considered. Local water sourcing, where possible, is the most ideal scenario.

The Ewaso Ngiro running dry was a shock to the managers and local residents at Mpala. For many of them, this was the first time of their, in some cases, decades long residence at Mpala to see the river bed completely dry. The river has not only provided the cattle with 'back-up' water when the reservoirs throughout the site run dry, they are also a culturally and functionally significant aspect of the lives of the Kenyans that live in the region. The river is their preferred source of water, but as of recent years, increased upstream abstraction, as well as long durations without rainfall, has contributed to its decreased flow. The absence of such a staple may not only lead to hardship of the people at Mpala and the surrounding communities, it could also lead to political and social unrest, as a common essential resource is threatened. Therefore, the reliance on the river water has become a risk to Mpala. In addition to its

consumptive needs, the river provides power to the Mpala Ranch and potentially to the Centre. A hydraulic turbine at the Mpala Ranch has provided electricity to the Ranch House and Village for almost a century. The current turbine is approximately 70 years old. Before the Mpala Wildlife Foundation can consider investment in a new turbine, the reliability of the river flow, at least during a majority of the year, must be assured. This will be covered in the energy portion of this report.

### **Borehole water**

The borehole, dug for Mpala in 2007, has become a steady and reliable source of water. It is located at a high elevation on the north portion of the property and is brought downhill using gravity and a diesel pump to provide water for both the Ranch and the Centre. It is first pumped at the borehole site into two main tanks. From there, it is sent to a secondary single supply tank. One line from there goes to the Ranch, the other goes down to the Centre. At the Centre, there is a storage tank from which water is transferred to large black plastic tanks on the back of a small truck and taken to the Centre, the Ranch Manager's house and the Campsite. There are also several taps that emerge from the ground throughout the Centre that provides this borehole water. The borehole water is used for washing, flushing toilets and drinking water for the researchers and visitors. Some staff and their families will use borehole water, but sparingly, as they don't like the way the mineral content affects their washing. They also don't like the taste of the borehole water. At the Ranch, it is used exclusively as drinking and cleaning water for the guest house and again sparingly for the Ranch Village. At both guest locations (Ranch and Centre), the borehole water is treated for consumption with a bone-char filter, which is used to remove fluoride, and with reverse osmosis, to sanitize the water.

### ***Borehole challenges***

The challenges facing this source of water are as follows. The source itself is not replenish-able. It is an ancient aquifer (also referred to as a *fossil* aquifer), and is used at a rate much higher than it is supplied. Therefore, it has a limited life and cannot be relied upon in the long term. There is also known to be more than one property in the area drawing from this source. The foundation is keeping track of its level and its usage, so that it knows how quickly it is using the water. The question remains, however, how much is left. The level appears to be dropping aquifer head at a rate of ~7m per year, and the location of the bottom and borders of this source remain unknown (Lane, 2010).

The second challenge is the transport of this water. With literally kilometers of piping carrying the water from the source to its destinations, the chance of great loss due to leaks and cracks are great. As can be seen in Appendix W-1, the amount measured from the extraction site is far more than the daily amount drawn from each destination, and over a long enough time period that it is clear water is being lost.

The third concern is the mineral content. There is a high level of fluoride in the water. Fluoride is considered essential for promotion of dental health. At a level of 0.5 to 1.5 ppm, fluoride does just that. However, at levels over 10 ppm, you begin to see severe osteoflourosis, a condition that cause digestive problems, neurological dysfunctions and arthritic-like symptoms (Schmidt, 2006). The water at the borehole currently in use at Mpala has levels of fluoride at 24 ppm (Lane, 2010). The filtering of this water is very expensive. Reverse osmosis, used for the drinking water of the guests, is a large expense, but the bone filters are also financial burden. This mineral content also makes for an unusual taste and a quality to the water that makes it difficult to wash with. As a result, the staff families complain of this quality and rarely use it.

Finally, the borehole is deep and currently requires a diesel pump to extract and deliver the water. This again, leads to cost, pollution and sustainability concerns. Solar and wind pumps can be looked into, but at the current depth, this borehole will require a substantial capital investment and a large solar array to provide adequate power (as explained later in this report).

### **Rainwater**

Rain is very intermittent at Mpala. There are distinct seasons – long rains, short rains, continental rains and dry season. This rain has supplied water for the cattle year round, human use and the small amount of irrigation needed. However, business as usual has become quite a challenge over the last several years. The dry season is drier and the rainy seasons have shorter, but more intense rain events. Three symptoms of this shift have been longer durations without rain, the local Ewaso Ngiro running dry for periods of time, and less frequent but more severe rain events causing an increase in damage to land and reservoirs throughout the site. These symptoms have brought painful consequences to Mpala. As mentioned, the droughts in the area have become more severe. The last drought, lasting four years and causing the Ewaso Ngiro to run dry for the first time in recent history, created an eye-opening experience for those at the Mpala Ranch and Research Centre. According to Michael Littleton (2010), Mpala Ranch Manager, 10% of their cattle were lost, and the Foundation had to campaign very hard to receive

aid from the local county council. If possible, the Foundation would like to avoid being in this position in the future, where further aid is not guaranteed.

In periods without rain, the river, while varying in flow, has always been present, if not ideal as an additional source. However, since rain feeds the river, and the long periods without rain among other things have led the river to run dry, the reliance on the river as a backup is no longer a viable option. The severe rain events have led to the destruction of ‘dams’ or artificial reservoirs throughout the Mpala property that serve to provide drinking water for the cattle and local wildlife. The droughts have caused the dams to run dry, and the more recently severe rain events have caused increased silting and in some cases, as mentioned above destruction of these reservoirs. What has been considered by Mpala, and rightly so, is an expansion of rain catchment and storage for use and back up during the dry seasons. These catchment systems include a weir constructed to withstand severe events and have a capacity of up to 200,000 cubic meters of rainwater for the Ranch Village inhabitants, cattle and wildlife. The other type of system, which this report supports, is an expanded rooftop rain catchment system that collects and stores drinking water for all of the people at Mpala during each season of the year, and is sufficiently sized to store emergency supply during long periods of drought.

### *Rainwater challenges*

Rain water as a source for consumption is the purest available at Mpala. However, the vehicle to catch the water (a metal roof top, for example) and the vessel it is stored in (an overland weir or constructed tank), add complications to the use of rain water for safe human consumption. For example, the metal roofs can experience rusting, waste droppings from local bird species, and air contaminants that settle on the roof and get washed into the tanks. The tank can also become contaminated by rodents or insects, or bacteria and fungi if not properly protected. Therefore, if the movement of rain from the sky to the glass can be properly constructed and monitored, then rain is an ideal source for drinking water at Mpala. Another challenge beyond sanitary collection and storage is the rate and amount of supply. As mentioned above, the rains in Kenya do not come in a consistent pattern. There are periods throughout the year that produce hard and fast events, dumping up to eight percent of the annual rainfall in one day, as it did on November 13, 2001 (Mpala Weather Station). There have then been situations, such as the extended dry seasons in 2008 and 2009, where rainfall was sparse from late November through April and then again dry in June, July. With these types of drastic variances,

designing an ideal storage capacity is quite a challenge. For weirs, considerations include evaporation; with the tanks, proper sizing; and with both, potential contamination. However, it seems as though the challenges for rainwater are surmountable and with proper engineering, a viable solution for the water supply at Mpala. See Appendix W-6 for historic rain patterns at Mpala Conservancy.

In an article by D. Mboyah published in the Africa Science News Service in 2008, a Maasai livestock farmer from Enkiroka in the Kajiado district, south of Nairobi, claimed that in the past, they would experience a drought every 10 years, but the frequency has increased to every year. “Climate change already caused massive losses to pastoralists in the northern parts of Kenya, as they are exposed to extreme drought that has led to soil erosion and drying of water pans.”

While 2010 brought above average rainfall, Dr. Joseph Mukabana, director of the Meteorology Department in Nairobi, predicts that Kenya will see more drought during the coming year. With another drought on the horizon, and more predicted from climate scientists, Mpala has an urgent need to store sufficient rain water when it comes and to manage the storms severity as best it can. That would require a stronger infrastructure to withstand the fierceness of the storm events. They would need to take advantage of the relief the land has to direct water most efficiently, and create storage that is large enough to serve Mpala humans and animals. A new infrastructure to deliver the water effectively would also be required, unless more local solutions are found.

## **Trends and perceived future challenges**

### **Population growth**

In addition to the challenges that Mpala faces now, providing its human and livestock populations with adequate water resources, it must consider the future needs. This includes an increase in population. Following is a short assessment of population estimates.

#### *Villages*

Present surveys estimate the total population at the Centre and Ranch from 400 people up to almost 700 during the summer when children and family members return (Table W-t 1). Estimates average a year-round population of around 550 people, but the Centre and Ranch

should consider constructing a system capable of handling the water needs of the largest potential population to extend the period until additions are required.

**Table W-t 1: Summary of population estimates for Mpala Research Centre and Ranch.**

Source	MRC	Ranch	Total
Aquasearch Ltd. Report (Lane, 2010)	149	367	516
2009 Census (Littlewood, 2010)	239	367	606
Director estimate (Kinnaird, 2010)	NA	NA	~600
Administrator estimate (Leting, n.d.)	NA	NA	~400-500; ~650 during summer
Operations Manager estimate (Tuni, 2010)	~225	NA	NA
Undated communication	191; 258 during summer	232; 441 during summer	423; 699 during summer

Assuming population growth in Mpala is consistent with Kenyan population growth rates (2.69%/year), village populations at the Centre and Ranch should reach 700 in eight years (United States Central Intelligence Agency, 2010). Establishing a more accurate population count at the Centre and Ranch Villages will be important step for any action on water resource management, because the differences will be compounded over time (Table W-t 2). Additionally, considering the higher standard for villagers at Mpala over Kenya more generally, the population growth rate may be considerably lower.

**Table W-t 2: Population predictions based on different initial populations, with most likely scenario highlighted.**

	<i>Year</i>	2010	2011	2012	2013	2014	2015	2016	2017	2018	2019	2020	2025	2030
<i>Population</i>														
400		411	422	433	445	457	469	482	495	508	522	536	612	699
500		513	527	541	556	571	586	602	618	635	652	670	765	873
<b>550</b>		<b>565</b>	<b>580</b>	<b>596</b>	<b>612</b>	<b>628</b>	<b>645</b>	<b>662</b>	<b>680</b>	<b>698</b>	<b>717</b>	<b>737</b>	<b>841</b>	<b>961</b>
600		616	633	650	667	685	704	723	742	762	782	804	918	1048
700		719	738	758	778	799	821	843	866	889	913	937	1071	1223

### *Researchers*

The population estimates for the MRC and Ranch are only for villagers and do not take into account visiting researchers housed at the Centre and the future expansion of facilities to accommodate more researchers. Although the number of researchers varies considerably

throughout the year, there is currently a maximum capacity of more than 60 visitors, spread between the river Campsite, the dormitories, and the bandas (Mpala Research Centre and Wildlife Foundation, 2010).

### *Livestock*

The Ranch has a peak livestock population of 2500 cattle, 100 sheep, and a handful of camels and goats (Littleton, 2010). The Ministry of Water and Irrigation (formerly the Ministry of Water Development) estimates livestock water demand at 50 l/day per livestock unit, which it defines as three indigenous cattle or 15 sheep or goats (Kalders, 1986). The draft report by Aquasearch Ltd. estimates demand at 50 l/day per head of cattle at Mpala because of the higher demand for water by grade cattle (Lane, 2010). Total demand by cattle is approximately 125 m<sup>3</sup>/day; including sheep and camels raises this estimate by less than .5 m<sup>3</sup>/day. The peak livestock populations seem unlikely to rise significantly in the near future.

For the purpose of this report, the human population at the Centre, current and future, will be evaluated and accommodated. At the request of the Mpala management, the future population will be measured at 200% of the current average visitor population (as the Research Centre hopes to accommodate more research studies in the future) and 133% of the current Centre Village population, to account for the increase in staff that will be needed to serve to additional visitor population.

### *Rainfall/climate change*

In addition to the conditions on site at Mpala, anyone attempting to solve the water issue at Mpala must consider external drivers. For example, increased horticulture on land upstream may be contributing to the dry river bed during the dry season. Certain factors such as these could be further impacting the challenges they face. In addition to human impact, there is also a more global issue that could be contributing to the water issue, climate change. Whether the change in the local climate is a result of global warming, or if there is simply a change in northeast Africa, changing conditions have been noted.

In Appendix W-6c it is apparent that over the last several decades, droughts have come and go (1999, 2000, and 2009). However, evidence shows that more recently, longer dry seasons and unseasonable drought has been observed. As a result of these patterns along with both an observed increase in wildlife migration through the region and the increased population of



humans at Mpala, there is an urgent need to pay close attention to these patterns. With the possibility that this pattern is a permanent change to the conditions in the region, and there continues to be an increase in population and commercial horticulture throughout North Central Kenya, it is important to listen to the experts.

According to Mukabana (2010), climate change has increased the minimum and maximum temperatures in Kenya, led to recession and drastic declining trends of glaciers on Mt. Kenya, increased the frequency and intensity of rainfall extremes (droughts, floods), and shrinking and decline in lakes and river levels where some streams have now become seasonal. The extreme cases, with floods for example have led to infrastructure damages. Mpala has been witness to all of this. Mike Littleton, Ranch Manager at Mpala has had to deal with a broken spillway at a dam site. The reservoir, one of many created by Mpala and built for flood overflow, did not withstand the strength of the mid-year storms and the spillway broke away under the force of the storm water. Now this reservoir sits empty and is not a resource this season for the Mpala cattle or local wildlife. The minimum and maximum temperatures could potentially damage plant life in this climate. Plants and their root systems slow storm water – therefore, the temperature extremes exacerbate the damage done by the intense storms.

## Energy

### Existing System

The existing system at Mpala is an off-grid electrical system that operates without a transmission system. The Mpala Research Centre has its own electrical system which is made up of diesel generators, solar PV panels, and batteries. The Ranch Headquarters is powered by a hydroelectric turbine and a backup generator that together provide electricity throughout the year. The Ranch Manager's house, called the Clifford's, is a remotely located standalone diesel generator system. There are two villages, where the employee family homes are located, each situated near the Centre and Ranch headquarters which currently do not receive any power. A detailed explanation of the existing situation at Mpala and the current challenges are explained in this section.

### Centre

The diesel generator at the Mpala Research Centre (MRC) is switched on twice a day (6:30 AM-10:30 AM and 6:30 PM to 10.30 PM), and during this time between 10 and 35 kW are available to the whole MRC. All connected buildings have lighting and electricity. Battery back-ups undergo charge cycles. When the generator is switched off, hybrid PV-battery back-ups provide power to the Admin Block, the Laboratory, the NSF lab and the Library. Such a system is set up with a hope to utilize and store maximum energy and when the generator is running. This enables the Mpala Research Centre to function with the generator running for only eight hours instead of for the entire day.

While the use of one large generator makes the existing system at Mpala appear as a centralized system, the presence of batteries in each building makes it quite decentralized. This is not uncommon in Africa and is referred to as a hybrid microgrid. Among the other factors that add to the decentralization of the existing system is that each of these buildings have a unique design. For example, one of the dorms does not have a battery system and is thus powered directly by the generator for only eight hours a day. The load in each building is also different. The kitchen, the labs, and the library are the major load bearers. The freezers in the kitchen and the labs take up most of the electricity. The library is open throughout the day and night, and researchers work here with their laptops and also charge their batteries in this room. Some of the buildings have a different power system in that they use solar panels and solar thermal devices in

addition to the diesel generator. The laboratories next to the admin building are a good example of this. They use solar energy from panels to power some of their 110 V power sockets. They have separate batteries in the laboratories for this purpose. The dorms use solar thermal heaters to generate hot water showers for those living in the dorms. Another interesting hybrid technology combining solar and wood boiling of water is the ‘kuni boosters.’ These are simply solar flat plate collectors that act like an oven, and are used by the researchers for keeping their samples or equipment warm.

There are risks in the current system. The way it is designed, the buildings will go without power if the batteries in the building stop working. Since all the laboratories have very important frozen samples (sometimes of endangered species) or the results of important experiments, such risks are unacceptable. The freezers in the kitchen store meat that will get spoiled if the batteries are not working properly to power them at all times. During our visit to Kenya, the batteries in the kitchen were not functioning, and thus the ice levels in the freezer had dropped below the level of food stores in the freezer. This is a systemic and problematic issue for Mpala. It is important to devise a simpler system that is more carefully designed with proper backup and easily maintained.

With an average energy consumption of 95 kWh, Mpala cannot afford to have a system that is not only unreliable but also very expensive to maintain. Each of the system components at the Research Centre have been discussed below in detail.

### *Generator*

The Mpala Research Centre primarily operates on two diesel generators that power almost all the buildings in the Centre. The exception to this is the Princeton Dorm which is a standalone system, entirely powered by solar PV. The primary power source is a five-year-old 30 kVA “Perkins 4126” genset with 13000 hours of running time to date. It is continuously rated at 30 kVA, but can peak at 34 kVA. It consumes about three liters/hour of diesel. There is a 20 kVA back-up generator (Lister, with 17,000 hrs running time) which is unable to handle the peak load of the Centre (Hankins, 2009). Thus, with a power factor of 0.8, the large generator has a nameplate capacity of  $30 * 0.8 = 24 \text{ kW}$  and the small generator has a nameplate of  $20 * 0.8 = 16 \text{ kW}^2$ . The capital cost and emission factors of these generators are as shown in Tables E-t1

---

<sup>2</sup> Power factor obtained from name plate of the generator

and E-t2. The emission factors listed below are typical for diesel fuel combustion in generators and have been obtained from the HOMER database.

These generators are modeled in HOMER and there were no constraints placed on operating hours of small generator. However, a schedule of eight hours/day (four in the morning and four in the evening) was imposed on the large generator. While the large generator is used to power the buildings in the Centre for eight hours every day, the small generator is used only in the event that the large generator fails to function. The large generator is connected directly to each building's main switchboard, allowing it to power all the appliances directly. It is also connected to a battery system in each of these buildings and continues to charge them until they get fully charged. A summary of the specifications of the two generators are shown in Table E-t3 below.

**Table E-t 1: Diesel generator costs**

Size (kW)	Capital (\$)
16.00	2500
24.00	3500

**Table E-t 2: Emissions factors of diesel generator**

Carbon monoxide (g/l of fuel )	6.5
Unburned hydrocarbons (g/l of fuel )	0.72
Particulate matter (g/l of fuel )	0.49
Proportion of fuel sulfur converted to PM (%)	2.2
Nitrogen oxides (g/l of fuel )	58

**Table E-t 3: Diesel gen-set specifications**

**Generator set**

Type	Rating	Age	Consumption
Perkins 4126	30 kVA	5 years old, 13,000 hours	3 l/hr
Lister	27 kVA	17,000 hrs	

### *Solar PV*

The secondary power source in the camp is a set of PV. Solar electric arrays located atop the various buildings total 3.63 kWp PV (Oloo, 2010). The modules, of various types and ages, are all in working order. There are about 12-14 modules in the store which have yet to be

installed. The specifications and quantity of the PV installations on top of each building along with the other power systems in each of those buildings are shown in Appendix E-2.

We see from these tables that the existing solar system consists of three different types of panels: 65, 75, and 160 watts. The costs of these panels are listed in Table E-t4. The solar panel is oriented at latitude tilt to maximize its efficiency. The lifetime of the PV panels is 25 years (Center for Alternative Technology, n.d.). The solar system installed does not have solar tracking abilities. The capital costs have been obtained from the suppliers to MRC. These include the costs of mounting hardware and installation. The operation and maintenance costs are based on the current labor costs in MRC (Hankins, 2006). These details are used in HOMER to design an efficient new system based on both economics and power output when compared to the existing system. Currently, the solar PV system is unable to meet the demand at MRC and is used to provide backup charge for the batteries in each building.

**Table E-t 4: PV panel cost**

Size (W)	Capital (\$)	O & M (\$/year)
65	300	7
75	300	8
160	900	16

Kenya, being located very close to the Equator has a tremendous potential for solar power. Not only does it receive intense light and heat through the day, it receives such sunlight throughout the year. Thus, solar energy is a very reliable source in Kenya and can be used both for generating solar power and for powering solar thermal devices. We therefore considered both of these options very carefully for our analysis. Solar also has also other advantages. It can be easily used and purchased in Kenya. It can also be located close to the load, and thus eliminates the need for transmission lines.

However, there are many challenges in installing solar power in Kenya. The initial cost of installing the panels required to support the entire conservancy will be very high, and there are maintenance costs attached to the system. The working of solar panels is not easily understood by the people in the Villages, thus leading to more expenses and vulnerability during the years of operation of the system. Solar panels are also subject to a loss in efficiency over a period of four to five years, and this happens faster in Kenya due to the high heat intensity of the sun's rays. While Solar is definitely a great option for Mpala, it cannot single handedly support the entire conservancy.

### *Hydro generator*

Mpala facility has a provision for a hydro power generation unit. The river is located about 10 km away from the facility. There exists a turbine of 31 KW at the river, but there is no infrastructure that enables the transmission of this power in the MRC. The new system accounts for the cost of developing the infrastructure and is included in the HOMER model. Table E-t5 lists the various specifications of the turbine

**Table E-t 5: Turbine specifications**

Available Head (m)	3.2
Design flow rate (L/s)	600
Efficiency	60

### *Batteries*

As mentioned earlier, the generators are connected to a battery system in each of the buildings and continue to charge them until they get fully charged. Inverters in the battery make sure that the current supply to the batteries is arrested when the batteries are fully charged. When the generator is switched off, the buildings are powered by the batteries. The battery systems are included in Appendix E-2.

Battery storage systems use Indian-made tubular plate batteries arranged in five banks of 24 volts (Hankins, 2006). These batteries perform better than the flat plate Chloride Exide units used previously (and now installed in the bandas) and are superior products. However, because the systems are under-sized, they are cycled heavily, and will have relatively short life times (i.e. less than five years). Some of the batteries are installed in poor locations --- i.e. in the ceiling spaces of the buildings where they cannot be seen, and where access is limited. Batteries should be mounted where they can be easily accessed and serviced in vented containers or rooms.

### *Converters*

Converters are devices used to convert the DC to AC and vice-versa. Inverter-chargers are used in every building that has solar PV mounted on it. The Trace-Xantrax inverter chargers are sophisticated power control units that are used to charge the batteries and power loads in the four active buildings with solar panels. Three of them are 2400W Xantrex Modified Square

Wave Inverter/Charger, 2400W, Off Grid, 24 V DC, 120 V AC, 60 Hz, DR2424 units , and one is a Xantrex SW3024 3000W, 24 V 220V AC, 50 Hz sine wave unit (Oloo, 2010). The capital and replacement costs of the converter are shown in Table E-t6. The lifetime of these inverters are around 15 years on an average.

**Table E-t 6: Converter costs (Oloo, 2010)**

<b>Size (kW)</b>	<b>Capital (\$)</b>
<b>2.40</b>	1000
<b>3</b>	2250

### **Ranch House**

The Ranch House power systems include a micro-hydro system (MHP), which if functioning to its full capacity can provide up to 12 kW, a backup generator, various wood cooking and water heating loads and a small solar PV power system. The MHP is a 70-year old Czechoslovakian micro-hydro system and it powers all of the electrical loads in the Ranch House (Hankins, 2006). The turbine and generator housing are located about 500 meters from the Ranch House, and a buried cable conveys the power to the complex. The power generated by the turbine is cheap, renewable and clean, and is more than enough to power not only the Ranch but also the Ranch Village. The excess power produced by the turbine is currently expelled by heating river water that is then returned to the river. Not only is this energy wasted, but it also has a risk of causing ecological damage in the long run for the Ewaso Ngiro. When the turbine is out of order or when the river is dry, the backup diesel generator is used to power the Ranch. During the dry season, the diesel generator is also used to pump water from the partially dry river, up the hill to water the cattle. Due to climate change, the dry seasons are expected to increase thus leaving the river dry for longer periods and also increasing the risk of floods during the wet months.

During our visit to Kenya, the turbine was not in operation due to failure of certain parts in the turbine. Thus the Ranch House was powered entirely by the backup diesel generator. The Ranch House received power only during part of the day. The load in the Ranch House is primarily comprised of lights, fans and a refrigerator. Solar thermal water heaters produce hot water in the showers. Throughout Mpala, LPG is used for cooking.

### Clifford's House

A 2.5 kW Honda petrol generator provides several hours of power for the house each night. Because of the lack of alternative power system, the gen-set must be turned ON each time any appliance is required. At present, all of the lights on the system are incandescent. Cooking loads are gas powered as is the refrigerator. The house has one kuni booster and one solar water heater. Combined, these are sufficient to supply all of the hot water needs of the house.

### Villages

There are two villages in the Mpala Conservancy one of which is a settlement near the Centre, and the other is near the Ranch House. The two Villages are also off the grid, and have either very little or no power supply. The people in the Village near the Centre often tend to charge car batteries on the main generator site, and they use these batteries to power their radios and televisions. There have been efforts taken by Mpala and researchers from other universities to help these villages power themselves with affordable solar panel designs. During our visit there, Eden Full from Princeton University planted a bamboo supported solar panel design in both of these villages. These panels rotate such that according the sun's angle thus increasing the efficiency.

Making the Village self sufficient in their electricity needs could benefit Mpala in more than one way. The lack of electricity, and thus the lack of recreation have proven to show a correlation with population growth many times in the past and having an electricity system in place could help Mpala. Additionally, the Villagers would also not have the necessity to draw power from the diesel generator sites, and this would decrease the daily load on the main generator. Finally, most of Mpala's employees live in the Villages along with their families. Providing a good comfortable home will increase the productivity of the people working for Mpala.

### Trends and perceived future challenges

The trends and challenges posed by climate change, increase in population and per capita demand and other economic factors such as diesel prices are important and should be taken into account to make sure that the solutions proposed to Mpala are meaningful, accurate and long lasting – and therefore, sustainable.



## Diesel prices

Kenya and more importantly the Mpala Conservancy is dependent on diesel for its electricity and thus for most of its basic needs. The diesel is used to power all of the appliances and lights for the labs and dorm, the diesel generators also pump water from the borehole which provides water for all the buildings in the Centre. The pump price for diesel fuel (US dollar per liter) in Kenya was reported at 1.14 in 2008, according to the World Bank (Trading Economics, 2010). Fuel prices refer to the pump prices of the most widely sold grade of diesel fuel. Prices have been converted from the local currency to U.S. dollars (see Image E-i1, below).

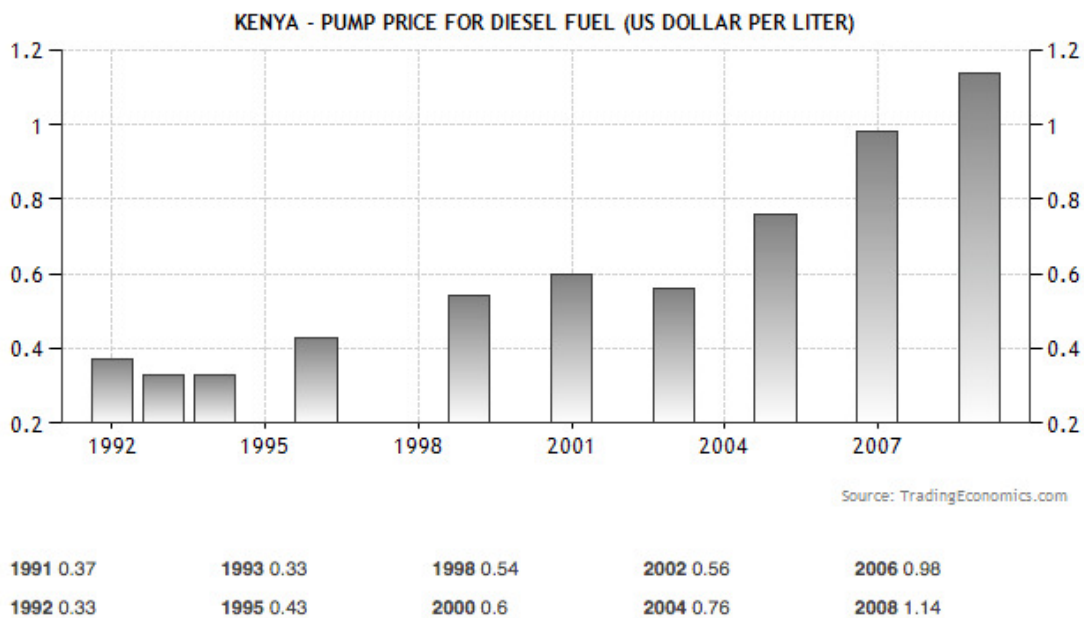

**Image E-i 1: Kenyan pump price for diesel fuel, in \$US.**

The prices have risen consistently ever since 2004, to reach a current price of \$1.15/l (Obulutsa, 2011). This is rather high compared to the costs in USA. While this will affect the electricity prices in MRC, it will increase the electricity prices and transport costs all over Kenya, thus leading to inflation in the consumer market. We can start by becoming independent of diesel for electricity and water, so that at the very least, the increase in direct costs for diesel can be tackled. Some of the reasons attributed for the increase in prices are the rising crude prices and political instability in the Arab world. The price rose by four per cent in February over January's 95.6 shillings a barrel. Factors that have affected the rise in Kenyan fuel prices include rising international costs, the weakening Shilling, and transport costs (Sambu, 2011).

## Population and demand per capita

Present surveys estimate the total population at the Centre and Ranch from 400 people up to almost 700 during the summer when children and family members return. Estimates average a year-round population of around 550 people, but the Centre and Ranch should consider constructing a system capable of handling the energy needs of the largest potential population to extend the period until additions are required.

The population estimates for the MRC and Ranch are only for villagers and do not take into account visiting researchers housed at the Centre and the future expansion of facilities to accommodate more researchers. Although the number of researchers varies considerably throughout the year, there currently a maximum capacity of more than 60 visitors, spread between the river campsite, the dormitories, and the bandas (Mpala Research Centre and Wildlife Foundation, 2010).

The Mpala Research Centre has been doing very well in the research areas of conservation biology, ecology and wildlife sciences and thus its popularity is increasing every year. While this would mean that there will be more number of researchers visiting the conservancy, it would also mean that there might be more experiments than before and more usage of electricity for experiments by each person. If there are more experiments happening, there might be a need for more freezers, and ovens. The simple solar powered ovens that are currently being used for incubating and drying purposes might not suffice. The kitchen may also need more refrigerators and LPG. The number of computers will increase, and there might be a need for more sockets to charge all the devices. The Research Centre may also need to equip itself with latest technology for its future needs and these instruments and devices may demand a lot of energy. Therefore, on Margaret's request we have scaled up the current demand to double the overall demand for our analysis.

## Climate change

Climate change is a great governing factor in deciding the trend in both energy supply and demand. In the supply side, climate change will be responsible for the increased seasonality of the river – thus making the river flood during the wet season and become almost empty during the dry months. This will greatly decrease reliability on turbine generated hydro power. General rise in temperatures can also affect the longevity of the solar panels. In the demand side, there will be greater demand for cool air in the summer months. Currently, Mpala functions

without any fans or air conditioners in most of the buildings. The thatched roofs keep some of the buildings cool in the summer months. This might change with increase in temperature. Additionally, the refrigerators and freezers may consume more electricity in the summer months thus skewing the load to Mpala's disadvantage. The water table has been falling consistently over the past years due to continuous pumping of water from the borehole. As a result, more and more energy is required for pumping this water. In the future, depending on borehole water will increase energy and diesel demand. The land, presumably originally chosen for its sun exposure, is quite suitable to be used for solar thermal energy production. The solar thermal technology may also function better with increasing intensity of the sun in summer months.

Global climate change has led to many policies to be developed all over the world to encourage the usage of renewable energy usage to generate clean electricity and reduce emissions. Africa specially is becoming more and more accessible to many developed nations who want to meet the demands of its emissions reduction obligation through the Clean Development Mechanism. Therefore, as the awareness of climate change spreads far and wide, it will be easier to avail such funds for clean technologies. A good example is biogas. When cow manure rots, it releases methane into the atmosphere that impacts the earth's greenhouse effect even more than carbon emissions (eHow.com, n.d.). This can be used to fight climate change by capturing this methane gas and using it for fuel. Thus in areas like Kenya, it is even possible to receive carbon credits for harnessing the humble power of cow dung.

## Methodology

### Water

#### Population estimates

##### *Bednights*

A bednight is equal to one visitor staying overnight for one night. Therefore, one visitor staying for five nights is equal to five bednights, two people staying for five nights is equal to ten bednights, and so on. Daily bednight data for Research Centre and campsite visitors for August 2007-August 2010 was obtained from the MRC Director, Dr. Kinnaird. Monthly values for January 2006-December 2009 were also provided for both the Centre and the campsite. For each location, total monthly bednights were recorded. For missing data, attempts were made to overestimate, rather than underestimate, the number of potential visitors to ensure greater flexibility of the final outputs. For September-December of 2010, the bednight estimate was the maximum recorded for that month for all previous years.

We determined which month from the whole time period had the greatest number of bednights. For the Centre, this was June 2010 with 1112 bednights, and for the campsite it was March 2009, with 846 bednights. These values were divided by the number of days in each month to arrive at an estimated 27 people per day staying at the campsite and an average of 37 people per day staying at the Research Centre.

##### Daily usage

###### *Fixture use*

Total water demand at the MRC was estimated at 189 liters per person per day (lcd) for visitors staying at the Research Centre, 20 lcd for Centre employees, 80 lcd for visitors at the Campsite, and 75 lcd at the Centre Village. Estimated usage for Centre visitors and employees was based on usage for fixtures and essential water demand (see 'Essential use,' below), while usage for villagers and campsite visitors was based on values in the Hydrogeological Assessment Study Report by I.M. Lane (2010).

For visitors at the Centre proper, average water use was broken into water from taps, toilets, and showers. Usage of taps was estimated at two and one half minutes per day, showers were estimated at ten minutes with one shower per day, and toilet use was estimated at five flushes per day. These estimates were multiplied by water usage per minute or flush from fixture

specifications and summed to find total fixture water usage (Kohler Worldwide, n.d; EPA WaterSense, 2007; United States Green Building Council, 2009). An additional eight lcd was included for essential water usage.

Fixture use by employees was also included in total water demand to account for employees using bathrooms and sinks on site, but not including showers. Employee use was calculated by estimating 40 employees working five days per week for 50 weeks per year using fixture specifications listed above.

For rainwater harvesting calculations, we estimated a generous eight lcd for drinking, cooking, and some washing. Employees are included in the Village population, so their essential consumption was not included as a separate component.

### *Essential use*

Per person daily needs of essential water includes drinking water, water for basic washing, cooking water and clothes washing water.

This breaks down to approximately two and one half liters for drinking (Mayo Clinic, 2007), two and one half liters for cooking, and three liters for laundry and basic washing. This totals eight liters per person per day. Essential water is the same for all people present at all locations and includes Village inhabitants and Centre inhabitants (visitors and Director).

### **Borehole supply estimates**

There are meters measuring the amount of water in cubic meters ( $m^3$ , 1000 liters) drawn from the borehole on a daily basis. There are currently three meters in place. The first is located at the source of the borehole, before the water is stored in the two initial tanks at the borehole site, which measures total water drawn from the borehole. There is a second meter that tracks the amount of water drawn from the borehole storage tank located at the Mpala Research Centre. There is a third meter that measures the amount of water drawn into the storage tank at the Mpala Ranch from the intermediary tank. Measurements were taken beginning 10 August 2010 and ending 29 December 2010. Appendix W-1 shows the dates of measurements for different meters; not all meters were measured every day.

### **Roof area**

Roof areas of the Centre buildings were collected from several sources. The Centre building areas were provided by the Centre Director, Margaret Kinnaird. These measurements

were cross-referenced with reports by Odhiambo et al. (n.d.) and Lane (2010), as well as floor plans provided by Joseph Leting for the Library, NSF lab, and library. Ajay Varadharajan and Chelsea Ransom manually measured the homes and buildings in the Centre Village and confirmed the number and materials of buildings with Dr. Kinnaird. The estimated total roof area calculated at the Centre location was 4255 m<sup>2</sup>. The estimated roof area currently equipped for catchment is 1973 m<sup>2</sup>.

At the Ranch headquarters, the roof areas were again collected from the Odhiambo and Lane reports, as well as a list of manually measured buildings provided by the Ranch Director, Michael Littleton. Director Littleton provided a detailed list of all of the Ranch buildings, including each individual Village home and school property buildings. A table of roof areas can be found in Appendix W-2.

### Roof area collection calculations

Rain water collection was calculated using the following formula:

Rainfall (mm) \* Roof Area (m<sup>2</sup>) \* (1m/1000mm) \* 85% = m<sup>3</sup> of water collected. 85% is a generally accepted coefficient of run-off for metal roofs.

### Rainfall calculations

Rainfall data came from the Mpala Weather Station, located at MRC, data supplied to us by Chris Odhiambo, who used to manage the operations surrounding the weather station. Daily, monthly and annual averages, minimums and maximums, and standard deviations were calculated. This rain data was used to populate our accumulation graphs and water collection scenarios, with monthly averages, minimums, and maximums used for accumulation graphs and actual daily precipitation used for the water collection scenarios.

### Accumulation graphs

The accumulations graphs illustrate the accumulated demand of water consumption for essential needs over the course of one year and the accumulated storage capabilities of different storage sizes over the course of one year.

The following assumptions apply to all accumulation graphs:

- The average person requires eight 'essential' liters of water per day for drinking, cooking, laundry and basic washing. Water is not needed in excess of this essential water.
- MRC visitors include visitors at both the campsite and the Centre.

- The current population of visitors consuming this water at the Research Centre a constant 64 (27 at Campsite, 37 at Centre) based on maximum monthly number of bednights over years 2007-2010 provided by Mpala Research Centre divided by the number of days in the maximum month (30 days).
- The current population consuming this water in the Centre Village is 239, from the 2009 census.
- The projected population for visitors is 128, 100% more than the current population, at the request of the Dr. Kinnaird.
- The projected population for the Village is 319, 33% more than the current population. It was assumed that as the visitor population grows, approximately 33 additional employees will be required per 100 additional visitors. This also assumes new employees will bring with them few to no additional family members. These are estimations.
- Total available roof area is 4255 m<sup>2</sup>. The actual current available metal roof area adequate for catchment is 1973 m<sup>2</sup> (46.4% of total available roof area).
- There are no storage constraints for these graphs. Accumulated storage simply equates to the total volume of run-off.

The methods used in these graphs were as following:

- Essential water needed is illustrated by a red line. Potential water capture for consumption is illustrated by a blue line.
- The variables for different scenarios included population size (current versus projected), percentage of roof area dedicated to collecting run-off (100%, 75%, 50%, and 46.4%), and monthly rainfall (average, high, and low).
- Rainfall data from the Mpala Weather Station for years 1999-2009 was used to find average, high, and low monthly rainfall values. Average rainfall was the average across this time period. High and low rainfall was the maximum and minimum rainfall for a month over this time period, respectively.
- The charts run from April through March of the following calendar year because the 'long rains' season begins in April.

On the following page, you will find two examples of the graphs provided, with the remainder found in Appendix W-3. The first, image W-i 2 (Graph 1, Appendix W-3a), illustrates accumulated storage for the total roof area in an average rainfall year and accumulated current

essential consumption demands. The second graph, image W-i 3 (Graph 16, Appendix W-3b), illustrates accumulated storage for the current roof area available for collection in a low rainfall year and accumulated projected essential consumption demands.



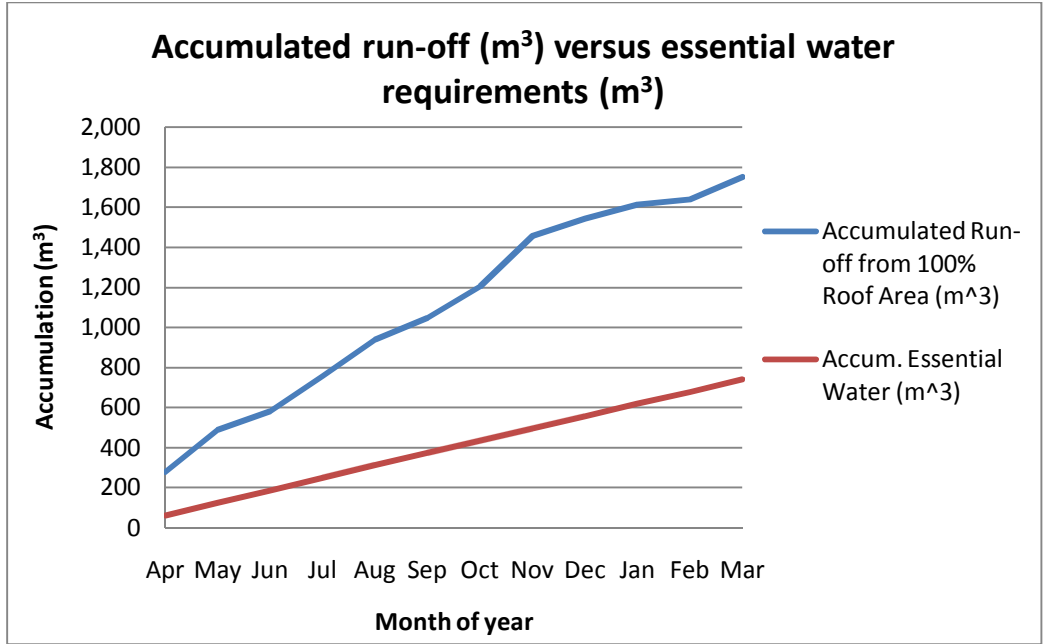

Image W-i 2: Accumulated run-off (m3) from entire roof area and essential water required (m3) for current population

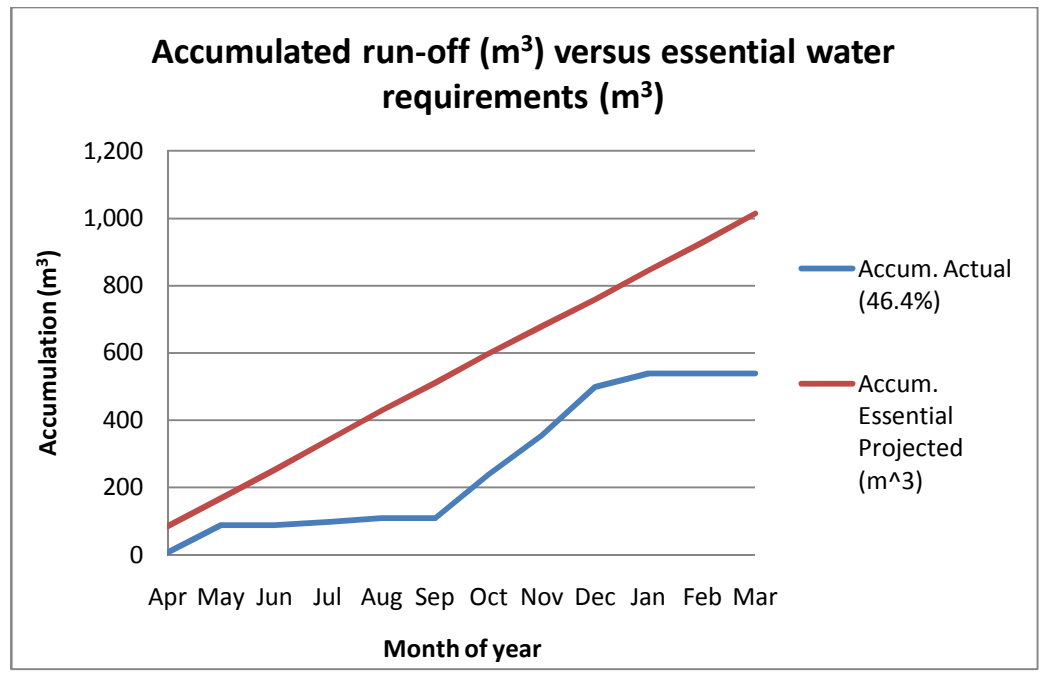

Image W-i 3: Accumulated run-off (m3) from current roof area converted to capture water and essential water required (m3) for projected future population

## Water collection scenarios

Rooftop rainwater collection and storage estimates were calculated for over 60 scenarios to account for a wide range of factors. A comprehensive list of scenarios and their results are included in Appendix W-4.

Scenarios were broken into two categories, the first based on current storage capacity and the second based on the potential expansion of rainwater storage capacity, with each scenario run based on current population levels and projected population growth. Each scenario has its own assumptions, but there are several general assumptions that went into the calculations.

- Essential water required is eight lcd.
- Current and projected populations were calculated as explained above in ‘Accumulation graphs.’
- Roof areas were collected as explained above in ‘Roof areas.’ Total roof area for the MRC includes all major buildings, all Village houses, and the bandas, but does not include the Keller or Princeton dorms. Newer buildings, for which we did not have area values, were not included. Area measurements are in m<sup>2</sup>.
- Current tank sizes for Village houses were gathered from Mburu Tunji while visiting MRC. Tank sizes for MRC buildings were based on information from Odhiambo et al (no date) for the library, two lab buildings, administrative building, mess hall and kitchen, work shop, and Store 15, as well as the Director’s, Jenga, Administrator, Grevy (formerly GIS), and Klee houses.
- The run-off efficiency coefficient for metal roofs is 85%.
- Volume of water is measured in liters.

### *Water collection scenario calculations*

Daily rainfall (mm) for January 1, 1999 – December 31, 2009 was multiplied by the total roof area and the run-off efficiency coefficient to find the daily volume of run-off. The volume captured and missed, space remaining in the storage tank, and number of empty days relied on a series of logical arguments, the formulas for which are listed in Appendix W4.

- **Run-off:** This figure is simply the area of the roof in meters squared times the amount of rainfall in millimeters. The resulting figure is in liters.

- **Day addition:** If the run-off minus daily use is less than 0, then day addition is 0 liters; otherwise day addition is daily use minus run-off.
- **Day shortfall:** If the day addition is greater than 0 liters, then more rain was going into the tank than being drawn out, and the day shortfall is 0; otherwise, the day shortfall is the daily use minus run-off. This figure is independent of what is currently in the tank.
- **Left over space:** Leftover space shows the amount of room remaining in a tank, with a maximum value of the tank size and a minimum value of zero (i.e., the tank is completely full). If the current day addition is greater than 0 liters and if the left over space from the day before minus the current daily addition is less than 0, then the left over space is 0; otherwise, the left over space is the leftover space of the day before minus the current day addition. However, if the left over space of the day before plus the current day's shortfall is bigger than the tank size, then the left over space equals the tank size; otherwise, it is the left over space of the day before plus the current day's shortfall.
- **Empty days:** If the amount of space left in the tank was equal to the volume of the tank, then the tank was completely empty and the day was coded with a 1. If the remaining space was less than the volume of the tank, then there was some water remaining and the day was coded with a 0.
- **Volume in tank:** This figure shows how much water is currently in the tank and is equal to the tank size minus the left over space in the tank.
- **Volume missed:** If the left over space in the tank from the day before minus the current day's day addition is less than 0 liters, then some run-off could not fit in the tank, and the volume missed is the current day's addition minus the left over space from the day before; otherwise the volume missed is 0.
- **Shortfall:** This figure indicates whether or not there is enough volume in the tank to supply the daily use or draw. If the volume in tank is 0, then the shortfall is daily use. However, if the volume in tank minus daily use is greater than 0, then the tank can supply all of the day's demand and the shortfall is 0; otherwise, the shortfall is daily use minus the volume in tank.

The empty days over the 11-year period were summed to find the total number of empty days and divided by 11 for the average number of empty days per year. The year with the

maximum number of empty days was used for the number of dry year empty days, while the year with the minimum number of empty days was used for the number of wet year empty days.

For volume missed in a wet year, the wet year was assumed to be the year with the greatest total rainfall missed. The dry year was assumed to be the year with the least total rainfall missed. The volume missed was the sum of daily volume missed over the course of that year.

### *Scenarios*

The following scenarios were evaluated based on current storage capacity:

- All Village houses, with only the villagers drinking the water, at current and predicted population. Roof area and tank size were based on the sum of the individual roofs and tanks in the Village.
- All MRC roofs, with only visitors drinking the water, at current and projected population. Roof area and tank sizes were based on the sum of individual roofs and tanks at the Centre and the Village that are currently equipped to catch and store rain, as explained previously. This was a total of 1973 m<sup>2</sup>.
- All MRC roofs, with villagers and visitors drinking the water, at current and predicted populations based on population growth as explained previously.
- One Village house, with only that family drinking the water, at 5 and 6.6 individuals in the house based on average family size provided by Dr. Kinnaird and projected growth.
- Each building at the Research Centre, with visitors and villagers drinking the water, at current and projected populations, with roof area and tank size as explained above.

The following scenarios were evaluated assuming expanded storage:

- All roofs, with villagers and visitors drinking the water, at current and projected populations, with one, two, three, and four additional 13,000 liter tanks. 13,000 liters was chosen because it is the mode of tank the tank volumes at the Centre.
- One Village house, with only that family drinking the water, at current and predicted population, with an additional 500 liters of storage (a 50% increase in storage).
- Each building at the Research Centre, with visitors and villagers drinking the water, at current and projected populations, with one additional tank at each building. The additional tank was assumed to be the same size as the current tank, or the largest tank connected to that building if it had different sized tanks.

### Hot water system sizing

Hot water needs were calculated for the Centre only, and the system was sized to accommodate showers in the visitors' and director's housing and gym. The assumptions are as follows:

- Hot water is needed for showers only.
- People showering at the Centre are visiting researchers, Dr. Kinnaird's family and her visitors.
- Each person will take one shower per day, at an average of eight minutes per shower.
- The ambient temperature of the unheated water is 60 degrees Fahrenheit.
- The desired water temperature is up to 115 degrees Fahrenheit.
- The shower heads will all be low-flow and generate 14 gallons of water/minute.

The calculations and conversions performed were:

- If the Centre is at full occupancy, there will be 69 daily showers, requiring 966 gallons (3,657 liters) of heated water.
- Solar insolation, or the amount of solar radiation reaching the Earth's surface, at Mpala is 6.44 kilowatt hours per meters squared per day (kWh/m<sup>2</sup>/day), found using the HOMER software.
- It takes 8.34 BTU to heat one gallon of water one degree Fahrenheit.
- There are 3412 BTU in 1 kWh.

Therefore, once determining the amount of water needed for showers per building per day at full occupancy, the estimated ambient tepid temperature of water, and the target heated temperature, the amount of energy in BTU needed to heat the water can be determined. Using the insolation estimate, the number of kWh required can be calculated. The quoted size of the panel available is 2.3 square meters (Modson, 2011). At 68% efficiency, and 6.44 kWh/m<sup>2</sup>/day insolation, the amount of energy produced each day from this panel is 10.9 kWh or 37,190.8 BTU per day (Wikipedia, n.d.). The size of the solar panels available and the amount of kWh that can be generated from each per day is used to determine the size and amount of panels needed. The total amount of hot water needed per day is also used to determine the appropriate tank sizes per building (which come in standard sizes). For this study, the 220 liter tank was determined as the ideal size. The data is displayed in Appendix W-5.

### Solar pump sizing

Our group was able to collect primary data for the depth of the water table on August 19, 2010. We have a personal video of the gentleman measuring the depth with an electric sounder (electric depth gauge). On August 19th, 2010, the water table was at 70.89 meters below ground level. This is consistent with previous measurements: Lane (2010) indicates that the water table depth was at 70.68 on June 26, 2010.

The size of the solar pump needed was determined by the graph provided by Grundfos Solar, a company out of Aarhus, Denmark (Grundfos, n.d.).

## Energy

### Collection of data

The data collected at Mpala falls under two broad categories: load data collection and source data collection. The chart below shows the methods and the sampling times for each of the data types.

The data for the power load at the Research Centre and the Ranch were sampled by the team during the two trips to Mpala Research Centre. During our first trip, the data were collected for eight days for all the buildings, except the library. The energy usage for the library alone was estimated using the inventory of equipments collected at Mpala. The power ratings of the equipments in the inventory were summed to get the peak power. This was divided by three to get a reasonable estimate of base load power. Using this base load power, a curve was created in HOMER software considering typical usage patterns such that the average energy consumed per day was still the same.

Readings were taken approximately every hour for 12 hours every day. This data was then extrapolated to get the load curve for the entire year.

The data for the energy sources like solar, wind, biogas and river flow were not sampled by us and were obtained from other agencies. The solar data were obtained from HOMER by entering the coordinates and extracting it from NASA's database stored in the software. This was taken for a year at an hourly interval. The wind speed density was measured by the Mpala Research Centre's meteorological station. A daily measurement of mean and maximum wind speed was obtained from the Mpala station. The river flow was obtained from CETRAD, Kenya and was sampled every day for 34 years. The biomass data were obtained from different sources which will be described later. A daily mean of the temperature data was obtained again from the meteorological station for a year. Appendix E-3 provides detailed information on data sampling durations, frequency, and sources if not directly measured.

The electrical load for Mpala conservancy can be classified into two main components: The electricity used by the Mpala Research Centre – The electric load profile for each of these locations was measured using standard analog single phase electricity meters. The electric load profile of the MRC was measured by meters attached to each building at the Research Centre. Using this, a load profile of the Mpala Research Centre was plotted by HOMER. It is essential to meter each building separately to understand when, during the day, the power consumption is

at its peak. The electricity meters (Image E-i 2) were purchased from Modsan Hardware Co., Nanyuki, Kenya for \$40/piece.



**Image E-i 2: Analog electricity meter (Centre) connected to one of the buildings at Mpala**

The buildings metered during our visits to Kenya, along with their projected future demand including implementation of energy efficiency methods (replacing incandescent with CFLs) are summarized in Table E-t 7, below.

**Table E-t 7: Buildings metered, with average and peak power consumption**

Serial number	Name of building	Average power consumption (kW)	Average energy consumption (kWh/day)	Peak power Consumption (kW)
1	NSF lab 1	2.54	11.86	6.71
2	NSF lab 2	1.65	12.17	6.13
3	Library ^	1.46	35.10	5.26
4	Kitchen	0.39	9.33	2.4
5	McCormack lab	0.29	7.09	1.65
6	Administration building	0.15	3.68	0.68
7	Jenga house#	0.10	2.92	0.22
8	Wilddog house*	0.10	2.39	0.22
9	Grevy house*	0.10	2.39	0.22
10	Klee house*	0.10	2.39	0.22
11	Heathrow house*	0.10	2.39	0.22
12	Banda+	0.07	1.73	0.15
13	Margaret's utility room	0.04	0.98	0.78
14	Main Dormitory	0.03	0.68	0.23



(Thatched)				
<b>15</b>	Princeton Dormitory	0.03	0.63	0.05
<b>16</b>	Margaret's house	0.03	0.63	0.06
<b>SUM</b>			<b>96.35</b>	
<b>Actual energy consumption per day (measured by meter at generator)</b>			<b>96.36</b>	

\* Scaled up, based on meter readings from Doug Young's house

# Based on meter readings from Jenga, scaled to estimate usage at full capacity

^ Based on meter readings taken by Peter Muhoro

+ Scaled up, based on meter readings from Andrea Durick's banda

Our individual building measurements along with the estimated library load matches the total power consumed as measured by meters at the generator site. Hence our building measurements are accurate. This also means that our building load curves for eight days are accurate.

Metering was done for six buildings initially – the kitchen, thatched-roofed dorm, Admin building, and the McCormack and NSF labs. Two meters were placed in the NSF laboratory. Using readings from the second trip, the rest of the buildings were covered – four researcher houses (scaled up based on readings from one house), the Director's house and utility room, Princeton dorm, 12 bandas (scaled up based on the load curve from Andrea's Banda). The aggregate usage for the Centre is 99.57 kWh/day on a weekday and 86.73 kWh/day on a weekend. The aggregate for the Ranch is 23.86 kWh/day on a weekday and 25.96/day for the weekends. When all building loads are added (by taking a sum of the load for the six buildings for eight days during the first trip and the load obtained by multiplying the second trip's daily average reading, taken over several days, by eight), we get a value of  $\sim 470$  kWh for eight days. But a meter at the generator showed us a usage of 770.9 kWh for eight days. Hence a scaling factor of  $770.9/470 = 1.645$  was used for obtaining the correct load curve.

### Processing raw data for HOMER

The data collected had to be processed to bring it to a form that can be used as inputs for HOMER. This included analysis for both types of information collected – load data and source data. The analysis carried out for this is explained in the following section.

### Processing Load data for HOMER

Single phase meters were attached to each of the buildings at the Mpala Research Centre and a three phase meter was attached at the diesel generator site which powered the entire Centre. This was done to check if the aggregate of individual buildings was equal to the actual power consumption of the Centre produced by the generator. The team members divided the day equally and recorded the data as regularly as possible. When we went on other field visits, for e.g. to the dam or the neighboring ranch, a research assistant at the Centre collected logged the readings. Ideally, the data should have been collected at one-hour intervals. But since they were recorded by humans, it could only be collected during the day and timing couldn't be perfectly maintained. Hence, the raw data had to be extrapolated in order to determine the hourly usage for each building. To do this, the readings were proportionally divided and their weighted mean was calculated to convert the data to this form. This process has been illustrated below (Table E-t 8) with a sample set of energy usage data collected at random times for a building at the Research Centre.

**Table E-t 8: Sample load data collected for a dormitory at MRC.**

Date	Time	Reading (R)(KWh)	Reading difference( $\Delta R$ )(KWh)
8/13/2010	6:21 AM	0.87	
8/13/2010	7:20 AM	0.95	0.08
8/13/2010	8:05 AM	1	0.05
8/13/2010	9:04 AM	1.01	0.01
8/13/2010	10:01 AM	1.04	0.03
8/13/2010	11:15 AM	1.05	0.01
<u>8/13/2010</u>	<u>12:08 PM</u>	<u>1.1</u>	<u>0.05</u>
8/13/2010	1:10 PM	1.13	0.03
8/13/2010	2:11 PM	1.18	0.05

Consider the underlined row from Table E-t8. The data for 8/13/2010 was recorded at 12:08 PM. As explained earlier, to make it useful for HOMER, we considered 1 hour intervals (for e.g. 6:00 AM-7:00AM) for the entire day and shifted our load data proportionally to match this new time interval. So in the current case, the kWh consumption was based on the adjacent set of data i.e. at 12:08 PM ( $t_1$ ), 11:15 AM ( $t_2$ ) and 1:10 PM ( $t_3$ ). A sample set of calculations is given below:

$$\text{Energy consumption (KWh) from 12:00 PM to 1:00 PM} = (\Delta R1 / (t1-t2)) * (12:00\text{PM}-t1) + (\Delta R2 / (t3 - t1)) * (1:00\text{PM}-t1)$$

This method was implemented for all rooms at the Research Centre and the individual energy consumptions were added to obtain net consumption by the Centre. Following the current trends of bednights (occupancy) at the Mpala Research Centre, we decided that a reasonable estimate for future energy demands was double the (calculated) current demand. The savings for replacement of all the incandescent bulbs by LED lights were then calculated and subtracted from this projected demand. The total energy consumed over the year is maintained to be the same as the sum of the measured weekly data over the year.

#### *Processing river flow data for HOMER*

The raw data from the Ewaso Ngiro BC4 gauging station obtained from the water engineer Tom Traexler was processed and extrapolated to estimate the flows at the turbine site in the Ewaso Nyiro river. The methodology for the above is as follows:

- a) The daily river flow data of the Ewaso Ngiro, from 1960 to 2004, was obtained from Mpala's water engineer, Tom Traexler. However, this gauging station is 350 kms (calculated based on the UTM coordinates of the two locations) away from the actual turbine.
- b) Catchment areas corresponding to these two gauging stations are known. Using the ratio of the sizes, the river flow was scaled down to get the correct flow data at the turbine. (Note: Ratio of catchment areas is inversely proportional to the flow rate).
- c) There were some missing entries. All the missing data were filled with the previous day's flow rate.
- d) Based on a discussion with the water engineer at Mpala, it was decided that two cases should be considered – Natural flow (from 1960 to 1982) and recently observed flow (from 1994 to 2004). The years in between these have a lot of missing data.
- e) The data were arranged year wise and the monthly average river flow rate for the specified years were considered to be entered in HOMER, for both cases.

f) Data for Feb 29 for the leap years was ignored because it is not taken into account in HOMER. The error due to this is so low that the annual average flow doesn't change at all. Hence it is not unreasonable to neglect it

### Introduction to HOMER

- HOMER stands for Hybrid Optimization Model for Electric Renewables. The HOMER model of the existing system at MRC is as shown in Image E-i-3. It is a powerful tool for designing and analyzing hybrid power systems. Image E-i 3 below shows a basic block

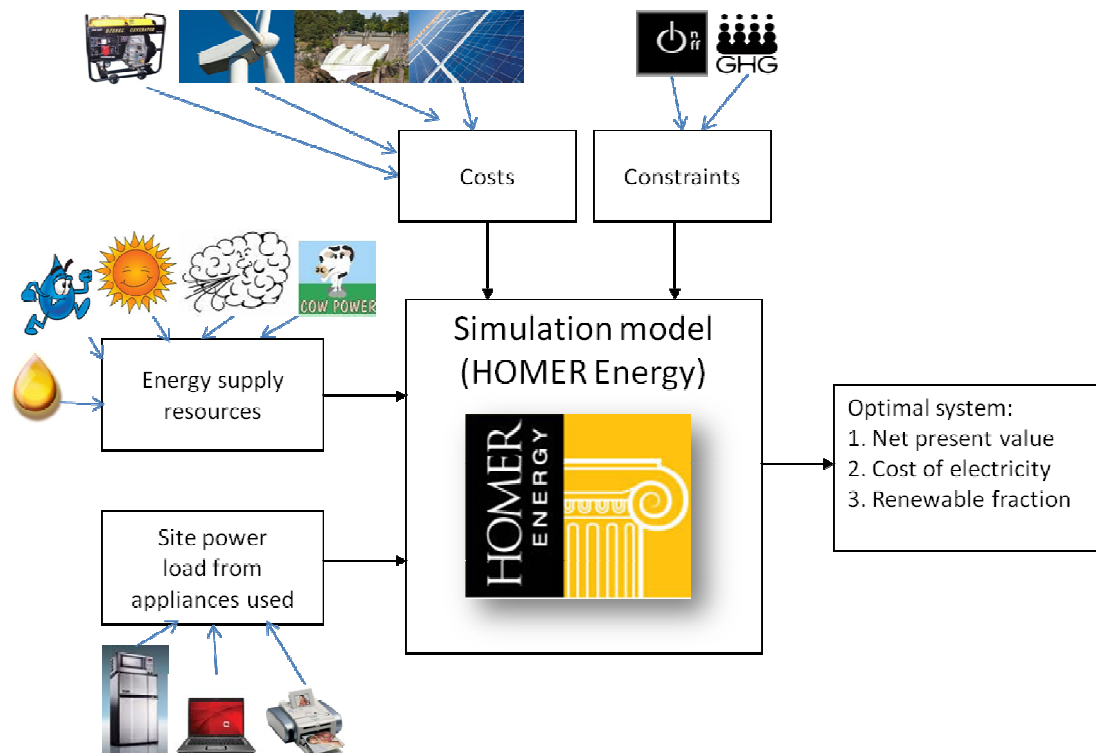
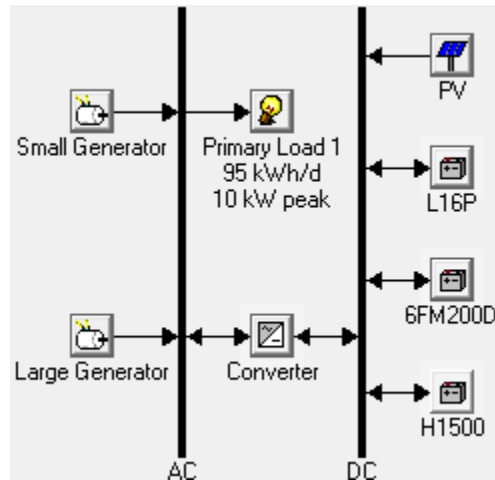

Image E-i 3: Block diagram of inputs and outputs to HOMER analysis used in this report

diagram of HOMER's components and Image E-i 4 below shows the existing system setup at Mpala Research Centre. This will be discussed again in the results section.

The basic components that HOMER uses as inputs are

- Power load (Electrical demand)
- Energy storage
- Energy supply sources
- Costs and constraints



**Image E-i 4: HOMER model of current system installed at the Mpala Centre**

This system is represented as blocks in HOMER, where the technical, economic and energy resource data of individual components are completely specified within these blocks. Each of these blocks is modeled exactly like the actual physical system run under various scenarios discussed a little later. Image E-i 5 shows the model of the existing system setup at the Ranch Headquarters. The specifications of each of the system components have been described later in the results section and again in the Appendix E-4a in detail.

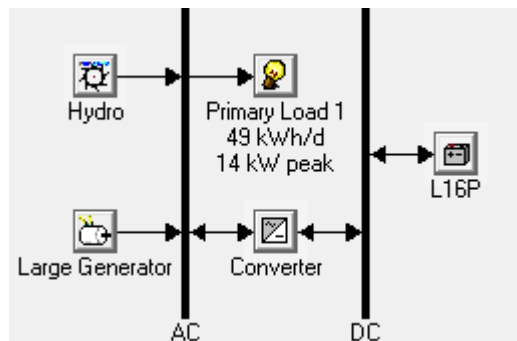

**Image E-i 5: HOMER model of current system installed at the Ranch**

In view of the shortcomings of the existing systems at MRC, many new scenarios have been designed with an aim of reducing the dependency of fossil fuels by increasing solar, hydro and other renewable power. One of the biggest disadvantages with renewable systems is that they are intermittent and can't provide base load. Thus, appropriate sizes of battery banks and converters also were installed for the new scenarios. A detailed system description along with outputs of each scenario is included in Appendix E-4b. Appendices E-4b, E-4c, E-4d, E-4e, E-4f, E-4g, E-4h, and E-4i show the complete set of results for all scenarios considered. One of

the scenarios consisting of the optimal mix of all renewable sources is shown in Figure E-i 6 and will be discussed in the results section.

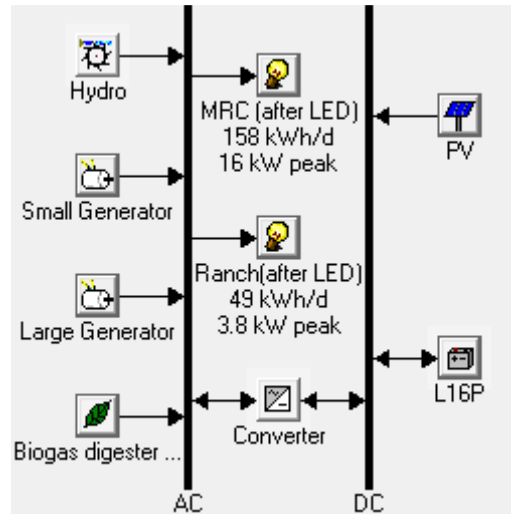

Image E-i 6: HOMER model of the new system design

The different scenarios analyzed in HOMER are listed below. Each of these scenarios was analyzed for both underground and overhead transmission.

### Definition of all scenarios

#### With transmission

1. Existing system – As explained before, this system is a weighted combination of the individual energy systems at the Research Centre and the Ranch.
2. Most optimal hybrid – A combination of all renewable sources – solar, hydro and biogas to provide the cheapest and most efficient mix of renewable power.
3. Only solar PV (with batteries and no generator) for entire conservancy – solar powering the entire conservancy. Uses large number of PV panels and a transmission line that increases the net present costs.
4. Only hydro – uses only hydro power with a transmission line to distribute the power. Unable to meet demand and has a high capacity shortage.
5. Solar PV (with batteries) and backup generator and transmission – solar PV installed to power the entire conservancy using transmission lines and a backup generator to provide power during the nighttime and reduce costs.
6. Hydro (with batteries) and backup generator – the same case as hydro (Case 4) except that it has a backup generator to provide for the unmet load by the hydro turbine.

7. Only biogas for the entire Conservancy – Includes the use of two biogas digesters and generators that use two bomas worth of dung to power the entire conservancy with the help of transmission lines.

### **Employing underground transmission costs**

The same HOMER model explained earlier was run for the new transmission costs obtained. This transmission cost is more accurate and suitable for Mpala. The distances between each of the points was calculated using UTM coordinates, and the cost per km for laying an underground transmission system for Kenya was obtained from Kenya Electricity Transmission Company. A more detailed explanation of the transmission system is given on the section on transmission. The model was re-run with these new initial costs to obtain the new results.

In the case with transmission lines, we are able to transmit extra power produced at any location to the entire conservancy. However, if there are no transmission lines, the extra power will have to be wasted.

### *Scenarios with no transmission*

1. Biogas for MRC alone - Analysis of case where biogas alone is installed at the Centre to entirely meet its needs.
2. Biogas for Ranch only - Analysis of case where biogas alone is installed at the Centre to entirely meet its needs.
3. Solar PV for MRC alone (with backup generators) – Analysis of case where solar PV alone is installed at the Centre to entirely meet its needs.
4. Solar PV for Ranch alone (with backup generators) – Analysis of case where solar PV alone is installed at the Ranch headquarters to entirely meet its needs.

### **Biogas-powered scenarios**

Using HOMER, a variety of scenarios were generated all of which use biogas as their only fuel for power generation.

### *Scenario 1 – Biogas with transmission lines*

In this scenario, the system is designed such that all of the biogas production and electricity generation will take place at the turbine site near the Ranch House. The dung from the boma will be transported back and forth from this site every day. The values for the cost and size of

the biogas generator were calculated using values from literature using the following assumptions.

- Every head of cattle produces 13 kg of dung. The value is obtained from literature.
- The dung produced during night time is about 40% of this value, and only this dung is available to be used for the biogas plants as it is easier to collect. This was chosen on the premise that cattle graze lesser in the night and they are usually sleeping, so they produce lesser dung.

As a first step, the amount of dung available for biogas production was calculated. Once this was calculated and verified with people working with the cattle at Mpala, the amount of biogas that can be produced from this was calculated. This was then matched with the load at Mpala Ranch and Centre so that the size of the biogas generator and the digester can be estimated. This was done with the help of literature. The actual calculations are available in the results sections. After the size was calculated using this methodology, it was verified with real world biogas system suppliers. Once the sizes were confirmed by the suppliers in China, the quotes for the upfront cost were sent to us. This was used in HOMER for further cost analysis. The lifetime of the project was set to 50 years. The generator was sized such that it could be forced on for eight hours during the day, and with the use of batteries it can power the conservancy throughout the day.

#### *Scenario 2 - biogas without transmission*

The same assumptions that were used for the system with transmission was used for this system with the exception that in this case, the system was designed differently. In this scenario, there will be a separate digester and generator at the Ranch, and a separate one at the Centre. Dung will have to be transported to both of these sites separately. While this might use a little extra diesel, it eliminates the use of transmission lines completely. The same methods were used for calculating the size and cost of the digesters, this time matching the load with the Ranch and Centre separately.



**Emissions avoided: a lifecycle ‘use phase’ perspective.**

To evaluate the reductions or increase in emissions in any system, it is important to take into consideration all the different stages in the production, operation and disposal of all the components in the system. In this case, we chose the system boundary such that it is predominantly the use phase. For this analysis, it was worth ignoring the manufacture and the end of life phases.

***Assumptions for the analysis***

1. The lifetime of the biogas generator and digester is 50 years. It is assumed to continue to work with the same efficiency throughout its lifetime.
2. The most likely end of life consequence for a generator in a conservancy like Mpala, is landfill. No excess energy is used in disposing into landfills. Moreover, there will be many new regulations and technologies available 50 years hence, and it is logically reasonable to ignore the disposal phase for this reason.
3. The dung undergoes a combination of both aerobic and anaerobic digestion. This is a safe assumption to make in a conservancy since there are a variety of conditions in which the dung will decompose depending upon the physical features of the area.
4. The batteries are used in the system irrespective of biogas and are thus not relevant in the lifecycle boundary.
5. The digester and generator are purchased from the same supplier who was contacted for all the prices and specifics of the plant.
6. The distance commuted by the dung is approximately 10 km everyday back and forth from boma to the digester site.

***Method for analysis***

For this analysis, we set out to calculate the delta, or the change in emissions from the base case or the current scenario at Mpala. The current system at Mpala is mostly powered by the diesel generators and batteries, with a small portion powered by solar. The results from the HOMER analysis for the current scenario were compared with the HOMER results for biogas to calculate the reduction in emissions by replacing diesel with Biogas. However there are other

energy consuming steps involved and should be taken into the analysis for an accurate assessment.

### **Lifecycle boundary**

Based on the above stated assumptions, a system boundary was proposed as outlined in Image E-i 7, below, which is an emissions assessment flow chart. The boundary is predominantly the “use phase” of the system with the exception of the transport of the biogas digesters and generators. The system boundary does not include the batteries used in the system since they will be used irrespective of whether or not biogas is the fuel. It accounts for the emissions involved in the following steps:

1. Dry/wet manure decomposition produces methane through a combination of aerobic and anaerobic digestion. When the dung is diverted into the biogas digesters, the emissions are saved from entering the atmosphere.
2. The digester and generator are shipped from the supplier in China.
3. The dung is transported from the boma to the digester site.
4. The generator produces electricity which is emissions-free.
5. The dung is transported back from the digester site to the boma.
6. Emissions reduction from the diversion of diesel for producing the electricity.
7. Transport of grey water from the septic tank to the digester.

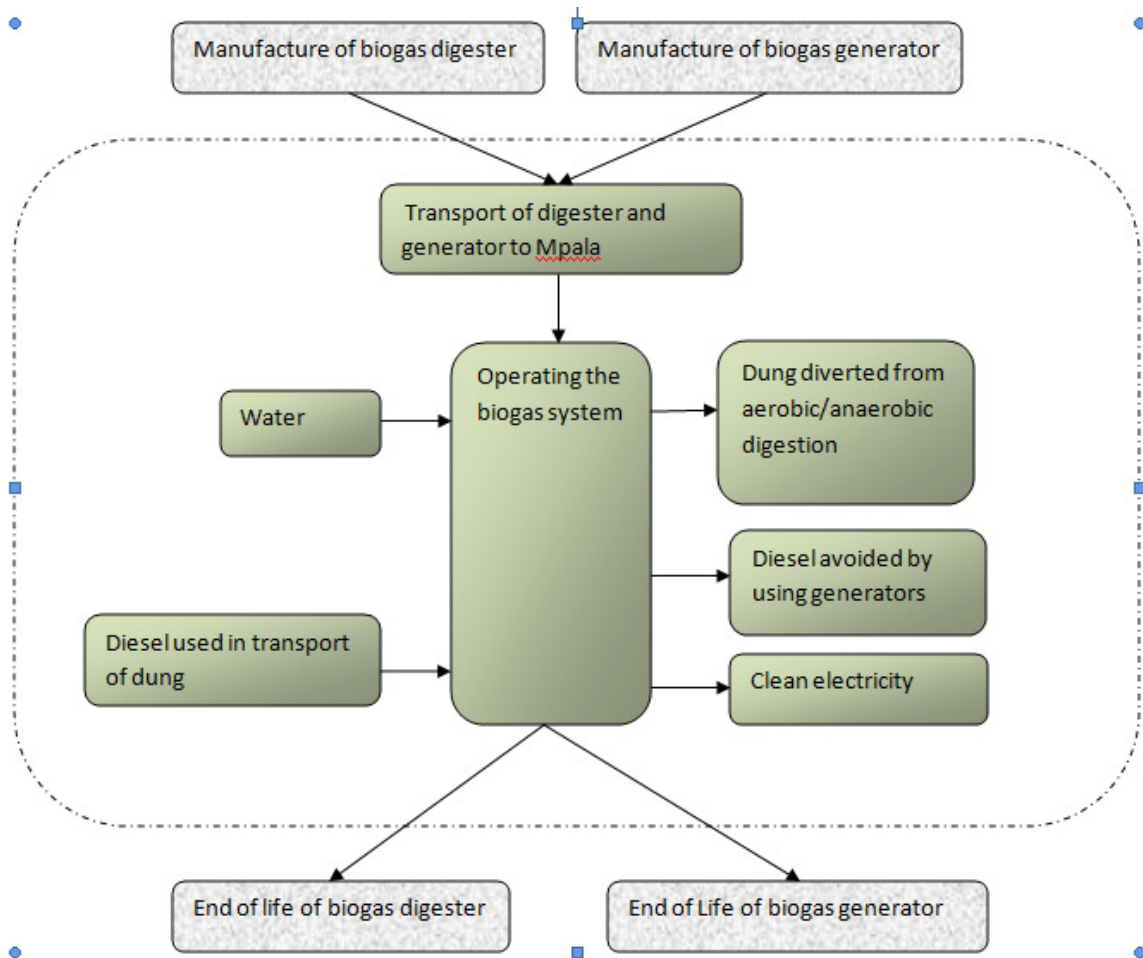

Image E-i 7: Diagram of life cycle system boundary

### *Functional unit*

The functional unit was taken to be one day at Mpala, or for a load of 207 kWh. All calculations were made for this functional unit, and the results are presented as 365 pieces, or annual results. This was chosen because we can estimate accurate numbers for transport in one day, dung required for one day, diesel diverted in one day and the power supply for one day.

### ***Using Sima Pro for analysis***

The analysis was done with the help of a lifecycle analysis software and database called Sima Pro. Some of the values were obtained from literature, and the others were those generated by Sima Pro lifecycle databases.

### **Upfront costs, maintenance costs and payback period**

As a next step, we calculated the total cost of installing such a system, and the payback period for the system. The total costs included

1. Cost of the biogas generator and digester: Both of these values were obtained from real world suppliers of biogas generators. The quotes are available in the Appendix E-6. These values are specifically generated for the load profiles generated for Mpala Centre and Ranch. This, along with the cost of shipping includes the total upfront costs.
2. Operation and maintenance costs: The costs for this included cost of diesel for transporting the dung on a daily basis, and the cost of labor for transporting the dung. It was assumed that a total of five persons are required to complete the job at any point. It was assumed that every worker received \$100 per month.

## Options for the future

### Water

#### Rainwater catchment systems

Rainwater is the most local source of drinking water for Mpala. Before we make recommendations for any adjustments or additions to the current rainwater catchments systems, it best to take a careful accounting of what existed as of our last data collection in late 2010. This is an analysis of the MRC, where a lion's share of our data was collected, and can serve as an example to be followed for the Ranch and other offsite communities.

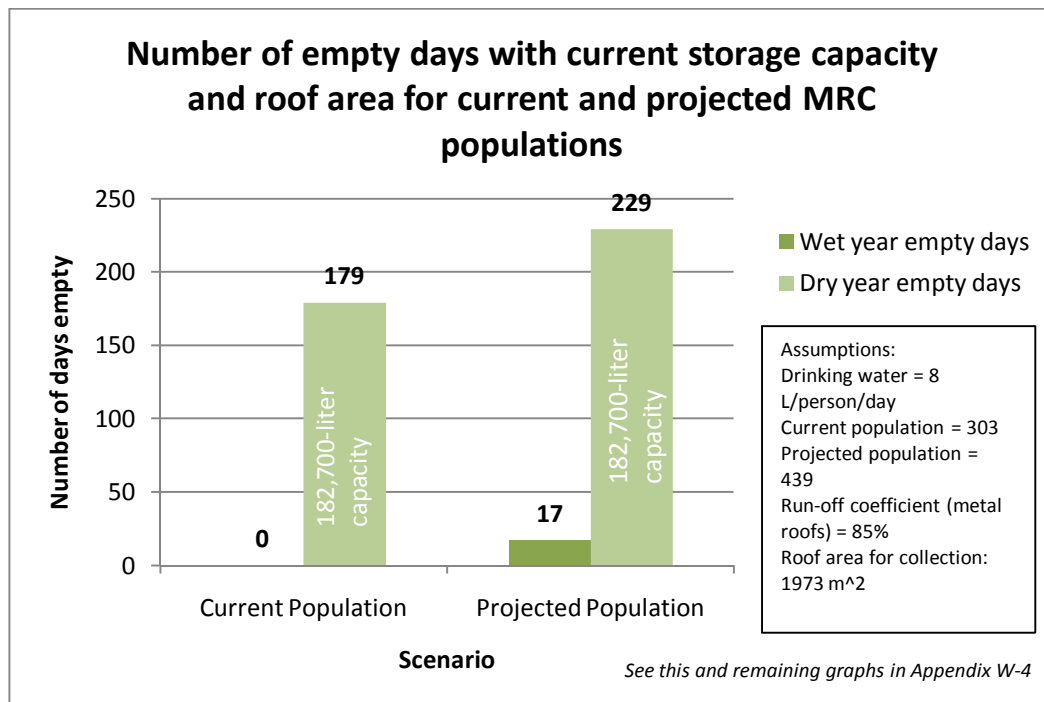

**Image W-i 4: Comparison of current storage capacity and roof catchment serving current and projected total MRC population.**

Image W-i 5 demonstrates how many days Mpala's current rainwater harvesting tanks will be empty under one scenario. Currently, with the tank capacity of 182,700 liters and 1973 m<sup>2</sup> of roof area equipped with rainwater catchment systems (Appendix W-2), there is sufficient storage in a wet year (above average rainfall) for the current population at the Centre<sup>3</sup> to have eight liters of water per person per day. Essential water is assumed as three liters for drinking and for cooking and three liters for laundry, and two for some washing for one person each day.

<sup>3</sup> Current Population = current estimated people living in the Village (239) and the average daily bednights during the busiest month on record (64) for a total of 303.

For the projected population of twice as many visitors and a third more Village inhabitants, for essential water use, in a wet year there are only 17 days in which there is not enough water for everyone. However, with the multitude of variables, the current system is not a sufficient one for Mpala. Such variables include the adherence to the eight liters per person per day allowance, human error in withdrawal, leaks in the system, rainfall, and the number people. In fact, ignoring all variables but rainfall, in a dry year (in this case, the modeled dry year is the rainfall amount from 1999), there would be an immense shortage as can be seen above.

With this in mind, our team looked at total potential run-off from the current roof area, the volume missed by the lack of sufficient storage to capture all of the run-off, and the potential for additional roof area and storage. The realistic implementation and construction of storage is considered in this case, and a careful look at filtration and specific methods of safe capture and storage are examined.

#### *Current rainfall catchment systems*

In summary, to capture enough rainfall in a dry year to suffice the essential water needs of all of the people at the MRC, there would need to be approximately 1050 m<sup>2</sup> of additional roof space converted to rainwater catchments systems than what currently exists. This takes into account current storage as sufficient to catch what will run off the current roof area. That addition to the system (additional roofs and storage) would take a lot of capital investment and resources. As is laid out in the cost section of this report, to add roof catchment systems at each Village home (~45 at 22m<sup>2</sup> on average per home), the cost would be approximately \$68,000<sup>4</sup>. Another ideal alternative is to optimize the current roof area for catchment in a wet year, and in doing so properly preparing for a dry year, by adding substantial storage. The following is a look at this possibility.

As you can see in Image W-i 6, the total accumulated run-off potential at Mpala during a wet year with the current roof catchment systems in place is over 1.4 million liters or 1400 cubic meters. Accumulated demand over a year for essential water is only around 800,000 liters or 800 cubic meters. That would provide an opportunity to store the excess 600 cubic meters for a dry year.

---

<sup>4</sup> Approximate price per Centre Village home rain catchment & storage system provided by Mburu Tunii

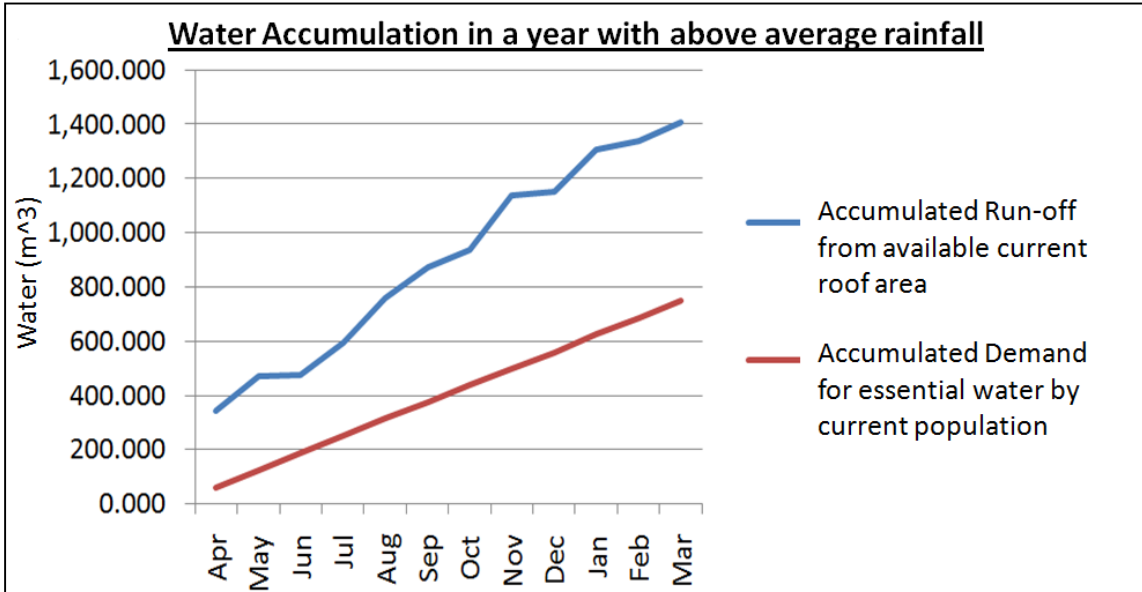

Image W-i 5: Accumulated water run-off in a wet year (m<sup>3</sup>) from current converted roof area versus accumulated demand (m<sup>3</sup>) by current population

Image W-i 7 (below) is an example of what the gap between supply and demand may be during a typical dry year at Mpala.

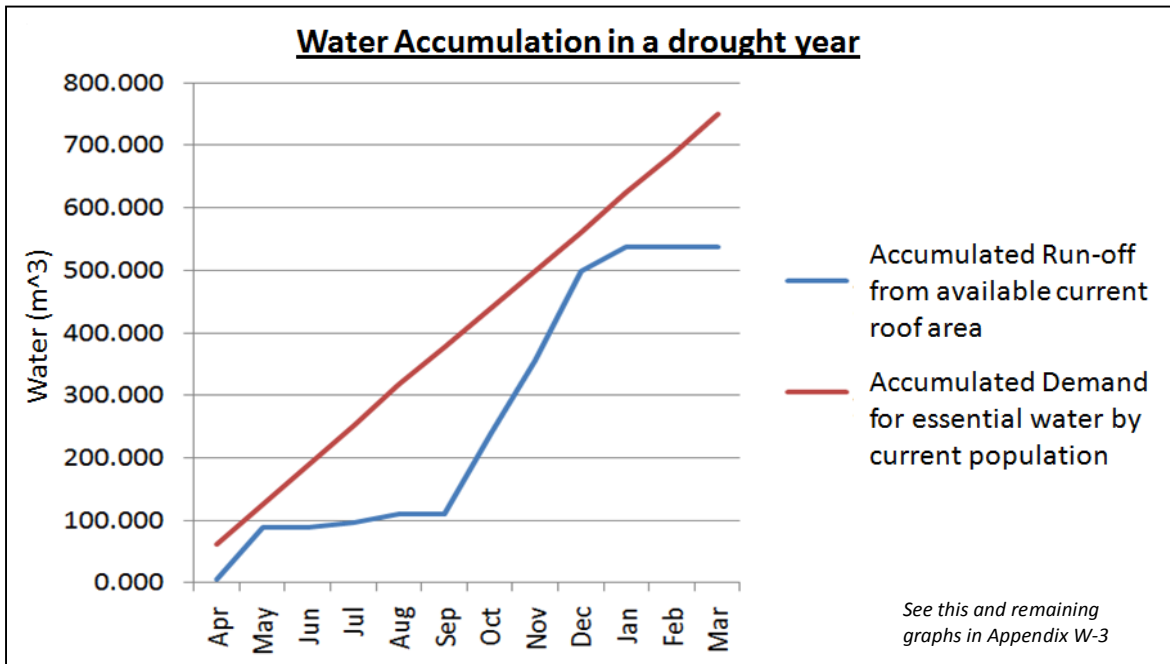

Image W-i 6: Accumulated water run-off in a drought year (m<sup>3</sup>) from current converted roof area versus accumulated demand (m<sup>3</sup>) by current population

Two challenges are illustrated here – the 200,000 liter or 200 m<sup>3</sup> discrepancy between what is demanded and what can be supplied and the variability of the supply throughout the year.

### *Potential solutions*

The solution we recommend, therefore, is to create enough storage so that during a wet year, back up or safety stock can be stored away for the shortage during one or two dry seasons because droughts can last years at a time, as the folks at Mpala know too well.

The analysis was based on several assumptions, outlined in the methodology section. Briefly reviewed here, it is assumed that the current population at the MRC is approximately 303 people. This is a generous estimate, as the visitor population is based upon the bednight count of a typically busy month. However, the visitors currently make up approximately 20% of the total, while Village inhabitants make up the remaining 80%. Another assumption is that with rainwater storage use rate of eight liters per day per person, there is another source of water to supplement the remaining needs, which can be minimized by low-flow fixtures and proper education on water conservation (as described later in this report).

The following table, Table W-t 3, is a detailed look at what the current storage could have provided for the current population at Mpala had rain been exactly the rain measured from the years 1999 to 2009 at the Mpala Weather Station. This assumes storage starts empty at the start of 1999.

**Table W-t 3: Water collection scenario considering all rooftops at MRC and current total population at Centre and Village (See Appendix W-4)**

<b>Scenario 5: All MRC roofs current, all drink current population</b>			
		Empty days	562
Current tank capacity (liters)	182700	Average/year	51
Total roof area (m <sup>2</sup> )	1973	Dry year empty days	179
Average number visitors (MRC+Campsite)	64	Wet year empty days	0
Villagers	239	Volume missed (liters)	2,501,345
Personal daily use (liters)	8	Average/year	227,395
Daily use (liters)	2424	Wet year volume missed	552,362
Run-off coefficient (metal roof)	85%	Dry year volume missed	0
		Shortfall (Total liters over 11 years)	1,426,269
		Average/year	129,661
		Wet year shortfall	0
		Dry year shortfall	447,254

What this demonstrates is a shortfall of 447,254 liters in the driest of years. We recommend that Mpala prepare for the driest potential of years to insure sufficient essential water for the people of Mpala. When calculating these figures using the projected population of



446 people, the dry year shortfall over this same time frame is over 800,000 liters. (See Appendix W-4) Therefore, we will offer two storage solutions to this dilemma with both scenarios in mind.

The first step in finding the solution was to evaluate which building roof was missing the most volume (volume missed). What this means is that with the run-off from the roof as input and the regular output of daily draw for use (as a function of percentage of total storage), there is water overflowing from the current tanks and not being captured during the rainy seasons. The buildings identified as missing the most volume that could be stored in a wet year are identified in Table W-t 4.

**Table W-t 4: Volume of rainwater missed or not captured during a wet year due to current storage sizes available for catchment (See Appendices W-4i – W-4ff)**

Mess Hall	124,699 liters
Jenga House	92,336 liters
Admin Block	68,181 liters
NSF Lab	63,919 liters
Director's House	59,857 liters
GIS House	49,695 liters
Klee House	49,695 liters
Library	23,749 liters
Small kitchen	37,733 liters
Admin House	31,875 liters
<b>TOTAL</b>	<b>601,739 liters</b>

It is important to keep in mind that this scenario prepares for the driest of years with the wettest of years. With climate change, these extremes may come more often, but on average historically, they come approximately every ten years.

The above scenario calls for an additional 600,000 liters of storage around Mpala. Currently there is approximately 182,700 liters of storage at the Centre plus a few thousand more observed but not documented at the Village homes. There are two solutions (or a hybrid of the two) that we have evaluated. One possibility is building above ground tanks that will add to some of the current roof catchment systems and add new catchment and storage systems throughout the Centre Village. The other is to direct the total volume missed from the current catchment systems to a common underground storage tank, locally positioned for efficient store and retrieval. There are benefits and limitations to both systems, including the cost aspect. This is outlined in the cost section of this paper.

Benefits to installing the above ground storage tanks are as follows. First, the installation can be phased. This allows the costs to be spread out over time. This also allows the employees

of the Centre to learn how to properly manage the system without being overwhelmed with the total capacity that will be added eventually. Another benefit is maintenance. Above ground storage is easier to maintain in that problems can be easily identified by sight. In addition, if one tank requires maintenance, the remainder of the supply in other tanks is still available and usable. There are also several benefits to having new storage throughout the Centre Village. People will have control and responsibility for their own water source, which will provide them with a certain percentage of their total needs. There will also be a closer eye on the proper functioning of the systems because of the locality. Since a majority of the water needs come from the Village, expanding storage into their space is also appropriate.

The challenges to this system are that moving water around will be more challenging. Management of the water draw will be required from the different locations, it will be more tedious and take more time and resources.

The benefits of the large common storage are the simplicity of the system, the ease of adding new buildings to the system by adding piping instead of just building new storage (if the sizing of the common tank is large enough to handle more capacity), and of course, the single location for draw.

The challenges to this system are many. It will be difficult to identify a fracture or malfunctioning of the system since it is below ground and more difficult to monitor. Also, if the system is contaminated, the entire store may be contaminated, destroying the back-up supply. The final challenge is the pumping required. There will need to be a pump installed to draw the water up from the underground tank, which will require either energy or labor.

Mpala should also consider a belowground cistern for excess roof run-off or surface run-off. Underground cisterns are hostile to algae and microorganisms that require sunlight, and simple pre-entry filtration can prevent mosquito infestation (Conservation Technology, 2008). However, belowground tanks cost more than above ground tanks because they require excavation, and they require slightly more complicated upkeep because the system components are often hidden underground (Conservation Technology, 2008).

If belowground cisterns are planned, Mpala should continue to construct rectangular belowground storage from concrete; as the cistern is likely to be mostly empty periodically during dry periods, plastic storage containers might collapse under the weight of the ground (Conservation Technology, 2008). Cylindrical fiberglass tanks can be as large as 20,000 gallons (~75,700 liters) and are as sturdy as concrete cisterns (Conservation Technology, 2008). These

would be appropriate for belowground tanks adjacent to buildings. A tank that is 12 x 12 x 2 meters could hold over 270,000 liters of water. If the water is intended for human consumption, it will require additional purification and filtration as described in the filtration section, below.

### Future considerations

The options described above, we believe, manage current demand. Dr. Kinnaird requested that the Mpala Masters project team consider twice the visitor population and with that an estimated 33% more employees will be required. Currently, if it is determined that current roof catchment capacity meets the roof-to-person ratio required for adequate essential water availability, approximately  $1973\text{m}^2/303$  or  $6.51\text{m}^2$ , then an additional 150 or so people at Mpala would require approximately  $1000\text{ m}^2$  of new roof catchment area. Again, this is a generous number since the number of current visitors is the bednight count of the busiest month. However, this is only for essential drinking water supply, and therefore, human error, abuse of this water or the desire to utilize roof rain water catchment for additional water uses could change the figures in this study.

While it is likely new buildings will need to be constructed to cater to the new visitors, and the current roof area is not all constructed currently for catchment, it is possible to expand the catchment roof area to the necessary amount. The next challenge would then be to provide each building with adequate storage – the more challenging part of this issue.

### Filtration systems

A rainwater harvesting (RWH) system is comprised of six general components: a catchment area or surface, such as a roof; gutters or pipes as a conveyance system from the catchment area to the storage tank; a roof washer, to filter major contaminants; a storage container; a method for distributing the water from the tank; and a process of purification, if the water is intended for human consumption (Kinkade-Levario, 2007). For human consumption, filtration and purification measures should occur during each of these stages. In order to make recommendations to Mpala, it might be best to approach the RWH system comprehensively and systematically.

### *Catchment area*

The best way to improve the efficiency of rainwater harvesting (RWH) systems is to ensure that the components are properly operated and maintained (Texas Water Development Board, 2005). While RWH can help Mpala move away from its reliance on borehole water pumped by the diesel generator, MRC and MRL must be conscientious of the effort required to keep the system functioning correctly.

One of the cheapest and easiest ways for Mpala to increase the efficiency of their rooftop water harvesting system would be to drive birds and other animals away from the rooftops. These animals reduce the efficiency of the rooftops as a collection surface by scratching at and roughing up the surface of the roofing material (a smoother surface collects rain more efficiently), and their droppings also contain acids which degrade the roofing and diminish the lifetime of the roof. This is already apparent at Mpala on buildings like the Mess Hall, where the roof has been seriously degraded in parts (Image W-i 8, below). Additionally, their droppings can contaminate the water that enters the storage tanks with any number of bird-carried diseases, which restricts the amount of usable water collected at Mpala (Steed, 2008). The addition of bird and animal deterrents to the roofs would thus help to meet the objective of clean water collection system at Mpala.



**Image W-i 7: Mess Hall roof, showing degradation as a result of animal activity.**

Bird deterrents take a number of forms: audio deterrents, such as speakers which play noises of birds in distress or predators to scare birds away; visual deterrents, such as plastic owls; taste deterrents, such as foul-tasting sprays to deter animals from chewing on the building; and physical barriers, such as ‘bird spikes,’ which prevent birds from nesting in gutters or on small surfaces (Zemsky, 2010).

Mpala should likely only consider the first two of these types of deterrents on a large scale. Because the water in the storage tanks is intended for human consumption, adding a foul taste to the run-off is undesirable. Additionally, taste deterrents are designed to prevent animals like woodpeckers or squirrels from burrowing into wood surfaces, which is not the primary concern for Mpala. Physical barriers are designed for small areas, like on top of an air conditioning system or the ledge of a building, whereas the birds at Mpala congregate all along the rooftops. Covering the entire rooftop in bird spikes would likely be cost-prohibitive and aesthetically undesirable. For these reasons, we have only considered audio and visual deterrents in this report. However, Mpala should consider bird spikes on gutter areas where birds have been known to nest, such as on the NSF lab roof, as seen in image W-i 9.



**Image W-i 8: birds' nests on NSF lab gutters. Photograph taken by Melissa Antokal, 7 August 2010.**

The roofing material also plays a role in the efficiency of collection. A general estimate is that roofs have approximately 70-90% efficiency (i.e., 10-30% of rain that falls on the roof is lost to evaporation, splashing, or other factors) (Libba, "How much water," no date). Metal roofs are among the most efficient at conveying water. Regularly cleaning the roof can increase the efficiency of water run-off, because water will cling to or splash off of debris on a dirty roof, rather than flowing into the gutters (Spratt, 2007).

### *Conveyance system*

Gutters and downspouts direct rain from the roof to cisterns or storage tanks (Kinkade-Levarios, 2007). Gutters are cheaper than new roofing, and Mpala should consider maximizing capture from each building by guttering those that are only partially guttered right now, such as the Administration Building and the Director's House (image W-i 10 below).



**Image W-i 9: Administration Building during a rainstorm, showing lost run-off due to insufficient conveyance.  
Photograph by Ajay Varadharajan, 28 December 2010.**

The gutters and downspouts should be regularly cleaned and inspected for clogs or damage (Meganck, Rast, & Rodgers, 1997). Additionally, having a screen over the gutter can help keep out large debris like leaves and twigs. Image W-i 9 [above] demonstrates how gutter screens could also help prevent animals from finding a place to live.

It should be noted that, like all parts of an effective RWH system, gutter screens must also be periodically cleaned to prevent clogging and to prevent the buildup of microorganisms in the dark, moist environment below blocked leaves (Pratt, 2005). However, gutter and spout screens are an inexpensive way to improve the quality of water entering the tanks, which reduces the degree of filtering required to make the water potable. As one author states, “Removing materials before they enter the system is far easier and less expensive than dealing with them afterwards” (Pushard, 2010).

#### ***Roof washer and first flush device***

Between rain events, dust, debris, and other contaminants can build up on a roof, and may then be washed into the storage tank when it rains. For the proper and successful operation

of an RWH system, the Organization of American States (OAS) recommends that the first 10 minutes of rainfall after a dry spell be diverted away from the storage tank (Meganck, Rast, & Rodgers, 1997). This “first flush” (or “foul flush”) allows rain to wash away contaminants that have accumulated on the roof during the dry period so that the water entering the tank is relatively clean. A good guideline for the amount of water that should be flushed is .05 mm/m<sup>2</sup> of rooftop (Pratt, 2005).

Roof washers and first flush devices are designed to clean the roof and maintain the quality of the water in the tank (Pratt, 2005). A roof washing system should include a corrosion-resistant debris screen with a first flush device to divert the water away from the tank, and should be located so that maintenance and repair are easy (Pratt, 2005). Even for the largest building, this amounts to only about 14 L of water diverted per rain event, which was negligible and not included in our calculation assumptions. Because the first flush is intended to clean off debris that has accumulated during a dry period, flushing is only needed on the first day of a rainy period (Kavarana, no date).

### *Storage container*

As observed at Mpala, mosquito larva may seriously compromise the quality of the water stored in some of the tanks (image W-i 11). Many mosquitoes can be filtered out using fine mesh screens before water enters the cistern (Libba, “Other safety,” no date). The tank should have a tight-fitting cover to prevent mosquito or other pest infestation (Meganck, Rast, & Rodgers, 1997). Water that sits stagnant for a long period of time is more likely to become contaminated with bacteria, insects, or parasites.





**Image W-i 10: Mosquito larvae and other contaminants in small tank by kitchen. Photograph by Melissa Antokal, 7 August 2010.**

However, in the event that mosquito larvae do enter the storage tank, non-toxic larvicides can be used to kill the larvae present and prevent reproduction and further contamination (Clean Air Gardening, 2010). In-tank filtration should include some form of larvicide, such as Mosquito Dunks or Mosquito Bits. The dried B.t.i (*Bacillus thuringiensis israelensis*) bacteria in these larvicides kill mosquitoes, but are safe for other animals (Aquabarrel, 2011). The World Health Organization (WHO) has evaluated the benefits and effects of B.t.i. and has approved it for use in drinking water “that will receive little or no further treatment” (WHO, 2009).

Giving the water in a tank time to settle following a rain allows sediments to sink to the bottom of the tank (Pushard, no date). The storage tanks should be emptied and the interior walls should be scrubbed with a chlorine solution at least annually (Meganck, Rast, & Rodgers, 1997; Pushard, no date). Between cleanings, a turbulence-calming attachment at the base of the inlet pipe can prevent remixing of sediments when additionally water flows into the tank (Kinkade-Levario, 2007). Inlet pipes should extend to near the base of the tank so that incoming

rainwater can oxygenate the water in the tank; turbulence-calming devices are essentially U-shaped attachments at the end of the inlet pipe that directs water up into the middle of the tank instead of directly at the bottom (Wheeler, 2010; Conservation Technology, 2008).

### *Distribution*

Because fine sediments will settle at the bottom of the tank, spouts for retrieving water should be no less than six inches (15 cm) above the bottom of the tank (Kinkade-Levario, 2007). There should also be a spout near the bottom of the tank for flushing the system (Pushard, no date). Image W-i 12 shows that the spouts used for drawing water currently are located near the bottom of tanks.



**Image W-i 11: plumbing set-up for small water tank by kitchen. Photograph by Melissa Antokal, 7 August 2010.**

Mpala should employ a floating filter to pump water from the rainwater tanks. Floating suction filters draw water from the middle of the tank, avoiding sediments on the bottom or anything that may have floated to the surface (Kavarana, no date). These filters float to just below the surface of the water and adjust as the water level rises or falls so that water is

constantly drawn from the oxygen-rich middle zone (Wheeler, 2010). Floating suction filters can be purchased in sizes ranging from 1.2 mm to .3 mm (1,200 micron to 300 micron), and thus require some additional filtration prior to drinking (Crawford, 2010).

### *Purification*

Filtered water from rainwater harvesting systems is regarded as among the best tasting water for drinking (Skeen, 2011). Rainwater collected using the methods above is a fine source of water for irrigation or toilets, but a final step is required to ensure the water is potable: water must be filtered to remove fine sediments and disinfected to remove any remaining microorganisms. These measures should occur before the water enters the storage tank, while it is being held in the tank, and while or after it is drawn from the tank. Presently, rainwater is boiled and filtered for consumption. There are a number of additional options for filtering and sanitizing water that is intended for human consumption, ranging from ultra-fine grade mesh filters to distillation to ozone generators (Pushard, 2010; Wiman, 2009; Kinkade-Levario, 2007).

### *Filtration*

One of the simplest methods of filtering water is to use in-line filters (filters arranged in a series) of increasing fineness placed either on the pipe leading into the tank or the spigot from which water is drawn (Pushard, 2010). These filters are measured by the size of the openings in the mesh, in microns (1 micron is  $1/1000^{\text{th}}$  of a meter). A 50 micron filter can be used to eliminate sand and larger particles, followed by a 10 micron filter to eliminate smaller particles, and finally a .5-1 micron filter to remove large bacteria and microorganisms (Kinkade-Levario, 2007). Upkeep involves cleaning the coarsest filter quarterly and the finer filters annually (Pushard, 2010). Of course, the filters should be inspected regularly and cleaned earlier if necessary. In the US, these filters cost approximately \$20 each, with replacement filters costing ~\$4 each (Ersson, 2006).

An alternative to in-line filters is a sand filter. There are a number of varieties of sand filters, including 'slow sand' and 'biosand.' Sand filters utilize gravity to draw water through a series of layers of gravel and sand of different sizes (Kavarana, no date). A major drawback is that water filters through the sand layers slowly relative to other filtration methods. For a place like Mpala, where large volumes of rain fall in a short period, sand filters may not be able to accommodate all of the run-off from many of the buildings, causing excessive overflows

(Kavarana, no date). For the smaller roofs, a sand filter like VARUN – an HDPE drum with sand and sponge layers to filter the water – would likely be able to handle the volume of rainfall (Kavarana, no date). The VARUN filter was designed by an Indian water harvesting expert and has proven to be a viable option for small-scale filtration in developing countries, and costs approximately \$50 USD.

An activated charcoal filter can remove particles that impact the taste and odor of water, such as chlorine, but generally do not remove harmful bacteria or cysts (Chiras, 2001). Charcoal filters are made of minute clusters of carbon atoms that are treated to strongly attract particles that pass through (Waite, 2010). Consequently, chemicals and bacteria can build up on the particle surfaces. The charcoal filter should be cleaned and replaced regularly, at least as often as recommended by the manufacturer (Kinkade-Levario, 2007). Because activated charcoal particles are primarily designed to improve the taste and odor of water by removing suspended minerals and chemicals, and because they are less effective at removing microorganisms from the water, they are not recommended for treating the rainwater which has few dissolved chemicals or minerals. Activated charcoal filters are generally located at the point of use, i.e. the tap on the tank from which water is drawn or in a separate smaller tank or jug in the kitchen (Kinkade-Levario, 2007).

Reverse osmosis (RO) is a form of membrane filtration, which works by passing water from through a semi-permeable membrane (Kinkade-Levario, 2007). However, RO filters produce wastewater with a high concentration of contaminants which then has to be discarded or processed (Pushard, 2010). One suggestion is that if an RO filter is used, the wastewater be used as grey water for irrigation or toilets so that it is not wasted (Pushard, 2010). Like charcoal filters, RO filters are placed at the point of use. This system is very costly, however, and currently in use at Mpala. Because of the financial burden, RO is not recommended.

### *Disinfection*

Water disinfection prior to consumption can take a number of forms, from the very low-tech to highly sophisticated. Simple options include boiling or chlorinating the water, while more complicated technologies can include ozonation and exposing the water to UV radiation (Jagadeesh, 2006). Currently, rainwater at Mpala is boiled prior to use, but heating the water for one hour at 50-60°C (122-144°F) can effectively kill 99.9% of bacteria and microorganisms in the water (Jagadeesh, 2006).

The most common mode of chemically sanitizing water is chlorinization. To effectively sanitize rainwater, a ratio of 2.3 ounces of household bleach to 1000 gallons water, or approximately  $\sim .02$  milliliters per 1000 liters (Pushard, no date). However, chlorinization is not recommended because it can easily combine with organic matter to create noxious fumes (Pushard, no date). Additionally, water treated with chlorine usually requires additional filtration to remove unpleasant taste and odor.

Another method of sanitizing water is through ultraviolet (UV) light. UV light attacks the DNA of microorganisms so that they cannot function or reproduce (Wiman, 2009). UV sanitation can destroy 99.9% of harmful microorganisms without requiring added chemicals as in chlorinization. UV sanitation is best “where chlorine-free, de-ionized, and/or carbon filtered water are extensively employed. Unattended carbon filters and ion-exchange tanks act as incubators for bacteria accumulation” (Mone, 2001). Because UV purification doesn’t provide residual disinfectant properties (i.e., when the light is turned off, microorganisms can colonize the tank again), following proper management protocols is essential to the effectiveness of a UV system (Wiman, 2009).

In order for UV purification to be effective, particulates larger than 50 microns must first be filtered out (Pushard, no date). If the water is not filtered properly, shadows of microorganisms or suspended solids will prevent the UV light from destroying all of the microorganisms (Pushard, no date). Ideally, the purification system should be expandable, have a window for visual monitoring, and have a single lamp per chamber (Mone, 2001). The glass enclosing the UV bulb should be cleaned periodically, as cloudy glass will block UV rays, and the bulbs should be replaced annually (Pushard, no date). If Mpala chooses to employ UV on a broad scale, they should invest in inexpensive alarms that warn when the bulb needs replacing and bulbs that automatically clean themselves (Pushard, no date).

Adding an ozonation generator into the tank or cistern can disinfect water through the process of ozonation. An ozone generator produces  $O_3$ , a highly unstable molecule that is strongly oxidizing (Wiman, 2009). This oxidization causes contaminants like iron, sulfur, and manganese to precipitate out, effectively eliminating these minerals from the rainwater (Wiman, 2009). Pure oxygen is created as a byproduct, which oxygenates the water and creates an aerobic environment that is hostile to most waterborne organisms, including viruses, algae, fungus, mold, and yeast (Wiman, 2009).

Boiling and distillation are two popular forms of sanitation, and boiling is what is employed by Mpala at present. Boiling is very effective at killing microorganisms, but requires energy inputs to heat the water and additional filtration afterwards. Distillation uses the sun's energy to heat water which then condenses on a glass plate and runs into a clean storage tank, which both sanitizes and filters water, but requires a large area and causes water losses of ~5-10% through evaporation (Pushard, no date).

### *Filtration system recommendations*

We recommend that Mpala maximize its ability to use for consumption the water presently captured before building additional storage or expanding rooftop areas. This could be accomplished very easily and with very little modification to the current system by adding an audio or visual deterrent to keep birds and other animals off of the roofs, adding gutter screens, putting B.t.i pellets into the storage tanks to kill mosquito larvae, and regularly flushing the tanks to remove sediments.

An ideal system, which Mpala should consider as they add additional systems and replace their present system, would include bird deterrents and gutters screens as mentioned above, but would also include a first-flush design to remove the dirtiest water prior to entering the tank. It should include in-line filters to remove particles greater than 50 microns and be sanitized with a UV water purifier. The inlet pipe should include a water-calming attachment to prevent remixing of sediments, and a pipe for overflow should extend from the bottom of the tank to remove the dirtiest water first. A tap at the bottom of the tank should be used to flush the system of sediments periodically, and the tap for drawing water should be supplied by a floating filter siphon.

This ideal system might sound complex, but the majority of the parts are quite inexpensive: gutter screens are about \$3.50 USD per meter. A combined first-flush device and downspout filter costs about \$90, and mosquito control dunks will cost ~\$2.50 per tank. Floating suction filters cost approximately \$150 USD. A UV purifier is a slightly greater investment at ~\$490 USD for a kitchen-stored device (i.e., set up similar to the current RO filter), but could purify approximately 60 liters/minute without requiring any additional treatment. All pipes, including the inlet, water-calming attachment, and overflow outlet, can be simple PVC. The cost of these additional products could be easily recouped by eliminating the

amount of LPG presently used to boil water for drinking and cleaning. The rest of the system could be purchased at the current price by Mpala's supplier.

With any RWH system, the users must feel ownership and should organize and establish maintenance routines for the system (Meganck, Rast, & Rodgers, 1997). Because the villagers and staff understand the water scarcity that Mpala faces, incorporating them into the upkeep of the individual harvesting structures will not only raise their feelings of accountability for their water usage, it will also establish a wide knowledge base so the system can be maintained into the future.

## Costs

### *Above ground tank*

To modify existing rainwater tanks to maximize storage, MRC would require 18 Mosquito Dunks per month (one per tank). At \$105 for 100, this would cost just over \$200 per year for all of the Centre's tanks, or about \$13 per tank for a year. Gutter screens cost ~\$170 to cover 50 lineal meters, which would effectively gutter one 10 x 15 m building. Flash tape, a visual bird deterrent which is tied to areas where birds congregate and wave around in the wind, costs \$3 for a 50 m length.

New tanks will cost approximately \$356 in concrete and \$234 in labor each. Prices for mosquito dunks, gutter screens, and bird deterrents are the same as above. Based on a survey of prices from the internet, a reasonable price for gutters is \$3/meter, so guttering the above 10 x 15 m building would cost \$150. A first-flush device and downspout filter would cost approximately \$40. Assuming each tank requires a generous eight meters of PVC piping (to transmit water from the gutter to the base of the tank, and wrapping from the base of the inside of the tank, over the top of the tank, and down to the ground as an overflow outlet), additional piping would cost ~\$30 per tank. A floating suction filter costs \$40.

The final cost per tank would be \$186 to retrofit each existing tank with bird deterrents, gutter screens, and mosquito larvicide. New tanks would cost an additional \$870 (for a total of \$1056) each, including concrete, labor, plumbing, and filtration. One UV water purifier could be used to clean water for the whole Centre and costs \$555, with additional bulbs costing \$85 annually. Obviously, these costs are not entirely comprehensive: things like spigots and pipe fittings are not included, nor are potentially larger investments like a secure metal lid for the tank.

However, the prices given provide a reasonable baseline that can be scaled to fit the size of the project.

If the total volume missed is to be captured with new storage, the following recommendations are made. For the Centre buildings, there need to be the equivalent of (30) 13 m<sup>3</sup> tanks at existing buildings, plus an additional (2) tanks at each Village home. This would amount to new filtering systems on each of the existing roof systems (13) at \$186 plus the 30 tanks at \$870 for a total of \$28,518. The Village home systems were quoted at approximate \$500 each plus an additional 1000-liter tank at \$111 to equal \$1611 each or \$23,031. The total estimate for adding above ground storage only is \$51,549 or 4,295,750Ksh.

### *Underground tank*

The costs associated with the installation of two underground tanks are as follows. The scenario of underground storage requires (2) underground tanks of approximately 225 m<sup>3</sup> located in front of the Princeton Dorm and to the northeast of the Library. These are two low points where water from the surrounding rooftops will naturally flow. Each tank will require approximately (252) 50-kg bags of cement, and approximately four masons (at 600Ksh per day) and four laborers (at 300Ksh per day)<sup>5</sup> approximately three months to complete, which must include digging, framing and pouring. The labor is estimated at \$4750 or 396,000 Ksh. Piping from the building tanks (as the underground will serve as overflow) is required. This must include the labor for the trenches the pipes are to be buried in, as well as the material. The labor is estimated at 2 laborer for 10 days or \$72 (6000 Ksh). The piping is the same as mentioned for the above ground tanks, at approximately \$3/meter. The amount is estimated at about 300 meters for the total lengths from all of the local tanks to the underground storage (based on approximate distances measured on a map). The cost then would be about \$900 or 100,416 Ksh. A floating suction filter should be installed in the tank for \$150 or 12,000Ksh. In addition to the underground tank, an above ground tank from which the underground water can be transferred and more economically filtered is necessary. As above, the cost will be about \$870 plus the necessary ozone filter with a solar kit for \$12, 000 or 100,000Ksh.

The total for each tank would be approximately \$10,000 or 857,000Ksh, for a total of \$20,000 or 1,714,000Ksh. There are several small details that have not been covered. A pump

---

<sup>5</sup> Labor rates and approximate time to build certain tanks provided by Mburu Tunji



for instance, will be necessary to extract the water from the underground tank. Therefore, please consider using this just as a guide for determining costs.

A tabular breakdown of costs for water storage systems can be found in Appendix W-7.

#### *Water saving technologies for borehole-sourced water*

As the visitor capacity and employee population at Mpala increases, methods of use will have to be considered when addressing water supply, along with collection capacity. There are ways to reuse or recycle water, as well as reduce the amount of water used in specific activities. One way to reduce water use is to install low-flow fixtures in the washrooms. An EPA study showed that a person in a developed country can reduce their water use by 1,700 gallons per year if switching from standard fixtures to low-flow fixtures (United States Environmental Protection Agency, 2009). Therefore, our group has created a table of recommended products, shown in table W-t 5. Local sourcing is recommended if available.

**Table W-t 5: Washroom fixtures, Standard and Low-Flow rates, costs and sources**

Fixture	Existing flow	Reduced flow	Cost (\$)	Source
Low flow faucet	2.2 gal/min	1.5 gal/min	68	EPA: Water sense, AquaSource N/A Nickel 2-handle WaterSense® Bathroom Faucet (Drain Included)
Faucet aerator	2.2 gal/min	1 gal/min	5.95	EarthEasy.com
Low flow dual flush toilet	3.5 gal/flush	1.28	253	Kohler website
Low flow showerhead	2.5 gal/min	1.5 gal/min	17	MetaEfficient.com
Timed showers	10 minute shower (avg)	8 min (timed)	82	Shower Manager

The user will not easily notice the difference when using a standard fixture or a low-flow fixture, such as the faucet aerator. Therefore, the transition to these fixtures will be more or less seamless. The shower manager, however, will be quite noticeable and therefore will require an adjustment to behavior. If a user is used to more than eight minutes to take a shower, they will

have to speed up their wash habits in order to complete their bathing. Some people have noted a difference in toilet performance with a dual or low-flow product, but it will likely perform as needed.

The water used in the bathroom facilities currently come from the borehole. With the supply available unknown from this source, it is wise to reduce use from the borehole where possible. In addition, while it is ideal to source drinking water from rainwater, as a backup source, borehole water will be used. Therefore, for both of these reasons, waste of this source is a concern at Mpala, and addressing this issue with low-flow bathroom fixtures will certainly impact the use of the visitor population.

After close observation, it has been determined that the total reduction of water use that can be attributed to low-flow bathroom fixtures is approximately 14% of total use at the Mpala Research Centre location. This is working with the assumption that most fixtures at Mpala are NOT currently functioning as low-flow (specifications provided by Tables W-t 5 & W-t 6). This is small percent reduction in water use from low-flow fixtures is due to the percentage of people at the Centre that utilize restrooms with such water fixtures – the Centre Manager and the visitors. The visitor population is only on average about 21% (64 out of 303) of the Centre Population, even less overall if the Ranch population is included, where the Village population is approximately 330, while the average bednight count for visitors is less than 1. In addition, only the visitors that stay at the Centre and Ranch House, and not the visitors that stay at the campsite (27 out of 303 total Centre population on average) utilize this type of facility.

Nevertheless, westerners tend to use more water on average than Africans. Therefore, it is not wasteful to spend resources on reducing their use where possible. For example, an average person will consume approximately eight liters of water per day for drinking, some bathing, cooking and clothes washing. However, when utilizing indoor taps and toilets, this number jumps to approximately 190 liters per day! That considers the addition of a long shower (approximately ten minutes) with a standard shower head, five visits to the toilet and several hand-washings/day. We will assume here that Kenyans in rural to semi-urban settings typically use more than the standard eight liters of essential water, but far less than 190. Without requiring any behavior change other than a shower that is two minutes shorter, when installing low-flow fixtures, water use can be reduced by 90 liters per day. That is almost half of the water use. Tables W-t 7 and W-t 8 show these reductions. (This is assuming the standard flows, times used and reduced flows indicated in Table W-t 5,above).

Table W-t 6: Calculated water use per person per bednight in washroom facilities using current and low-flow fixtures broken down by fixture

<b>TAPS</b>	GPM	Avg use in minutes/day	Avg Usage (gallons/bednight)
Current Flow	2.2	2.5	5.5
Reduced Flow	1.5	2.5	3.75
Reduced Flow (2)*	1	2.5	2.5

<b>TOILETS</b>	GPF	Average flushes/bednight	Avg Usage (gallons/bednight)
Current Flow	3.5	5	17.5
Reduced Flow	1.28	5	6.4

<b>Showers</b>	GPM	Avg shower time (minutes/day)	Avg Usage (gallons/bednight)
Current Flow	2.5	10	25
Reduced Flow	1.75	8 (timer included)	14

Table W-t 7: Calculated per person total washroom water use per bednight including both visitors and on-site employees using current versus low-flow fixtures

	Per Person per Day (ex. 1)	(ex. 2)*
Total Current Use from Fixtures	48.00	48.00
Total Reduced Use from Fixtures	24.15	22.9
	<b>Total/ Year (1)</b>	<b>(2)*</b>
Projected Total Bednights/ Year - Centre	18,356.00	18,356.00
Projected Total Employees days/Year- Centre**	10,000.00	10,000.00

Table W-t 8: Calculated annual washroom water use using current and reduced from low flow fixtures

ANNUAL	1	2*
Visitor Current Use	881,088.00	881,088.00
Visitor Reduced Use	443,297.40	420,352.40
Annual FTE*** Current Use	54,761.90	54,761.90
Annual FTE Reduced Use	24,166.67	21,190.48
Current Use -Total (Gallons)	935,849.90	935,849.90
Reduced Use Total (Gallons)	467,464.07	441,542.88
Total Water Savings (Gallons)	468,385.84	494,307.03
Percent Savings	50%	53%

<b>Reduced Total (liters)</b>	<b>1,771,689</b>
<b>Total Savings (liters)</b>	<b>1,775,182</b>

- \* Scenario 1 replaces standard faucets with low-flow faucets, Scenario 2 replaces them with aerators resulting in larger reduction of gallons per minute flow
- \*\* Approximately 40 employees, 5 days per week, approximately 50 weeks per year
- \*\*\* Full Time Equivalent = 1 Bednight (168hrs/week)  
Full Time Employees = Employees spending 40 hrs/wk at Mpala (=40hrs/168\*(FTE Usage- Showers))

The management at Mpala has indicated that they hope to receive twice as many visitors to the Centre in the future. Therefore, the installation and use of the reduced flow fixtures are even more urgent and necessary to control the amount of water used. Examples of the types of fixtures that can reduce the flow, and therefore the amount of water used, are faucets, showerheads, and dual-flush toilets. A shower time managing product may also be installed. The best faucet product is an aerator, which is low cost and reduces flow to about 1 gallon per minute. It saves 55% more water than a standard 2.2 GPM aerator, which is up to 13,140 gallons of water annually (EarthEasy.com, 2011). A faucet aerator is also very easy to install and replace. For the shower heads, there are several products available at a wide range of prices from ~\$5.00US to \$57.00US. Low-flow showerheads can reduce flows to 1.5 gallons or 5.7 liters per minute from as much as 2.5 gallons or 9.5 liters per minute or more. The average American takes approximately ten minutes to bathe. With that figure, in addition to the time it takes for

the water to become hot in the showers (approximately one minute), that is as much as 62.7 liters down that drain. However, if a shower manager is installed, which can automatically shut off the shower after five or eight minutes as programmed, as much as 17 liters of water per shower can be saved. Shower managers are far pricier than the low-flow fixtures (products at \$82.00 were found), however, and may not be cost effective.

A system of reducing water use that could be explored further is the use of grey water. Grey water is wastewater generated from domestic activities such as laundry, dishwashing, and bathing which can be recycled on-site for uses (Cross, n.d.). At the MRC, this on-site use is most likely limited to toilet water. Therefore, water used for hand washing can be reused in toilet flushing. For toilet flushing, after the dual flush option is in place, up to 24 liters per person per day can be saved from the borehole. When the Centre is at capacity, 888 liters of water per day can be saved. There are two options for implementing this type of grey water system, one of which would include a new plumbing system. The other would be a product such as the toilet lid sink by Gaiam (2011). This product, with retail prices starting at ~\$90.00 each, has a hand washing sink above the toilet tank. This allows the toilet to be refilled with the water used to wash the hands of the previous visitor (see product below). A future group or the managers at Mpala may want to consider this option in the future.



**Image W-i 12: Toilet Lid Sink**

Other uses indicated as safe would be for irrigation of plants that are not to be used for human consumption or for a biogas plant. The guest house located at the Ranch was landscaped with a beautiful garden containing non-native species. These plants require more water than those typically found in this savanna. Therefore, additional water is needed for irrigation. Since water availability is a substantial concern at Mpala, the best options for this garden would be to either remove all non-native, water-hungry plants or to utilize the grey water that would otherwise be disposed of. Therefore, if sink and cooking water were to be saved in a local and centralized vessel, it would be possible to use this grey water at the Ranch for irrigation of the garden.

As mentioned above, grey water can be used to produce biogas. A large amount of water is needed to produce this fuel from waste, and in a location where water is at times scarce, a grey water system would be ideal. If, say for cooking (approximately 1-2 liters per person per day) is saved, and 3 liters per person per day for laundry is saved, at the current population of 343 people that would amount to 1715 liters per day of grey water to be used for such purposes as biogas production. Please note that this does not include the estimated 2.5 gallons per hand wash that would be used for the toilet flushing if toilet sinks are installed. So there seems to be plenty of grey water to go around. The challenge remains to be the proper collection and

transport of the grey water from the kitchen and laundry to the desired destinations. It is, however, possible.

### **Alternative and additional water harvesting**

Additional water resources are obtained by pumping from the river and through collecting surface run-off into dams. Each has unique benefits and challenges.

As for river water, M.W.B. Airy recommends that river water be pumped to a settling tank so that the majority of suspended sediments can precipitate out of the murky water (Airy, no date). Additionally, he recommends that Mpala experiments with a sedimentation tank to determine its efficacy in improving the water quality before looking into filtration and sterilization systems for the river water (Airy, no date). Current river water storage is estimated at 21,700 liters, and could potentially be sterilized with solar stills rather than boiling and filtration with ceramic candles (Airy, no date).

Tom Traexler of Rural Focus, Ltd. (the company that planned locations and designs for new dams) stated that new dams will be located north of the Mpala Ranch and will store approximately 200,000 m<sup>3</sup> of run-off for consumption at the Ranch. Although this would theoretically be more than enough to supply all water needs, estimates ignore a few important factors: evaporation, which will significantly reduce water levels in the dams during the dry months, and water quality decline as a result of sedimentation buildup and animal use of the dam, which may require additional, expensive filtering mechanisms.

One method of filtration to consider for water from the dam or storm water is the “French drain” design, which is essentially a sloping ditch lined with sand and filled with gravel (Pratt, 2005). The large pore spaces between grains of gravel allow water to flow quickly through while still keeping out large contaminants, such as twigs or small animals. The sand then acts as a fine-mesh screen, filtering out many additional contaminants. By placing a perforated pipe below the French drain, this surface water run-off could be diverted to a large storage tank. The natural sand filter would greatly increase the quality of the water being captured, while keeping the water in an underground tank would reduce evaporation and contamination by animals. Natural sand filtration has been effectively used elsewhere in Africa to clean water run-off for harvesting (O’Neill, 2010).

### Financial benefits of altering the current water system

Reducing water demand and increasing rainwater utilization can ultimately save Mpala money in two ways: first, by reducing the amount of fuel used for pumping water from the borehole, and second, by reducing the amount of LPG required by filtering water in other ways.

In 2010, diesel prices charged to Mpala averaged 86 Ksh per liter. Over the time period for which we have borehole meter readings, an average of 37,600 liters were pumped per day, for a total of 13,724,000 liters per year.

Using low-flow fixtures can reduce water consumption by 1,775,182 liters per year, or an average of 4863.5 liters per day, reducing current borehole use by 12.9%. Making adjustments to the current storage tanks to switch to from borehole water to rainwater *just for drinking water* represents a reduction in borehole pumping of 276,488 liters per year – 2% of current pumping.

Additional above ground storage of 390,000 liters could reduce pumping by at least that much, which represents 2.8% of current pumping. Alternatively, installing two underground tanks to provide 450,000 liters total would reduce pumping by 3.3%. Total reduction in borehole use is summarized in Table W-t 9.

**Table W-t 9: Borehole pumping reductions**

Modification	Savings – liters	Savings - %
Low-flow fixtures	1,775,182	12.9
Maximize current RWH	276,488	2
Add'l belowground storage	450,000	3.3
<b>Total</b>	<b>2,501,670</b>	<b>18.2</b>

Diesel consumption for a Grundfos water pump is estimated at 120 liters per month, or 1440 liters per year (Bernt Lorentz, 2008). This equates to 123,840 Ksh. Reducing borehole pumping by 18.2%, then, could save 22,539 Ksh annually (\$267 USD).

Switching to a different method of purifying water, even if just for one tank from which all water would be drawn, would have additional benefits. Presently, the MRC disinfects and purifies its water by first boiling it in the kitchen, and then using ceramic candles. The kitchen uses LPG for cooking and boiling water. Using the calculations for sizing a hot water system (see the Methodology section), and the heating value of LPG (see the biogas sections), we were able to find the amount of LPG that could be reduced if water no longer needed to be boiled. Because of the sheer amount of water that must be boiled to become potable, alternative



sanitation and filtration mechanisms could reduce usage by 163 LPG cylinders per year. At 2,121 Ksh for a 13 kg cylinder of LPG, that equates to 344,829 Ksh (\$4083 US) per year (Mugwe, 2010). The most expensive sanitation and filtration systems that we looked at (a solar-powered ozone generator) was ~\$1400. Even if not all of this LPG reduction would occur (as some would still be used for cooking or cleaning, etc), Mpala could easily recoup its investment in a high-quality filtration and sanitation system in a year.

### **Behavior and education**

As mentioned, water is an essential and limited resource at the Mpala Conservancy. The current and anticipated situation makes this fact all the more challenging. Therefore, in addition to finding ways to increase the collection and availability of water, this report also recommends changing the use behavior of the people at Mpala. First of all, in the long term, a more thorough evaluation of the behaviors of both the Village population and the visiting population should be conducted to understand the habits and motivations of those using the water. Below is a short summary of some potential actionable options in the meantime.

On a grand scale, Mpala Wildlife Foundation may choose to make water conservation an official policy of the Centre. By doing so, the management is making clear that careful use and monitoring of water consumption is a top priority. This will send a message to all who inhabit the Centre that wasteful behaviors are not welcome there. Very often, when an institution implements a rule, it can become a norm and eventually a value within the boundaries of that institution. In Eugene Bardach's, "A Practical Guide to Policy Analysis" (2009), there is a type of government policy that serves as an "Education and Consultation Policy." Some examples of action under these policies are to warnings of hazards and dangers, the raising of consciousness through exhortation or inspiration, providing technical assistance, upgrading skills and competencies, or changing values. This type of policy can insure participation by increasing awareness and teaching participants how to comply, even if there are those that would rather not. There are also methods of reinforcement, or reward, when those who exceed the activities required by the policy are publicly recognized and rewarded for doing so.

To remain consistent with policy, it would then be prudent to acknowledge the distinctive water requirements in the research projects that are conducted at Mpala. For example, having projects indicate the approximate level of water needed, and accordingly administering charges in proportion to that need further reinforces the policy. Therefore, tracking water use of

the researchers could be a policy implemented at Mpala. The amount of the surcharge associated with water use should not necessarily be significant. Rather the presence and acknowledgment of such a policy would further communicate the values of the Centre.

In addition to implementing policy, education is key to compliance of conservation practices at Mpala. Two methods that can be used are by signage around the property and by formal education of the children in schools, the adults and the visitors.

Signage around the Centre, which currently doesn't exist, has a twofold effect. They educate those utilizing the water about the best ways to minimize their use while further reinforcing the value of conservation. The signs educate, but they also serve to constantly remind users to be aware of their water consumption. There are different types of signage. One is simply to inform. For example, signs that explain that the tap in the washroom is equipped with an aerator to reduce flow per minute are simply informative. Letting the user know that by using this fixture rather than a standard tap, they are saving 7.5 liters of water per minute, they are being educated, reminded and rewarded with praise with one sign.

The second type of signage is instructive. For example, by asking those using the taps at the storage tanks to make certain the tap is completely turned off, Mpala will save water. In addition to reminding people to behave in a certain way, it again is reinforcing the value of conservation. The signage can also educate the user by telling them how much water can be saved each hour/day/week/year if they are careful to follow the instructions correctly. This is another opportunity for intrinsic reward.

In addition to signage, a more personal and formal education can be provided. For visiting researchers, as part of the welcome and orientation to the Centre, an employee can be assigned to a short lecture or tour of the water facilities at the Centre. This allows Mpala to inform the visitors of the policy right at their arrival, drive home Mpala's value of conservation, and teach the visitors how to treat this precious resource during their visit. Most of the visitors to Mpala come from the developed world where seldom do they have to restrict their use of water. It would be responsible to educate them on the distinctions between living at home and inhabiting the sort of facility that is not connected to a centralized system to allow them unlimited resources.

While educating visitors at the Centre is an effective action, it is the Village inhabitants that live at the Centre year round and make up a large majority of the consumers at Mpala. Therefore, a similar type of education, as it pertains to their own water use would be even more

impactful. For both the adults and the children, there is a wonderful resource in the World Wise Schools of the Peace Corps. The World Wise School has developed a program called ‘Water in Africa,’ where people are educated in the dangers of unclean water, but also in the best and most efficient use of scarce resources (Peace Corps Coverdell World Wise Schools, n.d.). This program is tailored for specific countries in Africa, including Kenya, so that it addresses local cultural issues connected with water, as well as educates people how to better use and conserve water. Narratives and photos are provided. It is a highly recommended resource. Utilizing programs such as these is an economical and impactful way of educating those at the Centre.

While policy and educating can be highly affective, providing the proper tools will further compliance. For example, one of the challenges of converting the Village inhabitants to borehole water was the properties of the water that prevented a good lathering for washing. Therefore, the people prefer and use river water to wash their clothes. There is a product called Self-Foaming Soap that requires very little water to produce a good lather that would enable this group to use the borehole water to wash or to use less river water than they currently do for each washing. In the past, the Foundation has provided roof materials and catchment systems, including a tank, to catch rain water at individual homes within the Village. Providing these type of tools enables people to comply with the policy, but also sends the message that they will be supported and in some cases rewarded for embracing these values.

Further research into the culture, the motivations and the habits of the people that live at and visit the Centre is recommended for future research groups at Mpala. These types of studies will allow Mpala to find the most effective ways to encourage the conservation of water in the daily lives of those at Mpala. The brief overview provided above are simply suggestions for resources and methods to consider, but should be properly vetted before implementation.

## **Conclusion and Recommendations**

### *To the Mpala Research Centre*

The first step in water management is to reduce the amount of water used and wasted where possible. This is why our group recommends installing low-flow fixtures in all of the washrooms at the Centre. However, the visitors at the Centre make up a quarter or less of the people residing at the Centre throughout the year. The visitors use the washrooms, and therefore, while the water reduction could be as high as 4,000 liters per day, this is only a small fraction of total use (14%).

Therefore, a second step we recommend is the use of a grey water system. By ‘system’, that can mean it could involve a centralized collection tank connected to the plumbing throughout the entire Centre and Village sites. It could also mean something as simple as two employees collecting grey water from several smaller collection tanks throughout the site. This water can be used to reduce the strain caused by landscape irrigation at the Ranch, water used in the toilets and water that could be required for a biogas plant (as proposed in the energy portion of this report). This could reduce overall consumption at Mpala by an additional 24 liters per person per day at the Centre and at least 5.5 liters per person per day at the Village. The use per person could be moderately reduced, but the greatest impact would be on other draws from the supply, as mentioned above.

The third method of reduction recommended is through behavior change. A campaign to educate and implement policies at Mpala in the responsible use of water is the most challenging, but could be the most effective tool in conserving water.

The next step recommended is expanding the current roof rain water catchment system. The underground, centralized tanks will require less space, less capital investment and more than adequate water for the Centre and Village; however, it is less secure, as contamination can destroy the entire supply. The belowground option also leaves potential above ground space for future additional above ground storage, as well as tie-in of new buildings. The above ground option can be phased in, making less of an upfront financial impact, and spreading the risk of contamination out, so that if one tank loses its supply from contamination, the remainder is still secure. We leave it to the Mpala management to make a choice that best suits their immediate priorities.

### *To Future Masters Projects*

There are two areas that our team has identified as wonderful candidates for further study. The first is a study of the local watershed. By understanding the size of the watershed, the composition of the land cover and soils, and the land uses, there can be an understanding of the circumstances with the supply to the Ewaso Ngiro. In addition to supply, the quality of this water could be tested to determine if the water is safe for human, cattle and wildlife consumption. The river is culturally significant to the people, but also critical to the life that it

supports. This study would not only benefit those at Mpala, but also all of the other communities within the watershed.

Another project that would be of use to Mpala is a study of the water use behavior of both the visitors and full-time residents at Mpala. To understand how water is used and how it can be better conserved, the limited water supply can be stretched further and used longer.

### **Water-energy nexus**

At Mpala, there are several opportunities to conserve resources within the water-energy nexus. What that means in this case is solar thermal water heating and solar water pumping. This section focuses on the possibilities of these systems at Mpala. It was not an in-depth study, but we felt this could be an additional explored area for future masters project teams.

#### ***Solar thermal water heater***

A solar thermal water system at Mpala is best accomplished as rooftop systems. This will minimize the disturbance of the land around the buildings and allow more ground surface for rainwater collection systems. With the minimized occurrence of elephant traffic due to the new fence around the Centre, the ground can also be an option for these systems.

The panels that are available come in standard sizes, according to Mpala's local supplier. The most ideal size for the panels are 2.3m<sup>2</sup> (smallest available). The tanks are at 220 liters, for adequate roof installation. The Centre will only need approximately 11 tanks at full capacity, approximately one per building, with more for the buildings that hold more guests.



**Image W-i 13: Solar thermal water heating system.**

Image source: UNDP GEF Small Grants Programme, [http://sqp.undp.org/web/images/1494/a\\_model\\_of\\_solar\\_water\\_heater\\_2.html](http://sqp.undp.org/web/images/1494/a_model_of_solar_water_heater_2.html)

#### How solar thermal will work

Solar heating is the most efficient way to heat water. Mpala is located at an ideal location for optimal insolation. Therefore, in order to save the Centre on energy costs and minimize the harmful and wasteful burning of wood, these photovoltaic systems are a fit alternative. The system is sized based upon the amount of water needed and the estimated heating amount per liter of water. The former will allow for proper tank size and the latter will allow for proper photovoltaic panel size. If each person is to take one shower each day, using a low-flow shower head for a period of eight minutes, they will use 14 gallons of water. So a building with four beds should have a tank large enough to hold 56 gallons or 212 liters of water per day. For the panel sizing, an estimation of 60 degrees Fahrenheit as an initial temperature, and a target temperature of 115 degrees Fahrenheit was found to be ideal to calculate the amount of energy needed to heat that amount of water to the desired temperature. The United States Government's Department of Housing and Urban Development has a manual for mechanical systems that recommend domestic water not exceed 120 degrees Fahrenheit (U.S. Department of Housing and Urban Development, 1985). Please see the calculations and exact system recommendations in Appendix W-5.

#### Why use the system

Currently, there are two systems in place at Mpala to heat water. The first is solar flat plates, positioned on the ground, and backed-up by what is coined 'kuni boosters' or wood

burning stoves. The flat plates were being destroyed on occasion by elephants that had open access to the Centre and were attracted by the salty water from the borehole that feed the washrooms at Mpala Research Centre. As a result, the kuni boosters were being used frequently. Wood for fuel is dangerous for human lungs and not ideal for the natural ecological cycles of the local environment. Therefore, burning wood is not an ideal solution. As mentioned above, the elephant interaction has been controlled by new fencing, and this result is less of a concern. Nevertheless, a new system is recommended.

#### Limitations to this system

The challenge with solar heating, of course, is that the sun must make contact with the photovoltaic panels for a length of time each day before bringing the supply of water to its target temperature. Currently, at the Princeton dorm, a building with a solar hot water system in place, the hot water is not available for showers until approximately three o'clock in the afternoon. In this instance, behavior modification or a tolerance for cold showers is necessary for this system to be acceptable to guests.

#### Costs

The system described in Appendix W-5 will cost approximately 1,243,000 Kenyan Shillings or \$15,289 USD. If properly installed and maintained, a PV system can last up to 20 years, however the strength of the sun close to the equator, where Mpala is located, could degrade the system at a higher rate.

#### *Solar pumping*

Solar pumping is a potential solution for pumping water out of the borehole, where on average 37 cubic meters or 37,000 liters are extracted every day at Mpala. Unfortunately, the surface of the water is approximately 70 meters (or 230 feet) below the surface. Therefore, quite an extensive photovoltaic system would be required to pump up the water.

#### How photovoltaic will work

A photovoltaic pump can be purchased in Kenya by a company headquartered in Denmark, Grundfos. This has several sizes of pumps that are designed to pump a certain amount of water per day over a maximum vertical distance. The largest pump available is a 1700 Watt system, which can pump up to 17.5 cubic meters of water 70 meters in one day.

Unfortunately, that does not meet the current specifications needed to pump the current demand at Mpala. However, if Mpala replaces its drinking water with rainwater, and installs low-flow fixtures within the recommended parameters outlined in this report, the 1700 Watt system would be more than enough needed for Mpala's borehole water demand.

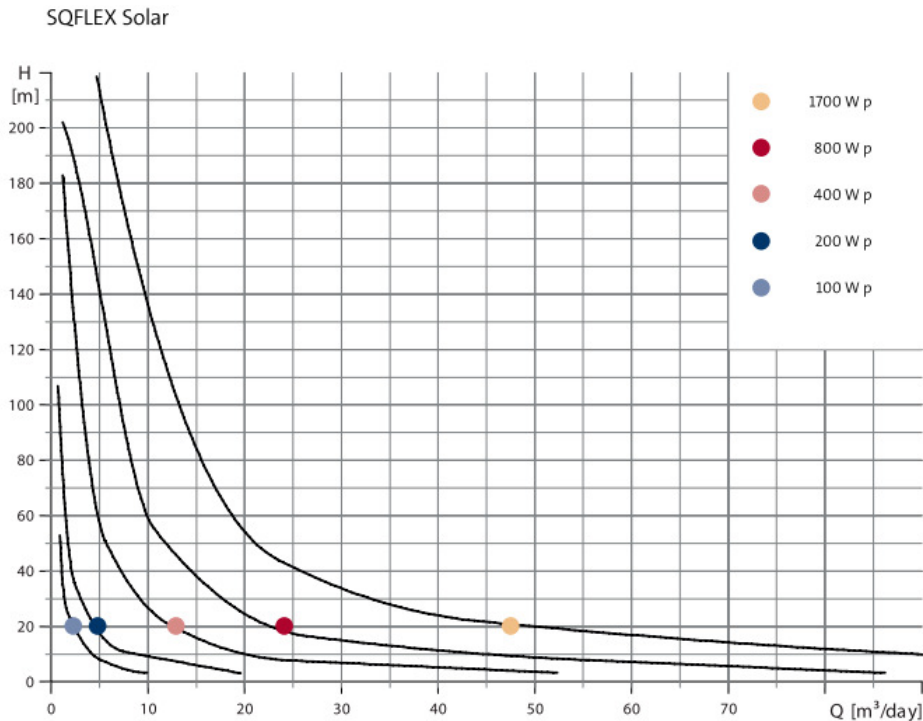

The SQFlex Solar performance curves are based on:

- Irradiation on a tilted surface
- $H_t = 6 \text{ kWh/m}^2$  per day
- $20^\circ$  tilt angle
- Ambient temperature at  $30^\circ\text{C}$
- $20^\circ$  northern latitude
- 120V DC

Source: [www.grundfos.com](http://www.grundfos.com)

**Image W-i 14: Grundfos solar pump sizing chart**

#### Why use the system

The current system runs purely on diesel. The pump runs for several hours per day. Therefore, fuel will be saved and pollution reduced. \$1,467US per year is spent on diesel to run the pump at the borehole. Even if the reduced consumption is considered, that is still an expenditure of \$1,200 per year. A solar pump, equipment only (not including specialized labor) can be found for a range of prices. The payback period for this type of project could range from two to six years.



## Energy

In view of the current system and its challenges, the following approaches were adopted in an attempt to tackle the energy challenges at Mpala.

- a. Efficiency of the system should be improved
- b. More renewable sources should be used as sources.

This section covers the different approaches that we considered to handle the issues at Mpala.

### Energy efficiency

The first step in making Mpala sustainable is to reduce the demand. Load demand is completely dependent on the lifestyle of the people living at the conservancy. (A detailed explanation is provided in the section on “Behavior and education”). However, even without changing the behavior and lifestyle of people, the demand can be significantly reduced by making the electrical devices more efficient. An inventory of all devices was taken by the solar systems engineer Haggai Oloo during our first visit to Mpala. A detailed list of the equipment in some of the important buildings is given in Appendix E-1.

Some of the technical efficiency improvements include:

1. Replacement of all incandescent with LEDs (Light Emitting Diodes) or CFLs (Compact Fluorescent Lights) which are highly energy efficient and last longer than traditional incandescent bulbs while giving better quality light.
2. Replacement of the freezers in the Kitchen with more efficient Energy Star freezers.

We have analyzed the replacement of LEDs in detail. We see that out of all buildings in the labs and office buildings in fact have few energy saving lights. These consume a quarter of the energy consumed by fluorescent and other types of lighting installed at the Centre. Hence, we decided to analyze the cost and emission savings of a complete replacement of all lights to the energy saving type. The cost savings due to reduced diesel consumption will differ based on the electricity mix. That is, a purely diesel based energy system (0% renewable fraction) will result in a higher cost savings compared to a case where half the electricity produced is from clean sources (50% renewable fraction).

Table E-t 9: Watts used by inefficient lights.

Building type	Qty	Watts	Total Wattage
Administration building	8	40	320
Eden's lab	10	40	400
GIS lab	25	40	1000
NSF lab	10	40	400
Total	53	40	2120

Thus, a total of 2120 Watts of electricity is used by the inefficient lights. If these are replaced by energy efficient lights, we shall save energy and hence on money as well.

### Potential renewable sources

The first step of analysis was to identify the inefficiencies in the current system including the design of the system, storage methods and distribution. The next step in the analysis is to supply this improved system with as much renewable energy as possible. The options that were considered for analysis were solar, hydro, biogas and wind.

#### *Solar PV*

Based on the location of the project site (Latitude: 0°19' N, Longitude: 36°52' E), HOMER calculates the solar irradiation and clearness index. Owing to its location at the equator, the average value of solar irradiation is very high compared to the rest of the world. It can be seen from Image E-i 8, that the average solar irradiation is 6.5 KWh/m<sup>2</sup>/day.

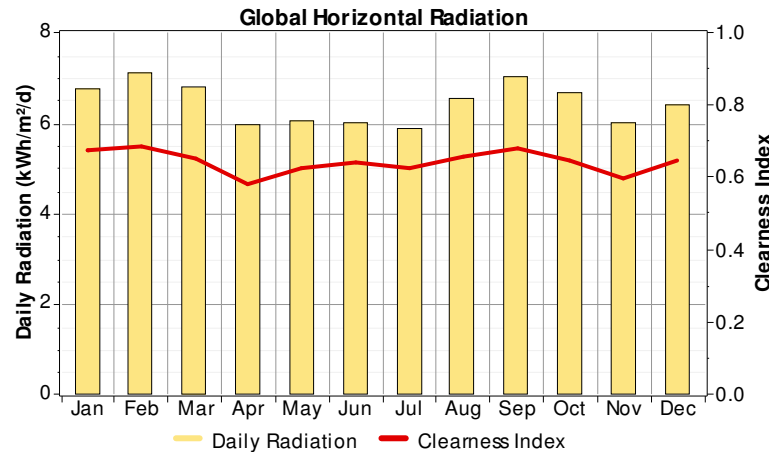

Image E-i 8: Annual Solar Irradiation Data in Laikipia, Kenya

Due to its geographic location, Kenya has considerable potential to harness solar energy for lighting, refrigeration, and other basic applications. The Mombassa and Kisumu regions receive ~ 12 hours of sunlight most of the year. The Clearness Index, (KTd)m conveys how much incoming solar irradiation is received at specific location, and provides better clarity about global “radiation variations due to climate impacts, i.e., site altitude, site cloudiness and atmospheric turbidity” among different regions (Setiawan, Zhao, & Nayar, 2008). The average monthly (KTd)m is provided for Sunsats37 (Kenya) in Image E-i 9:

Sunsat33	0.51	0.50	0.51	0.49	0.57	0.62	0.63	0.60	0.55	0.50	0.52	0.49
Sunsat30	0.59	0.58	0.52	0.52	0.51	0.52	0.49	0.53	0.48	0.47	0.51	0.58
Sunsat37	0.64	0.65	0.60	0.56	0.54	0.50	0.49	0.53	0.53	0.54	0.54	0.60
Sunsat34	0.64	0.60	0.58	0.56	0.54	0.51	0.43	0.45	0.50	0.52	0.56	0.63
Sunsat31	0.66	0.64	0.61	0.60	0.57	0.55	0.47	0.47	0.48	0.58	0.61	0.64
	Jan	Feb	Mar	Apr	May	Jun	Jul	Aug	Sep	Oct	Nov	Dec

Image E-i 9: Clearness Index in Laikipia, Kenya

The monthly average (KTd)m annually is approximately  $6.72/12 = 0.56$ , which means that 56% of the “extraterrestrial irradiation reaches the ground” (Rabah, 2005). This is slightly different than what HOMER predictions of (KTd)m = .643. This variation could be due to specific weather changes in a given year. The value given by the HOMER model is from NASA, so it was considered for our analysis.

### *Hydroelectric resources*

Hydro resources from the Ewaso Ngiro river constitute the largest and lowest cost resource that can be easily converted to mechanical or electrical energy. Over the last 20 years, flows from the Mt. Kenya catchment have become more and more unpredictable, and, with the

upstream irrigation and household needs increasing, flows of the river will undoubtedly reduce in the next 20 years. It is likely that there will be lengthy periods when the river is completely dry. However, the river could still provide an economically-viable power source during times when there is water, and this hydro power is of much lower cost than diesel gen-set or solar electricity.

### Processing the data using HOMER

Laikipia has been experiencing a serious and consistent drought for the last three years. The Ewaso Ngiro dries up frequently.

The monthly variation of flow for the last ten years with and without considering the recent droughts is shown in Figure E-f9 below. Once the data is entered into HOMER, it plots the annual flow in the form of a bar graph and calculates the power produced by the hydro turbine based on this data. The river flow data shown in Figure E-f9 reveals that the river typically runs at very low flow during the months of February, March, June, July, August, September and October. The annual average flow of the river is 1,628.2 liters/sec in the case of no draught. Our analysis takes into account this new trend and assumes that river is dry for six of the 12 months. August potentially has no flow if the recent trends are considered. However, under no climate change conditions, we still observed minimal flow during August and hence it was considered for our analysis. If, in the future, observations and analysis show that the river dries up during August, then the flow can be made zero by deleting the August flow from the first graph. The data for the river flow in the second graph below was used for our analysis. The annual average river flow in this case was found to be 1,270 liters/sec.

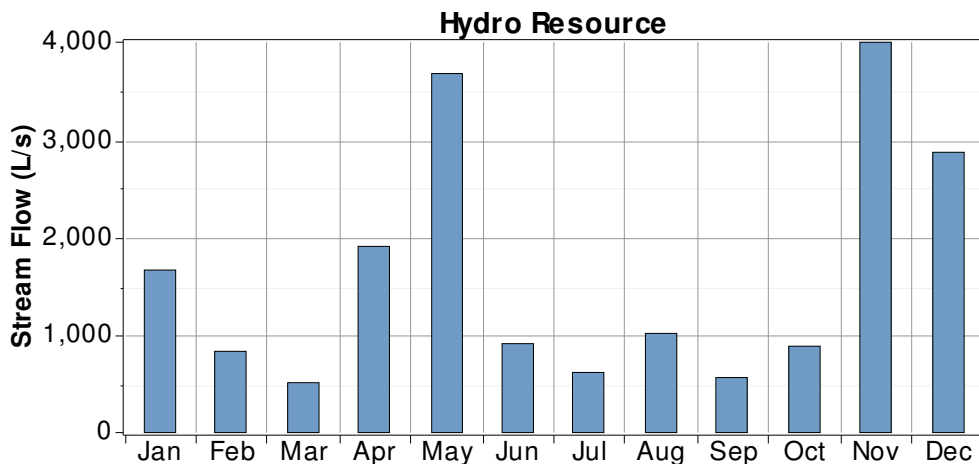

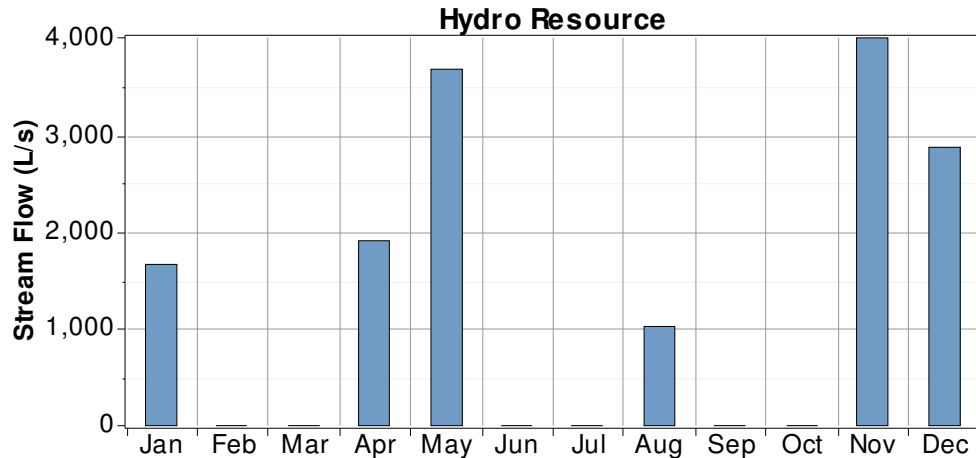

Image E-i 10: Average flow of Ewaso-Ngiro in a year

- Annual average flow = 1,270 L/s (from HOMER)
- Dry months are February, March, June, July, September and October
- Available head for the turbine = 3.2 m (measured)
- Design flow rate = 600 L/s
- Capacity factor = 60% (because observed output was 12 kW when the rated output was 20 kW)
- Generator type = A.C (as observed at Mpala)

### *Biogas*

When any organic matter, such as cow dung, crop residue and kitchen wastes, is fermented in the absence of oxygen, biogas is generated as a result of methanogenic microorganism activity. Biogas contains combustible methane (around 60-70%) along with carbon dioxide (30-40%), and traces of other gases (Pandey, Subedi, Sengendo, & Monroe, 2007). Biogas is not noxious, is colorless and odorless and is an ideal fuel that can be used for a variety of applications such as cooking, lighting and motive power. The spent waste that comes out of the biogas plant after the gas is produced is excellent organic manure that augments soil fertility. The spent waste material that emerges at the end of the biogas process, the slurry, is a high nutrient organic fertilizer that surpasses raw manure, and can be applied either directly or in conjunction with composted agricultural residue. If composted properly, the slurry will give higher fertilizer yields and increase overall crop yield and production, thereby augmenting income and restoring soil fertility in areas where soil degradation is prevalent; simultaneously, as

it replaces chemical fertilizers, the slurry saves the money previously spent on chemical fertilizers. Additionally methane is produced during the anaerobic (i.e., without oxygen) decomposition of organic material in livestock manure when deposited on fields and pastures. Methane has a global warming potential that is 25 times that of CO<sub>2</sub>. However, biogas plants need large quantities of water to function well.

### Biogas in Mpala:

In Mpala, there are six bomas with around ~2000 heads of cattle of all ages. As of June 2010, they were divided up unevenly in each boma, the distribution was as follows - (1) 300, (2) 500, (3) 800, (4) 200, (5) 200, (6) 50 (Yurco, 2011). However, this changes seasonally as the older bulls are sold for meat and as calves are born and shifted around boma-to-boma depending on age. The bomas are relocated periodically to ensure uniform grazing. The manure helps in plant growth, and Mpala uses this as a tool for ecological restoration.

For our analysis, we assumed that there will be a herd of 100 heads of cattle in each boma at any time of the year. On an average, 13 kg of dung is produced each day by one head of African cattle (Abbey, 2005). The cattle are less likely to produce dung in the night, than in the day since they are sleeping and relatively packed at night. Therefore, it is safe to assume that 40% of this dung is produced during night time. Therefore, for 100 heads of cattle, there is approximately 420 kg of dung produced in one boma in one night.

### Inputs to the biogas digester:

The common biogas digester's design projections assume that an input of four kg of wet manure per day, mixed with four liters of water fed into the one cubic meter tank would produce 0.20 m<sup>3</sup> of biogas every day. The manure is assumed to be about 83% water, thus the dry content added on a daily basis is around 0.68 kg. In Mpala, with 420 kg of dung available, it should be possible to produce 26 m<sup>3</sup> of dung in one single day per boma. This would however also require 420 liters of water to function.

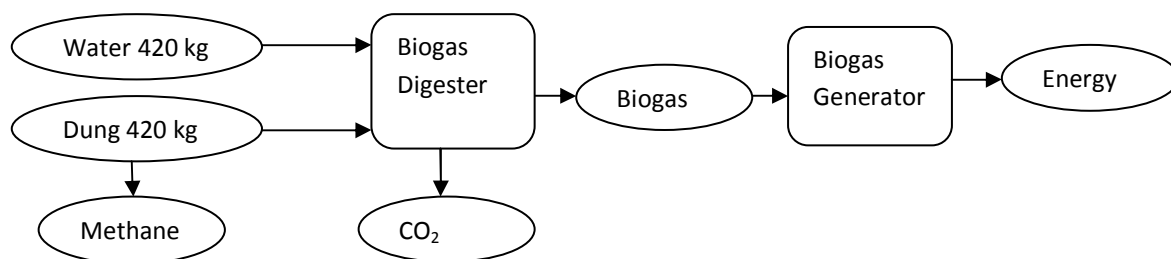

Image E-i 11: Schematic of a biogas energy system

A simple schematic diagram showing the throughput of the biogas system is shown in Figure E-f10. This system will require a biogas digester. For Mpala, we propose the use of a polyethylene biogas digester. This is because it is not only cheap and easily transported; it is also light and long lasting. This will allow the digesters to be moved along with the bomas if necessary. A sample biogas digester as sold by the manufacturer is shown in Figure E-f11, below.



Image E-i 12: Polyethylene biogas digester as sold by manufacturer (Liu, 2011)

### *Wind*

Laikipia lies between an area of low winds (Nyeri/Mt Kenya 1-2 m/s) and an area of high winds (Marsabit and the Turkana Jet - .6 m/s). In general, evidence suggests that Mpala's wind energy resources are on the low side, and that wind would not be a good choice for electricity power generation. Mpala Research Centre has its own meteorological station with an anemometer at a height of 2.5 m. According to measurements from this anemometer, average monthly speeds are about 2.0 m/s, with a peak of 2.3 m/s in the months of July and August, as seen in the figure below. Based on these measurements, we see that the levels of wind are not high enough to support a wind generator.

Measurements show that the average wind velocity = 2.166 m/s. Typical cut-in speed for horizontal axis wind turbines is 2.5 m/s (Puangpornpitak & Kumar, 2007). Basic calculations

show that the energy generated from wind turbine was 56 KWh/year as opposed to a load of 42 MWh/year. However, this is not the only issue with wind. A major issue with wind is that it is intermittent and hence needs to be stored. This would require a robust and reliable backup system.

It is important to note that the location of the anemometer at MRC is low, and in a sheltered location. If wind turbines could be built at a height of 10 m, wind could be a possible solution. It is possible that there are other locations on the Ranch that have better wind potential. However, based on our assumptions, is not recommended that wind is pursued as a major potential energy option.

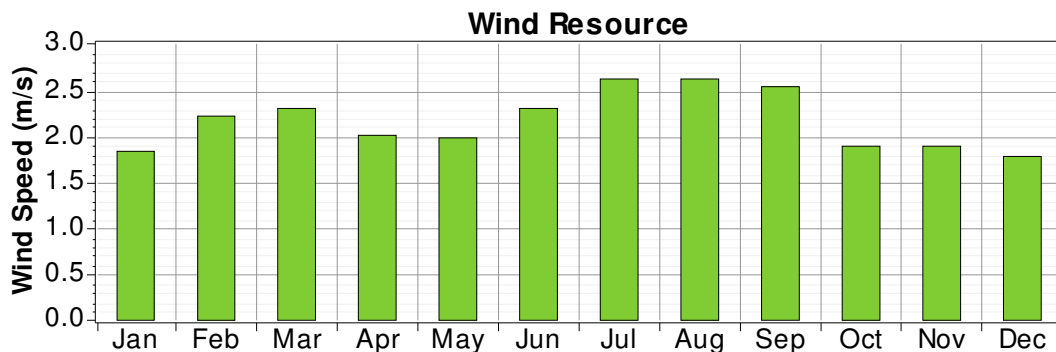

Image E-i 13: Wind resource for Laikipia, Kenya

## Behavior and Education

In order to ensure that the designed system will function efficiently, there are two main considerations in the context of Mpala.

- a. Training of personnel to operate and repair the system locally without any external help
- b. Influence the behavior of the researchers through education and incentives

### Training of Personnel

Currently, the operators of the energy and water systems do not understand the working of the system. This will not only deter their ability to maintain the system well but will also make it difficult for them to appreciate the importance of a new system. As stated by the World Bank, “For the generation system to be self-sustained, technical education and training for local



operators are vital.”(World Bank, 2006). However, in communities like Mpala, trained personnel are likely to leave their villages for working in cities with higher wages (a member of JICA, Pers. Comm., 2006). Thus, it is very difficult to keep required knowledge and skills in villages. A suggested approach by Dr. Abigail Mechtenberg from her research in Uganda might help solve such an issue for Mpala. Our interpretation of this is paraphrased below:

- Select villagers, and not an individual from outside, to be the operators. The villagers have stronger ties to the community and thus are less likely to leave the village.
- Moreover, attract one of these operator to work for the village’s community center, not only setting the salary to be competitive to jobs in cities but also bestowing honor on the work positions are necessary. This will offer the operator financial benefit and an honorable social status. This also explains why a villager is preferred to an outside individual. A villager will be more honored to receive this title than an outsider.
- Encourage the other operators to work with the village community center operator to design and build more electricity generating devices so that the knowledge can be transferrable outside of Mpala.

Understanding the design of the system and the impact it can have on the ecological balance in their immediate surroundings will not only help in ensuring better maintenance but will also influence the behavior of the researchers at Mpala. Some of the solutions like biogas without transmission, use of electricity to reduce usage, water storage tanks and timed showers are important to be maintained well to be able to use for a long time.

Making the people aware of the greater picture will also greatly help spread the idea of sustainability to the newly developing world. The energy users will get the opportunity to advance an organization's energy conserving potential, and personally experience the satisfaction of contributing to a progressive energy conservation initiative.

A change in behavior can be achieved by utilizing social and behavioral mechanisms that respond to each area’s environmental, workforce, and cultural needs. Some of the strategies that Mpala could use to involve all the people using the power, is by using signage liberally all over the Centre and the Ranch. This will help people remember and understand better as they read and re-read. Mpala could also use rewards in the form of incentives for e.g., the building or the room that has reduced the highest amount of electricity or water use since the last month can be awarded.

Often times, the people living in the Village use the generator at the MRC is used to charge their car batteries. This contributes to a significant amount of the inefficiency at the MRC today. One potential solution to this problem is reaching out to the people, and teaching them alternative ways to charge their car batteries. There was an attempt made in the past few years to charge car and motorcycle batteries with the use of what is called a bicycle generator. In such a system, human (mechanical) energy is converted into electrical current by means of a Direct Current (DC) generator that is connected by a common belt to a bicycle wheel. This was done by Peter. N. Muhoro and Abigail Mechtenberg, who are alumni of the University of Michigan. Muhoro traveled to Uganda with Mechtenberg and brought her research groups' innovation to Uganda. Initially, the bicycle generator did not show much interest among the villagers but after a site visit by the Board Directors, and the realization that one doesn't have to put too much into getting a full charge, it became a popular electricity generating device. The locals could rely on it more than they can at the charging station as they can go almost a week or two without a chance of getting their battery charged. Mechtenberg has continued this research and other such co-design innovations can be brought to Mpala including but not limited to the following: hand-crank lighting, merry-go-round generator, cattle generators, wind turbines from blades weaved by local women, and local hydroelectric generator. Such small solutions have now caused Mpala to build a gym that will be generating electricity as people exercise. Therefore, small solutions that are true to the nature of Mpala, and that can be easily accepted by the people there will last long and provide great benefits.



**Image E-i 14: Bicycle generator being used to charge a battery at Mpala (Muhuro, 2010).**

Educating the ones who use the electrical system about the way it works and the fuel it uses will ensure that they are able to maintain the systems themselves. Have in place over the performance period a building operation and maintenance staff education program that provides each staff person primarily working on building maintenance with at least 24 hours of education each year over the performance period. The education program should provide information on building and building systems operation, maintenance, and achieving sustainable building performance. This will lead to the system becoming a part of the daily system and a part and parcel of the Mpala life. Such a system will be true to the region and its needs, will last long and is truly sustainable.

## Results for Energy Analysis

In this section we are going to discuss our results and compare them with logical approaches in an attempt to find the best options for Mpala. This section covers the results from the energy audit of the buildings in Mpala, the use of local energy supply resources available, the simulation model constraints and the costs involved, the baseline scenario and the various proposed systems. The block diagram shown below (Image E-i 15) shows us the inputs and outputs of our simulation model - HOMER Energy used to calculate the optimal system. The inputs are our energy supply resources, our site power load, capital and operational costs and constraints (capacity shortage and renewable fraction). For either grid-tied or off-grid environments, HOMER models how variable resources such as solar and hydro can be optimally integrated into hybrid systems (Homer Energy, n.d.). Engineers and non-professionals alike use HOMER to run simulations of different energy systems, compare the results and get a realistic projection of their net present value, cost of electricity and renewable fraction.

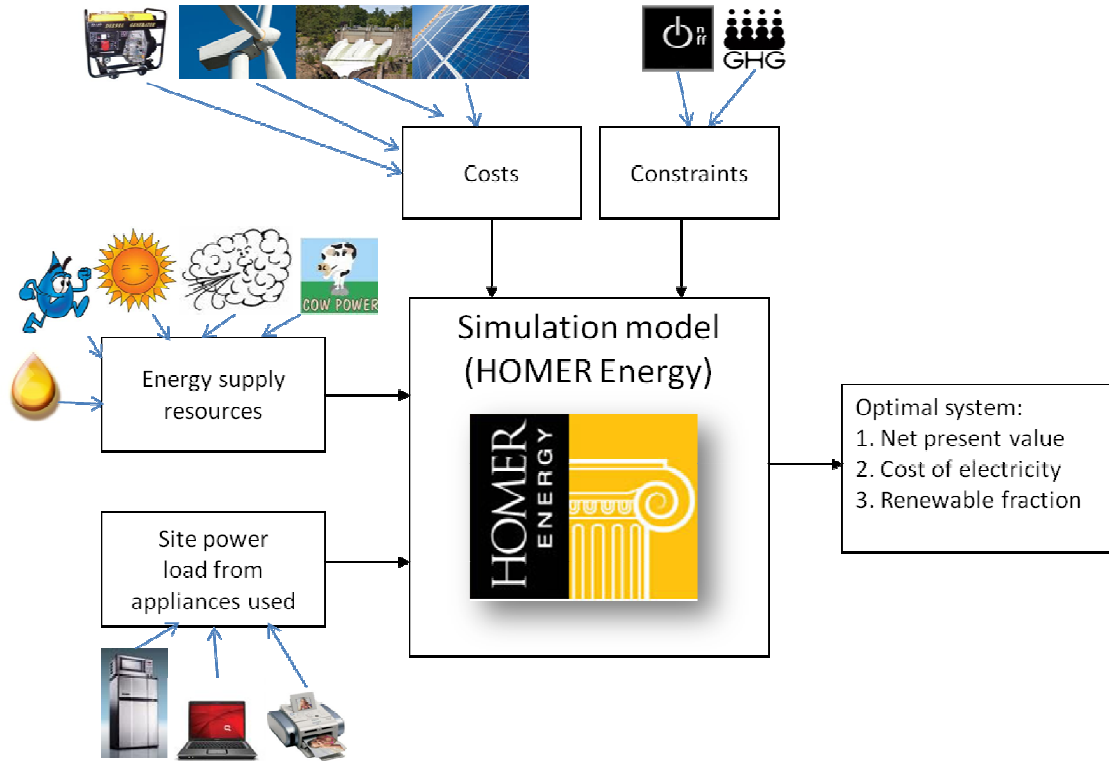

Image E-i 15: Basic block diagram of the HOMER software used in this analysis

## Energy Audit Results

An energy audit of all the buildings was performed during two trips to Mpala. The buildings were metered and their average and peak loads were obtained as discussed earlier in the methodology section as well as specific appliance loads. Figure WW below shows us a comparison of average power consumed by the various buildings at Mpala Research Centre.

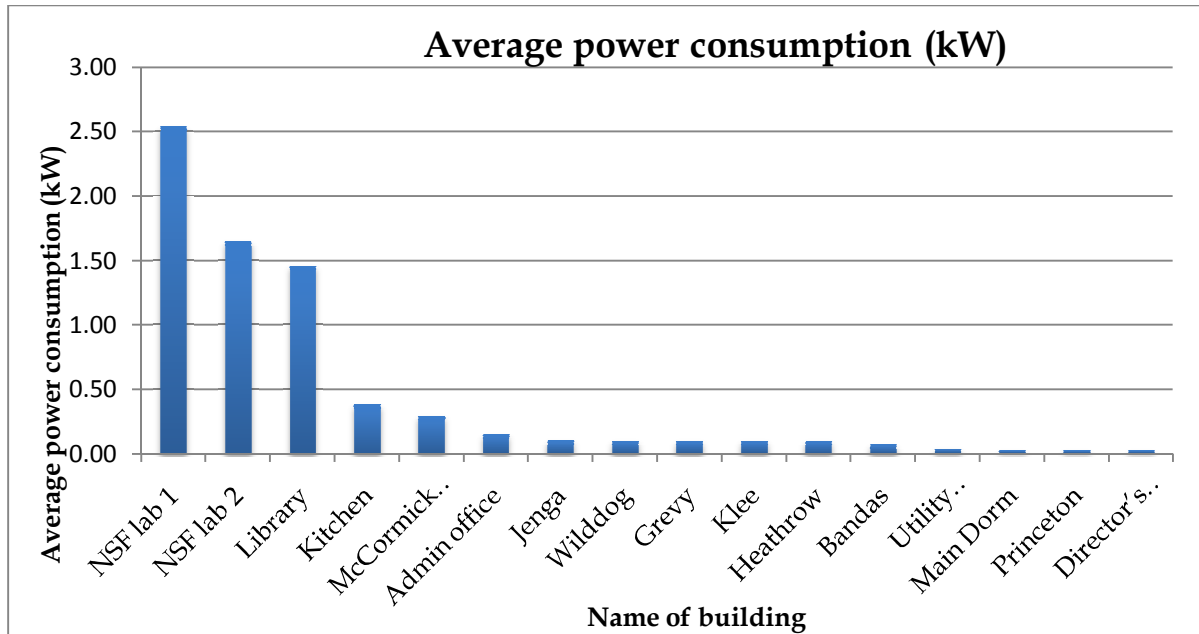

Image E-i 16: Energy Consumption of Mpala Research Centre's buildings

Thus, we see that that the NSF labs and library are the top consumers of energy at the Mpala Research Centre. These three buildings together consume three fourths the total power demand at the Mpala Research Centre. Opportunities exist to reduce energy consumption in these buildings. Although the demand side is incredibly important to consider, knowing that they have to live with the constraints of their appliances, we only considered replacing lights. We decided to concentrate more on the supply side of the energy system.

Some ways of reducing power consumption without making any sacrifices would be to make sure that all laptops operate on energy saving mode and that the server room is sufficiently and effectively cooled. Appendix E-1 lists the equipments used in the NSF labs, library and the administration buildings. We see that the single largest users of energy are the printers. Energy star printers are cheap and are great options to reduce energy use. They should be disconnected from the power supply at all times not in use in order to reduce stand-by power consumption.

### Baseline scenario

In this section, we talk about the baseline scenario and compare it with typical off-grid systems in Africa and elsewhere which use only diesel power. In a later section, we shall discuss optimizing the lighting system and our newly proposed scenarios to improve upon this existing baseline.

## Baseline scenario results

The table below (Table E-t 10) shows the final overall output of the individual systems for the Research Centre and the Ranch headquarters and also for the combined weighted system. This combined system is a representation of the entire Mpala conservancy and is used for comparison studies with new proposed energy systems.

**Table E-t 10: Outputs from HOMER for the individual and combined existing energy systems**

	<b>MRC with purely diesel (Most commonly observed)</b>	<b>MRC existing – Diesel, PV and batteries</b>	<b>Ranch existing – Hydro, diesel generator</b>	<b>Weighted (combined existing system)</b>
<b>Renewable fraction</b>	0	0.15	0.71	0.34
<b>Battery life (years)</b>	NA	2.09	4.29	2.84
<b>CO<sub>2</sub>Emissions (kg/yr)</b>	140,000	45,720	24,900	70,620
<b>Fuel consumption (liters)</b>	344,831	17,362	9,456	26,818
<b>Operating costs (\$/year)</b>	\$700,007	41,068	23,852	64,920
<b>Unmet load (%)</b>	0	-	-	-
<b>Cost of Electricity (\$/kWh)</b>	10.01 <sup>6</sup>	1.19	1.33	1.24
<b>Net present Costs (\$)</b>	NA	647,305	375,945	1,023,250

This is the existing system and is considered as our baseline scenario with which the outputs of all newly proposed energy systems will be compared. It is important to give credit to Mpala conservancy for operating on an already hybrid system with solar PV and batteries along with diesel generators. Some similar systems in Africa use only diesel generators to produce power which results in a cost of electricity of around \$11/kWh<sup>7</sup>. Mpala has improved on common diesel ‘generator only’ systems by hybridizing with PV and batteries. But there is opportunity to improve even more than this on the existing baseline energy system. This served

<sup>6</sup> We calculated \$10.01/kWh based on a single operating point

<sup>7</sup> From the thesis report of Abigail Mechtenberg, University of Michigan – Ann Arbor

as our motivation to propose systems with more hybridization and reliability. With Mpala's current renewable fraction of only 0.34, the current system is highly polluting even though it is more efficient than a diesel generator only system. It is unable to meet the demand imposed and has high operating costs due to increased usage of diesel. We want to improve on this baseline scenario.

### Optimizing the energy audit

Looking at demand side management required evaluation of appliance replacement. Only the replacement of lighting was modeled and analyzed in this section.

#### Methodology

Power at which the generator operated is 24 kW. Amount of fuel it consumes is 3 liters per hour (Hankins, 2006). Therefore, for one kWh, 0.125 liters of diesel is consumed.

The diesel costs are currently at a little more than \$1/liter but all our energy analysis has been done for the base case assumption of currently highest diesel costs in the world (European nations) to account for the rapid spike expected over the next few years (Gasoline-Germany.com, n.d.). This value is \$2.03/liter. Using this, we can calculate that it takes \$0.25/kWh electricity produced by the generator. This assumes that the generator is operating at its most optimal point. But as we discussed earlier, the cost of electricity for diesel could go up to \$11/kWh for generators that do not operate at its most optimal point. The carbon intensity factor for diesel combustion is 2.63 kg/liter (Endangered Islands Campaign, n.d.). Therefore, we see that the carbon emission for this diesel generator is 0.3287 kg/kWh.

The cost and lifetimes of the CFLs and LEDs have been obtained from manufacturers and are shown in Table SS (Walmart, n.d.; Amazon, n.d.; Tractor Supply, n.d.).

**Table E-t 11: Lifetimes of the two lighting options**

	Incandescent lamps	CFLs	LEDs
Lifetime	1500 hours	12000 hours	30000 hours
Cost	\$2.30	\$4.20	\$20

Using these values, the replacement of current bulbs with both LEDs and CFLs has been analyzed. Only a simple net present analysis has been done. It doesn't consider discounting of money over time.



**Results**

From Images E-i 17 & E-i 18, it is shown that LEDs are the least carbon intensive followed by CFLs. Incandescent lamps are highly carbon intensive. This is because of the higher power requirements of incandescent.

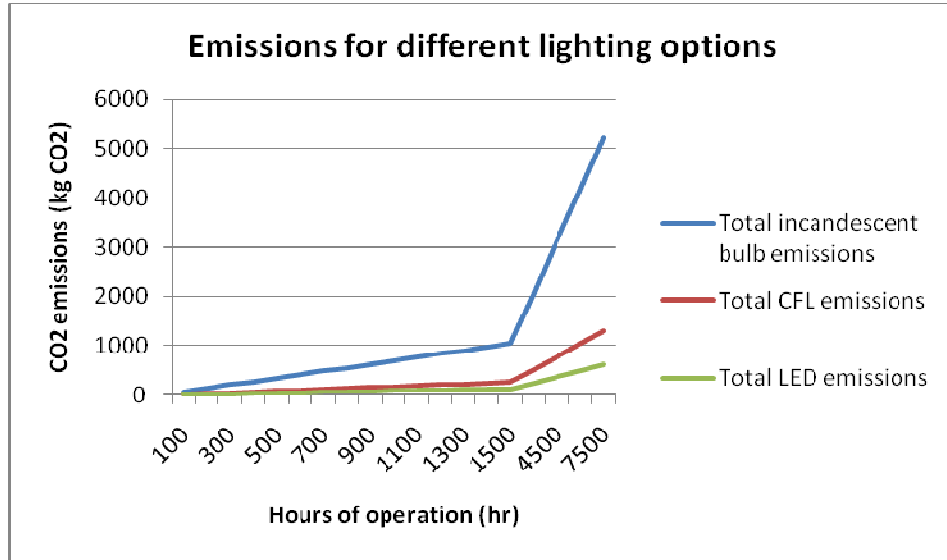

Image E-i 17: Emissions analysis of lighting over time

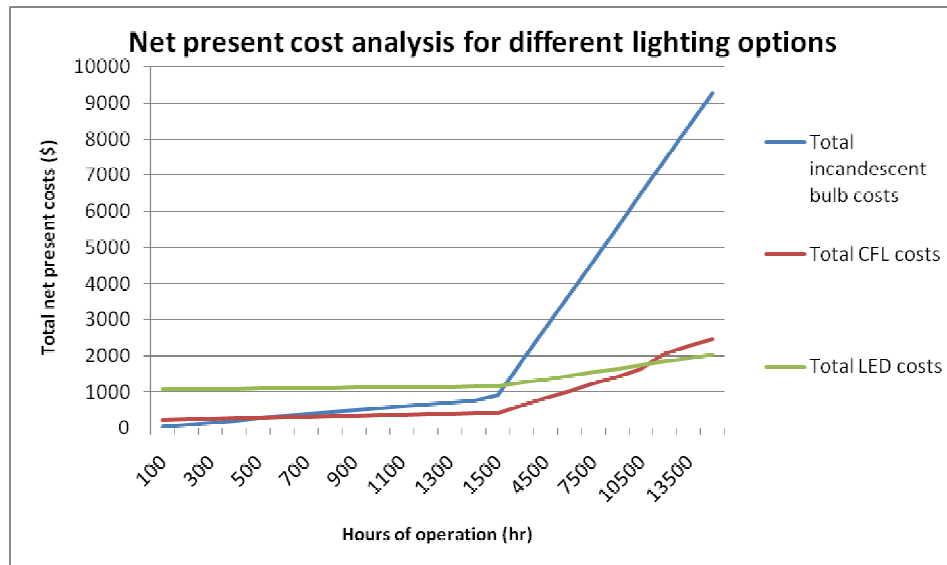

Image E-i 18: Net present cost analysis of lighting over time

We see that net present costs of incandescent lamps are lowest until 550 hours of operation. From the 550<sup>th</sup> hour to 11000 hours, CFLs are least expensive. However, after the 11,000<sup>th</sup> hour, LEDs are the cheapest option. In our case, if we assume 8 hours of operation per

day for 365.25 days/year, LEDs become the cheapest option within 3.75 years. This is a very short period of time compared to the lifetime of CFLs and LEDs. Hence, it is highly recommended that all incandescent be replaced by either CFLs or LEDs.

But, how do we choose between these two options? The emission savings for each type of replacement over the 11000 years is - CFLs =  $(8363.4 - 2090.9) = 6,273.5$  kg CO<sub>2</sub> and LEDs =  $(8363.4 - 1003.6) = 7360.8$  kg CO<sub>2</sub>. These can be considered as the environmental benefits of replacement. Hence a quick cost-benefit analysis tells us that the cost invested per unit emission saved is  $(\$2059.05)/6,273.5$  kg CO<sub>2</sub> = 0.33 \$/kg CO<sub>2</sub> saved. For LEDs, it comes up to \$0.25/kg CO<sub>2</sub> saved. Hence from an environmental perspective, LEDs are better as they reduce more overall emissions. However, for short project times, CFLs are more economical. Since the case with Mpala is not for short term, LEDs are also the cheaper option. Appendix E-7 shows us the results of net present costs and emissions for the different replacement scenarios. These savings have been incorporated into the primary load at the Mpala Research Centre for the new scenarios analyzed in HOMER.

## Proposed Systems

### System Topology

The systems being proposed for the Mpala conservancy power supply problem are a mix of renewable and fossil fuel generation coupled with smart energy storage. The obvious solution of supplying the load with off grid diesel generators is the present approach at many off grid sites. But considering the current energy crisis, an ideal system would be complete replacement of fuel-based energy sources with renewable generation, which at present might be uneconomical. Thus a possible system topology could consist of local renewable sources with fossil fuel powered sources such as diesel generators as backup and an energy storage system (James, 2010). The biggest disadvantage of renewable is that they are intermittent and hence can't provide base load. Thus, we need an efficient energy storage system to accommodate the intermittency due to renewable generation. The general topology of an off-grid hybrid system is shown below (Image E-i 19).

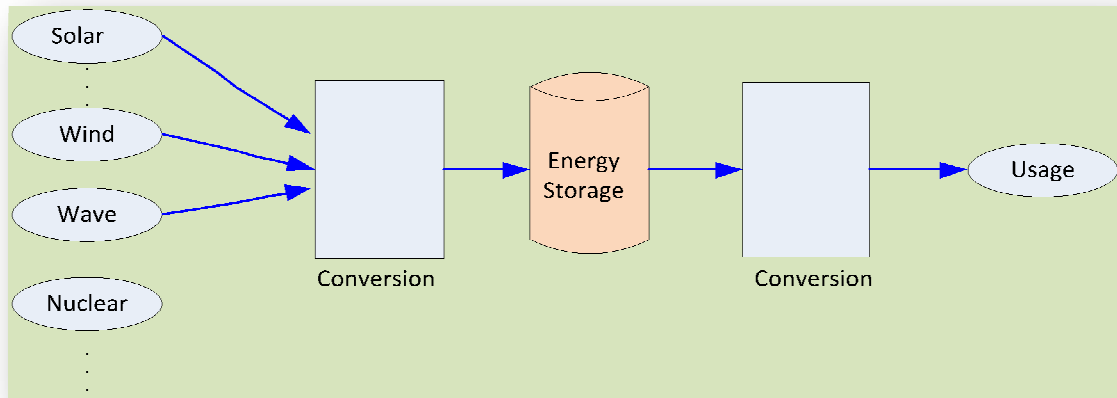

Image E-i 19: Off-grid hybrid energy system (Weldemariam, 2010)

## HOMER

Before we dive into the different proposed scenarios and their comparison, here is a quick recap of what HOMER is. As explained earlier in the methodology section, HOMER stands for Hybrid Optimization of Electric Renewables and is a tool provided by National Renewable Energy Labs, Department of Energy of the United States. It is an excellent tool that can be used to analyze, simulate and optimize various combinations of off-grid hybrid renewable energy systems and is used all over the world.

### Existing System

In order for us to be able to compare the proposed new systems with the existing one, the existing system has to be clearly understood.

The different sources of energy generation currently present at MRC, gathered from nameplates on the equipments are

1. Two diesel gen-sets of 16 kW and 24 kW capacities
2. Several solar PV panels of different providing up to 3.63 kW of power (Oloo, 2010)

The different sources of power at the Ranch headquarters are

1. One hydroelectric turbine that produces approximately 12 kWe power.
2. A 24 kW backup generator to meet its needs.

Now let us have a look at the different hybrid energy system scenarios proposed.

Image E-i 20 below shows us how the existing systems at the Mpala Research Centre and the Mpala Ranch headquarters look along with the specifications of each component.

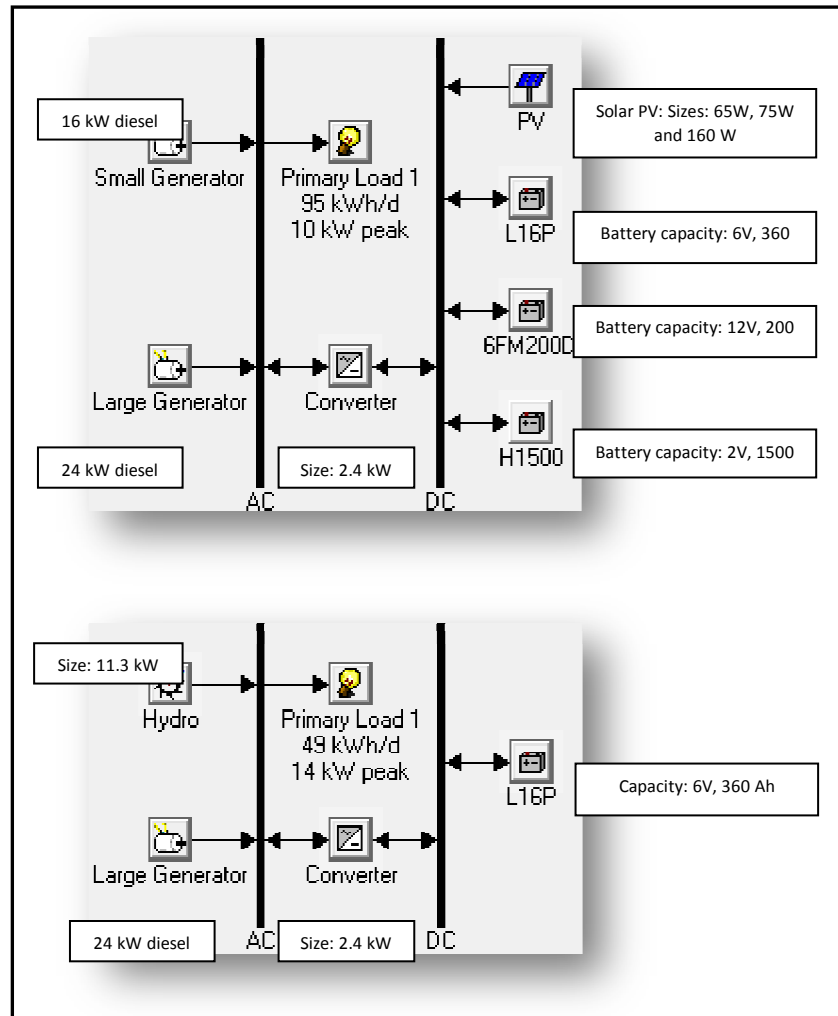
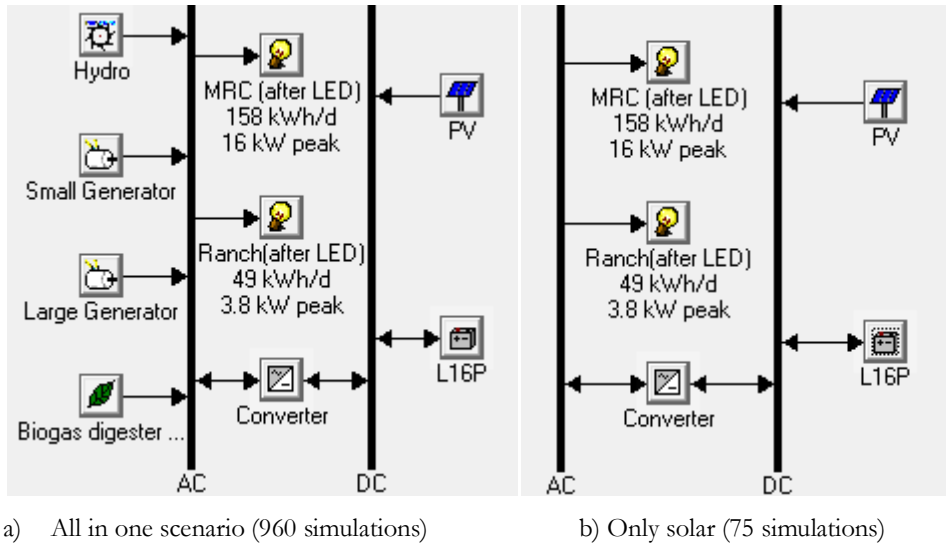

Image E-i 20: Existing energy systems at the Mpala Research Centre and the Ranch headquarters

## Scenario analysis results

As discussed in the ‘Existing situation’ scenario, many new scenarios have been designed with an aim of meeting the clients’ objectives. What they said was important was reducing the dependency of fossil fuels by increasing solar, hydro and other renewable power. As already discussed, renewable systems are intermittent and have difficulty in providing base load. This would require large storage options like battery banks. Thus, appropriate sizes of battery banks and converters also were installed for the new scenarios. A summary of the different scenarios considered along with the number of simulations in parenthesis are shown below in Images E-i 21 to E-i 24. A detailed system description along with outputs of each scenario is included in

Appendix E-8 to E-15. The simulation results of each of the scenarios analyzed are summed up in a table and shown below. Appendices E, F and G show the complete set of results for all scenarios considered.



a) All in one scenario (960 simulations)

b) Only solar (75 simulations)

**Image E-i 21: Scenarios modeled for two cases: Overhead and underground transmission lines**

The scenario on the left considers all energy supply options, namely, solar PV, biogas digester, hydro power and diesel generators. It also considers batteries for storage. HOMER calculates all combinations of these in terms of sizes of components. In this particular scenario, this leads to 960 combinations. The ‘Only solar’ scenario on the right considers only one power source, namely, solar PV. It also considers batteries for storage. HOMER calculates all combinations of these in terms of sizes of components. In this particular scenario, this leads to 75 combinations. The simulation results of these two scenarios (a and b) were then compared.

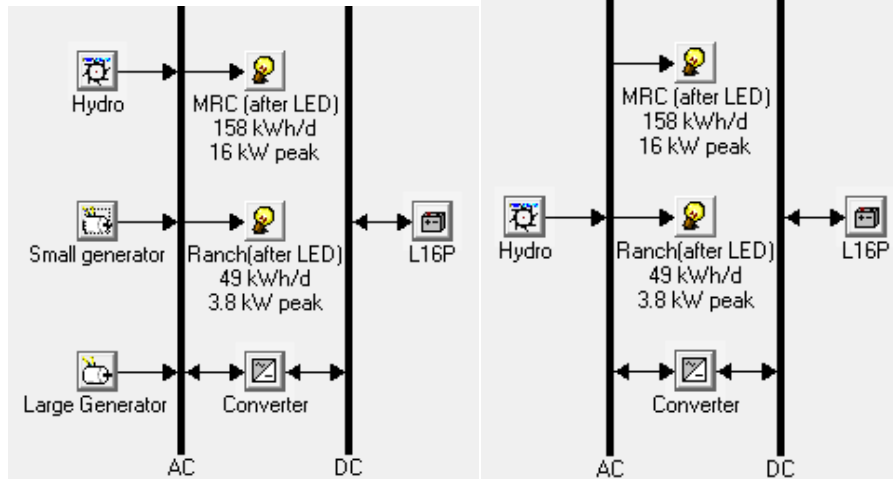

c) Hydro with backup generators (48 simulations)      d) Only hydro (8 simulations)

**Image E-i 22: Scenarios modeled for two cases: Overhead and underground transmission lines**

The scenario on the left considers only hydro power with backup generators to meet the remaining demand. It also considers batteries for storage. HOMER calculates all combinations of these in terms of sizes of components. In this particular scenario, this leads to 48 combinations. The ‘Only hydro’ scenario on the right considers again only considers hydro. But this scenario doesn’t consider backup generators nor batteries for storage. HOMER calculates all combinations of these in terms of sizes of components. In this particular scenario, this leads to 8 combinations. The simulations results of these two scenarios (c and d) were compared.

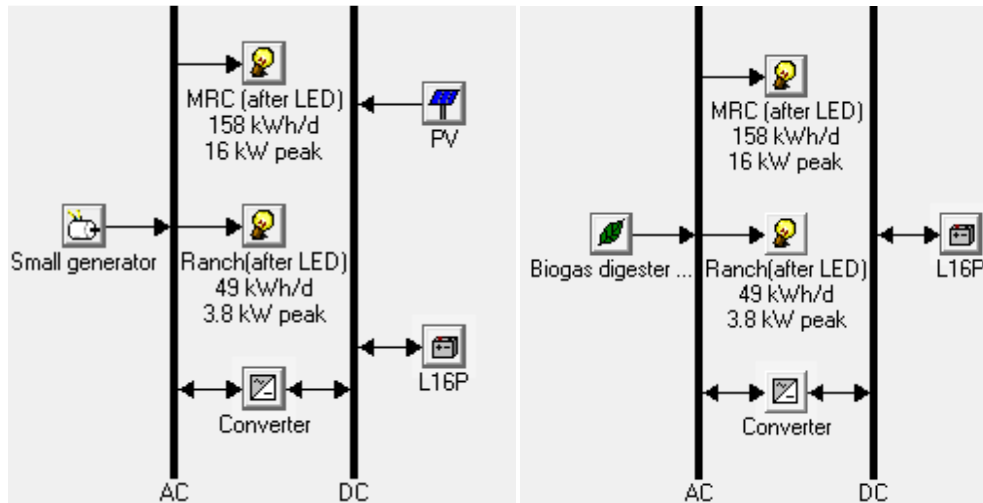

e) Solar with backup generators (72 simulations)      f) Only biogas (30 simulations)

**Image E-i 23: Scenarios modeled for two cases: Overhead and underground transmission lines**

The scenario on the left considers solar PV as the main power source with backup generators to provide for the remaining demand. It also considers batteries for storage. HOMER

calculates all combinations of these in terms of sizes of components. In this particular scenario, this leads to 72 combinations using which we assessed the solar potential at Mpala. The ‘Only biogas scenario on the right considers only one power source, namely, biogas power. It also considers batteries for storage and 30 combinations were simulated in this scenario to assess the biogas potential. The simulations results of these two scenarios (e and f) were then compared.

After modeling each of the above scenarios for two cases, namely overhead and underground transmission, they were compared two at a time as described. After this, they were all compared against one another. The results of these comparisons will be discussed in a later section.

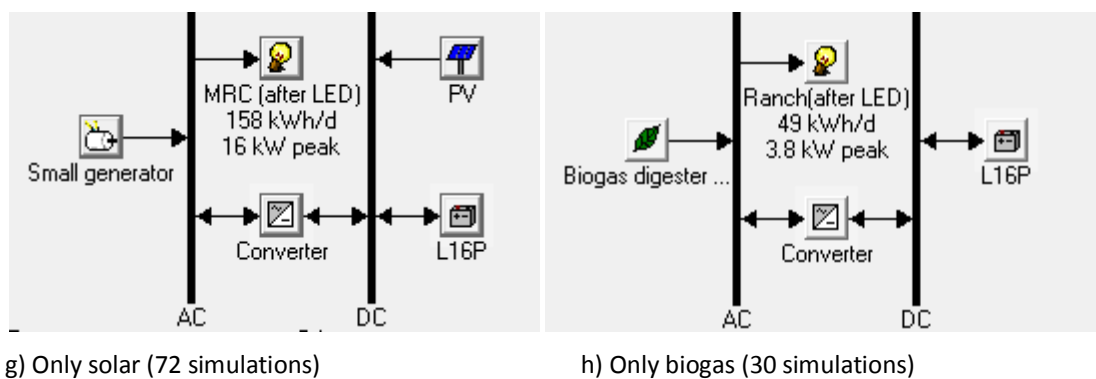

**Image E-i 24: Scenarios modeled considering no transmission lines, each for the Research Centre and Ranch separately.**

Hence, seven scenarios each for energy systems in Mpala assuming underground, seven for overhead transmissions and four for new energy stems with no transmission were simulated and analyzed. Image E-i 25 below shows us a complex system of how each scenario discussed above (from A to H) compares with each other.



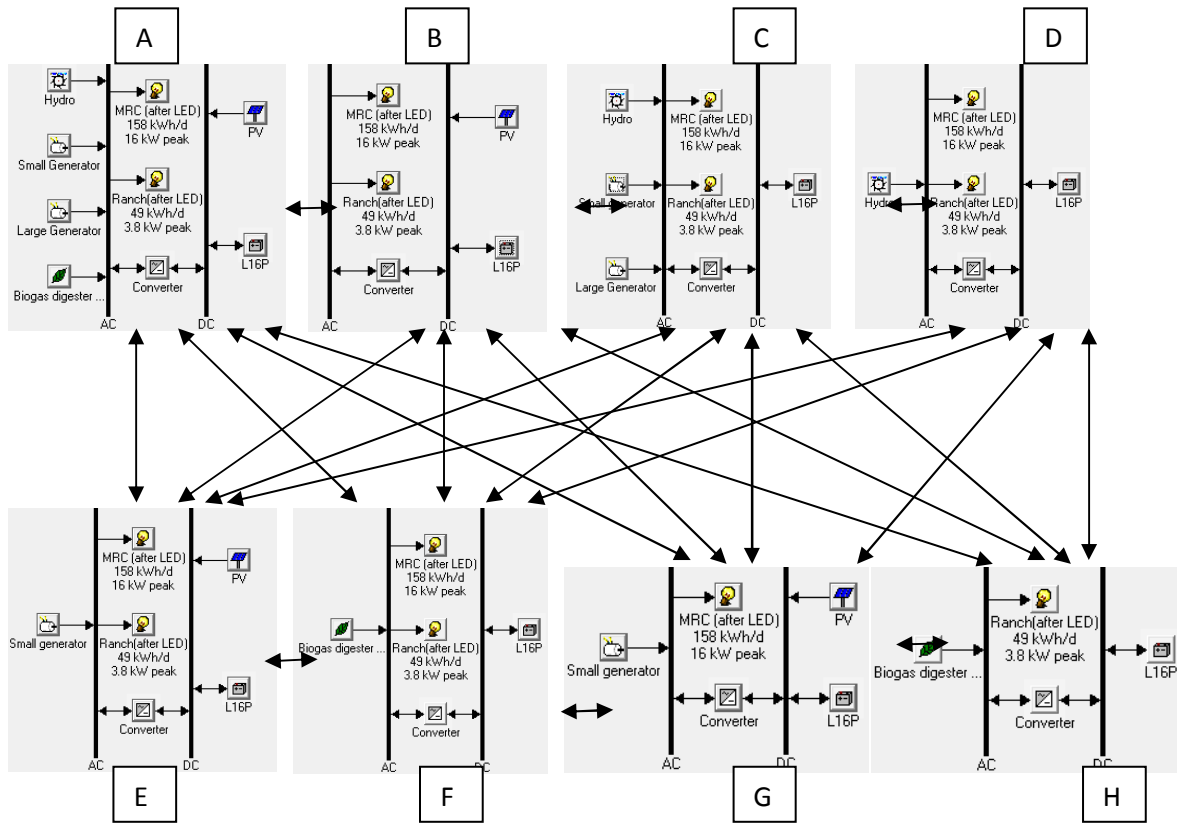

Image E-i 25: Arrows show all proposed optimal scenario combinations compared (A to H) with each other

## Comparison of different scenarios

### Metrics

To compare the different scenarios, we need standardized and reliable metrics. The metrics we decided to use for our analysis are net present costs (\$) and cost of electricity (\$/kWh) and renewable fraction. These were taken as the primary metrics because they are easy to understand. Apart from this, a metric that takes into account both costs and emissions in the same factor is the 'benefit-cost' ratio. Benefits are defined as the savings in carbon dioxide emissions due to installation of proposed energy system. The costs are defined as the incremental investment needed to install the proposed system. The cost benefit analysis is not in the scope of this results section and has been shown in Appendices E-11 to E-15.

1. Net present costs (years) – Net present costs denote the sum of the present value of all costs over the project lifetime. It is a good metric to assess as it is perceptible and hence easy for stakeholders to understand.
2. Cost of electricity (\$/kWh) – The second metric to compare our energy systems would be net cost of electricity in \$/kWh for the system in consideration.
3. Renewable fraction – The final metric is an indicator of the level of sustainability of every proposed energy system. It gives us the fraction of total power produced by renewable sources.

Tables E-t 12, E-t 13 and E-t 14 below show the comparison of the above discussed metrics for each scenario. Images E-i 26 to E-i 29 show the results in a graphical form for easy comparison.

## Overhead transmission scenarios

### *Net present costs*

When we compare different scenarios, it is important that they all produce the same amount of energy. This means that the ‘Only hydro’ scenario can’t be compared with the rest of the scenarios as the unmet load in this case is 57%. When we compare the net present costs of all other scenarios for the overhead transmission lines case, we see that ‘Biogas only scenario’ has the least net present costs. The second and third lowest costs are for the ‘All in one’ and ‘Hydro with backup generator’ scenarios. All these scenarios have net present costs of less than a million dollars. The net present cost of the existing system is a little more than a million dollars. Thus, investing in any of these three energy systems will result in a net cost savings for Mpala.

### *Cost of electricity*

On comparing cost of electricity (\$/kWh) for all scenarios except the ‘Only hydro’ case which doesn’t meet demand, we see that the lowest cost of electricity is for the ‘Biogas only’ scenario. The ‘All in one’ scenario has the next lowest electricity costs followed by the ‘Hydro and backup generator’ scenario. ‘Solar PV and backup generator’ as well as ‘Only solar PV’ scenarios have the highest costs of electricity.

### *Renewable fraction*

Of the proposed systems, all except solar with backup generator and hydro with backup generator have a renewable fraction of 1. Solar with backup generator produces more renewable power than hydro with backup generator. All the newly proposed systems are more sustainable than the existing system. Hence, investing in new systems will only improve the sustainability of Mpala Conservancy.

**Table E-t 12: Cost-benefit and Cost of electricity comparison – Overhead transmission case**

	<b>Existing System</b>	<b>All in one scenario</b>	<b>Only Solar PV</b>	<b>Only Hydro</b>	<b>Solar PV and backup generator</b>	<b>Hydro and backup generator</b>	<b>Biogas only</b>
<b>Net present costs (\$)</b>	1,023,250	512,055	6,356,467	252,401	5,417,346	790,252	288,061
<b>Cost of e- (\$/kWh)</b>	1.238	0.408	5.269	0.409	4.315	0.629	0.242
<b>Renewable fraction</b>	0.34	1.00	1.00	1.00	0.79	0.56	1.00

### **Underground transmission scenarios**

#### *Net present costs*

As discussed above, the ‘Only hydro’ scenario can’t be compared with the rest of the scenarios as the unmet load in this case is 57%. When we compare the net present costs of all other scenarios for underground transmission lines case, we see that ‘Biogas only scenario’ has the least net present costs again followed by ‘Hydro and backup generator’ and ‘All in one’ scenarios. These scenarios have smaller net present costs than that of the existing system. Hence, investing in any of these three energy systems again will result in a net cost savings for Mpala.

#### *Cost of electricity*

On comparing cost of electricity (\$/kWh) for the underground transmission lines scenarios, we see that the lowest cost of electricity is for the ‘Biogas only’ scenario followed by ‘Hydro and backup generator’ and the ‘All in one’ scenarios. Once again, ‘Solar PV and backup generator’ as well as ‘Only solar PV’ scenarios have the highest costs of electricity.

### Renewable fraction

The only difference between the scenarios with overhead transmission lines and those with underground transmission lines is that the cost of the transmission lines is vastly different. This does not affect the electricity mix and hence the same argument as the overhead transmission scenarios holds here too.

**Table E-t 13: Cost-benefit and Cost of electricity comparison – Underground transmission case**

	Existing System	All in one	Only Solar PV	Only Hydro	Solar PV and backup generator	Hydro and backup generator	Biogas only
<b>Net present costs (\$)</b>	1,023,250	1,017,153	27,356,466	672,401	22,300,974	947,470	708,061
<b>Cost of e- (\$/kWh)</b>	1.238	0.810	22.680	0.409	17.762	0.755	0.595
<b>Renewable fraction</b>	0.34	1.00	1.00	1.00	0.79	0.56	1.00

### Comparison of overhead and underground scenarios

When comparing just between underground and overhead transmission scenarios, we see that cost of electricity for overhead transmission lines is much lesser in general. This is because underground transmission costs are five to ten times that of overhead transmission. Moreover, it is very important to note that our analysis assumes that underground transmission lines last half as long as overhead lines. This means that the underground transmission lines usually last only for 12 years and will have to be replaced approximately 8 times over a 100 year lifetime. Thus increasing the cost of underground lines by a factor of 8 would only make it

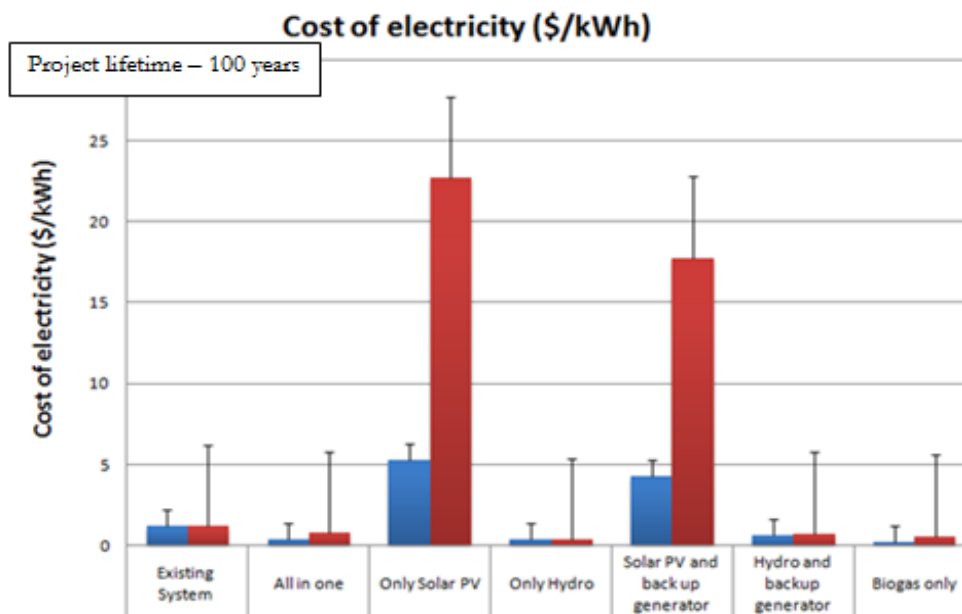

**Image E-i 26: Evaluating different hybrid systems – Metric: Cost of electricity (\$/kWh) – UG vs OH**

costlier. It is also important to note that transmission lines spike the cost of an energy system by approximately a million dollars thus strongly discouraging their adoption. The graph below (Image E-i 26) shows the costs per kWh for each of the systems, and the error bars account for the replacement costs for every 12 years since this was not taken into consideration when calculating the costs. Other potential options like hydrogen cells that might have lower net present costs over 100 years could be explored.

### Scenarios without Transmission

As seen in the previous section, using transmission lines can prove to be quite expensive. The system will not only have very high upfront costs, but may also pose high maintenance costs during times of system break down and be a hazard to wildlife. For this reason, it is important to analyze scenarios which can work independent of a transmission system. Below, we have shown results of the scenarios analyzed that do not need transmission lines at all.

#### *Net present costs*

For the scenarios without transmission lines, we see that net present costs are lowest for 'Biogas for Ranch; followed by 'Biogas for MRC', 'Solar PV and backup generators for Ranch alone' and 'Solar PV and backup generators for MRC alone' scenarios. It is important to note that these cannot be directly compared with the existing system which produces more power in order to provide for both the Research Centre and the Ranch.

#### *Cost of electricity*

For the scenarios without transmission lines, we see that cost of electricity is lowest for 'Biogas for MRC' scenario followed by 'Biogas for Ranch', 'Solar PV and backup generators for MRC alone' and 'Solar PV and backup generators for Ranch alone'.

#### *Renewable fraction*

All the proposed systems without transmission lines have a renewable fraction of one. This means that all electricity is produced by renewable sources alone. Each system, if implemented, will be better than the existing energy system in terms of sustainability.

Table E-t 14: Cost-benefit and Cost of electricity comparison – No transmission case

	Most common option: only diesel generator	Existing System	Solar PV for Ranch alone (with backup generators)	Solar PV for MRC alone (with backup generators)	Biogas for MRC	Biogas for Ranch
Net present costs (\$)	NA	1,023,250	527,827	1,150,260	258,512	161,141
Cost of e- (\$/kWh)	11.00	1.24	1.78	1.20	0.28	0.54
Renewable fraction	0	0.34	1.00	1.00	1.00	1.00

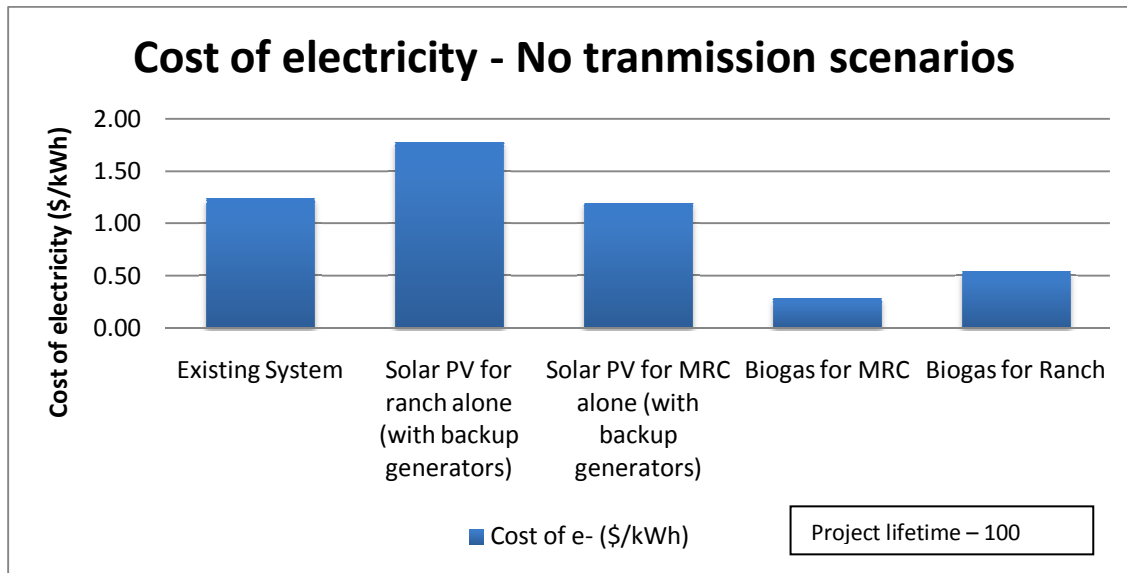

Image E-i 27: Evaluating different hybrid systems – Metric: COE (\$/kWh) for no transmission case

### Comparing scenarios with and without transmission lines

Images E-i 28 and E-i 29 below allow us to compare the net present costs and cost of electricity for cases where we choose to have transmission lines and cases where we don't.

#### Net present costs

The net present costs for three scenarios with transmission lines look comparable with scenarios that don't include transmission lines, namely, 'Biogas only', 'Hydro and backup generator' and 'All in one'. These three systems have net present costs comparable to the no transmission scenarios even though they produce power for the entire conservancy and use

transmission lines as opposed to the no transmission line scenarios which produce energy either for the Centre alone or for the Ranch alone. However, this is misleading because of two reasons:

- The ‘Only hydro’ does not meet needs and hence can’t be compared with scenarios that produce more energy and meet needs, as already discussed above.
- The transmission scenarios do not consider the replacement costs due to poor lifetime of underground transmission lines. The error bars in the graph are used to account for these costs.

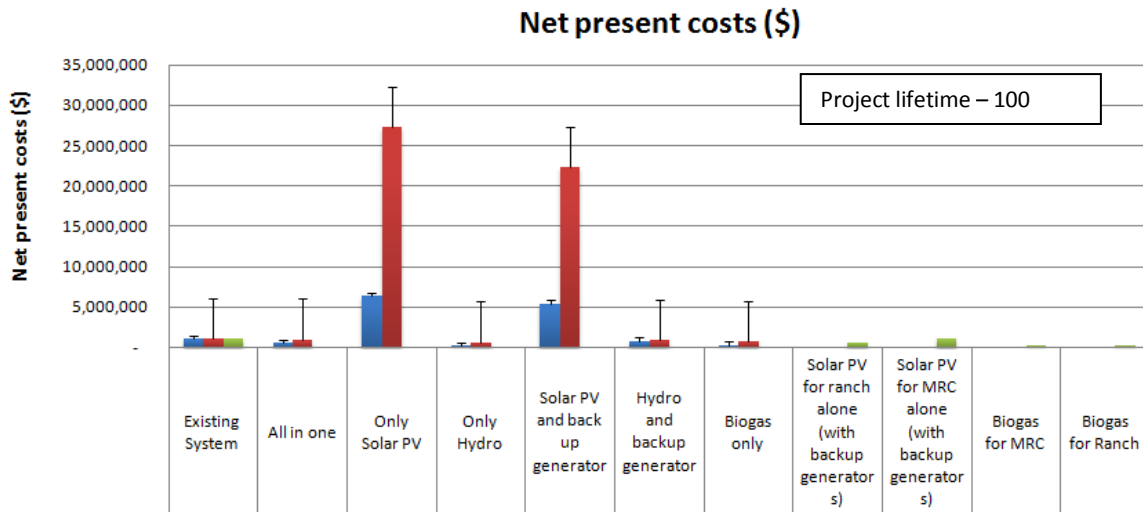

Image E-i 28: Comparison of transmission with no transmission case – Metric: Net present costs (\$)

*Cost of electricity*

Once again, the cost of electricity for three scenarios with transmission lines look comparable with scenarios that don’t include transmission lines, namely, ‘Biogas only’, ‘Hydro and backup generator’ and ‘All in one’. These three systems have lower costs of electricity than the no transmission line scenarios even though they produce power for the entire conservancy and have transmission lines as opposed to the no transmission line scenarios which produce

energy either for the Centre alone or for the Ranch alone.

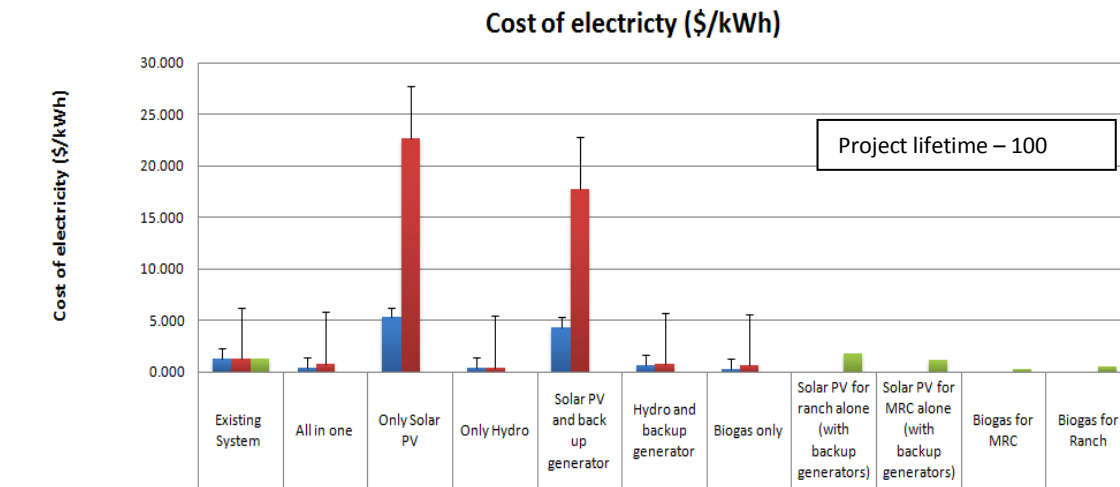

Image E-i 29: Comparison of transmission with no transmission case – Metric: Cost of electricity (\$/kWh)

### Biogas system design

Since the ‘only biogas scenario’ was featured repeatedly in the comparison above, our team decided to analyze it in more detail. SimaPro, a life cycle analysis software was used to perform a use-phase cost and emissions analysis.

In this system, we propose the use of two separate biogas generator systems (for the Centre and the Ranch separately), trucks to transport dung back and forth from the boma to the biogas digesters and also the use of human labor. This is a feasible system because it is cheap, and all of the required resources are available in Kenya. For example, there are trucks in the conservancy that are used for procuring goods from the nearby Nanyuki town that can be used to carry the dung. Using such a system would also create more jobs in Mpala for the Village people.

For such a case, two sets of biogas digesters and generators would be required one each at the Centre and Ranch. On a weekly basis, dung will have to be transported from the bomas to the digester site, and the previously digested dung can be taken back to the boma so that it can be used as a fertilizer. A fairly simple system, it can not only make electricity costs fall drastically in Mpala, it will also bring down the carbon dioxide emissions in the region thus making the whole system eligible to be funded by the Clean Development Mechanism. In order to accurately estimate the lifecycle emissions associated with such a scenario, we performed a lifecycle analysis with a system boundary that was predominantly “use phase”. The exact method used to calculate this has been explained in the section on “Methodology”.



## Life cycle analysis of 'biogas only' scenario

### *Life cycle emissions: Sima Pro Output*

The lifecycle emissions for a no-transmission scenario as calculated using SimaPro expressed in percentages are:

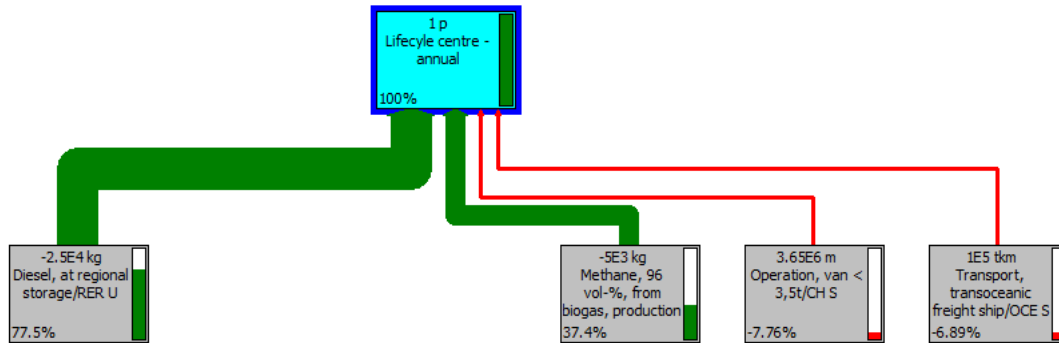

Image E-i 30: Results from Sima Pro lifecycle analysis

The total emissions that can be saved in this scenario are approximately 15400 kg annually, the greatest contribution for this coming from the elimination of diesel. There is also a considerable amount of savings from diverting manure into the biogas plant. The only CO<sub>2</sub> emitters are the transport of the generators from overseas and the truck used to transport the dung which cause a minor increase of 15% emissions which is offset by the 75% reduction from diesel elimination and dung diversion.

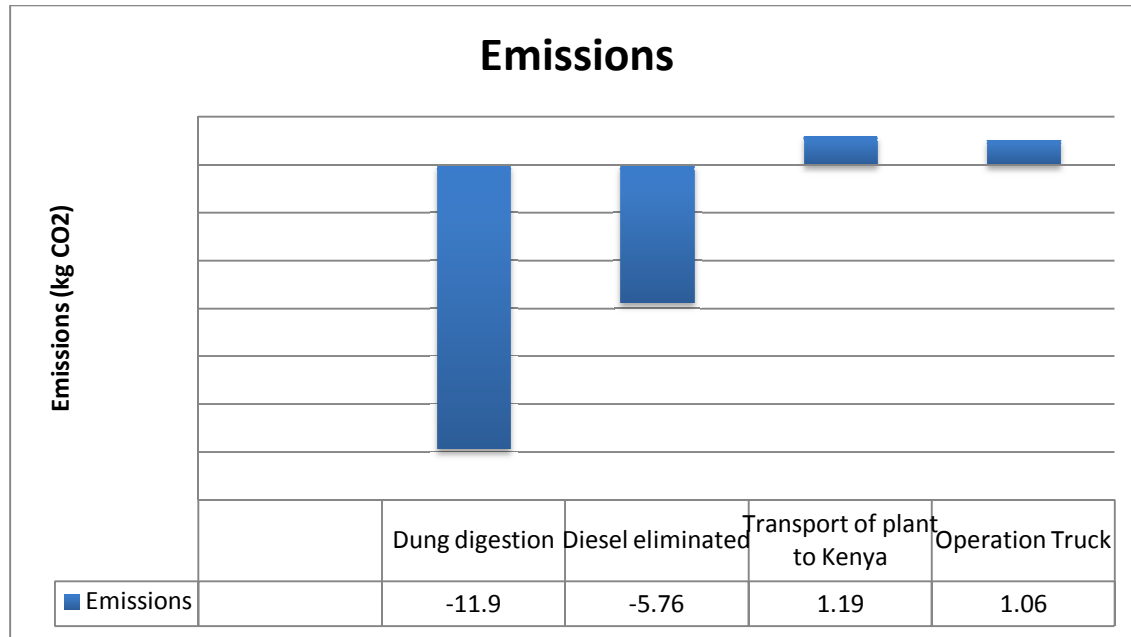

Image E-i 31: Emissions reductions

### Lifecycle Costing

For sizing the biogas plant and digester, we also approached companies that produce these machines. After specifying all the specifics of the system at Mpala, they suggested that the best options are a 20 kW generating system for both the Centre and the Ranch separately, and a 100 m<sup>3</sup> biogas digester. Actual quotations from the company are provided in the Appendix E-6.

Table E-t 15: Upfront costs of biogas system

Type	Cost	No. of pieces	Total
20 kW Generator set	9000	2	18000
Membrane structure Biogas Digester (100 m <sup>3</sup> )	1540	4	6160
Transmission costs	0		0
<b>Total Upfront Cost</b>			<b>24,160</b>

The total upfront cost was thus calculated to be \$ 24,160 (Table E-t 15). With additional shipping and transport charges, it was assumed that a total of \$35000 will be spent on biogas. This system would also have operation and maintenance costs throughout its lifetime. Assuming that we need 5 persons to manage the entire system and they are paid at the rate of \$10000 a year, the total cost will be \$45000 annually. The diesel costs about \$25000 annually, and when this is replaced, the payback period is 1.3 years. Thus the cost can be recovered in less than one

and a half years. This value is consistent with the payback period obtained from the HOMER analysis which was approximately 0.9 years.

## Recommendations

### Energy

#### To the Mpala Conservancy

The Mpala conservancy should act on its current electrical system immediately. Apart from the fiscal benefits it will receive in the long run, it will also be able to provide more reliable power to the residents at the Centre and the Ranch Headquarters. This potentially will increase the inflow of scientists to the Centre, and potentially increase the popularity of the research Centre and Mpala, with its new system to support the entire additional load.

- Mpala should replace its light bulbs with LED bulbs. Although these may pose a cost premium, it will save a lot of electricity in the long run. They also last longer than regular light bulbs.
- To have a single robust electrical system, Mpala could consider laying transmission lines since this *usually* makes the system robust and reliable. The most viable transmission system for Mpala is one that goes underground. This is because an overhead transmission system is more accessible to wildlife and can be broken down very easily by trespassing wildlife such as elephants and giraffes. *However, using an underground transmission system can prove to be 5-10 times more expensive, has a short lifespan and is more difficult to lay and maintain. We later recommend biogas with no transmission first and all-in-one hybrid with transmission second.*
- In the event that Mpala still chooses to lay transmission lines, it should follow the “all in one” scenario explained in the report. Although this is not the cheapest option, it should be chosen as having the highest reliability since it uses a mix of all energy resources available at Mpala such as hydro, solar, biogas and diesel. Such a hybrid system will prove to be reliable as each of these resources will complement each other in a way that the power is supplied continuously even if one of the sources die out. However, it is not entirely renewable in nature since it employs diesel as one of its sources.
- We recommend that Mpala does not use transmission lines for the following reasons

- Overhead Transmission lines are not feasible
- Underground Transmission lines are expensive and difficult to install and maintain.
- Cost of electricity is high
- Mpala should look into options that do not use transmission lines. The most obvious sources that will allow this are solar and biogas. From our analysis, we found that solar will be expensive. This is due to the high capital costs of solar.
- Mpala should consider the use of biogas to power the Centre and Ranch separately with the use of two sets of digesters and generators – one for each. It should consider Biogas seriously for the following reasons
  - This will eliminate the emissions caused by diesel generators.
  - It is a great way to use the dung available at Mpala, while still making digested dung to be used as manure.
  - It will redirect cattle dung methane generation caused by anaerobic digestion from being dissipated into the atmosphere by converting it into carbon dioxide instead.
  - It will have a negative net impact on emissions (reductions in emissions) in the area.
- Mpala should look deeper into the use of other sources such as Hydro-energy, as a potential source for powering the Centre as well. One potential method for doing this without the use of transmission lines is by the use of hydrogen fuel cells and carrying tanks of hydrogen from the Ranch to the Centre.
- Mpala should consider providing a program for training interested Village people to operate and run the system. This will not only make Mpala self sufficient but will also get the support of the Village people and the other users at Mpala to maintain such a system.
- Mpala should influence behavior of the people in the buildings and the users of the system by engaging them in the system and providing incentives for consuming lesser electricity.

### To Future Masters Projects

In our project, we analyzed all the possibilities for transmission lines, and completed a detailed analysis only for one no-transmission scenario. Since, it has been observed from our analysis that no-transmission scenarios make more sense for Africa, future masters projects should look at more such scenarios.

For example, they could look at

- Using only hydro all through the conservancy. The excess electricity could potentially be stored as compressed air and transported to the Centre. Thus, a detailed analysis of storage options for Mpala can be performed.
- Using a combination of solar and biogas (both of which do not need necessarily need transmission) and finding the sensitivities for such a system. The correct combination of the two might prove to be cheap, and reliable.

In the future, it is important to choose the best scenario and study it to a greater detail. After this is done, the students could also look to implement this in Mpala. A complete lifecycle analysis can be performed for the best scenario just like the one performed for the biogas system in this report.

Another concern for diesel consumption is the diesel used for transport. This has not been tracked in Mpala. They can thus also include transportation fuel consumption by the vehicles in Mpala to the total energy demand as this is a big consumer of gasoline.

Scaling up the system such that it can be used to power the villages surrounding Mpala is a potential direction to go especially in terms of locally manufacturing of electricity generating devices. This would require the students to dig deeper into the Clean Development Mechanism which was not analyzed in this project.

Biogas can also be produced from human waste. This can be analyzed since all the human waste at Mpala Research Centre go to one septic tank, and all the waste at the campsite can be used for composting waste.



## Literature Cited

- Abbey, A.T. (2005, March). Biogas in Uganda: a new experience. LEISA Magazine, 21(1), Retrieved from <http://www.agriculturesnetwork.org/magazines/global/energy-on-the-farm/biogas-in-uganda-a-new-experience>
- African Conservation Foundation. (2011). *African Conservation Foundation - Kenya - Mpala Wildlife Foundation*. Accessed 03/01/2011. Retrieved from <http://www.Africanconservation.org/explorer/Kenya/471-Mpala-wildlife-foundation/view-details.html>
- Ahuja, N., & Kishore, K.V.R. (2007). Methane emissions from dairy farms. *Proceedings of the methane to markets partnership expo*, [http://www.globalmethane.org/expo\\_china07/docs/postexpo/ag\\_india.pdf](http://www.globalmethane.org/expo_china07/docs/postexpo/ag_india.pdf).
- Airy, M.W.B. (No date). *Report on water supplies for Mpala Research Centre and Mpala Farm*. Mbagathi, Kenya.
- Alibaba (2011). Solar Water Pumps. Retrieved from [http://www.alibaba.com/trade/search?SearchText=solar+water+pumps&Country=&IndexArea=product\\_en&fsb=y](http://www.alibaba.com/trade/search?SearchText=solar+water+pumps&Country=&IndexArea=product_en&fsb=y)
- Amazon. (No date). Lighting Ever A19 5 Watt B22 LED light bulbs, 40 Watt incandescent bulbs replacement, B22 base, UL listed. Retrieved from <http://www.amazon.com/Lighting-EVER-Watt-Light-Bulbs/dp/B004BDABWY>
- Aquabarrel. (2011). *Mosquito control bits*. Retrieved from [http://www.aquabarrel.com/product\\_mosquito\\_control\\_bits.php](http://www.aquabarrel.com/product_mosquito_control_bits.php)
- Bardach, E. (2009). *A practical guide for policy analysis: the eightfold path to more effective problem solving (3rd edition)*. Washington, DC: CQ Press.
- Bernt Lorentz GmbH & Co., KG. (2008, August). *Solar water pumps in namibia: a comparison between solar and diesel*. Retrieved from [http://www.innovativesolar.com/images/File/lorentz\\_brochure\\_namibia\\_usd\\_en%20Solar%20VS%20Diesel.pdf](http://www.innovativesolar.com/images/File/lorentz_brochure_namibia_usd_en%20Solar%20VS%20Diesel.pdf)
- Center for Alternative Technology. (N.d.) How long do solar electric PV panels last? Retrieved from <http://info.cat.org.uk/questions/pv/life-expectancy-solar-PV-panels>
- Chiras, D.D. (2001). *The natural house: a complete guide to healthy, energy-efficient, environmental homes*. White River Junction, VT: Chelsea Green Publishing Company.
- Clean Air Gardening. (2010). *Summit mosquito control dunks*. Retrieved from <http://www.cleanairgardening.com/mosquito1.html>
- Conservation Technology. (2008). *Rainwater storage*. Retrieved from [http://www.conservationtechnology.com/rainwater\\_storage.html](http://www.conservationtechnology.com/rainwater_storage.html)
- Crawford, D. (2010). *Products*. Retrieved from <http://www.rainwatermanagement.com/products.php>
- Cross, M. (n.d.). *Water reuse & indoor water use*. Accessed 03/17/2011. Retrieved from [http://cas.illinoisstate.edu/sites/gmklass/?page\\_id=139](http://cas.illinoisstate.edu/sites/gmklass/?page_id=139)
- Daly, H.E. (1990). Toward some operational principles of sustainable development. *Ecological Economics*, (2), 1-6.
- Daly, Herman E. & Kenneth Townsend. (2003). *Valuing the earth: economics, ecology, ethics*. Cambridge: MIT Press.
- EarthEasy.com. (2011). *Low flow faucet aerator (2-pack) - 1.0 gpm*. Accessed 02/15/2011. Retrieved from <http://eartheasy.com/green-home/green-washroom/low-flow-faucet-aerator-2-pack-1-0-gpm>
- eHow.com. (N.d.). *How to fight climate change with cow dung*. Retrieved from [http://www.ehow.com/how\\_2294862\\_fight-climate-change-cow-dung.html#ixzz1HUQISIAq](http://www.ehow.com/how_2294862_fight-climate-change-cow-dung.html#ixzz1HUQISIAq)
- Endangered Islands Campaign. (No date). *Faqs*. Retrieved from <http://eic.climate.org/faq.html>
- Engelbertus, O. (2002). *The evolving context for hydropower development*. *Energy Policy*, 30(2002), PP-1215-1223.
- EPA WaterSense. (2007, September). *Faq: WaterSense labeled high-efficiency lavatory*. Accessed: 01/07/2011. Retrieved from [http://www.epa.gov/WaterSense/docs/ws\\_faq\\_faucet508.pdf](http://www.epa.gov/WaterSense/docs/ws_faq_faucet508.pdf)

- Ersson, Ole. (2006, November 14). *Rainwater harvesting and purification system*. Retrieved from <http://www.rwh.in/>
- Forster, P., V. Ramaswamy, P. Artaxo, T. Berntsen, R. Betts, D.W. Fahey, J. Haywood, J. Lean, D.C. Lowe, G. Myhre, J. Nganga, R. Prinn, G. Raga, M. Schulz and R. Van Dorland. (2007). Changes in Atmospheric Constituents and in Radiative Forcing. *In: Climate Change 2007: The Physical Science Basis. Contribution of Working Group I to the Fourth Assessment Report of the Intergovernmental Panel on Climate Change* [Solomon, S., D. Qin, M. Manning, Z. Chen, M. Marquis, K.B. Averyt, M.Tignor and H.L. Miller (eds.)]. Cambridge University Press, Cambridge, United Kingdom and New York, NY, USA.
- Foundation for International Environmental Law and Development. (2004). *Pros and cons of the cdm*. Retrieved from <http://www.cdmguide.net/cdm12.html>
- Gaiam. (2011). *Toilet lid sink*. Accessed 02/15/2011. Retrieved from <http://www.gaiam.com/product/toilet+lid+sink.do>
- Gasoline-Germany.com. (No date). Welcome to gasoline-germany.com. Retrieved from <http://www.gasoline-germany.com/statistik.phtml>
- Gathanju, D. (2010, June 16). Kenya bets big on renewable energy. *RenewableEnergyWorld.com*, Retrieved from <http://www.renewableenergyworld.com/rea/news/article/2010/06/Kenya-bets-big-on-renewable-energy>
- Global Ministerial Environmental ForumInitials (2004). Rainwater harvesting: a viable option in Kenya. *Proceedings of the 8th Special Session of the Governing Council/ Global ministerial Environment forum*, [www.unep.org/gc/gcss-viii/Kenya%20-%20Sanitation.doc](http://www.unep.org/gc/gcss-viii/Kenya%20-%20Sanitation.doc)
- Goodland, R. (2002). Sustainability: human, social, economic and environmental. Beau-Boekhout (Ed.), *Encyclopedia of Global Environmental Change* (pp. 1-3). Washington, DC, World Bank: John Wiley & Sons, Ltd.
- Hankins, M. (2006, April). Mpala Ranch energy audit findings and recommendations. Nairobi, Kenya: Energy Alternatives Africa.
- HOMER Energy. (No date). Optimizing clean power everywhere. Retrieved from <http://www.homerenergy.com/>
- Hopwood, B., M. Mellor, and G. O'Brien, (2005). Sustainable development: mapping different approaches. *Wiley InterScience*, (13), Retrieved from <http://www.interscience.wiley.com> doi: 10.1002/sd.244
- Jagadeesh, A. (2006). *Safe drinking for all through solar disinfection*. Retrieved from [http://www.harvesth2o.com/adobe\\_files/WaterForAllJagadeesh.pdf](http://www.harvesth2o.com/adobe_files/WaterForAllJagadeesh.pdf)
- James. (2010). Company info: Yueqing Zonhan Windpower Co., Ltd.. Retrieved from <http://zhwind.en.made-in-china.com/company-Yueqing-Zonhan-Windpower-Co-Ltd-.html>
- Kalders, J. Kenya Ministry of Water Development, (1986). *Design manual for water supply in Kenya*. Nairobi: Ministry of Water Development.
- Kavarana, G. (No date). *Components of a rainwater harvesting system*. Retrieved from <http://www.rainwaterharvesting.org/urban/Components.htm>
- Kenya Electricity Transmission Co. Ltd. (N.d.). *Faqs - underground construction*. Retrieved from [http://http://www.ketraco.co.ke/faqs/underground-construction.htmlwww.ehow.com/how\\_2294862\\_fight-climate-change-cow-dung.html#ixzz1HUQISIAq](http://http://www.ketraco.co.ke/faqs/underground-construction.htmlwww.ehow.com/how_2294862_fight-climate-change-cow-dung.html#ixzz1HUQISIAq)
- Kinkade-Levario, H. (2007). *Design for water: rainwater harvesting, stormwater catchment, and alternate water reuse*. BC, Canada: New Society Publishers.
- Kinnaird, M. (2010, August 14). Personal interview.
- Kohler Worldwide, (n.d.). *Cimarron® comfort height® elongated 1.28 gpf toilet with class six® technology - k-3609*. Accessed: 01/07/2011. Retrieved from [http://www.us.kohler.com/onlinecatalog/detail.jsp?from=thumb&frm=&module=Toilets&item=13362502&prod\\_num=3609§ion=2&category=13](http://www.us.kohler.com/onlinecatalog/detail.jsp?from=thumb&frm=&module=Toilets&item=13362502&prod_num=3609§ion=2&category=13)
- Laikipia Wildlife Forum. (2011). *Laikipia wildlife forum*. Accessed on 03/01/2011. Retrieved from <http://www.Laikipia.org/>



- Lane, I.M. (2010). Draft hydrogeological assessment study report; groundwater conditions in the southern part of Mpala Ranch, Laikipia North District . Lang'ata, Laikipia, Kenya: Aquasearch Limited.
- Liu, Andy. Dongguan Kindle Mechanical & Electrical Co., Ltd. Personal communication. 28 March 2011.
- Lea, M. (2008). Biological sand filters: low-cost bioremediation technique for production of clean drinking water. *Current Protocols in Microbiology*, 9, 1G1-28.
- Leting, J. (2010). Personal interview.
- Libba, G.C. (No date). *How much water can you collect in rain barrels during a rainfall*. Retrieved from <http://www.rainbarrelguide.com/how-much-water-can-you-collect-in-rain-barrels-during-a-rainfall/>
- Libba, G.C. (No date). *Other safety and maintenance concerns*. Retrieved from <http://www.rainbarrelguide.com/safety-maintenance/>
- Littleton, M. (2010, August 17). Personal interview.
- Mayo Clinic. (2007, August 13). How Much Water Should You Drink? It Depends. *ScienceDaily*. Retrieved April 3, 2011, from <http://www.sciencedaily.com/releases/2007/08/070811225126.htm>
- Mboyah, D. (2008). Climate change wreaks havoc to pastoralist communities in Kenya. *Africa Science News Service*, Accessed: 01/21/2011. Retrieved from [http://Africasciencenews.org/asns/index.php?option=com\\_content&task=view&id=567&Itemid=2](http://Africasciencenews.org/asns/index.php?option=com_content&task=view&id=567&Itemid=2)
- Meganck, R., Rast, W., & Rodgers, K.P. Organization of American States, Unit of Sustainable Development and Environment. (1997). *Source book of technologies for freshwater augmentation in Latin America and the Caribbean* Osaka/Shiga, Japan: UNEP International Environmental Technology Centre. Retrieved from <http://www.oas.org/dsd/publications/unit/oea59e/ch10.htm>
- Modson, Dipi. (2011, February 2011). Personal communication.
- Mone, J.G. (2001, August 9). *Ultraviolet water purification*. Retrieved from <http://www.cpesystems.com/data/WebSite/Processing%20Equipment%5CUV%20Sterilization%5CArticle1.pdf>
- Mpala Research Centre and Wildlife Foundation. (2010). *Facilities*. Retrieved from <http://Mpala.org/Facilities.php>
- Mpala Wildlife Foundation. (2009, November 25). *Mpala Research Centre objectives*. Accessed March 25, 2010. Retrieved from <http://mpala.org/researchctr/objectives.html>
- Mugwe, D. (2010, August 4). Petroleum price rally spurs search for clean energy. *Business Daily (Nairobi)*, Retrieved from <http://allafrica.com/stories/201008050107.html>
- Muhuro, P.N. (2010). Off-grid electricity access and its impact on micro-enterprises: evidence from rural Uganda. University of Michigan.
- Mukabana, J. (2010). Climate change, disaster management and environmental governance in Kenya: policy options and implementations by different institutions. *Proceedings of the 6th yadsti annual conference & exhibition* <http://www.yadsti.org/gallery&downloads.php>.
- O'Neill, J. (2010, September 15). *Villages awash in clean water thanks to group*. Retrieved from <http://www.redding.com/news/2010/sep/15/villages-awash-in-clean-water-thanks-to-group/>
- Obulutsa, G. (2011, March 23). Rpt-Kenya says \$100 oil to cost it extra \$700 mln in 2011. *Reuters Africa*. Retrieved from <http://af.reuters.com/article/KenyaNews/idAFLDE72M1U720110323?pageNumber=1&virtuaIBrandChannel=0>.
- Oloo, H. (2010). *Mpala Research Centre solar systems report*.
- Pandey, B., Subedi, P.S., Sengendo, M., & Monroe, I. (2007, May 29). Biogas for a better life: an african initiative. Retrieved from [http://www.snvworld.org/en/Documents/Biogas\\_for\\_better\\_life\\_an\\_African\\_initiative\\_Feasibility\\_study\\_Uganda\\_2007.pdf](http://www.snvworld.org/en/Documents/Biogas_for_better_life_an_African_initiative_Feasibility_study_Uganda_2007.pdf)
- Peace Corps Coverdell World Wise Schools. (n.d.). *Water in Africa*. Accessed 03/17/2011. Retrieved from <http://www.peacecorps.gov/www/educators/enrichment/Africa/about/index.html>

- Phuangpornpitak, N., & Kumar, S. (2007). PV hybrid systems for rural electrification in Thailand. *Renewable and Sustainable Energy Reviews*, 11(7), 1530-43.
- Pratt, A. (2005, July 8). *First flush: what is first flush?*. Retrieved from <http://www.rain-barrel.net/first-flush.html>
- Pushard, D. (2010, March 28). *First flush devices - a review*. Retrieved from [http://www.harvesth2o.com/first\\_flush.shtml](http://www.harvesth2o.com/first_flush.shtml)
- Pushard, D. (No date). *Potable rainwater: filtration and purification*. Retrieved from [http://www.harvesth2o.com/filtration\\_purification.shtml](http://www.harvesth2o.com/filtration_purification.shtml)
- Rabah, K.V.O., 2005, *Integrated Solar Energy Systems for Rural Electrification in Kenya*, *Journal of Renewable Energy*, 30, pp. 23-41.
- Rell, M.J., & Caruso, D.F. State of Connecticut, Connecticut Siting Council. (2007). *Life cycle 2007*. Retrieved from [http://www.ct.gov/csc/lib/csc/life\\_cycle\\_rfp/43714q1.pdf](http://www.ct.gov/csc/lib/csc/life_cycle_rfp/43714q1.pdf)
- Sambu, Z. (2011, March 21). Tough times ahead for business as oil price hits new high. *Business Daily Africa*. Retrieved from <http://www.businessdailyafrica.com/Corporate+News/Tough+times+ahead+for+business+as+oil+price+hits+new+high/-/539550/1129880/-/95e0flz/-/index.html>.
- Schmidt, T.C. (2006). Fluoride's effect on bone and related factors. *Illuminae*, Accessed 03/15/2011. Retrieved from <http://www.a-zholisticdentistry.com/illuminae/fluoride.htm>;
- Setiawan, A.A., Zhao, Y., & Nayar, C.V. (2008). Design, economic analysis and environmental considerations of mini-grid hybrid power system with reverse osmosis desalination plant for remote areas. *Journal of Renewable Energy*, 34, 374-83.
- Skeen, M. (2011, March 3). Rainwater Management Solutions recognized in international drinking water competition [Web log message]. Retrieved from <http://blogs.roanoke.com/ticker/2011/03/04/rainwater-management-solutions-recognized-in-international-drinking-water-competition/>
- Spratt, S. (2007, January). *Making rain gutters work!*. Retrieved from <http://www.harvesth2o.com/raingutters.shtml>
- Steed, S. (2008, June 30). *Rid the roof of birds*. Retrieved from <http://ezinearticles.com/?Rid-the-Roof-of-Birds&id=1281605>
- Tarsi, D. (2007, August 13). *Building a small slow sand water filter for individual use*. Retrieved from [http://www.shared-source-initiative.com/biosand\\_filter/biosand.html](http://www.shared-source-initiative.com/biosand_filter/biosand.html)
- Teleke, S., Baran, M.E., Bhattacharya, S., & Huang, A.Q. (2010). Rule-based control of matter energy storage for dispating intermittent renewable sources. *IEE Transactions on Sustainable Energy*, 1(3), 117-124.
- Texas Water Development Board, (2005). *The Texas manual on rainwater harvesting*. Austin, TX: Texas Water Development Board.
- Tractor Supply. (No date). Westinghouse Lighting 40W A15 clear long life incandescent light bulb, pack of 2. Retrieved from <http://www.tractorsupply.com/outlets-lighting-fixtures/light-bulbs/westinghouse-lighting-40w-a15-clear-long-life-incandescent-light-bulb-pack-of-2-3227295>
- Trading Economics. (2010). *Pump price for diesel fuel (U dollar per liter) in Kenya*. Retrieved from <http://www.tradingeconomics.com/Kenya/pump-price-for-diesel-fuel-us-dollar-per-liter-wb-data.html>
- Traexler, Tom. Personal Interview. 12 Aug 2010.
- Tuni, M. (2010, August 7). Personal interview.
- United States Central Intelligence Agency, (2010). *Kenya CIA - The World Factbook*. Retrieved from <https://www.cia.gov/library/publications/the-world-factbook/geos/ke.html>
- United States Environmental Protection Agency, (2009). *WaterSense water savings calculator* Retrieved from [http://www.epa.gov/WaterSense/calculate\\_your\\_water\\_savings.html](http://www.epa.gov/WaterSense/calculate_your_water_savings.html).
- U.S. Department of Housing and Urban Development. (1985). *Public and Indian housing handbook, Chapter 6: mechanical systems*. Retrieved from <http://www.hud.gov/offices/adm/hudclips/handbooks/pihh/74852/74852c6PIHH.pdf>

- United States Green Building Council, . (2009). *Leed reference guide for green building design and construction*. Retrieved from [http://assets.ecorussia.info/assets/paragraph\\_attaches/5564/paragraph\\_media\\_5564\\_original.pdf?1269257430](http://assets.ecorussia.info/assets/paragraph_attaches/5564/paragraph_media_5564_original.pdf?1269257430)Wikipedia. (n.d.). *Solar water heating*. Accessed: 1/15/2011. Retrieved from [http://en.wikipedia.org/wiki/Solar\\_water\\_heating](http://en.wikipedia.org/wiki/Solar_water_heating)
- Waite, M. (2010). *Sustainable water resources in the built environment*. London, UK: IWA Publishing.
- Walmart. (No date). GE CFL light bulb, mini: 10 watt (40w equiv), 4-pk. Retrieved from <http://www.walmart.com/ip/GE-CFL-Light-Bulb-Mini-10-Watt-40W-Equiv-4-Pk/5646245>
- Weldemariam, L.E. (2010). Genset-solar-wind hybrid power system of off-grid power station for rural applications. Master's thesis, Department of Electrical Power Engineering, Delft University of Technology, Delft, The Netherlands. Retrieved from <http://repository.tudelft.nl/view/ir/uuid%3A63fe5088-205f-4091-93ad-5f5130bac897/>
- Wheeler, J. (2010). *Four steps to high quality harvested rainwater: a non-mechanical process*. Retrieved from <http://www.rainfilters.com/index.html>
- Williams, A., & Porter, S. (2006). Comparison of hydropower options for developing countries with regard to the environmental, social and economic aspects. *Proceedings of the International conference on renewable energy for developing countries*, [http://www.udc.edu/cere/Williams\\_Porter.pdf](http://www.udc.edu/cere/Williams_Porter.pdf)
- Wiman, S. (2009, April 21). Water purification technology: what is "green" & what is not. *Sustainable Santa Fe Guide*, Retrieved from <http://www.sustainablesantafeguide.com/2009/117.html>
- World Health Organization, (2009). *Bacillus thuringiensis israelensis (Bti) in drinking water* Geneva, Switzerland: WHO Document Production Services. Retrieved from [http://www.who.int/water\\_sanitation\\_health/gdwqrevision/RevisedFourthEditionBacillusthuringiensis\\_Bti\\_July272009\\_2.pdf](http://www.who.int/water_sanitation_health/gdwqrevision/RevisedFourthEditionBacillusthuringiensis_Bti_July272009_2.pdf)
- Yurco, Kayla. Personal communication. 23 March 2011.
- Zemsky, M. (2010, June 14). *Deterring birds: protecting your garden and home from messy birds*. Retrieved from [http://gardening.about.com/od/gardenproblems/a/Deterring\\_Birds.htm](http://gardening.about.com/od/gardenproblems/a/Deterring_Birds.htm)

**Appendix W-1: Borehole meter Readings at Main (primary), Ranch & Centre borehole (secondary) (August – December 2010)**

	Ranch House (m <sup>3</sup> )	Ranch difference	MRC (m <sup>3</sup> )	MRC difference	Borehole (m <sup>3</sup> )	Borehole difference
10.08.2006			6031			
11.08.2007						
12.08.2007						
13.08.2008			6083			
14.08.2008	52		6107	23.75	25	
15.08.2009	55	3			44	19.38
16.08.2009						
17.08.2010			6196			
18.08.2010					217	
19.08.2010	110		6221		254	37
20.08.2010			6247	26	270	16
21.08.2010	113		6279	32	287	17
22.08.2010					341	54
23.08.2010					380	39
24.08.2010					401	21
25.08.2010					417	16
26.08.2010					447	30
27.08.2010					469	22
28.08.2010					487	18
29.08.2010					536	49
30.08.2010					593	57
31.08.2010					630	37
01.09.2010	177		6457		680	50
02.09.2010					695	15
03.09.2010					751	56
04.09.2010					786	35
05.09.2010					876	90
06.09.2010					912	36
07.09.2010					927	15
08.09.2010					1006	79
09.09.2010					1051	45
10.09.2010					1094	43
11.09.2010					1145	51
12.09.2010					1170	25
13.09.2010					1190	20
14.09.2010					1217	27

15.09.2010					1232	15
16.09.2010					1286	54
17.09.2010					1340	54
18.09.2010					1372	32
19.09.2010					1396	24
20.09.2010					1423	27
21.09.2010					1456	33
22.09.2010					1462	6
23.09.2010					1480	18
24.09.2010					1515	35
25.09.2010					1545	30
26.09.2010					1581	36
27.09.2010					1624	43
19.10.2010	345		7431		2259	635
20.10.2010	345	0	7452	21	2285	26
21.10.2010	345	0	7469	17	2316	31
22.10.2010	345	0			2342	26
23.10.2010	346	1	7508		2374	32
24.10.2010	369	23	7524	16		
25.10.2010	369	0	7542	18	2396	
26.10.2010	369	0	7565	23	2441	45
27.10.2010	369	0	7572	7	2503	107
28.10.2010	369	0	19		2550	47
29.10.2010	369	0	35	16	2567	64
30.10.2010	370	1	52	17		
31.10.2010						
1.11.2010	370		93	41	2650	
2.11.2010	370	0	112	19	2677	27
3.11.2010	370	0	129	17	2703	26
4.11.2010	382	12	145	16	2750	47
5.11.2010	382	0	160	15	2786	36
6.11.2010	421	39	188	28	2835	49
7.11.2010	424	3	210	22	2867	32
8.11.2010	430	6	210	0	2884	17
9.11.2010	430	0	240	30	2910	26
10.11.2010	430	0	259	19	2931	21
11.11.2010	460	30	261	2	2952	21
12.11.2010	460	0	268	7	2968	16
13.11.2010	479	19	297	29	3014	46
14.11.2010	479	0	319	22	3041	27
15.11.2010	479	0	337	18	3058	17

16.11.2010	479	0	337	0	3080	22
17.11.2010	481	2	369	32	3108	28
18.11.2010	481	0	390	21	3145	37
19.11.2010	481	0	417	27	3186	41
20.11.2010	481	0	435	18	3214	28
21.11.2010	481	0	456	21	3251	37
22.11.2010	481	0	468	12	3262	11
23.11.2010	481	0	480	12	3284	22
24.11.2010	481	0	511	31	3305	21
25.11.2010	481	0	530	19	3326	21
26.11.2010	481	0	531	1	3344	18
27.11.2010	481	0	562	31	3376	32
28.11.2010	481	0	585	23	3390	14
29.11.2010	481	0	602	17	3406	16
30.11.2010	481	0	602	0	3425	19
1.12.2010	481	0	635	33	3452	27
2.12.2010	481	0	658	23	3478	26
3.12.2010	481	0	678	20	3524	46
4.12.2010	565	84	697	19	3555	31
5.12.2010	565	0	697	0	3561	6
6.12.2010	565	0	714	17	3587	26
7.12.2010	565	0	747	33	3618	31
8.12.2010	565	0	770	23	3639	21
9.12.2010	565	0	789	19	3650	11
10.12.2010	663	98	800	11	3661	11
11.12.2010	663	0	807	7	3683	22
12.12.2010	663	0	880	73	3725	42
13.12.2010	663	0	880	0	3754	29
14.12.2010	663	0	825	-55	3797	43
15.12.2010	663	0	841	16	3834	37
16.12.2010	663	0	881	40	3870	36
17.12.2010	663	0	914	33	3901	31
18.12.2010	663	0	948	34	3940	39
19.12.2010	663	0	971	23	3967	27
20.12.2010	708	45	990	19	3998	31
21.12.2010	708	0	1010	20	4034	36
22.12.2010	708	0	1028	18	4051	17
23.12.2010	708	0	1044	16	4073	22
24.12.2010	726	18	1056	12	4095	22
25.12.2010	726	0	1089	33	4123	28
26.12.2010	726	0	1110	21	4160	37

27.12.2010	726	0	1126	16	4193	33
28.12.2010	726	0			4241	48
29.12.2010	772	46				
AVERAGE DAILY		6.14		18.98		37.67
PERCENT OF TOTAL		24%		76%		

SHARE OF TOTAL BOREHOLE IF NO LOSSES	9.21	28.46
--	------	-------

<b>MISSING/ DISCREPANCY</b>	<b>3.07</b>	<b>9.48</b>
---------------------------------	-------------	-------------

## Appendix W-2: Current buildings – roof size and water storage capabilities at MRC

Building	Roof Area (m <sup>2</sup> )	Quantity	Equipped to Catch	Current Storage Volume (liters)
Director's House	130	1	Yes	7000
Princeton Dorm	200	1	No	
Keller's Dorm		1	No	
Small Kitchen	66	1	Yes	2000
Mess Hall	286	1	Yes	16900
Store 15	65	1	Yes	14000
Admin Block	112	1	Yes	12000
McCormack Lab	175	1	Yes	39000
Library	199	1	Yes	26000
NSF Lab	175	1	Yes	13000
Jenga House	175	1	Yes	6900
GIS (Grevy) House	155	1	Yes	13000
Chris (Klee) House	155	1	Yes	13000
Admin (Wild Dog) House	90	1	Yes	6900
Heathrow House	226	1	No	
Workshop	145	1	No	
Gym	80	1	Yes	13000
Petrol Bunk	41	1	No	
Bandas (1-11)	39	11	No	
Julius's House	35	1	No	
Village House (Triplex1)	12	1	No	
Village House (Triplex2)	12	1	No	
Village House (1 Br)	19	35	No	
Village House (2 Br)	26	3	No	
Village House (1 Br plus)	30	12	No	
Storage for each house	5	52	No	



### Appendix W-3: Accumulation graphs

The following graphs were used to illustrate the discrepancy between the volume of rain run-off from different percentages of Mpala Research Centre building roof areas and current and projected human use. The purpose of accumulating the figure month after month is to show the variable run-off accumulation rate vs. the constant rate of use accumulation. It is also to show, after one calendar year, the amount of shortfall experienced due to the different roof collection area sizes and the two populations (current vs. projected). Below is the data and the process is explained in the Methodology section of this report.

#### Appendix W-3a. Accumulated roof runoff and water demand under average rain conditions

Month	Average Monthly Rain (mm)	Average Monthly Rain (m)	Roof area 100% (m <sup>2</sup> )	Roof area 75% (m <sup>2</sup> )	Roof area 50% (m <sup>2</sup> )	Current Roof Area (46.4% of total)
Apr	76.709	0.077	4,255	3,191	2,128	1,973
May	58.732	0.059	4,255	3,191	2,128	1,973
Jun	25.440	0.025	4,255	3,191	2,128	1,973
Jul	48.340	0.048	4,255	3,191	2,128	1,973
Aug	50.954	0.051	4,255	3,191	2,128	1,973
Sep	30.110	0.030	4,255	3,191	2,128	1,973
Oct	42.886	0.043	4,255	3,191	2,128	1,973
Nov	69.711	0.070	4,255	3,191	2,128	1,973
Dec	23.896	0.024	4,255	3,191	2,128	1,973
Jan	19.812	0.020	4,255	3,191	2,128	1,973
Feb	6.955	0.007	4,255	3,191	2,128	1,973
Mar	30.694	0.031	4,255	3,191	2,128	1,973

Month	Volume Run-off from 100% Roof Area (m <sup>3</sup> )	Accumulated Run-off from 100% Roof Area (m <sup>3</sup> )	Volume Run-off from 75% Roof Area(m <sup>3</sup> )	Accumulated Run-off from 75% Roof Area (m <sup>3</sup> )	Volume Run-off from 50% Roof Area(m <sup>3</sup> )	Accumulated Run-off from 50% Roof Area (m <sup>3</sup> )
Apr	277.4	277.4	208.078	208.078	138.719	138.719
May	212.4	489.9	159.314	367.392	106.209	244.928
Jun	92.0	581.9	69.009	436.401	46.006	290.934
Jul	174.8	756.7	131.124	567.525	87.416	378.350
Aug	184.3	941.0	138.217	705.742	92.144	470.495
Sep	108.9	1,049.9	81.674	787.416	54.449	524.944
Oct	155.1	1,205.0	116.331	903.747	77.554	602.498
Nov	252.1	1,457.1	189.096	1,092.842	126.064	728.562
Dec	86.4	1,543.5	64.819	1,157.661	43.213	771.774
Jan	71.7	1,615.2	53.741	1,211.403	35.828	807.602
Feb	25.2	1,640.4	18.867	1,230.270	12.578	820.180
Mar	111.0	1,751.4	83.260	1,313.530	55.507	875.687

Month	Run-off Actual (46.4%)	Accum. Actual (46.4%)	Visitor Bednights (Average Monthly)	Villager Bednights (per Month)	Essential water required (l)	Essential water required (m <sup>3</sup> )
Apr	128.645	128.645	520	7170	61522.7	61.5
May	98.496	227.141	311	7409	61757.3	61.8
Jun	42.665	269.806	493	7170	61304.0	61.3
Jul	81.068	350.874	648	7409	64456.0	64.5
Aug	85.453	436.327	541	7409	63597.3	63.6
Sep	50.495	486.822	332	7170	60013.3	60.0
Oct	71.922	558.744	497	7409	63250.7	63.3
Nov	116.909	675.653	220	7170	59122.7	59.1
Dec	40.075	715.728	88	7409	59978.7	60.0
Jan	33.226	748.953	584	7409	63946.7	63.9
Feb	11.665	760.618	433	6931	58909.3	58.9
Mar	51.476	812.094	608	7409	64138.7	64.1

Month	Accum. Essential Water (m <sup>3</sup> )	Monthly Average Visitor Bednight x2	Villager Monthly Bednight x1.33	Essential water required Projected (m <sup>3</sup> )	Accum. Essential Projected (m <sup>3</sup> )
Apr	61.5	1040.667	9536.1	84.6	84.6
May	123.3	621.3333	9853.97	83.8	168.4
Jun	184.6	986	9536.1	84.2	252.6
Jul	249.0	1296	9853.97	89.2	341.8
Aug	312.6	1081.333	9853.97	87.5	429.3
Sep	372.7	663.3333	9536.1	81.6	510.9
Oct	435.9	994.6667	9853.97	86.8	597.7
Nov	495.0	440.6667	9536.1	79.8	677.5
Dec	555.0	176.6667	9853.97	80.2	757.7
Jan	618.9	1168.667	9853.97	88.2	845.9
Feb	677.9	865.3333	9218.23	80.7	926.6
Mar	742.0	1216.667	9853.97	88.6	1,015.1

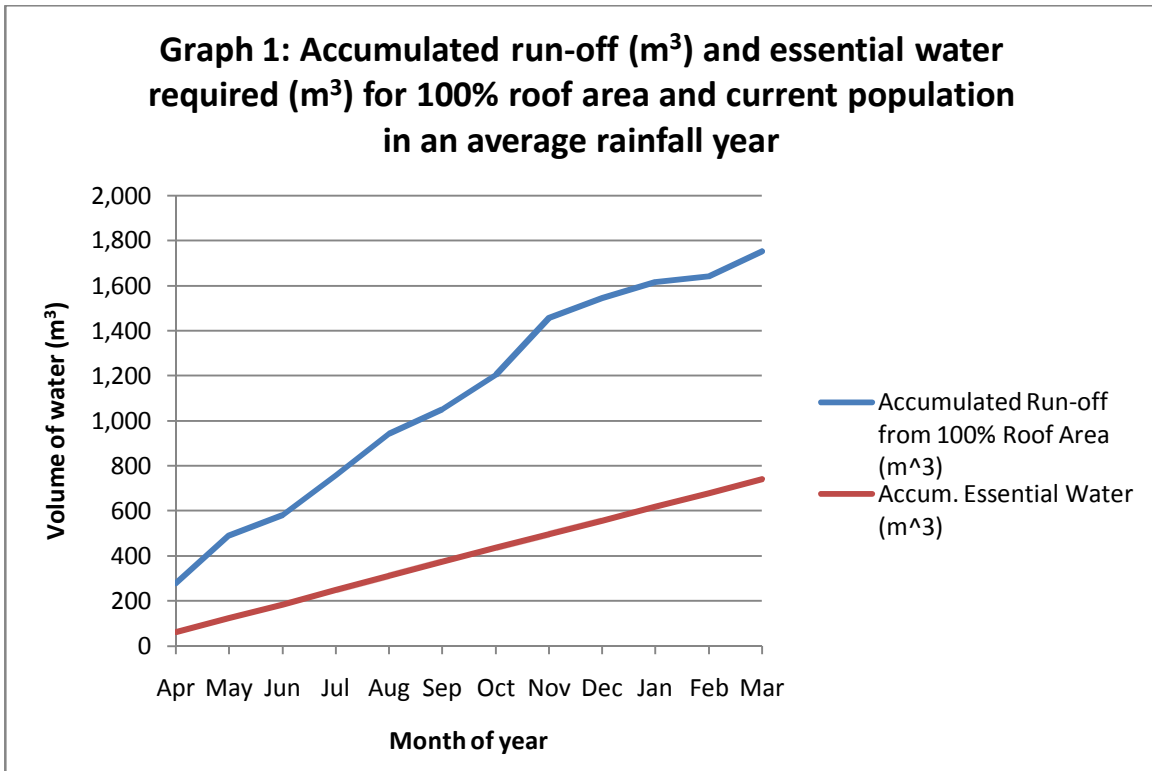

**Graph 2: Accumulated run-off (m<sup>3</sup>) and essential water required (m<sup>3</sup>) for 100% roof area and projected population in an average rainfall year**

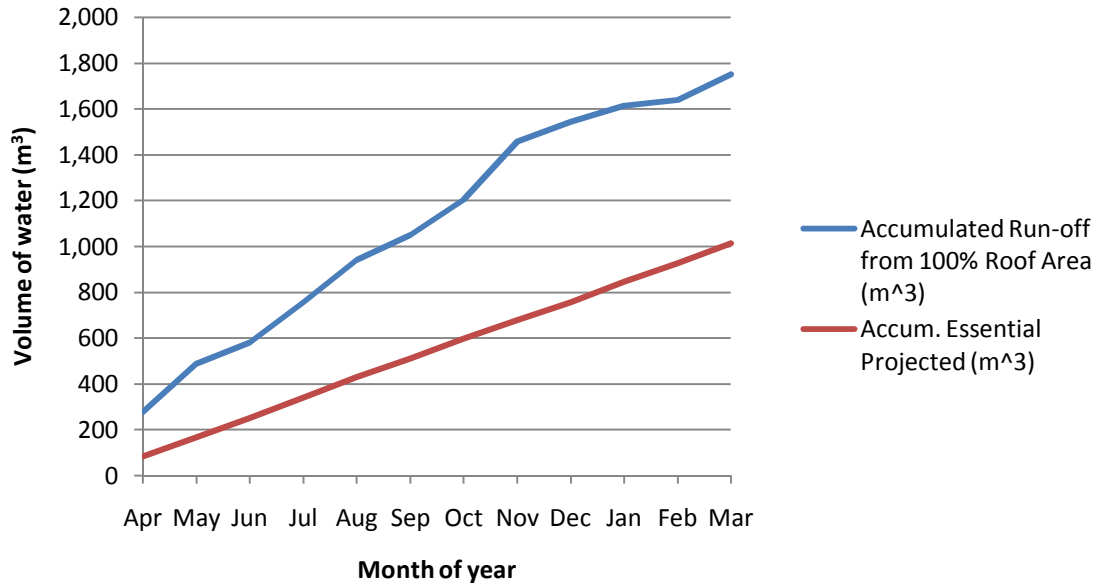

**Graph 3: Accumulated run-off (m<sup>3</sup>) and essential water required (m<sup>3</sup>) for 75% roof area and current population in an average rainfall year**

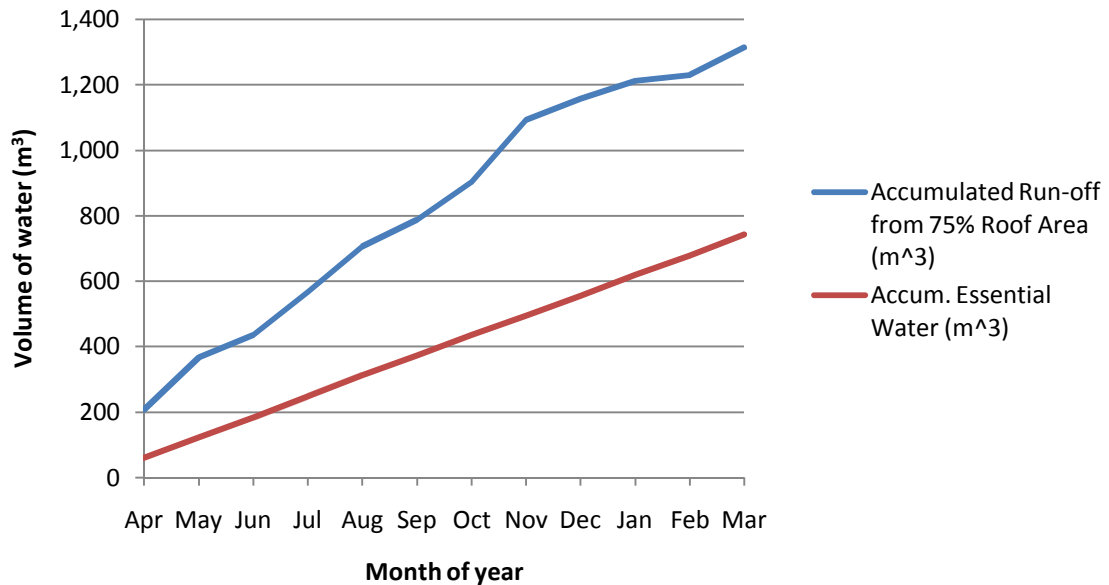

**Graph 4: Accumulated run-off (m<sup>3</sup>) and essential water required (m<sup>3</sup>) for 75% roof area and projected population in an average rainfall year**

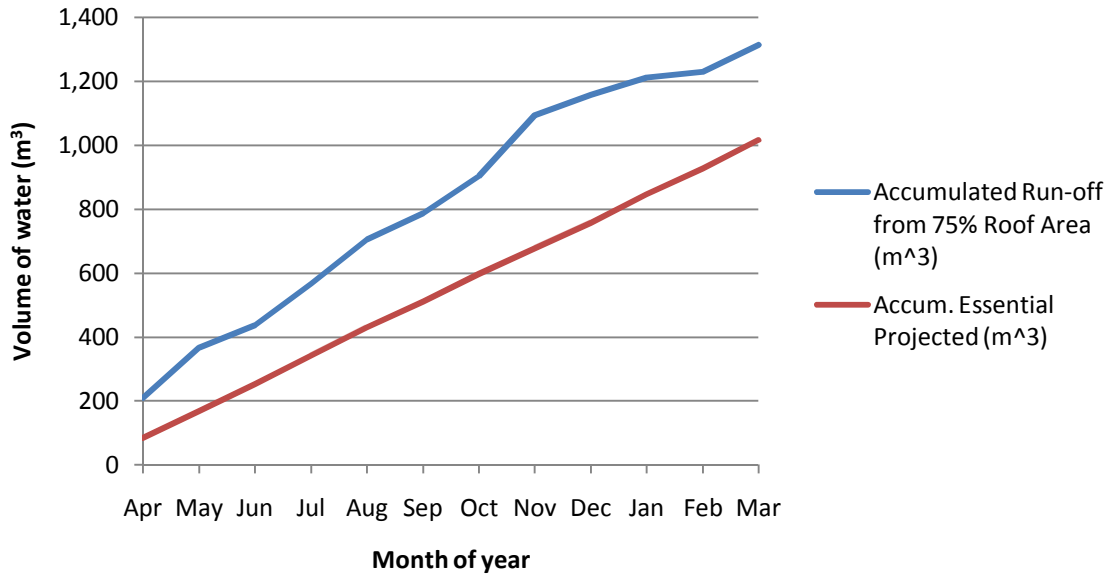

**Graph 5: Accumulated run-off (m<sup>3</sup>) and essential water required (m<sup>3</sup>) for 50% roof area and current population in an average rainfall year**

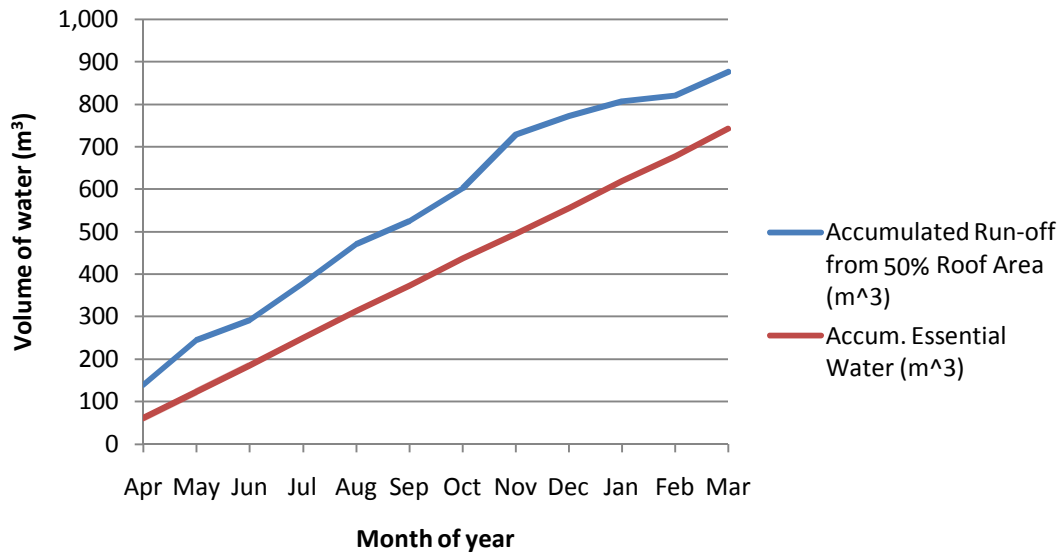

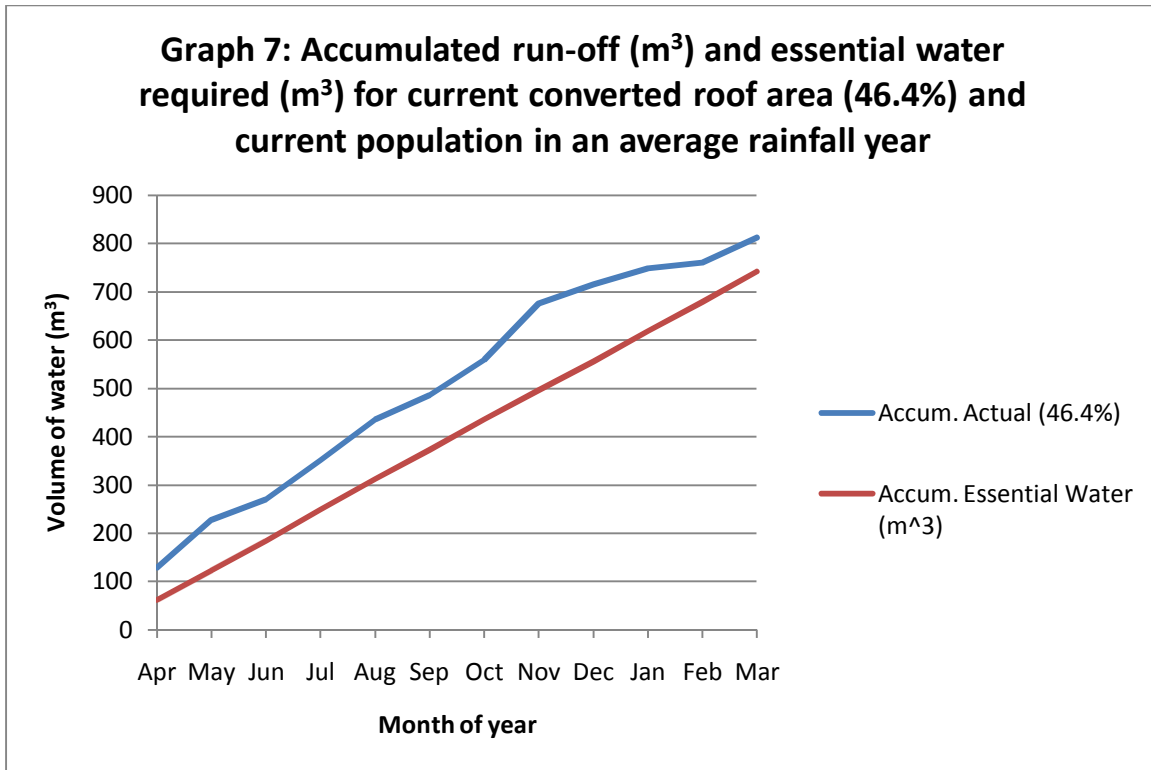
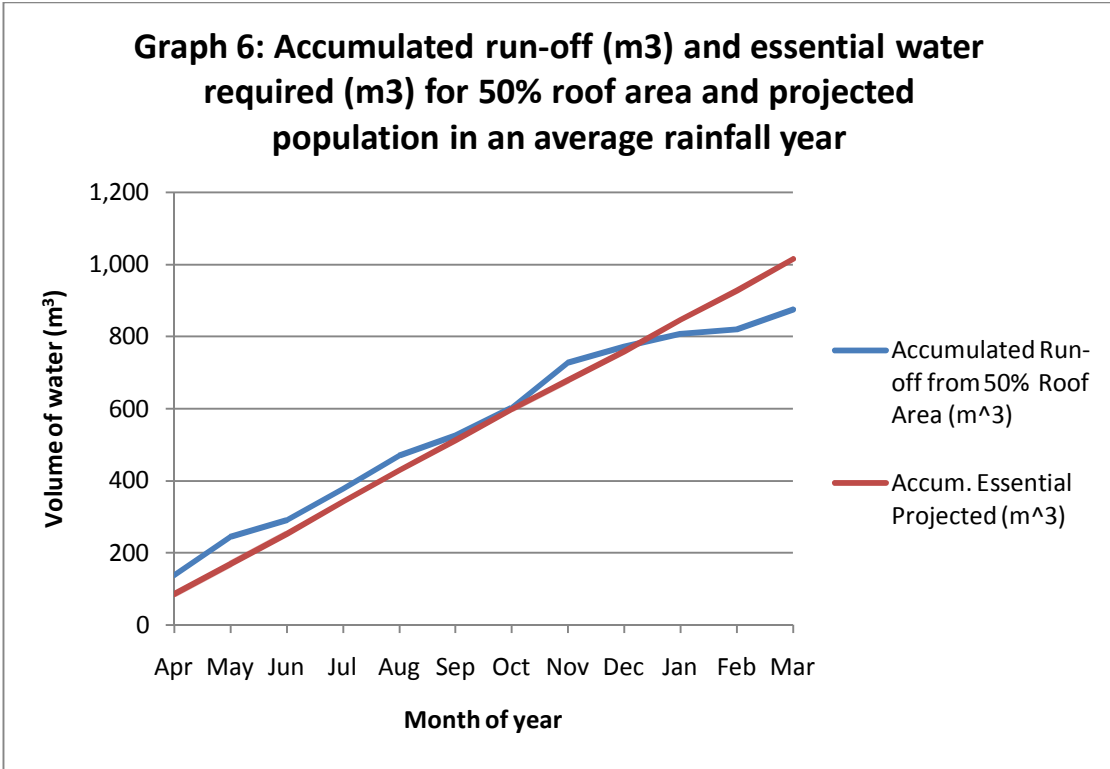

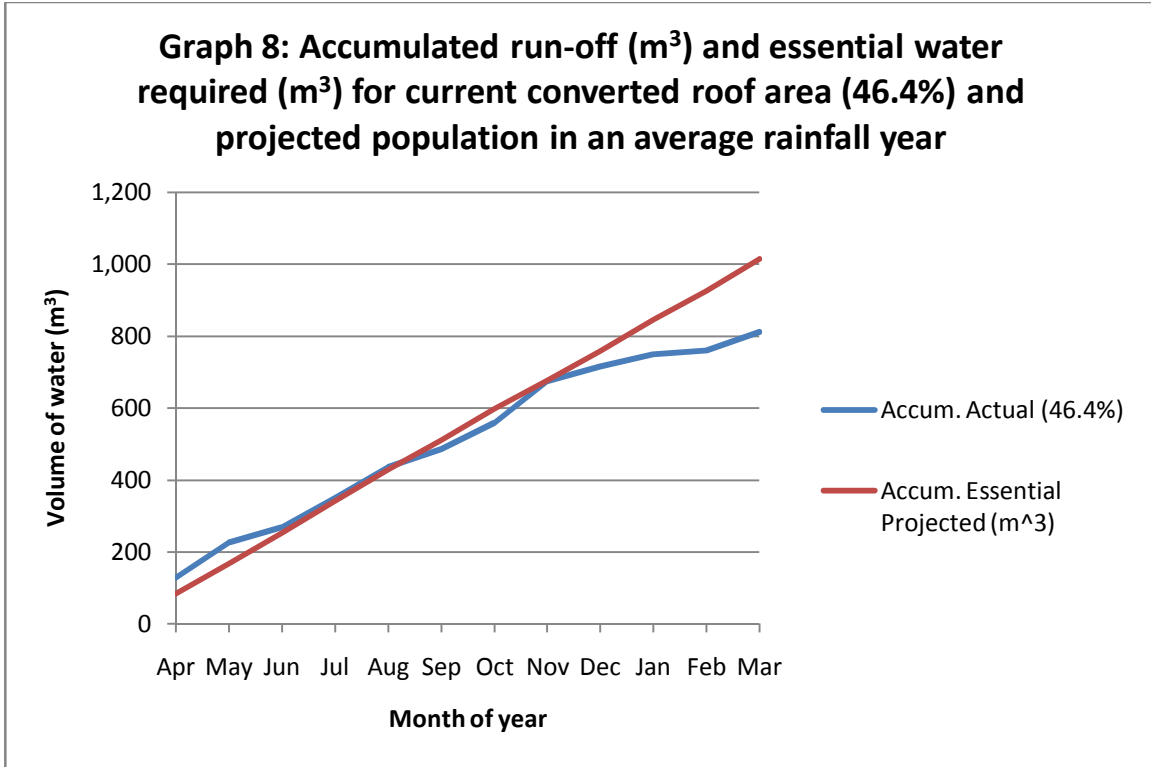

### Appendix W-3b. Accumulated roof runoff and water demand under low rain conditions

Month	Average Monthly Rain (mm)	Average Monthly Rain (m)	Roof area 100% (m <sup>2</sup> )	Roof area 75% (m <sup>2</sup> )	Roof area 50% (m <sup>2</sup> )	Current Roof Area (46.4%)
Apr	3.600	0.004	4,255	3,191	2,128	1,973
May	48.700	0.049	4,255	3,191	2,128	1,973
Jun	0.000	0.000	4,255	3,191	2,128	1,973
Jul	5.400	0.005	4,255	3,191	2,128	1,973
Aug	7.300	0.007	4,255	3,191	2,128	1,973
Sep	0.000	0.000	4,255	3,191	2,128	1,973
Oct	76.980	0.077	4,255	3,191	2,128	1,973
Nov	69.600	0.070	4,255	3,191	2,128	1,973
Dec	86.300	0.086	4,255	3,191	2,128	1,973
Jan	23.000	0.023	4,255	3,191	2,128	1,973
Feb	0.000	0.000	4,255	3,191	2,128	1,973
Mar	0.000	0.000	4,255	3,191	2,128	1,973

Month	Volume Run-off from 100% Roof Area(m <sup>3</sup> )	Accumulated Run-off from 100% Roof Area (m <sup>3</sup> )	Volume Run-off from 75% Roof Area (m <sup>3</sup> )	Accumulated Run-off from 75% Roof Area (m <sup>3</sup> )	Volume Run-off from 50% Roof Area (m <sup>3</sup> )	Accumulated Run-off from 75% Roof Area (m <sup>3</sup> )
Apr	13.020	13.020	9.765	9.765	6.510	6.510
May	176.136	189.156	132.102	141.867	88.068	94.578
Jun	0.000	189.156	0.000	141.867	0.000	94.578
Jul	19.530	208.686	14.648	156.515	9.765	104.343
Aug	26.402	235.089	19.802	176.317	13.201	117.544
Sep	0.000	235.089	0.000	176.317	0.000	117.544
Oct	278.417	513.506	208.813	385.130	139.209	256.753
Nov	251.726	765.232	188.794	573.924	125.863	382.616
Dec	312.126	1,077.357	234.094	808.018	156.063	538.679
Jan	83.185	1,160.543	62.389	870.407	41.593	580.271
Feb	0.000	1,160.543	0.000	870.407	0.000	580.271
Mar	0.000	1,160.543	0.000	870.407	0.000	580.271



Month	Run-off Actual (46.4%)	Accum. Actual (46.4%)	Visitor Bednights (Average Monthly)	Villager Bednights (per Month)	Essential water required (l)	Essential water required (m <sup>3</sup> )
Apr	6.036	6.036	520	7170	61522.66667	61.52266667
May	81.657	87.693	311	7409	61757.33333	61.75733333
Jun	0.000	87.693	493	7170	61304	61.304
Jul	9.054	96.747	648	7409	64456	64.456
Aug	12.240	108.987	541	7409	63597.33333	63.59733333
Sep	0.000	108.987	332	7170	60013.33333	60.01333333
Oct	129.074	238.061	497	7409	63250.66667	63.25066667
Nov	116.700	354.762	220	7170	59122.66667	59.12266667
Dec	144.701	499.463	88	7409	59978.66667	59.97866667
Jan	38.565	538.028	584	7409	63946.66667	63.94666667
Feb	0.000	538.028	433	6931	58909.33333	58.90933333
Mar	0.000	538.028	608	7409	64138.66667	64.13866667

Month	Accum. Essential Water (m <sup>3</sup> )	Monthly Average Visitor Bednight x2	Villager Monthly Bednight x1.33	Essential water required Projected (m <sup>3</sup> )	Accum. Essential Projected (m <sup>3</sup> )
Apr	61.523	1040.667	9536.1	84.61413	84.614
May	123.280	621.3333	9853.97	83.80243	168.417
Jun	184.584	986	9536.1	84.1768	252.593
Jul	249.040	1296	9853.97	89.19976	341.793
Aug	312.637	1081.333	9853.97	87.48243	429.276
Sep	372.651	663.3333	9536.1	81.59547	510.871
Oct	435.901	994.6667	9853.97	86.78909	597.660
Nov	495.024	440.6667	9536.1	79.81413	677.474
Dec	555.003	176.6667	9853.97	80.24509	757.719
Jan	618.949	1168.667	9853.97	88.18109	845.900
Feb	677.859	865.3333	9218.23	80.66851	926.569
Mar	741.997	1216.667	9853.97	88.56509	1,015.134

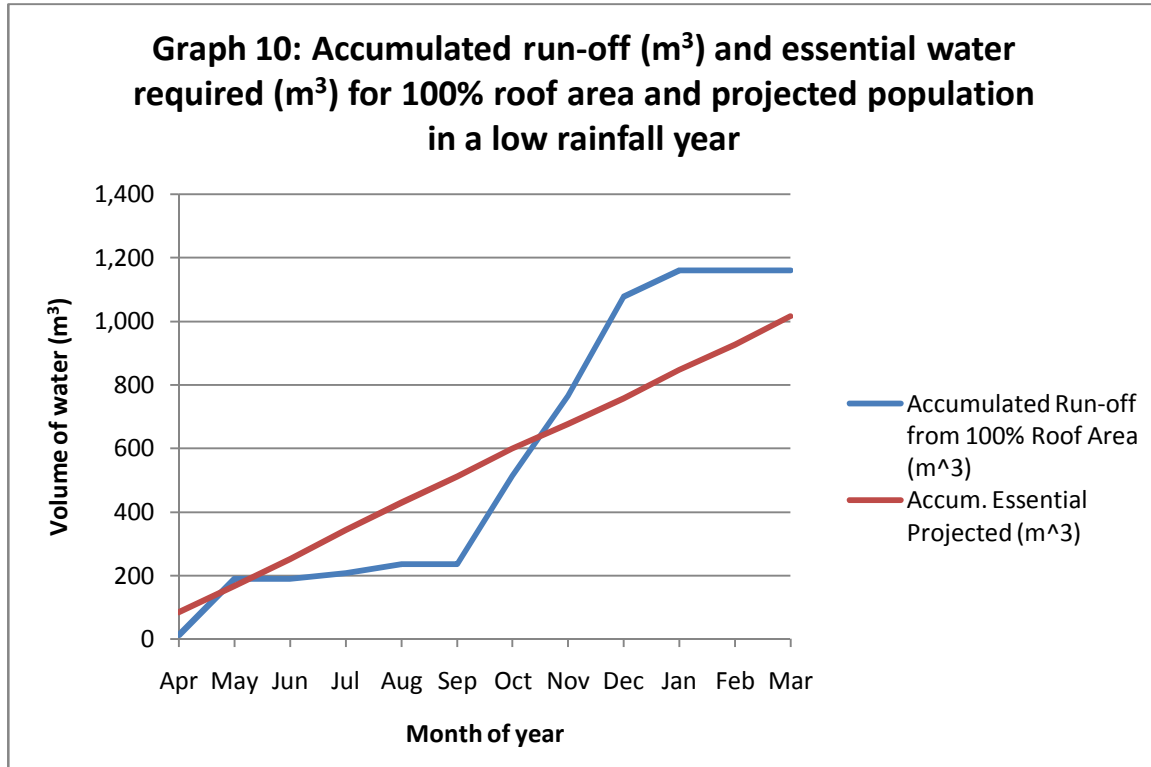
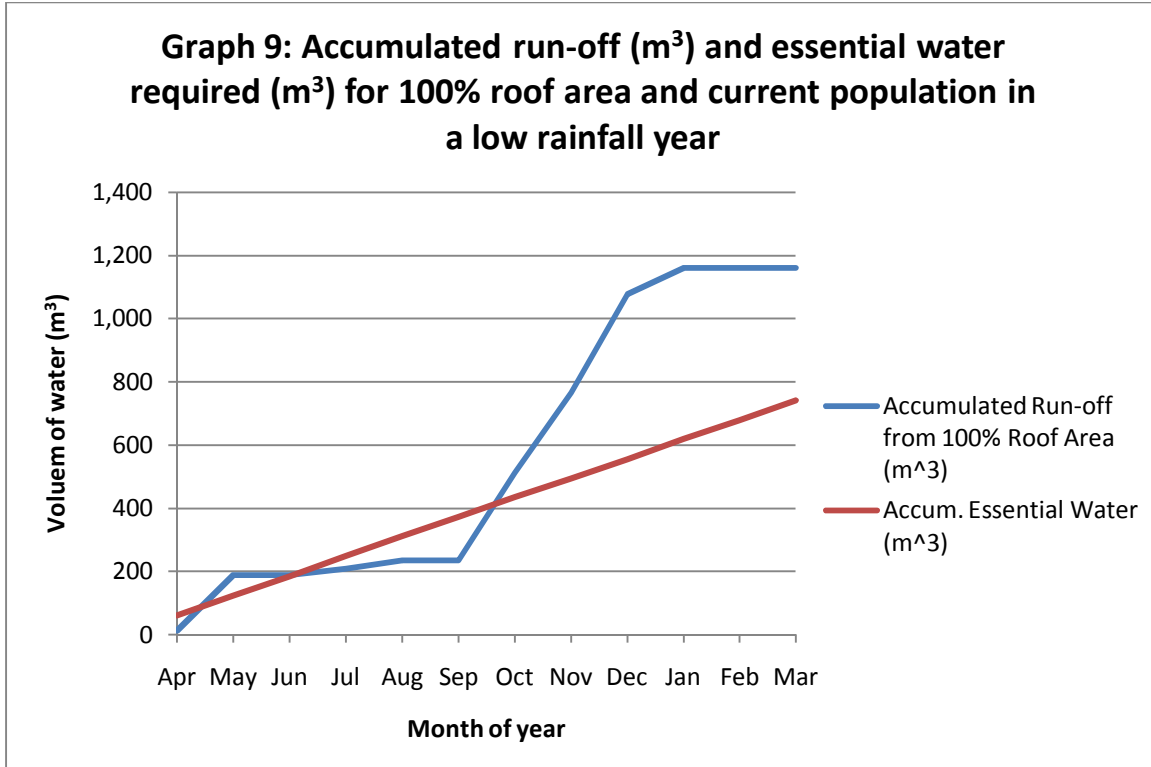

**Graph 11: Accumulated run-off (m<sup>3</sup>) and essential water required (m<sup>3</sup>) for 75% roof area and current population in a low rainfall year**

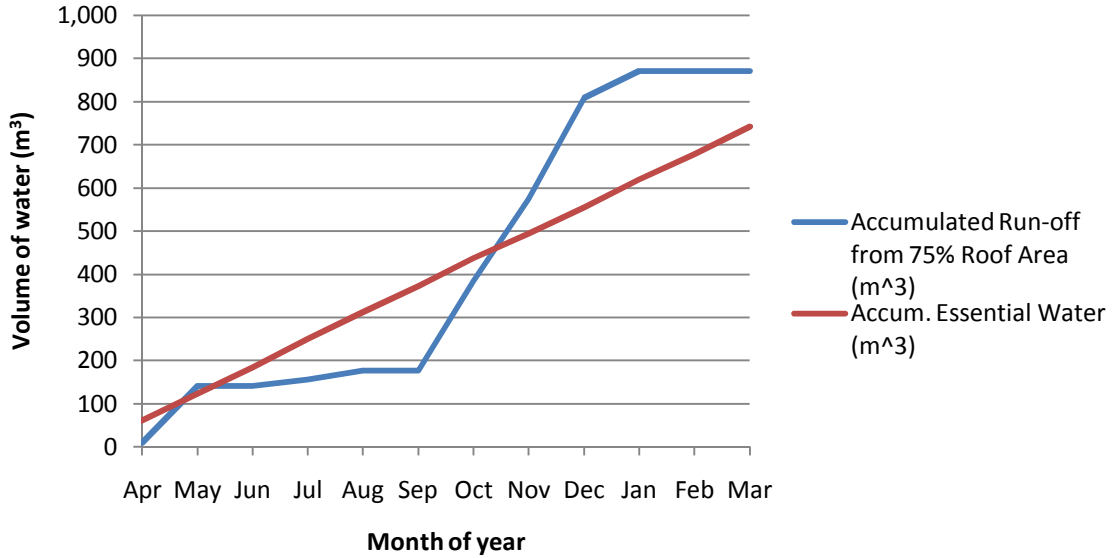

**Graph 12: Accumulated run-off (m<sup>3</sup>) and essential water required (m<sup>3</sup>) for 75% roof area and projected population in a low rainfall year**

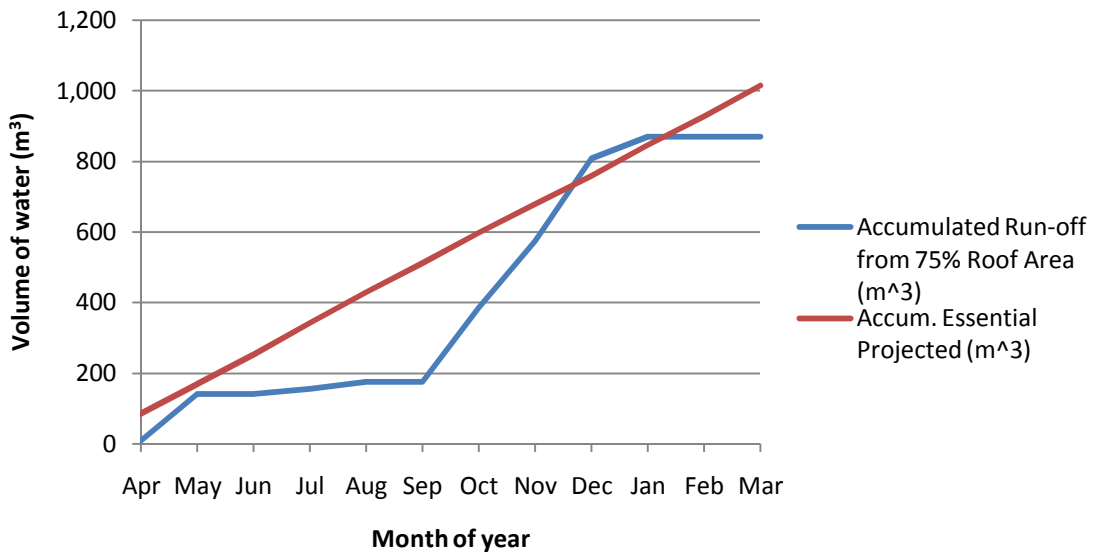

**Graph 13: Accumulated run-off (m<sup>3</sup>) and essential water required (m<sup>3</sup>) for 50% roof area and current population in a low rainfall year**

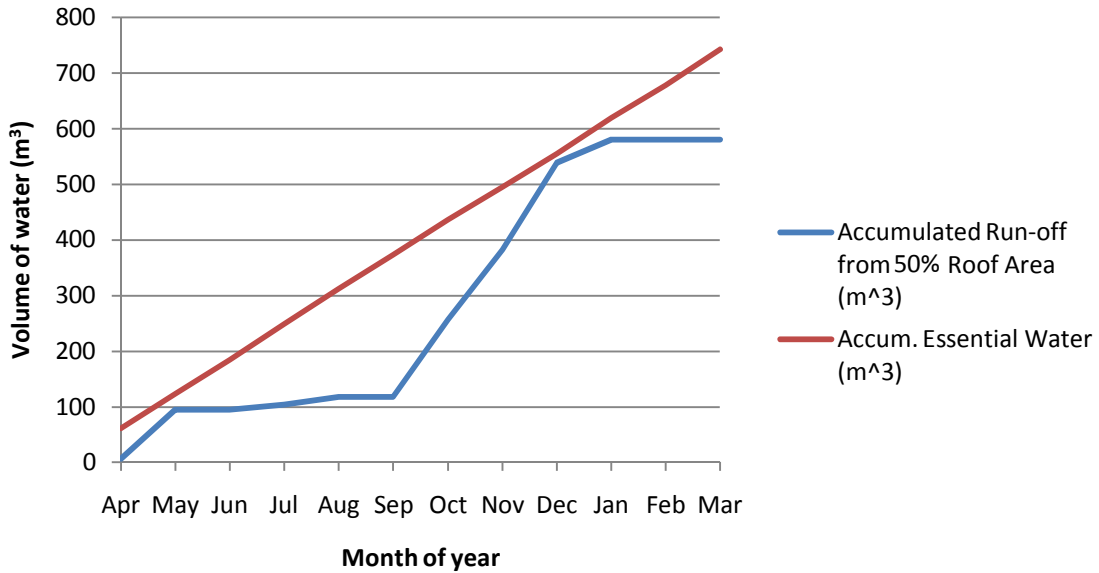

**Graph 14: Accumulated run-off (m<sup>3</sup>) and essential water required (m<sup>3</sup>) for 50% roof area and projected population in a low rainfall year**

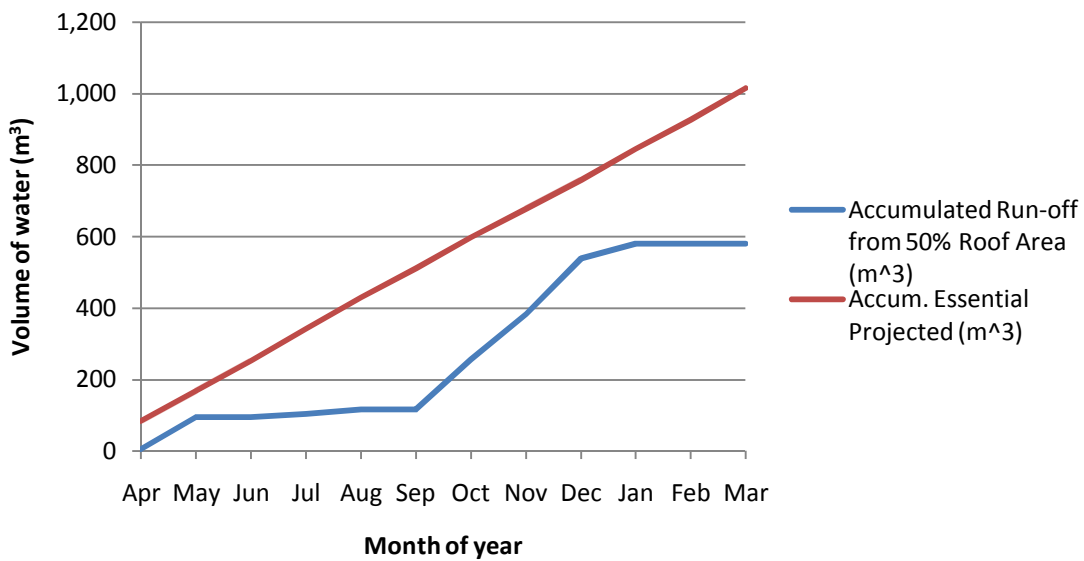

**Graph 15: Accumulated run-off (m<sup>3</sup>) and essential water required (m<sup>3</sup>) for current converted roof area (46.4%) and current population in a low rainfall year**

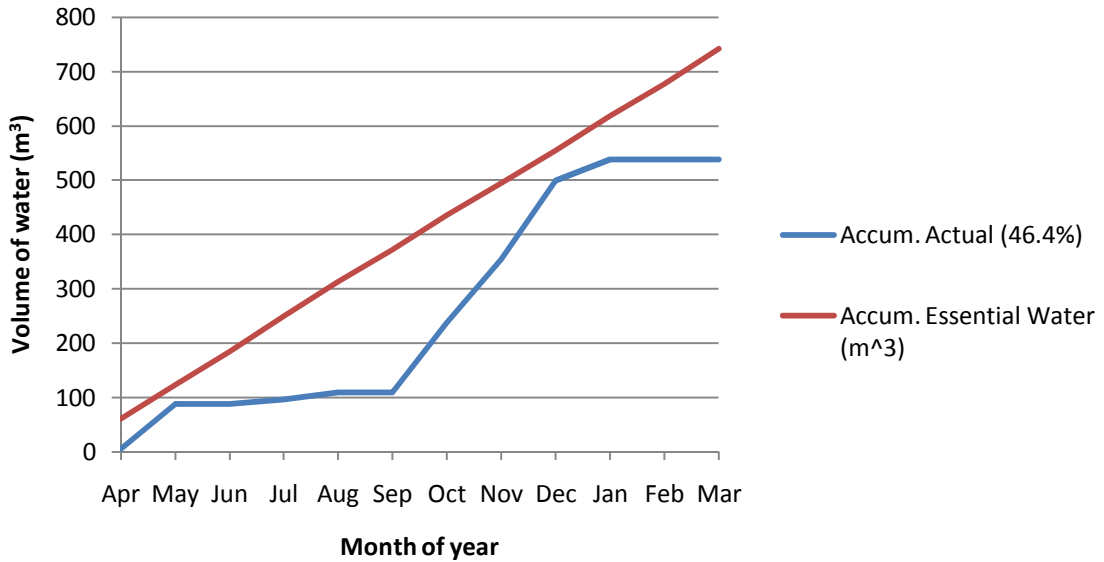

**Graph 16: Accumulated run-off (m<sup>3</sup>) and essential water required (m<sup>3</sup>) for current converted roof area (46.4%) and projected population in a low rainfall year**

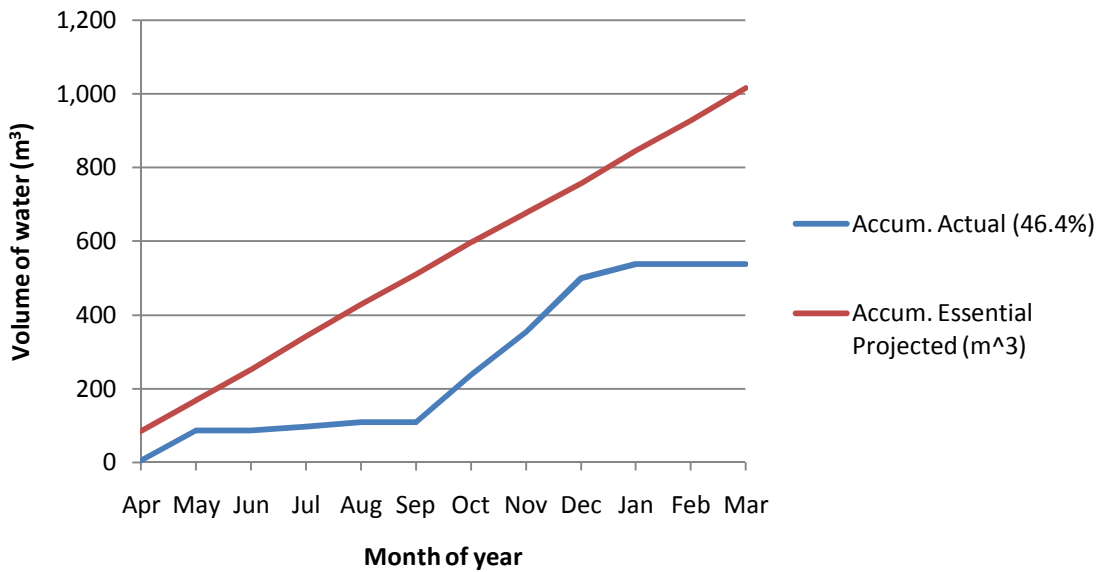

### Appendix W-3c. Accumulated roof runoff and water demand under high rain conditions

Month	Average Monthly Rain (mm)	Average Monthly Rain (m)	Roof area 100% (m <sup>2</sup> )	Roof area 75% (m <sup>2</sup> )	Roof area 50% (m <sup>2</sup> )	Current Roof Area (46.4%)
Apr	205.3	0.205	4,255	3,191	2,128	1,617
May	75.5	0.076	4,255	3,191	2,128	1,617
Jun	2.4	0.002	4,255	3,191	2,128	1,617
Jul	71.2	0.071	4,255	3,191	2,128	1,617
Aug	98.48	0.098	4,255	3,191	2,128	1,617
Sep	68.5	0.069	4,255	3,191	2,128	1,617
Oct	37	0.037	4,255	3,191	2,128	1,617
Nov	118.5	0.119	4,255	3,191	2,128	1,617
Dec	8.8	0.009	4,255	3,191	2,128	1,617
Jan	92.5	0.093	4,255	3,191	2,128	1,617
Feb	19.4	0.019	4,255	3,191	2,128	1,617
Mar	41.6	0.042	4,255	3,191	2,128	1,617

Month	Volume Run-off from 100% Roof Area (m <sup>3</sup> )	Accumulated Run-off from 100% Roof Area (m <sup>3</sup> )	Volume Run-off from 75% Roof Area (m <sup>3</sup> )	Accumulated Run-off from 75% Roof Area (m <sup>3</sup> )	Volume Run-off from 50% Roof Area (m <sup>3</sup> )	Accumulated Run-off from 75% Roof Area (m <sup>3</sup> )
Apr	742.519	742.519	556.889	556.889	371.3	371.3
May	273.065	1,015.583	204.798	761.688	136.5	507.8
Jun	8.680	1,024.264	6.510	768.198	4.3	512.1
Jul	257.513	1,281.776	193.134	961.332	128.8	640.9
Aug	356.178	1,637.954	267.133	1,228.465	178.1	819.0
Sep	247.747	1,885.701	185.811	1,414.276	123.9	942.9
Oct	133.820	2,019.521	100.365	1,514.641	66.9	1,009.8
Nov	428.585	2,448.106	321.439	1,836.079	214.3	1,224.1
Dec	31.827	2,479.933	23.871	1,859.950	15.9	1,240.0
Jan	334.549	2,814.483	250.912	2,110.862	167.3	1,407.2
Feb	70.165	2,884.647	52.624	2,163.486	35.1	1,442.3
Mar	150.457	3,035.104	112.843	2,276.328	75.2	1,517.6

Month	Run-off Actual (46.4%)	Accum. Actual (46.4%)	Visitor Bednights (Average Monthly)	Villager Bednights (per Month)	Essential water required (l)	Essential water required (m <sup>3</sup> )
Apr	282.2	282.2	520	7170	61522.7	61.5
May	103.8	385.9	311	7409	61757.3	61.8
Jun	3.3	389.2	493	7170	61304.0	61.3
Jul	97.9	487.1	648	7409	64456.0	64.5
Aug	135.3	622.4	541	7409	63597.3	63.6
Sep	94.1	716.6	332	7170	60013.3	60.0
Oct	50.9	767.4	497	7409	63250.7	63.3
Nov	162.9	930.3	220	7170	59122.7	59.1
Dec	12.1	942.4	88	7409	59978.7	60.0
Jan	127.1	1,069.5	584	7409	63946.7	63.9
Feb	26.7	1,096.2	433	6931	58909.3	58.9
Mar	57.2	1,153.3	608	7409	64138.7	64.1

Month	Accum. Essential Water (m <sup>3</sup> )	Monthly Average Visitor Bednight x2	Villager Monthly Bednight x1.33	Essential water required Projected (m <sup>3</sup> )	Accum. Essential Projected (m <sup>3</sup> )
Apr	61.5	1,040.7	9,536.1	84.6	84.6
May	123.3	621.3	9,854.0	83.8	168.4
Jun	184.6	986.0	9,536.1	84.2	252.6
Jul	249.0	1,296.0	9,854.0	89.2	341.8
Aug	312.6	1,081.3	9,854.0	87.5	429.3
Sep	372.7	663.3	9,536.1	81.6	510.9
Oct	435.9	994.7	9,854.0	86.8	597.7
Nov	495.0	440.7	9,536.1	79.8	677.5
Dec	555.0	176.7	9,854.0	80.2	757.7
Jan	618.9	1,168.7	9,854.0	88.2	845.9
Feb	677.9	865.3	9,218.2	80.7	926.6
Mar	742.0	1,216.7	9,854.0	88.6	1,015.1

**Graph 17: Accumulated run-off (m<sup>3</sup>) and essential water required (m<sup>3</sup>) for 100% roof area and current population in a high rainfall year**

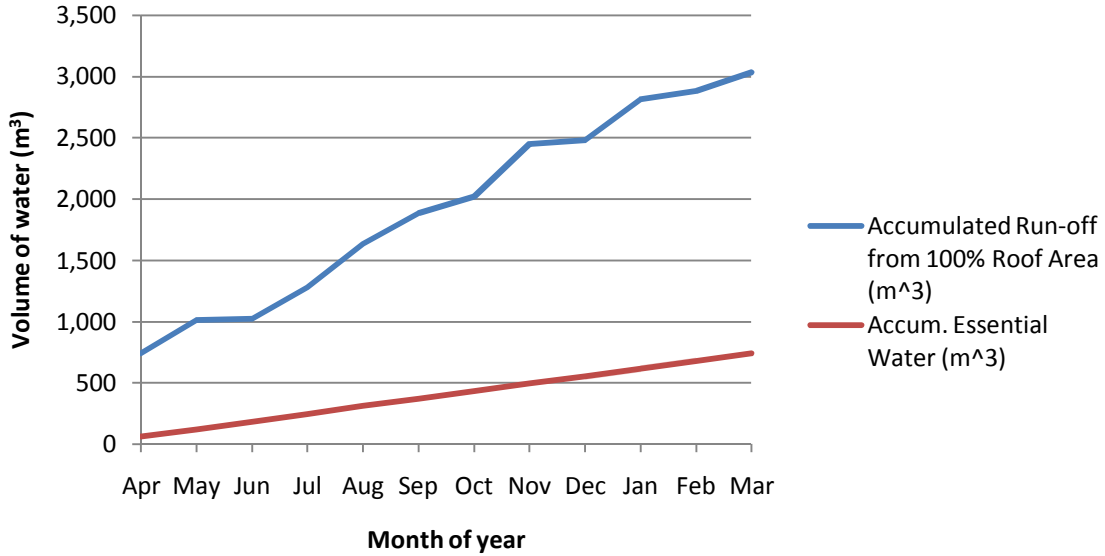

**Graph 18: Accumulated run-off (m<sup>3</sup>) and essential water required (m<sup>3</sup>) for 100% roof area and projected population in a high rainfall year**

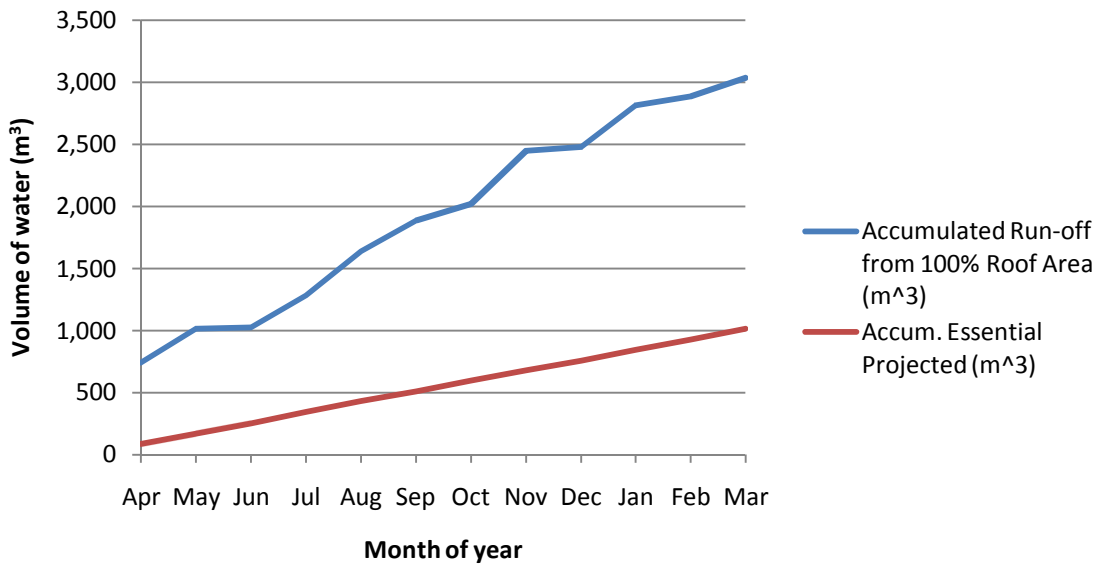



**Graph 19: Accumulated run-off (m<sup>3</sup>) and essential water required (m<sup>3</sup>) for 75% roof area and current population in a high rainfall year**

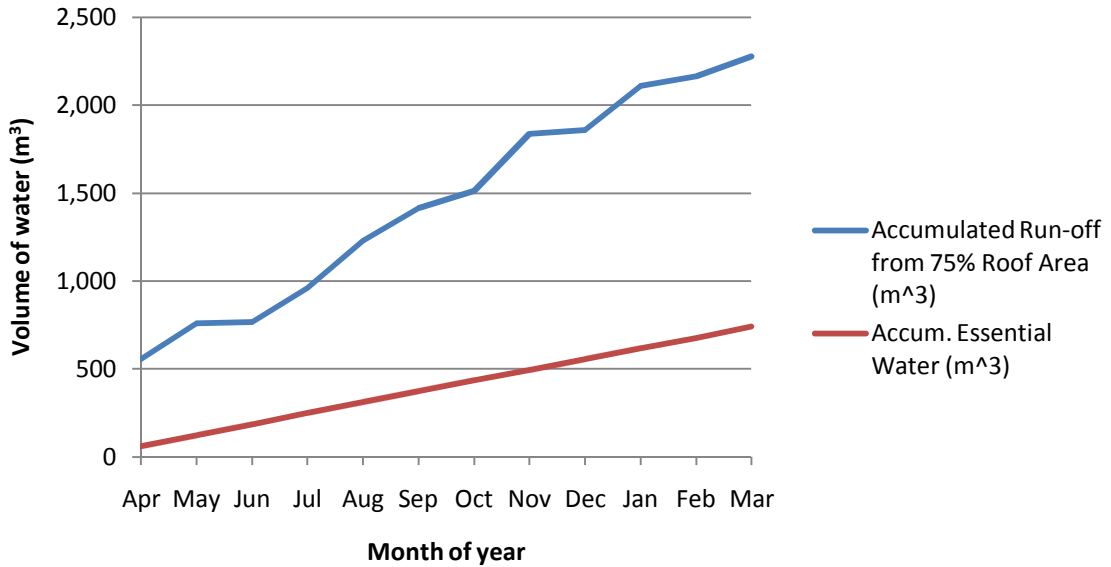

**Graph 20: Accumulated run-off (m<sup>3</sup>) and essential water required (m<sup>3</sup>) for 75% roof area and projected population in a high rainfall year**

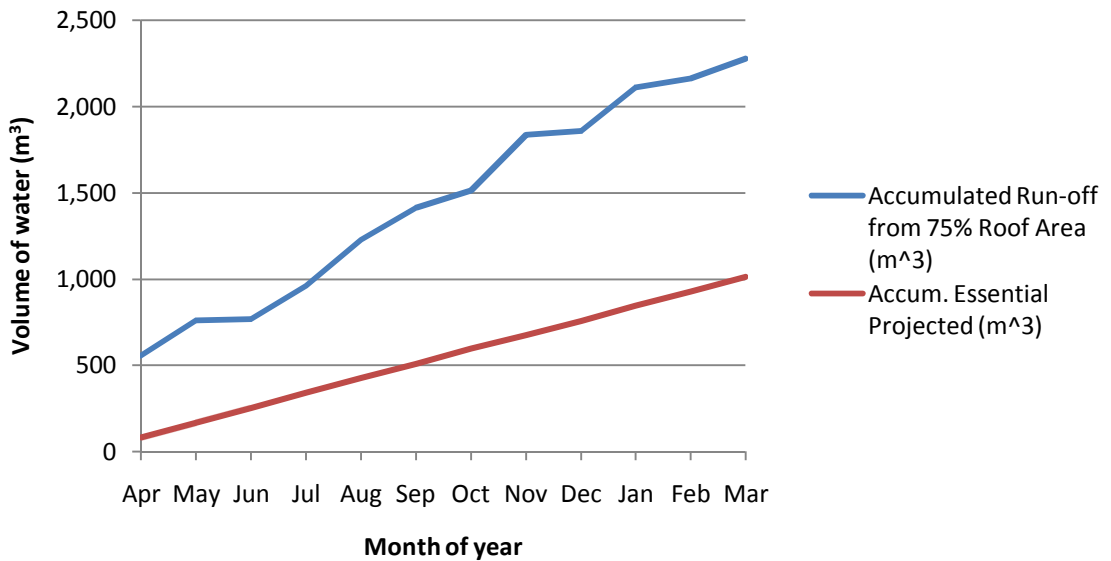

**Graph 21: Accumulated run-off (m<sup>3</sup>) and essential water required (m<sup>3</sup>) for 50% roof area and current population in a high rainfall year**

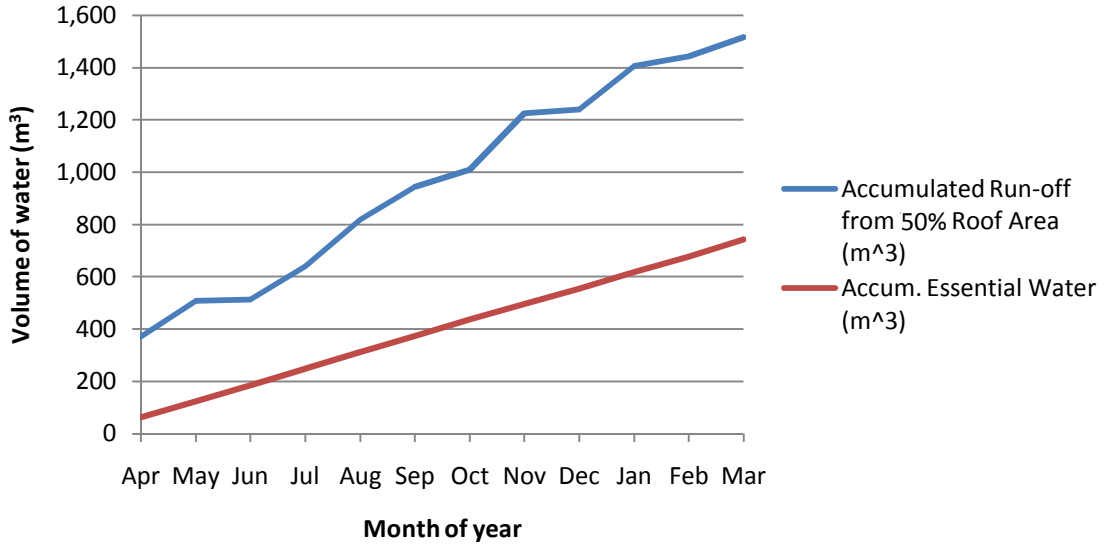

**Graph 22: Accumulated run-off (m<sup>3</sup>) and essential water required (m<sup>3</sup>) for 50% roof area and projected population in a high rainfall year**

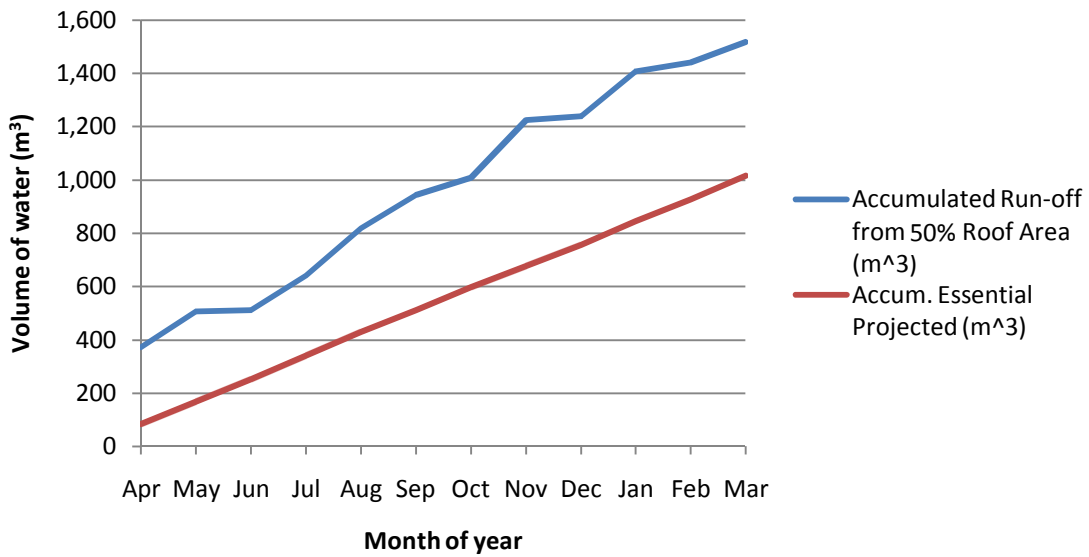

**Graph 23: Accumulated run-off ( $m^3$ ) and essential water required ( $m^3$ ) for current converted roof area (46.4%) and current population in a high rainfall year**

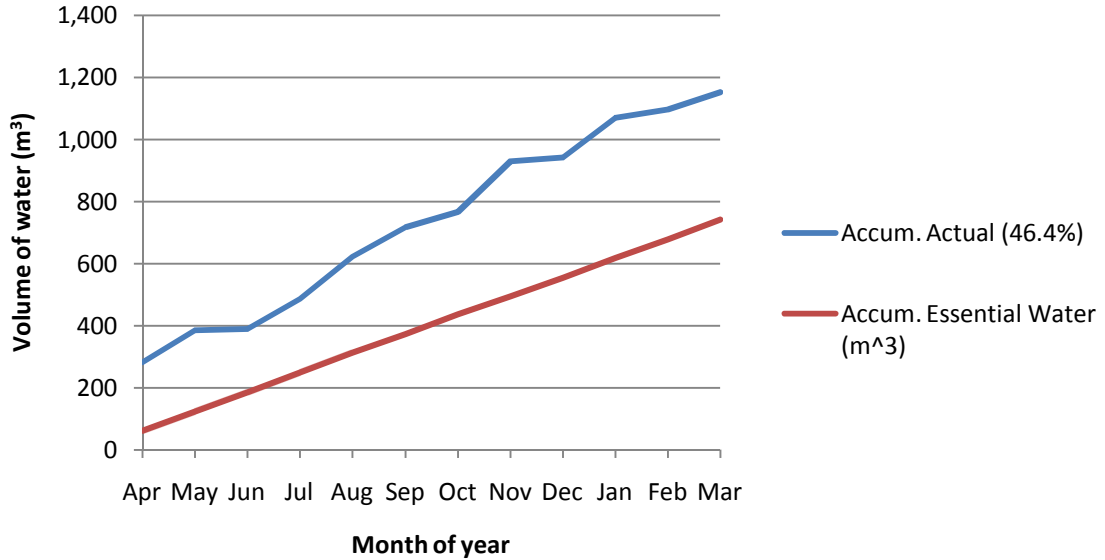

## Appendix W-4: Water collection scenarios

The following tables and charts were used to illustrate the relationship between different roof area and rainwater storage tank sizes and the amount of runoff missed and essential water requirements that would not be provided for (called ‘shortfall’). The tables show summaries of the results for empty days, volume missed, and shortfall over the total time period (11 years), the average over 11 years, and for low rainfall (dry) and high rainfall (wet) years for each scenario. The charts show a side-by-side comparison for two scenarios. Below is the data and the process is explained in the Methodology section of this report.

The following is a screenshot of the spreadsheet for one scenario (Scenario 5) to demonstrate the equations used for this analysis. **Data extends to row 4019.** “Repeating” a formula for a column means that the same formula is applied across all cells in the column, but the next cell down uses the next cell in the reference data as input. For example, consider the runoff column:  $C2=B2*.85*\$N\$2$ . The formula for the next cell down is  $C3=B3*.85*\$N\$2$ . The \$ sign is used to indicate that the equation should only use that cell as an input. For this example,  $\$N\$2$  means that each cell will use the roof area value in cell N2.

	A	B	C	D	E	F	G	H	I	J	K	L	M	N	O
			Day addition												
1	Date	Total Rainfall	Runoff (L)	(runoff-use)	Day shortfall	Leftover space	Empty?	Vol in tank	Vol missed	Shortfall		Daily use	Tank size	Roof area	
2	1-Jan-99	0.0	0	0	2424	182700	1	0	0	2424		2,424	182,700	1,973	
3	2-Jan-99	0.0	0	0	2424	182700	1	0	0	2424					
4	3-Jan-99	0.0	0	0	2424	182700	1	0	0	2424		SUMMARY			
5	4-Jan-99	0.0	0	0	2424	182700	1	0	0	2424			Empty days	Vol missed	Shortfall
6	5-Jan-99	0.0	0	0	2424	182700	1	0	0	2424		TOTAL	562	2,501,345	1,426,269
7	6-Jan-99	0.0	0	0	2424	182700	1	0	0	2424		MAX	179	552,362	447,254
8	7-Jan-99	0.0	0	0	2424	182700	1	0	0	2424		MIN	0	0	0

The formulas for the cells are as follows:

### Input data:

Columns A/B: Data from MRC meteorological station.

Daily use:  $L2=(\text{population}*8)$  [8 liters per person per day]

Tank size:  $M2=(\text{sum of MRC tank volumes})$

Roof area:  $N2=(\text{sum of MRC converted roof areas})$

### Equations:

$C2=B2*.85*\$N\$2$  [Repeated for entire column]

$D2=IF(C2-\$L\$2<0,0,C2-\$L\$2)$  [Repeated for entire column]

$E2=IF(D2>0,0,\$L\$2-C2)$  [Repeated for entire column]

$F2=\$M\$2$

$F3=IF(D3>0,IF(F2-D2<0,0,F2-D3),IF(F2+E3>\$M\$2,\$M\$2,F2+E3))$  [Repeated for remainder of column]

$G2=IF(F2=\$M\$2,1,0)$  [Repeated for entire column]

$H2=\$M\$2-F2$  [Repeated for entire column]

$I2=0$

$I3=IF(F2-D3<0,D3-F2,0)$  [Repeated for remainder of column]

$J2=IF(H2=0,\$L\$2,IF(H2-\$L\$2>0,\$L\$2-H2))$  [Repeated for entire column]

*Summaries:*

M6=SUM(G2:G4019)

M7=MAX(SUM(G2:G366),SUM(G367:G732),SUM(G733:G1097),SUM(G1098:G1462),SUM(G1463:G1827),SUM(G1828:G2193),SUM(G2194:G2558),SUM(G2559:G2923),SUM(G2924:G3288),SUM(G3289:G3654),SUM(G3655:G4019))

M8=MIN(SUM(G2:G366),SUM(G367:G732),SUM(G733:G1097),SUM(G1098:G1462),SUM(G1463:G1827),SUM(G1828:G2193),SUM(G2194:G2558),SUM(G2559:G2923),SUM(G2924:G3288),SUM(G3289:G3654),SUM(G3655:G4019))

N6=SUM(I2:I4019)

N7=MAX(SUM(I2:I366),SUM(I367:I732),SUM(I733:I1097),SUM(I1098:I1462),SUM(I1463:I1827),SUM(I1828:I2193),SUM(I2194:I2558),SUM(I2559:I2923),SUM(I2924:I3288),SUM(I3289:I3654),SUM(I3655:I4019))

N8=MIN(SUM(I2:I366),SUM(I367:I732),SUM(I733:I1097),SUM(I1098:I1462),SUM(I1463:I1827),SUM(I1828:I2193),SUM(I2194:I2558),SUM(I2559:I2923),SUM(I2924:I3288),SUM(I3289:I3654),SUM(I3655:I4019))

O6=SUM(J2:J4019)

O7=MAX(SUM(J2:J366),SUM(J367:J732),SUM(J733:J1097),SUM(J1098:J1462),SUM(J1463:J1827),SUM(J1828:J2193),SUM(J2194:J2558),SUM(J2559:J2923),SUM(J2924:J3288),SUM(J3289:J3654),SUM(J3655:J4019))

O8=MIN(SUM(J2:J366),SUM(J367:J732),SUM(J733:J1097),SUM(J1098:J1462),SUM(J1463:J1827),SUM(J1828:J2193),SUM(J2194:J2558),SUM(J2559:J2923),SUM(J2924:J3288),SUM(J3289:J3654),SUM(J3655:J4019))

## Appendix W-4a. All MRC Village houses, only villagers drink

<b>Scenario 1: All MRC Village houses current, only villagers drink</b>		Empty Days	
			1,793
Tank Size	1000	Average/year	163
Number of Village Homes	45	Dry Year Empty Days	257
Total tank volume	45000	Wet Year Empty Days	87
One roof area	22	Volume Missed	1,058,338
Total Roof	990	Average/year	96,213
Number individuals	239	Wet Year Volume Missed	244,230
Personal daily use	8	Dry Year Volume Missed	0
Daily Use	1912	Shortfall	3,596,162
Run-off Coefficient	85%	Average/year	326,924
		Wet year shortfall	175,498
		Dry year shortfall	507,872

<b>Scenario 2: All MRC Village houses * 1.33 population</b>		Empty Days	
			2,277
Tank Size	1000	Average/year	207
Number of Village Homes	45	Dry Year Empty Days	279
Total tank volume	45000	Wet Year Empty Days	139
One roof area	22	Volume Missed	715,745
Total Roof	990	Average/year	65,068
Number individuals	318	Wet Year Volume Missed	197,594
Personal daily use	8	Dry Year Volume Missed	0
Daily Use	2543	Shortfall	6,073,440
Run-off Coefficient	85%	Average/year	552,131
		Wet year shortfall	366,656
		Dry year shortfall	730,147

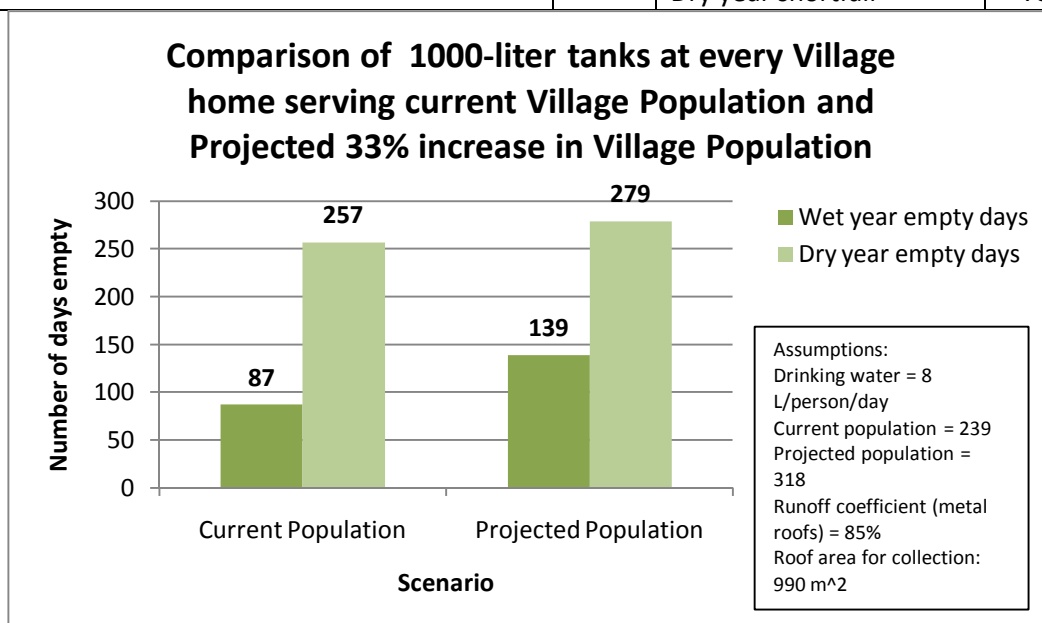

Appendix W-4b. All MRC roofs, only visitors drink

<b>Scenario 3: All MRC roofs current, only visitors drink</b>		Empty Days	
		Empty Days	29
Current tank capacity	182700	Average/year	3
Total roof area	1973	Dry Year Empty Days	29
Average number visitors (MRC + campsite)	64	Wet Year Empty Days	0
Personal daily use	8	Volume Missed	8,877,058
Daily Use	512	Average/year	807,005
Run-off Coefficient	85%	Wet Year Volume Missed	1,230,349
		Dry Year Volume Missed	0
		Shortfall	15,206
		Average/year	1,382
		Wet year shortfall	0
		Dry year shortfall	15,206

<b>Scenario 4: All MRC roofs current * 2 population visitors</b>		Empty Days	
		Empty Days	45
Tank Size	182700	Average/year	4
Total roof area	1973	Dry Year Empty Days	45
Average number visitors (MRC + campsite)	128	Wet Year Empty Days	0
Personal daily use	8	Volume Missed	6,851,074
Daily Use	1024	Average/year	622,825
Run-off Coefficient	85%	Wet Year Volume Missed	1,043,981
		Dry Year Volume Missed	0
		Shortfall	46,950
		Average/year	4,268
		Wet year shortfall	0
		Dry year shortfall	46,950

**Comparison of Current Storage Capacity and Current Roof Catchment Serving Current and Projected 100% Increase of Visitor Population**

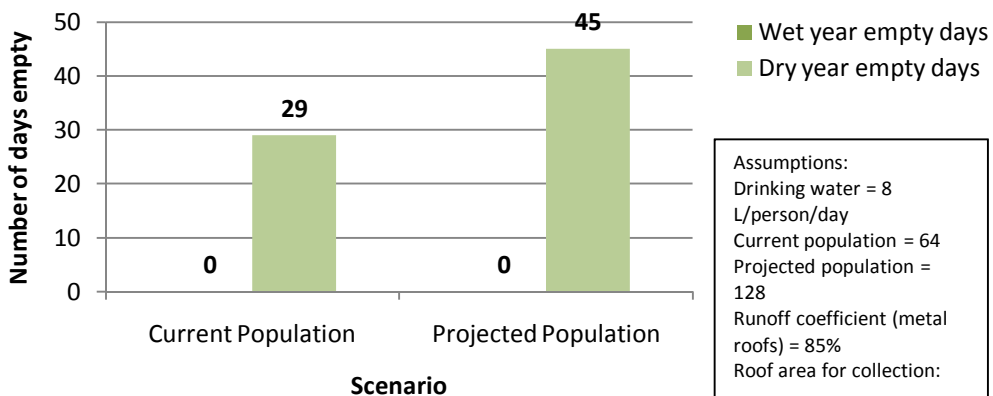

Appendix W-4c. All MRC roofs, everyone drinks

<b>Scenario 5: All MRC roofs current, all drink current population</b>		Empty Days	562
Current tank capacity	182700	Average/year	51
Total roof area	1973	Dry Year Empty Days	179
Average number visitors (MRC+Campsite)	64	Wet Year Empty Days	0
Villagers	239	Volume Missed	2,501,345
Personal Daily Use	8	Average/year	227,395
Daily Use	2424	Wet Year Volume Missed	552,362
Run-off Coefficient	85%	Dry Year Volume Missed	0
		Shortfall	1,426,269
		Average/year	129,661
		Wet year shortfall	0
		Dry year shortfall	447,254

<b>Scenario 6: All MRC roofs, all drink 2 x visitors + 1.3 x villagers</b>		Empty Days	1,244
Current tank capacity	182700	Average/year	113
Total roof area	1973	Dry Year Empty Days	229
Average number visitors (MRC+Campsite)	128	Wet Year Empty Days	17
Villagers	317.87	Volume Missed	884,469
Personal Daily Use	8	Average/year	80,406
Daily Use	3566.96	Wet Year Volume Missed	289,400
Run-off Coefficient	85%	Dry Year Volume Missed	0
		Shortfall	4,645,680
		Average/year	422,335
		Wet year shortfall	61,946
		Dry year shortfall	844,626

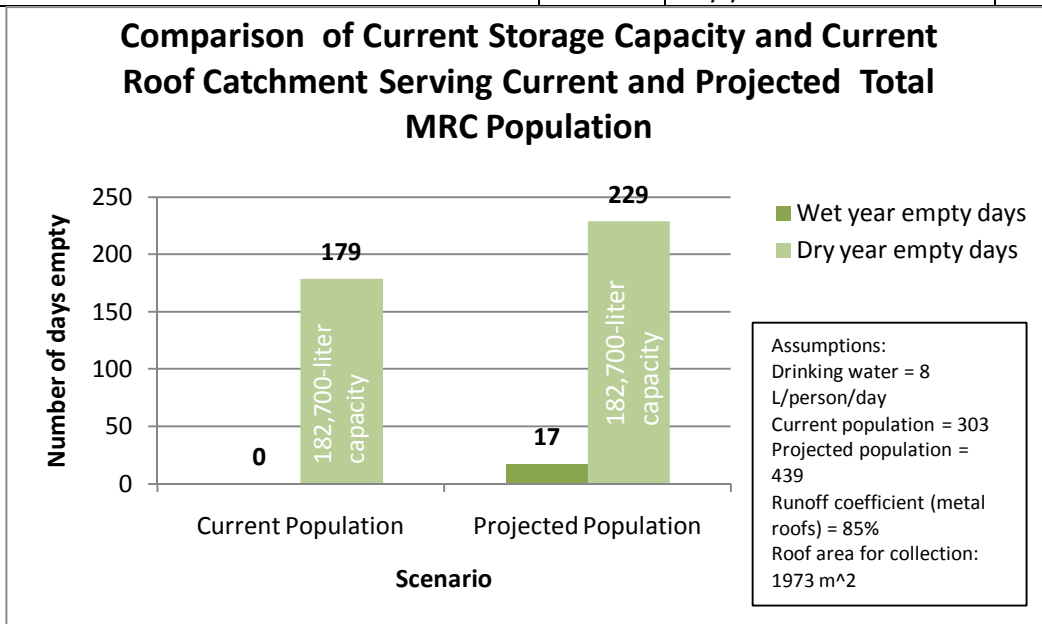



Appendix W-4d. All MRC roofs, everyone drinks, one additional tank

<b>Scenario 7: All MRC roofs, all drink current pop plus (1) add'l 13m<sup>3</sup> tank</b>		Empty Days	519
Current tank capacity	195700	Average/year	47
Total roof area	1973	Dry Year Empty Days	173
Average number visitors (MRC+Campsite)	64	Wet Year Empty Days	0
Villagers	239	Volume Missed	2,405,277
Personal Daily Use	8	Average/year	218,662
Daily Use	2424	Wet Year Volume Missed	552,362
Run-off Coefficient	85%	Dry Year Volume Missed	0
		Shortfall	1,312,586
		Average/year	119,326
		Wet year shortfall	0
		Dry year shortfall	434,254

<b>Scenario 8: All MRC roofs, all drink 2x visitors + 1.3 villagers plus (1) add'l 13m<sup>3</sup> tank</b>		Empty Days	1,220
Current tank capacity	195700	Average/year	111
Total roof area	1973	Dry Year Empty Days	226
Average number visitors (MRC+Campsite)	128	Wet Year Empty Days	13
Villagers	318	Volume Missed	787,852
Personal Daily Use	8	Average/year	71,623
Daily Use	3567	Wet Year Volume Missed	276,400
Run-off Coefficient	85%	Dry Year Volume Missed	0
		Shortfall	4,542,003
		Average/year	412,909
		Wet year shortfall	48,946
		Dry year shortfall	831,626

**Comparison of Current Roof Catchment and Current Storage plus (1) Additional 13 m<sup>3</sup> Tank Serving Current and Projected Total MRC Population**

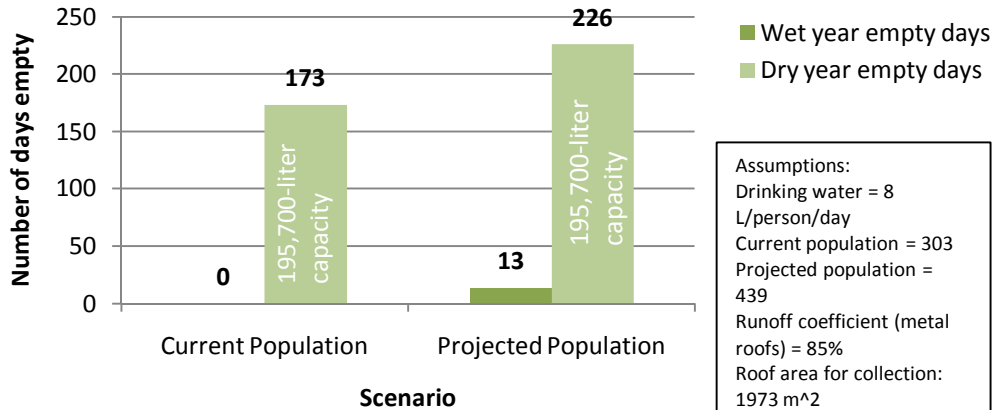

Appendix W-4e. All MRC roofs, everyone drinks, two additional tanks

<b>Scenario 9: All MRC roofs, all drink current pop plus (2) add'l 13m<sup>3</sup> tank</b>		Empty Days	480
Current tank capacity	208700	Average/year	44
Total roof area	1973	Dry Year Empty Days	168
Average number visitors (MRC+Campsite)	64	Wet Year Empty Days	0
Villagers	239	Volume Missed	2,316,222
Personal Daily Use	8	Average/year	210,566
Daily Use	2424	Wet Year Volume Missed	552,362
Run-off Coefficient	85%	Dry Year Volume Missed	0
		Shortfall	1,203,697
		Average/year	109,427
		Wet year shortfall	0
		Dry year shortfall	420,753

<b>Scenario 10: All MRC roofs, all drink 2x visitors + 1.3 villagers plus (2) add'l 13m<sup>3</sup> tank</b>		Empty Days	1,194
Current tank capacity	208700	Average/year	109
Total roof area	1973	Dry Year Empty Days	223
Average number visitors (MRC+Campsite)	128	Wet Year Empty Days	9
Villagers	318	Volume Missed	702,331
Personal Daily Use	8	Average/year	63,848
Daily Use	3566.96	Wet Year Volume Missed	263,400
Run-off Coefficient	85%	Dry Year Volume Missed	0
		Shortfall	4,453,976
		Average/year	404,907
		Wet year shortfall	33,441
		Dry year shortfall	819,443

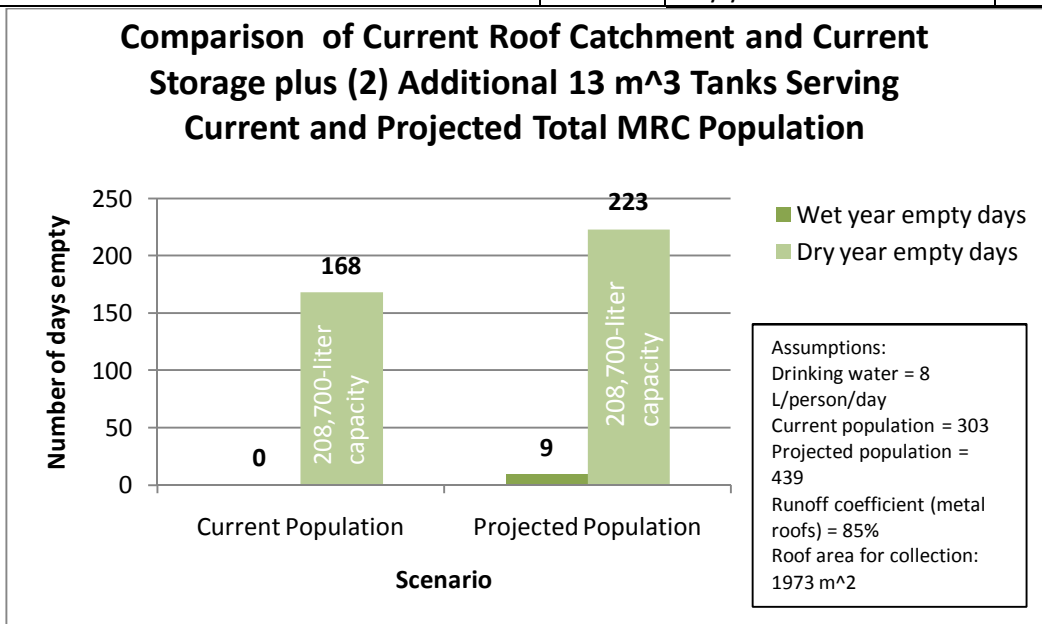

Appendix W-4f. All MRC roofs, everyone drinks, three extra tanks

<b>Scenario 11: All MRC roofs, all drink current pop(3) add'l 13m<sup>3</sup> tank</b>		Empty Days	455
Current tank capacity	221700	Average/year	41
Total roof area	1973	Dry Year Empty Days	162
Average number visitors (MRC+Campsite)	64	Wet Year Empty Days	0
Villagers	239	Volume Missed	2,265,093
Personal Daily Use	8	Average/year	205,918
Daily Use	2424	Wet Year Volume Missed	552,362
Run-off Coefficient	85%	Dry Year Volume Missed	0
		Shortfall	1,144,817
		Average/year	104,074
		Wet year shortfall	0
		Dry year shortfall	407,753

<b>Scenario 12: All MRC roofs, all drink 2x visitors + 1.3 villagers plus (3) add'l 13m<sup>3</sup> tank</b>		Empty Days	1,171
Current tank capacity	221700	Average/year	106
Total roof area	1973	Dry Year Empty Days	223
Average number visitors (MRC+Campsite)	128	Wet Year Empty Days	4
Villagers	317.87	Volume Missed	629,098
Personal Daily Use	8	Average/year	57,191
Daily Use	3566.96	Wet Year Volume Missed	250,400
Run-off Coefficient	85%	Dry Year Volume Missed	0
		Shortfall	4,374,670
		Average/year	397,697
		Wet year shortfall	16,874
		Dry year shortfall	819,443

**Comparison of Current Roof Catchment and Current Storage plus (3) Additional 13 m<sup>3</sup> Tanks Serving Current and Projected Total MRC Population**

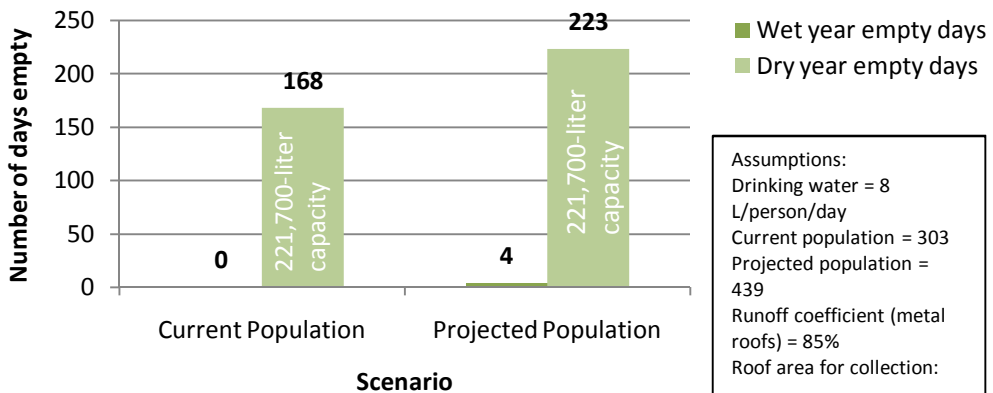

Appendix W-4g. All MRC roofs, everyone drinks, four extra tanks

<b>Scenario 13: All MRC roofs, all drink current pop plus (4) add'l 13m<sup>3</sup> tank</b>		Empty Days	439
Current tank capacity	234700	Average/year	40
Total roof area	1973	Dry Year Empty Days	157
Average number visitors (MRC+Campsite)	64	Wet Year Empty Days	0
Villagers	239	Volume Missed	2,226,093
Personal Daily Use	8	Average/year	202,372
Daily Use	2424	Wet Year Volume Missed	552,362
Run-off Coefficient	85%	Dry Year Volume Missed	0
		Shortfall	1,101,824
		Average/year	100,166
		Wet year shortfall	0
		Dry year shortfall	394,753

<b>Scenario 14: All MRC roofs, all drink 2x visitors + 1.3 villagers plus (4) add'l 13m<sup>3</sup> tank</b>		Empty Days	1,155
Current tank capacity	234700	Average/year	105
Total roof area	1973	Dry Year Empty Days	223
Average number visitors (MRC+Campsite)	128	Wet Year Empty Days	1
Villagers	317.87	Volume Missed	572,520
Personal Daily Use	8	Average/year	52,047
Daily Use	3566.96	Wet Year Volume Missed	237,400
Run-off Coefficient	85%	Dry Year Volume Missed	0
		Shortfall	4,305,888
		Average/year	391,444
		Wet year shortfall	3,874
		Dry year shortfall	819,443

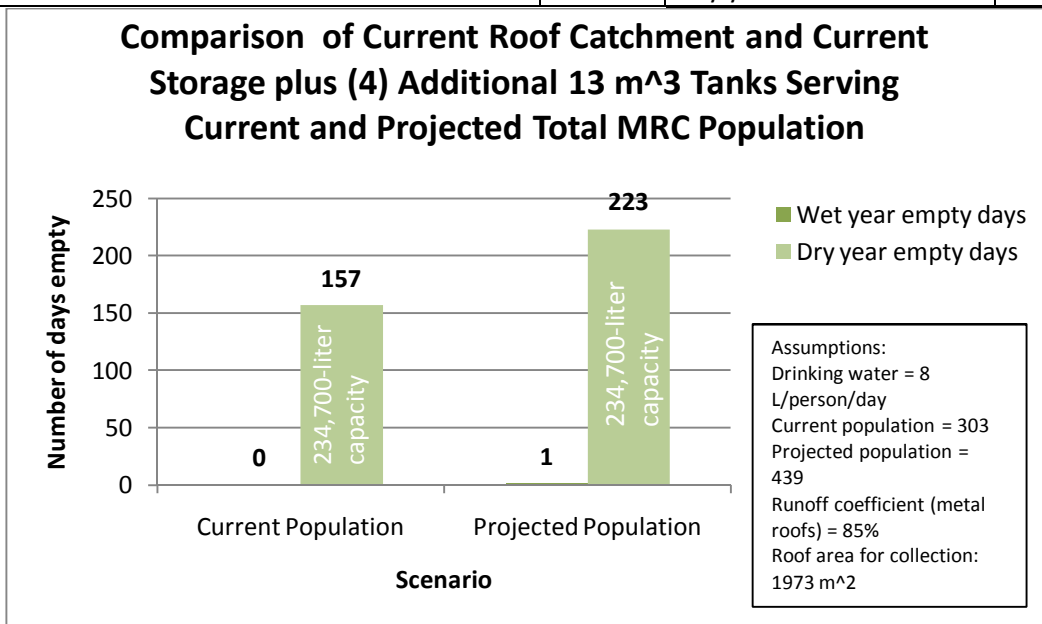

Appendix W-4h. One Village house, only that family drinks

<b>Scenario 15: 1 MRC Village house, only family drinks</b>		Empty Days	1,689
Tank Size	1000	Average/year	154
Number of Village Homes	1	Dry Year Empty Days	251
Total tank volume	1000	Wet Year Empty Days	79
One roof area	22	Volume Missed	25,339
Total Roof	22	Average/year	2,304
Number individuals	5	Wet Year Volume Missed	5,621
Personal daily use	8	Dry Year Volume Missed	0
Daily Use	40	Shortfall	70,691
Run-off Coefficient	85%	Average/year	6,426
		Wet year shortfall	3,295
		Dry year shortfall	10,365

<b>Scenario 16: 1 MRC Village house * 1.33 population</b>		Empty Days	2,171
Tank Size	1000	Average/year	197
Number of Village Homes	1	Dry Year Empty Days	273
Total tank volume	1000	Wet Year Empty Days	128
One roof area	22	Volume Missed	17,421
Total Roof	22	Average/year	1,584
Number individuals	7	Wet Year Volume Missed	4,628
Personal daily use	8	Dry Year Volume Missed	0
Daily Use	53	Shortfall	120,753
Run-off Coefficient	85%	Average/year	10,978
		Wet year shortfall	7,020
		Dry year shortfall	14,979

**Comparison of 1 Village House Roof and 1000 liter tank serving 1 current village family or 1 village family plus projected population increase of 33%**

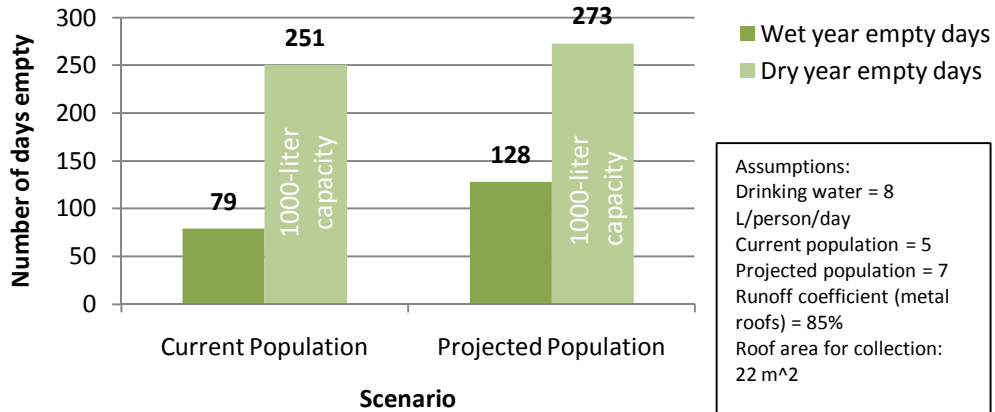

Appendix W-4i. Library, everyone drinks

<b>Scenario 67: Library roof, current storage, all drink current pop</b>		Empty Days	
Current tank capacity	26000	Average/year	93
Total roof area	199	Dry Year Empty Days	215
Population	303	Wet Year Empty Days	0
Personal daily use	8	Volume Missed	59,951
Daily Use	2424	Average/year	5,450
Run-off Coefficient	85%	Wet Year Volume Missed	23,749
Tank proportion of Total Storage	14%	Dry Year Volume Missed	0
Daily use as proportion	345	Shortfall	370,500
		Average/year	33,682
		Wet year shortfall	0
		Dry year shortfall	76,359

<b>Scenario 91: Library roof, current storage + 13000 L, all drink current pop</b>		Empty Days	
Tank capacity	39000	Average/year	168
Total roof area	199	Dry Year Empty Days	265
Population	303	Wet Year Empty Days	75
Personal daily use	8	Volume Missed	4,997
Daily Use	2424	Average/year	454
Run-off Coefficient	85%	Wet Year Volume Missed	4,997
Tank proportion of Total Storage	20%	Dry Year Volume Missed	0
Daily use as proportion	483	Shortfall	932,650
		Average/year	84,786
		Wet year shortfall	37,958
		Dry year shortfall	133,024

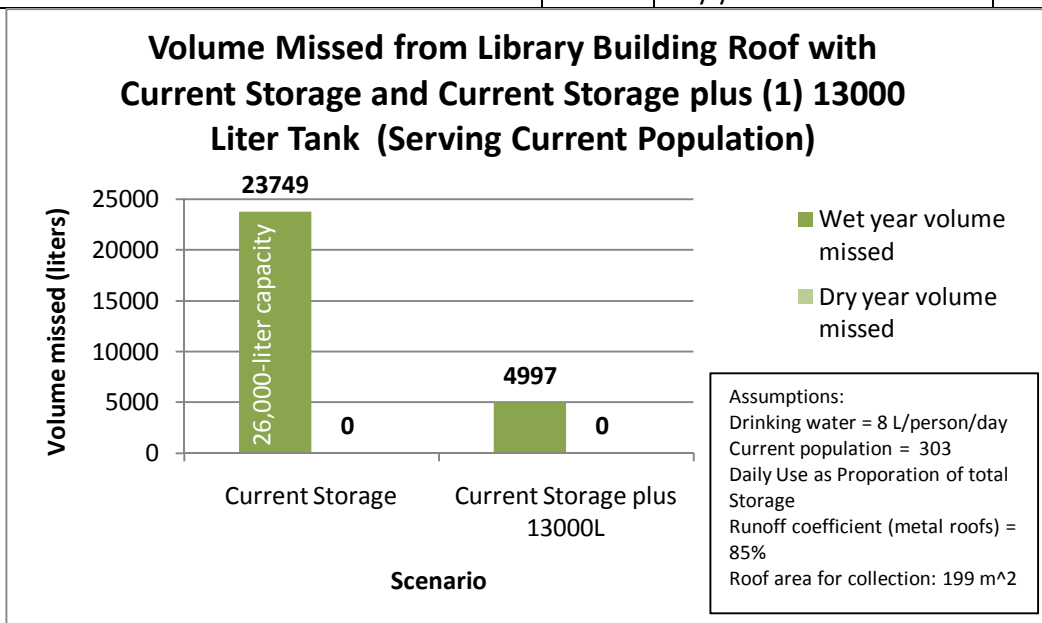

Appendix W-4j. Library, projected population

<b>Scenario 68: Library roof, current storage, all drink 2 x visitors + 1.3 x villagers</b>		Empty Days	2,010
Current tank capacity	26000	Average/year	183
Total roof area	199	Dry Year Empty Days	275
Population	446	Wet Year Empty Days	99
Personal daily use	8	Volume Missed	20,906
Daily Use	3568	Average/year	1,901
Run-off Coefficient	85%	Wet Year Volume Missed	17,528
Tank proportion of Total Storage	0.14	Dry Year Volume Missed	0
Daily use as proportion	507.76	Shortfall	1,068,667
		Average/year	97,152
		Wet year shortfall	52,679
		Dry year shortfall	144,678

<b>Scenario 92: Library roof, current storage + 13000 L, only visitors drink, all drink 2 x visitors + 1.3 x villagers</b>		Empty Days	2,636
Tank capacity	39000	Average/year	240
Total roof area	199	Dry Year Empty Days	304
Population	446	Wet Year Empty Days	181
Personal daily use	8	Volume Missed	774
Daily Use	3568	Average/year	70
Run-off Coefficient	85%	Wet Year Volume Missed	774
Tank proportion of Total Storage	0.20	Dry Year Volume Missed	0
Daily use as proportion	711.05	Shortfall	1,957,202
		Average/year	177,927
		Wet year shortfall	134,124
		Dry year shortfall	223,263

**Volume Missed from Library Building Roof with Current Storage and Current Storage plus (1) 13000 Liter Tank (Serving Projected Population)**

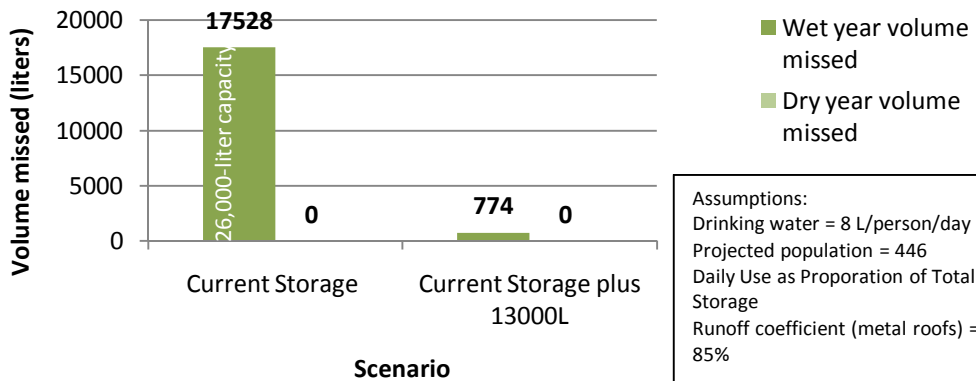

Appendix W-4k. Admin block, current population

<b>Scenario 69: Admin block roof, current storage, all drink current pop</b>		Empty Days	34
Current tank capacity	12000	Average/year	3
Total roof area	112	Dry Year Empty Days	34
Average number visitors (MRC+Campsite)	64	Wet Year Empty Days	0
Villagers	0	Volume Missed	484,228
Personal Daily Use	8	Average/year	44,021
Daily Use	512	Wet Year Volume Missed	68,181
Run-off Coefficient	85%	Dry Year Volume Missed	0
Tank proportion of Total Storage	7%	Shortfall	1,146
Daily use as proportion	33.63	Average/year	104
		Wet year shortfall	0
		Dry year shortfall	1,146

<b>Scenario 93: Admin block roof, current storage + 12000 L, all drink current pop</b>		Empty Days	47
Tank capacity	24000	Average/year	4
Total roof area	112	Dry Year Empty Days	47
Average number visitors (MRC+Campsite)	64	Wet Year Empty Days	0
Villagers	0	Volume Missed	355,561
Personal Daily Use	8	Average/year	32,324
Daily Use	512	Wet Year Volume Missed	57,501
Run-off Coefficient	85%	Dry Year Volume Missed	0
Tank proportion of Total Storage	12%	Shortfall	2,974
Daily use as proportion	63.11	Average/year	270
		Wet year shortfall	0
		Dry year shortfall	2,974

**Volume Missed from Admin Block Building Roof with Current Storage and Current Storage plus (1) 12000 Liter Tank (Serving Current Population)**

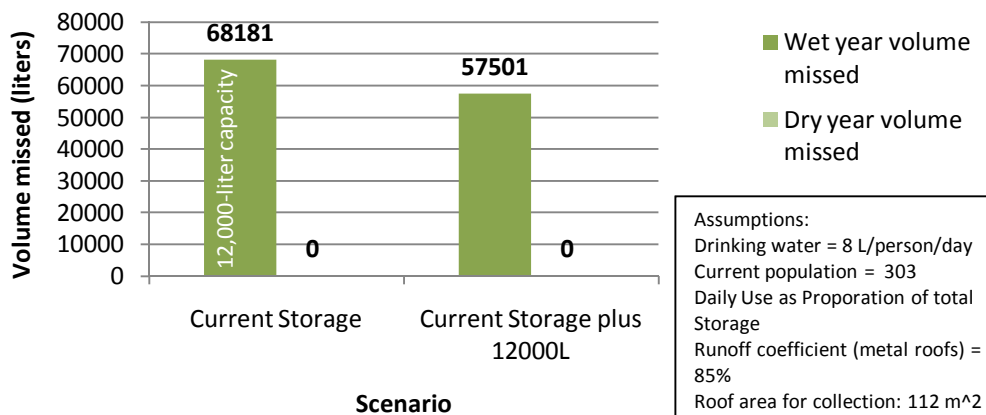



Appendix W-4l. Admin block, projected population

<b>Scenario 70: Admin block roof, current storage, all drink 2 x visitors + 1.3 x villagers</b>		Empty Days	1,567
Current tank capacity	12000	Average/year	142
Total roof area	112	Dry Year Empty Days	250
Average number visitors (MRC+Campsite)	128	Wet Year Empty Days	45
Villagers	318	Volume Missed	29,614
Personal Daily Use	8	Average/year	2,692
Daily Use	3568	Wet Year Volume Missed	13,475
Run-off Coefficient	85%	Dry Year Volume Missed	0
Tank proportion of Total Storage	7%	Shortfall	385,710
Daily use as proportion	234.35	Average/year	35,065
		Wet year shortfall	11,416
		Dry year shortfall	60,297

<b>Scenario 94: Admin block roof, current storage + 12000 L, all drink 2 x visitors + 1.3 x villagers</b>		Empty Days	2,781
Tank capacity	24000	Average/year	253
Total roof area	112	Dry Year Empty Days	312
Average number visitors (MRC+Campsite)	128	Wet Year Empty Days	200
Villagers	318	Volume Missed	0
Personal Daily Use	8	Average/year	0
Daily Use	3568	Wet Year Volume Missed	0
Run-off Coefficient	85%	Dry Year Volume Missed	0
Tank proportion of Total Storage	12%	Shortfall	1,282,210
Daily use as proportion	439.82	Average/year	116,565
		Wet year shortfall	92,939
		Dry year shortfall	141,417

**Volume Missed from Admin Block Building Roof with Current Storage and Current Storage plus (1) 12000 Liter Tank (Serving Projected Population)**

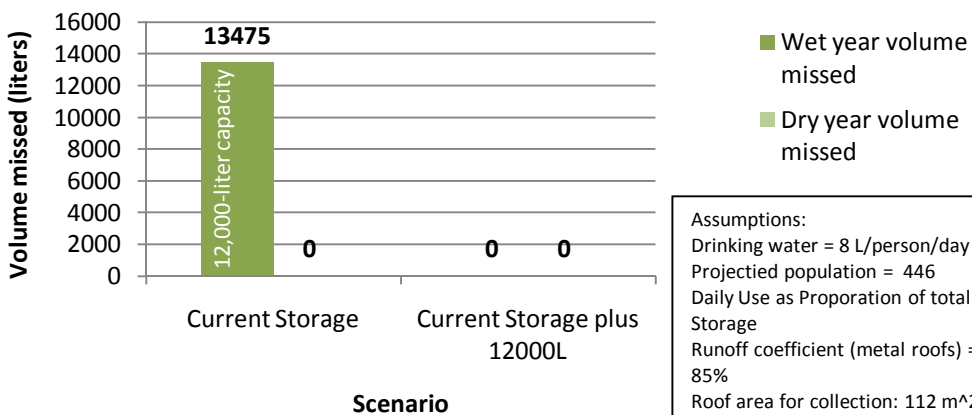

Appendix W-4m. McCormack lab, current population

<b>Scenario 71: McCormack lab roof, current storage, all drink current pop</b>		Empty Days	
Current tank capacity	39000	Average/year	208
Total roof area	175	Dry Year Empty Days	290
Average number visitors (MRC+Campsite)	64	Wet Year Empty Days	134
Villagers	239	Volume Missed	0
Personal Daily Use	8	Average/year	0
Daily Use	2424	Wet Year Volume Missed	0
Run-off Coefficient	85%	Dry Year Volume Missed	0
Tank proportion of Total Storage	21%	Shortfall	1,239,092
Daily use as proportion	517.44	Average/year	112,645
		Wet year shortfall	73,899
		Dry year shortfall	155,006

<b>Scenario 95: McCormack lab roof, current storage + 13000 L, all drink current pop</b>		Empty Days	
Tank capacity	52000	Average/year	243
Total roof area	175	Dry Year Empty Days	305
Average number visitors (MRC+Campsite)	64	Wet Year Empty Days	185
Villagers	239	Volume Missed	0
Personal Daily Use	8	Average/year	0
Daily Use	2424	Wet Year Volume Missed	0
Run-off Coefficient	85%	Dry Year Volume Missed	0
Tank proportion of Total Storage	27%	Shortfall	1,806,516
Daily use as proportion	644.09	Average/year	164,229
		Wet year shortfall	125,909
		Dry year shortfall	203,765

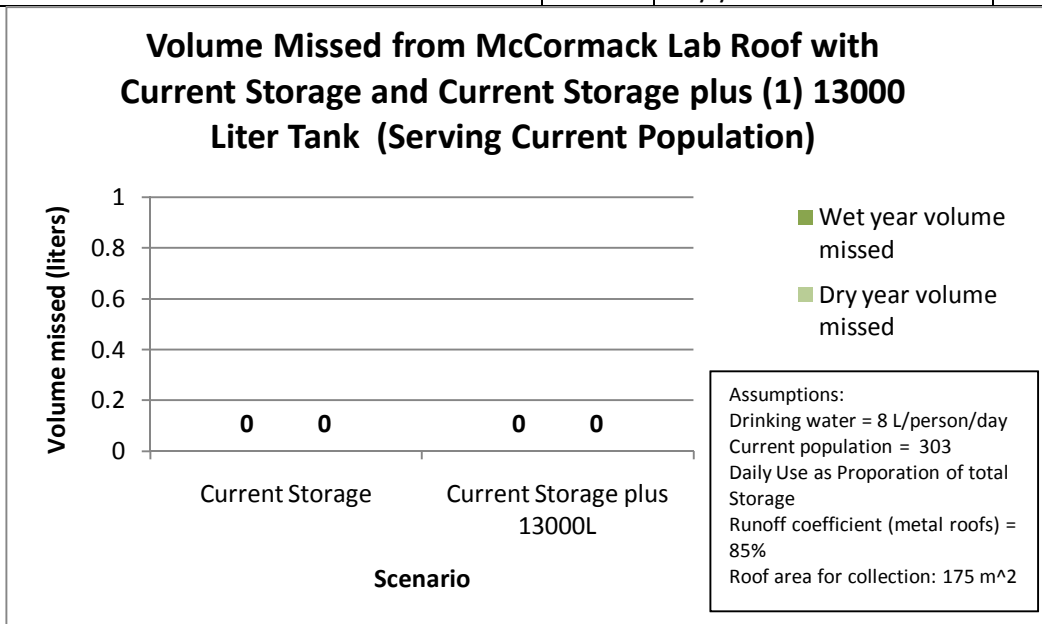

Appendix W-4n. McCormack lab, projected population

<b>Scenario 72: McCormack lab roof, current storage, all drink 2 x visitors + 1.3 x villagers</b>		Empty Days	2,949
Current tank capacity	39000	Average/year	268
Total roof area	175	Dry Year Empty Days	320
Average number visitors (MRC+Campsite)	128	Wet Year Empty Days	221
Villagers	318	Volume Missed	0
Personal Daily Use	8	Average/year	0
Daily Use	3568	Wet Year Volume Missed	0
Run-off Coefficient	85%	Dry Year Volume Missed	0
Tank proportion of Total Storage	21%	Shortfall	2,337,544
Daily use as proportion	761.64	Average/year	212,504
		Wet year shortfall	175,626
		Dry year shortfall	250,044

<b>Scenario 96: McCormack lab roof, current storage + 13000 L, all drink 2 x visitors + 1.3 x villagers</b>		Empty Days	3,212
Tank capacity	52000	Average/year	292
Total roof area	175	Dry Year Empty Days	331
Average number visitors (MRC+Campsite)	128	Wet Year Empty Days	254
Villagers	318	Volume Missed	0
Personal Daily Use	8	Average/year	0
Daily Use	3568	Wet Year Volume Missed	0
Run-off Coefficient	85%	Dry Year Volume Missed	0
Tank proportion of Total Storage	27%	Shortfall	3,167,088
Daily use as proportion	948.06	Average/year	287,917
		Wet year shortfall	249,757
		Dry year shortfall	323,001

**Volume Missed from McCormack Lab Roof with Current Storage and Current Storage plus (1) 13000 Liter Tank (Serving Projected Population)**

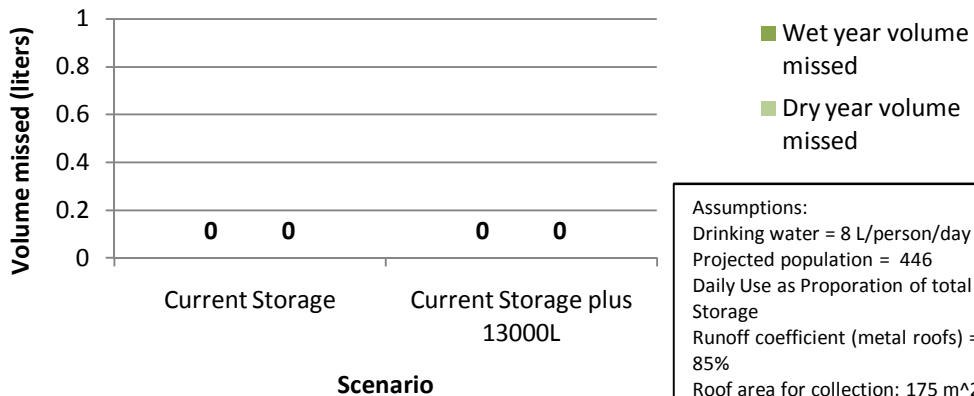

## Appendix W-4o. NSF lab, current population

<b>Scenario 73: NSF Lab roof, current storage, all drink current pop</b>		Empty Days	426
Current tank capacity	13000	Average/year	39
Total roof area	175	Dry Year Empty Days	162
Average number visitors (MRC+Campsite)	64	Wet Year Empty Days	0
Villagers	239	Volume Missed	349,155
Personal Daily Use	8	Average/year	31,741
Daily Use	2424	Wet Year Volume Missed	63,919
Run-off Coefficient	85%	Dry Year Volume Missed	0
Tank proportion of Total Storage	7%	Shortfall	75,514
Daily use as proportion	172.48	Average/year	6,865
		Wet year shortfall	0
		Dry year shortfall	28,434

<b>Scenario 97: NSF Lab roof, current storage + 13000 L, all drink current pop</b>		Empty Days	2,116
Tank capacity	26000	Average/year	192
Total roof area	175	Dry Year Empty Days	280
Average number visitors (MRC+Campsite)	64	Wet Year Empty Days	108
Villagers	239	Volume Missed	11,756
Personal Daily Use	8	Average/year	1,069
Daily Use	2424	Wet Year Volume Missed	11,756
Run-off Coefficient	85%	Dry Year Volume Missed	0
Tank proportion of Total Storage	13%	Shortfall	1,057,105
Daily use as proportion	322.04	Average/year	96,100
		Wet year shortfall	54,263
		Dry year shortfall	137,935

**Volume Missed from NSF Lab Roof with Current Storage and Current Storage plus (1) 13000 Liter Tank (Serving Current Population)**

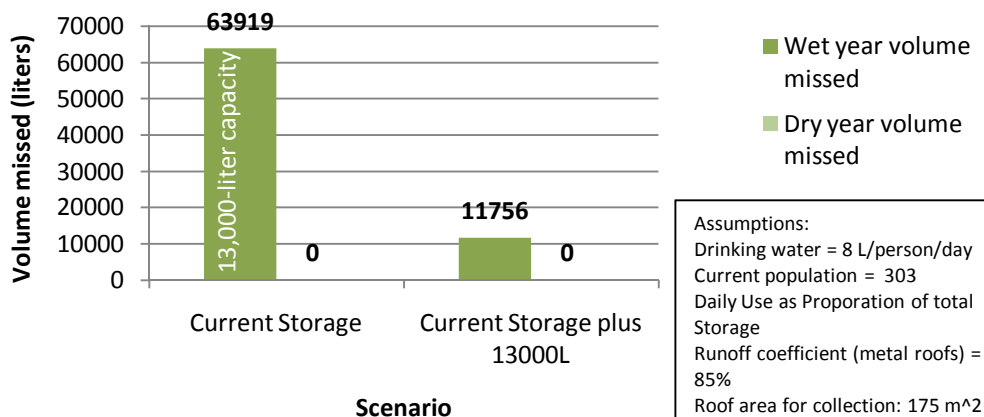

Appendix W-4p. NSF lab, projected population

<b>Scenario 74: NSF Lab roof, current storage, only visitors drink, all drink 2 x visitors + 1.3 x villagers</b>		Empty Days	965
Current tank capacity	13000	Average/year	88
Total roof area	175	Dry Year Empty Days	218
Average number visitors (MRC+Campsite)	128	Wet Year Empty Days	14
Villagers	318	Volume Missed	185,312
Personal Daily Use	8	Average/year	16,847
Daily Use	3568	Wet Year Volume Missed	41,523
Run-off Coefficient	85%	Dry Year Volume Missed	0
Tank proportion of Total Storage	7%	Shortfall	254,968
Daily use as proportion	253.88	Average/year	23,179
		Wet year shortfall	3,825
		Dry year shortfall	254,968

<b>Scenario 98: NSF Lab roof, current storage + 13000 L, only visitors drink, all drink 2 x visitors + 1.3 x villagers</b>		Empty Days	2,116
Tank capacity	26000	Average/year	192
Total roof area	175	Dry Year Empty Days	280
Average number visitors (MRC+Campsite)	128	Wet Year Empty Days	108
Villagers	318	Volume Missed	11,756
Personal Daily Use	8	Average/year	1,069
Daily Use	3568	Wet Year Volume Missed	11,756
Run-off Coefficient	85%	Dry Year Volume Missed	0
Tank proportion of Total Storage	13%	Shortfall	1,057,105
Daily use as proportion	474.03	Average/year	96,100
		Wet year shortfall	54,263
		Dry year shortfall	137,935

**Volume Missed from NSF Lab Roof with Current Storage and Current Storage plus (1) 13000 Liter Tank (Serving Projected Population)**

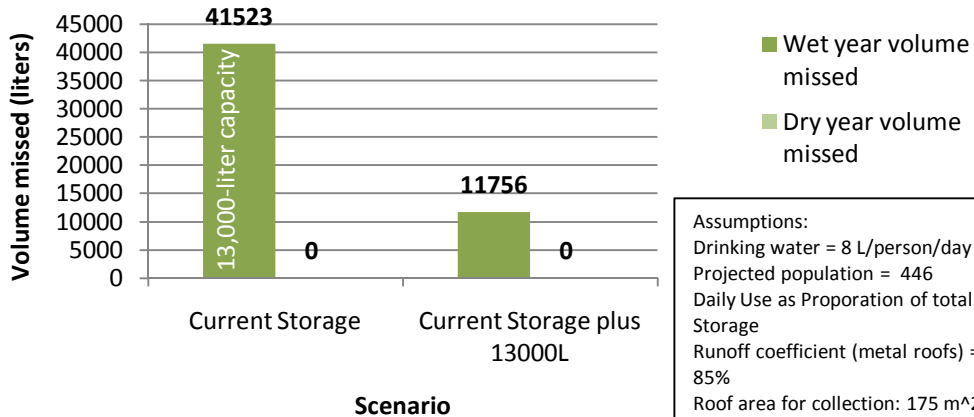

Appendix W-4q. Mess hall, current population

<b>Scenario 75: Mess Hall roof, current storage, all drink current pop</b>		Empty Days	318
Current tank capacity	16900	Average/year	29
Total roof area	286	Dry Year Empty Days	136
Average number visitors (MRC+Campsite)	64	Wet Year Empty Days	0
Villagers	239	Volume Missed	760,337
Personal Daily Use	8	Average/year	69,122
Daily Use	2424	Wet Year Volume Missed	124,699
Run-off Coefficient	85%	Dry Year Volume Missed	0
Tank proportion of Total Storage	9%	Shortfall	72,954
Daily use as proportion	224.22	Average/year	6,632
		Wet year shortfall	0
		Dry year shortfall	31,319

<b>Scenario 99: Mess Hall roof, current storage + 7450, all drink current pop</b>		Empty Days	453
Tank capacity	24350	Average/year	41
Total roof area	286	Dry Year Empty Days	167
Average number visitors (MRC+Campsite)	64	Wet Year Empty Days	0
Villagers	239	Volume Missed	473,050
Personal Daily Use	8	Average/year	43,005
Daily Use	2424	Wet Year Volume Missed	94,448
Run-off Coefficient	85%	Dry Year Volume Missed	0
Tank proportion of Total Storage	13%	Shortfall	145,643
Daily use as proportion	310.41	Average/year	13,240
		Wet year shortfall	0
		Dry year shortfall	53,216

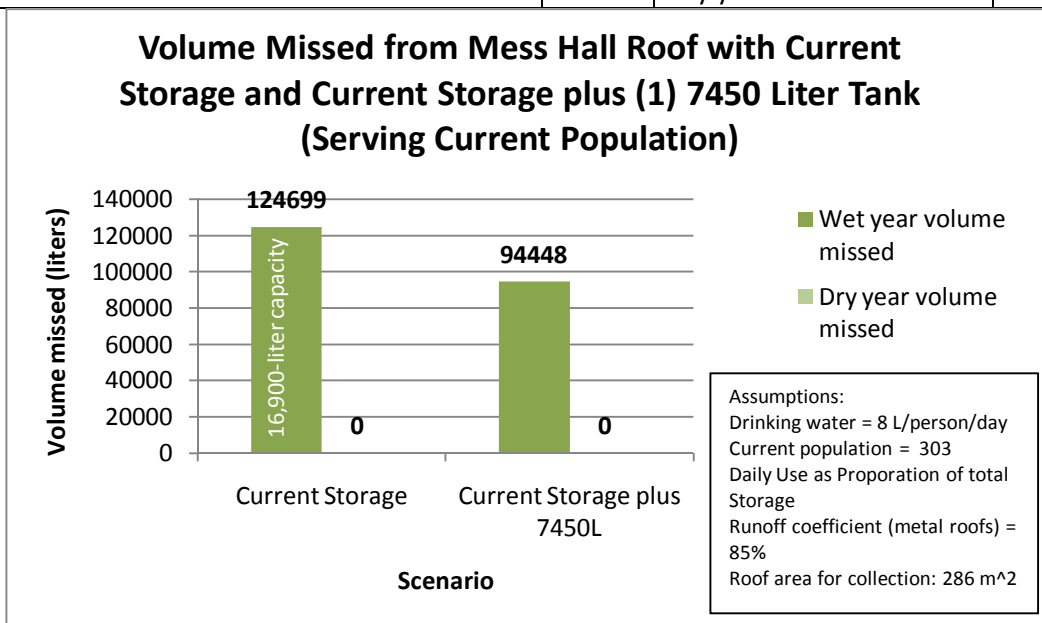

Appendix W-4r. Mess hall, projected population

<b>Scenario 76: Mess Hall roof, current storage, all drink 2 x visitors + 1.3 x villagers</b>		Empty Days	780
Current tank capacity	16900	Average/year	71
Total roof area	286	Dry Year Empty Days	200
Average number visitors (MRC+Campsite)	128	Wet Year Empty Days	10
Villagers	318	Volume Missed	511,301
Personal Daily Use	8	Average/year	46,482
Daily Use	3568	Wet Year Volume Missed	92,405
Run-off Coefficient	85%	Dry Year Volume Missed	0
Tank proportion of Total Storage	9%	Shortfall	269,716
Daily use as proportion	330.04	Average/year	24,520
		Wet year shortfall	3,943
		Dry year shortfall	67,732

<b>Scenario 100: Mess Hall roof, current storage + 7450, all drink 2 x visitors + 1.3 x villagers</b>		Empty Days	1,043
Tank capacity	24350	Average/year	95
Total roof area	286	Dry Year Empty Days	220
Average number visitors (MRC+Campsite)	128	Wet Year Empty Days	0
Villagers	318	Volume Missed	208,282
Personal Daily Use	8	Average/year	18,935
Daily Use	3568	Wet Year Volume Missed	54,762
Run-off Coefficient	85%	Dry Year Volume Missed	0
Tank proportion of Total Storage	13%	Shortfall	496,194
Daily use as proportion	456.91	Average/year	45,109
		Wet year shortfall	6,422
		Dry year shortfall	103,311

**Volume Missed from Mess Hall Roof with Current Storage and Current Storage plus (1) 7450 Liter Tank (Serving Projected Population)**

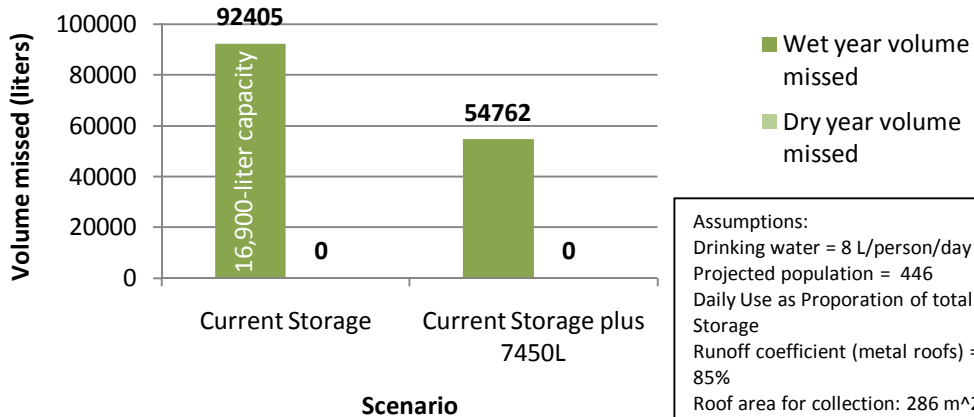

Appendix W-4s. Small kitchen, current population

<b>Scenario 77: Small kitchen roof, current storage, all drink current pop</b>		Empty Days	130
Current tank capacity	2000	Average/year	12
Total roof area	66	Dry Year Empty Days	48
Average number visitors (MRC+Campsite)	64	Wet Year Empty Days	0
Villagers	239	Volume Missed	266,085
Personal Daily Use	8	Average/year	24,190
Daily Use	2424	Wet Year Volume Missed	37,733
Run-off Coefficient	85%	Dry Year Volume Missed	0
Tank proportion of Total Storage	1%	Shortfall	3,567
Daily use as proportion	26.54	Average/year	324
		Wet year shortfall	0
		Dry year shortfall	1,328

<b>Scenario 101: Small kitchen roof, current storage + 2000, all drink current pop</b>		Empty Days	318
Tank capacity	4000	Average/year	29
Total roof area	66	Dry Year Empty Days	137
Average number visitors (MRC+Campsite)	64	Wet Year Empty Days	0
Villagers	239	Volume Missed	172,635
Personal Daily Use	8	Average/year	15,694
Daily Use	2424	Wet Year Volume Missed	28,513
Run-off Coefficient	85%	Dry Year Volume Missed	0
Tank proportion of Total Storage	2%	Shortfall	17,147
Daily use as proportion	52.50	Average/year	1,559
		Wet year shortfall	0
		Dry year shortfall	7,377

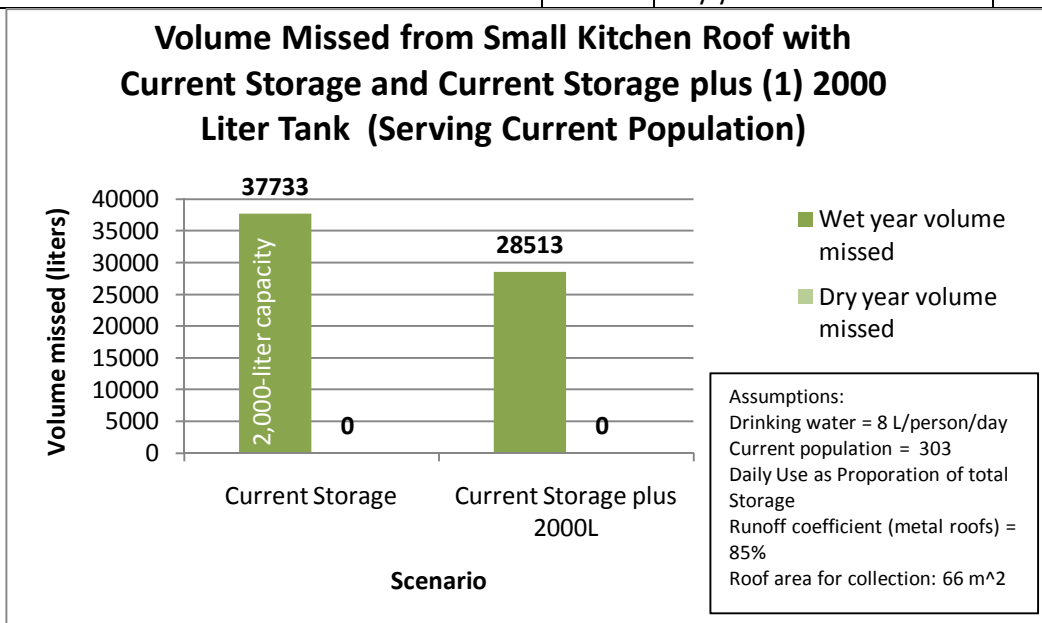



## Appendix W-4t. Small kitchen, projected population

<b>Scenario 78: Small kitchen roof, current storage, all drink 2 x visitors + 1.3 x villagers</b>		Empty Days	375
Current tank capacity	2000	Average/year	34
Total roof area	66	Dry Year Empty Days	130
Average number visitors (MRC+Campsite)	128	Wet Year Empty Days	0
Villagers	318	Volume Missed	226,496
Personal Daily Use	8	Average/year	20,591
Daily Use	3568	Wet Year Volume Missed	33,366
Run-off Coefficient	85%	Dry Year Volume Missed	0
Tank proportion of Total Storage	1%	Shortfall	15,152
Daily use as proportion	39.06	Average/year	1,377
		Wet year shortfall	0
		Dry year shortfall	5,202

<b>Scenario 102: Small kitchen roof, current storage + 2000 L, all drink 2 x visitors + 1.3 x villagers</b>		Empty Days	784
Tank capacity	4000	Average/year	71
Total roof area	66	Dry Year Empty Days	200
Average number visitors (MRC+Campsite)	128	Wet Year Empty Days	10
Villagers	318	Volume Missed	114,501
Personal Daily Use	8	Average/year	10,409
Daily Use	3568	Wet Year Volume Missed	20,961
Run-off Coefficient	85%	Dry Year Volume Missed	0
Tank proportion of Total Storage	2%	Shortfall	63,402
Daily use as proportion	77.27	Average/year	5,764
		Wet year shortfall	897
		Dry year shortfall	15,901

**Volume Missed from Small Kitchen Roof with Current Storage and Current Storage plus (1) 2000 Liter Tank (Serving Projected Population)**

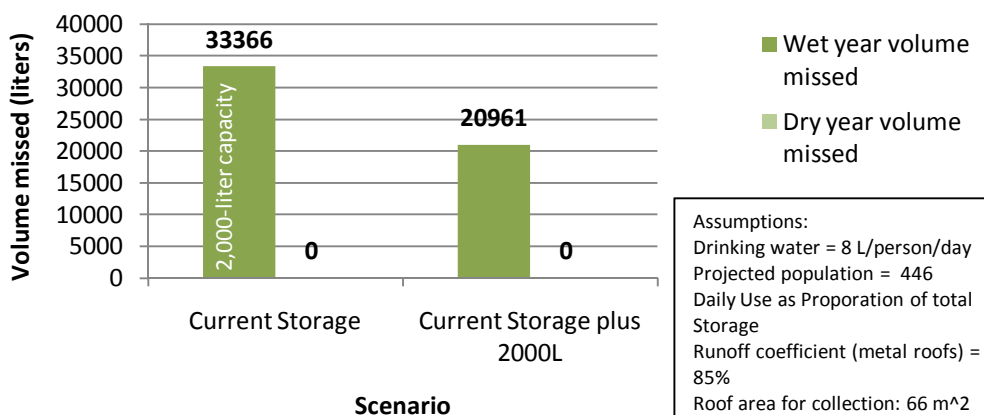

### Appendix W-4u. Director's house, current population

<b>Scenario 79: Director's house roof, current storage, all drink current pop</b>		Empty Days	289
Current tank capacity	7000	Average/year	26
Total roof area	130	Dry Year Empty Days	123
Population	303	Wet Year Empty Days	0
Personal daily use	8	Volume Missed	377,412
Daily Use	2424	Average/year	34,310
Run-off Coefficient	85%	Wet Year Volume Missed	59,857
Tank proportion	4%	Dry Year Volume Missed	0
Daily use as proportion	92.87	Shortfall	27,449
		Average/year	2,495
		Wet year shortfall	0
		Dry year shortfall	11,729

<b>Scenario 103: Director's house roof, current storage + 7000 L, all drink current pop</b>		Empty Days	661
Tank capacity	14000	Average/year	60
Total roof area	130	Dry Year Empty Days	185
Population	303	Wet Year Empty Days	0
Personal daily use	8	Volume Missed	115,926
Total daily Use	2424	Average/year	10,539
Run-off Coefficient	85%	Wet Year Volume Missed	29,664
Tank proportion of total storage	7%	Dry Year Volume Missed	0
Daily use as proportion of total storage	178.89	Shortfall	123,522
		Average/year	11,229
		Wet year shortfall	0
		Dry year shortfall	34,089

**Comparison of volume missed (L) from Director's house at current tank capacity and +7000 L capacity with current population**

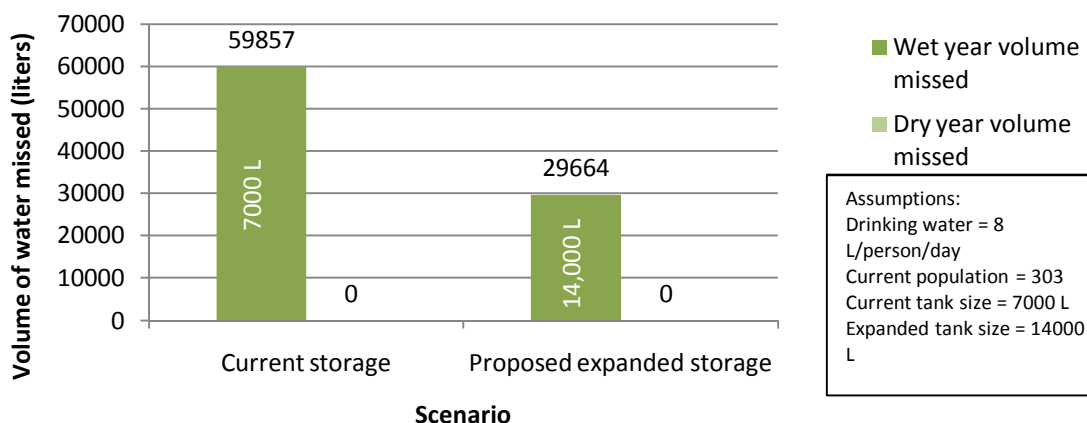

Appendix W-4v. Director’s house, projected population

<b>Scenario 80: Director's house roof, current storage, all drink 2 x visitors + 1.3 x villagers</b>		Empty Days	718
Current tank capacity	7000	Average/year	65
Total roof area	130	Dry Year Empty Days	192
Population	446	Wet Year Empty Days	8
Personal daily use	8	Volume Missed	268,231
Daily Use	3568	Average/year	24,385
Run-off Coefficient	85%	Wet Year Volume Missed	45,853
Tank proportion	4%	Dry Year Volume Missed	0
Daily use as proportion	136.70	Shortfall	102,271
		Average/year	9,297
		Wet year shortfall	1,422
		Dry year shortfall	26,985

<b>Scenario 104: Director's house roof, current storage + 7000 L, all drink 2 x visitors + 1.3 x villagers</b>		Empty Days	1,476
Tank capacity	14000	Average/year	134
Total roof area	130	Dry Year Empty Days	242
Average number visitors (MRC+Campsite)	128	Wet Year Empty Days	33
Villagers	318	Volume Missed	35,667
Personal Daily Use	8	Average/year	3,242
Daily Use	3568	Wet Year Volume Missed	15,735
Run-off Coefficient	85%	Dry Year Volume Missed	0
Tank proportion	7%	Shortfall	409,620
Daily use as proportion	263.32	Average/year	37,238
		Wet year shortfall	9,506
		Dry year shortfall	65,824

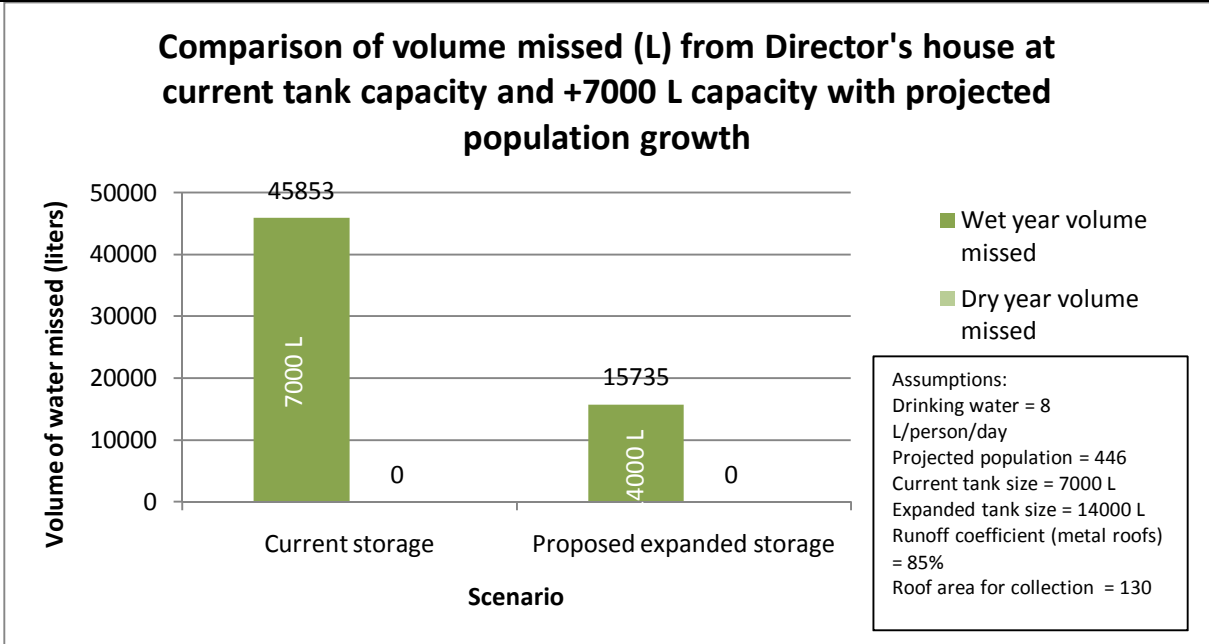

## Appendix W-4w. GIS house, current population

<b>Scenario 81: GIS House roof, current storage, all drink current pop</b>		Empty Days	490
Current tank capacity	13000	Average/year	45
Total roof area	155	Dry Year Empty Days	172
Average number visitors (MRC+Campsite)	64	Wet Year Empty Days	0
Villagers	239	Volume Missed	247,525
Personal Daily Use	8	Average/year	22,502
Daily Use	2424	Wet Year Volume Missed	49,695
Run-off Coefficient	85%	Dry Year Volume Missed	0
Tank proportion	7%	Shortfall	88,128
Daily use as proportion	172.48	Average/year	8,012
		Wet year shortfall	0
		Dry year shortfall	30,466

<b>Scenario 105: GIS House roof, current storage + 13000 L, all drink current pop</b>		Empty Days	1,439
Tank capacity	26000	Average/year	131
Total roof area	155	Dry Year Empty Days	243
Average number visitors (MRC+Campsite)	64	Wet Year Empty Days	2
Villagers	239	Volume Missed	9,299
Personal Daily Use	8	Average/year	845
Daily Use	2424	Wet Year Volume Missed	9,299
Run-off Coefficient	85%	Dry Year Volume Missed	0
Tank proportion	13%	Shortfall	487,038
Daily use as proportion	322.04	Average/year	44,276
		Wet year shortfall	839
		Dry year shortfall	80,757

**Comparison of volume missed (L) GIS house at current tank capacity and +13000 L capacity with current population**

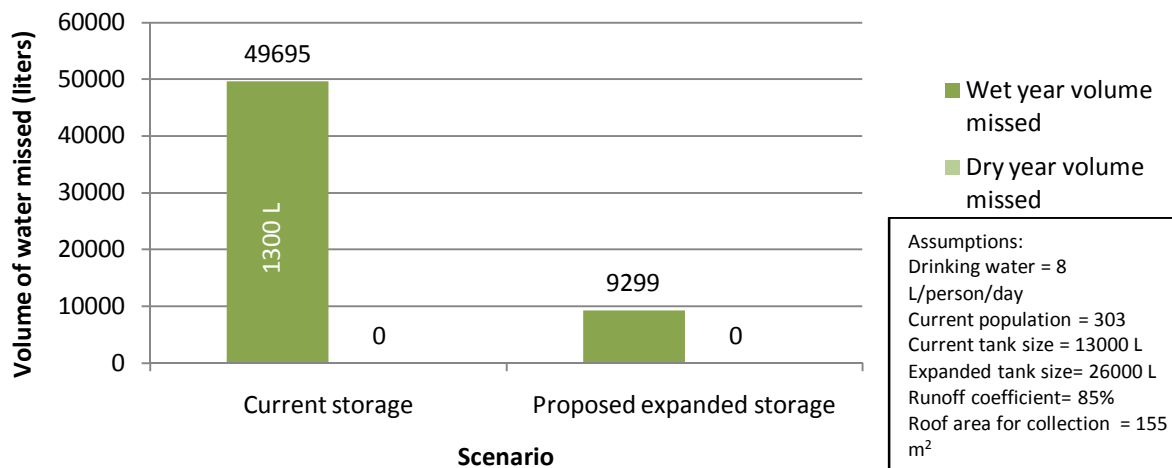

Appendix W-4x. GIS house, projected population

<b>Scenario 82: GIS House roof, current storage, all drink 2 x visitors + 1.3 x villagers</b>		Empty Days	1,098
Current tank capacity	13000	Average/year	100
Total roof area	155	Dry Year Empty Days	225
Average number visitors (MRC+Campsite)	128	Wet Year Empty Days	15
Villagers	318	Volume Missed	107,551
Personal Daily Use	8	Average/year	9,777
Daily Use	3568	Wet Year Volume Missed	28,386
Run-off Coefficient	85%	Dry Year Volume Missed	0
Tank proportion	7%	Shortfall	290,701
Daily use as proportion	253.88	Average/year	26,427
		Wet year shortfall	4,165
		Dry year shortfall	58,289

<b>Scenario 106: GIS House roof, current storage + 13000 L, all drink 2 x visitors + 1.3 x villagers</b>		Empty Days	2,373
Tank capacity	26000	Average/year	216
Total roof area	155	Dry Year Empty Days	294
Average number visitors (MRC+Campsite)	128	Wet Year Empty Days	143
Villagers	318	Volume Missed	6,412
Personal Daily Use	8	Average/year	583
Daily Use	3568	Wet Year Volume Missed	6,412
Run-off Coefficient	85%	Dry Year Volume Missed	0
Tank proportion	13%	Shortfall	1,174,999
Daily use as proportion	474.03	Average/year	106,818
		Wet year shortfall	71,896
		Dry year shortfall	143,399

**Comparison of volume missed (L) from GIS house at current tank capacity and +13000 L capacity with projected population growth**

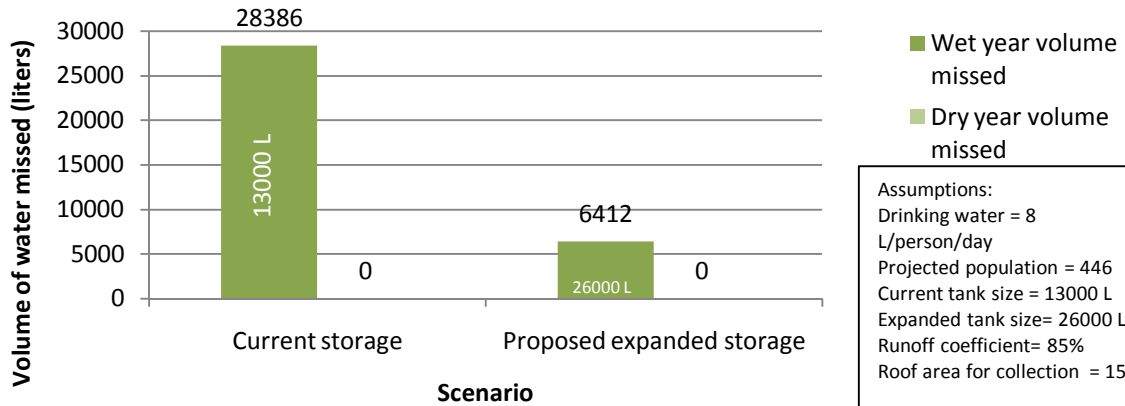

## Appendix W-4y. Klee house, current population

<b>Scenario 83: KLEE House roof, current storage, all drink current pop</b>		Empty Days	490
Current tank capacity	13000	Average/year	45
Total roof area	155	Dry Year Empty Days	172
Average number visitors (MRC+Campsite)	64	Wet Year Empty Days	0
Villagers	239	Volume Missed	247,525
Personal Daily Use	8	Average/year	22,502
Daily Use	2424	Wet Year Volume Missed	49,695
Run-off Coefficient	85%	Dry Year Volume Missed	0
Tank proportion	7%	Shortfall	88,128
Daily use as proportion	172.48	Average/year	8,012
		Wet year shortfall	0
		Dry year shortfall	30,466

<b>Scenario 107: KLEE House roof, current storage + 13000 L, all drink current pop</b>		Empty Days	1,439
Tank capacity	26000	Average/year	131
Total roof area	155	Dry Year Empty Days	243
Average number visitors (MRC+Campsite)	64	Wet Year Empty Days	2
Villagers	239	Volume Missed	9,299
Personal Daily Use	8	Average/year	845
Daily Use	2424	Wet Year Volume Missed	9,299
Run-off Coefficient	85%	Dry Year Volume Missed	0
Tank proportion	13%	Shortfall	487,038
Daily use as proportion	322.04	Average/year	44,276
		Wet year shortfall	839
		Dry year shortfall	80,757

**Comparison of volume missed (L) from KLEE house at current tank capacity and +13000 L capacity with current population**

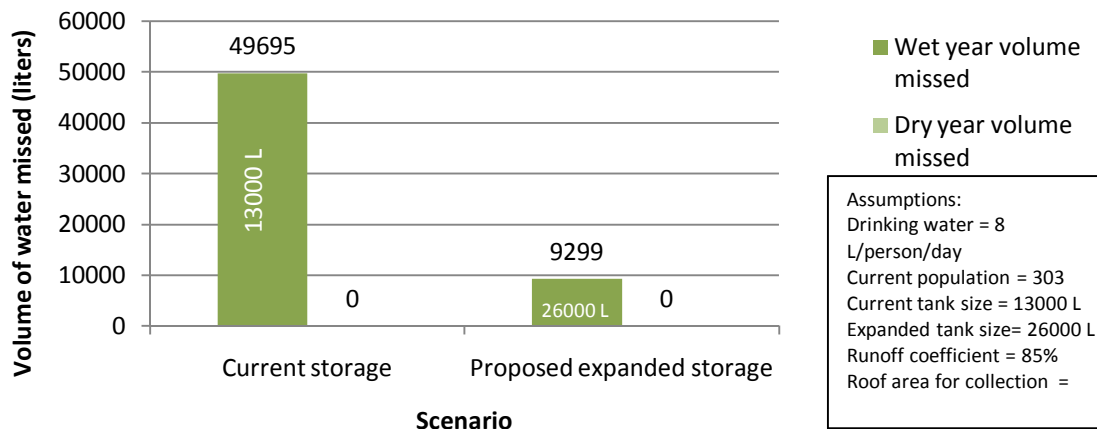

Appendix W-4z. Klee house, projected population

<b>Scenario 84: KLEE House roof, current storage, all drink 2 x visitors + 1.3 x villagers</b>		Empty Days	1,523
Current tank capacity	13000	Average/year	138
Total roof area	155	Dry Year Empty Days	241
Average number visitors (MRC+Campsite)	128	Wet Year Empty Days	65
Villagers	318	Volume Missed	207,911
Personal Daily Use	8	Average/year	18,901
Daily Use	3568	Wet Year Volume Missed	43,029
Run-off Coefficient	85%	Dry Year Volume Missed	0
Tank proportion	7%	Shortfall	403,587
Daily use as proportion	253.88	Average/year	36,690
		Wet year shortfall	17,107
		Dry year shortfall	63,173

<b>Scenario 108: KLEE House roof, current storage + 13000 L, all drink 2 x visitors + 1.3 x villagers</b>		Empty Days	2,373
Tank capacity	26000	Average/year	216
Total roof area	155	Dry Year Empty Days	294
Average number visitors (MRC+Campsite)	128	Wet Year Empty Days	143
Villagers	318	Volume Missed	6,412
Personal Daily Use	8	Average/year	583
Daily Use	3568	Wet Year Volume Missed	6,412
Run-off Coefficient	85%	Dry Year Volume Missed	0
Tank proportion	13%	Shortfall	1,174,999
Daily use as proportion	474.03	Average/year	106,818
		Wet year shortfall	71,896
		Dry year shortfall	143,399

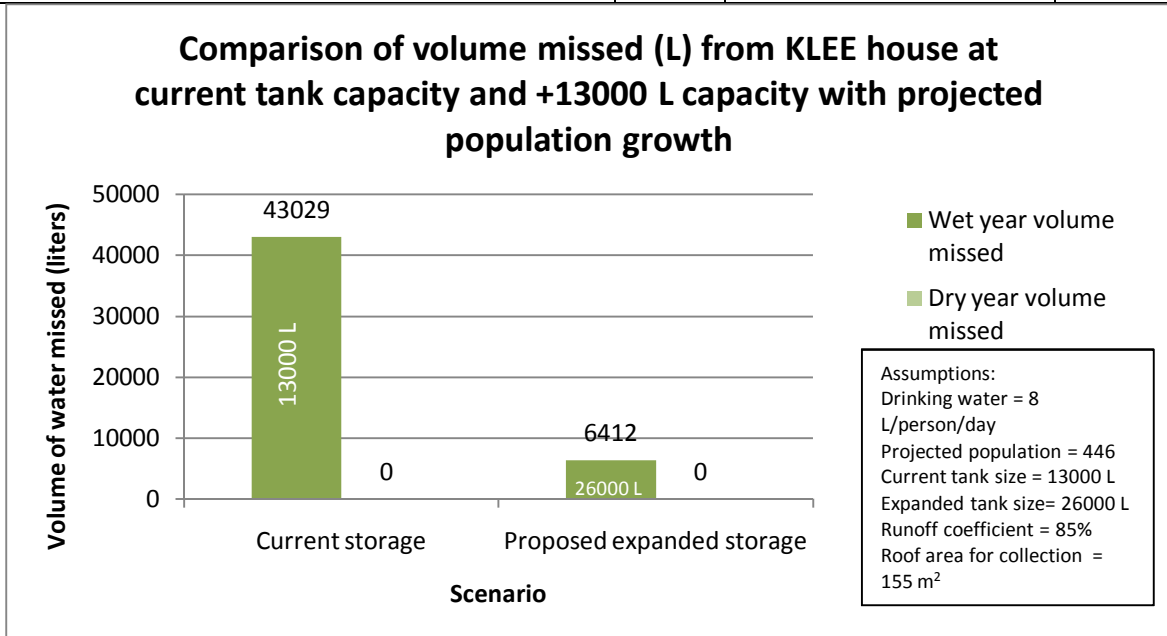

## Appendix W-4aa. Admin house, current population

<b>Scenario 85: Admin House roof, current storage, all drink current pop</b>		Empty Days	443
Current tank capacity	6900	Average/year	40
Total roof area	90	Dry Year Empty Days	164
Average number visitors (MRC+Campsite)	64	Wet Year Empty Days	0
Villagers	239	Volume Missed	170,506
Personal Daily Use	8	Average/year	15,501
Daily Use	2424	Wet Year Volume Missed	31,875
Run-off Coefficient	85%	Dry Year Volume Missed	0
Tank proportion	4%	Shortfall	41,623
Daily use as proportion	91.55	Average/year	3,784
		Wet year shortfall	0
		Dry year shortfall	15,384

<b>Scenario 109: Admin House roof, current storage + 6900 L, all drink current pop</b>		Empty Days	1,301
Tank capacity	13800	Average/year	118
Total roof area	90	Dry Year Empty Days	235
Average number visitors (MRC+Campsite)	64	Wet Year Empty Days	0
Villagers	239	Volume Missed	10,348
Personal Daily Use	8	Average/year	941
Daily Use	2424	Wet Year Volume Missed	6,897
Run-off Coefficient	85%	Dry Year Volume Missed	0
Tank proportion	7%	Shortfall	240,699
Daily use as proportion	176.43	Average/year	21,882
		Wet year shortfall	0
		Dry year shortfall	42,799

**Comparison of volume missed (L) from Admin house at current tank capacity and +6900 L capacity with current population**

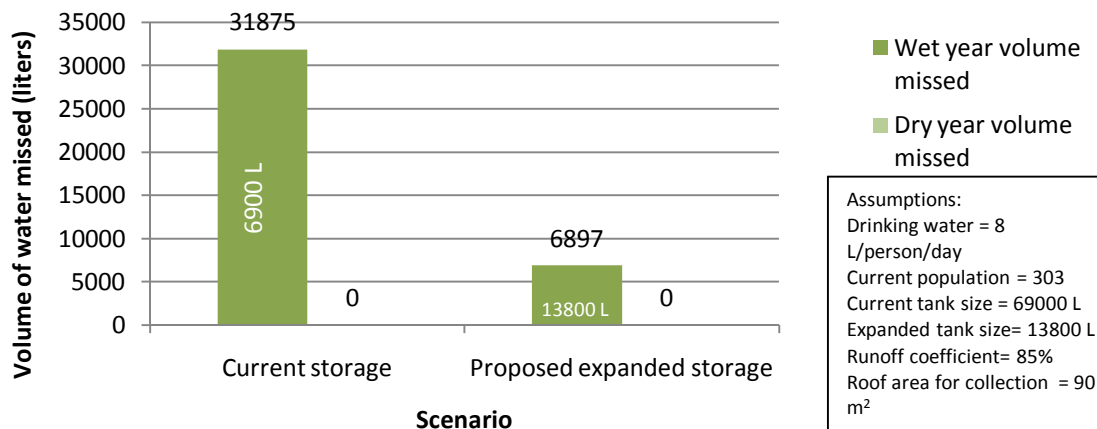



Appendix W-4bb. Admin house, projected population

<b>Scenario 86: Admin House roof, current storage, all drink 2 x visitors + 1.3 x villagers</b>		Empty Days	992
Current tank capacity	6900	Average/year	90
Total roof area	90	Dry Year Empty Days	219
Average number visitors (MRC+Campsite)	128	Wet Year Empty Days	14
Villagers	318	Volume Missed	86,807
Personal Daily Use	8	Average/year	7,892
Daily Use	3568	Wet Year Volume Missed	20,144
Run-off Coefficient	85%	Dry Year Volume Missed	0
Tank proportion	4%	Shortfall	139,865
Daily use as proportion	134.75	Average/year	12,715
		Wet year shortfall	2,079
		Dry year shortfall	30,236

<b>Scenario 110: Admin House roof, current storage + 6900 L, all drink 2 x visitors + 1.3 x villagers</b>		Empty Days	2,254
Tank capacity	13800	Average/year	205
Total roof area	90	Dry Year Empty Days	288
Average number visitors (MRC+Campsite)	128	Wet Year Empty Days	126
Villagers	318	Volume Missed	5,315
Personal Daily Use	8	Average/year	483
Daily Use	3568	Wet Year Volume Missed	5,315
Run-off Coefficient	85%	Dry Year Volume Missed	0
Tank proportion	7%	Shortfall	614,126
Daily use as proportion	259.70	Average/year	55,830
		Wet year shortfall	34,728
		Dry year shortfall	77,190

**Comparison of volume missed (L) from Admin house at current tank capacity and +6900 L capacity with projected population growth**

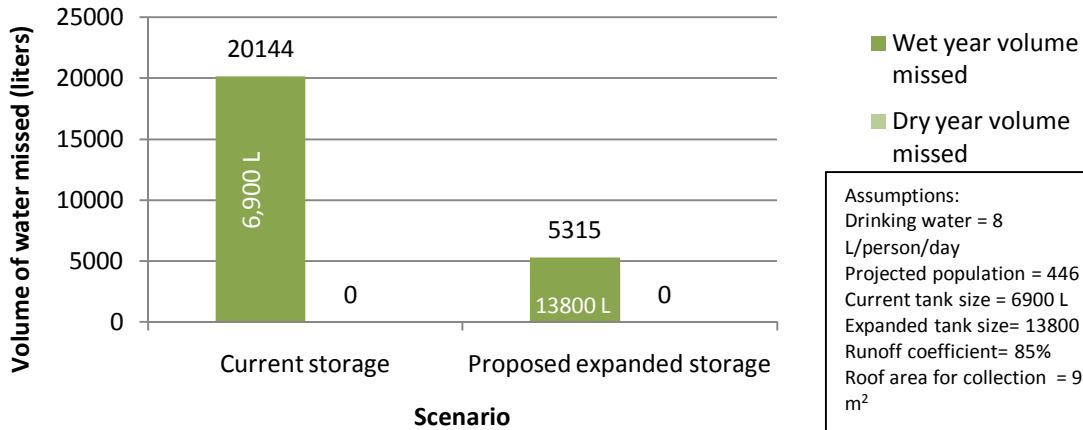

## Appendix W-4cc. Jenga house, current population

<b>Scenario 87: Jenga House roof, current storage, all drink current pop</b>		Empty Days	200
Current tank capacity	6900	Average/year	18
Total roof area	175	Dry Year Empty Days	77
Average number visitors (MRC+Campsite)	64	Wet Year Empty Days	0
Villagers	239	Volume Missed	627,368
Personal Daily Use	8	Average/year	57,033
Daily Use	2424	Wet Year Volume Missed	92,336
Run-off Coefficient	85%	Dry Year Volume Missed	0
Tank proportion	4%	Shortfall	18,628
Daily use as proportion	91.55	Average/year	1,693
		Wet year shortfall	0
		Dry year shortfall	7,160

<b>Scenario 111: Jenga House roof, current storage + 6900 L, all drink current pop</b>		Empty Days	417
Tank capacity	13800	Average/year	38
Total roof area	175	Dry Year Empty Days	161
Average number visitors (MRC+Campsite)	64	Wet Year Empty Days	0
Villagers	239	Volume Missed	333,049
Personal Daily Use	8	Average/year	30,277
Daily Use	2424	Wet Year Volume Missed	62,532
Run-off Coefficient	85%	Dry Year Volume Missed	0
Tank proportion	7%	Shortfall	75,896
Daily use as proportion	176.43	Average/year	6,900
		Wet year shortfall	0
		Dry year shortfall	28,950

**Comparison of volume missed (L) from Jenga house at current tank capacity and +6900 L capacity with current population**

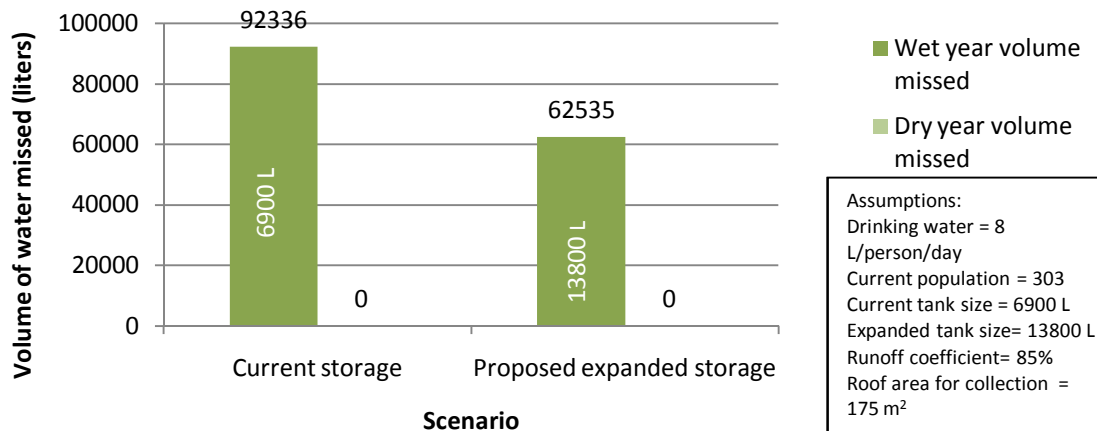

## Appendix W-4dd. Jenga house, projected population

<b>Scenario 88: Jenga House roof, current storage, all drink 2 x visitors + 1.3 x villagers</b>		Empty Days	511
Current tank capacity	6900	Average/year	46
Total roof area	175	Dry Year Empty Days	159
Average number visitors (MRC+Campsite)	128	Wet Year Empty Days	6
Villagers	318	Volume Missed	502,218
Personal Daily Use	8	Average/year	45,656
Daily Use	3568	Wet Year Volume Missed	77,860
Run-off Coefficient	85%	Dry Year Volume Missed	0
Tank proportion	4%	Shortfall	71,440
Daily use as proportion	134.75	Average/year	6,495
		Wet year shortfall	968
		Dry year shortfall	21,973

<b>Scenario 112: Jenga House roof, current storage + 6900 L, all drink 2 x visitors + 1.3 x villagers</b>		Empty Days	963
Tank capacity	13800	Average/year	88
Total roof area	175	Dry Year Empty Days	216
Average number visitors (MRC+Campsite)	128	Wet Year Empty Days	12
Villagers	318	Volume Missed	167,980
Personal Daily Use	8	Average/year	15,271
Daily Use	3568	Wet Year Volume Missed	39,339
Run-off Coefficient	85%	Dry Year Volume Missed	0
Tank proportion	7%	Shortfall	261,739
Daily use as proportion	259.70	Average/year	23,794
		Wet year shortfall	3,478
		Dry year shortfall	57,627

**Comparison of volume missed (L) from Jenga house at current tank capacity and +6900 L capacity with projected population growth**

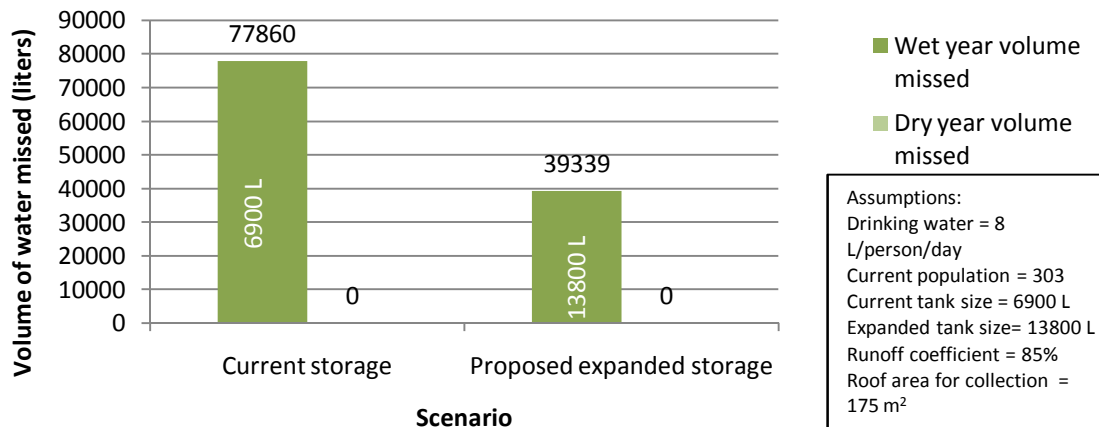

Appendix W-4ee. Store 15, current population

<b>Scenario 89: Store 15 roof, current storage, all drink current pop</b>		Empty Days	2,209
Current tank capacity	14000	Average/year	201
Total roof area	65	Dry Year Empty Days	288
Average number visitors (MRC+Campsite)	64	Wet Year Empty Days	125
Villagers	239	Volume Missed	0
Personal Daily Use	8	Average/year	0
Daily Use	2424	Wet Year Volume Missed	0
Run-off Coefficient	85%	Dry Year Volume Missed	0
Tank proportion	8%	Shortfall	430,780
Daily use as proportion	185.75	Average/year	39,162
		Wet year shortfall	24,111
		Dry year shortfall	55,037

<b>Scenario 113: Store 15 roof, current storage +14000 L, all drink current pop</b>		Empty Days	3,187
Tank capacity	28000	Average/year	290
Total roof area	65	Dry Year Empty Days	329
Average number visitors (MRC+Campsite)	64	Wet Year Empty Days	252
Villagers	239	Volume Missed	0
Personal Daily Use	8	Average/year	0
Daily Use	2424	Wet Year Volume Missed	0
Run-off Coefficient	85%	Dry Year Volume Missed	0
Tank proportion	14%	Shortfall	1,143,969
Daily use as proportion	345.05	Average/year	103,997
		Wet year shortfall	89,943
		Dry year shortfall	117,234

**Comparison of volume missed (L) from Store 15 at current tank capacity and +14000 L capacity with current population**

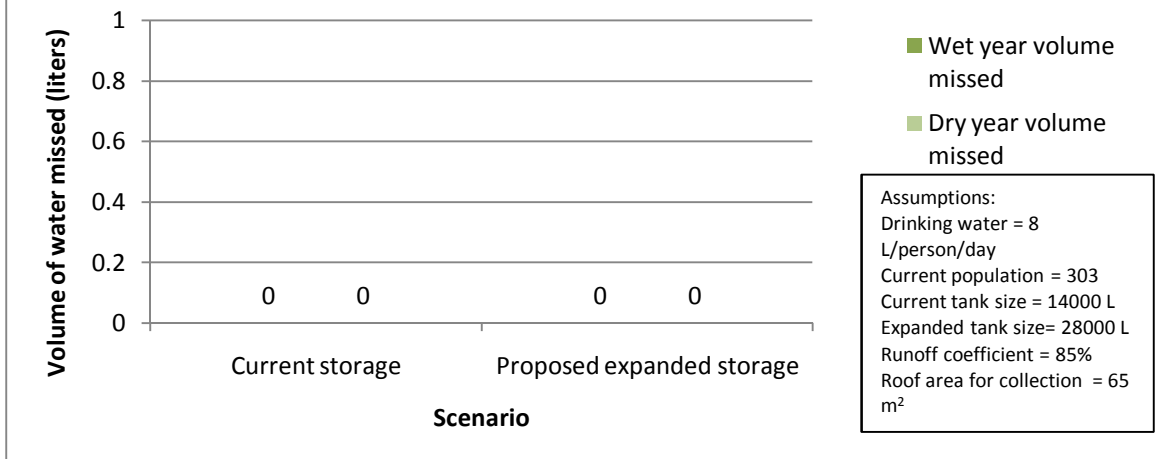

## Appendix W-4ff. Store 15, projected population

<b>Scenario 90: Store 15 roof, current storage, all drink 2 x visitors + 1.3 x villagers</b>		Empty Days	2,880
Current tank capacity	14000	Average/year	262
Total roof area	65	Dry Year Empty Days	316
Average number visitors (MRC+Campsite)	128	Wet Year Empty Days	212
Villagers	318	Volume Missed	0
Personal Daily Use	8	Average/year	0
Daily Use	3568	Wet Year Volume Missed	0
Run-off Coefficient	85%	Dry Year Volume Missed	0
Tank proportion	8%	Shortfall	826,089
Daily use as proportion	273.41	Average/year	75,099
		Wet year shortfall	61,427
		Dry year shortfall	89,179

<b>Scenario 114: Store 15 roof, current storage + 14000 L, all drink 2 x visitors + 1.3 x villagers</b>		Empty Days	3,541
Tank capacity	28000	Average/year	322
Total roof area	65	Dry Year Empty Days	346
Average number visitors (MRC+Campsite)	128	Wet Year Empty Days	296
Villagers	318	Volume Missed	0
Personal Daily Use	8	Average/year	0
Daily Use	3568	Wet Year Volume Missed	0
Run-off Coefficient	85%	Dry Year Volume Missed	0
Tank proportion	14%	Shortfall	1,860,775
Daily use as proportion	507.90	Average/year	169,161
		Wet year shortfall	156,439
		Dry year shortfall	179,572

## Appendix W-5: Hot water needs and solar thermal hot water sizing and costs

### HOT WATER SYSTEM SIZES

Total Shower Allowance/person/day		14 Gallons		Direct Solar	
Building	Beds	Hot Water/Day/Bu	BTUneeded	Btu/m2/day/panel	needed (m2)
Dorms/Bandas	36	504	231184.8	34366.20992	7
Jenga	4	56	25687.2	34366.20992	1
Grevy	4	56	25687.2	34366.20992	1
Klee	4	56	25687.2	34366.20992	1
Wild Dog	4	56	25687.2	34366.20992	1
Heathrow	4	56	25687.2	34366.20992	1
Smithsonian	4	56	25687.2	34366.20992	1
Gym	5	70	32109	34366.20992	1
Margaret's House	4	56	25687.2	34366.20992	1
Daily showers	69	966	443104.2	34366.20992	13
Needed Daily HW	966				

Location	Panels	Unit Cost	Notes
Dorms	3	113,000	220LT WITH 1X2.3SQ MT PANEL
Remainder	8	113,000	220LT WITH 1X2.3SQ MT PANEL
Total	11	1243000	Cost Ksh
		15288.9	Cost US\$

## Appendix W-6: Rainfall data

### W-6a. 2001 rainfall at MRC

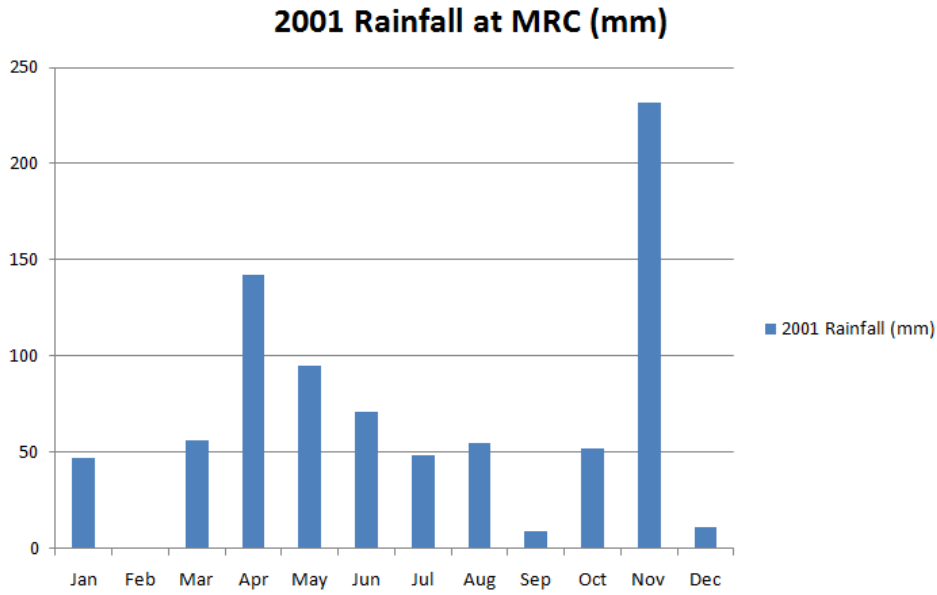

### W-6b. 2009-2010 MRC rainfall vs. long-term average

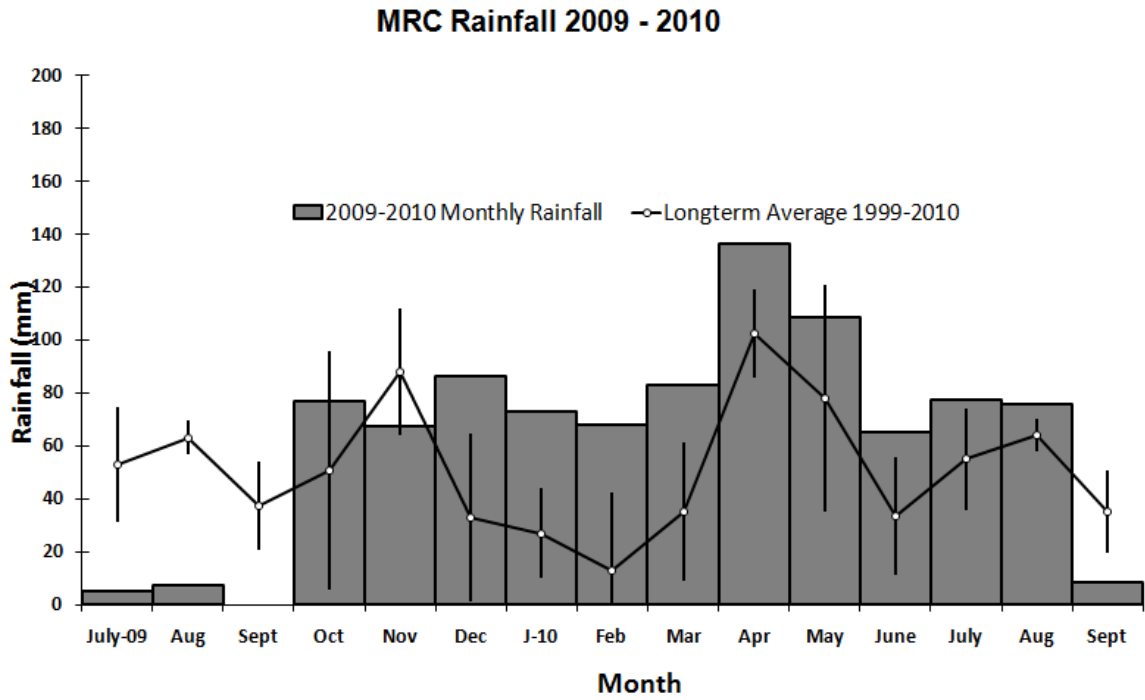

## W-6c. Total rainfall at MRC by year

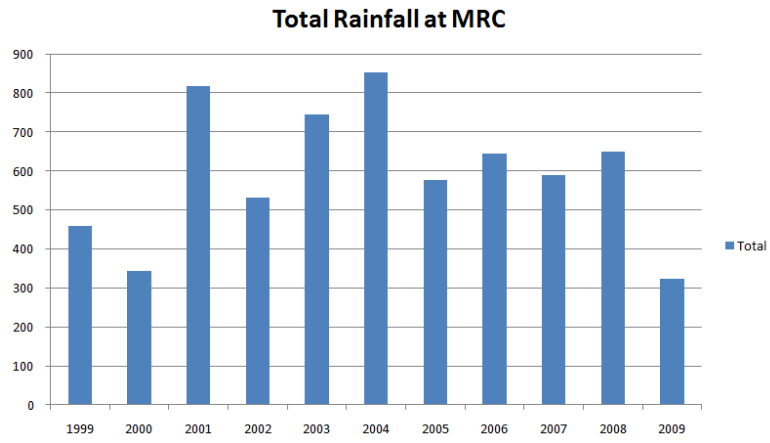



## Appendix W-7: Costs for building water tanks (above and belowground)

### Above ground tank

Item	Item Description	Unit Cost	Quantity	Total Cost	Notes
Mosquito Dunks	Larvicide	16,752	1	16752	
Gutter screens	Plastic screen	14,239	1	14239	
Flash tape	Bird deterrent	251	1	251	
Labor - Masonry	1 Mason Day plus 1 Labor day	900	10	9000	
Gutters	Plastic	251	50	12564	
First flush device		3,350	1	3350	
Piping	PVC	2,513	1	2513	
Floating suction filter		3,350	1	3350	
UV water purifier		46,487	1	46487	

**TOTAL COST**
**108,506.88 Ksh**
**\$ 1,302.08 US**

### Common Underground Tank by Library

Item	Item Description	Unit Cost	Quantity	Total Cost	Notes
Piping	PVC per linear meter	250	755	188750	
Labor for Digging Piping Trenches	1 laborer day	20	300	6000	
Labor -Digging for Storage Tank	1 laborer day	300	60	18000	4 men digging for 15 days
Labor - Masonry	1 Mason Day plus 1 laborer day	900	440	396000	2 Masons for 220 days, 2 laborers for 220 days or add more laborers
Cement	50 kg bad	800	252	201600	Surface area of 240m <sup>2</sup> , 10cm thick
Floating Suctions Filter		12,500	1	12500	
Above Ground Draw Tank	Similar to single building tank	4250	1	4250	Where treatment occurs, costs from above
Ozone Generator with Solar Kit	Sized for Local Above Ground	57143	1	57143	

**TOTAL COST**
**695,492.86 Ksh**
**\$ 8,345.91 US**

## Appendix E-1: Equipment lists

### Appendix E-1a. Administration office load description

Item Particulars	Qty	Watts	Total Wattage
Photocopier Machine	1	250	250
Laptop Computers	5	60	300
***LaserPrinter	2	500	1000
***Fluorescent lights	8	40	320
Energy Saving lights	5	11	55

### Appendix E-1b. McCormack lab load description

Item Particulars	Qty	Watts	Total Wattage
Freezers	1+1	1000+	1200
Microscope	1	40	40
Laptops	14	60	840
***Fluorescent lights	10	40	400
Energy saving lights	6	10	60

### Appendix E-1c. Library load description

Item Particulars	Qty	Watts	Total Wattage
VSAT	1	50	50
***Desktop Computer (TFT)	1	250	250
Laptops	7	60	420
Server	1	300	300
Fluorescent lights	25	40	1000
Energy Saving lights	4	10	40
Printer(laser)	1	800	800
Printer(inkjet)	1	300	300
Portable Fan	1	50	50
Scanner	1		

### Appendix E-1d. NSF lab load description

Item description	Qty	Watts	Total Wattage
Freezer	1		
Laptops	14	60	840
Fluorescent lights	10	40	400
Energy saving lights	6	10	60
Printers	4	400	1600
Microscope	1	60	60

Wireless Switchers/Routers..	2		
------------------------------	---	--	--

**Appendix E-2: Current PV installations and other power systems at Mpala.**

**Appendix E-2a. PV array and other power systems for the Administration office.**

Item particulars	Qty
DR2424 Xantrex Inverter	1
***6V, 350Ah Fulmen Batteries	4
40A Trace Charge Controllers	1
65W Solar Panels	3
75W Solar Panels	7

**Appendix E-2b. PV array and other power systems for McCormack laboratory.**

Item Particulars	Qty
DR2424 Xantrex Inverter	1
***12V, 140Ah Fulmen Batteries	12
40A Trace Charge Controller	1
75W Solar Panels	4
65W Solar Panels	6

**Appendix E-2c. PV array and other power systems for the Library.**

Item Particulars	Qty
SW3024 Xantrex Inverter	1
2V, 1200Ah Fulmen Batteries	12
40Ah Trace Controller with Meter	1
30A Prostar Controller with Meter	1
160W Solar Panels	6
75W Solar Panels	4

**Appendix E-2d. PV array and other power systems for NSF laboratory.**

Item Particulars	Qty
DR2424 Xantrex Inverter	1
6V, 350Ah Fulmen Batteries	4
40A Trace Charge Controller	1
160W Solar Panels	6

### Appendix E-3: Data sampling duration, frequency, and sources

Name	Time of sampling		Sampling rate	Source
	Years	Days		
<b>Power load MRC (Demand)</b>	0	5-8	Hourly for 12 hours everyday	Measured by UM students
<b>Power load Ranch HQ (Demand)</b>	1/3	60	Daily for 15 days every month	Measured by Ranch manager (Mike)
<b>Solar Radiance</b>	1	365	Hourly	HOMER – NASA
<b>Wind speed density (measured at approximately 2 stories)</b>	1	365	Daily mean, max	Mpala Meteorological Station
<b>River flow (Hydro electric)</b>	24	365	Daily mean	CETRAD, Kenya
	10	365	Daily mean	CETRAD, Kenya
<b>Biogas</b>	General	General	Idea	Research papers from Uganda; Information from Ranch manager (Mike); Kayla Yurco
<b>Temperature</b>	10	365	Daily mean	Mpala meteorological station

## Appendix E-4 – HOMER SCENARIOS

### Appendix E-4a – Existing System

#### A. System Scenario: Case of currently existing system at the Mpala Research Centre

Homer System		Input Parameters			
		Power (kW)	Energy (kWh/year)	Capital Cost (\$)	Operational Cost (\$)
Diesel	16+24	12960+22184	0		
Hydro	-	-	-	-	
Biogas	-	-	-	-	
PV	3.63	6,417	0 \$/W	\$/hr	
Battery	NA	51.8 kWh	0 \$/Ah		
Load (peak)	10	95 kWh/day	NA	NA	
Inverter	8.28	-	0		

Sensitivities: Ambient temperature – 19.6 C and 24 C  
 Diesel price - \$0.994 and \$2.03

Assumptions for the scenario: 6 months draught, Load = Current load, 35% maximum annual capacity shortage

Primary Load 1 (kWh/d)  Average Ambient Temperature (°C)  Diesel Price (\$/L)

System Architecture: 3.63 kW PV      24 Trojan L16P      Cycle Charging      Total NPC: \$ 647,305  
 16 kW Small Generator      8.28 kW Inverter      Levelized COE: \$ 1.189/kWh  
 24 kW Large Generator      8.28 kW Rectifier      Operating Cost: \$ 41,068/yr

Conclusion: The current system uses a lot of diesel due to which it has very high carbon dioxide emissions. Renewable power needs to be installed to make the system more sustainable.

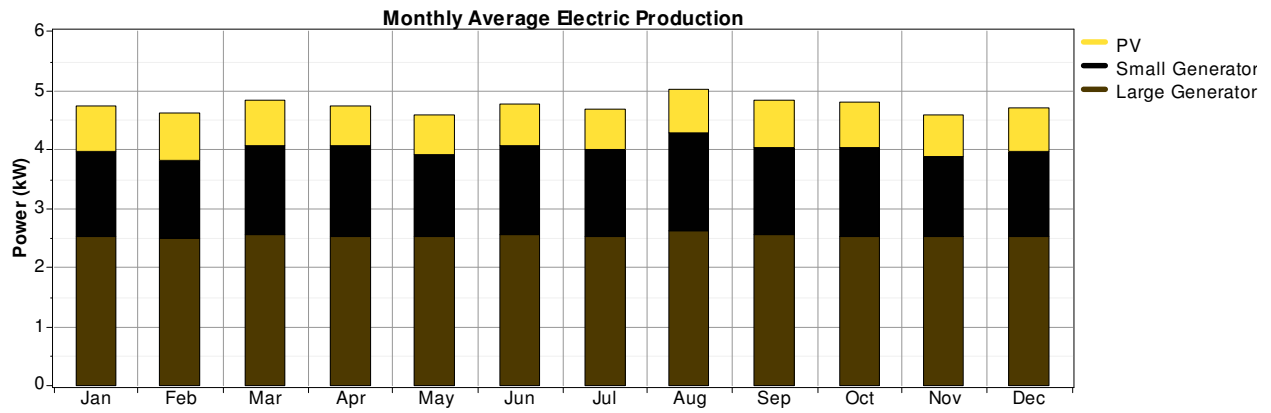
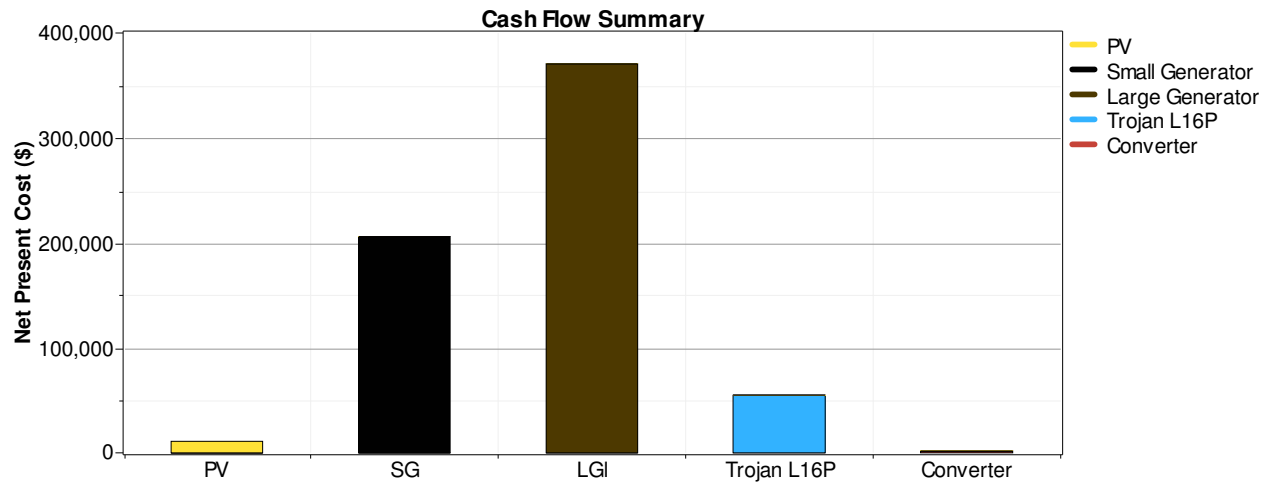

**B. System Scenario: Case of currently existing system at the Ranch headquarters**

Homer System	Input Parameters				
		Power (kW)	Energy (kWh/year)	Capital Cost (\$)	Operational Cost (\$)
	Diesel	24	18,641	0	
	Hydro	11.3 kW	44,733	0	
	Biogas	-	-	-	-
	PV	-	-	-	-
	Battery		17.3 kWh	0 \$/Ah	
	Load (Peak)	14	49 kWh/day	NA	NA
	Inverter	8.28		0	
	Sensitivities: Ambient temperature – 19.6 C and 24 C Diesel price - \$0.994 and \$2.03 Hydro head loss = 0% and 10%				

Assumptions for the scenario: 6 months draught, Load = Current load, 35% maximum annual capacity shortage

Diesel Price (\$/L) 
 Design Flow Rate (L/s) 
 Hydro Head Loss (%)

System Architecture:	11.3 kW Hydro	8.28 kW Inverter	Total NPC: \$ 375,945
	24 kW Large Generator	8.28 kW Rectifier	Levelized COE: \$ 1.334/kWh
	8 Trojan L16P	Cycle Charging	Operating Cost: \$ 23,852/yr

Conclusion: The energy system at the Ranch is primarily powered by a hydroelectric generator which currently produces excess electricity. This excess electricity is wasted by heating the river water and letting it back to the river. Hence there is tremendous opportunity to capture and transmit this energy.

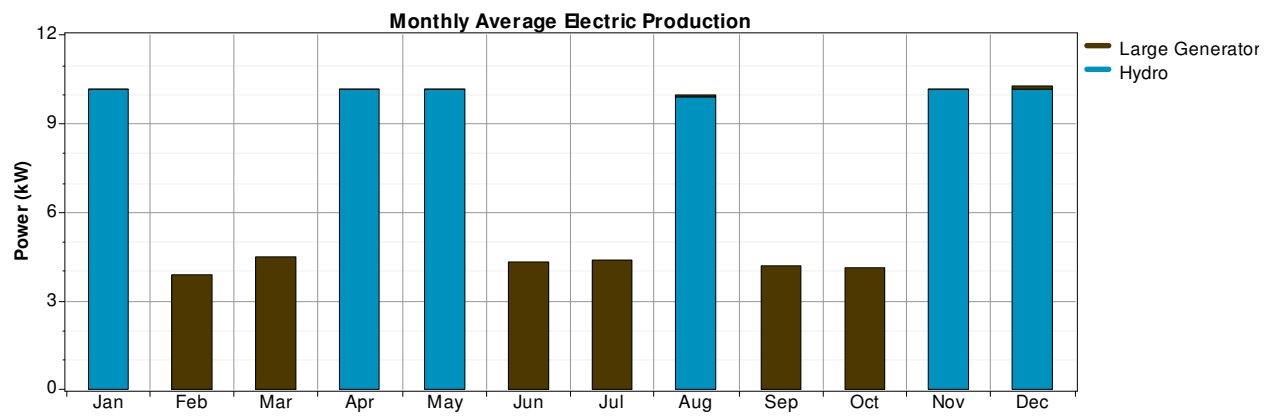
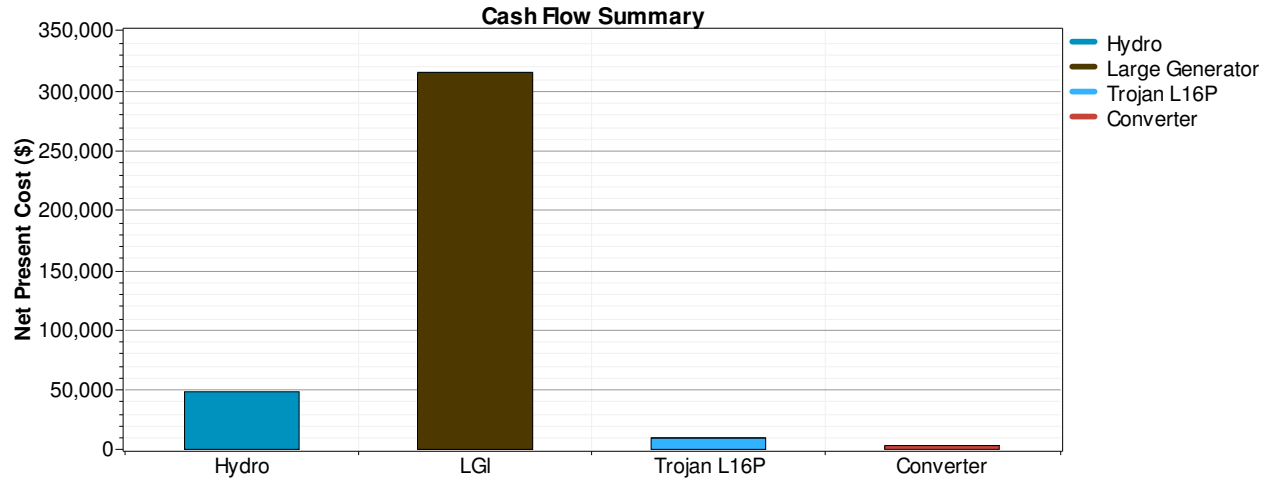



Appendix E-4b Scenario: Case of “All in One” hybrid system for the Mpala conservancy

A. Overhead Transmission (Ajay)

Homer System		Input Parameters				
			Power (kW)	Energy (kWh/year)	Capital Cost (\$)	Operational Cost (\$)
		Diesel	16+24	235	0	
		Hydro	11.3 kW	49,700	105,000	
		Biogas	10 kW	26,498	35,000	
		PV	15kW	26,517	150,000	\$/hr
		Battery		17.3 kWh	2,590	
		Load (Peak)	16 + 3.8 kW	207 kWh/day	NA	NA
		Inverter			11,863	
Sensitivities: Ambient temperature – 19.6 C and 24 C Diesel price - \$0.994 and \$2.03 Design flow rate – 600 l/s and 1500 l/s PV life – 25, 20 and 15 years						

Assumptions: 6 months draught, Load = Projected load after considering LED savings, 5% maximum annual capacity shortage, 40% minimum renewable fraction

Conclusion: This is an optimal mix of hybrid renewable systems and is able to meet demand at a low net present value. The system is also highly robust as failure of one source of energy would be complemented by other systems producing more. Hence, there is always a backup.

Average Ambient Temperature (°C)  Diesel Price (\$/L)  PV Life (yr)  Design Flow Rate (L/s)

System Architecture:	15 kW PV	24 kW Large Generator	10 kW Inverter	Total NPC: \$ 512,055
	11.3 kW Hydro	10 kW Biogas digester and	10 kW Rectifier	Levelized COE: \$ 0.408/kWh
	16 kW Small Generator	8 Trojan L16P	Cycle Charging	Operating Cost: \$ 12,493/yr

The chart below shows the cash flow summary for the system in consideration

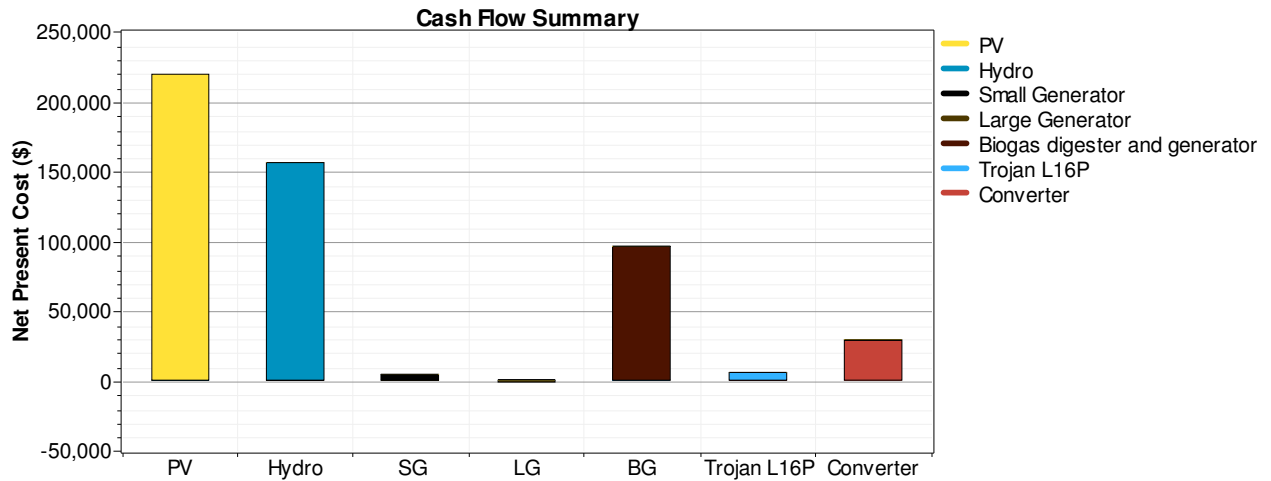

The chart below shows the Monthly average Electric production

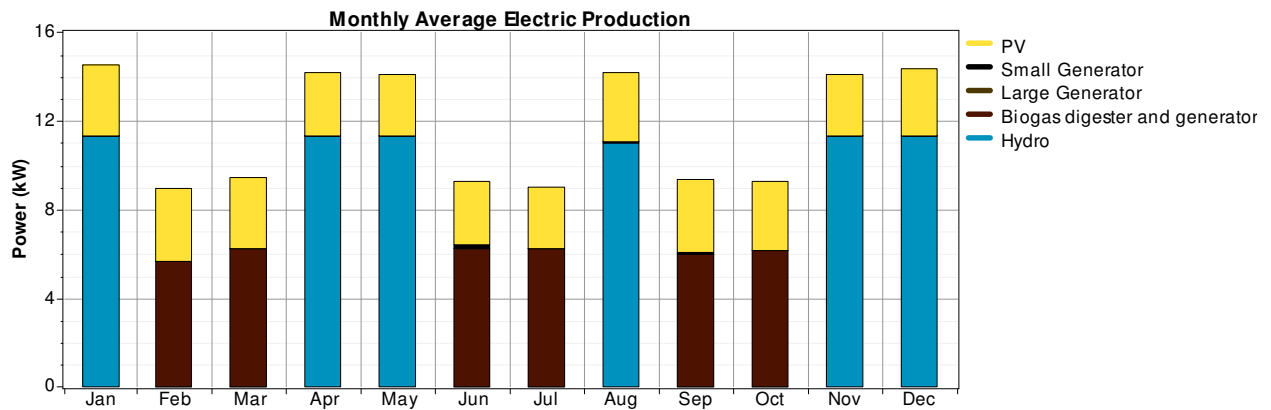

**System Scenario: Case of most optimal hybrid system for the Mpala conservancy**

**B. Underground Transmission**

Homer System		Input Parameters			
		Power (kW)	Energy (kWh/year)	Electricity Cost (\$)	Operational Cost (\$)
	Diesel	16+24	235		
	Hydro	11.3 kW	49700		
	Biogas	10 kW	26,498	\$0.810	
	PV	15kW	26,517	\$/W	\$/hr
	Battery		17.3 kWh	\$/Ah	
	Load	19.8 kW	207 kWh/day	NA	NA
	Inverter				
	Where were the sensitivities?				

Assumptions: 6 months draught, Load = Projected load including LED savings

Choose DMaps plus Optimization Result Table (NPC) and how much L of diesel or tonne of biomass.

Insert cool sensitivity chart where it makes sense.

Conclusion: whatever the conclusion is for this scenario.

Average Ambient Temperature (°C)  Diesel Price (\$/L)  PV Life (yr)  Design Flow Rate (L/s)

System Architecture:	15 kW PV	24 kW Large Generator	10 kW Inverter	Total NPC: \$ 1,017,153
	11.3 kW Hydro	10 kW Biogas digester and	10 kW Rectifier	Levelized COE: \$ 0.810/kWh
	16 kW Small Generator	8 Trojan L16P	Cycle Charging	Operating Cost: \$ 17,614/yr

The chart with the cash flow is presented below.

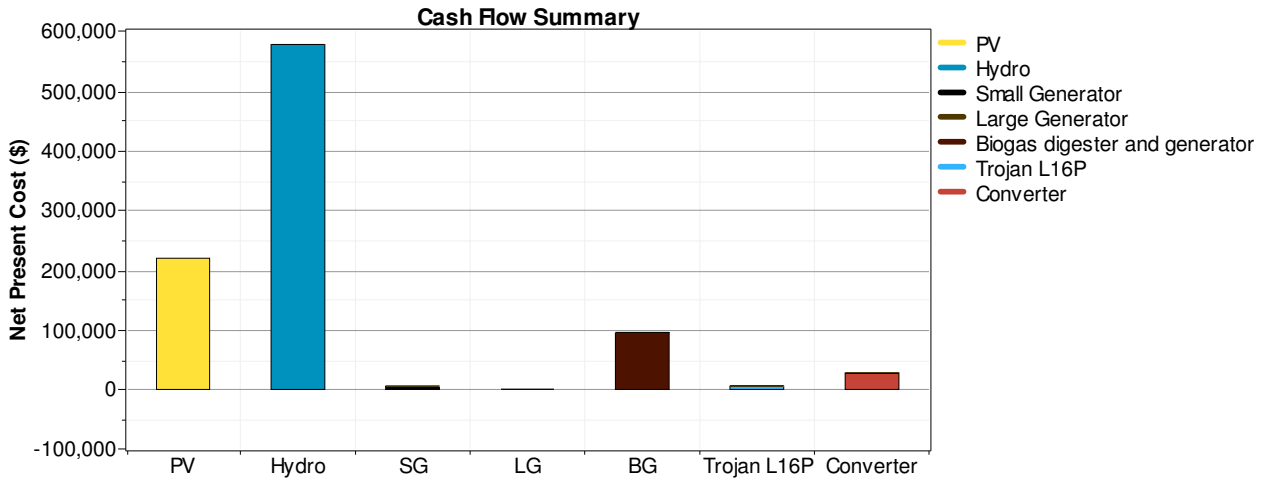

The chart below shows the Monthly average Electric production

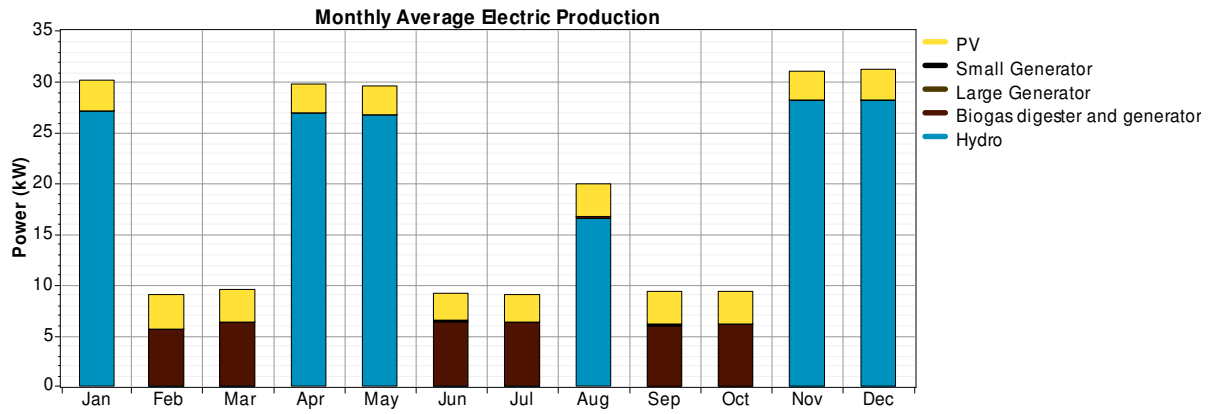

Appendix E-4c Scenario: With transmission - Only solar for the Mpala conservancy (with batteries and no generator)

A. Overhead

Homer System		Input Parameters				
	MRC (after LED) 158 kWh/d 16 kW peak	Power (kW)	Energy (kWh/year)	Capital Cost (\$)	Operational Cost (\$)	
	PV	-	-	-	-	
	Ranch(after LED) 49 kWh/d 3.8 kW peak	-	-	-	-	
	Battery	50 kW	88,389	5,750,000	-	
	Load (Peak)	16 + 3.8 kW	158 + 49 kWh/day	-	-	
	Converter	30 kW		39,330	-	
	AC	DC	Sensitivities: Ambient temperature – 19.6 C and 24 C PV life – 25, 20 and 15 years			

Assumptions and constraints: 6 months draught, Load = Projected load after considering LED savings, 5% maximum annual capacity shortage, 40% minimum renewable fraction

Conclusion: This scenario has very high capital costs due to the large size of the PV array and transmission lines. It also has a massive battery bank which increases the costs. Hence it is cost prohibitive.

Average Ambient Temperature (°C)  PV Life (yr)

System Architecture: 50 kW PV 400 Trojan L16P 30 kW Inverter	30 kW Rectifier	Total NPC: \$ 6,356,467 Levelized COE: \$ 5.269/kWh Operating Cost: \$ 26,424/yr
--	-----------------	--

The chart below shows the cash flow summary for the system in consideration

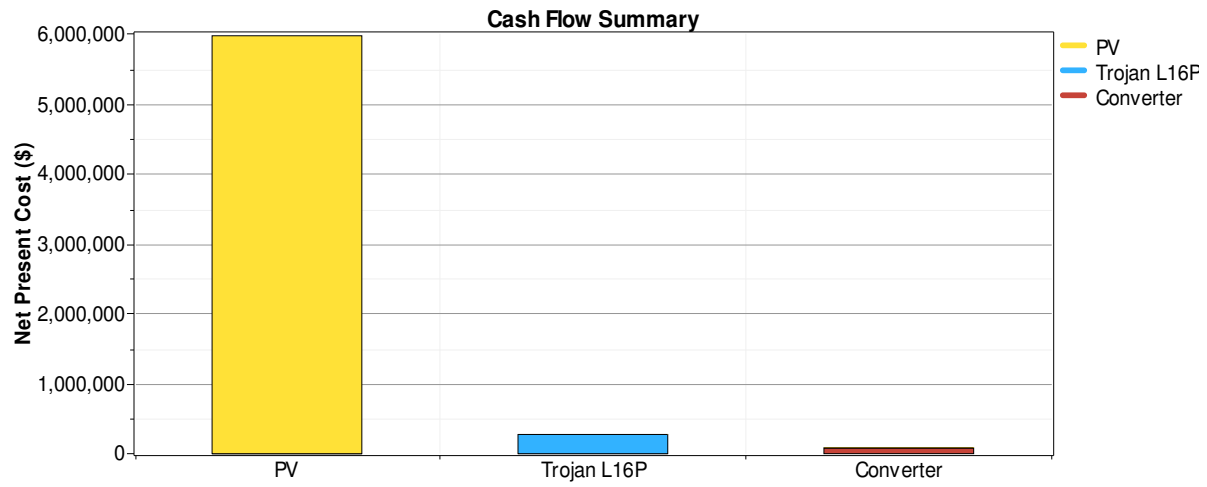

The chart below shows the Monthly average Electric production

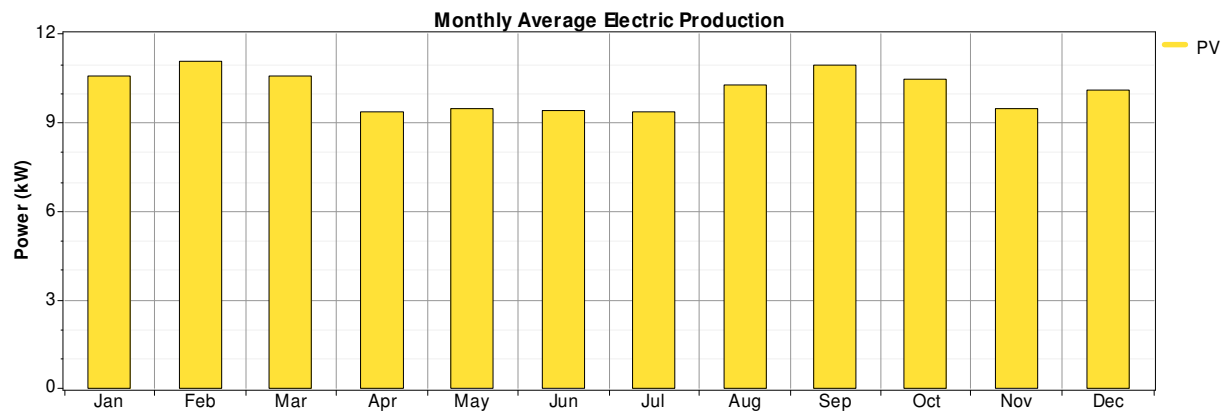

**System Scenario: - Only solar for the Mpala conservancy (with batteries and no generator)**

**B. Underground transmission**

Homer System		Input Parameters			
<p>The diagram shows a power system with an AC bus on the left and a DC bus on the right. A Converter connects the AC and DC buses. On the AC bus, there are two loads: MRC (after LED) with 158 kWh/d and 16 kW peak, and Ranch (after LED) with 49 kWh/d and 3.8 kW peak. On the DC bus, there are PV panels, a Rectifier, a Battery (L16P), and another PV panel. Arrows indicate power flow from PV to the DC bus, from the DC bus to the Rectifier, and from the AC bus to the loads.</p>		Power (kW)	Energy (kWh/year)	Capital Cost (\$)	Operational Cost (\$)
	Diesel	-	-	-	-
	Biogas	-	-	-	-
	Hydro	-	-	-	-
	Rectifier	30 kW			
	PV	50 kW	88,389	\$22.678/kWh	\$26,424/yr
	Battery		864 kWh		
	Load	16 kW	158 kWh/day	-	-
	Inverter	30 kW			
Sensitivities: Ambient temperature – 19.6 C and 24 C PV life – 25, 20 and 15 years					

Assumptions and constraints: 6 months draught, Load = Projected load after considering LED savings, 5% maximum annual capacity shortage, 40% minimum renewable fraction

Conclusion: This scenario has very high capital costs due to the large size of the PV array and transmission lines. It also has a massive battery bank which increases the costs. Hence it is cost prohibitive.

Average Ambient Temperature (°C)  PV Life (yr)

**Homer screenshot for results**

System Architecture: 50 kW PV	30 kW Rectifier	Total NPC: \$ 27,356,466
400 Trojan L16P		Levelized COE: \$ 22.678/kWh
30 kW Inverter		Operating Cost: \$ 26,424/yr

The chart with the cash flow is presented below.

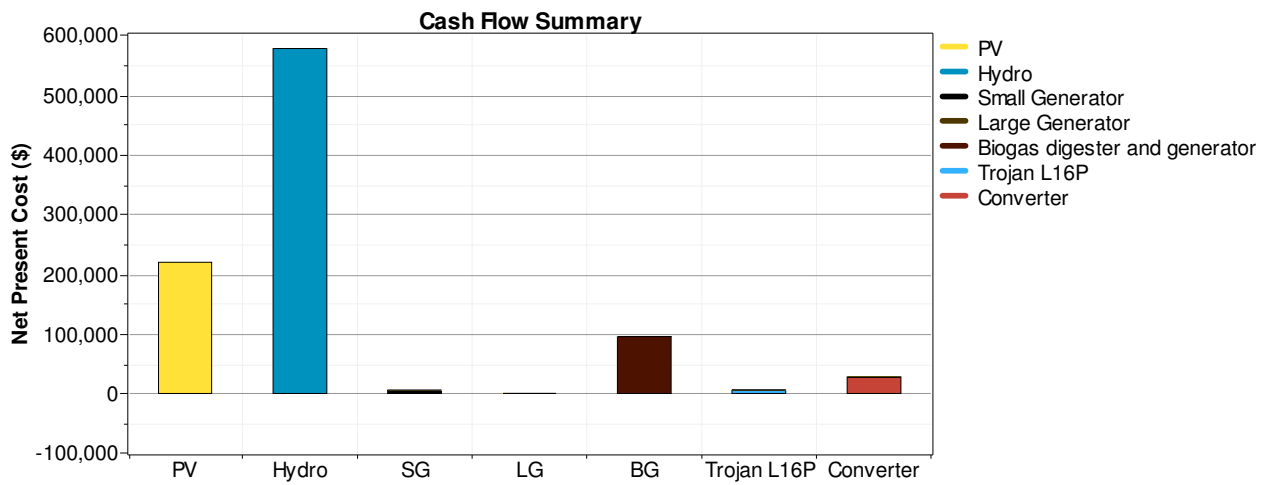

The chart below shows the Monthly average Electric production

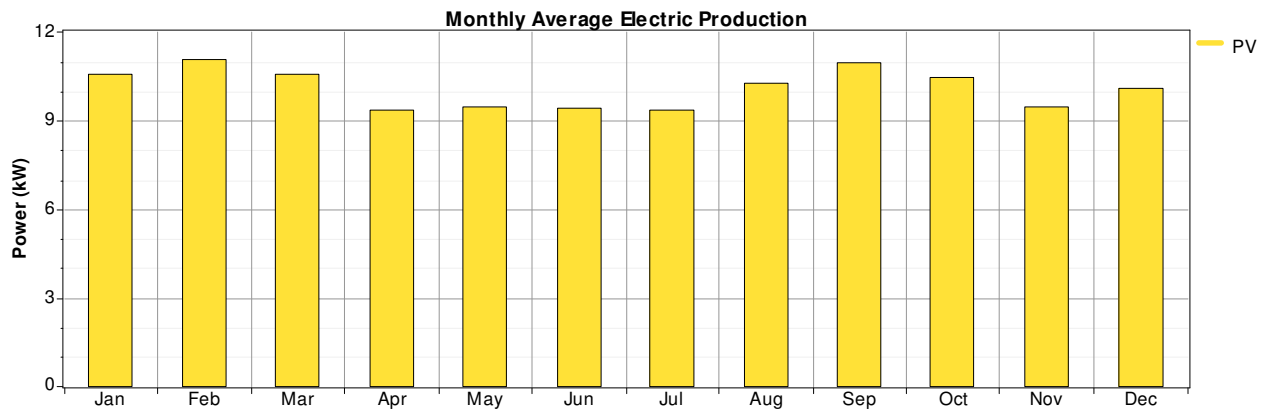



Appendix E-4d Scenario: With transmission – Hydro and backup generators for the Mpala conservancy

A. Overhead transmission

Homer System		Input Parameters				
		Power (kW)	Energy (kWh/year)	Capital Cost (\$)	Operational Cost (\$)	
		Diesel	16	39,138	0	-
		Biogas	-	-	-	-
		Hydro	11.3	49,700	105,000	-
		Converter	30		39,330	
		PV	-	-	-	-
		Battery	-	34.6 kWh	5,150	
		Load (Peak)	16 + 3.8	158 + 49 kWh/day	-	-
Sensitivities: Diesel price - \$0.994/l and \$2.03/l Design flow rate – 600l/s and 1500 l/s						

Assumptions and constraints: 6 months draught, Load = Projected load after considering LED savings, 60% maximum annual capacity shortage, 40% minimum renewable fraction.

Conclusion: Hydro with a backup generator ends up with a renewable fraction of just 56%. This means that 44% of the electricity is met by the diesel generator.

Diesel Price (\$/L)  Design Flow Rate (L/s)

System Architecture:	11.3 kW Hydro	30 kW Inverter	Total NPC: \$ 790,252
	16 kW Small generator	30 kW Rectifier	Levelized COE: \$ 0.629/kWh
	16 Trojan L16P	Cycle Charging	Operating Cost: \$ 38,560/yr

The chart with the cash flow is presented below.

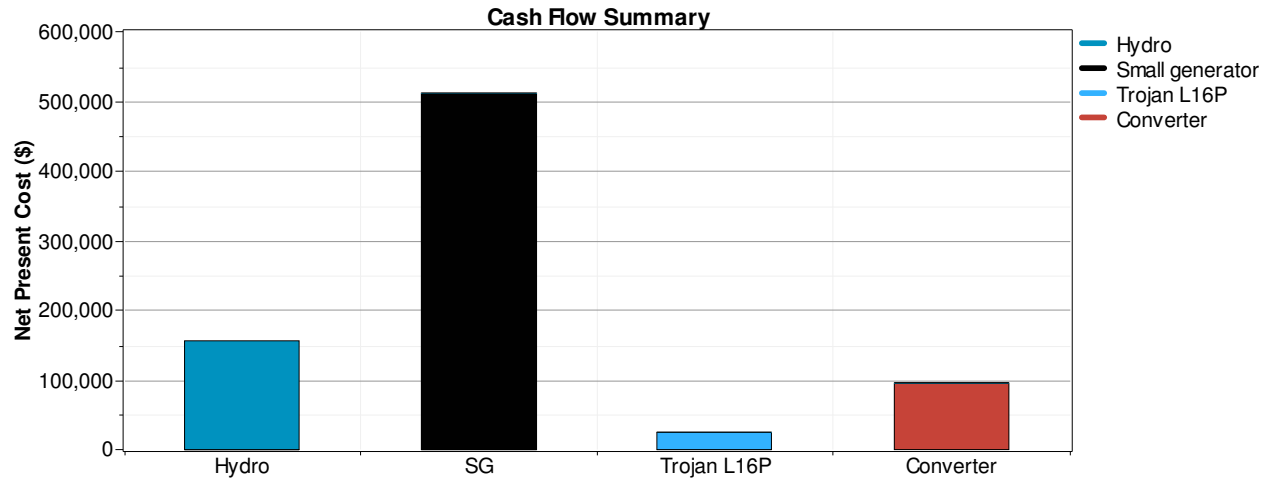

The chart below shows the Monthly average Electric production

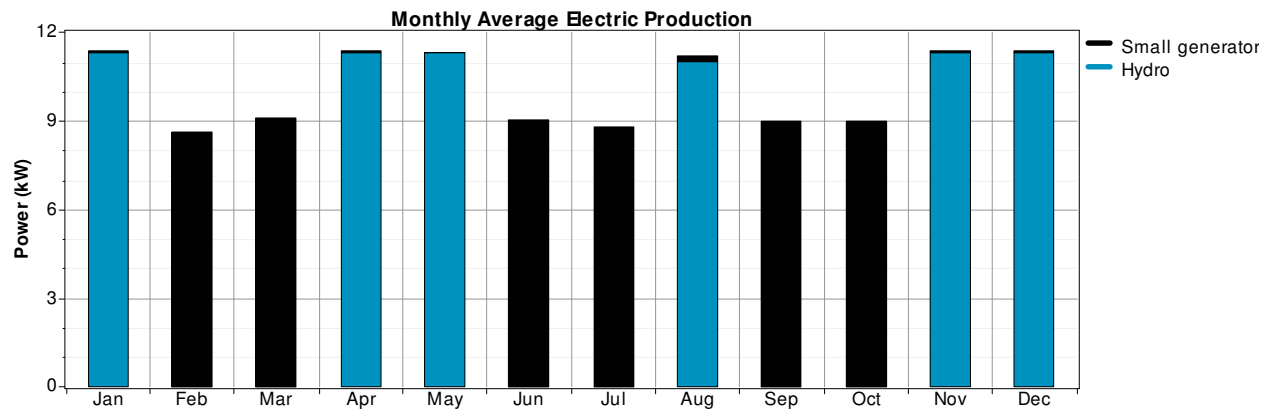

**B. Underground Transmission**

Homer System		Input Parameters			
		Power (kW)	Energy (kWh/year)	Capital Cost (\$)	Operational Cost (\$)
Diesel	16 kW	39,138	-	-	
Biogas	-	-	-	-	
Hydro	11.3 kW	49,700	\$0.755/kWh	\$22,746/yr	
Rectifier	30 kW				
PV	-		-	-	
Battery		34.6 kWh			
Load	19.8 kW	207 kWh/day	-	-	
Inverter	30 kW				

Sensitivities: Diesel price - \$0.994/l and \$2.03/l  
 Design flow rate – 600l/s and 1500 l/s

Assumptions and constraints: 6 months draught, Load = Projected load after considering LED savings, 60% maximum annual capacity shortage, 40% minimum renewable fraction.

Conclusion: Hydro with a backup generator ends up with a renewable fraction of just 56%. This means that 44% of the electricity is met by the diesel generator.

Diesel Price (\$/L)  Design Flow Rate (L/s)

**Screen shot of Homer Results**

System Architecture:	11.3 kW Hydro	30 kW Inverter	Total NPC: \$ 947,470
	16 kW Small generator	30 kW Rectifier	Levelized COE: \$ 0.755/kWh
	16 Trojan L16P	Cycle Charging	Operating Cost: \$ 22,746/yr

The chart with the cash flow is presented below.

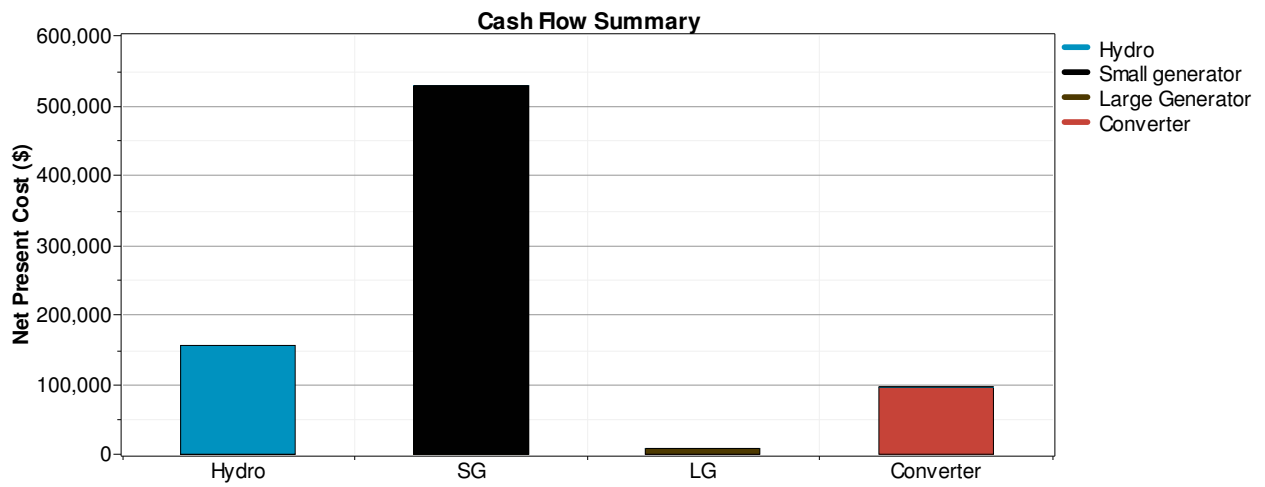

The chart below shows the Monthly average Electric production

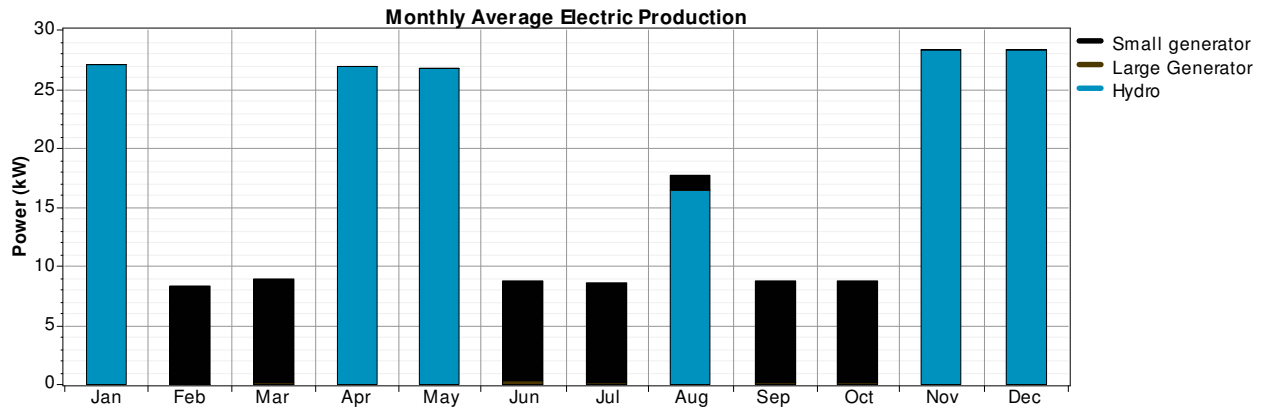

Appendix E-4e Scenario: With transmission – Only hydro for the Mpala conservancy

A. Overhead transmission

Homer System		Input Parameters					
			Power (kW)	Energy (kWh/year)	Capital Cost (\$)	Operational Cost (\$)	
		Diesel	-	-	-	-	
		Biogas	-	-	-	-	
		Hydro	11.3 kW	49,700	105,000	\$6503/yr	
		Converter	30 kW	-	39,330		
		PV	-	-	-	-	
		Battery	-	-	-	-	
		Load (Peak)	16 + 3.8	158 + 49 kWh/day	-	-	
		Sensitivities: Design flow rate – 600l/s and 1500 l/s					

Assumptions and constraints: 6 months draught, Load = Projected load after considering LED savings, 60% maximum annual capacity shortage, 40% minimum renewable fraction

Conclusion: Hydro without a backup generator for the entire conservancy ends up with a capacity shortage of just 57%. This means that 43% of the electricity is not provided at all.

Design Flow Rate (L/s)

System Architecture: 11.3 kW Hydro 30 kW Inverter 30 kW Rectifier	Total NPC: \$ 252,401 Levelized COE: \$ 0.409/kWh Operating Cost: \$ 6,503/yr
---	---

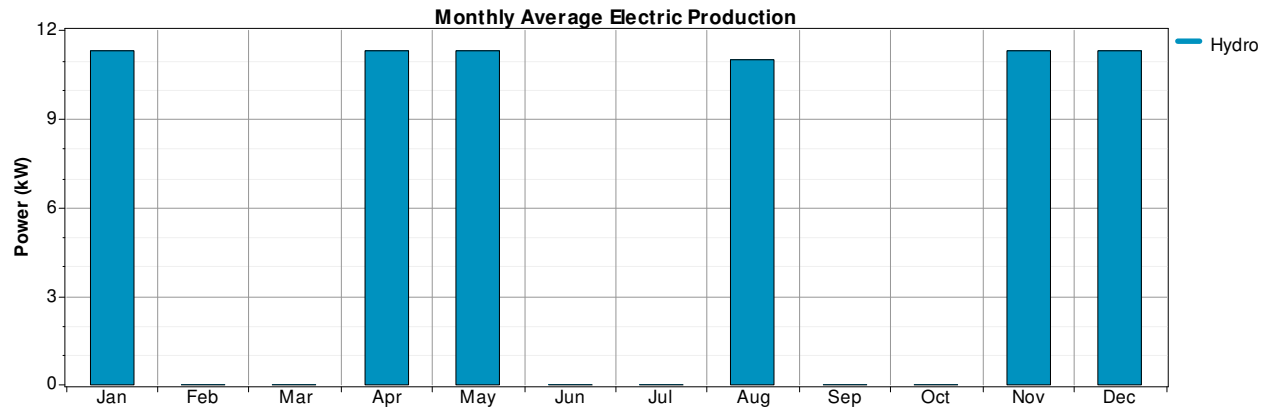
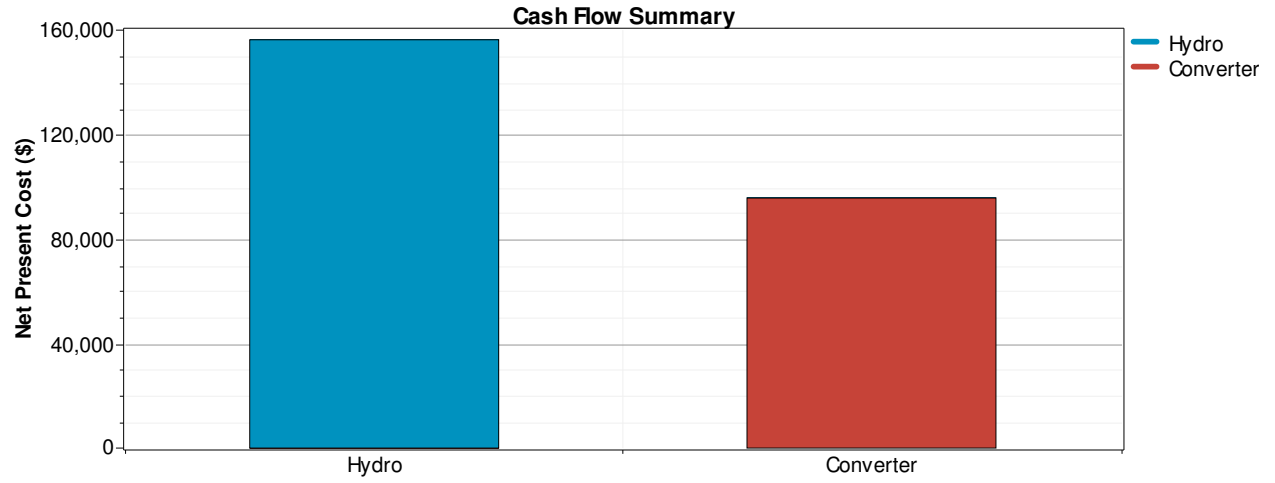

**B. Underground transmission**

Homer System		Input Parameters				
		Power (kW)	Energy (kWh/year)	Capital Cost (\$)	Operational Cost (\$)	
		Diesel	-	-	-	-
		Biogas	-	-	-	-
		Hydro	11.3 kW	49,700	\$1.088/kWh	\$6503/yr
		Rectifier	30 kW			
		PV	-	-	-	-
		Battery		-	-	
		Load	19.8	207 kWh/day	-	-
		Inverter	30 kW			

**Assumptions: 6 months draught, Load = Projected load including LED savings**

Design Flow Rate (L/s)

**Screenshot of HOMER output**

System Architecture: 11.3 kW Hydro  
30 kW Inverter  
30 kW Rectifier

Total NPC: \$ 672,401  
Levelized COE: \$ 1.088/kWh  
Operating Cost: \$ 6,503/yr

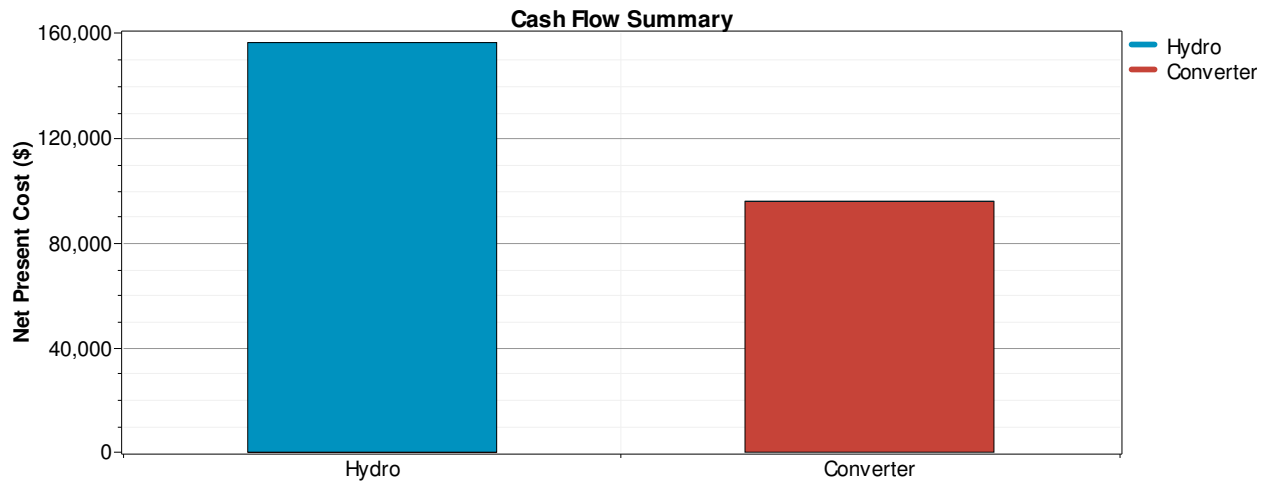

The chart below shows the Monthly average Electric production

(Shows no power supply during the dry months, thus only 50% of the load is met)

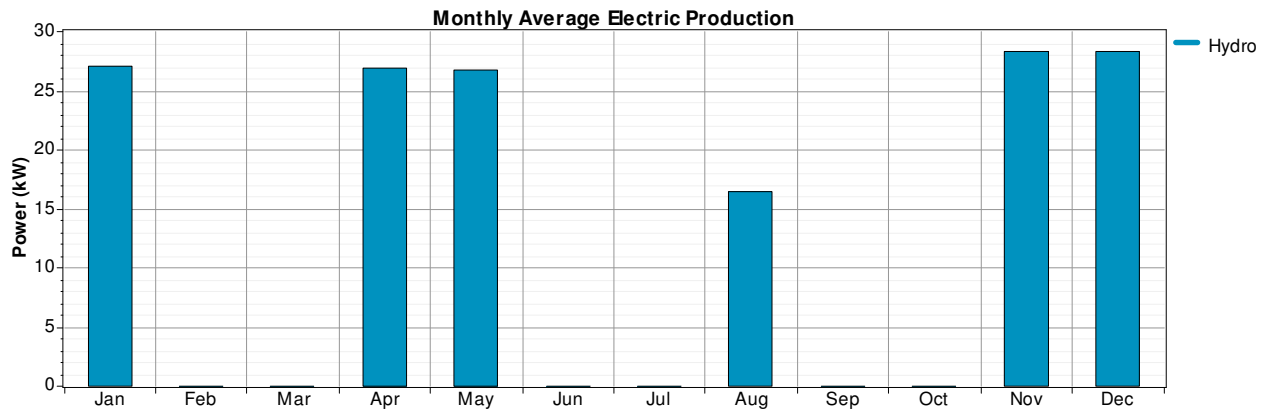



Appendix E-4f Scenario: With transmission – Solar with backup generators for the Mpala conservancy with transmission

A. Overhead Transmission

Homer System		Input Parameters				
		Power (kW)	Energy (kWh/year)	Capital Cost (\$)	Operational Cost (\$)	
		Diesel	16	19,146	-	-
		Biogas	-	-	-	-
		Hydro	-	-	-	-
		Converter	50		66,797	
		PV	40	70,711	4,600,000	
		Battery		648 kWh	96,030	
		Load (peak)	16 + 3.8	158 + 49 kWh/day	-	-
Sensitivities: Ambient temperature – 19.6 C and 24 C Diesel price - \$0.994/l and \$2.03/l PV life – 25, 20 and 15 years						

Assumptions and constraints: 6 months draught, Load = Projected load after considering LED savings, 0% maximum annual capacity shortage, 40% minimum renewable fraction

Conclusion: PV is highly expensive when considered for such huge demands.

Average Ambient Temperature (°C)  Diesel Price (\$/L)  PV Life (yr)

System Architecture:	40 kW PV	50 kW Inverter	Total NPC: \$ 5,417,346
	16 kW Small generator	50 kW Rectifier	Levelized COE: \$ 4.315/kWh
	300 Trojan L16P	Cycle Charging	Operating Cost: \$ 39,387/yr

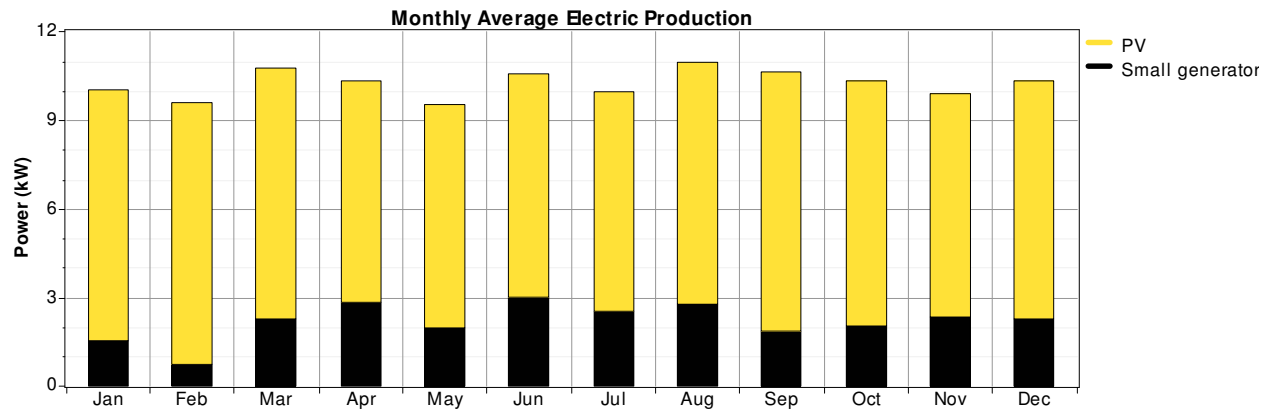
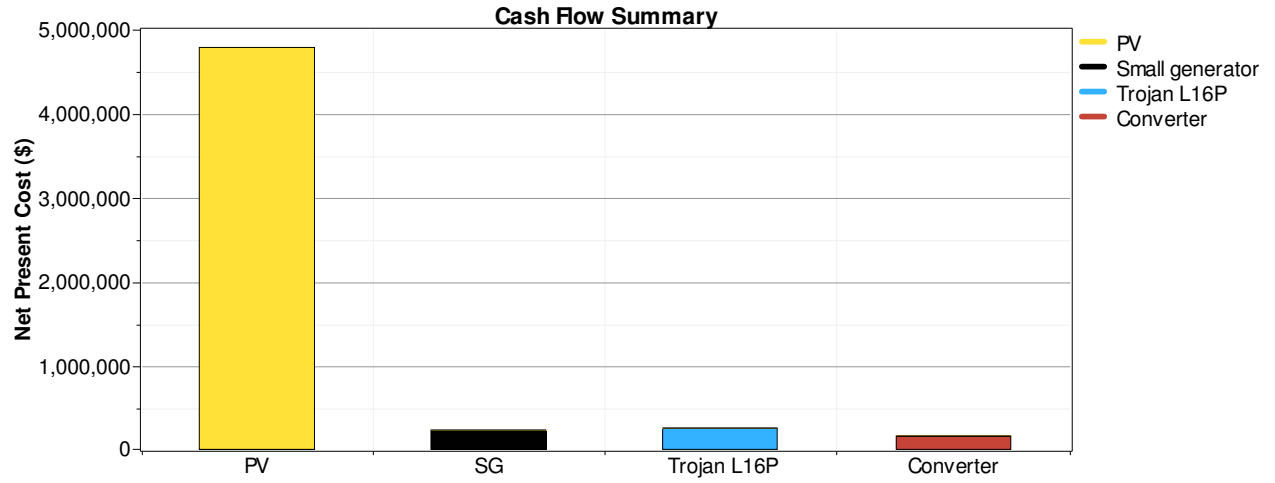

**B. Underground Transmission**

Homer System		Input Parameters				
			Power (kW)	Energy (kWh/year)	Capital Cost (\$)	Operational Cost (\$)
		Diesel	16 kW	19146	-	-
		Biogas	-	-	-	-
		Hydro	-	-	-	-
		Rectifier	50 kW			
		PV	40 kW	70,711	\$17.762/kWh	\$42,494/yr
		Battery		648 kWh	-	
		Load	19.8 kW	207 kWh/day	-	-
		Sensitivities: Ambient temperature – 19.6 C and 24 C Diesel price - \$0.994/l and \$2.03/l PV life – 25, 20 and 15 years				

**Assumptions**

6 months draught, Load = Projected load including LED savings

Average Ambient Temperature (°C)  Diesel Price (\$/L)  PV Life (yr)

**Screenshot of HOMER output**

System Architecture:	40 kW PV	50 kW Inverter	Total NPC: \$ 22,300,974
	16 kW Small generator	50 kW Rectifier	Levelized COE: \$ 17.762/kWh
	400 Trojan L16P	Cycle Charging	Operating Cost: \$ 42,494/yr

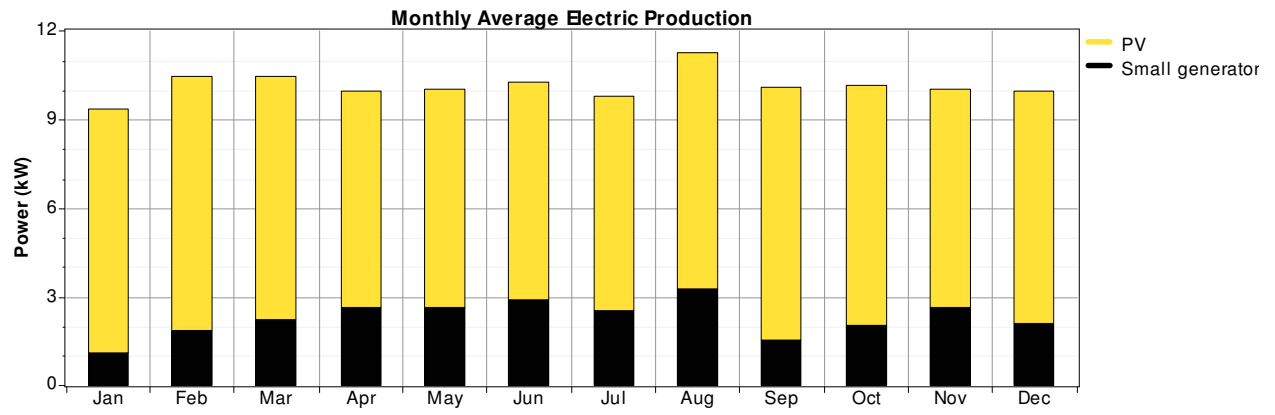
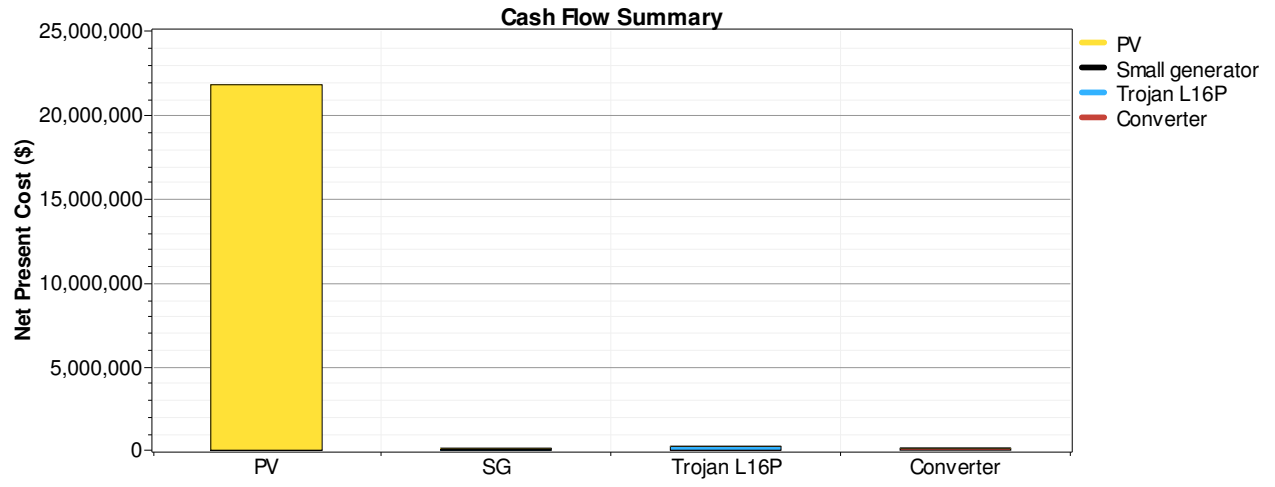

Appendix E-4g Scenario: With transmission – Only Biogas for Mpala conservancy

A. Overhead Transmission

Homer System		Input Parameters				
		Power (kW)	Energy (kWh/year)	Cost of Electricity (\$/ kWh)	Operational Cost (\$)	
		Diesel	-	-	-	-
		Biogas	20 kW	456,731	\$0.242/kWh	\$9,117/yr
		Hydro	-	-	-	-
		Rectifier	2.5 kW			
		PV	-	-	-	-
		Battery		6	-	
		Load	19.8 kW	207 kWh/day	-	-
		Inverter	2.5 kW			

Assumptions

- Projected load after doubling (accounting for increase in demand), and LED savings incorporated.
- Assuming the use of 2 bomas’ night dung only. Each boma contains 100 heads of cattle that can produce 420 kg of dung.
- System uses overhead transmission

Screenshot of HOMER output

System Architecture: 20 kW Biogas digester and 2.5 kW Rectifier	Total NPC: \$ 288,061
8 Trojan L16P Cycle Charging	Levelized COE: \$ 0.242/kWh
2.5 kW Inverter	Operating Cost: \$ 9,117/yr

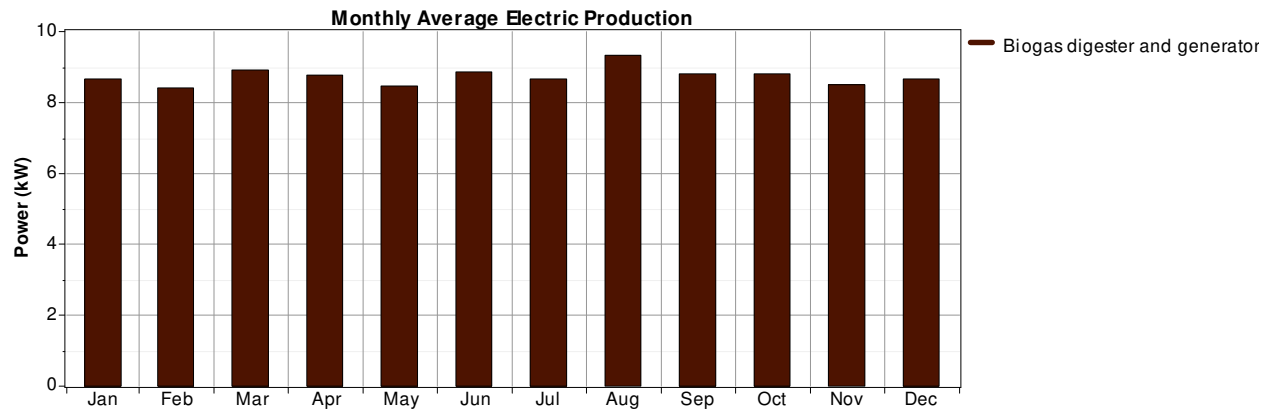
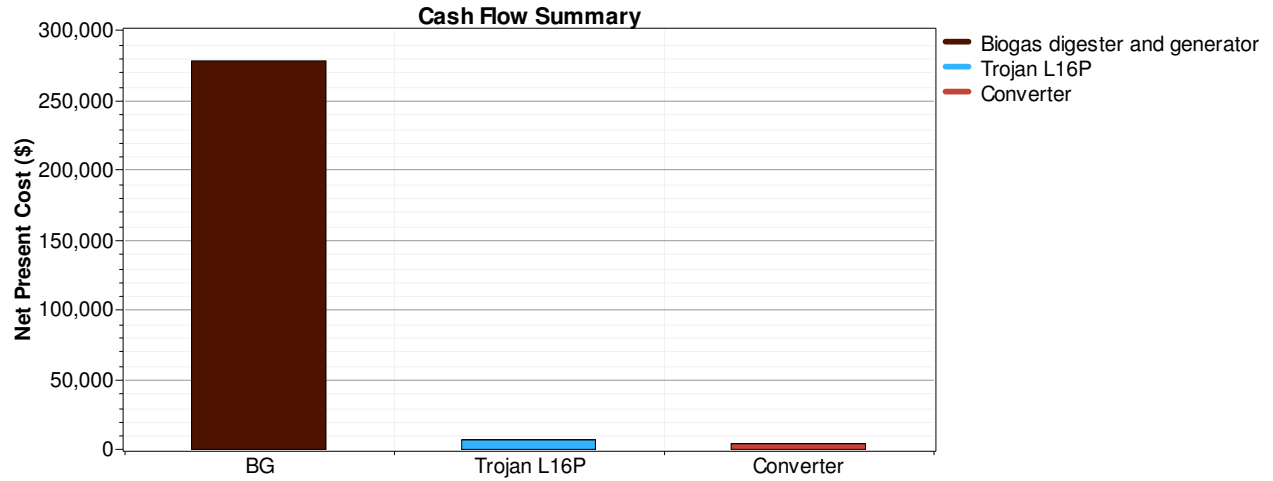

## B. Underground Transmission

Homer System		Input Parameters			
		Power (kW)	Energy (kWh/year)	Capital Cost (\$)	Operational Cost (\$)
		Diesel	-	-	-
		Biogas	20 kW	456,731	\$0.595/kWh \$9,117/yr
		Hydro	-	-	-
		Rectifier	2.5 kW		
		PV	-	-	
		Battery		6 kWh	
		Load	19.8 kW	207 kWh/day	
		Inverter	2.5 kW		

**Assumptions**

- Projected load after doubling (accounting for increase in demand), and LED savings incorporated.
- Assuming the use of 2 bomas' night dung only. Each boma contains 100 heads of cattle that can produce 420 kg of dung.
- System uses underground transmission which would cost 5 times the overhead system.

**Screenshot of HOMER output**

System Architecture:	20 kW Biogas digester and 2.5 kW Rectifier	Total NPC: \$ 708,061
	8 Trojan L16P                      Cycle Charging	Levelized COE: \$ 0.595/kWh
	2.5 kW Inverter	Operating Cost: \$ 9,117/yr

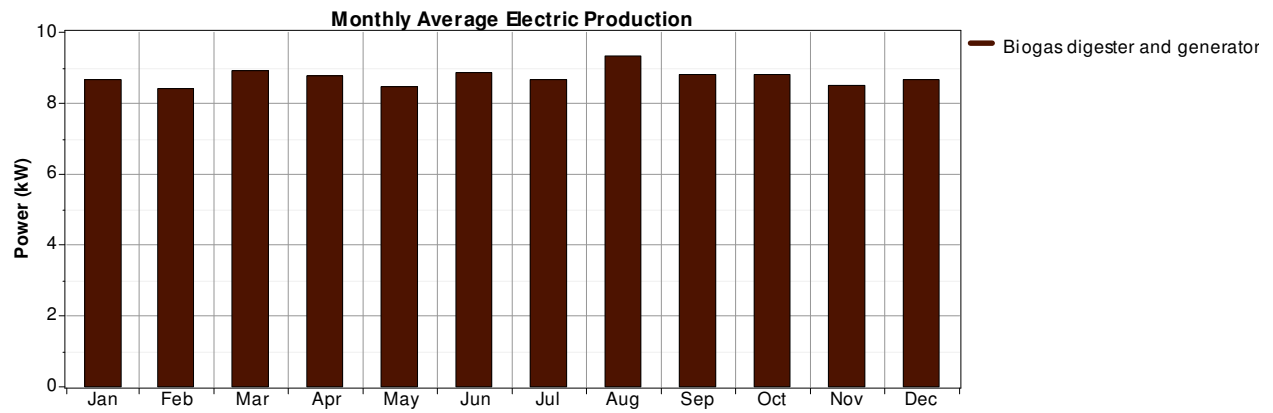
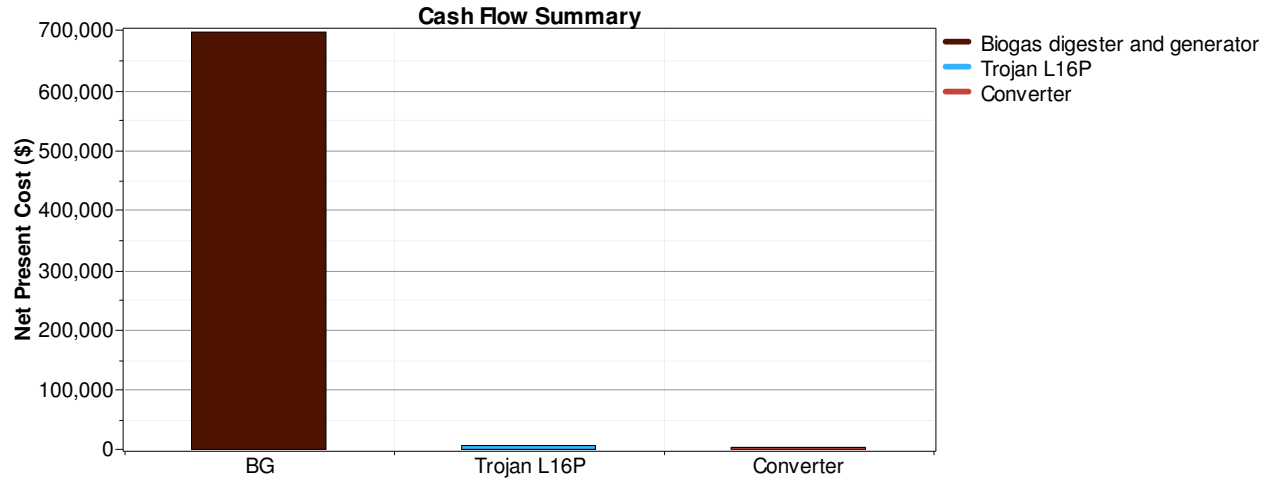



Appendix E-4h Scenario: No transmission – Only solar

A. For Centre only (Ajay)

Homer System		Input Parameters			
	Diesel	16	0	0	-
	Biogas	-	-	-	-
	PV	60	106,067	600,000	-
	Battery	-	648 kWh	96,030	
	Load (Peak)	16	158 kWh/day	NA	NA
	Converter	20	-	25,597	-
Sensitivities: Ambient temperature – 19.6 C and 24 C Diesel price - \$0.994/l and \$2.03/l PV life – 25, 20 and 15 years					

Assumptions and constraints: 6 months draught, Load = Projected load after considering LED savings, 0% maximum annual capacity shortage, 40% minimum renewable fraction

Conclusion: PV successfully meets demands but is very expensive due to high capital investment.

Average Ambient Temperature (°C)  Diesel Price (\$/L)  PV Life (yr)

System Architecture:	60 kW PV	20 kW Rectifier	Total NPC: \$ 1,150,260
	300 Trojan L16P		Levelized COE: \$ 1.200/kWh
	20 kW Inverter		Operating Cost: \$ 25,794/yr

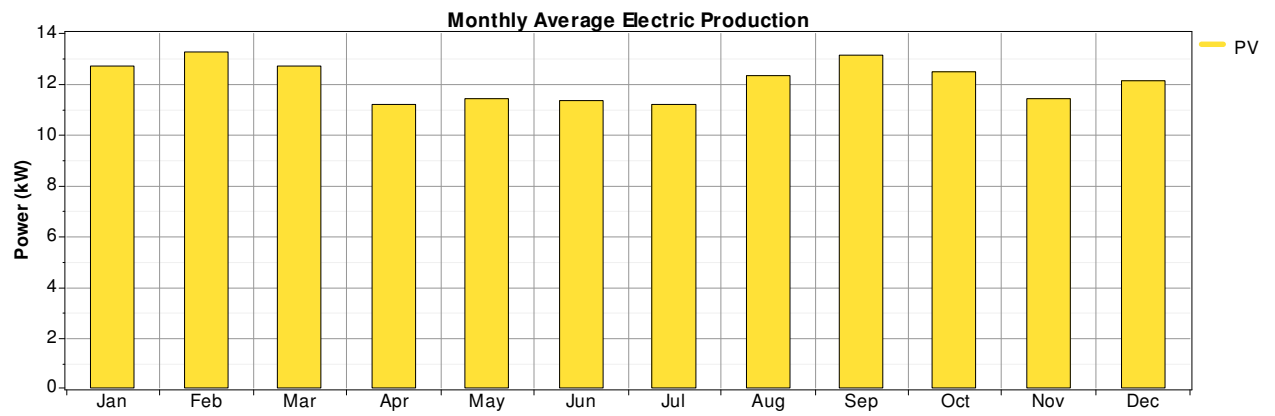
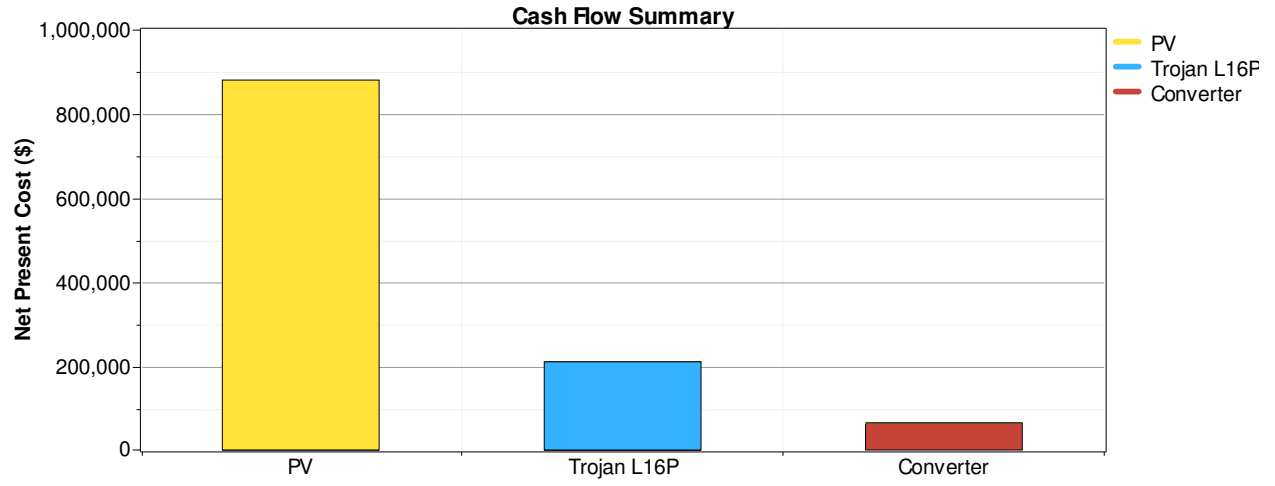

**B. For Ranch headquarters only**

Homer System		Input Parameters				
		Power (kW)	Energy (kWh/year)	Capital Cost (\$)	Operational Cost (\$)	
		Diesel	16	0	0	-
		Biogas	-	-	-	-
		PV	20	35,356	200,000	-
		Battery		648 kWh	96,030	-
		Load (peak)	3.8	49 kWh/day	NA	NA
		Inverter	10	-	11,863	-
Sensitivities: Ambient temperature – 19.6 C and 24 C Diesel price - \$0.994/l and \$2.03/l PV life – 25, 20 and 15 years						

Assumptions and constraints: 6 months draught, Load = Projected load after considering LED savings, 0% maximum annual capacity shortage, 40% minimum renewable fraction

Conclusion: PV successfully meets demands but is very expensive due to high capital investment.

Average Ambient Temperature (°C)  Diesel Price (\$/L)  PV Life (yr)

System Architecture: 20 kW PV	10 kW Rectifier	Total NPC: \$ 527,827
300 Trojan L16P		Levelized COE: \$ 1.776/kWh
10 kW Inverter		Operating Cost: \$ 13,235/yr

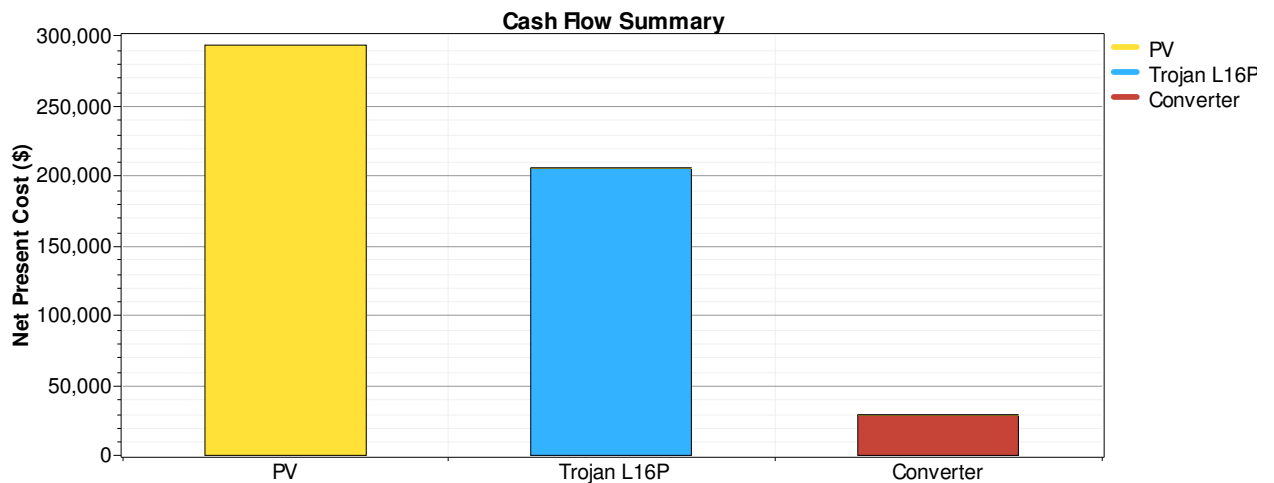

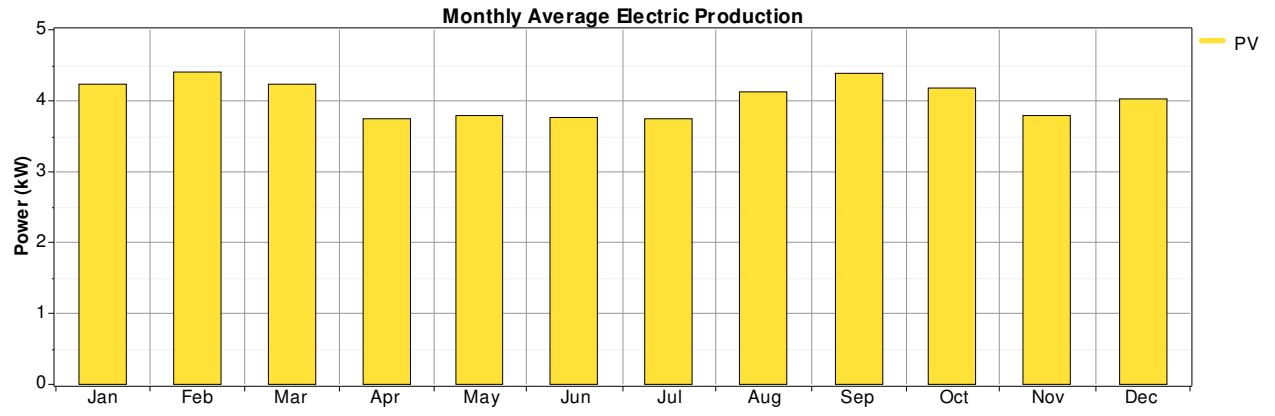

Appendix E-4i Scenario: No transmission – Biogas only

A. For Centre only

Homer System		Input Parameters			
	Power (kW)	Energy (kWh/year)	Cost of Electricity (\$/kWh)	Operational Cost (\$)	
Diesel	-	-	-	-	
Biogas	20 kW	417059	\$0.284/kWh	\$13,917/yr	
Hydro	-	-	-	-	
Rectifier	2.5 kW				
PV	-	-			
Battery		56 kWh			
Load	16 kW	158 kWh/day	-	-	
Inverter	2.5 kW				

Assumptions

- Projected load after doubling (accounting for increase in demand), and LED savings incorporated.
- Assuming the use of 1.5 boma’s night dung only. Each boma contains 150 heads of cattle that can produce approximately 600 kg of dung.
- System uses underground transmission which would cost 5 times the overhead system.

Screenshot of HOMER output

System Architecture: 20 kW Biogas digester and 2.5 kW Rectifier 8 Trojan L16P                      Cycle Charging 2.5 kW Inverter	Total NPC: \$ 258,512 Levelized COE: \$ 0.284/kWh Operating Cost: \$ 13,917/yr
---	--

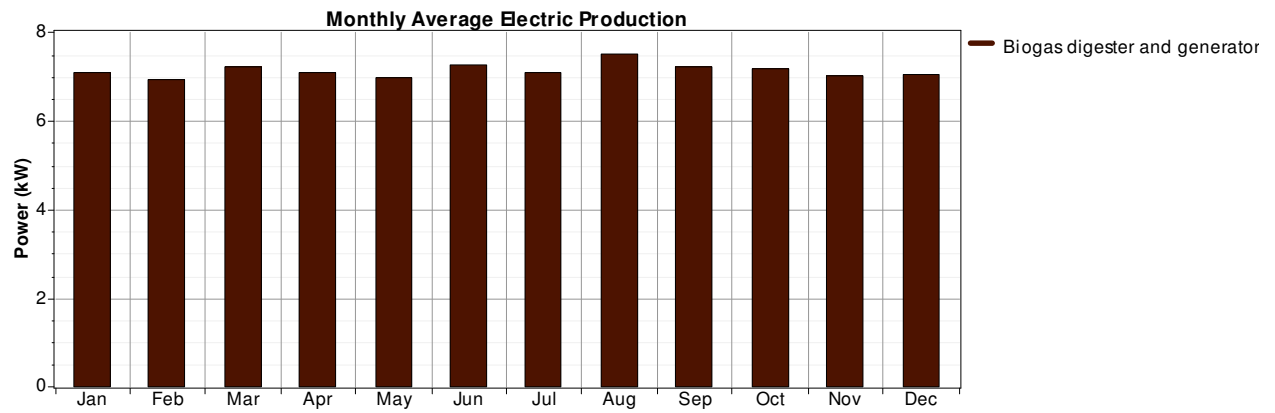
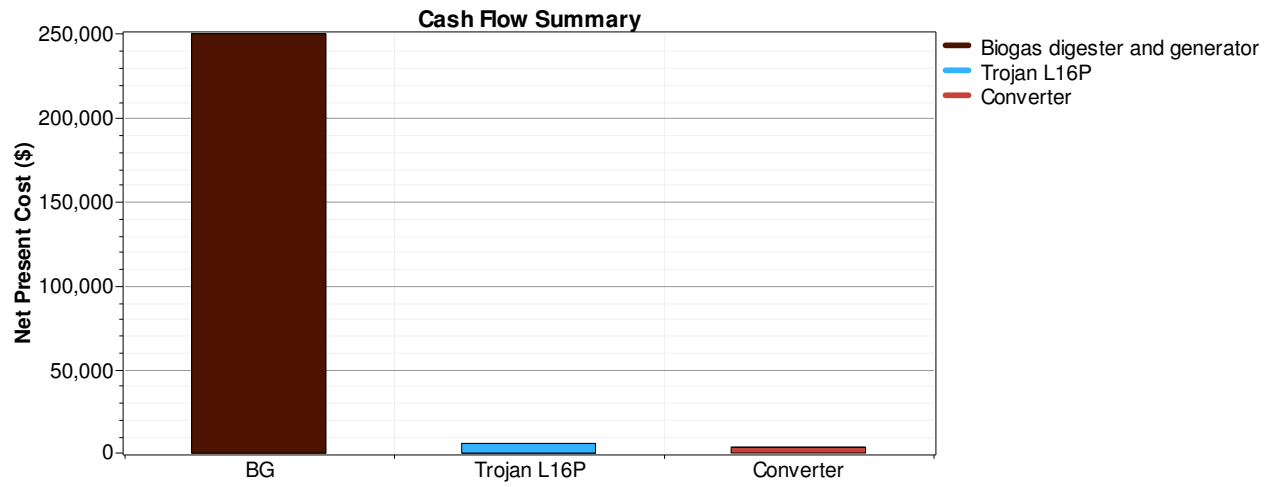

**B. For Ranch Headquarters only**

Homer System	Input Parameters				
		Power (kW)	Energy (kWh/year)	Cost of electricity (\$/kWh)	Operational Cost (\$)
	Diesel	-	-	-	-
	Biogas	10 kW	150,306	\$0.542/kWh	\$7,943/yr
	Hydro	-	-	-	-
	Rectifier	2.5 kW			
	PV	-	-		
	Battery		5190 kWh	-	
	Load	3.8 kW	49 kWh/day	-	-
	Inverter	2.5 kW			

**Assumptions**

- Projected load after doubling (accounting for increase in demand), and LED savings incorporated.
- Assuming the use of 1 boma's night dung only. Each boma contains 100 heads of cattle that can produce 420 kg of dung.
- System uses underground transmission which would cost 5 times the overhead system.

**Screenshot of HOMER output**

System Architecture: 10 kW Biogas digester and 2.5 kW Rectifier	Total NPC: \$ 161,141
8 Trojan L16P Cycle Charging	Levelized COE: \$ 0.542/kWh
2.5 kW Inverter	Operating Cost: \$ 7,943/yr

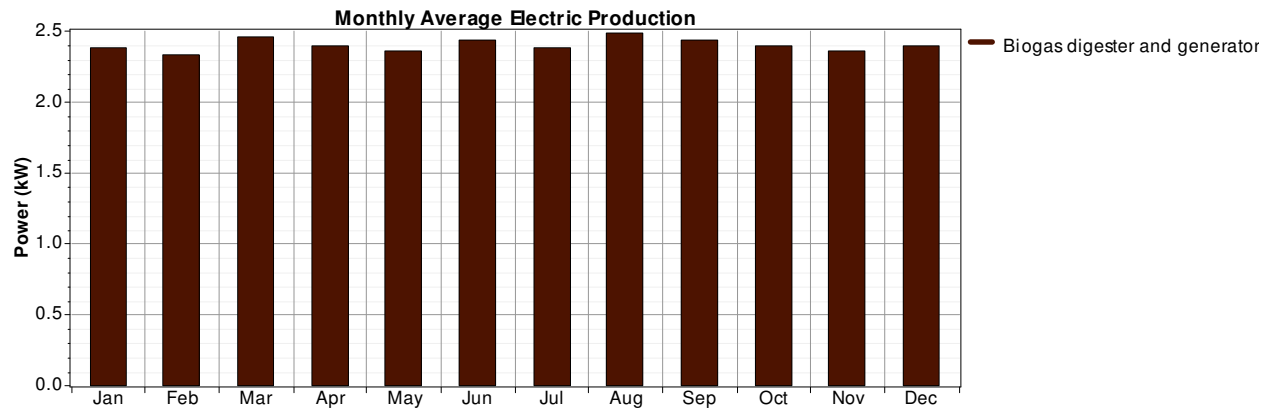
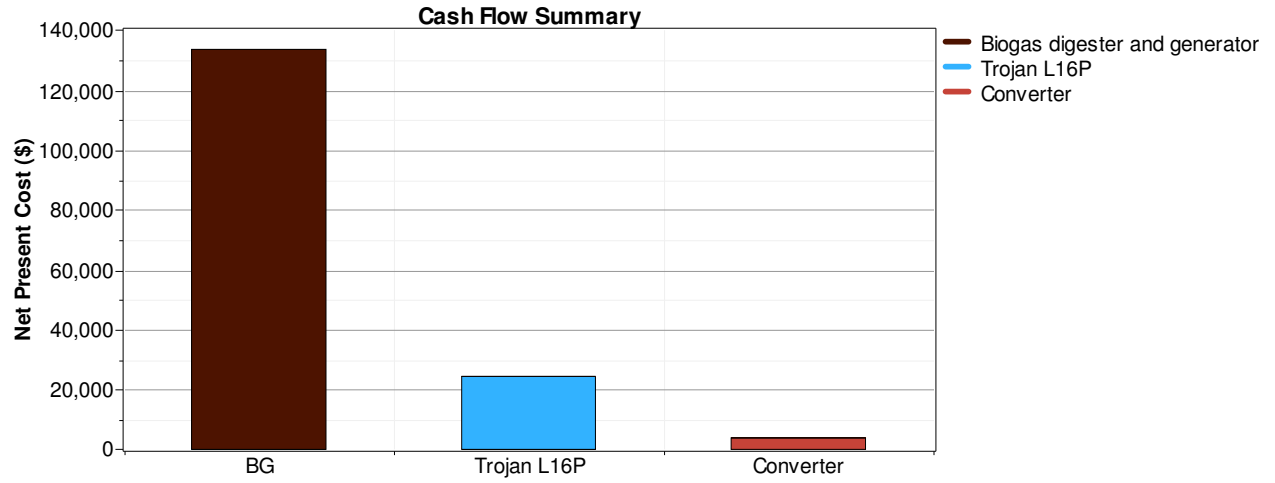



## Appendix E-5 – Lifecycle Analysis – Biogas with No Transmission

**(Nagapooja)**

Sima Pro Charts

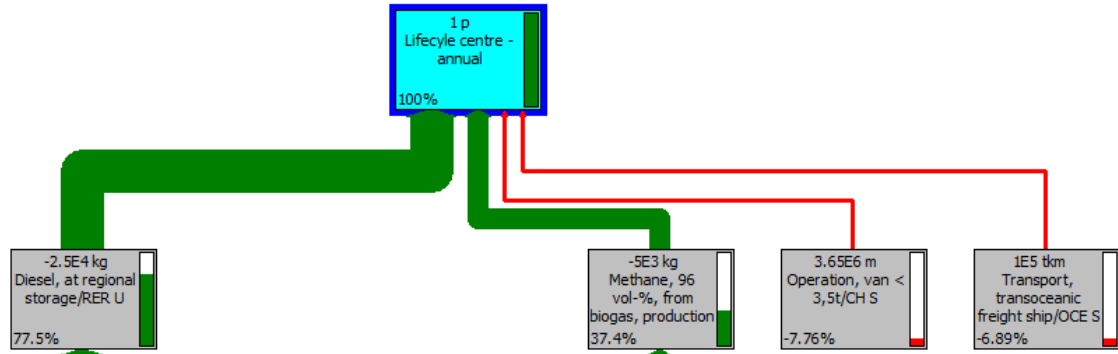

Name	Image					
Lifecycle centre - annual						
Status	None					
Materials/Assemblies		Amount	Unit	Distribution		
Diesel, at regional storage/RER U		-24600	kg	Undefined		
Methane, 96 vol-%, from biogas, production mix, at service station/CH U		-5000	kg	Undefined		
Carbon dioxide liquid, at plant/RER U		50	kg	Undefined		
(Insert line here)						
Processes		Amount	Unit	Distribution	SD <sup>^2</sup> or 2*SDMin	M
Operation, van < 3,5t/CH S		3650	km	Undefined		
Transport, transoceanic freight ship/OCE S		100000	tkm	Undefined		
(Insert line here)						

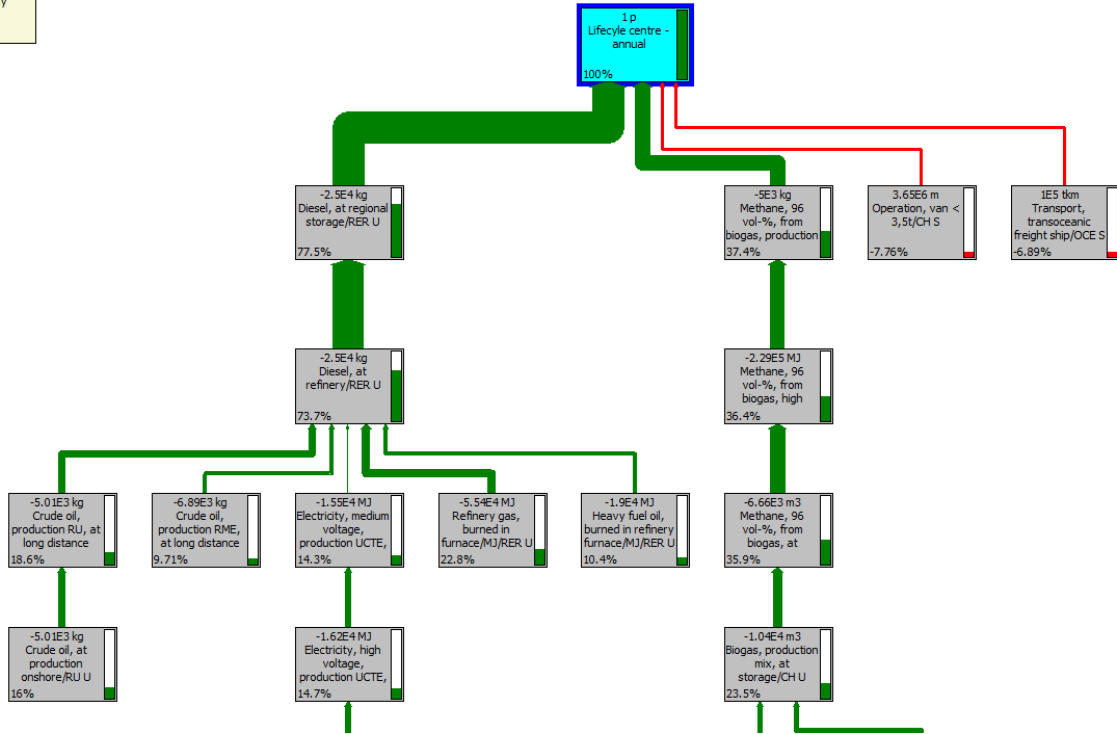
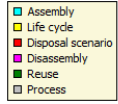

## Appendix E-6: Biogas Generating Set Technical Parameters and Costs

### 1. Biogas Generating Set Technical Parameters

Biogas Generating Set Brand	KD-Biogas Generating Set
Biogas Generating Set Model	KDBG20
Rated Power(kw/kva)	20/25
Standby Power(kw/kva)	22/27.5
Rated Frequency (Hz)	50
Rated Speed(rpm)	1500
Dimension(L×H×W)mm	1650×720×1250
Weight(kg)	750

### 2. Biogas Engine Technical Parameters

Biogas Engine Model	CR4100Q
Bore × Stroke(mm)	100×115
Cylinders No.	4
Displacement (L)	2.24
Compression Ratio	11.3:1
Crankshaft Rotation Direction	Anti-Clockwise(viewed from flywheel end)
Cooling Method	Enclosed Water Cooled
Aspiration Method	Natural Aspiration
Starting Method	24 Electrical Starting
Governing Method	Electronic Governing
Prime Power(kw)	25
Standby Power(kw)	27.5

Maximum Torque (N.m)	178
Gas-Fuel Type	Biogas
Gas Mixing Method	Single Point Injection + Pre-Mix
Gas Fuel Consumption (m <sup>3</sup> /kw.h)	<0.6
Oil Capacity (L)	50
Oil Grade	Special Oil ( Recommended)
Oil Temperature (□)	<98
Oil Pressure (Kpa)	345-483
Coolant Capacity (L)	91
Maximum Exhaust Temperature (□)	600□
Electrical Controlling System (V)	24

### 3. Alternator Technical Parameters

Exciting Method	Brushless
Rated Voltage (V)	400/230 (Adjustable)
Connection Method	3P4W
Power Factor	0.8 lagging
Rated Current(A)	36
Protection Class	IP23
Voltage Regulation	≥ ± 6%
Voltage Stable Rate	± 1.0%
Regulation Method	AVR

## 东莞康切机电有限公司

Dongguan Kindlecn Mechanical & Electrical Co., Ltd.

Address: Shang you gu Industrial Zone, Da ling shan Town, Dongguan City, Guanddong Province, China. Zip Code: 523800

Contact: Mr Andy Liu

Email: [wholesale@hotmail.com](mailto:wholesale@hotmail.com)

Mobile Phone: 0086-158 1834 8546

[andyliu1998@yahoo.cn](mailto:andyliu1998@yahoo.cn)

Tel: 0086-769-82813902

Skype: andyliu1920

Fax: 0086-769-82813902

Web: [www.kindlecn.cn](http://www.kindlecn.cn)

### Quotation

Attn: Graham Institute of Environmental Engineering (USA) Contact: Mr. Ajay Varadharajan Tel: 001-734-2529734 Fax: Mobile Phone: Email: <a href="mailto:ajayvrajan@gmail.com">ajayvrajan@gmail.com</a>	Quotation Date: 21 <sup>st</sup> , Feb. 2011 Quotation No. : 201110221001 Valid Date: 30 days <b>Quotation Content:</b> <b>Quotation for 5 Sets 10kw12.5 kva generating Set 50Hz, Open type</b>
---	---

Thanks for your inquiry! We make our quotation for you as following: \_

Quotation Method	Fob Shenzhen			
Package	Export Package			
Genset Model	Specification	Qty	Unit Price	Amount
KDBG10	10KW(Prime Power) Biogas Generating Set	5	USDS\$7,000.00	USDS\$35,000.00
Synchronization Panel( Paralleling Connection Cabinet)	A cabinet that used for generating set paralleling connection.	5	USDS\$2,600.00	USDS\$13,000.00
Outgoing wiring Cabinet	A Cabinet that used for wiring.	3	USDS\$1,520.00	USDS\$4,560.00
Ocean Freight				
Insurance				
Amount				

1 USD\$= 6.58 ¥ CNY

#### Remarks

Payment: T/T( 30% paid for deposit by T/T before production arranged, the balance to be paid before shipment)  
 Delivery Time: 45-90 Days  
 Time of Arival:  
 Warranty: 1(one) year or 1000 hours from commissioning of generating set, or 18 months from shipping, whichever comes first. For More details will be offered by the warranty card.

Thanks again for your inquiry!

Any question, please feel free to contact with us!

Best Regards

Yours Sincerely

Mr Andy Liu

Dongguan Kindlecn Mechanical & Electrical Co., Ltd.

2011-02-21

## Appendix E-7: Lighting replacement analysis

Cost of inc bulb	Cost of CFL	Cost of LED	Hours used	Qty	Incan desc bulb (W)	CFL (W)	LED (W)	Energy consumed: inc bulb	Energy consumed: CFL	Energy consumed: LED	Total incandescent bulb costs	Total CFL costs	Total LED costs	Total incandescent bulb emissions	Total CFL emissions	Total LED emissions
2.3	4.2	19.99	100	53	40	10	4.8	212.0	53.0	25.4	53.8	236.0	1065.9	69.7	17.4	8.4
2.3	4.2	19.99	200	53	40	10	4.8	424.0	106.0	50.9	107.6	249.5	1072.4	139.4	34.8	16.7
2.3	4.2	19.99	300	53	40	10	4.8	636.0	159.0	76.3	161.4	262.9	1078.8	209.1	52.3	25.1
2.3	4.2	19.99	400	53	40	10	4.8	848.0	212.0	101.8	215.2	276.4	1085.3	278.8	69.7	33.5
2.3	4.2	19.99	500	53	40	10	4.8	1060.0	265.0	127.2	269.0	289.8	1091.7	348.5	87.1	41.8
2.3	4.2	19.99	600	53	40	10	4.8	1272.0	318.0	152.6	322.8	303.3	1098.2	418.2	104.5	50.2
2.3	4.2	19.99	700	53	40	10	4.8	1484.0	371.0	178.1	376.6	316.7	1104.7	487.9	122.0	58.5
2.3	4.2	19.99	800	53	40	10	4.8	1696.0	424.0	203.5	430.4	330.2	1111.1	557.6	139.4	66.9
2.3	4.2	19.99	900	53	40	10	4.8	1908.0	477.0	229.0	484.2	343.6	1117.6	627.3	156.8	75.3
2.3	4.2	19.99	1000	53	40	10	4.8	2120.0	530.0	254.4	538.0	357.1	1124.0	697.0	174.2	83.6
2.3	4.2	19.99	1100	53	40	10	4.8	2332.0	583.0	279.8	591.7	370.5	1130.5	766.6	191.7	92.0
2.3	4.2	19.99	1200	53	40	10	4.8	2544.0	636.0	305.3	645.5	384.0	1136.9	836.3	209.1	100.4
2.3	4.2	19.99	1300	53	40	10	4.8	2756.0	689.0	330.7	699.3	397.4	1143.4	906.0	226.5	108.7
2.3	4.2	19.99	1400	53	40	10	4.8	2968.0	742.0	356.2	753.1	410.9	1149.8	975.7	243.9	117.1
2.3	4.2	19.99	1500	53	40	10	4.8	3180.0	795.0	381.6	928.3	424.3	1156.3	1045.4	261.4	125.5
2.3	4.2	19.99	3000	53	40	10	4.8	6360.0	1590.0	763.2	1856.6	626.1	1253.1	2090.9	522.7	250.9
2.3	4.2	19.99	4500	53	40	10	4.8	9540.0	2385.0	1144.8	2784.9	827.8	1350.0	3136.3	784.1	376.4
2.3	4.2	19.99	6000	53	40	10	4.8	12720.0	3180.0	1526.4	3713.2	1029.5	1446.8	4181.7	1045.4	501.8
2.3	4.2	19.99	7500	53	40	10	4.8	15900.0	3975.0	1908.0	4641.5	1231.3	1543.6	5227.1	1306.8	627.3
2.3	4.2	19.99	9000	53	40	10	4.8	19080.0	4770.0	2289.6	5569.8	1433.0	1640.5	6272.6	1568.1	752.7
2.3	4.2	19.99	10500	53	40	10	4.8	22260.0	5565.0	2671.2	6498.1	1634.7	1737.3	7318.0	1829.5	878.2
2.3	4.2	19.99	12000	53	40	10	4.8	25440.0	6360.0	3052.8	7426.4	2059.1	1834.1	8363.4	2090.9	1003.6
2.3	4.2	19.99	13500	53	40	10	4.8	28620.0	7155.0	3434.4	8354.7	2260.8	1930.9	9408.8	2352.2	1129.1
2.3	4.2	19.99	15000	53	40	10	4.8	31800.0	7950.0	3816.0	9283.0	2462.5	2027.8	10454.3	2613.6	1254.5
2.3	4.2	19.99	16500	53	40	10	4.8	34980.0	8745.0	4197.6	10211.2	2664.2	2124.6	11499.7	2874.9	1380.0
2.3	4.2	19.99	18000	53	40	10	4.8	38160.0	9540.0	4579.2	11139.5	2866.0	2221.4	12545.1	3136.3	1505.4
2.3	4.2	19.99	19500	53	40	10	4.8	41340.0	10335.0	4960.8	12067.8	3067.7	2318.3	13590.5	3397.6	1630.9
2.3	4.2	19.99	21000	53	40	10	4.8	44520.0	11130.0	5342.4	12996.1	3269.4	2415.1	14636.0	3659.0	1756.3
2.3	4.2	19.99	22500	53	40	10	4.8	47700.0	11925.0	5724.0	13924.4	3471.2	2511.9	15681.4	3920.3	1881.8
2.3	4.2	19.99	24000	53	40	10	4.8	50880.0	12720.0	6105.6	14852.7	3895.5	2608.8	16726.8	4181.7	2007.2
2.3	4.2	19.99	25500	53	40	10	4.8	54060.0	13515.0	6487.2	15781.0	4097.2	2705.6	17772.2	4443.1	2132.7
2.3	4.2	19.99	27000	53	40	10	4.8	57240.0	14310.0	6868.8	16709.3	4299.0	2802.4	18817.7	4704.4	2258.1
2.3	4.2	19.99	28500	53	40	10	4.8	60420.0	15105.0	7250.4	17637.6	4500.7	2899.3	19863.1	4965.8	2383.6
2.3	4.2	19.99	30000	53	40	10	4.8	63600.0	15900.0	7632.0	18565.9	4702.4	4055.6	20908.5	5227.1	2509.0
2.3	4.2	19.99	31500	53	40	10	4.8	66780.0	16695.0	8013.6	19494.2	4904.2	4152.4	21953.9	5488.5	2634.5
2.3	4.2	19.99	33000	53	40	10	4.8	69960.0	17490.0	8395.2	20422.5	5105.9	4249.2	22999.4	5749.8	2759.9

2.3	4.2	19.99	34500	53	40	10	4.8	73140.0	18285.0	8776.8	21350.8	5307.6	4346.1	24044.8	6011.2	2885.4
2.3	4.2	19.99	36000	53	40	10	4.8	76320.0	19080.0	9158.4	22279.1	5732.0	4442.9	25090.2	6272.6	3010.8
2.3	4.2	19.99	37500	53	40	10	4.8	79500.0	19875.0	9540.0	23207.4	5933.7	4539.7	26135.6	6533.9	3136.3
2.3	4.2	19.99	39000	53	40	10	4.8	82680.0	20670.0	9921.6	24135.7	6135.4	4636.5	27181.1	6795.3	3261.7
2.3	4.2	19.99	40500	53	40	10	4.8	85860.0	21465.0	10303.2	25064.0	6337.1	4733.4	28226.5	7056.6	3387.2
2.3	4.2	19.99	42000	53	40	10	4.8	89040.0	22260.0	10684.8	25992.3	6538.9	4830.2	29271.9	7318.0	3512.6
2.3	4.2	19.99	43500	53	40	10	4.8	92220.0	23055.0	11066.4	26920.6	6740.6	4927.0	30317.3	7579.3	3638.1
2.3	4.2	19.99	45000	53	40	10	4.8	95400.0	23850.0	11448.0	27848.9	6942.3	5023.9	31362.8	7840.7	3763.5
2.3	4.2	19.99	46500	53	40	10	4.8	98580.0	24645.0	11829.6	28777.1	7144.1	5120.7	32408.2	8102.0	3889.0
2.3	4.2	19.99	48000	53	40	10	4.8	101760.0	25440.0	12211.2	29705.4	7568.4	5217.5	33453.6	8363.4	4014.4
2.3	4.2	19.99	49500	53	40	10	4.8	104940.0	26235.0	12592.8	30633.7	7770.1	5314.4	34499.0	8624.8	4139.9
2.3	4.2	19.99	51000	53	40	10	4.8	108120.0	27030.0	12974.4	31562.0	7971.9	5411.2	35544.5	8886.1	4265.3
2.3	4.2	19.99	52500	53	40	10	4.8	111300.0	27825.0	13356.0	32490.3	8173.6	5508.0	36589.9	9147.5	4390.8
2.3	4.2	19.99	54000	53	40	10	4.8	114480.0	28620.0	13737.6	33418.6	8375.3	5604.9	37635.3	9408.8	4516.2
2.3	4.2	19.99	55500	53	40	10	4.8	117660.0	29415.0	14119.2	34346.9	8577.1	5701.7	38680.7	9670.2	4641.7
2.3	4.2	19.99	57000	53	40	10	4.8	120840.0	30210.0	14500.8	35275.2	8778.8	5798.5	39726.2	9931.5	4767.1
2.3	4.2	19.99	58500	53	40	10	4.8	124020.0	31005.0	14882.4	36203.5	8980.5	5895.3	40771.6	10192. 9	4892.6
2.3	4.2	19.99	60000	53	40	10	4.8	127200.0	31800.0	15264.0	37131.8	9404.9	7051.7	41817.0	10454. 3	5018.0

## Appendix E-8: HOMER Results - Overhead transmission scenarios

Parameters	Existing System	Most optimal hybrid	Only Solar PV (with batteries and no generator) - for entire conservancy	Only Hydro	Solar PV (with batteries) and backup generator and transmission	Hydro (with batteries) and backup generator	Biogas only
<b>Renewable fraction</b>	0.34	1.00	1.00	1.00	0.79	0.56	1.00
<b>Battery life (years)</b>	2.84	8.69	9.83	-	7.70	7.73	39.50
<b>CO<sub>2</sub>Emissions (kg/yr)</b>	70,620.00	331.00	0	0	16,777.00	38,993.00	0
<b>Fuel consumption (liters)</b>	26,818.00	122.00	-	-	6,371.00	14,759.00	0
<b>Biogas consumption (t/year)</b>	-	63.60	-	-	-	-	228
<b>Operating costs (\$/year)</b>	64,920.00	12,493.00	26,424.00	6,503.00	39,387.00	38,560.00	9117
<b>Unmet load (%)</b>	-	-	-	57.10	-	-	0.00
<b>Cost of Electricity (\$/kWh)</b>	1.24	0.41	5.27	0.41	4.32	0.63	0.24
<b>Net present costs (\$)</b>	1,023,250.00	512,055.00	6,356,467.00	252,401.00	5,417,346.00	790,252.00	288,061.00
<b>Net capital costs (\$)</b>	82,771.00	404,927.00	6,244,630.00	172,304.00	5,085,213.00	205,671.00	247,872.00
<b>Payback (years)</b>	-	6.14	160.06	1.53	195.92	4.66	2.96



## Appendix E-9: HOMER Results – Underground transmission scenarios

Parameters	Existing System	Most optimal hybrid	Only Solar PV (with batteries and no generator) – for entire conservancy	Only Hydro	Solar PV (with batteries) and backup generator and transmission	Hydro (with batteries) and backup generator	Biogas only
<b>Renewable fraction</b>	0.34	1.00	1.00	1.00	0.79	0.56	1.00
<b>Battery life (years)</b>	2.84	8.69	9.83	0.00	7.70	7.73	39.50
<b>CO<sub>2</sub>Emissions (kg/yr)</b>	70620.00	331.00	0.00	0.00	17360.00	38993.00	0.00
<b>Fuel consumption (liters)</b>	26818.00	122.00	0.00	0.00	6371.00	14759.00	0.00
<b>Biogas consumption (t/year)</b>	64920.00	17614.00	26424.00	6503.00	39387.00	22746.00	9117.00
<b>Operating costs (\$/year)</b>	0.00	0.00	0.00	51.10	-	0.00	0.00
<b>Unmet load (%)</b>	1.24	0.81	22.68	0.41	17.76	0.76	0.60
<b>Cost of Electricity (\$/kWh)</b>	1023250.00	1017153.00	27356466.00	672401.00	22300974.00	947470.00	708061.00
<b>Net present costs (\$)</b>	82771.00	905236.00	27244630.00	592304.00	22074847.00	614245.00	667872.00
<b>Net capital costs (\$)</b>	0.00	63.60	0.00	0.00	0.00	0.00	228.00
<b>Payback (years)</b>	0.00	17.39	705.58	8.72	861.32	12.60	10.49

## Appendix E-10: HOMER Results - No transmission scenarios

Parameters	Existing System	Solar PV for Ranch alone (with backup generators)	Solar PV for MRC alone (with backup generators)	Biogas for MRC	Biogas for Ranch
Renewable fraction	0.34	1.00	1.00	1.00	1.00
Battery life (years)	2.84	10.00	9.83	10.00	1.80
CO <sub>2</sub> Emissions (kg/yr)	70,620.00	-	0.00	36.00	13.00
Fuel consumption (liters)	26,818.00	-	0.00	-	-
Operating costs (\$/year)	64,920.00	13,235.00	25,794.00	13,917.00	7,943.00
Unmet load (%)	-	-	0.00	-	-
Cost of Electricity (\$/kWh)	1.24	1.78	1.20	0.28	0.54
Net present costs (\$)	1,023,250.00	527,827.00	1,150,260.00	258,512.00	161,141.00
capital cost + replacement - salvage (\$)	82,771.00	485,784.00	1,031,778.00	133,267.00	129,764.00
Biogas consumption (t/year)	-	-	0.00	208.00	75.10
Payback (years)		7.80	24.26	0.99	0.82

### Appendix E-11: HOMER Results - Cost benefit analysis: Overhead transmission scenarios

	Existing System	Most optimal hybrid	Only Solar PV	Only Hydro	Solar PV and backup generator	Hydro and backup generator	Biogas only
<b>Net present costs (\$)</b>	1,023,250	512,055	6,356,467	252,401	5,417,346	790,252	288,061
<b>CO2Emissions (kg/yr)</b>	70,620	331	-	-	16,777	38,993	-
<b>Increase in costs</b>		(511,195)	5,333,217	(770,849)	4,394,096	(232,998)	(735,189)
<b>Decrease in emissions</b>		70,289	70,620	70,620	53,843	31,627	70,620
<b>B/C</b>		(7.27)	75.52	(10.92)	81.61	(7.37)	(10.41)
<b>Cost of e- (\$/kWh)</b>	1.238	0.408	5.269	0.409	4.315	0.629	0.242

Cost-benefit and Cost of electricity comparison – **Overhead transmission case**

### Appendix E-12: HOMER Results – Cost benefit analysis: Underground transmission scenarios

	Existing System	Most optimal hybrid	Only Solar PV	Only Hydro	Solar PV and backup generator	Hydro and backup generator	Biogas only
<b>Net present costs (\$)</b>	1,023,250	1,017,153	27,356,466	672,401	22,300,974	947,470	708,061
<b>CO2Emissions (kg/yr)</b>	70,620	331	-	-	17,360	38,993	-
<b>Increase in costs</b>		(6,097)	26,333,216	(350,849)	21,277,724	(75,780)	(315,189)
<b>Decrease in emissions</b>		70,289	70,620	70,620	53,260	31,627	70,620
<b>B/C</b>		(0.09)	372.89	(4.97)	399.51	(2.40)	(4.46)
<b>Cost of e- (\$/kWh)</b>	1.238	0.810	22.680	0.409	17.762	0.755	0.595

Cost-benefit and Cost of electricity comparison – **Underground transmission case**

Appendix E-13: HOMER Results – Cost benefit analysis: Overhead vs Underground transmission scenarios

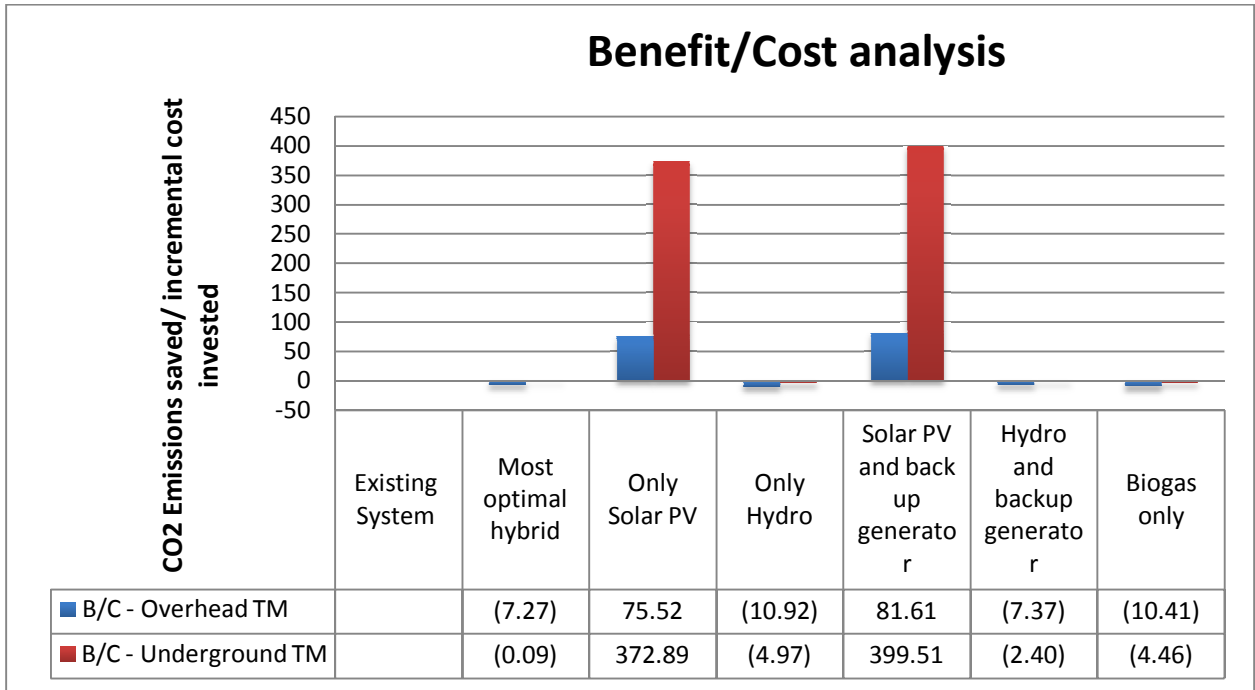

Evaluating different hybrid systems – Metric: Cost of electricity (\$/kWh) – UG vs OH

### Appendix E-14: HOMER Results - Cost benefit analysis: Overhead transmission scenarios

	Existing System	Solar PV for Ranch alone (with backup generators)	Solar PV for MRC alone (with backup generators)	Biogas for MRC	Biogas for Ranch
<b>Net present costs (\$)</b>	1,023,250	527,827	1,150,260.00	258,512	161,141
<b>CO2Emissions (kg/yr)</b>	70,620	-	1,798	36	13
<b>Increase in costs</b>		(695,430)	(535,974)	(764,738)	(862,109)
<b>Decrease in emissions</b>		70,620	68,822	70,584	70,607
<b>B/C</b>		(9.85)	(7.79)	(10.83)	(12.21)
<b>Cost of e- (\$/kWh)</b>	1.240	1.78	1.20	0.284	0.542

Cost-benefit and Cost of electricity comparison – **No transmission case**

Appendix E-15: HOMER Results - Cost benefit analysis: No transmission scenarios

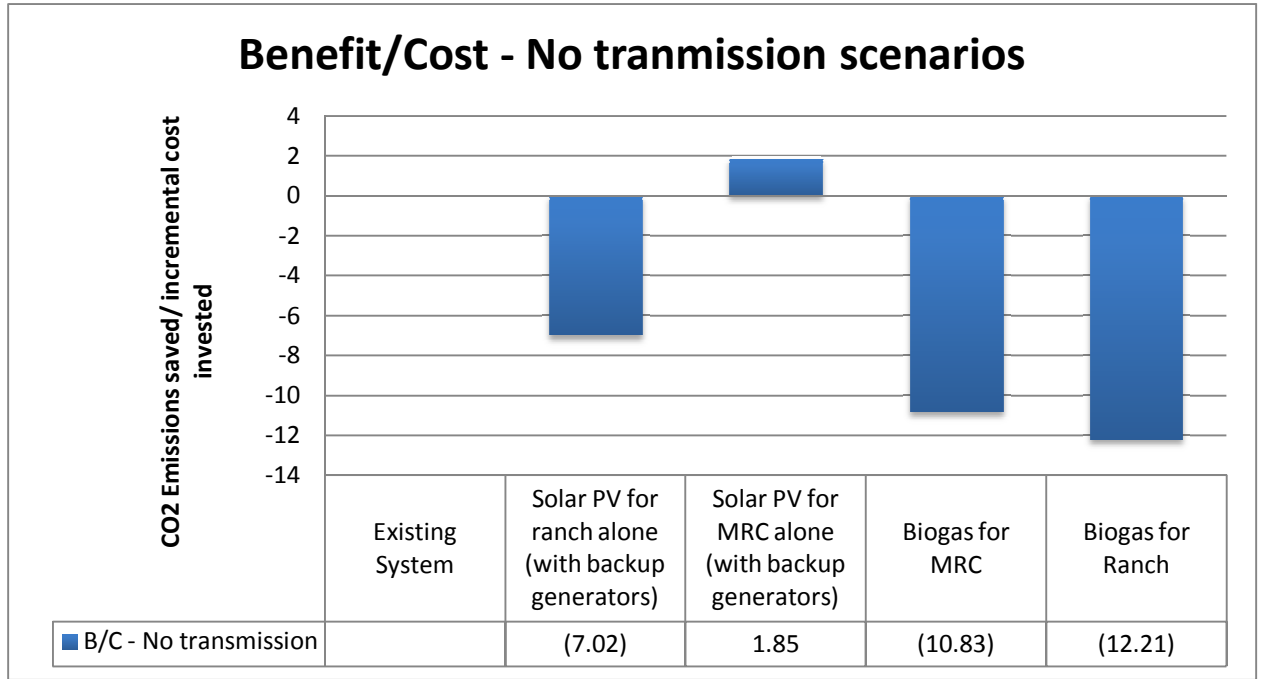

Evaluating different hybrid systems – Metric: B/C for no transmission case

## Appendix E -16: Initial Analysis Report

### ELECTRICITY METER READINGS AND DATA INTERPRETATION

#### Introduction

During our stay in Kenya, we were able to take readings for 8 days (consisting of 6 weekdays and a weekend). Our readings are based on electricity meters that we attached to the different buildings at the Centre and at the Ranch. This paper presents values and calculations for the Centre only.

We attached meters at 8 locations.

1. Main Generator Site
2. Kitchen
3. Admin building
4. Lab 1
5. Lab 2
6. Lab 3
7. Dorm 1
8. Jenga House

The Main generator takes readings of overall usage, and just by using these readings it is possible to estimate the total use of electricity by the Mpala Research Centre. However, we put meters at every building to understand the contribution and usage trend of each building.

We have *not taken* observations in some buildings. These are:

1. Margaret's House
2. Bandas
3. Dorm 2 (Princeton Dorm – net zero)
4. Library (values included are borrowed from Peter Muhoro. )

For each site,

The information provided includes:

- Electricity usage for each day
- Total and overall average for the 8 days
- Weekday average
- Weekend average

It is also possible and might be significant to find the peaks for each day to best optimize the system. We are waiting for the interpretation of our “hobo” data for finding these peaks.



**Energy Usage at each of the 8 sites:****Main Generator Site:**

There are two generators at Mpala. During our stay there, the large generator operated the whole day and stopped at 10 pm, and started again at 6 am. This is because the batteries were not functioning. The small generator is used as a backup. When the batteries are functioning, the timings for the generator are different.

Readings:

<b>Date (day)</b>	<b>Reading (kWh)</b>
08/13/2010 (F)	107
08/14/2010 (SA)	84.9
08/15/2010 (SU)	57.5
08/16/2010 (M)	127.6
08/17/2010 (T)	105.8
08/18/2010 (W)	85
08/19/2010 (R)	98.1
08/20/2010 (F)	74.6
<b>Sum</b>	<b>740.5</b>
<b>Average</b>	<b>92.563</b>
<b>Weekday Average</b>	<b>99.7</b>
<b>Weekend Average</b>	<b>71.2</b>

**Kitchen:**

Kitchen is used to prepare food for all the people working in the office and laboratories including students, staff and technicians. It includes freezers and refrigerators and uses up most of the electricity supplied to the kitchen.

Readings:

<b>Date (Day)</b>	<b>Usage (kWh)</b>
8/13/2010 (F)	12.5
8/14/2010 (SA)	8.11
8/15/2010 (SU)	11.34
8/16/2010 (M)	9.3
8/17/2010 (T)	9.08
8/18/2010 (W)	8.82
8/19/2010 (R)	9.6
8/20/2010 (F)	7.69
<b>Sum</b>	<b>76.44</b>
<b>Overall Average</b>	<b>9.56</b>
<b>Weekday Average</b>	<b>9.5</b>

<b>Weekend Average</b>	<b>9.725</b>
------------------------	--------------

**Admin Building:**

Readings:

<b>Date(day)</b>	<b>Usage (kWh)</b>
8/13/2010 (F)	4.65
8/14/2010 (SA)	3.75
8/15/2010 (SU)	4.27
8/16/2010 (M)	4.92
8/17/2010 (T)	4.95
8/18/2010 (W)	5.74
8/19/2010 (R)	error
8/20/2010 (F)	error
<b>Sum(6 days)</b>	<b>28.18</b>
<b>*Projected Sum (8days)</b>	<b>38.14</b>
<b>Overall Average</b>	<b>4.8</b>
<b>**Weekday Average</b>	<b>5.083</b>
<b>Weekend Average</b>	<b>4.01</b>

\*For 3 weekdays, the consumption was  $(4.92+4.95+5.74) = 15.51$  Therefore consumption for 5 days is 25.85 (assuming similar trend). This will lead us to calculate sum as  $4.65+25.85+3.75+4.27 = 38.14$

\*\*Weekday total =  $4.65+25.85 = 30.5$  Therefore average is calculated as  $30.5/6 = 5.083$  (since there are 6 weekdays).

### **Laboratory 1:**

This is one of the labs that handle projects funded by NSF. There are two such labs. This is the lab on the left.

<b>Date (day)</b>	<b>Usage(kWh)</b>
8/13/2010 (F)	9.98
8/14/2010 (SA)	9.83
8/15/2010 (SU)	12.04
8/16/2010 (M)	11.28
8/17/2010 (T)	14
8/18/2010 (W)	13.09
8/19/2010 (R)	12.4
8/20/2010 (F)	12.91
<b>Sum</b>	<b>95.53</b>
<b>Overall Average</b>	<b>11.94</b>
<b>Weekday Average</b>	<b>12.28</b>
<b>Weekend Average</b>	<b>10.94</b>

**Laboratory 2 :**

This is one of the labs that handle projects funded by NSF. There are two such labs. This is the lab on the right.

Readings:

<b>Date(day)</b>	<b>Usage(kWh)</b>
8/13/2010 (F)	10.6
8/14/2010 (SA)	10.15
8/15/2010 (SU)	12.23
8/16/2010 (M)	11.6
8/17/2010 (T)	12.15
8/18/2010 (W)	14.99
8/19/2010 (R)	12.98
8/20/2010 (F)	13.89
<b>Sum</b>	<b>98.59</b>
<b>Overall Average</b>	<b>12.32</b>
<b>Weekday Average</b>	<b>12.7</b>
<b>Weekend Average</b>	<b>11.19</b>

**Laboratory 3:**

Readings:

<b>Date(day)</b>	<b>Usage(kWh)</b>
8/13/2010 (F)	6.41
8/14/2010 (SA)	5.34
8/15/2010 (SU)	7.65
8/16/2010 (M)	6.88
8/17/2010 (T)	8.25
8/18/2010 (W)	7.39
8/19/2010 (R)	8.92
8/20/2010 (F)	7.79
<b>Sum</b>	<b>58.63</b>
<b>Overall Average</b>	<b>7.33</b>
<b>Weekday Average</b>	<b>8.84</b>
<b>Weekend Average</b>	<b>6.5</b>

**Dorm 1:**

This refers to the older dorm as opposed to the more recent Princeton Dorm.

<b>Date(day)</b>	<b>Usage(kWh)</b>
8/13/2010 (F)	0.6
8/14/2010 (SA)	0.52
8/15/2010 (SU)	0.74
8/16/2010 (M)	0.71
8/17/2010 (T)	0.71
8/18/2010 (W)	0.17 (error possible)
8/19/2010 (R)	1.5 (error possible)
8/20/2010 (F)	0.54
<b>Sum</b>	<b>5.49</b>
<b>Overall Average</b>	<b>0.69</b>
<b>Weekday Average</b>	<b>0.704</b>
<b>Weekend Average</b>	<b>0.63</b>

We would have expected a greater average in the weekend for the dorm, since people are not working on these days. However, there could be various reasons for not getting a higher weekend value:

- People could be visiting other places
- People could be working in their labs
- The data highlighted in red, could be erroneous thus using the right values might change the weekend average.

**Jenga House:**

The Jenga House can house up to four or five researchers. However, at the time when we were there, there were about 2 people living in this house.

<b>Date(day)</b>	<b>Usage(kWh)</b>
8/13/2010 (F)	7.75
8/14/2010 (SA)	7.95
8/15/2010 (SU)	6.94
8/16/2010 (M)	8.09
8/17/2010 (T)	Not available
8/18/2010 (W)	Not available
8/19/2010 (R)	Not available
8/20/2010 (F)	Not available
<b>Sum</b>	<b>28.09</b>
<b>Overall Average</b>	<b>7.02</b>
<b>Weekday Average</b>	<b>7.92</b>
<b>Weekend Average</b>	<b>7.45</b>

We have values for just 4 days in Jenga house.

Therefore, projecting to get 8 day value for Jenga House:

$$\text{Friday and Saturday} = 7.75 + 8.09 = 15.84$$

For two weekdays, 15.7 which implies that for 6 weekdays (assuming same trend is followed for weekdays), we have – 47.52

Therefore, total electricity used is 47.52 +weekends (7.95+6.94) = 62.11 kwh

$$\text{Average} = 7.76 \text{ kWh}$$

Data collection at the Jenga house was far more challenging than the Centre. We had to take readings keeping in mind the concerns of the residents and safety concerns after dark.

*Note: These readings are crude and are the calculations are not statistically verified for safety measures.*

### **Energy Accounting:**

Theoretically, the average electricity used by each of these buildings, should add up to the average electricity produced by the generator.

Power produced by generator = power used by (Kitchen + Admin building + Dorm + Jenga house + Lab 1+Lab2 + Lab3 + library)

$$92.56 = 7.76 + 0.69 + 7.33 + 12.32 + 11.94 + 9.56 + 4.8 + \text{library} + x$$

$$\text{Library} = 21.12 \text{ kWh (borrowed data)}$$

$$= 75.52 + x$$

$$X = 17.04 \text{ kWh}$$

This is the amount of electricity that we are not able to account for. There are various reasons that could contribute to this.

Calculations *do not include*:

- Margaret's house
- Bandas
- Other researcher houses not covered during energy audits.

- Electricity drawn by people working in the Centre and other locals in car batteries for their personal uses.

Sources of error:

- Averages and other calculations are approximate and not necessarily statistically acceptable.
- There might be errors in understanding the system and placement of the meters.
- Parallax error in noting the readings.

### Calculating cost savings

Calculating cost per kWh for diesel engine at Mpala

Efficiency of the engine is calculated as

$$= 92.56 / (24 * 16) = 0.24$$

Energy produced by the engine

$$24 \text{ kWh} * 3.6 \text{ MJ/kWh} * 0.24 \dots\dots\dots 1$$

However, one kg of diesel can give only 43.2 MJ/kg

The lower heating value of the diesel engine is taken from HOMER as 43.2 MJ/kg.....2

Therefore, 1 divided by 2 will give 8.33 kg/kWh

0.82 kg of diesel is equivalent to 1 l diesel.

$$\text{Cost per liter} = (\$0.994/\text{l}) * (1/0.82 \text{ kg/l}) * (8.33 \text{ kg/kWh})$$

$$= \$10.01/\text{kWh}$$