

UMTRI-86-35/I

The Influence of Weights and Dimensions on the Stability and Control of Heavy Duty Trucks in Canada

Final Report

Volume I - Technical Report

Robert D. Ervin
Yoram Guy

July, 1986

UMTRI The University of Michigan
Transportation Research Institute

Technical Report Documentation Page

1. Report No.	2. Government Accession No.	3. Recipient's Catalog No.	
4. Title and Subtitle THE INFLUENCE OF WEIGHTS AND DIMENSIONS ON THE STABILITY AND CONTROL OF HEAVY-DUTY TRUCKS IN CANADA - VOL. I - TECHNICAL REPORT		5. Report Date July 1986	
		6. Performing Organization Code 388762	
7. Author(s) Robert D. Ervin, Yoram Guy		8. Performing Organization Report No. UMTRI-86-35/I	
9. Performing Organization Name and Address The University of Michigan Transportation Research Institute 2901 Baxter Road Ann Arbor, Michigan 48109		10. Work Unit No. (TRAIS)	
		11. Contract or Grant No.	
12. Sponsoring Agency Name and Address Canroad Transportation Research Corporation 1765 Saint Laurent Boulevard Ottawa, K1G 3V4, CANADA		13. Type of Report and Period Covered Final 5/84 - 7/86	
		14. Sponsoring Agency Code	
15. Supplementary Notes Volumes II and III contain the appendices to this report			
16. Abstract <p>The stability and control characteristics of heavy-duty truck combinations used in Canada were determined as an aid for the development of new regulations on the weights and dimensions of vehicles in interprovincial trucking. Truck combinations which are currently in use in Canada were first identified through a survey activity. Parameters describing these vehicles were evaluated and an extensive computerized analysis of dynamic performance characteristics was conducted. Full-scale tests were run as a supplement to the computerized study for three of the selected vehicles.</p> <p>The results serve to classify the contrasting dynamic performance qualities of some 22 vehicle configurations, distinguished by number and placement of axles, number of trailers, and type of hitching mechanisms. Also, the sensitivity of the dynamic behavior of each configuration to variations in weights and dimensions, as well as certain component properties, is determined. Novel measures of performance were developed for characterizing (1) the dynamic stability of roll-coupled trailer combinations and the offtracking overshoot in a rapid path-change maneuver, and (2) the potential for low-speed jackknife while towing a trailer with multiple-wide-spread axles around a tight turn. Generalized performance evaluation techniques are outlined for future use in examining prospective new vehicle combinations.</p>			
17. Key Words trucks, safety, stability, control, offtracking, size and weight, regulation		18. Distribution Statement UNLIMITED	
19. Security Classif. (of this report) NONE	20. Security Classif. (of this page) NONE	21. No. of Pages 277	22. Price

Acknowledgements:

The "cross-Canada tour" survey of truck configurations was specifically enabled by the good offices of the Canadian Trucking Association and affiliated associations in the provinces of British Columbia, Alberta, Manitoba, Ontario, Quebec, and New Brunswick. The survey exercise was ably assisted by Mr. John Woodrooffe of the National Research Council, Ottawa, and by Mr. John Pearson of the Roads and Transportation Association of Canada.

Laboratory measurement of component parameters was conducted under the direction of Mr. Christopher Winkler, using the parameter measurement facilities at UMTRI. The laboratory effort was accomplished through the assisting skills of Mr. John Koch, Thomas Dixon, and Michael Campbell. Full scale demonstration tests were directed by Mr. John McHugh with the aid of UMTRI's senior test driver and program motivator, Mr. Donald Foster. Tire traction measurements using the UMTRI mobile apparatus was directed by Mr. Michael Hagan, who also accomplished the processing of data from component and full scale vehicle tests.

The computer study was achieved through the accomplishment of an entirely new "interface system" for accessing all of UMTRI's computer simulations from a central library of parametric data. This system was designed and developed by Mr. Yoram Guy, with the assistance of Ms. Patricia Dill, Mr. Scott Collins, and Mr. Arvind Mathews. The production of report graphics was also assisted by Mr. Luis Balderas-Ariza. Also, the supportive role of Mr. Charles MacAdam and Mr. Michael Sayers in accomplishing various aspects of the new computer system developments is appreciated.

TABLE OF CONTENTS

<i>Section</i>	<i>Page</i>
1 Introduction.....	1
2 Elements of an Analysis of the Dynamic Performance of Truck Combinations in Canada	4
2.1 The Identification of Truck Combinations Commonly Used in Canada	5
2.2 Parametric Data.....	11
2.2.1 Direct Parametric Measurements.....	12
2.2.2 Vehicle Specifications.....	12
2.2.3 Conventions for Tare-Vehicle Parameters.....	15
2.2.4 Conventions for Vehicle-Loading Parameters.....	15
2.3 Simulation Task.....	16
2.3.1 Vehicle Configurations.....	16
2.3.2 Performance Measures.....	18
2.3.3 Simulation Matrix.....	23
2.3.4 Simulation Models.....	24
3 Presentation of Results.....	26
3.1 Comparison of Performance Characteristics Among Reference Vehicle Configurations	26
3.1.1 Performance of Differing Configurations in a Quasi-Steady Turn at Highway Speed	27
3.1.2 Performance of Differing Configurations in a Transient Steering Maneuver (Rapid Path Change) at Highway Speed	37
3.1.3 Performance of Differing Configurations in a Tight-Radius, Intersection Turn at Near-Zero Speed	54
3.1.4 Braking Efficiency Performance of Differing Configurations.....	65

3.2	Illustration of the Parametric Sensitivities for Tractor Semitrailer Combinations	73
3.2.1	The Influence of Tractor and Trailer Length Dimensions.....	73
3.2.2	The Influence of Spread Dimension Associated with 2-Axle Tandems	76
3.2.3	Influence of 5th Wheel Offset.....	82
3.2.4	Influence of Tractor Suspension Selection.....	85
3.2.5	Influence of High Payload and Tractor Width Dimension.....	92
3.2.6	Influence of Partial Loading.....	94
3.2.7	Influence of Tire Selection.....	99
3.2.8	Influence of Axle Loading.....	103
3.2.9	Influence of Wide-Spread Trailer Axle Arrangements.....	109
3.3	Illustration of Parametric Sensitivities for A- and C-Type Doubles Combinations	117
3.3.1	Influence of Trailer Length and Hitch Placement Dimensions	117
3.3.2	Influence of Axle Loading.....	126
3.3.3	Influence of Partial Loading.....	134
3.3.4	Influence of Order of Placement of Differing Configuration Trailers	141
3.3.5	Influence of Tire Selection.....	145
3.3.6	Influence of the Steer-Centering Properties of B-Dollies.....	150
3.4	Illustration of Parametric Sensitivities for B-Type Doubles Combinations	156
3.4.1	Influence of Trailer Length and Placement of the Inter-Trailer Fifth Wheel	156
3.4.2	Influence of Axle Loading.....	165
3.4.3	Influence of Partial Loading.....	168
3.4.4	Influence of Compensator-Type 5th Wheel as the Inter-Trailer Coupling	173
3.4.5	Influence of Air Suspensions (at all axles).....	180
3.4.6	Influence of Belly Axle Installations.....	180

3.5	Illustration of Parametric Sensitivities for A- and C-Type Triples Combinations	192
3.5.1	Influence of Trailer Length and Hitch Placement Dimensions	192
3.5.2	Influence of Axle Loading.....	195
3.5.3	Influence of the Steer-Centering Properties of B-Dollies.....	200
3.5.4	Influence of Partial Loading.....	205
3.6	Productivity and Dynamic Performance Profiles for Each of the Reference Vehicles	210
3.6.1	Introduction of Reference Values.....	210
3.6.2	Presentation of Profiles.....	214
4	Performance Evaluation Techniques.....	239
4.1	Static Rollover Threshold.....	239
4.2	Tractor Understeer Coefficient at 0.25G Lateral Acceleration.....	243
4.3	High Speed Offtracking in a Steady State Turn.....	244
4.4	Amplification-Induced Rollover.....	245
4.5	Transient High Speed Offtracking.....	251
4.6	Low Speed Offtracking.....	252
4.7	Friction Demand in a Tight Turn.....	256
4.8	Braking Efficiency.....	258
5	Conclusions and Recommendations.....	260
6	References.....	269

1.0 INTRODUCTION

This document constitutes the final report on a research project conducted by the University of Michigan Transportation Research Institute (UMTRI) under sponsorship of the Canroad Transportation Research Corporation (CTRC). The study has intended to produce findings which assist in the formulation of more uniform weights and dimensions (W/D) regulations on interprovincial trucking in Canada and to generally upgrade the practice of evaluating the dynamic behavior of heavy-duty vehicles.

The primary national issue which has prompted this study pertains to the great diversity in W/D allowances which exist for truck combinations among the respective Canadian provinces and territories. Since this diversity is seen as imposing certain inefficiencies upon interprovincial trucking operations, there is an interest in developing technical data which may assist in the revision of W/D regulations. To this end, the project reported herein has produced findings addressing certain safety issues which interact with vehicle configuration and with specific W/D variables. Indeed, all of the elements of this study are premised, ultimately, upon a potential link between the physical makeup of the vehicle and traffic safety.

The specific aspects of performance addressed here cover the stability and control behavior of vehicles in response to steering and braking maneuvers. Prior research in this subject area has established that the response properties of vehicles differ as a result of not only the vehicle characteristics which are traditionally addressed under W/D regulations, but also the design and operating variables describing vehicle components and subsystems. In an attempt to provide the maximum yield under this research study, then, examination of the influence of W/D variables on vehicle performance has been supplemented with analyses of the influence of component selection as well as operational variables. While the latter information is not directly germane to the development of uniform interprovincial regulations on W/D limits, it does contribute to a broadened understanding of the behavior of trucks commonly used in Canada. These design-related results also will assist researchers who intend to further explore the state of practice in trucking and to seek improvements for the future.

In order to examine the spectrum of vehicle configurations which are currently in use or which are prospects for future application, the study undertook a multi-task research effort encompassing a survey of current Canadian truck configurations, laboratory

measurement of certain components and subsystems, demonstration testing of selected vehicles, and a very large scale computer-aided analysis of vehicle response properties. The text of the main report is assembled to provide the reader with an introduction to the methodology employed in each of these tasks. Appendices are provided for presentation of detailed expositions on methods and results.

The principal portion of the main report is devoted to describing and reporting the results of the computer-aided analysis, or "simulation," effort. It is the results of this task which form the primary findings of the study. These findings have been formulated in terms of measures of performance which are seen as expressing certain safety qualities of vehicles. Thus, insofar as new W/D regulations must pay cognizance to the potential safety implications of truck allowances, this body of findings serve as an information base to aid in making public policy. To the degree that the results indicate deficiencies in the performance levels of one existing truck configuration relative to another, they also identify opportunities for improving the overall safety of truck transportation.

In Section 2.0 of the report, the elements of the overall study are discussed in summary fashion. The reader must examine portions of Section 2.0 (especially 2.3) in order to understand the definition of various measures of performance which are used for rating the stability and control qualities of vehicles throughout Sections 3.0 and 4.0.

Section 3.0 presents the performance results in a context of comparisons of behavior across the spectrum of vehicles. In this regard, it is seen that the spectrum of vehicle types in use in Canada is as broad as exists in any jurisdiction in the world. As a result, Section 3.1 has been devoted exclusively to the presentation of variations in performance deriving simply from basic vehicle configuration, given certain uniform assumptions on components and vehicle loading. Sections 3.2 through 3.5 address the detailed parametric sensitivities of the various categories of vehicle configuration to variations in W/D limits as well as design variables. This group of four subsections, covering the parametric sensitivities of tractor-semitrailers, A- and C-train doubles, B-train doubles, and triples combinations, respectively, constitute the largest section of the overall report. Readers who are interested in details regarding the influence of a specific vehicle parameter on some aspect of performance would consult these sections, with the aid of the performance definitions in Section 2.3.

In Section 3.6, the results are summarized in a manner which consolidates the various measures of safety-related performance (such as braking, roll stability, offtracking,

etc.), together with the payload-carrying advantages of the differing vehicle configurations. The provided summaries give the simplest overall condensations of the study findings, as they pertain to the attractiveness of one configuration over another. Although other qualities than safety and payload size are surely of concern to the trucking industry and to public policymakers, the breakdown of results by these two categories serve as a useful overview of the safety vs. productivity tradeoffs.

In Section 4.0, a set of performance evaluation techniques are presented as a recommendation for future application in evaluating vehicle stability and control behavior. These techniques follow upon the rationale employed in the simulation study and address both simulation techniques and measurements which can be made on full-scale vehicles.

Finally, Section 5.0 presents conclusions and recommendations which are seen as having general significance to the issue of W/D regulation and related issues of safety in trucking.

Volume II of this report presents Appendices A and B which contain vehicle-descriptive data representing the truck configurations which are commonly found in Canada as well as computer-input parameters used to represent such vehicles in the simulation study. Volume III presents Appendices C through F which contain details for computing measures of performance, the matrix of vehicle cases which were simulated, results of a demonstration test program, and the data-base of simulation results.

2.0 ELEMENTS OF AN ANALYSIS OF THE DYNAMIC PERFORMANCE OF TRUCK COMBINATIONS IN CANADA

The conduct of a large-scale analytical effort for evaluating the stability and control properties of truck combinations required that various pieces of missing information be gathered and that the protocols for the analysis be developed within the study. In this section, these portions of the study effort will be described.

Shown in Figure 2.0.a is a block diagram of the elements of the overall analytical approach. The diagram outlines series and parallel steps which culminated in the simulation study, itself, in which measures of vehicle performance were generated. The steps were as follows:

- 1) In order to identify the specific vehicle configurations which warranted study, a so-called "cross-Canada tour" was conducted in which persons from the trucking industry were surveyed regarding the popular selections of equipment. This exercise resulted in two categories of information, namely, (a) descriptions of truck combinations, in terms of types and numbers of trailers and couplings, number and placement of axles, and approximate dimensions of vehicle units, and (b) identification of popular component selections.
- 2) Given the descriptions of truck combinations, a study matrix was designed providing coverage of all prominent vehicle types and the maximum feasible range of W/D variables and component selections.
- 3) An existing library of measurements on the mechanical properties of truck components was examined to determine which of the components found to be popular in Canada were unrepresented in the available data. Where data were unavailable, laboratory measurements of component properties were conducted. Both the applicable existing data and the new measurements were formatted as input data for running the computerized simulations.
- 4) The matrix which encompassed vehicles, W/D and design variations, and maneuvering conditions, was such that various revisions to existing computation methods were required in order to achieve a suitable level of efficiency and technical accuracy. These new software developments encompassed a general

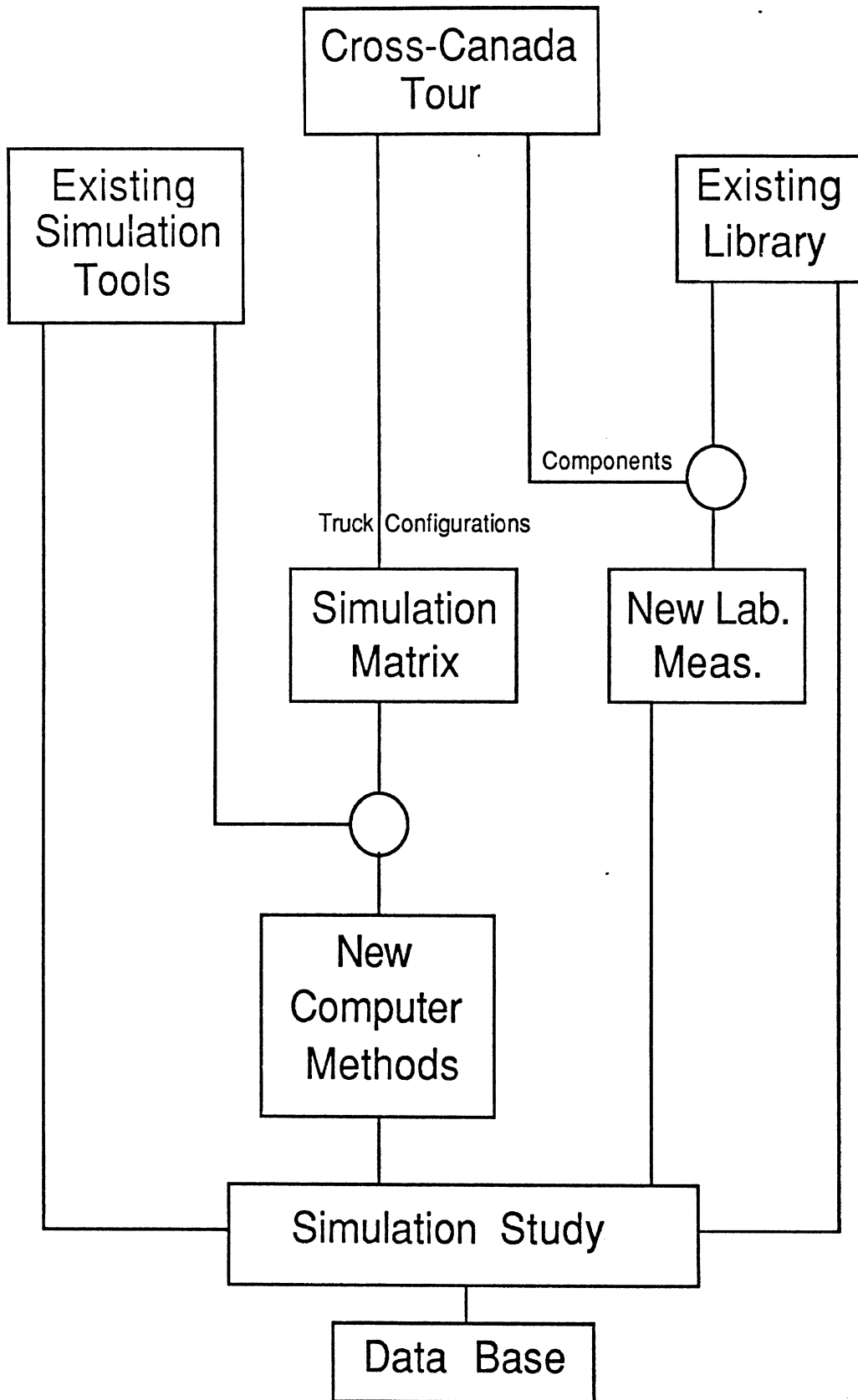

Figure 2.0.a

system for interfacing input data with a group of simulation models as well as pre- and post-processors which were warranted by the large scale of the computational exercise.

Moreover, these tasks enabled completion of the simulation study and the establishment of a computerized "data base" of the resulting measures of vehicle performance from which a versatile interrogation of findings could be conducted. The data base remains as an easily accessible file from which to conduct followup inquiry into the pattern of the study results.

2.1 The Identification of Truck Combinations Commonly Used in Canada

As the starting point in the study of vehicle stability and control, the project director from UMTRI, together with the principal persons from the National Research Council and The Roads and Transportation Association conducted a "cross-Canada tour" to obtain information from the Canadian trucking community on the configuration of truck combinations commonly used in Canada. The tour was necessitated by the desire to focus the study of stability and control on popular truck configurations which are currently in operation or which may be expected in the near future.

Also in order to conduct computerized analyses of the vehicles of interest, specific data were needed to describe the vehicles. Some of these data are simply related to overall dimensions, axle and hitch point locations, and the like. The tour was found to be a very useful and expedient means for establishing many of these dimensions. Other data required to conduct the simulation were obtained through subsequent laboratory measurements on tires, suspensions, steering systems, etc. The tour served to identify which specific components were in common usage in Canada. After comparing these components with those whose mechanical descriptions are already contained within an existing library of data, components meriting direct measurement in this study were selected.

In this section, the results of the information-gathering tour will be discussed. The "tour" exercise involved a methodical interrogation of groups representing the trucking industry which were convened at each of six sites. The cities in which these meetings occurred were Vancouver, Calgary, Winnipeg, Toronto, Montreal, and Moncton. In each meeting, the attending industry representatives were asked to address the vehicle equipment and practices used in over-the-road trucking operations in the immediate province being visited. Also, attendees in Alberta and Manitoba were asked to speak for practices in Saskatchewan, as well, and attendees in New Brunswick were asked to represent the

Maritime Provinces, collectively. The industry representatives came from both the for-hire and private trucking sector, and from vehicle manufacturers. In general, representatives from trucking fleets were those individuals directly responsible for developing vehicle specifications, and perhaps for directing maintenance operations also, within companies engaged in relatively long-haul trucking. The number of representatives present at each meeting ranged from 4 to 12.

In each meeting, a set of transparencies were used to provide a common format for prompting the group in identifying common truck configurations and various details concerning installed hardware. The industry representatives were asked to reach a consensus among themselves in responding to each of the questions. Although they were asked to speak for the entire province or region being represented, it was clear that some of the individuals possessed only limited knowledge of fleet configurations outside of their own operation. Although it is thought that the results of this interrogation process are reasonably representative, it should be recognized that the sample was rather limited.

Discussion of Results

The sequence of subjects covered and the general nature of the responses was as follows:

- 1) The total population of combination vehicles was broken down, by percentage representation, into tractor-semitrailers, A-, B-, and C- type doubles, and triples. Listed in Table 2.1a are the estimates of these percentages which were obtained at each of the six respective meetings.

Table 2.1a
% Distribution of All Combination Trucks in Each Region
Meeting Sites

Vehicle	Vancouver	Calgary	Winnipeg	Toronto	Montreal	Moncton
Tr/Semi	60	80	60	70	90	98
A-Dbls.	32	8	25	25	8	1
B-Dbls.	8	10	14	5	2	1
C-Dbls.	0	<2	<1	<1	<1	0
Triples	0	<1	<1	0	<1	0
Total	100	100	100	100	100	100

When the above data are weighted by the population of the citizenry in the respective regions represented, we find that some 77% of all heavy combination vehicles operating in Canada are tractor-semitrailers, 17% are A-doubles, 5% are B-doubles, and the remaining 1% or so are C-doubles and triples. A geographical illustration of the distribution of the three predominant vehicle types is shown in Figure 2.1.a.

2) Taking each type of combination vehicle, in turn, the distribution of axle configurations within the population of each vehicle type was determined. Among tractor-semitrailer combinations, for example, it was seen that the fractional representation of five-axle units, having a three-axle tractor and tandem semi, ranged from 75% of all tractor-semitrailers in British Columbia and Quebec to 95% in Alberta and Manitoba. Also, it was observed that there are virtually no two-axle tractors in highway trucking service in Canada. Rather, the two-axle tractors which are in service are predominantly employed in city delivery operations. Shown in Tables 2.1.b through 2.1.e are the complete listings of the estimated percentage distributions of the populations of tractor-semitrailers, A-doubles, B-doubles, and triples, according to axle configuration. The figures shown in these tables were all normalized so that a population total of 100% was essentially obtained.

A geographical illustration of the distribution of the various tractor-semitrailer configurations is shown in Figure 2.1.b. Together, Figures 2.1.a and 2.1.b establish that, notwithstanding the great diversity in truck configurations in service across Canada, by far the greatest portion of truck transportation is conducted using the conventional arrangement of a three-axle tractor coupled to a two-axle semitrailer.

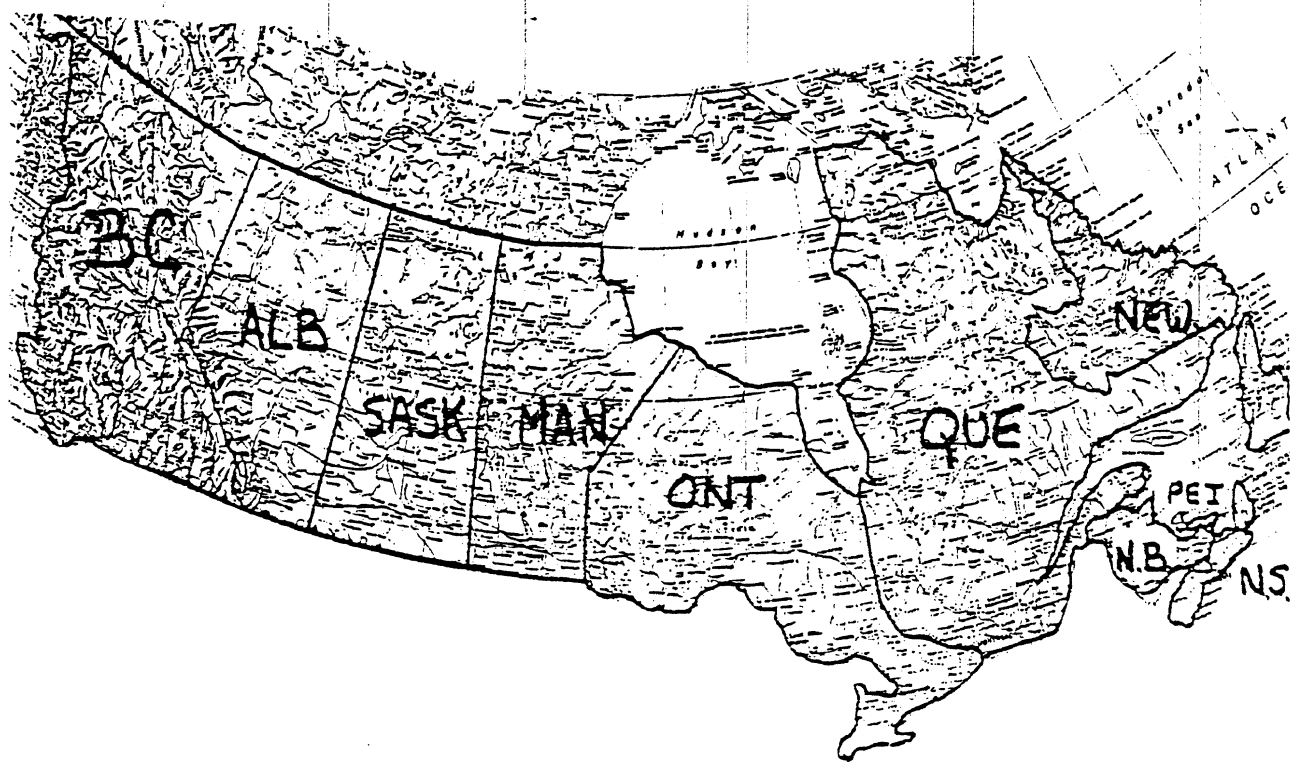
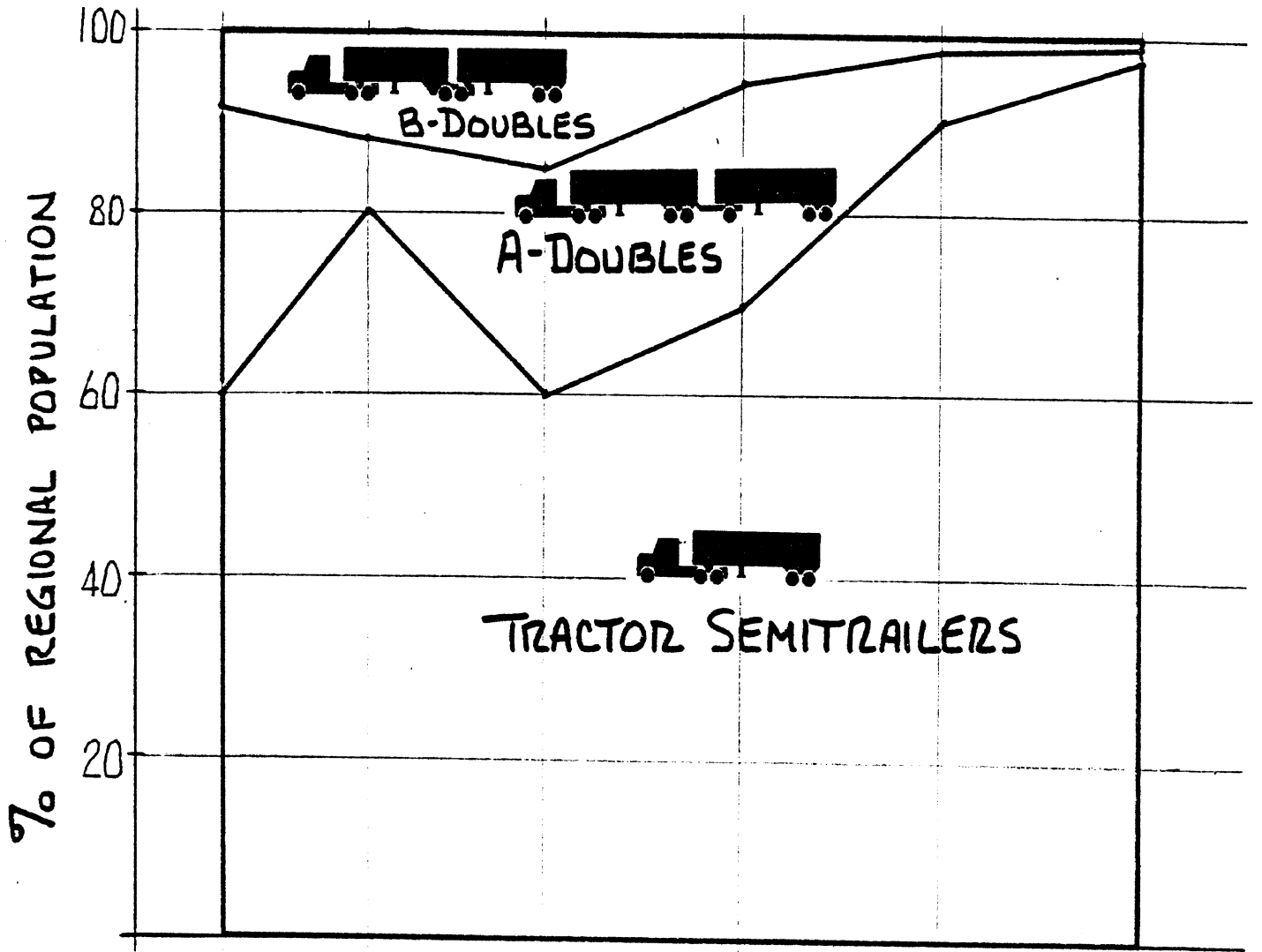

Figure 2.1.a

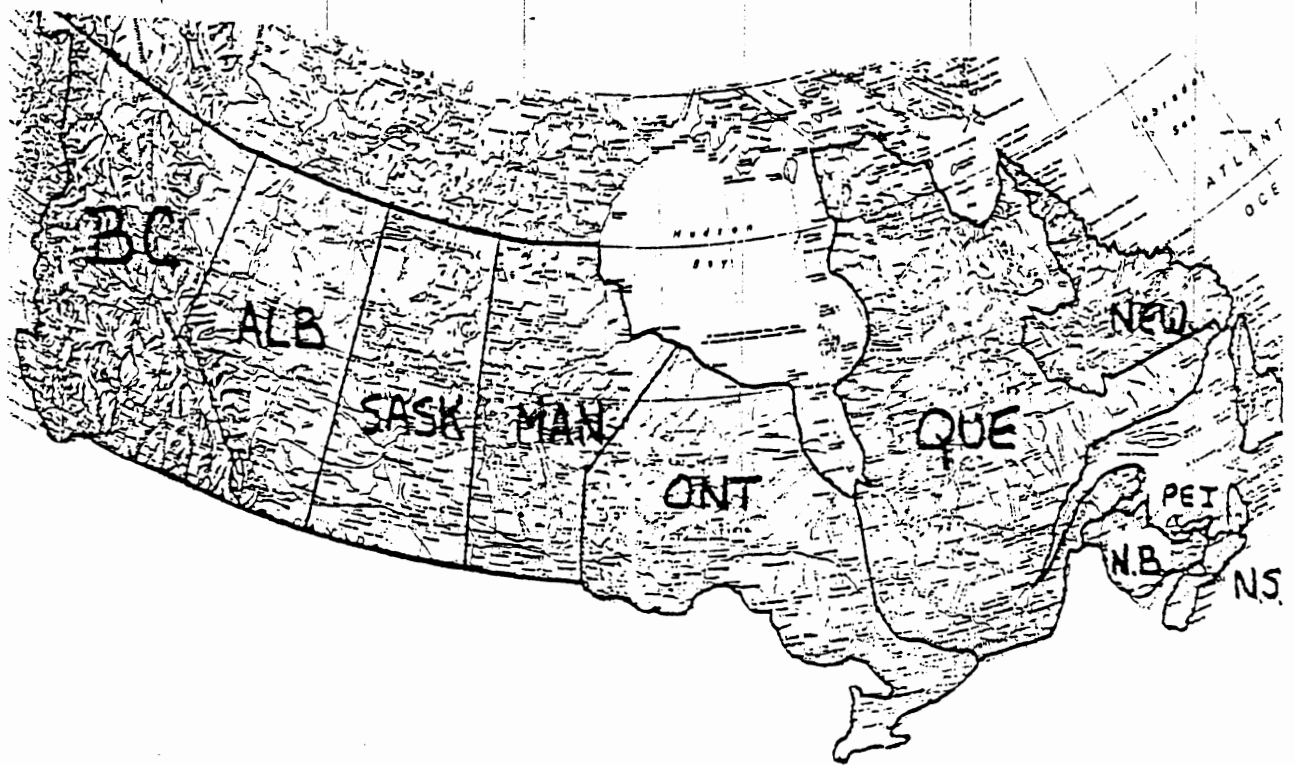
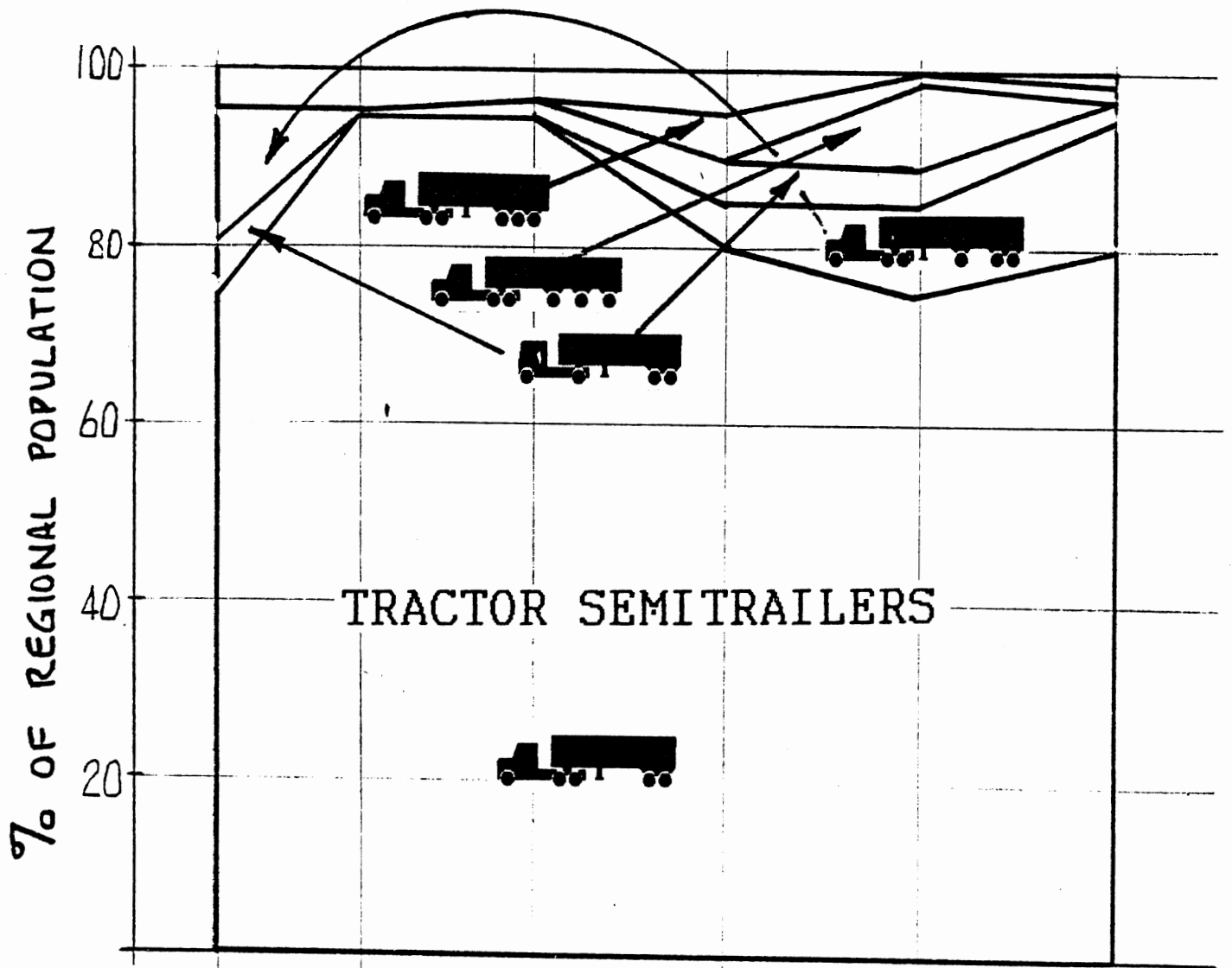

Figure 2.1.b

Figures 2.1.c and 2.1.d provide graphical illustrations of the distributions of A- and B-type doubles combinations identified in the tour exercise.. These illustrations make it clear that multi-trailer combinations are not at all homogeneously distributed across provinces and that a substantial diversity in axle configurations exists.

In general, the data showing the distribution of the populations of each generic vehicle type were useful to the study insofar as they permitted the simulation study to become focused upon the more popular configurations. While the rare vehicle configurations would not be entirely neglected, the effort to represent them would be kept in balance with the need to achieve the essential goals of the study.

3) For those axle configurations which had been identified as commonly operated within the province or region in question, more detailed information was sought pertaining to the following:

- dimensions locating the axles, hitch points, and trailer bed overhang
- axle load allowances, as well as loads commonly achieved in practice
- common selections of suspension types and load ratings

The dimensional information clearly revealed that great distinctions in vehicle configuration are seen across the various provinces, although many of the distinctive vehicle configurations represent rather small numbers. Most of the innovative designs are introduced by carriers hauling bulk commodities at the full gross weight allowance. These configurations invariably reflect (a) the peculiarities of the local regulations regarding the configurations yielding maximum vehicle weight, and (b) the operational preferences of the industry. Moreover, the trucking industry representatives were found to be very knowledgeable on the large number of dimensional details which bear upon the weight and volume of the payload that can be carried.

One dimension which is seen to be changing rapidly within the Canadian trucking community is the overall width across the trailer tires. Although nearly all van trailers purchased in the country in the last ten years or so have employed 102-inch-wide freight boxes, the outfitting of trailers with 102-inch-wide running gear has been very rare except in tanker operations. Since the passage of the Surface Transportation Assistance Act of 1982 in the U.S., however, a dramatic shift toward 102-inch widths in the U.S. has made the wider axles generally available. Accordingly, the Canadian trucking industry now

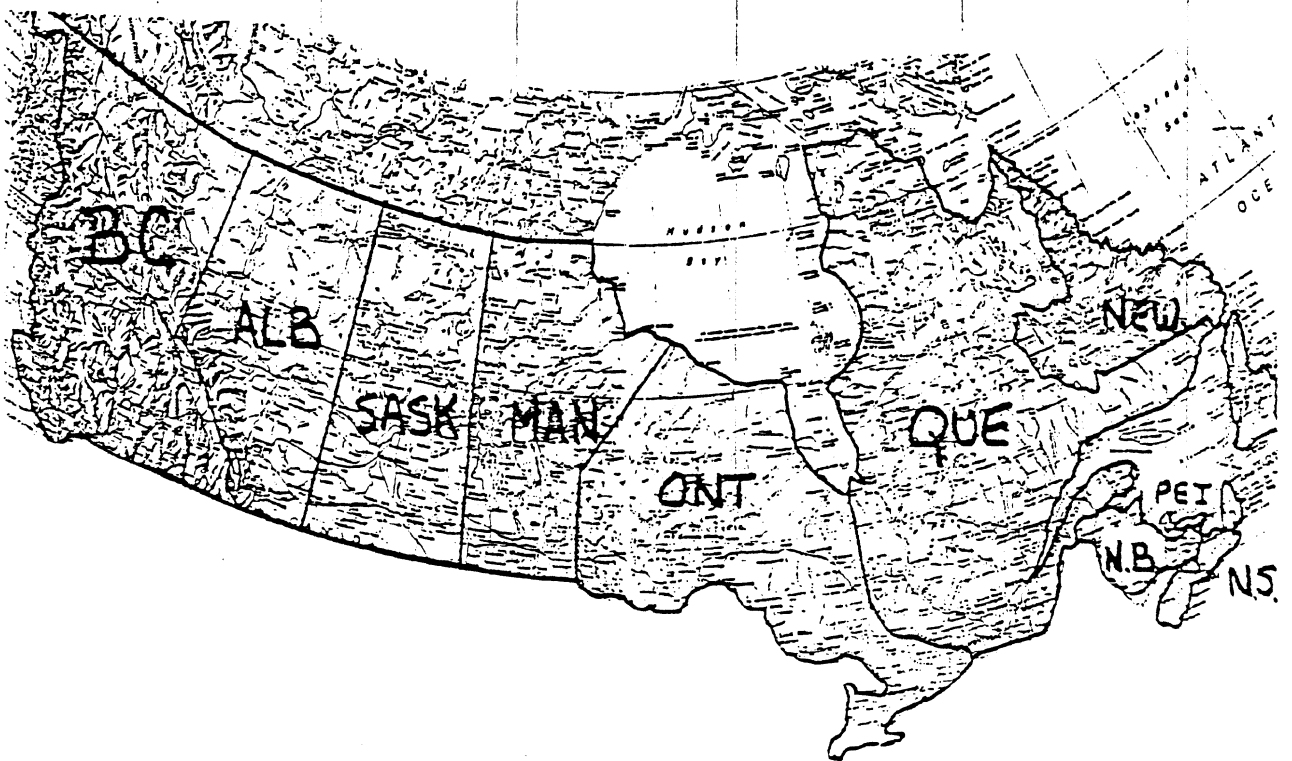
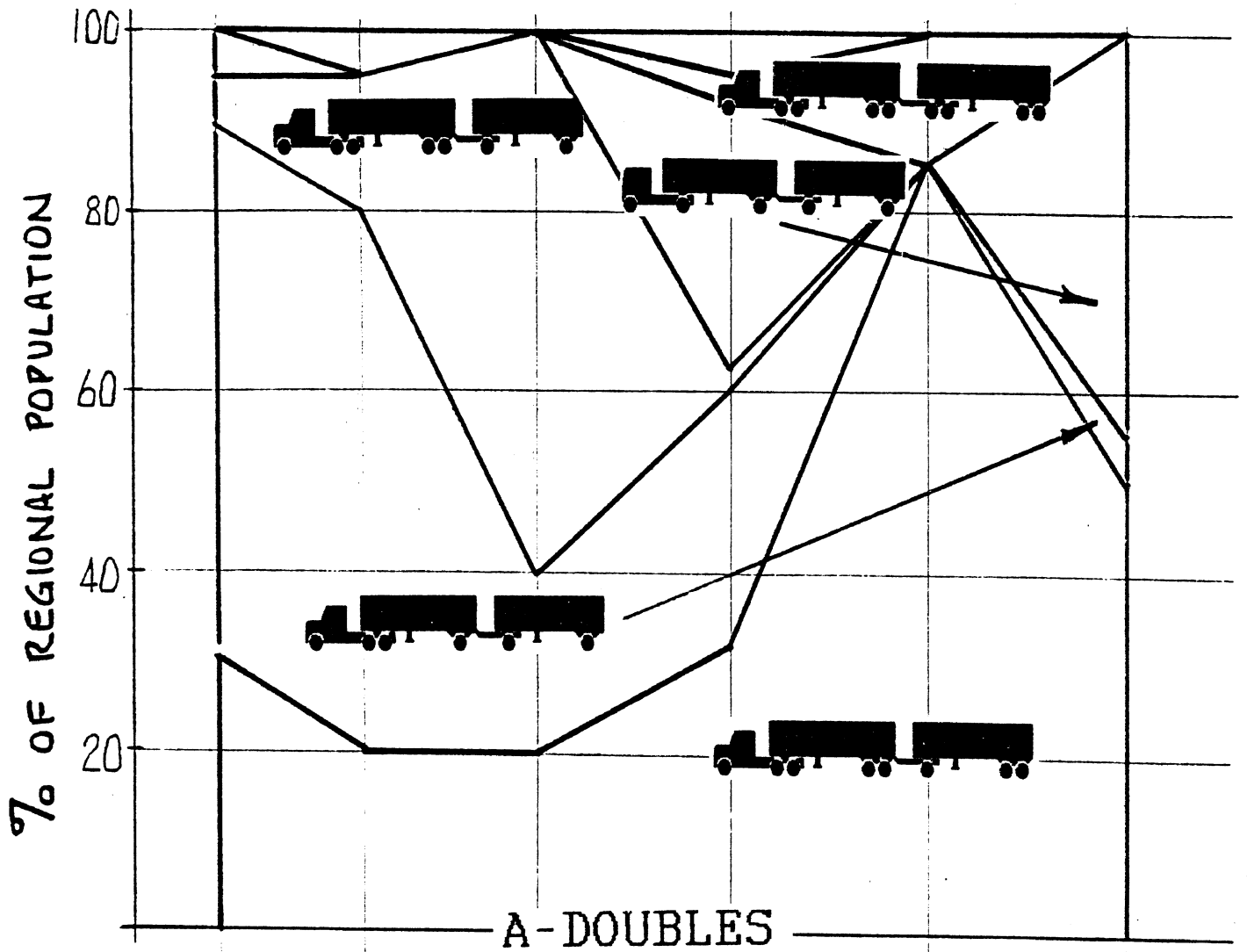

Figure 2.1.c

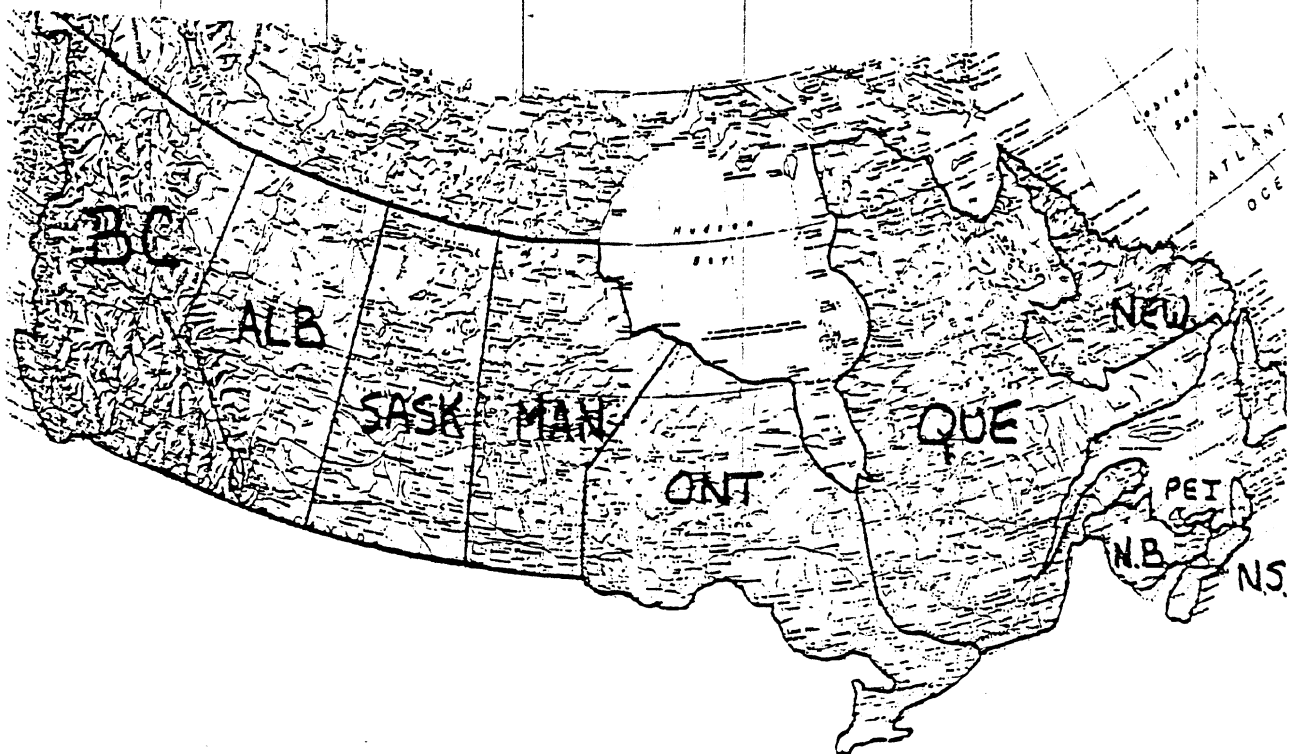
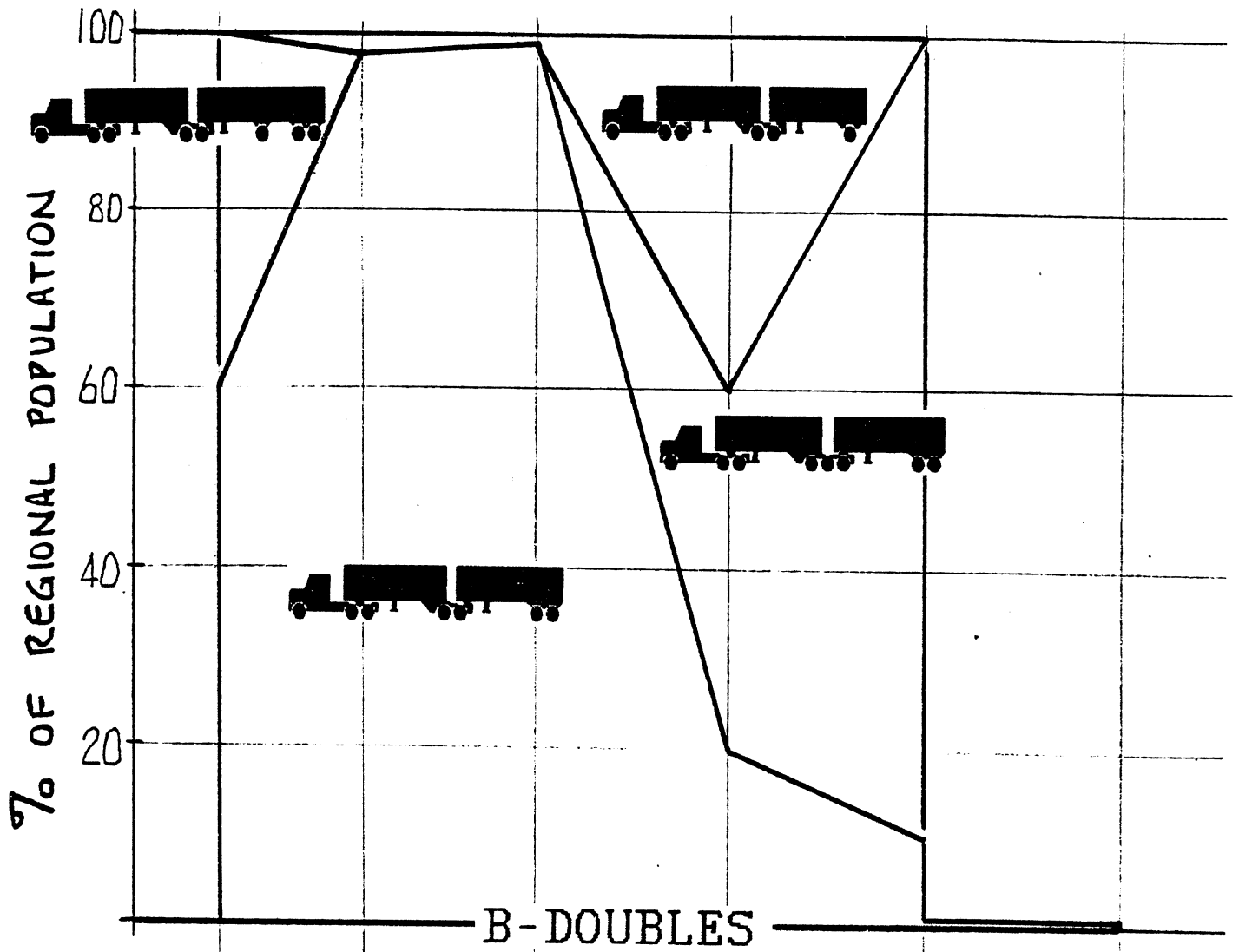

Figure 2.1.d

reports that virtually all new trailers are being purchased with full-width axles to match the traditionally wider freight boxes.

The most significant differences in loading allowances from province to province derive from (a) the practice, in certain provinces, of granting bonuses in tandem load allowance when the axle spread dimension is increased beyond the standard minimum of 1.22 m (48 in), and (b) from the allowance of additional axles in the combination. With regard to configurations having additional axles, the distinctions between provinces derive primarily from issues concerning particular types of suspension hardware. That is, certain provinces allow tri-axle groups and/or lift (belly) axles for supporting greater levels of gross weight, while other provinces do not accept such arrangements. The controversies regarding these items were explained by the interviewees to focus upon the following points:

1) Tri-axles are alleged to provide poor equalization of static loads. The general validity of this allegation has not been assessed in the open literature. Further, the possibility that certain suspension designs may be peculiarly responsible for this poor reputation has not been explored.

2) Air-suspended belly axles permit overloading at the other axle positions when the driver either intentionally or carelessly lifts the axle or mis-adjusts the regulator controlling air pressure to the suspension. In British Columbia, a belly axle is permitted, but the regulation has been written in such a way as to circumvent the problem of intentional lifting of the axle, under loaded conditions. The B.C. regulation stipulates that the axle incorporate passive caster-steering (thus obviating the need to lift the axle for negotiating tight turns) and that all controls for the axle are back on the trailer, rather than being accessible to the driver.

One general observation was that the suspensions found to be in use across Canada were remarkably uniform. The leaf-supported walking-beam suspension (e.g., Hendrickson RTE 380 or 440) was by far the most popular tractor suspension and the four-spring tandem (e.g., Reyco 21-B) was the most popular trailer suspension. Air- and rubber-sprung suspensions were also cited as being popular in certain applications.

The aspect of these observations that is in such contrast to U.S. vehicles involves the tractor drive-axle suspension. UMTRI staff estimated that walking-beam suspensions are installed on less than 5% of the highway tractors in the U.S. while, in Canada, the corresponding percentage appears to be at least 80%. Since the walking beam is generally

recognized as representing a more rugged (and, also, heavier) package than other types of tractor drive-axle suspensions, it may be that (a) the Canadian trucking environment calls for more durable running gear or (b) the more liberal load allowances in Canada permit economical operation with higher tare weight, given that somewhat lower maintenance costs may result from the more durable hardware.

The industry responses to this broad set of questions on hardware and dimensional data has been summarized in tabular form in Appendix A. The information is organized by the six regions of the country which were sampled, giving as complete an interpretation of the actual responses as possible. The data do reflect certain anomalous differences in the nature of the responses which were received at each of the six meetings. For example, one party may have responded to a question on the dimension of a trailer kingpin setting or axle location by citing a range of values where other respondents stated a single typical value. Likewise, some groups cited a variety of common suspension types used in a certain kind of service while another group may have only indicated the one dominant model which is seen most often. Thus, while the data suffers to some degree from variations in format, the overall picture is highly informative and serves reasonably well to define the vehicle population for the purpose of analyzing dynamic performance.

4) Some tractor equipment items of special interest from a vehicle performance point of view were also identified. The extent of power steering usage, as well as front brakes, automatic slack adjusters, and retarders were assessed. Additional questions pertained to tires, B-dollies, and compensating fifth wheels. Generalizations of interest from these data are the following:

- Estimates of the percentage of tractors equipped with power steering systems ranged from 85 to 100% across the six regions. (It is thought that there is a much lower rate of usage of power steering systems in U.S. trucks.)
- The usage of front brakes on tractors ranged from a level of 0% in British Columbia and Alberta (recognizing that trucking fleets operating through mountainous areas in North America have had a tradition of rejecting front brakes) to 50% in Quebec and 25% in New Brunswick.
- The usage of engine retarders for auxiliary braking ranged from 100% in British Columbia, to an unspecified minority in Manitoba and Ontario, and 50% in the Maritimes. Although the percentage of vehicles equipped with retarders varies a great deal from west to east across Canada, it is interesting that the reported

figures are much larger than in U.S. practice. A recent formal study of retarder application in the U.S. showed 40 to 70% usage in the western states, 5 to 15% in the eastern mountain states, and less than 5% through the midwest and south [1].

- The switch from bias-ply to radial tires on heavy trucks is occurring rapidly in Canada at this particular time. The 1984 estimate of the percentage of vehicles running on all-radial tires ranged from 50% to 90%, with four of the six groups of industry representatives estimating 100% radial usage by 1990.
- The usage of low-profile radial tires was just beginning, mostly on an experimental basis, in Canada. Most groups projected a substantial growth in the future use of low-profile radials, given the early performance results obtained with such designs.
- Usage of the B-dolly seems to be confined, almost exclusively, to the prairie provinces. Virtually no B-dollies exist east of Ontario or in British Columbia. The B-dolly has seen minimal application in Ontario, although, the so-called "goodbye dolly" (effectively a B-train-type configuration) is growing in popularity. In Saskatchewan, the B-Dolly is notable as a requirement for the operation of triples under special permit. Nevertheless, the interest in B-dollies was seen to be relatively small over the trucking community at large.
- B-trains which are configured as liquid and dry bulk tank vehicles invariably employ the so-called "compensating" fifth wheel as the element which couples the two trailers to one another. This fifth-wheel device permits a limited amount of roll freedom between the two trailers so that unevenness in the road can be accommodated without the trailers imposing torsional loads upon one another.

2.2 Parametric Data

This section lists all the vehicle component types and models that were subjected to direct parametric measurement as part of this study. The listing below is followed by a summary of vehicle specifications by major components, as used in the simulation task. Schemes devised for specifying the initial (or "reference," that is, without parametric variation) geometric and inertial parameters of empty and loaded sprung masses are mentioned, as well as those devised for subsequent parametric variations. A detailed compilation of all relevant vehicle and component parameters is provided in Appendix B.

2.2.1 Direct Parametric Measurements. The following tire, suspension, and self-steering axle types and models have been identified through the work described in Section 2.1 as widely specified in Canadian trucking practice, and thus were subjected to extensive laboratory measurements:

Tires (cornering property measurements on UMTRI's low-speed flat-bed):

Michelin XZA 11R22.5/G - Full tread, 50% tread depth, 30% tread depth
Michelin Pilote 11/80R22.5/G - Full tread

Tires (longitudinal traction measurements on UMTRI's mobile tire dynamometer):

Michelin XZA 11R22.5/G - Full tread, low- & high-friction wet pavement

Suspensions (full parametric measurements on UMTRI's suspension test facility):

Hendrickson RTE 380 - Tractor tandem walking-beam suspension, 38k rating
Hendrickson RTE 440 - Tractor tandem walking-beam suspension, 44k rating
Mack Camel-Back SS 38 C - Tractor tandem walking-beam suspension, 38k rating
Neway ARD 244 - Tractor tandem 4-spring air suspension, 44k rating
Neway AR 95-17 - Trailer single-axle air suspension, 25k rating

Self-Steering Axles (full parametric measurements on UMTRI's suspension test facility):

CESCHI - Air-centering, automotive-type, self-steering axle
KGI - Air-centering, automotive-type, self-steering axle

2.2.2 Vehicle Specifications. Following is a summary of the major properties of the vehicle units which were most extensively featured in the simulation task:

A) Tractor - The baseline power-unit used in most of the simulated cases is a "conventional" 3-axle 6x4 tractor equipped with a conventional fifth wheel providing for semitrailer motion which is fully coupled in roll and fully uncoupled in pitch and yaw to that of the tractor. The fifth wheel longitudinal location is adjusted to satisfy specified axle loads in various cases, a typical intermediate position being approximately 0.38 m (15 in)

ahead of the rear suspension centerline. The tractor specification is summarized in the following table:

<u>Parameter</u>	<u>Metric units</u>	<u>English units</u>
Wheelbase (defined to tandem-centerline) -	4.83 m	190.0 in.
Tandem-axle spread -	1.52 m	60.0 in.
Width across outside of tires -	2.44 m	96.0 in.
Curb weight -	8156.0 Kg	18000.0 lb.
Sprung weight -	5352.5 Kg	11800.0 lb.
Frame torsional stiffness about roll axis -	7000000.0 N-m/deg	40000.0 in-lb/deg
Front suspension - Navistar (IH) COF 9670 (multiple tapered-leaf steel-spring)		
Load rating -	5.5 Tonnes	12000.0 lb.
Unsprung weight -	544.0 Kg	1200.0 lb.
Rear suspension - Hendrickson RTE 440 (multi-leaf spring+ walking-beam tandem)		
Load rating -	20.0 Tonnes	44000.0 lb.
Unsprung weight/axle -	1134.0 Kg	2500.0 lb.
Tires (baseline) - Michelin XZA 11R22.5/G (radial-ply, G load rating, full tread)		
Front tires (high-load cases) - Michelin Pilote 11/80R22.5/G (low-profile; as above)		
Inflation pressure (all cases) -	689.5 kPa	100.0 psi

B) "Long" Semitrailer - This is the "standardized" semitrailer unit in the baseline tractor-semi-trailer, turnpike-doubles and Rocky-Mountain-doubles (front semi-trailer) configurations. The unit is a conventional van-type tandem-axle semi-trailer, with its specification generally derived from data for a typical Fruehauf model. The semi-trailer's torsional compliance about the roll axis is neglected, as considered appropriate for a stiff van body. The unit's major characteristics are listed in the following table:

<u>Parameter</u>	<u>Metric units</u>	<u>English units</u>
Overall length -	14.63 m	48.0 ft.
Tandem-axle spread -	1.22 m	48.0 in.
Kingpin setback -	0.91 m	36.0 in.
Rear overhang (from trailing axle) -	0.76 m	30.0 in.
Freight floor height -	1.37 m	54.0 in.
Width across outside of tires (and overall) -	2.59 m	102.0 in.
Empty weight -	6260.0 Kg	13800.0 lb.
Sprung weight -	4900.0 Kg	10800.0 lb.
Suspension -	Reyco 21-B	
	(multiple-leaf 4-spring tandem)	
	Load rating -	20.0 Tonnes 44000.0 lb.
	Unsprung weight/axle -	680.0 Kg 1500.0 lb.
Tires -	Michelin XZA 11R22.5/G	
	(radial-ply, G load rating, full tread)	
	Inflation pressure -	689.5 kPa 100.0 psi

C) "Short" Semitrailer (single and tandem-axle) - These semi-trailers are encountered in conventional doubles and triples, and, in the single-axle form, at the rear of Rocky-Mountain-doubles combinations. Their data is estimated or derived based on

similar Fruehauf units tested by UMTRI. Both single- and tandem-axle versions share essentially the same 8.23 m (27 ft) van length and kingpin setback of 0.61 m (24 in). Empty sprung weights are 2,270 Kg (5,000 lb) and 2,495 Kg (5,500 lb), respectively. All other dimensions and data are the same as in B), except that the single-axle semitrailer has a two-spring version of the same suspension, and "axle-spread" is naturally inapplicable for it.

For less popular or "standardized" units, such as B-train semitrailers, and for a comprehensive description of all initial ("reference") vehicle parameters, please refer to Appendix B.

2.2.3 Conventions for Tare-Vehicle Parameters. Appendix B.2 contains a detailed description of conventions adopted in setting and varying the various geometric and inertial properties of the empty sprung masses for all the unit types and variations encountered in the study. Basically, these conventions identify typical baseline vehicle properties based on data measured by UMTRI and/or supplied by authoritative sources (manufacturers and operators), as well as the formulae devised for their consistent interpolation or extrapolation to cover the whole range of vehicle parametric variations studied.

2.2.4 Conventions for Vehicle-Loading Parameters. The basic scheme for specifying vehicle loading involved first selecting the appropriate axle loads according to Canadian loading practices, bridge formulae and/or GCW restrictions as identified in the task reported in Section 2.1. From these values and the established data for the tare vehicle, the payload weight/s and longitudinal c.g. location/s are computed. Then, a protocol was adopted in which a homogeneous freight having a density of 0.545 tonnes/cu. m (34 lb/cu ft) was assumed to be uniformly placed in the trailer to achieve the computed payload weight. (This freight density, albeit arbitrary, has been selected in a previous size and weight study [2] as being reasonably representative of medium-density commodities.) Knowing the floor area of the trailer, the height of the freight stack above the 1.37 m (54 in) floor height is then determined, thus locating the c.g. height of the payload. In general, this "reference" loading protocol places the payload c.g. around 2.03 m (80 in) above the ground, except for certain multi-axle load-restricted cases resulting from GCW or bridge-formula regulations. Having assumed the payload to uniformly fill a rectangular box whose base is the van's full floor area, and whose height equals twice the payload's relative c.g. height above this floor, the payload moments of inertia about the box's three principal axes are then calculated. When axle locations are later varied as independent

parameters relative to the cargo bed, the originally computed payload data are kept fixed, and new axle loads are calculated. In the specific "high c.g." variations, which specify a payload c.g. height of 2.67 m (105 in) above ground, the payload weight remains as derived previously from the axle loads, but a lower uniform freight density and new moments of inertia are calculated to account for the "taller" payload box. In the actual study, most of these calculations are performed automatically by the UMTRI pre-processing program outlined in Section 2.3.5.

2.3 Simulation Task

This section outlines the total scope of the simulation task performed in this study. This is done by defining and describing all the vehicle configurations and parametric variations addressed, the dynamic maneuvers simulated and the respective performance measures derived, the total resultant simulation matrix covered, and the various computer-based models employed.

2.3.1 Vehicle Configurations. Four basic categories of vehicle configuration have been identified for study, namely, tractor-semitrailers, A- and C-train doubles, B-train doubles, and A- and C-train triples. In each of these categories, a baseline configuration is defined, incorporating a specific number and arrangement of axles and trailers. Several additional configurations, distinguished by their different number and/or arrangement of axles, and, for A- and C-train doubles, also by different relative trailer lengths, were also defined. Shown in Figures 2.3.1.a through 2.3.1.d are illustrations of the baseline plus all the additional axle/trailer configurations of the vehicles studied in each category. Thus, for example, the tractor-semitrailer category was examined in the form of a baseline five-axle configuration, plus three additional configurations in which the semitrailer is outfitted with differing three- and four-axle arrangements. The tridem axle arrangement, for example, is a close-spaced, fully equalized string of axles, while the "three-axle semi" involves three wide-spread axles. The "belly-axle semi" incorporates a close tandem at the rear plus an especially widely spread belly axle. The corresponding configurations shown for doubles and triples in Figures 2.3.1.b, 2.3.1.c and 2.3.1.d illustrate nominal axle positions as well as pictorial reference to the relative length of trailers. In each vehicle category, the baseline configuration is shown in the box at the top, and the additional configurations are shown below.

Per the original plan for the project, the so-called "baseline" configurations were to represent the most popular versions of the respective vehicle types. The general approach,

Category 1. TRACTOR/SEMITRAILER

Configurations:

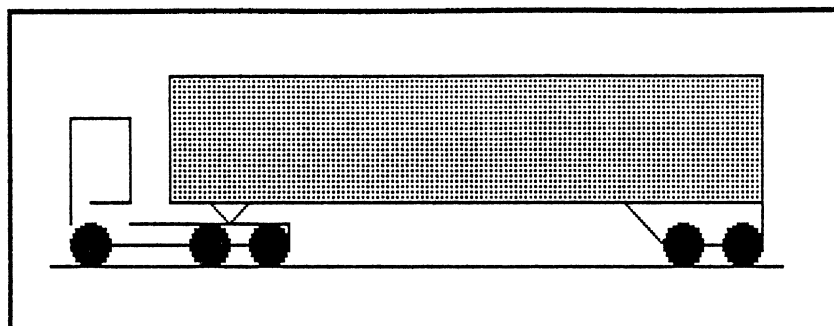

1.1

Baseline Semi

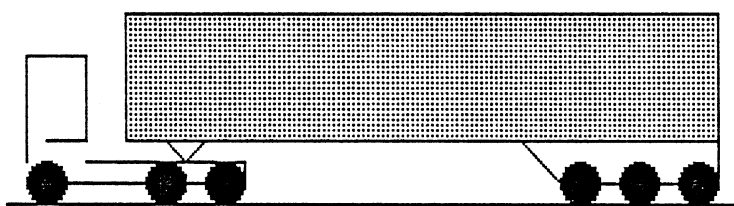

1.2

Tridem Semi

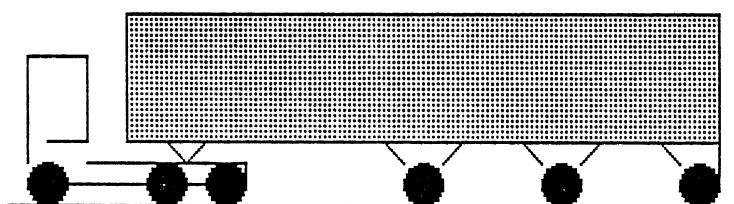

1.3

3-Axle Semi

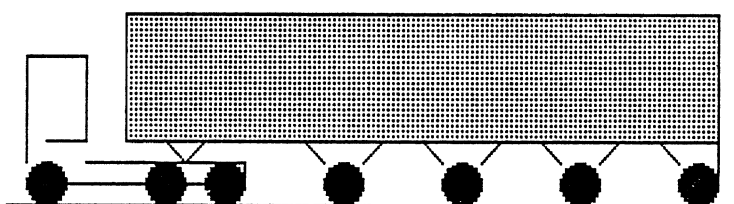

1.4

4-Axle Semi

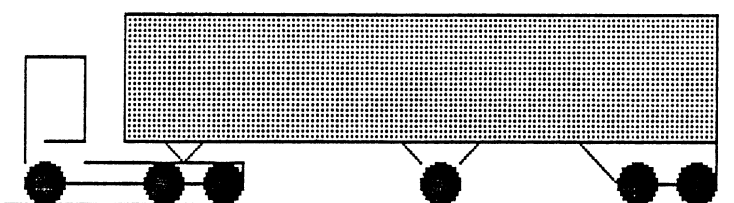

1.5

Belly-Axle Semi

Figure 2.3.1.a

Category 2. A & C-TRAIN DOUBLES

Configurations:

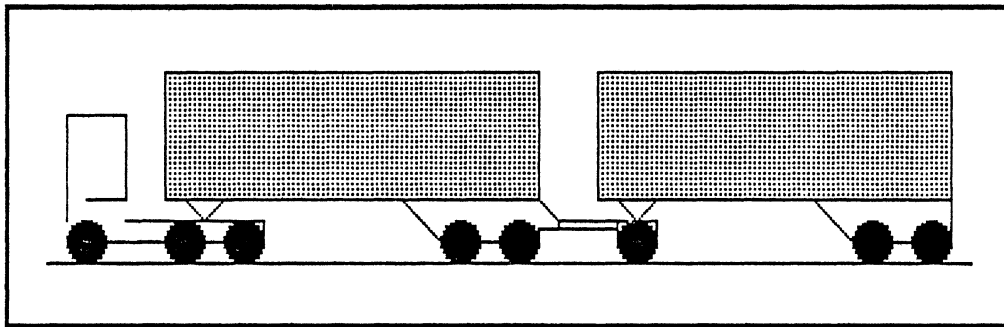

2.1
Baseline
Doubles

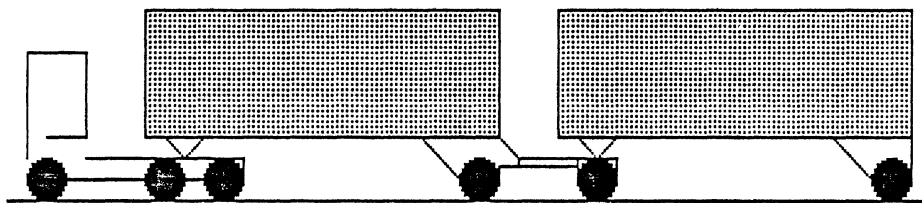

2.2
Single-Axle
Doubles

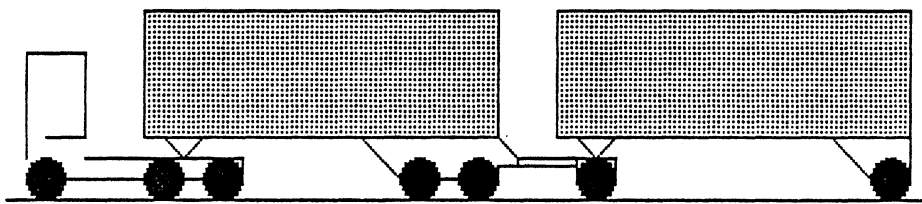

2.3
Mixed (7-Axle)
Doubles

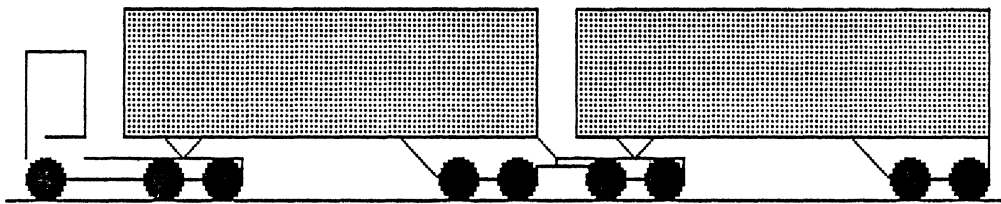

2.4
Turnpike
Doubles

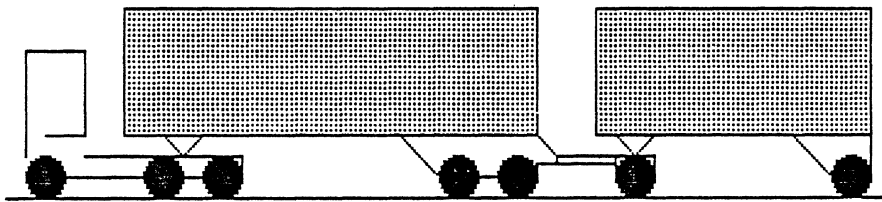

2.5
Rocky-Mountain
Doubles

Figure 2.3.1.b

Category 3. B-TRAIN DOUBLES

Configurations:

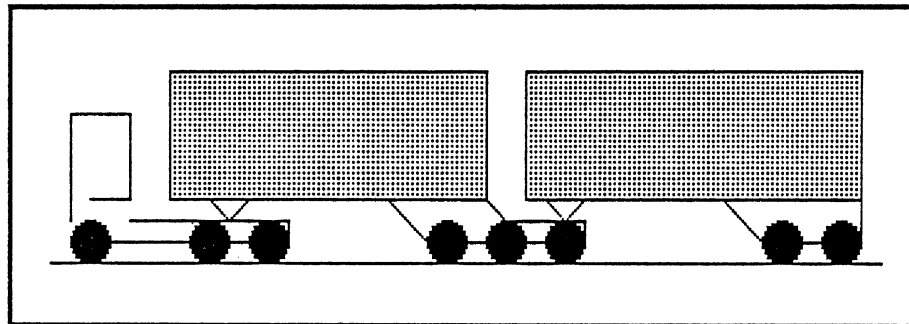

3.1
Baseline
B-Train

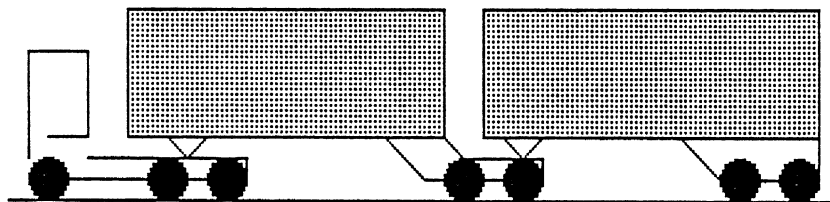

3.2
Tandem
Front Semi

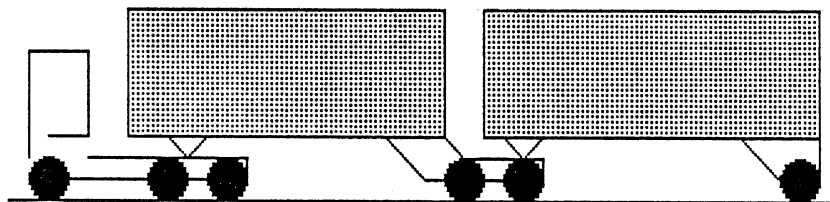

3.3
Single-Axle
Rear Semi

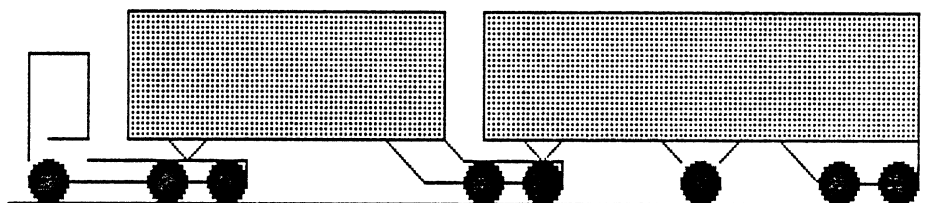

3.4
Belly-Axle
B-Train

Figure 2.3.1.c

Category 4. A & C-TRAIN TRIPLES

Configuration 4.1 Baseline Triples

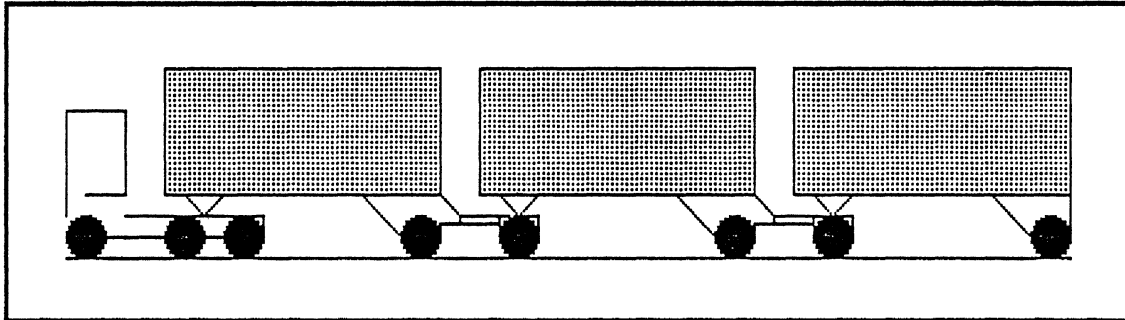

Configuration 4.2 Tandem-Axle-Semi Triples

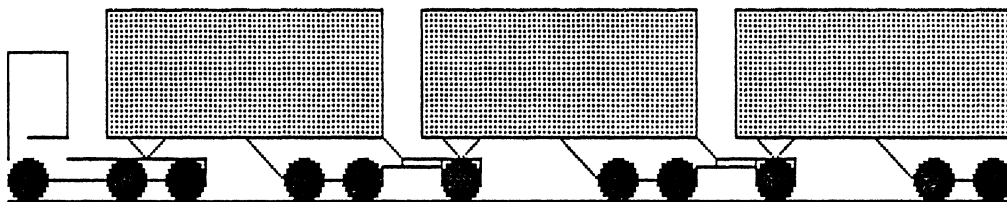
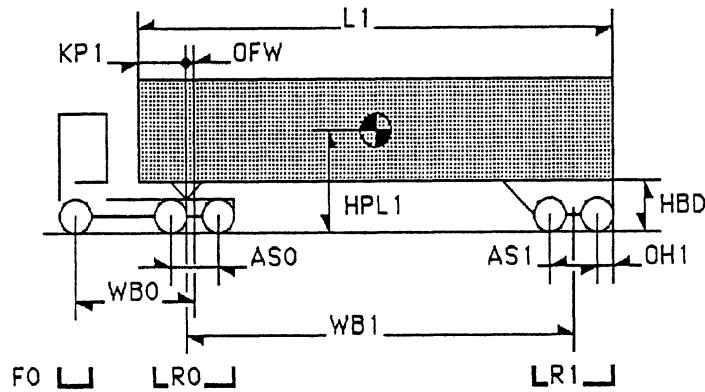

Figure 2.3.1.d

Category 1. TRACTOR/SEMITRAILER

Configuration 1.1 - Baseline Semi



<u>Weights:</u>	Tonnes	(k-lbs)	<u>Axle Loads:</u>	Tonnes	(k-lbs)
Tractor Tare	8.2	(18.0)	F0	5.5	(12.1)
Trailer Tare	6.3	(13.9)	R0	17.0	(37.5)
Payload	25.0	(55.1)	R1	17.0	(37.5)
GCW	39.5	(87.1)			

<u>Tractor Dimensions:</u>		meters	(inches)
WB0	Wheelbase	4.83	(190)
AS0	Tandem Spread	1.52	(60)
OFW	Fifth Wheel Offset	~0.41	(~15)

<u>Trailer Dimensions:</u>		meters	(inches)
WB1	Wheelbase	12.34	(486)
AS1	Tandem Spread	1.22	(48)
KP1	Kingpin Setback	0.91	(36)
L1	Bed/Van Length	14.63	(576)
OH1	Rear Overhang	0.76	(30)
HPL1	Payload C.G. Height	~2.00	(~79)
HBD	Bed Floor Height	1.37	(54)

Tires: Michelin XZA 11.00R22.5-G, full tread depth, @ 689.5 kPa (100 psi).

Figure 2.3.1.e

then, was to "invest" the largest extent of the parametric investigation in the baseline case on the rationale that findings derived for such cases would be most generally useful to evaluating vehicles in most common use. The additional configurations in each vehicle category were then to be examined only for those supplemental variations in parameters as were warranted by the peculiar character of the axle and trailer layout. Further, even the choice of the additional axle/trailer configurations was limited by considerations of project scope so that the vehicles more likely to be used in cross-Canada transportation would be included. The detailed discussion of the parameters which represent each configuration and the variations employed is presented in Appendix B.

For each baseline and additional axle configuration, a "reference" vehicle is defined which establishes the basic description of the vehicle in that configuration. Subsequent variations in parameters, then, are generally conducted one-at-a-time relative to the "reference" vehicle description. As is noted in Section 2.3.3, however, there are cases in which two or more parameters are being varied together on the basis of a particular rationale. For example, the tandem-spread dimension is varied in some cases, in concert with tandem load changes, in order to represent the likely regulatory scenario which ties the two together.

Shown in Figure 2.3.1.e is an example set of parameter data covering the weights and dimensions of the "reference" vehicle for the baseline axle configuration of tractor-semitrailer. The diagram of the vehicle defines each of the parametric variables whose numerical values are listed. In constructing the loading data shown on this and subsequent parameter lists, the reference axle loads were set to approach the maximum values allowed in the majority of the provinces which were found to use the vehicle configuration in question. Given those axle loads and knowledge of typical tare weights for power units and trailers, the payload weight was determined. The payload longitudinal and vertical c.g. locations and its moments of inertia were then computed according to the scheme outlined in Section 2.2.4.

Tractor dimensions are kept constant throughout all of the "reference" vehicles defined for study, except that the fifth-wheel offset is adjusted to satisfy the axle load distribution for each case. Further, the "reference" vehicles in every case incorporate a typical 5.5-tonne (12,000-lb) steering axle suspension and a Hendrickson RTE-44 tandem suspension on the tractor, with Reyco 21-B suspensions on all trailer positions (except for air-supported belly axles). Each vehicle is also represented with Michelin XZA 11R22.5/G tires in the "reference" configuration.

2.3.2 Performance Measures. The eight performance measures are defined in the text below, and their derivation algorithms are described in detail in Appendix C.

a(1) The Static Rollover Threshold is defined as the maximum level of lateral acceleration, in units of g's of lateral acceleration, beyond which the vehicle will suffer rollover in a steady turn. The measure is obtained by means of a quasi-steady turn condition using the UMTRI Yaw/Roll model (described in Section 2.3.4). The "quasi-steady" nature of the turn derives from the fact that a steadily increasing steer angle is input at the tractor--up to the point of rollover. This slow ramp-type input of steering results in a mild quasi-spiral path trajectory and provides for a maneuver which is essentially free of transient disturbances but also permits scanning the entire lateral acceleration range in a single computer run. The ramp-steer input rate is 2.0 degrees of steering wheel angle per second (about 0.04 degrees of front-wheel steer angle per second, when steering system compliance is included). The maneuver is conducted at a steady speed of 100 km/hr (63 mph).

a(2) The Steady-State Yaw Stability of a tractor unit was defined in terms of the value of the understeer coefficient, in units of radians per g, calculated at an arbitrary quasi-steady-state lateral acceleration of 0.25 g's. This is done, in effect, by calculating the inverse of the local slope of the handling diagram curve at the point where it crosses 0.25 g's, as obtained from the time history of the ramp-steer maneuver described above. In addition, the level of lateral acceleration above which the vehicle is directionally unstable at a forward speed of 100 km/hr (63 mph) is searched for by way of a continuous comparison of the local slope value with that of an initially calculated "critical slope" for the given vehicle. As lateral acceleration level increases, with the forward speed held constant, a vehicle may become increasingly oversteer until it arrives at such an oversteer level that 100 km/hr (63 mph) constitutes the critical speed, and then the local slope of the handling diagram equals the calculated critical slope. If this condition is achieved distinctly prior to reaching the rollover limit and not in conjunction with it, a second yaw stability performance measure (lateral acceleration in g's at yaw divergence) is produced in addition to the previous measure of the understeer coefficient at 0.25 g's. If the vehicle is sufficiently yaw stable that a divergency is not encountered prior to rollover, the second yaw stability measure is moot and the "null finding" indicates that the vehicle is effectively yaw stable up to its rollover threshold.

a(3) A High-Speed Offtracking measure has been defined as the extent of outboard offtracking of the last axle of the combination at an arbitrary value of 0.2 g's of lateral

acceleration. This measure is obtained in the initial, constant-radius part of the maneuver which later leads into the ramp-steer turn described above. That is, with the vehicle travelling at 100 km/hr (63 mph), it is controlled by the closed-loop driver model to track a circular path of 393 m (1290-ft) radius, corresponding to a lateral acceleration of 0.2 g's. After the lateral acceleration level of both first and last units stabilizes to within a small tolerance of 0.2 g's, the lateral distance between the trajectories of the tractor steering axle and the last axle in the combination is averaged along the path. The 0.2-g value was selected as a reasonably high, practicable level which can be reliably achieved and steadily maintained in the simulation without possible interference in the methodology due to overly oscillatory behavior or actual rollover of the most roll-unstable configuration to be simulated.

b] The Transient Response to Rapid Steering Reversals is evaluated by means of a sequence of simulated obstacle-avoidance maneuvers which are intended to examine the rearward amplification problem and its net implications for A-, B-, and C-trains. The maneuver involves an obstacle-avoidance path which is laid out in X/Y coordinates and which is "followed" through the operation of a simulated closed-loop "driver." The driver model is such that the tractor front axle tracks along the path with quite good fidelity. The path is designed to introduce a single sine wave of lateral acceleration response at the tractor mass center, with a fixed amplitude of 0.15 g's. Three differing paths are used so that this lateral acceleration peak is attained at sine wave periods of 2.0, 2.5, and 3.0 seconds. This crude "sweep" of frequencies is selected to cover the range in which the rearward amplification phenomenon is known to resonate without exceeding the apparent bounds of the ergonomic capability of drivers [3,4]. A sweep of frequencies was preferred to the selection of a fixed value so that the widely differing vehicle combinations used in Canada could be addressed without the arbitrary discrimination which would come from resonance matching with one vehicle and not another.

In each of these maneuvers, two distinct performance attributes are examined in roll and yaw response, namely, b(1) the relative level of dynamic rollover stability, and b(2) the relative level of transient high-speed offtracking (or tracking "overshoot"):

b(1) The Dynamic Rollover Stability is evaluated by monitoring the instantaneous proximity to rollover of each independently-rolling portion of the vehicle. Each "independently rolling" unit, hereafter referred to as a "unit" of the vehicle, involves simply a portion of a vehicle combination which is free to roll over independently of any other

portion. Two performance measures, one "primary" and one "supplemental," have been defined for characterizing dynamic rollover stability.

The primary measure was termed the "Load Transfer Ratio" (LTR) and serves to evaluate the dynamic load transfer from all of the tires on one side of a rolling unit to the tires on the other side. This measure ratios the absolute value of the difference in total right/left loads to their sum. Referring to Figure 2.3.2.a, this measure is expressed as:

$$\text{LTR} = | \Sigma (F_L - F_R) | / \Sigma (F_L + F_R)$$
, where Σ indicates summation over all of the unit's axles except the tractor steering axle.

This measure will have a value of zero when the unit is at rest and will rise to a value of 1.0 when a full transfer of load from one side to the other occurs, indicating liftoff of all tires on one side. Note, however, that the tractor steering axle is omitted in the computation of this measure due to the low stiffness suspensions typically employed and thus the inconsequential influence of load transfer at that axle position. Short of liftoff, the Load Transfer Ratio measure serves as a continuous analog indicator of the proximity to total wheel liftoff and can thus be used to distinguish between differing vehicles which were subjected to the same maneuvering demands.

For B-trains and C-trains, computation of the measure involves the summation of wheel loads on left and right side at all axles of the vehicle (except for the tractor's front axle), since the only kind of rollover which is possible is total vehicle rollover. Thus, for such "roll-coupled" combination vehicles, the Load Transfer Ratio measure addresses the fact that rollover in response to dynamic steering is determined by the "vector sum of roll moments" along the overall vehicle. Recognizing that the respective elements of a roll-coupled train actually "help to hold one another upright" in a rapid steering maneuver, the Load Transfer Ratio measure is designed to characterize the net effect of these mechanics for the overall vehicle train.

For A-trains, the clear hazard is the independent rollover of a separate unit (usually the last trailer) in the combination. With these vehicles, a separate Load Transfer Ratio is thus continuously computed for each independently-rolling unit.

Further, since the severity of the selected maneuver is such that some rear trailers on A-trains suffer wheel liftoff, a supplemental rollover stability measure termed the "Roll Margin" (RM) was defined in order to quantify, in cases of total liftoff only, how close the unit came to actually rolling over. The Roll-Margin measure is defined in essence as the

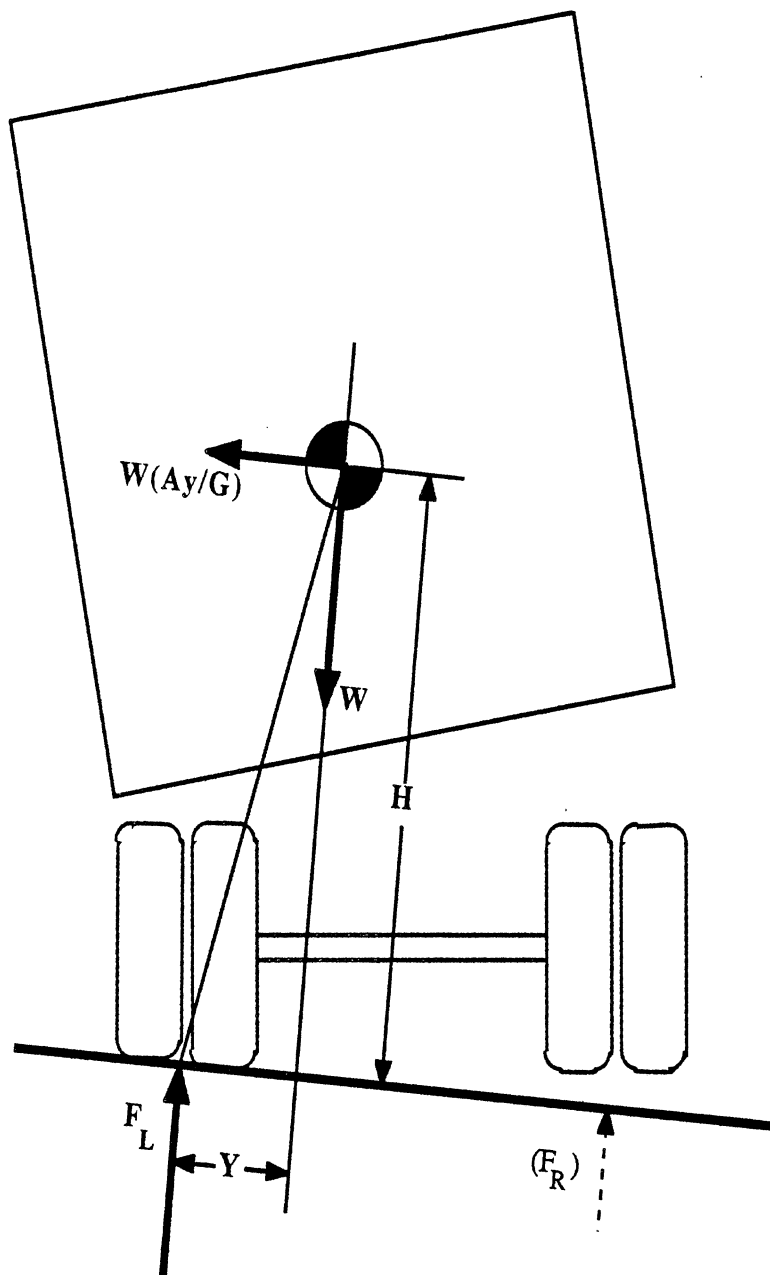

Figure 2.3.2.a Performance Measure b(1) - Dynamic Roll Stability

nominal half-track dimension, minus the lateral displacement of the total mass center, all divided by the height of the displaced total mass center. Referring back to Figure 2.3.2.a, this measure is defined as: $RM = Y / H$. Hence, on the verge of actual rollover, the total mass center is displaced sideways to a point directly above the outside wheels (that is, by an amount that equals the half-track dimension), yielding a Roll-Margin value of zero. The smaller the Roll-Margin value, the closer is the unit to rollover. This measure has not been computed for B- or C- trains since none of these vehicles achieved full lateral load transfer in response to the rapid steering application.

The Load Transfer Ratio for A-,B-, and C-trains, together with the Roll-Margin measure for A-trains exhibiting wheel liftoff, serves to display the whole range of dynamic rollover response levels produced by the matrix of vehicle cases.

b(2) The Transient High-Speed Offtracking measure is obtained from the same obstacle avoidance maneuver and is defined as the maximum lateral excursion of the rearmost axle relative to the final lateral path displacement of the front axle, the latter achieved after the tractor had completed the maneuver and stabilized in its new straight path, parallel to the original one. The amount of "overshoot" in the rearmost-axle path can be viewed as a relative indication of the severity of the potential intrusion into an adjacent lane of traffic, or the striking of a curb (risking an impact-induced rollover).

With all vehicle types, the sequence of "b-measure" runs is conducted at steering time periods of 2.0, 2.5 and 3.0 seconds, with the "worst" response of the three serving eventually for the actual characterization of the given vehicle.

c(1) Low-Speed Offtracking was defined as the maximum extent of lateral excursion of the last trailer axle, relative to a circular arc subtended by the tractor front axle during a right angle intersection maneuver. The tractor's front axle center-point tracks an arc of 9.8-meter (32-ft) radius (approximating an 11-meter, or 36-ft, outside-wheel path radius) through a 90-degree turn at near-zero speed. The Yaw/Roll model is employed for computing the low-speed offtracking measure for all combinations (except triples). The tractor forward velocity is 8.25 km/hr (7.5 ft/sec). The choice of the rather comprehensive Yaw/Roll model for use in this evaluation stems from the desire to authentically reflect the influence of spread axles on offtracking performance. However, since the Yaw/Roll model does not currently handle A- or C-train triples, and since the selected triples combinations are configured only with single axles or close-spaced tandems, a simplified offtracking model was employed for the triples.

c(2) The Tight-Turn Jackknife condition is one which pertains only to configurations having a front semitrailer with wide-spread axles which are either non-steerable or possessing high aligning (self-centering) stiffness in their steering mechanism. This performance characteristic is evaluated in response to the same 90 degree turn of 9.8-meter (32-ft) radius from an initial tangent path as in the determination of measure c(1) above. The degree of susceptibility to jackknife during a tight turn on a slippery surface is quantified by the peak frictional coefficient ("μ-peak") which is demanded at the tractor drive wheels in order to achieve the described maneuver. This measure is evaluated by continuous calculation during the maneuver of the non-dimensional quantity given by the ratio of {the sum of drive-wheel side forces, F_y , divided by the cosine of the tractor/semitrailer articulation angle, Γ } divided by {the sum of the drive-wheel vertical loads, F_z } to yield a friction-coefficient-type result. Referring to Figure 2.3.2.b, this quantity is given by:

$$\mu\text{-peak} = (\Sigma F_y / \cos (\Gamma)) / \Sigma F_z$$

Division by the cosine of the articulation angle, Γ , is intended to approximately yield the effective resultant of longitudinal and lateral shear forces at the tractor rear tires (since the longitudinal tire force, F_x , is not expressly computed in the simulation model). This computation assumes that the total resultant shear force between the drive wheels and the road acts perpendicular to the semitrailer longitudinal axis and just counteracts the total horizontal king-pin force, F_{kp} , applied by the semitrailer at the tractor's fifth wheel. The kingpin force, F_{kp} , is caused by the yaw-resisting moment created by the semitrailer's widely spread axles, whose tires are subjected to high slip angles and thus generate large side forces, F_t . (This calculation neglects tire rolling resistance, and would be absolutely accurate, had the tire/road shear forces at the tractor front wheels also been zero. The measure provides good approximation, however, since the location of the fifth wheel is very near that of the combined centroid of the drive-wheel shear forces.) Hence, the Tight-Turn Jackknife measure is defined as the minimum frictional coefficient necessary to avoid jackknife during the given maneuver, and the higher its value, the lesser will be the vehicle's resistance to jackknife in tight turns on slippery surfaces.

d] A Braking in a Turn measure was studied for its feasibility in examining the yaw disturbances experienced by vehicles equipped with self-steering trailer and dolly axles. The plan was for the vehicle to be put first into a steady circular turn of 200-m (656 ft) radius at a steady speed of 64 km/hr (40 mph). Brakes were then to be applied up to the point of locking the lightly-loaded tires on the self-steering axle/s (and possibly a few other

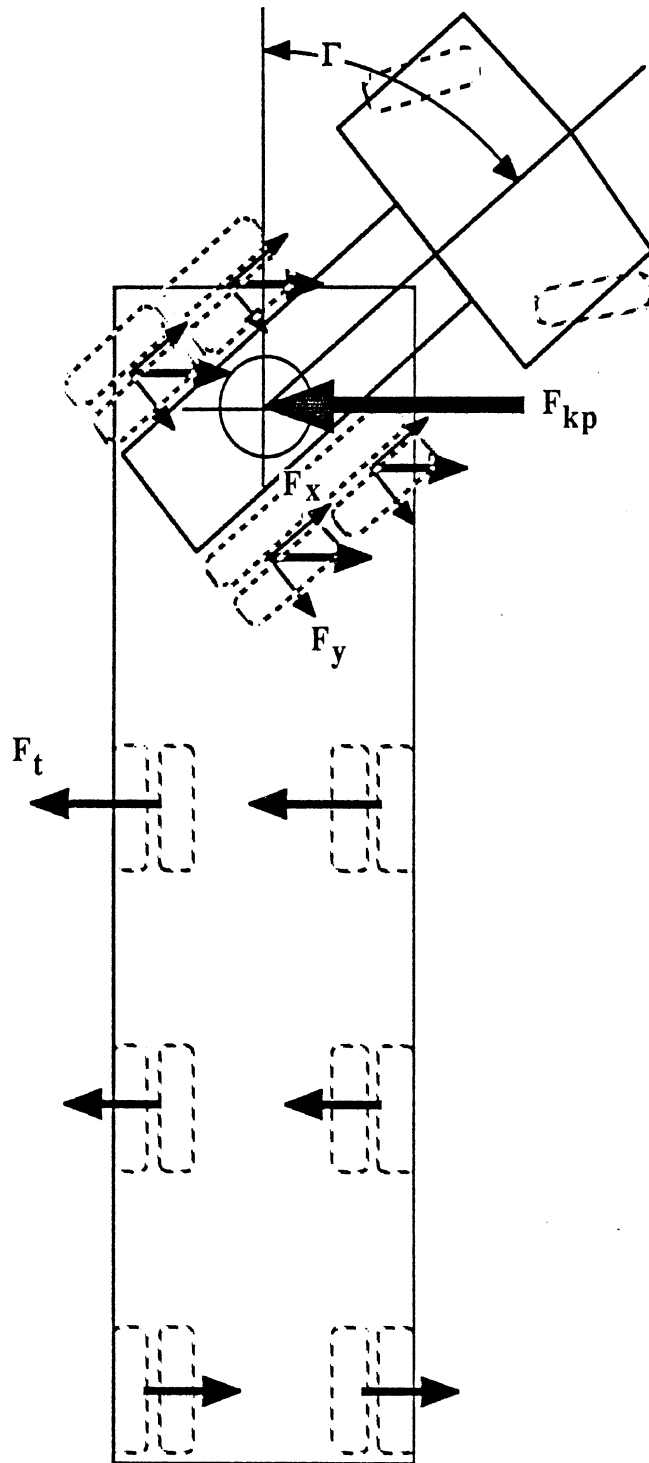

Figure 2.3.2.b Performance Measure c(2) - Tight Turn Jackknife Resistance

wheels, as well). The yaw response of the vehicle unit equipped with the self-steering axle/s was then to be examined to determine whether an anomalous response was induced by the steerable elements. No precise numerical measure for quantifying response to braking in a turn was defined, but rather the output time histories from the simulation runs were studied to determine whether anything notable was occurring and thus deserving of quantification and further study. The actual results from a preliminary investigation performed along these lines did not yield any indication of a significant and consistent contribution of the self steering axle/s to the overall combination's response, hence further pursuit of this performance measure was abandoned (see also Section 3.3.6).

e] Braking Efficiency is defined as the percentage of available tire/road friction limit that can be utilized in achieving an emergency stop without incurring wheel lockup. In other words, it is the ratio of the deceleration level, in g's, divided by the highest friction coefficient required by any axle, if no lockup is to occur. For example, a vehicle achieves a 50% braking efficiency level when wheel lockup first occurs at 0.2 g's of deceleration on a surface having a tire/road friction level of 0.4. The braking efficiencies of differing vehicle configurations were determined using the Simplified Braking program which computes the relationship between delivered brake torques and instantaneous wheel loads at each axle of a combination, over the wide range of deceleration levels, assuming unlimited available friction. Although results were produced covering a wide deceleration range, the braking efficiency measure is reported only for decelerations of 0.1 and 0.4 g's which illustrates braking performance in nominally low- and high-level braking runs. (Note that, for heavy-duty trucks, 0.4 g's constitutes a relatively high-level braking condition, given the inherent limitations in typical truck braking systems.) These two braking levels are chosen to depict the nominal brake balance which is achieved in, say, light braking during mountain descents and the heavy braking which is applied in highway emergencies, respectively.

f] Low-Speed Offtracking for A-train triples was evaluated using the simplified kinematic model. This model served also to validate the Yaw/Roll model suitability for low-speed, tight-turn simulation. The maneuver and the extracted measure are in essence the same as those described in c(1), except that the computation is purely kinematic and does not require a driver model.

2.3.3 Simulation Matrix. The complete simulation matrix is presented in detail in Appendix D, and includes notes explaining the principal parameter selections and the rationale behind the various choices which have been made for their types and values. The "reference" configuration vehicles are subjected to most of the full set of simulation

conditions. Certain runs in the reference configurations were eliminated from the matrix, however, where there was a clear absence of sensitivity, in the interest of containing the project's scope. Similarly, variations on the "reference" configuration included only those simulated maneuvers which are expected to yield a meaningful measure of performance. Thus, for example, the rapid steering response is not determined for all of the variation cases with the tractor-semitrailer since we know that tractor-semitrailers are essentially incapable of exhibiting an amplifying response. Likewise, some of the measures, such as the tight-turn jackknife, constitute "special-purpose" measures which are applied only in selected circumstances.

2.3.4 Simulation Models. Four UMTRI-developed computer-based simulation models were used in the study, namely, the Yaw/Roll model, the Phase-4 model, the Simplified Braking model and the Simplified Low-Speed Offtracking model. The application of these models by vehicle configuration types and by performance measures is summarized in Table 2.3.4.a. A detailed description of the models follows.

The Yaw/Roll model is an extensive, mainframe-based, constant-velocity dynamic simulation program providing the ability to study in detail the combined yaw, roll, and lateral displacement transient responses of articulated vehicles caused by either closed- or open-loop steering-input time histories. The vehicle combination can include up to 4 articulating units, and up to a total of 11 axles, arbitrarily distributed along the combination. Up to five axles (besides the front axle) at arbitrary locations may have steering capability of either dynamic self-aligning or kinematically controlled nature. Flexibility in the specification of articulation-joint properties enables the simulation of A-, B-, and C-train combinations. Minor program limitations include its inability to simulate longitudinal tire forces (drive- and brake-torque application) and the respective dynamic phenomena (longitudinal acceleration and longitudinal weight transfer) and its neglecting of the tire camber stiffness contribution to the cornering force developed. Complete documentation of the use and features of the "original" Yaw/Roll program is provided in Reference [5]. However, many features were enhanced to adapt the program for this study.

The Phase-4 model is a comprehensive, mainframe-based, heavy-vehicle handling simulation program, capable of predicting the combined yaw, roll, pitch, acceleration, braking (including antilock) and ride transient responses of articulated vehicles subjected to practically any combination of steering (open- and closed-loop), drive-thrust, braking, and road profile input. The program can simulate straight trucks, tractor-semitrailers and double or triple A- and C-train combinations. Its main limitations are its inability to

Table 2.3.4.a PERFORMANCE MEASURES, VEHICLE CATEGORIES & MANEUVERS

I. Simulation Models for given Performance Measures and Vehicle Types:

Performance Measures Code Name	Vehicle Category 1 & 2 (*)	B-Trains and B-Dollies	Multiple Axle Layouts	Triples	Self-Steer Axles
a(1) Static Rollover Threshold	YR	YR	YR	P4	--
a(2) Yaw Stability (Units 1 & 2)	YR	YR	YR	--	YR
a(3) High Speed Off-Tracking	YR	YR	YR	P4	YR
b(1) Amplification-Induced Dynamic Roll-over	YR	YR	YR	P4	YR
b(2) Amplification-Induced Transient Off-Tracking	YR	YR	YR	P4	YR
c(1) Low Speed Off-Tracking	YR	YR	YR	--	YR
c(2) Friction Demand in a Tight Turn	--	--	YR	--	--
d Braking in a Turn	--	--	--	--	--
e Braking Efficiency	SB(PC)	SB(PC)	SB(PC)	SB(PC)	SB(PC)
f Low Speed Off-Tracking	--	--	--	SOT(PC)	--

II. Legend:

YR - Yaw/Roll Simulation Program
 P4 - Phase 4 (Combined Steering & Braking) Program
 SOT - Simplified (kinematic) Off-Tracking Program
 SB - Simplified Braking
 (PC) - Microcomputer version
 (*) - Conventional axle configurations

III. Performance-Measure Code-Letter and Simulated Maneuver.

Code-Letter	Simulated Maneuver
a	Constant-Velocity Constant-Rate + Ramp-Steer Turn
b	Constant-Velocity Lateral Path Offset of 2-3 sec period & sinusoidal Tractor Ay (-15g amplitude) (**)
c	Low-Velocity, 90 deg 11 m (outside radius) Turn (**)
d	Constant-Steer Wheel-Selective Step-Braking
e	Straight-Line Constant-Pressure (& Decel) Braking
f	Zero velocity, 90 deg 11 m Turn (Kinematic)

(**) - Path Follower

simulate B-trains or truck/full-trailer combinations, its inability to simulate multiple- or belly axle layouts (by allowing only one, albeit either single- or tandem-axle suspension per articulating unit, plus the lead steer axle on the tractor), and the necessity to specify appropriate drive-thrust application in low-speed or long-duration maneuvers to maintain forward velocity. The "original" Phase-4 program use and features are generally documented in Reference [6]. The version of this program used in this study was again considerably enhanced to account for specific vehicle and maneuver features.

The Simplified Braking model is an interactive microcomputer-based program for studying the steady-state, straight-line, level-road braking behavior of articulated vehicles when neglecting any pitch-plane displacements, brake fade, and heat generation, yet while accounting for inter-axle and inter-unit load transfer caused by braking.

The Simplified Low-Speed Offtracking model is an interactive microcomputer-based simulation program for predicting the low-speed offtracking behavior of articulated vehicles steered along any input path trajectory that can be defined as a combination of one circular arc segment of arbitrary radius and angle, with tangential straight lines leading and trailing this arc segment. The limitation of the program is its strictly kinematic principle, such that no tire mechanics are accounted for. As a result, no multiple- or belly-axle configurations can be simulated without some prior approximate substitution of a single axle in place of any multiple axle set. Both simplified models are fully documented in Reference [7].

3.0 PRESENTATION OF RESULTS

In this section, the results of the simulation study are presented in the form of the numerical values of response measures computed for each vehicle case. The presentation of results is organized into five main sections. The first, section 3.1, presents a comparison of response measures obtained on the reference configurations of each vehicle type. These data serve to provide a broad comparison of the basic qualities which distinguish one vehicle type from the next. In the four following sections, 3.2 through 3.5, the parametric sensitivities of each type of vehicle configuration to variation in the W/D and design parameters are presented.

3.1 Comparison of Performance Characteristics Among Reference Vehicle Configurations

The evaluation of one basic vehicle type relative to another, in terms of stability and control properties, can be done comprehensively only by examination of behavior over a wide range of loading, component selection, and operational variables such as tire treadwear level, pavement friction condition, etc. Further, the actual selection of specific vehicles in trucking service tends to be guided by considerations of productivity such that some vehicles are more frequently loaded to full cubic capacity while others may be more frequently loaded full gross weight. Also, biased loading or slosh-liquid loadings may be more prevalent in the operation of one basic vehicle type than another -- simply because of the differing kinds of trucking operations which find the respective vehicles attractive. Thus, in an ideal sense, one would like to have evaluated vehicles in the specific loading and operational scenarios which match their likely applications. While the scope of this study did not permit an evaluation at this level of detail, the results presented in this section do serve to scale differing vehicle types in terms of gross performance distinctions, given the conventions in loading which were outlined in Section 2.2.4. Discrimination between vehicles on the basis of small percentage differences in these data, however, is probably not warranted.

The spread of results over the matrix of vehicle configurations will be presented here, firstly, as a rank ordering of the vehicles according to the computed values of the performance measure. Additionally, for those cases in which the performance level is clearly dependent upon distinctions in basic configuration, the influence of configuration features (such as number of axles on a trailer, type of hitch coupling, number of trailers, etc.) on the performance measure will be discussed by vehicle category (such as tractor-

semitrailers, A-doubles, C-doubles, etc.). By way of summary on all of the study of reference vehicles and their sensitivities to W/D and design parameters, Section 4.1 of the report provides a commentary on the overall performance quality of each











3.1.1 Performance of Differing Configurations in a Quasi-Steady Turn at Highway Speed. The simulated maneuver involving an essentially steady turn at highway speeds produced three different measures of performance. The so-called "static rollover threshold" is defined as the steady level of lateral acceleration which the vehicle will tolerate without rolling over. The "high-speed offtracking" measure describes the extent to which the rearmost trailer axle offtracks to the outside of the tractor wheelpaths, thus posing a possible hazard with striking outboard objects. The "understeer coefficient," representing the changing gain in steering response with increased maneuver severity, is not used to discriminate among the differing vehicles here since this measure is primarily determined by the properties of the tractor unit--and all of the reference vehicles employed identically the same tractor. Accordingly, in the discussion below, the contrasting performance of the various reference vehicle configurations will be presented in terms of the static rollover threshold and high-speed offtracking measures.

Rollover Threshold -- Comparison of Configurations

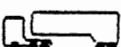
Shown in Figure 3.1.1a is a rank ordering of the reference vehicles characterized according to the static rollover threshold measure. This measure covers the very substantial range from 0.33 to 0.54 g over the matrix of examined vehicles. It should be noted, however, that each vehicle was loaded with the same reference freight, whose density was 545 kg/m^3 (34 lb/ft^3), and that this freight loading scheme results in differing heights of the payload center of gravity (c.g.) depending upon the gross vehicle weight and the floor area of the trailers involved. Please note that triples combinations are not shown on the figure since the static rollover threshold level will be the same as that of the doubles configuration having the same type of full trailer.

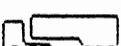
The payload c.g. heights employed with each of the respective vehicles are listed to the right of the performance measures, in a format that shows the c.g. heights for (1st trailer)/(2nd trailer) when a doubles combination is involved. A cursory scan of these c.g. height values shows that they correlate very closely with the ranking, and thus the rollover threshold values, themselves. Indeed, one can infer here a principle which analysis clearly supports; namely, that the addition of trailers, the longitudinal placement of axles, and the nature of coupling mechanisms, have rather little influence, per se, upon static roll stability.

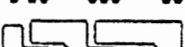
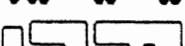
Ranked Order of Static Rollover Threshold for Reference Vehicles

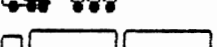
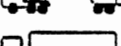
<u>Configuration</u>	<u>Vehicle</u>	<u>Rollover Threshold</u>	<u>Sprung Mass</u> <u>C.G. Height (meters)</u>
2.4	 **	0.539	1.79/1.79
2.5	 *	0.472	1.88/1.98
3.3		0.466	1.93/1.92
2.2		0.446	1.98/1.98
1.1		0.437	1.97
2.1		0.434	2.05/2.05
1.2		0.418	2.08
3.1		0.418	2.12/2.19
3.2		0.418	2.09/2.15
3.4		0.406	2.10/2.28
1.5		0.399	2.14
1.3		0.376	2.18
2.3		0.354	2.37/1.98
1.4		0.332	2.37

* Rocky Mountain Double

** Turnpike Double













FIGURE 3.1.1.a

Conversely, the rollover thresholds of dramatically differing vehicle configurations will be very nearly the same if (a) payload c.g. height is held constant (b) axles carry comparable loads, and (c) suspensions, tires, and width-related dimensions at respective tractor and trailer axles are kept the same. Accordingly, the rank ordering in Figure 3.1.1a primarily illustrates the rollover threshold result of the loading which can be placed upon each of the respective vehicles, given (a) the axle loading and GCW limitations which are found in the current applications of the respective vehicles in Canada, and (b) the floor areas of the involved trailers, such as determine the typical payload c.g. height, given the payload weight.

Shown in Figure 3.1.1b is a rank ordering of the respective vehicle configurations for the case of a fixed, maximum-height payload. Each vehicle carries the same payload weight as in the reference cases, above, but the payload center is placed uniformly at an elevation of 2.67 m (105 in) above the ground. These data show a much-reduced range of performance levels relative to the reference case results, and there is a substantial change in the ranking of various vehicles. We still see the multi-axle tractor-semitrailer configurations near the bottom of the performance range, but the vehicles appearing near the top are now those having relatively light values of axle load.

Again, since there is no first-order relationship between the axle layout configuration of differing combinations and the resulting rollover threshold performance, no further discussion of roll stability mechanisms will be presented here. It is important to recognize, however, that since the height of the payload mass center plays a most powerful role in determining the vehicle's roll stability level, changes in W/D allowances that introduce vehicle types with higher likely placement of the c.g. will result in a higher rate of rollover accidents for such vehicles [8]. Further, while the rank ordering in Figure 3.1.1a, above, might be looked upon as the result of a somewhat arbitrary loading protocol, it is a fact that, on the average, some such "protocol" does prevail in the normal process by which the trucking industry applies differing vehicle types to differing hauling missions. Thus, one should assume that vehicles which are allowed greater gross weight levels will, on the average, operate with elevated centers of gravity relative to similar-length vehicles which are allowed lower weights. On the other hand, the vehicles with longer trailers, such as Rocky Mountain doubles and turnpike doubles (configurations 2.5 and 2.4, respectively) may appeal to trucking operations which engage in characteristically "full cube" hauling such that the "high c.g." performance levels may be more nearly indicative of the common operating condition. Such observations beg, again, the issues of operating scenarios--which are beyond the scope of this work.

Ranked Order of Static Rollover Threshold for High Payload Vehicles

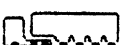
<u>Configuration</u>	<u>Vehicle</u>	<u>Static Rollover Threshold(g's)</u>
2.1		0.365
2.4		0.365
3.1		0.347
3.3		0.342
3.4		0.338
3.2		0.336
2.5		0.329
1.2		0.323
2.3		0.319
1.1		0.315
1.5		0.314
2.2		0.311
1.3		0.304
1.4		0.3

* Rocky Mountain Double

** Turnpike Double

FIGURE 3.1.1.b











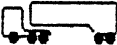

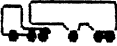
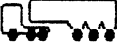
High-Speed Offtracking -- Comparison of Configurations

High-speed offtracking is known to be a performance property which is inherently sensitive to certain basic layout features of the vehicle configuration. Shown in Figure 3.1.1c is a rank ordering of the high-speed offtracking results for each of the reference vehicles. The values of this measure range from 0.30 to 0.58 meters (1.0 to 1.9 ft). In general, we see that tractor-semitrailers and other short combinations tend to be toward the top (more favorable end) of the ranked list, while triples and long C-train doubles rank toward the bottom. Falling in the middle are vehicles such as (a) the turnpike double, case 2.4, which is very long, overall, but which exhibits a very great inboard offtracking at zero speed (as will be shown in Section 3.1.3) and (b) the quad-axle semitrailer which, although not great in overall length, exhibits a very small value of inboard offtracking at zero speed, as will be seen later.

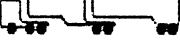
These observations are largely explainable on the basis of geometric considerations with the aid of analytical studies (e.g., [9]) which distinguish two key vehicle attributes that determine high-speed offtracking behavior. The offtracking response of example truck combinations is known to vary in a fashion such as illustrated in Figure 3.1.1d. That is, each combination vehicle will exhibit some degree of inboard offtracking at low speed, and thus low lateral acceleration, but will proceed to offtrack toward the outside as lateral acceleration level is increased. The extent of inboard offtracking is determined primarily by the sum of the squares of the elemental wheelbase lengths describing the vehicle [10]. Because of the wheelbase-squared effect, vehicle combinations having one or more long trailers will exhibit much higher inboard offtracking than vehicles having relatively short trailers. Thus, the length of the constituent elements of the combination are of greatest importance to the low-speed component of offtracking. The trend to more outboard paths with increasing lateral acceleration (that is, the slope of the lines in Figure 3.1.1d) has been shown to depend upon the overall length of the vehicle combination, from first axle to last axle.

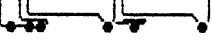
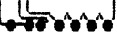
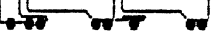
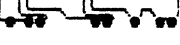
An illustration of the wheelbase vs. overall length effects which determine high-speed offtracking is apparent in Figure 3.1.1e, which shows the contrasting values of this measure for the differing configurations of tractor-semitrailer. Although all of these vehicle have exactly the same overall length, and the same distance from the fifth-wheel coupling to the rearmost axle on the semitrailer, the high-speed offtracking value differs markedly because of differences in the "effective wheelbase" of the semitrailer. That is, with an increasing number of axles spread toward the front of the semitrailer, the trailer

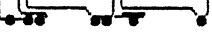
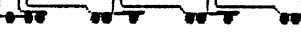
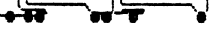
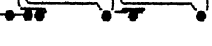
Ranked Order of High-Speed Offtracking for Reference Vehicles

<u>Configuration</u>	<u>Vehicle</u>	<u>Train Type</u>	<u>High-Speed Offtracking (meters)</u>
1.1		B	-0.303
1.2		B	-0.304
1.5		B	-0.36
1.3		B	-0.4
3.3		B	-0.408
3.1		B	-0.421
2.1		A	-0.431
3.2		B	-0.435
2.4	 **	A	-0.453
2.2		A	-0.478
1.4		B	-0.485
2.1		C	-0.488
3.4		B	-0.496
2.5	 *	A	-0.496
2.3		A	-0.509
4.2		A	-0.529
2.3		C	-0.552
2.2		C	-0.563
4.1		A	-0.577
2.5	 *	C	-0.578

* Rocky Mountain Double

** Turnpike Double

FIGURE 3.1.1.c

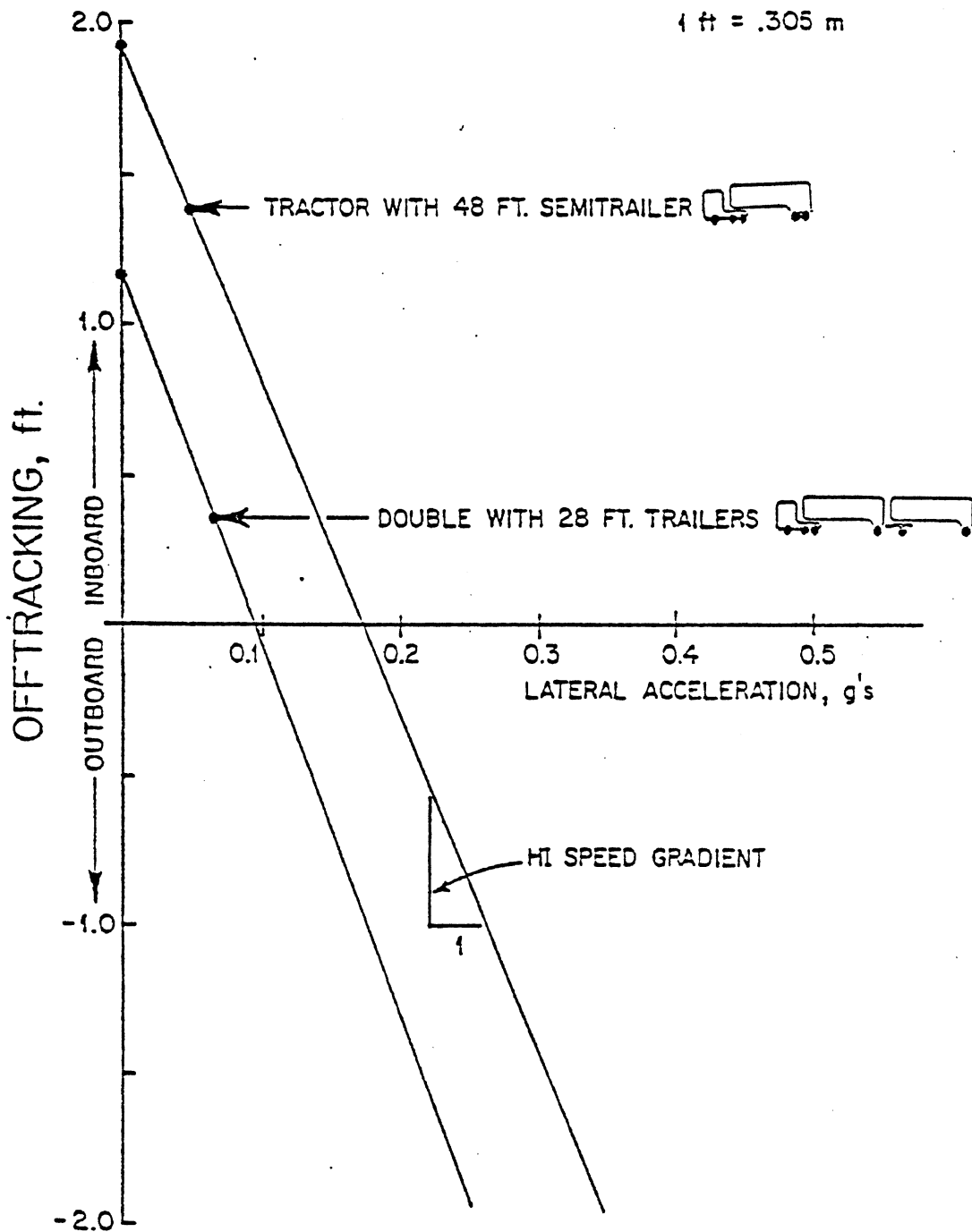

FIGURE 3.1.1.d Example offtracking behavior of tractor-semitrailer and doubles combination on 500-ft (152-m) radius curve.

Characteristic Behavior of Reference Vehicles on High-Speed Offtracking in Tractor/Semitrailers

34

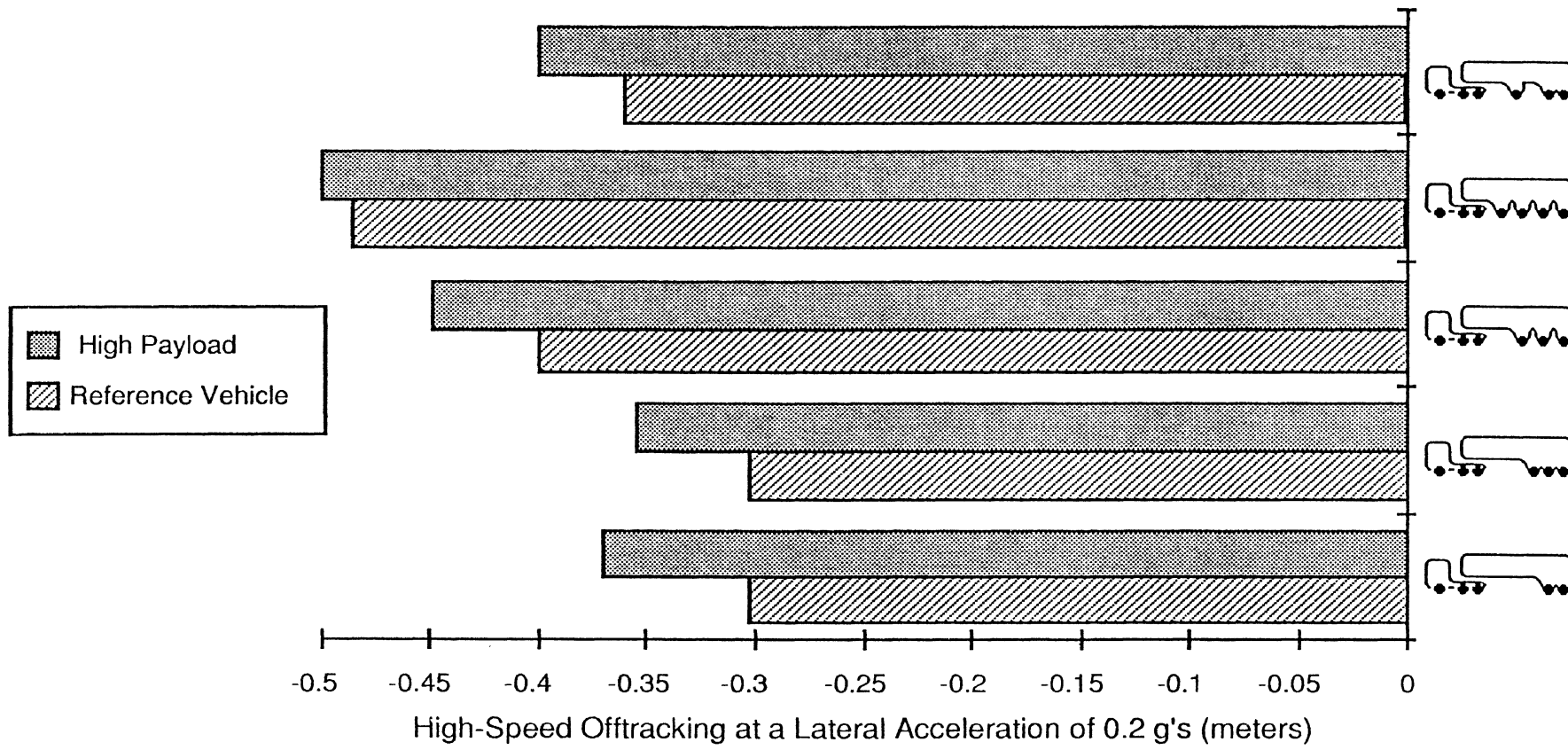

FIGURE 3.1.1.e

increasingly tracks as if it had a shorter wheelbase dimension. This result is demanded by the requirements for force and moment equilibrium on the trailer when operating in a steady turn. Thus, the three- and four-axle trailers tend to (a) track inboard less at low speed and thus, (b) achieve a greater outboard offtracking excursion at a given high-speed cornering condition. Accordingly, the observed rank order of vehicles by high-speed offtracking performance is generally explained by distinctions in wheelbase values and overall lengths.

One exception to this general rule is seen in the case of the C-train configurations. Since the C-train incorporates a dolly axle which yields a steer response as a function of tire cornering force, the dolly introduces a mechanism influencing high-speed offtracking which has not been addressed in classical analyses. It suffices to say here that the C-train dolly, depending upon its steer-centering characteristics, will tend to promote a greater degree of high-speed offtracking as the dolly axle steers toward the outside of the turn at an elevated level of lateral acceleration. This mechanism does explain the generally higher outboard offtracking observed with C-train configurations in Figures 3.1.1c. (Full-scale demonstration tests, reported in Appendix E, included a C-train double which exhibited a tremendous level of high-speed offtracking, reaching a value of almost 3 m (10 ft). This result reinforces the point that the steer-centering properties of a C-train dolly are crucial to the high-speed offtracking performance of such vehicles.) Although technical difficulties prevented computation of the high-speed offtracking response for C-train triples, it can be estimated that the magnitude of this measure would have been on the order of 17 to 24% greater than that exhibited by the corresponding A-train triple, depending upon axle configuration.

A second exception to the general rule that wheelbase and overall length dimensions are the primary W/D variables influencing high-speed offtracking is the influence of tire load on the cornering stiffness (that is, the rate of increase in tire slip angle with cornering force) property of the tire. Analysis of the high-speed offtracking phenomenon [11] indicates that the ratio of the cornering stiffness value to the prevailing vertical load on the tire, especially at trailer axle positions, will directly affect the magnitude of the outboard offtracking tendency. (The mentioned ratio will be referred to later in the text as the "normalized cornering stiffness.") The significance of this observation in a weights and dimensions context is that increased axle load allowance (and thus tire load level) causes a reduced level of this ratio because of the curved relationship between tire load and cornering stiffness, as illustrated in Figure 3.1.1f. Although cornering stiffness rises with increased tire load over most of the load range (especially with radials), the curvature in the function provides that the ratio of cornering stiffness to load will reduce as load, itself,

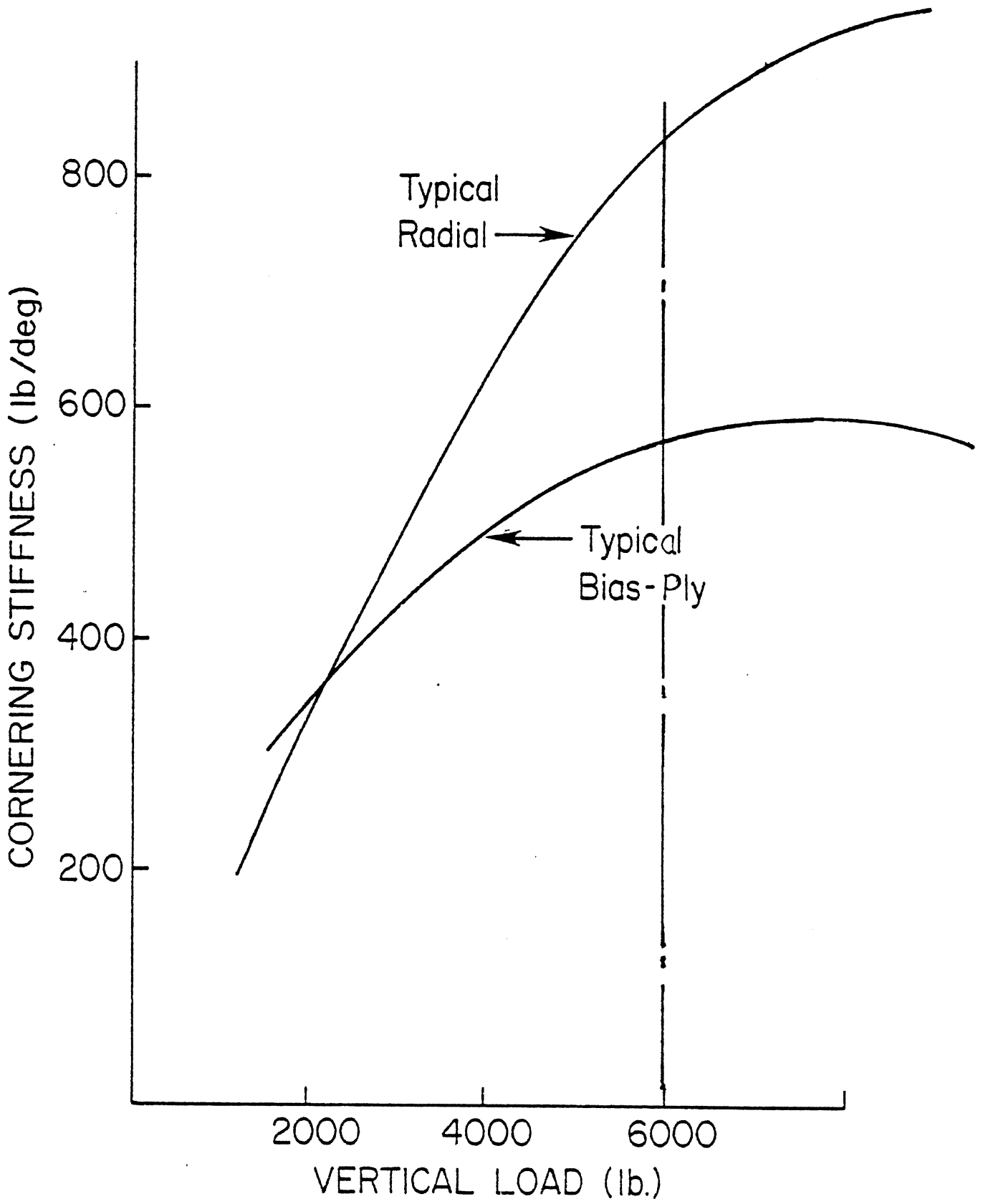

FIGURE 3.1.1.f The influence of vertical load on the Cornering Stiffness parameter

increases. Accordingly, some of the adjustments in rank among the differing vehicles in Figure 3.1.1c are attributed to the differing axle load levels which, in turn, have influenced the normalized cornering stiffness level. By way of example, the turnpike doubles configuration, number 2.4, is represented with light levels of axle load relative to other vehicles and thus enjoys some additional benefit in its high-speed offtracking response as a result.



















3.1.2 Performance of Differing Configurations in a Transient Steering Maneuver (Rapid Path Change) at Highway Speed. This section compares the high-speed transient response characteristics of the various vehicle combinations when subjected to a series of rapid path-change maneuvers. The performance is evaluated from two distinct aspects, namely, (a) dynamic roll stability, expressed as the "load transient ratio" measure, and (b) transient high-speed offtracking--a measure of the dynamic overshoot in trailer path occurring in the rapid path-change maneuver.

Load Transfer Ratio -- Comparison of Configurations

Shown in Figures 3.1.2a and 3.1.2b are the rank orderings of the examined vehicles by value of the load transfer ratio, for the cases of reference and "high c.g." loadings, respectively. The vehicle symbols are filled in to indicate the so-called "critical roll unit," or the portion of the vehicle on which the indicated level of load transfer ratio has been achieved (and which will roll over first, when the maneuver severity attains a sufficient level). With A-trains, the rearmost trailer is identified as the critical roll unit while, with B- and C-trains, the entire series of elements roll together and thus constitute the "critical unit."

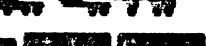
The column labelled "Roll Margin" indicates a specific value only for those vehicle configurations which experience complete load transfer on the critical roll unit during the maneuver. In such cases, the proximity of the roll margin value to zero indicates the proximity of the peak roll excursion to the point of complete rollover. The "Period" column lists the steering period, in seconds, which caused the most severe response for each vehicle. The rank ordering charts tend to show that A-train doubles and triples combinations fall toward the bottom of the list, with B-doubles, and C-triples showing up at the top. Further, the influence of the high c.g. condition, while obviously shifting the numerical values of the measures upwards (toward less dynamic roll stability), does not tend to alter the rank order of vehicles in any general way. (Nevertheless, a few individual vehicles which had conspicuously low centers of gravity in the reference case, such as the

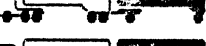
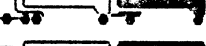
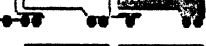
Ranked Order of Load Transfer Ratio and Roll Margin for Reference Vehicles

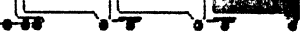
<u>Conf</u>	<u>Vehicle</u>	<u>Train Type</u>	<u>Load Transfer Ratio</u>	<u>Roll Margin</u>	<u>Period (sec)</u>	<u>Sprung Mass CG Height (meters)</u>
2.5	 *	C	0.285	---	3.0	1.88/1.98
4.1		C	0.294	---	3.0	1.88/1.88/1.88
4.2		C	0.332	---	3.0	1.75/1.75/1.75
1.1		B	0.384	---	3.0	1.97
2.2		C	0.387	---	3.0	1.98/1.98
3.3		B	0.401	---	3.0	1.93/1.92
1.2		B	0.408	---	3.0	2.08
2.4	 **	A	0.408	---	3.0	1.79/1.79
2.1		C	0.436	---	3.0	2.05/2.05
1.3		B	0.475	---	3.0	2.18
3.2		B	0.477	---	3.0	2.09/2.15
1.5		B	0.478	---	3.0	2.14
3.1		B	0.501	---	3.0	2.12/2.19
3.4		B	0.501	---	3.0	2.10/2.28
2.3		C	0.513	---	3.0	2.37/1.98
1.4		B	0.625	---	3.0	2.37
2.5	 *	A	0.649	---	3.0	1.88/1.98
2.2		A	0.785	---	2.5	1.98/1.98
2.1		A	0.795	---	2.5	2.05/2.05
2.3		A	0.813	---	3.0	2.37/1.98
4.1		A	1	0.473	2.5	1.88/1.88/1.88
4.2		A	1	0	3.0	1.75/1.75/1.75

* Rocky Mountain Double

** Turnpike Double

















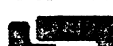



 indicates critical roll unit.

FIGURE 3.1.2.a

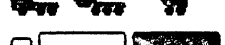
Ranked Order of Load Transfer Ratio and Roll Margin for High Payload Vehicles

Configuration	Vehicle	Train Type	Load Transfer Ratio	Roll Margin	Period sec
2.5	 *	C	0.398	--	3.0
4.1	 *	C	0.431	--	3.0
4.2	 *	C	0.444	--	3.0
2.3	 *	C	0.526	--	2.5
2.2	 *	C	0.531	--	3.0
1.2	 *	B	0.54	--	3.0
1.1	 *	B	0.548	--	3.0
3.3	 *	B	0.566	--	3.0
2.1	 *	C	0.569	--	3.0
3.4	 *	B	0.595	--	3.0
1.3	 *	B	0.596	--	3.0
3.2	 *	B	0.597	--	3.0
1.5	 *	B	0.608	--	3.0
3.1	 *	B	0.613	--	3.0
2.4	 **	A	0.668	--	3.0
1.4	 *	B	0.692	--	3.0
2.5	 *	A	0.983	--	3.0
2.1	 *	A	1	0.3	3.0
2.2	 *	A	1	0.189	3.0
2.3	 *	A	1	0	3.0
4.1	 *	A	1	0	2.0
4.2	 *	A	1	0	2.0

* Rocky Mountain Double

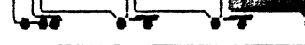
** Turnpike Double

 indicates critical roll unit.

FIGURE 3.1.2.b

turnpike double, configuration 2.4, show a relatively large drop in rank due to the greater net increase in c.g. height in the "high c.g." condition.)

Moreover, the ranking of the various vehicles by the load transfer ratio measure can be distinguished by four basic qualities, namely,

- 1) the number of trailers in combination
- 2) the nature of the coupling between trailers (viz., A-, B-, and C-trains)
- 3) the wheelbases of the trailers in the combination
- 4) the height of the loaded center of gravity, especially in the rearmost trailer

Regarding the first and second items, an increasing number of trailers will cause (a) an increase in the load transfer ratio response of A-train configurations, and (b) a decrease in the net response of B- and C-train configurations, if the roll coupling between trailers is quite stiff. Shown in Figure 3.1.2c, for example, is an illustration of the exponential relationship between the "rearward amplification" and the number of 8.2-m (27-ft) trailers employed in a vehicle combination, where the successive trailers are coupled with A-type converter dollies. (The rearward amplification measure is defined as the ratio of the peak value of lateral acceleration occurring at the rear trailer to the peak value which occurred at the tractor in a sine-steer maneuver [12].) This exponential sensitivity of A-train combinations to the number of trailers has been explained through a generalized analysis in Reference [13].

When multiple trailers are coupled in either B- or C-train configurations, such that each successive trailer is roll-constrained by the next unit, the addition of trailers can be actually beneficial to the net roll response as characterized in the load transfer ratio measure. Shown in Figure 3.1.2d, for example, are the lateral acceleration time histories for the tractor and each trailer of a C-train triples combination conducting a rapid path-change maneuver (having a nominal period of 3.0 seconds). The figure shows that, while the lateral acceleration level is certainly being amplified with each successive trailer toward the rear, the occurrence of the peak lateral acceleration condition at each trailer is also substantially lagging in phase behind that of the preceding unit. Noting the time associated with the vertical line drawn through the peak acceleration response of the rearmost trailer, we see that the simultaneous levels of lateral acceleration prevailing at the preceding units have receded to small or even opposite-polarity values because of their large phase lead

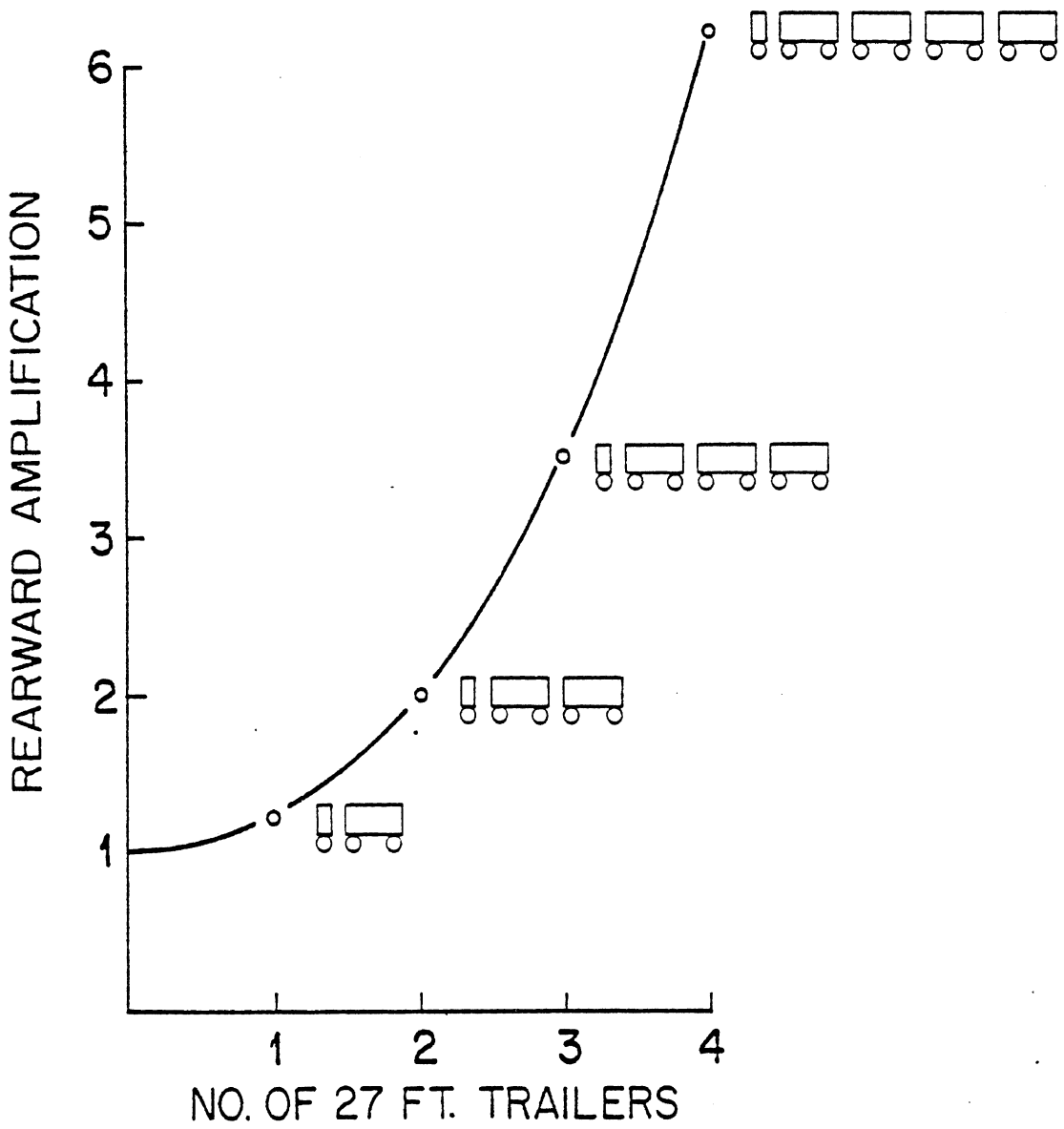

The influence of number of 27 Ft trailers on the Rearward Amplification of A-train combinations

FIGURE 3.1.2.c

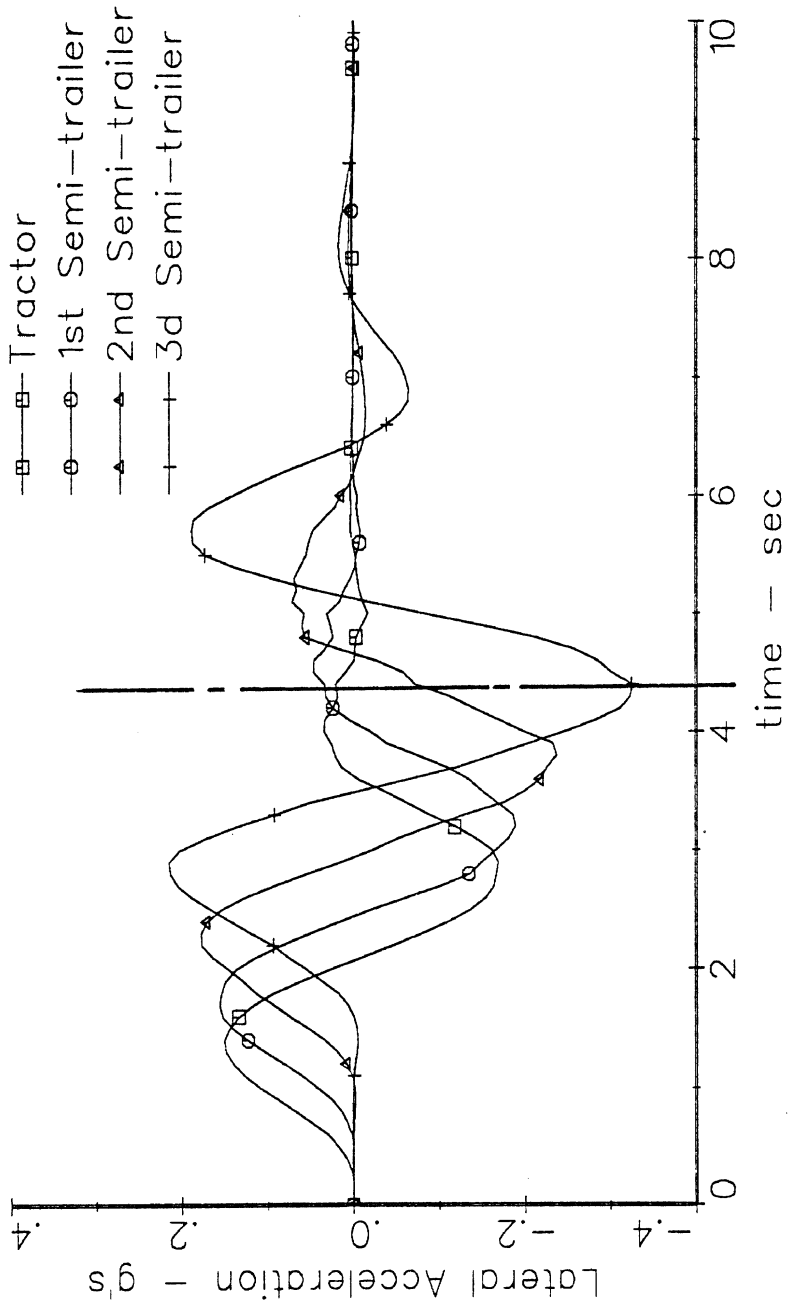

RTAC 8 axle C-train Triples (55t/121k GCW), conf. 4.1, var. 1.00

FIGURE 3.1.2.d Lateral acceleration time histories for the tractor and respective trailers of an 8-axle C-train triples combination.

relative to this rear trailer. Accordingly, at the occasion of the peak lateral acceleration response at this last unit, when the moment tending to cause rollover has maximized, the roll coupling of the C-train connection to the lead trailers affords a means for developing the large restoring roll moment such that rollover is resisted. Moreover, this figure illustrates a basic feature which renders roll-coupled multiple-trailer configurations highly resistant to rollover in dynamic steering maneuvers.

Regarding the influence of the trailer wheelbase values on the load transfer ratio response, there exists a large body of research [2,3,12,13,14] which establishes that this dimension has a first-order effect on the rearward amplification behavior of multiply-articulated truck combinations. Shown in Figure 3.1.2e, for example, is an illustration of the relationship between rearward amplification and the wheelbase (and trailer length) parameter for a five-axle, U.S.-style, A-doubles combination. The strong decline in rearward amplification with increasing trailer wheelbase explains the relatively high rankings, in Figures 3.1.2a and 3.1.2b, of the vehicle configurations incorporating one or two long (14.6-m (48-ft)) trailers, namely, numbers 2.4 (turnpike double) and 2.5 (Rocky Mountain double).

The height of the center of gravity directly influences the value of the load transfer ratio, as mentioned above, because the measure is essentially an indicator of the peak roll response during this dynamic maneuver. Accordingly, it is elemental that vehicles with more elevated payload locations will fare more poorly in the load transfer ratio ranking.

By way of elaboration on the contrast in the load transfer ratio performance among differing vehicle configurations, the following discussion addresses each basic vehicle type. Firstly, in Figure 3.1.2f, we see that a substantial range in this measure develops when the axle layout on a long (14.6-m (48-ft)) semitrailer departs in a major way from the conventional close-tandem installation. We see that while the conventional two-axle close tandem and the three-axle closely spaced "tridem" yield very low levels of the load transfer ratio measure, the response becomes much more pronounced when additional axles are spread to more forward positions on the semitrailer.

Although increasing response values for the "reference vehicle" cases, with increasing numbers of semitrailer axles, is partly explained by the fact that payload weight and payload c.g. height are both increasing, it is apparent that another effect is also at work. Namely, as we go toward the top of the range of configurations in Figure 3.1.2f, the effective wheelbase of the semitrailer is declining and the yaw moment of inertia is

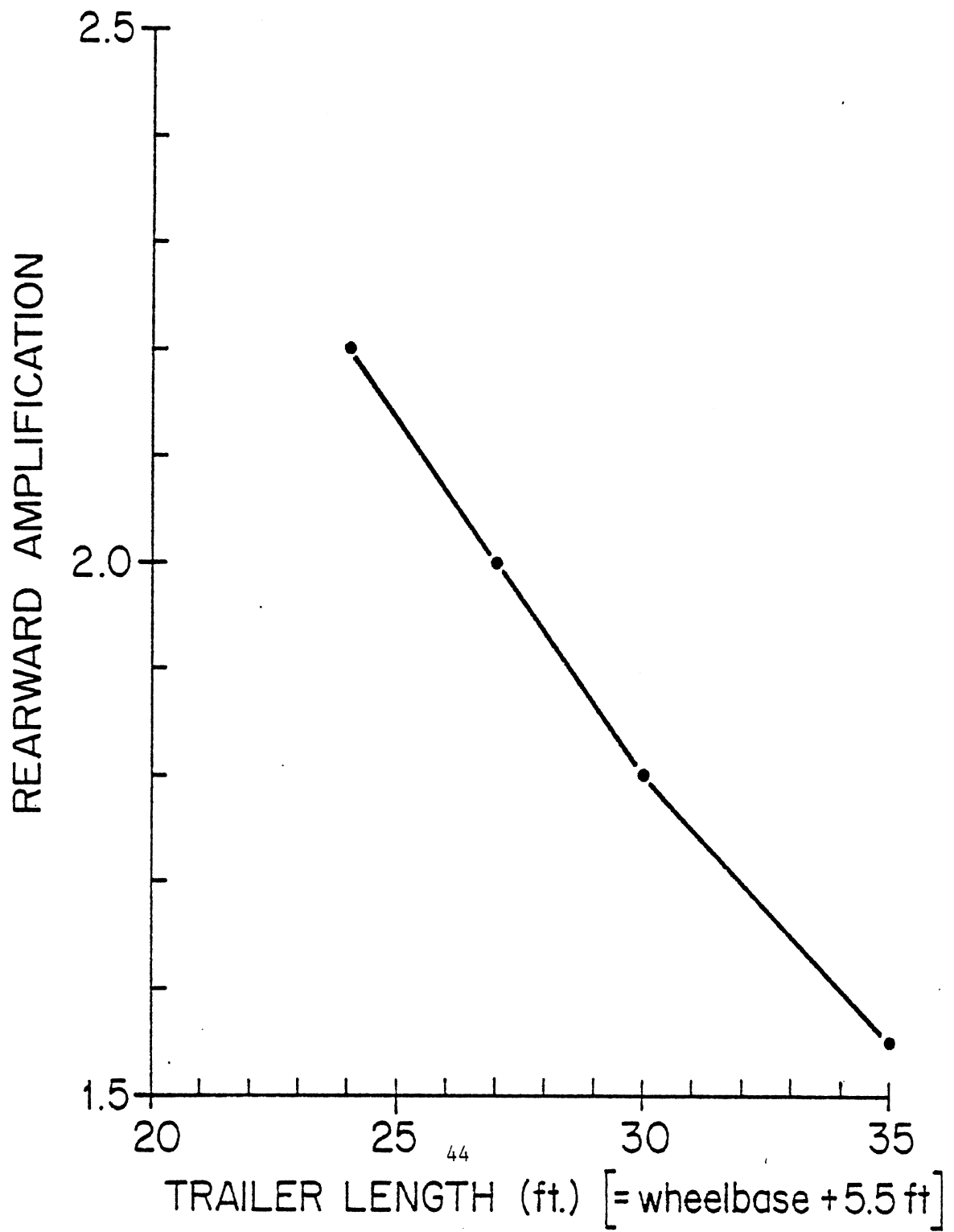

The influence of trailer length (and wheelbase) on Rearward Amplification for a 5-axle A-train double

FIGURE 3.1.2.e

Characteristic Behavior of Reference Vehicles on Load Transfer Ratio in Tractor/Semitrailers

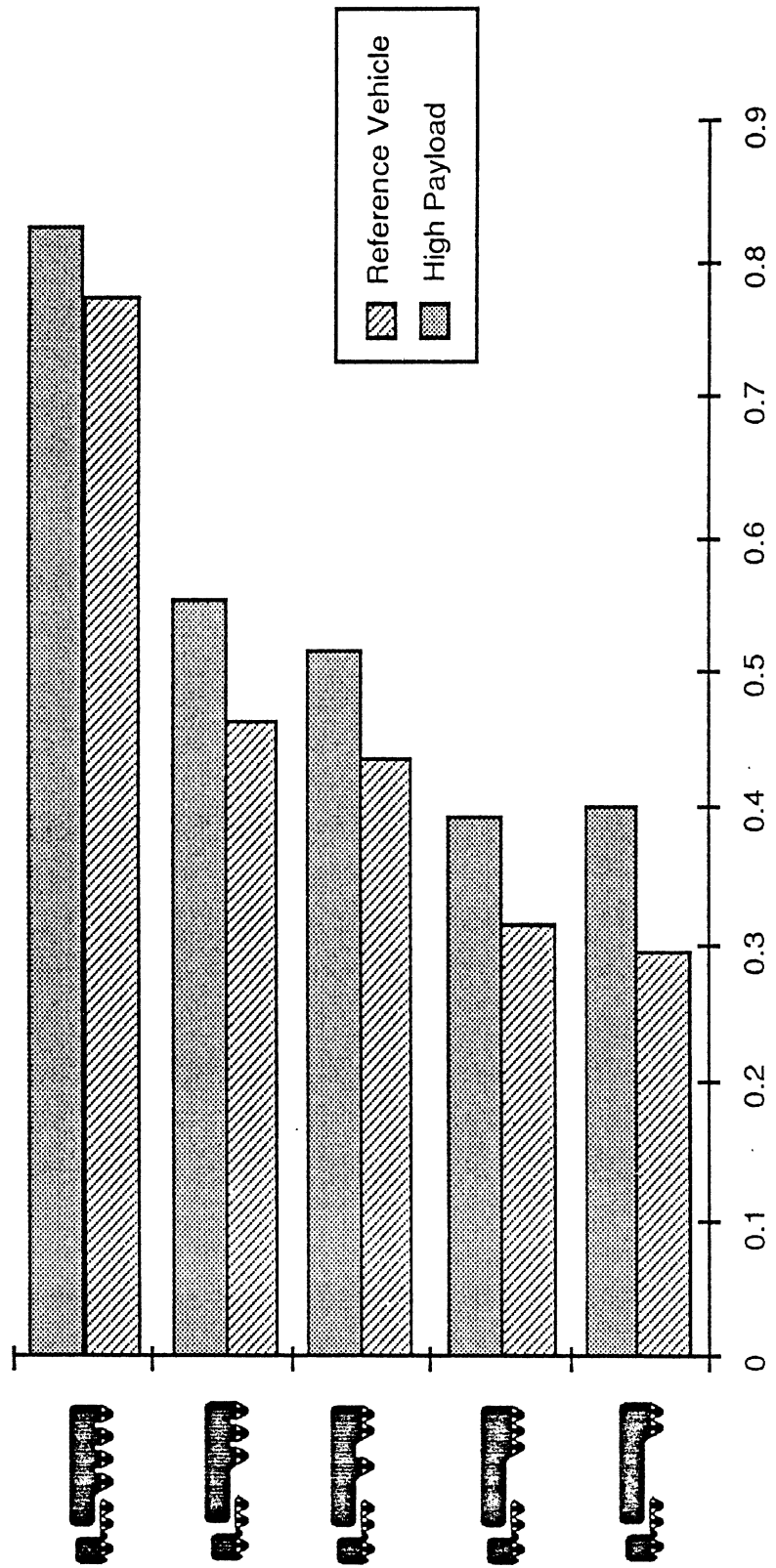

Load Transfer Ratio

FIGURE 3.1.2.f

increasing linearly with the increase in payload weight. Accordingly, the vehicles appearing toward the top of the chart exhibit quite different yaw response dynamics than those below, being both lower in yaw natural frequency and lower in yaw damping. When payload c.g. height is held constant at 2.67 m (105 in), we see that there is a clear increase in the load transfer ratio toward the top of the chart--primarily as a result of the differences in the yaw response properties which are instrumental in the rearward amplification mechanisms. (In fact, one could observe that it would probably be disastrous, from a total rearward amplification point of view, to assemble an A-train doubles combination out of trailers having the layout of the quad-axle trailer at the top.) Thus, both by means of reduced roll stability deriving from payload weight and c.g. height and by means of reduced effective wheelbase deriving from forward-spread trailer axles, the load transfer ratio response of tractor-semitrailer combinations is seen to be substantially dependent upon the axle layout arrangement on the semitrailer.

Shown in Figure 3.1.2g is a breakdown of the load transfer ratio values of A- and C-train doubles combinations. If we look only at the reference A-train combinations,, (tightly shaded bars), we see the influence of simple distinctions in trailer wheelbase, with the Rocky Mountain double and turnpike doubles at the bottom of the scale. The reference C-train cases (dark diagonal bars) indicate the profound improvement in this measure which derives from the combined roll-coupling mechanism described above plus the substantial reduction in rearward amplification which results from eliminating an articulation point at the pintle hitch location. In the "High Payload" cases, we see that the short A-train doubles will nearly roll over in this maneuver while the C-train alternative offers a great improvement. (Following on the parenthetical remark from the preceding paragraph, a turnpike double A-train comprised of the quad-axle semitrailer would be expected to register considerably worse than any other configuration on Figure 3.1.2g--notwithstanding the excellent dynamic stability of the "conventional" turnpike double in the illustrated data.)

Shown in Figure 3.1.2h are the load transfer ratios for B-doubles. Because a substantial level of rearward amplification is present in these relatively short-trailer B-trains, the results fall in the intermediate range of values for load transfer ratio. As with the tractor-semitrailers, the value of the measure is rising as additional axles are incorporated, thus shortening effective wheelbases and increasing payload mass and c.g. height. Overall, the B-train is seen as a much superior performer, from a dynamic stability point of view, than A-trains having corresponding payload capacity.

Characteristic Behavior of Reference Vehicles on Load Transfer Ratio in A and C Train Doubles

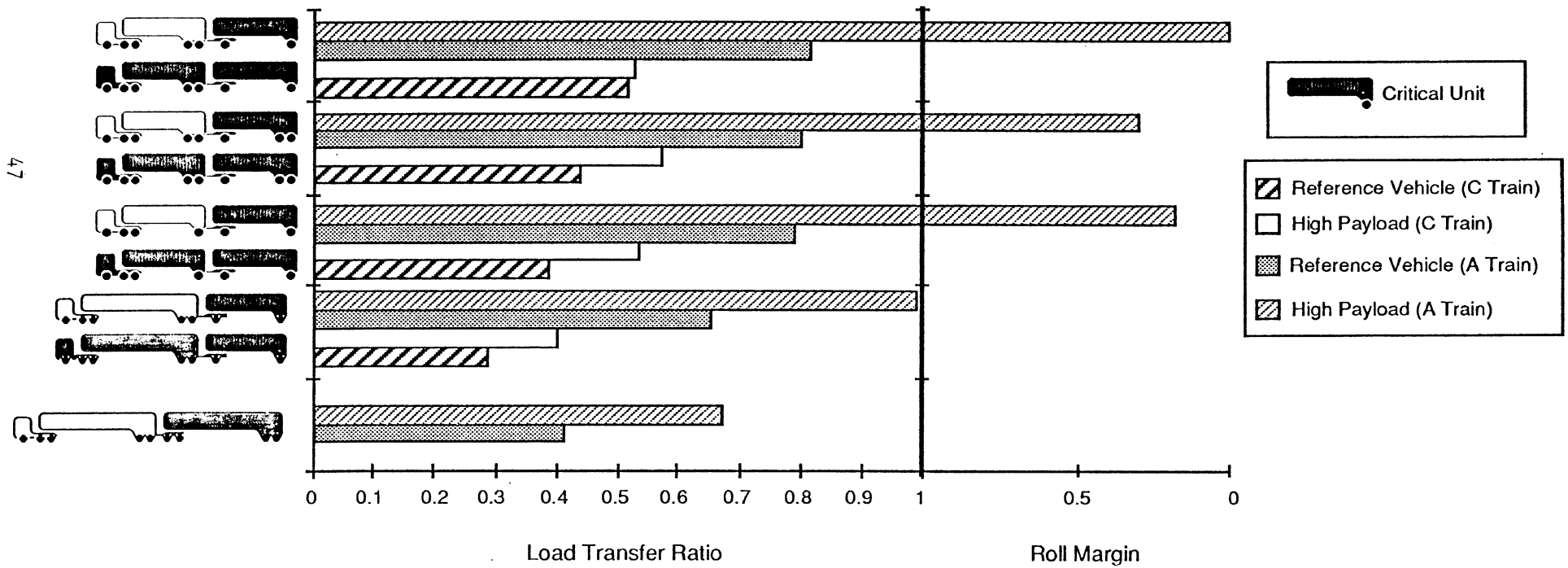

FIGURE 3.1.2.g

Characteristic Behavior of Reference Vehicles on Load Transfer Ratio in B Train Doubles

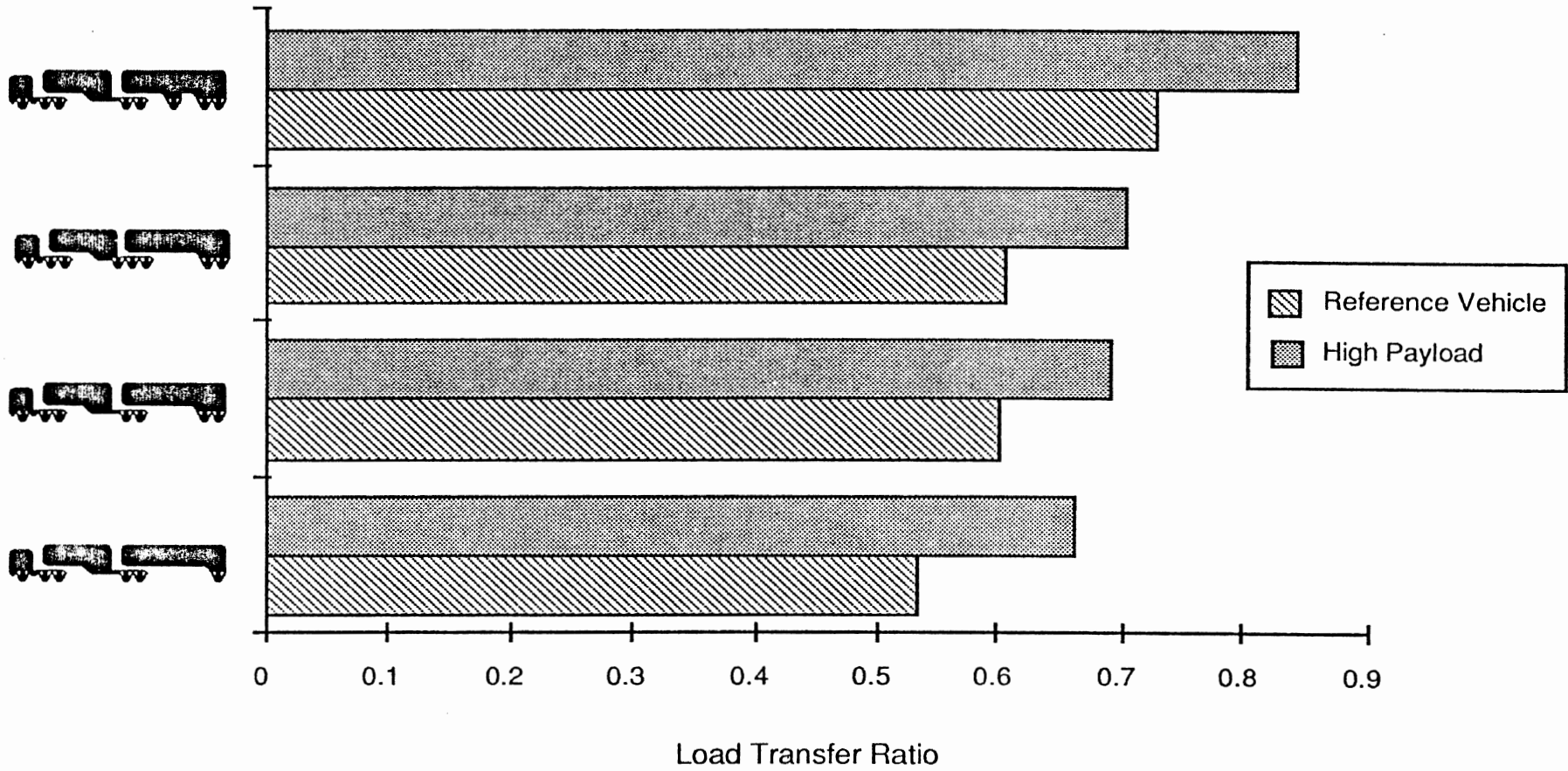

FIGURE 3.1.2.h

Figure 3.1.2i presents the load transfer ratio results for A- and C- triples combinations. Here we see the profound difference between the A- and C- configurations, with C-trains approximating the performance of the baseline five-axle tractor-semitrailer and A-trains either rolling over or very nearly approaching it. Relative to the A-train triple, the C-train version benefits by having eliminated one more articulation point, thus reducing rearward amplification, by having introduced roll coupling between trailers, and by the cumulative benefit of the increased phase lag in lateral acceleration response, from first to last unit.

It should also be noted that while truck / full-trailer combinations were not included in this study, there is clear evidence that they can also exhibit very substantial levels of rearward amplification and, thus, suffer excessive load transfer leading toward rollover in a rapid path change maneuver. [3,4,14,15,16]

Transient High-Speed Offtracking -- Comparison of Configurations

Shown in Figure 3.1.2j is the rank ordering of vehicle configurations according to the value of the transient high-speed offtracking measure. The total set of vehicles indicate a tremendous range of response values, from 0.3 m to over 1.6 m (1 to 5.3 ft). Recalling that the range of values for the steady-state measure of high-speed offtracking was only from 0.3 to 0.6 m (1 to 2 ft), it is clear that strong dynamic phenomena are available for producing an "overshoot" in high-speed offtracking in response to transient steering inputs, such as in the rapid path-change maneuver used here. The vehicles which have suffered the greatest increment in high-speed offtracking, from the steady-state response to the transient measure depicted here, are generally those which exhibit high levels of rearward amplification. Of course, the rearward amplification level must be inferred from other information about various vehicles (such as in Reference [2]) since this characteristic is rather obscured within the load transfer ratio measure--particularly for roll-coupled B- and C-trains. Nevertheless, for A- and B-trains the transient overshoot in high-speed offtracking is on the order of the rearward amplification value times the steady-state value of high-speed offtracking. Crude nominal values of the rearward amplification values are listed below for purposes of illustration:

Characteristic Behavior of Reference Vehicles on Load Transfer Ratio in A and C Train Triples

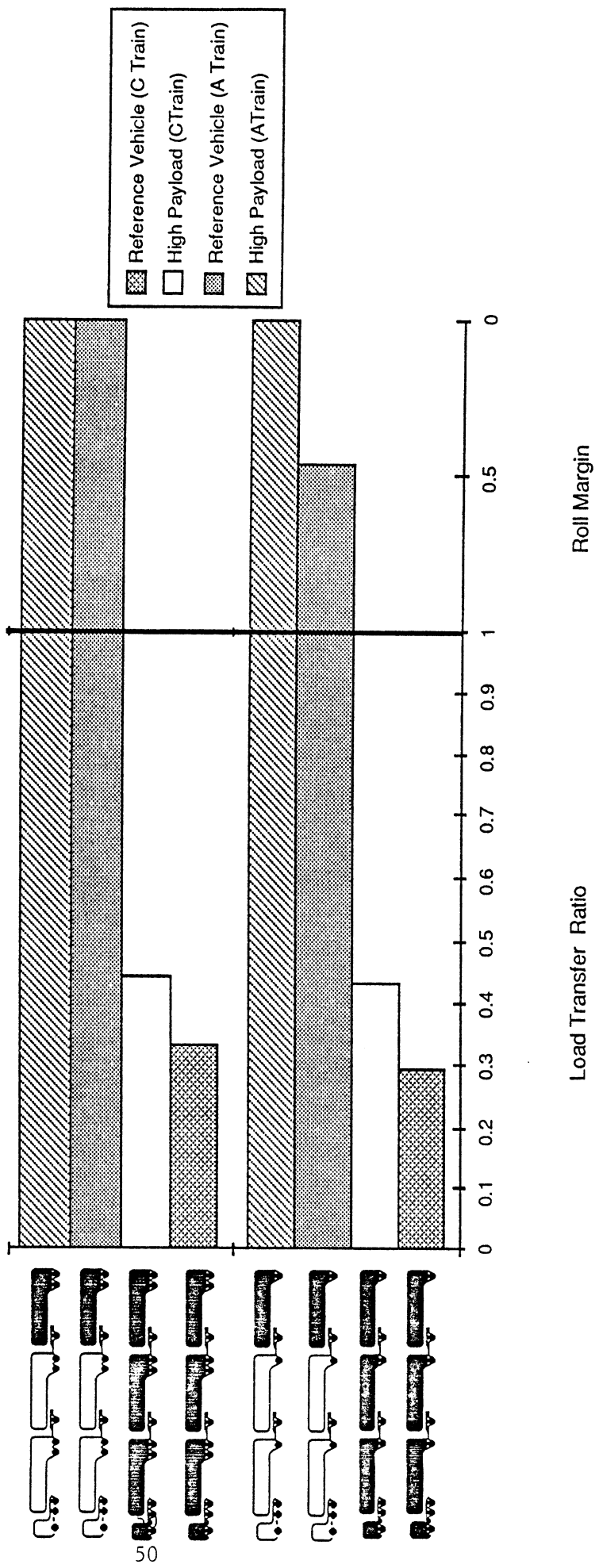
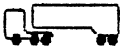



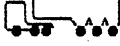
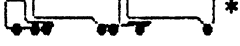



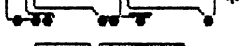
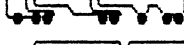

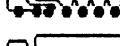
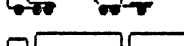
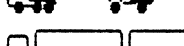

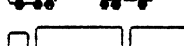
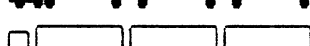

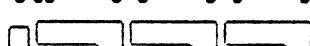



FIGURE 3.1.2.i

Ranked Order of Transient High-Speed Offtracking for Reference Vehicles

<u>Configuration</u>	<u>Vehicle</u>	<u>Train Type</u>	<u>Transient High-Speed Offtracking (meters)</u>	<u>Period (sec)</u>
1.1		B	0.298	3.0
1.2		B	0.318	3.0
1.5		B	0.436	3.0
2.4		A	0.453	3.0
1.3		B	0.463	3.0
2.5		C	0.522	3.0
3.3		B	0.533	3.0
3.2		B	0.599	3.0
3.1		B	0.608	3.0
2.5		A	0.684	3.0
3.4		B	0.728	3.0
2.2		C	0.743	3.0
2.1		C	0.753	3.0
1.4		B	0.772	3.0
2.1		A	0.783	2.5
2.2		A	0.852	2.5
2.3		C	0.913	3.0
2.3		A	0.999	3.0
4.1		C	1.003	3.0
4.2		C	1.218	3.0
4.1		A	1.62	2.5
4.2		A	Rollover	3.0

* Rocky Mountain Double

** Turnpike Double

FIGURE 3.1.2.j

<u>Vehicle Type</u>	<u>Nominal Rearward Amplification</u>
Tractor Semitrailer	1.0
B-Train Doubles	1.5
A-Train Doubles	2.0
A-Train Triples	3.0

Although there are certainly substantial variations on the indicated crude approximations of rearward amplification, one can obtain a reasonable estimate of the transient peak in high-speed offtracking by multiplying these numbers times the corresponding levels of steady-state high-speed offtracking seen earlier in Figure 3.1.1c. Moreover, we see the A-train triples standing well apart from the rest of the vehicle sample, with C-triples exhibiting quite high values as well. While the C-train configuration reduces the rearward amplification response in a major way, relative to A-trains, and provides a further dramatic reduction in load transfer ratio, it fails to strongly subdue transient high-speed offtracking when implemented through the caster-steered type of dolly designs which are popular in Canada. That is, because of the nature of caster-steered dolly axles, there may develop a substantial outboard-directed steer displacement such that a greater-than-desired extent of outboard offtracking accrues. The extent of this additional offtracking will depend entirely upon the character of the steer-centering features of the dolly axle design. Recent developments in kinematically steered dolly designs, however, may offer an opportunity for major reductions in transient high speed offtracking, as well as dramatic improvements in dynamic stability [17].

Shown in Figure 3.1.2k is an example time history of the transient high speed offtracking response of an eight-axle C-train triples combination. The figure illustrates the basic nature of the response; namely, that the trailing elements each produces its overshoot response, in turn, and that the axles on the rearmost trailer produce the largest outboard excursion, thus establishing the value of the transient high-speed offtracking measure. Clearly, the progressive growth in path deviation with each successively rearward trailer further reinforces the general observation that it is primarily rearward amplification mechanisms which promote the value of the subject measure. Accordingly, the sensitivities of this measure to differences in vehicle configuration are identically those which are well-documented as determining rearward amplification response. [2,3,4,12,13].

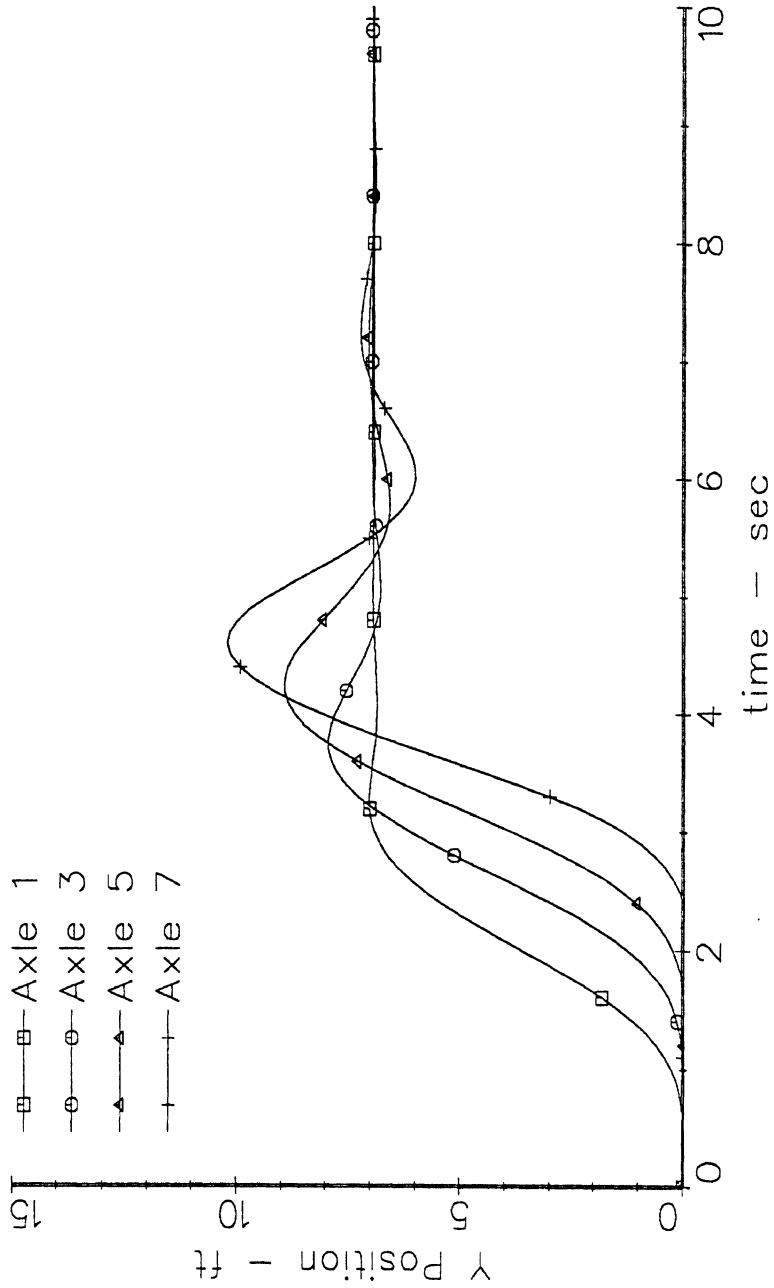

RTAC 8 axle C-train Triples (55t/121k GCW), conf. 4.1, var.

1.00

FIGURE 3.1.2.k Time histories of lateral displacement for differing axles of an 8-axle C-train showing transient high-speed offtracking.

3.1.3 Performance of Differing Configurations in a Tight-Radius, Intersection Turn at Near-Zero Speed. A wide range of performance levels are observed when the various reference truck configurations are subjected to the tight-turn maneuver. The spread in performance is discussed below in terms of both the "low-speed offtracking" measure and the "friction-demand" measure. Following a review of the performance levels exhibited across all combinations, the mechanics of response which distinguish between differing axle layouts within each vehicle category are discussed.

Low-Speed Offtracking -- Comparison of Configurations

Shown in Table 3.1.3a is a rank ordering of all the vehicles (neglecting C-trains in this presentation) for which the low-speed offtracking measure was computed. We see that the full range of results for these reference vehicle layouts covers offtracking values from 4.1 to 10.2 m (13.4 to 33.5 ft). Thirteen out of the eighteen illustrated cases exhibit less offtracking than the 5.9 m (19.4 ft) performance of the baseline 14.6-m (48-ft) 2-axle semitrailer and tractor. Thus, to the degree that this baseline vehicle is tolerable on Canadian roads, the bulk of the population of configurations pose no special problems with regard to low-speed offtracking. Moreover, only the triples and extra-length doubles combinations call for substantially greater maneuvering space at intersections than the cited baseline semitrailer.

It is also apparent that, for equal lengths of trailer beds and numbers of axles, A-train doubles perform slightly better than B-trains (compare, for example, A-train No. 2.1 with B-train No. 3.1). Additionally, the addition of axles to a vehicle having a given length invariably reduces offtracking, as will be discussed in more detail later (compare, for example, A-train No. 2.1 with A-train No. 2.2). The addition of more equal-length trailers to the combination, of course, contributes an increment in low-speed offtracking which is approximately proportional to the ratios of numbers of trailers (compare, for example, A-train double No. 2.1 with A-train triple No. 4.2).

Now, by means of selected sub-categories of vehicles, the primary distinctions in offtracking performance deriving from configuration details will be discussed. Shown in Figure 3.1.3b are the values of low-speed offtracking exhibited by each of the reference configurations of tractor-semitrailer. Although all of these trailers employ a 14.6-m (48-ft) bed length, large differences in low-speed offtracking are observed as a result of the trailer axle arrangements. We observe, simply, that the greater numbers of trailer axles serve to

Ranked Order of Low-Speed Offtracking for Reference Vehicles

<u>Configuration</u>	<u>Vehicle</u>	<u>Train Type</u>	<u>Low-Speed Offtracking (meters)</u>
2.1		C	4.113
1.4		B	4.166
2.1		A	4.293
2.3		C	4.407
3.1		B	4.473
2.3		A	4.593
2.2		C	4.753
3.2		B	4.754
2.2		A	4.881
1.3		B	4.942
3.4		B	5.051
3.3		B	5.061
1.5		B	5.492
1.2		B	5.577
1.1		B	5.906
4.2		A	6.172
4.1		A	6.791
2.5		C	7.489
2.5		A	7.606
2.4		A	10.207

* Rocky Mountain Double

** Turnpike Double

FIGURE 3.1.3.a
55

Characteristic Behavior of Reference Vehicles on Low-Speed Offtracking Tractor/Semitrailers

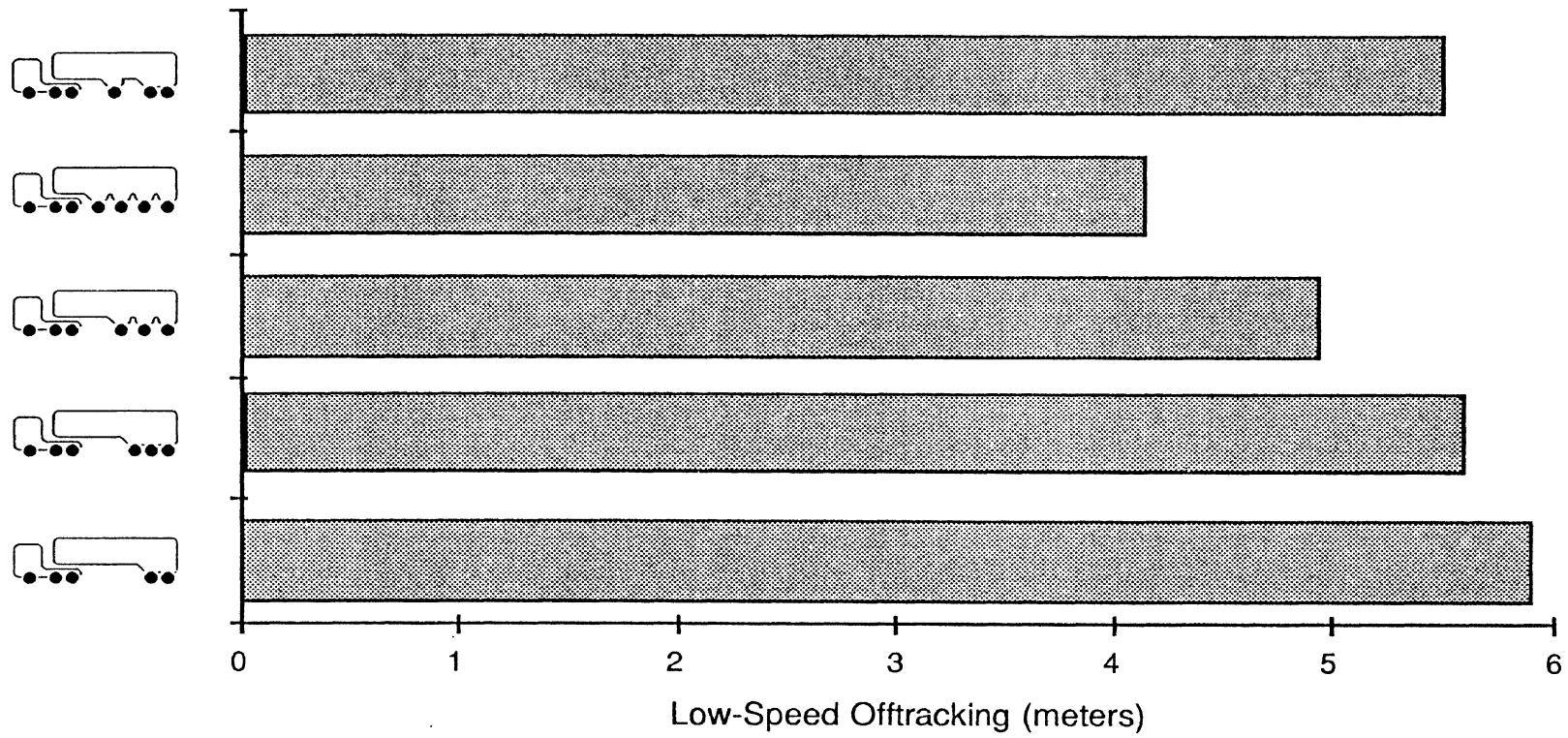

FIGURE 3.1.3.b

shorten the "effective wheelbase" of the trailer such that offtracking reduces--just as it would with a single-axle trailer having a correspondingly shortened geometric wheelbase.

The influence of multiple axle installations on offtracking have been illustrated in prior research [18,19] showing that the vehicle will track with a particular effective wheelbase at which the requirements for static equilibrium are satisfied. In order to appreciate how axle spread influences this effective wheelbase, one must recognize that tires on the spread axles will experience lateral slip when caused to track in a curved path. The manner in which the path is established must therefore result in tire slip angles, and thus lateral forces which satisfy the requirements for both force and yaw moment equilibrium. The characteristic result, for evenly spread and evenly loaded trailer axles, is that the effective wheelbase is somewhat longer than the geometric wheelbase measured to the center of the axle array.

Shown in Figure 3.1.3c are the low-speed offtracking results for the various configurations of A- and C-type doubles combinations. It is noted that three configurations at the bottom of the chart indicate minor differences from one another as a result of axle arrangements, even though all three incorporate the same pair of 8.2-m (27-ft) trailers. Again, the presence of a tandem axle pair on either trailer in these configurations serves to shorten the effective wheelbase relative to that achieved if a single axle is placed at the rear extremity of the trailer.

The two vehicle configurations yielding much higher values of offtracking response are the turnpike and Rocky Mountain doubles, respectively, which are seen as the first and second entries at the top of the chart. The extra large offtracking values exhibited by these two vehicles tend to place them in a class which is removed from the rest of the vehicle matrix and which is seen as generally in conflict with the space provided at most roadway intersections in North America. (For a recent treatment of this conflict issue, see Reference [20].)

We also note that the C-train version of each doubles configuration yields a 2 to 4% reduction in offtracking relative to the respective A-train configuration. This result, which is commonly recognized by the trucking community employing C-trains, derives from a classic "negative offtracking" [10] type of mechanism which arises due to the caster-steering nature of the dollies used on C-train combinations. That is, with the dolly rigidly coupled to the lead unit by two pintle hitches, the caster-steering feature permits the dolly to track somewhat outboard of the axles on the lead trailer. Accordingly, the net offtracking

Characteristic Behavior of Reference Vehicles on Low-Speed Offtracking in A and C Train Doubles

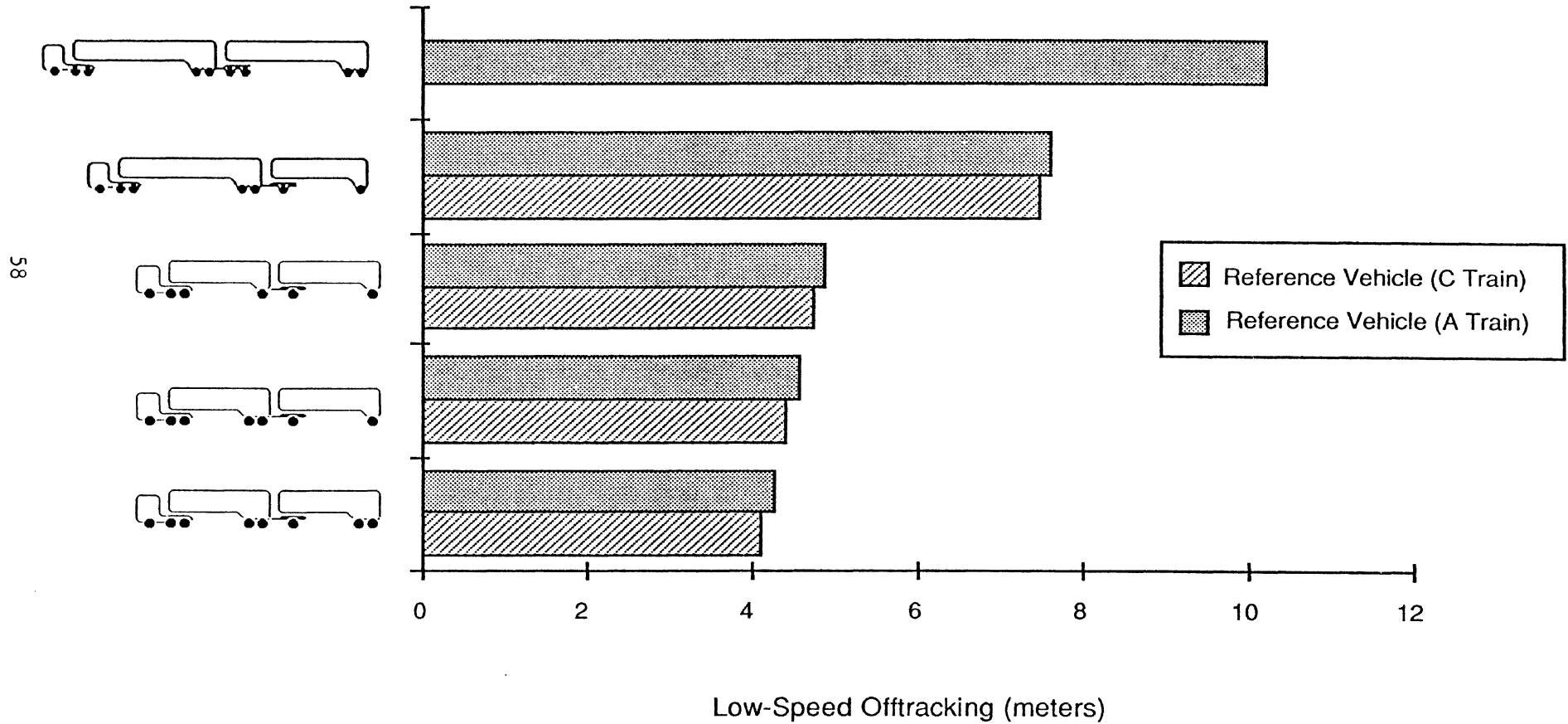

FIGURE 3.1.3.c

of the overall vehicle combination is reduced relative to that achieved when a conventional, inboard-tracking, A-dolly is employed.

Friction Demand in a Tight Turn -- Comparison of Configurations

Shown in Table 3.1.3d is a rank ordering of the vehicle configurations for which the "friction-demand" measure was computed. The results show that the value of this measure varies from the negligible range, well below 0.10 for various A- and B-doubles as well as two-axle tandem and three-axle tridem semitrailers, to a very demanding level of 0.71 in the case of the quad-axle semitrailer. While only the quad-axle semitrailer would seem likely to encounter general controllability problems due to this response property, it would appear that certain of the other semitrailer configurations would experience a substantial potential for a jackknife response during tight turning under wintertime conditions, on snow-covered pavement.

Looking more closely at the tractor-semitrailer combinations, in Figure 3.1.3e, we see that the configurations having a greater number, and greater geometric spread, of trailer axles suffer the largest levels of friction demand in this maneuver. By way of explanation, it is easily recognized that the demand for tire traction at the tractor rear wheels derives simply from the magnitude of the yaw-resisting moment which is produced when the non-steered trailer tires develop lateral slip while being drawn around a tight-radius turn. Analysis of the statics involved with simple, uniformly spaced, trailer axles [21] indicates that the lateral force, F_{y5} , which must be developed at the fifth-wheel coupling in order to satisfy equilibrium is described by the following relationship:

$$F_{y5} = \text{Summation of } (C_{\alpha} / R [d_i^2 / L])$$

where,

C_{α} = sum of the cornering stiffness of all tires on the i th trailer axle







R = instantaneous radius of turn

d_i = spread of the i th trailer axle from the geometric center of all trailer axles

L = trailer wheelbase (measured to the geometric center of all trailer axles)

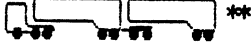
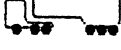
This relationship reveals that the summation of the ratios of the spread squared to the wheelbase of the trailer is the primary geometric determinant of the magnitude of the

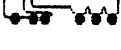
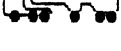
Ranked Order of Friction Demand in a Tight Turn for Reference Vehicles

<u>Configuration</u>	<u>Vehicle</u>	<u>Train Type</u>	<u>Friction Demand</u>
3.4		B	0.022
2.1		A	0.024
1.1		B	0.031
2.4	 **	A	0.045
1.2		B	0.051
3.1		B	0.078
2.1		C	0.112
1.3		B	0.217
1.5		B	0.303
1.4		B	0.709

** Turnpike Double

FIGURE 3.1.3.d

Characteristic Behavior of Reference Vehicles in a Tight Turn Jackknife Tractor/Semitrailers

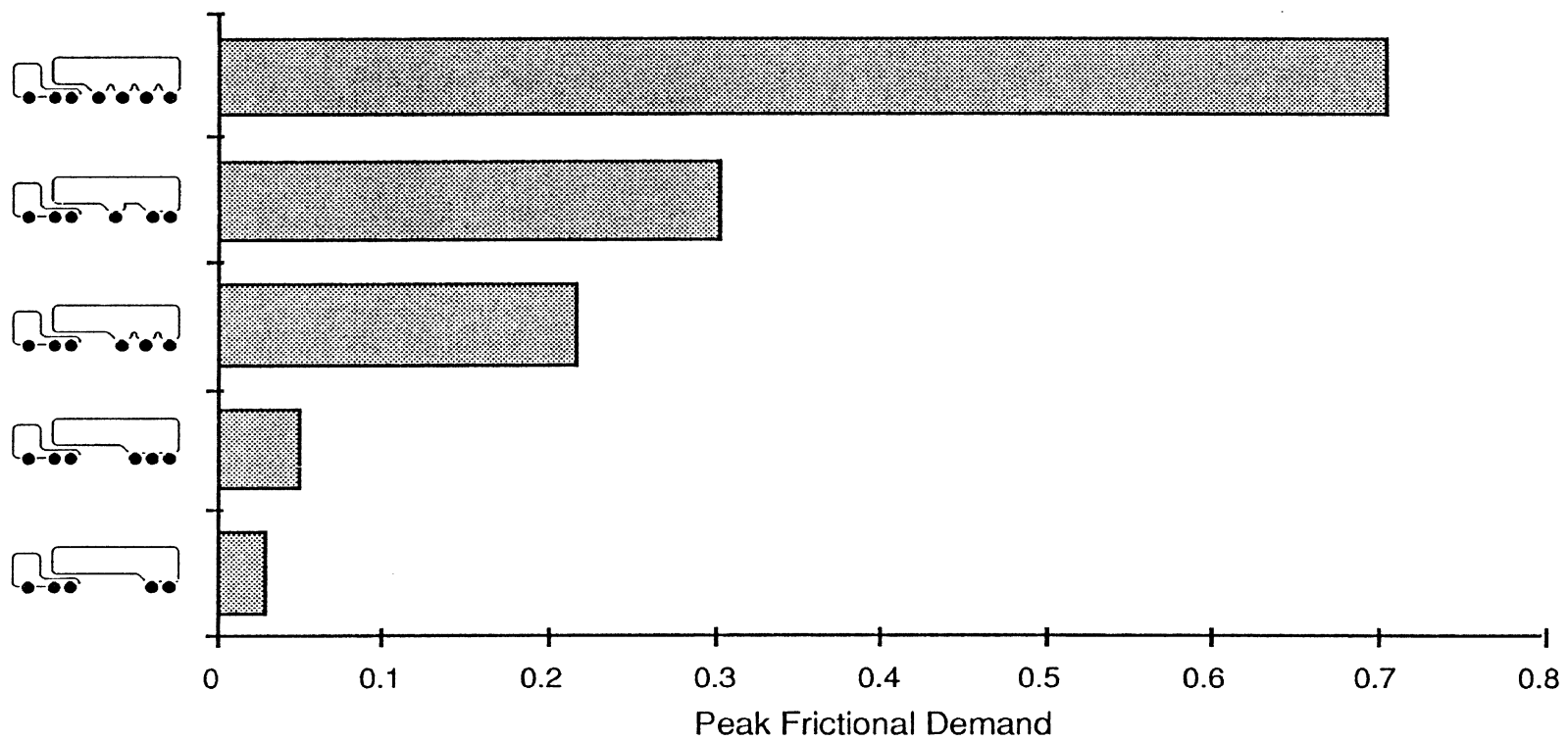

FIGURE 3.1.3.e

lateral force at the fifth wheel in a low-speed turn. Further, since the lateral force at the fifth wheel is approximately equal to the total traction forces developed at the tractor rear axles, the defined "friction-demand" measure is proportional to the summation of (d^2 / L) over all trailer axles. Applying this ratio as a descriptor of the respective semitrailers 1.1, 1.2, 1.3, and 1.4 which employ uniformly spaced sets of two, three, and four axles, respectively, Figure 3.1.3f confirms that the friction demand over a few widely differing configurations is, indeed, rather nearly proportional to the (d^2/L) normalizer.

Moreover, notwithstanding the simplified nature of this discussion, the (d^2/L) normalizer (together with axle load specifics if nonuniform loading prevails) can be used as a ready means for evaluating multi-axle semitrailer configurations to determine whether an inordinate friction demand should be expected from the vehicle layout.

Recognizing from the above discussion that the friction demand in a tight-radius, low-speed, turn maneuver is developed on the basis of trailer axle spread and wheelbase, there are few multi-trailer combinations which have the potential for posing a serious problem. Shown in Figure 3.1.3g, however, is an illustration of the relative implications of A- vs. C-train layouts with regard to the friction-demand measure. We see that while the A-train version of configuration 2.1 imposes a negligible 0.02 level of friction demand, the C-train configuration of the same vehicle registers a demand value which is approximately five times higher.

Clearly, this result reflects the wide spread dimension at which the C-train dolly axle is located. Recognizing that the frame of this type of dolly constitutes a rigid extension of the lead trailer, the dolly axle does impart a yaw-resistive moment to this trailer. The maximum value of this yaw moment is, of course, limited by the strength of the steer-centering mechanism in the individual dolly axle design. Nevertheless, the data in Figure 3.1.3g indicate that the steer-centering behavior of one example dolly is sufficiently stiff to yield a large increment in the friction demand level. Moreover, while there is no evidence here that the examined C-train vehicles pose a "problem level" of friction demand, the increase in demand level above that of corresponding A-trains is notable and readily explainable.

Results for other reference vehicle configurations will not be discussed here, recognizing that no cases other than those involving the very wide-spread semitrailer axle arrangements pose a significant problem per the friction demand measure. In

Friction Demand Results for Reference Tractor/Semitrailer Configurations:
 An illustration of the approximately linear relationship between
 Friction Demand and d^2/L characterization.

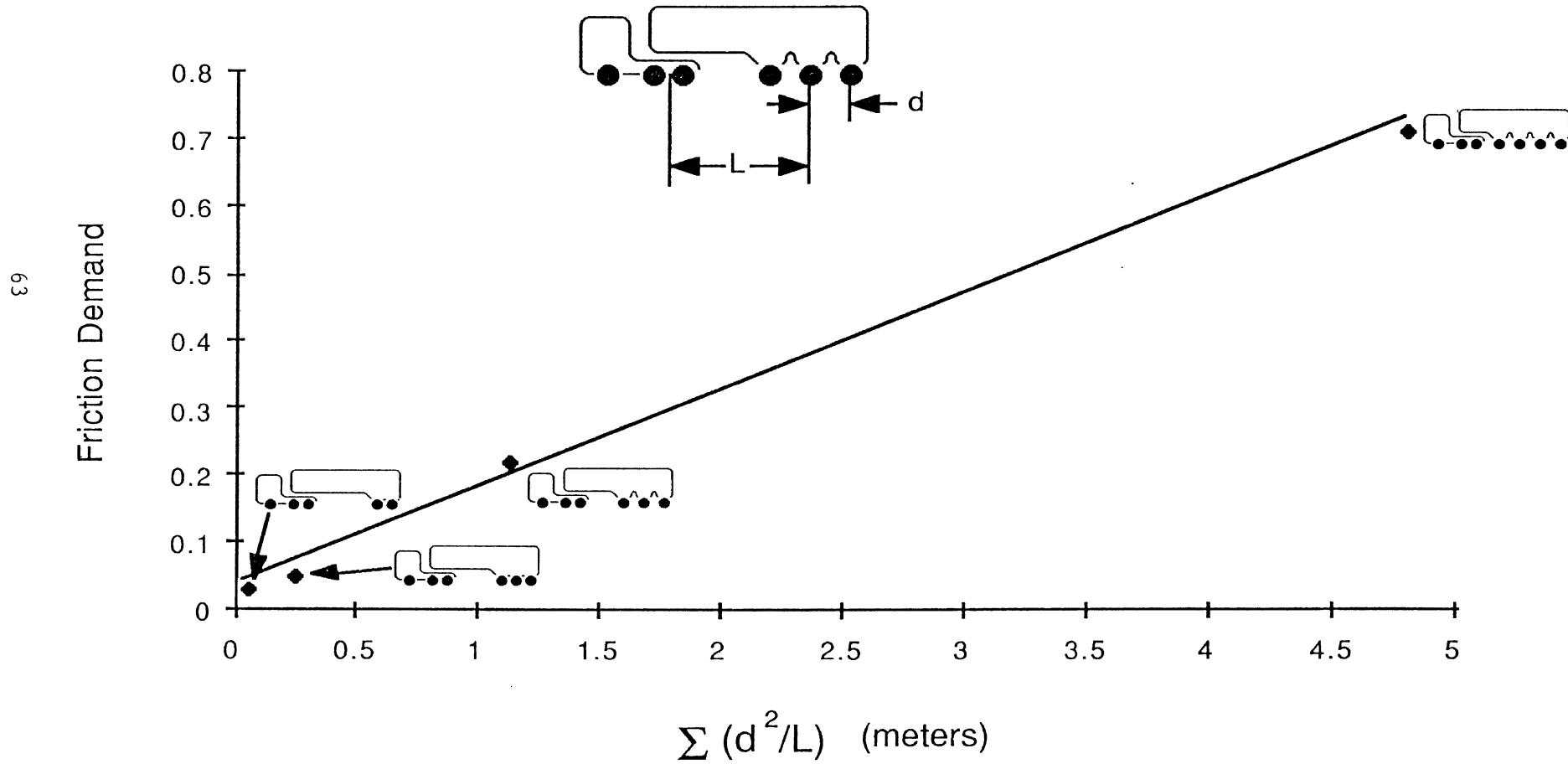

FIGURE 3.1.3.f

Mu Characteristic of Reference A and C Train Doubles

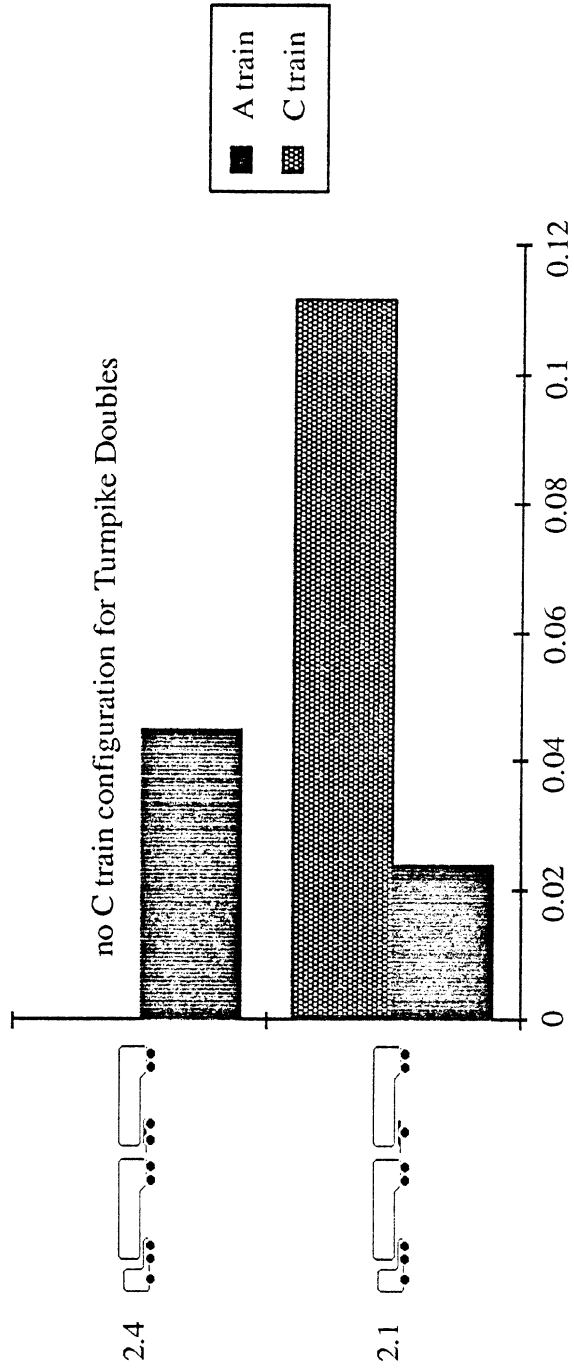

Figure 3.1.3.g

section 3.2.2, the influence of other variations in the tandem spread dimension on 2-axle semitrailers is explored over a range of values.

3.1.4 Braking Efficiency Performance of Differing Configurations.

The braking efficiency of the various truck configurations indicates the relative effectiveness with which the brake systems can utilize available tire/pavement friction level in achieving a given deceleration level. As explained in section 2.3, the 0.1 g level of deceleration pertains to very low level braking such as used to control speed on downgrades or to stop during normal operations. Stopping at the 0.4 g deceleration level constitutes a severe braking condition for heavy-duty trucks, since such vehicles are generally approaching their performance limits on dry pavements at this braking level. Performance measures presented below cover each of these two respective braking levels.

Braking Efficiency at a Low Level of Deceleration -- Comparison of Configurations







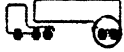

Shown in Figure 3.1.4.a is the rank ordering of the vehicles which were characterized by a braking efficiency computation at a deceleration level of 0.1 g. The data show a substantial range of efficiency values, from 72% to 96%. The differences in performance which are observed derive almost entirely upon two factors, namely,

- a) the protocol used to distribute brake torque gains on the respective tractor and trailer/dolly axles, and
- b) the distribution of static loads among the axles.

Vehicles which exhibit a high level of braking efficiency in this figure are those whose distribution of brake torque gains is proportional to the distribution of load across all of the vehicle's axles. The tractor-semitrailer, configuration 1.1, for example, enjoys a brake torque distribution which is almost identical to the static load distribution. The triples combination, No. 4.1, however, suffers a relatively low efficiency level because the tractor tandem axles are very lightly loaded (given the single-axle semitrailer layouts) such that a strong "overbraking" condition prevails at the tractor tandem axle positions. Likewise, other combination vehicles which do poorly are those which tend to "underload" the tractor tandem.

One could fairly assert that the indicated inefficiencies are not altogether necessary. That is, it would be possible to avoid the overbraking at tractor tandems which carry light

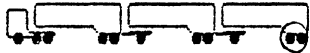
Ranked Order of Braking Efficiency at 0.1 G's for Reference Vehicles

<u>Configuration</u>	<u>Vehicle</u>	<u>Braking Efficiency (%)</u>
1.1		96.275
3.2		93.388
2.5	 *	91.977
2.4	 **	90.429
2.3		89.954
2.1		87.934
3.3		86.411
4.2		77.908
2.2		74.636
4.1		71.746

* Rocky Mountain Double

** Turnpike Double

Circle indicates the limiting axle set

FIGURE 3.1.4.a



loads by simply equipping the brakes on those axles with smaller air chambers, and/or shorter-length slack arms. Indeed, it may be that the more enlightened fleets operating such vehicles do attempt to "tailor" the brake system gains to match the expected loadings. Such an approach was not followed in designing the protocol for this study, however, in reflection of a more commonly perceived industry practice. Indeed, as long as there are tractors which will be applied in hauling differing kinds of trailer combinations from day to day, it may be impractical for brake torque gains to be more closely matched to static loads than the study protocol assumed.

Another aspect of the challenge for providing good braking efficiency, overall, pertains to the operation of the vehicle in the empty state. Shown in Figure 3.1.4b is a rank ordering of the vehicle combinations according to a computed efficiency at 0.1 g's of deceleration, with the vehicles empty. Here we see rather low levels of efficiency, simply as a result of the peculiar distributions of loads as prevails in the empty state. For example, no configuration is seen to be limited in braking efficiency under these conditions by overbraking of the tractor tandem axles--since these axles tend to be more heavily loaded in the empty condition than trailer axles. (Of course, in practice, drivers frequently experience jackknife accidents in the empty condition, thus implicating lockup at the tractor tandem, simply because (a) trailer brakes tend to be somewhat time-delayed in application behind tractor brakes, and (b) very little additional application of the brake treadle is needed to achieve lockup at the tractor tandem, thus precipitating the more rapidly-diverging jackknife instability.) Also, the low ranking for the B-train double, configuration 3.2, for example, derives from the fact that both the tractor tandem and the B-train centergroup of two axles are relatively more heavily loaded than the rearmost tandem. Thus, the rear tandem is overbraked in the empty state, producing a low level of efficiency (unless, again, the operator were to select brake components giving a more favorable distribution).

Braking Efficiency at a High Level of Deceleration -- Comparison of Configurations

Shown in Figures 3.1.4c and d are rank order listings of the various configurations which were characterized by means of the braking efficiency measure at a deceleration level of 0.4 g for cases of the reference and "high c.g." loading cases, respectively. The results show distinctly lower levels of efficiency and some change in the rank order relative to the results seen at the low braking level. At this braking level, load transfer is an important mechanism in determining the relative match between the axle load and the axle brake torque.

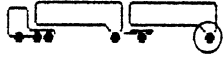
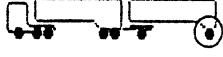
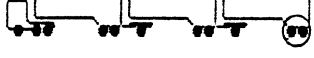
Ranked Order of Braking Efficiency at 0.1 G's for Empty Reference Vehicles

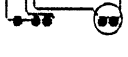
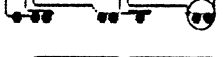
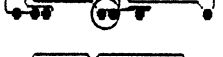
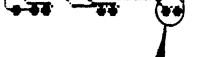









<u>Configuration</u>	<u>Vehicle</u>	<u>Braking Efficiency (%)</u>
4.1		77.516
2.2		71.809
2.5		69.393
4.2		69.216
2.4		67.913
3.3		67.808
1.1		67.216
2.1		64.362
2.3		61.606
3.2		55.997

* Rocky Mountain Double
 ** Turnpike Double

Circle indicates the limiting axle set

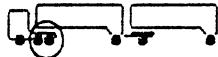
FIGURE 3.1.4.b

Ranked Order of Braking Efficiency at 0.4 G's for Reference Vehicles









<u>Configuration</u>	<u>Vehicle</u>	<u>Braking Efficiency (%)</u>
2.5	 *	87.78
3.3		85.565
1.1		83.52
2.3		79.989
3.2		75.504
2.4	 **	71.143
2.2		71.05
2.1		69.7
4.1		67.551
4.2		60.803

* Rocky Mountain Double
 ** Turnpike Double

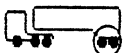
Circle indicates the limiting axle set

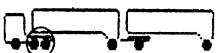
FIGURE 3.1.4.c

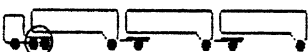
Ranked Order of Braking Efficiency at 0.4 G's for High Payload Vehicles

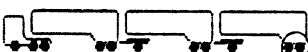
<u>Configuration</u>	<u>Vehicle</u>	<u>Braking Efficiency (%)</u>
3.3		88.434
2.5	 *	88.058
1.1		80.328
2.3		77.86
2.4	 **	74.748
2.2		74.494
3.2		72.122
4.1		71.111
2.1		65.167
4.2		55.826

* Rocky Mountain Double

** Turnpike Double

Circle indicates the limiting axle set

FIGURE 3.1.4.d





Note that Figures 3.1.4c and d provide indicators of the axle set that was most overbraked and, thus, constituted the determining factor in limiting the efficiency level for each overall vehicle. Recognizing that load transfer during braking places increased load forward, with aft loads getting lighter, a few examples serve to explain the pattern of performance differences seen across configurations.

Figure 3.1.4c indicates that since the tractor tandem axles on configuration 2.5, the Rocky Mountain double combination, are overbraking in the reference case, the high-c.g. condition is handled without a decline in braking efficiency (since the increase in load at the tractor tandem due to the greater load transfer from a high-c.g. payload tends to load up an "underloaded" axle. On the other hand, vehicles such as the B-train configuration, 3.2, which are limited at their rear trailer axles in the reference case suffer even more loss of load at the rear trailer axles under the high-c.g. case, with a resulting degradation in braking efficiency level. Similarly, we see that among the two triples combinations, 4.1 and 4.2, the former is limited at its tractor tandem such that an increase in c.g. height results in improved braking efficiency while the latter is limited at its rear trailer axles and suffers a corresponding loss in efficiency at the high-c.g. condition. Further, the increments in efficiency resulting from the change in c.g. elevation are greater with vehicles, such as the triples combinations, which incorporate relatively short trailers.

Shown in Figure 3.1.4e are the braking efficiency levels of empty vehicles at the 0.4 g level of deceleration. Braking efficiency levels are reduced below the results for the loaded vehicles and the rank order of differing vehicles is greatly changed, from the loaded to empty cases. All but two of the vehicles are limited by the overbraking of the rearmost axle on the combination--primarily due to the distribution of static loads (the dynamic load transfer occurring in the empty state is, of course, much reduced because c.g. heights are quite low).

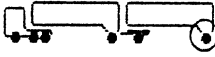
Moreover, substantial differences in braking efficiency can distinguish one vehicle configuration from another--primarily as a result of the prevailing distribution of brake torques and static loads. Also, however, the length of the unit wheelbases will influence the importance of load transfer, which increases when either the deceleration level or the c.g. height are raised.

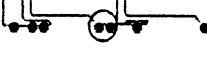
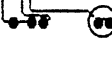
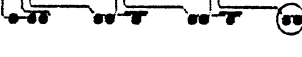
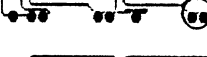
Ranked Order of Braking Efficiency at 0.4 G's for Empty Reference Vehicles

<u>Configuration</u>	<u>Vehicle</u>	<u>Braking Efficiency (%)</u>
4.1		69.551
2.2		65.403
2.5		62.395
3.3		61.019
2.3		57.391
1.1		57.048
4.2		56.192
2.1		52.313
2.4		51.235
3.2		42.144

* Rocky Mountain Double

** Turnpike Double

Circle indicates the limiting axle set

FIGURE 3.1.4.e

3.2 Illustration of the Parametric Sensitivities for Tractor-Semitrailer Combinations

In this section, the influence of changes in individual parameters on the various measures of performance will be addressed for the tractor-semitrailer category. In each subsection to follow, the discussion will primarily address those parametric sensitivities which are positive--that is, in which the examined change in the value of a parameter produces a measurable change in the behavior of the vehicle. Nevertheless, certain "negative" or "null" influences have also been documented and will be presented, as well.

3.2.1 The Influence of Tractor and Trailer Length Dimensions. In Figure 3.2.1a are results showing the influence of tractor wheelbase and trailer length on the high-speed offtracking measure. Variations in the trailer length parameter are, in fact, accompanied by corresponding changes in semitrailer wheelbase since the kingpin setting and the rear overhang dimension beyond the center of the trailer tandem are kept constant. We see that high-speed offtracking goes up with increasing tractor wheelbase and down with increasing semitrailer length (and semitrailer wheelbase). This result is in keeping with findings reported in Reference [2] in which the high-speed offtracking response in a steady curve reaches a maximum for wheelbase values in the vicinity of 7 m (23 ft) (given a selected set of tire cornering properties representing modern radials and a speed of 88 km/h (55 mph)). Although the speed value employed in the calculations shown here was 100 km/h (63 mph), the basic nature of the sensitivity is identical to that reported earlier. Thus, we see that for typical values of tractor wheelbase, the sensitivity of high-speed offtracking to increasing tractor wheelbase is positive since tractor wheelbase is always below the "maximum response" value--in the vicinity of 7 to 8 m (23 to 26 ft).

Alternatively, long semitrailers such as employed in conventional five-axle tractor-semitrailer combinations are characteristically longer in wheelbase than the "maximum response" value such that sensitivity of high-speed offtracking to variations in the wheelbases of such trailers is negative. Moreover, for reasonable variations in the wheelbases of tractors and semitrailers explored here, the high-speed offtracking of five-axle tractor-semitrailers remains within the relative modest range of 1/3 meter.

Shown in Figure 3.2.1b are data illustrating the influence of changes in the tractor wheelbase and the overall length of the two-axle semitrailer on low-speed offtracking. Firstly, it is worth noting that the increase in the offtracking measure over the common range of tractor wheelbases (from 3.81 to 6.35 m (150 to 250 in)) is not inconsequential. That is, the approximate 0.7 m (2.3 ft) change in offtracking due to tractor wheelbase

Influence of Tractor Wheelbase and Trailer Length on High-Speed Offtracking in Tractor/Semitrailers

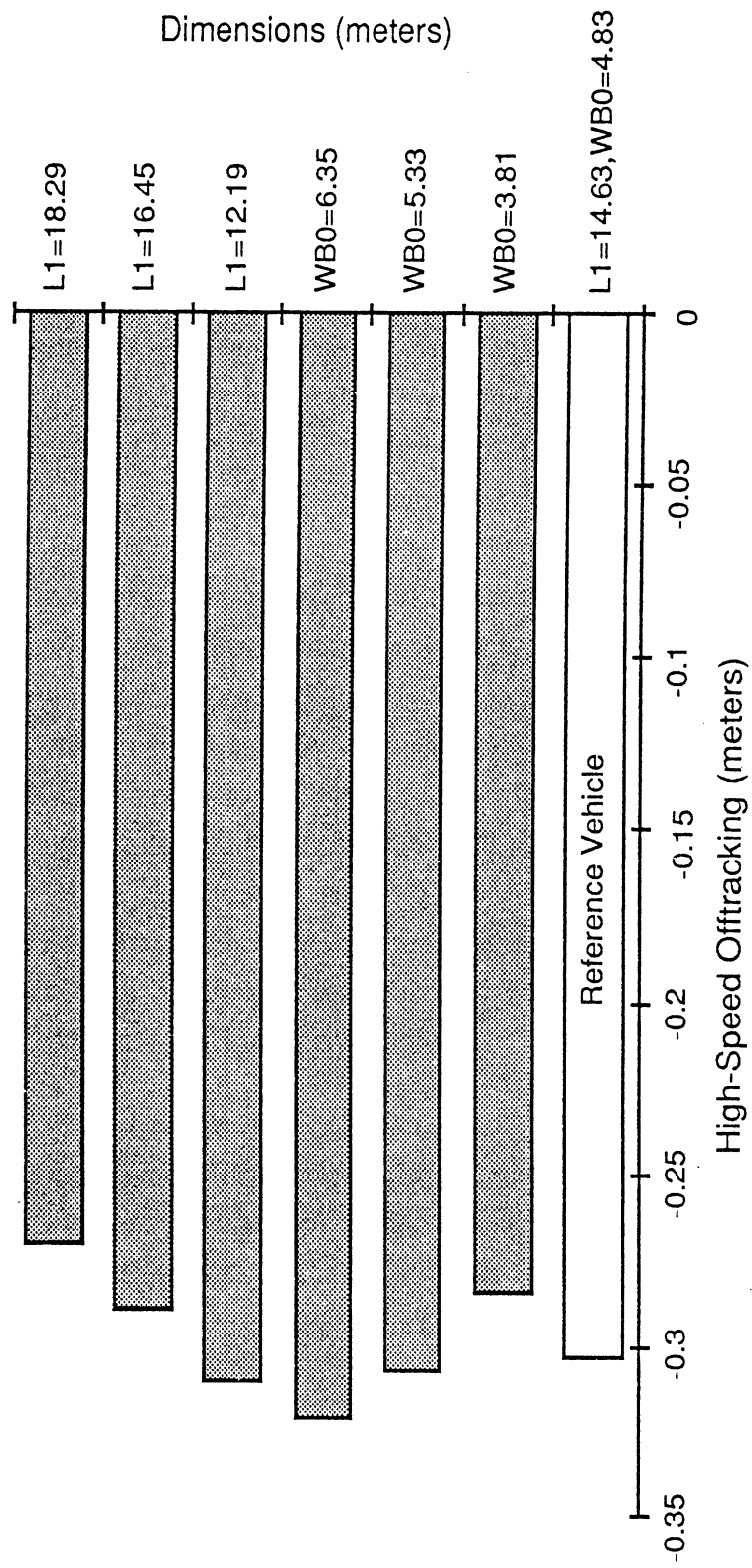
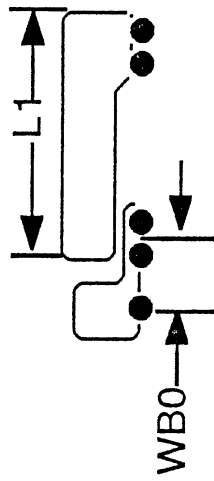

FIGURE 3.2.1.a

Influence of Tractor Wheelbase and Trailer Length on Low-Speed Offtracking in Tractor/Semitrailers

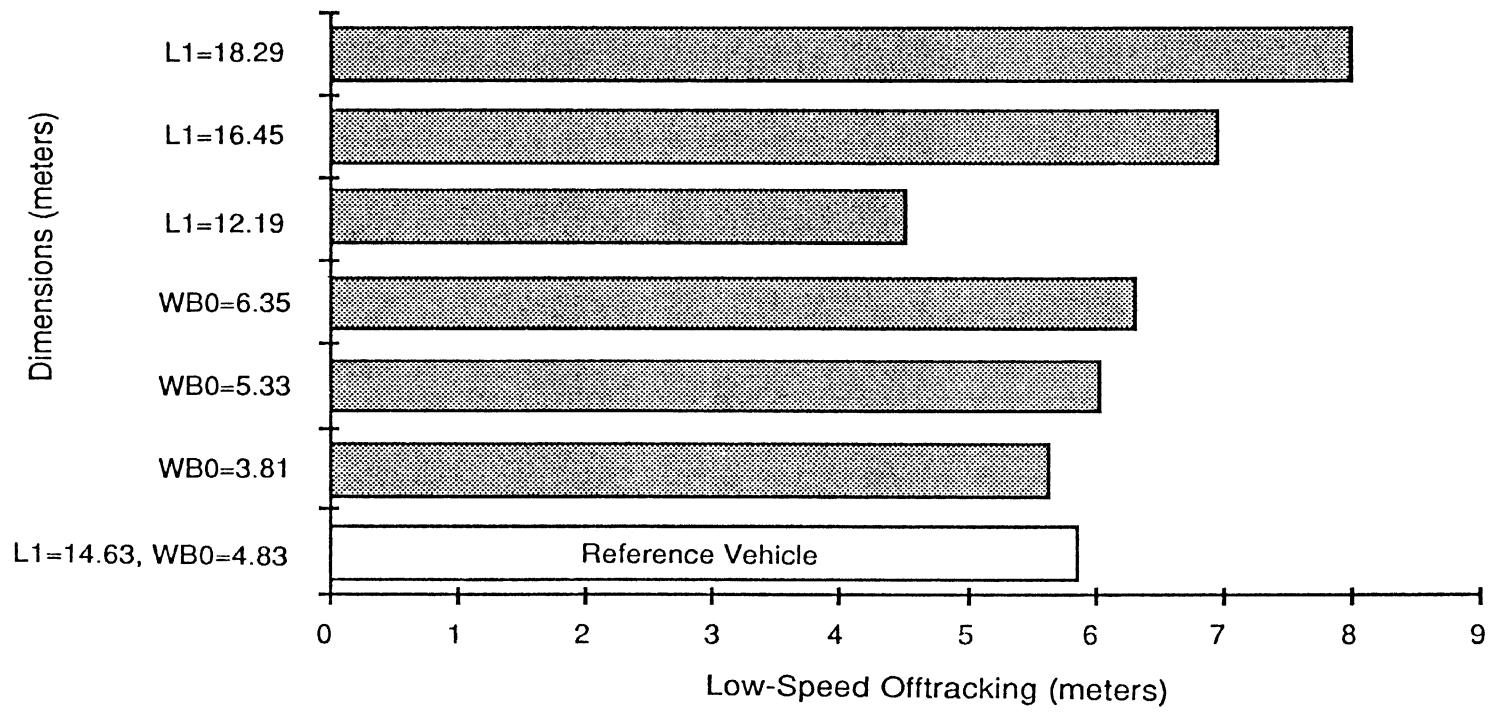
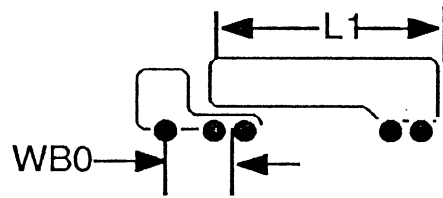

FIGURE 3.2.1.b

selection is, indeed, significant to the issue of vehicle clearances at intersections [22]. It is more common, however, to see attention being given to the much larger changes in offtracking deriving from variation in trailer length, and thus wheelbase. In each of the computations represented in Figure 3.2.1b, the wheelbase is equal to the indicated overall length value minus a constant dimension of 2.3 m (7.5 ft). The indicated range of trailer lengths, from 12.19 to 18.29 m (40 to 60 ft) is seen to result in an approximate 3.5 m (11.5 ft) increase in the offtracking dimension.

Moreover, the results indicated here illustrate the well known fact [10] that wheelbase elements influence low-speed offtracking in relation to the square of the wheelbase value. Thus, we see that each 1m (3 ft) increase in semitrailer wheelbase, relative to the reference case, results in some 0.6 m (2 ft) of additional low-speed offtracking while each meter increase in tractor wheelbase produces a 0.35 m (1.1 ft) increase in low-speed offtracking.

In Figure 3.2.1c are results showing the influence of tractor and trailer length dimensions on the braking efficiency measure. We see that very little sensitivity to the changes in wheelbase and length parameters occurs since the length changes do not result in a variation in static load distribution. Accordingly, the small changes in performance that are observable occur only as a result of the stronger load transfer function with decreasing wheelbase. Absolutely no change in the braking efficiency measure is observed with variations in tractor wheelbase since it is the trailer axles which are overbraked and which are limiting the efficiency of the overall system. Accordingly, we do see that shortening the semitrailer length, to 12.19 m (40 ft) from the reference value of 14.63 m (48 ft), for example, results in a greater amount of load transfer such that the load on the semitrailer axles reduces, especially at the 0.4 g braking level. This reduction in dynamic load during braking causes the trailer wheels to lockup at a lower level of deceleration and thus produce a lower value for the braking efficiency measure. It can be generalized, however, that modest changes in length, or wheelbase, do not strongly affect braking efficiency level as long as (a) static load distribution remains the same, or (b) whatever changes in static loads do occur are compensated with an equivalent redistribution of brake torque gains among the axles.

3.2.2 The Influence of Spread Dimension Associated with Two-Axle Tandems. In Figure 3.2.2a are results showing the influence of tandem spread and increased loading, which may accompany wider spread values, on high-speed offtracking of the five-axle tractor-semitrailer. Since the changes in spread dimension were

Influence of Tractor Wheelbase and Trailer Length on Braking Efficiency in Tractor/Semitrailers

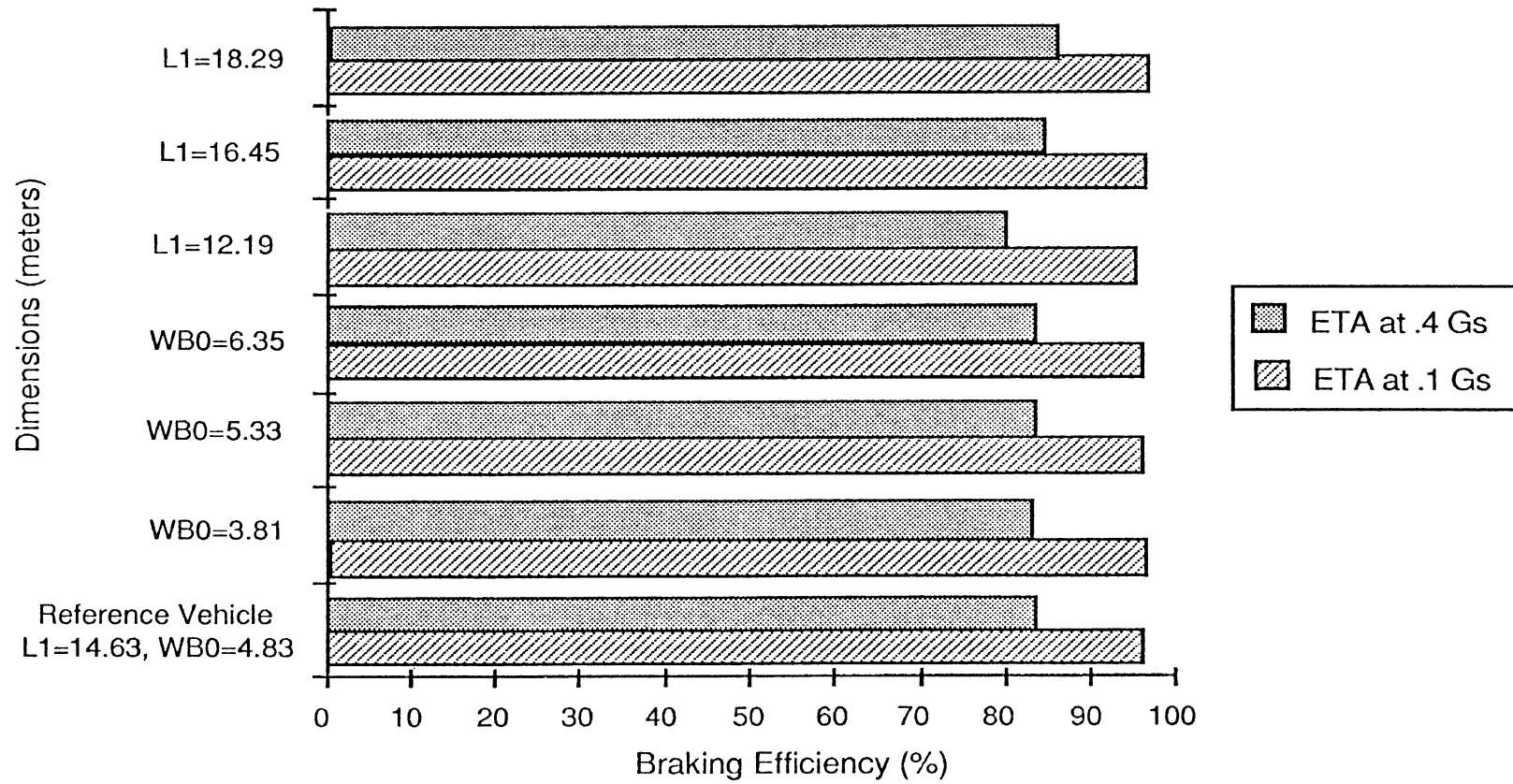
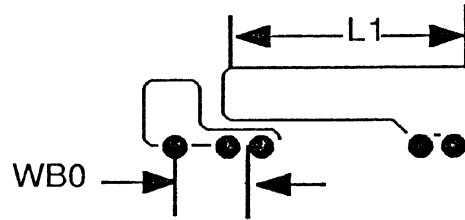
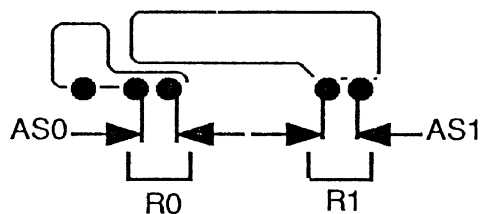

FIGURE 3.2.1.c

Influence of Tandem Spread Dimensions on High-Speed Offtracking in Tractor/Semitrailers



78

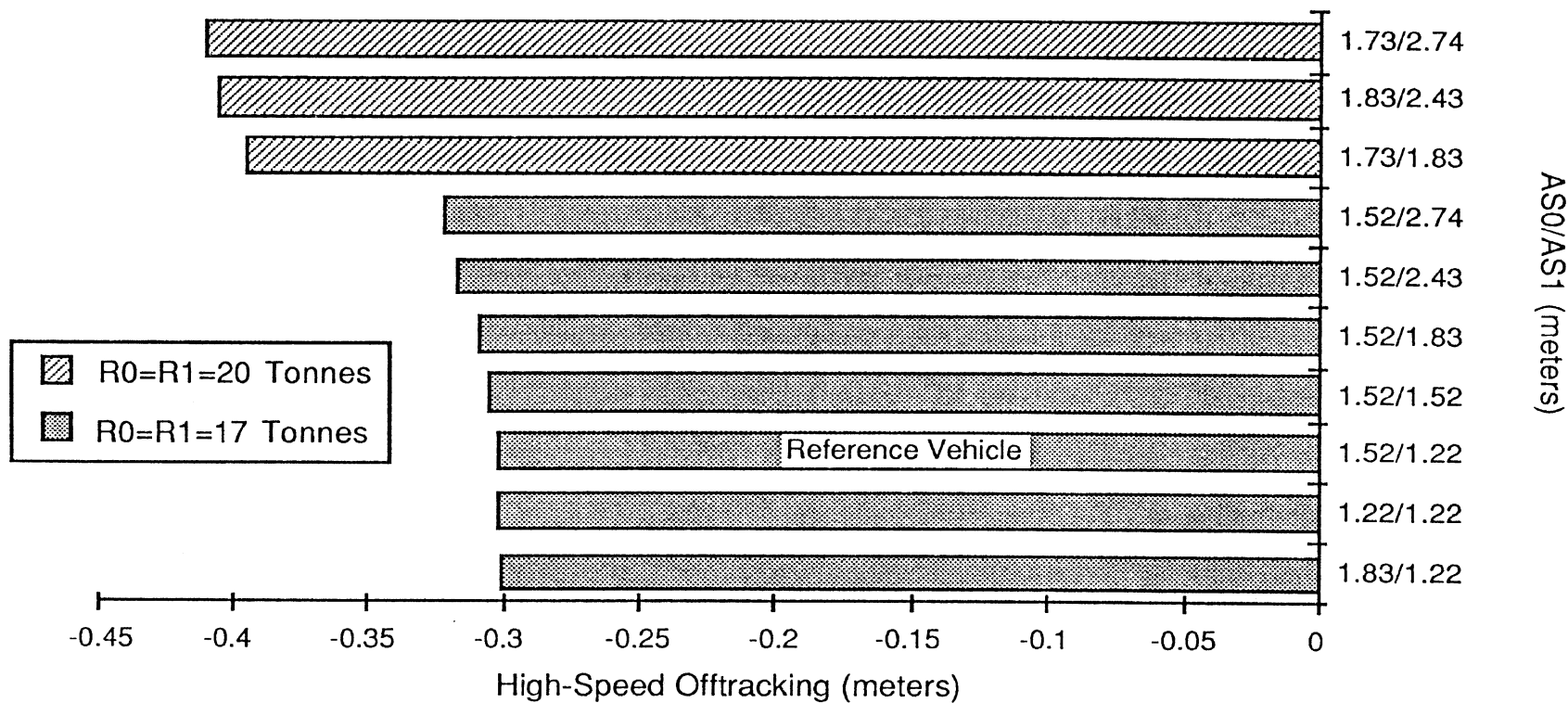

FIGURE 3.2.2.a

implemented here in such a way that wheelbases were not varied, the range of performance which is observed derives from variations in the operating conditions of the tires. Namely, for all of the cases in which the tandem loads are kept constant at 17 tonnes (37,468 lb), the small changes in high-speed offtracking derive from alterations in the slip angles prevailing at the various wheel positions as a result of the tandem-spread dimensions. Since the tire exhibits a nonlinear relationship between lateral force and slip angle, the variations in slip angle imposed by the turn-resistive nature of an increasingly spread tandem pair causes the tires to operate at effectively lower cornering stiffnesses, with high-speed offtracking slightly increasing as a result. When the spread change is accompanied by a substantial increase in load, to 20 tonnes (44,080 lb) on each tandem, the nonlinear sensitivity of tire cornering stiffness to increased loading causes a more significant increase in high-speed offtracking. Indeed, one can generalize that while load changes can significantly influence high-speed offtracking, modest variations in the spread of two-axle tandems does not result in a significant change in this response property.

Shown in Figure 3.2.2b are data illustrating the (lack of) influence of changes in spread on the trailer, tractor, and combined trailer/tractor tandem axles on low-speed offtracking performance. Note that the cases are labelled by tandem spread value and also include variations in axle load which, of course, have no influence on low-speed offtracking response. It is clear that reasonable variations in the spread dimension on two-axle tandems, however combined between tractor and trailer tandems, are basically inconsequential to low-speed offtracking. The lack of influence shown here derives from the convention that the variations in trailer and tractor tandem spread were implemented while holding the geometric wheelbases (measured to the tandem centers) constant. In Section 3.2.9, results will be presented in which the spread between the axles of a tridem arrangement are varied while holding the rearmost axle fixed such that effective wheelbase of the trailer increases, with consequent influence on low-speed offtracking performance.

Shown in Figure 3.2.2.c are the friction-demand values associated with the same set of tandem spread variations as discussed above. Although the influence of an increasing spread in the trailer axle layout was seen in Section 3.1.3 to result in profound levels of friction demand when three and four trailer axles were involved, the magnitude of the turn-resisting moment that can be generated with the baseline two-axle semitrailer is more modest. (See also Section 3.2.9.) Thus, the indicated sensitivities in Figure 3.2.2.c, while having the same trends as discussed earlier, do not suggest that a significant friction demand problem should derive with two-axle semitrailers as a result of tandem spreads (up to 2.7 m (108 in)).

Influence of Tandem Spread Dimensions on Low-Speed Offtracking in a Tractor/Semitrailer

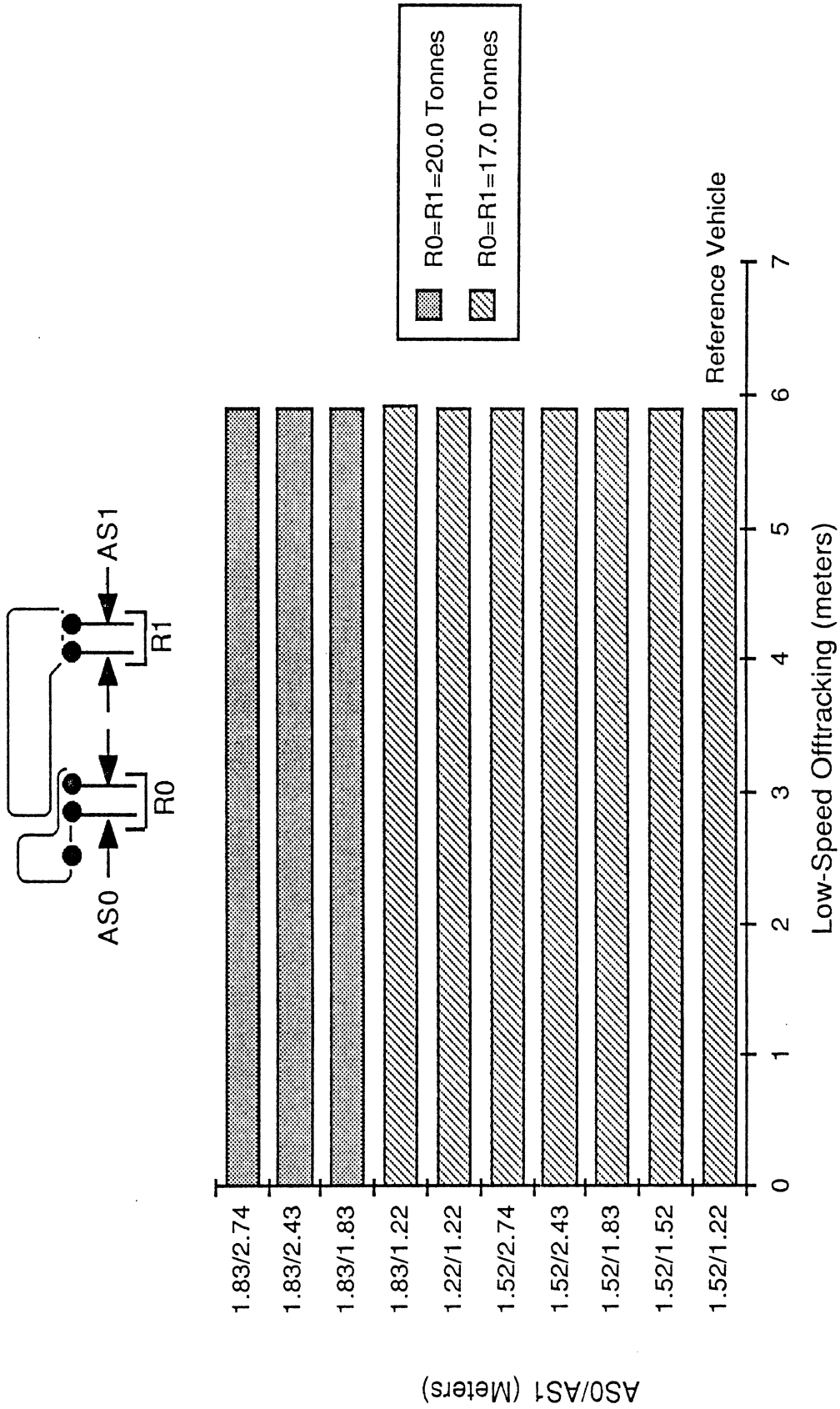

FIGURE 3.2.2.b

Influence of Tandem Spread Dimensions on a Tight Turn Jackknife in a Tractor/Semitrailer

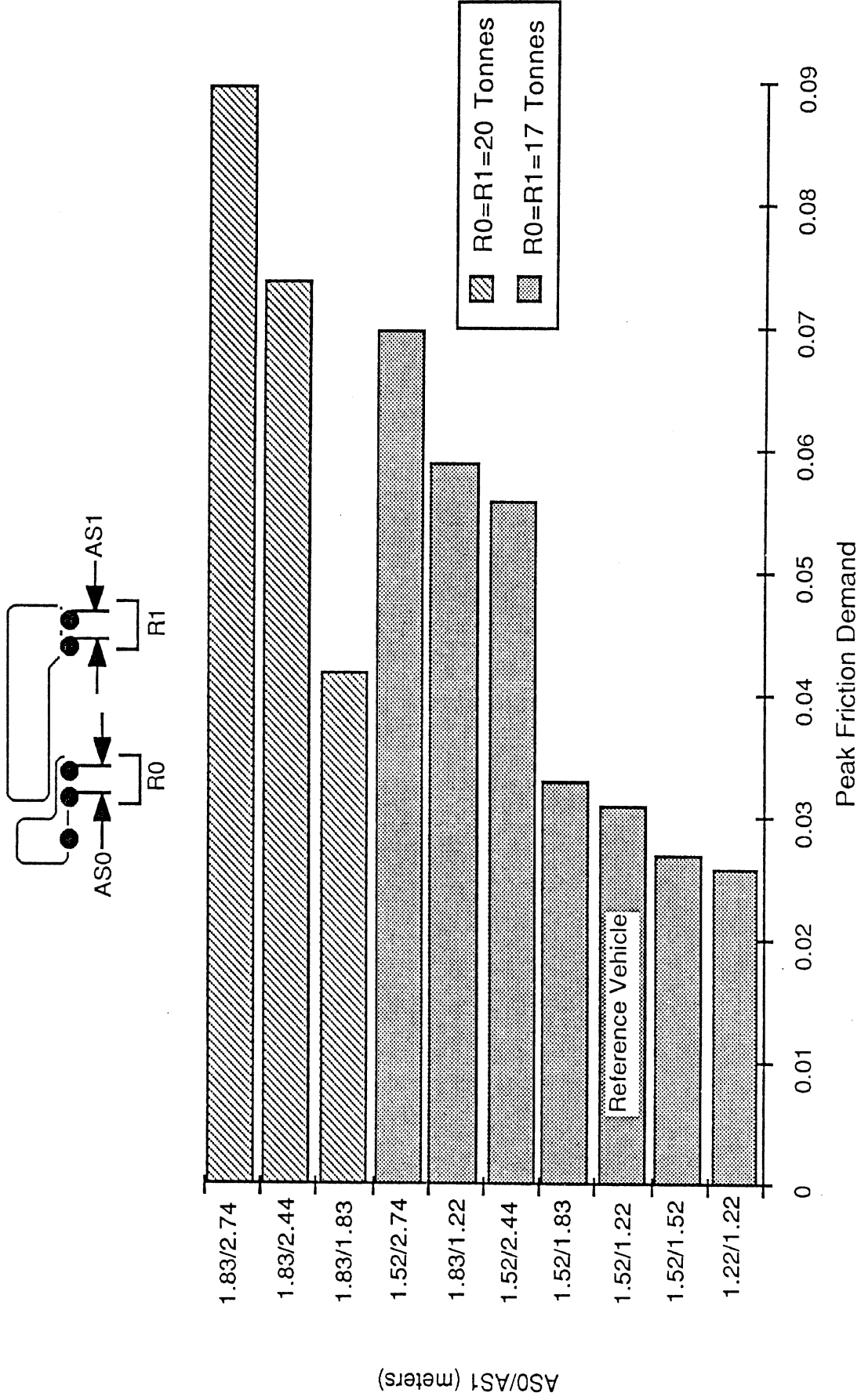

FIGURE 3.2.2.c

It is, perhaps, of academic interest to note that an increase in the spread of a tractor tandem will also increase the total friction demand at the tractor. This result comes about because the turn-resistive property of an increasingly spread tractor tandem causes a higher level of lateral force to be developed at the tractor steering axle in order to satisfy yaw moment equilibrium on the tractor. The achievement of lateral force equilibrium, then, demands that the total lateral force on the tractor rear tires increase, as well, such that the sum of the lateral forces at the tractor tandem due to the action of both tractor and trailer tandems is further increased.

3.2.3 Influence of Fifth-Wheel Offset. Shown in Figure 3.2.3a are the results indicating the influence of fifth-wheel offset on the static rollover threshold of the five-axle semitrailer. Given the rather minor extent of the variation in fifth wheel offset represented here, the influence on rollover threshold is indeed notable. The observation is that a more forward placement serves to degrade roll stability. This result derives from the fact that a more forward distribution of load on the tractor serves to remove load from the more stiffly sprung rear axles and place it, instead, on the softly sprung front axle. As explained in [23], the placement of load on such a lightly sprung axle eliminates some of the potential for generating restoring roll moments for resisting rollover. Accordingly, forward movement of the fifth wheel (or any other change which distributes load more heavily onto the more "softly sprung" axles) will degrade static roll stability. It should be recognized, of course, that such a result will follow from any change in size and weight allowances which encourages a higher load on the tractor's steering axle.

The influence of fifth-wheel offset (OFW) on the understeer coefficient is shown in Figure 3.1.3b. We see that a rather strong relationship exists between the indicated variables, given the relatively large variation in tractor load distribution which is associated with the differing cases. Note that the various cases span the range from an 18% front load distribution with OFW = 0, to a 27% front distribution with OFW = .686 m (2.25 ft). To the degree that these results show a somewhat accentuated sensitivity to fifth-wheel offset than that reported in an earlier study [2], the differences are assumed to be attributable to (a) tire properties--in particular, to the curvature in the relationship between cornering stiffness and vertical load, and (b) differences in the roll stiffness properties of the tractor rear suspensions--recognizing that the Hendrickson RTE-44 suspension used here is much stiffer in roll than the typical four-spring suspensions which have been selected previously as representing U.S. practice.

Influence of Fifth Wheel Offset on Rollover Threshold in Tractor/Semitrailers

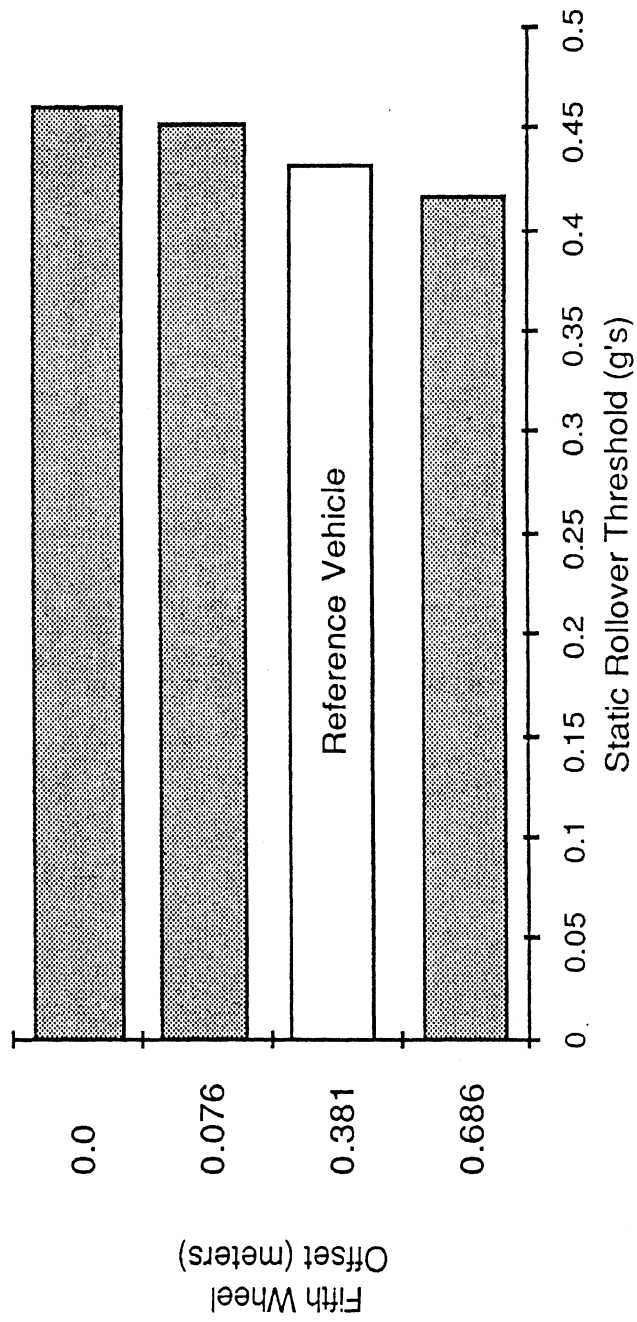
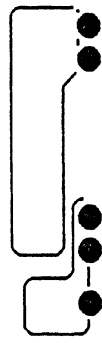

FIGURE 3.2.3.a

Influence of Fifth Wheel Offset on Understeer Coefficient in Tractor/Semitrailers

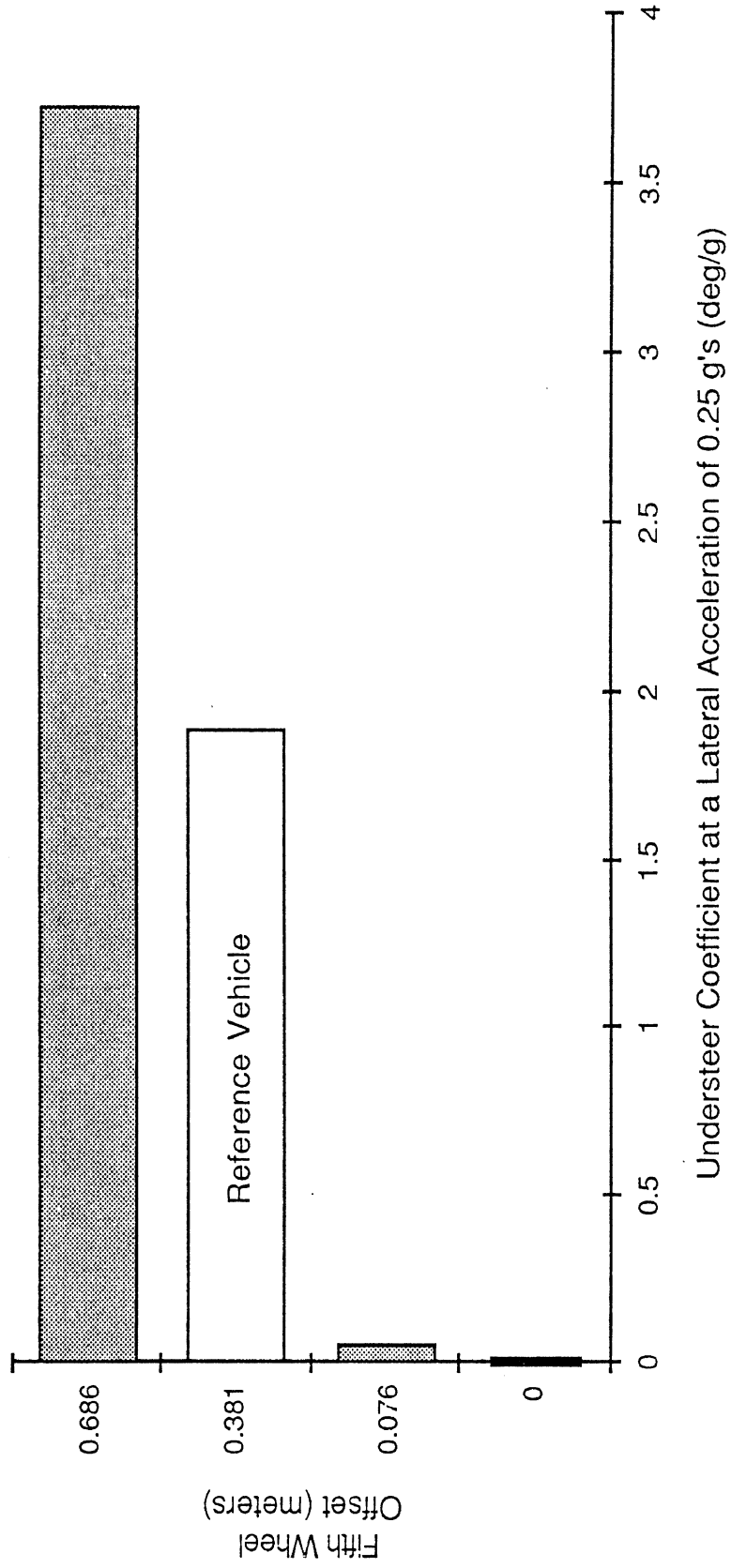

FIGURE 3.2.3.b

Shown in Figure 3.2.3c is the influence of fifth-wheel offset on the braking efficiency of the baseline tractor-semitrailer. The results show that, at the lower braking level of 0.1 g's, the vehicle is almost ideally balanced at a fifth wheel offset dimension of 0.381 m (1 ft). When the fifth wheel is moved aft from that position, the front axle becomes somewhat overbraked at 0.1 g. When moved forward, the tractor tandem becomes the limiting axle set.

At the 0.4 g braking level, the trailer axles constitute the critical end of the system, tending to reach lockup ahead of the other axles on the vehicle. Since fifth-wheel placement does not influence the load distribution between tractor and trailer, there is no observed influence of fifth-wheel placement on the braking efficiency of the vehicle at this higher braking level.

3.2.4 Influence of Tractor Suspension Selection. Shown in Figure 3.2.4a is the influence of various suspension selections on the static rollover threshold of the reference tractor-semitrailer. The differences in the respective roll stability levels derive from details which distinguish the mechanical properties of one suspension from one another. The prominent details are discussed below:

- The reference Hendrickson RTE-440 walking-beam suspension is very high in vertical stiffness at rated deflection, but it does become relatively soft as it approaches and passes through zero deflection. The spring set in this suspension exhibits an approximate 1 cm lash space as it passes from compression loading into tension.
- The Hendrickson RTE-380 suspension is very similar to the 44K-rated suspension above, although it does afford a significantly stiffer spring rate in tension than does the RTE-440. Accordingly, we see that virtually the same value of rollover threshold is exhibited with both of the Hendrickson tractor suspensions examined here.
- The Mack Camelback suspension rated for a tandem load of 169,000 N (38K-lbs) is seen to afford a very substantial loss in roll stability relative to the reference case. This suspension is characterized by a considerably lower stiffness in the vicinity of rated load, a much lower tension rate, and a relatively large lash space (nearly 2 cm). As a consequence, the static rollover threshold drops by some 0.08 g's simply through the alternative selection of this suspension.

Influence of Fifth Wheel Offset on Braking Efficiency in Tractor/Semitrailers

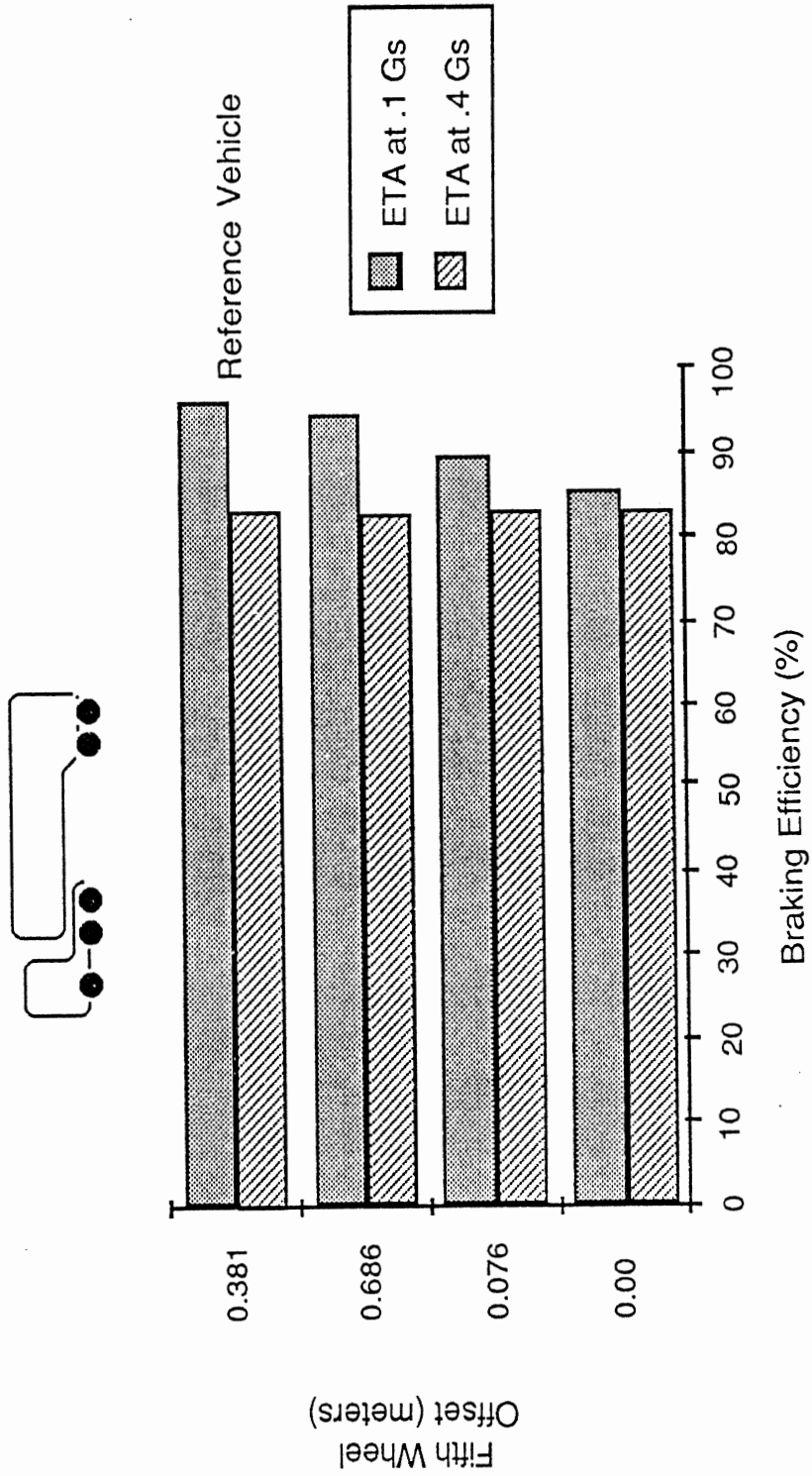

FIGURE 3.2.3.c

Influence of Suspension Type on Static Rollover Threshold in Tractor/Semitrailers

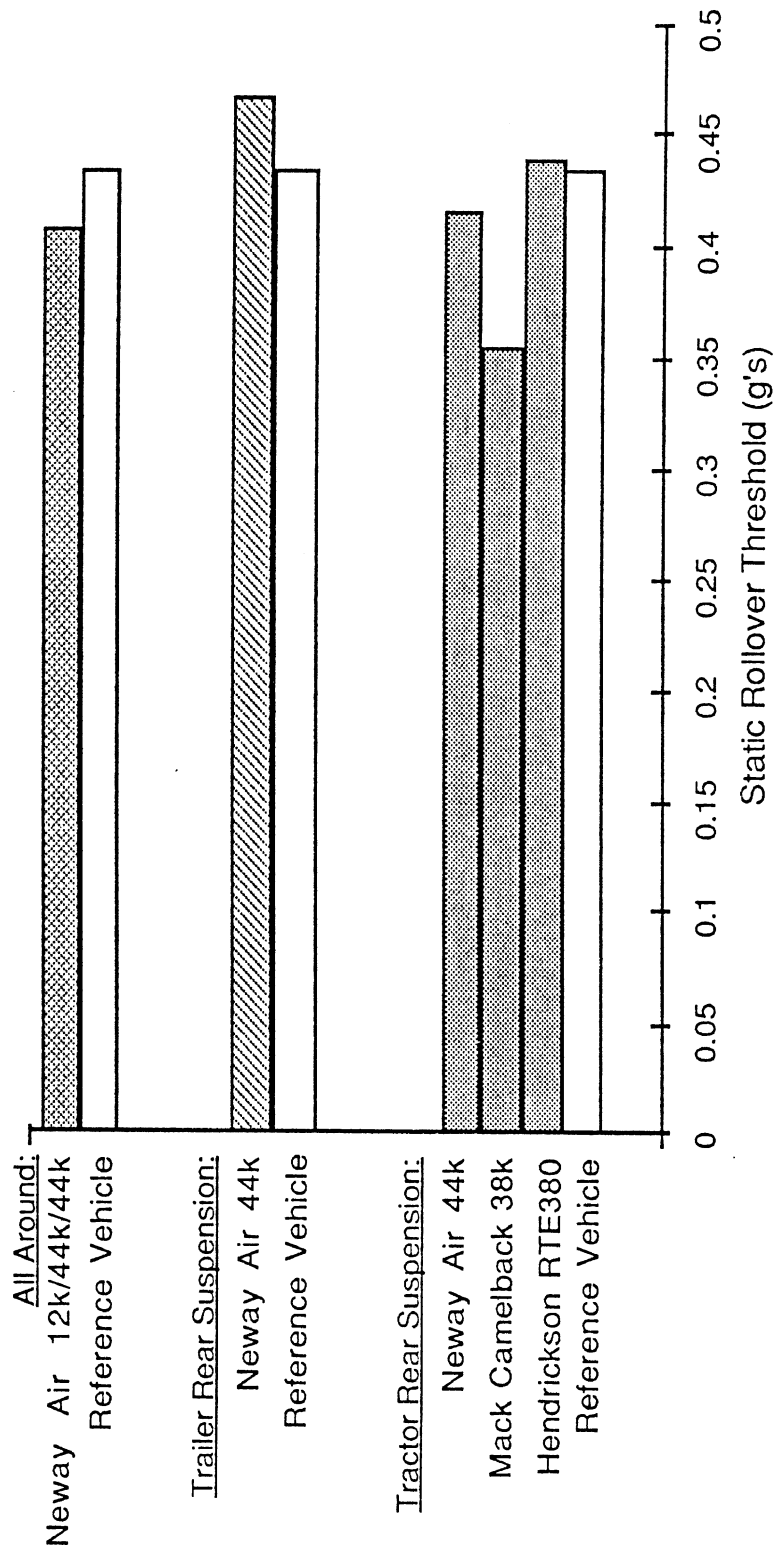
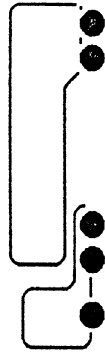

FIGURE 3.2.4.a

- The Neway ARD-244 air suspension is seen to yield an intermediate value for the static rollover threshold. This assembly is characterized by a rather low nominal value for total roll stiffness and the stiffness property is achieved predominantly through the auxiliary spring mechanism of the trailing-arm-to-axle connections. Such suspensions enable reasonably high degrees of static roll stability because of the continuous nature of the roll stiffness behavior over the range of roll angles, lacking any lash space mechanisms or transitions into zones of low stiffness. Also, the roll stiffness of the suspension rises dramatically when the "light side" of the axle has extended to such an extent that the shock absorber reaches its extension limit.
- Regarding the alternative trailer suspensions, the Neway AR 95-17 air suspension installed at the trailer tandem position is seen to improve overall roll stability as a consequence of its continuous roll stiffness characteristic.
- When the Neway air suspensions are installed at all axle positions, the roll stability level drops to approximately the same level as was obtained when the air suspension was installed at the tractor only. This result indicates that, with the air suspension installed in the drive axle position, the tractor tandem axle set becomes the determining group in establishing the roll stability level of the vehicle [14].

Moreover, the selection of alternative suspensions has been shown here, and in previous studies [14,23,24,25], to be a significant determinant of the static roll stability of heavy-duty vehicles. This observation is highly significant to trucking operations in North America since it is the common practice here for truck and trailer purchasers to specify the component assemblies to be provided on their vehicles. Given the general absence of information on, and concern for, the stability implications of this specification process, the roll stability of vehicles in service is often substantially less than current technology can provide.

Shown in Figure 3.2.4b is the influence of suspension selection on the understeer coefficient. We see that the alternative trailer suspension fails to significantly influence the understeer response because the two suspensions produce almost the same level of load transfer at the trailer axle, at this 0.25 g level of lateral acceleration. A study of the mechanics of the understeer response [26] has shown that the trailer suspension can alter tractor understeer only by altering the share of the total roll moment borne by the tractor, thus influencing the mechanisms of tire sensitivity to load transfer at the rear tractor axles.

Influence of Tractor Suspension on Understeer Coefficient in Tractor/Semitrailers

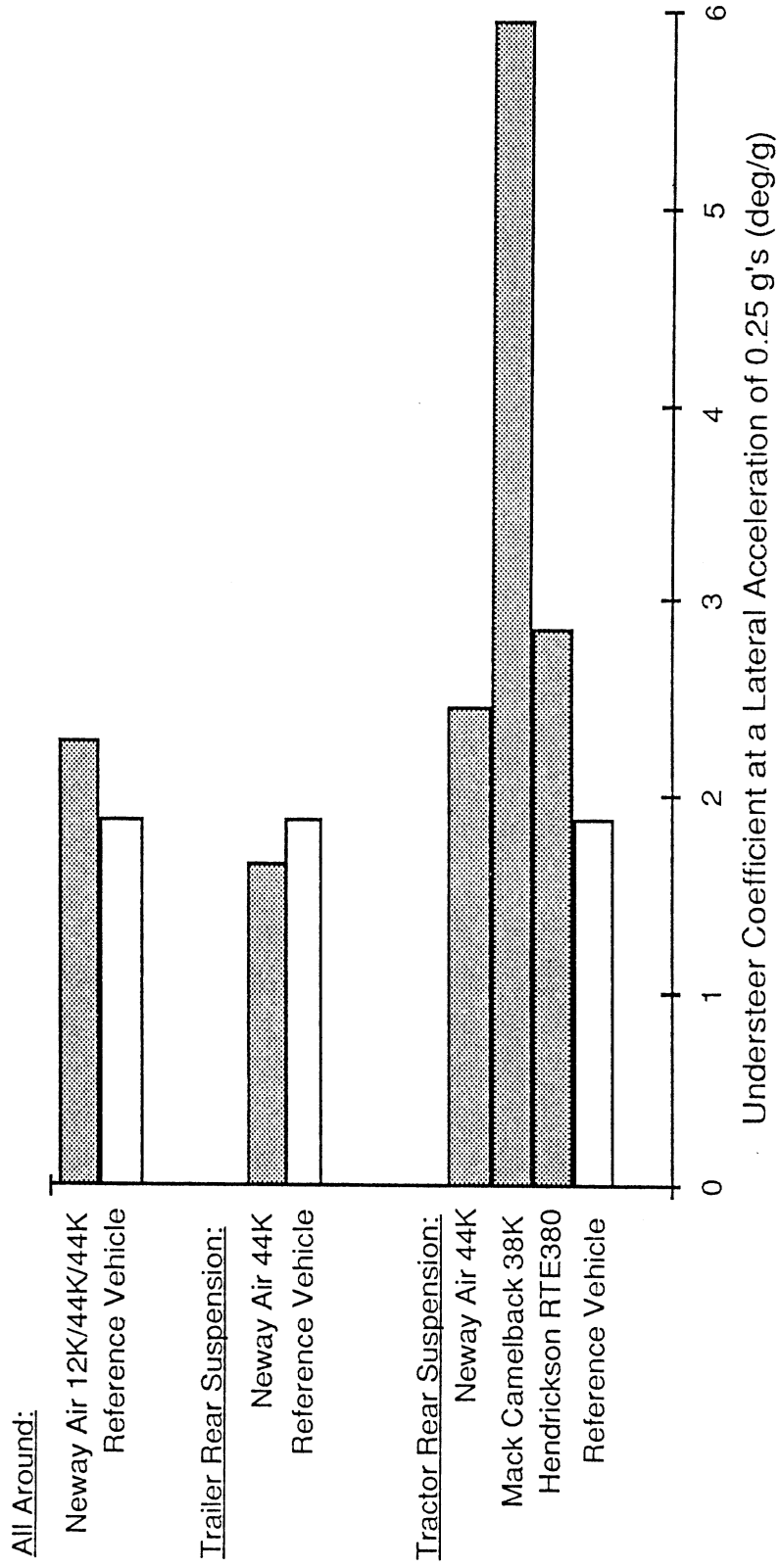
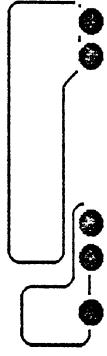

FIGURE 3.2.4.b

Looking at the results associated with changes in tractor tandem suspensions, the Mack Camelback 38K selection yields a very large increase in understeer level relative to the reference (Hendrickson RTE 440). Examination of the parametric distinctions between the respective Mack and Hendrickson suspensions (see Appendix B) reveals that the Mack suspension promotes understeer by (1) a considerably lower level of roll stiffness, (2) a strong roll understeer coefficient on the lead axle, with approximately zero roll steer on the aft axle, compared to strong roll oversteer with the Hendrickson, and (3) a remarkably low roll center height on the lead axle (8 cm (3 in) as opposed to the Hendrickson's value of 84 cm (33 in)). These features combine to yield a 6 deg/g understeer coefficient at 0.25 g's of lateral acceleration (and perhaps as much as 10 deg/g when the vehicle is proceeding in a straight line, at zero g's). Together, these results illustrate that the understeer coefficient is influenced by mechanical properties which derive from the details in suspension design. While some of these influential properties happen to have been varied substantially in the different types of suspensions selected for this study, one cannot generalize upon the influence of "suspension type," per se, on the understeer coefficient. Rather, the influential mechanical properties of differing suspension designs can cover a large range, regardless of the specific type of springing elements and axle constraints employed.

Figure 3.2.4c presents results showing the influence of differing suspension selections on the high-speed offtracking behavior of the five-axle tractor-semitrailer. Two differing mechanisms are seen to explain the differences in performance exhibited by the various cases. Namely,

- 1) The relative total roll stiffness, and roll center heights, of the respective tractor and trailer tandem suspensions determine the distribution of the total load transfer occurring, respectively, at tractor and trailer tires. Accordingly, when a suspension having high roll stiffness or high roll center is installed at the tractor, a relatively greater share of the total load transfer occurs at the tractor tandem such that the normalized tire cornering stiffness level accrued in the 0.2-g turn declines at the tractor tires. Conversely, the relieving of some degree of load transfer at the trailer tires causes them to increase in normalized cornering stiffness level such that normalized cornering stiffness level rises. Since the semitrailer is much longer in wheelbase than the tractor, the decline in tire slip angle developed at the trailer tires yields a reduced level of high-speed offtracking when a relatively "stiffer" suspension is installed at the tractor.

- 2) The installation of a suspension having a relatively high roll-steer coefficient (of the oversteer polarity) will result in a greater high-speed offtracking excursion since the

Influence of Suspension Type on High-Speed Offtracking in Tractor/Semitrailers

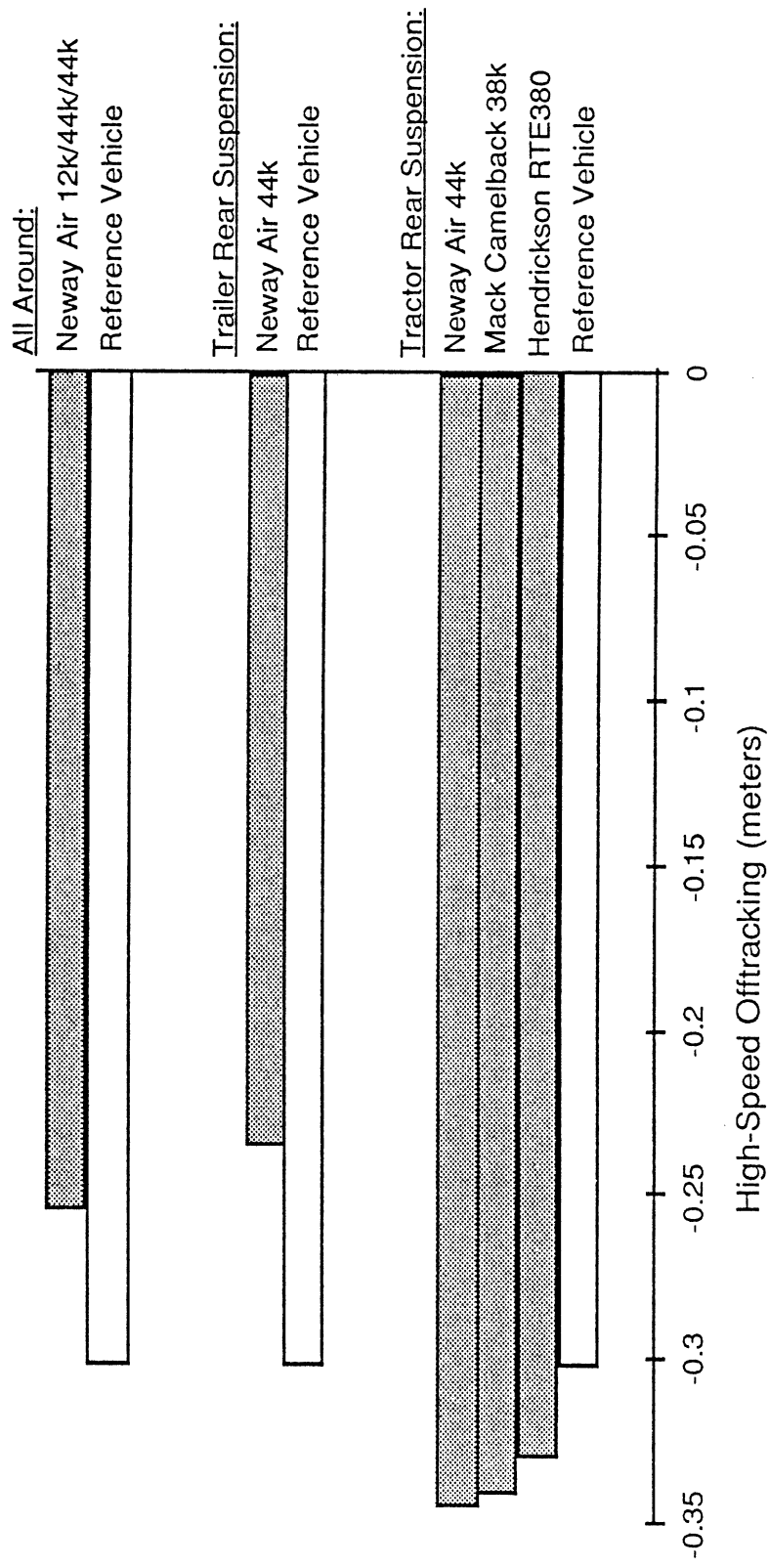
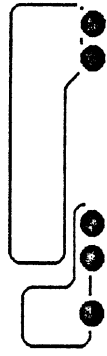

FIGURE 3.2.4.c

wheels on the involved axles will steer toward the outside in the turn. Again, since the trailer is the longer vehicle element, suspension roll steer is much more significant when implemented in the trailer suspension.

The reference vehicle case involves a tractor suspension (Hendrickson RTE-44) which is exceedingly high in roll stiffness. Thus, in the reference vehicle configuration, the tractor tandem is bearing such a large fraction of the load transfer distribution that the net high-speed offtracking value is relatively low. When alternative tractor suspensions are installed (see the lower set of bars in Figure 3.2.4c) the high-speed offtracking increases since each of the alternative suspensions, in turn, exhibits a reduced level of total roll stiffness (and in some cases, reduced roll center heights as well). The respective value of total roll stiffness, at static deflection, is listed below for each of the alternative tractor suspensions:

<u>Suspensions</u>	<u>Total Roll Stiffness (n-m per degree)</u>
Hendrickson RTE-440 (Ref. Vehicle)	26,700
Hendrickson RTE-380	16,200
Mack Camelback, 38K	9,300
Neway 244	6,400

In the two sets of bars at the top of the figure, high-speed offtracking is seen to reduce relative to the reference case when a Neway AR 95-17 suspension is installed at the trailer tandem position, incorporating a zero roll steer coefficient in place of the 0.23 degree per degree roll steer coefficient for the Reyco 21b suspension in the reference vehicle. In the case of the uppermost bar, the Neway trailer suspension is incorporated together with the Neway air suspension at the tractor such that one "positive" and one "negative" factor has been introduced relative to the baseline case. In the second pair of bars, the benefit of the zero-roll-steer trailer suspension is combined with the favorable roll stiffness distribution arrangement to yield a somewhat lower value of high-speed offtracking. (The reader should note that the mechanisms tending to improve high-speed offtracking performance do not necessarily improve other vehicle qualities.)

3.2.5 Influence of High Payload and Tractor Width Dimension. Shown in Figure 3.2.5a is the influence of tractor width variation on the static rollover threshold for the five-axle tractor-semitrailer in both its reference and "high-c.g."

Influence of High Payload and Tractor Width on Static Rollover Threshold in Tractor/Semitrailers

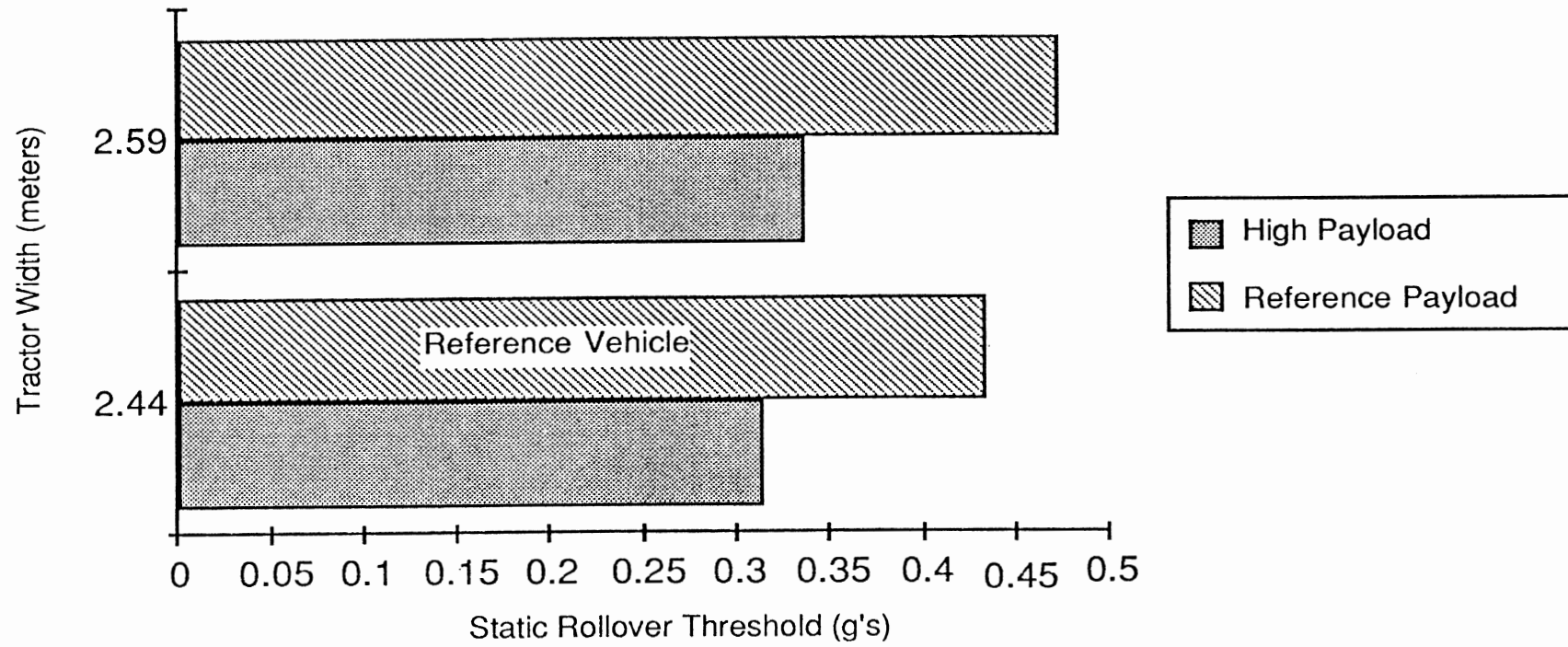
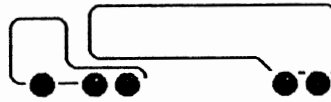

FIGURE 3.2.5.a

configuration. We see that the change from 2.44 to 2.59-m (96 to 102-in) width at the tractor axles produces a significant improvement in the static roll stability. When coupled with the evidence [23] that even modest improvements in static rollover threshold offer the potential for very substantive reductions in rollover accident involvement, there are clear safety advantages to be gained through implementation of tractors which reach the full width allowance in Canada.

Figure 3.2.5b presents the results showing the influence of variations in tractor width and payload c.g. height on the understeer coefficient measure. The results confirm previous findings [2] in a qualitative sense, although the absolute change in understeer with the increased payload c.g. height is approximately twice that computed earlier for typical U.S. vehicles. Again, it is assumed (without detailed study) that the differences in sensitivity derive from differences in tire mechanics and in the contrasting roll stiffness properties of the tractor rear suspensions.

Shown in Figure 3.2.5c is the influence of the tractor width variation on high-speed offtracking performance. The results show that high-speed offtracking is quite substantially reduced with an increase in tractor width. This outcome appears to be explained primarily by the reductions in lateral load transfer which occur at the greater width, thus serving to boost the effective cornering stiffness levels at both the tractor and the semitrailer. Please note that lateral load transfer at the trailer axles is altered as a result of the widened tractor layout because the tractor suspension is correspondingly widened, thus yielding a higher level of roll stiffness at the tractor. Accordingly, the tractor bears a larger fraction of the total roll moment needed for equilibrium in the reference turn when the tractor tandem is widened.

Shown in Figure 3.2.5d is an illustration of the influence of the high payload condition on the braking efficiency measure. Since the "critical axles" serving to limit the braking efficiency of this vehicle are the trailer axles, there is some negative influence of an increased payload height due to the increased load transfer from the trailer axles during braking. Of course, the extent of this influence is more noticeable at the higher level of deceleration.

3.2.6 Influence of Partial Loading. The influence of two partial loading conditions on the high-speed offtracking of the tractor-semitrailer is shown in Figure 3.2.6a. In general, high-speed offtracking improves whenever loading declines due to the benefit of an increased normalized cornering stiffness level at the involved tires. The

Influence of High Payload and Tractor Width on Understeer Coefficient
in Tractor/Semitrailers

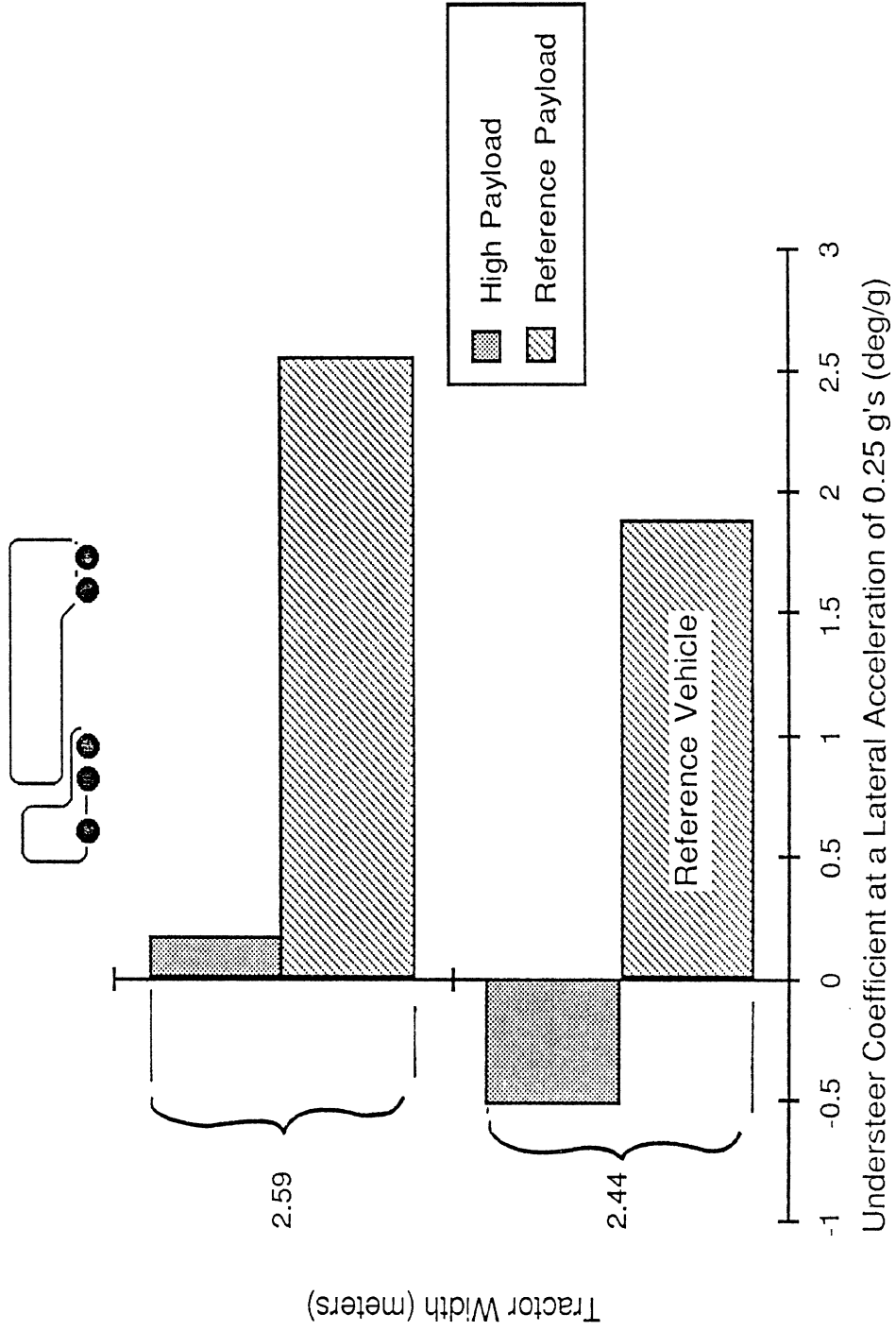

FIGURE 3.2.5.b

Influence of High Payload and Tractor Width
on High-Speed Offtracking in Tractor/Semitrailers

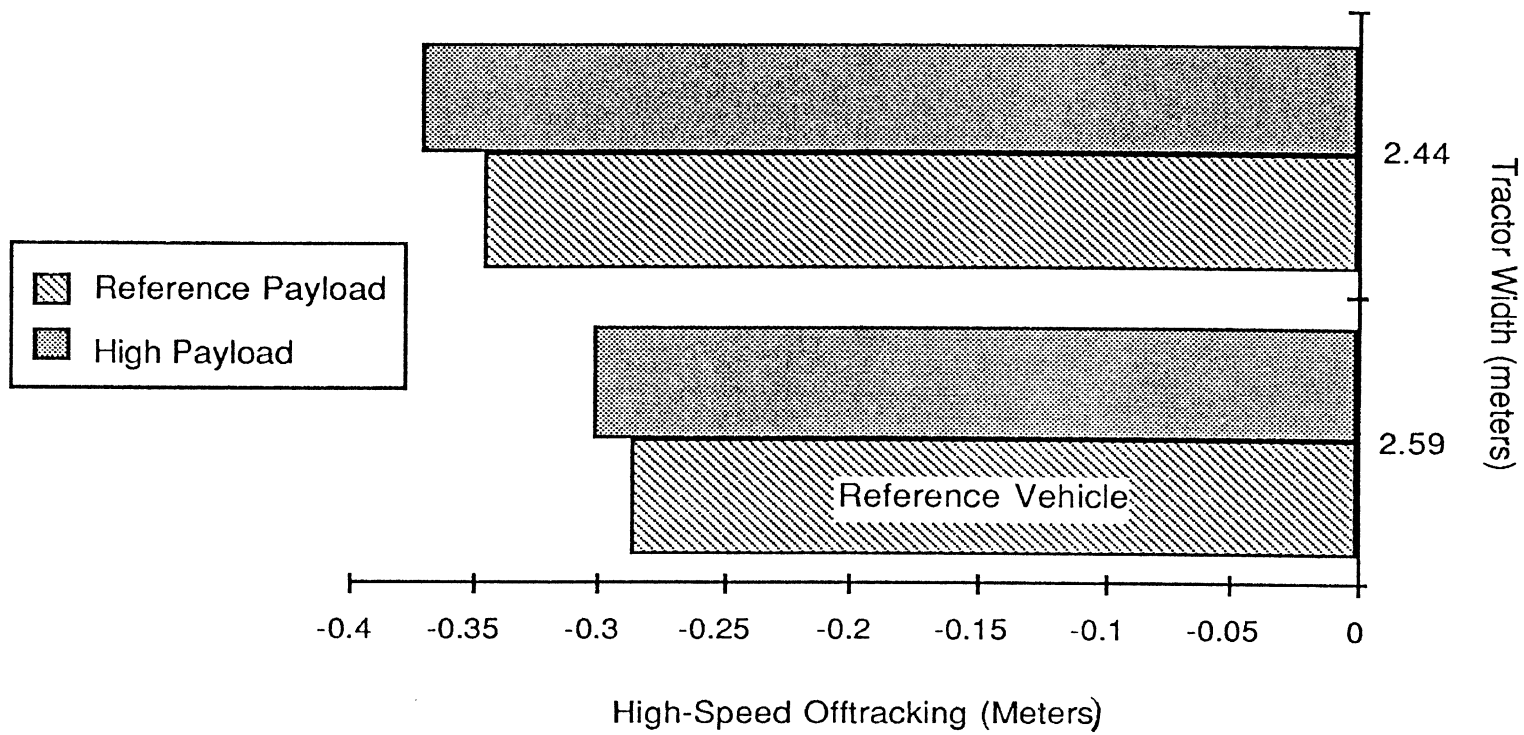
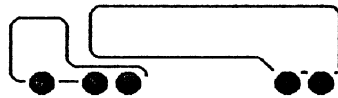

FIGURE 3.2.5.c

Influence of High Payload on Braking Efficiency in Tractor/Semitrailers

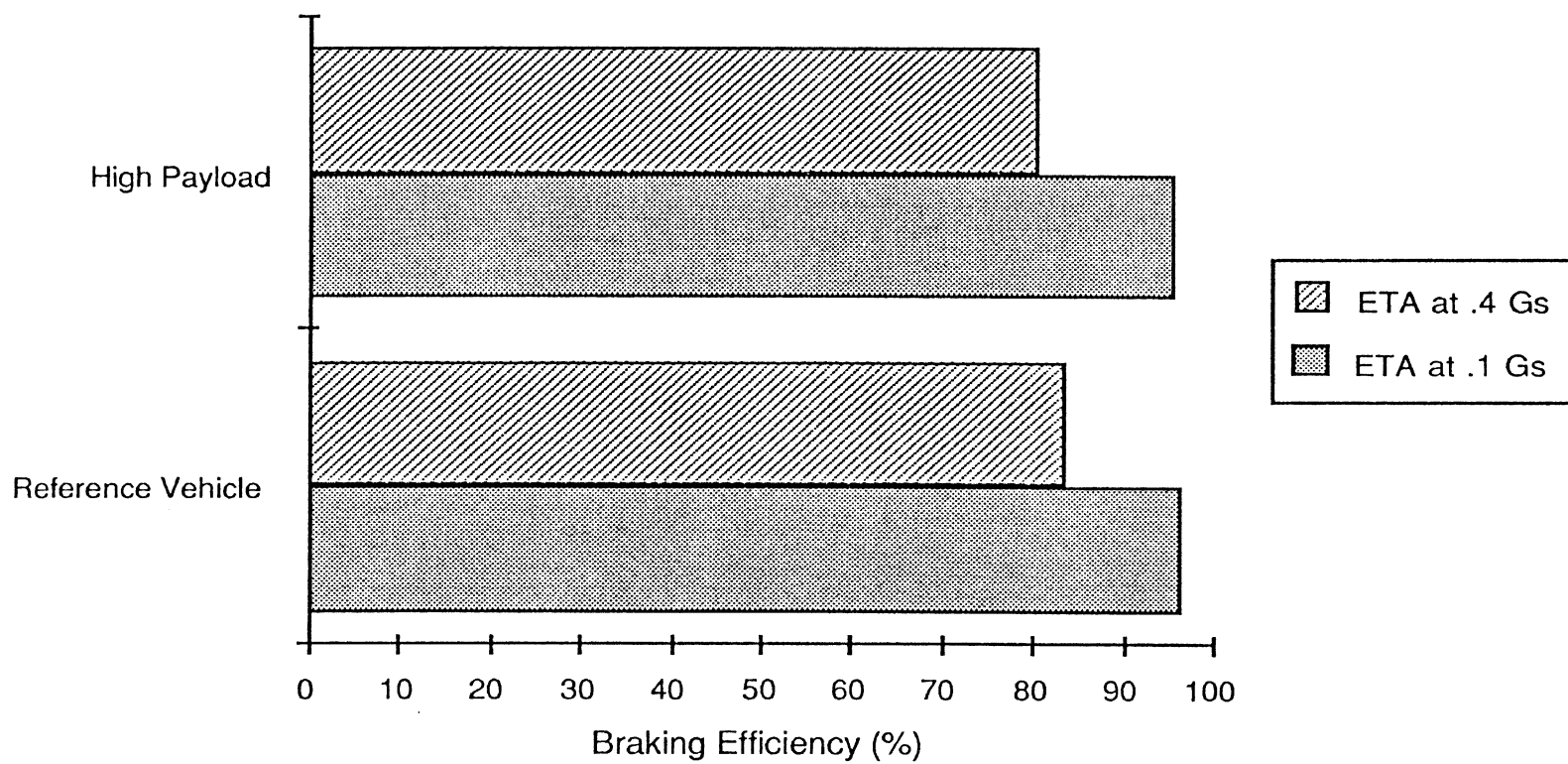
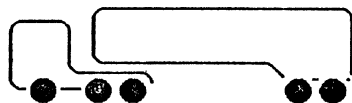

FIGURE 3.2.5.d

Influence of Partial Loading on High-Speed Offtracking in Tractor/Semitrailers

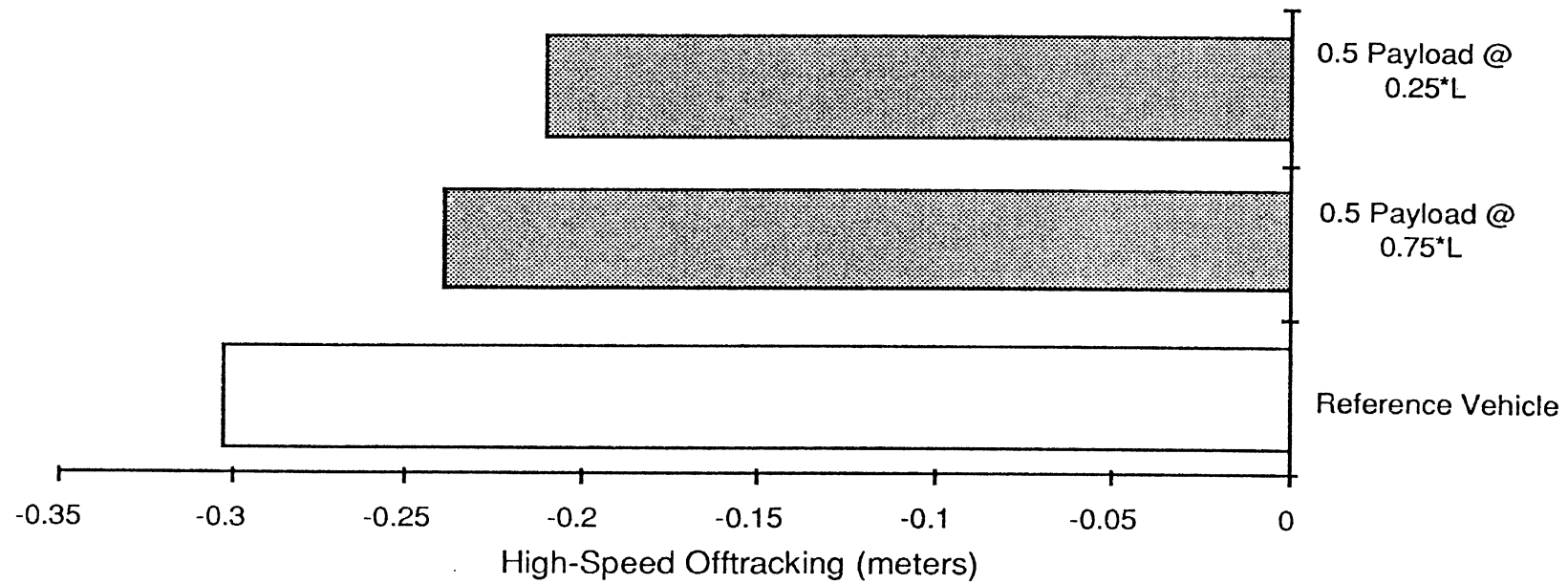
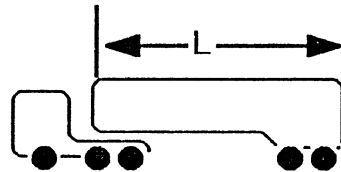

FIGURE 3.2.6.a

distribution of load is significant to the extent that the trailer tires, placed at the long "lever arm" associated with the trailer wheelbase, will more strongly improve high-speed offtracking as their load is reduced than will the tractor tires, given the short wheelbase of the tractor.

Shown in Figure 3.2.6b is the influence of partial loading on the braking efficiency of the tractor-semitrailer. The two "half-load" cases are seen to strongly reduce the braking efficiency level. With the 1/2- payload mass center moved forward to a distance ($0.25 \times L$) from the front wall of the trailer, the trailer axles become underloaded, relative to the tractor axles, and efficiency suffers due to early lockup of the trailer wheels. Conversely, with the payload moved aft to the $0.75L$ position, the tractor axles become underloaded and thus "overbraked." The resulting efficiency levels near 50% at $0.4g$'s of deceleration represent serious reductions in the control quality of the vehicle system.

3.2.7 Influence of Tire Selection. Figure 3.2.7a shows the influence of various tire installations on the measure for understeer coefficient. The reference vehicle configuration incorporates radial-ply tires with full tread depth at all wheel positions. In contrast to that reference, the figure shows, at the top, a mix in tire installations with worn radials (1/3 tread depth remaining) installed on the front axle and (a) new bias-ply rib-tread tires on the drive axles, or (b) new radials on the rear axles. These mixed-tire results indicate the very powerful influence of substantially differing tires placed at front and rear axle positions. Of course, the pertinent aspect of these front/rear mixes is that the effective cornering stiffness level is considerably higher with the radial specimens and the sensitivity of cornering stiffness to changes in vertical load is more profoundly curved in the case of the radials. Further, the more worn tire exhibits a considerable increase in cornering stiffness relative to the new-tread tire. When a change is made in the tire type that is installed at all wheel positions, the variation in understeer coefficient derives completely from the effects of load on cornering stiffness. That is, the absolute level of cornering stiffness at a given load does not influence the understeer outcome, but rather the difference in front/rear distribution of cornering stiffness levels such as is exercised only through sensitivities to loading when the same tire is installed at all wheel positions.

Shown in Figure 3.2.7b is the influence of tire selection and mixed tire installations on the high-speed offtracking measure. The three tires identified in the matrix of variations have cornering stiffness values, at rated load, as follows:

Influence of Partial Loading on Braking Efficiency in Tractor/Semitrailers

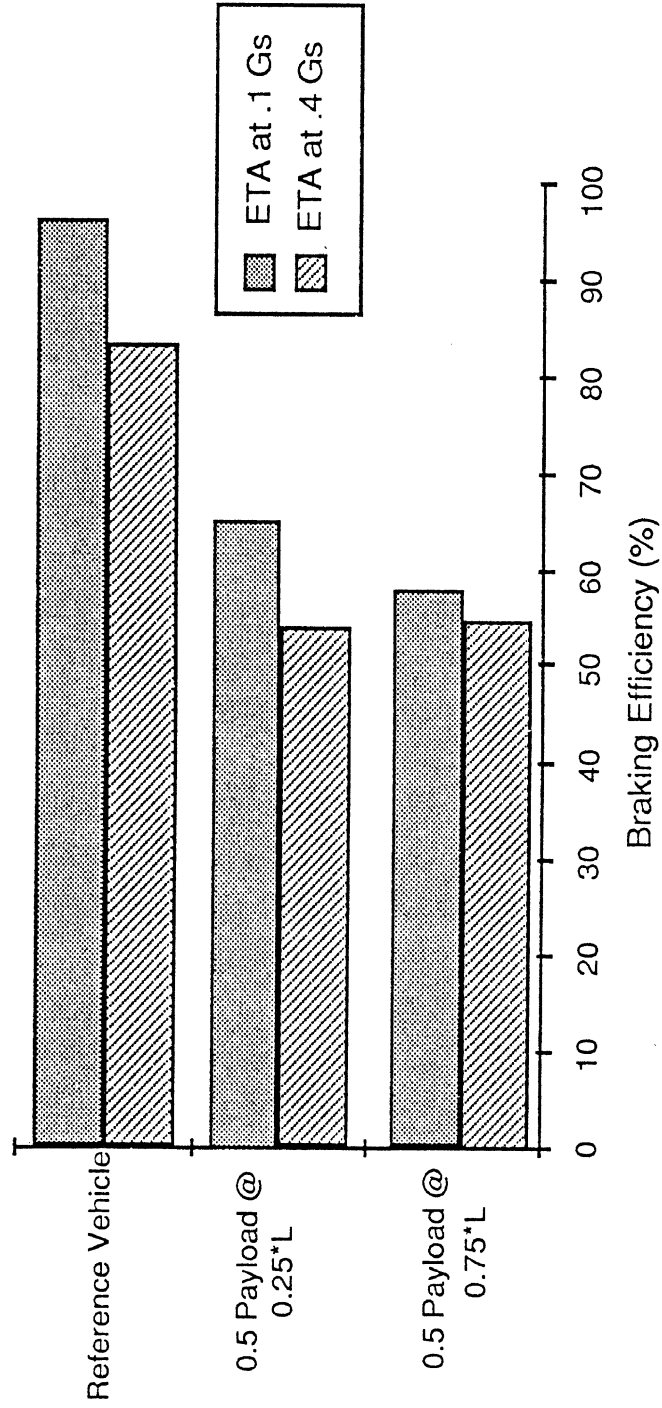
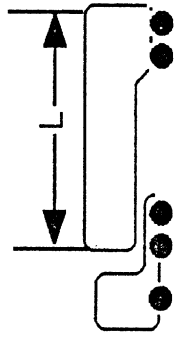

FIGURE 3.2.6.b

Influence of Tire Selection on Understeer Coefficient in Tractor/Semitrailers

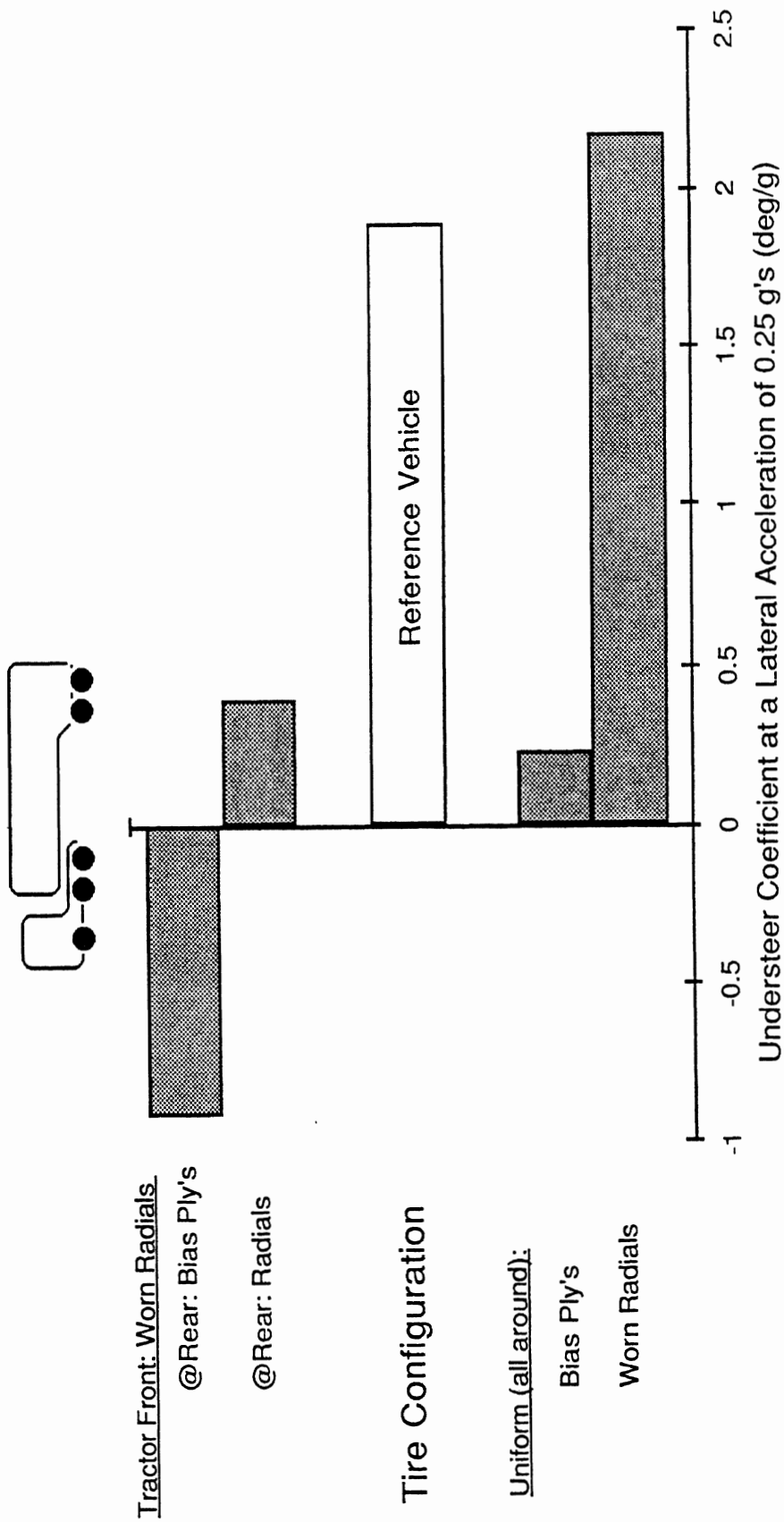

FIGURE 3.2.7.a

Influence of Tire Selection on High-Speed Offtracking in Tractor/Semitrailers

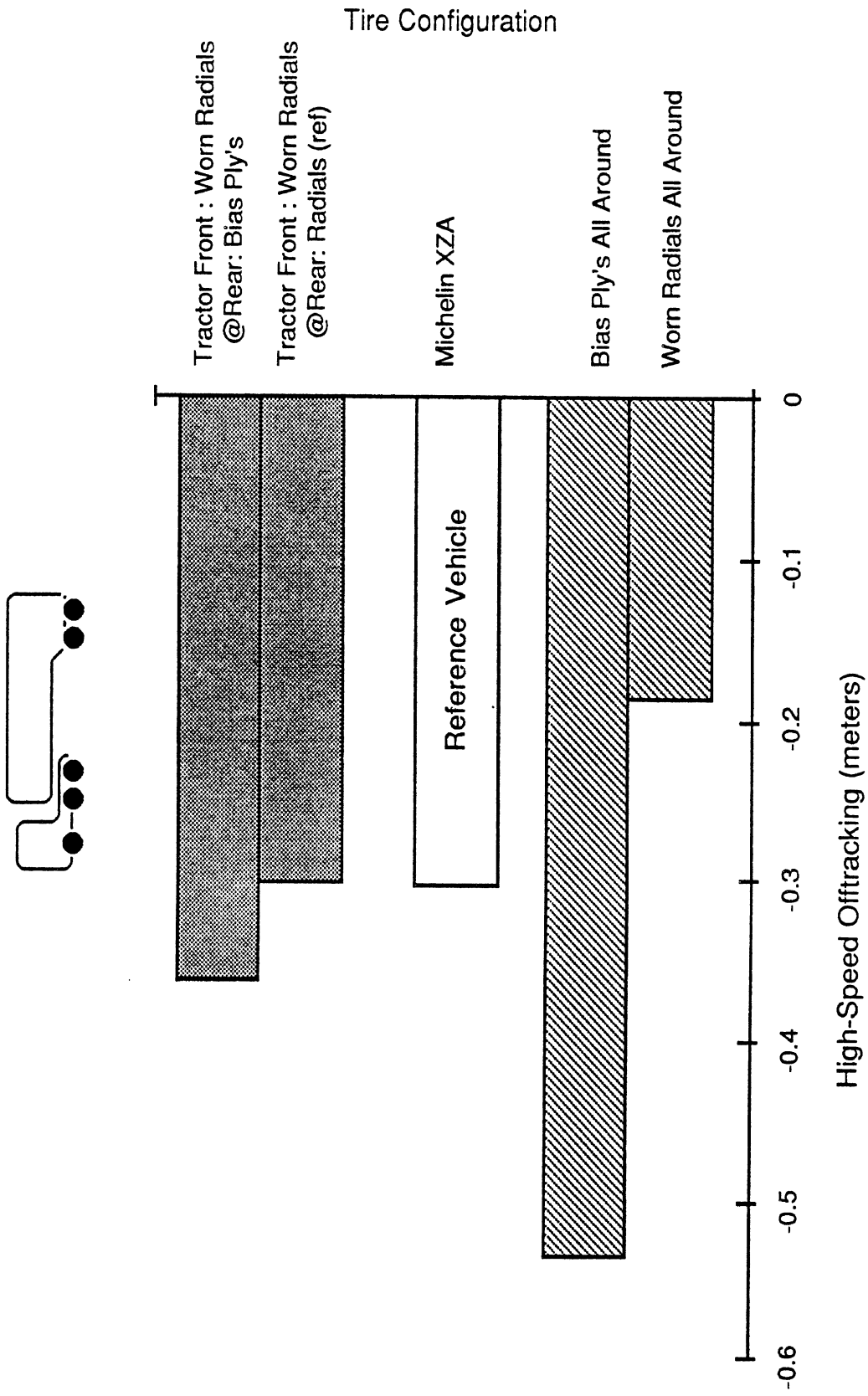

FIGURE 3.2.7.b

<u>Tire</u>	<u>Cornering Stiffness</u>
Worn Radials (Michelin XZA)	5000
Michelin XZA (new)	3900
Bias Ply (new Firestone Transport 1)	2500

The data show various examples of two simple principals; namely, that (a) high-speed offtracking is inversely related to tire cornering stiffness, and (b) the strength of this effect in relation to the various axle positions is of the approximate proportion, 0 : 1 : 2.5, from the tractor steering axle to the tractor rear tandem to the trailer tandem, respectively. This proportion simply reflects the relative lengths of the "lever arms," or wheelbase values, over which the lateral displacement of the high speed offtracking response accrues. Thus, for example, we see that a certain unit of increase in high-speed offtracking accompanies placement of bias-ply tires at the rear of the tractor (1st bar), but approximately 3.5 times that unit of increase occurs when bias-ply tires are placed at all axle positions. Noting that the change in tire properties at the steering axle has no effect, the "all around" installation of bias-ply tires effects one" unit" of increase from the increase in outboard offtracking at the tractor tandem plus approximately 2.5 "units" of additional offtracking at the trailer tandem. Conversely, the installation of worn radials "all around" serves to substantially reduce high-speed offtracking.

3.2.8 Influence of Axle Loading. A large number of variations in axle loading are shown in Figure 3.2.8a to have a very consistent influence on the static rollover threshold levels of differing tractor-semitrailers. That is, we see simply that increased axle loading results in reduced roll stability. In the case of the belly-axle-semitrailer at the top, we see that the axle load variations simply involve a constant total load which is redistributed in steps between the belly axle and the other two tandem axle sets at the tractor and rear of the semitrailer. In these cases, the influence on roll stability is negligible since the payload is not changed and since all three of the involved suspension sets are rather equivalent in aggregate roll stiffness properties (recognizing that while the air suspended belly axle incorporates a somewhat lower roll stiffness per axle than either of the two tandems, it tends to "make up" for that "deficiency" with a zero-lash response to roll, in contrast to non-zero lash features in the other two suspensions).

The other vehicle configurations having two, three, or four semitrailer axles show substantially declining roll stability with increased loading, primarily as a result of the

Influence of Axle Loading on Rollover Threshold in Tractor/Semitrailers

Axle Load (Tonnes)

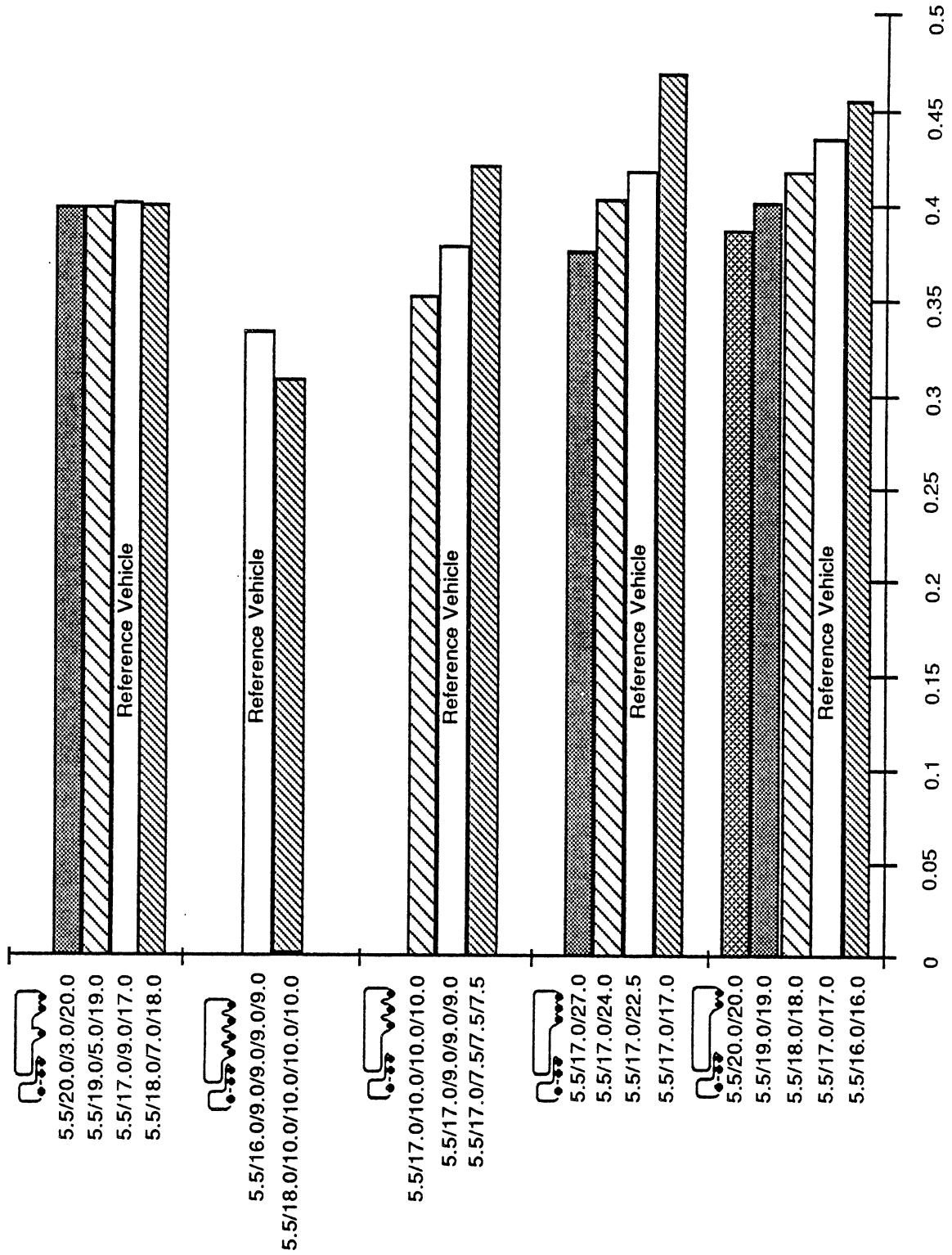

Static Rollover Threshold (g/s)

FIGURE 3.2.8.a

increased payload weight and payload c.g. height. Recognizing that any increase in a load allowance will result in trailers carrying a greater quantity of freight (unless they were "cube-limited" to start with), it is axiomatic that higher weight vehicles of the same length will definitely incorporate higher payload c.g. values, on the average. Recognizing further that a reduction in static rollover threshold will have a strong influence on the probability of rollover accidents, it follows that increased axle loading, without a corresponding adjustment in other vehicle properties, should be expected to result in an increase in the rate at which rollovers occur.

Figure 3.2.8b presents the influence of axle loading on the understeer coefficient. The clearly monotonic decline in understeer quality with increasing load derives from the combined influence of (a) the peculiar concentration of the load increases to only the rear axles of the tractor, such that only the rear tractor tires experience a loss in their normalized cornering coefficient level, and (b) the increase in payload c.g. height that accompanies increased loading. Clearly, axle load levels, as distributed in these examples, constitute a strong determinant of this steering response measure

Shown in Figure 3.2.8c is the influence of axle loading on high-speed offtracking. We see essentially the same sensitivities as occurred with the static rollover threshold values. Namely, that increased axle loading produced very consistent increases in the high-speed offtracking result due to the combined result of increased payload weight and increased payload height. Both factors combine to cause the tires to operate at a net reduction in normalized cornering stiffness level at each axle, thus serving to boost the high-speed offtracking response. Again, the semitrailer incorporating a belly axle shows no significant sensitivity to the loading changes in which the same payload weight is simply redistributed between the belly axle and the two fixed tandems.

Shown in Figure 3.2.8.d are low-speed offtracking values associated with changes in the distribution of axle loading on the belly-axle semitrailer. This vehicle is examined in the four indicated cases for which the total vehicle load is held constant, but the portion of the load carried on the air-suspended belly axle varies. We see the more-or-less obvious result that a decline in belly-axle load level results in a rearward shift in the effective wheelbase of the trailer such that offtracking increases. Clearly, when belly-axle load is reduced to zero, the rear tandem center would define the trailer wheelbase, thus producing an offtracking response which is identical to the five-axle baseline tractor-semitrailer combination.

Influence of Axle Loading on Understeer Coefficient in Tractor/Semitrailers

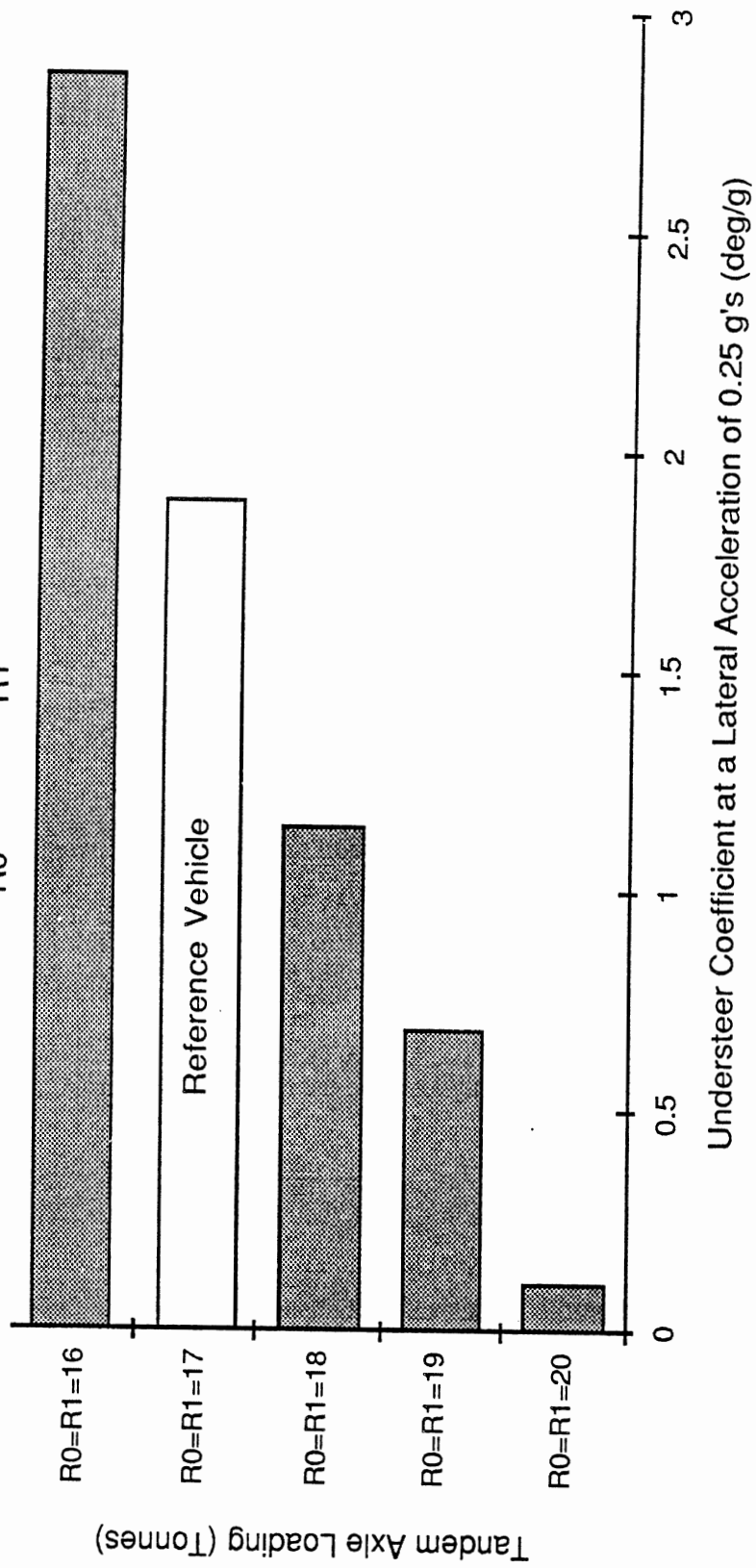
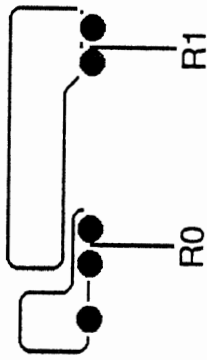
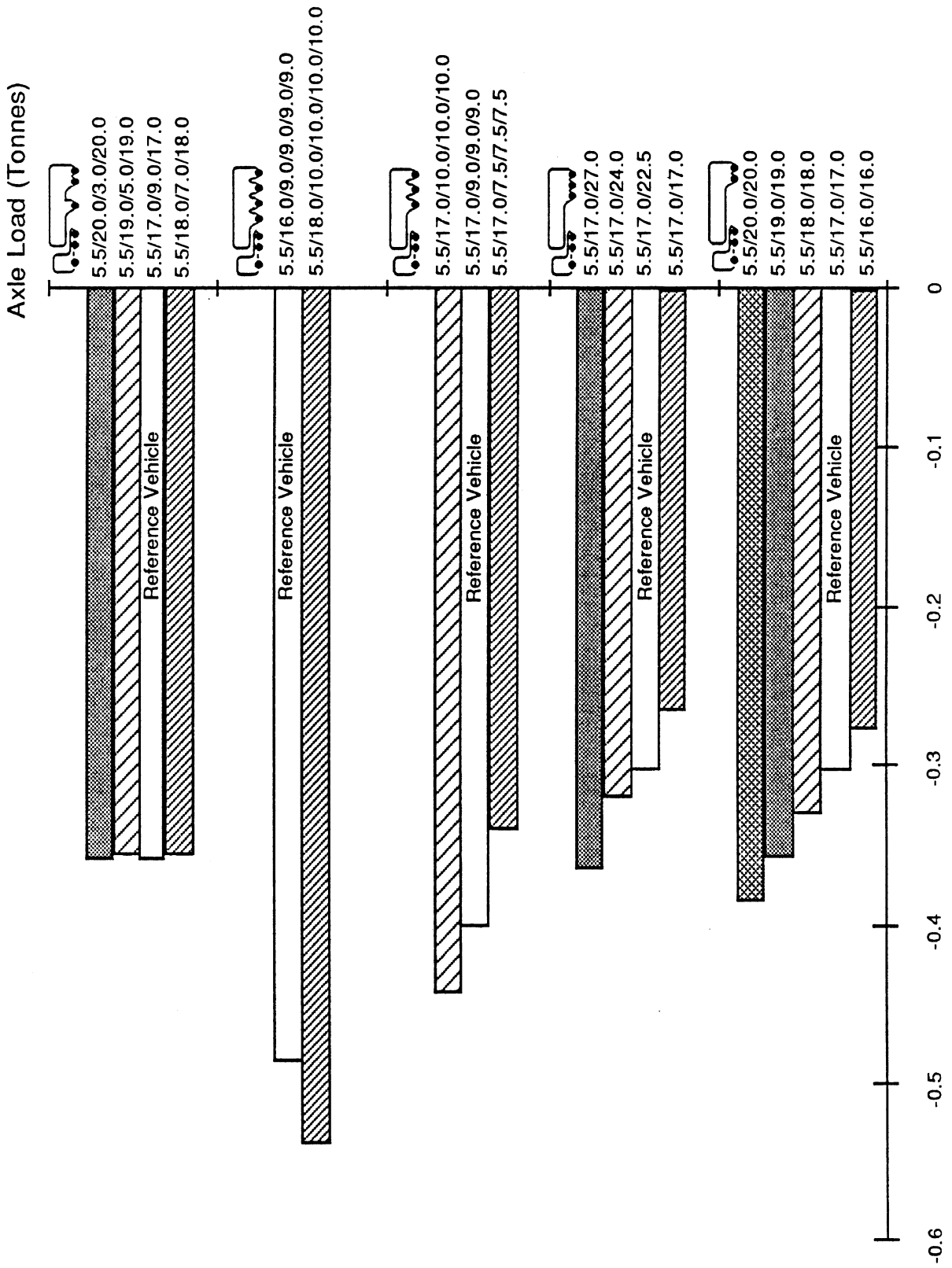

FIGURE 3.2.8.b

Influence of Axle Loading on High-Speed Offtracking in Tractor/Semitrailers



High-Speed Offtracking (Meters)

Figure 3.2.8.c

Influence of Axle Loading on Low-Speed Offtracking in Belly Axle Tractor/Semitrailers

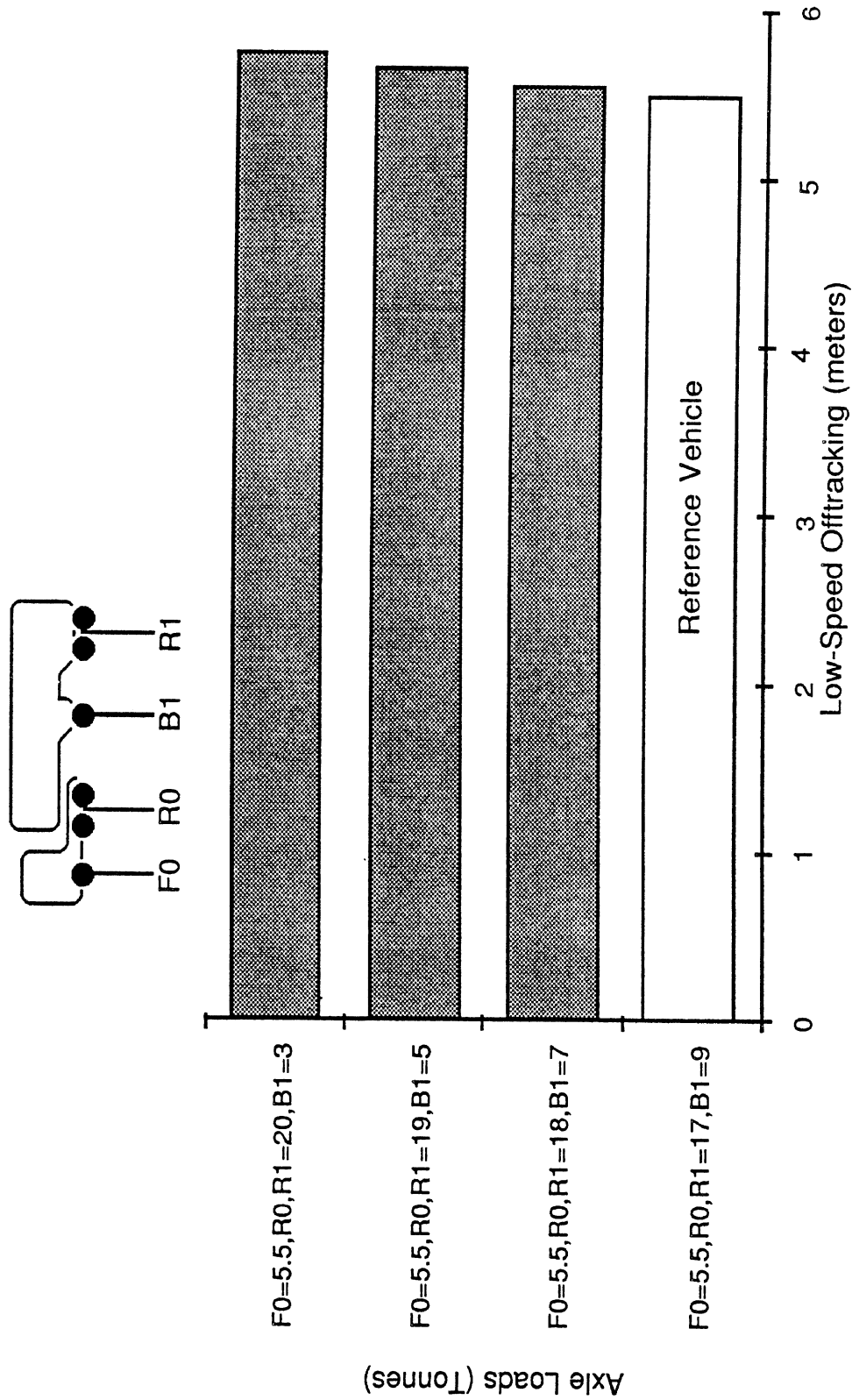

FIGURE 3.2.8.d

It can be generalized, however, that axle loading does not play a significant role in determining low-speed offtracking performance. Only when load distribution among a widely spread set of fixed axles is varied can one expect to see a measurable influence of loading on low-speed offtracking.

Shown in Figure 3.2.8.e are example cases illustrating the influence of the axle loading levels on the friction demand measure. We see that friction demand rises when load level increases. This phenomenon is explained upon noting that the absolute value of the cornering stiffness of truck tires increases rather strongly with increased load (even though the normalized cornering stiffness, C_{α}/F_z , declines with load due to the nonlinearity in the C_{α} vs. F_z relationship). Referring back to the discussion in Section 3.1.3, it was noted that the turn-resistive moment is proportional to the cornering stiffness level of the tires. Thus, increased load on trailer axles increases the friction-demand value by means of the connection to tire cornering stiffness. (Although not shown here, it should also be noted that the friction demand will also rise when load is removed from the tractor tandem axles. Clearly, if the vertical tire load at the tractor rear axles decreases, the frictional demand associated with a given value of turn-resistive moment, and thus tractor tire side force, will increase.)

The final illustration of sensitivity to axle loading is shown in Figure 3.2.8f. With balanced increases in tandem loading on both the tractor and semitrailer, the change in braking efficiency with increased axle load is essentially nil. This negligible effect, of course, depends heavily upon the assumed distribution of brake torque gains along the respective axle positions of the vehicle.

3.2.9 Influence of Wide-Spread Trailer Axle Arrangements: Shown in Figure 3.2.9a is the influence of variations in the spread dimension between trailer axles on the high-speed offtracking measure. We see two basic features, namely,

- 1) An increase in the spread dimension, per se, assuming that trailer overall length is fixed, results in the leading axles on the semitrailer moving more toward the front, such that the effective wheelbase is shortened. This result produces a higher value for high-speed offtracking.
- 2) Changes in the position of the belly axle on the vehicle at the top of the chart result in variations in effective wheelbase of that semitrailer in a fashion analogous to that seen with equally-spaced trailer axles. Introduction of a caster-steering feature in the belly axle serves to degrade the total cornering power at the

Influence of Axle Loading on a Tight Turn Jackknife in Tractor/Semitrailers

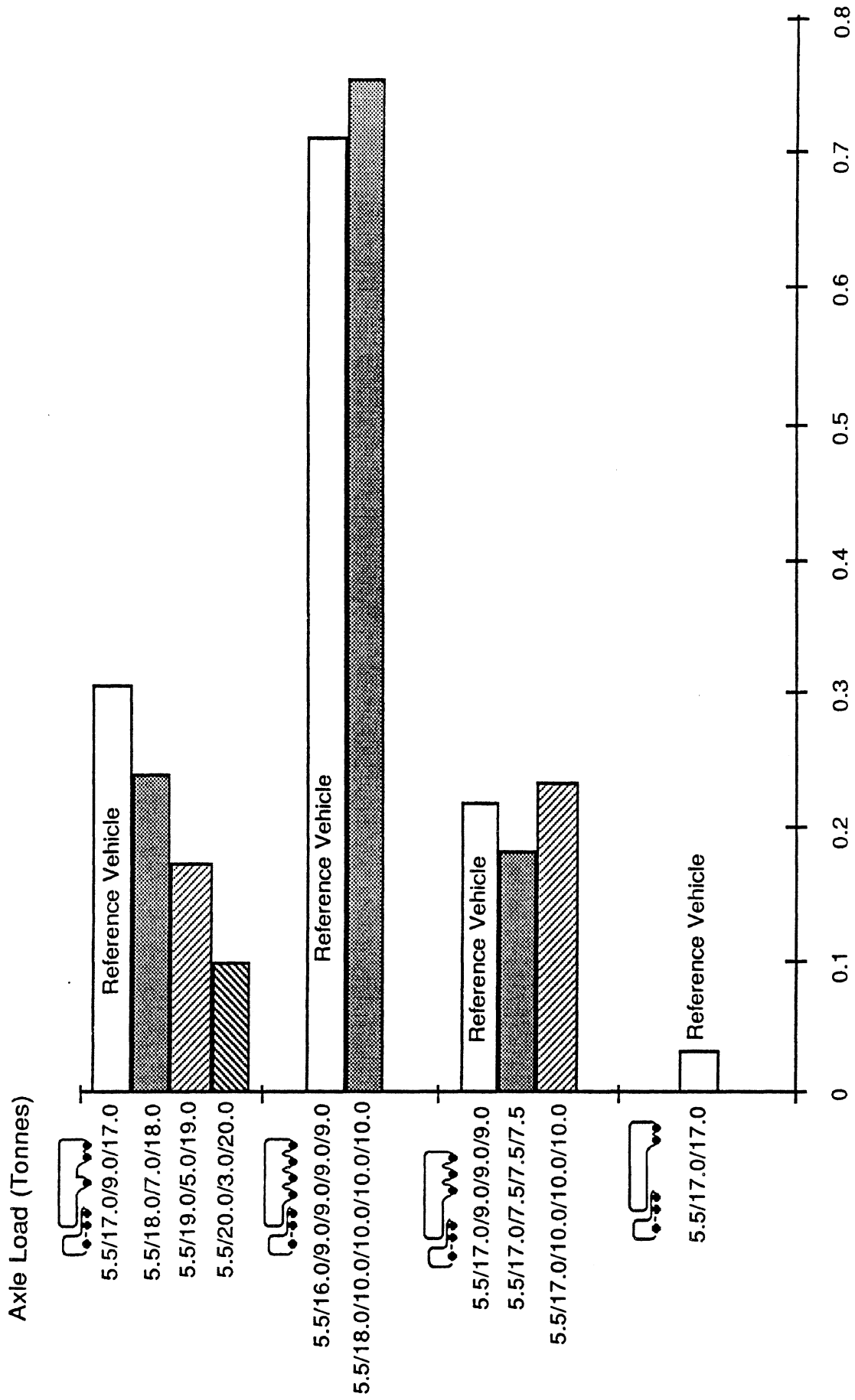

Peak Friction Demand

FIGURE 3.2.8.e

Influence of Axle Loading on Braking Efficiency in Tractor/Semitrailers

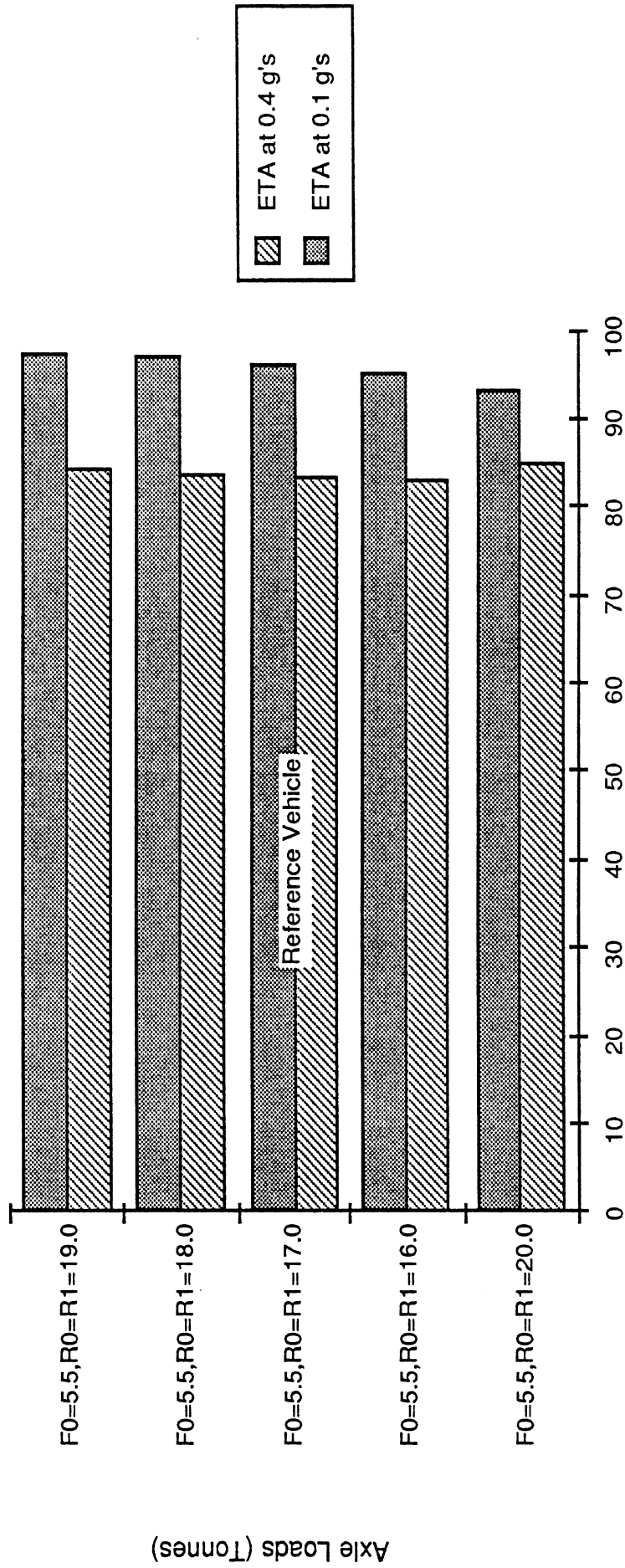
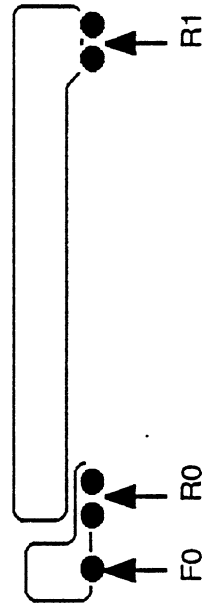

Braking Efficiency (%)

FIGURE 3.2.8.f

Influence of Trailer Axles Spread on High-Speed Offtracking in Tractor/Semitrailers

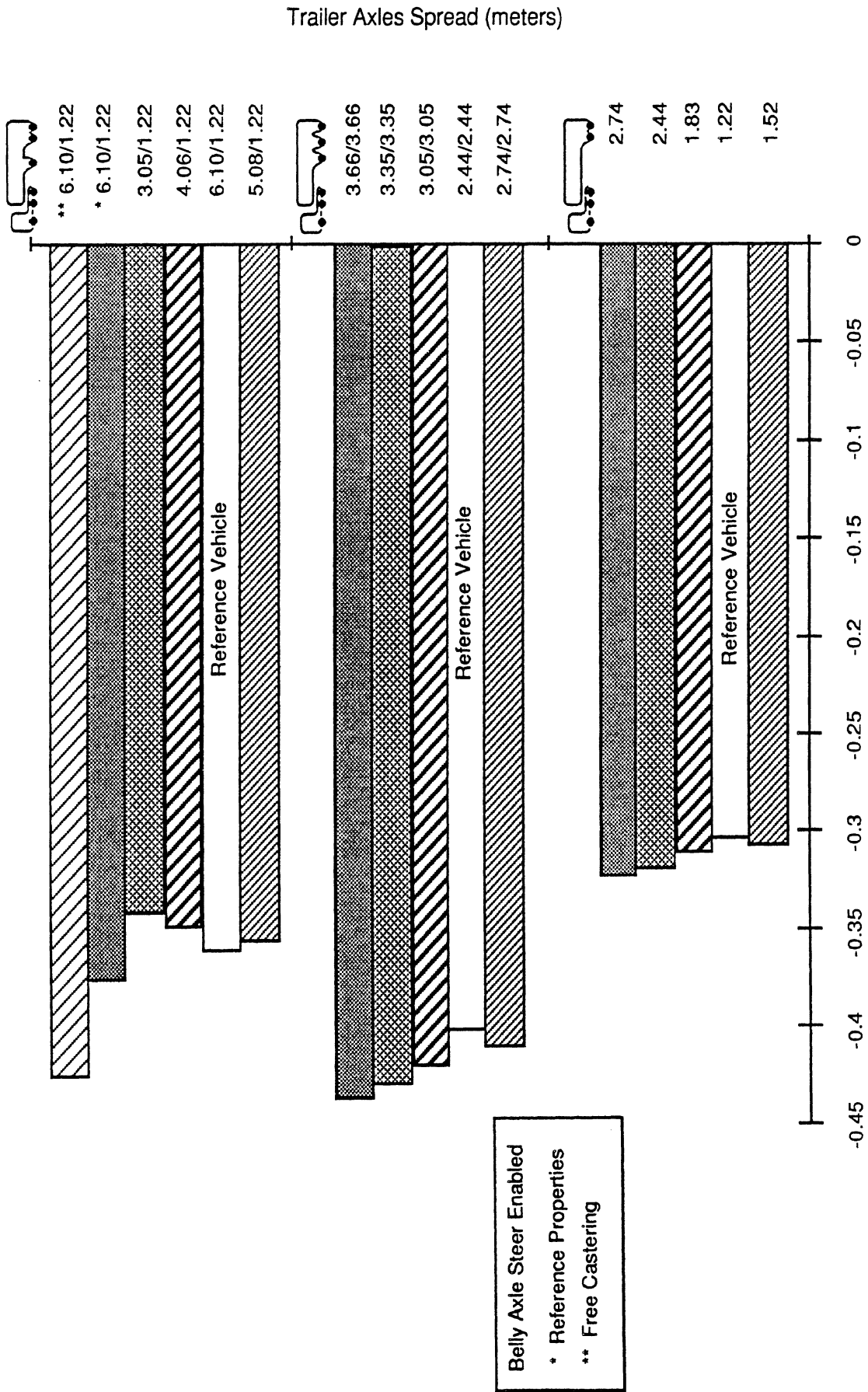

High-Speed Offtracking (Meters)

FIGURE 3.2.9.a

trailer axles such that the vehicles tracks further outboard in the turn. We see that with "reference properties" matching those of a CESCHI steerable axle at the belly axle position, the outboard offtracking is a small degree greater than that of the reference vehicle having a rigid belly axle. With the "free-castering" properties at the belly axle position, the trailer tracks considerably further outboard.

Shown in Figure 3.2.9b are low-speed offtracking results illustrating the influence of the spread dimension associated with selected trailer axle arrangements. The results show, again, that an increase in spread will serve to alter the low speed offtracking response to the degree that it moves the effective "center" of the trailer axle array forward. In the case of the bottom semitrailer with a two-axle tandem installation, no discernible change in performance is seen because the variations in tandem spread are accomplished while keeping the geometric center of the trailer tandem at a fixed wheelbase location.

On the other hand, the reduced offtracking with increased spread on the three-axle unit in the center of the figure is rather marked. In this case, the increased spread serves to shorten wheelbase because the rearmost axle is maintained at a fixed distance aft of the kingpin--and all increases in spread simply move the other two trailer axles further forward.

Also plotted at the top of the figure are the low speed offtracking influences of introducing a steerable feature to a forward-mounted belly axle. We see that with the "reference properties" corresponding to the CESCHI axle design, the effective wheelbase lengthens to yield a greater extent of low-speed offtracking (see the shaded bar having a single-asterisk, (*), designation) than with the same dimensions but a rigid belly-axle installation (see the white bar labelled with axle positions "6.10/1.22"). When the steerable feature is implemented as a "free castering" mechanism, (see the double- asterisk, (**), in the figure) such that the belly axle does not develop lateral slip, and thus tire side force, the trailer wheelbase reverts to the original two-axle case with a trailer tandem spread of 1.22 m (4 ft).

Shown in Figure 3.2.9c are values of friction demand which show the influence of variations in spread on the trailer axle layout for each of three different tractor-semitrailer combinations. As was presented in Section 3.1.3, the magnitude of the friction demand which develops at the tractor tandem tires in a tight turn derives primarily from the ratio, (d^2/L) , where d is the nominal spread dimension for a two-axle tandem. The upper vehicle

Influence of Trailer Axles Spread on Low-Speed Offtracking in Tractor/Semitrailers

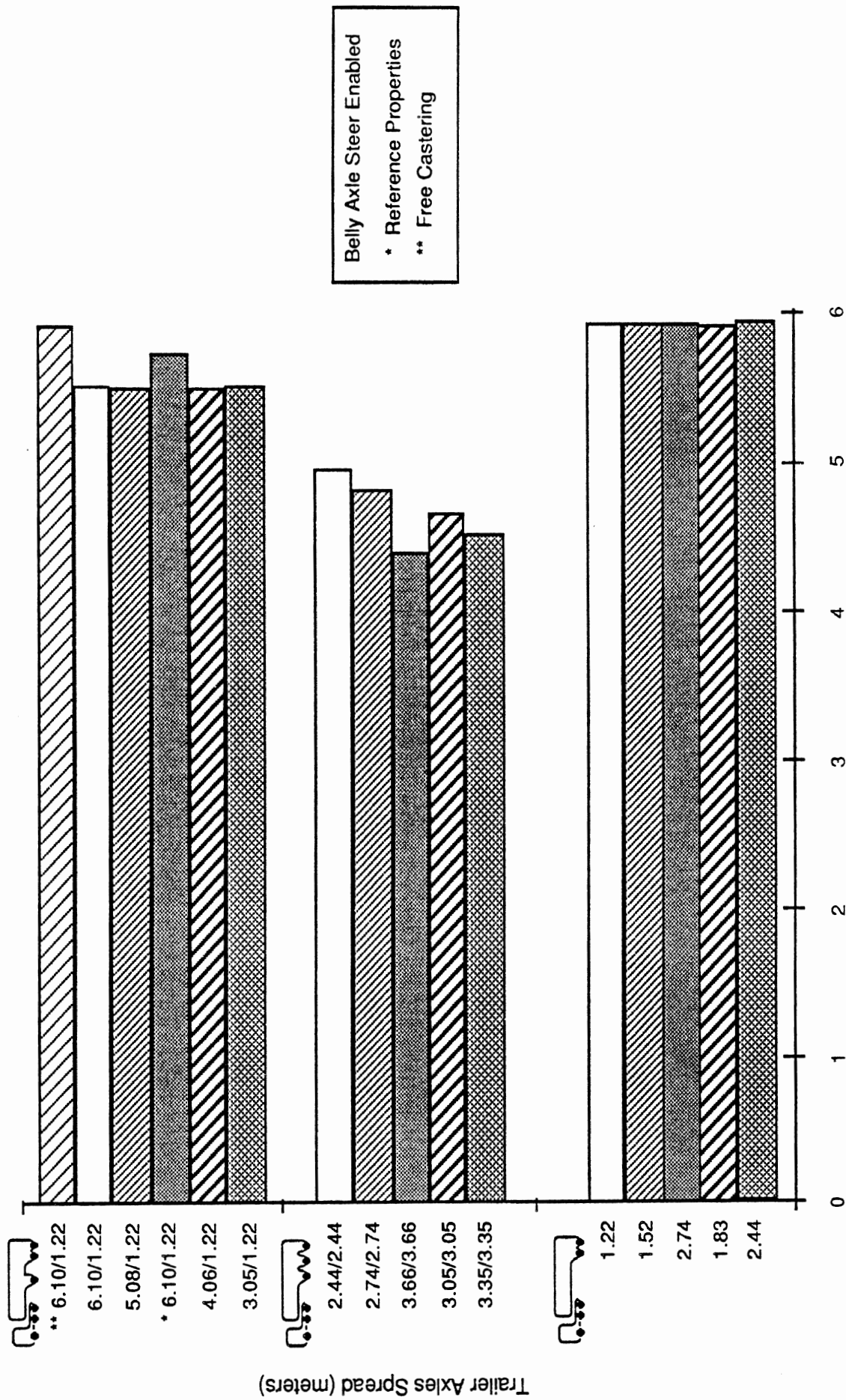
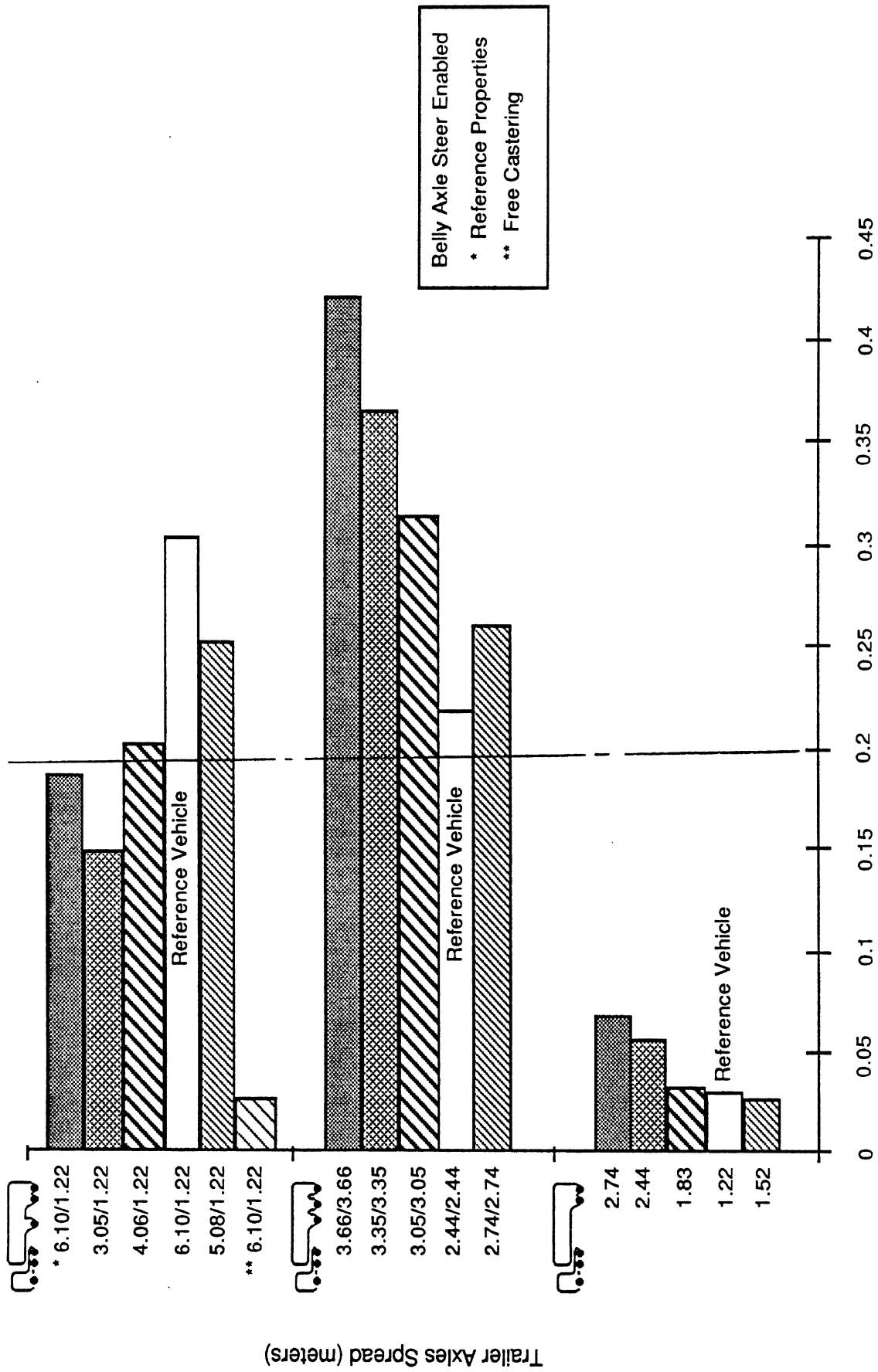

FIGURE 3.2.9.b

Influence of Trailer Axles Spread on a Tight Turn Jackknife in Tractor/Semitrailers



Peak Friction Demand
FIGURE 3.2.9.c

shown in figure 3.2.9c employs a closely spaced tandem at the rear of the semitrailer plus a belly axle set at a variable dimension forward of the lead axle of the tandem. The vehicle in the center of the figure employs three widely spaced trailer axles whose uniform spacing relative to one another is varied from one case to the next.

Recognizing that Canada enjoys winter driving conditions which frequently involve ice and snow on the roadway, it is reasonable to identify, say, a friction value of 0.2 or so above which many wintertime roadways will be unable to provide the demanded frictional coupling. Using the crude criterion of 0.2 for the friction "limit," we observe that all of the widely spaced three-axle trailers and half of the belly-axle-equipped trailer arrangements tend to demand significantly elevated levels of friction in an intersection turn.

The data for the case of the belly-axle trailer also include representation of steerable properties at the belly-axle position. The case with a single asterisk (*), for example, represents a steerable belly axle modelled after the steer-centering properties of the CESCHI axle which provides for effective resistance of steering up to lateral forces on the order of 0.2 times the vertical tire axle load. Vehicles having this type of layout are employed in certain western provinces of Canada. The results show that the steer-resistance of the CESCHI axle results in a friction demand which approaches a friction value of 0.2. The data shown with two asterisks (**), on the other hand, represent the case in which the belly axle carries the full load allotment but steers without resistance. In this case, the friction demands of the belly-axle trailer become equivalent to those of a semitrailer with a closely spaced, two-axle tandem. The other cases of the belly-axle trailer constitute fixed, non-steerable, belly-axle installations such as are popular in the central industrialized provinces of Canada.

The trailer having a widely spaced set of three axles is seen to demand such a high level of friction that one would reasonably wonder how vehicles of this type operate under even the conditions of poor, wet roads. The answer, of course, is that such widely spread axle layouts are employed with air-lift suspensions such that the driver of the truck unloads and lifts the forward-most axle clear of the pavement for negotiating tight-radius intersections.

3.3 Illustration of Parametric Sensitivities for A- and C-Type Doubles Combinations

3.3.1 Influence of Trailer Length and Hitch Placement Dimensions.

In Figure 3.3.1a are results showing the influence of trailer length and hitch placement on the high-speed offtracking of A- and C-train doubles. We see, in general, that the entire range of results, as influenced by these longitudinal dimension parameters, covers from approximately 0.4 to 0.6 m (1 to 2 ft) and that the C-train versions of the vehicle are consistently higher in value. The poorer performance of the C-train in this measure is due to both its superior performance in low-speed offtracking (thus providing a smaller inward bias in offtracking at zero lateral acceleration) and due to the sensitivity of the steerable dolly axle to lateral tire forces, thus providing a mechanism for greater outward offtracking at higher levels of lateral acceleration. The results show that the high-speed offtracking of A-trains increases with longer drawbar lengths (increasing value of DB) and with increased pintle hook (PH) and overhang (OH) dimensions. The longer drawbar primarily contributes to increasing the overall length of the vehicle combination, thus increasing the "gain" with which the outward component of high-speed offtracking is accrued with increasing lateral acceleration. The longer pintle hook dimension (representing the distance from the baseline location of the rear axle of the lead trailer to the pintle hook) serves to reduce the inward, or low-speed, component of offtracking as well as to increase overall combination length. An increase in the OH dimension serves to move the trailer axles forward relative to the baseline location of the pintle hook. This change shortens the effective wheelbase of the involved trailer and, as a result of increased load on trailer axles, produces greater high-speed offtracking due to reduction in the effective normalized cornering stiffness of the trailer tires.

With C-trains, an increase in either the PH, DB, or OH1 dimension will also serve to further increase the slip angle on the tires at the rear of the lead trailer if the steering properties of the dolly permit steering of the dolly wheels toward the outside in the maneuver. In this regard, it is notable that the variations in the OH1 dimension are seen in the figure to increase markedly for the C-train from the case of OH1=1.22 m (4 ft) to OH1=1.83 m (6 ft), with the C-train portion of the data missing for the case, OH1=2.44 m (8 ft). Not only was the value of high-speed offtracking seen to increase substantially between the two cases which are plotted, but the C-train vehicle became so oscillatory in response to the OH1=2.44-m (8-ft) arrangement that the computation of the measure

Influence of Trailer Length and Hitch Placement Dimensions on High-Speed Offtracking in A and C Train Doubles

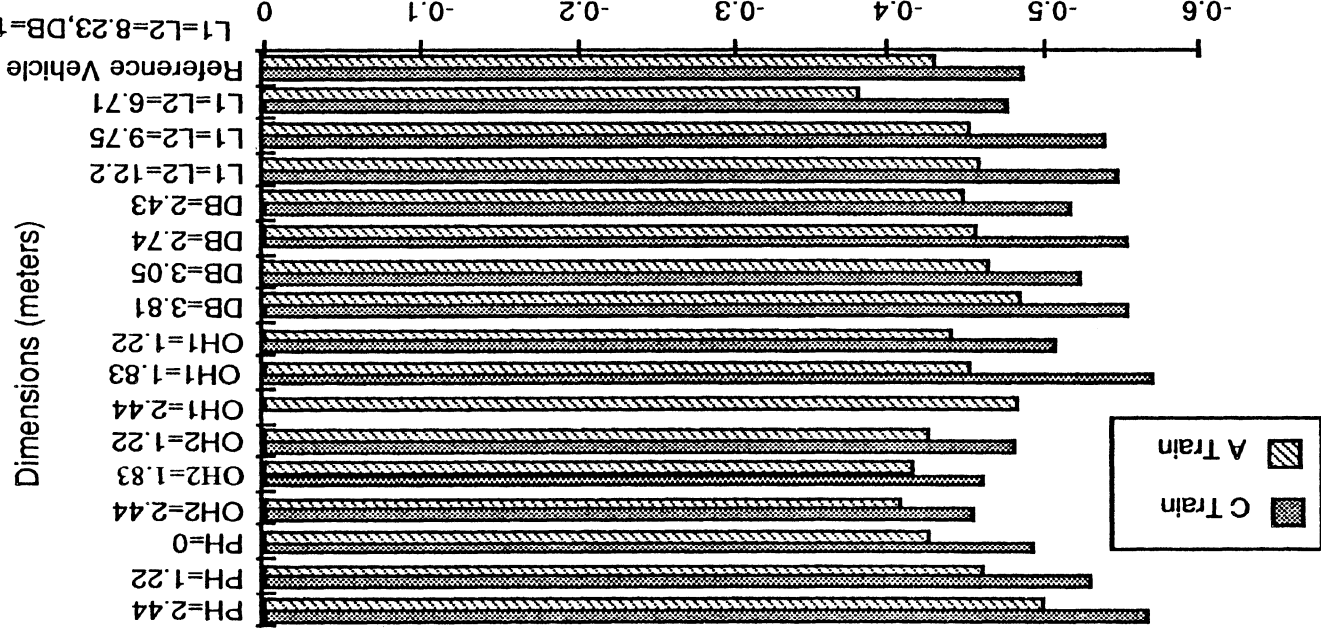
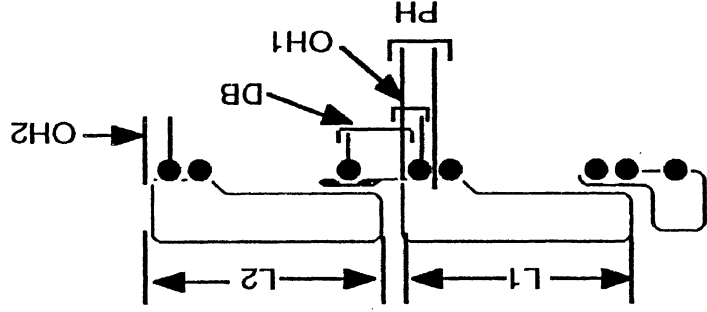

High-Speed Offtracking (meters)

FIGURE 3.3.1.a

defaulted. A discussion presented below, on the transient high-speed offtracking response to these same parametric variations, addresses the oscillatory character of the response which develops under this condition.

Shown in Figure 3.3.1b are results indicating the sensitivity of the load transfer ratio measure to variations in the trailer length and hitch placement dimensions for A- and C-doubles. The chart shows the value of this measure, directly, and indicates which unit of the vehicle train is involved in the rolling action producing the listed value of load transfer ratio. In these cases, (1) the rear trailer of the A-train and (2) both trailers and tractor of the C-train constitute the "critical units." At the very bottom of the chart we see the improved values of this measure which characterize the longer trailer lengths of 9.75 and 12.19 m (32 and 40 ft), in contrast to the reference length of 8.23 m (27 ft). By contrast, the shortening of trailer length to 6.71 m (22 ft) yields the increased level of load transfer ratio seen at the third bar from the top of the graph. Additionally, of course, the C-train combinations perform much better than the A-trains, regardless of the specific vehicle geometry involved (except for one case to be discussed below).

Regarding the sensitivity to hitch placement parameters, we see that changes in the drawbar length, DB, do not significantly disturb the load transfer ratio measure, given the indicated reference values for other parameters. As illustrated for a three-second-period steering maneuver in Figure 3.3.1c, the time histories of lateral acceleration response at the tractor and rear trailer of C-doubles having drawbar lengths of 1.83 and 3.81 m (6 and 13 ft) differ in both phase and amplitude with the change in drawbar length. The longer drawbar does not create an increase in the load transfer ratio value over that for the baseline drawbar case because the increased phase lag in the lateral acceleration response of the rear trailer counterbalances the modest increase in amplification which has resulted.

As either the pintle hitch or overhang dimensions, PH and OH1 and 2, are increased, this dynamic response characteristic worsens, with the most dramatic changes in response accompanying increases in OH1. Note that increases in the OH1 dimension result in (1) increases in the effective overhang from the bogie center to the pintle hitch (with the pintle hitch, itself, remaining fixed at the rear extremity of the trailer bed), (2) a reduction in the effective wheelbase of the lead trailer and, (3) an increase in load on axles four and five. Such a dimensional variation would be effected in real service, for example, when a slider bogie on the lead trailer is moved to a more forward location.

Influence of Trailer Length and Hitch Placement Dimensions on Load Transfer Ratio in A and C Train Doubles

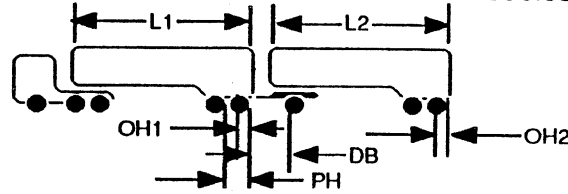

120

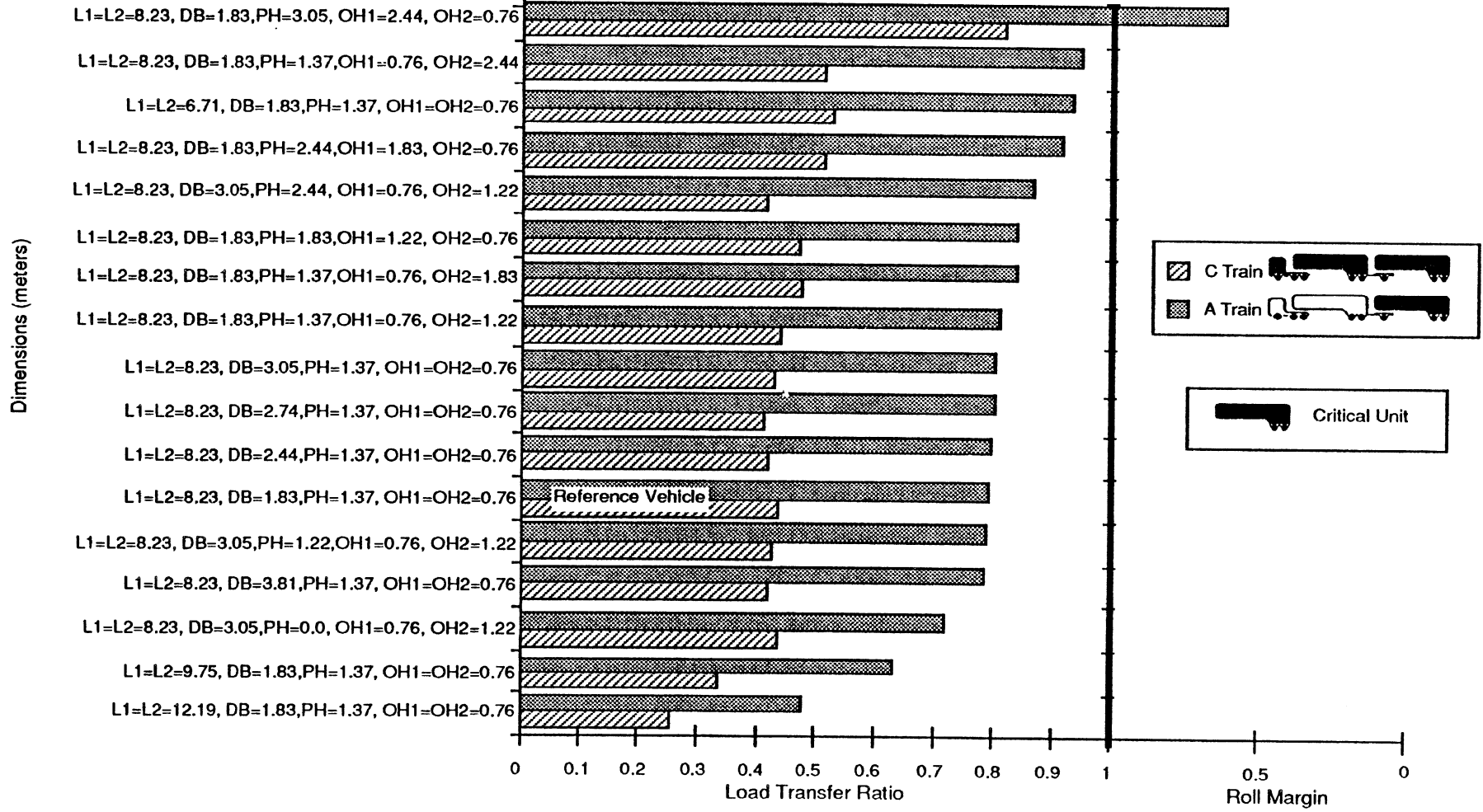
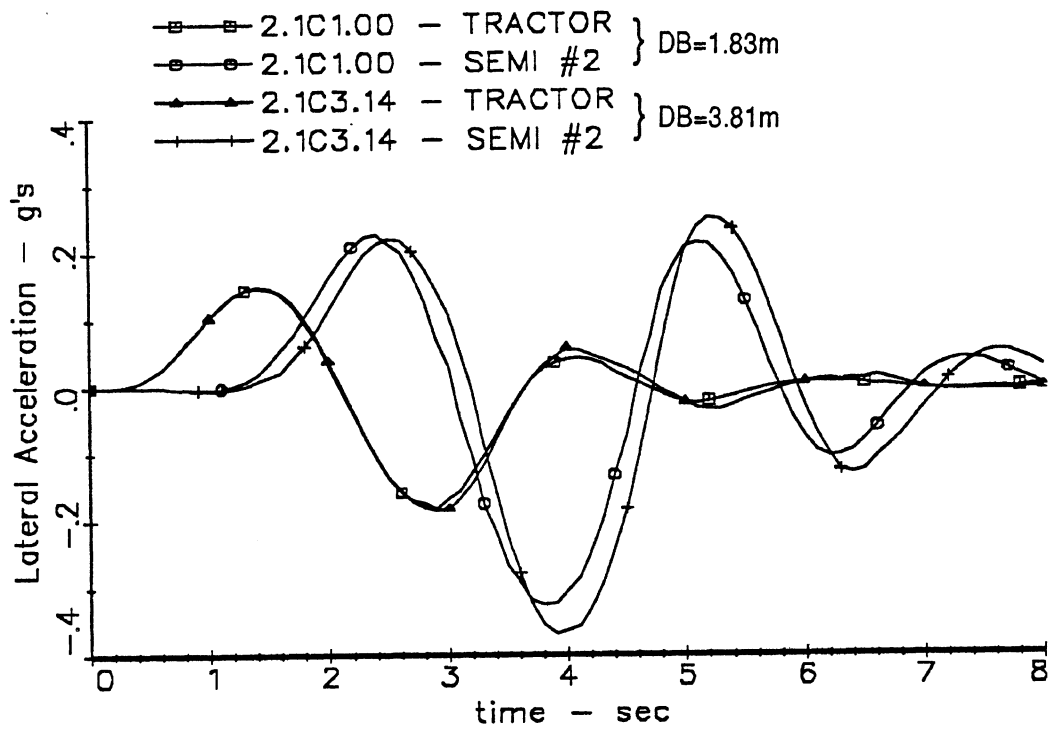

FIGURE 3.3.1.b



RTAC 8 axle C-train Doubles

FIGURE 3.3.1.c Lateral acceleration time histories showing the response of the 8-axle C-train for two cases of drawbar length.

Together, items (1), (2), and (3), above, produce profound increases in the load transfer ratio. In fact, when the OH1 dimension is increased to 2.44 m (8 ft) (top bar) the A-train double approaches a rollover response and the C-train double, while not achieving complete transfer of load within the specified portion of the maneuver, does exhibit a divergent oscillation. As shown in Figure 3.3.1d for each of three values of time period of the nominal maneuver with this C-train configuration, the time histories of lateral acceleration response at the tractor and second trailer grow in magnitude over the time of the total computation. Thus, at time equal to 3.5 to 4.0 seconds, the amplitude of oscillation was insufficient to cause rollover of the C-train--but by the end of the 8-second computation, the response had grown to a total loss of control.

This result should underscore a basic sensitivity of the C-train configuration. Namely, it is undesirable to implement C-train configurations such that a long distance exists from the axle(s) of the lead trailer to the dolly axle. The greater this distance, the greater will be (a) the potential for creating a dolly steer response during maneuvering, and (b) the size of the yaw moment which is imposed upon the lead trailer, for lack of sufficient steering resistance at the dolly axle. The divergent oscillatory response seen here is identified as the same as that which was reported in an accident report in Reference [27]. This type of response is most likely at elevated speeds and does not require the presence of nonlinear phenomena such as hitch slack for its manifestation.

Shown in Figure 3.3.1e is the influence of length and longitudinal placement of hitch elements on the transient high-speed offtracking of A- and C-train doubles. The data show many of the cases situated in virtually the same position on the rank ordering presentation as were seen above with regard to the load transfer ratio measure. Nevertheless, we do see an anomalous excursion of the single C-train case cited above as producing a divergent oscillation. Namely, with the OH1 dimension set at 2.44 m (8 ft), the oscillatory lateral displacement response of this vehicle takes on the real-time divergency shown in Figure 3.3.1f. This set of time histories show lateral displacement responses to all three values of steer input period, with a wholesale excursion beyond lane boundaries occurring in the case of the three-second input period. It is also interesting to note that the lateral displacement response of the tractor unit is growing in amplitude, albeit not as noticeably, with the general divergence of this combination. As stated above, this unstable outcome derives from the unfavorable introduction of a long distance from the axles on the lead trailer to the dolly axle.

- 2.0 sec — Tractor
- 2.0 sec — Semi #2
- ▲— 2.5 sec — Tractor
- +— 2.5 sec — Semi #2
- x— 3.0 sec — Tractor
- ◇— 3.0 sec — Semi #2

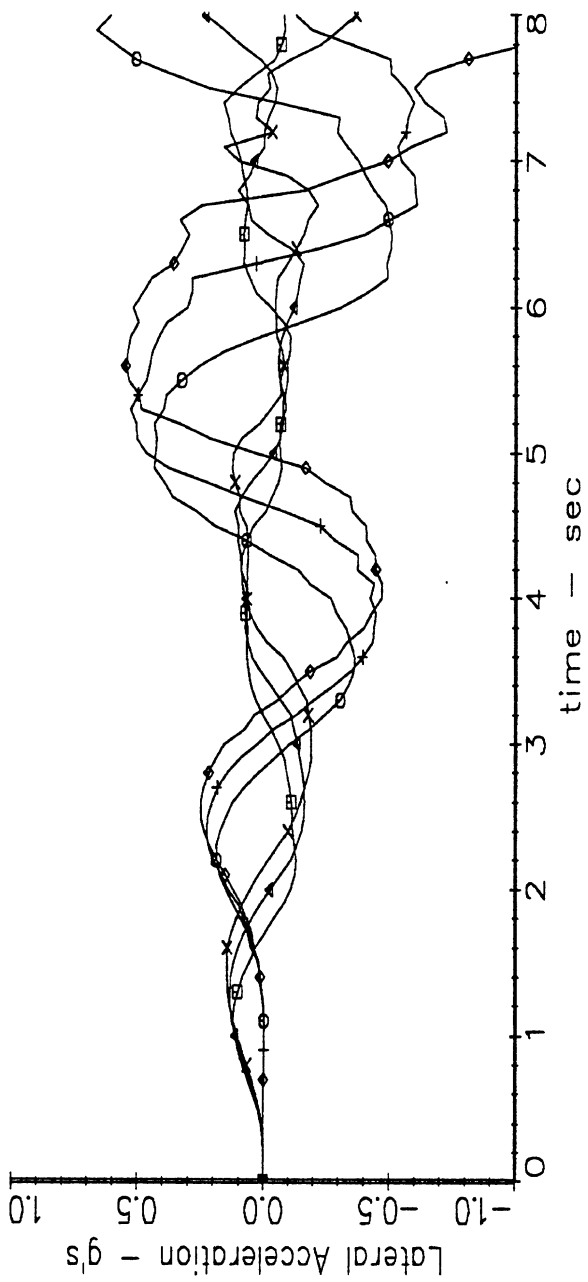

RTAC 8 axle C-train Doubles (49t/108k GCW), conf. 2.1,
var. 3.23

FIGURE 3.3.1.d Lateral acceleration time histories for tractor and second trailer of 8-axle C-train with OHI=2.44 meters.

Influence of Trailer Length and Hitch Placement Dimensions on Transient High-Speed Offtracking in A and C Train Doubles

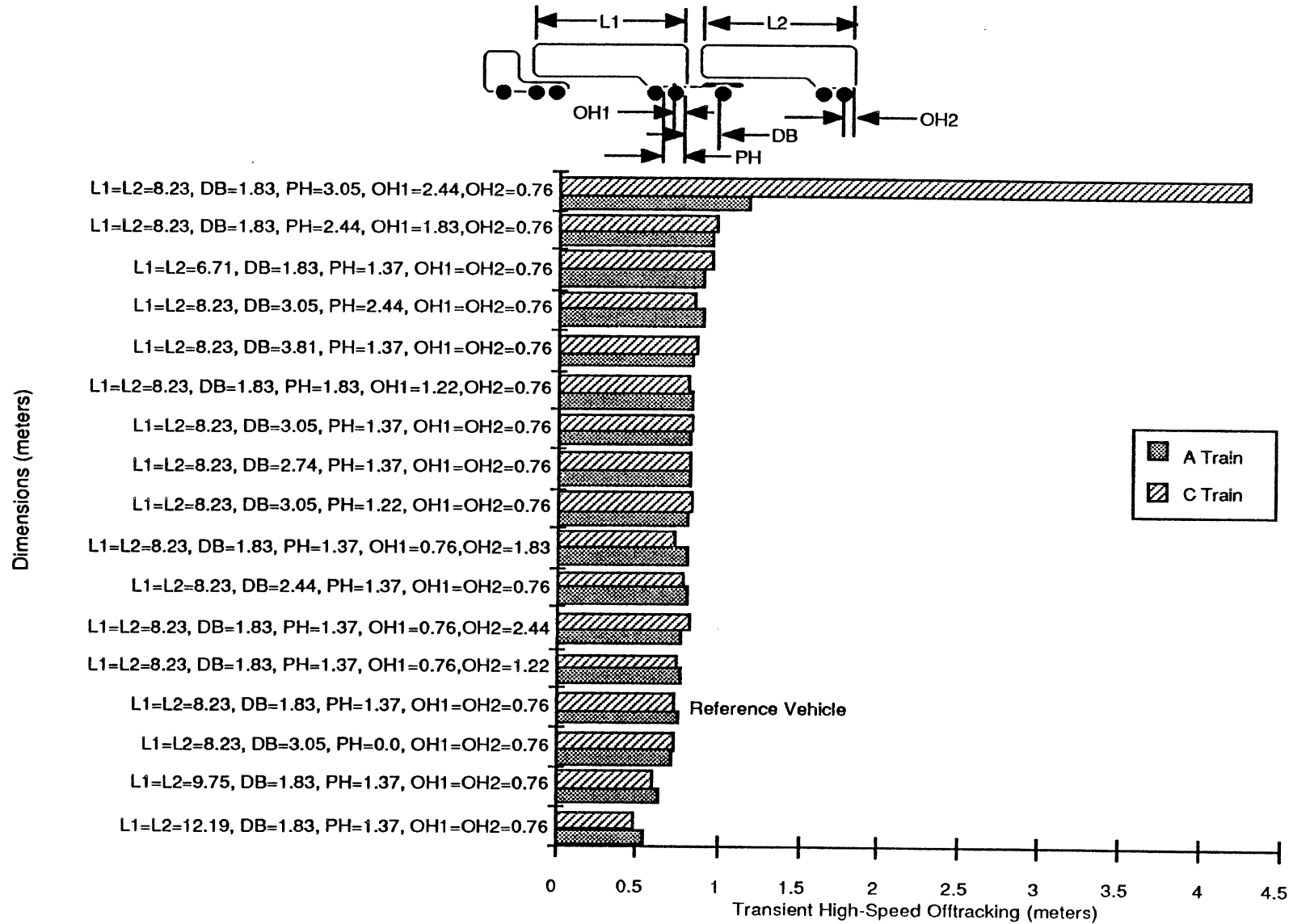
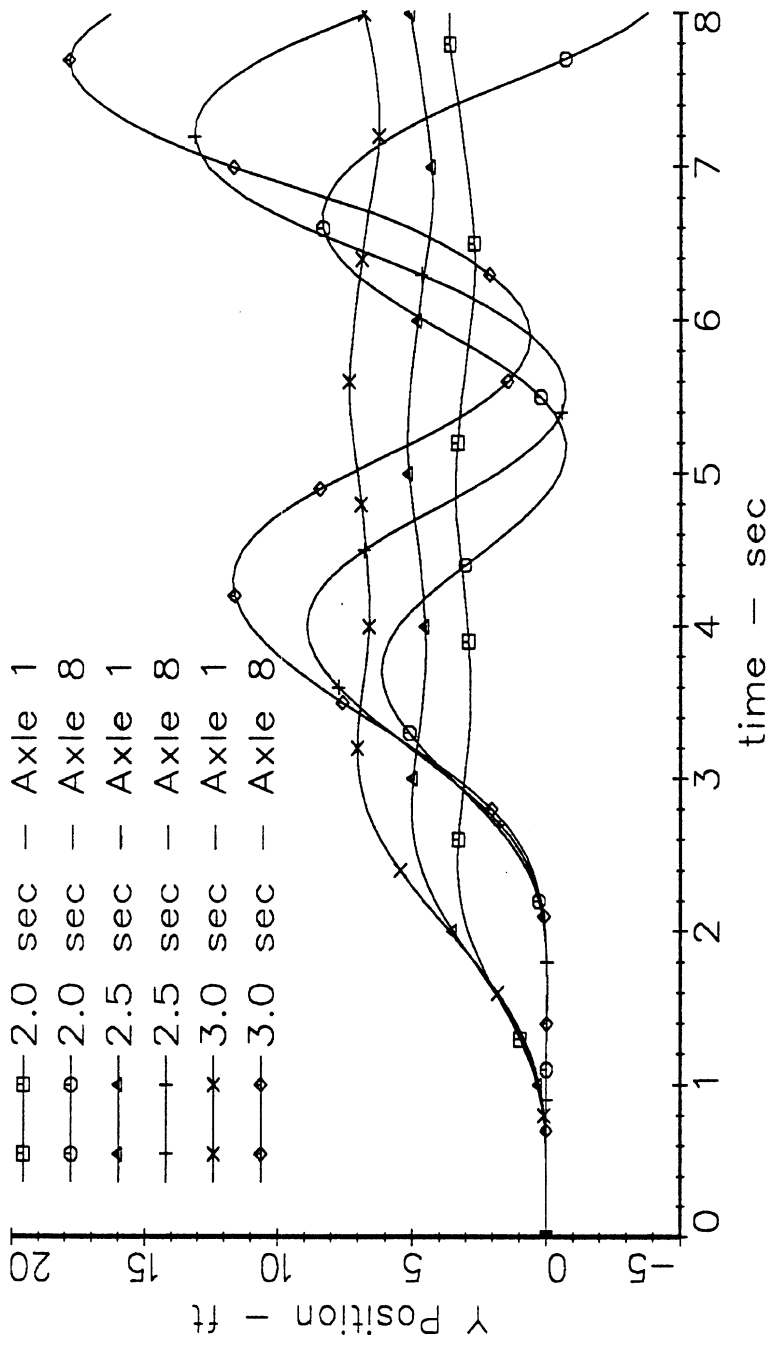

FIGURE 3.3.1.e



RTAC 8 axle C-train Doubles (49t/108k GCW), conf. 2.1, var. 3.23

FIGURE 3.3.1.f Time histories of lateral position showing divergent oscillation of 8-axle C-train.

The influence of trailer length and hitch placement parameters on low-speed offtracking for A- and C-train doubles is shown in Figure 3.3.1g. The three hitch and bogie-locating parameters, PH, OH1, and OH2, all are such that an increasing value of the parameter serves to increase the rear overhang of the pintle hitch aft of the trailer bogie centerline and/or to reduce the wheelbase of a trailer. Accordingly, we see that low-speed offtracking reduces with an increasing value of either of these three parameters. The classic, and powerful, influence of trailer length (and thus trailer wheelbase) on low-speed offtracking is seen in the results for variations in L1 and L2 near the bottom of the chart. It is perhaps useful to note that the approximate rate of increase in low-speed offtracking, per unit increase in the wheelbase of the two equal-length trailers, is approximately 0.85 m per m (3 ft per ft)--given modest perturbations around the reference case employed here.

Shown in Figure 3.3.1h is the influence of these longitudinal dimension parameters on the braking efficiency of the baseline doubles combination. A very substantial range of variations in braking efficiency are seen to derive from changes in length and hitch placement. In particular, changes in the OH2 dimension serve to change the position, and thus loading, on the tandem axles of the rear trailers. Since it is the wheels on this tandem axle set which are first to lock up, any mechanism which changes the load on the rear trailer's axles will influence the braking efficiency of the combination. For example, when OH2 is lengthened to 2.44 m (8 ft), the rear tandem bogie becomes set forward and the resulting load increase tends to provide an improved proportion of brake torques to wheel loads, with greater resulting braking efficiency. Likewise, when trailer length is increased, the dynamic loads prevailing at the rear trailer's tandem are greater because the dynamic load transfer mechanism is less strong. Accordingly, we see that longer trailer length improves the braking efficiency level achieved at 0.4 g (although the performance at 0.1 g is largely unaffected by the change in trailer length).

3.3.2 Influence of Axle Loading. The influence of increased axle loading on the static rollover threshold of A- and C-doubles is shown in Figure 3.3.2a. Increased axle load causes a decrease in the static rollover threshold as the payload c.g. height rises and as the payload weight, itself, increases. The variations in performance are, indeed, large recognizing that there is a very strong relationship between the absolute level of the rollover threshold and the probability of involvement in rollover accidents. [23] It is notable that the turnpike double, shown in the upper group of data in Figure 3.3.2a, illustrates higher values of rollover threshold, overall, as well as a reduced incremental change in the measure with increasing load. These features of response derive simply from the constant density freight protocol which was adopted for this study. That is, since the turnpike double

Influence of Trailer Length and Hitch Placement on the Low-Speed Offtracking in A- and C-Train Doubles

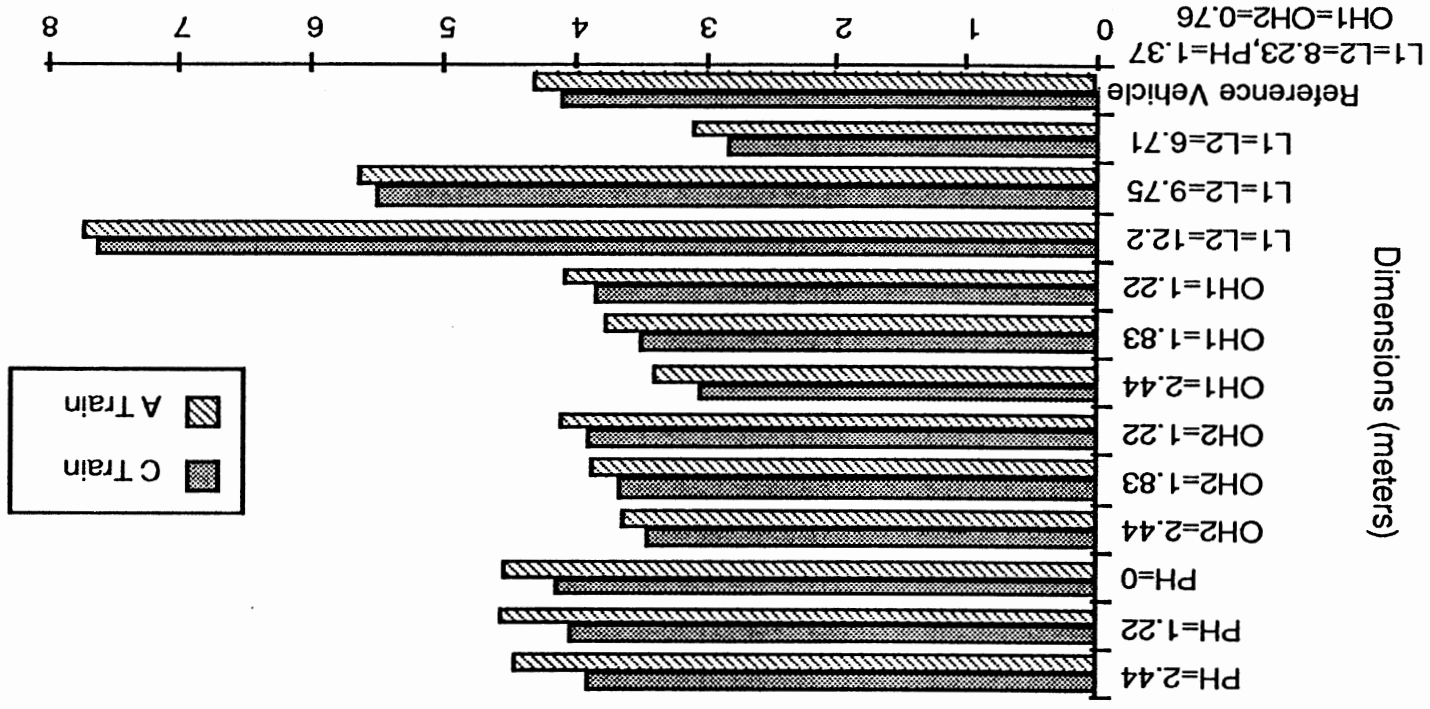
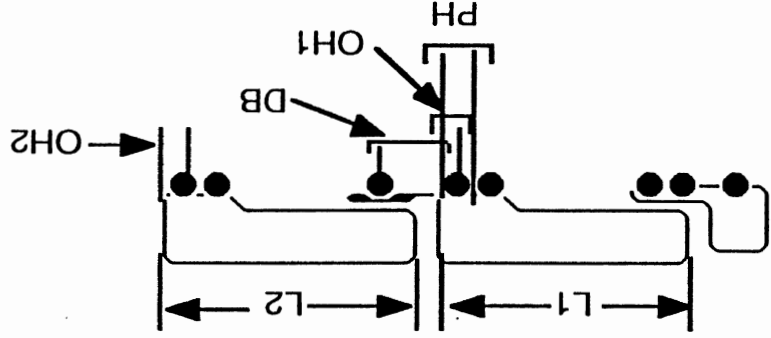

Figure 3.3.1.9 Low-Speed Offtracking (Meters)

Influence of Trailer Length and Hitch Placement Dimensions on Braking Efficiency in A and C Train Doubles

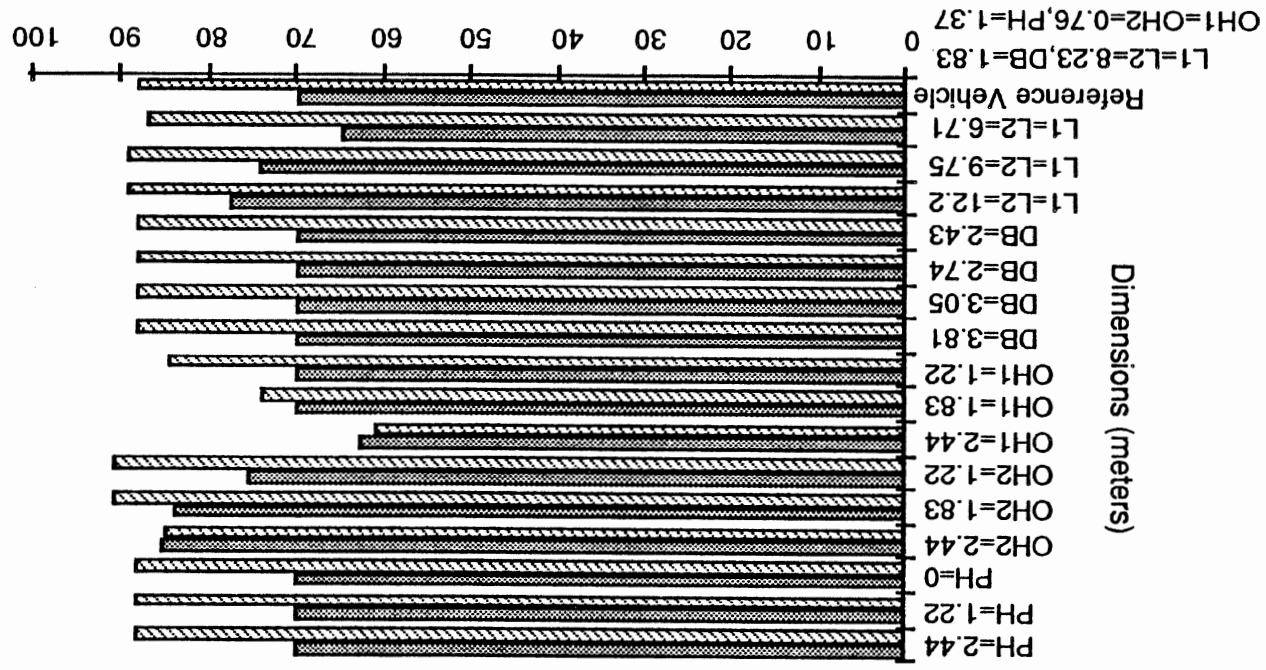
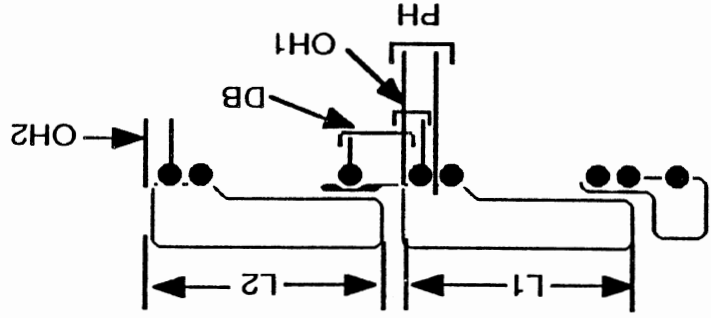
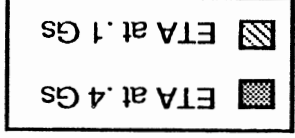
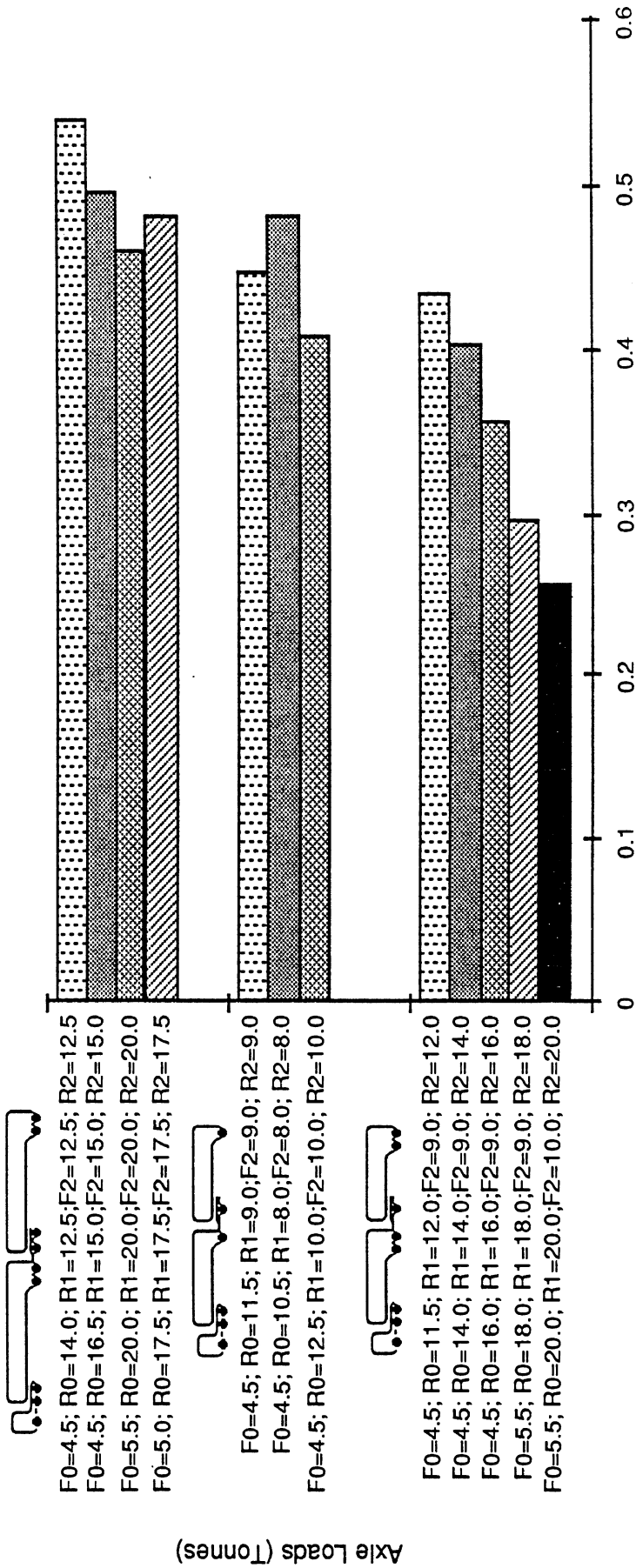
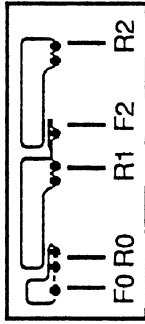

FIGURE 3.3.1.h
Braking Efficiency (%)



Influence of Axle Loading on Static Rollover Threshold in A and C Train Doubles



Static Rollover Threshold (g's)

FIGURE 3.3.2.a

employs two 14.6-m (48-ft) trailers, in contrast to the 8.2-m (27-ft) trailers employed in the other two doubles configurations illustrated in the figure, the payload stack in the turnpike double is situated considerably closer to the floor, such that rollover threshold is enhanced. Of course, for a differing loading protocol, the turnpike double could certainly exhibit considerably lower levels of rollover threshold than those computed here. Nevertheless, the results are of value for illustrating the nominal sensitivity in this important measure which may derive from a change in the allowance for axle loading. The selected loading protocol, tying an increase in payload c.g. height to increases in axle load, serves to alert those making weights and dimensions policy that any increase in load allowance will necessarily imply some reduction in roll stability over the average of the vehicle fleet.

Shown in Figure 3.3.2b is the influence of changes in axle loading on the high-speed offtracking behavior of A- and C-train doubles. The results show in a very uniform fashion that since increased axle load results in both higher static tire loads and a stronger load transfer gain during cornering, the resulting reductions in the normalized cornering stiffness of the installed tires causes high-speed offtracking to increase with increased loading.

Figure 3.3.2c presents the influence of various axle loadings on the load transfer ratio for A- and C-doubles. Basically, the values of load transfer ratio simply follow the increased axle load level. The reduced dynamic roll stability deriving from increased loading involves the altered tire properties, giving rise to greater rearward amplification plus the reduced static stability feature involving greater payload weight and increased height of the payload center of gravity. We see that the A-train combinations having tandem-axle, short-wheelbase, trailers (4th configuration from top), exhibit the phenomenon of complete wheel liftoff at the two higher load variations such that a roll margin value is computed. In the highest load case, this vehicle reaches a roll margin value of zero, and rolls over. Clearly, the C-train alternatives to the reference A-train doubles provide much greater tolerance to increased loading.

Figure 3.3.2d shows the influence of axle loading on the transient high-speed offtracking of A- and C-doubles. The data show that this measure increases in a very regular manner with increased load level. Although the differences are small, the A-train doubles indicate somewhat greater levels of the transient high-speed offtracking measure than the C-doubles. Both vehicle types show the same nominal gain, however, in terms of increased value of the measure per unit of increased axle load. Note, also, that the A-train double at the bottom of the figure exhibits a rollover response in this fixed-severity

Influence of Axle Loading on High-Speed Offtracking in A and C Train Doubles



FIGURE 3.3.2.b

Influence of Axle Loading on Load Transfer Ratio and Roll Margin in A and C Train Doubles

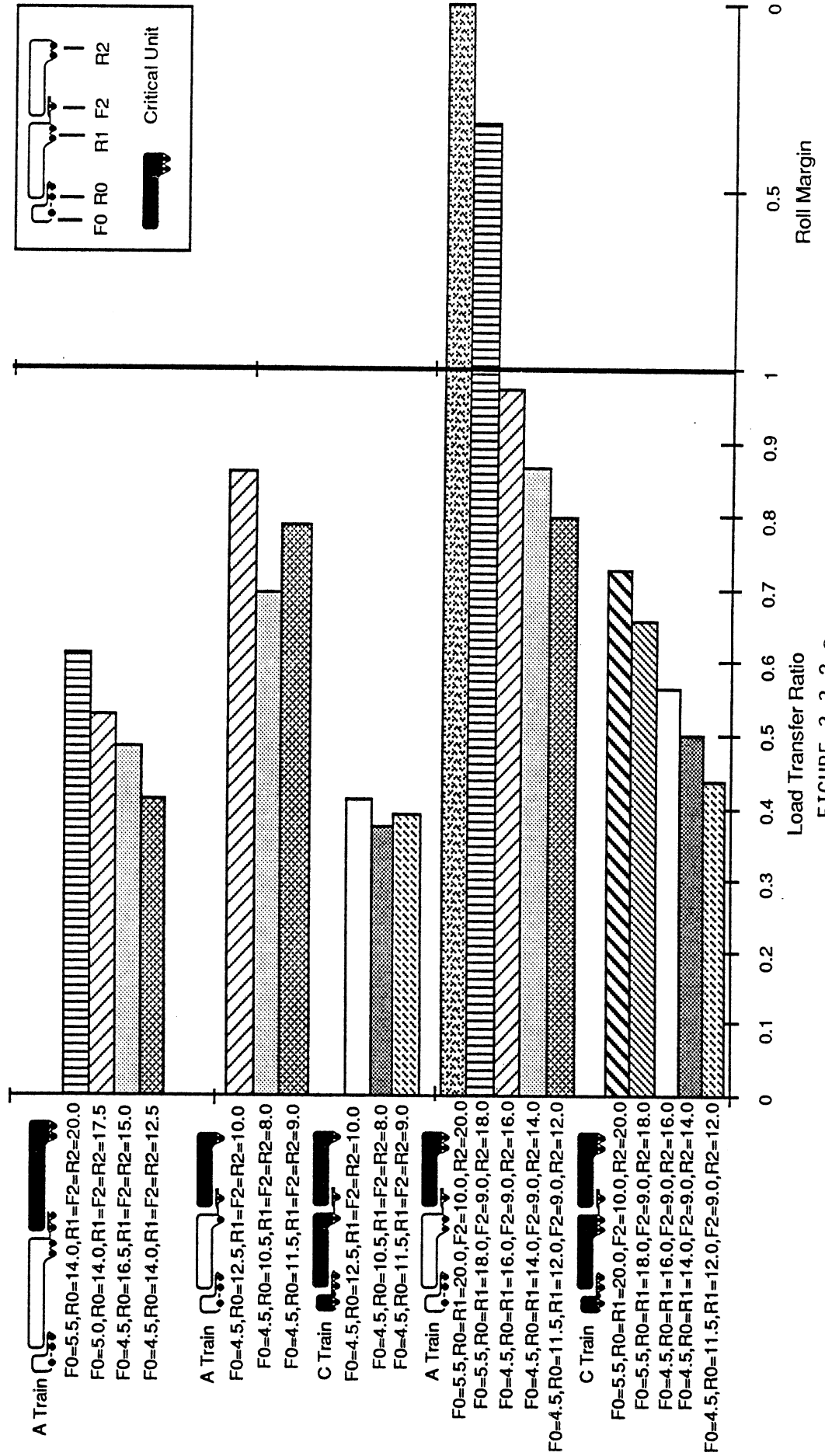
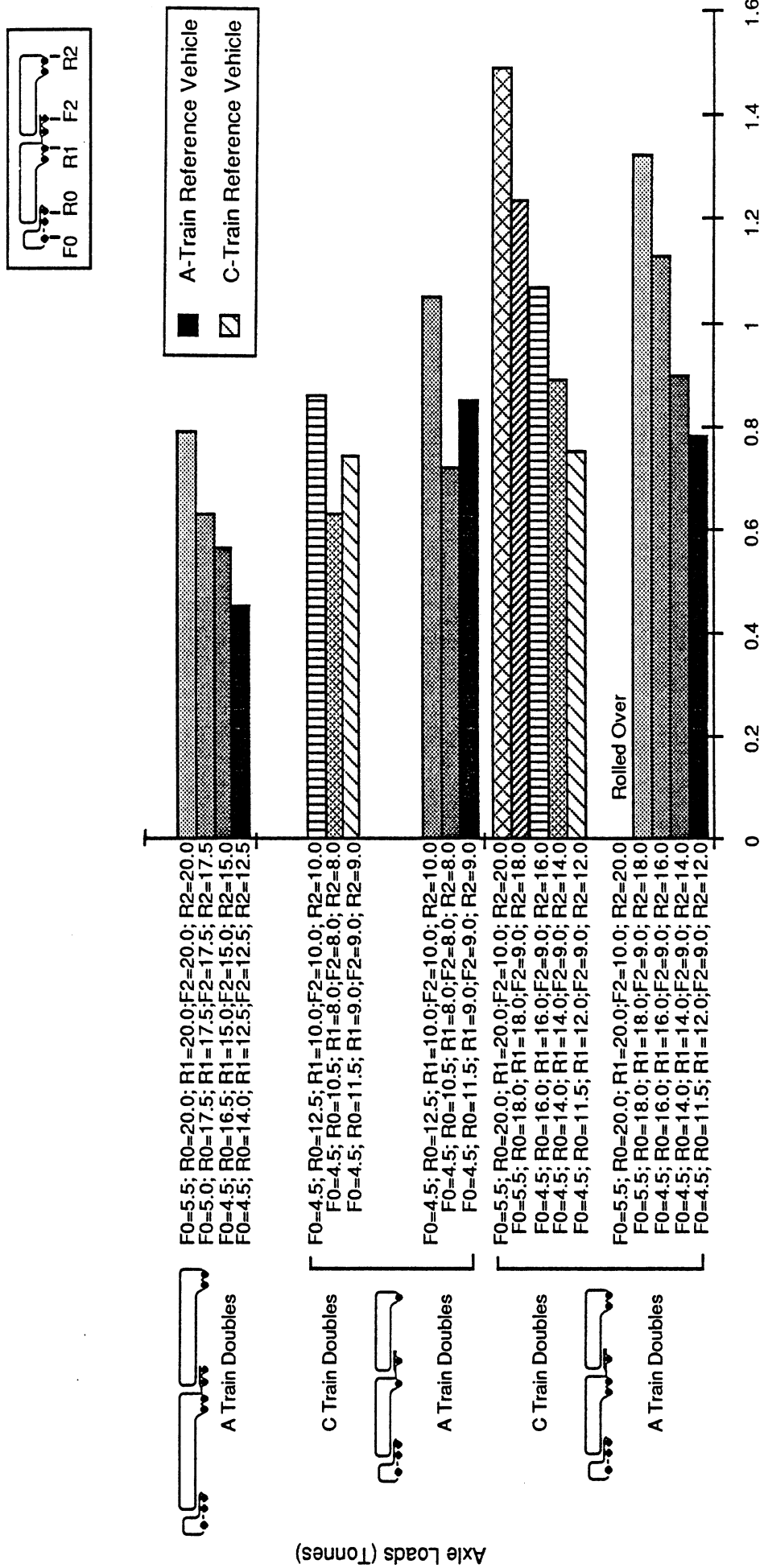

FIGURE 3.3.2.c

Influence of Axle Loading on Transient High-Speed Offtracking in A and C Train Doubles



Transient High-Speed Offtracking (meters)

FIGURE 3.3.2.d

maneuver as a combined result of the greater rearward amplification and the elevated payload c.g. height of the highest load condition.

Shown in Figure 3.3.2e is the influence of axle loading on the braking efficiency of A-train doubles. Since axle loading changes are introduced fairly uniformly along the vehicle, rather little change in the braking efficiency level is seen from one case to the next. Of course, we do see substantial differences in efficiency from the 0.1 to 0.4 g condition because of the redistribution of load as a result of dynamic load transfer. The doubles configuration shown at the bottom portion of the chart is less sensitive to deceleration level because the "critical" axles (that is, the most "overbraked" axles, given the imposed loads) are at the tractor tandem. Since there are typically rather small changes in load at the rear of a tractor during braking (while large load changes occur at the tractor front axle), there is little resulting change in braking efficiency with deceleration. The vehicle configuration at the upper portion of the chart has the tandem set on the rear trailer as its "critical axles," where substantial reductions in axle load accrue with increased deceleration. Accordingly, this vehicle shows a substantially reduced level of braking efficiency at the 0.4 g deceleration level, relative to the 0.1 g condition.

3.3.3 Influence of Partial Loading. Shown in Figure 3.3.3a is the influence of partial loading on the high-speed offtracking of A- and C-doubles. In general, the results show the basic finding that follows from consideration of the tire mechanics involved, namely that any reduction in load level will improve high-speed offtracking. The reduction in load on the truck tire causes the normalized cornering stiffness level to rise, thus reducing the outboard offtracking deriving from the lateral slip of tires in a turn.

Figure 3.3.3b presents the influence of the partial load variations on the load transfer ratio of A- and C-doubles. Again, this performance measure improves when loading is reduced, although the sensitivity to various distributions of load has a certain predictability, as follows:

- 1) The A-train exhibits higher values of the load transfer ratio when the load is biased aft in the rear trailer [3,12]. Thus, we see that the A-train versions having the 50% payload distributed at $(0.25 \times L1 / 0.75 \times L2)$, that is, with forward-biased load in the front trailer and aft-biased load in the rear trailer, exhibit higher values of load transfer than the converse loading, $(0.75 \times L1 / 0.25 \times L2)$. This sensitivity derives from the basic dynamics of the pup trailer of the A-double with its mass center moved far to the rear.

Influence of Axle Loading on Braking Efficiency in A Train Doubles

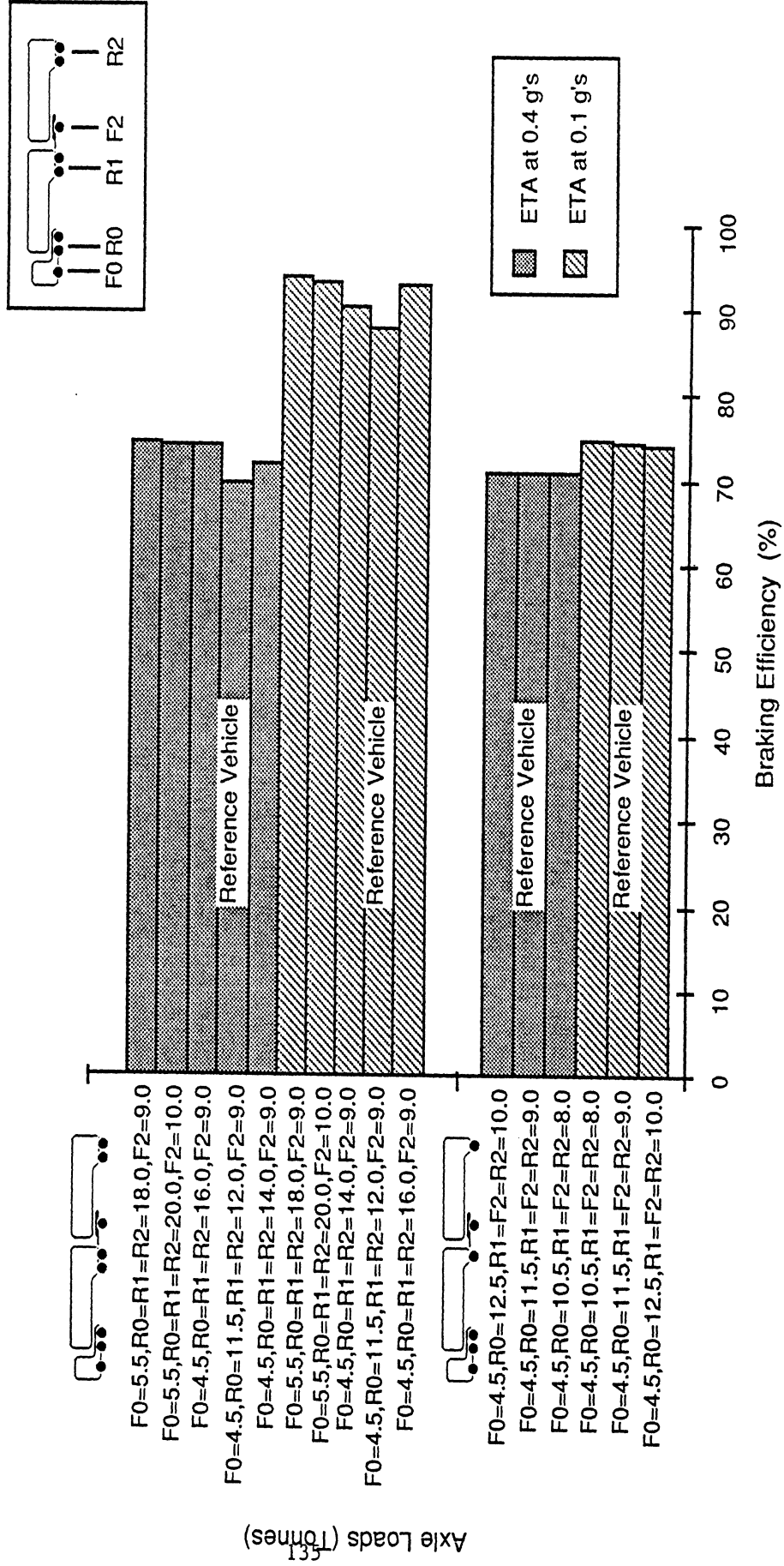

FIGURE 3.3.2.e

Influence of Partial Loading on High-Speed Offtracking in A and C Train Doubles

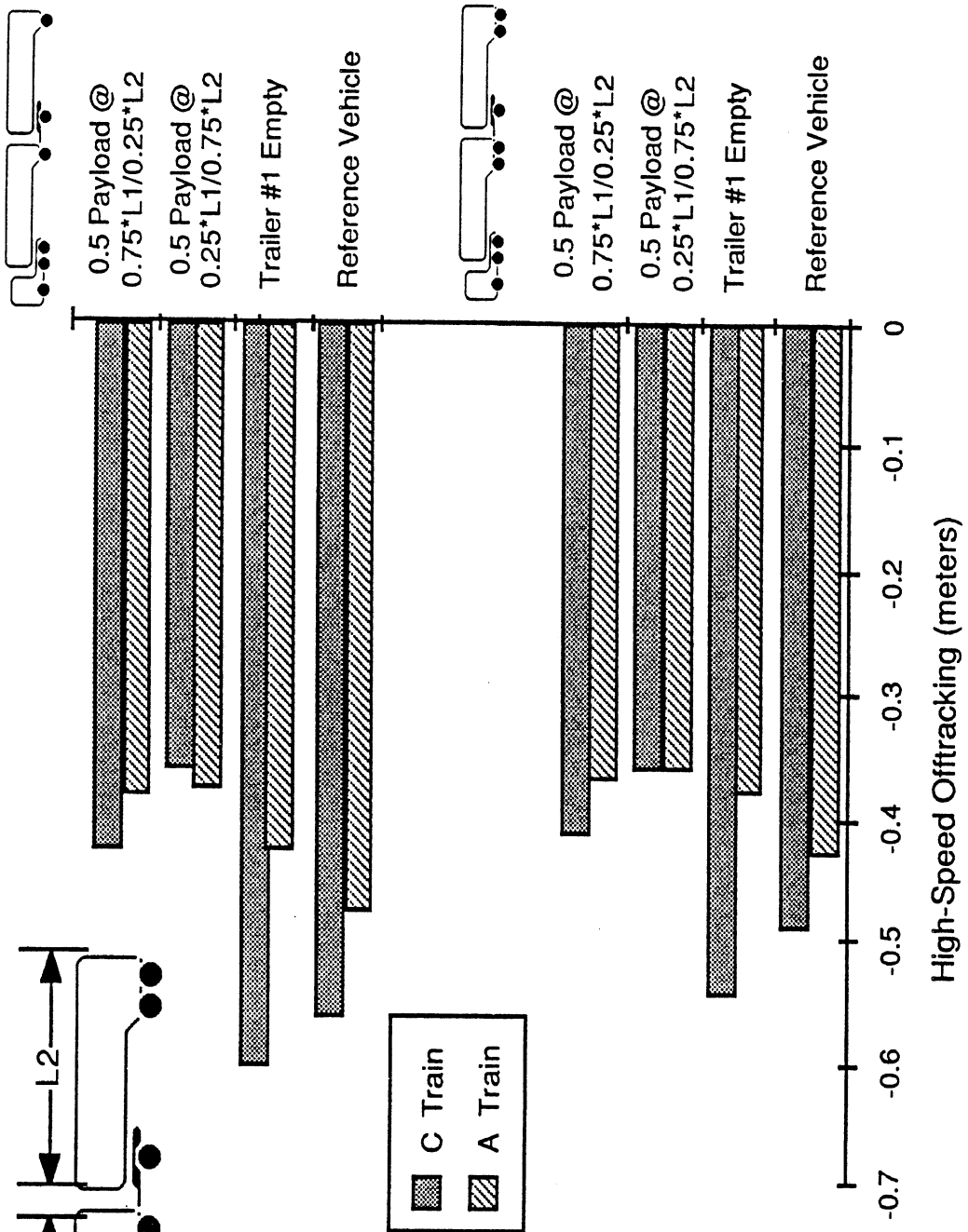

FIGURE 3.3.3.a

Influence of Partial Loading on Load Transfer Ratio in A and C Train Doubles

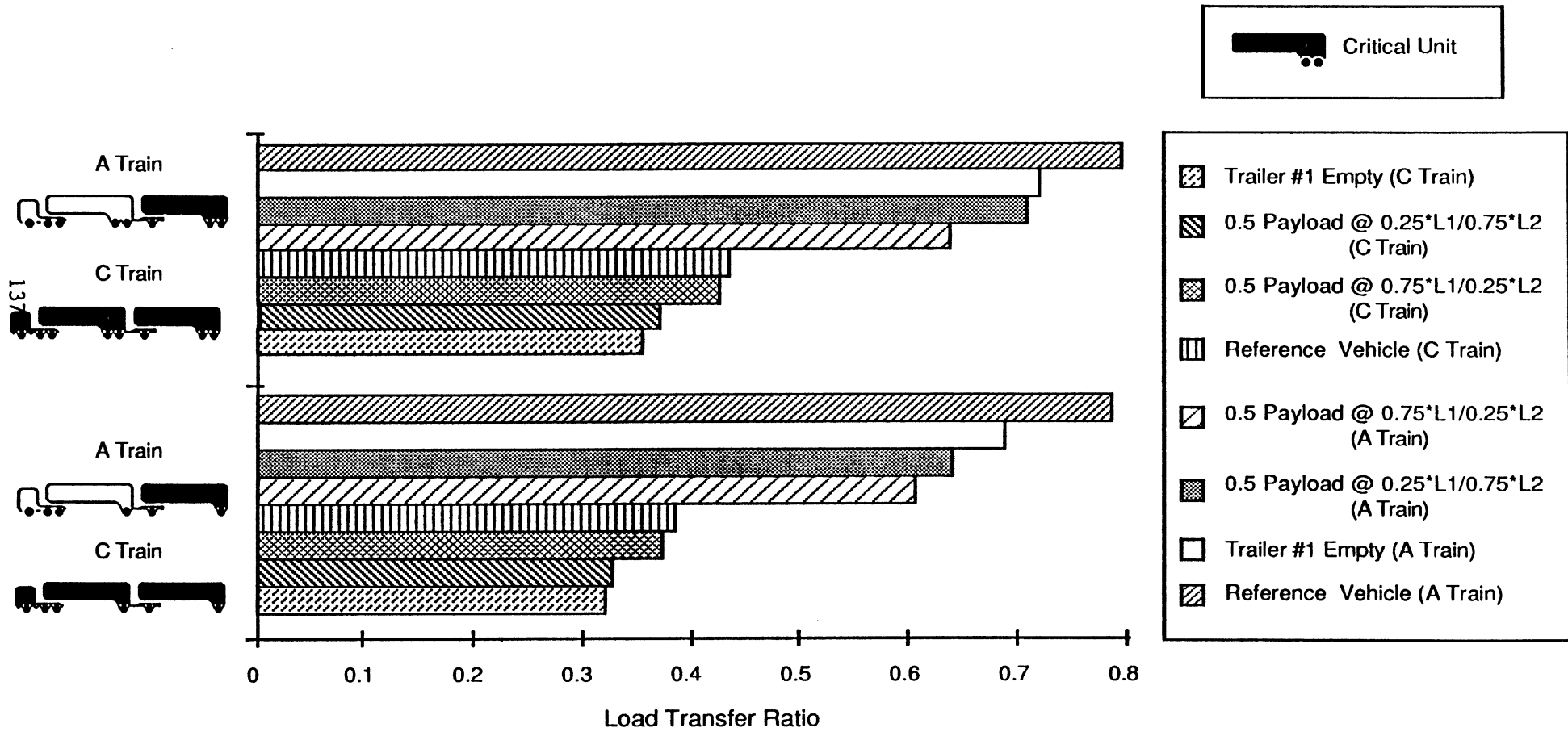

FIGURE 3.3.3.b

- 2) The C-train exhibits the converse sensitivity, as seen in the data. That is, the C-train having the forward-biased-front and aft-biased-rear loading exhibits a lower value of load transfer ratio than occurs with the aft-front, forward-rear loading. The apparent reason for a reduced performance of the C-train with both payloads biased toward the center is that this arrangement produces the largest demands for lateral force development by the steerable dolly axle--and produces roll moments across the heavily loaded first trailer and dolly axles at nearly the same phase relationship so as to maximize the load transfer ratio.

Shown in Figure 3.3.3c is the influence of partial loading on the transient high-speed offtracking measure for A- and C-doubles. We see that reduced loading always benefits this response characteristic, although the distinction between A- and C-train combinations is not very marked. It is interesting to note that the worst partial loading case with the A-train occurs when the front trailer is empty, while the C-train does somewhat better with its front trailer empty than in other partial loading cases. This result can apparently be related to the fact that the roll-stiff-coupling of the C-train enables a sharing of load transfer at other forward axles of the combination, thus providing a reduction in the net outboard offtracking at the rearmost axle of the vehicle.

The sensitivity of braking efficiency to the partial loading of doubles having single- and tandem-axle trailers is shown in Figure 3.3.3d. While in the reference, fully loaded, cases, braking efficiency levels around 70% are obtained, we see dramatic reductions in efficiency with various partial loading arrangements. For the reference combination having single axle trailers, the critical axle positions at the 0.4 g condition are at the tractor tandem since it is these axles which are peculiarly underloaded. For the reference configuration with tandem-axle trailers, the critical position at the 0.4 g condition is at the rear tandem of the second trailer. Accordingly, we see that either of the partial loading arrangements which serve to lighten these respective critical axle positions relative to other axles degrades braking efficiency the most. However, braking efficiency declines strongly under any of these non-balanced load cases simply because some axle is being operated in a particularly underloaded (or "overbraked") manner. When a full trailer is combined with an empty one, braking efficiency is especially low because the overall vehicle mass is still quite large while axle loads on the empty unit are so low that lockup occurs at a very low deceleration level. Also, with the empty trailer in front, tractor jackknife will be the loss-of-control mode--an outcome which is seen as the more generally hazardous of the various articulation instabilities. Efficiency levels which are computed to be in the vicinity of 20 to 40%

Influence of Partial Loading on Transient High-Speed Offtracking in A and C Train Doubles

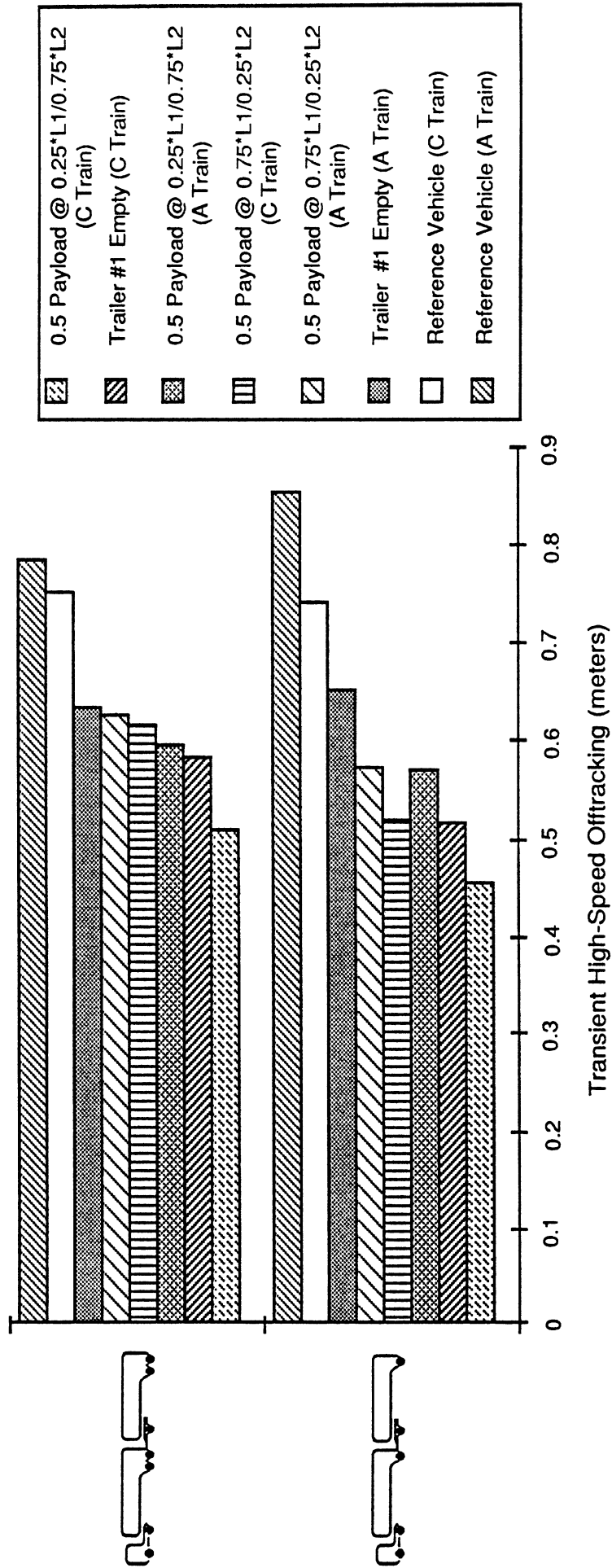

FIGURE 3.3.3.c

Influence of Partial Loading on Braking Efficiency in A and C Train Doubles.

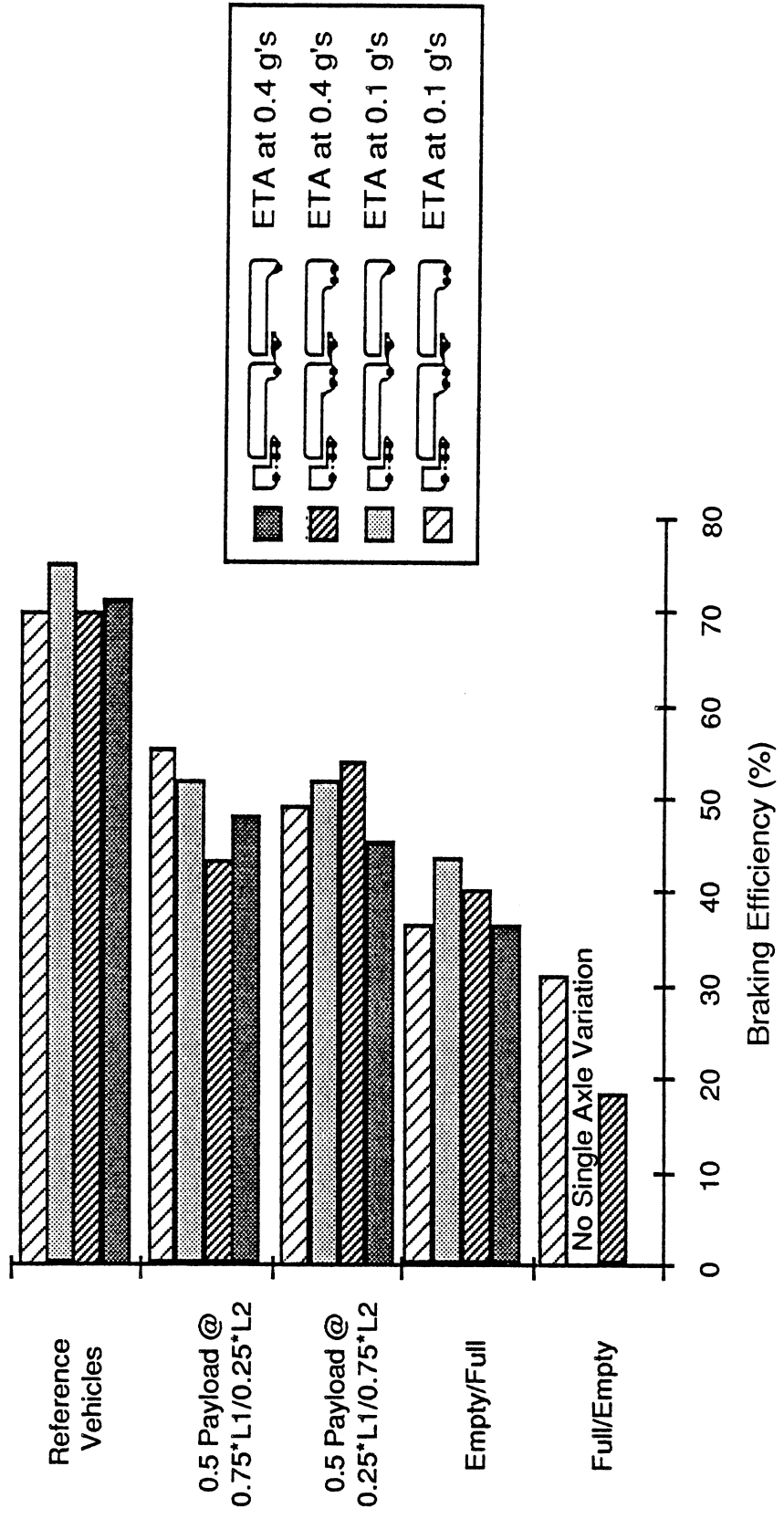

FIGURE 3.3.3.d

suggest an operating condition for which the probability of wheel lockup is extremely high [28].

3.3.4 Influence of Order of Placement of Differing Configuration Trailers Shown in Figure 3.3.4a is an illustration of the influence on high-speed offtracking of the order of placement of the two trailers in mixed-trailer doubles combinations. The two vehicle configurations used in this demonstration are the equal-length trailers at the bottom of the figure, having differing axle installations, and the Rocky Mountain doubles configuration, at the top, having one long trailer with tandem axles and one short trailer with a single axle. The results indicate reference cases, with the tandem-equipped trailers placed in the lead position, and "reversed" cases in which the tandem-equipped trailers are placed in the rear. With the equal-length trailers, a single-axle dolly was employed in both cases of the vehicle, such that it was necessary to download the tandem-equipped trailer when it was placed in the rear. With the Rocky Mountain double, a tandem dolly was employed in the "reversed" case, thus reflecting industry practice and maintaining the same gross weight condition. Basically, the results in Figure 3.3.4a show little change in performance with the reversal of order.

Similarly, in Figure 3.3.4b, we see that the reversed order case has a rather little influence on the load transfer ratio measure. The modest differences in behavior which do occur are due to fairly complex combinations of various influences, including (a) changes in the effective rear overhang dimension at the rear of the lead trailer (the tandem-equipped trailer incorporates a greater overhang dimension), (b) the substantial reduction in load that is necessary with the tandem-equipped short trailer when placed in the rear, in order to avoid overloading the single-axle dolly, (c) the inherent differences in the role played by the lead and aft trailers in the rearward amplification responses of A-train units [13] and, (d) the differences in phase relationship between the lateral acceleration responses of differing trailers in the lead and aft positions of C-trains (see Section 3.1.2).

Figure 3.3.4c shows the variations in transient high-speed offtracking deriving from the reversed order of trailer placement. The greater extent of high-speed offtracking with the short doubles having the single-axle trailer in the rear position results predominantly from the influence of the higher axle loads carried in that configuration. When the tandem-equipped trailer was placed in the rear, the reduced loading on the aft trailer yielded the higher level of normalized cornering stiffness which reduces transient high-speed offtracking.

Influence of Order of Placement of Differing Configuration in Trailers on High-Speed Offtracking in Mixed Doubles and Rocky Mountain Doubles

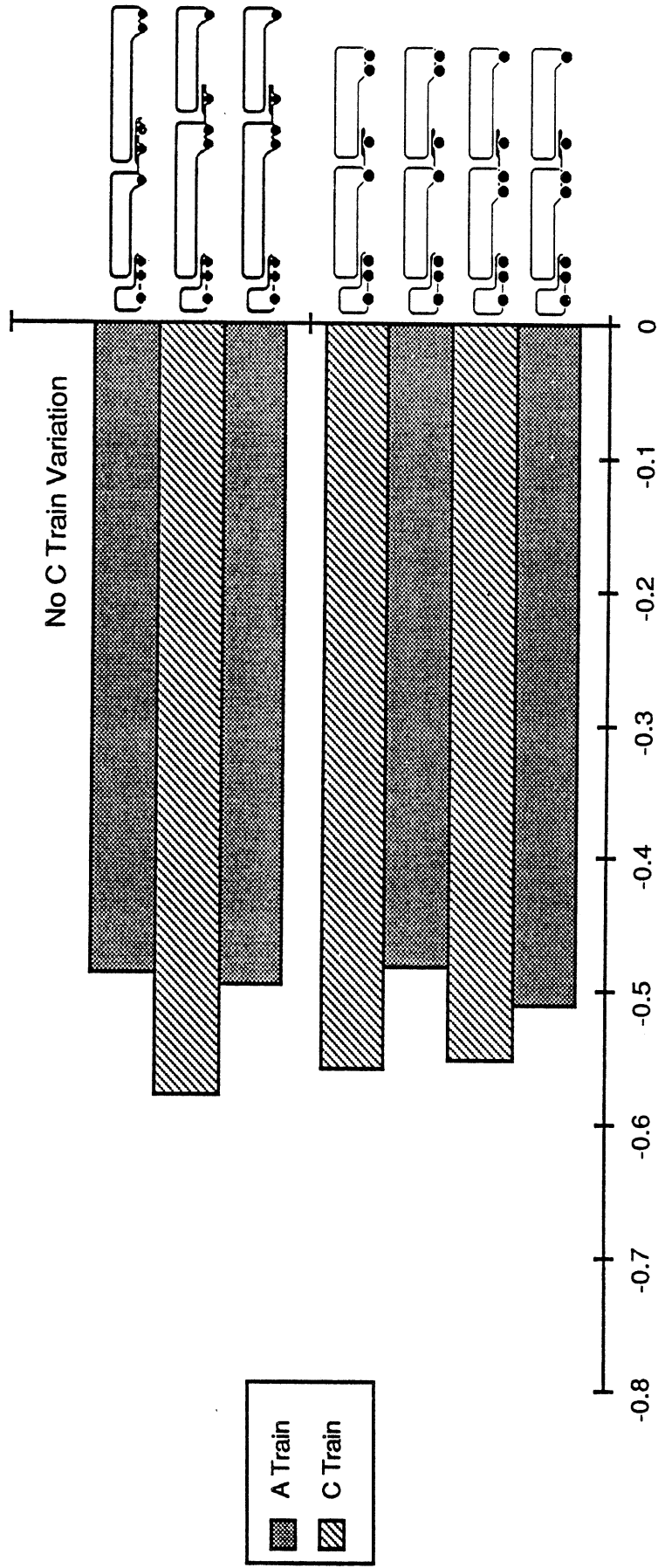

High-Speed Offtracking (meters)

FIGURE 3.3.4.a

Influence of Order of Placement of Differing Configuration in Trailers on Load Transfer Ratio in Mixed Doubles and Rocky Mountain Doubles

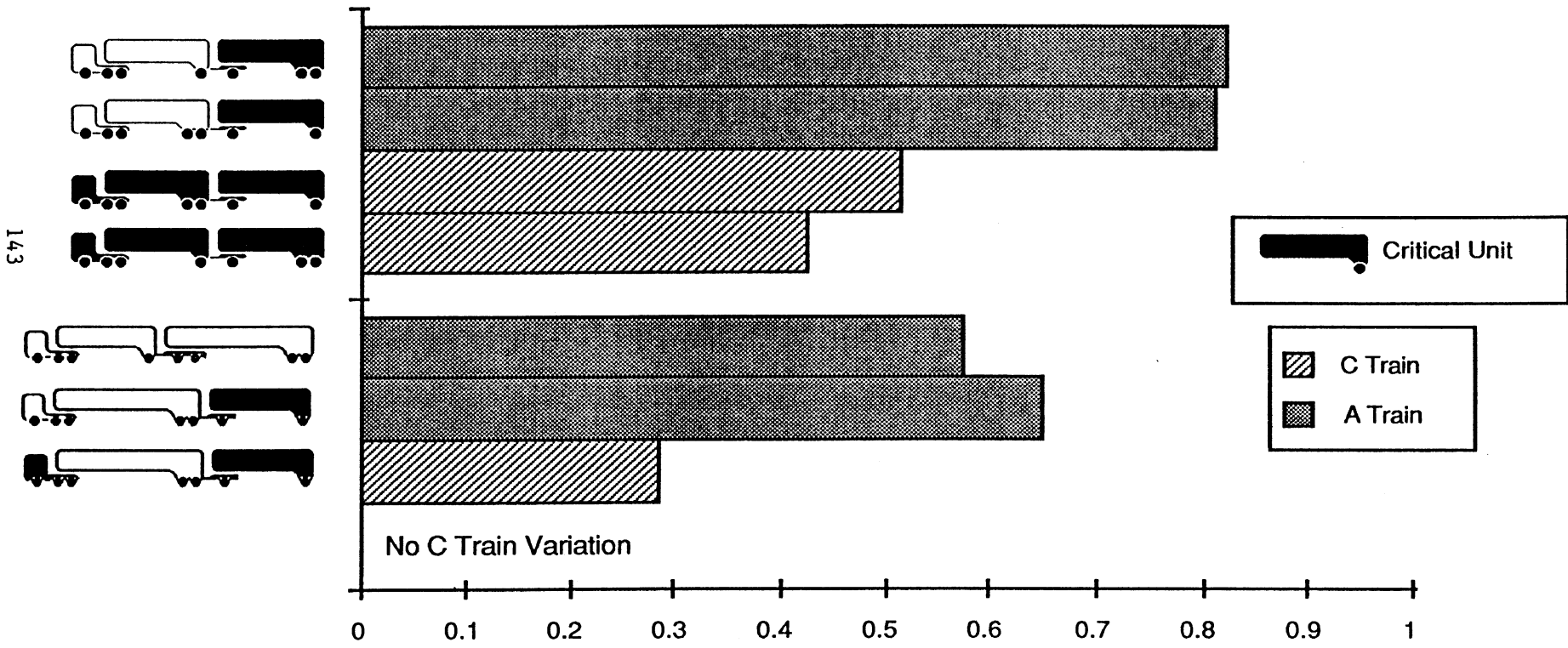

Load Transfer Ratio

FIGURE 3.3.4.b

Influence of Order of Placement of Differing Configuration in Trailers on Transient High-Speed Offtracking in Mixed Doubles and Rocky Mountain Doubles

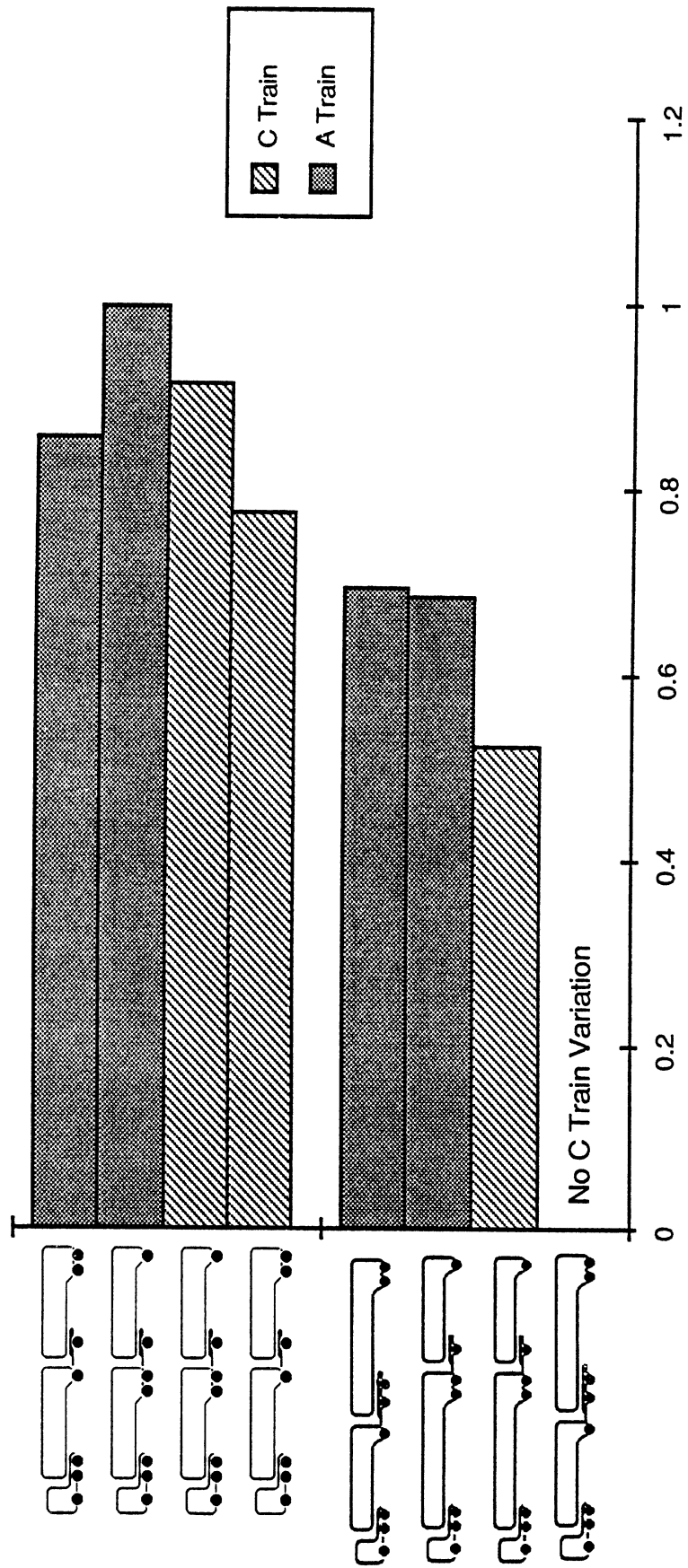

Transient High-Speed Offtracking (meters)

FIGURE 3.3.4.c

The influence of the reversed order cases on braking efficiency are shown in Figure 3.3.4d. The results all follow a simple pattern, namely, with the single-axle trailer in the lead position, the tractor tandem axles become overbraked due to reduced loading, such that braking efficiency is limited. In the case of the short trailers, there is also an overbraking on the trailer axles of the tandem-equipped trailer when it is downloaded for placement in the rear. These observations support the general rule that changes in axle load distribution that reduce the degree of uniformity of loading will degrade braking efficiency performance.

3.3.5 Influence of Tire Selection. The influence on high-speed offtracking response of a change from new radial-ply tires, in the reference case, to new bias-ply tires is shown for A- and C-train doubles in Figure 3.3.5a. We see that the approximate 32% reduction in tire cornering stiffness involved in this tire variation produces almost exactly the same percentage change in the high-speed offtracking measure, as would be expected from simple analysis [11].

Shown in Figure 3.3.5b are the corresponding influences of tire installation on the load transfer ratio in the same rapid-steering maneuver. In this case, we see a much smaller influence of the change from radial- to bias-ply tires than is manifest in the transient high-speed offtracking measure. In the case of the C-train, the roll coupling between respective trailers tends to moderate any of the influence of the tire cornering stiffness change on yaw response properties. In the case of the A-train, it is assumed that the rather severe nature of the response which brings the rear trailer near to its liftoff point is serving to also moderate the net significance of the tire variation on load transfer ratio.

Shown in Figure 3.3.5c is the influence of a change in tire construction, and primarily, the consequent cornering stiffness level, on the transient high-speed offtracking response of A- and C-train doubles. We see that both the A- and C-trains indicate a much larger degree of this transient overshoot measure when the lower-stiffness bias-ply tires are installed. In the A-train case, we see that the transient high-speed offtracking peak has increased by 67% when bias-ply tires are used, allowing the rearmost trailer axles to swing a maximum of 1.3 m (4 ft) to the outside of the tractor's path in this lateral excursion maneuver. Given the dynamic character of the transient high-speed offtracking measure, this result derives both from the reduction in yaw damping afforded with bias-ply tires and from the static aspects of increased deflection with a lower stiffness cornering characteristic. It is generally true to observe that bias-ply tires will categorically cause this overshoot measure to increase and that the extent of the resulting lateral excursions with

Influence of Order of Placement of Differing Configuration in Trailers on Braking Efficiency in Mixed Doubles and Rocky Mountain Doubles

146

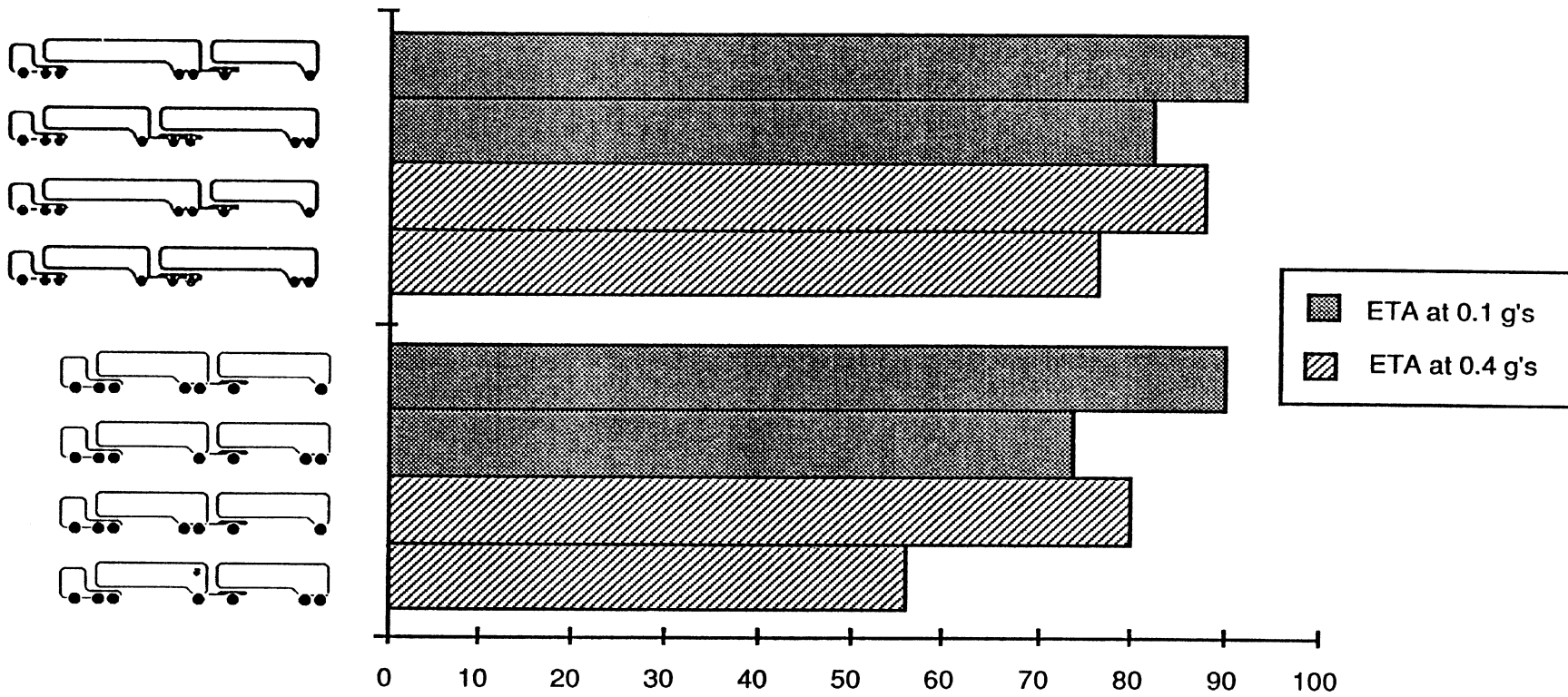

Braking Efficiency (%)

FIGURE 3.3.4.d

Influence of Tire Selection on High-Speed Offtracking in A and C Train Doubles

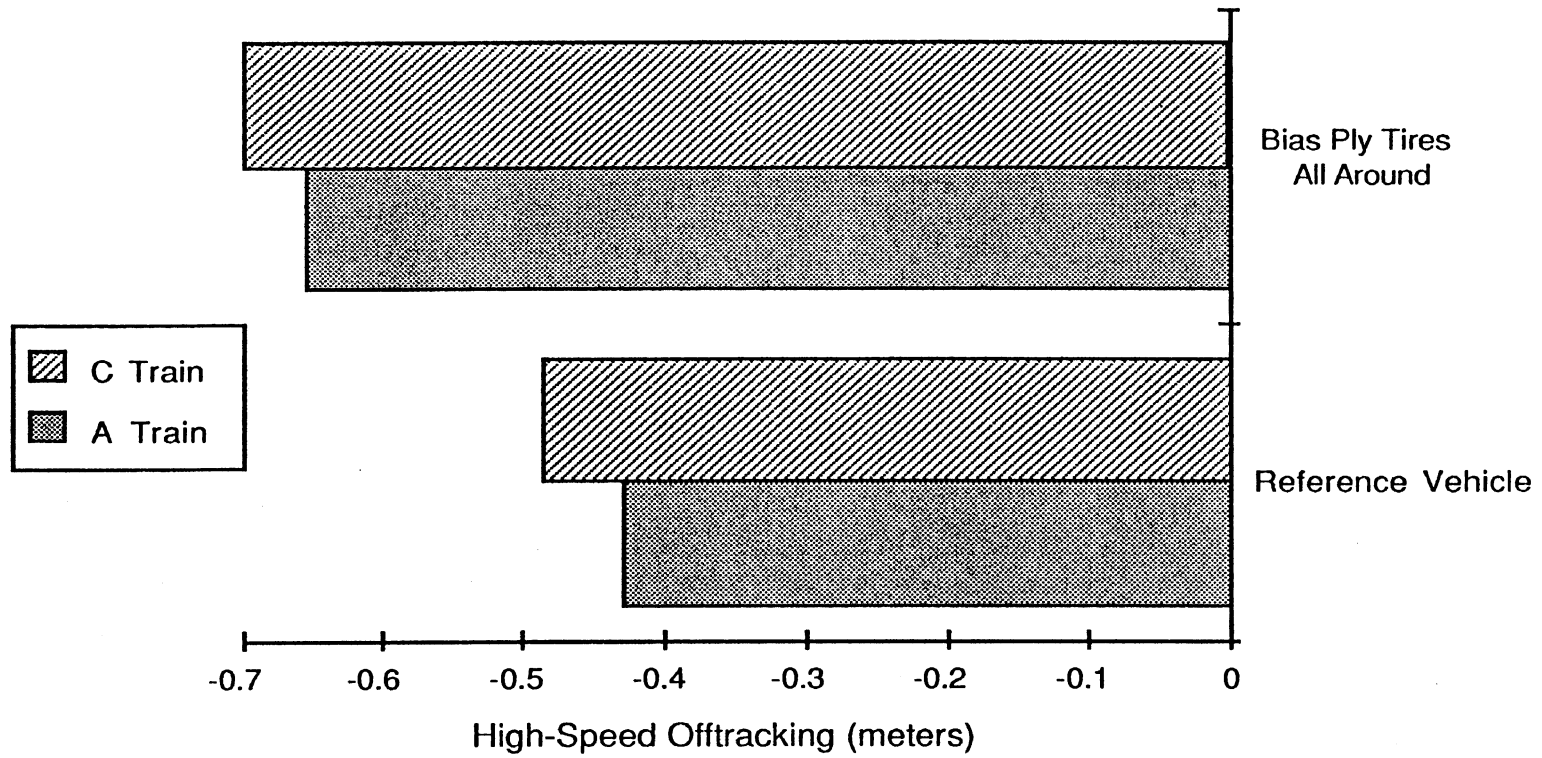

FIGURE 3.3.5a

Influence of Tire Selection on Load Transfer Ratio in A and C Train Doubles

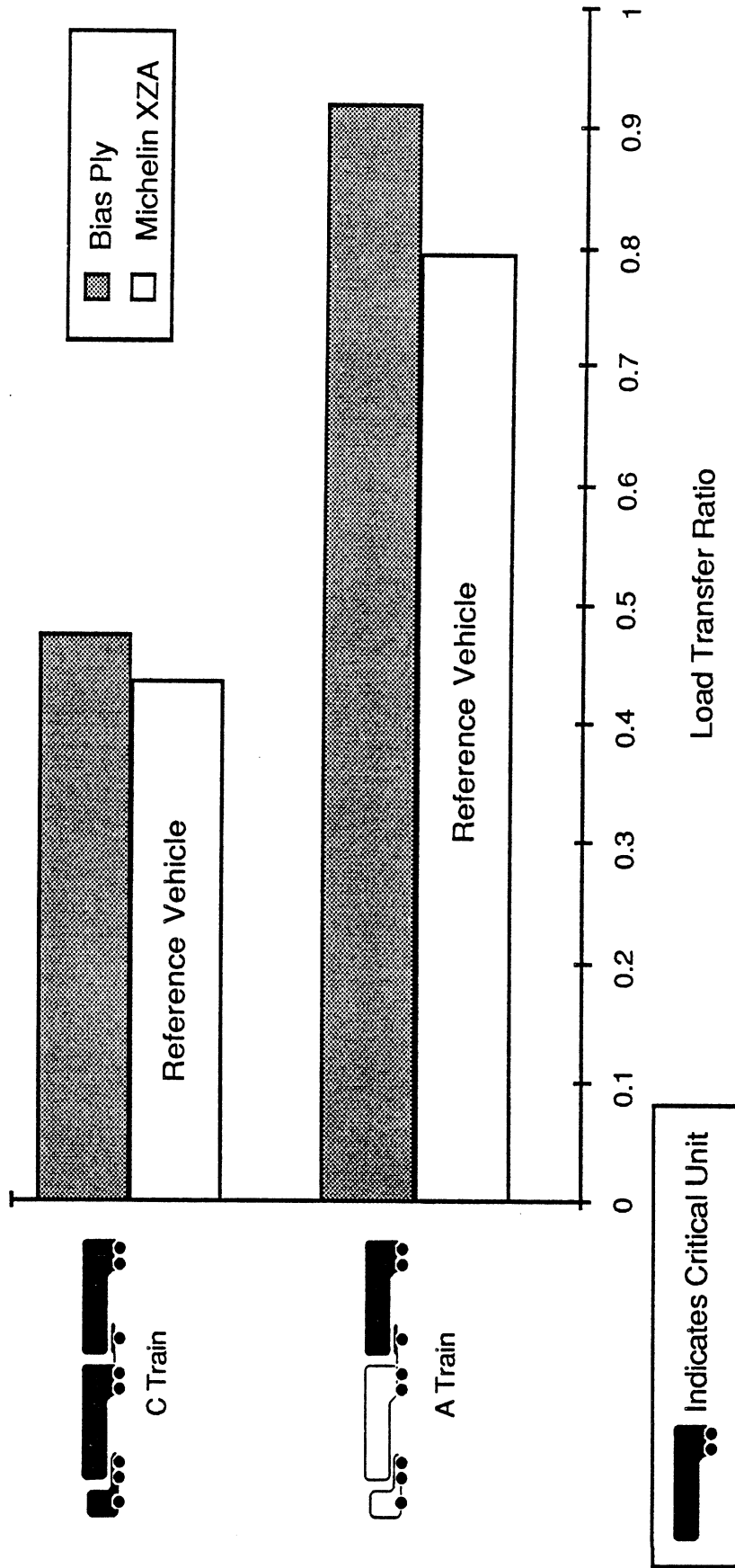

FIGURE 3.3.5.b

Influence of Tire Selection on Transient High-Speed Offtracking in A and C Train doubles

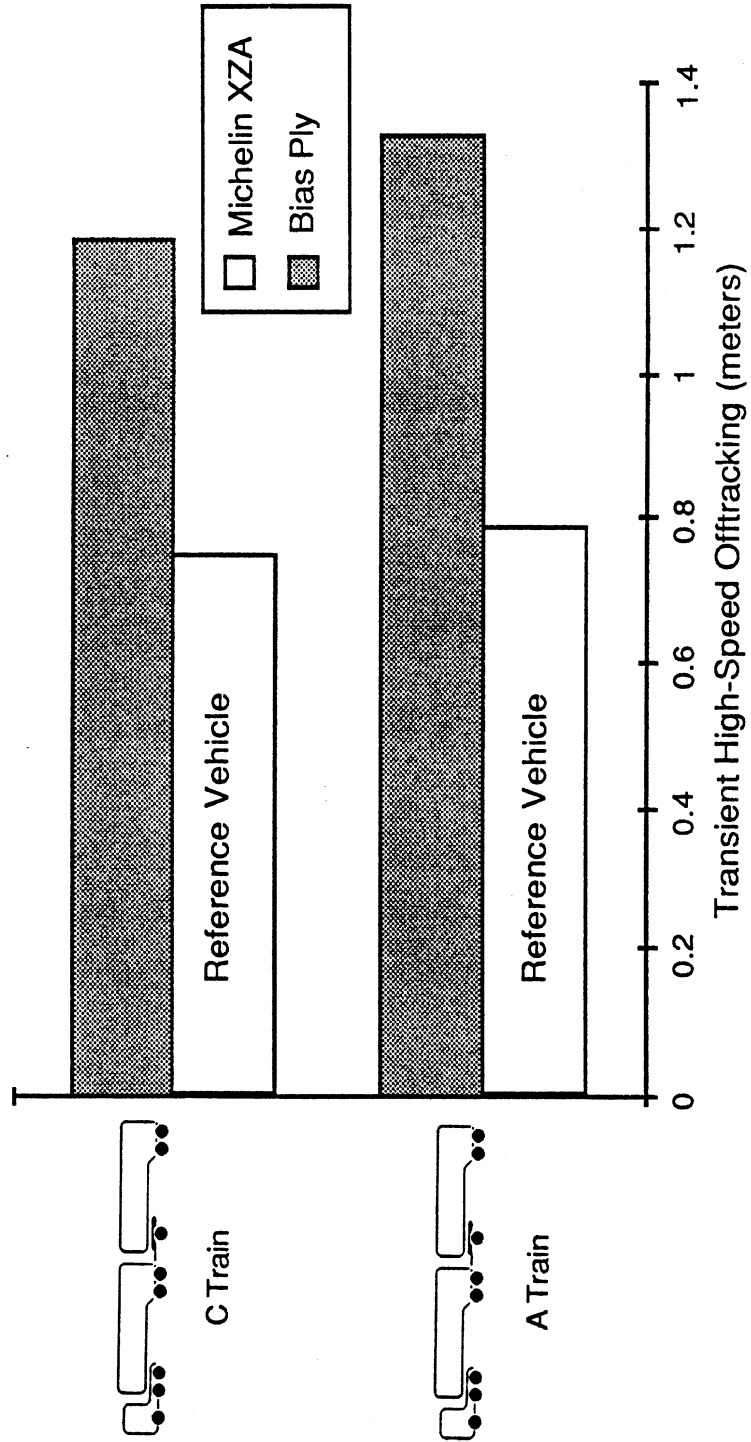

FIGURE 3.3.5.c

this vehicle configuration can be large enough to intrude beyond normally expected inter-vehicular clearances.

3.3.6 Influence of the Steer-Centering Properties of B-Dollies.

Shown in Figure 3.3.6a is the influence of the parameters of C-train dollies on the high-speed offtracking performance of a C-doubles configuration. The results are presented for two lengths of the dolly drawbar, 1.83 and 3.05 m (6 to 10 ft). Firstly, it is obvious that performance is improved when the dolly drawbar length is set at the shorter value. Other conditions of the steering axle that indicate a significant change in performance are as follows:

- 1) The free-castering dolly condition affords more outboard offtracking because the lack of tire side force at the dolly axle requires that the tires on the lead trailer must run at a larger slip angle in order to satisfy the need for equilibrium in this steady turn.
- 2) The "low stiffness" and "high friction" cases describing the dolly steering system constraint result in noticeable increases and decreases, respectively, in the high-speed offtracking response as a result of the net steer angle of the dolly axle which is enabled in each case.

It is somewhat surprising that the dolly did not swing outboard through the large, 6-degree, hitch lash angle when that parametric variation was introduced. Apparently, the 0.2 g level of lateral acceleration in this maneuver was insufficient to cause steering of the dolly axle significantly off of center so as to create the proper polarity yaw moment across the hitch to cause an outboard rotation through the lash angle. (Note that the dolly will be normally articulated through the lash angle, toward the inside of the turn, until dolly steering develops to the point to permit the dolly to take up the articulation lash toward the outside.)

Shown in Figure 3.3.6b is the remarkably insensitive array of results relating the dolly steering properties of the reference C-train to the load transfer ratio. We see that this measure is simply not influenced in a strong way either by the properties of the steering apparatus on the dolly axle or by the other parameters investigated here. Inspection of the time history data from the various cases studied reveals that the vehicle responses from one condition to the next can be wildly different, in terms of yaw rates, lateral accelerations, and tire slip angle histories. Nevertheless, the load transfer ratio measure has the ability to subdue these large variations in time-domain behavior because of the combined influence of

Influence of B-Dolly Properties on High-Speed Offtracking in C-Train Doubles

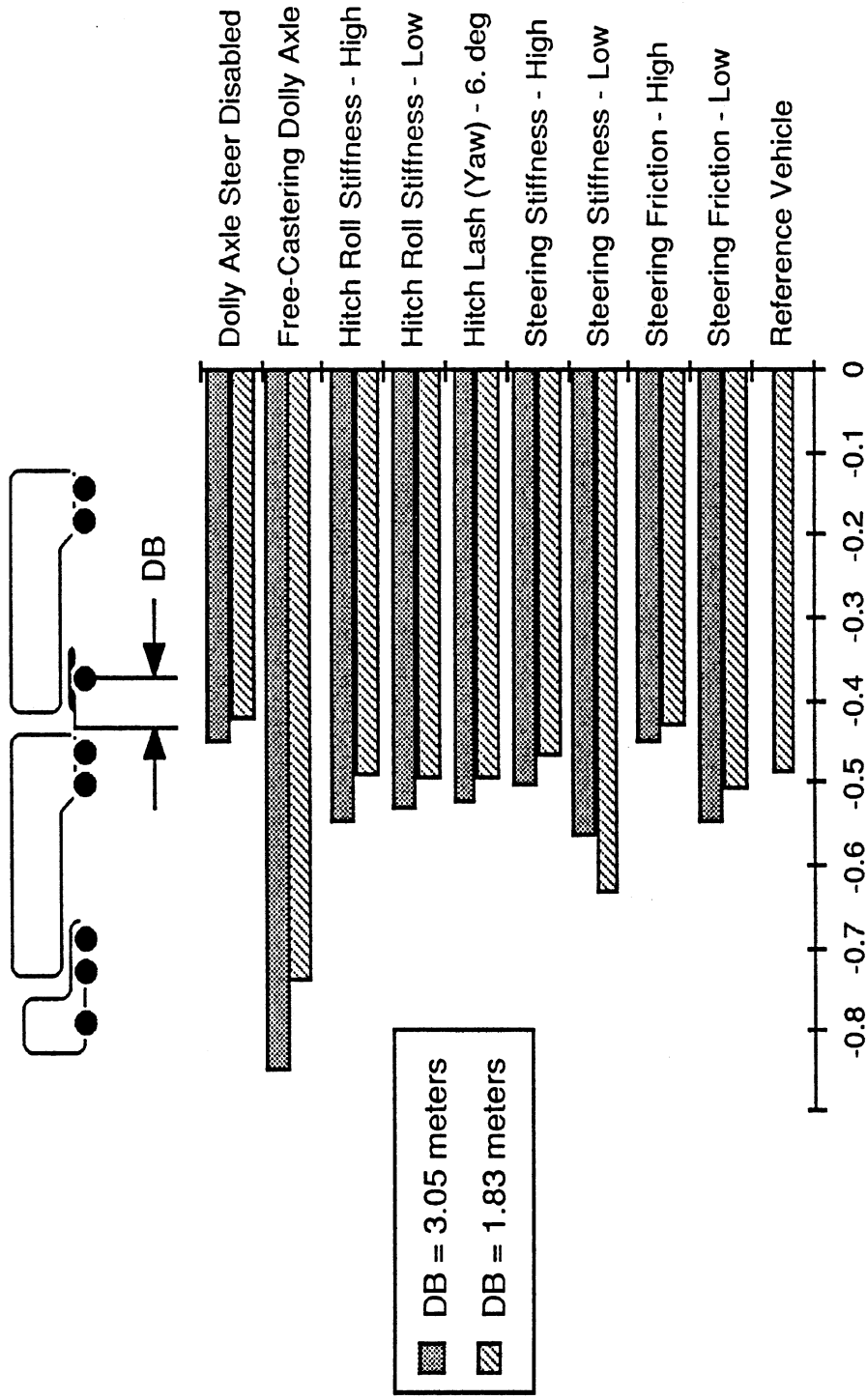

High-Speed Offtracking (meters)

FIGURE 3.3.6.a

Influence of B-Dolly Properties on Load Transfer Ratio in C Train Doubles

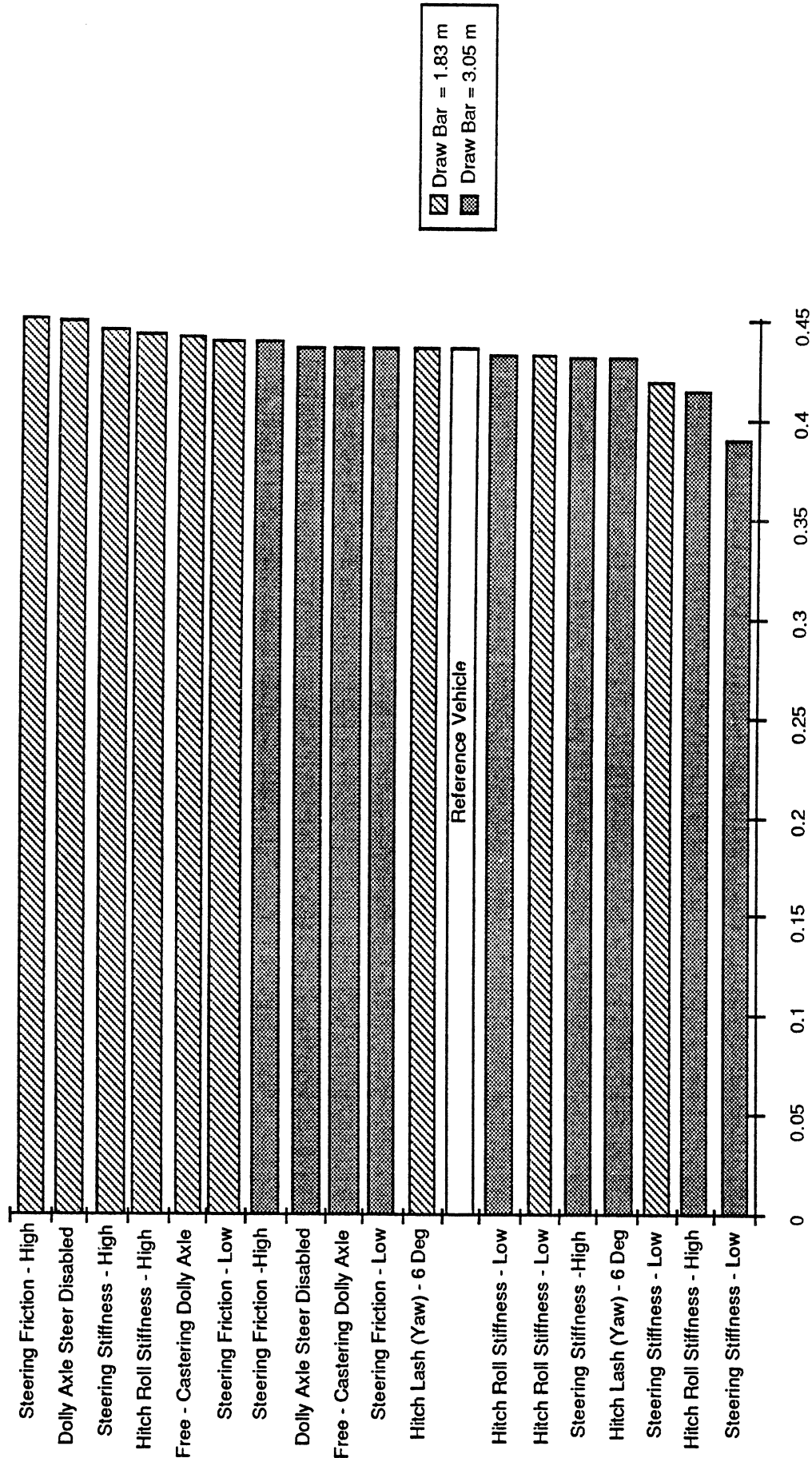

FIGURE 3.3.6.b

a roll-coupled hitch and the phase lag in the response of the successive trailer [8]. These results are also confirmed in the analyses and full-scale experiments reported in Reference [17].

Consider, for example, the great conceptual difference between the case labelled "dolly axle steer-disabled" (which means that the dolly axle is not steerable) and the "free-castering dolly axle" (which means that the dolly axle is freely steerable and cannot sustain lateral tire forces). In the steer-disabled case, the peak lateral acceleration level reached at the rear trailer was 0.31 g's in contrast to a value of 0.42 g's in the free-castering case. Further, the slip angles developed at the tires on the lead trailer peaked at a value of 1.8 degrees in the steer-disabled case as opposed to a whopping 7.0 degrees with the free-castering dolly. Of course, this latter phenomenon is attributed to the failure of the free-castering dolly to generate lateral tire forces such that the tires on the lead trailer have to "do all the work." Notwithstanding these tremendous differences in response details, the load transfer ratio measures for these two cases are virtually identical since a considerably greater phase lag develops between the responses of the front and rear trailers in the free-castering case, thus tending to "flatten" the load transfer measure.

Moreover, it is important to observe that the illustrations shown in Figure 3.3.6b represent one set of numerical results covering the very specific case of the indicated vehicle configuration. One should not conclude that the centering properties of dolly steering axles are generally inconsequential to the dynamic roll stability of C-train combinations without more in-depth research into the basic mechanics of these complex phenomena. Further, the more important, and very generalizeable, penalty arising from insufficient centering stiffness on C-train dollies is illustrated by the results in Figure 3.3.6c. This figure shows the effect of variations in dolly properties on the transient high-speed offtracking response of the C-train. The results show that powerful deterioration in this outboard overshoot measure derives from low levels of resistance to dolly steering. In the free-castering cases, at the top, the vehicle swings outward through a very large excursion. It is also notable that the magnitude of the outboard offtracking measure is considerably larger when the longer, 3.05 m (10 ft) dolly drawbar is employed. Clearly, there is ample evidence that increased spread between the dolly axle and the axles on the lead trailer is undesirable.

From the discussion above, it was apparent that the tire slip angles at the tandem axle on the lead trailer reached the near-saturation value of 7 degrees in a fairly modest avoidance maneuver (the peak value of lateral acceleration at the tractor is nominally 0.15

Influence of B-Dolly Properties on Transient High-Speed Offtracking in C Train Doubles

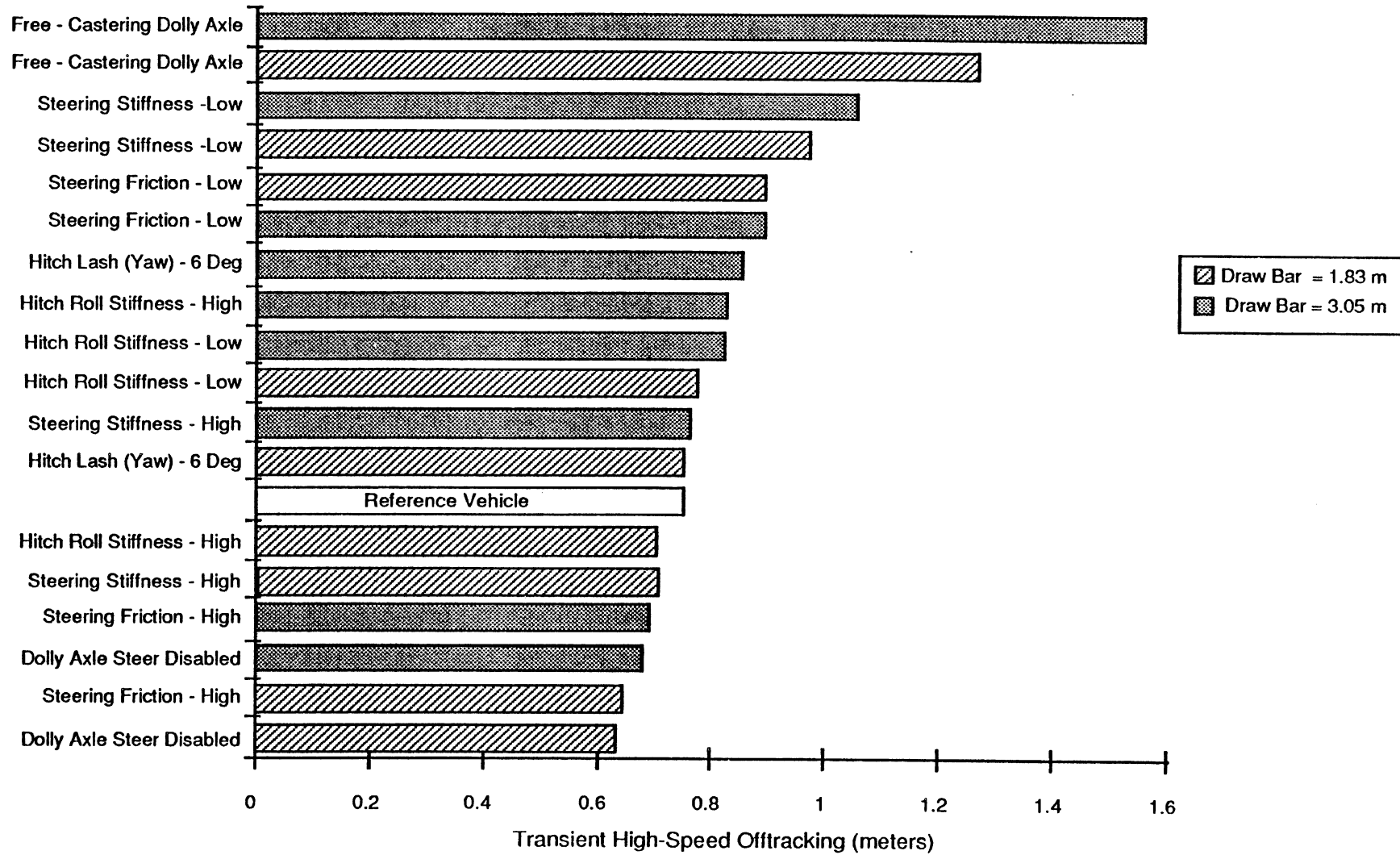

FIGURE 3.3.6.c

g's). It is also important to indicate that a much more dramatic outboard excursion will occur with poorly-centered dolly steering hardware when a slightly more severe maneuver is conducted such that side force saturation is reached at axles #4 and #5. When side force saturation occurs, there is no longer any "spring-like" property in the tire's response to restore the proper yaw attitude in the lead trailer. In such circumstances, the lead trailer and dolly can swing outward to sweep even a lane's width of traffic! Such a dolly system was included in full-scale tests conducted during the study and is reported in Appendix E.

An additional issue which was studied specifically with the C-train dolly involved the potential for a yaw disturbance, while braking on a split-friction surface and during a braking-in-a-turn maneuver, in which dolly steering would be induced. This subject was pursued in full-scale experiments and by means of analyses. Experiments conducted by UMTRI and also cooperatively between UMTRI and the Ministry of Transportation and Communications of Ontario showed that there were no anomalous disturbances in yaw response during braking with doubles combinations having (a) an ASTL automotive-style dolly, and (b) a Westank-Willock turntable dolly. In either case, when braking application arrived at the point of lockup of wheels on one side, substantial dolly-steering would ensue, but without an attendant disturbance in the gross motion response of the vehicle.

During braking-in-a-turn, the first wheels to arrive at lockup are those on the lightly-loaded side in the turn. Following lockup of these axles, the dolly axle steers toward the outside of the curve, but not to an extent that substantially disturbs the overall vehicle. At higher levels of braking, in which lockup of all wheels on an axle occurs, the motion response diverges in one of the classic modes of instability, depending upon which axle(s) lock. Moreover, it was found that dolly-steering due to braking was not able to significantly disturb vehicle motion response, short of the axle-lockup conditions at which unstable motions will occur, anyway.

3.4 Illustration of Parametric Sensitivities for B-Type Doubles Combinations

3.4.1 Influence of Trailer Length and Placement of the Inter-Trailer Fifth Wheel. The influence of trailer length and rear fifth-wheel location on the high-speed offtracking of B-train doubles is shown in Figure 3.4.1a. The results show the two basic sensitivities discussed in earlier sections of the report; namely, (a) that the sensitivity to trailer wheelbase involves a maximizing function such that trailer wheelbases in the vicinity of 7 to 8 m (23 to 26 ft) will yield maximum high-speed offtracking, and (b) that overhang-type dimensions which serve to increase overall length without changes in wheelbase will serve to increase high-speed offtracking. In the results of Figure 3.4.1a, we see that the reference trailer length of 8.23 m (27 ft) yields a high-speed offtracking value which is between those exhibited by shorter (6.71 m (22 ft)) and longer (9.75 m (32 ft)) trailer lengths. When trailer length reaches the 12.2-m (40-ft) value, we see that high-speed offtracking has fallen to the lowest level of the overall data set. On the other hand, the longitudinal offset of the rear fifth wheel is a monotonic determinant of high-speed offtracking, with the offtracking response increasing as the offset value becomes increasingly negative (i.e., with the fifth wheel moving rearward on the lead trailer).

Shown in Figure 3.4.1b is the influence of trailer length and rear fifth wheel placement on the load transfer ratio of the baseline B-train. We see, firstly, that the fifth-wheel placement parameter produces a negligible change in the load transfer ratio. On the other hand, of course, changes in trailer length are seen to have a first-order influence on this measure due in part to the well-established relationship between trailer length and rearward amplification. This relationship is illustrated in the lateral acceleration time histories in Figure 3.4.1c representing the best ($L=12.2$ m (40 ft)) and worst ($L=6.71$ m (22 ft)) cases of trailer length variation. We see that, although there is a small increase in phase lag between the two trailers of the longer unit, providing some benefit for the load transfer ratio measure, the primary distinction between the performance of the long and short units is in the amplitude of lateral acceleration peaks achieved. (Note that the results for the shorter trailer are plotted on a condensed vertical scale.) As a result of both the phase and amplification effects, the load transfer ratio measure, which effectively illustrates the vector sum of the roll moments borne by the overall vehicle combination, shows a decreased peak value with increasing trailer length.

Influence of Trailer Length and Rear Fifth Wheel Location on High-Speed Offtracking in B Train Doubles

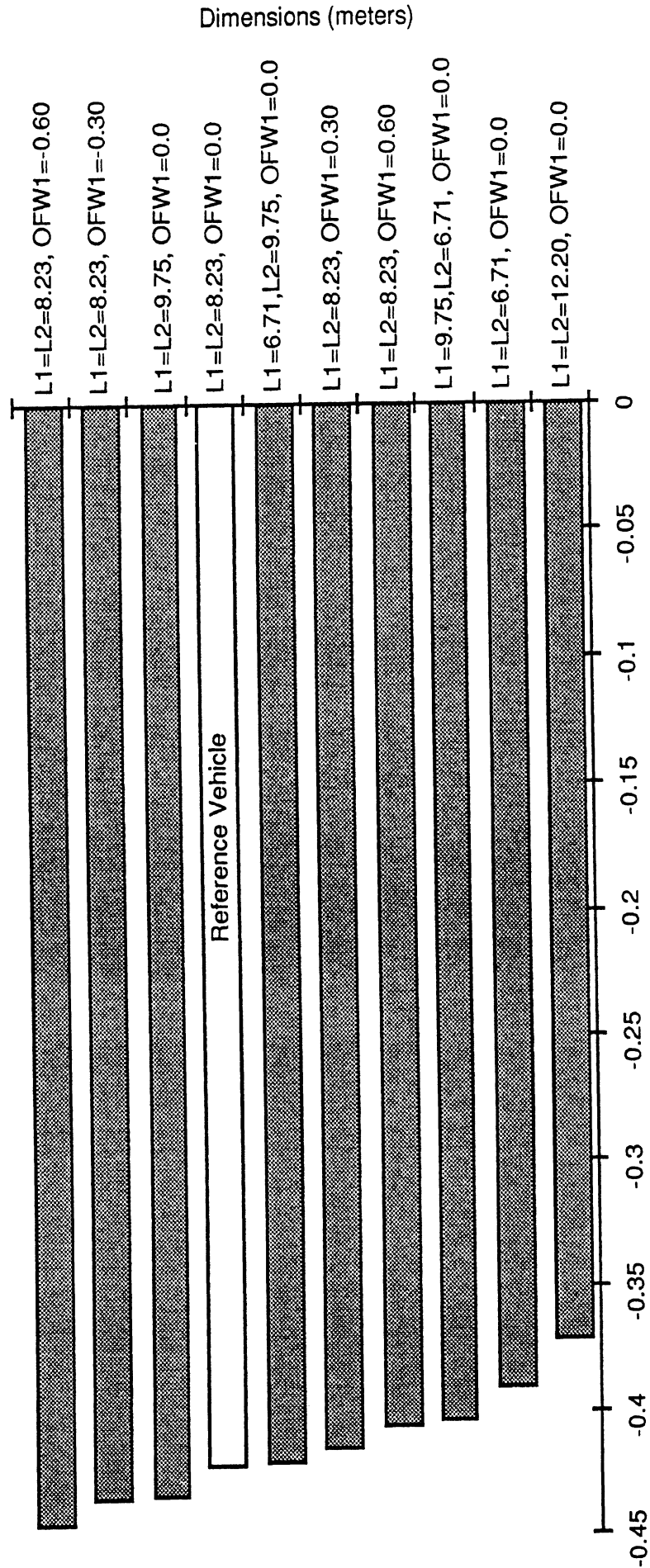
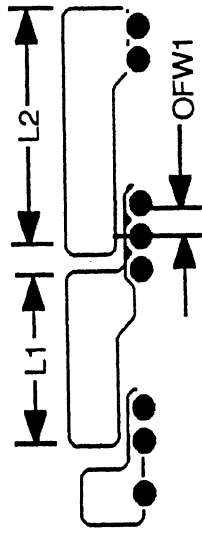

High-Speed Offtracking (Meters)

FIGURE 3.4.1.a

Influence of Trailer Length and Rear Fifth Wheel Location on Load Transfer Ratio in B-Train Doubles

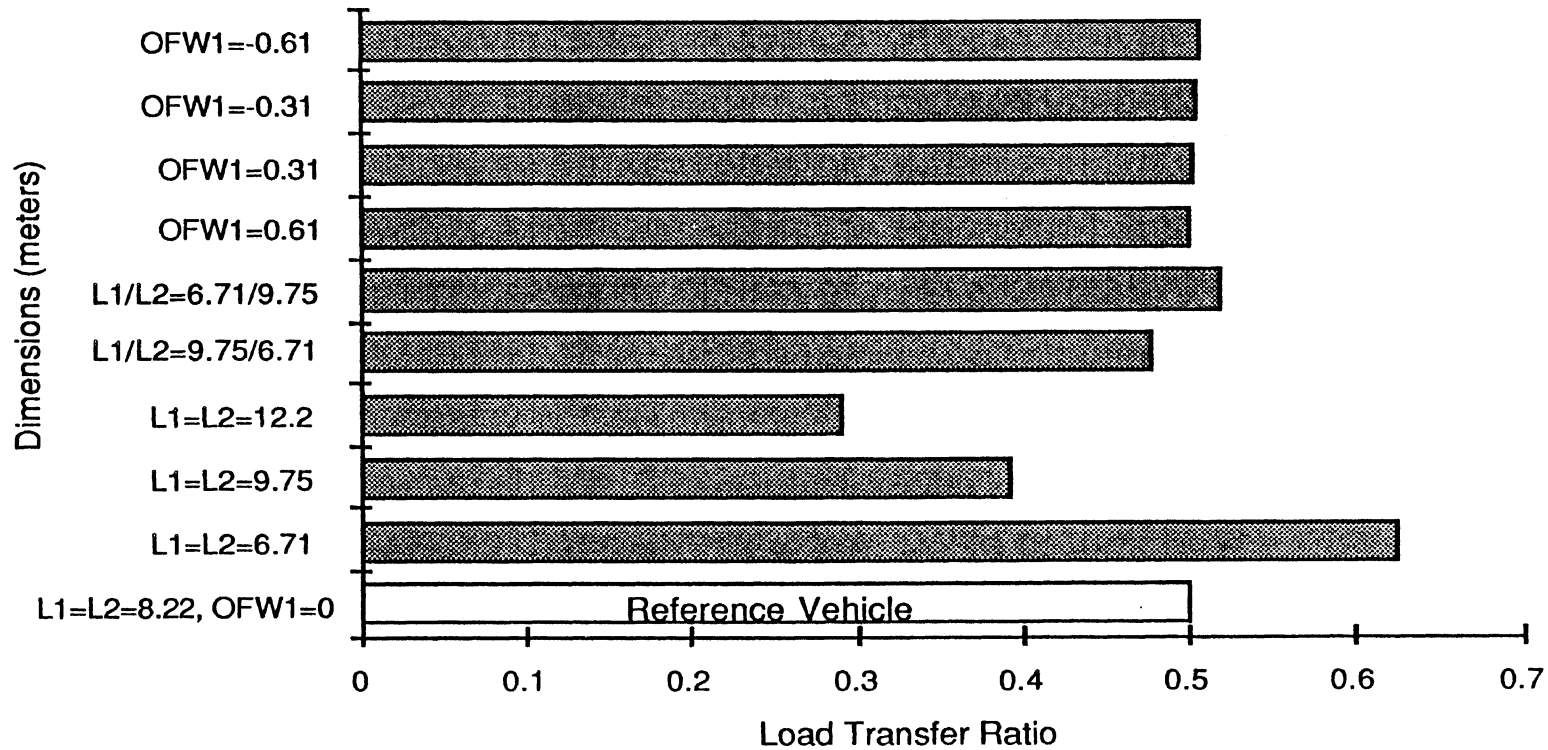
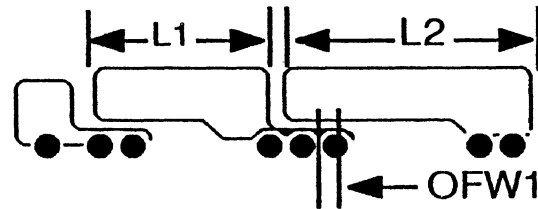
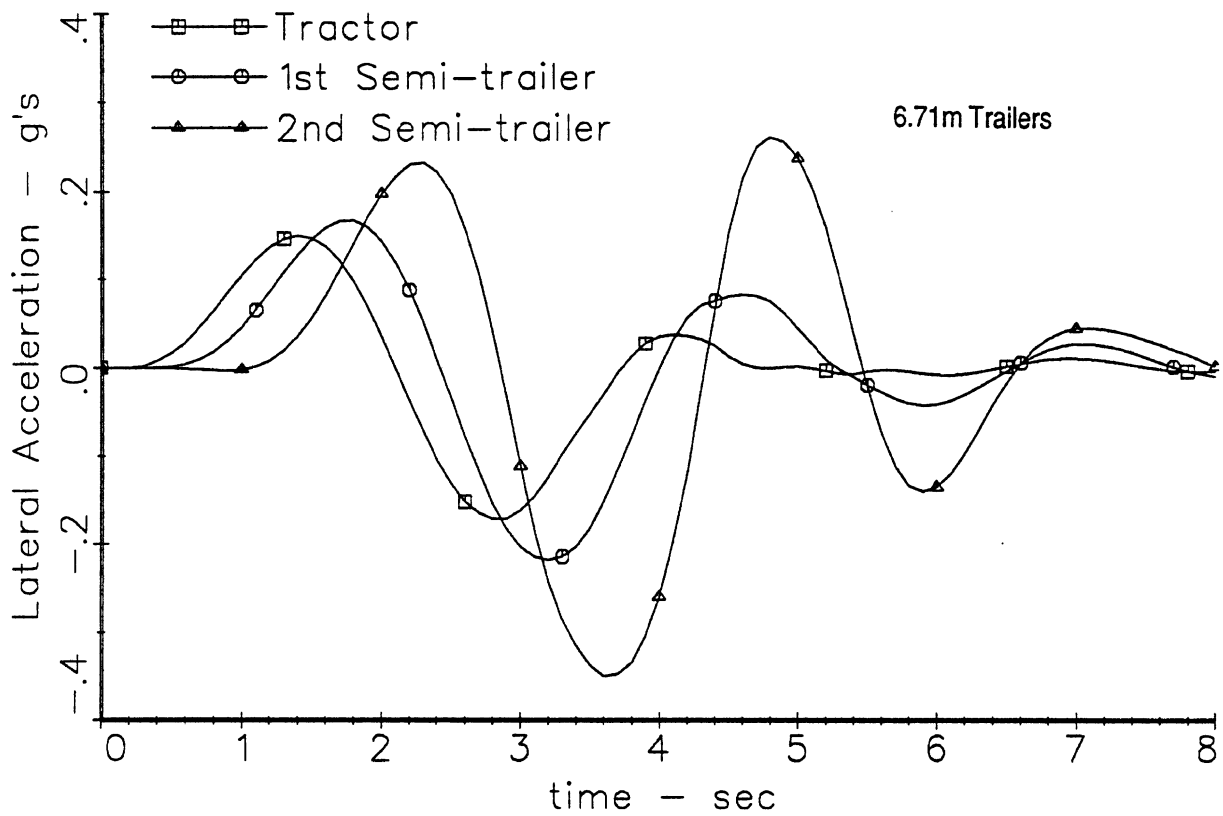
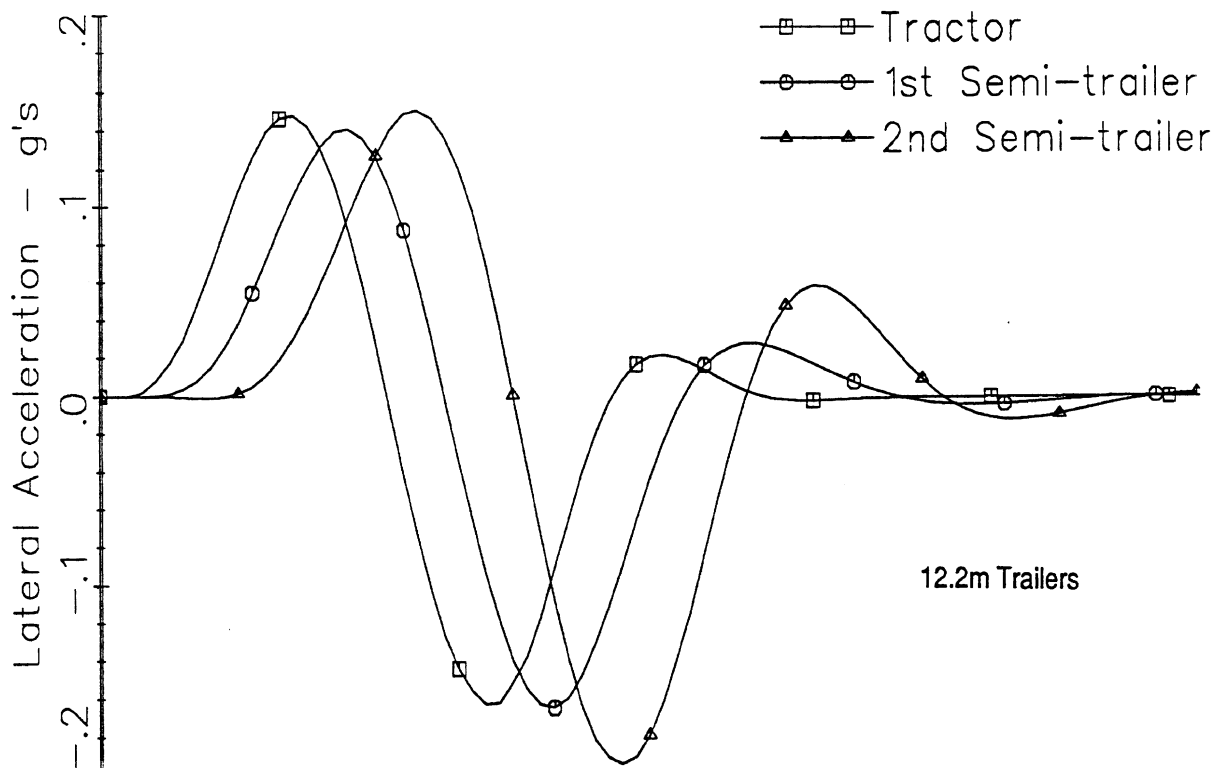

FIGURE 3.4.1.b



RTAC two-semi 8 axle B-train (56.5t/125k GCW), conf. 3.1, var. 2.11

FIGURE 3.4.1.c Lateral acceleration time histories for 8-axle B-trains having trailer lengths of 12.2 m (top) and 6.71 m (bottom).

The influence of trailer length and fifth wheel placement on the transient high-speed offtracking of the B-train is shown in Figure 3.4.1d. Again the placement of the fifth wheel is relatively insignificant, although greater rearward placements are mildly detrimental to this measure simply because the overall length of the vehicle is increased. Increased trailer length serves to reduce transient high-speed offtracking because the oscillatory overshoot in wheel paths is reduced. Shown in Figure 3.4.1e are the time-history responses of lateral displacement for the cases involving 12.2 and 6.71 m (40 and 22 ft) trailers, illustrating the more underdamped behavior of the unit having shorter trailers. Moreover, an increase in the wheelbase of any vehicle unit leads to a more powerful damping of yaw rotations generally, and thus a reduction in any yaw overshoot property such as the transient high-speed offtracking response.

Shown in Figure 3.4.1f are results representing the sensitivity of the low-speed offtracking measure to variations in (a) the equal length values for the trailer beds, and (b) unequal length of trailer beds, as well as changes in the longitudinal offset of the rear fifth wheel. The results show a strong change in the low-speed offtracking as a function of changes in bed length for equal-length trailers. This quantitative result is virtually identical to that seen when the same variations in trailer length were examined in the case of the baseline A-train double in Section 3.3.1.

The changes in bed length for the "unequal bed length" cases (3rd and 4th bars from the top of the chart) represent a 1.52 m (5 ft) reduction in the length of one trailer and an equal increase in the length of the other trailer relative to the equal-length (8.23 m (27 ft) bed length of both trailers' reference configuration. Both unequal length cases show virtually no change in low-speed offtracking from the reference value, except for a very slight increase in the measure due to the "length-squared effect" of one longer trailer.

Changes in fifth-wheel offset represent a small longitudinal shift in the location of the rear fifth wheel relative to the rear tridem axle in the centergroup. The most common location of this coupling in normal service would be the reference offset value of zero, with the fifth wheel directly over the rear tridem axle. We see that these small changes in fifth-wheel offset do not produce a significant change in the low-speed offtracking.

Shown in Figure 3.4.1g is the influence of variations in trailer length and placement of the rear fifth wheel on the friction demand of the reference B-train. These results can be summarized in two observations, namely,

Influence of Trailer Length and Rear Fifth Wheel Location on Transient High-Speed Offtracking in B-Train Doubles

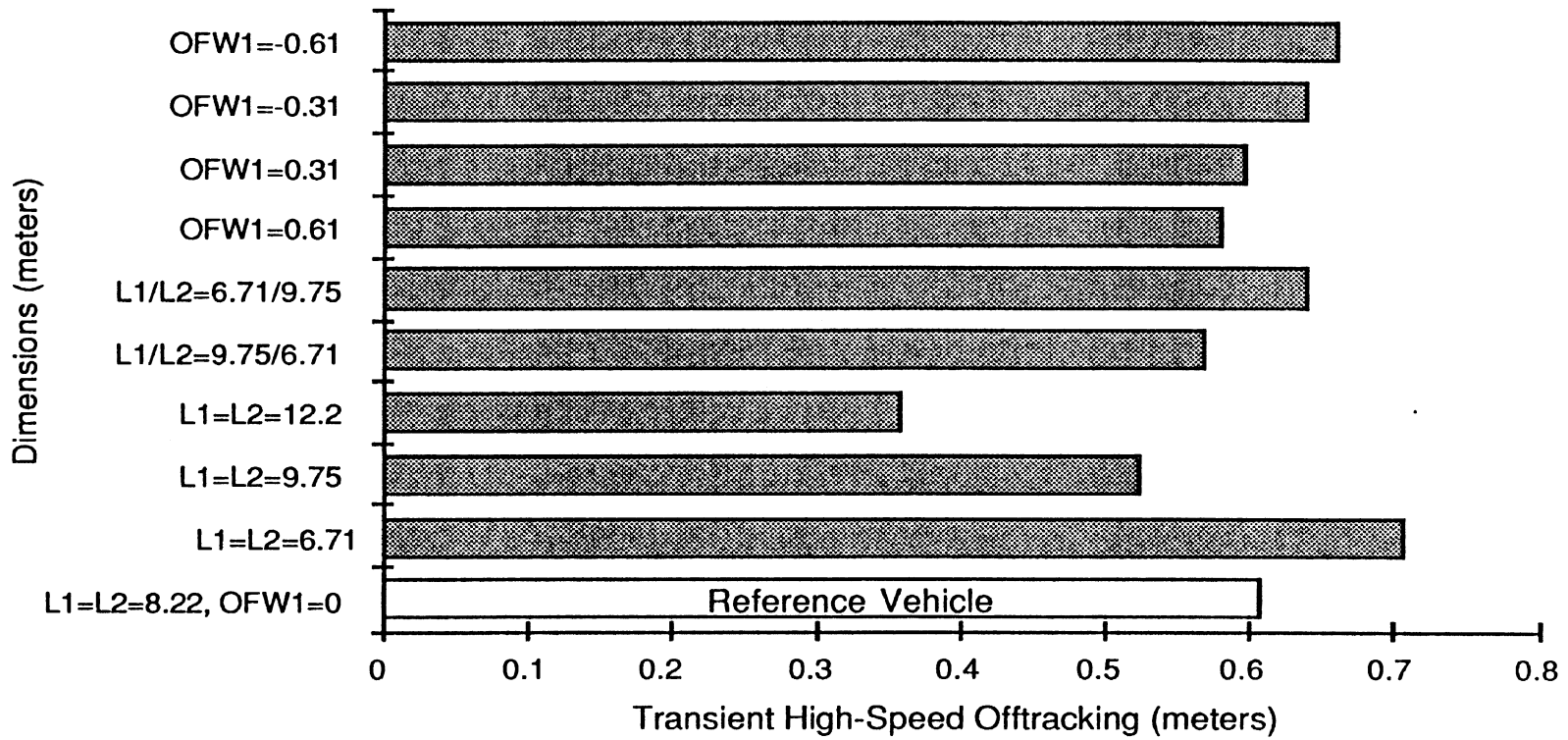
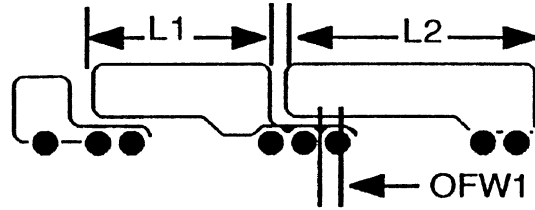
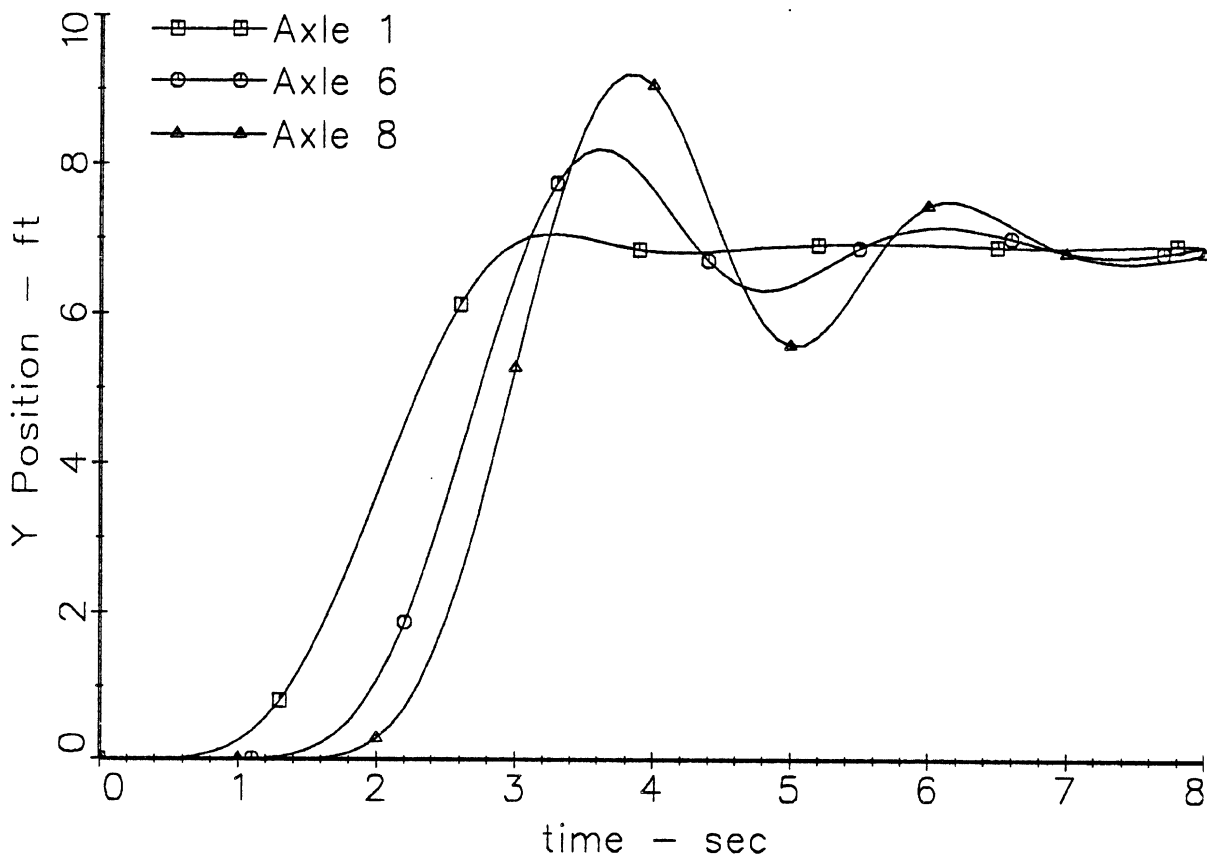
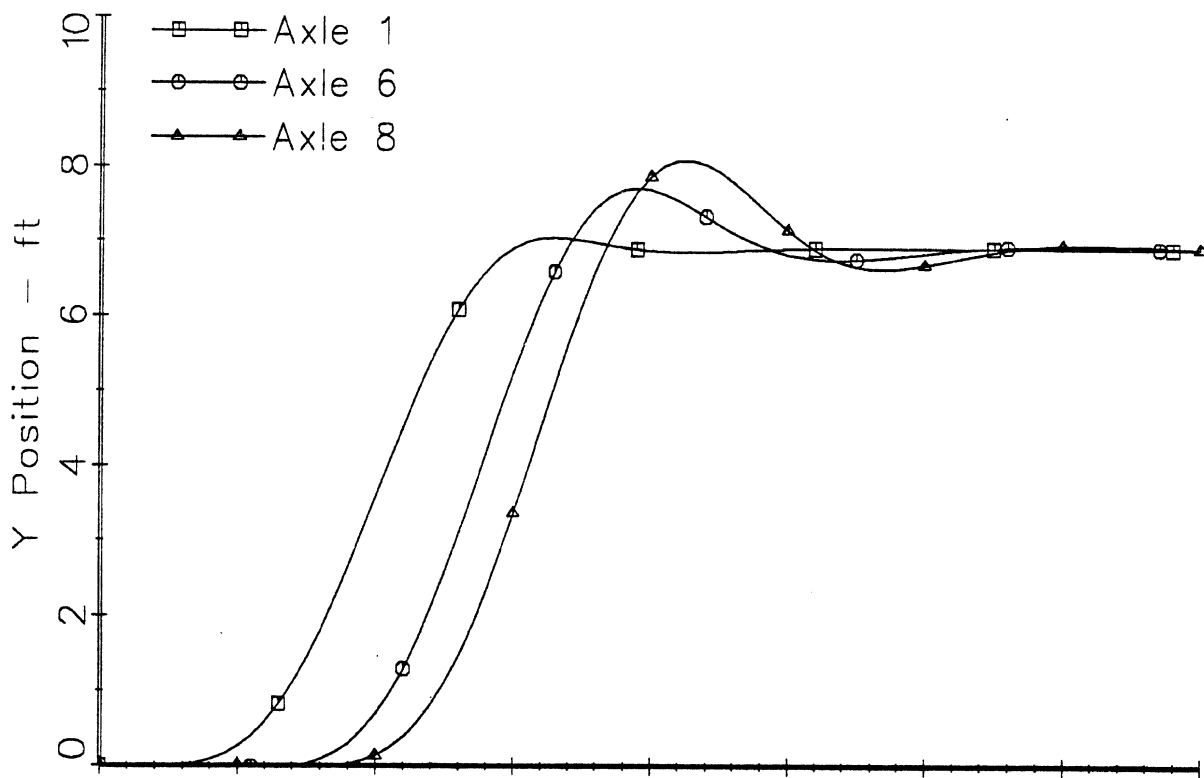

FIGURE 3.4.1.d



RTAC two-semi 8 axle B-train (56.5t/125k GCW), conf. 3.1, var. 2.11

FIGURE 3.4.1.e Lateral displacement time history of axle paths for 8-axle B-trains having trailer lengths of 12.2 m (top) and 6.21 m (bottom). 162

Influence of Trailer Length and Rear Fifth Wheel Location on Low-Speed Offtracking in B Train Doubles

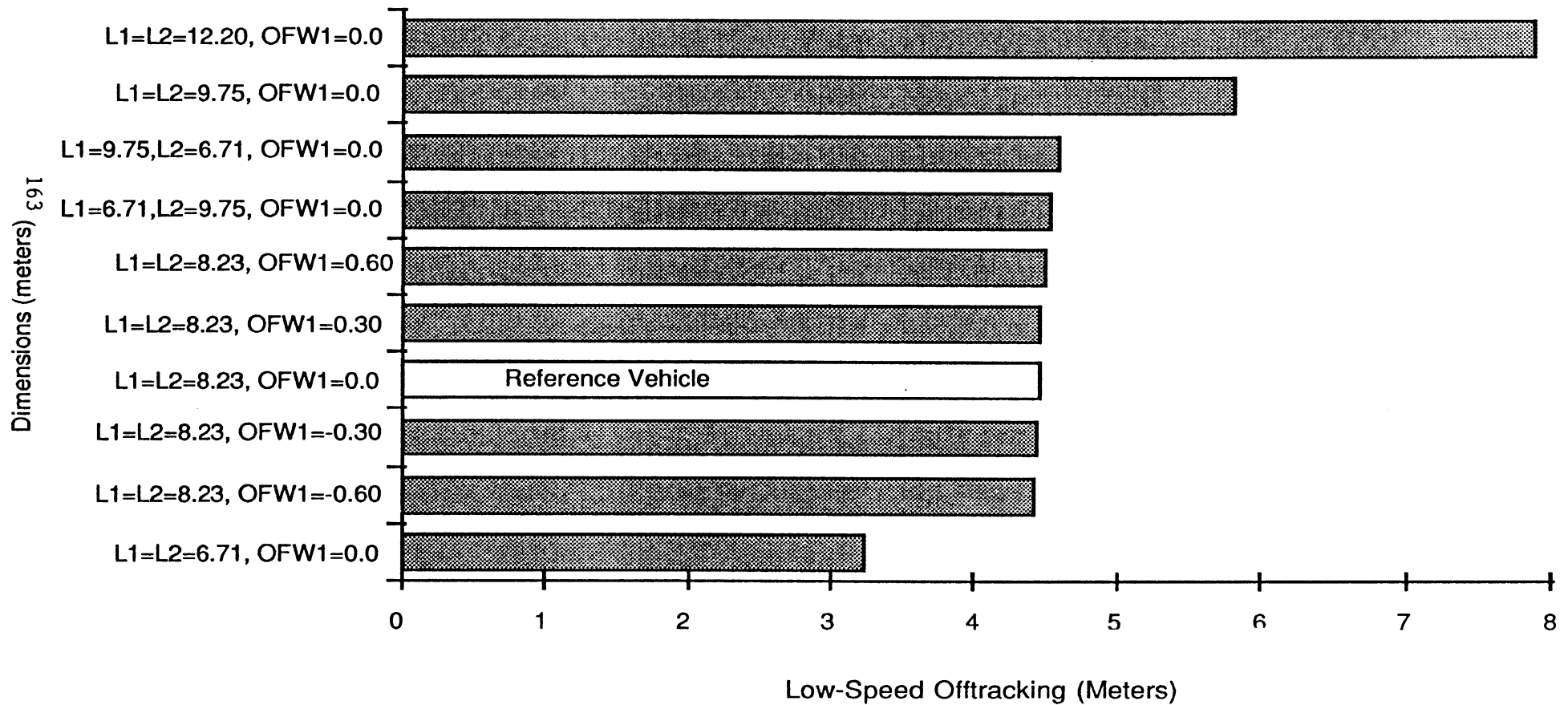
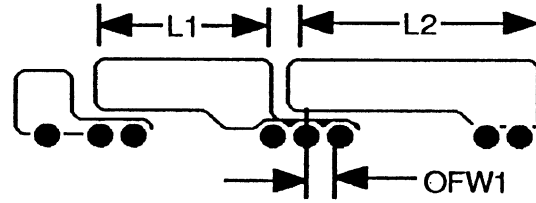
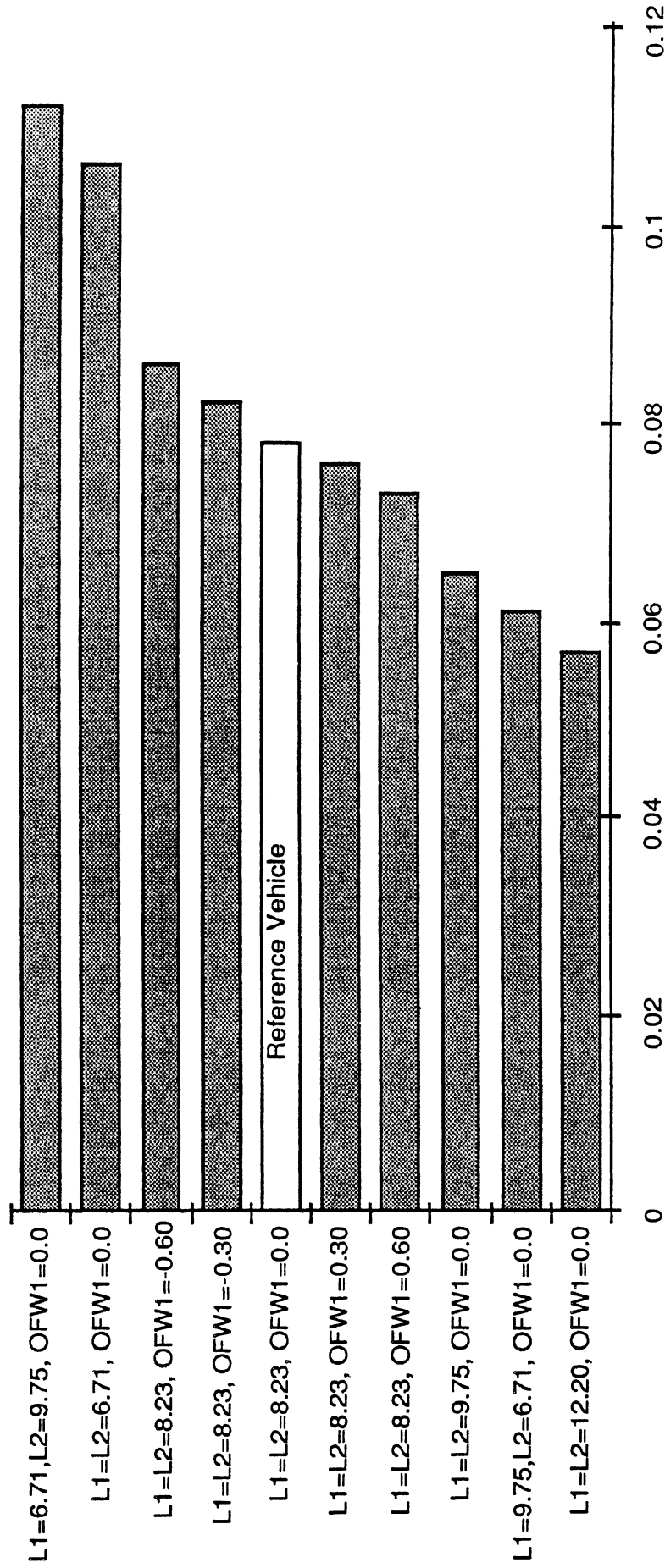
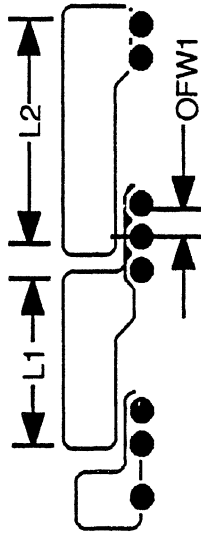

FIGURE 3.4.1.f

Influence of Trailer Length and Rear Fifth Wheel Location on a Tight Turn Jackknife in B Train Doubles



Peak Friction Demand

FIGURE 3.4.1.g

- 1) the peak friction demand is inversely related to the length, and thus wheelbase, of the lead trailer. This observation simply confirms the key influence of the (d^2/L) characterization presented in Section 3.1. The length of the second trailer of the B-train is basically inconsequential to this outcome.
- 2) the rearward movement of the rear fifth wheel (i.e., more negative values of OFW1) serves to alter the pitch moment balance on the lead trailer, thus reducing the load carried by the tractor and placing additional load onto the tridem centergroup of axles. As a result, rearward movement of the rear fifth wheel increases the friction demand at the tractor tandem both by increasing the yaw-resistive moment, through increase of the absolute level of tire cornering stiffnesses at the tridem centergroup of axles, and by reducing the load on the tractor tandem.

Notwithstanding the significant strength of these two mechanisms for varying the friction-demand measure, the absolute level of friction demand obtained with the reference B-train is seen as moderate.

3.4.2 Influence of Axle Loading. Shown in Figure 3.4.2a is the influence of axle loading on the static rollover threshold of various B-train doubles configurations. While the belly-axle B-train experiences load variations which simply redistribute the belly-axle load onto the two fixed tandems, the other three vehicles are operated with varied total load conditions which involve changes in both payload weight and payload c.g. height. The influences of increased loading on static rollover threshold derive from the destabilizing influences of both the weight and c.g. height aspects of the load variation. The reader should note that the highest end of the load ranges employed in each of the load-varied cases represents levels which are not currently allowed anywhere in Canada, except perhaps under special permit operations.

Shown in Figure 3.4.2b is the influence of axle loading variations on the high-speed offtracking of differing B-train combinations. The results show the increasingly outboard offtracking which results with increased loading because of the greater static and dynamic load excursions in tire loading, and thus normalized cornering stiffness levels. In the case of the belly-axle B-train at the top of the chart, increasing load on the belly axle also serves to reduce the effective wheelbase of the second trailer, resulting in a greater high-speed offtracking at the rearmost axle of the vehicle.

Influence of Axle Loading on Rollover Threshold in B Train Doubles

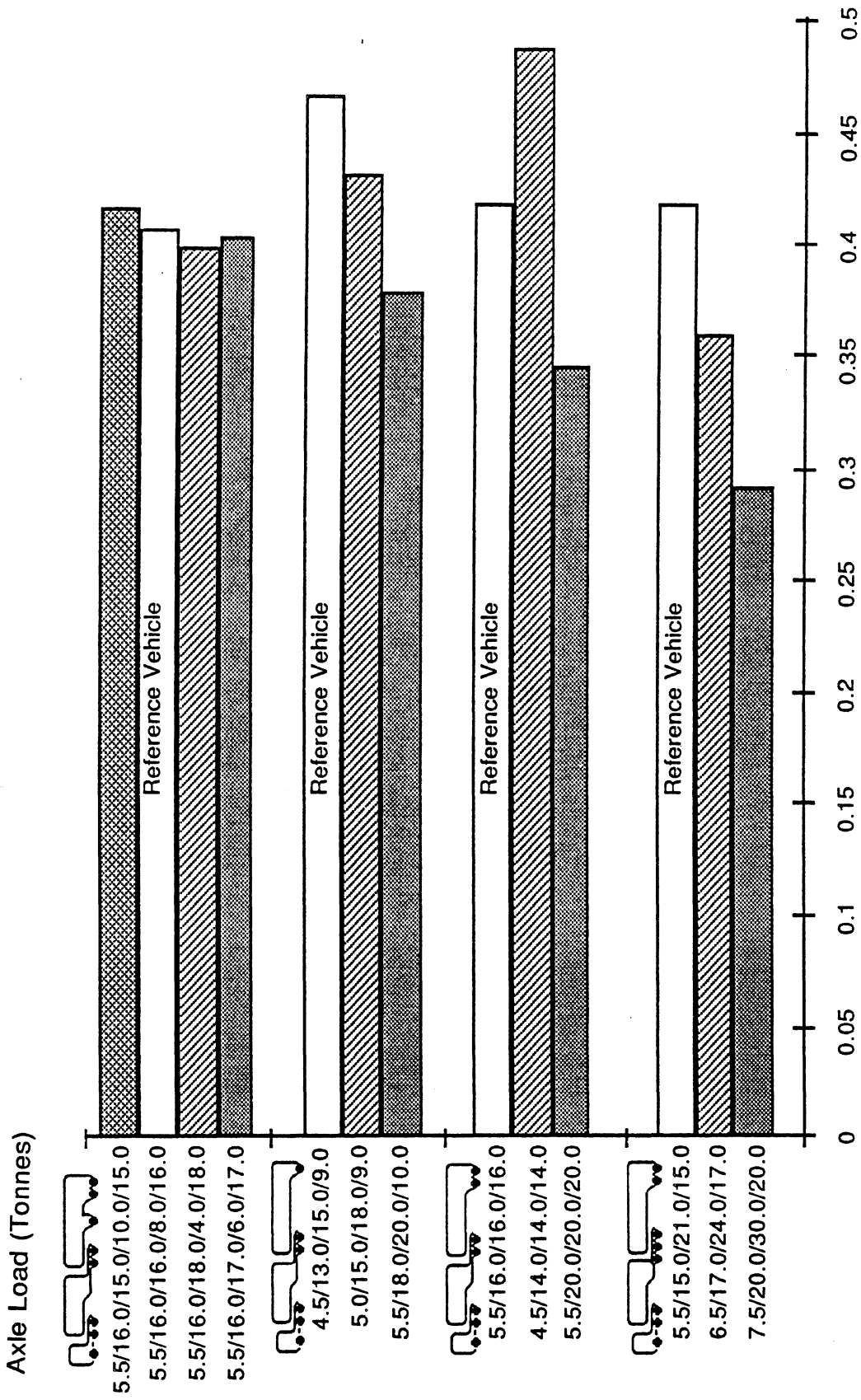

Static Rollover Threshold (g's)

FIGURE 3.4.2.a

Influence of Axle Loading on High-Speed Offtracking in B Train Doubles

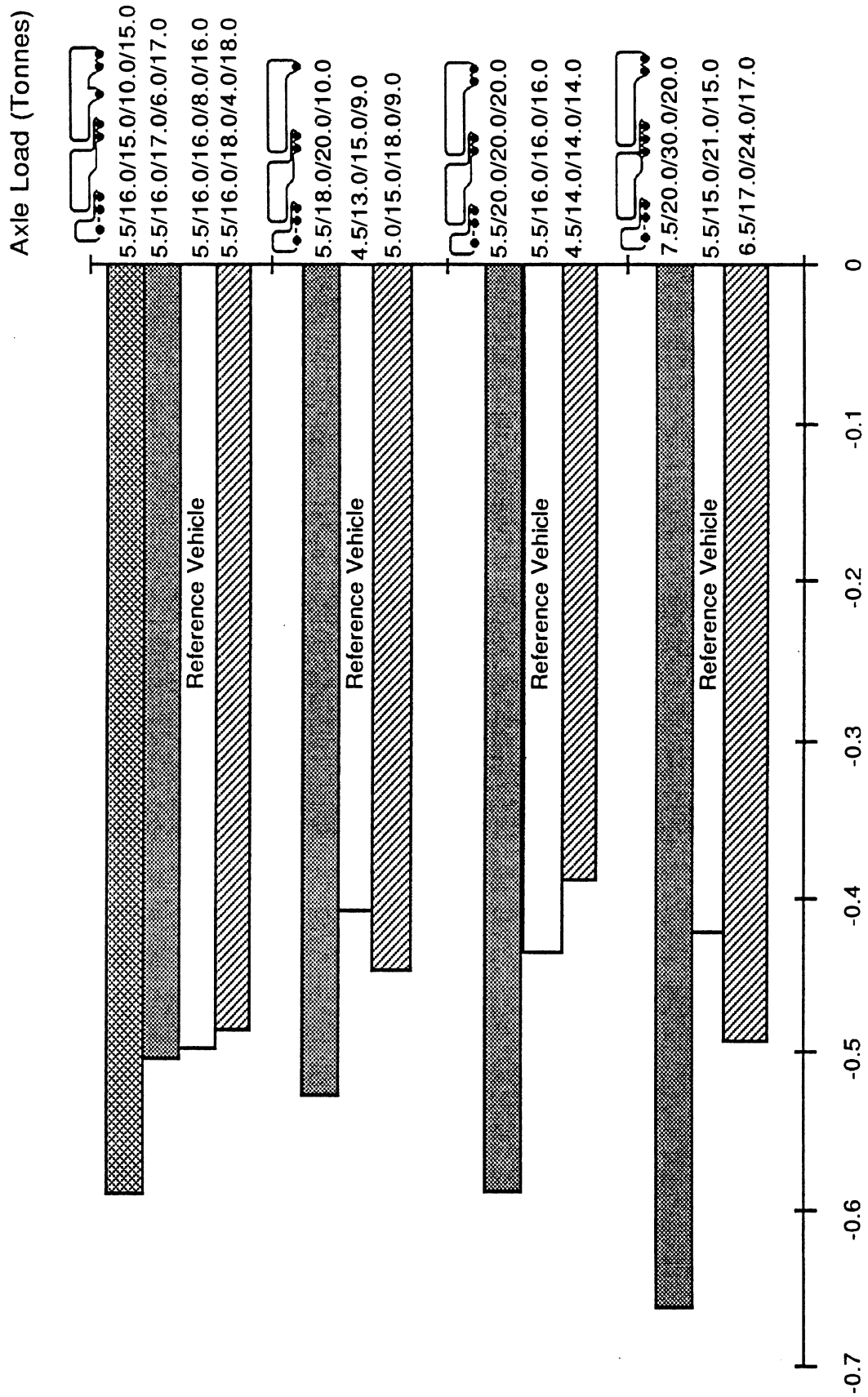

High-Speed Offtracking (Meters)

FIGURE 3.4.2.b

The influence of axle load variations on the load transfer ratio measure for various B-train combinations is shown in Figure 3.4.2c. The results show that increasing axle load is accompanied by an increase in the load transfer ratio, as would be expected by the associated increase in payload weight and c.g. height. Clearly, the increased loading and elevated payload c.g. result in increased tire loading and dynamic load transfer such that the vehicle combination experiences reduced levels of normalized cornering stiffness which, in turn, tends to aggravate the amplification of yaw motions in this maneuver. Further, the elevated center of gravity assures an increased peak level of load transfer ratio, even for the same lateral acceleration responses.

The influence of axle load variations on the transient high-speed offtracking of B-doubles is presented in Figure 3.4.2d. Increases in axle load produce rather regular and predictable increases in the transient high-speed offtracking measure. For the three vehicles shown in the lower portion of the chart, the load changes are simple enough that it is straightforward to observe an increasing sensitivity of this response measure to axle load as the absolute level of the load goes up. Of course, this observation is in keeping with the curved relationship between tire load and cornering stiffness. With the belly-axle B-train shown at the top of the figure, a redistribution of load from the belly axle to the two adjacent tandems produces a modest reduction in the transient offtracking response. Since the tandem on the rear trailer has a more favorable lever arm length with which to resist outboard articulation motion, the "investment" of a greater fraction of the trailer load on those rearmost axles serves to reduce the value of this response measure.

Shown in Figure 3.4.2e is the influence of axle loading on the braking efficiency level. Since the loads are applied rather uniformly in each case, rather little influence on braking efficiency is observed. Indeed, it is apparent that changes in loading which do not alter the distribution percentages of load among axles will not cause a change in braking efficiency except to the extent that a higher payload center of gravity accentuates the dynamic load transfer response. Clearly, among the two basic influence mechanisms, namely static load distribution and c.g. height, the static distribution issue is the more powerful.

3.4.3 Influence of Partial Loading. Shown in Figure 3.4.3a are the results illustrating the influence of partial loading on the high-speed offtracking of the B-double. The three cases representing various half-loading schemes all serve to reduce the response simply as a result of the benefits of reduced tire loading and the consequent increase in normalized cornering stiffness.

Influence of Axle Loading on Load Transfer Ratio in B-Train Doubles

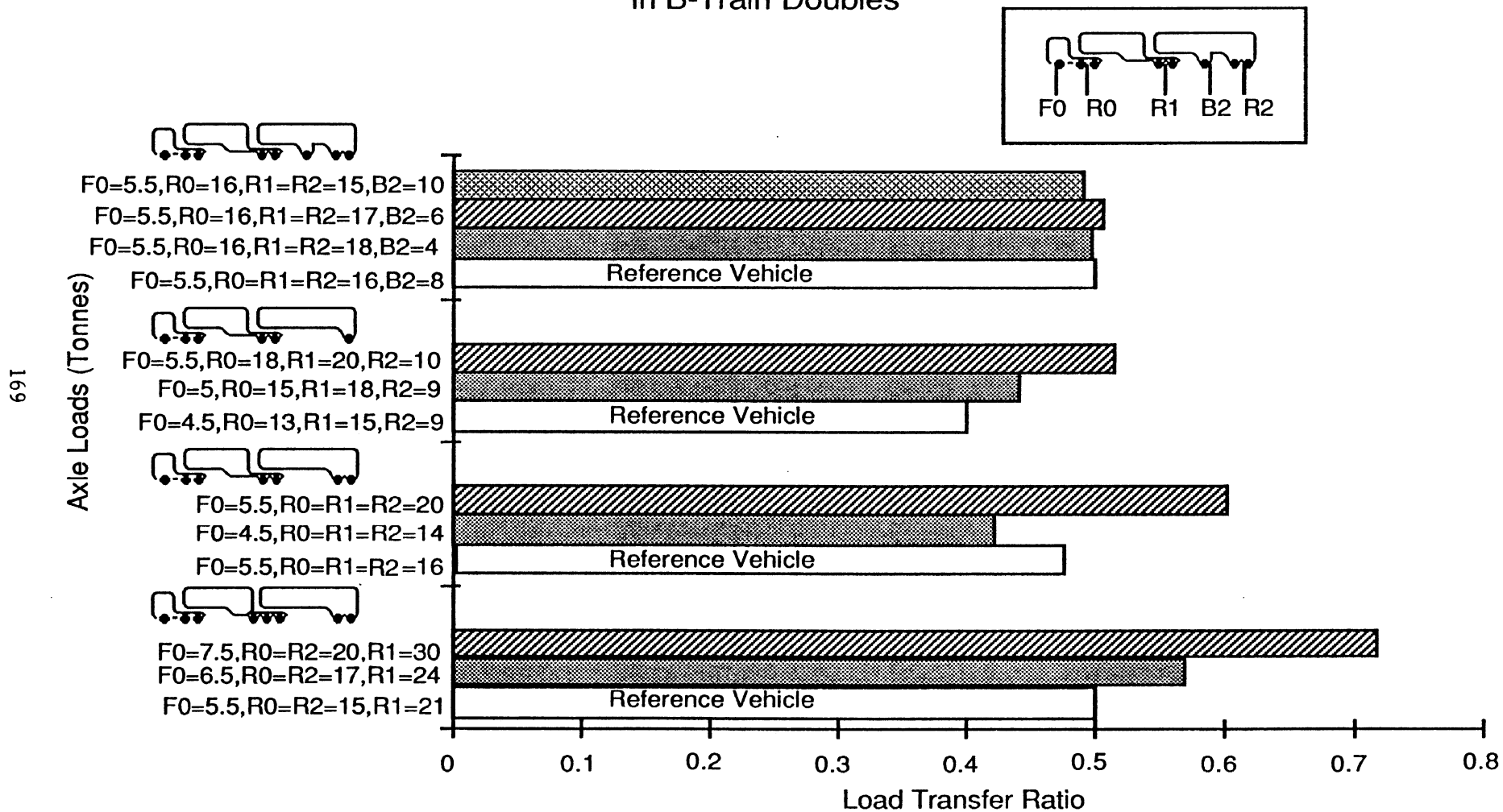

FIGURE 3.4.2.c

Influence of Axle Loading on Transient High-Speed Offtracking in B-Train Doubles

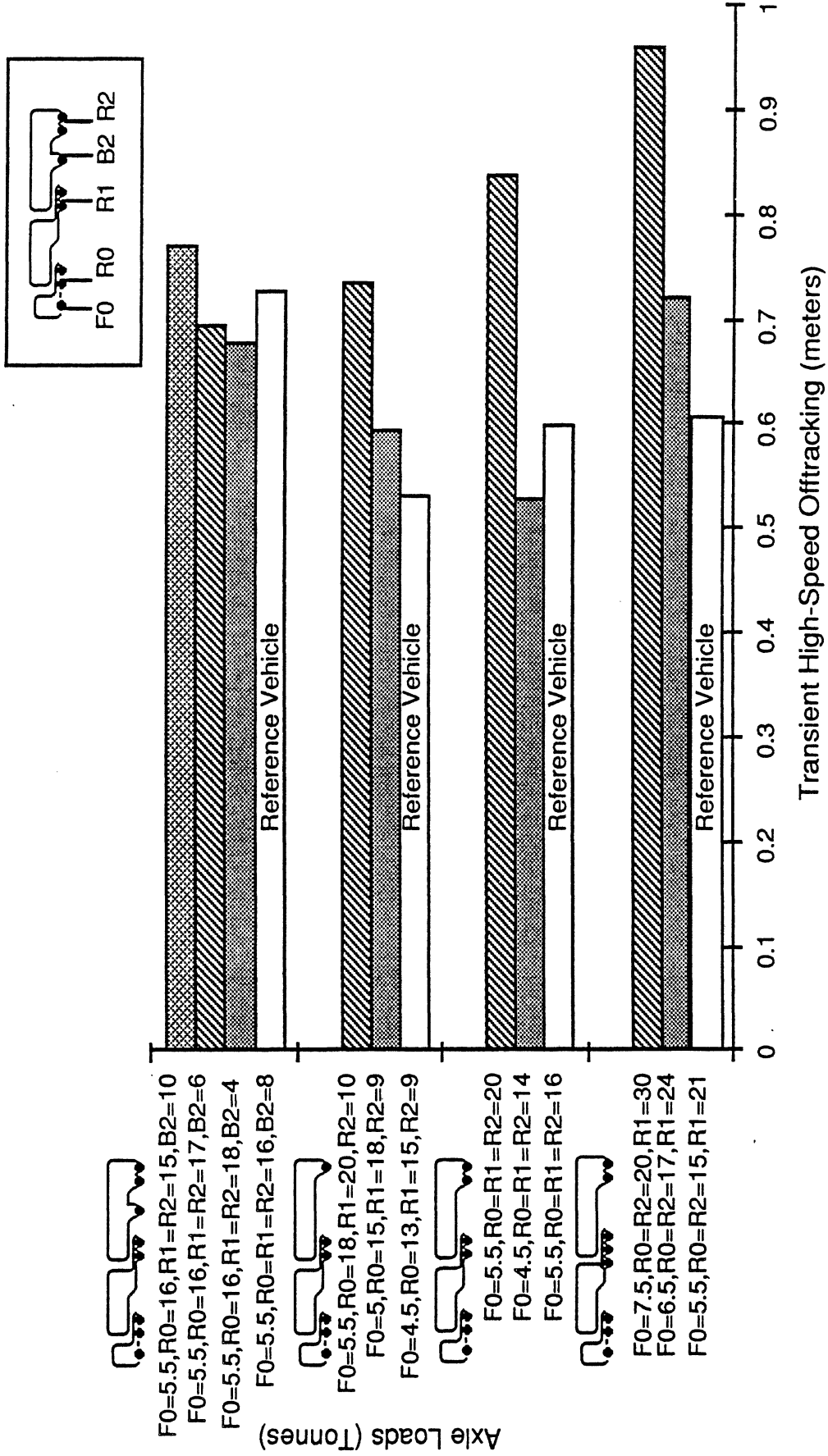

FIGURE 3.4.2.d

Influence of Axle Loading on Braking Efficiency in B-Train Doubles

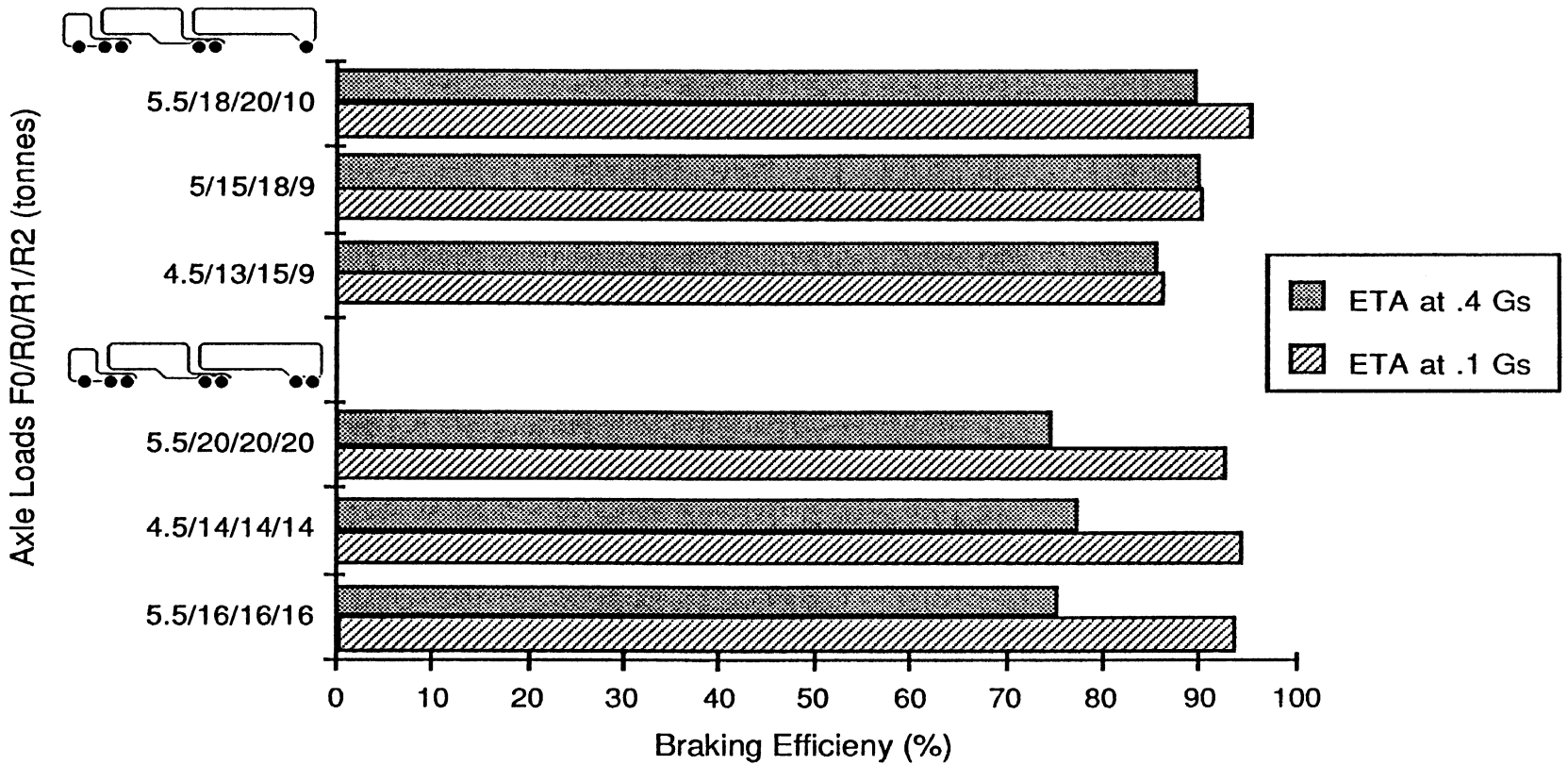
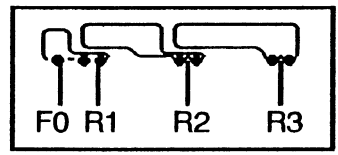
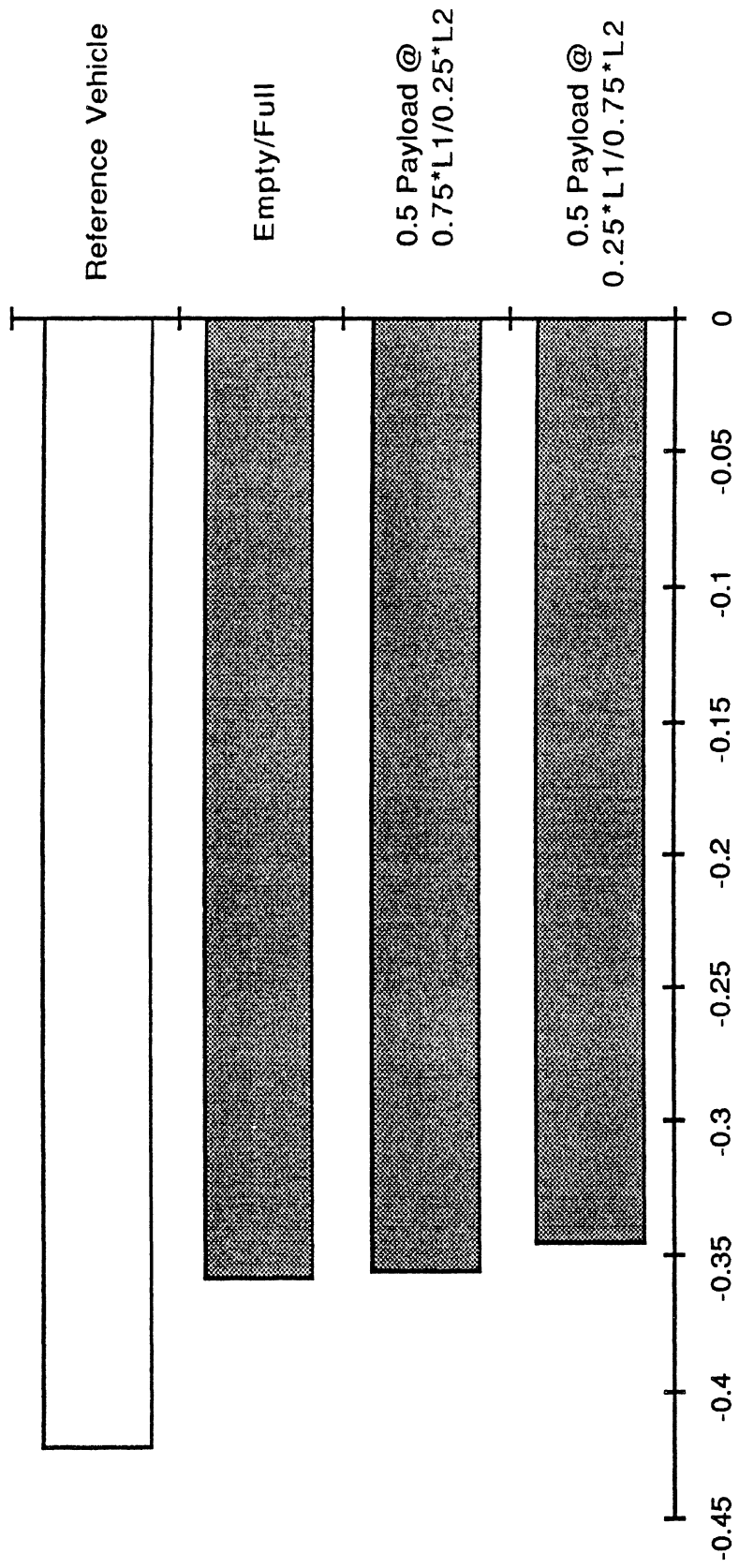
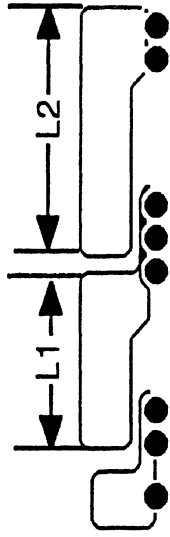

FIGURE 3.4.2.e

Influence of Partial Loading on High-Speed Offtracking in B Train Doubles



High-Speed Offtracking (meters)

FIGURE 3.4.3.a

In Figure 3.4.3b, results showing the influence of partial loading on the load transfer ratio of the baseline B-double are presented. All of the reductions in total load serve to reduce the load transfer ratio, regardless of the load distribution. Nevertheless, the vehicle indicates a higher value of the measure when the front and rear trailer loads are biased toward the center group of axles (with the respective payload mass centers set 25% of the way back from the front of the lead trailer and 75% of the way back from the front of the rear trailer). Inspection of the lateral acceleration time histories for the cases represented in the second bar from the top in the figure reveals that considerably more amplification occurs because of the rear-load-bias in the second trailer, but a greater phase lag in the lateral acceleration response of this trailer renders a rather low value of the load transfer ratio. Conversely, although the lateral acceleration peak at the rear trailer is lower in the case of the top bar in Figure 3.4.2b, the load transfer ratio is significantly higher because the phase lag between trailers is considerably smaller. A simple overview of these contrasting cases would state:

- a) when trailer mass centers are moved closer together, for the same axle layouts, the phase lag between trailers reduces, and,
- b) an aft-bias in load placement, especially on the rear trailer, causes the lateral acceleration response of the rear trailer to become more amplified.

The aggregate effect of these two differing mechanisms determines the influence of a given biased loading arrangement on the value of the load transfer ratio.

Shown in Figure 3.4.3c is the influence of partial loading of the B-train on its transient high-speed offtracking behavior. We see that all three of the partial loading conditions produce substantial reductions in the value of this measure. The simple explanation for the general reduction in the transient high-speed offtracking value with reduced loading, regardless of load distribution, derives from the effective increase in tire cornering stiffness per unit of tire load at the axles accruing reduced loading. Again, the increase in normalized cornering stiffness level serves to reduce rearward amplification and generally improve yaw damping. The incremental degradation in rearward amplification that might be expected from a rear-biased payload in the rear trailer does not show up in the transient high-speed offtracking measure as a result of the overall dynamic properties of the roll-coupled B-train layout.

3.4.4 Influence of Compensator-Type 5th Wheel as the Inter-Trailer Coupling. The compensator-type fifth wheel is a replacement for the conventional fifth-

Influence of Partial Loading on Load Transfer Ratio in B-Train Doubles

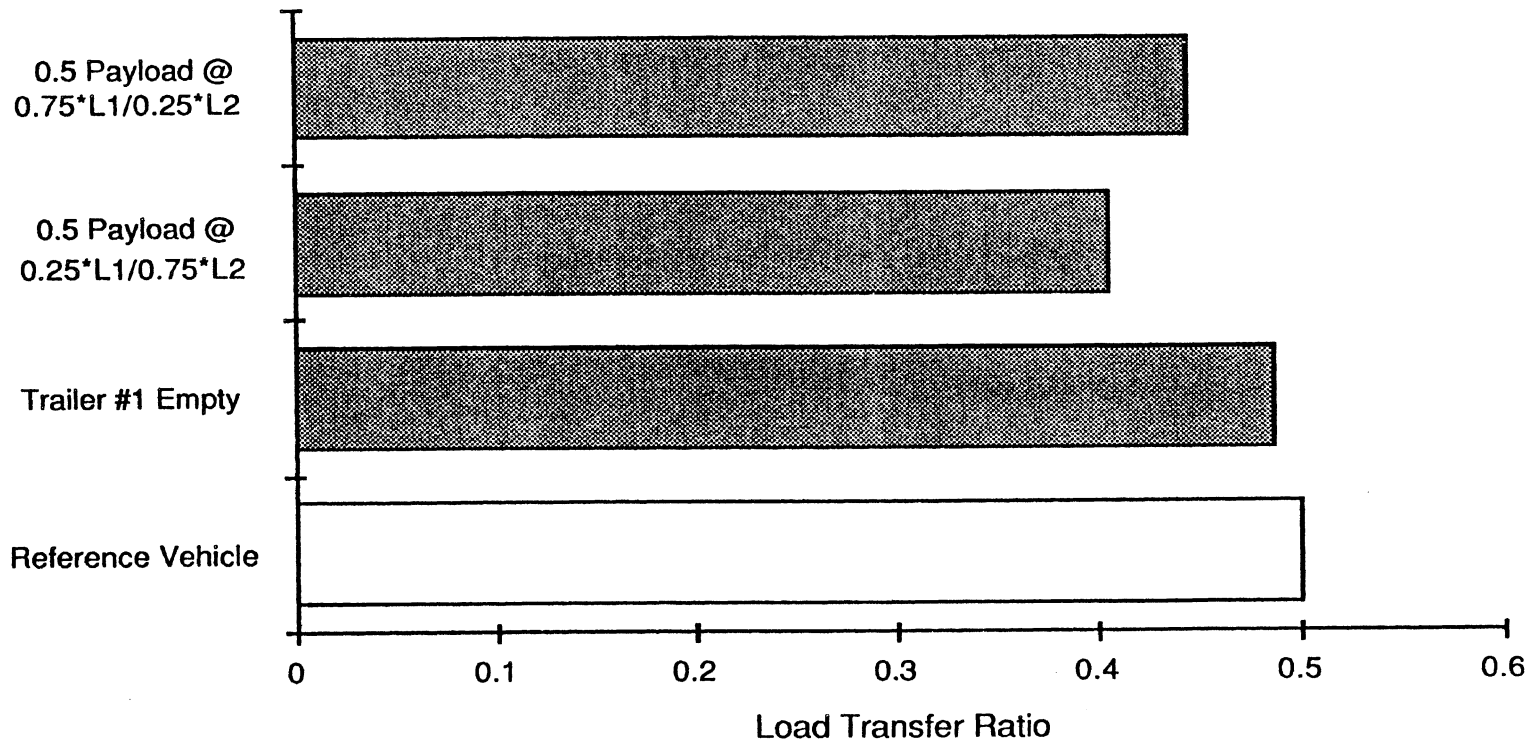

FIGURE 3.4.3.b

Influence of Partial Loading on Transient High-Speed Offtracking in B-Train Doubles

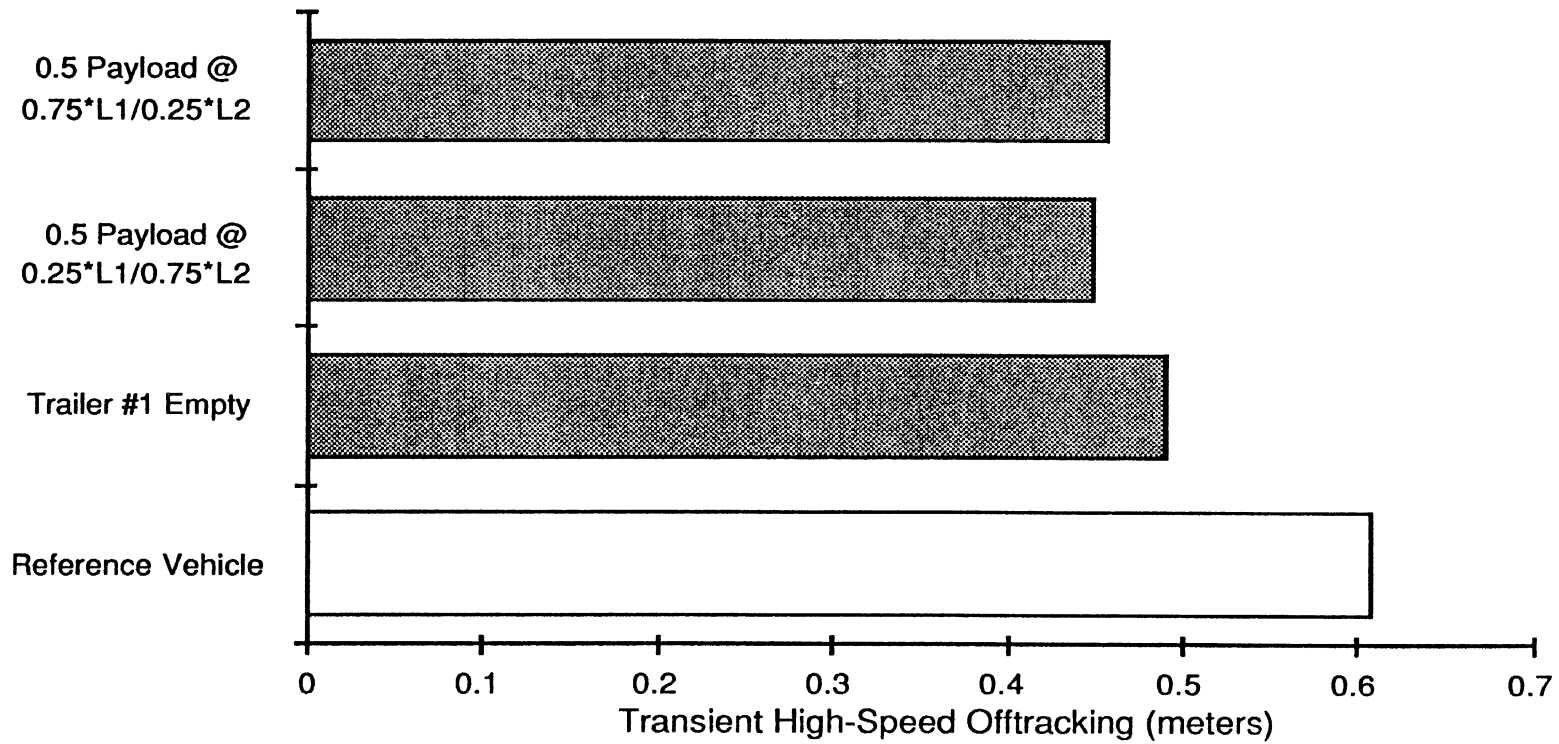

FIGURE 3.4.3.c

wheel assembly which introduces a certain amount of roll freedom into the inter-trailer coupling between the trailers of the B-train. The device which was represented in this study was equivalent to a product marketed by the Holland Hitch Corporation under the model name "Kompensator." This device establishes a kinematic center of roll rotation which is above the nominal surface of the fifth wheel itself. Since the elevation of this "instant center" of roll freedom of the compensating fifth wheel is only 0.3 m (.10 ft) below the sprung mass center of gravity, the steady-state roll moments arising from D'Alembert forces are effectively transmitted through the fifth wheel more or less the same as with a conventional style fifth-wheel coupling.

Shown in Figure 3.4.4a, for example, is the simple result that the static rollover threshold of the baseline B-train is essentially the same, whether a conventional or compensating fifth wheel is employed. Thus, the static roll moments developed in the steady-turn maneuver approaching rollover appear to be handled by the compensating fifth wheel in virtually the same manner as with conventional hardware.

The influence of the compensating fifth wheel on the load transfer ratio is shown in Figure 3.4.4b. We see essentially no influence of this device on the key measure of dynamic roll stability. The result indicates that the elevated kinematic center of rotation of the compensator does enable the device to effectively transmit the amplified roll moments developed at the rear trailer during this highly transient maneuver. This result confirms the very popular usage of this type of compensating fifth wheel on B-train tankers in Canada. The compensating fifth wheel has seen almost universal application to tank-type B-trains as a means of avoiding the high torsional stressing of the trailers which otherwise arises with roll-stiff fifth wheels due to random disturbances in road profile. Although the roll freedom of the compensating fifth wheel permits small random differences in the roll angles of front and rear trailers, the kinematic constraint in the device quite effectively transmits the roll moment developed at the rear trailer during maneuvering.

Shown in Figure 3.4.4c is a small increase in transient high-speed offtracking arising from the use of the compensating fifth wheel. Although the mechanics of the influence are rather complex, the increased value of the measure is assumed to be the result of the somewhat altered load transfer distribution which occurs in a transient manner during the maneuver, thus serving to adjust the effective cornering stiffnesses of tires at the involved axles.

Influence of Compensating Fifth Wheel on Static Rollover Threshold in B-Train Doubles

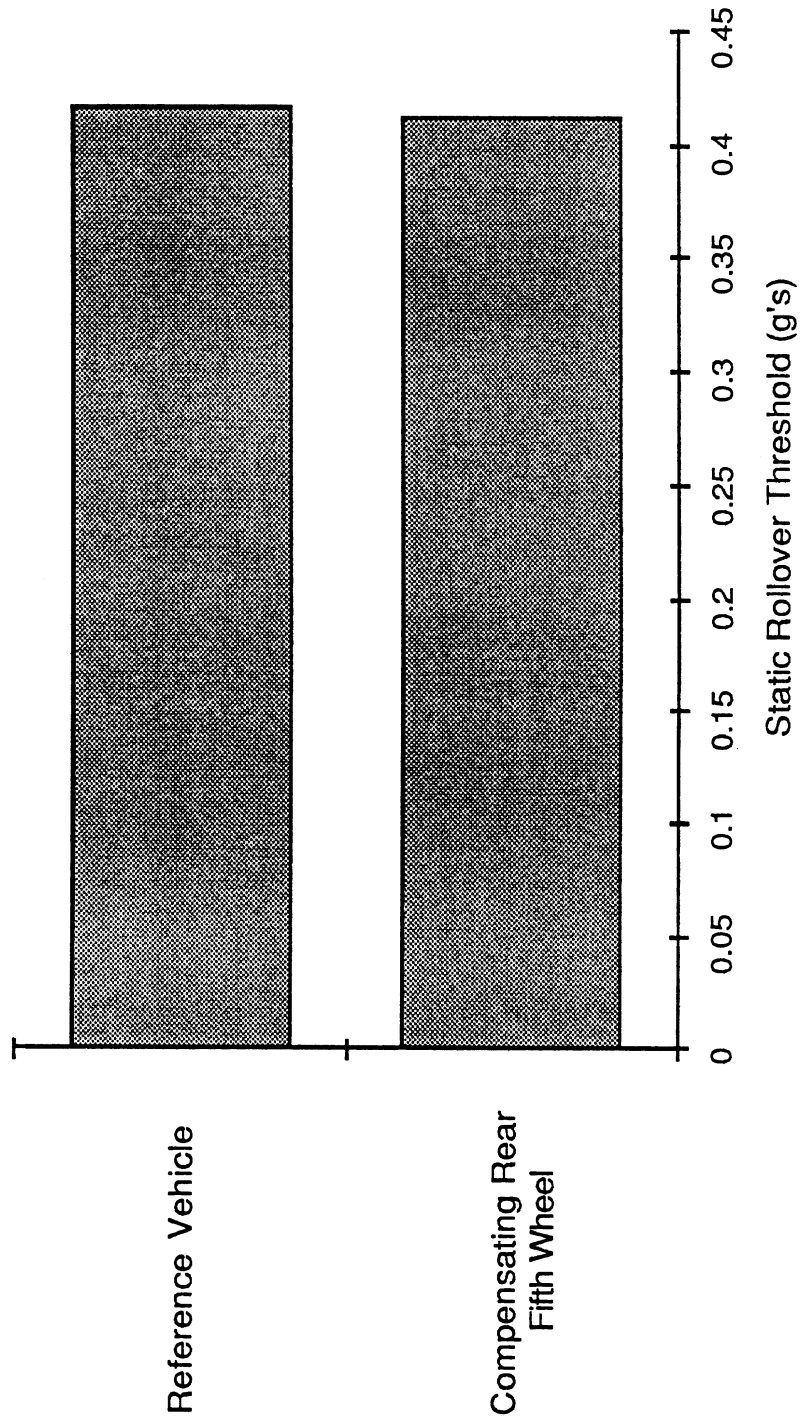

FIGURE 3.4.4.a

Influence of Compensating Fifth Wheel on Load Transfer Ratio in B-Train Doubles

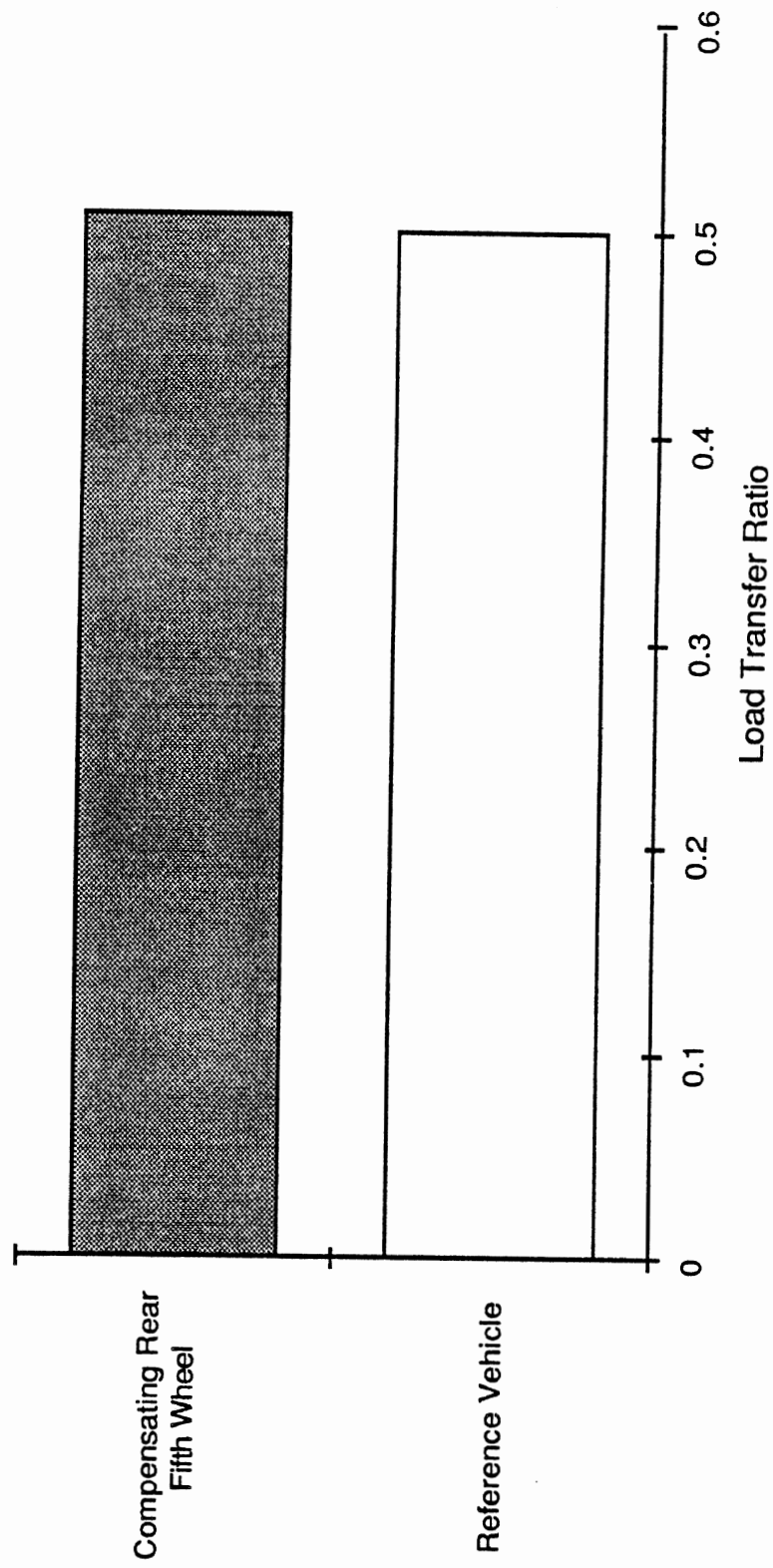
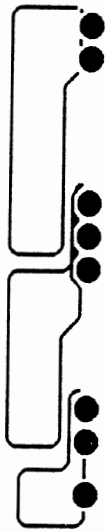

FIGURE 3.4.4.b

Influence of Compensating Fifth Wheel on Transient High-Speed Offtracking in B-Train Doubles

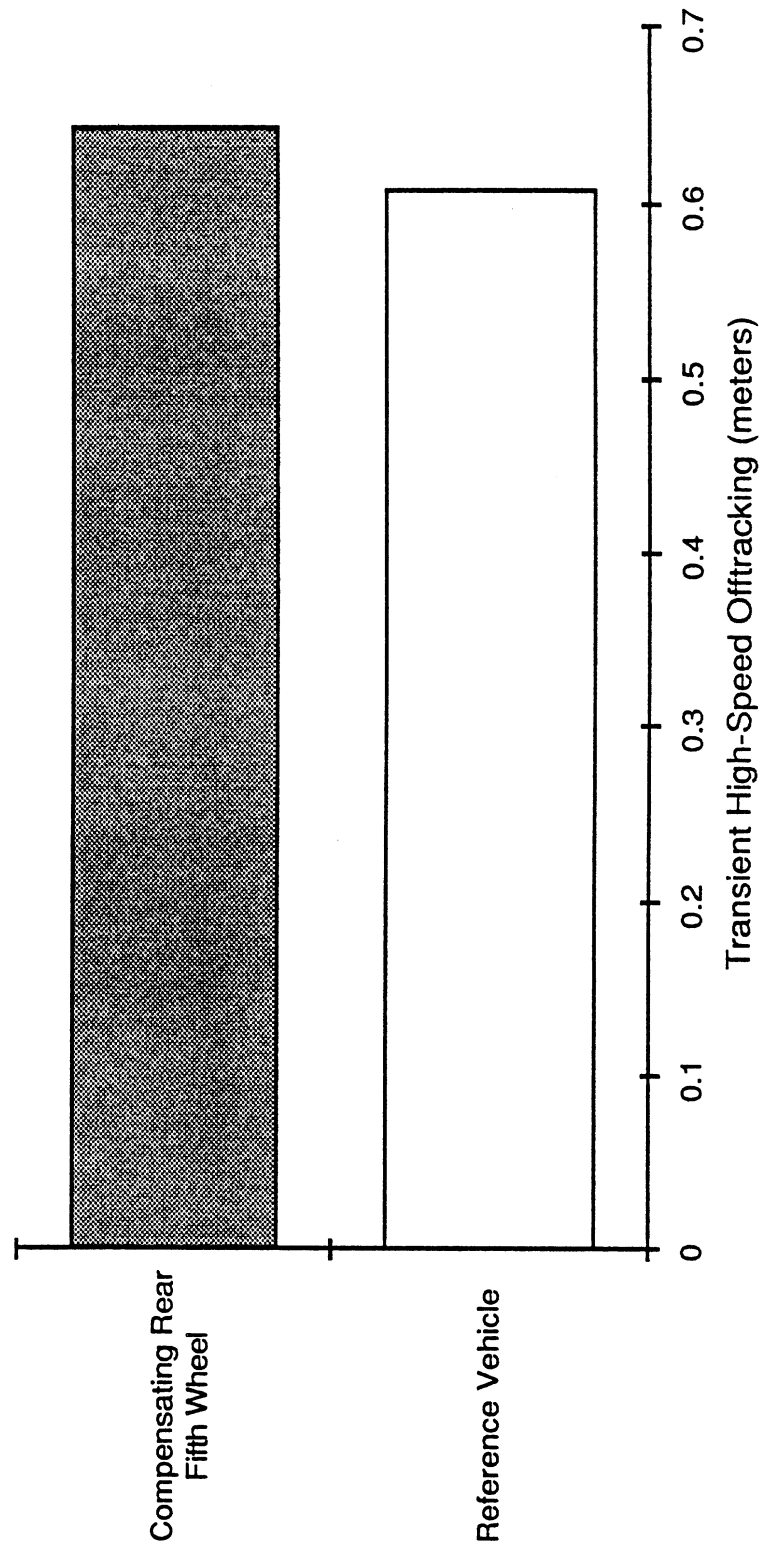

FIGURE 3.4.4.c

3.4.5 Influence of Air Suspensions (at all axles). Although the installation of an air suspension at all axles (other than the tractor steering axle) was implemented as a variation in the simulation matrix, it was recognized that the resulting variations in performance would derive from the sum of the specific properties that were assigned to the reference leaf and air spring alternatives. Thus, the reader should note that, while variations in performance are shown below, they derive primarily from artifacts of the design of the selected suspensions and do not illustrate general distinctions between air- and leaf-type suspensions.

Shown in Figure 3.4.5a is a reduced level of static rollover threshold for the air-suspension-equipped B-train. This result is seen as deriving primarily from the fact that the trailer and tractor suspensions exhibited some 50% higher levels of roll stiffness in the leaf as opposed to air suspension versions. In large measure, this contrast in roll stiffness values reflects the very high stiffness levels of the leaf suspensions which are popular in Canada (and whose properties are documented in Appendix B.3). On the other hand, there is nothing inherent to the design of air suspensions which precludes achievement of the same high levels of roll stiffness, should that be desirable.

The influence of the air-suspension installation on the load transfer ratio measure is shown in Figure 3.4.5b. We see virtually no influence of the sum of the suspension properties varied here on this dynamic roll stability measure. Of course, the fact that the load transfer ratio is derived through a summation of wheel loads all along the vehicle serves to mask any of the detailed differences in transient response through the maneuver.

Shown in Figure 3.4.5c is a substantial improvement in the transient high-speed offtracking performance in the case of the air suspension. This result can be traced directly to the fact that the represented air suspension embodies a zero value for roll-steer coefficient while the trailer leaf suspensions of the reference vehicle exhibit a roll-steer coefficient of 0.23 degrees per degree. Since any high-speed offtracking measure will be strongly influenced by the roll steer property of trailer suspensions, it is appropriate to observe that the difference in performance between these two cases derives from this detail in mechanical characteristic apart from the nature of the springing medium.

3.4.6 Influence of Belly-Axle Installations. Variations in the parameters defining the belly-axle installation of an eight-axle B-train are shown in Figure 3.4.6a to produce rather small changes in the static rollover threshold. The mechanism by which small changes in this property result from changes in the steering stiffness characteristics of

Influence of Air Suspension All Around on Static Rollover Threshold in B-Train Doubles

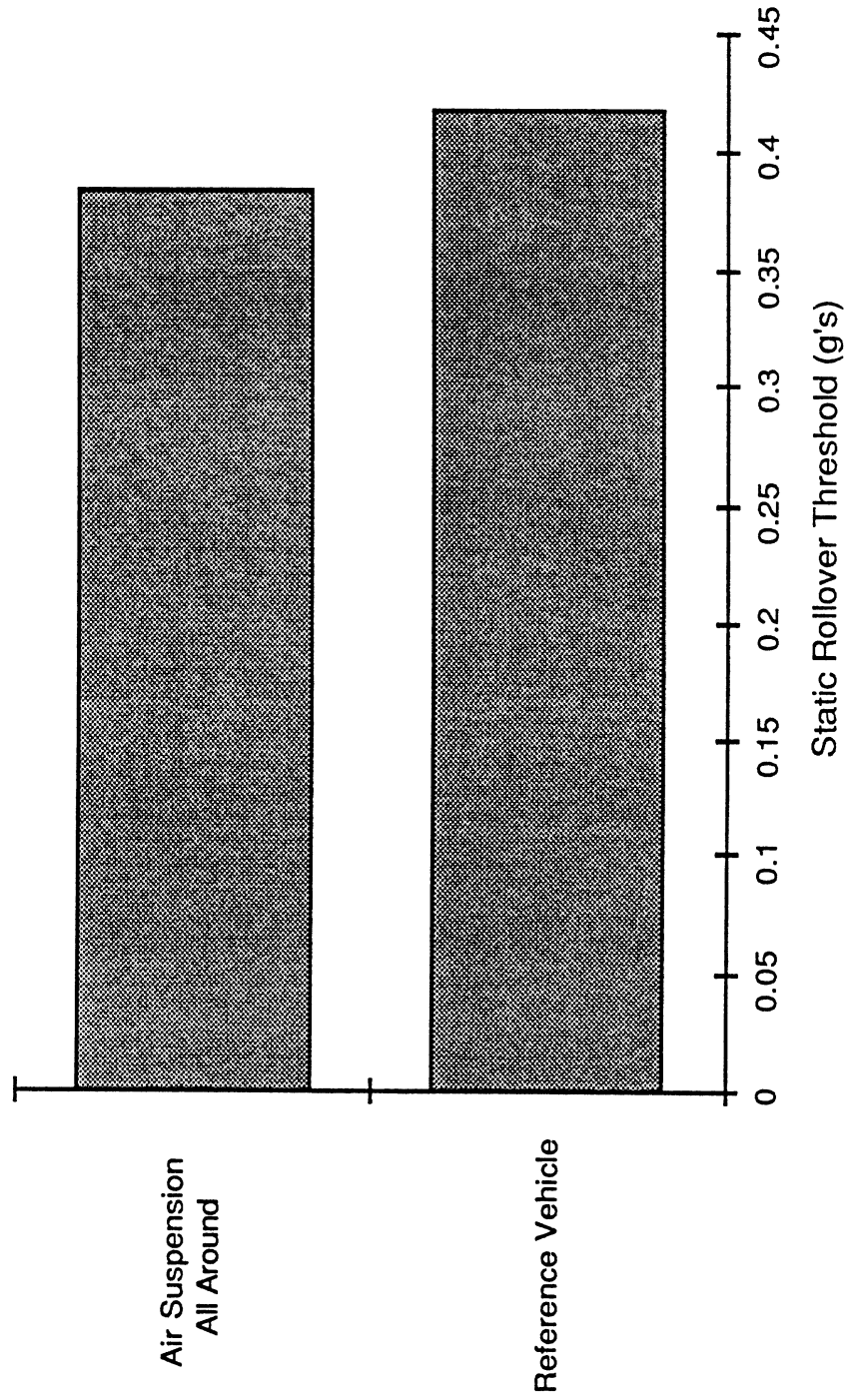
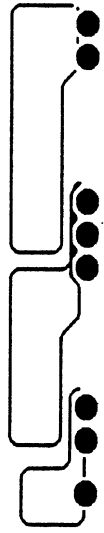

FIGURE 3.4.5.a

Influence of Air Suspension All Around on Load Transfer Ratio in B-Train Doubles

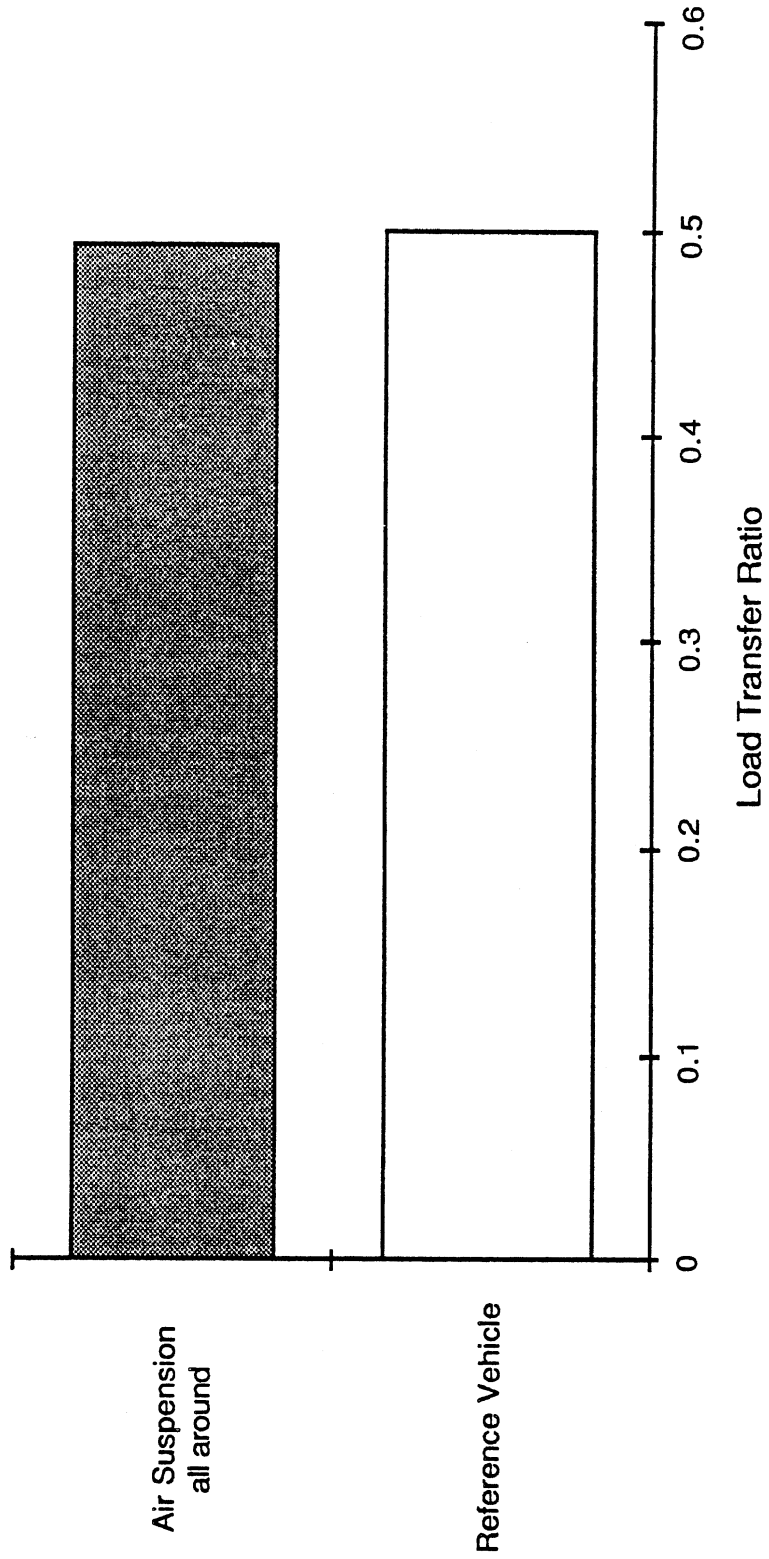
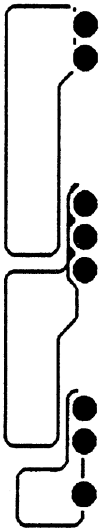

FIGURE 3.4.5.b

Influence of Air Suspension All Around on Transient High-Speed Offtracking in B-Train Doubles

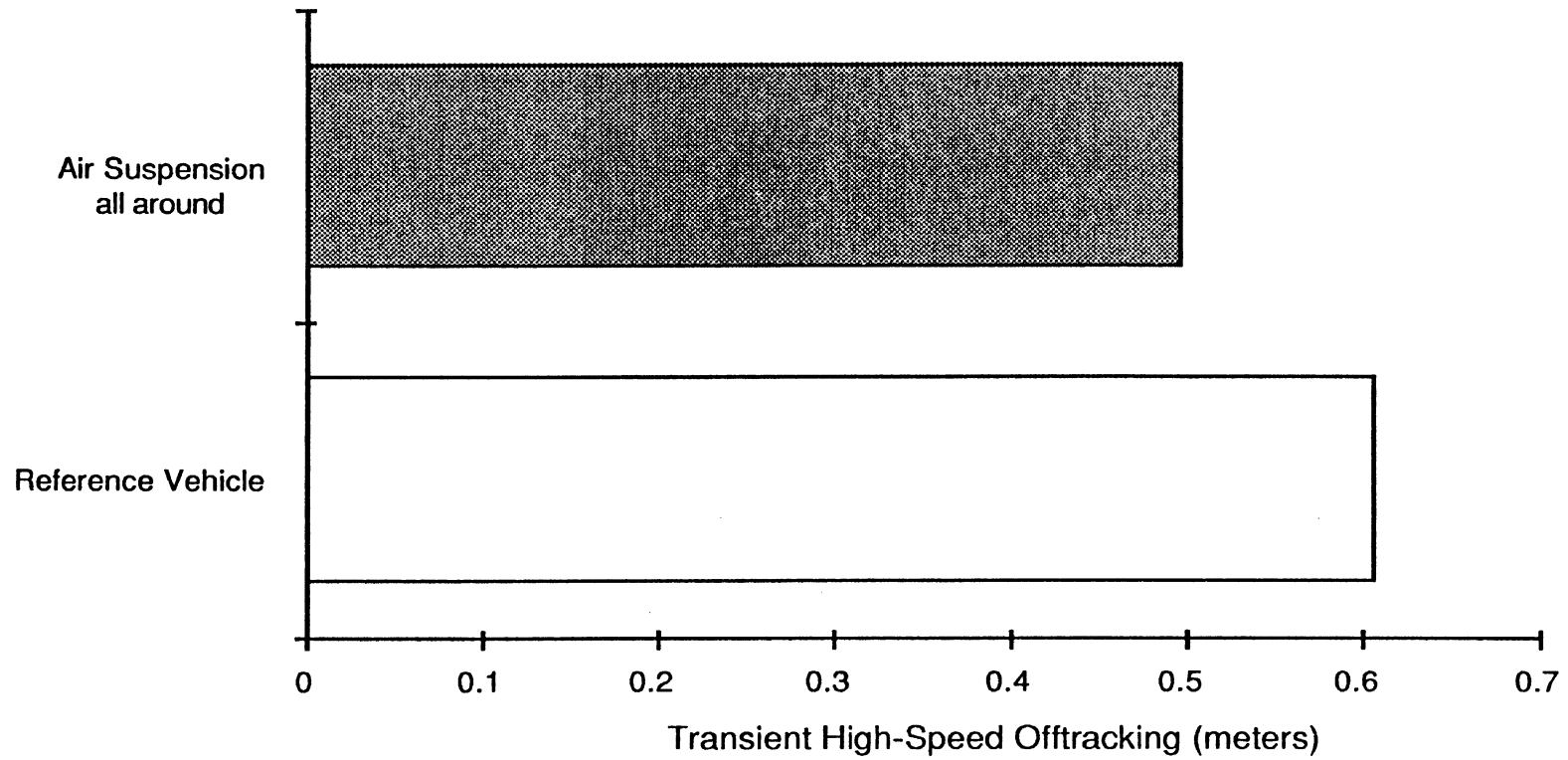

FIGURE 3.4.5.c

Influence of Belly Axle on Static Rollover Threshold in B-Train Doubles

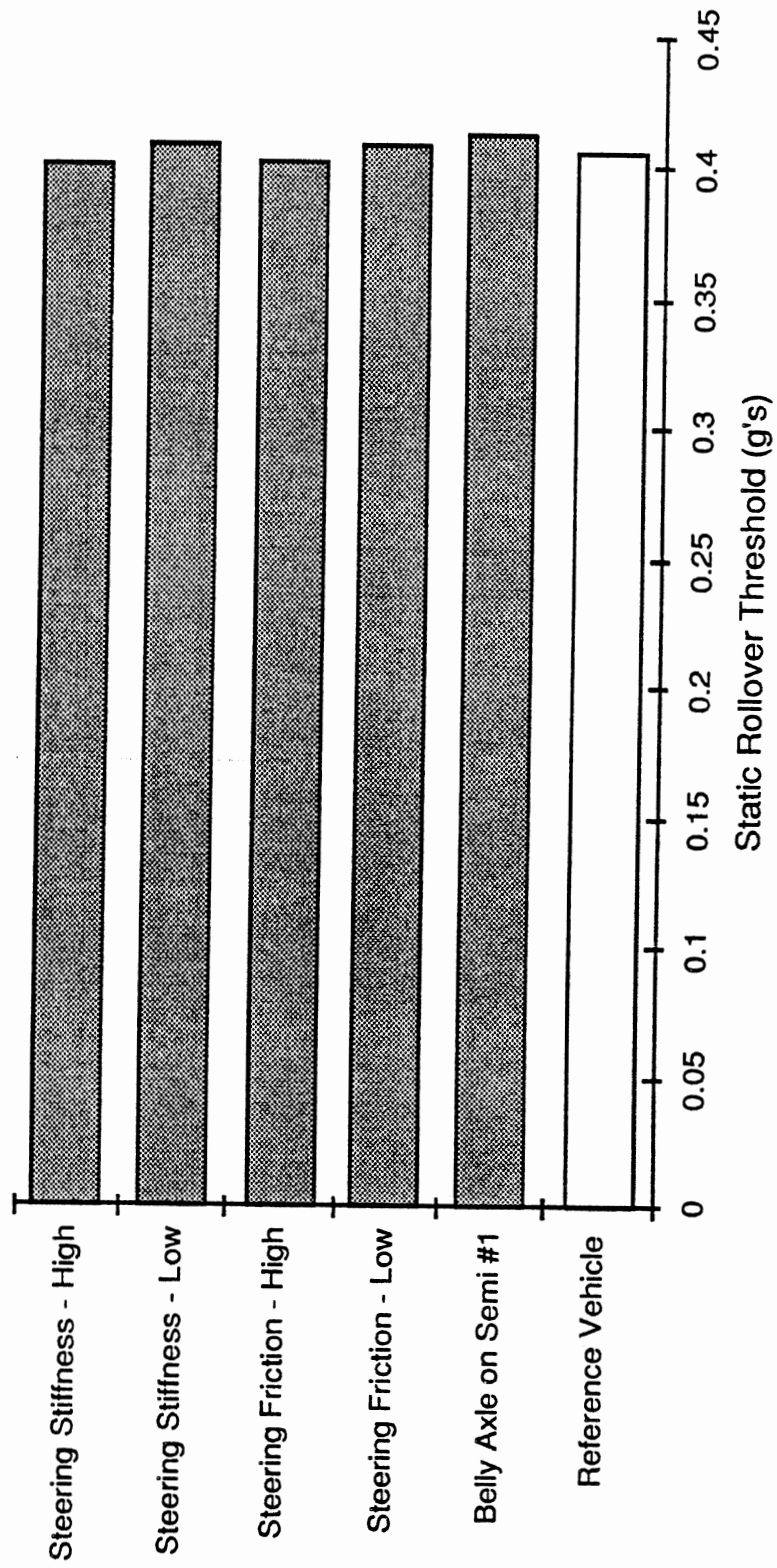
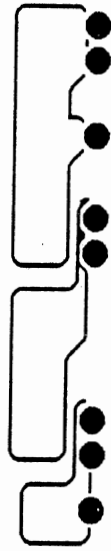

FIGURE 3.4.6.a

the belly axle involves the nonuniform distribution of tire slip angles among the axles on the involved trailer of the combination. That is, since tire slip angles cannot be uniform due to the spread between these axles, the lateral force which is "passed through" the roll center at each suspension becomes varied simply according to the spread [14]. When the steering stiffness of the belly axle is varied, the magnitude of the lateral forces at these axles is further disturbed, such that the total roll moments reacted through the respective axles are altered. Depending upon the detail distinctions in load, roll center heights, and suspension roll stiffness at each axle, the influence of the steering properties of the belly axle on roll stability can be either slightly positive or slightly negative. When the vehicle is driven around a turn having a much smaller radius than that represented by this high-speed maneuver, the influence of the belly-axle steering properties will become more significant.

The influence of various treatments of the belly-axle installation on the high-speed offtracking are illustrated in Figure 3.4.6b. In general, we see that the high-speed offtracking response improves mildly as the belly axle's steering mechanism is made more resistant to steer motion. However, the examined changes have little overall significance on this measure.

Shown in Figure 3.4.6c is the influence of variations in belly-axle installation on the load transfer ratio response of a B-train combination. In general, we see very little effect of the examined variations on this measure. It is apparent that when the steering stiffness or steering friction properties of the self-steering belly axle are increased, the belly axle is less able to steer in response to lateral forces in the maneuver such that the effective wheelbase of the trailer becomes shorter. Consequently, the rearward amplification response increases and is manifested by an increased level of load transfer ratio for the vehicle combination.

The corresponding influences of belly-axle variations on the transient high-speed offtracking measure are shown in Figure 3.4.6d. Rather minor variations in performance are seen in all cases except that for which the belly axle is installed under the lead trailer instead of the rear. While a full explanation of this influence seems to be unavailable without more extensive study, it would appear that the result derived in part from the higher center of gravity of the lead trailer which resulted from the increased loading of this unit as allowed by the belly axle. Since the lead trailer was configured with a shorter bed, the achievement of the full-load condition with the belly axle under the first trailer resulted in a higher center of gravity than occurred on the rear unit with belly axle in the rear.

Influence of Belly Axle on High-Speed Offtracking in B-Train Doubles

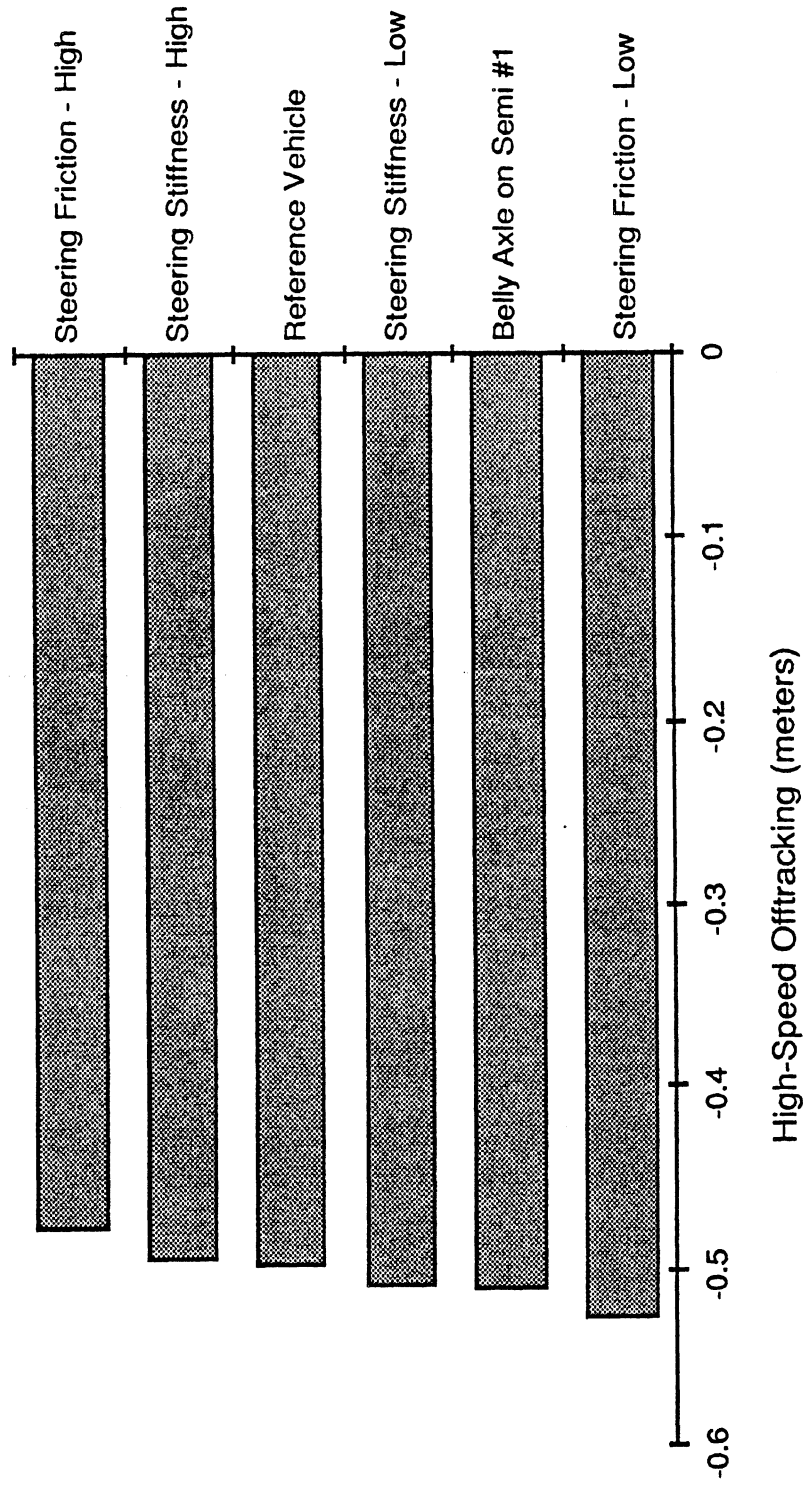

FIGURE 3.4.6.b

Influence of Belly Axle on Load Transfer Ratio in B-Train Doubles

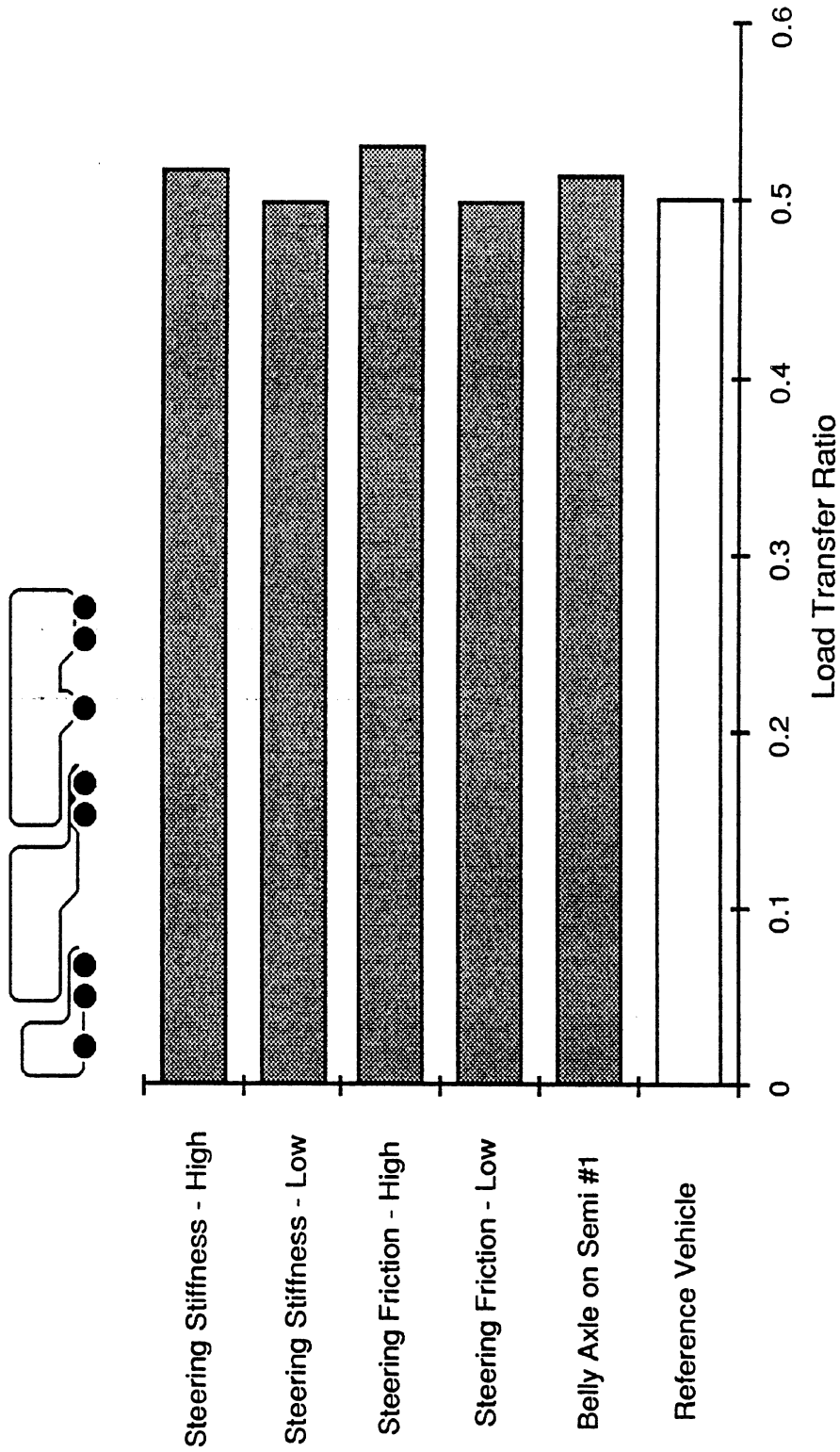

FIGURE 3.4.6.c

Influence of Belly Axle on Transient High-Speed Offtracking
in B-Train Doubles

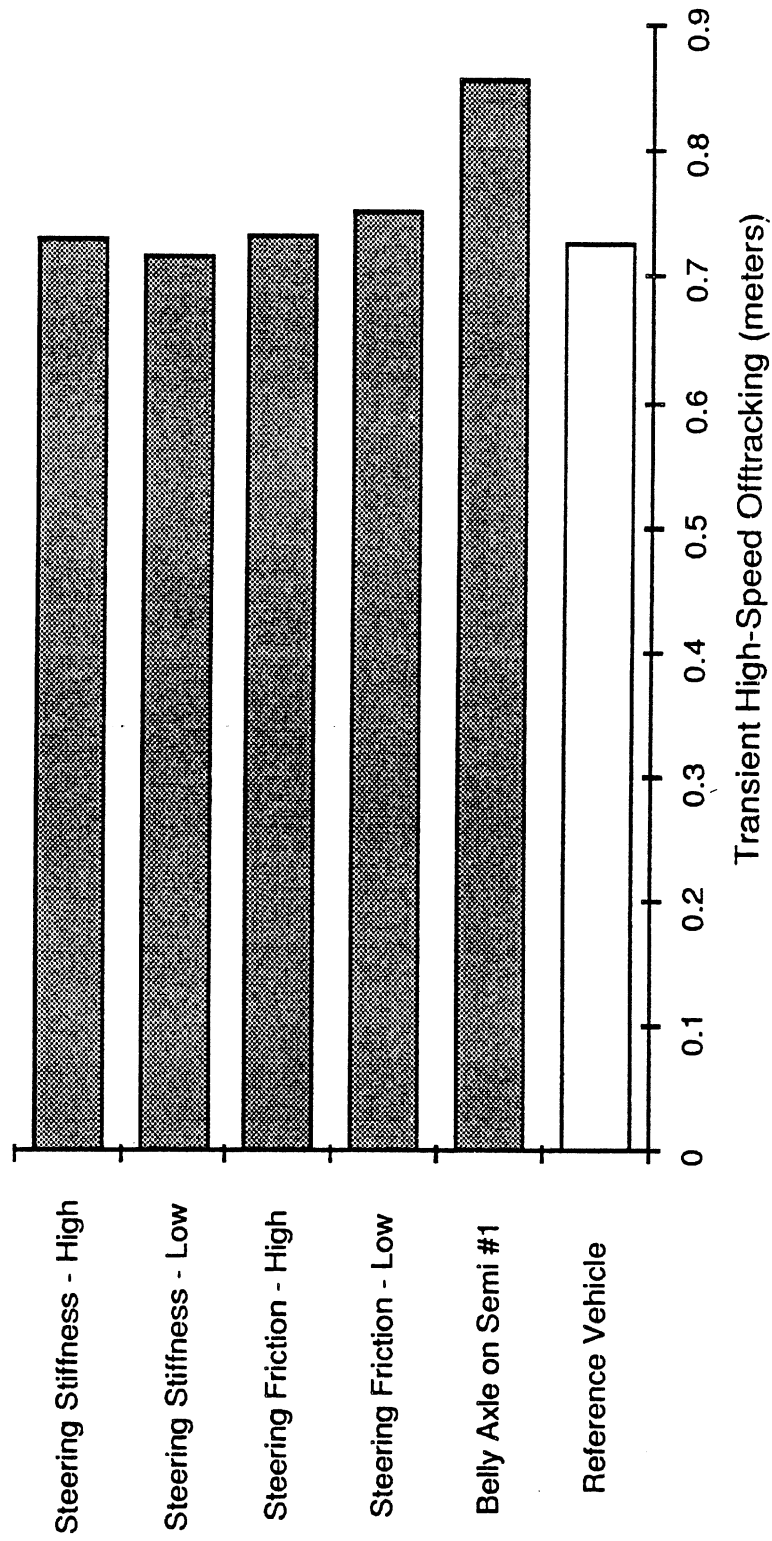
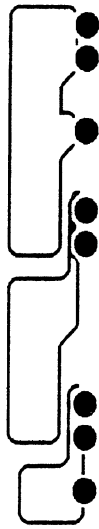

FIGURE 3.4.6.d

Figure 3.4.6e shows the lack of influence on low-speed offtracking of a shift in belly-axle location from one trailer of a B-double to the other. The lack of influence derives from the maintenance of essentially the same equivalent wheelbases of the respective trailers in both installations.

Shown in Figure 3.4.6f is the influence of belly-axle installation parameters on the friction-demand response of the reference B-train. We see that with the belly axle installed on the rear trailer, the steer properties of the belly axle are of no consequence to friction demand and that, indeed, the B-train with a two-axle centergroup imposes a negligible absolute level of such demand. When the belly axle is mounted on the relatively short lead trailer of a B-train, however, a substantial level of friction demand is developed.

Influence of Belly Axle on Low Speed Offtracking in B-Train Doubles

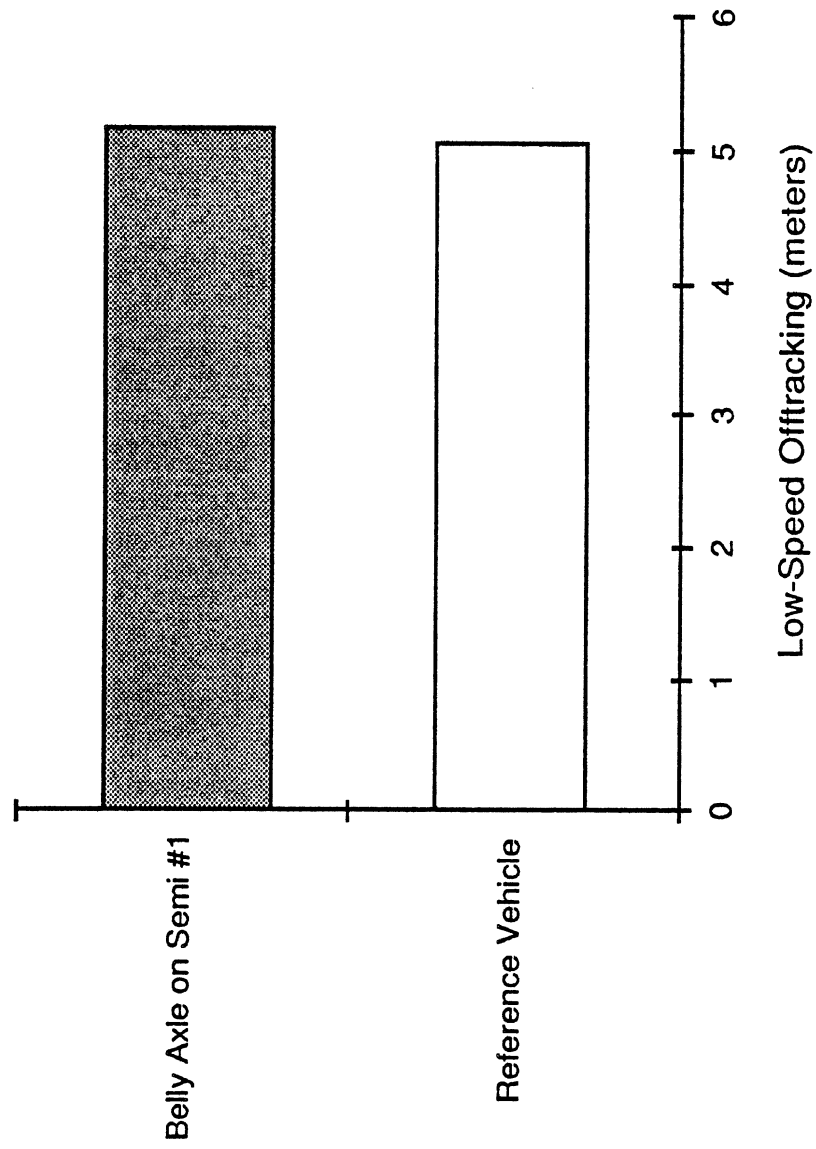
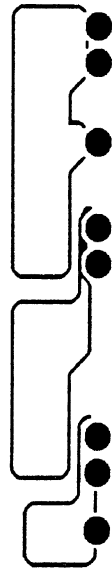

FIGURE 3.4.6.e

Influence of Belly Axle on a Tight Turn Jackknife in B-Train Doubles

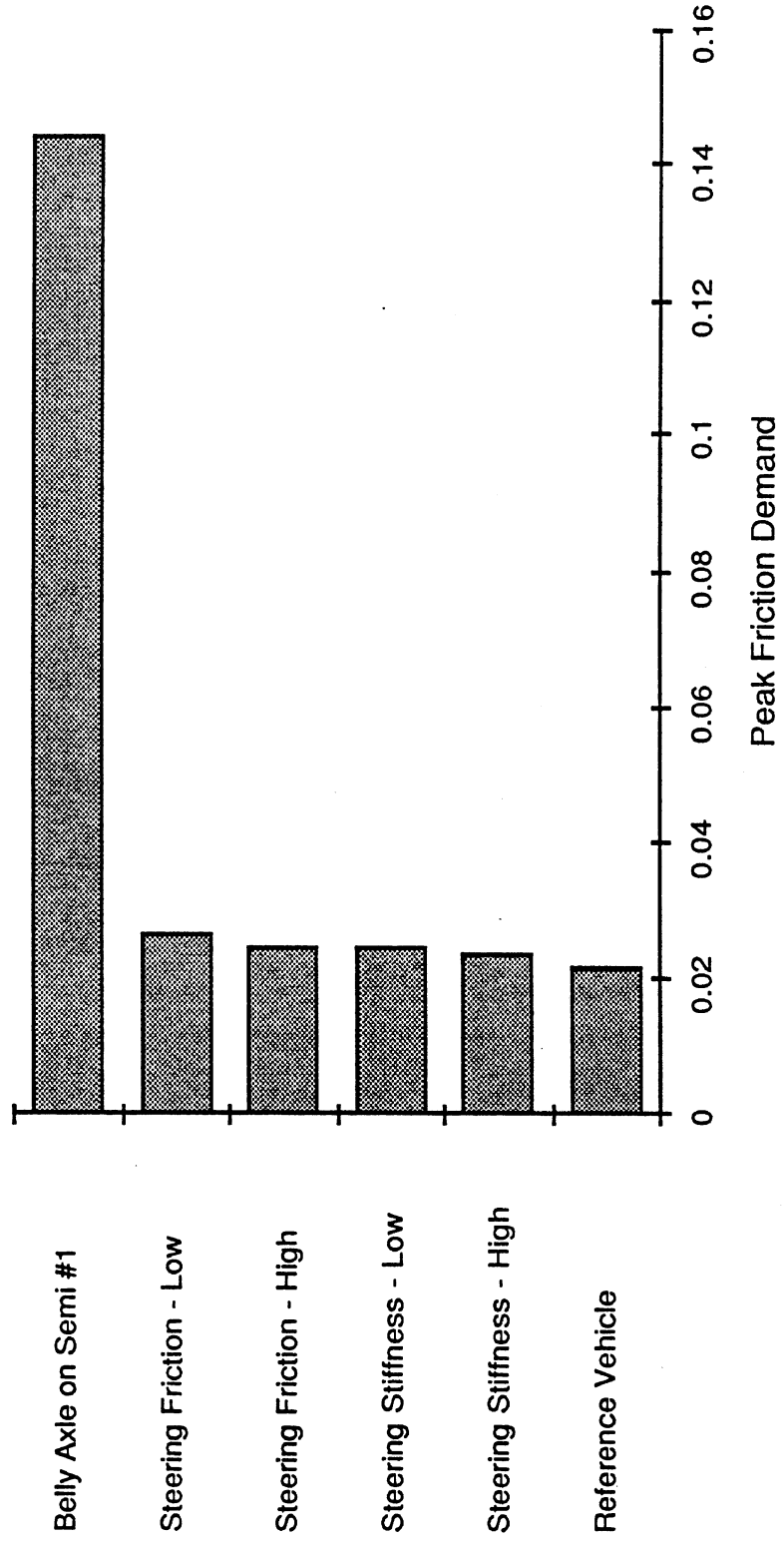
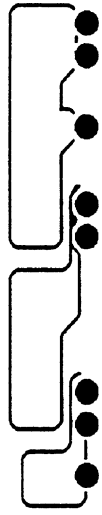

FIGURE 3.4.6.f

3.5 Illustration of Parametric Sensitivities for A- and C-Type Triples Combinations

3.5.1 Influence of Trailer Length and Hitch Placement Dimensions.

The influence of variations in hitch placement and trailer length on the load transfer ratio of A- and C-train triples combinations are shown in Figure 3.5.1a. The data show, firstly, that the A-train triple exhibits decidedly poor performance in this rapid steering maneuver, regardless of the variations in length dimensions which are employed and that the "critical unit" of the vehicle in response to this maneuver is the rearmost trailer. We see that shorter trailer lengths than the 8.2-m (27-ft) reference case simply produce a more severe dynamic roll response such that a roll margin value of zero is produced, with $L_1=L_2=L_3= 6.71$ or 7.32 m (22 or 24 ft) trailer lengths. Conversely, the load transfer ratio does reduce substantially when the trailer length is increased to 9.14 m (30 ft). Load transfer is also seen to improve when the pintle overhang dimension, PH, is reduced and when the drawbar length is increased to 3.05 m (10 ft).

Perhaps the most notable finding regarding the response of triples in the rapid-steering maneuver is the profound improvement in performance deriving from installation of a dual-drawbar dolly, thus constituting a C-train combination. Here we see also that a reduction in trailer length does serve to increase the value of the load transfer ratio measure, although the overall level of performance with the C-train is excellent for any of the examined length values. The primary benefit of the C-train arrangement, of course, is that the dual-drawbar dolly roll couples the units together such that the entire vehicle combination becomes the "critical unit" from a rollover point of view.

The influence of trailer length and hitch placement on the transient high-speed offtracking of A- and C-triples combinations is seen in Figure 3.5.1b. In keeping with the manifestation of high levels of load transfer ratio, the highly amplifying A-train triples also exhibit large values of offtracking overshoots in this maneuver (note that the occurrence of rollover in certain cases renders the transient high-speed offtracking measure invalid, and thus unplotted). Further, although the sensitivities of this measure to changes in vehicle longitudinal dimensions are qualitatively similar to those seen in the load transfer ratio measure, the C-train triple certainly exhibits relatively large values of transient high-speed offtracking. Accordingly, one can observe that the benefits of the C-train arrangement are most pronounced relative to the load transfer property, as was discussed in Section 3.1,

Influence of Trailer Length and Hitch Placement Dimensions on Load Transfer Ratio and Roll Margin in A and C Train Triples

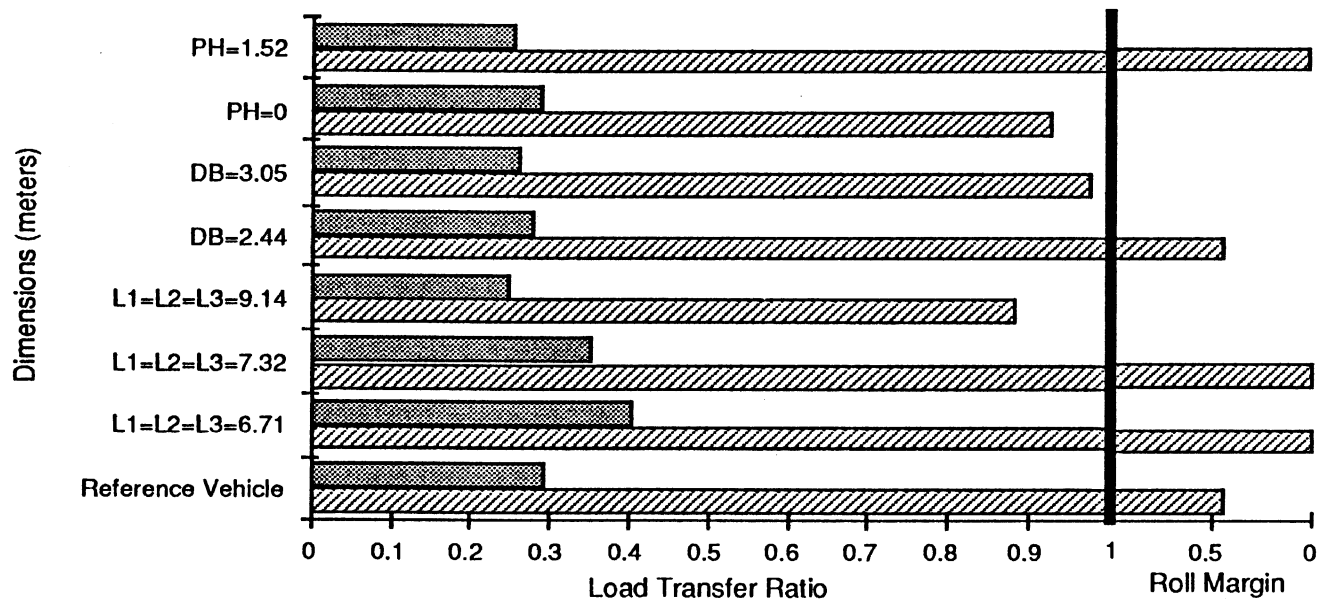
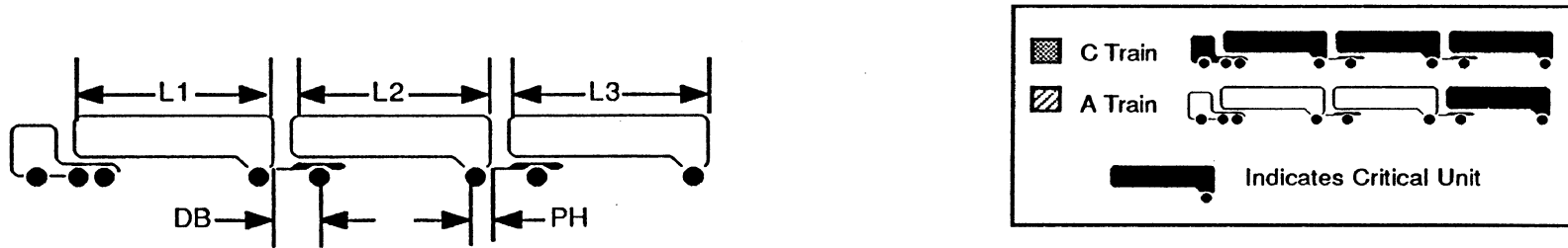

FIGURE 3.5.1.a

Influence of Trailer Length and Hitch Placement Dimensions on Transient High-Speed Offtracking in A and C Train Triples

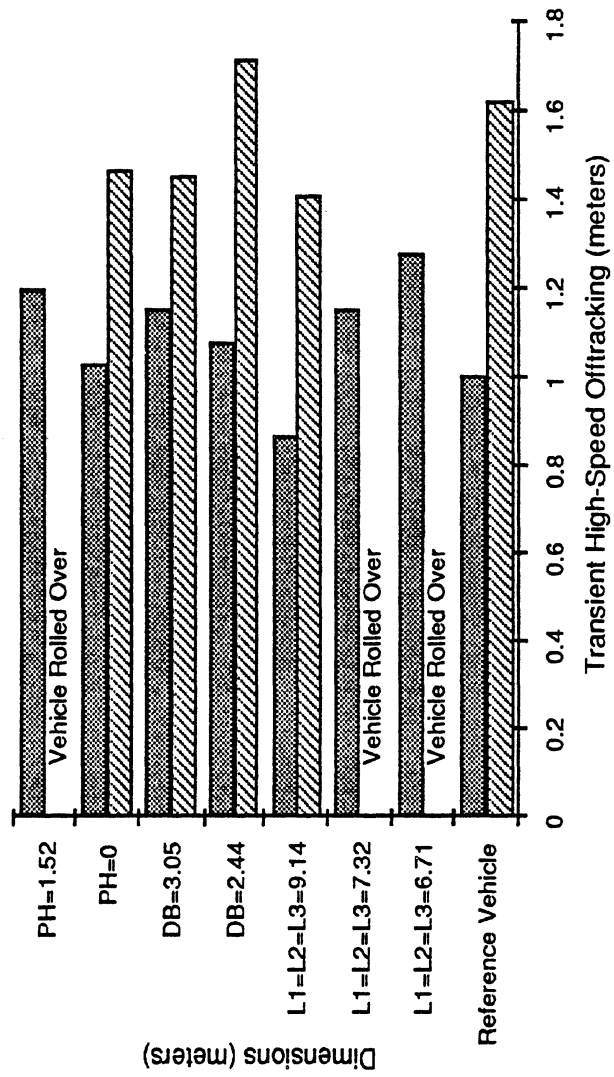
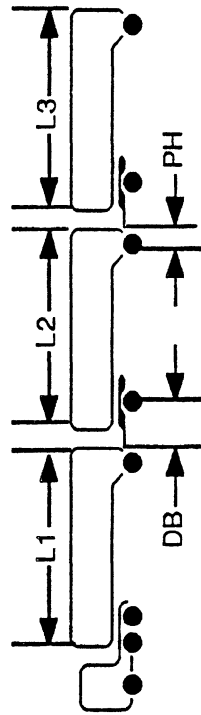
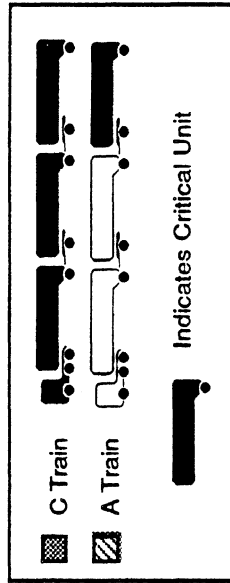

FIGURE 3.5.1.b

while the secondary benefit relative to transient high-speed offtracking is substantial, if not as profound.

Shown in Figure 3.5.1c are low-speed offtracking results showing the sensitivity of this measure to changes in trailer length and pintle hook overhang. The influence of trailer length is seen to follow the typically expected pattern, yielding a rather large change in offtracking as a result of the -20%, +10% variations in trailer length relative to the reference value. Although variations in drawbar length and pintle hook overhang dimensions produce relatively minor changes in low-speed offtracking compared to trailer wheelbase variations, these influences are not inconsequential to the total offtracking performance.

Shown in Figure 3.5.1d are results indicating the negligible influence of length and hitch placement parameters on the braking efficiency of the baseline triples combination. Since the obvious overbraked axle set in this vehicle combination is the tractor tandem axle pair, braking efficiency is unaffected by any dimensional changes which fail to alter the loading on the tractor tandem. Of course, as explained in Section 3.1.4, this result and any other illustrated influence on braking efficiency is dependent entirely upon the assumed distribution of brake torque gains and static axle loads. If the same triples combination were outfitted with substantially de-powered brakes on the tractor tandem axles, such that the rear axle on the last trailer became the "limiting axle," a substantial sensitivity to trailer length would prevail. Similarly, if the dolly axle were to become the "limiting axle," as a result of redistributing brake torques, both trailer length and drawbar length would be strongly influential in determining the braking efficiency level over the range of deceleration.

3.5.2 Influence of Axle Loading. The influence of axle loading on the load transfer ratio response of A- and C-train triples is shown in Figure 3.5.2a. The data show that the A- and C-train triples respond the same in terms of the sensitivity to both the higher payload weight and the higher placement of the payload center of gravity, with higher values of axle load. We see that increases in axle load at the trailer axle positions causes load transfer ratio to increase. The increased response level is due both to the reduction in normalized tire cornering stiffness with increased loading and the elevated payload c.g. height which directly increases the load transfer levels achieved in a given maneuver.

In Figure 3.5.2b are illustrations of the influence of variations in axle load on the transient high-speed offtracking levels produced by A- and C-train triples. In cases

Influence of Trailer Length, Dolly Drawbar and Hitch Placement Dimensions on Low-Speed Offtracking in Triples

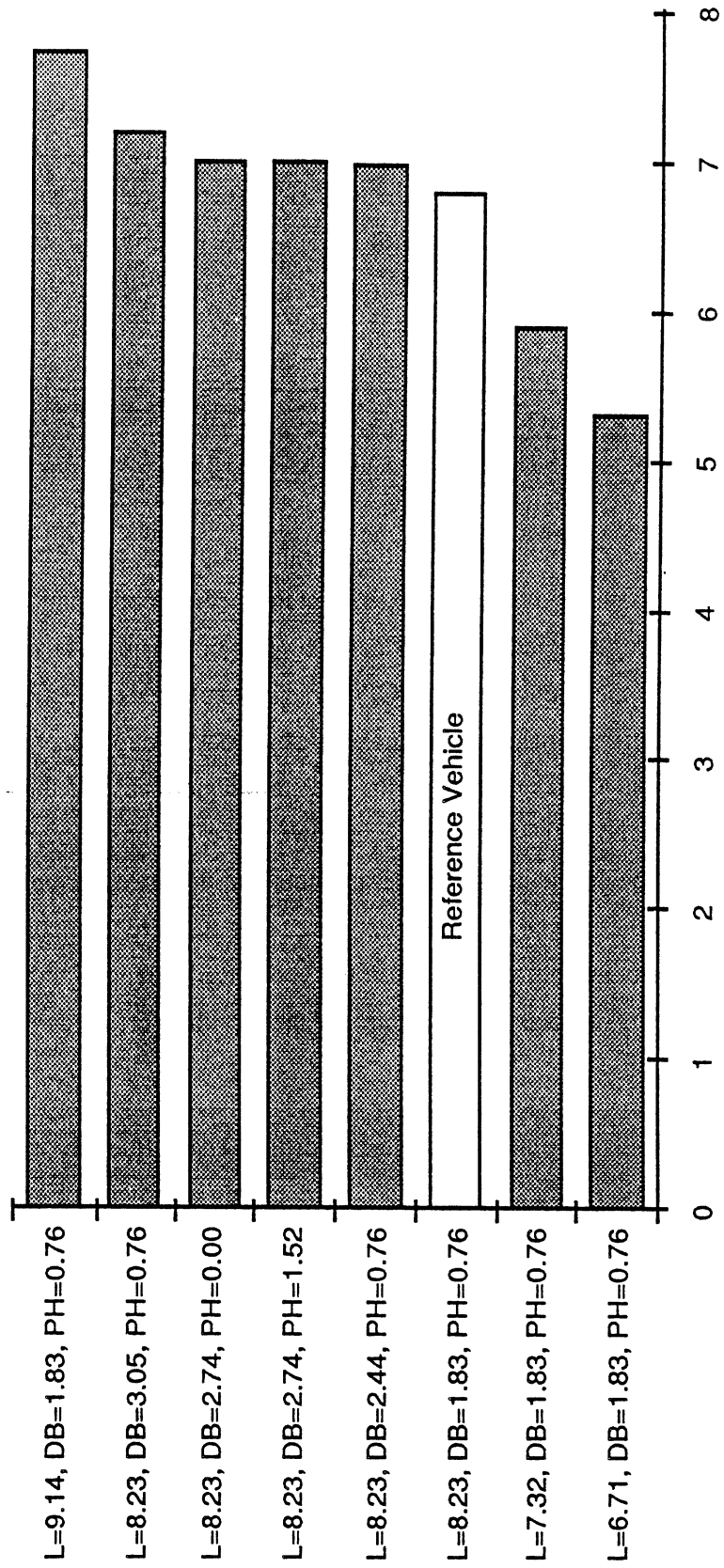
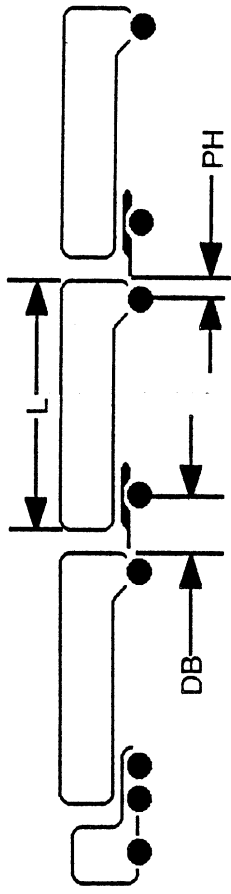

Low-Speed Offtracking (meters)
FIGURE 3.5.1.c

Influence of Trailer Length and Hitch Placement Dimensions on Braking Efficiency in Triples

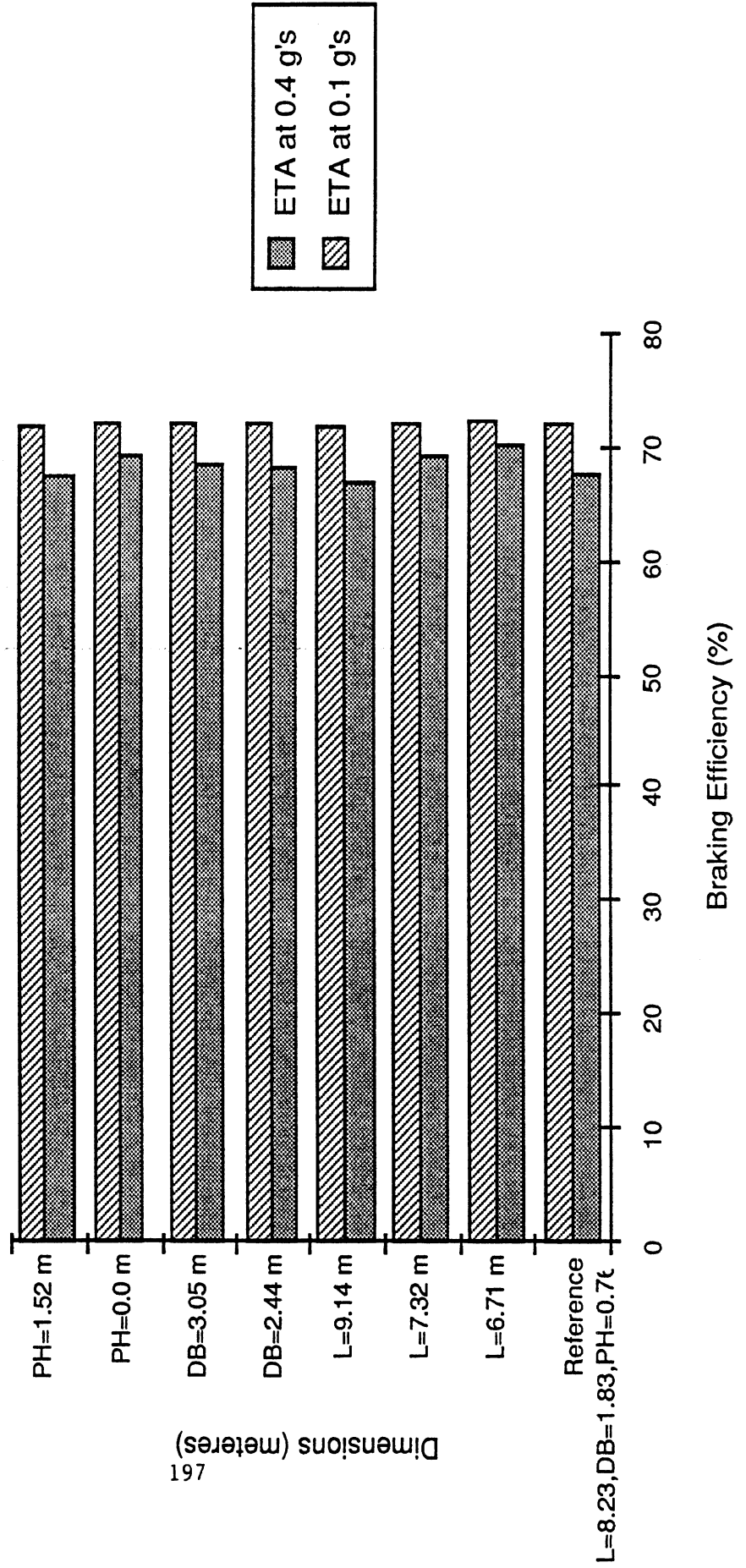
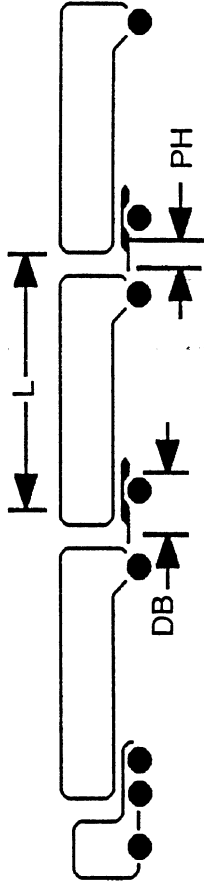
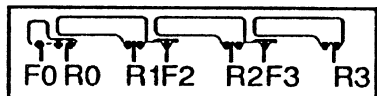

FIGURE 3.5.1.d

Influence of Axle Loading on Load Transfer Ratio and Roll Margin in A and C Train Triples



198

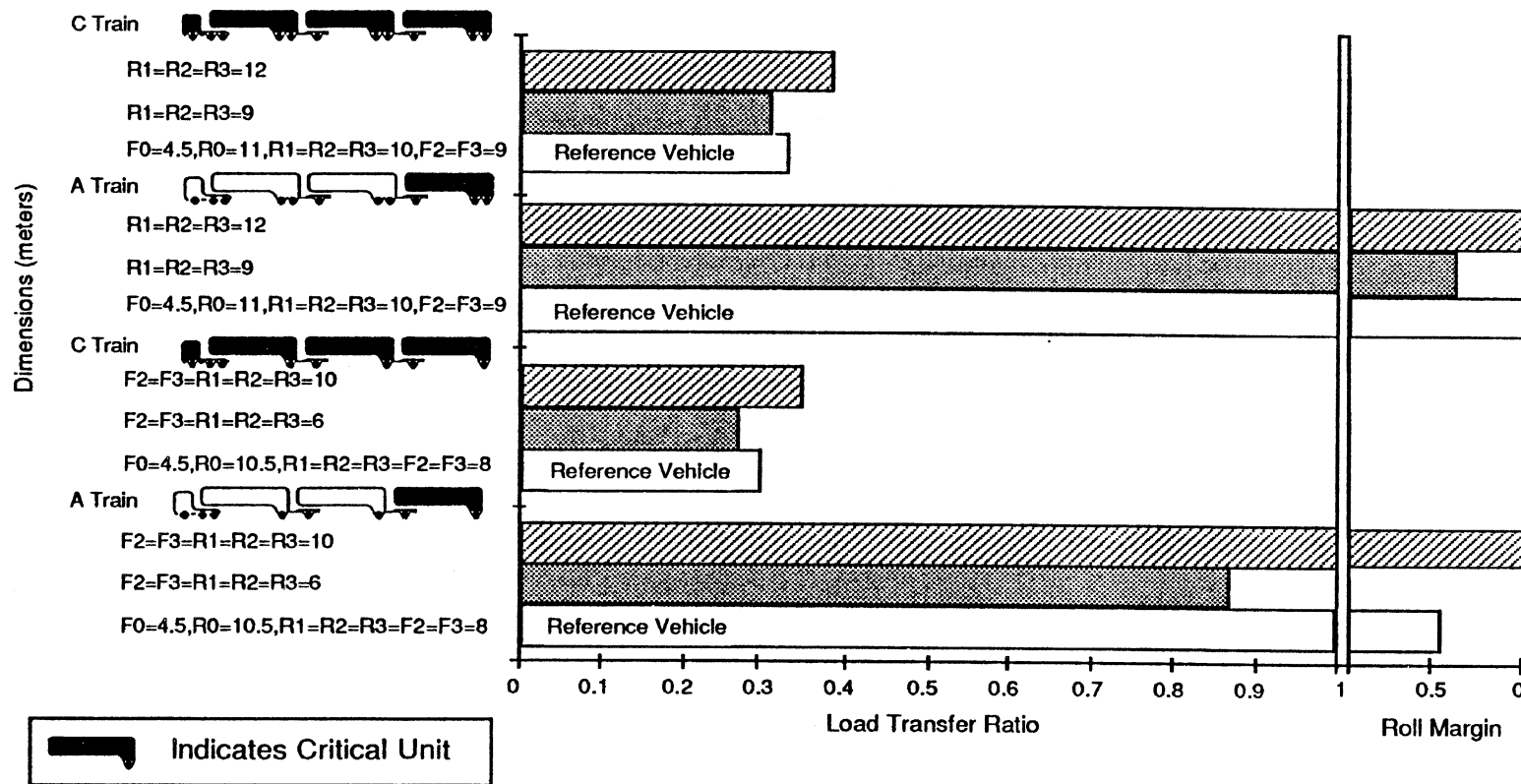

FIGURE 3.5.2.a

Influence of Axle Loading on Transient High-Speed Offtracking in A and C Train Triples

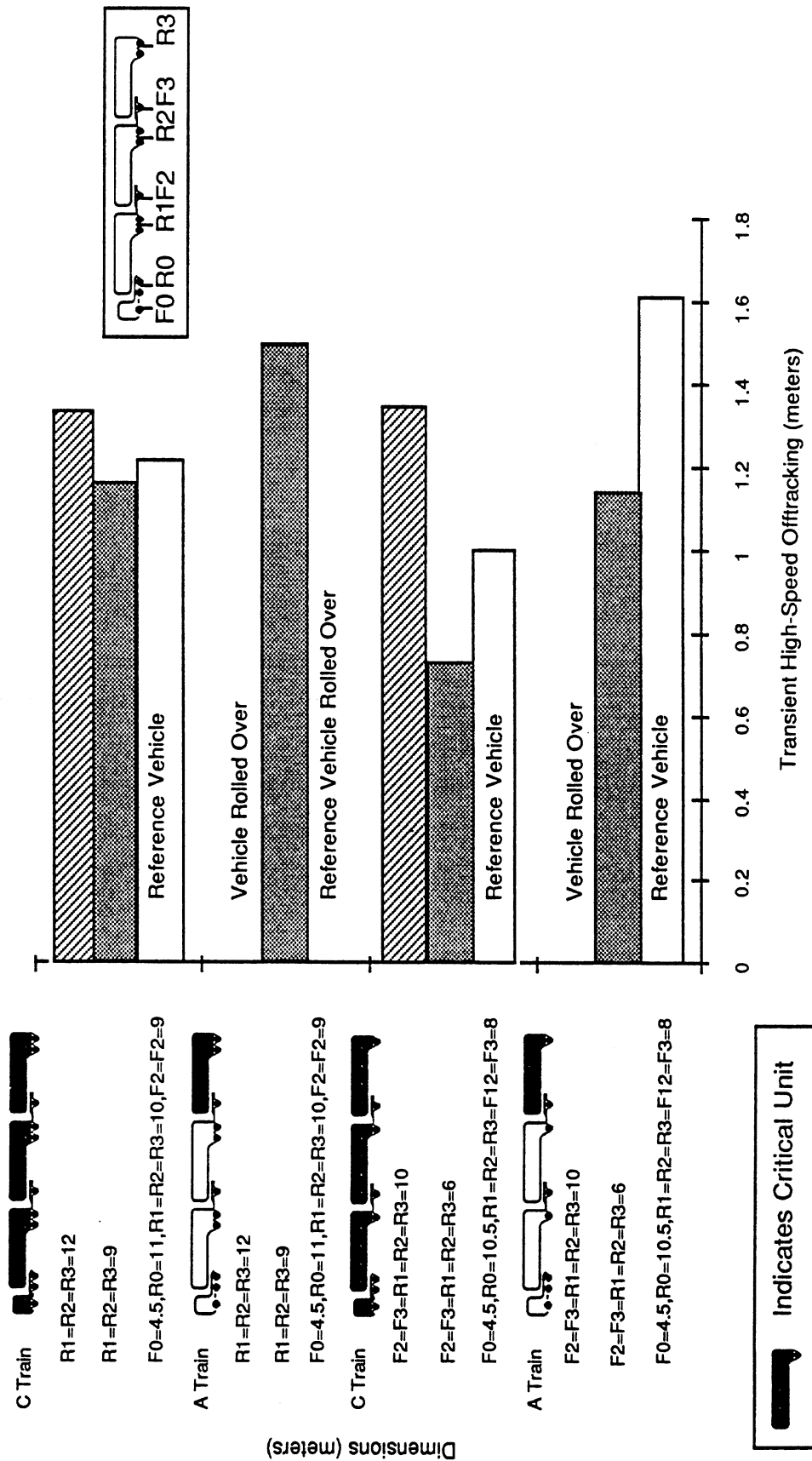

FIGURE 3.5.2.b

involving an increase in axle loading relative to the baseline case, the reduction in normalized tire cornering stiffness causes the tires to operate at greater slip angles such that the physical dimensions of the net lateral excursions of the vehicle are increased. Also, a reduction in the normalized tire cornering stiffness level results in trailer yaw motions which are less well damped such that overshoot phenomena, as classically defined, are exaggerated.

Shown in Figure 3.5.2c is an illustration of the influence of axle loading on the braking efficiency of the triples combinations having single- and tandem-axle trailers, respectively. Two distinct sensitivities are evident. Namely, increased loading on the trailer axle sets, R1, R2, R3, brings about a more favorable distribution of load for the triples combination having tandem-axle trailers. The limitation in braking efficiency for this vehicle is categorically the overbraking (or underloading) of the trailer tandem axles. Accordingly, increased load applied specifically to the trailer tandems improves the scaling of brake torques to vertical load level at those axle positions.

Alternatively, the triples combination with single-axle trailers is limited in braking efficiency by the lockup of the lightly loaded tandem at the tractor. Accordingly, additions in load to the trailer axle positions, without an increase in load at the tractor tandem simply increases the total mass of the vehicle combination without adding load to the critically underloaded axles. Again, insofar as the specific numerical results here derive simply from the illustrative cases having a tandem-axle tractor with its rear axles underloaded, the reader should note that these data do not establish a general finding. Rather, the influence of axle loading on braking efficiency will be to improve performance whenever the load variation results in an increased loading of axles which previously had tended toward early lockup due to underloading. To the extent that the trucking industry may fail to accommodate their brake torque distribution practices to the corresponding distribution of loads, however, the results do probe an important issue concerning the loss in braking performance that might accompany a change in loading allowance.

3.5.3 Influence of the Steer-Centering Properties of B-Dollies. The influence of B-dolly characteristics on the load transfer ratio response of C-train triples combinations is shown in Figure 3.5.3a. The results show that the excellent roll stability of the C-train triple in this maneuver can be substantially improved by implementation of a higher level of torsional rigidity in the dolly frame and hitch mechanism. Other changes in the dolly centering mechanism exhibit a relatively minor influence on the load transfer ratio measure, especially given the dramatic initial improvement that came with the use of the C-

Influence of Axle Loading on Braking Efficiency in Triples

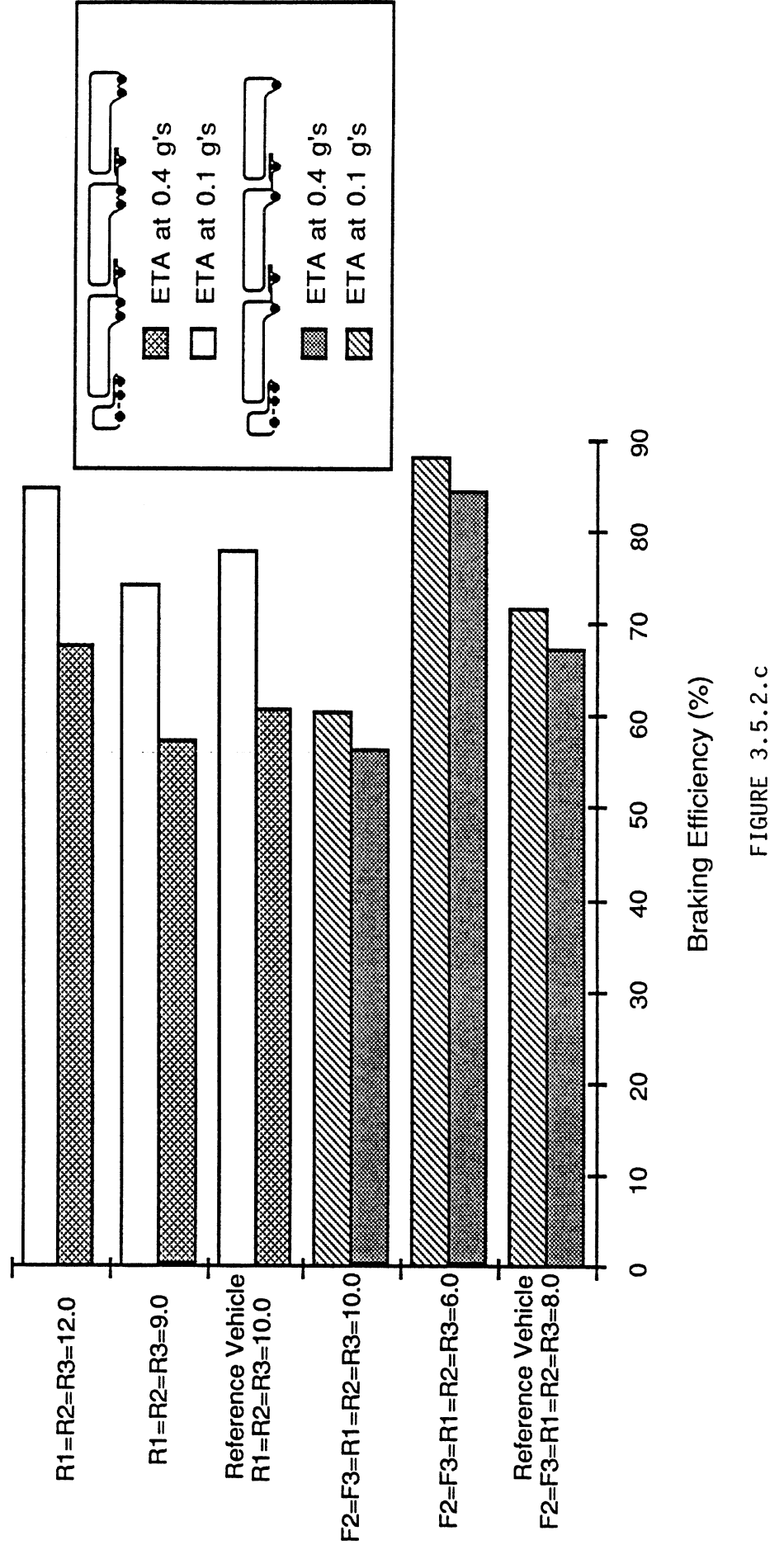
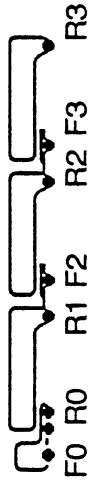

FIGURE 3.5.2.c

Influence of B-Dolly Characteristics on Load Transfer Ratio in C Train Triples

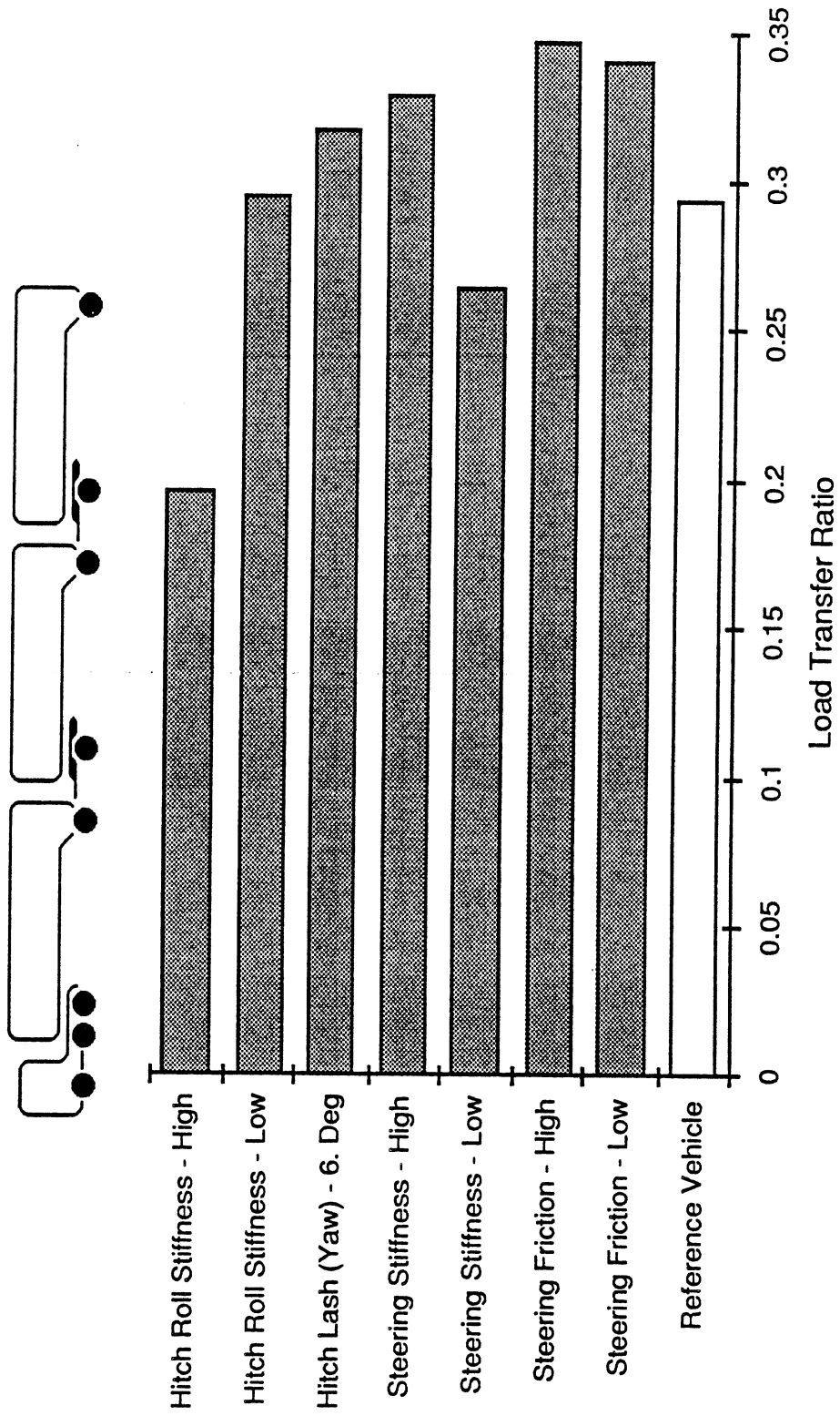

FIGURE 3.5.3.a

train dolly, per se. Another result (see the data base in Appendix F, Case 4.1 C 6.08) indicates that even with a free-castering dolly axle, the load transfer ratio only reaches a load transfer ratio value of 0.38. Moreover, the centering properties of the C-train dolly are not of great significance to this dynamic roll stability property (but are powerfully important in determining the transient high-speed offtracking, which is discussed next).

Shown in Figure 3.5.3b is the influence of crude variations in the properties of a B-dolly on the transient high-speed offtracking response of a C-train triples combination. We see that large changes in this property were produced as follows:

- 1) A very substantial reduction in the transient high speed offtracking measure occurs when the torsional (or "roll") stiffness of the frame of the dual drawbar dolly is increased from a reference value of 3,400 to 10,200 N-m (30,000 to 90,000 in-lbs) per degree of roll angle subtended across the dolly. This outcome derives from the attenuation of dynamic changes in load transfer with increased torsional stiffness which, in turn, causes a reduction in normalized cornering stiffness at the involved tires.
- 2) A large increase in the measure when lash, or free play, is present at the pintle hitch connections to the dual-drawbar dolly such that the dolly can yaw through an angle of +/- 6 degrees within the lash zone. Such a mechanism may derive, in the worst case, if pintle hitches become excessively worn and take-up devices are not employed. The 6-degree yaw freedom in the dolly results in a total of 0.38 m (1 ft) of lateral motion, summed across the two dollies--a value which essentially explains the whole of the increase in the transient high-speed offtracking measure, relative to the reference case.
- 3) The low steering friction condition results in a rather major amount of steer motion at the dolly axles such that the offtracking overshoot is substantially increased. The importance of the steering friction issue, per se, points up the significance of friction as the principal mechanism serving to limit the steer activity of common automotive style converter dollies. When the friction level reduces, the elastic, or spring-type devices which are used to achieve steer-centering on such dollies are basically incapable of keeping the steer motion within acceptable bounds. An extreme case involving a freely-steering dolly axle (not shown in the figure but presented in Appendix F, case 4.1 C 6.09), indicates a whopping-big transient high-speed offtracking value of 2.9 m (9.5

Influence of B-Dolly Characteristics on Transient High-Speed Offtracking in C Train Triples

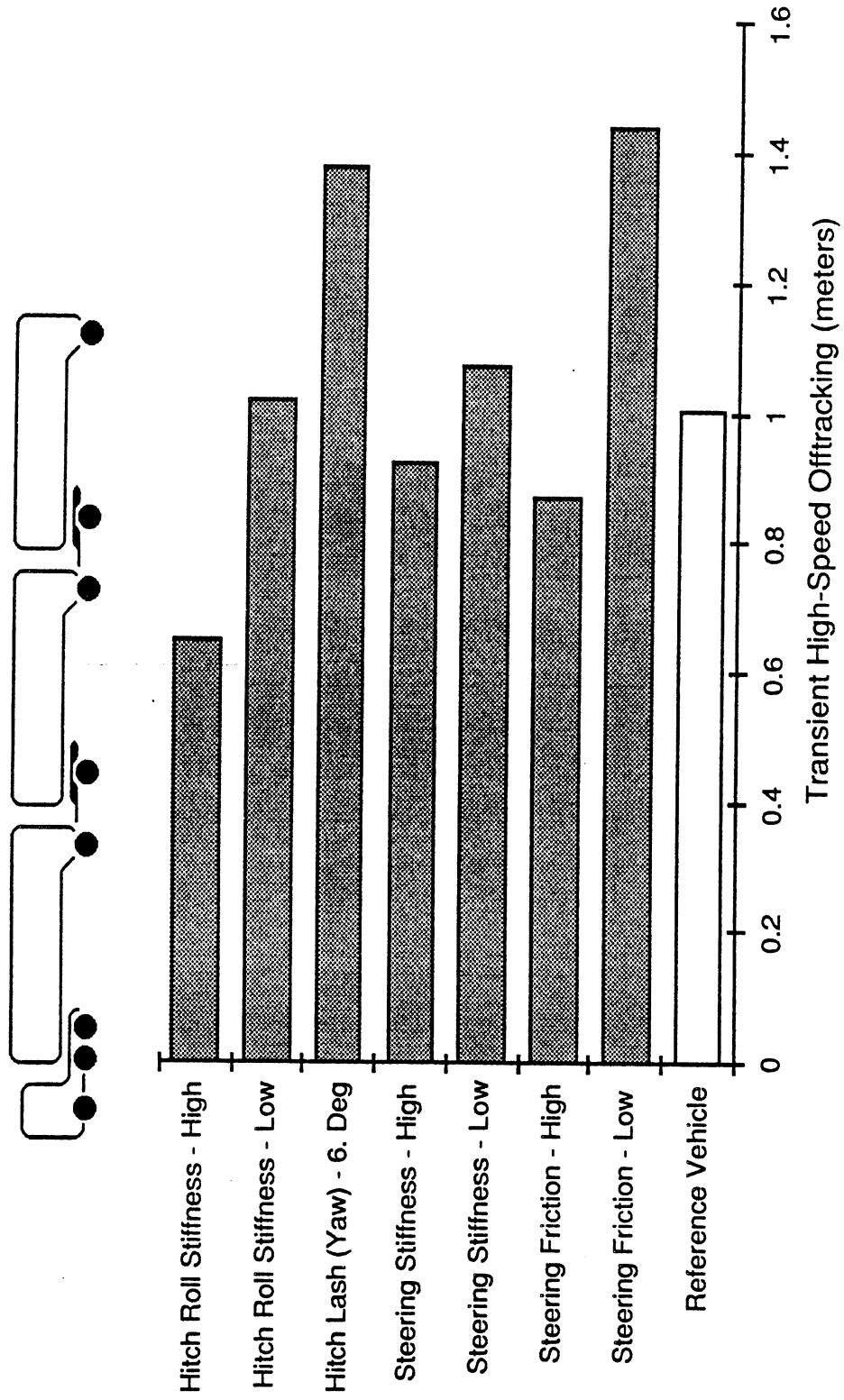

FIGURE 3.5.3.3.b

ft)! Such a result underscores the fact that the centering properties of the C-train dolly are highly significant to this performance measure, especially for triples.

- 4) The results obtained with either high steering stiffness or high steering friction give evidence that the C-train triple can be made to exhibit a more moderate level of transient high-speed offtracking when it becomes more nearly a B-train--that is when the steer action at the dolly axle becomes essentially rigid. This result shows an avenue for promise in achieving an overall attractive set of performance qualities of the triples combination.

3.5.4 Influence of Partial Loading. In Figure 3.5.4a are results showing the influence of various partial-loading cases on the load transfer ratio of A- and C-train triples. Although the results generally indicate that this measure of dynamic roll stability improves as load is removed from the trailers, one interesting variation from this norm is observed when the first two trailers of the C-train triple are empty and only the rear trailer is filled with freight. Namely, we see that the load transfer ratio more than doubles relative to the value obtained with the fully loaded C-train. The reason for this anomaly is that the rearward amplification of lateral acceleration of the C-train triple is still rather high in this maneuver (around 2.0) while the roll coupling of the dual-drawbar dollies acts to provide sharing of dynamic roll moments among the respective units of the vehicles. When only the rearmost trailer is loaded (a practice which is avoided in real service), the amplified lateral acceleration at the heavy rear trailer provides for a peak level of dynamic load transfer which approaches total load transfer on the otherwise very light set of trailers. Thus, one might say that a sufficiently heavy "tail" may succeed in wagging a rather light "dog."

Shown in Figure 3.5.4b are the corresponding influences of partial loading on the transient high-speed offtracking measure. The large value of this measure which is seen in the reference case reduces with virtually any change which reduces the total load on the vehicle. This outcome is again explained simply by the increase in normalized cornering stiffness which accompanies a reduced tire loading. Also note that the C-train condition having trailers #1 and #2 empty yields a much reduced level of transient high-speed offtracking, notwithstanding the anomalous level of load transfer ratio cited above.

Figure 3.5.4c provides a graphic illustration of the wholesale reductions in braking efficiency which accrue when axles are not uniformly loaded in proportion to the brake torque levels being developed. When a 50% payload weight is placed in either a forward-

Influence of Partial Loading on Load Transfer Ratio and Roll Margin in A and C Train Triples

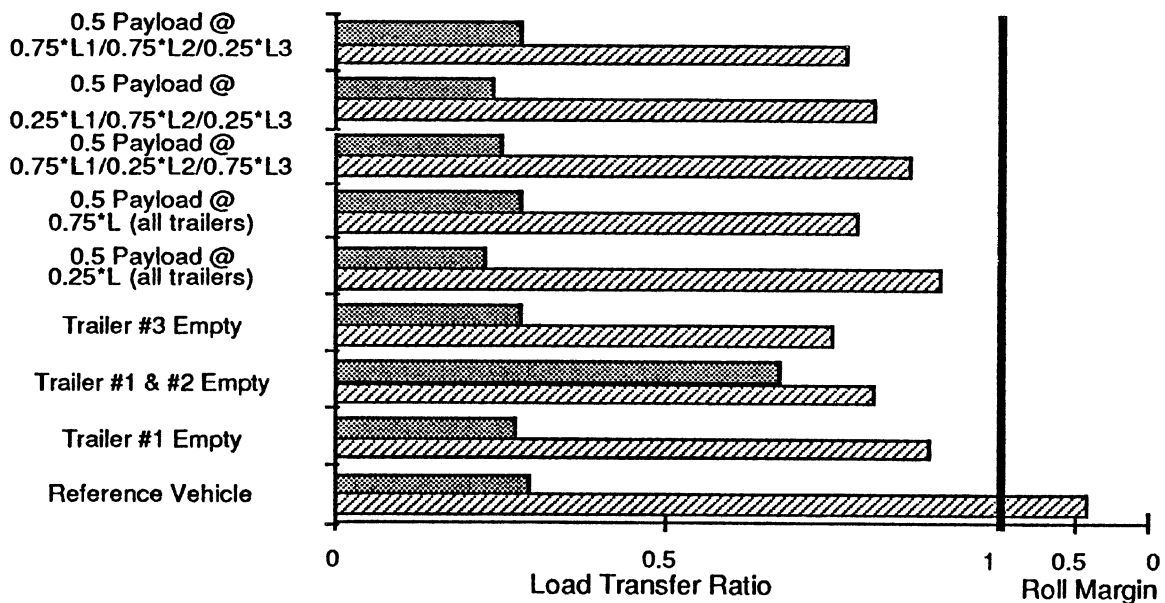
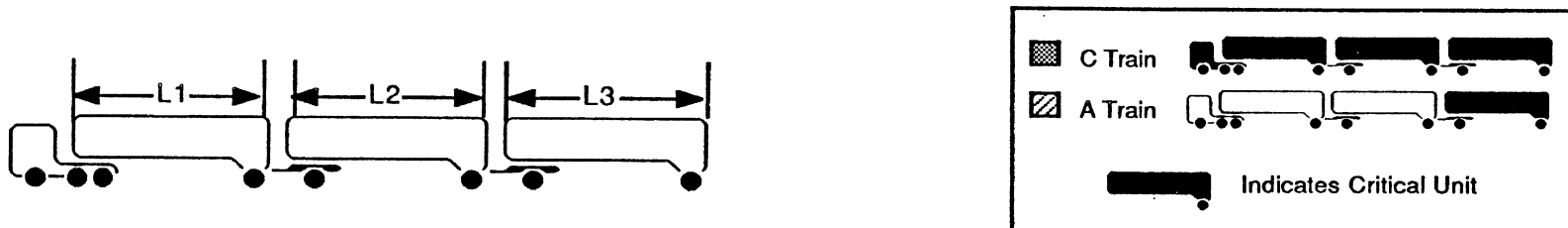

FIGURE 3.5.4.a

Influence of Partial Loading on Transient High-Speed Offtracking in A and C Train Triples

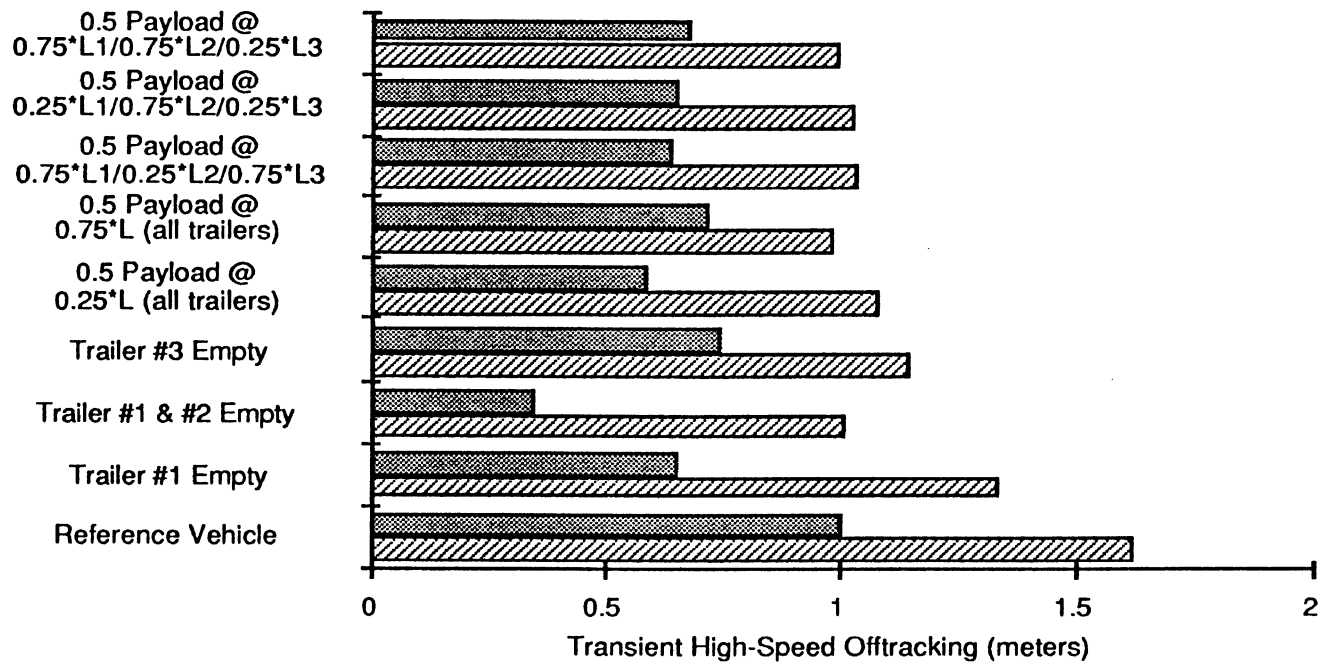
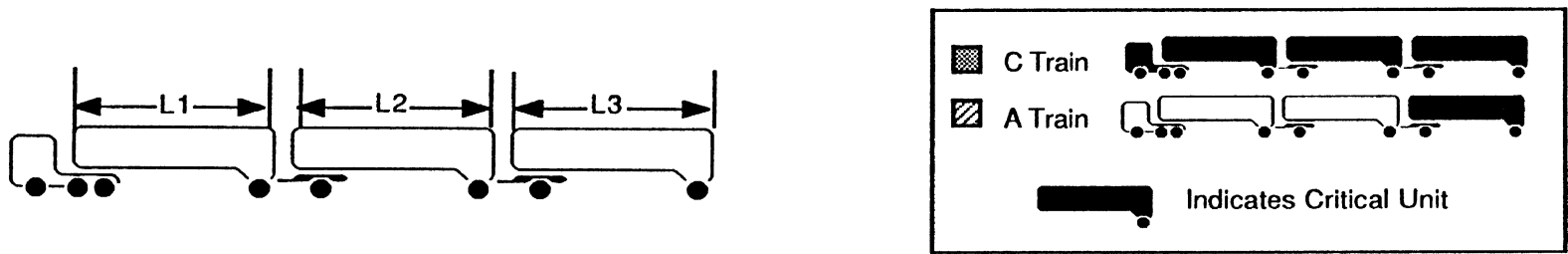
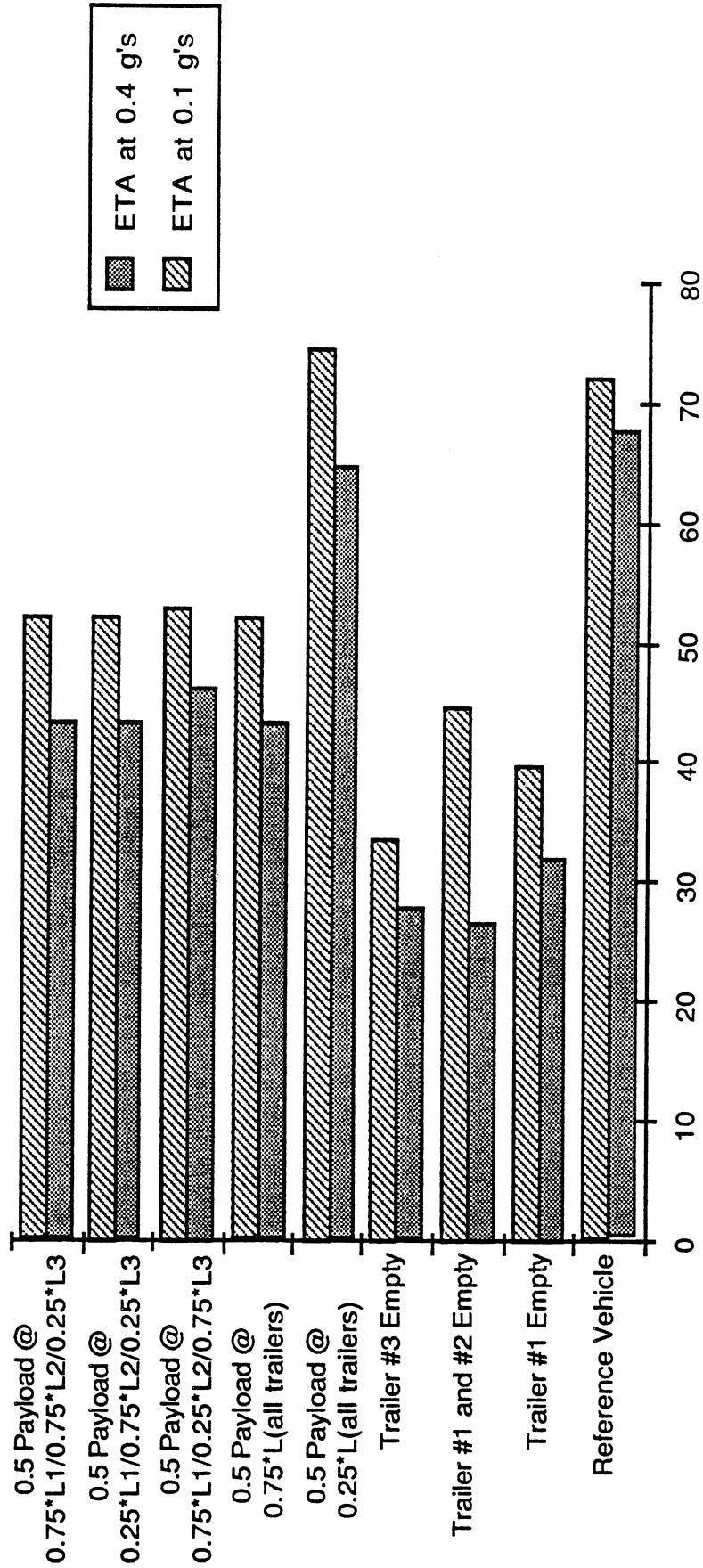
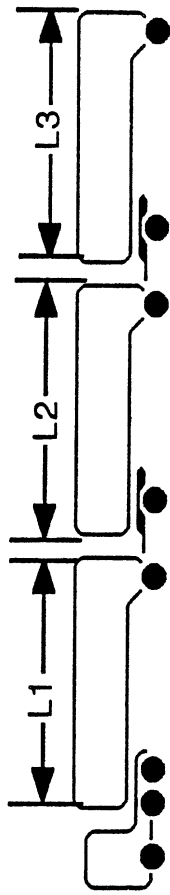

FIGURE 3.5.4. b

Influence of Partial Loading on Braking Efficiency in Triples



Braking Efficiency (%)

FIGURE 3.5.4.c

or aft-biased position on the trailers, the load is redistributed between dolly and trailer axles such that the braking efficiency level is reduced. In the top four illustrated bars in Figure 3.5.4c, the full trailers having the payload placed 0.75 L aft of the front wall of the trailer cause braking efficiency to be limited through underloading of the dolly axle. Since the dolly axle suffers a strong reduction in load with increased deceleration, a reduction in static weight at the dolly axle sets up a condition in which early lockup of the dolly wheels will occur. When the payload is placed rather forward in all three trailers, however, a substantial improvement in braking efficiency relative to the aft-biased loadings accrues since the otherwise critical dolly axles, as well as the underloaded tractor tandem, gain an increased fraction of the load. The reader should note, again, that the particular nature of these results, and the identification of "critical axle" positions can be altered simply through a redistribution of brake torque gains among the axles.

The partial loading conditions in which some trailers are empty while others are full produce the poorest levels of braking efficiency. For any of the cases in which at least one trailer is empty, the braking efficiency of the combination falls into the vicinity of 30% - a level which is exceedingly poor and which should be expected to result in frequent incidences of lockup at the lightly loaded axles [28]. Given that the carriage of an empty trailer at the rear of a triples combination is a common practice where triples are allowed, there is reason for concern that the braking performance of the vehicle in such a configuration is markedly deficient.

3.6 Productivity and Dynamic Performance Profiles for each of the Reference Vehicles

In this section, the general indicators of productivity and dynamic performance of each of the reference vehicle configurations is summarized by means of a diagram showing how much "better" or "worse" the respective performance qualities of the vehicle are than a fixed set of comparison performance values. Although these presentations provide a rather simplistic view of overall performance, they do give a handy means of identifying the strong and weak points in the productivity and performance characteristics of each vehicle. The simple productivity indicators presented here cover only the magnitude of the payload and do not reflect more subtle operating efficiencies which distinguish one vehicle type from the next. Also, the comparative performance levels shown here give a narrow view of the properties of each vehicle insofar as they only represent the reference, full load, condition.

3.6.1 Introduction of Reference Values. Nine measures are presented characterizing each vehicle on a normalized scale showing percentage better or worse than the reference value. By means of this format, the presentation does not introduce an absolute scale for "judgment" of vehicle performance, but simply assembles the differing qualities on one chart so that others can make their own judgments on the relative merits of each vehicle case. At the same time, the reference values for each performance measure have been selected so that they do collectively represent a crude "target" for performance, given current technology and the range of vehicle types of interest in Canada.

The reader will note, of course, that the respective measures of performance constitute a collection of very dissimilar characteristics which cannot be simply "averaged together." For example, if a vehicle exhibits such a large degree of low speed offtracking that it will not fit on the road system, it is probably not important that it otherwise shows a very high rollover threshold, or a high level of braking efficiency. Moreover, individual users of these data may well tend to apply differing emphases on the importance of one measure over another.

Each of the nine measures are discussed below, in terms of the rationale for selection of the "reference value" of the measure. Also, some reflections are offered for the interpretation of each measure.

- 1) Payload Volume - The volumetric envelope of the 14.6-m (48-ft) semitrailer was selected as a reference value for showing the contrast in payload volume from one vehicle to the next. The envelope is described by the outside dimensions of the freight "box," namely, 14.6 m (48 ft) long X 2.59 m (102 in) wide X 2.74 m (108 in) high. The height dimension assumes that the floor height of the trailer is 1.39 m (54 in) above the ground and that the overall height of the trailer is 4.11 m (13 ft, 6 in).

- 2) Payload Weight - The reference value for payload weight is equal to the 25 tonne (55,100 lbs) payload which is carried in the baseline 5-axle tractor-semitrailer combination. The payload weight reflects a gross combination weight of 39.5 tonne (87,060 lbs) and an assumed tare weight of 14.5 tonne (31,960 lbs). Together, the payload volume and weight values provide for assessing the nominal contrast in productivity between vehicles. It is recognized that some vehicles which are, perhaps, high in volumetric capacity relative to payload weight may appeal to the haulers of low-density commodities and thus offer substantial benefits for productivity in that application. Those typically hauling dense commodities, such as bulk liquids, will rate productivity with a focus upon the payload weight benefits. Moreover, greater values of payload weight and/or volume should imply a safety gain insofar as fewer truck-trips will be needed to carry the same quantity of freight, thus reducing accident exposure.

- 3) Braking Efficiency - The reference braking efficiency level was placed arbitrarily at 70% and applies to a deceleration level of 0.4 g's. Although the computed values for this measure are included here, the authors recognize that these results provide a greatly simplified view of braking performance. In practical terms, these results only serve to identify a few cases in which the tractor tandem axles are peculiarly over- or under-loaded in the vehicle combination such that, lacking special treatment of brake torque gain (which seems to be rarely done in practice), would render the vehicle lower in braking efficiency capability. The reader will note that braking efficiencies were not computed for any vehicles having more than two axles in a group. Also, please note the data presented in Section 3.1 regarding the braking efficiencies of differing reference vehicles in their unladen condition. While it is clear that braking efficiencies are typically lower in the unladen vs. laden state, the absolute levels of braking efficiencies

for empty vehicles are seen as even less dependent upon weights and dimensions constraints than in the loaded state and, instead, more dependent upon the design philosophy which distributes brake torque gains.

- 4) Friction Demand in a Tight Turn - The friction demand measure was given a reference value of 0.10. This value is suggested as a reasonable target for a maximum level. That is, for vehicles which demand greater than a 0.10 value of tire/road friction during tight turning, it is expected that incidents of tire force saturation, with potential for loss-of-control, will occur at tractor drive axles on ice- or snow- covered surfaces. This reference level reflects concern for the need to simultaneously generate longitudinal forces for accelerating the vehicle through an intersection turn, as well as the lateral forces which arise from the conflicts of turning multiple non-steered trailer axles. A frictional coefficient of 0.2 for snow-covered pavement [29] has been assumed. Since the Canadian environment is characterized by an extensive period of wintery driving conditions each year, the need to keep friction demand performance within the rather low value of 0.1 may be particularly compelling.

- 5) Low-Speed Offtracking - The reference value for low-speed offtracking has been set at 6.00 m (19.7 ft). As defined in Section 2.3, the low speed offtracking measure is premised upon a 90-degree turn using a reference arc of 11 m (36 ft) radius. The 6-m (20-ft) value for reference performance was selected recognizing that such a performance essentially "consumes" all of the available space which was originally designed into intersections which are common in the general U.S. (and, it is assumed, Canadian) road system. The highway design protocol employed in this assumed "common" intersection is defined in the policy of the American Association of State Highway and Transportation Officials (AASHTO), using a WB-50 design vehicle.[22] The 6 meter offtracking performance implies that all of the right- and left-boundary margins incorporated in the advisory design policy are "used up" and the vehicle must operate at the extremities of the provided pavement in order to make a right-hand turn.[20] It is suggested that vehicles registering "worse" than the 6-m (20-ft) performance level be looked upon as severely pressing the geometric limits of the general road system.

- 6) Amplification-Induced Transient Offtracking - The transient overshoot in offtracking is seen as indicating a potential for collision, curb-strike, or intrusion

off of the paved roadway resulting from a rapid path-change maneuver. In a broader sense, it reveals a vehicle property that may be excited to some degree in response to any abrupt steer input at highway speed. A value of 0.8 m (2.6 ft) has been arbitrarily selected as the nominal mid-range of performance by vehicles examined in this study. While no specific guidance can be given for scaling the importance of this measure, it seems that high values should be looked upon as a matter of safety concern, especially for vehicles that may be operated in dense traffic at highway speeds.[21]

- 7) Amplification-Induced Rollover - The load transfer ratio measure has been used to indicate the potential for amplification-induced rollover, using a reference value of 0.60. This value is arbitrarily selected as representing, again, a mid-range level that is achieved only by roll-coupled vehicle combinations. Recognizing that substantial evidence exists implicating higher amplification tendencies in rear-trailer-rollover accidents [12,30,31,32], elevated levels of this measure should be looked upon as forecasting a potential for rollover in dynamic steering maneuvers.

(It should be noted that some operators may compensate for poorly-performing vehicles by placing their best drivers on those vehicles. While the net safety record of such driver/vehicle systems may be as good or better than average, the vehicle part of the system is still poor. Thus, one could surmise that the safety record of those good drivers in better-performing vehicles would have been even better.)

- 8) High Speed Offtracking - Although the steady-state measure of high speed offtracking is somewhat redundant to the transient value, there are sensitivities of each that are not common to the other. Thus, this measure is included in the overall vehicle profiles as a supplement to the other information. A value of 0.46 m (18 in) has been arbitrarily selected to depict the condition in which a minimal clearance of 0.15 m (6 in) remains between the trailer tires and the outside of a 3.66 m- (12 ft)-wide conventional traffic lane, with a 2.44 m- (96 in)-wide tractor following a path down the centerline of the lane. This reference condition provides some registry on the relative threat of curb strike which may be experienced during operation at a moderate level of lateral acceleration through, say, a curved freeway exit ramp.

9) Static Rollover Threshold - Although it is recognized that a wide range of rollover threshold values can ensue from differing payload placements, the measure presented here is useful for illustrating the general influence of the combined weight and volume capacities of each vehicle on roll stability. The reference value of 0.4 g's was arbitrarily selected to represent a mid-range performance. As stated earlier in the text, while there is a clear, powerful, relationship between rollover threshold level and the likelihood of involvement in rollover accidents, this property does not generally distinguish one basic vehicle configuration from another (unless the weight/volume characteristic strongly drives the mass center of the typical loading condition upwards). Rather, individual vehicles vary greatly in static rollover threshold as a result of loading and the variety of design details influencing roll compliances.

3.6.2 Presentation of Profiles. On the following pages, Figures 3.6.2a through 3.6.2v present graphical illustrations of the performance profiles for each of the 23 reference vehicle configurations. The reader will note that certain entries in the various charts are identified by an asterisk indicating that the value of the entry was estimated. Estimations were necessary in a few cases because of special computational difficulties and to avoid the computation of trivial results that could be directly estimated. The following specific estimation items appear:

- The friction demand level produced by a single-axle trailer is estimated to be equal to 0.00, recognizing that the only mechanism contributing to the friction demand measure, as defined, is the yaw-resistive moment arising from the scrubbing of the dual-tire pair. [19]
- The friction demand level prevailing with a vehicle configuration having an identical axle layout but slightly differing loads than those of a corresponding vehicle was estimated to be equal to the demand level computed on the corresponding vehicle. (For example, the friction demand performance of an A-train triple was made equal to that of the corresponding A-double, despite slight differences in axle load. Note that the friction demand measure involves an interaction only between the tractor and lead semitrailer such that differences in other A-train trailers is superfluous).
- The static rollover thresholds of C-train doubles were made equal to the performance levels for corresponding A-train doubles.

- The low-speed offtracking for C-train triples was extrapolated from that of the corresponding A-train triples, using a technique of pro-rating the differences between A- and C-train performances seen with corresponding doubles.
- Likewise, the high-speed offtracking for C-train triples was extrapolated from that of corresponding A- triples, using a scaled pro-rating of the contrast in A- vs. C- performance seen with doubles.

The figures presenting the performance profile for each vehicle appear on subsequent pages in the following order:

Figure Number	Vehicle Description
3.6.2a	Baseline Tractor and 2-Axle Semitrailer
3.6.2b	Tractor and Close-Tridem Semitrailer
3.6.2c	Tractor and Wide-Spread 3-Axle Semitrailer
3.6.2d	Tractor and Quad-Axle Semitrailer
3.6.2e	Tractor and Belly-Axle Semitrailer
3.6.2f	Baseline 8-axle Doubles (A-Train)
3.6.2g	Baseline 8-Axle Doubles (C-Train)
3.6.2h	6-Axle Doubles (A-Train)
3.6.2i	6-Axle Doubles (C-Train)
3.6.2j	Mixed 7-Axle Doubles (A-Train)
3.6.2k	Mixed 7-Axle Doubles (C-Train)
3.6.2l	Turnpike Doubles
3.6.2m	Rocky Mountain Doubles (A-Train)
3.6.2n	Rocky Mountain Doubles (C-Train)

3.6.2o	Baseline 8-Axle B-Train
3.6.2p	7-Axle B-Train
3.6.2q	6-Axle B-Train
3.6.2r	Belly-Axle B-Train
3.6.2s	Baseline 8-Axle Triples (A-Train)
3.6.2t	Baseline 8-Axle Triples (C-Train)
3.6.2u	11-Axle Triples (A-Train)
3.6.2v	11-Axle Triples (C-Train)

The charts are presented without further comment here, although the reader is referred back to the discussion in Section 3.1 for explanations of the differences in stability and control among the various reference configurations. Conclusions to be drawn from the contrasting profiles are included within the various statements presented in Section 5.0

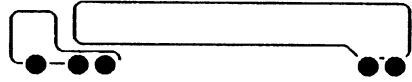

Baseline Tractor and 2-Axle Semitrailer

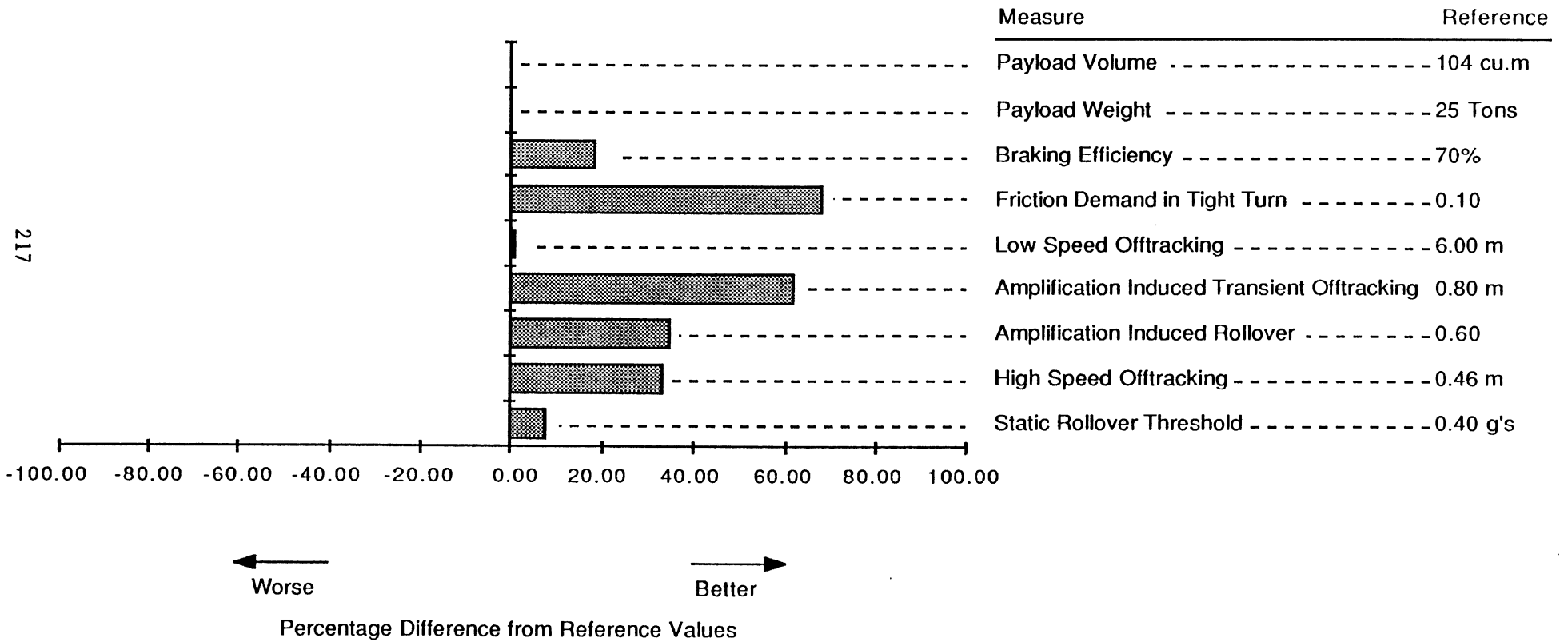
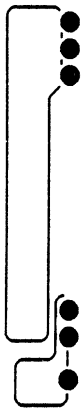

FIGURE 3.6.2.a



Tractor and Close-Tridem Semitrailer

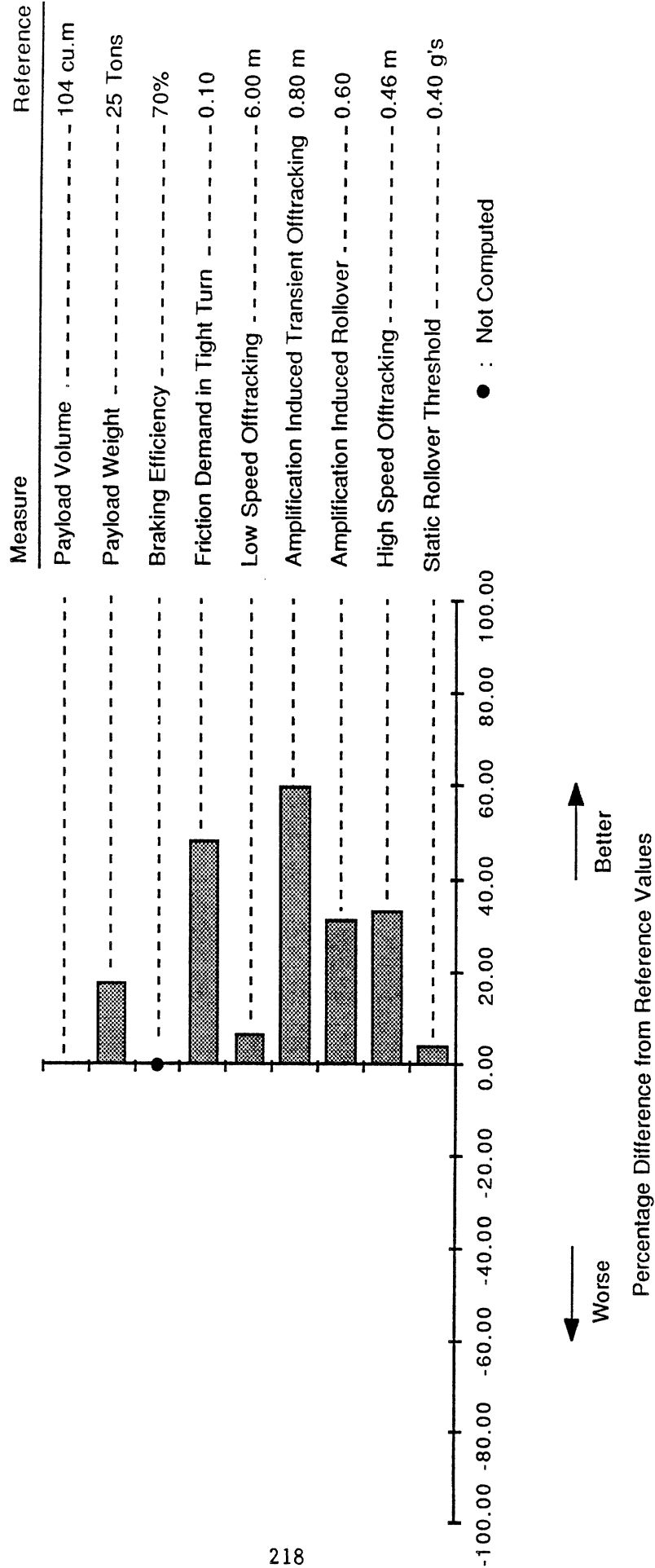
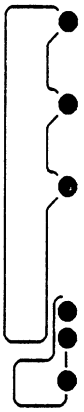
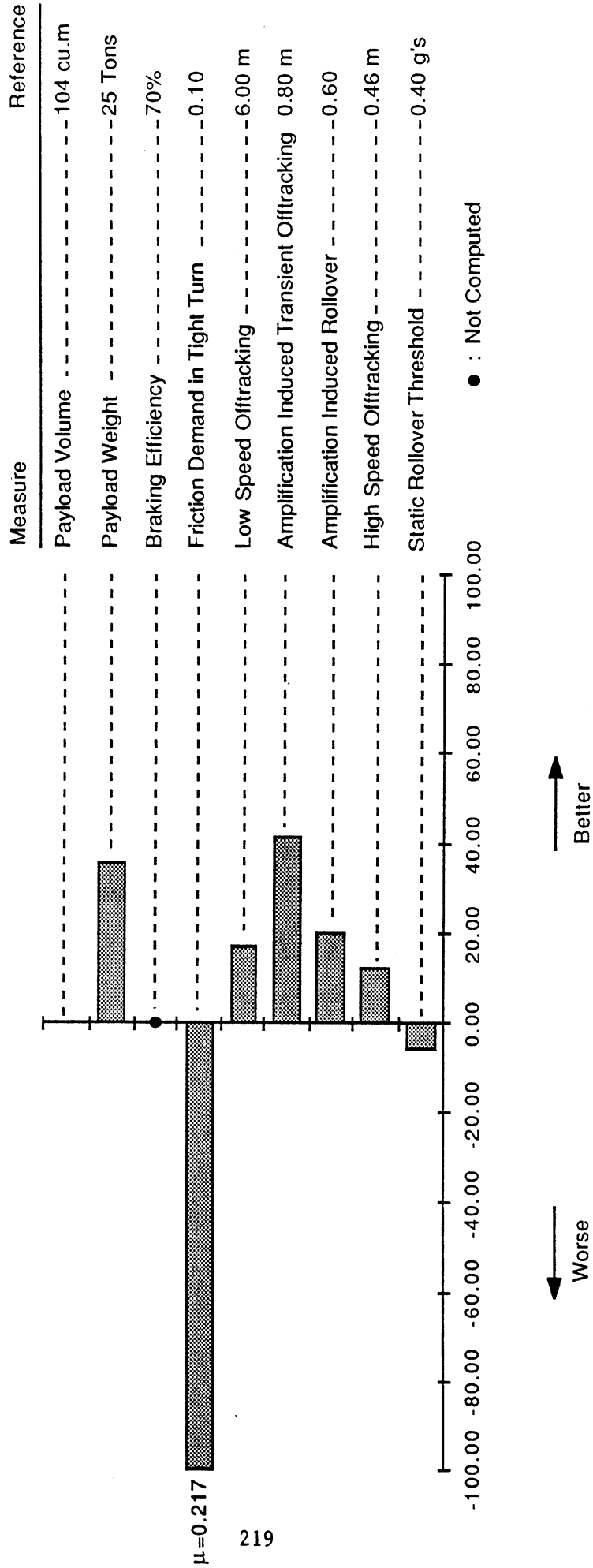

FIGURE 3.6.2.b



Tractor and Wide-Spread 3-Axle Semitrailer



Percentage Difference from Reference Values

FIGURE 3.6.2.c



Tractor and Quad-Axle Semitrailer

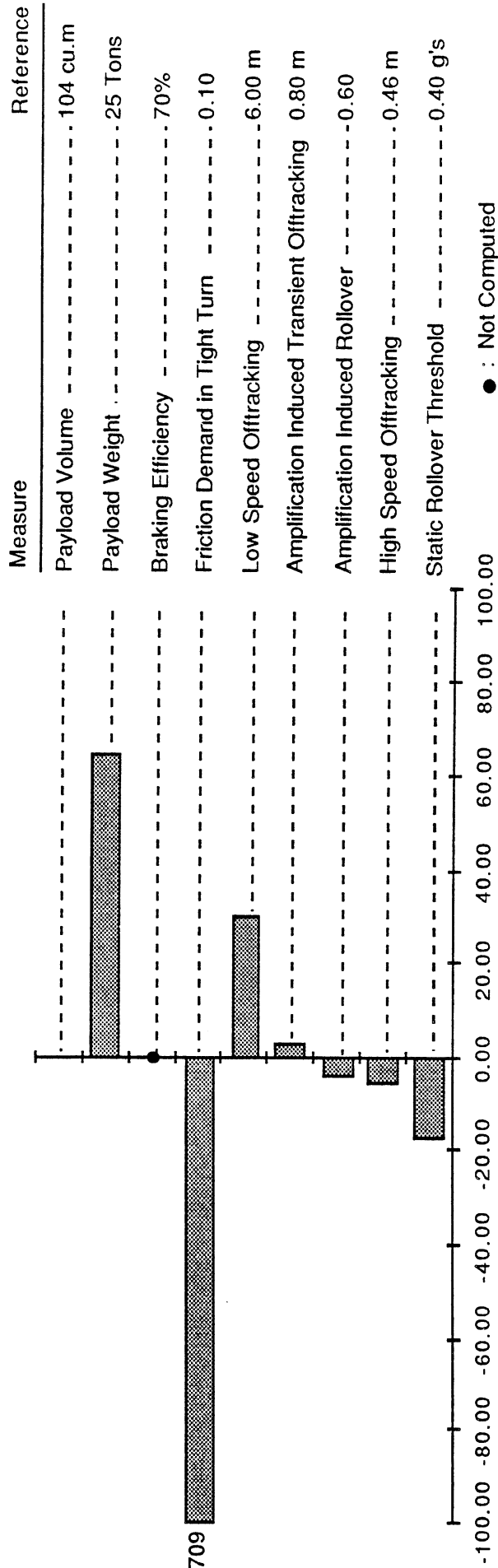

$\mu=0.709$
220

Worse → Better
Percentage Difference from Reference Values

FIGURE 3.6.2.d

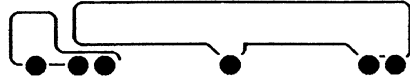

Tractor and Belly-Axle Semitrailer

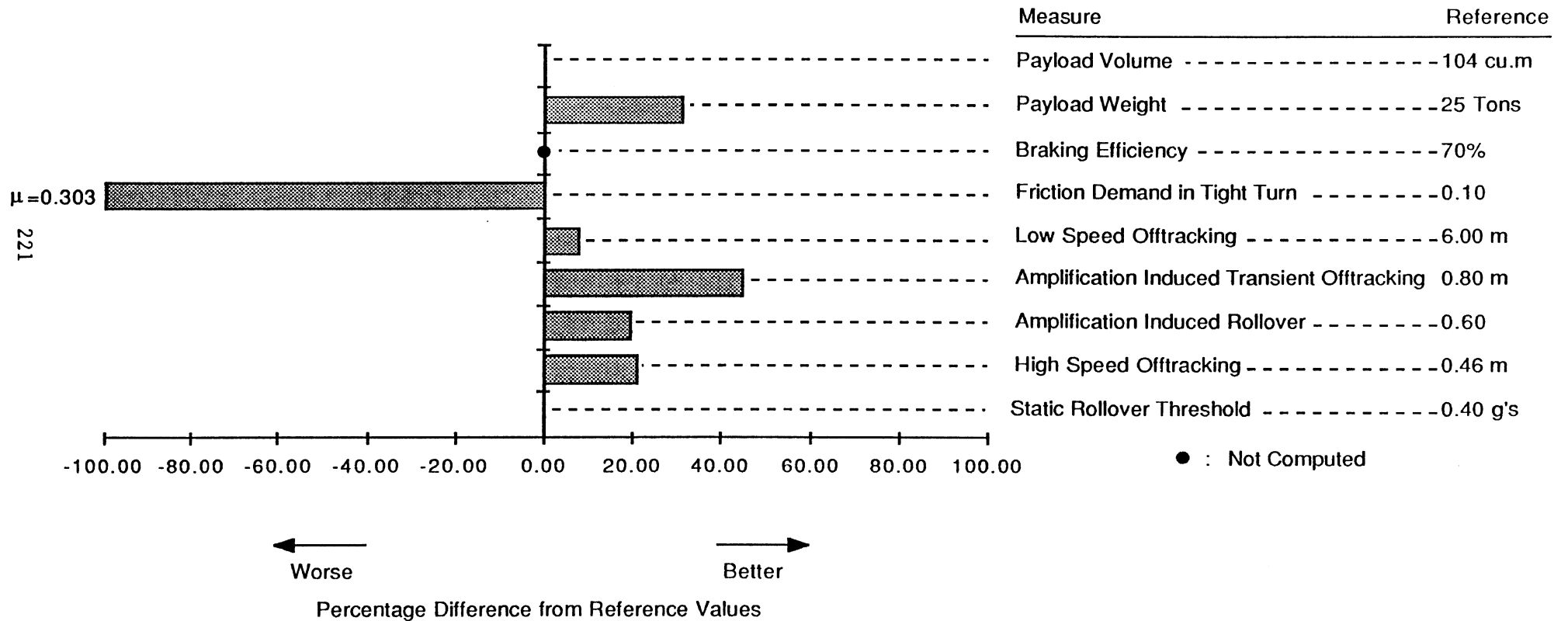
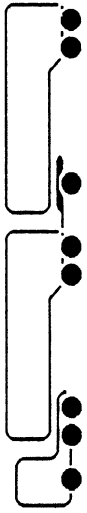

FIGURE 3.6.2.e



Baseline 8-Axle Doubles (A-Train)

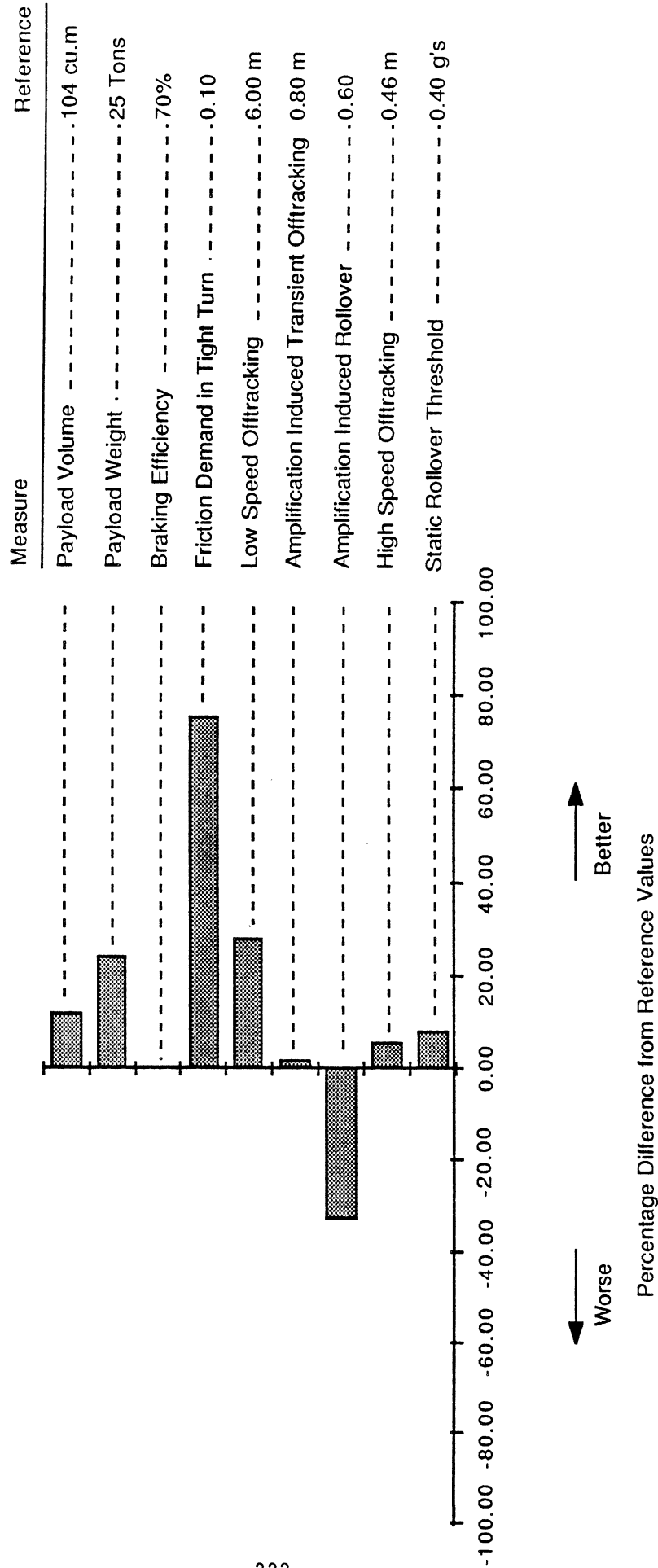

FIGURE 3.6.2.f



Baseline 8-Axle Doubles (C-Train)

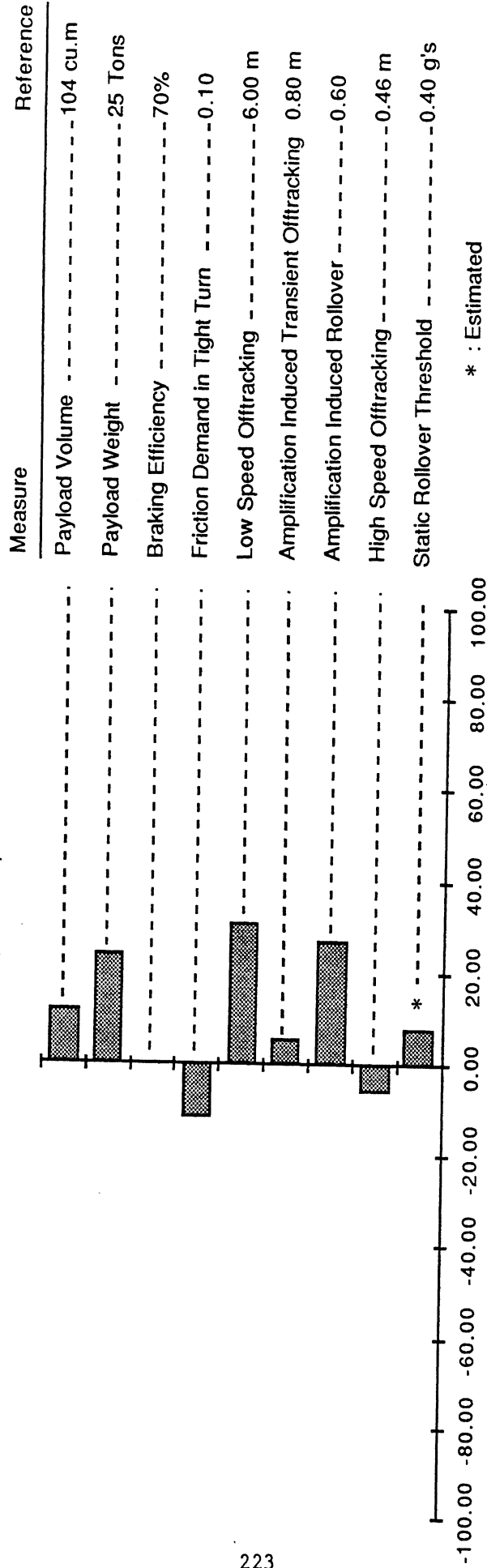
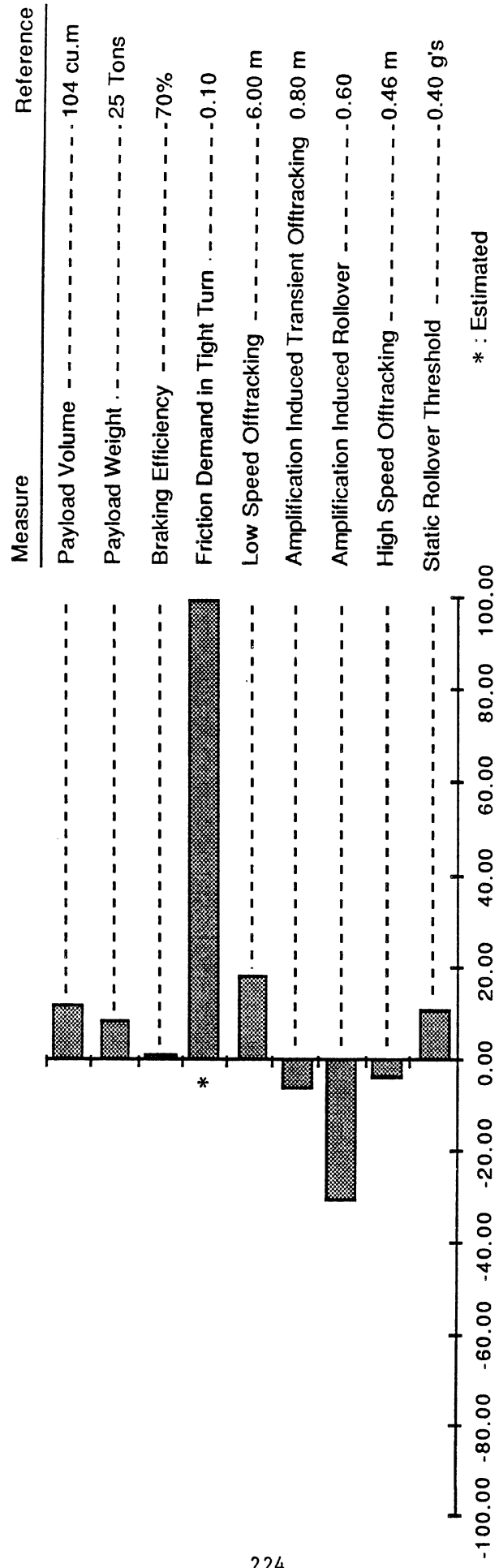

FIGURE 3.6.2.g



6-Axle Doubles (A-Train)



Worse ← Better

Percentage Difference from Reference Values

FIGURE 3.6.2.h



6-Axle Doubles (C-Train)

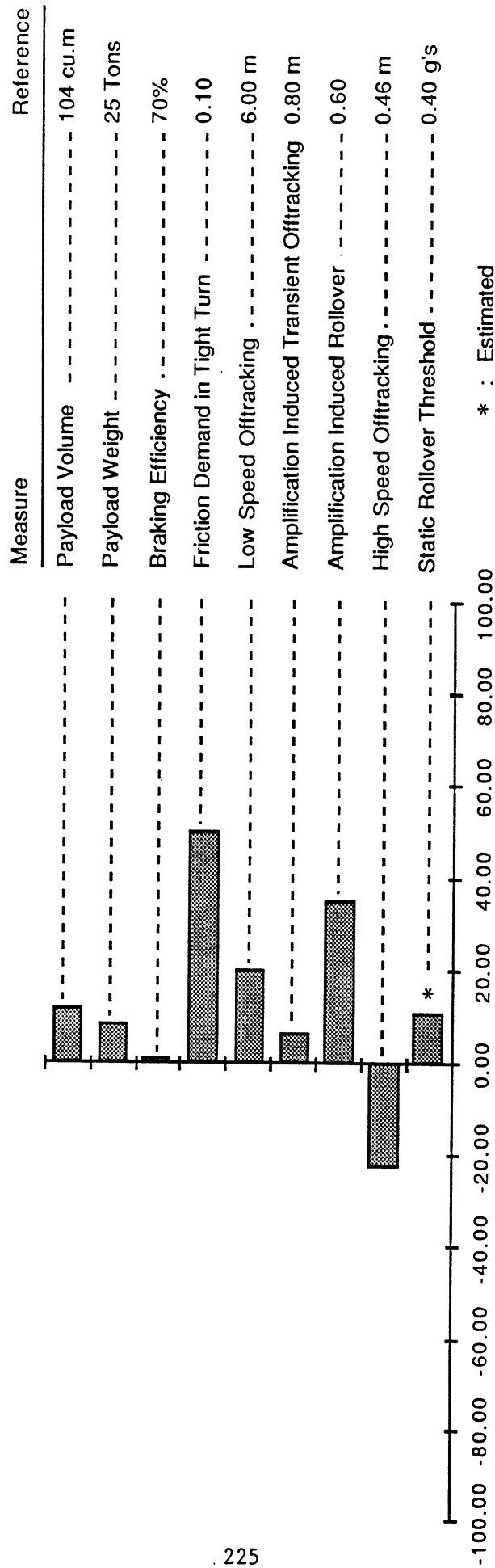

Worse → Better
Percentage Difference from Reference Values

FIGURE 3.6.2.i



Mixed 7-Axle Doubles (A-Train)

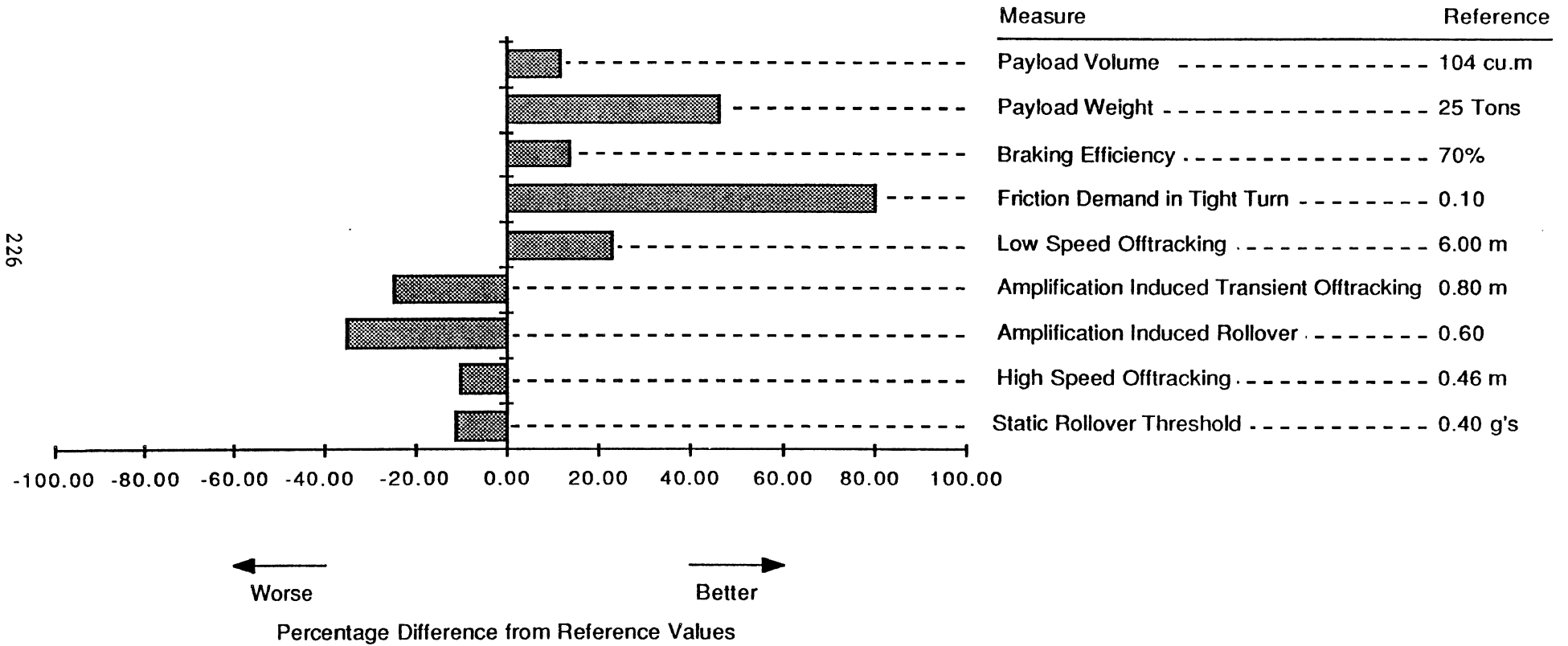
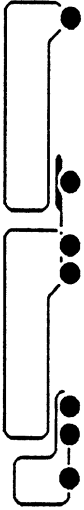

FIGURE 3.6.2.j



Mixed 7-Axle Doubles (C-Train)

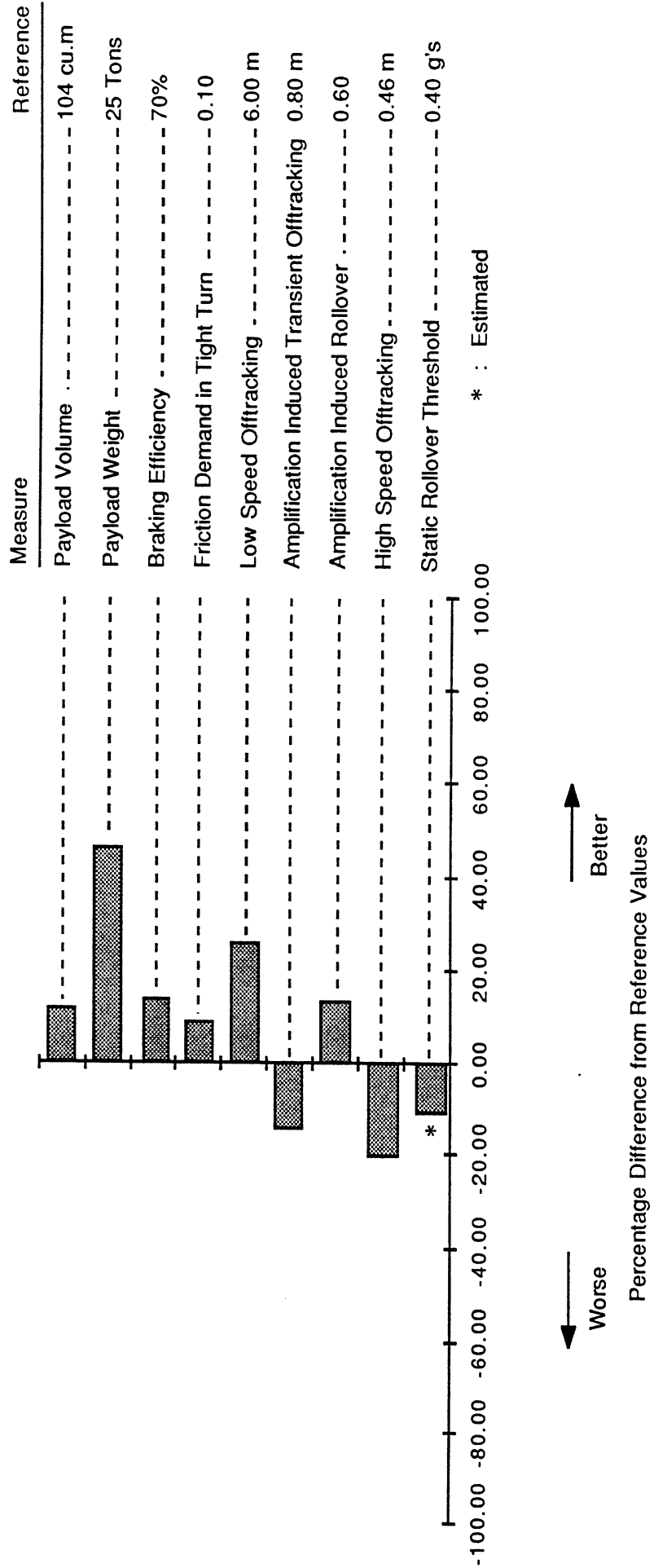
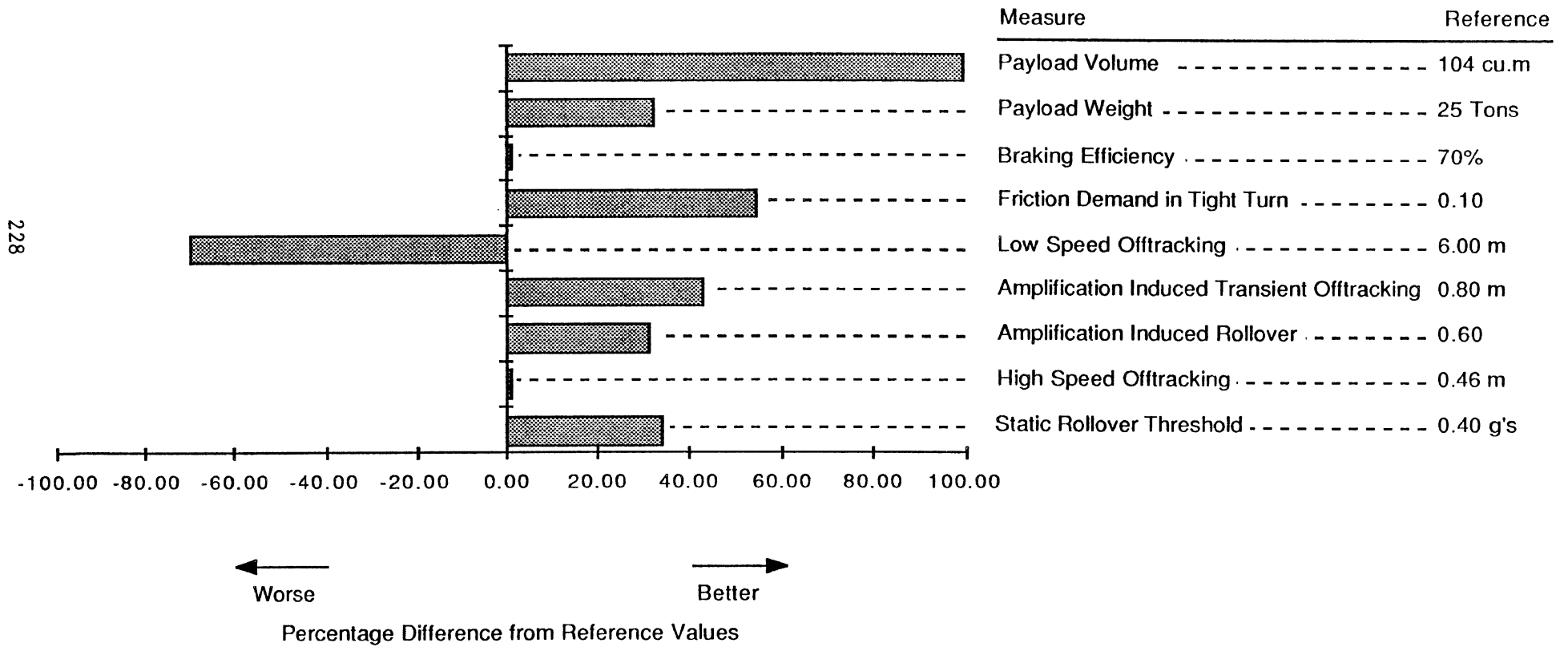

FIGURE 3.6.2.k



Turnpike Doubles



228

FIGURE 3.6.2.1

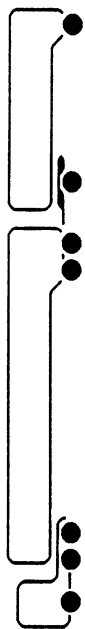

Rocky-Mountain Doubles (A-Train)

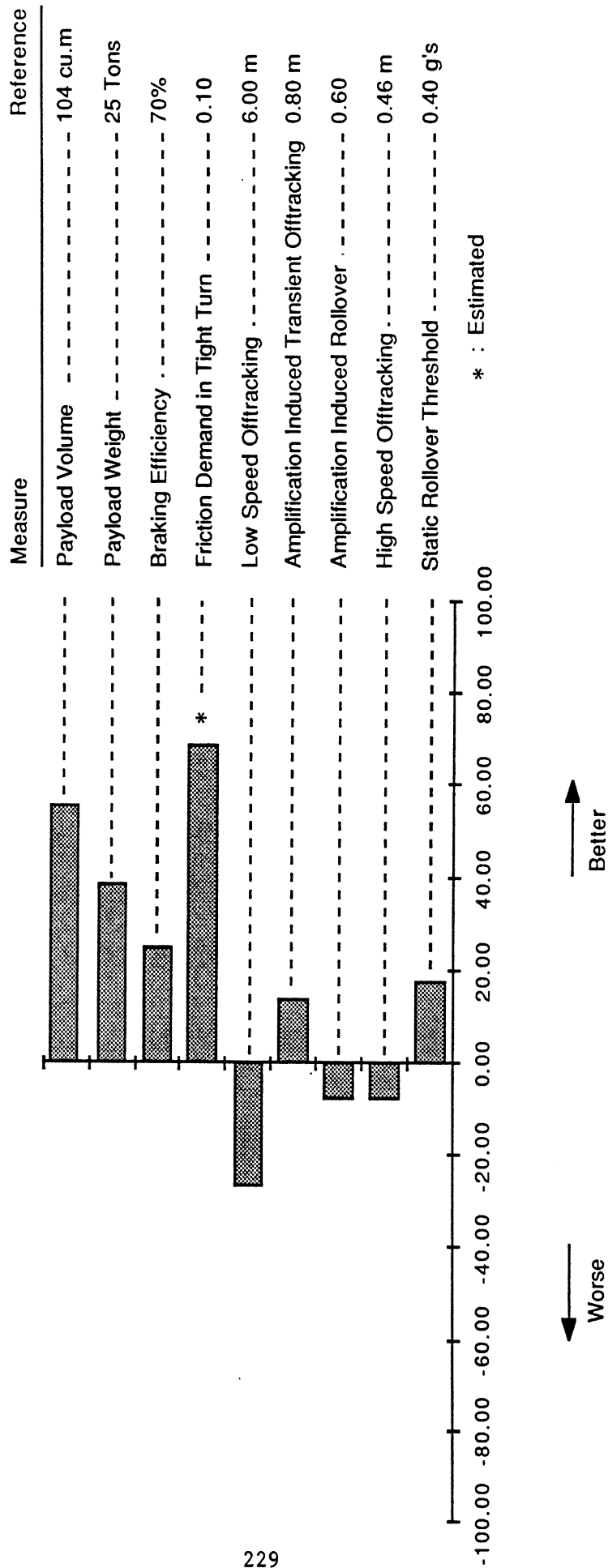

Percentage Difference from Reference Values

FIGURE 3.6.2.m

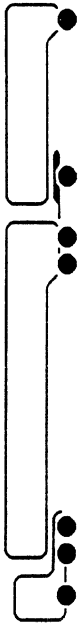

Rocky-Mountain Doubles (C-Train)

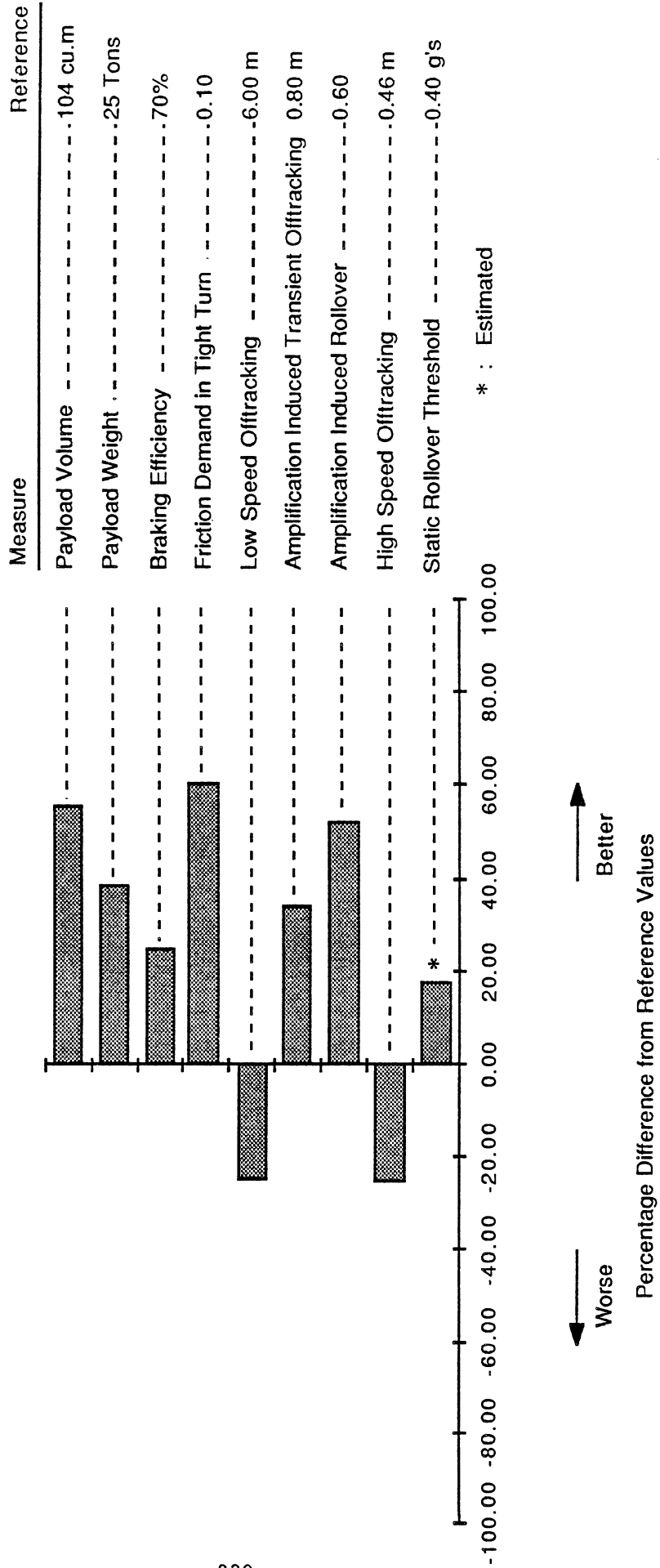

FIGURE 3.6.2.n



Baseline 8-Axle B-Train

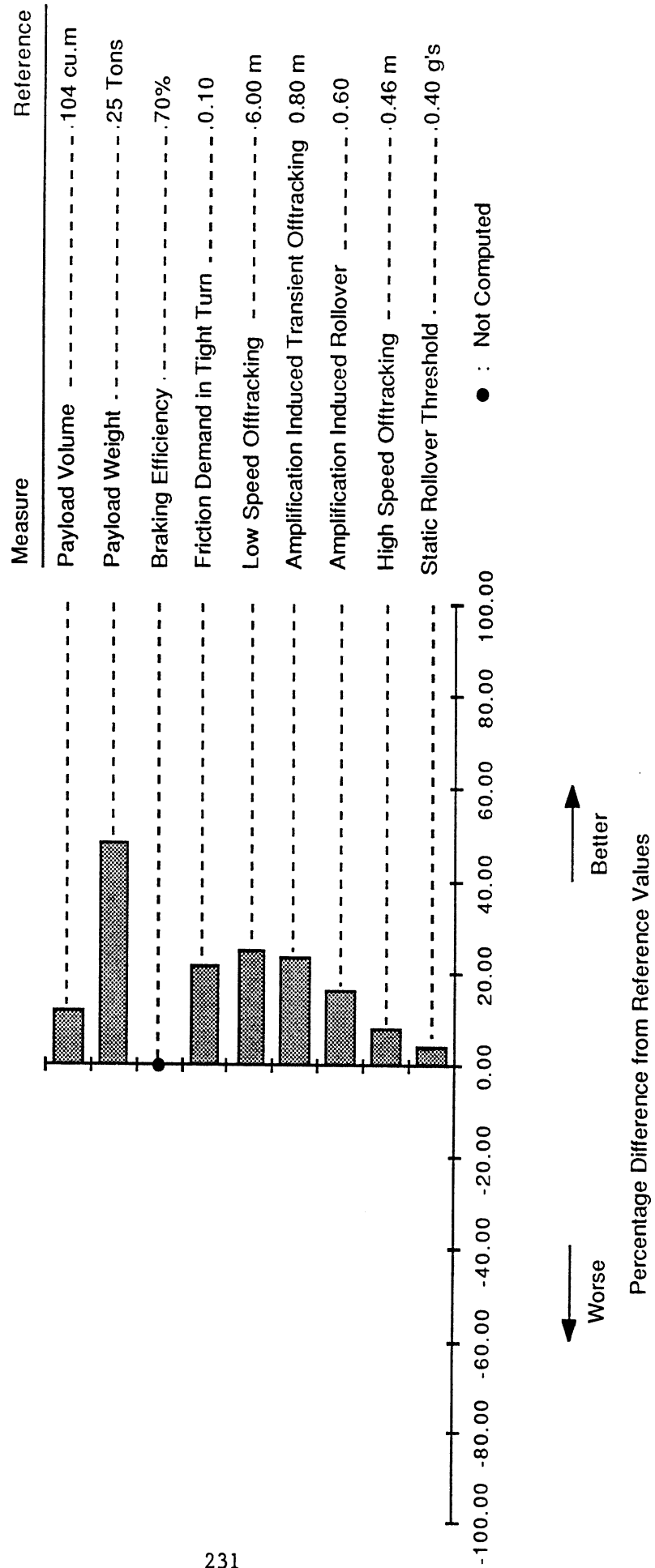
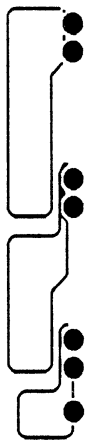
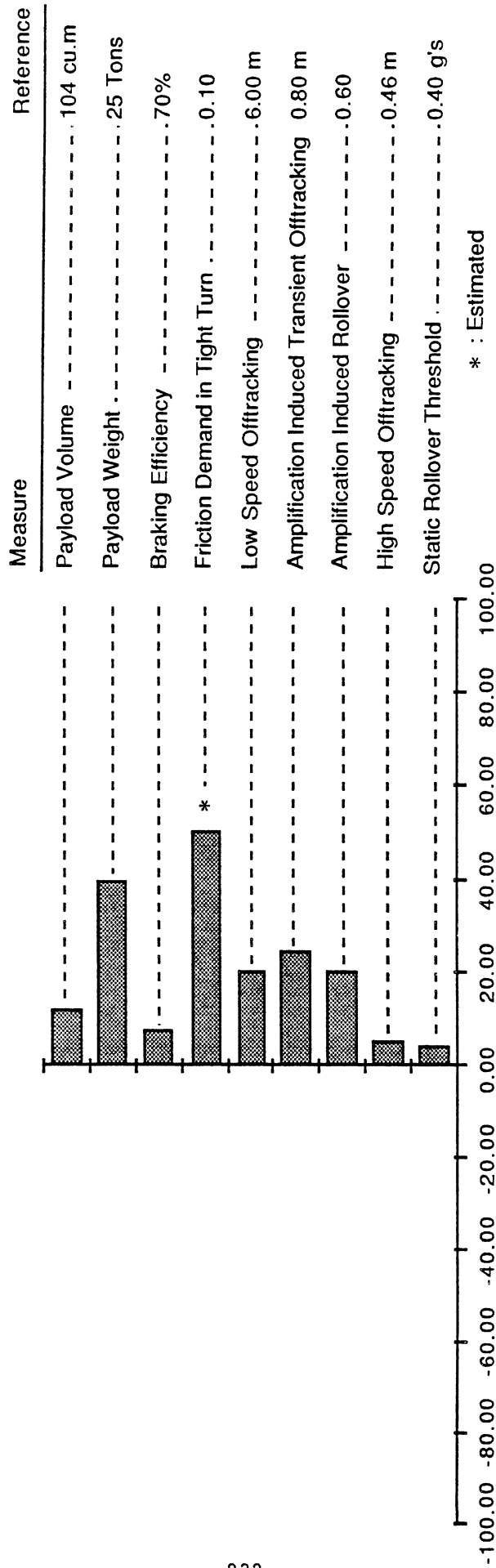

FIGURE 3.6.2.0



7-Axle B-Train



Worse → Better
Percentage Difference from Reference Values

FIGURE 3.6.2.p



6-Axle B-Train

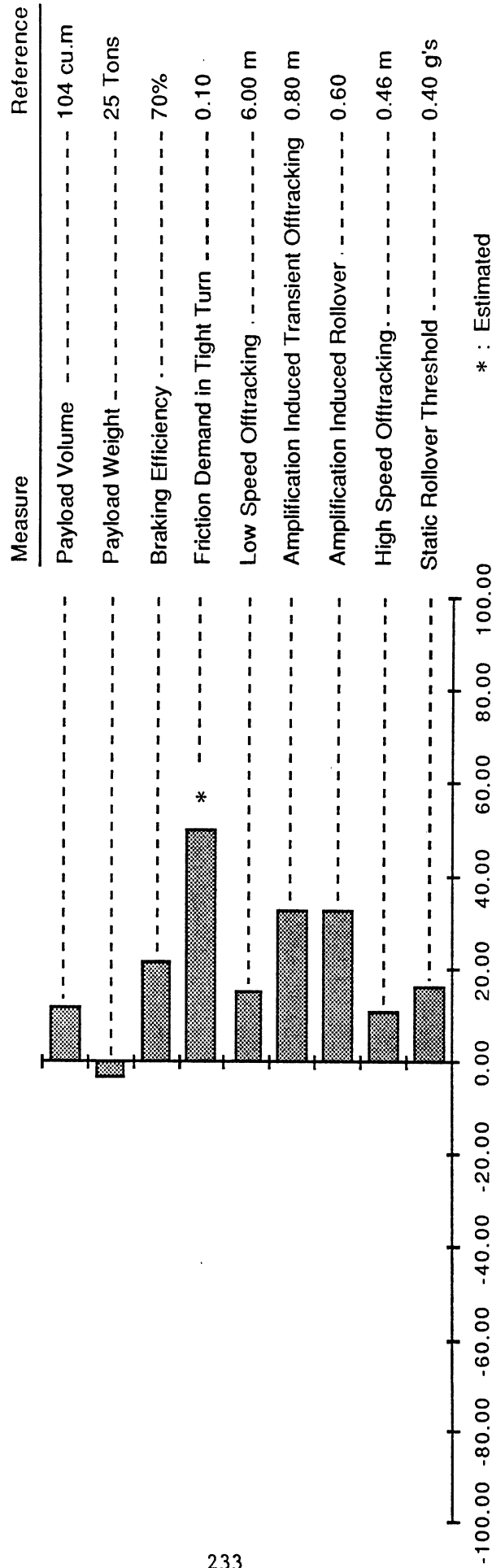

Worse → Better
Percentage Difference from Reference Values

FIGURE 3.6.2.q



Belly-Axle B-Train

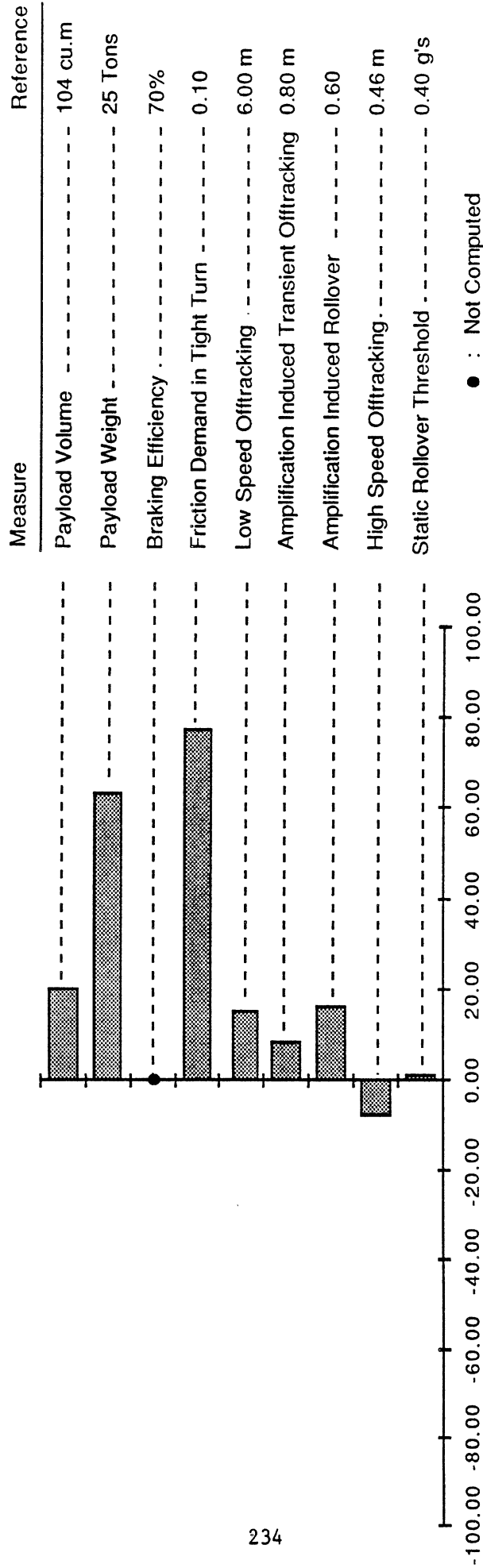

Worse → Better

Percentage Difference from Reference Values

FIGURE 3.6.2.r



Baseline 8-Axle Triples (A-Train)

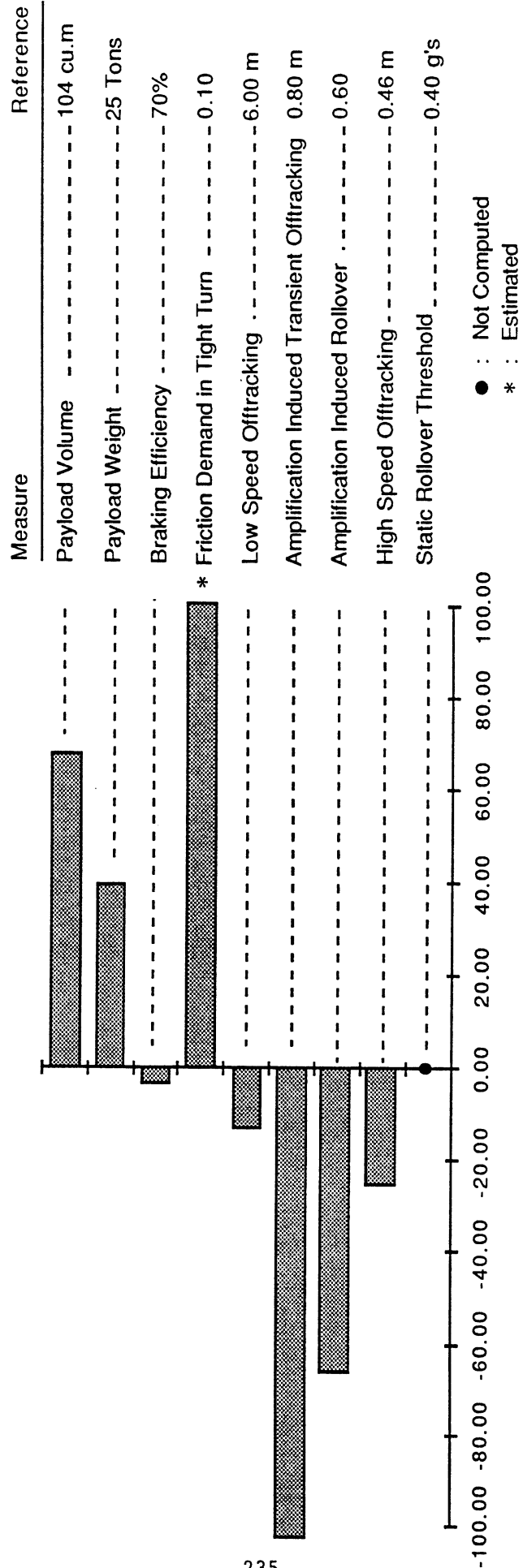

Worse ← Better →

Percentage Difference from Reference Values

FIGURE 3.6.2.s

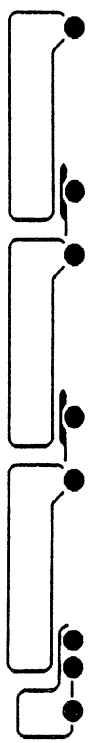

Baseline 8-Axle Triples (C-Train)

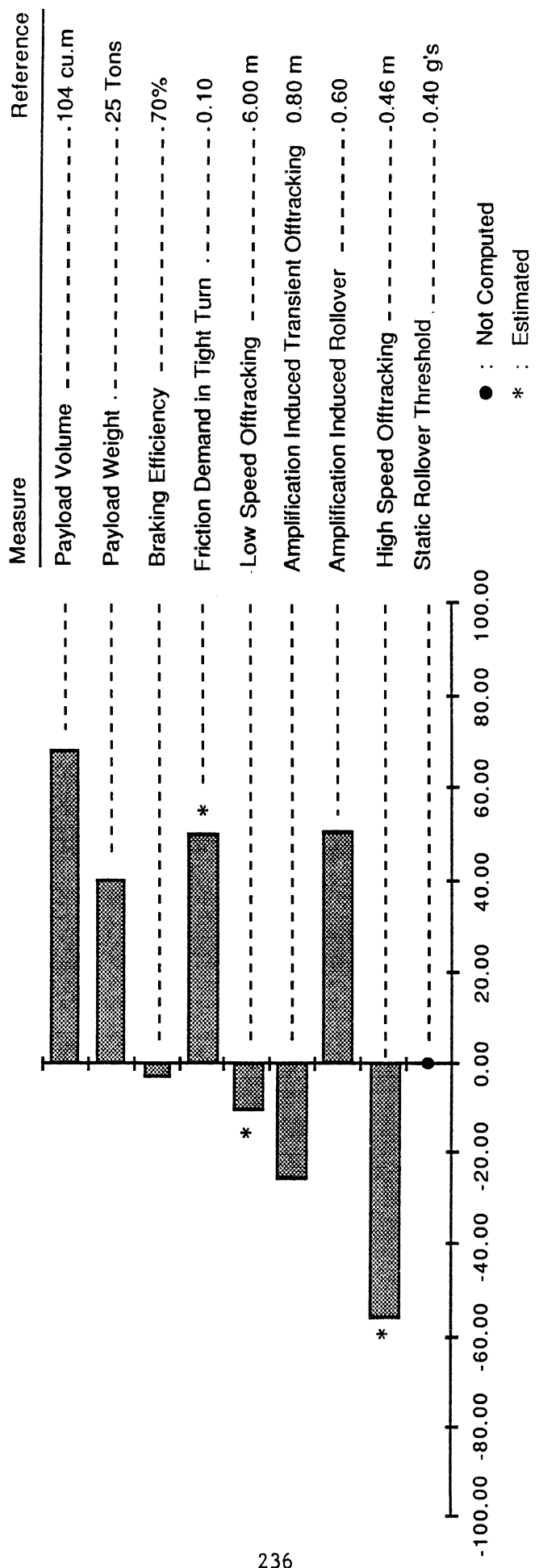

Worse ← Better

Percentage Difference from Reference Values

FIGURE 3.6.2.t

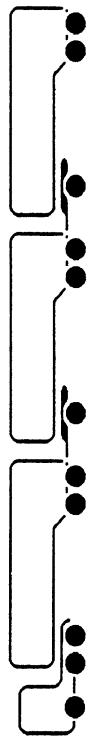

11-Axle Triples (A-Train)

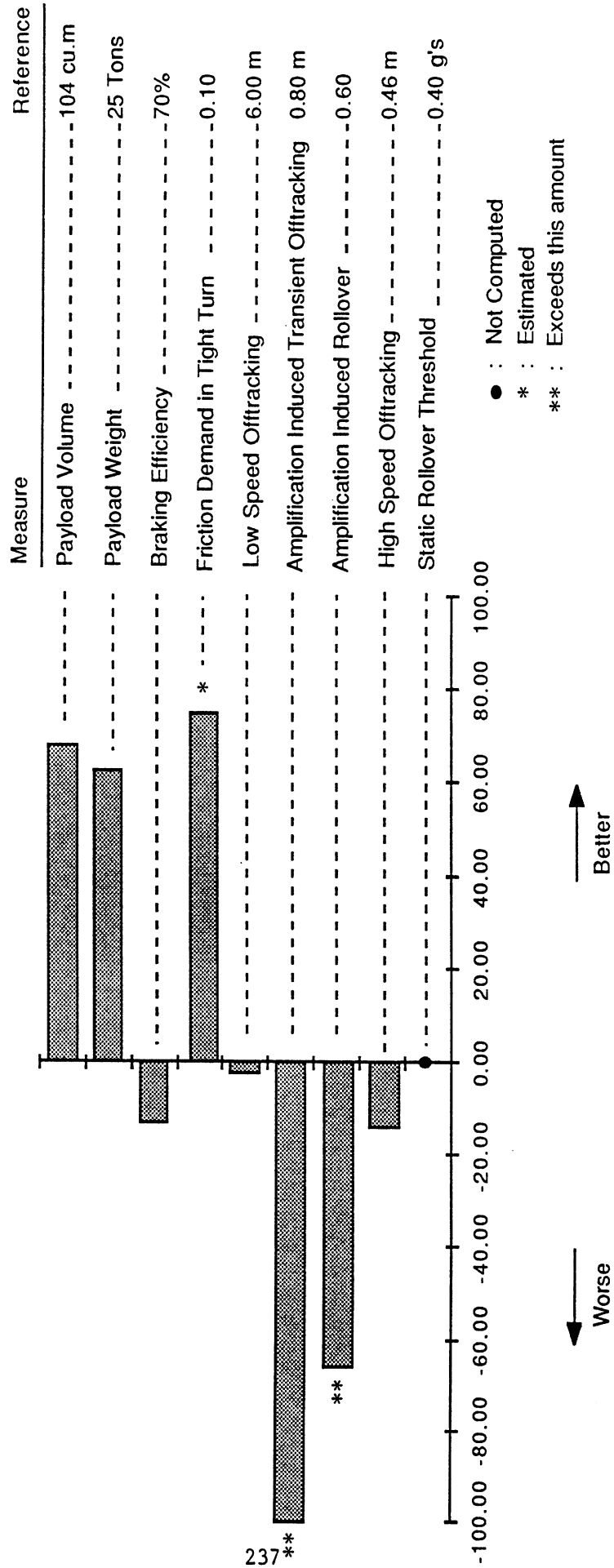
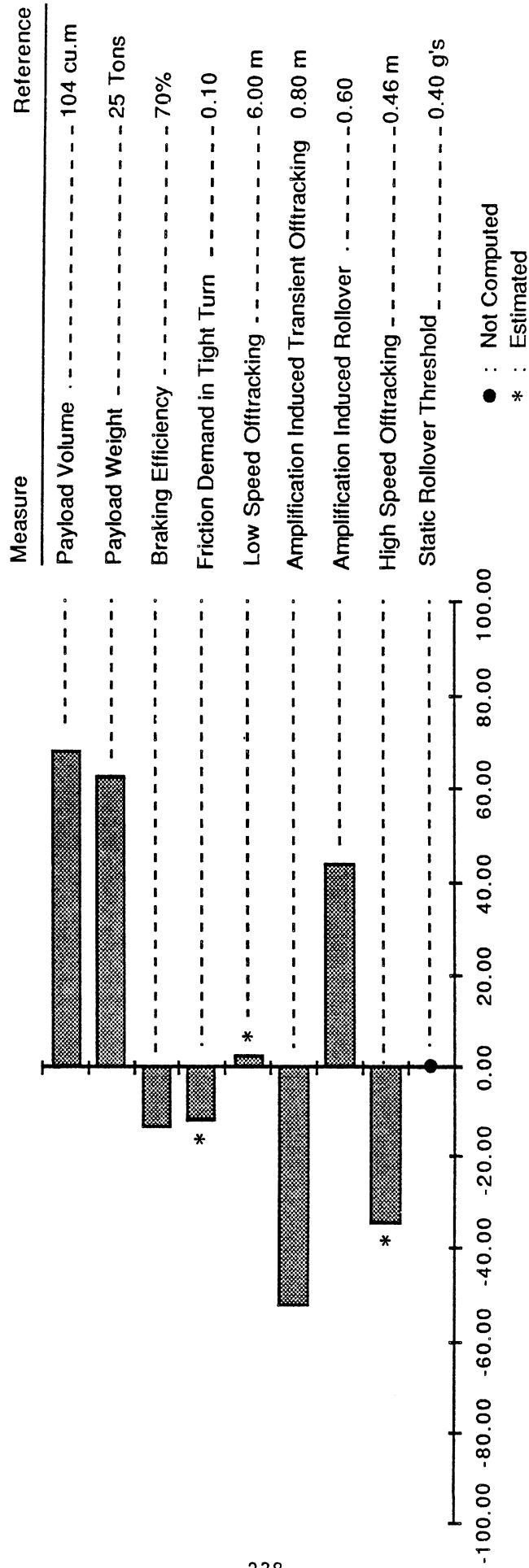

FIGURE 3.6.2.u



11-Axle Triples (C-Train)



Worse → Better

Percentage Difference from Reference Values

FIGURE 3.6.2.v

4.0 PERFORMANCE EVALUATION TECHNIQUES

This section of the report addresses certain generalized techniques that may be applied by Canadian practitioners in the future to evaluate the stability and control properties of heavy-duty vehicles. To a large extent, this discussion merely examines the practicality of implementing the same measures of performance as were used for comparing vehicle response properties in this study. The discussion also comments on the warrants which exist for implementing any such performance measures for the sake of either assuring improvements, or avoiding deterioration, in traffic safety on the occasion of allowing new truck configurations to operate on public highways. The presentation will follow an outline form, covering the basic elements upon which an evaluation technique might be rationalized.

4.1 Static Rollover Threshold

Definition: The static rollover threshold (SRT) is that level of steady lateral acceleration which the vehicle can sustain without suffering a divergent roll response, i.e., rollover.

Warrants: Assurance that heavy-duty truck combinations exhibit at least some minimum level of static roll stability seems warranted by the fact that (a) loaded trucks exhibit very low levels of the SRT measure, (b) this measure has been shown to correlate in a profound manner with rollover accidents [8,23], and (c) truck rollovers are known to cause the majority of truck driver fatalities, are responsible for some 95% of the incidents in which bulk spillage of hazardous commodities occurs [8] and create extended traffic tie-ups. Shown in Figure 4.1a is a plot of accident data analyzed in Reference [8] which show the relationship between the percent of rollovers occurring among single-vehicle accidents involving tractor semitrailers and the computed static rollover threshold of each vehicle. This plot represents some 2,000 rollovers involving 5-axle tractor-semitrailer combinations, having van-type trailer bodies and carrying general freight, and which were being operated by interstate carriers in the United States over the years 1976 through 1979. These data show that the rollover of tractor semitrailers is highly sensitive to the vehicle's inherent rollover threshold, especially in the range below 0.4, or so, which pertains to many loaded vehicles. Because of the profound relationship between the vehicle's basic roll stability level and the likelihood of involvement in rollover accidents, there is reason to examine the roll stability of vehicles in operation on behalf of traffic safety.

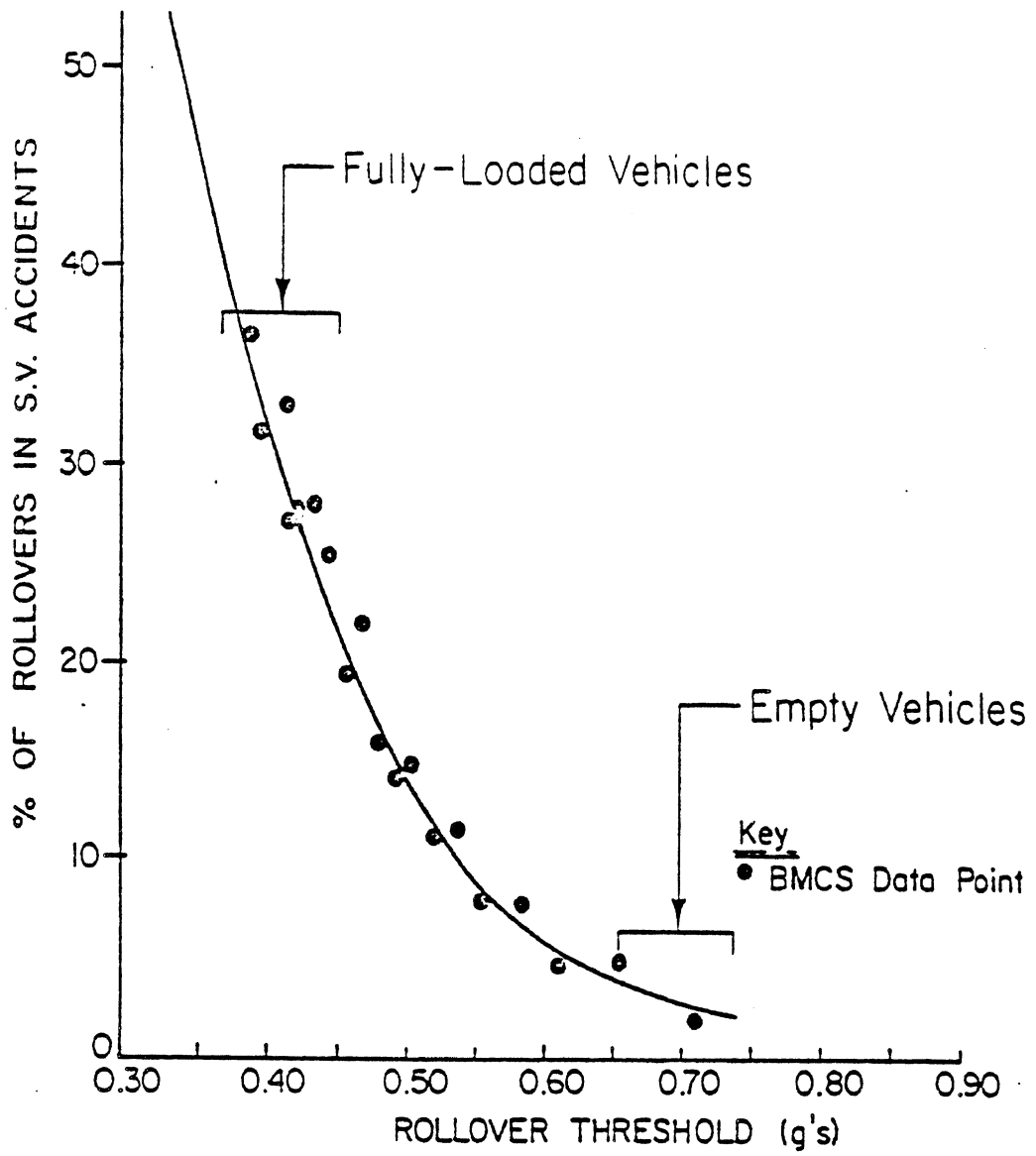

FIGURE 4.1.a Plot of rollover accident data versus calculated value of rollover threshold.

Applicable Operating Conditions: Since the greatest reductions in roll stability occur when the vehicle is fully loaded, the operating condition most pertinent to the rollover problem involves the maximum gross vehicle weight level. Further, for vehicles configured with van or flat-bed trailer bodies, the pertinent payload c.g. condition would appear to be that highest payload elevation occurring with reasonable frequency in common service. For vehicles in general freight service, having a maximum overall vehicle height of 4.11 m (13.5 ft) and a bed height of approximately 1.37 m (54 in), the highest practicable payload c.g. position is 2.67 m (105 in), occurring with a full-cube load of homogeneous freight. With bulk tank vehicles, the maximum c.g. height condition is determined by tank configuration and is achieved when the vessel is fully loaded with that maximum density commodity which is hauled in a volumetrically-full condition. Thus, for example, with petroleum tankers which may carry a wide range of distillates having widely differing densities, that particular fluid which achieves the maximum gross weight level while also filling the vessel (except for the minimum ullage space) establishes the highest-c.g. loading. (Note that the "highest c.g." condition implies the highest payload weight at the greatest height so that the tare and payload masses combined to yield the highest elevation for the c.g. of the composite sprung mass.)

Evaluation Method: The preferred test method for characterization of the static rollover threshold is by means of a tilt-table device.[8,15,25,33-36]. While a coincident CRTIC project [37] has already focussed upon development of a tilt-table device and associated test procedure, some supplementary comments are offered below:

- 1) Firstly, there is a need to closely examine the issue of the overturning moments generated statically by tires on the tilt table versus the condition prevailing with the rolling tire. The particular concern is that changes in tire technology, or perhaps the use of wide-base singles as a replacement for dual tires, may so adjust the relationship between the overturning moment responses under static vs. rolling conditions as to introduce an anomalous measurement on the tilt table. Such an examination may seek to identify any special treatment in the tire/platform contact relationship which can assure fidelity in the overturning moment response.
- 2) A related issue pertains to the lateral constraint of the tires on multiple trailer or tractor axles having substantially differing suspension roll center heights. Since such vehicles, when approaching rollover in an actual steady-turn condition, would be free to translate axles laterally relative to one another as the sprung

mass rolled, the roll stability outcome may be significantly different than that which prevails on the tilt table, with all tires loaded onto a rigid deck. (An example of such a vehicle is examined in Reference [14].)

- 3) Air suspensions having self-levelling systems should be dealt with on the tilt table such that self-levelling, right/left, is prevented during the test. This should be accomplished in a way that still assures that the suspension is operating at a representative static ride height.
- 4) It should be recognized that flat bed and other torsionally compliant trailers may introduce substantial reductions in roll stability and great variation in the apparent effectiveness of differing tractor and trailer suspensions relative to the roll stability levels achievable with a more torsionally stiff trailer. Thus, caution must be taken to avoid generalization across trailer types on the basis of parametric sensitivities observed with one type. Recognizing that van and tank trailers are effectively rigid in torsion, relative to flat bed trailers, and that they comprise together approximately 70% of the trailer fleet [38], the most generally useful data regarding the sensitivity of roll stability to parametric variations would derive from studies using torsionally rigid trailers.
- 5) Concerning the procedure for actually determining the maximum tilt angle beyond which rollover occurs, it should be recognized that some vehicles will become unstable immediately following the first axle liftoff event while others, especially those having (a) substantially differing suspension roll properties, and (b) torsionally stiff trailers, will remain roll-stable beyond the first liftoff condition. Thus, it is desirable to develop a general tilt table test methodology that assures that an unstable response has been observed, regardless of the number of axles that may be lifted off of the platform to achieve it. On the other hand, if the table is being inclined very slowly and, yet, the passage through a suspension lash zone or some other response discontinuity leads to a transient roll motion culminating in vehicle instability, the point of the discontinuity certainly defines the rollover threshold. (One can reasonably assume that the slow rate of change of tilt angle introduces much less dynamic input than would derive from the random accelerations occurring during any moving operation of the vehicle.)

The measure of the static rollover threshold is, of course, the equivalent level of lateral acceleration, $(A_y/g) = \tan(\text{max. tilt table inclination angle})$, expressed in g's. In this study, a "reference value" of 0.4 g's was used for illustrating the contrast between differing vehicles in Section 4.0 of the report. While many Canadian vehicles can approach the 0.4-g rollover threshold, given the 2.59-m (102-in) width across the outside of the trailer tires and the very high levels of suspension stiffness, most tractor semitrailers in the U.S. would be unable to achieve such a level of rollover threshold in typical fully-loaded conditions.

4.2 Tractor Understeer Coefficient at 0.25 g Lateral Acceleration

Definition: The understeer coefficient of interest, $(U_{.25g})$, in "degrees per g", is defined by the expression:

$$U_{.25g} = 57.3 \times d [(1/R) - (\delta / N_s)] / d (V^2 / Rg)$$

where, l = tractor wheelbase

R = path radius

δ = steering wheel angle

N_s = nominal steering ratio between the front wheels and the steering wheel (a number between 18 and 35, typically)

V = vehicle velocity

g = acceleration due to gravity

This definition establishes that the understeer coefficient is evaluated at a centripetal acceleration level of 0.25 g's and is determined by the slope of a difference between two steer-related angles with respect to centripetal acceleration. The angles of interest are (1) the so-called Ackerman angle, $(1/R)$, which is precisely the front-wheel steer angle needed to negotiate a turn of radius, R , at zero speed (for a simple 2-axle truck), and (2) the equivalent front-wheel steer angle, (δ / N_s) , which is not quite equal to $(1/R)$ as a result of all of the factors which influence steady state yaw response at speed. In layman's terms, the defined understeer coefficient indicates how much more aggressively a truck will respond to steering when operated in a moderately severe turn.

Warrants: The understeer behavior of heavy duty vehicles has been seen to vary markedly over the range of centripetal acceleration. [14,26] It has been hypothesized that this marked change in response to steering may make the vehicle difficult to control when

the driver negotiates a curve at a higher-than-prudent speed, but still short of the rollover limit. Low, and particularly, negative values of the understeer coefficient are of concern if they do, in fact, limit the usable maneuvering envelope of the vehicle to less than that range which is otherwise limited by the rollover threshold. The hypothesized significance of the cited research observations has not been demonstrated, nor is there any direct way to link the understeer characteristic to the accident record. Accordingly, it seems premature at this point to suggest that policymaking bodies evaluate and regulate truck configurations on the basis of the understeer property.

4.3 High-Speed Offtracking in a Steady State Turn

Definition: High-speed offtracking is defined as the extent to which any trailing axles in a vehicle combination track toward the outside of the path of the tractor steering axle in a steady turn.

Warrants: The involvement of outboard tracking of trailer axles in certain types of truck accidents has been inferred in recent research examining the accident problems of tractor semitrailers on interchange ramps. [39] This study isolated various cases of truck rollover on ramps having a curb installed along the outside of a curved lane. In some cases, the truck rollover problem at the site essentially disappeared when the curb was removed. Although curbs can aggravate the occurrence of rollover regardless of outboard tracking phenomena, the possibility of trailer axles operating at larger radii than the tractor fundamentally increases the probability that curb-strike would occur. In a major accident involving a tractor semitrailer hauling hazardous liquids, (reported in [40]), followup analysis revealed that the minor high-speed offtracking of the semitrailer axles produced a curb strike which precipitated a catastrophic rollover. Moreover, the authors' view is that high-speed offtracking is patently undesirable and that attention should be given to minimizing it, wherever practicable.

Applicable Operating Conditions: As indicated in various portions of Section 3.0 of this report, the high-speed offtracking response is maximized when both the payload weight and the payload c.g. height are maximized, as a result of their combined influence on the normalized cornering stiffness level of the tires. Further, since high-speed offtracking only achieves a net "outboard" displacement (relative to the tractor's path) when the initial inboard (low-speed) offtracking displacement is minimized, the critical conditions for high speed offtracking involve relatively large-radius turns. Also, high-speed

offtracking occurs only when the lateral acceleration has become sufficiently large as to create the substantive levels of tire slip angle needed to obtain an outboard deflection.

Evaluation Method: In order to assure that a measurable high speed offtracking response is obtained, the vehicle is operated in a shallow turn of radius, 393 m (1,290 ft), at a speed of 100 km/h (62.5 mph) thus attaining a lateral acceleration level of 0.2 g's. With the outside front wheel of the tractor following this path, the lateral displacement of the paths of trailing outside wheels is observed. Such paths can be traced on the pavement, in full-scale tests, using a pressurized water stream or another marking medium. Recognizing that transient responses may tend to dominate in the more lightly-damped A-doubles and triples, care is required to assure that the "steady-state offtracking" measure is truly derived from steady-state behavior.

If this property is to be assessed through simulation, it is important that nonlinear tire behavior be represented. That is, it is quite clear from the further exploration of this subject during the current study that linear tire representations will substantially underestimate the extent of high-speed offtracking. Also, it appears important that the roll-steer behavior of suspensions be properly accounted in computations of high speed offtracking.

The pertinent measure is the radial difference in wheel paths between the outside tires on the trailing axles and the outside tractor tire. In general, the trailing axle of interest will be the rearmost axle on the vehicle combination. However, it may be that an axle other than the rearmost axle would render a most outboard path in some unusual configuration. In this study, a value of 0.46 m (18 in) has been identified as the "reference value" for steady-state high-speed offtracking. This value was arbitrarily selected as providing a minimal remaining clearance of 0.15 m (6 in) to the outside of a 3.66 m- (12 ft)-wide conventional traffic lane if a 2.44 m- (96 in)-wide tractor followed a path down the centerline of the lane. The simulation results in this study showed that some vehicles substantially exceeded this reference value.

4.4 Amplification-Induced Rollover

Definition: The classical measure used to define the tendency toward rollover deriving from rearward amplification in a rapid path-change maneuver is the amplification ratio. The amplification ratio measure is defined as the ratio of the peak value of lateral acceleration achieved at the mass center of the rearmost trailer to that developed at the mass center of the tractor in a maneuver causing the vehicle to move laterally onto a path which is

parallel to the initial path. Certain shortcomings in this definition are known to develop when the lateral acceleration response at the tractor is rather asymmetric during the transition from the initial to final path. In such cases, it has been found preferable [4] to replace the tractor-based denominator term in the ratio with an equivalent lateral acceleration defined by a predetermined path. That is, a transition path is laid out so that, if followed exactly, it would produce a symmetric sine wave of tractor lateral acceleration. The tractor of the subject vehicle is caused to track this path such that the amplified lateral acceleration of the rearmost trailer can be ratioed to the pre-established amplitude of lateral acceleration, thus yielding an improved measure of rearward amplification.

While the above measure is highly informative for evaluating the behavior of A-train combinations, it fails to account for the benefits of roll-coupled hitching arrangements, such as with B-trains and C-trains. Accordingly, in this study a new measure has been developed called the "load transfer ratio" (LTR). The LTR measure serves to evaluate the dynamic load transfer from all of the tires on one side of a rolling unit to the tires on the other side. The result is a ratio of the absolute value of the difference in total right/left loads to their sum. On a roll-coupled B- or C-train combination, the sum of the right-side wheel loads, except for the tractor's steering axle, are subtracted from the sum of all left-side wheel loads (except for the tractor steering axle) throughout the maneuver, and are ratioed to the total vehicle weight (less the tractor axle load). The maximum value of the right/left difference, at a particular point in the maneuver, establishes the condition of greatest transfer of load from one side of the vehicle to the other, tending to produce rollover.

Warrants: There appear to be substantial warrants for assuring that vehicles exhibiting a poor level of dynamic roll stability in rapid path-change maneuvers be discouraged or prohibited. Various research studies have found persuasive evidence that highly amplifying vehicle types are heavily involved in rollover accidents and that, further, a substantially greater-than-random portion of these rollovers have involved the rearmost unit rolling over alone.[12,30,31,32].

The underlying hypothesis which would explain the safety-significance of the vehicle's resistance to amplification-induced rollover is identical to that which would be offered regarding static roll stability. Namely, vehicles providing a narrower range of survivable maneuvers will experience an increased rate of involvement in accidents deriving from more frequent exceedance of that range. For those who would argue that the truck driver will learn the extent of the "survivable range" in his vehicle and provide all of the necessary compensation, the data shown earlier in Figure 4.1a suggest that whatever

compensation the driver does introduce is grossly inadequate for subduing the powerful effects of performance limits which approach the normal operating range. Indeed, amplification-induced rollover involves even more subtle mechanisms, most of which cannot be felt by the driver because of the effective decoupling provided by the single pintle hitch connections in A-trains. Thus, it seems even less likely that drivers will obtain the needed feedback from A-train amplification responses such that a "compensatory" control practice could be developed over time. Moreover, the authors hold the conviction, based upon persuasive technical evidence and common sense, that the tendencies of multi-trailer vehicles toward amplification-induced rollover should be subject to controls.

Applicable Operating Conditions : Again, the most important operating condition involves the fully loaded vehicle. The most demanding payload types will be those rendering the highest center of gravity position. Since rearward amplification increases with increasing speed [3,12], the velocity at which the pertinent properties are evaluated should be the highest value at which the subject vehicle will be commonly operated.

Evaluation Method: Based upon the findings of this study concerning the development of the dynamic rollover response over a range of excitation periods, it appears that a period value of 3.0 seconds is the appropriate choice for evaluation of amplification-induced rollover responses. (Although it is always possible that a peculiar vehicle might be presented, having substantially differing period sensitivities than the vehicles examined here, it seems a practicable choice at this juncture to simply employ a 3.0-second period in evaluating any vehicle which is nominally embraced within the range of vehicle types and dimensions examined in this study.)

The performance of A-train combinations can be suitably evaluated by means of the rearward amplification ratio. This characterization can be obtained through either simulation or test by conducting a path change maneuver from 100 kmh (63 mph), yielding a lateral acceleration amplitude at the tractor of 0.15 g's and a time period of 3.0 seconds. Since a full-scale test of this type is much simpler if a symmetric input of steering is used, with the aid of an adjustable steering-stop device, this method would be preferred as the first trial step. Should the resulting lateral acceleration response of the tractor appear excessively asymmetric (say, more than 10 or 15% difference from the (+) to (-) lobes of the waveform) then additional steps will be necessary to obtain a suitably symmetric response from which to derive a rearward amplification ratio.

Two simple options for such "additional steps" are (a) to implement a harmonic reference path such as defined for simulation of the rapid path change maneuver in Appendix C, or (b) to iteratively adjust an asymmetric steering input so as to yield a symmetric lateral acceleration response from the tractor. Although the latter of these options may sound awkward, it is a relatively simple process if the test is facilitated with an adjustable steering-stop device which permits independent adjustment of both the clockwise and counterclockwise steering limits. Note, again, that the total test burden is not excessive since the A-train vehicle can be reasonably characterized at a single test condition, namely, with lateral acceleration amplitude = 0.15 and the time period = 3.0 seconds.

Regarding the evaluation of amplification-induced rollover response in roll-coupled B- and C-trains using simulation, the technique employed in this study appears to be quite acceptable. The load transfer ratio algorithm is bug-free and permits a totalized assessment of the net benefits of roll coupling. The computation used in the LTR algorithm requires, however, explicit knowledge of the instantaneous wheel loads at all wheel positions except at the front of the tractor. Thus, it is not clear how such a measure could be obtained in a practical full-scale test scenario. Of course, one alternative is to simply increase the amplitude of the input at the tractor until total liftoff is achieved. For most roll-coupled combinations, such a test condition would involve a remarkably severe maneuver -- one which might pose a rather exaggerated risk of tire or wheel failure and, potentially, failure of a coupling element. At this stage, there is an insufficient amount of experience with testing at such levels of severity to deduce the risks involved.

One option which was examined for possible use as a crude approximation of the load transfer ratio measure, using sub-limit test data, involved the derivation of a "vector sum of roll moments," (VSM), using instantaneous lateral acceleration signals from instrumentation on each unit of the vehicle train. Ratioing this vector sum of roll moments to the "total moment capacity" (TM) of the vehicle combination yields a nondimensional variable which is directly analogous to the load transfer ratio measure, although it lacks treatment of certain load transfer mechanisms. This alternative "moment ratio" measure is defined by the relation,

$$VSM / TM = [\sum (W_i A_i h_i / g)] / [\sum (W_i t_i)]$$

where, W_i = weight of vehicle unit, (i), (i.e. tractor, 1st semi, 2nd semi, etc. C-train trailers aft of the 1st semitrailer would include the weight of the dolly in the trailer weight term.)

A_i = instantaneous lateral acceleration at the mass center of unit, (i).

h_i = nominal height of the sprung mass center of unit, (i).

g = acceleration due to gravity.

t_i = half-track width at unit, (i).

An example computation of this measure can be illustrated by reference to Figure 4.4a (shown earlier, also, in Section 3.1). This figure shows the sequential lateral acceleration responses for the units of the reference C-train triples combination in the path change maneuver. Taking the W_i , h_i , and t_i values characterizing each of the four units of this vehicle combination from Appendix D, and evaluating the instantaneous levels of lateral acceleration, A_i , at the time of the peak response for the rearmost trailer (see vertical line drawn on the figure), a "moment ratio" value of 0.42 was obtained. Comparing this result to the value, 0.29, which was computed by simulation for the rigorously-defined load transfer ratio in this same maneuver, indicates that various details have caused the crude approximation to overestimate the load transfer response. Considering that the load transfer ratio of the rear trailer of this combination, alone, comes out to a value of 1.20, we could observe that the crudely approximated value of 0.42 "isn't half bad" as a rough indicator of the influence of roll coupling. Nevertheless, it is possible that a somewhat more complex version of the moment ratio type of measure could be practicably implemented as a more accurate means of reducing full-scale test data for roll-coupled trailer combinations.

When simulation methods are to be used to evaluate the load transfer ratio response of roll-coupled vehicles, it should be recognized that a rather complete simulation model must be employed, such as the UMTRI Yaw/Roll model or its equivalent. Further, data are needed representing the nonlinear tire sensitivities in producing lateral force over a wide range of vertical load. Suspension properties must be defined both in terms of stiffness characteristics and roll-steer kinematics. Finally, in addition to all of the obvious inertial and geometric data describing the tare vehicle and its loading, it is necessary to have a reasonable approximation of the torsional stiffness of the roll-coupling connections. The torsional stiffness of a C-train dolly, for example, is relatively important as a determinant of the total load transferred in the path-change maneuver.

Although not explicitly addressed in this study of stability and control, it should also be recognized that, since the roll-coupled trains achieve their very high levels of dynamic stability by managing to transmit large roll moments across their hitch points, it is

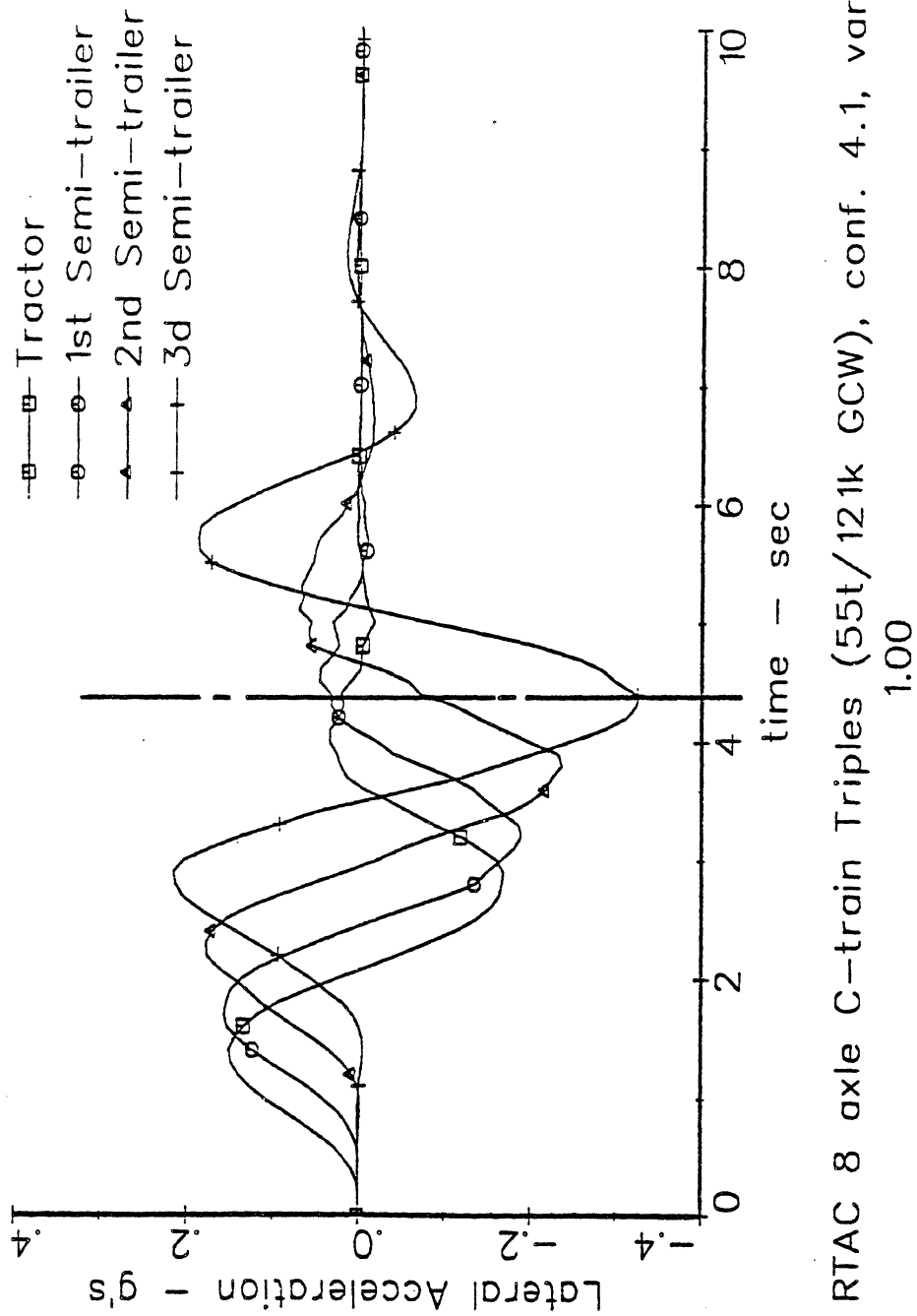

RTAC 8 axle C-train Triples (55t/121k GCW), conf. 4.1, var.

FIGURE 4.4.a Lateral acceleration time histories for the tractor and respective trailers of an 8-axle C-train triples combination.

imperative that such hitching elements be able to develop the imposed moments. In this regard, it is not only the strength of pintle-hitch and fifth-wheel assemblies that warrant scrutiny, but also the strength of B-train and C-train dolly frame structures. Methods for assuring the needed strength characteristics were not addressed in this study.

A "reference value" of 0.60 for the load transfer ratio was employed in Section 3.6 for scaling the performance of differing vehicle combinations in the 0.15-g, 3.0-second, rapid path-change maneuver. This level can basically be met only by B- and C-train doubles and triples, the turnpike doubles A-train, and the more conventional style tractor semitrailers. It is estimated that the maximum level of rearward amplification which could be developed by an A-train, while still remaining within a 0.60 level of load transfer ratio, as defined here, is approximately 1.40. Such a level falls about 40% of the way between the performance of a turnpike double and a Rocky Mountain double.

4.5 Transient High-Speed Offtracking

Definition: Transient high-speed offtracking is the peak value of offset, normal to the path, between the path of the outside front tire on the tractor and the path of the most outboard trailing axle in response to a transient steering maneuver.

(This study has, to the knowledge of the authors, introduced for the first time a quantification of the transient overshoot in high-speed offtracking response. The method of quantification implemented here involved characterization of the path overshoot occurring in the rapid path-change maneuver--a maneuver exercise which was designed primarily for examining the dynamic rollover phenomenon. Thus, it was simply efficient to derive the transient overshoot data, given that simulations of this highly transient steering maneuver were already being conducted for other purposes. The question of a generally suitable means of characterizing transient high-speed offtracking has not been resolved, however. On the one hand, any test or simulation exercise conducted under the subject of "amplification-induced rollover" could simply "tack on" the determination of wheel paths so as to yield a measure analogous to the transient high-speed offtracking results reported here. On the other hand, it seems attractive to develop a simpler method which looks, explicitly, at the offtracking transient occurring when a vehicle is brought abruptly from a tangent to a curved path. It is this scenario which would appear to most readily represent the problem involving truck rollover on exit ramps following contact between trailer tires and an outboard curb, as outlined in Section 4.3.)

Warrants: The transient high-speed offtracking results which were computed in the rapid path-change maneuver of this study have clearly shown that very large dynamic overshoots in wheel paths can occur. The magnitude of the overshoot is so much larger than the steady-state offtracking response, in certain cases, that this phenomenon seems to patently warrant attention as a safety issue. While this study has not explored the development of a maneuver specifically to look at the "ramp entry" transient, the findings of the study of truck accidents on ramps, cited in Section 4.3, clearly support the application of such a measure. Although the matter has not been studied, there is reason to believe that tractor semitrailers having 2-axle tandem and 3-axle tridem trailer installations, which showed virtually no difference between their steady-state and transient high-speed offtracking in the rapid path change maneuver, would show some measurable overshoot in a "ramp entry" transient.

Moreover, the authors' view is that transient high-speed offtracking response should be looked upon as a potentially serious safety concern and that further development of characterization methods is warranted. At the present time, however, no generalized method is proposed.

4.6 Low-Speed Offtracking

Definition: Low-speed offtracking is defined as the peak offset in wheel paths, measured from the outside of the outer front tire on the tractor to the inside of the innermost-trailing trailer tire, when the tractor conducts a 90-degree turn with the outside of its outer front tire tracking at a radius of 11 m (36 ft), and exits along a tangent to this curve. A supplemental measure of the low speed kinematic motions is the "swing out" excursion [21], defined as the maximum outboard intrusion of the outer rear extremity of any trailing element, measured, as shown in Figure 4.6a, from the initial tangent approach of the 11-m (36-ft) curve to the point of greatest outboard intrusion.

Warrants: The problems posed by the low-speed offtracking response derive from the conflict between the space demands of the vehicle and the space which has been provided in the geometric design of the roadway, especially at intersections at-grade and tight-radius curves. Among the apparent issues posed by excessive offtracking are:

a) abuse of the roadside when trailer wheels track off of the provided pavement, perhaps in contact with an inside curb.

b) intrusion of the tractor over the road centerline into the space occupied by other traffic, as a result of the truck driver negotiating to avoid intrusion by trailer wheels on the inside of the turn.

c) traffic delays associated with the slower, and possibly intrusive, movement of strongly offtracking truck combinations at sites having confining geometry.

d) the potential for low-speed collisions with smaller vehicles which attempt to turn inside of combination trucks at intersections.

Although the total burden associated with these problems is not known, both the nature and extent of such problems is expected to strongly increase as offtracking performance degrades beyond that exhibited by the baseline combination of a 3-axle tractor with 14.6 m- (48 ft)-long, 2-axle semitrailer, which was examined in this study. In recent research [20] examining the introduction of longer semitrailers into general service in Michigan, it was observed that the 14.6-m (48-ft) semitrailer which is currently a common configuration in both Canada and the U.S. "uses up" all of the margins which were employed in the design of typical at-grade intersections. In reference to the policy of the American Association of State Highway and Transportation Officials (AASHTO) for geometric design [22], the common protocol for intersection design in much of the U.S. has, since the sixties or so, involved the so-called WB-50 design vehicle. By means of this protocol, certain space requirements were established, with margins provided for the vehicle to clear both the lane centerline and the inboard pavement edge. Except in new construction and at rehabilitated sites where modernization of the available space has been achieved, the 14.6-m (48-ft) semitrailer, with tandem bogie in the full rearward position, constitutes the most strongly-offtracking vehicle that can be tolerated without unavoidable intrusions over the centerline and beyond the pavement edge.

Accordingly, to the degree that the Canadian road system involves similar geometric space constraints, especially at intersections, there are clear warrants for scrutinizing the offtracking demands of alternative truck combinations. Although arguments may be made that originally provided clearance margins were unnecessary, the fact that all of the margin is now consumed by the most common truck combination in operation suggests that resistance to even greater offtracking demands without a major program to widen intersections may be in order.

Regarding the swing-out phenomenon, there is no known documentation of a safety problem arising from intrusions of this type. Nevertheless, there are clear pressures

for (a) the further extension of semitrailer length without (b) the accrual of additional offtracking response. The resolution of these conflicts may well be embodied in semitrailers having their axles set substantially far forward of the rear extremity, such that the ratio, (A/B), in Figure 4.6a becomes rather large. Recognizing that values of (A/B) exceeding 1.5, or so, will yield a swing-out dimension on the order of 0.5 m (20 in) in an 11-m (36-ft) turn, a clear safety concern is raised by vehicles that are currently being promoted for use in differing parts of North America. The safety issue is posed by the scenario of a truck driver who (a) begins his intersection maneuver rather near to the left edge of this lane while (b) putting his attention on tractor path and the inboard offtracking of right-side trailer wheels, the left rear corner of the trailer can swing across the centerline into the opposing traffic lane. The swing-out motion thus would occur without particular note by the truck driver. Further, the height of the typical trailer bed is such that the swing-out motion threatens contact with automobiles at the vulnerable elevation of the windshield. Moreover, there appears to be a clear warrant for examining the swing-out potential of candidate truck configurations, at least from the viewpoint of the (A/L) geometry of axle placement.

Applicable Operating Conditions: The offtracking response of vehicles having single or closely-coupled tandem axles is essentially independent of vehicle loading or the pavement friction level. Although analysis indicates [18,19] that there are mechanisms by which spread axles can influence the offtracking response, relative to single axles placed at the same geometric centers, there is a complex and non-monotonic relationship between vehicle load and the incremental changes in offtracking due to tandem spread. Given that the tandem effects are generally small and that the load influence on this effect is variable, it is reasonable to simply adopt a test practice which evaluates offtracking response in the empty condition.

Evaluation Method: Low-speed offtracking is evaluated by first lining up the articulated units such that initial articulation angles are zero. The tractor is then steered such that the outside of its outer front tire tracks through 90 degrees of a circular path 11 m (36ft) in radius, exiting the curve along a tangent. The maximum inboard offtracking of any trailer axle is established, over the duration of the maneuver. This peak inboard excursion typically occurs at a point in the arc which is beyond the 45-degree position.

It is suggested that the swing-out response of a vehicle can simply be observed and characterized at the time of studying low-speed offtracking. Additionally, simple

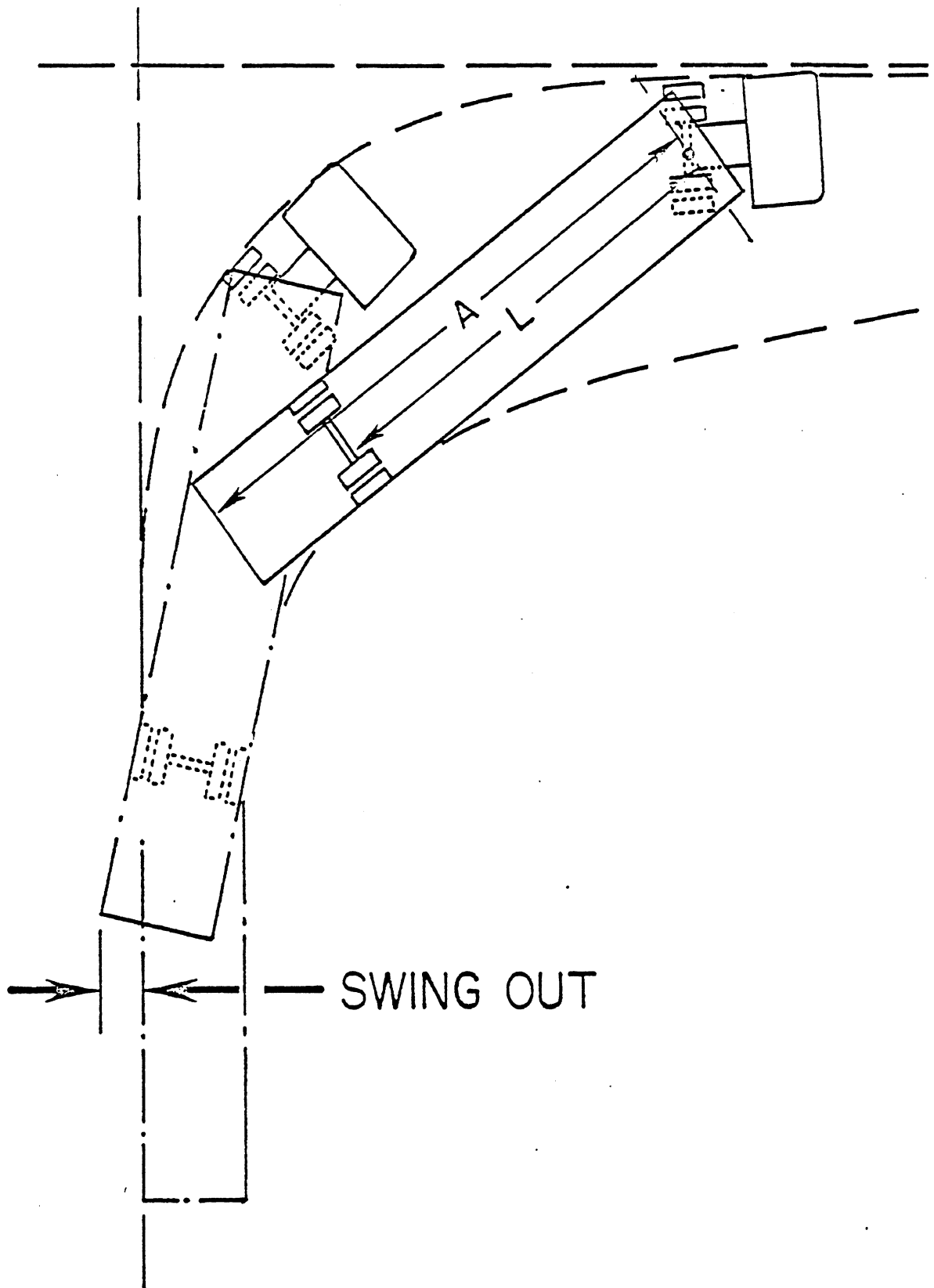

FIGURE 4.6.a The swing-out phenomenon occurring in a low-speed turn with a semitrailer having a relatively high value of A/L .

examination of the (A/L) quantity, defined above, will indicate whether the vehicle is a candidate for substantial low-speed swing-out.

The measures obtained from the suggested low-speed offtracking and swing-out responses are simply dimensions of vehicle excursions, in meters. The reference value for low speed offtracking used in the rating of differing vehicles in this study is 6.00 m (20 ft) --a rounded-off value which approximates the offtracking demands of the tractor and 14.6-m (48-ft) semitrailer. To the degree that at-grade intersections were designed to a protocol that approximates the AASHTO WB-50 provision, the 6-m (20-ft) offtracking performance should be looked upon as completely consuming the available space. While no corresponding reference value for the swing-out response has been employed in this study, it is suggested that a 0.3 m (12 in) intrusion be looked upon, tentatively, as a value beyond which a serious safety hazard may begin to accrue.

4.7 Friction Demand in a Tight Turn

Definition: The friction level demanded of the tires on the rear of the tractor, in a tight-radius turn, is defined as the ratio of the resultant shear force arising simply due to the curvilinear travel, to the vertical load imposed on those tires.

Warrants: The loss of traction capability at the tractor drive wheels, during tight radius turning with a trailer having a widely-spread axle set, will result in a low-speed loss-of-control, possibly culminating in tractor jackknife and possibly risking low-speed collisions with other vehicles. It is apparent that the cited phenomenon has been observed by the trucking community, especially in jurisdictions such as the State of Michigan and the Provinces of Ontario and Quebec where trailers having very widely-spread axle layouts are in broad use. Concern for this phenomenon (as well as excessive tire wear) is precisely the reason that such vehicles are commonly equipped with air-lift axles such that intersection turns can be negotiated with one or more axles lifted. Further, the problem with friction demand obviously becomes of greatest significance when the prevailing tire/road friction condition is lowest--namely, in wintertime with ice- or snow-covered surfaces. In Michigan, many operators of a semitrailer having an 8-axle array are known to simply park the vehicles in winter, recognizing that the friction demand frequently exceeds the available friction level at that time of the year. Regardless of the countermeasure practice which may be selected to deal with this phenomenon, the prospect of loss-of-control with heavy-duty vehicles, even at low speed, is sufficiently sobering that concern for the friction demand performance seems warranted.

Applicable Operating Conditions: The friction demand level maximizes when the vehicle is fully loaded and, especially, when it assumes whatever load biases as cause an increased loading on the trailer axles and/or a decrease in loading on the tractor rear axle(s). As stated above, the most troublesome environmental condition causing actual loss-of-control involves low-friction pavement. Nevertheless, the performance of a given vehicle is most reasonably characterized, through either test or simulation, on dry pavement.

Evaluation Method: The friction demand response of a given vehicle can be characterized in a maneuver which is identical to that outlined above for low speed offtracking; namely, involving a 90-degree intersection turn, with an 11-m (36 ft) reference radius. In the case of a simulation method, it is straightforward to obtain either the shear forces developed at the tractor rear axle(s), directly, or the lateral component of the reaction force at the fifth wheel coupling to the tractor. Either of these variables may pose difficulty, however, relative to measurement in a full-scale test. That is, such measurements require specialized transducers which are very expensive and are rarely available. Thus, for the present, it would appear that the friction demand evaluation cannot be generally practiced through a physical test.

On the other hand, results presented in this study showed that the friction demand level was rather linearly related to the term, $\{\sum (d_i^2 / L)\}$, where d is the spread of each (i -th) trailer axle away from the geometric center of the array of trailer axles and L is the trailer wheelbase measured to that geometric center. As was seen in Section 3.1, the d^2/L term is quite a useful predictor by itself, and could serve as a crude screen for detecting vehicle configurations likely to pose an unusually high level of friction demand.

The reference value of friction demand employed for rating vehicles was 0.10. This level was selected to give some margin for the development of additional friction demand due to drive thrust, recognizing that friction levels on snow-covered surfaces fall in the range of 0.20 to 0.40 for passenger car tires[29] (data for heavy truck tires are not known to exist). Considering that d^2/L for a friction demand of 0.10 is approximately 0.50 m (1.6 ft), one could say that the "reference value" for the d^2/L term is 0.50 m (1.6 ft). For vehicles having unusual axle load distributions or steerable trailer axles, the use of this dimensional term is not suggested. Rather, a simulation technique such as that used in this study is recommended.

4.8 Braking Efficiency

Definition: The braking efficiency of a vehicle at a given braking level is defined as the ratio of the deceleration attained, in g's, to the minimum tire/pavement friction level required to achieve such a deceleration level without wheel lockup.

Warrants: The warrants for efficient braking performance seem intuitively apparent, although it is very difficult to demonstrate the relationship between such performance and accident rate. It suffices to say that braking performance is the primary controllability feature of vehicles that has been regulated around the world. Insofar as heavy duty trucks are known to be decidedly deficient in emergency braking capability relative to passenger cars [41,42] the warrants for evaluating and controlling for the braking efficiency aspects of truck braking performance seem axiomatic.

Applicable Operating Conditions: The matching of brake torques with wheel loads is as much needed in the full state as it is in the empty condition. North American vehicles which incorporate fixed distribution of braking effort among the axles are typically designed so that the brake torque gains are roughly proportional to the static load distribution when fully loaded. As a consequence, the brake proportioning renders a low level of efficiency when the vehicle is empty. This study has also provided results which indicate the extremely low level of braking efficiency which can occur under certain partial loading conditions. For example, we saw that efficiency levels in the range of 20 to 30% were obtained with doubles and triples combination with one trailer empty and the other(s) full. Moreover, the applicable loading levels, from the viewpoint of characterizing braking efficiency, cover essentially the entire spectrum of load levels and distributions which will occur in normal service. Indeed, it is primarily because of the difficult compromises that must be made in distributing a fixed-proportioning braking system that variable proportioning and antilock technology are especially of interest for trucks.

Evaluation Method: While the braking efficiency measure is an attractive analytical scheme for portraying the utilization of available adhesion, or friction, at the respective axles of a vehicle configuration, the results certainly offer only a tenuous guess at the actual performance limits of a real commercial vehicle. The reason for the tenuous nature of this prediction is that truck brakes are tremendously variable in their torque response and truck air delivery systems frequently incorporate valves which vary substantially in their threshold "crack pressures." Accordingly, there is reason to be cautious with the utility of a braking efficiency computation method as a means of predicting the performance of a

given vehicle. Notwithstanding the need for such caution, there is distinct value in showing that the basic design approach taken to distribute brake torques among the axles of a vehicle is at least conceptually sound. By such reasoning, there are standards in the European community requiring so-called "type approval" of brake system designs. The braking efficiency model used in this study provides an evaluation which is conceptually the same as those used in efficiency type type approval standards.

Moreover, while the braking performance of heavy duty vehicles is seen as a complex subject evoking much controversy within the technical community, there seems a clear need for improvement in hardware technology and maintenance practices. The reader is referred to a broad consideration of the related issue in Reference [43].

5.0 CONCLUSIONS AND RECOMMENDATIONS

The most significant finding of this study is that there exists a very large range of stability and control performance among the differing truck configurations currently operating in Canada. Many of the differences in performance are seen as implicating safety issues. Although it is not generally possible to quantify the magnitude of the safety risks, there is good reason to believe that the probability of involvement in certain kinds of accidents is significantly higher with some types of vehicles than others, when operated under identical conditions.

On the basis of the dynamic performance considerations alone, the matrix of vehicle configurations has been broken down into four rough categories, namely,

- A) Overall performance as good as, or better than, the "reference values" defined herein. Placement in this category indicates that the vehicle configuration compares favorably with the baseline five-axle tractor-semitrailer in terms of dynamic behavior. This level of overall performance is not looked upon as optimum or even "high," in an absolute sense, but merely as the better end of the spectrum of contemporary performance. The qualifying vehicles are:

5-axle tractor semitrailer

Tractor and close-tridem semitrailer

8-axle B-train (tridem center-group)

7-axle B-train (tandem center-group)

6-axle B-train (tandem center-group)

- B) 1st-Level Performance Limitations. This category includes vehicles which have marginal reductions in performance below the reference values. Limitations derive from either: (a) higher demand for friction level in tight turns, (b) larger steady-state or transient high-speed offtracking. There is a reasonable prospect that evolutions in technology will resolve the deficiencies in high-speed offtracking. The vehicles in this group are identified below, with their respective types of deficiencies, as in (a) and (b), above:

Tractor and wide-spread 3-axle semitrailer (a)

8-axle C-train doubles (b)

7-axle C-train doubles (b)

6-axle C-train doubles (b)

Belly-axle B-train (tandem center-group) (b)

C) 2nd-Level Performance Limitations. This group includes vehicles which, to a rather major degree: (a) violate the geometric limits of the general road system, (b) demand apparently excessive friction levels in tight turns, (c) amplify lateral acceleration (to a point known to yield observable incidents of rear-trailer rollover), or, (d) exhibit a large transient overshoot in high-speed offtracking. Certain of these limitations may be resolved through developing technology. The included vehicles are listed below, together with indication of the key limitation (per the designation, a,b,c, or d, above):

5-axle tractor semitrailer plus fixed belly-axle (b)

8-axle A-train doubles (c)

7-axle A-train doubles (c)

6-axle A-train doubles (c)

Rocky Mountain A-train doubles (a)

Rocky Mountain C-train doubles (a)

8-axle C-train triples (d)

11-axle C-train triples (d)

D) 3rd-Level Performance Limitations. This group includes vehicles which, to a rather profound degree: (a) violate the geometric limits of the general road system, (b) demand excessive friction levels in tight turns, (c) amplify lateral acceleration, (d) exhibit a large transient overshoot in high-speed offtracking, or, (e) exhibit an unusually low static rollover threshold. Again, some of these

deficiencies may yield to technological development. The vehicles are listed below, together with indication of the key limitations:

Tractor and quad-axle semitrailer (b) (e)

Turnpike double (a)

8-axle A-train triple (c) (d)

11-axle A-train triple (c) (d)

The authors recognize that the construction of a breakdown such as this involves some judgement as to the relative seriousness of differing performance limitations. And yet, insofar as this project was explicitly designed to assist the formulation of a public policy, it is expected that the categorization will have value for decisionmakers. It must be pointed out, however, that stability and control properties are only part of the traffic-safety picture and safety is certainly only one consideration in the formulation of road-use regulations. Relative to the specific categorization that is used here, the following recommendations and additional comments are offered:

- 1) It is recommended that hazardous commodities be transported in bulk only in those vehicles exhibiting superior dynamic performance qualities. In particular, the risk of spillage of hazardous bulk products is reduced in vehicles having a higher level of both static and dynamic roll stability. It is recommended that such transportation be confined to vehicles in category A.
- 2) The tractor with close-tridem semitrailer provides improved productivity at no significant cost to stability and control performance, relative to the baseline tractor and two-axle semitrailer. Indeed, the close-tridem axle group, whether incorporated on the single long semitrailer or the center-group of a B-train, introduces improved stability insofar as these axles are characteristically underloaded relative to two-axle tandems and insofar as more nearly level-loading of freight is permitted (given details concerning load distribution constraints).

It should be noted, however, that the use of tridems on long semitrailers may encourage a more frequent forward-placement of the trailer axle group, on behalf of load distribution. Such practices may exacerbate the occurrence of the lethal rear-underride type of accident and potential "swing-out" motions of the trailer

during intersection turning. To overcome these problems, it may be prudent to require rear-underride protection and/or limit the minimum trailer wheelbase when tridem-axle arrays are installed on long semitrailers.

- 3) The B-train doubles combination is a superior basic configuration for applications which (a) require the higher productivity and maneuverability of multiple trailers, and (b) can tolerate non-interchangeable trailers. Among the B-doubles, the eight-axle variety, with tridem center-group, offers the greatest productivity advantages while suffering no significant loss in dynamic performance (relative to the five-axle tractor-semitrailer). Recognizing the safety benefits of the reduced exposure which accompanies increased payload capacity plus the high performance, yet simplicity, of this vehicle, the eight-axle B-train is looked upon as the closest-to-ideal configuration of the overall group of vehicles. If one vehicle configuration were to be encouraged for transporting all hazardous materials in bulk, for example, it is the authors' view that this is it.
- 4) The C-train combination, with a steerable-axle, dual-drawbar, dolly installed in place of the conventional A-train dolly, offers great improvements in dynamic response characteristics over the A-train, particularly in the range of 8.2-m (27-ft) trailer lengths. Nevertheless, the rankings of such vehicles would be substantially improved, especially in terms of steady-state and transient high-speed offtracking, if dolly-steering schemes were both improved and closely regulated. At the current juncture, the total lack of regulatory control over dolly-steering behavior (except in certain Provinces granting special permits), together with the potential for performance degradation due to dolly properties, gives the C-train a somewhat unresolved status.
- 5) The C-train triples combination, particularly in the eight-axle version, holds promise for the future. Firstly, the triple with 8.2-m (27 ft) trailers is a particularly productive combination for the transport of low density freight. Secondly, the C-train implementation resolves most of the severe deficiencies in performance exhibited by the A-train triple. Nevertheless, in its current implementation, the C-train triple does exhibit a disturbingly high level of transient high-speed offtracking. Resolution of this remaining shortcoming, perhaps together with regulation of the steerable dolly to assure its performance qualities, would render the C-train triples highly attractive (simply considering productivity and dynamic performance).

- 6) An additional vehicle configuration which qualifies for group (B), above, is the tractor and belly-axle semitrailer, with the belly-axle steerable rather than fixed. In this implementation, all of the performance characteristics of the vehicle are as good or better than those with the rigid (non-steerable) belly axle. Additionally, this vehicle is not perceptibly sensitive to the centering properties of the steerable axle.
- 7) The quad-axle semitrailer is seen as exhibiting a major performance limitation in the friction demands which it develops during tight turning and in its roll stability characteristic. The friction demand deficiencies can be, and are, overcome in service through the use of "lift" axles. This study has not evaluated multi-axle trailers with axles lifted, however, since such a practice introduces gross overloading of the other axles. It was not assumed that such a practice is justified, thus warranting inclusion of the axles-lifted cases in the study.

The large payload weight capacity of this vehicle suggests that the roll stability level would be regularly quite low because of the high payload center of gravity. Although the payload c.g. height is determined, in practice, by the payload densities hauled, there is certainly a high probability that the quad-axle trailer will experience unusually high c.g. positions, from day-to-day, thus posing the threat of more frequent rollovers.

- 8) Rocky Mountain doubles exhibit only modest limitations in all performance qualities, relative to the reference values, except in the case of low-speed offtracking performance. Although this vehicle was placed in category (C), above, its dynamic properties would merit a considerably higher "rating" if the concerns over limitations in roadway geometrics did not apply--that is, if more generous geometric provisions were available in the selected road system.
- 9) Likewise, the turnpike double exhibits such high levels of dynamic performance that it would merit inclusion in group (A), if the concerns over limitations in roadway geometrics did not apply. For example, the use of turnpike doubles on turnpike facilities in the U.S., where easy access to breakdown areas are provided at the perimeter of the turnpike, appears to be a practice which is in harmony with the findings on the total performance characteristics of this vehicle.

Concerning the results of the parametric sensitivity studies, the following generalized conclusions can be drawn:

- 1) Variations in tractor wheelbase values should be considered as a significant element in determining the low-speed offtracking performance of truck combinations.
- 2) The "friction demand", F , experienced by tractor semitrailers during tight turning is found to be proportional to the term, $\Sigma (d_i^2/L)$, assuming that all trailer axles are equally loaded-- where (d_i) is the spread of each (i-th) individual trailer axle from the geometric center of the trailer axle group and L is the geometric wheelbase of the trailer.
- 3) Substantial variations in the dynamic response of truck combinations used in Canada occur due to differences in the mechanical properties of the alternative suspensions which are purchased.
- 4) An increase in the outside width across tractor axles from the current 2.44 m (96 in) to 2.59 m (102 in), thus matching the legal overall width allowance, would yield substantial improvements in dynamic performance.
- 5) Increased allowances for axle load yield substantial degradations in dynamic performance, unless the mechanical properties of suspensions and tires are altered to provide the needed compensation.
- 6) The dynamic performance of C-train doubles and triples degrades whenever the distance from the axle ahead of a dolly to the dolly axle, itself, is increased. This sensitivity applies to increases in both the overhang dimension (from trailer axle(s) to pintle hitches) and the length of the dolly drawbar (from pintle hitches to dolly axle(s)). It is particularly problematic to place the axle(s) on the lead trailer in a more forward position, such as with slider-bogie equipment. Such dimensional variations were shown to produce a divergent oscillation in the case of one C-train doubles combination having 8.2-m (27-ft) trailers. It is clear, however, that sensitivity to small changes in the location of hitches and axles declines with increasing trailer length.
- 7) Dolly devices which effect a roll-coupling between successive trailers of a vehicle combination will provide great benefit for dynamic roll stability in a

rapid path change maneuver as long as the coupling elements are sufficiently stiff in transmitting roll moments.

- 8) Operation of partially-loaded vehicles can introduce a profound loss in braking efficiency, especially in the case of doubles and triples combinations when one trailer is full and another is empty.
- 9) The almost-exclusive use of tandem-equipped tractors in long-haul trucking operations in Canada renders a situation in which the tractor's tandem axles are peculiarly underloaded, and thus overbraked, when single-axle trailers are hauled. Together with the practice of operating without front brakes, such arrangements pose rather severe limitations in braking performance. Indeed, there appears to be a need for educating the trucking community to adopt a more rational proportioning of brake torques to axle loads, generally.
- 10) An increase in trailer length and in particular, trailer wheelbase, will generally serve to improve the dynamic qualities of truck systems. Practical limits are imposed upon trailer lengths, however, by the need to avoid excessive levels of low-speed offtracking.
- 11) The compensating fifth wheel, in the version studied here, does not significantly degrade the stability and control performance of B-trains which incorporate the device as the inter-trailer coupling.

Concerning the study of vehicle dynamics, the following observations and recommended future study areas deserve special note:

- 1) When many differing multi-trailer combinations were examined for their most severe dynamic roll response to a harmonic steer input over period values ranging from 2.0 to 3.0 seconds, the great majority of cases showed the largest roll response at the 3.0-second value of input period. This result indicates that the phenomenon of rearward-amplified responses, which characterize A-trains with relatively short trailers, is more likely to be stimulated in day-to-day truck operations than previously thought (since an input period of 3.0 seconds is thought to be much closer to the normal spectrum of steer-input frequencies than the previously-studied 2.0-second input.)

It is recommended that the steering behavior of truck drivers be studied in real service so as to characterize the magnitude and frequency of the maneuvering demands which are imposed through steering control. Such a study would permit a clearer projection of the risks posed by specific vehicle responses and the potential safety benefits which would accrue from new developments in performance.

- 2) The transient overshoot in high-speed offtracking can be much larger than the steady-state value, particularly for vehicle cases which exhibit large levels of rearward amplification. Further, the nonlinear aspects of tire response to static loading and load transfer across an axle yield substantial degradation in high-speed offtracking performance beyond that predicted by linear models. These findings suggests that the potential for accidents involving this property may be considerably greater than previously assumed.

It is recommended that the significance of the high-speed offtracking response to safety be more vigorously examined, through closer scrutiny of the detailed accident record and through assessment of driver tracking strategies on curved roadways and ramps. There is a need for development of a method, and characteristic response data, for evaluating the extent of the transient overshoot in high-speed offtracking occurring when a vehicle makes an abrupt transition from a tangent to a curved path. Further, the transient overshoot response should be included on the list of important response categories, when characterizing the dynamic behavior of multi-trailer combinations.

- 3) The roll-steer kinematics of trailer suspensions play an important role in determining various yaw response characteristics of both single and multi-trailer combinations. Because the roll-steer mechanism is an exceedingly simple hardware matter, its optimization on behalf of improved dynamics in truck and trailer systems should be straightforward.

It is recommended that a systematic study be made of both the positive and negative influences of various roll-steer arrangements among trailer and dolly axle positions, with the prospect of recommending a standard practice for implementing roll-steer in the design of suspensions for trailing axles.

- 4) The mechanical properties of the truck tire play a fundamental role in determining almost every response property examined in this study. Research on various aspects of truck tire behavior has lagged, in the public arena, such that work is needed on a range of issues.

It is recommended that studies be made of the following aspects of truck tire mechanics:

- the relationship between lateral force production and vertical load at high levels of overload (such as correspond to the heavily-loaded tire during intermediate and severe maneuvering of trucks) for differing tire constructions and treadwear conditions. Also, the overturning-moment response of differing truck tires at high overload, with combined slip angle and inclination angle deserves study as part of the developing understanding on roll stability.
 - the problem of traction limits of truck tires under conditions of light load and wetted surfaces.
 - the mechanical characteristics of modern wide-base single tires and the implications of that behavior on the full range of vehicle dynamic response properties (recognizing that it is simply a matter of time before truck operations in North America begin to employ wide base tires as a replacement for duals).
- 5) The only significant performance limitation that was peculiar to the C-train configurations involved both steady-state and transient offtracking. It is clear that this response characteristic is heavily dependent upon the steer-centering properties of the C-train dolly. Further, the C-train configuration appears to warrant development as the obvious alternative to A-trains in general freight transportation (recognizing the desire for interchangeable trailers, detachable dollies, and van trailer configurations that can be conveniently loaded from the rear, at conventional loading docks).

It is recommended that a major effort be launched to wring out the various performance requirements for the C-train dolly and to seriously take on the development of this technology so as to achieve a broadly acceptable alternative to the A-dolly. This work should follow upon the results of the recent study of dolly concepts sponsored by the Federal Highway Administration in the U.S. [17]. The trucking industry should be encouraged to support such developments as a significant step toward improving the safety performance of multi-trailer combinations (and even as a step toward removing impediments to the wider acceptance of triples).

6.0 References

1. Fancher, P.S., et al. "Retarders for Heavy Vehicles: Evaluation of Performance Characteristics and In-Service Costs." Final Rept., Phase I, Contract No. DOT-HS-9-02239, Highway Safety Res. Inst., Univ. of Michigan, Rept. No. UM-HSRI-81-8, February 1981.
2. Ervin, R.D. et al. "Influence of Size and Weight Variables on the Stability and Control Properties of Heavy Trucks." Final Report, Contract No. FH-11-9577, Transportation Res. Inst., Univ. of Michigan, Rept. No. UMTRI-83-10, March 1983.
3. Hazemoto, T. "Analysis of Lateral Stability for Doubles." SAE Paper No. 730688, June 1973.
4. Ervin, R.D. and MacAdam, C.C. "The Dynamic Response of Multiply-Articulated Truck Combinations to Steering Input." SAE Paper No. 820973, August 1982.
5. Gillespie, T.D. and MacAdam, C.C. "Constant Velocity Yaw/Roll Program: User's Manual." Final Report, Transportation Res. Inst., Univ. of Michigan, Rept. No. UMTRI-82-39, October 1982.
6. MacAdam, C.C., et al. "A Computerized Model for Simulating the Braking and Steering Dynamics of Trucks, Tractor-Semitrailers, Doubles, and Triples Combinations -- User's Manual, Phase 4." Highway Safety Res. Inst., Univ. of Michigan, Rept. No. UM-HSRI-80-58, September 1, 1980.
7. Mathew, A. "Simple Models -- User's Manual." Transportation Res. Inst., Univ. of Michigan, February 1986.
8. Ervin, R.D., Mallikarjunarao, C., and Gillespie, T.D. "Future Configuration of Tank Vehicles Hauling Flammable Liquids in Michigan." Final report. HSRI, December, 1980. 2 vol. UM-HSRI-80-73. Sponsored by the Michigan Department of State Highways and Transportation.
9. Fancher, P.S., et al. "Tracking and Stability of Multi-Unit Truck Combinations." Final report. UMTRI. July 1984. 54 p. UMTRI-84-25. Sponsored by MVMA.
10. "Offtracking Characteristics of Trucks and Truck Combinations." Western Highway Institute, February 1970.
11. Bernard, J.E. and Vanderploeg, M. "Static and Dynamic Offtracking of Articulated Vehicles." SAE paper No. 800151, 1980.
12. Ervin, R.D., et al. "Ad Hoc Study of Certain Safety-Related Aspects of Double-Bottom Tankers." Final Rept., Highway Safety Res. Inst., Univ. of Michigan, Rept. No. UM-HSRI-78-18, Sponsored by Mich. State Office of Highway Safety Planning, Contract No. MPA-78-002A, May 7, 1978.
13. Fancher, P.S. "The Transient Directional Response of Full Trailers." SAE Paper No. 821259, November 1982.

14. Winkler, C.B., et al. "Parametric Analysis of Heavy Duty Truck Dynamic Stability." Vol. I, Technical report. Transportation Res. Inst., Univ. of Michigan, Rept. No. UMTRI-83-17, March, 1983. Sponsored by NHTSA, Contract No. DTNH22-80-C-07344.
15. Strandberg, L., et al. "Safety Problems in Commercial Vehicle Handling." Proceedings of a Symposium on Commercial Vehicle Braking and Handling, Highway Safety Res. Inst., Univ. of Michigan, May 5-7, 1975, Rept. No. UM-HSRI-PF-75-6, 1975, pp. 463-528.
16. Mischke, A., et al. "Contribution to the Development of a Concept of Driving Mechanics for Commercial Vehicles." SAE Paper No. 830643, February 1983.
17. Winkler, C.B., et al. "Improving the Dynamic Performance of Multi-Trailer Vehicles: A Study of Innovative Dollies." Final Technical Report. Transportation Res. Inst., Univ. of Michigan, Rept. No. UMTRI-86-26 (expected September, 1986). Sponsored by FHWA, Contract No. DTFH61-84-C-00026.
18. Morrison, W.R.B. "A Swept Path Model Which Includes Tyre Mechanics." Proceedings, 6th Conference, Australian Road Research Board, Vol. 6, Part 1, Canberra, 1972.
19. Gillespie, T.D. and Winkler, C.B. "On the Directional Response Characteristics of Heavy Vehicles." Proceedings of the 5th VSD-2nd IUTAM Symposium, Vienna, Austria, September, 1977, pp. 165-183.
20. Ervin, R.D., and Gillespie, T.D. "Safety and Operational Impacts of 53-foot Truck Trailer Combinations." Final Report. Transportation Res. Inst., Univ. of Michigan, Rept. No. UMTRI-86-13, March 25, 1986. 208 p. Sponsored by the Michigan Department of Transportation.
21. Ervin, R.D. and Guy, Y. "Axioms Relating Size and Weight to Vehicle Controllability" (Presented at the International Symposium on Heavy Vehicle Weights and Dimensions, June 8-13, 1986, Kelowna, B.C., Canada.).
22. "A Policy on Geometric Design of Highways and Streets.", 1984. AASHTO, Washington, D.C. 1087 p.
23. Ervin, R.D. "The Influence of Size and Weight Variables on the Roll Stability of Heavy Duty Trucks." SAE Paper No. 831163, August 1983.
24. Ervin, R.D. and Nisonger, R.L. "Analysis of the Roll Stability of Cryogenic Tankers." Final Report. Highway Safety Res. Inst., Univ. of Michigan, Rept. No. UM-HSRI-82-32, September 1982. Sponsored by Union Carbide Corporation, Linde Division.
25. Mai, L. and Sweatman, P. "Articulated Vehicle Stability - Phase II: Tilt Tests and Computer Model." Australian Road Research Board, Rept. No. AIR 323-2, March 1984/
26. Ervin, R.D., et al. "The Yaw Stability of Tractor-Semitrailers During Cornering." Final Report, Contract No. DOT-HS-7-01602, Highway Safety Res. Inst., Univ. of Michigan, Rept. No. UM-HSRI-79-21, June 1979.

27. Woodrooffe, J.H.F. "Accident Investigation Report." National Research Council, Division of Mechanical Engineering, Report TR-RW-1, June 1984.
28. Ervin, R.D., and Winkler, C.B. "Estimation of the Probability of Wheel Lockup" (Presented at the Third International Association of Vehicle Design Congress on Vehicle Design and Components, March 3-6, 1986, Geneva, Switzerland.).
29. Clark, S.K. "Mechanics of Pneumatic Tires." Univ. of Michigan / NHTSA, DoT-HS-805-952, August 1981 (U.S. Government Printing Office, Washington, D.C. 20402).
30. Heath, W.M. "California Tank Truck Accident Survey - February 1, 1980 to January 31, 1981." California Highway Patrol, Sacramento, December 1981.
31. Consolidated Freightways Corp. of Delaware vs. Larson, et al., Civil No. 81-1230 (M.A.P.A., Filed October 27, 1981), Exhibits 1010 through 1024 and 1070 through 1094.
32. Ervin, R.D. and Winkler, C.B. "Private Communications with Operators of Petroleum Transport A-Trains in Western Canada."
33. Kemp, R.N., et al. "Articulated Vehicle Roll Stability: Methods of Assessment and Effects of Vehicle Characteristics." Transport and Road Research Laboratory, Rept. No. TRRL 788, Crowthorne, England, 1978.
34. Miller, D.W.G. and Barter, N.F. "Roll-Over of Articulated Vehicles." Inst. of Mech. Engrs., Paper No. C203/73, March 1973.
35. Isermann, H. "Overturning Limits of Articulated Vehicles with Solid and Liquid Loads." Motor Industry Research Assoc., Translation No. 58/70, 1970.
36. Nordstrom, O. and Nordmark, S. "Test Procedures for the Evaluation of the Lateral Dynamics of Commercial Vehicle Combinations." Automobil Industrie, Vol. 23, No. 2, June 1978, pp. 63-69.
37. Delisle, G. "Investigating Articulated Vehicle Roll Stability Using a Tilt Table" (Presented at the International Symposium on Heavy Vehicle Weights and Dimensions, June 8-13, 1986, Kelowna, B.C., Canada.).
38. "Truck Trailer Shipments." (Source: Current Industrial Reports of U.S. Bureau of Census) Compiled by the Truck Trailer Manufacturers Assoc., Alexandria, Virginia. Published Annually.
39. Ervin, R.D., et al. "Impact of Specific Geometric Features on Truck Operations and Safety at Interchanges." Final report. UMTRI, Aug 1985. 2 vol. UMTRI-85-53. Sponsored by FHWA.
40. "Highway Accident Report, Houston, Texas, May 11, 1976." NTRB Rept. No. NTSB-HAR-77-1, Washington, D.C.
41. Olson, P.L., et al. "Parameters Affecting Stopping Sight Distance." UMTRI. National Cooperative Highway Research Program Report No. 270, June 1984.

42. Radlinski, R.W. and Williams, S.F. "NHTSA Heavy Duty Vehicle Brake Research Program: Report No. 1 -- Stopping Capability of Air Braked Vehicles; Volume 1 -- Technical Report." NHTSA, Interim Report DOT-HS-806-738, April 1985.
43. Pending Report entitled, "Heavy Truck Study" by NHTSA to the U.S. Congress, pursuant to Section 216 of the Motor Carrier Safety Act of 1984 -- Publication expected September, 1986.