

# MECHANICAL CHARACTERISTICS OF TRUCK TIRES DURING COMBINED SLIP

C. B. Winkler  
S. Bogard  
Z. Bareket

Final Technical Report to  
The Motor Vehicle Manufacturers Association

MVMA Project #2165

April, 1992



Technical Report Documentation Page

1. Report No. UMTRI-92-33		2. Government Accession No.		3. Recipient's Catalog No.	
4. Title and Subtitle MECHANICAL CHARACTERISTICS OF TRUCK TIRES DURING COMBINED SLIP				5. Report Date August, 1992	
				6. Performing Organization Code	
7. Author(s) Winkler C.B., Bogard S., and Bareket Z.				8. Performing Organization Report No. UMTRI-92-33	
9. Performing Organization Name and Address The University of Michigan Transportation Research Institute 2901 Baxter Road, Ann Arbor, Michigan 48109				10. Work Unit No. (TRAIS)	
				11. Contract or Grant No. MVMA #2165	
12. Sponsoring Agency Name and Address Motor Vehicle Manufacturers Association 7430 2nd Avenue, Suite 300 Detroit, MI 48202				13. Type of Report and Period Covered Final Technical Report July 1, 1991 to June 30, 1992	
				14. Sponsoring Agency Code	
15. Supplementary Notes					
16. Abstract <p>Combined slip testing of three heavy-truck tires using the UMTRI mobile tire tester was accomplished. The testing constituted a pilot activity to investigate the influence of test induced wear and to try to establish an appropriate test matrix for combined slip testing. Data indicated that the work done on the tire during testing had a significant influence on measured behavior. The expected change in traction behavior due to test-induced wear is clearly illustrated. There is also evidence that short-term work history (i.e., insufficient to cause significant wear) can significantly influence traction behavior.</p> <p>The findings of this project have implications for future efforts. There is clearly a need to modify the Mobile Tire Tester to allow the efficient conduct of testing in a manner less sensitive to the test-induced wear process. The results of this work have been shared with the members of the SAE Truck Tire Task Force and used to prepare a work plan for further tire testing.</p>					
17. Key Words tire, traction, braking, lateral slip, longitudinal slip, combined slip, tire testing			18. Distribution Statement		
19. Security Classif. (of this report)		20. Security Classif. (of this page)		21. No. of Pages 93	22. Price

10/10/10

## **DISCLAIMER**

The research reported herein was conducted using funds provided by the Motor Vehicle Manufacturers Association. The findings, conclusions, and opinions set forth are those of the authors, not necessarily those of MVMA.

11/11/11

## TABLE OF CONTENTS

<i>SECTION</i>	<i>PAGE</i>
INTRODUCTION .....	1
MOBILE TIRE TESTING PROCEDURES .....	1
TEST MATRIX .....	2
TIRE DATA.....	5
WEAR AND THE INFLUENCE OF WEAR .....	6
PLANS FOR FURTHER WORK .....	13
REFERENCES.....	15
APPENDIX 1 — EXPLANATION OF THE CARPET PLOT FORMAT .....	17
APPENDIX 2 — TIRE DATA, GOODYEAR G159 295/75R22.5, LOAD RANGE G, UMTRI ID 32.....	19
APPENDIX 3 — TIRE DATA, GOODYEAR G159 295/75R22.5, LOAD RANGE G, UMTRI ID 34.....	49
APPENDIX 4 — TIRE DATA, GOODYEAR G159 295/75R22.5, LOAD RANGE G, UMTRI ID 31.....	53
APPENDIX 5 — SAE TRUCK TIRE TASK FORCE: TRUCK TIRE CHARACTERIZATION; STATEMENT OF WORK .....	75

00000000



## **Introduction**

Under this project, UMTRI conducted a program of combined slip testing of three heavy-truck tires using the Mobile Tire Tester. The testing conducted constituted a pilot activity to investigate the influence of test-induced wear and to try to establish an appropriate test matrix for combined slip testing. This activity yielded remarkable data indicating that work done on the tire during testing has a significant influence on measured behavior. The expected change in traction behavior due to test-induced wear is clearly illustrated. But, there is also evidence that short-term work history (i.e., insufficient to cause significant wear) can significantly influence traction behavior.

The findings of this project have significant implications for future efforts. There is clearly a need to modify the Mobile Tire Tester to allow the efficient conduct of testing in a manner less sensitive to the test-induced wear process. The results of this work have been shared with the members of the SAE Truck Tire Task Force and used to prepare a work plan for further tire testing. UMTRI expects to modify the Mobile Tire Tester in the fall and winter of 1992, and conduct a substantial tire-test program under SAE funding in the spring of 1993.

The original plan for this project included considerably more tire testing than was actually achieved. Elements of the project which consumed more resources than expected included modifying and maintaining the Mobile Tire Tester hardware, the very considerable effort required to develop software for post-processing of test data., and the learning process involved in testing itself. In the end, the actual tire testing process was more expensive than expected, also.

## **Mobile Tire Testing Procedures**

With the current configuration of the Mobile Tire Tester, each test run is conducted at one nominal value of vertical load and one nominal value of velocity. Each run may include one or more values of slip angle and may or may not included a braking cycle (to lockup) at each slip angle.

In conducting a run, the operator initially decides on the run program consisting of the vertical load, velocity, slip-angle values, and braking/no braking. The driver is charged with establishing the proper velocity. The vertical load condition is established by setting the appropriate pressure setting in the air regulating system, which will charge the air springs which load the test axle. The desired slip-angle values are entered into the system-control computer program as is the braking/no braking command.

A run begins with the vehicle traveling at speed and with the test axle elevated above the road. Initial steer angle is zero degrees. The axle is lowered and loaded to the appropriate level. Then the control program is started. The steer system moves quickly to the first desired slip angle. At that slip angle, the tire travels two revolutions before data collection begins. Then data is collected for two revolutions with no braking. If braking is requested, the brakes are applied with a constant ramp pressure application. When the control system senses slip above a preestablished level, the brakes are released. (Control parameters are set in an attempt to achieve more than 90% slip, but to have virtually no dwell at full lock.) Now the tire steers quickly to the next slip angle and repeats the process. When data has been gathered at all requested slip angles, the tire steers back to the zero position and the operator is signaled that the run is complete.

In this process, test axle braking can slow the vehicle appreciably, at higher axle loads and velocities, reasonable maintenance of test speed may limit the process to one slip angle per run. After the run the driver must reestablish the proper speed.

## **Test Matrix**

The initial matrix for testing is shown in table 1 and is composed of some 63 runs. This matrix represents an examination of lateral, longitudinal, and combined slip performance at five loads (3000 through 10,000 lb.), three velocities (20, 40, 60 mph.), and slip angles from -1 to 6 deg. (lateral slip at -1, 0, 1, 2, 4, 6 and combined slip at 2,4,6 deg.). Additional tests are conducted at 8 and 12 deg. at two loads and one velocity.

Generally, this matrix does not include repeat runs. However, spaced through the matrix are a number of check runs meant to allow tracking of the influence of test-induced wear. These are conducted at the baseline condition of a 6000 lb. load and 40 mph. The two check runs are (1) lateral slip at 2,4, and 6 deg., and (2) longitudinal slip (braking at 0 deg.). The check runs are indicated by the shading in table 1.

The first part of the matrix (runs 1 through 24) involves pure lateral and pure longitudinal slip tests, but no combined slip. The remainder of the runs examine combined slip (except, of course, for the check runs).

It was assumed that the amount of testing indicated in table 1 would be excessive for one tire sample. That is, this amount of activity would be expected to wear the tire appreciably and therefore alter the measured results. The intent of running a single tire through the complete matrix was to examine just that matter.

Table 1. Test Run Schedule for Series 1

Sheet 1 of 2

Run No.	Vertical load kilo lb	Velocity mph	Slip Angle degrees	Braking (y or n)	Comment
1	6	40	-1,0,1,2,4,6	n	Check Runs (measure tread depth)
2	6	40	0	Y	
3	2	40	-1,0,1,2,4,6	n	Lateral and Longitudinal
4	2	40	0	Y	
5	4	40	-1,0,1,2,4,6	n	
6	4	40	0	Y	
7	8	40	-1,0,1,2,4,6	n	
8	8	40	0	Y	
9	10	40	-1,0,1,2,4,6	n	
10	10	40	0	Y	
11	6	40	0,2,4	n	Check Runs (measure tread depth)
12	6	40	0	Y	
13	4	60	-1,0,1,2,4,6	n	Lateral and Longitudinal
14	4	60	0	Y	
15	6	60	-1,0,1,2,4,6	n	
16	6	60	0	Y	
17	8	60	-1,0,1,2,4,6	n	
18	8	60	0	Y	
19	4	20	-1,0,1,2,4,6	n	
20	4	20	0	Y	
21	6	20	-1,0,1,2,4,6	n	
22	6	20	0	Y	
23	8	20	-1,0,1,2,4,6	n	
24	8	20	0	Y	
25	6	40	0,2,4	n	Check Runs (measure tread depth)
26	6	40	0	Y	
27	10	40	2	Y	Combined Slip Runs
28	10	40	4	Y	
29	10	40	6	Y	
30	2	40	2,4,6	Y	Split to keep del V $\approx$ 5mph or less
31	6	60	2,4,	Y	
32	6	60	6	Y	
33	6	20	2,4,	Y	
34	6	20	6	Y	
35	6	40	0,2,4	n	Check Runs (measure tread depth)
36	6	40	0	Y	
37	4	20	2,4,	Y	Combined Slip Runs
38	4	20	6	Y	
39	8	20	2	Y	
40	8	20	4	Y	Split to keep del V $\approx$ 5mph or less
41	8	20	6	Y	
42	4	60	2,4,	Y	
43	4	60	6	Y	

Run No.	Vertical load kilo lb	Velocity mph	Slip Angle degrees	Braking (y or n)	Comment
44	8	60	2	Y	
45	8	60	4	Y	
46	8	60	6	Y	
47	6	40	0,2,4	n	Check (measure, tread depth) Runs
48	6	40	0	Y	
49	4	40	2,4	Y	Combined Slip Runs Split to keep del V ≈ 5mph or less
50	4	40	6	Y	
51	6	40	2,4	Y	
52	6	40	6	Y	
53	8	40	2	Y	
54	8	40	4	Y	
55	8	40	6	Y	
56	6	40	0,2,4	n	Check (measure tread depth) Runs
57	6	40	0	Y	
58	4	40	8,12	Y	Combined Slip Runs Split to keep del V ≈ 5mph
59	6	40	8,12	Y	
60	8	40	8	Y	
61	8	40	12	Y	
62	6	40	-1,0,1,2,4,6	n	Check (measure tread depth) Runs
63	6	40	0	Y	

## Tire Data

Two tires have been subject to the complete matrix (in chronological order, UMTRI ID 32 and 31) and a third was subject to the first section of pure lateral and longitudinal testing (UMTRI ID 34). (This tire was ruined by a sustained lockup in run 27.) All three tires were Goodyear model G159 tires, size 295/75R22.5, load range G.

Data plots of the results of these tests are appended. The plots include:

Carpet plots <sup>1</sup>	Side force vs slip angle and vertical load, one plot for each velocity
$\mu$ -slip curves	Normalized longitudinal force vs longitudinal slip, a graph for each velocity with a line plotted for each vertical load, and a graph for each load with a line plotted for each velocity.
F <sub>y</sub> /F <sub>z</sub> under combined slip	Normalized lateral force vs longitudinal slip, a graph for each load and velocity condition with a line plotted for each slip angle.
F <sub>x</sub> /F <sub>z</sub> under combined slip	Normalized longitudinal force vs longitudinal slip, a graph for each load and velocity condition with a line plotted for each slip angle.

In producing the carpet plots, a test run produces a single data point from each segment of free rolling data. Thus, these points have a certain "averaging" quality since data is gathered for two full revolutions. The many check run data points are apparent on the 6000-lb. load line of the 40 mph carpet graphs. Duplicate points at other points on the carpet plots come mostly from the initial free rolling segment of the combined slip runs. The carpet plots show well ordered data of the general form expected. The influence of wear hinted at by the scatter in the check-run data will be discussed later.

The longitudinal and combined slip data are gathered during the transient braking cycle. Each line on these types of plots represents the "instantaneous" data taken during a single braking cycle. Thus there is no averaging quality to these data; the higher noise level is apparent.

The longitudinal data shown in the  $\mu$ -slip curves show the expected shape as well as the expected influence of vertical load and velocity. That is, F<sub>x</sub>/F<sub>z</sub> is generally larger for light loads and for low speeds. The load influence extends over the range of loads examined. The velocity influence is strongest from 20 to 40 mph.

---

<sup>1</sup> See Appendix 1 for a brief discussion of the carpet-plot format.

The combined slip plots are of the expected form. The plots of  $F_x/F_z$  show that increasing slip angle reshapes the  $\mu$ -slip curve in the area of peak friction, but has very little influence on slide friction. The effect on the peak is to moderately lower the peak-friction value and to cause it to occur at higher values of slip. One interesting aspect of these plots is that the maximum value of  $F_x/F_z$  often occurs with 2-deg. slip angle rather than with 0-deg. slip. While this at first seems odd, CALSPAN reports observing similar behavior.[1]<sup>2</sup>

The combined slip plots which show  $F_y/F_z$  are also of the expected form. These data show the severe degrading influence that high values of longitudinal slip have on side force generation.

### **Wear and the Influence of Wear**

Figures 1 and 2 illustrate the wear of tires 32 and 31, respectively, as they were subject to the test matrix of table 1. Wear measures were taken at each set of check runs to track wear through the matrix. At first, tread depth was measured at 16 points—in each of the four tread grooves at 90 deg. intervals about the circumference of the tire. Later this was increase to 32 positions by using 45 deg. intervals.

The figures each contain two graphs. The upper graph shows tread profile by plotting the average of each groove depth (average of four or eight circumferentially spaced measures). The lower plot shows flat spotting by plotting the average depth at each circumferential position (average of four grooves).

In general, it can be seen that the amount of testing in one pass through the matrix consumed about 1/4 to 1/3 of the tread depth. The asymmetric properties of the Mobile Tire Tester (-1.5 to 15 deg. slip) produced some conicity in the tread profile. The 100% slip braking resulted in significant flat spotting of the tire.

Figures 3 and 4 show the influence of general wear and conicity on cornering stiffness. The upper graph shows the change in cornering stiffness from the check-run data over the course of the matrix of tests. The graphs show two interesting behaviors. First, when the tire is new it appears to be rather stiff, but by the second check run, it is much softer. Note that both of these tires had been broken in prior to any testing by running them for two hours at rated load and 30 mph (on a laboratory road wheel). Nevertheless, a clear change takes place in the early testing of the tire. (A similar effect has been observed by Marshall, et.al. in passenger car tires.[2] They also found a significant decrease in cornering

---

<sup>2</sup> Numbers in brackets refer to bibliographic references listed on page 15.

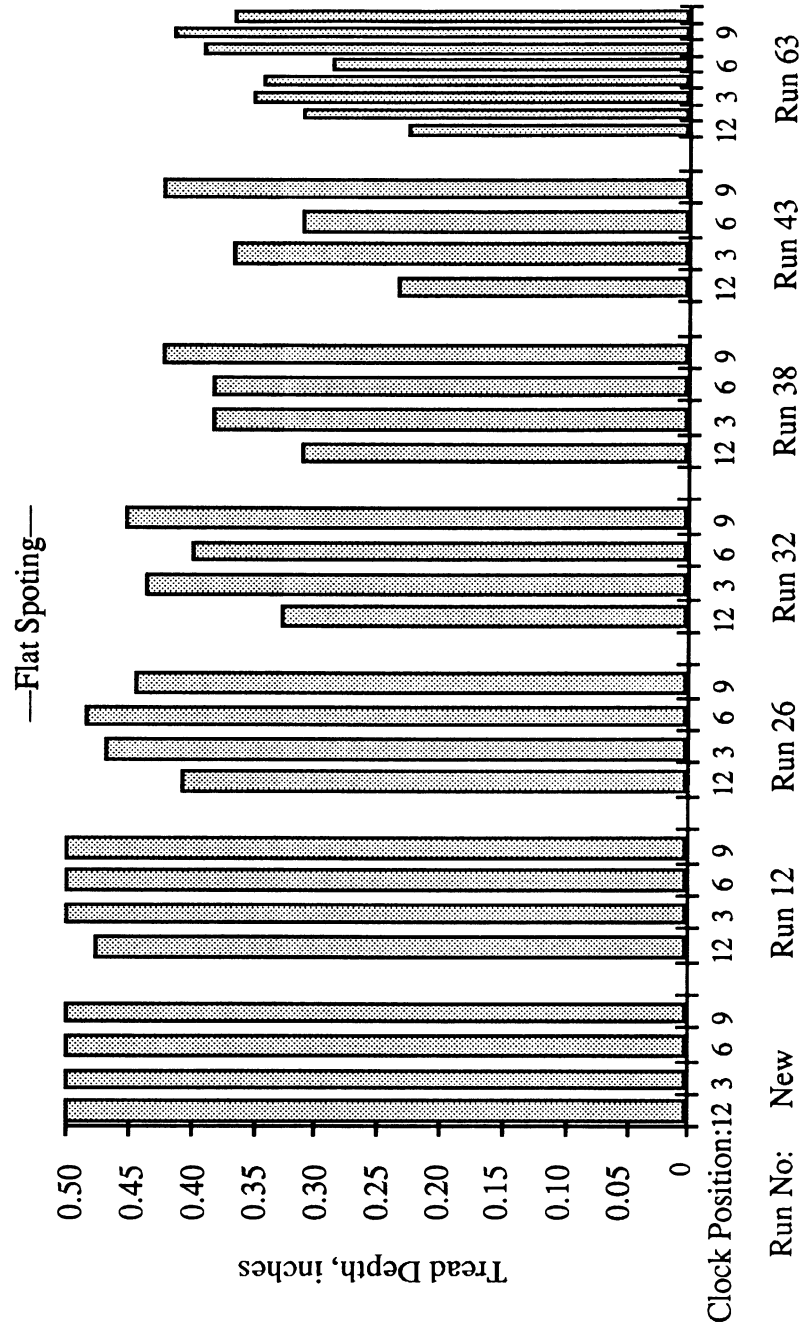
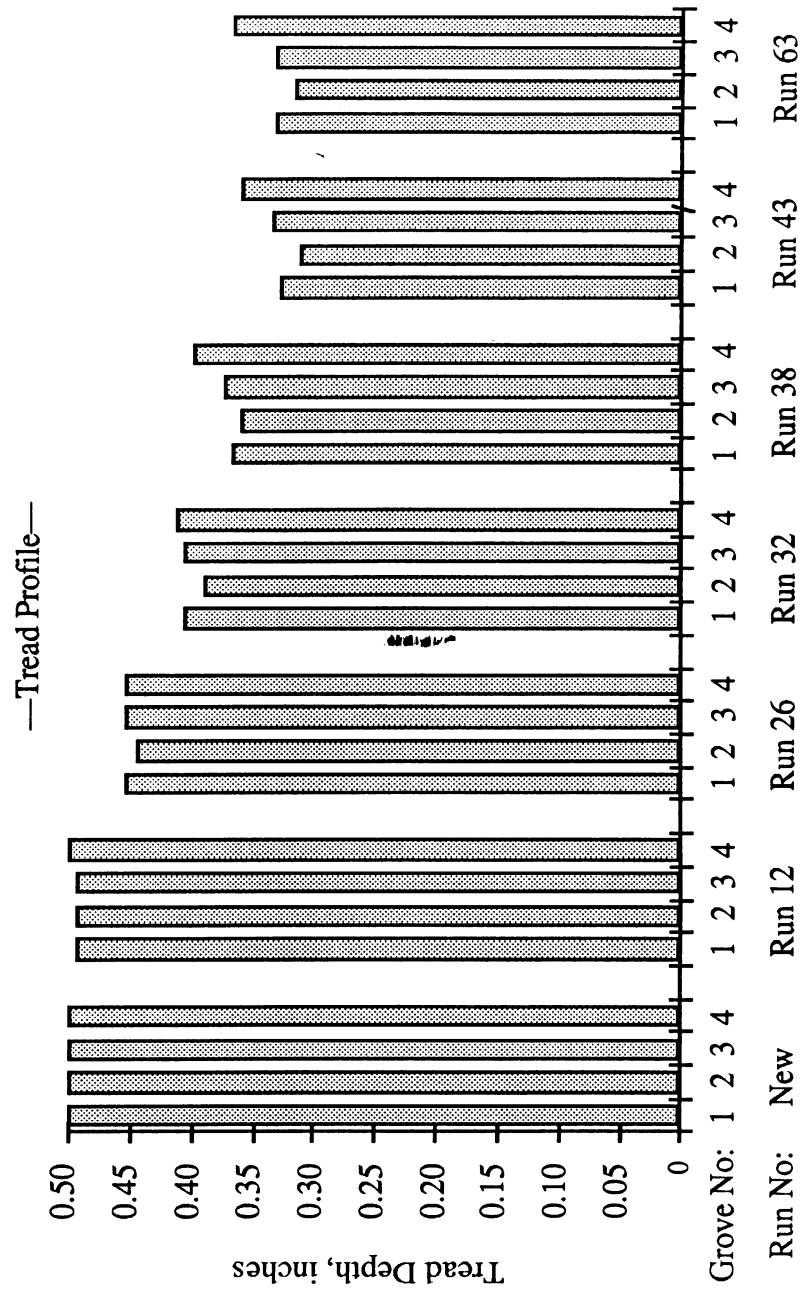

Figure 1. Tire Wear With Testing of Tire ID 32 (#2)

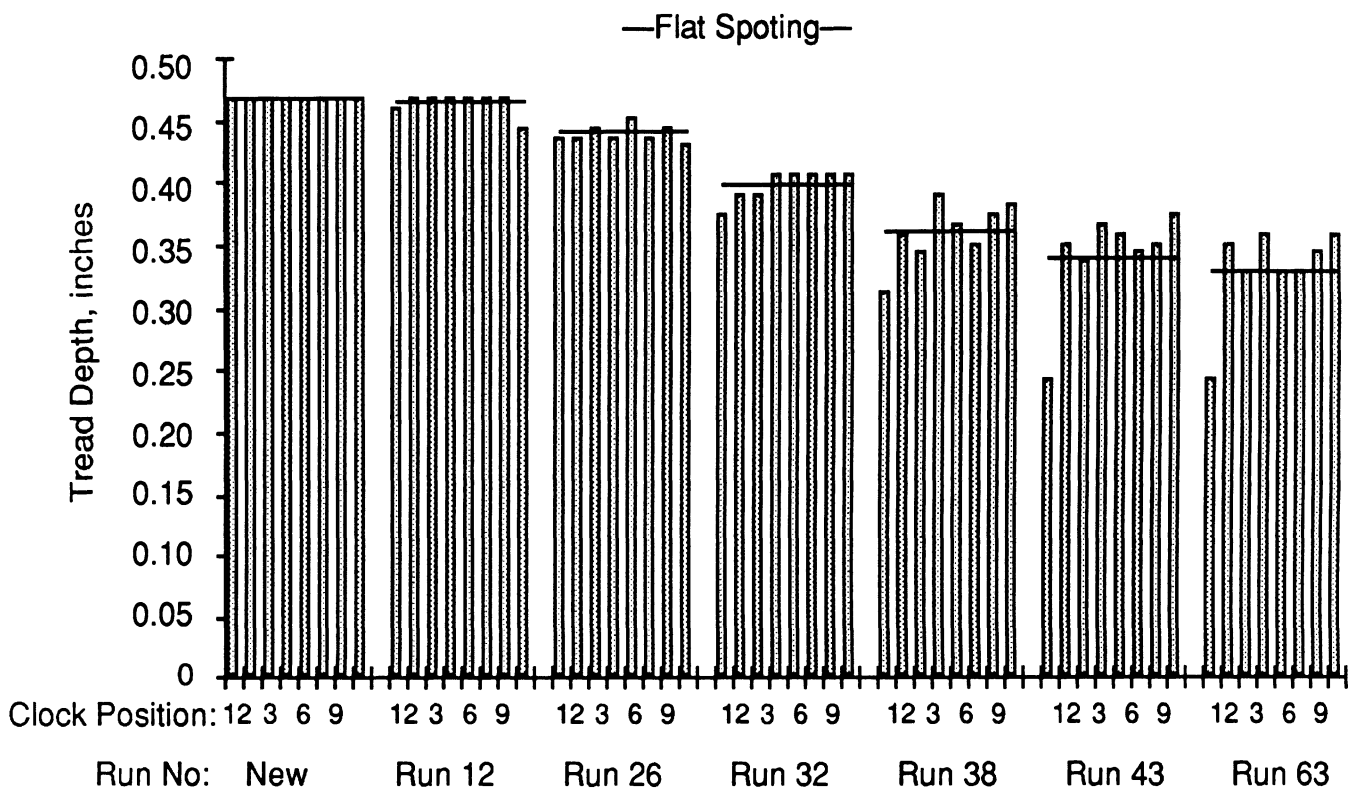
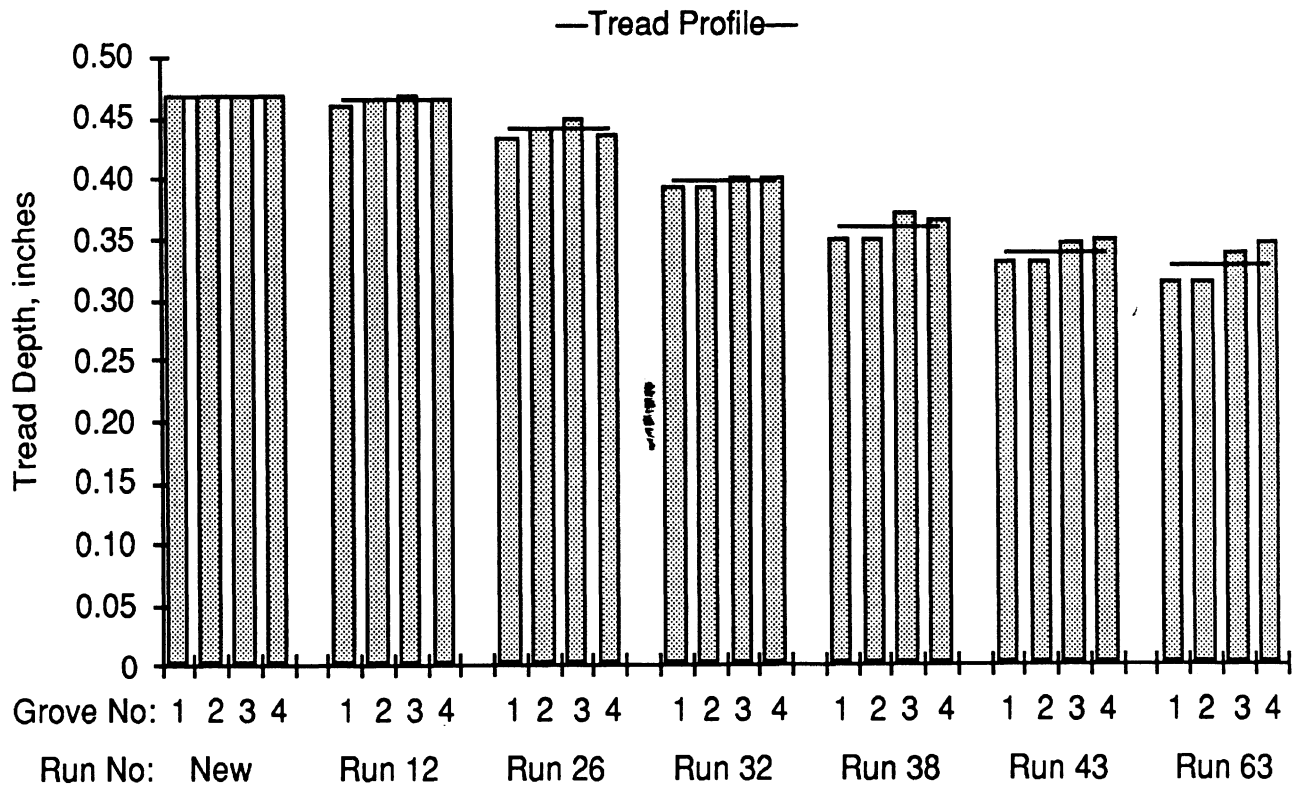

Figure 2. Tire Wear With Testing of Tire ID 31 (#4)



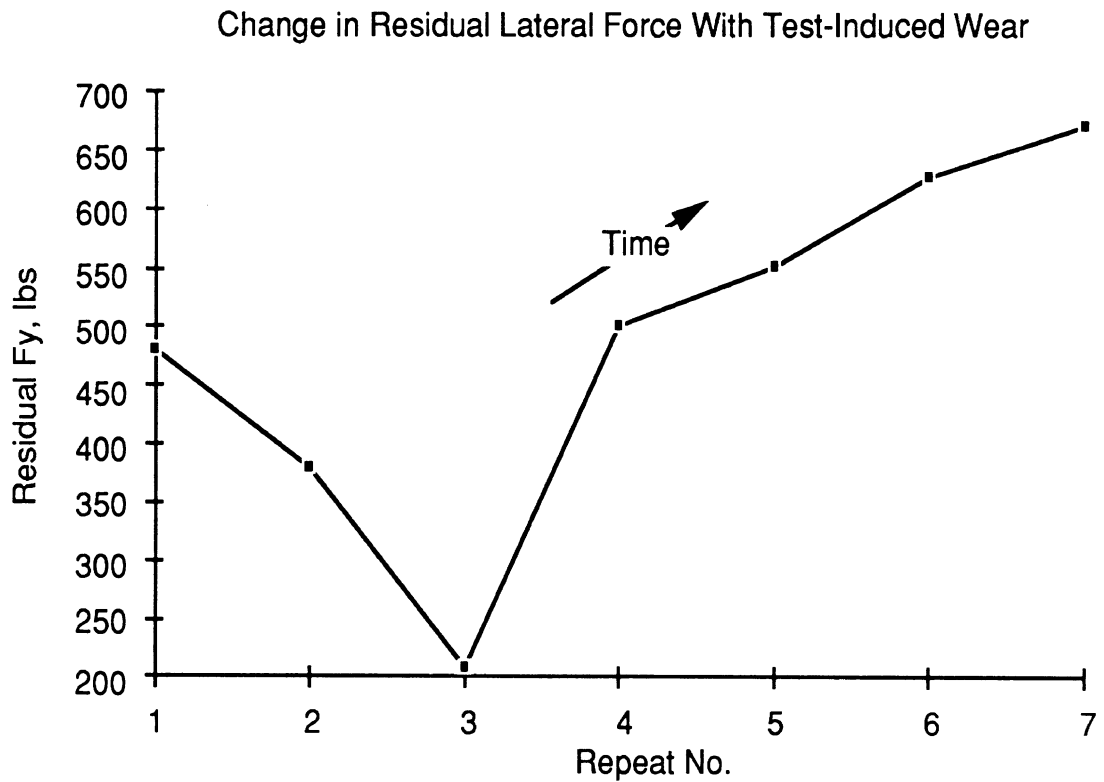
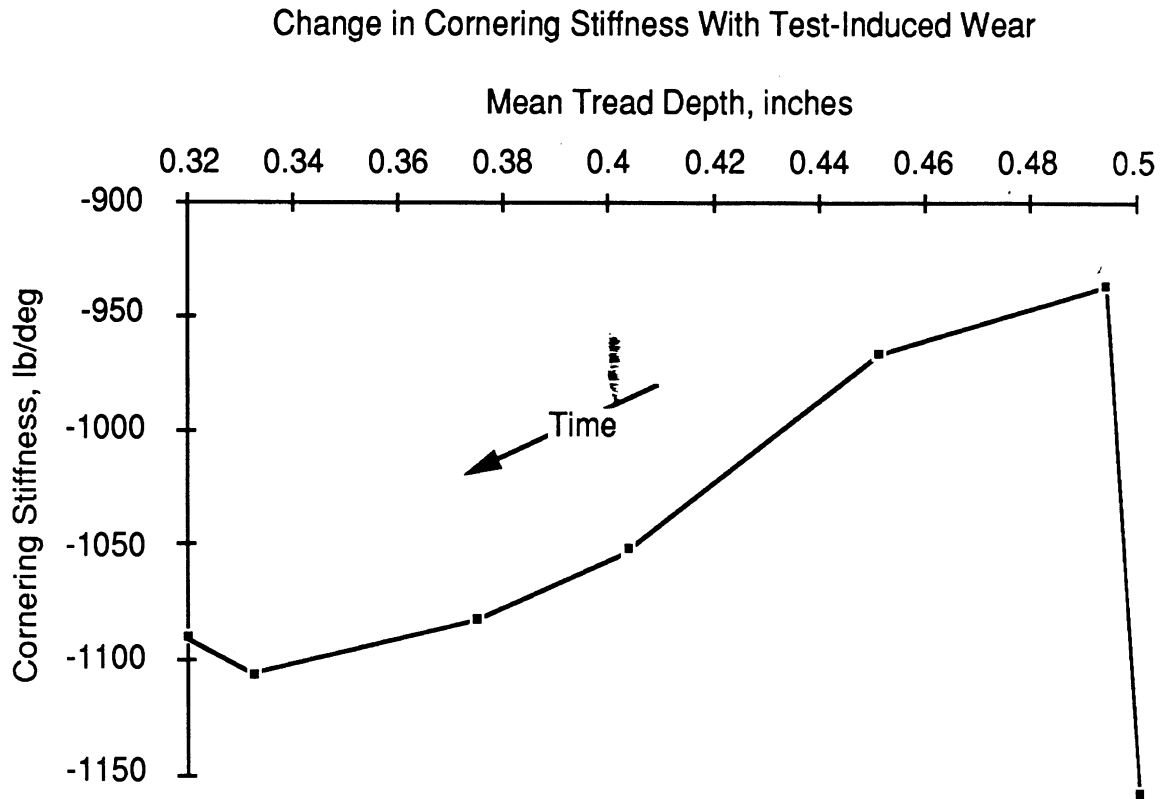

Figure 3. Influence of Test-Induced Wear on Lateral Response Parameters, Tire ID 32 (#2)

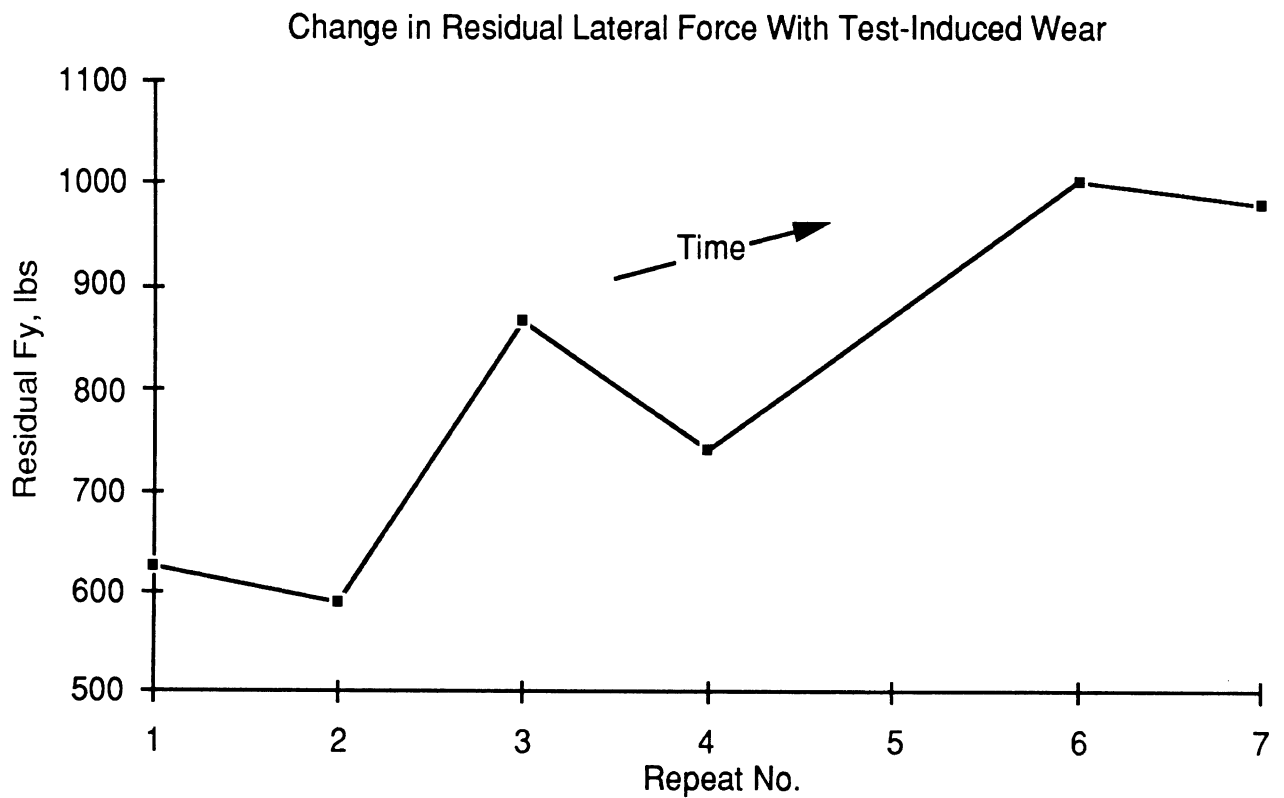
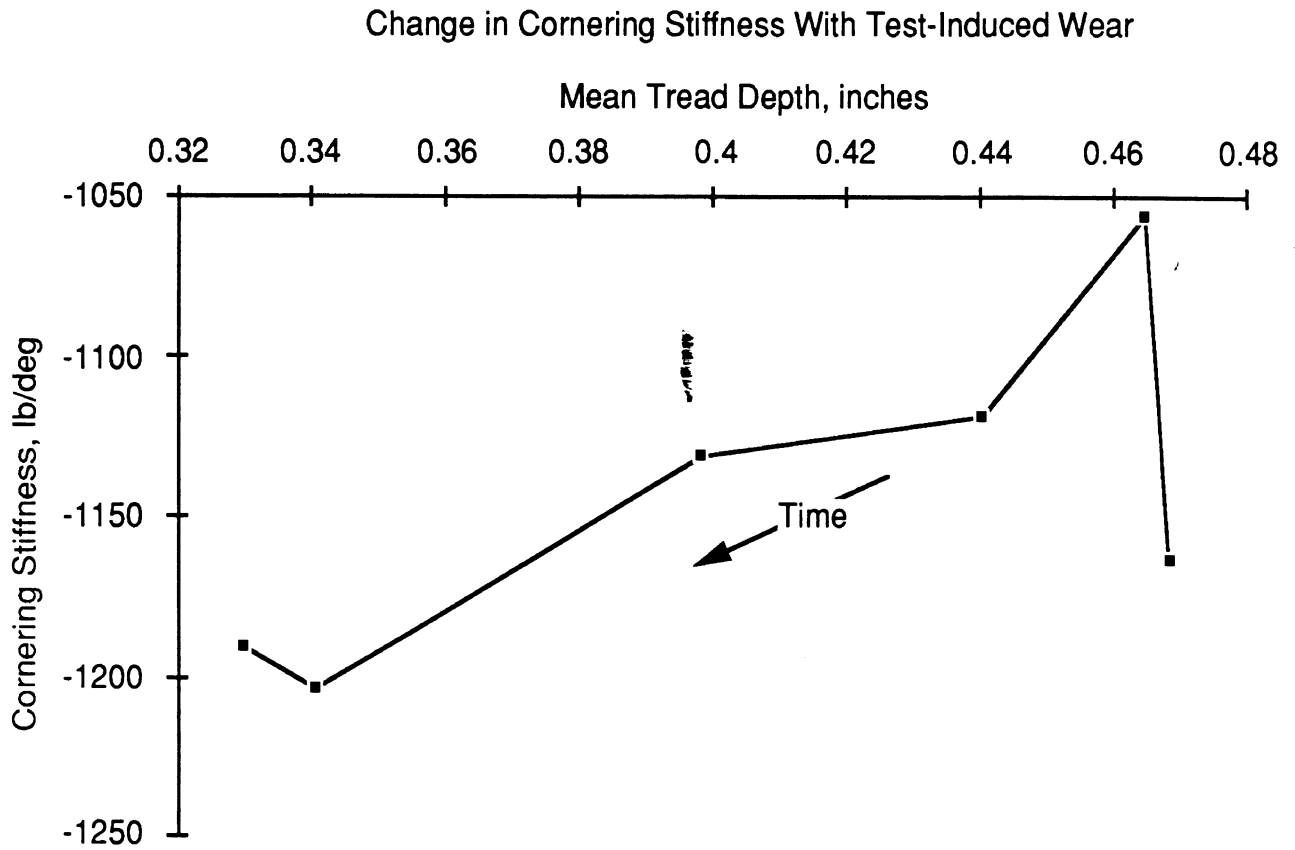

Figure 4. Influence of Test-Induced Wear on Lateral Response Parameters, Tire ID 31 (#4)

stiffness upon the first application of high lateral slip. The observed behavior here seems similar.)

The second behavior is the clear increase in cornering stiffness with tread wear. This is consistent with previous measurements made on the UMTRI flatbed machine. We have observed that, typically, cornering stiffness may increase 30 to 40% as the tire wears from new to 1/3 of new-tread depth.

The lower graph shows that residual lateral force ( $F_y$  at zero slip angle) increases during the course of testing as the wear conicity increases. As expected, there is a clear tendency for the cornering stiffness of the tire to increase with wear. Also, the residual lateral force of the tire increases over the course of testing, presumably due to the asymmetric slip history and conical wear patterns.

Figures 5 and 6 show the influence of test wear on the longitudinal friction properties of the tire. The plots show peak and slide friction versus average tread depth for the two tires. There seems to be little or no significant trends in these data. At most, there may be a mild tendency for peak friction to increase as testing proceeds and the tire wears.

These data suggest that testing on a given tire should be limited, and the full matrix completed by using more than one tire. That raises the question of how repeatable results are from tire to tire. Figure 7 shows carpet plots (6000 lb. and 40 mph.) of the three test tires (31, 32, 34) superimposed. The data for each of the three tires were collected in accordance with the test schedule of table 1. Clearly, the difference between tires is at least on the order of the change in properties of one tire. (It should be pointed out that these tires were tested on an outdoor facility on different days at substantially different temperatures, etc.)

The data thus far show a substantial bias of lateral force, even with the tires in their new state. While new tires are not expected to be perfectly symmetric, the residual side force at zero slip seemed high.

Slip-angle measurement on the Mobile Tire Tester is made by measuring the steer angle of the test tire relative to the vehicle frame and assuming that the vehicle slip angle is negligible. It was hypothesized that the large residual side force observed could be partly the result of an appreciable vehicle side slip, and, thus a bias in slip-angle measurement. A "trolley" side slip transducer was fabricated using a velocity fifth-wheel arrangement with an angle transducer to sense the absolute steer angle of the fifth-wheel with respect to the mobile-tire-tester longitudinal axis. Limited measurements indicated the steady-state side slip angle of the Mobile Tire Tester on the test facility to be about 0.2 deg. This would account for about 40% of the residual side force observed in new tires.

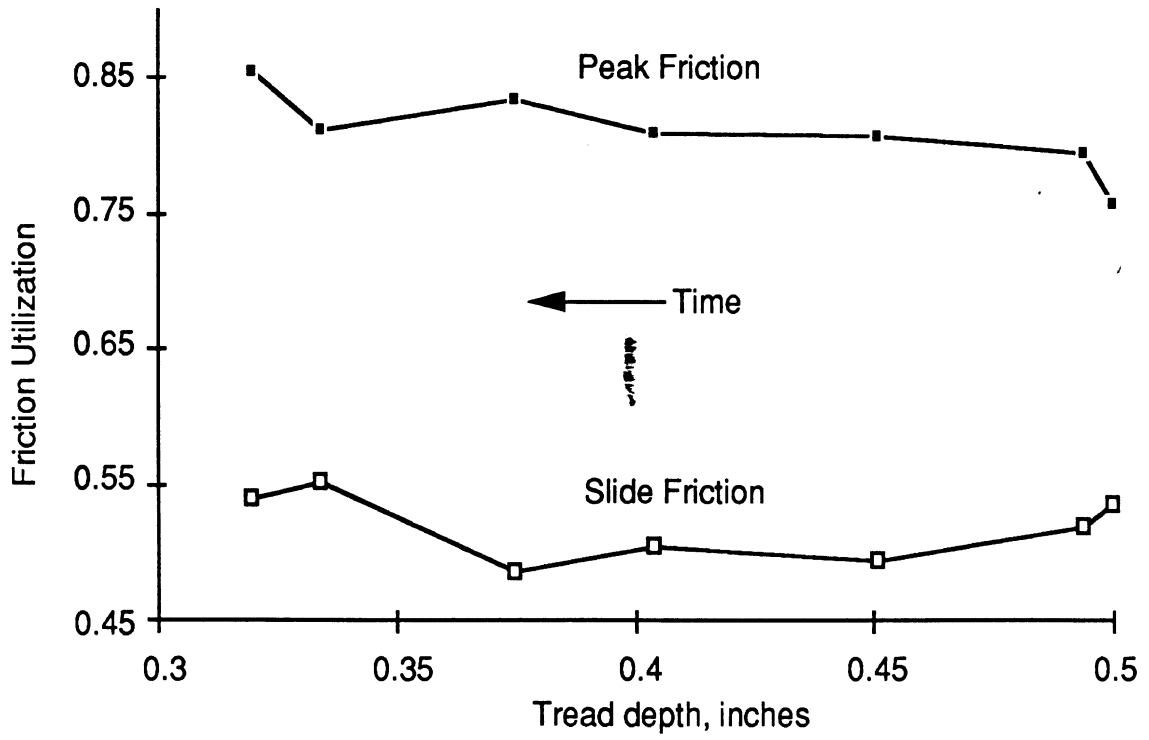

Figure 5. Influence of tread wear on friction utilization for tire UMTRI ID 32 (#2)

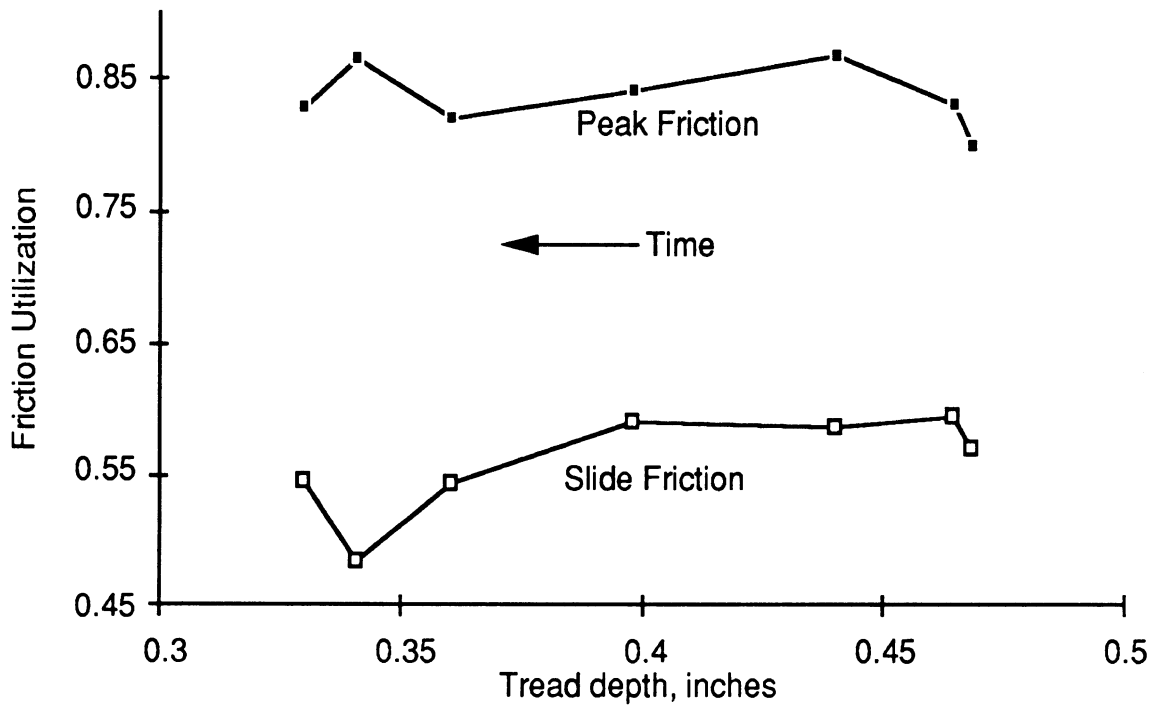

Figure 6. Influence of tread wear on friction utilization for tire UMTRI ID 31 (#4)

## Plans for Further Work

UMTRI is now participating in a joint effort, directed by the SAE Truck Tire Task Force, aimed at the development of heavy-truck-tire testing procedures. The program will be funded from several sources, including NHTSA, RMA, and MVMA and will be implemented through the SAE Truck Tire Task Force. UMTRI, with the Mobile Tire Tester, and CALSPAN, with TIRF, will both participate. Smithers Scientific, in the person of Marion Pottinger will oversee the project and analyze results.

The statement of work developed by the Tire Task Force is attached as appendix 5. This document describes a substantial program whose stated objectives are to develop "meaningful tire characterization test procedures and quantify their repeatability..." To do this, a very substantial program of tire testing is defined. The program includes rather strict instructions for tire storage, break-in, warm-up, and testing. Not only are the specific test matrix points identified, but the precise order of testing is strictly established. Much of the test matrix will be repeated with five tire samples in order to evaluate repeatability of the laboratory and test track procedures to be used.

UMTRI's portion of the test program is intended to examine issues of repeatability and the effect of induced wear on free-rolling cornering, straight braking, and combined cornering and braking tire behavior. UMTRI will also investigate the influences of speed, friction, and tread depth on free-rolling cornering and straight braking. Tests include both

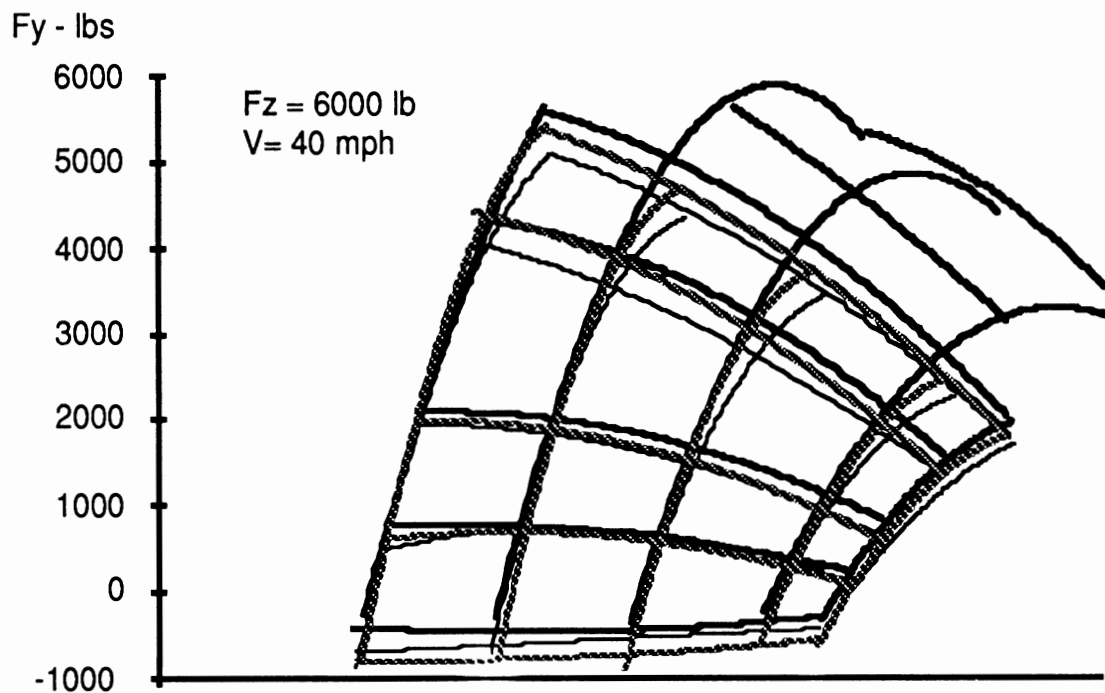

Figure 7. Lateral Force Carpet Plots for Three G159 Tires

dry and wet surface work.

This test plan requires the steering system modifications cited above. It will also require an additional, significant change to the vertical-load control system. The plan calls for a procedure in which slip angle is held fixed while data are gathered at several values of vertical load. This approach is very inefficient with the current control system, which was designed to slew through slip angles while holding constant vertical load. The findings to date regarding test-induced wear argue strongly for the new approach, however. Accordingly, we have proposed to alter the vertical-load control system from the current set-by-hand configuration to a computer-controlled servo system.

The wet surface portion of the testing matrix will require further modification to the Mobile Tire Tester. There are basically two means for accomplishing wet surface testing, namely, using an on-board watering system, or by testing on pre-wetted surfaces. Prewetting does not appear to be a very good option. Prewetting requires a very good quality surface equipped with controllable watering system if water depth is to be consistent as required for repeatable results. Such surfaces exist at various proving grounds, but approach roads typically are designed for use with passenger cars. The acceleration capability of the Mobile Tire Tester is the equivalent of a moderately powered, Class 8 truck at GVWR. That is, it is not very quick. Acceleration to 55 mph. on a level surface requires about 2 mi. Generally, track facilities available for tire testing do not meet this need.

The Mobile Tire Tester is equipped with an on board water supply system for self-wetting of the test surface. An 18-in. wide nozzle spreads water just ahead of the test tire. Assuming no standing water on the surface, water depth is established by the relationship between nozzle width, water flow rate, and forward speed. Water depth as a function of speed and flow for an 18-in. wide stream is shown in the chart below.

On the Mobile Tire Tester, the nozzle is currently serviced by a 200 gpm. pump drawing from an 800 gal. tank. Water flow at rates less than the pump rate is achieved by a calibrated restriction. The control system is open-loop and depends on a preestablished calibration of nozzle water flow versus restriction valve setting.

The matrix of test conditions in the SAE program includes testing at water depths up to 0.08 in. at speeds to 55 mph. From the chart on the following page, it can be seen that, given the current 200 gpm. capability of the system, we can only achieve the requested 0.08-in. water depth at speeds up to about 30 mph. At 55 mph., we can provide a depth of a little over 0.04 in. To meet the requirements of the study an additional, higher volume pump with separate flow-control system will be added to the Mobile Tire Tester. The new pump will service the test tire, while the old system will be used to wet the surface at the "dummy" tire.

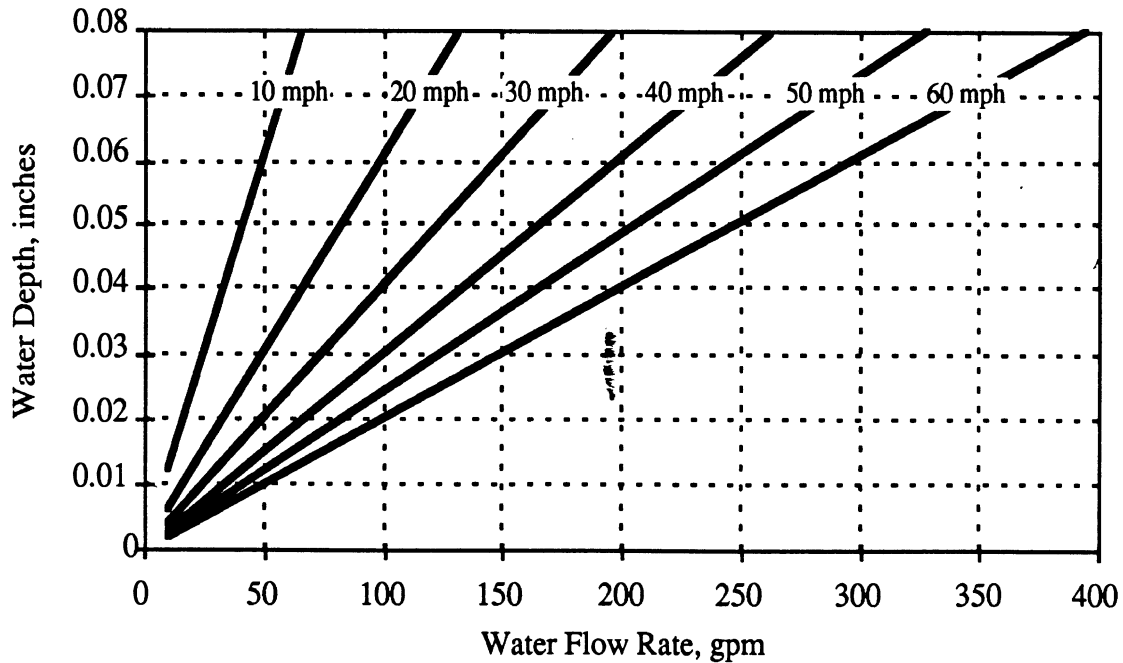

**Figure 8. Water Depth as a Function of Water Flow Through an 18" Nozzle and Forward Speed**

UMTRI expects to begin work on the SAE project in October of 1992. Mobile-Tire-Tester modifications will be undertaken in the fall and winter, and testing will take place in the spring. Testing is to be conducted at the Dana Technology Center in Ottawa Lake, Michigan.

### References

1. Conversations with Tapia, G. CALSPAN Corporation. Buffalo, New York. 1992.
2. Marshall, KZ, Phelps, RL, Pottinger, MG, and Pelz, W. "The effects of tire brake-in [sic] on force and moment properties." SAE Paper No. 770870. Passenger Car Meeting. Detroit. September 26-30, 1979.

16



## APPENDIX 1

### Explanation of the Carpet Plot Format

The so-called carpet plot is the traditional means for the graphical presentation of tire side-force ( $F_y$ ) as a function of two variables, most typically slip angle ( $\alpha$ ) and vertical load ( $F_z$ ). In this format,  $F_y$  is plotted on the vertical axis and a combination of  $\alpha$  and  $F_z$  is plotted on the horizontal axis. Mathematically speaking, if we call the variable of the horizontal axis  $x$ , then  $x = c_0 + c_1*\alpha - c_2*F_z$ , where  $c_0$ ,  $c_1$ , and  $c_2$  are constants chosen to provide the desired appearance for the plot. After plotting the individual data points on the  $F_y$  vs  $x$  grid, lines of constant  $\alpha$  and of constant  $F_z$  are drawn in and labeled. The result is a "carpet" plot which readily shows the influence of both  $\alpha$  and  $F_z$  on the generation of  $F_y$ .

More intuitively, the carpet plot can be thought of as individual plots of  $F_y$  vs  $\alpha$ , one for each value of  $F_z$ . These are spaced along the x-axis, by giving each a separate zero- $\alpha$  reference position. Then, additional lines of constant  $\alpha$  are added to the plot.

In the carpet plots in the appendices which follow, the actual values for  $\alpha$  and  $F_z$  are listed beside the plot rather than presented as labels. For slip angle, the lowest listed value always applies to the lowest line of the plot, and then progresses upward; for vertical load, the lowest value applies to the right-most plot, and progresses toward the left.

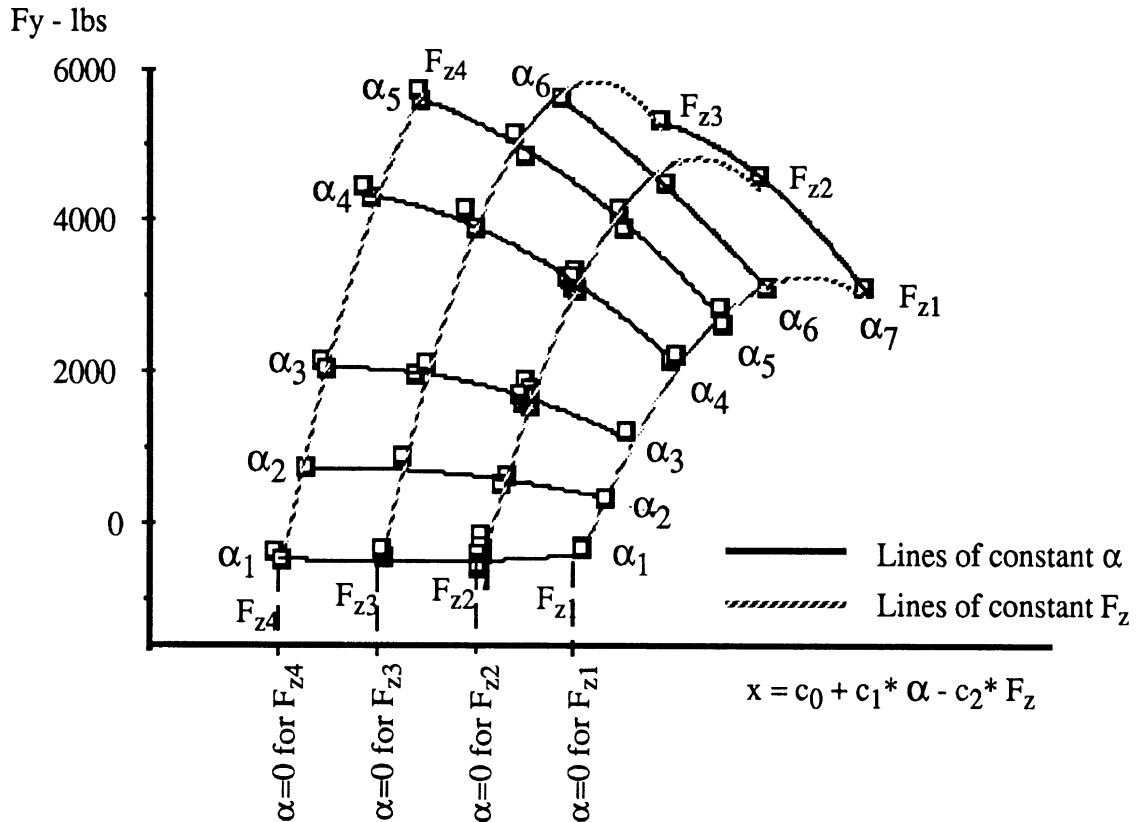

18

**APPENDIX 2  
TIRE DATA**

**1**

**Goodyear G159  
295/75R22.5  
Load Range G**

**UMTRI ID 32  
(Tire #2)**

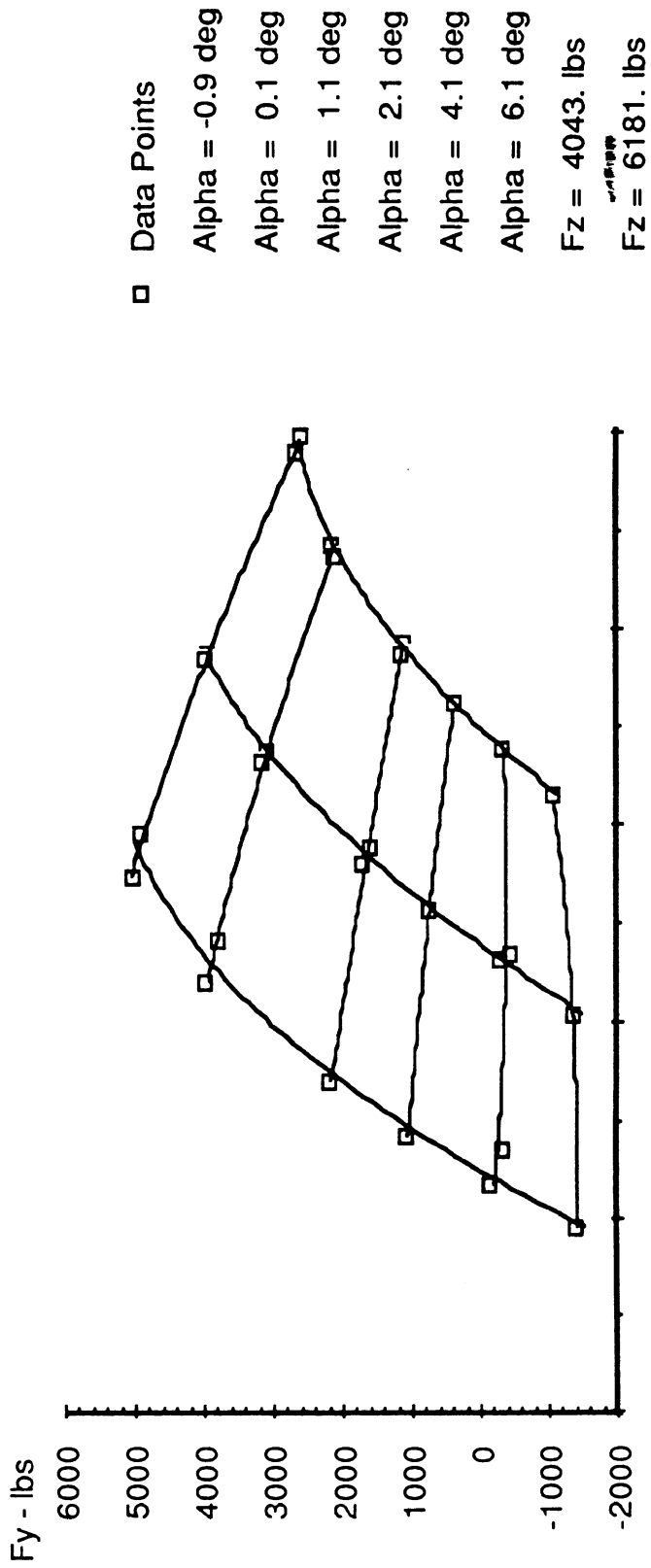

GY,G159,295/75R22.5,G,TP=110,123,TEMP=50,U=20.1MPH,22-JAN-92Fz = 8329. lbs

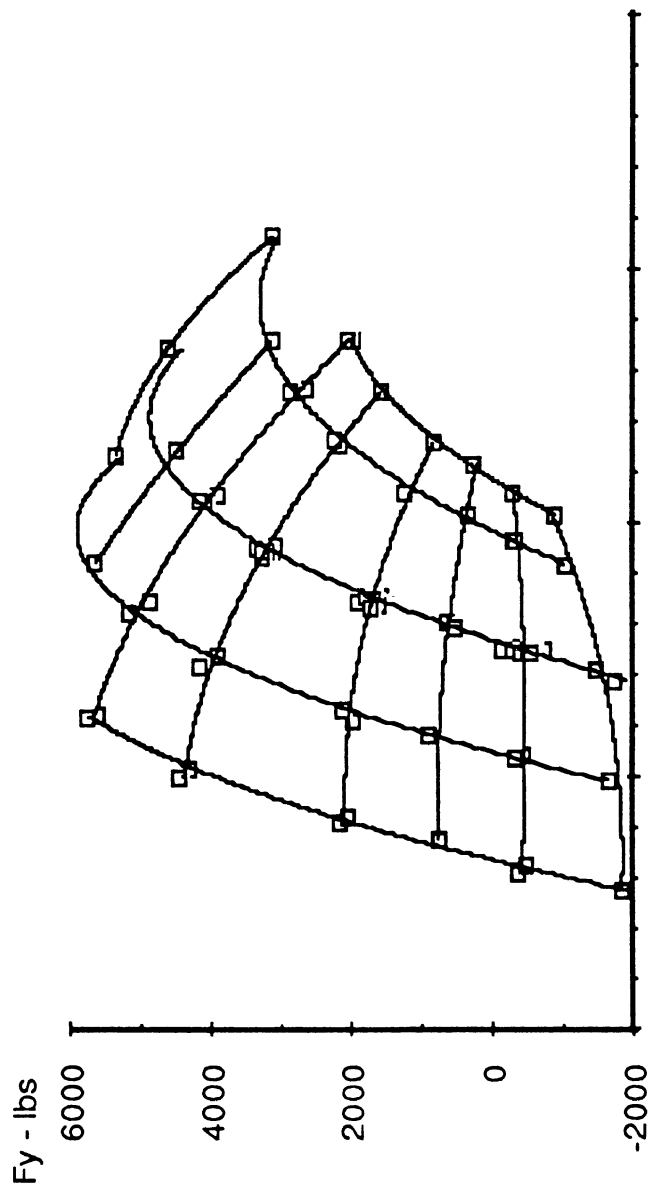

- Data Points
- Alpha = -0.9 deg
- Alpha = 0.1 deg
- Alpha = 1.1 deg
- Alpha = 2.1 deg
- Alpha = 4.1 deg
- Alpha = 6.1 deg
- Alpha = 8.1 deg
- Alpha = 12.1 deg
- Fz = 3036. lbs
- Fz = 4026. lbs
- Fz = 6188. lbs
- Fz = 8361. lbs

GY,G159,295/75R22.5,G,TP=110,123,TEMP=50,U=39.1MPH,22-JAN-95,Fz = 10487. lbs

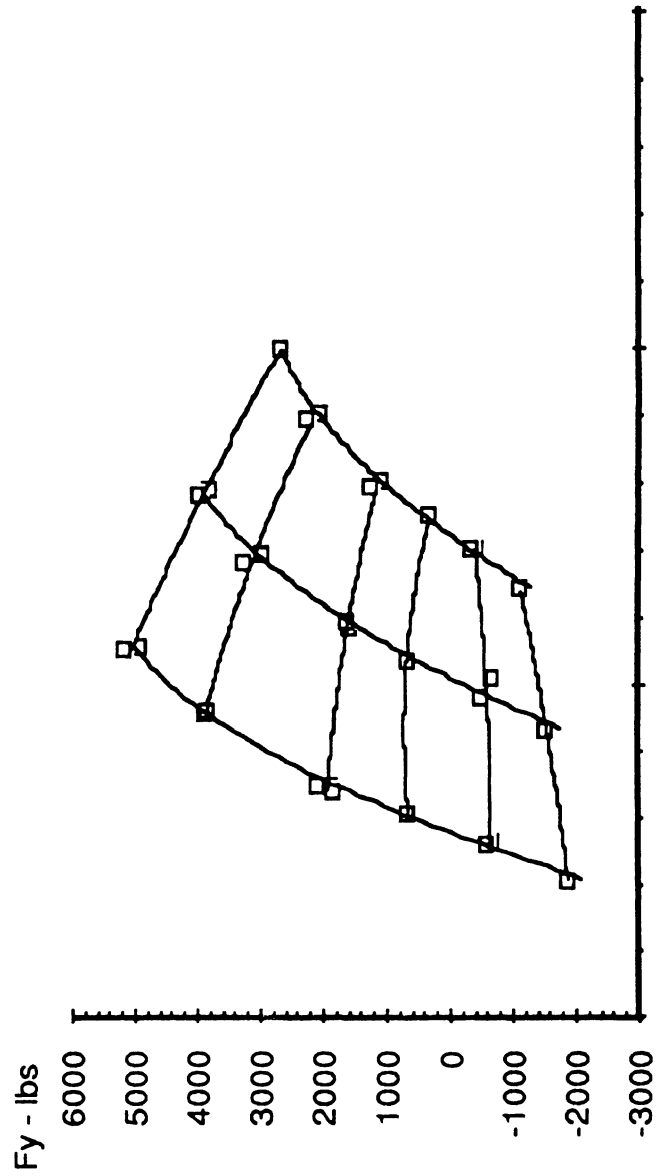

- Data Points
- Alpha = -0.9 deg
- Alpha = 0.1 deg
- Alpha = 1.1 deg
- Alpha = 2.1 deg
- Alpha = 4.1 deg
- Alpha = 6.1 deg
- Fz = 3992. lbs
- Fz = 6102. lbs

GY,G159,295/75R22.5,G,TP=110,123,TEMP=50,U=58.9MPH,22-JAN-92Fz = 8440. lbs

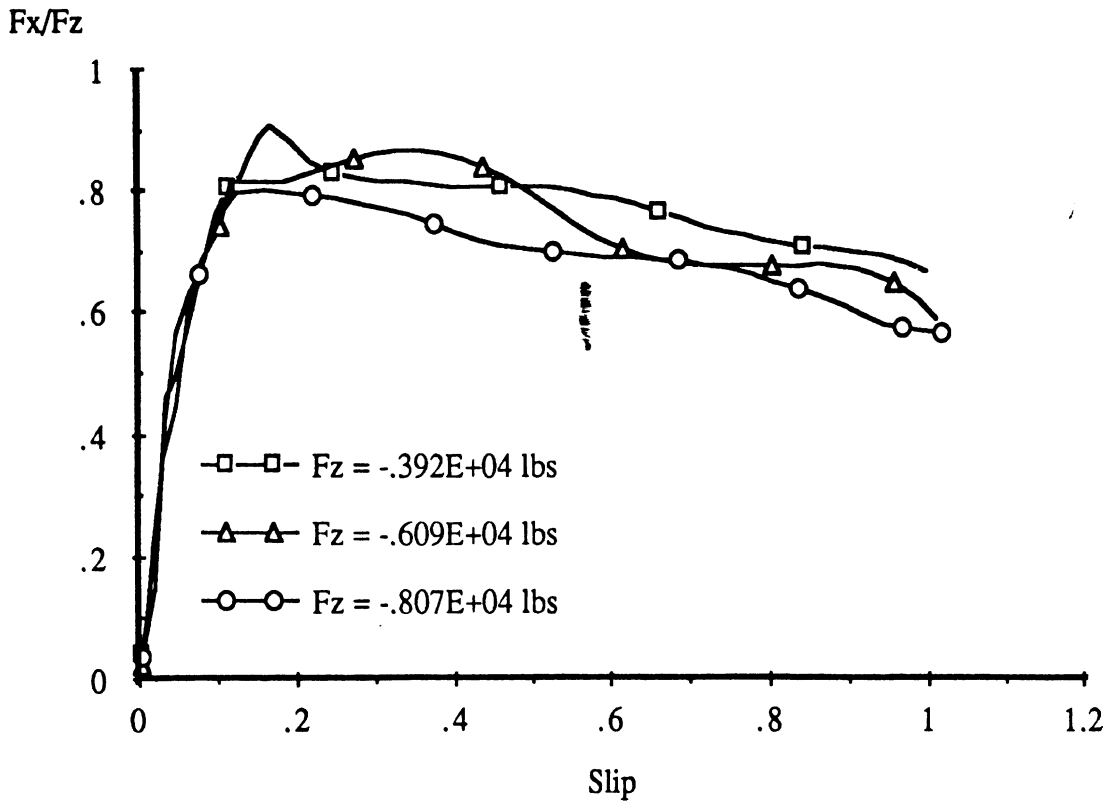

GDYR,G159,295/75R22.5,G,TP=110,123,TEMP=50,U=19.3MPH,22-JAN-92

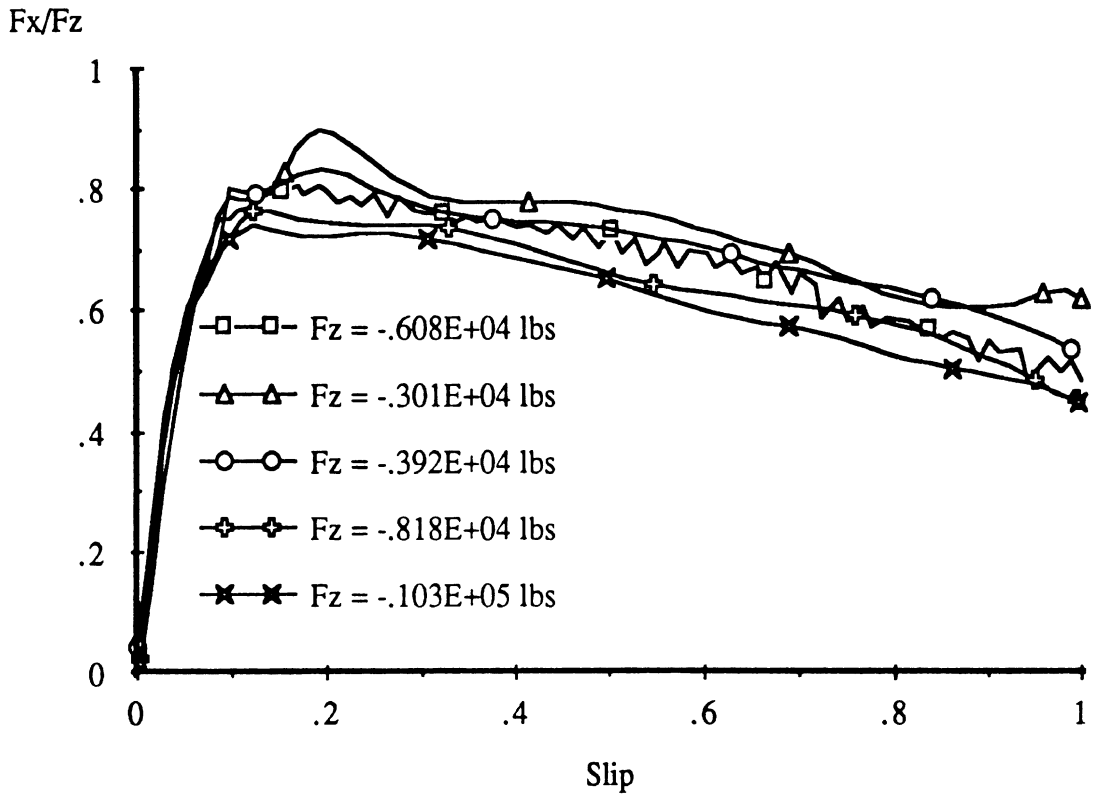

GDYR,G159,295/75R22.5,G,TP=110,123,TEMP=50,U=37.6MPH,22-JAN-92

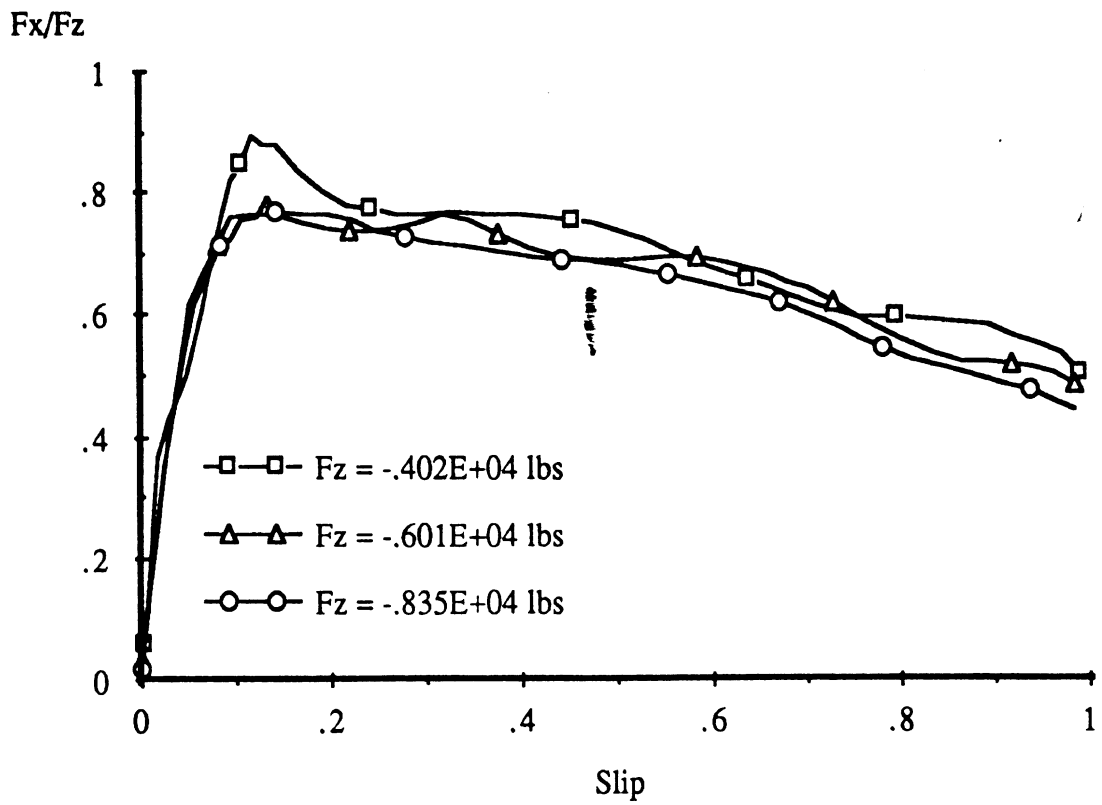

GDYR,G159,295/75R22.5,G,TP=110,123,TEMP=50,U=56.5MPH,22-JAN-92

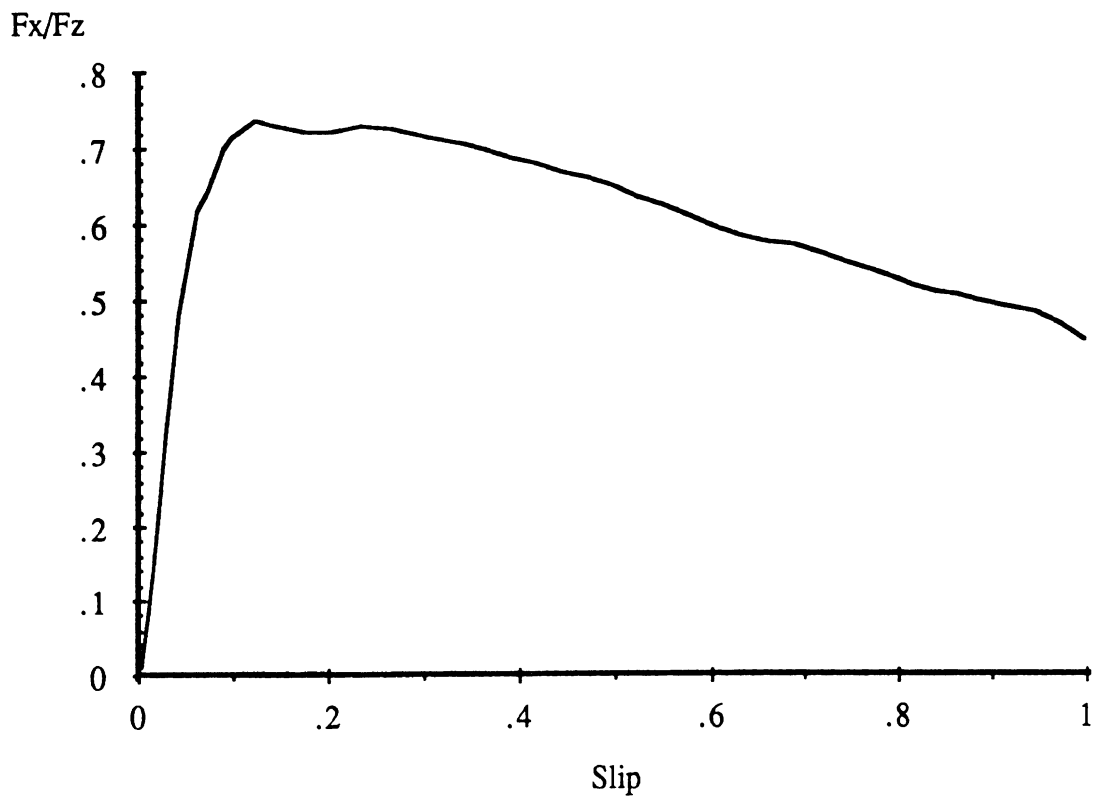

GDYR,G159,295/75R22.5,G,TP=110,123,TEMP=50,FZ=-10290.9LBS,22-JAN-92



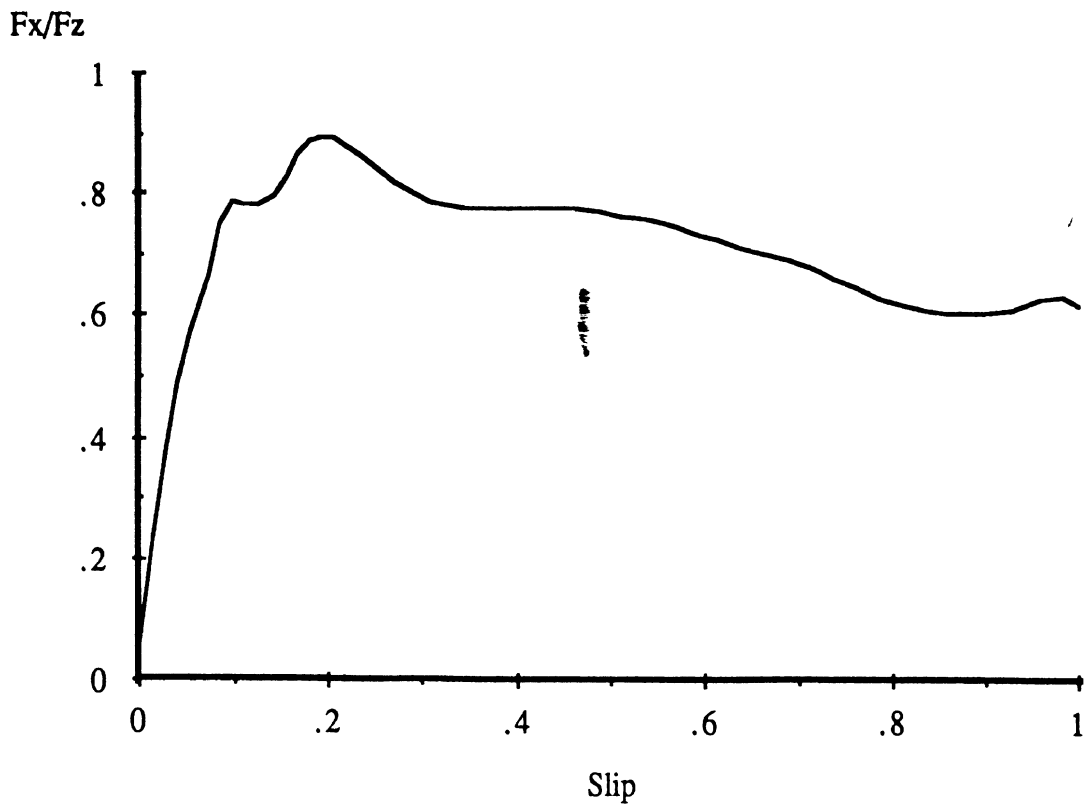

GDYR,G159,295/75R22.5,G,TP=110,123,TEMP=50,FZ=-3005.6LBS,22-JAN-92

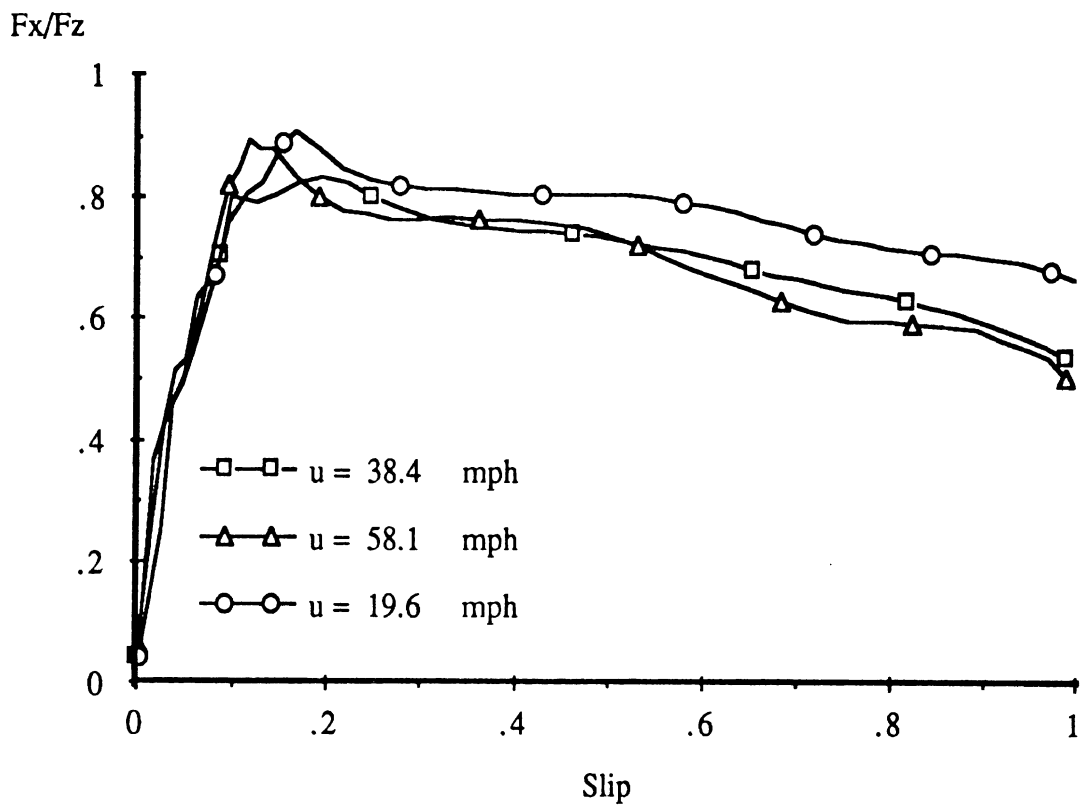

GDYR,G159,295/75R22.5,G,TP=110,123,TEMP=50,FZ=-3950.1LBS,22-JAN-92

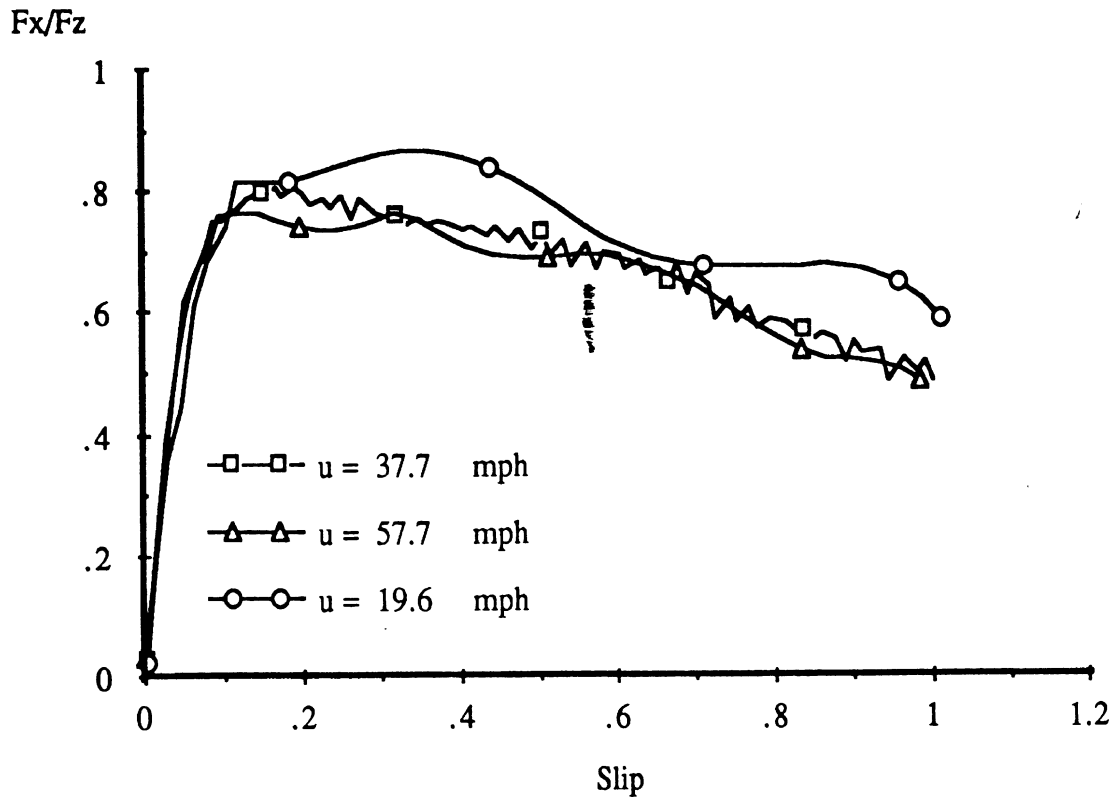

GDYR,G159,295/75R22.5,G,TP=110,123,TEMP=50,FZ=-6076.5LBS,22-JAN-92

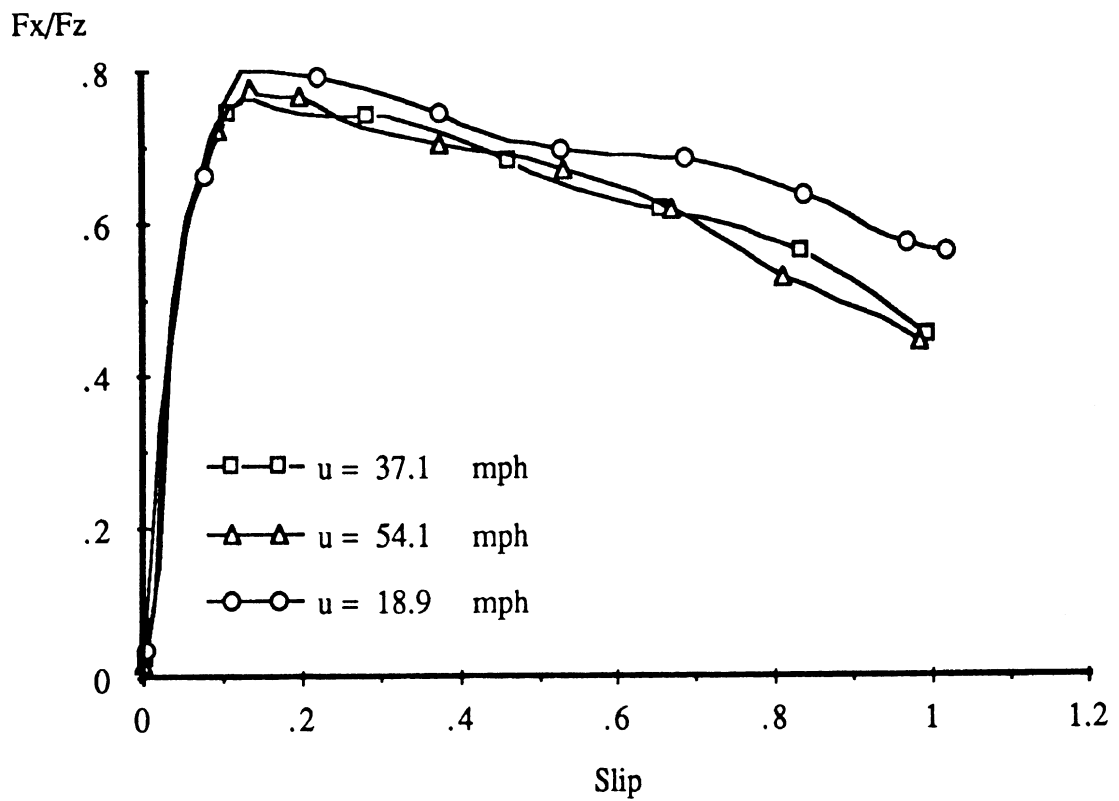

GDYR,G159,295/75R22.5,G,TP=110,123,TEMP=50,FZ=-8200.2LBS,22-JAN-92

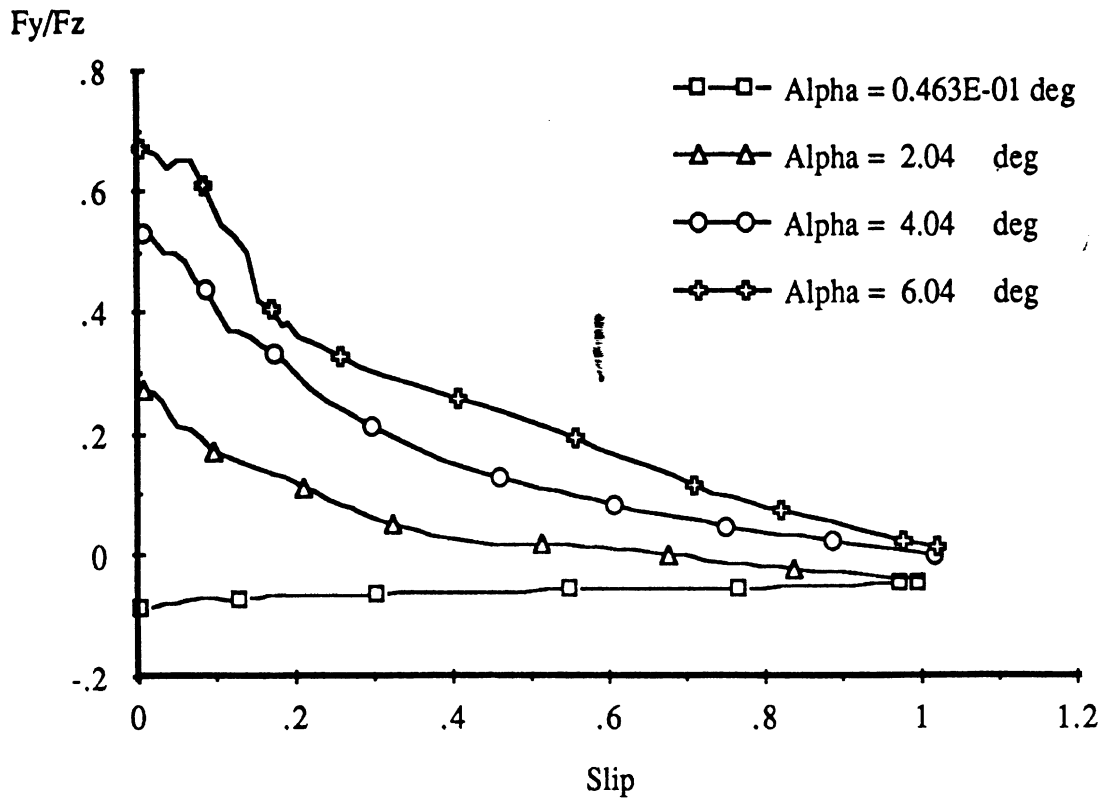

GDYR,G159,295/75R22.5,G,TP=110,123,TEMP=50,U=19.3MPH,FZ=-3904.5LBS,22-J

AN-92

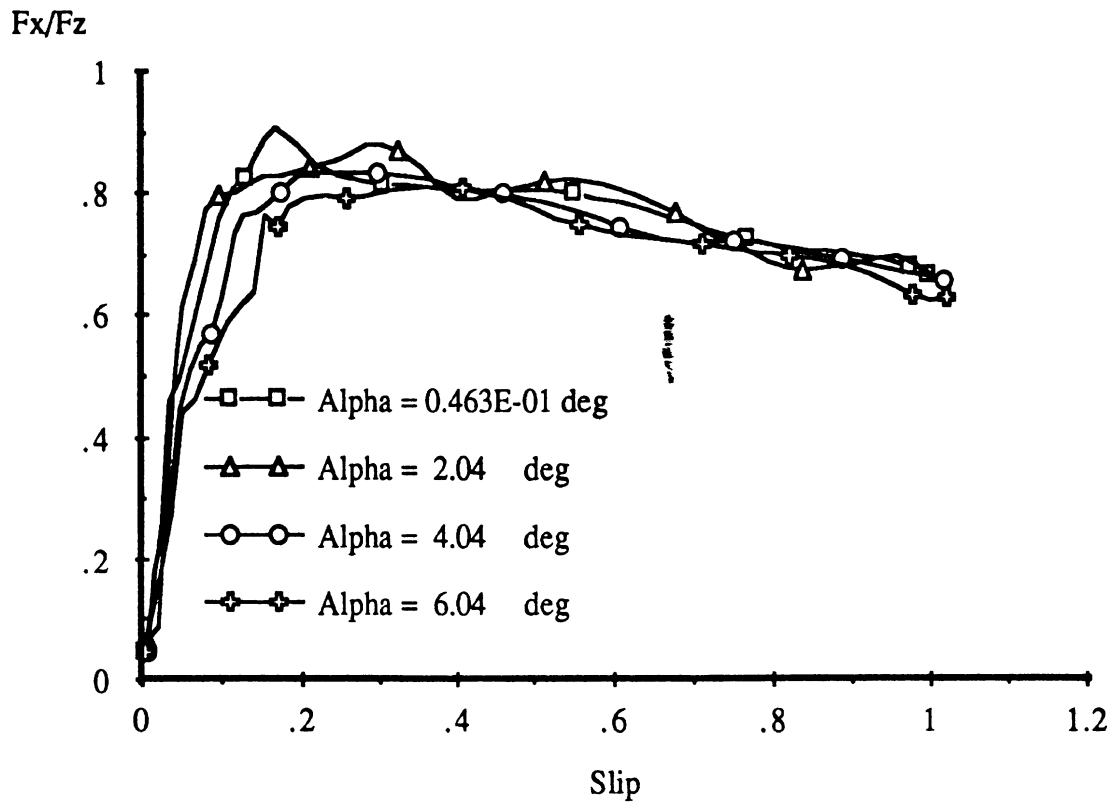

GDYR,G159,295/75R22.5,G,TP=110,123,TEMP=50,U=19.3MPH,FZ=-3904.5LBS,22-J

AN-92

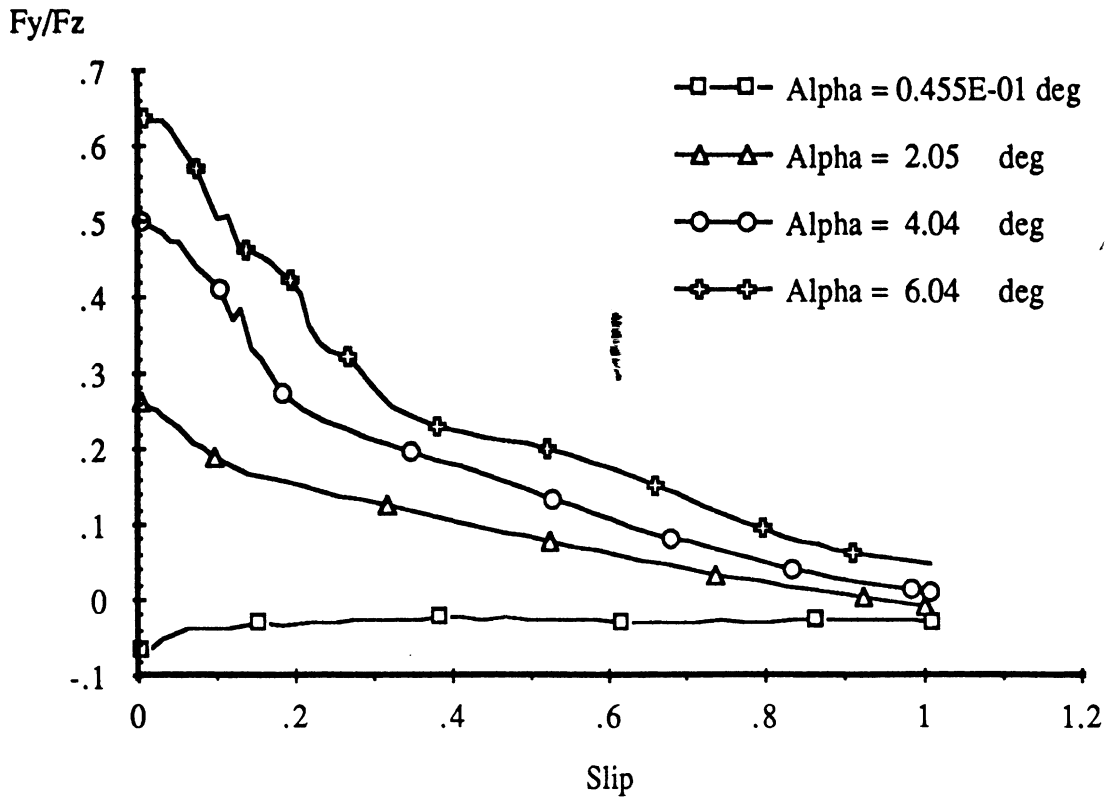

GDYR,G159,295/75R22.5,G,TP=110,123,TEMP=50,U=19.3MPH,FZ=-5931.9LBS,22-J

AN-92

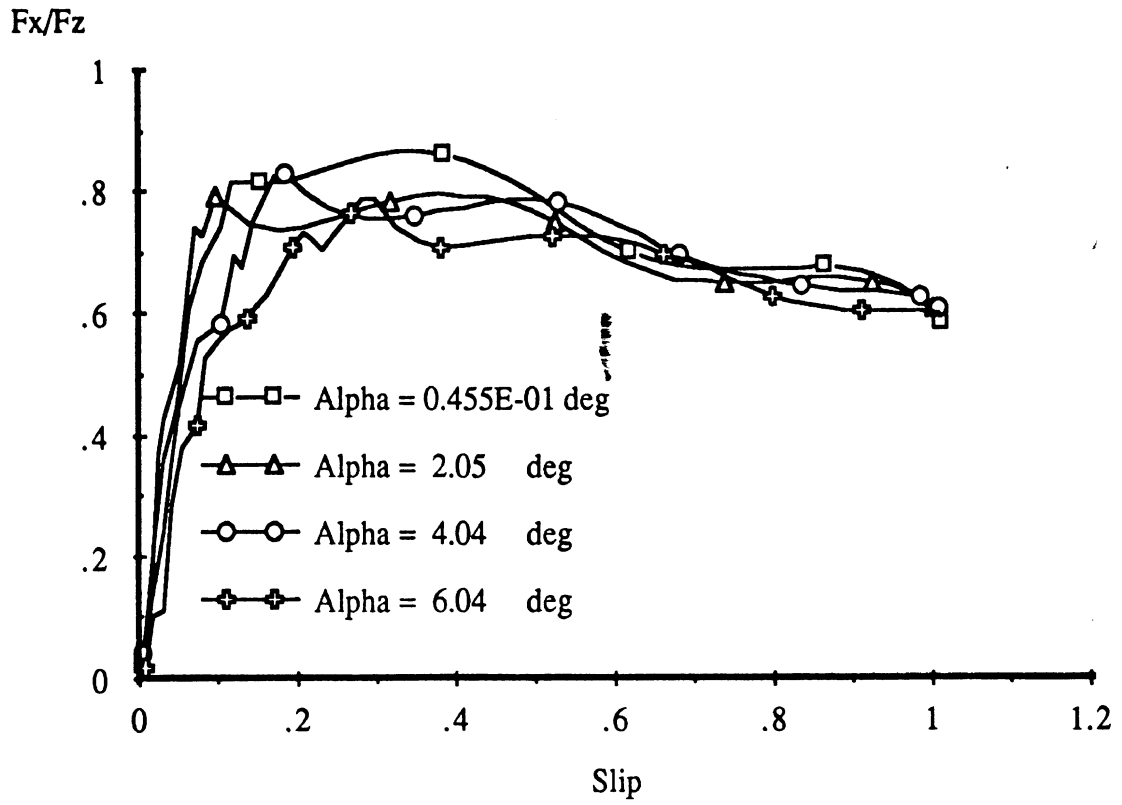

GDYR,G159,295/75R22.5,G,TP=110,123,TEMP=50,U=19.3MPH,FZ=-5931.9LBS,22-J

AN-92

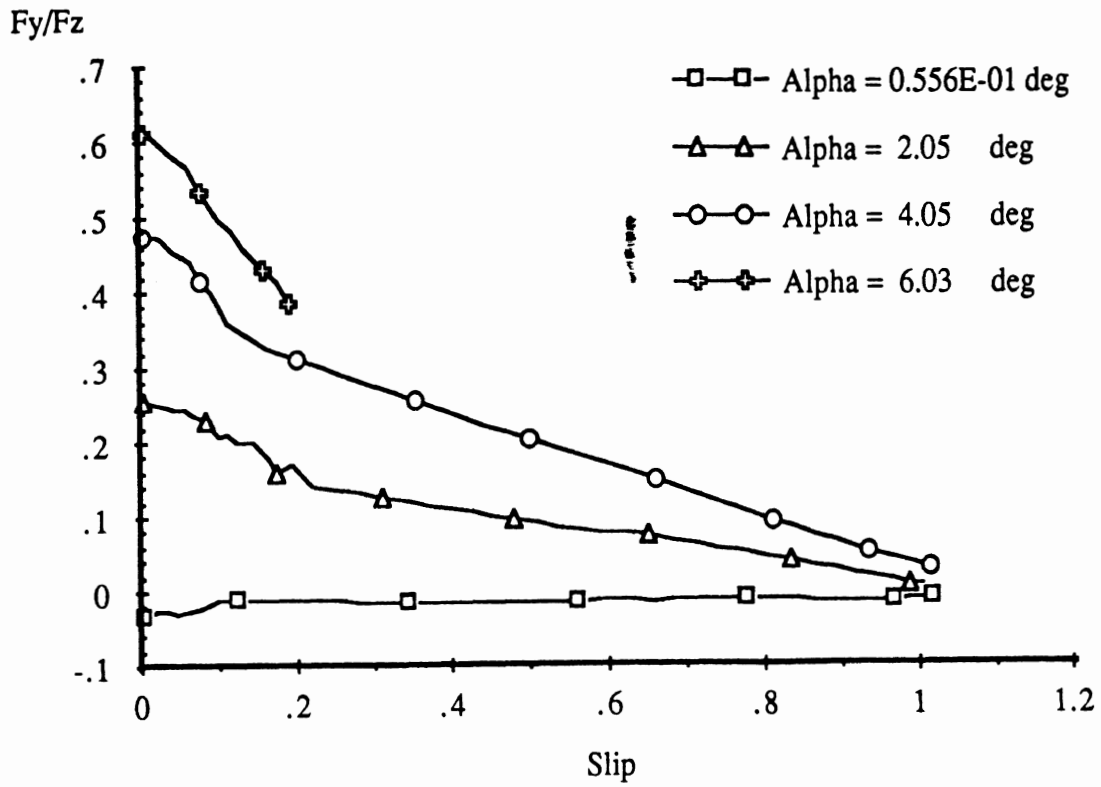

GDYR,G159,295/75R22.5,G,TP=110,123,TEMP=50,U=19.3MPH,FZ=-8010.8LBS,22-JA

AN-92

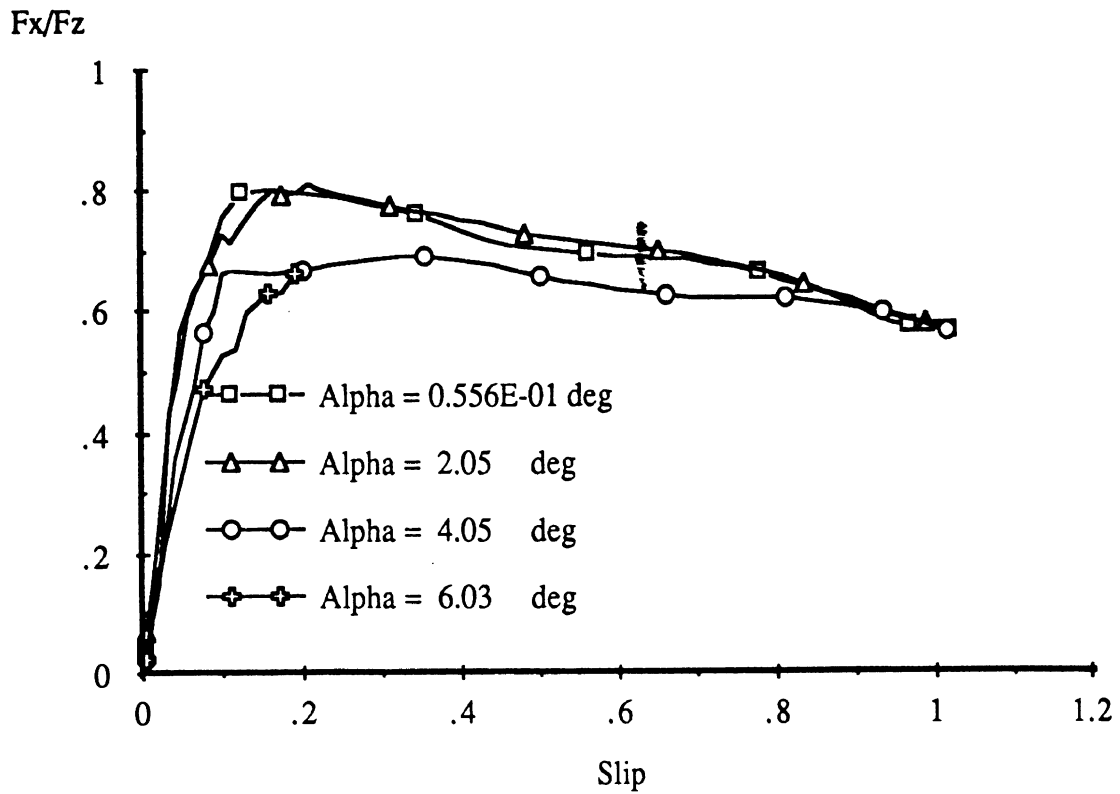

GDYR,G159,295/75R22.5,G,TP=110,123,TEMP=50,U=19.3MPH,FZ=-8010.8LBS,22-JA

AN-92



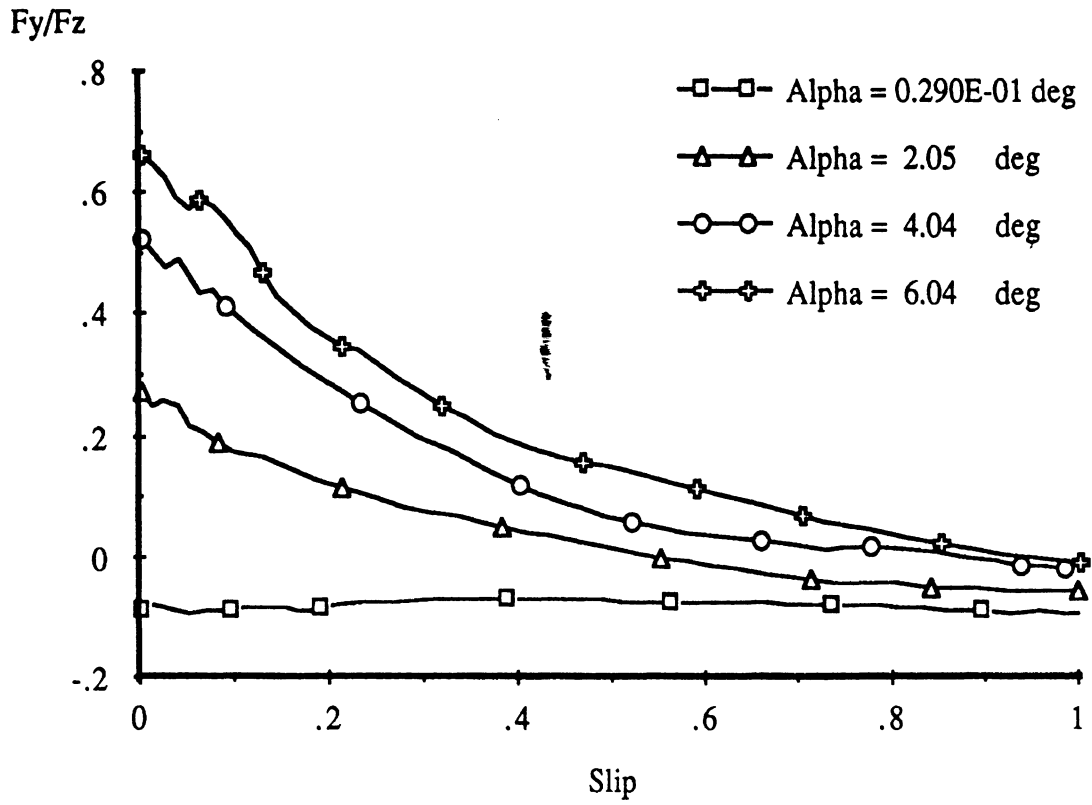

G DYR,G159,295/75R22.5,G,TP=110,123,TEMP=50,U=37.2MPH,FZ=-3057.0LBS,22-J

AN-92

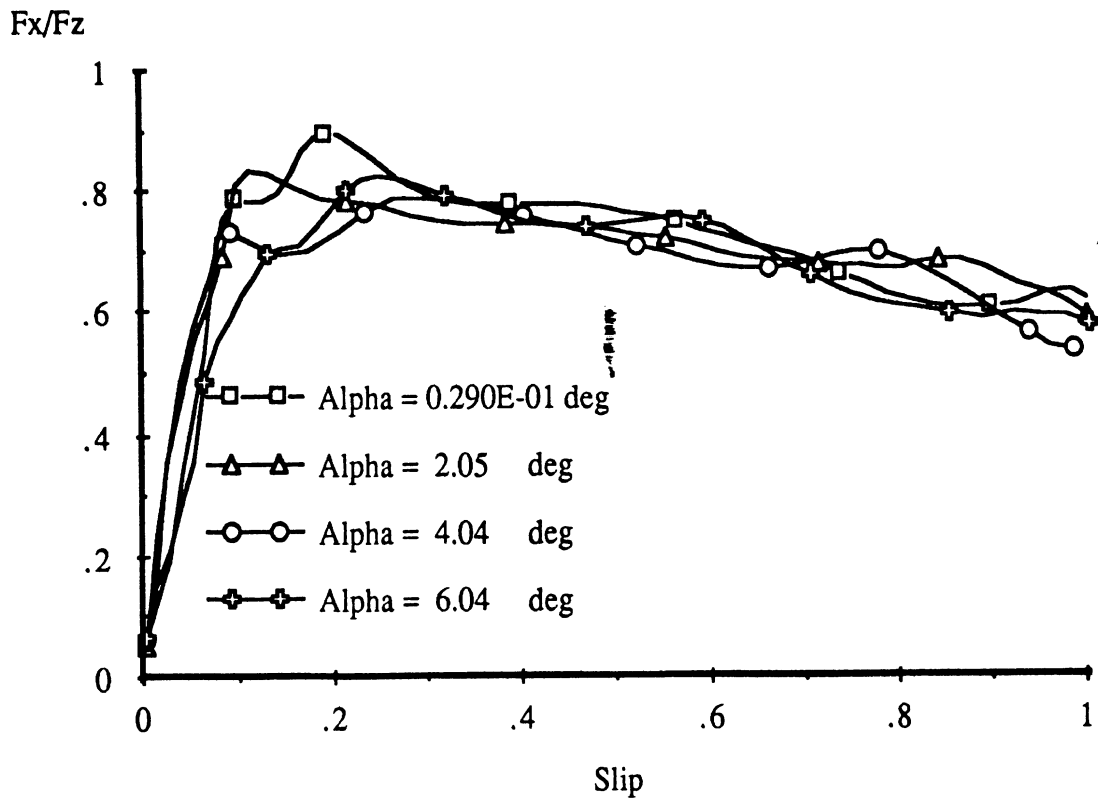

GDYR,G159,295/75R22.5,G,TP=110,123,TEMP=50,U=37.2MPH,FZ=-3057.0LBS,22-J

AN-92

- Alpha = 0.461E-01 deg
- △—△— Alpha = 2.06 deg
- Alpha = 4.06 deg
- +—+— Alpha = 6.05 deg
- ×—×— Alpha = 8.05 deg
- ☆—☆— Alpha = 12.1 deg

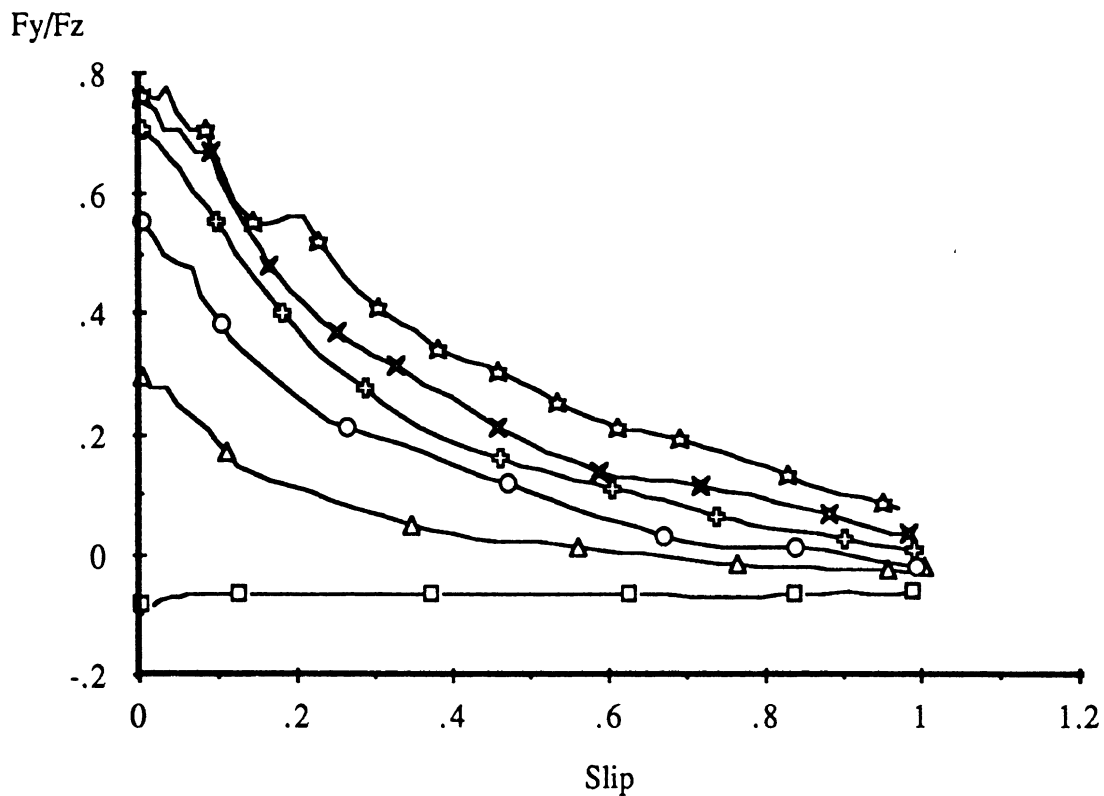

GDYR,G159,295/75R22.5,G,TP=110,123,TEMP=50,U=37.2MPH,FZ=-3938.6LBS,22-J

AN-92

- Alpha = 0.461E-01 deg
- △-△- Alpha = 2.06 deg
- Alpha = 4.06 deg
- +--+ Alpha = 6.05 deg
- ×-×- Alpha = 8.05 deg
- ☆-☆- Alpha = 12.1 deg

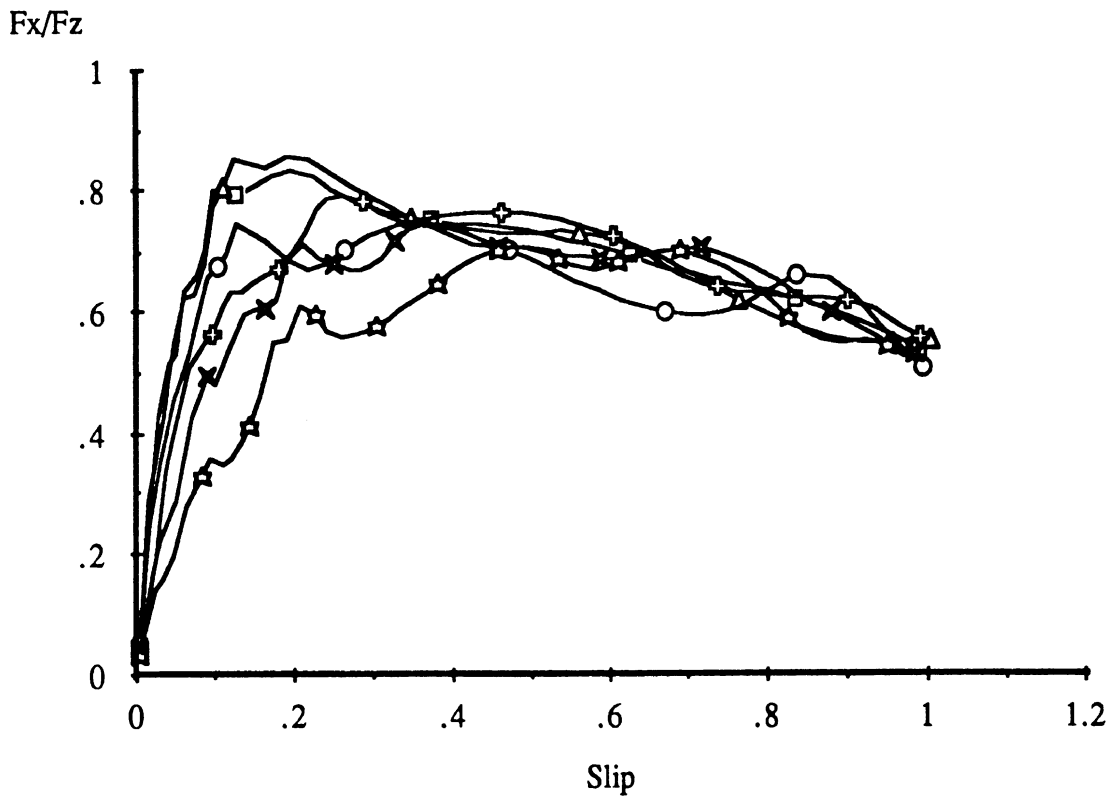

GDYR,G159,295/75R22.5,G,TP=110,123,TEMP=50,U=37.2MPH,FZ=-3938.6LBS,22-J

AN-92

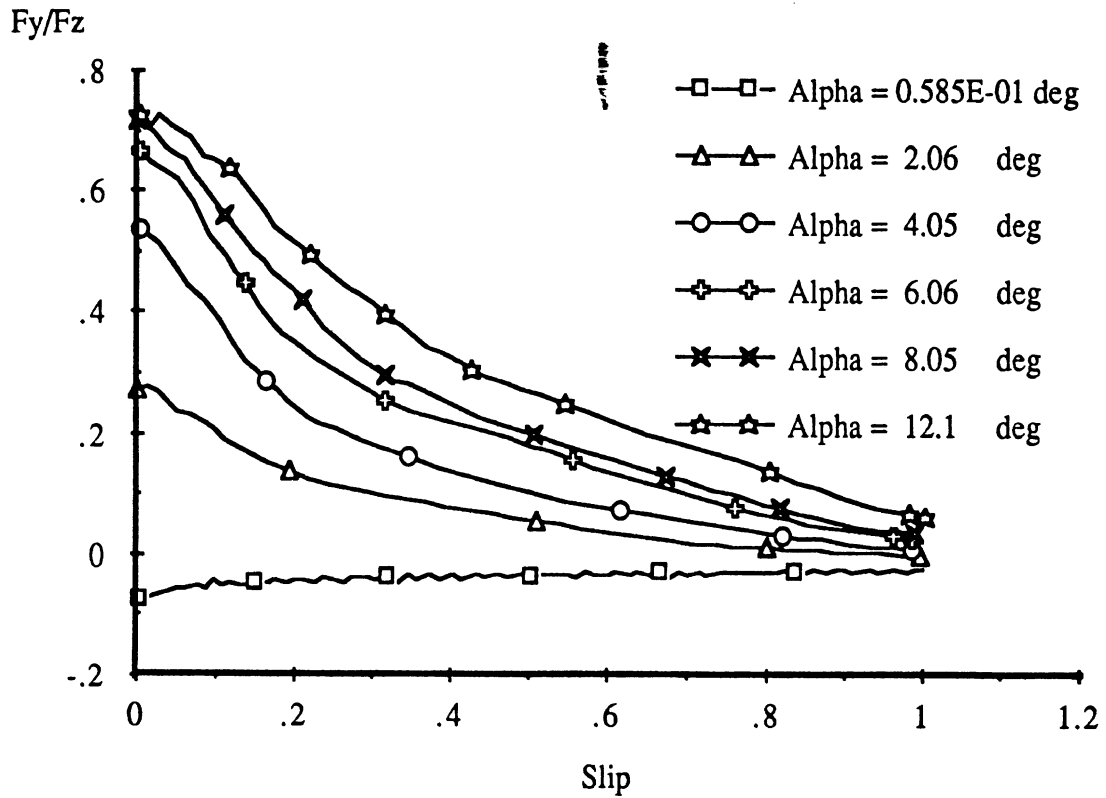

G DYR, G159, 295/75R22.5, G, TP=110, 123, TEMP=50, U=37.2MPH, FZ=-6056.1LBS, 22-J

AN-92

- Alpha = 0.585E-01 deg
- ▲-▲- Alpha = 2.06 deg
- Alpha = 4.05 deg
- ◆-◆- Alpha = 6.06 deg
- ×-×- Alpha = 8.05 deg
- ☆-☆- Alpha = 12.1 deg

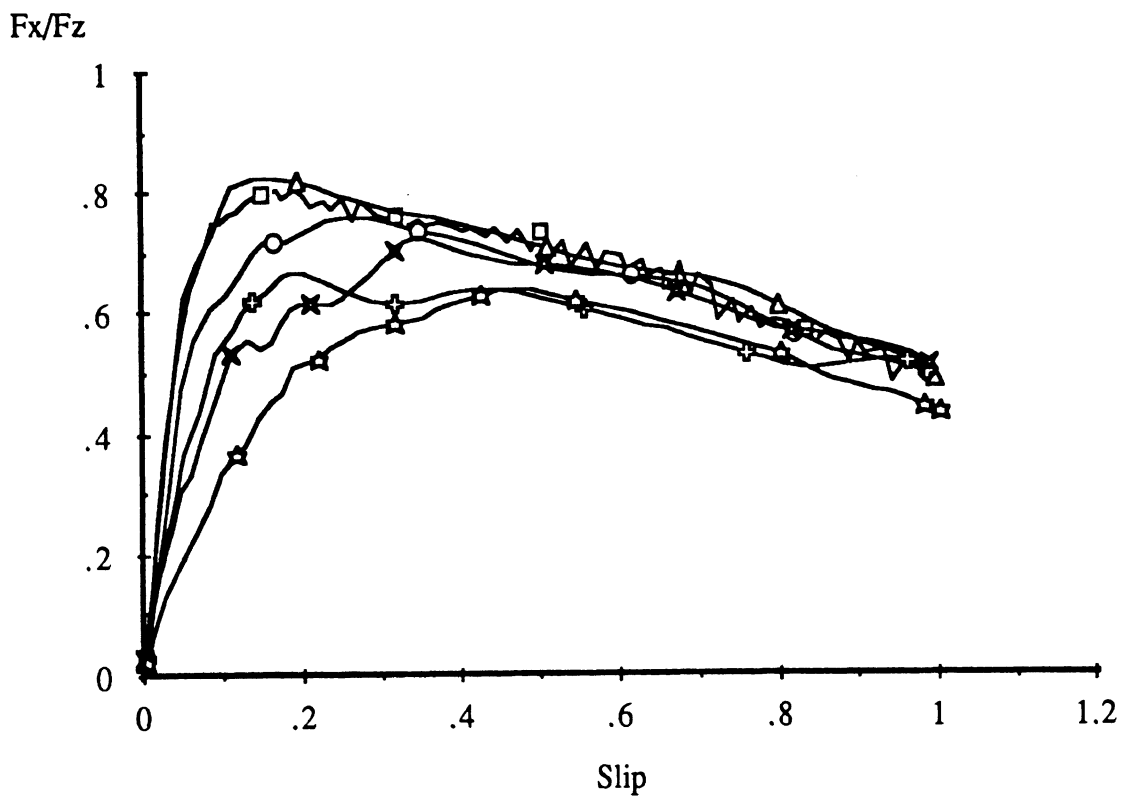

G DYR, G159, 295/75R22.5, G, TP=110, 123, TEMP=50, U=37.2MPH, FZ=-6056.1LBS, 22-J

AN-92

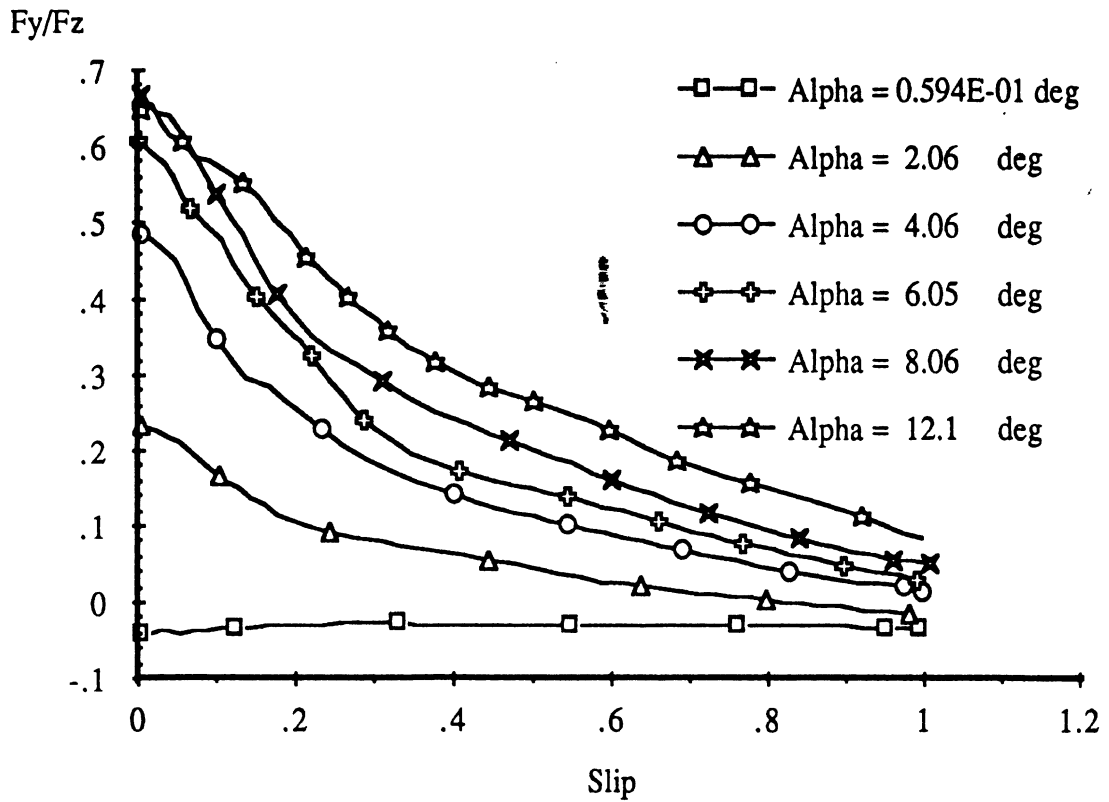

GDYR,G159,295/75R22.5,G,TP=110,123,TEMP=50,U=37.2MPH,FZ=-8229.5LBS,22-J

AN-92

- Alpha = 0.594E-01 deg
- △—△— Alpha = 2.06 deg
- Alpha = 4.06 deg
- +—+— Alpha = 6.05 deg
- ×—×— Alpha = 8.06 deg
- ☆—☆— Alpha = 12.1 deg

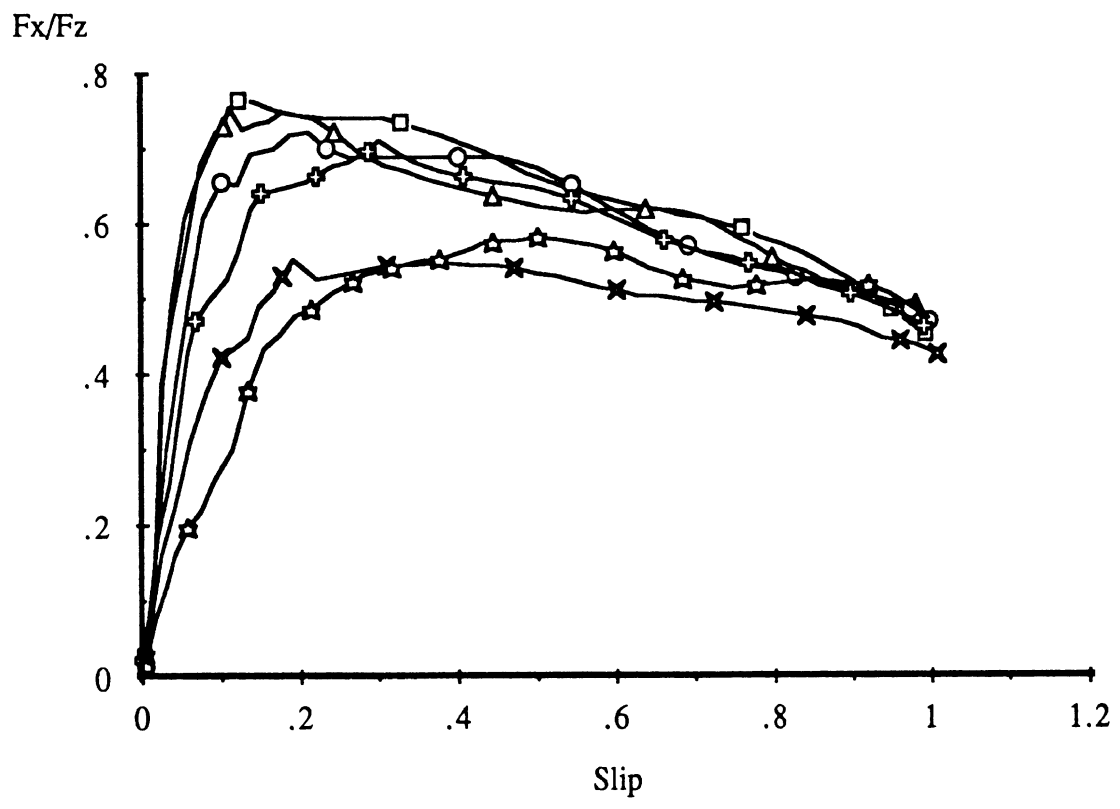

GDYR,G159,295/75R22.5,G,TP=110,123,TEMP=50,U=37.2MPH,FZ=-8229.5LBS,22-J

AN-92



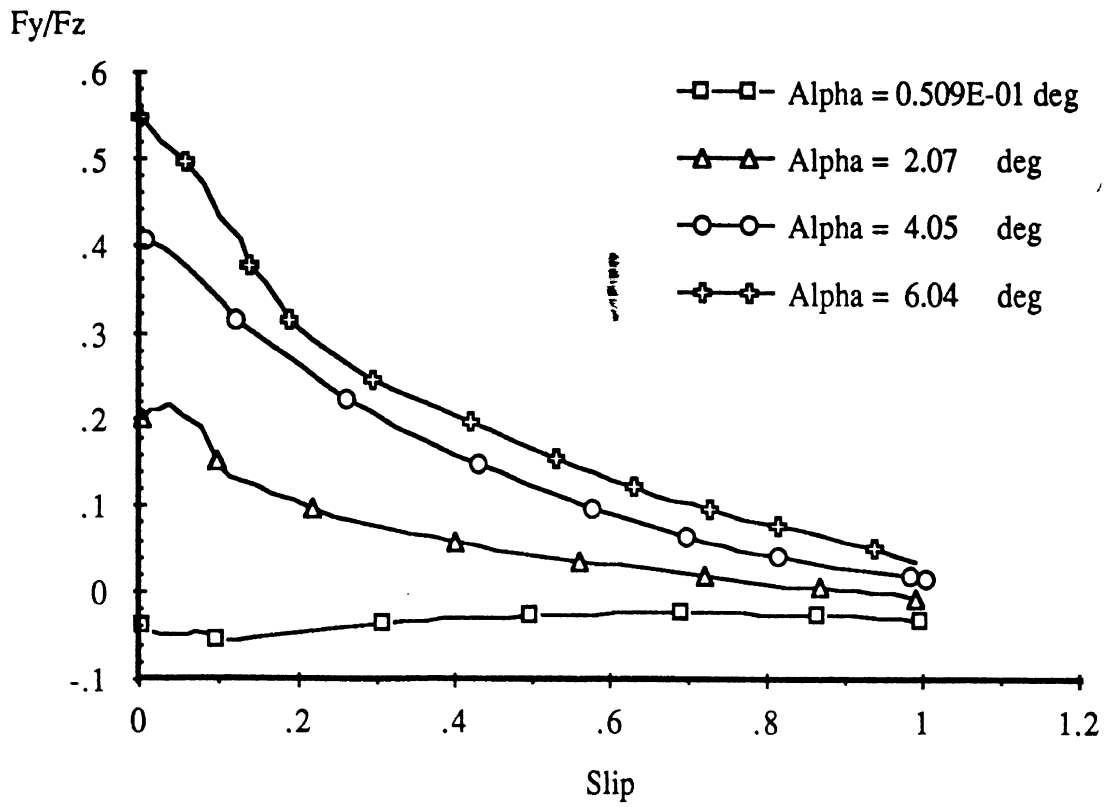

GDYR,G159,295/75R22.5,G,TP=110,123,TEMP=50,U=37.2MPH,FZ=-10231.3LBS,22

JAN-92

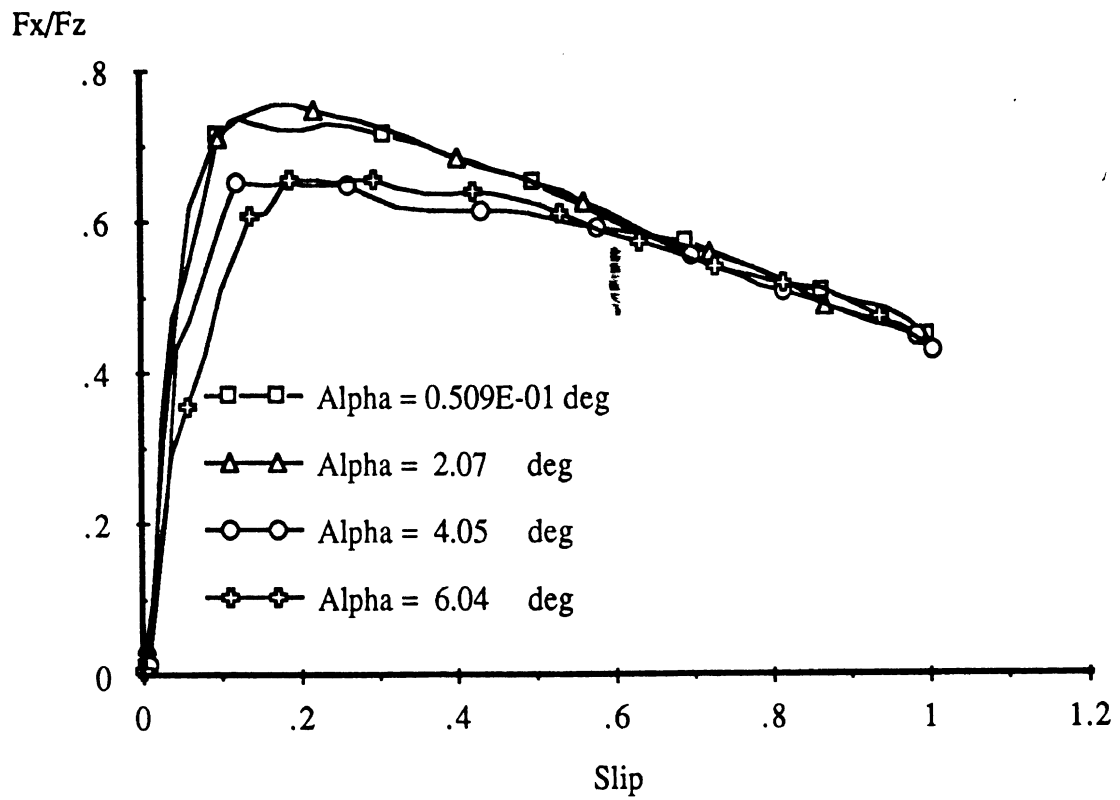

GDYR,G159,295/75R22.5,G,TP=110,123,TEMP=50,U=37.2MPH,FZ=-10231.3LBS,22

JAN-92

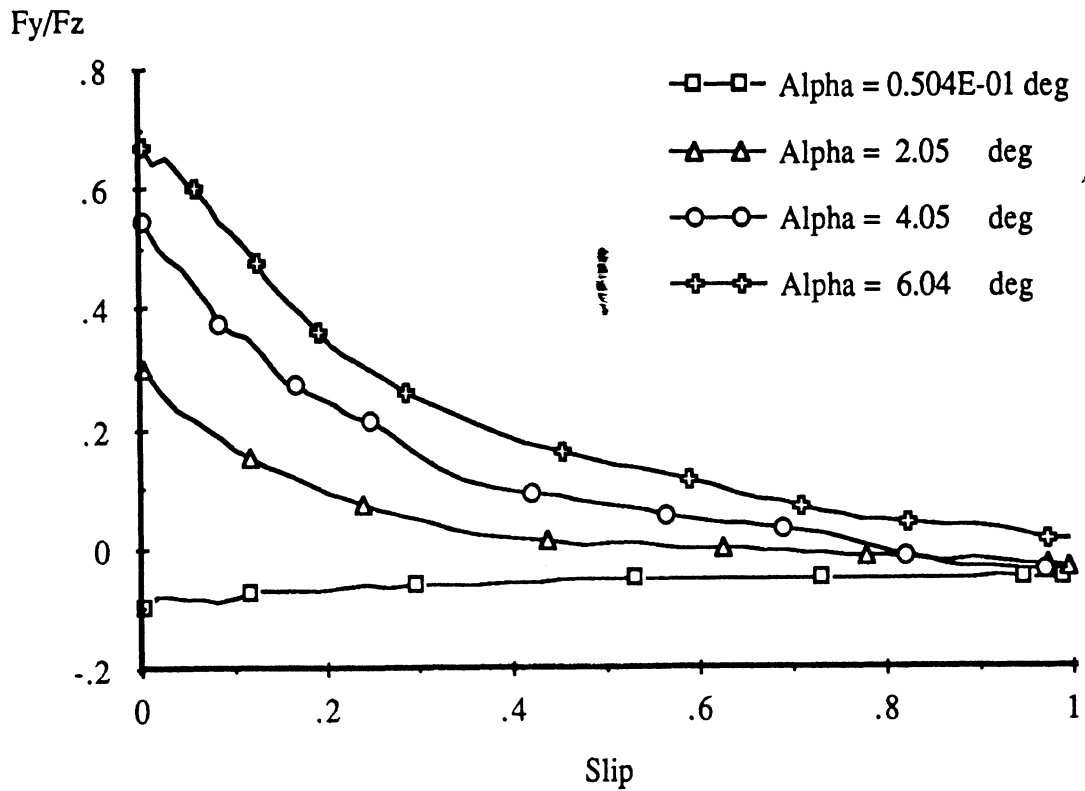

GDYR,G159,295/75R22.5,G,TP=110,123,TEMP=50,U=56.3MPH,FZ=-3924.9LBS,22-J

AN-92

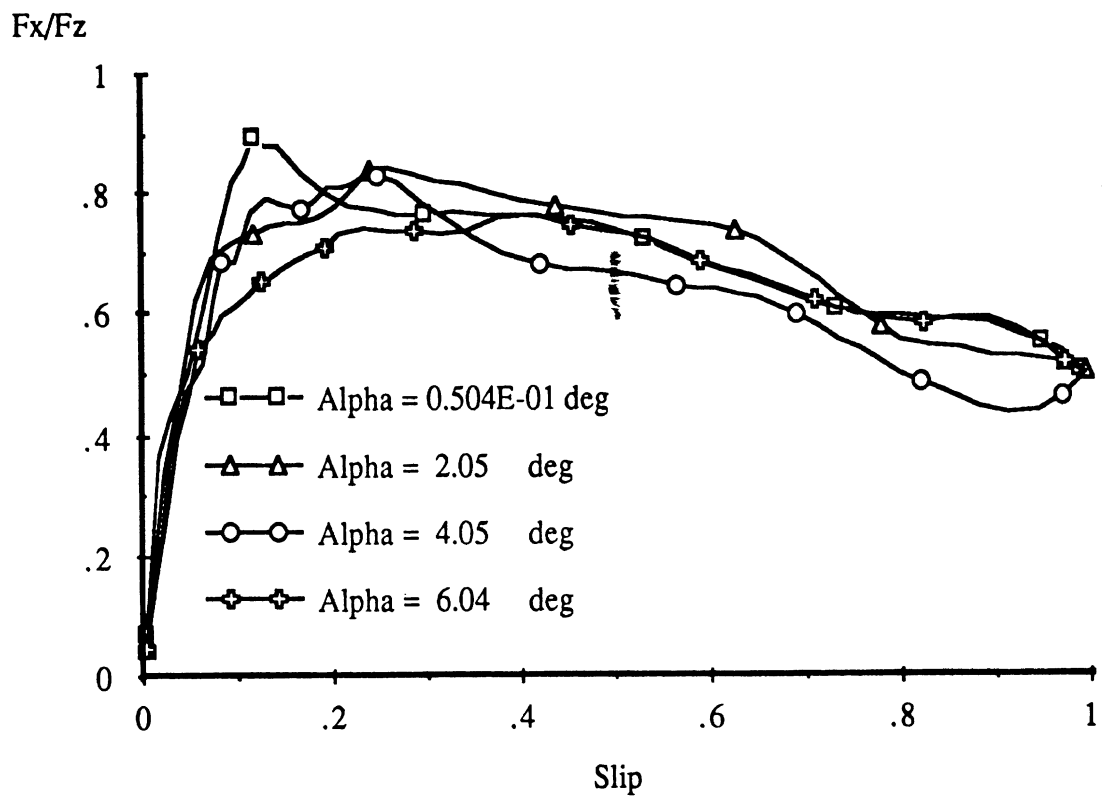

G DYR, G159, 295/75R22.5, G, TP=110, 123, TEMP=50, U=56.3MPH, FZ=-3924.9LBS, 22-J

AN-92

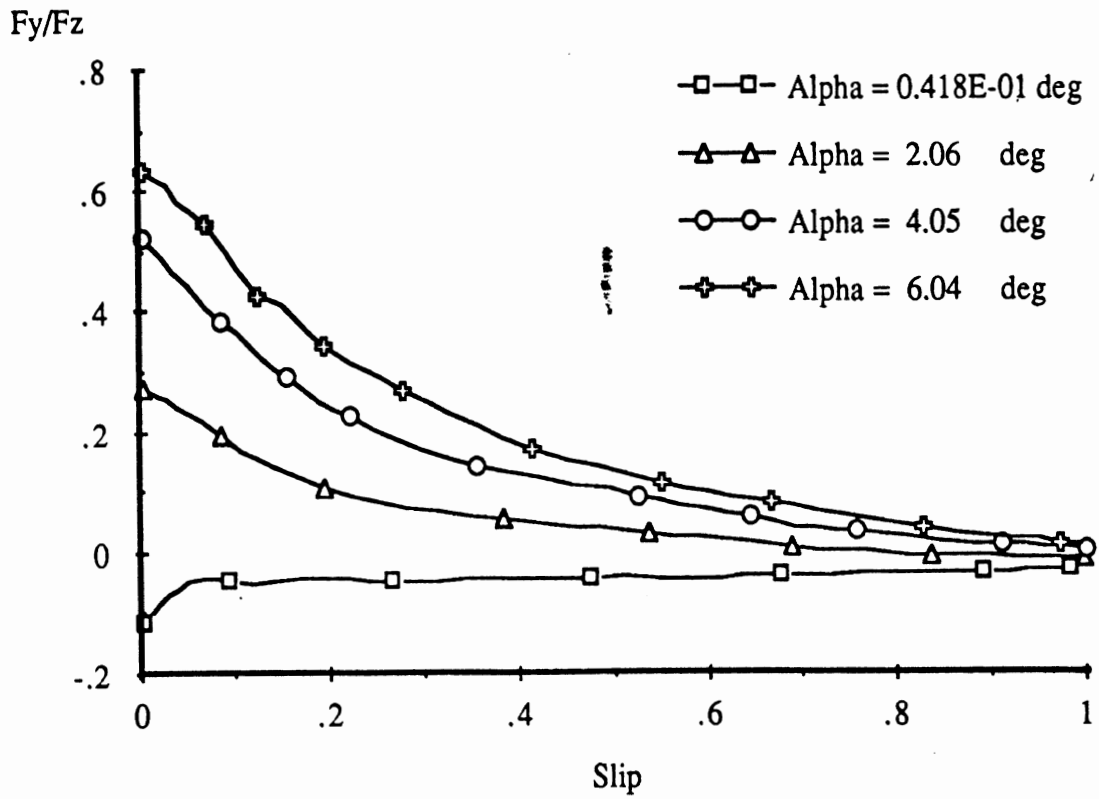

GDYR,G159,295/75R22.5,G,TP=110,123,TEMP=50,U=56.3MPH,FZ=-5944.8LBS,22-J

AN-92

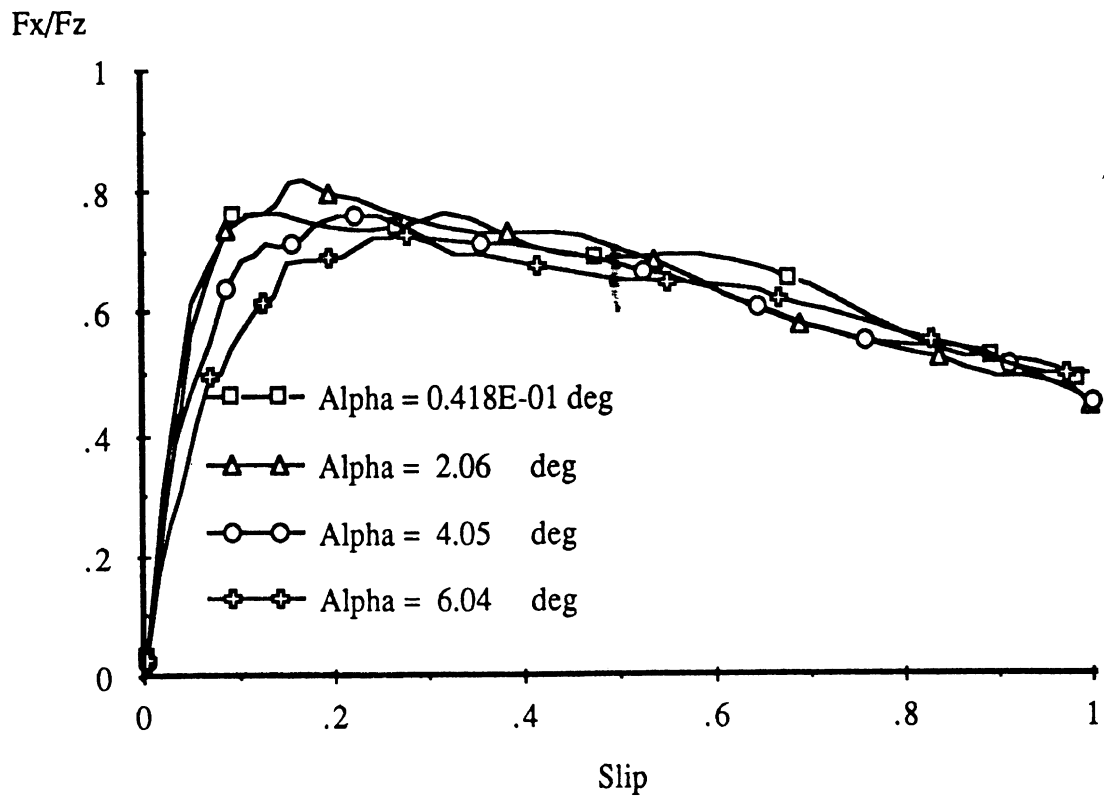

GDYR,G159,295/75R22.5,G,TP=110,123,TEMP=50,U=56.3MPH,FZ=-5944.8LBS,22-J

AN-92

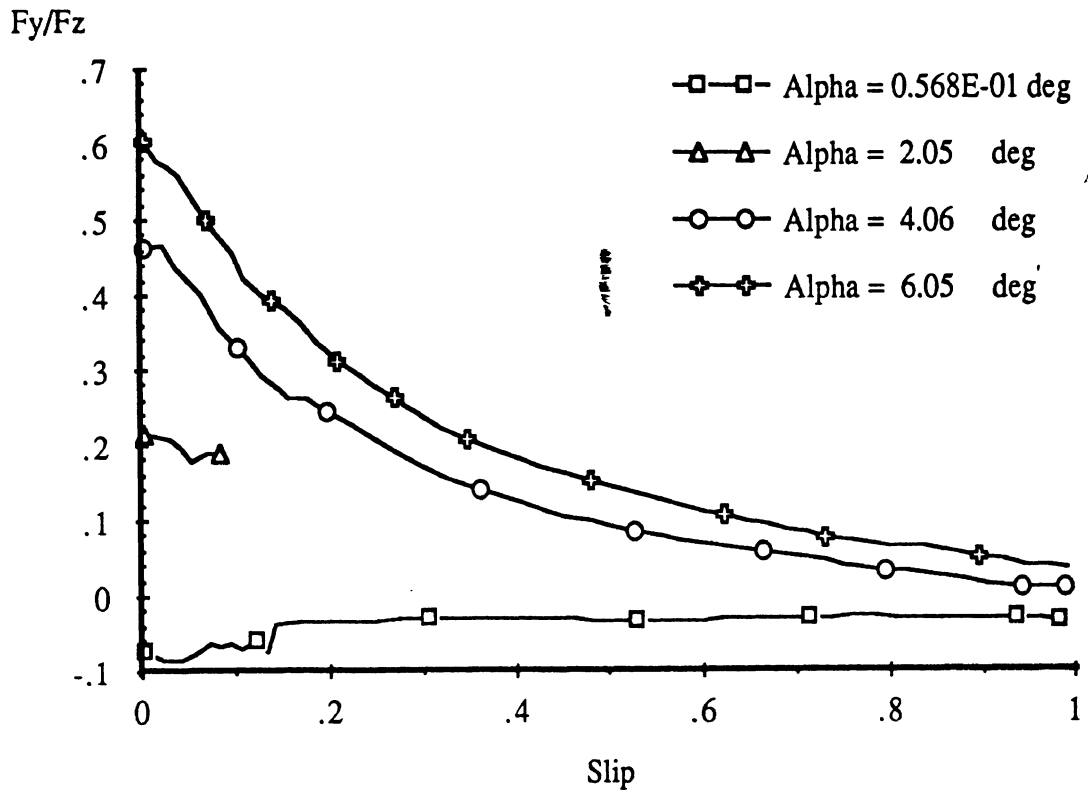

GDYR,G159,295/75R22.5,G,TP=110,123,TEMP=50,U=56.3MPH,FZ=-8248.3LBS,22-J

AN-92

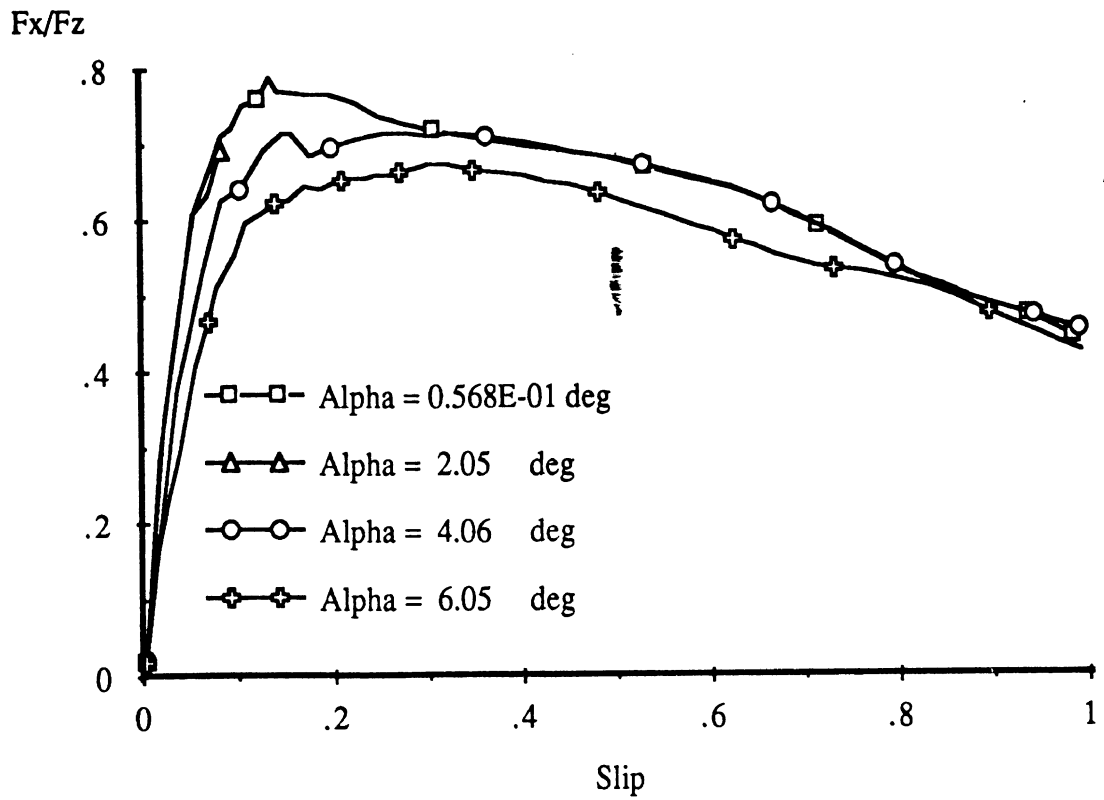

GDYR,G159,295/75R22.5,G,TP=110,123,TEMP=50,U=56.3MPH,FZ=-8248.3LBS,22-J

AN-92



**APPENDIX 3  
TIRE DATA**

4/11/13

**Goodyear G159  
295/75R22.5  
Load Range G**

**UMTRI ID 34  
(Tire #3)**

Tire 3 # 34

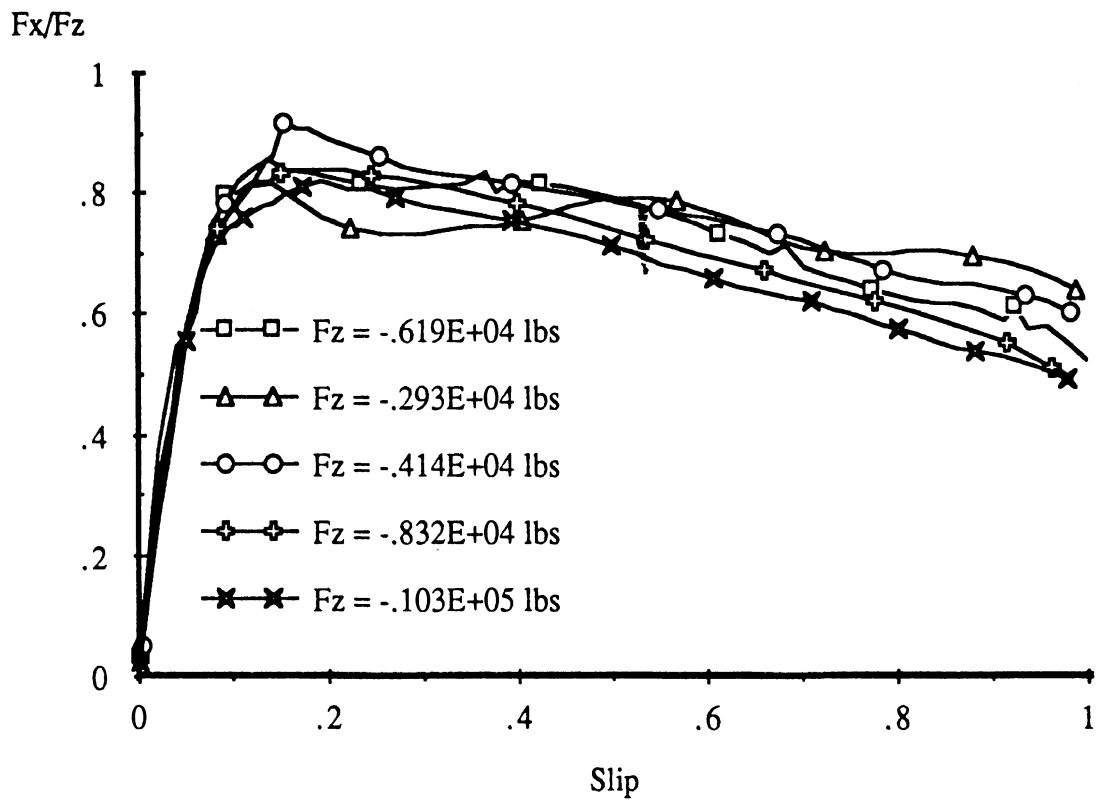

GY,G159,295/75R22.5,G,TP=110,123,TEMP=34,U=37.4MPH,22-JAN-92

Tire # 3 UMPB1 ID = 34

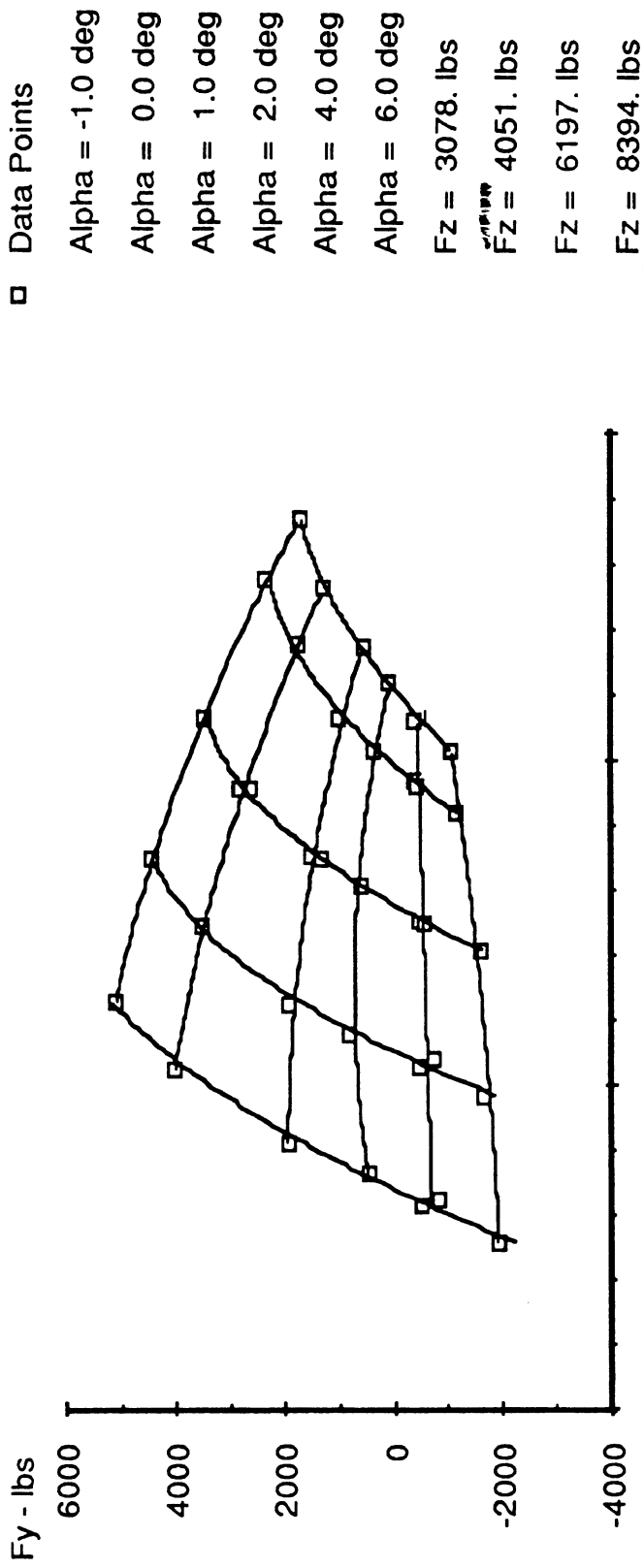

GY, G159, 295/75R22.5, G, TP=110, 123, TEMP=34, U=39.4MPH, 22-JAN-92 Fz = 10574. lbs

44444

**APPENDIX 4  
TIRE DATA**

**1**

**Goodyear G159  
295/75R22.5  
Load Range G**

**UMTRI ID 31  
(Tire #4)**

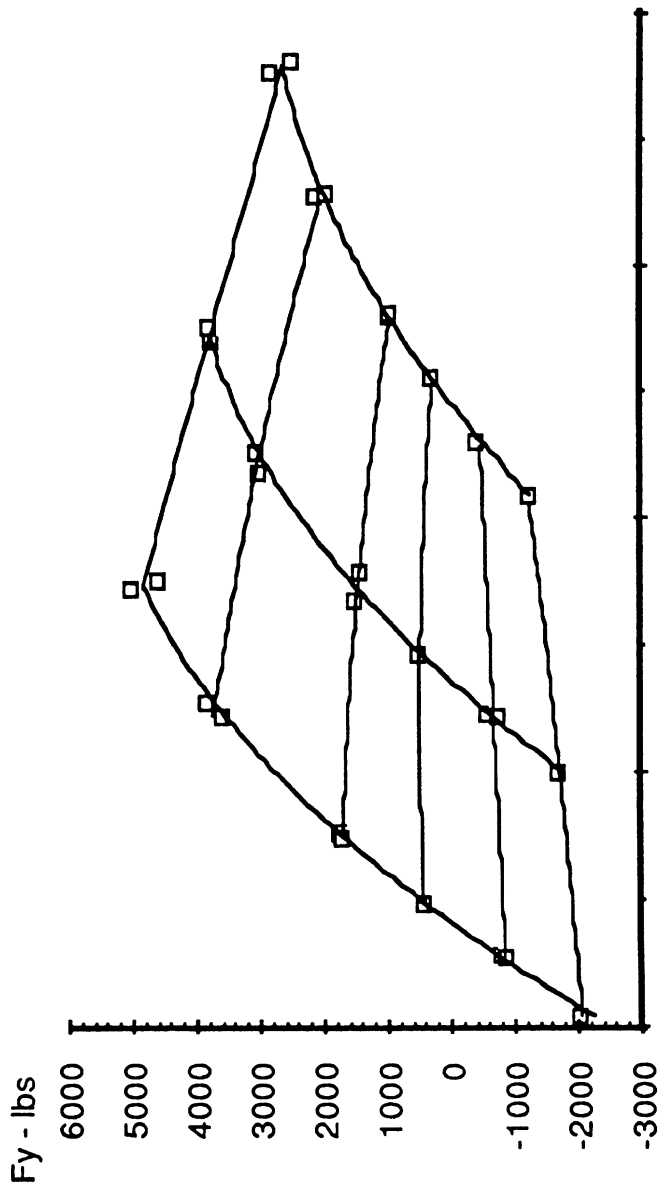

- Data Points
- Alpha = -0.9 deg
- Alpha = 0.1 deg
- Alpha = 1.1 deg
- Alpha = 2.1 deg
- Alpha = 4.1 deg
- Alpha = 6.1 deg
- Fz = 4193. lbs
- Fz = 6344. lbs
- Fz = 8279. lbs

GY,ID=31,G159,295/75R22.5,G,  
 TP=110,123,TEMP=38,U=21.1MPH,23-JAN-92

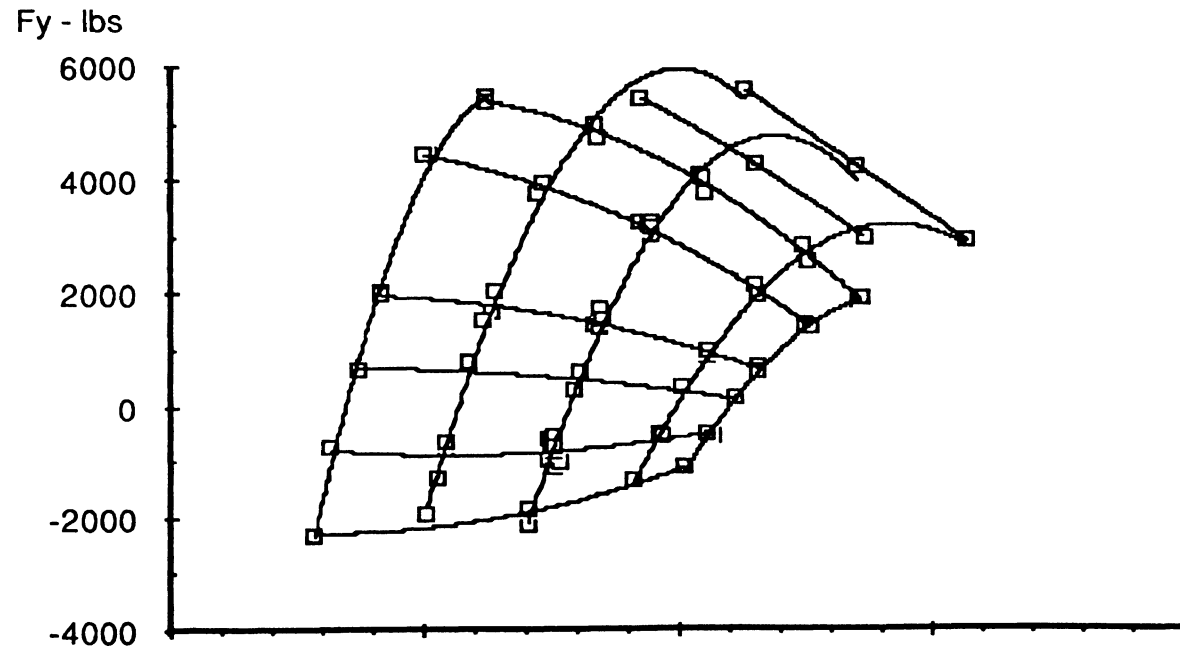

- Data Points
- Alpha = -0.9 deg
- Alpha = 0.1 deg
- Alpha = 1.1 deg
- Alpha = 2.1 deg
- Alpha = 4.1 deg
- Alpha = 6.1 deg
- Alpha = 8.0 deg
- Alpha = 12.0 deg
- Fz = 3100. lbs
- Fz = 4090. lbs
- Fz = 6199. lbs
- Fz = 8339. lbs
- Fz = 10502. lbs

GY,ID=31,G159,295/75R22.5,G,  
TP=110,123,TEMP=38,U=39.2MPH,23-JAN-92

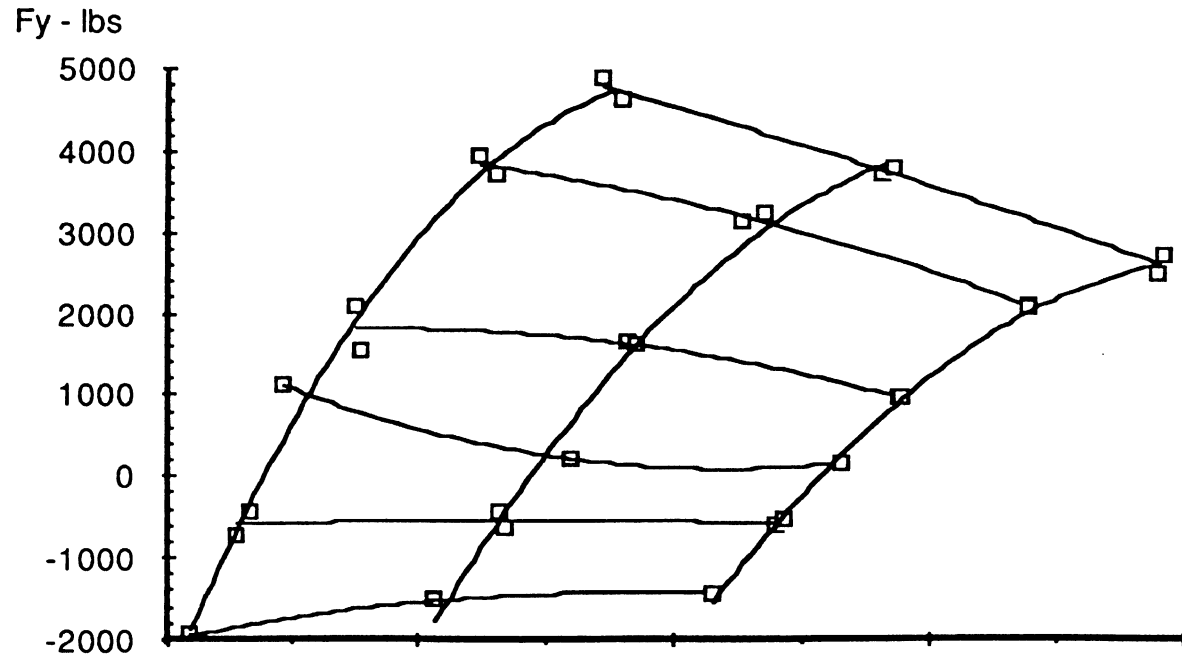

- Data Points
- Alpha = -0.9 deg
- Alpha = 0.1 deg
- Alpha = 1.1 deg
- Alpha = 2.1 deg
- Alpha = 4.1 deg
- Alpha = 6.1 deg
- Fz = 4160. lbs
- Fz = 6311. lbs
- Fz = 8411. lbs

GY,ID=31,G159,295/75R22.5,G,  
TP=110,123,TEMP=38,U=58.5MPH,23-JAN-92



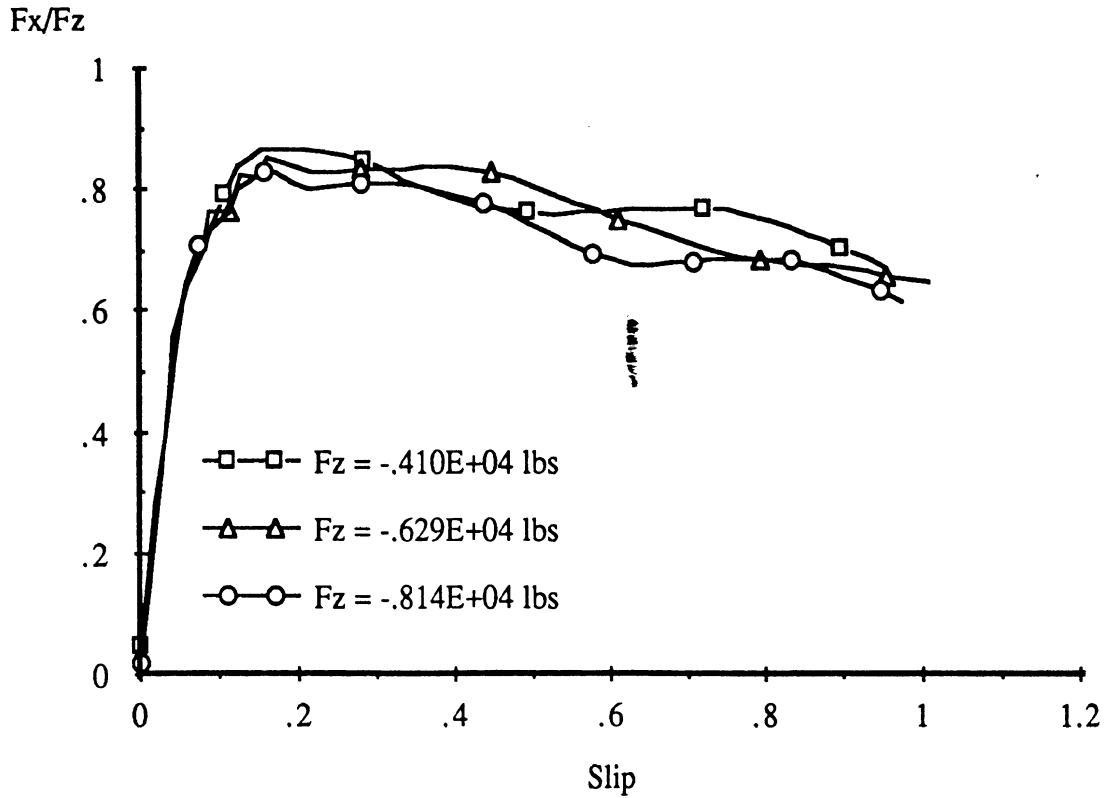

GY,ID=31,G159,295/75R22.5,G,TP=110,123,TEMP=38,U=18.8MPH,23-JAN-92

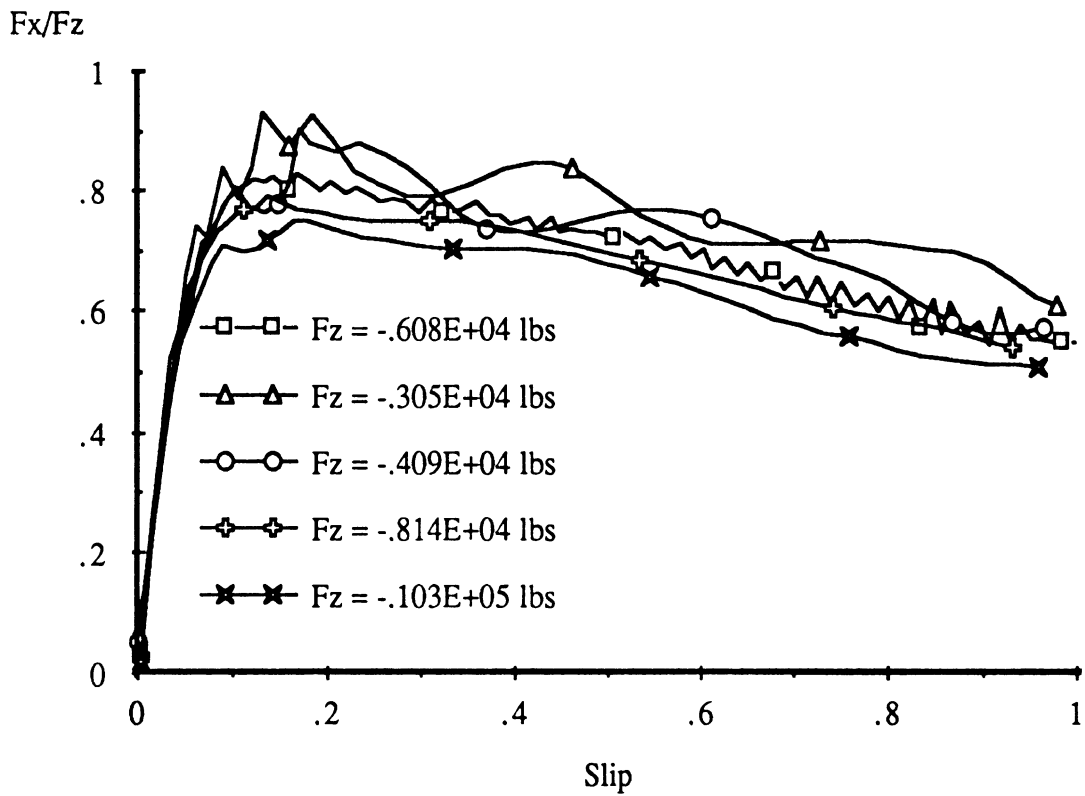

GY,ID=31,G159,295/75R22.5,G,TP=110,123,TEMP=38,U=37.1MPH,23-JAN-92

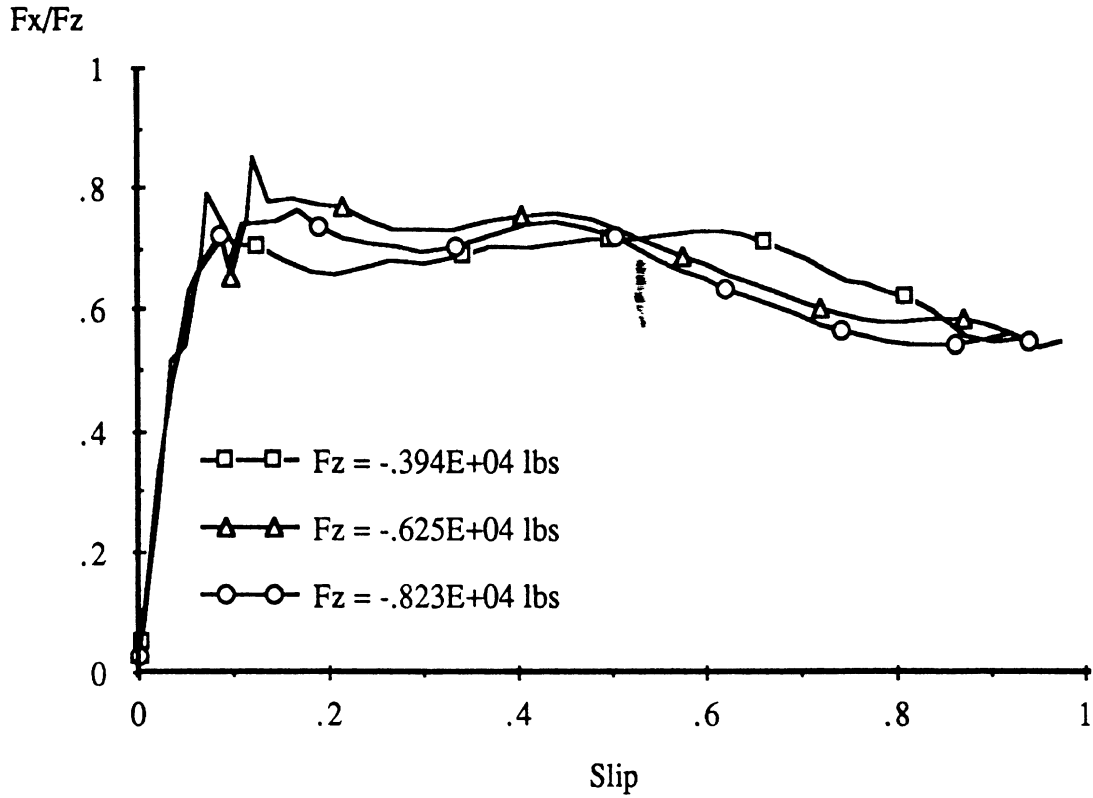

GY,ID=31,G159,295/75R22.5,G,TP=110,123,TEMP=38,U=56.3MPH,23-JAN-92

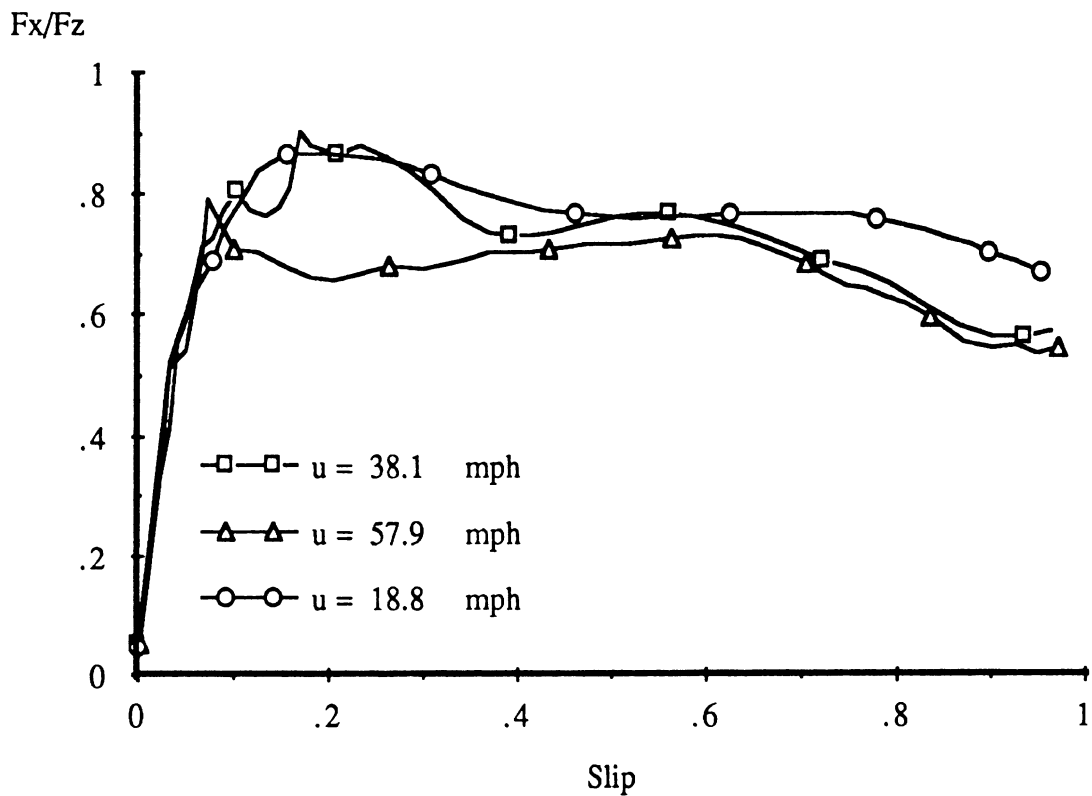

GY,ID=31,G159,295/75R22.5,G,TP=110,123,TEMP=38,FZ=-4044.6LBS,23-JAN-92

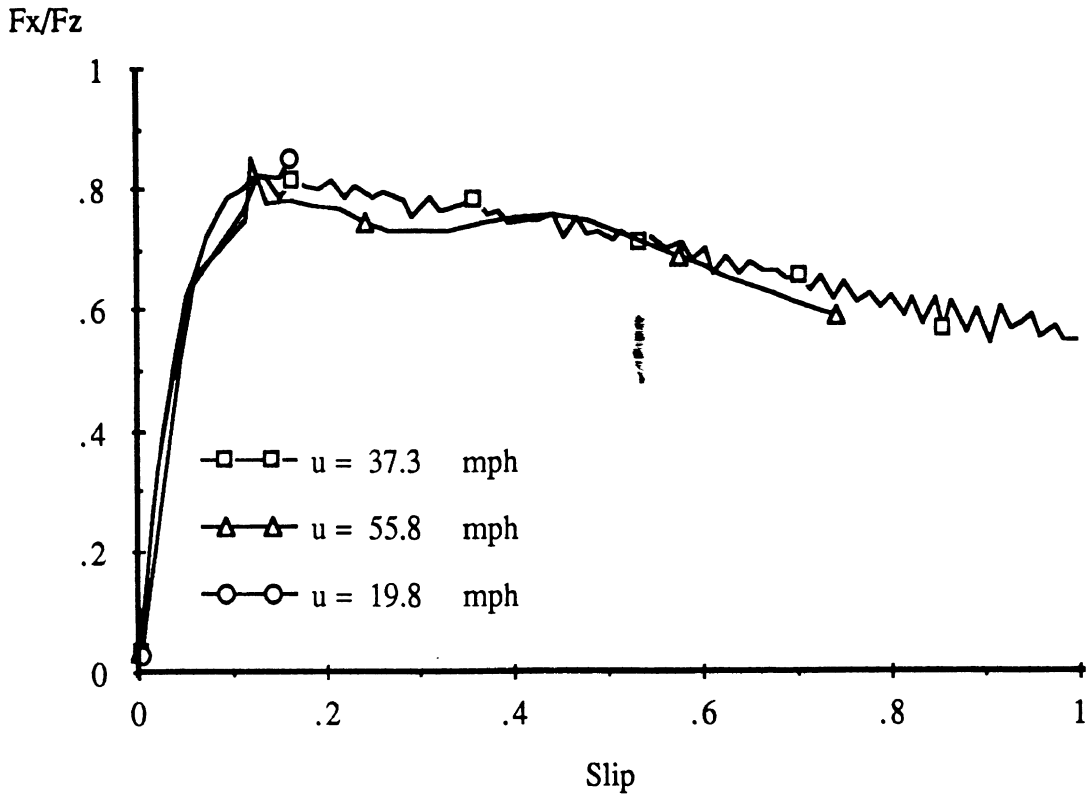

GY,ID=31,G159,295/75R22.5,G,TP=110,123,TEMP=38,FZ=-6043.1LBS,23-JAN-92

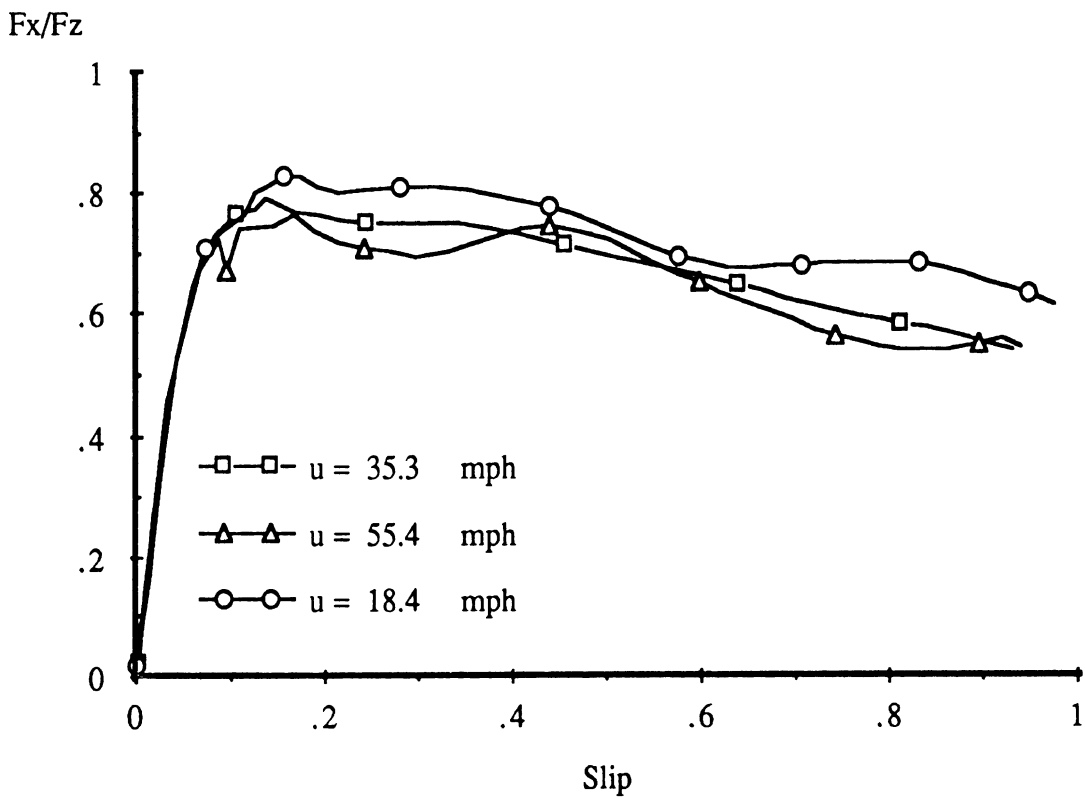

GY,ID=31,G159,295/75R22.5,G,TP=110,123,TEMP=38,FZ=-8170.5LBS,23-JAN-92

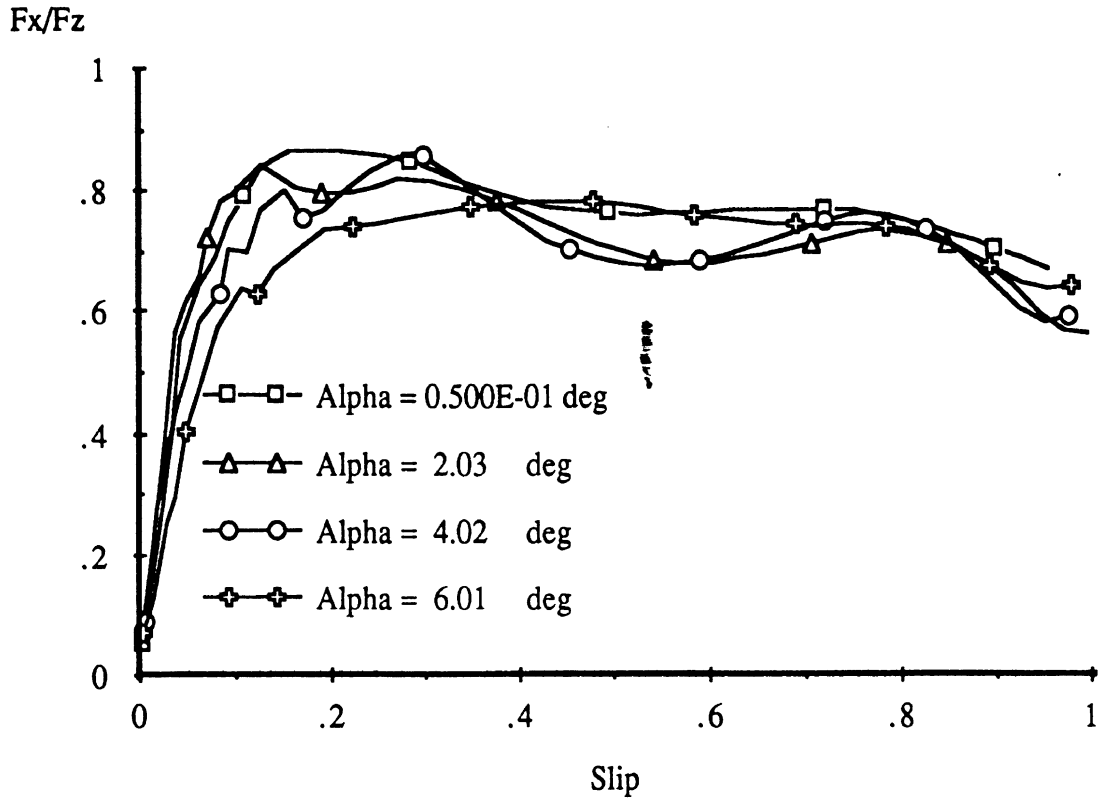

GY,ID=31,G159,295/75R22.5,G,TP=110,123,TEMP=38,U=19.5MPH,FZ=-4118.9LBS,

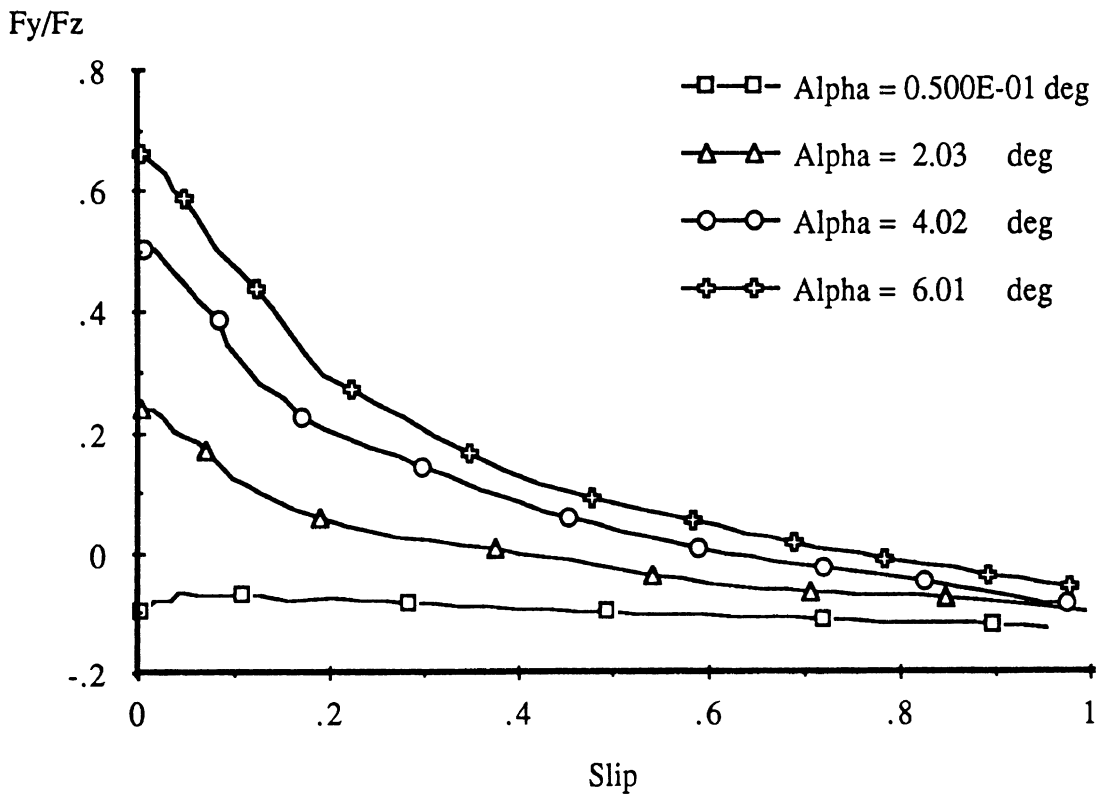

GY,ID=31,G159,295/75R22.5,G,TP=110,123,TEMP=38,U=19.5MPH,FZ=-4118.9LBS,

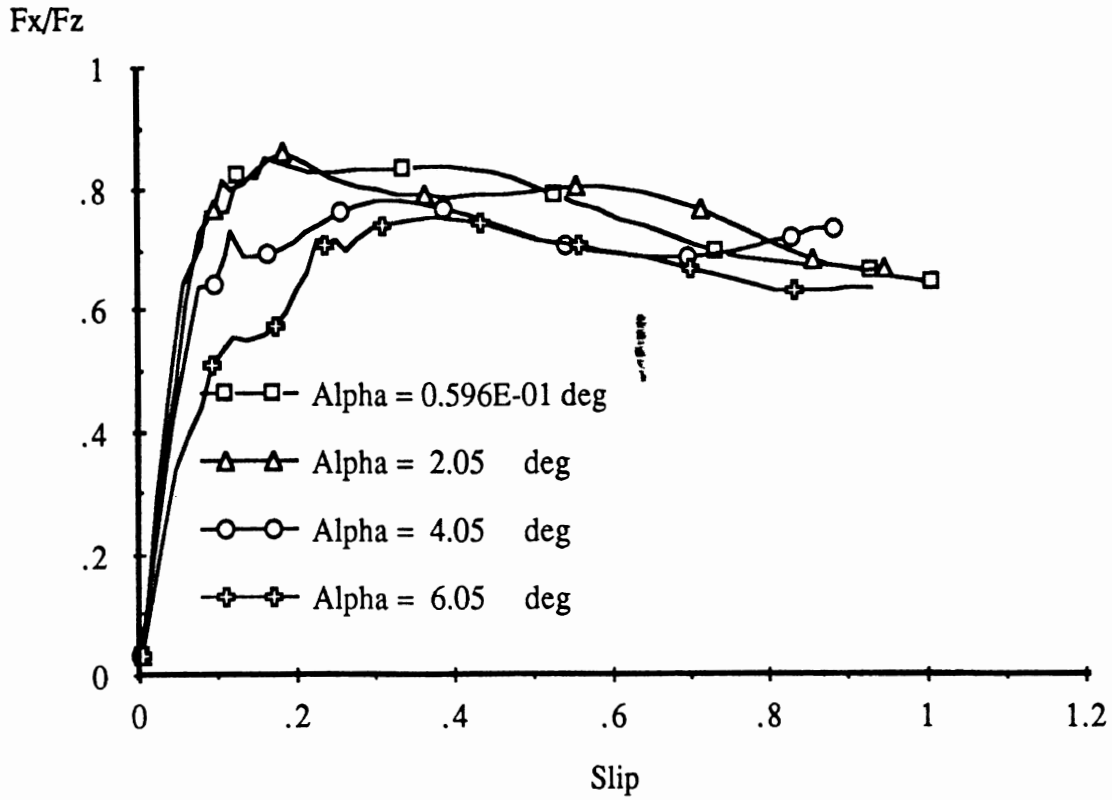

GY,ID=31,G159,295/75R22.5,G,TP=110,123,TEMP=38,U=19.5MPH,FZ=-6171.0LBS,

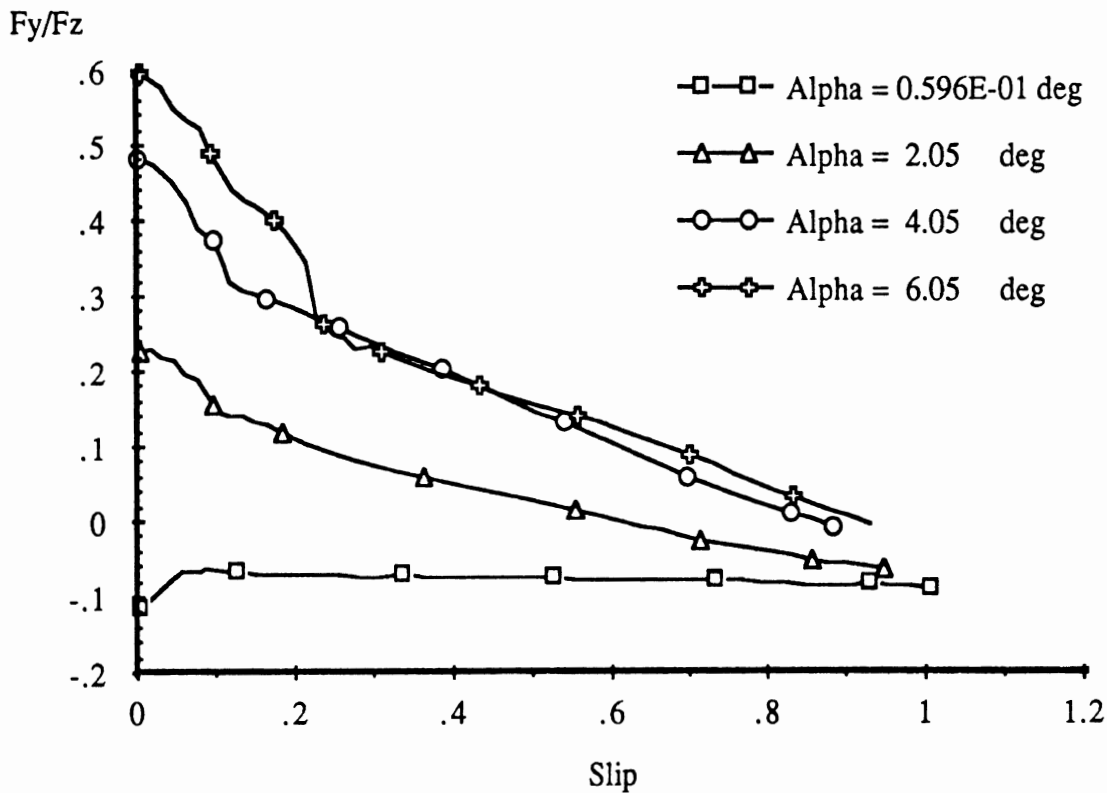

GY,ID=31,G159,295/75R22.5,G,TP=110,123,TEMP=38,U=19.5MPH,FZ=-6171.0LBS,

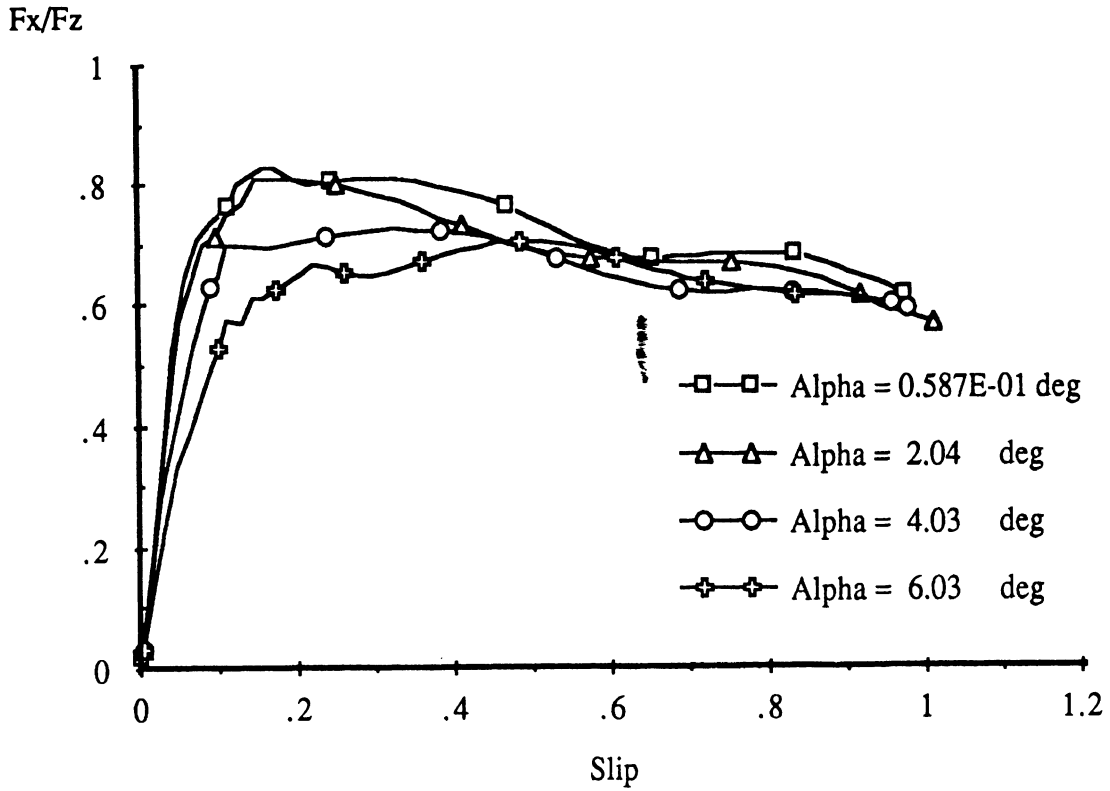

GY, ID=31, G159, 295/75R22.5, G, TP=110, 123, TEMP=38, U=19.5MPH, FZ=-8128.1LBS,

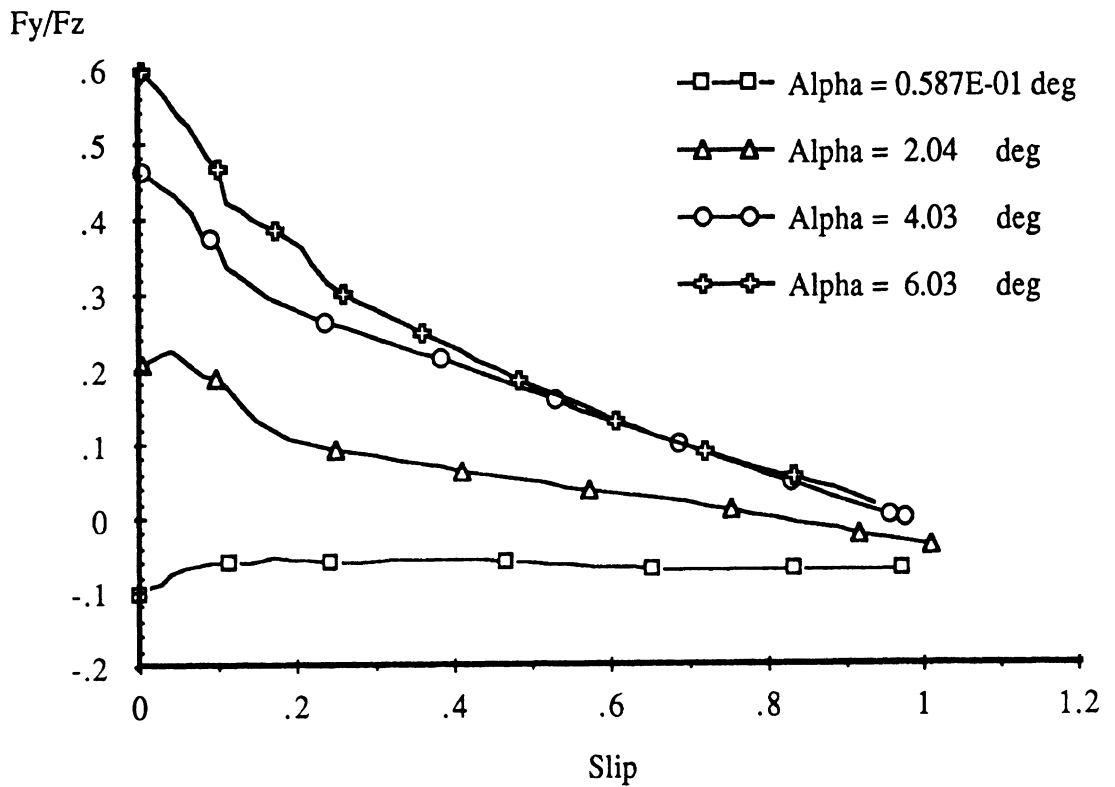

GY, ID=31, G159, 295/75R22.5, G, TP=110, 123, TEMP=38, U=19.5MPH, FZ=-8128.1LBS,

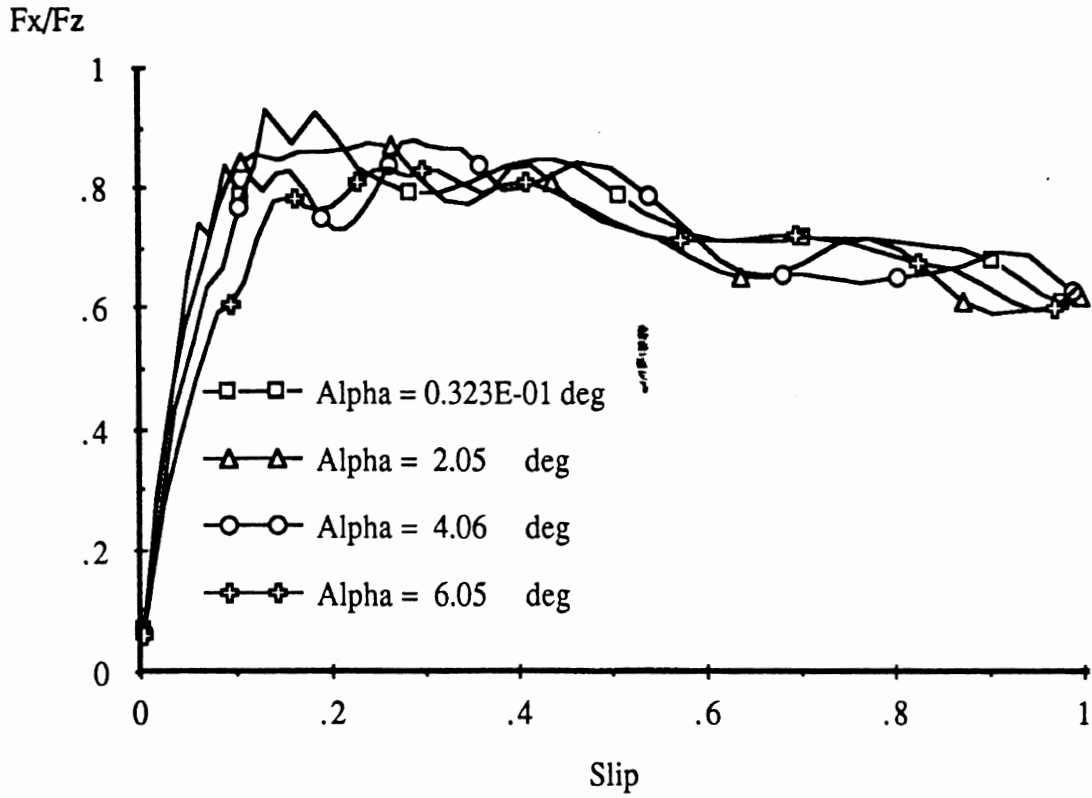

GY,ID=31,G159,295/75R22.5,G,TP=110,123,TEMP=38,U=37.2MPH,FZ=-3084.8LBS,

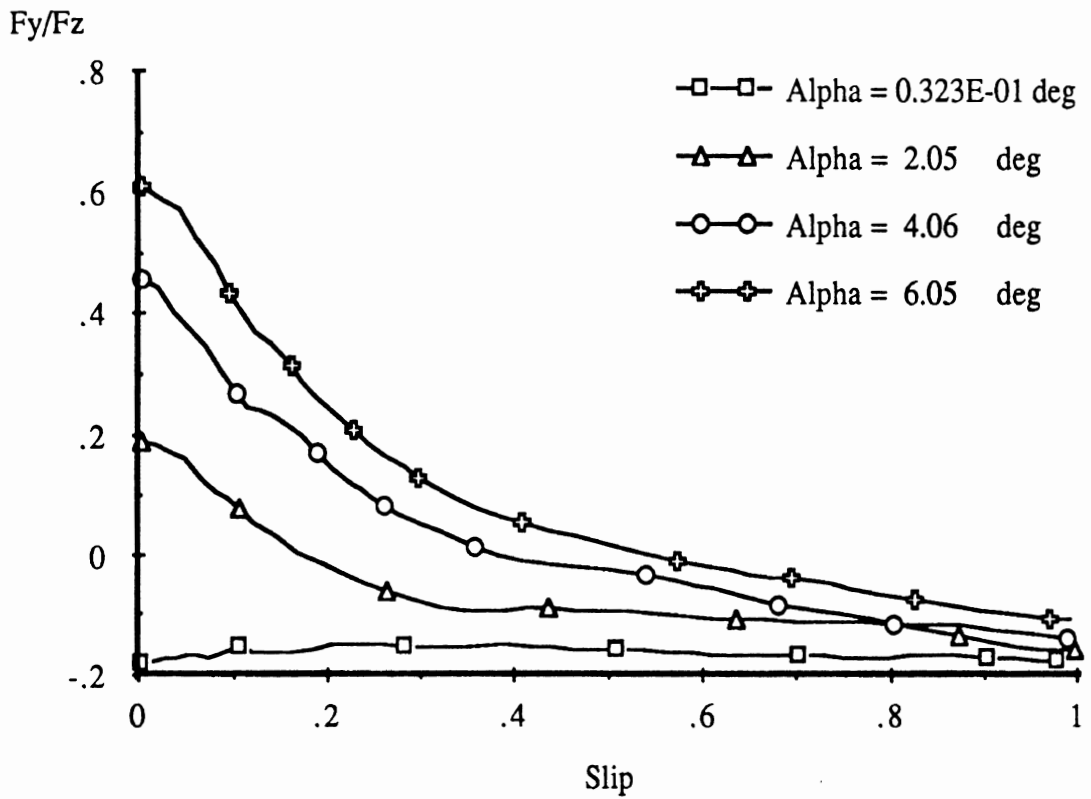

GY,ID=31,G159,295/75R22.5,G,TP=110,123,TEMP=38,U=37.2MPH,FZ=-3084.8LBS,

- Alpha = 0.308E-01 deg
- △-△- Alpha = 2.03 deg
- Alpha = 4.02 deg
- ◇-◇- Alpha = 6.00 deg
- ×-×- Alpha = 8.01 deg
- ☆-☆- Alpha = 12.0 deg

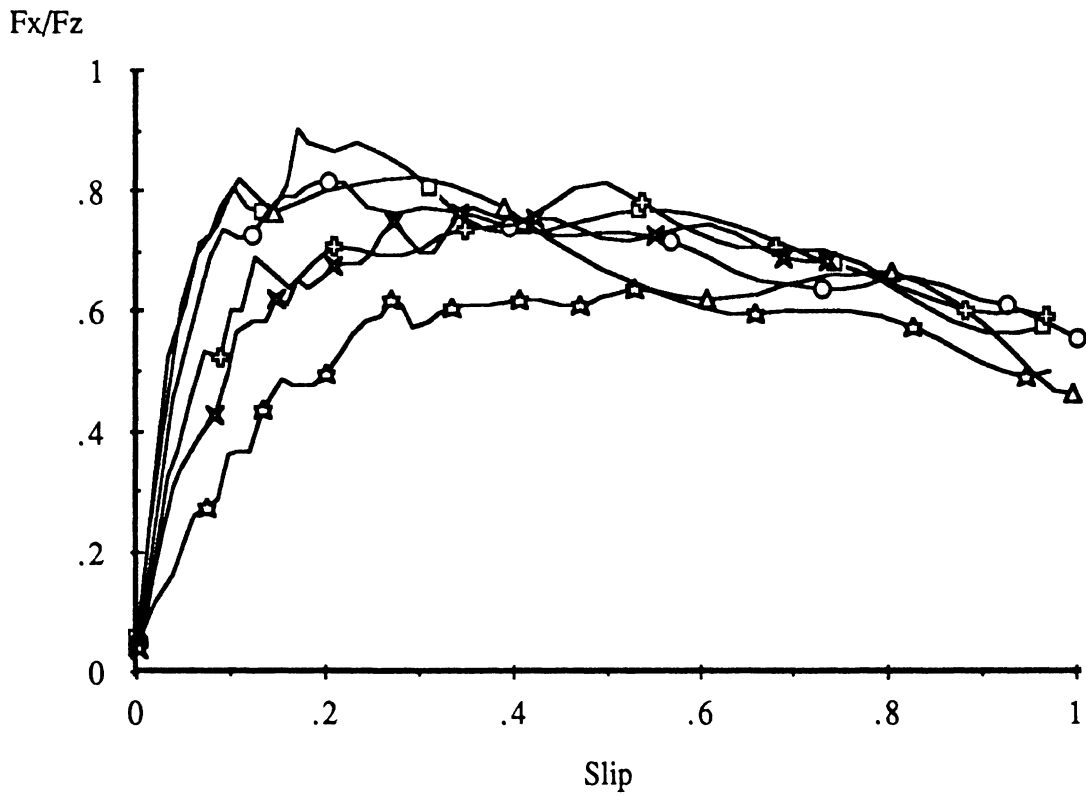

GY,ID=31,G159,295/75R22.5,G,TP=110,123,TEMP=38,U=37.2MPH,FZ=-4067.7LBS,



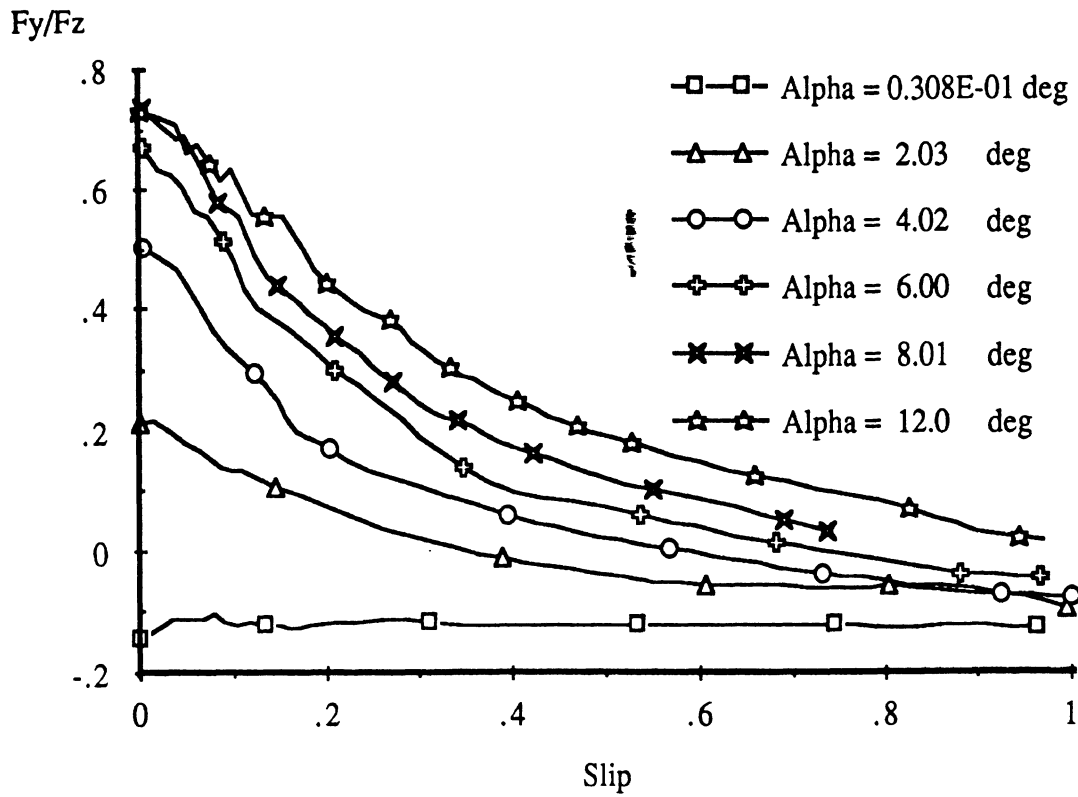

GY, ID=31, G159, 295/75R22.5, G, TP=110, 123, TEMP=38, U=37.2MPH, FZ=-4067.7LBS,

- Alpha = 0.421E-01 deg
- △-△- Alpha = 2.04 deg
- Alpha = 4.01 deg
- +--+ Alpha = 6.01 deg
- x-x- Alpha = 8.01 deg
- ☆-☆- Alpha = 12.0 deg

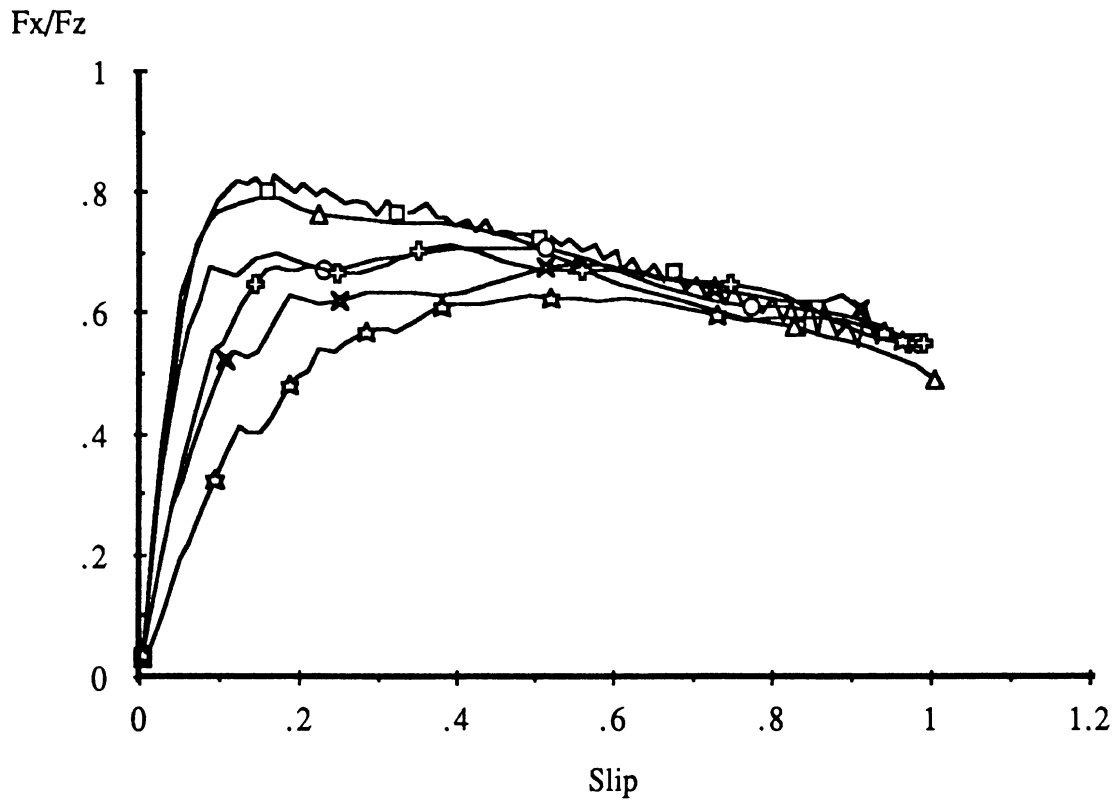

GY,ID=31,G159,295/75R22.5,G,TP=110,123,TEMP=38,U=37.2MPH,FZ=-6066.3LBS,

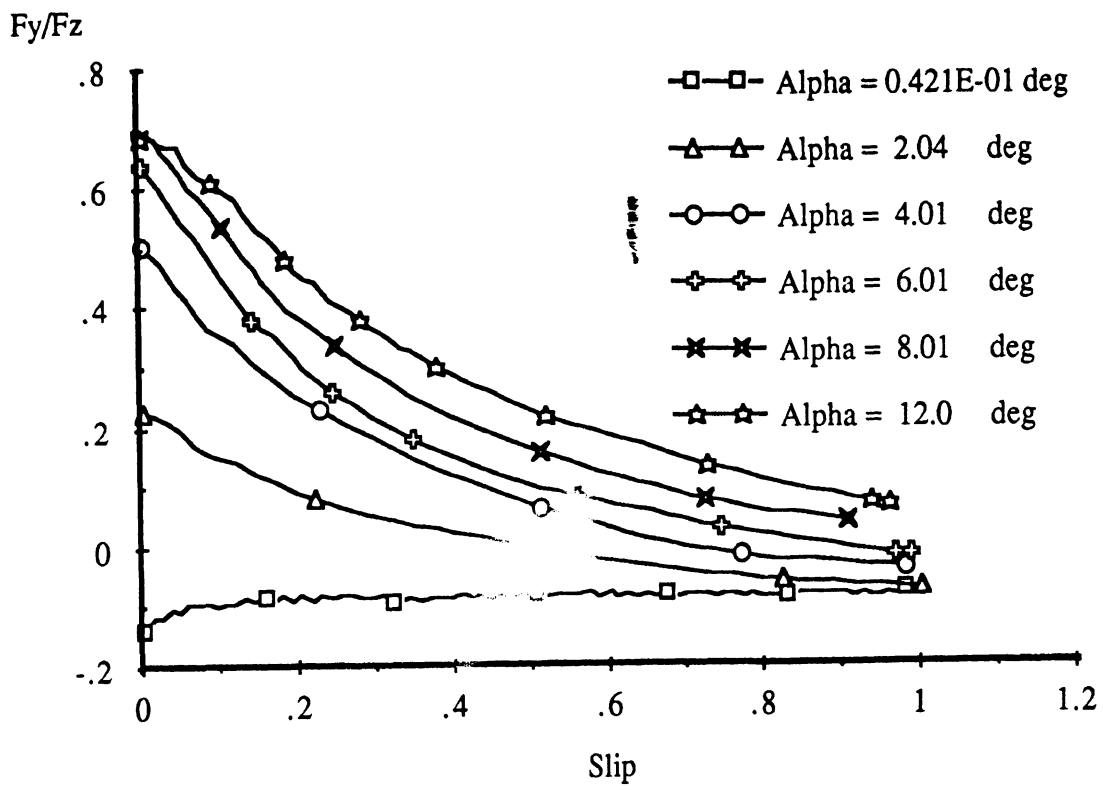

GY, ID=31, G159, 295/75R22.5, G, TP=110, 123, TEMP=38, U=37.2MPH, FZ=-6066.3LBS,

- Alpha = 0.413E-01 deg
- △-△- Alpha = 2.03 deg
- Alpha = 4.01 deg
- ◇-◇- Alpha = 5.99 deg
- ×-×- Alpha = 8.01 deg
- ☆-☆- Alpha = 12.0 deg

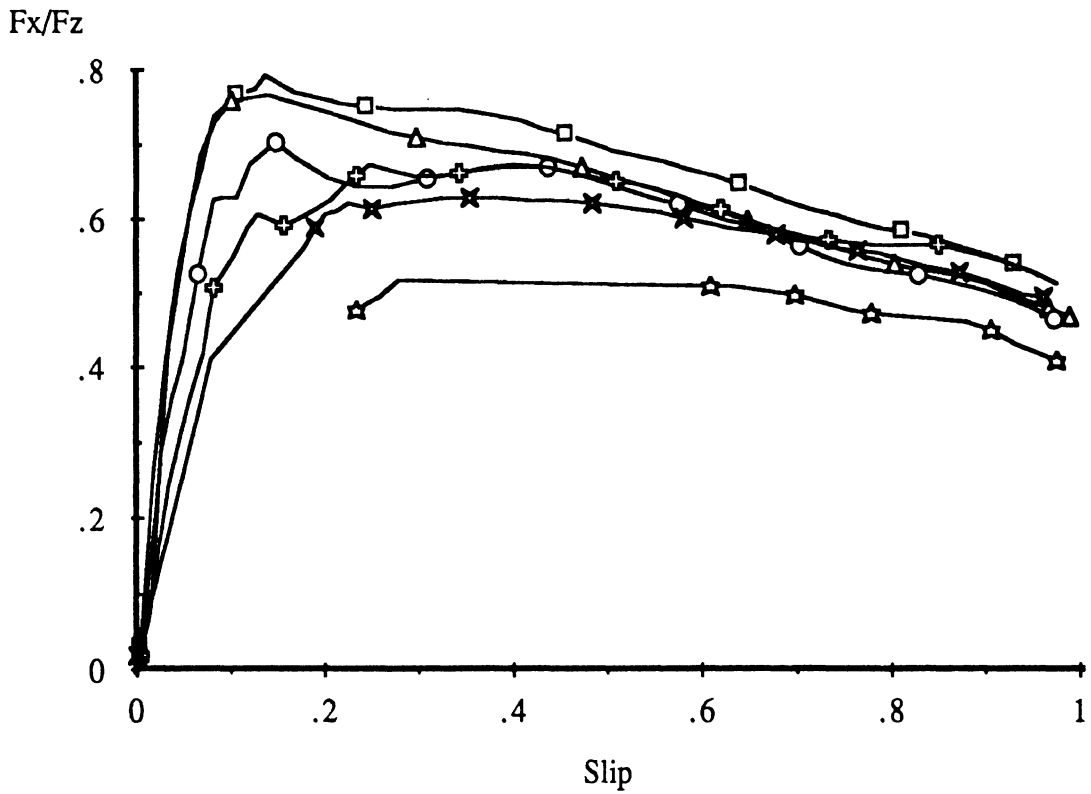

GY, ID=31, G159, 295/75R22.5, G, TP=110, 123, TEMP=38, U=37.2MPH, FZ=-8122.1LBS,

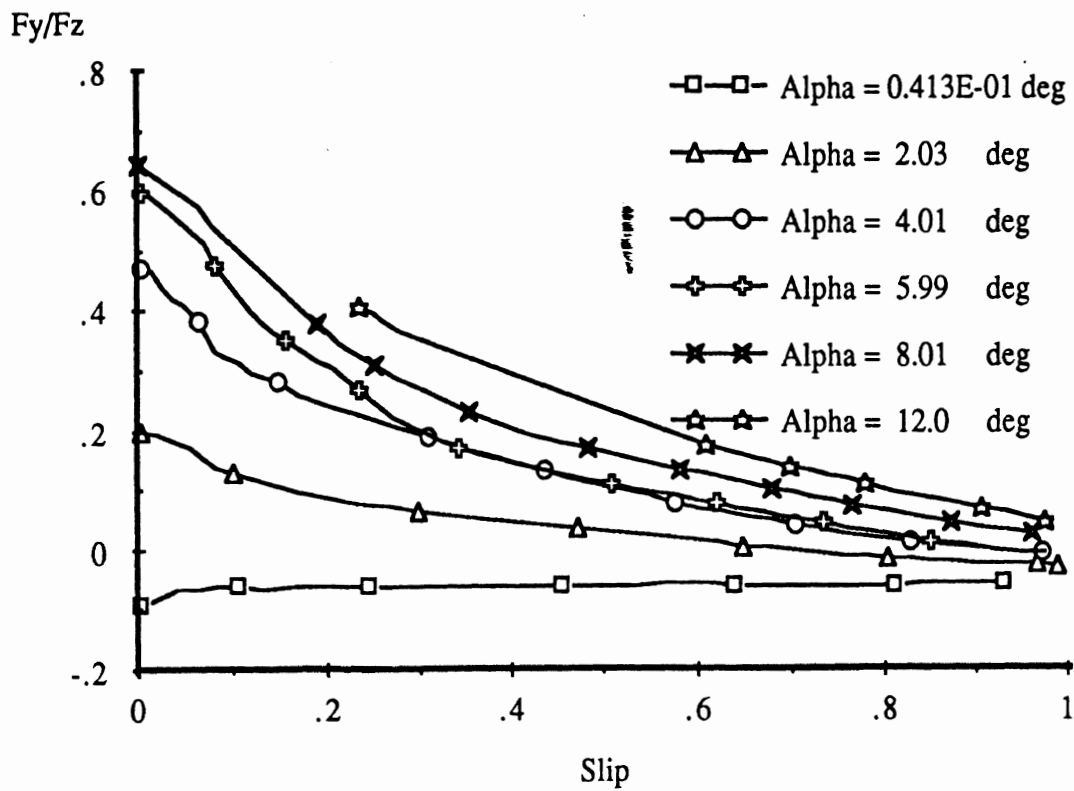

GY,ID=31,G159,295/75R22.5,G,TP=110,123,TEMP=38,U=37.2MPH,FZ=-8122.1LBS,

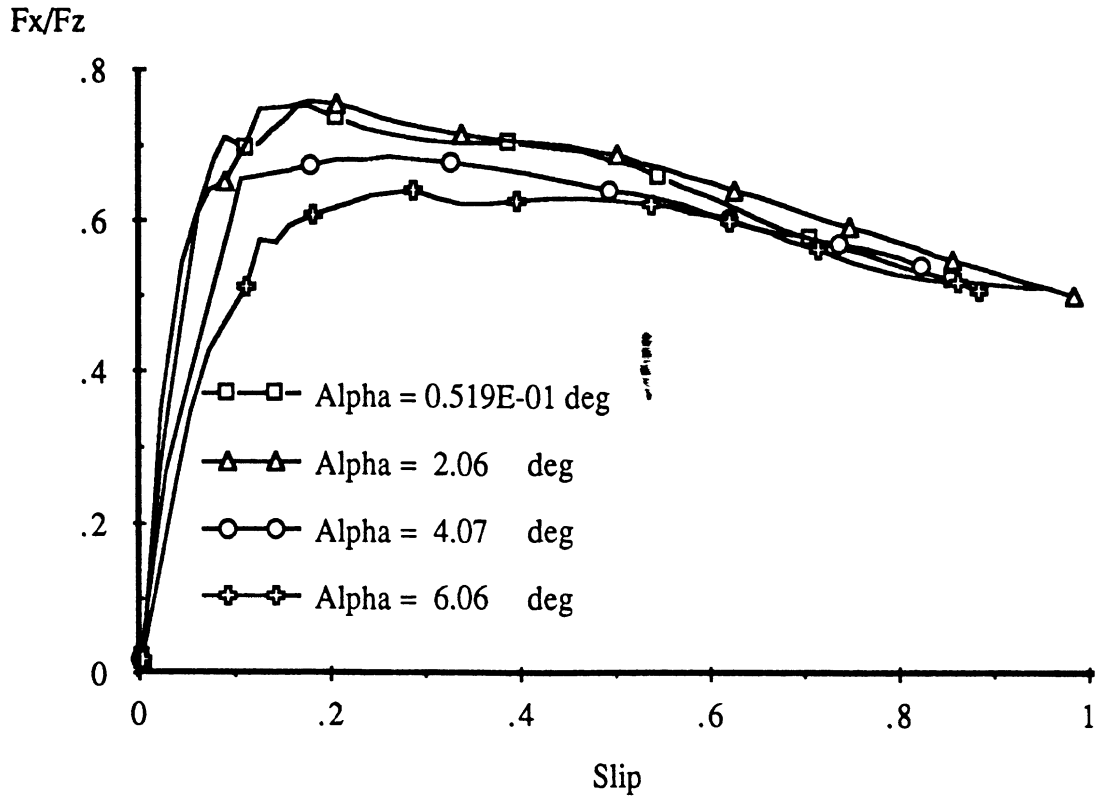

GY,ID=31,G159,295/75R22.5,G,TP=110,123,TEMP=38,U=37.2MPH,FZ=-10249.1LBS,

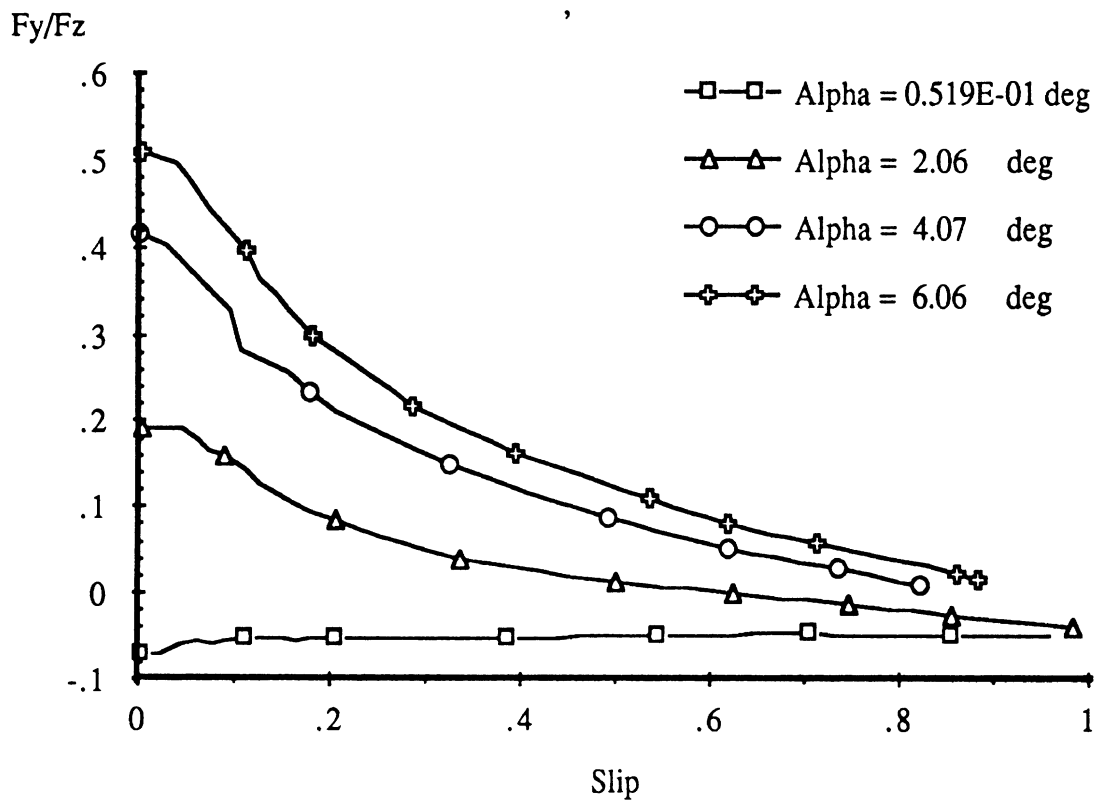

GY,ID=31,G159,295/75R22.5,G,TP=110,123,TEMP=38,U=37.2MPH,FZ=-10249.1LBS,

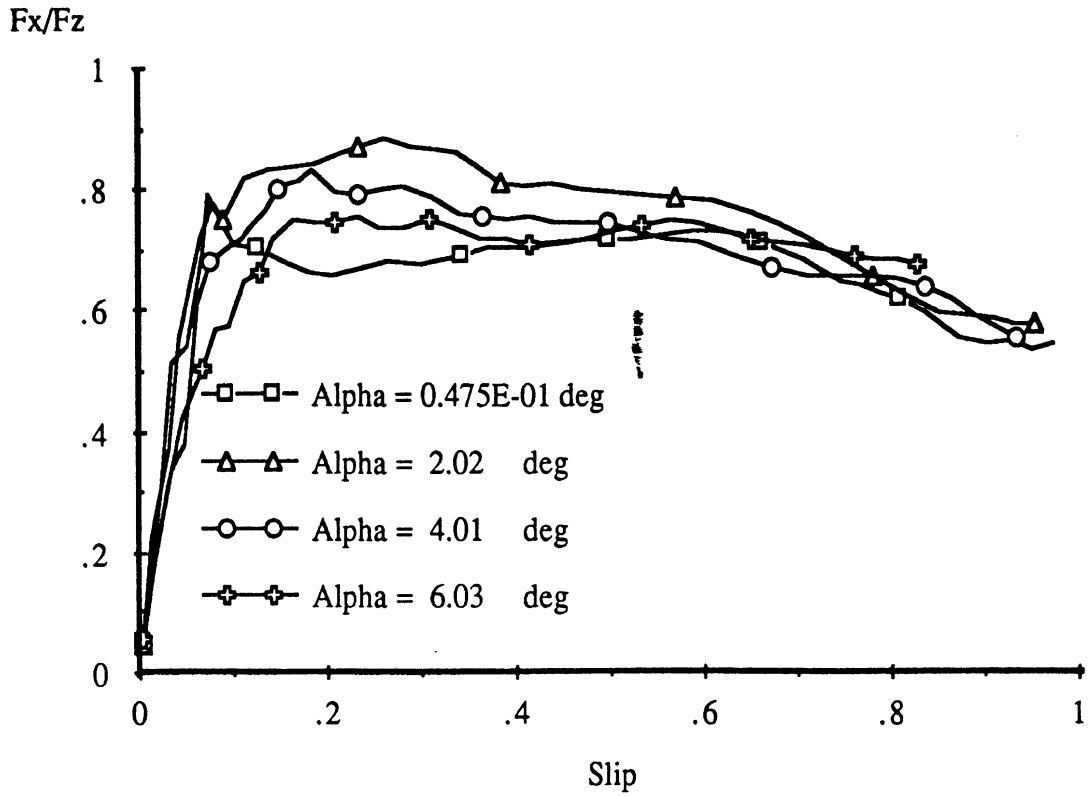

GY,ID=31,G159,295/75R22.5,G,TP=110,123,TEMP=38,U=56.1MPH,FZ=-4024.3LBS,

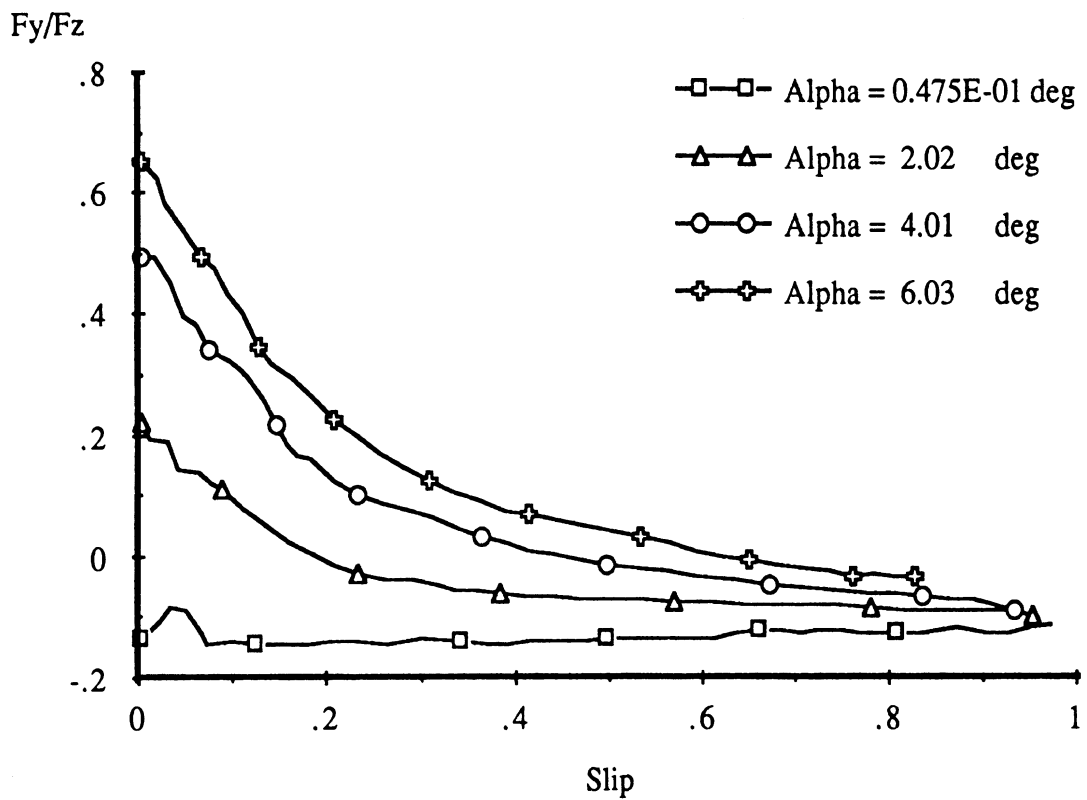

GY,ID=31,G159,295/75R22.5,G,TP=110,123,TEMP=38,U=56.1MPH,FZ=-4024.3LBS,

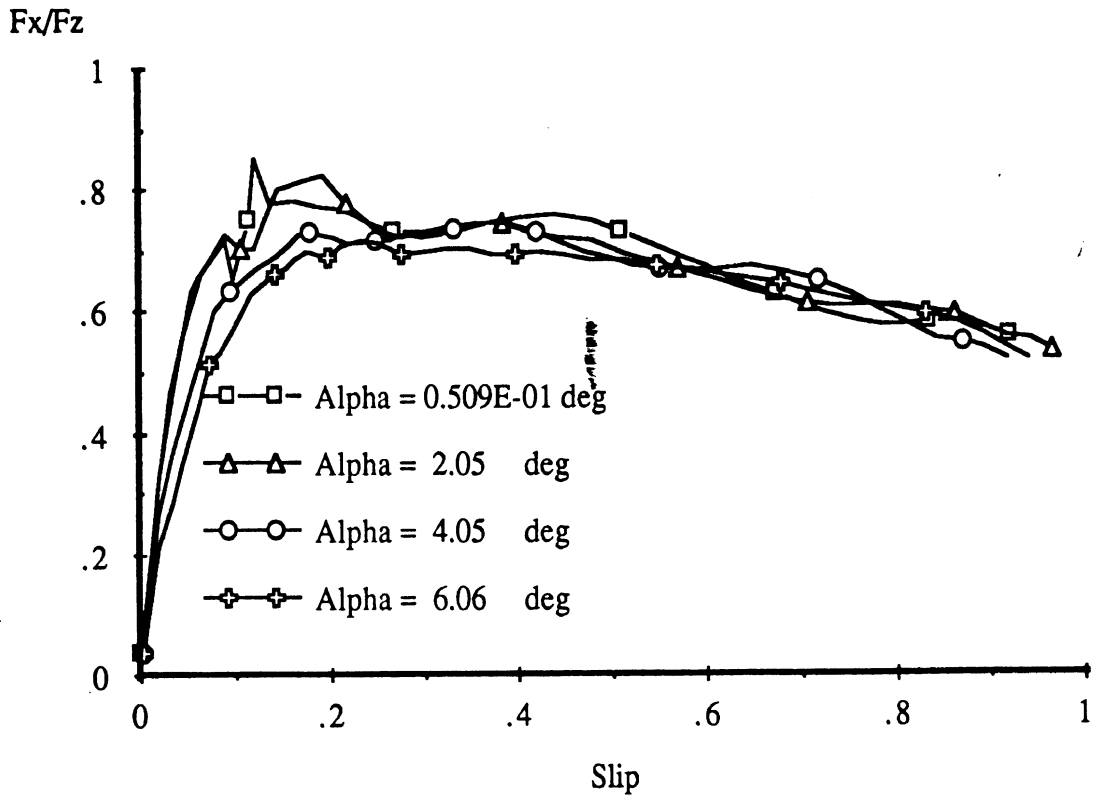

GY,ID=31,G159,295/75R22.5,G,TP=110,123,TEMP=38,U=56.1MPH,FZ=-6117.6LBS,

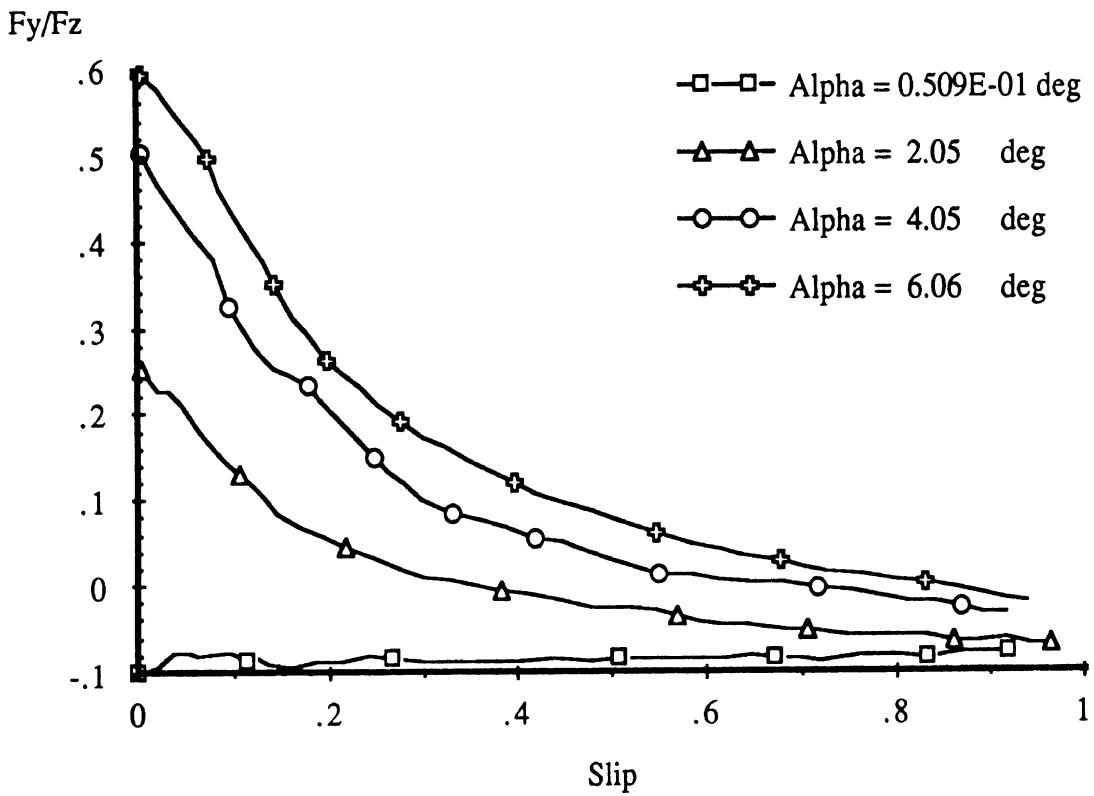

GY,ID=31,G159,295/75R22.5,G,TP=110,123,TEMP=38,U=56.1MPH,FZ=-6117.6LBS,



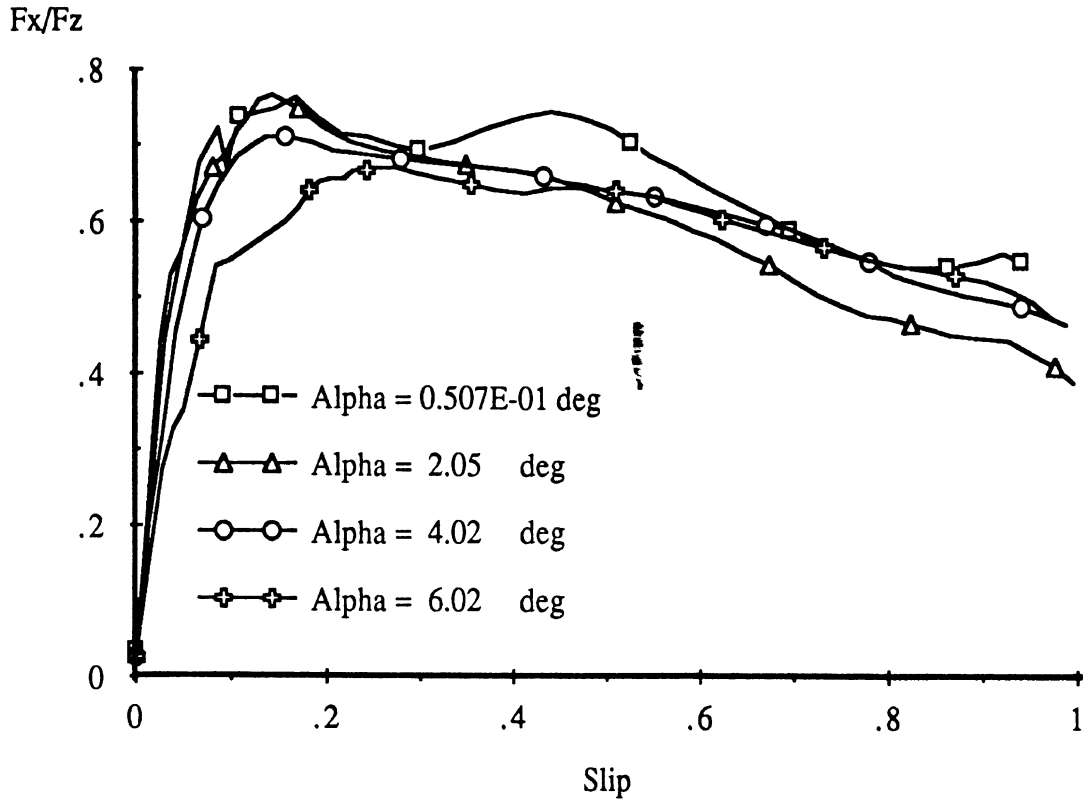

GY,ID=31,G159,295/75R22.5,G,TP=110,123,TEMP=38,U=56.1MPH,FZ=-8351.6LBS,

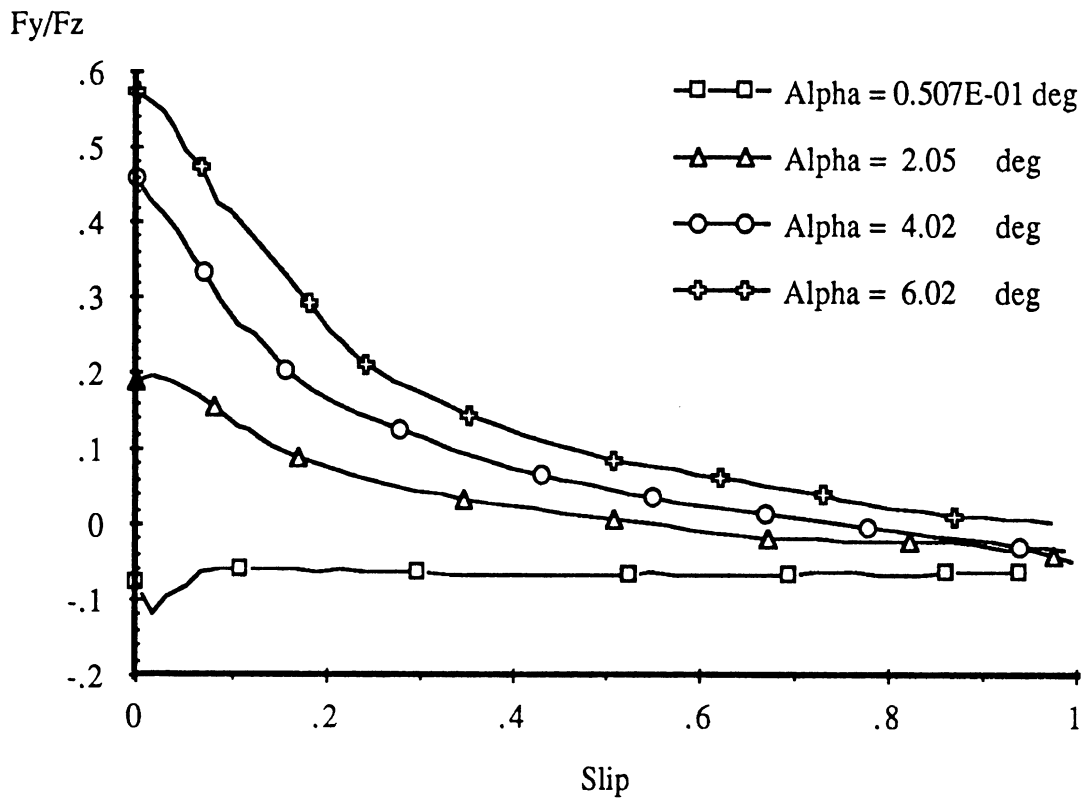

GY,ID=31,G159,295/75R22.5,G,TP=110,123,TEMP=38,U=56.1MPH,FZ=-8351.6LBS,

1111111111

**APPENDIX 5**

**1**

**SAE Truck Tire Task Force**

**TRUCK TIRE CHARACTERIZATION  
Statement of Work**

## 1. STATEMENT OF WORK

Braking, tracking, control/stability and roll-over have been identified as key vehicle performance safety issues which are directly affected by physical properties of tires. Pertinent tire properties include: friction during straight ahead and cornering maneuvers<sup>1</sup>, lateral force and aligning torque in cornering, lateral/longitudinal force interactions during braking and braking stiffness.

The increasing importance of obtaining data of this type has highlighted the fact that the publicly available truck tire data is extremely limited and that industry standardized test procedures do not exist to gather those data. Two public domain machines have been identified in the United States which have the capability to provide this type of data:

- The mobile dynamometer at the University of Michigan Transportation Research Institute (UMTRI); and
- The flat belt laboratory machine at CALSPAN

Accordingly, a program is in order to:

1. Develop three (3) standardized test procedures.
  - A. Free Rolling cornering
  - B. Straight ahead traction
  - C. Combined cornering and braking
2. Refine the procedures by evaluating the influence of selected variables.

This statement of work addresses the first portion of a comprehensive program.

<sup>1</sup>Peak and slide in the traditional sense are only well defined for small slip angles (up to about an absolute value of 2°).

C.2 Objective:

The objective of this project is to develop standardized meaningful tire characterization test procedures<sup>2</sup> and quantify their repeatability on the CALSPAN flat belt laboratory machine and on UMTRI's mobile dynamometer.

C.3 Specific Requirements - Task Statement:

The contractor<sup>3</sup> shall utilize a single typical radial low profile truck tire construction for this project. The tires shall be tested on the design rim width rim (T & RA). The contractor shall obtain tires from the same production run to minimize tire to tire variation during the tests.

The contractor shall have data collected at UMTRI's and CALSPAN's facilities and produce at a minimum:

- A quantitative assessment of test repeatability.
- A determination of the sensitivity of the results to key test conditions.
- A comparison between UMTRI and CALSPAN means and variances.

The contractor shall include the following tasks in the tire testing; validation of results and development of a standardized procedure.

<sup>2</sup>Nomenclature used in this document is given in Appendix A.

<sup>3</sup>SAE

<sup>4</sup>The contractor shall store tires in a dark, low temperature environment until the tires are needed for testing.

1. Test Repeatability:

1.1 Tire Break-In:

The break-in shall be done in accordance with the following table in all cases except for the testing in Section 2.4 which contains special instructions:

DISTANCE Miles	S Mph	Fz % Rated	P psig.	SA Deg.	IA Deg.
55	55	100	P	0	0
1/2	55	100	P	+1	0
1/2	55	100	P	-1	0

P is the specified test inflation pressure. It is a regulated pressure. P is the average pressure observed in three (3) tires after the tires have been subject to the warm up of Section 1.1.1. The starting pressure for determination of P is the cold rated pressure for single application at the maximum allowed for the tire load range (T&RA).

1.1.1 Warm up in Case of Broken Test:

If a test must be stopped because of an equipment problem or other limitation not due to a tire problem, the tire shall be warmed up as follows prior to test resumption.

DISTANCE Miles	S Mph	Fz % Rated	P psig.	SA Deg.	IA Deg.
55	55	100	P	0	0

## 1.2 Repeatability of Tests:

Prior to and at the conclusion of each test sequence, the tread profile shall be measured from tread shoulder to tread shoulder at three (3) locations spaced at 120° intervals around the tire circumference. The tread depth of each groove for each tire shall be measured at eight (8) locations spaced at 45° intervals around the tire circumference. One (1) 8 x 10 glossy photograph and the negative for producing it shall be provided for each tire as it is at the end of the test. The data from these measurements shall be provided to the analysis sub-contractor on 3.5" 1.44 meg diskettes in a form mutually agreed to by the analysis sub-contractor and UMTRI and CALSPAN.

Following documentation of the worn state of each tire at the conclusion of its test use, the previously tested tires may be used as "dummy" tires on the UMTRI machine.

A single dry pavement shall be used for this test at each test site. The pavement at CALSPAN does not have to be the same one used at UMTRI. It shall be characterized by the use of the ASTM peak friction E1136 test tire and the E1337-90 test procedure.

Ambient temperature shall be between 60 and 80° Fahrenheit and the ambient temperature and the temperature of the pavement surface shall be recorded at a sufficient number of intervals to give a picture of the thermal environment existing during testing. The data shall be provided to the analysis sub-contractor.

### 1.2.1 Repeatability of the Free-Rolling Cornering Test:

Five (5) repetitions of this test are to be run at each site. Each repetition requires the use of one (1) tire. The sequence of the experiment is as specified in the following table and description:

IA = 0°  
P = Specified Test Inflation Pressure (See Section 1.1)  
S = 55 mph

SA = 0, 1, -1, -2, 2, 4, -4, -6, 6°

FZ = 25, 50, 75, 100, 125, 150, 200% Rated Load (Single)

The right front rotation sense is used.

The test is performed in this precise manner. The tire is set at 0° slip angle and then sequentially loaded to 25, 50, 75, 100, 125, 150, and 200% of rated load. The slip angle is then set to +1° and the tire is loaded to the following loads: 25%, 50%, 75%, 100%, 125%, 150% and 200% rated load. The sequence continues as explained until the final step which is a +6° slip angle step in which the entire load sequence is once again repeated in order.

Without stopping the flow of testing, the Wear State Experiment (2.3.2) is to be run on each tire.

#### Data

Data averaged for two (2) revolutions at each test condition shall be provided. The data shall include: Fx, Fy, Fz, Mx, Mz, IA, Rl, SA and also, provide tread temperatures at the conclusion of testing. The data are to be presented in ASCII format on 3.5" 1.44 meg diskettes for use by the analysis sub-contractor.

#### 1.2.2 Straight Ahead Traction:

Five (5) repetitions of this test are to be run at each site. Each repetition requires the use of one (1) tire. The sequence of the experiment is as specified in the following table and description:

IA = SA = 0°  
P = Specified Test Inflation Pressure (See Section 1.1)  
S = 55 mph

Braking occurs at each Fz.

Fz = 25, 50, 75, 100, 125, 150, 200% Rated Load (Single)

-80% < SR < 0%

SR Rate = -80%/sec.

The right front rotation sense is used.

Without a break in the flow of testing, the Wear State Experiment (2.3.2) is to run on each tire.



Data

Fx, Fy, Fz, Mx, Mz, IA, Rl, SA, and also tread temperature data at the conclusion of testing are to be presented in ASCII format on 3.5" 1.44 meg diskettes as a function of SR at each 1% SR for use by the analysis sub-contractor.

1.2.3 Combined Cornering and Braking Test:

Five (5) repetitions of this test are to be run at each site. Each repetition requires the use of four (4) tires. The sequence of the experiment is as specified in the following table and description:

IA = 0°  
P = Specified Test Inflation Pressure (See Section 1.1)  
S = 55 mph

Sequence:

Slip Angle = 1, -1, -2, 2, 4, -4, -6, 6°

Fz = 25, 50, 75, 100, 125, 150, 200% Rated Load

-80% < SR < 0%

SR Rate = -80%/sec.

A new tire is used for each SA pair for a total of four (4) tires to complete one test.

The Straight Ahead Traction Sequence, Section 1.2.2, provides 0° slip angle data that will be considered part of this experiment.

The sequence of testing is exactly as follows:

TIRE 1

Fz = 25%, SA = + 1°, SR = 0 to 80%

Fz = 25%, SA = - 1°, SR = 0 to 80%

Fz = 50%, SA = - 1°, SR = 0 to 80%

.

.

.

Fz = 200%, SA = + 1°, SR = 0 to 80%

Fz = 200%, SA = - 1°, SR = 0 to 80%

TIRE 2

Fz = 25%, SA = + 2°, SR = 0 to 80%

Fz = 25%, SA = - 2°, SR = 0 to 80%

.

.

.

TIRE 3

.

.

.

TIRE 4

.

.

.

Fz = 200%, SA = + 6°, SR = 0 to 80%

Fz = 200%, SA = - 6°, SR = 0 to 80%

Without a break in the flow of testing, the Wear State Experiment (2.3.2) is to be run on each tire.

Data

Fx, Fy, Fz, Mx, Mz, IA, Rl, SA and also tread temperature data at the conclusion of testing are to be presented in ASCII format on 3.5" 1.44 meg diskettes as a function of SR at each 1% SR for use by the analysis sub-contractor.

1.3 Tread Temperature Measurements:

Tread temperatures shall be measured in both shoulders and the crown by needle probe at one half the non-skid depth of the tire at the start of the test. The measurements shall be taken at three (3) circumferential locations spaced 120° apart.

1.4 Test Tires Required for Repeatability:

	<u>UMTRI</u>	<u>CALSPAN</u>
Free Rolling Cornering	5	5
Straight Ahead Traction	5	5
Combined Cornering and Braking	20	20
Spares	<u>5</u>	<u>5</u>
	35	35
SECTION 1 TOTAL:		<u>70 Tires</u>

1.5 Statistical Analysis:

Statistically analyze the results from 1.2 and determined test repeatability for all three (3) test to see:

1. If a valid perspective simplification of the procedures can be produced and;
2. To guide the testing of Section 2.0.

2.0 Test Sensitivity To Key Test Conditions:

2.1

The estimated importance of key test conditions not considered in the repeatability study was assessed by the SAE Truck Tire Characterization Task Force on 4/20/92. The categorization was:

- A. Most important,
- B. Second important, and
- C. Of third importance.

The following table shows the Task Force's ranking:

TEST CONDITION ESTIMATED IMPORTANCE:

<u>Category</u>	<u>Condition</u>
A	Vehicle Speed Wet/Dry Surface Wear - Tread Depth - Test Induced
B	Break-In
C	Load Sequence Inclination Inflation Pressure Ambient Temperature Surface Temperature

The category choice is based on a combination of probable importance and how much is known. A category "A" choice may arise from either estimated great importance or a lack of data.

It is logical to split the work dependent upon the ability of the two (2) different test machines so as to best use their capabilities to efficiently conduct this part of the program.

2.2

Before proceeding with Section 2 of the statement of work, modify the details of Section 2 to reflect the lessons that have been learned in Section 1, Test Repeatability. Only Section 2.3.2

will be conducted without review. Without the repeatability information, it is impossible to say exactly how many tires must be tested and how many times a given tire must be tested to achieve the objective of Section 2.

### 2.3 Category A - Key Test Conditions:

Vehicle speed, surface friction and worn tread depth were all seen to be important characteristics.

#### 2.3.1 Investigation of Vehicle Speed, Surface Friction and Tread Depth State For Free Rolling and Brake:

This experiment is to be performed using the UMTRI over-the-road tester. The tires will be broken in as in Section 1.1.

*The use of the water depths in the strategy requires that UMTRI be given access to a test facility with external watering. There needs to be about a two (2) mile acceleration run prior to the pad if the UMTRI machine must start from a standing stop. If on-board watering must be used, the water depths will have to be reduced.*

##### 2.3.1.1:

One set of tires will be tested at:

Load = 100% rated  
P = Specified Test Inflation Pressure (See Section 1.1)  
IA = 0°  
SA = +1°, -1°

After the completion of the entire test strategy at SA = +1°, -1°, the set of tires is to be run at:

Load = 100% rated  
P = Specified Test Inflation Pressure (See Section 1.1)  
IA = 0°  
SA = +4°, -4°

2.3.1.2:

A separate set of tires will be tested at:

Load = 100% rated  
P = Specified Test Inflation Pressure (See Section 1.1)  
IA = SA = 0°

-80% < SR < 0%

SR Rate = -80%/sec

Two repeats of braking

Using the experimental design in the table shown, the number of tests will be decided by the work in Section 2.2. Each repetition of the experimental design will use two (2) three tire sets (one each 100%, 66% and 33% tread depth).

TEST STRATEGY FOR UMTRI  
CATEGORY A VARIABLES

MEASUREMENT	VEHICLE SPEED MPH	SURFACE*	PERCENT WORN**
1	25	80	33
2	40	80	0
3	55	80	66
4	25	40	66
5	40	40	33
6	55	40	0
7	25	DRY	0
8	40	DRY	66
9	55	DRY	33

\* The same surface will be used in all tests. 40 signifies 0.040" water depth on the surface. 80 signifies 0.080" water depth on the surface.

\*\* This is the reduction in tread depth from the new state at the start of break-in. Tread depth will be reduced using a tire truing machine.

#### Data

Fx, Fy, Fz, Mx, Mz, IA, Rl, SA and also tread temperature data at the conclusion of testing data are to be presented in ASCII format on 3.5" 1.44 meg diskettes as a function of SR at each 1% SR for use by the analysis sub-contractor.

#### 2.3.2 Effect of Wear State Induced in Repeatability Testing:

At the conclusion of each test tire in the repeatability section of this document, each tire will be run straight ahead at Fz = 100% of rated load and 55 mph for fifteen (15) minutes without a stop in testing action. At the end of this fifteen (15) minute run, each tire is to be tested at + and - 1° slip angle and then at + and -4° slip angle at 100% of rated load and 55 mph.

*The repeatability experiments will produce a variety of worn states. By examining the force and moment data produced in these worn states, much information on the effect of test induced wear can be gained efficiently.*

#### Data

Fx, Fy, Fz, Mx, Mz, IA, Rl, SA and also tread temperature data at the conclusion of testing data are to be presented in ASCII format on 3.5" 1.44 meg diskettes for use by the analysis sub-contractor.

2.4 Class B Break-In:

Break-in will be examined by performing the following free rolling cornering test sequence in which each test tire is exercised at a slip angle for specified distances and then measured at:

Load = 100% Rated  
 P = Specified Test Inflation Pressure (See Section 1.1)  
 IA = 0°  
 SA = +1°, -1°  
 Speed = 55 mph

The sequence will be performed at CALSPAN only. Each tire will be warmed up as follows prior to test:

DISTANCE Miles	S Mph	Fz % Rated	P psig.	SA Deg.	IA Deg.
55	55	100	P	0	0

Tread profiling as required for repeatability shall be done on each test tire.

TIRE	STEP	SLIP ANGLE DEG	LOAD % T&RA	DISTANCE FT.	
A	Test				
	Exercise	+2°	50%	100	
	Exercise	-2°	50%	100	
	Test				
	Exercise	+2°	50%	200	
	Exercise	-2°	50%	200	
	Test				
	Exercise	+2°	50%	400	
	Exercise	-2°	50%	400	
	Test				
	B	Test			
		Exercise	+2°	75%	100
Exercise		-2°	75%	100	
Test					
Exercise		+2°	75%	200	
Exercise		-2°	75%	200	
Test					
Exercise		+2°	75%	400	
Exercise		-2°	75%	400	
Test					



C	Test			
	Exercise	+2°	100%	100
	Exercise	-2°	100%	100
	Test			
	Exercise	+2°	100%	200
	Exercise	-2°	100%	200
	Test			
	Exercise	+2°	100%	400
	Exercise	-2°	100%	400
	Test			
D	Test			
	Exercise	+4°	50%	100
	Exercise	-4°	50%	100
	Test			
	Exercise	+4°	50%	200
	Exercise	-4°	50%	200
	Test			
	Exercise	+4°	50%	400
	Exercise	-4°	50%	400
	Test			
E	Test			
	Exercise	+4°	75%	100
	Exercise	-4°	75%	100
	Test			
	Exercise	+4°	75%	200
	Exercise	-4°	75%	200
	Test			
	Exercise	+4°	75%	400
	Exercise	-4°	75%	400
	Test			
F	Test			
	Exercise	+4°	100%	100
	Exercise	-4°	100%	100
	Test			
	Exercise	+4°	100%	200
	Exercise	-4°	100%	200
	Test			
	Exercise	+4°	100%	400
	Exercise	-4°	100%	400
	Test			

G	Test			
	Exercise	+6°	50%	100
	Exercise	-6°	50%	100
	Test			
	Exercise	+6°	50%	200
	Exercise	-6°	50%	200
	Test			
	Exercise	+6°	50%	400
	Exercise	-6°	50%	400
	Test			
H	Test			
	Exercise	+6°	75%	100
	Exercise	-6°	75%	100
	Test			
	Exercise	+6°	75%	200
	Exercise	-6°	75%	200
	Test			
	Exercise	+6°	75%	400
	Exercise	-6°	75%	400
	Test			
I	Test			
	Exercise	+6°	100%	100
	Exercise	-6°	100%	100
	Test			
	Exercise	+6°	100%	200
	Exercise	-6°	100%	200
	Test			
	Exercise	+6°	100%	400
	Exercise	-6°	100%	400
	Test			

### Data

Fx, Fy, Fz, Mx, Mz, IA, Rl, SA and also tread temperature data at the conclusion of the testing of each tire are to be presented in ASCII format on 3.5" 1.44 meg diskettes for use by the analysis sub-contractor.

### 2.5 Class C Variables:

The following designed experiment shall be run to examine a number of variables. Each test tire will be broken in as indicated

in Section 1.1. The free rolling cornering measurement sequence is described as shown:

Load = 100% Rated  
P = That existing at that point in the sequence  
SA = +1°, -1°  
Speed = 55 mph

TEST STRATEGY FOR CALSPAN  
CATEGORY C VARIABLES

NUMBER	SURFACE TEMP. °F	AMBIENT TEMP. °F	INFLATION PRESSURE % RATED	LOAD SEQUENCE % T&RA	INCLINATION ANGLE DEG.
1	90	90	100	100	1
2	90	90	100	80	-1
3	90	90	80	100	-1
4	90	90	80	80	1
5	90	70	100	100	-1
6	90	70	100	80	1
7	90	70	80	100	1
8	90	70	80	80	-1
9	70	90	100	100	1
10	70	90	100	80	-1
11	70	90	80	100	-1
12	70	90	80	80	1
13	70	70	100	100	-1
14	70	70	100	80	1
15	70	70	80	100	1
16	70	70	80	80	-1

Data

Fx, Fy, Fz, Mx, Mz, IA, Rl, SA and also tread temperature data at the conclusion of the test sequence are to be presented in ASCII format on 3.5" 1.44 meg diskettes for the use of the analysis sub-contractor.

2.6 Required Tires:

TIRES PER REPETITION		
	UMTRI	CALSPAN
2.3.1 Tires Full Depth	3*	-
1/3 Worn	3*	-
2/3 Worn	3*	-
2.4 Tires Full Depth	-	12*
2.5 Tires Full Depth	3*	3*
Now Assuming as many as 4 Possible Repetitions Section 2.2	48	60
		<u>108 Tires</u>

\* Includes spares.

2.7 Statistical Analysis and Potential Further Testing:

Statistically analyze the data to define the effects of key test conditions. At the conclusion of the analysis of the results from Section 2, it may prove necessary to do further testing because some of the key test conditions may not be adequately defined.

3.0 Comparison of UMTRI and CALSPAN Data Means and Variances:

Statistically analyze the test results to compare CALSPAN and UMTRI means and variances.

4.0 Modelling Combined Slip Angle and Slip Ratio:

The data from Section 1 will be modeled using available technology to see if the free rolling cornering and straight line braking data can probably be used to project combined cornering and braking results with acceptable accuracy.

5.0 Test Procedure Revision:

Based on the data from Sections 1 and 2, propose any necessary revisions required to establish the three (3) standardized test procedures.

6.0 Future Plan:

Based on the results of Sections 1, 2, 3, and 4 propose an overall plan for continuation of this work to produce data on a cross section of the tire population.

Total Required Tires = 178 Tires

Recommended Purchase = 200 Tires

Appendix A:

Nomenclature:

This statement of work uses the following Nomenclature and assumes the tire axis system of SAE J670E and is used for all test conditions and test data. Rated loads, inflation pressures, etc., are as defined in the 1992 Tire and Rim Association Year Book.

Fx = Longitudinal Force  
Fy = Lateral Force  
Fz = Specified Test Normal Force  
IA = Specified Test Inclination Angle  
Mx = Overturning Moment  
P = Specified Test Inflation Pressure  
Rl = Loaded Radius  
S = Specified Test Speed  
SA = Specified Test Slip Angle  
SR = Specified Test Slip Ratio  
TA = Ambient Temperature  
TS = Road Surface Temperature

