

# **Study of RF Plasma Technology Applied to Air-Breathing Electric Propulsion**

**by**

**Adam Shabselowitz**

A dissertation submitted in partial fulfillment  
of the requirements for the degree of  
Doctor of Philosophy  
(Aerospace Engineering)  
in the University of Michigan  
2013

Doctoral Committee:

Professor Alec D. Gallimore, Chair  
Associate Professor John E. Foster  
Assistant Professor Benjamin Longmier  
Dean R. Massey, ElectroDynamic Applications, Inc.

$$N = R^* \times f_p \times n_e \times f_l \times f_i \times f_c \times L = 10$$

– Dr. Frank Drake, 1961

© Adam Shabshelowitz 2013

---

All Rights Reserved

For my friends and family. Thank you.

## ACKNOWLEDGMENTS

We did it! Of course, I say “we” because there is no way I could have done this all on my own. I would like to thank everyone for everything that they did to help me get to this point. First, thanks to my advisor, Alec Gallimore. Thank you for your giving me you unwavering support and sage wisdom throughout my time at Michigan. I am truly grateful for the opportunities and experiences that you have provided for me, and I am proud to be a part of the PEPL family.

Thanks also to my dissertation committee members. Professor Foster, thank you for being so encouraging, for listening to and understanding the woes of RF plasma research, and for being so friendly at conferences and in the hallways. Professor Longmier, welcome to Michigan, and thank you for being a part of my dissertation committee. It was great getting to know you first as an Ad Astra employee at PEPL, then at conferences, and now I am glad that Michigan has added a great Professor to the Aerospace department. I look forward to seeing the great things that you will accomplish. And finally, thank you, Dr. Dean. Our time in Ann Arbor overlapped almost exactly, and I am grateful to have had the opportunity both to work with you in the lab and to become your friend. You took an interest in my research, provided me with encouragement and advice, and were always willing to just try stuff out in the lab. Your honesty, creativity, and multi-disciplinary-mindedness is an inspiration to us all.

I would also like to thank the National Science Foundation for accepting me as a Graduate Research Fellow. The NSF fellowship provided me with that extra bit of encouragement to follow through with a research plan and get a Ph.D.

My thanks also go to the members of PEPL, past and present. To those who came before me and made PEPL the great place it is, and to those who have showed me how to continue that tradition. A special thanks goes to Tim Smith not only for being a knowledge base for all my PEPL questions, but also for allowing me to be a lab instructor for Aero 305. Thank you for continuing to teach the undergrads how to properly use the lab equipment and for being a great mentor to me. Thank you, Pete, for patiently showing me how to work with Hall thrusters. To the PEPL members that I have met at conferences and during visits to Ann Arbor: Prashant, Dan, Dave, Rich, and Brad. It has been great getting

to know you all. To the PEPL people who came before me: Thank you, Bryan, for showing me the ropes at PEPL. I look forward to working with you again at Lincoln Laboratory. Thank you, Kristina, for teaching me the RF rain dance and for getting me involved with helicon research at PEPL. Thank you, Sonca, for helping my NSF application succeed. Thank you, Robbie, for always being curious and willing to teach me about whatever either of us were working on. Thank you, Tom, for being the voice of reason and showing us all what a strong work ethic really is. Thank you, Rohit, for always sticking with a problem until it is solved, and for being Giggles. Thank you, Ricky, for always being courteous and helpful in the lab. Thank you, Wensheng, for teaching me both about lasers and how to manage my ninjas. Thanks to Mike M. for always being willing to share equipment stashes or show me how to use LabView codes.

To my contemporaries at PEPL: Thank you, Laura, for being my RF buddy, and for the pumpkin pie cupcakes. Those are awesome. And stop making that look while you're reading this. Thank you Ray ("Monk"), for being a great quals study partner, and for always making things nicer in the lab, both in terms of the equipment and the general cheerfulness. I wish you all the best at Space Systems Loral.

To the younger/more recent members of PEPL: Roland("CE"), just remember to relax. The X3 will be here soon, and then we'll all be expecting pictures like the baby photos that get sent out. Mike S., Kim, and Chris D., keep up the good work and hang in there. It's been a great pleasure working with you all. Chris B., I hope you come back to continue working at the lab. Your enthusiasm for everything to do with space is great for morale. Scott, I know you're the new guy now, but before you know it you'll be the senior lab member. Keep up the PEPL tradition.

Extra special thanks to Denise, Tom, Terry, Chris, Eric, Dave, Suzanne, Cindy E., and Aaron for everything that you do for all of us graduate students. We wouldn't get through it without your help and support. Thank you, Colleen, for helping us always find a time to meet with Alec. A special thank you also goes to Peggy Gramer for helping me get through all the paperwork for my NERS MSE.

Many thanks also go to Anthony Sebastian of the University of Michigan's Lurie Nanofabrication Facility for showing me a great deal about implementing RF hardware in plasma systems. I'd also like to thank Professor Mitchell Walker, Logan Williams, and Alex Kieckhafer of Georgia Tech for many helpful discussions regarding RF. I also would like to acknowledge the Air Force Research Laboratory and Aerojet for their creation of the HHT.

Thank you to all of the friends that I've met while in Ann Arbor. In particular, to the Aero Scotch and Wine Clubs, the med students, the golf course tailgate, and the Michigan

Marlies for helping me keep a healthy level of work-life balance, and for introducing me to Michigan sports. I don't have enough space to list every one, but each and every one of you has helped me along the way, and I hope you all know that you are appreciated.

Thank you to all of my friends back home for constantly asking me when I'll be done. Well, I'm done and I'm moving back home, so I'll see you all very shortly. Finally, thanks to my family for being so supportive of me all the time. Eric and Leah, I look forward to seeing you more often. Mom and Dad, thank you for trusting me enough to take some time off. I love you, and even though I'm not great at showing it, I really do appreciate all of the love and support that you always give to me.

Adam Shabselowitz

January 2013

# TABLE OF CONTENTS

<b>Dedication</b> . . . . .	<b>ii</b>
<b>Acknowledgments</b> . . . . .	<b>iii</b>
<b>List of Figures</b> . . . . .	<b>ix</b>
<b>List of Tables</b> . . . . .	<b>xii</b>
<b>List of Appendices</b> . . . . .	<b>xiii</b>
<b>List of Abbreviations</b> . . . . .	<b>xiv</b>
<b>Nomenclature</b> . . . . .	<b>xvi</b>
<b>Abstract</b> . . . . .	<b>xxiii</b>
<b>Chapter</b>	
<b>1 Introduction</b> . . . . .	<b>1</b>
1.1 Motivation . . . . .	2
1.2 History of Air-Breathing Spacecraft . . . . .	6
1.2.1 Early Studies . . . . .	6
1.2.2 Other Applications . . . . .	8
1.2.3 Recent Work . . . . .	10
1.3 Research Goals . . . . .	14
<b>2 Background</b> . . . . .	<b>15</b>
2.1 Earth's Atmosphere . . . . .	15
2.2 Kinetic Theory . . . . .	17
2.3 Propulsion Systems . . . . .	20
2.3.1 Rocket Propulsion . . . . .	20
2.3.2 Augmented Rocket Propulsion . . . . .	24
2.3.3 Electric Propulsion . . . . .	25
2.4 Air-Breathing Spacecraft . . . . .	27
2.4.1 Model . . . . .	29
2.4.2 Example . . . . .	33



2.4.3	Practicality . . . . .	39
2.5	Propulsion Requirements . . . . .	41
2.5.1	Why RF? . . . . .	42
2.6	Conclusion . . . . .	44
<b>3</b>	<b>RF Plasma Systems . . . . .</b>	<b>45</b>
3.1	RF Engineering Principles . . . . .	45
3.1.1	Impedance and Admittance . . . . .	48
3.1.2	Transmission Lines . . . . .	50
3.1.3	Impedance Matching . . . . .	53
3.1.4	Smith Chart . . . . .	56
3.2	Plasma . . . . .	58
3.2.1	Magnetic Field Interactions . . . . .	65
3.2.2	RF Plasma . . . . .	68
<b>4</b>	<b>Thrusters . . . . .</b>	<b>71</b>
4.1	Radio frequency Plasma Thruster . . . . .	71
4.1.1	Preliminary Investigations . . . . .	72
4.1.2	RPT Design . . . . .	73
4.1.3	RPT Assembly . . . . .	76
4.2	Helicon Hall Thruster . . . . .	78
4.2.1	HHT Principle of Operation . . . . .	80
4.2.2	HHT Assembly . . . . .	81
4.2.3	Previous Work . . . . .	81
<b>5</b>	<b>Experiment Setup . . . . .</b>	<b>83</b>
5.1	Test Facility . . . . .	83
5.2	RF Power System . . . . .	84
5.3	Performance Diagnostics . . . . .	88
5.3.1	Dual-Directional Coupler . . . . .	88
5.3.2	Thrust Stand . . . . .	91
5.3.3	Faraday Probe . . . . .	95
5.3.4	Retarding Potential Analyzer . . . . .	97
5.3.5	Langmuir Probe . . . . .	99
5.4	Thruster Setup . . . . .	101
5.4.1	RPT . . . . .	102
5.4.2	HHT . . . . .	102
<b>6</b>	<b>Results . . . . .</b>	<b>103</b>

6.1	RPT Results . . . . .	103
6.1.1	RF Power Measurements . . . . .	104
6.1.2	Argon Performance . . . . .	105
6.1.3	Argon Probe Measurements . . . . .	109
6.1.4	RPT Operating on Nitrogen & Air . . . . .	111
6.2	HHT Results . . . . .	113
6.2.1	Single-stage operation . . . . .	115
6.2.2	Two-stage operation . . . . .	117
<b>7</b>	<b>Discussion . . . . .</b>	<b>120</b>
7.1	RPT . . . . .	120
7.1.1	RPT Methodology . . . . .	121
7.1.2	Probe Results . . . . .	122
7.2	HHT . . . . .	128
7.2.1	HHT Efficiency Methodology . . . . .	129
7.2.2	HHT Single-Stage . . . . .	131
7.2.3	HHT Two-Stage . . . . .	136
<b>8</b>	<b>Conclusions . . . . .</b>	<b>139</b>
8.1	Air-Breathing Thrusters . . . . .	140
8.2	Future Work . . . . .	141
	<b>Appendices . . . . .</b>	<b>143</b>
	<b>Bibliography . . . . .</b>	<b>146</b>

## LIST OF FIGURES

1.1	Density of orbital debris objects larger than 10 centimeters. . . . .	4
2.1	Mass density of atmospheric gas versus altitude from the NRLMSISE-00 model at different levels of solar activity . . . . .	16
2.2	Atmospheric composition versus altitude from the NRLMSISE-00 model for mean solar and geomagnetic activity . . . . .	17
2.3	Kinetic description of flat plate moving through ambient gas. . . . .	19
2.4	Diagram of rocket operation. . . . .	21
2.5	Operating parameters of different types of rockets. . . . .	23
2.6	Diagram of ducted or air-augmented rocket. . . . .	25
2.7	Notional diagram of air-breathing mission. . . . .	29
2.8	Pegasus <sup>®</sup> payload fairing . . . . .	34
2.9	Rendering of the GOCE satellite during mission operations . . . . .	35
2.10	Cross-section of a notional air-breathing spacecraft . . . . .	36
2.11	Drag on the example spacecraft. . . . .	36
2.12	Mass flow rate for the example spacecraft. . . . .	37
2.13	Minimum specific impulse required for the example propulsion system. . . . .	37
2.14	Power required for the example air-breathing propulsion system. . . . .	38
2.15	Feasibility parameter for the example air-breathing spacecraft . . . . .	38
2.16	Lifetime for a non-air-breathing spacecraft . . . . .	40
3.1	Model of an electrically short (i.e. shorter than one-tenth of the RF wavelength) section of coaxial cable. . . . .	51
3.2	Simple model of an electrically long (i.e. longer than one-tenth of an RF wavelength) transmission line. . . . .	51
3.3	Cross-section of a typical coaxial cable. . . . .	52
3.4	Behavior of RF power at the load end of a transmission line. . . . .	54
3.5	Matching network types. . . . .	56
3.6	Smith chart showing both impedance and admittance coordinates. . . . .	57
3.7	Smith chart showing matching network design procedure. . . . .	58
3.8	Maxwellian electron energy distribution functions for 3 eV and 10 eV electron populations. . . . .	64
3.9	Argon rate coefficients versus electron temperature. . . . .	64
4.1	Setup of helicon plasma source for preliminary investigation. . . . .	73
4.2	Optical emission spectra and photographs showing presence of “blue core” when operating with argon. . . . .	74

4.3	Optical emission spectra looking along center axis of tube during nitrogen operation at low (top) and high (bottom) power. . . . .	74
4.4	Cross-section of the RPT with major components and dimensions labeled. . . .	77
4.5	Exploded view of RPT assembly without flexible mica sheet. . . . .	77
4.6	RPT antenna details. . . . .	78
4.7	HHT notional sketch. . . . .	80
4.8	Photograph of HHT. . . . .	82
5.1	Diagram of RF power system in LVTF. . . . .	85
5.2	Photograph of the RPT experimental setup in the LVTF. . . . .	87
5.3	Photograph and diagram of the -60 dB dual-directional coupler. . . . .	89
5.4	Diagram of thrust stand operation. . . . .	92
5.5	Schematic of the Faraday probe used for RPT measurements. . . . .	96
5.6	Cross-section of the RPA. . . . .	97
5.7	Electrical schematic of the RPA. . . . .	98
5.8	Typical data from the RPA. Data shown are from the RPT operating condition at 2.4 mg/s, 550 G, and 1080 W. . . . .	99
5.9	Typical data from the Langmuir probe. Data shown are from the RPT operating condition at 2.4 mg/s, 550 G, and 1080 W. . . . .	100
5.10	RPT centerline axial magnetic fields, simulated with measured solenoid currents	101
6.1	Two views of the RPT argon blue core plasma during operation in LVTF. . . .	104
6.2	Comparison between RF power measurements from the CPS-3000 and the dual-directional coupler . . . . .	104
6.3	Measured cold gas thrust and specific impulse for argon flow in the RPT . . . .	105
6.4	RPT total thrust versus net RF power . . . . .	106
6.5	RPT specific impulse versus net RF power. Specific impulse is calculated using the sum of the cold gas thrust and the RF thrust. Horizontal error bars shown are representative for the entire dataset. . . . .	107
6.6	RPT RF thrust efficiency versus net RF power. . . . .	108
6.7	RPT plume electron temperature and floating voltage measured by the Hiden Langmuir probe. . . . .	109
6.8	RPT plume density and plasma potential. . . . .	110
6.9	Most probable potential from RPA versus RF power. . . . .	111
6.10	Photograph of RPT operating with nitrogen, with end-on view on left. No blue core was observed, perhaps due to the fact that nitrogen ions strongly emit in the ultraviolet. . . . .	112
6.11	RPA data for the RPT operating on nitrogen at 1000 watts . . . . .	112
6.12	RPA data for the RPT operating on air at 1000 watts . . . . .	113
6.13	Single-stage HHT operation with xenon (top), argon (middle) and nitrogen (bottom) propellants. No significant change to the plume structure was observed when operating in two-stage mode. . . . .	114
6.14	HHT single-stage thrust versus mass flow rate . . . . .	116
6.15	HHT single-stage anode specific impulse versus mass flow rate. . . . .	116
6.16	HHT single-stage thrust-to-power versus mass flow rate. . . . .	117

6.17	HHT two-stage thrust versus RF power . . . . .	118
6.18	HHT two-stage anode specific impulse versus RF power. . . . .	118
6.19	HHT two-stage thrust-to-power, including both $P_{DC}$ and $P_{RF}$ , versus RF power. . .	119
6.20	HHT two-stage thrust-to-power for the argon and nitrogen operating points. . .	119
7.1	RPT propellant utilization efficiency calculated from Faraday probe data. . . .	123
7.2	RPT thrust due to RF power versus most probable potential measured from RPA124	
7.3	Ion beam most probable potential measured by the RPA minus local plasma potential measured by a Langmuir probe. . . . .	125
7.4	Mean free path for charge exchange collisions between argon ions and neutrals	128
7.5	HHT single-stage voltage exchange parameter versus anode mass flow rate . . .	131
7.6	HHT single-stage mass exchange parameter versus anode mass flow rate. $E_2$ relates the output flow of charge in the thruster to the inflow of propellant. . . .	132
7.7	HHT single-stage beam efficiency versus anode mass flow rate. Higher beam efficiency is equivalent to a less divergent plume. . . . .	133
7.8	HHT voltage utilization efficiency plotted versus anode mass flow rate. . . . .	134
7.9	HHT propellant utilization deduced from $E_1$ , $\Psi_B$ , and $\eta_V$ , and plotted versus anode mass flow rate . . . . .	135
7.10	HHT two-stage voltage exchange parameter versus RF power. . . . .	136
7.11	HHT two-stage mass exchange parameter versus RF power. . . . .	137
7.12	HHT two-stage beam divergence efficiency versus RF power. . . . .	137
7.13	HHT two-stage voltage utilization efficiency versus RF power. . . . .	138
B.1	TDK ZCAT 3035-1330s ferrite material characteristics. . . . .	145
B.2	API Delevan BF2390 ferrite material characteristics. . . . .	145

## LIST OF TABLES

2.1	Electric propulsion performance characteristics. . . . .	26
2.2	Example air-breathing spacecraft summary, operating in a sun-synchronous orbit during average solar and geomagnetic conditions. . . . .	41
4.1	RPT Design Summary. . . . .	76
6.1	Summary of HHT operating conditions and measurements. . . . .	115
7.1	RPT Probe analysis and theoretical acceleration potential results. . . . .	124
A.1	Altitude profiles of atmospheric constituents for low solar and geomagnetic activity. . . . .	143
A.2	Altitude profiles of atmospheric constituents for mean solar and geomagnetic activity. . . . .	144
A.3	Altitude profiles of atmospheric constituents for high solar and geomagnetic activity. . . . .	144

## LIST OF APPENDICES

<b>A Atmospheric Data</b> . . . . .	<b>143</b>
<b>B Ferrite Material Data</b> . . . . .	<b>145</b>

## **LIST OF ABBREVIATIONS**

**AC** Alternating Current

**DC** Direct Current

**DSMC** Direct Simulation Monte Carlo

**EMI** Electromagnetic Interference

**EP** Electric Propulsion

**FCC** Federal Communications Commission

**FRC** Field Reversed Configuration

**GOCE** Gravity field and steady-state Ocean Circulation Explorer

**HHT** Helicon Hall Thruster

**ISM** Industrial, Scientific, and Medical

**ISRU** In-Situ Resource Utilization

**IVD** Ion Voltage Distribution

**JAXA** Japan Aerospace eXploration Agency

**LEO** Low Earth Orbit

**LVTF** Large Vacuum Test Facility

**MHD** Magnetohydrodynamic

**NASA** National Aeronautics and Space Administration

**PEPL** Plasmadynamics and Electric Propulsion Laboratory

**PHARO** Propellant Harvesting of Atmospheric Resources in Orbit

**PPIMO** Propellant Production in Mars Orbit



**PROFAC** Propulsive Fluid Accumulator

**RF** Radio frequency

**RPA** Retarding Potential Analyzer

**RPT** Radio frequency Plasma Thruster

**SLATS** Super Low Altitude Test Satellite

**SMAD** Space Mission Analysis and Design

## NOMENCLATURE

### Constants

$c$	Speed of light, $2.9979 \times 10^8$	[m/s]
$e$	Elementary charge, $1.6022 \times 10^{-19}$	[C]
$eV$	Electron Volt, $1.6022 \times 10^{-19}$ or 11604	[J or K]
$\mathcal{F}$	Faraday constant, 96485	[C/mol]
$G$	Universal gravitational constant, $6.6738 \times 10^{-11}$	[m <sup>3</sup> /kg/s <sup>2</sup> ]
$g_0$	Earth standard gravity acceleration, 9.8067	[m/s <sup>2</sup> ]
$j$	Imaginary number, $\sqrt{-1}$	[-]
$k_B$	Boltzmann constant, $1.3807 \times 10^{-23}$	[J/K]
$m_e$	Electron mass, $9.1094 \times 10^{-31}$	[kg]
$M_{\oplus}$	Mass of Earth, $5.9722 \times 10^{24}$	[kg]
$R_e$	Radius of Earth, $6.3781 \times 10^6$	[m]
$\varepsilon_0$	Vacuum permittivity, $8.8542 \times 10^{-12}$	[F/m]
$\mu_0$	Vacuum permeability, $4\pi \times 10^{-7}$	[H/m]
$\pi$	3.1416	[-]

### Variables

$a$	Coaxial cable shield inner diameter	[m]
$A$	Area	[m <sup>2</sup> ]
$A_{c,eff}$	Effective probe collection surface area	[m <sup>2</sup> ]
$A_{drag}$	Spacecraft cross-sectional area, excluding inlet	[m <sup>2</sup> ]
$A_{inlet}$	Area of spacecraft gas collector inlet	[m <sup>2</sup> ]
$b$	Coaxial cable center conductor outer diameter	[m]

$B$	Susceptance	$[\Omega^{-1}]$
$\vec{B}$	Magnetic field	[T]
$B_z$	Axial magnetic field strength	[T]
$C$	Capacitance	[F]
$C_D$	Drag coefficient	[-]
$C_{gas}$	Ion gauge gas correction factor	[-]
$D$	Diffusion coefficient	$[m^2/s]$
$D_A$	Optical payload aperture diameter	[m]
$d_{hs}$	Gas molecule hard-sphere diameter	[m]
$\vec{E}$	Electric field	$[V/m]$
$E_1$	Voltage exchange parameter	[-]
$E_2$	Mass exchange parameter	[-]
$f$	Circular frequency	$[1/s]$
$F$	Force	[N]
$f(\varepsilon)$	Electron energy distribution function	$[1/J]$
$f(V)$	Ion voltage distribution	$[1/V]$
$F_{CG}$	Thrust due to cold gas	[N]
$F_D$	Drag force	[N]
$\vec{F}_{el}$	Electric force	[N]
$F_i$	Theoretical thrust due to accelerated ions	[N]
$F_{RF}$	Thrust due to RF power	[N]
$F_T$	Thrust force	[N]
$G$	Conductance	$[\Omega^{-1}]$
$h$	Orbit altitude	[km]
$I$	Current	[A]
$I_{axial}$	Axial ion beam current	[A]
$I_{beam}$	Total ion beam current	[A]

$I_c$	Current collected by probe	[A]
$I_f$	RF forward current amplitude	[A]
$I_L$	RF current through load	[A]
$I_r$	RF reflected current amplitude	[A]
$I_{sp}$	Specific impulse	[s]
$k$	mass fraction or Wave number $\equiv 2\pi/\lambda$	[- or $m^{-1}$ ]
$k_G$	Spacecraft solar panel area geometry factor	[-]
$k_l$	Rate constant for process $l$	[ $m^3/s$ ]
$Kn$	Knudsen number	[-]
$l$	Transmission line length	[m]
$L$	Inductance	[H]
$L_{sc}$	Spacecraft length	[m]
$m$	Mass	[kg]
$\dot{m}$	Mass flow rate	[kg/s]
$\mathcal{M}$	Molar mass	[kg/mol]
$M$	Vehicle mass	[kg]
$M_0$	Initial vehicle mass	[kg]
$M_f$	Final vehicle mass	[kg]
$n$	Number density	[ $m^{-3}$ ]
$p$	True pressure	[Torr]
$P$	True RF power delivered	[W]
$\bar{P}$	Measured RF power delivered	[W]
$P_3$	Normal momentum flux incident on flat plate	[ $N/m^2$ ]
$p_b$	Base pressure	[Torr]
$P_{elec}$	Electrical power delivered to thruster	[W]
$P_{FWD}$	Forward RF power	[W]
$P_{jet}$	Exhaust jet power	[W]

$p_{ob}$	Observed ion gauge pressure	[Torr]
$P_{REF}$	Reflected RF power	[W]
$P_{req}$	Power required	[W]
$P_{RFA}$	Antenna RF power	[W]
$q$	Charge	[C]
$r$	Faraday probe distance from thruster	[m]
$r_L$	Larmor or cyclotron radius	[m]
$R$	Resistance	[ $\Omega$ ]
$s$	Distance along trajectory	[m]
$s_3$	Speed ratio	[-]
$t$	Time	[s]
$t_b$	Thrust duration time	[s]
$T$	Temperature	[K]
$v, \vec{v}$	Velocity	[m/s]
$v_B$	Bohm velocity	[m/s]
$V$	Voltage or electric potential	[V]
$V_{bias}$	Probe bias voltage	[V]
$v_{ex}$	Effective exhaust velocity of thruster	[m/s]
$v_f$	Final vehicle velocity	[m/s]
$V_f$	Floating potential or RF forward voltage amplitude	[V]
$V_i$	Effective ion acceleration voltage	[V]
$V_{mp}$	Exhaust ion most probable potential	[V]
$v_o$	Orbital velocity	[m/s]
$V_p$	Plasma potential	[V]
$V_r$	RF reflected voltage amplitude	[V]
$V_{ret}$	RPA Ion retarding grid potential	[V]
$v_{th}$	Mean thermal velocity	[m/s]

$v_0$	Initial vehicle velocity	[m/s]
$v_3$	Flat plate velocity normal to surface area	[m/s]
$ V_- $	Reflected voltage amplitude	[V]
$ V_+ $	Forward voltage amplitude	[V]
$x$	Spatial coordinate	[m]
$X$	Reactance	[ $\Omega$ ]
$X'$	Ground resolution	[m]
$Y$	Admittance	[ $\Omega^{-1}$ ]
$Z$	Impedance	[ $\Omega$ ]
$Z_{cap}$	Capacitor impedance	[ $\Omega$ ]
$Z_{ind}$	Inductor impedance	[ $\Omega$ ]
$Z_s$	Source impedance	[ $\Omega$ ]
$Z_0$	Characteristic impedance	[ $\Omega$ ]
$ \Gamma $	Magnitude of the reflection coefficient $\equiv  V_-  /  V_+ $	[-]
$\varepsilon$	Electric permittivity or electron energy	[F/m or J]
$\varepsilon_r$	Relative permittivity	[-]
$\varepsilon_{v_-}$	Reflected voltage amplitude measurement error	[V]
$\varepsilon_{v_+}$	Forward voltage amplitude measurement error	[V]
$\varepsilon_p$	Relative power error	[-]
$\varepsilon_{v_{\pm}}$	Relative voltage measurement error $\equiv \Delta V_{\pm} /  V_{\pm} $	[-]
$\eta$	efficiency	[-]
$\eta_A$	Antenna efficiency	[-]
$\eta_{BP}$	Beam power efficiency	[-]
$\eta_I$	Current utilization efficiency	[-]
$\eta_M$	Matching network efficiency	[-]
$\eta_{PRF}$	RF power factor	[-]
$\eta_{PV}$	Solar panel photovoltaic efficiency	[%]

$\eta_{RF}$	Thrust efficiency due to RF power	[-]
$\eta_t$	Thruster efficiency	[-]
$\eta_V$	Voltage utilization efficiency	[-]
$\theta$	Angular position of Faraday Probe	[rad]
$\theta_{div}$	Effective exhaust divergence half-angle	[degrees]
$\lambda$	Wavelength	[m]
$\lambda_D$	Debye length	[m]
$\lambda_{mfp}$	Mean free path for collision	[m]
$\lambda_z$	Helicon axial wavelength	[m]
$\mu$	Magnetic permeability or electric mobility	[H/m or m <sup>2</sup> /V/s]
$\mu_r$	Relative permeability	[-]
$\nu$	Collision frequency	[1/s]
$\Pi_{AB}$	Air-breathing spacecraft feasibility parameter	[-]
$\rho$	Mass density	[kg/m <sup>3</sup> ]
$\rho_q$	Charge density	[C/m <sup>3</sup> ]
$\sigma_l$	Cross section for process $l$	[m <sup>2</sup> ]
$\tau_L$	Spacecraft lifetime	[-]
$\Phi_3$	Normal mass flux incident on flat plate	[kg/m <sup>2</sup> /s]
$\Phi_p$	Propellant utilization efficiency	[-]
$\Psi_B$	Beam divergence efficiency	[-]
$\omega$	Angular frequency	[rad/s]
$\omega_c$	Cyclotron frequency	[1/s]
$\omega_p$	Plasma frequency	[1/s]

### Subscripts

$a$	Anode or ambipolar
$bus$	Spacecraft bus

<i>c</i>	Cathode or collector or cyclotron
<i>d</i>	Discharge
<i>DC</i>	Direct current
<i>e</i>	Electron
<i>fuel</i>	Spacecraft fuel
<i>g</i>	Neutral gas
<i>i</i>	Ion
<i>in</i>	Inlet or input
<i>k</i>	Species <i>k</i>
<i>L</i>	Load or lifetime
<i>m</i>	Momentum exchange
<i>mag</i>	Magnet
<i>p</i>	Components in parallel
<i>p/l</i>	Spacecraft payload
<i>pr</i>	Propellant
<i>RF</i>	Radio frequency
<i>s</i>	Components in series
<i>s/c</i>	Spacecraft
<i>tot</i>	Total
	Parallel to magnetic field
⊥	Perpendicular to magnetic field



## **ABSTRACT**

### **Study of RF Plasma Technology Applied to Air-Breathing Electric Propulsion**

**by**

**Adam Shabselowitz**

**Chair: Alec D. Gallimore**

Satellites in low Earth orbit experience an aerodynamic drag force due to the finite density of gas in the thermosphere. Left unchecked, this drag force acts to reduce satellite altitude, eventually causing re-entry. To maintain a satellite in its intended orbit, an on-board propulsion system is typically implemented to counteract the drag. The initial satellite mass delivered to a particular orbit is fixed by the launch vehicle, and the propulsion system requires a significant portion of this mass to be allocated to propellant. These and other altitude-dependent factors strongly affect spacecraft design and cost of the mission.

Electric propulsion systems use electric and magnetic fields rather than chemical energy to accelerate propellant to high exhaust velocities. The physical mechanisms that produce thrust are independent of propellant species, and so the ambient gas in the thermosphere may be used as propellant. However, the atmosphere consists of gases that are not typically used in electric propulsion systems, and previous studies have shown that operating with these gases may reduce thruster performance and lifetime. Radio frequency (RF) plasma systems are used by the semiconductor manufacturing industry to efficiently create a dense plasma source from a wide variety of gases, and therefore may be capable of increasing the performance of electric propulsion systems operating with atmospheric gases.

This dissertation presents an experimental investigation into the use of RF plasma in an air-breathing electric propulsion system. Based on the requirements for such a system, two novel thrusters are tested in the laboratory. The first thruster uses only RF power and a magnetic field to create thrust. The second is a two-stage thruster that uses an RF ionization stage to increase the propellant utilization efficiency of a traditional Hall thruster. Thruster performance measurements are presented in the context of an air-breathing system, as well as plasma probe measurements of the exhaust to characterize the major loss mechanisms. The results suggest that an air-breathing satellite is feasible with currently available technology.

# CHAPTER 1

## Introduction

On October 4<sup>th</sup> 1957, the launch of Sputnik by the former Soviet Union marked the beginning of the Space Age. Today, only 55 years later, the satellite industry operates nearly a thousand spacecraft in orbit around the Earth, employs over 240,000 people in the United States, and earned \$177 billion in revenues in 2011 [1]. Satellites have become a part of everyday life, playing essential roles in personal navigation, global communications, weather prediction, and emergency response. For scientists, satellites are an essential tool for investigating deep, far-reaching questions like how the universe began, and practical, close-to-home questions like how solar activity affects the power grid on Earth. Satellites are produced in many shapes and sizes, and the rise in popularity of inexpensive, university-built nano- and pico-satellites demonstrates an interest in exploring innovative uses for alternative satellite form factors [2].

Although the density of the atmosphere decreases with increasing altitude, satellites in Low Earth Orbit (LEO) experience an aerodynamic drag force. This drag force causes satellites in LEO to fall toward the Earth, and eventually burn up in the Earth's atmosphere. On-board propulsion systems are generally employed to maintain LEO satellites in their intended orbit. These propulsion systems all fall under the category of *rockets*. One downside of rocket systems is that they must store all of the propellant on the vehicle. Since satellites are not typically refueled in space, the usable lifetime of a state-of-the-art LEO satellite is fundamentally limited by the amount of propellant that it initially carries with it

during launch. Launch vehicles can only deliver a fixed amount of mass into a given orbit, and so the mass of propellant required for a specific satellite lifetime directly takes away from mass that could be dedicated to other subsystems, including the payload.

Because the total amount of mass that a spacecraft may use for its entire mission duration is set by the launch vehicle, In-Situ Resource Utilization (ISRU) is critical for a long-term space exploration program that ventures beyond LEO [3]. Recent ISRU demonstration activities at the National Aeronautics and Space Administration (NASA) have focused on the production of oxygen from lunar regolith, which is useful both for sustaining astronauts and fueling a lunar launch vehicle [4]. Earlier studies have also considered using the gas in the Earth's upper atmosphere as a resource [5]. In LEO, the atmospheric composition is mostly nitrogen and oxygen, which are useful both for life support and potentially for rocket propulsion. The development of ISRU capabilities will yield enabling and sustaining technologies for future space missions.

## 1.1 Motivation

Satellites are purpose-built to perform a particular set of tasks, referred to as the *mission*. Many engineering trades must be considered when designing a spacecraft to fulfill the specific mission objectives. Typically, there is more than one system architecture that will fulfill all of the requirements for accomplishing the mission, but the most desirable solution is the one that accomplishes all of the goals of the mission at the lowest cost. As the well-known textbook Space Mission Analysis and Design (SMAD) states, "Space is expensive. Cost is a fundamental limitation to nearly all space missions and is becoming more so" [6]. It is therefore important to investigate concepts that may have a profound impact on cost. Based on publicly available information for one of the least expensive launch vehicles, the Space Exploration Technologies (SpaceX) Falcon 9, the cost-per-mass to LEO is currently approximately \$4,100 per kilogram [7].

Some aspects of mission design for all satellites are altitude-dependent. For example, for a given launch vehicle and orbit inclination, more mass can be launched into a lower-altitude orbit. Assuming that the total launch vehicle cost is independent of the orbit, choosing a lower altitude for a particular mission will allow for a more massive spacecraft, thereby reducing the cost-per-mass of the satellite. This effect is stronger for smaller launch vehicles. Since smaller launch vehicles tend to be less expensive than larger ones, the largest reduction in cost will be realized by using a small launch vehicle in a low orbit.

Many LEO satellites are used for Earth observation. An important figure of merit for observation is the *ground resolution*,  $X'$ , which is the length scale of the smallest feature that the satellite can image on the ground. The ground resolution is physically limited by the aperture diameter of the optics,  $D_A$ , the wavelength of light being observed,  $\lambda$ , and the satellite altitude,  $h$ . The diffraction-limited resolution is given by Eq. 1.1 [6], where all variables are in units of meters and the constant factor of 2.44 is two times the first zero of the Bessel function of the first kind.

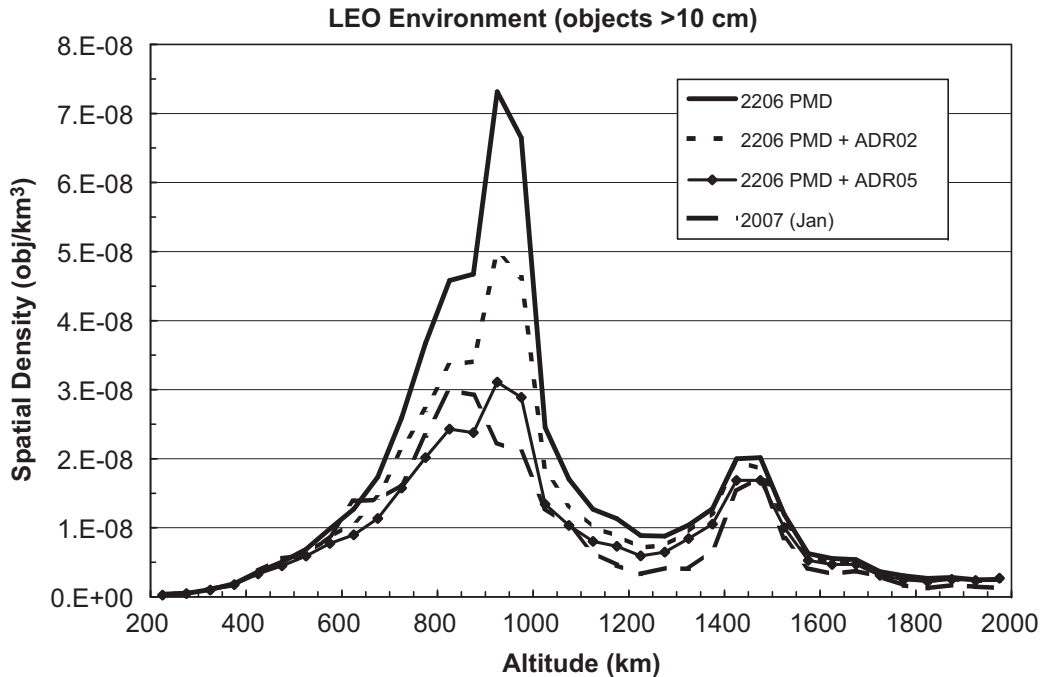
$$X' = 2.44 \frac{h\lambda}{D_A} \quad (1.1)$$

This means that the minimum diameter of the optical instrument for a required ground resolution linearly decreases with decreasing orbit altitude. One study estimated that the cost of large, space-based telescopes scales with the square of aperture diameter (i.e.  $\text{Cost} \propto D_A^2$ ), and so a reduction in the required aperture size would likely yield significant cost savings even for a smaller optical system. The Super Low Altitude Test Satellite (SLATS) was developed to take advantage of this property [8]. The Japan Aerospace eXploration Agency (JAXA) is planning to launch SLATS in 2013 [9], showing that there is potential long-term interest in developing satellites that operate at lower altitudes. Other performance gains, such as increased communication signal-to-noise ratio and strategic observation advantages, have also been cited as benefits to operating at lower altitudes [10].

Risk is another major consideration for satellite mission planning. The impact probability of a piece of debris with a spacecraft,  $P_C$ , can be estimated using Eq. 1.2, where  $n_d$  is the density of debris objects,  $A_x$  is the collision cross-section,  $\tau_m$  is the mission duration, and  $v_{rel}$  is the relative velocity between the spacecraft and the debris [6]. There is a high probability that most spacecraft will encounter micrometeoroids and small orbital debris during their operational lifetime, and so passive shielding is used to protect the spacecraft components.

$$P_C = 1 - e^{-n_d A_x \tau_m v_{rel}} \quad (1.2)$$

Orbital debris populations (a.k.a. “space junk”) in LEO significantly increase with altitude up to about 1000 kilometers, as shown by Fig. 1.1 [11]. This is particularly troublesome in high-inclination orbits, which are greatly valued for Earth observation missions [12].



**Figure 1.1: Density of orbital debris objects larger than 10 centimeters. The known debris environment at the beginning of 2007 and projected debris populations after 200 years are shown, including the effects of post-mission disposal (PMD) and active debris removal (ADR). The plot indicates that PMD must be observed and five LEO objects must be actively removed (ADR05) in order to keep the future LEO debris environment stable. [11].**

Debris populations will naturally increase when there is enough debris in orbit such that collisions between the pieces of debris occur more frequently than the pieces re-enter. The collisions cause the pieces of debris to break up into more, smaller fragments, and the smaller fragments may still be large enough to cause significant damage to a spacecraft. Recent studies have shown that the current debris population is sufficiently large that it will continue to increase, even if there are no more launches in the future [11]. Thus, another benefit of operating a satellite in a lower altitude orbit is a significant reduction in the risk of an on-orbit collision with an uncontrolled object. If the risk of collision is sufficiently reduced, this could translate to an increase in payload mass by eliminating the need for passive shielding used to protect the satellite. Operating at a lower altitude will also naturally dispose of the satellite in Earth's atmosphere rapidly at end-of-life, and would therefore be far less likely to contribute to the long-term problem of debris population growth.

One disadvantage to operating at a lower altitude is that the atmospheric drag increases significantly. If a satellite operating in a circular orbit below 300 kilometers does not compensate for drag, it is likely re-enter the Earth's atmosphere within a few months [6]. If the spacecraft does constantly compensate for drag, a large portion of the launch mass would necessarily be allocated for propellant to appreciably extend the satellite lifetime. The required mass of propellant mitigates any gains discussed above, and this one disadvantage is the main reason why there are almost no satellites operating in such low orbits.

The increased drag is due to an increase in ambient gas density. To counter this increase in drag, one way that a satellite could be sustained at lower altitudes without having a high propellant mass fraction at launch is by using the ambient gas as propellant for an on-board propulsion system. This type of a propulsion scheme is referred to as an *air-breathing* system, even though the chemical composition of the gas in LEO may be different than that found on the Earth's surface. The development of an air-breathing propulsion system for satellites also has the potential to effect a significant cost reduction to satellites, especially for Earth-observing LEO missions.

The cost savings would be realized by extending the useful lifetime of satellites in very low LEO orbits, thereby allowing launch vehicles to deliver a greater amount of mass into orbit. Lowering the orbit also reduces the size of observation instrument required for a given ground resolution. If the propulsion system is able to produce more than the minimum thrust necessary for station-keeping, it may also enable high- $\Delta v$  maneuvers, such as orbit inclination changes, without a reduction in payload mass or spacecraft lifetime. The development of an air-breathing spacecraft would also provide a strong example of the benefit of ISRU without requiring the large budget and risk associated with missions beyond Earth's orbit. In addition, it would allow greater access to very low LEO altitudes for scientists. This part of the thermosphere interesting because is not currently well-characterized.

## **1.2 History of Air-Breathing Spacecraft**

Concepts for using ambient gas in the upper atmosphere as rocket propellant are nearly as old as Sputnik. In the 1960s, solar cells were only about 12% efficient [13] and it was anticipated that nuclear reactors would be tested on-orbit within the decade [14]. So, early studies focused on the feasibility of higher-power systems. The later development of more advanced propulsion systems has led to a revival of interest in the past decade, with much of the recent work focusing on inlet and thruster design.

### **1.2.1 Early Studies**

The first published studies analyzing the potential for air-breathing orbital vehicles came about in the late-1950s, and attempted to determine the optimal vehicle parameters for the accumulation of air [5, 15, 16]. The vehicles would be stationed in LEO and used as propellant depots for refueling lunar or interplanetary vehicles that were coming from the Earth's surface. These studies mainly pointed out the characteristics of the power and propulsion systems that would be necessary and/or optimal for operation, which were



within reach of current technology, but not readily available at the time.

In 1959, Sterge Demetriades, a research scientist at Northrop Corporation, described a Propulsive Fluid Accumulator (PROFAC) that was intended to operate at 85–120-kilometer altitudes, and collect 400 kilograms of air per day for every square meter of inlet area [5]. He suggested that solar power could make the PROFAC feasible above 150 kilometers, but that the idea is not economical above 130 kilometers, and so the baseline design would use a 1958 state-of-the-art 6-megawatt reactor in an 11-ton vehicle at 100 kilometers to collect 43 tons of air every 100 days. Demetriades also suggests that a larger PROFAC system could be used for lunar travel with a nuclear thermal rocket, or that the accumulated air could be transferred to a separate vehicle to be used as oxidizer with hydrogen lifted from the Earth's surface. Demetriades noted that it would be necessary to design a Magnetohydrodynamic (MHD) accelerator to use as a thruster for the PROFAC in order to achieve the exhaust velocity required to compensate for drag with the collected nitrogen as a propellant [5].

Around the same time that the PROFAC concept appeared, Felix Berner and Morton Camac of the Avco-Everett Research Laboratory described a similar “air scooping vehicle” that would operate at altitudes from 75 kilometers up to and above 170 kilometers [15]. They gave a more thorough mathematical treatment of the problem than Demetriades, including technical details, such as the required heat flux rejection, and consideration of the “breakeven time” after which an air scooping system gives an economical advantage over a conventional vehicle. They found that the optimum collection vehicle for circular orbits would require a propulsion system with a specific impulse of approximately twice the orbital velocity, or  $I_{sp} \approx 1600$  seconds. They also noted that the break even time strongly depends on the specific weight of the power system and launch costs (they estimated that launch costs will be \$100 per pound-mass to LEO in the future). They concluded that nuclear reactors would be appropriate for 100–110-kilometer altitudes, and that the vehicle would reach an economical break even time after only 10s–100s of days, even in the case

of low specific power. Like Demetriades, they concluded that an efficient accelerator for nitrogen must be developed in order to make the concept possible, with arcjets of the time having too low of an efficiency and gridded ion engines having too low efficiency at the ideal specific impulse [15].

A. Zukerman and C. B. Kretschmer from the Aerojet-General Corporation instead studied the feasibility of using chemical energy stored in the upper atmosphere as fuel for a ramjet [17]. The concept relies on the fact that atomic oxygen is the majority component of the atmosphere above 100 km, and that atomic oxygen recombination is an exothermic reaction. They gave a detailed treatment that deemed this concept to be infeasible without the addition of auxiliary propellant. They also examined whether the heat could be transferred to an on-board coolant fluid that could be expanded through a nozzle to produce thrust, but found that there is no advantage to using this concept over a traditional chemical propulsion system [17].

Finally, Aleksander Dolgich presented early Soviet research of the 1960s regarding air-breathing satellites. His work mainly summarized ten papers that appeared in Soviet journals. Dolgich focused mainly on the power required for the concept, and he found that a satellite optimally employing a low-thrust, air-scooping space engine is capable of carrying a payload up to 2.5 times greater than one without such a system [16].

### **1.2.2 Other Applications**

Although the work in this dissertation focuses on applications in very low LEO, it is worth noting that similar concepts to air-breathing or atmospheric scooping vehicles have been proposed for much more ambitious programs. One can envision different missions that may be able to achieve a sustainable air-breathing platform, and which present different engineering challenges for different locations. For example, the air-breathing concept would not be physically possible at the moon because there is no appreciable atmosphere. Compared to Earth, Mars is slightly less massive, has a much thinner atmosphere, and a

lower intensity of available sunlight. Around Mars, both the drag and the mass available for use as propellant would be significantly smaller, and a mission that uses solar power would require larger solar panels. So, a detailed analysis would be required to determine whether current technology might satisfy the power and propulsion requirements for an air-breathing Mars mission. Another interesting body to study might be Saturn's moon Titan, which is much less massive than Earth, yet has a thicker atmosphere [18].

Perhaps the most ambitious air-breathing-like concept is the "interstellar ramjet" published by Robert Bussard of the Los Alamos National Laboratory in 1960 [19]. Bussard's vehicle would ingest interstellar gases, which would undergo nuclear fusion, and then be expelled to produce thrust. This idea was popularized in a science fiction novel titled *Tau Zero* that described an interstellar mission undertaken by fifty people from Earth [20]. An interesting side note is that Bussard's concept is relatively insensitive to starting velocity, and so a large rocket is not needed to accelerate the interstellar vehicle to near light-speed prior to ignition of the fusion ramjet. An actual mission requires a very large vehicle that would be difficult to construct, but as Bussard aptly stated in his conclusions, "nothing worthwhile is ever achieved easily" [19].

Bryan Palaszewski of the NASA Glenn Research Center presented purely conceptual missions for extracting resources from the atmospheres of the outer planets [21]. The major focus of his work was the mining of Helium-3 for fusion energy sources, but he also noted that many natural resources may be extracted for life support and building materials to sustain permanent establishments in the outer solar system. Two of these concepts use "scoopers" and "cruisers" to skim materials from the atmospheres of the gas giants. Although this concept would require a more detailed treatment depending on the particular application, it suggested that harvested atmospheric gases would likely be the source of propellant for transporting the mined materials.

Michael Minovitch described an overview of a transportation system that uses Berner and Camac's air scooping vehicle to enable re-fueling of a high-mass orbital transfer ve-

hicle [22]. The concept relies on beaming microwave power between ground antenna arrays and the orbiting vehicles to enable an economical “interorbital transportation system.” The propellant-accumulating vehicle that Minovitch proposed would operate at 100–110-kilometer altitudes, and so the incoming air flow would flow through intense shock waves. The shock waves would ionize a large fraction of the flow, and so Minovitch proposed that the vehicle could use an MHD generator to extract electrical power from the incoming ionized air. This electrical power would then help to power the compression and liquefaction equipment as well as the MHD accelerator that produces thrust for the vehicle. The system Minovitch imagined is quite large, with the MHD generator producing up to 300 megawatts, and the vehicle accumulating a net 4000 kilograms of air per day through a 50-meter diameter air scoop. Minovitch preferred to attain the highest specific impulse possible, and so the MHD accelerator was designed to consume 30 megawatts of power at a specific impulse of  $I_{sp} = 3000$  seconds [22].

In 2004, Julien-Alexandre Lamamy explored the benefit of Propellant Production in Mars Orbit (PPIMO) for a robotic sample return mission. Mars missions typically use aerobraking maneuvers to reduce the spacecraft speed upon arrival, and so Lamamy proposed that during these maneuvers the spacecraft could both collect ambient carbon dioxide and generate heat. The heat would be used to drive chemical reactions between the collected carbon dioxide and hydrogen carried from Earth. The products of the PPIMO system could be used to re-fuel a rocket propulsion system. Lamamy concluded that utilizing PPIMO with a chemical propulsion system offers a practical benefit over an electric propulsion system when a short trip duration is required [23].

### **1.2.3 Recent Work**

The early studies described above focused on determining the appropriate performance parameters for air-accumulating vehicles, and especially noted the requirements for the power and propulsion systems that would make them economically advantageous. Notably,

most of these concepts relied on the availability of multi-megawatt-class nuclear power sources in LEO. Although on-orbit nuclear power solutions are technically feasible with current technology, it is generally known that current social and political obstacles are sufficient to eliminate the possibility of employing a large nuclear power source on orbit. Therefore, most of the current research has focused on applications for smaller satellites. Some work in Japan has focused on designing an efficient inlet/collection scheme [24], and others around the world are currently investigating thruster concepts that may have the appropriate performance characteristics when operating with atmospheric constituents [25–27].

Timothy Pigeon and Ryan Whitaker, two undergraduate students at the Massachusetts Institute of Technology, analyzed the potential for a “Near-Vacuum Hall Thruster,” that would ingest ambient gas and accelerate it using the Hall effect. Initial experiments suggested that the thruster may work [28], but later experiments by Omar Bashir and Regina Sullivan measured properties in the exhaust plume that indicated the performance at all operating conditions would be far too low to compensate for satellite drag at the altitudes of interest [29].

Two similar concepts were introduced by Gordon Dressler of the Northrop Grumman Corporation [30], and Leonid Pekker of ERC Incorporated with Michael Keidar of George Washington University [31]. Dressler’s concept, called the “Ambient Atmosphere Ion Thruster,” used an open set of grids to electrostatically accelerate ambient gas that is already ionized, without needing any sort of scooping structure, but this work did not address some of the more challenging technical details of the concept. Pekker and Keidar presented a thorough model of a similar concept that uses a Hall accelerator instead of grids. They came to the conclusion that the concept could work at 80–90-kilometer altitudes with megawatts of power, but used optimistic assumptions for some of the characteristics of Hall thrusters in their calculations [31].

Kazutaka Nishiyama of JAXA noted that scientists do not currently have access to the region of the atmosphere at altitudes of 60–200 kilometers. He proposed using an “Air

Breathing Ion Engine,” or ABIE, to compensate for the drag of a satellite in a 150–200-kilometer orbit in order to study the atmosphere at those altitudes for a mission duration of at least several months. Nishiyama stated that an efficient air inlet design is the key to making the concept viable, and that the inlet materials must be resistant to degradation when interacting with atomic oxygen. He determined reasonable characteristics for a small satellite mission, with a 4.1–5.6-kilowatt ion engine providing the thrust at a specific impulse of 7,300–10,000 seconds. His work also identifies many of the engineering challenges that must be overcome to make this concept a reality [32].

Following from Nishiyama’s work, Masahito Tagawa et al. created a fast atomic oxygen source to simulate the environment that the ABIE would experience on orbit [33]. The experiment indirectly measured the thrust produced from an ABIE-like set of grids, but the authors noted that the experiment was fundamentally different than operation in LEO because the atomic oxygen source was pulsed, rather than steady-state. This led to the development of a steady-state atomic oxygen source capable of providing the conditions necessary to test a small-scale ABIE in a representative very low LEO atmosphere [27].

Jones et al. revived Demetriades’s PROFAC work, and presented a concept called Propellant Harvesting of Atmospheric Resources in Orbit (PHARO). The proposed PHARO mission was a propellant depot that would collect 300 metric tons of oxygen from the Earth’s atmosphere during one year of operation. The PHARO vehicle would then load the collected oxygen onto a Mars-transfer vehicle. Jones’s work mainly presented the Direct Simulation Monte Carlo (DSMC) analysis of various inlet designs, with computational results for the continuum-rarefied transitional flow regime at about 100 kilometers. The study determined that the propulsion system must be capable of providing at least 134 newtons of thrust at a minimum 1000-second specific impulse, although the thrust could be distributed among multiple vehicles or engines [34].

DiCara et al. also presented DSMC results of an inlet design, along with a reasonable mission concept for using a “RAM-EP” propulsion system. The study gave a very detailed

description of the proposed demonstration mission that mostly uses off-the-shelf technology. It determined that a mission is possible down to an altitude of 180 kilometers, and that the RAM-EP concept is only advantageous at altitudes below about 250 kilometers. For the designed demonstration mission, the thrusters would need to provide 2–20 millinewtons of thrust with approximately 1 kilowatt of electrical power. The authors noted that both the inlet design and thruster performance with atmospheric gases must be verified before further system development can occur [25].

Other studies have focused specifically on using or modifying existing thruster technologies in air-breathing applications. Kevin Diamant of the Aerospace Corporation experimentally studied a two-stage thruster concept that is designed to have a very long lifetime [35]. Diamant’s experiments used xenon propellant, and the results suggested that there was no advantage to using a two-stage thruster design over a more traditional Hall thruster. David Kirtley of MSNW LLC plans to use a Field Reversed Configuration (FRC) thruster concept with neutral flow entrainment to achieve appropriate performance characteristics for an air-breathing propulsion system [26]. The FRC thruster is currently under development and no direct performance results are yet available to assess the applicability of this technology. However, recent measurements suggest that the FRC technology shows promise, and testing is planned for future use with Mars and Earth atmospheric propellants, as well as materials possibly found in asteroids [36].

In addition to the work presented at academic conferences and in peer-reviewed journals, two patents have been awarded by the United States Patent and Trade Office in the past decade regarding air-breathing space propulsion technology. One is for an “air breathing electrically powered hall effect thruster,” which is similar to the concepts described by Pigeon and Whitaker, and by Pekker and Keidar [37]. The other is for the “air-breathing electrostatic ion thruster,” which is most similar to those described by Nishiyama and Dressler [38].

## 1.3 Research Goals

Two unknowns are frequently cited in literature regarding the feasibility of air-breathing spacecraft concepts: the 1) the efficiency and 2) the performance characteristics of space propulsion systems operating with atmospheric gases. Another unknown that is not as frequently cited is the lifetime of these propulsion systems. This dissertation aims to address the feasibility and practicality of operating an air-breathing propulsion system on a small satellite in very low LEO with currently available technology. The approach taken is to choose representative, appropriate thrusters to test, and measure their performance in the laboratory. Radio frequency (RF) plasma technology is used widely in the multi-billion dollar semiconductor manufacturing industry, and so the aptitude for this technology to increase the performance of an air-breathing system is a major focus of the investigation.

Chapter 2 presents some background information and a feasibility analysis used to determine the appropriate thruster technologies to test in the laboratory. Chapter 3 gives a brief discussion of RF plasma systems. Chapter 4 details the designs of the thrusters used in this study. Chapter 5 describes the facilities and diagnostics used. Chapter 6 presents the results of thruster performance testing. Chapter 7 discusses the physics of thruster operation. Finally, Chapter 8 makes some concluding remarks regarding the future application of these thrusters to a satellite mission employing an air-breathing propulsion system.



## CHAPTER 2

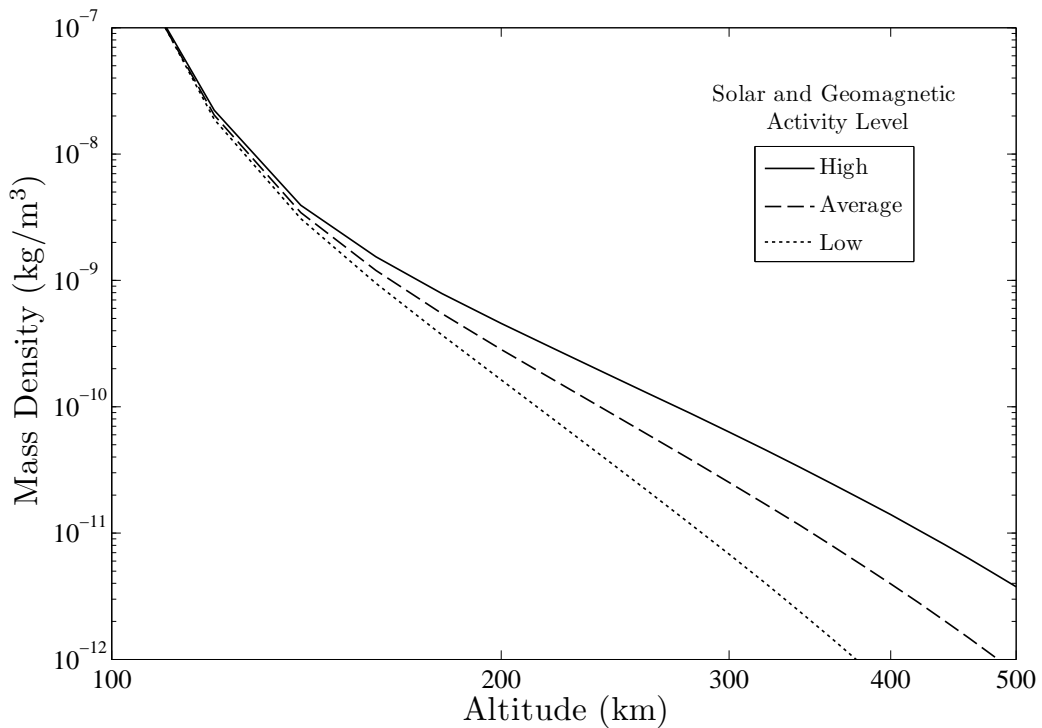
# Background

This chapter addresses the feasibility of using Earth’s atmosphere as propellant for drag compensation, and the process for determining which thruster concepts to investigate. First, the properties of the Earth’s atmosphere in very low LEO are given. Then, the analysis used to determine the propulsion requirements for an air-breathing system is presented. A reference mission is defined to give representative values for a small demonstration spacecraft that would use currently available technology. Finally, the decision regarding the appropriate thruster technology to investigate is described.

### 2.1 Earth’s Atmosphere

The MSISE-90 model is a standard global atmospheric model used by NASA in the range of altitudes from 0–1000 kilometers above the Earth’s surface. The “MSIS” stands for *Mass Spectrometer and Incoherent Scatter*, the “E” denotes that the model extended the MSIS-86 model into the middle and lower thermosphere, and “90” indicates that it was released in the year 1990. It is an empirical model based on mass spectrometry and incoherent scatter radar measurements taken by satellites and ground stations, as well as supplemental data from sounding rocket experiments and space shuttle flights. A website supported by NASA’s Goddard Space Flight Center provides the mass density, temperature, and gas composition of the atmosphere versus altitude according to the MSIS-E-90 model [39]. Atmospheric conditions vary by altitude, latitude, longitude, and over the

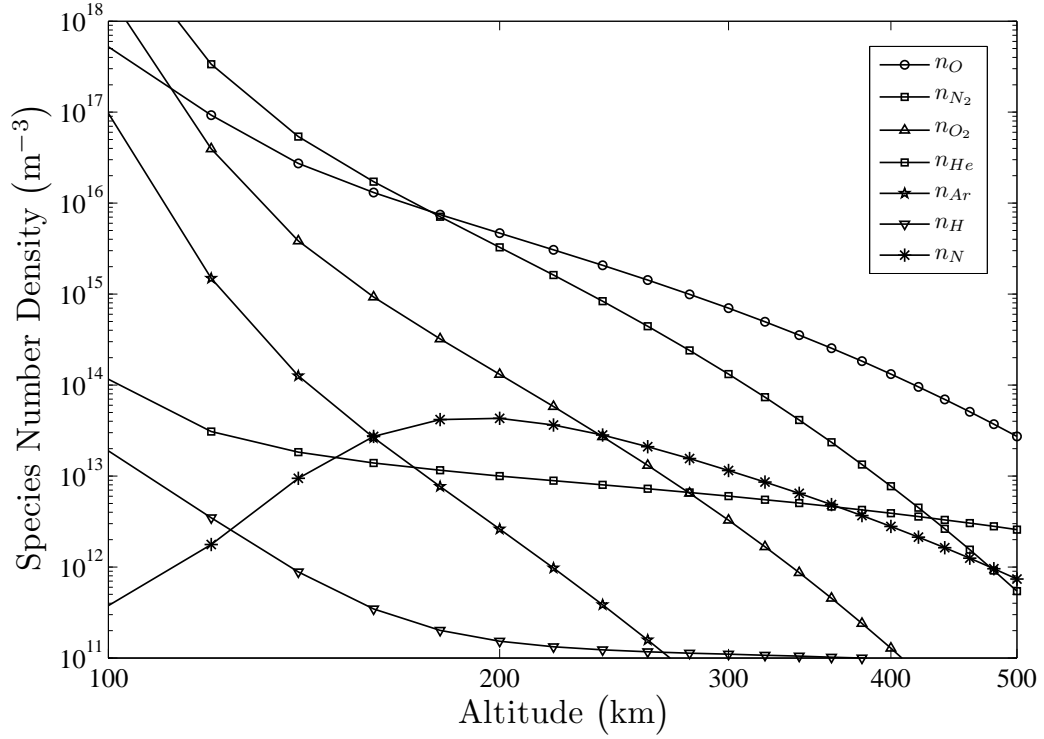
course of a day/night cycle, the yearly seasonal cycle, and the solar cycle (approximately an 11-year period). To assess the feasibility of an air-breathing system, the MSISE-90 data for January 1, 2000 at 01:30 UTC, at 55 degrees North latitude, 45 degrees East longitude (the default settings on the webpage) is used. The values used for the atmospheric properties are given in Appendix A. Although many gas properties are important for determining the required performance of an air-breathing propulsion system, one of primary importance is the mass density of the gas, plotted in Fig. 2.1.



**Figure 2.1: Mass density of atmospheric gas versus altitude from the NRLMSISE-00 model at different levels of solar activity, reported by ISO/DIS 14222 [40]. Solar and geomagnetic activity may vary over time scales as short as an hour and as long as a decade.**

Atmospheric composition is also important when considering the development of an air-breathing spacecraft. Argon, helium, and molecular nitrogen are inert, but atomic oxygen and hydrogen are very reactive, and can increase the erosion of spacecraft materials. Also, candidate methods of propulsion must be able to effectively use the atmosphere’s constituent gases as propellant. For example, even though atomic oxygen is the majority component of the upper atmosphere, as shown in Fig. 2.2 [39], Zukerman calculated that an

atomic oxygen-recombination ramjet would have insufficient performance to compensate for drag [17].



**Figure 2.2:** Atmospheric composition versus altitude from the NRLMSISE-00 model for mean solar and geomagnetic activity, reported by ISO/DIS 14222 [40]. Atomic oxygen is the majority component above approximately 200 km.

## 2.2 Kinetic Theory

Kinetic theory is a description of macroscopic gas behavior that treats the gas as a collection of individual microscopic particles, or molecules. The individual molecules are in a constant state of motion, and they interact with material surfaces and other molecules in the gas through frequent collisions [41]. The average distance that a molecule will travel before it collides with another molecule is called the *mean free path*,  $\lambda_{mfp}$ . To describe the macroscopic behavior of the gas in a real system, an important non-dimensional quantity for Kinetic theory is the *Knudsen number*,  $Kn$ . The Knudsen number is the ratio of the mean free path of the molecules to the length scale of the system. The systems analyzed

in this dissertation are spacecraft, and so the length scale used to calculate the Knudsen number is the characteristic length of the spacecraft,  $L_{s/c}$ , as shown in Eq. 2.1.

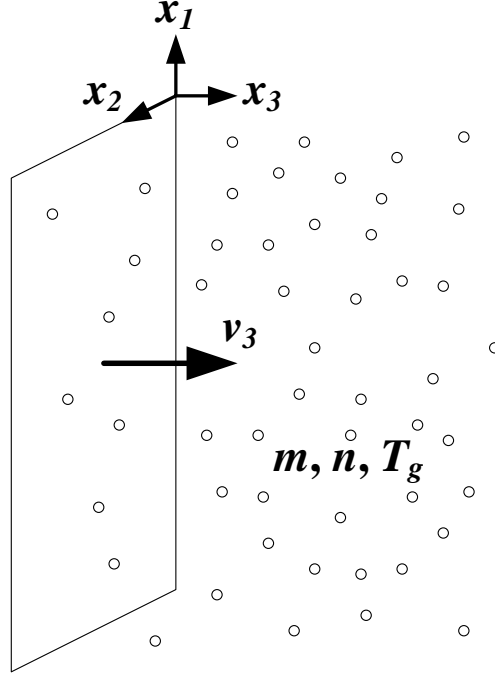
$$Kn = \frac{\lambda_{mfp}}{L_{s/c}}, \quad (2.1)$$

The Knudsen number gives the ratio of the length scale that a molecule travels between microscopic interactions to the length scale of the whole system. When the Knudsen number is greater than or equal to one, the flow in the system is said to be in the *free-molecular* flow regime. In free-molecular flow, the material surfaces are not large enough to cause flow discontinuities to develop. Thus, shocks are not present, and the sound speed is not an important quantity for describing flow behavior.

In order to obtain an estimate of the mass flow rate and drag for an air-breathing satellite, it is assumed that the gas surrounding an air-breathing spacecraft is in a free-molecular flow regime. This assumption is dependent on the specific atmospheric conditions and the size of the spacecraft being analyzed, and it is checked for all analyses presented later. Because the satellite is in a free-molecular flow, simplified equations may be used to describe the interactions between the satellite and the atmosphere. The front surface of the spacecraft is modeled as a flat surface moving through a stationary gas that is characterized by the gas species mass,  $m$ , the number density,  $n$ , and temperature,  $T_g$ , as shown by Fig. 2.3. The ratio of the plate velocity,  $v_3$ , to the most probable thermal speed of the gas is known as the *speed ratio*, or  $s_3$ , and is defined in Eq. 2.2.

$$s_3 \equiv \frac{v_3}{\sqrt{\frac{2k_B T_g}{m_g}}} \quad (2.2)$$

Assuming that the ambient gas has a Maxwellian energy distribution, Eqs. 2.3 and 2.4 give the solutions to the Boltzmann relations for incident mass flux,  $\Phi_3$ , and momentum flux,  $P_3$ , on the flat plate, respectively. Note that the speed ratio is the critical parameter for



**Figure 2.3: Kinetic description of flat plate moving through ambient gas.**

determining the asymptotic solutions.

$$\Phi_3 = \frac{1}{4} m_g n_g \left( \frac{8k_B T_g}{\pi m_g} \right)^{1/2} \left[ \exp(-s_3^2) + \sqrt{\pi} s_3 (\operatorname{erf}(s_3) + 1) \right] \quad (2.3)$$

$$P_3 = n_g k_B T_g \left[ \frac{s_3}{\sqrt{\pi}} \exp(-s_3^2) + \left( \frac{1}{2} + s_3^2 \right) (1 + \operatorname{erf}(s_3)) \right] \quad (2.4)$$

As discussed later, the plate velocity for the spacecraft model is the orbital velocity. At the altitudes of interest for an air-breathing spacecraft, the speed ratio remains above 8. This is sufficiently large that the asymptotic solutions for free-molecular mass and momentum flux apply to the spacecraft front surface, given by Eqs. 2.5 and 2.6, respectively.

$$\lim_{s_3 \rightarrow \infty} \Phi_3 = m_g n_g v_3 \quad (2.5)$$

$$\lim_{s_3 \rightarrow \infty} P_3 = m_g n_g v_3^2 \quad (2.6)$$

## 2.3 Propulsion Systems

Most satellites employ a propulsion system to exert a force for the purpose of orbit maintenance, attitude control, and/or orbit raising. According to Newton’s third law, any force exerted on a mass (i.e. an *action*) must cause a force equal in magnitude and opposite in direction to another mass (i.e. a *reaction*). Propulsion systems near the Earth’s surface, such as boat or airplane propellers, may use the atmosphere as a reaction mass by “pushing” against the surrounding water or air. The density of the atmosphere a few tens of kilometers above the Earth’s surface is too low for this type of propulsion system to effectively “push” against. Rather, at high altitudes, the vehicle must carry all of the reaction mass on board.

### 2.3.1 Rocket Propulsion

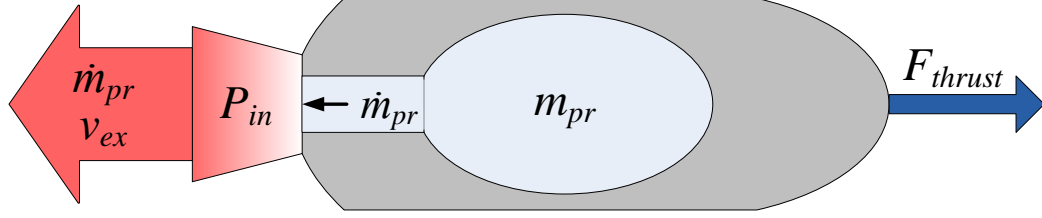
A propulsion system that uses no external sources of reaction mass is called a *rocket*, and the stored reaction mass is called the *propellant*. The force provided by a rocket is called the *thrust*,  $F_T$ , and it is equal to the rate at which propellant mass is expelled from the vehicle (the *propellant mass flow rate*),  $\dot{m}_{pr}$ , multiplied by the velocity of the expelled propellant relative to the vehicle (the *effective exhaust velocity*),  $v_{ex}$ , according to Eq. 2.7.

$$F_T = M(t) \frac{dv(t)}{dt} = \frac{dm_{pr}}{dt} v_{ex} = \dot{m}_{pr} v_{ex} \quad (2.7)$$

Note that both the mass,  $M(t)$ , and the velocity,  $v(t)$ , of the vehicle are functions of time because the propellant mass is expelled from the vehicle and the vehicle is being accelerated by the thrust force. The effective exhaust velocity is simply a property of the particular type of rocket that is used.

The initial mass of the vehicle is given as  $M_0$ , and if the flow rate and effective exhaust velocity are assumed to be constant, then the mass of the vehicle decreases linearly with time, as shown by Eq. 2.8.

$$M(t) = M_0 - \dot{m}_{pr} t \quad (2.8)$$



**Figure 2.4: Diagram of rocket operation.**

Because a real vehicle may only carry a finite amount of propellant,  $m_{pr}$ , all of the propellant mass will eventually be expended after the total burn time,  $t_b$ . The mass remaining when the propellant is expended is the final mass of the vehicle,  $M_f$ , as shown in Eq. 2.9.

$$M(t_b) \equiv M_f = M_0 - \dot{m}_{pr}t_b \quad (2.9)$$

Equation 2.7 can then be rewritten as Eq. 2.10, and carrying out the integration yields Eq. 2.11, where  $v_0$  is the initial vehicle velocity and  $v_f$  is the final vehicle velocity. This equation was originally published by Russian schoolteacher Konstantin Eduardovich Tsiolkovsky in 1903 [42], and it is still commonly referred to as “the rocket equation.”

$$\int_{M_0}^{M_f} \frac{dM'}{M'} = \frac{1}{v_{ex}} \int_{v_0}^{v_f} dv' \quad (2.10)$$

$$\frac{M_f}{M_0} = e^{-\frac{\Delta v}{v_{ex}}} \quad (2.11)$$

The maneuver that the rocket pushes the vehicle through defines the “delta-vee” required,  $\Delta v$ . This is the change in velocity imparted to the final vehicle mass when  $M_0 - M_f$  amount of propellant mass is consumed. Note that for a given  $\Delta v$  (i.e. vehicle maneuver), a rocket with a higher effective exhaust velocity requires less propellant mass to complete the maneuver.

The thrust integrated over the entire “burn time” of the rocket represents the total momentum change that the propulsion system can impart to the vehicle, and it is called the

*total impulse*. A commonly cited figure of merit for rocket systems is the *specific impulse*,  $I_{sp}$ , which is the impulse imparted to the spacecraft per unit weight of propellant. This quantity is defined in Eq. 2.12, where  $g_0$  is the acceleration due to gravity at sea level on Earth. Specific impulse is a measure of how effectively the rocket system uses the propellant mass.

$$I_{sp} \equiv \frac{\int_0^{t_b} F_T(t') dt'}{g_0 \int_0^{t_b} \dot{m}_{pr}(t') dt'} \quad (2.12)$$

If the average values of thrust and flow rate are determined for the entire burn time, then calculating the specific impulse is equivalent to determining the average effective exhaust velocity, as shown by Eq. 2.13.

$$I_{sp} = \frac{\overline{F}_T}{g_0 \dot{m}_{pr}} = \frac{\dot{m}_{pr} v_{ex}}{g_0 \dot{m}_{pr}} = \frac{v_{ex}}{g_0} \quad (2.13)$$

Assuming that it is initially stationary on the vehicle, some source of potential energy (e.g. gas pressure, chemical bond energy, electric potential energy, etc.) must be converted to kinetic energy in order to accelerate the propellant to the exhaust velocity. The power contained in the rocket exhaust that contributes to the thrust is called the *jet power*,  $P_{jet}$ , and it can be defined using different characteristics of the rocket, as shown by Eq. 2.14.

$$P_{jet} = \frac{1}{2} \dot{m}_{pr} v_{ex}^2 = \frac{1}{2} F_T v_{ex} = \frac{1}{2} F_T g_0 I_{sp} = \frac{1}{2} \dot{m}_{pr} (g_0 I_{sp})^2 \quad (2.14)$$

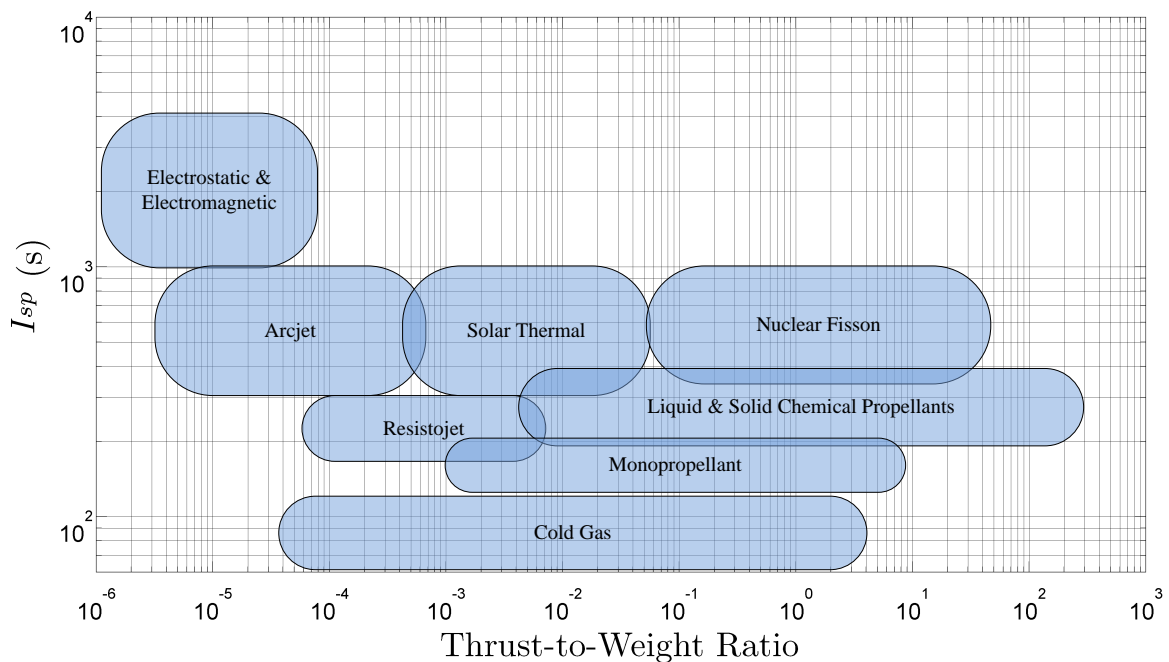
No matter what the original source of energy is, the *total efficiency*,  $\eta_{tot}$ , of a rocket can be defined by the fraction of the input power,  $P_{in}$ , that is converted to jet power, as shown in Eq. 2.15.

$$\eta_{tot} \equiv \frac{P_{jet}}{P_{in}} = \frac{P_{jet}}{P_{chemical}}, \text{ or } \frac{P_{jet}}{P_{electrical}}, \text{ or } \frac{P_{jet}}{P_{nuclear}}, \text{ etc.} \quad (2.15)$$

Rockets can be categorized by the source of power used to generate thrust. One fundamental categorization of rocket types is the distinction between chemical and electric



rockets. Chemical rockets use only the internal energy that is contained in the propellant itself. This internal energy can be stored as a high pressure or as chemical bonds in the propellant molecules. Once the chemical energy is released, the propellant flows through a nozzle to convert the isotropic thermal energy into a directed exhaust jet. Electric rockets instead use an electrical power source to add energy to the propellant. Depending on the method for electrical energy input, a nozzle may or may not be used. Figure 2.5 shows the operating regimes for the different types of rockets.



**Figure 2.5: Operating Parameters of different types of rockets [43].**

The input power for chemical propulsion systems is fundamentally limited by the density of the internal energy stored in the propellant. The maximum specific impulse is limited by the temperature that the combustion products can attain, and the efficiency of the nozzle. For example, unavoidable “frozen flow” losses (losses due to the propellant molecules carrying internal energy into the exhaust) prevent all of the chemical bond energy from being converted into directed kinetic energy that produces thrust. The practical maximum specific impulse in modern chemical rockets is approximately 450 seconds, which is attained by using liquid oxygen and liquid hydrogen as propellant. Higher specific impulse

has been demonstrated with more energetic propellant combinations (e.g. 532 seconds in a lithium-fluorine-oxygen rocket [44]). These exotic propellants are generally more difficult to handle or store, and the modest performance gains realized would not offset the large development costs required to make these propellants viable [45].

### 2.3.2 Augmented Rocket Propulsion

The above analysis applies specifically to rockets, which by definition carry all propellant on-board the vehicle. However, the same principles can be applied to a system that uses an external source of propellant. A chemical rocket typically requires both a fuel and an oxidizer to release the stored chemical energy. In the Earth's lower atmosphere, oxygen is available at densities large enough such that the surrounding air can be used as an oxidizer. The air can therefore be used to react with the fuel that is stored on the vehicle in either a *duct jet* propulsion system (e.g. ramjet, turbojet, etc.) or a *ducted rocket* or *air-augmented rocket*, such as that depicted in Fig. 2.6. Because this type of vehicle uses ambient gas as propellant, the equation for specific impulse is modified. For a constant total propellant flow rate, Eq. 2.16 applies, and Eq. 2.13 can be re-written as Eq. 2.17 because although both the fuel and air contribute to the thrust, only fuel is consumed in the process.

$$\dot{m}_{pr} \equiv \dot{m}_{fuel} + \dot{m}_{air} \quad (2.16)$$

$$I_{sp} = \frac{(\dot{m}_{fuel} + \dot{m}_{air})v_{ex}}{g_0\dot{m}_{fuel}} = \frac{v_{ex}}{g_0} \left( 1 + \frac{\dot{m}_{air}}{\dot{m}_{fuel}} \right) \quad (2.17)$$

Equation 2.17 shows that the specific impulse of a propulsion system can be drastically increased if a significant amount of the propellant can be drawn from the vehicle surroundings, and if the exhaust velocity is not significantly diminished. This is the reason why commercial airplanes use turbofan engines instead of rockets. It also explains why there is a considerable research effort dedicated to replacing rocket propulsion with ramjet and scramjet engines for endo-atmospheric missions. Previous work has shown that a purely

air-breathing chemical rocket is not feasible, and that an augmented chemical rocket is not practical for orbital applications [17].

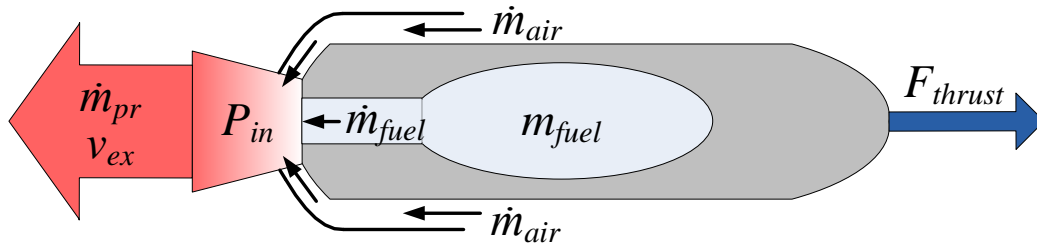


Figure 2.6: Diagram of ducted or air-augmented rocket.

### 2.3.3 Electric Propulsion

Electric Propulsion (EP) refers to rocket systems that convert electrical energy into kinetic energy of the propellant. The source of electrical energy is external to the propellant, and so the exhaust velocity is not fundamentally limited by the internal energy that can be stored in the propellant. EP can be further sub-divided into categories based on the physical process that converts the electrical energy to jet power of the propellant. The three categories are described below, and a comparison of typical performance parameters is given in Table 2.1

1. **Electrothermal** Thrusters operate by heating propellant, and expanding it through a nozzle. Examples of electrothermal propulsion include resistojets and arcjets.
2. **Electrostatic** Thrusters operate by ionizing the propellant, and accelerating the ion species to high velocity with an applied electric field. Examples of electrostatic propulsion include gridded ion thrusters, Hall/Stationary Plasma Thrusters (SPTs), and colloid thrusters.
3. **Electromagnetic** Thrusters operate by ionizing and driving electrical current through the propellant. The driven current interacts with an applied magnetic field to accel-

erate the ionized propellant. Examples of electromagnetic propulsion include Pulsed Plasma Thrusters (PPTs), Magnetoplasmadynamic thrusters (MPDs), Pulsed Inductive Thrusters (PITs), and Field-Reversed Configuration Thrusters (FRCs).

**Table 2.1: Electric propulsion performance characteristics [43, 46–50].**

Type	Power (kW)	$I_{sp}$ (s)	$\eta_{tot}$ (%)	Life (hrs)	Status
Resistojet ( $N_2H_4$ )	0.5–1.5	300	80	500	Flight
Arcjet ( $N_2H_4$ )	0.3–2	500–700	35	> 1,000	Flight
Arcjet ( $H_2$ )	0.005–100	1000–1500	25–40	—	R & D
Hall Thruster (Xe)	0.1–50	1000–3000	40–70	> 7,000	Flight
Hall Thruster (Kr)	1–74	1500–4500	30–65	—	R & D
Ion Thruster (Xe)	0.2–40	2000–10000	60–75	> 40,000	Flight
MPD ( $NH_3$ , $H_2$ , Ar)	0.001–4000	2000–5000	30–50	—	R & D

A plasma is an ionized gas that can experience body forces due to applied electric and magnetic fields. It logically follows that electrostatic and electromagnetic EP systems employ the use of plasmas. The exhaust velocities of these systems are dictated by the strength of the applied fields, and the thrust force is transmitted to the thruster through the fields themselves. The latter fact implies that the ionized propellant does not need to collide with any thruster components or other propellant to exert a force on the vehicle.

As will be discussed in the next section, if a satellite uses propellant only from the collection of ambient atmospheric gas, the minimum specific impulse required from the propulsion system to sustain it in a 200-kilometer orbit is approximately 800 seconds. In addition, for an air-breathing satellite to yield a practical gain over a non-air-breathing satellite, the propulsion system must have an operating lifetime of at least 30,000 hours. The combination of these two requirements eliminates resistojets and arcjets for consideration in an air-breathing system.

Table 2.1 shows that Hall thrusters are not be capable of operating for the long lifetime required to make the air-breathing system practical. However, recent research suggests that Hall thrusters can be designed to dramatically increase Hall thruster lifetime. This can be accomplished either by continuously replenishing the eroded thruster materials or

by altering the magnetic field geometry. The High Voltage Hall Thruster program at the NASA Glenn Research Center has demonstrated that the material replenishment concept can extend thruster lifetime beyond 15,000 hours [51]. The operation of a Hall thruster in a “magnetically-shielded” configuration at the Jet Propulsion Laboratory demonstrated that material erosion rates can be reduced by three orders of magnitude, which would extend the lifetime of a magnetically-shielded Hall thruster to the order of 1,000,000 hours [52].

Although electric propulsion systems can generally operate with different propellants, each specific propellant can affect overall thruster performance. For example, Table 2.1 shows how the operation of an arcjet can change when operating with hydrazine ( $N_2H_4$ ) versus hydrogen propellant. In addition to altering performance characteristics, using different propellants can affect the thruster material compatibility. Hall thrusters and gridded ion thrusters are life-limited due to the erosion of thruster materials. These thrusters are generally designed to operate with xenon propellant, and recent experiments have shown increased erosion rates when operating with oxygen propellant [53]. Ion thrusters have been successfully operated on the Gravity field and steady-state Ocean Circulation Explorer (GOCE) satellite at low altitudes where there is a significant amount of atomic oxygen [54], but the performance of ion and Hall thrusters operating with nitrogen and oxygen propellant is not well-documented.

## **2.4 Air-Breathing Spacecraft**

Air-breathing space propulsion is an enabling technology that could allow a spacecraft to perform propellant-expensive maneuvers at low orbit altitudes without suffering a reduction in the payload mass or lifetime. At a minimum, the air-breathing propulsion system must be capable of compensating for drag. It is important to quantify the altitudes where this is possible, and the practical benefit that an air-breathing system might achieve over a non-air-breathing system. This section describes the procedure used to calculate the per-

formance requirements of the propulsion system.

First, it is important to understand the properties of a non-air-breathing spacecraft. In general, a spacecraft can be divided into three major sources of mass: the bus (i.e. the structure, wiring harness, communications subsystems, solar panels, etc.), the propellant, and the payload, given by Eq. 2.18. Although the payload requirements generally drive the properties of the spacecraft bus, the mass available as payload is the most valuable to the customer. The total mass delivered to a particular orbit is set by the launch vehicle, and is primarily a function of the orbit altitude and inclination. For a given launch vehicle, less mass can be delivered to higher orbits.

$$M_0(h) = M_{bus} + m_{fuel} + M_{p/l} = M_0 (k_{bus} + k_{fuel} + k_{p/l}) \quad (2.18)$$

The drag force on a spacecraft in LEO is calculated according to Eq. 2.19, where  $\rho$  is the mass density of the atmosphere,  $v_{s/c}$  is the spacecraft velocity,  $A_{s/c}$  is the frontal area of the spacecraft, and  $C_d$  is the drag coefficient. For typical spacecraft, the drag coefficient is in the range of 2–4 [6].

$$F_d = \frac{1}{2} \rho v_{s/c}^2 C_d A_{s/c} \quad (2.19)$$

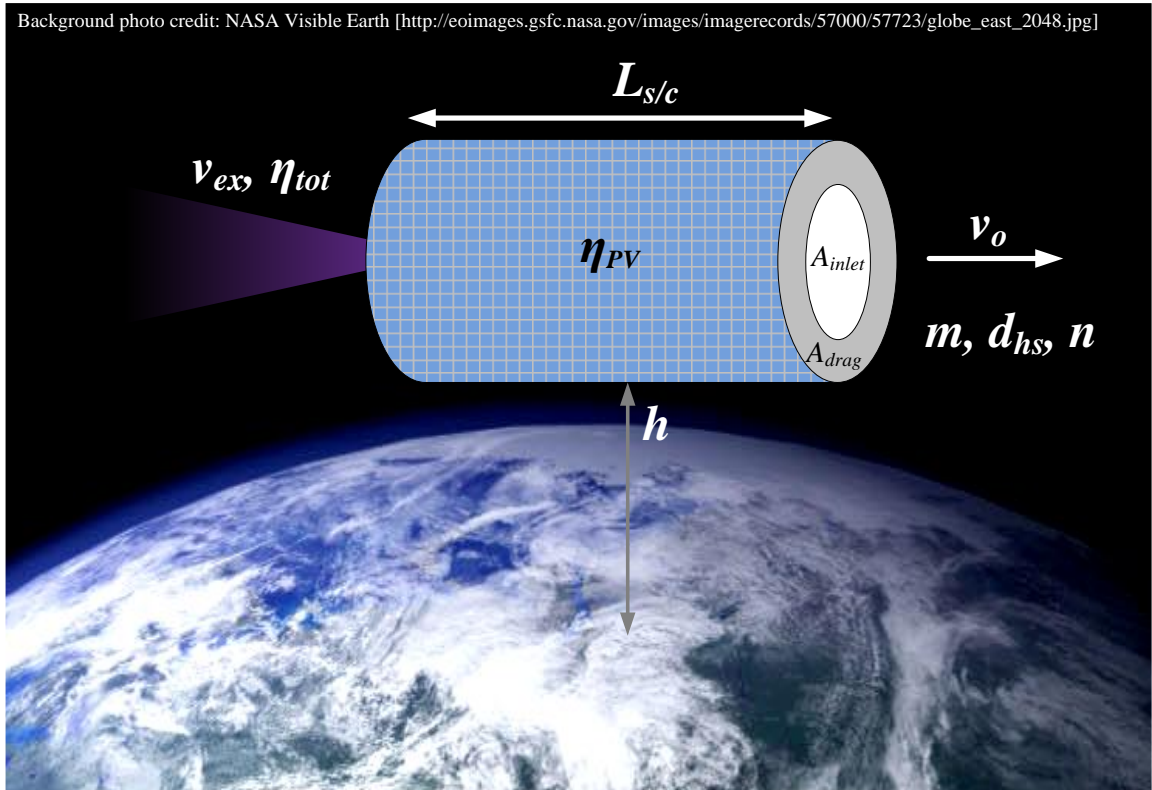
Assuming that the spacecraft ends its mission when all of the propellant has been expended, and that the drag, propellant flow rate,  $\dot{m}_{pr}$ , and specific impulse,  $I_{sp}$ , of the propulsion system are constant, the lifetime of the spacecraft,  $\tau_L$ , is calculated according to Eq. 2.20.

$$\tau_L = \frac{m_{fuel}}{\dot{m}_{fuel}} = \frac{k_{fuel} M_0}{\frac{F_d}{I_{sp} g_0}} \quad (2.20)$$

If an electric propulsion system is used, and the thrust is exactly equal to the drag, then

the electrical power required by the propulsion system may be calculated using Eq. 2.21.

$$P_{req} = \frac{1}{2\eta_{tot}} F_D I_{sp} g_0 \quad (2.21)$$



**Figure 2.7: Notional diagram of air-breathing mission.**

### 2.4.1 Model

The goal of the air-breathing spacecraft is to eliminate the need to store propellant on-board the spacecraft at launch (i.e. to reduce  $k_{fuel}$  to zero). The elimination of the stored propellant allows more spacecraft mass to be allocated to other systems, such as the payload. In addition, the on-orbit lifetime of the air-breathing propulsion system must not be significantly reduced in order for it to yield a practical benefit over a conventional propulsion system. Although alternative spacecraft geometries might be imagined to optimize the capabilities of an air-breathing mission, the model for a simple spacecraft is analyzed to

give a first-order estimate of the feasibility and potential benefit of an air-breathing spacecraft. Figure 2.7 shows a diagram of the simple air-breathing spacecraft analyzed here, showing the important variables.

1. **Geometry:** The spacecraft geometry is assumed to have a well-defined length,  $L_{s/c}$ , and a surface area normal to the orbit trajectory,  $A_{s/c}$ . The normal surface area is divided into an inlet area,  $A_{inlet}$ , through which incident flow is collected, and a drag area,  $A_{drag}$ , which causes a drag force without collecting ambient gas.

$$A_{inlet}; A_{drag}; L_{s/c} \quad (2.22)$$

2. **Velocity:** The spacecraft is assumed to be in a circular orbit at an altitude,  $h$ , above the Earth's surface. The bulk velocity of the incoming flow is equal to the spacecraft orbital velocity. Referring to the kinetic theory discussed above, the normal velocity,  $v_3$  in Fig. 2.3, is the orbital velocity of the spacecraft,  $v_o$  in Fig. 2.7. Note that the radius of the Earth is approximately 6,378 kilometers, and that the altitudes of interest for an air-breathing spacecraft are in the range of roughly 100–400 kilometers. Thus, the Earth's radius is much larger than the orbit altitude, and so the orbit velocity is nearly constant (approximately 7.7–7.8 kilometers per second) in this altitude range.

$$v_o = \sqrt{\frac{GM_{\oplus}}{R_e + h}} \quad (2.23)$$

3. **Flow Regime:** The gas behavior in the vicinity of the spacecraft is assumed to be in free-molecular flow, rather than a flow with transitional or hypersonic flow effects. To check that this assumption is valid, the Knudsen number,  $Kn$ , is calculated from the gas mean free path,  $\lambda_{mfp}$ , and the spacecraft length according to Eq. 2.1. The mean free path is determined from the number-density-weighted hard-sphere diameter of the atmospheric gas,  $\overline{d_{HS}}$ , according to Eq. 2.24, and so it is a function of gas



composition as well as number density [55].

$$\lambda_{mfp} = \frac{1}{\sqrt{2\pi}\overline{d_{HS}}^2 \sum n_k}; \quad \overline{d_{HS}} \equiv \frac{\sum n_k d_{HS,k}}{\sum n_k} \quad (2.24)$$

4. **Mass Flow Rate:** It is assumed that the spacecraft operates in steady-state, such that the air-breathing propulsion system is able to use the gas that is incident on the inlet area as propellant. The incident mass flow,  $\dot{m}_{in}$ , is defined in Eq. 2.25 where the inlet efficiency,  $\eta_{inlet}$ , is the fraction of mass incident on the inlet area that is collected by the spacecraft. A propulsion system that uses the maximum amount of gas flow requires a lower exit velocity to compensate for the drag. Thus, the spacecraft is assumed to use all of the collected mass flow as propellant in order to determine the *minimum* thruster exit velocity required.

$$\dot{m}_{in} \equiv nmv_o A_{inlet} \eta_{inlet} \quad (2.25)$$

5. **Drag:** The drag force,  $F_D$ , is calculated by treating the inlet area and drag area separately, and summing the force of the incident gas on each area. It is assumed that all of the gas molecules are initially at zero mean velocity (relative to the Earth). When collecting ambient gas, the spacecraft must accelerate all of the collected molecules to the orbital velocity. It is assumed that the gas molecules incident on the inlet area, whether collected or not, experience an average change in velocity equal to the spacecraft orbital velocity. For the drag area, it is assumed that incident molecules are elastically scattered by the spacecraft surface. Thus, the total change in momentum of the gas incident on the drag area is equal to twice the incident momentum (the most conservative assumption). The result of summing the force on the inlet and drag areas is given by Eq. 2.26. Note that this formulation is the same as choosing a drag coefficient in the range from 2 ( $A_{inlet} \gg A_{drag}$ ) to 4 ( $A_{drag} \gg A_{inlet}$ ), which is an

appropriate range for a satellite in LEO with an elongated shape [56].

$$F_D = nmv_o^2 (2A_{drag} + A_{inlet}) \quad (2.26)$$

6. **Thruster Exhaust Velocity:** The minimum thruster exhaust velocity required is calculated by setting thrust equal to drag, and dividing by the mass flow rate, as shown in Eq. 2.27. Note that this quantity is equivalent to the specific impulse of a thruster, since  $v_{ex} = I_{sp}g_0$ . An equivalent voltage for a Direct Current (DC) acceleration,  $V_{eq}$ , is also determined from Eq. 2.28, assuming that there is no change in the composition of the propellant as it passes through the spacecraft.

$$v_{ex} = \frac{F_D}{\eta_{inlet}\dot{m}_{in}} = \frac{v_o}{\eta_{inlet}} \left( 2 \left( \frac{A_{drag}}{A_{inlet}} \right) + 1 \right) \quad (2.27)$$

$$V_{eq} = \frac{mv_{ex}^2}{2q}; \quad m \equiv \frac{\sum n_k m_k}{\sum n_k} \quad (2.28)$$

7. **Power Required:** The minimum electrical power that must be supplied to the propulsion system to compensate for drag,  $P_{req}$ , is calculated using the above relations and the total efficiency of the thruster,  $\eta_{tot}$ , according to Eq. 2.29.

$$P_{req} = \frac{\dot{m}_{in}v_{ex}^2}{2\eta_{tot}} = \frac{1}{2\eta_{tot}\eta_{inlet}} nmv_o^3 A_{inlet} \left( 2 \left( \frac{A_{drag}}{A_{inlet}} \right) + 1 \right)^2 \quad (2.29)$$

8. **Spacecraft Power:** It is assumed that the spacecraft uses solar power in the form of photovoltaic cells that completely cover the cylindrical outer surface. The characteristic power available on the spacecraft,  $P_{s/c}$ , is then determined by the product of the insolation on orbit, the efficiency the photovoltaic cells,  $\eta_{pv}$ , and the photovoltaic area normal to the solar radiant flux. Assuming that the length of the spacecraft is always normal to the solar radiant flux, the normal photovoltaic area may be calculated using the inlet and drag area, the spacecraft length, and a geometric factor,  $k_G$ .

For a cylindrical spacecraft geometry,  $k_G = \sqrt{\pi} \approx 1.77$ . In the vicinity of the Earth, insolation is approximately 1,367 watts per square meter [6], and so the characteristic spacecraft power may be calculated according to Eq. 2.30. Note that the photovoltaic efficiency is not necessarily equal to the efficiency of a single cell. For example, even though Spectrolab’s NeXt Triple Junction (XTJ) Solar Cells are 29.5% efficient [57], a solar panel smaller than 2.5 square meters using those cells only produces 345 watts per square meter, corresponding to a 25% efficiency [58].

$$P_{s/c} \approx 1367 \text{ W/m}^2 \eta_{PV} k_G L_{s/c} \sqrt{A_{inlet} + A_{drag}} \quad (2.30)$$

9. **Feasibility:** The air-breathing feasibility parameter,  $\Pi_{AB}$ , is defined as the characteristic power of the spacecraft,  $P_{s/c}$ , divided by the power required for the air-breathing propulsion system,  $P_{req}$ , given by Eq. 2.31. A value of  $\Pi_{AB} \geq 1$  is deemed to be feasible, and greater values have some margin over the minimum power requirement. For a given spacecraft geometry, the feasibility parameter is primarily a function of altitude.

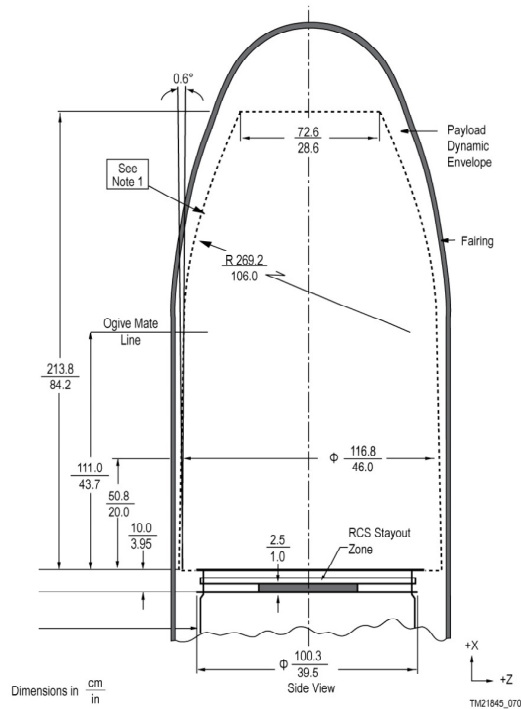
$$\Pi_{AB} \equiv \frac{P_{s/c}}{P_{req}} \quad (2.31)$$

## 2.4.2 Example

Based on the model described above, an example spacecraft is imagined. The example spacecraft is intended to be a “reasonable size” for a small air-breathing demonstration mission. This spacecraft is then analyzed according to the procedure in the previous section to determine the altitudes where the air-breathing satellite can be operated, and the performance requirements for the air-breathing propulsion system. For simplicity, the spacecraft is assumed to have a cylindrically symmetric geometry.

The example spacecraft is designed to fit on a currently available launch vehicle, and for a small demonstration mission, the Pegasus<sup>®</sup> launch vehicle available from Orbital Sci-

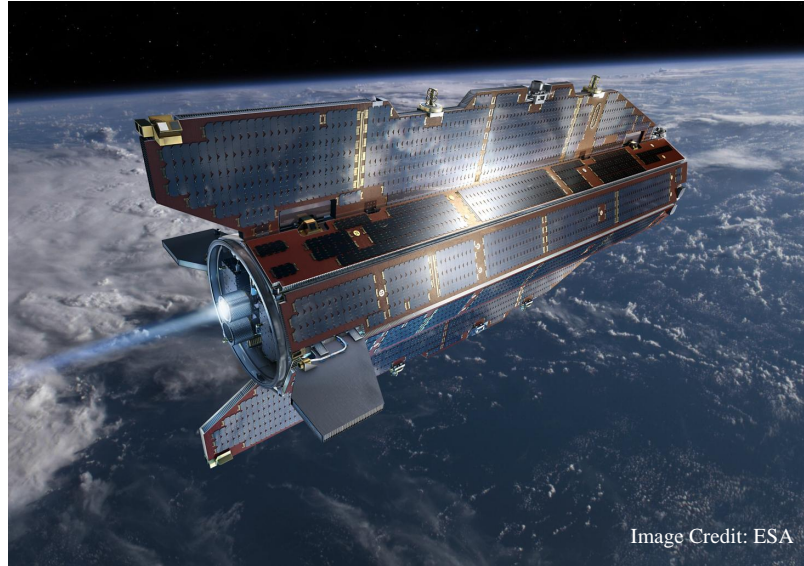
ences Corporation may be appropriate. The standard payload fairing for Pegasus® is shown in Fig. 2.8 [59].



**Figure 2.8: Pegasus® payload fairing [59].**

The GOCE satellite is a similar size and shape as the example spacecraft, and operates down to an orbit altitude of about 260 kilometers. Information listed on GOCE’s website states that GOCE produces 1300 watts of electrical power from a 9-square-meter solar array [60]. Assuming that a similar solar array can be used for the example air-breathing spacecraft mission, this gives an approximate value of 145 watts per square meter for a photovoltaic array in low-altitude LEO, corresponding to a 10.6% photovoltaic efficiency. This is a conservative estimate considering the 345-watts-per-square-meter capability of newer arrays produced by Spectrolab [58]. However, the specifications listed by GOCE are used due to their flight heritage near the altitudes of interest for an air-breathing spacecraft.

To fit inside of the Pegasus payload fairing without requiring any moving parts, the example satellite has a 0.7-meter outer diameter and a 2.1-meter length. At this size, the spacecraft is in a free-molecular flow regime for altitudes above approximately 115 kilome-

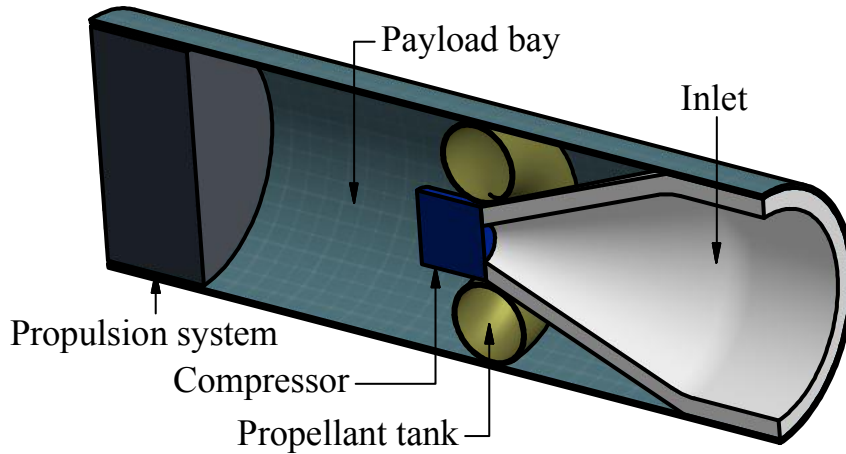


**Figure 2.9: Rendering of the GOCE satellite during mission operations. GOCE is similar in size and shape to the example air-breathing spacecraft, and operates at an orbit altitude of 260 kilometers. GOCE continuously compensates for drag with a gridded ion thruster assembly that uses xenon propellant.**

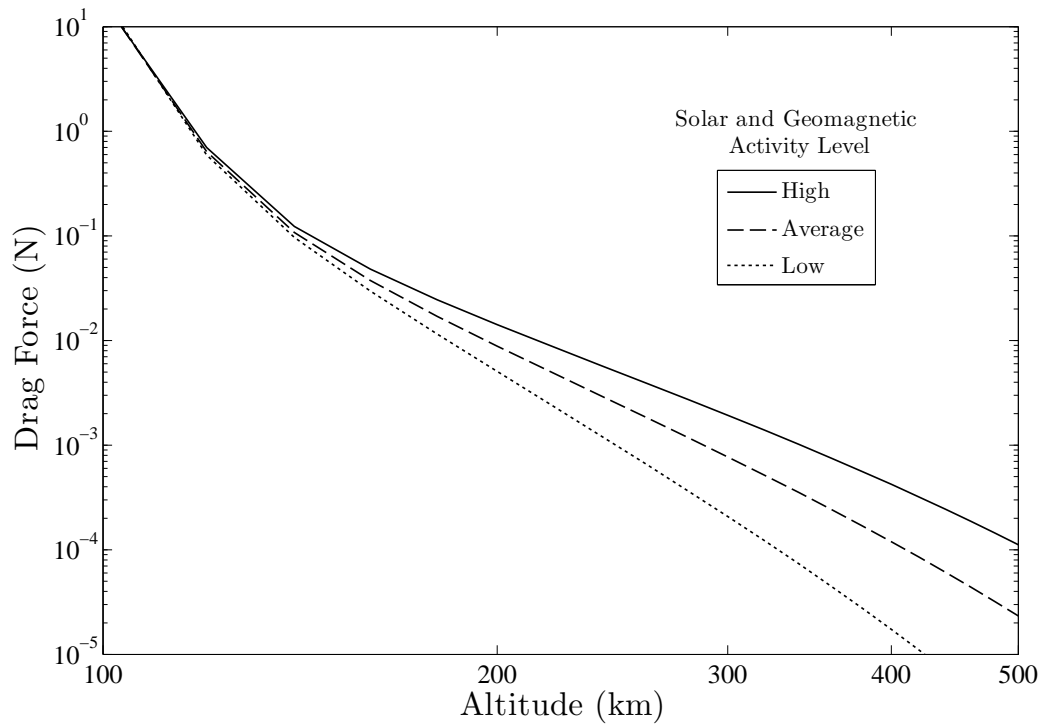
ters. The total frontal area of the spacecraft,  $A_{drag} + A_{inlet}$ , is equal to 0.385 square meters. The drag-to-inlet area ratio,  $A_{drag}/A_{inlet}$ , is arbitrarily chosen to be 0.5. The resulting example spacecraft is shown in Fig. 2.10. Note that a propellant tank is included because gas density on orbit fluctuates, and so the spacecraft may use the tank as ballast for the propellant supply.

The results of the feasibility study taken with the example spacecraft properties are shown in Figs. 2.11–2.15. For a mission at an altitude of 200 kilometers, the example air-breathing spacecraft would experience approximately 8.8 millinewtons of drag. The spacecraft inlet is assumed to have an inlet efficiency of 0.90 (i.e. 90% of the gas molecules incident on the inlet area are collected), and so the spacecraft collects 0.51 milligrams of atmospheric gas per second. This necessitates a propulsion system with a specific impulse of at least 1730 seconds, corresponding to an equivalent DC acceleration voltage of approximately 33 volts for the average molar mass of the atmosphere at that altitude.

If the air-breathing propulsion system has a total efficiency of 0.25, then spacecraft

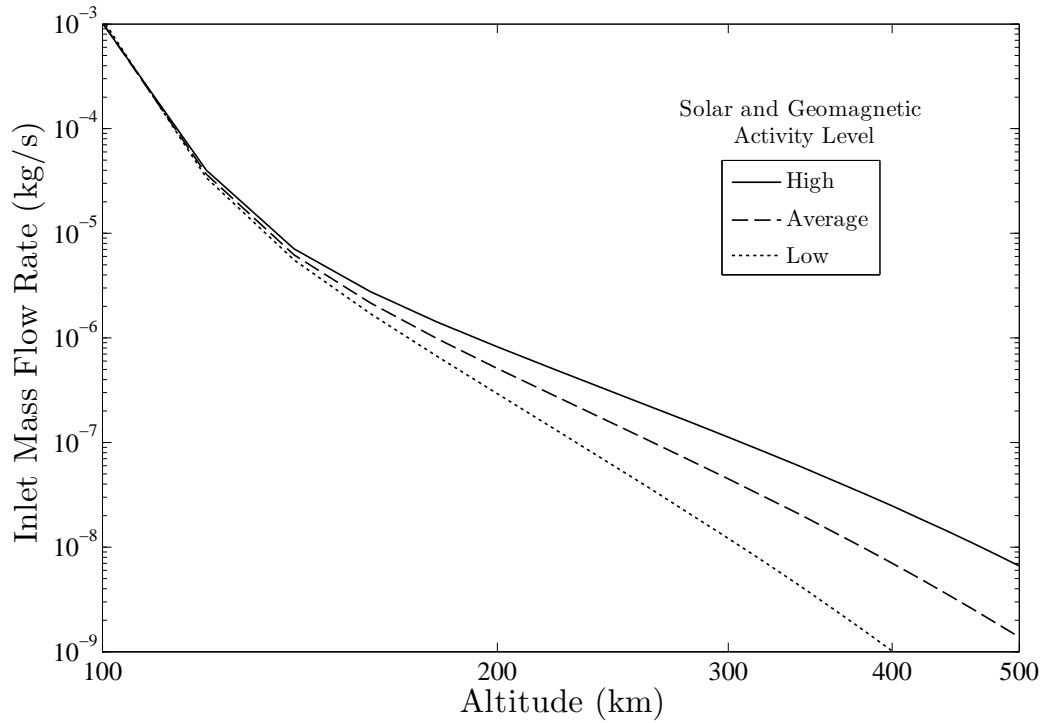


**Figure 2.10:** Cross-section of a notional air-breathing spacecraft, with  $L_{s/c} = 2.1$  meters,  $A_{drag}/A_{inlet} = 0.5$ , and a 0.7-meter outer diameter. The compressor moves air from the inlet to the propellant tank. Spacecraft volume allocated for a payload is shown. The propellant line from the tank to the propulsion system is not shown.

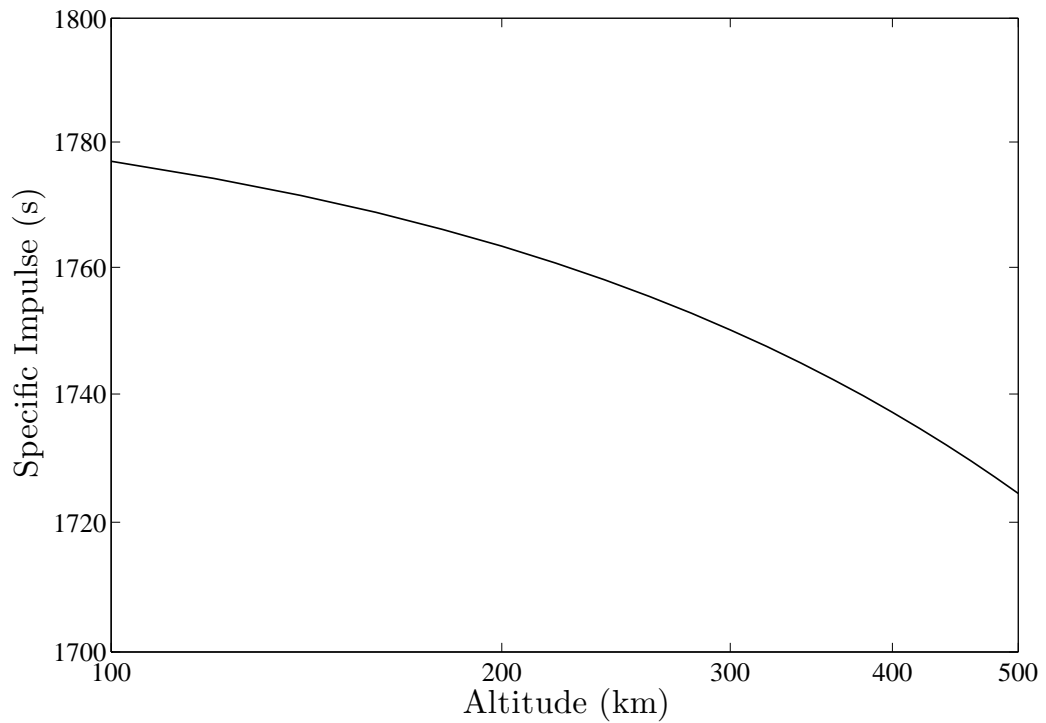


**Figure 2.11:** Drag on the example spacecraft.

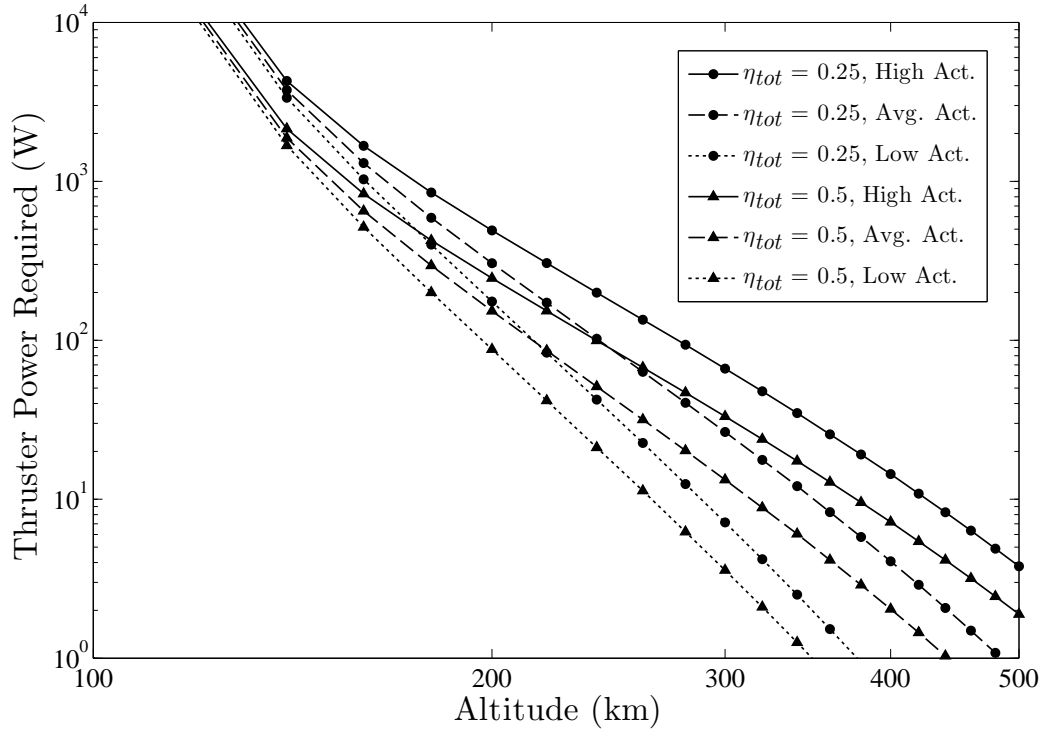
must supply about 306 watts to the propulsion system. The characteristic power of the spacecraft,  $P_{s/c}$ , is 334 watts, and so the air-breathing spacecraft is deemed to be feasible at this altitude if such a propulsion system can be created.



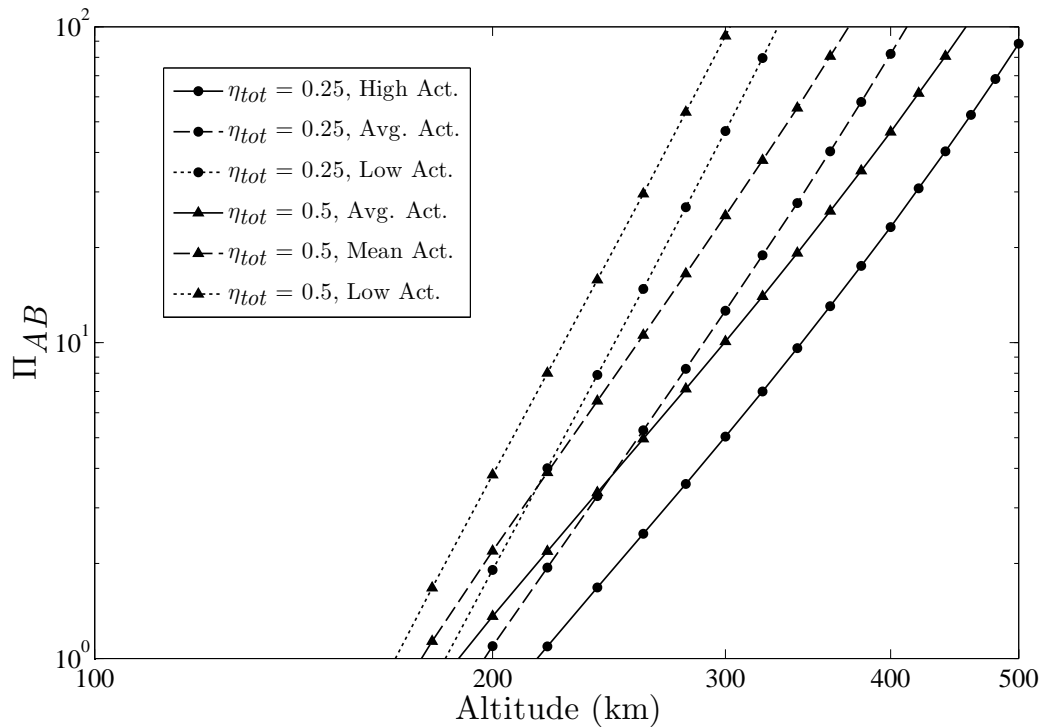
**Figure 2.12: Mass flow rate for the example spacecraft.**



**Figure 2.13: Minimum specific impulse required for the example propulsion system.**



**Figure 2.14: Power required for the example air-breathing propulsion system.**



**Figure 2.15: Feasibility parameter for the example air-breathing spacecraft, assuming  $k_G = 1.77$ , and a solar array power of  $= 145 \text{ W/m}^2$ .**



One performance metric for electric propulsion systems that is sometimes presented is the *thrust-to-power*. From the above model presented, the required thrust-to-power can be calculated from Eqs. 2.26 and 2.29, according to Eq. 2.32.

$$\frac{F_T}{P_{req}} = \frac{nmv_o^2(2A_{drag} + A_{inlet})}{\frac{1}{2\eta_{tot}\eta_{inlet}}nmv_o^3A_{inlet}\left(2\left(\frac{A_{drag}}{A_{inlet}}\right) + 1\right)^2} = \frac{2\eta_{tot}\eta_{inlet}}{v_o}\left(2\left(\frac{A_{drag}}{A_{inlet}}\right) + 1\right)^{-1} \quad (2.32)$$

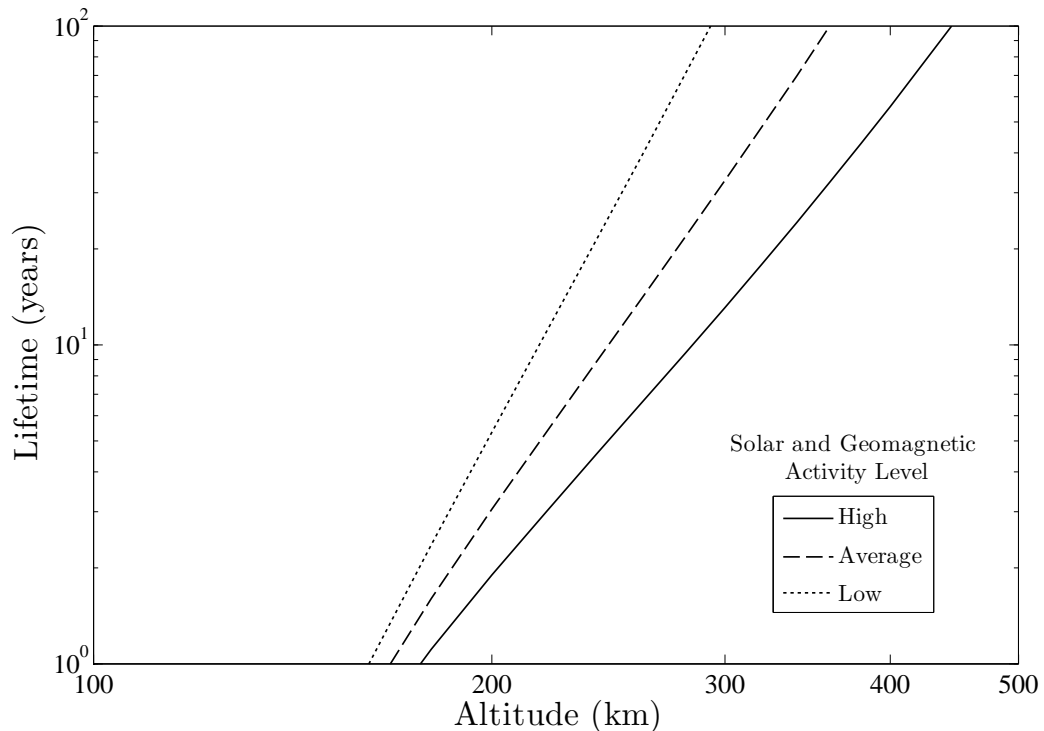
Note that the thrust-to-power is not a function of atmospheric density or composition. Also recall that the orbital velocity is nearly constant at the altitudes of interest. So, the thrust-to-power required for the air-breathing propulsion system is only a function of the spacecraft geometry and the thruster and inlet efficiencies. The example air-breathing spacecraft has a 90% inlet efficiency and a drag-to-inlet area ratio of 0.5. If the total efficiency of the propulsion system is 25–50%, then the thrust-to-power is approximately 29–59 millinewtons per kilowatt.

### 2.4.3 Practicality

Many ideas may be deemed “feasible,” but it is equally important to understand when a concept becomes practical. In the case of Berner and Camac [15], the goal was to accumulate large amounts of ambient gas in the shortest time possible, but that is not the case here. Consider that launch vehicle mass-to-orbit capability decreases with increasing orbit altitude. In practical terms, this means that for a given launch vehicle (i.e. cost) a more massive spacecraft can be launched into a lower-altitude orbit. However, for a given spacecraft size and mass, atmospheric drag decreases with increasing altitude, so the lifetime of the satellite increases with increasing altitude. Here we consider the satellite lifetime beyond which an air-breathing system becomes practical. The satellite lifetime is determined for a spacecraft *without* an air-breathing propulsion system in order to demonstrate where an air-breathing system might achieve a practical benefit.

For the practicality study, it is assumed that the propulsion system of a competing non-

air-breathing spacecraft has the same geometry as the air-breathing spacecraft described above, and that the drag force exerted on both spacecraft is equal. The non-air-breathing spacecraft is allowed a 10% initial propellant mass fraction, and its propulsion system has a total efficiency of 50% at a specific impulse of 3000 seconds. The non-air-breathing spacecraft's mission ends when the spacecraft runs out of propellant. Figure 2.16 shows the lifetime for the non-air-breathing spacecraft, assuming that it continuously uses propellant to compensate for drag. The air-breathing spacecraft yields a practical benefit for a mission that has a greater lifetime than the plotted line. Reading from Fig. 2.16, for example, an air-breathing propulsion system on a spacecraft of this size would be practical for keeping the payload in a 200 kilometer, circular, and sun-synchronous orbit for longer than 3 years, all else being equal.



**Figure 2.16:** Lifetime for a non-air-breathing spacecraft, assuming  $k_{fuel} = 0.1$ ,  $I_{sp} = 3000$  s,  $\eta_{tot} = 0.5$ , and the example spacecraft geometry. An air-breathing spacecraft yields practical benefit for lower altitudes and greater lifetimes than the  $\tau_L$ -line (i.e. above and to the left of the lines in the plot).

**Table 2.2: Example air-breathing spacecraft summary, operating in a sun-synchronous orbit during average solar and geomagnetic conditions.**

Property	Value
Length	$L_{s/c} = 2.1 \text{ m}$
Outer diameter	$OD_{s/c} = 0.7 \text{ m}$
Total Mass	$M_0 = 325 \text{ kg}$
Area Ratio	$A_{drag}/A_{inlet} = 0.5$
Inlet Efficiency	$\eta_{inlet} = 0.90$
Thruster Efficiency	$\eta_{tot} = 0.25$
Orbit Altitude	$h = 200 \text{ km}$
Mass flow rate	$\dot{m}_{pr} = 0.51 \text{ mg/s}$
Thrust	$F_T = 8.8 \text{ mN}$
Minimum specific impulse	$I_{sp} = 1730 \text{ s}$
Equivalent minimum voltage	$V_{eq} = 33 \text{ V}$
Thruster power required	$P_{req} = 306 \text{ W}$
Minimum lifetime	$\tau_L = 3 \text{ years}$

## 2.5 Propulsion Requirements

The absolute lower limit on propulsion system performance is determined by Eq. 2.27, where a spacecraft with nearly zero drag area requires an effective exhaust velocity approximately equal to the orbital velocity. This theoretical lower limit corresponds to a specific impulse of about 800 seconds. The Earth’s radius is much larger than altitudes in very low LEO. Thus, the orbital velocity does not change significantly with altitude, and so the specific impulse required is essentially independent of orbit altitude, as shown by Fig. 2.13. Figure 2.1 showed that the normal mass flux at 150–300-kilometer altitudes is on the order of 0.1–10 milligrams per second per square meter of inlet area, and Fig. 2.11 suggests that the thrust required of the propulsion system will be on the order of 1s–100s of millinewtons per square meter of total spacecraft frontal area. These numbers translate to the propulsion system exhaust jet containing 10s–100s of watts of power for each square meter of ram area.

In order for air-breathing propulsion to be practical for the example used above, it would need to operate nearly continuously for just over 3 years, or about 27,000 hours. Ongoing

experiments have shown that gridded ion thrusters can run for more than 42,000 hours [61], but this is with xenon propellant. Rather, a high thrust-to-power, long-lived plasma thruster that is capable of operating with oxygen and nitrogen propellant is the desired propulsion system for the air-breathing spacecraft.

### **2.5.1 Why RF?**

Most developed EP systems use electrically-biased metal electrodes that are directly exposed to the plasma to apply a DC electric field that accelerates the propellant. When operating with atmospheric gases, these electrodes can introduce materials compatibility issues that are not present when operating with inert propellants. Recent experiments have shown that oxygen propellant will chemically react with EP thruster components, in some cases causing metal parts to form oxide coatings [53]. Thrusters that use DC electric fields also require the use of thermionic cathodes to produce electrons. The cathode materials must be heated to very high temperatures to emit electrons, and they are “poisoned” when heated in an environment with a high partial pressure of oxygen [62], rendering them useless.

The use of RF power in space propulsion systems has been of particular interest to the EP research community due to its potential for improving thruster lifetime and the possibility for it to eliminate the need for thermionic cathodes [63]. As will be discussed in the next chapter, RF plasma systems are capable of ionizing a gas without directly exposing electrodes to the plasma. Satellite missions have successfully employed RF and microwave ion thrusters that use RF power to ionize the propellant gas [64, 65]. For example, the GOCE mission’s propulsion system consists of gridded ion thrusters that use RF to ionize the propellant in the discharge chamber (though the exhaust plume-neutralizing cathodes are still DC, thermionic hollow cathodes). The success of the propulsion system on the GOCE mission shows that RF is capable of operating in EP systems at low orbit altitudes, where the spacecraft is surrounded by a relatively high amount of oxygen.

Some other space propulsion systems have been suggested that employ only RF power and a magnetic field to ionize and accelerate the propellant. These systems are similar to the devices described by Jahn as *magnetic expansion thrusters* and *cyclotron-resonance thrusters*, and do not necessarily fit well under a single EP classification [66]. These RF thruster concepts are currently at varying levels of development [67–73].

Most EP systems have specific life-limiting mechanisms due to the erosion of thruster materials. This erosion is caused by the impact of high-energy exhaust with the thruster [74]. The use of atmospheric propellant may cause the erosion rates to be higher due to chemical interactions between the propellant and the thruster materials. Thus, the lifetime limitation of current flight-model EP systems is likely exacerbated when using atmospheric gases as propellant. The energy of the propellant in the exhaust of some of the RF EP concepts previously mentioned is relatively low. In addition, these thrusters may be designed to have only inert materials in contact with the plasma. Only a few recent experiments have begun to measure the performance of some of these concepts [68, 69], but the data suggest that they may be capable of providing a useful amount of thrust. Because the exhaust energies are lower than in electrostatic thrusters, it is likely that the erosion of thruster materials can be reduced.

In addition to the potential for addressing the issue of limited thruster lifetime, RF technology may significantly reduce compatibility concerns by eliminating the need for thermionic materials. Alternative cathodes employing RF or microwaves have been operated in multiple laboratories, and microwave cathodes have successfully flown as neutralizers for the  $\mu 10$  microwave ion thrusters on the Hayabusa mission, which returned a sample of asteroid material to Earth [65].

Currently, the two most mature electrostatic EP systems are gridded ion and Hall thrusters. Both suffer from a very low efficiency when operating at moderate specific impulse. In particular, Hall thrusters operating at low voltage suffer from poor propellant utilization efficiency (conversion of propellant atoms to thrust-producing ions), and the overall

efficiency is lower when using alternative propellants [49,75]. Using an RF-augmented system may increase overall Hall thruster performance by increasing the propellant utilization efficiency. Recent studies have shown that the Hall thruster magnetic field configuration may be changed to drastically increase thruster lifetime [52], and so an RF-augmented, magnetically-shielded Hall thruster may be appropriate as the thruster for an air-breathing spacecraft.

## **2.6 Conclusion**

This chapter demonstrated that an air-breathing satellite is feasible, and showed where such a system would be practical to implement over a non-air-breathing system. The performance characteristics of EP is in the range appropriate for an air-breathing orbital vehicle. In particular, the ability to operate with any gas species as a propellant, and EP's higher specific impulse than chemical rocket systems make it an attractive option for an air-breathing orbital mission. The capability of RF systems to eliminate the need for a thermionic cathode merits further investigation into their aptitude for improving EP performance.

## CHAPTER 3

# RF Plasma Systems

The previous chapters presented the background and motivation for implementing RF technology in an EP system in order to provide in-space propulsion for an air-breathing satellite. This chapter discusses exactly what is meant by “RF plasma technology.” The first section introduces basic RF concepts important for implementing any RF system, and the second section gives a brief treatment of physical processes in plasmas.

### 3.1 RF Engineering Principles

All Alternating Current (AC) signals radiate some energy into free space. This energy is radiated in the form of electromagnetic waves. The amount of energy radiated is very low at power-line AC frequencies (50-60 hertz). However, it has been found the energy radiated from a conductor at 10 kilohertz can be transmitted and received across large distances on Earth if a sufficiently large antenna is used. When frequencies above approximately 100 gigahertz are used, the energy can be radiated more as heat than radio waves. So, although there are no absolute theoretical constraints on the range of frequencies, *radio frequency* (RF) power refers to AC power in the frequency range that is practically useful on Earth, about 3 kilohertz to 300 gigahertz. Circuits that operate in the RF frequency range must be designed with careful consideration of the unique properties of RF power (e.g. RF is radiated from conductors, and so energy is not strictly confined to a circuit board) [76].

A large number of industries (primarily communication-related) have formed around

the ability to control, transmit, and receive RF energy. For example, the plasma processing/semiconductor manufacturing industry uses RF technology to enable a wireless transfer of energy from an AC electrical outlet to the electrons in low-pressure gas reactors. It is also important to note that the plasma processing industry uses oxygen and nitrogen as working gases for processes such as nitriding metals and sputtering wafer material, showing that it is compatible with LEO atmospheric components.

In the United States, the Federal Communications Commission (FCC) regulates the use of electromagnetic radiation across the RF spectrum. The Code of Federal Regulations defines Radio Waves as “electromagnetic waves of frequencies arbitrarily lower than 3,000 GHz, propagated in space without artificial guide” [77]. The FCC is responsible for assigning and licensing the use of frequencies between 9 kilohertz and 275 gigahertz [78]. The FCC allocates certain frequencies for Industrial, Scientific, and Medical (ISM) uses, referred to as the ISM radio bands. Frequencies in the ISM bands can be used in the laboratory without creating the danger of interfering with communications networks. The frequency in the ISM bands that is most commonly used by the plasma processing industry is 13.56 megahertz, and so there are many medium-power RF generators readily available and relatively inexpensive at that frequency.

The frequency of RF typically referred to is the *circular frequency*,  $f$ , given in units of cycles per second or hertz. Electrical calculations that are dependent on the frequency, however, generally use the *angular frequency*,  $\omega$ , which has units of radians per second. Circular frequency and angular frequency are related by Eq. 3.1.

$$\omega = 2\pi f \tag{3.1}$$

Electromagnetic radiation of a given frequency may generally be thought of as a traveling plane wave that moves through a material at the speed given by Eq. 3.2, where  $\mu$  is the magnetic permeability and  $\varepsilon$  is the electric permittivity of the material. In vacuum, the



permittivity and permeability are that of free space, and the wave propagates at the speed of light,  $c$ , approximately  $3.0 \times 10^8$  meters per second.

$$c = \sqrt{\frac{1}{\mu\varepsilon}} \quad (3.2)$$

Based on the speed and the frequency, the wavelength of the electromagnetic wave,  $\lambda$ , is determined by Eq. 3.3. The wavelength is an important characteristic length to consider when employing RF power because it is the length scale over which large voltage differences can be driven, even in a conductor. For 13.56 megahertz in free space,  $\lambda \approx 22$  meters.

$$\lambda = \frac{c}{f} \quad (3.3)$$

When working with RF power, the *electrical length* is an important parameter. The electrical length is the ratio of the physical length of a conductor to the wavelength of the electromagnetic energy. The electrical length is a property that gives a general sense of the behavior of RF waves in the components and transmission lines of an electrical circuit. A conductor whose physical length is a large fraction of an RF wavelength or larger is considered to be “electrically large” or “long,” and a conductor whose physical length is a small fraction of the RF wavelength are considered to be “electrically small” or “short.” In this dissertation, “a small fraction of a wavelength” refers to one-tenth of the RF wavelength (e.g. 2 meters for 13.56 megahertz in free space). Note that the electrical length is a function of the RF frequency and the properties of the material that the RF energy is traveling through. Note also that the electrical length does define a particular rule. Rather, the electrical length is a concept that provides a guideline to understand how RF energy will behave in a particular system [79].

### 3.1.1 Impedance and Admittance

The electromagnetic wave may also be thought of as a traveling, AC voltage signal. An important quantity when considering an AC signal propagating through a space larger than one-tenth of the wavelength is the *characteristic impedance*. The characteristic impedance in a material, typically labeled  $Z_0$ , is determined by Eq. 3.4. Note that permeability is in units of inductance per unit length, and permittivity is capacitance per unit length, and the square root of their ratio is in units of resistance, ohms. In free space,  $Z_0 \approx 377 \Omega$ .

$$Z_0 = \sqrt{\frac{\mu}{\varepsilon}} = \sqrt{\frac{\mu_0 \mu_r}{\varepsilon_0 \varepsilon_r}} \quad (3.4)$$

$Z_0$  comes from the necessity to satisfy generalized Ohm's law, given by Eq. 3.5. Characteristic impedance is not resistance, but simply the ratio of voltage to current of a time-varying signal propagating in a medium. Note that the characteristic impedance may be dependent on the frequency of the electromagnetic energy.

$$V(t) = Z(\omega)I(t) \quad (3.5)$$

Impedance is a complex quantity that has a real component called *resistance*,  $R$ , and an imaginary component called *reactance*,  $X$ , as shown in Eq. 3.6, where  $j \equiv \sqrt{-1}$ .

$$Z \equiv R + jX \quad (3.6)$$

The frequency dependence of impedance may be illustrated by applying an AC voltage across an ideal, lossless inductor. Inductors are described by a property called the *inductance*,  $L$ , and a lossless inductor identically has zero resistance. The impedance of the lossless inductor therefore consists only of the inductive reactance, which is a linear function of frequency, as shown in Eq. 3.7.

$$Z_{ind} = j\omega L \quad (3.7)$$

Similarly for an ideal lossless capacitor with *capacitance*,  $C$ , the impedance is a purely imaginary quantity called the capacitive reactance, also a function of frequency, as shown in Eq. 3.8.

$$Z_{cap} = \frac{1}{j\omega C} = \frac{-j}{\omega C} \quad (3.8)$$

Pure resistances or inductances add when connected in series, but the reciprocal of capacitances adds in series. This is clear when looking at Eqs. 3.6– 3.8, and understanding that it is the *impedance* that adds in series, as shown by Eq. 3.9.

$$Z_{equiv} = \sum_{series} Z_s \quad (3.9)$$

To analyze parallel circuit components with the same arithmetic ease as series components, the *admittance*,  $Y$ , may be used. The admittance is the reciprocal of the impedance, as shown by Eq. 3.10.

$$\frac{1}{Z} \equiv Y \equiv G + jB \quad (3.10)$$

For a purely resistive circuit component, the admittance is equal to the reciprocal of resistance,  $Y = G = 1/R$ , where  $G$  is called the *conductance*. For a purely reactive circuit component, the admittance is equal to the reciprocal of reactance,  $Y = B = 1/X$ , where  $B$  is called the *susceptance*. The admittance of circuit components in parallel add, as shown by Eq. 3.11.

$$Y_{equiv} = \sum_{parallel} Y_p \quad (3.11)$$

Admittance is a useful property to consider if circuits with parallel components are to be quickly understood or designed. Note that admittance, conductance, and susceptance are all in units of 1/ohms, also known as “mhos” or Siemens.

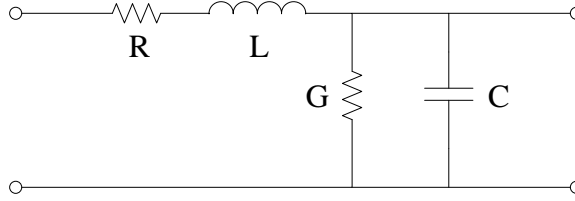
### 3.1.2 Transmission Lines

As previously described, RF energy has an associated wavelength, and the guideline for determining whether a circuit is “electrically large” is if its length scale is larger than one-tenth of a wavelength. Coaxial cable is commonly used to transmit RF power between points in a circuit. In a coaxial cable, the RF wave propagates through the dielectric material between the inner conductor and the outer conductor. Two common materials used as dielectric material are polytetrafluoroethylene (PTFE), also known as “Teflon,” and polyethylene. These materials have relative permittivities,  $\epsilon_r$ , that are greater than unity, and so the wavelength of the RF wave is shorter in these materials than in vacuum.

Relative permittivity is defined as  $\epsilon_r \equiv \epsilon/\epsilon_0$ , where  $\epsilon$  is used with Eqs. 3.2 and 3.3 to determine the wavelength. For PTFE,  $\epsilon_{r,PTFE} = 2.1$ , so the wavelength of 13.56 megahertz RF energy in PTFE,  $\lambda_{PTFE}$ , is approximately 15.3 meters. For polyethylene,  $\epsilon_{r,PE} = 2.25$ , and  $\lambda_{PE}$  is approximately 14.7 meters. Thus, the lengths associated with the one-tenth of a wavelength guideline are shorter in coaxial cables than in vacuum. PTFE is vacuum compatible and has a higher melting temperature than polyethylene, but it is more lossy and more expensive, and so an engineering trade must be considered when choosing which coaxial cable to implement.

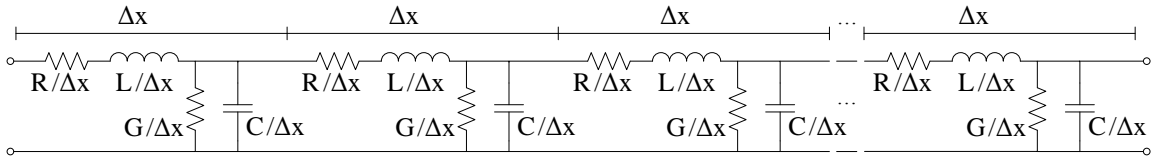
The electrical length of a transmission line is useful when considering how to model the transmission line in an electrical circuit. An electrically short cable can be modeled as a set of discrete circuit components called a *lumped element model*, shown in Fig. 3.1. Thus, the behavior of the RF energy through the cable can be simply represented in a circuit schematic. For a lossless coaxial cable, the series resistance and parallel conductance are identically zero.

When many short cables are connected in series, an electrically long cable may be created. A model of a long cable can then be implemented by placing many of the lumped-element cable sections in series. Such a circuit is considerably more difficult to analyze than the one in Fig. 3.1. Instead, an electrically long cable may be described by properties



**Figure 3.1: Model of an electrically short (i.e. shorter than one-tenth of the RF wavelength) section of coaxial cable.**

per unit length, as depicted in Fig. 3.2. In the limit where the discrete sections of the coaxial cable are infinitely short (i.e.  $\Delta x$  approaches zero), the analysis may be simplified by using a *distributed-element* model.



**Figure 3.2: Simple model of an electrically long (i.e. longer than one-tenth of an RF wavelength) transmission line.**

In a distributed-element model, the resistance, inductance, conductance, and capacitance of a cable are defined per unit length. For a fixed RF driving frequency,  $\omega$ , the sinusoidal, steady-state voltage and current along a one-dimensional, uniform transmission line then follow Eqs. 3.12 and 3.13, respectively.

$$\frac{dV}{dx} = -(R + j\omega L)I(x) \quad (3.12)$$

$$\frac{dI}{dx} = -(G + j\omega C)V(x) \quad (3.13)$$

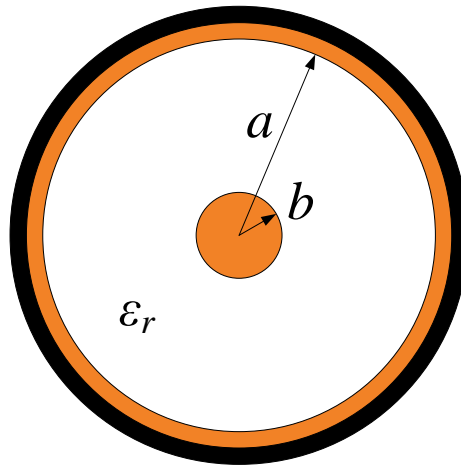
These two equations are known as the “transmission line equations” or “Telegrapher’s Equations” in phasor form, and they describe a traveling wave in the transmission line [80]. From these equations, the *characteristic impedance*,  $Z_0$ , for the transmission line can be

calculated from the electrical properties, as shown by Eq. 3.14.

$$Z_0 = \sqrt{\frac{R + j\omega L}{G + j\omega C}} \quad (3.14)$$

The cables used for RF transmission are designed to be low-loss. At frequencies greater than 10 kilohertz, typically  $\omega L \gg R$  and  $\omega C \gg G$ . Thus, the approximation  $Z_0 \approx \sqrt{L/C}$  is generally used for transmission lines in RF systems. Although transmission lines can be made in many shapes, one of the most commonly available profiles is the coaxial cable, which is a center conductor surrounded by an insulating dielectric material, and concentrically surrounded by an outer conductor, as shown in Fig. 3.3. The electrical properties of coaxial cables are defined according to the geometry of the cross-section and the material properties of the dielectric. The characteristic impedance for a coaxial cable is given by Eq. 3.15, where the variables refer to Fig. 3.3.

$$Z_{0, coax} = \frac{1}{2\pi} \sqrt{\frac{\mu}{\varepsilon}} \ln\left(\frac{a}{b}\right) \approx \frac{60}{\sqrt{\varepsilon_r}} \ln\left(\frac{a}{b}\right) \quad (3.15)$$



**Figure 3.3: Cross-section of a typical coaxial cable.**

Typically, the relative permeability of the dielectric material is unity,  $\mu_r = 1$ , and so  $Z_0$  is only dependent on  $\varepsilon_r$ . The RF industry has adopted fifty ohms, 50- $\Omega$ , as the standard characteristic impedance for a majority of coaxial cables due to a compromise between

reducing cable attenuation (theoretical minimum at  $77\text{-}\Omega$  for air dielectric) and peak power handling (theoretical maximum at  $30\text{-}\Omega$  for air dielectric) [79].

Real transmission lines are not infinitely long, and are terminated at both ends either by a *power supply* or a *load*. RF power supplies are designed to have an output impedance that is equal to the transmission line characteristic impedance. However, the load impedance may be quite different than the characteristic impedance of the power supply and transmission line. When this is the case, the transmission line acts as a transformer for the load impedance. For a finite-length transmission line, the load impedance is transformed according to Eq. 3.16, where  $k$  is the wave number, defined according to Eq. 3.17, and  $l$  is the distance from the transmission line input to the load [79].

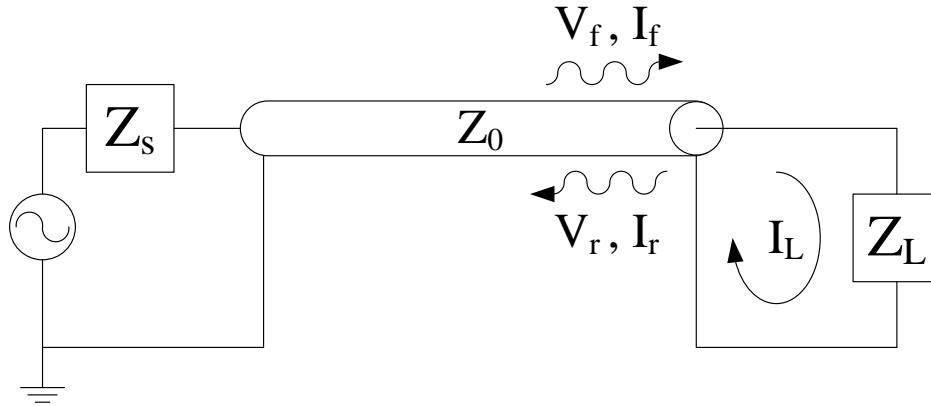
$$Z_{in} = Z_0 \frac{Z_L + jZ_0 \tan kl}{Z_0 + jZ_L \tan kl} \quad (3.16)$$

$$k = \frac{2\pi}{\lambda} \quad (3.17)$$

Note for a single input RF frequency, the input impedance is equal to the load impedance if the transmission line length is an integer multiple of a half-wavelength. Some experiments therefore use a half-wavelength-long transmission line between the matching network and the load in order to avoid an impedance discontinuity, such as that described by Kieckhafer and Walker [81].

### 3.1.3 Impedance Matching

If the load impedance is not equal to the transmission line characteristic impedance, then an impedance discontinuity exists at the connection between the transmission line and the load. Ohm's law must be satisfied everywhere in the system, and because the RF power is a traveling wave in the coaxial cable, the impedance discontinuity at the load causes a fraction of the incident RF power to be reflected back toward the power supply. Kirchoff's



**Figure 3.4: Behavior of RF power at the load end of a transmission line.**

current law applies at the load end of the transmission line, and so Eq. 3.20 also applies in the circuit depicted by Fig. 3.4.

$$V_f = I_f Z_0, \quad V_r = I_r Z_0, \quad V_L = I_L Z_L \quad (3.18)$$

$$V_L = V_f + V_r \quad (3.19)$$

$$I_L = I_f - I_r \quad (3.20)$$

Combining the above equations gives Eq. 3.21, and rearranging this equation gives the amplitude of the reflected voltage,  $V_-$ , which is related to the impedance difference according to Eq. 3.22.

$$V_f + V_r = \frac{Z_L}{Z_0} V_f - \frac{Z_L}{Z_0} V_r \quad (3.21)$$

$$\Gamma = \frac{V_r}{V_f} = \frac{|V_-|}{|V_+|} = \frac{Z_L - Z_0}{Z_L + Z_0} \quad (3.22)$$

Reflections cause an RF power system to be less efficient because power that is reflected cannot be delivered to the load, and instead must be dissipated by the power supply or cable. Real transmission lines are not perfectly lossless, and so reflected power can also cause increased dissipation in the transmission line, leading to cable heating. Reflected



power also creates locations of increased voltage in the transmission line. When there is a significant amount of reflected power, the voltage in the cable may be high enough to cause electrical breakdown, even while operating below the cable power rating.

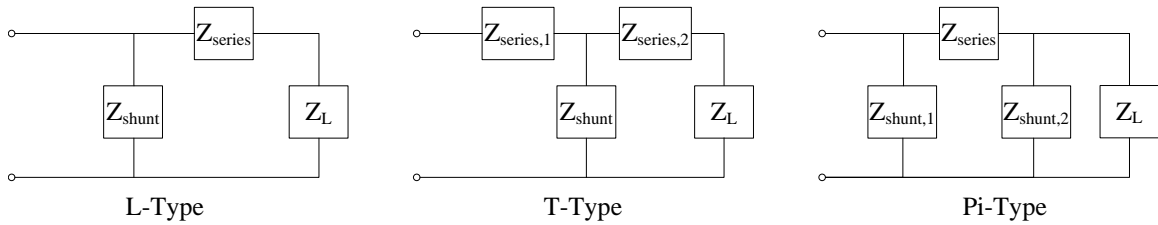
In a real system, the RF power supply is typically placed at some finite distance from the load. Thus, a transmission line must be used to transmit the RF power from the supply to the load. In order to eliminate an impedance discontinuity at the load, a circuit of discrete components must be implemented at the connection between the transmission line and the load. This circuit is generally referred to as a *matching network* because its purpose is to match the load impedance to the transmission line characteristic impedance.

The goal of the matching network is to maximize power transfer from the transmission line to the load, and so the matching network typically uses low-loss reactive components (i.e. *high Q* where  $Q = X/R$ ) to transform the load impedance to the standard 50- $\Omega$ . Using a smaller number of matching components simplifies the design and analysis of the matching network, and also reduces the probability of exciting internal self-resonance modes. The types of matching networks that are typically implemented in RF plasma systems are named according to the arrangement of the matching circuit components. The most common types are depicted in Fig. 3.5, and the associated equivalent impedances of the network and load are given by Eqs. 3.23 – 3.25.

$$Z_{eq,L} = \left( \frac{1}{Z_{shunt}} + \frac{1}{Z_{series} + Z_L} \right)^{-1} \quad (3.23)$$

$$Z_{eq,T} = Z_{series,1} + \left( \frac{1}{Z_{shunt}} + \frac{1}{Z_{series,2} + Z_L} \right)^{-1} \quad (3.24)$$

$$Z_{eq,\Pi} = \left( \frac{1}{Z_{shunt,1}} + \left( Z_{series} + \left( \frac{1}{Z_{shunt,2}} + \frac{1}{Z_L} \right)^{-1} \right)^{-1} \right)^{-1} \quad (3.25)$$



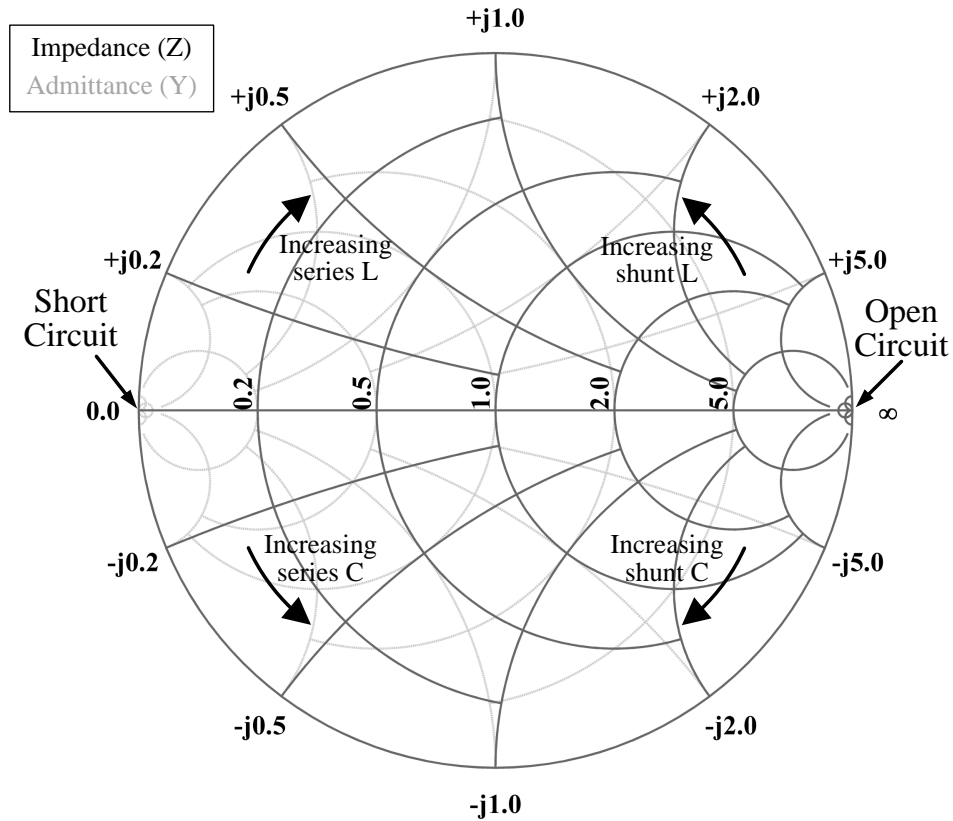
**Figure 3.5: Matching network types.**

### 3.1.4 Smith Chart

The Smith chart is a commonly used tool for designing RF circuits [80]. Although images of the Smith chart sometimes look overwhelmingly complicated to the untrained eye, it is actually a quite simple and very powerful set of coordinates that can be used to quickly understand and design RF circuits. Impedance is a complex quantity, and so the Smith chart displays the real and imaginary components of impedance. The horizontal axis is the real axis, and circles of constant real resistance are tangent to the right side of the chart. As labeled in Fig. 3.6, the right side of the real axis represents an open circuit, and the left side of the real axis represents a short circuit. The Smith chart is normalized to the system characteristic impedance, such that the center of the chart is equal to the characteristic impedance (typically  $50\text{-}\Omega$ ), and therefore represents a matched condition. Note that inductance has a positive imaginary impedance, while capacitance has a negative imaginary impedance.

The Smith chart may also be plotted in admittance coordinates, as displayed in gray in Fig. 3.6, where the admittance coordinates are the same as the impedance coordinates, but rotated by 180 degrees. Positive susceptance is below the real axis, in the opposite arrangement as reactance. Having both the impedance and admittance coordinates displayed allows for quick graphical calculations of the components required to match any given load impedance.

As an example, arbitrarily taking a load impedance  $Z_L = (5 + 45j)\Omega$  in a system with a  $50\text{-}\Omega$  characteristic impedance (i.e.  $Z_0 = 50\ \Omega$ ) Fig. 3.7 shows how the Smith chart may be used to design a matching network. In the example, an L-type configuration is used



**Figure 3.6: Smith chart showing both impedance and admittance coordinates.**

with two ideal capacitors to transform the load impedance to the characteristic impedance. Referring to Fig. 3.7 and working from the load toward the transmission line, capacitor “A” is connected in series with the load, and adds  $-1/\omega C_A$  to the reactance of the load impedance. Switching to the admittance coordinates, capacitor ”B” is then connected in parallel, and adds  $\omega C_B$  to the susceptance. In this example, the coordinates on the Smith chart show that  $-j/\omega C_A = (0.3j - 0.9j) \times 50 \Omega = 30j \Omega$ , and  $j\omega C_B = (0.0j - 3.0j) \times (1/50) \Omega^{-1} = 0.06j \Omega^{-1}$ . For a 13.56 MHz system, the matching capacitors have the values  $C_A = 391$  pF and  $C_B = 704$  pF in order to match  $Z_L$  to  $50\text{-}\Omega$ .

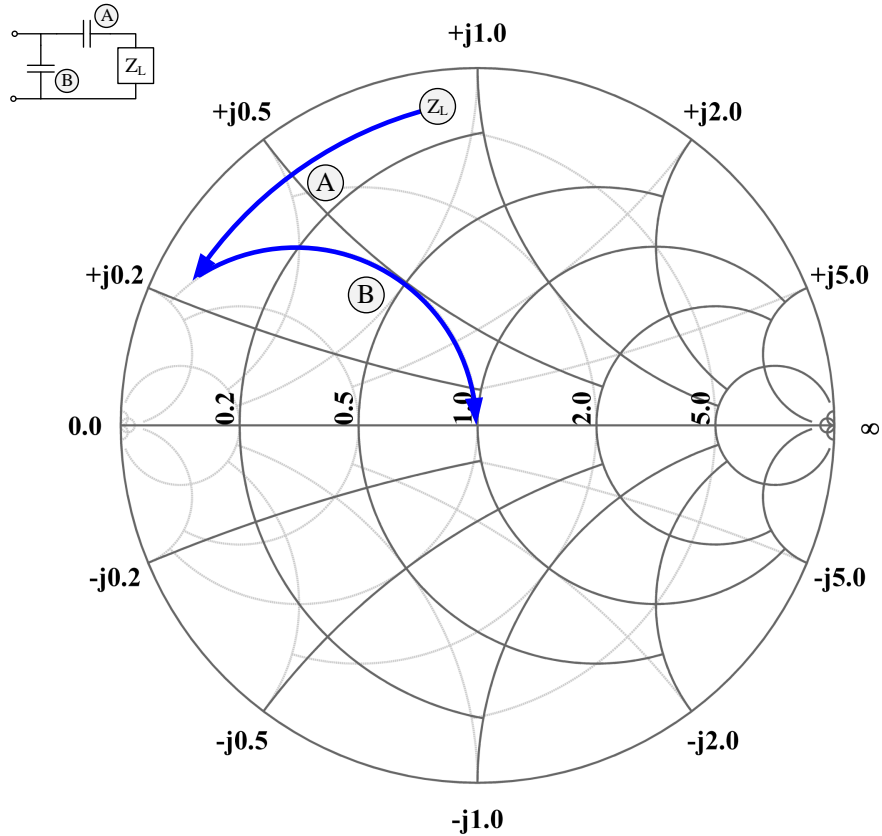


Figure 3.7: Smith chart showing matching network design procedure.

## 3.2 Plasma

Simply stated, plasma is an ionized gas that collectively reacts to externally applied electric and magnetic fields. Typically thought of as being “the fourth state of matter,” the characteristic property of a plasma is that a significant portion of the gas is electrically charged. It is this electric charge that allows the particles to interact with electric and magnetic fields through the Lorentz force, given by Eq. 3.26, where  $m$  is the particle mass,  $\vec{v}$  is the particle velocity,  $t$  is time,  $q$  is the particle charge,  $\vec{E}$  is the electric field, and  $\vec{B}$  is the magnetic field.

$$m \frac{d\vec{v}}{dt} = q(\vec{E} + \vec{v} \times \vec{B}) \quad (3.26)$$

The forces acting on charged particles are a function of mass, charge, and velocity. Because there can be a large disparity in the the mass and temperature of the ions and

electrons, the time-dependent behavior of a plasma may be very complicated. The different time scales associated with different physics are typically expressed as frequencies. A higher characteristic frequency corresponds to a faster time scale.

By definition, a plasma also has approximately an equal number of positive and negative charges, such that the sum of charge over the entire plasma is nearly equal to zero. This property is referred to as *quasineutrality*, and this is expressed by  $qn_i \approx en_e$ . Although the plasma is quasineutral, the ions and electrons are able to move relative to each other, creating spontaneous regions of net charge density. This charge separation creates an electric field that can be determined from Poisson's equation, Eq. 3.27, where  $\rho_q$  is the charge density.

$$\nabla \cdot \vec{E} = \frac{\rho_q}{\varepsilon_0} \quad (3.27)$$

The electric field exerts a force on the charged particles,  $\vec{F}_{el}$ , causing an acceleration determined by Eq. 3.28.

$$\vec{F}_{el} = q\vec{E} \quad (3.28)$$

Because the ions are much heavier than the electrons, one may assume that the ions are stationary, and that the electric field force acts to change the velocity of the electrons, according to Eq. 3.29, where  $\vec{v}_e$  is the electron velocity.

$$m_e \frac{d\vec{v}_e}{dt} = -e\vec{E} \quad (3.29)$$

To simplify the analysis, the behavior is examined in one dimension in Eqs 3.30 – 3.32.

$$\frac{dE}{dx} = \frac{\rho_q}{\varepsilon_0} \quad (3.30)$$

$$\frac{dE}{dt} = \frac{dE}{dx} \frac{dx}{dt} = v_e \frac{en_e}{\varepsilon_0} \quad (3.31)$$

$$\frac{d^2v_e}{dt^2} = \frac{e}{m_e} \frac{dE}{dt} = v_e \left( \frac{e^2 n_e}{m_e \varepsilon_0} \right) \quad (3.32)$$

Equation 3.32 describes oscillatory behavior, which in the plasma represents the “sloshing” of electrons about the ions. The time scale of this behavior is described by a characteristic frequency called the *electron plasma frequency*,  $\omega_p$ , given by Eq. 3.33.

$$\omega_p = \sqrt{\frac{q^2 n_e}{m_e \varepsilon_0}} \quad (3.33)$$

Because the plasma has a temperature associated with it, this oscillatory behavior naturally arises from thermal motion of the charged particles. This example illustrates the time-dependent nature of plasma physics. Note that this analysis could also be performed for ions to obtain an ion plasma frequency. In a quasineutral plasma,  $\omega_{pe} \gg \omega_{pi}$  because  $\omega_{pe}/\omega_{pi} \approx \sqrt{m_i/m_e}$ .

The collective nature of a plasma acts to shield out external electric fields from the bulk population. The characteristic length over which the plasma is able to collectively re-arrange charges is called the *Debye Length*,  $\lambda_D$ , and is given by Eq. 3.34.

$$\lambda_D = \sqrt{\frac{k_B T_e}{n_e e^2}} \quad (3.34)$$

In an infinitely large plasma, spontaneous electric fields may develop over length scales of a few Debye lengths. In laboratory plasma systems, some part of the plasma interacts with a material surface, around which the plasma forms a *sheath*. The sheath is not

quasineutral, and the thickness of the sheath is generally on the order of a few Debye lengths. Note that the Debye length is a function of the electron temperature and density.

The characteristic speed for the plasma can be found by multiplying the ion plasma frequency by the Debye length. This speed is referred to as the *Bohm speed* or the *ion acoustic speed*, and is shown in Eq. 3.35.

$$v_B = \sqrt{\frac{k_B T_e}{m_i}} \quad (3.35)$$

If the plasma is not bounded by a material surface, then the Bohm speed represents the speed at which ions and electrons collectively propagate through free space. This is also known as the *ambipolar speed*.

The plasmas used in space propulsion systems are generally operated at low pressure. Electrostatic propulsion systems in particular use *non-thermal, low-temperature* plasmas; *non-thermal* because they are not in thermodynamic equilibrium, and so the ion and electron energy distributions are characterized by much different temperatures, and *low-temperature* because the isotropic part of the ion energy distribution is at a temperature that is not much greater than room temperature. This type of plasma is common in everyday life, as it is the same type of plasma that powers fluorescent light bulbs, neon signs, and flat-panel displays. Non-thermal, low-temperature plasmas are characterized by weak ionization (i.e. only a small fraction of the gas is ionized). Therefore, the behavior of the uncharged gas, typically referred to as the *neutrals*, also has a strong effect on the plasma properties.

Because the neutrals are not influenced by electric or magnetic fields, they only interact with the electrons, ions, and other neutrals in the plasma through collisions. The length scale that is relevant for neutral behavior is the *mean free path* mentioned previously, which is the average distance that a gas particle will travel before it experiences a collision with another gas particle. Typically, the individual gas particles are modeled as hard-spheres or

“billiard balls.” The mean free path for a homogeneous, single-species, neutral ideal gas is given in Eq. 3.36, where  $n_g$  is the neutral gas density and  $\sigma_m$  is the cross-section for a momentum-exchange collision. Note that if the length scale of an open system is much smaller than the mean free path, it is unlikely that particles will participate in collisions before leaving the system.

$$\lambda_{mfp} = \frac{1}{n_g \sigma_m} \quad (3.36)$$

The expected time between collisions for the neutral gas particles determines the characteristic time scale for the neutral gas, which is expressed as the *collision frequency*,  $\nu_m$ . The collision frequency is a function of the number density of the gas,  $n_g$ , the hard-sphere cross-sectional area of the colliding particles,  $\sigma_m$ , and the relative velocity of the interacting particles,  $v$ , according to Eq. 3.37. Note that the product of the cross-section and the velocity is expressed in angle brackets because the cross-section is a function of the interaction velocity.

$$\nu_m = \frac{v}{\lambda_{mfp}} = n_g \langle \sigma_m v \rangle \quad (3.37)$$

The neutral gas is typically assumed to have an isotropic, Maxwellian velocity distribution, and so the temperature of the gas defines the mean speed of the neutrals according to Eq. 3.38. This velocity is referred to as the *thermal velocity*,  $v_{th}$ .

$$v_{th} = \sqrt{\frac{8k_B T_g}{\pi m_g}} \quad (3.38)$$

The full equation of motion for the charged particles in the absence of a magnetic field is given by Eq. 3.39.

$$mn \frac{dv}{dt} = nqE - \nabla \cdot n - mn\nu v \quad (3.39)$$

Assuming that the particles are isothermal and at steady-state, Eq. 3.39 can be rearranged as Eq. 3.40.

$$v = \frac{q}{k_B T} E - \frac{k_B T}{m\nu} \frac{\nabla n}{n} \quad (3.40)$$



The transport of particles due to density gradients can then be described by the diffusion coefficient,  $D$ , given by Eq. 3.41. Eq. 3.40.

$$D = \frac{k_B T}{m \nu_m} \quad (3.41)$$

Charged particle transport due to electric fields can be described by the mobility,  $\mu$ , given by Eq. 3.42.

$$\mu = \frac{q}{m \nu_m} \quad (3.42)$$

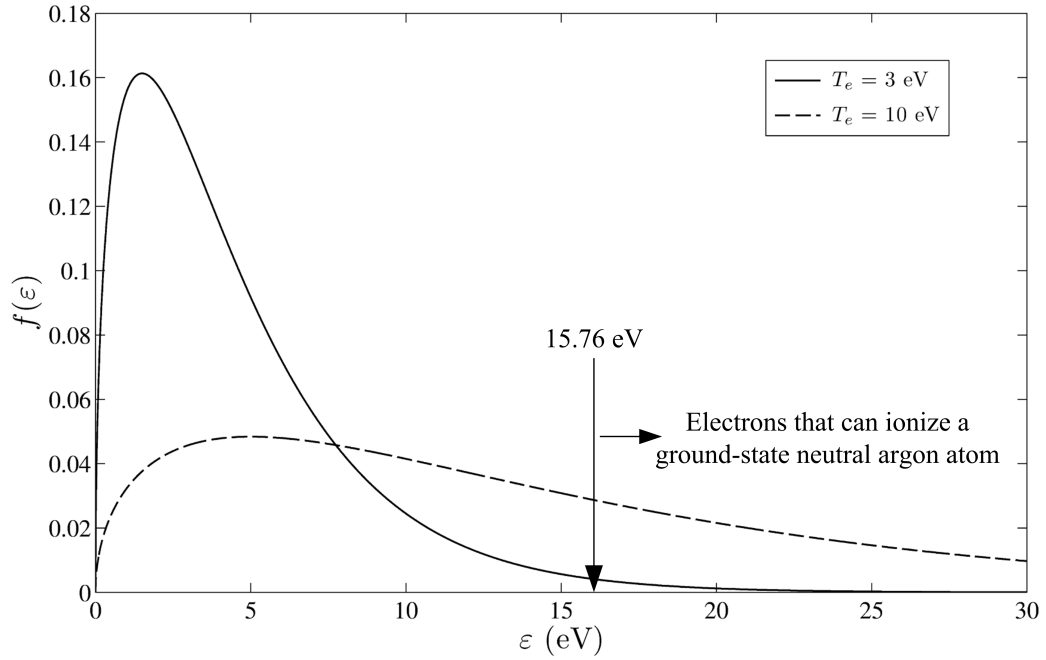
Typically, it is assumed that collisions within the plasma cause the electrons to have an energy distribution,  $f(\varepsilon)$ , that is Maxwellian and described by a temperature,  $T_e$ , according to Eq. 3.43, where  $k_B$  is the Boltzmann constant.

$$f(\varepsilon) = \frac{2}{\sqrt{\pi}} (k_B T_e)^{-3/2} \varepsilon^{1/2} \exp\left(\frac{-\varepsilon}{k_B T_e}\right) \quad (3.43)$$

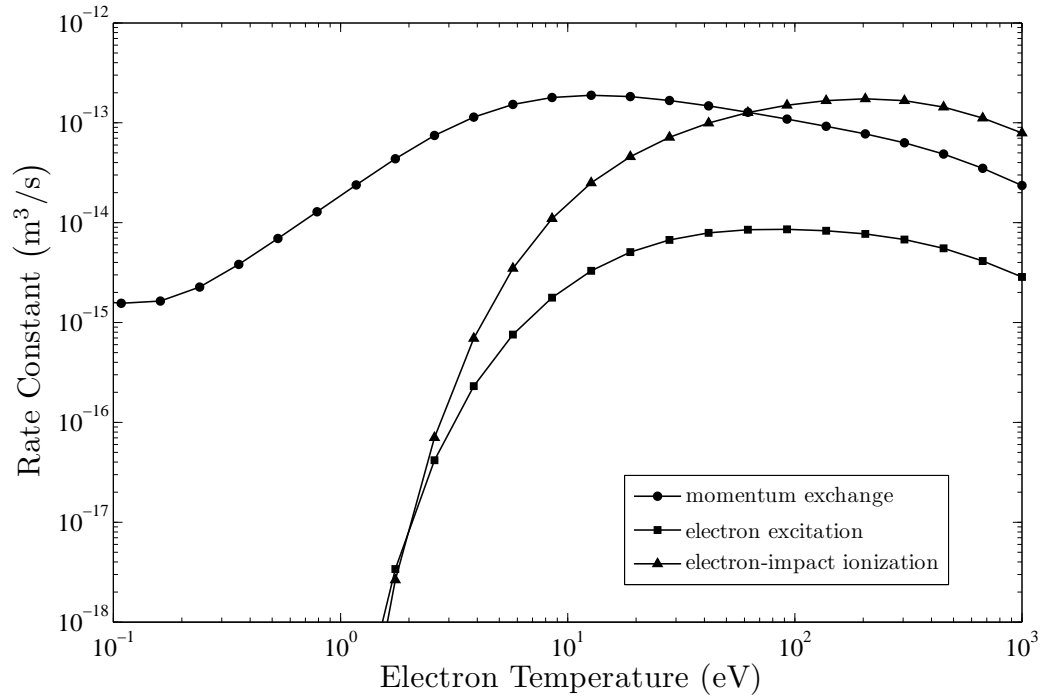
In most low-pressure, low-temperature plasma systems, collisions between electrons and neutrals are responsible for most of the ionization events, termed *electron-impact ionization*. The population of electrons at higher energy that can participate in ionization events increases with temperature, as shown in Fig. 3.8.

The cross-section for collisional processes is also a function of the interaction energy. The rate constant of an electron-impact process  $l$ ,  $k_l$ , accounts for these competing effects, as calculated by Eq. 3.44. Figure 3.9 shows how the rate constants in argon are a function of the electron temperature.

$$k_l = \int_0^{\infty} f(\varepsilon) \left(\frac{2\varepsilon}{m_e}\right)^{1/2} \sigma_l(\varepsilon) d\varepsilon \quad (3.44)$$



**Figure 3.8:** Maxwellian electron energy distribution functions for 3 eV and 10 eV electron populations.



**Figure 3.9:** Argon rate coefficients versus electron temperature.

### 3.2.1 Magnetic Field Interactions

As shown by Eq. 3.26, a force can be exerted on a charged particle with both electric and magnetic fields. Although magnetic fields will not influence a stationary charged particle, the probability of a stationary particle existing within a plasma is zero. Another important equation when considering charged particles in a magnetic field is Eq. 3.45, which states that no magnetic monopoles may exist in nature. Physically, this means that a static magnetic field cannot deposit power into the plasma.

$$\nabla \cdot \vec{B} = 0 \quad (3.45)$$

Looking again at Eq. 3.26, magnetic fields can only impose a force that is perpendicular to both the charged particle direction of motion and the magnetic field direction. Therefore, in the absence of an electric field, a single charged particle in a uniform magnetic field will travel unimpeded parallel to the magnetic field, but will only travel in circles perpendicular to the magnetic field. This means that the average motion of the plasma across the magnetic field can be severely restricted compared to motion along the magnetic field, and so the properties of a magnetized plasma can be highly anisotropic. For ease of analysis, the coordinate system for the magnetized plasma is typically transformed to be aligned with the magnetic field. Therefore, instead of using Cartesian coordinates for velocity,  $(v_x, v_y, v_z)$ , the plasma is described by the velocity components that are perpendicular and parallel to the magnetic field,  $(v_{\parallel}, v_{\perp})$ .

Plasma is a diamagnetic material, and so the circular motion of the charged particles about the magnetic field lines will act to oppose the applied magnetic field. The circular motion has an associated characteristic time and length scale that are called the *cyclotron frequency* or *gyrofrequency*,  $\omega_c$ , and the *Larmor radius* or *gyroradius*,  $r_L$ , and these are shown by Eqs. 3.46 and 3.47, respectively. Typically, the perpendicular velocity is assumed to be the same as the thermal velocity, and ions are assumed to be singly-charged, so the

gyroradius is proportional to  $\sqrt{mT}/B$ . Because the ions are much more massive than the electrons, even in a non-thermal plasma typically  $r_{L,i} \gg r_{L,e}$ .

$$\omega_c = \frac{qB}{m} \quad (3.46)$$

$$r_L = \frac{v_\perp}{\omega_c} \quad (3.47)$$

The guiding center of motion for a charged particle in a uniform magnetic field theoretically cannot cross the magnetic field lines. However, in a real plasma there are many particles and collisional interactions can “bump” the charged particles across the magnetic field. If collisional interactions occur at a faster rate than the electron cyclotron frequency (i.e.  $\nu_m \gg \omega_c$ ), then the effects of the magnetic field are unimportant for charged particle transport. The same is true if the length scale of the system perpendicular to the magnetic field is much smaller than the electron gyroradius.

The diffusion coefficient and mobility given in Eqs. 3.41 and 3.42 described charged particle transport in the absence of a magnetic field. These equations still hold when describing motion parallel to a magnetic field, but to describe transport perpendicular to magnetic fields, the equations must be modified according to Eq. 3.48.

$$(D, \mu)_\perp = \frac{(D, \mu)}{1 + \left(\frac{\omega_c}{\nu_m}\right)^2} \quad (3.48)$$

Because the individual coefficients may be very different for ions and electrons, the perpendicular coefficients are typically combined to give a coefficient that describes the net transport of both ions and electrons across the magnetic field lines, called the *cross-field ambipolar diffusion coefficient*,  $D_{\perp,a}$ , and given by Eq. 3.49.

$$D_{\perp,a} = \frac{\mu_{\perp,i} D_{\perp,e} + \mu_{\perp,e} D_{\perp,i}}{\mu_{\perp,i} + \mu_{\perp,e}} \quad (3.49)$$

Assuming the ion mobility is much greater than the electron mobility, the cyclotron frequency is much greater than the electron collision frequency, and the electron temperature is much greater than the ion temperature, an expression for the cross-field diffusion of electrons is given by Eq. 3.50 [82].

$$D_{\perp,e} = 1.66 \times 10^{-12} \frac{n_e}{T_e^{1/2} B^2} \text{ in } \frac{\text{m}^2}{\text{s}} \quad (3.50)$$

One active area of research in EP is the use of a magnetic field that is aligned with the thrust axis. This arrangement is sometimes referred to as a *magnetic nozzle* because the behavior in such devices is described similarly to a converging/diverging gasdynamic nozzle [83]. The issue that is then of greatest concern is the detachment of the plasma from the magnetic field [84, 85]. In addition to the statement that a static magnetic field cannot impart energy to a plasma, Eq. 3.45 also states that magnetic fields only exist as closed loops. For an EP system with a magnetic field parallel to the thrust axis, this means that the magnetic field must curve around and impinge somewhere on the spacecraft. Although a detailed study of the physics in the diverging part of the magnetic field is beyond the scope of this work, it should be noted that there are certain specific assumptions that must hold true in order for a plasma to be considered magnetized. Besides the collision frequency and length scale considerations previously mentioned, the assumptions given by Eqs. 3.51 and 3.52 state that the magnetic field must change slowly relative to the streaming motion of the charged particles.

$$\frac{\partial B}{\partial t} \ll \frac{1}{\omega_c} \quad (3.51)$$

$$\vec{v} \frac{\partial B}{\partial s} \ll \frac{1}{\omega_c} \quad (3.52)$$

The effects of high curvature, low magnetic field strength, low pressure, and low plasma temperature may also allow complicated drift motions to exist in the exit and detachment

regions of magnetic nozzle devices. In regions of the plasma where the magnetic fields are sharply curved, there are drift motions associated with  $\nabla B$  drift, and curvature drift that may cause the plasma to exhibit anomalous transport behavior. Most of these drift motions will enhance the plasma's cross-field mobility.

### 3.2.2 RF Plasma

In order to impart energy to the plasma, an electric field is applied to exert a force on the electrons and ions. Accelerated electrons interact with the heavy particles through collisions, which cause momentum transfer, excitation of higher electron energy modes, and ionization. These collisional processes occur at rates related to the densities of the interacting particles, and the rate constants that are calculated according to Eq. 3.44. The electric field may be applied either by a DC electric field, or an oscillating voltage or current, for example at a frequency  $\omega$ . For plasmas excited by the application of RF voltages and currents, stochastic or collisionless heating in the sheath can also impart energy to the electrons.

The properties of the plasma may be affected by the coupling mode by which RF energy is imparted to the electrons. Three main coupling modes are typically described in the literature: capacitive coupling, inductive coupling, and wave coupling. Textbooks discuss the details of the physical mechanisms present in each, for example by Lieberman and Lichtenberg [86].

Capacitively coupled plasmas are characterized by high voltage sheaths, high electron temperatures, and low plasma densities. Electrode materials are typically in direct contact with the plasma, and so ion bombardment can sputter electrode materials into the bulk plasma. This may cause two undesired effects: erosion or slow disintegration of the discharge driving electrodes, and introduction of undesired material into the discharge or plasma process.

Inductive plasmas couple energy into the electrons through an oscillating magnetic

field. A large, time-varying current is driven through an antenna, and the axial magnetic field produced by this current couples to the plasma through an azimuthal electric field that is created due to Faraday's law, given in Eq. 3.53.

$$\nabla \times \vec{E} = -\frac{\partial \vec{B}}{\partial t} \quad (3.53)$$

Inductively coupled plasmas typically have a much colder electron population than capacitive plasmas, but can create much more dense plasma. The antenna for an inductively coupled plasma is generally not in contact with the plasma, eliminating many of the sputtering and erosion problems of capacitive plasmas; however, due to the lower voltage sheaths, it is generally more difficult to initiate an inductive discharge.

Helicon plasma sources are an example of a wave-heated plasma. Helicon waves are bounded, right-handed, circularly polarized electromagnetic waves that propagate along a magnetic field. Helicon plasma sources generally consist of an antenna and solenoid magnets surrounding an insulating dielectric tube. A gas fills the tube, typically to a pressure  $\approx 1$  mTorr, RF power is applied to the antenna, typically at 13.56 MHz, and a magnetic field is applied parallel to the axis of the tube. The antenna is shaped to excite helicon wave modes in the gas, and particle-wave interactions from Landau damping and Trivelpiece-Gould coupling deposit the RF power into the plasma species [87].

Plasma naturally has oscillatory behavior at frequencies dependent on the properties of the plasma. Wave-heated plasma sources use this oscillatory behavior to couple power into the ions and/or electrons by exciting resonances at the natural oscillation frequencies. Textbooks describe the multitude of waves that naturally occur in plasmas, for example by Stix [88]. Helicon plasma sources generate a specific type of wave-heated plasma that utilizes the helicon wave to deposit power into the plasma.

Helicon plasma sources have been studied since the 1960's, with early studies focusing on their ability to efficiently produce high-density, low-temperature plasma for materials

processing [89, 90]. The theory of helicon wave propagation assumes that the RF driving frequency is high enough such that ion motion can be neglected, but low enough such that electron cyclotron motion can be neglected. The axial wavelength of the helicon wave,  $\lambda_z$ , is determined by the axial magnetic field strength,  $B_z$ , the RF driving frequency,  $f_{RF}$ , and the density of the plasma,  $n_e$ , according to Eq. 3.54. Note that the RF driving frequency is typically set by a power supply, and a half-wavelength-long antenna is employed with the intent to ionize a large fraction of the gas flowing in a system based on the applied axial magnetic field strength.

$$\lambda_z = \left( \frac{2\pi B_z}{e\mu_0 n_e f_{RF}} \right)^{1/2} \quad (3.54)$$

Although most helicon experiments use a cylindrical geometry, previous work has also demonstrated the operation of an annular helicon source [91]. Theoretical considerations of annular helicon waves suggest that the maximum power deposition requires careful choice of antenna and frequency [92].



## CHAPTER 4

# Thrusters

In order to investigate whether air-breathing EP may benefit from the implementation of RF plasma technology, measurements of the performance of two thrusters were taken at the Plasmadynamics and Electric Propulsion Laboratory (PEPL). The performance requirements of an air-breathing propulsion system were determined in Chapter 2, and the thrusters described in this chapter are chosen based on the likelihood that they have the appropriate performance characteristics. The first thruster described is the Radio frequency Plasma Thruster (RPT), and is designed primarily based on helicon plasma source scaling. The second thruster is the Helicon Hall thruster (HHT), and is a two-stage thruster that employs an RF ionization stage intended to increase the performance of a Hall thruster operating at high thrust-to-power. This chapter describes the two thrusters in detail.

### 4.1 Radio frequency Plasma Thruster

Much development work toward using helicon sources in EP systems has been performed. Some work involves the use of a helicon source alone as a thruster [69, 71, 93, 94], and some attempts to use the helicon source as an ionization stage with a separate acceleration stage [67, 95, 96]. Measurements of helicon sources operating with argon have suggested that they produce an exhaust ion beam with an energy that corresponds to an approximately 30 volt acceleration [73, 97, 98]. Recalling the results from Chapter 2, this

places the exhaust velocity in the range desired for an air-breathing propulsion system. Although most helicon experiments focus on the use of argon in order to simplify analysis of the physics, measurements also suggest that helicon plasma sources are able to accelerate other gases, including nitrogen [99]. One major benefit of helicon plasma sources is that they do not require a thermionic cathode to operate. As discussed above, this would mitigate the materials compatibility issues in an air-breathing system that would be present in other types of thrusters.

The Radio frequency Plasma Thruster (RPT) is a propulsion device that is designed to excite a helicon wave in the propellant gas. The helicon wave is only excited in an axial magnetic field, and Eq. 3.54 implied that a stronger magnetic field enables the production of higher plasma densities. The stronger axial magnetic field also insulates the plasma from the thruster, potentially improving thruster lifetime. However, in order to produce thrust, the plasma generated by the RPT must detach from the diverging axial magnetic field in the exhaust region. How the magnetic field shape and strength affects plasma detachment and thruster efficiency is an active area of research [83–85], and so the RPT is designed to be capable of producing a wide range of magnetic fields.

#### **4.1.1 Preliminary Investigations**

In order to determine whether a helicon source may be appropriate for use as a plasma thruster with atmospheric gases, a helicon source was first constructed at PEPL to take measurements of plasmas created with argon, nitrogen, and air, as shown in Fig. 4.1.

Most helicon experiments operate with argon, and it is commonly known that helicon coupling modes are indicated by the presence of a “blue core” in the plasma column. The “blue core” refers to light in the blue wavelengths of the visible spectrum, which is known to indicate intense emission of argon ions (Ar II) and the presence of helicon wave modes [100, 101]. Figure 4.2 shows photographs and emission spectra of argon operation with and without a blue core. The appearance of a blue core gave a strong indication that



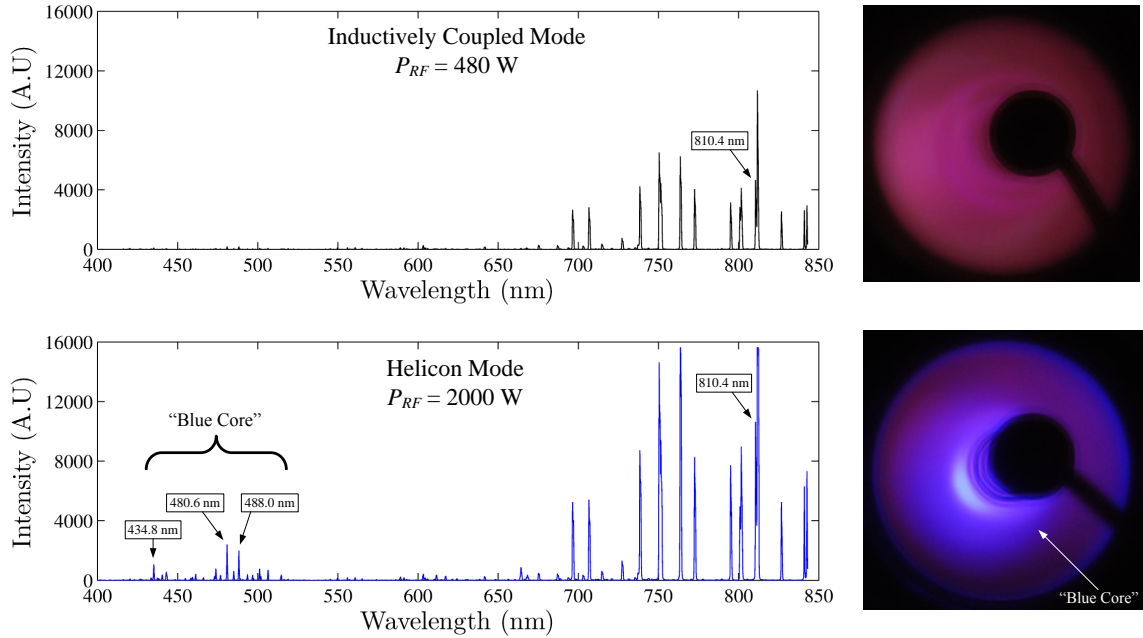
**Figure 4.1: Setup of helicon plasma source for preliminary investigation.**

helicon waves were excited in the preliminary helicon experiments at PEPL. One method for confirming that helicon waves are present is by using a B-dot probe to measure the RF-magnetic-field fluctuations induced in the plasma by the helicon wave [102].

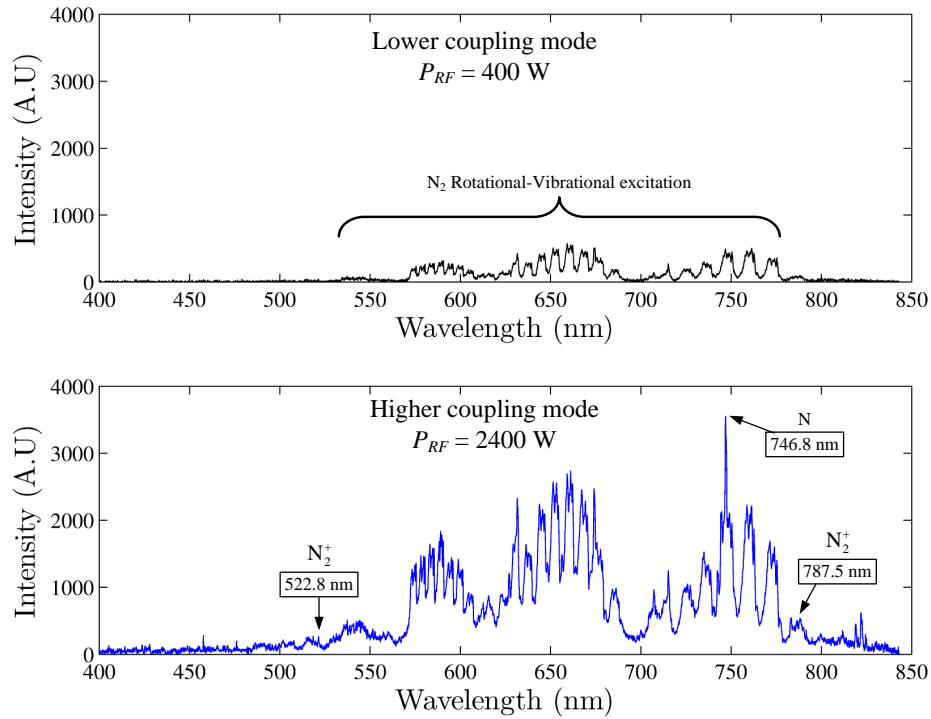
Although less pronounced than with argon, visible changes in the plasma indicated that higher coupling modes may also be achieved with nitrogen. Changes in the shape of the plasma when operating with nitrogen at higher powers correlated with the appearance of additional peaks in the emission spectra, as shown in Fig. 4.3. This gave an indication that a higher ion density was being produced. As was previously discussed, the appearance of a blue core in an argon helicon plasma is due to the emission spectrum of argon ions. The most intense emission lines of diatomic nitrogen ions are in the ultraviolet part of the spectrum [103]. Thus, any core structure may not have been readily visible.

### **4.1.2 RPT Design**

The RPT is designed to test whether a helicon plasma source can be an effective thruster for the purpose of enabling a long-lived, air-breathing spacecraft. Using the air-breathing spacecraft and atmospheric model from Chapter 2, a spacecraft with a one-square-meter inlet area in a circular orbit between 170 and 230 kilometers has an inlet mass flow rate of



**Figure 4.2:** Optical emission spectra and photographs showing presence of “blue core” when operating with argon. Known argon ion lines are identified [104]. Photographs look along the center axis of the glass tube shown in Fig. 4.1, along the center axis of tube.



**Figure 4.3:** Optical emission spectra looking along center axis of tube during nitrogen operation at low (top) and high (bottom) power. Rotational-vibrational modes of neutral  $N_2$  are excited at both low and high powers. Molecular nitrogen ion lines appear at high power. A strong neutral atomic nitrogen line may indicate dissociative recombination of  $N_2^+$  [103, 105–108].

approximately 1 to 7 milligrams per second, or a number flow rate,  $\dot{n}$  of about  $3.0 \times 10^{16}$  to  $1.8 \times 10^{17}$  per second. Because most helicon plasma sources in the laboratory operate at a pressure of approximately 1 millitorr, the diameter of the tube is sized such that the operating pressure in the tube is one millitorr. When testing in the laboratory, the propellant comes from a compressed gas cylinder, and so the inlet temperature of the gas,  $T_g$ , is approximately room temperature, 290 degrees kelvin. Based on these assumptions and scalings, the diameter of the source tube should be 4 to 11 centimeters to operate at the number density of a typical helicon experiment with either argon or nitrogen propellant.

From the number density in the tube, the magnetic field strength and antenna length are chosen based on the helicon wavelength scaling from Eq. 3.54. Taking the RF driving frequency to be 13.56 megahertz, and assuming that 10% of the propellant will be ionized at any given time, the helicon wavelength,  $\lambda_z$ , will have the scaling given by Eq. 4.1, where  $B_z$  is the axial magnetic field strength.

$$\lambda_z[m] = 0.83\sqrt{B_z[T]} \quad (4.1)$$

While a 10% ionization fraction is large for conventional low-temperature plasmas, this is not an unreasonable estimate for designing the RPT based on Langmuir probe measurements in other helicon plasma sources [82]. Equation 3.54 showed that higher plasma densities can be achieved for a given helicon wavelength with a higher magnetic field. Previous studies have also suggested that longer antennas may have higher coupling efficiencies. However, the solenoid coils that produce the magnetic field are made of copper, and due to the relatively large diameter of the source tube, an engineering trade study must be made to compromise between the magnetic field strength, the weight of the magnet assembly, and the price of the copper magnet wire. For the RPT, the compromise is made at a magnetic field strength of 0.1 tesla, or 1000 gauss. At this magnetic field strength, the dominant  $m = +1$  helicon mode has an axial wavelength of 26 centimeters.

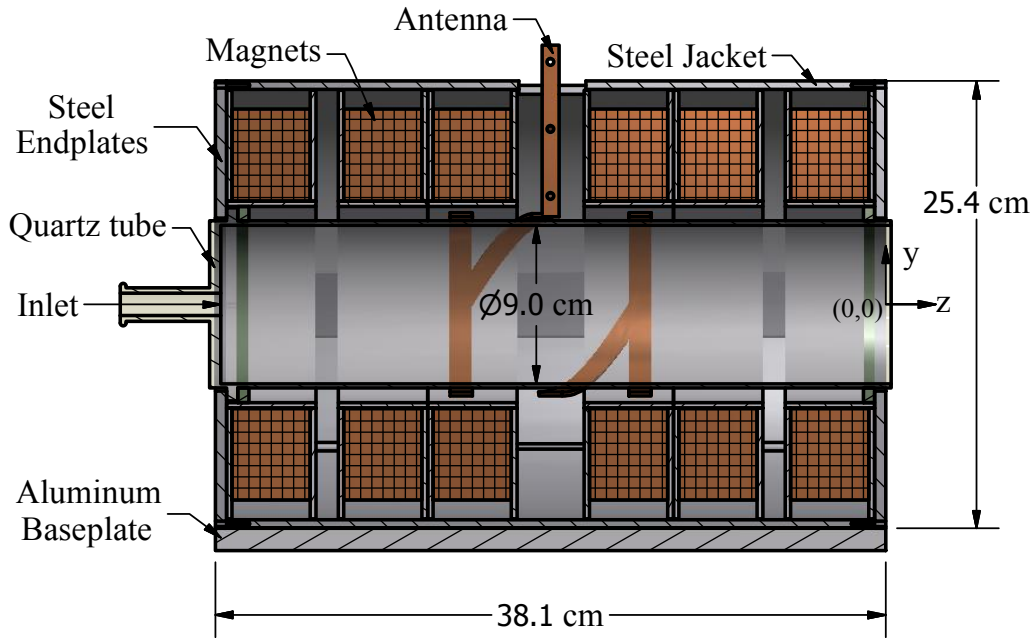
**Table 4.1: RPT Design Summary.**

Property	Value
Inlet	$A_{inlet} = 1 \text{ m}^2$
Altitude	$h = 170\text{--}230 \text{ km}$
Mass Flow Rate	$\dot{m}_{pr} = 1\text{--}7 \text{ mg/s}$
Operating Pressure	$P_{tube} = 1 \text{ mTorr}$
Driving Frequency	$f_{RF} = 13.56 \text{ MHz}$
Helicon Wavelength	$\lambda_z = 26 \text{ cm}$
Magnetic Field	$B_z = 0.1 \text{ T}$

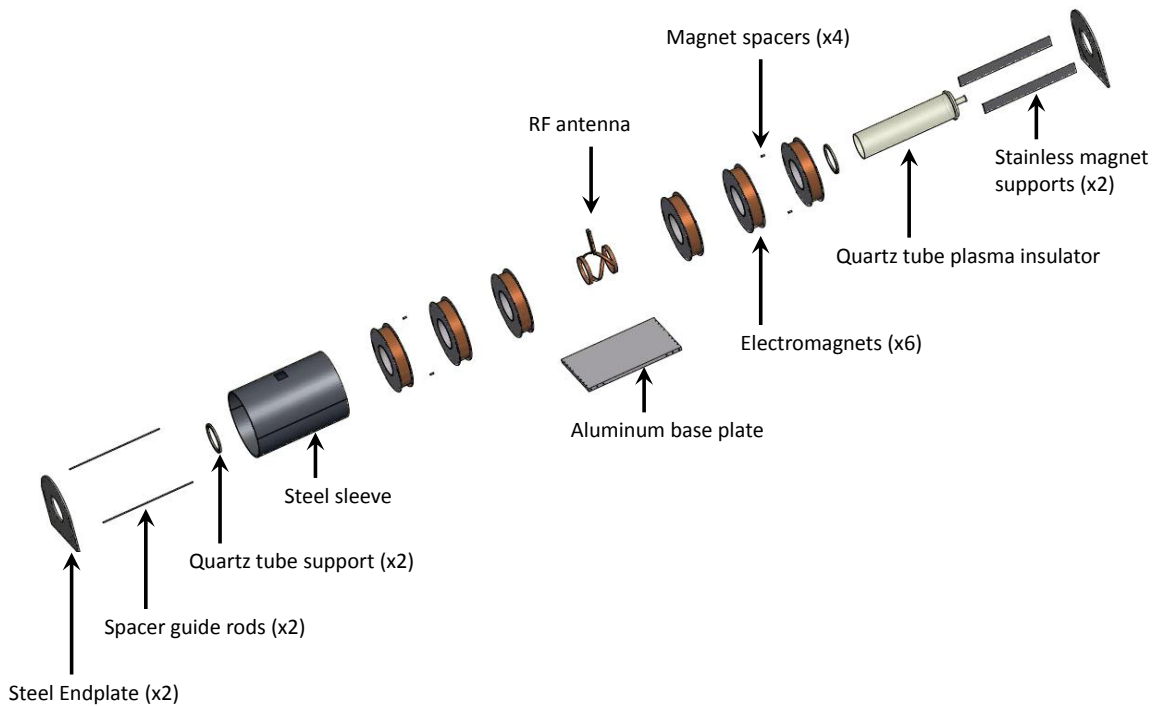
### 4.1.3 RPT Assembly

The RPT is an assembly of six solenoid coils surrounding a quartz tube and an antenna, and surrounded by a low-carbon steel case, as shown in cross-section in Fig. 4.4. The RPT is designed to be a cohesive unit, such that all the components, including the magnets, quartz tube, and antenna, are fixed in place relative to each other. This design feature is unique to the RPT among other RF/helicon thruster experiments [68, 69, 109]. The RPT is also designed as a rapidly reconfigurable experiment, such that the internal components can be replaced with relative ease. An exploded view of the RPT components is shown in Fig. 4.5.

The low-carbon steel case enhances the magnetic capabilities of the RPT. The steel case increases the magnetic field strength and uniformity in the quartz tube, and also enables a steep magnetic field gradient at the exit. The magnet assembly, including the solenoids and the steel case, is capable of producing a uniform axial magnetic field up to 0.11 tesla in the quartz tube. Although the performance measurements reported in this dissertation refer to simulated magnetic field strengths, measurements of the magnetic field profile were collected at atmospheric pressure for multiple solenoid currents with a Lake Shore Cryotronics Model 460 3-channel Gaussmeter, and the measured magnetic fields were less than  $\pm 1\%$  different from the simulated fields [93].

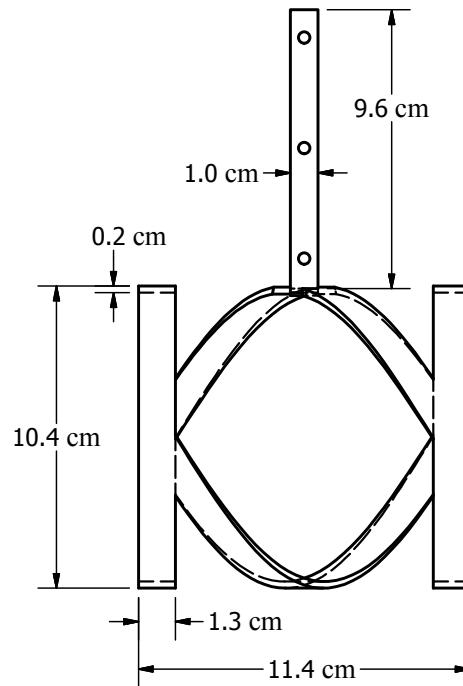


**Figure 4.4: Cross-section of the RPT with major components and dimensions labeled.**



**Figure 4.5: Exploded view of RPT assembly without flexible mica sheet.**

The RPT quartz tube has an inner diameter of 9.0 centimeters and an internal length of 38.1 centimeters, and it electrically isolates the plasma from the antenna and magnets. The



**Figure 4.6: RPT antenna details.**

antenna is a bifilar, half-turn helical antenna (also known as a “Twisted Nagoya” antenna) that is intended to excite the  $m = +1$  helicon wave [110]. Shown in Fig. 4.6, the antenna is machined from a single piece of copper, and it has two copper leads that extend from the RPT body. The leads are welded directly to the antenna where a short section in the center of one of the helical sections is removed. Although not shown in the exploded view, multiple layers of flexible mica sheet hold the antenna tightly in the center of the magnet assembly.

## 4.2 Helicon Hall Thruster

Hall thrusters were first employed in space by the former Soviet Union in the 1970’s, but it was not until the early 1990’s that significant Hall thruster development work occurred in the United States [111]. Current Hall thruster research activities primarily focus on improv-



ing thruster lifetime [112], using propellants other than the traditional xenon [113, 114], increasing the power and thrust density [115, 116], and extending the range of performance [117, 118]. The success seen by many of these research efforts show that Hall thrusters are a robust and versatile technology.

As previously discussed, an air-breathing thruster would be most directly applicable to a mission with a long lifetime, and Hall thrusters have well-characterized life-limiting mechanisms due to the erosion of thruster materials. Recent experiments have shown that a Hall thruster can be operated in such a way that the erosion is dramatically reduced, implying that Hall thruster lifetime can be significantly increased [52]. Although that work was performed only with xenon, the concept is likely applicable for use with other propellants. If Hall thruster lifetime can be extended with other gases, nitrogen and oxygen in particular, then Hall thrusters would be a much more viable option for an air-breathing spacecraft.

The Helicon Hall Thruster (HHT) was constructed to attempt to improve the total efficiency of a Hall thruster operating at high thrust-to-power with xenon. For Hall thrusters, “high thrust-to-power” is synonymous with low-voltage operation. At the lowest feasible altitudes, the accelerating voltages required for drag compensation of an air-breathing electric propulsion system are very low for a typical Hall thruster. Thus, the HHT is designed to operate closer to the operating parameters of interest for an air-breathing electric propulsion application.

The performance characteristics of Hall thrusters operating with alternative propellants are not well-characterized, and theory predicts that the efficiency and thrust of a traditional Hall thruster will be much lower when operating with alternate propellants, simply due to the higher ionization energy and lower mass of the lighter propellant species. In order to investigate whether the performance characteristics of a Hall thruster operating with atmospheric gases can be improved, the HHT was operated with argon and nitrogen propellant. The HHT experiments presented in this dissertation are an investigation into the use of alternative propellants in Hall thrusters. The HHT Hall acceleration stage is operated with the

RF ionization stage to determine if the overall efficiency can be increased at high thrust-to-power. This section briefly describes the theory of the HHT operation, and also discusses its novel design features.

### 4.2.1 HHT Principle of Operation

The HHT is a two-stage Hall thruster concept that is designed to utilize the efficient ionization of a helicon plasma source with the acceleration mechanism of a Hall thruster. In particular, the HHT was designed to excite annular helicon wave modes in the plasma in the upstream section of the discharge chamber of a Hall thruster [119]. Figure 4.7 shows an illustration of the HHT cross-section with the major components labeled.

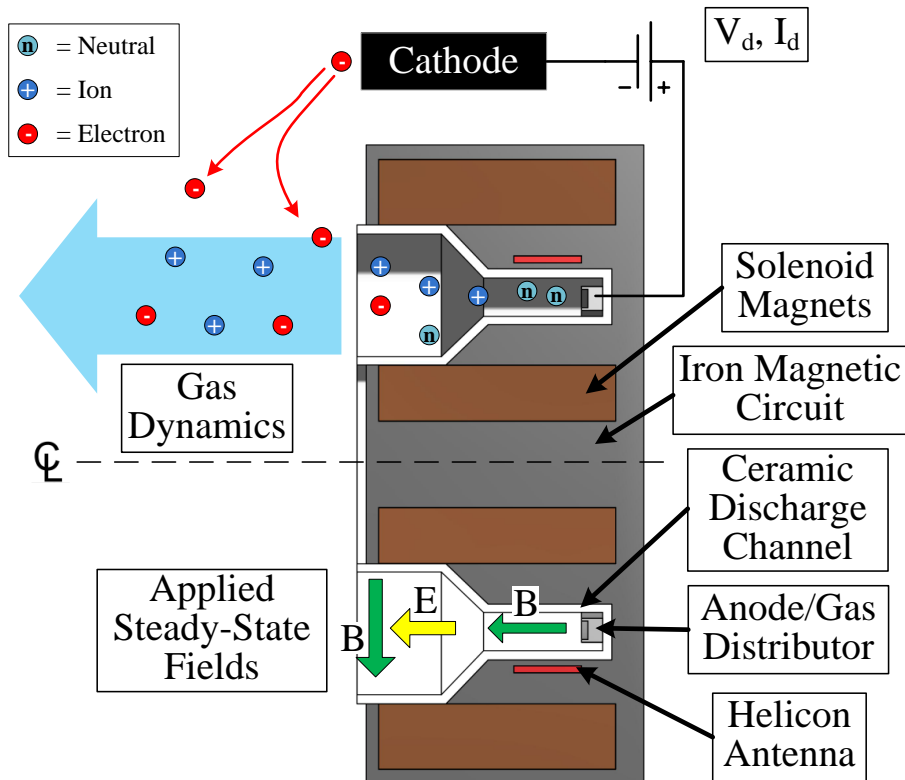


Figure 4.7: HHT notional sketch.

In the first stage, RF power is applied to the helicon antenna to ionize the neutral propellant flowing out through the gas distributor. An applied axial magnetic field in the same

region allows the antenna to couple annular helicon waves into the ionized propellant just downstream of the gas distributor, increasing the ionization efficiency.

In the second stage, a radial magnetic field and a voltage applied between the the anode and an external hollow cathode create a traditional Hall accelerator. Electrons emitted from the hollow cathode neutralize the ion beam exiting the discharge channel. Some electrons also travel into the discharge channel, where they become trapped by the radial magnetic field, concentrating the electric field into a very small region. Note that the topology of the magnetic field is critical to the efficient operation of the HHT.

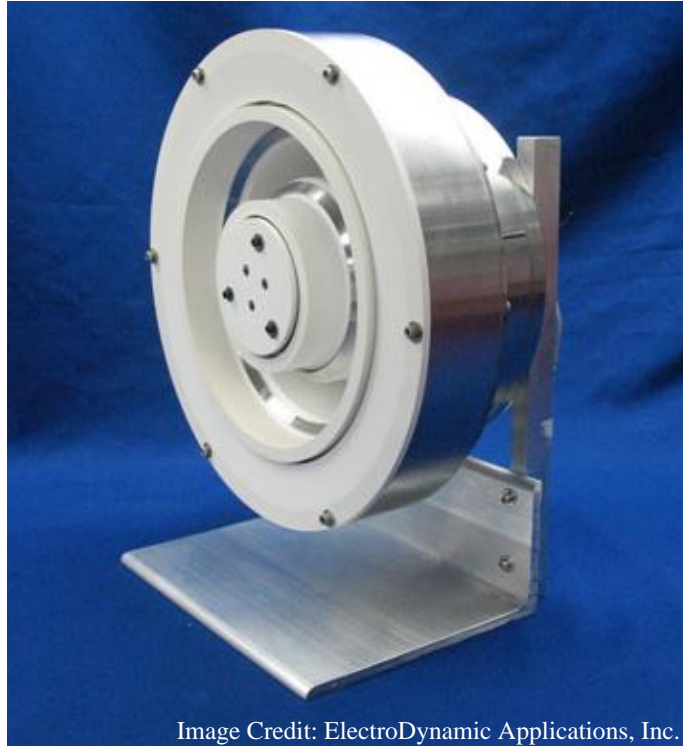
### **4.2.2 HHT Assembly**

The HHT was designed mainly at ElectroDynamic Applications, Inc., with partners from Aerojet. Figure 4.8 shows a photograph of the assembled HHT. The acceleration stage of the HHT is designed to use auxiliary electrodes with an external cathode to create the traditional Hall accelerator, with the auxiliary electrodes shown in the photograph. For more detailed discussions regarding the HHT design, see Martinez et al. [117] and Peterson et al. [120].

### **4.2.3 Previous Work**

The first two-stage performance measurements of the HHT operating with xenon propellant showed a trend suggesting that performance was improved by applying higher levels of RF power to the helicon antenna [120]. Upon further investigation, the possibility arose that an improperly implemented RF power delivery system was used, and that Electromagnetic Interference (EMI) may have been affecting the thrust measurements. So, a follow-on study was performed with a different RF power delivery system to confirm the original results.

During the follow-on study, the auxiliary electrodes were removed, and the propellant distributor was used as the Hall accelerator anode. The results presented in this disser-



**Figure 4.8: Photograph of HHT.**

tation were taken during the follow-on study. The follow-on study repeated and further investigated some of the original xenon operating conditions. The performance of the HHT operating with argon and nitrogen was also measured during the follow-on study.

## CHAPTER 5

# Experiment Setup

The RPT and HHT are experimental space propulsion systems, and so all experiments are performed in a vacuum chamber to simulate the space environment. A very low background pressure and far-removed chamber walls are desired to reduce any facility effects that would not be present in space. Because both thrusters under investigation use RF power, the RF engineering principles described in Chapter 3 were followed when implementing the RF power transmission system.

This chapter describes the vacuum facility, the RF power delivery system, and the diagnostics used to characterize the RPT and HHT. Plasma properties in the exhaust plume were measured concurrently with thrust and telemetry. The performance parameters of thrust, specific impulse, and efficiency were determined by the propellant mass flow rate, the force measured by an inverted pendulum thrust stand, the net RF power measured by a dual-directional coupler, and other thruster telemetry data. The plasma plume properties of interest include the total ion beam current, ion beam average kinetic energy, and exhaust plume divergence. These properties are determined by a nude Faraday probe, a Retarding Potential Analyzer (RPA), and a commercial Langmuir probe.

### 5.1 Test Facility

All experiments were performed in PEPL's Large Vacuum Test Facility (LVTF) at the University of Michigan. The LVTF is a 6-meter diameter by 9-meter long cylindri-

cal, stainless-clad steel vacuum chamber. Seven CVI TM-1200 nude (reentry) cryopumps maintain the pressure in the LVTF with a combined pumping speed of 500,000 liters per second on air or 245,000 liters per second on xenon. The pressure in the LVTF is measured by a nude Bayert-Alpert ionization gauge. A Varian XGS-600 gauge controller powers the ionization gauge and reads out a pressure. The corrected chamber pressure,  $p$ , is calculated from Eq. 5.1, where  $p_{ob}$  is the pressure indicated by the XGS-600. The gas correction factors,  $C_{gas}$ , are 1.20 for argon, 2.87 for xenon, and 1.00 for nitrogen.

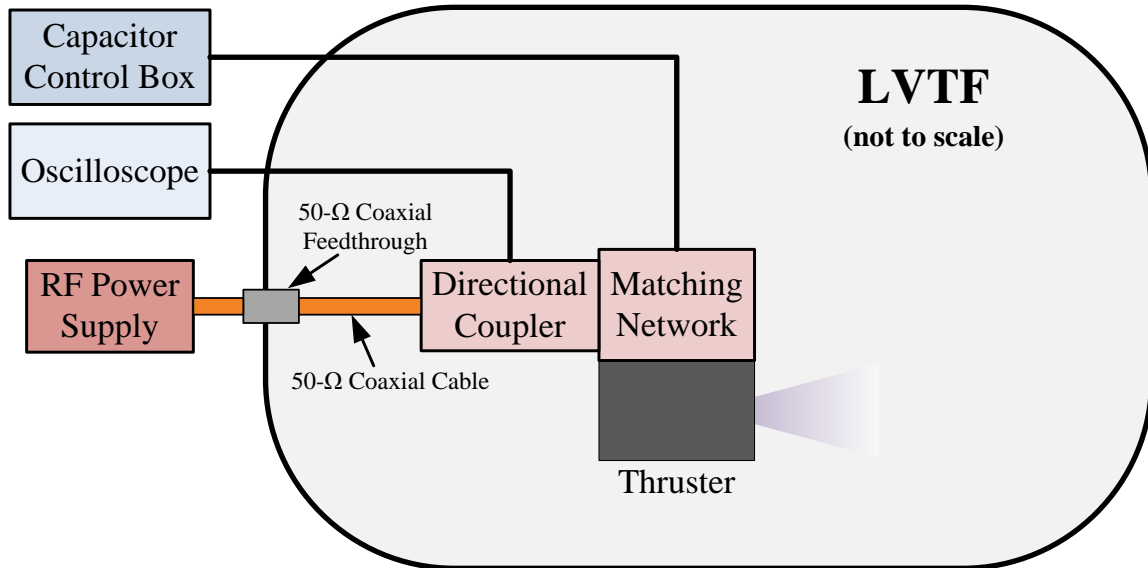
$$p = \frac{p_{ob} - p_b}{C_{gas}} + p_b \quad (5.1)$$

During the experiments reported in this dissertation, the LVTF base (no load) pressure,  $p_b$ , was measured to be  $7.4 \times 10^{-8}$  Torr.

## 5.2 RF Power System

As the previous discussion of RF engineering principles implied, the details of the implementation of the RF power delivery system are critical to ensure a proper characterization of the thruster efficiency. A diagram of the RF electrical setup in the LVTF is shown in Fig. 5.1.

The goal of the RF power transmission system is to transfer as much energy as possible from the RF generator to the plasma. As previously discussed, any RF power system with a standard  $50\text{-}\Omega$  characteristic impedance that delivers power to a non- $50\text{-}\Omega$  load requires a matching network to transform the load impedance to  $50\text{-}\Omega$ . Otherwise, a large impedance discontinuity at the load will cause most of the incident RF power to be reflected back the transmission line toward the generator. The impedance of an antenna-and-plasma load is generally different for different operating conditions and coupling modes (e.g. capacitive, inductive, helicon). Thus, a manually-tunable matching network was implemented to compensate for the anticipated range of load impedances.



**Figure 5.1: Diagram of RF power system in LVTF.**

For the RF power system implemented in the LVTF, a Comdel CPS-3000 RF generator supplies power at a fixed frequency of 13.56 megahertz and a  $50\text{-}\Omega$  output impedance. The maximum output power is 3000 watts. The CPS-3000 has an internal protection circuit that automatically limits the forward power output when reflected power exceeds 600 watts. Standard  $50\text{-}\Omega$  RG-213 coaxial cable carries the RF power from the CPS-3000 output port to a hermetically-sealed,  $50\text{-}\Omega$  bulkhead connector at the LVTF wall that acts as a vacuum feedthrough. Inside the LVTF, a 5-meter length of  $50\text{-}\Omega$  RG-393 coaxial cable transmits the RF power from the feedthrough to the thrust stand support structure. To minimize forces on the thrust stand due to thermal expansion of the RF cable, the final connection to the matching network is made with a 0.66-meter length of RG-393 that is arranged perpendicular to the thrust axis, as shown in Fig. 5.2. Thus, a  $50\text{-}\Omega$  system is maintained from the RF generator to the matching network on the thrust stand. This is a feature that is unique to the RF power delivery system at PEPL.

No coaxial cable is perfectly lossless, and so a small amount of the RF power will be dissipated in the cable, leading to cable heating. It is well-known that for a given forward power, the amount of power dissipated in a coaxial cable increases with increasing re-

flected power [121]. Thus, an RF power delivery system aims to minimize reflected power not only to increase the efficiency of the system, but also to prevent the coaxial cable from overheating. To ensure that the cable does not approach its maximum temperature rating of 200 degrees celsius, three thermocouples are placed on the outside of the RG-393 RF power cable shown in Fig. 5.2, and their outputs are monitored throughout the experiment. The thermocouples were slightly affected by EMI when RF power was used with either the RPT or HHT. However, the thermocouples return to normal operation when RF power is turned off.

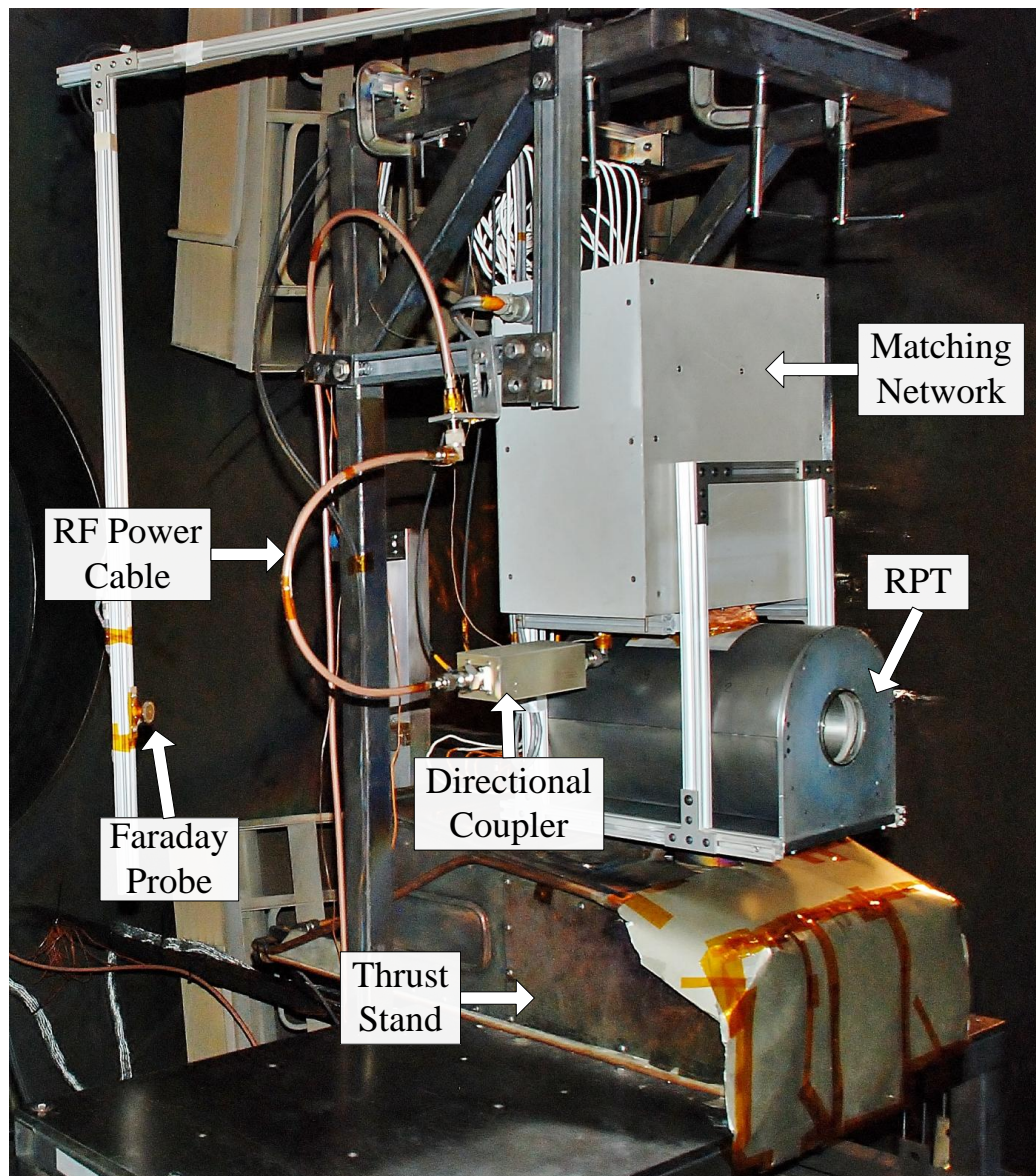
Without a matching network, very little power will be delivered to the plasma because the impedance of the antenna-and-plasma system is typically quite different than  $50 \Omega$ . In most RF systems, the forward and reflected power are measured inside the generator or in a  $50\text{-}\Omega$  transmission line section upstream of the matching network input port. The power that is transmitted downstream of the matching network may be dissipated, radiated, or coupled away from any conductor that is connected to the matching network output leads. Without a direct measurement of the current and voltage at the antenna input leads, the actual power delivered to the antenna is unknown.

In order to increase the likelihood that the RF power measured at the matching network input port represents the power delivered to the thruster antenna, the matching network is placed on the thrust stand and connected to the antenna with the shortest output leads possible. Following from the one-tenth RF wavelength guideline discussed in Chapter 3, the short output length scale decreases the probability of power radiating or coupling away prior to the antenna. Furthermore, all RF electrical connections in the matching network are made with a large surface area to minimize contact resistance, and high-Q matching capacitors are used to minimize dissipation in circuit components.

The matching network used to couple power to the RPT and HHT antennas is in an L-type configuration. Two vacuum variable capacitors in the matching network are manually adjusted using DC motors that are remotely controlled from outside the LVTF. The



shunt or “load” capacitor is a vacuum variable capacitor manufactured by Comet. The measured capacitance range of the load capacitor was 50 to 1150 picofarads. The series or “tune” capacitor is a Jennings model UCS-500-15S, with a capacitance range of 25 to 500 picofarads and a withstanding voltage rating of 15 kilovolts. The range of output impedances that the matching network can provide is designed to encompass the conjugate of the vacuum impedance of the antenna, which was measured to be  $(0.001 + 13.6j)\Omega$  at 13.56 megahertz using an Agilent E5071C network analyzer.



**Figure 5.2: Photograph of the RPT experimental setup in the LVTF.**

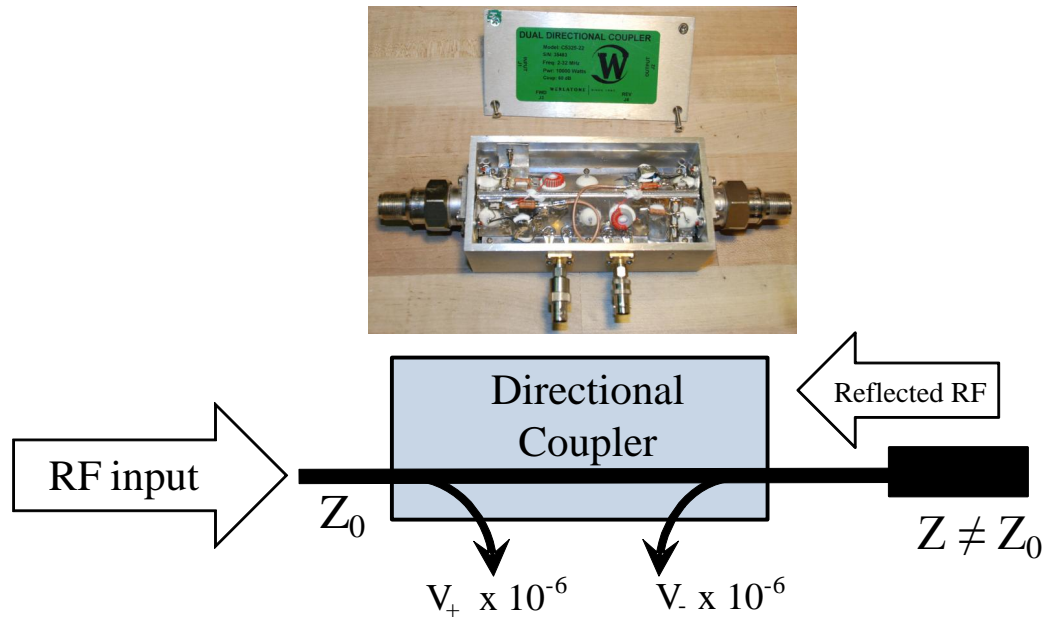
## 5.3 Performance Diagnostics

Plasma properties in the thruster exhaust plumes are measured concurrently with performance. The performance parameters of thrust, specific impulse, and efficiency are determined by the propellant mass flow rate, the force measured by an inverted pendulum thrust stand, and the net RF power measured by a dual-directional coupler. The measured plume properties include the total ion beam current, ion beam kinetic energy, and exhaust plume divergence. These properties are determined by a nude Faraday probe, an RPA, and a commercial Langmuir probe that are described below.

### 5.3.1 Dual-Directional Coupler

Because the Comdel CPS-3000 RF generator used in this experiment does not have a filtered RF output port, the nonlinear load presented by the antenna and plasma will introduce other frequencies (in particular, higher harmonics of 13.56 megahertz) in the transmission line. Even if the CPS-3000 forward and reflected power meters are calibrated according to the operating manual, these other frequencies may induce errors in the generator RF power measurements. In order to make accurate measurements of the forward and reflected power at the dominant frequencies in the transmission line, a Werlatone  $-60\text{dB}$  dual-directional coupler (Model #C5389-32), shown in Fig. 5.3, is connected in-line at the RF input port of the matching network. Connecting the directional coupler at the load end of the transmission line eliminates the need to account for attenuation in the coaxial cable leading from the generator to the matching network.

The dual-directional coupler is a four-port device that samples the forward and reflected voltage waveforms from the main transmission line. Although the particular coupler used in this experiment is designed to work in the 2- to 32-megahertz frequency range, its response from 9 kilohertz to 100 megahertz was characterized with an Agilent E5071C network analyzer. Both the forward and reflected coupling port responses were measured to



**Figure 5.3: Photograph and diagram of the  $-60$  dB dual-directional coupler.**

be a constant  $-60$ dB from 1 to 60 megahertz. The directivity in this frequency range was measured at a constant  $-30$ dB. This showed that the forward and reflected power measurements are well-isolated from each other.

The sampled waveforms are sent to an Agilent DSOX3024A oscilloscope outside of the vacuum chamber. The oscilloscope records and saves 2 milliseconds of the forward and reflected voltage waveforms measured at  $10^9$  samples per second. In order to determine the RF power in the transmission line, Parseval's theorem is applied to the power spectrum of each waveform. The power of the signals at the fundamental frequency (13.56 MHz) and the first three harmonics (27.12 MHz, 40.68 MHz, and 54.2 MHz) are summed to estimate the average RF power delivered to and reflected from the matching network. These are the dominant frequency components of the signal in every operating point analyzed, and they fall within the range of frequencies for which the directional coupler has been characterized. Calculations of the forward and reflected power from the spectra account for the frequency-dependent attenuation in the smaller coaxial cables used to transmit the signals from the directional coupler to the oscilloscope [121].

In order to determine the uncertainty in the RF power measurements from the direc-

tional coupler, the procedure outlined by Garvin et al. was followed [122]. The dual-directional coupler gives measurements of the forward and reflected voltage in the transmission line,  $|V_+|$  and  $|V_-|$ , respectively. The true power delivered to the matching network,  $P$ , is given by Eq. 5.2, whereas the power measured by the directional coupler and oscilloscope,  $\bar{P}$ , is given by Eq. 5.3, where  $\varepsilon_{V_{\pm}}$  is the absolute voltage measurement uncertainty. The relative power error,  $\varepsilon_p$ , is determined by the measurement uncertainty in  $|V_+|$  and  $|V_-|$ , and by the reflection coefficient,  $|\Gamma|$ , according to Eq. 5.4.

$$P = \frac{|V_+|^2 - |V_-|^2}{Z_0} \quad (5.2)$$

$$\bar{P} = \frac{(|V_+|^2 (1 + \varepsilon_{V_+}))^2 - (|V_-|^2 (1 + \varepsilon_{V_-}))^2}{Z_0} \quad (5.3)$$

$$\varepsilon_p = \frac{\bar{P} - P}{P} = \frac{2\varepsilon_{V_+} + \varepsilon_{V_+}^2 - |\Gamma|^2 (2\varepsilon_{V_-} + \varepsilon_{V_-}^2)}{1 - |\Gamma|^2} \quad (5.4)$$

The oscilloscope manual lists a voltage measurement uncertainty of  $\pm 2.25\%$ . The directional coupler response was calibrated with a network analyzer, and each voltage measurement error is conservatively rounded to  $\pm 4\%$  relative uncertainty. The observed reflection coefficient,  $|\Gamma|$ , ranged from 0.0 to 0.4, and so the measurement uncertainty for each RF power measurement,  $\varepsilon_p$ , is between  $\pm 4\%$  and  $\pm 11\%$ .

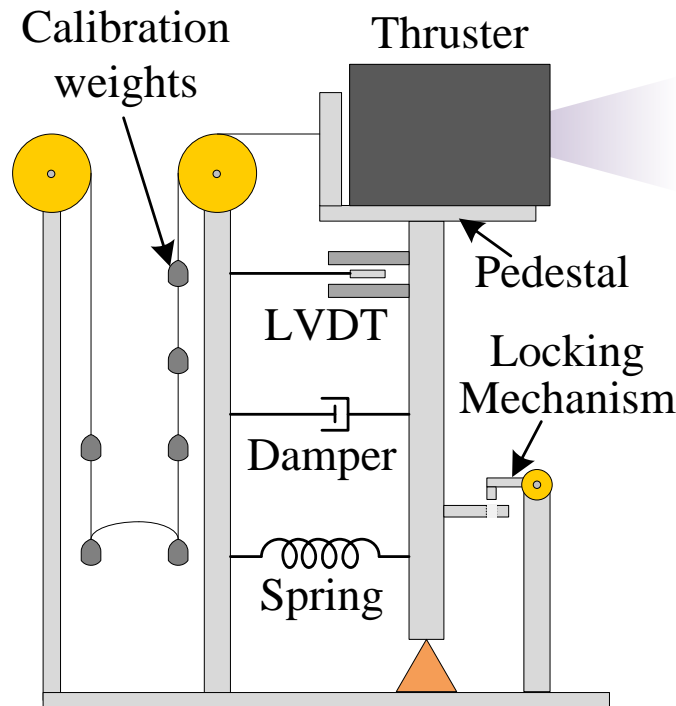
It is important to note that the RF power reported in this experiment is the net RF power delivered to the matching network input port. In order to quantify the exact amount of power that is delivered to the plasma, a thorough characterization of the losses due to ohmic dissipation in the matching network and antenna, coupling to the surrounding structure, and electromagnetic radiation would be required. Determination of the antenna-plasma coupling mechanism is also required to determine the true efficiency of the RF power delivery system. The assessment of the specific loss mechanisms and the antenna-plasma coupling efficiency is beyond the scope of this dissertation.

### 5.3.2 Thrust Stand

The performance of each thruster is measured with an inverted pendulum-type thrust stand at PEPL run in displacement-mode. The thrust stand is based on a design from the NASA Lewis Research Center (now Glenn Research Center) [123]. When the thrust stand is run in displacement-mode, the inverted pendulum can move in a direction parallel to the thrust vector. The instantaneous pendulum position is measured by a linear variable differential transformer (LVDT). The LVDT output is sent in real-time to a controller that actuates a non-contact, electromagnetic damper to remove oscillations in the pendulum position. A linear spring holds the pendulum in an equilibrium position, such that a steady force produced by the thruster causes a linear displacement of the pendulum. Force versus displacement calibration is performed in-situ using a set of calibration weights connected by a string to the mounting pedestal at the top of the pendulum. Figure 5.4 shows a diagram of the thrust stand principle of operation, with the major components labeled.

The LVDT in the thrust stand at PEPL is a Schaevitz model HR-100. The HR-100 is driven by a Measurement Specialties model ATA-2001 transducer amplifier, which outputs a voltage that is linearly related to the position of a magnetic core inside the HR-100. The ATA-2001 output voltage is buffered and sent to a Stanford Research Systems model SIM960 analog PID controller and an Opto 22 SNAP PAC data acquisition system. The SIM960 output voltage is sent to a Trust Automation TA115 motor amplifier that drives the electromagnetic damper. A LabView Virtual Instrument communicates with the Opto 22 SNAP PAC, and records the ATA-2001 output voltage every 0.1 s.

Although the thrust stand at PEPL is typically operated as a null-type thrust stand, such as that described by Xu and Walker [124], preliminary experiments found that the signal-to-noise ratio (SNR) and thrust measurement sensitivity were maximized when it was operated as a displacement-type thrust stand. The thermal drift was slightly greater in this displacement-type mode of operation. For the RPT, the zero position was checked and recorded immediately before and after each operating point to ensure accurate thrust



**Figure 5.4:** Diagram of the inverted-pendulum thrust stand. The mounting pedestal is at the top of the inverted pendulum. The spring holds the pedestal in an equilibrium position, and the LVDT measures the instantaneous position. An electro-mechanical damper reduces high-frequency oscillations in the pedestal position.

measurements. During HHT operation, the thermal drift rate was highest during two-stage operation, and so the zero position was checked before and after two-stage operating points.

### 5.3.2.1 Uncertainty Estimates

Calibrations were carried out at the beginning and end of each day of testing. During the RPT experiments, the end-of-day-calibration slope values were consistently 4–5% less than those at the beginning of the day. Observations suggested that the change in the calibration slope is due to slow thermal drift, and so individual thrust values were determined with a calibration slope that is linearly interpolated from the day’s calibrations and the time of the thrust measurement. Testing with the HHT yielded less variability in the calibration slopes, and so the absolute thrust measurement error is estimated to be  $\pm 2.5\%$  for HHT

measurements.

Because the RPT thrust is quite low, it was also important to quantify the resolution of the thrust stand at the low thrust levels. The noise level on the LVDT signal is approximately  $\pm 1.5$  mV, and so by averaging 25 consecutive instantaneous measurements, the uncertainty in the steady-state voltage measurement is reduced to  $\pm 0.3$  mV. Since the average value of the RPT thrust stand calibration slope was 200.5 mN/V, the uncertainty in each individual thrust measurement was conservatively estimated to be  $\pm 0.1$  mN. Although it is anticipated that the drift in thrust calibration slope was accounted for properly, the variation in the thrust stand calibration provides a conservative estimate of  $\pm 5\%$  for thrust measurement uncertainty.

### **5.3.2.2 EMI Mitigation**

In addition to increased sensitivity and SNR, operating the thrust stand in a displacement-type mode allowed for a simple, in-situ procedure to check that the LVDT position signal is not influenced by electromagnetic interference (EMI) with the RF components or plasma. The procedure is as follows: after the LVTF is evacuated, the thrust stand pendulum is mechanically locked in place such that an applied force cannot cause a displacement. This is checked by loading all calibration weights on the thrust stand and observing no change in the LVDT position signal. The RPT is then operated normally, and any displacement indicated by the LVDT signal is noted to be the result of EMI. When locked in place, the RMS fluctuation level in the LVDT signal is approximately 0.4 millivolts, and by averaging 10 consecutive, instantaneous LVDT measurements, the observation threshold for steady-state EMI was reduced to approximately 0.13 millivolts. This lower limit on EMI detection is more than a factor of 2 lower than the above stated thrust stand measurement resolution for the RPT, and so the thrust measurement uncertainty for small thrust values is still estimated at  $\pm 5\%$  due to the variation in calibration slope.

Although the initial setup was severely affected by EMI during operation with RF

plasma, the implementation of multiple mitigation strategies eliminated these effects. There is no analytical solution to removing EMI from an electrical setup, but the strongest EMI reduction was observed when ferrite beads were applied to all wires leading to the thrust stand. It is important to note that the proper choice of ferrite material to maximize the impedance at the RF driving frequency was critical to the success of this strategy. The datasheets for the ferrite beads implemented at PEPL are given in Appendix B. For wires that could not be removed, if there was enough slack in the line, two or three loops of the wire were wrapped around the ferrite material in order to further increase the impedance to the ambient RF.

After the EMI is eliminated, the pendulum is released so that the thrust stand returns to the displacement-type configuration. A calibration is then performed to confirm that the thrust stand is operating normally, and then thrust measurements are taken. Every operating point presented in this work was tested first with the thrust stand in the EMI-checking configuration. After this initial EMI check and prior to venting the LVTF, the full experiment is completed, and then another EMI check is performed for all operating points according to the above procedure.

A check is also performed to verify that the thrust stand calibration slope is unaffected by EMI. The procedure for checking the calibration slope is as follows: while the RPT is operating, one or two calibration weights are loaded on the pendulum to increase the force acting on the thrust stand spring. The masses are then unloaded and the RPT is turned off, and then a regular thrust stand calibration is performed. The change in the LVDT output caused by the additional force of the calibration weights is then checked against the predicted force according to the normal calibration. This check showed that any change in the calibration slope due to EMI was smaller than the thrust measurement resolution.



### 5.3.3 Faraday Probe

A nude Faraday probe is used to measure the ion current density in the thruster exhaust plumes. The Faraday probe used for the HHT is described in detail by Liang and Gallimore [125], and is modeled after the nested Faraday probe design described by Brown and Gallimore [126]. The Faraday probe is mounted to a rotation stage such that it can move in an arc about the centerline of the thruster exit plane. To take data, the collector(s) and guard ring are biased into ion saturation. The current drawn by the collector is recorded as the probe is swept between  $-90$  and  $90$  degrees, where  $0$  degrees is along the thruster centerline.

The total ion beam current,  $I_{beam}$ , may be determined by assuming that the exhaust plume is axisymmetric. The Faraday probe collected current,  $I_c(\theta)$ , is then integrated according to Eq. 5.5, where  $r$  is the distance from the Faraday probe collector to the thruster exit plane. For the HHT, the effective collector area,  $A_{c,eff}$ , includes all correction factors described by Brown [75].

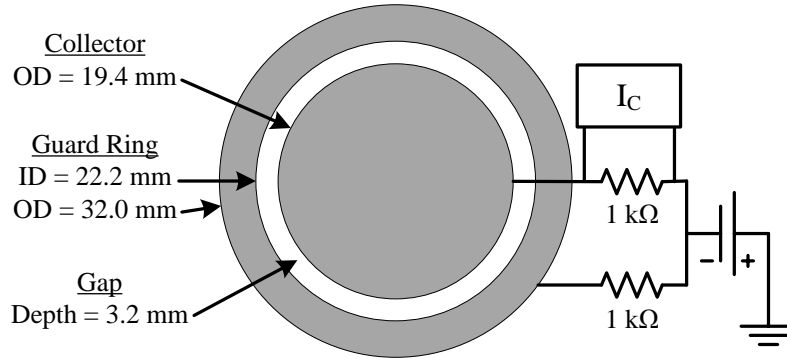
$$I_{beam} = 2\pi r^2 \int_0^{\pi/2} \frac{I_c(\theta)}{A_{c,eff}} \sin \theta d\theta \quad (5.5)$$

Using the same Faraday probe data, the axial component of the ion beam current,  $I_{axial}$ , is calculated from Eq. 5.6.

$$I_{axial} = 2\pi r^2 \int_0^{\pi/2} \frac{I_c(\theta)}{A_{c,eff}} \sin \theta \cos \theta d\theta \quad (5.6)$$

The Faraday probe used to measure the plasma in the RPT exhaust plume has been used in previous studies of Hall thrusters, for example by Hofer [111], and a diagram is shown in Fig. 5.5. For the RPT, the guard ring and collector are both biased below  $-58$  volts with respect to facility ground into ion saturation. The current drawn by the collector is recorded via the voltage drop across a 1 kilohm resistor as the Faraday probe collection

surface is swept from  $-90$  to  $90$  degrees at a constant distance of  $96 \pm 0.5$  centimeters from the center of the RPT exit plane. The Faraday probe angular alignment was checked before and after the experiment with a laser bore sight inserted into the RPT gas inlet, and the alignment uncertainty is conservatively estimated to be  $\pm 0.6$  degrees.



**Figure 5.5: Schematic of the Faraday probe used for RPT measurements.**

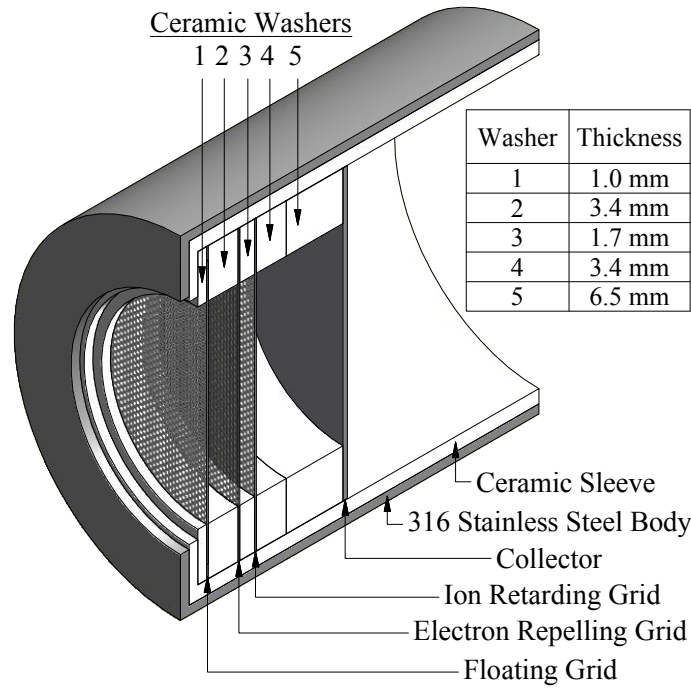
For analysis of the RPT Faraday probe data, it is assumed that the RPT is a point source of plasma, and the effective collector area is taken to be the geometric area of the collector face. The total ion beam current is calculated from Eq. 5.5, and the axial beam current is calculated from Eq. 5.6. The RPT effective exhaust divergence angle,  $\theta_{div}$ , is then calculated according to Eq. 5.7.

$$\theta_{div} = \cos^{-1} \left( \frac{I_{axial}}{I_{beam}} \right) \quad (5.7)$$

Following the analysis by Brown [75], and because Faraday probe data for each thruster operating condition are taken at one downstream distance and one facility backpressure, the uncertainty in the total and axial ion beam current measurements are initially taken to be  $\pm 6\%$  and  $\pm 10\%$ , respectively. This translates to an uncertainty of approximately  $\pm 9$  degrees in the measured effective exhaust divergence angles.

### 5.3.4 Retarding Potential Analyzer

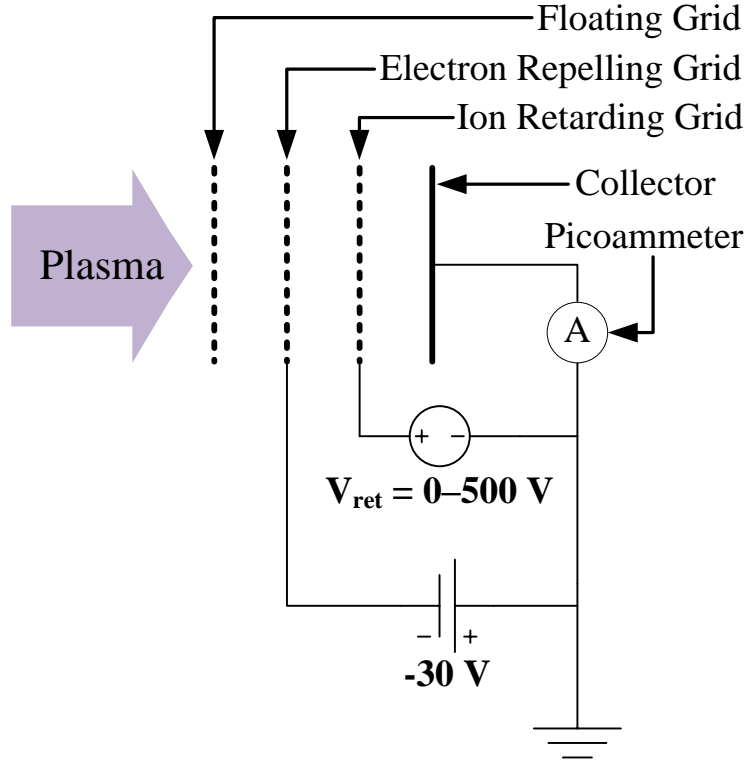
The Ion Voltage Distribution (IVD) is measured with a Retarding Potential Analyzer (RPA) that has been previously used to measure plasma properties in a helicon plasma source [127], as well as in Hall thruster plumes [111,115]. The RPA at PEPL is based on the multi-gridded energy analyzer described by Hutchinson [128]. It consists of three stainless steel grids and a collector contained in a stainless steel housing, as shown in Fig. 5.6. The grids and collector are isolated from each other and the housing by ceramic washers that also serve to set the spacing between the grids.



**Figure 5.6: Cross-section of the RPA.**

A schematic of the RPA is shown in Fig. 5.7. The electron repelling grid is biased with a Kikusui PAD 55-6L power supply, the ion retarding grid is powered with a Keithley 2410 SourceMeter, and a Keithley 6485 Picoammeter measures the current to the collector.

To collect measurements of the IVD, the floating grid first accepts charged particles from the plasma in a minimally disruptive manner. Then, the electron repelling grid is biased to a constant  $-30$  V potential with respect to facility ground to prevent the incident

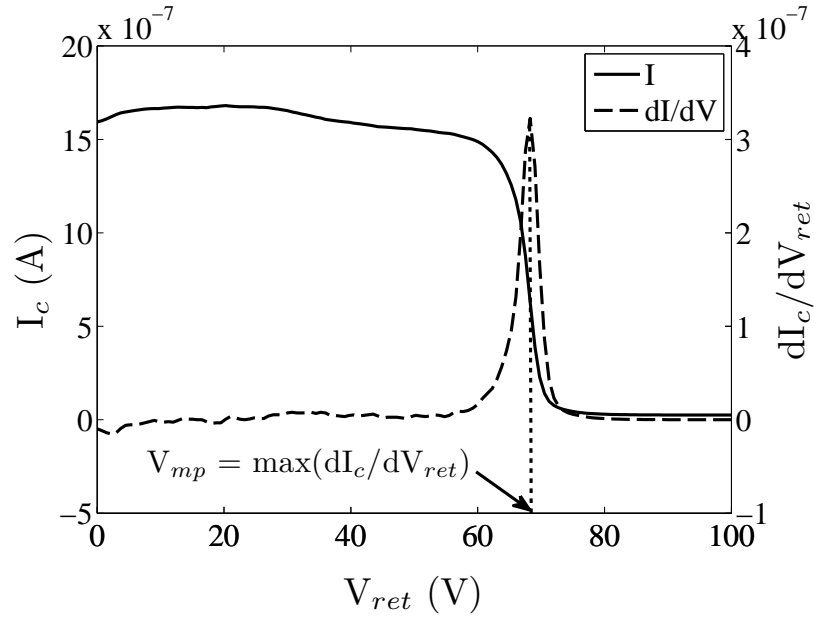


**Figure 5.7: Electrical schematic of the RPA.**

electrons from reaching the collector. The ion retarding grid is then swept from 0 to 500 V above ground to progressively filter out higher energy ions. The current to the collector is recorded at each ion retarding voltage, and the IVD is directly proportional to the first derivative of the measured current-voltage characteristic, as shown in Eq. 5.8 [127]. The peak in the first derivative is called the *most probable potential*,  $V_{mp}$ , as shown in Fig. 5.8.

$$\frac{dI_c}{dV_{ret}} = - \left( \frac{n_i}{m_i} \right) q^2 f(V) A_{c,eff} \quad (5.8)$$

Previous studies using this particular RPA have estimated the uncertainty in the most probable potential measurement to be  $\pm 10$  V [75, 111]. The uncertainty can be attributed to broadening of the peak due to the RPA's large acceptance half-angle (approximately  $45^\circ$ ), and the effects of smoothing and numerical differentiation of the raw RPA data. The half-width at half-maximum (HWHM) of the peak in the first derivative of the RPA current-voltage characteristic also gives a conservative measure of the uncertainty. The results



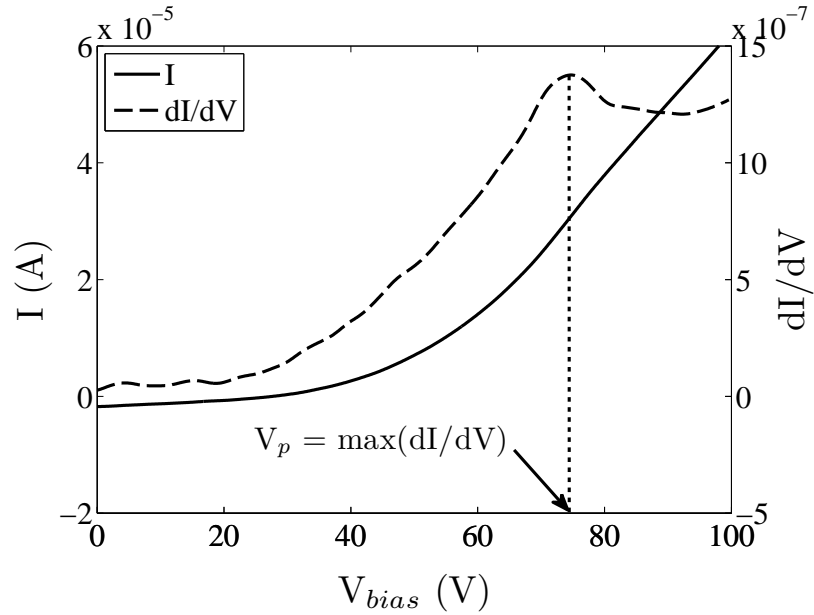
**Figure 5.8:** Typical data from the RPA. Data shown are from the RPT operating condition at 2.4 mg/s, 550 G, and 1080 W.

reported in this dissertation as the HWHM to represent the uncertainty in the most-probably potential measurement from the RPA.

The RPA is mounted to a linear translation stage, and a Langmuir probe is mounted next to it so that both the RPA and Langmuir probe data can be taken at the same position. For the RPT experiments, the RPA floating grid is 124 cm downstream of the RPT exit plane, and for the HHT experiments, the RPA floating grid is  $\approx 6$  m downstream of the HHT exit plane.

### 5.3.5 Langmuir Probe

An *ESPION* Langmuir probe system manufactured by Hiden Analytical is used to determine the plasma potential in the RPT thruster exhaust plume, and a cylindrical, uncompensated Langmuir probe is used for the HHT. The *ESPION* probe has been used in previous experiments with RF plasmas at PEPL, for example by Lemmer [127]. It is an RF-compensated Langmuir probe driven by the HAL IV ESP Controller. A computer connected to the controller runs the program “ESPsoft” to bias the probe tip from  $-100$  V to

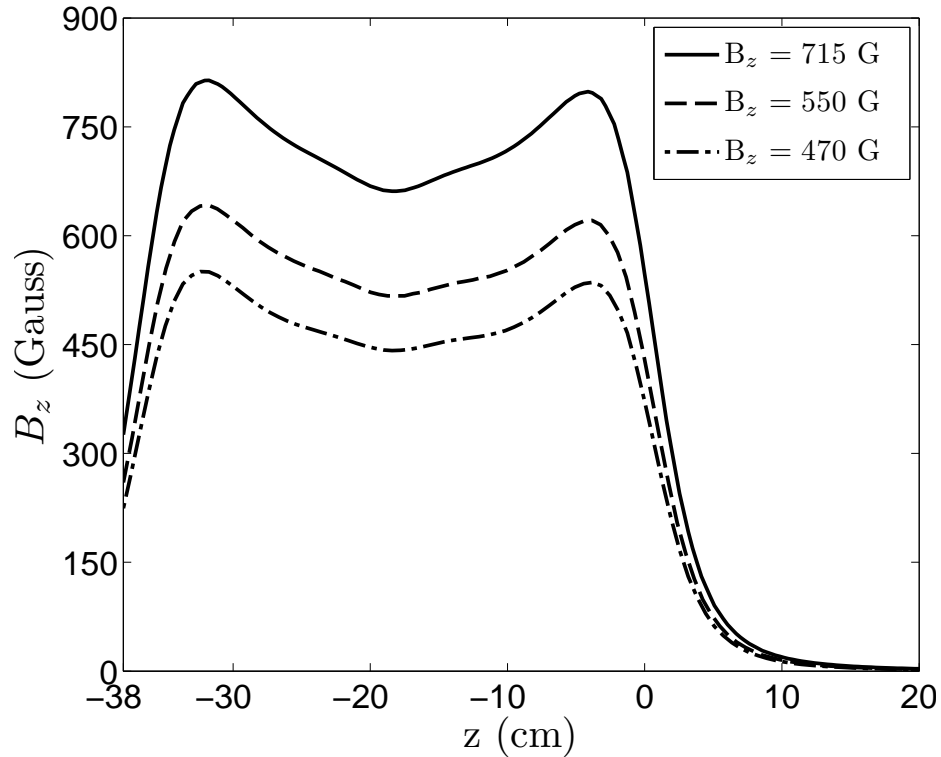


**Figure 5.9:** Typical data from the Langmuir probe. Data shown are from the RPT operating condition at 2.4 mg/s, 550 G, and 1080 W.

100 V, and records the probe current. The Langmuir probes are mounted to the RPA translation stage so that the IVD and plasma potential can be collected in the same location, on the centerline of the thruster.

The *ESPION* probe tip is a tungsten wire that is 0.15-mm in diameter by 10-mm long, and at least five individual current-voltage characteristics are averaged prior to analysis. The derivative method for determining plasma potential from a Langmuir probe characteristic, shown in Fig. 5.9 was found by Shastry to have the closest agreement with emissive probe measurements, and so the derivative method is used in this experiment, with an estimated uncertainty in the plasma potential of  $\pm 20\%$  [129].

The Langmuir probe used to measure the plasma potential in the HHT exhaust plume was a 0.025 cm-diameter, 0.57 cm-long tungsten wire, and the probe holder was a 0.15 cm diameter alumina tube that is mounted to the RPA translation stage. The probe tip is powered by a 1-Hz -50 V-to-150 V triangle wave by a Kepco BOP 500M bipolar amplifier that is driven by an Agilent 33220A Arbitrary Waveform Generator.



**Figure 5.10: RPT centerline axial magnetic fields, simulated with measured solenoid currents. The exit plane is at  $z = 0$  cm, and the legend refers to the average field in the RPT.**

## 5.4 Thruster Setup

Both the RPT and HHT were electrically isolated from the vacuum chamber and the thrust stand by placing a 0.635-cm-thick mica plate between the thruster mounting plate and the pedestal of the thrust stand. In addition, the propellant flows through an insulating torturous path immediately upstream of the thruster gas inlet connection that prevents an upstream connection to ground. The matching network is mounted on the thrust stand pedestal, and held in place by an aluminum structure. The antenna leads are connected directly to the matching network output leads, and the connection is covered with Kapton tape and surrounded by copper mesh to reduce the probability of local ionization of background neutral gas. Further details unique to the individual thruster setups are described below.

### 5.4.1 RPT

For the RPT thrust measurements, ultra high purity (99.999% pure) argon is used as the propellant. The gas flow rate during both nitrogen and argon operation is regulated by an Alicat MC-500SCCM-D mass flow controller, which has an accuracy of  $\pm 0.8\%$  of the setting plus  $\pm 0.2\%$  of full scale. Each RPT solenoid coil is independently powered by a Lambda EMS-series power supply, and the current of each solenoid is measured across a Deltec MKA-25-100 current shunt. An isolated Opto 22 SNAP PAC data acquisition system records the magnet currents, and the forward and reflected power output by the CPS-3000 concurrently with LVDT data from the thrust stand. The magnetic field was non-uniform during RPT operation, and the maximum magnetic field was approximately 810 Gauss, as shown in Fig. 5.10. The magnetic field of the RPT data points are labeled by the average centerline axial magnetic field in the magnet assembly.

### 5.4.2 HHT

The HHT used an externally-mounted thermionic cathode with a lanthanum hexaboride ( $\text{LaB}_6$ ) insert to produce electrons for the Hall acceleration stage. Research-grade xenon (99.999% purity) was used for the cathode flow for all HHT operating conditions, and the cathode flow was regulated by an MKS 1179A mass flow controller, which has a specified accuracy of  $\pm 1\%$  of full scale. The cathode is mechanically connected to the HHT on the thrust stand, and so the thrust measurements include any force that is produced by the cathode. An MKS model 1159B mass flow controller regulated the flow of research-grade xenon to the HHT anode, whereas an Alicat MC-500SCCM-D mass flow controller was used for the argon and nitrogen operating conditions. After LVTF pumpdown and prior to taking any performance or probe measurements, the HHT was operated for a length of time in order to bake out any condensable materials from the thruster.



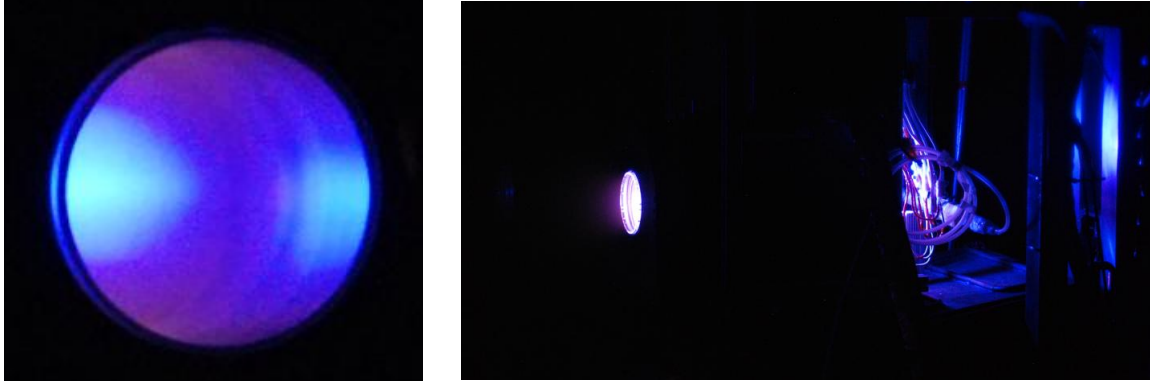
## CHAPTER 6

### Results

The RPT and HHT were both operated successfully on the thrust stand at PEPL. Simultaneous performance and plasma plume measurements were collected to investigate the loss mechanisms. This represents the first time such measurements have been made with a matching network located inside the vacuum chamber on the thrust stand. The RPT operated with argon, nitrogen, and ambient air, and the HHT operated with xenon, argon, and nitrogen. The first section reports the RPT performance and probe measurements while operating with argon, followed by the results of the RPT operating with nitrogen and air. The second section then presents the single- and two-stage performance measurements of the HHT operating with xenon, argon, and nitrogen propellant.

#### 6.1 RPT Results

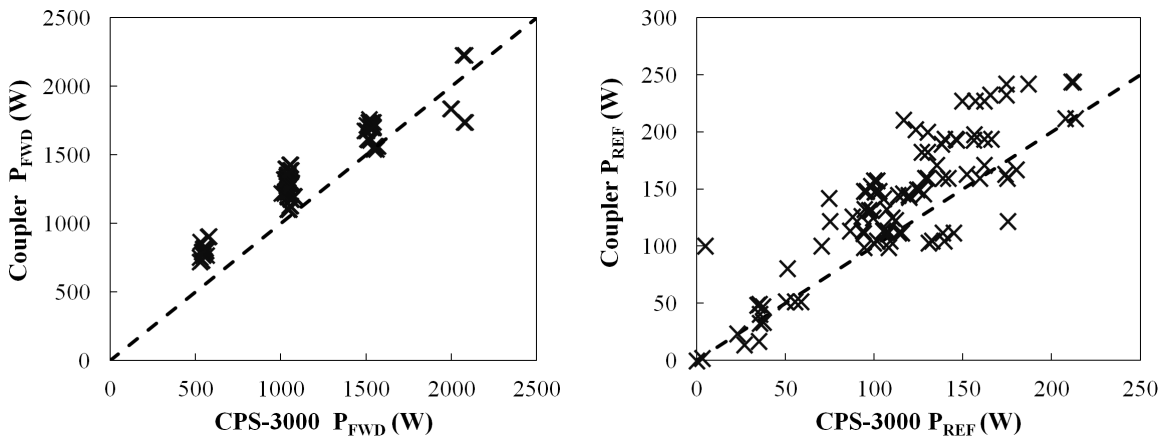
The corrected LVTF operating pressure during RPT experiments remained below  $4.7 \times 10^{-6}$  Torr. Despite this low pressure, and the large bore of the quartz tube, the RPT operated with a bright blue core at nearly all argon operating conditions analyzed. This provided strong visible evidence of significantly improved power coupling to the plasma over previous RPT experiments in the LVTF during which the matching network remained outside the vacuum chamber.



**Figure 6.1:** Two views of the RPT argon blue core plasma during operation in LVTF. The end-on view of the exhaust (left) shows the blue core. Light from the blue core shines through the inlet side of the RPT quartz tube and reflects off the thrust stand structure (right).

### 6.1.1 RF Power Measurements

As previously discussed, the antenna-and-plasma load may be nonlinear. This can cause some of the RF power to be reflected from the load at frequencies that are not 13.56 megahertz (the driving frequency). This arises from the natural behavior of the plasma, and cannot be avoided. The CPS-3000 does not have a filtered output and is not calibrated for frequencies other than 13.56 megahertz, and so the effect of other frequencies on the forward and reflected power measurements output by the CPS-3000 is unknown. Forward and reflected powers determined from the directional coupler during RPT operation with argon are plotted versus the RF power readings output from the CPS-3000 in Fig. 6.2.

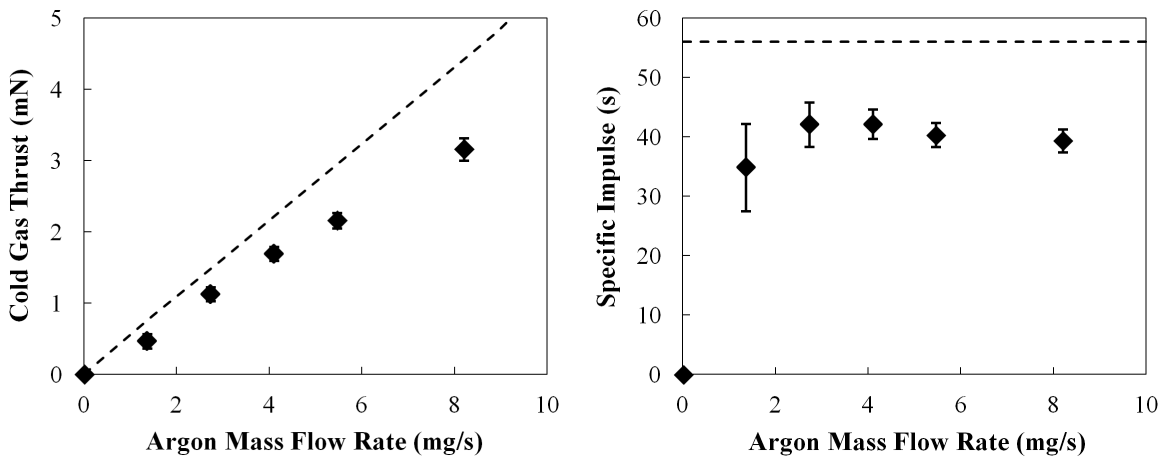


**Figure 6.2:** Comparison between measurements from the CPS-3000 and the dual-directional coupler for forward (left) and reflected (right) RF power. CPS-3000 data are from the calibrated analog 0–10 V outputs. Points lie on the dotted line when both measurements agree.

The attenuation in the coaxial cable is accounted for so that the points in Fig. 6.2 represent the power at the CPS-3000 output port [121]. The magnitude of the reflection coefficient,  $|\Gamma|$ , never exceeds 0.41 for all RPT operating points analyzed, yet the CPS-3000 power meters typically indicated lower forward and reflected powers than those determined by analysis of the corresponding directional coupler signals. The discrepancy between the two measurements may be caused by a non-uniform frequency response or poor directivity in the CPS-3000 measurement circuit.

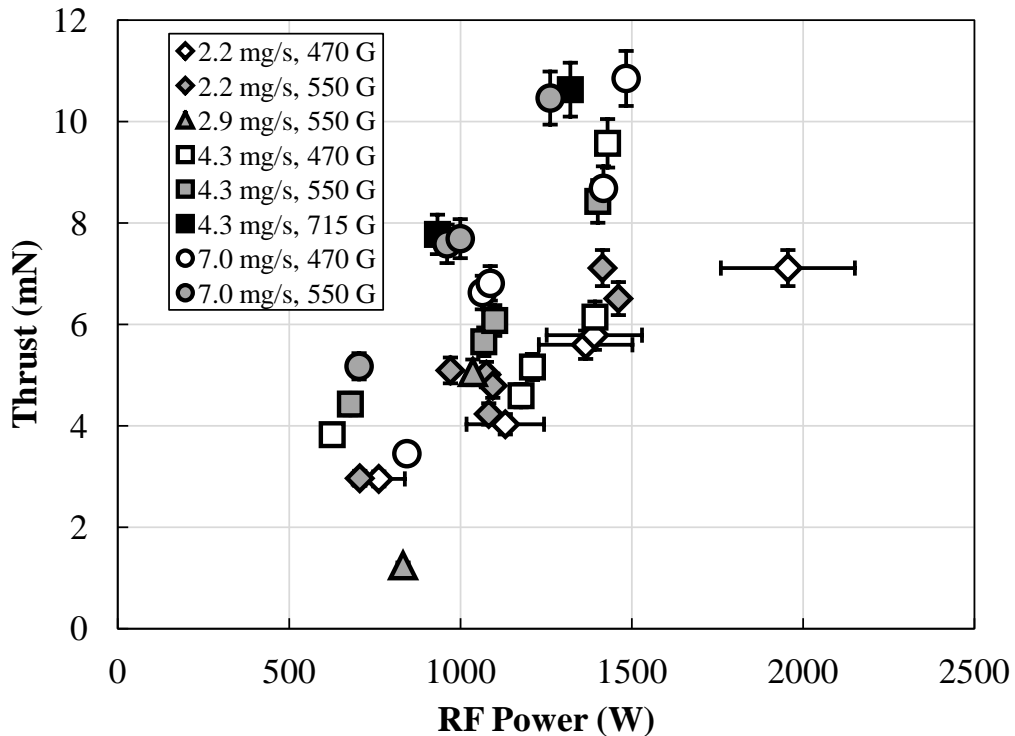
### 6.1.2 Argon Performance

The performance of the RPT due to cold gas expansion of argon in the quartz tube is measured first. The cold gas thrust is measured with zero input RF power, and the specific impulse is calculated. The results are plotted in Fig. 6.3. The theoretical cold gas thrust can be estimated by assuming the quartz tube as an ideal nozzle, and using supersonic isentropic flow equations, given by Anderson [130]. The resulting thrust and specific impulse using the real RPT geometry and argon mass flow rates are shown by the dotted lines in Fig. 6.3. Since the RPT quartz tube has discrete changes in area, it was anticipated that cold gas performance would be lower than that for an isentropic nozzle. This agrees with the results shown in Fig. 6.3, within an order of magnitude.



**Figure 6.3:** Measured cold gas thrust (left) and specific impulse (right) for argon flow in the RPT. Dotted lines represent theoretical performance from isentropic flow theory.

The thrust due to RF power and cold gas flow are separately measured. The measurements are summed to determine the total thrust at a given operating condition. The RPT thrust measurements with RF power applied were taken at argon flow rates from 2.2–7.0 milligrams per second. This corresponded to an LVTF operating pressure range of  $1.5 - 4.7 \times 10^{-6}$  Torr. All measurements of total thrust for the RPT operating with argon are plotted in Fig. 6.4.

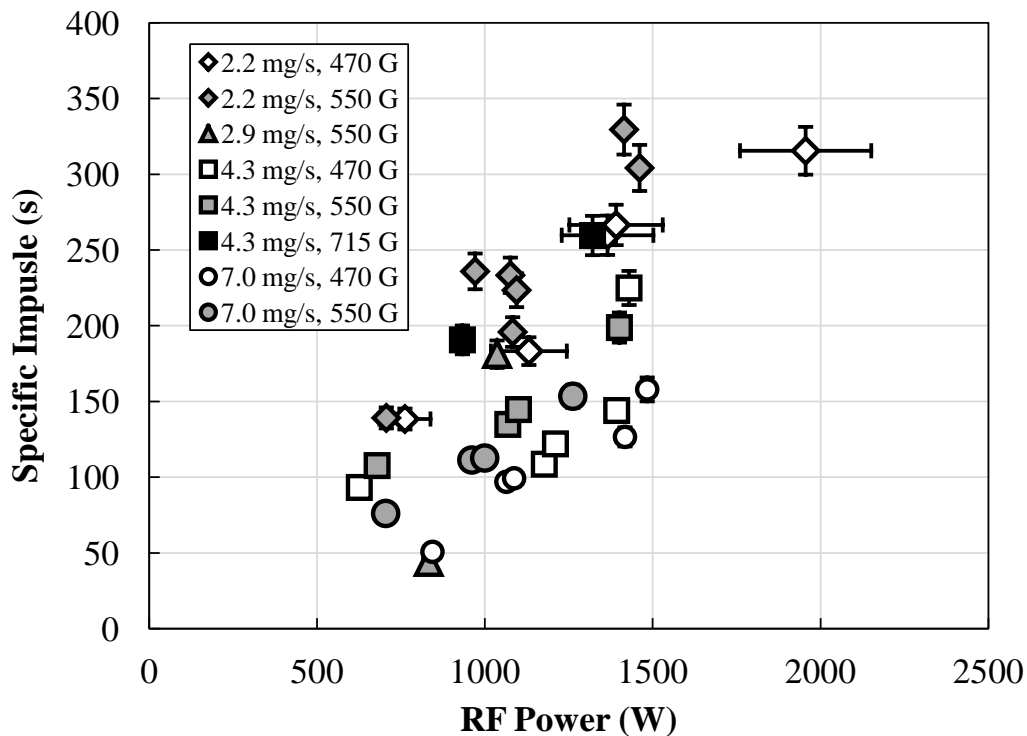


**Figure 6.4: RPT total thrust versus net RF power. To reduce clutter, horizontal error bars are plotted only for the first data series, but they are representative for the entire dataset.**

Total thrust increases both with increasing RF power and increasing magnetic field strength. Total thrust also increases with increasing flow rate, but it is important to note that the cold gas thrust contributes 2.7 millinewtons to the total force at the 7.0-milligram per second operating conditions. The lowest thrust measured was 1.2 millinewtons at the 2.9-milligram per second, 550-gauss operating condition at 830 watts. The RPT plasma for this data point did not exhibit a strong blue core. The cold gas thrust at 2.9 milligrams per second of argon is 1.1 millinewtons. Thus, the application of RF power did not significantly

contribute to the total thrust. Another interesting result is that the total thrust is equal for the 4.3-milligram per second, 715-gauss and 7.0-milligram per second, 550-gauss operating conditions at the same RF power. The cold gas thrust is approximately 1 millinewton less at 4.3-milligram per second flow rates, and this difference is made up by the RF power. The maximum total thrust measured is 10.8 millinewtons at a specific impulse of 158 seconds and RF thrust efficiency of 0.5%.

The RPT specific impulse also increases with increasing RF power, and tends to increase with increasing magnetic field strength. The RPT specific impulse is calculated from the total thrust and propellant mass flow rate, and the results shown in Fig. 6.5.

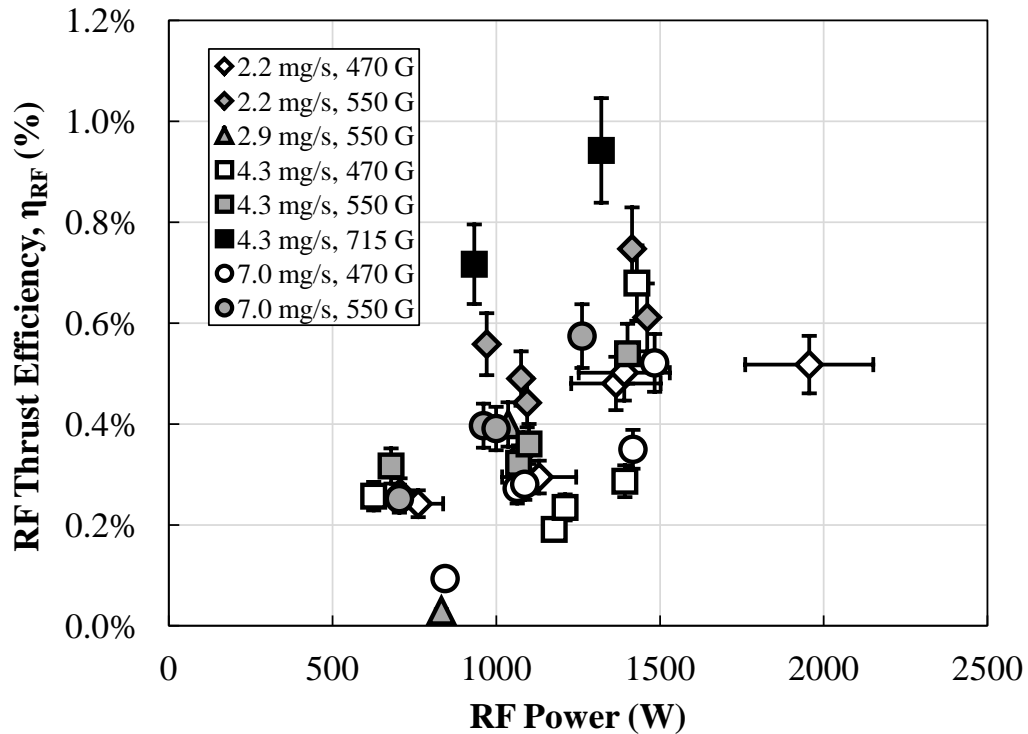


**Figure 6.5: RPT specific impulse versus net RF power. Specific impulse is calculated using the sum of the cold gas thrust and the RF thrust. Horizontal error bars shown are representative for the entire dataset.**

The RPT specific impulse decreases with increasing flow rate because the measured increase in thrust is much less than the increase in mass flow rate. The specific impulse at 4.3-milligrams per second and 715-gauss is approximately equal to the specific impulse at 2.2-milligram per second and 470-gauss for a given RF power. The maximum specific

impulse measured is 330 seconds at a total thrust of 7.1 millinewtons and an RF thrust efficiency of 0.7%.

The RF thrust efficiency of the RPT,  $\eta_{RF}$ , is calculated from the net RF power delivered to the matching network and the thrust due to RF power. The RF thrust efficiency of the RPT operating with argon is shown in Fig. 6.6. Note that the definition of RF thrust efficiency reported here includes the matching network and antenna coupling efficiency, but not the DC power supplied to the RPT magnets.

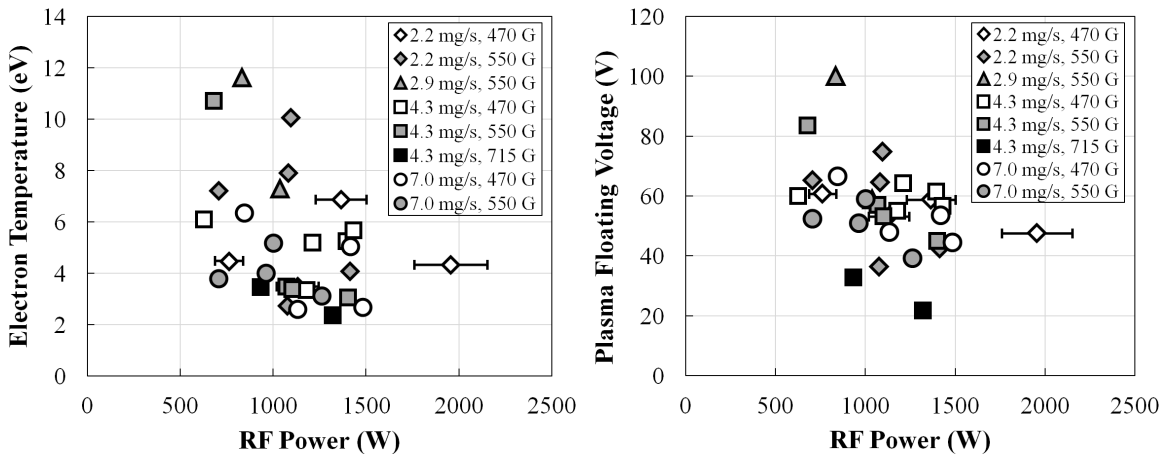


**Figure 6.6: RPT RF thrust efficiency versus net RF power.**

The RF thrust efficiency of the RPT increases with increasing RF power and with increasing magnetic field strength. Efficiency also increases with decreasing flow rate, but remains below 1% for all operating conditions. Note that the uncertainty in the RF power measurement increases the uncertainty in the RF thrust efficiency to  $\pm 11\%$  of the value. The maximum RF thrust efficiency measured is 0.9% at a total thrust of 10.6 millinewtons and a specific impulse of 260 seconds.

### 6.1.3 Argon Probe Measurements

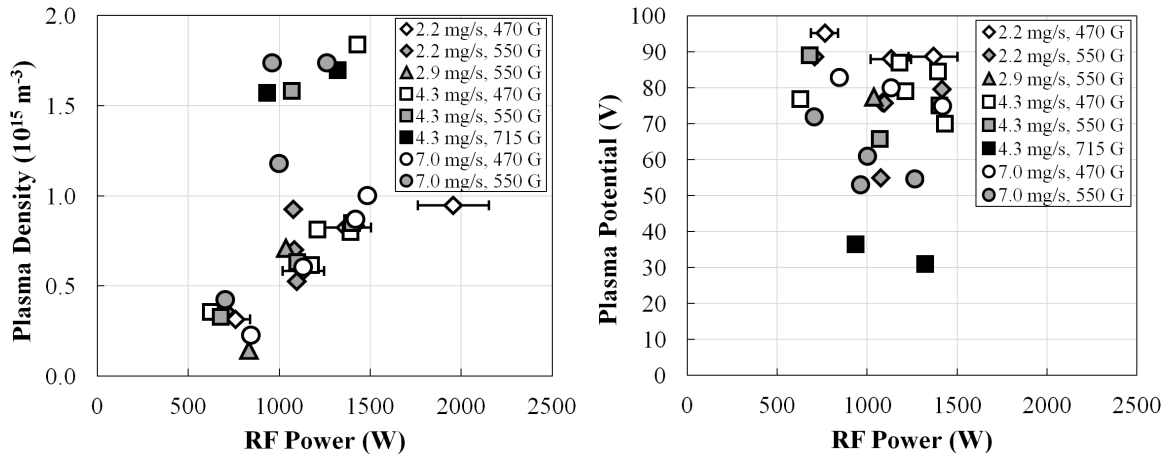
The RPA and Langmuir probe are mounted to a motion table so that the plasma potential and the most probable ion voltage can be measured at the same location. The Langmuir probe tip is aligned such that the length of the probe is parallel to the RPT axis. The electron temperature and plasma floating voltage measured by the Langmuir probe are plotted in Fig. 6.7. Electron temperature is determined by the inverse slope of the natural logarithm of the electron current in the vicinity of the floating voltage [127].



**Figure 6.7: RPT plume electron temperature (left) and floating voltage (right) measured by a Hidden Langmuir probe system. Helicon sources typically produce 3–5 eV electron temperatures.**

Typical helicon sources produce plasma at 3–5 eV electron temperature, and temperatures in the 10–15 eV range may be indicative of a capacitively coupled plasma [86]. The absolute uncertainty in the electron temperature is estimated at  $\pm 20\%$  [128], but the relative error between measurements in the same setup is lower [131]. Oscillations in the floating potential were not observed, and since multiple current-voltage characteristics were averaged, the uncertainty in the floating potential measurement is conservatively estimated to be  $\pm 2$  volts.

The plasma density is determined using orbit-motion limited theory in the ion saturation part of the current-voltage characteristic [127, 132]. The plasma potential is determined as the peak in the first derivative of the current-voltage characteristic. The plasma potential and density measured in the RPT plume by the Langmuir probe are plotted in Fig. 6.8.



**Figure 6.8: RPT plume density (left) and plasma potential (right) measured by a Hidden Langmuir probe system. Plasma potential is determined by the derivative method.**

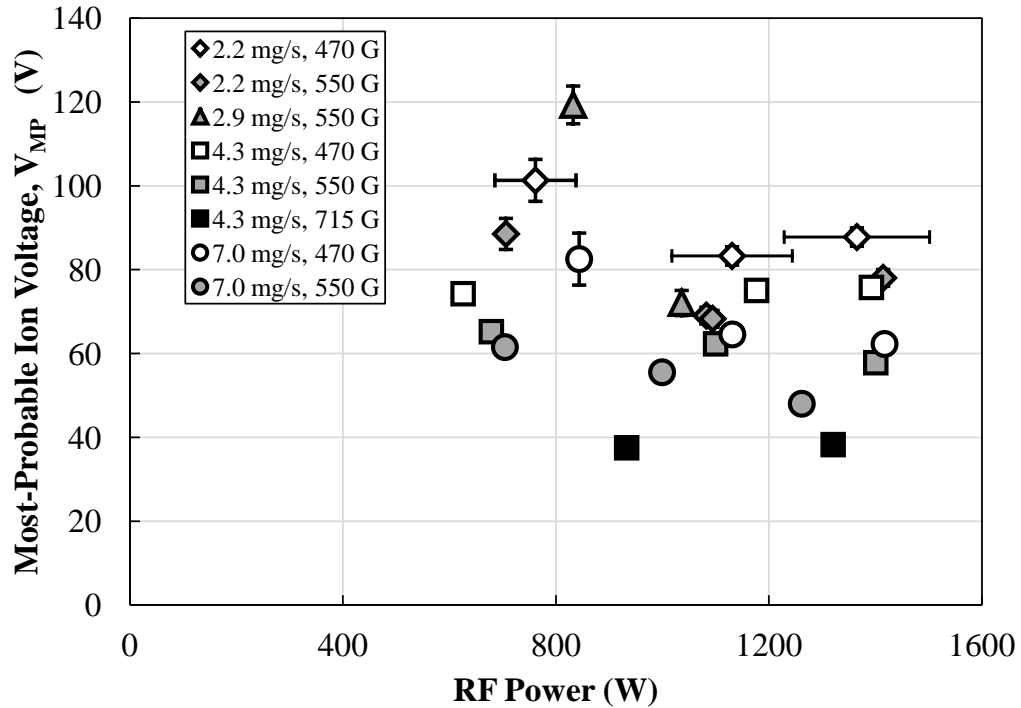
The plasma density mainly increases with increasing RF power, showing a nonlinear increase for some of the flow rate and magnetic field combinations. The plasma potential does not show any clear trends with RF power or flow rate, but the plasma potential is lower at the operating conditions with higher plasma density.

RPA data for the RPT operating on argon exhibited one dominant peak in the first derivative of the current-voltage characteristic. Other experiments have observed Ion Voltage Distributions (IVDs) with two peaks [68, 69, 73]. However, secondary peaks in this experiment are two orders of magnitude smaller than the dominant peak at higher voltage. So, the RPA was used only to determine the most probable voltage of the RPT exhaust plasma. The RPA results are plotted versus RF power in Fig. 6.9.

The most-probable exhaust ion voltage decreases both with increasing flow rate and with increasing magnetic field strength. Note that the vertical error bars in Fig. 6.9 represent the half-width at half-maximum in the IVD peak, and so the distribution of ions about  $V_{mp}$  is generally on the order of a few volts.

Faraday probe current density data was only collected for four RPT operating conditions. Assuming that the exhaust is axisymmetric, Faraday probe current density characteristics were integrated to determine the total and axial ion beam currents in the positive hemisphere, from which the effective divergence half-angle can be calculated. The four





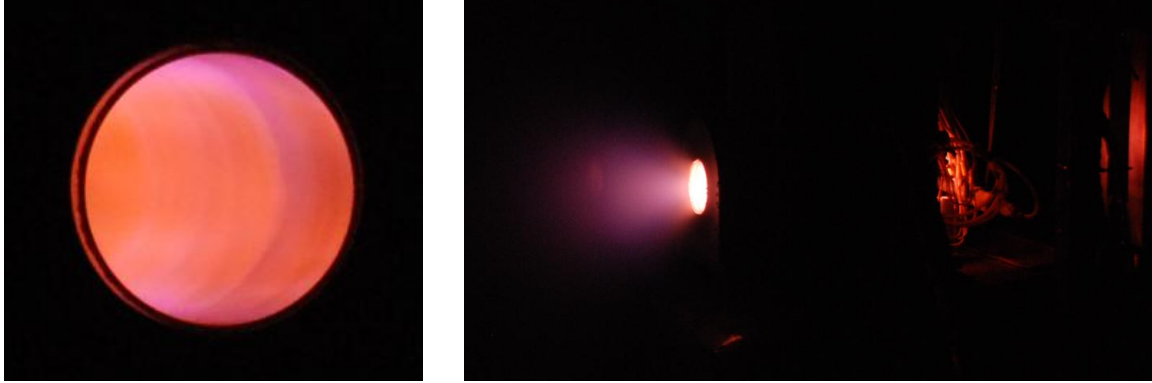
**Figure 6.9: Most probable potential from RPA versus RF power. Note that the plasma potential must be subtracted to determine the most-probable ion kinetic energy.**

points analyzed all had an effective divergence half-angle of approximately 48 degrees. Further analyses of the RPT Faraday probe data are presented in the following chapter.

#### 6.1.4 RPT Operating on Nitrogen & Air

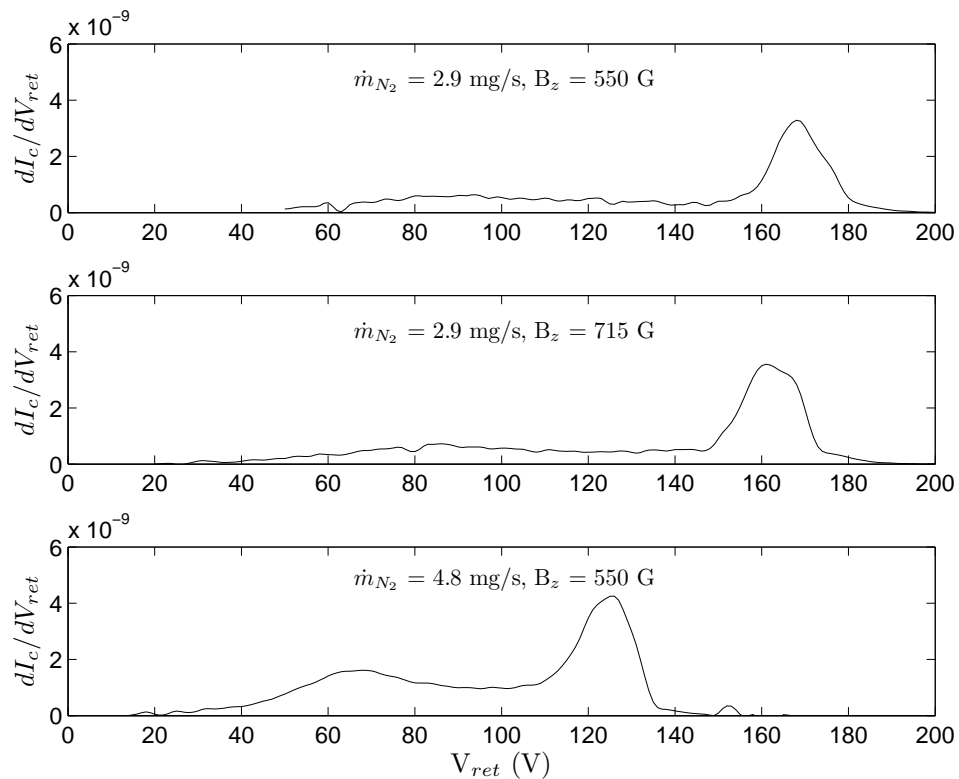
The helicon wave dispersion relation depends on the number density of plasma, not the mass flow rate. So, the number flow rate was held constant for the different species, with 4.3- and 7.0-milligrams per second of argon corresponding to approximately 150- and 250-standard cubic centimeters per minute, respectively. Figure 6.10 shows two photographs of the RPT operating with nitrogen propellant. Although there was visible evidence that the RPT coupling to nitrogen and air propellant was strong, no thrust was measured.

Due to the low thrust measured, relatively few operating conditions were investigated. The Faraday probe data qualitatively gave lower ion current densities by about a factor of ten compared to argon operating conditions. This suggests that the low thrust may be due to



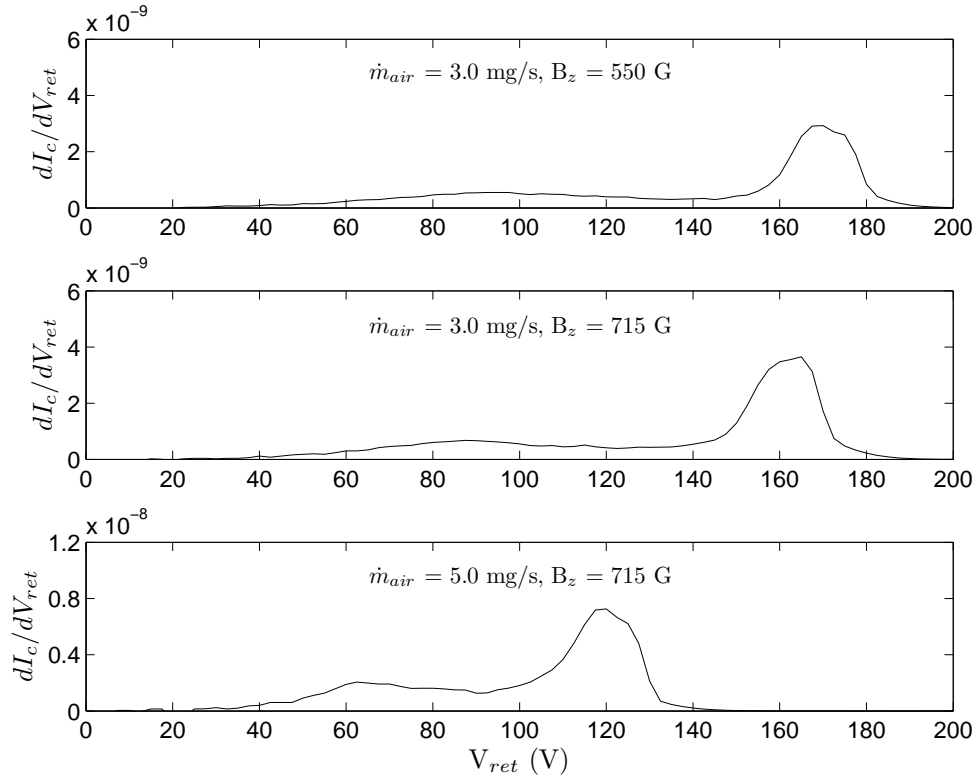
**Figure 6.10:** Photograph of RPT operating with nitrogen, with end-on view on left. No blue core was observed, perhaps due to the fact that nitrogen ions strongly emit in the ultraviolet.

low ion production by the RPT operating with nitrogen. The Langmuir probe did not reach electron saturation at the upper limit on bias voltage of 100 volts. Figure 6.11 shows data from the three operating conditions where data were taken. The plasma floating potential for these three nitrogen operating conditions were all measured to be approximately  $50 \pm 5$  volts.



**Figure 6.11:** RPA data for the RPT operating on nitrogen at 1000 watts.

The RPT operating conditions with air yielded similar results as those with nitrogen, with flow rate having the strongest effect on peak voltage. RPA data for the air operating conditions is shown in Fig. 6.12.



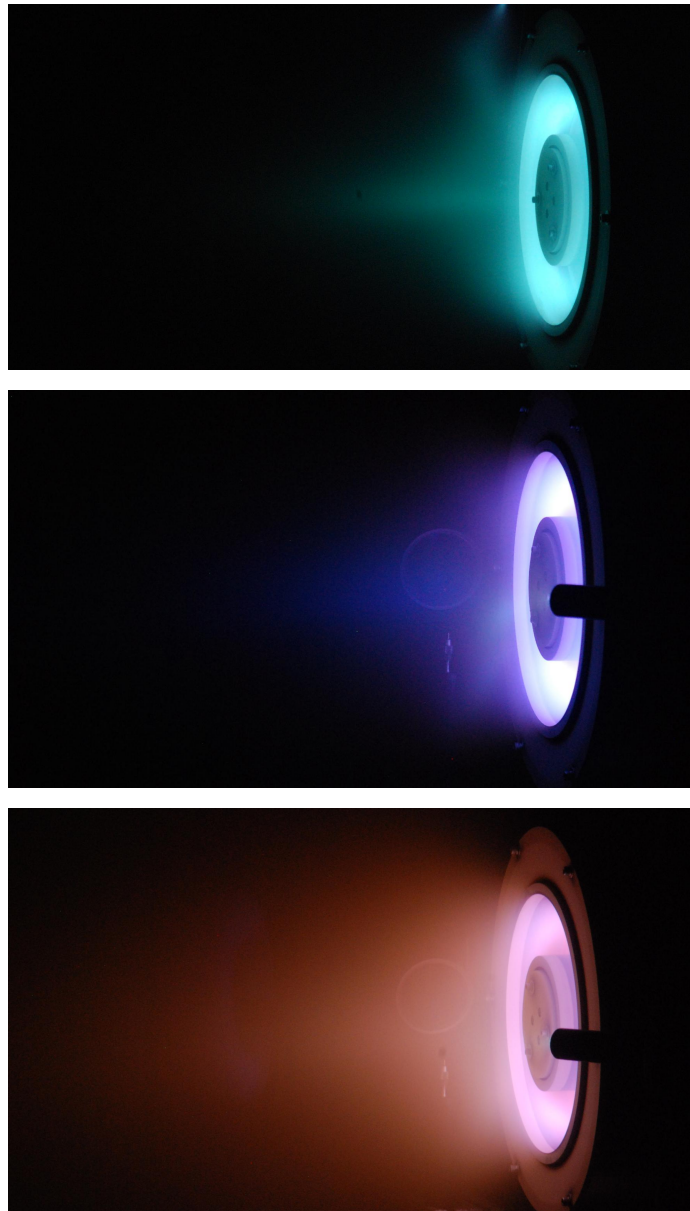
**Figure 6.12: RPA data for the RPT operating on air at 1000 watts. Note that the vertical scale in the bottom subplot is twice as large as that in the other RPA data plots. As in Fig. 6.11, no independent measurement of plasma potential is available.**

For the RPT operating on air, the plasma floating potential measured by Langmuir probe was approximately  $58 \pm 5$  volts for the 2.9-milligram per second operating conditions, and the floating potential for the 4.8-milligram per second operating condition was 43 volts.

## 6.2 HHT Results

The performance of the HHT was measured on xenon, argon, and nitrogen propellants with and without the RF stage operating. For the argon and nitrogen operating conditions, the external hollow cathode was operated with research-grade xenon (99.999%

purity). The HHT total flow rate when operating with xenon was in the range from 10.7–26.7 milligrams per second, corresponding to LVTF corrected pressures of about  $4.6 \times 10^{-6}$  to  $1.5 \times 10^{-5}$  Torr. During argon and nitrogen operation, the corrected LVTF pressure was measured at  $3.9 \times 10^{-6}$  Torr and  $3.6 \times 10^{-6}$  Torr, respectively. Figure 6.13 shows the HHT operating on each propellant.



**Figure 6.13: Single-stage HHT operation with xenon (top), argon (middle) and nitrogen (bottom) propellants. No significant change to the plume structure was observed when operating in two-stage mode.**

The HHT was constructed to investigate whether an RF ionization stage could increase the efficiency of a Hall thruster operating in a low-specific impulse regime, and so the operating conditions mainly focused on low discharge voltage operation with xenon propellant. Table 6.1 summarizes all the HHT operating conditions that were tested, with the “Plume Measurements” column indicating when probes were used to make measurements in single-stage mode and/or while the RF stage was operating.

**Table 6.1: Summary of HHT operating conditions and measurements.**

<b>Propellant</b>	<b>Anode Flow Rate (mg/s)</b>	<b>Discharge Voltage (V)</b>	<b>RF Power Range (W)</b>	<b>Cathode Flow Fraction</b>	<b>Plume Measurements<sup>a</sup></b>
xenon	10.0	200	0 – 1036	7.1%	1s
xenon	14.9	100	0 – 1028	5.0%	1s
xenon	14.9	150	0 – 1041	5.0%	1s
xenon	14.9	200	0 – 1032	5.0%	1s
xenon	20.0	100	0 – 994	5.0%	1s & 2s
xenon	20.0	150	0 – 1205	5.0%	1s & 2s
xenon	20.0	200	0 – 986	5.0%	1s
xenon	25.0	200	0 – 613	7.0%	-
argon	5.48	300	0 – 270	16.8% <sup>b</sup>	1s & 2s
nitrogen	4.80	200	0 – 302	38.4% <sup>b</sup>	1s

<sup>a</sup>1s = single-stage operation, 2s = two-stage operation

<sup>b</sup>cathode flow was set to 1.0 mg/s of xenon for argon and nitrogen operating conditions

### 6.2.1 Single-stage operation

Results of the HHT single-stage performance test are shown in Figs. 6.14–6.16. Figure 6.14 shows the expected result that thrust increases with both discharge voltage and anode mass flow rate, and Fig. 6.15 shows that anode specific impulse mainly increases with discharge voltage for xenon, but is also affected by the propellant species. Figure 6.16 shows that the thrust-to-power for the HHT operating with xenon is between 60 and 72 millinewtons per kilowatt.

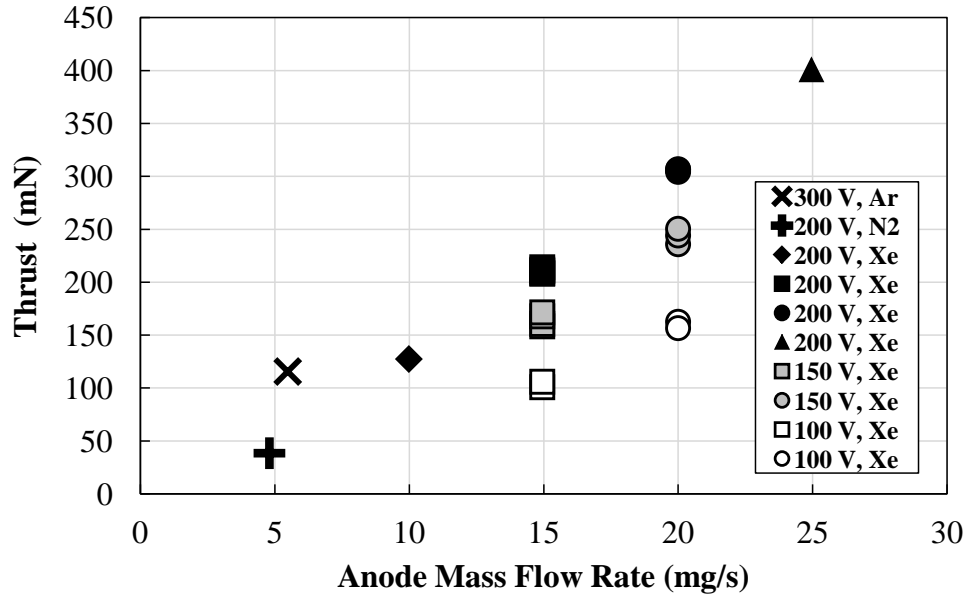


Figure 6.14: HHT single-stage thrust versus mass flow rate. No RF power is applied during single-stage operation.

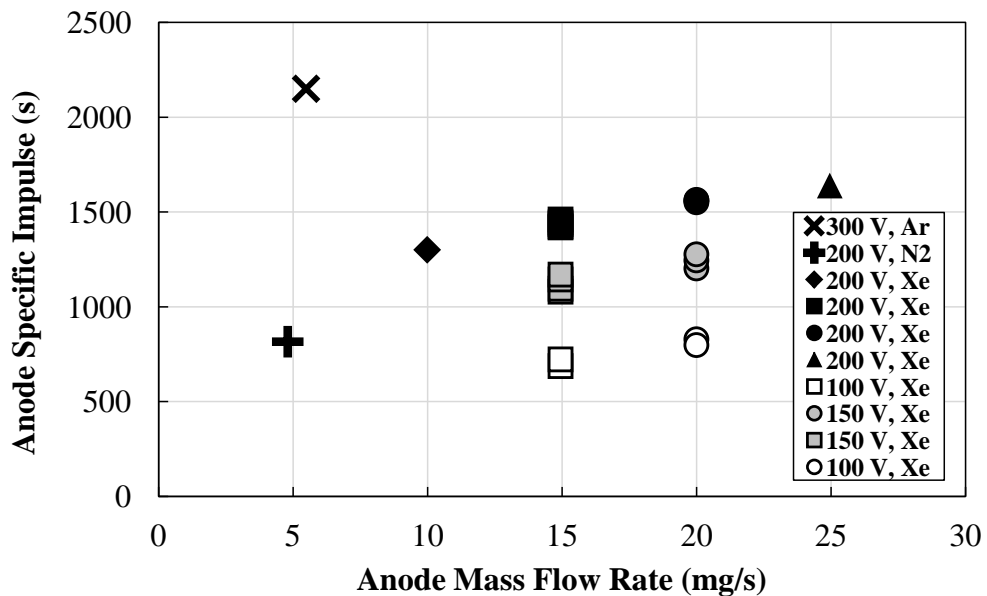


Figure 6.15: HHT single-stage anode specific impulse versus mass flow rate.

When operating with xenon propellant, thrust-to-power increases slightly with increasing discharge voltage, and is maximized at the intermediate anode mass flow rates. The HHT performance operating on argon and nitrogen was measured at higher discharge voltages, but thrust-to-power was only 30 and 21 millinewtons per kilowatt, respectively.

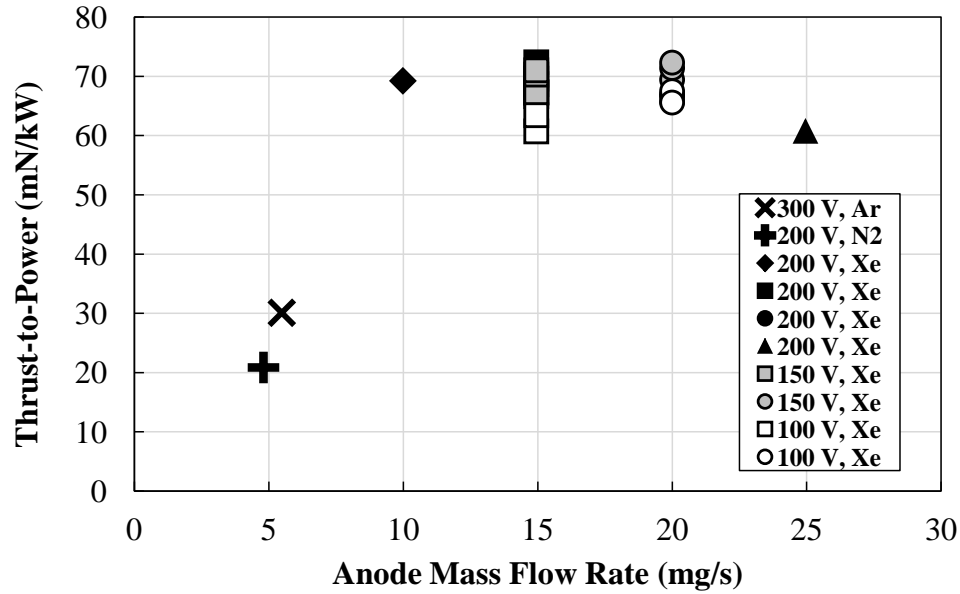


Figure 6.16: HHT single-stage thrust-to-power versus mass flow rate.

## 6.2.2 Two-stage operation

During two-stage operation, the RF ionization stage was powered in the attempt to increase HHT anode efficiency at high thrust-to-power operating points. The magnets in the helicon section were held constant as RF power was increased, since it was seen that the magnets for the helicon stage could act as trim coils for the Hall stage when no RF power was used. Figures 6.17 and 6.18 show that thrust and specific impulse increased slightly with RF power for most operating conditions; however, Fig. 6.19 shows that the rate of increase in thrust was always exceeded by the rate of increase in RF power, such that the overall thrust-to-power decreased with increasing RF power.

Assuming that nitrogen is a good analogue for the performance of the HHT operating with atmospheric air components, Fig. 6.20 focuses on the gas species and performance metric of greatest interest to air-breathing electric propulsion. The results show more clearly that RF stage does not improve the overall thrust-to-power in the HHT.

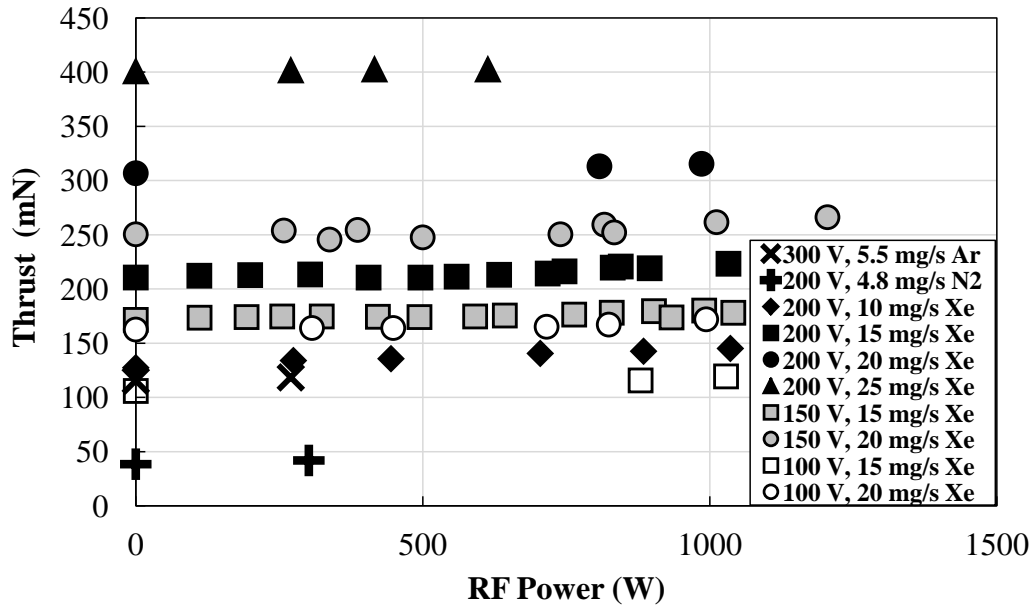


Figure 6.17: HHT two-stage thrust versus RF power. During two-stage operation, the magnet settings and DC discharge power are held constant while RF power is increased.

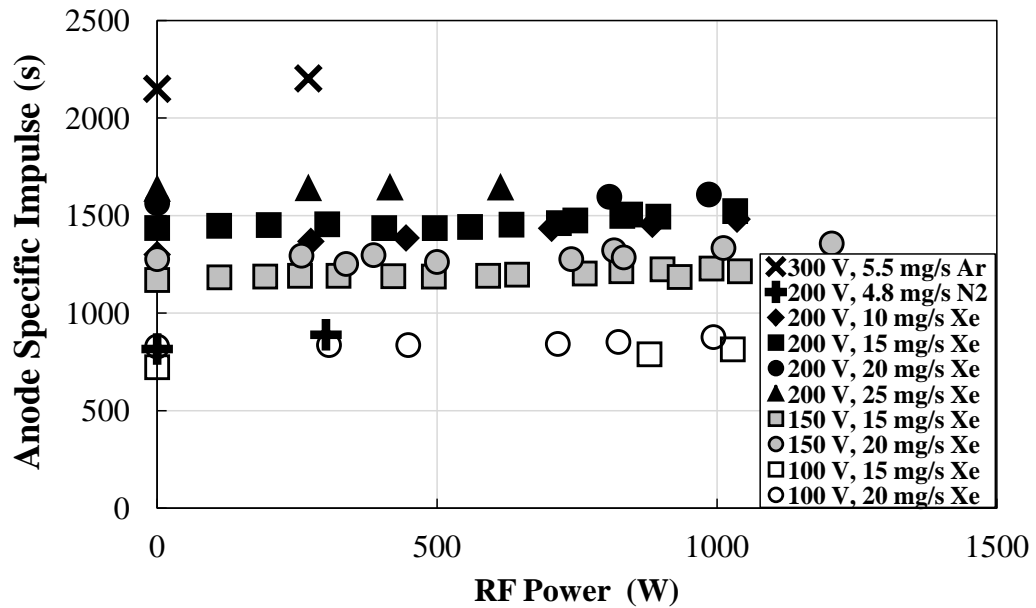


Figure 6.18: HHT two-stage anode specific impulse versus RF power.



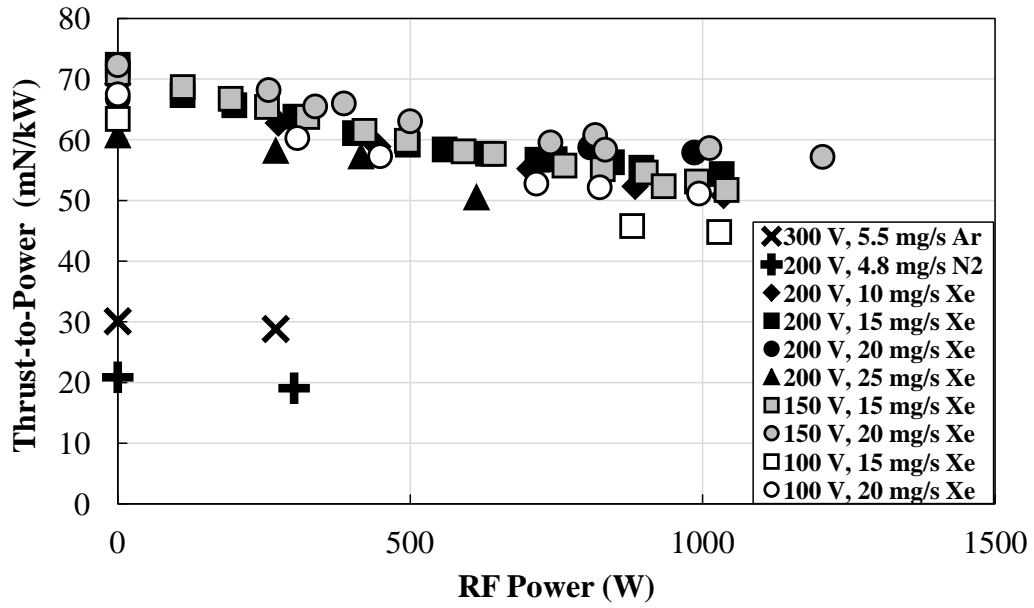


Figure 6.19: HHT two-stage thrust-to-power, including both  $P_{DC}$  and  $P_{RF}$ , versus RF power.

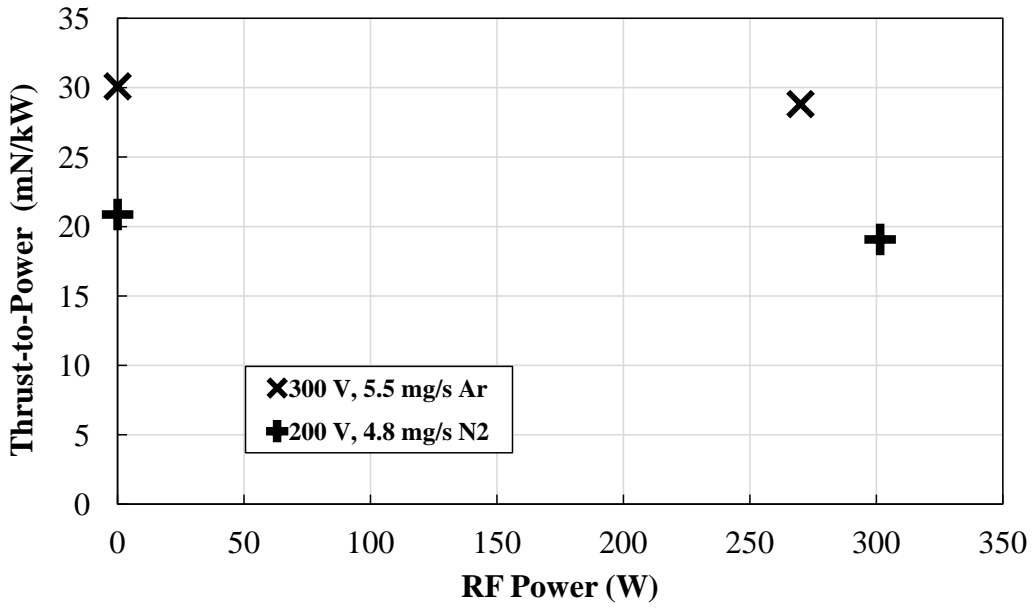


Figure 6.20: HHT two-stage thrust-to-power for the argon and nitrogen operating points.

## CHAPTER 7

### Discussion

This chapter discusses the results of RPT and HHT performance testing with the intent of identifying the loss mechanisms in the thrusters. The efficiency of the RPT was measured to be very low, and although the RF stage increased the thrust of the HHT, it did not improve the overall efficiency. This chapter first describes an efficiency methodology for each thruster to lay a framework for examining the loss mechanisms in the RPT and the HHT. Following the descriptions, the plasma probe results are analyzed according to the methodologies.

#### 7.1 RPT

The efficiency of the RPT is measured to be quite low. Previous work in similar devices measured ion beams emanating from the exit of the plasma source tube [73,97,133]. Thus, an ion beam is thought to be the physical mechanism for producing thrust in the RPT. The efficiency methodology described below assumes that this is the case, as well. Although the physics of devices similar to the RPT is an active area of research, describing the methodology for analysis provides a basis for examining the plasma emanating from the thruster with probe diagnostics.

### 7.1.1 RPT Methodology

The efficiency of a thruster may be broken down into components to reveal the loss mechanisms responsible for lowering performance. The thrust of the RPT is assumed to be the reaction force of an ion beam. In order to study the losses in the RPT, the thrust-producing ion beam is broken into three main components that can be related to plasma plume measurements: 1) the flow rate of ions in the exhaust,  $\dot{m}_i$ , 2) the velocity of the exhaust ions,  $v_i$ , and 3) the effective divergence of the beam,  $\cos \theta_{div}$ . These components can be determined by plasma measurements in the exhaust plume, as shown in Eq. 7.1, where  $I_{beam}$  is the total current of accelerated ions emanating from the thruster,  $V_i$  is the effective acceleration voltage of the beam ions, and  $I_{axial}$  is the axial component of the beam ion current. The ions are assumed to be of identical mass,  $m_i$ , and charge,  $q$ .

$$F_i = \dot{m}_i v_i \cos \theta_{div} = \left( \frac{I_{beam} m_i}{q} \right) \left( \frac{2qV_i}{m_i} \right)^{1/2} \left( \frac{I_{axial}}{I_{beam}} \right) \quad (7.1)$$

The total thruster efficiency,  $\eta_t$ , is calculated by dividing the kinetic power contained in the thrust-producing ion beam by the total electrical power supplied to the RPT. The RPT is designed to produce a wide range of magnetic field geometries, but it is not optimized for magnet power dissipation. So, the RF power,  $P_{RF}$ , and the power supplied to the magnets,  $P_{mag}$  are separated according to Eq. 7.2, where  $F_{RF}$  is the thrust due to RF power, and  $\dot{m}$  is the propellant mass flow rate.

$$\eta_t = \frac{F_{RF}^2}{2\dot{m}(P_{RF} + P_{mag})} = \frac{F_{RF}^2}{2\dot{m}P_{RF}} \frac{1}{\left(1 + \frac{P_{mag}}{P_{RF}}\right)} = \eta_{RF} \eta_{mag} \quad (7.2)$$

If a measurement of the true RF power delivered to the antenna,  $P_{RFA}$  is taken, then the RF power transmission efficiency and antenna efficiency,  $\eta_A$ , may be determined. Assuming that the cables used to transmit the RF power are lossless, the transmission efficiency is reduced to a matching network efficiency,  $\eta_M$ , as shown by Eq. 7.3, where  $\eta_{RF}$  is the RF

thrust efficiency. Note that this further breakdown requires measurements of the RF voltage and current at the antenna, which are not available in the RPT experiment. Detailed measurements of the plasma may also theoretically determine the plasma-antenna coupling efficiency (i.e. the fraction of the RF power delivered to the antenna that is absorbed by the plasma), but this is generally very difficult to implement and verify.

$$\eta_{RF} = \frac{F_{RF}^2}{2\dot{m}P_{RFA}} \frac{P_{RFA}}{P_{RF}} = \eta_A \eta_M \quad (7.3)$$

The RF thrust efficiency is further broken down into three components that represent physical attributes of the thruster exhaust. These component efficiencies can be determined from telemetry and plasma measurements according to Eq. 7.4. Other methodologies instead refer to the specific losses that certain measurements determine [67].

$$\eta_{RF} = \Phi_p \eta_{BP} \Psi_B = \left[ \frac{I_{beam} m_i}{q \dot{m}} \right] \left[ \frac{I_{beam} V_i}{P_{RF}} \right] \left[ \frac{I_{axial}}{I_{beam}} \right]^2 \quad (7.4)$$

The propellant utilization efficiency,  $\Phi_p$ , represents the fraction of the neutral gas flow that is ionized and contributes to the exhaust ion beam. The beam power efficiency,  $\eta_{BP}$ , is the ratio of the total power in the beam to the input RF power. Finally, the beam efficiency,  $\Psi_B$ , accounts for the cosine losses due to the divergence of the exhaust plume.

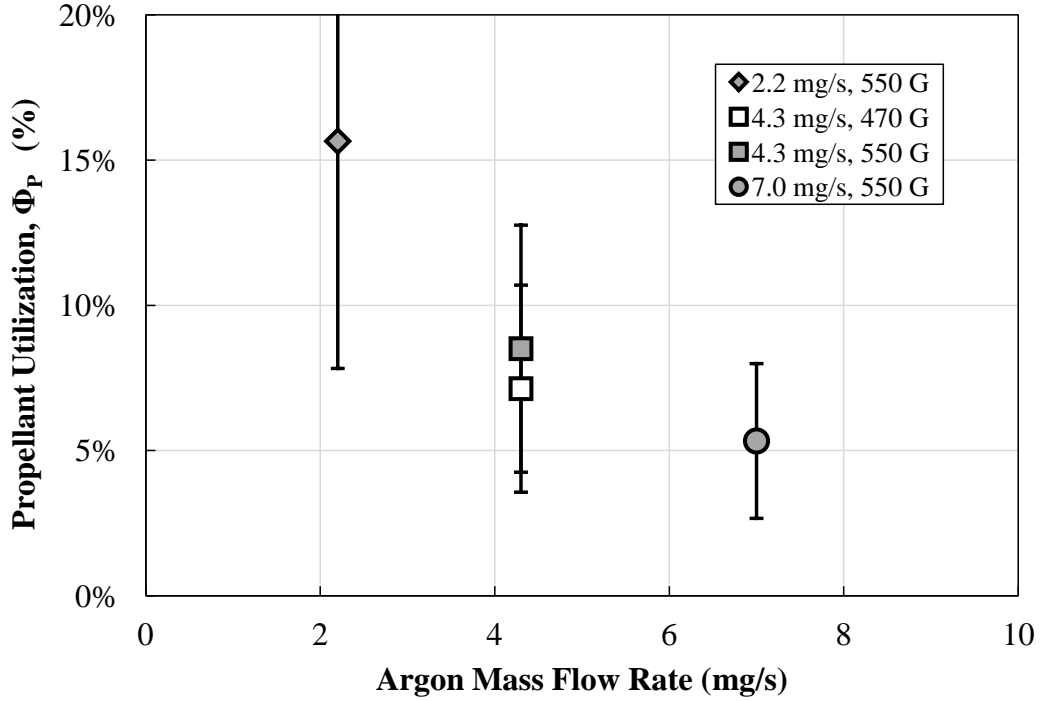
### 7.1.2 Probe Results

From the Faraday probe results, and assuming that only singly-charged ion species are present, the propellant utilization efficiency is calculated according to Eq. 7.4. The beam efficiency is calculated from Eq. 7.5.

$$\Psi_B = \left( \frac{I_{axial}}{I_{beam}} \right)^2 \quad (7.5)$$

Four data points were taken with the Faraday probe in ion saturation, and the results

are shown in Fig. 7.1. The measured propellant utilization efficiency in the RPT remained below 16%. Although differences in the RF power may confound the trends observed, the propellant utilization clearly decreased with increasing flow rate.



**Figure 7.1: RPT propellant utilization efficiency calculated from Faraday probe data.**

From Eq. 7.1 and the Faraday probe results, the average acceleration voltage of the exhaust ions required to account for the measured thrust,  $V_i$ , can be determined with Eq. 7.6. Results from this calculation and the probe measurements are presented in Table 7.1.

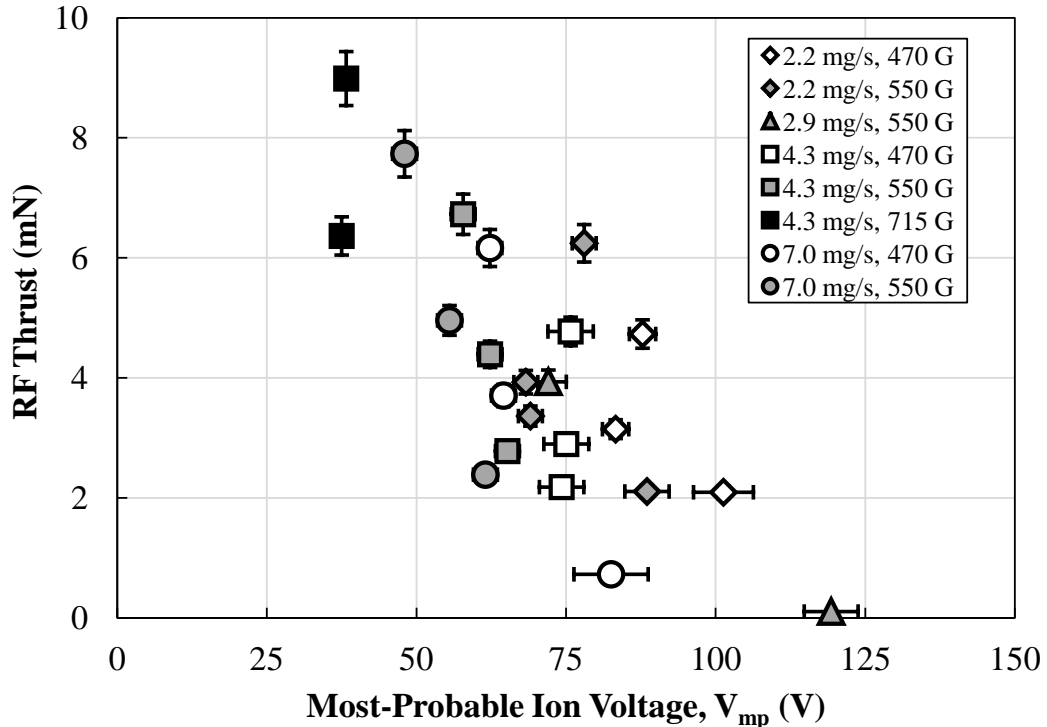
$$V_i = \left( \frac{e}{2m_i} \right) \left( \frac{F_{RF}}{I_{axial}} \right)^2 \quad (7.6)$$

If the ions measured by the probe diagnostics are the thrust-bearing species in the RPT, then the thrust due to RF should increase both with increasing axial beam current and with increasing beam ion energy, assuming that beam divergence does not change significantly between operating conditions. The results in Table 7.1 indicate that the thrust does indeed correlate with axial ion beam current, and that there is relatively little change in the beam

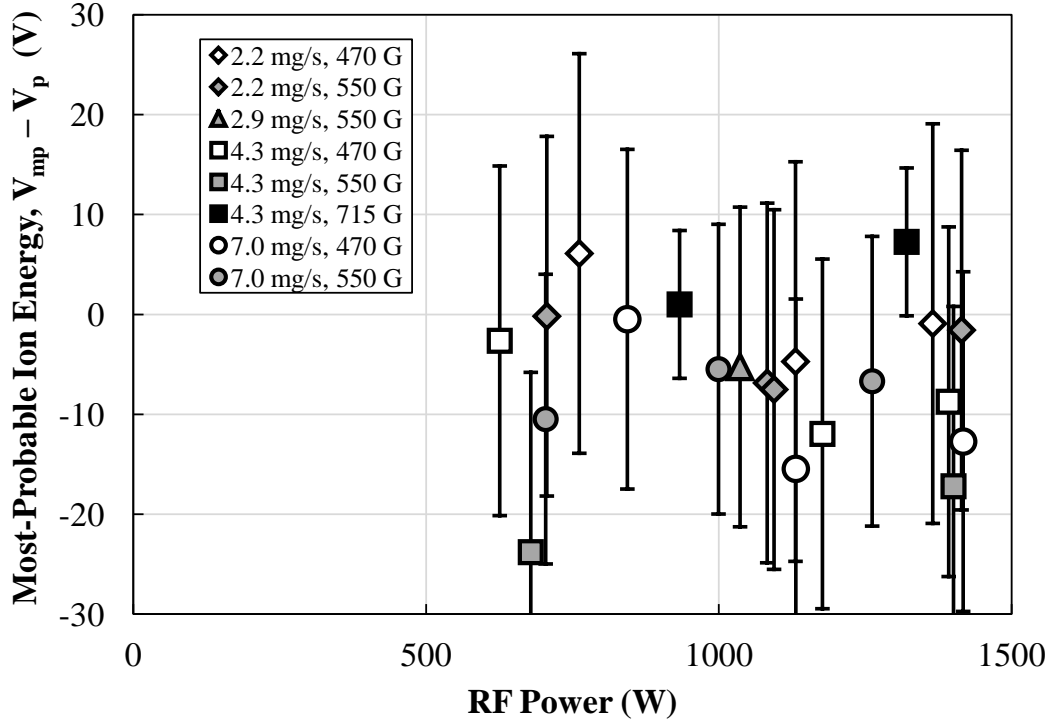
**Table 7.1: RPT Probe analysis and theoretical acceleration potential results.**

$\dot{m}$ (mg/s)	$B_z$ (G)	$P_{RF}$ (W)	$F_{RF}$ (mN)	$\eta_{RF}$ (%)	$I_{beam}$ (A)	$I_{axial}$ (A)	$\theta_{div}$ (deg)	$\Psi_B$ (%)	$\Phi_P$ (%)	$V_i$ (V)	$V_{mp}$ (V)
2.4	550	1080	4.15	0.34	0.82	0.55	48	45	14	33.7	68.4
4.7	470	1210	3.47	0.11	0.74	0.48	49	42	6.5	30.9	75.0
4.7	550	1068	3.98	0.16	0.87	0.60	46	48	7.8	26.2	62.3
7.6	550	961	4.86	0.16	0.89	0.59	48	44	4.9	40.9	55.5

divergence between conditions. Table 7.1 also suggests that the most probable voltage of the ions measured by the RPA is sufficient to provide the kinetic energy necessary to explain the thrust. If all else remains equal, the thrust should be proportional to the square root of the average beam ion kinetic energy (i.e. thrust should correlate with  $\sqrt{V_{mp}}$ ). However, the results plotted in Fig. 7.2 show that there is a negative correlation between thrust and most probable potential in the RPT. One explanation for this trend might be that the beam current decreases when beam voltage increases, with the net result that thrust decreases.



**Figure 7.2: RPT thrust due to RF power versus most probable potential measured from RPA. The negative correlation between most probable potential and thrust may be due to a decreasing beam ion current. However, the amount of beam current data available is not sufficiently large to confirm or refute this.**



**Figure 7.3: Ion beam most probable potential measured by the RPA minus local plasma potential measured by a Langmuir probe.**

Typically in Hall thruster plume analysis, the plasma potential from a Langmuir probe is subtracted from the most probable potential determined by the RPA to obtain the true exhaust ion acceleration voltage [111]. The same analysis should hold for the RPT, and if the assumption is made that only singly-charged ions are present, then the difference  $V_{mp} - V_p$  represents the kinetic energy of beam ions emanating from the RPT. This quantity is approximately zero, within the uncertainty limits, for almost all RPT operating conditions, as shown in Fig. 7.3, suggesting that the kinetic energy each exhaust ion contributes to the thrust is not necessarily related to  $V_{mp}$ . The high plasma potential may be explained by the fact that the quartz tube and magnetic field isolate the plasma from the facility ground. Due to the higher mobility of electrons, the plasma is expected to have a plasma potential that is greater than the facility ground. Thus, the outflow of plasma ions from the quartz tube should be governed by ambipolar diffusion.

If an ion beam is not the source of the thrust in the RPT, then there must be another

explanation for the increase in performance seen with increasing RF power. The measured cold gas thrust of the RPT nearly matched the theoretical result using the supersonic isentropic flow equations, and gas heating mechanisms are considered here to explain the RPT thrust. To give a first-order estimate for the potential performance gain due to gas heating in the RPT, two scenarios are considered: supersonic, isentropic expansion, and free-molecular thermalization with the quartz tube.

Assuming that the nozzle area ratio and specific heat ratio are both constant, the exit velocity of a supersonic, isentropic expansion is determined only by the stagnation temperature. The melting point of quartz is approximately 2000 degrees kelvin. No deformation of the RPT quartz tube was observed during RPT testing, but this is taken to be an upper limit on the effective temperature caused by the RF power. The result of the calculation using a 2000-degree kelvin inlet stagnation temperature and the real RPT geometry gives a specific impulse of 145 seconds. Comparing this to Fig. 6.5, there is some evidence that gas heating may have an effect at higher flow rates, as the RPT specific impulse does not exceed 160 seconds at any 7.0-milligram per second operating condition. However, this result is an optimistic assessment of the upper bound of this effect in the RPT, and the calculation requires some assumptions that are not strictly satisfied in the real RPT. That said, charge-exchange collisions may produce hot or “super-thermal” argon neutrals with a translational temperature greater than 2000 degrees kelvin. These hot neutrals may increase the effective temperature of the propellant, depending on the rates at which they are produced and lost.

A free-molecular thermalization process may also be considered for the acceleration of argon neutrals. Recall that the mean speed of a Maxwellian distribution of gas particles is determined by the temperature and the mass of the gas species, according to Eq. 3.38. If the argon propellant enters at room temperature, thermalizes to the quartz tube by collisions with the wall, and exits at this thermal velocity, then a net force can be imparted to the tube due to the change in velocity. Again taking the melting temperature of quartz as the upper

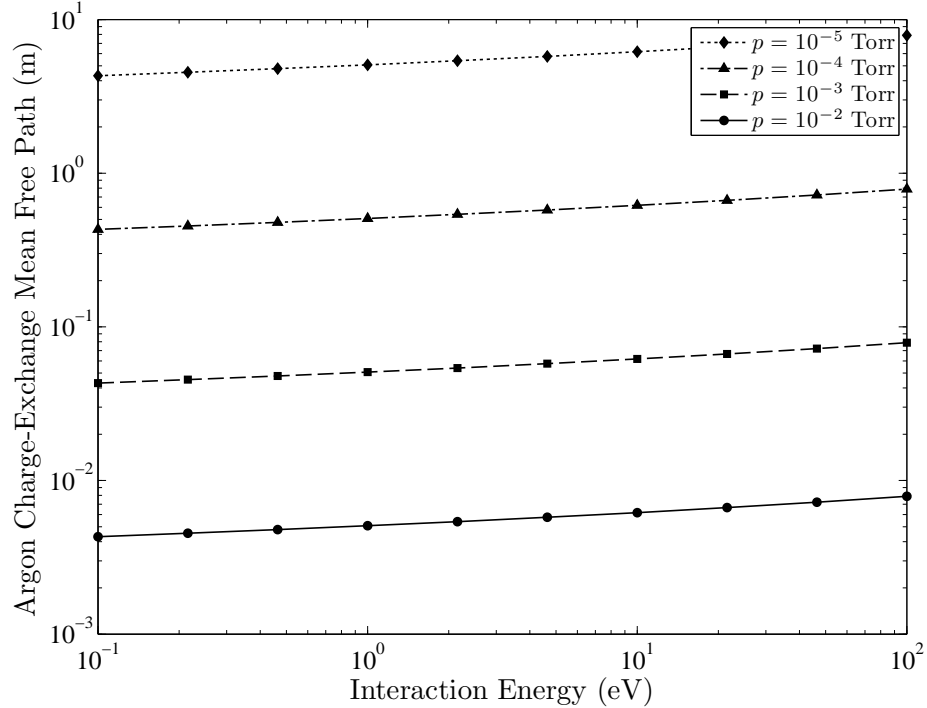


limit on the gas exit temperature, a population of argon at 2000 degrees kelvin has a mean thermal speed of 1030 meters per second, corresponding to a specific impulse of 105 seconds. The 2000-degree kelvin assumption is again optimistic (and perhaps unrealistic) for the real RPT conditions, and comparing this result to Fig. 6.5 suggests that this type of gas heating is unlikely to have a strong influence on RPT performance.

Although a gas heating mechanism should contribute to the thrust of all gases (not necessarily equally), nitrogen and air have vibrational and rotational energy modes that can absorb some of the RF power. If the rotationally and vibrationally excited molecules escape the RPT before reaching equilibrium with the translational energy modes, then the gas “heating” will not contribute to thrust. This loss mechanism is analogous to the “frozen flow” losses in chemical rocket nozzles. However, the flow in the RPT is a weakly collisional, non-equilibrium flow, and so it is difficult to model the gas behavior accurately.

Recent work has measured the thrust in similar devices to be the result of increased electron pressure in the quartz tube combined with an azimuthal electron current in the expanding magnetic field region that exerts a  $\mathbf{J} \times \mathbf{B}$  force [109]. Others have suggested that “neutral pumping” due to charge-exchange collisions in the source tube [134]. Measurements in a low-pressure argon processing chamber suggest that a significant amount of fast neutrals can be created due to charge-exchange collisions [135]. Argon charge-exchange collision cross-sections taken from Hegerberg et al. [136] and Rao et al. [137], are used to calculate the effective mean free path for charge-exchange versus collision energy. The result of this calculation is plotted for multiple neutral pressures in Fig. 7.4.

Reid demonstrated that flow simulations using FLUENT gives an order of magnitude agreement with DSMC and PIC simulations of the flow in a Hall thruster discharge channel [138]. FLUENT simulations of the RPT gas path showed that the pressure inside the quartz tube ranges from 1 to 10 millitorr [139]. This puts the mean free path for argon charge-exchange collisions in the range of approximately 0.4 to 8 centimeters. Most of the ions created in the quartz tube are therefore likely to undergo charge-exchange collisions



**Figure 7.4: Mean free path for charge exchange collisions between argon ions and neutrals. The corrected LVTF pressure when operating with argon did not exceed  $4.7 \times 10^{-6}$  Torr, but the pressure in the RPT quartz tube may be as high as a few millitorr during operation.**

that can create fast neutrals, which are not influenced by electric or magnetic fields. Argon ions created near the exit of the quartz tube, on the other hand, may be able to escape prior to experiencing a charge-exchange collision, since the low background pressure outside of the RPT increases the mean free path for charge-exchange to many meters. The single-voltage population of ions seen by the RPA may therefore represent this population of ions that are created near the exit plane and escape into the LVTF at the ambipolar velocity. The results would then agree with the theory suggested by Fruchtmann for a collisional-plasma thruster [134].

## 7.2 HHT

The plasma in the exhaust plume of the HHT operating in both single-stage and two-stage modes with argon, nitrogen, and xenon propellant was measured with a Faraday

probe, an RPA, and a Langmuir probe. When comparing the single- and two-stage operation modes, thrust increased slightly with RF power (except at the 25-milligram per second xenon operating condition). However, thrust-to-power and total anode efficiency of the HHT both consistently decreased with increasing RF power. The probe results are used with the methodology described below in order to investigate the effect of the RF stage on the physics of the HHT operation.

### 7.2.1 HHT Efficiency Methodology

There is much previous work regarding the breakdown of the total efficiency of a Hall thruster into component quantities [111, 140]. The component efficiencies are generally determined by thruster telemetry, performance measurements, and probe diagnostics, and they are used to reveal the physical nature of thruster loss mechanisms. The total efficiency,  $\eta_t$ , of any EP thruster is simply the kinetic power of the thrust-producing component of the exhaust,  $P_{jet}$ , divided by the total electrical power consumed by the thruster,  $P_{elec}$ , as shown by Eq. 7.7, where  $\dot{m}$  is the propellant mass flow rate,  $v_{ex}$  is the effective propellant exhaust velocity,  $P_d$  is the discharge power, and  $P_{mag}$  is the power supplied to the magnets.

$$\eta_t = \frac{P_{jet}}{P_{elec}} = \frac{\frac{1}{2}\dot{m}v_{ex}^2}{P_d + P_{mag}} \quad (7.7)$$

In laboratory-model Hall thrusters, such as the HHT, the magnetic circuit design is generally not optimized for power consumption, and so a magnet power efficiency,  $\eta_{mag}$ , is separated accordingly. In addition, the cathode is not always optimized as it would be on a flight model thruster, so the cathode efficiency,  $\eta_c$ , is also separated. The results of this breakdown allow the discharge or anode efficiency,  $\eta_d$  or  $\eta_a$ , respectively, to be individually examined, as shown in Eq. 7.8, where  $\dot{m}_a$  is the anode mass flow rate, and  $\dot{m}_c$  is the cathode mass flow rate.

$$\eta_t = \frac{\frac{1}{2}\dot{m}_a v_{ex}^2}{P_d} \left(1 + \frac{\dot{m}_c}{\dot{m}_a}\right) \frac{1}{\left(1 + \frac{P_{mag}}{P_d}\right)} = \eta_a \eta_c \eta_{mag} = \eta_d \eta_{mag} \quad (7.8)$$

Brown et al. suggest that using the “voltage exchange parameter,”  $E_1$ , and the “mass exchange parameter,”  $E_2$ , can help reveal loss mechanisms using only telemetry and thrust measurements, as represented in Eq. 7.9 [140], where  $F_{thrust}$  is the thrust force,  $V_d$  is the discharge voltage,  $\mathcal{F}$  is the Faraday constant,  $\mathcal{M}$  is the propellant molar mass,  $I_d$  is the discharge current,  $\Phi_p$  is the propellant utilization efficiency,  $\Psi_B$  is the beam efficiency,  $\eta_v$  is the voltage utilization, and  $\eta_i$  is the current utilization.

$$\eta_d = E_1 E_2 = \left[ \frac{\frac{1}{2} \left( \frac{F_{thrust}}{\dot{m}} \right)^2}{V_d \left( \frac{\mathcal{F}}{\mathcal{M}} \right)} \right] \left[ \frac{\dot{m} \mathcal{F}}{I_d \mathcal{M}} \right] = [\Phi_p \Psi_B \eta_v] [\eta_i] \quad (7.9)$$

The voltage exchange parameter is proportional to the square of the thrust, and it relates the acceleration voltage to the divergence and dispersion of the exhaust jet. The mass exchange parameter is inversely proportional to the discharge current, and it relates the input propellant flow rate to the output charge flow rate. Determination of any further component efficiencies requires the use of probe diagnostics in the thruster exhaust plume, which were previously described.

The difference between single-stage and two-stage operation is that two-stage operation uses RF power to affect the discharge in the vicinity of the gas inlet manifold. This is accounted for in the efficiency architecture by separating the DC and RF components of electrical power in the discharge,  $P_{DC}$  and  $P_{RF}$ , respectively, as shown in Eq. 7.10, where  $\eta_{PRF}$  is called the “RF efficiency.”

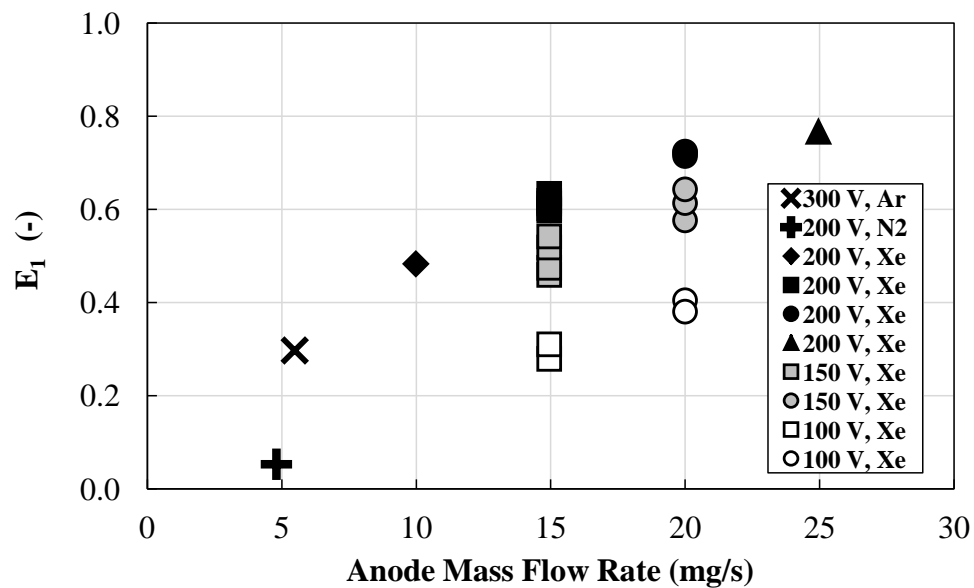
$$\eta_d = \frac{\frac{1}{2}\dot{m}_a v_{ex}^2}{P_{DC} + P_{RF}} \eta_c = \eta_a \frac{1}{\left(1 + \frac{P_{RF}}{P_{DC}}\right)} \eta_c = \eta_a \eta_{PRF} \eta_c \quad (7.10)$$

This definition of RF efficiency is consistent with the single-stage architecture, since  $\eta_{PRF} = 1$  when zero RF power is used. The exchange parameters can therefore retain their

definition from Eq. 7.9. This allows the effect of the RF power on thruster performance characteristics to be examined through the exchange parameters. In order to evaluate the net effect of RF power on propulsive efficiency, however, the RF efficiency must also be included.

### 7.2.2 HHT Single-Stage

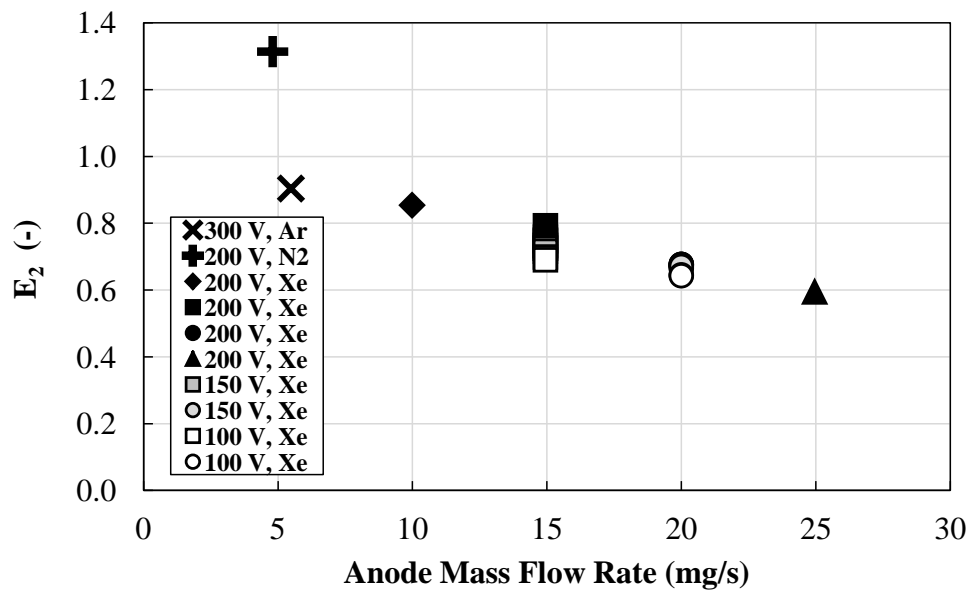
In order to investigate the HHT loss mechanisms during operation with alternative propellants without using probe data, the exchange parameters are plotted as a function of anode mass flow rate in Figs. 7.5 and 7.6. Because the cathode flow is xenon for all operating conditions, the weighted average molar mass of the cathode and anode flow is used in the calculations.



**Figure 7.5: HHT single-stage voltage exchange parameter versus anode mass flow rate.  $E_1$  relates the effective exhaust velocity of the plume to the discharge voltage, taking into account the molar mass of the propellant.**

Figure 7.5 shows that the voltage exchange parameter generally increases with anode mass flow rate and voltage. Although the nitrogen and argon operating conditions were at higher discharge voltages,  $E_1$  remained low. The argon operating condition  $E_1$  was compa-

rable to the 100-volt, 15-milligram per second xenon case, despite operating at 300 volts. Linearly extrapolating the 100-volt xenon points to lower flow rates would appear to intersect the nitrogen operating point. Thus, it may simply be the low mass flow rate that explains the low value of  $E_1$ . However, the argon point appears that it may have a lower  $E_1$  than would a 300-volt operating condition with an equivalent xenon mass flow rate. The lower  $E_1$  for argon and nitrogen reflects the fact that the effective exhaust velocity of the propellant is very low considering the low molar mass of the propellant and the high discharge voltage. This means that HHT is suffering from either much lower propellant utilization, larger beam divergence, or lower voltage utilization when operating with argon and nitrogen as opposed to xenon.

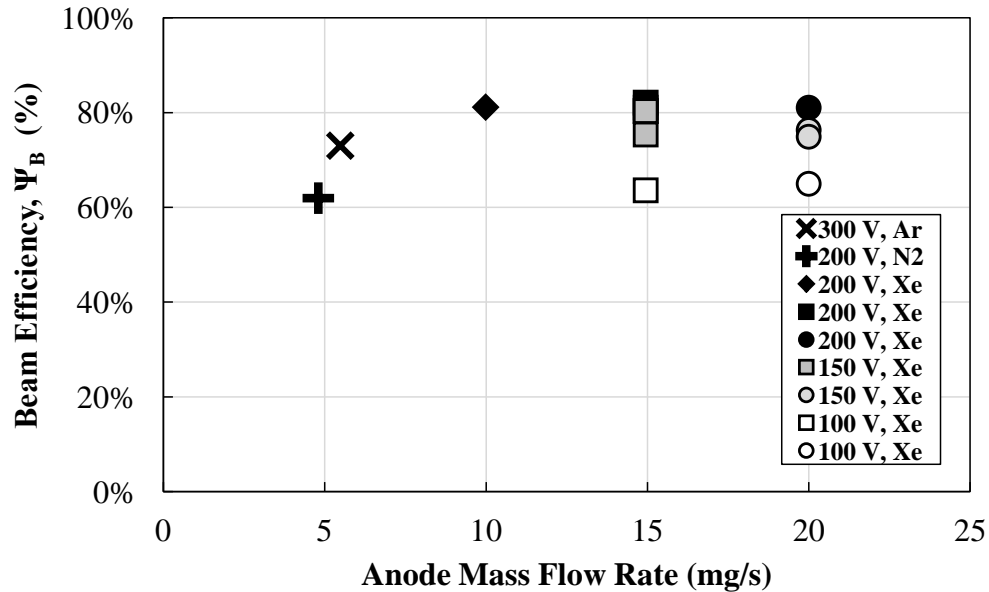


**Figure 7.6: HHT single-stage mass exchange parameter versus anode mass flow rate.  $E_2$  relates the output flow of charge in the thruster to the inflow of propellant.**

Figure 7.6 shows that the mass exchange parameter,  $E_2$ , for xenon operation decreases with anode mass flow rate, and is not significantly affected by discharge voltage.  $E_2$  for argon appears to follow the trend for xenon, but  $E_2$  for nitrogen is much higher. The mass exchange parameter compares the charge flow in the thruster to the inflow of propellant molecules to the thruster. Thus, the high value of  $E_2$  may suggest that a significant portion

of the molecular nitrogen propellant is dissociating into atomic nitrogen.

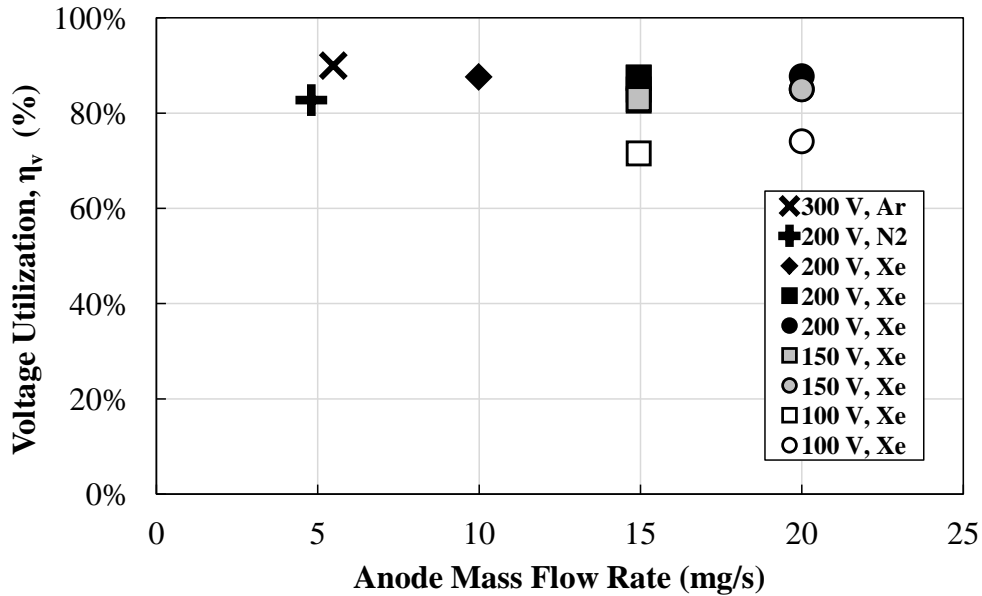
The HHT beam efficiency is calculated from the Faraday probe data, and the results are shown in Fig. 7.7.



**Figure 7.7: HHT single-stage beam efficiency versus anode mass flow rate. Higher beam efficiency is equivalent to a less divergent plume.**

Previous experiments have shown that beam efficiency increases with increasing discharge voltage, and weakly increases with increasing anode flow rate [140]. However, Fig. 7.7 shows that the HHT's beam divergence for the 200-volt nitrogen condition is equivalent to the 100-volt xenon conditions, and the divergence of the 300-volt argon condition is nearly the same as the 150-volt xenon conditions. This result suggests that the beam divergence efficiency is affected by propellant gas species, and not simply mass flow rate. This finding is consistent with the results seen by Linell, who showed that krypton propellant consistently had a lower beam efficiency than xenon for equivalent operating conditions in the NASA-173Mv1 Hall thruster [49]. Although the beam efficiency is lower for the nitrogen and argon operating points, divergence alone does not entirely account the lower values of the voltage exchange parameter seen in both.

Results calculated from the RPA and Langmuir probe data are plotted in Fig. 7.8.



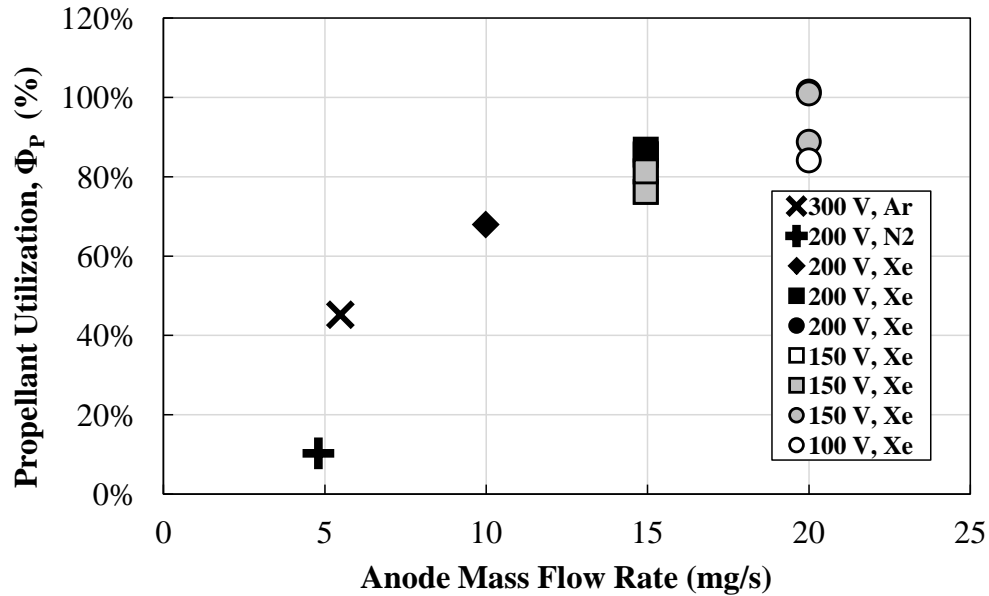
**Figure 7.8: HHT voltage utilization efficiency plotted versus anode mass flow rate.**

The data show that argon and nitrogen voltage utilization efficiency does not have a significant deficit compared to xenon. The slightly higher voltage utilization of the argon operating point may simply be explained by the fact that voltage utilization tends to increase with increasing discharge voltage. The nitrogen operating point appears to fall in line with the 200-volt xenon trend. Discharge voltage is the dominant factor in determining voltage utilization, further evidenced by the lower voltage utilization of the 100-volt xenon operating points.

The voltage exchange parameter is the product of the propellant utilization, the beam efficiency, and the voltage utilization. So, taking the results from Figs. 7.5 to 7.8 with Eq. 7.9, the propellant utilization is calculated by dividing  $E_1$  by the beam efficiency and the voltage utilization. The resulting values are shown in Fig. 7.9.

This calculation shows that the HHT suffers from a very poor propellant utilization when operating with nitrogen and argon in single-stage mode. This conclusion again follows well with the results reported by Linnell, who stated that “the beam divergence accounts for a loss equally important as propellant utilization” when referring to operation with krypton versus xenon propellant [49].





**Figure 7.9: HHT propellant utilization deduced from  $E_1$ ,  $\Psi_b$ , and  $\eta_v$ , and plotted versus anode mass flow rate. The uncertainty in the 20-mg/s extends below 100%.**

Diatomic nitrogen and argon have nearly the same first ionization energy, 15.58 eV and 15.76 eV, respectively, compared to 12.13 eV for xenon [141]. However, the decrease in propellant utilization, especially for nitrogen, is disproportionately larger than the 30% difference in ionization energy compared to xenon. Although rotational and vibrational excitation can sink energy away from a nitrogen discharge, no significant difference in voltage utilization or propellant utilization is seen between nitrogen and argon. While the low efficiency measured in the 100-volt xenon operating conditions is spread across multiple loss mechanisms, the major loss for argon and nitrogen is due to the significantly lower propellant utilization. In particular, the poor nitrogen propellant utilization may be explained by the fact that a nitrogen molecule, with a bond energy of 9.8 eV, can split into a pair of nitrogen atoms that each have a 14.53 eV first ionization energy [141]. Thus, dissociation of the nitrogen molecule can sink energy away from the discharge, and transform the propellant into gas species that require even more energy to ionize.

### 7.2.3 HHT Two-Stage

Because RF efficiency is defined separately from anode efficiency, the exchange parameters can be used to investigate how the RF power affects the overall thruster behavior. The voltage and mass exchange parameters are plotted against RF power in Fig. 7.10 and 7.11, respectively. Figure 7.10 shows that the voltage exchange parameter increases slightly with RF power. The trend decreases with increasing anode mass flow rate for xenon operating conditions, with RF power having no effect for the 25-milligram per second xenon conditions. The value of  $E_1$  for the 100-volt, 20-milligram per second xenon operating condition increased by 26% with the application of 1030 watts of RF power. Only one operating point each for argon and nitrogen with RF power were measured, but 270 watts of RF caused the argon  $E_1$  value to increase by approximately 5%, and 300 watts of RF caused the nitrogen  $E_1$  value to increase by approximately 17%.

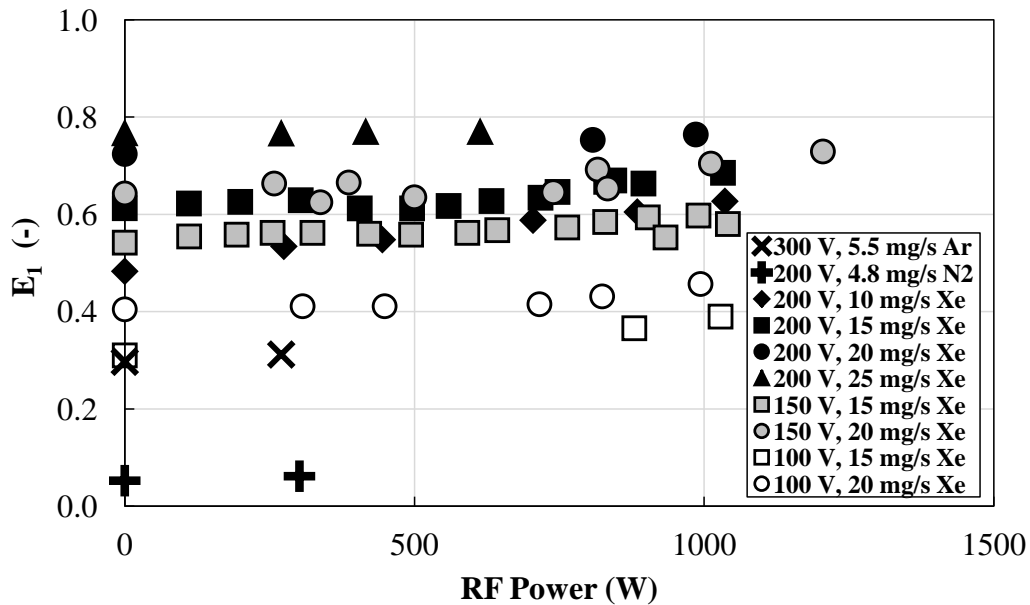


Figure 7.10: HHT two-stage voltage exchange parameter versus RF power.

Current utilization, which is equal to the mass exchange parameter, was not significantly affected by RF power, as shown in Fig. 7.11. However, an approximately 10% decrease in the mass exchange parameter was measured for the 200-volt, 25-milligram per

second xenon condition operating with 610 watts of RF power. The value of  $E_2$  for nitrogen decreased by about 2% with 300 watts of RF applied.

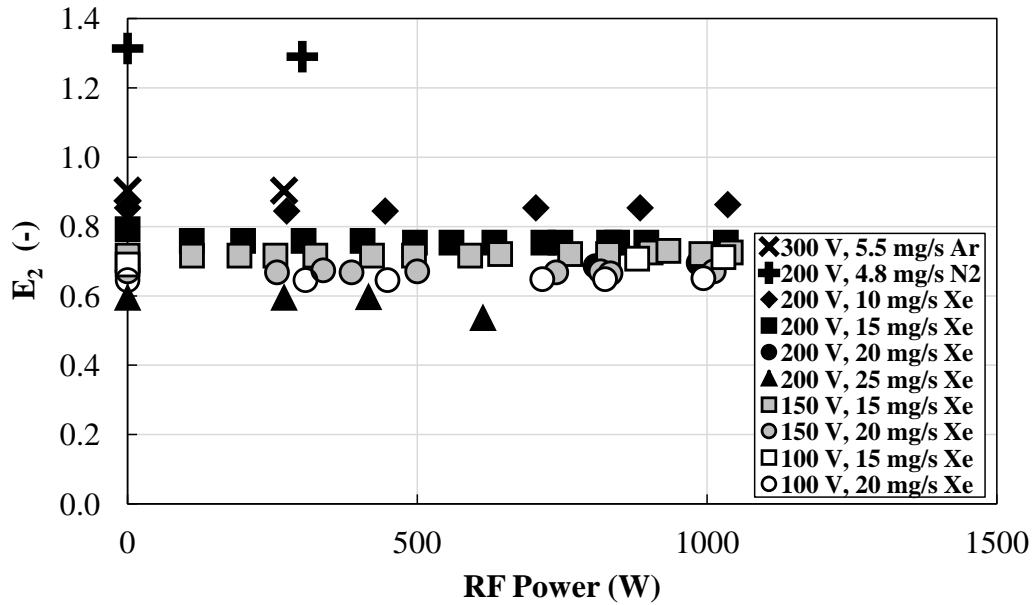


Figure 7.11: HHT two-stage mass exchange parameter versus RF power.

Faraday probe measurements were taken to determine the beam efficiency of the HHT operating in two-stage mode. The results are plotted in Fig. 7.12, and suggest that the RF-stage did not significantly affect the beam efficiency for the conditions that were measured.

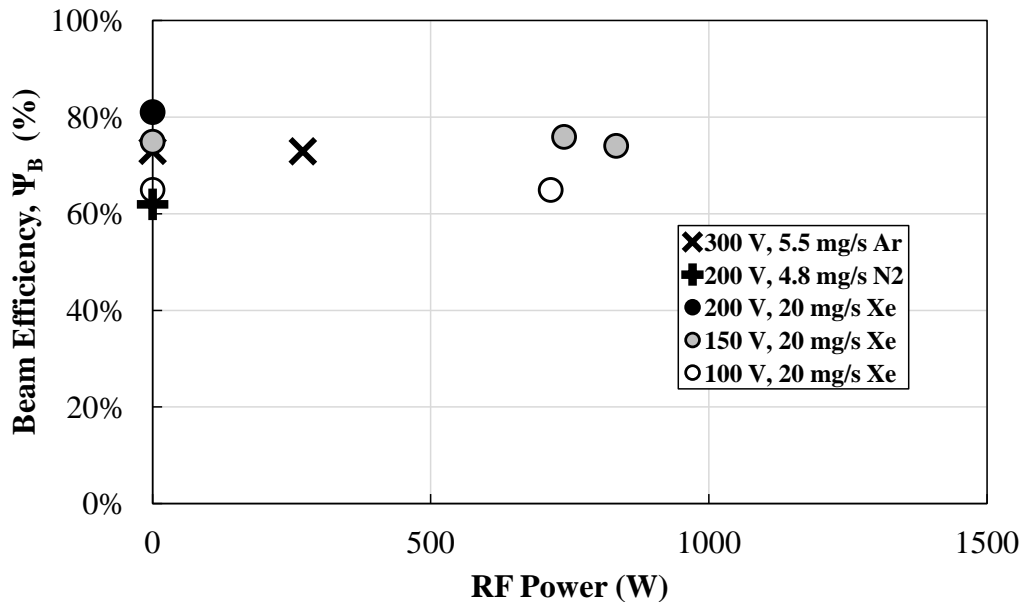
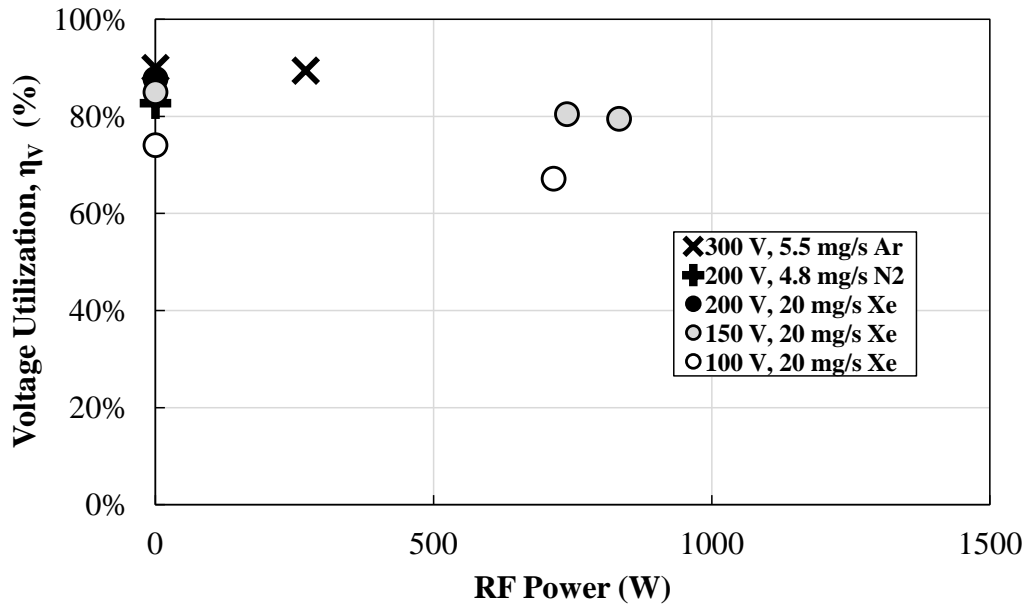


Figure 7.12: HHT two-stage beam divergence efficiency versus RF power.

The voltage utilization was calculated using the RPA and Langmuir probe measurements, as well as the HHT discharge current. The results are plotted in Fig. 7.13 as a function of RF power. The results indicate that the voltage utilization tended to decrease with increasing RF power. Probe data was not taken for the nitrogen operating point in two-stage mode, but the 100-volt, 20-milligram per second xenon operating condition experienced a 9% decrease in the voltage utilization when 720 watts of RF power was applied.



**Figure 7.13: HHT two-stage voltage utilization efficiency versus RF power.**

The probe results together with the voltage and mass exchange parameter measurements plotted in Fig. 7.10 and 7.11 indicate that the RF power indeed increased propellant utilization efficiency. The propellant utilization of the 100-volt, 20-milligram per second xenon condition increased by 13% with 720 watts of RF power, and the propellant utilization of the argon operating condition increased by about 6%. However, the increase in propellant utilization is not sufficient to overcome the reduced efficiency due to the use of RF power, and so the thrust-to-power decreases with increasing RF power for all operating conditions.

## **CHAPTER 8**

### **Conclusions**

This dissertation has explored whether air-breathing EP is possible with currently available technology. In particular, RF plasma technology was applied to investigate whether it may increase the performance of an air-breathing thruster. Chapter 2 showed that the concept of an air-breathing spacecraft is feasible, and that it may provide a practical benefit over a conventional electric propulsion system if it is possible to operate at approximately 200-kilometer orbit altitudes. The specific impulse requirements of an air-breathing thruster matched well with reported ion beam energies measured downstream of a helicon plasma source; however, there were no published direct thrust measurements available. To address this void in the literature, the RPT was designed and built to test whether a helicon source could provide the thrust necessary for a small, air-breathing demonstration mission. Hall thrusters have the appropriate performance characteristics when operating with xenon, but they have specific life-limiting mechanisms, and do not operate efficiently with alternative propellants. So, the HHT was operated with nitrogen to determine whether an RF ionization stage could increase the overall efficiency of a Hall thruster operating with atmospheric gas.

## 8.1 Air-Breathing Thrusters

Performance measurements of the RPT showed that the overall thrust and efficiency are quite low, and that the current theoretical descriptions of helicon plasma source operation are not necessarily sufficient for designing an RF plasma thruster. Although the elimination of the hollow cathode provides a strong motivation to continue pursuing this type of thruster, the physics responsible for thrust production must be determined more concretely in order to guide the design process. The lack of thrust generated by the RPT with nitrogen and air, despite a double-peaked RPA structure and bright plasma suggests that there is still much to be understood about how an RF thruster interacts with the propellant.

The DC acceleration voltage required for an air-breathing electric thruster is lower than the efficient operating range of Hall thrusters, and the thrust-to-power is on the high side for typical Hall thrusters that use xenon propellant. Hall thrusters also operate at lower efficiency when using alternate propellants, so the HHT was used to test whether an RF ionization stage could boost the overall efficiency of a Hall thruster operating with nitrogen propellant.

At approximately 20 millinewtons per kilowatt, the HHT thrust-to-power for nitrogen operation is in the range where it could allow an air-breathing spacecraft to operate below 300-kilometer orbit altitudes. However, the RF stage did not improve the overall efficiency of the HHT. These results merit the investigation of a single-stage Hall thruster that is designed to work with nitrogen propellant. Magnetic shielding and erosion rates have not been studied in Hall thrusters operating with atmospheric gases, and the lifetime of a Hall thruster operating with nitrogen and oxygen must be explored in order to determine whether Hall thrusters can provide a long-term air-breathing propulsion solution. In addition, the material compatibility issues between hollow cathode inserts and atmospheric gases must be resolved before a fully air-breathing Hall thruster is possible.

## 8.2 Future Work

Eliminating the need for a hollow cathode would greatly simplify the task of creating an air-breathing EP system. This one factor merits further investigation into ambipolar and magnetic nozzle thruster concepts like the RPT. Future work should focus on improving the knowledge of the physics responsible for producing thrust in devices similar to the RPT. Some of the physics, such as magnetic field detachment of the plasma, are difficult to study in ground-based facilities. However, using proper scaling, smaller thrusters, and larger facilities may mitigate the facility effects to the point where practical knowledge can be gained.

State-of-the-art DC thrusters already have the appropriate performance characteristics to operate with atmospheric propellant. However, they require an electron source to operate. The creation of a high-current, low-power, oxygen-compatible cathode would greatly aid the development of any DC air-breathing thruster concept. Microwave cathodes have been operated on DC EP systems that have flown in space. These cathodes typically operate with xenon propellant. So, it would be beneficial to determine a microwave cathode is capable of operating at high current with atmospheric gases. Other future work related to DC thrusters might focus on the development of a Hall thruster that is magnetically shielded, and that is designed to operate with nitrogen and oxygen propellant.

In addition to the thruster, there has been very little experimental research into the design of an inlet for the air-breathing spacecraft. An efficient inlet would reduce the performance requirements of the propulsion system, and so it is an equally important component that must be developed concurrently with an air-breathing thruster.

To continue working with the RPT and HHT at PEPL, the following specific work could greatly improve the body of knowledge regarding RF plasma thrusters:

1. Helicon waves were not measured in the HHT or RPT. It would be beneficial to the helicon community to perform a B-dot probe study with the RPT to determine

whether helicon waves are excited. There is very little published experimental work regarding annular helicon plasma sources, and no published experimental measurements of annular helicon waves.

2. The RPT thrust increased most strongly with magnetic field strength. This merits a thorough plume study with the RPT operating at even higher magnetic field strengths.
3. The matching network and antennas were not optimized to reduce ohmic dissipation. To improve RF efficiency, applying a silver-coating to all RF connections will reduce the RF circuit resistances (including connectors and antennas).
4. The losses in the matching network are unknown. The matching network should be instrumented so that measurements of the antenna voltage and current can be recorded. This will allow the study of matching network and plasma-antenna coupling efficiencies, on which there is very little published experimental work.
5. The HHT and RPT antenna designs may not have been optimal for plasma coupling, yet the HHT results indicated an increased propellant utilization efficiency. This merits a further design study for both the RPT and HHT.



# APPENDIX A

## Atmospheric Data

Tables A.1– A.3 show the data that was used for the air-breathing spacecraft calculations. The data is from a draft international standard by the International Organization for Standardization titled “Space environment (natural and artificial) – Earth upper atmosphere” (ISO/DIS 14222) [40]. ISO/DIS 14222 lists equatorial atmospheric reference data for 0–900-kilometer altitudes from the NRLMSISE-00 model for different levels of solar and geomagnetic activity. The data at 100–500-kilometer altitudes for low, moderate, and high solar and geomagnetic activity levels are given in Table A.1, A.2, and A.3, respectively.

**Table A.1: Altitude profiles of atmospheric constituents for low solar and geomagnetic activity.**

Altitude (km)	Density (kg/m <sup>3</sup> )	Temp. (K)	Gas Species Number Densities (m <sup>-3</sup> )							
			$n_O$	$n_{N_2}$	$n_{O_2}$	$n_{He}$	$n_{Ar}$	$n_H$	$n_N$	$n_{Anom. O}$
100	6.18E-07	1.71E+02	4.78E+17	1.02E+19	2.38E+18	1.17E+14	1.04E+17	2.70E+13	3.10E+11	2.24E-37
120	1.88E-08	3.53E+02	7.23E+16	3.11E+17	4.36E+16	2.50E+13	1.36E+15	6.07E+12	1.19E+12	1.41E-27
140	3.08E-09	5.21E+02	2.12E+16	4.89E+16	4.45E+15	1.50E+13	1.09E+14	2.17E+12	6.16E+12	2.44E-19
160	9.49E-10	6.05E+02	9.37E+15	1.38E+16	1.06E+15	1.16E+13	1.88E+13	1.09E+12	1.61E+13	1.12E-12
180	3.70E-10	6.48E+02	4.88E+15	4.76E+15	3.34E+14	9.61E+12	4.23E+12	7.31E+11	2.20E+13	1.45E-07
200	1.63E-10	6.70E+02	2.73E+15	1.80E+15	1.15E+14	8.21E+12	1.08E+12	5.94E+11	2.02E+13	1.20E-03
220	7.80E-11	6.82E+02	1.59E+15	7.14E+14	4.11E+13	7.12E+12	2.98E+11	5.32E+11	1.51E+13	1.22E+00
240	3.97E-11	6.88E+02	9.42E+14	2.93E+14	1.51E+13	6.21E+12	8.62E+10	4.98E+11	1.04E+13	2.43E+02
260	2.13E-11	6.92E+02	5.66E+14	1.23E+14	5.66E+12	5.45E+12	2.59E+10	4.75E+11	6.85E+12	1.40E+04
280	1.18E-11	6.94E+02	3.44E+14	5.27E+13	2.16E+12	4.78E+12	8.02E+09	4.57E+11	4.50E+12	3.08E+05
300	6.80E-12	6.95E+02	2.10E+14	2.30E+13	8.42E+11	4.21E+12	2.54E+09	4.41E+11	2.96E+12	3.26E+06
320	4.01E-12	6.96E+02	1.30E+14	1.01E+13	3.33E+11	3.71E+12	8.22E+08	4.27E+11	1.96E+12	1.96E+07
340	2.41E-12	6.96E+02	8.05E+13	4.54E+12	1.33E+11	3.28E+12	2.71E+08	4.13E+11	1.30E+12	7.64E+07
360	1.47E-12	6.96E+02	5.02E+13	2.06E+12	5.42E+10	2.90E+12	9.06E+07	4.00E+11	8.74E+11	2.13E+08
380	9.14E-13	6.96E+02	3.15E+13	9.43E+11	2.23E+10	2.56E+12	3.07E+07	3.87E+11	5.88E+11	4.60E+08
400	5.75E-13	6.96E+02	1.99E+13	4.37E+11	9.29E+09	2.27E+12	1.06E+07	3.75E+11	3.98E+11	8.15E+08
420	3.66E-13	6.96E+02	1.26E+13	2.04E+11	3.91E+09	2.01E+12	3.66E+06	3.64E+11	2.70E+11	1.24E+09
440	2.35E-13	6.96E+02	8.06E+12	9.61E+10	1.66E+09	1.78E+12	1.29E+06	3.53E+11	1.85E+11	1.69E+09
460	1.53E-13	6.96E+02	5.17E+12	4.56E+10	7.13E+08	1.58E+12	4.55E+05	3.42E+11	1.26E+11	2.09E+09
480	1.01E-13	6.96E+02	3.33E+12	2.18E+10	3.09E+08	1.41E+12	1.63E+05	3.32E+11	8.68E+10	2.42E+09
500	6.79E-14	6.96E+02	2.15E+12	1.05E+10	1.35E+08	1.25E+12	5.87E+04	3.22E+11	5.99E+10	2.66E+09

**Table A.2: Altitude profiles of atmospheric constituents for mean solar and geomagnetic activity.**

Altitude (km)	Density (kg/m <sup>3</sup> )	Temp. (K)	Gas Species Number Densities (m <sup>-3</sup> )							
			$n_O$	$n_{N_2}$	$n_{O_2}$	$n_{He}$	$n_{Ar}$	$n_H$	$n_N$	$n_{Anom. O}$
100	5.73E-07	1.88E+02	5.22E+17	9.60E+18	2.00E+18	1.16E+14	9.71E+16	1.89E+13	3.76E+11	7.28E-37
120	2.03E-08	3.65E+02	9.27E+16	3.36E+17	3.95E+16	3.08E+13	1.49E+15	3.47E+12	1.77E+12	5.52E-27
140	3.44E-09	6.10E+02	2.73E+16	5.38E+16	3.84E+15	1.83E+13	1.26E+14	8.82E+11	9.45E+12	8.98E-19
160	1.20E-09	7.59E+02	1.31E+16	1.72E+16	9.29E+14	1.39E+13	2.64E+13	3.46E+11	2.73E+13	4.12E-12
180	5.46E-10	8.53E+02	7.47E+15	7.08E+15	3.22E+14	1.16E+13	7.67E+12	2.01E+11	4.18E+13	5.33E-07
200	2.84E-10	9.11E+02	4.67E+15	3.27E+15	1.31E+14	1.00E+13	2.61E+12	1.53E+11	4.31E+13	4.43E-03
220	1.61E-10	9.49E+02	3.06E+15	1.62E+15	5.81E+13	8.91E+12	9.73E+11	1.33E+11	3.64E+13	4.48E+00
240	9.60E-11	9.73E+02	2.07E+15	8.36E+14	2.71E+13	8.00E+12	3.84E+11	1.23E+11	2.82E+13	8.94E+02
260	5.97E-11	9.88E+02	1.43E+15	4.44E+14	1.31E+13	7.24E+12	1.58E+11	1.17E+11	2.10E+13	5.14E+04
280	3.83E-11	9.98E+02	9.94E+14	2.40E+14	6.48E+12	6.59E+12	6.69E+10	1.13E+11	1.56E+13	1.14E+06
300	2.52E-11	1.00E+03	7.00E+14	1.32E+14	3.27E+12	6.01E+12	2.90E+10	1.10E+11	1.15E+13	1.20E+07
320	1.69E-11	1.01E+03	4.96E+14	7.35E+13	1.67E+12	5.50E+12	1.28E+10	1.07E+11	8.60E+12	7.22E+07
340	1.16E-11	1.01E+03	3.54E+14	4.13E+13	8.66E+11	5.04E+12	5.75E+09	1.05E+11	6.45E+12	2.81E+08
360	7.99E-12	1.01E+03	2.54E+14	2.35E+13	4.54E+11	4.62E+12	2.61E+09	1.02E+11	4.86E+12	7.85E+08
380	5.60E-12	1.01E+03	1.83E+14	1.34E+13	2.40E+11	4.24E+12	1.20E+09	1.00E+11	3.68E+12	1.69E+09
400	3.96E-12	1.02E+03	1.32E+14	7.74E+12	1.28E+11	3.90E+12	5.61E+08	9.79E+10	2.79E+12	3.00E+09
420	2.83E-12	1.02E+03	9.56E+13	4.50E+12	6.90E+10	3.59E+12	2.64E+08	9.59E+10	2.13E+12	4.57E+09
440	2.03E-12	1.02E+03	6.96E+13	2.63E+12	3.74E+10	3.30E+12	1.25E+08	9.38E+10	1.63E+12	6.21E+09
460	1.47E-12	1.02E+03	5.08E+13	1.55E+12	2.05E+10	3.04E+12	6.00E+07	9.19E+10	1.25E+12	7.70E+09
480	1.07E-12	1.02E+03	3.72E+13	9.15E+11	1.13E+10	2.80E+12	2.90E+07	9.00E+10	9.59E+11	8.92E+09
500	7.85E-13	1.02E+03	2.73E+13	5.44E+11	6.24E+09	2.58E+12	1.41E+07	8.81E+10	7.39E+11	9.81E+09

**Table A.3: Altitude profiles of atmospheric constituents for high solar and geomagnetic activity.**

Altitude (km)	Density (kg/m <sup>3</sup> )	Temp. (K)	Gas Species Number Densities (m <sup>-3</sup> )							
			$n_O$	$n_{N_2}$	$n_{O_2}$	$n_{He}$	$n_{Ar}$	$n_H$	$n_N$	$n_{Anom. O}$
100	5.64E-07	2.02E+02	5.70E+17	9.71E+18	1.72E+18	1.21E+14	9.73E+16	1.43E+13	5.38E+11	1.57E-36
120	2.22E-08	3.80E+02	1.15E+17	3.72E+17	3.37E+16	3.61E+13	1.62E+15	2.13E+12	3.08E+12	1.36E-26
140	3.93E-09	7.10E+02	3.51E+16	6.07E+16	3.02E+15	2.09E+13	1.43E+14	3.93E+11	1.76E+13	2.12E-18
160	1.54E-09	9.16E+02	1.86E+16	2.17E+16	6.80E+14	1.59E+13	3.51E+13	1.24E+11	5.84E+13	9.74E-12
180	7.87E-10	1.05E+03	1.15E+16	1.00E+16	2.29E+14	1.34E+13	1.21E+13	6.34E+10	1.02E+14	1.26E-06
200	4.57E-10	1.14E+03	7.72E+15	5.24E+15	9.68E+13	1.17E+13	4.91E+12	4.52E+10	1.18E+14	1.05E-02
220	2.86E-10	1.19E+03	5.42E+15	2.93E+15	4.65E+13	1.05E+13	2.18E+12	3.83E+10	1.09E+14	1.06E+01
240	1.87E-10	1.23E+03	3.93E+15	1.71E+15	2.42E+13	9.62E+12	1.03E+12	3.51E+10	9.18E+13	2.11E+03
260	1.27E-10	1.25E+03	2.90E+15	1.03E+15	1.32E+13	8.85E+12	5.02E+11	3.34E+10	7.39E+13	1.22E+05
280	8.87E-11	1.27E+03	2.17E+15	6.30E+14	7.43E+12	8.19E+12	2.52E+11	3.23E+10	5.87E+13	2.68E+06
300	6.31E-11	1.28E+03	1.64E+15	3.91E+14	4.28E+12	7.60E+12	1.30E+11	3.15E+10	4.65E+13	2.84E+07
320	4.56E-11	1.29E+03	1.25E+15	2.46E+14	2.51E+12	7.07E+12	6.77E+10	3.08E+10	3.70E+13	1.71E+08
340	3.34E-11	1.30E+03	9.53E+14	1.56E+14	1.49E+12	6.59E+12	3.59E+10	3.02E+10	2.95E+13	6.65E+08
360	2.47E-11	1.30E+03	7.32E+14	1.00E+14	8.94E+11	6.16E+12	1.93E+10	2.97E+10	2.36E+13	1.85E+09
380	1.85E-11	1.30E+03	5.65E+14	6.44E+13	5.41E+11	5.75E+12	1.05E+10	2.91E+10	1.90E+13	4.00E+09
400	1.40E-11	1.30E+03	4.37E+14	4.18E+13	3.30E+11	5.38E+12	5.75E+09	2.86E+10	1.54E+13	7.10E+09
420	1.06E-11	1.30E+03	3.39E+14	2.73E+13	2.03E+11	5.04E+12	3.18E+09	2.82E+10	1.24E+13	1.08E+10
440	8.13E-12	1.31E+03	2.64E+14	1.79E+13	1.26E+11	4.72E+12	1.78E+09	2.77E+10	1.01E+13	1.47E+10
460	6.26E-12	1.31E+03	2.06E+14	1.18E+13	7.84E+10	4.42E+12	1.00E+09	2.72E+10	8.21E+12	1.82E+10
480	4.84E-12	1.31E+03	1.62E+14	7.85E+12	4.91E+10	4.14E+12	5.66E+08	2.68E+10	6.69E+12	2.11E+10
500	3.76E-12	1.31E+03	1.27E+14	5.23E+12	3.10E+10	3.89E+12	3.23E+08	2.64E+10	5.47E+12	2.32E+10

## APPENDIX B

### Ferrite Material Data

Two types of ferrite materials were used in the EMI mitigation scheme at PEPL:

Ferrite 1: TDK part # ZCAT3035-1330s

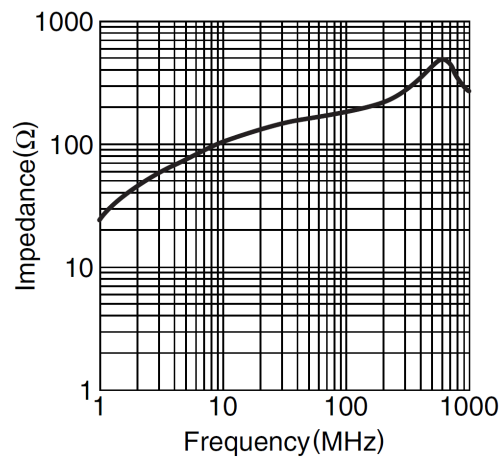


Figure B.1: TDK ZCAT 3035-1330s ferrite material characteristics.

Ferrite 2: API Delevan part # BF2390

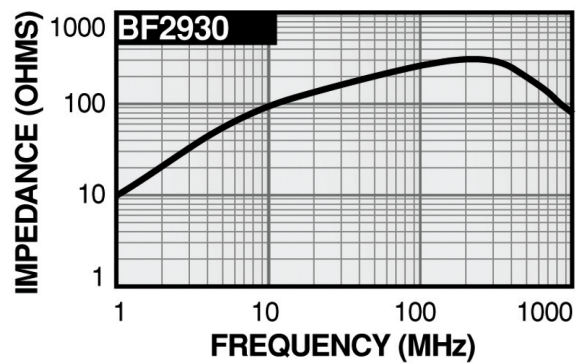


Figure B.2: API Delevan BF2390 ferrite material characteristics.

## BIBLIOGRAPHY

- [1] Futron Corporation, “State of the Satellite Industry Report – May 2012,” Satellite Industry Association, 1200 18<sup>th</sup>, NW, Suite 1001, Washington, DC, 20036, Retrieved July 17, 2012 from <http://www.sia.org/wp-content/uploads/2012/06/Final-2012-State-of-Satellite-Industry-Report.pdf>. 1
- [2] Swartwout, M., “A statistical survey of rideshares (and attack of the CubeSats, part deux),” *IEEE Aerospace Conference*, Big Sky, MT, March 2012. 1
- [3] Sanders, G. B., “ISRU: An Overview of NASA’s Current Development Activities and Long-Term Goals,” *38<sup>th</sup> AIAA Aerospace Sciences Meeting & Exhibit*, AIAA-2000-1062, Reno, NV, January 2000. 2
- [4] Larson, W. E., Sanders, G. B., and Sacksteder, K. R., “NASA’s In-Situ Resource Utilization Project: Current Accomplishments and Exciting Future Plans,” *AIAA SPACE 2010 Conference & Exhibit*, AIAA-2010-8603, Anaheim, CA, August – September 2010. 2
- [5] Demetriades, S. T., “A Novel System for Space Flight Using a Propulsive Fluid Accumulator,” *Journal of the British Interplanetary Society*, Vol. 17, Sept. 1959, pp. 114–119. 2, 6, 7
- [6] Wertz, J. R. and Larson, W. J., editors, *Space Mission Analysis and Design*, Microcosm Press and Springer, Hawthorne, CA and New York, NY, 3rd ed., 1999. 2, 3, 4, 5, 28, 33
- [7] “Space Exploration Technologies Corporation - Falcon 9,” Retrieved November 10, 2012 from <http://www.spacex.com/falcon9.php>. 2
- [8] Fujita, K. and Noda, A., “Rarefied Aerodynamics of a Super Low Altitude Test Satellite,” *41<sup>st</sup> AIAA Thermophysics Conference*, AIAA-2009-3606, San Antonio, TX, 22–25 June 2009. 3
- [9] “Research and development of an ion engine for a super-low-altitude satellite,” *Sora to Sora*, No. 42, Japan Aerospace Exploration Agency – Aerospace Research and Development Directorate, 2011, Retrieved July 17, 2012 from [http://www.ard.jaxa.jp/eng/publication/sorasora/2011\\_no42/ss2011no42\\_02.html](http://www.ard.jaxa.jp/eng/publication/sorasora/2011_no42/ss2011no42_02.html). 3

- [10] Kruger, J. K., “CLOSeSat: Perigee-Lowering Techniques and Preliminary Design for a Small Optical Imaging Satellite Operating in Very Low Earth Orbit,” M.S. Thesis, Massachusetts Institute of Technology, May 2010. 3
- [11] Liou, J.-C., Johnson, N., and Hill, N., “Controlling the growth of future LEO debris populations with active debris removal,” *Acta Astronautica*, Vol. 66, No. 5-6, 2010, pp. 648 – 653, doi: 10.1016/j.actaastro.2009.08.005. 4, 5
- [12] Liou, J.-C., “An active debris removal parametric study for LEO environment remediation,” *Advances in Space Research*, Vol. 47, No. 11, 2011, pp. 1865 – 1876, doi: 10.1016/j.asr.2011.02.003. 4
- [13] Goetzberger, A., Luther, J., and Willeke, G., “Solar cells: past, present, future,” *Solar Energy Materials and Solar Cells*, Vol. 74, No. 1-4, 2002, pp. 1–11, doi: 10.1016/S0927-0248(02)00042-9. 6
- [14] Pedersen, E. S., *Nuclear Energy in Space*, Prentice-Hall, Englewood Cliffs, NJ, 1964. 6
- [15] Berner, F. and Camac, M., “Air scooping vehicle,” *Planetary and Space Science*, Vol. 4, 1961, pp. 159 – 183, doi: 10.1016/0032-0633(61)90130-1. 6, 7, 8, 39
- [16] Dolgich, A., “Soviet studies on low-thrust orbital propellant-scooping systems,” *Foreign Science Bulletin*, Vol. 5, No. 7, July 1969, pp. 1–9, Retrieved July 17, 2012 from <http://www.dtic.mil/dtic/tr/fulltext/u2/690999.pdf>. 6, 8
- [17] Zukerman, A. and Kretschmer, C., “A study of the feasibility of an atomic oxygen ramjet,” *Planetary and Space Science*, Vol. 4, Jan. 1961, pp. 60–76, doi: 10.1016/0032-0633(61)90123-4. 8, 17, 25
- [18] Justus, C. G., Duvall, A., Keller, V. W., Spilker, T. R., and Lockwood, M. K., “Connecting atmospheric science and atmospheric models for aerocapture at Titan and the outer planets,” *Planetary and Space Science*, Vol. 53, No. 5, 2005, pp. 601–605, doi: 10.1016/j.pss.2004.12.002. 9
- [19] Bussard, R. W., “Galactic Matter and Interstellar Flight,” *Astronautica Acta*, Vol. 6, No. 4, Feb. 1960, pp. 1–14, Retrieved July 17, 2012 from <http://www.askmar.com/Robert%20Bussard/Galactic%20Matter%20and%20Interstellar%20Flight.pdf>. 9
- [20] Anderson, P., *Tau Zero*, Doubleday, Garden City, NY, 1st ed., 1970. 9
- [21] Palaszewski, B., “Atmospheric Mining in the Outer Solar System,” *41<sup>st</sup> AIAA/ASME/SAE/ASEE Joint Propulsion Conference & Exhibit*, AIAA-2005-4319, Tucson, AZ, 10–13 July 2005. 9
- [22] Minovitch, M. A., “Solar Powered, Self-Refueling, Microwave Propelled Interorbital Transportation System,” *18<sup>th</sup> AIAA Thermophysics Conference*, AIAA-83-1446, Montreal, Canada, June 1983. 10

- [23] Lamamy, J.-A., *Enhancing the science return of Mars missions via sample preparation, robotic surface exploration, and in orbit fuel production*, Master's thesis, Massachusetts Institute of Technology, Cambridge, MA, 2004. 10
- [24] Fujita, K., "Air Intake Performance of Air Breathing Ion Engines," *Journal of the Japan Society for Aeronautical and Space Sciences*, Vol. 52, No. 610, 2004, pp. 514–521. 11
- [25] DiCara, D., Gonzalez del Amo, J., Santovincenzo, A., Dominguez, B. C., Arcioni, M., Caldwell, A., and Roma, I., "RAM Electric Propulsion for Low Earth Orbit Operation: an ESA study." *30<sup>th</sup> International Electric Propulsion Conference*, IEPC-2007-162, Florence, Italy, September 2007. 11, 13
- [26] Kirtley, D., Slough, J., Pihl, C., Meier, E., and Milroy, R., "Pulsed Plasmoid Propulsion: Air-Breathing Electromagnetic Propulsion," *32<sup>nd</sup> International Electric Propulsion Conference*, IEPC-2011-015, Wiesbaden, Germany, September 2011. 11, 13
- [27] Hisamoto, Y., Nishiyama, K., and Kuninaka, H., "Development Statue of Atomic Oxygen Simulator for Air Breathing Ion Engine," *32<sup>nd</sup> International Electric Propulsion Conference*, IEPC-2011-294, Wiesbaden, Germany, September 2011. 11, 12
- [28] Pigeon, T. D. and Whitaker, R. B., "Analysis of a Near-Vacuum Hall Thruster," *42<sup>nd</sup> AIAA Aerospace Sciences Meeting and Exhibit*, AIAA-2004-127, Reno, NV, January 2004. 11
- [29] Bashir, O. S. and Sullivan, R. M., "Near-Vacuum Hall Thruster for Drag Compensation," Massachusetts Institute of Technology, 16.622 Final Report, December 7, 2004. 11
- [30] Dressler, G. A., "Spacecraft Propulsive Device Using Ambient Upper Atmospheric Constituents for Reaction Mass," *42<sup>nd</sup> AIAA/ASME/SAE/ASEE Joint Propulsion Conference & Exhibit*, AIAA-2006-4650, Sacramento, CA, July 2006. 11
- [31] Pekker, L. and Keidar, M., "Analysis of Air Breathing Hall Effect Thruster," *42<sup>nd</sup> AIAA Plasmadynamics and Lasers Conference*, AIAA-2011-3737, Honolulu, HI, June 2011. 11
- [32] Nishiyama, K., "Air Breathing Ion Engine," *24<sup>th</sup> International Symposium on Space Technology and Science*, ISTS 2004-o-3-05v, Miyazaki City, Japan, May–June 2004. 12
- [33] Tagawa, M., Nishiyama, K., Yokota, K., Yoshizawa, Y., Yamamoto, D., and Kuninaka, H., "An Experimental Study on Air Breathing Ion Engine Concept Using Laser-Detonation Atomic Oxygen Beam Source as an LEO Space Environment Simulator," *27<sup>th</sup> International Symposium on Space Technology and Science*, ISTS 2009-b-04, Tsukuba City, Japan, July 2009. 12

- [34] Jones, C., Masse, D., Glass, C., Wilhite, A., and Walker, M., “PHARO – Propellant Harvesting of Atmospheric Resources in Orbit,” *2010 IEEE Aerospace Conference*, IEEEAC paper No. 1089, Big Sky, MT, March 2010. 12
- [35] Diamant, K. D., “A 2-Stage Cylindrical Hall Thruster for Air Breathing Electric Propulsion,” *46<sup>th</sup> AIAA/ASME/SAE/ASEE Joint Propulsion Conference & Exhibit*, AIAA-2010-6522, Nashville, TN, July 2010. 13
- [36] Kirtley, D., Pancotti, A., Slough, J., and Pihl, C., “Steady Operation of an FRC Thruster on Martian Atmosphere and Liquid Water Propellants,” *48<sup>th</sup> AIAA/ASME/SAE/ASEE Joint Propulsion Conference & Exhibit*, AIAA-2012-4071, Atlanta, GA, July – August 2012. 13
- [37] Hruby, V., Pote, B., Brogan, T., Hohman, K., Szabo, J., and Rostler, P., “Air Breathing Electrically Powered Hall Effect Thruster,” U.S. Patent 6,834,492 B2, December 28, 2004, Assigned to Busek Company, Inc. 13
- [38] Wahl, E. L., “Air-Breathing Electrostatic Ion Thruster,” U.S. Patent 7,581,380 B2, September 1, 2009. 13
- [39] Hedin, A. E., “Extension of the MSIS Thermospheric Model into the Middle and Lower Atmosphere,” *Journal of Geophysical Research*, Vol. 96, No. A2, Feb. 1991, pp. 1159–1172, Accessed from [http://omniweb.gsfc.nasa.gov/vitmo/msis\\_vitmo.html](http://omniweb.gsfc.nasa.gov/vitmo/msis_vitmo.html), doi: 10.1016/0032-0633(61)90123-4. 15, 16
- [40] ISO/DIS 14222, *Space environment (natural and artificial) – Earth upper atmosphere*, ISO, Geneva, Switzerland. 16, 17, 143
- [41] Vincenti, W. G. and Kruger, Jr., C. H., *Introduction to Physical Gas Dynamics*, Krieger, Malabar, FL, 1965 [Reprint 2002]. 17
- [42] Choueiri, E. Y., “A Critical History of Electric Propulsion: The First 50 Years (1906–1956),” *Journal of Propulsion and Power*, Vol. 20, No. 2, Mar.-Apr. 2004, pp. 193–203, doi: 10.2514/1.9245. 21
- [43] Sutton, G. P. and Biblarz, O., *Rocket Propulsion Elements*, John Wiley & Sons, New York, 7th ed., 2001. 23, 26
- [44] Arbit, H. A., Clapp, S. D., and Nagai, C. K., “Investigation of the lithium-fluorine-hydrogen tripropellant system,” *Journal of Spacecraft and Rockets*, Vol. 7, No. 10, 1970, pp. 1221–1227, doi: 10.2514/3.30138. 24
- [45] Mead Jr, F., “Advanced Propulsion Concepts - Project Outgrowth,” Tech. rep., DTIC Document AFRPL-TR-72-31, 1972. 24
- [46] Martinez-Sanchez, M. and Pollard, J. E., “Spacecraft Electric Propulsion—An Overview,” *Journal of Propulsion and Power*, Vol. 14, No. 5, Sept. 1998, pp. 688–699, doi: 10.2514/2.5331. 26

- [47] Foster, J. E., Haag, T., Kamhawi, H., Patterson, M., Malone, S., Elliot, F., George J. Williams, Jr., G. J., Sovey, J. S., and Carpenter, C., “The High Power Electric Propulsion (HiPEP) Ion Thruster,” *40<sup>th</sup> AIAA/ASME/SAE/ASEE Joint Propulsion Conference & Exhibit*, AIAA-2004-3812, Fort Lauderdale, FL, July 2004. 26
- [48] Soulas, G. C., Haag, T. W., Herman, D. A., Huang, W., Kamhawi, H., and Shastri, R., “Performance Test Results of the NASA-457M v2 Hall Thruster,” *48<sup>th</sup> AIAA/ASME/SAE/ASEE Joint Propulsion Conference & Exhibit*, AIAA-2012-3940, Atlanta, GA, July–August 2012. 26
- [49] Linnell, J. A., *An Evaluation of Krypton Propellant in Hall Thrusters*, Ph.D. thesis, University of Michigan, Ann Arbor, MI, 2007. 26, 44, 133, 134
- [50] Curran, F. M. and Byers, D. C., “New Developments and Research Findings: NASA Hydrazine Arcjets,” *25<sup>th</sup> AIAA Plasmadynamics and Lasers Conference*, AIAA-84-2463, Colorado Springs, CO, June 1994. 26
- [51] Mathers, A. J., Aadland, R. S., Manzella, D., and Kamhawi, H., “Development Status of the HiVHAC Hall Thruster,” *44<sup>th</sup> AIAA/ASME/SAE/ASEE Joint Propulsion Conference & Exhibit*, AIAA-2008-4524, Hartford, CT, July 2008. 27
- [52] Hofer, R. R., Goebel, D. M., Mikellides, I. G., and Katz, I., “Design of a Laboratory Hall Thruster with Magnetically Shielded Channel Walls, Phase II: Experiments,” *48<sup>th</sup> AIAA/ASME/SAE/ASEE Joint Propulsion Conference & Exhibit*, AIAA-2012-3788, Atlanta, GA, July – August 2012. 27, 44, 79
- [53] Cifali, G., Misuri, T., Rossetti, P., Andrenucci, M., Valentian, D., and Feili, D., “Preliminary characterization test of HET and RIT with Nitrogen and Oxygen,” *47<sup>th</sup> AIAA/ASME/SAE/ASEE Joint Propulsion Conference & Exhibit*, AIAA-2011-6073, San Diego, CA, July – August 2011. 27, 42
- [54] Wallace, N., Jameson, P., Saunders, C., Fehringer, M., Edwards, C., and Floberghagen, R., “The GOCE Ion Propulsion Assembly – Lessons Learnt from the First 22 Months of Flight Operations,” *32<sup>nd</sup> International Electric Propulsion Conference*, IEPC-2011-327, Wiesbaden, Germany, September 2011. 27
- [55] Haynes, W. M., editor, *CRC Handbook of Chemistry and Physics*, CRC Press/Taylor and Francis, Boca Raton, FL, 92nd ed., (Internet Version 2012). 31
- [56] Sutton, E. K., “Normalized Force Coefficients for Satellites with Elongated Shapes,” *Journal of Spacecraft and Rockets*, Vol. 46, No. 1, Jan.-Feb. 2009, pp. 112–116, doi: 10.2514/1.40940. 32
- [57] “29.5% NeXt Triple Junction (XTJ) Solar Cells,” Spectrolab, Inc., September 2012, Retrieved December 12, 2012 from <http://www.spectrolab.com/DataSheets/cells/PV%20XTJ%20Cell%205-20-10.pdf>. 33
- [58] “Space Solar Panels,” Spectrolab, Inc., May 2010, Retrieved December 12, 2012 from <http://www.spectrolab.com/DataSheets/Panel/panels.pdf>. 33, 34



- [59] “Pegasus<sup>®</sup> User’s Guide Release 7.0,” Orbital Sciences Corporation, April 2010, Retrieved July 17, 2012 from [http://www.orbital.com/NewsInfo/Publications/Pegasus\\_UG.pdf](http://www.orbital.com/NewsInfo/Publications/Pegasus_UG.pdf). 34
- [60] “ESA - Living Planet Programme - GOCE - GOCE satellite,” Retrieved July 17, 2012 from [http://www.esa.int/esaLP/ESA1MK1VMOC\\_LPgoce\\_0.html](http://www.esa.int/esaLP/ESA1MK1VMOC_LPgoce_0.html). 34
- [61] Shastry, R., Herman, D. A., Soulas, G. C., and Patterson, M. J., “NASAs Evolutionary Xenon Thruster (NEXT) Long-Duration Test as of 736 kg of Propellant Throughput,” *48<sup>th</sup> AIAA/ASME/SAE/ASEE Joint Propulsion Conference & Exhibit*, AIAA-2012-4023, Atlanta, GA, July – August 2012. 42
- [62] Gallagher, H. E., “Poisoning of LaB<sub>6</sub> Cathodes,” *Journal of Applied Physics*, Vol. 40, No. 1, Jan. 1969, pp. 44–51, doi: 10.1063/1.1657092. 42
- [63] Goebel, D. M. and Katz, I., *Fundamentals of Electric Propulsion: Ion and Hall Thrusters*, John Wiley & Sons, New York, 2007. 42
- [64] Killinger, R., Kukies, R., Surauer, M., Tomasetto, A., and van Holtz, L., “ARTEMIS Orbit Raising Inflight Experience with Ion Propulsion,” *Acta Astronautica*, Vol. 53, No. 4–10, 2003, pp. 607–621, doi: 10.1016/S0094-5765(03)80022-X. 42
- [65] Kuninaka, H., Nishiyama, K., Funaki, I., Yamada, T., Shimizu, Y., and Kawaguchi, J., “Powered Flight of Electron Cyclotron Resonance Ion Engines on Hayabusa Explorer,” *Journal of Propulsion and Power*, Vol. 23, No. 3, May-Jun. 2007, pp. 544–551, doi: 10.2514/1.25434. 42, 43
- [66] Jahn, R. G., *Physics of Electric Propulsion*, McGraw-Hill, New York, 1st ed., 1968. 43
- [67] Longmier, B. W., Cassady, L. D., Ballenger, M. G., Carter, M. D., Chang-Daz, F. R., Glover, T. W., Ilin, A. V., McCaskill, G. E., Olsen, C. S., and Squire, J. P., “VX-200 Magnetoplasma Thruster Performance Results Exceeding Fifty-Percent Thruster Efficiency,” *Journal of Propulsion and Power*, Vol. 27, No. 4, Jul.-Aug. 2011, pp. 915–920, doi: 10.2514/1.B34085. 43, 71, 122
- [68] Williams, L. T. and Walker, M. L. R., “Thrust Measurements of a Helicon Plasma Source,” *47<sup>th</sup> AIAA/ASME/SAE/ASEE Joint Propulsion Conference & Exhibit*, AIAA-2011-5893, San Diego, CA, July – August 2011. 43, 76, 110
- [69] Pottinger, S., Lappas, V., Charles, C., and Boswell, R., “Performance characterization of a double layer thruster using direct thrust measurements,” *Journal of Applied Physics D: Applied Physics*, Vol. 44, No. 23, June 2011, pp. 235201, doi: 10.1088/0022-3727/44/23/235201. 43, 71, 76, 110
- [70] Motomura, T., Ohno, E., Katanami, H., Sakei, Y., Yasutake, T., Mori, J., Shinohara, S., and Hada, T., “Novel Electromagnetic Propulsion System Using High-Density Helicon Plasma,” *52<sup>nd</sup> Annual Meeting of the APS Division of Plasma Physics*,

Chicago, IL, Retrieved from <http://meetings.aps.org/link/BAPS.2010.DPP.TP9.55>, November 2011. 43

- [71] Pavarin, D., Ferri, F., Manente, M., Curreli, D., Güçlü, Y., Melazzi, D., Rondini, D., Suman, S., Carlsson, J., Bramanti, C., Ahedo, E., Lancellotti, V., Katsonis, K., and Markelov, G., “Design of a 50 W Helicon Plasma Thruster,” *31<sup>st</sup> International Electric Propulsion Conference*, IEPC-2009-205, Ann Arbor, MI, September 2009. 43, 71
- [72] Winglee, R., Ziemba, T., Giersch, L., Prager, J., Carscadden, J., and Roberson, B. R., “Simulation and laboratory validation of magnetic nozzle effects for the high power helicon thruster,” *Physics of Plasmas*, Vol. 14, No. 6, June 2007, pp. 063501–1–14, doi: 10.1063/1.2734184. 43
- [73] Wiebold, M., Sung, Y., and Scharer, J. E., “Experimental observation of ion beams in the Madison Helicon eXperiment,” *Physics of Plasmas*, Vol. 18, No. 6, June 2011, pp. 063501, doi: 10.1063/1.3596537. 43, 71, 110, 120
- [74] Huang, W., *Study of Hall Thruster Discharge Channel Wall Erosion via Optical Diagnostics*, Ph.D. thesis, University of Michigan, Ann Arbor, MI, 2011. 43
- [75] Brown, D. L., *Investigation of Low Discharge Voltage Hall Thruster Characteristics and Evaluation of Loss Mechanisms*, Ph.D. thesis, University of Michigan, Ann Arbor, MI, 2009. 44, 95, 96, 98
- [76] Gottlieb, I. M., *Practical RF Power Design Techniques*, TAB Books, Blue Ridge Summit, PA, 1st ed., 1993. 45
- [77] “Terms and Definitions,” *Electronic Code of Federal Regulations* Title 47, Pt. 2.1, Retrieved December 11, 2012 from <http://www.ecfr.gov/>. 46
- [78] “Assignment of frequencies,” *Electronic Code of Federal Regulations* Title 47, Pt. 2.102, Retrieved December 11, 2012 from <http://www.ecfr.gov/>. 46
- [79] Kaiser, K. L., *Transmission Lines, Matching, and Crosstalk*, CRC Press, Taylor & Francis Group, Boca Raton, FL, 2006. 47, 53
- [80] Ulaby, F. T., *Fundamentals of Applied Electromagnetics*, Pearson Prentice Hall, Upper Saddle River, NJ, 5th ed., 2007. 51, 56
- [81] Kieckhafer, A. W. and Walker, M. L. R., “RF Power System for Thrust Measurements of a Helicon Plasma Source,” *Review of Scientific Instruments*, Vol. 81, No. 7, July 2010, pp. 075106, doi: 10.1063/1.3460263. 53
- [82] Chen, F. F., “Experiments on helicon plasma sources,” *Journal of Vacuum Science & Technology A: Vacuum, Surfaces, and Films*, Vol. 10, No. 4, Jul.-Aug. 1998, pp. 1389–1401, doi: 10.1116/1.578256. 67, 75

- [83] Gerwin, R. A., “Integrity of the Plasma Magnetic Nozzle,” NASA/TP–2009-213439, NASA Glenn Research Center, Cleveland, OH, 2009. 67, 72
- [84] Ebersohn, F. H., Girimaji, S. S., Staak, D., Shebalin, J. V., Longmier, B., and Olsen, C., “Magnetic Nozzle Plasma Plume: Review of Crucial Physical Phenomena,” 48<sup>th</sup> AIAA/ASME/SAE/ASEE Joint Propulsion Conference & Exhibit, AIAA-2012-4274, Atlanta, GA, July–August 2010. 67, 72
- [85] Deline, C. A., *Characterization of the Magnetic Nozzle Region of High Powered Electric Propulsion Thrusters Using Numerical Simulation, RF Interferometry and Electrostatic Probes*, Ph.D. thesis, University of Michigan, Ann Arbor, MI, 2008. 67, 72
- [86] Lieberman, M. A. and Lichtenberg, A. J., *Principles of Plasma Discharges and Materials Processing*, John Wiley & Sons, Hoboken, 2nd ed., 2005. 68, 109
- [87] Blackwell, D. D., Madziwa, T. G., Arnush, D., and Chen, F. F., “Evidence for Trivelpiece-Gould Modes in a Helicon Discharge,” *Physical Review Letters*. 69
- [88] Stix, T. H., *Waves in Plasmas*, American Institute of Physics, New York, 1992. 69
- [89] Boswell, R. W. and Chen, F. F., “Helicons – The Early Years,” *IEEE Transactions on Plasma Science*, Vol. 25, No. 6, Dec. 1997, pp. 1229–1244, doi: 10.1109/27.650898. 70
- [90] Chen, F. F. and Boswell, R. W., “Helicons – The Past Decade,” *IEEE Transactions on Plasma Science*, Vol. 25, No. 6, Dec. 1997, pp. 1245–1257, doi: 10.1109/27.650899. 70
- [91] Palmer, D. D. and Walker, M. L. R., “Operation of an Annular Helicon Plasma Source,” *Journal of Propulsion and Power*, Vol. 25, No. 5, Sep.-Oct. 2009, pp. 1013–1019, doi: 10.2514/1.38092. 70
- [92] Yano, M. and Walker, M. L. R., “Plasma ionization by annularly bounded helicon waves,” *Physics of Plasmas*, Vol. 13, No. 6, June 2006, pp. 063501–1–5, doi: 10.1063/1.2207125. 70
- [93] Shabshelowitz, A. and Gallimore, A. D., “Divergence Angle of Ion Beams Emanating from an Immersed Radiofrequency Plasma Source,” 32<sup>nd</sup> International Electric Propulsion Conference, IEPC-2011-166, Wiesbaden, Germany, September 2011. 71, 76
- [94] Palmer, D., Walker, M. L. R., Manente, M., Carlsson, J., Bramanti, C., and Pavarin, D., “Performance Analysis of a Low-Power Helicon Thruster,” 44<sup>th</sup> AIAA/ASME/SAE/ASEE Joint Propulsion Conference & Exhibit, AIAA-2008-4925, Hartford, CT, July 2008. 71

- [95] Nakamura, T., Yokoi, K., Nishida, H., Shinohara, S., Funaki, I., Matsuoka, T., Tanikawa, T., Hada, T., Shamrai, K. P., and Rudenko, T. S., “Experimental Investigation of Plasma Acceleration by Rotating Electric Field for Electrodeless Plasma Thruster,” *32<sup>nd</sup> International Electric Propulsion Conference*, IEPC-2011-279, Wiesbaden, Germany, September 2011. 71
- [96] Slough, J., Kirtley, D., and Weber, T., “Pulsed Plasmoid Propulsion: The ELF Thruster,” *31<sup>st</sup> International Electric Propulsion Conference*, IEPC-2009-265, Ann Arbor, MI, September 2009. 71
- [97] Charles, C. and Boswell, R. W., “Laboratory evidence of a supersonic ion beam generated by a current-free “helicon” double-layer,” *Physics of Plasmas*, Vol. 11, No. 4, 2004, pp. 1706–1714, doi: 10.1063/1.1652058. 71, 120
- [98] Cohen, S. A., Siefert, N. S., Stange, S., Boivin, R. F., Scime, E. E., and Levinton, F. M., “Ion acceleration in plasmas emerging from a helicon-heated magnetic-mirror device,” *Physics of Plasmas*, Vol. 10, No. 6, 2003, pp. 2593–2598, doi: 10.1063/1.1568342. 71
- [99] Batishchev, O., “Minihelicon Plasma Thruster,” *IEEE Transactions on Plasma Science*, Vol. 37, No. 8, Aug. 2009, pp. 1563–1571, doi: 10.1109/TPS.2009.2023990. 72
- [100] Boswell, R. W., “Very efficient plasma generation by whistler waves near the lower hybrid frequency,” *Plasma Physics and Controlled Fusion*, Vol. 26, No. 10, Oct. 1984, pp. 1147–1162, doi: 10.1088/0741-3335/26/10/001. 72
- [101] Tysk, S. M., Denning, C. M., Scharer, J. E., and Akhtar, K., “Optical, wave measurements, and modeling of helicon plasmas for a wide range of magnetic fields,” *Physics of Plasmas*, Vol. 11, No. 3, March 2004, pp. 878–887, doi: 10.1063/1.1642656. 72
- [102] Ellingboe, A. R. and Boswell, R. W., “Capacitive, inductive and helicon-wave modes of operation of a helicon plasma source,” *Physics of Plasmas*, Vol. 3, No. 7, 1996, pp. 2797 – 2804, doi: 10.1063/1.871713. 73
- [103] Pearse, R. W. B. and Gaydon, A. G., *The Identification of Molecular Spectra*, Chapman and Hall, New York, 4th ed., 1976. 73, 74
- [104] Kramida, A., Ralchenko, Y., Reader, J., and NIST ASD Team (2012), *NIST Atomic Spectra Database ver. 5.0*, [Online], National Institute of Standards and Technology, Gaithersburg, MD. Retrieved December 18, 2012 from <http://physics.nist.gov/asd>. 74
- [105] Carroll, P. K. and Sayers, N. D., “The Band Spectrum of Nitrogen: New Studies of the Triplet Systems,” *Proceedings of the Physical Society. Section A*, Vol. 66, No. 12, 1953, pp. 1138, doi: 10.1088/0370-1298/66/12/309. 74

- [106] Jamroz, P. and Zyrnicki, W., “Optical emission spectroscopy study for nitrogenacetyleneargon and nitrogenacetylenehelium 100 kHz and dc discharges,” *Vacuum*, Vol. 84, No. 7, 2010, pp. 940 – 946, doi: 10.1016/j.vacuum.2009.12.019. 74
- [107] Suraj, K. S., Bharathi, P., Prahlad, V., and Mukherjee, S., “Near cathode optical emission spectroscopy in N<sub>2</sub>H<sub>2</sub> glow discharge plasma,” *Surface and Coatings Technology*, Vol. 202, No. 2, 2007, pp. 301 – 309, doi: 10.1016/j.surfcoat.2007.05.063. 74
- [108] Xu, N., cheng Du, Y., feng Ying, Z., min Ren, Z., and ming Li, F., “An arc discharge nitrogen atom source,” *Review of Scientific Instruments*, Vol. 68, No. 8, 1997, pp. 2994 – 3000, doi: 10.1063/1.1148232. 74
- [109] Takahashi, K., Lafleur, T., Charles, C., Alexander, P., and Boswell, R. W., “Electron Diamagnetic Effect on Axial Force in an Expanding Plasma: Experiments and Theory,” *Physical Review Letters*, Vol. 107, Nov. 2011, pp. 235001–1–4, doi: 10.1103/PhysRevLett.107.235001. 76, 127
- [110] Kamenski, I. V. and Borg, G. G., “An evaluation of different antenna designs for helicon wave excitation in a cylindrical plasma source,” *Physics of Plasmas*, Vol. 3, No. 12, 1996, pp. 4396–4409, doi: 10.1063/1.872057. 78
- [111] Hofer, R. R., *Development and Characterization of a High-Efficiency, High-Specific Impulse Xenon Hall Thruster*, Ph.D. thesis, University of Michigan, Ann Arbor, MI, 2004. 78, 95, 97, 98, 125, 129
- [112] Mikellides, I. G., Katz, I., Hofer, R. R., Goebel, D. M., de Grys, K., and Mathers, A., “Magnetic Shielding of the Acceleration Channel Walls in a Long-Life Hall Thruster,” *46<sup>th</sup> AIAA/ASME/SAE/ASEE Joint Propulsion Conference & Exhibit*, AIAA-2010-6942, Nashville, TN, July 2010. 79
- [113] Makela, J. M., Washeleski, R. L., Massey, D. R., King, L. B., and Hopkins, M. A., “Development of a Magnesium and Zinc Hall-Effect Thruster,” *Journal of Propulsion and Power*, Vol. 26, No. 5, Sep.-Oct. 2010, pp. 1029–1035, doi: 10.2514/1.47410. 79
- [114] Szabo, J., Robin, M., Duggan, J., and Hofer, R. R., “Light Metal Propellant Hall Thrusters,” *31<sup>st</sup> International Electric Propulsion Conference*, IEPC-2009-138, Ann Arbor, MI, September 2009. 79
- [115] Liang, R. and Gallimore, A. D., “Constant-Power Performance and Plume Properties of a Nested-Channel Hall-Effect Thruster,” *32<sup>nd</sup> International Electric Propulsion Conference*, IEPC-2011-030, Wiesbaden, Germany, September 2011. 79, 97
- [116] Florenz, R., Gallimore, A. D., and Peterson, P. Y., “Developmental Status of a 100-kW Class Laboratory Nested Channel Hall Thruster,” *32<sup>nd</sup> International Electric Propulsion Conference*, IEPC-2011-246, Wiesbaden, Germany, September 2011. 79

- [117] Martinez, R. A., Hoskins, W. A., Peterson, P. Y., and Massey, D. R., “Development Status of the Helicon Hall Thruster,” *31<sup>st</sup> International Electric Propulsion Conference*, IEPC-2009-120, Ann Arbor, MI, September 2009. 79, 81
- [118] Kamhawi, H., Manzella, D., Pinero, L., Haag, T., Mathers, A., and Liles, H., “In-Space Propulsion High Voltage Hall Accelerator Development Project Overview,” *45<sup>th</sup> AIAA/ASME/SAE/ASEE Joint Propulsion Conference & Exhibit*, AIAA-2010-5282, Denver, CO, August 2009. 79
- [119] Beal, B. E., Gallimore, A. D., Morris, D. P., Davis, C., and Lemmer, K. M., “Development of an Annular Helicon Source for Electric Propulsion Applications,” *42<sup>nd</sup> AIAA/ASME/SAE/ASEE Joint Propulsion Conference & Exhibit*, AIAA-2006-4841, Atlanta, GA, July 2006. 80
- [120] Peterson, P. Y., Massey, D. R., Shabshelowitz, A., Shastry, R., and Liang, R., “Performance and Plume Characterization of a Helicon Hall Thruster,” *32<sup>nd</sup> International Electric Propulsion Conference*, IEPC-2011-269, Wiesbaden, Germany, September 2011. 81
- [121] Wilson, M. J., editor, *The ARRL Handbook For Radio Communications*, ARRL - the national association for Amateur Radio, Newington, CT, 86th ed., 2008. 86, 89, 105
- [122] Garvin, C., Grimard, D., Grizzle, J., and Gilchrist, B. E., “Measurement and error evaluation of electrical parameters at plasma relevant frequencies and impedances,” *Journal of Vacuum Science & Technology A: Vacuum, Surfaces, and Films*, Vol. 16, No. 2, Mar.-Apr. 1998, pp. 595–606, doi: 10.1116/1.581098. 90
- [123] Haag, T. W., “Thrust stand for high-power electric propulsion devices,” *Review of Scientific Instruments*, Vol. 62, No. 5, 1991, pp. 1186–1191, doi: 10.1063/1.1141998. 91
- [124] Xu, K. and Walker, M. L. R., “High-Power, Null-Type, Inverted Pendulum Thrust Stand,” *Review of Scientific Instruments*, Vol. 80, No. 5, May 2009, pp. 055103, doi: 10.1063/1.3125626. 91
- [125] Liang, R. and Gallimore, A. D., “Far-Field Plume Measurements of a Nested-Channel Hall-Effect Thruster,” *49<sup>th</sup> AIAA Aerospace Sciences Meeting*, AIAA-2011-1016, Orlando, FL, January 2011. 95
- [126] Brown, D. L. and Gallimore, A. D., “Evaluation of ion collection area in Faraday probes,” *Review of Scientific Instruments*, Vol. 81, No. 6, June 2010, pp. 063504, doi: 10.1063/1.3449541. 95
- [127] Lemmer, K. M., *Use of a Helicon Source for Development of a Re-Entry Blackout Amelioration System*, Ph.D. thesis, University of Michigan, Ann Arbor, MI, 2009. 97, 98, 99, 109
- [128] Hutchinson, I. H., *Principles of Plasma Diagnostics*, Cambridge University Press, New York, NY, 2002. 97, 109

- [129] Shastry, R., *Experimental Characterization of the Near-Wall Region in Hall Thrusters and its Implications on Performance and Lifetime*, Ph.D. thesis, University of Michigan, Ann Arbor, MI, 2010. 100
- [130] Anderson, J. D., *Fundamentals of Aerodynamics*, McGraw-Hill, New York, 3rd ed., 2001. 105
- [131] Foster, J. E., “Intercusp Electron Transport in an NSTAR-Derivative Ion Thruster,” *Journal of Propulsion and Power*, Vol. 18, No. 1, Jan. 2002, pp. 213–217, doi: 10.2514/2.5922. 109
- [132] Demidov, V. I., Ratynskaia, S. V., and Rypdal, K., “Electric probes for plasmas: The link between theory and instrument,” *Review of Scientific Instruments*, Vol. 73, No. 10, 2002, pp. 3409–3439, doi: 10.1063/1.1505099. 109
- [133] Sun, X., Keesee, A. M., Biloiu, C., Scime, E. E., Meige, A., Charles, C., and Boswell, R. W., “Observations of Ion-Beam Formation in a Current-Free Double Layer,” *Physical Review Letters*, Vol. 95, July 2005, pp. 025004–1–4, doi: 10.1103/PhysRevLett.95.025004. 120
- [134] Fruchtman, A., “The Thrust of a Collisional-Plasma Source,” *IEEE Transactions on Plasma Science*, Vol. 39, No. 1, Jan. 2011, pp. 530–539, doi: 10.1109/TPS.2010.2089067. 127, 128
- [135] Kaepelin, V., Carrère, M., and Layet, J.-M., “Ion energy distribution functions and Langmuir probe measurements in low pressure argon discharges,” *Journal of Vacuum Science & Technology A: Vacuum, Surfaces, and Films*, Vol. 20, No. 2, Mar.-Apr. 2002, pp. 526–529, doi: 10.1116/1.1451274. 127
- [136] Hegerberg, R., Elford, M. T., and Skullerud, H. R., “The cross section for symmetric charge exchange of  $\text{Ne}^+$  in Ne and  $\text{Ar}^+$  in Ar at low energies,” *Journal of Physics B: Atomic and Molecular Physics*, Vol. 15, No. 5, March 1982, pp. 797–811, doi: 10.1088/0022-3700/15/5/022. 127
- [137] Rao, M. V. V. S., Van Brunt, R. J., and Olthoff, J. K., “Resonant charge exchange and the transport of ions at high electric-field to gas-density ratios ( $E/N$ ) in argon, neon, and helium,” *Physical Review E: Statistical, nonlinear, and soft matter physics*, Vol. 54, No. 5, Nov. 1996, pp. 5641–5656, doi: 10.1103/PhysRevE.54.5641. 127
- [138] Reid, B. M., *The Influence of Neutral Flow Rate in the Operation of Hall Thrusters*, Ph.D. thesis, University of Michigan, Ann Arbor, MI, 2009. 127
- [139] Shabshelowitz, A. and Gallimore, A. D., “Ion Energy Distribution Measurements of a Radiofrequency Plasma Source Immersed in Vacuum,” *38<sup>th</sup> IEEE International Conference on Plasma Science*, Chicago, IL, doi: 10.1109/PLASMA.2011.5993301, June 2011. 127

- [140] Brown, D. L., Larson, C. W., Beal, B. E., and Gallimore, A. D., "Methodology and Historical Perspective of a Hall Thruster Efficiency Analysis," *Journal of Propulsion and Power*, Vol. 25, No. 6, Nov.-Dec. 2009, pp. 1163–1177, doi: 10.2514/1.38092. 129, 130, 133
- [141] Lias, S. G., "Ionization Energy Evaluation," *NIST Chemistry WebBook, NIST Standard Reference Database Number 69*, Eds. P. J. Linstrom and W. G. Mallard, National Institute of Standards and Technology, Gaithersburg, MD, 20899, <http://webbook.nist.gov>, retrieved May 31, 2012. 135