

UMTRI — 48670

Research Information and Publications Center
UNIVERSITY OF MICHIGAN
TRANSPORTATION RESEARCH INSTITUTE



ICE STRENGTHENING OF GREAT LAKES BULK CARRIERS

By

Movses J. Kaldjian

and

William R. Reid, Jr.

**Transportation
Research Institute**

MICHU-SG-82-200

UMTRI

48670

PB83 21061

ICE STRENGTHENING OF
GREAT LAKES BULK CARRIERS

Movses J. Kaldjian
William R. Reid, Jr.

Department of Naval Architecture and Marine Engineering
The University of Michigan

MICHU-SG-82-200
N.A.M.E. Report No. 263
\$2.00

Michigan Sea Grant Publications Department
2200 Bonisteel Boulevard - Ann Arbor, Michigan 48109

This publication is a result of work sponsored by the Michigan Sea Grant Program, project number R/T-9, with a grant, NA-80-AA-D-00072, from the Office of Sea Grant, National Oceanic and Atmospheric Administration (NOAA), U.S. Department of Commerce, and funds from the State of Michigan.

Transportation
Research Institute

ABSTRACT

This report reviews ten Great Lakes ships that were strengthened for winter operation on the Great Lakes. Where ice damage occurred, the affected areas and extent of repairs are described. The purposes of the study are to determine ice damage patterns and to evaluate the state of the art of ice strengthening. Ice pressure indices for failure of shell plates and frames are used to make comparisons of scantlings (dimensions) and structural arrangements in damaged and re-inforced areas. From these comparisons and the information assembled, conclusions have been drawn which could provide guidelines for designing against ice damage and make more effective winter operations on the Great Lakes. Directions for additional research are suggested.

TABLE OF CONTENTS

Introduction	1
Ice Pressure Indices	3
Comments on and Illustrations of Ice Damage and Ice Strengthening Modifications	7
Conclusions and Recommendations	17
References	22

ACKNOWLEDGMENTS

The authors extend their thanks and appreciation to Bay Shipbuilding Corporation, Fraser Shipyards, Inc., Marine Consultants and Designers, Inc., and United States Steel Corporation for their cooperation and assistance in supplying the basic information used in preparing this report.

INTRODUCTION

Over the past decade or so it has been shown that winter navigation on the Great Lakes is technically achievable, and indeed United States Steel Corporation and other Great Lakes ship operators have extended operations into the winter months.

The length of the extended navigation season no doubt will depend on the condition of the operator's fleet including ice strengthening, and the severity of the winter. Winter delays and notably ice damage are the ship operators' main concerns.

Transiting through ice infested waters, ice ridges, and narrow ice channels causes ice pressures to build up on the ship's hull. Thus, to withstand the resulting forces, additional structural strength around the ship's ice belt is needed. Operation in ice infested waters imposes novel requirements on ship designers.

The Great Lakes ship operators have each developed unique and practical ways of ice strengthening their ships to suit their immediate need from their own experience with ice conditions and observed ice damages. Many ships over the span of a few years have had new frames, stringers and plates added to various locations along their length or have been reinforced at three or four different times in line with new experience gained from winter navigation. But experience in ice strengthening has not been incorporated into systematic techniques. It remains an empirical art.

To date there has been no systematic study done by any group to put together the various procedures or rules of thumb each ship operator follows to ice strengthen their ships. The lessons learned in ice transiting are indeed very valuable; however, without a thorough correlation between ice strengthening design, operating ice conditions and type and severity of damage to ships it will not be possible to understand the ice-ship structure interaction behavior and to establish good analytical techniques to properly reinforce the Great Lakes ore carriers. The fact that the modern day trend is to build longer and wider ships makes the solution to the latter more urgent than ever.

Ice classification rules of the American Bureau of Shipping (ABS 1978) are for ocean-going ships and are based essentially on the Finnish experience in ice strengthening. Experience with such ships in ice is inadequate for statistical conclusions to be made. Design ice pressures in the ABS rules are based on the ship's displacement and propulsive power (SHP). Since the ratio of displacement to SHP of the Great Lakes ore carriers is very much larger than those of ocean-going ships, and they each have very different bows, specific ice rules are needed for strengthening Great Lakes bulk carriers for winter navigation. The existing Classification Rules cannot be adopted for Great Lakes use without verifying their suitability to this situation.

In general, Great Lakes ships have not been specifically designed for operation in ice. However, at times, these ships operate during the winter season and, on occasion, have been damaged by ice. When ice damage occurred, and the ship operators wished to reduce or prevent a repeat experience, the ship's structure was repaired and modified by ice strengthening. In other instances, ship operators prepared their ships for winter operation, and estimated the ice strengthening required without the dubious advantage of already having experienced ice damage. This report summarizes and analyzes the damages sustained and the ice strengthening measures employed.

This report is based on information from drawings and descriptions of modifications and repairs made to ten Great Lakes ships which operated in the extended winter season. Detailed information on ice damage is sparse and in most cases, the amount and extent of the damage was inferred from repair descriptions. There was no readily available information regarding geographical location of the ship, ship speed, ice thickness, or other environmental data, such as winds or visibility, reported when the ice damage occurred. U.S. Coast Guard collision reports from 1968 through 1979, were reviewed, but were not included in this report. Two ice collisions were noted in the U.S.C.G. report, but we failed to locate descriptions of the structure of these ships or a description of the ice conditions at the time of the collision. The information on ice damage and repairs spans about twenty years; many interesting details are not available. The repaired or modified areas of each of the ten ships are illustrated, and the description of damage is summarized when known.

Table I describes the 10 vessels reviewed in the study. All dimensions have been rounded off.

TABLE I

SHIP	LBP	BEAM	DEPTH	DRAFT	SHIP	SERVICE
A	390'	53'	27'	22'	2400	TANKER
B	629'	67'	30'	25'	5500	BULKCARRIER
C	1000'	105'	56'	34'	14000	BULKCARRIER
D	670'	75'	38'	27'	6600	BULKCARRIER
E	388'	56'	22'	17'	5500	PASS-CAR FERRY
F	512'	54'	27'	21'	1600	BULKCARRIER
G	630'	70'	36'	25'	7700	BULKCARRIER
H	660'	70'	37'	27'	7700	BULKCARRIER
I	750'	70'	36'	26'	7700	BULKCARRIER
J	629'	70'	36'	26'	7700	BULKCARRIER

ICE PRESSURE INDICES

Two Pressure Indices have been used to make comparisons of structural arrangements and scantlings. These two indices approximate the "failure" pressure of shell plates and frames, and are formulated on the basis of the fully developed plastic hinge. Index formulation and application are explained below (Johanson, 1967).

Formulation of Pressure Index for Shell Plating

For a plate simply supported on two edges, a distance b apart, and which has a length much greater than the distance b , the energy method of analysis indicates that plastic failure will occur when:

$$p = 2(t/b)^2 \sigma_y \quad (1)$$

where

- p = the uniform pressure normal to the plate at which plastic yielding occurs, (psi)
- t = the thickness of the plate (inches)
- b = the distances between supports (inches)
- σ_y = the yield stress of the plate material (psi)

Similarly for a plate with fixed supports on two edges, plastic failure will occur when:

$$p = 4(t/b)^2 \sigma_y \quad (2)$$

The shell plates of ships are considered to be supported in a manner somewhere between these two extremes. Here the Pressure Index has been patterned after the Finnish Classification Society Rules (1971) which is equivalent to a pressure for plastic failure of:

$$p = (9/4)(t/b)^2 \sigma_y \quad (3)$$

The Pressure Index used in this report assumes that shell plates are supported on four edges. Roark and Young 1971, indicate a variation of maximum stress according to the ratio of distances between supports. The graph of Figure 1, based on Roark and Young's information, was used to modify the pressure for plastic failure given in the Finnish Classification Society Rules, thus this study's Pressure Index for shell plates is given by the expression:

$$\text{Pressure Index} = (9/4)(t/b)^2 \sigma_y f \quad (4)$$

f = the modification factor, is found from the graph of Figure 1 according to the distances between supports.

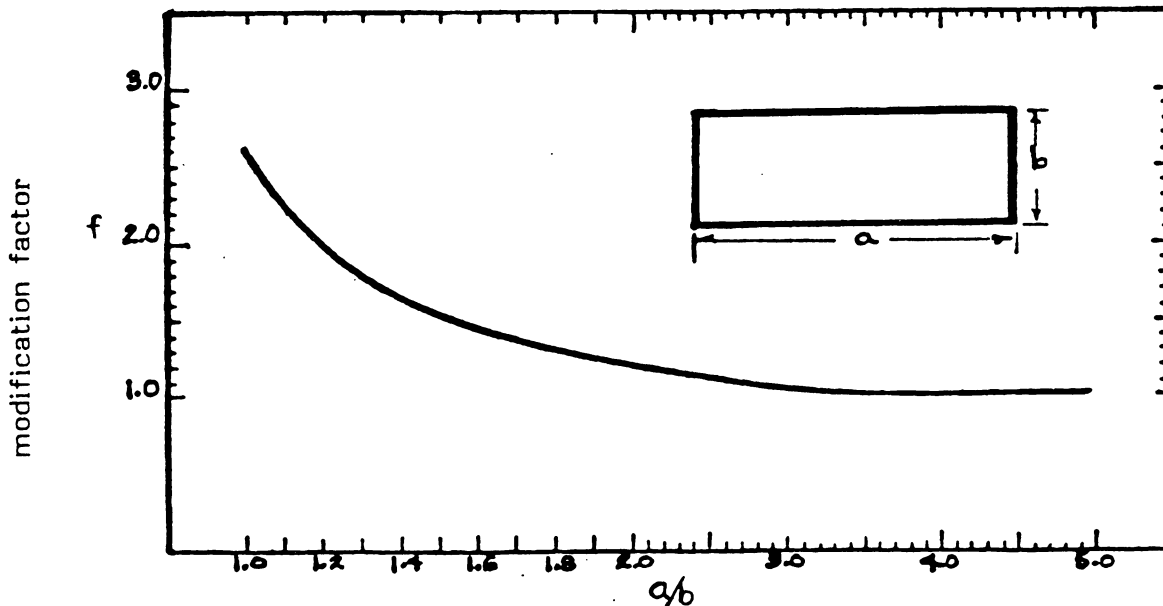

FIGURE 1. Uniformly loaded plate - supported on all four edges

Formulation of a Pressure Index for Frames

For a system of identical beams equally spaced, simply supported at their ends, and subjected to a uniformly distributed force system of length C , centered at the mid-span of the beam, plastic yielding is predicted when:

$$p = \frac{8\sigma_y Z}{S C (2L-C)} \quad (5)$$

where

- p = the pressure at which plastic yielding occurs (psi)
- σ_y = the yield stress of the beam material (psi)
- Z = the plastic section modulus of the beam with attached plating (inches³)
- S = spacing of beams (inches)
- L = the length of the beam between supports (inches)
- C = the distance along the beam, over which the pressure system extends (inches)

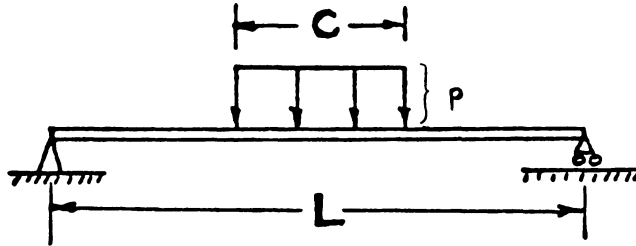

FIGURE 2

Similarly, for the same beam system with fixed end supports the predicted plastic yielding pressure is:

$$p = \frac{16\sigma_y Z}{S C (2L-C)} \quad (6)$$

Again, the actual support conditions of frames are somewhere between these two extremes. In this report the supports are considered closer to the fixed end type and are taken at 80% constrained. The ice belt width, C , is assumed to be a constant of three feet. A reduction in beam length of six inches has been used to account for bracket support of frames. The beam length is defined as the distance between center lines of support.

The Pressure Index, P, for frames can be expressed as:

$$P \text{ Index} = \frac{\sigma_y Z}{55(L-24)} \quad (7)$$

The corresponding expression given by ABS(4) is,

$$p = \frac{\sigma_y SM}{4.92 s(L-15.72)} \quad \text{where SM} = \text{section modulus}$$

Application of Pressure Indices

Shell plates were doubled in one case; the indicated Pressure Index was taken as the sum of the individual Pressure Indices for each plate. However, in calculating the contribution of the doubled plates to the plastic section modulus of the frames, the two shell plates were considered to act as one simple, solid plate.

In several ice strengthening cases flat bars on edge were placed intercostal with the frames. This was credited to ice strengthening of the plate by reducing the aspect ratio a/b of Figure 1 thereby increasing the value of f. However, no credit was given to the ice strengthening of frames.

In several cases shell stringers were extended or intermediate stringers installed. These were credited to the ice strengthening of the plate through the factor f and credited to the frames through the reduction in beam length.

When intermediate frames were installed, which had scantlings different from the full frames, an average value plastic section modulus was used to calculate the Pressure Index for frames. Similarly, when beam length varied an average beam length was used.

It should be noted that the Pressure Index for frames assumes a transverse framing system because only one ship had a longitudinal frame. Consequently, one must avoid comparing the frame Pressure Index of a longitudinal frame with a transverse frame. However, the comparison of the indices for two longitudinally framed systems may still be significant.

Similarly, comparisons of Pressure Indices for hull plates with those for frames do not give realistic evaluations. There are too many assumptions and approximations in the formulation of the Pressure Indices to make them satisfactory for uses other than comparison of Plate System A with Plate System B, or Frame System C with Frame System D.

**COMMENTS ON AND ILLUSTRATIONS OF ICE DAMAGE
AND ICE STRENGTHENING MODIFICATIONS**

Illustrations and summaries of ice damages, repairs, and ice strengthening modifications follow. Pressure Indices are given for both plates and frames, and referenced in the illustration. In the table accompanying each illustration P_o refers to the Pressure Index of the referenced area prior to damage or ice strengthening, and P_a refers to the Pressure Index after ship modifications. Drawings are not to scale. The yield stress for mild steel was taken as 32,000 psi.

SHIP A

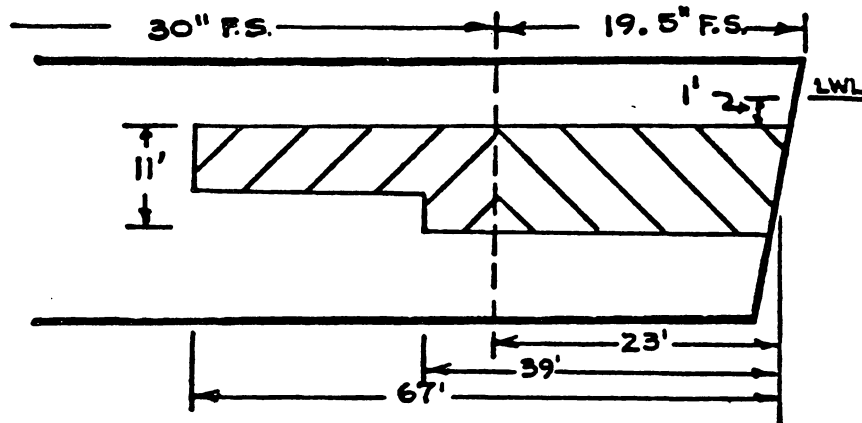



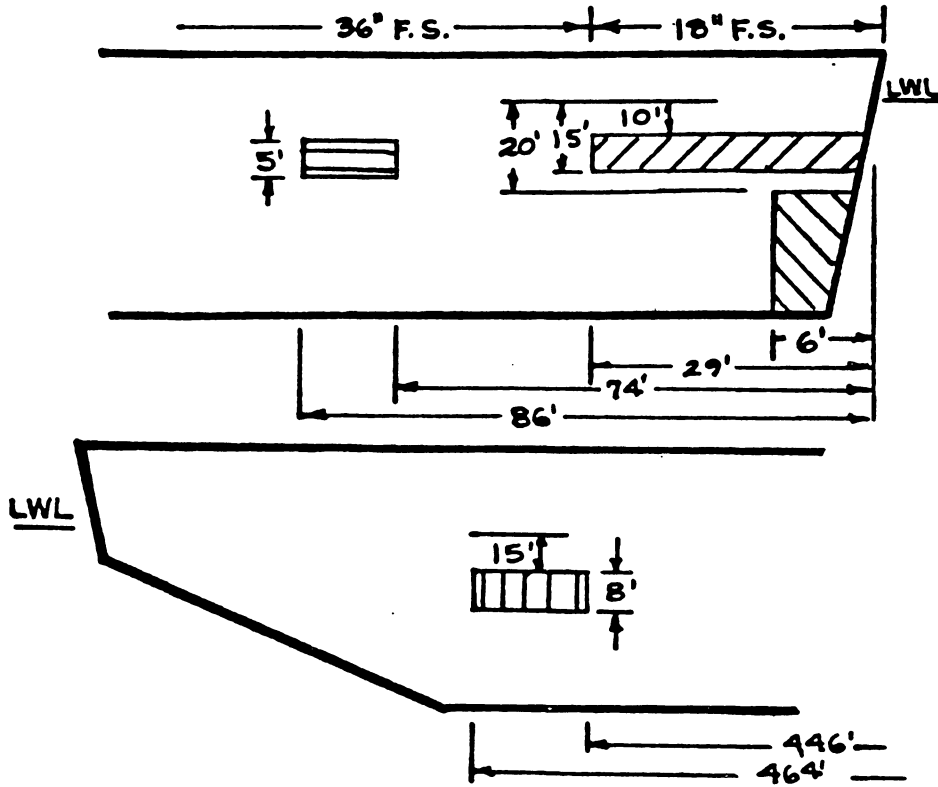

AREA REFERENCED	PRESSURE INDEX			
	PLATE		FRAME	
	P_o	P_a	P_o	P_a
#1	58	190	295	339
#2	24	80	267	348

Damages caused by operation in ice were incurred on several occasions over a span of twenty years. Some of the repaired areas were subsequently damaged again. Eventually, the original 22.5 lb. mild steel plate of both areas indicated above was replaced with 40.8 lb. mild steel plate, giving the results shown in the table. There is no indication that repairs were ever made to the frames.

SHIP B

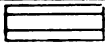



AREA REFERENCED	PRESSURE INDEX			
	PLATE		FRAME	
	Po	Pa	Po	Pa
#1 	102	318	338	338
#2 	102	318	271	271
#3 	36	318	272	495
#4 	24	79	97	97

Ice damages occurred in 1977 and were located both port and starboard in the vicinity of the areas indicated. Repairs were made to the shell plate using 100,000 psi yield stress material of the same weight as the original 25.5 lb. mild steel plate. The survey report indicated that many frames had failed and in all areas, but it was proposed to replace them in kind in areas 1, 2, and 4, and to halve the spacing in area 3.

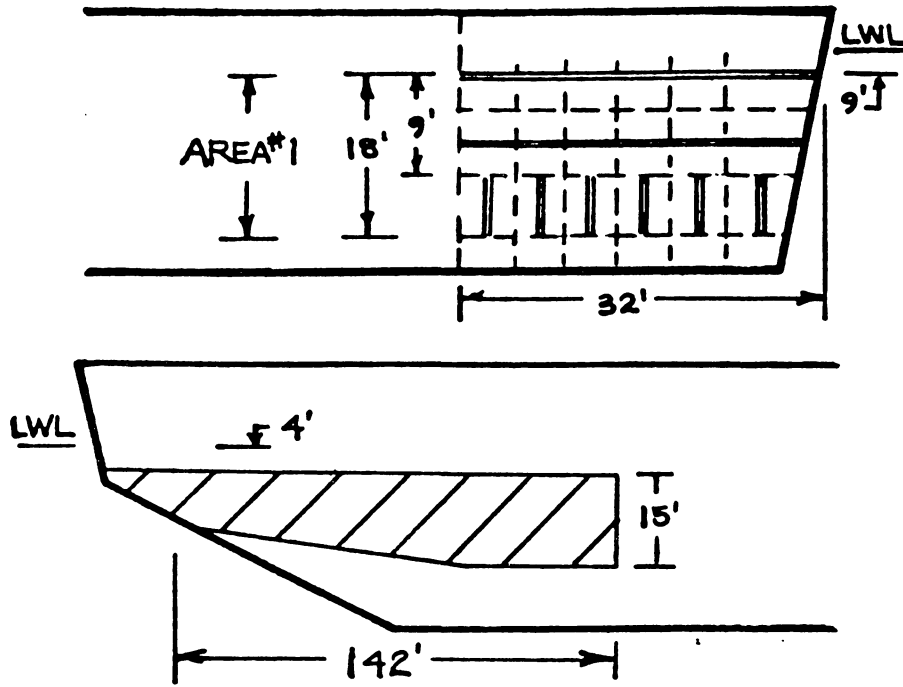
SHIP C

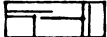



AREA REFERENCED	PRESSURE INDEX			
	PLATE		FRAME	
	P _o	P _a	P _o	P _a
#1 	391	527	440	1764
#2 	161	391	294	294

This ship was initially fitted with 100,000 psi yield stress plating. The weight of plate in the modified area is 30.6 lb. It is presumed that no ice damages were incurred but that ice strengthening was done in anticipation of winter operation. In area #1 two shell stringers and intermediate frames were added as indicated by the doubled lines in the illustration. Area #2 is longitudinally framed. Here, transverse pieces were placed between longitudinal frames to divide the plating into three equal spaces between web frames.

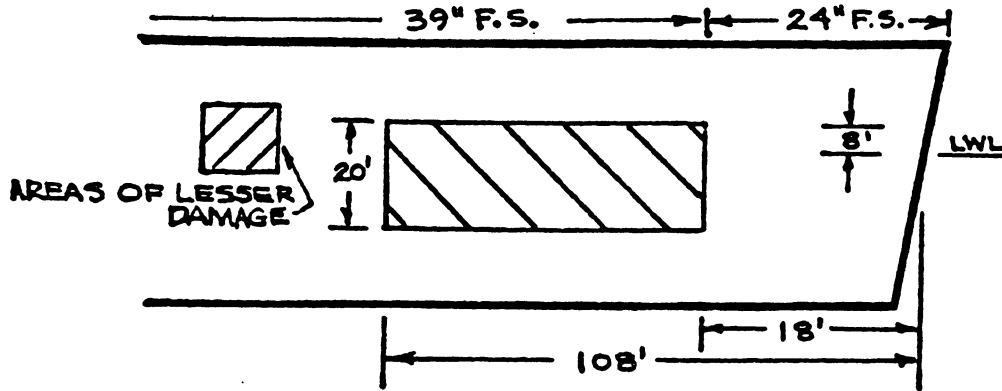
SHIP D





NOTE: THERE WAS NO DAMAGE AT BOW WHERE PLATE $P_0 = 125$ AND FRAME $P_0 = 220$

AREA REFERENCED	PRESSURE INDEX			
	PLATE		FRAME	
	P_0	P_a	P_0	P_a
#1 	23	231	143	276
#2 	23	61	143	143

Ice damage did not occur at the bow of this ship where one might normally expect. The area forward of area #1 is of 40.8 lb. mild steel plate, but in areas #1 and #2 the plate was 25.5 lb. mild steel. There was apparently no damage to frames. Area #1 was strengthened with additional intermediate frames, and 100,000 psi yield stress plating of 25.5 lb. weight. Area #2 damage was small and was repaired using high yield strength plating of 100,000 psi yield stress.

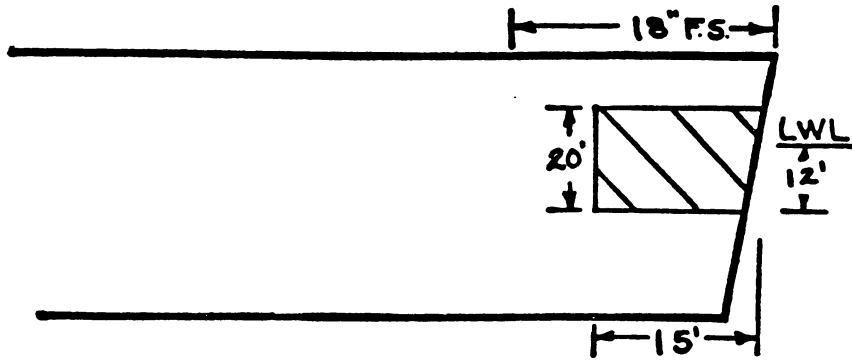
SHIP E





AREA REFERENCED	PRESSURE INDEX			
	PLATE		FRAME	
	Po	Pa	Po	Pa
#1 	182	267	251	1946

Ship E represents two sister ships which incurred almost identical damages in the same winter season. Ice damages in the stern area were quite severe. The plating had been stove-in, rivets had been broken, and the plating had started to tear in several locations. Frames, shell stringers and breast hooks were crippled. The original shell plate was doubled in this area with two thicknesses of 25.5 lb. mild steel plate. The damaged area was completely rebuilt. The doubled shell plate was replaced by one thickness of 40.8 lb. mild steel plate. New stringers were built, and frames were replaced using heavier material and larger brackets.

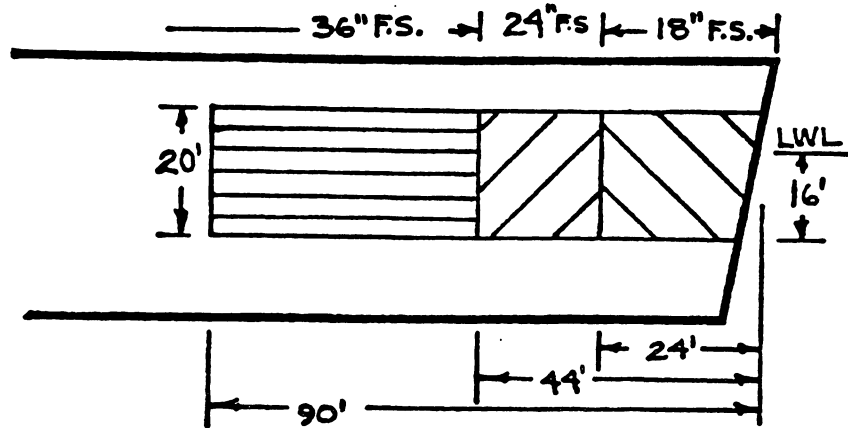
SHIP F



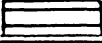

AREA REFERENCED	PRESSURE INDEX			
	PLATE		FRAME	
	Po	Pa	Po	Pa
#1 	74	233	340	1184
#2 	45	144	227	491
#3 	25	79	151	339

It is not certain whether this ship suffered ice damage or was ice strengthened in anticipation of winter operation. Original scantlings were not readily available and therefore, were estimated for the comparisons. For ice strengthening, 40.8 lb. mild steel plate replaced the assumed 22.95 lb. mild steel plate. The frames in areas #1, #2, and #3 were replaced with 15" x 5" x 1/2" F.P. The original frames were assumed to be 8" x 3-1/2" x 21.4# C-sections in area #1, and 10" x 3-1/2" x 28.3# C-sections in areas #2 and #3.

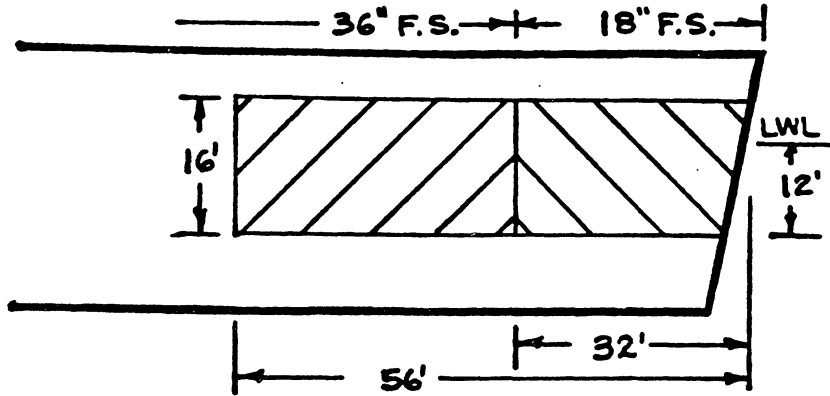
SHIP G



AREA REFERENCED	PRESSURE INDEX			
	PLATE		FRAME	
	P _o	P _a	P _o	P _a
#1 	81	199	231	231
#2 	24	69	159	159

In preparation for winter operation two sister ships were ice strengthened as illustrated above. The shell plate was reinforced by the use of flat bars on edge running longitudinally and intercostal with the frames so as to reduce the vertical spacing of shell plate supports. No modifications were made to frames.

SHIP H

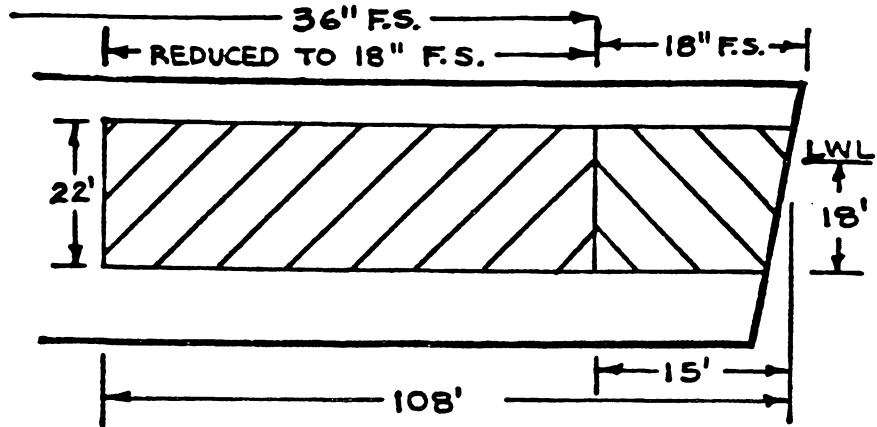

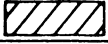

AREA REFERENCED		PRESSURE INDEX			
		PLATE		FRAME	
		P _o	P _a	P _o	P _a
#1		107	335	1698	1698
#2		31	335	159	558

The forward part of this ship, area #1 above, had 28.05 lb. mild steel plate which suffered ice damage and was replaced with 100,000 psi yield stress material of the same scantling. The major portion of the ice strengthening modification took place in area #2 where plating and some frames had been ice damaged. In area #2 shell plating of mild steel was replaced with high yield stress material of the same, 28.05 lb. weight, and intermediate frames were added. Shell stringers were extended from area #1 through area #2.

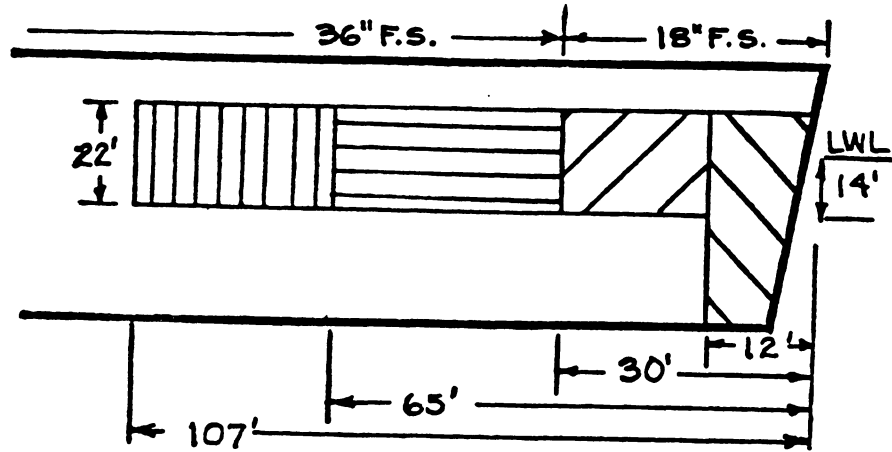
SHIP I

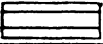
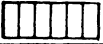

AREA REFERENCED	PRESSURE INDEX			
	PLATE		FRAME	
	Po	Pa	Po	Pa
#1 	81	336	318	566
#2 	81	252	318	318
#3 	27	84	238	238
#4 	21	84	119	238

This ship incurred ice damages on several occasions and repairs were often made to local areas as required. Eventually ice strengthening was completed as illustrated above. The original 28.05 lb. mild steel plate was replaced with 100,000 psi yield stress plating of the same weight in all four areas. Stringers were extended into area #4. Stringers and breast hooks were reinforced in areas #1 and #2. The shell plating in area #1 was reinforced by the use of flat bars on edge intercostal with frames.

SHIP J

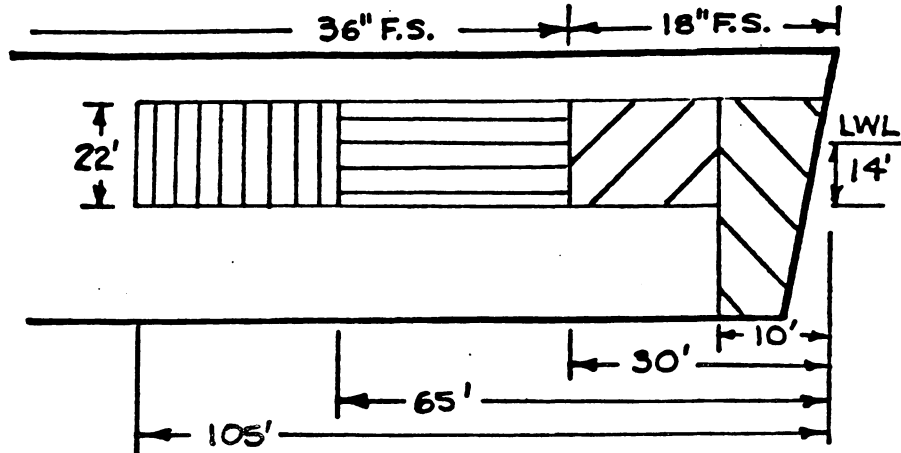

AREA REFERENCED	PRESSURE INDEX			
	PLATE		FRAME	
	P _o	P _a	P _o	P _a
#1	81	336	318	566
#2	81	252	318	318
#3	27	84	238	238
#4	21	84	119	238

This ship had a record of ice damages and repairs similar to those of Ship I. Although the ice strengthening modifications varied in minor detail, the end result was essentially the same as for Ship I.

CONCLUSIONS AND RECOMMENDATIONS

The quantity of data is small and, consequently, does not permit a penetrating statistical analysis. However, a simple review of the collected information reveals several interesting points.

Table II lists those ships known to have incurred ice damage at the bow, arranged in order of the length of damage (LD) as a percentage of Length Between Perpendiculars, (LBP).

TABLE II

Ship	Length Damaged	LBP	$\frac{LD \times 100\%}{LBP}$
E	15	388	3.9%
B	86	629	13.7%
I	107	750	14.3%
D	108	670	16.1%
H	108	660	16.4%
J	105	629	16.7%
A	67	390	17.2%

The entrance length of Great Lakes bulk carriers is about 17 to 22 percent of LBP. Table II indicates, as one might expect, that the area of a ship most subject to ice damage extends over the entrance.

Ships sustaining damage to the bow are given in Table III. They are listed in increasing order, according to the distance above low water line (LWL) to which the ice damage occurred.

TABLE III

Ship	Distance above LWL to which damage occurred
B	-10 ft
A	- 1 ft
H	+ 4 ft
I	+ 8 ft
J	+ 8 ft
D	+ 8 ft
E	+ 8 ft

Table III shows quite clearly that the ice damage seldom extends more than eight feet above LWL, and the location of shell stringers undoubtedly influences this distance. The distance below LWL where damages were found depends upon the conditions appropriate for ballast operation as well as ice conditions. Both Tables II and III appear to bear out what one might expect: that damage is most likely to occur where the ship is entering the ice.

A list of ice damaged ships is given in Table IV in ascending order of Pressure Index for original plates. Similarly, Table V indicates the Pressure Index for original frames. Only ships which actually incurred ice damage to plate or frame are listed.

TABLE IV

Ship	Pressure Index for Original Plate
I	21
J	21
D	23
A	24
B	24
I	27
J	27
H	31
B	36
A	58
I	81
J	81
B	102
H	107
E	182

TABLE V

Ship	Pressure Index for Original Frame
B	97
H	159
E	251
B	271
B	272
B	338

The maximum values in Tables IV and V show that plate failure occurred at a Pressure Index of 182, and a frame failure occurred at a Pressure Index of 338. Both the American Bureau of Shipping Rules and the Finnish Board of Navigation Rules presume that the maximum ice pressure to be used in calculations for plate or frames is 234.5 psi. Their formulas for calculating required plate thickness or section modulus are similar to those used in this report. Rearrangement of their formulas for required plate thickness to express a calculation of pressure would show that, except for the factor f , their expressions for pressure would be the

same as the Pressure Index for plate used in this report. Similarly their expressions for required section modulus of the frames, if rearranged, would show a close resemblance of the Pressure Index for frames used in this report. However, there is a difference. They use elastic section modulus, but this study uses the plastic section modulus. Sample comparisons of the two moduli show that the plastic section modulus is at least one and a half times as large as the elastic section modulus. (Note: The shell plate is included for both calculations.) To correct for this difference their maximum pressure of 234.5 psi can be multiplied by 1.5. Comparison with this reports Pressure Index for frames, results in an equivalent maximum Pressure Index of 352. Tables IV and V show that no ice damage occurred when the Pressure Indices were greater than the 234.5 for shell plate or 352 for frames. However, the maximum Pressure Indices shown in these tables are sufficiently close in relation to the maximum ice pressures suggested by the American Bureau of Shipping and the Finnish Navigation Board that consideration should be given to their use in designing Great Lakes ships engaged in winter operation.

Table VI is a compilation of the ice strengthening methods used and their effect on the two Pressure Indices. In the two right columns, note the ratios of change in Pressure Indices to change of steel weight per square foot. Presumably the higher ratios reflect the more efficient use of steel. The lower values of these ratios may, however, reflect expediency in repairs to ice damaged structure rather than well considered ice strengthening. The use of high strength steel of about 100,000 psi yield seems to be a popular as well as economical ice strengthening method. Without increasing the steel weight the Pressure Index for plate is increased over three times. But this method has no great effect on frames unless they too are of the same material, in which case the Pressure Index for frames is also increased by a factor of three.

The use of plate stiffeners (usually flat plates welded on edge to the plate) is an effective way to increase the Pressure Index for plating, but, because they are intercostal to frames, add no stiffness to the frames. Intermediate frames, well connected to stringers or similar structures have the effect of doubling the Pressure Index for frames and quadrupling that for plate, but, of course, the steel weight per square foot increases, too.

Thus, several ice strengthening methods are open to those who wish to operate ships in the winter season. It is hoped this report provides insight so that ship designers and operators may determine the method most economical for them.

Further Research

Additional research could include further evaluation of the prevailing ice strengthening practices and development of most effective design concepts for ice strengthening based on strength and economy. Ship operators, classification societies, governmental groups and other parties with technical interest in these problems should continue to share their experience and knowledge so that rational methods and guidelines for ice strengthening Great Lakes bulk carriers can be developed.

TABLE VI

SHIP & AREA	ICE STRENGTHENING USED	Δ ST. WT.	Δ PI PLATE	Δ PI FRAME	Δ PI PLATE Δ ST.WT.	Δ PI FRAME Δ ST.WT.
A1	Plate t increased	18.3	132	44	7.2	2.4
A2	"	18.3	56	81	3.1	4.4
B1	Replace plate with "Hi-S" steel	0	216	0	*	*
B2	"	0	216	0	*	*
B3	Replace plate with "Hi-S" steel and fr. spacing reduced by added frames	12.7	282	223	22.2	17.6
B4	Replace plate with "Hi-S" Steel	0	55	0	*	0
C1	Added stringers & intermediate frames	13.3	136	1324	10.2	99.5
C2	Added plate stiff's intercostal to long'l frames	4.8	230	0	47.9	0
D1	Replace plate with "Hi-S" steel and added int. frames	17.4	208	133	11.9	7.6
D2	Replace plate with "Hi-S", steel	0	38	0	*	0
E1	Added stringers, increased frame size, dbl'd plating replaced with single t.	12.2	85	1696	7.0	139.0
F1	Increase plate t and frame scantlings	21.7	159	844	7.3	38.9
F2	Increase plate t and frame scantlings	20.7	99	264	4.8	12.8
F3	Increase plate t and frame scantlings	19.8	54	188	2.7	9.5
G1	Plate stiff's added	7.9	118	0	14.9	0
G2	Plate stiff's added	7.9	45	0	5.7	0
H1	Replace plate with "Hi-S" steel	0	228	0	*	0
H2	Replace plate with "Hi-S" steel, extend stringers & add intermediate frames	21.3	304	398	14.3	18.7
I1	Replace plate with "Hi-S" steel, added breast hooks and plate stiff's	13.5	255	248	18.9	18.3
I2	Replace plate with "Hi-S" steel and added bkt's at fr's and stringers	5.0	171	0	34.2	0
I3	Replace plate with "Hi-S" steel	0	57	0	*	0
I4	Replace plate with "Hi-S" steel, and extend stringers	5.0	57	119	11.4	23.8
J1	Replace plate with "Hi-S" steel, added breast hooks and plate stiff's	13.5	255	248	18.9	18.3
J2	Replace plate with "Hi-S" steel and added bkt's at fr's and stringers	5.0	171	0	34.2	0
J3	Replace plate with "Hi-S" steel	0	57	0	*	0
J4	Replace plate with "Hi-S" steel, and extend stringers	5.0	57	119	11.4	23.8

"Hi-S" indicates High Strength Steel

ST.WT. indicates lbs./Sq. Ft.

REFERENCES

U.S. Coast Guard Damage Report Print-Outs 1968-1979. Summary of Extracton of Major Collision with over \$50,000 in Damages and Detailed Summary of Damages Incurred.

Finnish Board of Navigation, "Rules for Assigning Ships Separate Ice-Due Classes."

Roark, Raymond J. and Warren C. Young, "Formulas in Stress and Strain," 5th Edition, McGraw-Hill Book Company. p. 386.

"Rules for Building and Classing Steel Vessels" 1978. American Bureau of Shipping, New York, New York.

Johanson, B.M., "On The Ice-Strengthening of Ship Hulls." International Shipbuilding Progress, Vol. 14, No. 154, June 1967.

UMTRI



3 9015 07543 9102

**Transportation
Research Institute**

**Transportation
Research Institute**

AIIM SCANNER TEST CHART # 2

Spectra

4 PT ABCDEFGHIJKLMNOPQRSTUVWXYZabcdefghijklmnopqrstuvwxyz;"/?0123456789
 6 PT ABCDEFGHIJKLMNOPQRSTUVWXYZabcdefghijklmnopqrstuvwxyz;"/?0123456789
 8 PT ABCDEFGHIJKLMNOPQRSTUVWXYZabcdefghijklmnopqrstuvwxyz;"/?0123456789
 10 PT ABCDEFGHIJKLMNOPQRSTUVWXYZabcdefghijklmnopqrstuvwxyz;"/?0123456789

Times Roman

4 PT ABCDEFGHIJKLMNOPQRSTUVWXYZabcdefghijklmnopqrstuvwxyz;"/?0123456789
 6 PT ABCDEFGHIJKLMNOPQRSTUVWXYZabcdefghijklmnopqrstuvwxyz;"/?0123456789
 8 PT ABCDEFGHIJKLMNOPQRSTUVWXYZabcdefghijklmnopqrstuvwxyz;"/?0123456789
 10 PT ABCDEFGHIJKLMNOPQRSTUVWXYZabcdefghijklmnopqrstuvwxyz;"/?0123456789

Century Schoolbook Bold

4 PT ABCDEFGHIJKLMNOPQRSTUVWXYZabcdefghijklmnopqrstuvwxyz;"/?0123456789
 6 PT ABCDEFGHIJKLMNOPQRSTUVWXYZabcdefghijklmnopqrstuvwxyz;"/?0123456789
 8 PT ABCDEFGHIJKLMNOPQRSTUVWXYZabcdefghijklmnopqrstuvwxyz;"/?0123456789
 10 PT ABCDEFGHIJKLMNOPQRSTUVWXYZabcdefghijklmnopqrstuvwxyz;"/?0123456789

News Gothic Bold Reversed

4 PT ABCDEFGHIJKLMNOPQRSTUVWXYZabcdefghijklmnopqrstuvwxyz;"/?0123456789
 6 PT ABCDEFGHIJKLMNOPQRSTUVWXYZabcdefghijklmnopqrstuvwxyz;"/?0123456789
 8 PT ABCDEFGHIJKLMNOPQRSTUVWXYZabcdefghijklmnopqrstuvwxyz;"/?0123456789
 10 PT ABCDEFGHIJKLMNOPQRSTUVWXYZabcdefghijklmnopqrstuvwxyz;"/?0123456789

Bodoni Italic

4 PT ABCDEFGHIJKLMNOPQRSTUVWXYZabcdefghijklmnopqrstuvwxyz;"/?0123456789
 6 PT ABCDEFGHIJKLMNOPQRSTUVWXYZabcdefghijklmnopqrstuvwxyz;"/?0123456789
 8 PT ABCDEFGHIJKLMNOPQRSTUVWXYZabcdefghijklmnopqrstuvwxyz;"/?0123456789
 10 PT ABCDEFGHIJKLMNOPQRSTUVWXYZabcdefghijklmnopqrstuvwxyz;"/?0123456789

Greek and Math Symbols

4 PT ΑΒΓΔΕΕΘΗΙΚΑΜΝΟΠΦΡΣΤΥΩΧΨΖαβγδεξθηικλμνοπφρστνωχψζ≧≧≧",./≤±=≠'><><><≡
 6 PT ΑΒΓΔΕΕΘΗΙΚΑΜΝΟΠΦΡΣΤΥΩΧΨΖαβγδεξθηικλμνοπφρστνωχψζ≧≧≧",./≤±=≠'><><><≡
 8 PT ΑΒΓΔΕΕΘΗΙΚΑΜΝΟΠΦΡΣΤΥΩΧΨΖαβγδεξθηικλμνοπφρστνωχψζ≧≧≧",./≤±=≠'><><><≡
 10 PT ΑΒΓΔΕΕΘΗΙΚΑΜΝΟΠΦΡΣΤΥΩΧΨΖαβγδεξθηικλμνοπφρστνωχψζ≧≧≧",./≤±=≠'><><><≡

White



Black



Isolated Characters

e	m	1	2	3	a
4	5	6	7	o	-
8	9	0	h	l	B

MESH HALFTONE WEDGES

65

85

100

110

133

150

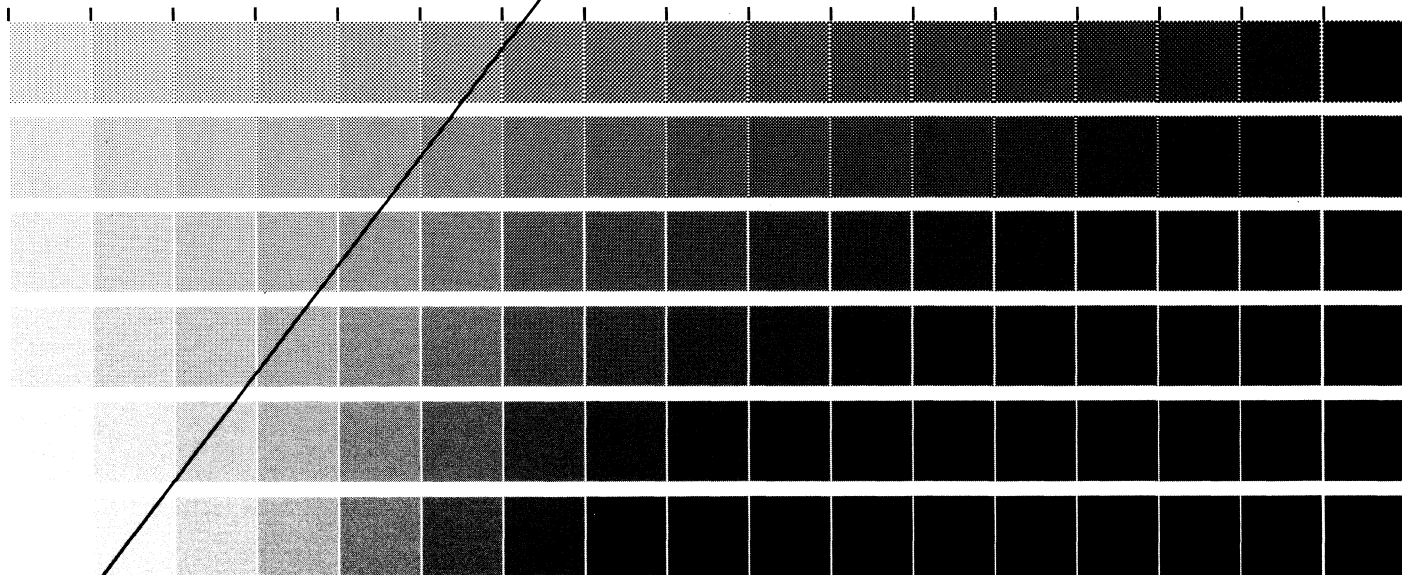

MEMORIAL DRIVE, ROCHESTER, NEW YORK 14623

ROCHESTER INSTITUTE OF TECHNOLOGY, ONE LOMB

RIT ALPHANUMERIC RESOLUTION TEST OBJECT, RT-171

PRODUCED BY GRAPHIC ARTS RESEARCH CENTER



0	3E	0	2E	0	3E	0	2E
1	253	1	253	1	253	1	253
2	23E	2	23E	2	23E	2	23E
3	3E8	3	3E8	3	3E8	3	3E8
4	E25	4	E25	4	E25	4	E25
5	523	5	523	5	523	5	523
6	2E5	6	2E5	6	2E5	6	2E5
7		7		7		7	



0	3E	0	2E	0	3E	0	2E
1	253	1	253	1	253	1	253
2	23E	2	23E	2	23E	2	23E
3	3E8	3	3E8	3	3E8	3	3E8
4	E25	4	E25	4	E25	4	E25
5	523	5	523	5	523	5	523
6	2E5	6	2E5	6	2E5	6	2E5
7		7		7		7	

