

Solar-Powered Irrigation System

Design Review 5

The University of Michigan

ME 450 Fall 2015

12/14/15

Section Instructor: Andre Boehman

Team 11 Members:

Spencer Abbott

Isaac Baker

RJ Nakkula

ABSTRACT

The city of Shelek, Kazakstan receives inconsistent access to electricity due to an expensive and unstable grid. As a highly agrarian society, it is important that family produced market gardens have access to water in order to supply their families with food and income provided from the crops sale. In order to assist with this problem, a scale prototype of solar-powered irrigation system was designed and analyzed. Additionally, a mathematical model was created to obtain design recommendations for a full-scale implementation. The main requirements for this project include a solar power source to drive a water pump that can feed an irrigation system. With the water pump and solar panel specifications mostly dependent on the amount of water necessary to properly irrigate the crops, it became clear that the main design driver was water needs. That specification along with the depth of the well then determines the specification of the water pump which in turn specifies the power requirements for the solar panel. Several concepts were generated and functional decomposition was conducted to specify the goals of the irrigation system and outline the engineering specifications. The remaining details such as the irrigation system, water storage, and energy storage were varied to examine the design parameters and understand what was feasible, necessary, and cost effective. A scoring system was developed in order to rank the concepts and bring to light the advantages and disadvantages of each concept. Ultimately, the system that utilizes an elevated water storage reservoir that provides potential energy fed water lines to a drip irrigation system was chosen for its efficiency at delivering water in an arid region. The scale model, which acts as a proof of concept, was empirically analyzed as a means to evaluate the system and the efficacy of the theoretical model.

Table of Contents

1. BACKGROUND	4
2. STAKEHOLDER REQUIREMENTS & ENGINEERING SPECIFICATIONS	5
Irrigation System	5
Water Pump	6
Solar Panel and Irradiance Data	7
3. CONCEPT DEVELOPMENT	7
Concept Generation	7
Concept Selection	8
Chosen Design Mockup	10
4. PRIMARY DESIGN DRIVERS AND CHALLENGES	11
Project Scope	12
5. FINAL DESIGN	12
Full-Scale Irrigation System	13
Scale Prototype Irrigation System	15
6. ENGINEERING ANALYSIS	17
Theoretical Modeling	17
FMEA / Risk Analysis	22
7. MANUFACTURING, ASSEMBLY, AND VALIDATION OF SCALE PROTOTYPE	23
Scale Model Prototype	23
8. FULL-SCALE IMPLEMENTATION	24
Significance of Calculator and Accurate Environment Details	24
Full-Scale Design Suggestions	24
<i>Picking the Right System Components:</i>	24
<i>Elaboration of Additional Implementation of Components:</i>	25
Future Use of Prototype for Educational Purposes	26
9. DESIGN CRITIQUE AND DISCUSSION	26
References	28
APPENDIX	30
SECTION A:	30
5. FINAL DESIGN	35
Basic Assembly of a Full-Scale Implementation	46
SECTION B:	46

Individual Assignments	50
AUTHORS	51

Executive Summary

This project aims to design a model of a solar-powered irrigation system for use in the city of Shelek, Kazakhstan, a city with expensive and inconsistent access to electricity. A highly agrarian society, it is important that family produced market gardens have access to water in order to supply their families with food and income provided from crop sale. Therefore, we have been tasked with developing a mathematical model for the design of a full-scale solar-powered irrigation system as well as developing a scaled model for analysis.

The main requirements for our project include a solar power source to drive a water pump that can feed an irrigation system. With the water pump and solar panel specifications mostly dependent on the amount of water necessary to properly irrigate the crops, it became clear that the main design driver was water needs. That specification along with the depth of the well then determines the specification of the water pump which in turn specifies the power requirements for the solar panel.

Several concepts were generated and helped to develop a functional decomposition which was created to specify the goals of the irrigation system and outline the engineering specifications. Twenty design concepts were analyzed to determine their merits and drawbacks. The remaining details such as the irrigation system, water storage, energy storage, and sensors were varied to examine the design parameters and understand what was feasible, necessary, and cost effective.

A scoring system was developed in order to rank the concepts and bring to light the advantages and disadvantages of each concept. Ultimately, the system that utilizes an elevated water storage reservoir that provides potential energy fed water lines to a drip irrigation system was chosen for its efficiency at delivering water in an arid region. This system also only requires the pump to extract water from the well and transport it to the reservoir and thus reduces the size and cost of a solar panel required to run the pump.

Several design considerations were taken into account for our project. First and foremost was risk analysis and FMEA to prevent any injury as a result of construction and daily interaction. With those goals in mind simplicity of assembly was considered as access to tools and resources may be limited. One of the other important considerations was the environmental impact and sustainability of resources as well as the longevity of the system itself.

In addition to creating a mathematical model we also outline our proposed empirical analysis that was conducted on a scale model. This scale model will utilize hardware component specifications predicted from our mathematical model and will act not only as a proof of concept but as a means to evaluate the system and the efficacy of the theoretical model. With the proposed analysis of the scale model we may be able to adjust our mathematical model to more closely resemble real world scenarios.

Testing of the solar panel efficiency has been conducted. Flow rates, at different valve settings, were examined to determine the effect that the ball valve will have on volumetric flow rate, as it is an important factor in water needs for crops. Additionally, the water pumps flow characteristics were compared to design specifications. Finally, this document ends with a critique of the design and an assessment of future work.

1. BACKGROUND

Kazakhstan is a large landlocked nation that has a largely agrarian economy. One quarter of its residents make their living from the farming industry. Many residents in the town of Shelek, Kazakhstan rely on small market gardens to provide their families with food and additional income that can be obtained from selling their surplus crops at local farmer's markets. Shelek however has infrastructure deficits that make access to the electrical grid cost prohibitive. In addition, those that can afford to have electricity lines run to their houses experience inconsistent power due to high wind speeds that plague the area. When winds reach upwards of 70 mph the electrical grid is shut down. This poses a problem for families that require electricity to irrigate their crops. Some well-water extracting pumps, because of age and power fluctuations due to inconsistent electricity, are no longer working. With these issues in mind our sponsor REFRESCH saw an opportunity to improve upon the situation by implementing solar powered irrigation systems.

The particular homeowner we are hoping to assist works as a teacher, but she has very few work hours since the school hires many of the city members to be teachers as an attempt to provide more people with some means of income. There are existing products that could resolve Shelek's irrigation problem but they have not been implemented mostly due to a lack of funds. High winds in the area, while seemingly good for the implementation of wind turbines, approach velocities too great for most turbines to handle. Assuming the implementation of a GE wind turbine model 1.5 xle, 70 mph winds would be on the upper end of its rated tolerance, assuming the air density to be at sea level (Shelek air density is approximately 1.11 kg/m^3) [1&2]. The implementation of renewable energy by the city can provide new jobs and also long term social and economic development for the country [3]. While the main issue of reliable energy solutions remain in the works, our goal is to alleviate this hardship by removing the reliance on the city's energy at the location of our project.

There are current solar irrigation systems that are working effectively in Africa and are achieving the goal we are also trying to accomplish (See Figure 1.2 of appendix). One of these systems is developed by SunCulture and relies on solar energy from a stationary panel that powers a DC pump that is placed in a well close to the land that is to be irrigated [4]. The water is then pumped into a storage vessel which feeds the irrigation lines with potential energy as the vessel is often raised or at a higher elevation than the irrigating lines. The connection between the panel and the pump uses a controller that keeps the voltage from varying too much and damaging the pump. Some systems have pipes that can be filled with fertilizer so the water feeding the plants already has some nutrients. This system is similar in function to that invented by Wen Yuelin and Zhu Jianyun [5]. These systems are designed for specific locations so they are designed with the area in mind; thus there does not seem to be just a generic layout for the entire system.

The cost associated with the infrastructure for renewable forms of energy is the main reason for a lack of implementation in the area. Kazakhstan has regions of extreme wealth and poverty and many families have no expendable income. The government is also lacking funds and the country instead relies on donations from outside supporters. One of the project goals is to reduce the cost of implementation of a solar-powered irrigation system. If most of the materials are cheap and easy to buy then our system could be implemented in more locations where income is limited. Of course we cannot reduce the cost of all the hardware components, as the system still needs a solar panels and a water pump. Solar panels have become more affordable in the recent years, but they would still be one of the most expensive pieces of equipment in the system [6].

2. STAKEHOLDER REQUIREMENTS & ENGINEERING SPECIFICATIONS

A discussion with our sponsor, REFRESCH, brought to light the detailed user requirements necessary for our project. In order to achieve a successful system, three main components are necessary: a solar panel, water pump, and irrigation system. A detailed discussion of stakeholder requirements and engineering specifications follows Table 2.1, which outlines the information to successfully establish a solar-powered irrigation system.

Table 2.1: Stakeholder requirements and engineering specifications

User Requirements	Relative Priority	Engineering Specifications	Rationale
Obtain Water	High	Water Pump: Self-prime 4.5m >3m of head	Water extraction necessary
Store Water	Moderate	Hold up to 1000L	Must hold up to the maximum amount of water required during peak watering season
Properly distribute water	High	Overcome 1m of head loss	Water is properly distributed to optimize crop growth
Minimize water usage	Moderate	Drip irrigation	Limits evaporative losses in arid environment
Remove reliance on electrical grid	High	Solar panel: 40W	Necessary to power water pump and other electrical components

Irrigation System

The current method of irrigating the garden in Shelek, Kazakhstan is to run a pump attached to a well and flood the garden one to two times a day [7]. This method is not ideal as it wastes water and it does not properly control the amount of water that individual plants need for ideal growth. Additionally, electric power to run the pump is inconsistent. This method of irrigating has been implemented to prevent the crops from drying out when the electric grid is shut off.

With power to run the pump being inconsistent, one user requirement is the ability to store water in such a way that will allow for irrigation without the use of power which can also arise when a solar panel is not able to collect enough energy. Therefore it becomes necessary to implement a water storage device that not only keeps a store of water for times when power is lacking, but that can also utilize potential energy to provide irrigation without the need for electrical energy consumption during its use. To accomplish this an elevated water reservoir has been proposed to store enough water for the maximum daily crop consumption.

In addition, a drip irrigation system which utilizes low pressure, between 10-30 psi, makes potential energy a viable source for that pressure [8]. The irrigation system, excluding the water pump and solar panel, consists of two parts: a water storage container and a drip irrigation system. The water storage

container needs to be large enough to store water for a day's worth of water while also having the ability to be mounted high enough to utilize potential energy as source of distribution power similar to a device patented by Jianjun, Lyu [9]. Plant water consumption is determined by growth phases and evapotranspiration figures relevant to a particular region. Based on formulas for the growth phases of tomato plants and utilizing evapotranspiration data for Shelek, Kazakhstan the daily water reserve needs to reach a maximum of 1000L [10, 11, 12].

The drip system, ideal for arid environments such as those seen in Shelek, Kazakhstan, can also be optimized for this specific application [8]. In order to appropriately water the crops it needs to have properly spaced holes that allow for specific drip rates as well as being cheap, robust, and semi-flexible in its implementation. In order to meet these user needs the drip system will likely use a semi-flexible material, such as polyethylene, commonly used for drip irrigations systems. This is also cheaper and easier to implement when compared to alternatives such as hard plastics [13].

Water Pump

The method of flooding a garden for irrigation can put a lot of strain on the pump with the surges in electricity being so great as the power in the city is constantly being turned on and off. The proposed design would have a pump obtaining consistent power derived from the solar panel and would not be affected by power fluctuations in the grid as a controller could be implemented. Many of the pumps date back 20-30 years and given Kazakhstan's economic ties with Russia a down surge in the economies make replacement unlikely [14]. The equipment is available but there are not many people with the expendable income to pay for them. With the consistent voltage and a newer pump, the pump will operate more efficiently than the one they were previously using.

Full-scale pump specifications are given as recommendations instead of a specific model as it is determined by the water demands and head loss calculations which are variable and dependent on the theoretical model which allows for various user input. A pump can be selected that has the flow rate capability as well as the power to draw from the water table in the area. Faced with the challenge of providing a pump based on conflicting data from REFRESCH and locals in Shelek, a calculator, which is adjustable for differing implementations, provides specifications for determining pump characteristics. Initial information about the water table suggests that it was located around 12-15 feet but in the last few years that may have lowered [7]. Therefore a pump needs to self-prime up to 4.5m and pump water an additional 3m above ground level to fill the water storage vessel [15]. The Remco 12 Volt Self-priming pump will meet these requirements [16].

The chosen design will work without the need for batteries for power storage however REFRESCH has decided to use a 12V battery for energy storage and to consistently run the pump when solar power is unavailable. Therefore, the pump should be compatible with either the solar panel or battery output which could ultimately necessitate a controller to maintain the energy supply to the DC pump. One challenge comes from finding a potential DC powered motor that is cheap and easy to maintain. The family would not have the resources to go out and buy a new one or have someone come and repair it if it were to break down. Therefore, pump reliability while difficult to quantify is crucial to the project. The addition of a

voltage controller may be likely to reduce any inconsistencies that could arise from fluctuations in irradiation.

Solar Panel and Irradiance Data

The development of the solar panel portion of our system requires data driven decisions. The decision to implement a solar panel as a power source is well justified by the country's irradiance levels (1300-1800 kw/m² year) and because of the poor reliability of the electrical grid [17]. Since it will be the main source of energy, it must have a mutual relationship with the devices it will power. With a pump selected power rating for a solar panel can be determined.

Some necessary requirements of the panel itself, which will remain constant regardless of our model, include reliability, safety, and weather resistant. There is a solar panel manufacturer in Kazakhstan but it is preferred to obtain the panels from a source that has a strong reputation for reliability, such as a German or Japanese product [7]. Additionally, the panel will need to withstand a range of temperatures and forces that it would experience in a specific location such as Shelek. The cost of the panel will be covered by REFRESCH and they do currently have two solar panels with a total output of 40W [7].

The average irradiance of the Almaty area is 5.26 kWh/m²/day between the farming months of April and September, assuming a 100 watt solar panel at 47 degrees from vertical [18]. Ann Arbor's average irradiance for April to September is 5.12 kWh/m²/day in comparison [18]. The panel will need to be positioned to receive maximum sunlight throughout the summer months. The panel should be oriented at 20.5 degrees up from horizontal in order to maximize its energy capture during the summer months [19, 20].

3. CONCEPT DEVELOPMENT

In order to develop an optimized solar-powered irrigation system several concepts were analyzed and subsequently ranked for their positive and negative attributes. Below is a description on the concept generation and selection process.

Concept Generation

Developing concepts for the solar-powered irrigation system was done as individually and in a group during brainstorming sessions. Some research was conducted before these sessions to understand all of the components that would be required in the implementation of an irrigation system. Some of these factors such as a photovoltaic solar panel, water pump, and an inverter/controller are crucial to the design requirements as they accomplish our task and add some control to the system. With the major components and user requirements in mind, functional decomposition was performed to lay out the critical actions that the various components would need to perform (see appendix for Functional Decomposition.). The component with the most flexibility in implementation would be the irrigation system attached to the water pump. Spray, furrow, flooding, above and below ground drip systems were the major concepts analyzed. While they all have their advantages and disadvantages one unique system is well suited for the particular climate, crop, cost, and size of the system being modeled for Shelek, Kazakhstan.

One of the concepts to be generated was to include all of the key factors needed to successfully irrigate the plot and preferably optimize the model. This system included a photovoltaic solar panel that powers a water pump through an inverter/controller as to not damage the pump due to power fluctuations. From there water would be pumped into an elevated water storage container at a height appropriate to provide the necessary potential energy to fill and distribute the water to a network of drip irrigation lines.

While this system holds the most potential for our application other concepts were also evaluated. These all require the water pump be powered by a solar panel but differ in the irrigation system. Other irrigation systems researched include a sprinkler type system and a furrow system, both of which are inefficient in their water usage and not well adapted for arid regions. Buried drip lines and the use of hard plastic lines were deemed too difficult to install and maintain, especially if the farm's layout changes. Additional features can also be added to the system to make it more automated but add cost to the project and may not be necessary. Battery storage that would allow the pump to be run when solar power is low is being considered but may be unnecessary with a large enough water storage container. A float sensor, on the other hand, which is designed to shut off the water pump when the storage container is full may be one item that is cheap and easy to implement and reduces the risk of the pump running for too long and wasting water and energy.

Concept Selection

With a user determined task of providing water through an irrigation system to a small farm utilizing a solar panel to power the well water extraction process, we had the opportunity to create an array of solutions that would help us accomplish this task. Our concept selection began by acknowledging various combinations of components that would utilize solar power to irrigate a garden. Some environmental details considered when creating concepts included: no standard garden layout and the system will be managed by four individuals. With this information, we knew our system would have to be flexible in its ability to water different locations while still being able to perform reliably. Still unclear is who will be building the final system. Necessary components of the system include the solar panel and the pump, but other components could be interchanged to create various interfaces of the system and allow for the watering process to occur in different ways. Implementing a battery for energy storage or a reservoir water storage would allow for a larger range of scenarios that can outperform some concepts, but the components have the potential to add complexity and unnecessary cost to a system that will already be expensive.

Our concept selection process was focused on the layout, efficiency, cost, and ease of implementations of our system, rather than establishing individual component specifications. Since the solar panel and pump can be optimized for the specific application, these details would be determined after the water use requirements were established. In order to determine our system layout, a pugh chart was created with various criteria of different weights. Criteria such as adaptability and low maintenance were weighted the most valuable. This is because we want our system to be able to adapt to the farm and the plants our users decide to harvest. Since our location is on the other side of the globe with inconsistent communication, our ability to provide assistance on our system is very difficult; thus having a robust design that has a long life span is important. Further down the road this mentality of minimal maintenance will come into play again when we decide which components to purchase. Safety and ease of use will have greater weight when model choice and installation of these components comes closer to fruition. Additional criteria in the current pugh chart were assigned weights from 1-5, and concepts were graded on a -3 to 3 scale. We chose a system that is comprised of a solar panel and water pump that floods the garden as our base when considering other designs as it most closely resembles the current farming technique with the exception of

a solar powered pump which is a user requirement. The highest ranked systems are outlined in Table 3.1 and 3.2 below.

Table 3.1: The system which obtained the second highest score (23/75), #1, was a very simplistic drip irrigation system.

System 1 Components:	pump,panel,reservoir, drip lines, regulator
Pros: <ul style="list-style-type: none"> ● Location of water is able to be changed ● Can store water and be used when desired ● Simple 	Cons: <ul style="list-style-type: none"> ● Requires constant user interaction <ul style="list-style-type: none"> ○ To fill and empty tank ● Nothing extraordinary ● May not have enough water pressure at all times during the tank's emptying
Logic: User is able to store water and use it at their own will. Not many parts can break and if they do it is a simple fix. Watering lines can be placed at user's discretion	Logic: There is no level of feedback from the system, so the user must turn on the pump and after a certain amount of time turn off the pump and then open watering lines at their own discretion. The water pressure in the tubes is also very subjective to the shape of our reservoir as it relies on water pressure.

Table 3.2: Concept #6 received the highest score (26/75) and is a fully autonomous system.

System 6 Components:	pump,panel, elevated reservoir, drip lines, regulator, water level sensor, additional controller
Pros: <ul style="list-style-type: none"> ● Location of water is able to be changed ● Can store water and be used when desired with manual override ● "Smart" programmable system allows for more effective watering schedules based on plants in the garden ● Less need for user interaction ● No battery, so no needed storage unit ● Easily made weatherproof year round 	Cons: <ul style="list-style-type: none"> ● Numerous electrical components that can break ● Additional costs ● Ability to hold water at desired elevation may be costly ● Difficult maintenance if parts break ● May not be able to have program adjusted once installed
Logic: User is able to store water and use it at their own will given there is a manual override installed. The programmable system can allow for watering to occur at the correct time of day and will eliminate the need for the user to worry about watering. Not having a battery means we can focus on our system more and less on the additional housing needed to safely and cheaply hold a battery with proper ventilation.	Logic: Complexity of the system may not be justified if their garden has minimal organization. Risk for components to break is high given the additional components. Maintenance if parts break or need to be adjusted would also be difficult.

Concept number six is our ideal candidate as it allows for the greatest impact to be made on the user's life style. Our sophisticated system will allow for more precise watering and improving farm efficiency. A

smarter watering schedule will produce a greater yield in their farm, thus creating additional goods to be used at home and sold at markets. Saving energy costs, increasing farm yield, and creating additional free time for our user is an ideal situation as they can then use their extra time on other productive projects. However, since our team only consists of three individuals, our scope will most likely be adjusted. Our goal will still be to develop our solar powered irrigation system and increase the quality of life at our location, but within reason due to our limited manpower. This will most likely result in the elimination of the full controller/autonomous system. We hope to still take advantage of sensors to improve feedback between the reservoir and pump. As we continue to work on this system we will gain a better grasp of our abilities and limitations. With this in mind, we intend to build a scale model or system model to act as proof of concept, this will allow REFRESCH to scale the system appropriately when they decide to implement the system in Shelek. Additionally, this will allow us to effectively assess the system functions, efficiencies, and any potential issues before a full scale is constructed.

Chosen Design Mockup

For our mock up we used materials that we found in the 350/450 lab room as well as materials we had collected from home and other design courses. Though it is not to scale we wanted to show the overall design of what our system would look like.

Figure 3.1: Concept Mockup showing the major components.

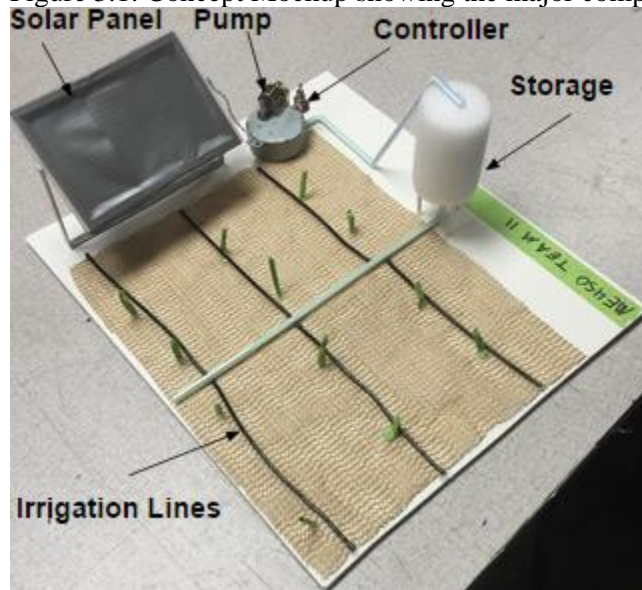

As seen above there is a solar panel, the rectangle of duct tape, connected to the pump which is an old broken motor which feeds the storage tank which is just a cylindrical piece of foam. The pipes are drinking straws and the drip tape is old bits of wire. This model shows how condensed the whole system could be depending on available space in the existing garden. We also see how our design can be changed and have different options for growing rows as the drip tape could be arranged in different sections depending on the grouping of plants.

The system would be put together rather simply. The solar panel will be mounted to a bracket that could be attached on the roof or buried into the backyard. There would also be a mount for the control box for the panel mounted onto the brackets or off to the side in a protected area. The pump would already have a

mounting position that exists from the old pump that was working. For the storage tank a larger stand or mount would be made to hold it up. Then the stand would have to be stood on either a concrete pad or cinder blocks for stability. Irrigation lines would be connected from the pump to the storage tank as well as from the storage tank into the irrigation fields. With simple threading and PVC sealant the pipes could be easily assembled. Finally from the main irrigation lines the drip lines would come out with basic outlets and would just be threaded into the main flow pipe.

4. PRIMARY DESIGN DRIVERS AND CHALLENGES

In developing concepts to fulfill our user's needs several design drivers became apparent. Two aspects critical to the design were the solar panel and the water pump. While these features are absolutely necessary to irrigate the garden without power from the electrical grid, their specifications are both determined by the amount of water necessary to irrigate the given garden. Determining irrigation lines and storage that adequately waters the garden poses the largest challenge. This system will have to distribute the water utilizing cheap and locally available resources while also providing water storage during times when solar power is not available.

Table 4.1 of the appendix outlines the primary design drivers critical to the implementation of a solar-powered irrigation system. The drip irrigation system will consist of two parts, the water storage tank and the drip lines that are fed by that tank. The water tank will need to store a maximum 1000 Liters to feed the lines on a daily basis [10, 11, 12]. This volume is based on a crop solely consisting of tomatoes planted across the full 1/8th acre. The water pump therefore will need to be capable of pumping that much water in a reasonable amount of time while also being powerful enough to reach the water source and pump it into the top of the storage container.

While we are moving forward with the calculations for selecting the solar panel and pump we need to keep in mind our scope for this project is not to build a working full-scale model. The calculations being made can help REFRESCH decide on what they ultimately want to build with our recommendations for the overall design and equipment that they should use. Our calculations will allow them to adapt to other neighboring locations and allow for the growth of this project if they choose to do so. We will also be building a scale model that we can do some limited testing on for voltage supply and water flow. This is what we will be focusing on as our project moves into the later stages of the term.

One major challenge may come from the depth of the well. According to the locals the water table has been decreasing and the aquifer is now at a depth of 15 m [7]. This poses a challenge in that the pump will have to have a significant power rating in order to extract water from such a depth. Based on calculations from our mathematical model we have determined that a 20.6 W pump will be required to extract water from the well and pump it to the top of the water reservoir at a volumetric flow rate of 0.14 liters/sec. This would take a pump 2 hours to fill a 1000 liter tank. A less powerful pump can be utilized as long as it can overcome the head loss associated with extracting water from the well and pumping it to the top of the reservoir. The associated reduction in volumetric flow rate would then simply reduce the time required to fill the reservoir. This also effectively increases the need for a larger and more efficient solar panel. Our calculator indicates that a 40W solar panel will meet the requirements to run a pump or charge a 12V battery that REFRESCH has proposed using.

The solar panel poses its own challenge in where and how to mount it. As wind speeds can be excess of 70mph the panel will need to be securely mounted to either a roof or on a stand alone base. Risk analysis, presented later in this document examines these challenges in greater detail. Additionally, the cost is something that would usually be a concern in this area and the supports may not be something easily

obtained. Our sponsors have said that the cost of the solar panel will be covered by their budgets but for the scope of our project we will be building a scale model that will come out of our budget.

Due to the user requirements of using a solar panel and pump, our chosen design is no more difficult to assemble than any of our other concepts. Mounting the panel and connecting the electrical system with controller will have to be done by the REFRESCH Team or by skilled technicians. Installation of the irrigation system however is something we intend to be performed by the local users. Here the difficulty lies in mounting the reservoir on a stand to provide potential energy for the irrigation piping. Due to the size requirement of the reservoir it will be necessary for a few stronger individuals to carry out this task. Connections of the piping and drip tubes can be done by anyone with instructions and given the flexibility of the system leaves some autonomy in the design layout.

Project Scope

Due to time restrictions and project limitations due to the geographical barrier between us and our proposed implementation site we have chosen to orient this project to accomplishing two goals. First is the development of a mathematical model that outputs relevant design criteria based on user input and can be adapted to a diverse set of implementation criteria. The second is the construction of a scaled model that acts as not only a proof of concept but a means to substantiate and test the model's predictions for hardware requirements. These two components of our project scope give insight into the requirements for building a full-scale solar-powered irrigation system. To accomplish these goals we first examine different full-scale design concepts and choose a final design to which we can identify key design drivers, create a theoretical model based on engineering analysis and thereby design and build a scale prototype for empirical testing and analysis.

Governing equations obtained in the construction of a mathematical model are being utilized in an Excel spreadsheet in order to create a document that our sponsor REFRESCH or another user could utilize to obtain necessary component specifications based on the plot of land intended for use. The document will require little user input but will output most of the necessary design specifications for a full-scale implementation. Some of the user inputs include the plot dimensions, amount and type of crop to be produced, and desired time for irrigation. Outputs should include irrigation pipe layout and dimensions, number and size of drip holes, water reservoir size and mounting height, and watering times per phase. This calculator will also be used in association with the prototype to confirm its ability to predict the system's behavior. Directions on the calculators use can be found in section B of the appendix.

5. FINAL DESIGN

In order to develop an optimized solar-powered irrigation system we analyzed several mathematical models and plan to create a scale model for engineering analysis. Additionally, we determined associated risks and modes of failure, along with assessment criteria of the hardware components. Below is a detailed description of that analysis. Our final concept can be broken down into five main components: power source, water supply, water storage, controls, and water distribution. Below is a description of the components as they would apply to a full-scale implementation. The hardware specifics were calculated for a single crop type and an 1/8th of an acre. The provided Excel calculator should be referenced before final design decisions are made. Following the discussion of the full-scale irrigation system is the final design of the scale prototype and its components.

Full-Scale Irrigation System

Due to the impracticality of building a full-scale irrigation system it was decided to limit our project scope to providing design and hardware recommendations based on our mathematical model and our empirical testing conducted on our scale prototype model. Figure 5.1 demonstrates the final design that we recommend using for a single crop implementation on an $\frac{1}{8}$ of an acre plot.

Figure 5.1: Full-scale model depicted for $\frac{1}{8}$ th of an acre with a single crop type.

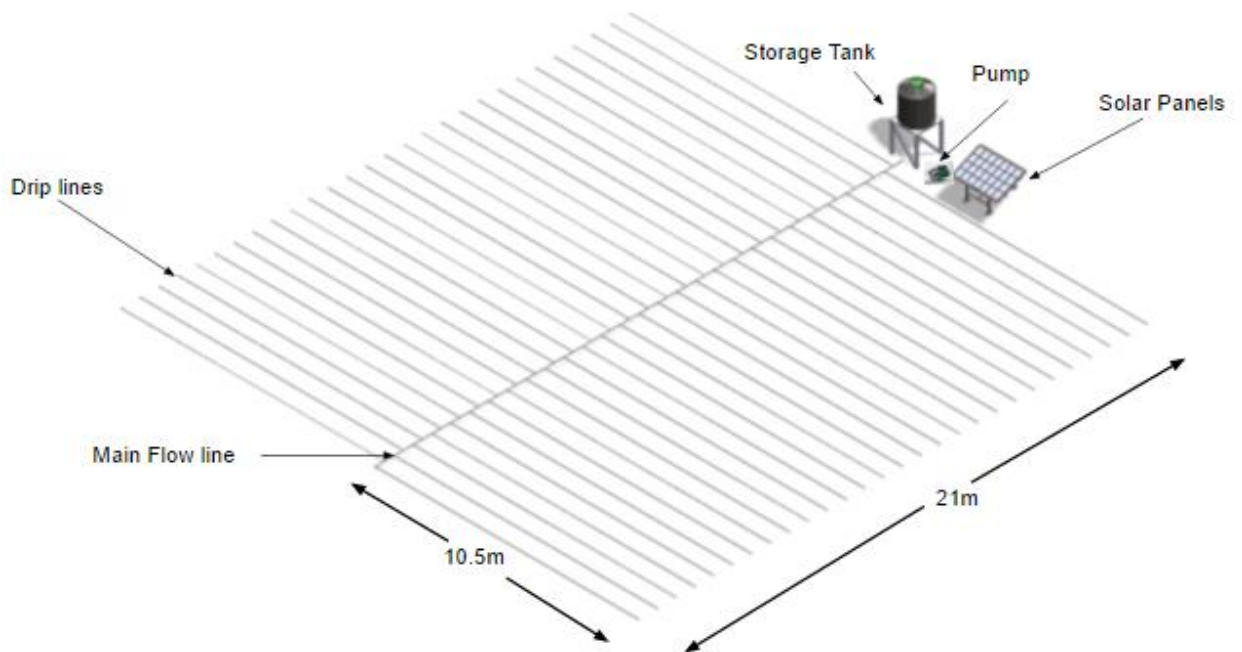

This design and its specific hardware requirements are determined from our mathematical model that is largely driven by crop water needs. These specification details can be obtained from the provided Excel calculator. This calculator can also be adjusted to account for additional crop types which in turn changes the design layout from what is seen above in Figure 5.1 to the Figures in section 8 of the appendix. These design layouts show how the complexity of the system depicted in Figure 5.1, specifically the need for multiple mainlines with flow rate regulators, can increase from multiple crop types and their water needs.

Power source. Power is supplied by one or several solar panels, depending on the application. These solar panels will provide enough power for a water pump to extract water from a well and deliver it to a water storage reservoir. With solar panel efficiency in mind, it is important to create a system capable of providing 1.5-2 times the required power to guarantee that the system will run. Current calculations indicate that a solar panel capable of producing 40 W will be necessary to power the pump.

Water supply. The full-scale pump must be appropriately chosen to overcome head losses and move water from the well to our storage container. Ideally our full-scale system will have a pump that is quiet and quick to extract the water during the daylight hours. The mathematical model indicates that a 20.6 W pump will be required to extract water from the well and pump the water high enough to reach the top of the water reservoir. This value is based on head loss calculations obtained from major losses found in the PVC main line and polyethylene lateral lines of the irrigation system. Additionally, it is important to either obtain a pump that has a filter or run a filter before the pump in order to reduce sediment contamination to the pump and lines which will ultimately reduce the effective lifetime of both.

Water storage. Our water storage unit must be able to hold 1000 liters at a time and will look similar to the tank seen in Figure 5.2 [27]. Additional tank requirements include:

- Provide appropriate pressure at the point of distribution to fill the irrigation tape.
- Fillable by the chosen water pump
- Encased water level sensors
- Withstand weather and basic outside forces
- Can be elevated to overcome head loss in the irrigation system
- Possibility of an overflow pipe added to the top

Figure 5.2: Full scale tank example



Controls. Because of the safety factor in the panels and the available power being more than necessary, a charge controller (Fig. 5.3) should be implemented to allow for the appropriate amount of power to consistently reach our pump. This would increase the safety of the system to prevent surges and other electrical hazards caused by an inconsistent power source. Water level sensors could also be implemented, similar to that seen in Figure 5.4. This would allow the system to appropriately fill the tank, and create an interface for the users to understand the amount of water at their disposal thereby improving their ability to control the system. A programmable logic device would also be good at maintaining control over the system to prevent overflow and to simplify the use of the system for the user.

Fig. 5.3: Example of solar charge controller [28]



Fig.5.4: Example of a water level switch [29]



Water distribution. The water distribution would likely be comprised of PVC and polyethylene tubes. The full-scale system analyzed has a main line made of PVC will be 21 m in length with a 62.5mm ID. Then branching off of this main tube is 56 drip polyethylene lines, each 10.5 m in length with 17 drips and a 25mm ID. These specifications give a calculated volumetric flow rate of 0.14 liters/sec for the assumed garden. A visual of the layout for these pipes can be seen in Figure 5.1.

Scale Prototype Irrigation System

The scaled prototype design is similar in layout to our full-scale design proposal. It will however have fewer irrigation lines and components specifications will not be to exact scale. It will allow us to make comparisons to our calculations as a way to anticipate any shortcomings in the assumptions made in our equations. Below is a description of the key components.

Power source. The solar panel is an Anker 14W Dual Port Solar Charger, that has four separate panels that can be covered to examine different outputs. The solar panel is intended for charging a cellular phone and therefore has an output limited to 5V and 2 amps per USB port, of which there are two. The panel chosen for our prototype seen in Figure 5.5 is able to output 14W and easily power both small pumps we purchased independently.

Figure 5.5 Anker 14W Solar Panel [30]



Water pump. The pump we are currently testing is a 5V submersible water pump that is also USB powered. This pump however can also be used as a non-submersible but needs to be primed. It is rated to pump 110L/H. It has a vertical lift of just over a meter.

Figure 5.6: 5V USB powered submersible water pump [31]



Irrigation system. The irrigation system we are designing will have a main line constructed from $\frac{3}{8}$ inch inner, $\frac{1}{2}$ inch outer diameter PVC. It will have 2-4 lateral lines that will act as drip lines, leading off of each side. The drip lines are $\frac{1}{4}$ inch polyethylene, the same material used in full-scale drip lines. The drip holes are $\frac{1}{16}$ inch and there are four holes per lateral line. Not pictured in Figure 5.7 is the ball valve between the elbow and the main line that controls flow rates for testing. The material choices are representative of full-scale materials in order to analyze the effects of friction. A water reservoir will be constructed out of a plastic container and will be elevated to various heights to examine the effects of potential energy and head loss in the system.

Figure 5.7: Scale Prototype irrigation piping

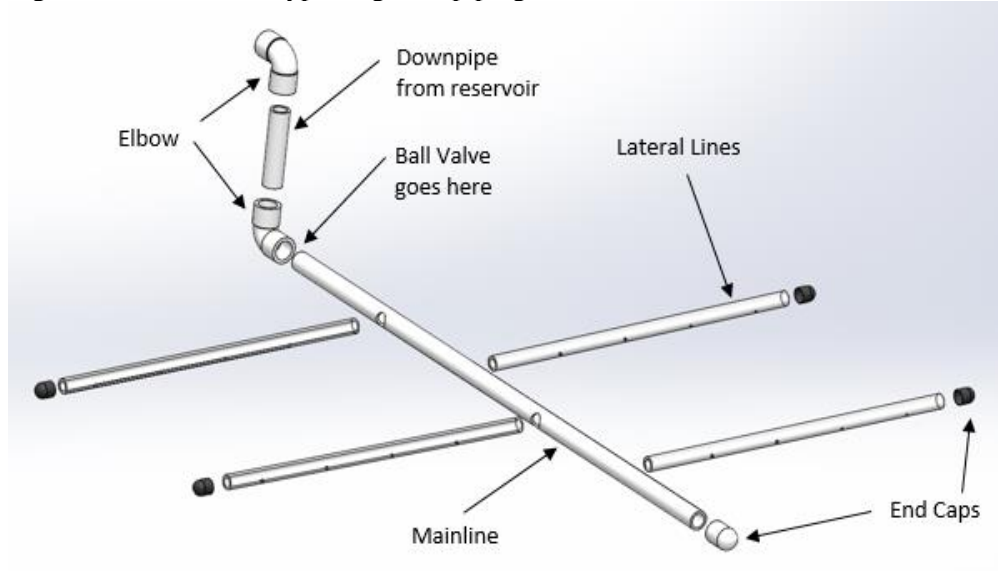

The storage container for our prototype can be a smaller bucket or tank with a known volume and ability to have a distribution port added or modified (Figure 5.8) A list of components purchased for this prototype can be seen in section 5 of the appendix

Figure 5.8: Water storage container similar to the one that will be implemented for the prototype scale model [32].



6. ENGINEERING ANALYSIS

The project scope is twofold; developing a mathematical model that can be adapted to diverse implementation criteria and the construction of a scaled model that acts as not only a proof of concept but also as a means to substantiate and test the model's predictions for hardware requirements. Below is an outline of a theoretical model that depicts a full-scale implementation, set for 1/8th of an acre, with the relevant governing equations and results. Following that is a plan for empirical testing that was conducted on a scale model that was built and assessed base on the predicting factors of the mathematical model. These results represent example calculations and do not represent the various layouts determined by crop types. The provided Excel calculator should be referred to before any final design is to be implemented.

Theoretical Modeling

An illustration of the full-scale model, depicted in Figure 6.1, shows the general layout and hardware components of the full-scale system. The solar panel stands at the Northern end of the plot facing South to reduce blocking sunlight from hitting the crops. The panel powers a water pump in close proximity that extracts water from a nearby well. The pump feeds water into a raised water reservoir that is elevated to provide the necessary potential energy to overcome head loss associated with the network of irrigation pipes. It then feeds water into the larger mainline of the irrigation system, constructed from PVC and polyethylene. Figure 6.1 depicts a layout that is suitable for a single crop and has a main pipe has a length of 21m and an inner diameter of 62.5mm. From the mainline there are 28 lateral lines that branch from either side. These polyethylene drip lines are 10.5m in length with an inner diameter of 25mm and each has 17 drip holes. Analysis of this system results, with the appropriate safety factor results in a head loss of 1m [21]. Further layout configurations set for multiple layouts are depicted in the appendix.

Figure 6.1: Illustration of solar-powered irrigation system.

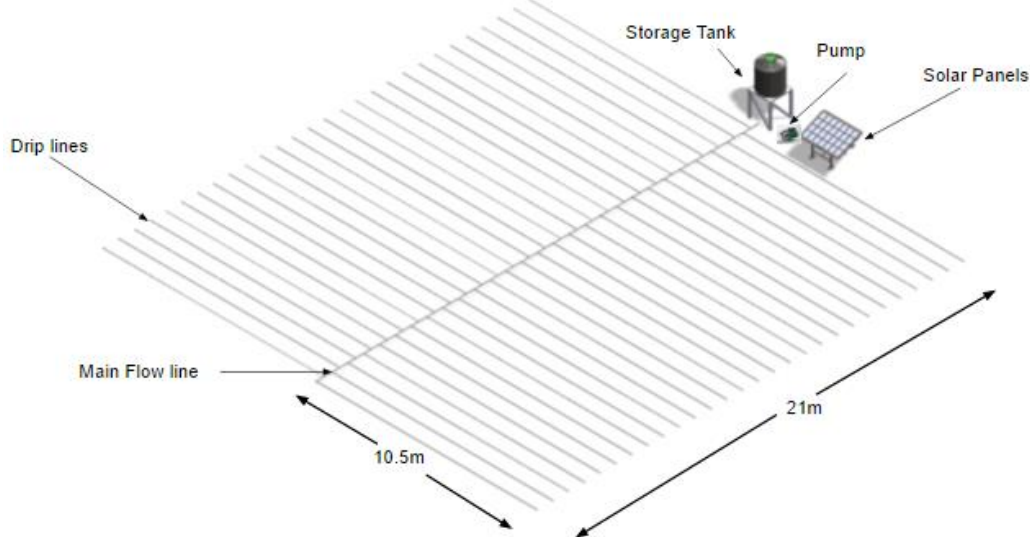

In order to characterize a full-scale implementation of the system, research began with water needs calculations. Environmental features such as plot size, crop type, local hydrology, and meteorology determine hardware component specifications. Table 6.1 below lists the governing equations pertinent to this project with results specific to the application in Shelek, Kazakhstan.

Table 6.1: Governing equations for determination of hardware components with subsequent results calculated for the specific implementation in Shelek, Kazakhstan.

(Equation number) Description	Governing Equations	Variables	Results
(1) Water Needs [22, 23, 24]	$Wph = Kc \times Et \times Dph$	Wph = water needs per phase Kc = crop coefficient per phase Et = evapotranspiration rate Dph = days per phase	1.16 kL/day
(2) Darcy-Weisbach Head Loss Equation [25]	$h_f = f_D \times \frac{L}{D} \times \frac{V^2}{2g}$	h_f = head loss due to friction f_D = Darcy friction factor L = length of pipe D = hydraulic diameter of pipe V = average velocity of fluid flow g = acceleration due to gravity	0.013m
Darcy Friction Factor	$f_D = \frac{64}{Re}$ for laminar	f_D = Darcy friction factor Re = Reynolds number	0.5
Reynolds Number (Flow in pipe)	$Re = \frac{\rho V D_H}{\mu} = \frac{V D_H}{\nu}$	Re = Reynolds number ρ = density V = mean velocity D_H = hydraulic diameter μ = dynamic viscosity ν = kinematic viscosity	127.79
(4) Hazen-Williams Head Loss Equation [21]	$h_f = \frac{KL \left(\frac{Q}{C}\right)^{1.852}}{D^{4.87}}$	h_f = head loss due to friction $K = 1.21 \times 10^{10}$ conversion factor. Q = pipeline discharge C = friction coefficient D = inside diameter L = pipe length	2.81 m
(5) Water Pump Power Requirement [25]	$P = \rho ghQ$	P = hydraulic power ρ = density g = acceleration due to gravity h = height Q = volume flow rate	20.6 Watts
(6) Solar Panel Optimum Angle [26]	$\theta = L - \delta$	δ = declination angle of the world on July 1st. L = latitude θ = angle of panel from horizontal	20.5° from the horizontal

(7) Solar Panel Lateral Force Requirement	$F = ma$	F = lateral force m = mass a = acceleration	142N (No safety factor included)
(8) Water Reservoir Structure Vertical Force Requirement	$F = mg$	F = horizontal force m = mass g = acceleration due to gravity	11.14kN (No safety factor included)

Irrigation system. The amount of water necessary for crop irrigation is the single most important design driver. Determining the water requirement at the peak phase in the plant growth cycle allows all the irrigation system components to be optimized for a particular application. This water requirement is based on plant type, evapotranspiration rates, stage of plant growth, and the geometric layout determined by the available land and required plant spacing. Details of local soil type and meteorology are also key factors. Equation 1 outputs the necessary water requirement in depth of water per plant per day. This result is then converted to a volume based on the plant root radius thereby reducing water usage to an efficient surface area. The result above is based on a tomato plant with line spacing of 1.52m and drip spacing of 0.46m. This represents the largest possible water usage for the system and is therefore the upper bound for the reservoir size needed.

Also critical to determining component requirements is Equation 2 and 3 which are used to calculate head loss, the measure of friction inherent in the irrigation piping. The Darcy-Weisbach equation (Eq. 2) in particular details the amount of head loss present in the system and thus the pressure required to overcome that friction. In this case however head loss is directly correlated to the minimum height requirement for our water storage reservoir to provide enough potential energy to maintain a set flow rate for the drip lines. The given result also does account for minor losses such as those associated with bends and valves in the system.

Water pump. With water needs calculated and a minimum reservoir height determined the water pump can then be chosen for the full-scale model with specifications appropriate to extracting water from the well and pumping it vertically into the top of the reservoir. Power required to run the pump was determined from Equation 4 with the height of 12m used that includes a well depth of 8m and the height from the pump to the top of the water reservoir (1m for stand, 1m for the tank and 2 meters for safety factor and pump efficiency reduction due to altitude). These values can be adjusted in the mathematical model to provide specifications unique to the environment of implementation.

Solar panel. Solar panel power output was determined by the pump power requirement. There is a safety factor built into the final result to account for days with limited irradiation. Additionally, there should be a controller between the solar panel and pump in order to limit the power output and thus remove the risk of damaging the pump due to power fluctuations. The optimal angle and orientation of the solar panel however is determined from Equation 6 and give a result of 20.5 degrees from horizontal [26].

Mathematical Model. The above governing equations are not wholly representative of the entire mathematical model. They account for the geometric analysis for an 1/8th of an acre and a crop consisting of only tomatoes, the most water intensive plant to be harvested. The calculation results reported here represent a worst case scenario in that they represent a system that requires the most water and therefore greatest hardware requirements. These governing equations have been utilized in an Excel spreadsheet that takes a minimum amount of user input in order to output the necessary design and component

specifications required for a full-scale irrigation system with added safety factors for robustness of the system.

Insight into the complexity of a system that has several different crop types has been provided by the mathematical model. Most farms, especially those with irrigation systems, typically grow a single crop. This allows the irrigation system to adapt to the growth phases of that particular plant as its water requirement varies throughout the growing season. The water requirements for both tomatoes and potatoes allowed for the examination of the water requirements for a longer growth season and also the ability to examine how different crop types affect the water requirement throughout the season. Potatoes start growing earlier in the season and require more water early as tomatoes start later and require more water later in the season. The analysis yielded interesting results in that flow rates and water needs would vary several times over the season; thus requiring adjustments in the irrigation system as often as every five days. This analysis is only for two different plant types and with additional crop types comes additional complexity. Each crop type will necessitate its own main irrigation line that can have its flow rate varied in order to not over or under water a particular crop. See the provided Excel calculator for monthly crop water needs.

Empirical Testing of a Full-Scale System

When the mathematical model is complete hardware components will be selected based on that model to be used in empirical testing to evaluate the accuracy of the model. Detailed below is the engineering analysis to be conducted on the scale-model as well as general testing to exhibit proper function of our components. An additional test on float switches was included for possible use with the full scale implementation. The outcome of this testing will be used to refine the model and lessons learned can be applied to a full-scale application. During our implementation of the prototype, which for beneficial purposes we consider itself a test, we noticed various qualities to help guide future design of both our prototype and full scale model. The levelness of the irrigation branches is important as to guarantee equal flow through both sides of the spine. If it is too difficult to be that precise given a rough terrain which our full scale model may experience additional parts such as a pressure equalizer can be implemented to resolve this issue. For the prototype, we noticed how it was beneficial to have a clear reservoir so that our system can more easily show the flow of water through our system and how the system can exist in either a steady or nonsteady state.

Figure 6.2: Depiction of switch testing setup.

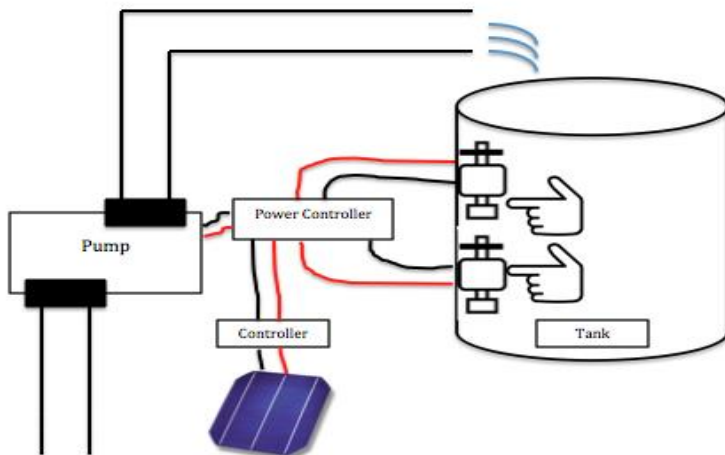

Test: Water level switch test

Goal: Confirm water level switches work appropriately to control power diversion to the pump and also to communicate water level through user interface.

Equipment: power source, power controller, pump, switches.

Assumptions: Controller is appropriately programmed. Tests will confirm or deny this assumption.

Figure 6.2 depicts the setup and placement of switches and where our physical interaction will occur. The water source, set heights, and power source (wall socket not a panel) will be different than the image because of the scale model size and equipment at our disposal.

1. Connect both switches to appropriately locations on controller. Both switches should not be triggered (set to 0, if switches are binary).
2. Connect pump to the power source. Power source should a reliable outlet and not the panel for the duration for the test.
3. Pump should be active.
4. With your hand, trigger the switch that would be the lowest in the storage tank. Pump should continue to run.
5. While still triggering the bottom switch, trigger the top switch. The pump should stop.
6. Release the top trigger, simulating the decrease in water level. Pump should remain off.
7. Release the bottom trigger and pump should then go on (assuming we programmed our system to automatically pump water into the reservoir if it is empty).
8. If all steps were completed as stated. The trigger system is working as programmed. Any adjustments made to the program can be further tested by simulating the water levels with our hands as previously seen in this experiment.

Test: Solar panel output test:

Goal: Observe output of solar panel in outside conditions to confirm its ability to function

Equipment: solar panel with attached wires, multimeter.

Notes: Do not test for AMPS while solar panel is exposed to solar rays as possible spark may damage panel.

Assumptions:

1. Testing for voltage output
2. Set multimeter to DC voltage-a setting higher than what the panel is rated
3. Connect the red multimeter clip to the positive terminal and black clip of the multimeter to the negative terminal of the panel, and proceed to take the reading
4. Testing for amperage
5. Place panel in shaded area (prior to switching multimeter to Ampere mode) and then connect clips as stated in step 3 if not already connected
6. Switch reading to DC Amperes at an appropriate setting given the panels specs
7. Place panel in sunlight and obtain reading.
8. Place panel in shade before disconnecting

Test: Pump flow rate.

Goal: Quantify the flow from our various system components

Equipment: pump with tubes attached, power and water source, stopwatch, tools to measure water volume and tube dimensions.

Notes: Calculations from pump specs may be used to compare to physical results for consistency of our mathematical models.

1. With pump on table, place the input tube in a water source at some measurable level below the table.

2. Place the output tube near a storage container at a measureable height above the pump. The water in this container will be measured eventually. Tube should not be placed directly into container until steady flow has formed.
3. Plug pump into reliable power source, not solar panel, and allow water to begin to flow through the system (you or the equipment may get wet, point tube end in safe location such as another bucket)
4. Once water begins to flow through the output tube at a steady rate place that end of the tube into the container above the pump and simultaneously start your stopwatch.
5. After a minute. Measure the volume of water in your container. This will give you the flow rate in units (volume/time)
6. By measuring the inside area of the the output tube we can then use the equation $Q(\text{flowrate})=(\text{Velocity})(\text{Area})$ to solve for the output velocity. These values can aid in future pump analysis.

Test: Pump Head

Goal: Quantify the height at which the pump can extract/push water vertically

Equipment: pump with tubes attached, power and water source, stopwatch, tools to measure water height

Notes: Calculations from pump specs may be used to compare to physical results for consistency of our mathematical models.

1. Place pump or inlet tube in water, and elevate exit tube vertically to simulate the flow of water up to the reservoir
2. Plug in pump to a reliable power source capable of powering the pump based on its specific specs
3. Measure the height of the water in the tubes (extract+push)
 - a. If it is a submersible pump you will only need the vertical distance it can push the water
4. Compare specs to real data and calculations

FMEA / Risk Analysis

With any engineering task assessing risk and failure are two considerations that are essential to any design, specifically those that require human interaction. Our project is both product-focused and process-focused. Product-focused in that we are building a scale model to act as a proof of concept and to assess design parameters and outputs. Process-focused in that we are developing mathematical models that can be applied to a variety of irrigation needs outlining the necessary hardware requirements. A chart outlining the failure modes effects analysis (FMEA) is presented in the appendix which outlines the failure modes that could be present in a full scale implementation of a solar-powered irrigation system. Additional analysis of possible risk for our scale model will also be conducted prior to assembly as seen in our DR 4 project plan.

The greatest risk lies in the construction of such a system as it typically requires heavy objects to be raised into place and properly mounted. Both the solar panel and the water reservoir sit atop structures designed to securely and effectively orient them to meet their user’s requirements. The solar panel can be mounted to a roof of a building or alternatively use its own mounting system secured into the ground. Similarly, it is likely the water reservoir needs to be elevated to provide potential energy for water flow into the irrigation lines. Both pose challenges in construction and both have design constraints specific to their location. If either structure supporting the solar panel or the water reservoir were to fail, damage to their components would likely occur. More importantly is the risk that an individual could be injured if the structures collapse. Collapsing structures and a resultant injury are unlikely however. Both structures would feature a safety factor well above the lateral and vertical forces that either structure would experience. There is still risk associated with the installation of said structures and to counteract those risks proper training or professional installers will be utilized.

The design of these support structures is outside of the scope of our project however since we are creating mathematical and scale models that can be utilized for full-scale implementation. While we are not specifically designing these structures we still see the importance in analyzing all risk that could be associated with future designs and constructions. These considerations will need to be considered in more detail in before construction takes place. Also, likely is that risk associated with a solar panel structure will be minimized as typically the company providing these panels will also have the associated mounting hardware. The water reservoir and associated mounting height is a parameter that results from the geography of the irrigated land which would include overall size and local elevation changes. These factors can reduce the need for an elevated mounting structure all together.

7. MANUFACTURING, ASSEMBLY, AND VALIDATION OF SCALE PROTOTYPE

Scale Model Prototype

Our prototype seen below in Figure 7.1 consists of scaled down components of what would be implemented in Shelek. The final prototype acts as a proof of concept, exhibiting that our system model and its equations are accurate in determining the capabilities of our system components. The full-scale system, and even our prototype will consist mainly of purchased parts. The solar panel, pump, tubing, irrigation, float switches, controller and wires, will all be purchased.

Figure 5.7 and 7.1 exhibits the basic format of our model, as the system components such as the pump, storage tank, and panel are relatively consistent in their setup between our full-scale and prototype. Components for the system implemented in Shelek may have a different need for custom manufactured components, such as a larger rack for the panels or housing for the motor and electrical components. Further assessment of the implementation site is required for this.

Figure 7.1: Prototype model.



Details describing the manufacturing plan (Table 7.1-7.3), assembly plans (Table 7.4), bill of materials (Table 7.5), engineering drawings (Figure 7.2-7.3), Scale Prototype Changes and Corrections from Design Review 4 (Table 7.6) and validation/verification (Table 7.7) can all be found in section 7 of the appendix..

8. FULL-SCALE IMPLEMENTATION

Significance of Calculator and Accurate Environment Details

The full-scale implementation of a solar-powered irrigation system requires knowledge of the location that it will be implemented. Necessary details include the size of the plot, the crops to be grown, the well depth, irradiation in the area, soil type, and general climate. These factors all contribute to determining the overall water needs, water phases per crop, general layout of the irrigation system, water pump and solar panel specifications. Additional flow rates, pipe diameters, head loss, and crop spacing are other details that contribute to final design. In order to obtain this data we have created an Excel spreadsheet that requires minimum user input to output the necessary hardware requirements to establish a full-scale solar-powered irrigation system. This calculator created in Microsoft Excel 2011 utilizes several of the governing equations along with some necessary assumptions to output the component specifications and watering cycles [33]. The Excel document will accompany the final report. Directions on the basic use and interpretation of calculator outputs can be seen in Section B of the appendix.

Using the Excel calculator can help determine several key characteristics in order to implement a full-scale system in Shelek, Kazakhstan. The irrigation system can take several different forms in order to meet the crop's water needs for a season. Each time a different crop is added to the system the complexity of the system increases to account for different water needs associated with the different crops. To allow for the most efficient use of water, control valves, such as the ball valves used on the scale prototype, are suggested to be used to control the volume of water that each crop type receives. These various layouts for our calculator can be seen in Figure 8.1-8.5 of the appendix. These allow for up to five different crop types, and any combination of the five can be used. The calculator specifically utilizes tomatoes, potatoes, peppers, cabbage, and carrots as these were the crops designated by our end user. The calculator outputs various pipe and drip tube lengths based on the dimensions of the plot to be irrigated. Additionally, the calculator takes crop spacing into account to output the necessary dimensions.

With the size and crop types chosen the calculator then outputs the head loss, measured in distance, for the system to overcome. This value is used to determine the minimum height requirement of the reservoir in order for all the water to reach the ends of the drip system and adequately water the crops. The calculator also provides a watering schedule and maximum water requirements in order to properly set the valve openings and determine the water reservoir size respectively. These do allow for some variation as it is possible that with a desire to reduce reservoir size more than one watering cycle per day may be required. This decision can also influence pump specifications to aid in quickly refilling the reservoir.

Full-Scale Design Suggestions

From our mathematical analysis and research on irrigation systems, we have compiled suggestions and recommendations with regards to the purchasing, building, and use of a solar powered irrigation system.

Picking the Right System Components:

Determining the components of the system rely on a large number of factors including but not limited to:

- Plot Dimensions
- Well Depth
- Plant Type
- Budget

- Elevation
- Region
- Available Resources

The right combination of system components can create a simple system which extracts water using solar power and distributes it directly to the field using drip lines, or a more complex system that utilizes a battery, various tape lines with controlled valves all run through a digital controller to strategically distribute water. Depending on the time, money, and output desired by the farm, a pugh chart should be utilized to help guide decisions depending on whether the users' or the creators' requirements take priority. For our system our goal was to create a financially reasonable, durable, and reliable way to effectively transport water to various plants without the need for grid power. Considering batteries, switches, and electronic systems improves the flexibility of the system, but also increases the cost and risk of required maintenance.

Elaboration of Additional Implementation of Components:

Water pmp: The current setup in Shelek utilizes a non-submersible pump and that style pump will continue to be utilized. The reservoir size and height can be used in part to determine the water pump specifications. With these values the pump specifications can be determined. The pump needs to be self-priming to at least the well depth and then be able to pump the water from the ground to the top of the water reservoir. A factor of safety should be considered as well as the pump losing about a meter of pumping ability for every 1000 ft of the location's elevation.

Batteries: We were told late into the semester that our sponsors are considering the idea of using 12 V, 10 amp hour, Nickel Metal Hydride batteries to power the pump instead of powering directly from the 40W solar panels they have obtained. This allows for additional irrigation during times of low solar irradiance. Our concept does not require batteries and simplifies certain aspects of the installation and also eliminates additional components that could require maintenance. The use of a battery does extend possibilities for the system in the future. We would suggest creating a housing unit for these batteries and electrical components that is resistant to Shelek's weather and also provides air circulation if the battery used prompts this.

Switches: Switches are a simple, cheap, and easy way to help prevent the waste of solar energy and water. The implementation of two switches could be inserted into the reservoir to help the system recognize the need to fill or not fill the tank. Any electrical components such as a breadboard with the controller should be housed from weather exposure. A sample method of installation and method of testing its function can be seen in Figure 6.2

Filters for the pump: It is also important to obtain a filtering system to be set before the pump in order to reduce sediment contamination to the pump which could shorten its lifetime. The losses associated with a filter and the specifications for that filter fall outside of our project scope. Some pumps will have built in filters or can handle small amounts of sediment.

Controller: A controller should be considered if it is anticipated that a fluctuating power from the solar panels will harm electrical components. Even for a simple solar panel and pump system a controller can help extend the life of the pump by removing these fluctuations. We were told the life of the previous pump might have been harmed by an inconsistent power source. The use of a controller can also prevent any fire hazards from other electrical components and thus add to the safety of the system.

Future Use of Prototype for Educational Purposes

While the semester is over, the life of the provided prototype can still continue as an education tool. The design of this system easily conveys the use of solar energy to power an irrigation system. The layout also includes lessons on fluid flow and potential energy. This prototype design can be rebuilt in Shelek and be exhibited at local schools or libraries as a way to educate local students and families about various topics such as: sustainability, renewable energy, advanced farming methods, and physics. Various University of Michigan Project Teams utilize models to help familiarize users with their product so that they may better understand and ultimately appreciate the products at their disposal. If the project is continued with BLUElab, our current design can easily be modified to accommodate a more hands on educational approach with younger individuals.

9. DESIGN CRITIQUE AND DISCUSSION

After designing the prototype of the solar powered irrigation system was completed, several observations were made during the fabrication and testing phase of the system. These observations are valuable as they provide critiques and suggestions on the materials, procedures, and implementation of such a system. The use of polyethylene branches have some strong and weak attributes. The density and length of the polyethylene branches used in construction of the prototype made it difficult for them to be laid straight. This particular type may be difficult in an implementation that requires straight lines. However, most drip lines used in irrigation tend to be longer and more flexible allowing them to be configured in straight lines. One strength that was noticed for such a tube was its ability to withstand forces that could pinch off the flow of water. This quality is important in that it will be resistant to damage caused by humans, animals, and any debris or large plant branches land on the tubing and possibly inhibit water flow. These observed qualities of polyethylene lead to the suggestion that a tube should be selected on its ability to be easily manipulated to effectively distribute water, and it must also be able to withstand environmental forces. Another issue observed with the prototype design was the process of manually drilling drip holes. This is time consuming task and can lead to inconsistent water flow because of debris build up on the inside of the tube. The purchase of irrigation pipes or tape with pre-made holes is recommended to save time and improve efficiency. The decision on what materials to use, however, comes down to the financial budget, time, and the size of the project.

Future Plan

Future options of this project can be very diverse. We suggest collaboration with the University student group BLUElab, as they have resources and experience working with human centered engineering. We also feel an additional needs assessment should be conducted on the implementation site, and local area to regauge interest. A reevaluation of whether a drip irrigation system is appropriate or not should also be done based mainly on the property size, as these systems are typically implemented on larger scales. This is mentioned because of the possibility of a small site of implementation. There is also some risk implementing an expensive system in a private residential property. The household can move or decide they are no longer interested in utilizing the system. Some collaboration with the city itself or a local school system could provide larger participation and interest in the project, expanding the benefits of such an expensive system. With there being some communication with a school already, we would recommend trying to implement some aspect of education with this project. BLUElab is familiar with this type of work and public interaction.

With respect to the system itself, the information and calculator provided can stand as a valuable foundation to future work. Depending on the time and budget, the possibility of creating an autonomous system is possible. The benefits of this complex system include simplicity of use, and a very successful yield from the farm or garden. The use of batteries can also increase the complexity of the system both in positive and negative ways. When implementing components such as a battery or control system, maintenance must be considered. A complex system isn't valuable if it cannot be fixed easily. Currently the calculator only focuses on having a solar panel, pump, elevated reservoir, and piping. Further expansion to an equation based solver could be beneficial depending on the future scope of this project. If various systems intend to be implemented, this solver will help adjust the layout based on the unique site of installation. Ultimately we recommend moving forward from the research and testing that has already been conducted. Reaffirmed site data is necessary to a successful implementation and future collaboration with students or student groups can be beneficial as the possible configurations and methods of implementation are vast, and are only limited to financial and time constraints.

Acknowledgement

Special Thank You to...
University of Michigan Energy Institute
REFRESCH: Roy Clarke and Brenda Vyletel
Professor Andre Boehman and Amy Hortop

References

- [1]: Ubarana, Vinicius, and Philippe Giguere. "Extreme Wind Speed-Risk and Mitigation." 2007. Web. 20 Sept. 2015. <[http://www.noturbine.com/images/ger4277_ExtremeWind\[1\].pdf](http://www.noturbine.com/images/ger4277_ExtremeWind[1].pdf)>.
- [2]. "Air - Altitude, Density and Specific Volume." *Air - Altitude, Density and Specific Volume*. Web. 20 Sept. 2015. <http://www.engineeringtoolbox.com/air-altitude-density-volume-d_195.html>.
- [3] Kombarov, Sayan. "Renewable Energy for Sustainable Development of Kazakhstan Competitiveness Factors and SWOT Analysis." Web. 22 Sept. 2015. <<http://group-global.org/sites/default/files/publications/5b.pdf>>.
- [4] "SunCulture Solar Irrigation." *Partnering for Innovation*. Web. 22 Sept. 2015. <<http://www.partneringforinnovation.org/sunculture.aspx>>.
- [5] Yuelin, W., Jianyun, Z.(2015), Solar agricultural irrigation and water supply equipment, CN204157389, 2-18-15
- [6] "13 Charts On Solar Panel Cost & Growth Trends." *CleanTechnica*. 4 Sept. 2014. Web. 22 Sept. 2015. <<http://cleantechnica.com/2014/09/04/solar-panel-cost-trends-10-charts/>>.
- [7] B. Vyletel and R. Clarke, personal interview, September 15, 2015.
- [8] Butcher, Ken J.. (2004). CIBSE Guide G - Public Health Engineering (2nd Edition). CIBSE. Web. 21 Sept. 2015 <http://app.knovel.com/hotlink/toc/id:kpCIBSEGG1/cibse-guide-g-public/cibse-guide-g-public>
- [9] Jianjun, Lyu. (2014) Zero-energy-consumption roof recycled rainwater utilizing system. CN104213599 2014-12-17
- [10] Singandhupe, R.B. et al. "Fertigation studies and irrigation scheduling in drip irrigation system in tomato crop." *Europ J. Agronomy* 19 (2003) 327-340. Web. 19 Sept. 2015.
- [11] Nye, J. "How much water is needed for trickle irrigation?" Web. 19 Sept. 2015
- [12] Yuan, B. et al. 2003. "The effects of different irrigation regimes on the growth and yield of drip-irrigated potatoes." *Agricultural Water Management* 63 153-167. Web 19 Sept. 2015
- [13] Woodroof, Eric A.. (2009). *Green Facilities Handbook - Simple and Profitable Strategies for Managers*. Fairmont Press, Inc.. Web. 21 Sept. 2015
<http://app.knovel.com/hotlink/toc/id:kpGFHSPSM2/green-facilities-handbook/green-facilities-handbook>
- [14] Maria Syntkova, "Kazakhstan braces for economic crisis, holds hands with Russia" 19 Feb. 2015, <http://english.pravda.ru/business/companies/19-02-2015/129857-kazakhstan-0/>
- [15] Orien N. Justice, (1981) Submersible well pump, US4417860 A
- [16] Remco 12 Volt Self-Priming Water Pump, http://www.northerntool.com/shop/tools/product_200330141_200330141
- [17] Baigarin, K. A., and V. A. Dvornikov. "Development of Renewable Power Engineering in Kazakhstan." *Appl. Sol. Energy Applied Solar Energy*: 250-53. Print.
- [18] "The Solar Electricity Handbook - 2015 Edition." *Solar Electricity Handbook*. Web. 4 Oct. 2015.
- [19] Stanciu, Camelia, and Dorin Stanciu. "Optimum Tilt Angle for Flat Plate Collectors All over the World – A Declination Dependence Formula and Comparisons of Three Solar Radiation Models." *Energy Conversion and Management* (2014): 133-43. Print.
- [20] "Solar Irradiance Calculator." *Solar Electricity Handbook*. Greenscreen Publishing. Web. 21 Sept. 2015. <<http://solarelectricityhandbook.com/solar-irradiance.html>>.
- [21] Sodiki, J. and Adigio, E. "A Review On The Development And Application Of Methods For Estimating Head Loss Components In Water Distribution Pipework." *American Journal of Engineering Research (AJER)* (2014): 91-96. Web: [http://www.ajer.org/papers/v3\(9\)/L039091096.pdf](http://www.ajer.org/papers/v3(9)/L039091096.pdf)
- [22] "National Communication of the Republic of Kazakhstan." 2013. Web. 22 Sept. 2015. <https://unfccc.int/files/national_reports/annex_i_natcom/_application/pdf/kaz_nc3,4,5,6_eng.pdf>.
- [23] B. Vyletel, personal interview, September 15, 2015.
- [24] "AQUASTAT - FAO's Information System on Water and Agriculture." *AQUASTAT - FAO's Information System on Water and Agriculture*. Web. 21 Sept. 2015. <http://www.fao.org/nr/water/aquastat/countries_regions/kaz/index.stm>.

- [25] Pritchard, P. "Fox and McDonald's Introduction to Fluid Mechanics". 8th. (2011) John Wiley and Son's Inc. Chap. 8.
- [26] Stanciu, Camelia, and Dorin Stanciu. "Optimum Tilt Angle for Flat Plate Collectors All over the World – A Declination Dependence Formula and Comparisons of Three Solar Radiation Models." *Energy Conversion and Management* (2014): 133-43. Print.
- [27]http://www.tanksforless.com/p/976/polymart-500gallon-emergency-plastic-water-storage-tank?gclid=CLz0_reLhskCFRCqaQod47cHpg
- [28]http://shop.pkys.com/BlueSolar-PWM-Pro-Solar-Charge-Controller-1224V-10A_p_4312.html?gclid=CKSY-vCLhskCFQIOaQodn6oH5g
- [29]<http://www.dx.com/p/20902-nut-shape-pp-floating-water-level-switch-cable-light-blue-yellow-36cm-203331#.VkiDAa6rTEY>
- [30]http://www.amazon.com/Anker-Dual-Port-Charger-PowerIQ-Technology/dp/B00E3OL5U8/ref=sr_1_1?ie=UTF8&qid=1447382232&sr=8-1&keywords=anker+14W
- [31]http://www.amazon.com/gp/product/B008OCZUK6?psc=1&redirect=true&ref=oh_aui_detailpage_o02_s00
- [32] <http://www.homedepot.com/p/Unbranded-2-1-2-Qt-Blue-Pail-with-Handle-0255030/204694319>
- [33]http://fluid.itcmp.pwr.wroc.pl/~znmp/dydaktyka/fundam_FM/Lecture11_12.pdf

APPENDIX

SECTION A:

1. BACKGROUND

Figure 1.1: Photograph of the proposed implementation site in Shelek, Kazakhstan.

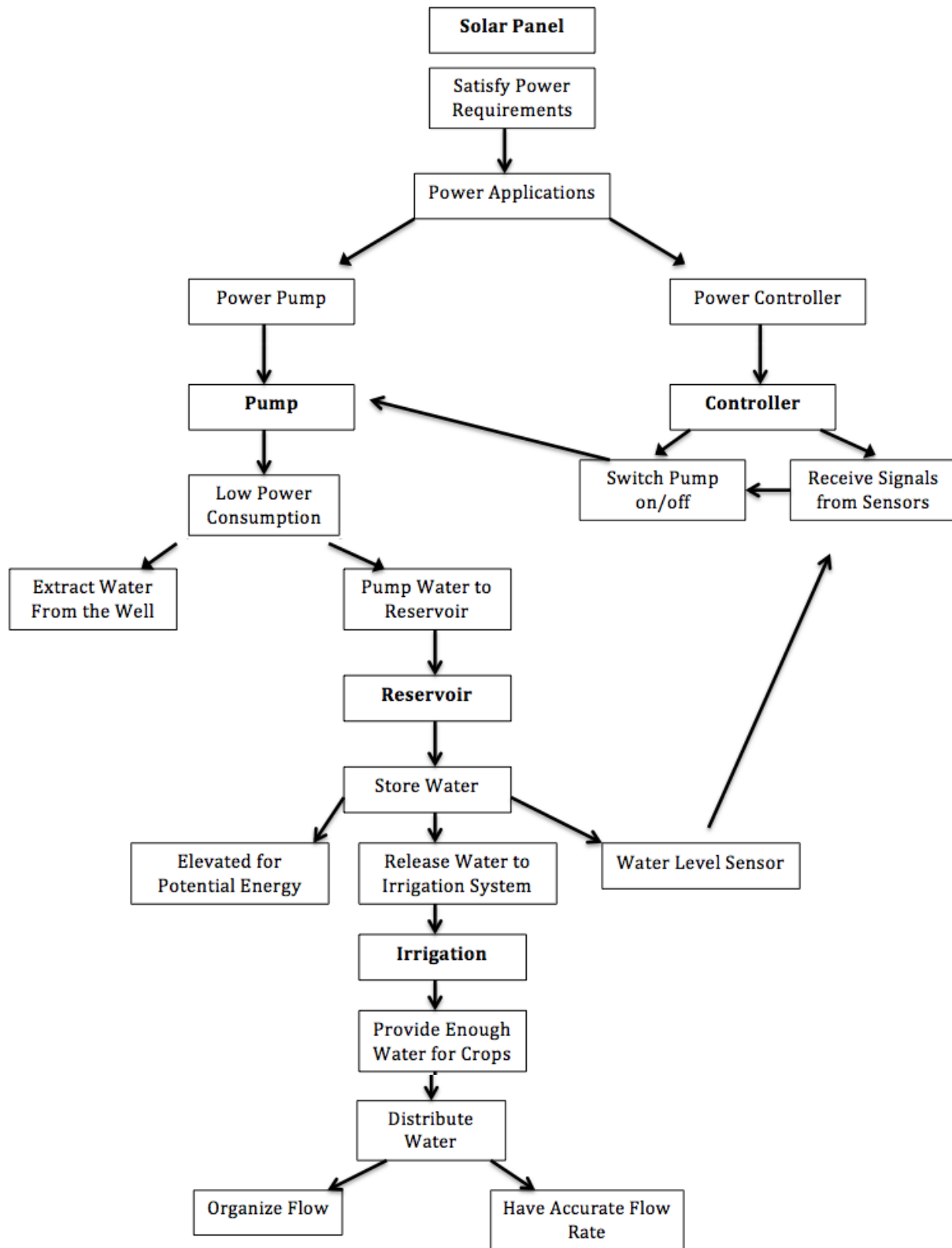

Figure 1.2: SunCulture solar-powered irrigation system [4].



2. STAKEHOLDER REQUIREMENTS & ENGINEERING SPECIFICATIONS

Figure 2.1: Functional Decomposition



3. CONCEPT DEVELOPMENT

Proposed Concepts:

1. Panel, inverter/regulator/controller, pump, storage, drip lines
2. Panel, inverter/regulator/controller, pump that has low feed rate directly into pvc pipe that feeds drip lines
3. Panel, inverter/regulator/controller, battery storage for lack of solar energy, pump feeds into storage container/rain barrel that is elevated for potential energy fed irrigation lines, filter included to remove sand and other sediments
4. panel, inverter/regulator/controller, pump that supplies water to furrows, flooded a few times a day
5. panel, inverter/regulator/controller, pump that feeds a spray type irrigation system
6. panel, inverter/regulator/controller, pump that feeds storage container with sensor that detects low level and turns pump on to fill, drip lines fed by potential energy, fully autonomous system
7. panel, inverter/regulator/controller, pump to fill buckets or watering can to manually irrigate
8. Panel, inverter/regulator/controller, pump that feeds buried drip lines
9. Panel, inverter/regulator/controller, pump that feeds an overhead sprinkler system
10. Panel, inverter/regulator/controller, pump, water storage with separate drip lines to feed every row of the irrigated plot
11. Panel, inverter/regulator/controller, battery storage to pump at night for irrigation
12. Panel, inverter/regulator/controller, pump feeds storage container that would be opened at night for night time irrigation
13. Panel, inverter/regulator/controller, pump that runs continuously feeding drip lines
14. Panel, inverter/regulator/controller, pump that could be turned on throughout the day and feed a hose for irrigation
15. Panel, inverter/regulator/controller, pump with elevated storage that has backflow valve so when pump shuts off the water will flow out another pipe into the irrigation system and then close when the pump is turned back on
16. Panel, inverter/regulator/controller, pump and water storage fitted with adjustable flow rates at different points in a main PVC line to adjust for plant age and different consumption
17. Panel, inverter/regulator/controller, pump that can be turned on and off at the owner's leisure
18. Panel, inverter/regulator/controller, pump, reservoir with nozzle
19. Panel, inverter/regulator/controller, pump, elevated reservoir, irrigation lines with adjustable flow rates, battery powered release mechanism for night time irrigation
20. Panel, inverter/regulator/controller, pump, reservoir, battery, submerged and above ground line.

Concept Drawings (Not all concepts drawn)

Figure 3.1: Concept Design 3

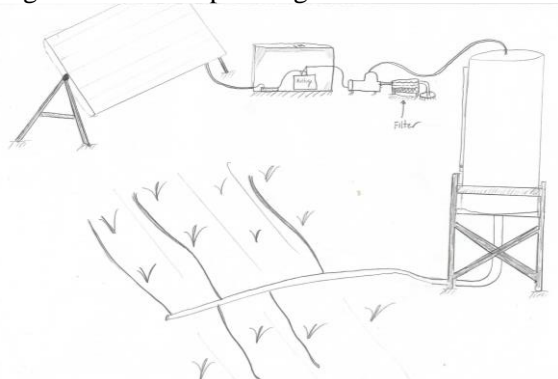

Figure 3.2: Concept Design 4

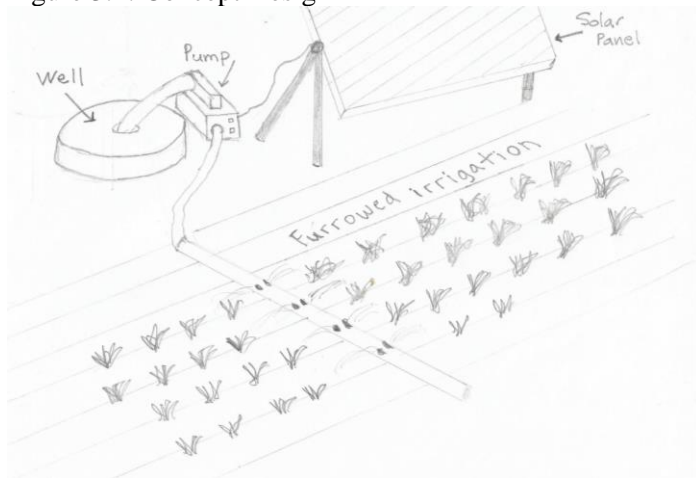

Figure 3.3: Concept Design 5

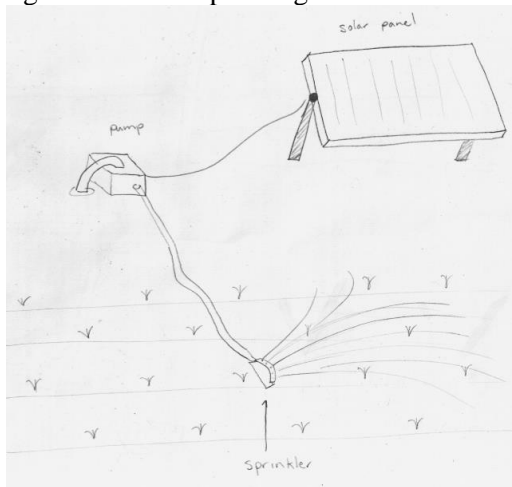

Figure 3.4: Concept Design 6

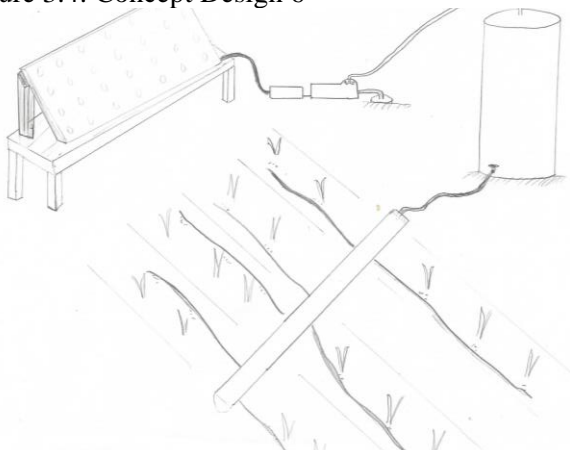

Figure 3.5: Concept Design 7

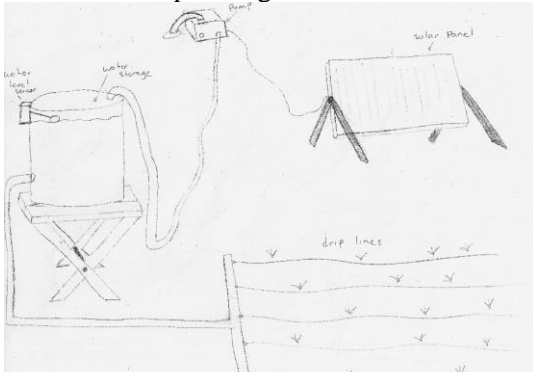
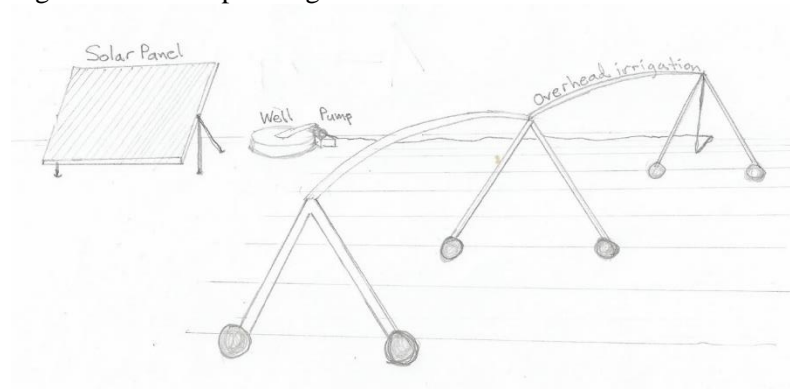

Figure 3.6: Concept Design 9



4. PRIMARY DESIGN DRIVERS AND CHALLENGES

Table 4.1: Design Drivers

Driver ID	Description	Importance	Design Driver Analysis	Validation
Drip Irrigation System	Need to provide enough water for the crop size and type of plant on a daily basis.	If the system is not adequately designed the crops will not get enough water	Determine amount of water necessary for crops. Determine proper flow rates.	Measure flow rates. Confirm appropriate flow so watering time is consistent for all rows.
Water Pump	Needs to be able to adequately pump water from a well of a designated depth and up into a storage container. It must also be able to pump the amount needed during times of sunlight.	Without the pump the crops will not receive enough water.	Assess necessary power ratings and pumping ability for required depths. Analytical model of hydrology.	Assess pumps ability to move water with flow rate and functionality at determined depth.
Solar Panel	Needs to provide enough power for the pump to pump enough water given the solarly of the region	Without the solar panel the pump cannot work.	Analytical model of the amount of power produced from regional metrology.	Assess the power output on a day with similar solarly as experienced in Shelek.
Water Storage	Needs to store enough water to properly irrigate the garden. Needs to be elevated to provide potential energy to feed irrigation drip lines.	Without water storage the crops may not get enough water on days without sun to feed solar panel.	Analytical model of amount of water needed and proper height for potential energy.	Assess its volume and calculate the necessary height to provide enough potential energy.

5. FINAL DESIGN

Figure 5.1: Full-scale model depicted for 1/8th of an acre with a single crop type.

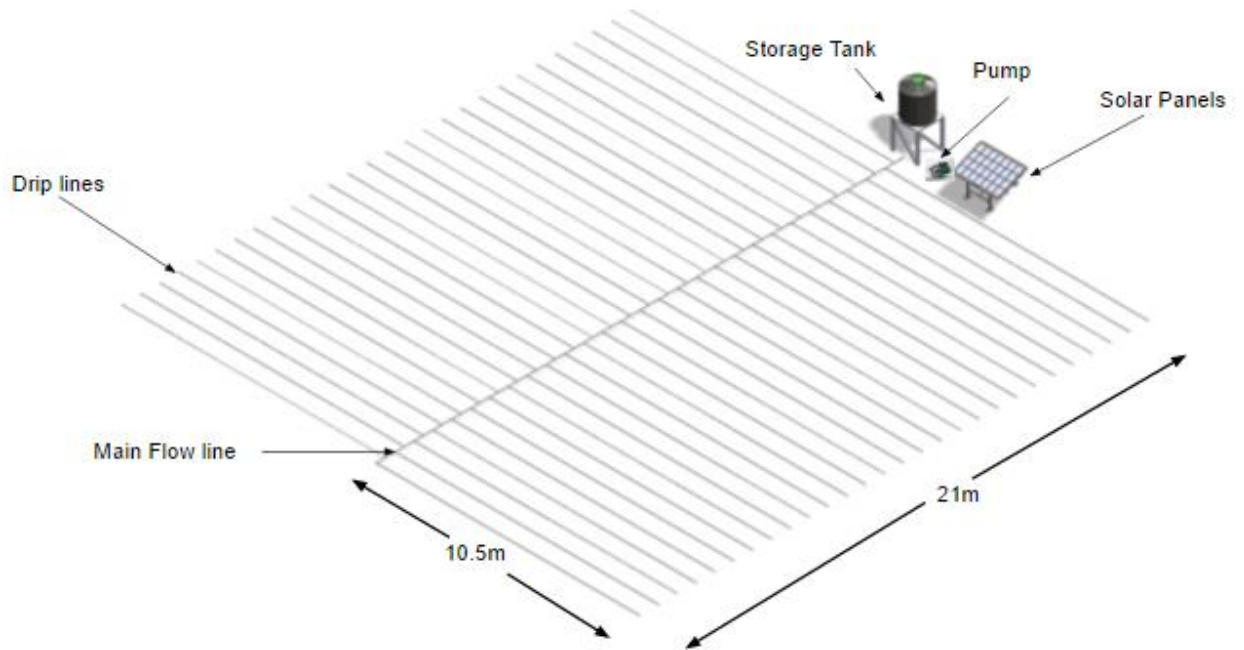

Figure 5.2: Scale prototype demonstrates a two crop system.



6. ENGINEERING ANALYSIS

Below is an example of sample calculations for water needs. The provided Excel calculator goes into greater detail.

Table 6.1: Evapotranspiration Data: Shelek, Kazakstan [11].

	Jan	Feb	Mar	Apr	May	Jun	Jul	Aug	Sep	Oct	Nov	Dec
Et (mm/m)	15.42	23	53	100.35	144.81	167.85	181	157.51	106.18	61.33	26.72	16.25
Et (mm/d)	0.49	0.82	1.71	3.35	4.671	5.60	5.84	5.08	3.54	1.98	0.89	0.52
Irradiance (kWh/m ² /day)	3.06	3.70	4.21	4.81	4.99	5.28	5.39	5.62	5.47	4.58	3.45	2.69

Irrigation Water Needs Calculations:

Evapotranspiration, the sum of the amount of water that evaporates out of the soil and through the plant's leaves and stems, is a good indicator of the amount of water necessary to properly hydrate crops. Daily evapotranspiration values for Shelek, Kazakhstan are available in the appendix. The evapotranspiration (E_t) is empirically related to a reference evapotranspiration (E_{tr}) as follows [11]:

$$E_t = K_c E_{tr} \quad (\text{Eq. X})$$

where K_c is the crop coefficient.

Table 5
Water needs and crop coefficient versus vegetative phase of potato

Vegetative phase	D_{ph} (day)	K_c	Dk_c (day)	Water needs equation per K_c	W_{ph} (mm)
Phase1	25	$K_{c10}=0.40$	25	$K_{c10} \times E_{tr}(3) \times 25$	61.70
Phase2	30	$K_{c21}=0.52$	15	$K_{c21} \times E_{tr}(3) \times 6 + K_{c21} \times E_{tr}(4) \times 9$	152.31
		$K_{c22}=0.89$	15	$K_{c22} \times E_{tr}(4) \times 15$	
Phase3	30	$K_{c30}=1.15$	30	$K_{c30} \times E_{tr}(4) \times 6 + K_{c30} \times E_{tr}(5) \times 24$	267.58
Phase4	20	$K_{c41}=1.04$	07	$K_{c41} \times E_{tr}(5) \times 7$	148.11
		$K_{c42}=0.84$	13	$K_{c42} \times E_{tr}(6) \times 13$	

Where D_{ph} is the number of day per phase, K_c is the crop coefficient per phase and $K_{c,ij}$ is the crop coefficient for j sections of the phase i , Dk_c is the number of day for K_c and W_{ph} is the water needs per phase.

Table 6
Water needs and crop coefficient versus vegetative phase of tomato

Vegetative phase	D_{ph} (day)	K_c	Dk_c (day)	Water needs equation per K_c	W_{ph} (mm)
Phase1	30	$K_{c10}=0.36$	30	$K_{c10} \times E_{tr}(4) \times 30$	79.70
Phase2	40	$K_{c21}=0.46$	15	$K_{c21} \times E_{tr}(5) \times 15$	232.58
		$K_{c22}=0.77$	16	$K_{c22} \times E_{tr}(5) \times 16$	
		$K_{c23}=1.01$	09	$K_{c23} \times E_{tr}(6) \times 9$	
Phase3	45	$K_{c30}=1.2$	45	$K_{c30} \times E_{tr}(6) \times 21 + K_{c30} \times E_{tr}(7) \times 24$	474.30
Phase4	30	$K_{c41}=1.01$	15	$K_{c41} \times E_{tr}(7) \times 7 + K_{c41} \times E_{tr}(8) \times 8$	225.82
		$K_{c42}=0.74$	15	$K_{c42} \times E_{tr}(8) \times 15$	

Where D_{ph} is the number of day per phase, K_c is the crop coefficient per phase and $K_{c,ij}$ is the crop coefficient for j sections of the phase i , Dk_c is the number of day for K_c and W_{ph} is the water needs per phase.

For Shelek, Kazakhstan...

Phase 1:

$$W_{ph} = K_c \times E_{tr}(\text{Apr}) \times 30 = 36.126 \text{mm/phase} = 1.2 \text{mm/day}$$

Phase 2:

$$W_{ph} = 0.46 \times E_{tr}(\text{May}) \times 15 = 32.23 \text{mm/phase} = 2.15 \text{mm/day}$$

Wph=0.77*Ett(May)*16=57.55mm/phase=3.60mm/day
Wph=1.01*Ett(May)*9=42.46mm/phase=4.71mm/day

Phase 3:

Wph=1.2*Ett(Jun)*21+1.2Ett(Jul)*24=309.16mm/phase=6.87mm/day

Phase 4:

Wph=1.01*Ett(Jul)*7+1.01*Ett(Aug)*8=82.34mm/phase=5.49mm/day

Wph=0.74*Ett(Aug)*17=63.92mm/phase=4.26mm/day

Max Water need=6.87mm/day

- One inch of rain falling on 1 acre of ground is equal to about 27,154 gallons
- 6.87mm/day=0.27in/day
- 1.89in/week
- (1.89in/week)(27,154gal/in*acre)(1/8acre)(1/7week/day)^(1/3)=**305 gal/day max**

7. MANUFACTURING, ASSEMBLY, AND VALIDATION OF SCALE PROTOTYPE

Manufacturing Plans for Non-purchased Scale Prototype Components

Table 7.1: Water Storage

Procedure:	Materials:	Tools:
1. Drill holes in bottom of bucket at 180 degrees from each other and mount spout in holes using caulk to seal.	<ul style="list-style-type: none"> ● 2.5 quart plastic bucket ● PVC spouts ● Caulk 	<ul style="list-style-type: none"> ● Drill ● Caulk
2. Allow caulk to cure for 72 hours before exposing to water.	<ul style="list-style-type: none"> ● Caulk 	<ul style="list-style-type: none"> ● Caulk

Table 7.2 Irrigation Piping (Main Line)

Procedure:	Materials:	Tools:
1. Cut ½ inch OD, ⅜ inch ID PVC piping to a length of 18 inches	<ul style="list-style-type: none"> ● Two ½ inch OD, ⅜ inch ID PVC piping 	<ul style="list-style-type: none"> ● Saw
2. Drill 4, ⅜ inch holes, 2 per side 180 degrees apart on the horizontal axis, in PVC equal distance as per the manufacturing plans in appendix	<ul style="list-style-type: none"> ● Two ½ inch OD, ⅜ inch ID PVC piping 	<ul style="list-style-type: none"> ● Drill ● Center drill bit ● ⅜ inch bit

Table 7.3 Irrigation Piping (Drip Branching)

Procedure:	Materials:	Tools:
1. Cut 3/8 inch OD, 1/4 inch ID polyethylene piping to a length of 9 inches	<ul style="list-style-type: none"> • Eight 3/8 inch OD, 1/4 inch ID polyethylene piping 	<ul style="list-style-type: none"> • Scissors
2. Drill 4, 1/16 inch holes, in polyethylene equal distance as per the manufacturing plans in appendix	<ul style="list-style-type: none"> • Eight 3/8 inch OD, 1/4 inch ID polyethylene piping 	<ul style="list-style-type: none"> • Drill • 1/16 inch bit

Assembly

Table 7.4 Assembly process for scale prototype components (See Figure 5.7 and Figure 7.1)

Procedure:	Materials:	Tools:
1. Insert the polyethylene tubes into the holes on the PVC piping	<ul style="list-style-type: none"> • Eight 3/8 inch OD, 1/4 inch ID polyethylene piping • Two 1/2 inch OD, 3/8 inch ID PVC piping 	N/A
2. Place 1/2 inch end caps onto end of PVC piping	<ul style="list-style-type: none"> • Two 1/2 inch OD, 3/8 inch ID PVC piping • Two 1/2 inch PVC end cap 	N/A
3. Place 3/8 inch end caps onto polyethylene branches	<ul style="list-style-type: none"> • Eight 3/8 inch OD, 1/4 inch ID polyethylene piping • Eight 3/8 inch end caps 	N/A
4. Place ball valve onto other end of PVC pipe	<ul style="list-style-type: none"> • Two 1/2 inch OD, 3/8 inch ID PVC piping • Two ball valves 	N/A
5. Place elbow into ball valve	<ul style="list-style-type: none"> • Two ball valves • Two elbows 	N/A
6. Place 1/2 inch PVC, cut to 3 inches, into elbow	<ul style="list-style-type: none"> • Two elbows • Two 1/2 inch PVC, 3 inch length 	N/A
7. Place elbow on top of 3 inch piece	<ul style="list-style-type: none"> • Two elbows • Two 1/2 inch PVC, 3 inch length 	N/A
8. Insert elbow into spout of water container	<ul style="list-style-type: none"> • Two elbows • Two spouts 	N/A
9. Place water container on top of aluminum cylinder	<ul style="list-style-type: none"> • One bucket • One aluminum cylinder 	N/A
10. Place assembled irrigation lines over top of large plastic container to collect water	<ul style="list-style-type: none"> • Two assembled irrigation lines • Two large plastic containers 	N/A
11. Place pump in large plastic container with tubing feeding to top of water container	<ul style="list-style-type: none"> • Submersible pump • Plastic tubing 	N/A

Figure 7.1: Elevated bucket with irrigation piping entrance set up

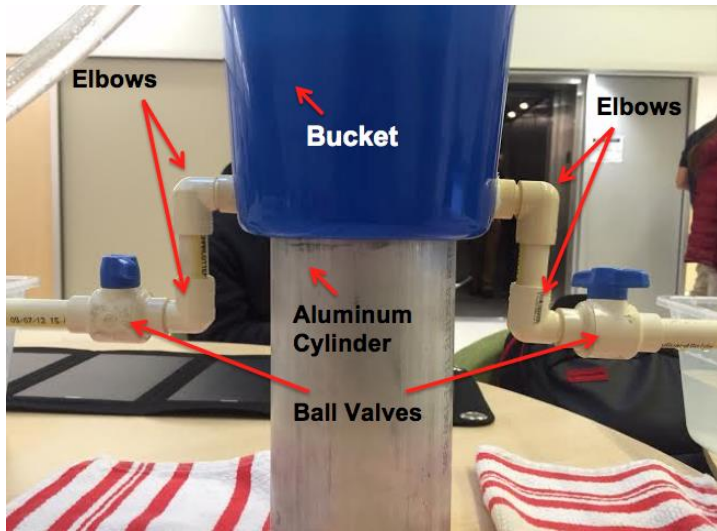

Bill of Materials

Table 7.5 Bill of materials used in the construction of the scale prototype.

Item	Price (\$)	Quantity	Total (\$)
Pail	2.35	1	2.35
PVC (1/2")	1.52	3	4.56
PVC	1.32	1	1.32
Plastic tote	6.27	2	12.54
Elbow	0.79	4	3.16
Spout	0.49	2	0.98
Ball Valve	5.49	2	10.98
Caps	0.59	2	1.18
Branch Caps	1.49	2	2.98
Original Adapter	1.29	1	1.29
PE Tube (3/8")	0.74	1	0.74
PE Tube (3/8")	0.19	1	0.19
Caulk	2.99	1	2.99
Submersible Pump	8.99	1	8.99

Anker Solar Panel	45.99	1	45.99
Vinyl Tubing (Pumps)	6.90	1	6.90
DC Pump	5.41	1	5.41
Subtotal			112.55
Tax			6.75
Total			119.30

Engineering Drawings

Figure 7.2: Mainline constructed of PVC

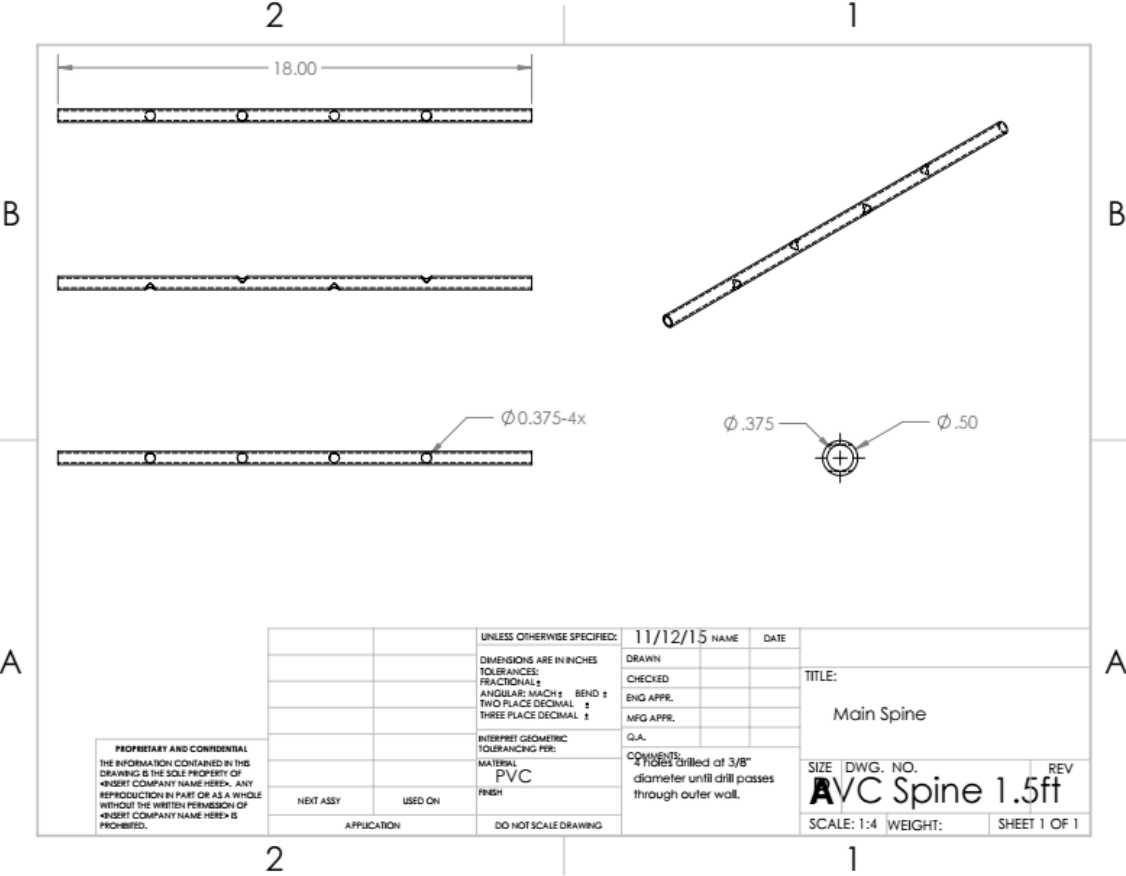
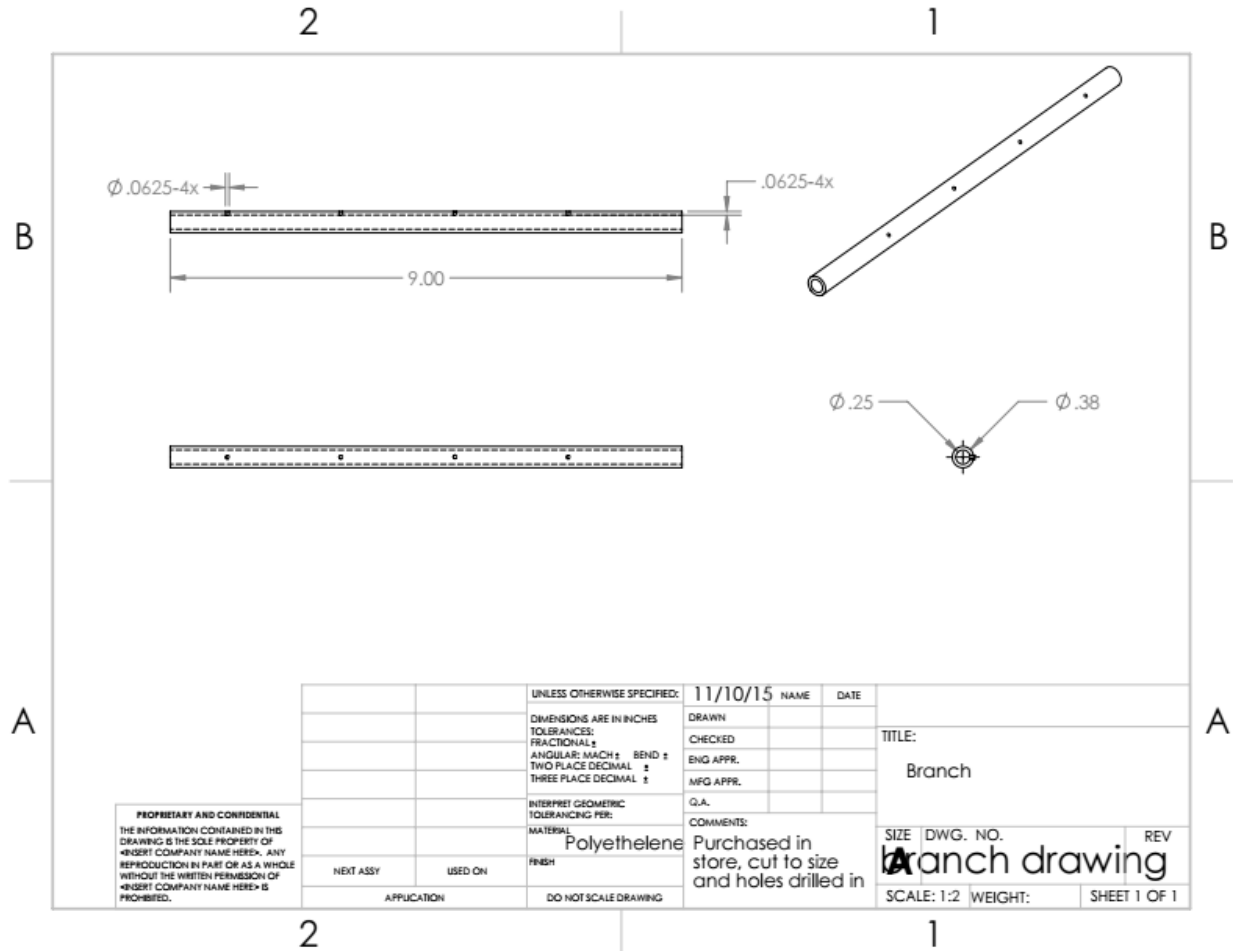

Figure 7.3: Lateral line constructed of polyethylene



Scale Prototype Changes and Corrections from Design Review 4

After creating the first prototype portion of our system, we were able to notice aspects that could hinder full scale production or make the performance of the system less efficient. With the creation of the second half we were able to attempt to fix these issues with simple solutions. This addition was not a redesign, but an addition to provide evidence that corrective measures would be successful to simple complications. Problems we encountered before making the second half included leaks, too high of a reservoir, debris accumulation, and uneven side branches that prevented equal flow of water through our system. To fix these issues, we performed the following: purchased appropriate sealants, obtained a new reservoir with an appropriate height for the feeding tube. In table 7.6 we elaborate on the simple solutions utilized in the creation of the second half of the prototype. Another benefit of creating this portion other than testing our methods of addressing problems, is the additional information this layout can provide us on the accuracy of our calculations and also how water can be distributed using two main lines. We can more easily examine whether the full scale model can appropriately water plants without running out of water. In the validation protocol we explain our process for calculating flow rate values.

Table 7.6: Problem and implemented method to address the issue

Problem	Component modification	Method of adjustment
Leaks	Apply sealant to parts of anticipated leakage	Purchased sealant
Height of reservoir	Found a reservoir with the ability to easily have an input tube for water	Purchased a new reservoir. We will adjust it more if we encounter unseen issues.
Unequal water flow	Holes on the sides for branches need to be level	We took more time marking the side holes using a ruler and drilling holes more carefully to ensure similar angles of the holes.
Debris build up	Holes drilled into polyethylene need to not cause debris	Rely on drill bit speed as opposed to the pushing force to break through the material

Validation and Interpretation of Test Results and Observations

In order to empirically test our prototype's effectiveness to meet user requirements we conducted several empirical tests on the irrigation piping, water pump, and solar panel. These tests are outlined in Table 7.4 below demonstrating the test type, equipment used and the procedure to implement the test. The results from both qualitative and quantitative data will allow us to include any strengths, weaknesses or other observations we find important with our suggestions.

Table 7.7: Prototype empirical validation tests and procedures.

Empirical Measurements	Equipment	Procedure	Analysis	Measured Value
Flow rate per branch	bucket, stopwatch, caliper	Measure volume of water over several different time periods. Dimensions of branch diameters are needed for equations in analysis.	Volume moved by either branch determines possible ball valve settings for full scale water needs.	(1.6mm drip hole): 0.6 L/min (2.0mm drip hole): 1.3 L/min
Ball valve control over flow rate	bucket, stopwatch	Measure volume flow for the two different ball valves at different settings.	Volume moved by either branch determines possible ball valve settings for full scale water needs.	Ball valve adjustment resulted in inconclusive flow rates due to limitations in aperture design
Flow rate of pump	bucket, stopwatch, caliper	Measure volume of water over several different time periods, and position changes. Dimensions of output tube diameters are	Will be compared to the pumps specifications	(5.0V, 1.0A): 1.8 L/min (5.2V, 2.4A): 1.7 L/min

		needed for equations in analysis.		
Pump head loss	tubing, measuring tape	The vertical height the pump is able to displace water will be measured.	Will be compared to the pumps specifications.	(5.0V, 1.0A): 1.02m (5.2V, 2.4A): 1.08m
Solar panel output	Multimeter	Measure voltage and current output for 1-4 exposed panels with varied light inputs from the sun.	Solar panel efficiency can be determined from testing its power output under varied solar inputs.	See Figure 7.2

Figure 7.4: Solar power as measured at horizontal (blue) and 45 degrees from horizontal (yellow).

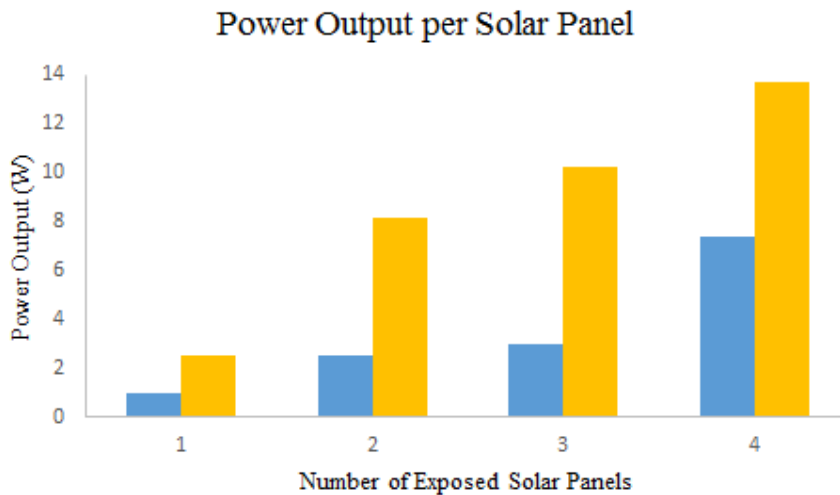

As seen in Table 7.7, most tests yielded quantifiable results, proving our methods of acquiring such values can be utilized in future full scale tests. The test done to observe the flow rate from our pump showed it is necessary to power the pump at its suggested performance values, as over powering it can cause it to lose effectiveness and may also cause damage the part itself. This result implies that a controller would be a valuable implementation to the full scale system to optimize the performance of the water pump used. This is assuming that submersible pumps and above ground pumps are affected the same way by this power difference.

The results of our testing showed us that potential energy works well to accomplish the task of pushing water through the system. Do to its size, however, the use of our calculator wouldn't be able to accurately allow a direct comparison, as the losses in our system are very small. Our calculator was intended for analysis of a larger system. The use of this calculator for future analysis is discussed in the future work section. Some additional qualitative observations made from our testing caused us to notice that additional calculations could be done to estimate watering schedules if more than one type of plant is grown. This allows for the possibility to adjust components to simplify the watering approach. Solutions such as changing branch emitter sizes, ball valve locations, and watering times can be used after additional calculations are performed. Deriving these calculations is outside of our current scope, as we

discovered the complexity that can occur based on the addition of an additional plant type to the farm during our testing.

8. FULL-SCALE IMPLEMENTATION

Full-Scale Layouts as Utilized by the Excel Calculator

Figure 8.1: Five branch system utilized for five different crop types.

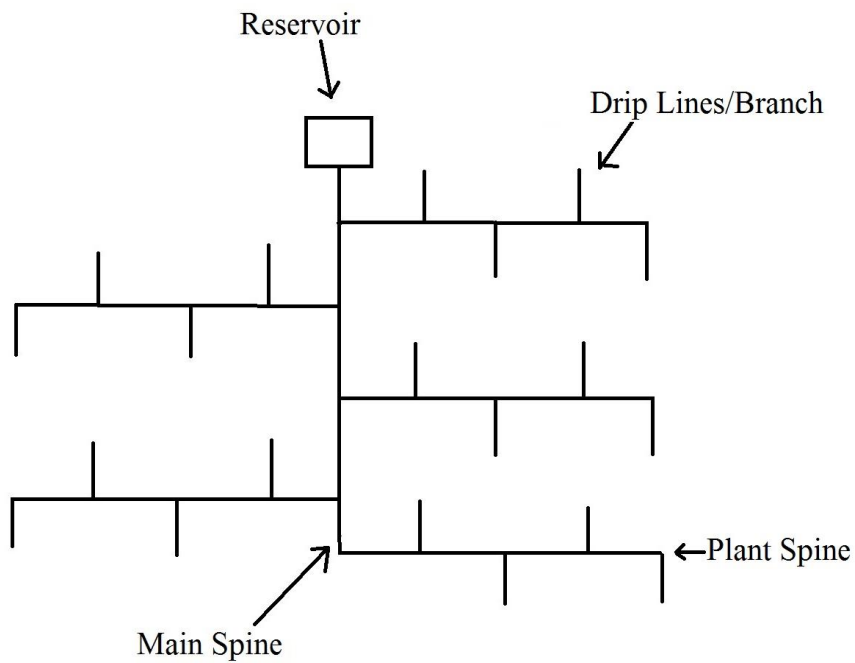

Figure 8.2: Four branch system.

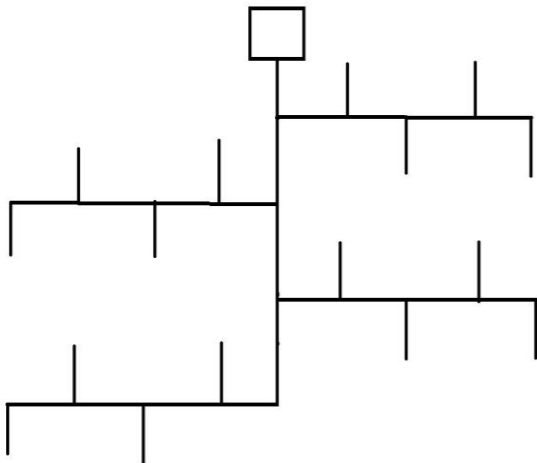

Figure 8.3: Three branch system.

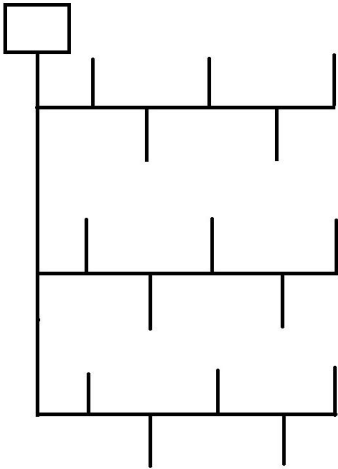

Figure 8.4: Two branch system

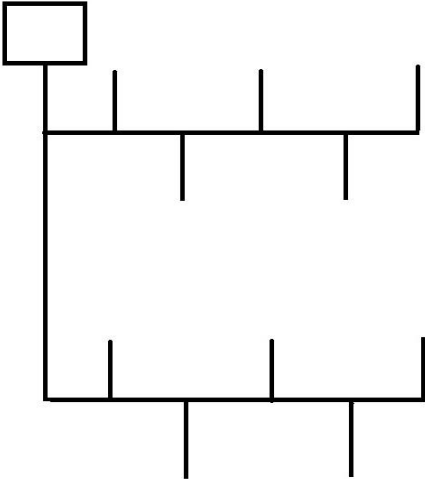
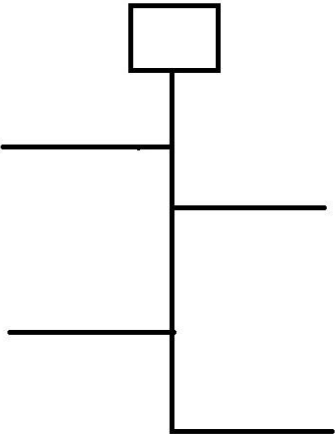

Figure 8.5: Single main line system.



Basic Assembly of a Full-Scale Implementation

Table 8.1: Basic Assembly Instructions for a full-scale implementation

Procedure:	Materials:	Tools:
1. Rest the panel on the rack and connect the panel's wires to that of the controller.	<ul style="list-style-type: none"> Panel Rack Controller 	Shrink tube or solder
2. Connect the pump's wires to that of the controller.	<ul style="list-style-type: none"> Controller Pump 	Shrink tube, solder
3. Place the intake tube of the pump in water supply and dispensing tube into the water storage tank.	<ul style="list-style-type: none"> Pump tube tank 	Fasteners
4. Place switches in appropriate locations in the tank, and attach switch wires to the controller in order to activate and deactivate power when necessary	<ul style="list-style-type: none"> tank switches wires controller 	fasteners, shrink tube, solder
5. Attach a tube to the tank dispensing nozzle and then attach the irrigation tape to the other end of this tube.	<ul style="list-style-type: none"> irrigation tape tank tube 	fasteners
6. Lay our irrigation tape on model garden and connect garden to water source	<ul style="list-style-type: none"> Irrigation tape model garden tube 	fasteners

SECTION B:

Calculator Directions for Use and Interpretation

1	User Inputs	USER INPUT	Plant Preference	Input Plant	Emitter Spacing
	Plot Length	20	Type of Plant 1	Cabbage	
	Plot Width	20	Type of Plant 2	Pepper	
	Depth of Well	12	Type of Plant 3	Potato	
	ID Spine	0.0254	Type of Plant 4	None	
	Length of Spine Max with set back	19.4	Type of Plant 5	None	
	Set back from Length/width	0.3048	Plants Chosen	3	
	Set back from branches	0.3048			
	ID Branch	0.0254			
	Reservoir Volume (Gal)	200			

C1: Location of user inputs for plants and site qualities

1. User inputs/confirms in yellow cells:
 - a. Plot dimensions
 - b. Well depth
 - c. ID of Main Spine
 - d. ID of watering Branches
 - e. And reservoir volume
2. User Selects Plant desired.
 - a. The selection of plants must be done in order of Plant 1, to Plant 2 and so forth. Cells will become red in irrigation info if this is not done correctly (C2).

Two Plants Elevation Needed (m)	#DIV/0!	TI
Spine for this system	14.7	
Plant Type 1	Cabbage	
# of Plants	105	
Plant Spine Length	19.39	
# of branches	15	
Length of Branches	4.77	
Emitters per branch	7	
Plant Spine Dist to Tank	4.8	
Plant Type 2	None	
# of Plants	#DIV/0!	
Plant Spine Length	19.39	
# of branches	#DIV/0!	
Length of Branches	4.77	
Emitters per branch	#DIV/0!	
Plant Spine Dist to Tank	14.4	

C2: Example of Error Message

2			
Irrigation Pipe Output			
One Plant Elevation Needed (m)		Two Plants Elevation Needed (m)	
Spine for this system	19.4	Spine for this system	14.7
Plant Type	Cabbage	Plant Type 1	Cabbage
# of Plants	225	# of Plants	105
Plant Spine Length	19.69	Plant Spine Length	19.39
# of branches	15	# of branches	15
Length of Branch	9.69	Length of Branches	4.77
Emitters per branch	15	Emitters per branch	7
		Plant Spine Dist to Tank	4.8
		Plant Type 2	Pepper
		# of Plants	105
		Plant Spine Length	19.39
		# of branches	15
		Length of Branches	4.77
		Emitters per branch	7
		Plant Spine Dist to Tank	14.4

C3: Location of pipe dimension data for irrigation system

- Users will then turn their attention to 2. Of the calculator where they can obtain irrigation pipe information. The number of plants, drip holes, and length of branches of spines can be seen under the highlighted portion, which is determined by the number of plants selected.
- Noting the number of plant types is important and will then require the user to reference section 8 of the appendix to determine the layout of the irrigation system and then appropriately implement the suggested piping dimensions.
- Respective emitter flow rate is shown near the plant selection option (C4). This will aid in the purchase of branches with appropriate emitter sizes

Input Plant	Emitter Spacing	Emitter Flow Rate/per emitter	S
Cabbage	0.6096	3.15833E-07	
Pepper	0.6096	3.15833E-07	
None	0	0	
None	0	0	
None	0	0	
2			

C4: Emitter flow rate per type of plant

- Suggested Elevation of the reservoir is noted in the orange bracketed area in image C3. This value does not have a safety factor included.

Suggested Pump Based on Well Depth							
Pumps	Amps	Watts	Voltage	\$\$	Priming	Head	Flowrate (Gal/min)
Shurflo 2088	4.5		12	214.6	10		3.6
Remco 12v model RTV	10		12	200	15	14	5.3
Whale gulper 12v	5		12	200	10	10	3.3
Remco 12v model AES	6.5		12	170	14	14	3.4
AMT 3/4"x 1/8 HP Marine Pump 4850-97	5		12	252	13		2.5
3							

C5: Image of Pump Data

7. In area 3, pumps that are appropriate for the well depth, not including pumping head to reach reservoir, are highlighted with green. Their respective specs are noted to the right.

4					
Water Usage for		Plants_2			
Select Month		May.	gal/Day-Plant	Gallons total	% Open
Plant 1	Cabbage	1.2192	128.0	50%	
Plant 2	Pepper	1.2192	128.0	50%	
Plant 3	None	0	0.0	0%	
Plant 4	None	0	0.0	0%	
Plant 5	None	0	0	0%	
Pump Chosen			Remco 12v model	Total Water/Day (gal)	256
				# Reservoir Fills	1.28
				Aprox Fill Time (min)	38

C6: Region of interest that shows user the amount of water required by the portions of the irrigation system based on plant type.

8. In area 4, the user is able to obtain information on plant watering and reservoir filling times, as well as water needed in a day. Output data labeled in green boxed

9. The user inputs the current month in which watering is occurring and the calculator outputs water needed in a day per plant, and total. The percentage is also noted (% Open, C6), which depicts the amount of the total water that region of plants requires in a day. This will aid in determining flow through the certain regions of the irrigation system.

10. The user can then adjust the pump to be used for the system, it is strongly recommended to select a pump that has been highlighted green in section 3, as this pump will be more appropriate for the system. There is currently no error message included incase the user selects a pump that is not recommended based on the well depth. This change influences the approximate fill time of the reservoir which can help guide the user when scheduling watering times (C7)

Total Water/Day (gal)	256
Remco 12v model # Reservoir Fills	1.28
Aprox Fill Time (min)	38

C7: Pump choice alters Fill time value

1 Plant		2 Plant		3 Plant	
Losses from Branches (m)	4E-05	Losses from Branches (m)	9.9E-06	Losses from Branches (m)	9.9E-06
Plant 1	4E-05	Plant 1	5E-06	Plant 1	5E-06
Plant 2		Plant 2	5E-06	Plant 2	5E-06
Plant 3		Plant 3		Plant 3	
Plant 4		Plant 4		Plant 4	
Plant 5		Plant 5		Plant 5	
Plant Spine Losses (m)	0.0089	Plant Spine Losses (m)	0.00462	Plant Spine Losses (m)	0.00462
Plant 1	0.0089	Plant 1	0.00231	Plant 1	0.00231
Plant 2		Plant 2	0.00231	Plant 2	0.00231
Plant 3		Plant 3		Plant 3	
Plant 4		Plant 4		Plant 4	
Plant 5		Plant 5		Plant 5	
Main Spine Losses (m)	0.0088	Main Spine Losses (m)	0.00589	Main Spine Losses (m)	0.00589
Q tot Out (m/s)	7E-05	Q tot Out (m/s)	6.6E-05	Q tot Out (m/s)	6.6E-05
Loss Total System	0.0177	Loss Total System	0.01052	Loss Total System	0.01052
Elevation Needed (ft)	0.0581	Elevation Needed (ft)	0.03449	Elevation Needed (ft)	0.03449
Length of pipe	164.75	Length of pipe	157.8	Length of pipe	157.8

C8: Head losses for various piping components

11. C8 Depicts a visual of specific head losses for labeled components. This is a region where additional loss analysis should be added if future work is conducted. The suggested reservoir height is determined by these values.

Individual Assignments

Ethics

Ethical Design: Spencer Abbott

At the forefront of our design was always concern for safety, the health and welfare of the individuals who would be using our design and assembling it. The type of system we have been asked to design already exists so we continued to pick materials that were safe to use and assemble as they had a proven record of being utilized. Since the pipes are carrying water to irrigate crops it is important to use pipes that do not contain any chemicals that could end up contaminating the crops or ground. Additionally, it is important to utilize a filter before the water pump to remove particulate matter from the water. We have slowly worked to become experts in the area of solar powered irrigation in order that our recommendations are trustworthy. With this in mind we feel that our research and knowledge will have become trustworthy enough to give a presentation at the end of the semester with our design recommendations. We have also striven to be faithful to our sponsors needs and have worked very hard to meet their user requirements for a specific application while also giving enough guidelines for a wide range of applications. Throughout this semester we have not deceived anyone in our progress or our knowledge. Additionally we have conducted ourselves honorably, responsibly, ethically, and lawfully in order to enhance the honor, reputation, and usefulness of the profession [1]. We have continually worked to acknowledge our resources and design and create a system that is functional and safe for the end users. Also, of importance is our goal of engineering for sustainability. One of the main goals of our project is to more effectively utilize the limited resources available in order to increase efficiency, reduce waste, and reduce pollution all while supplying both economic and agricultural sustenance to the people we are assisting in Kazakhstan. We hope that the work we have put forth shows the commitment to engineering ethics that we have followed throughout the semester.

Ethical Design: RJ

Our task this semester was to design and provide information about a solar powered irrigation system, with this task comes a final list of suggestions and recommendations in order to help guide future work by the REFRESCH team. These calculations, which act as suggestions need to be created with integrity in mind, as these values are anticipated to be trusted and utilized. We obtained equations and concepts from reputable resources and cited them appropriately for reference. When we came across opinions on design, we did not initially take those words as “truth”, we performed a large deal of research to observe consistent observations made on aspects of our system. This data exists since our design has already been done and implemented across the world. It is expected that we provide valuable information for our sponsors, and I believe when we make our final suggestions, it is appropriate for us to cite and also mention any data when are still questionable about. On top of these suggestions and recommendations, our designs were also influenced by the ethics of engineering. We considered the end users of our product and also those installing it. We did not want to have the need to use dangerous chemicals or components. The possible dangers of these parts are considered in the installation, use, and disposal phases of our system. Our final suggestions will point out and include any known safety issues of our system. This work is a representation of us as engineers, so quality is of the utmost importance.

Ethical Design: Isaac Baker

For our design the biggest areas of concern for our ethics talks were safety and sustainability. The system needs to work for the well being of these people in Kazakhstan so our calculations need to be able to prove that our system will work and be sustainable for this family. Ethically we would want to use the best materials we could find but in reality this family wouldn't be able to afford these materials. So we not only need to work and be reliable but they need to be materials that can be commonly found and are relatively cheap so this family can afford it. The team sponsoring us will be supplying the pump and solar panels so our calculations and selection of these pieces of equipment need to be rational and supported. In designing the system we also needed to think about the sizes of some of the parts we were recommending. The area of Kazakhstan we are working in is relatively poor so there would be a chance if we put up big solar panels in the family's backyard they might become a target for burglary. The family needs our system for their own livelihood with the extra income from selling the produce as well as just feeding themselves. If they were to become targets of burglary then they may lose more than they what we are providing them and it could really take a toll on the family. Finally since we know that there probably won't be anyone that would be able to fix the pump or panels if they broke down we need to make sure that the lifetimes on this materials won't break down after a year or two. Besides the lack of technical knowledge, they may not have the money to replace things if they break so our materials need to last for a long time with little to no maintenance for several years for this family to really thrive with our system.

AUTHORS

Spencer Abbott: Has a degree in Psychology from the University of Michigan and is currently in his last semester of obtaining his BS in Mechanical Engineering. He has worked at Nissan Technical Center for

the last two summers as an intern in safety and restraints and vehicle body systems and will be returning to Nissan after graduation.



Isaac Baker: Will be getting his BS in Mechanical Engineering in the spring of 2016. He has held two internships in the last three years as well as studied abroad in Dublin, Ireland for a summer. One internship was with an iron foundry that produces parts for various car manufactures and the other with an electrical construction company that builds and maintains distribution and transmission lines around the midwest.

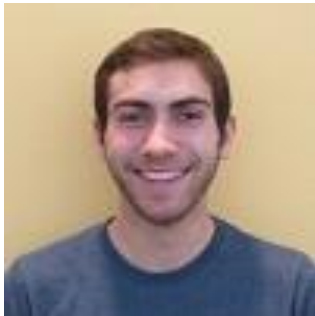

RJ Nakkula: Intends to obtain a master's degree in Biomedical Engineering upon completing his B.S.E in Mechanical Engineering. He has worked with renewable energy sources through BLUElab and is continuing his research on environmental factors on bone strength indices. He is also President of the on campus juggling club.