

2016

# Upper Body Powered Exoskeleton

Rabideau, Kevin

<https://hdl.handle.net/2027.42/122853>

<http://creativecommons.org/licenses/by-nc/4.0/>

---

*Downloaded from Deep Blue, University of Michigan's institutional repository*



# Aluminum Prototype of Right Arm Exoskeleton Strength Augmenting Robotic Exoskeletons (STARX)



## INTRODUCTION

Currently there are few exoskeletons that are outside of research and military applications. STARX works toward building practical strength augmenting exoskeletons that can be used in an everyday setting. Over the course of the Fall 2015 and Winter 2016 semester, we designed, manufactured, and instrumented our first aluminum arm prototype. The goal for our arm exoskeleton was to lift 10-15 lbs more than a person is capable of. With the intention of making this technology mainstream, we have made our progress open source.

## DESIGN PROCESS

For our design process, we first brainstormed factors that we considered most important to our design. Those factors included safety, weight, adjustability, ease of movement, practicality, and longevity. After deciding on the main considerations and reviewing existing exoskeleton designs, we were able to generate sketches (Fig.1,2). Once sketches were complete, we were able to proceed with creating our mechanical design.

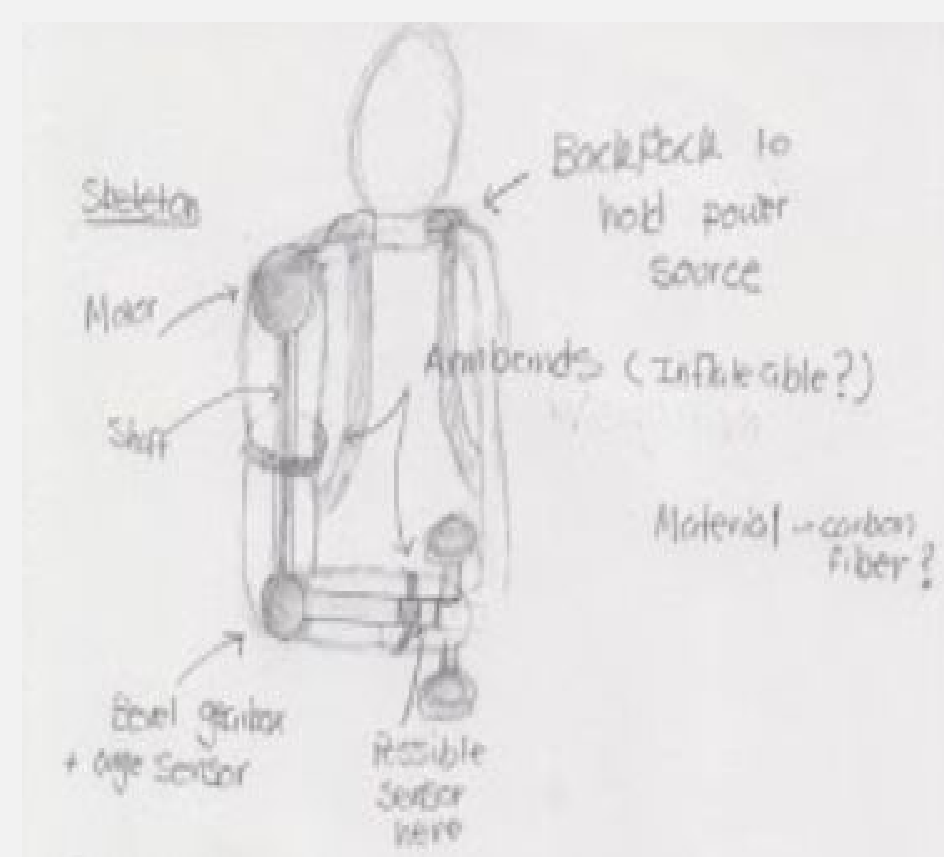

**Figure 1.** Sketch of our basic design of the arm exoskeleton. Key features included a backpack to distribute the weight and adjustable arm bands for attachment.

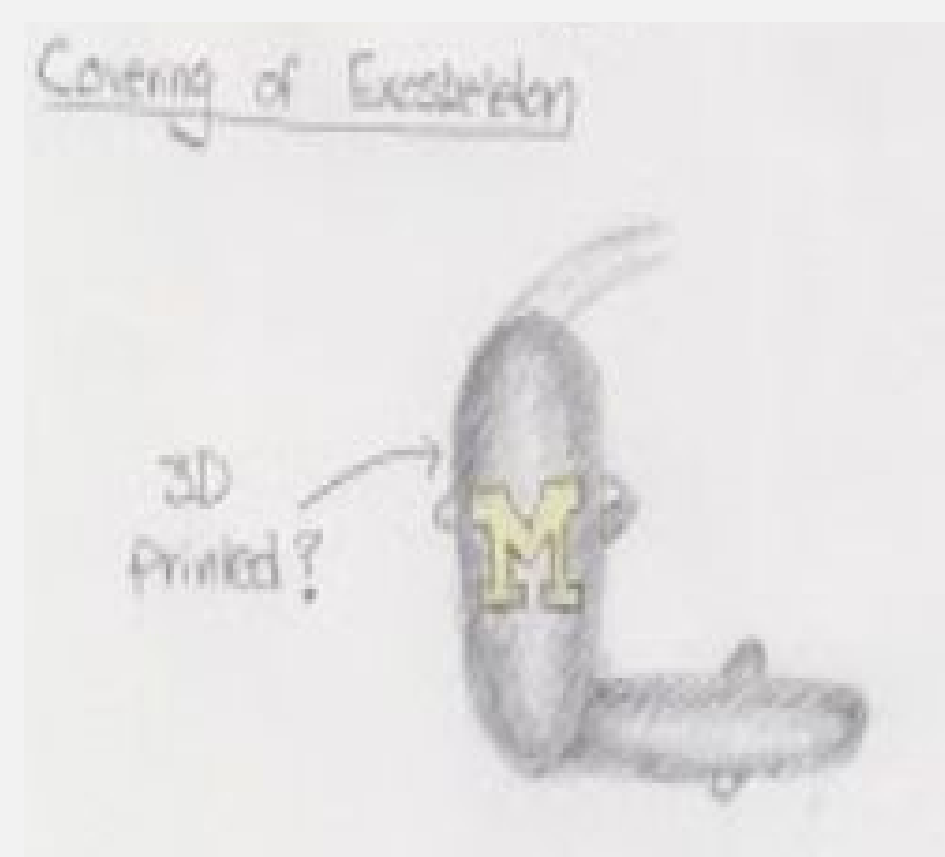

**Figure 2.** Sketch of our covering for the exoskeleton. We considered one that was 3D printed to cover the electronics and improve aesthetics.

## MECHANICAL DESIGN

There were five aspects of the design that we wanted to focus on for the mechanical design of the exoskeleton. Those five aspects were the material, shoulder, elbow, back, and transmission.

### A. MATERIAL

In order to make our exoskeleton durable, cost effective, and lightweight, we decided to build our prototype mostly out of multipurpose 6061 aluminum. For parts of the design that were subjected to high stress or strain, we used high strength aluminum or steel.

## B. SHOULDER DESIGN

For the shoulder, the biggest factor was that the exoskeleton should move naturally with the user's arm. The shoulder has three degrees of freedom and we attempted to achieve that by using a pivoting hinge system.

## C. ELBOW DESIGN

The key features that we wanted for the elbow was adjustability, comfort, and safety. To investigate designs that would fit this criteria, we looked at elbow braces, specifically the Bledsoe elbow brace (Fig 3). This brace was adjustable in length and had malleable cuffs with padding, which targeted a wide range of people. Below, you can compare our design (Fig. 4) to the Bledsoe. The main safety concern we had was the risk of hyperextending the elbow if there was a misread of control signals. To resolve this, a small stop was put to prevent the elbow from extending more than 90°.



**Figure 3.** Bledsoe extender arm post-op elbow brace that inspired our design, in particular the malleable cuffs with padding and the adjustability.

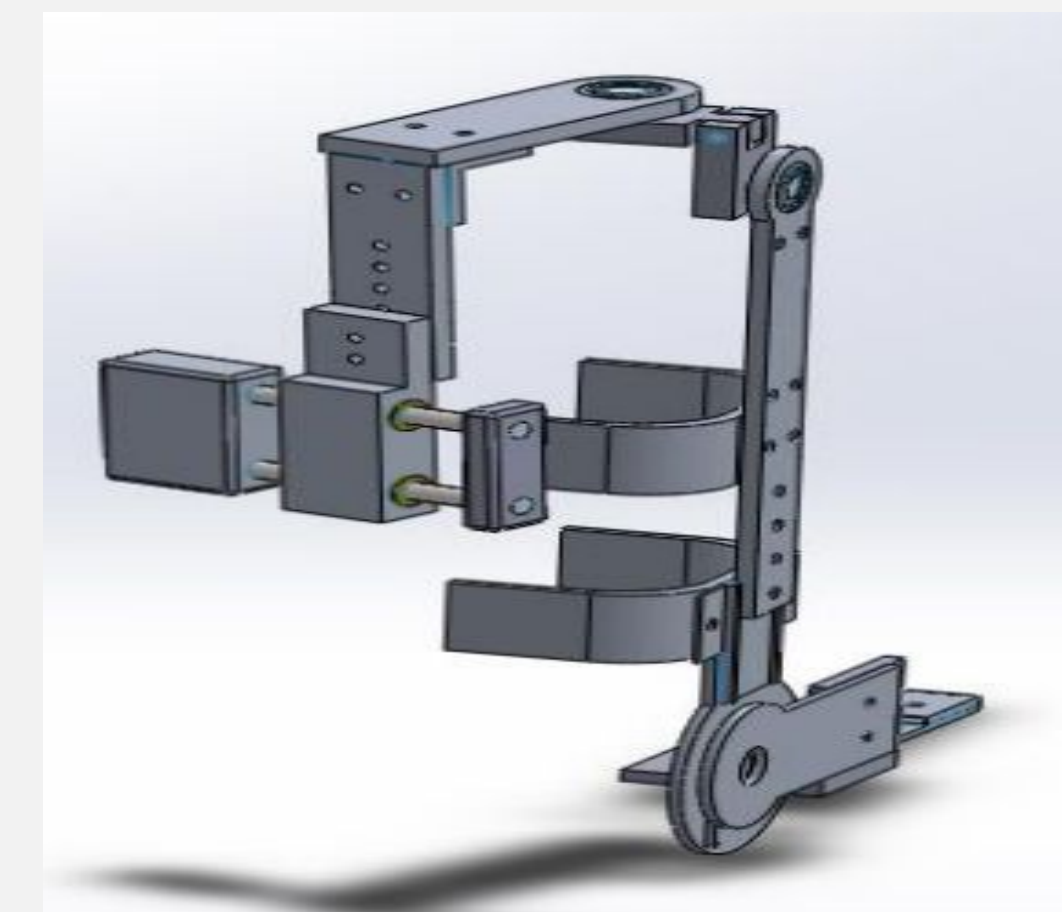

**Figure 4.** Complete CAD model of our arm exoskeleton. We mimicked the adjustability and removed the cuffs from the Bledsoe arm to incorporate into our design.

## D. BACK DESIGN

The back design was designed in a way that compensates for the weight imbalance caused by only having one arm exoskeleton as well as properly holds the electronic components. We used a MOLLE frame as the base for our suit due to its light weight.

## E. TRANSMISSION DESIGN

When an arm curls a weight, most of the work is from the torque about the elbow. To achieve augmentation of strength in the arm, we used a pulley system with Bowden cables. Bowden cables allow us to transmit the force of the motor on the back to the elbow without a complex arrangement of pulleys for an open cable system.

## ELECTRICAL DESIGN

For the electrical design, we had to focus on three areas: sensors, control algorithm, and motor control. For sensors, our system relies on two surface electrode EMG sensors, two pressure sensors, and an angle sensor. These allow for direct control of the exoskeleton based on arm movements alone.

### A. CONTROL ALGORITHM

The control algorithm ideally consists of two control loops, one for free movement without EMG signals and one for movement under load. Free movement uses a PI controller with the force sensors, while the load controller relies on EMG signals from the user's bicep and tricep.

### B. MOTOR CONTROL

For our motor, we chose to use a Milwaukee Brushless power drill. The reason behind this choice is the many convenient functions of the drill that suited our application. The drill has the proper torque and speed with its gearbox, a slip clutch to prevent stalling, and all associated electronics for controlling it. To control it, we simply controlled the speed and direction using signal inputs from our microcontroller while keeping the internal workings as a black box.



## FUTURE WORK

On future version we plan to focus on making this a more practical device for daily use. The main steps are using lighter materials, finding a more ideal motor and motor casing, and all around reducing the material and space needed.

## ACKNOWLEDGEMENT

Special thanks to:

David Remy, Jeff Koller, Dan Johnson, Leena Lalwani, Tim Obermann, Bill, Zechariah Schneider, UM Library

This project is sponsored by a 2015-2016 mini-grant awarded through the University Library's Student Engagement Program. As part of the mini-grant, we were paired with Engineering Librarian Leena N Lalwani