

The Dynamics of Tank-Vehicle Rollover
and the
Implications for Rollover-Protection Devices

Final Report
UMTRI-98-53

November 1998

Prepared by
The University of Michigan
Transportation Research Institute
2901 Baxter Road, Ann Arbor, Michigan 48109
under Contract No. DTFH61-96-C-00038, Task Order #1

for
Federal Highway Administration
U.S. Department of Transportation
400 Seventh Street S.W., Washington, D.C. 20590

UMTRI The University of Michigan
Transportation Research Institute



080291

Technical Report Documentation Page

1. Report No.		2. Government Accession No.		3. Recipient's Catalog No.	
4. Title and Subtitle The Dynamics of Tank-Vehicle Rollover and the Implications for Rollover-Protection Devices				5. Report Date November, 1998	
				6. Performing Organization Code	
7. Author(s) Winkler, C., Bogard, S., Zhou, J.				8. Performing Organization Report No. UMTRI-98-53	
9. Performing Organization Name and Address The University of Michigan Transportation Research Institute 2901 Baxter Road, Ann Arbor, MI 48109-2150				10. Work Unit No. (TRAIS)	
				11. Contract or Grant No. DTFH61-96-C-00038, T. O. #1	
12. Sponsoring Agency Name and Address Federal Highway Administration U.S. Department of Transportation 400 7th Street S.W. Washington, D.C. 20590				13. Type of Report and Period Covered Final Report	
				14. Sponsoring Agency Code	
15. Supplementary Notes					
16. Abstract The dynamic behavior of tanker vehicles is examined through a vehicle simulation study. A modified version of TruckSim is used as the simulation program. Two straight trucks and a five tractor semitrailer combinations serve as test vehicles. Each is subject to a matrix of 126 runs. Test maneuvers range from the minimum-severity quasi-static turns resulting in rollover to high-speed curb strikes resulting in rapid and highly dynamic rollover. The final conditions of the vehicles as they strike the ground are examined and distilled into a basic set of parameters describing the dynamic impact conditions of rollover. These parameters are then employed in simple impact simulations to characterize the force-deflection characteristics required of rollover-protection devices and the tanks structure to which they attached. Conclusions are presented and recommendations are made.					
17. Key Words truck, semitrailer, stability, impact, accident			18. Distribution Statement Unrestricted		
19. Security Classif. (of this report) None		20. Security Classif. (of this page) None		21. No. of Pages 187	22. Price

EXECUTIVE SUMMARY

Federal regulations DOT 406, 407, and 412 require that cargo tank motor vehicles used on U.S. highways be equipped with *rollover-protection devices* to protect manhole covers, valves, vents, and other top-mounted hardware from damage and to prevent leakage of product during rollover accidents. In its 1992 *Special Investigation Report* entitled "Cargo Tank Rollover Protection," the National Transportation Safety Board was critical of existing rollover-protection devices and found that "insufficient guidance...[exists] about the factors and assumptions that a cargo tank manufacturer must consider when calculating loads on the rollover-protection devices..." and that "there is inadequate information about the forces that can be encountered in a rollover accident and the extent to which rollover-protection devices for cargo tanks can reasonably be designed to withstand these forces..."

This study has attempted to expand the knowledge base on the dynamics of tank vehicle rollover events in order that such *guidance* and *information* can be improved.

DYNAMICS OF TANK-VEHICLE ROLLOVER

The primary contribution of this study is a broad-ranging examination of the dynamics of tank-vehicle rollover accomplished through computer simulation. Seven cargo tank motor vehicles, two tank trucks, and five tractor semitrailer combinations were simulated. Each was subjected to 126 simulated maneuvers intended to result in rollover. Test maneuvers included mild, low-speed turns that just barely produced rollover, more dynamic maneuvers on smooth surfaces, and high-speed impacts with curbs and guardrails that result in rapid rollover combined with substantial pitch and yaw.

Simulation runs were allowed to continue until the moment that the vehicle tank contacted the ground. Measures of the dynamic motions of the vehicles at that instant of impact were compiled and analyzed. The results describe the range of initial conditions of the common impact events that can occur subsequent to a rollover and that engage the rollover-protection devices. Three such impact scenarios were defined and analyzed:

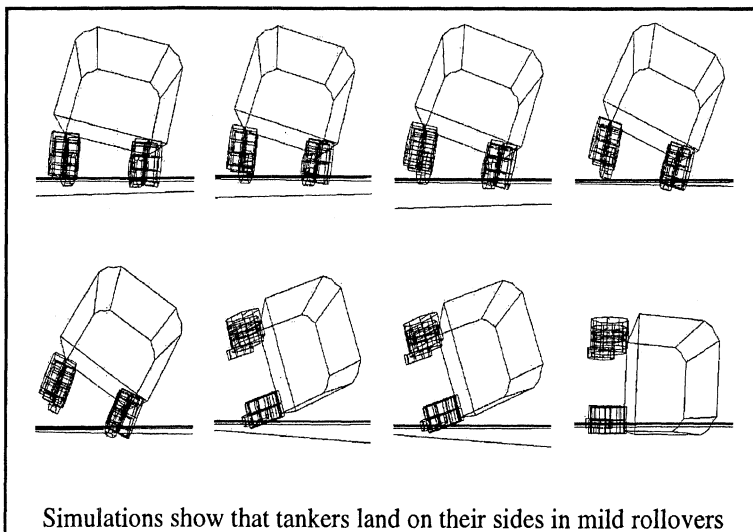

- In a mild rollover, the vehicle may fall onto its side but continue to roll on the flat ground surface to engage the rollover-protection devices. The primary dynamic parameter of interest in this mechanism is the value of roll rate at touchdown. Vehicles in the least severe of such rollovers achieve roll rates on the order of 100 deg/sec. Vehicles

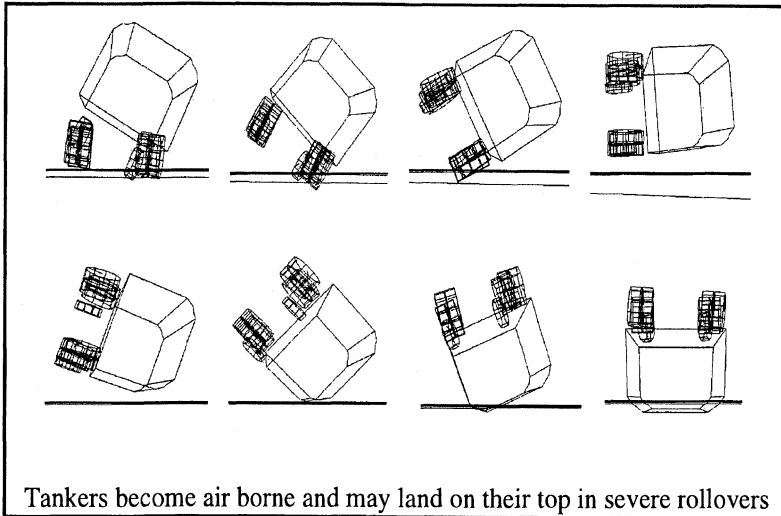

landing on their sides in more energetic events have roll rates up to and beyond 150 deg/sec.

- In more dramatic rollover events, the vehicle may become airborne and roll rapidly enough to bring the rollover-protection devices into direct impact with the ground. This result can occur with unit

trucks on level ground but appears to require a sloping or depressed roadside surface for it to happen to a semitrailer tank. Trucks landing on their tops on the road achieve downward speeds of at least 6 ft/sec. but rarely more than 18 ft/sec. The semitrailers allowed to fall sufficiently to reach 180 degrees of roll achieve downward speeds as high as 30 ft/sec.

- In moderate and severe rollovers, the vehicle may land on its side and slide sideways into any of the many objects with vertical surfaces that are typically oriented parallel to the roadway such as guardrails, retaining walls, or embankments. Simulation showed that the impact speed normal to such a surface often exceeds 20 or 30 percent of the initial forward speed and occasionally can reach well beyond 40 percent.

IMPLICATIONS FOR ROLLOVER-PROTECTION DEVICES

A supplemental element of this study was an effort to provide some insight into the design and engineering requirements for rollover-protection devices and the tanks to which they are mounted, given the type and severity of impact conditions that developed in the process of rollover.

Simple impact simulation models using idealized force/deflection characteristics were developed and applied in a large matrix of conditions to evaluate the design implications for the impacts defined in the vehicle dynamics study. The effort was intended to provide broad guidance for the design of protective systems rather than precise determination of forces in any given device.

Results indicate that impact due to rolling is of little concern for low-profile, rail-style rollover-protection devices but may be a major challenge for discrete devices which constitute a significant discontinuity in the profile of the tank. This is true even for roll velocities associated with the mildest of rollovers.

Vertical and lateral impacts, even into simple planar surfaces, appear to pose a significant challenge for all impact protection devices. The dynamic simulation study showed that virtually every rollover event involved impact speeds of at least 6 ft/sec and that 24 ft/sec was a reasonable upper bound to cover the majority of impacts.

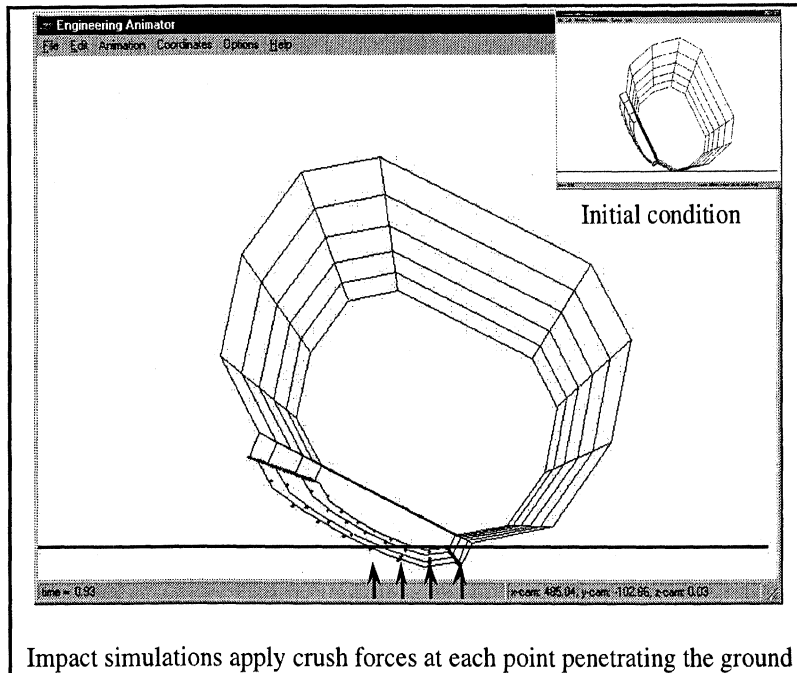

Impact simulations apply crush forces at each point penetrating the ground

Initial velocities of 6, 12, 18, and 24 ft/sec were used in the impact study. Of these velocities, 12 ft/sec is the lowest which could be judged as covering a significant fraction of realistic events. In many impacts at this velocity, if the combined structure of tank and protection devices provided a foot of crush distance, then it was often the case that the protective structure had to be of

such strength that it could support ten times the weight of the vehicle. Since impact energy is proportional to velocity squared, the situation is four times more severe for impacts at 24 ft/sec.

Angular orientation of the tank relative to the impact surface was found to be an important factor. Compared to impact flat against the top surface of the tank, angular misalignments of just 10 and 15 degrees can increase the effective severity of impact by about ten-fold.

These observations suggest that effective protective systems that could survive such impacts would represent a substantial increase in performance relative to that required by today's regulations. The magnitude of the forces involved would appear to demand that effective designs spread the loading over a large portion of the tank structure, a fact which probably eliminates the so-called staple-type devices and other discrete styles of protective devices. Further, it appears that effective protective systems must involve controlled crush of the tank to provide adequate crush distances without resorting to excessively large, high-profile devices.

RECOMMENDATIONS

Three recommendations are presented below. By way of preamble, however, we take care to note the nature of this study. The study was theoretical in that all results were obtained from computer simulations. Although the vehicle dynamics simulation that was used is well established and rather comprehensive, the impact simulations were newly developed for this purpose. Further, the study endeavored to examine the dynamic and physical properties of a large range of rollover events. However, as noted in the previous section on background and philosophy, there is no adequate accident data base to establish how these properties are distributed among accidents occurring in the real world. Thus, while the second recommendation below is quantitative and suggests some

consideration of costs versus benefits, we frankly acknowledge that it is in part based on the authors' experience and judgement rather than wholly on the content of the study. The third recommendation recognizes the need for substantive cost/benefit considerations to be accomplished in the future.

- **Performance goals for rollover-protection devices should be expressed in terms of impact events to be survived, not in terms of the strength of the device.**

Rollover-protection devices must effectively manage impact energy. To do this, good designs may benefit by allowing greater crush deformations, thereby maintaining low forces. Such engineering trade-offs are best left to the design process, but designers need to know the basic parameters describing the design task. A description of the impact event is what is needed and such descriptions constitute the primary product of this study. Expressing requirements through a description of the impact event is the approach already employed by the USDOT in bumper standards and in standards for the impact protection of passenger car occupants.

- **A minimum design goal for rollover-protection systems should be effective performance in impacts onto flat surfaces at speeds normal to the surface of *at least 12 ft/sec* and with representative angular orientations of the tank with respect to the impact surface. Designing for impact at speeds up to 24 ft/sec is desirable.**

The vehicle dynamics study showed that virtually all rollover events yield impact velocities of at least 6 ft/sec and that impact speeds of 24 ft/sec can be achieved in many situations. It seems reasonable to recommend that any rollover-protection device, if it is to deserve such a name, must be able to protect tank fittings during impacts covering at least a significant portion of this range.

At the very least, protection should be ensured when the impact occurs squarely in relation to the top surface of the tank, but consideration should also be given to covering a representative range of angular misalignments between the tank and the impacted surface.

- **Evaluation of the cost effectiveness of performance standards for rollover protection should be undertaken.**

This study has sought to identify the pertinent physical properties of cargo tank rollover events as a basis for specifying performance requirements for rollover-protection devices. The question of the cost-effectiveness of such devices remains to be addressed.

By way of example, impact velocities of 12 and 24 ft/sec could be attained by dropping a tank from rest onto a flat surface through distances of 2.2 and 8.9 feet, respectively. The latter number certainly suggests a significant design challenge even if the impact were square against the top surface of the tank. Reasonably representative angular misalignments could increase the effective severity of impact by about ten-fold. Evaluation of the incremental cost to the transportation versus the potential societal savings which might result from various levels of such performance requirements is appropriate. Such analysis will require, among other things, knowledge of the statistical distribution of rollover accidents in terms of their physical severity and the occurrence of cargo spillage.

Table of Contents

EXECUTIVE SUMMARY	I
DYNAMICS OF TANK-VEHICLE ROLLOVER	I
IMPLICATIONS FOR ROLLOVER-PROTECTION DEVICES	II
RECOMMENDATIONS.....	III
INTRODUCTION.....	1
BACKGROUND AND PHILOSOPHY.....	3
DYNAMICS OF TANK-VEHICLE ROLLOVER	7
VEHICLE SIMULATIONS.....	7
SIMULATED VEHICLES	8
SIMULATED MANEUVERS	12
Intersection turn (I-turn).....	12
Highway or exit-ramp turn (H-turn)	13
Curb-strike and rail-strike maneuvers (trip and rail).....	13
Spiral turn (spiral).....	13
High-speed avoidance maneuver (swerve)	13
Step-turns (step).....	13
RESULTS FROM THE VEHICLE-DYNAMICS SIMULATION RUNS.....	14
ANALYSIS OF SIMULATION RESULTS.....	17
Description of sample rollover events.....	17
Quantitative examination of the simulation results.....	24
IMPLICATIONS OF THE RESULTS FOR MINIMUM PERFORMANCE REQUIREMENTS FOR ROLLOVER-PROTECTION DEVICES.....	31
IMPLICATIONS FOR THE STRUCTURE OF ROLLOVER-PROTECTION DEVICES AND TANKS.....	33
IMPACT SIMULATION MODELS	33
IMPACT SIMULATION MATRIX.....	39
RESULTS OF THE IMPACT SIMULATION STUDY.....	44
Observations on the results of the rolling-impact model.....	45
Observations on the results of the normal-impact model	48
OBSERVATIONS REGARDING THE CURRENT REGULATIONS.....	56
CONCLUSIONS AND RECOMMENDATIONS	57
DYNAMICS OF TANK-VEHICLE ROLLOVER	57
IMPLICATIONS FOR ROLLOVER-PROTECTION DEVICES	57
RECOMMENDATIONS.....	59
REFERENCES.....	61
APPENDIX A. VEHICLE ROLLOVER SIMULATION INPUT PARAMETERS	A-1
APPENDIX B. VEHICLE ROLLOVER SIMULATION RESULTS	B-1
APPENDIX C. IMPACT SIMULATION RESULTS	C-1

List of Figures

Figure 1. Photo of a truck similar to that of the Bronx accident	9
Figure 2. Line drawing of the Hamilton accident vehicle with photo of the tank	9
Figure 3. Photo of a semitrailer similar to that of the Albuquerque accident	10
Figure 4. Photo of the vehicle from the Columbus accident.....	10
Figure 5. Photo of the vehicle from the Lantana accident.....	10
Figure 6. Estimating the roll moment of inertia of the liquid load	11
Figure 7. Closed-loop simulated maneuvers.....	12
Figure 8. The open-loop high-speed avoidance maneuver	14
Figure 9. Plan-view of a vehicle rolled onto its side at the completion of a simulation run.....	16
Figure 10. The Bronx vehicle in a minimal rollover (run #116, $\Delta t = 0.25$ sec)	18
Figure 11. Plan-view sketch of the Bronx vehicle at the end of run #116.....	19
Figure 12. The Hamilton vehicle in a rapid, flat-surface rollover (run #63, $\Delta t=0.1$ sec)	19
Figure 13. Plan-view sketch of the Hamilton vehicle at the end of run #63.....	20
Figure 14. The Bronx vehicle rolling over after striking a curb (run #28, $\Delta t=0.1$ sec).....	20
Figure 15. Plan-view sketch of the Bronx vehicle at the end of run #28.....	21
Figure 16. The Hamilton vehicle rolling over after striking a rail(run #52, $\Delta t=0.1$ sec).....	21
Figure 17. Plan-view sketch of the Hamilton vehicle at the end of run #52.....	22
Figure 18. The Albuquerque vehicle rolling over and falling after striking a curb at 20 degrees and 45 mph (run #124)	23
Figure 19. The Albuquerque vehicle rolling over and falling after striking a curb at 30 degrees and 45 mph (run #126)	24
Figure 20. The final roll angle for all successful simulated test runs.....	25
Figure 21. Final vertical speeds of the centers of gravity of the tank units	26
Figure 22. Comparison of final vertical speeds from the simulation and from the simple calculation based on the center of gravity falling from its apex height.....	27
Figure 23. Final pitch angles of the tank units	27
Figure 24. Final roll rates of the tank units.....	28
Figure 25. Final speed of the tank units across the roadway.....	29
Figure 26. Final speed of the tank units across the roadway grouped by maneuver.....	29
Figure 27. Final yaw angle of the tank units relative to a vertical surface parallel to the road....	30
Figure 28. Impact deformation may take place in the tank or in the rollover-protection devices. 34	
Figure 29. Comparison of the energy dissipation performance of idealized and realistic structures	35
Figure 30. Animation frames from a simple run of the normal-impact model	37
Figure 31. Animation frames from a simple run of the rolling-impact model.....	38
Figure 32. The design variations of the rollover-protection devices.....	40

Figure 33. Dimensional properties of the rollover-protection devices represented in the impact-simulation study.....	41
Figure 34. Example results from the impact simulation study.....	44
Figure 35. Rolling-impact results for the trucks in their as-designed configurations.....	46
Figure 36. Rolling-impact results for the semitrailers in their as-designed configurations.....	46
Figure 37. Forces on the protectors during rolling impact.....	47
Figure 38. The influence of variations of discrete-element design on the rolling-impact results for the Albuquerque vehicle.....	48
Figure 39. The relationship between percent of initial forward speed in miles per hour and impact speed in ft/sec.....	49
Figure 40. Comparison of results from similar vertical and lateral impacts of the Lantana semitrailer (all at 12 ft/sec).....	49
Figure 41. The influence of velocity on the results from simulations of the Lantana semitrailer in flat-on-the-top impacts.....	50
Figure 42. Comparison of results from the as-design vehicles in 12-ft/sec impacts, flat against the top.....	51
Figure 43. The performance of discrete elements approaches that of rails as their numbers increase.....	51
Figure 44. The impact data of figure 43 presented in normalized form.....	52
Figure 45. Results from impacts at 12 ft/sec and -5 degrees of pitch presented in normalized form.....	53
Figure 46. Results from lateral impacts of the Lantana semitrailer (R1) at 18 ft/sec and at various roll and yaw angles.....	54
Figure 47. Comparison of results for various protector configurations.....	55

List of Tables

Table 1. Example of results from the simulation study: semitrailer of the Albuquerque vehicle .	15
Table 2. Results from the example simulation runs of figures 10 through 19	18
Table 3. Simulation matrix for rail-style overturn protectors	39
Table 4. Simulation matrix for discrete-style overturn protectors (Albuquerque)	39
Table 5. Linear feet of rail and number of discrete elements by vehicle design configuration.....	41
Table 6. Vehicle mass, inertia, and center of gravity positions.....	41
Table 7. Crush-force levels for the rolling-impact and normal-impact model.....	42
Table 8. Initial conditions for simulations of rolling impacts	42
Table 9. Initial conditions for simulations of vertical impacts.....	43
Table 10. Initial conditions for simulations of lateral impacts.....	43

INTRODUCTION

This document is the final report of the University of Michigan Transportation Research Institute (UMTRI) on the research project entitled "Determination of Forces in Cargo Tank Rollover-Protection Devices." Funding for the project was provided by the Federal Highway Administration (FHWA) of the U.S. Department of Transportation (USDOT) under Task Order No. 1 of Contract No. DTFH61-96-C-00038.

The purpose of the study was to outline requirements for cargo tank rollover-protection devices, typically affixed to the top of tank vehicles, which are meant to protect manhole covers, valves and other tank openings during rollover events. The project was analytical in nature. Conventional vehicle simulations were used to examine the dynamics of the rollover of tank vehicles up to the point of crash impact. Additional computer-based analyses were then used to broadly characterize the force-deflection qualities required of rollover-protection devices to be effective in such events.

This report begins with a discussion of the background for and philosophy of the project. Two technical sections follow which address the dynamics of tank-vehicle rollover and the implied requirements for protection devices, respectively. The final section of the main text presents conclusions and recommendations. Other technical materials are appended.

BACKGROUND AND PHILOSOPHY

U.S. Federal regulations DOT 406, 407, and 412 require that cargo tank motor vehicles used on U.S. highways be equipped with *rollover-protection devices*[1].¹ Such devices are typically mounted on the top of the tank body and are intended to protect manhole covers, valves, piping, vents, et cetera. from damage and potential leakage of product during rollover accidents.

In 1992, the National Transportation Safety Board (NTSB) issued a *Special Investigation Report* entitled “Cargo Tank Rollover ” [2]. This report was critical of both the rollover-protection devices which are commonly deployed on the U.S. cargo-tank fleet and the adequacy of the related regulations and their application. The report examined seven cargo tank rollover accidents. Given that a rollover had occurred in each case, these accidents, with one exception, can be broadly characterized as ranging from mild to moderate. Nonetheless, substantial cargo leakage occurred in each of these accidents due to failure, in one form or another, of manhole covers and fittings on the top of the cargo tank. The report concluded that some rollover-protection devices involved in these accidents simply did not meet federal requirements. However, it also found that “insufficient guidance...[exists] about the factors and assumptions that a cargo tank manufacturer must consider when calculating loads on the rollover-protection devices...” and that “there is inadequate information about the forces that can be encountered in a rollover accident and the extent to which rollover-protection devices for cargo tanks can reasonably be designed to withstand these forces...”²

It should be specifically noted, however, that the NTSB investigated this particular set of accidents partly *because* leakage was reported. There is no effort in [2] to establish the probability of cargo leakage in all accidents of comparable severity. In fact, there is little basis in the various national accident data bases by which to establish statistical relationships between rollover events, their physical severity, and the occurrence of leakage by the failure of rollover-protection devices.

The most detailed information on truck accidents collected annually is in the Trucks Involved in Fatal Accidents (TIFA) files produced by the UMTRI Center for National Truck Statistics. As the name implies, only fatal accidents are covered by this file. The

¹ Numbers in brackets designate bibliographic references given at the end of this text.

² Note that the applicable federal regulations in 1992 were MC 306, 307, and 312. These have since been replaced with DOT 406, 407 and 412 which call for some increase in the strength of rollover-protection devices. In later sections of this report, results will be presented suggesting that the new specification are not likely to be effective.

TIFA files include data elements from the NHTSA Fatality Analysis Reporting System³ (FARS). UMTRI collects additional information that provides a more detailed physical description of the truck and a more detailed collision classification. Cargo body style is coded for each unit in a combination truck and cargo tanks are identified specifically. Dry bulk tanks are distinguished from liquid/gas tanks. The length, width, number of axles, type of dolly, empty weight, cargo type and cargo weight are also collected. A separate variable indicates whether the cargo included hazardous materials or not. Rollover is coded as a primary event or a subsequent event for the truck. Whether individual units rolled or not is not identified. Cargo spill is coded as none, spill of hazardous cargo, or spill of nonhazardous cargo. The TIFA data files do not include information describing the nature of the damage to the cargo tank that resulted in the spill (location or failure mode) or the nature of the impact that produced the damage (object or surface contacted, direction of force, impact severity). To our knowledge, the only source for information of this type has been the NTSB investigations [2].

This lack of statistical evidence notwithstanding, it is clear that rollover accidents of cargo tank vehicles cover a very large range of severity. At the mildest end of this range are accidents in which the vehicle simply rolls over onto its side on a relatively flat road or road-side surface and strikes nothing else (but may continue to rotate in roll so as to involve the rollover-protection devices).⁴ Next in severity might be those events in which the rolling motion of the vehicle is more rapid and/or the road-side surface falls away such that the vehicle more or less lands on its top rather than its side. In yet another category are those accidents in which the vehicle rolls over and then slides sideways into one of the many common objects that present a vertical surface beside the roadway, objects such as guardrails, retaining walls, or embankments. Of the seven accidents examined by NTSB, six more or less fit into these categories. These six cases were those selected by FHWA in their request for proposal as reference events for this study.⁵

Relatively milder accidents such as these surely compose a large fraction of all rollovers of tankers. However, there remain many accidents which are much more severe in terms of the mechanical event. They will typically involve striking a *specific* strong, rigid obstacle in a *specific* manner. Indeed, one can imagine an almost endless set of scenarios involving impact with such elements as bridge abutments, fire hydrants, other vehicles, utility poles, trees, et cetera, all resulting in severe point-loading of a rollover-protection device. The level of severity will largely depend on the specifics. In short, as this type of accident becomes more severe, it is likely to be more "individualized" and

³ Formerly the Fatal Accident Reporting System.

⁴ The accident at Albuquerque, New Mexico [1].

⁵ The accidents at Albuquerque, New York, Columbus, Ohio, Edenton, North Carolina, Ethelsville, Alabama, Hamilton, Ontario, and Lantana, Florida [1].

less readily classifiable. Indeed, looking at cause and effect, the greater the severity, the more likely the cause is rare or unique.

In this context, the NTSB findings imply that even the large class of mild accidents can be too much for many rollover-protection devices to manage. It follows that to improve rollover-protection devices to a level at which they could be effective in these relatively mild events would be to make substantial progress with a large fraction of tanker rollover accidents. However, to proceed beyond that level is to advance into a morass of highly individual events which (1) would require extraordinary effort to characterize, and (2) are probably not amenable to “standard” solutions—and even if they were, the solutions would be excessively expensive.

If the unique qualities of a crash event can be expected to influence the forces in rollover-protection devices, so too, of course, can the very design of the device itself (as well as the design of the tank on which it is mounted). Rollover-protection devices suffer the forces they do as a result of impact events. As in all impact events, the magnitude of the forces involved is related to the dissipation of kinetic energy. The moving vehicle possesses kinetic energy in proportion to its mass (M) times the square of its velocity (V). This energy must be dissipated through the action of forces (F) exerted on it during the event times distance traveled during that exertion (D). That is, in the simplest form: $FD = 1/2MV^2$. The vehicle’s mass and velocity are given for a particular event, but force and distance are influenced by design characteristics. If the vehicle and the object it strikes are nearly rigid, then the distance traveled during impact is very small and the force required to stop the vehicle in this very short distance is very large. On the other hand, if the vehicle or the object it strikes is designed to crush, then distance is increased and the required force is proportionately smaller. Thus, on modern passenger cars there are such things as energy absorbing bumpers and collapsing steering columns, and by the roadside we find various types of barriers intended to deform during a crash. Likewise, if rollover-protection devices and/or the tanks to which they are attached give way during impact, forces in the structures are reduced. Of course, the design challenge is to insure that crush takes place in a way that leaves the tank openings protected. One approach is to provide crush space in the design of the protection devices themselves, in which case forces experienced by these devices would depend mostly on their own design. But, in concept, it is also possible to mount rather rigid protection devices on top of a tank structure which, itself, provides the needed deformation. In this case, forces experienced in the devices depend more heavily on the tank design. Realistic solutions probably encompass both of these design elements.

In light of all this, this project has sought to:

- generally describe the dynamic vehicle motion conditions which prevail in tank-vehicle rollover events and to distill from that broad description simplified crash

conditions that could be used to describe performance demands for rollover-protection devices, and

- examine in a broadly applicable manner, the force-deflection characteristics required of rollover-protection devices and the tank structure if they are to meet these demands.

The first bulleted item—a broad description of rollover dynamics and related “performance requirements” for rollover-protection devices—is viewed by the authors as the primary result of the project. Regardless of whether or not these results are ever used in a regulatory scenario, they provide tank designers with a heretofore unavailable resource to aid in the development of effective rollover-protection devices.

The second element of the study is intended to provide a fundamental basis for the design of protective systems and to serve as an aid to the reader in interpreting the engineering demands implied by specified crash parameters.

DYNAMICS OF TANK-VEHICLE ROLLOVER

A broad examination of the dynamic conditions which prevail during the rollover of tank vehicles was undertaken via computer simulation. UMTRI's TruckSim computer programs, with modifications, were used as the basic simulation tool. The set of test vehicles simulated were essentially defined by the vehicles of the NTSB special report. Rollovers were elicited with turns on flat surfaces, turns involving contact with curbs and guard-rails, and evasive lane-change-like maneuvers. Severity of the maneuvers ranged from the minimum required to produce rollover to very severe maneuvering. The simulation runs were allowed to proceed until the point in time when either the vehicle tank profile contacted the ground or, in some cases, when the roll angle reached 180 degrees. The motion variables of the tank at these final impact conditions were assembled and analyzed. In the following subsections, we will briefly describe the technical elements of the simulation study and then examine the results.

VEHICLE SIMULATIONS

UMTRI's TruckSim computer simulation system formed the basis of the vehicle dynamics models used in this study [3]. TruckSim is a software package for predicting braking, steering, and roll behavior of heavy trucks and combination vehicles. It combines advanced simulation models with an easy to use point-and-click interface. The vehicle models are built on over twenty years of research at UMTRI where the emphasis has been on understanding the most important factors contributing to the vehicle dynamics. TruckSim includes a "fleet" of simulation models covering single-unit and combination heavy trucks and busses. The models range in complexity from a 26-degree-of-freedom (DOF) 2-axle truck model to a 67-DOF tractor-semitrailer model. The TruckSim models have been used extensively by UMTRI in previous research for the USDOT (e.g., [4]) and are currently used by many others interested in truck dynamics. FHWA has recently acquired a version of the TruckSim models for aiding in highway design [5].

For this study, the TruckSim models were modified (1) to allow the simulations to proceed to high vehicle roll angles, (2) to include forces applied to the vehicle due to contact with curbs and guardrails, and (3) to include a description of the geometry of the tank shell, including protection devices, and identify the time of impact of the tank with the ground plane.

In traditional vehicle dynamics analyses, the investigator's interest in vehicle behavior typically ends when it is clear that the vehicle is rolling over. Consequently, simulation programs often include provision to automatically stop when a specified roll angle is passed. Such programs often take advantage of the certain knowledge that roll angles are small to make appropriate simplifications in the calculations. The TruckSim

programs used in this project were modified to allow valid calculation of very large roll angles (180 degrees of roll angle and beyond).

Rollover of heavy trucks may take place due to relatively severe maneuvering on flat road surfaces, but rollover events in the real world often involve “tripping” over curbs or “tumbling” over guard-rails. In its original form, TruckSim does not include provisions for forces imposed by curbs or guardrails. These forces were included through the addition of rather simple functions. Forces normal to the road-side object were introduced using a spring-like function of contact interference, and forces tangential to the object were included as a friction force. Interference was determined by tracking the position of specified points on the vehicle relative to a defined arc on the ground plane. Location of the interference points on the vehicle (i.e., low on the tires, or higher up on unsprung and sprung masses) determined whether the arc represented a curb or a guard-rail.

Finally a matrix of points fixed in the vehicle’s sprung mass was added to the simulation. The position of these points in the vehicle coordinate system represented the outline of the tank shell. The programs tracked the position of the points in the earth coordinate system during the simulated runs. Decent of any point on the tank to the ground plane indicates the occurrence of a “strike” of the tank and the end of the simulation run. (In some cases, simulations were allowed to proceed further on the assumption of a downward-sloped road-side surface.)

SIMULATED VEHICLES

The descriptions of the simulated vehicles were derived from the seven vehicles reported on in the NTSB special report [2]. In simplified outline, the simulated vehicles were

- a three-axle unit truck like the gasoline delivery truck of the Bronx, New York accident (figure 1),
- a two-axle unit truck like the fuel-oil delivery truck of the Hamilton, Ontario accident (figure 2),
- a five-axle tractor semitrailer combination like the vehicle of the Albuquerque, New Mexico accident, that is, with relatively low-volume, round-profile tank intended for high-density liquids (hydrochloric acid in the accident) (figure 3),
- a five-axle tractor semitrailer combination like the vehicle of the Columbus, Ohio accident, that is, having oval-profile tanks nominally intended for petroleum products (figure 4),
- a five-axle tractor semitrailer combination like the vehicle of the Lantana, Florida accident, that is, having oval-profile tanks nominally intended for petroleum products (figure 5).



Figure 1. Photo of a truck similar to that of the Bronx accident



Figure 2. Line drawing of the Hamilton accident vehicle with photo of the tank

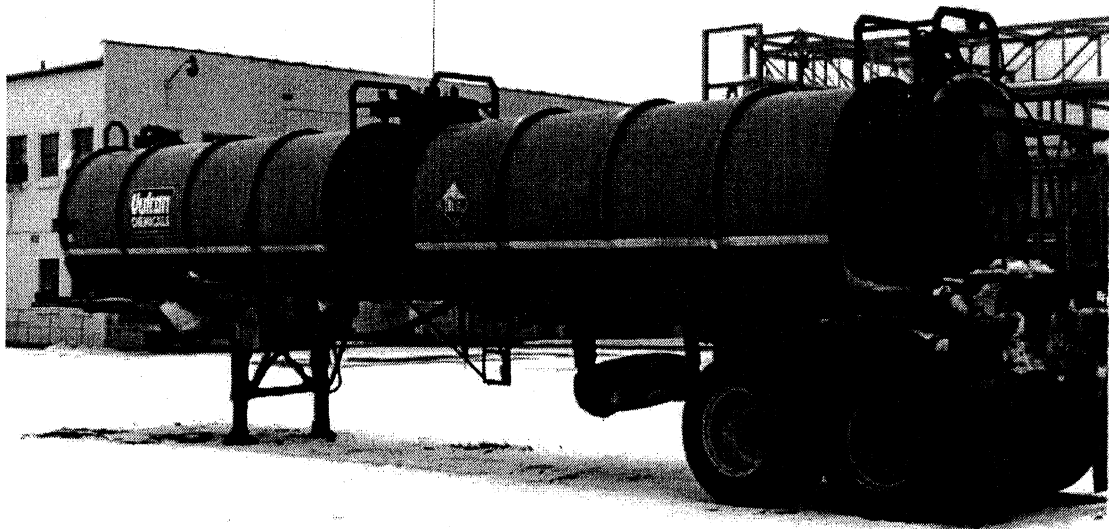

Figure 3. Photo of a semitrailer similar to that of the Albuquerque accident

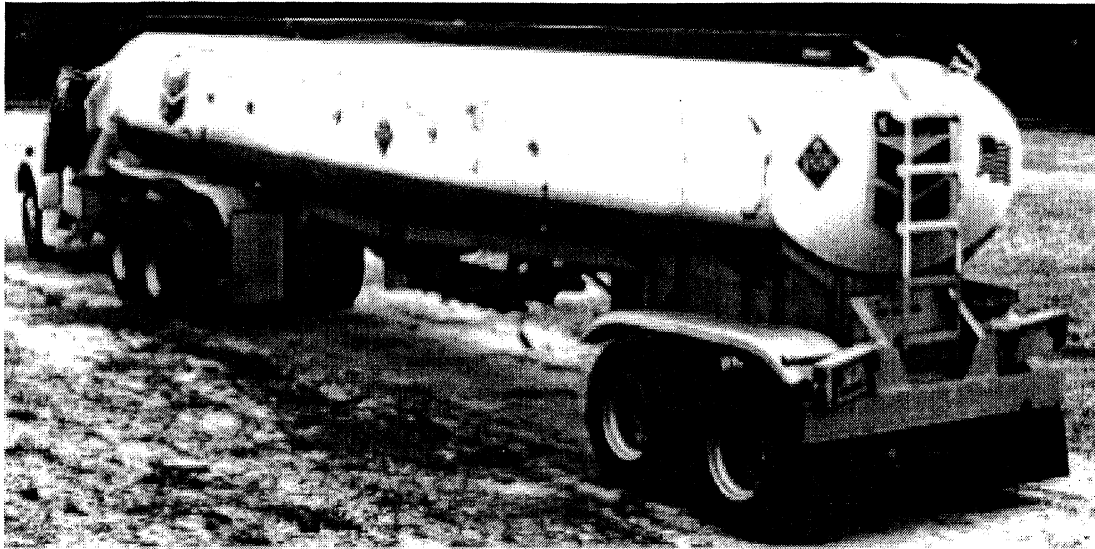

Figure 4. Photo of the vehicle from the Columbus accident



Figure 5. Photo of the vehicle from the Lantana accident

The latter two vehicles differ primarily in cross-sectional geometry of the tank, the trailer of the Columbus vehicle being a longer lower design than that of Lantana. The vehicles of the other two accidents (Edenton, North Carolina and Ethelsville, Alabama) were very similar tankers hauling petroleum products.

The truck from the Bronx accident was simulated as carrying a full load of gasoline (6.1 lb/gal), and the Hamilton truck as having a full load of fuel oil (8.0 lb/gal). The Albuquerque semi was simulated as filled with hydrochloric acid (9.8 lb/gal). Each of the other two semitrailers were simulated with two full loads, one of gasoline and one of fuel oil. With payload differences, there were then seven test vehicles.

The geometric properties of the vehicles were taken from the design drawings available from the NTSB investigation file. Tire and suspension properties were "typical" as derived from UMTRI's library data files.

In developing the parameter sets describing these vehicles, mass, center of gravity location, and inertial properties were derived from a combination of the cargo type, tank volume, vehicle weight data available in the NTSB file, and UMTRI's understanding of the tare properties of truck, tractor, and trailer chassis. Distributions of cargo as implied by the tank geometry were used to determine payload moments of inertia. Also in regard to mass properties, note that the TruckSim programs do not have special capabilities to simulate liquid loads, but in large part liquid motion is not at issue for full loads. The exception is in regards to the roll moment of inertia of the payload. The general

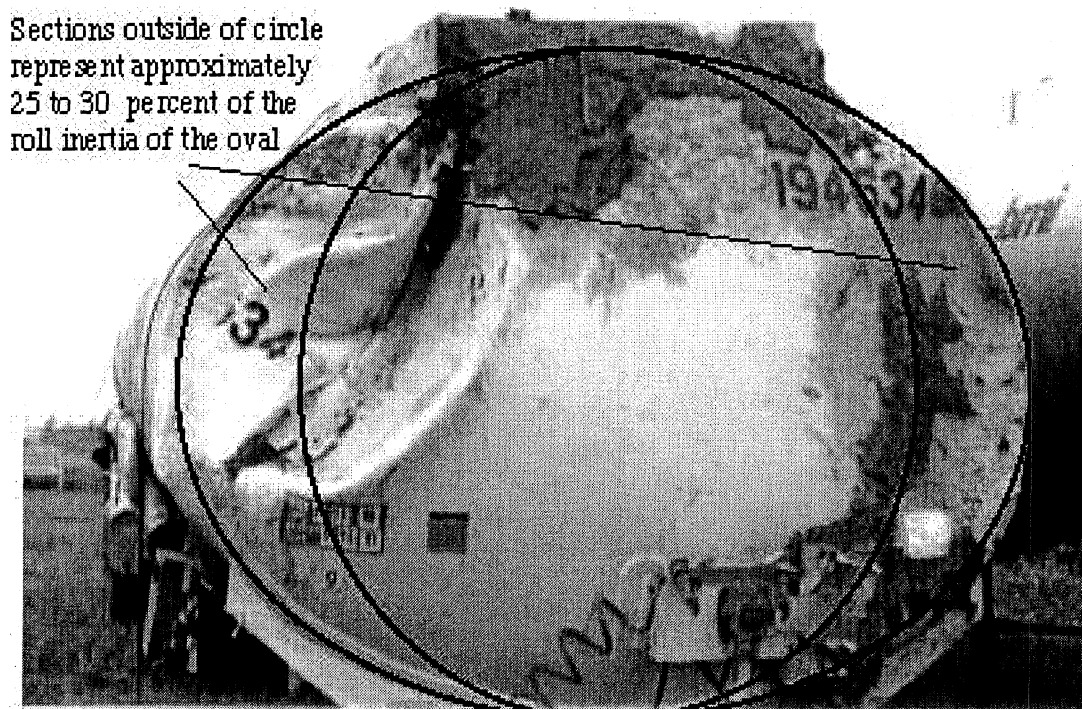

Figure 6. Estimating the roll moment of inertia of the liquid load

cylindrical shape of the tanks and the absence of longitudinal baffles implies that much of the cargo mass does not rotate in roll along with the tank shell. To account for this, roll moments of inertia were represented as a fraction of the inertia which would result from a solid load of the same geometry and density. Two values believed to span the range of reasonable representations were used. For the oval tanks, values equal to 25 percent and 50 percent of the rigid-material values were used. (Twenty-five percent was identified as a minimum estimate for the case of an elliptical tank as shown in figure 6.) For a tank of circular cross section, 10 percent and 50 percent were the values used.

More detailed parametric descriptions of the simulated vehicles appear in appendix A.

SIMULATED MANEUVERS

Each test vehicle was run through some 126 simulated maneuvers. Rollover occurred in the majority of these runs but not in all since some maneuvers were designed to search out a minimum condition for rollover. Many maneuvers were conducted on a flat surface. Other maneuvers had the vehicle “tripping” over a raised curb or a guardrail. Some maneuvers were executed in a closed-loop manner with the vehicle attempting to follow a predefined, constant-radius turn. Other maneuvers were open-loop, that is, using a predefined steering time-history. A brief description of each type of maneuver follows. Sketches showing the geometry of some of the maneuvers appear in figures 7 and 8.

Intersection turn (I-turn)

The intersection turn is a closed-loop maneuver in which the vehicle attempts to follow a 100-foot radius curve. The maneuver was conducted at speeds of 20, 23, 25, 27, 40, and 55 miles per hour. The approach and the accident landing area were level and flat. Runs at lower speeds were intended to search out a minimum rollover condition. The

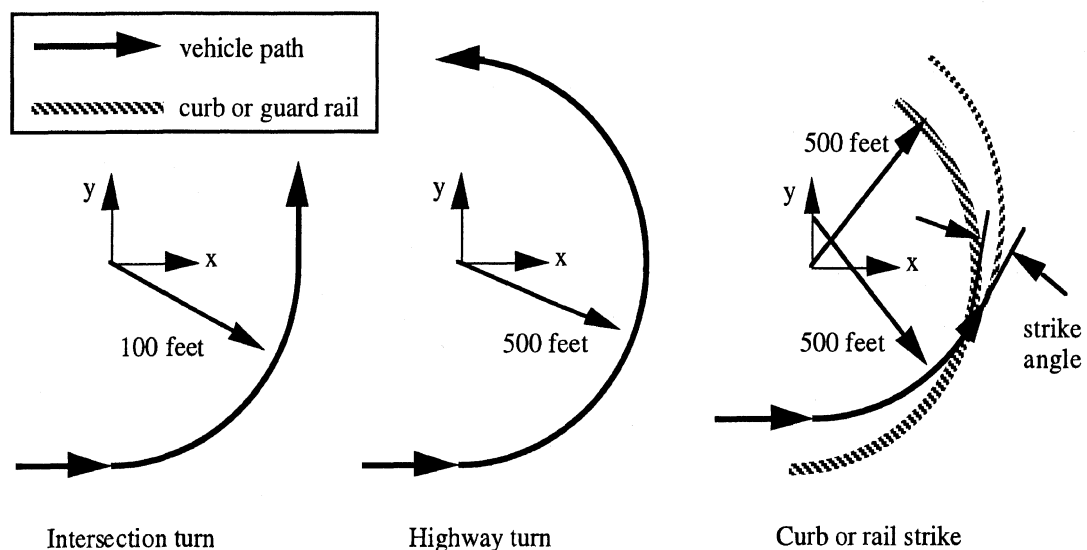

Figure 7. Closed-loop simulated maneuvers

maneuvers at higher speeds were meant to represent a surprise, avoidance maneuver.

Highway or exit-ramp turn (H-turn)

The highway turn is a closed-loop maneuver in which the vehicle attempts to follow a 500-foot radius curve. The maneuver was conducted at speeds of 50, 55, 60 and 70 miles per hour. The approach and the accident landing area were level and flat. The maneuver was intended to represent rollover due to excessive speed in highway or exit-ramp turns.

Curb-strike and rail-strike maneuvers (trip and rail)

These maneuvers are adaptations of the highway turn in which the vehicle strikes either a six-inch curb or a guardrail—a vertical surface from 16 to 36 inches above the ground. The object struck is also arranged on a 500-foot radius arc but the path of the vehicle has been offset to result in a specific angle of impact with the object. These maneuvers were conducted at 35, 40, 45, 50, and 55 miles per hour and with impact angles of 5, 10, 20, and 30 degrees. In most cases the surface landing area was flat and level. Two additional maneuvers were conducted, however, in which the landing area was assumed to lie outside the curb and to fall down and away from the road surface. In these maneuvers, the rollover event was precipitated just as in the trip maneuvers using 20 and 30-degree curb-strike angles and a forward speed of 45 miles per hour. However, the vehicle was allowed to roll up to 180 degrees regardless of vertical position of the tank. These maneuvers are designated as *trip-fall* maneuvers.

Spiral turn (spiral)

The spiral turn is an open-loop maneuver in which the steering-wheel angle is slowly increased (at a rate of 2 deg/sec) in order to elicit a quasi-steady-state rollover of the vehicle. The maneuver was conducted at 40 miles per hour and was intended to produce a minimum-severity rollover for this speed range. The approach and the landing area were level and flat.

High-speed avoidance maneuver (swerve)

The high-speed avoidance maneuver is an open-loop maneuver simulating a severe lane change. The maneuver begins with a turn to the right which is not sufficient to rollover the vehicle but does initiate rolling motion. This is followed by a strong correction to the left which results in rollover. The maneuver was conducted at 50 miles per hour. The approach and the landing area were level and flat. The maneuver is intended to elicit higher levels of roll rate than do the other flat-surface maneuvers.

Step-turns (step)

The step turn is an open-loop maneuver in which the steering wheel is displaced very rapidly (i.e., within an interval of 0.2 seconds) from the straight-ahead position to a

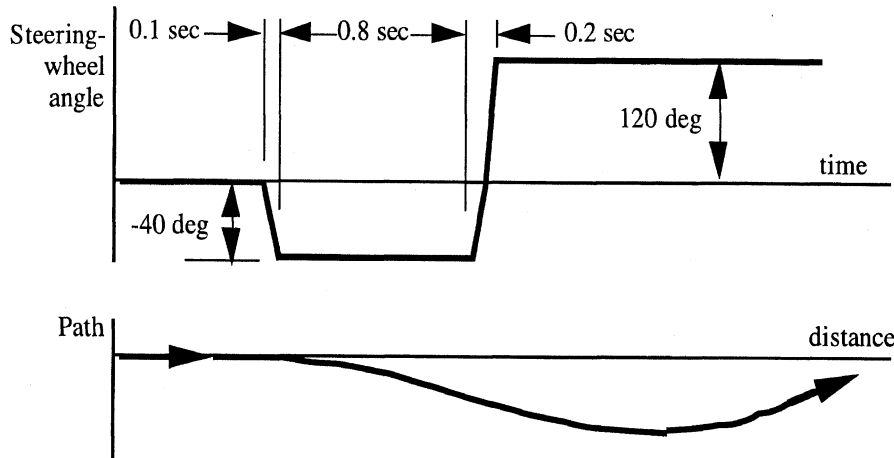

Figure 8. The open-loop high-speed avoidance maneuver

predefined angle and then is held fixed. The maneuver was conducted with steering-wheel angles and speeds as follows: 80 degrees at 45, 60 and 70 miles per hour; 100 degrees at 35, 50, and 65 miles per hour, 120 degrees at 30, 45, and 60 miles per hour. The approaches and the landing areas were level and flat. These maneuvers were conducted essentially to insure that the simulation matrix included maneuvers with steering inputs of the highest possible frequency content.

RESULTS FROM THE VEHICLE-DYNAMICS SIMULATION RUNS

A compilation of results from all the vehicle dynamics simulation runs is presented in appendix B. This section will explain the data presentation of appendix B using table 1 as an example. A discussion of the analysis of these data follows in the next section.

The first six columns of table 1 identify the simulation run. Column 1 presents the run number for the vehicle. Column 2 identifies the test vehicle, including the roll inertia factor. Column 3 gives the maneuver type per the previous discussion. Column 4 gives the vehicle's forward speed. For runs involving impact with curbs or guardrails, column 5 presents the angle at which the vehicle strikes the object. For runs in which the vehicle follows a prescribed path, the radius of the curve is given in column 6.

The remainder of the table presents results of the run in terms of the conditions which prevail at its completion. *Completion* is nominally defined as the first moment at which the tank strikes the ground. In some cases the vehicle does not rollover, in which case the run simply times out. In others, the ground is assumed to slope down and away beside the road, in which case the run is allowed to proceed to high roll angle even though some points on the tank may have penetrated the nominal ground plane.

Before describing the content of the individual columns, we will define some related terminology. The axis systems and angles referred to are in accordance to ISO definitions and nomenclature [6]. The axes systems are right-hand orthogonal. The earth axes (X_E ,

Table 1. Example of results from the simulation study: semitrailer of the Albuquerque vehicle

Vehicle Run & inertia no.	Run Type	Strike			Conditions at end of run:			Angular rate [deg/sec]			CG hgt			CG velocity [ft/sec]			Strike pt velocity [ft/sec]			Path change [deg]			Vn/Vi	
		Speed [mph]	angle [deg]	radius [ft]	Roll-over	Angular position [deg]	Pitch	Yaw	Roll	Pitch	Yaw	Z [ft]	X	Y	Z	X	Y	Z	Curb	Path	Angle of V [deg]	Yaw [deg]		Vn [ft/sec]
43	Alb10 Rail	45	10	500	yes	106.9	-0.5	32.5	138.8	20.7	-7.0	2.7	62.0	-15.6	-17.2	63.4	-15.5	-26.3	8.4	-1.6	8.4	5.7	9.3	0.14
44	Alb10 Rail	50	10	500	on flat	97.8	0.1	-6.9	105.9	11.3	-3.8	2.3	73.1	-13.0	-17.6	73.0	-4.1	-18.6	16.7	6.7	16.7	-6.6	21.3	0.29
45	Alb10 Rail	55	10	500	on flat	97.5	0.1	-5.2	109.1	11.3	-3.7	2.4	72.8	-13.0	-17.6	72.7	-4.0	-18.6	16.8	6.8	16.8	-6.6	21.3	0.26
46	Alb50 Rail	35	10	500	no	2.0	0.0	62.1	0.1	0.2	5.9	6.9	51.2	0.7	0.0	58.9	-6.2	-28.8	0.0	-10.0	0.0	-0.7	0.0	0.00
47	Alb50 Rail	40	10	500	yes	107.9	-3.9	32.7	176.2	22.7	12.5	3.8	55.8	-8.5	-12.8	62.4	-4.5	-17.3	6.3	-3.7	6.3	2.4	6.2	0.11
48	Alb50 Rail	45	10	500	yes	98.4	1.1	29.3	110.3	10.0	-2.3	2.7	62.4	-13.0	-16.8	62.4	-4.5	-17.3	9.5	-0.5	9.5	2.2	10.6	0.16
49	Alb50 Rail	50	10	500	on flat	97.4	0.1	-7.0	106.1	11.3	-3.5	2.4	73.1	-12.9	-17.6	73.0	-4.1	-18.5	16.6	6.6	16.6	-6.6	21.2	0.29
50	Alb50 Rail	55	10	500	on flat	97.3	0.2	-5.5	105.2	11.5	-3.5	2.4	72.8	-13.0	-17.5	72.8	-4.0	-18.5	16.7	6.7	16.7	-6.6	21.3	0.26
51	Alb10 Rail	35	20	500	yes	103.6	-4.2	39.2	121.0	32.6	-2.1	3.6	44.2	-18.7	-16.1	47.4	-22.1	-27.7	13.8	-6.2	13.8	9.2	11.4	0.22
52	Alb10 Rail	40	20	500	yes	100.0	-0.6	44.3	30.6	27.1	13.1	2.5	52.7	-28.7	-18.4	53.5	-31.4	-23.6	13.9	-6.1	13.9	14.7	14.4	0.25
53	Alb10 Rail	45	20	500	yes	122.0	5.1	44.3	227.4	33.3	-42.3	4.3	57.9	-31.9	-11.6	58.6	-8.4	-25.5	13.5	-6.5	13.5	15.4	15.4	0.23
54	Alb10 Rail	50	20	500	on flat	97.8	0.1	-6.9	105.9	11.3	-3.8	2.3	73.1	-13.0	-17.6	73.0	-4.1	-18.6	26.7	6.7	26.7	-16.6	33.3	0.45
55	Alb10 Rail	55	20	500	on flat	97.5	0.1	-5.2	109.1	11.3	-3.7	2.4	72.8	-13.0	-17.6	72.7	-4.0	-18.6	26.8	6.8	26.8	-16.6	33.3	0.41
56	Alb50 Rail	35	20	500	yes	107.5	-3.2	39.5	136.7	31.9	-6.3	3.6	44.2	-18.4	-16.2	47.1	-20.5	-27.7	13.2	-6.8	13.2	9.4	11.0	0.21
57	Alb50 Rail	40	20	500	yes	99.7	-1.0	42.2	-26.9	10.7	29.0	2.6	58.4	-25.7	-18.5	59.8	-24.7	-27.6	11.4	-8.6	11.4	12.3	12.6	0.22
58	Alb50 Rail	45	20	500	yes	123.5	5.4	44.4	277.9	26.4	-47.6	4.5	58.4	-31.0	-10.6	58.2	-6.6	-28.5	12.6	-7.4	12.6	15.4	14.4	0.22
59	Alb50 Rail	50	20	500	on flat	97.4	0.1	-7.0	106.1	11.3	-3.5	2.4	73.1	-12.9	-17.6	73.0	-4.1	-18.5	26.6	6.6	26.6	-16.6	33.3	0.45
60	Alb50 Rail	55	20	500	on flat	97.3	0.2	-5.5	105.2	11.5	-3.5	2.4	72.8	-13.0	-17.5	72.8	-4.0	-18.5	26.7	6.7	26.7	-16.6	33.3	0.41
61	Alb10 I-turn	25		100	yes	97.9	-0.1	57.5	103.3	26.8	-5.5	2.4	33.1	-10.8	-17.6	33.1	-14.4	-17.3	20.6	20.6	20.6	-2.5	12.2	0.33
62	Alb10 I-turn	40		100	yes	110.3	-0.2	36.7	137.7	34.7	-12.9	2.9	53.4	-21.0	-17.1	55.7	-25.1	-25.0	30.5	30.5	30.5	-9.0	29.1	0.50
63	Alb10 I-turn	55		100	yes	118.8	0.1	31.8	162.8	34.8	-19.6	3.3	73.5	-29.5	-16.2	75.6	-31.9	-25.0	35.9	35.9	35.9	-14.1	46.4	0.58
64	Alb10 H-turn	55		500	yes	104.6	-0.5	30.1	127.2	20.1	-5.0	2.6	77.0	-21.3	-17.4	78.4	-21.9	-26.3	9.4	9.4	9.4	6.1	13.1	0.16
65	Alb10 H-turn	60		500	yes	108.3	-0.1	28.5	130.6	22.0	-7.6	2.7	83.7	-24.5	-17.2	85.2	-24.8	-26.2	10.7	10.7	10.7	5.6	16.2	0.18
66	Alb10 H-turn	70		500	yes	113.2	0.2	26.8	149.7	24.2	-11.4	2.9	97.3	-30.6	-16.9	98.8	-30.5	-25.9	12.6	12.6	12.6	4.8	22.3	0.22
67	Alb10 80 stp	45			yes	109.1	0.0	32.2	136.0	28.5	-10.4	2.7	61.5	-21.4	-17.2	63.3	-23.7	-26.0						
68	Alb10 80 stp	60			yes	114.9	-0.1	28.3	153.0	29.4	-14.0	3.1	82.1	-29.5	-16.6	84.0	-30.7	-25.6						
69	Alb10 80 stp	75			yes	119.5	0.0	26.7	168.0	30.1	-17.3	3.3	102.6	-37.7	-16.1	104.4	-37.9	-25.2						
70	Alb10 100 stp	35			yes	104.2	-0.3	38.0	120.3	29.5	-7.4	2.5	47.3	-16.8	-17.6	49.4	-20.6	-26.0						
71	Alb10 100 stp	50			yes	112.7	-0.1	30.7	145.4	31.3	-13.3	3.0	67.8	-25.4	-16.8	69.9	-27.8	-25.8						
72	Alb10 100 stp	65			yes	118.7	0.0	28.6	162.3	32.2	-17.9	3.3	88.1	-34.1	-16.2	90.1	-35.3	-25.2						
73	Alb10 120 stp	30			yes	99.9	-0.6	42.6	106.8	30.5	-4.6	2.5	40.2	-14.4	-17.5	40.2	-19.0	-17.7						
74	Alb10 120 stp	45			yes	111.3	-0.1	32.3	135.7	33.0	-13.0	2.9	60.6	-23.5	-17.0	62.8	-26.8	-25.8						
75	Alb10 120 stp	60			yes	118.9	0.0	29.9	160.1	34.0	-19.1	3.3	80.7	-32.5	-16.2	82.7	-34.5	-25.1						
76	Alb10 Spiral	40			yes	104.0	-0.4	57.2	122.3	25.0	-6.3	2.5	55.0	-17.5	-17.6	56.7	-19.9	-25.9	20.5	20.5	20.5	-2.5	12.2	0.33
77	Alb50 I-turn	25		100	yes	97.9	-0.1	57.9	108.3	26.7	-5.8	2.3	33.1	-10.7	-17.6	33.1	-14.4	-17.2	30.6	30.6	30.6	-8.9	29.1	0.50
78	Alb50 I-turn	40		100	yes	109.8	-0.2	37.1	131.1	34.8	-12.3	2.8	53.2	-21.1	-17.1	55.6	-25.5	-25.8	36.2	36.2	36.2	-14.1	46.7	0.58
79	Alb50 I-turn	55		100	yes	117.6	-0.1	32.2	154.6	35.2	-18.4	3.3	73.3	-29.8	-16.3	75.5	-32.7	-25.0	36.2	36.2	36.2	-14.1	46.7	0.58
80	Alb50 H-turn	55		500	yes	103.9	-0.5	30.4	118.8	20.0	-4.4	2.6	76.9	-21.5	-17.5	78.4	-22.3	-26.1	9.4	9.4	9.4	6.2	13.1	0.16
81	Alb50 H-turn	60		500	yes	107.6	-0.2	28.9	133.0	22.0	-7.0	2.7	83.6	-24.7	-17.3	85.1	-25.3	-26.1	10.7	10.7	10.7	5.8	16.2	0.18
82	Alb50 H-turn	70		500	yes	112.5	0.1	27.1	140.8	24.3	-10.8	2.9	97.1	-31.0	-17.0	98.7	-31.1	-25.9	12.7	12.7	12.7	5.0	22.4	0.22
83	Alb50 80 stp	45			yes	108.6	-0.1	32.6	128.1	28.6	-9.8	2.7	61.4	-21.6	-17.3	63.3	-24.1	-25.9	20.5	20.5	20.5	-2.5	12.2	0.33
84	Alb50 80 stp	60			yes	113.9	-0.2	28.7	144.2	29.6	-13.0	3.1	82.0	-29.8	-16.6	83.9	-31.3	-25.7	30.6	30.6	30.6	-8.9	29.1	0.50

Y_E, Z_E) and the vehicle axes (X_V, Y_V, Z_V) do not appear in the table directly but are the reference axes for the roll, pitch, and yaw angles. The earth system is fixed in the earth with X_E and Y_E in the ground plane and $+Z_E$ measured upward. The vehicle system is fixed in the vehicle. With the vehicle in its initial position, the $+X_V$ direction is defined as forward, the $+Y_V$ direction is to the left, and the $+Z_V$ direction is upward. The system designated by $X, Y,$ and Z (these symbols do appear in the table) is called the *intermediate* system. The X and Y axes are in the ground plane and the Z axis is vertical. The X and Y axes move with the vehicle so that the X axis is always the projection of the X_V axis on the ground. Yaw is the angle (X_E, X) about the Z_E axis. Pitch is the angle (X, X_V) about the Y axis. Roll is the angle (Y, Y_V) about the X_V axis.

The first column of results within the section headed, "conditions at end," simply presents the qualitative result vis-a-vis rollover. That is, rollover occurred—*yes*—or it did not—*no*. A third category—*on flat*—indicates that the vehicle rolled over while still on the flat surface in a run intended to involve striking a curb or guard-rail.

The next three columns give the angular position of the tank (i.e., the orientation of the truck or of the semitrailer) at ground strike. These are followed by three columns giving the related angular rates. Next comes the height of the center of gravity above the ground and the velocity components of the center of gravity. In the X and Y directions, these are speeds over the ground forward and to the right with respect to the vehicle. In the Z direction, negative speed is speed toward the ground. The next three columns give the same components of velocity for the first point striking the ground.

The last six columns describe the orientation and motion of the vehicle at the time of ground strike. The first two of these columns give the angular deflection of the final velocity relative to the intended path and relative to the curb or rail. The final four columns give parameters oriented relative to a wall parallel to the nominal roadway. (This wall is not a fixed distance from the road, but is imagined to be located so as to contact the vehicle just as it lands.) The parameters are illustrated in figure 9. For curb- and rail-strike runs (as show in the figure), the wall is parallel to the object. For I-turn and H-turn runs which have no such object, the wall is parallel to the intended curved path. In the swerve runs, the wall runs parallel to the original straight-ahead direction of travel of the vehicle. A path is not defined, and therefore a wall is not defined, for the step-steer runs.

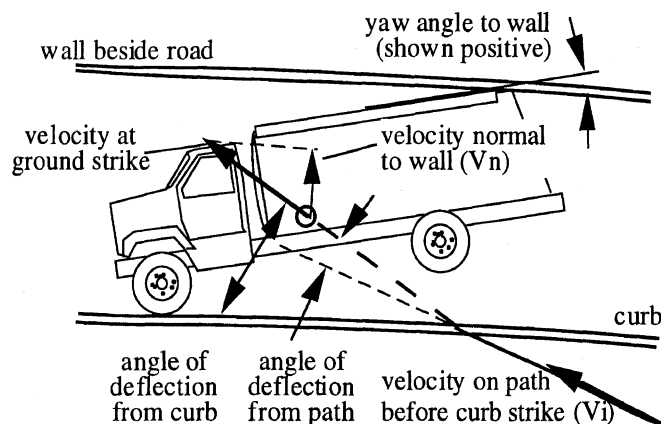

Figure 9. Plan-view of a vehicle rolled onto its side at the completion of a simulation run

The first of these four columns shows the angle of final velocity into the wall. This is followed by the yaw angle of the vehicle relative to the wall. The next column presents the component of velocity normal to the wall, and the last column repeats this value as a fraction of the initial speed of the vehicle in the maneuver.

ANALYSIS OF SIMULATION RESULTS

This section will examine the results of the simulated test program with the specific purpose of deriving a set of crash conditions which could be used to specify the performance requirements of rollover-protection devices. As indicated in the opening discussion of this report, the intention is not to be representative of *all* rollover accidents, but only of that subset composed of mild to moderate rollover events characterized by a final crash into common, simple roadside surfaces. In this analysis, these surfaces are generalized as (1) a horizontal plane representing the road and road-side ground surfaces and (2) a vertical surface parallel to the roadway representing roadside guardrails, barriers and embankments. As implied by the content of table 1, we intend to characterize the test vehicles' relationships with these surfaces at the time of impact in ways that can lead to relatively simple, minimum-performance requirements for rollover-protection devices.

The discussion will open with some qualitative observations on the nature of rollover events and will then move on to quantitative review of the simulation results. The discussion will focus largely on the rollovers of the trucks, since the motion of these single-unit vehicles are simpler than that of the tractor-semitrailer combinations. Semitrailer rollovers will be considered by way of comparison with those of trucks.

Description of sample rollover events

Table 2 summarizes the results different simulated rollovers of the Bronx and Hamilton trucks. Figures 10, 12, 14, and 16 present views taken from wire-frame animation of these simulations. The observations are made from a "camera" which remains directly behind the trucks as they rollover. Only the tank and wheels are shown in the figures to reduce clutter. In each figure, the views start at the upper left, just as the vehicle begins to rollover, and ends at the lower right as the tank strikes the ground. In each figure, the frames are evenly spaced in time, but the time step is not the same in all the figures. (In some figures, the vehicle may appear to have penetrated the ground. The vehicle is actually contacting the ground at a middle distance, but because the camera is located above the ground and the horizon is at a great distance, the parts of the vehicle appear well below the dark line of the horizon.) Figures 11,13,15, and 17 present plan views of the same four events, respectively. These figures show the path of the center of gravity and the position of the vehicle at the end of the event.

Table 2. Results from the example simulation runs of figures 10 through 19

Run no.	Vehicle & inertia factor	Run Type	Strike Speed [mph]	Strike angle [deg]	Turn radius [ft]	Roll-over	Conditions at end of run:						
							Angular position [deg]			Angular rate [deg]			CG ht. Z [ft]
							Roll	Pitch	Yaw	Roll	Pitch	Yaw	Z
116	Brx50	I-turn	27		100	yes	92.4	0.0	81.9	118.4	28.2	-0.2	3.5
63	Ham25	I-turn	55		100	yes	120.4	-2.5	42.8	167.7	45.6	-14.3	4.3
28	Brx50	Trip	45	20	500	yes	179.9	-0.2	79.5	119.2	14.5	-93.6	3.7
52	Ham25	Rail	40	20	500	yes	127.8	9.0	58.5	173.0	27.2	-29.8	4.6
124	Alb10	Trip.fall	45	20	500	yes	176.6	4.0	74.8	86.1	-3.7	-89.6	-5.8
126	Alb10	Trip.fall	45	30	500	yes	183.3	-5.0	59.7	203.3	6.2	-85.5	-0.5
23	Alb10	Trip	45	20	500	yes	126.7	1.3	44.5	160.4	44.7	-40.1	3.3
97	Alb10	Trip	45	30	500	yes	124.2	-3.3	36.4	158.0	58.9	-37.5	4.6

Run no.	Conditions at end of run (continued):						Path change relative to [deg]		Relative to wall beside curb/rail/path			
	CG velocity [ft/sec]			Strike pt velocity [ft/s]			Curb	Path	Strike [deg]	Yaw [deg]	Vn [ft/sec]	Vn/Vi
	X	Y	Z	X	Y	Z						
116	33.2	-13.6	-12.8	18.1	31.4	-14.2	17.8	17.8	17.8	4.6	11.0	0.28
63	66.8	-40.2	-10.8	68.0	-37.2	-13.9	33.6	33.6	33.6	-2.6	43.1	0.53
28	27.3	-53.1	-11.7	28.2	-56.2	-14.7	14.0	-6.0	14.0	48.8	14.5	0.22
52	43.3	-35.1	-9.4	42.7	-19.5	-9.6	10.6	-9.4	10.6	28.4	10.3	0.18
124	30.6	-53.5	-29.4				-3.9	-23.9	-3.9	64.2	-4.2	-0.06
126	37.7	-49.0	-20.3				1.7	-28.3	1.7	50.7	1.8	0.03
23	53.2	-36.0	-16.0	55.4	-43.5	-21.8	19.1	-0.9	19.1	15.0	21.0	0.32
97	55.0	-31.7	-13.3	59.0	-41.8	-22.1	20.9	-9.1	20.9	9.0	22.7	0.34

Figure 10 illustrates the Bronx vehicle as it attempts to negotiate an intersection turn at 27 miles per hour (Bronx run #116). The frames in the figure are spaced at 0.25 second intervals so that the figure spans 1.75 seconds. The vehicle just barely rolls over after it has proceeded

well into the turn—this is one of the mildest rollover events of the study. The vehicle rolls very slowly at first, just getting over the apex, and then falls onto its side picking up some rotational speed as it falls. The

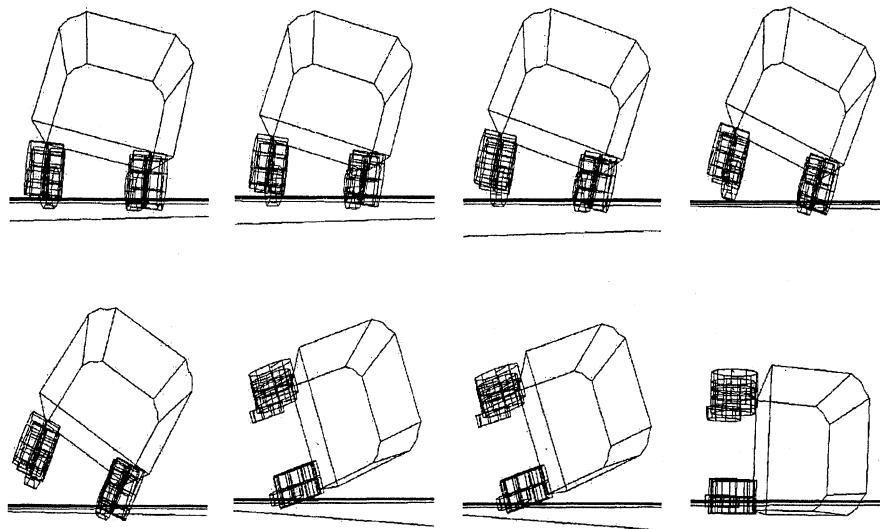

Figure 10. The Bronx vehicle in a minimal rollover (run #116, $\Delta t = 0.25$ sec)

tires on the right side barely leave the ground during the process. The vehicle has rolled to 92 degrees and has a roll rate of 96 deg/sec at the time of contact with the ground. The center of gravity is falling at 12.8 ft/sec as the tank hits. The vehicle lands flat on its side, i.e., pitch is virtually zero. Figure 11 shows that at the end of the event, the vehicle is traveling with a significant component of velocity sideways to the nominal road path. This velocity, which may be interpreted as the

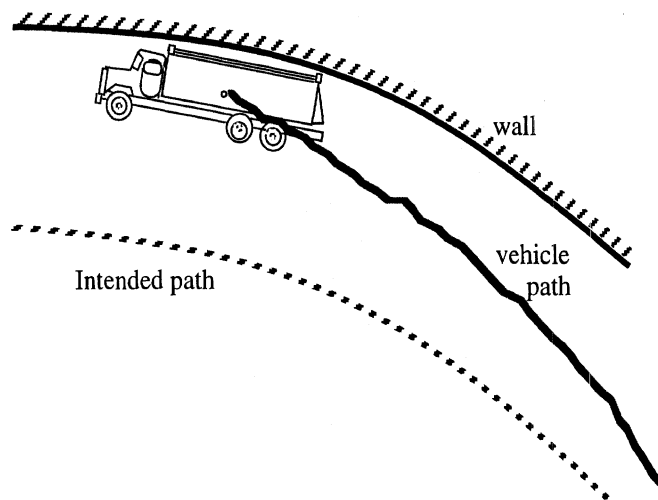

Figure 11. Plan-view sketch of the Bronx vehicle at the end of run #116

component which is normal to a hypothetical wall that is parallel to the road edge, is 11.0 ft/sec (7.5 mph) or 28 percent of the original forward speed. Speed component parallel to the wall is 34 ft/sec (23 mph). The yaw response is such that the vehicle is positioned nearly parallel to the wall. Thus, while the vehicle landed on its side on the road, it will strike the wall nearly flat against its top. All of this is fairly typical of a “minimal” rollover event.

Figure 12 illustrates the Hamilton vehicle in one of the more dramatic rollovers during a maneuver on a flat surface (Hamilton run #63). Since this event occurs more rapidly, the frames of this figure are spaced at only 0.1 second intervals. The total time

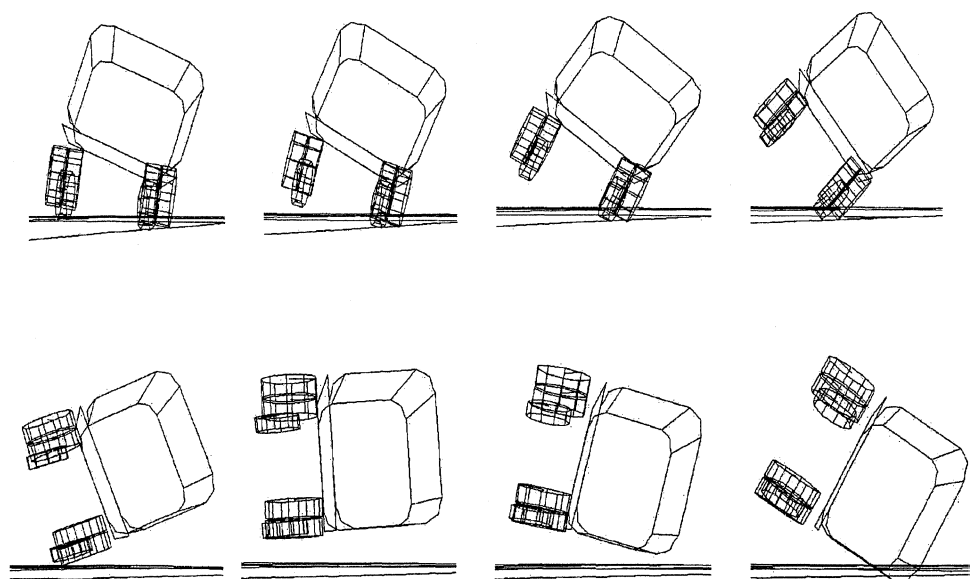

Figure 12. The Hamilton vehicle in a rapid, flat-surface rollover (run #63, $\Delta t=0.1$ sec)

span of the figure is 0.7 seconds. In this case, the vehicle is also attempting to negotiate the intersection turn but is traveling at 55 mph. As the vehicle tries to enter the turn, the rapid introduction of large tire side forces quickly produces a high rate of roll motion (about 164 deg/sec). Roll angle passes 45 degrees in less than 0.5 seconds. The vehicle "rolls faster than it falls" so that all the tires leave the ground and the vehicle becomes airborne. It continues to roll as it starts to fall towards the ground. It has rolled to 120 degrees and is still rotating at 164 deg/sec when it hits the ground. (Similar behavior has been observed in an earlier study of tanker rollover [5].) Essentially by falling from its maximum height, the center of gravity has reached a terminal downward speed of 10.8 ft/sec. Figure 13 shows the vehicle continued straight ahead rather than negotiating the turn such that, when contacting the ground, it has a velocity component toward the wall of a very substantial 43 ft/sec (29 mph) or 53 percent of its original forward speed. Again, however, the vehicle lies nearly parallel to the wall.

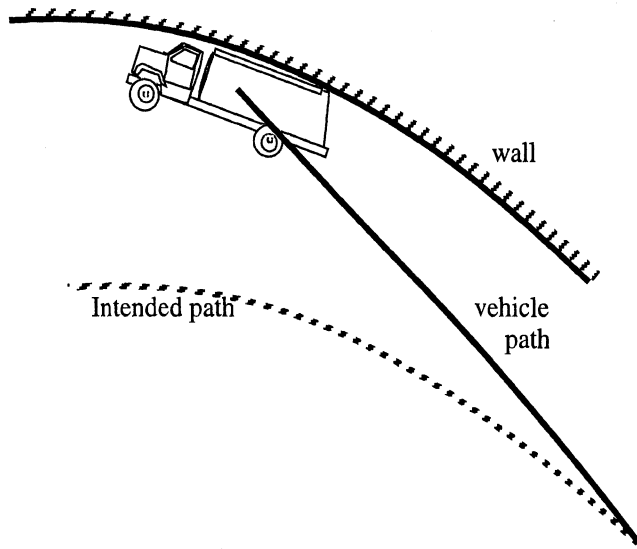

Figure 13. Plan-view sketch of the Hamilton vehicle at the end of run #63

Figure 14 illustrates the Bronx vehicle once again (Bronx run #28). The frame spacing in this figure is also 0.1 seconds with a total span of 0.7 seconds. The vehicle was following the 500-foot radius curve at 45 mph when it struck the curb at a 20-degree

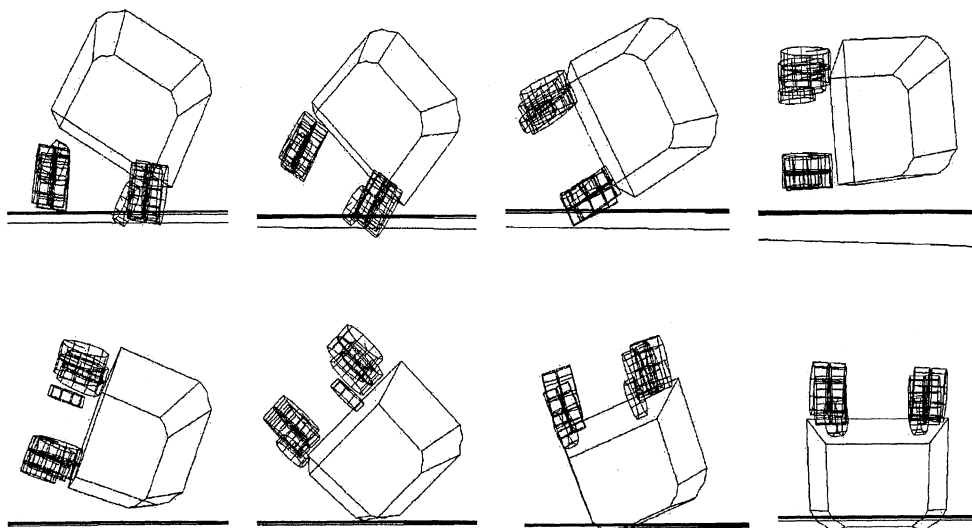

Figure 14. The Bronx vehicle rolling over after striking a curb (run #28, $\Delta t=0.1$ sec)

angle. The rollover event is much like the one of figure 11, but even more dramatic. At 45 mph on the 500-foot radius curve, the vehicle would not have rolled over on a flat surface, but it was certainly operating at an elevated level approaching rollover when it struck the curb. The impact produces a strong impulse of side forces low on the vehicle causing it to flip over very rapidly. Roll rate jumps to nearly 250 deg/sec and the vehicle has rolled to almost 180 degrees when it hits the ground. The fall has resulted in a vertical velocity of 11.7 ft/sec at the time of ground strike. Figure 15 shows that the curb strike has deflected the path of the vehicle about 6 degrees, redirecting it so that its speed toward the wall is 14.5 ft/sec (10 mph) or 22 percent of its initial speed. However, the curb strike (in which the front wheel hits the curb first and hardest) has also spun the vehicle about a vertical axis so that it is yawed nearly 50 degrees relative to the wall.

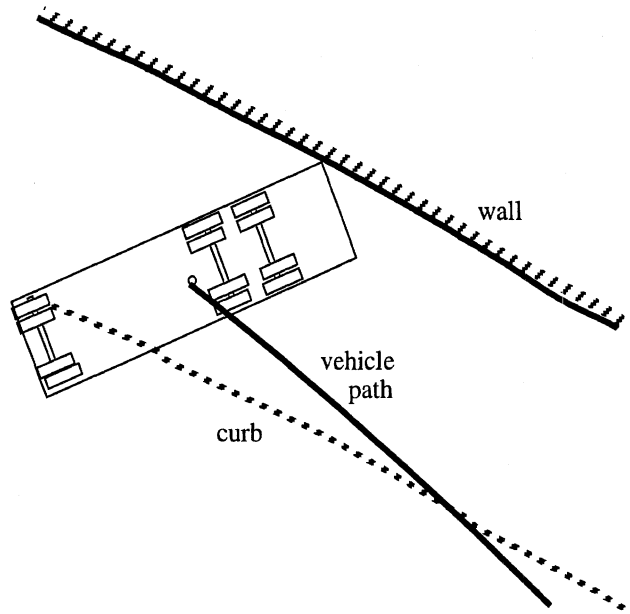

Figure 15. Plan-view sketch of the Bronx vehicle at the end of run #28

Figure 16 illustrates the Hamilton vehicle just after a 20-degree impact with the guardrail while traveling at 40 mph (Hamilton #52). Frame spacing is again 0.1 seconds. This is much like the previous run except that forces from the rail act higher up on the

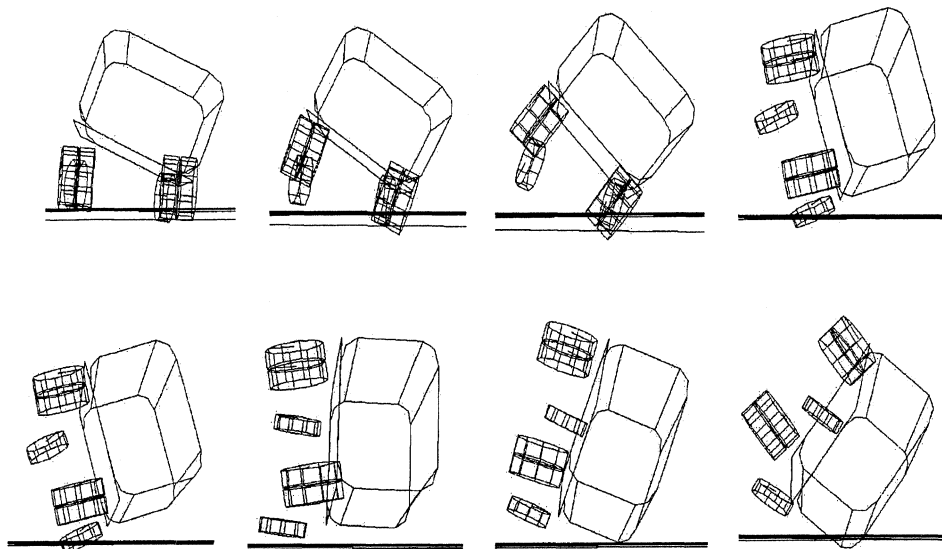

Figure 16. The Hamilton vehicle rolling over after striking a rail(run #52, $\Delta t=0.1$ sec)

vehicle and, therefore, do not generate quite so fast a roll rate as in a curb-strike. The vehicle rolls at about 185 deg/sec and strikes the ground at an intermediate roll angle of 128 degrees. Unlike the previous runs, this crash has ended with an appreciable pitch angle of 9 degrees. Referring to figure 17, the velocity of the vehicle into the ground is 9.4 ft/sec and velocity into the wall is 10.3 ft/sec (7.0 mph) or 18 percent of its original speed.

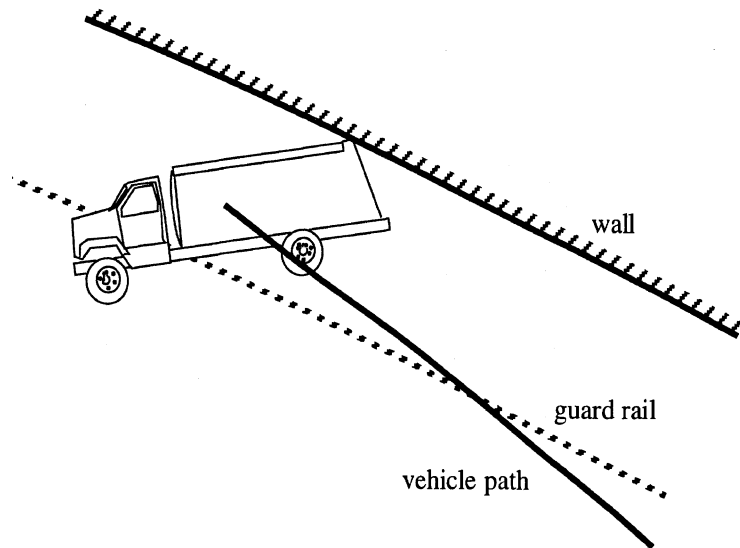

Figure 17. Plan-view sketch of the Hamilton vehicle at the end of run #52

Examination of individual rollover events of the tractor-semitrailer combinations reveals responses which are generally similar to those of the unit trucks with one rather distinct difference. Namely, rollovers caused by very severe steering or by striking a curb or rail do not generally elicit as high a roll rate or result in as large a roll angle at the moment of impact. In fact, the largest roll angle for a semitrailer as it strikes the ground was about 127 degrees (Albuquerque run #27, 20-degree curb strike at 45 mph). The articulated connection between the tractor (the unit on which the strong, initial impulse forces are generated) and the trailer (the unit wherein the large majority of the mass resides) apparently limits the ability of the system to rapidly accelerate the trailer to high roll rates. Final pitch and yaw angles of the semitrailers also tend to be smaller than those for the trucks. However, velocities across the roadway toward the parallel wall tend to be a bit higher.

The high-speed avoidance maneuver (i.e., the swerve) was included in the simulation matrix in an unsuccessful effort to elicit larger roll angles from the semitrailers. Roll angles in the range of 180 degrees were obtained by these vehicles only in the trip-fall maneuvers which were simply allowed to continue for the necessary time period (in the range of one to one and a quarter seconds) following curb strike. Two such maneuvers are illustrated in figures 18 and 19. The time interval between frames in these figures is 0.15 seconds; the figures each span 1.05 seconds. Both figures show the Albuquerque vehicle traveling at 45 mph. The vehicle strikes the curb at 20 degrees in figure 18 and at 30 degrees in figure 19. Each figure includes a side view and a plan view. From the side, the vehicle can be seen falling below the road-plane surface as it might do if the shoulder sloped down and away from the road. At the end of each maneuver, roll of the semitrailer

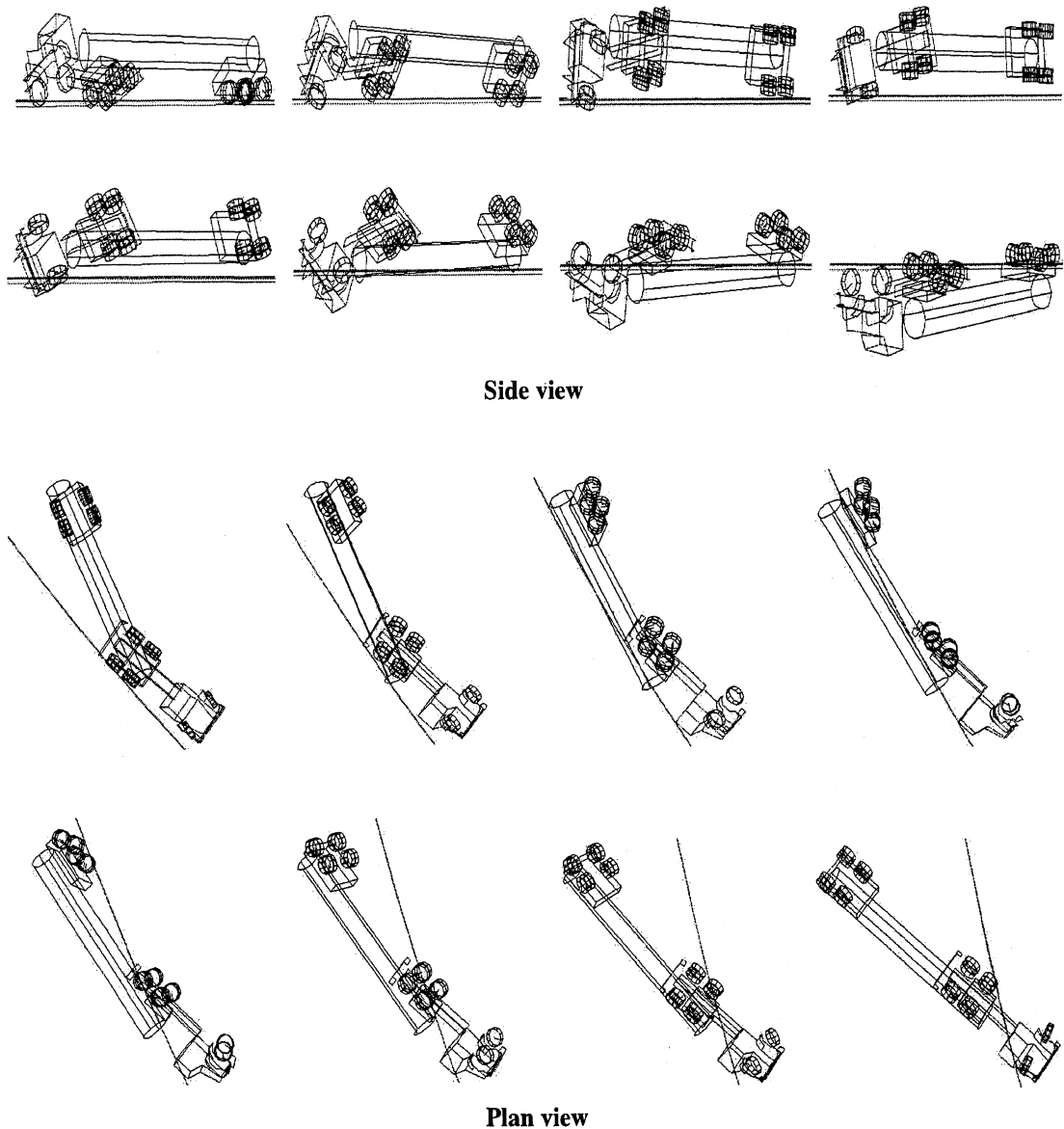
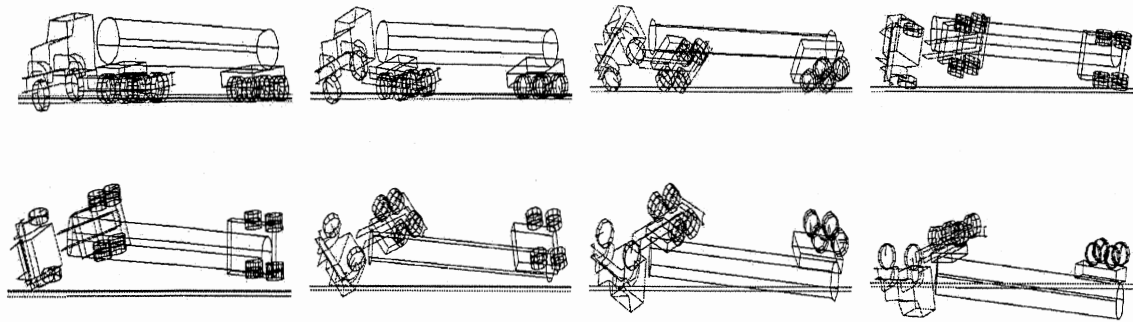
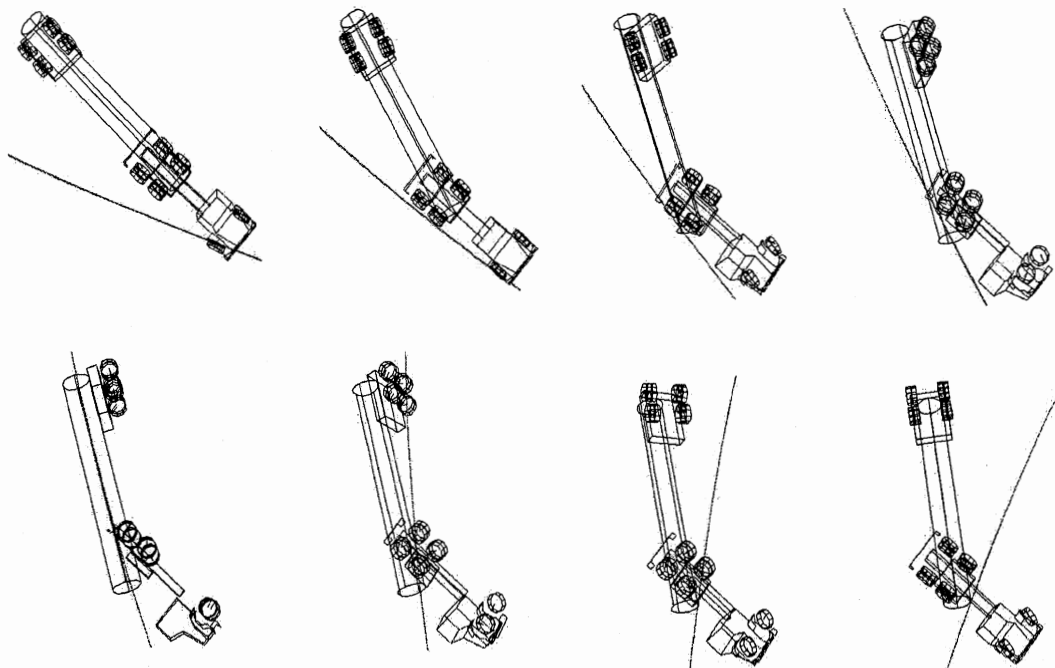

Figure 18. The Albuquerque vehicle rolling over and falling after striking a curb at 20 degrees and 45 mph (run #124)

is within ± 4 degrees of 180 degrees. At the end of the event of figure 18, the center of gravity of the semitrailer is about 6 feet below the road surface and falling at about 30 ft/sec. At the end of figure 19, the center of gravity is about 0.5 feet below the road surface and falling at 20 ft/sec. The two events also end with the tractors and the semitrailers in quite different conditions of pitch and yaw articulation. Note also that figures 18 and 19 can represent the associated trip runs of the Albuquerque vehicle (#23, 20-degree curb strike, and #97, 30-degree curb strike) except that these latter runs would end at the moment of ground strike (in the time between the sixth and seventh frames of the sequences).



Side view



Plan view

Figure 19. The Albuquerque vehicle rolling over and falling after striking a curb at 30 degrees and 45 mph (run #126)

Quantitative examination of the simulation results

The discussion of the example rollover events has highlighted the dynamic parameters which can be assumed to represent the primary demand on the performance of rollover-protection devices. These are:

- roll, pitch and yaw attitude upon ground strike, which (1) indicate whether impact with the horizontal or with the vertical reference surface is the more significant event vis-a-vis the prospect of impacting the rollover-protection devices, and (2) define the attitude of the tank as it strikes the reference surface;
- vertical velocity, the primary impact velocity normal to the horizontal surface;

- lateral velocity relative to the path, the primary impact velocity normal to the vertical surface;
- roll velocity, which may contribute to the vehicle rolling onto its top after impact.

In this subsection, the data describing the final conditions of the tank units in all of the successful simulation runs (i.e., rollover = yes in appendix B) will be reviewed to describe the ranges covered by and the relationships observed between these variables.

Final roll angle Final roll angle is the key determinant of the primary potential damage mechanisms to rollover-protection devices. When the vehicle essentially lands on its side, the mechanisms of interest are (1) the vehicle sliding sideways into a vertical surface parallel to the nominal roadway and (2) the vehicle continuing to roll onto its top. When the vehicle lands on its top, the mechanism of interest is (3) impact with the horizontal surface.

Figure 20 is a graph showing the final roll angle of each successful simulated test run.⁶ Except in the trip-fall runs, the final roll angle is the roll angle at the time the tank strikes the level ground. (In the trip-fall runs, the vehicle was allowed to fall through this plane until reaching a roll angle of approximately 180 degrees.) The runs of the two test trucks are on the left in the figure and those of the five semitrailer combinations are on the right. Roll angles greater and less than 135 degrees (the 45-degree split between 90

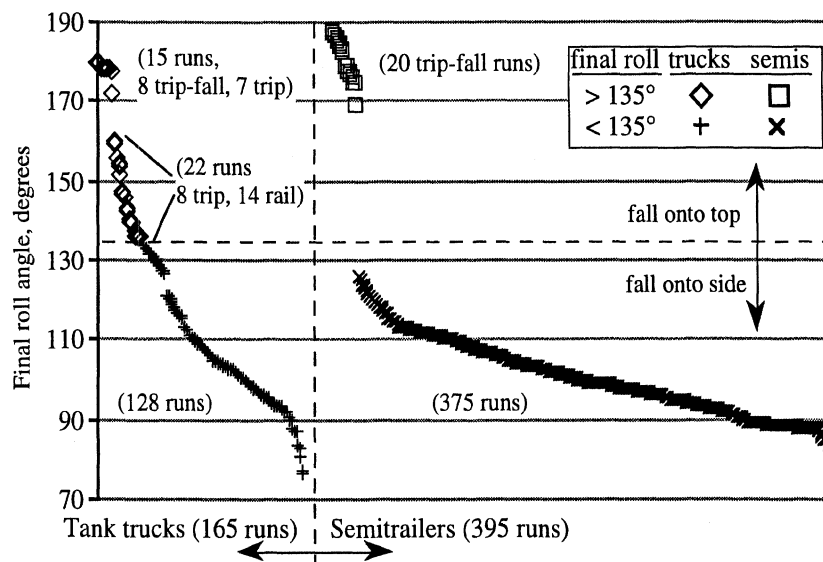

Figure 20. The final roll angle for all successful simulated test runs

⁶ Results presented in this and many of the following graphs are ordered, left to right, from the highest response value to the lowest within each vehicle category. The purpose of the format is simply to present the range of the response variable observed within each vehicle category and the relative frequency of occurrence of different values of the variable.

and 180 degrees) are separated by a horizontal dashed line. Of the 165 runs of unit trucks, twenty-two (13 percent) end with roll angles greater than 135 degrees, and fifteen (9 percent) are in the near vicinity of 180 degrees. Seven of these are from curb-trip runs, and the others are the eight trip-fall runs for the trucks. On the other hand, of the 395 runs of combination vehicles, only the twenty trip-fall runs (5 percent) result in the higher range of roll angles. (Note that these percentages relate only to the runs of this matrix. The intent of this matrix is to *span* the full range of dynamic conditions which might reasonably be expected to exist in fairly common rollover accidents, but not to represent the statistical distribution of those conditions. Thus, no inference should be taken from these values relative to the population of rollover events occurring in the real world.)

Final vertical speed Vertical speed toward the ground is of primary interest for impact with the ground plane. Figure 21 shows the final vertical speed of the centers of gravity of the tank vehicles from each of the successful simulation runs.

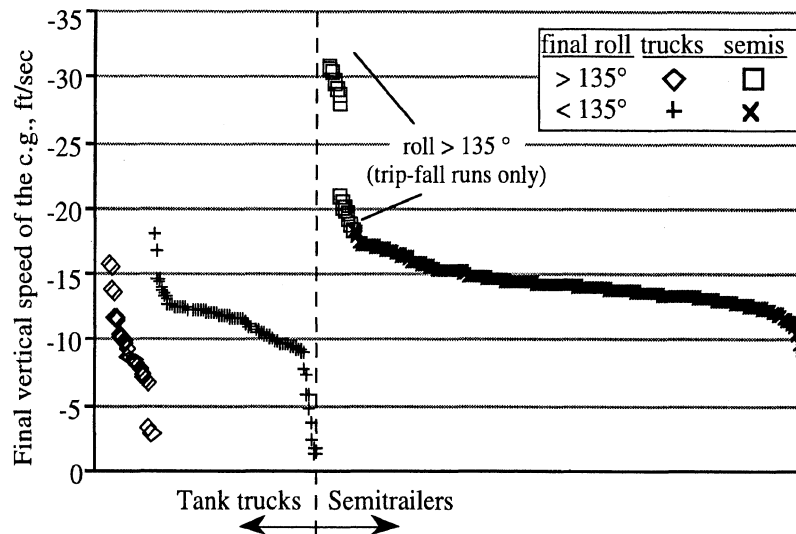

Figure 21. Final vertical speeds of the centers of gravity of the tank units

The data of figure 21 are again divided according to tanker type (trucks or semitrailers) and according to final roll angle. Final vertical speeds cover approximately the same range for each of these categories except for runs in which the semitrailers roll beyond 135 degrees. These results—in the range of -30 ft/sec—derive exclusively from the trip-fall runs in which the vehicle was allowed to fall well below the nominal road surface. Otherwise, the bulk of the data range from about -7 ft/sec to -18 ft/sec. On average, the semitrailers strike the ground faster, largely because their centers of gravity are typically higher (with the vehicle in its normal stance) than those of the trucks. A few data points fall below -7 ft/sec. In general, the lower strike velocities result from the fact that some vehicles pitch substantially during the rollover event so that one end of the tank strikes the ground (and the simulation is terminated) before the center of gravity falls substantially.

Figure 22 is presented to strengthen the point that vertical strike speed results essentially from the falling center of gravity. The figure includes a graph showing the final vertical speed from the simulations plotted against a calculated speed. This calculation is based on the simple assumption that vertical speed results purely from the fall of the center of gravity from its “apex” height, as shown on the right in figure 22, to its height at the end of the simulation. The scatter plot in figure 22 shows that the correlation between the vertical speed based on this simple assumption and the final vertical speed obtained from the simulation runs is quite strong.

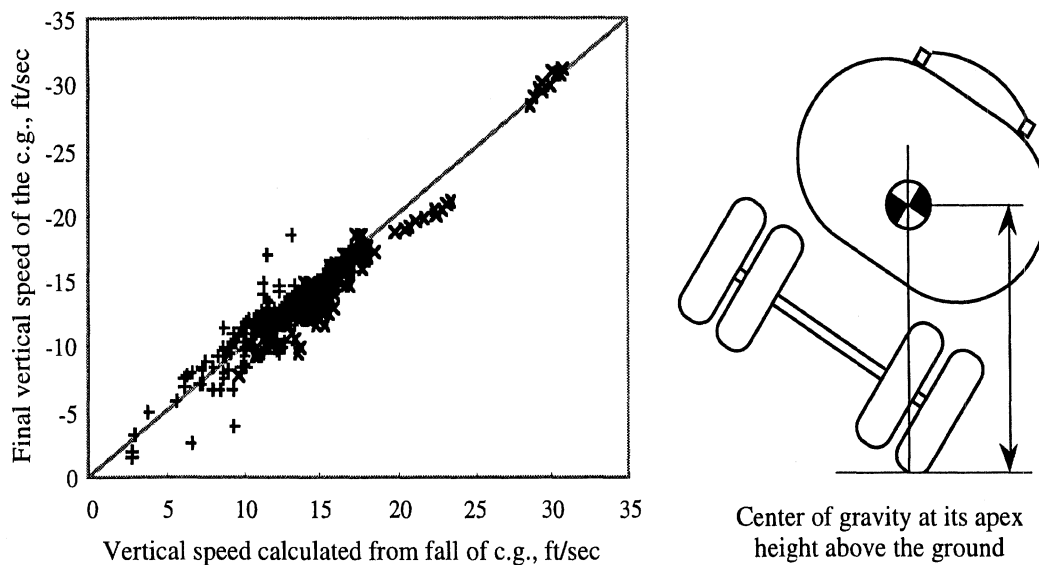

Figure 22. Comparison of final vertical speeds from the simulation and from the simple calculation based on the center of gravity falling from its apex height

Final pitch angle Final pitch angle of the tank unit plays a part in establishing the attitude of the tank upon impact with the ground and, thus, is important in establishing the distribution of loads suffered by the tank and its fittings. A pitch angle of zero implies

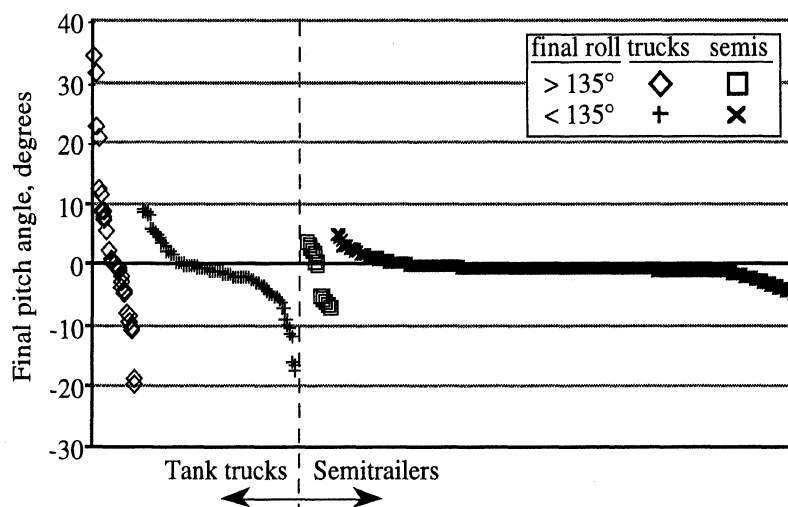

Figure 23. Final pitch angles of the tank units

that a tank rolled to 180 degrees would strike the ground flat on its top. Positive pitch implies that the front end of the tank would strike the ground first. Figure 23 shows the distribution of final pitch angles from the successful simulation runs.

The data of figure 23 show that trucks tend to strike the ground with pitch angles in the ± 10 -degree range with the majority of events favoring a negative pitch angle (i.e., rear of tank striking first). However, in a few events, this measure reaches as far as ± 20 degrees and even $+30$ degrees. These tend to be cases in which unit trucks have rolled beyond 135 degrees. Final pitch angles of the semitrailers tend to fall in the ± 5 degree range, again with a slight bias toward negative angles. Only a few events exceed this range, the greatest excursion being a pitch angle of -6.8 degrees.

Final roll rate Final roll rate is of interest because, if roll rate is sufficient, a tank which initially landed on its side may roll onto its top and engaging the rollover-protection devices. Figure 24 shows the distribution of final roll rates from the successful simulation runs.

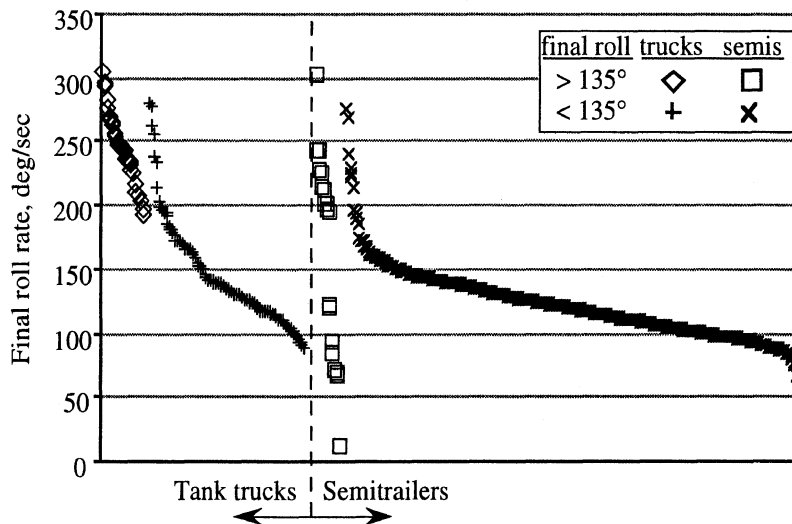

Figure 24. Final roll rates of the tank units

In the great majority of cases, final roll rates fall between 90 and 180 deg/sec. This is especially true for vehicles landing at less than 135 degrees of roll. On the other hand, final roll rates usually exceed 180 deg/sec when the vehicle lands at roll angles greater than 135 degrees. In a few cases, the complex interactions between tractor and semitrailer result in surprisingly slow roll rates at the moment of impact.

Final speed across the roadway Speed across, or lateral to, the roadway is of primary importance with respect to impact with a vertical surface parallel to the roadway. Figure 25 shows the distribution of a normalized version of this speed at the moment the tank strikes the ground. Normalization has been accomplished by dividing the lateral speed by the initial forward speed of the vehicle in the maneuver.

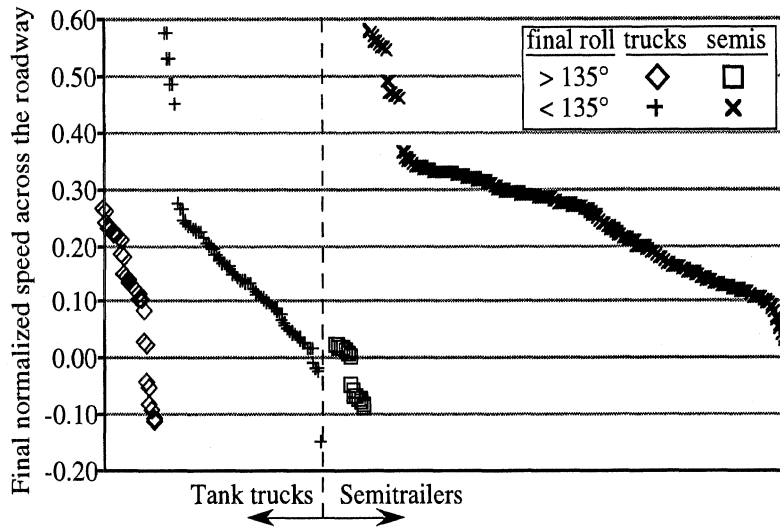

Figure 25. Final speed of the tank units across the roadway

Figure 25 shows that the large majority of events involving unit trucks ended with a speed across the roadway in the range of 0 to 30 percent of the initial forward speed, and the majority of events involving semitrailers ended with the value of this parameter between 0 and 40 percent. The handful of data points which lie between 0.40 and 0.60 on the graph all derive from intersection turns conducted at higher speeds. In these maneuvers the vehicle rolls rapidly and essentially continues straight ahead instead of negotiating the 100-foot radius turn.

Figure 26 presents the same data as shown in figure 25. In this figure, the points have been ordered left to right by vehicle type and final roll angle as before, but then also by maneuver type. Trip and rail maneuvers are further ordered by increasing strike angle,

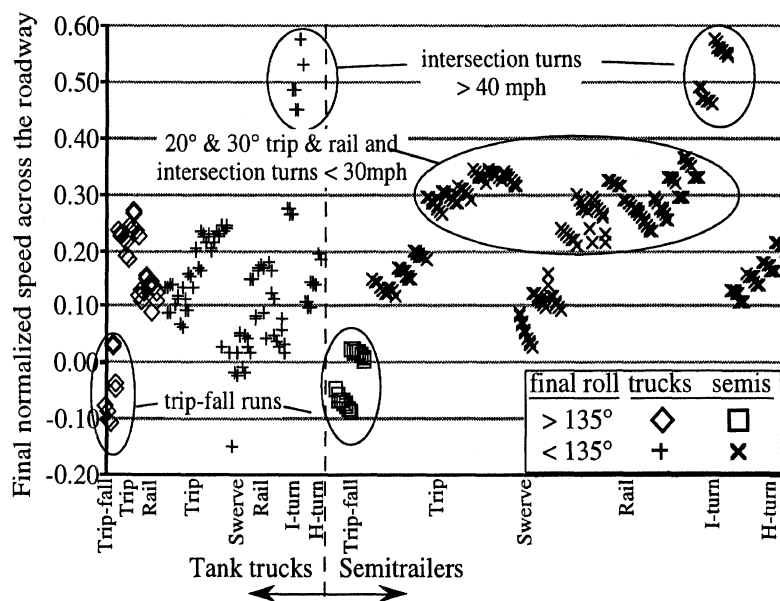

Figure 26. Final speed of the tank units across the roadway grouped by maneuver

reading from left to right. Maneuver type has been shown on the horizontal axis, and the exceptional clusters of data points (both high and low) have been labeled to identify the maneuver types from whence they derive.

Figure 26 shows that the highest normalized lateral speeds occur in the high speed intersection turns of either unit trucks or combination vehicles. The 20-degree and 30-degree curb- and rail-strike runs of combination vehicles account for most of the remaining higher values. Apparently, curbs and rails are not as effective at redirecting the semitrailer back toward the roadway as they are for the unit truck. Within each maneuver type, the data are further ordered by initial speed. The slope upward toward the right within some groups of data points shows a tendency for this measure to increase with forward speed in those maneuvers.

Final yaw angle The yaw angle of the tank unit is important in establishing the loads it experiences during impact with a vertical surface. (A relative yaw angle of zero implies that a tank rolled to 90 degrees would strike the wall flat against its top. Positive yaw implies that the rear end of the tank would strike the wall first.) Figure 27 shows the distribution of final yaw angles relative to a vertical surface running parallel to the nominal roadway path.

The figure shows that the final yaw angle lies between ± 20 degrees for virtually all semitrailers landing on their side, but ranges from -10 degrees to $+ 50$ degrees for trucks landing on their side. When roll angle has gone beyond 135 degrees, yaw also tends to be large, and the unit trucks again exhibit a much larger range.

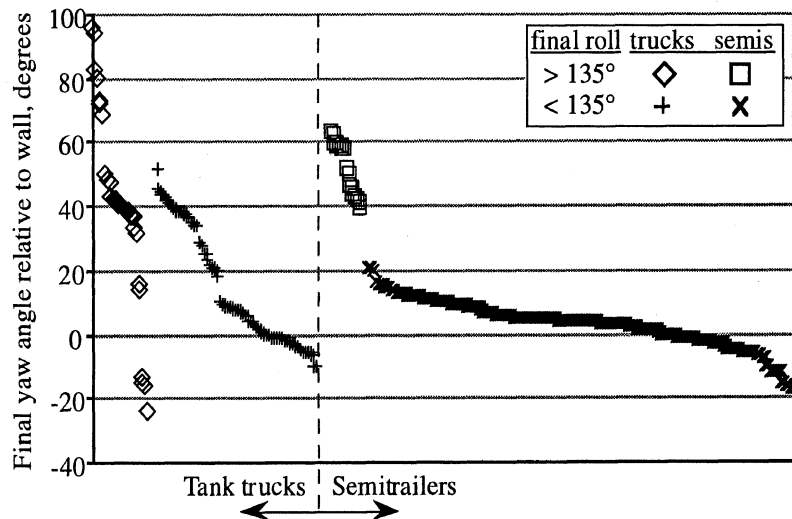

Figure 27. Final yaw angle of the tank units relative to a vertical surface parallel to the road

IMPLICATIONS OF THE RESULTS FOR MINIMUM PERFORMANCE REQUIREMENTS FOR ROLLOVER-PROTECTION DEVICES

This research study was undertaken largely because the NTSB, in its 1992 *Special Investigation Report* "Cargo Tank Rollover," implied that many so-called rollover-protection devices in place today may be ineffectual and stated further that "insufficient guidance...[exists] about the factors and assumptions that a cargo tank manufacturer must consider when calculating loads on the rollover-protection devices..."[2]. Accordingly, this study has *not* sought to establish if the use of rollover-protection devices is warranted, but rather, to paraphrase the Board, it has attempted to advance the knowledge base regarding "the factors and assumptions [available to] a cargo tank manufacturer...when calculating loads on the rollover-protection devices." In so doing, however, it has begun to lay the groundwork for performance standards based on rationally developed criterion.

To do that, this study has examined, by computer simulation, the dynamics of tank-vehicle rollover across a broad range of maneuvers which are thought to span at least a major portion of the real-world scenarios that lead to rollover accidents.

Further, it has been asserted that, while the world presents a nearly infinite variety of road-side environments for the rolled-over vehicle to strike, the most common impediments are simple horizontal surfaces (e.g., the road or road side surface) and simple vertical surfaces nominally oriented parallel to the roadway (e.g., guardrails, retaining walls, embankments, etc.).

Accordingly, the dynamic conditions observed at the termination of rollover events (i.e., at the moment of impact with the ground) have been distilled to a few parameters which characterize, in the most basic ways, the impact of the tank unit with these simple surfaces.

Three impact scenarios have been proposed and have been characterized by dynamic quantities of primary importance to each.

(1) In a mild rollover, the vehicle may fall onto its side but continue to roll on the flat ground surface to engage the rollover-protection devices. The primary dynamic parameter of interest in this mechanism is final roll rate. It has been noted that the mildest rollovers (the spiral turn and low-speed intersection turns) achieve roll rates on the order of 100 deg/sec. Figure 24 shows that many events in which the vehicle rolled onto its side (i.e., with roll angles less than 135 degrees) involved roll rates up to and beyond 150 deg/sec.

(2) In more severe rollover events, the vehicle may roll rapidly enough while airborne to involve the rollover-protection devices in direct impact with the ground. (This result can happen with unit trucks on level ground, but appears to require a sloping or depressed

roadside surface for it to happen to a semitrailer tank.) In such events, vertical velocity of the tank is the variable of primary interest. The attitude of the tank upon impact, as indicated by pitch and roll angles is also of interest. It has been shown that vertical velocity at impact is primarily related to the distance the center of gravity falls during the event. Figure 21 showed that trucks landing on their tops on the road achieve a downward speed that is typically at least 6 ft/sec and rarely more than 12 ft/sec. The semi trailers allowed to fall sufficiently to reach 180 degrees of roll were seen to achieve downward speeds as high as 30 ft/sec. Pitch angles in these events are typically within the range of ± 5 degrees for semitrailers but can be much larger for unit trucks (figure 23). Roll angles, of course, can range to 180 degrees and are of particular interest over the range in which the rollover-protection devices may strike the ground directly.

(3) In moderate and severe rollovers, the vehicle may land on its side and slide sideways into a vertical surface that is oriented parallel to the roadway. The velocity component sideways to the direction of the roadway constitutes the primary impact velocity. Yaw of the vehicle with respect to the vertical surface, along with roll angle, determines the attitude of the vehicle at impact. Figure 25 shows that speed into the parallel wall would exceed 10 percent of the initial forward velocity in most types of rollover events. This speed can often exceed 20 or 30 percent of the initial forward speed and occasionally even reach beyond 40 percent. Yaw angles with respect to the parallel vertical surface typically range over ± 20 degrees but can go beyond 40 degrees for unit trucks.

In concluding this evaluation of the dynamic qualities of rollover events, then, it is the basic premise of this undertaking that any "rollover-protection device," if it is to deserve such a name, must be able to successfully accomplish its protective function during impacts covering at least some significant portion of those events described above. The remaining section of this report will examine, in a very simplified way, the structural demands that such a requirement might place on rollover-protection devices and the tanks to which they are attached.

IMPLICATIONS FOR THE STRUCTURE OF ROLLOVER-PROTECTION DEVICES AND TANKS

The purpose of the work presented in this section is to provide some insight into the design and engineering requirements for rollover-protection devices and the tanks to which they are mounted, given the type and severity of impact conditions identified in the previous section. To this end, the idealized force/deflection characteristic which would be required of the combined structure of the tank and protection devices in order to manage the impact energy of the defined events will be examined. The results of this approach are fundamental such that they apply to, and provide basic guidance for, any design. They are necessarily simplified, however, and do not provide the precise forces which would be experienced by any specific rollover-protection device.

The following subsection presents a description of the impact simulation models used in the study. It begins with a discussion of the underlying engineering philosophy of the calculations and then presents more specific description of the models. Finally a broad set of results are presented and several basic relationships are highlighted.

IMPACT SIMULATION MODELS

In the opening discussion of this report on *background and philosophy*, it was observed that “rollover-protection devices suffer the forces they do as a result of impact events. As in all impact events, the magnitude of the forces involved is related to the dissipation of kinetic energy.” It was also noted that, before the impact, the kinetic energy of the tank unit (according to its simplest description) is $1/2MV^2$, where M is mass and V is velocity, and that this kinetic energy is absorbed during the impact by the deforming structure in proportion to the force (F) required for deformation and the distance (D) of the deformation. In the simplest mathematical form, $FD = 1/2MV^2$.⁷ If the structure is designed to allow large crush distances, then the force can be smaller and the structure need not be so strong. Alternatively, if the structure can be made very strong, it need not crush over so long a distance. Although it is beyond the control of the tank designer, force is also reduced if some additional deformation takes place in the object struck. (Thus, for example, roadside guardrails are typically designed to give way in a controlled fashion.) However, since many of the objects available to be struck in a rollover are

⁷ The expression $1/2MV^2$ is the simplest expression of kinetic energy based only on linear motion. Kinetic energy may also include a components associated with rotational motion calculated using rotational speed and moment of inertia. Further, for vertical impact into a horizontal surface, the tank also gives up potential energy as it falls. Total energy to be absorbed is the sum of kinetic energy at first contact plus the potential energy from the small additional distance the mass falls after first contact.

practically rigid relative to the tanker, this analysis assumes all the required deflection must take place in the tank and its protective devices.

A tank and its protective devices may be designed such that the crush takes place in either the tank or in the devices (or in both). Figure 28 is a sketch showing these two approaches.

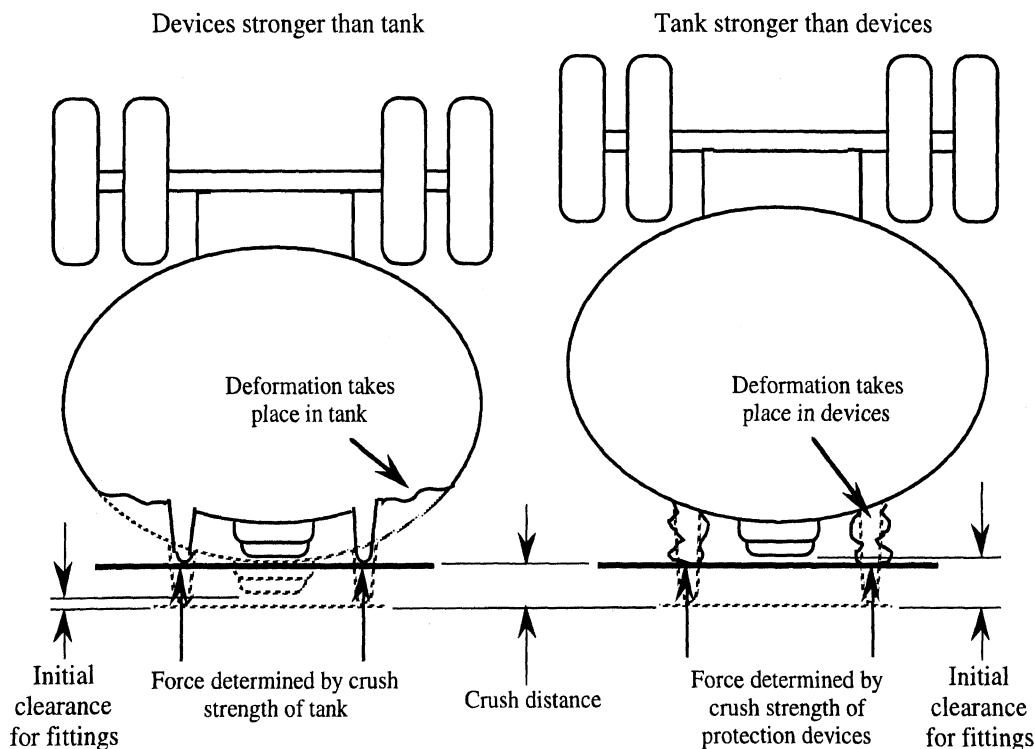

Figure 28. Impact deformation may take place in the tank or in the rollover-protection devices

In the vehicle on the left of the figure, the rollover-protection devices are stronger than the tank. On impact, the forces in both the tank and the devices rise together until the tank reaches its limit and begins to crush. From that point on, the force in both the tank and the protection devices is determined by the crush strength of the tank. Since there is no deformation of the protection devices, they need to provide only a relatively small initial clearance between the impact plane and the fittings they protect. Of course, for this approach to be successful, the tank must be capable of deforming in a controlled manner without rupture.

In the vehicle on the right, the tank structure is stronger than the devices. Forces in the devices are now determined by the crush strength of the devices themselves. However, since the deformation takes place in the devices, they must provide ample initial clearance between the impact plane and the protected fittings.

For either design, the necessary crush distance will depend on the energy to be dissipated and the crush force. The relationship between energy, distance, and force remains essentially the same regardless of which mechanism (or what combination of both) are involved.

To this point, the discussion has tacitly assumed that, for a given design, the crush force is one constant value over the entire crush distance. In practice this is not so.

Consider figure 29. The figure is a graph with crush force represented on the vertical axis and crush distance shown on the horizontal axis. Crush force over the crush distance is shown for two systems: (1) An idealized structure is represented by the dashed line in which the crush force is constant. (2) A more realistic system is represented by the solid line, in which the force varies. (This curve is a generic example intended to show qualities common to most mechanical structures. It is not specific to any particular rollover protection device.) In either case, the area under the curve is equal to the integral of F and D (which for the constant force, is also the simple product, FD), and therefore is a graphical representation of the energy dissipated by the crushed structure. The energy dissipated by the idealized structure is represented by the lighter diagonal shading, and that of the more realistic structure by the heavier shading.

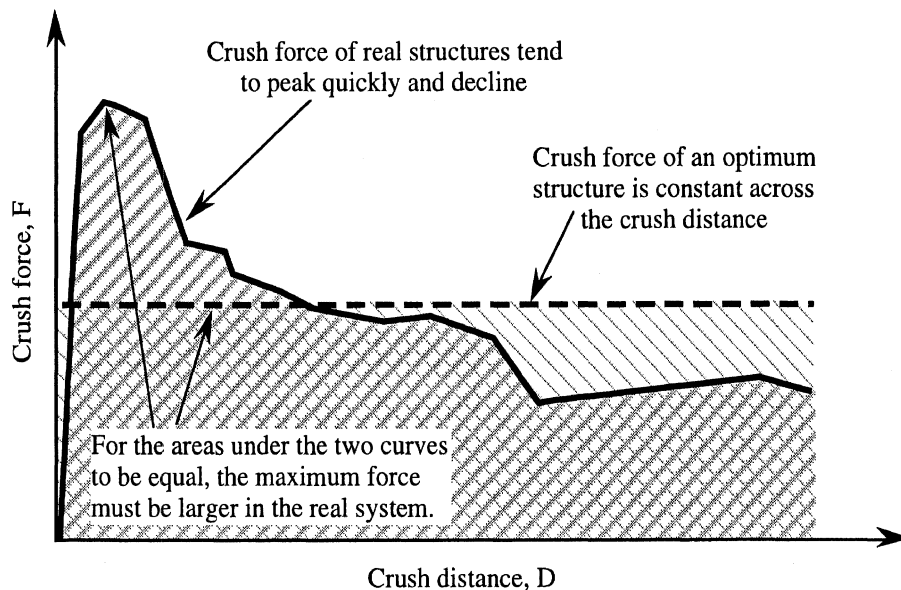

Figure 29. Comparison of the energy dissipation performance of idealized and realistic structures

The form of the curve for the more realistic structure is fairly typical. Just at the start of impact, force and distance both have values of zero (lower left on the graph). As the very initial deflection occurs, force rises rapidly as the structure essentially maintains its shape and the material responds in the elastic range. In this mode of behavior, the structure reaches its maximum strength with very little deflection. At this point, some

part of the structure begins to deform plastically and the structure changes shape appreciably. Typically, with this large deformation, the force that the structure can support falls off to some lesser value. Depending on the details of the structure and the event, force may continue to decline with deflection or at some point it may recover.

Fundamental to this discussion is the idea that the requirement for impact management is dissipation of energy. A key observation derived from figure 29 is that constant crush force is the characteristic which results in an optimum system for energy dissipation. To dissipate the same amount of impact energy, a less-than-optimum system (i.e., one with varying crush force) must either provide greater peak forces sometime during the crush process to compensate for lesser force at other times, or it must allow for greater crush distance.

The impact simulation models used in this study have been simplified and idealized according to the ideas which have been discussed. There are two basic models: (1) the normal-impact model for examining impact of roll-protection devices with a flat plane arising from velocity normal to the plane; (2) a rolling-impact model for examining impact of rollover-protection devices with a flat plane for cases in which the tank is simply rolling on the plane. The first model is subdivided into two, one including the minor influence of gravity and potential energy for vertical impact with the horizontal plane, and the other without these influences for lateral impact with a vertical plane.

In each of these models, the vehicle's tank unit is represented as a mass (with appropriate moments of inertia) moving in space with six degrees of freedom (i.e., three translations and three rotations). The rollover-protection devices are represented by a matrix of up to 210 points defining the geometric profile of the devices in relation to the center of mass. A constant crush-strength parameter is defined and is applied uniformly to each point of this matrix. As in figure 28 and its related discussion, the model assumes that the impact forces against the plane are borne by and transmitted to the tank by the rollover-protection devices. (No distinction is made as to whether that strength derives from the design of the protection devices, the tank structure, or the combination thereof.) For designs in which the protection device is essentially continuous and linear (as in length-wise rails, end dams, and mid-vehicle cross rails), the matrix points are located at 0.5-foot spacing and the crush-strength parameter is interpreted in terms of strength per linear foot. For discrete protection devices (represented by the staple-type devices of the Albuquerque vehicle but also applicable to the so-called tombstone-style devices used on other vehicles), matrix points are located at the lateral ends of the upright elements and crush strength is interpreted simply as strength per discrete element.

For the normal-impact models, the initial conditions of the simulation establish the tank attitude (roll angle and pitch angle for strikes with the horizontal plane, or roll angle and yaw angle for strikes with the vertical plane) and initial normal velocity at the

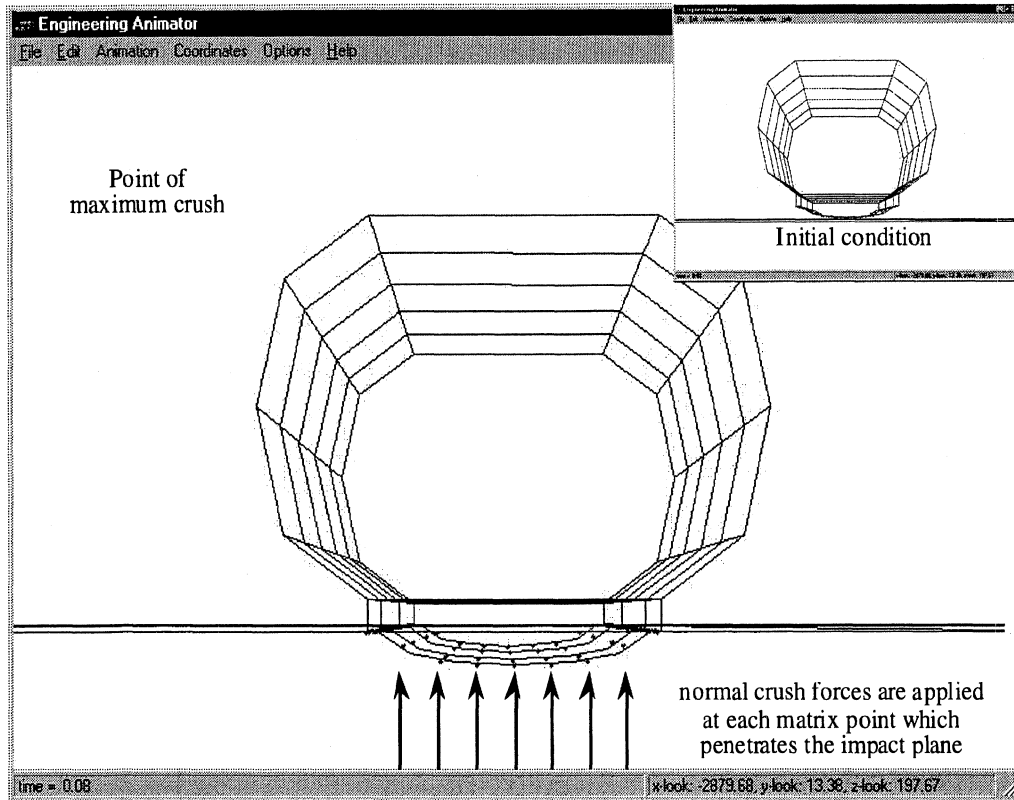

Figure 30. Animation frames from a simple run of the normal-impact model

moment of first contact with the surface. The models proceed to calculate the resulting motion of the body under the influence of crush forces which are applied at any of the matrix points interfering with the plane and maintaining a velocity into the plane (i.e., it is assumed that there are no significant forces due to rebound of structural deflection). Penetration of each matrix point into the impacted plane (i.e., crush distance of each point) is calculated. Figure 30 presents two animation frames from a simulation run of a tank striking a horizontal plane. The run begins with the tank at the very simple attitude of 180 degrees of roll and zero degrees of pitch and moving toward the plane. The initial condition is shown in the small, inserted frame. The larger frame shows the structure at the point of greatest deflection. The structure is not shown deformed, but the crush distance is represented by the distance that the undeformed structure has penetrated the plane.

The rolling-impact model initiates with the tank lying on the horizontal plane and moving with the prescribed rolling and lateral velocities. If initial velocities are sufficient, the tank continues rolling onto its top, thus engaging the rollover-protection devices. Tank-body points contacting the plane are modeled as essentially nondeformable. Frictional forces on the tank, as well as forces normal to the ground, are included to ensure realistic rolling action. Constant crush forces normal to the plane are applied to the

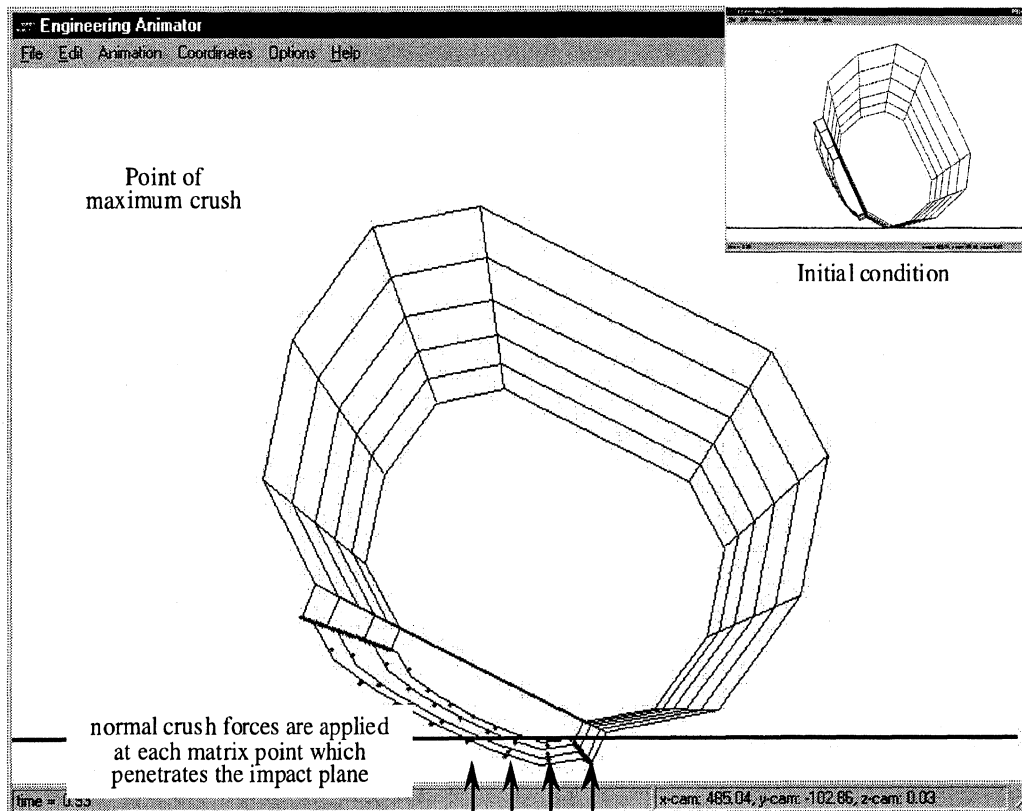

Figure 31. Animation frames from a simple run of the rolling-impact model

matrix points representing the protection devices which penetrate the ground plane. Figure 31 shows animation frames from the rolling-impact model.

The impact models used in this study are intended to identify structural design requirements which are broadly applicable to all types of rollover-protection devices and tank structures. As such, these models are both simplified and idealized. On one hand, they are “optimistic” in that they assume the optimum design quality of constant crush force over the entire crush distance and, further, that the protector is of uniform strength over its length. On the other hand they are “pessimistic” in that they assume that only the protectors actually engage the impact plane. These models are not intended to provide precise calculations of either the forces or the deflections which would occur in any particular design of tank or protector. While such an undertaking might be of great benefit to those interested in one or another of the limited set of specific designs which could be examined in great detail, the approach used here hopefully provides a resource for (1) interpreting the crash scenarios revealed by the vehicle dynamics simulations in terms of design implications and (2) defining generalized mechanical performance targets which could be applied across a variety of specific designs.

IMPACT SIMULATION MATRIX

A matrix of 3066 individual impact simulation runs was conducted. The matrix was derived from five basic vehicles (Albuquerque, Bronx, Columbus, Hamilton, and Lantana), each with several variations of geometry and strength for the protective devices, and each simulated in the different types of impacts under a variety of initial conditions of speed and orientation.

The complete matrix of rollover-protection designs is shown in tables 3 and 4. The designs for tankers having continuous, rail-style rollover protectors are shown in table 3. Table 4 presents the matrix for the Albuquerque tanker, which has discrete-type rollover protectors. The letter D in the tables indicates the overturn protectors simulated to represent the actual design on the accident vehicle. The letter V indicates a variation of the actual design. Conditions not simulated are left blank. Figure 32 is an illustration of the different overturn protection designs shown in column 1 of tables 3 and 4. For the rail-style models, the matrix points were evenly spaced every six inches to simulate the effect of a continuous type of support. The discrete types of protectors were modeled with matrix points at the lateral ends of the device. Each pair of points then corresponds to an individual discrete element. (See figure 3.)

Table 5 shows the number of linear feet of rail for the different designs of the rail-style tankers and the number of discrete elements for the design variations of the Albuquerque tanker. The geometric dimensions are given in figure 33.

Table 3. Simulation matrix for rail-style overturn protectors

<i>Design No</i>	<i>Design features</i>	<i>Roll-impact model</i>				<i>Normal-impact model</i>			
		<i>Bronx</i>	<i>Colmb.</i>	<i>Hamlt.</i>	<i>Lantn.</i>	<i>Bronx</i>	<i>Colmb.</i>	<i>Hamlt.</i>	<i>Lantn.</i>
R1	end dams only	D	D	D	V	D	D	D	
R2	dams every 6 ft				V	V	V	V	
R3	crowned dams every 6 ft	D			D	V	V	V	

Where: D = protectors based on actual design
V = variation on the actual design

Table 4. Simulation matrix for discrete-style overturn protectors (Albuquerque)

<i>Design No</i>	<i>Design features</i>	<i>Impact model</i>	
		<i>Roll</i>	<i>Normal</i>
D1	5 elements as designed	D	D
D2	10 elements	V	
D3	half-height elements	V	
D4	quarter-height elements	V	
D5	elements every 4 ft		V
D6	elements every 2 ft		V

Where: D = protectors based on actual design
V = variation on the actual design

Top View	Rear View	
		Configuration R1 Flat Rails with flat end dams only
		Configuration R2 Flat Rails with flat dams every 6 ft.
		Configuration R3 Flat rails with crowned dams every 6 ft.
		Configuration D1 5 Staples (as designed)
		Configuration D2 10 Staples
		Configuration D3 5 Staples - half the original design height
		Configuration D4 5 Staples - 1/4 of the original design height
		Configuration D5 Staples every 4 ft.
		Configuration D6 Staples every 2 ft.

Rail-type designs are represented in the impact models with one crush point per 1/2 linear foot of longitudinal or lateral rail. Discrete-element designs are represented with one crush point at either end of each element.

Figure 32. The design variations of the rollover-protection devices

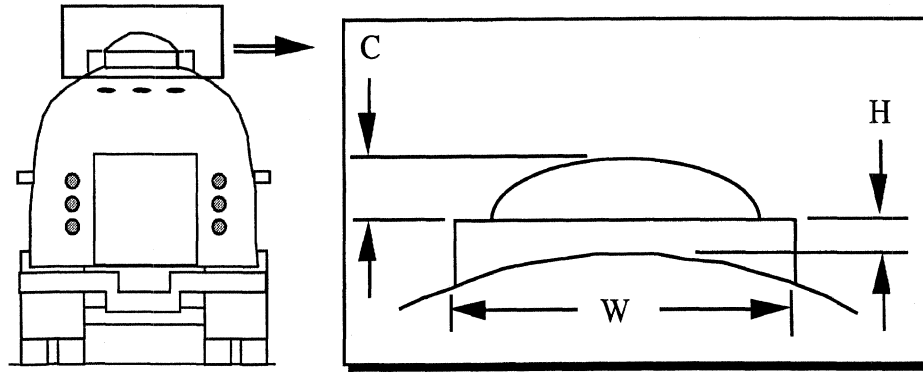

Rail-style overturn protectors

Vehicle	Design	W, in.	H, in.	C, in.
Bronx	R1, R2	48	3.25	0
Bronx	R3	48	3.25	5
Columbus	R1, R2	36	3	0
Columbus	R3	36	3	6
Hamilton	R1, R2	36	5.5	0
Hamilton	R3	36	5.5	6
Lantana	R1, R2	36	5.3	0
Lantana	R3	36	5.3	6

Discrete-element overturn protectors
Albuquerque

Position	Design	W, in.	H, in.	C, in.
Front	D1, D2	12	10	0
Center	D1, D2	36	12	0
Rear	D1, D2	36	14	0
Front	D3	12	5	0
Center	D3	36	6	0
Rear	D3	36	7	0
Front	D4	12	2.5	0
Center	D4	36	3	0
Rear	D4	36	3.5	0
Uniform	D5, D6	36	12	0

Figure 33. Dimensional properties of the rollover-protection devices represented in the impact-simulation study

Table 5. Linear feet of rail and number of discrete elements by vehicle design configuration

<i>Linear feet of rail</i>				
<i>Design</i>	<i>Bronx</i>	<i>Columbus</i>	<i>Hamilton</i>	<i>Lantana</i>
R1	44	90	30	88
R2	52	108	33	106
R3	52	108	33	106

<i>Number of discrete elements, Albuquerque</i>			
<i>Design</i>	<i>No. of elements</i>	<i>Design</i>	<i>No. of elements</i>
D1	5	D4	5
D2	10	D5	10
D3	5	D6	19

Table 6. Vehicle mass, inertia, and center of gravity positions

<i>Vehicle</i>	<i>Weight lbs</i>	<i>Moment of Inertia in-lb-sec²</i>			<i>CG Location (relative to center of tank), in</i>		
		<i>Roll</i>	<i>Pitch</i>	<i>Yaw</i>	<i>X</i>	<i>Y</i>	<i>Z</i>
Albuquerque	63,135	72,683	2,996,910	2,964,940	-12.2	0	-6.1
Bronx	50,800	132,683	1,096,450	1,059,790	24.0	0	-16.0
Columbus	63,424	113,404	3,902,160	3,873,390	-19.1	0	-6.8
Hamilton	33,760	93,676	526,106	501,305	35.0	0	-16.5
Lantana	63,039	118,969	3,660,040	3,624,850	11.2	0	-2.3

The inertial, mass, and geometric parameters for each vehicle are given in table 6. These values represent the entire truck in the case of the Bronx and Hamilton vehicles and the entire semitrailer for the Albuquerque, Columbus, and Lantana vehicles.

As explained previously, a constant crush force is applied at each point of the matrix describing the protective devices. Table 7 shows the levels of crush force that were used. These forces were not determined by analysis of any particular design. Rather they were selected simply to yield maximum crush distances ranging from very short distances through at least 12 inches—a range felt to be “practical” for the protective function. (Consequently the crush forces used are different for different styles of protective devices.)

Tables 8 presents the initial kinematic conditions for the rolling-impact model as a function of the vehicle type and severity of the event. The table shows the initial roll angle, roll rate, and lateral velocity. Tables 9 and 10 show the initial kinematic conditions for the vertical and lateral implementations of the normal-impact model.

Table 7. Crush-force levels for the rolling-impact and normal-impact model

<i>Albuquerque pounds per matrix point</i>		<i>All others pounds per linear foot</i>
<i>Rolling- impact model</i>	<i>Normal- impact models</i>	<i>Rolling- and normal- impact models</i>
1,000	20,000	5,000
2,500	40,000	20,000
5,000	80,000	40,000
10,000	160,000	80,000
20,000	320,000	160,000
40,000	640,000	320,000

Table 8. Initial conditions for simulations of rolling impacts

<i>Vehicle:</i>	<i>Bronx and Hamilton</i>		<i>Columbus and Lantana</i>		<i>Albuquerque</i>	
<i>Severity:</i>	<i>Slow</i>	<i>Fast</i>	<i>Slow</i>	<i>Fast</i>	<i>Slow</i>	<i>Fast</i>
<i>Roll Angle, deg</i>	93	115	89	111	98	98
<i>Roll Rate, deg/sec</i>	100	160	98	152	116	162
<i>Lateral Velocity, ft/sec</i>	14	40	8.7	25.8	10.6	29.6

Table 9. Initial conditions for simulations of vertical impacts

<i>Bronx and Hamilton</i>			<i>Columbus/Lantana/Albuquerque</i>		
<i>Vertical vel., ft/s</i>	<i>Roll angle, deg</i>	<i>Pitch angle, deg</i>	<i>Vertical vel., ft/s</i>	<i>Roll angle, deg</i>	<i>Pitch angle, deg</i>
6	180	0	6	180	0
6	180	15	6	180	-5
6	170	0	6	170	0
12	180	0	6	160	0
12	180	15	6	170	-5
12	180	30	12	180	0
12	170	0	12	180	-5
12	160	0	12	170	0
12	170	30	12	160	0
18	180	0	12	170	-5
18	180	15	18	180	0
18	170	0	18	180	-5
N/A	N/A	N/A	18	170	0
N/A	N/A	N/A	18	160	0
N/A	N/A	N/A	18	170	-5

Table 10. Initial conditions for simulations of lateral impacts

<i>Bronx and Hamilton</i>			<i>Columbus/Lantana/Albuquerque</i>		
<i>Lateral Vel., ft/s</i>	<i>Roll Angle, deg</i>	<i>Yaw Angle, deg</i>	<i>Lateral Vel., ft/s</i>	<i>Roll Angle, deg</i>	<i>Yaw Angle, deg</i>
12	90	0	12	90	0
12	90	10	12	90	5
12	90	30	12	90	15
12	90	40	12	80	0
12	80	0	12	80	5
12	70	0	12	80	15
12	80	30	18	90	0
18	90	0	18	90	5
18	90	10	18	90	15
18	90	30	18	80	0
18	90	40	18	80	5
18	80	0	18	80	15
18	70	0	24	90	0
18	80	30	24	90	5
24	90	0	24	90	15
24	90	10	24	80	0
24	90	30	24	80	5
24	90	40	24	80	15
24	80	0	N/A	N/A	N/A
24	70	0	N/A	N/A	N/A
24	80	30	N/A	N/A	N/A

RESULTS OF THE IMPACT SIMULATION STUDY

The full set of results from the impact simulation study are presented in appendix C. The results are presented as data plots of the form shown in figure 34 and in tabular form. The vertical axis in the figure represents crush strength and the horizontal axis represents maximum crush distance.

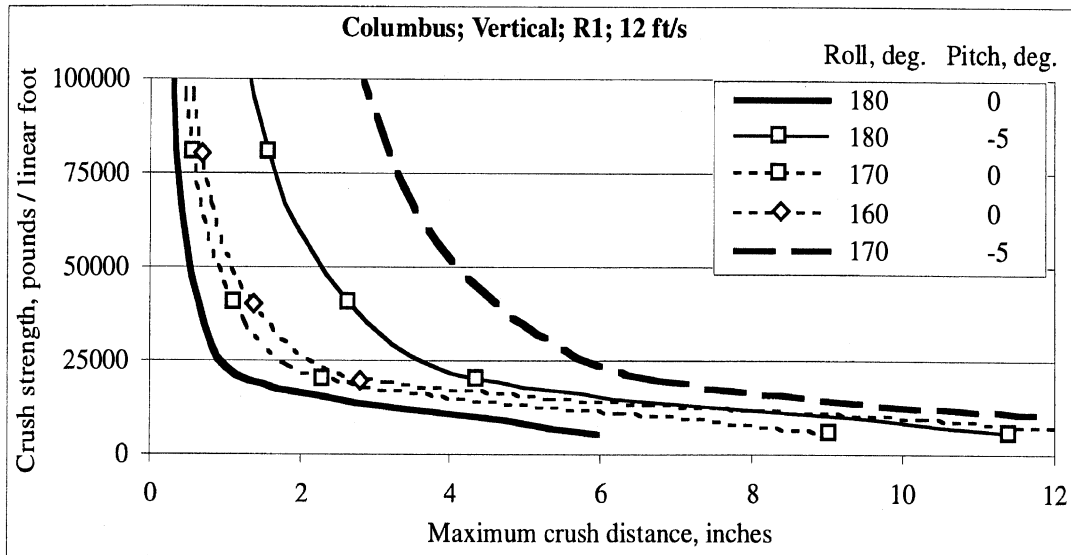

Figure 34. Example results from the impact simulation study

Crush strength is an input parameter to the simulation model that describes the idealized, constant crush strength of the protector/tank structure as was presented in figure 30 and the associated discussion. Since the vehicle represented in figure 34 used rail-type protectors, crush strength is given in terms of pounds per linear foot of rail. For designs with discrete protectors, crush strength is given in pounds per load point. In the sample of vehicles considered here, the Albuquerque vehicle is the only example of a discrete type of protector design. These protectors are of the so-called *staple* type, but the problems revealed below for this design can be interpreted as potential difficulties for any discrete design style.

Maximum crush distance is defined as the largest “deflection” of any single matrix point which occurred during the simulation run (per figures 30 and 31 and the associated discussion). In any given run, many of the matrix points describing the protectors interfere with the ground. The time histories of the crush distance of each matrix point constitute the primary outputs of the simulation. After the run, these time histories are searched for the maximum deflection among relevant points. This value is reported as the maximum crush distance.

Individual impact simulation runs appear on the graph as a single data point defined by these crush-force and crush-distance parameters. The data points are joined with lines to associate results from a series of simulations using different crush strengths as input.

The data line shows the relationship between crush strength provided and the resulting maximum crush distance (or vice versa) for a given vehicle/crash scenario.

The general shape of the curves in figure 34 is characteristic of each of the plots contained in appendix C. This shape is in keeping with expectations based on the previous discussion of energy management during impact. That is, each point on a particular line in these plots represents the same vehicle impacting the same surface at the same velocity—i.e., the initial kinetic energy is the same. The different points on the curve represent different ways of managing that energy by trading force against distance. A simplified representation of this relationship derives from rearranging equation 1 to solve for F as a function of D, given a constant value of kinetic energy:

$$F = (1/2MV^2)/D = KE/D, \quad (2)$$

where KE is constant. Equation 2, when plotted on a graph like that of figure 34, takes the same general form as the data lines in the figure.

Appendix C contains a large number of graphs of this form covering most of the range of crash scenarios identified by the vehicle-dynamics simulation study. Tabular data from which the graphs were prepared are also presented. This section attempts to consolidate these data to some extent and examine a few of the more significant relationships that they reveal.

Observations on the results of the rolling-impact model

Rolling impact has been included in the impact-simulation study primarily to represent the mildest accidents in which the vehicle falls onto its side and rolls onto its top. Each of the vehicle types is simulated under the two impact conditions defined earlier in table 8. The *slow* rolling-impact simulations represent the mildest rollovers simulated: the spiral turn and/or the slower of the intersection turns. The *fast* rolling-impact simulations, included simply to cover a range of severity, are generally representative of the more severe events in which the vehicle lands at less than 135 degrees of roll angle. All rolling runs are with zero pitch angle. The precise initial conditions vary slightly for the trucks (Bronx and Hamilton), the oval petroleum semitrailers (Columbus and Lantana) and the round, acid tanker (Albuquerque).

Figure 35 presents results for the two straight trucks in their respective, as-designed configurations (i.e., configuration R3 with crowned cross members for Bronx and configuration R1 with flat cross members for Hamilton; see figures 32 and 33). Except at the very lowest strengths, deflection is very small for these vehicles. The relatively low profile of the rail-style protective devices, combined with the oval shape of the tank result in a rather low impact on the rails and little disturbance of the rolling motion as the vehicle rolls from its side onto its top. Especially in the midstrength range, the Bronx vehicle can be seen to benefit even more from the rounded profile of its cross members.

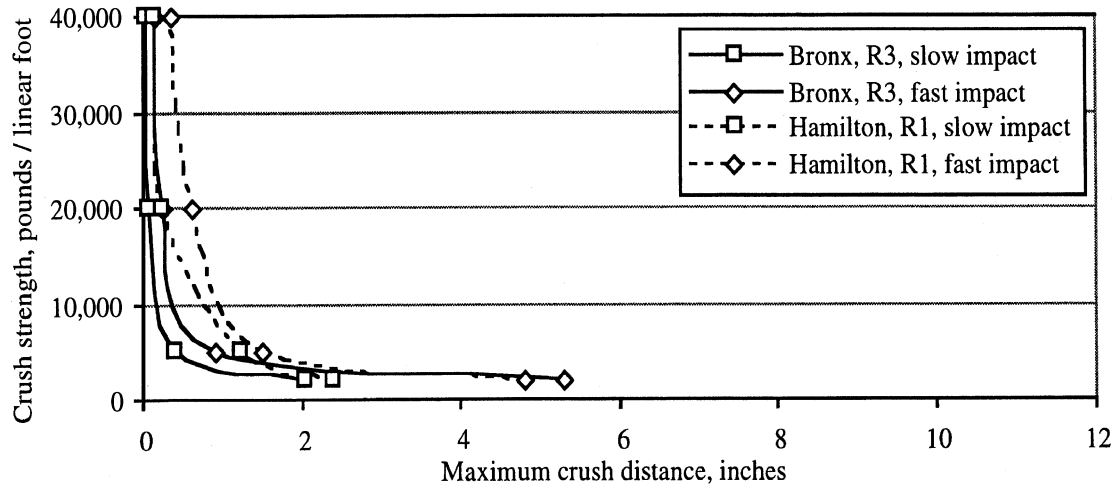

Figure 35. Rolling-impact results for the trucks in their as-designed configurations

The greater crush strength (or crush distance) required in the faster impacts is apparent throughout.

Figure 36 presents the results for the semitrailers in their as-designed configurations. The results for the two petroleum tanks with rail-style protectors are similar to each other and to the results for the trucks. However, the results for the acid tanker (Albuquerque) stand out as quite different. This vehicle is equipped with high-profile, discrete-element devices on a round tank as shown on the left in figure 37. (The sketches in the figure are nominally proportional to the tank profiles of the Albuquerque and Columbus vehicles.) Unlike rails (on the right of figure 37), these devices present dramatic discontinuities in the overall profile of the rolling vehicle. As they strike the ground, they generate forces which tend to both stop the rolling motion and lift the vehicle. If crush strength is low, there is little lift, but the crush distance required to absorb the kinetic energy and stop the rolling is large. Conversely, if strength is high, rolling is stopped more abruptly and the

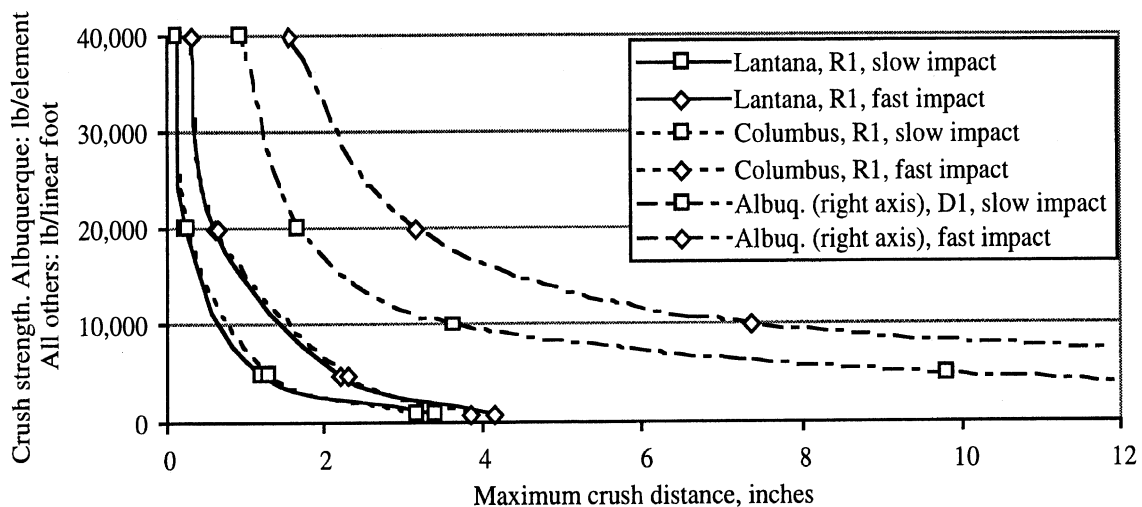

Figure 36. Rolling-impact results for the semitrailers in their as-designed configurations

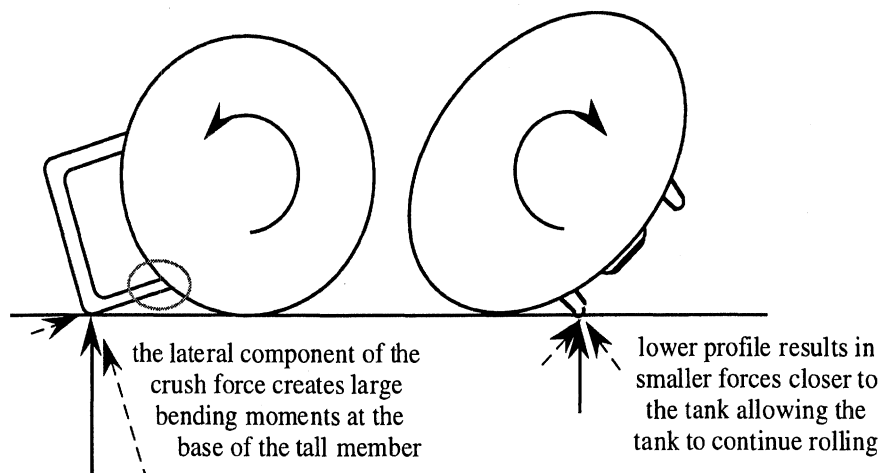

Figure 37. Forces on the protectors during rolling impact

tank may “hop” off the ground during the process. In any case, there are only five elements available for managing the roll energy of the Albuquerque tank, and, because they are of differing heights and widths, they do not hit the ground simultaneously. Consequently, the maximum crush distance is relatively long and/or the forces required are high.

Not only do high-profile devices tend to generate larger forces, they are inherently less capable of supporting large forces because of their geometry. The high-profile device strikes the ground after rolling only a few degrees past 90 degrees. Thus, the largest component of the impact force acts laterally on the device and creates a large bending moment at the base of the member near the tank. If the design can provide as much as 8 to 10 inches of clearance between the device and the fitting it protects, figure 36 indicates that the device would need to provide a controlled crush force of about 5000 pounds or more throughout that deflection in order to manage even the mildest rollover. While tombstones may be capable of supporting such loads, tall staples are likely to fail in bending at their root. Also, as opposed to providing a constant crush force, either device are equally likely to “collapse” quickly as was shown for realistic systems in figure 29.

The influence of some modifications to staple design is shown in figure 38. The figure presents data from slow rolling impacts. The results for the as-designed vehicle (D1) are augmented with three variations: one in which the number of staples has been doubled and two others in which the staples are made shorter. While it is no surprise that doubling the number of discrete devices reduces the crush strength required of each, the fact that the shorter elements appear to result in no change is at first surprising. On reflection, however, this result is readily understandable from an energy-content point of view. That is, the vehicle possesses a certain initial energy content at impact that must be dissipated by force acting through distance. The range of height change examined is not sufficient to change the basic deceleration mechanism, and the five available points must

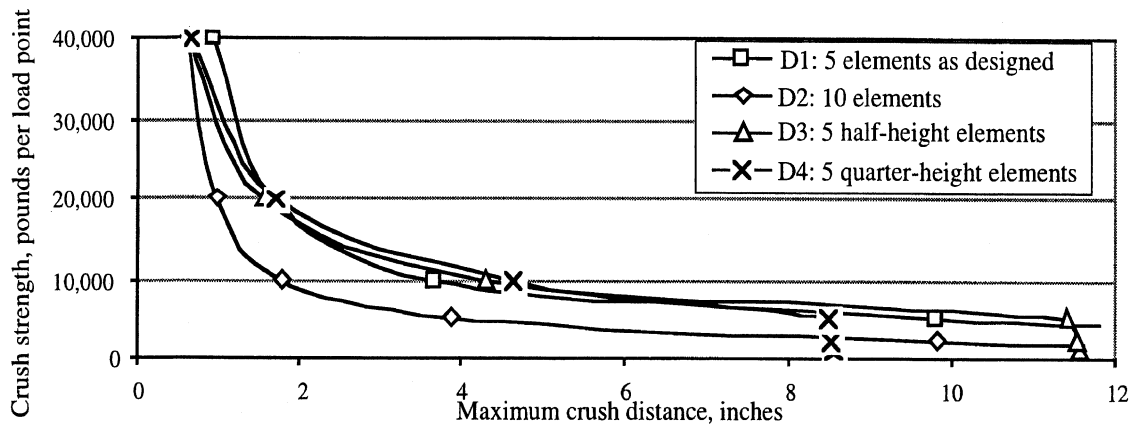

Figure 38. The influence of variations of discrete-element design on the rolling-impact results for the Albuquerque vehicle

deflect through essentially the same distance as long as they crush at the same load. On the other hand, considering the implications of figure 37, it is recognized that it would be easier to design the shorter elements to handle the load. (Obviously, however, shorter elements might not “cover” the fittings they protect.)

Observations on the results of the normal-impact model

This section will examine some of the results of simulation runs of the normal-impact model—the graphs labeled as *vertical* and *lateral* in appendix C. Before opening the discussion, however, note that the initial velocities used in simulations of vertical impacts were 6, 12 and 18 ft/sec (shown earlier in table 8). These velocities were selected to nominally cover the range of vertical impact velocities for vehicles landing at large roll angles. As indicated in figure 21 and the associated discussion, only semitrailers that were allowed to fall well below the road surface show vertical impact speeds above 18 ft/sec. Impact velocities of 12, 18, and 24 ft/sec are used in simulations of lateral impact events. Figure 39 is presented as an aid to interpreting these impact velocities in the context of figure 25. In figure 25, the large majority of lateral velocities were seen to be less than 30 percent of the initial forward speed, and all but the most severe were less than 40 percent. Figure 39 shows that an impact speed of 24 ft/sec would cover the 40-percent criterion for initial forward speeds of up to 40 mph and the 30-percent criterion for speeds of up to 55 mph. An intuitive sense of the relative violence of impacts at these speeds might be gained by describing equivalent drop-tests. That is, if one were to drop tanks onto a horizontal surface to produce impact velocities of 6, 12, 18 and 24 ft/sec, the tanks would have to fall through distances of 0.5, 2.2, 5.0, and 8.9 feet, respectively.

Figure 40 shows, not surprisingly, that the influence of gravity and potential energy in the vertical impact situations is small. The figure compares lateral and vertical impacts of the Lantana vehicle. The initial velocity of all impacts represented in the figure is 12 ft/sec. There are various conditions of initial pitch and roll attitude. (Recall that the

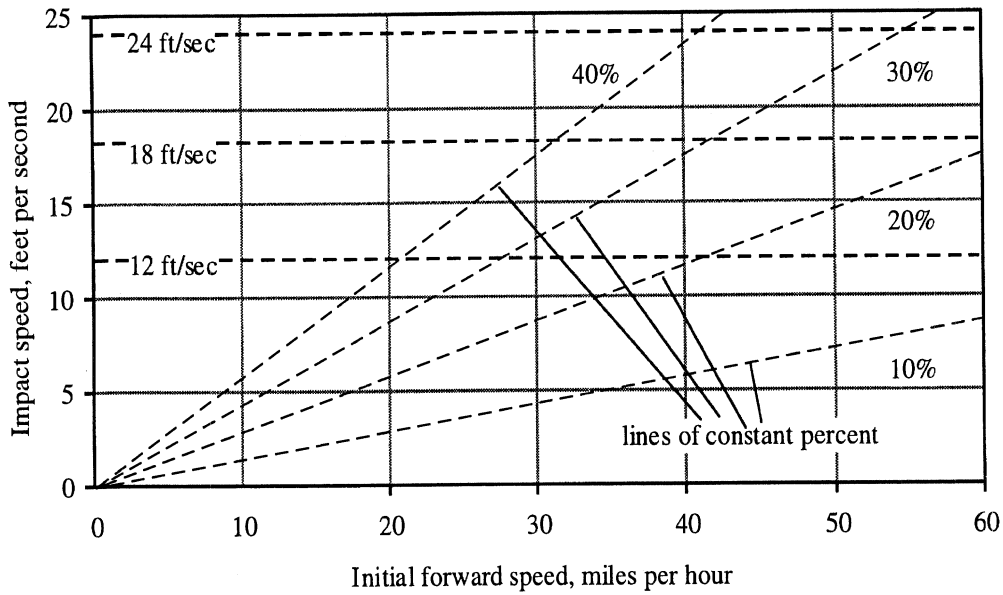

Figure 39. The relationship between percent of initial forward speed in miles per hour and impact speed in ft/sec

influence of yaw in a lateral impact is similar to the influence of pitch in the vertical impact.) The plot shows the tendency for the vertical impacts to be a bit more severe than the comparable lateral impact especially for low crush strengths. With low strength, crush distance is greater and potential energy becomes more significant for the falling vehicle. However, these differences are not large and are not particularly significant in the context of these analyses. Thus, the results which appear in appendix C and are labeled as *vertical-impact* and *lateral-impact* results may be interpreted simply as a single, broader set of *normal-impact* results.

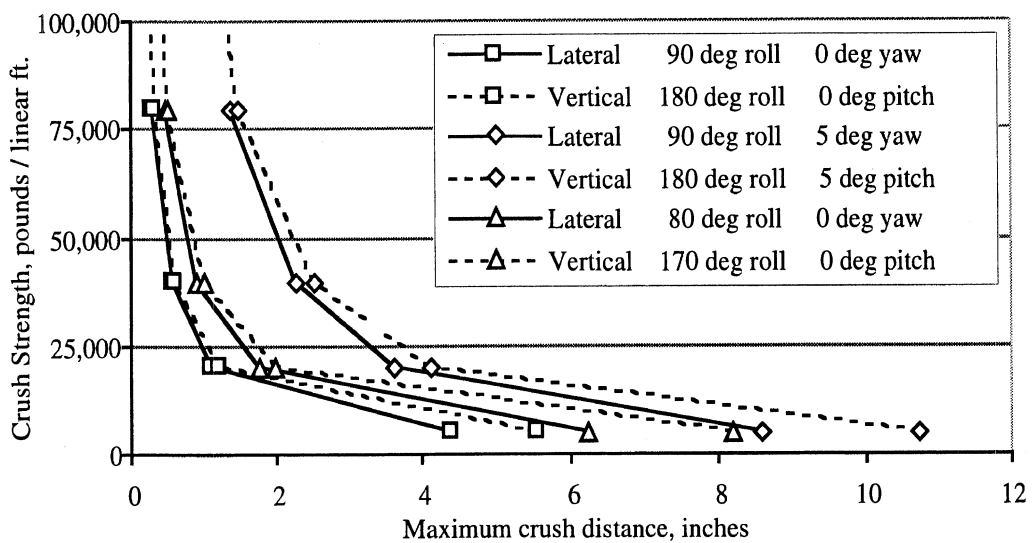

Figure 40. Comparison of results from similar vertical and lateral impacts of the Lantana semitrailer (all at 12 ft/sec)

Figure 41 illustrates the influence of velocity on the results of the simulations of normal impacts. The figure shows results for impacts in which the vehicle strikes the wall flat against its top with initial velocities of 6, 12, 18, and 24 ft/sec. (All were lateral impacts except the slowest, which was vertical.) The influence seen in the figure is proportional to the square of velocity. (For example, if one were to divide the crush strength at each data point by the square of the initial velocity for that impact, the resulting curves would lie nearly on top of one another.) This is as expected, given the presence of the square of velocity in equation 1.

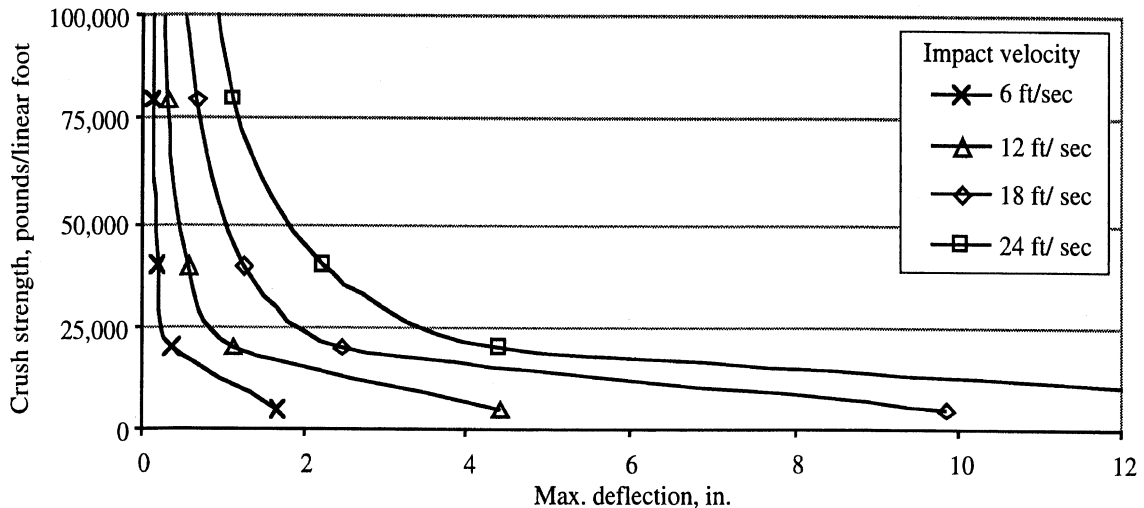

Figure 41. The influence of velocity on the results from simulations of the Lantana semitrailer in flat-on-the-top impacts

Figure 42 compares some of the results of the five vehicle types, each with protectors similar to those of the actual accident vehicles. However, note that the Bronx vehicle is equipped with flat, rather than crowned, cross members. Also note that crush strength is given in terms of pounds per linear foot (i.e., per two matrix loading points) for the vehicles with rail-style protectors and in terms of pounds per discrete element (also per two loading points) for the Albuquerque vehicle. The data in the figure all derive from vertical impacts initiated at 12 ft/sec with the vehicle oriented flat against the surface (i.e., roll = 180 deg and pitch = 0 degrees in a vertical impact). The two petroleum semitrailers do best and are very similar. The two trucks are next and are also very similar. The acid tanker does by far the poorest. The differences among vehicle types are due largely to differences in total length of protector relative to mass of the vehicle. The trucks and tankers all have two long rails spanning the length of the tank and each carry about the same amount of product per foot of length. The trucks, because they include cabs, engines, etc., carry a good deal more tare weight than do the semitrailers. The acid tanker, on the other hand, has only five elements (ten loading points) but weighs about the same as the other semitrailers. Each element clearly must endure a much greater proportion of the load than the equivalent section of rail bears in the other vehicles.

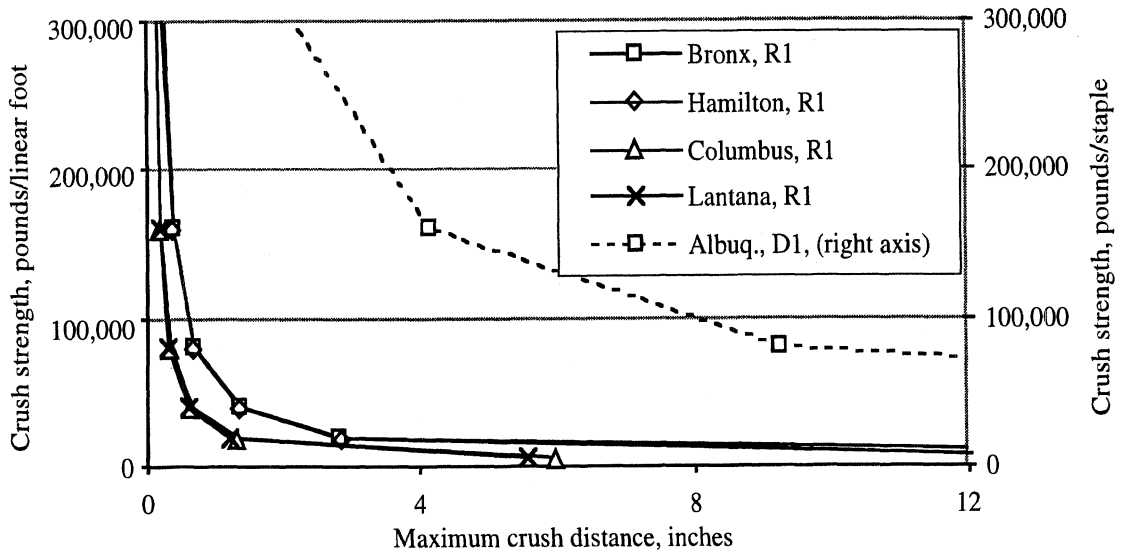

Figure 42. Comparison of results from the as-design vehicles in 12-ft/sec impacts, flat against the top

This point is emphasized in figure 43 by presenting the same data and adding two variations of discrete-element protector designs. Configuration D5 has 10 elements spaced at 4-foot intervals and configuration D6 has 19 elements at 2-foot spacing. As the number of elements increases, the layout of loading points approaches that of two longitudinal rails and the performance of the design approaches that of the designs using rails. The message is clear and simple: it is advantageous to spread the impact load over a greater area than can be provided by a few discrete protectors.

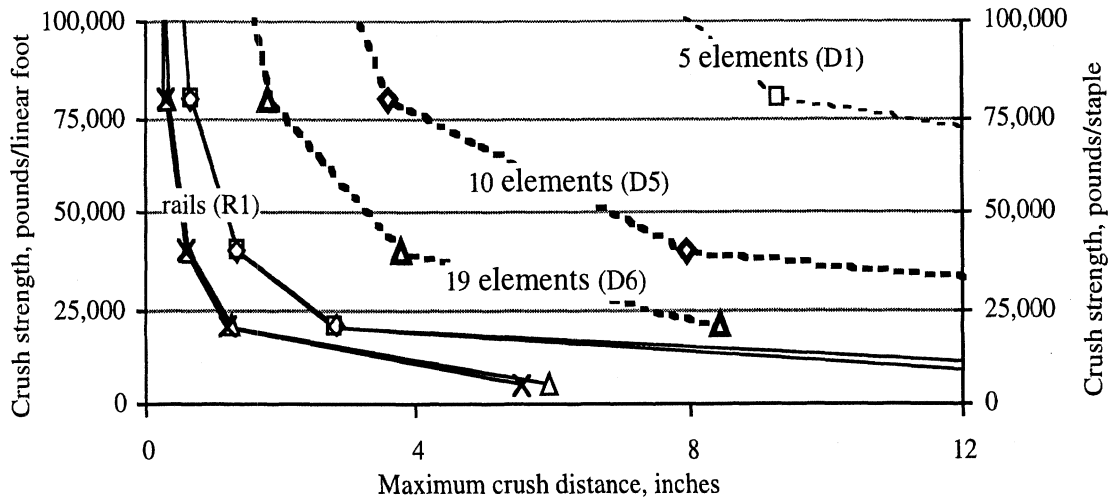

Figure 43. The performance of discrete elements approaches that of rails as their numbers increase

The previous discussion suggests a means for normalizing results so that they can be applied to vehicles with mass and protector designs differing from those considered here. The normalization process is as follows:

$$CS_{\text{norm}} = \frac{CS}{W/N}, \quad (2)$$

where

CS	is crush strength in pounds per linear foot or pounds per element,
N	is the total length of protector rails in feet or the number of discrete elements,
W	is the weight of the vehicle in pounds, and
CS_{norm}	is the normalized crush strength and is nondimensional.

Figure 44 presents the results of figure 43, including those of the alternative designs, but with the crush strength expressed in normalized form according to equation 2. The apparent differences of figure 43 have been markedly reduced: the method is an effective normalizer. The implication is that the more-or-less single curve could be used in a reverse fashion to determine the crush force-deflection relationship for other vehicles in similar events.

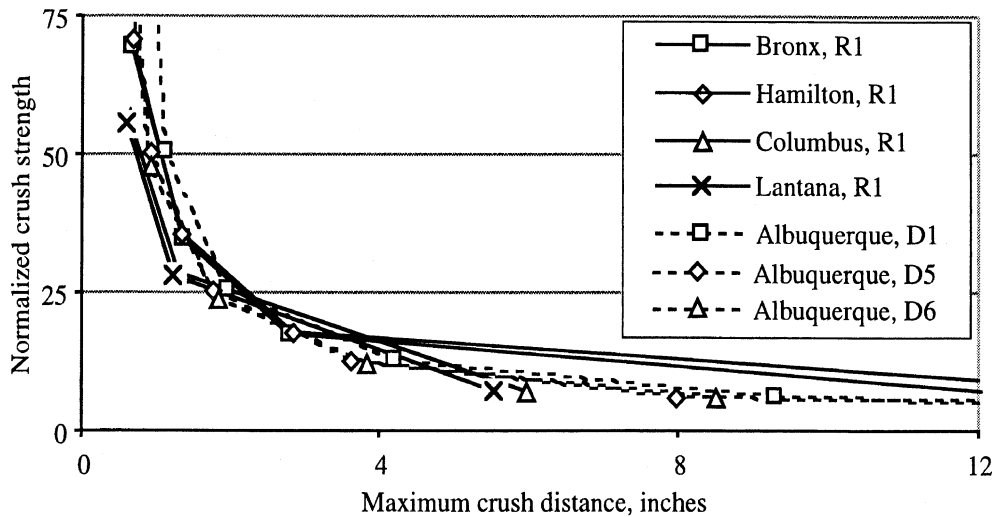

Figure 44. The impact data of figure 43 presented in normalized form

The good agreement in figure 44 is partially due to the simplicity of this particular test. The initial condition of the simulation runs involved included a pitch angle of zero. Further, except for version D1 of the Albuquerque, the all crush points are a uniform height in each vehicle. Thus, in most of these runs, all the crush points engage the surface at virtually the same time and the load is immediately distributed nearly evenly over the vehicle. The differences that are seen in figure 44 probably derive mostly from two sources: (1) The centers of gravity do not lie at the longitudinal centers of the tanks, and some pitch occurs during the strike as a result. The vehicles are long and even a small amount of pitch implies that crush distance at one end of the tank will be appreciably greater than at the other end. (2) The D1 version of the Albuquerque vehicle has discrete elements of differing heights, the longest of which engages the surface first and

consequently tends to crush further. Loading points striking at different times also tend to produce pitch.

Normalization by equation 2 is less successful for data in which (1) the vehicles are substantially pitched, yawed, or rolled upon impact, and (2) substantial numbers of impact points lie significantly out-of-plane relative to others (in particular, the designs with crowned cross members). For example, see figure 45 in which data for impacts initiated at -5 degrees of pitch are presented in normalized form. The vehicles are the two fuel semitrailers in their as-designed configurations (flat rails and end dams) and the Albuquerque vehicle with 10 and 19 discrete elements. These vehicles are chosen since they provide a large spread in results when crush force is not normalized (similar to the spread of the data from these vehicles in figure 43), and all crush points lie in a common plane on each vehicle. In normalized form, the different vehicles appear similar, but the spread of the plots is a bit more than in figure 44. Normalization becomes less and less effective as the angular misalignment of the vehicle relative to the impact plane increases.

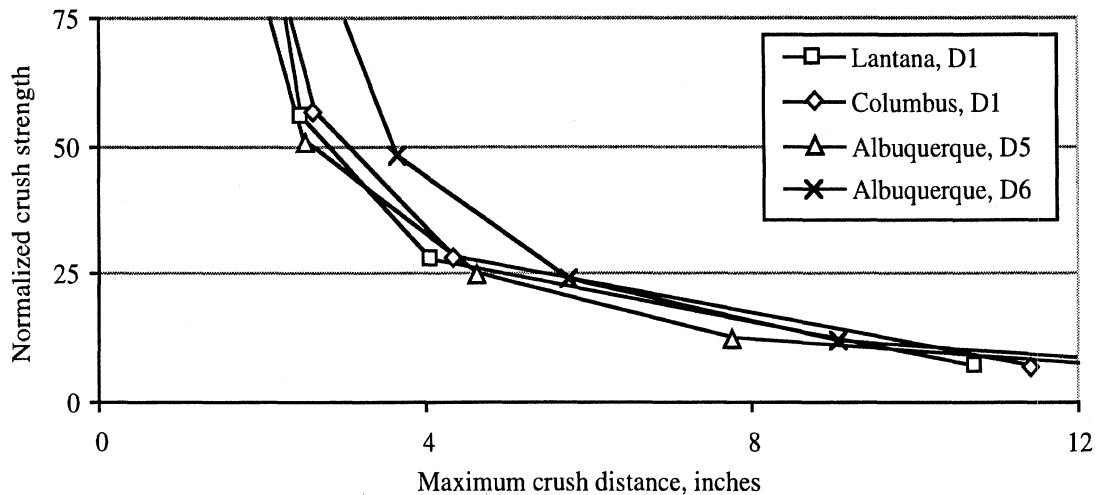

Figure 45. Results from impacts at 12 ft/sec and -5 degrees of pitch presented in normalized form

Note also that all the results of figure 45 are quite different from those of 44. The initial pitch of -5 degrees means that one end of the vehicle crushes quite a bit more, and the maximum crush distance is increased as a result. Consequently, figure 45 indicates substantially greater crush distances at a given normalized crush force than does figure 44. The tendency increases with greater pitch angles. Normalization is not effective across different conditions of vehicle attitude.

It is also useful to note that, while we have said that the *normalized* crush force resulting from equation 2 is dimensionless, this measure can also be interpreted in terms of “g loading.” In fact, if one were to calculate the constant deceleration, in gravitational units, required to stop a body initially traveling at 12 ft/sec in distances ranging from zero to 12 inches, the resulting curve would be of the same form as those of figure 44 and 45.

Such a curve would fall below the curves of either of these figures and would represent the performance of a perfectly symmetric tank with perfectly symmetric protective devices in a perfectly symmetric impact.

Examining figures 44 and 45 and interpreting normalized crush forces as “g-loads,” it becomes quite apparent that the required strength under these impact conditions is very substantial, especially if tank and protector designs allow for only small crush distances before damage is done to the protected objects. For example, at the far right of figure 45, where maximum crush distance is a full foot, the normalized crush force indicates that the entire structure is capable of supporting ten times the weight of the tank unit. Recall that these graphs apply to *optimized* structures providing constant crush force throughout the crush distance, and they are impacting smooth surfaces. Further, the impact velocity is 12 ft/sec. Since energy is proportional to velocity squared, impacts at 24 ft/sec imply four times the severity indicated here.

These reflections make it obvious that designing rollover-protective systems to survive such events is a significant challenge. The magnitude of the loads involved imply that effective systems must spread the load over large areas of the tank structure. Further it would seem that design of protective systems must involve controlled crush of the tank in order to provide adequate crush distances without resorting to high-profile devices.

Figure 46 further examines the influence of angular orientation of the tank on the requirements for crush strength and maximum crush distance. The figure contains results from lateral impact simulations of the Lantana semitrailer (configuration R1: rail-style protective devices per the actual vehicle). All of the data are for impacts at 18 ft/sec. All of the simulation runs represent a condition in which the vehicle that has nominally landed on its side slides sideways into a vertical surface. When roll angle is 90 degrees and yaw angle (relative to the surface) is 0 degrees, then the vehicle is striking the surface

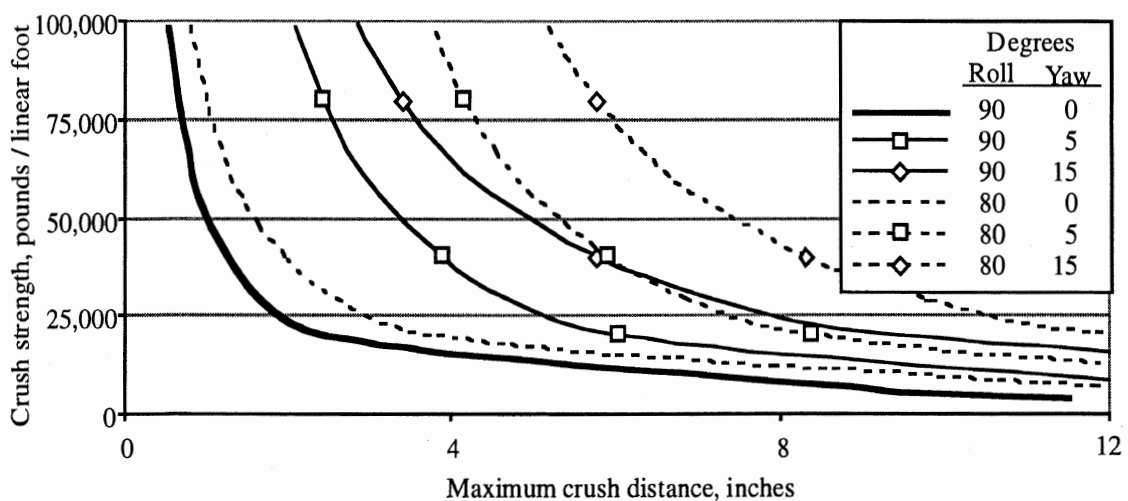

Figure 46. Results from lateral impacts of the Lantana semitrailer (R1) at 18 ft/sec and at various roll and yaw angles

flat against its top. This impact condition is represented by the heavy, solid line in the figure. All the other lines plotted in the figure represent conditions of misalignment in roll (80 degrees) or yaw (5 and 15 degrees) or the combination of both. When the tank is misaligned in roll, one rail strikes the surface first and more directly than the other. When the tank is misaligned in yaw, the rear of the tank strikes the surface before the front.

The figure indicates that misalignments in yaw result in very substantial increases in the requirements for either crush strength or crush distance. Misalignment in roll in combination with misalignment in yaw further aggravates the situation. Clearly, when the tank is aligned such that its edge or corner strikes the surface first, that area must either support greater forces or allow greater crush than is the case when the initial impact is more evenly distributed. In the worst case shown, the vehicle rolled to 80 degrees and yawed to 15 degrees requires either a crush strength or crush distance that is on the order of ten times greater than that required when impact is flat against the surface. (The figure also shows that misalignment in roll alone results in less severe requirements. In this situation, one rail strikes first, but that entire rail is engaged uniformly, spreading the impact loading rather effectively.)

Clearly, a "representative" real-world situation which might be incorporated in a performance standard should involve some amount of both yaw and roll misalignment. How much misalignment might be stipulated is an open question that can only be addressed by statistical and cost/benefit analyses.

Figure 47 presents the final point we will cover here. Those who examine appendix C carefully are likely to note that designs with crowned dams often stand out in the normal-impact data. Figure 47 compares a few versions of the Lantana vehicle in 12-ft/sec impacts in which the tops of the tanks strike flat against the surface. The crowned design stands out as requiring a great deal more crush distance than do the other designs. This

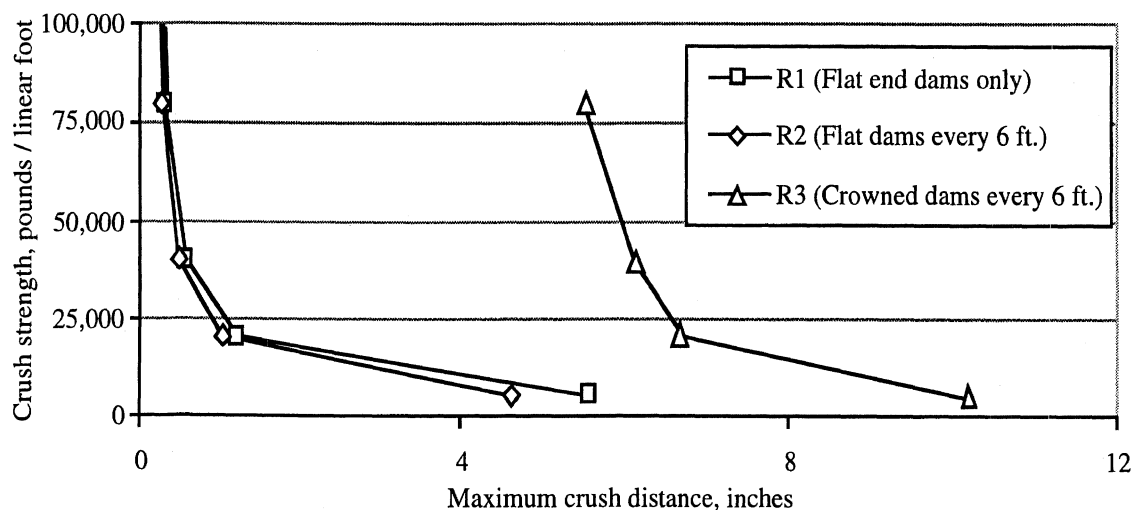

Figure 47. Comparison of results for various protector configurations

comes about simply because the crown extends 6 inches above the flat rails. Thus the relatively few load points on the crowns contact the surface 6 inches before the bulk of the load points on the rails. It is one of these points of the crown which always defines the maximum crush distance. Since there are only a few of these points, their forces do not slow the vehicle a great deal as it crushes down to the rails, and so this design usually shows substantially greater maximum crush. If the height of the crown represents *additional* clearance for the protected fitting beyond the clearance provided by side rails, then crowns are advantageous. However, if crowning is provided because some fittings project beyond rails, then crowns are not advantages because they begin to appear as discrete elements proving little protection.

OBSERVATIONS REGARDING THE CURRENT REGULATIONS

Federal regulations DOT 406, 407, and 412 require that “a rollover damage protection device on a cargo tank motor vehicle must be designed and installed to withstand loads equal to twice the weight of the loaded cargo tank motor vehicle applied...normal to the cargo tank...and tangential...from any direction.” [1] The regulation goes on to discuss allowed stresses under such loads but makes no mention of any requirement for sustaining the specified strength through any deflection.

This report has stressed that fundamental challenge to rollover-protection devices is the management of impact energy and that, for the purpose of energy management, strength is only part of the needed specification. To absorb the energy of impact, strength must be sustained through appreciable distance.

Having recognized this basic short coming of the current standard, then what can be said for the strength specification alone? Reconsider figures 44 and 45 and the related discussion suggesting that normalized crush strength can be interpreted as “g loading.” The strength requirement of “twice the weight of the...vehicle” is equivalent to a 2-g load or a normalized crush strength of 2. Visual extrapolation of the curves of figure 44 suggest that the data lines will not fall to a normalized crush force as low as 2 until maximum crush distance is several times the full 12 inches which is shown. That is, devices just meeting the required strength would also have to *sustain that strength through several feet of crush* to manage the rather mild impact represented in figure 44 (impact at 12 ft/sec flat against the upper surface of the tank). It is doubtful that any current rollover-protection devices are intended to do this.

CONCLUSIONS AND RECOMMENDATIONS

DYNAMICS OF TANK-VEHICLE ROLLOVER

The primary contribution of this study is a broad examination of the dynamics of tank-vehicle rollover. The results of a large simulation study of rollover dynamics were distilled to a set of fundamental and broadly-applicable measures for defining the initial conditions of common impact events that occur subsequent to a rollover and which are likely to engage the rollover-protection devices. Three simple scenarios were defined and have yielded results as follows.

(1) In a mild rollover, the vehicle may fall onto its side but continue to rotate in roll on the flat ground surface to engage the rollover-protection devices. The primary dynamic parameter of interest is final roll rate, and that interest is constrained to milder rollover events. Vehicles in the least severe of such rollovers achieve roll rates on the order of 100 deg/sec. Vehicles landing on their sides in more energetic events have roll rates up to and beyond 150 deg/sec.

(2) In the more dramatic rollovers, the vehicle may roll rapidly enough while airborne to bring the rollover-protection devices into direct impact with the ground. This result can occur with unit trucks on level ground but appears to require a sloping or depressed roadside surface for it to happen to a semitrailer tank. Trucks landing on their tops on the road achieve downward speeds of at least 6 ft/sec but rarely more than 18 ft/sec. Semitrailers allowed to fall sufficiently to reach 180 degrees of roll angle achieved downward speeds as high as 30 ft/sec. Pitch angle at impact in these events is typically within the range of ± 5 degrees for semitrailers but can be much larger for unit trucks.

(3) In moderate and severe rollovers, the vehicle may land on its side and slide sideways into any of many vertical surfaces that are typically oriented parallel to the roadway. The velocity component that is sideways to the roadway constitutes the primary impact velocity. This speed often exceeds 20 or 30 percent of the initial forward speed and occasionally can reach well beyond 40 percent. Yaw angles with respect to the road-parallel vertical surface typically fall in the range of ± 20 degrees but can be greater than 40 degrees for unit trucks.

IMPLICATIONS FOR ROLLOVER-PROTECTION DEVICES

The second element of this study provides insight into the design and engineering requirements for rollover-protection devices and the tanks to which they are mounted.

Simple impact simulation models using idealized force/deflection characteristics of the combined structure of the tank and protection devices were developed. These models were applied in a large matrix of conditions to evaluate the design implications of the impact conditions defined in the vehicle dynamics study. The full set of results of this exercise are appended. These data are intended to provide guidance for the design of protective systems of all types rather than precise determination of forces in any given device.

Results from this exercise indicate that impact due to rolling is of little concern for low-profile, rail-style rollover-protection devices but may be a major challenge for discrete devices which constitute a significant discontinuity in the profile of the tank. The problem posed by discrete devices is true even for roll velocities associated with the mildest of rollovers.

Vertical and lateral impacts, even into simple planar surfaces, appear to pose a significant challenge for all impact protection devices. The dynamic simulation study showed that virtually every rollover event involved impact speeds of at least 6 ft/sec and that a speed of 24 ft/sec was a reasonable upper bound for covering the majority of impacts. Initial velocities of 6, 12, 18, and 24 ft/sec were used in the impact study. Of these velocities, 12 ft/sec is the very lowest which could be judged as covering a significant fraction of realistic events. In many impacts at this velocity, if the combined structure of tank and protection devices provided a foot of crush distance, then it is often the case that the protective structure must be of such a strength that it could support ten times the weight of the vehicle. Since impact energy is proportional to velocity squared, the situation is nominally four times more severe for impacts at 24 ft/sec.

The vehicle dynamics study also showed that the tank may strike an impact surface over a range of angular orientations. The impact study showed this orientation has a strong effect on the required crush strength and/or crush distance. When compared to impacts in which the tank strikes flat against its top surface, combined misalignments of 10 degrees in roll and 15 degrees in yaw (relative to a vertical surface) may raise the requirement for either crush strength or crush distance on the order of ten times. Current standards (DOT 406, 407, and 412) require only that rollover-protection devices be strong enough to support twice the weight of the vehicle and make no comment on sustaining that strength through a prescribed crush distance[1].

These observations suggest that effective protective systems which could survive such impacts would represent a substantial increase in performance relative to that required by current regulations. The magnitude of the forces involved would appear to demand that effective designs spread the loading over a large portion of the tank structure, a fact which probably eliminates the so-called staple-type devices and other discrete styles of protective devices. Further, it appears that effective protective systems

must involve controlled crush of the tank to provide adequate crush distances without resorting to excessively large, high-profile devices.

RECOMMENDATIONS

Three recommendations are presented below. By way of preamble, however, we take care to note the nature of this study. The study was theoretical in that all results were obtained from computer simulations. Although the vehicle dynamics simulation that was used is well established and rather comprehensive, the impact simulations were newly developed for this purpose. Further, the study endeavored to examine the dynamic and physical properties of a large range of rollover events. However, as noted in the previous section on background and philosophy, there is no adequate accident data base to establish how these properties are distributed among accidents occurring in the real world. Thus, while the second recommendation below is quantitative and suggests some consideration of costs versus benefits, we frankly acknowledge that it is in part based on the authors' experience and judgement rather than wholly on the content of the study. The third recommendation recognizes the need for substantive cost/benefit considerations to be accomplished in the future.

- **Performance goals for rollover-protection devices should be expressed in terms of impact events, not in terms of the strength of the device.**

Rollover-protection devices suffer the forces they do as a result of impact events. As is the case for all impact-protection devices, good design demands effective management of impact energy. Effective designs may benefit from maintaining low forces by allowing greater crush deformations. Such engineering trade-offs are best left to the design process.

However, designers need to know the basic parameters for which the design is intended. Most basic to the impact situation is the energy content of the moving mass. The weight of the tank will be known to the designer. A description of the impact event is what is needed and such descriptions constitute the primary product of this study. This is the philosophy already employed in USDOT requirements relating to bumper standards and the impact protection of passenger car occupants.

- **A minimum design goal for rollover-protection systems should be effective performance in impacts onto flat surfaces at speeds normal to the surface of *at least* 12 ft/sec and with representative angular orientations of the tank with respect to the impact surface. Designing for impact at speeds up to 24 ft/sec is desirable.**

The vehicle dynamics study showed that virtually all rollover events will yield vertical and/or lateral impact velocities of at least 6 ft/sec and that vertical speeds of 18 ft/sec and lateral speeds of 24 ft/sec can be achieved in many situations. It seems reasonable

to recommend that any rollover-protection device, if it is to deserve such a name, must be able to protect tank fittings during impacts with simple planar surfaces at velocities covering at least a significant portion of this range.

At the very least, protection should be ensured when the impact occurs squarely in relation to the top surface of the tank. However, reasonably representative angular misalignments could increase the severity of the problem approximately ten-fold.

- **Evaluation of the cost effectiveness of performance standards for rollover-protection devices should be undertaken.**

This study has sought to identify the pertinent physical properties of cargo tank rollover events as a basis for specifying performance requirements for rollover-protection devices. The question of the cost-effectiveness of such devices remains to be addressed.

By way of example, impact velocities of 12 and 24 ft/sec could be attained by dropping a tank from rest onto a flat surface through distances of 2.2 and 8.9 feet, respectively. The latter number certainly suggests a significant design challenge even if the impact were square against the top surface of the tank. Reasonably representative angular misalignments could increase the effective severity of impact by about ten-fold. Evaluation of the incremental cost to transportation versus the potential societal savings which might result from various levels of such performance requirements is appropriate. Such analysis will require, among other things, knowledge of the statistical distribution of rollover accidents in terms of their physical severity and the occurrence of cargo spillage.

REFERENCES

1. "Specifications for Packagings," Title 49 *Code of Federal Regulations*, Pt. 178.345, 1997 ed.
2. National Transportation Safety Board. *Special Investigation Report*, "Cargo Tank Rollover Protection." Washington, D.C. 1992. 58 p. NTSB/SIR-92/01. PB92-917002.
3. *TruckSim User Reference Manual*. Version 4.0.2. Mechanical Simulation Corporation, Ann Arbor, MI. 1997. 287 p.
4. Ervin, R., Winkler, C., Fancher, P., Hagan, M., Krishnaswami, V., Zhang, H., Bogard, S. "Two Active Systems for Enhancing Dynamic Stability in Heavy Truck Operations." Final technical report. University of Michigan Transportation Research Institute. Ann Arbor, MI. 1998. 206 p. UMTRI-98-39. DTHN22-95-H-0702.
5. Sayers, M. "Vehicle Dynamics Programs for Roadway and Roadside Studies." Final technical report. University of Michigan Transportation Research Institute. Ann Arbor, MI. 1998. 51 p. UMTRI-98-20. DTFH61-93-R-00142.
6. *International standard. Road vehicles—Vehicle dynamics and road-holding ability—Vocabulary*. International Organization for Standardization . Geneva. 1991. 28 p. ISO 8855:1991.
7. Ervin, R.D., Mallikarjunarao, C., Gillespie, T.D. "Future configuration of tank Vehicles Hauling Flammable Liquids in Michigan." Volume I. Final report. Highway Safety Research Institute, Ann Arbor, MI. 1980. 243 p. UM-HSRI-80-73-1.

Appendix A.

Vehicle Rollover Simulation Input Parameters

Bronx, Tandem drive straight truck with chassis mounted straight-elliptical tank

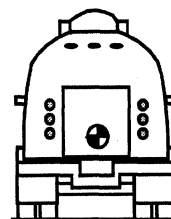
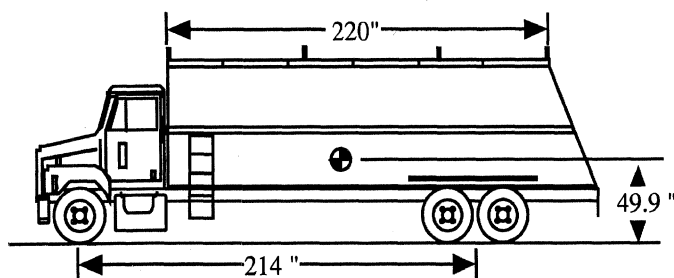

	<u>Axle 1</u>	<u>Axle 2</u>	<u>Axle 3</u>
Height above ground (inches):	14	19	19
Height of roll center above ground (in.):	20	29	29
Auxiliary roll stiffness (in-lb/deg):	8,800	10,000	10,000
Distance between springs (in):	38	38	38
Distance between dampers (in):	38	38	38
Half track (in):	80	72	72
Tire spring rate (lb/in):	4,600	4,600	4,600
Dual tire spacing (in):	0	13	13
Mass (lbm):	1,500	2,500	2,500
Unladen load (lb):	9,124	8,837	8,837
Laden load (lb):	13,498	18,650	18,650
Roll-steer coef.:	.1	.05	.05
Load distribution ratio:	0.1	0.45	0.45
Wheel spin inertia (in-lb-s ²):	100	100	100
Yaw and roll moment of inertia (in-lb-s ²):	4,603	5,594	5,594

Wheelbase (in):	214
Cargo load (lb):	24,000
Unladen CG height (in):	46.9
Width of cargo box (in):	30.3
Height of cargo floor (in):	47
Height of cargo box (in):	30.3
Length of cargo box (in):	220

Hamilton, Single drive straight truck with chassis mounted straight-elliptical tank

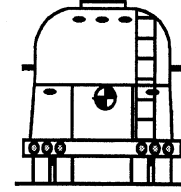
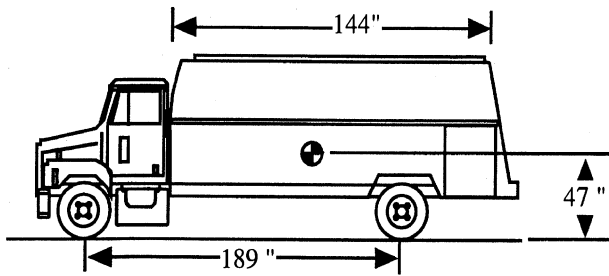

	<u>Axle 1</u>	<u>Axle 2</u>
Height above ground (inches):	14	19
Height of roll center above ground (in.):	20	29
Auxiliary roll stiffness (in-lb/deg):	8,800	10,000
Distance between springs (in):	38	38
Distance between dampers (in):	38	38
Half track (in):	80	72
Tire spring rate (lb/in):	4,600	4,600
Dual tire spacing (in):	0	13
Mass (lbm):	1,500	2,500
Unladen load (lb):	7,299	10,601
Laden load (lb):	10,898	22,862
Roll-steer coef.:	.1	.05
Load distribution ratio:	0.12	0.88
Wheel spin inertia (in-lb-s ²):	100	100
Yaw and roll moment of inertia (in-lb-s ²):	4,603	5,594

Wheelbase (in): 189
 Cargo load (lb): 15,860
 Unladen CG height (in): 47.1
 Height of cargo floor (in): 49
 Width of cargo box (in): 28.6
 Height of cargo box (in): 28.6
 Length of cargo box (in): 144

Columbus (gasoline), Tractor with a elliptical-double-conical tank semi-trailer

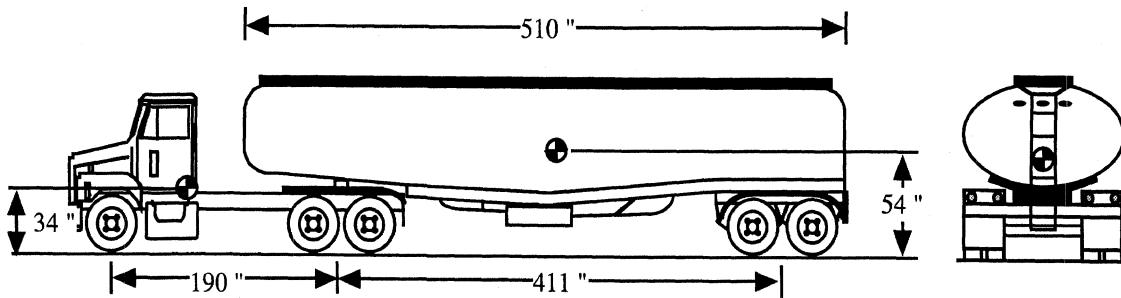

	<u>Axle 1</u>	<u>Axle 2</u>	<u>Axle 3</u>	<u>Axle 4</u>	<u>Axle 5</u>	<u>Tractor</u>
Height above ground (inches):	14	19	19	20	20	Wheelbase (in): 190
Height of roll center above ground (in.):	20	29	29	29	29	Unladen CG height (in): 34
Auxiliary roll stiffness (in-lb/deg):	8,800	10,000	10,000	20,000	20,000	Moment of inertia (IXX in-lb-s ²): 60,000
Distance between springs (in):	38	38	38	38	38	Moment of inertia (IYY in-lb-s ²): 300,000
Distance between dampers (in):	38	38	38	38	38	Moment of inertia (IZZ in-lb-s ²): 300,000
Half track (in):	80	72	72	72	72	
Tire spring rate (lb/in):	4,600	4,600	4,600	4,600	4,600	<u>Trailer</u>
Dual tire spacing (in):	0	13	13	13	13	Wheelbase (in): 411
Mass (lbm):	1,435	2,466	2,466	1,750	1,750	Cargo load (lb): 52,824
Unladen load (lb):	7,250	3,200	3,200	3,626	3,626	Unladen CG height (in): 54
Laden load (lb):	12,529	17,562	17,562	17,735	17,735	Height of cargo floor (in): 53
Roll-steer coef.:	.1	.05	.05	.05	.05	Width of cargo box (in): 45
Load distribution ratio:	0.05	0.223	0.223	0.253	0.253	Height of cargo box (in): 45
Wheel spin inertia (in-lb-s ²):	100	100	100	100	100	Length of cargo box (in): 510
Yaw and roll moment of inertia (in-lb-s ²):	4,603	5,594	5,594	4,642	4,642	

Columbus (fuel oil), Tractor with a elliptical- double-conical tank semi-trailer

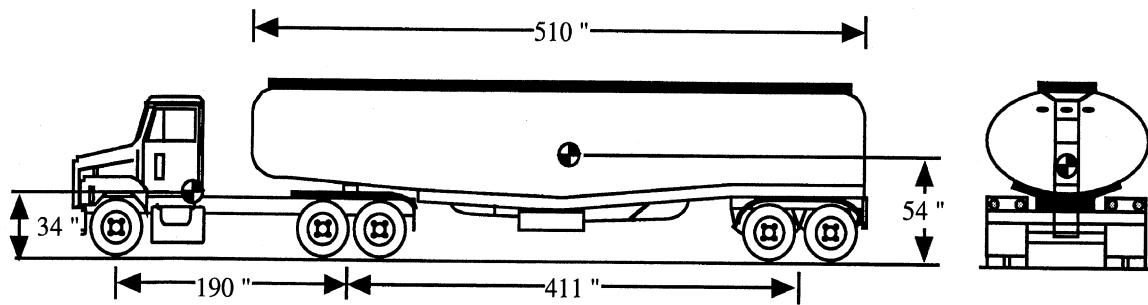

	<u>Axle 1</u>	<u>Axle 2</u>	<u>Axle 3</u>	<u>Axle 4</u>	<u>Axle 5</u>	<u>Tractor</u>
Height above ground (inches):	14	19	19	20	20	Wheelbase (in): 190
Height of roll center above ground (in.):	20	29	29	29	29	Unladen CG height (in): 34
Auxiliary roll stiffness (in-lb/deg):	8,800	10,000	10,000	20,000	20,000	Moment of inertia (IXX in-lb-s ²): 60,000
Distance between springs (in):	38	38	38	38	38	Moment of inertia (IYY in-lb-s ²): 300,000
Distance between dampers (in):	38	38	38	38	38	Moment of inertia (IZZ in-lb-s ²): 300,000
Half track (in):	80	72	72	72	72	
Tire spring rate (lb/in):	4,600	4,600	4,600	4,600	4,600	<u>Trailer</u>
Dual tire spacing (in):	0	13	13	13	13	Wheelbase (in): 411
Mass (lbm):	1,435	2,466	2,466	1,750	1,750	Cargo load (lb): 58,875
Unladen load (lb):	7,250	3,200	3,200	3,626	3,626	Unladen CG height (in): 54
Laden load (lb):	12,529	17,562	17,562	17,735	17,735	Height of cargo floor (in): 53
Roll-steer coef.:	.1	.05	.05	.05	.05	Width of cargo box (in): 46.5
Load distribution ratio:	0.05	0.223	0.223	0.253	0.253	Height of cargo box (in): 46.5
Wheel spin inertia (in-lb-s ²):	100	100	100	100	100	Length of cargo box (in): 510
Yaw and roll moment of inertia (in-lb-s ²):	4,603	5,594	5,594	4,642	4,642	

Albuquerque, Tractor with a straight-cylindrical tank semi-trailer

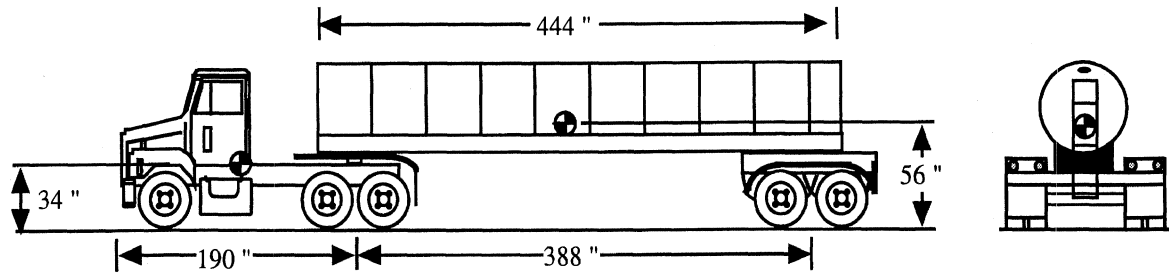

	<u>Axle 1</u>	<u>Axle 2</u>	<u>Axle 3</u>	<u>Axle 4</u>	<u>Axle 5</u>	<u>Tractor</u>
Height above ground (inches):	14	19	19	20	20	Wheelbase (in): 190
Height of roll center above ground (in.):	20	29	29	29	29	Unladen CG height (in): 34
Auxiliary roll stiffness (in-lb/deg):	8,800	10,000	10,000	20,000	20,000	<u>Trailer</u> Wheelbase (in): 388
Distance between springs (in):	38	38	38	38	38	Cargo load (lb): 48,500
Distance between dampers (in):	38	38	38	38	38	Unladen CG height (in): 64.8
Half track (in):	80	72	72	72	72	Height of cargo floor (in): 56.
Tire spring rate (lb/in):	4,600	4,600	4,600	4,600	4,600	Width of cargo box (in): 33.6
Dual tire spacing (in):	0	13	13	13	13	Height of cargo box (in): 33.6
Mass (lbm):	1,435	2,466	2,466	1,750	1,750	Length of cargo box (in): 444
Unladen load (lb):	7,250	3,200	3,200	4,653	4,653	
Laden load (lb):	11,842	15,693	15,693	16,777	16,777	
Roll-steer coef.:	.1	.05	.05	.05	.05	
Load distribution ratio:	0.05	0.223	0.223	0.253	0.253	
Wheel spin inertia (in-lb-s ²):	100	100	100	100	100	
Yaw and roll moment of inertia (in-lb-s ²):	4,603	5,594	5,594	4,642	4,642	

Lantana (gasoline), Tractor with a straight-elliptical tank semi-trailer

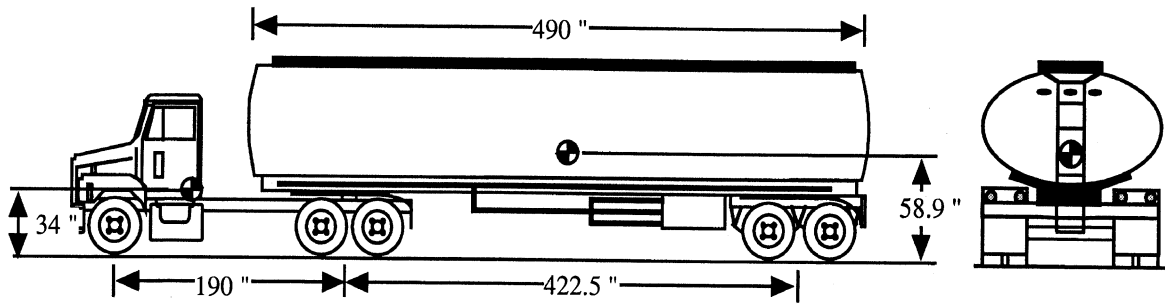

	<u>Axle 1</u>	<u>Axle 2</u>	<u>Axle 3</u>	<u>Axle 4</u>	<u>Axle 5</u>	<u>Tractor</u>
Height above ground (inches):	14	19	19	20	20	Wheelbase (in): 190
Height of roll center above ground (in.):	20	29	29	29	29	Unladen CG height (in): 34
Auxiliary roll stiffness (in-lb/deg):	8,800	10,000	10,000	20,000	20,000	<u>Trailer</u>
Distance between springs (in):	38	38	38	38	38	Wheelbase (in): 422.5
Distance between dampers (in):	38	38	38	38	38	Cargo load (lb): 52,799
Half track (in):	80	72	72	72	72	Unladen CG height (in): 58.9
Tire spring rate (lb/in):	4,600	4,600	4,600	4,600	4,600	Height of cargo floor (in): 54.5
Dual tire spacing (in):	0	13	13	13	13	Width of cargo box (in): 45.1
Mass (lbm):	1,435	2,466	2,466	1,750	1,750	Height of cargo box (in): 45.1
Unladen load (lb):	7,250	3,200	3,200	3,454	3,454	Length of cargo box (in): 490
Laden load (lb):	12,007	16,140	16,140	16,201	16,201	
Roll-steer coef.:	.1	.05	.05	.05	.05	
Load distribution ratio:	0.05	0.223	0.223	0.253	0.253	
Wheel spin inertia (in-lb-s ²):	100	100	100	100	100	
Yaw and roll moment of inertia (in-lb-s ²):	4,603	5,594	5,594	4,642	4,642	

Lantana (fuel oil), Tractor with a straight-elliptical tank semi-trailer

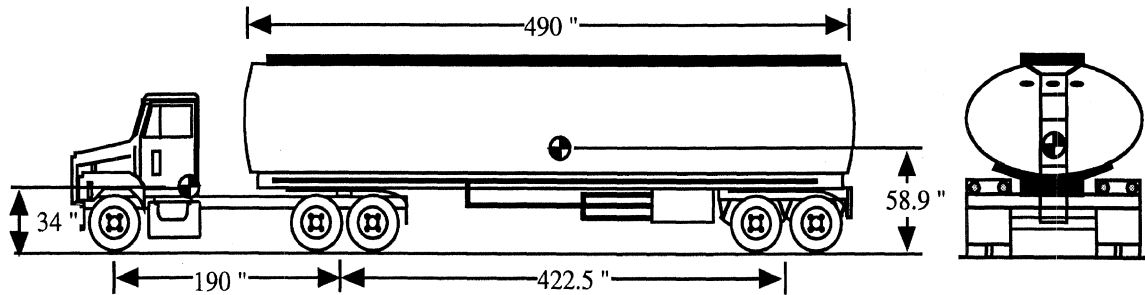

	<u>Axle 1</u>	<u>Axle 2</u>	<u>Axle 3</u>	<u>Axle 4</u>	<u>Axle 5</u>	<u>Tractor</u>
Height above ground (inches):	14	19	19	20	20	Wheelbase (in): 190
Height of roll center above ground (in.):	20	29	29	29	29	Unladen CG height (in): 34
Auxiliary roll stiffness (in-lb/deg):	8,800	10,000	10,000	20,000	20,000	<u>Trailer</u>
Distance between springs (in):	38	38	38	38	38	Wheelbase (in): 422.5
Distance between dampers (in):	38	38	38	38	38	Cargo load (lb): 58,875
Half track (in):	80	72	72	72	72	Unladen CG height (in): 58.9
Tire spring rate (lb/in):	4,600	4,600	4,600	4,600	4,600	Height of cargo floor (in): 54.5
Dual tire spacing (in):	0	13	13	13	13	Width of cargo box (in): 41.5
Mass (lbm):	1,435	2,466	2,466	1,750	1,750	Height of cargo box (in): 41.2
Unladen load (lb):	7,250	3,200	3,200	3,454	3,454	Length of cargo box (in): 490
Laden load (lb):	12,495	17,467	17,467	17,668	17,668	
Roll-steer coef.:	.1	.05	.05	.05	.05	
Load distribution ratio:	0.05	0.223	0.223	0.253	0.253	
Wheel spin inertia (in-lb-s ²):	100	100	100	100	100	
Yaw and roll moment of inertia (in-lb-s ²):	4,603	5,594	5,594	4,642	4,642	

Table A-1. Lantana Input Parameters

Description	LantanaG25	LantanaG50	LantanaFO25	LantanaFO50
CALC -- CG height of box load (in)	86.7	86.7	82.6	82.7
CALC -- CG height of sprung mass of laden Semitrailer (in)	85.8	85.8	82.2	82.3
CALC -- CG height of sprung mass of laden Tractor (in)	48.1	48.1	48.1	48.1
CALC -- CG height of total laden Semitrailer (in)	82.2	82.2	79.1	79.2
CALC -- Mass of box load (lb)	52799.0	52799.0	58875.0	58875.0
CALC -- Moment of inertia for total laden Semitrailer (in-lb-s ²)-IXX	118969.0	95802.6	111272.0	89760.3
CALC -- Moment of inertia for total laden Semitrailer (in-lb-s ²)-IYY	3660040.0	3648450.0	3971310.0	3960600.0
CALC -- Moment of inertia for total laden Semitrailer (in-lb-s ²)-IZZ	3624850.0	3613270.0	3940600.0	3929790.0
CALC -- Moment of inertia for sprung mass of laden Semitrailer (in-lb-s ²)-IYY	3212800.0	3201210.0	3525380.0	3514580.0
CALC -- Moment of inertia for sprung mass of laden Semitrailer (in-lb-s ²)-IXX	72569.7	49403.7	68648.5	47040.7
CALC -- Moment of inertia for sprung mass of laden Semitrailer (in-lb-s ²)-IZZ	3205440.0	3193860.0	3518730.0	3507920.0
CALC -- Moment of inertia for box load (in-lb-s ²)-IXX	46359.7	23193.6	43140.7	21521.8
CALC -- Moment of inertia for box load (in-lb-s ²)-IYY	2759390.0	2747810.0	3072660.0	3061850.0
CALC -- Moment of inertia for box load (in-lb-s ²)-IZZ	2759390.0	2747810.0	3072660.0	3061850.0
CALC -- Product of inertia for total laden Semitrailer (in-lb-s ²)-IXZ	36114.9	36114.9	42767.4	42584.4
CALC -- Product of inertia for sprung mass of laden Semitrailer (in-lb-s ²)-IXZ	158670.0	158670.0	159275.0	159260.0
CALC -- Sprung laden mass of Semitrailer (lb)	59539.0	59539.0	65615.0	65615.0
CALC -- Total laden mass of Semitrailer (lb)	63039.0	63039.0	69115.0	69115.0
CALC -- Total unladen mass of Semitrailer (lb)	10240.0	10240.0	10240.0	10240.0
CALC -- Total unladen mass of Tractor (lb)	13650.0	13650.0	13650.0	13650.0
CALC -- X dist (to rear) of sprung mass of laden Semitrailer CG (in)	205.1	205.1	205.0	205.0
CALC -- X dist (to rear) of total unladen Semitrailer CG (in)	285.0	285.0	285.0	285.0
CALC -- X dist (to rear) of box load CG (in)	204.0	204.0	204.0	204.0
CALC -- X dist (to rear) of total laden Semitrailer CG (in)	217.2	217.2	216.0	216.0
Height of box load (in)	45.1	31.9	41.2	29.1
Height of box load bottom above cargo floor (in)	9.7	16.3	7.5	13.7
Height of hitch 1 above ground (in)	49.0	49.0	49.0	49.0
Height of semitrailer cargo floor above ground	54.5	54.5	54.5	54.5

Description	LantanaG25	LantanaG50	LantanaFO25	LantanaFO50
(in)				
Height of total unladen semitrailer CG above ground (in)	58.9	58.9	58.9	58.9
Kingpin offset (at wheel center) for LF wheel (in)	28.0	28.0	28.0	28.0
Kingpin offset (at wheel center) for RF wheel (in)	28.0	28.0	28.0	28.0
Laden load for Axle 1 (lbm)	12007.0	12007.0	12495.0	12495.0
Laden load for Axle 2 (lbm)	16140.0	16140.0	17467.0	17467.0
Laden load for Axle 3 (lbm)	16140.0	16140.0	17467.0	17467.0
Laden load for Axle 4 (lbm)	16201.0	16201.0	17668.0	17668.0
Laden load for Axle 5 (lbm)	16201.0	16201.0	17668.0	17668.0
Length of box load (in)	490.0	490.0	490.0	490.0
Mass of total unloaded semitrailer (lbm)	10240.0	10240.0	10240.0	10240.0
Moment of inertia for total unladen semitrailer (in-lb-s ²)	55441.0	55441.0	55441.0	55441.0
Moment of inertia for total unladen semitrailer (in-lb-s ²)	737664.0	737664.0	737664.0	737664.0
Moment of inertia for total unladen semitrailer (in-lb-s ²)	719649.0	719649.0	719649.0	719649.0
Product of inertia for total unladen semitrailer (in-lb-s ²)	86148.0	86148.0	86148.0	86148.0
Unladen load for Axle 4 (lbm)	3454.0	3454.0	3454.0	3454.0
Unladen load for Axle 5 (lbm)	3454.0	3454.0	3454.0	3454.0
Wheelbase of semitrailer (in)	422.5	422.5	422.5	422.5
Width of box load (in)	45.1	31.9	41.2	29.1

Table A-2. Columbus Input Parameters

Description	ColumbusG50	ColumbusG25	ColumbusFO50	ColumbusFO25
CALC -- CG height of box load (in)	81.0	81.0	79.0	79.0
CALC -- CG height of sprung mass of laden Semitrailer (in)	80.5	80.5	78.8	78.7
CALC -- CG height of sprung mass of laden Tractor (in)	48.1	48.1	48.1	48.1
CALC -- CG height of total laden Semitrailer (in)	77.2	77.2	75.8	75.8
CALC -- Mass of box load (lb)	52824.0	52824.0	58875.0	58875.0
CALC -- Moment of inertia for total laden Semitrailer (in-lb-s ²)-I _{XX}	113404.0	90287.7	120346.0	92853.1
CALC -- Moment of inertia for total laden Semitrailer (in-lb-s ²)-I _{YY}	3902160.0	3890600.0	4247240.0	4233470.0
CALC -- Moment of inertia for total laden Semitrailer (in-lb-s ²)-I _{ZZ}	3873390.0	3861830.0	4220310.0	4206590.0
CALC -- Moment of inertia for sprung mass of laden Semitrailer (in-lb-s ²)-I _{YY}	3481830.0	3470270.0	3825790.0	3812070.0
CALC -- Moment of inertia for	72776.2	49659.4	81343.1	53895.1

Description	ColumbusG50	ColumbusG25	ColumbusFO50	ColumbusFO25
CALC -- CG height of box load (in)	81.0	81.0	79.0	79.0
CALC -- CG height of sprung mass of laden Semitrailer (in)	80.5	80.5	78.8	78.7
CALC -- CG height of sprung mass of laden Tractor (in)	48.1	48.1	48.1	48.1
sprung mass of laden Semitrailer (in-lb-s2)-IXX				
CALC -- Moment of inertia for sprung mass of laden Semitrailer (in-lb-s2)-IZZ	3475120.0	3463560.0	3819300.0	3805570.0
CALC -- Moment of inertia for box load (in-lb-s2)-IXX	46176.2	23059.4	54953.9	27509.6
CALC -- Moment of inertia for box load (in-lb-s2)-IYY	2988630.0	2977070.0	3332720.0	3319000.0
CALC -- Moment of inertia for box load (in-lb-s2)-IZZ	2988630.0	2977070.0	3332720.0	3319000.0
CALC -- Product of inertia for total laden Semitrailer (in-lb-s2)-IXZ	41688.0	41688.0	44832.1	44930.0
CALC -- Product of inertia for sprung mass of laden Semitrailer (in-lb-s2) -IXZ	151332.0	151332.0	151978.0	151995.0
CALC -- Sprung laden mass of Semitrailer (lb)	59924.0	59924.0	65975.0	65975.0
CALC -- Total laden mass of Semitrailer (lb)	63424.0	63424.0	69475.0	69475.0
CALC -- Total unladen mass of Semitrailer (lb)	10600.0	10600.0	10600.0	10600.0
CALC -- Total unladen mass of Tractor (lb)	13650.0	13650.0	13650.0	13650.0
CALC -- X dist (to rear) of sprung mass of laden Semitrailer CG (in)	199.4	199.4	199.2	199.2
CALC -- X dist (to rear) of total unladen Semitrailer CG (in)	281.2	281.2	281.2	281.2
CALC -- X dist (to rear) of box load CG (in)	197.0	197.0	197.0	197.0
CALC -- X dist (to rear) of total laden Semitrailer CG (in)	211.1	211.1	209.8	209.8
Height of box load (in)	45.0	31.8	46.5	32.9
Height of box load bottom above cargo floor (in)	5.5	12.1	2.8	9.5
Height of hitch 1 above ground (in)	51.0	51.0	51.0	51.0
Height of semitrailer cargo floor above ground (in)	53.0	53.0	53.0	53.0
Height of total unladen semitrailer CG above ground (in)	58.0	58.0	58.0	58.0
Kingpin offset (at wheel center) for LF wheel (in)	29.5	29.5	29.5	29.5
Kingpin offset (at wheel center) for RF wheel (in)	29.5	29.5	29.5	29.5
Laden load for Axle 1 (lbm)	12040.4	12040.4	12529.6	12529.6
Laden load for Axle 2 (lbm)	16231.5	16231.5	17562.2	17562.2
Laden load for Axle 3 (lbm)	16231.5	16231.5	17562.2	17562.2

Description	ColumbusG50	ColumbusG25	ColumbusFO50	ColumbusFO25
CALC -- CG height of box load (in)	81.0	81.0	79.0	79.0
CALC -- CG height of sprung mass of laden Semitrailer (in)	80.5	80.5	78.8	78.7
CALC -- CG height of sprung mass of laden Tractor (in)	48.1	48.1	48.1	48.1
Laden load for Axle 4 (lbm)	16285.4	16285.4	17735.5	17735.5
Laden load for Axle 5 (lbm)	16285.4	16285.4	17735.5	17735.5
Length of box load (in)	510.0	510.0	510.0	510.0
Mass of total unloaded semitrailer (lbm)	10600.0	10600.0	10600.0	10600.0
Moment of inertia for total unladen semitrailer (in-lb-s ²)	55132.0	55132.0	55132.0	55132.0
Moment of inertia for total unladen semitrailer (in-lb-s ²)	739351.0	739351.0	739351.0	739351.0
Moment of inertia for total unladen semitrailer (in-lb-s ²)	722680.0	722680.0	722680.0	722680.0
Product of inertia for total unladen semitrailer (in-lb-s ²)	85967.0	85967.0	85967.0	85967.0
Unladen load for Axle 4 (lbm)	3626.0	3626.0	3626.0	3626.0
Unladen load for Axle 5 (lbm)	3626.0	3626.0	3626.0	3626.0
Wheelbase of semitrailer (in)	411.0	411.0	411.0	411.0
Width of box load (in)	45.0	31.8	46.5	32.9

Table A-3. Albuquerque Input Parameters

Description	Albur50	Albur10
CALC -- CG height of box load (in)	83.5	83.5
CALC -- CG height of sprung mass of laden Semitrailer (in)	82.6	82.6
CALC -- CG height of sprung mass of laden Tractor (in)	48.1	48.1
CALC -- CG height of total laden Semitrailer (in)	79.2	79.2
CALC -- Mass of box load (lb)	48500.0	48500.0
CALC -- Moment of inertia for total laden Semitrailer (in-lb-s ²)-I _{XX}	91609.1	72683.3
CALC -- Moment of inertia for total laden Semitrailer (in-lb-s ²)-I _{YY}	3006370.0	2996910.0
CALC -- Moment of inertia for total laden Semitrailer (in-lb-s ²)-I _{ZZ}	2974400.0	2964940.0
CALC -- Moment of inertia for sprung mass of laden Semitrailer (in-lb-s ²)-I _{YY}	2650180.0	2640720.0
CALC -- Moment of inertia for sprung mass of laden Semitrailer (in-lb-s ²)-I _{XX}	48729.4	29803.7
CALC -- Moment of inertia for sprung mass of laden Semitrailer (in-lb-s ²)-I _{ZZ}	2642520.0	2633060.0
CALC -- Moment of inertia for box load (in-lb-s ²)-I _{XX}	23636.4	4710.7
CALC -- Moment of inertia for box load (in-lb-s ²)-I _{YY}	2075480.0	2066020.0
CALC -- Moment of inertia for box load (in-lb-s ²)-I _{ZZ}	2075480.0	2066020.0
CALC -- Product of inertia for total laden Semitrailer (in-lb-s ²)-I _{XZ}	61959.9	61959.9
CALC -- Product of inertia for sprung mass of laden Semitrailer (in-lb-s ²)-I _{XZ}	165183.0	165183.0
CALC -- Sprung laden mass of Semitrailer (lb)	59635.0	59635.0

Description	Albur50	Albur10
CALC -- Total laden mass of Semitrailer (lb)	63135.0	63135.0
CALC -- Total unladen mass of Semitrailer (lb)	14635.0	14635.0
CALC -- Total unladen mass of Tractor (lb)	13650.0	13650.0
CALC -- X dist (to rear) of sprung mass of laden Semitrailer CG (in)	195.5	195.5
CALC -- X dist (to rear) of total unladen Semitrailer CG (in)	246.7	246.7
CALC -- X dist (to rear) of box load CG (in)	194.0	194.0
CALC -- X dist (to rear) of total laden Semitrailer CG (in)	206.2	206.2
Height of box load (in)	33.6	15.0
Height of box load bottom above cargo floor (in)	10.7	20.0
Height of hitch 1 above ground (in)	48.0	48.0
Height of semitrailer cargo floor above ground (in)	56.0	56.0
Height of total unladen semitrailer CG above ground (in)	64.8	64.8
Kingpin offset (at wheel center) for LF wheel (in)	29.5	29.5
Kingpin offset (at wheel center) for RF wheel (in)	29.5	29.5
Laden load for Axle 1 (lbm)	11842.7	11842.7
Laden load for Axle 2 (lbm)	15693.7	15693.7
Laden load for Axle 3 (lbm)	15693.7	15693.7
Laden load for Axle 4 (lbm)	16777.5	16777.5
Laden load for Axle 5 (lbm)	16777.5	16777.5
Length of box load (in)	444.0	444.0
Mass of total unloaded semitrailer (lbm)	14635.0	14635.0
Moment of inertia for total unladen semitrailer (in-lb-s ²)	57790.0	57790.0
Moment of inertia for total unladen semitrailer (in-lb-s ²)	839750.0	839750.0
Moment of inertia for total unladen semitrailer (in-lb-s ²)	817962.0	817962.0
Product of inertia for total unladen semitrailer (in-lb-s ²)	90671.0	90671.0
Unladen load for Axle 4 (lbm)	4653.0	4653.0
Unladen load for Axle 5 (lbm)	4653.0	4653.0
Wheelbase of semitrailer (in)	388.0	388.0
Width of box load (in)	33.6	15.0

Table A-4. Common Input Parameters for all 5-axle Combinations

Description	Value
Aerodynamic drag coefficient (-)	0.65
Air density (slug/ft ³)	0.00234
Axle 1 auxiliary roll stiffness (in-lb/deg)	8800
Axle 1 ltk (to center of dual tires) (in)	80
Axle 1 rolling resistance coefficient speed proportionality constant (1/mph)	0.000041
Axle 1 roll-steer coefficient (axle steer / axle roll) (-)	0.1
Axle 1 tire spring rate (lb/in)	4600
Axle 1 yaw and roll moment of inertia (in-lb-s ²)	4603
Axle 1 zero speed nominal rolling resistance coefficient (-)	0.0041
Axle 2 auxiliary roll stiffness (in-lb/deg)	10000
Axle 2 dual tire spacing (use 0 for singles) (in)	13

Description	Value
Axle 2 ltk (to center of dual tires) (in)	72
Axle 2 rolling resistance coefficient speed proportionality constant (1/mph)	0.000041
Axle 2 roll-steer coefficient (axle steer / axle roll) (-)	0.05
Axle 2 tire spring rate (lb/in)	4600
Axle 2 yaw and roll moment of inertia (in-lb-s ²)	5594
Axle 2 zero speed nominal rolling resistance coefficient (-)	0.0041
Axle 3 auxiliary roll stiffness (in-lb/deg)	10000
Axle 3 dual tire spacing (use 0 for singles) (in)	13
Axle 3 ltk (to center of dual tires) (in)	72
Axle 3 rolling resistance coefficient speed proportionality constant (1/mph)	0.000041
Axle 3 roll-steer coefficient (axle steer / axle roll) (-)	0.05
Axle 3 tire spring rate (lb/in)	4600
Axle 3 yaw and roll moment of inertia (in-lb-s ²)	5594
Axle 3 zero speed nominal rolling resistance coefficient (-)	0.0041
Axle 4 auxiliary roll stiffness (in-lb/deg)	20000
Axle 4 dual tire spacing (use 0 for singles) (in)	13
Axle 4 ltk (to center of dual tires) (in)	72
Axle 4 rolling resistance coefficient speed proportionality constant (1/mph)	0.000041
Axle 4 roll-steer coefficient (axle steer / axle roll) (-)	0.05
Axle 4 tire spring rate (lb/in)	4600
Axle 4 yaw and roll moment of inertia (in-lb-s ²)	4642
Axle 4 zero speed nominal rolling resistance coefficient (-)	0.0041
Axle 5 auxiliary roll stiffness (in-lb/deg)	20000
Axle 5 dual tire spacing (use 0 for singles) (in)	13
Axle 5 ltk (to center of dual tires) (in)	72
Axle 5 rolling resistance coefficient speed proportionality constant (1/mph)	0.000041
Axle 5 roll-steer coefficient (axle steer / axle roll) (-)	0.05
Axle 5 tire spring rate (lb/in)	4600
Axle 5 yaw and roll moment of inertia (in-lb-s ²)	4642
Axle 5 zero speed nominal rolling resistance coefficient (-)	0.0041
Bump-steer ratio: steer/jounce (deg/in)	0.000159
CALC -- CG height of total laden Tractor (in)	34
CALC -- Moment of inertia for sprung mass of laden Tractor (in-lb-s ²)-I _{XX}	75661.6
CALC -- Moment of inertia for sprung mass of laden Tractor (in-lb-s ²)-I _{YY}	36098.6
CALC -- Moment of inertia for sprung mass of laden Tractor (in-lb-s ²)-I _{ZZ}	67981
CALC -- Moment of inertia for total laden Tractor (in-lb-s ²)-I _{XX}	60000
CALC -- Moment of inertia for total laden Tractor (in-lb-s ²)-I _{YY}	300000
CALC -- Moment of inertia for total laden Tractor (in-lb-s ²)-I _{ZZ}	300000
CALC -- Product of inertia for sprung mass of laden Tractor (in-lb-s ²)-I _{XZ}	26221.5
CALC -- Sprung laden mass of Tractor (lb)	7283
CALC -- Total laden mass of Tractor (lb)	13650
CALC -- X dist (to rear) of sprung mass of laden Tractor CG (in)	38.2974
CALC -- X dist (to rear) of hitch 1	160.499
CALC -- X dist (to rear) of total laden Tractor CG (in)	89.0842
CALC -- X dist (to rear) of total unladen Tractor CG (in)	89.0842

Description	Value
Caster angle for LF wheel (deg)	5.2
Caster angle for RF wheel (deg)	5.2
coefficient in argument to IFTHEN in argument to IFTHEN in FR_A1_TRIP_1 (lb/in)	1000000
coefficient in argument to IFTHEN in FT_A1_TRIP_1 (-)	0.1
Dimensionless integrator error tolerance (-)	0.01
Distance between dampers on Axle 1 (in)	38
Distance between dampers on Axle 2 (in)	38
Distance between dampers on Axle 3 (in)	38
Distance between dampers on Axle 4 (in)	38
Distance between dampers on Axle 5 (in)	38
Distance between springs on Axle 1 (in)	38
Distance between springs on Axle 2 (in)	38
Distance between springs on Axle 3 (in)	38
Distance between springs on Axle 4 (in)	38
Distance between springs on Axle 5 (in)	38
Height of Axle 1 CG above ground (in)	14
Height of Axle 1 roll center above ground (in)	20
Height of Axle 2 CG above ground (in)	19
Height of Axle 2 roll center above ground (in)	29
Height of Axle 3 CG above ground (in)	19
Height of Axle 3 roll center above ground (in)	29
Height of Axle 4 CG above ground (in)	20
Height of Axle 4 roll center above ground (in)	29
Height of Axle 5 CG above ground (in)	20
Height of Axle 5 roll center above ground (in)	29
Height of total unladen tractor CG above ground (in)	34
Hitch roll torsional stiffness (in-lb/deg)	5750000
Initial integration step (s)	0.00001
Kingpin inclination angle for LF wheel (deg)	7.2
Kingpin inclination angle for RF wheel (deg)	7.2
Longitudinal tandem axle spacing for Semitrailer (in)	49
Longitudinal tandem axle spacing for Tractor (in)	50
Mass of Axle 1 (lbm)	1435
Mass of Axle 2 (lbm)	2466
Mass of Axle 3 (lbm)	2466
Mass of Axle 4 (lbm)	1750
Mass of Axle 5 (lbm)	1750
Maximum force applied at the trip point (lb)	50000
Minimum allowable integration step (s)	0.0000001
Moment of inertia for total unladen tractor (in-lb-s ²)	60000
Moment of inertia for total unladen tractor (in-lb-s ²)	300000
Moment of inertia for total unladen tractor (in-lb-s ²)	300000
Radius of the trip curb (ft)	500
Ratio: steer due to axle wrap (-)	0.14
Roll angle for stopping the simulation (deg)	180

Description	Value
simulation stop time (s)	25
simulation time step (s)	0.00025
Steering shaft compliance (deg/lb/in)	0.000251
Tire relaxation length, axle 1 (in)	24
Tire relaxation length, axle 2 (in)	24
Tire relaxation length, axle 3 (in)	24
Tire relaxation length, axle 4 (in)	24
Tire relaxation length, axle 5 (in)	24
Tire/ground friction coefficient (-)	0.8
Torsional steering system complinace due to tie rods (deg/lb/in)	0.0000475
Unladen load for Axle 1 (lbm)	7250
Unladen load for Axle 2 (lbm)	3200
Unladen load for Axle 3 (lbm)	3200
Wheel spin inertia, Axle 1 (in-lb-s ²)	100
Wheel spin inertia, Axle 2 (in-lb-s ²)	100
Wheel spin inertia, Axle 3 (in-lb-s ²)	100
Wheel spin inertia, Axle 4 (in-lb-s ²)	100
Wheel spin inertia, Axle 5 (in-lb-s ²)	100
Wheelbase of tractor (in)	190
Width of guard rail (in)	24
Wrap-up compliance of front axle (deg/lb/in)	0.000021

Table A-5. Input Parameters for Bronx

Description	Bronx25	Bronx50
Aerodynamic drag coefficient (-)	0.65	0.65
Aerodynamic frontal area (ft ²)	0	0
Air density (slug/ft ³)	2.34E-03	2.34E-03
Axle 1 auxiliary roll stiffness (in-lb/deg)	8800	8800
Axle 1 ltk (to center of dual tires) (in)	80	80
Axle 1 rolling resistance coefficient speed proportionality constant (1/mph)	4.10E-05	4.10E-05
Axle 1 roll-steer coefficient (axle steer / axle roll) (-)	0.1	0.1
Axle 1 tire spring rate (lb/in)	4600	4600
Axle 1 yaw and roll moment of inertia (in-lb-s ²)	4603	4603
Axle 1 zero speed nominal rolling resistance coefficient (-)	4.10E-03	4.10E-03
Axle 2 auxiliary roll stiffness (in-lb/deg)	10000	10000
Axle 2 dual tire spacing (use 0 for singles) (in)	13	13
Axle 2 ltk (to center of dual tires) (in)	72	72
Axle 2 rolling resistance coefficient speed proportionality constant (1/mph)	4.10E-05	4.10E-05
Axle 2 roll-steer coefficient (axle steer / axle roll) (-)	5.00E-02	5.00E-02
Axle 2 tire spring rate (lb/in)	4600	4600
Axle 2 yaw and roll moment of inertia (in-lb-s ²)	5594	5594
Axle 2 zero speed nominal rolling resistance coefficient (-)	4.10E-03	4.10E-03
Axle 3 auxiliary roll stiffness (in-lb/deg)	10000	10000

Description	Bronx25	Bronx50
Axle 3 dual tire spacing (use 0 for singles) (in)	13	13
Axle 3 ltk (to center of dual tires) (in)	72	72
Axle 3 rolling resistance coefficient speed proportionality constant (1/mph)	4.10E-05	4.10E-05
Axle 3 roll-steer coefficient (axle steer / axle roll) (-)	5.00E-02	5.00E-02
Axle 3 tire spring rate (lb/in)	4600	4600
Axle 3 yaw and roll moment of inertia (in-lb-s ²)	5594	5594
Axle 3 zero speed nominal rolling resistance coefficient (-)	4.10E-03	4.10E-03
Bump-steer ratio: steer/jounce (deg/in)	1.59E-04	1.59E-04
CALC -- CG height of box load (in)	73.95	74
CALC -- CG height of sprung mass of laden Vehicle (in)	65.8176	65.8447
CALC -- CG height of total laden Vehicle (in)	59.6795	59.7032
CALC -- Computational efficiency (sec/sim. sec) (-)	13.8	0
CALC -- Mass of box load (lb)	24000	24000
CALC -- Moment of inertia for sprung mass of laden Vehicle (in-lb-s ²) -IYY	916550	921334
CALC -- Moment of inertia for sprung mass of laden Vehicle (in-lb-s ²) -IXX	83031.6	92548.9
CALC -- Moment of inertia for sprung mass of laden Vehicle (in-lb-s ²) -IZZ	897964	902697
CALC -- Moment of inertia for box load (in-lb-s ²)-IXX	9511.71	18978.5
CALC -- Moment of inertia for box load (in-lb-s ²)-IYY	255476	260209
CALC -- Moment of inertia for box load (in-lb-s ²)-IZZ	255476	260209
CALC -- Moment of inertia for total laden Vehicle (in-lb-s ²) -IXX	132683	142238
CALC -- Moment of inertia for total laden Vehicle (in-lb-s ²) -IYY	1.10E+06	1.10E+06
CALC -- Moment of inertia for total laden Vehicle (in-lb-s ²) -IZZ	1.06E+06	1.06E+06
CALC -- Product of inertia for sprung mass of laden Vehicle (in-lb-s ²)-IXZ	32878.5	32937.5
CALC -- Product of inertia for total laden Vehicle (in-lb-s ²) -IXZ	30036.3	30091.8
CALC -- Sprung laden mass of Vehicle (lb)	44300	44300
CALC -- Total laden mass of Vehicle (lb)	50800	50800
CALC -- Total unladen mass of Vehicle (lb)	26800	26800
CALC -- X dist (to rear) of sprung mass of laden Vehicle CG (in)	156.039	156.039
CALC -- X dist (to rear) of box load CG (in)	175	175
CALC -- X dist (to rear) of total laden Vehicle CG (in)	157.137	157.137
CALC -- X dist (to rear) of total unladen Vehicle CG (in)	141.14	141.14
Caster angle for LF wheel (deg)	5.2	5.2
Caster angle for RF wheel (deg)	5.2	5.2
Distance between dampers on Axle 1 (in)	38	38
Distance between dampers on Axle 2 (in)	38	38
Distance between dampers on Axle 3 (in)	38	38
Distance between springs on Axle 1 (in)	38	38
Distance between springs on Axle 2 (in)	38	38
Distance between springs on Axle 3 (in)	38	38
Forward speed/spin rate initialization switch: if 0.0 --> do not initialize, initialized otherwise (-)	1	1
Height of Axle 1 CG above ground (in)	14	14
Height of Axle 1 roll center above ground (in)	20	20
Height of Axle 2 CG above ground (in)	19	19
Height of Axle 2 roll center above ground (in)	29	29

Description	Bronx25	Bronx50
Height of Axle 3 CG above ground (in)	19	19
Height of Axle 3 roll center above ground (in)	29	29
Height of box load (in)	30.3	42.8
Height of box load bottom above cargo floor (in)	11.8	5.6
Height of total unladen vehicle CG above ground (in)	46.9	46.9
Height of vehicle cargo floor above ground (in)	47	47
Ht above ground of vehicle ref. pt. (in)	0	0
Integral control gain for speed controller (rev/s ²)	0.157	0.157
Kingpin inclination angle for LF wheel (deg)	7.2	7.2
Kingpin inclination angle for RF wheel (deg)	7.2	7.2
Kingpin offset (at wheel center) for LF wheel (in)	3.9	3.9
Kingpin offset (at wheel center) for RF wheel (in)	3.9	3.9
Laden load for Axle 1 (lbm)	13498.4	13498.4
Laden load for Axle 2 (lbm)	18650.8	18650.8
Laden load for Axle 3 (lbm)	18650.8	18650.8
Length of box load (in)	220	220
Longitudinal tandem axle spacing for Vehicle (in)	50	50
Low-speed condition for stopping the simulation (mph)	-1	-1
Low-speed threshold for modified longitudinal slip equations, axle 1 (mph)	6	6
Low-speed threshold for modified longitudinal slip equations, axle 2 (mph)	6	6
Low-speed threshold for modified longitudinal slip equations, axle 3 (mph)	6	6
Low-speed threshold for modified tire relaxation equations, axle 1 (mph)	10	10
Low-speed threshold for modified tire relaxation equations, axle 2 (mph)	10	10
Low-speed threshold for modified tire relaxation equations, axle 3 (mph)	10	10
Low-speed threshold for modified wheel spin equations, Axle 1 (mph)	3	3
Low-speed threshold for modified wheel spin equations, Axle 2 (mph)	3	3
Low-speed threshold for modified wheel spin equations, Axle 3 (mph)	3	3
Mass of Axle 1 (lbm)	1500	1500
Mass of Axle 2 (lbm)	2500	2500
Mass of Axle 3 (lbm)	2500	2500
Maximum force applied at the trip point (lb)	50000	50000
Moment of inertia for total unladen vehicle (in-lb-s ²) -IXX	99175.7	99175.7
Moment of inertia for total unladen vehicle (in-lb-s ²) -IYY	779379	779379
Moment of inertia for total unladen vehicle (in-lb-s ²) -IZZ	766719	766719
Product of inertia for total unladen vehicle (in-lb-s ²) -IXZ	0	0
Proportional control gain for speed controller (rev/s)	0.141	0.141
Ratio: steer due to axle wrap (-)	0.14	0.14
Roll angle for stopping the simulation (deg)	180	180
Rolling resistance road surface coefficient (-)	0	0
Run ID number (echoed in ERD file header) (-)	544	544
Speed control switch (0.0 -> off, 1.0 -> on) (-)	1	1
Speed of headwind (toward driver) relative to ground (negative values are set to zero) (mph)	0	0
Steering shaft compliance (deg/lb/in)	2.51E-04	2.51E-04
Time constant for air chambers for brakes on axle 1 (s)	0.3	0.3

Description	Bronx25	Bronx50
Time constant for air chambers for brakes on axle 2 (s)	0.3	0.3
Time constant for air chambers for brakes on axle 3 (s)	0.3	0.3
Tire relaxation length, axle 1 (in)	24	24
Tire relaxation length, axle 2 (in)	24	24
Tire relaxation length, axle 3 (in)	24	24
Tire/ground friction coefficient (-)	0.8	0.8
Torsional steering system complinace due to tie rods (deg/lb/in)	4.75E-05	4.75E-05
Transport delay for air to brakes on axle 1 (s)	0.5	0.5
Transport delay for air to brakes on axle 2 (s)	0.5	0.5
Transport delay for air to brakes on axle 3 (s)	0.5	0.5
UMTRI spring init: 0.0 -> equilibrium, otherwise use initial condition (-)	1	1
Unladen load for Axle 1 (lbm)	9124.53	9124.53
Unladen load for Axle 2 (lbm)	8837.73	8837.73
Unladen load for Axle 3 (lbm)	8837.73	8837.73
Vehicle pitch, roll and height initialization switch: if 0.0 --> do not initialize, initialized otherwise (-)	1	1
Wheel spin inertia, Axle 1 (in-lb-s2)	100	100
Wheel spin inertia, Axle 2 (in-lb-s2)	100	100
Wheel spin inertia, Axle 3 (in-lb-s2)	100	100
Wheelbase of vehicle (in)	214	214
Width of box load (in)	30.3	42.8
Width of guard rail (in)	24	24
Wrap-up compliance of front axle (deg/lb/in)	2.10E-05	2.10E-05
X coord. of vehicle ref. pt. (in)	0	0
Y coord. of vehicle ref. pt. (in)	0	0

Table A-5. Input Parameters for Hamilton

Description	Hamilton25	Hamilton50
Aerodynamic drag coefficient (-)	0.65	0.65
Aerodynamic frontal area (ft2)	0	0
Air density (slug/ft^3)	2.34E-03	2.34E-03
Axle 1 auxiliary roll stiffness (in-lb/deg)	8800	8800
Axle 1 ltk (to center of dual tires) (in)	80	80
Axle 1 rolling resistance coefficient speed proportionality constant (1/mph)	4.10E-05	4.10E-05
Axle 1 roll-steer coefficient (axle steer / axle roll) (-)	0.1	0.1
Axle 1 tire spring rate (lb/in)	4600	4600
Axle 1 yaw and roll moment of inertia (in-lb-s2)	4603	4603
Axle 1 zero speed nominal rolling resistance coefficient (-)	4.10E-03	4.10E-03
Axle 2 auxiliary roll stiffness (in-lb/deg)	10000	10000
Axle 2 dual tire spacing (use 0 for singles) (in)	13	13
Axle 2 ltk (to center of dual tires) (in)	72	72
Axle 2 rolling resistance coefficient speed proportionality constant (1/mph)	4.10E-05	4.10E-05
Axle 2 roll-steer coefficient (axle steer / axle roll) (-)	5.00E-02	5.00E-02
Axle 2 tire spring rate (lb/in)	4600	4600

Description	Hamilton25	Hamilton50
Axle 2 yaw and roll moment of inertia (in-lb-s ²)	5594	5594
Axle 2 zero speed nominal rolling resistance coefficient (-)	4.10E-03	4.10E-03
Bump-steer ratio: steer/jounce (deg/in)	1.59E-04	1.59E-04
CALC -- CG height of box load (in)	75	75
CALC -- CG height of sprung mass of laden Vehicle (in)	65.9976	65.9976
CALC -- CG height of total laden Vehicle (in)	60.207	60.207
CALC -- Computational efficiency (sec/sim. sec) (-)	7.55287	7.66448
CALC -- Mass of box load (lb)	15860	15860
CALC -- Moment of inertia for sprung mass of laden Vehicle (in-lb-s ²) -IYY	413590	416350
CALC -- Moment of inertia for sprung mass of laden Vehicle (in-lb-s ²) -IZZ	400467	403227
CALC -- Moment of inertia for sprung mass of laden Vehicle (in-lb-s ²)-IXX	56085.5	61604.7
CALC -- Moment of inertia for box load (in-lb-s ²) -IYY	73784	76543.5
CALC -- Moment of inertia for box load (in-lb-s ²)-IXX	5600.12	11119.2
CALC -- Moment of inertia for box load (in-lb-s ²)-IZZ	73784	76543.5
CALC -- Moment of inertia for total laden Vehicle (in-lb-s ²) -IXX	88157.2	93676.4
CALC -- Moment of inertia for total laden Vehicle (in-lb-s ²) -IYY	523346	526106
CALC -- Moment of inertia for total laden Vehicle (in-lb-s ²) -IZZ	498545	501305
CALC -- Product of inertia for total laden Vehicle (in-lb-s ²) -IXZ	20769.8	20769.8
CALC -- Product of inertia for sprung mass of laden Vehicle (in-lb-s ²) -IXZ	13480.5	13480.5
CALC -- Sprung laden mass of Vehicle (lb)	29760	29760
CALC -- Total laden mass of Vehicle (lb)	33760	33760
CALC -- Total unladen mass of Vehicle (lb)	17900	17900
CALC -- X dist (to rear) of sprung mass of laden Vehicle CG (in)	129.315	129.315
CALC -- X dist (to rear) of box load CG (in)	146.112	146.112
CALC -- X dist (to rear) of total laden Vehicle CG (in)	127.989	127.989
CALC -- X dist (to rear) of total unladen Vehicle CG (in)	111.932	111.932
Caster angle for LF wheel (deg)	5.2	5.2
Caster angle for RF wheel (deg)	5.2	5.2
Distance between dampers on Axle 1 (in)	38	38
Distance between dampers on Axle 2 (in)	38	38
Distance between springs on Axle 1 (in)	38	38
Distance between springs on Axle 2 (in)	38	38
Forward speed/spin rate initialization switch: if 0.0 --> do not initialize, initialized otherwise (-)	1	1
Height of Axle 1 CG above ground (in)	14	14
Height of Axle 1 roll center above ground (in)	20	20
Height of Axle 2 CG above ground (in)	19	19
Height of Axle 2 roll center above ground (in)	29	29
Height of box load (in)	28.6	40.3
Height of box load bottom above cargo floor (in)	11.7	5.85
Height of the above side of guard rail (in)	36	36
Height of the low side of guard rail (in)	16	16
Height of total unladen vehicle CG above ground (in)	47.1	47.1
Height of vehicle cargo floor above ground (in)	49	49
Ht above ground of vehicle ref. pt. (in)	0	0

Description	Hamilton25	Hamilton50
Integral control gain for speed controller (rev/s ²)	0.157	0.157
Kingpin inclination angle for LF wheel (deg)	7.2	7.2
Kingpin inclination angle for RF wheel (deg)	7.2	7.2
Kingpin offset (at wheel center) for LF wheel (in)	3.9	3.9
Kingpin offset (at wheel center) for RF wheel (in)	3.9	3.9
Laden load for Axle 1 (lbf)	10898	10898
Laden load for Axle 2 (lbf)	22862	22862
Length of box load (in)	144	144
Low-speed condition for stopping the simulation (mph)	-1	-1
Low-speed threshold for modified longitudinal slip equations, axle 1 (mph)	6	6
Low-speed threshold for modified longitudinal slip equations, axle 2 (mph)	6	6
Low-speed threshold for modified tire relaxation equations, axle 1 (mph)	10	10
Low-speed threshold for modified tire relaxation equations, axle 2 (mph)	10	10
Low-speed threshold for modified wheel spin equations, Axle 1 (mph)	3	3
Low-speed threshold for modified wheel spin equations, Axle 2 (mph)	3	3
Mass of Axle 1 (lbf)	1500	1500
Mass of Axle 2 (lbf)	2500	2500
Maximum force applied at the trip point (lb)	50000	50000
Moment of inertia for total unladen vehicle (in-lb-s ²) -IXX	65603	65603
Moment of inertia for total unladen vehicle (in-lb-s ²) -IYY	407164	407164
Moment of inertia for total unladen vehicle (in-lb-s ²) -IZZ	399317	399317
Product of inertia for total unladen vehicle (in-lb-s ²)-IXZ	0	0
Proportional control gain for speed controller (rev/s)	0.141	0.141
Ratio: steer due to axle wrap (-)	0.14	0.14
Roll angle for stopping the simulation (deg)	180	180
Rolling resistance road surface coefficient (-)	0	0
Run ID number (echoed in ERD file header) (-)	543	543
Speed control switch (0.0 -> off, 1.0 -> on) (-)	1	1
Speed of headwind (toward driver) relative to ground (negative values are set to zero) (mph)	0	0
Steering shaft compliance (deg/lb/in)	2.51E-04	2.51E-04
Time constant for air chambers for brakes on axle 1 (s)	0.3	0.3
Time constant for air chambers for brakes on axle 2 (s)	0.3	0.3
Tire relaxation length, axle 1 (in)	24	24
Tire relaxation length, axle 2 (in)	24	24
Tire/ground friction coefficient (-)	0.8	0.8
Torsional steering system compliance due to tie rods (deg/lb/in)	4.75E-05	4.75E-05
Transport delay for air to brakes on axle 1 (s)	0.5	0.5
Transport delay for air to brakes on axle 2 (s)	0.5	0.5
UMTRI spring init: 0.0 -> equilibrium, otherwise use initial condition (-)	1	1
Unladen load for Axle 1 (lbf)	7299	7299
Unladen load for Axle 2 (lbf)	10601	10601
Vehicle pitch, roll and height initialization switch: if 0.0 --> do not initialize, initialized otherwise (-)	1	1
Wheel spin inertia, Axle 1 (in-lb-s ²)	100	100
Wheel spin inertia, Axle 2 (in-lb-s ²)	100	100

Description	Hamilton25	Hamilton50
Wheelbase of vehicle (in)	189	189
Width of box load (in)	28.6	40.3
Width of guard rail (in)	24	24
Wrap-up compliance of front axle (deg/lb/in)	2.10E-05	2.10E-05
X coord. of vehicle ref. pt. (in)	0	0
Y coord. of vehicle ref. pt. (in)	0	0

Appendix B.

Vehicle Rollover Simulation Results

Table B-1. Results from simulation runs with Bronx 3-axle truck

Run no.	Vehicle & inertia factor	Run Type	Speed [mph]	Turn radius [ft]	Strike angle [deg]	Roll-over	Angular position [deg]				Angular rate [deg/sec]			Conditions at end of run				Strike pt velocity [ft/sec]			Path change [deg] relative to Curb Path			Relative to wall beside curb/rail/path		
							Roll	Pitch	Yaw	Roll	Pitch	Yaw	Z [ft]	CG ht [ft]	CG rate	X	Y	Z	X	Y	Z	Curb	Path	Strike [deg]	Yaw [deg]	Vn [ft/sec]
1	Brx25	Trip	35	500	5	no	4.7	0.1	58.6	2.5	0.4	5.8	5.5	51.7	1.9	0.0	60.6	6.1	-12.6	-0.4	-5.4	-0.4	-1.7	-0.3	-0.01	
2	Brx25	Trip	40	500	5	no	0.5	-0.4	64.3	4.9	1.3	8.6	5.5	59.1	2.3	0.3				-0.7	-5.7	-0.7	-1.5	-0.7	-0.01	
3	Brx25	Trip	45	500	5	yes	106.8	0.5	23.0	170.7	7.9	-11.0	3.8	61.1	-5.1	-9.9				5.7	0.7	5.7	-0.9	6.1	0.09	
4	Brx25	Trip	50	500	5	yes	95.8	4.9	14.6	132.2	11.2	-75.4	4.2	60.0	-3.2	-12.8	54.7	6.2	-23.1	7.4	2.4	7.4	-4.3	7.7	0.11	
5	Brx25	Trip	55	500	5	on flat	99.2	-0.5	-2.5	118.3	12.6	2.0	3.7	81.6	-20.6	-12.5	82.1	-15.8	-15.5	10.5	5.5	10.5	3.7	15.3	0.19	
6	Brx50	Trip	35	500	5	no	5.5	0.1	58.6	3.7	0.6	6.3	5.5	51.8	1.6	0.0				-0.1	-5.1	-0.1	-1.7	-0.1	0.00	
7	Brx50	Trip	40	500	5	no	2.2	-0.4	64.3	4.3	-1.6	6.7	5.5	58.8	2.9	0.1				-1.2	-6.2	-1.2	-1.6	-1.3	-0.02	
8	Brx50	Trip	45	500	5	yes	107.2	0.3	23.9	141.9	9.3	-3.4	3.8	61.0	-5.5	-10.2	61.0	5.1	-11.7	5.7	0.7	5.7	-0.5	6.1	0.09	
9	Brx50	Trip	50	500	5	yes	101.6	2.0	14.0	138.9	3.6	-31.2	3.9	68.3	-1.5	-13.5	66.4	6.7	-19.1	6.7	1.7	6.7	-5.4	8.0	0.11	
10	Brx50	Trip	55	500	5	on flat	98.8	-0.6	-2.2	118.4	12.7	2.2	3.7	81.6	-21.0	-12.5	82.2	-16.2	-15.6	10.5	5.5	10.5	3.9	15.3	0.19	
11	Brx25	Trip	35	10	500	yes	95.8	-3.2	32.3	142.1	10.2	14.9	4.2	44.5	-3.2	-9.4	45.8	4.3	-13.8	4.8	-5.2	4.8	-0.7	3.8	0.07	
12	Brx25	Trip	40	10	500	yes	94.0	3.9	21.3	116.7	7.8	-64.9	4.1	44.1	-1.2	-12.6	39.7	6.3	-21.8	7.5	-2.5	7.5	-6.0	5.8	0.10	
13	Brx25	Trip	45	10	500	yes	98.1	-1.1	26.4	105.2	1.1	19.1	3.8	63.7	-8.8	-13.9	65.0	-3.7	-19.3	8.1	-1.9	8.1	-0.3	9.1	0.14	
14	Brx25	Trip	50	10	500	yes	116.3	-2.5	28.2	199.4	19.2	13.4	4.3	69.8	-14.4	-10.7	71.3	-4.5	-14.8	9.8	-0.2	9.8	1.9	12.1	0.16	
15	Brx25	Trip	55	10	500	on flat	99.2	-0.5	-2.5	118.3	12.6	2.0	3.7	81.6	-20.6	-12.5	82.1	-15.8	-15.5	14.5	4.5	14.5	-0.3	21.1	0.26	
16	Brx50	Trip	35	10	500	yes	103.3	-0.5	34.8	128.4	7.0	-8.1	3.8	42.6	-2.5	-9.9	42.3	4.0	-10.5	4.6	-5.4	4.6	-1.3	3.5	0.07	
17	Brx50	Trip	40	10	500	yes	96.7	3.7	22.4	126.5	2.0	-88.0	4.1	47.6	-1.3	-14.2	41.6	5.1	-27.0	6.7	-3.3	6.7	-5.1	5.6	0.10	
18	Brx50	Trip	45	10	500	yes	99.9	-0.4	24.9	111.2	-1.0	5.8	3.7	62.6	-6.8	-13.2	63.0	1.1	-16.5	8.2	-1.8	8.2	-2.0	9.0	0.14	
19	Brx50	Trip	50	10	500	yes	107.5	-3.0	27.2	183.5	15.7	21.6	4.4	69.9	-13.7	-10.2	72.0	-3.9	-17.0	10.1	0.1	10.1	0.9	12.5	0.17	
20	Brx50	Trip	55	10	500	on flat	98.8	-0.6	-2.2	118.4	12.7	2.2	3.7	81.6	-21.0	-12.5	82.2	-16.2	-15.6	14.5	4.5	14.5	-0.1	21.1	0.26	
21	Brx25	Trip	35	20	500	yes	100.1	8.6	50.0	112.3	37.1	-20.0	4.8	38.4	-27.1	-9.7	37.8	-14.6	-13.5	14.5	-5.5	14.5	20.7	11.7	0.23	
22	Brx25	Trip	40	20	500	yes	131.8	5.8	64.0	186.0	50.3	-60.8	4.5	36.0	-39.5	-10.0	36.5	-17.1	-16.2	13.2	-6.8	13.2	34.4	12.2	0.21	
23	Brx25	Trip	45	20	500	yes	178.3	0.0	78.6	246.8	15.5	-94.2	3.7	27.6	-53.0	-11.6	28.6	-56.3	-14.7	14.5	-5.5	14.5	47.9	15.0	0.23	
24	Brx25	Trip	50	20	500	yes	180.1	-2.8	70.9	267.0	9.6	-92.9	4.9	38.5	-53.9	-7.0			14.0	-6.0	14.0	40.4	16.0	0.22		
25	Brx25	Trip	55	20	500	on flat	99.2	-0.5	-2.5	118.3	12.6	2.0	3.7	81.6	-20.6	-12.5	82.1	-15.8	-15.5	24.5	4.5	24.5	-10.3	34.9	0.43	
26	Brx50	Trip	35	20	500	yes	100.9	8.7	51.5	119.2	40.1	-22.2	4.8	37.9	-27.6	-9.7	37.2	-14.4	-13.6	13.9	-6.1	13.9	22.2	11.3	0.22	
27	Brx50	Trip	40	20	500	yes	132.0	5.4	65.5	184.1	51.5	-60.5	4.4	35.3	-40.0	-10.1	35.9	-17.5	-16.1	12.8	-7.2	12.8	35.8	11.8	0.20	
28	Brx50	Trip	45	20	500	yes	179.9	-0.2	79.5	246.3	14.5	-93.6	3.7	27.3	-53.1	-11.7	28.2	-56.2	-14.7	14.0	-6.0	14.0	48.8	14.5	0.22	
29	Brx50	Trip	50	20	500	yes	180.0	-4.0	72.2	266.2	13.0	-93.7	4.9	37.6	-54.2	-7.2			13.6	-6.4	13.6	41.7	15.5	0.21		
30	Brx50	Trip	55	20	500	on flat	98.8	-0.6	-2.2	118.4	12.7	2.2	3.7	81.6	-21.0	-12.5	82.2	-16.2	-15.6	24.5	4.5	24.5	-10.1	35.0	0.43	
31	Brx25	Rail	35	5	500	no	-1.8	0.1	59.4	24.4	-2.2	3.6	5.5	51.5	-0.1	0.0				1.0	-4.0	1.0	-0.9	0.9	0.02	
32	Brx25	Rail	40	5	500	no	7.0	-0.2	66.5	1.0	0.5	1.9	5.5	58.5	0.5	-0.1				-0.8	-5.8	-0.8	0.3	-0.8	-0.01	
33	Brx25	Rail	45	5	500	no	2.9	0.1	86.6	15.1	0.3	10.1	5.5	66.0	0.6	0.0				0.9	-4.1	0.9	-1.5	1.1	0.02	
34	Brx25	Rail	50	5	500	no	3.6	1.0	107.8	14.8	-1.0	1.7	5.6	72.7	-0.3	0.0				0.7	-4.3	0.7	-0.5	0.9	0.01	
35	Brx25	Rail	55	5	500	on flat	99.2	-0.5	-2.5	118.3	12.6	2.0	3.7	81.6	-20.6	-12.5	82.1	-15.8	-15.5	10.5	5.5	10.5	3.7	15.3	0.19	
36	Brx50	Rail	35	5	500	no	1.2	0.1	58.9	-2.7	2.8	19.3	5.5	51.2	2.7	0.1				-1.6	-6.6	-1.6	-1.4	-1.5	-0.03	
37	Brx50	Rail	40	5	500	no	8.0	-0.2	67.6	6.4	1.3	9.9	5.5	58.4	0.1	0.0				-1.5	-6.5	-1.5	1.4	-1.5	-0.03	
38	Brx50	Rail	45	5	500	no	3.0	-0.1	87.3	12.9	3.3	25.7	5.5	66.0	1.8	0.1				-0.8	-5.8	-0.8	-0.8	-0.9	-0.01	
39	Brx50	Rail	50	5	500	no	4.3	-0.4	111.0	4.9	5.8	15.5	5.5	73.1	-4.3	0.0				0.6	-4.4	0.6	2.7	0.8	0.01	
40	Brx50	Rail	55	5	500	on flat	98.8	-0.6	-2.2	118.4	12.7	2.2	3.7	81.6	-21.0	-12.5	82.2	-16.2	-15.6	10.5	5.5	10.5	3.9	15.3	0.19	
41	Brx25	Rail	35	10	500	no	-2.5	0.1	63.4	-11.8	-1.7	-0.3	5.5	51.1	0.9	0.0				0.3	-9.7	0.3	-1.2	0.2	0.00	
42	Brx25	Rail	40	10	500	yes	104.3	0.5	44.9	119.1	9.1	-25.4	3.8	53.7	-7.6	-13.6	52.4	2.0	-18.1	-0.3	-10.3	-0.3	8.4	-0.3	0.00	

Table B-2. Results from simulation runs with Hamilton 2-axle truck

Run no.	Vehicle factor	Inertia Type	Speed [mph]	Turn radius [ft]	Roll-over	Angular position [deg]			Angular rate [deg/sec]			CG velocity [ft/sec]			Strike pt velocity [ft/sec]			Path change [deg] relative to			Relative to wall beside curb/rail/path		
						Roll	Pitch	Yaw	Roll	Pitch	Yaw	X	Y	Z	X	Y	Z	Curb	Path	Strike [deg]	Yaw [deg]	Vn [ft/sec]	Vn/Vi
1	Ham25	Trip	35	5	500	no	4.2	0.0	60.3	0.1	0.5	6.0	5.5	51.3	0.1	0.0	0.0	-5.0	0.0	-0.1	0.0	0.00	
2	Ham25	Trip	40	5	500	no	7.4	0.1	66.0	2.9	0.3	9.7	5.5	58.7	0.9	0.0	-0.6	-5.6	-0.6	-0.3	-0.6	-0.01	
3	Ham25	Trip	45	5	500	yes	92.7	-2.2	23.4	92.6	13.0	33.9	3.9	61.8	-8.8	-12.2	8.4	3.4	8.4	-0.3	9.1	0.14	
4	Ham25	Trip	50	5	500	yes	94.5	-0.9	20.6	132.2	6.0	48.1	3.7	72.0	-10.4	-13.4	75.2	-6.3	-23.6	8.3	-0.1	10.5	0.14
5	Ham25	Trip	55	5	500	on flat	95.7	2.9	2.4	118.0	13.9	-11.3	3.8	80.9	-15.2	-12.1	80.5	-7.0	-15.4	10.9	-0.3	15.6	0.19
6	Ham50	Trip	35	5	500	no	4.2	0.0	60.3	0.2	0.4	5.7	5.5	51.3	0.1	0.0	0.0	-5.0	0.0	-0.1	0.0	0.00	
7	Ham50	Trip	40	5	500	no	10.6	0.2	65.9	4.6	1.4	7.4	5.5	59.1	0.4	0.0	0.0	-5.0	0.0	-0.4	0.0	0.00	
8	Ham50	Trip	45	5	500	yes	93.9	-2.0	24.2	116.4	11.6	24.0	3.9	61.5	-8.9	-11.2	63.5	-5.1	-17.6	8.4	-0.1	9.1	0.14
9	Ham50	Trip	50	5	500	yes	92.4	-1.5	20.6	97.9	4.4	49.3	3.7	72.1	-10.1	-14.7	75.4	-9.0	-23.9	8.2	-0.2	10.3	0.14
10	Ham50	Trip	55	5	500	on flat	95.2	2.9	2.6	115.8	14.0	-11.2	3.8	80.9	-15.2	-12.1	80.5	-7.1	-15.4	10.9	-0.3	15.6	0.19
11	Ham25	Trip	35	10	500	yes	94.5	-0.4	32.0	122.6	12.2	-40.7	3.6	41.7	-5.7	-18.5	39.5	-9.8	-11.0	8.2	-0.4	6.0	0.12
12	Ham25	Trip	40	10	500	yes	93.8	-0.5	25.6	94.8	24.0	-4.2	3.6	49.0	-5.8	-14.6	49.4	-7.7	-15.0	9.4	-2.6	8.1	0.14
13	Ham25	Trip	45	10	500	yes	95.7	-2.7	27.5	136.9	2.9	7.3	4.0	62.7	-10.8	-12.1	63.4	-3.9	-15.9	9.4	0.4	10.4	0.16
14	Ham25	Trip	50	10	500	yes	96.7	-0.6	22.0	107.6	-7.7	14.3	3.7	70.7	-8.9	-12.6	71.4	-0.2	-17.3	12.2	-5.1	15.1	0.21
15	Ham25	Trip	55	10	500	on flat	95.7	2.9	2.4	118.0	13.9	-11.3	3.8	80.9	-15.2	-12.1	80.5	-7.0	-15.4	15.1	-4.5	21.5	0.27
16	Ham50	Trip	35	10	500	yes	93.2	-1.1	31.7	99.0	14.8	-15.6	3.7	40.5	-5.6	-16.9	39.9	-8.8	-14.1	8.7	-0.9	6.2	0.12
17	Ham50	Trip	40	10	500	yes	96.8	-0.5	28.9	145.2	-2.2	-59.0	3.7	58.2	-7.8	-14.7	54.6	-0.6	-7.1	6.6	-3.4	6.7	0.11
18	Ham50	Trip	45	10	500	yes	95.8	-1.6	25.9	124.6	-2.1	2.9	3.8	62.9	-9.0	-12.4	63.1	-1.1	-15.5	9.6	-0.4	10.6	0.16
19	Ham50	Trip	50	10	500	yes	100.9	-1.5	22.1	120.3	-6.9	24.4	3.9	70.5	-8.6	-11.7	71.9	1.7	-17.8	12.0	-5.0	14.7	0.20
20	Ham50	Trip	55	10	500	on flat	95.2	2.9	2.6	115.8	14.0	-11.2	3.8	80.9	-15.2	-12.1	80.5	-7.1	-15.4	15.1	-4.5	21.5	0.27
21	Ham25	Trip	35	20	500	yes	102.9	8.8	49.3	112.6	25.8	-15.6	4.3	39.2	-26.8	-11.0	38.6	-17.5	-13.3	15.0	-5.0	12.3	0.24
22	Ham25	Trip	40	20	500	yes	117.7	6.1	58.7	161.1	56.1	-40.1	4.3	39.6	-37.2	-10.4	39.4	-21.7	-12.8	14.5	-5.5	13.6	0.23
23	Ham25	Trip	45	20	500	yes	136.7	0.8	70.8	193.7	67.3	-67.0	4.0	35.0	-50.3	-10.3	36.1	-29.4	-11.9	14.5	-5.5	15.4	0.23
24	Ham25	Trip	50	20	500	yes	128.5	-6.7	65.4	264.6	104.7	-56.6	5.1	44.5	-52.7	-7.6	46.0	-56.4	-10.5	14.1	-5.9	16.8	0.23
25	Ham25	Trip	55	20	500	on flat	95.7	2.9	2.4	118.0	13.9	-11.3	3.8	80.9	-15.2	-12.1	80.5	-7.0	-15.4	25.1	-14.4	34.9	0.43
26	Ham50	Trip	35	20	500	yes	103.4	8.8	50.6	115.8	28.4	-17.0	4.3	38.5	-27.4	-10.9	37.9	-17.6	-13.1	14.7	-5.3	12.0	0.23
27	Ham50	Trip	40	20	500	yes	117.5	6.1	59.4	157.1	56.4	-39.8	4.3	39.3	-37.3	-10.5	39.2	-21.8	-12.8	14.2	-5.8	13.3	0.23
28	Ham50	Trip	45	20	500	yes	136.5	-0.9	72.7	197.1	73.3	-66.3	4.1	33.7	-51.0	-10.1	35.2	-54.7	-13.3	13.9	-6.1	14.7	0.22
29	Ham50	Trip	50	20	500	yes	133.3	-6.7	67.3	258.6	99.8	-61.3	5.1	43.1	-53.3	-7.9	47.1	-56.9	-14.8	13.6	-6.4	16.1	0.22
30	Ham50	Trip	55	20	500	on flat	95.2	2.9	2.6	115.8	14.0	-11.2	3.8	80.9	-15.2	-12.1	80.5	-7.1	-15.4	25.1	-14.4	34.9	0.43
31	Ham25	Rail	35	5	500	no	49.6	-2.4	41.8	10.6	-25.6	-22.1	5.6	43.9	8.1	3.8	6.9	1.9	6.9	-17.4	5.4	0.11	
32	Ham25	Rail	40	5	500	yes	98.7	0.3	32.0	144.0	-22.0	-3.7	3.6	55.2	-2.5	-12.3	54.3	5.0	-15.5	-0.9	-5.9	-0.8	-0.01
33	Ham25	Rail	45	5	500	yes	81.4	-15.6	45.2	166.4	2.4	38.1	5.8	60.8	-1.2	-4.9	65.7	6.9	-14.5	1.4	-3.6	1.5	0.02
34	Ham25	Rail	50	5	500	yes	87.4	-11.3	106.1	91.3	88.8	68.3	5.3	70.1	-5.8	-2.5	78.0	-14.4	-14.7	3.4	-1.6	4.2	0.06
35	Ham25	Rail	55	5	500	on flat	95.7	2.9	2.4	118.0	13.9	-11.3	3.8	80.9	-15.2	-12.1	80.5	-7.0	-15.4	10.9	-0.3	15.6	0.19
37	Ham50	Rail	40	5	500	yes	99.3	-0.8	35.5	164.7	-18.6	-3.0	3.8	55.0	-5.7	-11.7	54.3	7.4	-13.5	-1.0	-6.0	-1.0	-0.02
38	Ham50	Rail	45	5	500	no	47.6	0.4	97.4	39.3	-31.2	-4.1	6.2	63.8	-9.7	-2.1	63.5	-14.3	-14.7	-0.2	-5.2	-0.3	0.00
39	Ham50	Rail	50	5	500	yes	88.5	-9.6	81.4	95.1	86.1	57.9	5.0	69.7	-6.1	-3.8	76.3	-14.3	-14.7	3.1	-1.9	3.8	0.05
40	Ham50	Rail	55	5	500	on flat	95.2	2.9	2.6	115.8	14.0	-11.2	3.8	80.9	-15.2	-12.1	80.5	-7.1	-15.4	10.9	-0.3	15.6	0.19
41	Ham25	Rail	35	10	500	no	-13.7	1.2	58.2	47.6	12.3	-37.2	5.5	52.2	6.1	0.2	63.5	8.6	-14.7	0.3	-9.7	0.3	0.01
42	Ham25	Rail	40	10	500	no	11.6	3.9	69.2	12.0	-4.6	-8.2	6.1	50.8	3.0	-2.0	63.5	8.6	-14.7	-3.8	-13.8	0.4	-0.06
43	Ham25	Rail	45	10	500	yes	83.5	-10.0	24.6	118.2	-3.0	11.6	5.0	62.0	0.7	-9.9	63.5	8.6	-14.7	3.1	-6.9	3.4	0.05

Table B-2 (continued). Results from simulation runs with Hamilton 2-axle truck

Run no.	Vehicle & inertia factor	Type	Speed [mph]	Strike angle [deg]	Turn radius [ft]	Roll-over	Angular position [deg]			Angular rate [deg/sec]			Conditions at end of run			CG velocity [ft/sec]			Strike pt velocity [ft/sec]			Path change [deg] relative to			Relative to wall beside curb/rail/path		
							Roll	Pitch	Yaw	Roll	Pitch	Yaw	X	Y	Z	X	Y	Z	Curb	Path	Strike	Yaw	Vn	Vn/Vi			
44	Ham25	Rail	50	10	500	yes	87.6	-0.8	24.9	101.4	-13.6	1.8	3.5	70.0	-8.5	-11.8	69.9	1.0	-14.4	9.1	-0.9	9.1	-2.2	11.2	0.15		
45	Ham25	Rail	55	10	500	on flat	95.7	2.9	2.4	118.0	13.9	-11.3	3.8	80.9	-15.2	-12.1	80.5	-7.0	-15.4	15.1	5.1	15.1	-4.5	21.5	0.27		
46	Ham50	Rail	35	10	500	no	5.2	0.1	64.9	16.9	-0.3	4.2	5.5	51.9	-1.7	-0.2				2.0	-8.0	2.0	-0.2	1.8	0.04		
47	Ham50	Rail	40	10	500	yes	91.4	-2.4	61.7	166.6	-19.3	-3.4	3.9	56.9	-9.1	-11.7	56.3	4.2	-15.4	-0.9	-10.9	-0.9	10.0	-0.9	-0.02		
48	Ham50	Rail	45	10	500	yes	84.2	-10.9	31.3	131.4	7.4	11.3	5.2	61.5	-6.2	-9.8	63.1	0.0	-14.2	3.0	-7.0	3.0	2.8	3.2	0.05		
49	Ham50	Rail	50	10	500	yes	87.6	-0.8	24.5	108.2	-14.5	0.6	3.5	70.1	-7.7	-11.7	69.9	2.0	-14.1	9.0	-1.0	9.0	-2.7	11.0	0.15		
50	Ham50	Rail	55	10	500	on flat	95.2	2.9	2.6	115.8	14.0	-11.2	3.8	80.9	-15.2	-12.1	80.5	-7.1	-15.4	15.1	5.1	15.1	-4.5	21.5	0.27		
51	Ham25	Rail	35	20	500	yes	120.7	9.4	52.3	163.5	13.9	-21.3	4.6	40.8	-26.3	-9.7	39.9	-12.5	-11.7	10.4	-9.6	10.4	22.4	8.8	0.17		
52	Ham25	Rail	40	20	500	yes	127.8	9.0	58.5	173.0	27.2	-29.8	4.6	43.3	-35.1	-9.4	42.7	-19.5	-9.6	10.6	-9.4	10.6	28.4	10.3	0.18		
53	Ham25	Rail	45	20	500	yes	139.9	2.2	71.6	204.2	56.2	-41.9	4.2	41.2	-49.8	-9.9	42.7	-29.9	-9.9	8.8	-11.2	8.8	41.6	9.9	0.15		
54	Ham25	Rail	50	20	500	yes	116.9	-4.7	67.4	166.5	67.4	81.3	4.7	59.9	-51.6	-11.4	68.7	-48.1	-30.1	2.6	-17.4	2.6	38.2	3.5	0.05		
55	Ham25	Rail	55	20	500	on flat	95.7	2.9	2.4	118.0	13.9	-11.3	3.8	80.9	-15.2	-12.1	80.5	-7.0	-15.4	25.1	5.1	25.1	-14.4	34.9	0.43		
56	Ham50	Rail	35	20	500	yes	118.6	8.7	53.9	153.2	16.8	-18.8	4.5	40.4	-27.2	-9.9	39.8	-14.3	-12.1	10.1	-9.9	10.1	23.9	8.5	0.17		
57	Ham50	Rail	40	20	500	yes	127.2	8.8	59.5	173.7	28.5	-29.6	4.6	42.8	-35.5	-9.5	42.3	-20.0	-9.8	10.4	-9.6	10.4	29.3	10.0	0.17		
58	Ham50	Rail	45	20	500	yes	140.6	2.4	73.1	204.7	56.8	-44.6	4.2	39.9	-50.4	-9.9	41.3	-30.3	-9.7	8.6	-11.4	8.6	43.1	9.6	0.15		
59	Ham50	Rail	50	20	500	yes	115.8	-4.9	68.5	169.9	68.6	81.3	4.7	58.5	-52.0	-11.7	67.4	-48.6	-30.6	2.4	-17.6	2.4	39.3	3.3	0.04		
60	Ham50	Rail	55	20	500	on flat	95.2	2.9	2.6	115.8	14.0	-11.2	3.8	80.9	-15.2	-12.1	80.5	-7.1	-15.4	25.1	5.1	25.1	-14.4	34.9	0.43		
61	Ham25	I-turn	25		100	no	-0.3	0.0	90.0	0.0	0.0	0.0	5.5	36.7	0.0	0.0				0.0	0.0	0.0	0.0	0.0	0.00		
62	Ham25	I-turn	40		100	yes	108.8	-1.6	47.7	142.4	41.5	-7.9	4.0	49.0	-27.6	-11.9	50.4	-25.8	-15.8	28.4	28.4	28.4	0.9	26.8	0.46		
63	Ham25	I-turn	55		100	yes	120.4	-2.5	42.8	167.7	45.6	-14.3	4.3	66.8	-40.2	-10.8	68.0	-37.2	-13.9	33.6	33.6	33.6	-2.6	43.1	0.53		
64	Ham25	H-turn	55		500	yes	98.3	2.2	39.6	119.3	15.7	-8.9	3.8	75.8	-18.0	-12.3	75.6	-9.4	-15.0	6.1	6.1	6.1	7.3	8.2	0.10		
65	Ham25	H-turn	60		500	yes	106.4	0.5	35.4	131.4	19.6	-6.1	3.8	82.0	-24.8	-12.4	82.2	-14.8	-13.8	8.5	8.5	8.5	8.3	12.7	0.14		
66	Ham25	H-turn	70		500	yes	114.0	-0.8	33.0	152.0	24.9	-6.4	4.0	94.4	-34.2	-11.9	95.1	-28.6	-14.9	11.2	11.2	11.2	8.7	19.5	0.19		
67	Ham25	80 stp	45			no	11.0	0.1	-27.2	0.4	2.1	10.9	5.5	66.0	-3.5	0.0											
68	Ham25	80 stp	60			yes	105.4	0.7	27.6	133.6	18.4	-6.8	3.8	83.1	-23.0	-12.4	83.2	-12.9	-14.0								
69	Ham25	80 stp	75			yes	109.8	-0.8	25.7	143.7	20.1	-3.2	3.9	103.6	-31.7	-12.2	104.3	-25.8	-15.7								
70	Ham25	100 stp	35			no	10.8	0.1	58.3	0.2	2.6	13.8	5.5	51.3	-2.1	0.0											
71	Ham25	100 stp	50			yes	104.6	0.3	31.7	131.2	22.2	-6.4	3.7	67.9	-22.6	-12.6	68.1	-12.4	-14.2								
72	Ham25	100 stp	65			yes	109.5	-1.5	29.6	140.7	25.2	-2.5	4.0	87.7	-32.6	-12.0	88.7	-27.6	-15.9								
73	Ham25	120 stp	30			no	10.8	0.1	127.4	0.2	3.0	16.1	5.5	44.0	-1.5	0.0											
74	Ham25	120 stp	45			yes	103.6	-0.5	34.8	128.8	26.0	-4.3	3.8	59.9	-23.1	-12.6	60.4	-19.4	-14.6								
75	Ham25	120 stp	60			yes	111.7	-1.7	32.9	142.7	30.0	-4.0	4.1	79.1	-34.2	-11.7	80.2	-29.8	-15.5								
76	Ham25	Spiral	40			yes	96.3	2.7	136.5	117.6	23.6	-11.6	3.8	52.5	-16.2	-12.1	52.4	-7.2	-15.2								
77	Ham50	I-turn	25		100	no	-0.3	0.0	90.0	0.0	0.0	0.0	5.5	36.7	0.0	0.0				0.0	0.0	0.0	0.0	0.0	0.00		
78	Ham50	I-turn	40		100	yes	108.0	-1.6	47.9	141.1	41.3	-7.0	4.0	48.9	-27.6	-11.9	49.8	-25.8	-14.1	28.5	28.5	28.5	0.9	26.8	0.46		
79	Ham50	I-turn	55		100	yes	119.1	-2.6	43.0	161.6	45.5	-12.7	4.4	66.7	-40.2	-10.9	68.1	-37.3	-14.2	33.7	33.7	33.7	-2.7	43.3	0.54		
80	Ham50	H-turn	55		500	yes	97.8	2.2	39.7	118.5	15.6	-8.7	3.8	75.8	-18.0	-12.3	75.6	-9.5	-15.1	6.0	6.0	6.0	7.3	8.2	0.10		
81	Ham50	H-turn	60		500	yes	105.6	0.5	35.6	130.5	19.4	-5.8	3.8	82.0	-24.8	-12.5	82.1	-14.9	-13.9	8.5	8.5	8.5	8.3	12.6	0.14		
82	Ham50	H-turn	70		500	yes	113.1	-0.8	33.1	147.8	24.7	-5.9	4.0	94.3	-34.3	-11.9	95.1	-28.8	-15.0	11.2	11.2	11.2	8.8	19.5	0.19		
83	Ham50	80 stp	45			no	11.0	0.1	-27.2	0.5	2.0	11.0	5.5	66.0	-3.5	0.0											
84	Ham50	80 stp	60			yes	104.7	0.8	27.6	132.7	18.2	-6.8	3.8	83.1	-22.9	-12.4	83.2	-13.0	-14.1								
85	Ham50	80 stp	75			yes	108.8	-0.9	25.7	141.8	19.8	-2.8	3.9	103.6	-31.7	-12.3	104.3	-25.9	-15.9								

Table B-3 (continued). Results from simulation runs: semitrailer of the Alburquerque vehicle

Run no.	Vehicle factor	Run Type	Speed [mph]	Strike angle [deg]	Turn radius [ft]	Conditions at end of run			Angular position [deg]			Angular rate [deg/sec]			CG ht [ft]			CG velocity [ft/sec]			Strike pt velocity [ft/sec]			Path change [deg] relative to		Relative to wall beside curb/rail/path		
						Roll-over	Roll	Pitch	Yaw	Roll	Pitch	Yaw	Roll	Pitch	Yaw	Z	X	Y	Z	X	Y	Z	Curb	Path	Strike [deg]	Yaw [deg]	Vn	Vn/Vi
85	Alb50	80 stp	75	0	yes	118.2	-0.2	27.1	158.0	30.3	-16.0	3.3	102.4	-38.1	-16.2	104.3	-38.8	-25.3										
86	Alb50	100 stp	35	0	yes	103.6	-0.4	38.3	113.1	29.6	-6.8	2.5	47.2	-16.9	-17.6	49.3	-20.9	-25.8										
87	Alb50	100 stp	50	0	yes	111.8	-0.2	31.1	137.5	31.4	-12.4	3.0	67.7	-25.7	-16.9	69.8	-28.3	-25.8										
88	Alb50	100 stp	65	0	yes	117.4	-0.2	29.0	153.0	32.5	-16.6	3.3	87.9	-34.5	-16.2	90.0	-36.2	-25.4										
89	Alb50	120 stp	30	0	yes	99.1	-0.7	42.9	101.1	30.5	-3.9	2.5	40.1	-14.4	-17.5	40.2	-19.1	-17.9										
90	Alb50	120 stp	45	0	yes	110.8	-0.3	32.7	139.4	33.2	-12.3	2.9	60.5	-23.7	-17.0	62.7	-27.2	-25.8										
91	Alb50	120 stp	60	0	yes	117.6	-0.1	30.3	151.3	34.3	-17.7	3.3	80.5	-32.9	-16.3	82.6	-35.3	-25.3										
92	Alb50	Spiral	40	0	yes	103.4	-0.4	57.6	114.4	25.0	-5.7	2.5	54.9	-17.6	-17.6	56.7	-20.2	-25.9										
93	Alb10	I-turn	23	100	yes	97.9	0.3	72.8	115.6	23.3	-5.3	2.4	30.3	-8.4	-17.2	30.2	4.7	-18.1	17.5	17.5	17.5	17.5	17.5	17.5	17.5	17.5	17.5	
94	Alb10	I-turn	27	100	yes	97.6	-0.6	51.0	104.5	29.6	-4.8	2.5	35.8	-12.6	-17.5	35.9	-16.9	-17.4	22.7	22.7	22.7	22.7	22.7	22.7	22.7	22.7	22.7	
95	Alb10	Trip	35	30	yes	100.5	3.3	37.9	149.8	54.1	-14.2	3.5	41.1	-25.7	-15.6	40.8	-0.6	-16.9	21.6	-8.4	21.6	-8.4	21.6	-8.4	21.6	-8.4	21.6	
96	Alb10	Trip	40	30	yes	120.2	-1.0	40.6	160.0	58.5	-34.3	3.7	46.3	-31.4	-15.1	49.9	-41.9	-23.7	21.2	-8.8	21.2	-8.8	21.2	-8.8	21.2	-8.8	21.2	
97	Alb10	Trip	45	30	yes	124.2	-3.3	36.4	175.0	58.9	-37.5	4.6	55.0	-31.7	-13.3	59.0	-41.8	-22.1	20.9	-9.1	20.9	-9.1	20.9	-9.1	20.9	-9.1	20.9	
98	Alb10	Trip	50	30	yes	97.8	0.1	-6.9	105.9	11.3	-3.8	2.3	73.1	-13.0	-17.6	73.0	-4.1	-18.6	31.5	1.5	31.5	1.5	31.5	1.5	31.5	1.5	31.5	
99	Alb10	Trip	55	30	yes	97.5	0.1	-5.2	109.1	11.3	-3.7	2.4	72.8	-13.0	-17.6	72.7	-4.0	-18.6	31.5	1.5	31.5	1.5	31.5	1.5	31.5	1.5	31.5	
100	Alb50	Trip	35	30	yes	100.2	3.0	38.9	146.2	54.2	-12.7	3.4	40.7	-26.2	-15.7	40.5	-1.1	-16.6	21.3	-8.7	21.3	-8.7	21.3	-8.7	21.3	-8.7	21.3	
101	Alb50	Trip	40	30	yes	120.8	-1.0	41.7	156.1	58.4	-34.8	3.7	45.8	-31.8	-15.1	49.4	-4.1	-18.6	20.8	-9.2	20.8	-9.2	20.8	-9.2	20.8	-9.2	20.8	
102	Alb50	Trip	45	30	yes	125.6	-3.4	37.8	173.4	59.7	-39.1	4.6	54.3	-32.5	-13.2	58.3	-42.9	-21.8	20.5	-9.5	20.5	-9.5	20.5	-9.5	20.5	-9.5	20.5	
103	Alb50	Trip	50	30	yes	97.4	0.1	-7.0	106.1	11.3	-3.5	2.4	73.1	-12.9	-17.6	73.0	-4.1	-18.5	31.5	1.5	31.5	1.5	31.5	1.5	31.5	1.5	31.5	
104	Alb50	Trip	55	30	yes	97.3	0.2	-5.5	105.2	11.5	-3.5	2.4	72.8	-13.0	-17.5	72.8	-4.0	-18.5	31.5	1.5	31.5	1.5	31.5	1.5	31.5	1.5	31.5	
105	Alb10	Rail	40	30	yes	107.7	0.0	48.9	65.8	63.3	-5.0	2.7	43.5	-35.3	-16.8	48.1	-53.6	-21.5	17.8	-12.2	17.8	-12.2	17.8	-12.2	17.8	-12.2	17.8	
106	Alb10	Rail	45	30	yes	108.2	-0.9	48.2	111.6	63.6	18.8	3.0	50.6	-36.9	-17.5	56.0	-55.9	-25.3	15.3	-14.7	15.3	-14.7	15.3	-14.7	15.3	-14.7	15.3	
107	Alb10	Rail	50	30	yes	97.8	0.1	-6.9	105.9	11.3	-3.8	2.3	73.1	-13.0	-17.6	73.0	-4.1	-18.6	31.5	1.5	31.5	1.5	31.5	1.5	31.5	1.5	31.5	
108	Alb10	Rail	55	30	yes	97.5	0.1	-5.2	109.1	11.3	-3.7	2.4	72.8	-13.0	-17.6	72.7	-4.0	-18.6	31.5	1.5	31.5	1.5	31.5	1.5	31.5	1.5	31.5	
109	Alb50	Rail	35	30	yes	96.3	-1.2	40.7	90.7	40.2	0.5	2.7	39.6	-26.0	-16.7	39.9	-34.2	-18.4	20.7	-9.3	20.7	-9.3	20.7	-9.3	20.7	-9.3	20.7	
110	Alb50	Rail	40	30	yes	108.3	-0.1	49.7	97.3	66.1	-14.6	2.7	42.6	-35.8	-16.6	47.2	-52.5	-23.4	17.9	-12.1	17.9	-12.1	17.9	-12.1	17.9	-12.1	17.9	
111	Alb50	Rail	45	30	yes	108.4	-0.9	49.3	84.2	68.5	8.0	3.0	50.0	-37.6	-17.2	55.4	-55.7	-26.9	15.2	-14.8	15.2	-14.8	15.2	-14.8	15.2	-14.8	15.2	
112	Alb50	Rail	50	30	yes	97.4	0.1	-7.0	106.1	11.3	-3.5	2.4	73.1	-12.9	-17.6	73.0	-4.1	-18.5	31.5	1.5	31.5	1.5	31.5	1.5	31.5	1.5	31.5	
113	Alb50	Rail	55	30	yes	97.3	0.2	-5.5	105.2	11.5	-3.5	2.4	72.8	-13.0	-17.5	72.8	-4.0	-18.5	31.5	1.5	31.5	1.5	31.5	1.5	31.5	1.5	31.5	
114	Alb10	Rail	35	30	yes	102.3	0.3	41.7	102.4	43.0	-9.1	2.4	39.9	-26.6	-17.2	39.8	-7.2	-17.0	20.0	-10.0	20.0	-10.0	20.0	-10.0	20.0	-10.0	20.0	
115	Alb50	I-turn	23	100	yes	97.9	0.4	73.0	114.6	23.2	-5.2	2.4	30.2	-8.4	-17.1	30.2	4.7	-18.0	17.4	17.4	17.4	17.4	17.4	17.4	17.4	17.4	17.4	
116	Alb50	I-turn	27	100	yes	97.8	-0.5	51.3	112.2	29.6	-5.8	2.5	35.8	-12.5	-17.4	35.8	-16.8	-17.1	22.6	22.6	22.6	22.6	22.6	22.6	22.6	22.6	22.6	
117	Alb50	I-turn	20	100	no	0.0	0.0	90.0	0.0	0.0	0.0	6.9	29.3	0.0	0.0	0.0	0.0	0.0	0.0	0.0	0.0	0.0	0.0	0.0	0.0	0.0	0.0	
118	Alb10	I-turn	20	100	no	0.0	0.0	90.0	0.0	0.0	0.0	6.9	29.3	0.0	0.0	0.0	0.0	0.0	0.0	0.0	0.0	0.0	0.0	0.0	0.0	0.0	0.0	
119	Alb50	H-turn	50	500	yes	96.8	-0.9	32.9	99.9	16.4	-0.9	2.6	70.3	-17.4	-17.4	70.4	-17.8	-17.9	7.7	7.7	7.7	7.7	7.7	7.7	7.7	7.7	7.7	
120	Alb10	H-turn	50	500	yes	97.7	-0.9	32.7	106.6	16.7	-1.2	2.6	70.3	-17.4	-17.4	70.4	-17.8	-17.9	7.7	7.7	7.7	7.7	7.7	7.7	7.7	7.7	7.7	
121	Alb50	Swerve	50	0	yes	112.8	-0.3	17.5	142.3	33.3	-13.6	3.1	67.4	-26.9	-16.7	75.3	-7.7	-25.7	4.3	4.3	4.3	4.3	4.3	4.3	4.3	4.3	4.3	
122	Alb10	Swerve	50	0	yes	113.8	-0.2	17.1	149.6	33.0	-14.6	3.1	67.5	-26.6	-16.7	75.2	-7.6	-25.6	4.4	4.4	4.4	4.4	4.4	4.4	4.4	4.4	4.4	
123	Alb50	Trip/fall	45	20	yes	179.4	2.9	73.3	120.9	-3.3	-81.3	-5.3	31.5	-53.4	-28.4	0.0	0.0	0.0	-3.3	-23.3	-3.3	-23.3	-3.3	-23.3	-3.3	-23.3	-3.3	
124	Alb10	Trip/fall	45	20	yes	176.6	4.0	74.8	86.1	-3.7	-89.6	-5.8	30.6	-53.5	-29.4	0.0	0.0	0.0	-3.9	-23.9	-3.9	-23.9	-3.9	-23.9	-3.9	-23.9	-3.9	
125	Alb50	Trip/fall	45	30	yes	183.1	-5.1	61.1	196.3	7.0	-85.9	-0.2	36.8	-49.5	-20.0	0.0	0.0	0.0	1.3	-28.7	1.3	-28.7	1.3	-28.7	1.3	-28.7	1.3	
126	Alb10	Trip/fall	45	30	yes	183.3	-5.0	59.7	203.3	6.2	-85.5	-0.5	37.7	-49.0	-20.3	0.0	0.0	0.0	1.7	-28.3	1.7	-28.3	1.7	-28.3	1.7	-28.3	1.7	1.8

Table B-4. Results from simulation runs: semitrailer of the Columbus fuel oil vehicle

Run no.	Vehicle & inertia factor	Run Type	Strike			Turn			Conditions at end of run			Angular rate [deg/sec]			CG ht velocity [ft/sec]			Strike pt velocity [ft/sec]			Path change [deg] relative to			Relative to wall beside curb/rail/path		
			Speed [mph]	[ft]	[deg]	Roll	Pitch	Yaw	Roll	Pitch	Yaw	Roll	Pitch	Yaw	X	Y	Z	X	Y	Z	Curb	Path	Strike [deg]	Yaw [deg]	Vn	Vn/Vi
1	CoF25	Trip	35	5	500	no	2.2	0.0	57.6	0.0	0.2	6.0	6.6	51.3	0.8	0.0	0.0	0.0	0.0	0.0	0.0	-5.0	0.0	-0.9	0.0	0.00
2	CoF25	Trip	40	5	500	no	3.0	0.0	64.0	0.2	0.3	6.8	6.6	58.4	0.5	0.0	0.0	0.0	0.0	0.0	0.0	-5.0	0.0	-0.5	0.0	0.00
3	CoF25	Trip	45	5	500	yes	96.3	-0.9	19.5	137.0	9.5	5.8	4.2	63.3	-7.3	-12.6	61.1	18.8	-16.9	8.0	3.0	8.0	-1.3	8.8	0.13	
4	CoF25	Trip	50	5	500	on flat	88.8	-0.6	-11.6	103.0	9.0	1.3	4.0	75.2	-12.0	-13.8	72.0	-24.5	-16.1	11.5	6.5	11.5	-2.5	15.2	0.21	
5	CoF25	Trip	55	5	500	on flat	88.8	-0.6	-11.7	102.3	9.1	1.3	4.0	75.1	-11.9	-13.8	71.9	-24.7	-16.1	11.5	6.5	11.5	-2.5	15.2	0.19	
6	CoF50	Trip	35	5	500	no	2.3	0.0	57.6	0.1	0.2	5.9	6.6	51.3	0.8	0.0	0.0	0.0	0.0	0.0	0.0	-5.0	0.0	-0.9	0.0	0.00
7	CoF50	Trip	40	5	500	no	3.0	0.0	64.0	0.0	0.3	6.7	6.6	58.4	0.5	0.0	0.0	0.0	0.0	0.0	0.0	-5.0	0.0	-0.5	0.0	0.00
8	CoF50	Trip	45	5	500	yes	94.0	-1.0	20.1	130.9	10.4	6.4	4.3	63.2	-7.8	-12.4	61.4	18.3	-17.0	7.9	2.9	7.9	-0.9	8.8	0.13	
9	CoF50	Trip	50	5	500	on flat	88.7	-0.5	-11.2	104.2	9.1	0.8	3.9	75.2	-12.0	-13.8	72.1	-24.0	-16.0	11.5	6.5	11.5	-2.5	15.2	0.21	
10	CoF50	Trip	55	5	500	on flat	88.6	-0.5	-11.5	103.0	9.1	0.8	3.9	75.1	-12.0	-13.8	72.0	-24.3	-16.0	11.6	6.6	11.6	-2.5	15.2	0.19	
11	CoF25	Trip	35	10	500	no	2.5	0.0	62.2	-0.3	0.3	6.1	6.6	53.2	0.7	0.0	0.0	0.0	0.0	0.0	-0.1	-10.1	-0.1	-0.7	-0.1	0.00
12	CoF25	Trip	40	10	500	yes	100.4	0.0	27.3	127.6	7.0	1.7	3.9	51.7	-9.7	-13.0	48.8	18.7	-14.9	10.6	0.6	10.6	0.0	9.7	0.16	
13	CoF25	Trip	45	10	500	yes	98.2	1.6	28.5	159.2	11.1	-5.0	4.4	62.6	-15.4	-12.9	55.1	29.3	-15.3	11.3	1.3	11.3	2.6	12.6	0.19	
14	CoF25	Trip	50	10	500	on flat	88.8	-0.6	-11.6	103.0	9.0	1.3	4.0	75.2	-12.0	-13.8	72.0	-24.5	-16.1	15.5	5.5	15.5	-6.4	20.3	0.28	
15	CoF25	Trip	55	10	500	on flat	88.8	-0.6	-11.7	102.3	9.1	1.3	4.0	75.1	-11.9	-13.8	71.9	-24.7	-16.1	15.5	5.5	15.5	-6.5	20.3	0.25	
16	CoF50	Trip	35	10	500	no	2.5	0.0	62.2	-0.1	0.2	6.1	6.6	52.5	0.7	0.0	0.0	0.0	0.0	-0.1	-10.1	-0.1	-0.8	-0.1	0.00	
17	CoF50	Trip	40	10	500	yes	99.2	-0.7	27.3	146.8	6.7	3.2	4.2	55.3	-9.0	-12.1	50.0	24.5	-15.0	9.4	-0.6	9.4	-0.1	9.1	0.16	
18	CoF50	Trip	45	10	500	yes	96.9	1.7	28.0	142.0	10.5	-8.7	4.4	59.5	-14.6	-13.3	53.0	25.9	-16.9	11.9	1.9	11.9	1.9	12.6	0.19	
19	CoF50	Trip	50	10	500	on flat	88.7	-0.5	-11.2	104.2	9.1	0.8	3.9	75.2	-12.0	-13.8	72.1	-24.0	-16.0	15.5	5.5	15.5	-6.4	20.3	0.28	
20	CoF50	Trip	55	10	500	on flat	88.6	-0.5	-11.5	103.0	9.1	0.8	3.9	75.1	-12.0	-13.8	72.0	-24.3	-16.0	15.5	5.5	15.5	-6.4	20.3	0.25	
21	CoF25	Trip	35	20	500	yes	93.3	1.8	33.9	110.6	33.9	-2.5	4.4	45.6	-18.9	-13.1	38.7	24.9	-14.9	17.4	-2.6	17.4	5.1	14.8	0.29	
22	CoF25	Trip	40	20	500	yes	90.8	2.9	34.2	111.3	44.7	-10.1	4.7	51.7	-22.4	-12.5	43.0	28.4	-17.4	17.8	-2.2	17.8	5.6	17.3	0.29	
23	CoF25	Trip	45	20	500	yes	112.6	-0.9	36.4	146.6	48.4	-20.9	4.4	57.4	-27.9	-12.8	70.3	2.9	-15.3	18.4	-1.6	18.4	7.5	20.2	0.31	
24	CoF25	Trip	50	20	500	on flat	88.8	-0.6	-11.6	103.0	9.0	1.3	4.0	75.2	-12.0	-13.8	72.0	-24.5	-16.1	25.5	5.5	25.5	-16.4	32.8	0.45	
25	CoF25	Trip	55	20	500	on flat	88.8	-0.6	-11.7	102.3	9.1	1.3	4.0	75.1	-11.9	-13.8	71.9	-24.7	-16.1	25.5	5.5	25.5	-16.5	32.8	0.41	
26	CoF50	Trip	35	20	500	yes	92.4	1.0	35.0	98.3	32.6	4.7	4.1	46.2	-19.6	-14.0	40.7	24.0	-13.4	16.9	-3.1	16.9	6.0	14.6	0.28	
27	CoF50	Trip	40	20	500	yes	89.9	2.8	35.3	103.1	45.0	-8.9	4.6	51.3	-23.0	-12.7	42.5	28.7	-17.6	17.5	-2.5	17.5	6.7	16.9	0.29	
28	CoF50	Trip	45	20	500	yes	112.4	-1.1	37.7	141.5	50.1	-21.1	4.4	56.8	-28.4	-12.7	70.2	3.7	-15.4	17.8	-2.2	17.8	8.8	19.4	0.29	
29	CoF50	Trip	50	20	500	on flat	88.7	-0.5	-11.2	104.2	9.1	0.8	3.9	75.2	-12.0	-13.8	72.1	-24.0	-16.0	25.5	5.5	25.5	-16.4	32.8	0.45	
30	CoF50	Trip	55	20	500	on flat	88.6	-0.5	-11.5	103.0	9.1	0.8	3.9	75.1	-12.0	-13.8	72.0	-24.3	-16.0	25.5	5.5	25.5	-16.5	32.8	0.41	
31	CoF25	Rail	35	5	500	no	2.1	0.0	57.6	0.0	0.2	5.9	6.6	51.3	0.8	0.0	0.0	0.0	0.0	0.0	0.0	-5.0	0.0	-0.9	0.0	0.00
32	CoF25	Rail	40	5	500	no	2.8	0.0	63.9	0.0	0.3	6.8	6.6	58.6	0.5	0.0	0.0	0.0	0.0	0.0	0.0	-5.0	0.0	-0.5	0.0	0.00
33	CoF25	Rail	45	5	500	no	4.3	0.0	86.2	-0.3	0.6	7.7	6.6	66.1	0.3	0.0	0.0	0.0	0.0	0.0	0.0	-5.0	0.0	-0.2	0.0	0.00
34	CoF25	Rail	50	5	500	on flat	88.8	-0.6	-11.6	103.0	9.0	1.3	4.0	75.2	-12.0	-13.8	72.0	-24.5	-16.1	11.5	6.5	11.5	-2.5	15.2	0.21	
35	CoF25	Rail	55	5	500	on flat	88.8	-0.6	-11.7	102.3	9.1	1.3	4.0	75.1	-11.9	-13.8	71.9	-24.7	-16.1	11.5	6.5	11.5	-2.5	15.2	0.19	
36	CoF50	Rail	35	5	500	no	2.1	0.0	57.6	0.0	0.2	5.9	6.6	51.3	0.8	0.0	0.0	0.0	0.0	0.0	0.0	-5.0	0.0	-0.9	0.0	0.00
37	CoF50	Rail	40	5	500	no	2.8	0.0	63.9	0.0	0.3	6.8	6.6	58.6	0.5	0.0	0.0	0.0	0.0	0.0	0.0	-5.0	0.0	-0.5	0.0	0.00
38	CoF50	Rail	45	5	500	no	4.9	0.1	86.1	1.5	0.5	7.8	6.6	66.0	0.5	0.0	0.0	0.0	0.0	-0.2	-5.2	-0.2	-0.2	-0.2	0.0	0.00
39	CoF50	Rail	50	5	500	on flat	88.7	-0.5	-11.2	104.2	9.1	0.8	3.9	75.2	-12.0	-13.8	72.1	-24.0	-16.0	11.5	6.5	11.5	-2.5	15.2	0.21	
40	CoF50	Rail	55	5	500	on flat	88.6	-0.5	-11.5	103.0	9.1	0.8	3.9	75.1	-12.0	-13.8	72.0	-24.3	-16.0	11.6	6.6	11.6	-2.5	15.2	0.19	
41	CoF25	Rail	35	10	500	no	2.1	0.0	61.9	0.0	0.2	5.9	6.6	51.3	0.8	0.0	0.0	0.0	0.0	0.0	0.0	-10.0	0.0	-0.9	0.0	0.00
42	CoF25	Rail	40	10	500	yes	89.6	-0.1	31.5	103.0	7.1	-2.4	3.8	54.7	-6.5	-12.8	47.9	26.5	-13.7	7.1	-2.9	7.1	-0.4	6.8	0.12	

Table B-4 (continued). Results from simulation runs: semitrailer of the Columbus fuel oil vehicle

Run no.	Vehicle & inertia		Strike Speed [mph]	Turn angle [deg]	Turn radius [ft]	Conditions at end of run						CG ht Z [ft]	CG velocity [ft/sec]			Strike pt velocity [ft/sec]			Path change [deg]		Relative to wall beside curb/rail/path					
	factor	Type				Roll-over	Angular position [deg]			Angular rate [deg/sec]			X	Y	Z	X	Y	Z	relative to		Strike [deg]	Yaw [deg]	Vn [ft/sec]	Vn/Vi		
							Roll	Pitch	Yaw	Roll	Pitch								Yaw	Curb					Path	
43	CoF25	Rail	45	10	500	yes	86.4	-4.4	26.3	125.5	14.2	22.1	5.5	62.4	-7.2	-7.7	60.7	23.9	-19.4	6.1	-3.9	6.1	0.5	6.7	0.10	
44	CoF25	Rail	50	10	500	on flat	88.8	-0.6	-11.6	103.0	9.0	1.3	4.0	75.2	-12.0	-13.8	72.0	-24.5	-16.1	15.5	5.5	15.5	-6.4	20.3	0.28	
45	CoF25	Rail	55	10	500	on flat	88.8	-0.6	-11.7	102.3	9.1	1.3	4.0	75.1	-11.9	-13.8	71.9	-24.7	-16.1	15.5	5.5	15.5	-6.5	20.3	0.25	
46	CoF50	Rail	35	10	500	no	2.1	0.0	61.9	-0.1	0.2	6.0	6.6	51.3	0.8	0.0	0.0	0.0	0.0	0.0	0.0	-10.0	0.0	-0.9	0.0	0.00
47	CoF50	Rail	40	10	500	no	3.4	0.0	68.3	-0.2	-0.5	7.4	6.6	59.3	0.2	0.1	0.0	0.0	0.0	0.4	-9.6	0.4	-0.6	0.4	0.01	
48	CoF50	Rail	45	10	500	yes	95.1	-1.8	28.4	112.7	16.0	1.9	4.6	63.3	-8.7	-12.1	61.2	20.9	-14.4	6.0	-4.0	6.0	1.8	6.7	0.10	
49	CoF50	Rail	50	10	500	on flat	88.7	-0.5	-11.2	104.2	9.1	0.8	3.9	75.2	-12.0	-13.8	72.1	-24.0	-16.0	15.5	5.5	15.5	-6.4	20.3	0.28	
50	CoF50	Rail	55	10	500	on flat	88.6	-0.5	-11.5	103.0	9.1	0.8	3.9	75.1	-12.0	-13.8	72.0	-24.3	-16.0	15.5	5.5	15.5	-6.4	20.3	0.25	
51	CoF25	Rail	35	20	500	yes	85.4	-2.5	34.8	76.9	24.4	11.1	4.7	43.8	-16.2	-12.4	49.5	7.9	-18.2	15.1	-4.9	15.1	5.2	12.1	0.24	
52	CoF25	Rail	40	20	500	yes	93.7	0.2	39.2	87.2	37.8	-0.1	3.9	49.5	-26.0	-13.5	44.4	25.0	-13.9	17.6	-2.4	17.6	10.1	16.9	0.29	
53	CoF25	Rail	45	20	500	yes	100.0	0.1	41.4	117.4	51.7	-6.1	3.9	55.0	-31.6	-13.0	47.4	30.2	-12.7	17.1	-2.9	17.1	12.7	18.7	0.28	
54	CoF25	Rail	50	20	500	on flat	88.8	-0.6	-11.6	103.0	9.0	1.3	4.0	75.2	-12.0	-13.8	72.0	-24.5	-16.1	25.5	5.5	25.5	-16.4	32.8	0.45	
55	CoF25	Rail	55	20	500	on flat	88.8	-0.6	-11.7	102.3	9.1	1.3	4.0	75.1	-11.9	-13.8	71.9	-24.7	-16.1	25.5	5.5	25.5	-16.5	32.7	0.41	
56	CoF50	Rail	35	20	500	yes	85.8	-1.7	33.6	95.8	18.9	3.7	4.4	44.9	-15.0	-13.3	46.7	12.1	-16.9	14.6	-5.4	14.6	3.8	12.0	0.23	
57	CoF50	Rail	40	20	500	yes	83.7	-1.4	38.4	80.0	30.8	10.8	4.2	49.2	-25.8	-12.1	61.0	4.5	-17.2	18.5	-1.5	18.5	9.1	17.7	0.30	
58	CoF50	Rail	45	20	500	yes	96.8	-0.3	42.3	116.7	51.5	-1.1	4.0	54.6	-32.1	-12.7	73.7	1.5	-15.7	16.9	-3.1	16.9	13.5	18.5	0.28	
59	CoF50	Rail	50	20	500	on flat	88.7	-0.5	-11.2	104.2	9.1	0.8	3.9	75.2	-12.0	-13.8	72.1	-24.0	-16.0	25.5	5.5	25.5	-16.4	32.8	0.45	
60	CoF50	Rail	55	20	500	on flat	88.6	-0.5	-11.5	103.0	9.1	0.8	3.9	75.1	-12.0	-13.8	72.0	-24.3	-16.0	25.5	5.5	25.5	-16.5	32.8	0.41	
61	CoF25	I-turn	25		100	yes	88.5	-0.7	56.1	107.0	24.9	1.4	4.0	33.5	-8.6	-13.6	29.6	21.1	-15.9	18.6	18.6	18.6	-4.1	11.0	0.30	
62	CoF25	I-turn	40		100	yes	102.4	-0.3	33.6	120.3	33.2	-6.1	4.0	54.1	-17.4	-14.1	58.2	10.5	-15.0	28.6	28.6	28.6	-10.8	27.2	0.46	
63	CoF25	I-turn	55		100	yes	112.5	-0.3	29.1	145.8	33.8	-12.8	4.1	74.5	-25.3	-13.8	80.4	10.3	-16.9	34.3	34.3	34.3	-15.5	44.3	0.55	
64	CoF25	H-turn	55		500	yes	95.7	-0.5	29.0	107.7	18.4	0.7	4.0	77.4	-18.7	-14.0	77.6	20.6	-16.2	8.4	8.4	8.4	5.2	11.7	0.14	
65	CoF25	H-turn	60		500	yes	100.4	-0.2	27.4	115.1	20.5	-2.3	3.9	84.2	-21.8	-14.2	85.5	18.6	-15.5	9.8	9.8	9.8	4.7	14.9	0.17	
66	CoF25	H-turn	70		500	yes	106.5	-0.1	25.5	130.1	23.6	-5.9	3.9	97.9	-27.4	-14.3	100.7	16.4	-14.5	11.9	11.9	11.9	3.8	20.9	0.20	
67	CoF25	80 stp	45		0	yes	101.4	-0.1	30.3	118.9	27.2	-4.4	3.9	62.1	-18.2	-14.2	64.9	12.5	-15.2							
68	CoF25	80 stp	60		0	yes	108.2	-0.4	26.4	134.5	28.7	-7.7	4.0	82.9	-25.8	-14.0	87.8	11.3	-17.8							
69	CoF25	80 stp	75		0	yes	113.6	-0.3	24.8	146.3	29.3	-10.8	4.1	103.6	-33.4	-13.7	109.6	11.4	-17.0							
70	CoF25	100 stp	35		0	yes	95.3	-0.4	35.8	107.6	27.6	-0.7	4.0	47.9	-13.7	-14.0	50.3	13.0	-16.0							
71	CoF25	100 stp	50		0	yes	105.2	-0.4	28.3	128.2	30.3	-6.7	4.0	68.6	-21.8	-14.0	72.9	9.7	-14.7							
72	CoF25	100 stp	65		0	yes	112.8	-0.3	26.3	143.6	31.4	-11.4	4.1	89.2	-29.8	-13.8	95.3	10.0	-17.1							
73	CoF25	120 stp	30		0	yes	91.6	-0.6	40.6	94.9	28.2	1.9	4.0	40.7	-11.5	-13.8	42.9	13.6	-16.4							
74	CoF25	120 stp	45		0	yes	103.7	-0.4	29.4	124.9	32.0	-6.2	4.1	61.4	-19.8	-14.0	65.9	8.5	-14.9							
75	CoF25	120 stp	60		0	yes	113.2	-0.2	27.3	143.7	33.0	-12.6	4.1	81.7	-28.2	-13.8	88.1	9.0	-17.0							
76	CoF25	Spiral	40		0	yes	95.7	-0.4	57.4	103.3	23.9	-0.5	4.0	55.5	-14.8	-14.0	45.4	37.3	-15.9							
77	CoF50	I-turn	25		100	yes	88.3	-0.6	56.5	104.0	24.8	1.2	4.0	33.5	-8.6	-13.6	29.3	21.4	-15.8	18.5	18.5	18.5	-4.0	10.9	0.30	
78	CoF50	I-turn	40		100	yes	101.5	-0.4	34.1	120.5	33.5	-5.5	4.0	54.0	-17.5	-14.1	58.2	10.7	-15.2	28.7	28.7	28.7	-10.7	27.3	0.46	
79	CoF50	I-turn	55		100	yes	110.8	-0.4	29.6	141.0	34.3	-11.5	4.1	74.3	-25.6	-13.9	80.5	10.3	-17.3	34.6	34.6	34.6	-15.5	44.6	0.55	
80	CoF50	H-turn	55		500	yes	94.9	-0.5	29.3	110.9	18.5	1.0	4.0	77.4	-18.9	-14.0	77.5	20.8	-16.3	8.4	8.4	8.4	5.3	11.6	0.14	
81	CoF50	H-turn	60		500	yes	99.5	-0.2	27.7	115.8	20.9	-2.0	3.9	84.1	-22.0	-14.3	85.5	18.8	-15.7	9.8	9.8	9.8	4.9	14.8	0.17	
82	CoF50	H-turn	70		500	yes	105.3	-0.2	25.8	129.3	23.8	-5.3	4.0	97.8	-27.7	-14.3	100.7	16.5	-14.8	11.9	11.9	11.9	3.9	20.9	0.20	
83	CoF50	80 stp	45		0	yes	100.8	-0.2	30.7	117.2	27.4	-4.1	3.9	62.0	-18.3	-14.3	64.8	12.7	-15.3							
84	CoF50	80 stp	60		0	yes	106.6	-0.5	26.7	134.9	28.9	-6.7	4.1	82.8	-26.0	-14.0	87.2	11.2	-14.5							

B-11

Table B-4 (continued). Results from simulation runs: semitrailer of the Columbus fuel oil vehicle

Run no.	Vehicle factor	Run Type	Strike angle [deg]	Turn radius [ft]	Conditions at end of run				Angular rate [deg/sec]				CG ht			Strike pt velocity [ft/sec]			Path change [deg] relative to		Relative to wall beside curb/rail/path													
					Roll over	Pitch	Yaw	Roll	Pitch	Yaw	Z [ft]	X	Y	Z	X	Y	Z	Curb	Path	Strike [deg]	Yaw [deg]	Vn	Vn/Vi											
85	CoF50	80 stp	75	0	yes	111.5	-0.5	25.2	146.6	29.7	-9.3	4.2	103.5	-33.8	-13.7	109.9	11.3	-17.5																
86	CoF50	100 stp	35	0	yes	94.8	-0.4	36.2	103.0	27.8	-0.5	4.0	47.9	-13.8	-14.0	50.2	13.2	-16.1																
87	CoF50	100 stp	50	0	yes	103.9	-0.5	28.7	128.3	30.6	-5.9	4.1	68.5	-21.9	-14.0	72.9	9.9	-14.9																
88	CoF50	100 stp	65	0	yes	110.6	-0.5	26.7	144.1	31.9	-9.6	4.2	89.0	-30.1	-13.8	95.5	10.0	-17.6																
89	CoF50	120 stp	30	0	yes	91.1	-0.7	41.0	98.2	28.2	2.1	4.1	40.6	-11.5	-13.8	42.7	13.9	-16.5																
90	CoF50	120 stp	45	0	yes	102.5	-0.5	29.9	124.6	32.1	-5.4	4.1	61.3	-19.9	-14.0	65.9	8.7	-15.2																
91	CoF50	120 stp	60	0	yes	111.2	-0.4	27.8	144.5	33.5	-11.0	4.1	81.6	-28.6	-13.9	88.4	9.0	-17.5																
92	CoF50	Spiral	40	0	yes	95.1	-0.4	57.9	106.2	24.1	-0.3	4.0	55.4	-14.8	-14.0	45.2	37.5	-15.0																
93	CoF25	I-turn	23	100	yes	89.0	-0.1	77.9	106.9	19.5	-1.5	3.7	30.4	-6.8	-13.7	14.5	28.3	-16.0																
94	CoF25	I-turn	27	100	yes	88.7	-0.8	48.4	102.1	27.3	3.1	4.1	36.3	-10.0	-13.6	36.3	17.3	-16.5																
95	CoF25	Trip	35	30	500	yes	89.9	2.0	31.3	111.4	47.9	-6.3	4.4	43.5	-20.5	-13.1	35.9	25.2	-17.4															
96	CoF25	Trip	40	30	500	yes	104.6	-2.5	30.6	134.1	52.5	-12.4	5.0	50.7	-23.5	-11.8	62.6	-6.1	-12.4															
97	CoF25	Trip	45	30	500	yes	113.7	-3.7	25.6	223.7	64.2	-21.6	5.6	59.3	-20.7	-9.3	70.2	-5.1	-15.1															
98	CoF25	Trip	50	30	500	on flat	88.8	-0.6	-11.6	103.0	9.0	1.3	4.0	75.2	-12.0	-13.8	72.0	-24.5	-16.1															
99	CoF25	Trip	55	30	500	on flat	88.8	-0.6	-11.7	102.3	9.1	1.3	4.0	75.1	-11.9	-13.8	71.9	-24.7	-16.1															
100	CoF50	Trip	35	30	500	yes	89.6	1.7	32.6	105.6	48.0	-4.9	4.3	43.1	-20.9	-13.3	35.8	24.9	-17.1															
101	CoF50	Trip	40	30	500	yes	107.5	-2.4	32.5	130.1	54.0	-14.8	4.9	49.7	-24.3	-11.9	62.9	-6.3	-12.5															
102	CoF50	Trip	45	30	500	yes	115.1	-3.9	27.7	232.1	65.9	-23.9	5.7	58.7	-22.0	-9.1	70.4	-4.1	-14.8															
103	CoF50	Trip	50	30	500	on flat	88.7	-0.5	-11.2	104.2	9.1	0.8	3.9	75.2	-12.0	-13.8	72.1	-24.0	-16.0															
104	CoF50	Trip	55	30	500	on flat	88.6	-0.5	-11.5	103.0	9.1	0.8	3.9	75.1	-12.0	-13.8	72.0	-24.3	-16.0															
105	CoF25	Rail	40	30	500	yes	95.8	-0.6	37.1	129.8	62.3	-2.2	4.1	47.7	-25.7	-12.6	65.2	-5.4	-15.8															
106	CoF25	Rail	45	30	500	yes	115.8	0.3	38.4	123.3	71.3	-29.1	3.9	53.7	-27.6	-13.2	39.6	35.5	-10.4															
107	CoF25	Rail	50	30	500	on flat	88.8	-0.6	-11.6	103.0	9.0	1.3	4.0	75.2	-12.0	-13.8	72.0	-24.5	-16.1															
108	CoF25	Rail	55	30	500	on flat	88.8	-0.6	-11.7	102.3	9.1	1.3	4.0	75.1	-11.9	-13.8	71.9	-24.7	-16.1															
109	CoF50	Rail	35	30	500	yes	84.0	-1.5	33.7	97.5	28.7	9.1	4.3	42.1	-21.3	-11.9	51.8	0.4	-16.6															
110	CoF50	Rail	40	30	500	yes	93.7	-0.9	38.0	123.3	61.6	1.6	4.2	47.4	-26.0	-12.3	65.1	-4.3	-16.5															
111	CoF50	Rail	45	30	500	yes	112.8	0.3	39.5	145.4	72.0	-25.1	4.0	53.4	-28.5	-13.3	39.5	35.4	-10.8															
112	CoF50	Rail	50	30	500	on flat	88.7	-0.5	-11.2	104.2	9.1	0.8	3.9	75.2	-12.0	-13.8	72.1	-24.0	-16.0															
113	CoF50	Rail	55	30	500	on flat	88.6	-0.5	-11.5	103.0	9.1	0.8	3.9	75.1	-12.0	-13.8	72.0	-24.3	-16.0															
114	CoF25	Rail	35	30	500	yes	91.2	-0.3	34.7	94.3	36.6	3.8	3.9	41.5	-22.0	-13.3	52.6	-1.5	-16.9															
115	CoF50	I-turn	23	100	yes	88.7	0.0	77.8	105.6	19.5	-1.5	3.7	30.4	-6.8	-13.7	14.5	28.3	-14.9																
116	CoF50	I-turn	27	100	yes	88.5	-0.8	48.9	100.3	27.2	2.8	4.1	36.3	-10.0	-13.6	35.9	17.7	-16.4																
117	CoF50	I-turn	20	100	no	0.1	0.0	90.0	0.0	0.0	0.0	6.6	29.3	0.0	0.0	0.0	0.0	0.0																
118	CoF25	I-turn	20	100	no	0.1	0.0	90.0	0.0	0.0	0.0	6.6	29.3	0.0	0.0	0.0	0.0	0.0																
119	CoF50	H-turn	50	500	yes	89.1	-0.9	32.4	99.6	14.4	3.7	4.1	70.6	-15.4	-13.7	68.4	25.0	-16.9																
120	CoF25	H-turn	50	500	yes	89.8	-0.8	32.2	96.0	14.5	3.7	4.1	70.7	-15.3	-13.7	68.6	24.7	-16.9																
121	CoF50	Sverve	50	500	yes	105.0	-0.6	16.6	129.2	32.6	-6.7	4.1	68.2	-22.8	-13.9	73.5	-7.2	-14.8																
122	CoF25	Sverve	50	500	yes	106.6	-0.5	16.3	131.6	32.3	-7.8	4.1	68.3	-22.7	-14.0	73.4	-7.2	-14.5																
123	CoF50	Trip/fall	45	20	500	yes	179.4	-0.1	70.1	93.8	-5.6	-83.0	-6.1	35.6	-49.4	-29.5	0.0	0.0																
124	CoF25	Trip/fall	45	20	500	yes	177.9	0.6	69.5	71.2	-4.4	-83.3	-6.5	35.6	-49.6	-29.9	0.0	0.0																
125	CoF50	Trip/fall	45	30	500	yes	187.4	-6.8	50.7	243.7	0.3	-72.2	0.9	45.2	-41.6	-18.6	0.0	0.0																
126	CoF25	Trip/fall	45	30	500	yes	188.8	-6.6	48.6	244.9	-0.8	-70.3	0.5	46.5	-40.5	-19.1	0.0	0.0																

Table B-5. Results from simulation runs: semitrailer of the Columbus gasoline vehicle

Run no.	Vehicle & inertia factor	Run Type	Speed [mph]	Strike angle [deg]	Turn radius [ft]	Conditions at end of run			Angular position [deg]			Angular rate [deg/sec]			CG velocity [ft/sec]			Strike pt velocity [ft/sec]			Path change [deg] relative to			Relative to wall beside curb/rail/path		
						Roll- over	Pitch	Yaw	Roll	Pitch	Yaw	Roll	Pitch	Yaw	X	Y	Z	X	Y	Z	Curb	Path	Strike [deg]	Yaw [deg]	Vn [ft/sec]	Vn/Vi
1	CoG25	Trip	35	5	500	no	2.1	0.0	57.6	-0.2	0.2	5.9	6.7	51.2	0.8	0.0	0.0	0.0	0.0	0.0	-5.0	0.0	-0.9	0.0	0.00	
2	CoG25	Trip	40	5	500	no	2.8	0.0	63.9	-0.1	0.3	6.7	6.7	58.4	0.5	0.0	0.0	0.0	0.0	-5.0	0.0	-0.5	0.0	0.00		
3	CoG25	Trip	45	5	500	yes	95.6	-1.0	20.3	150.9	12.0	5.8	4.2	63.0	-7.5	-12.9	63.7	-2.2	-17.2	7.7	2.7	-0.9	8.5	0.13		
4	CoG25	Trip	50	5	500	on flat	88.6	-0.3	-8.2	98.3	9.8	0.2	3.8	74.6	-11.9	-14.4	74.8	-9.9	-16.0	11.8	6.8	-2.8	15.5	0.21		
5	CoG25	Trip	55	5	500	on flat	88.6	-0.3	-7.1	99.0	10.0	0.1	3.8	74.5	-11.9	-14.4	74.6	-10.0	-16.0	11.9	6.9	-2.8	15.5	0.19		
6	CoG50	Trip	35	5	500	no	2.3	0.0	57.6	1.8	0.2	6.4	6.7	51.2	0.9	0.0	0.0	0.0	0.0	-5.1	-0.1	-0.9	-0.1	0.00		
7	CoG50	Trip	40	5	500	no	2.8	0.0	63.9	-0.6	0.4	6.9	6.7	59.0	0.6	0.0	0.0	0.0	0.0	-5.1	-0.1	-0.5	-0.1	0.00		
8	CoG50	Trip	45	5	500	yes	92.9	-1.2	20.6	133.8	11.7	7.7	4.3	62.9	-7.6	-12.6	63.7	-4.2	-17.6	7.7	2.7	-0.8	8.5	0.13		
9	CoG50	Trip	50	5	500	on flat	88.6	-0.2	-8.2	101.0	9.8	-0.3	3.8	74.7	-11.9	-14.5	74.8	-9.8	-15.9	11.8	6.8	-2.8	15.5	0.21		
10	CoG50	Trip	55	5	500	on flat	88.5	-0.2	-7.4	99.0	10.0	-0.3	3.8	74.5	-11.9	-14.5	74.6	-9.9	-15.9	11.9	6.9	-2.8	15.5	0.19		
11	CoG25	Trip	35	10	500	no	2.3	0.0	62.1	-0.1	0.3	6.0	6.7	52.5	0.8	0.0	0.0	0.0	0.0	-10.1	-10.1	-0.8	-0.1	0.00		
12	CoG25	Trip	40	10	500	yes	101.4	-0.1	27.3	128.5	6.9	2.6	3.9	55.0	-9.0	-13.3	55.2	-3.8	-15.2	9.5	-0.5	-0.2	9.2	0.16		
13	CoG25	Trip	45	10	500	yes	97.8	1.8	27.9	146.1	9.0	-8.4	4.4	62.3	-14.6	-13.7	61.8	-3.7	-16.6	11.3	1.3	1.9	12.5	0.19		
14	CoG25	Trip	50	10	500	on flat	88.6	-0.3	-8.2	98.3	9.8	0.2	3.8	74.6	-11.9	-14.4	74.8	-9.9	-16.0	15.9	5.9	-6.8	20.7	0.28		
15	CoG25	Trip	55	10	500	on flat	88.6	-0.3	-7.1	99.0	10.0	0.1	3.8	74.5	-11.9	-14.4	74.6	-10.0	-16.0	15.9	5.9	-6.8	20.7	0.26		
16	CoG50	Trip	35	10	500	no	2.2	0.0	62.1	-0.4	0.2	5.8	6.7	52.2	0.8	0.0	0.0	0.0	0.0	-10.0	0.0	-0.8	0.0	0.00		
17	CoG50	Trip	40	10	500	yes	99.6	-0.1	27.4	122.2	7.0	1.7	3.9	54.1	-8.7	-13.5	54.3	-4.2	-15.2	9.3	-0.7	-0.2	8.9	0.15		
18	CoG50	Trip	45	10	500	yes	93.5	1.1	28.2	112.5	11.9	-9.5	4.1	57.6	-14.6	-14.8	57.1	-4.4	-18.6	12.4	2.4	1.9	12.8	0.19		
19	CoG50	Trip	50	10	500	on flat	88.6	-0.2	-8.2	101.0	9.8	-0.3	3.8	74.7	-11.9	-14.5	74.8	-9.8	-15.9	15.9	5.9	-6.8	20.7	0.28		
20	CoG50	Trip	55	10	500	on flat	88.5	-0.2	-7.4	99.0	10.0	-0.3	3.8	74.5	-11.9	-14.5	74.6	-9.9	-16.0	15.9	5.9	-6.8	20.7	0.26		
21	CoG25	Trip	35	20	500	yes	92.9	1.5	34.7	110.5	34.7	-1.3	4.3	45.4	-19.4	-13.7	45.8	-1.3	-14.8	17.3	-2.7	5.8	14.7	0.29		
22	CoG25	Trip	40	20	500	yes	89.9	2.9	35.0	108.3	44.9	-9.0	4.7	51.2	-23.1	-13.0	51.1	-1.0	-17.7	17.9	-2.1	6.4	17.3	0.29		
23	CoG25	Trip	45	20	500	yes	115.5	-0.5	38.2	153.7	48.9	-24.8	4.2	56.7	-29.4	-13.7	57.2	-40.9	-15.0	18.2	-1.8	9.2	20.0	0.30		
24	CoG25	Trip	50	20	500	on flat	88.6	-0.3	-8.2	98.3	9.8	0.2	3.8	74.6	-11.9	-14.4	74.8	-9.9	-16.0	25.9	5.9	-16.9	33.0	0.45		
25	CoG25	Trip	55	20	500	on flat	88.6	-0.3	-7.1	99.0	10.0	0.1	3.8	74.5	-11.9	-14.4	74.6	-10.0	-16.0	26.0	6.0	-16.9	33.0	0.41		
26	CoG50	Trip	35	20	500	yes	92.2	0.8	35.7	100.1	31.0	7.8	4.0	47.4	-19.9	-14.5	48.4	-5.1	-12.7	16.2	-3.8	6.6	14.3	0.28		
27	CoG50	Trip	40	20	500	yes	89.1	2.9	36.0	105.2	45.0	-7.4	4.6	50.9	-23.6	-13.0	50.8	-2.3	-17.4	17.6	-2.4	7.3	17.0	0.29		
28	CoG50	Trip	45	20	500	yes	115.7	-0.6	39.4	149.2	49.5	-24.7	4.2	56.1	-30.0	-13.6	56.6	-42.8	-15.0	17.8	-2.2	10.3	19.5	0.30		
29	CoG50	Trip	50	20	500	on flat	88.6	-0.2	-8.2	101.0	9.8	-0.3	3.8	74.7	-11.9	-14.5	74.8	-9.8	-15.9	25.9	5.9	-16.8	33.0	0.45		
30	CoG50	Trip	55	20	500	on flat	88.5	-0.2	-7.4	99.0	10.0	-0.3	3.8	74.5	-11.9	-14.5	74.6	-9.9	-15.9	26.0	6.0	-16.8	33.0	0.41		
31	CoG25	Rail	35	5	500	no	2.0	0.0	57.5	-0.1	0.2	5.9	6.7	51.3	0.8	0.0	0.0	0.0	0.0	-5.0	0.0	-0.9	0.0	0.00		
32	CoG25	Rail	40	5	500	no	2.6	0.0	63.9	0.0	0.3	6.7	6.7	58.6	0.5	0.0	0.0	0.0	0.0	-5.0	0.0	-0.5	0.0	0.00		
33	CoG25	Rail	45	5	500	no	4.8	0.1	86.1	-1.2	0.4	8.5	6.7	65.8	0.6	0.0	0.0	0.0	-0.3	-5.3	-0.3	-0.3	-0.3	0.00		
34	CoG25	Rail	50	5	500	on flat	88.6	-0.3	-8.2	98.3	9.8	0.2	3.8	74.6	-11.9	-14.4	74.8	-9.9	-16.0	11.8	6.8	-2.8	15.5	0.21		
35	CoG25	Rail	55	5	500	on flat	88.6	-0.3	-7.1	99.0	10.0	0.1	3.8	74.5	-11.9	-14.4	74.6	-10.0	-16.0	11.9	6.9	-2.8	15.5	0.19		
36	CoG50	Rail	35	5	500	no	2.0	0.0	57.5	0.0	0.2	5.9	6.7	51.3	0.8	0.0	0.0	0.0	0.0	-5.0	0.0	-0.9	0.0	0.00		
37	CoG50	Rail	40	5	500	no	2.6	0.0	63.9	-0.1	0.3	6.8	6.7	58.6	0.5	0.0	0.0	0.0	0.0	-5.0	0.0	-0.5	0.0	0.00		
38	CoG50	Rail	45	5	500	no	4.5	0.1	86.2	-0.2	0.6	7.4	6.7	66.1	0.3	0.0	0.0	0.0	0.0	-5.0	0.0	-0.2	0.0	0.00		
39	CoG50	Rail	50	5	500	on flat	88.6	-0.2	-8.2	101.0	9.8	-0.3	3.8	74.7	-11.9	-14.5	74.8	-9.8	-15.9	11.8	6.8	-2.8	15.5	0.21		
40	CoG50	Rail	55	5	500	on flat	88.5	-0.2	-7.4	99.0	10.0	-0.3	3.8	74.5	-11.9	-14.5	74.6	-9.9	-15.9	11.9	6.9	-2.8	15.5	0.19		
41	CoG25	Rail	35	10	500	no	2.0	0.0	61.9	0.0	0.2	5.9	6.7	51.3	0.8	0.0	0.0	0.0	0.0	-10.0	0.0	-0.9	0.0	0.00		
42	CoG25	Rail	40	10	500	yes	89.7	-1.0	33.2	115.3	8.0	4.5	4.2	54.0	-6.1	-11.9	54.5	-1.6	-15.7	7.1	-2.9	-0.7	6.7	0.11		

Table B-5 (continued). Results from simulation runs: semitrailer of the Columbus gasoline vehicle

Run no.	Vehicle & inertia factor	Run Type	Speed [mph]	Strike angle [deg]	Turn radius [ft]	Conditions at end of run			Angular rate [deg/sec]			CG ht [ft]			CG velocity [ft/sec]			Strike pt velocity [ft/sec]			Path change [deg] relative to		Relative to wall beside curb/rail/path		
						Roll-over	Angular position [deg]	Pitch	Yaw	Roll	Pitch	Yaw	Z [ft]	X	Y	Z	X	Y	Z	Curb	Path	Strike [deg]	Yaw [deg]	Vn	Vn/Vi
43	CoG25	Rail	45	10	500	yes	92.3	-2.7	25.1	116.3	10.3	11.0	4.9	62.8	-6.7	-11.3	64.0	-2.8	-17.7	7.2	-2.8	7.2	-1.2	8.0	0.12
44	CoG25	Rail	50	10	500	on flat	88.6	-0.3	-8.2	98.3	9.8	0.2	3.8	74.6	-11.9	-14.4	74.8	-9.9	-16.0	15.9	5.9	15.9	-6.8	20.7	0.28
45	CoG25	Rail	55	10	500	on flat	88.6	-0.3	-7.1	99.0	10.0	0.1	3.8	74.5	-11.9	-14.4	74.6	-10.0	-16.0	15.9	5.9	15.9	-6.8	20.7	0.26
46	CoG50	Rail	35	10	500	no	2.0	0.0	61.9	0.0	0.2	5.9	6.7	51.3	0.8	0.0	0.0	0.0	0.0	0.0	-10.0	0.0	-0.9	0.0	0.00
47	CoG50	Rail	40	10	500	yes	89.8	0.3	31.4	110.9	6.1	0.2	3.8	54.7	-6.0	-12.5	54.8	3.7	-14.3	7.9	-2.1	7.9	-1.7	7.6	0.13
48	CoG50	Rail	45	10	500	yes	96.5	-2.6	31.5	111.0	17.8	3.1	5.0	61.7	-12.7	-11.7	62.3	-14.1	-14.5	6.8	-3.2	6.8	4.8	7.5	0.11
49	CoG50	Rail	50	10	500	on flat	88.6	-0.2	-8.2	101.0	9.8	-0.3	3.8	74.7	-11.9	-14.5	74.8	-9.8	-15.9	15.9	5.9	15.9	-6.8	20.7	0.28
50	CoG50	Rail	55	10	500	on flat	88.5	-0.2	-7.4	99.0	10.0	-0.3	3.8	74.5	-11.9	-14.5	74.6	-9.9	-15.9	15.9	5.9	15.9	-6.8	20.7	0.26
51	CoG25	Rail	35	20	500	yes	89.7	-2.2	35.8	95.7	26.7	8.0	4.7	43.6	-16.6	-13.1	44.7	-20.9	-18.1	14.7	-5.3	14.7	6.2	11.8	0.23
52	CoG25	Rail	40	20	500	yes	92.5	0.6	40.1	85.7	39.9	-0.7	4.0	49.3	-26.3	-13.7	49.8	-8.3	-14.4	17.1	-2.9	17.1	10.9	16.4	0.28
53	CoG25	Rail	45	20	500	yes	99.9	0.5	42.6	114.8	54.4	-7.7	4.0	54.8	-32.1	-13.2	55.1	-8.1	-13.0	16.5	-3.5	16.5	13.9	18.0	0.27
54	CoG25	Rail	50	20	500	on flat	88.6	-0.3	-8.2	98.3	9.8	0.2	3.8	74.6	-11.9	-14.4	74.8	-9.9	-16.0	25.9	5.9	25.9	-16.9	33.0	0.45
55	CoG25	Rail	55	20	500	on flat	88.6	-0.3	-7.1	99.0	10.0	0.1	3.8	74.5	-11.9	-14.4	74.6	-10.0	-16.0	26.0	6.0	26.0	-16.9	33.0	0.41
56	CoG50	Rail	35	20	500	yes	85.2	-2.2	35.2	80.9	22.1	9.0	4.6	43.7	-15.7	-13.0	44.8	-19.9	-17.8	14.3	-5.7	14.3	5.4	11.5	0.22
57	CoG50	Rail	40	20	500	yes	85.8	-0.9	39.9	76.2	34.9	9.3	4.1	48.7	-26.5	-13.1	49.9	-37.8	-17.2	18.0	-2.0	18.0	10.6	17.2	0.29
58	CoG50	Rail	45	20	500	yes	98.6	0.1	44.1	104.7	53.9	-4.6	3.9	54.0	-33.2	-13.4	54.5	-11.1	-12.7	16.4	-3.6	16.4	15.2	17.8	0.27
59	CoG50	Rail	50	20	500	on flat	88.6	-0.2	-8.2	101.0	9.8	-0.3	3.8	74.7	-11.9	-14.5	74.8	-9.8	-15.9	25.9	5.9	25.9	-16.8	33.0	0.45
60	CoG50	Rail	55	20	500	on flat	88.5	-0.2	-7.4	99.0	10.0	-0.3	3.8	74.5	-11.9	-14.5	74.6	-9.9	-15.9	26.0	6.0	26.0	-16.8	33.0	0.41
61	CoG25	I-turn	25	100	0	yes	88.6	-0.4	57.2	103.0	25.2	0.7	3.9	33.5	-8.7	-14.2	33.9	-13.2	-15.9	18.5	18.5	18.5	-4.0	11.0	0.30
62	CoG25	I-turn	40	100	0	yes	101.5	-0.3	33.8	118.8	33.2	-5.8	4.0	54.2	-17.4	-14.6	54.3	-23.5	-15.2	28.8	28.8	28.8	-11.0	27.4	0.47
63	CoG25	I-turn	55	100	0	yes	111.4	-0.2	29.3	142.8	33.6	-12.4	4.0	74.5	-25.4	-14.4	75.2	-30.3	-17.2	34.7	34.7	34.7	-15.9	44.8	0.56
64	CoG25	H-turn	55	500	0	yes	93.4	-0.6	29.1	100.6	18.2	1.7	4.0	77.5	-18.6	-14.2	77.9	-19.7	-16.6	8.4	8.4	8.4	5.1	11.6	0.14
65	CoG25	H-turn	60	500	0	yes	98.6	-0.3	27.4	112.8	20.7	-1.5	3.9	84.3	-21.6	-14.5	84.5	-22.7	-15.8	9.8	9.8	9.8	4.6	14.8	0.17
66	CoG25	H-turn	70	500	0	yes	105.6	0.0	25.5	131.1	23.5	-5.8	3.9	98.0	-27.3	-14.8	97.9	-28.4	-14.7	11.9	11.9	11.9	3.7	21.0	0.20
67	CoG25	80 stp	45	0	0	yes	100.1	-0.2	30.4	115.3	27.4	-3.8	3.9	62.1	-18.2	-14.6	62.3	-22.1	-15.5						
68	CoG25	80 stp	60	0	0	yes	107.2	-0.3	26.5	137.7	28.5	-7.6	4.0	83.0	-25.8	-14.5	82.9	-28.8	-14.3						
69	CoG25	80 stp	75	0	0	yes	112.0	-0.3	24.9	152.6	29.2	-10.4	4.0	103.7	-33.4	-14.3	104.3	-35.8	-17.3						
70	CoG25	100 stp	35	0	0	yes	93.7	-0.5	36.0	98.4	27.9	0.3	4.0	47.9	-13.8	-14.3	48.4	-19.2	-16.3						
71	CoG25	100 stp	50	0	0	yes	104.3	-0.3	28.4	126.7	30.3	-6.5	4.0	68.7	-21.8	-14.5	68.7	-26.0	-14.9						
72	CoG25	100 stp	65	0	0	yes	111.0	-0.3	26.4	148.2	31.2	-10.7	4.0	89.2	-29.9	-14.4	89.9	-33.4	-17.5						
73	CoG25	120 stp	30	0	0	yes	89.7	-0.7	40.9	90.7	28.3	3.0	4.1	40.7	-11.5	-14.1	41.4	-17.9	-16.7						
74	CoG25	120 stp	45	0	0	yes	102.6	-0.4	29.6	124.5	31.9	-5.8	4.0	61.5	-19.8	-14.5	61.6	-25.0	-15.1						
75	CoG25	120 stp	60	0	0	yes	111.3	-0.2	27.5	147.5	32.9	-11.7	4.0	81.8	-28.3	-14.4	82.5	-32.6	-17.4						
76	CoG25	Spiral	40	0	0	yes	93.8	-0.5	57.4	102.4	23.9	0.5	4.0	55.5	-14.7	-14.3	55.9	-18.3	-16.3						
77	CoG50	I-turn	25	100	0	yes	88.4	-0.4	57.6	100.9	25.1	0.4	3.9	33.4	-8.6	-14.2	33.9	-13.0	-15.8	18.4	18.4	18.4	-3.9	10.9	0.30
78	CoG50	I-turn	40	100	0	yes	100.9	-0.3	34.3	119.5	33.4	-5.3	4.0	54.0	-17.5	-14.6	54.2	-30.8	-15.4	28.9	28.9	28.9	-11.0	27.4	0.47
79	CoG50	I-turn	55	100	0	yes	110.0	-0.3	29.7	138.4	34.0	-11.2	4.0	74.4	-25.6	-14.4	75.1	-23.9	-17.5	35.0	35.0	35.0	-15.9	45.1	0.56
80	CoG50	H-turn	55	500	0	yes	92.7	-0.7	29.4	101.3	18.3	2.0	4.1	77.4	-18.7	-14.2	77.9	-19.9	-16.7	8.3	8.3	8.3	5.2	11.6	0.14
81	CoG50	H-turn	60	500	0	yes	97.9	-0.3	27.8	113.3	20.9	-1.1	4.0	84.2	-21.8	-14.5	84.5	-23.1	-16.0	9.7	9.7	9.7	4.8	14.7	0.17
82	CoG50	H-turn	70	500	0	yes	104.6	-0.1	25.9	127.6	23.6	-5.2	3.9	97.8	-27.6	-14.7	97.9	-29.0	-14.9	11.9	11.9	11.9	3.8	21.0	0.20
83	CoG50	80 stp	45	0	0	yes	99.6	-0.2	30.8	115.0	27.6	-3.5	3.9	62.0	-18.3	-14.6	62.2	-22.4	-15.6						
84	CoG50	80 stp	60	0	0	yes	105.9	-0.4	26.8	133.2	28.7	-6.7	4.0	82.9	-26.0	-14.5	82.9	-29.3	-14.6						

Table B-5 (continued). Results from simulation runs: semitrailer of the Columbus gasoline vehicle

Run no.	Vehicle & inertia factor	Run Type	Speed [mph]	Strike angle [deg]	Turn radius [ft]	Conditions at end of run			Angular rate [deg/sec]			CG ht			Strike pt velocity [ft/sec]			Path change [deg] relative to			Relative to wall beside curb/rail/path							
						Roll-over	Pitch	Yaw	Roll	Pitch	Yaw	Z [ft]	X [ft/sec]	Y [ft/sec]	Z [ft/sec]	Curb	Path	Strike [deg]	Yaw [deg]	Vn [ft/sec]	Vn/Vi							
85	CoG50	100 stp	75	0	0	yes	110.2	-0.4	25.2	144.1	29.4	-9.0	4.1	103.5	-33.8	-14.3	104.2	-36.6	-17.7									
86	CoG50	100 stp	35	0	0	yes	93.2	-0.5	36.4	98.6	28.0	0.6	4.0	47.9	-13.9	-14.3	48.3	-19.3	-16.4									
87	CoG50	100 stp	50	0	0	yes	103.2	-0.4	28.8	127.0	30.4	-5.8	4.0	68.6	-21.9	-14.5	68.7	-26.3	-15.1									
88	CoG50	100 stp	65	0	0	yes	109.3	-0.4	26.8	141.2	31.5	-9.3	4.0	89.1	-30.2	-14.4	89.8	-34.2	-17.8									
89	CoG50	120 stp	30	0	0	yes	89.2	-0.8	41.2	93.3	28.3	3.2	4.1	40.6	-11.5	-14.2	41.3	-17.9	-16.8									
90	CoG50	120 stp	45	0	0	yes	101.8	-0.4	30.0	122.9	32.0	-5.2	4.0	61.4	-19.9	-14.5	61.5	-25.2	-15.3									
91	CoG50	120 stp	60	0	0	yes	109.5	-0.4	27.9	141.0	33.3	-10.2	4.0	81.7	-28.6	-14.4	82.4	-33.4	-17.8									
92	CoG50	Spiral	40	0	0	yes	93.2	-0.5	57.8	99.6	24.0	0.7	4.0	55.4	-14.8	-14.3	55.8	-18.5	-16.4									
93	CoG25	1-turn	23	100	yes	88.7	0.1	82.8	108.0	17.4	-1.5	3.7	30.4	-6.6	-13.8	30.5	6.0	-16.3	17.1	17.1			17.1	17.1	-4.8	9.1	0.27	
94	CoG25	1-turn	27	100	yes	88.4	-0.7	49.2	99.8	27.5	2.2	4.0	36.3	-10.0	-14.1	36.9	-15.6	-16.3	20.6	20.6			20.6	20.6	-5.1	13.2	0.33	
95	CoG25	Trip	35	30	500	yes	89.2	1.9	32.3	115.9	49.5	-4.6	4.3	43.1	-21.0	-13.5	43.5	2.4	-17.2	20.8	-9.2			20.8	-9.2	5.2	17.0	0.33
96	CoG25	Trip	40	30	500	yes	107.4	-2.1	32.5	135.7	53.5	-15.6	4.8	49.9	-24.7	-12.6	49.7	-39.3	-12.4	21.0	-9.0			21.0	-9.0	5.4	19.9	0.34
97	CoG25	Trip	45	30	500	yes	114.1	-3.7	27.5	198.0	65.2	-21.3	5.5	58.6	-22.1	-9.9	60.3	-38.8	-15.3	19.9	-10.1			19.9	-10.1	0.8	21.4	0.32
98	CoG25	Trip	50	30	500	on flat	88.6	-0.3	-8.2	98.3	9.8	0.2	3.8	74.6	-11.9	-14.4	74.8	-9.9	-16.0	30.8	0.8			30.8	0.8	-21.8	38.7	0.53
99	CoG25	Trip	55	30	500	on flat	88.6	-0.3	-7.1	99.0	10.0	0.1	3.8	74.5	-11.9	-14.4	74.6	-10.0	-16.0	30.8	0.8			30.8	0.8	-21.7	38.6	0.48
100	CoG50	Trip	35	30	500	yes	89.0	1.7	33.3	108.5	48.9	-4.7	4.3	42.9	-21.4	-13.7	43.2	2.5	-17.5	20.3	-9.7			20.3	-9.7	6.1	16.7	0.32
101	CoG50	Trip	40	30	500	yes	109.0	-2.1	34.0	132.7	55.2	-16.9	4.8	49.2	-25.2	-12.6	50.5	-40.3	-16.1	20.3	-9.7			20.3	-9.7	6.7	19.2	0.33
102	CoG50	Trip	45	30	500	yes	115.9	-3.9	29.3	215.0	65.6	-24.6	5.6	58.0	-23.4	-9.9	59.5	-39.5	-14.7	19.5	-10.5			19.5	-10.5	2.5	20.9	0.32
103	CoG50	Trip	50	30	500	on flat	88.6	-0.2	-8.2	101.0	9.8	-0.3	3.8	74.7	-11.9	-14.5	74.8	-9.8	-15.9	30.8	0.8			30.8	0.8	-21.7	38.7	0.53
104	CoG50	Trip	55	30	500	on flat	88.5	-0.2	-7.4	99.0	10.0	-0.3	3.8	74.5	-11.9	-14.5	74.6	-9.9	-15.9	30.8	0.8			30.8	0.8	-21.7	38.6	0.48
105	CoG25	Rail	40	30	500	yes	96.8	-0.4	39.0	122.1	63.5	-3.7	4.0	47.1	-26.9	-13.2	47.8	-47.1	-15.6	17.6	-12.4			17.6	-12.4	12.1	16.4	0.28
106	CoG25	Rail	45	30	500	yes	112.8	0.4	39.7	124.3	74.0	-26.5	3.9	53.2	-28.5	-13.5	52.6	4.0	-10.8	15.2	-14.8			15.2	-14.8	13.0	15.8	0.24
107	CoG25	Rail	50	30	500	on flat	88.6	-0.3	-8.2	98.3	9.8	0.2	3.8	74.6	-11.9	-14.4	74.8	-9.9	-16.0	30.8	0.8			30.8	0.8	-21.8	38.7	0.53
108	CoG25	Rail	55	30	500	on flat	88.6	-0.3	-7.1	99.0	10.0	0.1	3.8	74.5	-11.9	-14.4	74.6	-10.0	-16.0	30.8	0.8			30.8	0.8	-21.7	38.6	0.48
109	CoG50	Rail	35	30	500	yes	83.8	-1.3	34.7	97.2	30.8	6.9	4.2	41.8	-21.7	-12.6	42.8	-28.5	-16.4	20.5	-9.5			20.5	-9.5	6.9	16.5	0.32
110	CoG50	Rail	40	30	500	yes	95.7	-0.6	39.7	121.7	62.5	-1.1	4.1	46.9	-27.1	-12.9	47.8	-47.1	-16.0	17.4	-12.6			17.4	-12.6	12.7	16.2	0.28
111	CoG50	Rail	45	30	500	yes	111.2	0.4	40.9	124.1	74.6	-23.7	3.9	52.9	-29.3	-13.7	52.5	2.9	-11.0	15.0	-15.0			15.0	-15.0	14.0	15.6	0.24
112	CoG50	Rail	50	30	500	on flat	88.6	-0.2	-8.2	101.0	9.8	-0.3	3.8	74.7	-11.9	-14.5	74.8	-9.8	-15.9	30.8	0.8			30.8	0.8	-21.7	38.7	0.55
113	CoG50	Rail	55	30	500	on flat	88.5	-0.2	-7.4	99.0	10.0	-0.3	3.8	74.5	-11.9	-14.5	74.6	-9.9	-15.9	30.8	0.8			30.8	0.8	-21.7	38.6	0.48
114	CoG25	Rail	35	30	500	yes	89.0	-0.3	35.4	88.4	37.6	5.2	3.9	41.4	-22.2	-13.7	42.3	-32.8	-17.0	20.5	-9.5			20.5	-9.5	7.7	16.4	0.32
115	CoG50	1-turn	23	100	yes	88.5	0.0	82.9	106.8	17.3	-1.4	3.7	30.4	-6.6	-13.7	30.5	6.0	-16.2	17.1	17.1			17.1	17.1	-4.9	9.1	0.27	
116	CoG50	1-turn	27	100	yes	88.2	-0.7	49.6	102.5	27.4	1.9	4.0	36.2	-10.0	-14.1	36.8	-15.4	-16.3	20.4	20.4			20.4	20.4	-5.0	13.1	0.33	
117	CoG50	1-turn	20	100	no	0.0	0.0	90.0	0.0	0.0	0.0	6.7	29.3	0.0	0.0	0.0	0.0	0.0	0.0	0.0	0.0			0.0	0.0	0.0	0.0	0.00
118	CoG25	1-turn	20	100	no	0.0	0.0	90.0	0.0	0.0	0.0	6.7	29.3	0.0	0.0	0.0	0.0	0.0	0.0	0.0	0.0			0.0	0.0	0.0	0.0	0.00
119	CoG50	H-turn	50	500	yes	88.7	-0.7	32.7	102.6	13.8	2.1	4.0	70.7	-14.9	-14.2	71.0	-14.5	-16.6	6.4	6.4			6.4	6.4	5.5	8.1	0.11	
120	CoG25	H-turn	50	500	yes	88.5	-0.8	32.4	96.6	13.8	2.9	4.1	70.7	-15.0	-14.1	71.1	-14.9	-16.8	6.5	6.5			6.5	6.5	5.5	5.9	0.11	
121	CoG50	Swerve	50	0	0	yes	103.9	-0.5	15.9	130.0	32.3	-6.4	4.1	68.3	-22.8	-14.4	73.4	-8.0	-15.0	2.5	2.5			2.5	2.5	15.9	3.2	0.04
122	CoG25	Swerve	50	0	0	yes	105.3	-0.4	15.7	133.8	32.1	-7.5	4.0	68.4	-22.7	-14.5	73.3	-8.0	-14.7	2.7	2.7			2.7	2.7	15.7	3.4	0.05
123	CoG50	Trip/fall	45	20	500	yes	179.1	0.7	69.1	123.7	-3.3	-73.9	-5.7	35.5	-50.1	-29.0	0.0	0.0	0.0	-3.8	-23.8			-3.8	-23.8	58.5	-4.1	-0.06
124	CoG25	Trip/fall	45	20	500	yes	175.4	1.7	70.3	71.8	-2.3	-85.6	-6.3	35.0	-49.7	-30.1	0.0	0.0	0.0	-4.9	-24.9			-4.9	-24.9	59.7	-5.2	-0.08
125	CoG50	Trip/fall	45	30	500	yes	186.5	-6.5	53.1	227.0	2.6	-74.8	0.5	43.6	-43.0	-19.0	0.0	0.0	0.0	0.4	-29.6			0.4	-29.6	44.2	0.5	0.01
126	CoG25	Trip/fall	45	30	500	yes	187.8	-6.4	51.4	228.3	0.8	-73.3	0.2	44.6	-42.2	-19.4	0.0	0.0	0.0	0.9	-29.1			0.9	-29.1	42.6	0.9	0.01

Table B-6. Results from simulation runs: semitrailer of the Lantana fuel oil vehicle

Run no.	Vehicle & inertia factor	Run Type	Strike			Conditions at end of run			Angular rate [deg/sec]			CG ht			CG velocity [ft/sec]			Strike pt velocity [ft/sec]			Path change [deg] relative to		Relative to wall beside curb/rail/path			
			Speed [mph]	angle [deg]	Turn radius [ft]	Roll	Pitch	Yaw	Roll	Pitch	Yaw	Roll	Pitch	Yaw	X	Y	Z	X	Y	Z	Curb	Path	Strike [deg]	Yaw [deg]	Vn	Vn/Vi
1	Lnf25	Trip	35	5	500	no	2.4	0.0	57.5	0.0	0.3	6.0	6.9	51.3	0.9	0.0	0.0	0.0	0.0	0.0	0.0	-5.0	0.0	-1.0	0.0	0.00
2	Lnf25	Trip	40	5	500	no	3.6	0.0	64.0	0.1	0.4	6.7	6.9	58.6	0.5	0.0	0.0	0.0	0.0	0.0	0.0	-5.0	0.0	-0.5	0.0	0.00
3	Lnf25	Trip	45	5	500	yes	97.5	-0.6	18.4	128.7	7.3	2.0	4.0	63.6	7.5	-13.8	61.4	17.8	-15.9	8.7	3.7	8.7	-1.9	9.7	0.15	
4	Lnf25	Trip	50	5	500	on flat	89.4	-0.5	-14.2	97.9	9.2	0.7	3.9	73.2	-11.6	-14.5	68.9	-27.0	-16.3	11.8	6.8	11.8	-2.8	15.1	0.21	
5	Lnf25	Trip	55	5	500	on flat	89.3	-0.5	-14.2	97.8	9.3	0.8	3.9	73.0	-11.5	-14.5	68.8	-26.9	-16.3	11.8	6.8	11.8	-2.8	15.1	0.19	
6	Lnf50	Trip	35	5	500	no	2.4	0.0	57.5	0.2	0.3	5.9	6.9	51.2	0.9	0.0	0.0	0.0	0.0	0.0	0.0	-5.0	0.0	-1.0	0.0	0.00
7	Lnf50	Trip	40	5	500	no	3.5	0.0	64.0	0.5	0.4	6.7	6.9	58.6	0.5	0.0	0.0	0.0	0.0	0.0	0.0	-5.0	0.0	-0.5	0.0	0.00
8	Lnf50	Trip	45	5	500	yes	96.6	-0.7	18.9	134.1	8.2	4.6	4.0	63.1	-7.9	-13.4	61.3	17.3	-16.5	8.7	3.7	8.7	-1.6	9.7	0.15	
9	Lnf50	Trip	50	5	500	on flat	89.3	-0.4	-13.9	99.7	9.3	0.4	3.8	73.3	-11.6	-14.5	69.1	-26.6	-16.3	11.8	6.8	11.8	-2.7	15.1	0.21	
10	Lnf50	Trip	55	5	500	on flat	89.3	-0.4	-14.0	100.2	9.4	0.3	3.8	73.1	-11.6	-14.5	68.9	-26.7	-16.2	11.8	6.8	11.8	-2.8	15.1	0.19	
11	Lnf25	Trip	35	10	500	yes	96.8	-0.6	29.7	129.3	9.8	1.8	4.0	47.6	-6.6	-12.8	42.5	22.1	-15.1	8.5	-1.5	8.5	-0.7	7.1	0.14	
12	Lnf25	Trip	40	10	500	yes	99.6	-0.2	27.4	124.9	10.6	2.7	3.9	54.9	-10.8	-13.6	52.5	18.8	-15.9	10.6	0.6	10.6	0.6	10.3	0.17	
13	Lnf25	Trip	45	10	500	yes	99.6	2.1	27.7	162.4	10.8	-9.7	4.5	62.9	-15.2	-13.0	54.9	29.5	-16.5	11.6	1.6	11.6	2.0	13.0	0.20	
14	Lnf25	Trip	50	10	500	on flat	89.4	-0.5	-14.2	97.9	9.2	0.7	3.9	73.2	-11.6	-14.5	68.9	-27.0	-16.3	15.6	5.6	15.6	-6.6	19.9	0.27	
15	Lnf25	Trip	55	10	500	on flat	89.3	-0.5	-14.2	97.8	9.3	0.8	3.9	73.0	-11.5	-14.5	68.8	-26.9	-16.3	15.6	5.6	15.6	-6.6	19.9	0.25	
16	Lnf50	Trip	35	10	500	yes	101.7	-0.3	30.1	164.6	12.8	8.3	3.9	46.9	-6.3	-11.7	41.3	23.7	-16.3	8.3	-1.7	8.3	-0.7	6.8	0.13	
17	Lnf50	Trip	40	10	500	yes	101.0	-0.2	27.4	144.6	9.9	3.2	3.9	54.8	-10.4	-13.3	51.0	21.6	-15.8	10.3	0.3	10.3	0.4	10.0	0.17	
18	Lnf50	Trip	45	10	500	yes	98.7	1.1	27.8	137.7	13.8	-4.4	4.1	58.5	-15.3	-14.0	53.0	24.6	-15.5	12.8	2.8	12.8	1.9	13.4	0.20	
19	Lnf50	Trip	50	10	500	on flat	89.3	-0.4	-13.9	99.7	9.3	0.4	3.8	73.3	-11.6	-14.5	69.1	-26.6	-16.3	15.6	5.6	15.6	-6.6	20.0	0.27	
20	Lnf50	Trip	55	10	500	on flat	89.3	-0.4	-14.0	100.2	9.4	0.3	3.8	73.1	-11.6	-14.5	68.9	-26.7	-16.2	15.6	5.6	15.6	-6.6	19.9	0.25	
21	Lnf25	Trip	35	20	500	yes	94.9	1.7	33.6	113.1	34.7	-3.7	4.3	45.7	-19.2	-13.8	38.6	25.1	-15.2	17.8	-2.2	17.8	-2.2	17.8	0.30	
22	Lnf25	Trip	40	20	500	yes	89.7	3.3	33.3	106.1	44.4	-9.1	4.7	51.9	-22.3	-12.7	43.6	28.0	-17.7	18.4	-1.6	18.4	4.9	17.8	0.30	
23	Lnf25	Trip	45	20	500	yes	121.2	0.1	38.6	160.7	45.3	-29.9	3.7	56.4	-30.5	-14.9	44.5	32.7	-12.3	18.9	-1.1	18.9	9.5	20.8	0.31	
24	Lnf25	Trip	50	20	500	on flat	89.4	-0.5	-14.2	97.9	9.2	0.7	3.9	73.2	-11.6	-14.5	68.9	-27.0	-16.3	25.6	5.6	25.6	-16.6	32.0	0.44	
25	Lnf25	Trip	55	20	500	on flat	89.3	-0.5	-14.2	97.8	9.3	0.8	3.9	73.0	-11.5	-14.5	68.8	-26.9	-16.3	25.6	5.6	25.6	-16.6	31.9	0.40	
26	Lnf50	Trip	35	20	500	yes	94.5	1.1	34.5	109.0	34.9	-1.9	4.1	45.5	-19.7	-14.2	38.6	24.9	-15.1	17.7	-2.3	17.7	5.7	15.1	0.29	
27	Lnf50	Trip	40	20	500	yes	89.1	3.2	34.2	107.9	45.1	-8.4	4.7	51.6	-22.7	-12.9	42.8	28.7	-18.0	18.0	-2.0	18.0	5.7	17.5	0.30	
28	Lnf50	Trip	45	20	500	yes	122.6	0.0	40.1	158.6	44.3	-31.4	3.6	55.7	-31.6	-15.2	43.5	32.7	-12.4	18.7	-1.3	18.7	10.9	20.5	0.31	
29	Lnf50	Trip	50	20	500	on flat	89.3	-0.4	-13.9	99.7	9.3	0.4	3.8	73.3	-11.6	-14.5	69.1	-26.6	-16.3	25.6	5.6	25.6	-16.6	32.0	0.44	
30	Lnf50	Trip	55	20	500	on flat	89.3	-0.4	-14.0	100.2	9.4	0.3	3.8	73.1	-11.6	-14.5	68.9	-26.7	-16.2	25.6	5.6	25.6	-16.6	32.0	0.40	
31	Lnf25	Rail	35	5	500	no	2.2	0.0	57.4	0.0	0.2	5.9	6.9	51.3	0.9	0.0	0.0	0.0	0.0	0.0	0.0	-5.0	0.0	-1.0	0.0	0.00
32	Lnf25	Rail	40	5	500	no	3.0	0.0	63.8	0.2	0.4	6.7	6.9	58.6	0.5	0.0	0.0	0.0	0.0	0.0	0.0	-5.0	0.0	-0.5	0.0	0.00
33	Lnf25	Rail	45	5	500	no	6.3	0.1	86.1	3.5	0.9	7.9	6.9	65.8	0.3	0.0	0.0	0.0	0.0	0.0	0.0	-5.0	0.0	-0.2	0.0	0.00
34	Lnf25	Rail	50	5	500	on flat	89.4	-0.5	-14.2	97.9	9.2	0.7	3.9	73.2	-11.6	-14.5	68.9	-27.0	-16.3	11.8	6.8	11.8	-2.8	15.1	0.21	
35	Lnf25	Rail	55	5	500	on flat	89.3	-0.5	-14.2	97.8	9.3	0.8	3.9	73.0	-11.5	-14.5	68.8	-26.9	-16.3	11.8	6.8	11.8	-2.8	15.1	0.19	
36	Lnf50	Rail	35	5	500	no	2.2	0.0	57.4	0.0	0.2	6.0	6.9	51.3	0.9	0.0	0.0	0.0	0.0	0.0	0.0	-5.0	0.0	-1.0	0.0	0.00
37	Lnf50	Rail	40	5	500	no	3.0	0.0	63.8	0.1	0.4	6.7	6.9	58.6	0.5	0.0	0.0	0.0	0.0	0.0	0.0	-5.0	0.0	-0.5	0.0	0.00
38	Lnf50	Rail	45	5	500	no	5.8	0.1	86.1	3.7	0.8	7.8	6.9	65.8	0.0	0.0	0.0	0.0	0.0	0.2	-4.8	0.2	-0.2	0.2	0.00	
39	Lnf50	Rail	50	5	500	on flat	89.3	-0.4	-13.9	99.7	9.3	0.4	3.8	73.3	-11.6	-14.5	69.1	-26.6	-16.3	11.8	6.8	11.8	-2.7	15.1	0.21	
40	Lnf50	Rail	55	5	500	on flat	89.3	-0.4	-14.0	100.2	9.4	0.3	3.8	73.1	-11.6	-14.5	68.9	-26.7	-16.2	11.8	6.8	11.8	-2.8	15.1	0.19	
41	Lnf25	Rail	35	10	500	no	2.2	0.0	61.8	-0.1	0.2	5.9	6.9	51.2	0.9	0.0	0.0	0.0	0.0	0.0	0.0	-10.0	0.0	-1.0	0.0	0.00
42	Lnf25	Rail	40	10	500	yes	88.3	-3.0	25.9	119.3	7.1	8.4	4.8	55.1	-4.5	-10.9	49.9	25.5	-16.5	6.8	-3.2	6.8	-2.1	6.5	0.11	

Table B-7. Results from simulation runs: semitrailer of the Lantana gasoline vehicle

Run no.	Vehicle & inertia factor	Run Type	Strike			Conditions at end of run			CG ht			Strike pt velocity			Path change [deg] relative to Curb Path			Relative to wall beside curb/rail/path				
			Speed [mph]	angle [deg]	radius [ft]	Roll- over	Roll- over	Pitch [deg]	Yaw [deg]	Z [ft]	X [ft]	Y [ft]	Z [ft]	X [ft]	Y [ft]	Z [ft]	Curb	Path	Strike [deg]	Yaw [deg]	Vn [ft/sec]	Vn/Vi
1	LnG25	Trip	35	5	500	no	2.3	0.0	57.4	0.1	0.3	5.7	7.2	51.2	0.9	0.0	0.0	0.0	0.0	-1.0	0.0	0.0
2	LnG25	Trip	40	5	500	no	3.9	0.0	63.6	0.6	0.5	6.9	7.2	61.4	0.5	0.0	0.0	0.0	0.0	-0.5	0.0	0.0
3	LnG25	Trip	45	5	500	yes	96.9	-0.3	17.8	105.0	7.1	-5.5	3.8	61.6	-7.7	-15.4	61.3	-9.8	-13.6	9.3	-2.2	10.1
4	LnG25	Trip	50	5	500	on flat	89.0	-0.1	-14.5	95.3	9.7	-0.8	3.7	72.0	-11.4	-15.4	72.0	-9.2	-16.2	12.0	-3.0	15.2
5	LnG25	Trip	55	5	500	on flat	88.9	-0.1	-13.3	94.3	9.9	-0.7	3.7	71.7	-11.4	-15.4	71.8	-9.3	-16.2	12.1	-3.0	15.2
6	LnG50	Trip	35	5	500	no	2.3	0.0	57.5	-1.9	-0.7	5.8	7.1	50.9	0.8	-0.2	0.0	0.0	0.0	-0.9	0.0	0.0
7	LnG50	Trip	40	5	500	no	3.3	0.0	63.5	0.9	0.5	6.8	7.2	61.2	0.5	0.0	0.0	0.0	0.1	-0.6	0.1	0.0
8	LnG50	Trip	45	5	500	yes	97.5	-0.9	18.9	141.3	10.2	5.5	4.1	62.7	-8.2	-13.6	63.2	-3.8	-16.5	8.8	-1.4	9.6
9	LnG50	Trip	50	5	500	on flat	89.0	0.0	-14.4	95.8	9.7	-1.1	3.7	72.0	-11.4	-15.4	72.0	-2.2	-17.0	12.0	-3.0	15.2
10	LnG50	Trip	55	5	500	on flat	88.9	0.0	-13.2	96.0	9.9	-1.1	3.7	71.8	-11.4	-15.4	71.8	-2.2	-17.0	12.1	-3.0	15.2
11	LnG25	Trip	35	10	500	yes	99.6	-0.4	29.3	149.9	11.5	4.1	3.9	47.4	-6.7	-13.4	47.8	-2.6	-15.7	8.5	-0.5	7.1
12	LnG25	Trip	40	10	500	yes	102.0	-0.4	27.6	136.5	12.1	1.6	3.9	55.1	-10.6	-14.0	55.4	-5.2	-15.3	10.3	0.6	10.0
13	LnG25	Trip	45	10	500	yes	95.4	1.0	27.8	99.2	12.0	-10.8	4.0	61.5	-15.5	-16.1	60.9	-7.8	-19.4	12.2	1.9	13.4
14	LnG25	Trip	50	10	500	on flat	89.0	-0.1	-14.5	95.3	9.7	-0.8	3.7	72.0	-11.4	-15.4	72.0	-9.2	-16.2	15.9	-6.8	19.9
15	LnG25	Trip	55	10	500	on flat	88.9	-0.1	-13.3	94.3	9.9	-0.7	3.7	71.7	-11.4	-15.4	71.8	-9.3	-16.2	16.0	-6.9	20.0
16	LnG50	Trip	35	10	500	yes	97.6	-0.7	29.6	140.0	12.5	6.6	4.0	47.3	-6.6	-12.8	47.9	-2.2	-16.3	8.4	-0.4	7.0
17	LnG50	Trip	40	10	500	yes	99.8	-0.5	27.9	131.8	13.8	3.9	4.0	54.9	-10.6	-13.8	55.3	-6.7	-16.2	10.0	0.9	9.7
18	LnG50	Trip	45	10	500	yes	102.6	0.2	28.1	141.9	13.6	-1.6	3.8	61.3	-15.4	-15.2	61.3	-1.8	-14.3	12.2	1.9	13.4
19	LnG50	Trip	50	10	500	on flat	89.0	0.0	-14.4	95.8	9.7	-1.1	3.7	72.0	-11.4	-15.4	72.0	-2.2	-17.0	15.9	-6.8	19.9
20	LnG50	Trip	55	10	500	on flat	88.9	0.0	-13.2	96.0	9.9	-1.1	3.7	71.8	-11.4	-15.4	71.8	-2.2	-17.0	16.0	-6.9	20.0
21	LnG25	Trip	35	20	500	yes	94.2	1.5	34.5	111.7	35.8	-2.7	4.2	45.5	-19.8	-14.5	45.7	-0.9	-15.3	17.8	5.7	15.2
22	LnG25	Trip	40	20	500	yes	88.8	3.3	34.1	111.9	45.1	-7.5	4.7	51.6	-23.0	-13.5	51.4	-0.8	-17.7	18.4	5.6	17.9
23	LnG25	Trip	45	20	500	yes	120.3	0.4	39.4	157.0	45.4	-29.6	3.6	55.6	-31.1	-15.7	54.2	-3.9	-12.9	19.0	10.2	20.8
24	LnG25	Trip	50	20	500	on flat	89.0	-0.1	-14.5	95.3	9.7	-0.8	3.7	72.0	-11.4	-15.4	72.0	-9.2	-16.2	25.8	-16.8	31.7
25	LnG25	Trip	55	20	500	on flat	88.9	-0.1	-13.3	94.3	9.9	-0.7	3.7	71.7	-11.4	-15.4	71.8	-9.3	-16.2	25.9	-16.9	31.8
26	LnG50	Trip	35	20	500	yes	93.3	0.8	35.4	92.5	33.7	8.1	4.0	46.3	-20.3	-15.5	47.2	-5.3	-12.8	17.1	6.5	14.9
27	LnG50	Trip	40	20	500	yes	88.7	3.1	35.2	102.4	45.6	-7.0	4.7	51.2	-23.4	-13.6	51.0	-1.2	-17.7	18.1	6.5	17.4
28	LnG50	Trip	45	20	500	yes	121.2	0.3	40.7	154.5	43.9	-30.6	3.6	54.9	-32.1	-16.0	53.5	-4.8	-13.2	18.8	11.5	20.5
29	LnG50	Trip	50	20	500	on flat	89.0	0.0	-14.4	95.8	9.7	-1.1	3.7	72.0	-11.4	-15.4	72.0	-2.2	-17.0	25.8	-16.8	31.7
30	LnG50	Trip	55	20	500	on flat	88.9	0.0	-13.2	96.0	9.9	-1.1	3.7	71.8	-11.4	-15.4	71.8	-2.2	-17.0	25.9	-16.9	31.8
31	LnG25	Rail	35	5	500	no	2.2	0.0	57.4	0.1	0.2	5.9	7.2	51.3	0.9	0.0	0.0	0.0	0.0	-1.0	0.0	0.0
32	LnG25	Rail	40	5	500	no	3.2	0.0	63.8	0.1	0.4	6.8	7.2	58.6	0.6	0.0	0.0	0.0	0.0	-0.6	0.0	0.0
33	LnG25	Rail	45	5	500	no	2.4	0.0	86.5	-10.3	-0.8	4.4	7.2	66.2	0.4	-0.1	0.0	0.0	-0.6	0.2	-0.6	-0.01
34	LnG25	Rail	50	5	500	on flat	89.0	-0.1	-14.5	95.3	9.7	-0.8	3.7	72.0	-11.4	-15.4	72.0	-9.2	-16.2	12.0	-3.0	15.2
35	LnG25	Rail	55	5	500	on flat	88.9	-0.1	-13.3	94.3	9.9	-0.7	3.7	71.7	-11.4	-15.4	71.8	-9.3	-16.2	12.1	-3.0	15.2
36	LnG50	Rail	35	5	500	no	2.2	0.0	57.4	0.0	0.2	5.9	7.2	51.3	0.9	0.0	0.0	0.0	0.0	-1.0	0.0	0.0
37	LnG50	Rail	40	5	500	no	3.2	0.0	63.8	-0.1	0.4	6.7	7.2	58.6	0.6	0.0	0.0	0.0	0.0	-0.6	0.0	0.0
38	LnG50	Rail	45	5	500	no	3.3	0.1	85.6	17.6	-0.6	9.1	7.1	66.2	0.8	0.1	0.0	0.0	0.0	-0.7	0.0	0.0
39	LnG50	Rail	50	5	500	on flat	89.0	0.0	-14.4	95.8	9.7	-1.1	3.7	72.0	-11.4	-15.4	72.0	-2.2	-17.0	12.0	-3.0	15.2
40	LnG50	Rail	55	5	500	on flat	88.9	0.0	-13.2	96.0	9.9	-1.1	3.7	71.8	-11.4	-15.4	71.8	-2.2	-17.0	12.1	-3.0	15.2
41	LnG25	Rail	35	10	500	no	2.2	0.0	61.7	0.0	0.2	5.9	7.2	51.1	0.9	0.0	0.0	0.0	0.0	-1.0	0.0	0.0
42	LnG25	Rail	40	10	500	yes	87.4	-0.4	23.9	68.2	-1.4	3.4	3.8	55.3	-3.6	-14.5	55.6	2.0	-17.0	7.8	-4.1	7.5

Table B-7 (continued). Results from simulation runs: semitrailer of the Lantana gasoline vehicle

Run no.	Vehicle & inertia factor	Run Type	Strike			Conditions at end of run			Angular rate [deg/sec]			CG ht			CG velocity [ft/sec]			Strike pt velocity [ft/sec]			Path change [deg] relative to		Relative to wall beside curb/rail/path		
			Speed [mph]	angle [deg]	radius [ft]	Roll over	Pitch	Yaw	Roll	Pitch	Yaw	Z [ft]	X	Y	Z	X	Y	Z	Curb	Path	Strike [deg]	Yaw [deg]	Vn [ft/sec]	Vn/Vi	
43	LnG25	Rail	45	10	500	yes	99.8	-2.5	31.2	154.9	21.1	4.0	4.7	62.3	-13.6	-13.3	62.9	-13.0	-16.2	7.3	-2.7	7.3	5.0	8.1	0.12
44	LnG25	Rail	50	10	500	on flat	89.0	-0.1	-14.5	95.3	9.7	-0.8	3.7	72.0	-11.4	-15.4	72.0	-9.2	-16.2	15.9	5.9	15.9	-6.8	19.9	0.27
45	LnG25	Rail	55	10	500	on flat	88.9	-0.1	-13.3	94.3	9.9	-0.7	3.7	71.7	-11.4	-15.4	71.8	-9.3	-16.2	16.0	6.0	16.0	-6.9	20.0	0.25
46	LnG50	Rail	35	10	500	no	2.2	0.0	61.7	0.0	0.2	5.9	7.2	51.2	0.9	0.0	0.0	0.0	0.0	0.0	-10.0	0.0	-1.0	0.0	0.00
47	LnG50	Rail	40	10	500	yes	86.6	-1.6	26.9	88.8	4.8	5.8	4.3	54.9	-6.1	-12.9	55.5	-1.5	-16.6	7.6	-2.4	7.6	-1.3	7.3	0.12
48	LnG50	Rail	45	10	500	yes	99.9	-0.9	30.8	119.0	19.0	-2.0	4.1	62.1	-12.6	-14.4	62.2	-14.5	-14.9	7.3	-2.7	7.3	-4.1	8.1	0.12
49	LnG50	Rail	50	10	500	on flat	89.0	0.0	-14.4	95.8	9.7	-1.1	3.7	72.0	-11.4	-15.4	72.0	-2.2	-17.0	15.9	5.9	15.9	-6.8	19.9	0.27
50	LnG50	Rail	55	10	500	on flat	88.9	0.0	-13.2	96.0	9.9	-1.1	3.7	71.8	-11.4	-15.4	71.8	-2.2	-17.0	16.0	6.0	16.0	-6.9	20.0	0.25
51	LnG25	Rail	35	20	500	yes	93.5	-3.4	34.9	124.1	31.9	7.5	5.1	45.2	-16.2	-13.2	46.3	-22.2	-17.5	14.2	-5.8	14.2	5.6	11.7	0.23
52	LnG25	Rail	40	20	500	yes	96.8	1.3	40.0	86.7	45.2	-5.9	4.2	49.6	-26.1	-14.0	49.7	-5.6	-14.4	16.5	-3.5	16.5	11.2	16.0	0.27
53	LnG25	Rail	45	20	500	yes	105.2	3.1	37.8	269.8	27.0	-47.7	4.7	60.1	-27.4	-9.8	56.8	7.4	-20.1	15.3	-4.7	15.3	9.2	17.4	0.26
54	LnG25	Rail	50	20	500	on flat	89.0	-0.1	-14.5	95.3	9.7	-0.8	3.7	72.0	-11.4	-15.4	72.0	-9.2	-16.2	25.8	5.8	25.8	-16.8	31.7	0.43
55	LnG25	Rail	55	20	500	on flat	88.9	-0.1	-13.3	94.3	9.9	-0.7	3.7	71.7	-11.4	-15.4	71.8	-9.3	-16.2	25.9	5.9	25.9	-16.9	31.8	0.39
56	LnG50	Rail	35	20	500	yes	95.2	-2.9	35.4	117.1	31.2	4.3	4.9	45.2	-16.2	-13.7	46.0	-21.2	-17.0	13.8	-6.2	13.8	5.9	11.5	0.22
57	LnG50	Rail	40	20	500	yes	96.3	0.6	41.1	87.4	44.4	-3.8	3.9	49.2	-26.9	-14.4	49.4	-6.8	-14.4	16.5	-3.5	16.5	12.2	16.0	0.27
58	LnG50	Rail	45	20	500	yes	95.4	0.7	41.3	95.8	47.9	-2.6	4.0	54.7	-31.9	-14.1	55.1	-11.2	-13.9	17.9	-2.1	17.9	12.4	19.4	0.29
59	LnG50	Rail	50	20	500	on flat	89.0	0.0	-14.4	95.8	9.7	-1.1	3.7	72.0	-11.4	-15.4	72.0	-2.2	-17.0	25.8	5.8	25.8	-16.8	31.7	0.43
60	LnG50	Rail	55	20	500	on flat	88.9	0.0	-13.2	96.0	9.9	-1.1	3.7	71.8	-11.4	-15.4	71.8	-2.2	-17.0	25.9	5.9	25.9	-16.9	31.8	0.39
61	LnG25	I-turn	25		100	yes	89.0	-0.4	49.6	96.9	25.2	0.3	3.8	33.9	-9.1	-15.1	34.2	-12.9	-16.2	20.4	20.4	20.4	-5.4	12.2	0.33
62	LnG25	I-turn	40		100	yes	100.6	-0.3	32.0	115.9	32.3	-5.1	3.9	54.6	-17.6	-15.6	54.6	-22.3	-15.8	29.0	29.0	29.0	-11.2	27.8	0.47
63	LnG25	I-turn	55		100	yes	111.4	-0.2	28.5	145.4	32.8	-12.5	3.7	74.9	-26.0	-15.8	74.5	-29.9	-13.9	34.9	34.9	34.9	-15.8	45.4	0.56
64	LnG25	H-turn	55		500	yes	93.6	-0.5	26.7	99.6	18.3	1.1	3.9	77.8	-18.5	-15.2	78.1	-19.0	-16.8	9.3	9.3	9.3	4.1	12.9	0.16
65	LnG25	H-turn	60		500	yes	97.7	-0.3	25.4	109.3	20.2	-1.4	3.8	84.7	-21.3	-15.5	84.8	-21.7	-16.3	10.5	10.5	10.5	3.6	15.9	0.18
66	LnG25	H-turn	70		500	yes	103.4	-0.1	24.0	122.7	22.7	-5.0	3.8	98.4	-26.9	-15.7	98.4	-27.1	-15.3	12.4	12.4	12.4	2.9	21.9	0.21
67	LnG25	80 stp	45		0	yes	98.4	-0.2	28.1	110.1	26.2	-2.9	3.8	62.6	-18.1	-15.6	62.7	-20.7	-16.2						
68	LnG25	80 stp	60		0	yes	105.1	-0.3	25.1	129.3	27.4	-6.6	3.9	83.4	-25.7	-15.6	83.3	-27.6	-15.1						
69	LnG25	80 stp	75		0	yes	111.4	-0.3	24.1	141.7	28.1	-10.4	3.8	104.1	-33.6	-15.7	103.7	-35.2	-13.8						
70	LnG25	100 stp	35		0	yes	93.0	-0.5	32.5	96.1	26.6	0.6	3.9	48.4	-13.8	-15.3	48.7	-17.8	-16.8						
71	LnG25	100 stp	50		0	yes	102.4	-0.4	27.0	123.7	29.1	-5.4	3.9	69.1	-21.8	-15.5	69.1	-24.8	-15.5						
72	LnG25	100 stp	65		0	yes	110.5	-0.3	25.6	138.5	30.2	-10.6	3.8	89.6	-30.2	-15.7	89.3	-32.7	-14.0						
73	LnG25	120 stp	30		0	yes	89.9	-0.7	36.1	86.8	27.1	2.7	4.0	41.2	-11.7	-15.0	41.7	-16.7	-17.0						
74	LnG25	120 stp	45		0	yes	101.2	-0.4	28.1	119.1	30.8	-4.9	3.9	61.9	-19.9	-15.5	61.9	-23.8	-15.8						
75	LnG25	120 stp	60		0	yes	111.1	-0.2	26.8	149.3	31.9	-11.8	3.8	82.2	-28.8	-15.7	81.8	-32.1	-13.9						
76	LnG25	Spiral	40		0	yes	92.2	-0.6	50.4	94.1	22.2	1.2	3.9	55.9	-14.4	-15.2	56.3	-16.8	-16.8	20.3	20.3	20.3	-5.3	12.1	0.33
77	LnG50	I-turn	25		100	yes	88.8	-0.4	50.0	99.0	25.1	0.0	3.8	33.8	-9.0	-15.2	34.1	-12.8	-16.1	29.1	29.1	29.1	-11.1	27.9	0.48
78	LnG50	I-turn	40		100	yes	99.9	-0.4	32.4	114.5	32.5	-4.6	3.9	54.5	-17.7	-15.6	54.6	-22.6	-16.0	35.1	35.1	35.1	-15.8	45.6	0.57
79	LnG50	I-turn	55		100	yes	109.6	-0.3	28.8	138.0	33.1	-11.0	3.8	74.8	-26.2	-15.7	74.5	-30.4	-14.3	9.2	9.2	9.2	4.2	12.8	0.16
80	LnG50	H-turn	55		500	yes	93.0	-0.6	27.0	98.6	18.3	1.4	3.9	77.7	-18.6	-15.3	78.0	-19.2	-17.0	10.5	10.5	10.5	3.8	15.8	0.18
81	LnG50	H-turn	60		500	yes	97.0	-0.3	25.7	108.2	20.3	-1.0	3.9	84.6	-21.5	-15.5	84.8	-22.1	-16.4	12.4	12.4	12.4	3.1	21.9	0.21
82	LnG50	H-turn	70		500	yes	102.5	-0.2	24.3	124.0	22.8	-4.4	3.8	98.3	-27.2	-15.7	98.3	-27.7	-15.6						
83	LnG50	80 stp	45		0	yes	97.9	-0.2	28.5	110.6	26.3	-2.6	3.8	62.5	-18.2	-15.6	62.6	-21.1	-16.3						
84	LnG50	80 stp	60		0	yes	103.9	-0.4	25.4	125.5	27.5	-5.6	3.9	83.4	-25.9	-15.5	83.3	-28.1	-15.4						

Appendix C.

Impact Simulation Results

LIST OF FIGURES

Figure C-1. Roll results for Albuquerque for the “slow” roll simulation	2
Figure C-2. Roll results for Albuquerque for the “fast” roll simulation	2
Figure C-3. Roll results for Bronx and Hamilton simulation.	3
Figure C-4. Roll results for Columbus and Lantana simulation	4
Figure C-5. Vertical results for Albuquerque as designed.....	6
Figure C-6. Vertical results for Albuquerque with staples every 4 ft.	8
Figure C-7. Vertical results for Albuquerque with staples every 2 ft.	10
Figure C-8. Vertical results for Bronx with flat rails and flat end dams only.....	12
Figure C-9. Vertical results for Bronx with flat rails and flat dams every 6 ft	14
Figure C-10. Vertical results for Bronx with flat rails and crowned dams as designed.....	16
Figure C-11. Vertical results for Hamilton with flat rails and flat end dams only.....	18
Figure C-12. Vertical results for Hamilton with flat rails and flat dams every 6 ft.	20
Figure C-13. Vertical results for Hamilton with flat rails and crowned dams.	22
Figure C-14. Vertical results for Columbus with flat rails and flat end dams.	24
Figure C-15. Vertical results for Columbus with flat rails and flat dams every 6 ft.	26
Figure C-16. Vertical results for Columbus with flat rails and crowned dams.....	28
Figure C-17. Vertical results for Lantana with flat rails and flat end dams only.....	30
Figure C-18. Vertical results for Lantana with flat rails and flat dams every 6 ft.	32
Figure C-19. Vertical results for Lantana with flat rails and crowned dams.	34
Figure C-20. Lateral results for Albuquerque as designed	36
Figure C-21. Lateral results for Albuquerque with staples every 4 ft.....	38
Figure C-22. Lateral results for Albuquerque with staples every 2 ft.....	40
Figure C-23. Lateral results for Bronx with flat rails and flat end dams only.	42
Figure C-24. Lateral results for Bronx with flat rails and flat dams every 6 ft.....	45
Figure C-25. Lateral results for Bronx with flat rails and crowned dams every 6 ft.	48
Figure C-26. Lateral results for Hamilton with flat rails and flat end dams only.	51
Figure C-27. Lateral results for Hamilton with flat rails and dams every 6 ft.	54
Figure C-28. Lateral results for Hamilton with flat rails and crowned dams every 6 ft.	57
Figure C-29. Lateral results for Columbus with flat rails and flat end dams only.....	60
Figure C-30. Lateral results for Columbus with flat rails and flat end dams every 6 ft.....	62
Figure C-31. Lateral results for Columbus with flat rails and crowned end dams every 6 ft.	64
Figure C-32. Lateral results for Lantana with flat rails and flat end dams only.	66
Figure C-33. Lateral results for Lantana with flat rails and flat dams every 6 ft.	68
Figure C-34. Lateral results for Lantana with flat rails and crowned dams every 6 ft.....	70

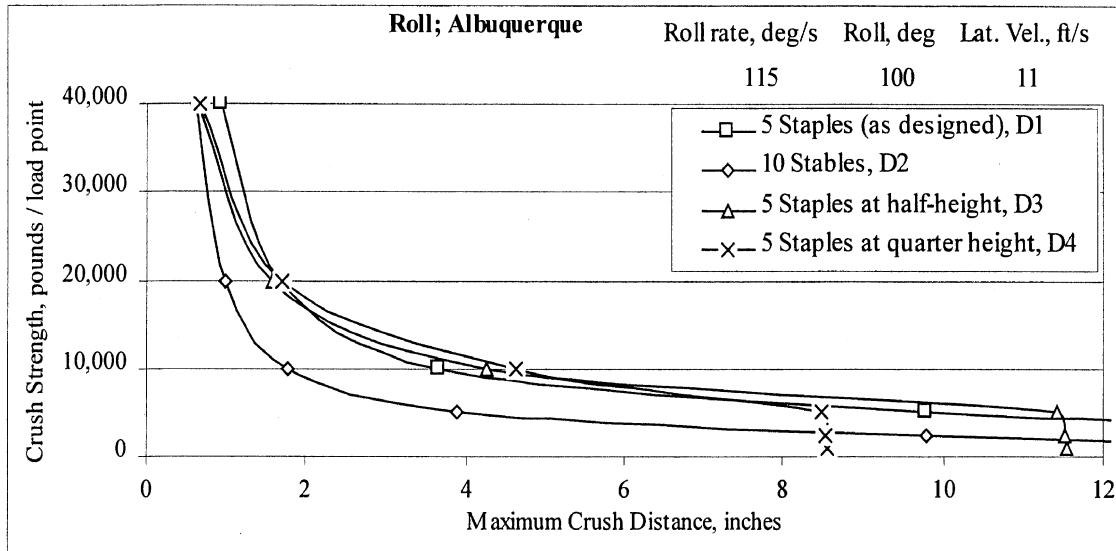

Figure C-1. Roll results for Albuquerque for the “slow” roll simulation

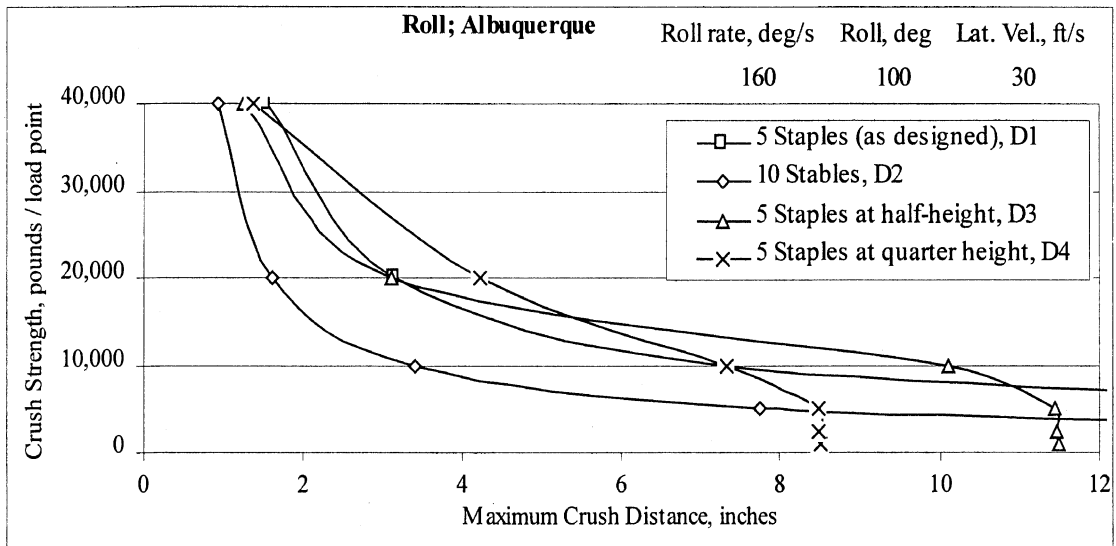

Figure C-2. Roll results for Albuquerque for the “fast” roll simulation

Table C-1. Tabular roll results for Albuquerque

Roll Test Results for Albuquerque									
Roll rate, deg/s	Roll Agl, deg	Lateral Vel. Ft/s	Force, lbs	Max. Defl., in	Roll rate, deg/s	Roll Agl., deg	Lateral Vel. Ft/s	Force, lbs	Max. Defl., in
5 Staples (as designed)					Half-height Staples				
116	98	10.6	1000	17.48676	116	98	10.6	1000	11.53903
116	98	10.6	2500	17.41534	116	98	10.6	2500	11.50366
116	98	10.6	5000	9.79489	116	98	10.6	5000	11.40533
116	98	10.6	10000	3.658848	116	98	10.6	10000	4.249352
116	98	10.6	20000	1.673108	116	98	10.6	20000	1.561517
116	98	10.6	40000	0.938156	116	98	10.6	40000	0.638225

Roll Test Results for Albuquerque									
Roll rate, deg/s	Roll Agl, deg	Lateral Vel. Ft/s	Force, lbs	Max. Defl., in	Roll rate, deg/s	Roll Agl., deg	Lateral Vel. Ft/s	Force, lbs	Max. Defl., in
5 Staples (as designed)					Half-height Staples				
162	98	29.6	1000	17.43596	162	98	29.6	1000	11.48253
162	98	29.6	2500	17.41429	162	98	29.6	2500	11.46945
162	98	29.6	5000	17.29409	162	98	29.6	5000	11.44212
162	98	29.6	10000	7.340052	162	98	29.6	10000	10.1012
162	98	29.6	20000	3.163883	162	98	29.6	20000	3.12601
162	98	29.6	40000	1.53526	162	98	29.6	40000	1.240307
10 Staples					Quarter-height Staples				
116	98	10.6	1000	17.44611	116	98	10.6	1000	8.545259
116	98	10.6	2500	9.795969	116	98	10.6	2500	8.524997
116	98	10.6	5000	3.882422	116	98	10.6	5000	8.482618
116	98	10.6	10000	1.767626	116	98	10.6	10000	4.616207
116	98	10.6	20000	0.984581	116	98	10.6	20000	1.690622
116	98	10.6	40000	0.611731	116	98	10.6	40000	0.674007
162	98	29.6	1000	17.42365	162	98	29.6	1000	8.506269
162	98	29.6	2500	17.29014	162	98	29.6	2500	8.49733
162	98	29.6	5000	7.760339	162	98	29.6	5000	8.48461
162	98	29.6	10000	3.422982	162	98	29.6	10000	7.346969
162	98	29.6	20000	1.629847	162	98	29.6	20000	4.215189
162	98	29.6	40000	0.942264	162	98	29.6	40000	1.375409

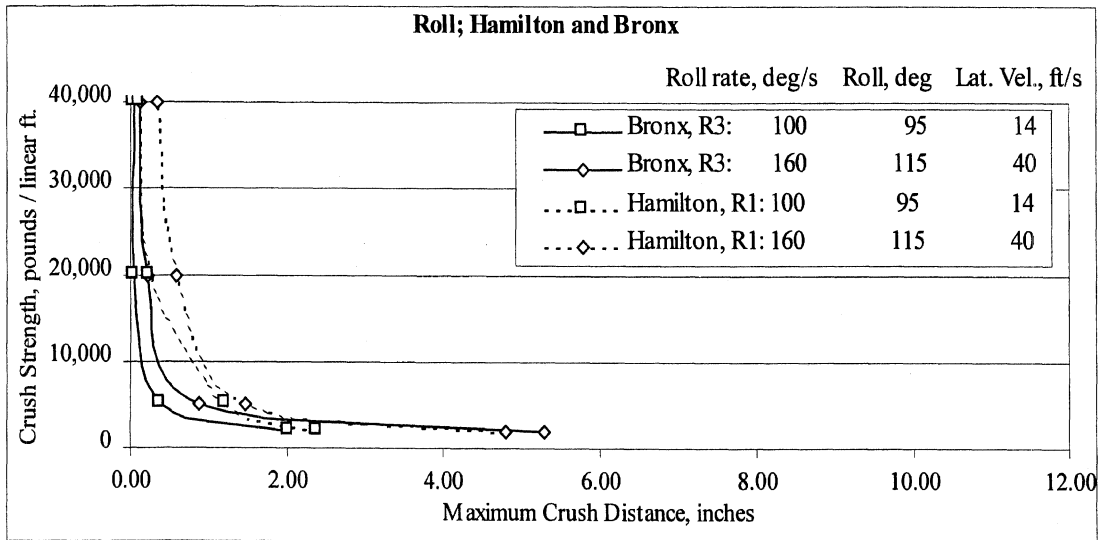

Figure C-3. Roll results for Bronx and Hamilton simulation.

Table C-2. Tabular roll results for Bronx and Hamilton

Roll Test Results for Albuquerque									
Roll rate, deg/s	Roll Agl, deg	Lateral Vel. Ft/s	Strength, lbs/ft	Max. Defl., in	Roll rate, deg/s	Roll Agl., deg	Lateral Vel. Ft/s	Strength, lbs/ft	Max. Defl., in
Bronx					Hamilton				

Roll Test Results for Albuquerque									
Roll rate, deg/s	Roll Agl, deg	Lateral Vel. Ft/s	Strength, lbs/ft	Max. Defl., in	Roll rate, deg/s	Roll Agl., deg	Lateral Vel. Ft/s	Strength, lbs/ft	Max. Defl., in
Bronx					Hamilton				
100	93	14	2000	2.0315	100	93	14	2000	2.401
100	93	14	5000	0.3824	100	93	14	5000	1.223
100	93	14	20000	0.0605	100	93	14	20000	0.236
100	93	14	40000	0.0388	100	93	14	40000	0.128
100	93	14	80000	0.0355	100	93	14	80000	0.084
100	93	14	160000	0.0284	100	93	14	160000	0.076
160	115	40	2000	5.3066	160	115	40	2000	4.811
160	115	40	5000	0.8889	160	115	40	5000	1.480
160	115	40	20000	0.2306	160	115	40	20000	0.593
160	115	40	40000	0.1256	160	115	40	40000	0.342
160	115	40	80000	0.0806	160	115	40	80000	0.228
160	115	40	160000	0.0720	160	115	40	160000	0.204

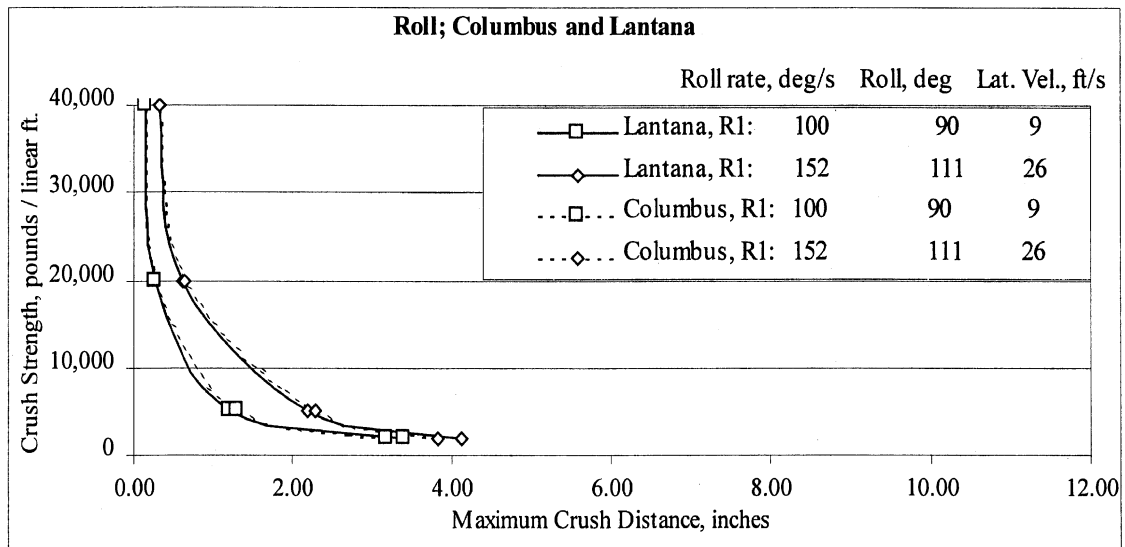

Figure C-4. Roll results for Columbus and Lantana simulation

Table C-3. Tabular roll results for Lantana and Columbus

Roll Test Results for Lantana and Columbus									
Roll rate, deg/s	Roll Agl, deg	Lateral Vel. Ft/s	Strength, lbs/ft	Max. Defl., in	Roll rate, deg/s	Roll Agl., deg	Lateral Vel. Ft/s	Strength, lbs/ft	Max. Defl., in
Lantana					Columbus				
100	90	9	2,000	3.4207	100	90	9	2,000	3.2053
100	90	9	5,000	1.2026	100	90	9	5,000	1.2925
100	90	9	20,000	0.2698	100	90	9	20,000	0.2812
100	90	9	40,000	0.1373	100	90	9	40,000	0.1427
100	90	9	80,000	0.0813	100	90	9	80,000	0.0843
100	90	9	160,000	0.0723	100	90	9	160,000	0.0716
152	111	26	2,000	4.1247	152	111	26	2,000	3.8302
152	111	26	5,000	2.1821	152	111	26	5,000	2.2777

Roll Test Results for Lantana and Columbus									
Roll rate, deg/s	Roll Agl, deg	Lateral Vel. Ft/s	Strength, lbs/ft	Max. Defl., in	Roll rate, deg/s	Roll Agl., deg	Lateral Vel. Ft/s	Strength, lbs/ft	Max. Defl., in
Lantana					Columbus				
152	111	26	20,000	0.6098	152	111	26	20,000	0.6380
152	111	26	40,000	0.3191	152	111	26	40,000	0.3304
152	111	26	80,000	0.1767	152	111	26	80,000	0.1811
152	111	26	160,000	0.1647	152	111	26	160,000	0.1207

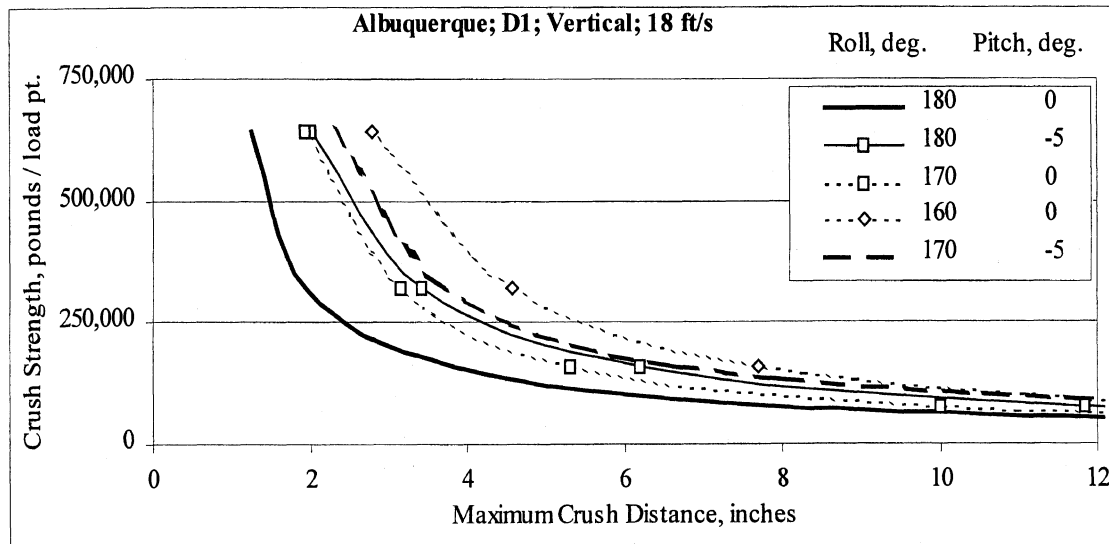
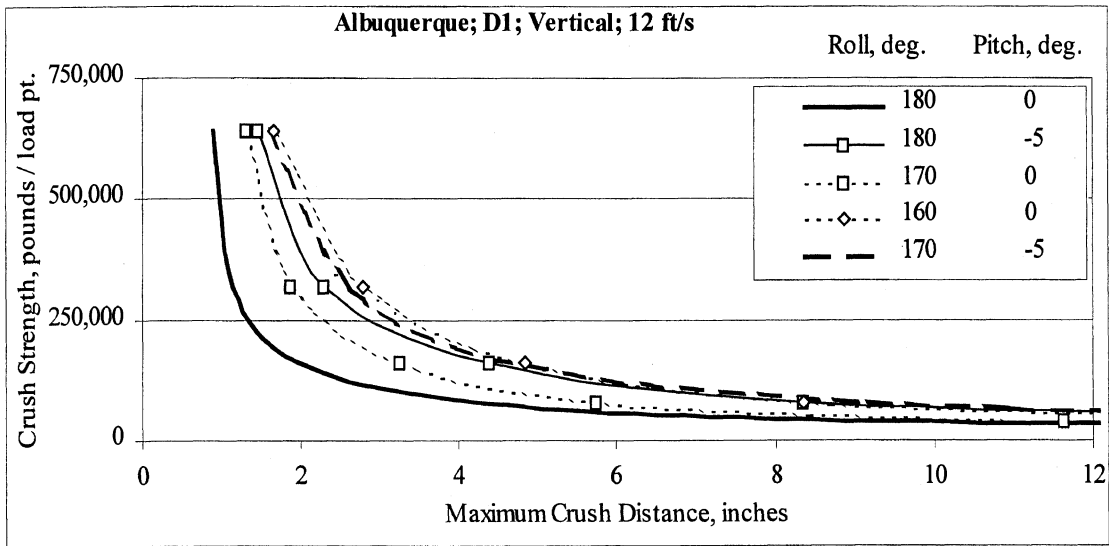
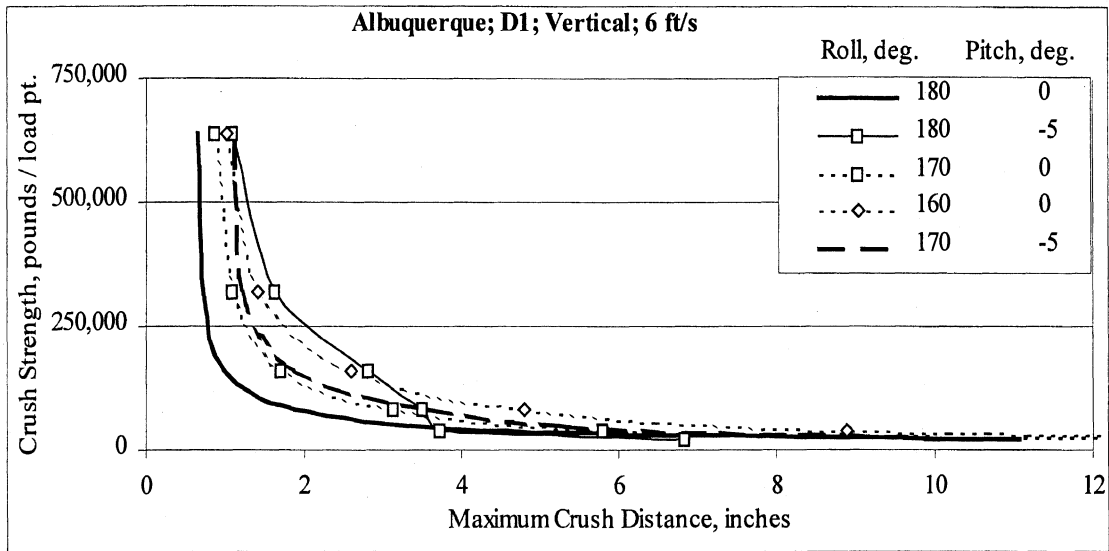

Figure C-5. Vertical results for Albuquerque as designed

Table C-4. Tabular vertical results for Albuquerque as designed

Vertical Impact Results for Albuquerque (as designed)									
Vel., ft/s	Roll, deg	Pitch, deg	Force, lbs	Defl., in.	Vel., ft/s	Roll, deg	Pitch, deg	Force, lbs	Defl., in.
12	180	0	20,000	23.52	18	170	0	160,000	5.31
12	180	0	40,000	9.30	18	170	0	320,000	3.15
12	180	0	80,000	4.21	18	170	0	640,000	1.94
12	180	0	160,000	1.98	18	170	-5	20,000	35.10
12	180	0	320,000	1.13	18	170	-5	40,000	24.56
12	180	0	640,000	0.89	18	170	-5	80,000	13.48
12	180	-5	20,000	21.03	18	170	-5	160,000	6.64
12	180	-5	40,000	16.79	18	170	-5	320,000	3.72
12	180	-5	80,000	8.36	18	170	-5	640,000	2.30
12	180	-5	160,000	4.40	18	160	0	20,000	31.95
12	180	-5	320,000	2.30	18	160	0	40,000	21.06
12	180	-5	640,000	1.45	18	160	0	80,000	13.44
12	170	0	20,000	25.05	18	160	0	160,000	7.69
12	170	0	40,000	11.64	18	160	0	320,000	4.57
12	170	0	80,000	5.73	18	160	0	640,000	2.77
12	170	0	160,000	3.26	6	180	0	20,000	11.05
12	170	0	320,000	1.87	6	180	0	40,000	4.29
12	170	0	640,000	1.30	6	180	0	80,000	1.87
12	170	-5	20,000	20.80	6	180	0	160,000	0.99
12	170	-5	40,000	17.30	6	180	0	320,000	0.71
12	170	-5	80,000	9.05	6	180	0	640,000	0.64
12	170	-5	160,000	4.65	6	180	-5	20,000	6.85
12	170	-5	320,000	2.60	6	180	-5	40,000	3.73
12	170	-5	640,000	1.60	6	180	-5	80,000	3.51
12	160	0	20,000	24.33	6	180	-5	160,000	2.82
12	160	0	40,000	15.55	6	180	-5	320,000	1.62
12	160	0	80,000	8.35	6	180	-5	640,000	1.10
12	160	0	160,000	4.83	6	170	0	20,000	13.72
12	160	0	320,000	2.78	6	170	0	40,000	5.81
12	160	0	640,000	1.66	6	170	0	80,000	3.12
18	180	0	20,000	41.71	6	170	0	160,000	1.71
18	180	0	40,000	17.35	6	170	0	320,000	1.10
18	180	0	80,000	7.95	6	170	0	640,000	0.87
18	180	0	160,000	3.83	6	170	-5	20,000	10.65
18	180	0	320,000	1.94	6	170	-5	40,000	6.10
18	180	0	640,000	1.24	6	170	-5	80,000	3.56
18	180	-5	20,000	37.43	6	170	-5	160,000	1.89
18	180	-5	40,000	25.04	6	170	-5	320,000	1.22
18	180	-5	80,000	11.85	6	170	-5	640,000	1.11
18	180	-5	160,000	6.20	6	160	0	20,000	17.14
18	180	-5	320,000	3.44	6	160	0	40,000	8.88
18	180	-5	640,000	2.01	6	160	0	80,000	4.80
18	170	0	20,000	37.07	6	160	0	160,000	2.60
18	170	0	40,000	20.17	6	160	0	320,000	1.41
18	170	0	80,000	10.00	6	160	0	640,000	1.02

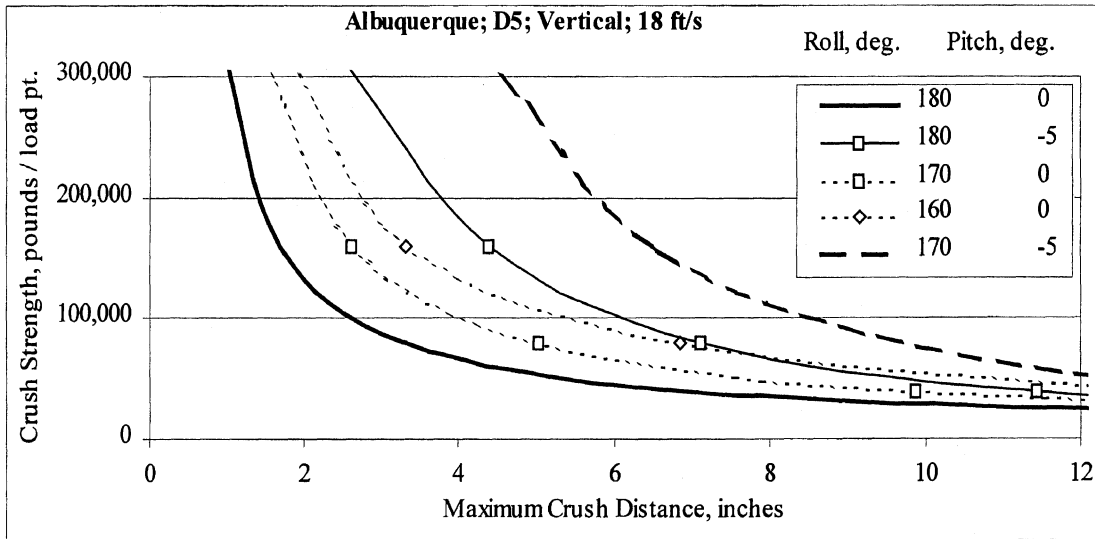
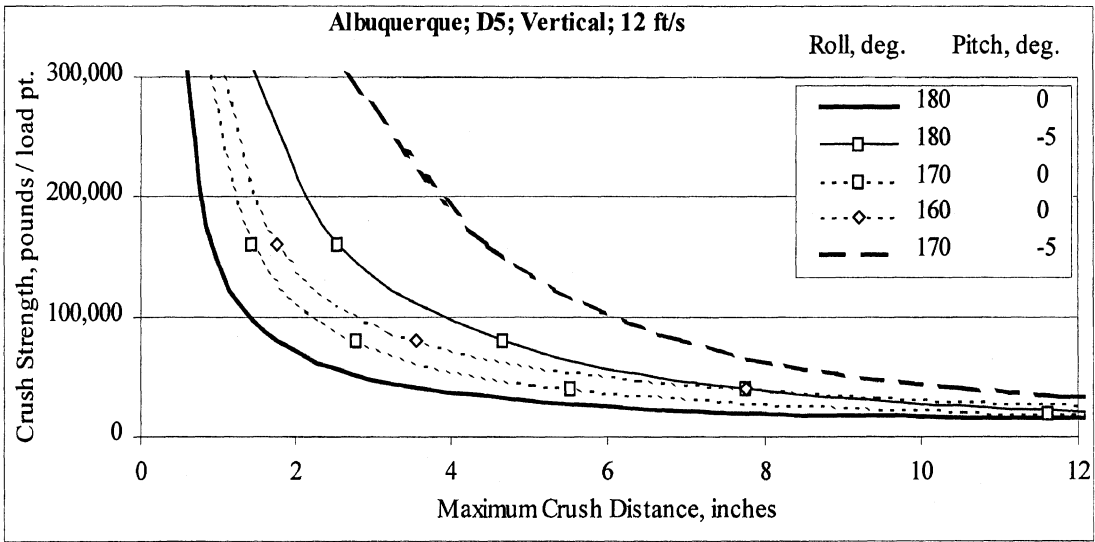
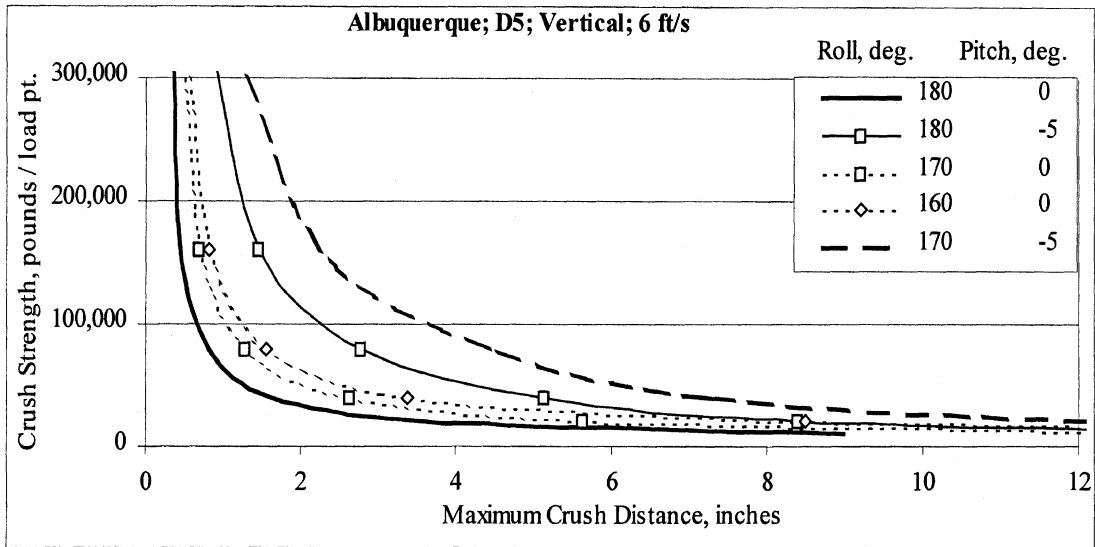

Figure C-6. Vertical results for Albuquerque with staples every 4 ft.

Table C-5. Tabular vertical results for Albuquerque with staples every 4 ft.

Vertical Impact Results for Albuquerque with staples every 4 ft.									
Vel., ft/s	Roll, deg	Pitch, deg	Force, lbs	Defl., in.	Vel., ft/s	Roll, deg	Pitch, deg	Force, lbs	Defl., in.
12	180	0	10,000	20.19	18	170	0	80,000	5.05
12	180	0	20,000	7.96	18	170	0	160,000	2.64
12	180	0	40,000	3.61	18	170	0	320,000	1.44
12	180	0	80,000	1.75	18	170	-5	10,000	45.61
12	180	0	160,000	0.92	18	170	-5	20,000	23.31
12	180	0	320,000	0.58	18	170	-5	40,000	14.52
12	180	-5	10,000	25.23	18	170	-5	80,000	9.71
12	180	-5	20,000	12.92	18	170	-5	160,000	6.51
12	180	-5	40,000	7.75	18	170	-5	320,000	4.28
12	180	-5	80,000	4.65	18	160	0	10,000	34.76
12	180	-5	160,000	2.53	18	160	0	20,000	22.83
12	180	-5	320,000	1.35	18	160	0	40,000	13.63
12	170	0	10,000	29.11	18	160	0	80,000	6.85
12	170	0	20,000	11.63	18	160	0	160,000	3.33
12	170	0	40,000	5.51	18	160	0	320,000	1.75
12	170	0	80,000	2.78	6	180	0	10,000	8.99
12	170	0	160,000	1.43	6	180	0	20,000	3.55
12	170	0	320,000	0.83	6	180	0	40,000	1.62
12	170	-5	10,000	31.13	6	180	0	80,000	0.80
12	170	-5	20,000	17.00	6	180	0	160,000	0.45
12	170	-5	40,000	10.55	6	180	0	320,000	0.35
12	170	-5	80,000	6.95	6	180	-5	10,000	14.95
12	170	-5	160,000	4.46	6	180	-5	20,000	8.40
12	170	-5	320,000	2.44	6	180	-5	40,000	5.14
12	160	0	10,000	26.85	6	180	-5	80,000	2.78
12	160	0	20,000	15.85	6	180	-5	160,000	1.45
12	160	0	40,000	7.76	6	180	-5	320,000	0.86
12	160	0	80,000	3.54	6	170	0	10,000	14.39
12	160	0	160,000	1.75	6	170	0	20,000	5.63
12	160	0	320,000	0.98	6	170	0	40,000	2.63
18	180	0	10,000	38.92	6	170	0	80,000	1.28
18	180	0	20,000	15.31	6	170	0	160,000	0.68
18	180	0	40,000	6.93	6	170	0	320,000	0.46
18	180	0	80,000	3.34	6	170	-5	10,000	19.49
18	180	0	160,000	1.69	6	170	-5	20,000	12.13
18	180	0	320,000	0.96	6	170	-5	40,000	7.23
18	180	-5	10,000	42.47	6	170	-5	80,000	4.45
18	180	-5	20,000	19.06	6	170	-5	160,000	2.26
18	180	-5	40,000	11.46	6	170	-5	320,000	1.19
18	180	-5	80,000	7.12	6	160	0	10,000	19.92
18	180	-5	160,000	4.39	6	160	0	20,000	8.50
18	180	-5	320,000	2.43	6	160	0	40,000	3.38
18	170	0	10,000	40.97	6	160	0	80,000	1.56
18	170	0	20,000	21.69	6	160	0	160,000	0.81
18	170	0	40,000	9.90	6	160	0	320,000	0.52

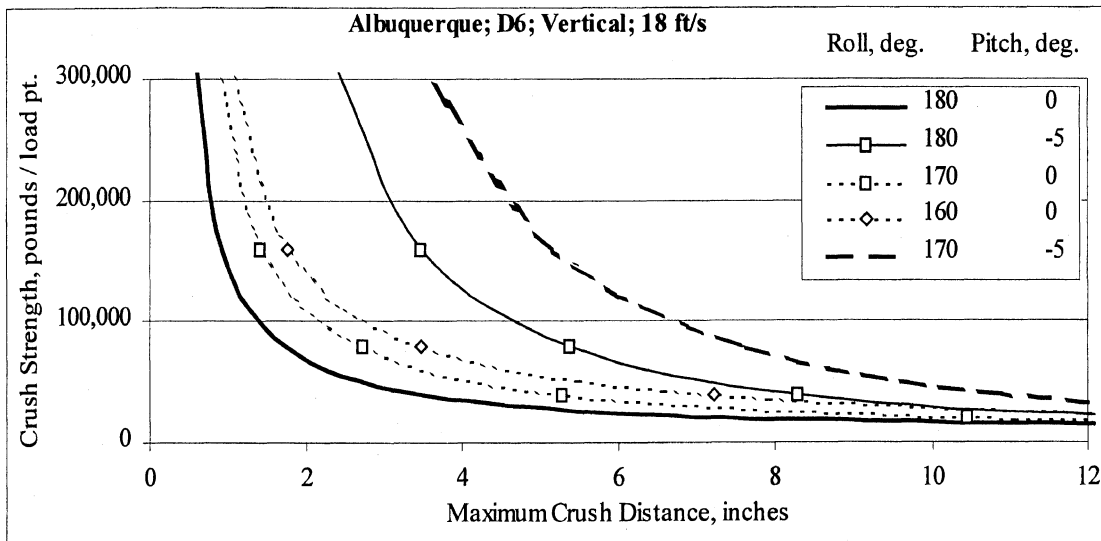
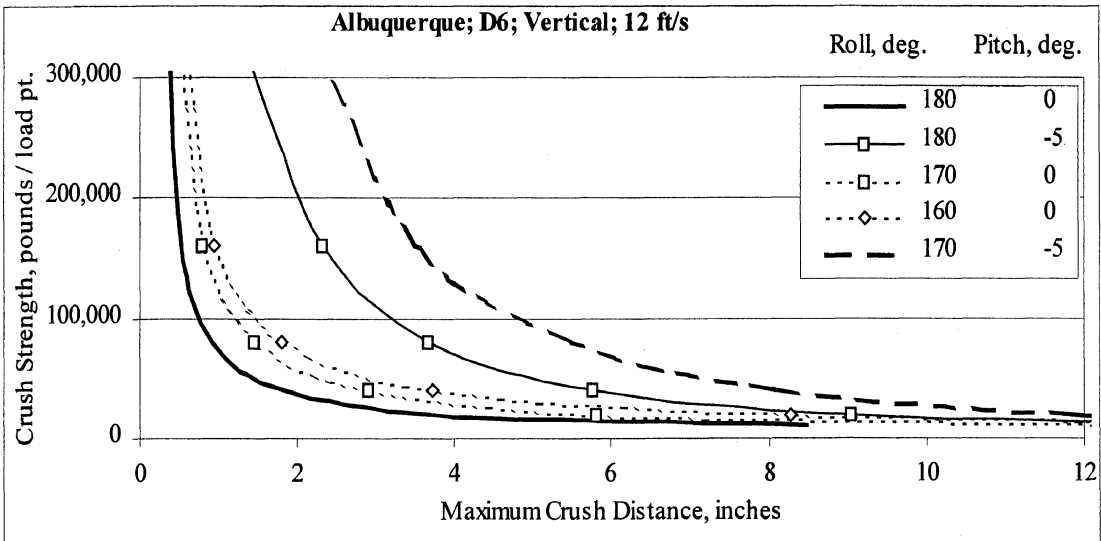
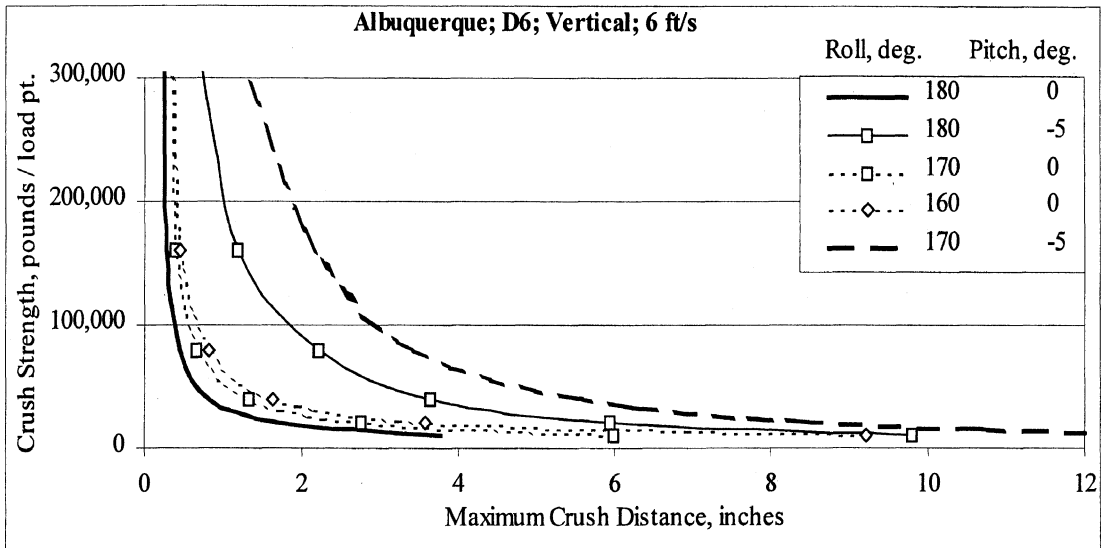

Figure C-7. Vertical results for Albuquerque with staples every 2 ft.

Table C-6. Tabular vertical results for Albuquerque with staples every 2 ft

Vertical Impact Results for Albuquerque with staples every 2 ft									
Vel., ft/s	Roll, deg	Pitch, deg	Force, lbs	Defl., in.	Vel., ft/s	Roll, deg	Pitch, deg	Force, lbs	Defl., in.
12	180	0	10,000	8.48	18	170	0	80,000	2.74
12	180	0	20,000	3.81	18	170	0	160,000	1.43
12	180	0	40,000	1.83	18	170	0	320,000	0.83
12	180	0	80,000	0.92	18	170	-5	10,000	25.88
12	180	0	160,000	0.52	18	170	-5	20,000	15.99
12	180	0	320,000	0.38	18	170	-5	40,000	10.91
12	180	-5	10,000	14.54	18	170	-5	80,000	7.59
12	180	-5	20,000	9.05	18	170	-5	160,000	5.17
12	180	-5	40,000	5.76	18	170	-5	320,000	3.38
12	180	-5	80,000	3.66	18	160	0	10,000	23.64
12	180	-5	160,000	2.32	18	160	0	20,000	14.18
12	180	-5	320,000	1.35	18	160	0	40,000	7.24
12	170	0	10,000	12.42	18	160	0	80,000	3.48
12	170	0	20,000	5.82	18	160	0	160,000	1.76
12	170	0	40,000	2.91	18	160	0	320,000	0.99
12	170	0	80,000	1.46	6	180	0	10,000	3.78
12	170	0	160,000	0.78	6	180	0	20,000	1.70
12	170	0	320,000	0.51	6	180	0	40,000	0.83
12	170	-5	10,000	18.11	6	180	0	80,000	0.43
12	170	-5	20,000	11.89	6	180	0	160,000	0.28
12	170	-5	40,000	8.09	6	180	0	320,000	0.25
12	170	-5	80,000	5.49	6	180	-5	10,000	9.79
12	170	-5	160,000	3.50	6	180	-5	20,000	5.94
12	170	-5	320,000	2.30	6	180	-5	40,000	3.65
12	160	0	10,000	16.76	6	180	-5	80,000	2.23
12	160	0	20,000	8.27	6	180	-5	160,000	1.19
12	160	0	40,000	3.73	6	180	-5	320,000	0.70
12	160	0	80,000	1.81	6	170	0	10,000	5.99
12	160	0	160,000	0.94	6	170	0	20,000	2.78
12	160	0	320,000	0.59	6	170	0	40,000	1.32
18	180	0	10,000	16.33	6	170	0	80,000	0.67
18	180	0	20,000	7.33	6	170	0	160,000	0.39
18	180	0	40,000	3.50	6	170	0	320,000	0.32
18	180	0	80,000	1.74	6	170	-5	10,000	13.03
18	180	0	160,000	0.92	6	170	-5	20,000	8.51
18	180	0	320,000	0.58	6	170	-5	40,000	5.60
18	180	-5	10,000	21.20	6	170	-5	80,000	3.44
18	180	-5	20,000	12.87	6	170	-5	160,000	2.16
18	180	-5	40,000	8.29	6	170	-5	320,000	1.19
18	180	-5	80,000	5.39	6	160	0	10,000	9.22
18	180	-5	160,000	3.47	6	160	0	20,000	3.59
18	180	-5	320,000	2.30	6	160	0	40,000	1.63
18	170	0	10,000	23.09	6	160	0	80,000	0.81
18	170	0	20,000	10.46	6	160	0	160,000	0.46
18	170	0	40,000	5.29	6	160	0	320,000	0.35

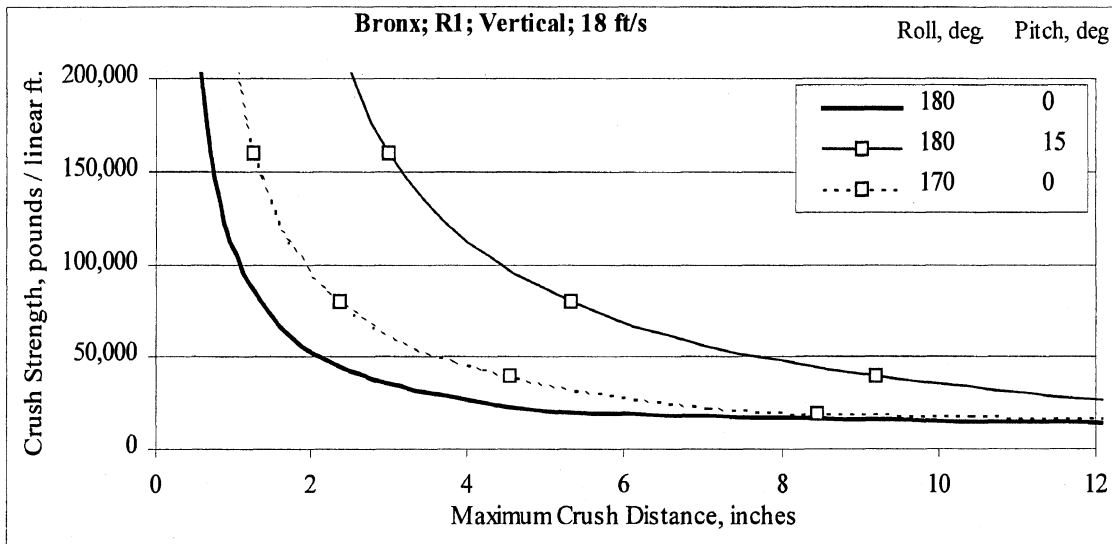
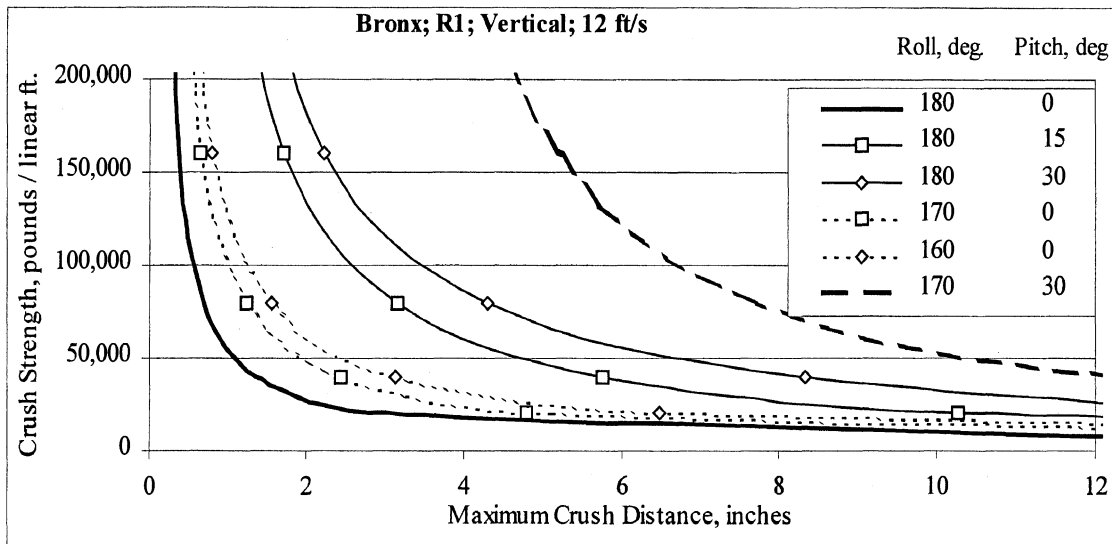
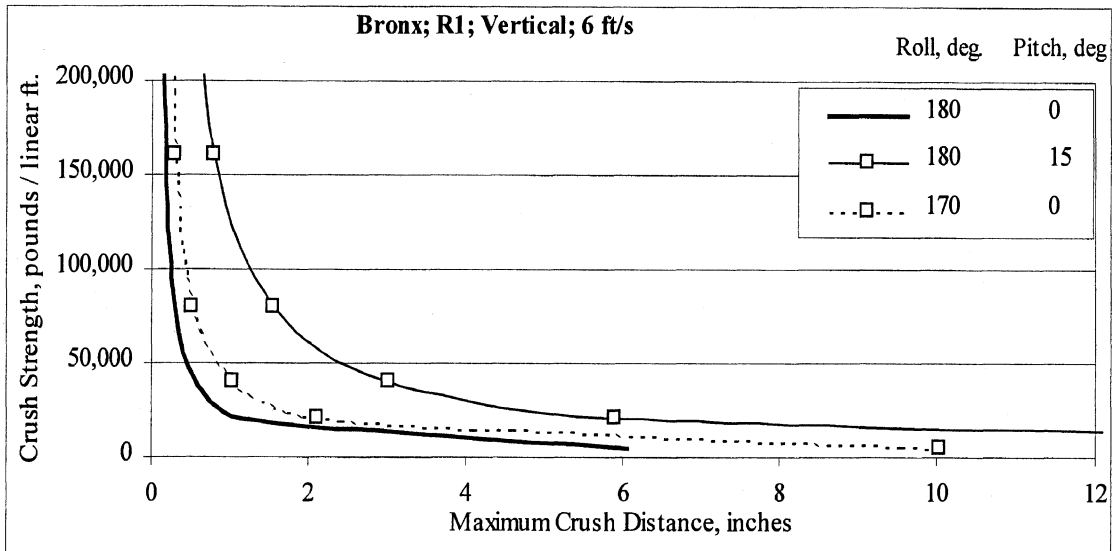

Figure C-8. Vertical results for Bronx with flat rails and flat end dams only.

Table C-7. Tabular vertical results for Bronx with flat rails and flat end dams only.

Vertical results for Bronx with flat rails and flat end dams only									
Vel., ft/s	Roll, deg	Pitch, deg	Strength, lbs/ft.	Max. Defl., in.	Vel., ft/s	Roll, deg	Pitch, deg	Strength, lbs/ft.	Max. Defl., in.
12	180	0	5,000	14.97	18	180	0	5,000	34.13
12	180	0	20,000	2.81	18	180	0	20,000	9.98
12	180	0	40,000	1.36	18	180	0	40,000	7.13
12	180	0	80,000	0.68	18	180	0	80,000	5.87
12	180	0	160,000	0.37	18	180	0	160,000	4.99
12	180	0	320,000	0.24	18	180	0	320,000	3.02
12	180	15	5,000	33.83	18	180	15	5,000	54.80
12	180	15	20,000	10.27	18	180	15	20,000	19.24
12	180	15	40,000	5.76	18	180	15	40,000	12.47
12	180	15	80,000	3.16	18	180	15	80,000	8.07
12	180	15	160,000	1.70	18	180	15	160,000	5.10
12	180	15	320,000	0.91	18	180	15	320,000	3.12
12	180	30	5,000	51.02	18	170	0	5,000	40.92
12	180	30	20,000	15.70	18	170	0	20,000	11.16
12	180	30	40,000	8.34	18	170	0	40,000	7.14
12	180	30	80,000	4.31	18	170	0	80,000	4.60
12	180	30	160,000	2.22	18	170	0	160,000	3.38
12	180	30	320,000	1.14	18	170	0	320,000	2.79
12	170	0	5,000	21.89	6	180	0	5,000	10.23
12	170	0	20,000	4.81	6	180	0	20,000	5.76
12	170	0	40,000	2.44	6	180	0	40,000	4.00
12	170	0	80,000	1.25	6	180	0	80,000	2.04
12	170	0	160,000	0.66	6	180	0	160,000	1.12
12	170	0	320,000	0.39	6	180	0	320,000	0.75
12	170	30	5,000	55.85	6	180	15	5,000	25.77
12	170	30	20,000	20.66	6	180	15	20,000	8.27
12	170	30	40,000	12.27	6	180	15	40,000	4.66
12	170	30	80,000	7.72	6	180	15	80,000	3.55
12	170	30	160,000	5.21	6	180	15	160,000	2.99
12	170	30	320,000	3.60	6	180	15	320,000	1.91
12	160	0	5,000	29.38	6	170	0	5,000	12.58
12	160	0	20,000	6.48	6	170	0	20,000	4.41
12	160	0	40,000	3.14	6	170	0	40,000	3.16
12	160	0	80,000	1.56	6	170	0	80,000	2.63
12	160	0	160,000	0.79	6	170	0	160,000	2.22
12	160	0	320,000	0.45	6	170	0	320,000	1.55

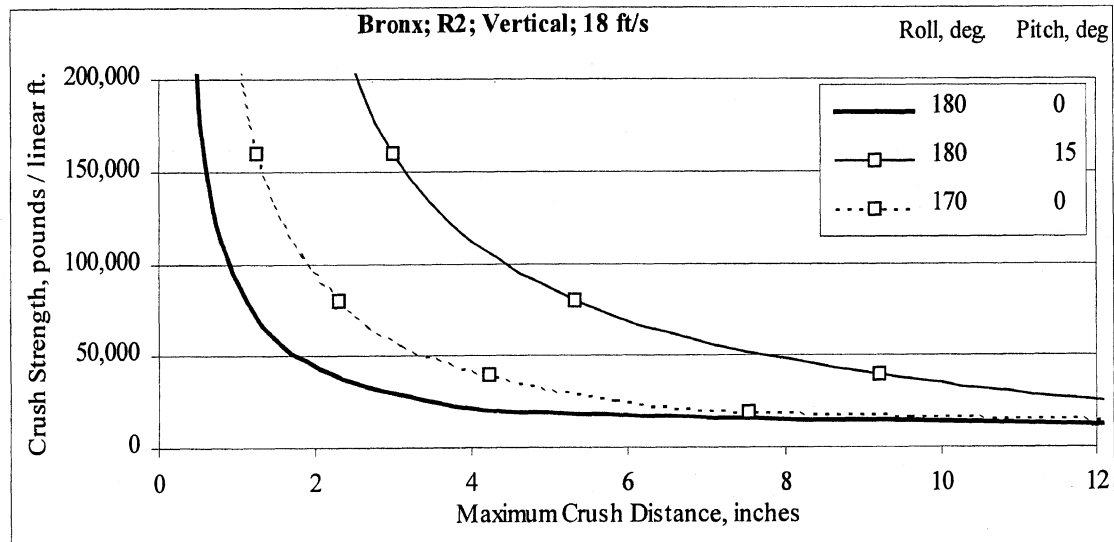
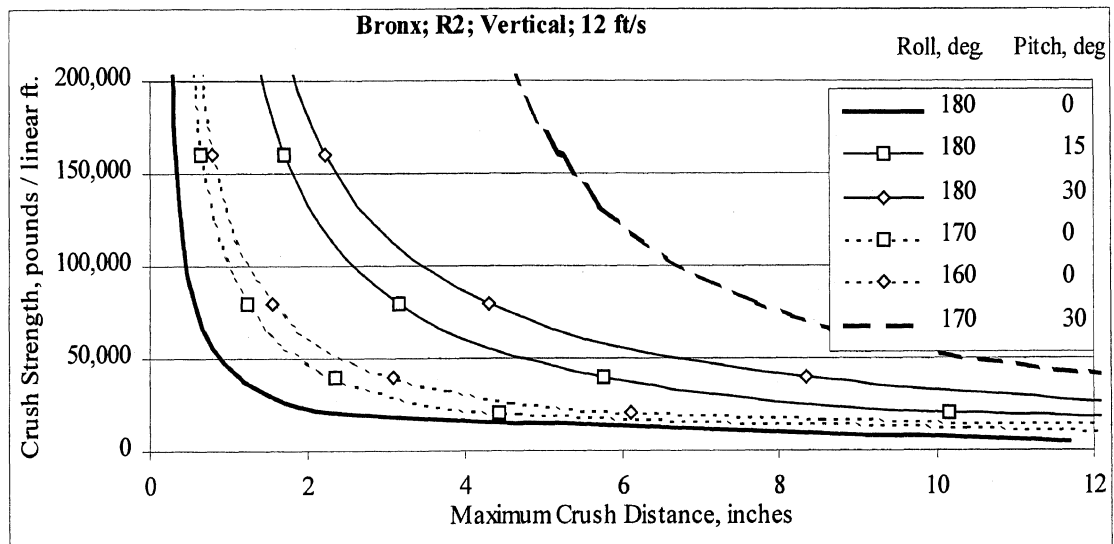
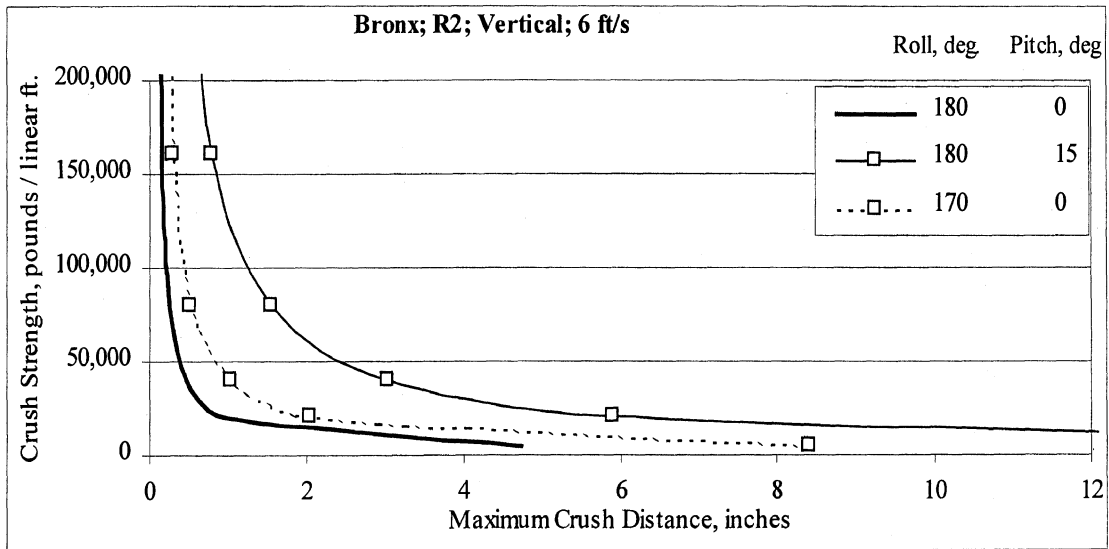

Figure C-9. Vertical results for Bronx with flat rails and flat dams every 6 ft

Table C-8. Tabular vertical results for Bronx with flat rails and flat dams every 6 ft

Vertical results for Bronx with flat rails and flat dams every 6 ft									
Vel., ft/s	Roll, deg	Pitch, deg	Strength, lbs/ft.	Max. Defl., in.	Vel., ft/s	Roll, deg	Pitch, deg	Strength, lbs/ft.	Max. Defl., in.
12	180	0	5000	11.67	18	180	0	5000	23.33
12	180	0	20000	2.32	18	180	0	20000	4.61
12	180	0	40000	1.13	18	180	0	40000	2.23
12	180	0	80000	0.57	18	180	0	80000	1.11
12	180	0	160000	0.31	18	180	0	160000	0.58
12	180	0	320000	0.22	18	180	0	320000	0.35
12	180	15	5000	29.38	18	180	15	5000	42.24
12	180	15	20000	10.16	18	180	15	20000	14.63
12	180	15	40000	5.76	18	180	15	40000	9.20
12	180	15	80000	3.16	18	180	15	80000	5.31
12	180	15	160000	1.70	18	180	15	160000	3.00
12	180	15	320000	0.91	18	180	15	320000	1.67
12	180	30	5000	38.26	18	170	0	5000	32.37
12	180	30	20000	15.70	18	170	0	20000	7.54
12	180	30	40000	8.34	18	170	0	40000	4.22
12	180	30	80000	4.31	18	170	0	80000	2.30
12	180	30	160000	2.22	18	170	0	160000	1.24
12	180	30	320000	1.14	18	170	0	320000	0.69
12	170	0	5000	17.68	6	180	0	5000	4.72
12	170	0	20000	4.42	6	180	0	20000	0.94
12	170	0	40000	2.35	6	180	0	40000	0.46
12	170	0	80000	1.24	6	180	0	80000	0.24
12	170	0	160000	0.66	6	180	0	160000	0.15
12	170	0	320000	0.39	6	180	0	320000	0.13
12	170	30	5000	41.14	6	180	15	5000	18.87
12	170	30	20000	20.61	6	180	15	20000	5.91
12	170	30	40000	12.27	6	180	15	40000	3.05
12	170	30	80000	7.72	6	180	15	80000	1.57
12	170	30	160000	5.21	6	180	15	160000	0.78
12	170	30	320000	3.60	6	180	15	320000	0.44
12	160	0	5000	23.94	6	170	0	5000	8.42
12	160	0	20000	6.11	6	170	0	20000	2.06
12	160	0	40000	3.08	6	170	0	40000	1.04
12	160	0	80000	1.56	6	170	0	80000	0.52
12	160	0	160000	0.79	6	170	0	160000	0.29
12	160	0	320000	0.45	6	170	0	320000	0.20

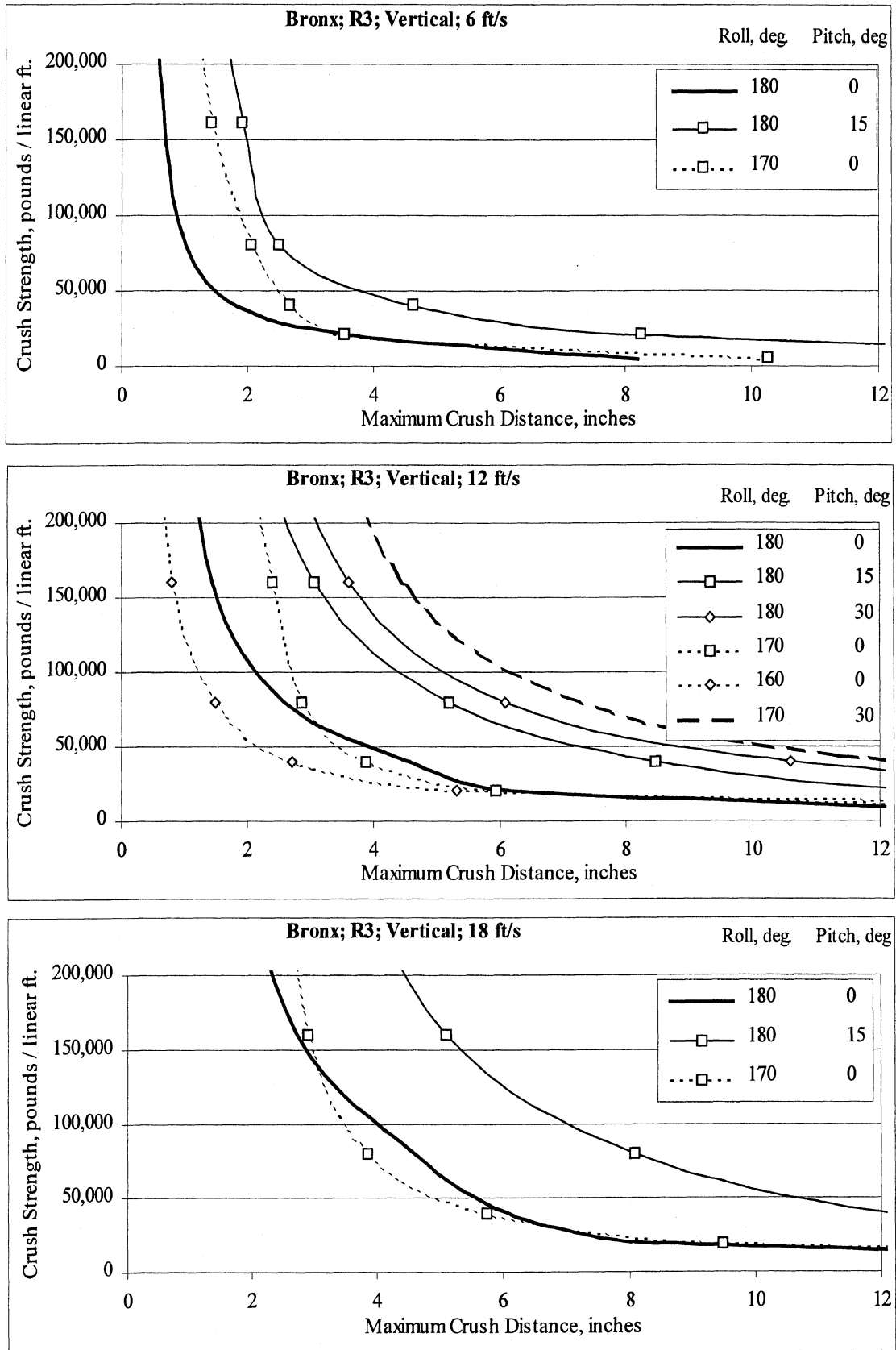

Figure C-10. Vertical results for Bronx with flat rails and crowned dams as designed.

Table C-9. Tabular vertical results for Bronx with flat rails and crowned dams as designed.

Vertical results for Bronx with flat rails and crowned dams as designed									
Vel., ft/s	Roll, deg	Pitch, deg	Strength, lbs/ft.	Max. Defl., in.	Vel., ft/s	Roll, deg	Pitch, deg	Strength, lbs/ft.	Max. Defl., in.
12	180	0	5000	15.10	18	180	0	5000	26.75
12	180	0	20000	6.14	18	180	0	20000	8.39
12	180	0	40000	4.57	18	180	0	40000	6.10
12	180	0	80000	2.61	18	180	0	80000	4.59
12	180	0	160000	1.44	18	180	0	160000	2.71
12	180	0	320000	0.91	18	180	0	320000	1.54
12	180	15	5000	32.75	18	180	15	5000	46.34
12	180	15	20000	12.91	18	180	15	20000	17.74
12	180	15	40000	8.45	18	180	15	40000	12.11
12	180	15	80000	5.20	18	180	15	80000	8.07
12	180	15	160000	3.07	18	180	15	160000	5.10
12	180	15	320000	1.70	18	180	15	320000	3.09
12	180	30	5000	50.97	18	170	0	5000	32.64
12	180	30	20000	18.50	18	170	0	20000	9.47
12	180	30	40000	10.59	18	170	0	40000	5.73
12	180	30	80000	6.08	18	170	0	80000	3.84
12	180	30	160000	3.60	18	170	0	160000	2.89
12	180	30	320000	2.11	18	170	0	320000	2.43
12	170	0	5000	18.10	6	180	0	5000	8.20
12	170	0	20000	5.93	6	180	0	20000	3.68
12	170	0	40000	3.88	6	180	0	40000	1.84
12	170	0	80000	2.88	6	180	0	80000	1.02
12	170	0	160000	2.39	6	180	0	160000	0.68
12	170	0	320000	1.69	6	180	0	320000	0.44
12	170	30	5000	52.43	6	180	15	5000	22.71
12	170	30	20000	20.46	6	180	15	20000	8.27
12	170	30	40000	12.15	6	180	15	40000	4.66
12	170	30	80000	7.27	6	180	15	80000	2.52
12	170	30	160000	4.44	6	180	15	160000	1.93
12	170	30	320000	2.88	6	180	15	320000	1.21
12	160	0	5000	23.92	6	170	0	5000	10.27
12	160	0	20000	5.31	6	170	0	20000	3.56
12	160	0	40000	2.71	6	170	0	40000	2.69
12	160	0	80000	1.47	6	170	0	80000	2.07
12	160	0	160000	0.78	6	170	0	160000	1.44
12	160	0	320000	0.48	6	170	0	320000	0.91

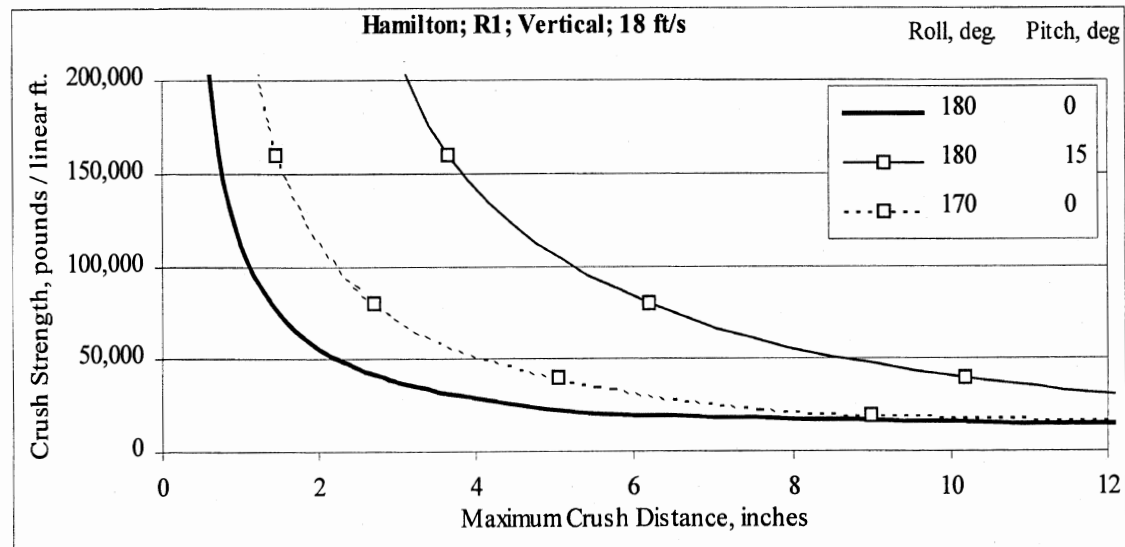
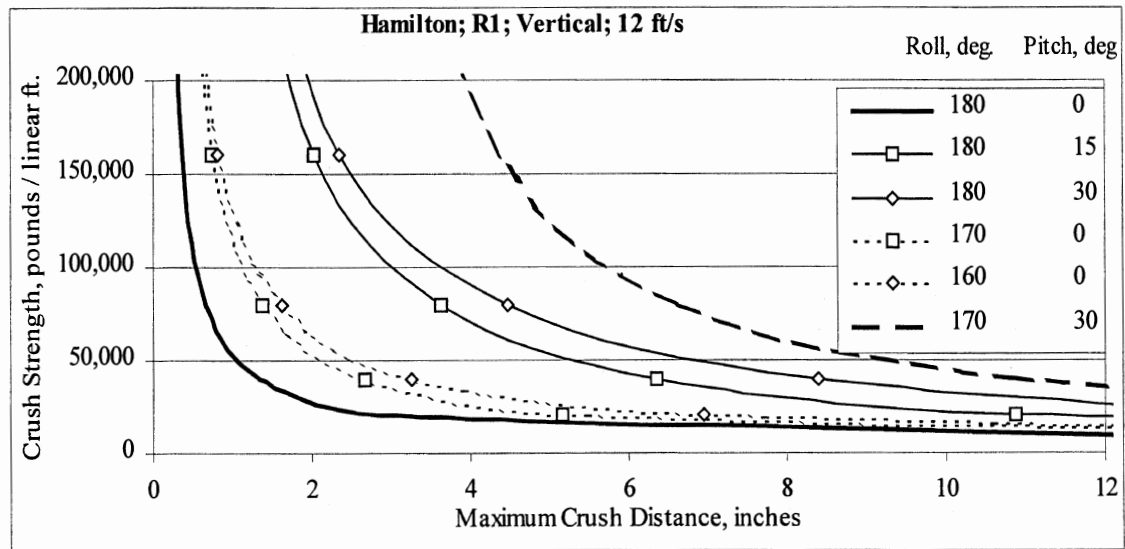
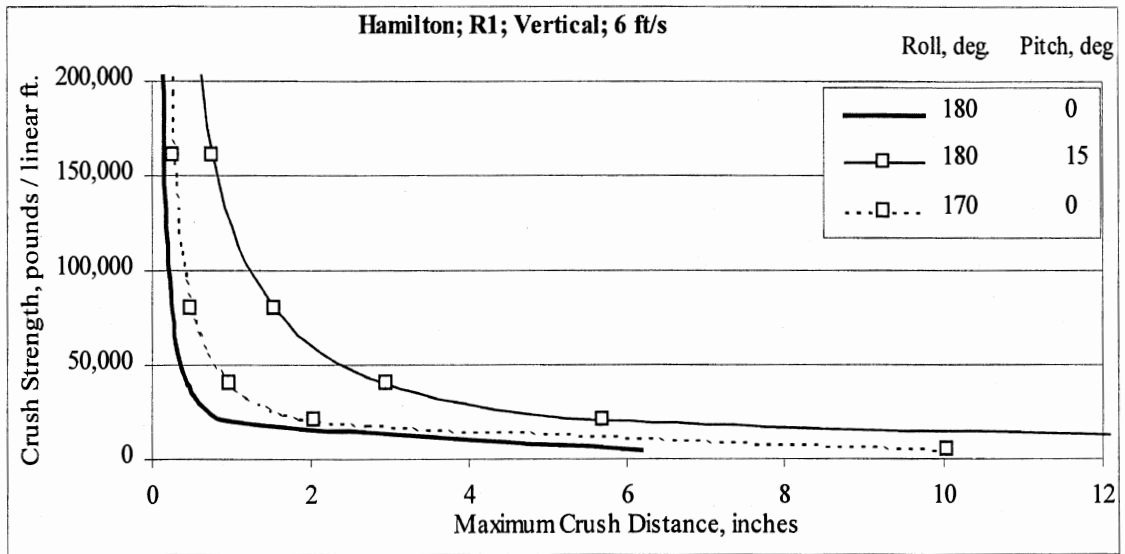

Figure C-11. Vertical results for Hamilton with flat rails and flat end dams only.

Table C-10. Tabular vertical results for Hamilton with flat rails and flat end dams only.

Vertical results for Hamilton with flat rails and flat end dams only									
Vel., ft/s	Roll, deg	Pitch, deg	Strength, lbs/ft.	Max. Defl., in.	Vel., ft/s	Roll, deg	Pitch, deg	Strength, lbs/ft.	Max. Defl., in.
12	180	0	5000	16.92	18	180	0	5000	31.63
12	180	0	20000	2.85	18	180	0	20000	6.02
12	180	0	40000	1.35	18	180	0	40000	2.84
12	180	0	80000	0.67	18	180	0	80000	1.40
12	180	0	160000	0.36	18	180	0	160000	0.72
12	180	0	320000	0.24	18	180	0	320000	0.42
12	180	15	5000	32.88	18	180	15	5000	46.90
12	180	15	20000	10.87	18	180	15	20000	16.60
12	180	15	40000	6.35	18	180	15	40000	10.18
12	180	15	80000	3.63	18	180	15	80000	6.18
12	180	15	160000	2.03	18	180	15	160000	3.65
12	180	15	320000	1.12	18	180	15	320000	2.11
12	180	30	5000	41.14	18	170	0	5000	36.80
12	180	30	20000	15.30	18	170	0	20000	8.97
12	180	30	40000	8.38	18	170	0	40000	5.04
12	180	30	80000	4.47	18	170	0	80000	2.71
12	180	30	160000	2.36	18	170	0	160000	1.44
12	180	30	320000	1.20	18	170	0	320000	0.80
12	170	0	5000	22.26	6	180	0	5000	6.18
12	170	0	20000	5.16	6	180	0	20000	0.95
12	170	0	40000	2.68	6	180	0	40000	0.46
12	170	0	80000	1.38	6	180	0	80000	0.24
12	170	0	160000	0.73	6	180	0	160000	0.15
12	170	0	320000	0.42	6	180	0	320000	0.13
12	170	30	5000	43.43	6	180	15	5000	20.59
12	170	30	20000	18.50	6	180	15	20000	5.71
12	170	30	40000	10.90	6	180	15	40000	2.97
12	170	30	80000	6.64	6	180	15	80000	1.55
12	170	30	160000	4.37	6	180	15	160000	0.76
12	170	30	320000	3.07	6	180	15	320000	0.43
12	160	0	5000	25.69	6	170	0	5000	10.06
12	160	0	20000	6.94	6	170	0	20000	2.06
12	160	0	40000	3.27	6	170	0	40000	1.00
12	160	0	80000	1.64	6	170	0	80000	0.49
12	160	0	160000	0.81	6	170	0	160000	0.27
12	160	0	320000	0.46	6	170	0	320000	0.20

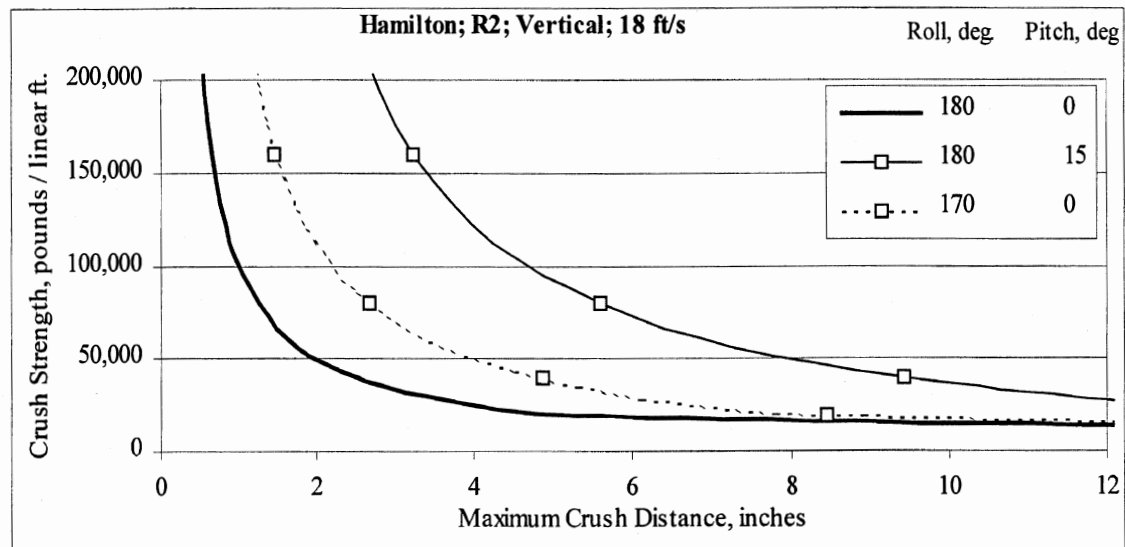
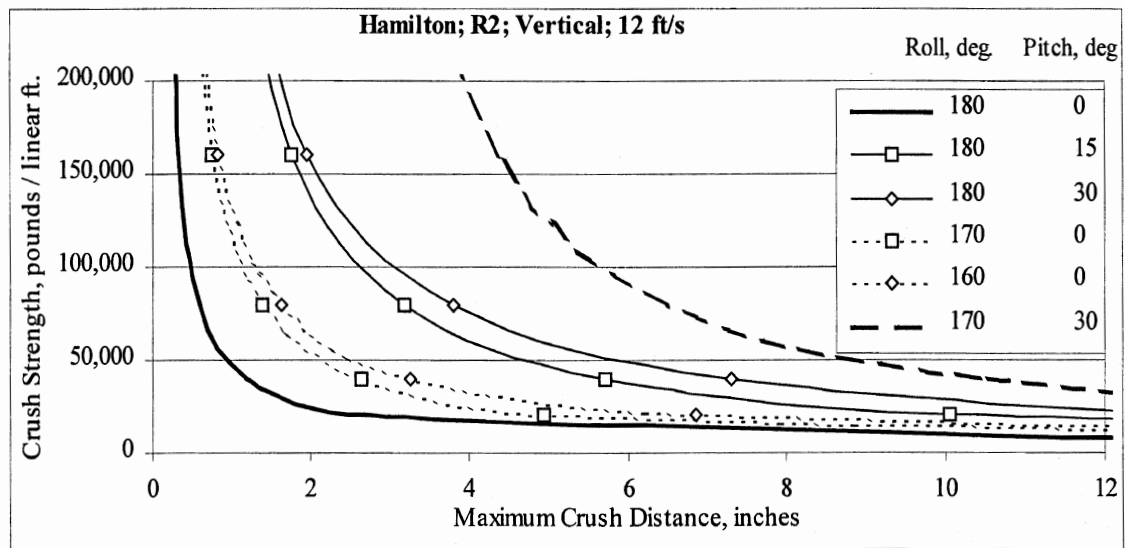
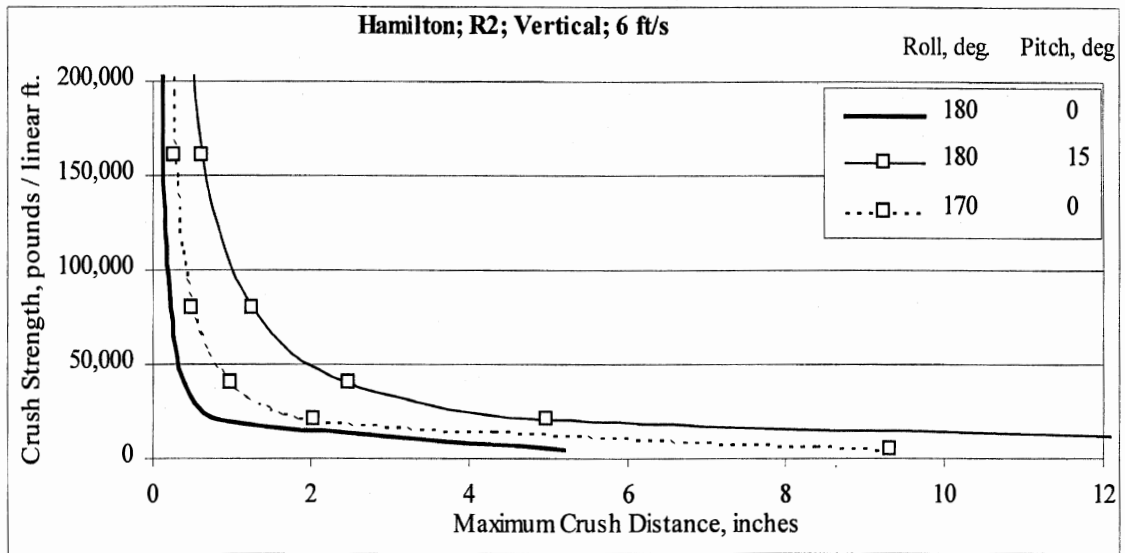

Figure C-12. Vertical results for Hamilton with flat rails and flat dams every 6 ft.

Table C-11. Tabular vertical results for Hamilton with flat rails and flat dams every 6 ft.

Vertical results for Hamilton with flat rails and flat dams every 6 ft.									
Vel., ft/s	Roll, deg	Pitch, deg	Strength, lbs/ft.	Max. Defl., in.	Vel., ft/s	Roll, deg	Pitch, deg	Strength, lbs/ft.	Max. Defl., in.
12	180	0	5000	14.72	18	180	0	5000	28.23
12	180	0	20000	2.50	18	180	0	20000	5.27
12	180	0	40000	1.20	18	180	0	40000	2.51
12	180	0	80000	0.60	18	180	0	80000	1.24
12	180	0	160000	0.33	18	180	0	160000	0.64
12	180	0	320000	0.22	18	180	0	320000	0.38
12	180	15	5000	30.40	18	180	15	5000	43.97
12	180	15	20000	10.04	18	180	15	20000	15.66
12	180	15	40000	5.72	18	180	15	40000	9.43
12	180	15	80000	3.20	18	180	15	80000	5.59
12	180	15	160000	1.75	18	180	15	160000	3.23
12	180	15	320000	0.94	18	180	15	320000	1.83
12	180	30	5000	40.02	18	170	0	5000	34.13
12	180	30	20000	13.76	18	170	0	20000	8.45
12	180	30	40000	7.30	18	170	0	40000	4.86
12	180	30	80000	3.82	18	170	0	80000	2.67
12	180	30	160000	1.94	18	170	0	160000	1.44
12	180	30	320000	1.00	18	170	0	320000	0.80
12	170	0	5000	20.63	6	180	0	5000	5.20
12	170	0	20000	4.96	6	180	0	20000	0.83
12	170	0	40000	2.64	6	180	0	40000	0.40
12	170	0	80000	1.38	6	180	0	80000	0.21
12	170	0	160000	0.73	6	180	0	160000	0.14
12	170	0	320000	0.42	6	180	0	320000	0.13
12	170	30	5000	42.84	6	180	15	5000	19.33
12	170	30	20000	17.71	6	180	15	20000	4.99
12	170	30	40000	10.44	6	180	15	40000	2.50
12	170	30	80000	6.52	6	180	15	80000	1.26
12	170	30	160000	4.37	6	180	15	160000	0.63
12	170	30	320000	3.07	6	180	15	320000	0.37
12	160	0	5000	24.28	6	170	0	5000	9.32
12	160	0	20000	6.85	6	170	0	20000	2.04
12	160	0	40000	3.27	6	170	0	40000	1.00
12	160	0	80000	1.64	6	170	0	80000	0.49
12	160	0	160000	0.81	6	170	0	160000	0.27
12	160	0	320000	0.46	6	170	0	320000	0.20

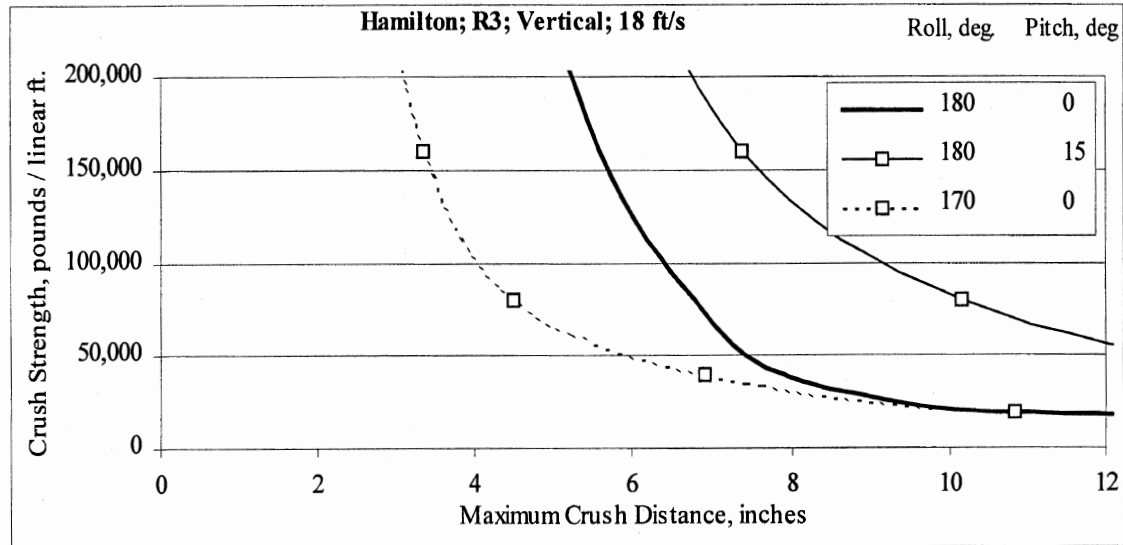
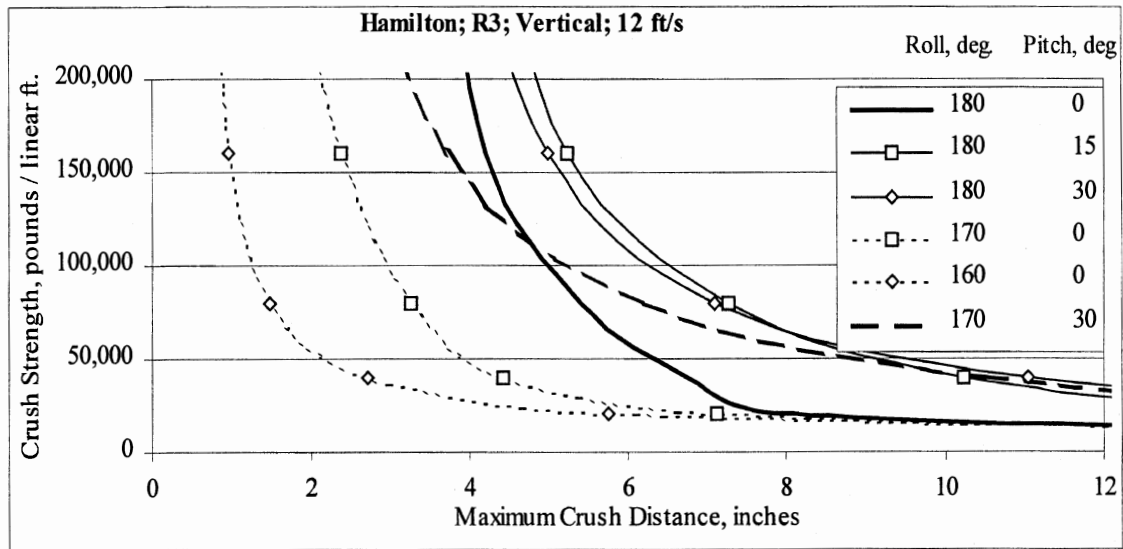
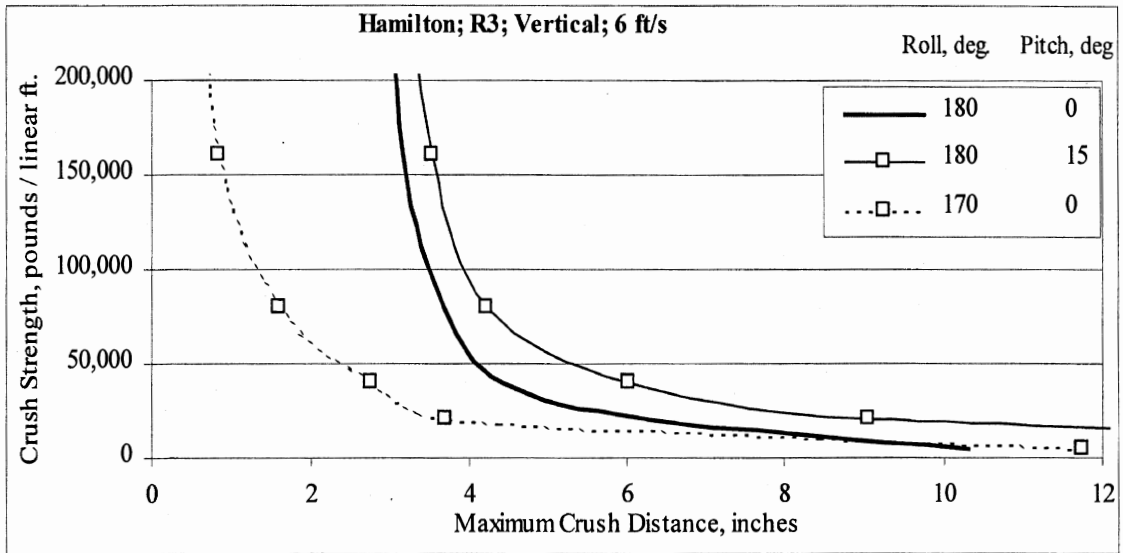

Figure C-13. Vertical results for Hamilton with flat rails and crowned dams.

Table C-12. Tabular vertical results for Hamilton with flat rails and crowned dams.

Vertical results for Hamilton with flat rails and crowned dams									
Vel., ft/s	Roll, deg	Pitch, deg	Strength, lbs/ft.	Max. Defl., in.	Vel., ft/s	Roll, deg	Pitch, deg	Strength, lbs/ft.	Max. Defl., in.
12	180	0	5000	19.75	18	180	0	5000	33.24
12	180	0	20000	7.87	18	180	0	20000	10.57
12	180	0	40000	6.75	18	180	0	40000	7.90
12	180	0	80000	5.42	18	180	0	80000	6.79
12	180	0	160000	4.22	18	180	0	160000	5.58
12	180	0	320000	3.61	18	180	0	320000	4.33
12	180	15	5000	35.19	18	180	15	5000	48.79
12	180	15	20000	14.86	18	180	15	20000	20.57
12	180	15	40000	10.22	18	180	15	40000	14.33
12	180	15	80000	7.26	18	180	15	80000	10.16
12	180	15	160000	5.24	18	180	15	160000	7.38
12	180	15	320000	4.05	18	180	15	320000	5.42
12	180	30	5000	44.44	18	170	0	5000	33.16
12	180	30	20000	17.82	18	170	0	20000	10.83
12	180	30	40000	11.05	18	170	0	40000	6.91
12	180	30	80000	7.10	18	170	0	80000	4.49
12	180	30	160000	5.01	18	170	0	160000	3.34
12	180	30	320000	3.72	18	170	0	320000	2.51
12	170	0	5000	20.30	6	180	0	5000	10.29
12	170	0	20000	7.12	6	180	0	20000	6.26
12	170	0	40000	4.43	6	180	0	40000	4.44
12	170	0	80000	3.27	6	180	0	80000	3.68
12	170	0	160000	2.38	6	180	0	160000	3.17
12	170	0	320000	1.44	6	180	0	320000	2.93
12	170	30	5000	43.31	6	180	15	5000	23.80
12	170	30	20000	17.68	6	180	15	20000	9.05
12	170	30	40000	10.48	6	180	15	40000	6.04
12	170	30	80000	6.21	6	180	15	80000	4.24
12	170	30	160000	3.71	6	180	15	160000	3.53
12	170	30	320000	2.41	6	180	15	320000	3.01
12	160	0	5000	23.49	6	170	0	5000	11.75
12	160	0	20000	5.76	6	170	0	20000	3.72
12	160	0	40000	2.72	6	170	0	40000	2.77
12	160	0	80000	1.48	6	170	0	80000	1.60
12	160	0	160000	0.96	6	170	0	160000	0.83
12	160	0	320000	0.71	6	170	0	320000	0.49

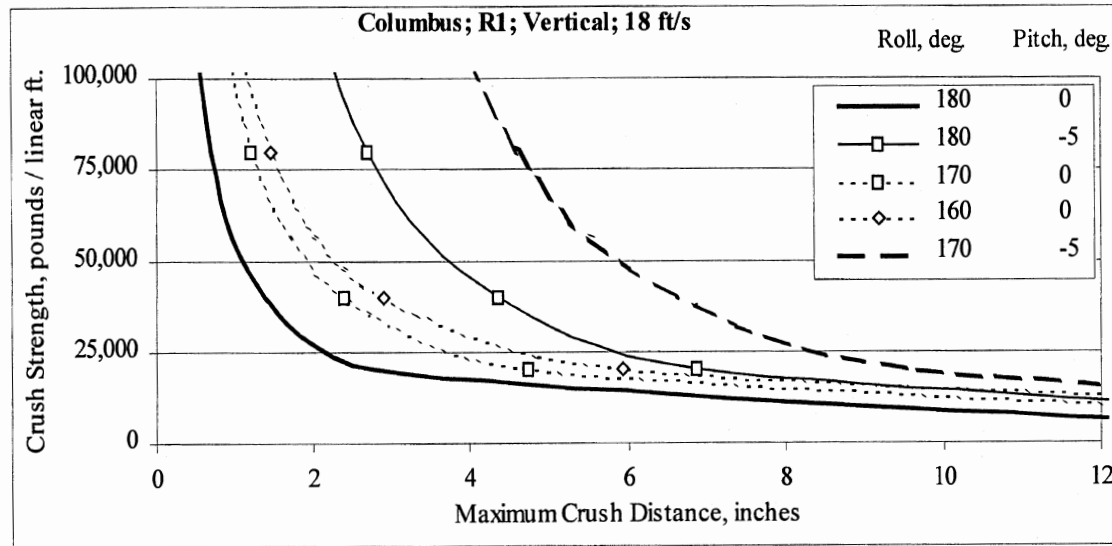
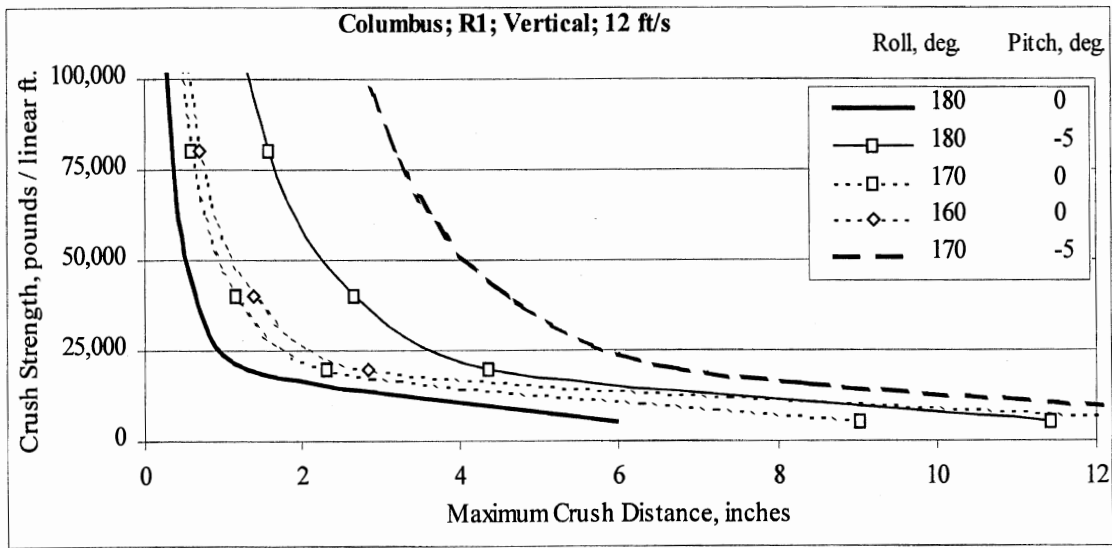
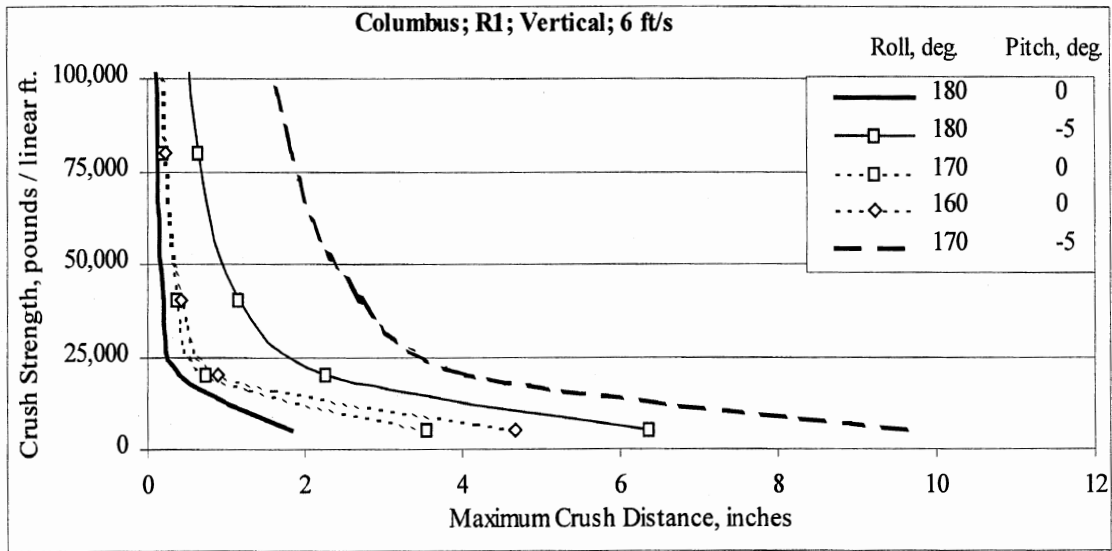

Figure C-14. Vertical results for Columbus with flat rails and flat end dams.

Table C-13. Tabular vertical results for Columbus with flat rails and flat end dams.

Vertical results for Columbus with flat rails and flat end dams									
Vel., ft/s	Roll, deg	Pitch, deg	Strength, lbs/ft.	Max. Defl., in.	Vel., ft/s	Roll, deg	Pitch, deg	Strength, lbs/ft.	Max. Defl., in.
12	180	0	5000	5.97	18	170	0	80,000	1.23
12	180	0	20000	1.31	18	170	0	160,000	0.64
12	180	0	40000	0.65	18	170	0	320,000	0.38
12	180	0	80000	0.34	18	170	-5	5,000	20.82
12	180	0	160000	0.20	18	170	-5	20,000	9.53
12	180	0	320000	0.16	18	170	-5	40,000	6.65
12	180	-5	5000	11.42	18	170	-5	80,000	4.60
12	180	-5	20000	4.36	18	170	-5	160,000	3.23
12	180	-5	40000	2.66	18	170	-5	320,000	2.30
12	180	-5	80000	1.59	18	160	0	5,000	21.34
12	180	-5	160000	0.93	18	160	0	20,000	5.95
12	180	-5	320000	0.57	18	160	0	40,000	2.91
12	170	0	5000	9.05	18	160	0	80,000	1.46
12	170	0	20000	2.32	18	160	0	160,000	0.75
12	170	0	40000	1.15	18	160	0	320,000	0.43
12	170	0	80000	0.59	6	180	0	5,000	1.83
12	170	0	160000	0.32	6	180	0	20,000	0.40
12	170	0	320000	0.22	6	180	0	40,000	0.20
12	170	-5	5000	14.77	6	180	0	80,000	0.12
12	170	-5	20000	6.76	6	180	0	160,000	0.09
12	170	-5	40000	4.60	6	180	0	320,000	0.09
12	170	-5	80000	3.18	6	180	-5	5,000	6.36
12	170	-5	160000	2.22	6	180	-5	20,000	2.28
12	170	-5	320000	1.58	6	180	-5	40,000	1.15
12	160	0	5000	13.05	6	180	-5	80,000	0.63
12	160	0	20000	2.82	6	180	-5	160,000	0.35
12	160	0	40000	1.37	6	180	-5	320,000	0.23
12	160	0	80000	0.69	6	170	0	5,000	3.56
12	160	0	160000	0.37	6	170	0	20,000	0.74
12	160	0	320000	0.24	6	170	0	40,000	0.36
18	180	0	5000	12.88	6	170	0	80,000	0.19
18	180	0	20000	2.81	6	170	0	160,000	0.13
18	180	0	40000	1.38	6	170	0	320,000	0.12
18	180	0	80000	0.70	6	170	-5	5,000	9.63
18	180	0	160000	0.38	6	170	-5	20,000	4.05
18	180	0	320000	0.25	6	170	-5	40,000	2.69
18	180	-5	5000	17.26	6	170	-5	80,000	1.82
18	180	-5	20000	6.88	6	170	-5	160,000	1.26
18	180	-5	40000	4.36	6	170	-5	320,000	0.89
18	180	-5	80000	2.72	6	160	0	5,000	4.68
18	180	-5	160000	1.66	6	160	0	20,000	0.88
18	180	-5	320000	1.01	6	160	0	40,000	0.43
18	170	0	5000	17.39	6	160	0	80,000	0.22
18	170	0	20000	4.76	6	160	0	160,000	0.14
18	170	0	40000	2.42	6	160	0	320,000	0.13

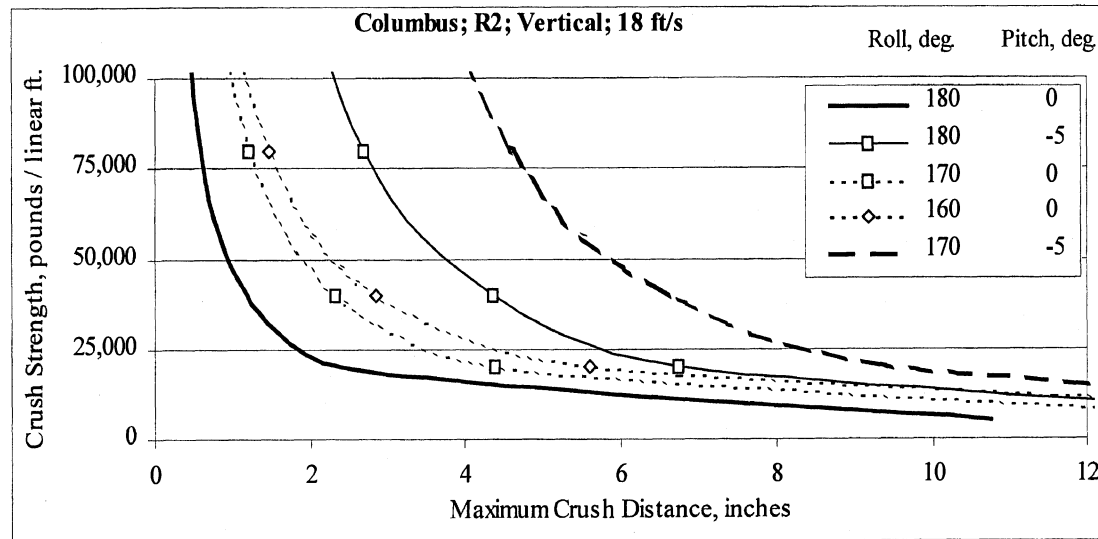
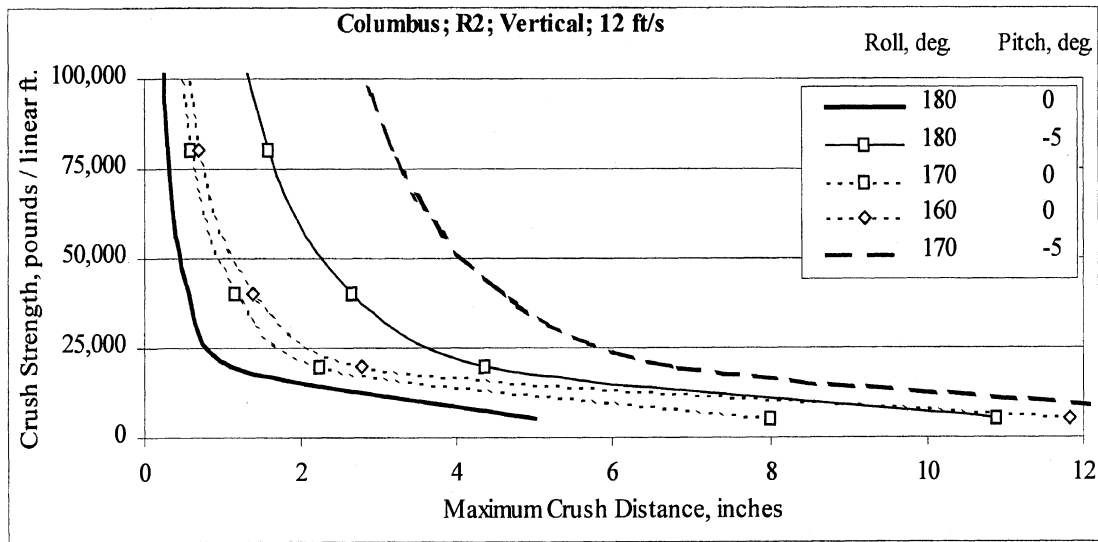
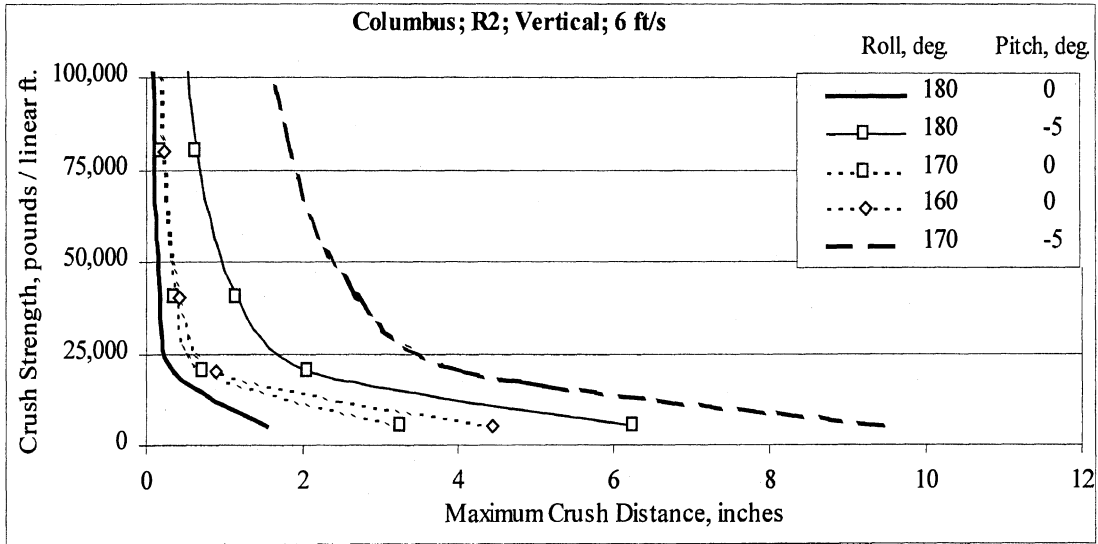

Figure C-15. Vertical results for Columbus with flat rails and flat dams every 6 ft.

Table C-14. Tabular vertical results for Columbus with flat rails and flat dams every 6 ft.

Vertical results for Columbus with flat rails and flat dams every 6 ft.									
Vel., ft/s	Roll, deg	Pitch, deg	Strength, lbs/ft.	Max. Defl., in.	Vel., ft/s	Roll, deg	Pitch, deg	Strength, lbs/ft.	Max. Defl., in.
12	180	0	5000	4.99	18	170	0	80,000	1.22
12	180	0	20000	1.12	18	170	0	160,000	0.64
12	180	0	40000	0.56	18	170	0	320,000	0.38
12	180	0	80000	0.29	18	170	-5	5,000	19.63
12	180	0	160000	0.17	18	170	-5	20,000	9.41
12	180	0	320000	0.15	18	170	-5	40,000	6.64
12	180	-5	5000	10.89	18	170	-5	80,000	4.60
12	180	-5	20000	4.36	18	170	-5	160,000	3.23
12	180	-5	40000	2.66	18	170	-5	320,000	2.30
12	180	-5	80000	1.59	18	160	0	5,000	18.83
12	180	-5	160000	0.93	18	160	0	20,000	5.62
12	180	-5	320000	0.57	18	160	0	40,000	2.86
12	170	0	5000	8.01	18	160	0	80,000	1.46
12	170	0	20000	2.24	18	160	0	160,000	0.75
12	170	0	40000	1.15	18	160	0	320,000	0.43
12	170	0	80000	0.59	6	180	0	5,000	1.53
12	170	0	160000	0.32	6	180	0	20,000	0.34
12	170	0	320000	0.22	6	180	0	40,000	0.18
12	170	-5	5000	14.19	6	180	0	80,000	0.10
12	170	-5	20000	6.75	6	180	0	160,000	0.08
12	170	-5	40000	4.60	6	180	0	320,000	0.08
12	170	-5	80000	3.18	6	180	-5	5,000	6.27
12	170	-5	160000	2.22	6	180	-5	20,000	2.07
12	170	-5	320000	1.58	6	180	-5	40,000	1.15
12	160	0	5000	11.83	6	180	-5	80,000	0.63
12	160	0	20000	2.78	6	180	-5	160,000	0.35
12	160	0	40000	1.37	6	180	-5	320,000	0.23
12	160	0	80000	0.69	6	170	0	5,000	3.29
12	160	0	160000	0.37	6	170	0	20,000	0.74
12	160	0	320000	0.24	6	170	0	40,000	0.36
18	180	0	5000	10.77	6	170	0	80,000	0.19
18	180	0	20000	2.40	6	170	0	160,000	0.13
18	180	0	40000	1.19	6	170	0	320,000	0.12
18	180	0	80000	0.60	6	170	-5	5,000	9.47
18	180	0	160000	0.33	6	170	-5	20,000	4.05
18	180	0	320000	0.22	6	170	-5	40,000	2.69
18	180	-5	5000	16.16	6	170	-5	80,000	1.82
18	180	-5	20000	6.77	6	170	-5	160,000	1.26
18	180	-5	40000	4.36	6	170	-5	320,000	0.89
18	180	-5	80000	2.72	6	160	0	5,000	4.45
18	180	-5	160000	1.66	6	160	0	20,000	0.88
18	180	-5	320000	1.01	6	160	0	40,000	0.43
18	170	0	5000	14.97	6	160	0	80,000	0.22
18	170	0	20000	4.39	6	160	0	160,000	0.14
18	170	0	40000	2.32	6	160	0	320,000	0.13

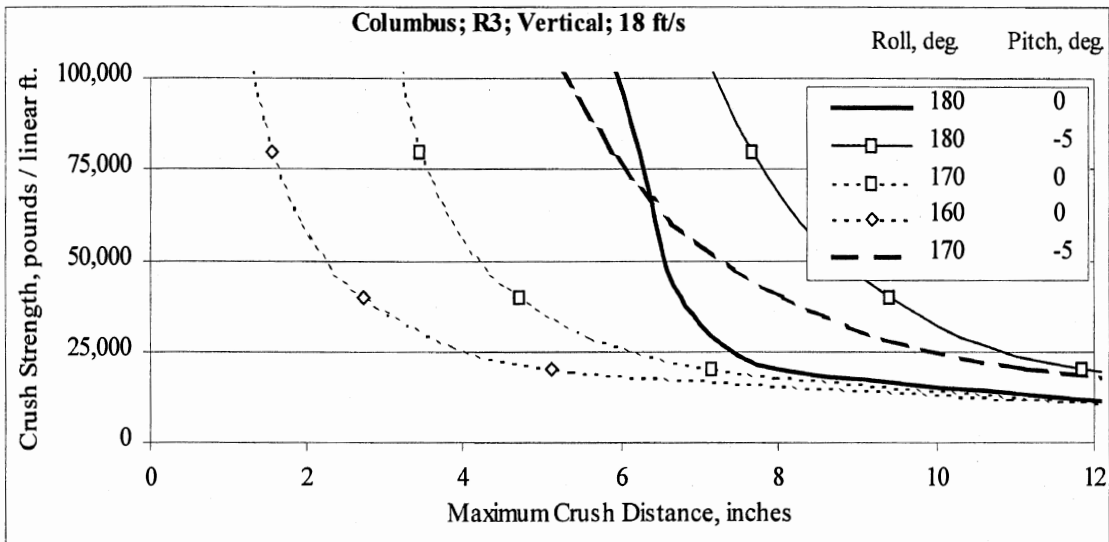
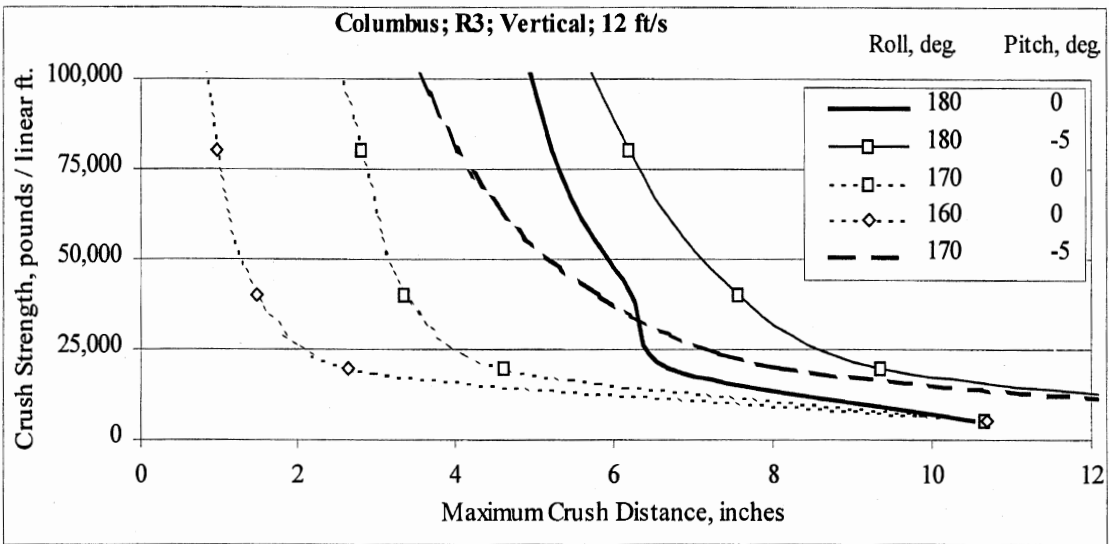
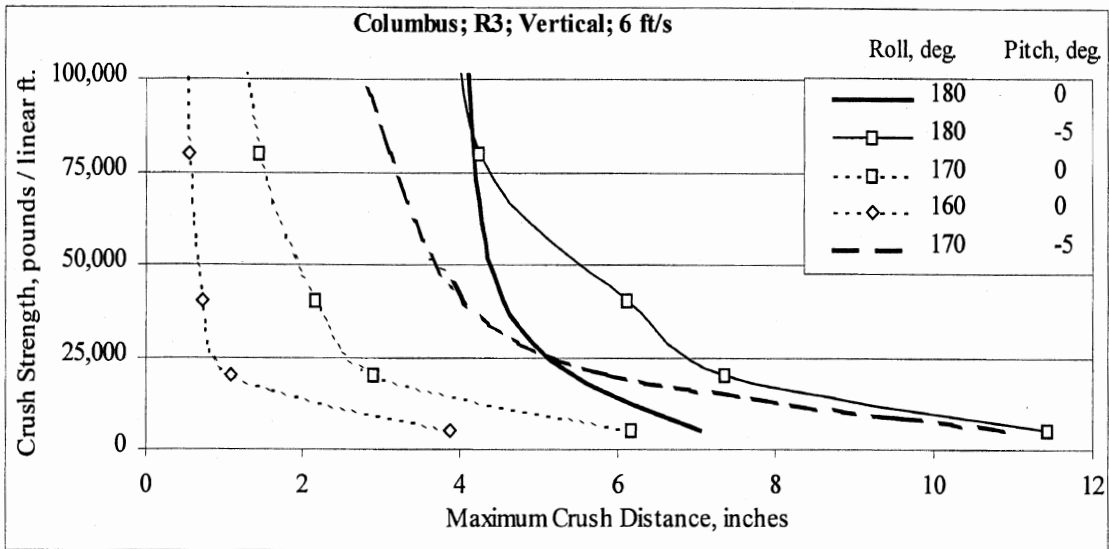

Figure C-16. Vertical results for Columbus with flat rails and crowned dams.

Table C-15. Tabular vertical results for Columbus with flat rails and crowned dams.

Vertical results for Columbus with flat rails and crowned dams.									
Vel., ft/s	Roll, deg	Pitch, deg	Strength, lbs/ft.	Max. Defl., in.	Vel., ft/s	Roll, deg	Pitch, deg	Strength, lbs/ft.	Max. Defl., in.
12	180	0	5,000	10.51	18	170	0	80,000	3.45
12	180	0	20,000	6.69	18	170	0	160,000	2.87
12	180	0	40,000	6.20	18	170	0	320,000	2.11
12	180	0	80,000	5.20	18	170	-5	5,000	21.19
12	180	0	160,000	4.50	18	170	-5	20,000	11.12
12	180	0	320,000	4.17	18	170	-5	40,000	8.07
12	180	-5	5,000	15.95	18	170	-5	80,000	5.88
12	180	-5	20,000	9.36	18	170	-5	160,000	4.15
12	180	-5	40,000	7.58	18	170	-5	320,000	2.90
12	180	-5	80,000	6.18	18	160	0	5,000	18.09
12	180	-5	160,000	4.88	18	160	0	20,000	5.12
12	180	-5	320,000	4.23	18	160	0	40,000	2.73
12	170	0	5,000	10.67	18	160	0	80,000	1.56
12	170	0	20,000	4.61	18	160	0	160,000	1.01
12	170	0	40,000	3.36	18	160	0	320,000	0.74
12	170	0	80,000	2.81	6	180	0	5,000	7.05
12	170	0	160,000	1.99	6	180	0	20,000	5.42
12	170	0	320,000	1.41	6	180	0	40,000	4.55
12	170	-5	5,000	15.85	6	180	0	80,000	4.18
12	170	-5	20,000	8.12	6	180	0	160,000	4.01
12	170	-5	40,000	5.82	6	180	0	320,000	3.92
12	170	-5	80,000	4.03	6	180	-5	5,000	11.43
12	170	-5	160,000	2.81	6	180	-5	20,000	7.35
12	170	-5	320,000	2.02	6	180	-5	40,000	6.12
12	160	0	5,000	10.70	6	180	-5	80,000	4.26
12	160	0	20,000	2.63	6	180	-5	160,000	3.91
12	160	0	40,000	1.49	6	180	-5	320,000	3.76
12	160	0	80,000	0.95	6	170	0	5,000	6.18
12	160	0	160,000	0.68	6	170	0	20,000	2.91
12	160	0	320,000	0.57	6	170	0	40,000	2.16
18	180	0	5,000	16.29	6	170	0	80,000	1.47
18	180	0	20,000	7.97	6	170	0	160,000	1.03
18	180	0	40,000	6.77	6	170	0	320,000	0.82
18	180	0	80,000	6.23	6	170	-5	5,000	10.90
18	180	0	160,000	5.33	6	170	-5	20,000	5.87
18	180	0	320,000	4.58	6	170	-5	40,000	4.04
18	180	-5	5,000	21.30	6	170	-5	80,000	3.11
18	180	-5	20,000	11.84	6	170	-5	160,000	2.17
18	180	-5	40,000	9.41	6	170	-5	320,000	1.42
18	180	-5	80,000	7.68	6	160	0	5,000	3.88
18	180	-5	160,000	6.32	6	160	0	20,000	1.09
18	180	-5	320,000	5.02	6	160	0	40,000	0.72
18	170	0	5,000	16.26	6	160	0	80,000	0.54
18	170	0	20,000	7.14	6	160	0	160,000	0.47
18	170	0	40,000	4.71	6	160	0	320,000	0.41

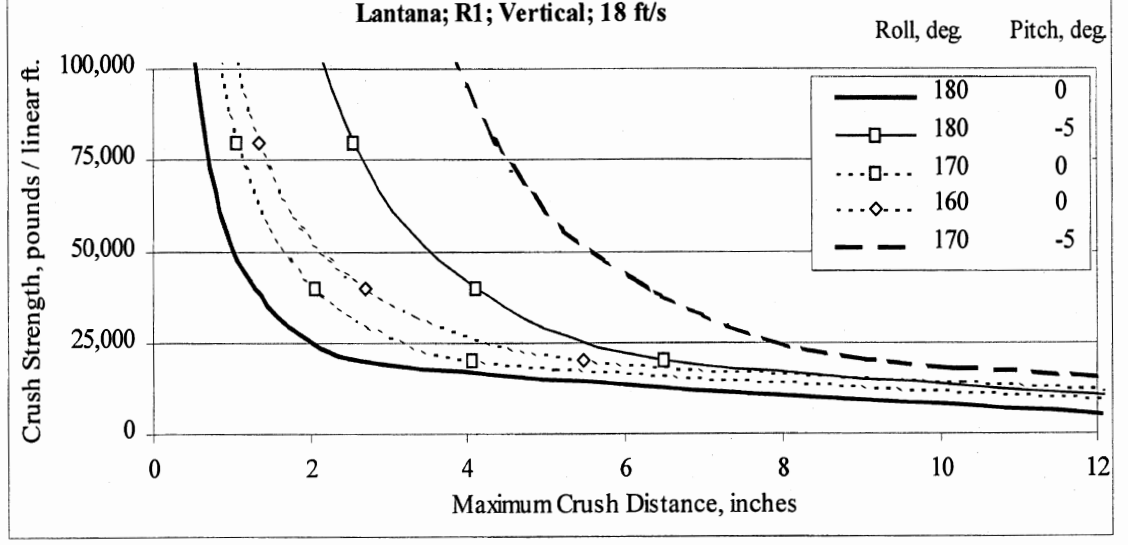
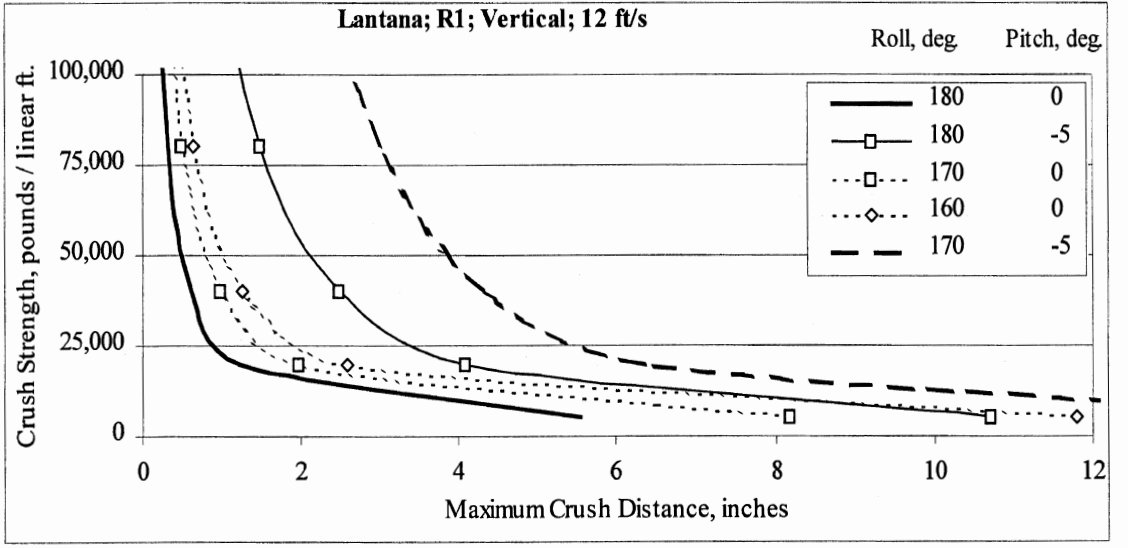
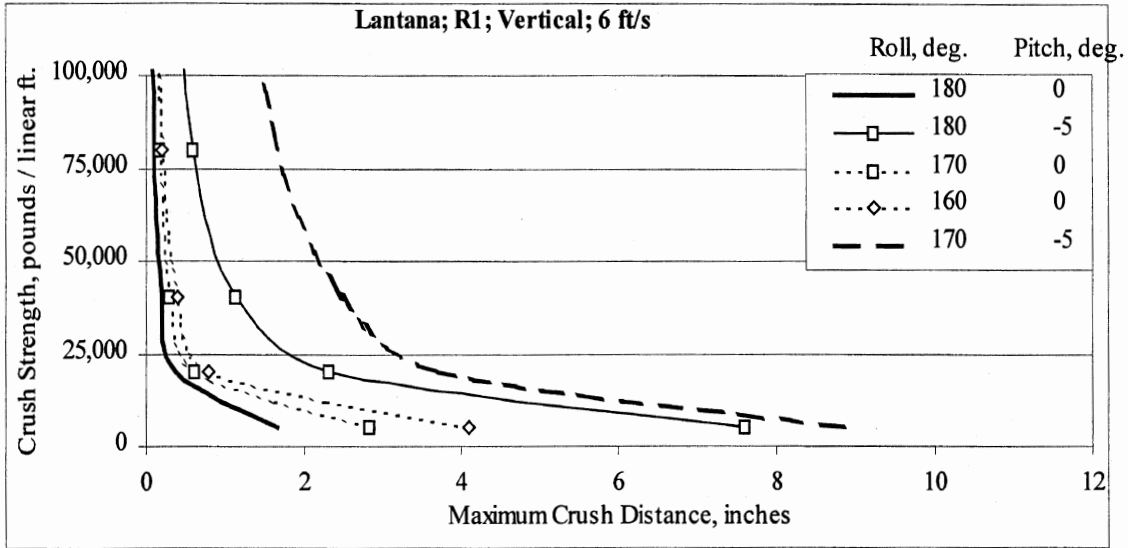

Figure C-17. Vertical results for Lantana with flat rails and flat end dams only.

Table C-16. Tabular vertical results for Lantana with flat rails and flat end dams only.

Vertical results for Lantana with flat rails and flat end dams only.									
Vel., ft/s	Roll, deg	Pitch, deg	Strength, lbs/ft.	Max. Defl., in.	Vel., ft/s	Roll, deg	Pitch, deg	Strength, lbs/ft.	Max. Defl., in.
12	180	0	5000	5.55	18	170	0	80,000	1.06
12	180	0	20000	1.22	18	170	0	160,000	0.56
12	180	0	40000	0.61	18	170	0	320,000	0.34
12	180	0	80000	0.31	18	170	-5	5,000	21.69
12	180	0	160000	0.19	18	170	-5	20,000	9.07
12	180	0	320000	0.15	18	170	-5	40,000	6.30
12	180	-5	5000	10.72	18	170	-5	80,000	4.36
12	180	-5	20000	4.08	18	170	-5	160,000	3.06
12	180	-5	40000	2.48	18	170	-5	320,000	2.19
12	180	-5	80000	1.47	18	160	0	5,000	20.68
12	180	-5	160000	0.85	18	160	0	20,000	5.50
12	180	-5	320000	0.52	18	160	0	40,000	2.70
12	170	0	5000	8.17	18	160	0	80,000	1.35
12	170	0	20000	1.97	18	160	0	160,000	0.70
12	170	0	40000	0.99	18	160	0	320,000	0.41
12	170	0	80000	0.50	6	180	0	5,000	1.65
12	170	0	160000	0.28	6	180	0	20,000	0.37
12	170	0	320000	0.20	6	180	0	40,000	0.19
12	170	-5	5000	15.20	6	180	0	80,000	0.11
12	170	-5	20000	6.35	6	180	0	160,000	0.08
12	170	-5	40000	4.33	6	180	0	320,000	0.08
12	170	-5	80000	3.00	6	180	-5	5,000	7.60
12	170	-5	160000	2.10	6	180	-5	20,000	2.32
12	170	-5	320000	1.49	6	180	-5	40,000	1.13
12	160	0	5000	11.80	6	180	-5	80,000	0.58
12	160	0	20000	2.59	6	180	-5	160,000	0.32
12	160	0	40000	1.26	6	180	-5	320,000	0.24
12	160	0	80000	0.63	6	170	0	5,000	2.83
12	160	0	160000	0.34	6	170	0	20,000	0.61
12	160	0	320000	0.23	6	170	0	40,000	0.30
18	180	0	5000	12.06	6	170	0	80,000	0.16
18	180	0	20000	2.64	6	170	0	160,000	0.11
18	180	0	40000	1.30	6	170	0	320,000	0.11
18	180	0	80000	0.66	6	170	-5	5,000	8.87
18	180	0	160000	0.36	6	170	-5	20,000	3.69
18	180	0	320000	0.24	6	170	-5	40,000	2.46
18	180	-5	5000	16.32	6	170	-5	80,000	1.66
18	180	-5	20000	6.52	6	170	-5	160,000	1.17
18	180	-5	40000	4.13	6	170	-5	320,000	0.80
18	180	-5	80000	2.56	6	160	0	5,000	4.11
18	180	-5	160000	1.56	6	160	0	20,000	0.79
18	180	-5	320000	0.94	6	160	0	40,000	0.38
18	170	0	5000	16.63	6	160	0	80,000	0.20
18	170	0	20000	4.07	6	160	0	160,000	0.13
18	170	0	40000	2.07	6	160	0	320,000	0.12

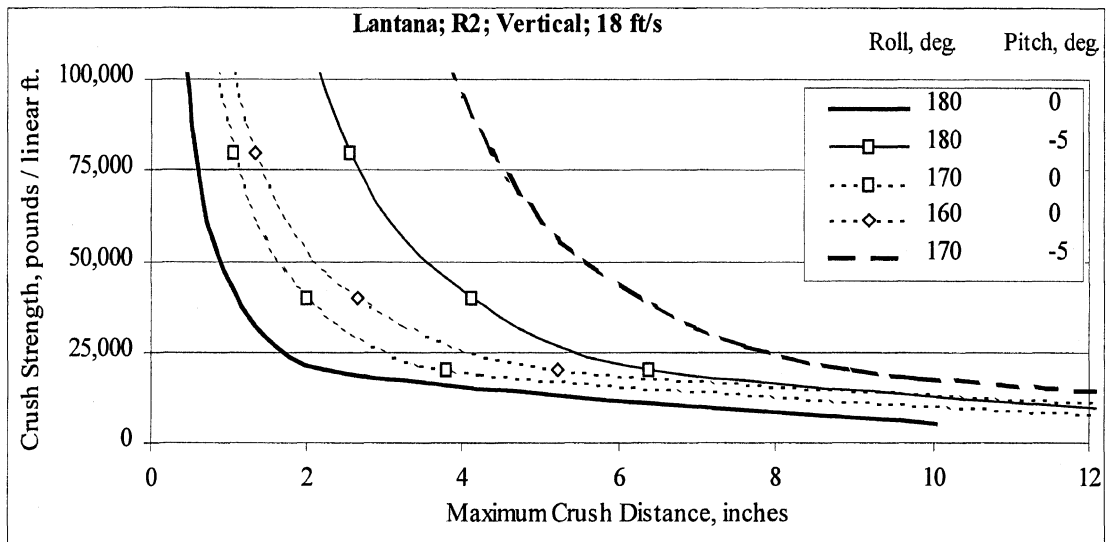
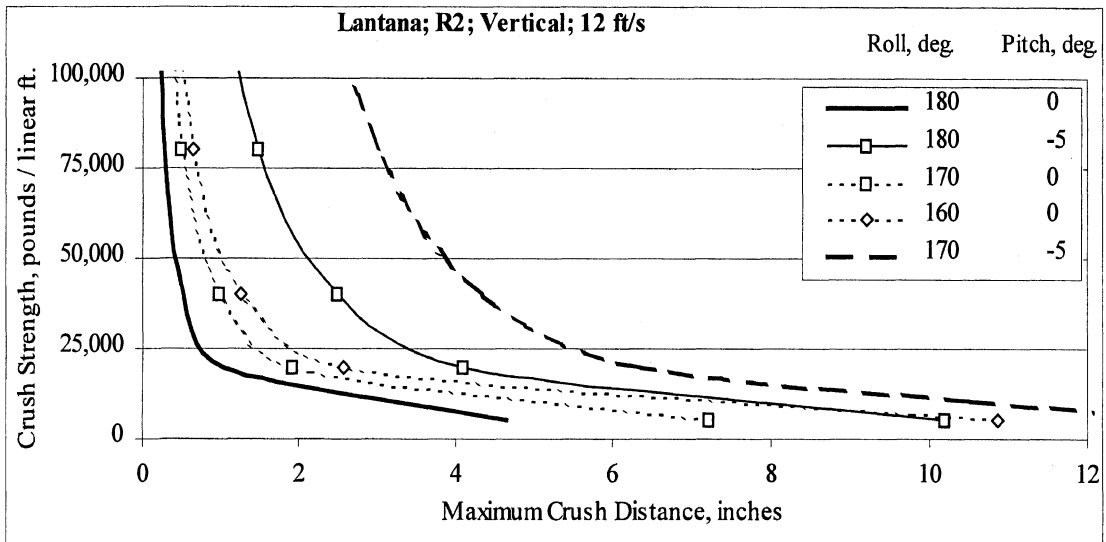
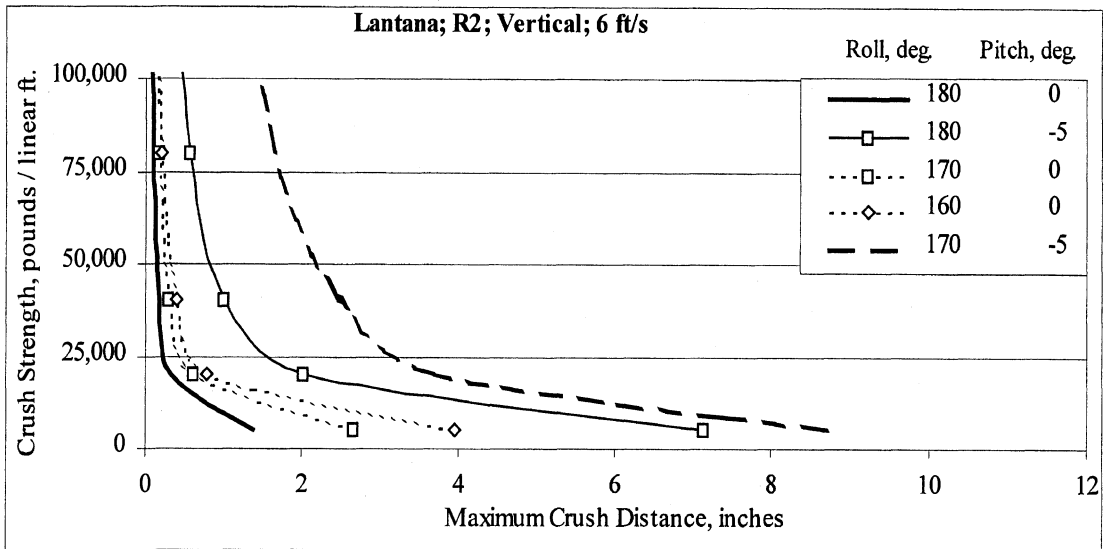

Figure C-18. Vertical results for Lantana with flat rails and flat dams every 6 ft.

Table C-17. Tabular vertical results for Lantana with flat rails and flat dams every 6 ft.

Vertical results for Lantana with flat rails and flat dams every 6 ft.									
Vel., ft/s	Roll, deg	Pitch, deg	Strength, lbs/ft.	Max. Defl., in.	Vel., ft/s	Roll, deg	Pitch, deg	Strength, lbs/ft.	Max. Defl., in.
12	180	0	5000	4.62	18	170	0	80,000	1.06
12	180	0	20000	1.04	18	170	0	160,000	0.56
12	180	0	40000	0.52	18	170	0	320,000	0.34
12	180	0	80000	0.27	18	170	-5	5,000	18.67
12	180	0	160000	0.17	18	170	-5	20,000	8.93
12	180	0	320000	0.14	18	170	-5	40,000	6.30
12	180	-5	5000	10.19	18	170	-5	80,000	4.36
12	180	-5	20000	4.08	18	170	-5	160,000	3.06
12	180	-5	40000	2.48	18	170	-5	320,000	2.19
12	180	-5	80000	1.47	18	160	0	5,000	18.21
12	180	-5	160000	0.85	18	160	0	20,000	5.21
12	180	-5	320000	0.52	18	160	0	40,000	2.66
12	170	0	5000	7.23	18	160	0	80,000	1.35
12	170	0	20000	1.92	18	160	0	160,000	0.70
12	170	0	40000	0.99	18	160	0	320,000	0.41
12	170	0	80000	0.50	6	180	0	5,000	1.37
12	170	0	160000	0.28	6	180	0	20,000	0.31
12	170	0	320000	0.20	6	180	0	40,000	0.16
12	170	-5	5000	13.39	6	180	0	80,000	0.09
12	170	-5	20000	6.35	6	180	0	160,000	0.08
12	170	-5	40000	4.33	6	180	0	320,000	0.08
12	170	-5	80000	3.00	6	180	-5	5,000	7.12
12	170	-5	160000	2.10	6	180	-5	20,000	2.01
12	170	-5	320000	1.49	6	180	-5	40,000	1.02
12	160	0	5000	10.87	6	180	-5	80,000	0.56
12	160	0	20000	2.56	6	180	-5	160,000	0.31
12	160	0	40000	1.26	6	180	-5	320,000	0.22
12	160	0	80000	0.63	6	170	0	5,000	2.67
12	160	0	160000	0.34	6	170	0	20,000	0.61
12	160	0	320000	0.23	6	170	0	40,000	0.30
18	180	0	5000	10.04	6	170	0	80,000	0.16
18	180	0	20000	2.25	6	170	0	160,000	0.11
18	180	0	40000	1.11	6	170	0	320,000	0.11
18	180	0	80000	0.57	6	170	-5	5,000	8.71
18	180	0	160000	0.31	6	170	-5	20,000	3.69
18	180	0	320000	0.22	6	170	-5	40,000	2.46
18	180	-5	5000	15.24	6	170	-5	80,000	1.66
18	180	-5	20000	6.39	6	170	-5	160,000	1.17
18	180	-5	40000	4.13	6	170	-5	320,000	0.80
18	180	-5	80000	2.56	6	160	0	5,000	3.94
18	180	-5	160000	1.56	6	160	0	20,000	0.79
18	180	-5	320000	0.94	6	160	0	40,000	0.38
18	170	0	5000	14.25	6	160	0	80,000	0.20
18	170	0	20000	3.79	6	160	0	160,000	0.13
18	170	0	40000	2.01	6	160	0	320,000	0.12

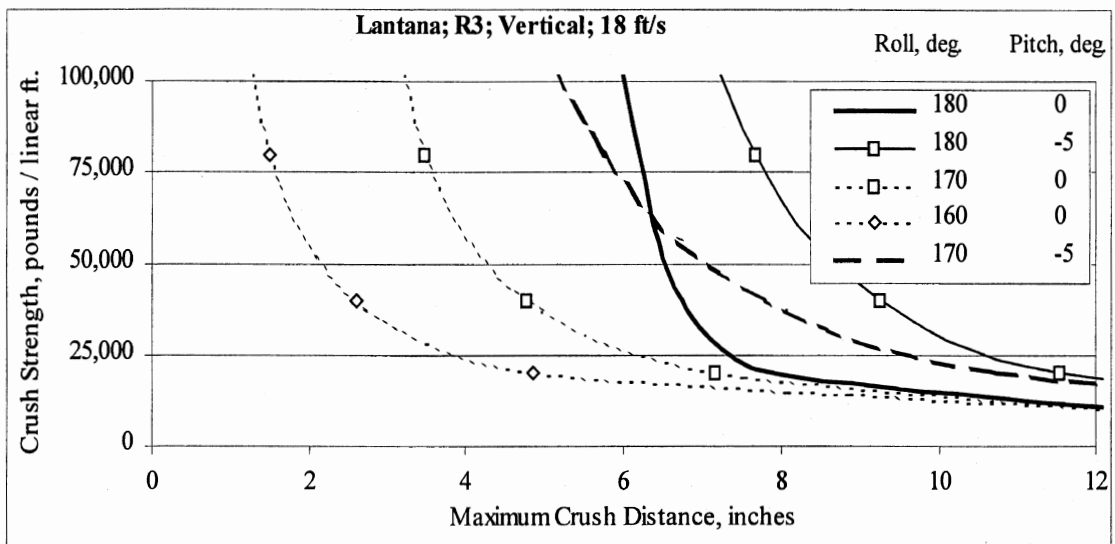
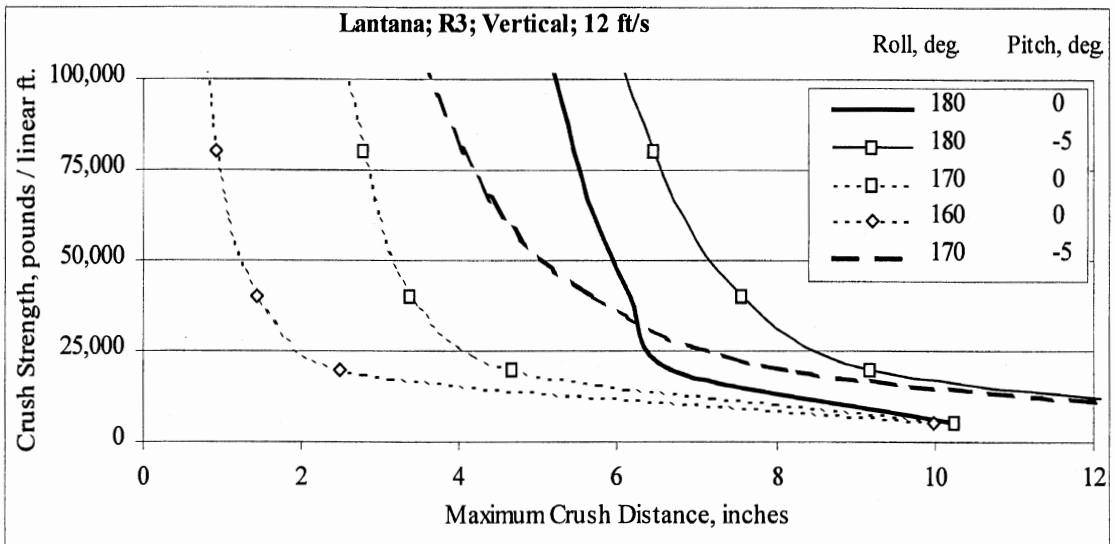
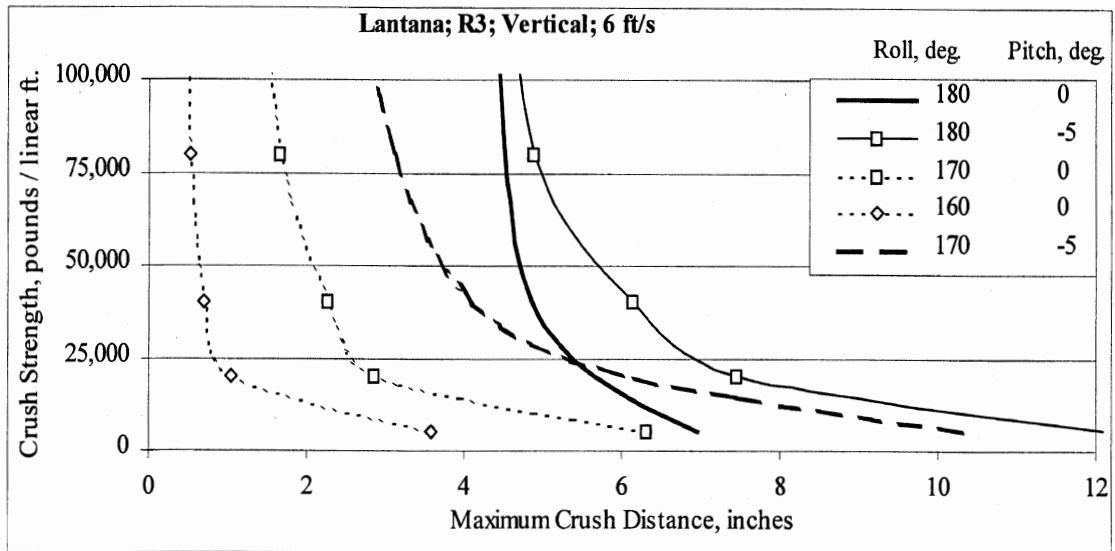

Figure C-19. Vertical results for Lantana with flat rails and crowned dams.

Table C-18. Tabular vertical results for Lantana with flat rails and crowned dams.

Vertical results for Lantana with flat rails and crowned dams.									
Vel., ft/s	Roll, deg	Pitch, deg	Strength, lbs/ft.	Max. Defl., in.	Vel., ft/s	Roll, deg	Pitch, deg	Strength, lbs/ft.	Max. Defl., in.
12	180	0	5000	10.22	18	170	0	80,000	3.48
12	180	0	20000	6.67	18	170	0	160,000	2.84
12	180	0	40000	6.16	18	170	0	320,000	2.25
12	180	0	80000	5.45	18	170	-5	5,000	20.24
12	180	0	160000	4.81	18	170	-5	20,000	10.73
12	180	0	320000	4.50	18	170	-5	40,000	7.80
12	180	-5	5000	15.31	18	170	-5	80,000	5.78
12	180	-5	20000	9.19	18	170	-5	160,000	4.18
12	180	-5	40000	7.58	18	170	-5	320,000	3.07
12	180	-5	80000	6.45	18	160	0	5,000	17.55
12	180	-5	160000	5.46	18	160	0	20,000	4.86
12	180	-5	320000	4.85	18	160	0	40,000	2.60
12	170	0	5000	10.25	18	160	0	80,000	1.50
12	170	0	20000	4.69	18	160	0	160,000	0.98
12	170	0	40000	3.38	18	160	0	320,000	0.72
12	170	0	80000	2.79	6	180	0	5,000	6.97
12	170	0	160000	2.14	6	180	0	20,000	5.65
12	170	0	320000	1.63	6	180	0	40,000	4.86
12	170	-5	5000	15.12	6	180	0	80,000	4.51
12	170	-5	20000	8.13	6	180	0	160,000	4.35
12	170	-5	40000	5.69	6	180	0	320,000	4.28
12	170	-5	80000	4.05	6	180	-5	5,000	12.22
12	170	-5	160000	2.94	6	180	-5	20,000	7.44
12	170	-5	320000	2.20	6	180	-5	40,000	6.15
12	160	0	5000	9.97	6	180	-5	80,000	4.89
12	160	0	20000	2.50	6	180	-5	160,000	4.56
12	160	0	40000	1.42	6	180	-5	320,000	4.41
12	160	0	80000	0.92	6	170	0	5,000	6.33
12	160	0	160000	0.66	6	170	0	20,000	2.88
12	160	0	320000	0.55	6	170	0	40,000	2.27
18	180	0	5000	15.63	6	170	0	80,000	1.65
18	180	0	20000	7.88	6	170	0	160,000	1.34
18	180	0	40000	6.75	6	170	0	320,000	1.16
18	180	0	80000	6.21	6	170	-5	5,000	10.32
18	180	0	160000	5.58	6	170	-5	20,000	6.01
18	180	0	320000	4.88	6	170	-5	40,000	4.11
18	180	-5	5000	20.44	6	170	-5	80,000	3.10
18	180	-5	20000	11.55	6	170	-5	160,000	2.37
18	180	-5	40000	9.27	6	170	-5	320,000	1.43
18	180	-5	80000	7.68	6	160	0	5,000	3.57
18	180	-5	160000	6.57	6	160	0	20,000	1.03
18	180	-5	320000	5.58	6	160	0	40,000	0.69
18	170	0	5000	15.53	6	160	0	80,000	0.52
18	170	0	20000	7.19	6	160	0	160,000	0.45
18	170	0	40000	4.79	6	160	0	320,000	0.38

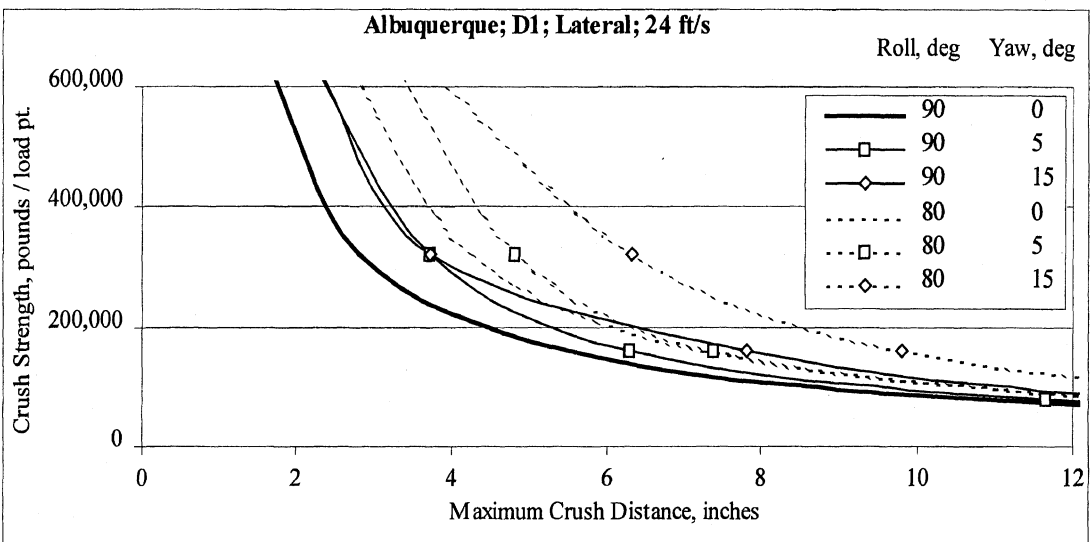
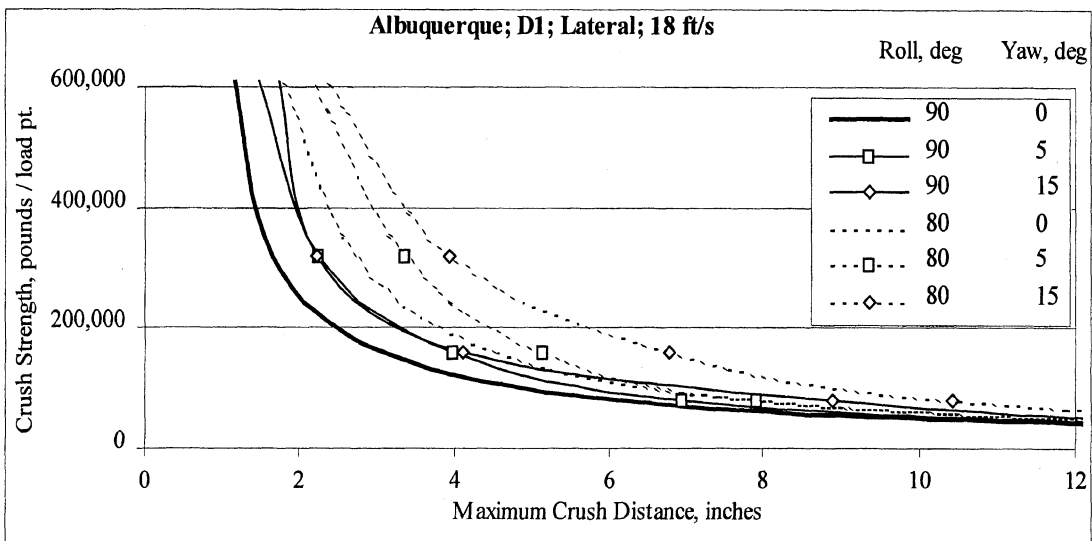
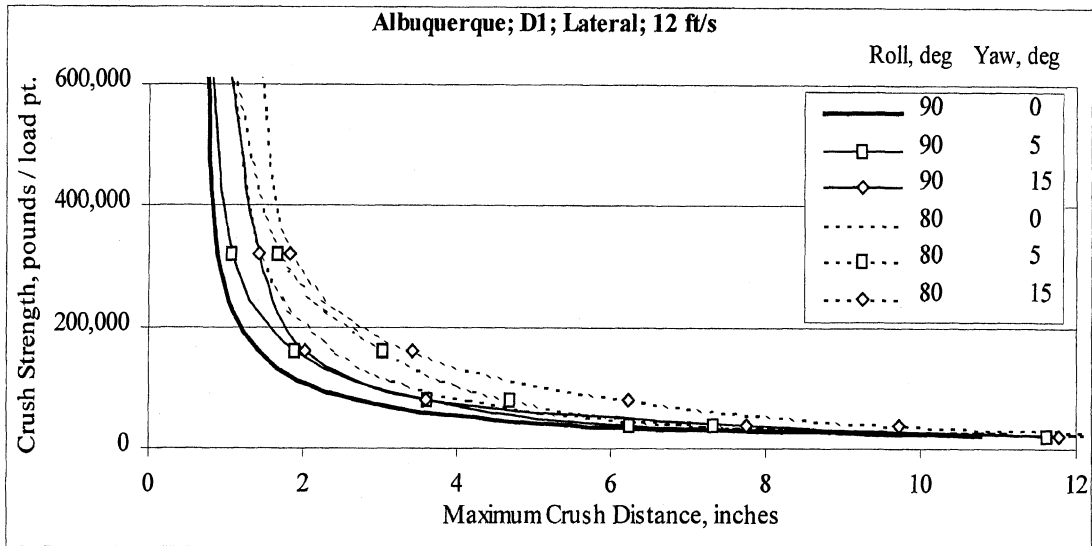

Figure C-20. Lateral results for Albuquerque as designed

Table C-19. Tabular lateral results for Albuquerque as designed

Later impact results for Albuquerque (as designed)									
Vel., ft/s	Roll, deg	Yaw, deg	Force, lbs	Defl., in.	Vel., ft/s	Roll, deg	Yaw, deg	Force, lbs	Defl., in.
12	90	0	20,000	10.76	18	80	0	20,000	25.39
12	90	0	40,000	5.47	18	80	0	40,000	14.40
12	90	0	80,000	2.70	18	80	0	80,000	7.98
12	90	0	160,000	1.43	18	80	0	160,000	4.55
12	90	0	320,000	0.90	18	80	0	320,000	2.73
12	90	0	640,000	0.77	18	80	0	640,000	1.72
12	90	5	20,000	11.64	18	80	5	20,000	24.24
12	90	5	40,000	6.26	18	80	5	40,000	14.43
12	90	5	80,000	3.61	18	80	5	80,000	7.93
12	90	5	160,000	1.92	18	80	5	160,000	5.14
12	90	5	320,000	1.09	18	80	5	320,000	3.37
12	90	5	640,000	0.81	18	80	5	640,000	2.03
12	90	15	20,000	11.78	18	80	15	20,000	24.88
12	90	15	40,000	7.75	18	80	15	40,000	17.21
12	90	15	80,000	3.60	18	80	15	80,000	10.41
12	90	15	160,000	2.03	18	80	15	160,000	6.78
12	90	15	320,000	1.44	18	80	15	320,000	3.93
12	90	15	640,000	1.05	18	80	15	640,000	2.21
12	80	0	20,000	13.00	24	90	0	20,000	41.87
12	80	0	40,000	7.22	24	90	0	40,000	21.17
12	80	0	80,000	4.13	24	90	0	80,000	10.79
12	80	0	160,000	2.40	24	90	0	160,000	5.53
12	80	0	320,000	1.43	24	90	0	320,000	2.82
12	80	0	640,000	1.07	24	90	0	640,000	1.66
12	80	5	20,000	13.05	24	90	5	20,000	43.61
12	80	5	40,000	7.33	24	90	5	40,000	21.59
12	80	5	80,000	4.70	24	90	5	80,000	11.67
12	80	5	160,000	3.06	24	90	5	160,000	6.32
12	80	5	320,000	1.68	24	90	5	320,000	3.73
12	80	5	640,000	1.08	24	90	5	640,000	2.22
12	80	15	20,000	14.79	24	90	15	20,000	42.07
12	80	15	40,000	9.73	24	90	15	40,000	22.91
12	80	15	80,000	6.22	24	90	15	80,000	13.24
12	80	15	160,000	3.43	24	90	15	160,000	7.81
12	80	15	320,000	1.84	24	90	15	320,000	3.73
12	80	15	640,000	1.45	24	90	15	640,000	2.26
18	90	0	20,000	23.75	24	80	0	20,000	38.43
18	90	0	40,000	12.07	24	80	0	40,000	23.19
18	90	0	80,000	6.16	24	80	0	80,000	13.03
18	90	0	160,000	3.10	24	80	0	160,000	7.28
18	90	0	320,000	1.66	24	80	0	320,000	4.25
18	90	0	640,000	1.13	24	80	0	640,000	2.64
18	90	5	20,000	24.17	24	80	5	20,000	36.17
18	90	5	40,000	13.00	24	80	5	40,000	22.38
18	90	5	80,000	6.95	24	80	5	80,000	13.08
18	90	5	160,000	3.98	24	80	5	160,000	7.39
18	90	5	320,000	2.25	24	80	5	320,000	4.82
18	90	5	640,000	1.42	24	80	5	640,000	3.28
18	90	15	20,000	25.34	24	80	15	20,000	38.29
18	90	15	40,000	14.42	24	80	15	40,000	22.91
18	90	15	80,000	8.89	24	80	15	80,000	15.69
18	90	15	160,000	4.12	24	80	15	160,000	9.79
18	90	15	320,000	2.24	24	80	15	320,000	6.34
18	90	15	640,000	1.70	24	80	15	640,000	3.67

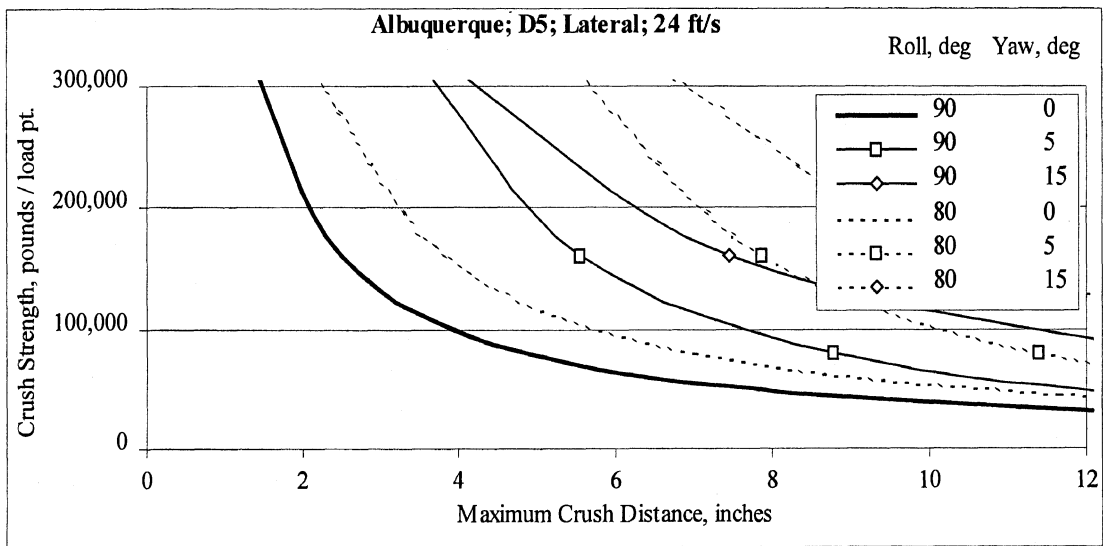
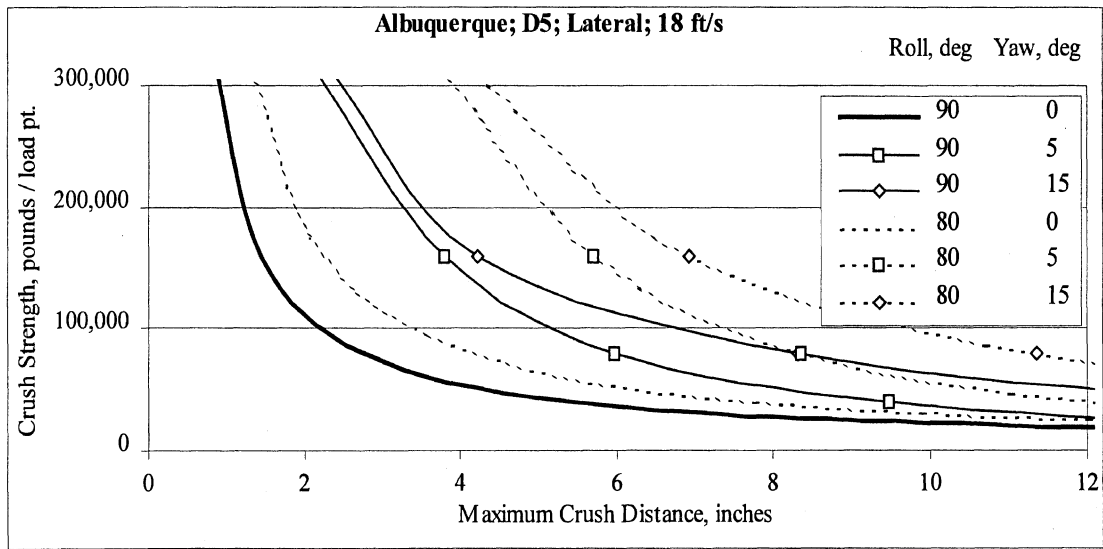
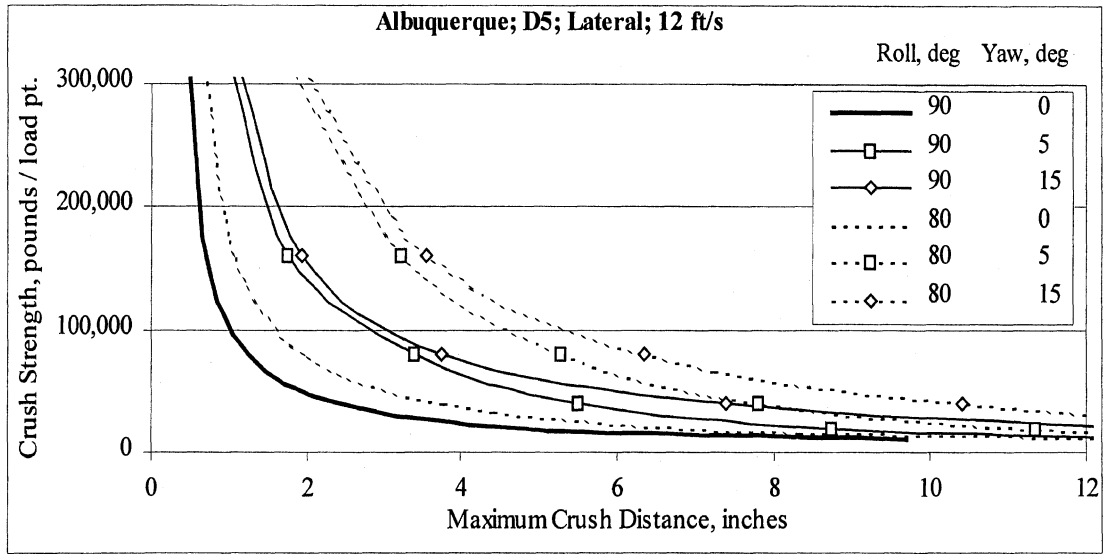

Figure C-21. Lateral results for Albuquerque with staples every 4 ft.

Table C-20. Tabular lateral results for Albuquerque with staples every 4 ft.

Later impact results for Albuquerque with staples every 4 ft.									
Vel., ft/s	Roll, deg	Yaw, deg	Force, lbs	Defl., in.	Vel., ft/s	Roll, deg	Yaw, deg	Force, lbs	Defl., in.
12	90	0	10,000	9.69	18	80	0	10,000	27.34
12	90	0	20,000	4.85	18	80	0	20,000	14.74
12	90	0	40,000	2.44	18	80	0	40,000	7.77
12	90	0	80,000	1.25	18	80	0	80,000	4.23
12	90	0	160,000	0.68	18	80	0	160,000	2.24
12	90	0	320,000	0.46	18	80	0	320,000	1.25
12	90	5	10,000	13.66	18	80	5	10,000	28.17
12	90	5	20,000	8.76	18	80	5	20,000	17.80
12	90	5	40,000	5.50	18	80	5	40,000	12.13
12	90	5	80,000	3.39	18	80	5	80,000	8.35
12	90	5	160,000	1.76	18	80	5	160,000	5.71
12	90	5	320,000	1.00	18	80	5	320,000	3.68
12	90	15	10,000	21.36	18	80	15	10,000	39.82
12	90	15	20,000	13.33	18	80	15	20,000	26.47
12	90	15	40,000	7.38	18	80	15	40,000	17.52
12	90	15	80,000	3.73	18	80	15	80,000	11.36
12	90	15	160,000	1.93	18	80	15	160,000	6.92
12	90	15	320,000	1.08	18	80	15	320,000	4.04
12	80	0	10,000	13.18	24	90	0	10,000	38.79
12	80	0	20,000	6.99	24	90	0	20,000	19.38
12	80	0	40,000	3.78	24	90	0	40,000	9.70
12	80	0	80,000	1.96	24	90	0	80,000	4.88
12	80	0	160,000	1.05	24	90	0	160,000	2.50
12	80	0	320,000	0.65	24	90	0	320,000	1.37
12	80	5	10,000	16.64	24	90	5	10,000	40.18
12	80	5	20,000	11.37	24	90	5	20,000	21.84
12	80	5	40,000	7.81	24	90	5	40,000	13.67
12	80	5	80,000	5.27	24	90	5	80,000	8.79
12	80	5	160,000	3.22	24	90	5	160,000	5.56
12	80	5	320,000	1.73	24	90	5	320,000	3.51
12	80	15	10,000	24.65	24	90	15	10,000	51.88
12	80	15	20,000	16.21	24	90	15	20,000	33.27
12	80	15	40,000	10.42	24	90	15	40,000	21.38
12	80	15	80,000	6.35	24	90	15	80,000	13.36
12	80	15	160,000	3.53	24	90	15	160,000	7.44
12	80	15	320,000	1.89	24	90	15	320,000	3.85
18	90	0	10,000	21.80	24	80	0	10,000	41.43
18	90	0	20,000	10.90	24	80	0	20,000	24.84
18	90	0	40,000	5.47	24	80	0	40,000	13.19
18	90	0	80,000	2.76	24	80	0	80,000	7.02
18	90	0	160,000	1.44	24	80	0	160,000	3.84
18	90	0	320,000	0.84	24	80	0	320,000	2.08
18	90	5	10,000	23.97	24	80	5	10,000	44.34
18	90	5	20,000	14.74	24	80	5	20,000	25.69
18	90	5	40,000	9.47	24	80	5	40,000	16.65
18	90	5	80,000	5.99	24	80	5	80,000	11.40
18	90	5	160,000	3.82	24	80	5	160,000	7.87
18	90	5	320,000	2.04	24	80	5	320,000	5.39
18	90	15	10,000	35.85	24	80	15	10,000	56.10
18	90	15	20,000	23.04	24	80	15	20,000	37.17
18	90	15	40,000	14.40	24	80	15	40,000	24.67
18	90	15	80,000	8.32	24	80	15	80,000	16.24
18	90	15	160,000	4.23	24	80	15	160,000	10.48
18	90	15	320,000	2.24	24	80	15	320,000	6.47

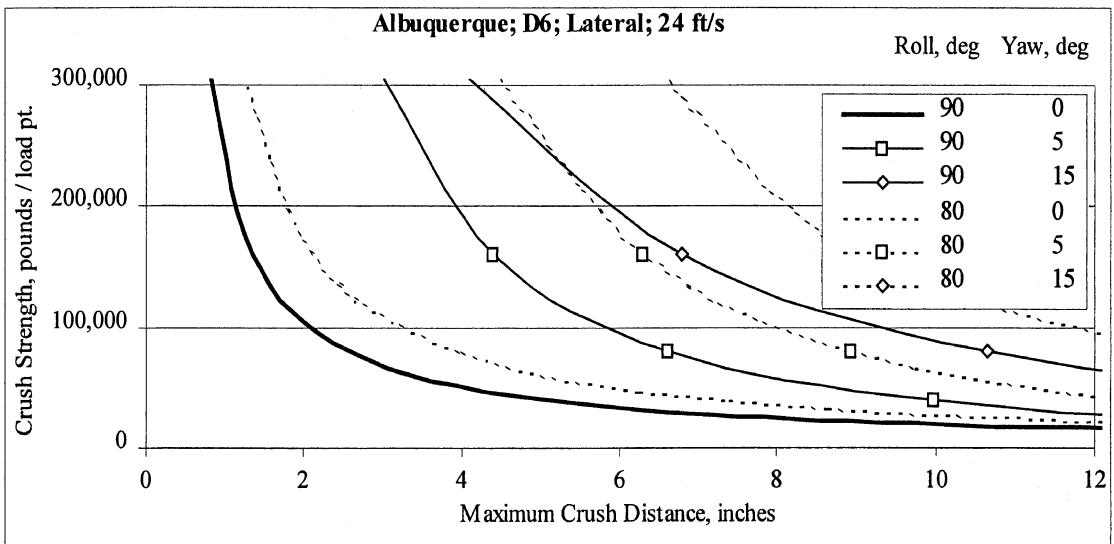
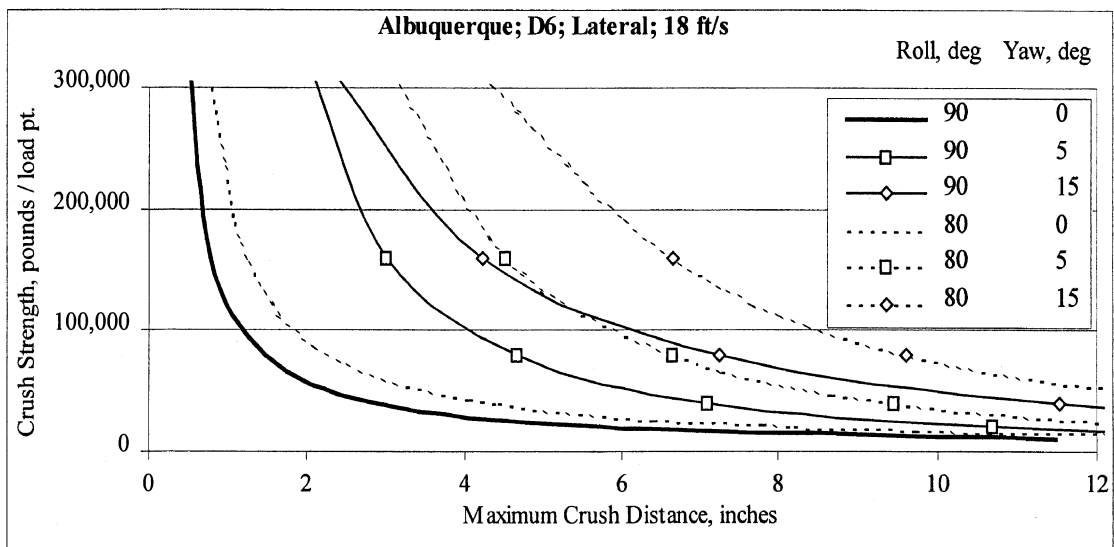
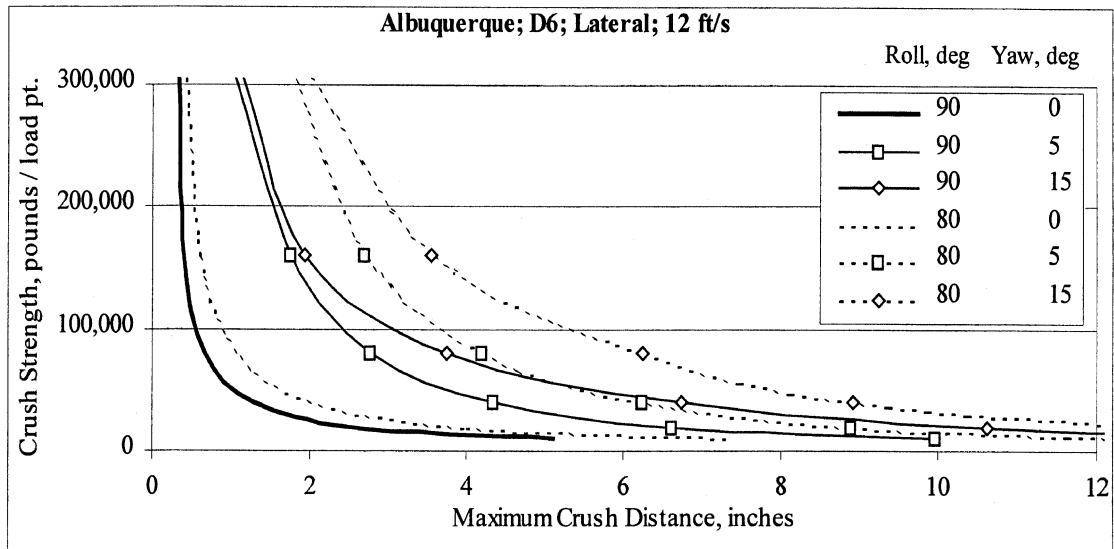

Figure C-22. Lateral results for Albuquerque with staples every 2 ft.

Table C-21. Tabular lateral results for Albuquerque with staples every 2 ft.

Later impact results for Albuquerque with staples every 2 ft.									
Vel., ft/s	Roll, deg	Yaw, deg	Force, lbs	Defl., in.	Vel., ft/s	Roll, deg	Yaw, deg	Force, lbs	Defl., in.
12	90	0	10,000	5.11	18	80	0	10,000	15.51
12	90	0	20,000	2.56	18	80	0	20,000	8.14
12	90	0	40,000	1.30	18	80	0	40,000	4.41
12	90	0	80,000	0.68	18	80	0	80,000	2.31
12	90	0	160,000	0.40	18	80	0	160,000	1.23
12	90	0	320,000	0.32	18	80	0	320,000	0.74
12	90	5	10,000	9.96	18	80	5	10,000	19.28
12	90	5	20,000	6.61	18	80	5	20,000	13.36
12	90	5	40,000	4.34	18	80	5	40,000	9.45
12	90	5	80,000	2.77	18	80	5	80,000	6.67
12	90	5	160,000	1.76	18	80	5	160,000	4.54
12	90	5	320,000	1.00	18	80	5	320,000	2.98
12	90	15	10,000	16.37	18	80	15	10,000	29.96
12	90	15	20,000	10.62	18	80	15	20,000	20.62
12	90	15	40,000	6.74	18	80	15	40,000	14.14
12	90	15	80,000	3.73	18	80	15	80,000	9.60
12	90	15	160,000	1.93	18	80	15	160,000	6.65
12	90	15	320,000	1.08	18	80	15	320,000	4.04
12	80	0	10,000	7.33	24	90	0	10,000	20.43
12	80	0	20,000	3.96	24	90	0	20,000	10.22
12	80	0	40,000	2.04	24	90	0	40,000	5.12
12	80	0	80,000	1.06	24	90	0	80,000	2.59
12	80	0	160,000	0.59	24	90	0	160,000	1.36
12	80	0	320,000	0.42	24	90	0	320,000	0.80
12	80	5	10,000	12.58	24	90	5	10,000	23.87
12	80	5	20,000	8.91	24	90	5	20,000	15.05
12	80	5	40,000	6.25	24	90	5	40,000	9.98
12	80	5	80,000	4.20	24	90	5	80,000	6.64
12	80	5	160,000	2.70	24	90	5	160,000	4.40
12	80	5	320,000	1.73	24	90	5	320,000	2.89
12	80	15	10,000	19.34	24	90	15	10,000	37.09
12	80	15	20,000	13.29	24	90	15	20,000	24.69
12	80	15	40,000	8.93	24	90	15	40,000	16.38
12	80	15	80,000	6.24	24	90	15	80,000	10.65
12	80	15	160,000	3.53	24	90	15	160,000	6.80
12	80	15	320,000	1.89	24	90	15	320,000	3.85
18	90	0	10,000	11.49	24	80	0	10,000	25.99
18	90	0	20,000	5.75	24	80	0	20,000	13.88
18	90	0	40,000	2.89	24	80	0	40,000	7.34
18	90	0	80,000	1.47	24	80	0	80,000	3.99
18	90	0	160,000	0.80	24	80	0	160,000	2.10
18	90	0	320,000	0.52	24	80	0	320,000	1.18
18	90	5	10,000	16.17	24	80	5	10,000	27.94
18	90	5	20,000	10.68	24	80	5	20,000	18.07
18	90	5	40,000	7.11	24	80	5	40,000	12.60
18	90	5	80,000	4.68	24	80	5	80,000	8.94
18	90	5	160,000	3.03	24	80	5	160,000	6.31
18	90	5	320,000	2.04	24	80	5	320,000	4.32
18	90	15	10,000	26.45	24	80	15	10,000	41.01
18	90	15	20,000	17.56	24	80	15	20,000	28.13
18	90	15	40,000	11.53	24	80	15	40,000	19.36
18	90	15	80,000	7.26	24	80	15	80,000	13.32
18	90	15	160,000	4.23	24	80	15	160,000	8.99
18	90	15	320,000	2.24	24	80	15	320,000	6.36

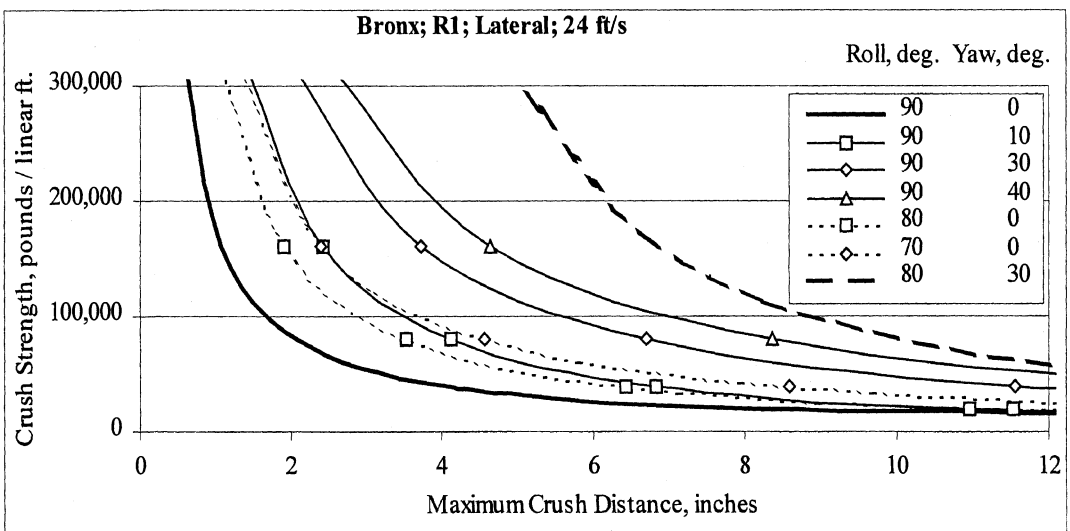
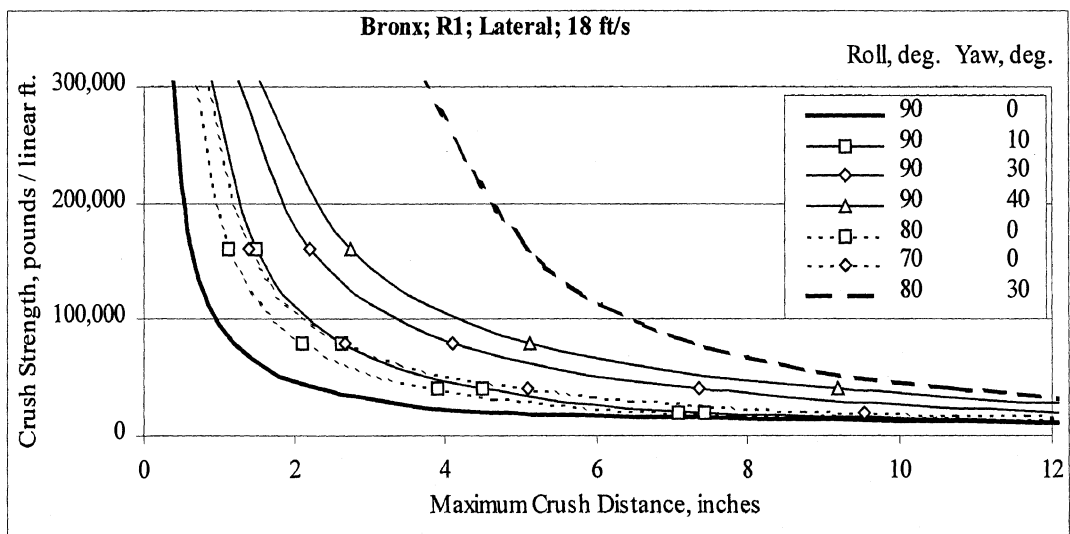
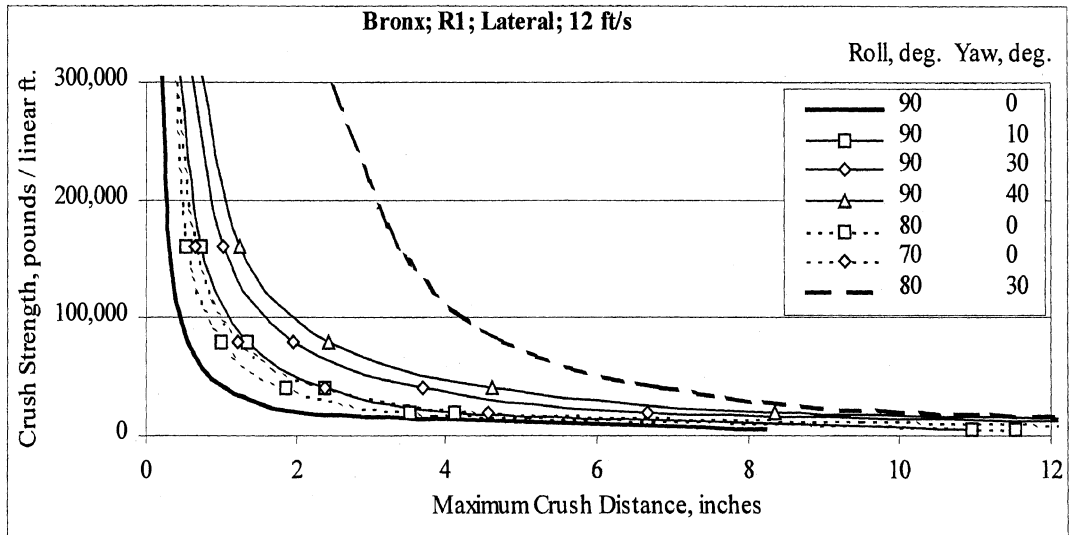

Figure C-23. Lateral results for Bronx with flat rails and flat end dams only.

Table C-22. Tabular lateral results for Bronx with flat rails and flat end dams only.

Later impact results for Bronx with flat rails and flat end dams only.									
Vel., ft/s	Roll, deg	Yaw, deg	Force, lbs	Defl., in.	Vel., ft/s	Roll, deg	Yaw, deg	Force, lbs	Defl., in.
12	90	0	5,000	8.23	18	90	40	80,000	5.11
12	90	0	20,000	2.06	18	90	40	160,000	2.74
12	90	0	40,000	1.04	18	90	40	320,000	1.43
12	90	0	80,000	0.53	18	80	0	5,000	24.15
12	90	0	160,000	0.30	18	80	0	20,000	7.07
12	90	0	320,000	0.21	18	80	0	40,000	3.91
12	90	10	5,000	10.95	18	80	0	80,000	2.09
12	90	10	20,000	4.12	18	80	0	160,000	1.12
12	90	10	40,000	2.38	18	80	0	320,000	0.62
12	90	10	80,000	1.33	18	70	0	5,000	28.46
12	90	10	160,000	0.72	18	70	0	20,000	9.51
12	90	10	320,000	0.42	18	70	0	40,000	5.10
12	90	30	5,000	19.05	18	70	0	80,000	2.66
12	90	30	20,000	6.68	18	70	0	160,000	1.39
12	90	30	40,000	3.70	18	70	0	320,000	0.76
12	90	30	80,000	1.95	18	80	30	5,000	37.26
12	90	30	160,000	1.01	18	80	30	20,000	16.23
12	90	30	320,000	0.56	18	80	30	40,000	10.72
12	90	40	5,000	23.77	18	80	30	80,000	7.28
12	90	40	20,000	8.35	18	80	30	160,000	5.10
12	90	40	40,000	4.62	18	80	30	320,000	3.62
12	90	40	80,000	2.42	24	90	0	5,000	33.06
12	90	40	160,000	1.24	24	90	0	20,000	8.23
12	90	40	320,000	0.68	24	90	0	40,000	4.12
12	80	0	5,000	11.52	24	90	0	80,000	2.07
12	80	0	20,000	3.52	24	90	0	160,000	1.07
12	80	0	40,000	1.87	24	90	0	320,000	0.59
12	80	0	80,000	0.98	24	90	10	5,000	27.63
12	80	0	160,000	0.52	24	90	10	20,000	10.95
12	80	0	320,000	0.38	24	90	10	40,000	6.83
12	70	0	5,000	15.55	24	90	10	80,000	4.13
12	70	0	20,000	4.56	24	90	10	160,000	2.41
12	70	0	40,000	2.37	24	90	10	320,000	1.39
12	70	0	80,000	1.22	24	90	30	5,000	47.50
12	70	0	160,000	0.64	24	90	30	20,000	19.06
12	70	0	320,000	0.38	24	90	30	40,000	11.55
12	80	30	5,000	22.95	24	90	30	80,000	6.70
12	80	30	20,000	10.01	24	90	30	160,000	3.73
12	80	30	40,000	6.84	24	90	30	320,000	2.01
12	80	30	80,000	4.76	24	90	40	5,000	58.89
12	80	30	160,000	3.37	24	90	40	20,000	23.77
12	80	30	320,000	2.35	24	90	40	40,000	14.43
18	90	0	5,000	18.55	24	90	40	80,000	8.36
18	90	0	20,000	4.63	24	90	40	160,000	4.65
18	90	0	40,000	2.32	24	90	40	320,000	2.48
18	90	0	80,000	1.18	24	80	0	5,000	41.25
18	90	0	160,000	0.62	24	80	0	20,000	11.52
18	90	0	320,000	0.37	24	80	0	40,000	6.44
18	90	10	5,000	18.64	24	80	0	80,000	3.53
18	90	10	20,000	7.41	24	80	0	160,000	1.90
18	90	10	40,000	4.51	24	80	0	320,000	1.04
18	90	10	80,000	2.63	24	70	0	5,000	42.13

Later impact results for Bronx with flat rails and flat end dams only.									
Vel., ft/s	Roll, deg	Yaw, deg	Force, lbs	Defl., in.	Vel., ft/s	Roll, deg	Yaw, deg	Force, lbs	Defl., in.
18	90	10	160,000	1.49	24	70	0	20,000	15.56
18	90	10	320,000	0.85	24	70	0	40,000	8.58
18	90	30	5,000	32.82	24	70	0	80,000	4.58
18	90	30	20,000	12.60	24	70	0	160,000	2.40
18	90	30	40,000	7.35	24	70	0	320,000	1.28
18	90	30	80,000	4.10	24	80	30	5,000	52.49
18	90	30	160,000	2.21	24	80	30	20,000	22.95
18	90	30	320,000	1.17	24	80	30	40,000	15.10
18	90	40	5,000	40.84	24	80	30	80,000	10.02
18	90	40	20,000	15.73	24	80	30	160,000	6.87
18	90	40	40,000	9.18	24	80	30	320,000	4.82

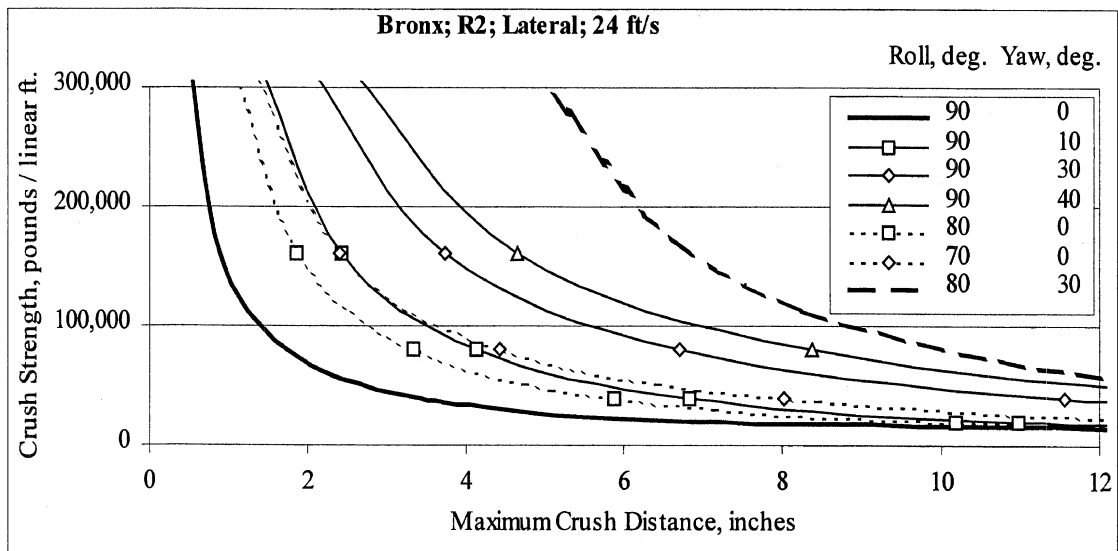
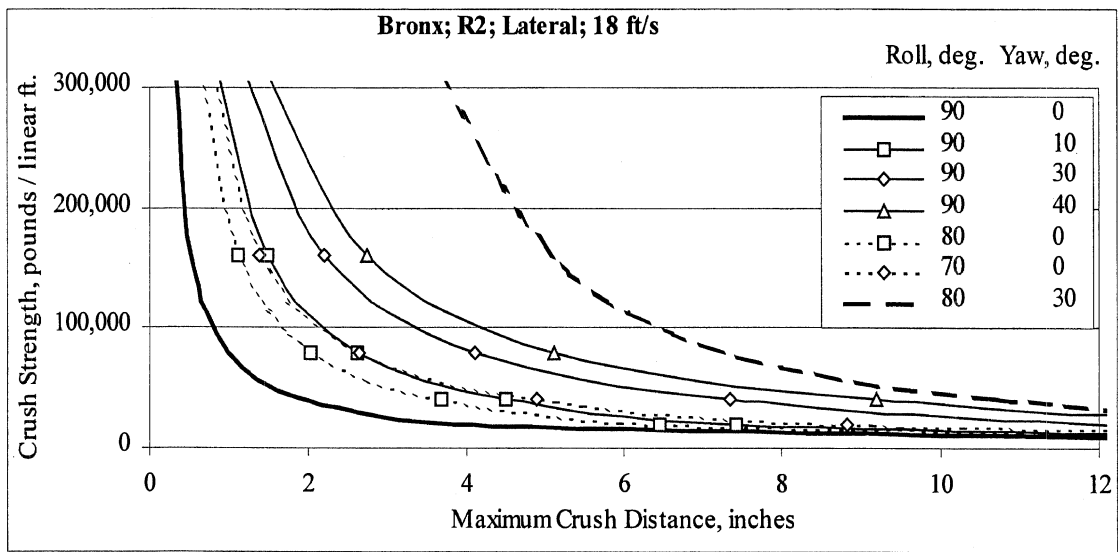
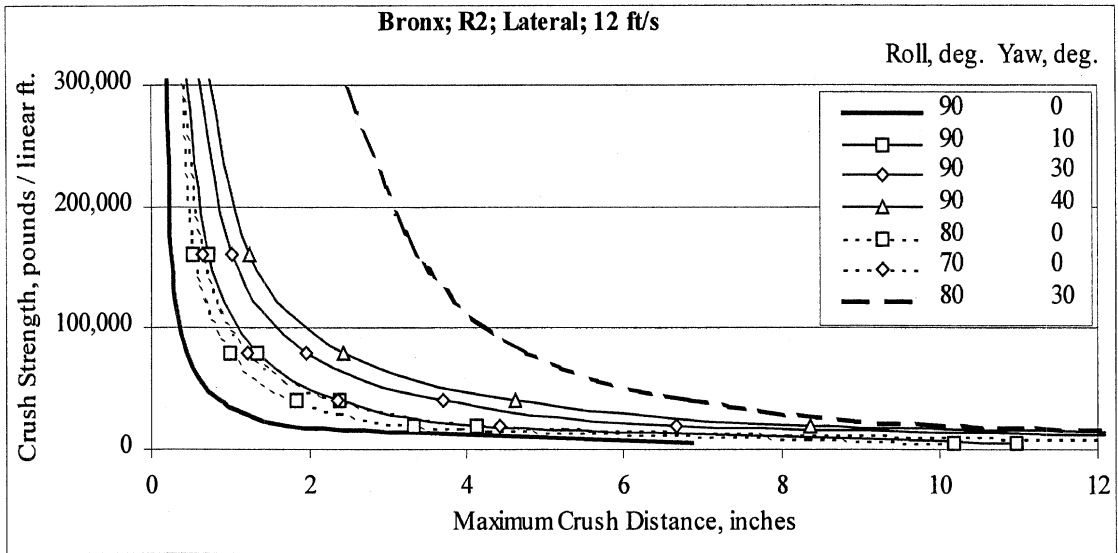

Figure C-24. Lateral results for Bronx with flat rails and flat dams every 6 ft.

Table C-23. Tabular lateral results for Bronx with flat rails and flat dams every 6 ft.

Later impact results for Bronx with flat rails and flat dams every 6 ft.									
Vel., ft/s	Roll, deg	Yaw, deg	Force, lbs	Defl., in.	Vel., ft/s	Roll, deg	Yaw, deg	Force, lbs	Defl., in.
12	90	0	5,000	6.86	18	90	40	80,000	5.11
12	90	0	20,000	1.72	18	90	40	160,000	2.74
12	90	0	40,000	0.87	18	90	40	320,000	1.43
12	90	0	80,000	0.45	18	80	0	5,000	20.79
12	90	0	160,000	0.25	18	80	0	20,000	6.46
12	90	0	320,000	0.19	18	80	0	40,000	3.68
12	90	10	5,000	10.95	18	80	0	80,000	2.04
12	90	10	20,000	4.12	18	80	0	160,000	1.11
12	90	10	40,000	2.38	18	80	0	320,000	0.62
12	90	10	80,000	1.33	18	70	0	5,000	25.17
12	90	10	160,000	0.72	18	70	0	20,000	8.81
12	90	10	320,000	0.42	18	70	0	40,000	4.90
12	90	30	5,000	19.05	18	70	0	80,000	2.64
12	90	30	20,000	6.68	18	70	0	160,000	1.39
12	90	30	40,000	3.70	18	70	0	320,000	0.76
12	90	30	80,000	1.95	18	80	30	5,000	37.24
12	90	30	160,000	1.01	18	80	30	20,000	16.23
12	90	30	320,000	0.56	18	80	30	40,000	10.72
12	90	40	5,000	23.77	18	80	30	80,000	7.28
12	90	40	20,000	8.35	18	80	30	160,000	5.10
12	90	40	40,000	4.62	18	80	30	320,000	3.62
12	90	40	80,000	2.42	24	90	0	5,000	27.53
12	90	40	160,000	1.24	24	90	0	20,000	6.86
12	90	40	320,000	0.68	24	90	0	40,000	3.44
12	80	0	5,000	10.17	24	90	0	80,000	1.73
12	80	0	20,000	3.33	24	90	0	160,000	0.90
12	80	0	40,000	1.83	24	90	0	320,000	0.51
12	80	0	80,000	0.98	24	90	10	5,000	26.37
12	80	0	160,000	0.52	24	90	10	20,000	10.95
12	80	0	320,000	0.38	24	90	10	40,000	6.83
12	70	0	5,000	13.98	24	90	10	80,000	4.13
12	70	0	20,000	4.42	24	90	10	160,000	2.41
12	70	0	40,000	2.36	24	90	10	320,000	1.39
12	70	0	80,000	1.22	24	90	30	5,000	46.65
12	70	0	160,000	0.64	24	90	30	20,000	19.06
12	70	0	320,000	0.38	24	90	30	40,000	11.55
12	80	30	5,000	22.95	24	90	30	80,000	6.70
12	80	30	20,000	10.01	24	90	30	160,000	3.73
12	80	30	40,000	6.84	24	90	30	320,000	2.01
12	80	30	80,000	4.76	24	90	40	5,000	58.01
12	80	30	160,000	3.37	24	90	40	20,000	23.77
12	80	30	320,000	2.35	24	90	40	40,000	14.43
18	90	0	5,000	15.45	24	90	40	80,000	8.36
18	90	0	20,000	3.86	24	90	40	160,000	4.65
18	90	0	40,000	1.94	24	90	40	320,000	2.48
18	90	0	80,000	0.98	24	80	0	5,000	35.31
18	90	0	160,000	0.52	24	80	0	20,000	10.17
18	90	0	320,000	0.32	24	80	0	40,000	5.89
18	90	10	5,000	18.16	24	80	0	80,000	3.34
18	90	10	20,000	7.41	24	80	0	160,000	1.86
18	90	10	40,000	4.51	24	80	0	320,000	1.04
18	90	10	80,000	2.63	24	70	0	5,000	37.24

Later impact results for Bronx with flat rails and flat dams every 6 ft.									
Vel., ft/s	Roll, deg	Yaw, deg	Force, lbs	Defl., in.	Vel., ft/s	Roll, deg	Yaw, deg	Force, lbs	Defl., in.
18	90	10	160,000	1.49	24	70	0	20,000	13.99
18	90	10	320,000	0.85	24	70	0	40,000	8.01
18	90	30	5,000	32.82	24	70	0	80,000	4.43
18	90	30	20,000	12.60	24	70	0	160,000	2.39
18	90	30	40,000	7.35	24	70	0	320,000	1.28
18	90	30	80,000	4.10	24	80	30	5,000	51.58
18	90	30	160,000	2.21	24	80	30	20,000	22.95
18	90	30	320,000	1.17	24	80	30	40,000	15.10
18	90	40	5,000	40.84	24	80	30	80,000	10.02
18	90	40	20,000	15.73	24	80	30	160,000	6.87
18	90	40	40,000	9.18	24	80	30	320,000	4.82

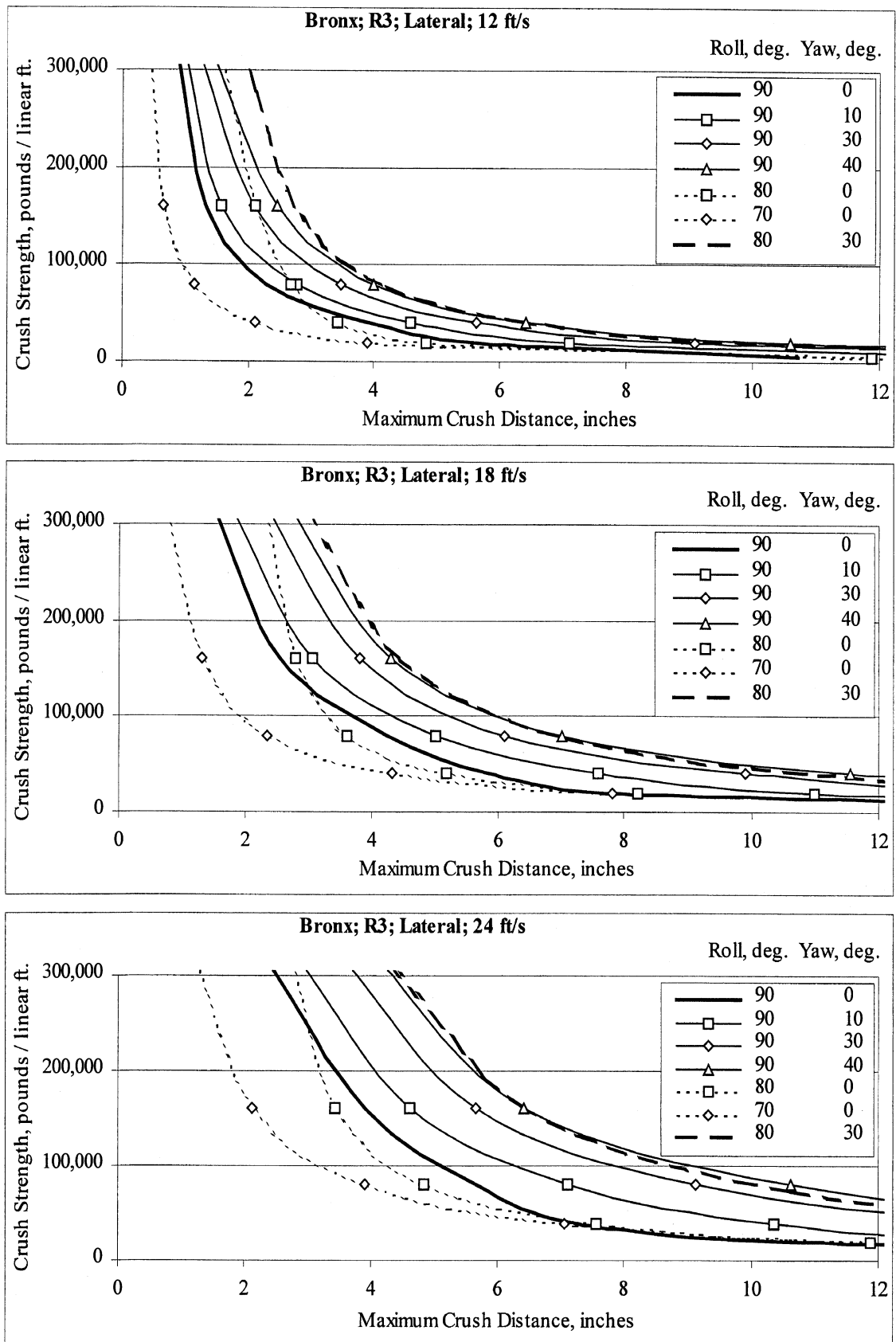

Figure C-25. Lateral results for Bronx with flat rails and crowned dams every 6 ft.

Table C-24. Tabular lateral results for Bronx with flat rails and crowned dams every 6 ft.

Later impact results for Bronx with flat rails and crowned dams every 6 ft.									
Vel., ft/s	Roll, deg	Yaw, deg	Force, lbs	Defl., in.	Vel., ft/s	Roll, deg	Yaw, deg	Force, lbs	Defl., in.
12	90	0	5,000	10.71	18	90	40	80,000	7.03
12	90	0	20,000	5.65	18	90	40	160,000	4.31
12	90	0	40,000	3.89	18	90	40	320,000	2.69
12	90	0	80,000	2.27	18	80	0	5,000	21.07
12	90	0	160,000	1.31	18	80	0	20,000	8.22
12	90	0	320,000	0.86	18	80	0	40,000	5.19
12	90	10	5,000	14.68	18	80	0	80,000	3.61
12	90	10	20,000	7.11	18	80	0	160,000	2.79
12	90	10	40,000	4.59	18	80	0	320,000	2.31
12	90	10	80,000	2.78	18	70	0	5,000	24.28
12	90	10	160,000	1.57	18	70	0	20,000	7.82
12	90	10	320,000	0.99	18	70	0	40,000	4.32
12	90	30	5,000	22.39	18	70	0	80,000	2.35
12	90	30	20,000	9.11	18	70	0	160,000	1.30
12	90	30	40,000	5.63	18	70	0	320,000	0.75
12	90	30	80,000	3.48	18	80	30	5,000	37.74
12	90	30	160,000	2.07	18	80	30	20,000	16.65
12	90	30	320,000	1.22	18	80	30	40,000	10.82
12	90	40	5,000	26.89	18	80	30	80,000	6.95
12	90	40	20,000	10.60	18	80	30	160,000	4.45
12	90	40	40,000	6.41	18	80	30	320,000	2.95
12	90	40	80,000	3.99	24	90	0	5,000	31.36
12	90	40	160,000	2.45	24	90	0	20,000	10.71
12	90	40	320,000	1.42	24	90	0	40,000	7.31
12	80	0	5,000	11.88	24	90	0	80,000	5.66
12	80	0	20,000	4.84	24	90	0	160,000	3.92
12	80	0	40,000	3.42	24	90	0	320,000	2.33
12	80	0	80,000	2.68	24	90	10	5,000	30.34
12	80	0	160,000	2.12	24	90	10	20,000	14.68
12	80	0	320,000	1.54	24	90	10	40,000	10.34
12	70	0	5,000	12.64	24	90	10	80,000	7.13
12	70	0	20,000	3.90	24	90	10	160,000	4.62
12	70	0	40,000	2.11	24	90	10	320,000	2.84
12	70	0	80,000	1.15	24	90	30	5,000	50.40
12	70	0	160,000	0.64	24	90	30	20,000	22.39
12	70	0	320,000	0.42	24	90	30	40,000	14.45
12	80	30	5,000	23.55	24	90	30	80,000	9.12
12	80	30	20,000	10.04	24	90	30	160,000	5.66
12	80	30	40,000	6.42	24	90	30	320,000	3.54
12	80	30	80,000	4.11	24	90	40	5,000	61.59
12	80	30	160,000	2.73	24	90	40	20,000	26.89
12	80	30	320,000	1.93	24	90	40	40,000	17.10
18	90	0	5,000	19.29	24	90	40	80,000	10.61
18	90	0	20,000	7.73	24	90	40	160,000	6.44
18	90	0	40,000	5.85	24	90	40	320,000	4.05
18	90	0	80,000	4.25	24	80	0	5,000	34.33
18	90	0	160,000	2.54	24	80	0	20,000	11.89
18	90	0	320,000	1.47	24	80	0	40,000	7.57
18	90	10	5,000	22.02	24	80	0	80,000	4.85
18	90	10	20,000	10.99	24	80	0	160,000	3.44
18	90	10	40,000	7.60	24	80	0	320,000	2.74
18	90	10	80,000	5.03	24	70	0	5,000	36.20

Later impact results for Bronx with flat rails and crowned dams every 6 ft.									
Vel., ft/s	Roll, deg	Yaw, deg	Force, lbs	Defl., in.	Vel., ft/s	Roll, deg	Yaw, deg	Force, lbs	Defl., in.
18	90	10	160,000	3.08	24	70	0	20,000	12.64
18	90	10	320,000	1.76	24	70	0	40,000	7.07
18	90	30	5,000	36.52	24	70	0	80,000	3.91
18	90	30	20,000	15.61	24	70	0	160,000	2.14
18	90	30	40,000	9.90	24	70	0	320,000	1.21
18	90	30	80,000	6.12	24	80	30	5,000	51.63
18	90	30	160,000	3.81	24	80	30	20,000	23.55
18	90	30	320,000	2.33	24	80	30	40,000	15.51
18	90	40	5,000	44.40	24	80	30	80,000	10.06
18	90	40	20,000	18.53	24	80	30	160,000	6.45
18	90	40	40,000	11.55	24	80	30	320,000	4.17

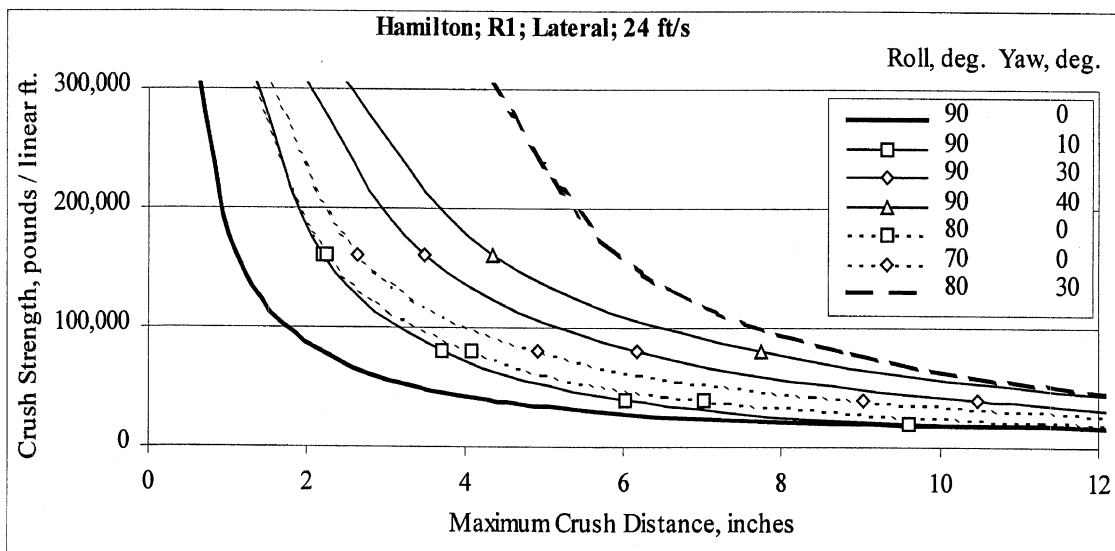
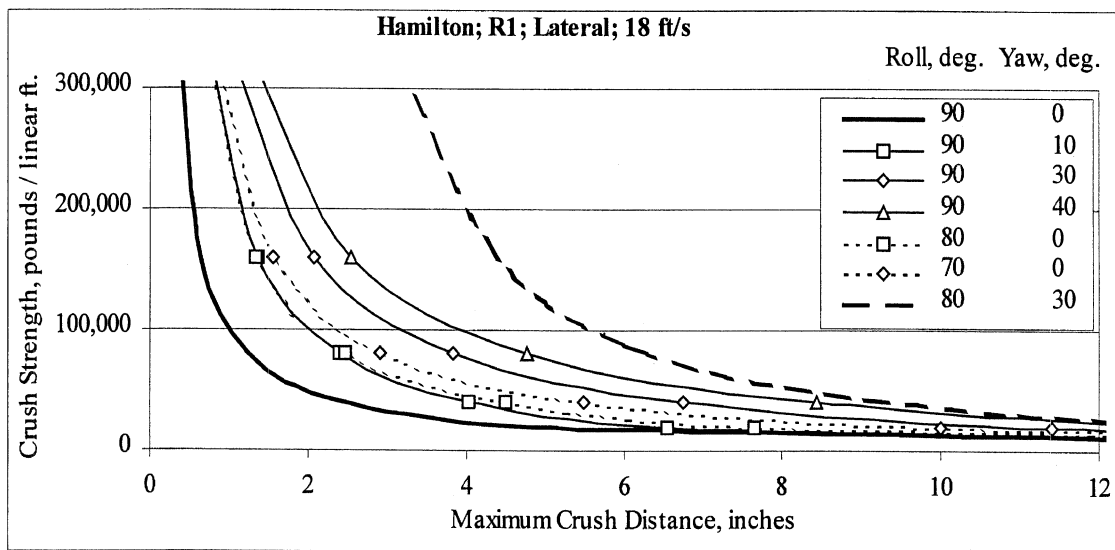
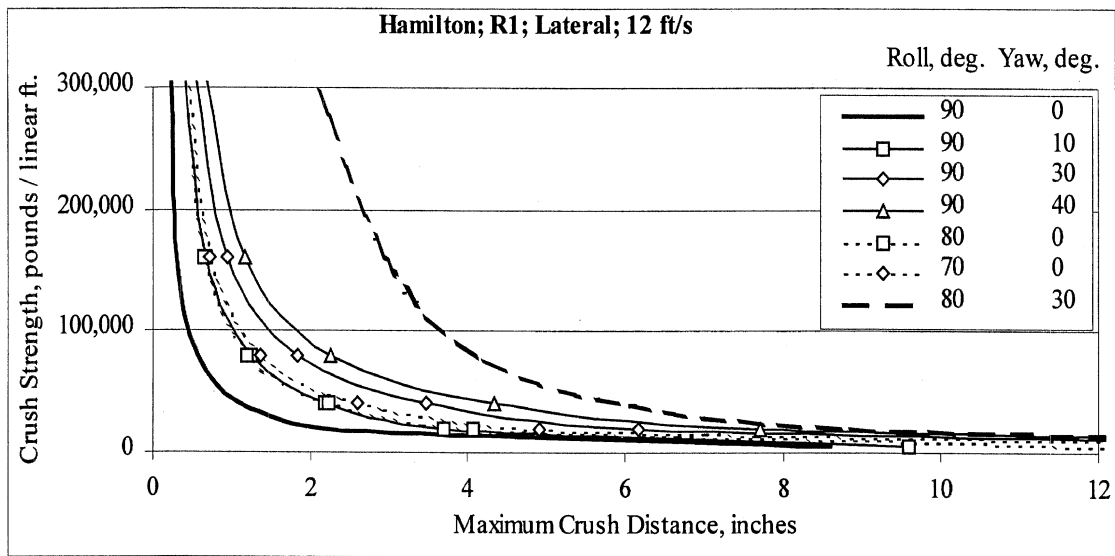

Figure C-26. Lateral results for Hamilton with flat rails and flat end dams only.

Table C-25. Tabular lateral results for Hamilton with flat rails and flat end dams only.

Later impact results for Hamilton with flat rails and flat end dams only.									
Vel., ft/s	Roll, deg	Yaw, deg	Force, lbs	Defl., in.	Vel., ft/s	Roll, deg	Yaw, deg	Force, lbs	Defl., in.
12	90	0	5,000	8.61	18	90	40	80,000	4.77
12	90	0	20,000	2.16	18	90	40	160,000	2.56
12	90	0	40,000	1.09	18	90	40	320,000	1.34
12	90	0	80,000	0.56	18	80	0	5,000	24.51
12	90	0	160,000	0.31	18	80	0	20,000	7.64
12	90	0	320,000	0.22	18	80	0	40,000	4.51
12	90	10	5,000	9.59	18	80	0	80,000	2.48
12	90	10	20,000	3.70	18	80	0	160,000	1.34
12	90	10	40,000	2.17	18	80	0	320,000	0.76
12	90	10	80,000	1.23	18	70	0	5,000	26.20
12	90	10	160,000	0.67	18	70	0	20,000	9.99
12	90	10	320,000	0.40	18	70	0	40,000	5.48
12	90	30	5,000	17.05	18	70	0	80,000	2.92
12	90	30	20,000	6.17	18	70	0	160,000	1.56
12	90	30	40,000	3.47	18	70	0	320,000	0.84
12	90	30	80,000	1.82	18	80	30	5,000	32.23
12	90	30	160,000	0.94	18	80	30	20,000	14.19
12	90	30	320,000	0.53	18	80	30	40,000	9.36
12	90	40	5,000	21.30	18	80	30	80,000	6.30
12	90	40	20,000	7.72	18	80	30	160,000	4.41
12	90	40	40,000	4.33	18	80	30	320,000	3.16
12	90	40	80,000	2.26	24	90	0	5,000	33.96
12	90	40	160,000	1.16	24	90	0	20,000	8.61
12	90	40	320,000	0.64	24	90	0	40,000	4.32
12	80	0	5,000	12.22	24	90	0	80,000	2.17
12	80	0	20,000	4.08	24	90	0	160,000	1.12
12	80	0	40,000	2.22	24	90	0	320,000	0.62
12	80	0	80,000	1.19	24	90	10	5,000	25.22
12	80	0	160,000	0.64	24	90	10	20,000	9.59
12	80	0	320,000	0.38	24	90	10	40,000	6.05
12	70	0	5,000	15.75	24	90	10	80,000	3.71
12	70	0	20,000	4.92	24	90	10	160,000	2.20
12	70	0	40,000	2.61	24	90	10	320,000	1.29
12	70	0	80,000	1.37	24	90	30	5,000	41.77
12	70	0	160,000	0.71	24	90	30	20,000	17.05
12	70	0	320,000	0.42	24	90	30	40,000	10.48
12	80	30	5,000	19.98	24	90	30	80,000	6.19
12	80	30	20,000	8.76	24	90	30	160,000	3.50
12	80	30	40,000	5.92	24	90	30	320,000	1.88
12	80	30	80,000	4.12	24	90	40	5,000	51.85
12	80	30	160,000	2.95	24	90	40	20,000	21.31
12	80	30	320,000	2.01	24	90	40	40,000	13.07
18	90	0	5,000	19.28	24	90	40	80,000	7.74
18	90	0	20,000	4.85	24	90	40	160,000	4.36
18	90	0	40,000	2.43	24	90	40	320,000	2.32
18	90	0	80,000	1.23	24	80	0	5,000	39.41

Later impact results for Hamilton with flat rails and flat end dams only.									
Vel., ft/s	Roll, deg	Yaw, deg	Force, lbs	Defl., in.	Vel., ft/s	Roll, deg	Yaw, deg	Force, lbs	Defl., in.
18	90	0	160,000	0.65	24	80	0	20,000	12.22
18	90	0	320,000	0.38	24	80	0	40,000	7.02
18	90	10	5,000	16.20	24	80	0	80,000	4.09
18	90	10	20,000	6.55	24	80	0	160,000	2.25
18	90	10	40,000	4.03	24	80	0	320,000	1.25
18	90	10	80,000	2.39	24	70	0	5,000	37.58
18	90	10	160,000	1.37	24	70	0	20,000	15.75
18	90	10	320,000	0.79	24	70	0	40,000	9.03
18	90	30	5,000	29.02	24	70	0	80,000	4.94
18	90	30	20,000	11.42	24	70	0	160,000	2.64
18	90	30	40,000	6.76	24	70	0	320,000	1.43
18	90	30	80,000	3.83	24	80	30	5,000	45.24
18	90	30	160,000	2.07	24	80	30	20,000	19.99
18	90	30	320,000	1.10	24	80	30	40,000	13.20
18	90	40	5,000	36.16	24	80	30	80,000	8.77
18	90	40	20,000	14.27	24	80	30	160,000	5.95
18	90	40	40,000	8.45	24	80	30	320,000	4.18

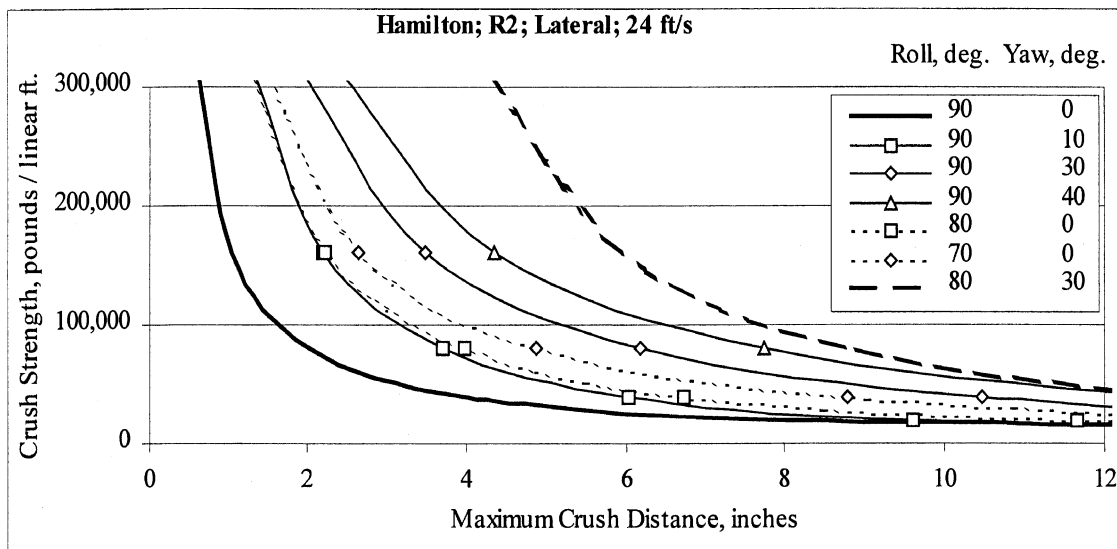
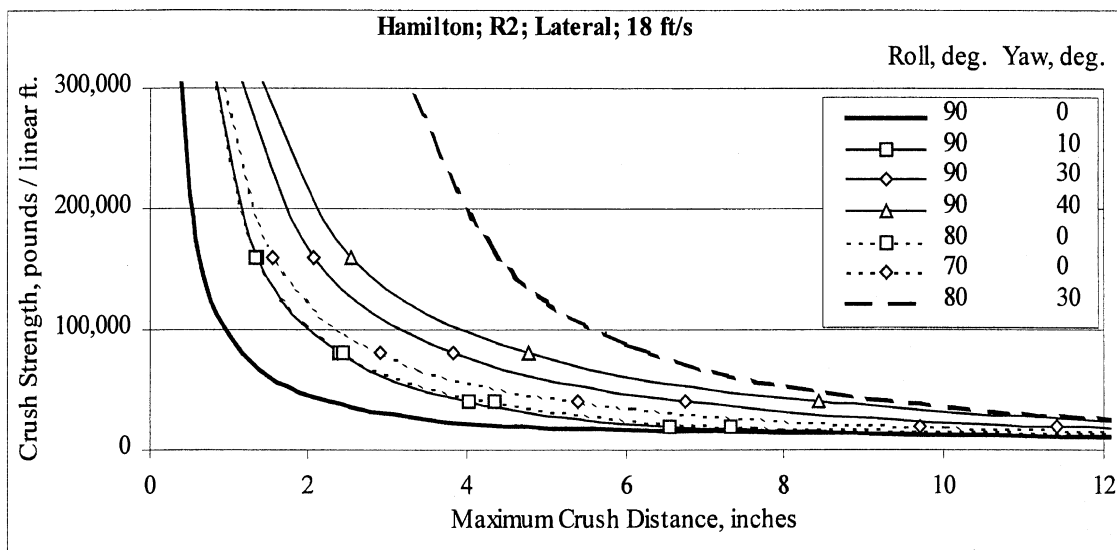
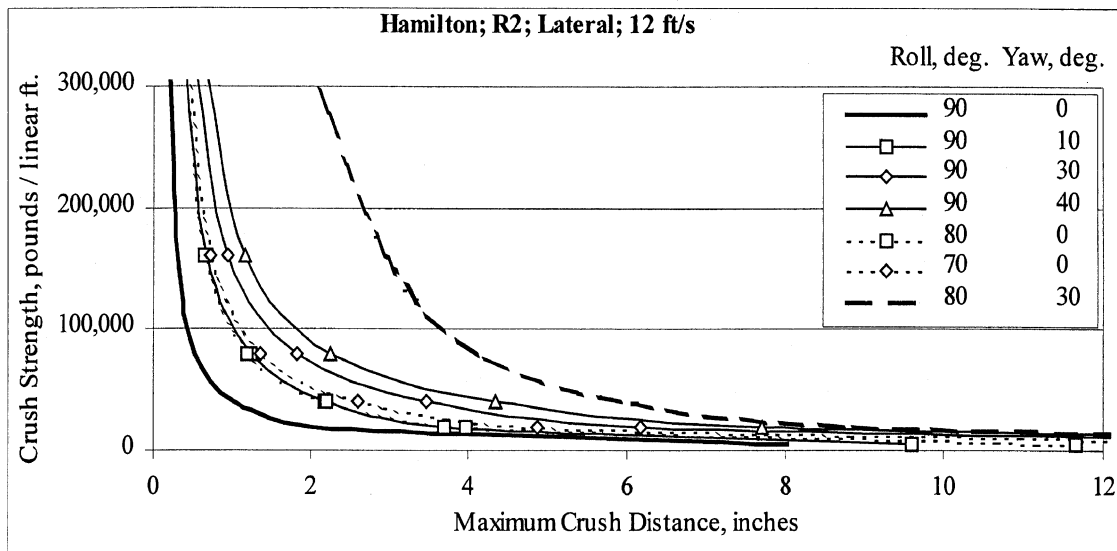

Figure C-27. Lateral results for Hamilton with flat rails and dams every 6 ft.

Table C-26. Tabular lateral results for Hamilton with flat rails and dams every 6 ft.

Later impact results for Hamilton with flat rails and dams every 6 ft.									
Vel., ft/s	Roll, deg	Yaw, deg	Force, lbs	Defl., in.	Vel., ft/s	Roll, deg	Yaw, deg	Force, lbs	Defl., in.
12	90	0	5,000	8.04	18	90	40	80,000	4.77
12	90	0	20,000	2.02	18	90	40	160,000	2.56
12	90	0	40,000	1.02	18	90	40	320,000	1.34
12	90	0	80,000	0.52	18	80	0	5,000	23.25
12	90	0	160,000	0.29	18	80	0	20,000	7.33
12	90	0	320,000	0.21	18	80	0	40,000	4.37
12	90	10	5,000	9.59	18	80	0	80,000	2.45
12	90	10	20,000	3.70	18	80	0	160,000	1.34
12	90	10	40,000	2.17	18	80	0	320,000	0.76
12	90	10	80,000	1.23	18	70	0	5,000	25.10
12	90	10	160,000	0.67	18	70	0	20,000	9.69
12	90	10	320,000	0.40	18	70	0	40,000	5.40
12	90	30	5,000	17.05	18	70	0	80,000	2.92
12	90	30	20,000	6.17	18	70	0	160,000	1.56
12	90	30	40,000	3.47	18	70	0	320,000	0.84
12	90	30	80,000	1.82	18	80	30	5,000	32.22
12	90	30	160,000	0.94	18	80	30	20,000	14.19
12	90	30	320,000	0.53	18	80	30	40,000	9.36
12	90	40	5,000	21.30	18	80	30	80,000	6.30
12	90	40	20,000	7.72	18	80	30	160,000	4.41
12	90	40	40,000	4.33	18	80	30	320,000	3.16
12	90	40	80,000	2.26	24	90	0	5,000	31.73
12	90	40	160,000	1.16	24	90	0	20,000	8.05
12	90	40	320,000	0.64	24	90	0	40,000	4.04
12	80	0	5,000	11.64	24	90	0	80,000	2.03
12	80	0	20,000	3.96	24	90	0	160,000	1.05
12	80	0	40,000	2.20	24	90	0	320,000	0.58
12	80	0	80,000	1.19	24	90	10	5,000	23.02
12	80	0	160,000	0.64	24	90	10	20,000	9.59
12	80	0	320,000	0.38	24	90	10	40,000	6.05
12	70	0	5,000	15.17	24	90	10	80,000	3.71
12	70	0	20,000	4.86	24	90	10	160,000	2.20
12	70	0	40,000	2.61	24	90	10	320,000	1.29
12	70	0	80,000	1.37	24	90	30	5,000	41.08
12	70	0	160,000	0.71	24	90	30	20,000	17.05
12	70	0	320,000	0.42	24	90	30	40,000	10.48
12	80	30	5,000	19.98	24	90	30	80,000	6.19
12	80	30	20,000	8.76	24	90	30	160,000	3.50
12	80	30	40,000	5.92	24	90	30	320,000	1.88
12	80	30	80,000	4.12	24	90	40	5,000	51.10
12	80	30	160,000	2.95	24	90	40	20,000	21.31
12	80	30	320,000	2.01	24	90	40	40,000	13.07
18	90	0	5,000	18.01	24	90	40	80,000	7.74
18	90	0	20,000	4.53	24	90	40	160,000	4.36
18	90	0	40,000	2.28	24	90	40	320,000	2.32
18	90	0	80,000	1.15	24	80	0	5,000	37.29

Later impact results for Hamilton with flat rails and dams every 6 ft.									
Vel., ft/s	Roll, deg	Yaw, deg	Force, lbs	Defl., in.	Vel., ft/s	Roll, deg	Yaw, deg	Force, lbs	Defl., in.
18	90	0	160,000	0.61	24	80	0	20,000	11.65
18	90	0	320,000	0.36	24	80	0	40,000	6.74
18	90	10	5,000	15.84	24	80	0	80,000	3.98
18	90	10	20,000	6.55	24	80	0	160,000	2.23
18	90	10	40,000	4.03	24	80	0	320,000	1.25
18	90	10	80,000	2.39	24	70	0	5,000	35.81
18	90	10	160,000	1.37	24	70	0	20,000	15.18
18	90	10	320,000	0.79	24	70	0	40,000	8.79
18	90	30	5,000	29.02	24	70	0	80,000	4.87
18	90	30	20,000	11.42	24	70	0	160,000	2.64
18	90	30	40,000	6.76	24	70	0	320,000	1.43
18	90	30	80,000	3.83	24	80	30	5,000	44.53
18	90	30	160,000	2.07	24	80	30	20,000	19.99
18	90	30	320,000	1.10	24	80	30	40,000	13.20
18	90	40	5,000	36.16	24	80	30	80,000	8.77
18	90	40	20,000	14.27	24	80	30	160,000	5.95
18	90	40	40,000	8.45	24	80	30	320,000	4.18

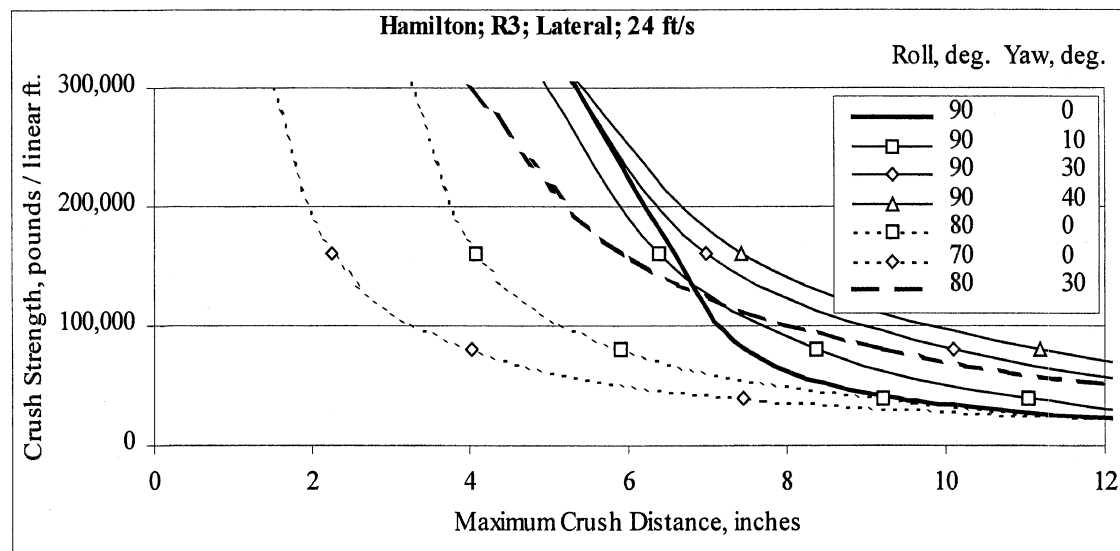
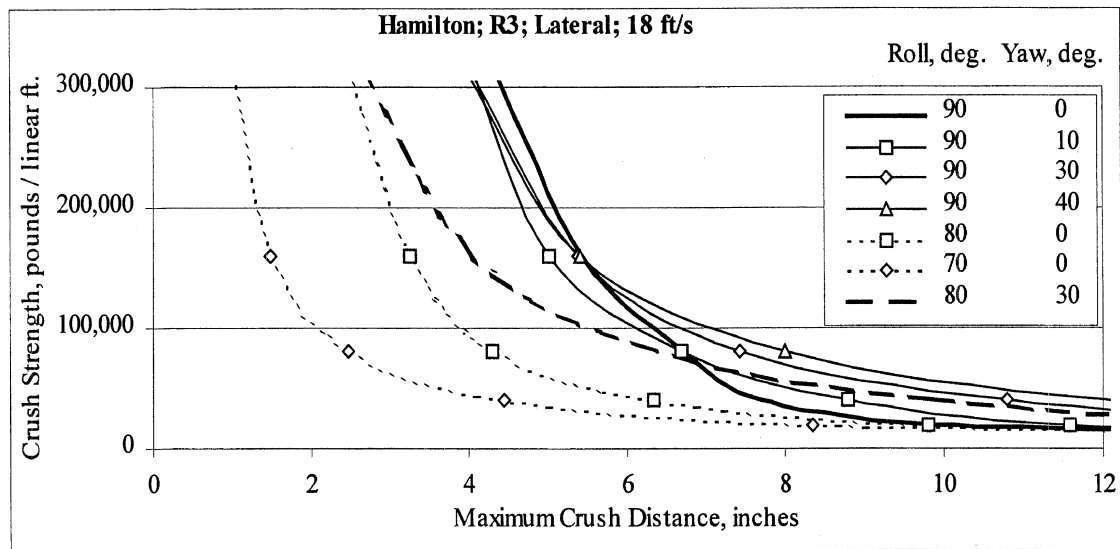
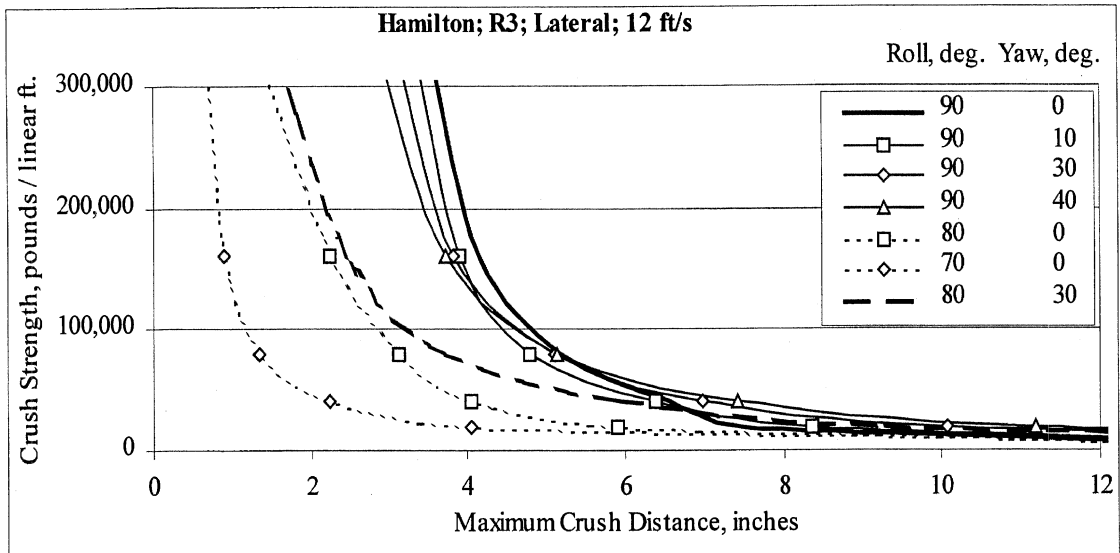

Figure C-28. Lateral results for Hamilton with flat rails and crowned dams every 6 ft.

Table C-27. Tabular lateral results for Hamilton with flat rails and crowned dams every 6 ft.

Later impact results for Hamilton with flat rails and crowned dams every 6 ft.									
Vel., ft/s	Roll, deg	Yaw, deg	Force, lbs	Defl., in.	Vel., ft/s	Roll, deg	Yaw, deg	Force, lbs	Defl., in.
12	90	0	5,000	13.37	18	90	40	80,000	7.98
12	90	0	20,000	7.45	18	90	40	160,000	5.43
12	90	0	40,000	6.56	18	90	40	320,000	3.93
12	90	0	80,000	5.18	18	80	0	5,000	22.48
12	90	0	160,000	4.15	18	80	0	20,000	9.80
12	90	0	320,000	3.58	18	80	0	40,000	6.35
12	90	10	5,000	14.64	18	80	0	80,000	4.29
12	90	10	20,000	8.36	18	80	0	160,000	3.27
12	90	10	40,000	6.37	18	80	0	320,000	2.44
12	90	10	80,000	4.78	18	70	0	5,000	24.45
12	90	10	160,000	3.90	18	70	0	20,000	8.33
12	90	10	320,000	3.37	18	70	0	40,000	4.45
12	90	30	5,000	21.68	18	70	0	80,000	2.47
12	90	30	20,000	10.08	18	70	0	160,000	1.47
12	90	30	40,000	6.97	18	70	0	320,000	0.99
12	90	30	80,000	5.10	18	80	30	5,000	33.09
12	90	30	160,000	3.81	18	80	30	20,000	14.98
12	90	30	320,000	3.16	18	80	30	40,000	9.88
12	90	40	5,000	25.52	18	80	30	80,000	6.38
12	90	40	20,000	11.18	18	80	30	160,000	4.05
12	90	40	40,000	7.41	18	80	30	320,000	2.65
12	90	40	80,000	5.13	24	90	0	5,000	36.85
12	90	40	160,000	3.71	24	90	0	20,000	13.38
12	90	40	320,000	2.92	24	90	0	40,000	9.40
12	80	0	5,000	13.17	24	90	0	80,000	7.46
12	80	0	20,000	5.91	24	90	0	160,000	6.58
12	80	0	40,000	4.04	24	90	0	320,000	5.21
12	80	0	80,000	3.13	24	90	10	5,000	28.21
12	80	0	160,000	2.22	24	90	10	20,000	14.64
12	80	0	320,000	1.37	24	90	10	40,000	11.04
12	70	0	5,000	14.08	24	90	10	80,000	8.37
12	70	0	20,000	4.03	24	90	10	160,000	6.39
12	70	0	40,000	2.23	24	90	10	320,000	4.81
12	70	0	80,000	1.34	24	90	30	5,000	45.98
12	70	0	160,000	0.89	24	90	30	20,000	21.68
12	70	0	320,000	0.68	24	90	30	40,000	14.77
12	80	30	5,000	20.94	24	90	30	80,000	10.09
12	80	30	20,000	9.18	24	90	30	160,000	6.99
12	80	30	40,000	5.91	24	90	30	320,000	5.13
12	80	30	80,000	3.71	24	90	40	5,000	55.68
12	80	30	160,000	2.45	24	90	40	20,000	25.53
12	80	30	320,000	1.60	24	90	40	40,000	16.95
18	90	0	5,000	23.28	24	90	40	80,000	11.19
18	90	0	20,000	9.89	24	90	40	160,000	7.43
18	90	0	40,000	7.69	24	90	40	320,000	5.16
18	90	0	80,000	6.70	24	80	0	5,000	36.47
18	90	0	160,000	5.45	24	80	0	20,000	13.17
18	90	0	320,000	4.30	24	80	0	40,000	9.21
18	90	10	5,000	20.97	24	80	0	80,000	5.92
18	90	10	20,000	11.58	24	80	0	160,000	4.07
18	90	10	40,000	8.77	24	80	0	320,000	3.19
18	90	10	80,000	6.69	24	70	0	5,000	34.95

Later impact results for Hamilton with flat rails and crowned dams every 6 ft.									
Vel., ft/s	Roll, deg	Yaw, deg	Force, lbs	Defl., in.	Vel., ft/s	Roll, deg	Yaw, deg	Force, lbs	Defl., in.
18	90	10	160,000	5.01	24	70	0	20,000	14.08
18	90	10	320,000	4.03	24	70	0	40,000	7.46
18	90	30	5,000	33.85	24	70	0	80,000	4.04
18	90	30	20,000	15.76	24	70	0	160,000	2.26
18	90	30	40,000	10.79	24	70	0	320,000	1.40
18	90	30	80,000	7.43	24	80	30	5,000	45.02
18	90	30	160,000	5.39	24	80	30	20,000	20.95
18	90	30	320,000	3.99	24	80	30	40,000	14.00
18	90	40	5,000	40.73	24	80	30	80,000	9.20
18	90	40	20,000	18.18	24	80	30	160,000	5.94
18	90	40	40,000	12.06	24	80	30	320,000	3.77

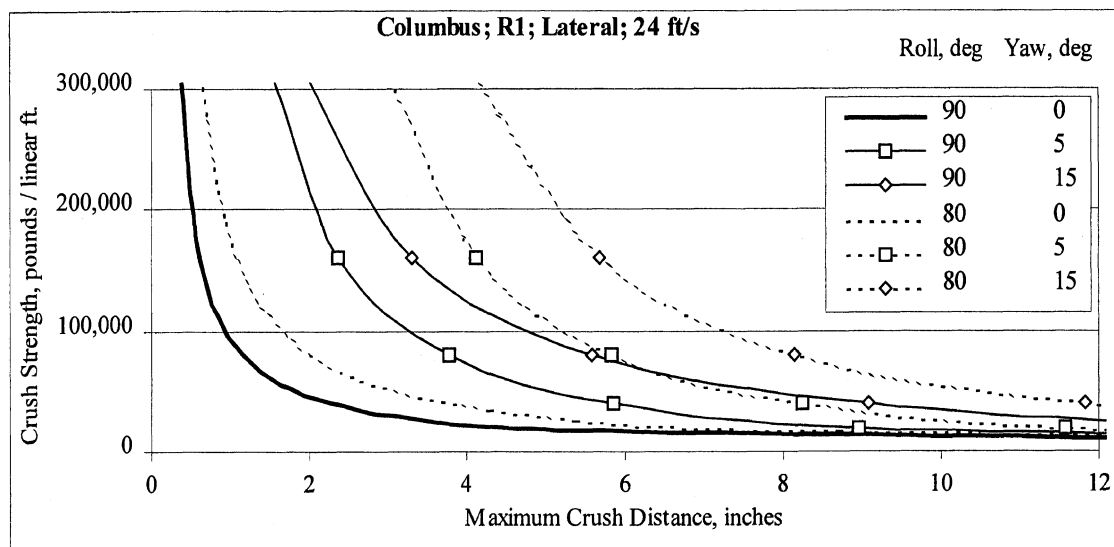
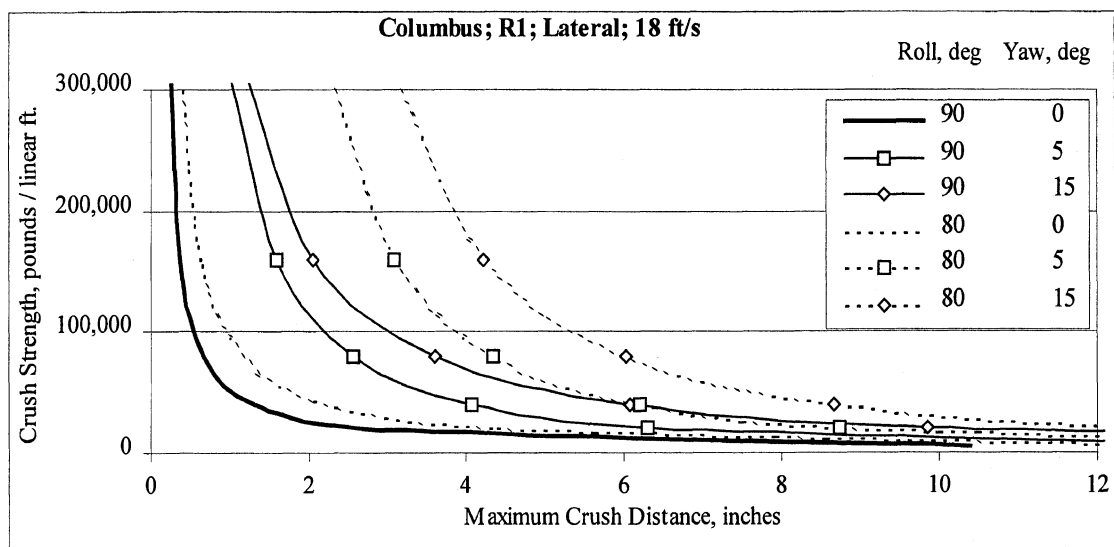
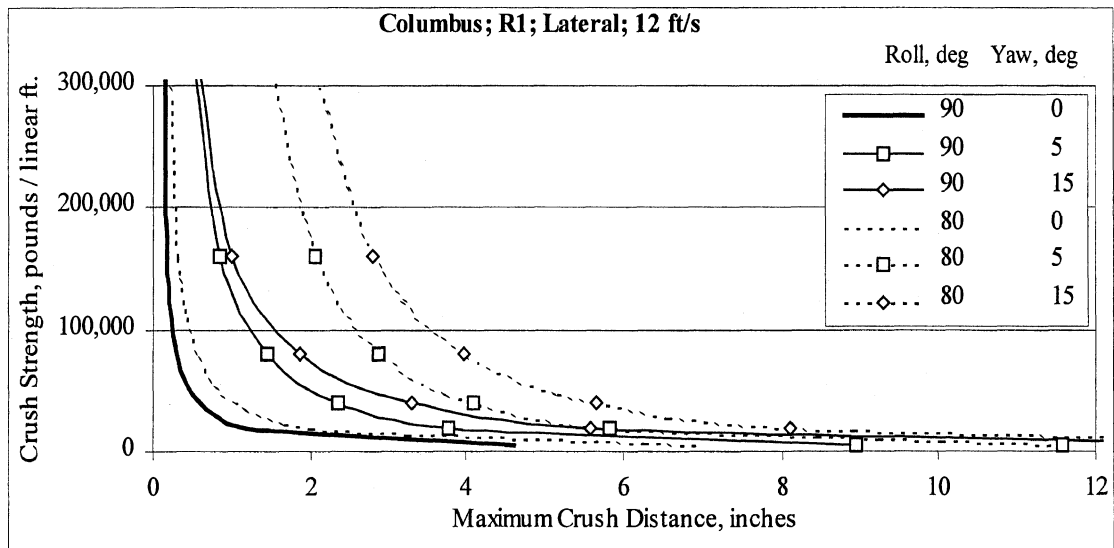

Figure C-29. Lateral results for Columbus with flat rails and flat end dams only.

Table C-28. Tabular lateral results for Columbus with flat rails and flat end dams only.

Later impact results for Columbus with flat rails and flat end dams only.									
Vel., ft/s	Roll, deg	Yaw, deg	Force, lbs	Defl., in.	Vel., ft/s	Roll, deg	Yaw, deg	Force, lbs	Defl., in.
12	90	0	5,000	4.62	18	80	0	5,000	13.65
12	90	0	20,000	1.16	18	80	0	20,000	4.34
12	90	0	40,000	0.59	18	80	0	40,000	2.26
12	90	0	80,000	0.31	18	80	0	80,000	1.16
12	90	0	160,000	0.18	18	80	0	160,000	0.62
12	90	0	320,000	0.15	18	80	0	320,000	0.37
12	90	5	5,000	8.95	18	80	5	5,000	17.52
12	90	5	20,000	3.77	18	80	5	20,000	8.74
12	90	5	40,000	2.36	18	80	5	40,000	6.20
12	90	5	80,000	1.43	18	80	5	80,000	4.36
12	90	5	160,000	0.84	18	80	5	160,000	3.09
12	90	5	320,000	0.52	18	80	5	320,000	2.22
12	90	15	5,000	14.29	18	80	15	5,000	26.77
12	90	15	20,000	5.58	18	80	15	20,000	12.59
12	90	15	40,000	3.29	18	80	15	40,000	8.66
12	90	15	80,000	1.85	18	80	15	80,000	6.03
12	90	15	160,000	1.00	18	80	15	160,000	4.24
12	90	15	320,000	0.56	18	80	15	320,000	3.05
12	80	0	5,000	6.91	24	90	0	5,000	18.49
12	80	0	20,000	2.01	24	90	0	20,000	4.62
12	80	0	40,000	1.03	24	90	0	40,000	2.32
12	80	0	80,000	0.53	24	90	0	80,000	1.17
12	80	0	160,000	0.30	24	90	0	160,000	0.62
12	80	0	320,000	0.21	24	90	0	320,000	0.37
12	80	5	5,000	11.59	24	90	5	5,000	20.93
12	80	5	20,000	5.83	24	90	5	20,000	8.95
12	80	5	40,000	4.10	24	90	5	40,000	5.87
12	80	5	80,000	2.89	24	90	5	80,000	3.78
12	80	5	160,000	2.06	24	90	5	160,000	2.39
12	80	5	320,000	1.47	24	90	5	320,000	1.49
12	80	15	5,000	17.21	24	90	15	5,000	33.29
12	80	15	20,000	8.12	24	90	15	20,000	14.30
12	80	15	40,000	5.66	24	90	15	40,000	9.09
12	80	15	80,000	3.98	24	90	15	80,000	5.59
12	80	15	160,000	2.81	24	90	15	160,000	3.32
12	80	15	320,000	2.01	24	90	15	320,000	1.91
18	90	0	5,000	10.40	24	80	0	5,000	23.00
18	90	0	20,000	2.60	24	80	0	20,000	6.92
18	90	0	40,000	1.31	24	80	0	40,000	3.90
18	90	0	80,000	0.67	24	80	0	80,000	2.03
18	90	0	160,000	0.36	24	80	0	160,000	1.06
18	90	0	320,000	0.24	24	80	0	320,000	0.59
18	90	5	5,000	14.58	24	80	5	5,000	24.20
18	90	5	20,000	6.31	24	80	5	20,000	11.59
18	90	5	40,000	4.07	24	80	5	40,000	8.25
18	90	5	80,000	2.57	24	80	5	80,000	5.85
18	90	5	160,000	1.58	24	80	5	160,000	4.13
18	90	5	320,000	0.96	24	80	5	320,000	2.95
18	90	15	5,000	23.58	24	80	15	5,000	36.74
18	90	15	20,000	9.84	24	80	15	20,000	17.21
18	90	15	40,000	6.09	24	80	15	40,000	11.82
18	90	15	80,000	3.61	24	80	15	80,000	8.13
18	90	15	160,000	2.06	24	80	15	160,000	5.69
18	90	15	320,000	1.16	24	80	15	320,000	4.04

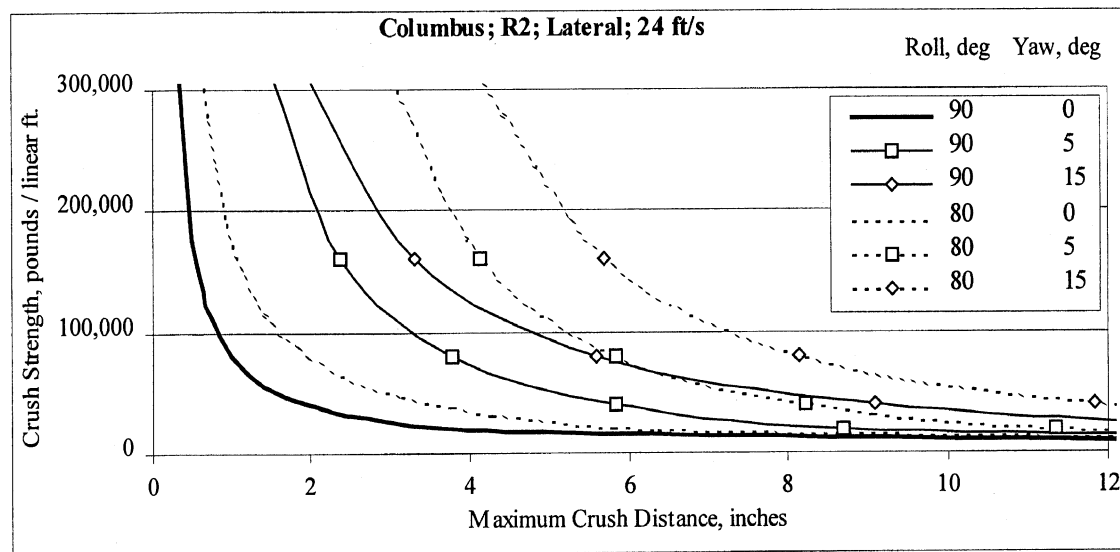
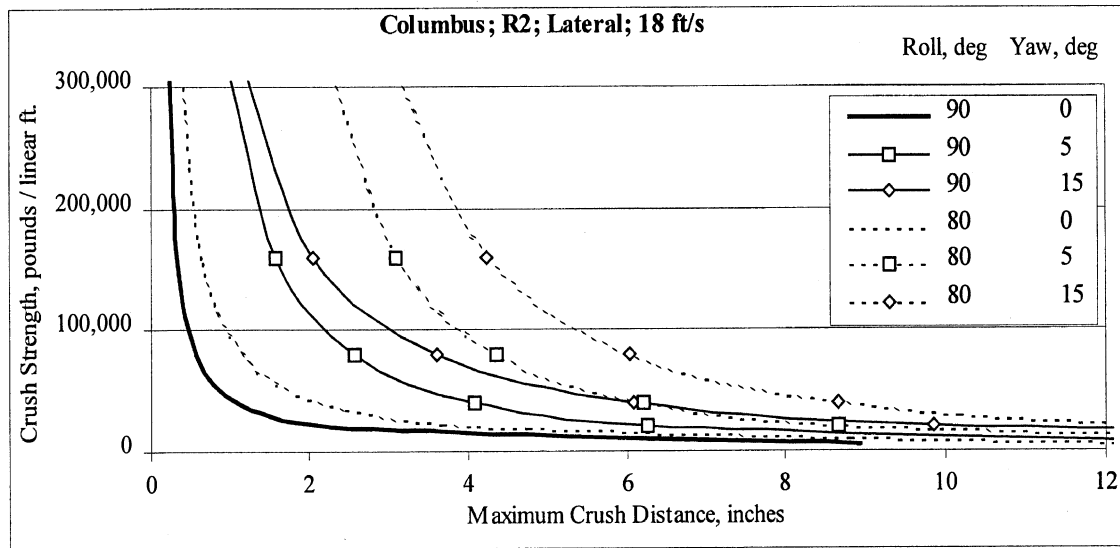
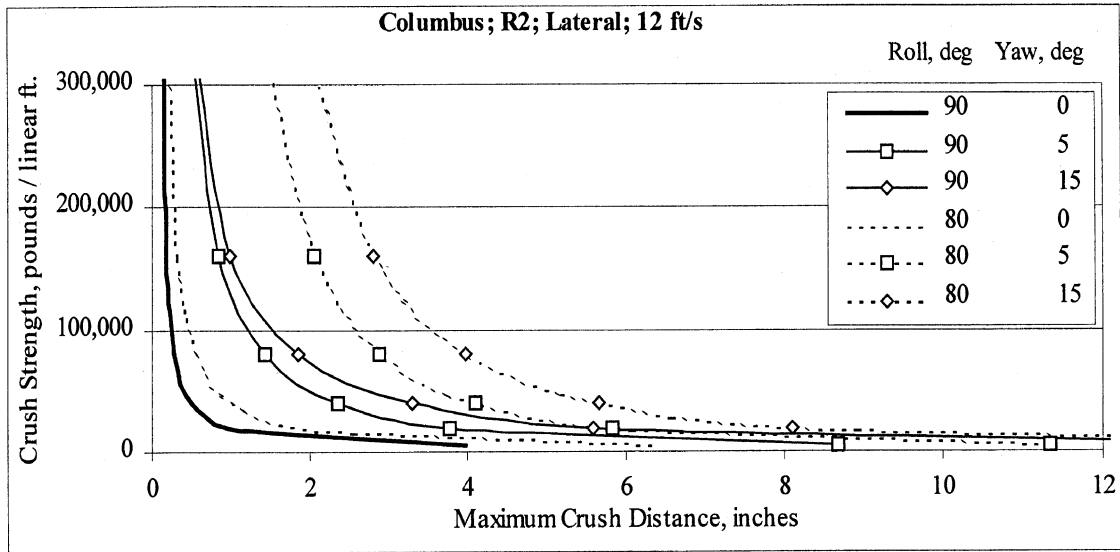

Figure C-30. Lateral results for Columbus with flat rails and flat end dams every 6 ft.

Table C-29. Tabular lateral results for Columbus with flat rails and flat end dams every 6 ft.

Later impact results for Columbus with flat rails and flat end dams every 6 ft.									
Vel., ft/s	Roll, deg	Yaw, deg	Force, lbs	Defl., in.	Vel., ft/s	Roll, deg	Yaw, deg	Force, lbs	Defl., in.
12	90	0	5,000	3.97	18	80	0	5,000	12.13
12	90	0	20,000	1.00	18	80	0	20,000	4.03
12	90	0	40,000	0.51	18	80	0	40,000	2.18
12	90	0	80,000	0.27	18	80	0	80,000	1.16
12	90	0	160,000	0.16	18	80	0	160,000	0.62
12	90	0	320,000	0.14	18	80	0	320,000	0.37
12	90	5	5,000	8.68	18	80	5	5,000	16.79
12	90	5	20,000	3.77	18	80	5	20,000	8.66
12	90	5	40,000	2.36	18	80	5	40,000	6.20
12	90	5	80,000	1.43	18	80	5	80,000	4.36
12	90	5	160,000	0.84	18	80	5	160,000	3.09
12	90	5	320,000	0.52	18	80	5	320,000	2.22
12	90	15	5,000	14.29	18	80	15	5,000	26.19
12	90	15	20,000	5.58	18	80	15	20,000	12.59
12	90	15	40,000	3.29	18	80	15	40,000	8.66
12	90	15	80,000	1.85	18	80	15	80,000	6.03
12	90	15	160,000	1.00	18	80	15	160,000	4.24
12	90	15	320,000	0.56	18	80	15	320,000	3.05
12	80	0	5,000	6.31	24	90	0	5,000	15.88
12	80	0	20,000	1.96	24	90	0	20,000	3.97
12	80	0	40,000	1.03	24	90	0	40,000	1.99
12	80	0	80,000	0.53	24	90	0	80,000	1.01
12	80	0	160,000	0.30	24	90	0	160,000	0.54
12	80	0	320,000	0.21	24	90	0	320,000	0.33
12	80	5	5,000	11.34	24	90	5	5,000	19.56
12	80	5	20,000	5.83	24	90	5	20,000	8.68
12	80	5	40,000	4.10	24	90	5	40,000	5.85
12	80	5	80,000	2.89	24	90	5	80,000	3.78
12	80	5	160,000	2.06	24	90	5	160,000	2.39
12	80	5	320,000	1.47	24	90	5	320,000	1.49
12	80	15	5,000	17.21	24	90	15	5,000	32.03
12	80	15	20,000	8.12	24	90	15	20,000	14.30
12	80	15	40,000	5.66	24	90	15	40,000	9.09
12	80	15	80,000	3.98	24	90	15	80,000	5.59
12	80	15	160,000	2.81	24	90	15	160,000	3.32
12	80	15	320,000	2.01	24	90	15	320,000	1.91
18	90	0	5,000	8.93	24	80	0	5,000	20.21
18	90	0	20,000	2.24	24	80	0	20,000	6.31
18	90	0	40,000	1.13	24	80	0	40,000	3.64
18	90	0	80,000	0.58	24	80	0	80,000	1.97
18	90	0	160,000	0.32	24	80	0	160,000	1.06
18	90	0	320,000	0.22	24	80	0	320,000	0.59
18	90	5	5,000	13.86	24	80	5	5,000	22.78
18	90	5	20,000	6.25	24	80	5	20,000	11.34
18	90	5	40,000	4.07	24	80	5	40,000	8.20
18	90	5	80,000	2.57	24	80	5	80,000	5.85
18	90	5	160,000	1.58	24	80	5	160,000	4.13
18	90	5	320,000	0.96	24	80	5	320,000	2.95
18	90	15	5,000	23.01	24	80	15	5,000	35.45
18	90	15	20,000	9.84	24	80	15	20,000	17.21
18	90	15	40,000	6.09	24	80	15	40,000	11.82
18	90	15	80,000	3.61	24	80	15	80,000	8.13
18	90	15	160,000	2.06	24	80	15	160,000	5.69
18	90	15	320,000	1.16	24	80	15	320,000	4.04

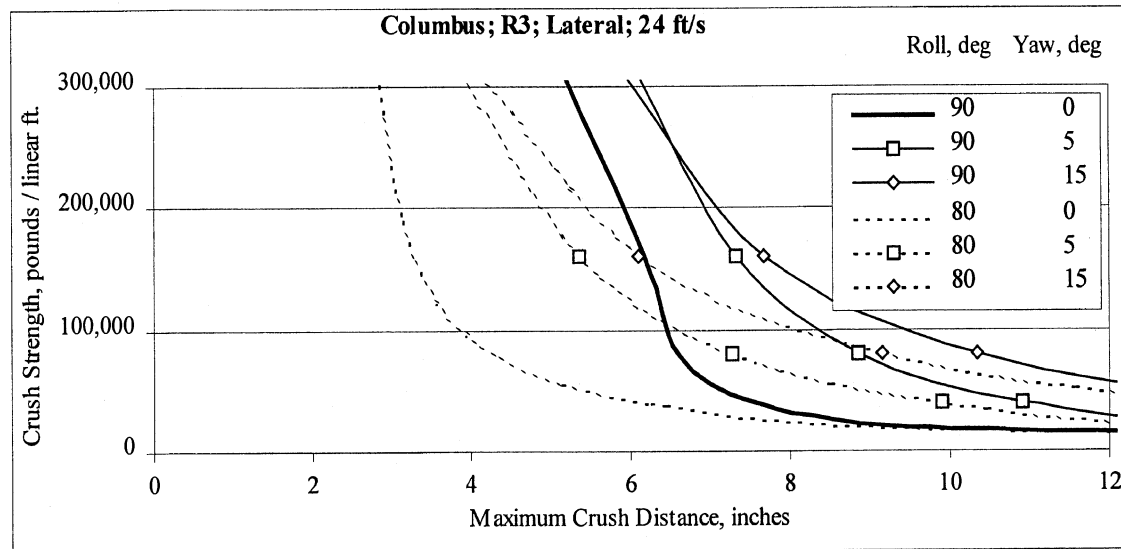
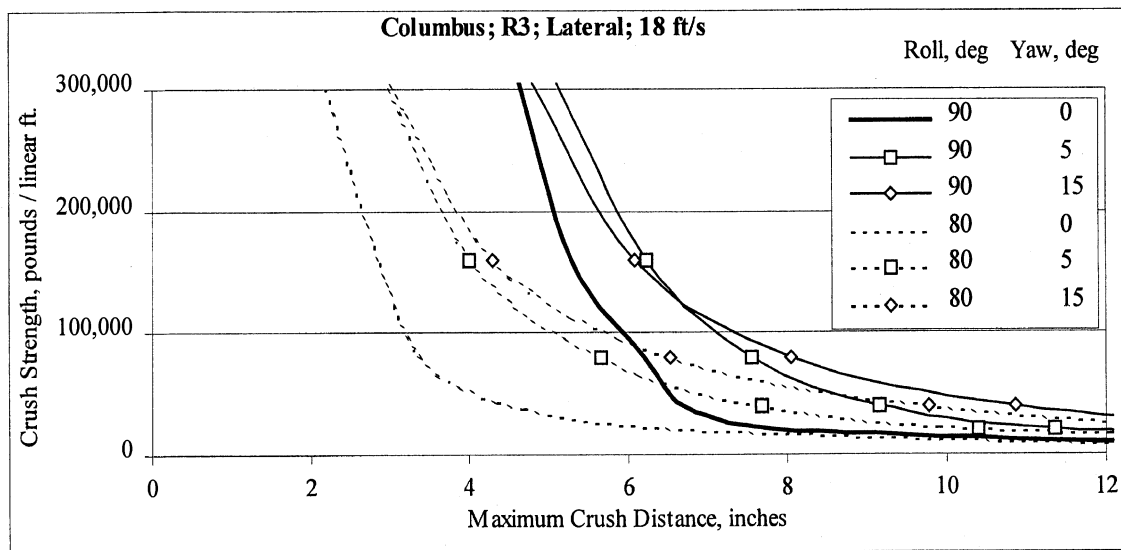
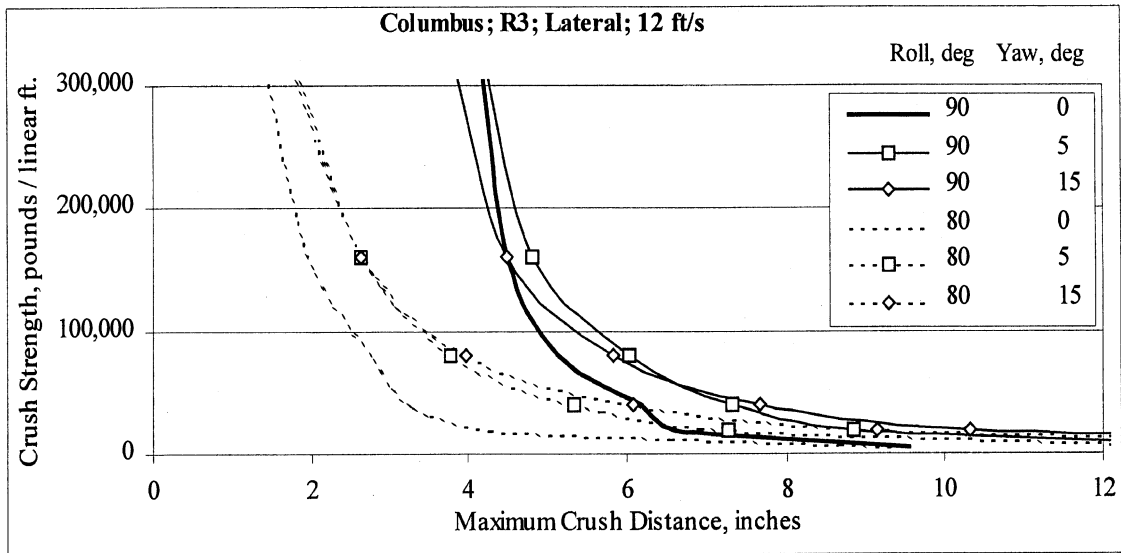

Figure C-31. Lateral results for Columbus with flat rails and crowned end dams every 6 ft.

Table C-30. Tabular lateral results for Columbus with flat rails and crowned end dams every 6 ft.

Later impact results for Columbus with flat rails and crowned end dams every 6 ft.									
Vel., ft/s	Roll, deg	Yaw, deg	Force, lbs	Defl., in.	Vel., ft/s	Roll, deg	Yaw, deg	Force, lbs	Defl., in.
12	90	0	5,000	9.56	18	80	0	5,000	14.01
12	90	0	20,000	6.58	18	80	0	20,000	6.68
12	90	0	40,000	6.17	18	80	0	40,000	4.55
12	90	0	80,000	5.13	18	80	0	80,000	3.39
12	90	0	160,000	4.49	18	80	0	160,000	2.85
12	90	0	320,000	4.16	18	80	0	320,000	2.08
12	90	5	5,000	13.87	18	80	5	5,000	18.59
12	90	5	20,000	8.84	18	80	5	20,000	10.40
12	90	5	40,000	7.31	18	80	5	40,000	7.66
12	90	5	80,000	6.02	18	80	5	80,000	5.67
12	90	5	160,000	4.82	18	80	5	160,000	4.02
12	90	5	320,000	4.22	18	80	5	320,000	2.84
12	90	15	5,000	19.43	18	80	15	5,000	27.51
12	90	15	20,000	10.32	18	80	15	20,000	14.09
12	90	15	40,000	7.65	18	80	15	40,000	9.77
12	90	15	80,000	5.82	18	80	15	80,000	6.52
12	90	15	160,000	4.48	18	80	15	160,000	4.30
12	90	15	320,000	3.82	18	80	15	320,000	2.85
12	80	0	5,000	9.32	24	90	0	5,000	21.47
12	80	0	20,000	4.29	24	90	0	20,000	9.56
12	80	0	40,000	3.25	24	90	0	40,000	7.58
12	80	0	80,000	2.75	24	90	0	80,000	6.60
12	80	0	160,000	1.94	24	90	0	160,000	6.19
12	80	0	320,000	1.38	24	90	0	320,000	5.13
12	80	5	5,000	13.17	24	90	5	5,000	24.84
12	80	5	20,000	7.27	24	90	5	20,000	13.87
12	80	5	40,000	5.34	24	90	5	40,000	10.92
12	80	5	80,000	3.78	24	90	5	80,000	8.85
12	80	5	160,000	2.64	24	90	5	160,000	7.33
12	80	5	320,000	1.76	24	90	5	320,000	6.05
12	80	15	5,000	18.76	24	90	15	5,000	37.17
12	80	15	20,000	9.14	24	90	15	20,000	19.43
12	80	15	40,000	6.09	24	90	15	40,000	14.11
12	80	15	80,000	3.97	24	90	15	80,000	10.34
12	80	15	160,000	2.63	24	90	15	160,000	7.67
12	80	15	320,000	1.70	24	90	15	320,000	5.84
18	90	0	5,000	14.52	24	80	0	5,000	20.85
18	90	0	20,000	7.82	24	80	0	20,000	9.32
18	90	0	40,000	6.71	24	80	0	40,000	6.23
18	90	0	80,000	6.21	24	80	0	80,000	4.30
18	90	0	160,000	5.29	24	80	0	160,000	3.28
18	90	0	320,000	4.57	24	80	0	320,000	2.79
18	90	5	5,000	19.10	24	80	5	5,000	24.35
18	90	5	20,000	11.35	24	80	5	20,000	13.18
18	90	5	40,000	9.16	24	80	5	40,000	9.89
18	90	5	80,000	7.55	24	80	5	80,000	7.28
18	90	5	160,000	6.24	24	80	5	160,000	5.36
18	90	5	320,000	4.99	24	80	5	320,000	3.82
18	90	15	5,000	28.10	24	80	15	5,000	36.59
18	90	15	20,000	14.90	24	80	15	20,000	18.76
18	90	15	40,000	10.86	24	80	15	40,000	13.27
18	90	15	80,000	8.04	24	80	15	80,000	9.16
18	90	15	160,000	6.07	24	80	15	160,000	6.12
18	90	15	320,000	4.66	24	80	15	320,000	4.03

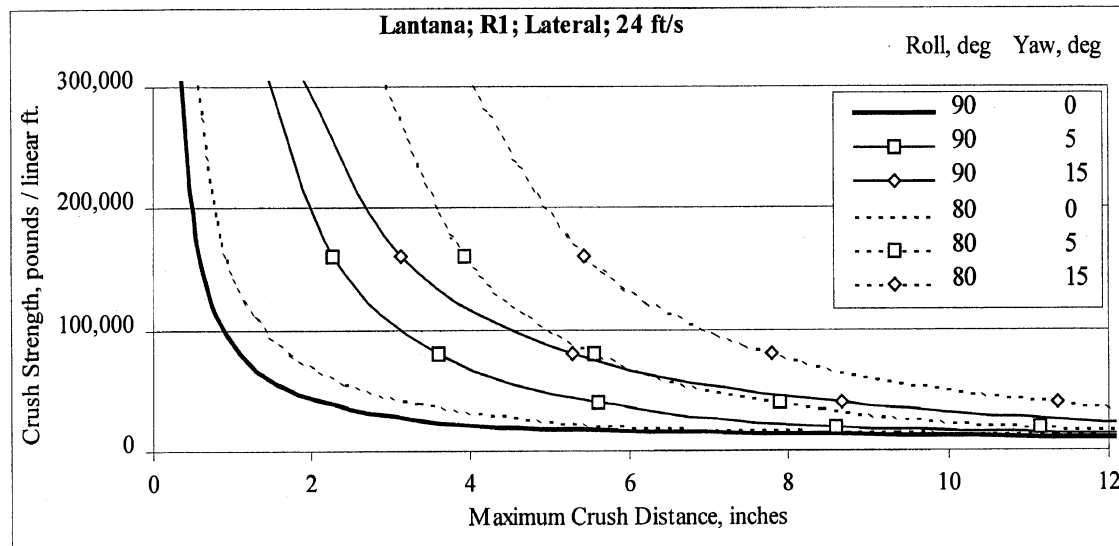
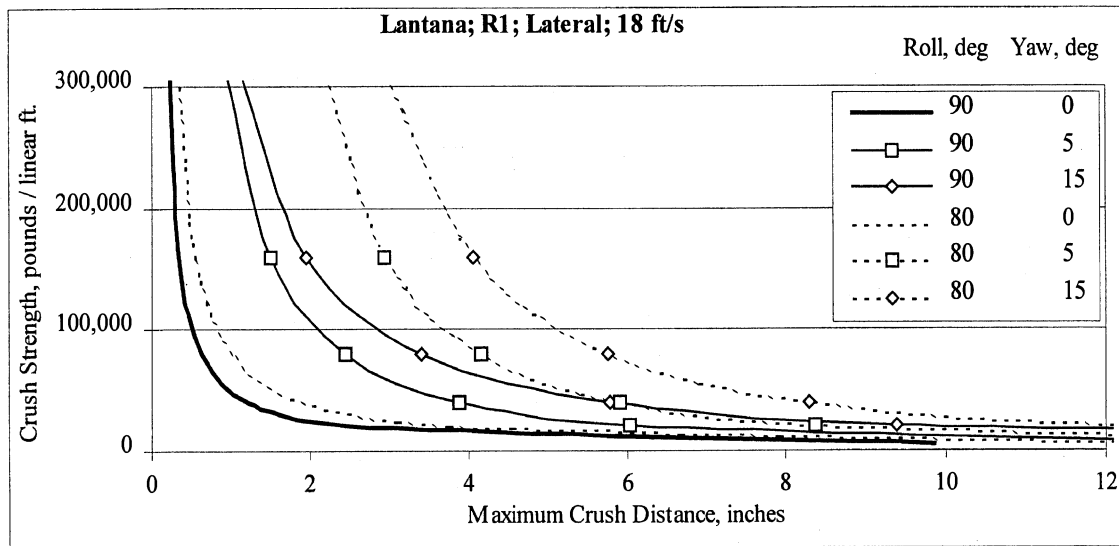
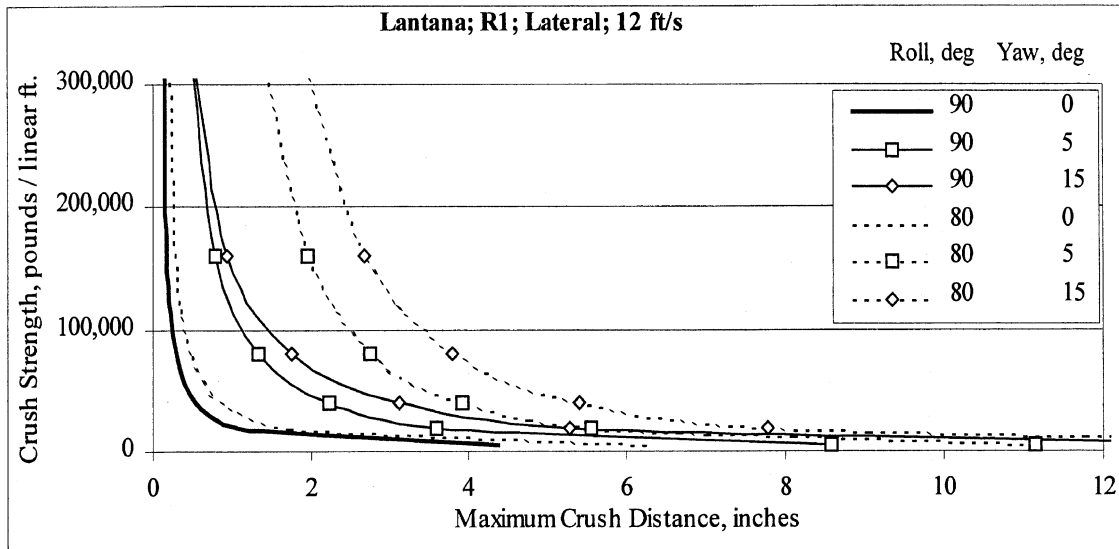

Figure C-32. Lateral results for Lantana with flat rails and flat end dams only.

Table C-31. Tabular lateral results for Lantana with flat rails and flat end dams only.

Later impact results for Lantana with flat rails and flat end dams only.									
Vel., ft/s	Roll, deg	Yaw, deg	Force, lbs	Defl., in.	Vel., ft/s	Roll, deg	Yaw, deg	Force, lbs	Defl., in.
12	90	0	5,000	4.38	18	80	0	5,000	13.02
12	90	0	20,000	1.10	18	80	0	20,000	3.75
12	90	0	40,000	0.56	18	80	0	40,000	1.96
12	90	0	80,000	0.29	18	80	0	80,000	1.01
12	90	0	160,000	0.18	18	80	0	160,000	0.54
12	90	0	320,000	0.15	18	80	0	320,000	0.33
12	90	5	5,000	8.57	18	80	5	5,000	16.87
12	90	5	20,000	3.59	18	80	5	20,000	8.37
12	90	5	40,000	2.24	18	80	5	40,000	5.92
12	90	5	80,000	1.35	18	80	5	80,000	4.16
12	90	5	160,000	0.79	18	80	5	160,000	2.95
12	90	5	320,000	0.49	18	80	5	320,000	2.12
12	90	15	5,000	13.66	18	80	15	5,000	25.86
12	90	15	20,000	5.29	18	80	15	20,000	12.10
12	90	15	40,000	3.12	18	80	15	40,000	8.30
12	90	15	80,000	1.75	18	80	15	80,000	5.77
12	90	15	160,000	0.93	18	80	15	160,000	4.05
12	90	15	320,000	0.53	18	80	15	320,000	2.90
12	80	0	5,000	6.24	24	90	0	5,000	17.51
12	80	0	20,000	1.74	24	90	0	20,000	4.38
12	80	0	40,000	0.90	24	90	0	40,000	2.20
12	80	0	80,000	0.47	24	90	0	80,000	1.11
12	80	0	160,000	0.26	24	90	0	160,000	0.59
12	80	0	320,000	0.19	24	90	0	320,000	0.35
12	80	5	5,000	11.13	24	90	5	5,000	20.02
12	80	5	20,000	5.56	24	90	5	20,000	8.58
12	80	5	40,000	3.91	24	90	5	40,000	5.61
12	80	5	80,000	2.75	24	90	5	80,000	3.61
12	80	5	160,000	1.96	24	90	5	160,000	2.27
12	80	5	320,000	1.40	24	90	5	320,000	1.41
12	80	15	5,000	16.58	24	90	15	5,000	31.92
12	80	15	20,000	7.79	24	90	15	20,000	13.66
12	80	15	40,000	5.41	24	90	15	40,000	8.67
12	80	15	80,000	3.80	24	90	15	80,000	5.30
12	80	15	160,000	2.67	24	90	15	160,000	3.15
12	80	15	320,000	1.91	24	90	15	320,000	1.81
18	90	0	5,000	9.85	24	80	0	5,000	22.47
18	90	0	20,000	2.47	24	80	0	20,000	6.25
18	90	0	40,000	1.24	24	80	0	40,000	3.37
18	90	0	80,000	0.64	24	80	0	80,000	1.76
18	90	0	160,000	0.35	24	80	0	160,000	0.93
18	90	0	320,000	0.23	24	80	0	320,000	0.53
18	90	5	5,000	13.97	24	80	5	5,000	23.32
18	90	5	20,000	6.03	24	80	5	20,000	11.14
18	90	5	40,000	3.89	24	80	5	40,000	7.90
18	90	5	80,000	2.45	24	80	5	80,000	5.58
18	90	5	160,000	1.50	24	80	5	160,000	3.94
18	90	5	320,000	0.91	24	80	5	320,000	2.81
18	90	15	5,000	22.59	24	80	15	5,000	35.53
18	90	15	20,000	9.37	24	80	15	20,000	16.58
18	90	15	40,000	5.78	24	80	15	40,000	11.35
18	90	15	80,000	3.42	24	80	15	80,000	7.80
18	90	15	160,000	1.95	24	80	15	160,000	5.44
18	90	15	320,000	1.08	24	80	15	320,000	3.86

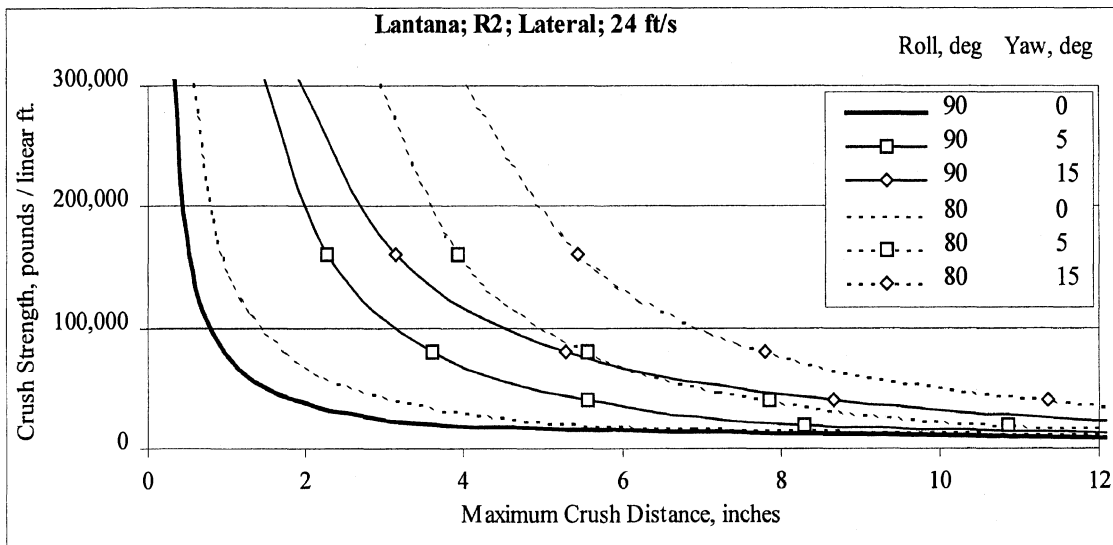
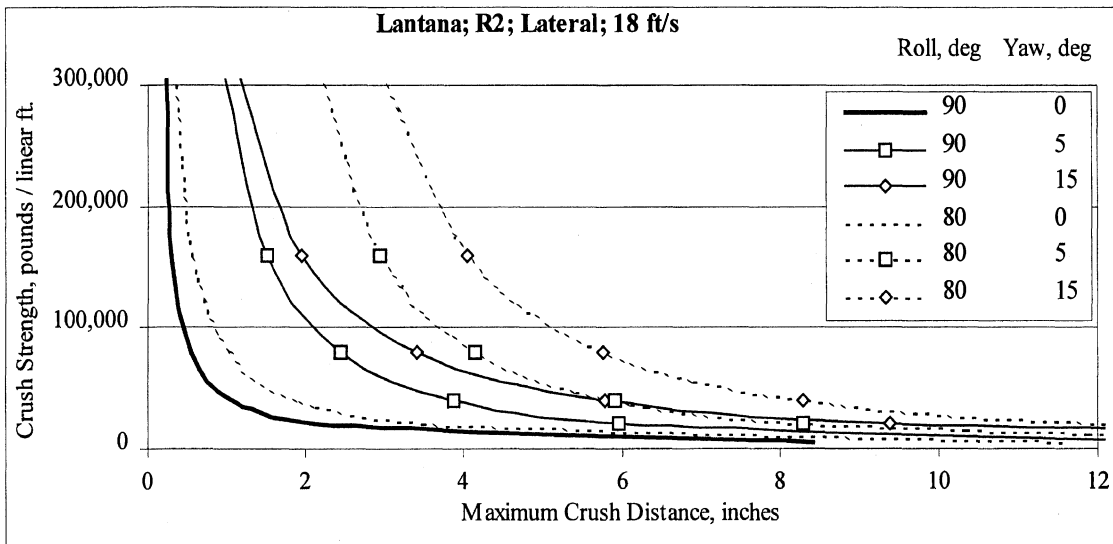
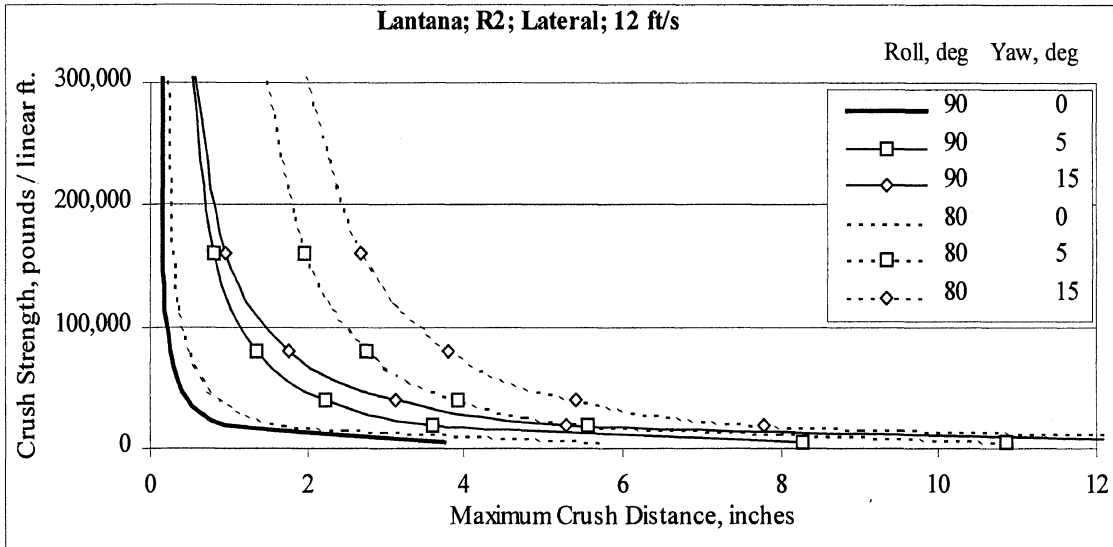

Figure C-33. Lateral results for Lantana with flat rails and flat dams every 6 ft.

Table C-32. Tabular lateral results for Lantana with flat rails and flat dams every 6 ft.

Later impact results for Lantana with flat rails and flat dams every 6 ft.									
Vel., ft/s	Roll, deg	Yaw, deg	Force, lbs	Defl., in.	Vel., ft/s	Roll, deg	Yaw, deg	Force, lbs	Defl., in.
12	90	0	5,000	3.74	18	80	0	5,000	11.55
12	90	0	20,000	0.94	18	80	0	20,000	3.52
12	90	0	40,000	0.48	18	80	0	40,000	1.90
12	90	0	80,000	0.25	18	80	0	80,000	1.01
12	90	0	160,000	0.16	18	80	0	160,000	0.54
12	90	0	320,000	0.14	18	80	0	320,000	0.33
12	90	5	5,000	8.28	18	80	5	5,000	16.14
12	90	5	20,000	3.59	18	80	5	20,000	8.29
12	90	5	40,000	2.24	18	80	5	40,000	5.92
12	90	5	80,000	1.35	18	80	5	80,000	4.16
12	90	5	160,000	0.79	18	80	5	160,000	2.95
12	90	5	320,000	0.49	18	80	5	320,000	2.12
12	90	15	5,000	13.66	18	80	15	5,000	25.19
12	90	15	20,000	5.29	18	80	15	20,000	12.10
12	90	15	40,000	3.12	18	80	15	40,000	8.30
12	90	15	80,000	1.75	18	80	15	80,000	5.77
12	90	15	160,000	0.93	18	80	15	160,000	4.05
12	90	15	320,000	0.53	18	80	15	320,000	2.90
12	80	0	5,000	5.70	24	90	0	5,000	14.97
12	80	0	20,000	1.70	24	90	0	20,000	3.74
12	80	0	40,000	0.90	24	90	0	40,000	1.88
12	80	0	80,000	0.47	24	90	0	80,000	0.95
12	80	0	160,000	0.26	24	90	0	160,000	0.51
12	80	0	320,000	0.19	24	90	0	320,000	0.31
12	80	5	5,000	10.86	24	90	5	5,000	18.66
12	80	5	20,000	5.56	24	90	5	20,000	8.28
12	80	5	40,000	3.91	24	90	5	40,000	5.58
12	80	5	80,000	2.75	24	90	5	80,000	3.61
12	80	5	160,000	1.96	24	90	5	160,000	2.27
12	80	5	320,000	1.40	24	90	5	320,000	1.41
12	80	15	5,000	16.57	24	90	15	5,000	30.59
12	80	15	20,000	7.79	24	90	15	20,000	13.66
12	80	15	40,000	5.41	24	90	15	40,000	8.67
12	80	15	80,000	3.80	24	90	15	80,000	5.30
12	80	15	160,000	2.67	24	90	15	160,000	3.15
12	80	15	320,000	1.91	24	90	15	320,000	1.81
18	90	0	5,000	8.42	24	80	0	5,000	19.68
18	90	0	20,000	2.11	24	80	0	20,000	5.71
18	90	0	40,000	1.06	24	80	0	40,000	3.18
18	90	0	80,000	0.55	24	80	0	80,000	1.72
18	90	0	160,000	0.30	24	80	0	160,000	0.93
18	90	0	320,000	0.21	24	80	0	320,000	0.53
18	90	5	5,000	13.24	24	80	5	5,000	21.90
18	90	5	20,000	5.96	24	80	5	20,000	10.87
18	90	5	40,000	3.89	24	80	5	40,000	7.84
18	90	5	80,000	2.45	24	80	5	80,000	5.58
18	90	5	160,000	1.50	24	80	5	160,000	3.94
18	90	5	320,000	0.91	24	80	5	320,000	2.81
18	90	15	5,000	21.95	24	80	15	5,000	34.15
18	90	15	20,000	9.37	24	80	15	20,000	16.58
18	90	15	40,000	5.78	24	80	15	40,000	11.35
18	90	15	80,000	3.42	24	80	15	80,000	7.80
18	90	15	160,000	1.95	24	80	15	160,000	5.44
18	90	15	320,000	1.08	24	80	15	320,000	3.86

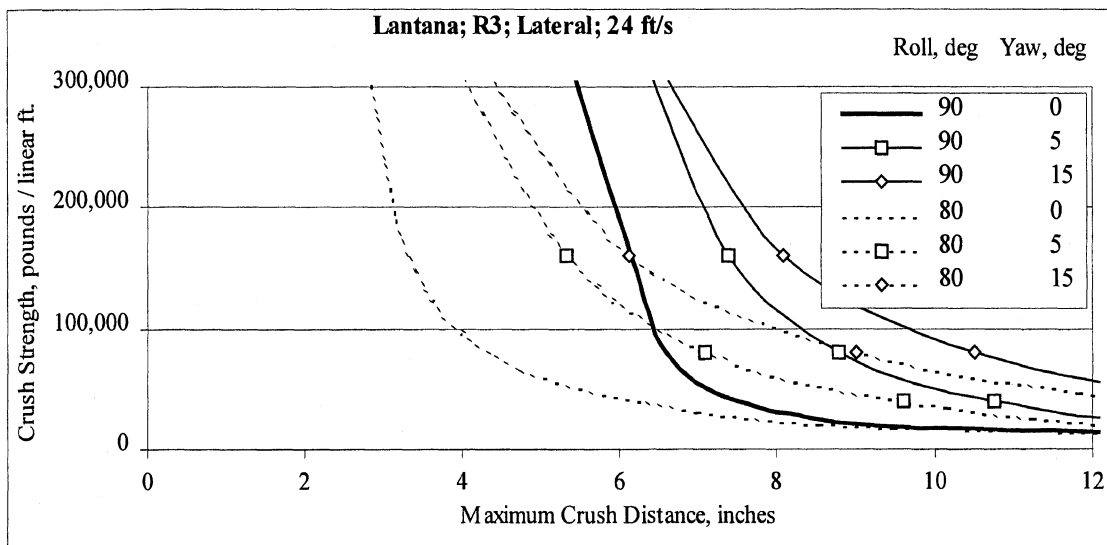
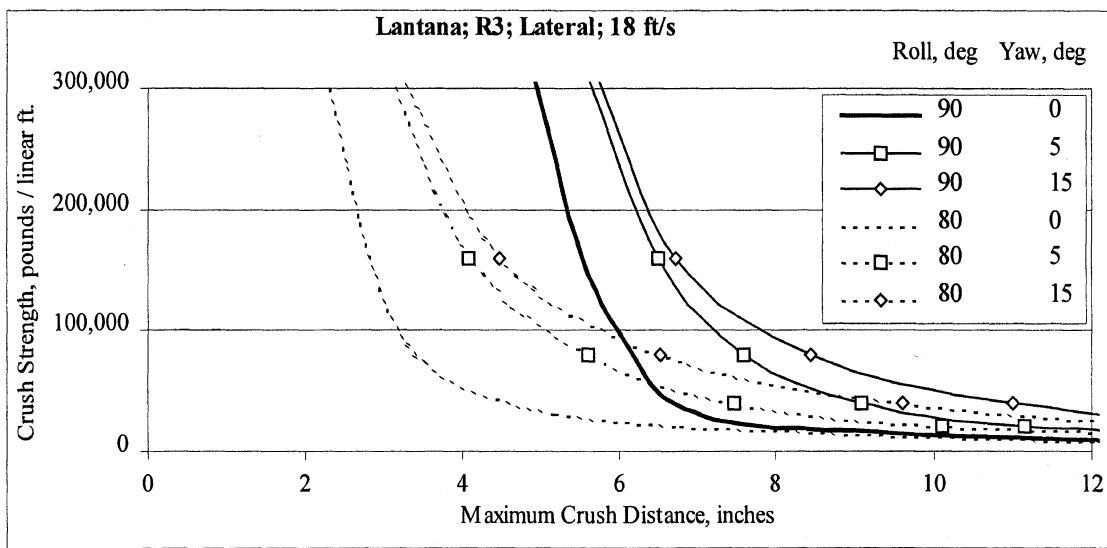
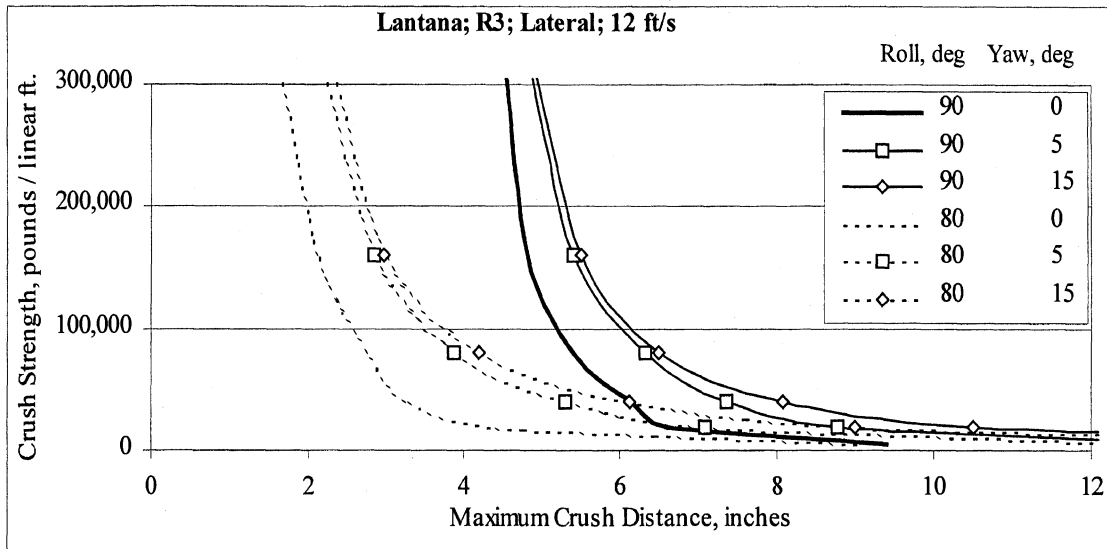

Figure C-34. Lateral results for Lantana with flat rails and crowned dams every 6 ft.

Table C-33. Tabular lateral results for Lantana with flat rails and crowned dams every 6 ft.

Later impact results for Lantana with flat rails and crowned dams every 6 ft.									
Vel., ft/s	Roll, deg	Yaw, deg	Force, lbs	Defl., in.	Vel., ft/s	Roll, deg	Yaw, deg	Force, lbs	Defl., in.
12	90	0	5,000	9.39	18	80	0	5,000	13.50
12	90	0	20,000	6.59	18	80	0	20,000	6.72
12	90	0	40,000	6.14	18	80	0	40,000	4.62
12	90	0	80,000	5.40	18	80	0	80,000	3.42
12	90	0	160,000	4.80	18	80	0	160,000	2.83
12	90	0	320,000	4.50	18	80	0	320,000	2.23
12	90	5	5,000	13.53	18	80	5	5,000	17.95
12	90	5	20,000	8.78	18	80	5	20,000	10.10
12	90	5	40,000	7.37	18	80	5	40,000	7.46
12	90	5	80,000	6.33	18	80	5	80,000	5.61
12	90	5	160,000	5.41	18	80	5	160,000	4.09
12	90	5	320,000	4.84	18	80	5	320,000	3.02
12	90	15	5,000	18.96	18	80	15	5,000	26.45
12	90	15	20,000	10.49	18	80	15	20,000	13.71
12	90	15	40,000	8.08	18	80	15	40,000	9.59
12	90	15	80,000	6.49	18	80	15	80,000	6.53
12	90	15	160,000	5.51	18	80	15	160,000	4.48
12	90	15	320,000	4.88	18	80	15	320,000	3.15
12	80	0	5,000	9.03	24	90	0	5,000	20.62
12	80	0	20,000	4.35	24	90	0	20,000	9.39
12	80	0	40,000	3.28	24	90	0	40,000	7.53
12	80	0	80,000	2.76	24	90	0	80,000	6.60
12	80	0	160,000	2.10	24	90	0	160,000	6.16
12	80	0	320,000	1.62	24	90	0	320,000	5.40
12	80	5	5,000	12.77	24	90	5	5,000	23.97
12	80	5	20,000	7.10	24	90	5	20,000	13.53
12	80	5	40,000	5.32	24	90	5	40,000	10.73
12	80	5	80,000	3.86	24	90	5	80,000	8.79
12	80	5	160,000	2.86	24	90	5	160,000	7.39
12	80	5	320,000	2.16	24	90	5	320,000	6.35
12	80	15	5,000	18.10	24	90	15	5,000	35.84
12	80	15	20,000	9.00	24	90	15	20,000	18.97
12	80	15	40,000	6.12	24	90	15	40,000	14.01
12	80	15	80,000	4.20	24	90	15	80,000	10.50
12	80	15	160,000	2.97	24	90	15	160,000	8.09
12	80	15	320,000	2.28	24	90	15	320,000	6.51
18	90	0	5,000	14.07	24	80	0	5,000	19.92
18	90	0	20,000	7.76	24	80	0	20,000	9.03
18	90	0	40,000	6.71	24	80	0	40,000	6.28
18	90	0	80,000	6.19	24	80	0	80,000	4.36
18	90	0	160,000	5.55	24	80	0	160,000	3.30
18	90	0	320,000	4.88	24	80	0	320,000	2.79
18	90	5	5,000	18.52	24	80	5	5,000	23.41
18	90	5	20,000	11.13	24	80	5	20,000	12.77
18	90	5	40,000	9.07	24	80	5	40,000	9.60
18	90	5	80,000	7.59	24	80	5	80,000	7.11
18	90	5	160,000	6.51	24	80	5	160,000	5.34
18	90	5	320,000	5.55	24	80	5	320,000	3.90
18	90	15	5,000	27.18	24	80	15	5,000	35.13
18	90	15	20,000	14.76	24	80	15	20,000	18.11
18	90	15	40,000	10.99	24	80	15	40,000	12.93
18	90	15	80,000	8.43	24	80	15	80,000	9.01
18	90	15	160,000	6.72	24	80	15	160,000	6.15
18	90	15	320,000	5.67	24	80	15	320,000	4.23

